

SECTION **INT**
INTERIOR

A
B
C
D
E
F
G
H
I
INT
K
L
M
N
O
P

CONTENTS

PRECAUTION	2	SQUEAK AND RATTLE TROUBLE DIAG- NOSES	9
PRECAUTIONS	2	Work Flow	9
Precaution for Supplemental Restraint System (SRS) "AIR BAG" and "SEAT BELT PRE-TEN- SIONER"	2	Generic Squeak and Rattle Troubleshooting	11
Precaution for Work	2	Diagnostic Worksheet	13
Service Notice	2	REMOVAL AND INSTALLATION	15
PREPARATION	4	DOOR FINISHER	15
PREPARATION	4	Removal and Installation	15
Special Service Tool	4	BODY SIDE TRIM	18
Commercial Service Tools	4	Component	18
CLIP LIST	5	Removal and Installation	19
Descriptions for Clips	5	FLOOR TRIM	23
SYMPTOM DIAGNOSIS	9	Removal and Installation	23
		HEADLINING	25
		Removal and Installation	25

PRECAUTIONS

< PRECAUTION >

PRECAUTION

PRECAUTIONS

Precaution for Supplemental Restraint System (SRS) "AIR BAG" and "SEAT BELT PRE-TENSIONER"

INFOID:000000008790127

The Supplemental Restraint System such as "AIR BAG" and "SEAT BELT PRE-TENSIONER", used along with a front seat belt, helps to reduce the risk or severity of injury to the driver and front passenger for certain types of collision. This system includes seat belt switch inputs and dual stage front air bag modules. The SRS system uses the seat belt switches to determine the front air bag deployment, and may only deploy one front air bag, depending on the severity of a collision and whether the front occupants are belted or unbelted. Information necessary to service the system safely is included in the SR and SB section of this Service Manual.

WARNING:

- To avoid rendering the SRS inoperative, which could increase the risk of personal injury or death in the event of a collision which would result in air bag inflation, all maintenance must be performed by an authorized NISSAN/INFINITI dealer.
- Improper maintenance, including incorrect removal and installation of the SRS, can lead to personal injury caused by unintentional activation of the system. For removal of Spiral Cable and Air Bag Module, see the SR section.
- Do not use electrical test equipment on any circuit related to the SRS unless instructed to in this Service Manual. SRS wiring harnesses can be identified by yellow and/or orange harnesses or harness connectors.

PRECAUTIONS WHEN USING POWER TOOLS (AIR OR ELECTRIC) AND HAMMERS

WARNING:

- When working near the Airbag Diagnosis Sensor Unit or other Airbag System sensors with the Ignition ON or engine running, DO NOT use air or electric power tools or strike near the sensor(s) with a hammer. Heavy vibration could activate the sensor(s) and deploy the air bag(s), possibly causing serious injury.
- When using air or electric power tools or hammers, always switch the Ignition OFF, disconnect the battery, and wait at least 3 minutes before performing any service.

Precaution for Work

INFOID:000000009241993

- When removing or disassembling each component, be careful not to damage or deform it. If a component may be subject to interference, be sure to protect it with a shop cloth.
- When removing (disengaging) components with a screwdriver or similar tool, be sure to wrap the component with a shop cloth or vinyl tape to protect it.
- Protect the removed parts with a shop cloth and prevent them from being dropped.
- Replace a deformed or damaged clip.
- If a part is specified as a non-reusable part, always replace it with a new one.
- Be sure to tighten bolts and nuts securely to the specified torque.
- After installation is complete, be sure to check that each part works properly.
- Follow the steps below to clean components:
 - Water soluble dirt:
 - Dip a soft cloth into lukewarm water, wring the water out of the cloth and wipe the dirty area.
 - Then rub with a soft, dry cloth.
 - Oily dirt:
 - Dip a soft cloth into lukewarm water with mild detergent (concentration: within 2 to 3%) and wipe the dirty area.
 - Then dip a cloth into fresh water, wring the water out of the cloth and wipe the detergent off.
 - Then rub with a soft, dry cloth.
 - Do not use organic solvent such as thinner, benzene, alcohol or gasoline.
 - For genuine leather seats, use a genuine leather seat cleaner.

Service Notice

INFOID:000000008790129

- When removing or installing various parts, place a cloth or padding on the vehicle body to prevent scratches.

PRECAUTIONS

< PRECAUTION >

- Handle trim, molding, instruments, grille, etc. carefully during removing or installing. Be careful not to soil or damage them.
- Apply sealing compound where necessary when installing parts.
- When applying sealing compound, be careful that the sealing compound does not protrude from parts.
- When replacing any metal parts (for example body outer panel, members, etc.), be sure to take rust prevention measures.

A

B

C

D

E

F

G

H

I

INT

K

L

M

N

O

P

PREPARATION

< PREPARATION >

PREPARATION

PREPARATION

Special Service Tool

INFOID:000000008790130

The actual shapes of Kent-Moore tools may differ from those of special service tools illustrated here.

Tool number (Kent-Moore No.) Tool name	Description
— (J-39570) Chassis ear	Locating the noise
— (J-43980) NISSAN Squeak and Rattle Kit	Repairing the cause of noise
— (J-46534) Trim Tool Set	Removing trim components

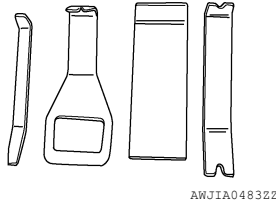
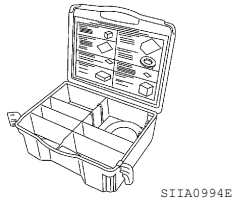
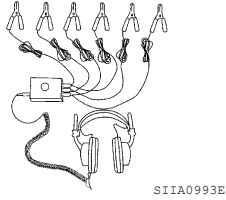

Commercial Service Tools

INFOID:000000008790131

Tool name	Description
Engine ear	Locating the noise
Power tool	Loosening nuts, screws and bolts

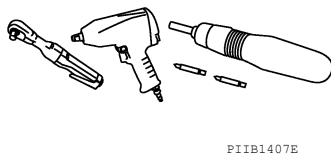
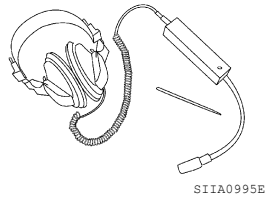

CLIP LIST







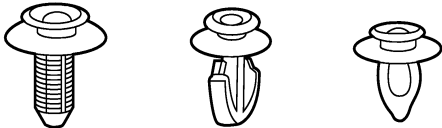

< PREPARATION >

CLIP LIST

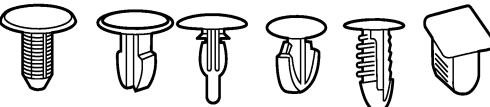
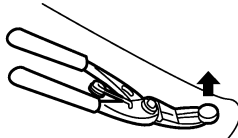
Descriptions for Clips

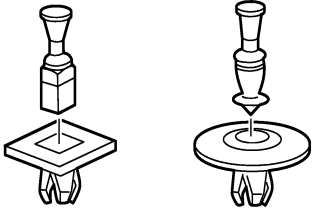
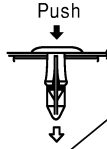
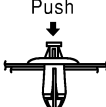
INFOID:000000008790132

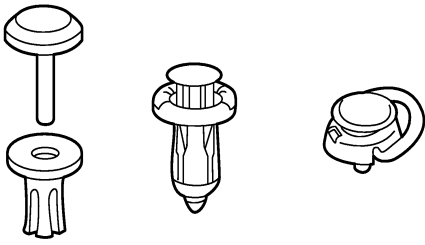
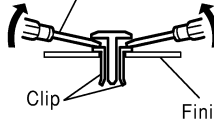
Replace any clips which are damaged during removal or installation.

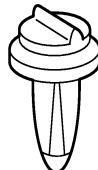
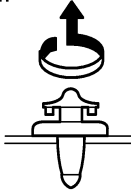





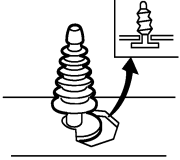
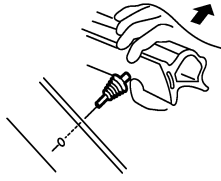

Symbol No.	Shapes	Removal & Installation
C101 		<p>Removal: Remove by bending up with flat-bladed screwdrivers or clip remover.</p> 
C103 		 <p>Removal: Remove with a clip remover.</p>
C203 		<p>Removal: Push center pin to catching position. (Do not remove center pin by hitting it.)</p> <p>Push</p>  <p>Installation:</p> <p>Push</p> 
C205 		<p>Removal: Flat-bladed screwdriver</p>  <p>Clip</p> <p>Finisher</p>
C206 		<p>Removal:</p> 

SIIA0315E

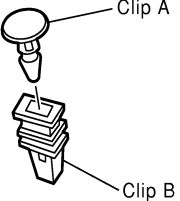
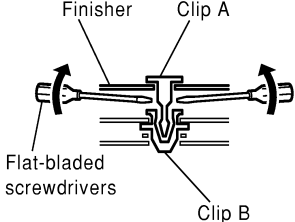
A
B
C
D
E
F
G
H
I
INT
K
L
M
N
O
P

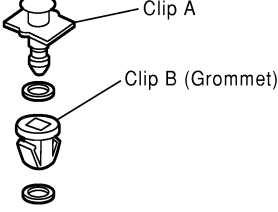
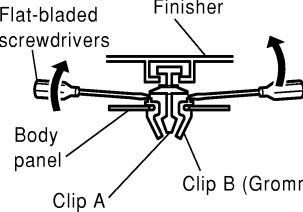
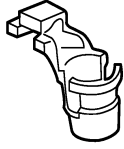
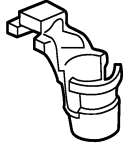
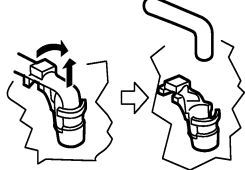
CLIP LIST

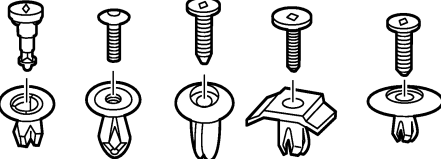







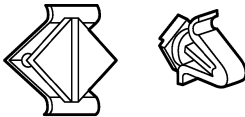

< PREPARATION >

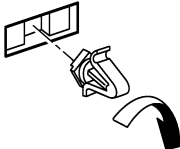
Symbol No.	Shapes	Removal & Installation
<p>CE103</p> 		<p>Removal:</p> 
<p>CF110</p> 		<p>Removal:</p> 
<p>CF118</p> 		<p>Removal:</p> 
<p>CR103</p> 		<p>Removal: Holder portion of clip must be spread out to remove rod.</p> 
<p>CS101</p> 		<p>Removal:</p> <ol style="list-style-type: none"> 1. Screw out with a Phillips screwdriver. 2. Remove female portion with flat-bladed screwdriver. 

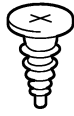
SIIA0316E

CLIP LIST

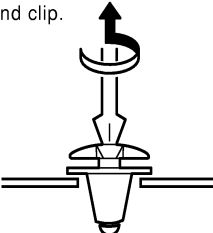
< PREPARATION >

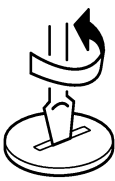



Symbol No.	Shapes	Removal & Installation	
CG101 		Removal:  Rotate 45° to remove	Installation: 
CS102 			
CS113 		Removal: Disconnect upper connection of clip with a flat-bladed screwdriver, then remove clip while inserting a flat-bladed screwdriver between body panel and clip. 	
C111 			

SIIA0317E

A
B
C
D
E
F
G
H
I
INT
K
L
M
N
O
P

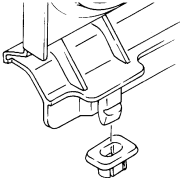
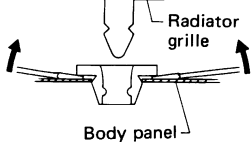
CLIP LIST

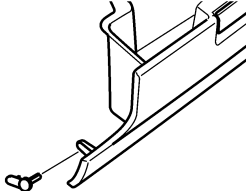
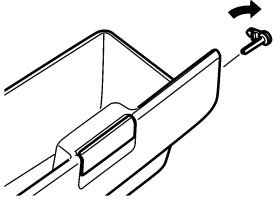
< PREPARATION >

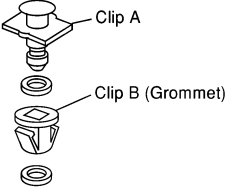
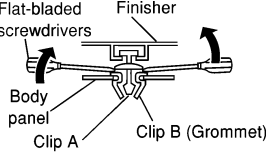
Symbol No.	Shapes	Removal & Installation
<p>CG104</p> 		<p>Removal: Remove by bending up with flat-bladed screwdrivers.</p> 
<p>CE114</p> 		
<p>CF118</p> 		<p>Removal: Flat-bladed screwdrivers Finisher screwdrivers</p> 

ALJIA0564GB

SQUEAK AND RATTLE TROUBLE DIAGNOSES

< SYMPTOM DIAGNOSIS >

SYMPTOM DIAGNOSIS

SQUEAK AND RATTLE TROUBLE DIAGNOSES

Work Flow

INFOID:000000009241997

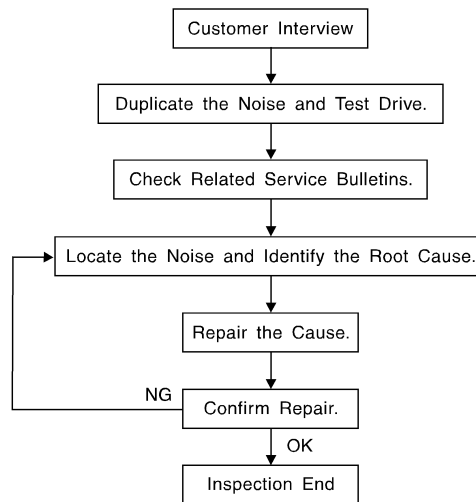

SBT842

CUSTOMER INTERVIEW

Interview the customer if possible, to determine the conditions that exist when the noise occurs. Use the Diagnostic Worksheet during the interview to document the facts and conditions when the noise occurs and any customer's comments; refer to [INT-13, "Diagnostic Worksheet"](#). This information is necessary to duplicate the conditions that exist when the noise occurs.

- The customer may not be able to provide a detailed description or the location of the noise. Attempt to obtain all the facts and conditions that exist when the noise occurs (or does not occur).
- If there is more than one noise in the vehicle, be sure to diagnose and repair the noise that the customer is concerned about. This can be accomplished by test driving the vehicle with the customer.
- After identifying the type of noise, isolate the noise in terms of its characteristics. The noise characteristics are provided so the customer, service adviser and technician are all speaking the same language when defining the noise.
- Squeak —(Like tennis shoes on a clean floor)
Squeak characteristics include the light contact/fast movement/brought on by road conditions/hard surfaces = higher pitch noise/softer surfaces = lower pitch noises/edge to surface = chirping.
- Creak—(Like walking on an old wooden floor)
Creak characteristics include firm contact/slow movement/twisting with a rotational movement/pitch dependent on materials/often brought on by activity.
- Rattle—(Like shaking a baby rattle)
Rattle characteristics include the fast repeated contact/vibration or similar movement/loose parts/missing clip or fastener/incorrect clearance.
- Knock —(Like a knock on a door)
Knock characteristics include hollow sounding/sometimes repeating/often brought on by driver action.
- Tick—(Like a clock second hand)
Tick characteristics include gentle contacting of light materials/loose components/can be caused by driver action or road conditions.
- Thump—(Heavy, muffled knock noise)
Thump characteristics include softer knock/dead sound often brought on by activity.
- Buzz—(Like a bumble bee)
Buzz characteristics include high frequency rattle/firm contact.
- Often the degree of acceptable noise level will vary depending upon the person. A noise that you may judge as acceptable may be very irritating to the customer.
- Weather conditions, especially humidity and temperature, may have a great effect on noise level.

DUPLICATE THE NOISE AND TEST DRIVE

SQUEAK AND RATTLE TROUBLE DIAGNOSES

< SYMPTOM DIAGNOSIS >

If possible, drive the vehicle with the customer until the noise is duplicated. Note any additional information on the Diagnostic Worksheet regarding the conditions or location of the noise. This information can be used to duplicate the same conditions when you confirm the repair.

If the noise can be duplicated easily during the test drive, to help identify the source of the noise, try to duplicate the noise with the vehicle stopped by doing one or all of the following:

- 1) Close a door.
 - 2) Tap or push/pull around the area where the noise appears to be coming from.
 - 3) Rev the engine.
 - 4) Use a floor jack to recreate vehicle "twist".
 - 5) At idle, apply engine load (electrical load, half-clutch on M/T model, drive position on CVT and A/T models).
 - 6) Raise the vehicle on a hoist and hit a tire with a rubber hammer.
- Drive the vehicle and attempt to duplicate the conditions the customer states exist when the noise occurs.
 - If it is difficult to duplicate the noise, drive the vehicle slowly on an undulating or rough road to stress the vehicle body.

CHECK RELATED SERVICE BULLETINS

After verifying the customer concern or symptom, check ASIST for Technical Service Bulletins (TSBs) related to that concern or symptom.

If a TSB relates to the symptom, follow the procedure to repair the noise.

LOCATE THE NOISE AND IDENTIFY THE ROOT CAUSE

1. Narrow down the noise to a general area. To help pinpoint the source of the noise, use a listening tool (Chassis Ear: J-39570, Engine Ear: J-39565 and mechanic's stethoscope).
2. Narrow down the noise to a more specific area and identify the cause of the noise by:
 - removing the components in the area that you suspect the noise is coming from.
Do not use too much force when removing clips and fasteners, otherwise clips and fasteners can be broken or lost during the repair, resulting in the creation of new noise.
 - tapping or pushing/pulling the component that you suspect is causing the noise.
Do not tap or push/pull the component with excessive force, otherwise the noise will be eliminated only temporarily.
 - feeling for a vibration with your hand by touching the component(s) that you suspect is (are) causing the noise.
 - placing a piece of paper between components that you suspect are causing the noise.
 - looking for loose components and contact marks.
Refer to [INT-11, "Generic Squeak and Rattle Troubleshooting"](#).

REPAIR THE CAUSE

- If the cause is a loose component, tighten the component securely.
- If the cause is insufficient clearance between components:
 - separate components by repositioning or loosening and retightening the component, if possible.
 - insulate components with a suitable insulator such as urethane pads, foam blocks, felt cloth tape or urethane tape. A NISSAN Squeak and Rattle Kit (J-43980) is available through your authorized NISSAN Parts Department.

CAUTION:

Do not use excessive force as many components are constructed of plastic and may be damaged.

Always check with the Parts Department for the latest parts information.

The following materials are contained in the NISSAN Squeak and Rattle Kit (J-43980). Each item can be ordered separately as needed.

URETHANE PADS [1.5 mm (0.059 in) thick]

Insulates connectors, harness, etc.

76268-9E005: 100×135 mm (3.94×5.31 in)/76884-71L01: 60×85 mm (2.36×3.35 in)/76884-71L02: 15×25 mm (0.59×0.98 in)

INSULATOR (Foam blocks)

Insulates components from contact. Can be used to fill space behind a panel.

73982-9E000: 45 mm (1.77 in) thick, 50×50 mm (1.97×1.97 in)/73982-50Y00: 10 mm (0.39 in) thick, 50×50 mm (1.97×1.97 in)

INSULATOR (Light foam block)

80845-71L00: 30 mm (1.18 in) thick, 30×50 mm (1.18×1.97 in)

FELT CLOTH TAPE

Used to insulate where movement does not occur. Ideal for instrument panel applications.

68370-4B000: 15×25 mm (0.59×0.98 in) pad/68239-13E00: 5 mm (0.20 in) wide tape roll. The following materials not found in the kit can also be used to repair squeaks and rattles.

SQUEAK AND RATTLE TROUBLE DIAGNOSES

< SYMPTOM DIAGNOSIS >

UHMW (TEFLON) TAPE

Insulates where slight movement is present. Ideal for instrument panel applications.

SILICONE GREASE

Used instead of UHMW tape that will be visible or not fit.

Note: Will only last a few months.

SILICONE SPRAY

Use when grease cannot be applied.

DUCT TAPE

Use to eliminate movement.

CONFIRM THE REPAIR

Confirm that the cause of a noise is repaired by test driving the vehicle. Operate the vehicle under the same conditions as when the noise originally occurred. Refer to the notes on the Diagnostic Worksheet.

Generic Squeak and Rattle Troubleshooting

INFOID:000000009241995

Refer to Table of Contents for specific component removal and installation information.

INSTRUMENT PANEL

Most incidents are caused by contact and movement between:

1. Cluster lid A and the instrument panel
2. Acrylic lens and combination meter housing
3. Instrument panel to front pillar finisher
4. Instrument panel to windshield
5. Instrument panel pins
6. Wiring harnesses behind the combination meter
7. A/C defroster duct and duct joint

These incidents can usually be located by tapping or moving the components to duplicate the noise or by pressing on the components while driving to stop the noise. Most of these incidents can be repaired by applying felt cloth tape or silicone spray (in hard to reach areas). Urethane pads can be used to insulate wiring harness.

CAUTION:

Do not use silicone spray to isolate a squeak or rattle. If you saturate the area with silicone, you will not be able to recheck the repair.

CENTER CONSOLE

Components to pay attention to include:

1. Shift selector assembly cover to finisher
2. A/C control unit and cluster lid C
3. Wiring harnesses behind audio and A/C control unit

The instrument panel repair and isolation procedures also apply to the center console.

DOORS

Pay attention to the:

1. Finisher and inner panel making a slapping noise
2. Inside handle escutcheon to door finisher
3. Wiring harnesses tapping
4. Door striker out of alignment causing a popping noise on starts and stops

Tapping or moving the components or pressing on them while driving to duplicate the conditions can isolate many of these incidents. You can usually insulate the areas with felt cloth tape or insulator foam blocks from the NISSAN Squeak and Rattle Kit (J-43980) to repair the noise.

TRUNK

Trunk noises are often caused by a loose jack or loose items put into the trunk by the owner.

In addition look for:

1. Trunk lid bumpers out of adjustment
2. Trunk lid striker out of adjustment
3. The trunk lid torsion bars knocking together

A
B
C
D
E
F
G
H
I
INT
K
L
M
N
O
P

SQUEAK AND RATTLE TROUBLE DIAGNOSES

< SYMPTOM DIAGNOSIS >

4. A loose license plate or bracket

Most of these incidents can be repaired by adjusting, securing or insulating the item(s) or component(s) causing the noise.

SUNROOF/HEADLINING

Noises in the sunroof/headlining area can often be traced to one of the following:

1. Sunroof lid, rail, linkage or seals making a rattle or light knocking noise
2. Sun visor shaft shaking in the holder
3. Front or rear windshield touching headlining and squeaking

Again, pressing on the components to stop the noise while duplicating the conditions can isolate most of these incidents. Repairs usually consist of insulating with felt cloth tape.

OVERHEAD CONSOLE (FRONT AND REAR)

Overhead console noises are often caused by the console panel clips not being engaged correctly. Most of these incidents are repaired by pushing up on the console at the clip locations until the clips engage.

In addition look for:

1. Loose harness or harness connectors.
2. Front console map/reading lamp lens loose.
3. Loose screws at console attachment points.

SEATS

When isolating seat noise it's important to note the position the seat is in and the load placed on the seat when the noise is present. These conditions should be duplicated when verifying and isolating the cause of the noise.

Cause of seat noise include:

1. Headrest rods and holder
2. A squeak between the seat pad cushion and frame
3. The rear seatback lock and bracket

These noises can be isolated by moving or pressing on the suspected components while duplicating the conditions under which the noise occurs. Most of these incidents can be repaired by repositioning the component or applying urethane tape to the contact area.

UNDERHOOD

Some interior noise may be caused by components under the hood or on the engine wall. The noise is then transmitted into the passenger compartment.

Causes of transmitted underhood noise include:

1. Any component installed to the engine wall
2. Components that pass through the engine wall
3. Engine wall mounts and connectors
4. Loose radiator installation pins
5. Hood bumpers out of adjustment
6. Hood striker out of adjustment

These noises can be difficult to isolate since they cannot be reached from the interior of the vehicle. The best method is to secure, move or insulate one component at a time and test drive the vehicle. Also, engine rpm or load can be changed to isolate the noise. Repairs can usually be made by moving, adjusting, securing, or insulating the component causing the noise.

SQUEAK AND RATTLE TROUBLE DIAGNOSES

< SYMPTOM DIAGNOSIS >

Diagnostic Worksheet

INFOID:000000008790135

Dear Customer:

We are concerned about your satisfaction with your vehicle. Repairing a squeak or rattle sometimes can be very difficult. To help us fix your vehicle right the first time, please take a moment to note the area of the vehicle where the squeak or rattle occurs and under what conditions. You may be asked to take a test drive with a service advisor or technician to ensure we confirm the noise you are hearing.

SQUEAK & RATTLE DIAGNOSTIC WORKSHEET

I. WHERE DOES THE NOISE COME FROM? (circle the area of the vehicle)

The illustrations are for reference only, and may not reflect the actual configuration of your vehicle.

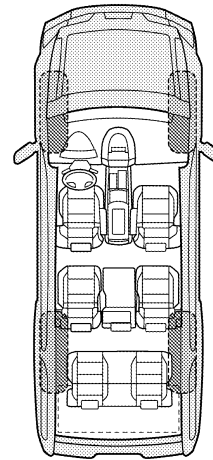
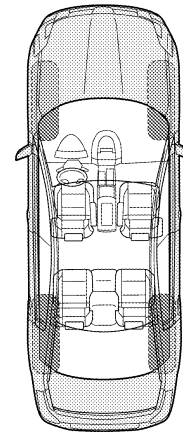
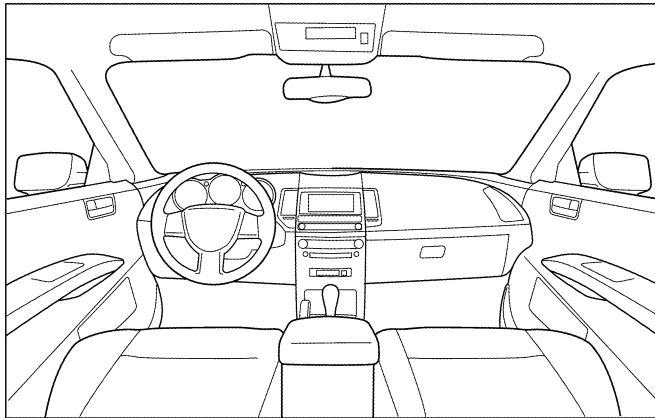

Continue to page 2 of the worksheet and briefly describe the location of the noise or rattle. In addition, please indicate the conditions which are present when the noise occurs.

A
B
C
D
E
F
G
H
I
INT
K
L
M
N
O
P

SQUEAK AND RATTLE TROUBLE DIAGNOSES

< SYMPTOM DIAGNOSIS >

SQUEAK & RATTLE DIAGNOSTIC WORKSHEET - page 2

Briefly describe the location where the noise occurs:

II. WHEN DOES IT OCCUR? (please check the boxes that apply)

- | | |
|---|--|
| <input type="checkbox"/> Anytime | <input type="checkbox"/> After sitting out in the rain |
| <input type="checkbox"/> 1st time in the morning | <input type="checkbox"/> When it is raining or wet |
| <input type="checkbox"/> Only when it is cold outside | <input type="checkbox"/> Dry or dusty conditions |
| <input type="checkbox"/> Only when it is hot outside | <input type="checkbox"/> Other: |

III. WHEN DRIVING:

- Through driveways
- Over rough roads
- Over speed bumps
- Only about ____ mph
- On acceleration
- Coming to a stop
- On turns: left, right or either (circle)
- With passengers or cargo
- Other: _____
- After driving ____ miles or ____ minutes

IV. WHAT TYPE OF NOISE

- Squeak (like tennis shoes on a clean floor)
- Creak (like walking on an old wooden floor)
- Rattle (like shaking a baby rattle)
- Knock (like a knock at the door)
- Tick (like a clock second hand)
- Thump (heavy muffled knock noise)
- Buzz (like a bumble bee)

TO BE COMPLETED BY DEALERSHIP PERSONNEL

Test Drive Notes:

	YES	NO	Initials of person performing
Vehicle test driven with customer	<input type="checkbox"/>	<input type="checkbox"/>	_____
- Noise verified on test drive	<input type="checkbox"/>	<input type="checkbox"/>	_____
- Noise source located and repaired	<input type="checkbox"/>	<input type="checkbox"/>	_____
- Follow up test drive performed to confirm repair	<input type="checkbox"/>	<input type="checkbox"/>	_____

VIN: _____ Customer Name _____

W.O.# _____ Date: _____

This form must be attached to Work Order

LATA0071E

DOOR FINISHER

< REMOVAL AND INSTALLATION >

REMOVAL AND INSTALLATION

DOOR FINISHER

Removal and Installation

INFOID:000000008790136

FRONT DOOR

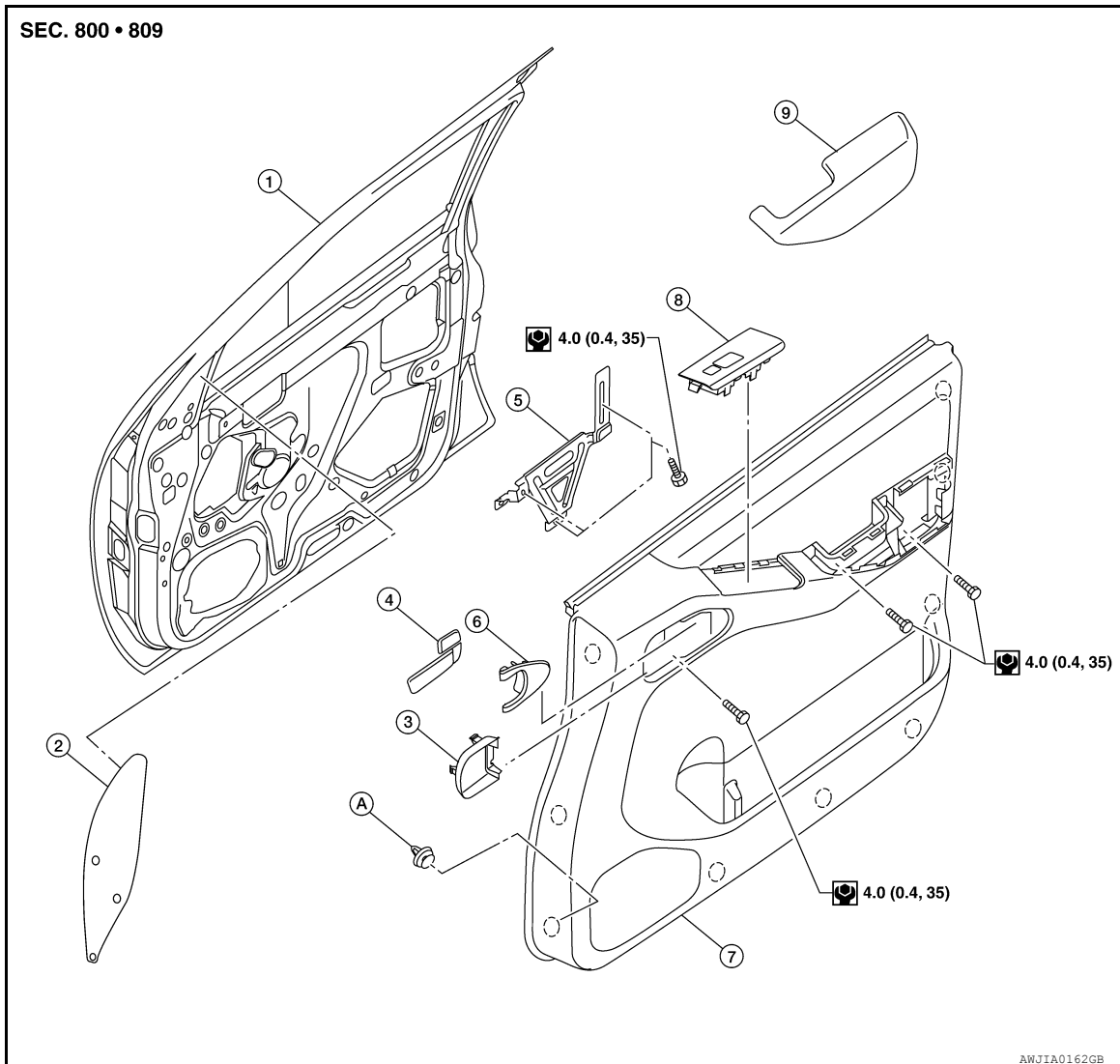

- | | | |
|------------------------------------|----------------------------------|---------------------------|
| 1. Front door | 2. Mirror bolt cover | 3. Pull handle escutcheon |
| 4. Pull handle/lock lever assembly | 5. Front door handle bracket | 6. Pull handle cover |
| 7. Front door finisher (RH shown) | 8. Power window/door lock switch | 9. Armrest |
| A. Clip C101 | | |

Removal

1. Remove window crank handle or power window/door lock switch (if equipped). Refer to [PWC-73, "Removal and Installation"](#) (LH) or [PWC-74, "Removal and Installation"](#) (RH).
2. Remove pull handle escutcheon.
3. Remove pull handle cover, then remove door finisher screw.
4. Remove armrest.
 - a. While pushing on the side of the armrest, pull up on the rear of the armrest releasing the lower fastening points.
 - b. With the rear of the armrest pulled upward, pull the front of the armrest toward you and remove.

A
B
C
D
E
F
G
H
I
INT
K
L
M
N
O
P

DOOR FINISHER

< REMOVAL AND INSTALLATION >

5. Remove screws behind armrest.
6. Release clips and reposition front door finisher.
7. Remove pull handle/lock lever assembly.
8. Disconnect lock lever cable and pull handle cable from lever assembly. Refer to [DLK-136. "Removal and Installation"](#).
9. Remove front door finisher.

Installation

Installation is in the reverse order of removal.

REAR DOOR - CREW CAB

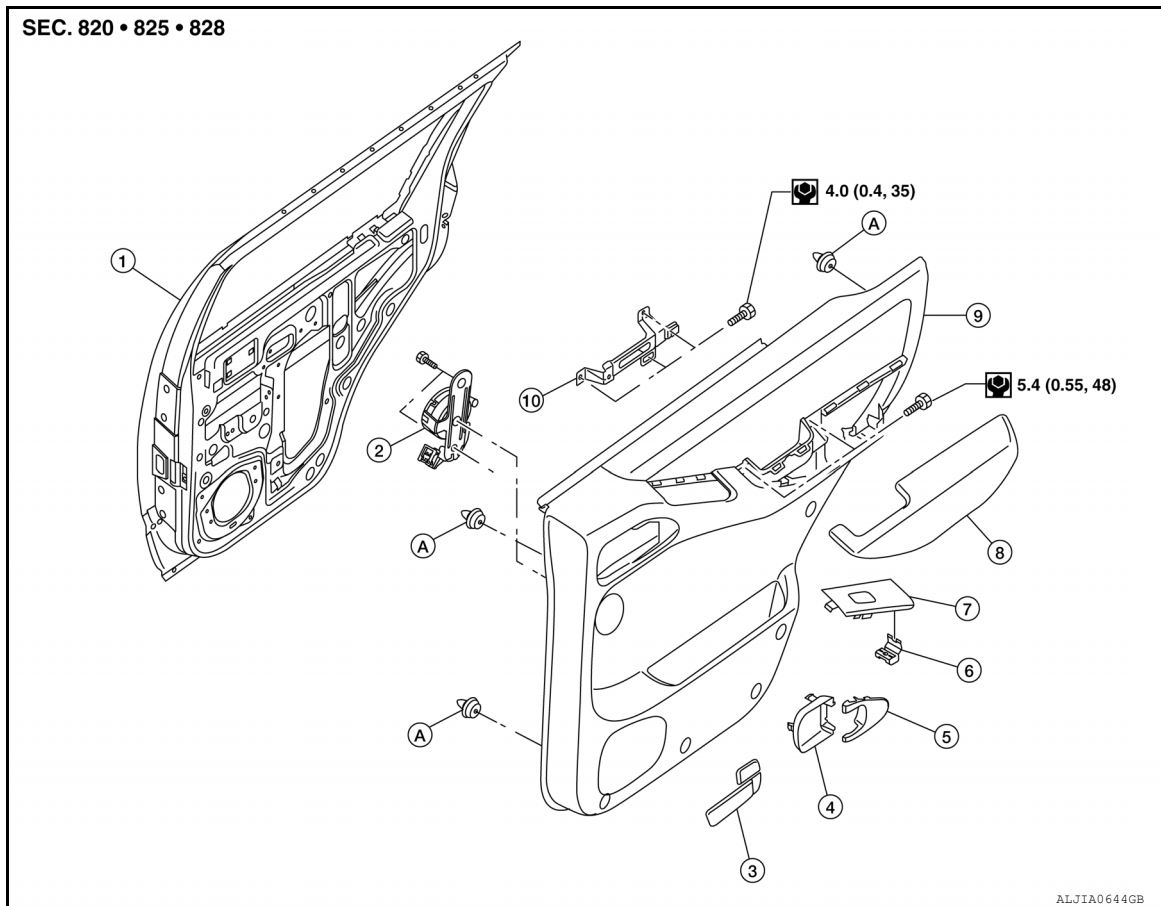

- | | | |
|---------------------------------|----------------------|------------------------------------|
| 1. Rear door | 2. Rear tweeter | 3. Pull handle/lock lever assembly |
| 4. Pull handle escutcheon | 5. Pull handle cover | 6. Metal clip |
| 7. Power window switch assembly | 8. Armrest | 9. Rear door finisher (RH shown) |
| 10. Rear door handle bracket | A. Clip C101 | |

Removal

1. Remove window crank handle or rear power window switch (if equipped). Refer to [PWC-75. "Removal and Installation - Rear Door Switch \(If Equipped\)"](#).
2. Remove pull handle cover.
 - Remove screw behind pull handle cover.
3. Remove pull handle escutcheon.
4. Lift upward to release clips and remove armrest.
5. Remove screws behind armrest.
6. Release the clips and remove rear door finisher.
 - Disconnect the harness connector from rear tweeter, then remove the rear tweeter screws and the rear tweeter.

DOOR FINISHER

< REMOVAL AND INSTALLATION >

- Remove pull handle/lock lever assembly.
 - Disconnect lock lever cable and pull handle cable from lever assembly. Refer to [DLK-136, "Removal and Installation"](#).

Installation

Installation is in the reverse order of removal.

REAR DOOR - KING CAB

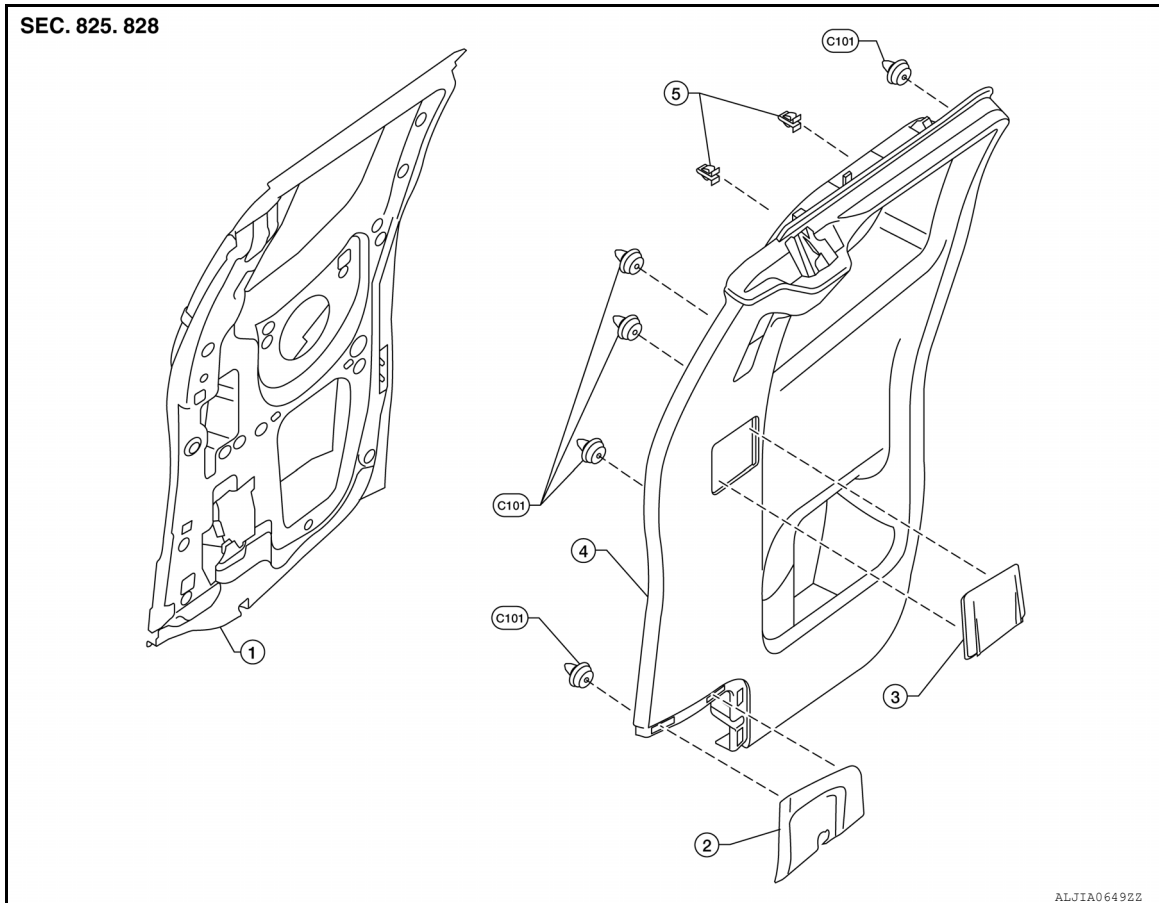

- | | | |
|-----------------------|----------------|----------|
| 1. Rear door | 2. Latch cover | 3. Guide |
| 4. Rear door finisher | 5. Metal clip | |

Removal

- Remove lower seat belt anchor bolt. Refer to [SB-13, "Removal and Installation"](#).
 - Disconnect harness connector for passenger side.
- Release the clips and remove rear door finisher.
- Remove lock lever assembly.
 - Disconnect lock lever cable and lever assembly. Refer to [DLK-140, "Removal and Installation"](#).

Installation

Installation is in the reverse order of removal.

BODY SIDE TRIM

< REMOVAL AND INSTALLATION >

BODY SIDE TRIM

Component

INFOID:000000008790137

CREW CAB

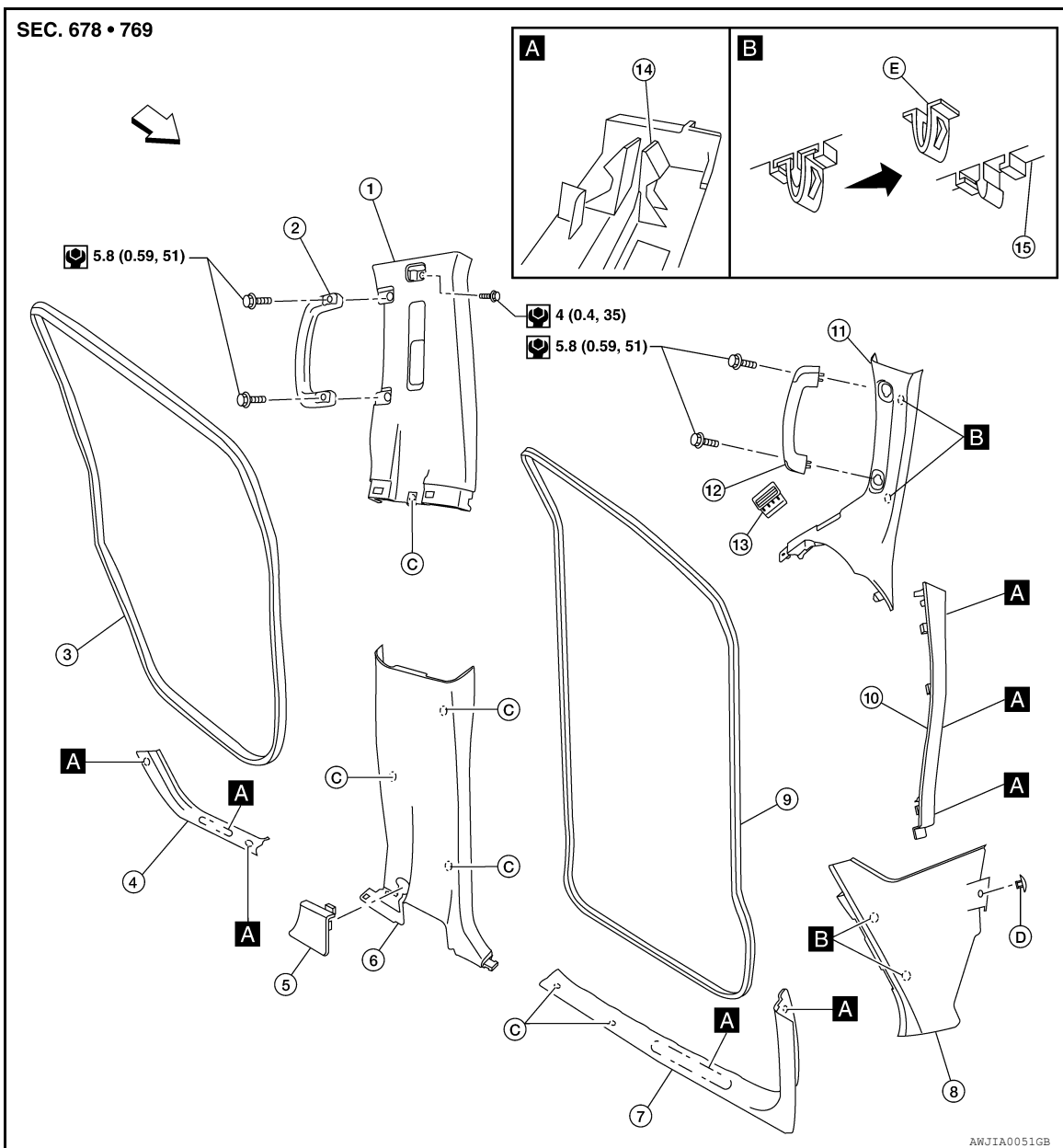

- | | | |
|---------------------------------|---------------------------------|---------------------------------|
| 1. Center pillar upper finisher | 2. Center pillar assist grip | 3. Rear door welt |
| 4. Rear kick plate | 5. Access cover (RH side only) | 6. Center pillar lower finisher |
| 7. Front kick plate | 8. Lower dash side finisher | 9. Front door welt |
| 10. Front pillar lower finisher | 11. Front pillar upper finisher | 12. Front pillar assist grip |
| 13. LH side demister grille | 14. Molded plastic clip | 15. Finisher |
| C. Clip C101 | D. Clip C111 | E. Metal clip |

↶ Front

CAUTION:

- When removing or installing body side welts, do not allow butyl seal to come in contact with pillar finisher.
- Wrap a cloth around suitable tool when removing metal clips from finishers.

BODY SIDE TRIM

< REMOVAL AND INSTALLATION >

KING CAB

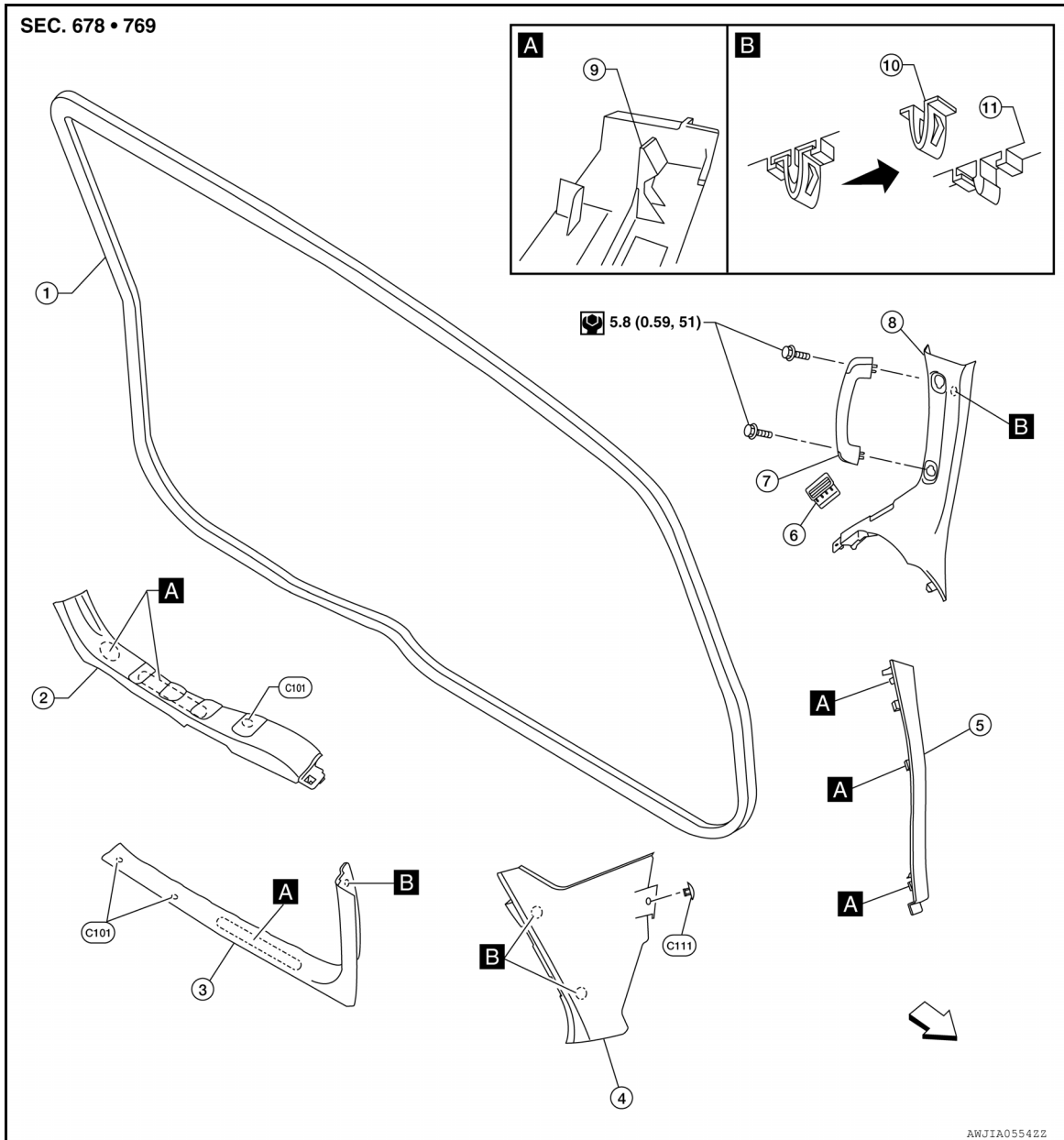

- | | | |
|-----------------------------|--------------------------------|-------------------------|
| 1. Door welt | 2. Rear kick plate | 3. Front kick plate |
| 4. Lower dash side finisher | 5. Front pillar lower finisher | 6. Side demister grille |
| 7. Front pillar assist grip | 8. Front pillar upper finisher | 9. Molded plastic clip |
| 10. Metal clip | 11. Garnish | ← Front |

CAUTION:

- When removing or installing body side welts, do not allow butyl seal to come in contact with pillar finisher.
- Wrap a cloth around suitable tool when removing metal clips from finishers.

Removal and Installation

INFOID:000000008790138

LOWER DASH SIDE FINISHER

Removal

1. Remove front kick plate. Refer to KICK PLATE REMOVAL AND INSTALLATION procedure in this section.
2. Remove push pin from lower dash side finisher.

A
B
C
D
E
F
G
H
I
INT
K
L
M
N
O
P

BODY SIDE TRIM

< REMOVAL AND INSTALLATION >

3. Remove lower dash side finisher.

Installation

Installation is in the reverse order of removal.

CENTER PILLAR LOWER FINISHER

Removal

1. Partially remove front and rear door welts as necessary.
2. Remove seat belt anchor. Refer to [SB-13. "Removal and Installation"](#).
 - On RH side, remove the cover and disconnect seat belt tension sensor.
3. Remove front and rear kick plates. Refer to KICK PLATE REMOVAL AND INSTALLATION procedure in this section.
4. Release clips and remove center pillar lower finisher.

Installation

Installation is in the reverse order of removal.

CENTER PILLAR UPPER FINISHER

Removal

1. Remove center pillar lower finisher. Refer to CENTER PILLAR LOWER FINISHER REMOVAL AND INSTALLATION procedure in this section.
2. Remove bolts, then assist grip.
3. Remove clips and bolts, then center pillar upper finisher.

Installation

Installation is in the reverse order of removal.

FRONT PILLAR UPPER FINISHER

Removal

1. Remove front pillar lower finisher. Refer to FRONT PILLAR LOWER FINISHER REMOVAL AND INSTALLATION procedure in this section.
2. Remove bolts, then front pillar assist grip.
3. Remove the front pillar upper finisher bolt.
4. Remove the front pillar upper finisher.

Installation

Installation is in the reverse order of removal.

FRONT PILLAR LOWER FINISHER

Removal

1. Partially remove front door welt as necessary.
2. Release clips and remove front and/or rear kick plates.
3. Release clips and remove the front pillar lower finisher.

Installation

Installation is in the reverse order of removal.

KICK PLATES

Removal

Release clips, then remove front and/or rear kick plates.

Installation

Installation is in the reverse order of removal.

REAR TRIM

BODY SIDE TRIM

< REMOVAL AND INSTALLATION >

SEC. 769 • 799

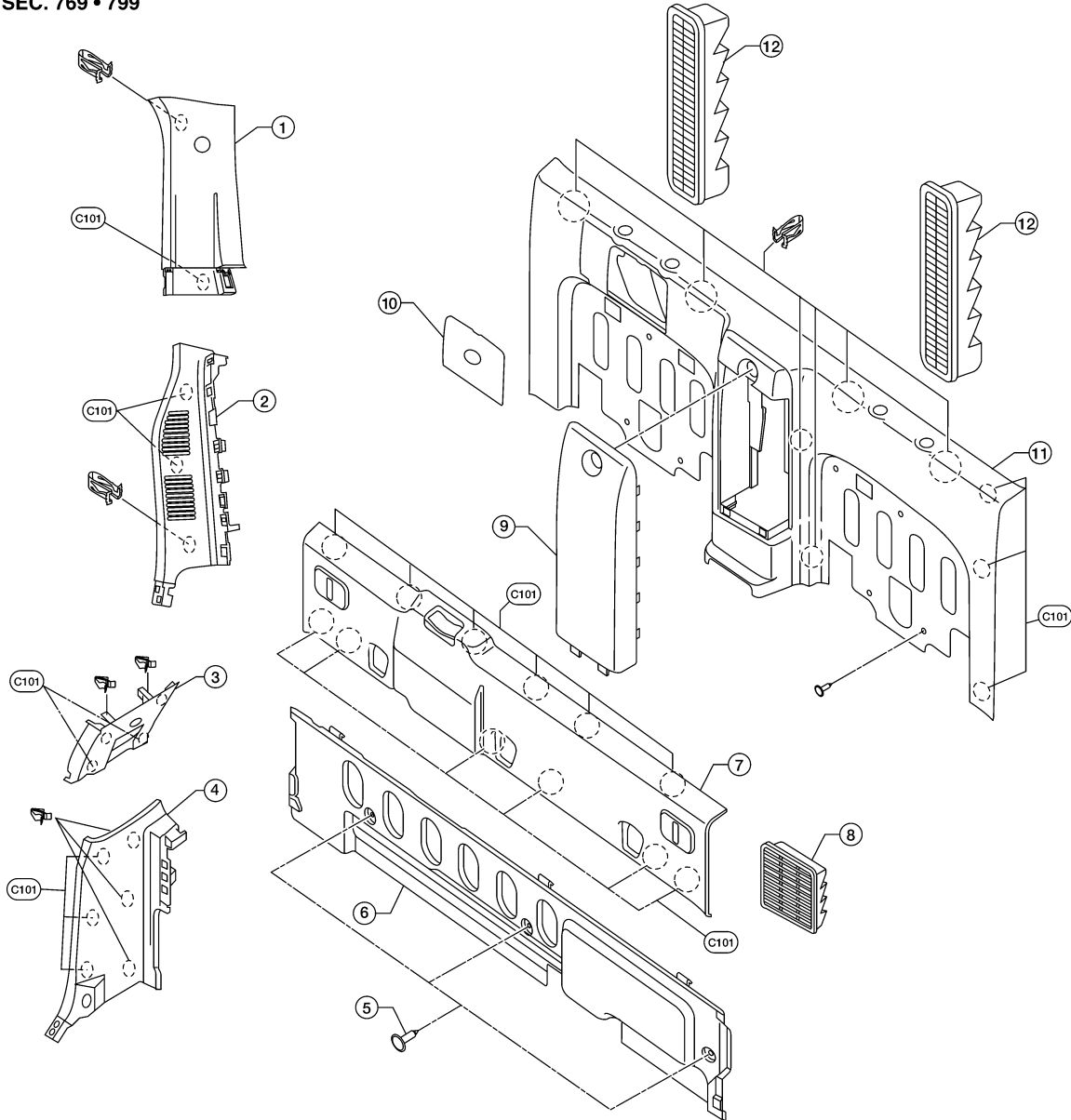

LIT1A1966E

- | | | |
|-----------------------------------|-----------------------------------|-----------------------------------|
| 1. Rear upper finisher (King cab) | 2. Rear lower finisher (King cab) | 3. Rear upper finisher (Crew cab) |
| 4. Rear lower finisher (Crew cab) | 5. Pushpin | 6. Rear panel lower (Crew cab) |
| 7. Rear panel upper (Crew cab) | 8. Drafter duct (Crew cab) | 9. Jack storage cover |
| 10. Child seat anchor cover | 11. Rear panel (King cab) | 12. Drafter ducts (King cab) |

CAUTION:

Wrap a cloth around suitable tool when removing metal clips from finishers.

Removal

1. Remove rear seats. Refer to [SE-33. "Removal and Installation"](#).
2. Remove storage boxes (if equipped).
3. Remove rear kick plates (RH/LH) and seat belt anchor bolts.
4. Remove seatback latch strikers (Crew cab models).
5. Remove child seat anchor cover (if equipped) and rear panel(s).
6. Remove first rear lower, then rear upper finishers (RH/LH).
7. Remove drafter duct(s).

Installation

A

B

C

D

E

F

G

H

I

INT

K

L

M

N

O

P

BODY SIDE TRIM

< REMOVAL AND INSTALLATION >

Installation is in the reverse order of removal.

FLOOR TRIM

< REMOVAL AND INSTALLATION >

FLOOR TRIM

Removal and Installation

INFOID:000000008790139

Crew Cab and King Cab Floor Carpet

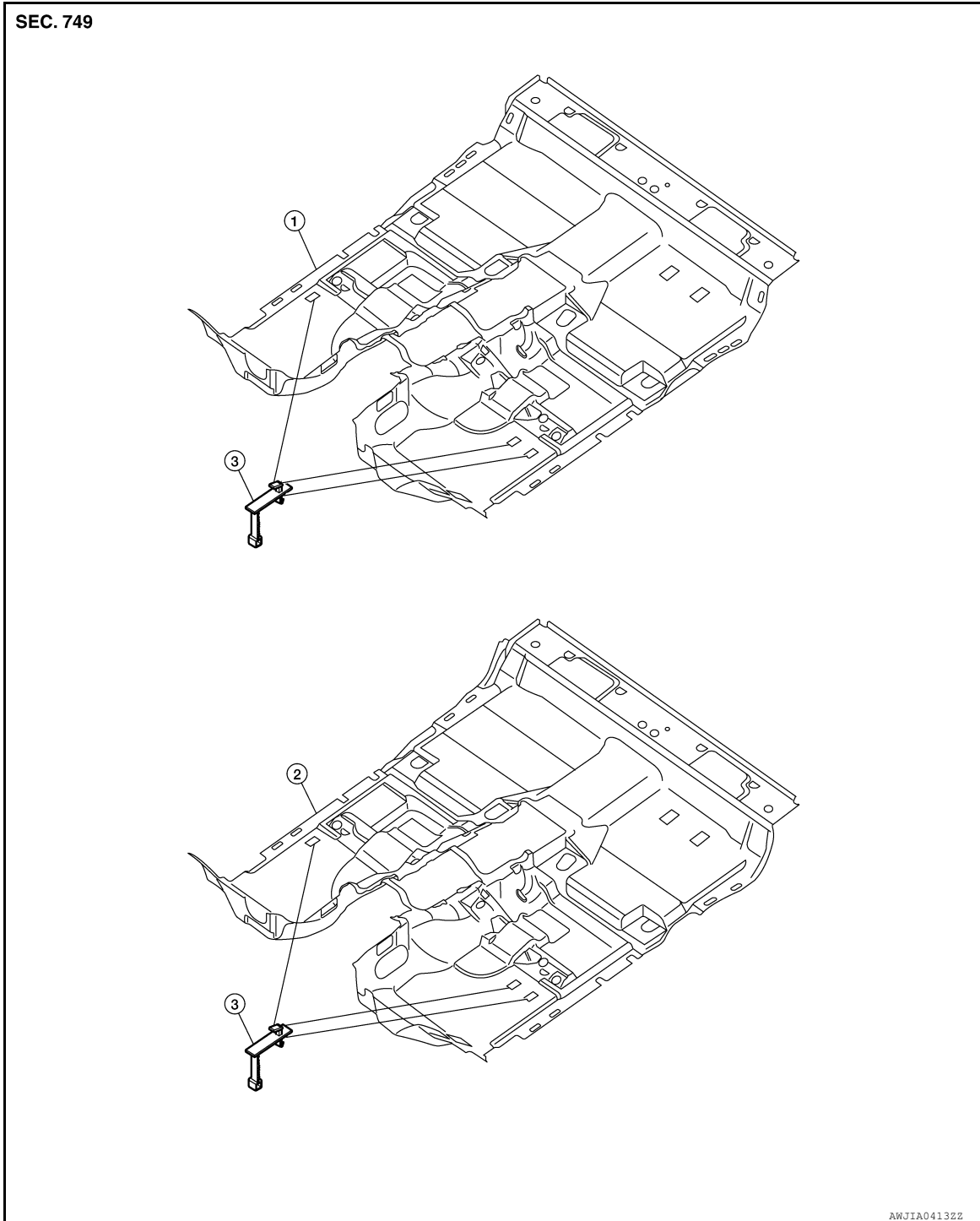

1. Crew cab carpet

2. King cab carpet

3. Floor mat hook

A
B
C
D
E
F
G
H
I
INT
K
L
M
N
O
P

FLOOR TRIM

< REMOVAL AND INSTALLATION >

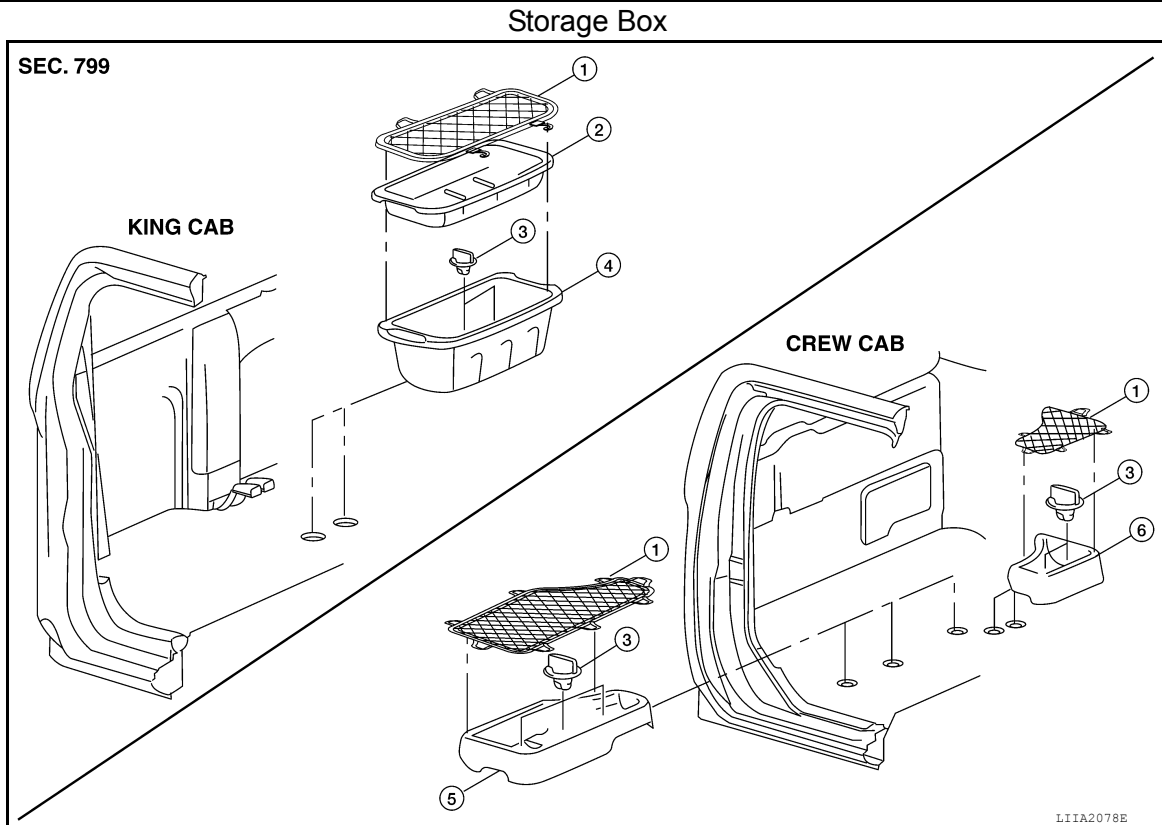

- | | | |
|---------------------------|--------------------------------|--|
| 1. Net | 2. Tray (King Cab) | 3. Locking clip |
| 4. Storage box (King Cab) | 5. Storage box (RH) (Crew Cab) | 6. Storage box (LH) (Crew Cab) (if equipped) |

REMOVAL

1. Remove front seats. Refer to [SE-32, "Removal and Installation"](#).
2. Remove rear seats. Refer to [SE-33, "Removal and Installation"](#).
3. Remove storage boxes (if equipped).
4. Remove lower seat belt anchors (crew cab only). Refer to [SB-13, "Removal and Installation"](#).
5. Remove lower body side trim panels. Refer to [INT-19, "Removal and Installation"](#).
6. Remove center console. Refer to [IP-26, "Removal and Installation"](#).
7. Remove floor mat hooks.
8. Remove carpet.

INSTALLATION

Installation is in the reverse order of removal.

HEADLINING

< REMOVAL AND INSTALLATION >

HEADLINING

Removal and Installation

INFOID:000000008790140

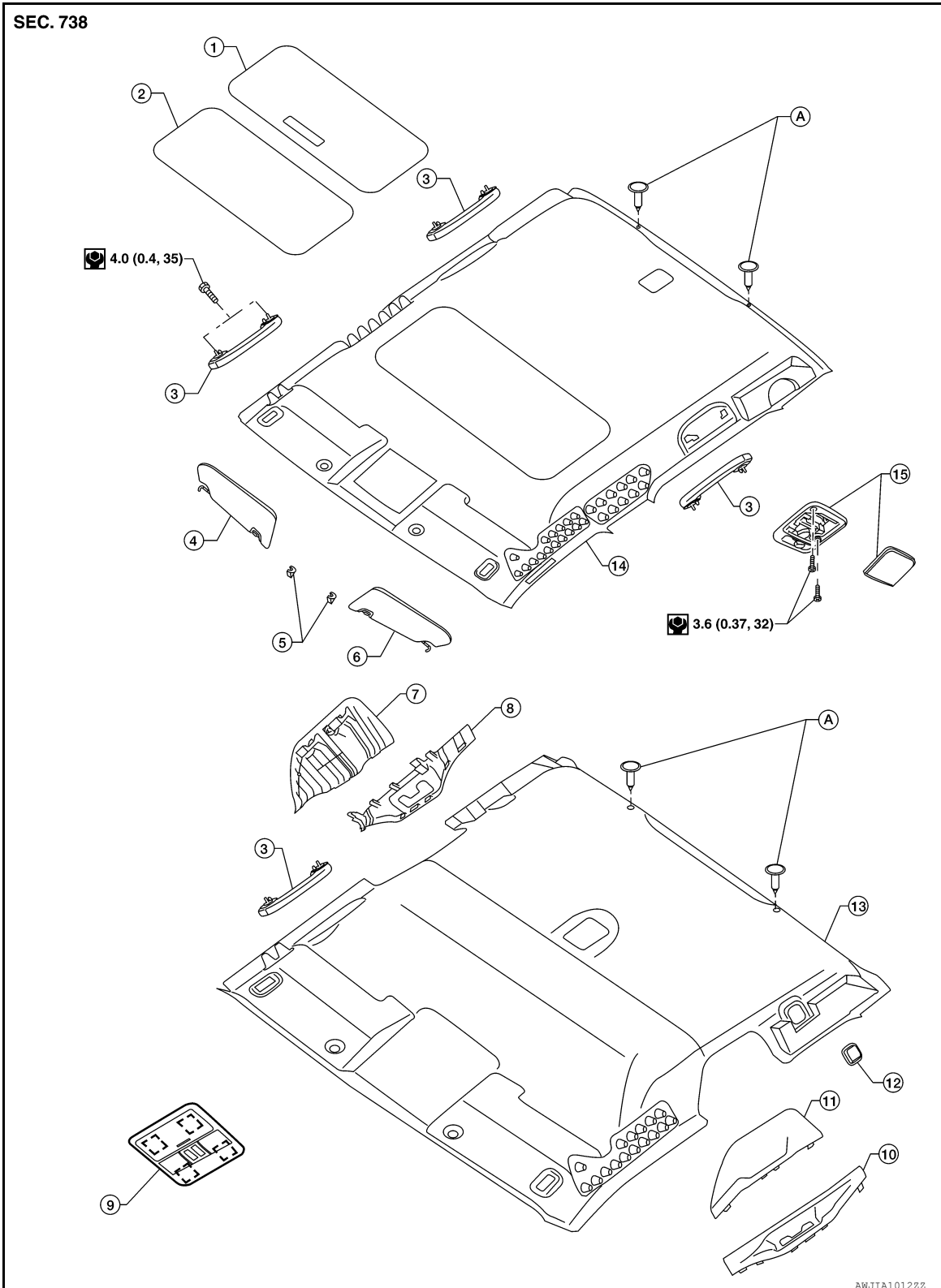

A
B
C
D
E
F
G
H
I
K
L
M
N
O
P

INT

- | | | |
|--------------------------------------|-------------------------------|----------------------------|
| 1. Sunroof shade cover (if equipped) | 2. Sunroof welt (if equipped) | 3. Assist grip |
| 4. Sun visor assembly (RH) | 5. Sun visor holder (RH/LH) | 6. Sun visor assembly (LH) |

HEADLINING

< REMOVAL AND INSTALLATION >

- | | | |
|--|--|---|
| 7. Striker cover outer (RH)(King Cab) | 8. Striker cover inner (RH)(King Cab) | 9. Roof console with front room/map lamp and sunglass bin (if equipped) |
| 10. Striker cover outer (LH)(King Cab) | 11. Striker cover inner (LH)(King Cab) | 12. Coat hook |
| 13. Headlining (King Cab) | 14. Headlining (Crew cab w/sunroof) | 15. Room lamp |

REMOVAL

1. Remove body side trim panels. Refer to [INT-18, "Component"](#) and [INT-19, "Removal and Installation"](#).
2. Remove rear trim. Refer to [INT-18, "Component"](#) and [INT-19, "Removal and Installation"](#).
3. Remove the sun visor assemblies (RH/LH).
4. Insert a suitable thin tool (A) at approximately a 30 degree angle into the sun visor holder notch on the front of the sun visor holder (1) and press in the locking tab (B) to release it. While holding in lock tab (B), turn the sun visor holder (1) 90 degrees to release it from the headliner.

- If the sun visor holder (1) does not fully rotate, make sure that the suitable thin tool (A) is pressing in on the locking tab (B) and is not positioned under locking tab (B). Reinsert the suitable thin tool (A) as necessary to release the locking tab (B).

-  Front

CAUTION:

Do not force the sun visor holder when removing as the locking tab may be damaged if the suitable thin tool is not positioned correctly.

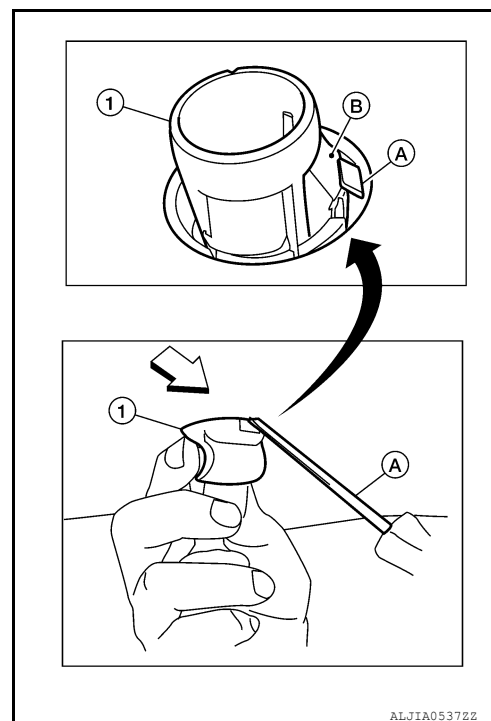

5. Remove roof console with front room/map lamp and sunglass bin (if equipped).
 - Disconnect harness.
6. Remove room lamp. Refer to [INL-62, "Removal and Installation"](#) (with power door locks) or [INL-114, "Removal and Installation"](#) (without power door locks).
7. Remove striker covers (King Cab only).
8. Remove assist grips.
9. Remove rear window glass (Crew Cab only). Refer to [GW-14, "Removal and Installation"](#).
10. Remove headlining.

NOTE:

Use an assistant to steady the headlining while lowering from roof.

- Remove clips from center of headlining (if equipped).
- Remove headlining by tilting through rear window opening on Crew Cab models.
- Remove headlining through door opening on King Cab models.

11. Remove assist grip brackets from roof.

INSTALLATION

Installation is in the reverse order of removal.