

A
B

SECTION PG

C D

POWER SUPPLY, GROUND & CIRCUIT ELEMENTS

E

CONTENTS

<p>PRECAUTION 2</p> <p>PRECAUTIONS 2</p> <p style="padding-left: 20px;">Precaution for Supplemental Restraint System (SRS) "AIR BAG" and "SEAT BELT PRE-TENSIONER"2</p> <p style="padding-left: 20px;">Precaution for Power Generation Variable Voltage Control System2</p> <p>PREPARATION 3</p> <p>PREPARATION 3</p> <p style="padding-left: 20px;">Special Service Tool3</p> <p style="padding-left: 20px;">Commercial Service Tool3</p> <p>BASIC INSPECTION 4</p> <p>BATTERY 4</p> <p style="padding-left: 20px;">How to Handle Battery4</p> <p style="padding-left: 20px;">Work Flow4</p> <p>INSPECTION AND ADJUSTMENT 7</p> <p>ADDITIONAL SERVICE WHEN REMOVING BATTERY NEGATIVE TERMINAL7</p> <p style="padding-left: 20px;">ADDITIONAL SERVICE WHEN REMOVING BATTERY NEGATIVE TERMINAL : Special Repair Requirement7</p> <p>DTC/CIRCUIT DIAGNOSIS 8</p> <p>POWER SUPPLY ROUTING CIRCUIT 8</p> <p style="padding-left: 20px;">Wiring Diagram—Battery Power Supply8</p> <p style="padding-left: 20px;">Wiring Diagram—Accessory Power Supply 17</p> <p style="padding-left: 20px;">Wiring Diagram—Ignition Power Supply20</p> <p style="padding-left: 20px;">Fuse26</p> <p style="padding-left: 20px;">Fusible Link26</p>	<p>GROUND27</p> <p style="padding-left: 20px;">Ground Distribution27</p> <p>HARNESS39</p> <p style="padding-left: 20px;">Harness Layout39</p> <p>ELECTRICAL UNITS LOCATION70</p> <p style="padding-left: 20px;">Electrical Units Location70</p> <p>HARNESS CONNECTOR73</p> <p style="padding-left: 20px;">Description73</p> <p>STANDARDIZED RELAY76</p> <p style="padding-left: 20px;">Description76</p> <p>FUSE BLOCK - JUNCTION BOX (J/B)78</p> <p style="padding-left: 20px;">Terminal Arrangement78</p> <p>FUSE, FUSIBLE LINK AND RELAY BOX79</p> <p style="padding-left: 20px;">Terminal Arrangement79</p> <p>FUSE AND RELAY BOX80</p> <p style="padding-left: 20px;">Terminal Arrangement80</p> <p>IPDM E/R (INTELLIGENT POWER DISTRIBUTION MODULE ENGINE ROOM)81</p> <p style="padding-left: 20px;">IPDM E/R Terminal Arrangement81</p> <p>REMOVAL AND INSTALLATION82</p> <p>BATTERY82</p> <p style="padding-left: 20px;">Removal and Installation82</p> <p>SERVICE DATA AND SPECIFICATIONS (SDS)83</p> <p>SERVICE DATA AND SPECIFICATIONS (SDS)83</p> <p style="padding-left: 20px;">Battery83</p>	<p>F</p> <p>G</p> <p>H</p> <p>I</p> <p>J</p> <p>K</p> <p>L</p> <p>PG</p> <p>N</p> <p>O</p> <p>P</p>
--	---	--

PRECAUTIONS

< PRECAUTION >

PRECAUTION

PRECAUTIONS

Precaution for Supplemental Restraint System (SRS) "AIR BAG" and "SEAT BELT PRE-TENSIONER"

INFOID:000000008792539

The Supplemental Restraint System such as "AIR BAG" and "SEAT BELT PRE-TENSIONER", used along with a front seat belt, helps to reduce the risk or severity of injury to the driver and front passenger for certain types of collision. This system includes seat belt switch inputs and dual stage front air bag modules. The SRS system uses the seat belt switches to determine the front air bag deployment, and may only deploy one front air bag, depending on the severity of a collision and whether the front occupants are belted or unbelted. Information necessary to service the system safely is included in the SR and SB section of this Service Manual.

WARNING:

- To avoid rendering the SRS inoperative, which could increase the risk of personal injury or death in the event of a collision which would result in air bag inflation, all maintenance must be performed by an authorized NISSAN/INFINITI dealer.
- Improper maintenance, including incorrect removal and installation of the SRS, can lead to personal injury caused by unintentional activation of the system. For removal of Spiral Cable and Air Bag Module, see the SR section.
- Do not use electrical test equipment on any circuit related to the SRS unless instructed to in this Service Manual. SRS wiring harnesses can be identified by yellow and/or orange harnesses or harness connectors.

PRECAUTIONS WHEN USING POWER TOOLS (AIR OR ELECTRIC) AND HAMMERS

WARNING:

- When working near the Airbag Diagnosis Sensor Unit or other Airbag System sensors with the Ignition ON or engine running, DO NOT use air or electric power tools or strike near the sensor(s) with a hammer. Heavy vibration could activate the sensor(s) and deploy the air bag(s), possibly causing serious injury.
- When using air or electric power tools or hammers, always switch the Ignition OFF, disconnect the battery, and wait at least 3 minutes before performing any service.

Precaution for Power Generation Variable Voltage Control System

INFOID:000000008792540

CAUTION:

For this model, the battery current sensor that is installed to the negative battery cable measures the charging/discharging current of the battery and performs various engine controls. If an electrical component is connected directly to the negative battery terminal, the current flowing through that component will not be measured by the battery current sensor. This condition may cause a malfunction of the engine control system and battery discharge may occur. Do not connect an electrical component or ground wire directly to the battery terminal.

PREPARATION

< PREPARATION >

PREPARATION

PREPARATION

Special Service Tool

INFOID:000000008792541

The actual shapes of Kent-Moore tools may differ from those of special service tools illustrated here.

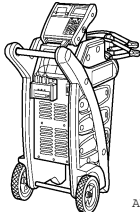
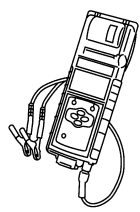
Tool number (Kent-Moore No.) Tool name		Description
<p>— (—) Model GR8-1200 NI Multitasking battery and electrical diagnostic station</p>	 AWI1A12392Z	<p>Tests batteries, starting and charging systems and charges batteries. For operating instructions, refer to diagnostic station instruction manual.</p>
<p>— (—) Model EXP-800 NI Battery and electrical diagnostic analyzer</p>	 JSMIA08062Z	<p>Tests batteries and charging systems. For operating instructions, refer to diagnostic analyzer instruction manual.</p>

Commercial Service Tool

INFOID:000000008792542

Tool name		Description
<p>Power tool</p>	 PIIB1407E	<p>Loosening nuts, screws and bolts</p>

A
B
C
D
E
F
G
H
I
J
K
L

PG

BATTERY

< BASIC INSPECTION >

BASIC INSPECTION

BATTERY

How to Handle Battery

INFOID:000000008792543

CAUTION:

- If it becomes necessary to start the engine with a booster battery and jumper cables, use a 12-volt booster battery.
- After connecting battery cables, ensure that they are tightly clamped to battery terminals for good contact.
- Never add distilled water through the hole used to check specific gravity.

METHODS OF PREVENTING OVER-DISCHARGE

The following precautions must be taken to prevent over-discharging a battery.

- The battery surface (particularly its top) should always be kept clean and dry.
- The terminal connections should be clean and tight.
- At every routine maintenance, check the electrolyte level.
This also applies to batteries designated as "low maintenance" and "maintenance-free".

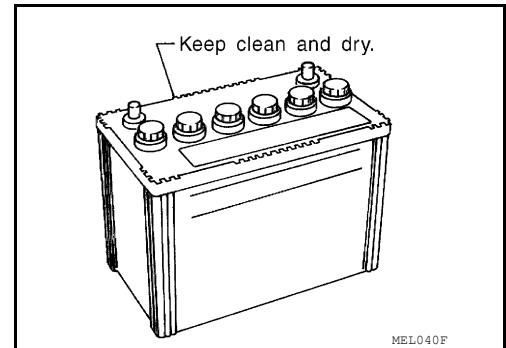

- When the vehicle is not going to be used over a long period of time, disconnect the battery cable from the negative terminal. (If the vehicle has an extended storage switch, turn it off.)

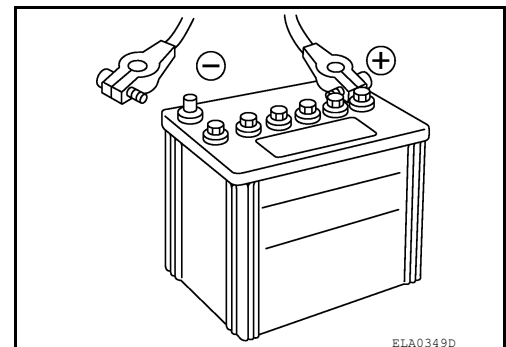

Work Flow

INFOID:000000008792544

BATTERY DIAGNOSIS WITH EXP-800 NI OR GR8-1200 NI

To diagnose and confirm the condition of the battery, use the following special service tools:

- EXP-800 NI Battery and electrical diagnostic analyzer
- GR8-1200 NI Multitasking battery and electrical diagnostic station

NOTE:

Refer to the applicable Instruction Manual for proper battery diagnosis procedures.

BATTERY DIAGNOSIS WITHOUT EXP-800 NI OR GR8-1200 NI

Checking Electrolyte Level

WARNING:

Never allow battery fluid to come in contact with skin, eyes, fabrics, or painted surfaces. After touching a battery, never touch or rub your eyes until you have thoroughly washed your hands. If acid contacts eyes, skin or clothing, immediately flush with water for 15 minutes and seek medical attention. Failure to do this may cause personal injury or damage to clothing or the painted surfaces.

BATTERY

< BASIC INSPECTION >

- Remove the cell plug using a suitable tool.
- Add distilled water up to the MAX level.

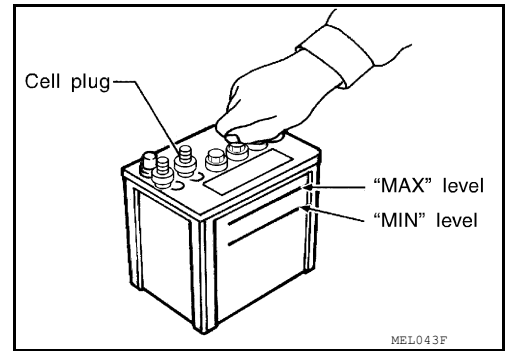

SULFATION

- **A battery will be completely discharged if it is left unattended for a long time and the specific gravity will become less than 1.100. This may result in sulfation on the cell plates.**
- **To determine if a battery has been “sulfated”, note its voltage and current when charging it. As shown in the figure, less current and higher voltage are observed in the initial stage of charging sulfated batteries.**
- **A sulfated battery may sometimes be brought back into service by means of a long, slow charge, 12 hours or more, followed by a battery capacity test.**

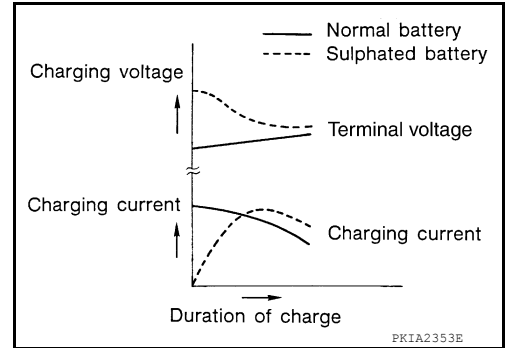

Specific Gravity Check

NOTE:

Check the charge condition of the battery.

Periodically check the specific gravity of the electrolyte. Keep a close check on charge condition to prevent over-discharge.

1. Read hydrometer and thermometer indications at eye level.
2. Use the chart below to correct your hydrometer reading according to electrolyte temperature.

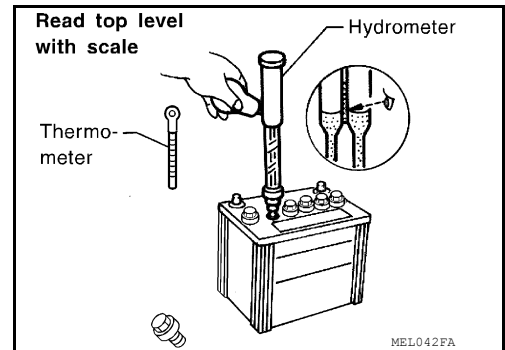

Hydrometer Temperature Correction

Battery electrolyte temperature [°C (°F)]	Add to specific gravity reading
71 (160)	0.032
66 (150)	0.028
60 (140)	0.024
54 (130)	0.020
49 (120)	0.016
43 (110)	0.012
38 (100)	0.008
32 (90)	0.004
27 (80)	0
21 (70)	-0.004
16 (60)	-0.008
10 (50)	-0.012

A
B
C
D
E
F
G
H
I
J
K
L
N
O
P

BATTERY

< BASIC INSPECTION >

Battery electrolyte temperature [°C (°F)]	Add to specific gravity reading
4 (40)	-0.016
-1 (30)	-0.020
-7 (20)	-0.024
-12 (10)	-0.028
-18 (0)	-0.032

Corrected specific gravity	Approximate charge condition
1.260 - 1.280	Fully charged
1.230 - 1.250	3/4 charged
1.200 - 1.220	1/2 charged
1.170 - 1.190	1/4 charged
1.140 - 1.160	Almost discharged
1.110 - 1.130	Completely discharged

Charging The Battery

CAUTION:

- Never “quick charge” a fully discharged battery.
- Keep the battery away from open flame while it is being charged.
- When connecting the charger, connect the leads first, then turn on the charger. Never turn on the charger first, as this may cause a spark.
- If battery electrolyte temperature rises above 55 °C (131 °F), stop charging. Always charge battery at a temperature below 55 °C (131 °F).

Charging Rates (Standard Charge)

Approximate charge condition	Charge current (A)	Charge time (h)
Fully charged	7	2
3/4 charged		2.5
1/2 charged		5
1/4 charged		7.5
Almost discharged		9
Completely discharged		10

Charging Rates (Quick Charge)

Approximate charge condition	Charge current (A)	Charge time (h)
Fully charged	—	—
3/4 charged	16	0.5
1/2 charged	33	
1/4 charged		
Almost discharged	—	—
Completely discharged	—	

NOTE:

The ammeter reading on your battery charger will automatically decrease as the battery charges. This indicates that the voltage of the battery is increasing normally as the state of charge improves. The charging amps indicated above refer to initial charge rate.

- If, after charging, the specific gravity of any two cells varies more than 0.050, the battery should be replaced.

INSPECTION AND ADJUSTMENT

< BASIC INSPECTION >

INSPECTION AND ADJUSTMENT

ADDITIONAL SERVICE WHEN REMOVING BATTERY NEGATIVE TERMINAL

ADDITIONAL SERVICE WHEN REMOVING BATTERY NEGATIVE TERMINAL : Special Repair Requirement

INFOID:000000008792545

Required Procedure After Battery Disconnection

System	Item	Reference
Engine Control System	Idle Air Volume Learning	EC-591 (VQ40DE) EC-124 (QR25DE)
Brake Control System	Steering Angle Sensor Neutral Position	BRC-12 (Type 1) BRC-122 (Type 2)
Roof	Sunroof Memory Reset/Initialization	RF-5
Audio, Visual & Navigation System	Audio (Radio Preset)	Refer to Owner's Manual.

A

B

C

D

E

F

G

H

I

J

K

L

PG

N

O

P

POWER SUPPLY ROUTING CIRCUIT

< DTC/CIRCUIT DIAGNOSIS >

⬅ A ➡ : WITH AT

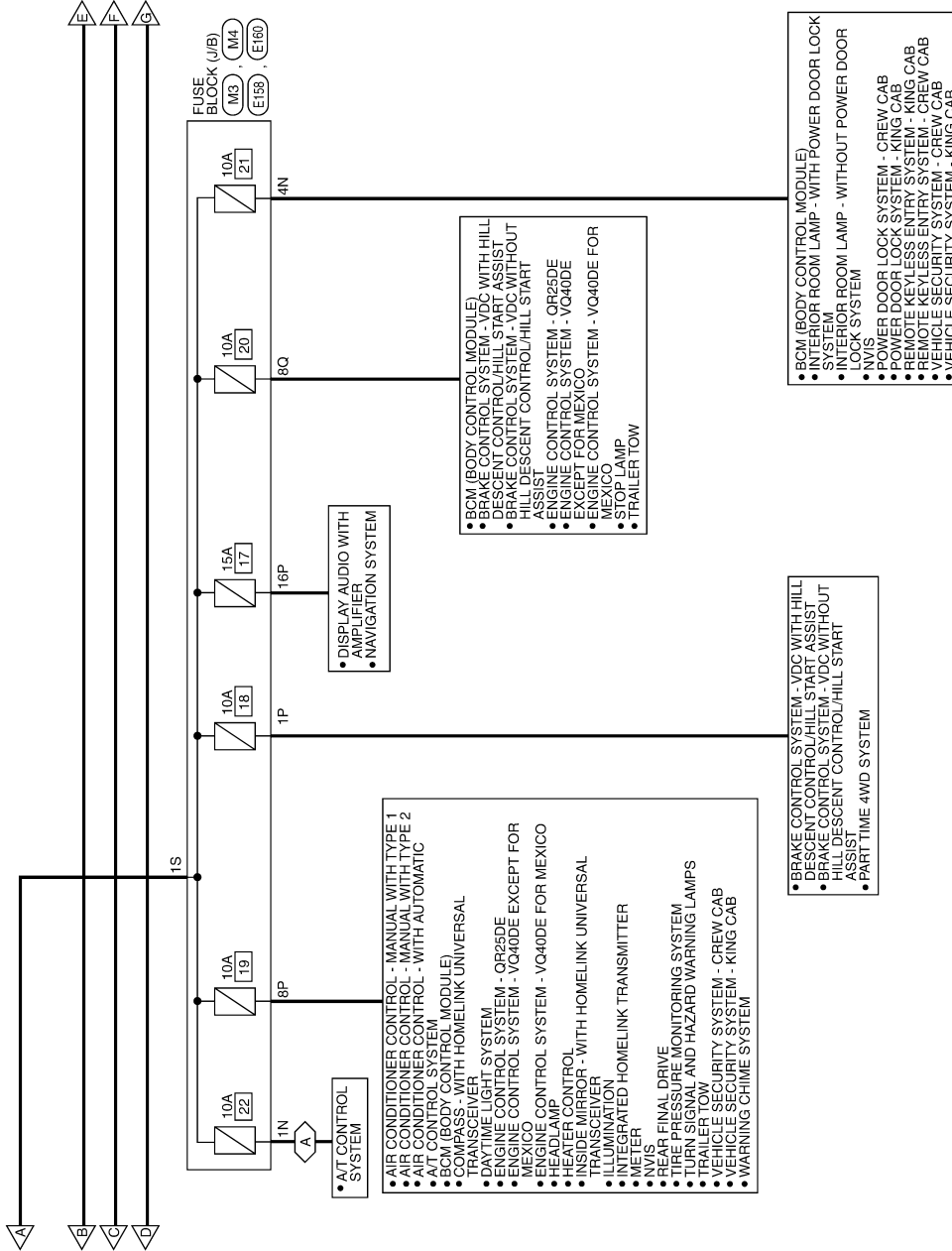

ABMWA1866GB

A
B
C
D
E
F
G
H
I
J
K
L
PG
N
O
P

POWER SUPPLY ROUTING CIRCUIT

< DTC/CIRCUIT DIAGNOSIS >

QR : WITH QR25DE
 ZV : WITH VQ40DE

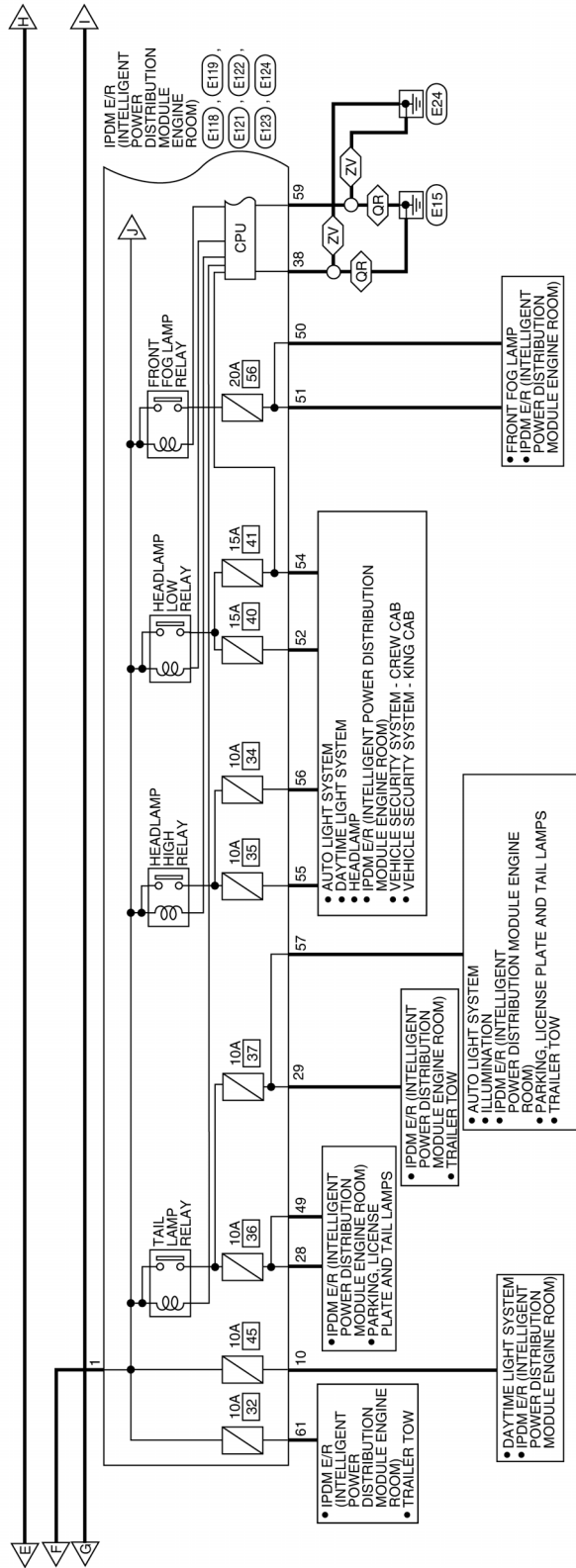

ABMWA1436GB

POWER SUPPLY ROUTING CIRCUIT

< DTC/CIRCUIT DIAGNOSIS >

BATTERY POWER SUPPLY CONNECTORS

Connector No.	M3
Connector Name	FUSE BLOCK (J/B)
Connector Color	WHITE

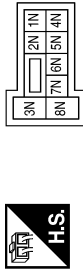

Terminal No.	Color of Wire	Signal Name
1N	R/B	-
4N	R/Y	-

Connector No.	M4
Connector Name	FUSE BLOCK (J/B)
Connector Color	WHITE



Terminal No.	Color of Wire	Signal Name
1P	R/B	-
8P	R/Y	-
16P	R/B	-

Connector No.	M6
Connector Name	WIRE TO WIRE
Connector Color	WHITE



Terminal No.	Color of Wire	Signal Name
2	W/G	-

Connector No.	M31
Connector Name	WIRE TO WIRE
Connector Color	WHITE

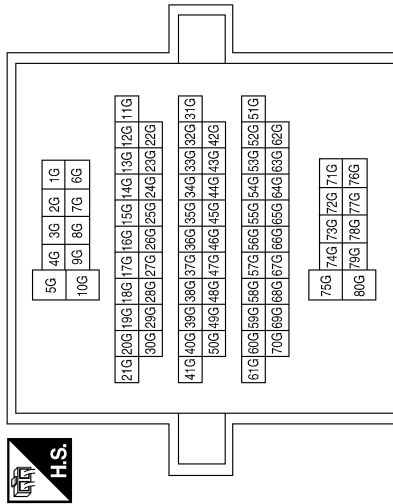

Terminal No.	Color of Wire	Signal Name
21G	V	-

Connector No.	M82
Connector Name	CIRCUIT BRAKER-2
Connector Color	WHITE



Terminal No.	Color of Wire	Signal Name
1	G	-
2	P	-

Connector No.	M152
Connector Name	TRANSFER CONTROL UNIT
Connector Color	WHITE

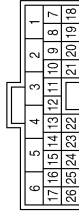

Terminal No.	Color of Wire	Signal Name
25	W/G	IGN SW

POWER SUPPLY ROUTING CIRCUIT

< DTC/CIRCUIT DIAGNOSIS >

Connector No.	E30
Connector Name	FUSIBLE LINK BOX (BATTERY)
Connector Color	-



Terminal No.	3	Color of Wire	R	Signal Name	-
--------------	---	---------------	---	-------------	---

Connector No.	E10
Connector Name	WIRE TO WIRE
Connector Color	WHITE



Terminal No.	2	Color of Wire	W/G	Signal Name	-
--------------	---	---------------	-----	-------------	---

Connector No.	M153
Connector Name	TRANSFER CONTROL UNIT
Connector Color	WHITE

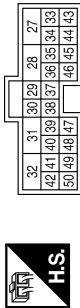

Terminal No.	40	Color of Wire	V	Signal Name	SSOF
--------------	----	---------------	---	-------------	------

Connector No.	E120
Connector Name	IPDM E/R (INTELLIGENT POWER DISTRIBUTION MODULE ENGINE ROOM)
Connector Color	WHITE

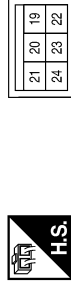

Terminal No.	20	Color of Wire	BR	Signal Name	MOTOR FAN 1
	22		G		F/L MOTOR FAN
	23		LG		HEATED MIRROR
	24		P		MOTOR FAN 2

Connector No.	E119
Connector Name	IPDM E/R (INTELLIGENT POWER DISTRIBUTION MODULE ENGINE ROOM)
Connector Color	WHITE

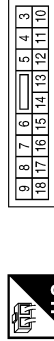

Terminal No.	3	Color of Wire	G	Signal Name	IGN COIL
	4		P		ECM (FOR MEXICO)
	4		R		ECM (EXCEPT FOR MEXICO)
	6		V		ETC
	7		BR		ECM RLY CONT
	10		R/B		DTRL RLY SUPPLY

Connector No.	E118
Connector Name	IPDM E/R (INTELLIGENT POWER DISTRIBUTION MODULE ENGINE ROOM)
Connector Color	BLACK



Terminal No.	1	Color of Wire	W	Signal Name	F/L USM
	2		R		F/L MAIN

ABMIA4368GB

A
B
C
D
E
F
G
H
I
J
K
L
N
O
P

PG

POWER SUPPLY ROUTING CIRCUIT

< DTC/CIRCUIT DIAGNOSIS >

Connector No.	E123
Connector Name	IPDM E/R (INTELLIGENT POWER DISTRIBUTION MODULE ENGINE ROOM)
Connector Color	BROWN



51	50	49
56	55	54 53 52

Terminal No.	Color of Wire	Signal Name
49	GR	CLEARANCE FRONT RH
50	W	FR FOG LAMP LH
51	V	FR FOG LAMP RH
52	P	H/LAMP LO LH
54	R	H/LAMP LO RH
55	G	H/LAMP HI LH
56	L	H/LAMP HI RH

Connector No.	E122
Connector Name	IPDM E/R (INTELLIGENT POWER DISTRIBUTION MODULE ENGINE ROOM)
Connector Color	WHITE



42	41	40	39	38	37
48	47	46	45	44	43

Terminal No.	Color of Wire	Signal Name
38	B	GND (SIGNAL)
47	W	ETC RLY CONT (FOR MEXICO)
47	O	ETC RLY CONT (EXCEPT FOR MEXICO)

Connector No.	E121
Connector Name	IPDM E/R (INTELLIGENT POWER DISTRIBUTION MODULE ENGINE ROOM)
Connector Color	BROWN



28	26	27	26	25
36	35	34	33	32 31 30

Terminal No.	Color of Wire	Signal Name
28	R	CLEARANCE FRONT LH
29	G	TRAILER RLY CONT
30	R/B	ECM BAT

Connector No.	E129
Connector Name	FUSIBLE LINK BOX (BATTERY)
Connector Color	BLACK



2	1
---	---

Terminal No.	Color of Wire	Signal Name
1	W	-
2	R	-

Connector No.	E128
Connector Name	FUSIBLE LINK BOX (BATTERY)
Connector Color	GRAY



4	7
---	---

Terminal No.	Color of Wire	Signal Name
4	W	-
7	W	-

Connector No.	E124
Connector Name	IPDM E/R (INTELLIGENT POWER DISTRIBUTION MODULE ENGINE ROOM)
Connector Color	BLACK



59	58	57
62	61	60

Terminal No.	Color of Wire	Signal Name
57	GR	TAIL LAMP
59	B	GND (POWER)
61	R/B	TRAIL RLY SUPPLY

ABMIA4369GB

POWER SUPPLY ROUTING CIRCUIT

< DTC/CIRCUIT DIAGNOSIS >

Connector No.	E152
Connector Name	WIRE TO WIRE
Connector Color	WHITE

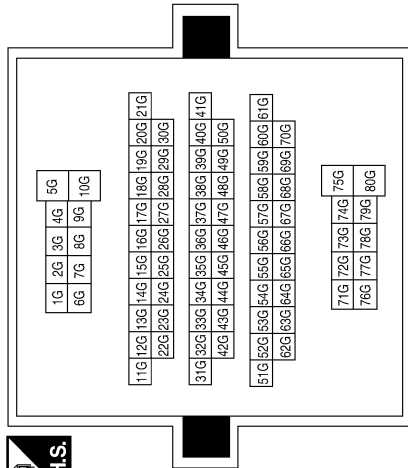

Terminal No.	Color of Wire	Signal Name
21G	V	-

Connector No.	E156
Connector Name	TRANSFER SHUT OFF RELAY 1
Connector Color	BLUE



Terminal No.	Color of Wire	Signal Name
1	W/G	-
2	B	-
3	B	-
5	W	-

Connector No.	E157
Connector Name	TRANSFER SHUT OFF RELAY 2
Connector Color	BLUE



Terminal No.	Color of Wire	Signal Name
1	G	-
2	V	-
3	B	-
5	W	-

Connector No.	E158
Connector Name	FUSE BLOCK (J/B)
Connector Color	BLACK



Terminal No.	Color of Wire	Signal Name
1S	W	-

Connector No.	E160
Connector Name	FUSE BLOCK (J/B)
Connector Color	WHITE



Terminal No.	Color of Wire	Signal Name
8Q	F/B	-

Connector No.	E202
Connector Name	FUSIBLE LINK BOX (BATTERY)
Connector Color	-



Terminal No.	Color of Wire	Signal Name
5	B/R	-

ABMIA0379GB

A B C D E F G H I J K L N O P

PG

POWER SUPPLY ROUTING CIRCUIT

< DTC/CIRCUIT DIAGNOSIS >

Connector No.	E210
Connector Name	STARTER MOTOR
Connector Color	-



Terminal No.	2	Color of Wire	B/R	Signal Name	-
--------------	---	---------------	-----	-------------	---

Connector No.	E206
Connector Name	GENERATOR
Connector Color	-



Terminal No.	1	Color of Wire	B/R	Signal Name	-
--------------	---	---------------	-----	-------------	---

Connector No.	E204
Connector Name	FUSIBLE LINK BOX (BATTERY)
Connector Color	-



Terminal No.	6	Color of Wire	B/R	Signal Name	-
--------------	---	---------------	-----	-------------	---

ABMIA4370GB

POWER SUPPLY ROUTING CIRCUIT

< DTC/CIRCUIT DIAGNOSIS >

Wiring Diagram—Accessory Power Supply

INFOID:000000008792547

ACCESSORY POWER SUPPLY

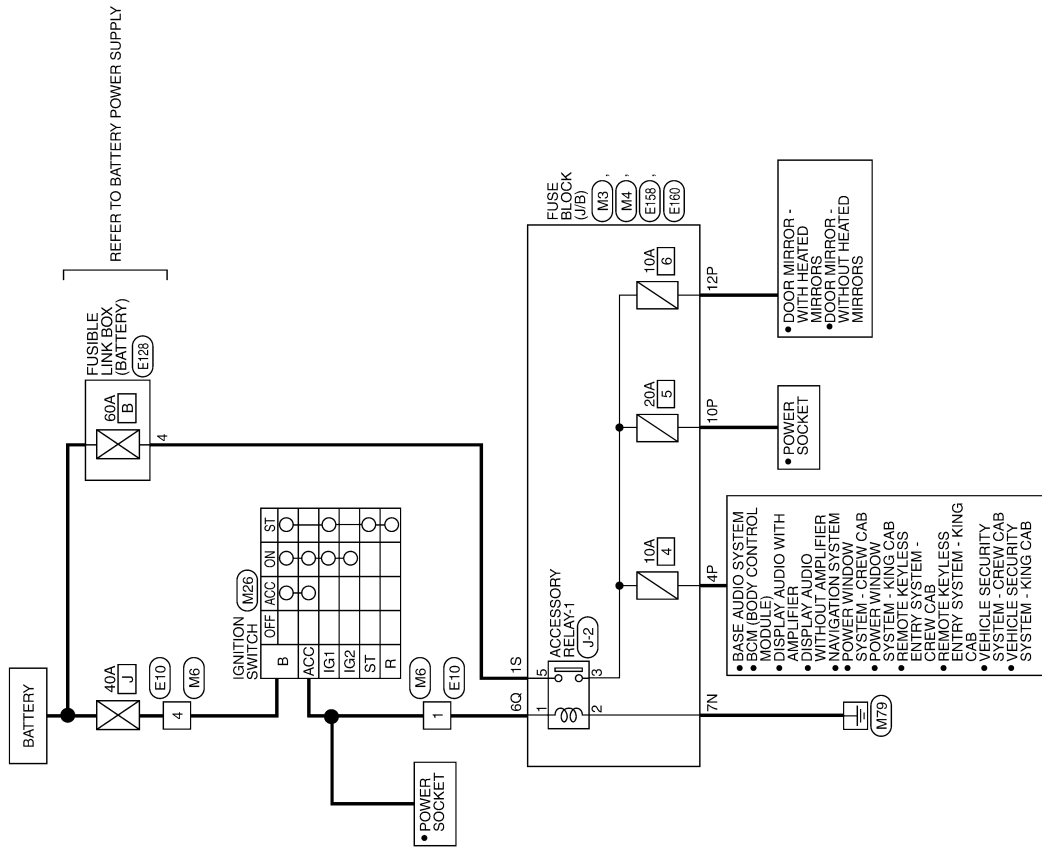

ABMWA1871GB

A
B
C
D
E
F
G
H
I
J
K
L
N
O
P

POWER SUPPLY ROUTING CIRCUIT

< DTC/CIRCUIT DIAGNOSIS >

ACCESSORY POWER SUPPLY CONNECTORS

Connector No.	M3
Connector Name	FUSE BLOCK (J/B)
Connector Color	WHITE

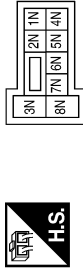

Terminal No.	7N	Color of Wire	B	Signal Name	-
--------------	----	---------------	---	-------------	---

Connector No.	M4
Connector Name	FUSE BLOCK (J/B)
Connector Color	WHITE



Terminal No.	4P	Color of Wire	G/B	Signal Name	-
10P	G/Y	-	-		
12P	G/Y	-	-		

Connector No.	M6
Connector Name	WIRE TO WIRE
Connector Color	WHITE



Terminal No.	1	Color of Wire	G/Y	Signal Name	-
4	G	-	-		

Connector No.	M26
Connector Name	IGNITION SWITCH
Connector Color	WHITE



Terminal No.	B	Color of Wire	G	Signal Name	-
ACC	G/Y	-	-		

Connector No.	E10
Connector Name	WIRE TO WIRE
Connector Color	WHITE



Terminal No.	1	Color of Wire	G/Y	Signal Name	-
4	G	-	-		

Connector No.	E128
Connector Name	FUSIBLE LINK BOX (BATTERY)
Connector Color	GRAY



Terminal No.	4	Color of Wire	W	Signal Name	-
--------------	---	---------------	---	-------------	---

ABMIA0380GB

POWER SUPPLY ROUTING CIRCUIT

< DTC/CIRCUIT DIAGNOSIS >

Connector No.	E160
Connector Name	FUSE BLOCK (J/B)
Connector Color	WHITE

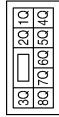

Terminal No.	Color of Wire	Signal Name
6Q	G/Y	-

Connector No.	E158
Connector Name	FUSE BLOCK (J/B)
Connector Color	BLACK



Terminal No.	Color of Wire	Signal Name
1S	W	-

Connector No.	J-2
Connector Name	FUSE BLOCK (J/B) (ACCESSORY RELAY-1)
Connector Color	-

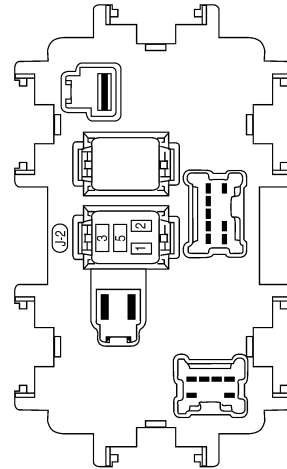

ABMIA4371GB

A
B
C
D
E
F
G
H
I
J
K
L
PG
N
O
P

POWER SUPPLY ROUTING CIRCUIT

< DTC/CIRCUIT DIAGNOSIS >

Wiring Diagram—Ignition Power Supply

INFOID:000000008792548

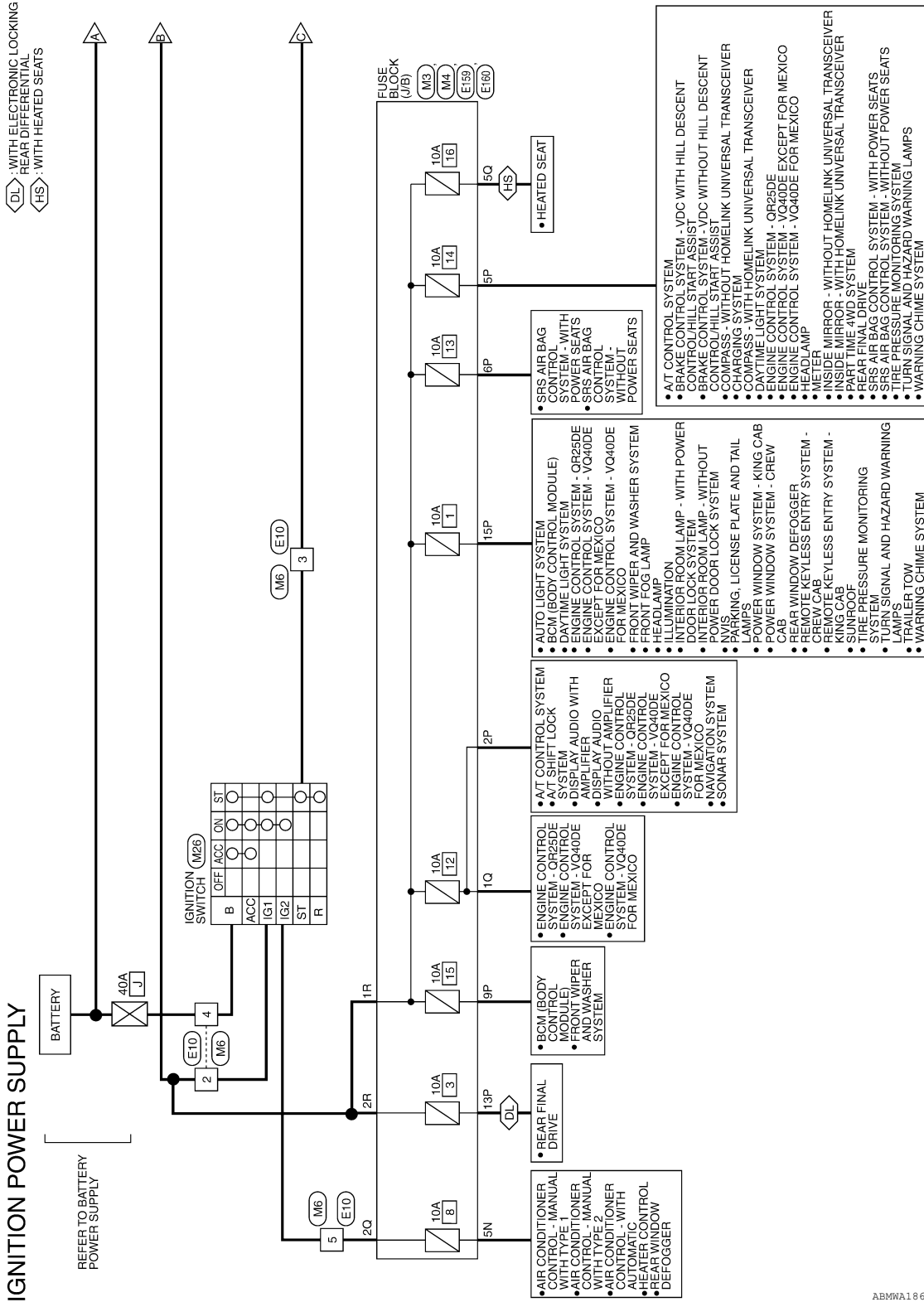

ABMWA1868GB

POWER SUPPLY ROUTING CIRCUIT

< DTC/CIRCUIT DIAGNOSIS >

OR : WITH QR25DE
ZV : WITH VQ40DE

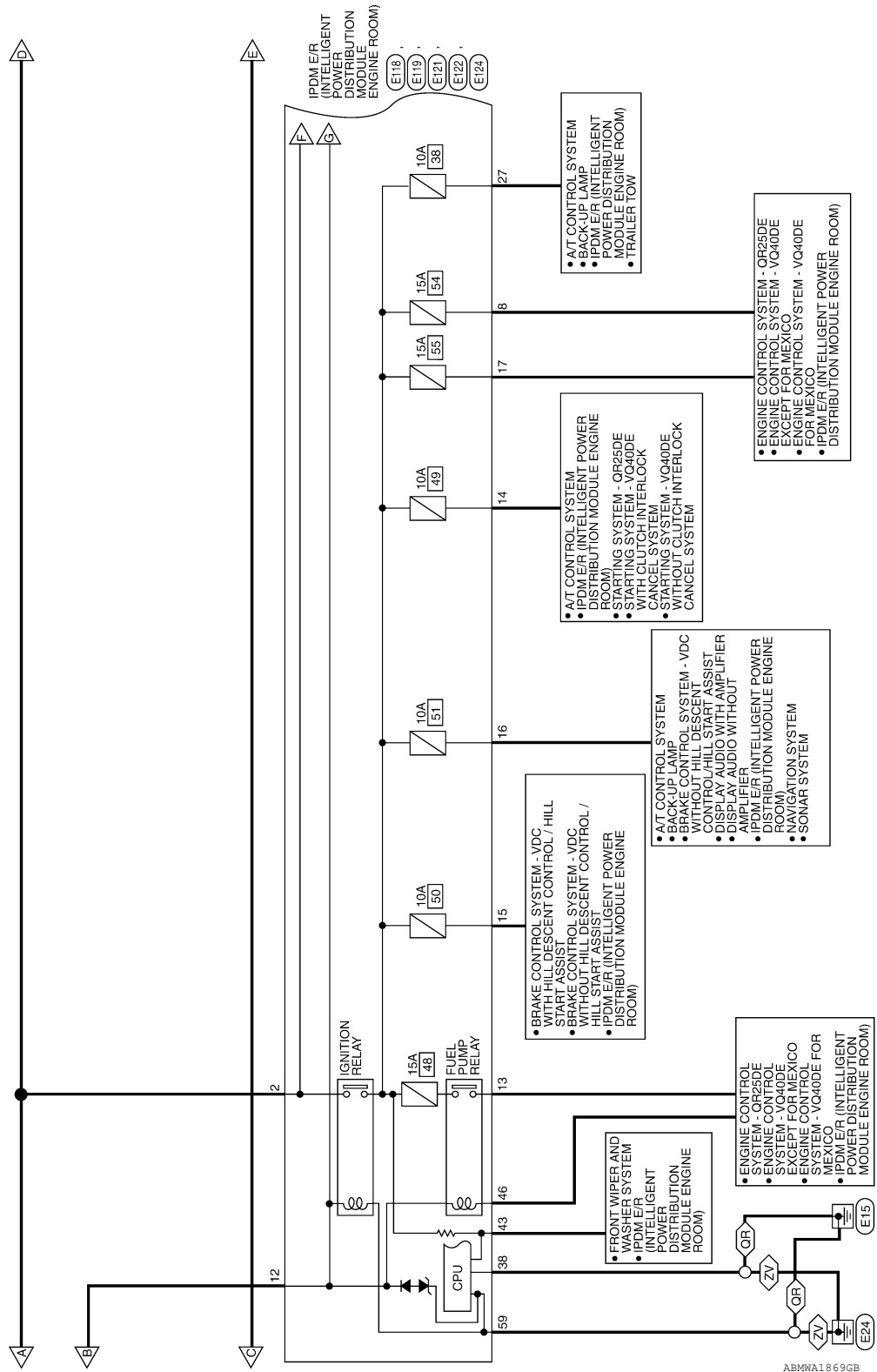

ABMWA1869GB

A
B
C
D
E
F
G
H
I
J
K
L
PG
N
O
P

POWER SUPPLY ROUTING CIRCUIT

< DTC/CIRCUIT DIAGNOSIS >

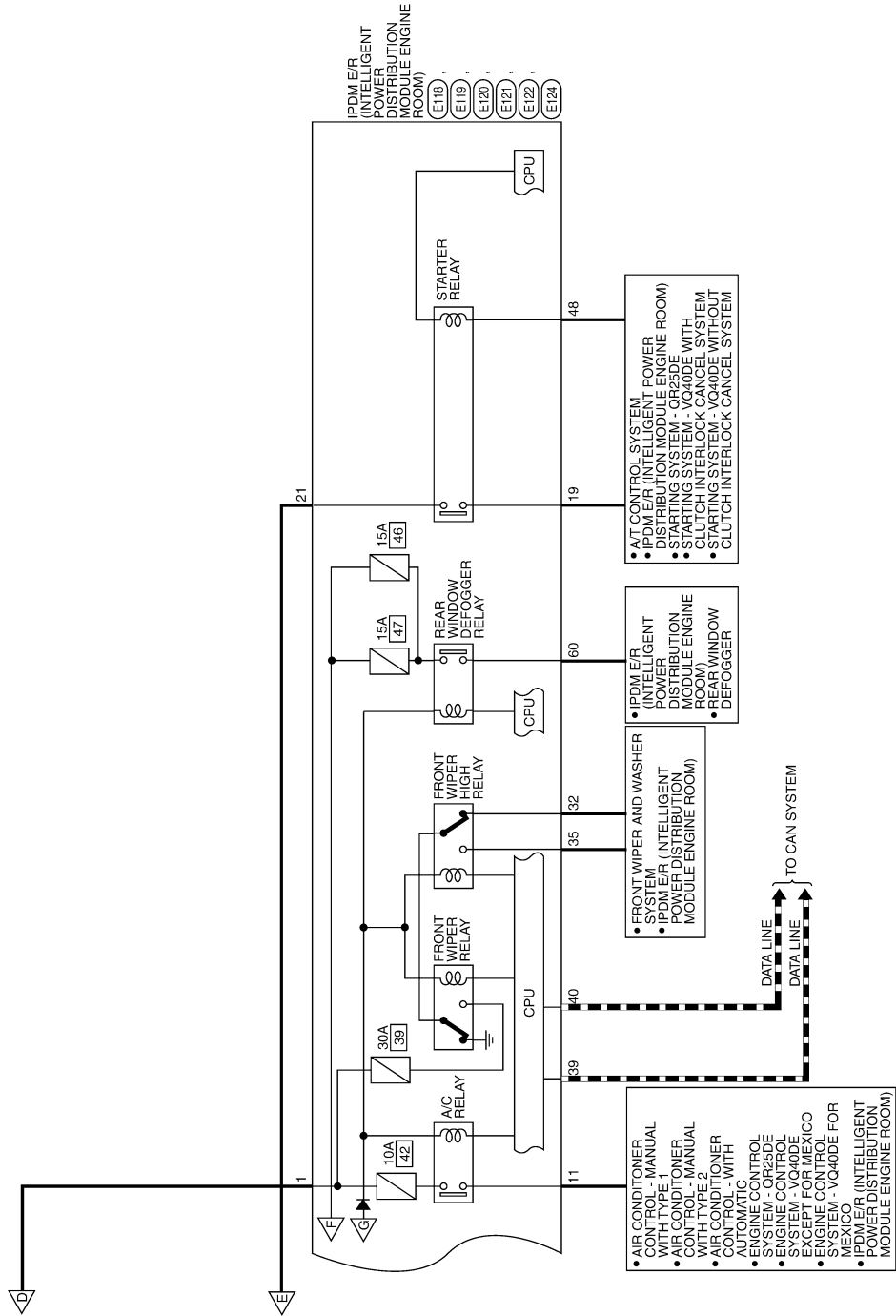

ABMWA1870GB

POWER SUPPLY ROUTING CIRCUIT

< DTC/CIRCUIT DIAGNOSIS >

IGNITION POWER SUPPLY CONNECTORS

Connector No.	M3
Connector Name	FUSE BLOCK (J/B)
Connector Color	WHITE

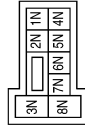

Terminal No.	Color of Wire	Signal Name
5N	W/G	-

Connector No.	M4
Connector Name	FUSE BLOCK (J/B)
Connector Color	WHITE



Terminal No.	Color of Wire	Signal Name
2P	W/G	-
5P	W/G	-
6P	W/R	-
9P	W/G	-
13P	W/G	-
15P	W/R	-

Connector No.	M6
Connector Name	WIRE TO WIRE
Connector Color	WHITE



Terminal No.	Color of Wire	Signal Name
2	W/G	-
3	GR	-
4	G	-
5	R	-

Connector No.	M26
Connector Name	IGNITION SWITCH
Connector Color	WHITE



Terminal No.	Color of Wire	Signal Name
B	G	-
ST	GR	-
IG1	W/G	-
IG2	R	-

Connector No.	E10
Connector Name	WIRE TO WIRE
Connector Color	WHITE



Terminal No.	Color of Wire	Signal Name
2	W/G	-
3	GR	-
4	G	-
5	R	-

Connector No.	E118
Connector Name	IPDM E/R (INTELLIGENT POWER DISTRIBUTION MODULE ENGINE ROOM)
Connector Color	BLACK



Terminal No.	Color of Wire	Signal Name
1	W	F/L USM
2	R	F/L MAIN

A
B
C
D
E
F
G
H
I
J
K
L
PG
N
O
P

POWER SUPPLY ROUTING CIRCUIT

< DTC/CIRCUIT DIAGNOSIS >

Connector No.	E120
Connector Name	IPDM E/R (INTELLIGENT POWER DISTRIBUTION MODULE ENGINE ROOM)
Connector Color	WHITE

21	20	19
24	23	22



Terminal No.	Color of Wire	Signal Name
19	W	STARTER MTR
21	GR	IGN SW (ST)

Terminal No.	Color of Wire	Signal Name
15	W/R	ABS IGN SUPPLY
16	W/G	REVERSE LAMP
17	W/G	INJECTOR

Connector No.	E119
Connector Name	IPDM E/R (INTELLIGENT POWER DISTRIBUTION MODULE ENGINE ROOM)
Connector Color	WHITE

9	8	7	6	5	4	3
18	17	16	15	14	13	12
11	10					



Terminal No.	Color of Wire	Signal Name
8	W/R	O2 SENSOR
11	Y	A/C COMPRESSOR
12	W/G	IGN SW (IG)
13	R	FUEL PUMP
14	W/G	A/T ECU IGN SUPPLY

Connector No.	E124
Connector Name	IPDM E/R (INTELLIGENT POWER DISTRIBUTION MODULE ENGINE ROOM)
Connector Color	BLACK

59	58	57
62	61	60



Terminal No.	Color of Wire	Signal Name
59	B	GND (POWER)
60	GR	RR DEF

Connector No.	E122
Connector Name	IPDM E/R (INTELLIGENT POWER DISTRIBUTION MODULE ENGINE ROOM)
Connector Color	WHITE

42	41	40	39	38	37
48	47	46	45	44	43



Terminal No.	Color of Wire	Signal Name
38	B	GND (SIGNAL)
39	L	CAN-H
40	P	CAN-L
43	G	AUTO STOP SW
46	V	FUEL PUMP RLY CONT
48	R	RANGE SW

Connector No.	E121
Connector Name	IPDM E/R (INTELLIGENT POWER DISTRIBUTION MODULE ENGINE ROOM)
Connector Color	BROWN

29	28	27	26	25
36	35	34	33	32
31	30			



Terminal No.	Color of Wire	Signal Name
27	W/G	T TOW REV LAMP
32	GR	FR WIPER LO
35	L	FR WIPER HI

ABMIA2567GB

POWER SUPPLY ROUTING CIRCUIT

< DTC/CIRCUIT DIAGNOSIS >

A
B
C
D
E
F
G
H
I
J
K
L
PG
N
O
P

Connector No.	E160
Connector Name	FUSE BLOCK (J/B)
Connector Color	WHITE

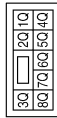

Terminal No.	Color of Wire	Signal Name
1Q	W/G	-
2Q	R	-
5Q	W/R	-

Connector No.	E159
Connector Name	FUSE BLOCK (J/B)
Connector Color	BLACK



Terminal No.	Color of Wire	Signal Name
1R	W/G	-
2R	W/G	-

ABMIA1464GB

POWER SUPPLY ROUTING CIRCUIT

< DTC/CIRCUIT DIAGNOSIS >

Fuse

INFOID:000000008792549

- If fuse is blown, be sure to eliminate cause of malfunction before installing new fuse.
- Use fuse of specified rating. Never use fuse of more than specified rating.
- Do not partially install fuse; always insert it into fuse holder properly.
- Remove fuse for "ELECTRICAL PARTS (BAT)" if vehicle is not used for a long period of time.

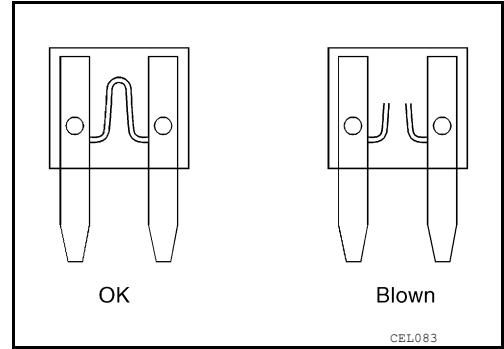

Fusible Link

INFOID:000000008792550

A melted fusible link can be detected either by visual inspection or by feeling with finger tip. If its condition is questionable, use circuit tester or test lamp.

1 : Fusible link

←: Vehicle front

CAUTION:

- If fusible link should melt, it is possible that critical circuit (power supply or large current carrying circuit) is shorted. In such a case, carefully check and eliminate cause of malfunction.
- Never wrap outside of fusible link with vinyl tape. Important: Never let fusible link touch any other wiring harness, vinyl or rubber parts.

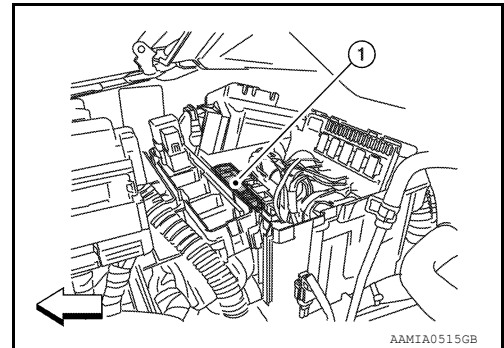

GROUND

< DTC/CIRCUIT DIAGNOSIS >

GROUND

Ground Distribution

INFOID:000000008792551

MAIN HARNESS

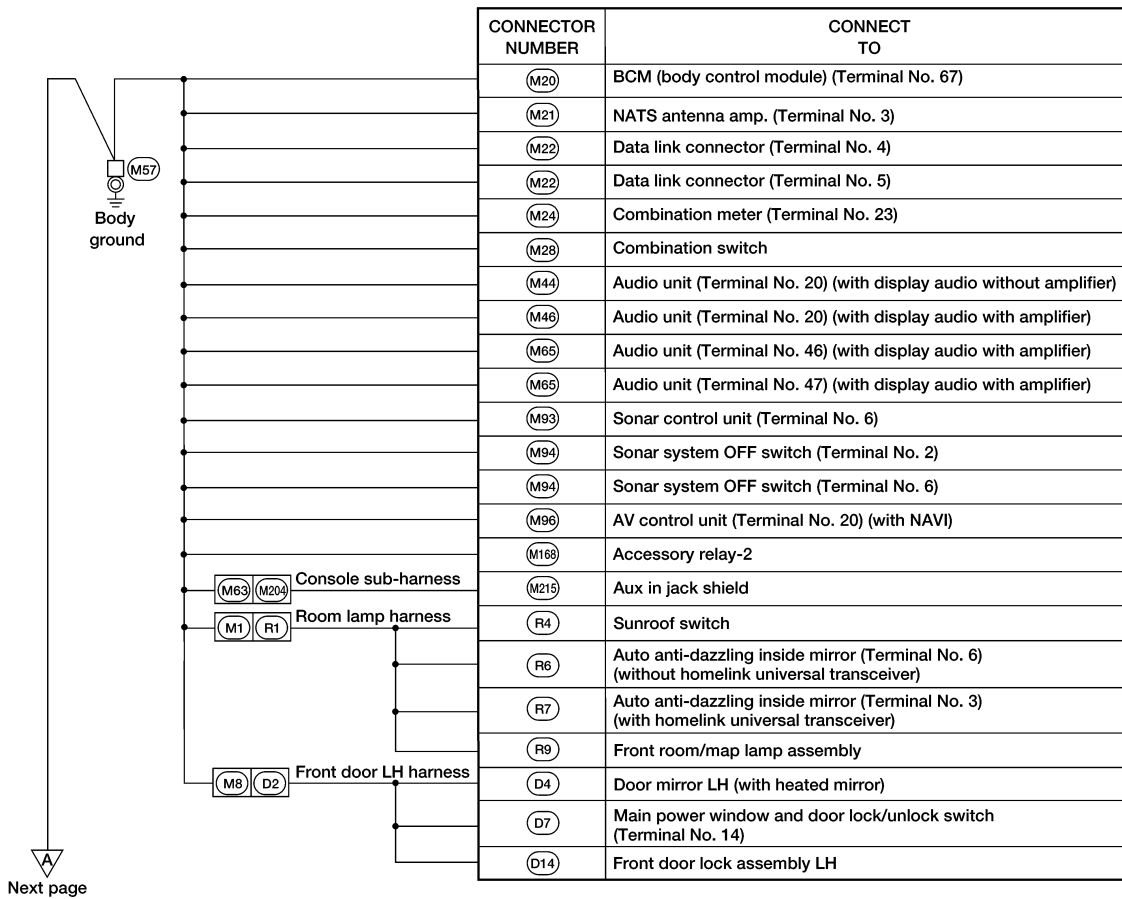
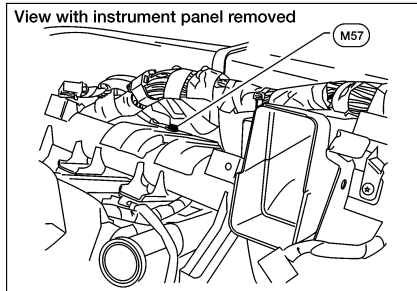

A
B
C
D
E
F
G
H
I
J
K
L
PG
N
O
P

ABMIA4382GB

GROUND

< DTC/CIRCUIT DIAGNOSIS >

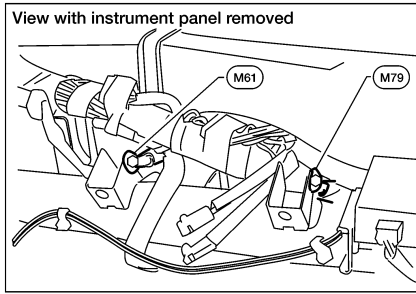

Preceding page

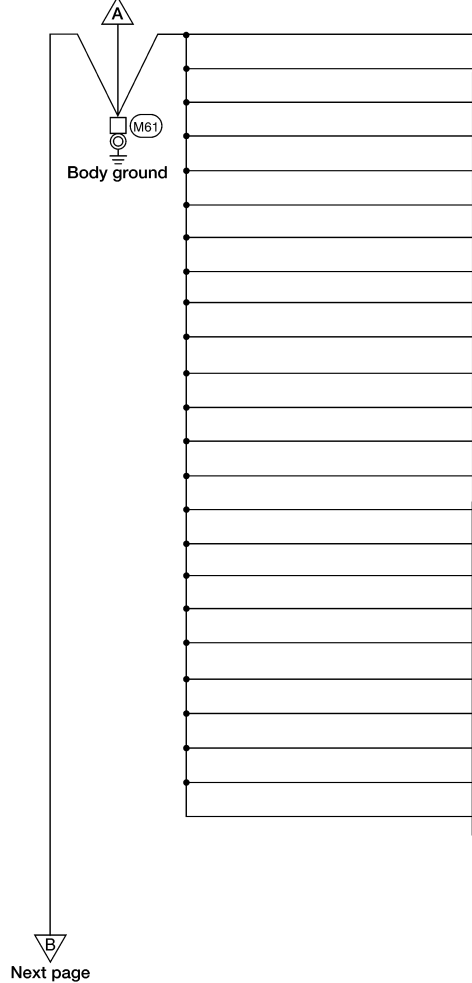

CONNECTOR NUMBER	CONNECT TO
(M13)	Front passenger air bag OFF indicator
(M24)	Combination meter (Terminal No. 13)
(M34)	In-vehicle sensor
(M35)	Air bag diagnosis sensor unit (Terminal No. 2)
(M47)	Steering angle sensor
(M49)	Front air control (Terminal No. 20) (manual with type 2)
(M50)	Front air control (Terminal No. 13) (manual with type 1)
(M51)	Front blower switch
(M55)	Hazard switch
(M56)	Front air control (Terminal No. 35) (with auto A/C)
(M71)	Cargo lamp switch
(M121)	Variable blower control (front)
(M152)	Transfer control unit (Terminal No. 6)
(M152)	Transfer control unit (Terminal No. 18)
(M153)	Transfer control unit (Terminal No. 32)
(M154)	VDC OFF switch
(M155)	Hill descent control switch
(M156)	A/T shift selector (Terminal No. 2)
(M156)	A/T shift selector (Terminal No. 8)
(M156)	A/T shift selector (Terminal No. 10)
(M159)	Door mirror remote control switch
(M160)	Front heated seat switch RH
(M161)	Front heated seat switch LH
(M163)	Clutch interlock cancel switch

ABMIA4383GB

GROUND

< DTC/CIRCUIT DIAGNOSIS >

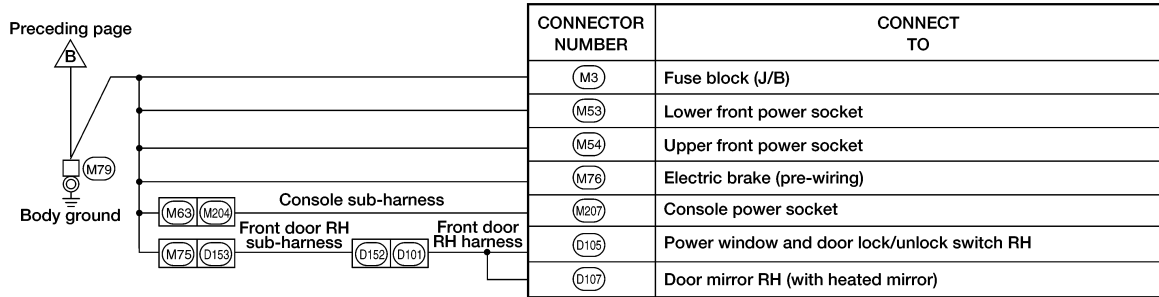
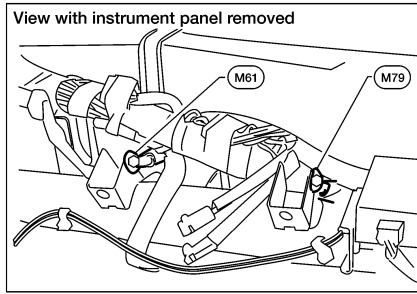

A
B
C
D
E
F
G
H
I
J
K
L
PG
N
O
P

GROUND

< DTC/CIRCUIT DIAGNOSIS >

ENGINE ROOM HARNESS

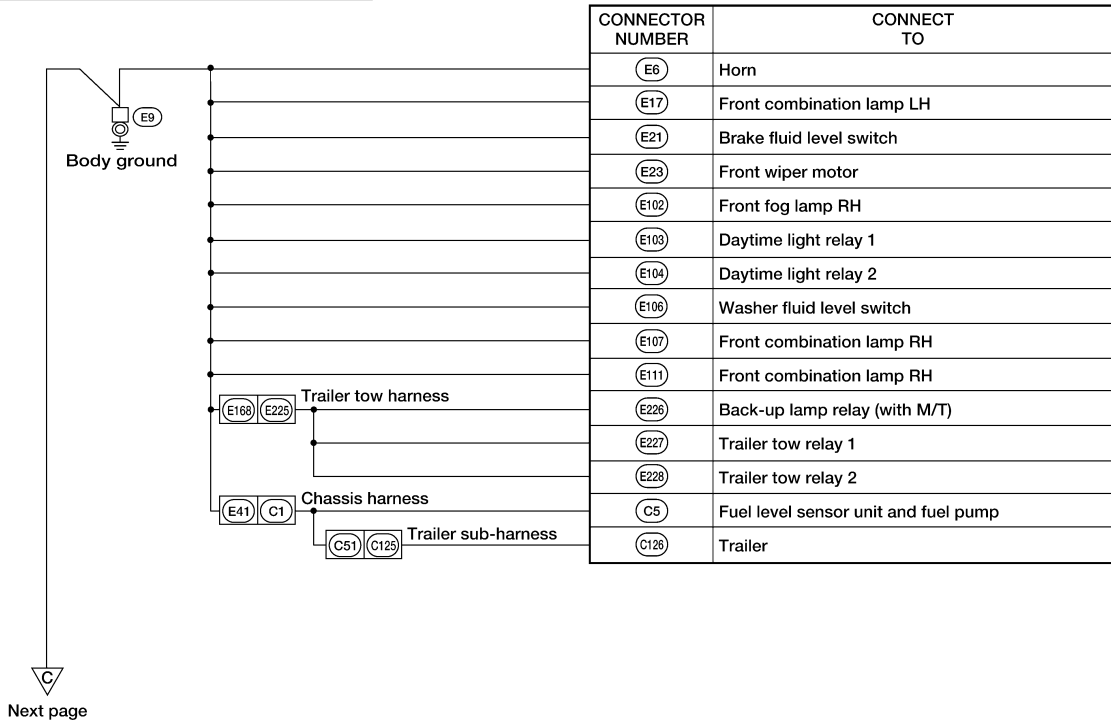
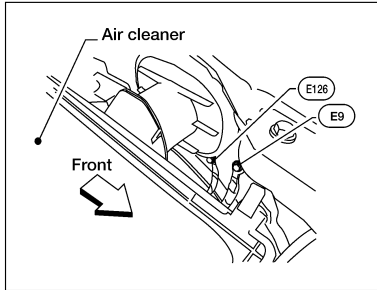

ABMIA3485GB

GROUND

< DTC/CIRCUIT DIAGNOSIS >

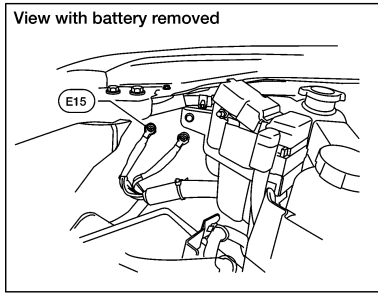

ⓏV : WITH VQ40DE

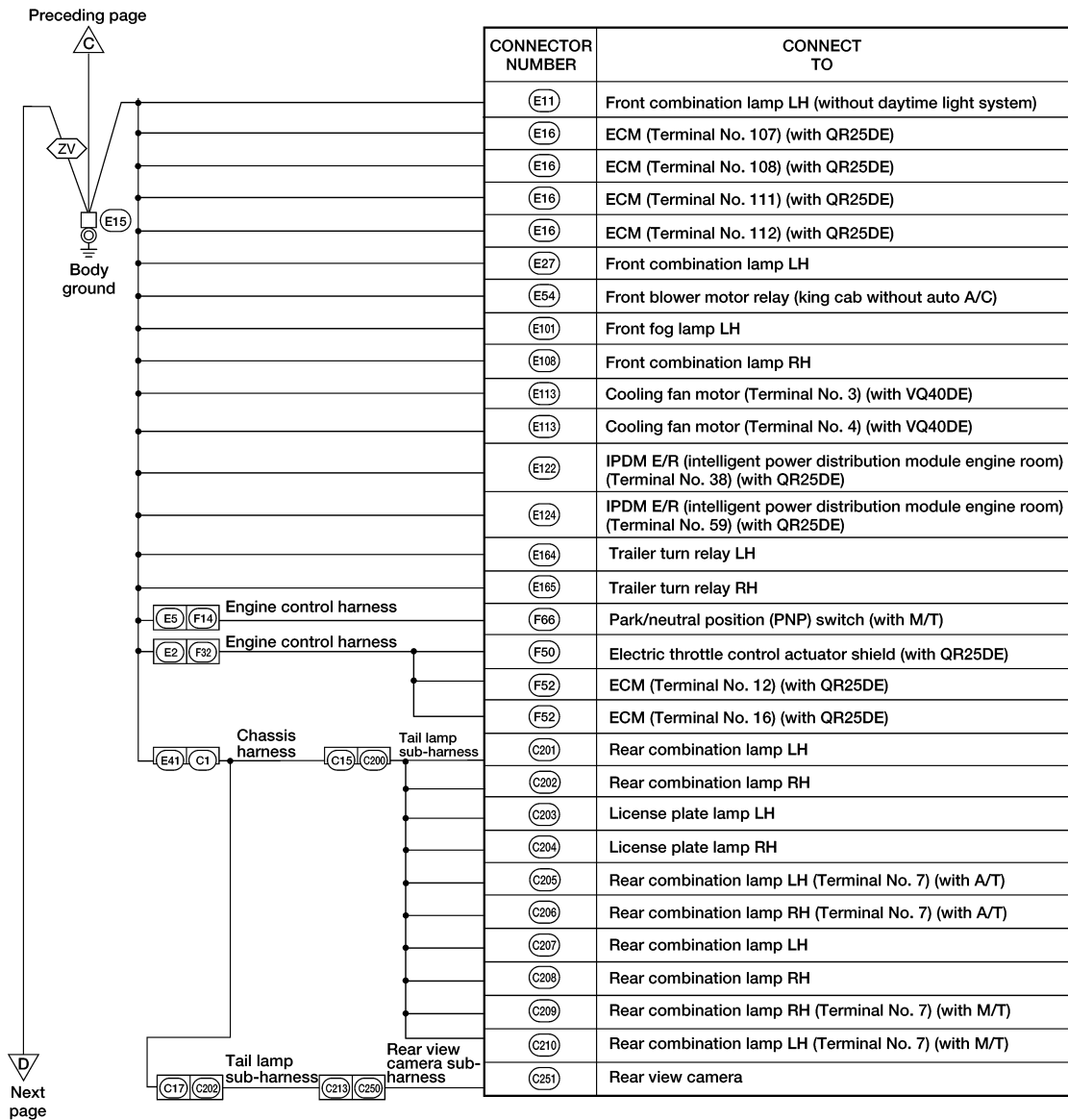

ABMIA4385GB

A
B
C
D
E
F
G
H
I
J
K
L
PG
N
O
P

GROUND

< DTC/CIRCUIT DIAGNOSIS >

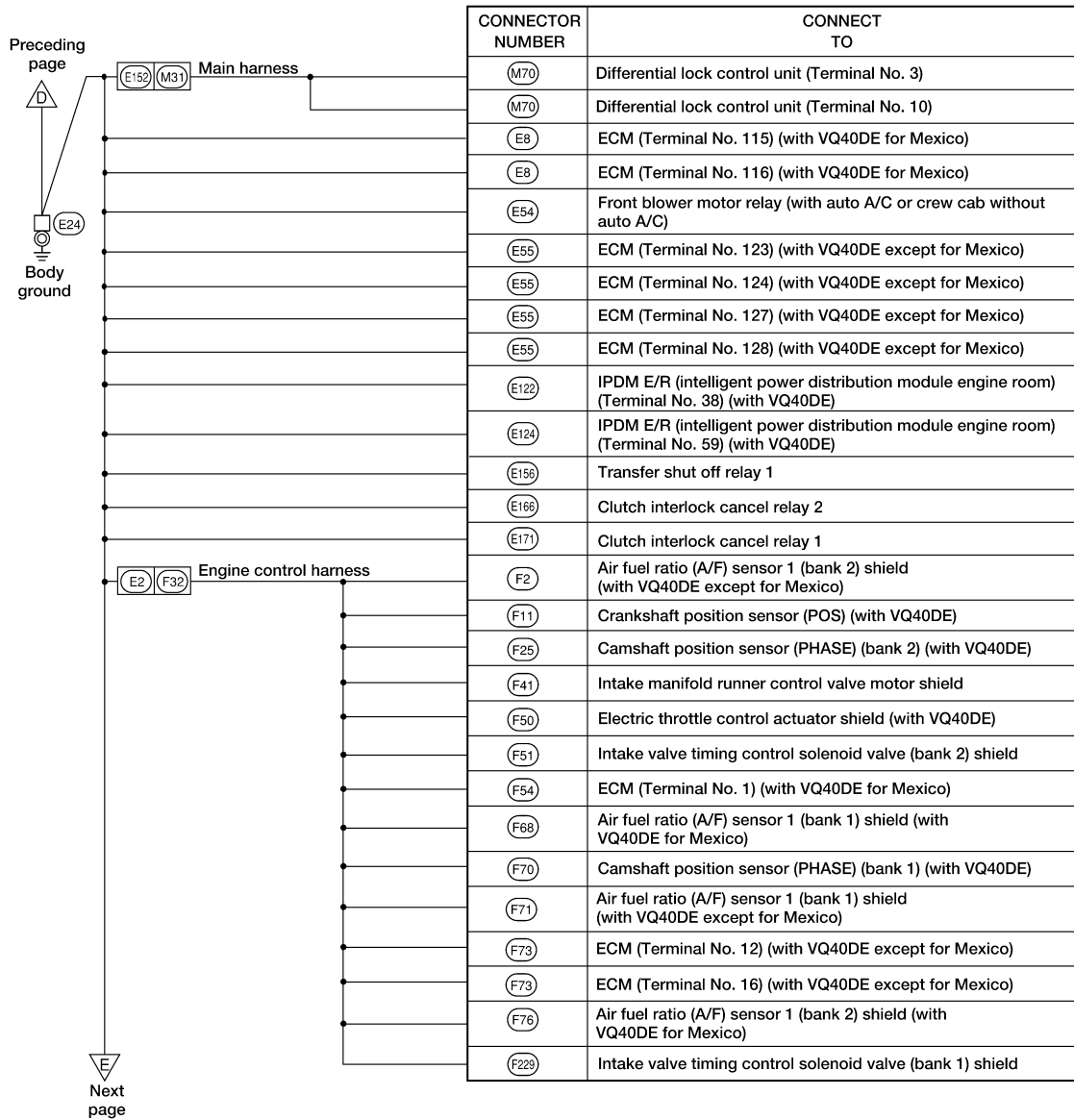
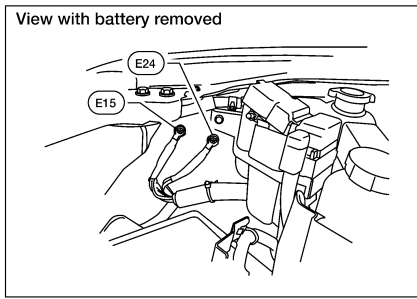

ABMIA4386GB

GROUND

< DTC/CIRCUIT DIAGNOSIS >

Preceding
page
△

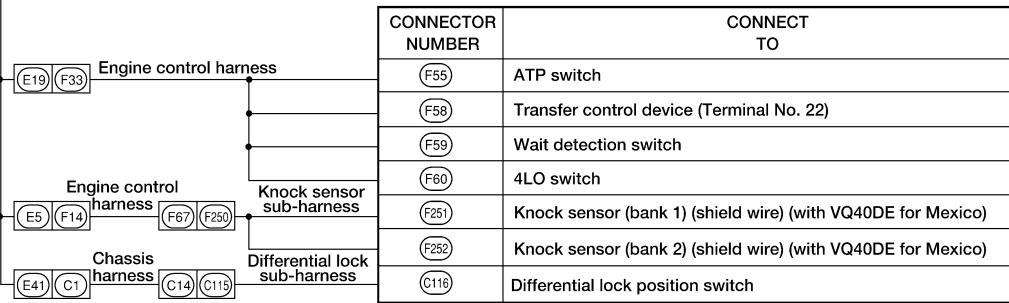

A
B
C
D
E
F
G
H
I
J
K
L
N
O
P

PG

ABMIA4393GB

GROUND

< DTC/CIRCUIT DIAGNOSIS >

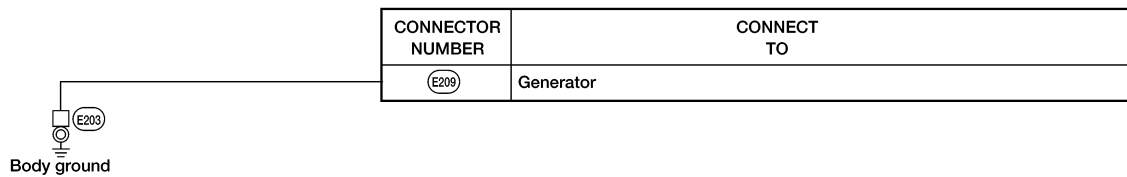
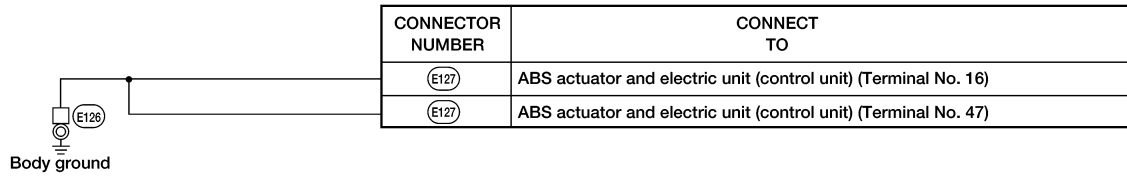
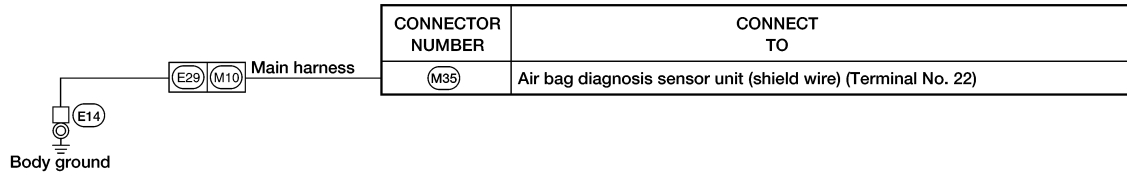
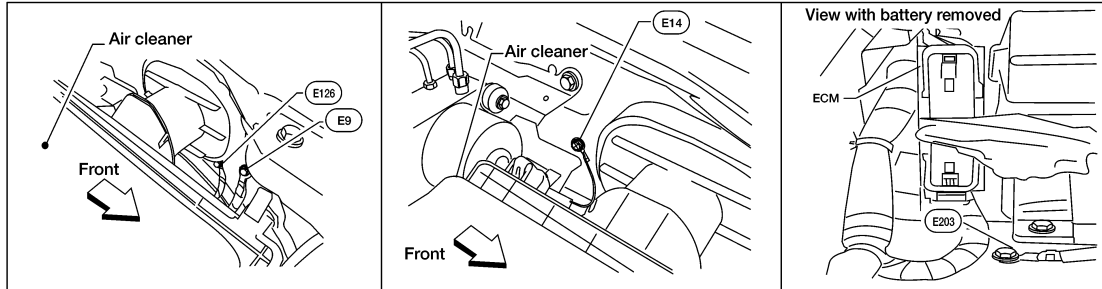

ABMIA4387GB

GROUND

< DTC/CIRCUIT DIAGNOSIS >

ENGINE CONTROL HARNESS (VQ40DE MODELS)

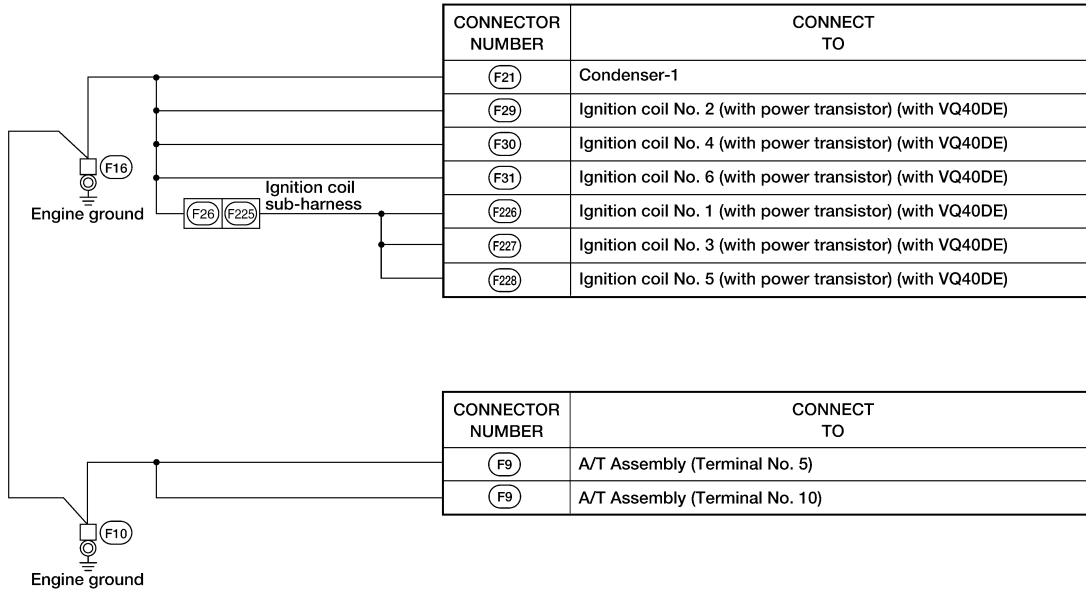
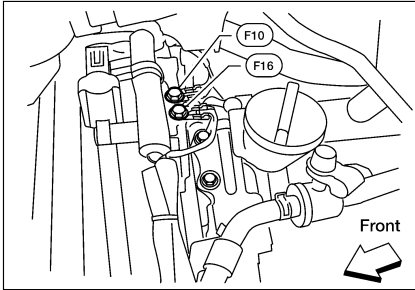

A
B
C
D
E
F
G
H
I
J
K
L
PG
N
O
P

ABMIA0372GB

GROUND

< DTC/CIRCUIT DIAGNOSIS >

ENGINE CONTROL HARNESS (QR25DE MODELS)

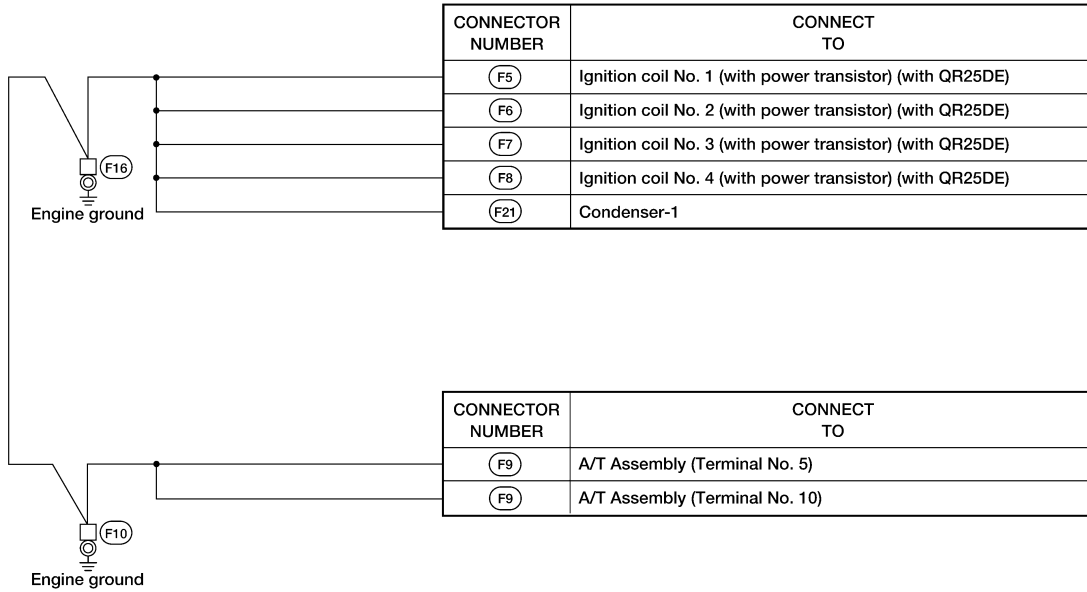
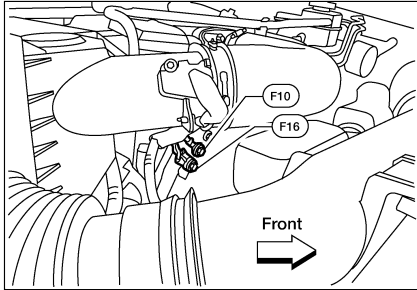

ABMIA0373GB

GROUND

< DTC/CIRCUIT DIAGNOSIS >

BODY HARNESS

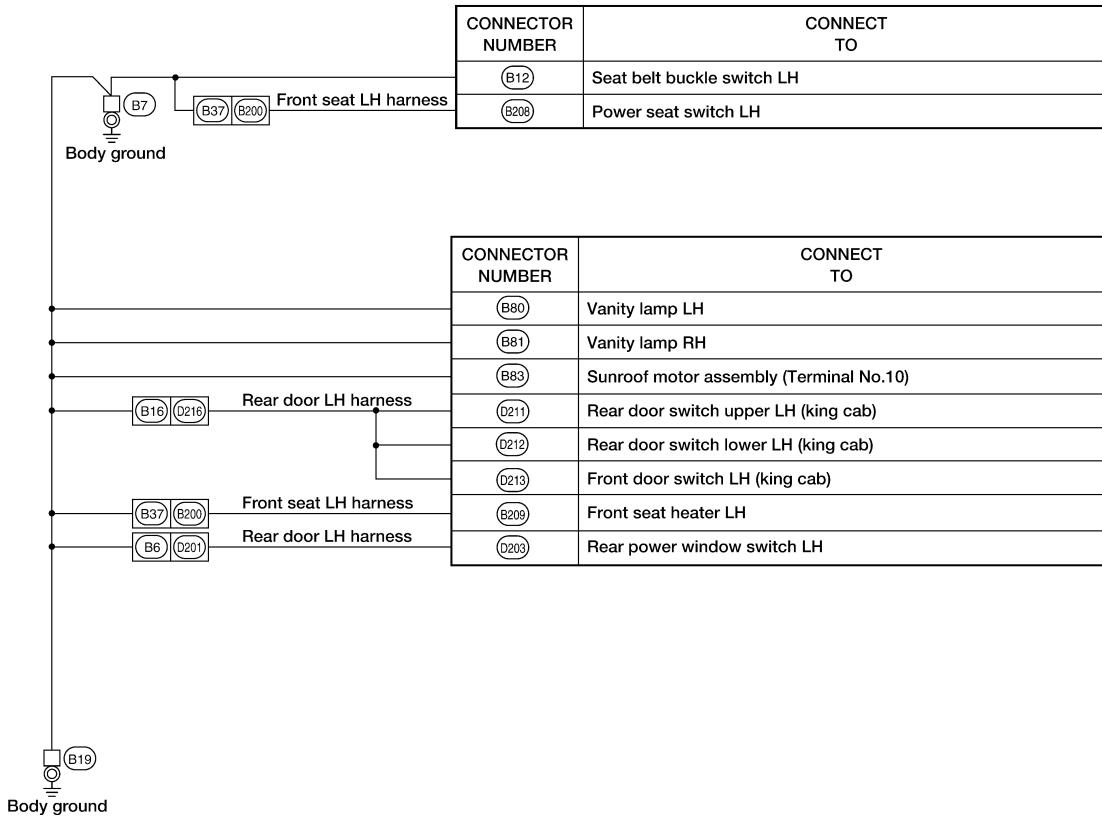
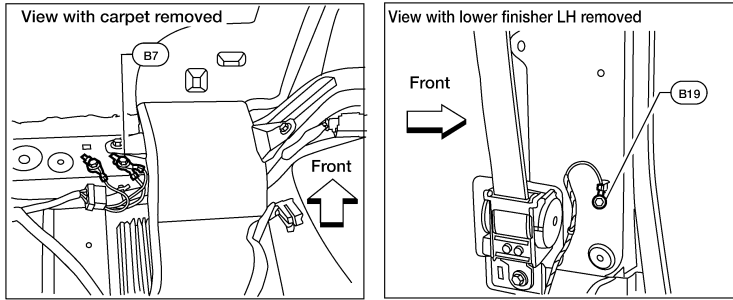

ABMIA3491GB

A
B
C
D
E
F
G
H
I
J
K
L
PG
N
O
P

GROUND

< DTC/CIRCUIT DIAGNOSIS >

BODY NO. 2 HARNESS

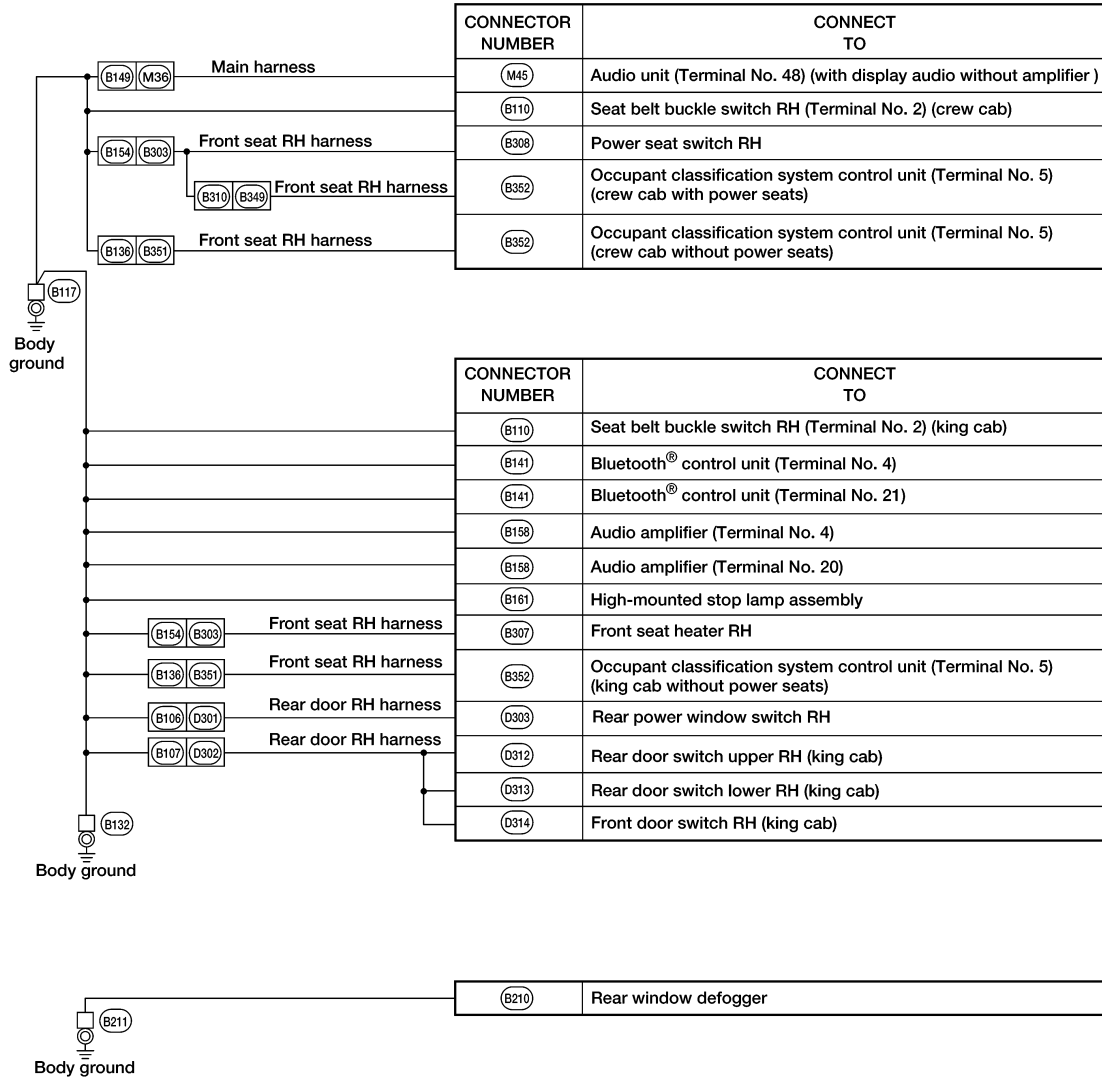
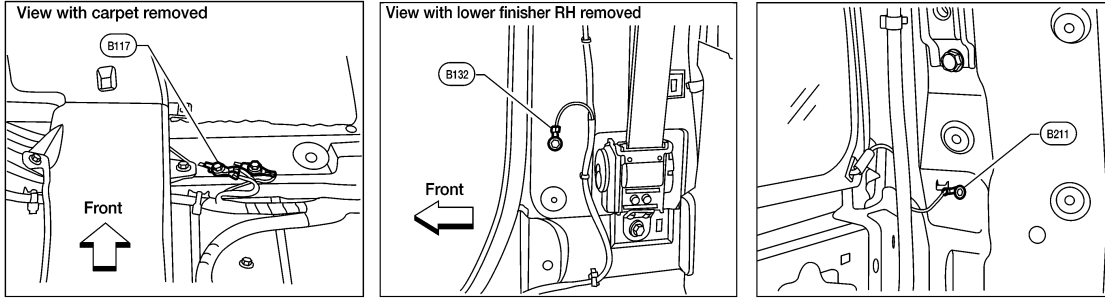

ABMIA4388GB

HARNESS

< DTC/CIRCUIT DIAGNOSIS >

HARNESS

Harness Layout

INFOID:000000008792552

HOW TO READ HARNESS LAYOUT

The following Harness Layouts use a map style grid to help locate connectors on the drawings:

- Main Harness and Console Sub-harness
- Engine Room Harness (RH View), Generator Sub-harness and Trailer Tow Harness
- Engine Room Harness (Passenger Compartment)
- Engine Room Harness (LH View)
- Engine Control Harness (QR25DE Models) and Injector Sub-harness
- Engine Control Harness (VQ40DE Models), Injector Sub-harness, Ignition Coil Sub-harness and Knock Sensor Sub-harness
- Chassis Harness, Differential Lock Sub-harness, Trailer Sub-harness and Tail Lamp Sub-harness, Rear sonar sub-harness, Rear view camera sub-harness
- Body Harness (King Cab Models) and Front Seat LH Harness
- Body Harness (Crew Cab Models) and Front Seat LH Harness
- Body No. 2 Harness (King Cab Models) and Front Seat RH Harness
- Body No. 2 Harness (Crew Cab Models) and Front Seat RH Harness
- Room Lamp Harness

To use the grid reference

1. Find the desired connector number on the connector list.
2. Find the grid reference.
3. On the drawing, find the crossing of the grid reference letter column and number row.
4. Find the connector number in the crossing zone.
5. Follow the line to the connector.

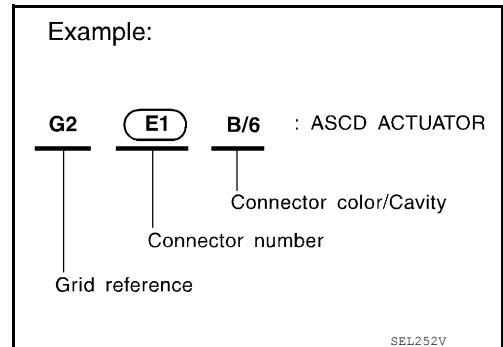

A
B
C
D
E
F
G
H
I
J
K
L
PG
N
O
P

HARNESS

< DTC/CIRCUIT DIAGNOSIS >

OUTLINE (KING CAB MODELS)

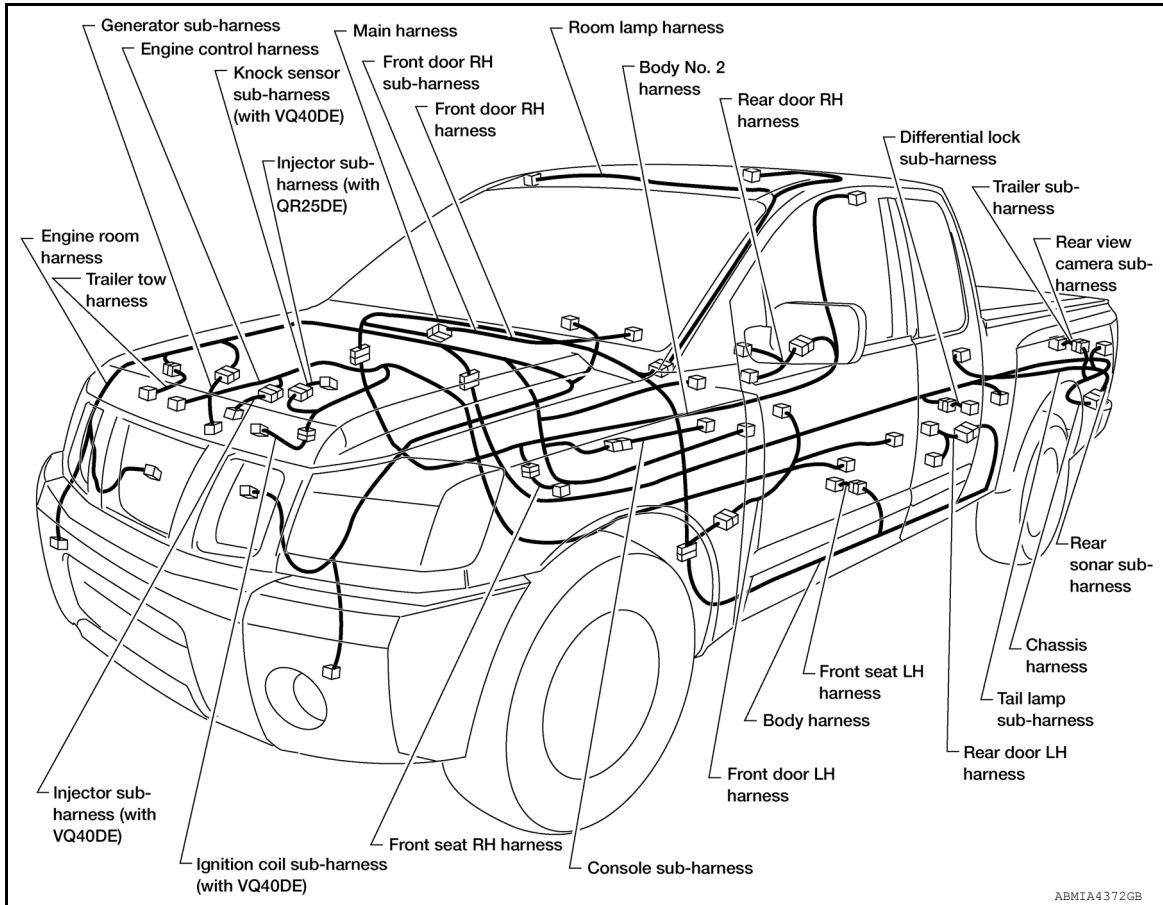

HARNESS

< DTC/CIRCUIT DIAGNOSIS >

OUTLINE (CREW CAB MODELS)

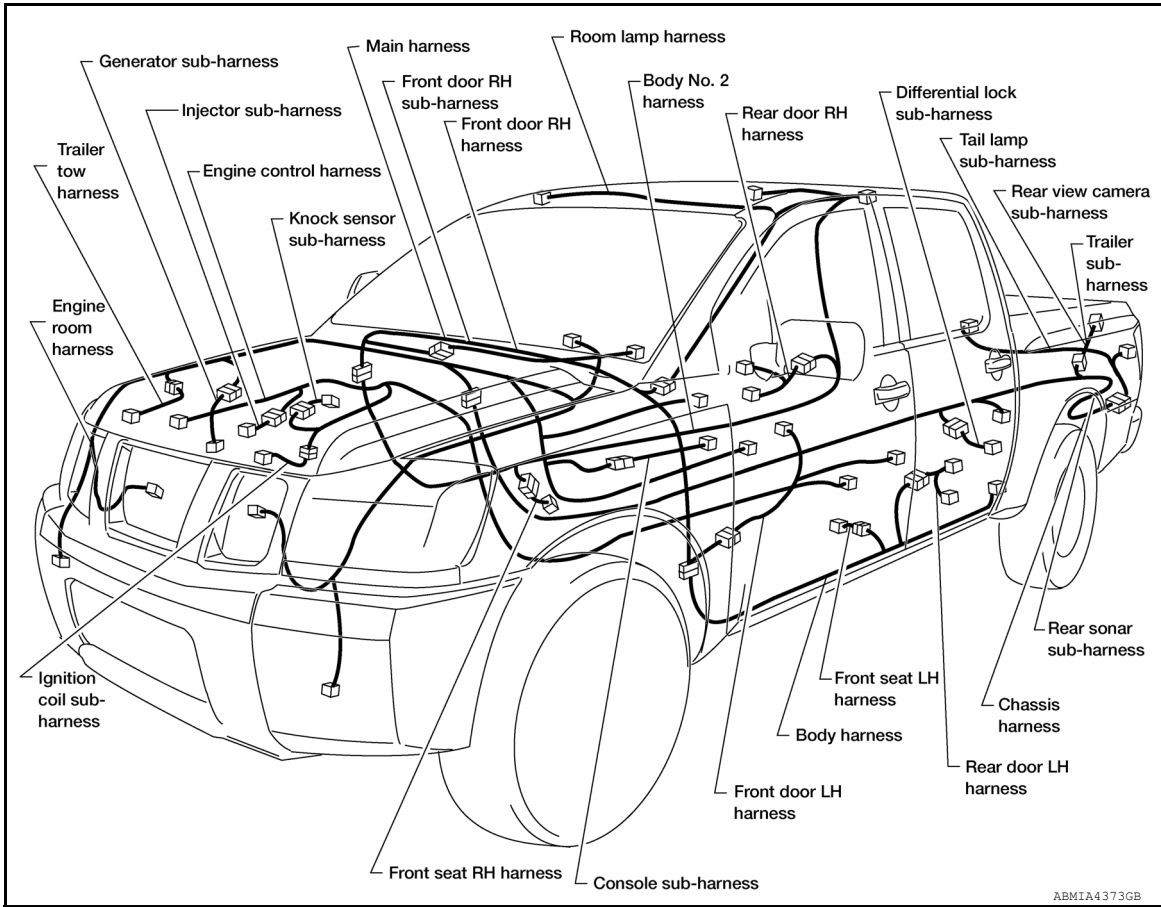

A
B
C
D
E
F
G
H
I
J
K
L
PG
N
O
P

HARNESS

< DTC/CIRCUIT DIAGNOSIS >

MAIN HARNESS

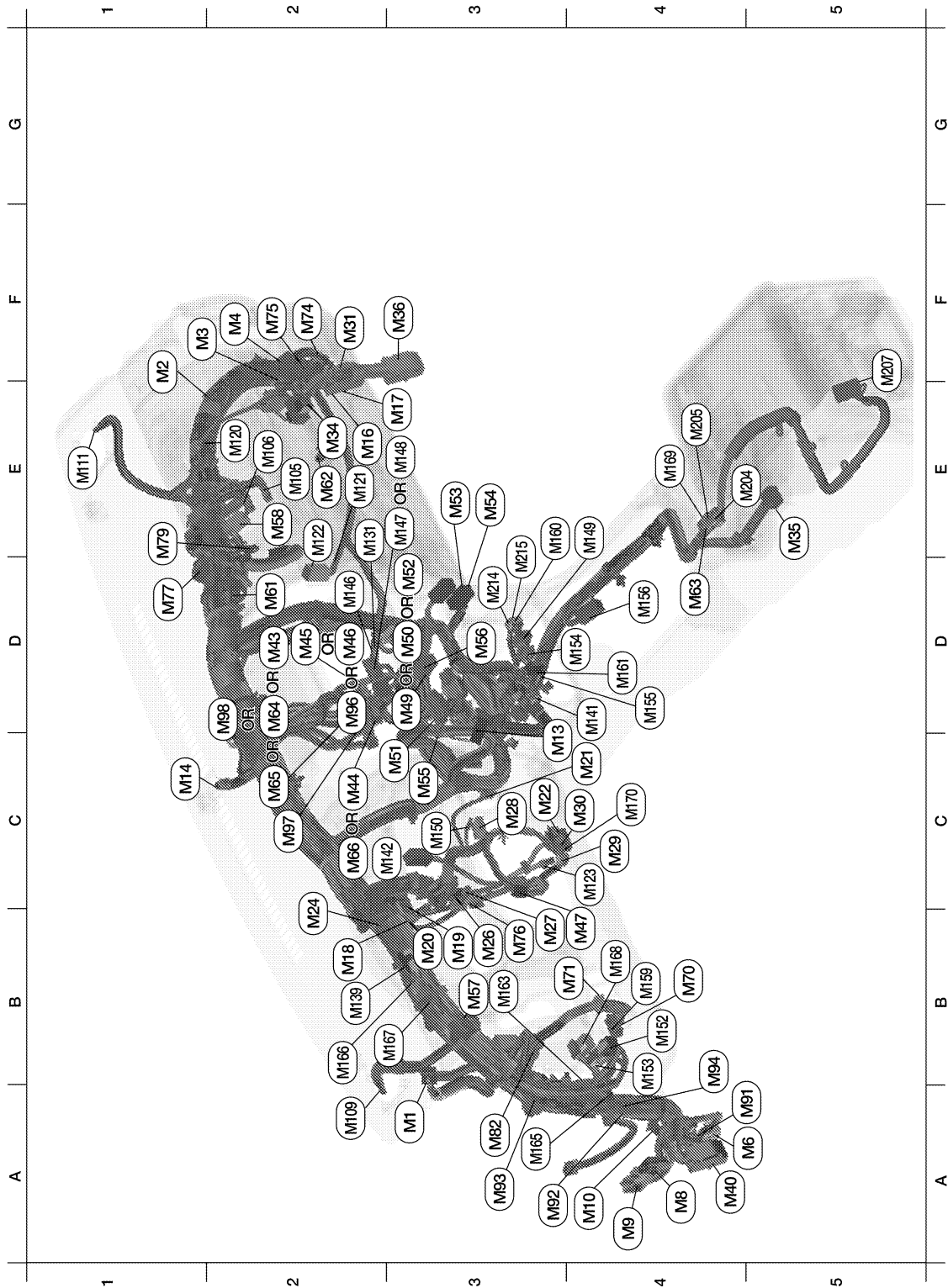

ABMIA4374GB

A3	M1	W/24	: To R1	F2	M74	W/16	: To D102
F1	M2	G/20	: Joint connector-M03	F2	M75	W/12	: To D101
F1	M3	W/8	: Fuse block (J/B)	B3	M76	W/6	: Electric brake (pre-wiring)
F2	M4	W/16	: Fuse block (J/B)	D1	M77	Y/4	: Front passenger air bag module (service replacement)
A5	M6	W/6	: To E10	E1	M79	—	: Body ground

HARNESS

< DTC/CIRCUIT DIAGNOSIS >

A4	M8	BR/12	: To D2	A3	M82	W/2	: Circuit breaker-2	A	
A4	M9	W/16	: To D1	A4	M91	W/16	: To E26	B	
A4	M10	Y/4	: To E29	A3	M92	B/2	: Sonar buzzer	C	
C3	M13	BR/3	: Front passenger air bag OFF indicator	A3	M93	W/16	: Sonar control unit	D	
C1	M14	B/4	: Optical sensor and sunload sensor	A4	M94	GR/8	: Sonar system off switch	E	
E2	M16	W/12	: To B162	D2	M96	W/20	: AV control unit (with NAVI)	F	
E3	M17	W/16	: To B163	C2	M97	W/24	: AV control unit (with NAVI)	G	
B2	M18	W/40	: BCM (body control module)	D2	M98	G/5	: AV control unit (with NAVI)	H	
B3	M19	W/15	: BCM (body control module)	E2	M105	Y/2	: Front passenger air bag module	I	
B3	M20	B/15	: BCM (body control module)	E2	M106	O/2	: Front passenger air bag module	J	
C4	M21	W/4	: NATS antenna amp.	A2	M109	BR/2	: Front tweeter LH	K	
C3	M22	W/16	: Data link connector	E1	M111	BR/2	: Front tweeter RH	L	
B2	M24	W/40	: Combination meter	E2	M120	W/4	: Remote keyless entry receiver		
B3	M26	W/6	: Ignition switch	E2	M121	W/4	: Variable blower control (front)		
B3	M27	W/2	: Key switch	E2	M122	W/4	: Front blower motor resistor		
C3	M28	W/16	: Combination switch	C4	M123	W/2	: Tire pressure warning check connector		
C4	M29	Y/6	: Combination switch (spiral cable)	E2	M131	B/6	: Air mix door motor (passenger)		
C4	M30	GR/8	: Combination switch (spiral cable)	B2	M139	B/2	: Diode-6		
F2	M31	SMJ	: To E152	D4	M141	GR/8	: 4WD shift switch		
E2	M34	W/4	: In-vehicle sensor	C3	M142	B/6	: Mode door motor		
E5	M35	Y/28	: Air bag diagnosis sensor unit	E2	M146	GR/2	: Intake sensor		
F3	M36	SMJ	: To B149	D2	M147	B/6	: Air mix door motor		
A4	M40	SMJ	: To B69	E2	M148	B/6	: Air mix door motor (driver)		
D2	M43	W/20	: Audio unit (base audio system)	E4	M149	W/6	: Differential lock mode switch		
C2	M44	W/20	: Audio unit (with display audio without amplifier)	C3	M150	W/2	: Ignition keyhole illumination		
D2	M45	W/32	: Audio unit (with display audio without amplifier)	B4	M152	W/26	: Transfer control unit		
D2	M46	W/20	: Audio unit (with display audio with amplifier)	B4	M153	W/24	: Transfer control unit		
B4	M47	W/8	: Steering angle sensor	D4	M154	GR/6	: VDC off switch		
D3	M49	B/26	: Front air control (manual with type 2)	D4	M155	W/8	: Hill descent control switch		
D3	M50	B/26	: Front air control (manual with type 1)	D4	M156	W/10	: A/T shift selector	PG	
C3	M51	W/8	: Front blower switch	B4	M159	W/16	: Door mirror remote control switch		
D2	M52	B/26	: Front air control (with auto A/C)	E3	M160	BR/6	: Front heated seat switch RH		
D3	M53	B/3	: Lower front power socket	D4	M161	W/6	: Front heated seat switch LH	N	
E3	M54	GR/3	: Upper front power socket	B3	M163	W/8	: Clutch interlock cancel switch	O	
C3	M55	W/4	: Hazard switch	A3	M165	L/4	: Cargo lamp relay	P	
B3	M56	B/18	: Front air control (with auto A/C)	B3	M166	L/20	: Joint connector-M01		
B3	M57	—	: Body ground	B3	M167	L/20	: Joint connector-M02		
E2	M58	B/6	: Intake door motor	B4	M168	L/4	: Accessory relay-2		
D2	M61	—	: Body ground	E4	M169	L/7	: To M205		
E2	M62	B/2	: Front blower motor	C4	M170	B/2	: Resistor		
D4	M63	W/6	: To M204	Console sub-harness					
D2	M64	G/5	: Audio unit (with display audio without amplifier)	E5	M204	W/6	: To M63		

HARNESS

< DTC/CIRCUIT DIAGNOSIS >

C2	M65	W/32	: Audio unit (with display audio with amplifier)	E4	M205	L/7	: To M169
C2	M66	G/5	: Audio unit (with display audio with amplifier)	F5	M207	B/3	: Console power socket
B4	M70	W/26	: Differential lock control unit	D3	M214	L/5	: USB interface
B4	M71	W/6	: Cargo lamp switch	D3	M215	W/4	: Aux in jack

ENGINE ROOM HARNESS (RH VIEW)

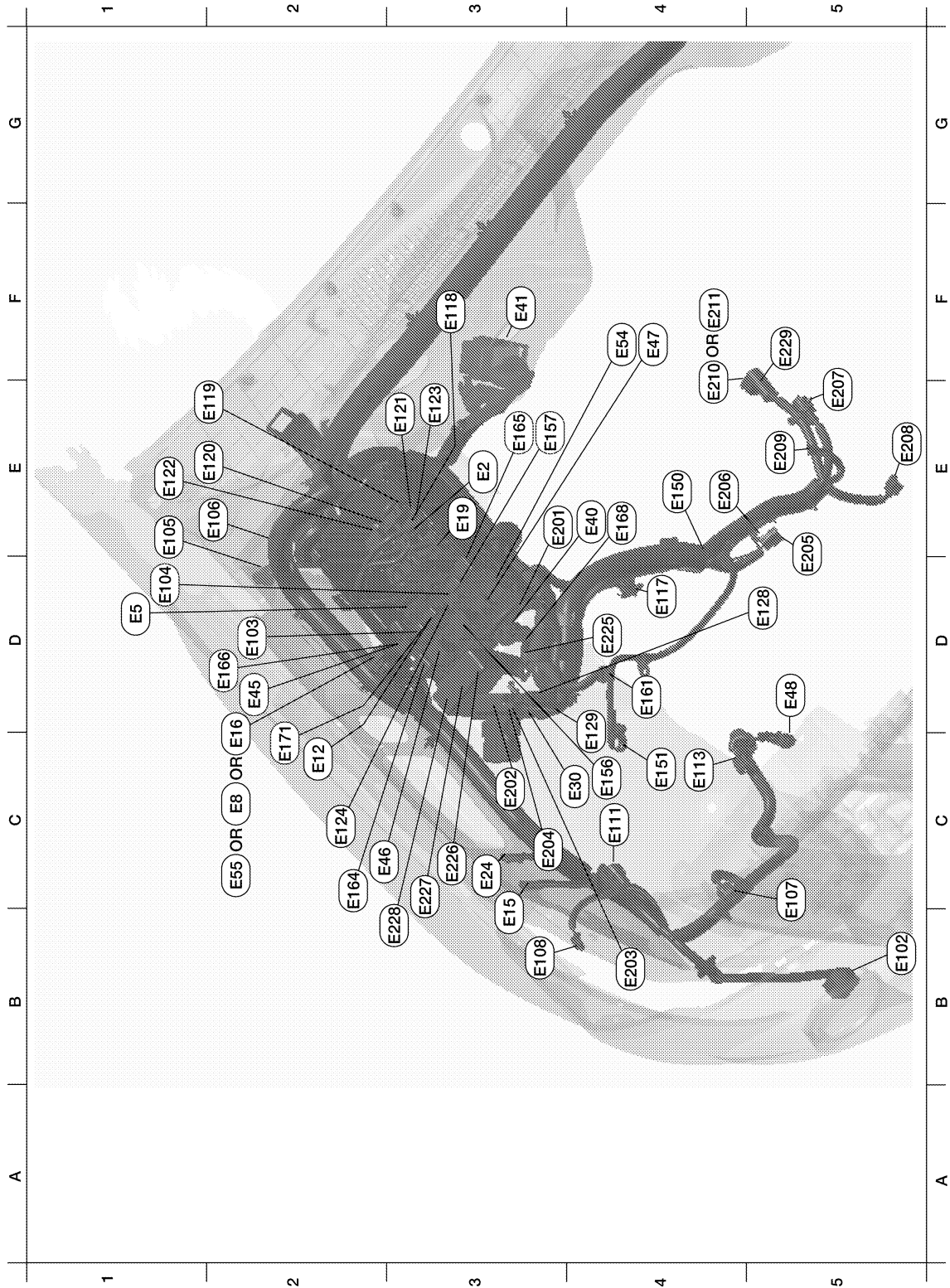

HARNESS

< DTC/CIRCUIT DIAGNOSIS >

Refer to "ENGINE ROOM HARNESS (LH VIEW)" for continuation of engine room harness.

E3	E2	W/16	: To F32	E3	E123	BR/8	: IPDM E/R (intelligent power distribution module engine room)	A	
D1	E5	W/24	: To F14	C2	E124	B/6	: IPDM E/R (intelligent power distribution module engine room)	B	
C2	E8	B/40	: ECM (with VQ40DE for Mexico)	D5	E128	GR/2	: Fusible link box (battery)	C	
C2	E12	L/4	: Stop lamp relay	D4	E129	B/2	: Fusible link box (battery)	D	
B3	E15	—	: Body ground	E4	E150	—	: Battery ground	E	
D2	E16	B/32	: ECM (with QR25DE)	C4	E151	—	: Negative battery cable	F	
E3	E19	W/16	: To F33	C4	E156	L/4	: Transfer shut off relay 1	G	
C3	E24	—	: Body ground	E3	E157	L/4	: Transfer shut off relay 2	H	
C3	E30	—	: Fusible link box (battery)	D4	E161	B/3	: Battery current sensor	I	
E4	E40	GR/9	: To E201	C2	E164	L/4	: Trailer turn relay LH	J	
F3	E41	SMJ	: To C1	E3	E165	L/4	: Trailer turn relay RH	K	
D2	E45	BR/6	: Back-up lamp relay (with A/T)	D2	E166	BR/6	: Clutch interlock cancel relay 2	L	
C3	E46	B/5	: Transfer shift high relay	E4	E168	W/12	: To E225	PG	
F4	E47	B/5	: Transfer shift low relay	C2	E171	B/5	: Clutch interlock cancel relay 1	N	
D5	E48	B/3	: Refrigerant pressure sensor	Generator sub-harness					O
F4	E54	BR/6	: Front blower motor relay	E3	E201	GR/9	: To E40	P	
C2	E55	GR/32	: ECM (with VQ40DE except for Mexico)	C3	E202	—	: Fusible link box (battery)		
B5	E102	B/2	: Front fog lamp RH	B4	E203	—	: Body ground		
D2	E103	B/5	: Daytime light relay 1	C3	E204	—	: Fusible link box (battery)		
D1	E104	L/4	: Daytime light relay 2	E5	E205	B/3	: Generator		
E1	E105	B/2	: Front washer motor	E4	E206	—	: Generator		
E2	E106	BR/2	: Washer fluid level switch	F5	E207	GR/1	: Starter motor (with VQ40DE)		
C5	E107	B/3	: Front combination lamp RH	E5	E208	GR/1	: Oil pressure switch (with VQ40DE)		
B3	E108	GR/2	: Front combination lamp RH	E5	E209	—	: Generator		
C4	E111	GR/3	: Front combination lamp RH	E4	E210	—	: Starter motor		
C4	E113	GR/4	: Cooling fan motor	F4	E211	GR/1	: Starter motor (with QR25DE)		
D4	E117	GR/2	: Front wheel sensor RH	Trailer tow harness					
F3	E118	B/2	: IPDM E/R (intelligent power distribution module engine room)	D4	E225	W/12	: To E168		
E1	E119	W/16	: IPDM E/R (intelligent power distribution module engine room)	C3	E226	L/4	: Back-up lamp relay (with M/T)		
E1	E120	W/6	: IPDM E/R (intelligent power distribution module engine room)	C3	E227	L/4	: Trailer tow relay 1		
E3	E121	BR/12	: IPDM E/R (intelligent power distribution module engine room)	B3	E228	BR/6	: Trailer tow relay 2		
E1	E122	W/12	: IPDM E/R (intelligent power distribution module engine room)	F5	E229	GR/2	: Engine oil temperature sensor		

HARNESS

< DTC/CIRCUIT DIAGNOSIS >

ENGINE ROOM HARNESS (PASSENGER COMPARTMENT)

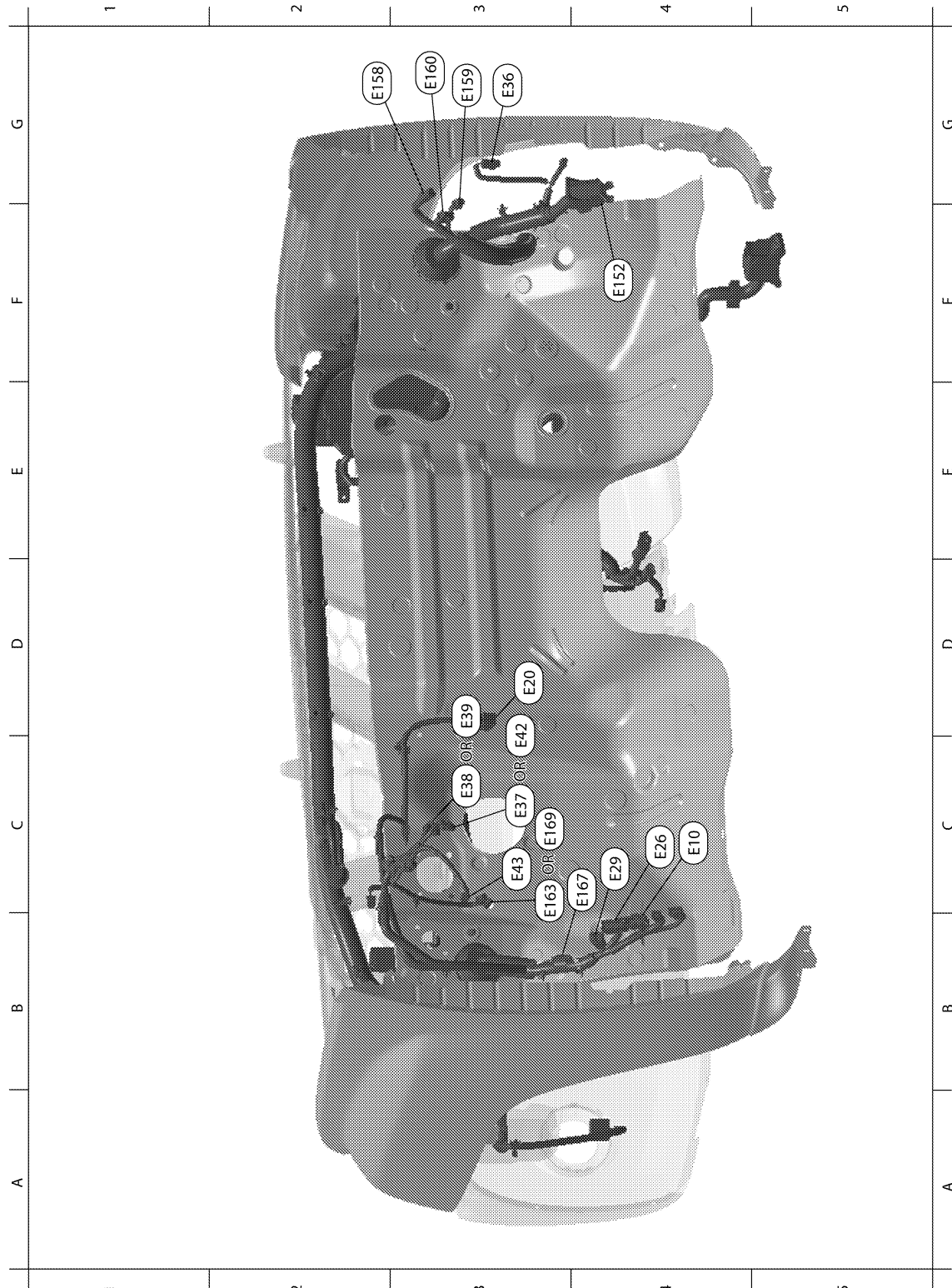

ABMIA0398GB

Refer to "ENGINE ROOM HARNESS (LH VIEW)" for continuation of engine room harness.

C4	E10	W/6	: To M6	C3	E43	L/2	: Clutch pedal position switch
D3	E20	B/6	: Accelerator pedal position (APP) sensor	F4	E152	SMJ	: To M31
C4	E26	W/16	: To M91	G2	E158	B/1	: Fuse block (J/B)
C4	E29	Y/4	: To M10	G3	E159	B/2	: Fuse block (J/B)

HARNES

< DTC/CIRCUIT DIAGNOSIS >

G3	E36	W/2	: To B102	G3	E160	W/8	: Fuse block (J/B)
C3	E37	BR/2	: Brake pedal position switch (with M/T)	C3	E163	L/2	: Clutch interlock switch (with clutch interlock cancel system)
C3	E38	B/2	: Stop lamp switch (with M/T)	C4	E167	B/2	: Diode-3
D3	E39	W/4	: Stop lamp switch (with A/T)	C3	E169	L/2	: Clutch interlock switch (without clutch interlock cancel system)
C3	E42	BR/2	: Brake pedal position switch (with A/T)				

A
B
C
D
E
F
G
H
I
J
K
L

PG

N
O
P

HARNESS

< DTC/CIRCUIT DIAGNOSIS >

ENGINE ROOM HARNESS (LH VIEW)

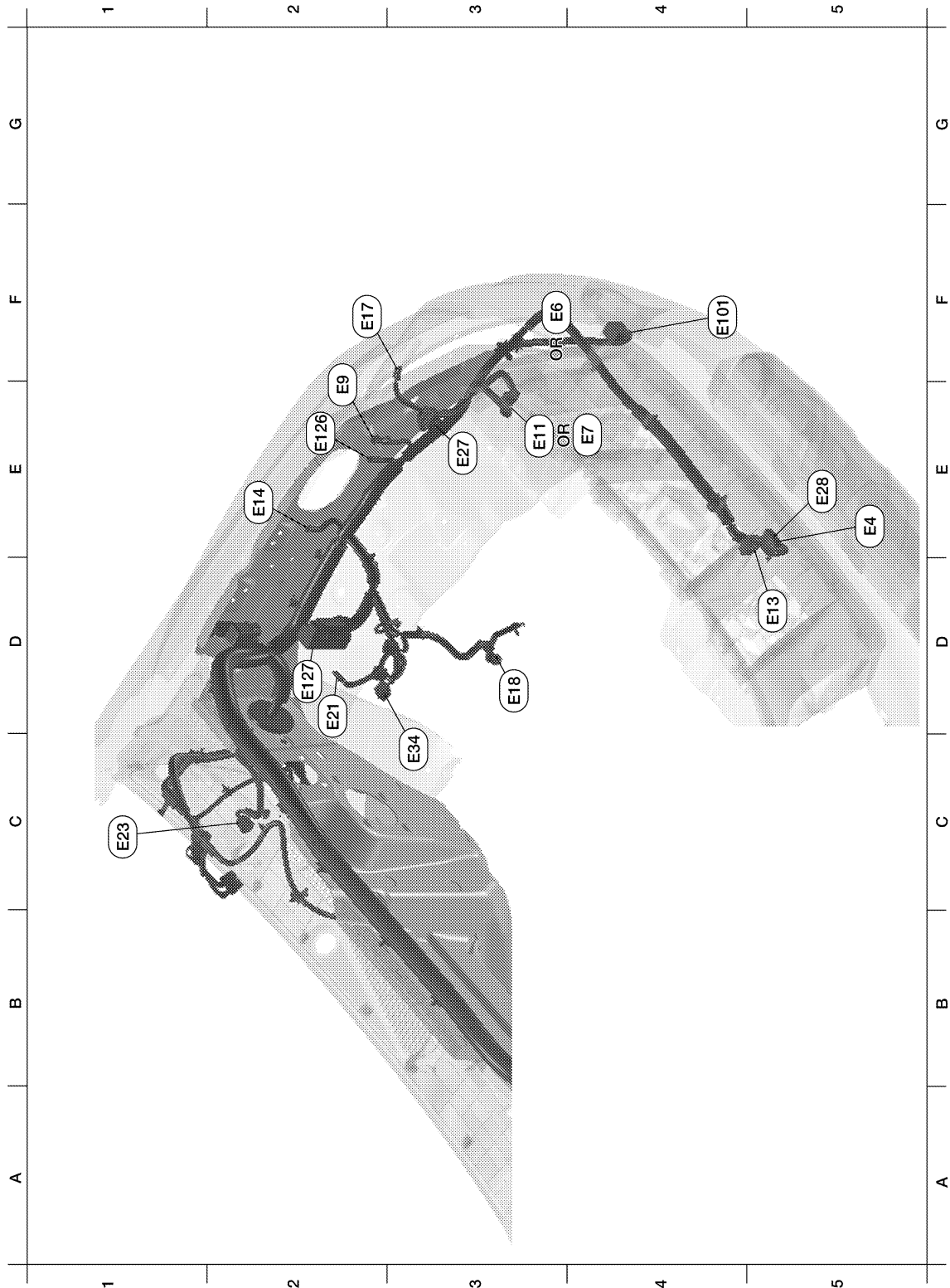

ABMIA4392GB

Refer to "ENGINE ROOM HARNESS (RH VIEW)" for continuation of engine room harness.

E5	E4	Y/2	: Crash zone sensor	D2	E21	GR/2	: Brake fluid level switch
F3	E6	B/2	: Horn	C1	E23	GR/5	: Front wiper motor
E4	E7	B/3	: Front combination lamp LH (with daytime light system)	E3	E27	GR/3	: Front combination lamp LH
F2	E9	—	: Body ground	E5	E28	B/2	: Ambient sensor

HARNESS

< DTC/CIRCUIT DIAGNOSIS >

E3	E11	B/3	: Front combination lamp LH (without daytime light system)	C3	E34	W/8	: To B40
D5	E13	B/2	: Ambient sensor 2	F4	E101	B/2	: Front fog lamp LH
E2	E14	—	: Body ground	E2	E126	—	: Body ground
F2	E17	GR/2	: Front combination lamp LH	D2	E127	B/47	: ABS actuator and electric unit (control unit)
D3	E18	GR/2	: Front wheel sensor LH				

A

B

C

D

E

F

G

H

I

J

K

L

PG

N

O

P

HARNESS

< DTC/CIRCUIT DIAGNOSIS >

ENGINE CONTROL HARNESS (QR25DE MODELS)

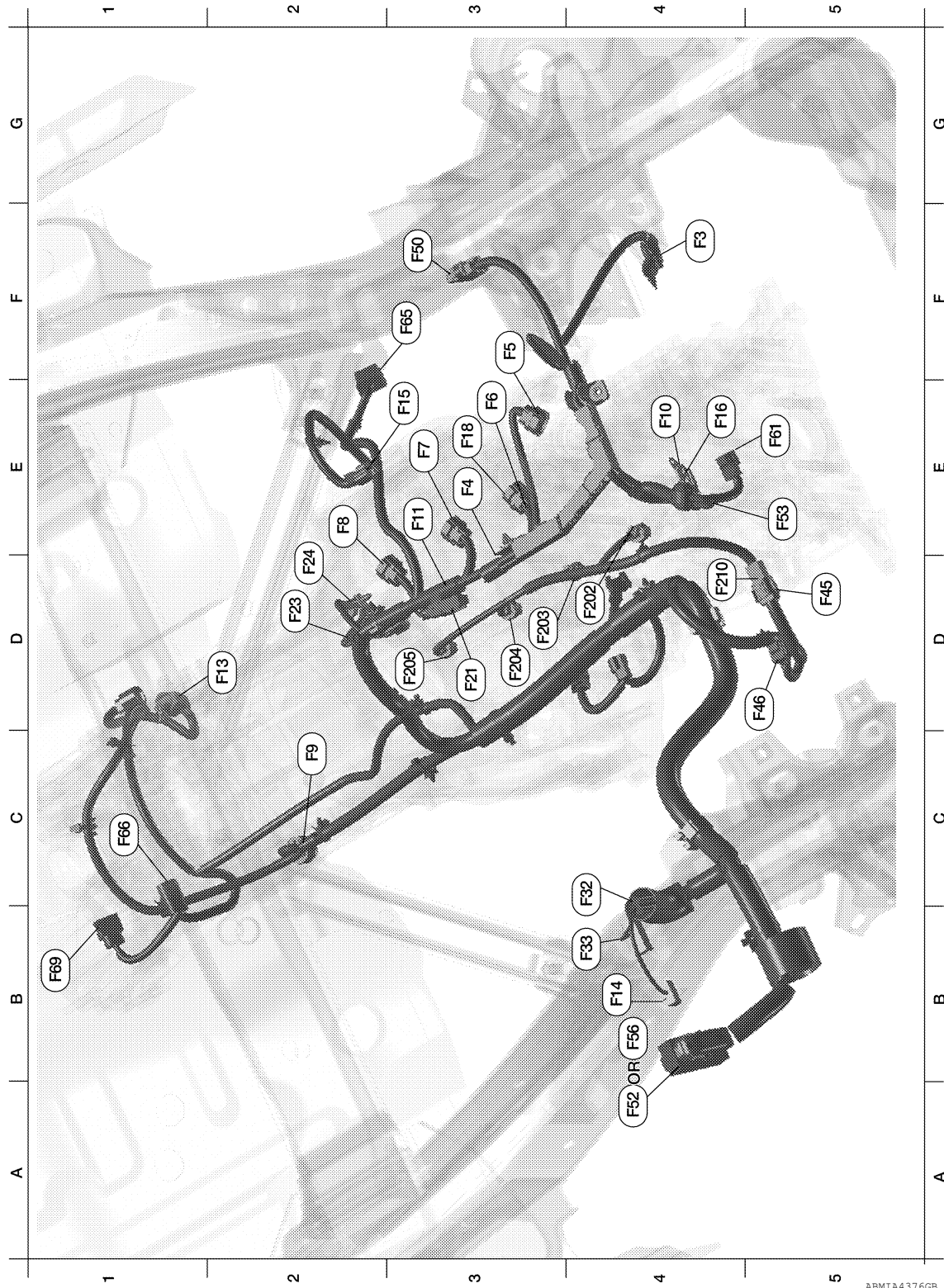

ABMIA4376GB

F4	F3	B/1	: A/C Compressor	B4	F33	W/16	: To E19
E3	F4	GR/1	: Oil pressure switch	D5	F45	B/6	: To F210
E3	F5	GR/3	: Ignition coil No. 1 (with power transistor)	C5	F46	B/3	: Power steering pressure sensor
E3	F6	GR/3	: Ignition coil No. 2 (with power transistor)	F3	F50	W/6	: Electric throttle control actuator
E3	F7	GR/3	: Ignition coil No. 3 (with power transistor)	A4	F52	GR/32	: ECM (with QR25DE)

HARNESSES

< DTC/CIRCUIT DIAGNOSIS >

E2	F8	GR/3	: Ignition coil No. 4 (with power transistor)	E5	F53	B/6	: Mass air flow sensor	A
C2	F9	G/10	: A/T assembly	B4	F56	BR/48	: ECM (with QR25DE)	B
E4	F10	—	: Engine ground	E5	F61	G/2	: Intake valve timing control solenoid valve	B
E3	F11	B/3	: Crankshaft position sensor (POS)	F3	F65	GR/4	: Air fuel ratio (A/F) sensor 1	C
D2	F13	G/4	: Heated oxygen sensor 2	C1	F66	B/2	: Park/neutral position (PNP) switch	C
B4	F14	W/24	: To E5	B1	F69	W/2	: Back-up lamp switch	D
E3	F15	GR/2	: EVAP canister purge volume control solenoid valve (with QR25DE)	Injector sub-harness				D
E4	F16	—	: Engine ground	D4	F202	GR/2	: Fuel injector No. 1	E
E3	F18	B/2	: Knock sensor	D3	F203	GR/2	: Fuel injector No. 2	E
D3	F21	W/2	: Condenser-1	D3	F204	GR/2	: Fuel injector No. 3	F
D2	F23	B/3	: Camshaft position sensor (PHASE)	D3	F205	GR/2	: Fuel injector No. 4	F
D2	F24	GR/2	: Engine coolant temperature sensor	D4	F210	B/6	: To F45	F
B4	F32	W/16	: To E2					F

PG

HARNESS

< DTC/CIRCUIT DIAGNOSIS >

ENGINE CONTROL HARNESS (VQ40DE MODELS)

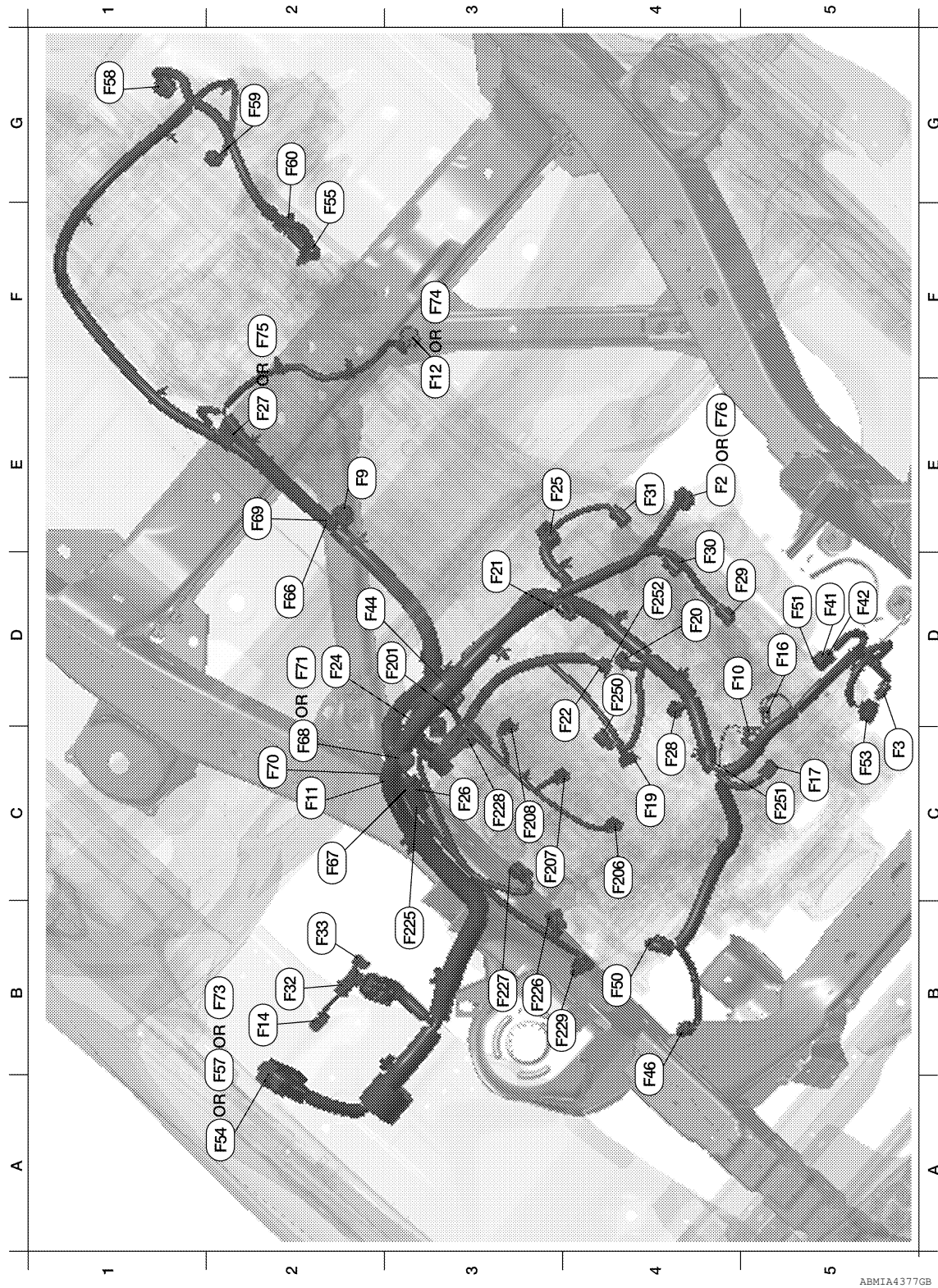

ABMIA4377GB

E4	F2	GR/4	: Air fuel ratio (A/F) sensor 1 (bank 2) (with VQ40DE except for Mexico)	F2	F55	B/2	: ATP switch
C5	F3	B/1	: A/C Compressor	B2	F57	BR/48	: ECM (with VQ40DE except for Mexico)
E2	F9	G/10	: A/T assembly	G1	F58	B/8	: Transfer control device
D4	F10	—	: Engine ground	G2	F59	GR/2	: Wait detection switch

HARNESSES

< DTC/CIRCUIT DIAGNOSIS >

C2	F11	B/3	: Crankshaft position sensor (POS)	F2	F60	GR/2	: 4LO switch	A
F3	F12	B/4	: Heated oxygen sensor 2 (bank 2) (with VQ40DE except for Mexico)	D2	F66	B/2	: Park/neutral position (PNP) switch	B
B2	F14	W/24	: To E5	C2	F67	L/4	: To F250	B
D5	F16	—	: Engine ground	C2	F68	GR/4	: Air fuel ratio (A/F) sensor 1 (bank 1) (with VQ40DE for Mexico)	C
C5	F17	GR/2	: EVAP canister purge volume control solenoid valve (with VQ40DE)	E2	F69	W/2	: Back-up lamp switch	C
C4	F19	B/2	: VIAS control solenoid valve	C2	F70	G/3	: Camshaft position sensor (PHASE) (bank 1)	D
D4	F20	GR/2	: Fuel injector No. 4	D2	F71	GR/4	: Air fuel ratio (A/F) sensor 1 (bank 1) (with VQ40DE except for Mexico)	D
D3	F21	W/2	: Condenser-1	B2	F73	B/48	: ECM (with VQ40DE except for Mexico)	E
D4	F22	GR/2	: Fuel injector No. 6	F3	F74	G/4	: Heated oxygen sensor 2 (bank 2) (with VQ40DE for Mexico)	E
D2	F24	GR/2	: Engine coolant temperature sensor	F2	F75	L/4	: Heated oxygen sensor 2 (bank 1) (with VQ40DE for Mexico)	F
E3	F25	B/3	: Camshaft position sensor (PHASE) (bank 2)	E4	F76	GR/4	: Air fuel ratio (A/F) sensor 1 (bank 2) (with VQ40DE for Mexico)	F
C3	F26	G/8	: To F225	Injector sub-harness				G
E2	F27	B/4	: Heated oxygen sensor 2 (bank 1) (with VQ40DE except for Mexico)	D2	F201	G/4	: To F44	H
C4	F28	GR/2	: Fuel injector No. 2	C4	F206	GR/2	: Fuel injector No. 1	H
D5	F29	GR/3	: Ignition coil No. 2 (with power transistor)	C3	F207	GR/2	: Fuel injector No. 3	I
D4	F30	GR/3	: Ignition coil No. 4 (with power transistor)	C3	F208	GR/2	: Fuel injector No. 5	I
E4	F31	GR/3	: Ignition coil No. 6 (with power transistor)	Ignition coil sub-harness				J
B2	F32	W/16	: To E2	B3	F225	G/8	: To F26	J
B2	F33	W/16	: To E19	B3	F226	GR/3	: Ignition coil No. 1 (with power transistor)	K
D5	F41	B/2	: Intake manifold runner control valve motor	B3	F227	GR/3	: Ignition coil No. 3 (with power transistor)	K
D5	F42	B/3	: Intake manifold runner control valve position sensor	C3	F228	GR/3	: Ignition coil No. 5 (with power transistor)	L
D2	F44	G/4	: To F201	B4	F229	G/2	: Intake valve timing control solenoid valve (bank 1)	L
B4	F46	B/3	: Power steering pressure sensor	Knock sensor sub-harness				PG
B4	F50	W/6	: Electric throttle control actuator	D4	F250	L/4	: To F67	PG
D5	F51	G/2	: Intake valve timing control solenoid valve (bank 2)	C5	F251	GR/2	: Knock sensor (bank 1)	N
C5	F53	B/6	: Mass air flow sensor	D4	F252	GR/2	: Knock sensor (bank 2)	N
A2	F54	B/81	: ECM (WITH VQ40DE except for Mexico)					O
								P

HARNESS

< DTC/CIRCUIT DIAGNOSIS >

CHASSIS HARNESS

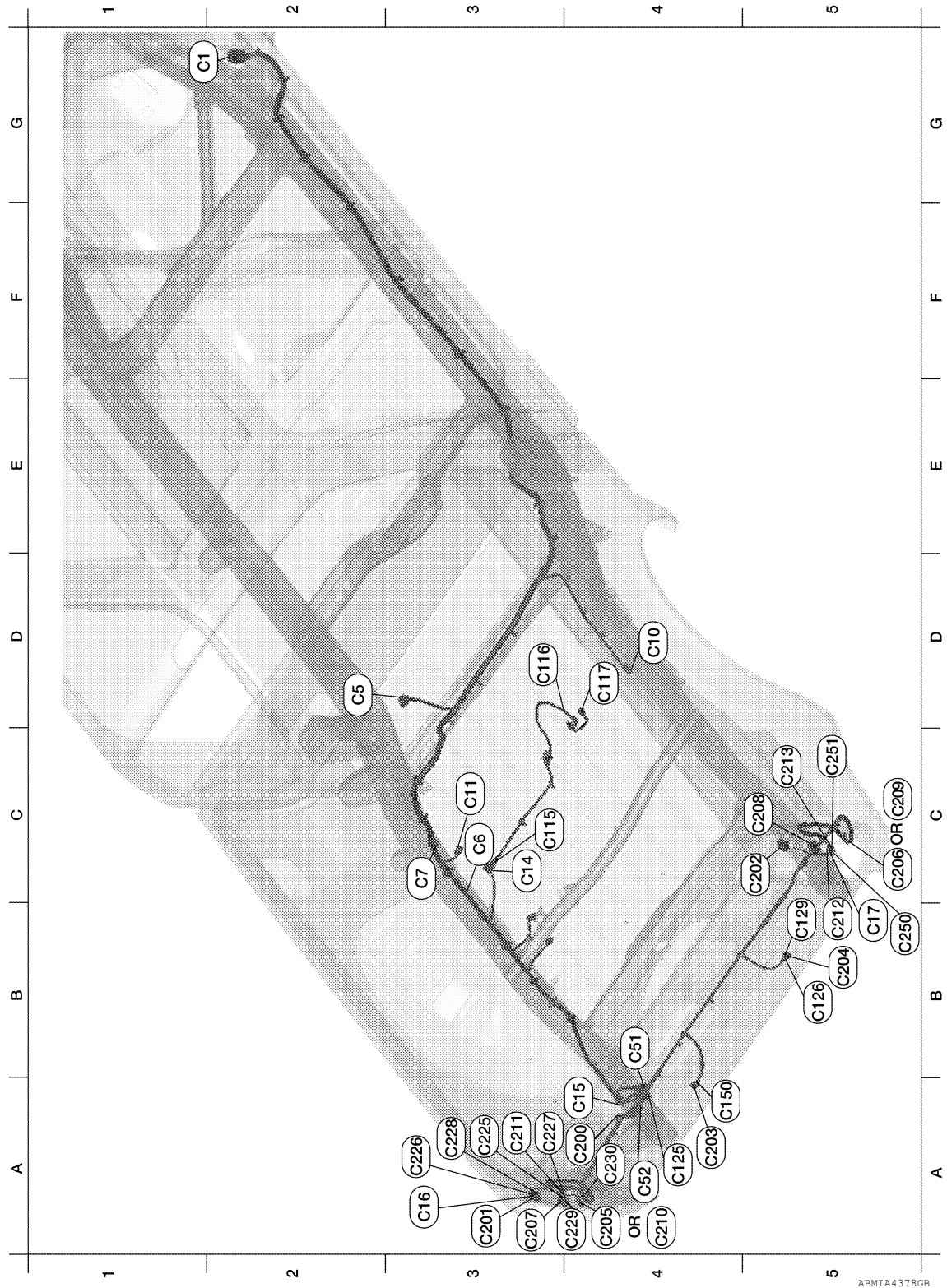

ABMIA4378GB

G2	C1	SMJ	: To E41	A3	C201	BR/3	: Rear combination lamp LH
D2	C5	GR/5	: Fuel level sensor unit and fuel pump	C5	C202	BR/3	: Rear combination lamp RH
C3	C6	B/2	: EVAP canister vent control valve	A4	C203	GR/2	: License plate lamp LH
C3	C7	GR/3	: EVAP control system pressure sensor	B5	C204	GR/2	: License plate lamp RH
D4	C10	GR/2	: Rear wheel sensor RH	A4	C205	GR/2	: Rear combination lamp LH (with A/T)

HARNESS

< DTC/CIRCUIT DIAGNOSIS >

C3	C11	BR/2	: Rear wheel sensor LH	C5	C206	GR/2	: Rear combination lamp RH (with A/T)	A
C3	C14	GR/4	: To C115	A3	C207	GR/2	: Rear combination lamp LH	B
B4	C15	GR/8	: To C200	C5	C208	GR/2	: Rear combination lamp RH	C
A3	C16	B/6	: To C226	C5	C209	GR/2	: Rear combination lamp RH (with M/T)	D
B5	C17	GR/10	: To C212	A4	C210	GR/2	: Rear combination lamp LH (with M/T)	E
B4	C51	GR/6	: To C125	A3	C211	B/6	: To C225	F
A4	C52	B/2	: To C150	B5	C212	GR/10	: To C17	G
Differential lock sub-harness				C5	C213	B/6	: To C250	H
C3	C115	GR/4	: To C14	Rear sonar sub-harness				I
D3	C116	GR/2	: Differential lock position switch	A3	C225	B/6	: To C211	J
D4	C117	B/2	: Differential lock solenoid	A3	C226	B/6	: To C16	K
Trailer sub-harness				A3	C227	B/3	: Rear sonar sensor LH outer	L
A4	C125	GR/8	: To C51	A3	C228	B/3	: Rear sonar sensor LH inner	M
B5	C126	B/7	: Trailer	A4	C229	B/3	: Rear sonar sensor RH inner	N
B5	C129	B/7	: Trailer receptacle	A4	C230	B/3	: Rear sonar sensor RH outer	O
A4	C150	B/2	: To C52	Rear view camera sub-harness				P
Tail lamp sub-harness				B5	C250	B/6	: To C213	
A4	C200	GR/8	: To C15	C5	C251	GR/6	: Rear view camera	

PG

HARNESSES

< DTC/CIRCUIT DIAGNOSIS >

				Front seat LH harness			
F3	B16	W/8	: To D216				
F3	B19	—	: Body ground	D5	B200	W/16	: To B37
C5	B37	W/16	: To B200	C4	B204	GR/2	: Sliding motor LH
D2	B38	Y/2	: LH side curtain air bag module	D4	B205	W/2	: Reclining motor LH
B5	B40	W/8	: To E34	C4	B206	GR/2	: Lifting motor (front)
B4	B69	SMJ	: To M40	D4	B207	GR/2	: Lifting motor (rear)
D3	B73	B/4	: Yaw rate/side/decel G sensor	D5	B208	W/10	: Power seat switch LH
F3	B76	W/2	: Rear door speaker LH				

A
B
C
D
E
F
G
H
I
J
K
L

PG

N
O
P

HARNESS

< DTC/CIRCUIT DIAGNOSIS >

BODY HARNESS (CREW CAB MODELS)

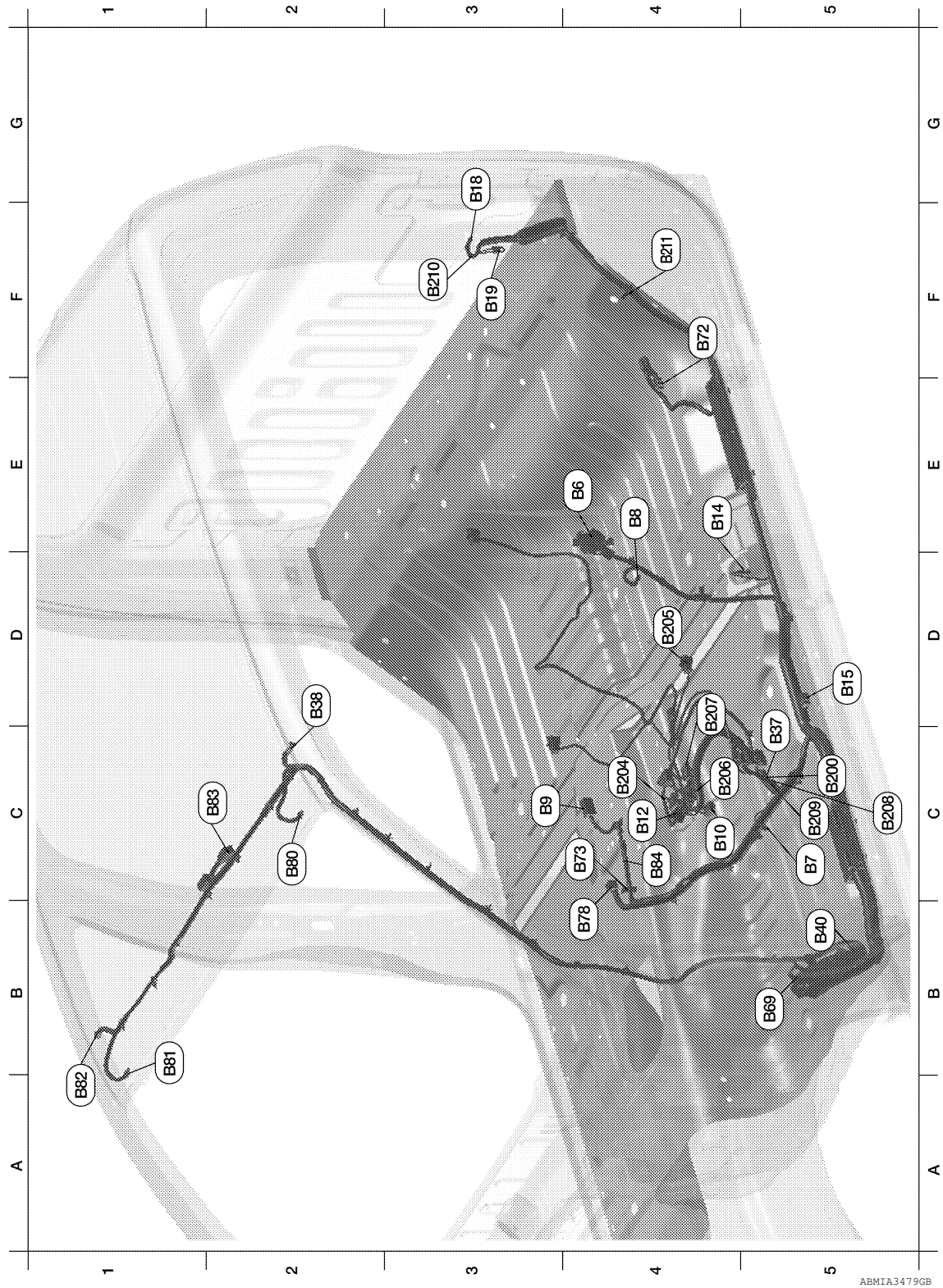

ABMIA3479GB

E4	B6	W/12	: To D201	B4	B78	Y/2	: To B157
C5	B7	—	: Body ground	C2	B80	W/2	: Vanity lamp LH
E4	B8	W/3	: Front door switch LH	B1	B81	W/2	: Vanity lamp RH
C3	B9	Y/22	: Air bag diagnosis sensor unit	A1	B82	Y/2	: RH side curtain air bag module
C4	B10	Y/2	: Front LH side air bag module	C2	B83	GR/10	: Sunroof motor assembly

HARNESS

< DTC/CIRCUIT DIAGNOSIS >

C4	B12	W/4	: Seat belt buckle switch LH	C4	B84	B/1	: Parking brake switch
E4	B14	Y/2	: Front LH seat belt pre-tensioner	Front seat LH harness			
D5	B15	Y/2	: LH side air bag (satellite) sensor	C5	B200	W/16	: To B37
G3	B18	W/3	: Rear door switch LH	C4	B204	GR/2	: Sliding motor LH
F3	B19	—	: Body ground	D4	B205	W/2	: Reclining motor LH
C5	B37	W/16	: To B200	C4	B206	GR/2	: Lifting motor (front)
D2	B38	Y/2	: LH side curtain air bag module	D4	B207	GR/2	: Lifting motor (rear)
B5	B40	W/8	: To E34	C5	B208	W/10	: Power seat switch LH
B5	B69	SMJ	: To M40	C5	B209	W/3	: Front seat heater LH
F4	B72	GR/4	: Subwoofer	F3	B210	B/1	: Rear window defogger
C4	B73	B/4	: Yaw rate/side/decel G sensor	F4	B211	—	: Body ground

A
B
C
D
E
F
G
H
I
J
K
L
PG
N
O
P

HARNESS

< DTC/CIRCUIT DIAGNOSIS >

BODY NO. 2 HARNESS (KING CAB MODELS)

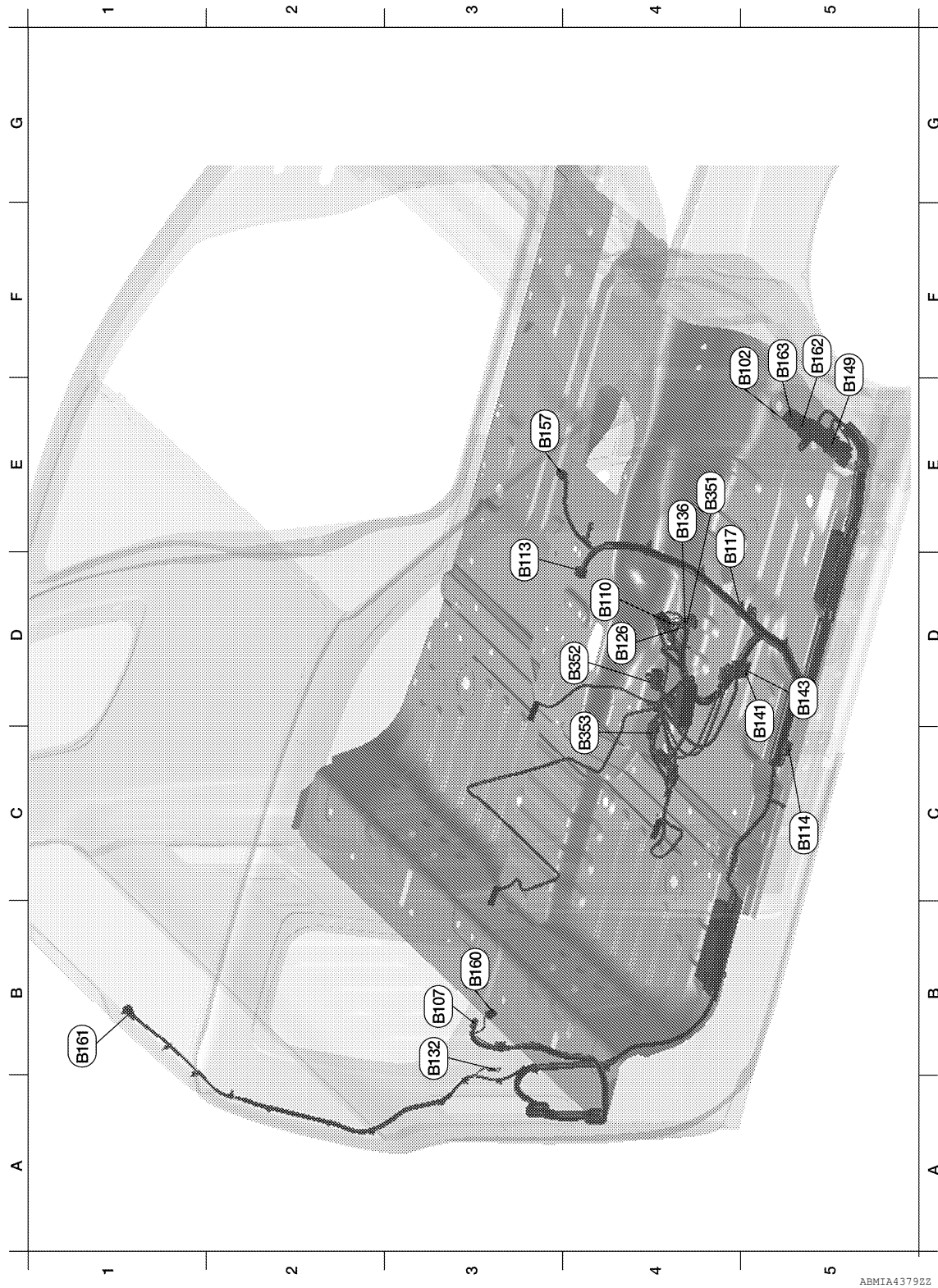

F4	B102	W/2	: To E36	F5	B149	SMJ	: To M36
B3	B107	W/8	: To D302	E3	B157	Y/2	: To B78
D4	B110	W/4	: Seat belt buckle switch RH	B3	B160	W/2	: Rear door speaker RH
D3	B113	Y/22	: Air bag diagnosis sensor unit	B1	B161	W/3	: High-mounted stop lamp assembly
C5	B114	Y/2	: RH side air bag (satellite) sensor	F5	B162	W/12	: To M16

HARNESS

< DTC/CIRCUIT DIAGNOSIS >

E4	B117	—	: Body ground	F5	B163	W/16	: To M17
D4	B126	Y/2	: Front RH side air bag module	Front seat RH harness			
B3	B132	—	: Body ground	E4	B351	W8	: To B136
E4	B136	W/8	: To B351	D4	B352	B/18	: Occupant classification system control unit
D5	B141	W/32	: Bluetooth® control unit	C4	B353	B/3	: Occupant classification system sensor
D5	B143	W/8	: Bluetooth® control unit				

BODY NO. 2 HARNESS (CREW CAB MODELS)

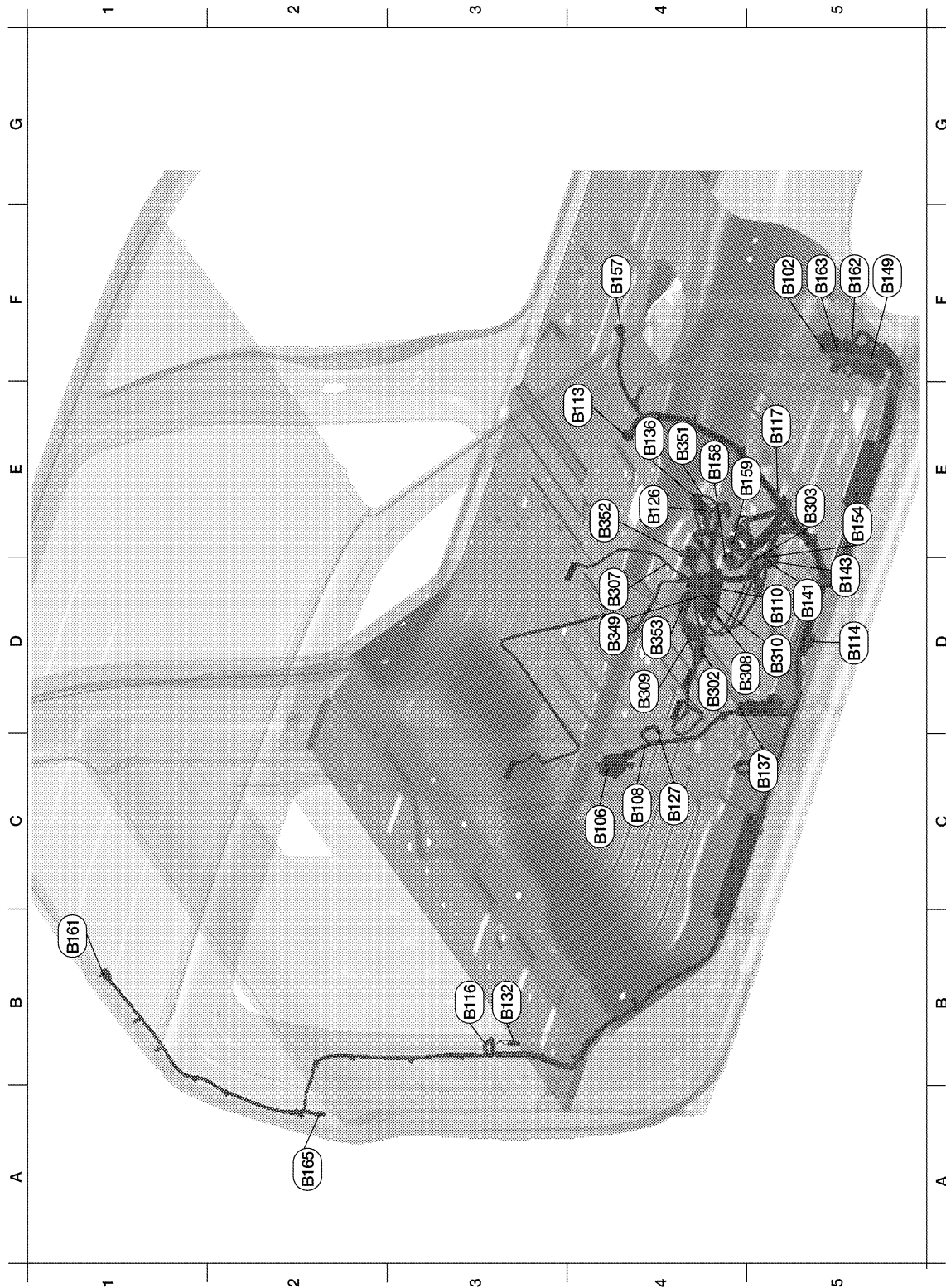

ABMIA43802Z

A
B
C
D
E
F
G
H
I
J
K
L
M
N
O
P

PG

HARNESS

< DTC/CIRCUIT DIAGNOSIS >

F5	B102	W/2	: To E36	D4	B158	W/8	: Audio amplifier
C4	B106	W/12	: To D301	E4	B159	W/24	: Audio amplifier
C4	B108	W/3	: Front door switch RH	B1	B161	W/3	: High-mounted stop lamp assembly
D4	B110	W/4	: Seat belt buckle switch RH	F5	B162	W/12	: To M16
E4	B113	Y/22	: Air bag diagnosis sensor unit	F5	B163	W/16	: To M17
D5	B114	Y/2	: RH side air bag (satellite) sensor	A2	B165	B/1	: Rear window defogger
B3	B116	W/3	: Rear door switch RH	Front seat RH harness			
E5	B117	—	: Body ground	D4	B302	W/2	: Reclining motor RH
E4	B126	Y/2	: Front RH side air bag module	E5	B303	W/16	: To B154
C4	B127	Y/2	: Front RH seat belt pretensioner	D4	B307	W/3	: Front seat heater RH
B3	B132	—	: Body ground	D4	B308	W/6	: Power seat switch RH
E4	B136	W/8	: To B351	D4	B309	GR/2	: Sliding motor RH
C5	B137	B/3	: Belt tension sensor	D4	B310	W/8	: To B349
D5	B141	W/32	: Bluetooth® control unit	D4	B349	W/8	: To B310
D5	B143	W/8	: Bluetooth® control unit	E4	B351	W/8	: To B136
F5	B149	SMJ	: To M36	E4	B352	B/18	: Occupant classification system control unit
E5	B154	W/16	: To B303	D4	B353	B/3	: Occupant classification system sensor
F4	B157	Y/2	: To B78				

HARNESS

< DTC/CIRCUIT DIAGNOSIS >

ROOM LAMP HARNESS

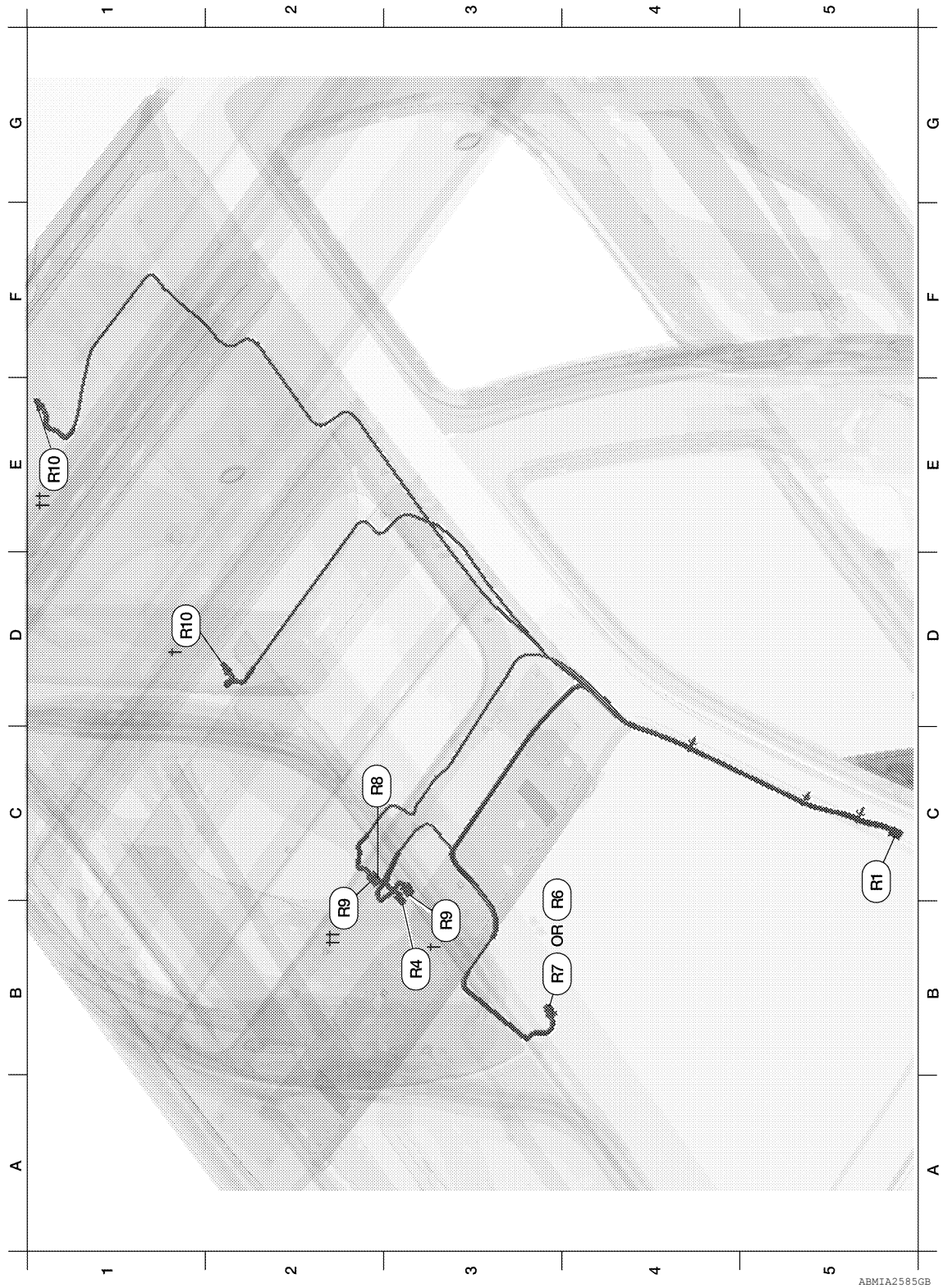

A
B
C
D
E
F
G
H
I
J
K
L
PG
N
O
P

C5	R1	W/24	: To M1	B3	R9†	W/3	: Front room/map lamp assembly (with sunroof)
B3	R4	W/3	: Sunroof switch	B2	R9††	W/3	: Front room/map lamp assembly (without sunroof)
B3	R6	W/7	: Auto anti-dazzling inside mirror (without homelink universal transceiver)	D1	R10†	W/2	: Room lamp 2nd row (king cab)

HARNESS

< DTC/CIRCUIT DIAGNOSIS >

B3	R7	B/10	: Auto anti-dazzling inside mirror (with homelink universal transceiver)	E1	R10††	W/2	: Room lamp 2nd row (crew cab)
C3	R8	W/4	: Microphone				

FRONT DOOR LH HARNESS

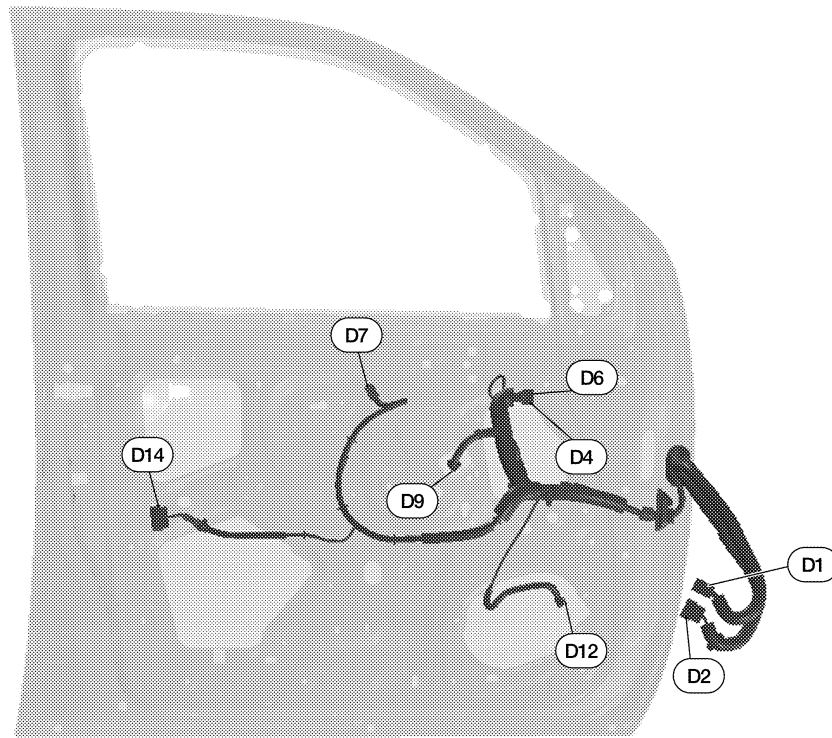

ABMIA2586GB

D1	W/16	: To M9	D7	W/16	: Main power window and door lock/unlock switch
D2	BR/12	: To M8	D9	BR/2	: Front power window motor LH
D4	B/10	: Door mirror LH (with heated mirror)	D12	W/2	: Front door speaker LH
D6	B/3	: Door mirror LH (without heated mirror)	D14	GR/6	: Front door lock assembly LH

HARNESS

< DTC/CIRCUIT DIAGNOSIS > FRONT DOOR RH HARNESS

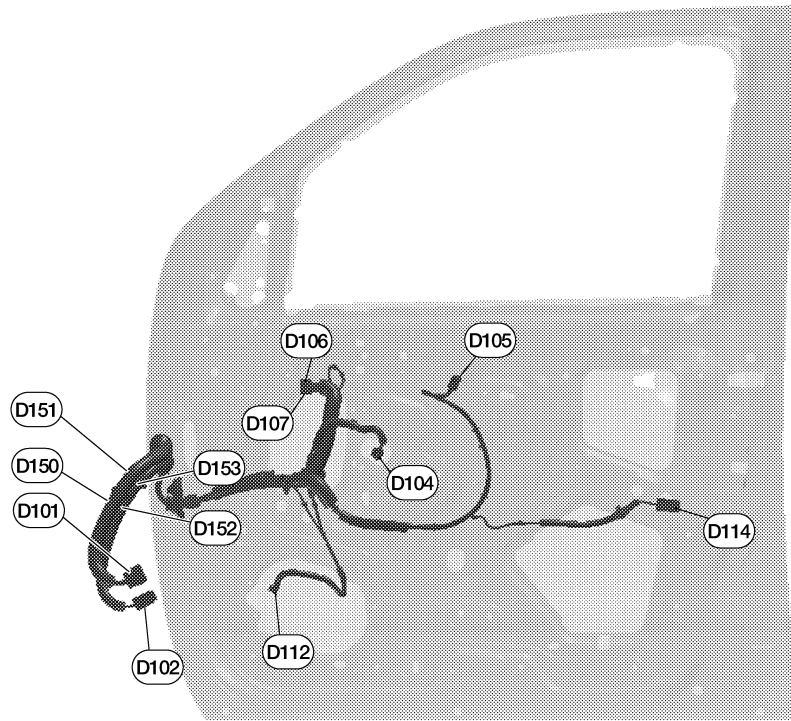

ABMIA4381ZZ

D101	W/12	: To M75	D114	BR/2	: Front door lock actuator RH
D102	W/16	: To M74	Front door RH sub-harness		
D104	BR/2	: Front power window motor RH	D150	W/16	: To D102
D105	W/12	: Power window and door lock/unlock switch RH	D151	W/16	: To M74
D106	B/3	Door mirror RH (without heated mirror)	D152	W/12	: To D101
D107	B/10	Door mirror RH (with heated mirror)	D153	W/12	: To M75
D112	W/2	: Front door speaker RH			

A
B
C
D
E
F
G
H
I
J
K
L
PG
N
O
P

HARNESS

< DTC/CIRCUIT DIAGNOSIS >

REAR DOOR LH HARNESS (KING CAB MODELS)

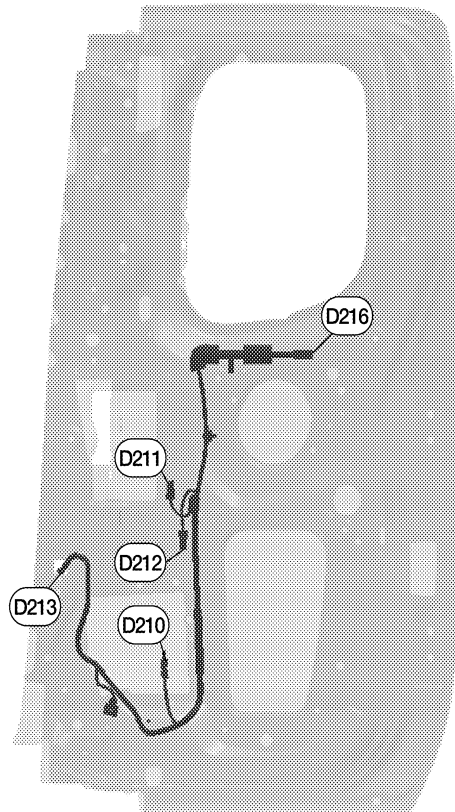

ABMIA0453GB

D210	Y/2	: Front LH seat belt pre-tensioner	D213	W/3	: Front door switch LH
D211	B/2	: Rear door switch upper LH	D216	W/8	: To B16
D212	B/2	: Rear door switch lower LH			

HARNESS

< DTC/CIRCUIT DIAGNOSIS >

REAR DOOR RH HARNESS (KING CAB MODELS)

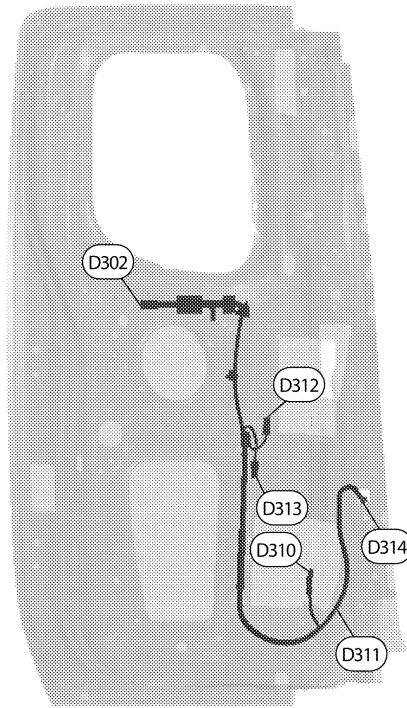

ABMIA0409GB

D302	W/8	: To B107	D312	B/2	: Rear door switch upper RH
D310	Y/2	: Front RH seat belt pre-tensioner	D313	B/2	: Rear door switch lower RH
D311	B/3	: Belt tension sensor	D314	W/3	: Front door switch RH

A
B
C
D
E
F
G
H
I
J
K
L
PG
N
O
P

HARNESS

< DTC/CIRCUIT DIAGNOSIS >

REAR DOOR LH HARNESS (CREW CAB MODELS)

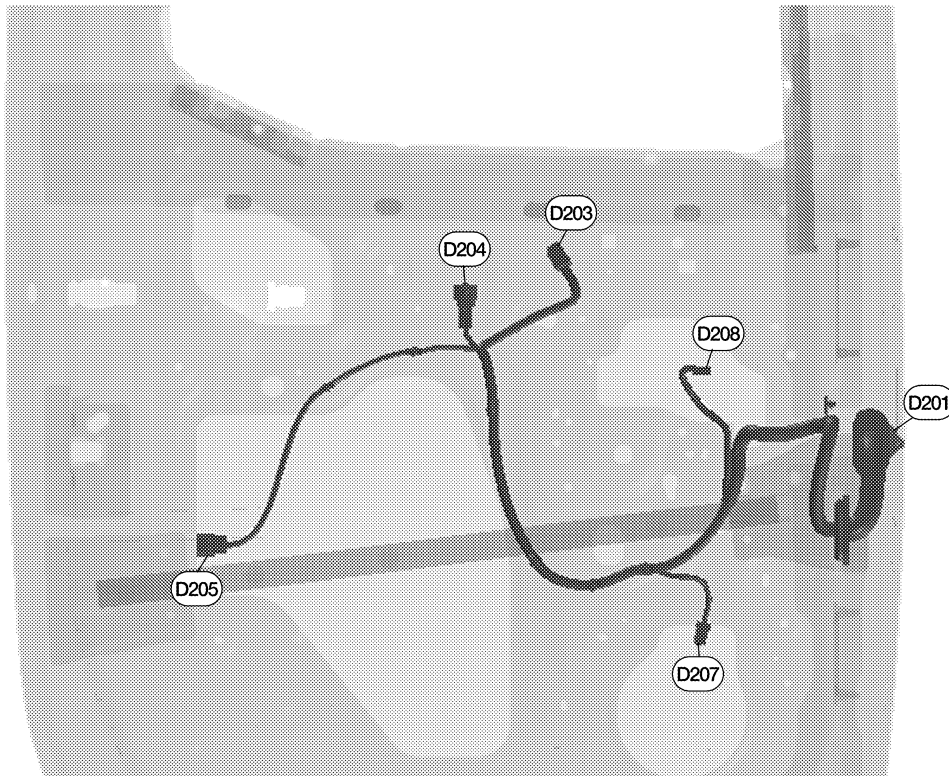

ABMIA2588GB

D201	W/12	: To B6	D205	BR/2	: Rear door lock actuator LH
D203	W/8	: Rear power window switch LH	D207	W/2	: Rear door speaker LH
D204	B/2	: Rear power window motor LH	D208	BR/2	: Rear tweeter LH

HARNESS

< DTC/CIRCUIT DIAGNOSIS >

REAR DOOR RH HARNESS (CREW CAB MODELS)

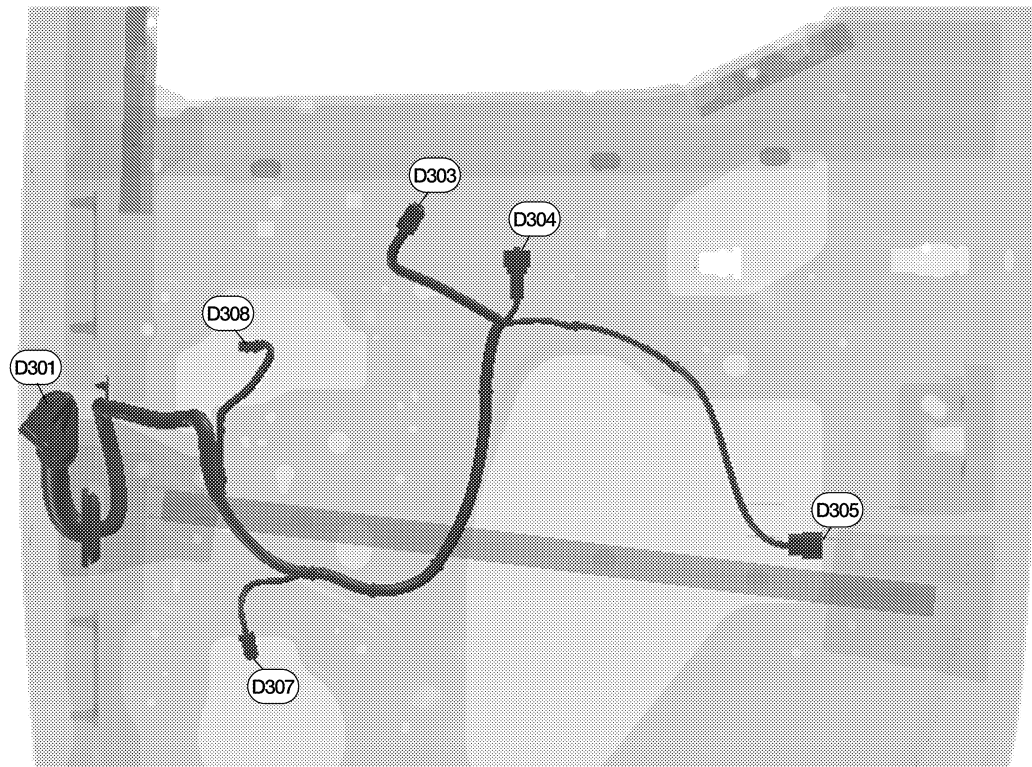

ABMIA2589GB

D301	W/12	: To B106	D305	BR/2	: Rear door lock actuator RH
D303	W/8	: Rear power window switch RH	D307	W/2	: Rear door speaker RH
D304	B/2	: Rear power window motor RH	D308	BR/2	: Rear door tweeter RH

A
B
C
D
E
F
G
H
I
J
K
L
N
O
P

PG

ELECTRICAL UNITS LOCATION

< DTC/CIRCUIT DIAGNOSIS >

ELECTRICAL UNITS LOCATION

Electrical Units Location

INFOID:000000008792553

ENGINE COMPARTMENT

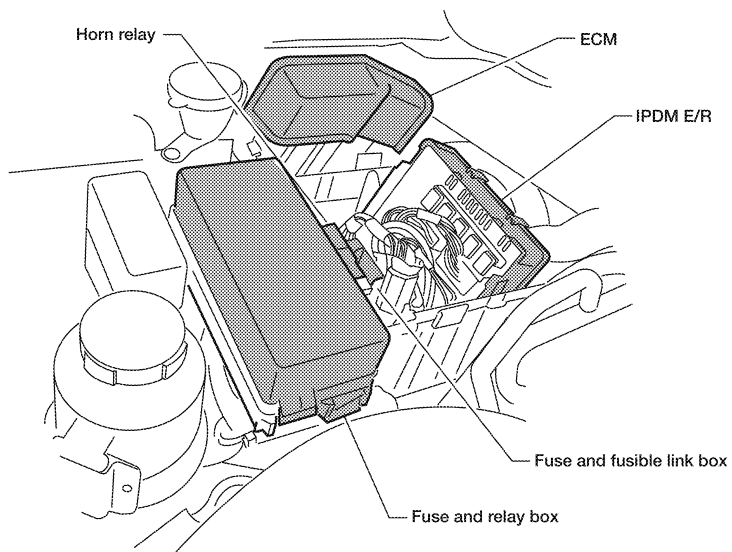
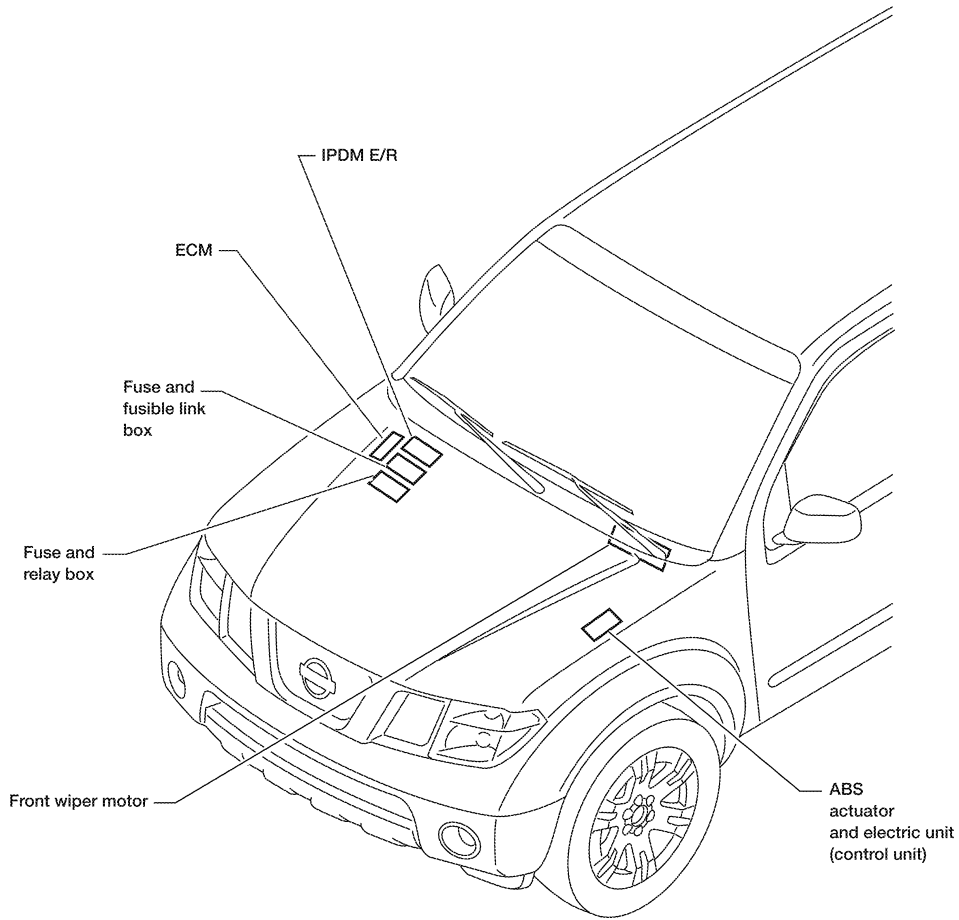

ABMIA0357GB

ELECTRICAL UNITS LOCATION

< DTC/CIRCUIT DIAGNOSIS >
PASSENGER COMPARTMENT

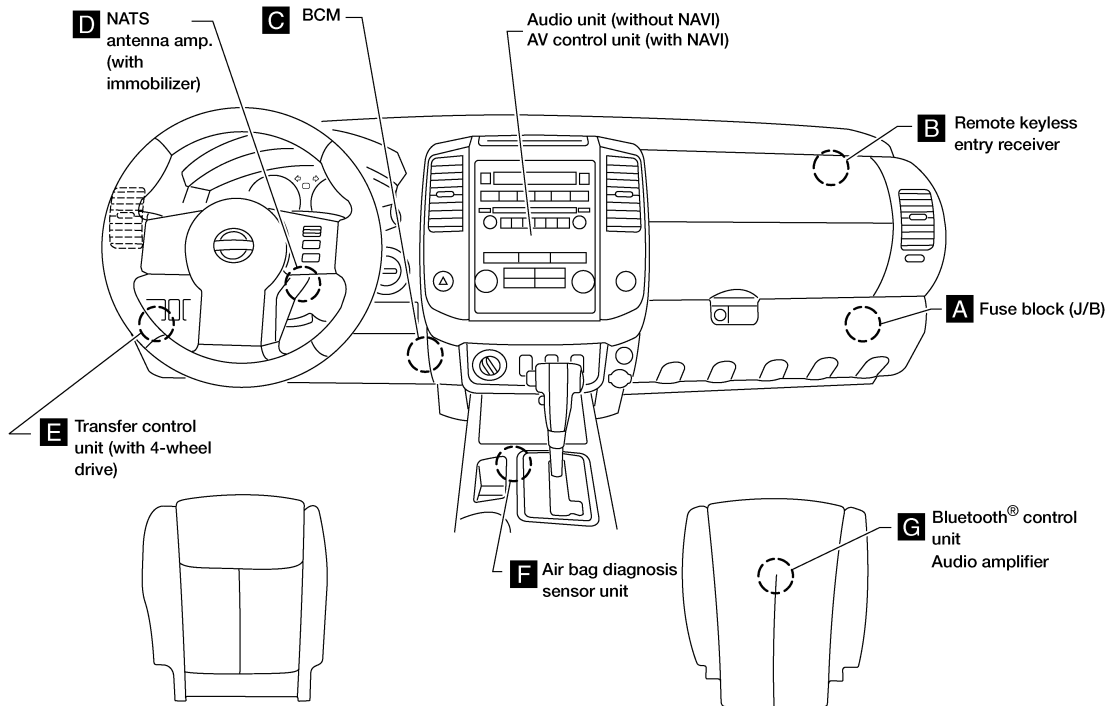

A Instrument panel side RH

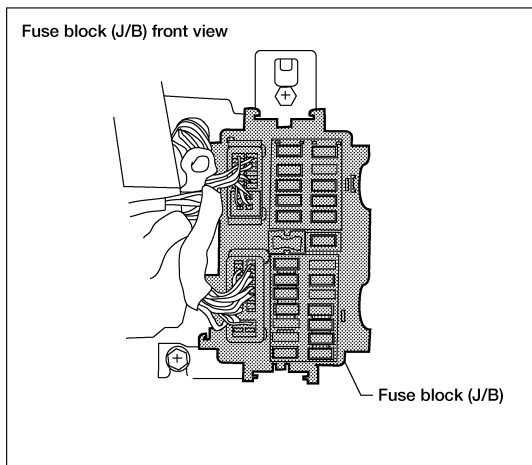

ABMIA4365GB

A
B
C
D
E
F
G
H
I
J
K
L
PG
N
O
P

ELECTRICAL UNITS LOCATION

< DTC/CIRCUIT DIAGNOSIS >

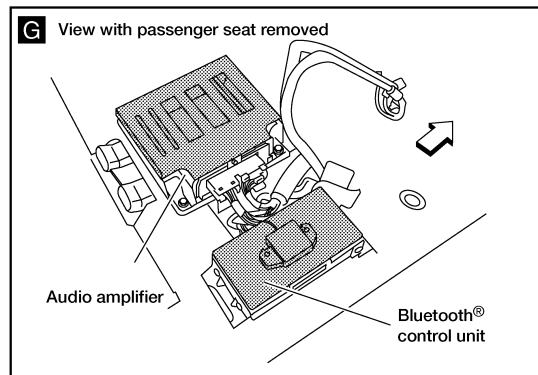
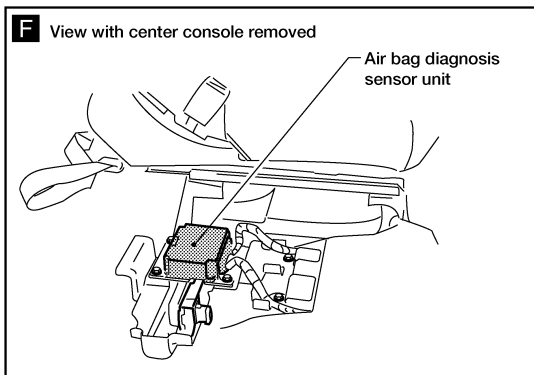
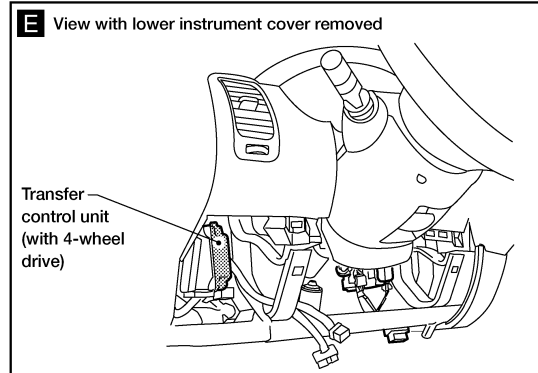
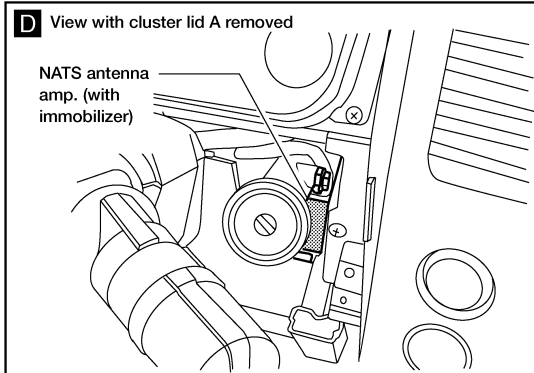
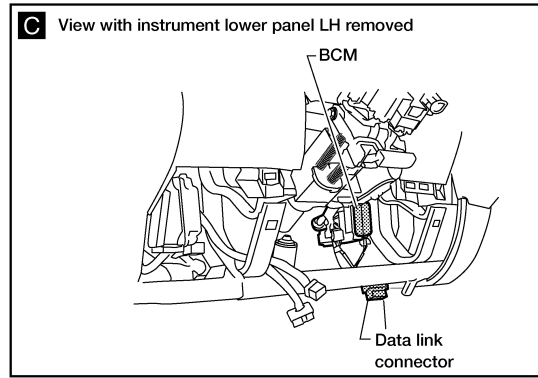
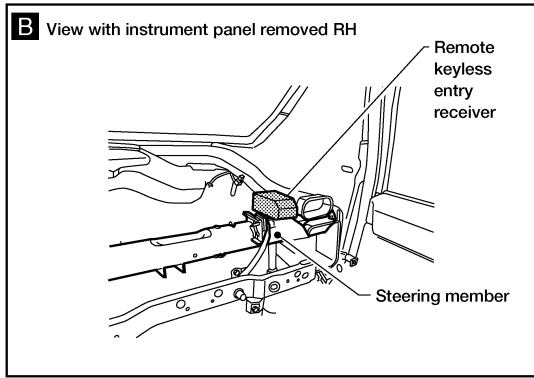

ABMIA4366GB

HARNESS CONNECTOR

< DTC/CIRCUIT DIAGNOSIS >

HARNESS CONNECTOR

Description

INFOID:000000008792554

HARNESS CONNECTOR (TAB-LOCKING TYPE)

- The tab-locking type connectors help prevent accidental looseness or disconnection.
- The tab-locking type connectors are disconnected by pushing or lifting the locking tab(s). Refer to the figure below.

Refer to the next page for description of the slide-locking type connector.

CAUTION:

Do not pull the harness or wires when disconnecting the connector.

[Example]

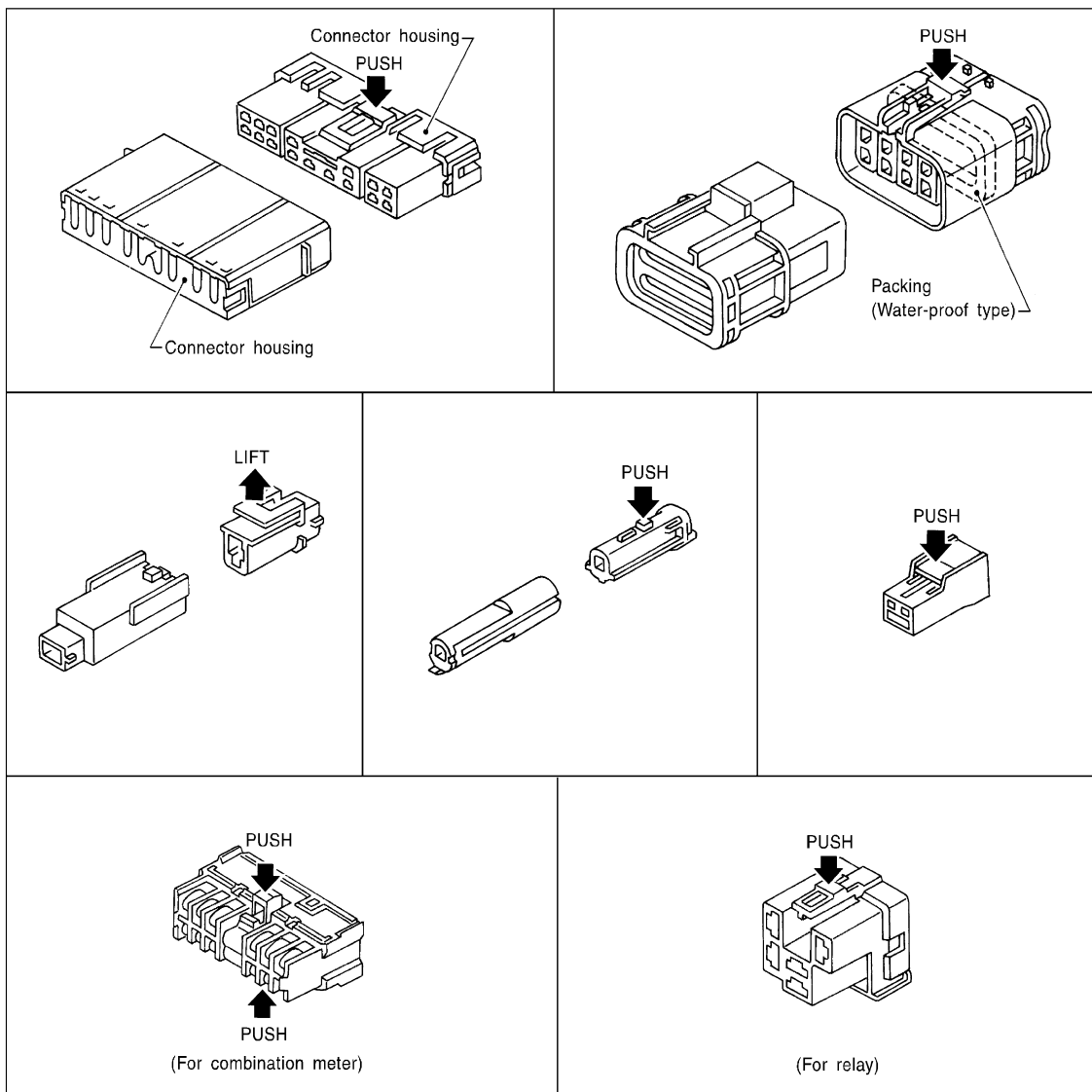

HARNESS CONNECTOR (SLIDE-LOCKING TYPE)

- A new style slide-locking type connector is used on certain systems and components, especially those related to OBD.
- The slide-locking type connectors help prevent incomplete locking and accidental looseness or disconnection.

HARNESS CONNECTOR

< DTC/CIRCUIT DIAGNOSIS >

- The slide-locking type connectors are disconnected by pushing or pulling the slider. Refer to the figure below.

CAUTION:

- Do not pull the harness or wires when disconnecting the connector.
- Be careful not to damage the connector support bracket when disconnecting the connector.

[Example]

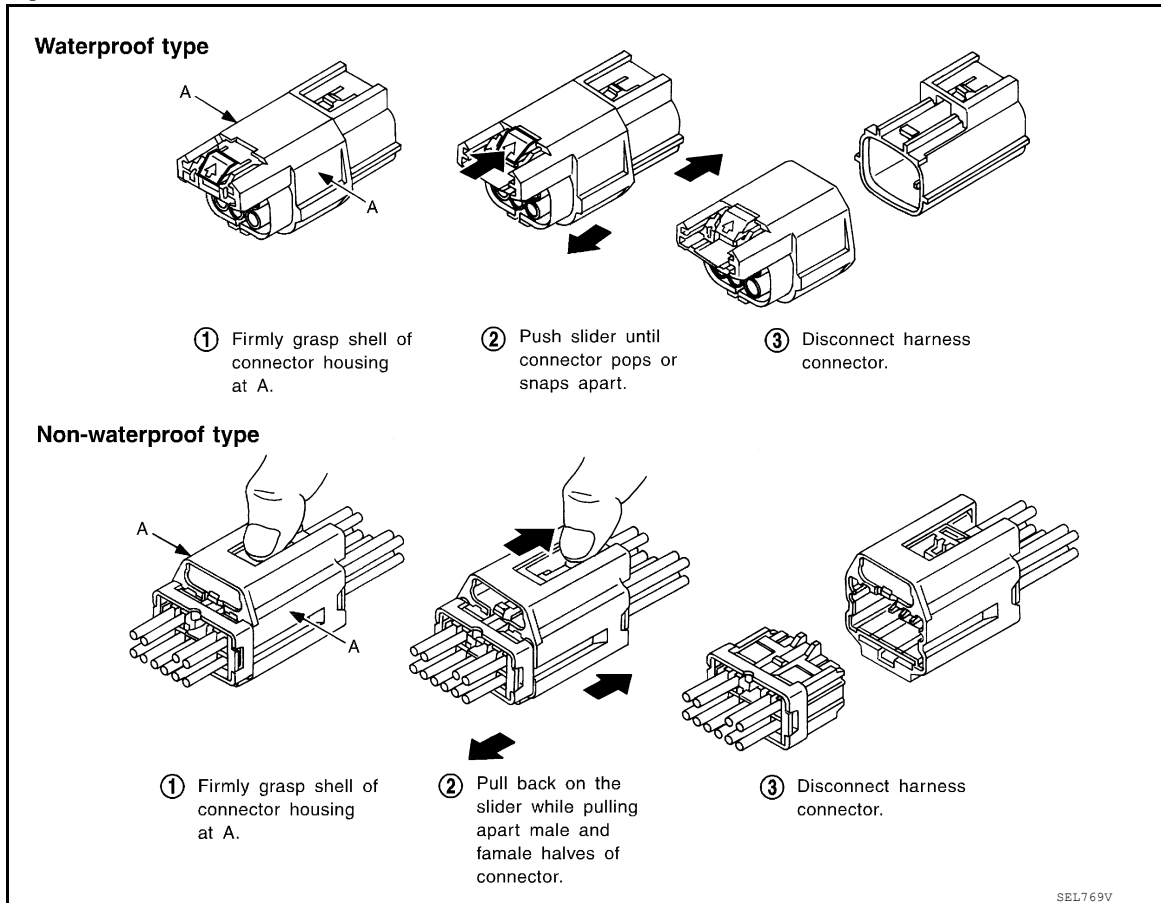

HARNESS CONNECTOR (LEVER LOCKING TYPE)

- Lever locking type harness connectors are used on certain control units and control modules such as ECM, ABS actuator and electric unit (control unit), etc.
- Lever locking type harness connectors are also used on super multiple junction (SMJ) connectors.
- Always confirm the lever is fully locked in place by moving the lever as far as it will go to ensure full connection.

CAUTION:

HARNESS CONNECTOR

< DTC/CIRCUIT DIAGNOSIS >

- Always confirm the lever is fully released (loosened) before attempting to disconnect or connect these connectors to avoid damage to the connector housing or terminals.

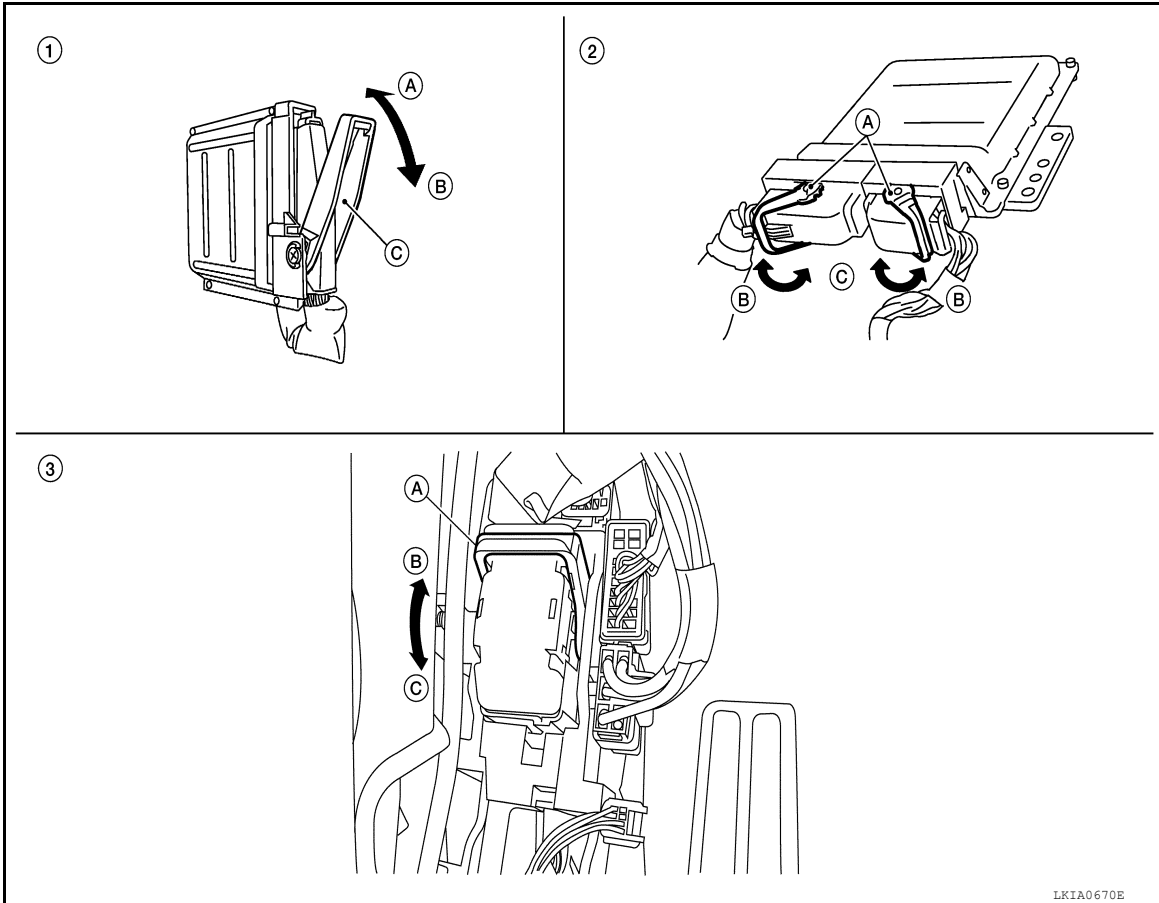

- | | | |
|-----------------------------------|---------------------------------|------------------|
| 1. Control unit with single lever | 2. Control unit with dual lever | 3. SMJ connector |
| A. Fasten | A. Levers | A. Lever |
| B. Loosen | B. Fasten | B. Fasten |
| C. Lever | C. Loosen | C. Loosen |

HARNESS CONNECTOR (DIRECT-CONNECT SRS COMPONENT TYPE)

- SRS direct-connect type harness connectors are used on certain SRS components such as air bag modules and seat belt pre-tensioners.
- Always pull up to release black locking tab prior to removing connector from SRS components.
- Always push down to lock black locking tab after installing connector to SRS components. When locked, the black locking tab is level with the connector housing.

CAUTION:

- Do not pull the harness or wires when removing connectors from SRS components.

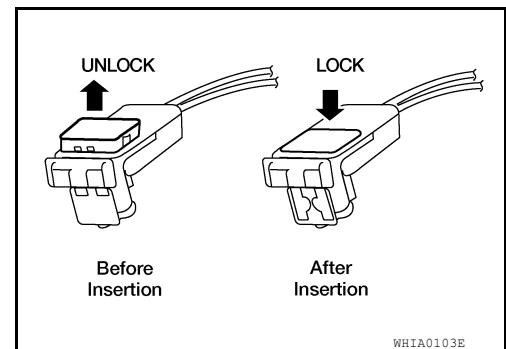

STANDARDIZED RELAY

< DTC/CIRCUIT DIAGNOSIS >

STANDARDIZED RELAY

Description

INFOID:000000008792555

NORMAL OPEN, NORMAL CLOSED AND MIXED TYPE RELAYS

Relays can mainly be divided into three types: normal open, normal closed and mixed type relays.

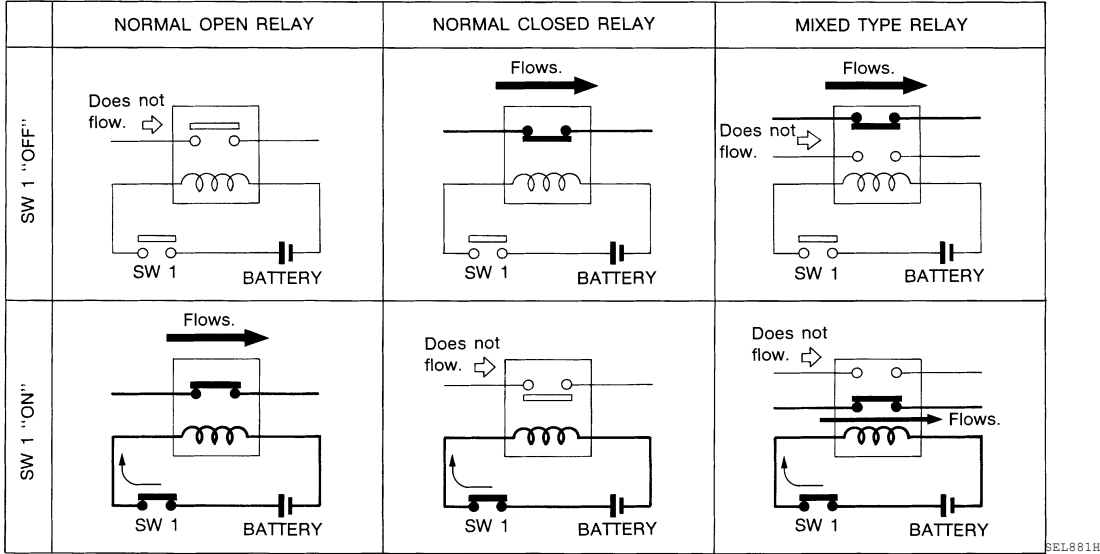

SEL881H

TYPE OF STANDARDIZED RELAYS

- 1M 1 Make
- 2M 2 Make
- 1T 1 Transfer
- 1M·1B 1 Make 1 Break

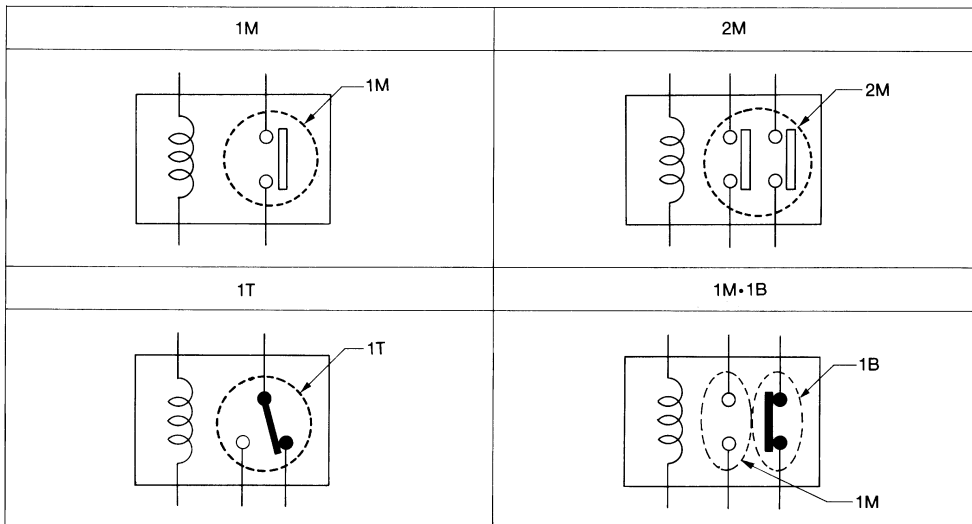

SEL882H

STANDARDIZED RELAY

< DTC/CIRCUIT DIAGNOSIS >

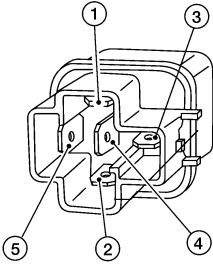
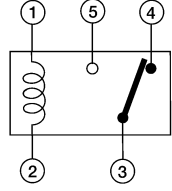
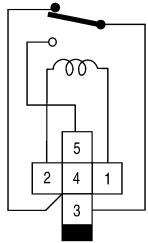
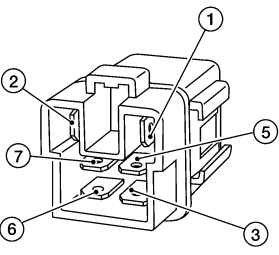
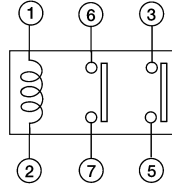
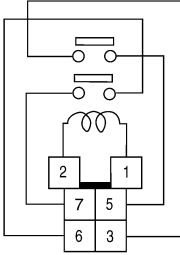
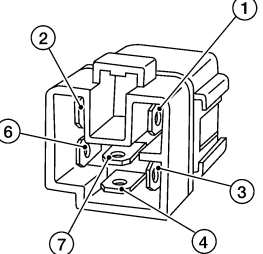
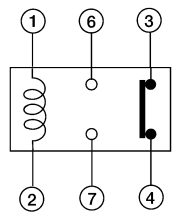
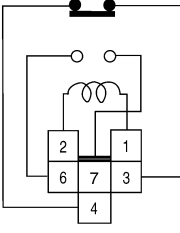
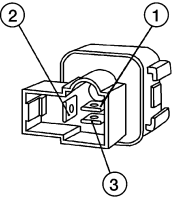
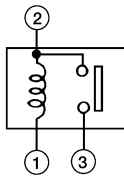
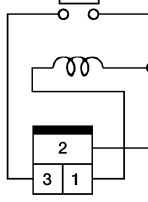
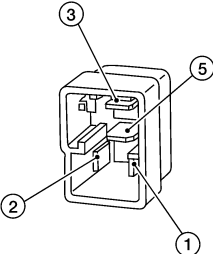
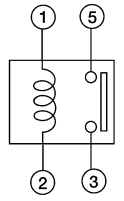
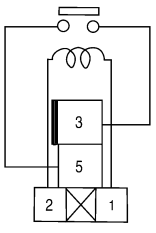
Type	Outer view	Circuit	Connector Symbol and connection	Case color
1T				BLACK
2M				BROWN
1M-1B				GRAY
1M				BLACK
				BLUE

The arrangement of terminal numbers on the actual relays may differ from those shown above.

WKIA0253E

A
B
C
D
E
F
G
H
I
J
K
L
PG
N
O
P

FUSE BLOCK - JUNCTION BOX (J/B)

< DTC/CIRCUIT DIAGNOSIS >

FUSE BLOCK - JUNCTION BOX (J/B)

Terminal Arrangement

INFOID:000000008792556

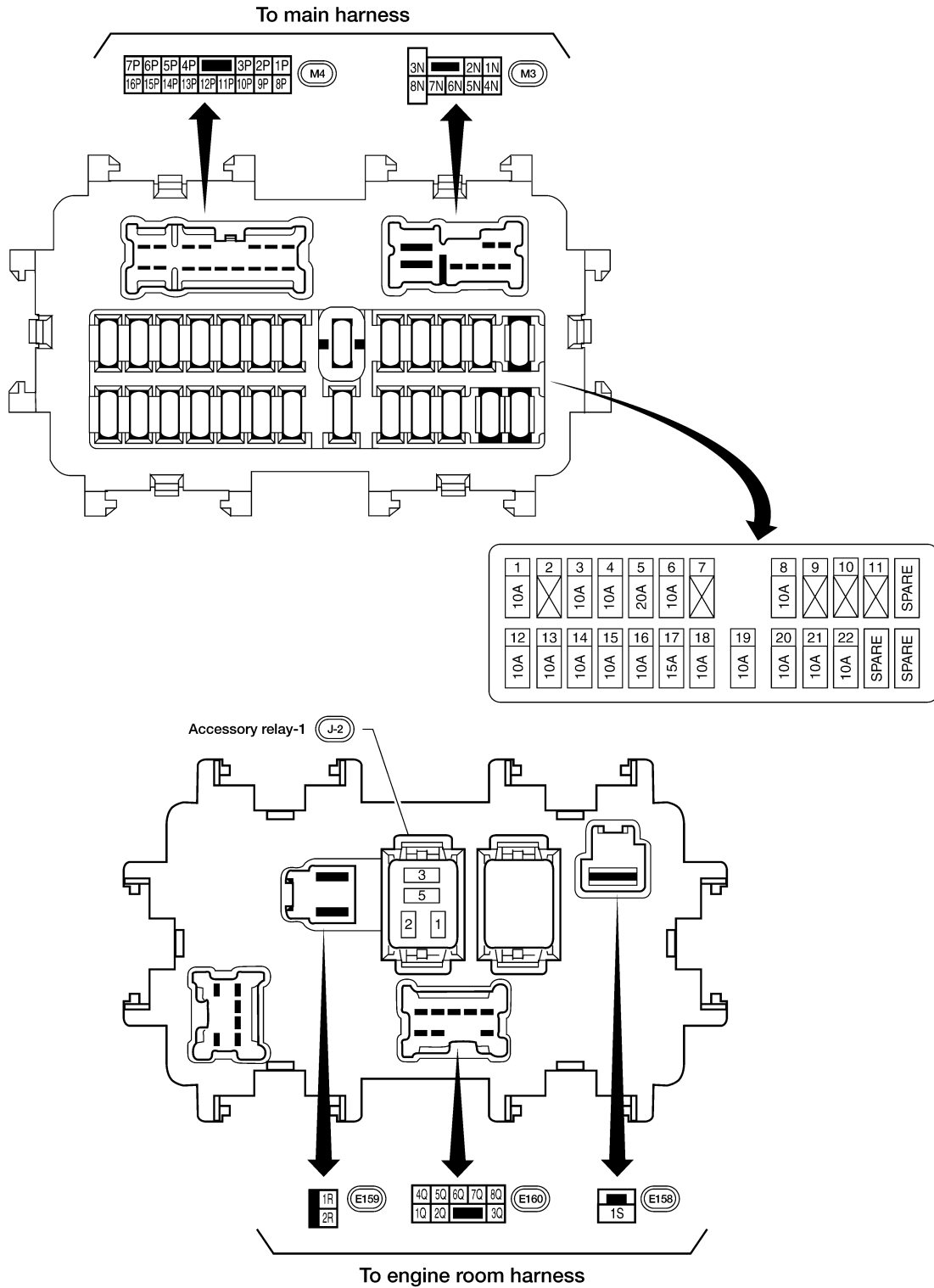

ABMIA4367GB

FUSE, FUSIBLE LINK AND RELAY BOX

< DTC/CIRCUIT DIAGNOSIS >

FUSE, FUSIBLE LINK AND RELAY BOX

Terminal Arrangement

INFOID:000000008792557

FUSE AND FUSIBLE LINK BOX

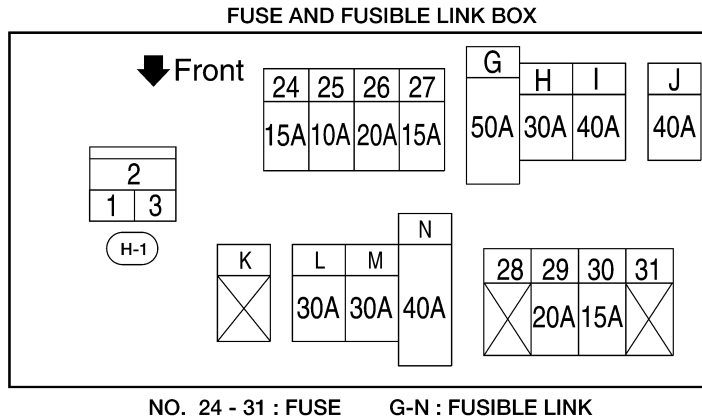

FUSIBLE LINK BOX (BATTERY)

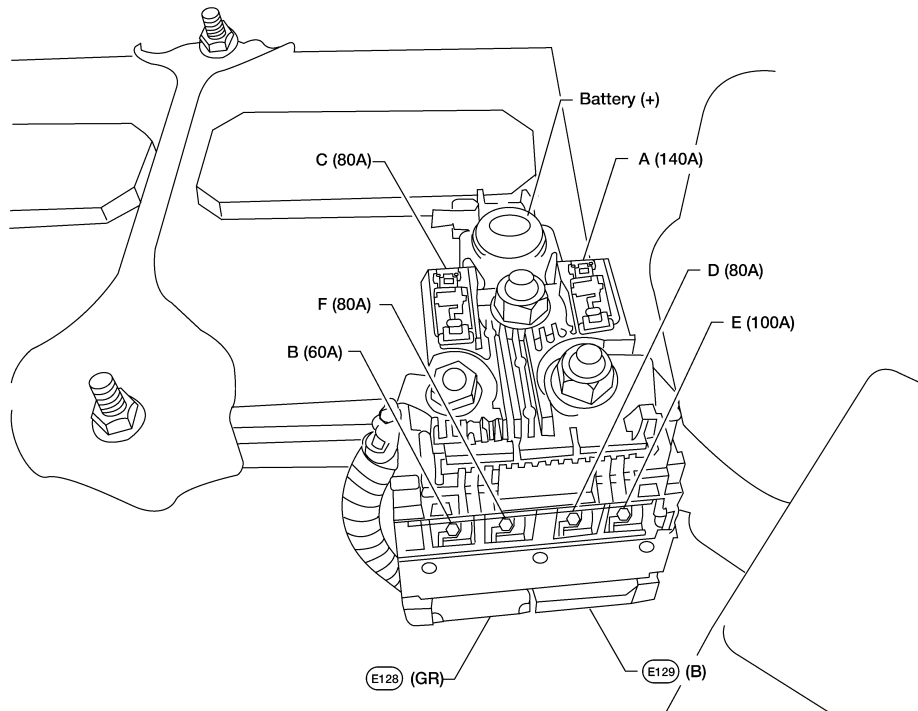

ABMIA1482GB

FUSE AND RELAY BOX

< DTC/CIRCUIT DIAGNOSIS >

FUSE AND RELAY BOX

Terminal Arrangement

INFOID:000000008792558

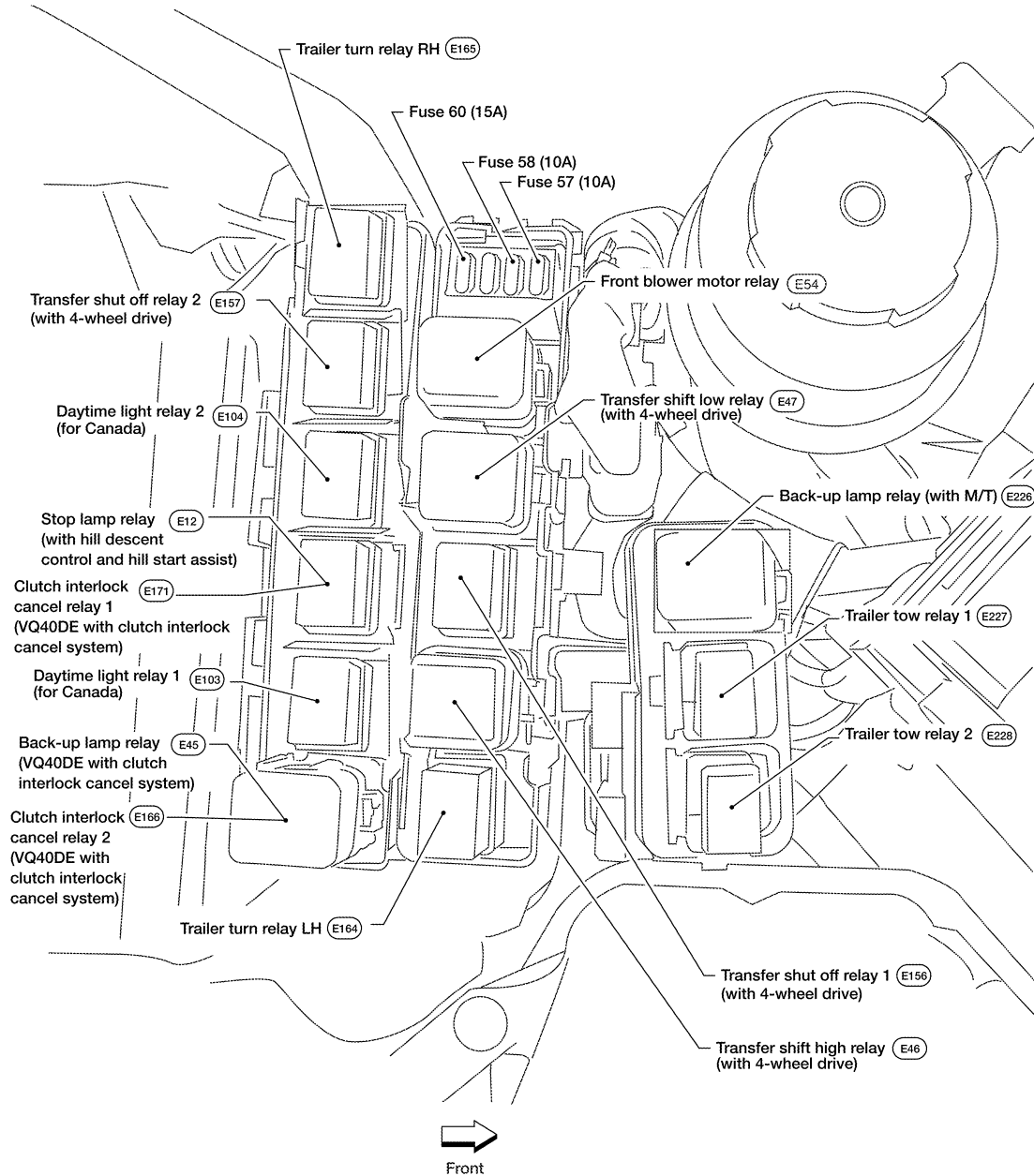

ABMIA2593GB

IPDM E/R (INTELLIGENT POWER DISTRIBUTION MODULE ENGINE ROOM)

< DTC/CIRCUIT DIAGNOSIS >

IPDM E/R (INTELLIGENT POWER DISTRIBUTION MODULE ENGINE ROOM)

IPDM E/R Terminal Arrangement

INFOID:000000008792559

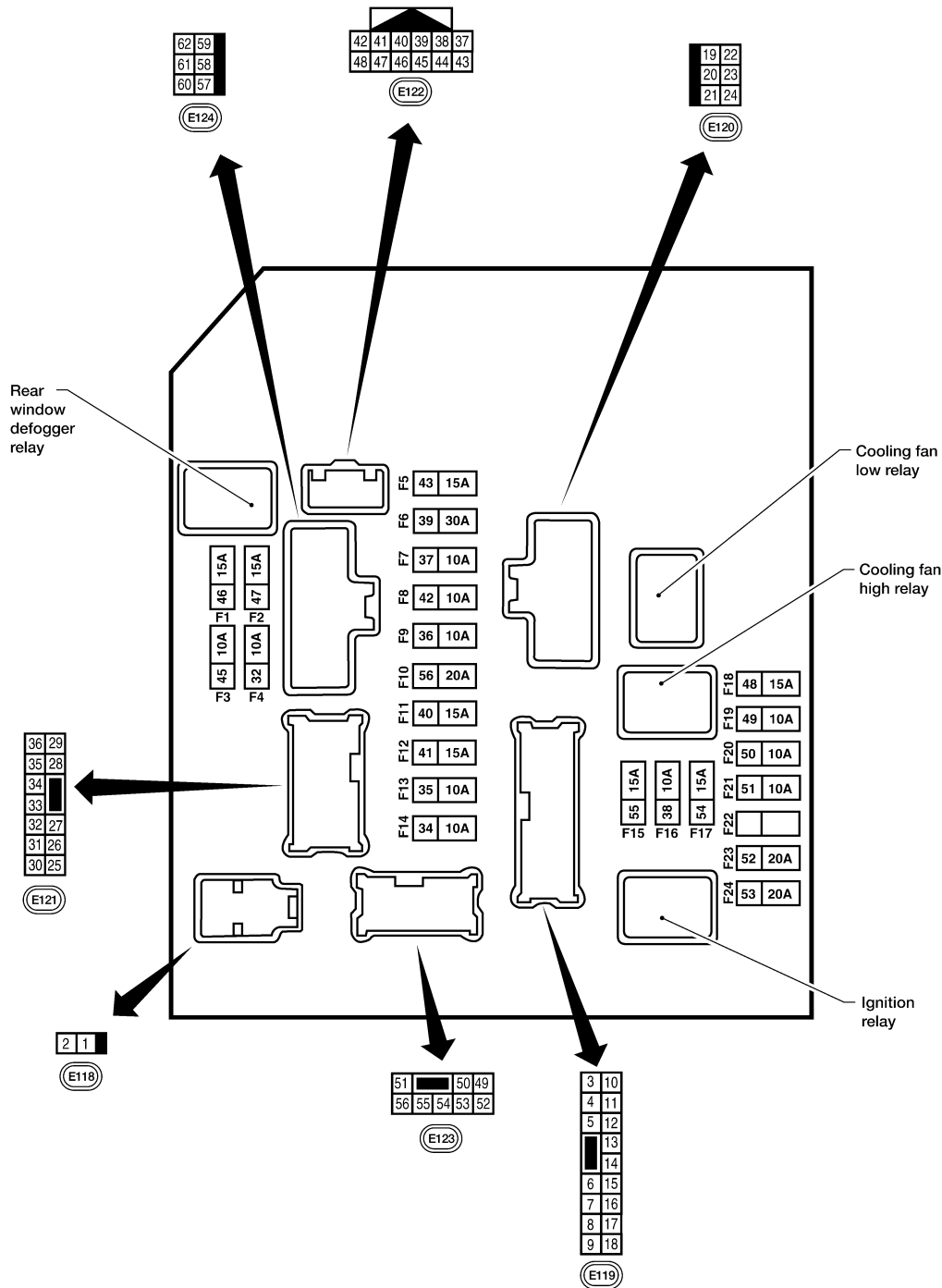

NOTE:

Numbers preceded by an "F" represent the fuse numbers imprinted on the IPDM E/R. The other numbers represent the fuse numbers as they appear in the wiring diagrams.

ABMIA4408GB

BATTERY

< REMOVAL AND INSTALLATION >

REMOVAL AND INSTALLATION

BATTERY

Removal and Installation

INFOID:000000008792560

REMOVAL

1. Disconnect both negative and positive battery terminals. Refer to [PG-82. "Removal and Installation"](#).

CAUTION:

- Before servicing, turn the ignition switch off and wait at least three minutes.
 - Disconnect negative battery terminal first.
2. Remove battery clamp nuts and battery clamp.
 3. Remove battery cover.
 4. Remove battery.

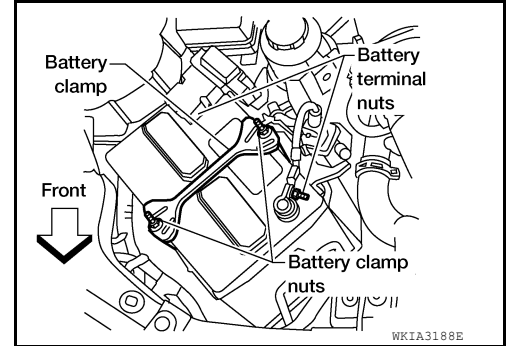

INSTALLATION

Installation is in the reverse order of removal.

CAUTION:

Connect positive battery terminal first.

Battery clamp nuts : 3.92 N·m (0.40 kg-m, 35 in-lb)

Battery terminal nut : 3.4 N·m (0.35 kg-m, 30 in-lb)

Reset electronic systems as necessary. Refer to [PG-7. "ADDITIONAL SERVICE WHEN REMOVING BATTERY NEGATIVE TERMINAL : Special Repair Requirement"](#).

SERVICE DATA AND SPECIFICATIONS (SDS)

< SERVICE DATA AND SPECIFICATIONS (SDS)

SERVICE DATA AND SPECIFICATIONS (SDS)

SERVICE DATA AND SPECIFICATIONS (SDS)

Battery

INFOID:000000008792561

Type*	GR35
Capacity (20 HR) minimum V-AH	12-60
Cold cranking current A [For reference value at -18°C (0°F)]	550

*: Always check with the Parts Department for the latest parts information.

A

B

C

D

E

F

G

H

I

J

K

L

PG

N

O

P