

# SECTION **PWC**

## POWER WINDOW CONTROL SYSTEM

A  
B  
C  
D  
E  
F  
G  
H  
I  
J  
L  
M  
N  
O  
P

### CONTENTS

<p><b>BASIC INSPECTION</b> ..... 3</p> <p><b>DIAGNOSIS AND REPAIR WORKFLOW</b> ..... 3</p> <p style="padding-left: 20px;">Work Flow .....3</p> <p><b>SYSTEM DESCRIPTION</b> ..... 4</p> <p><b>POWER WINDOW SYSTEM</b> ..... 4</p> <p style="padding-left: 20px;">System Diagram .....4</p> <p style="padding-left: 20px;">System Description .....4</p> <p style="padding-left: 20px;">Component Parts Location - King Cab .....5</p> <p style="padding-left: 20px;">Component Parts Location - Crew Cab .....6</p> <p style="padding-left: 20px;">Component Description .....6</p> <p><b>DIAGNOSIS SYSTEM (BCM)</b> ..... 8</p> <p><b>COMMON ITEM</b> .....8</p> <p style="padding-left: 20px;">COMMON ITEM : CONSULT Function (BCM - COMMON ITEM) .....8</p> <p><b>RETAINED PWR</b> .....8</p> <p style="padding-left: 20px;">RETAINED PWR : CONSULT Function (BCM - RETAINED PWR) .....9</p> <p><b>DTC/CIRCUIT DIAGNOSIS</b> .....10</p> <p><b>POWER SUPPLY AND GROUND CIRCUIT</b> .....10</p> <p><b>BCM</b> ..... 10</p> <p style="padding-left: 20px;">BCM : Diagnosis Procedure ..... 10</p> <p><b>POWER WINDOW MAIN SWITCH (CREW CAB)</b> .... 11</p> <p style="padding-left: 20px;">POWER WINDOW MAIN SWITCH (CREW CAB) : Description ..... 11</p> <p style="padding-left: 20px;">POWER WINDOW MAIN SWITCH (CREW CAB) : Component Function Check ..... 11</p> <p style="padding-left: 20px;">POWER WINDOW MAIN SWITCH (CREW CAB) : Diagnosis Procedure ..... 11</p> <p style="padding-left: 20px;">POWER WINDOW MAIN SWITCH (CREW CAB) : Component Inspection ..... 14</p> <p><b>POWER WINDOW MAIN SWITCH (KING CAB)</b> ..... 16</p>	<p>POWER WINDOW MAIN SWITCH (KING CAB) : Description .....16</p> <p>POWER WINDOW MAIN SWITCH (KING CAB) : Component Function Check .....16</p> <p>POWER WINDOW MAIN SWITCH (KING CAB) : Diagnosis Procedure .....16</p> <p>POWER WINDOW MAIN SWITCH (KING CAB) : Component Inspection .....18</p> <p><b>FRONT POWER WINDOW SWITCH</b> .....18</p> <p style="padding-left: 20px;">FRONT POWER WINDOW SWITCH : Description ..... 18</p> <p style="padding-left: 20px;">FRONT POWER WINDOW SWITCH : Component Function Check .....19</p> <p style="padding-left: 20px;">FRONT POWER WINDOW SWITCH : Diagnosis Procedure ..... 19</p> <p><b>REAR POWER WINDOW SWITCH</b> .....20</p> <p style="padding-left: 20px;">REAR POWER WINDOW SWITCH : Description...20</p> <p style="padding-left: 20px;">REAR POWER WINDOW SWITCH : Component Function Check .....20</p> <p style="padding-left: 20px;">REAR POWER WINDOW SWITCH : Diagnosis Procedure .....20</p> <p style="padding-left: 20px;">REAR POWER WINDOW SWITCH : Component Inspection .....22</p> <p><b>POWER WINDOW MOTOR</b> .....24</p> <p><b>DRIVER SIDE</b> .....24</p> <p style="padding-left: 20px;">DRIVER SIDE : Description .....24</p> <p style="padding-left: 20px;">DRIVER SIDE : Component Function Check .....24</p> <p style="padding-left: 20px;">DRIVER SIDE : Diagnosis Procedure .....24</p> <p style="padding-left: 20px;">DRIVER SIDE : Component Inspection .....25</p> <p><b>PASSENGER SIDE</b> .....25</p> <p style="padding-left: 20px;">PASSENGER SIDE : Description .....25</p> <p style="padding-left: 20px;">PASSENGER SIDE : Component Function Check .....25</p> <p style="padding-left: 20px;">PASSENGER SIDE : Diagnosis Procedure .....25</p> <p style="padding-left: 20px;">PASSENGER SIDE : Component Inspection .....26</p> <p><b>REAR LH</b> .....27</p>
---	---

PWC

REAR LH : Description .....	27	<b>DRIVER SIDE POWER WINDOW ALONE DOES NOT OPERATE</b> .....	64
REAR LH : Component Function Check .....	27	Diagnosis Procedure .....	64
REAR LH : Diagnosis Procedure .....	27	<b>FRONT PASSENGER SIDE POWER WINDOW ALONE DOES NOT OPERATE</b> .....	65
REAR LH : Component Inspection .....	28	Diagnosis Procedure .....	65
<b>REAR RH</b> .....	<b>28</b>	<b>REAR LH SIDE POWER WINDOW ALONE DOES NOT OPERATE</b> .....	<b>66</b>
REAR RH : Description .....	28	Diagnosis Procedure .....	66
REAR RH : Component Function Check .....	28	<b>REAR RH SIDE POWER WINDOW ALONE DOES NOT OPERATE</b> .....	<b>67</b>
REAR RH : Diagnosis Procedure .....	29	Diagnosis Procedure .....	67
REAR RH : Component Inspection .....	30	<b>AUTO OPERATION DOES NOT OPERATE BUT MANUAL OPERATES NORMALLY (DRIVER SIDE)</b> .....	<b>68</b>
<b>DOOR SWITCH</b> .....	<b>31</b>	Diagnosis Procedure .....	68
<b>KING CAB</b> .....	<b>31</b>	<b>POWER WINDOW RETAINED POWER OPERATION DOES NOT OPERATE PROPERLY</b> .....	<b>69</b>
KING CAB : Description .....	31	Diagnosis Procedure .....	69
KING CAB : Component Function Check .....	31	<b>POWER WINDOW LOCK SWITCH DOES NOT FUNCTION</b> .....	<b>70</b>
KING CAB : Diagnosis Procedure .....	31	Diagnosis Procedure .....	70
<b>CREW CAB</b> .....	<b>33</b>	<b>PRECAUTION</b> .....	<b>71</b>
CREW CAB : Description .....	33	<b>PRECAUTIONS</b> .....	<b>71</b>
CREW CAB : Component Function Check .....	33	Precaution for Supplemental Restraint System (SRS) "AIR BAG" and "SEAT BELT PRE-TENSIONER" .....	71
CREW CAB : Diagnosis Procedure .....	33	Precaution for Work .....	71
<b>POWER WINDOW LOCK SWITCH</b> .....	<b>36</b>	<b>PREPARATION</b> .....	<b>72</b>
Description .....	36	<b>PREPARATION</b> .....	<b>72</b>
Component Function Check .....	36	Special Service Tool .....	72
<b>ECU DIAGNOSIS INFORMATION</b> .....	<b>37</b>	<b>REMOVAL AND INSTALLATION</b> .....	<b>73</b>
<b>POWER WINDOW SYSTEM</b> .....	<b>37</b>	<b>POWER WINDOW MAIN SWITCH</b> .....	<b>73</b>
Terminal Layout for Power Window Main Switch ...	37	Removal and Installation .....	73
Physical Values for Power Window Main Switch ...	37	<b>FRONT POWER WINDOW SWITCH</b> .....	<b>74</b>
<b>BCM (BODY CONTROL MODULE)</b> .....	<b>38</b>	Removal and Installation .....	74
Reference Value .....	38	<b>REAR POWER WINDOW SWITCH</b> .....	<b>75</b>
Terminal Layout .....	41	Removal and Installation - Rear Door Switch (If Equipped) .....	75
Physical Values .....	41		
Fail Safe .....	46		
DTC Inspection Priority Chart .....	46		
DTC Index .....	47		
<b>WIRING DIAGRAM</b> .....	<b>49</b>		
<b>POWER WINDOW SYSTEM</b> .....	<b>49</b>		
Wiring Diagram - King Cab .....	49		
Wiring Diagram - Crew Cab .....	56		
<b>SYMPTOM DIAGNOSIS</b> .....	<b>63</b>		
<b>NONE OF THE POWER WINDOWS CAN BE OPERATED USING ANY SWITCH</b> .....	<b>63</b>		
Diagnosis Procedure .....	63		

# DIAGNOSIS AND REPAIR WORKFLOW

< BASIC INSPECTION >

## BASIC INSPECTION

### DIAGNOSIS AND REPAIR WORKFLOW

Work Flow

INFOID:000000008789363

DETAILED FLOW

#### 1. OBTAIN INFORMATION ABOUT SYMPTOM

Interview the customer to obtain the malfunction information (conditions and environment when the malfunction occurred) as much as possible when the customer brings the vehicle in.

>> GO TO 2

#### 2. REPRODUCE THE MALFUNCTION INFORMATION

Check the malfunction on the vehicle that the customer describes.  
Inspect the relation of the symptoms and the condition when the symptoms occur.

>> GO TO 3

#### 3. IDENTIFY THE MALFUNCTIONING SYSTEM WITH "SYMPTOM DIAGNOSIS"

Use "Symptom diagnosis" from the symptom inspection result in step 2 and then identify where to start performing the diagnosis based on possible causes and symptoms.

>> GO TO 4

#### 4. IDENTIFY THE MALFUNCTIONING PARTS WITH "DTC/CIRCUIT DIAGNOSIS"

Perform the diagnosis with "DTC/Circuit diagnosis" of the applicable system.

>> GO TO 5

#### 5. REPAIR OR REPLACE THE MALFUNCTIONING PARTS

Repair or replace the specified malfunctioning parts.

>> GO TO 6

#### 6. FINAL CHECK

Check that malfunctions are not reproduced when obtaining the malfunction information from the customer, referring to the symptom inspection result in step 2.

Are the malfunctions corrected?

YES >> Inspection End.

NO >> GO TO 3

A  
B  
C  
D  
E  
F  
G  
H  
I  
J  
PWC  
L  
M  
N  
O  
P

# POWER WINDOW SYSTEM

< SYSTEM DESCRIPTION >

## SYSTEM DESCRIPTION

### POWER WINDOW SYSTEM

#### System Diagram

INFOID:000000008789364

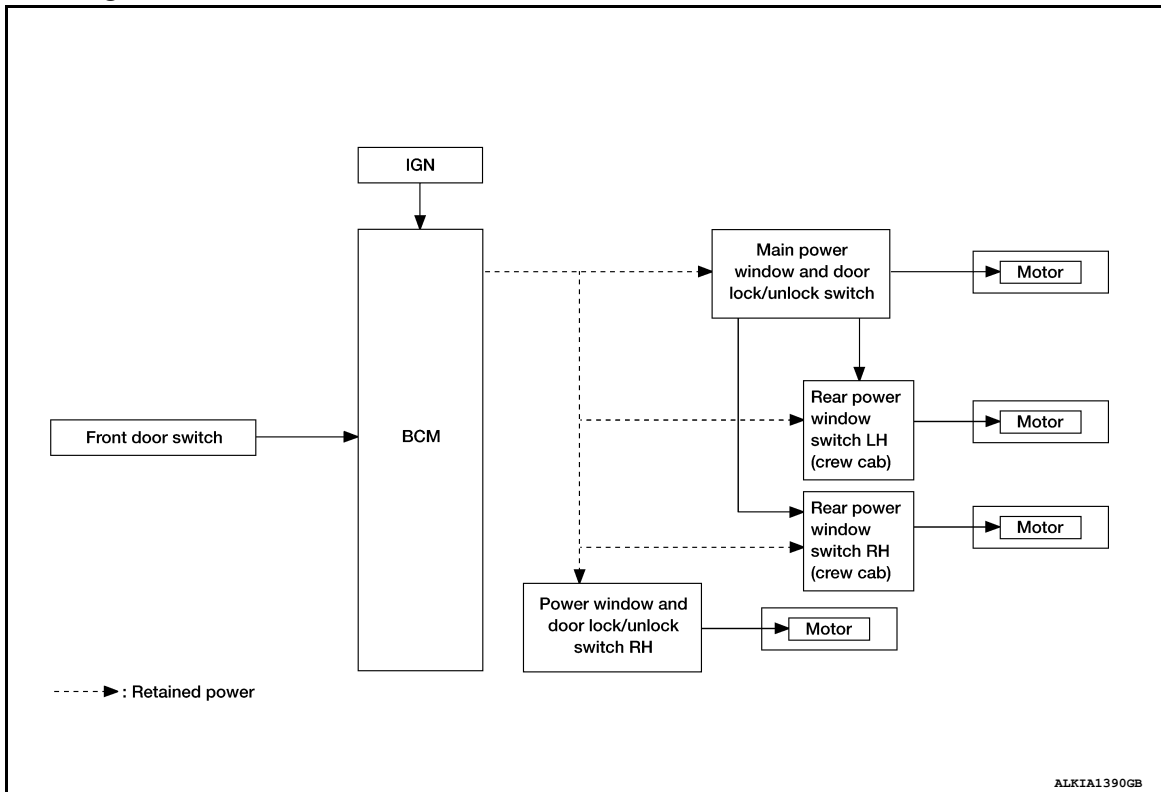

#### System Description

INFOID:000000008789365

#### MAIN POWER WINDOW AND DOOR LOCK/UNLOCK SWITCH INPUT/OUTPUT SIGNAL CHART

Item	Input signal to main power window and door lock/unlock switch	Main power window and door lock/unlock switch function	Actuator
Main power window and door lock/unlock switch	All power window motor UP/DOWN signal	Power window control	Power window motors
Power window and door lock/unlock switch RH	Front power window motor RH UP/DOWN signal		Front power window motor RH
Rear power window switch (crew cab)	Rear power window motor UP/DOWN signal		Rear power window motor
BCM	RAP signal		Power window motors

#### POWER WINDOW AND DOOR LOCK/UNLOCK SWITCH RH INPUT/OUTPUT SIGNAL CHART

Item	Input signal to front power window switch	Front power window switch function	Actuator
Power window and door lock/unlock switch RH	Front power window motor RH UP/DOWN signal	Power window control	Front power window motor RH
BCM	RAP signal		

# POWER WINDOW SYSTEM

## < SYSTEM DESCRIPTION >

### POWER WINDOW OPERATION

- Power window system is operable during the retained power operation timer after turning ignition switch ON and OFF.
- Main power window and door lock/unlock switch can open/close all windows.
- Power window and door lock unlock switch RH & rear power window switches LH and RH (crew cab) can open/close the corresponding windows.

### POWER WINDOW AUTO DOWN OPERATION (FRONT LH)

- AUTO DOWN operation can be performed when main power window turns to AUTO.

### RETAINED POWER OPERATION

- Retained power operation is an additional power supply function that enables power window system to operate during the 45 seconds even when ignition switch is turned OFF

#### Retained power function cancel conditions

- Front door CLOSE (door switch OFF)→OPEN (door switch ON).
- When ignition switch is ON.
- When timer time passes. (45 seconds)

### POWER WINDOW LOCK

Ground circuit inside main power window and door lock/unlock switch shuts off when power window lock switch is ON. This inhibits power window switch operation except with the main power window and door lock/unlock switch.

## Component Parts Location - King Cab

INFOID:000000008789366

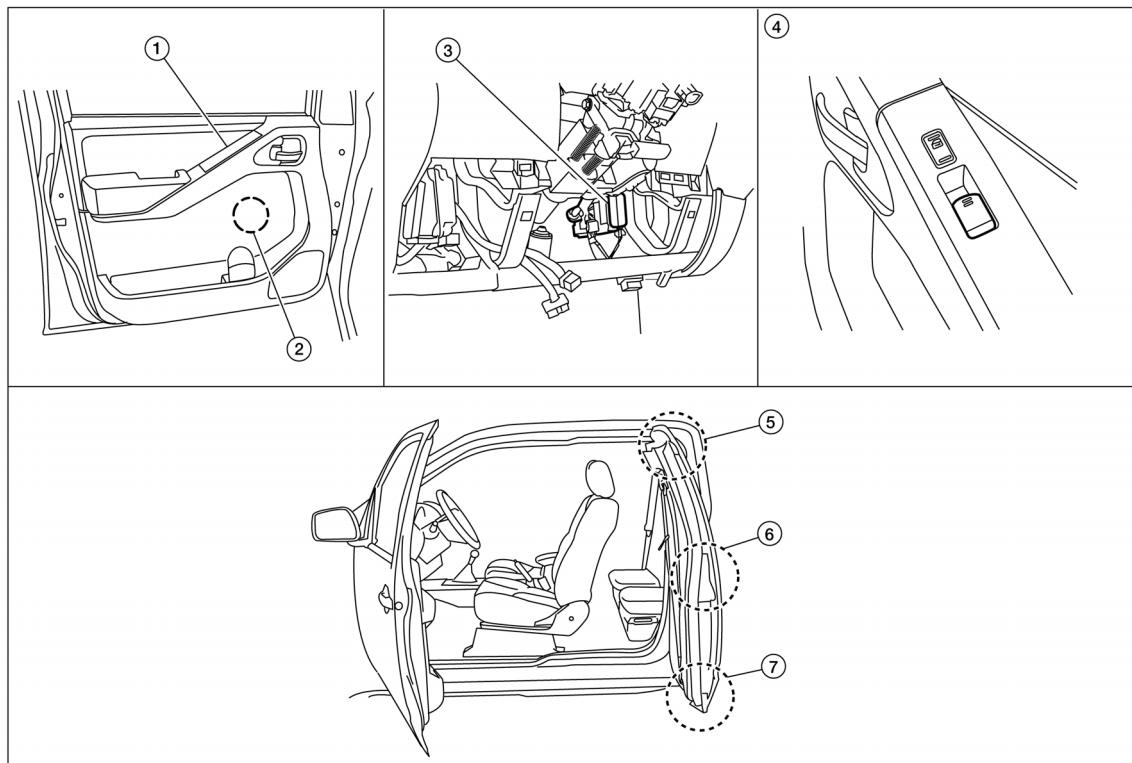

1. Main power window and door lock/unlock switch D7
2. Front power window motor LH D9, RH D104
3. BCM M18, M19, M20 (view with lower instrument panel LH removed)
4. Power window and door lock/unlock switch RH D105
5. Rear door switch upper LH D211, RH D312
6. Front door switch LH D213, RH D314
7. Rear door switch lower D212, RH D313

# POWER WINDOW SYSTEM

< SYSTEM DESCRIPTION >

## Component Parts Location - Crew Cab

INFOID:000000008789367

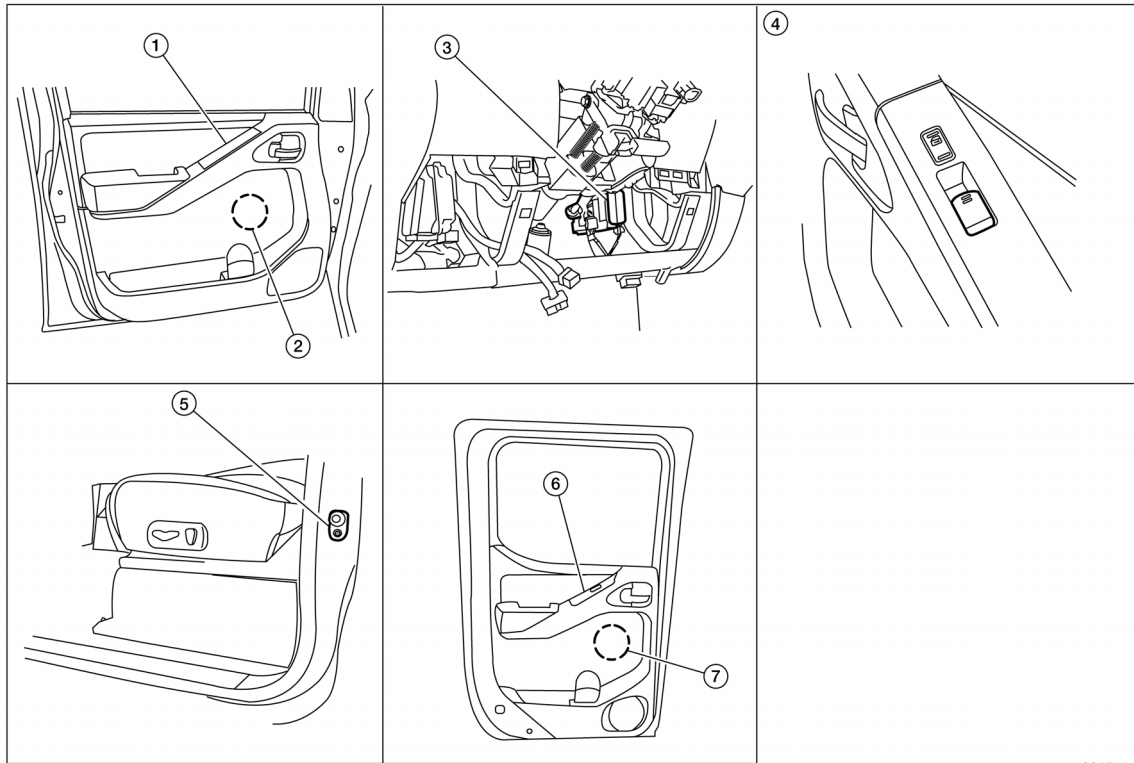

ABKIA2917ZZ

- |   |  |  |
|---|--|--|
| 1. Main power window and door lock/unlock switch D7 | 2. Front power window motor LH D9, RH D104 | 3. BCM M18, M19, M20 (view with lower instrument panel LH removed) |
| 4. Power window and door lock/unlock switch RH D105 | 5. Front door switch LH B8, RH B108        | 6. Rear power window switch LH D203, RH D303                       |
| 7. Rear power window motor LH D204, RH D304         |  |  |

## Component Description

INFOID:000000008789368

### POWER WINDOW SYSTEM

Component	Function
BCM	<ul style="list-style-type: none"> <li>Supplies power supply to power window switch.</li> <li>Controls retained power.</li> </ul>
Main power window and door lock/unlock switch	Directly controls all power window motor of all doors.
Power window and door lock/unlock switch RH	Controls front power window motor RH.
Rear power window switch LH or RH (crew cab)	Controls rear power window motors LH and RH.
Front power window motor LH	Starts operating with signals from main power window and door lock/unlock switch.
Front power window motor RH	Starts operating with signals from main power window and door lock/unlock switch & power window and door lock/unlock switch RH.
Rear power window motor LH or RH (crew cab)	Starts operating with signals from main power window and door lock/unlock switch & rear power window switch.

# POWER WINDOW SYSTEM

## < SYSTEM DESCRIPTION >

Component	Function
Rear door switch upper LH or RH (king cab)	Detects door open/close condition and transmits to BCM.
Rear door switch lower LH or RH (king cab)	
Front door switch LH or RH	

A

B

C

D

E

F

G

H

I

J

PWC

L

M

N

O

P

## DIAGNOSIS SYSTEM (BCM)

< SYSTEM DESCRIPTION >

### DIAGNOSIS SYSTEM (BCM)

#### COMMON ITEM

COMMON ITEM : CONSULT Function (BCM - COMMON ITEM)

INFOID:000000009233089

#### APPLICATION ITEM

CONSULT performs the following functions via CAN communication with BCM.

Direct Diagnostic Mode	Description
Ecu Identification	The BCM part number is displayed.
Self Diagnostic Result	The BCM self diagnostic results are displayed.
Data Monitor	The BCM input/output data is displayed in real time.
Active Test	The BCM activates outputs to test components.
Work support	The settings for BCM functions can be changed.
Configuration	<ul style="list-style-type: none"> <li>• The vehicle specification can be read and saved.</li> <li>• The vehicle specification can be written when replacing BCM.</li> </ul>
CAN Diag Support Mntr	The result of transmit/receive diagnosis of CAN communication is displayed.

#### SYSTEM APPLICATION

BCM can perform the following functions.

System	Sub System	Direct Diagnostic Mode						
		Ecu Identification	Self Diagnostic Result	Data Monitor	Active Test	Work support	Configuration	CAN Diag Support Mntr
Door lock	DOOR LOCK			x	x	x		
Rear window defogger	REAR DEFOGGER			x	x			
Warning chime	BUZZER			x	x			
Interior room lamp timer	INT LAMP			x	x	x		
Remote keyless entry system	MULTI REMOTE ENT			x	x	x		
Exterior lamp	HEAD LAMP			x	x	x		
Wiper and washer	WIPER			x	x	x		
Turn signal and hazard warning lamps	FLASHER			x	x			
Air conditioner	AIR CONDITIONER			x				
Combination switch	COMB SW			x				
BCM	BCM	x	x			x	x	x
Immobilizer	IMMU		x	x	x			
Interior room lamp battery saver	BATTERY SAVER			x	x	x		
Vehicle security system	THEFT ALM			x	x	x		
RAP system	RETAINED PWR			x	x	x		
Signal buffer system	SIGNAL BUFFER			x	x			
TPMS	AIR PRESSURE MONITOR		x	x	x	x		
Panic alarm system	PANIC ALARM				x			

#### RETAINED PWR



# DIAGNOSIS SYSTEM (BCM)

< SYSTEM DESCRIPTION >

## RETAINED PWR : CONSULT Function (BCM - RETAINED PWR)

INFOID:000000009233090

### DATA MONITOR

Monitor Item [Unit]	Description
IGN ON SW [On/Off]	Indicates condition of ignition switch ON position.
DOOR SW-DR [On/Off]	Indicates condition of front door switch LH.
DOOR SW-AS [On/Off]	Indicates condition of front door switch RH.

### ACTIVE TEST

Test Item	Description
RETAINED PWR	This test is able to check retained power operation [Off/On].

### WORK SUPPORT

Support Item	Setting	Description
RETAINED PWR SET	MODE3	2 min
	MODE2	OFF
	MODE1*	45 sec

\*: Initial setting

A  
B  
C  
D  
E  
F  
G  
H  
I  
J  
L  
M  
N  
O  
P

PWC

# POWER SUPPLY AND GROUND CIRCUIT

< DTC/CIRCUIT DIAGNOSIS >

## DTC/CIRCUIT DIAGNOSIS

### POWER SUPPLY AND GROUND CIRCUIT

#### BCM

#### BCM : Diagnosis Procedure

INFOID:000000009233091

Regarding Wiring Diagram information, refer to [BCS-43, "Wiring Diagram"](#).

### 1. CHECK FUSES AND FUSIBLE LINK

Check that the following fuses and fusible link are not blown.

Terminal No.	Signal name	Fuses and fusible link No.
57	Battery power supply	21 (10A)
70		G (50A)
11	Ignition ACC or ON	4 (10A)
38	Ignition ON or START	1 (10A)

#### Is the fuse blown?

YES >> Replace the blown fuse or fusible link after repairing the affected circuit.

NO >> GO TO 2

### 2. CHECK POWER SUPPLY CIRCUIT

1. Turn ignition switch OFF.
2. Disconnect BCM.
3. Check voltage between BCM harness connector and ground.

Connector	Terminals		Power source	Condition	Voltage (V) (Approx.)
	(+)	(-)			
M18	11	Ground	ACC power supply	Ignition switch ACC or ON	Battery voltage
	38	Ground	Ignition power supply	Ignition switch ON or START	Battery voltage
M20	57	Ground	Battery power supply	Ignition switch OFF	Battery voltage
	70	Ground	Battery power supply	Ignition switch OFF	Battery voltage

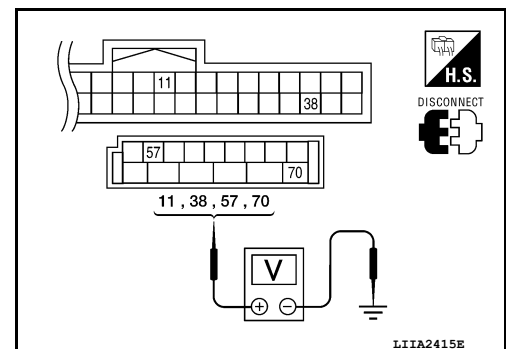

#### Is the measurement value normal?

YES >> GO TO 3

NO >> Repair or replace harness.

### 3. CHECK GROUND CIRCUIT

# POWER SUPPLY AND GROUND CIRCUIT

## < DTC/CIRCUIT DIAGNOSIS >

Check continuity between BCM harness connector and ground.

BCM		Ground	Continuity
Connector	Terminal		
M20	67		Yes

### Does continuity exist?

- YES >> Inspection End.
- NO >> Repair or replace harness.

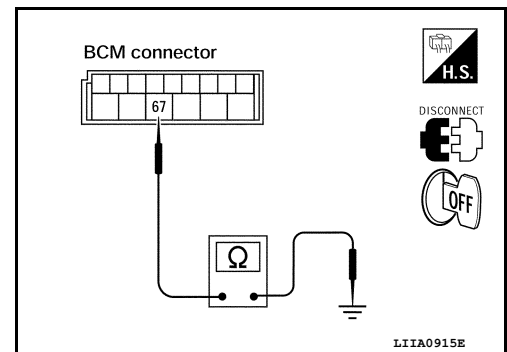

## POWER WINDOW MAIN SWITCH (CREW CAB)

### POWER WINDOW MAIN SWITCH (CREW CAB) : Description

INFOID:000000008789372

- BCM supplies power.
- It operates each power window motor via corresponding power window switch and makes window move up/down when main power window and door lock/unlock switch is operated.

### POWER WINDOW MAIN SWITCH (CREW CAB) : Component Function Check

INFOID:000000008789373

#### Main Power Window And Door Lock/Unlock Switch

### 1. CHECK MAIN POWER WINDOW AND DOOR LOCK/UNLOCK SWITCH FUNCTION

Check power window motor operation with main power window and door lock/unlock switch.

#### Is the inspection result normal?

- YES >> Main power window and door lock/unlock switch power supply and ground circuit are OK.
- NO >> Refer to [PWC-11. "POWER WINDOW MAIN SWITCH \(CREW CAB\) : Diagnosis Procedure"](#).

### POWER WINDOW MAIN SWITCH (CREW CAB) : Diagnosis Procedure

INFOID:000000008789374

Regarding Wiring Diagram information, refer to [PWC-56. "Wiring Diagram - Crew Cab"](#).

### 1. CHECK POWER SUPPLY CIRCUIT

1. Turn ignition switch ON.
2. Check voltage between main power window and door lock/unlock switch connector D7 terminal 5 and ground.

**5 - Ground** : **Battery voltage**

#### Is the measurement value within the specification?

- YES >> GO TO 2
- NO >> GO TO 3

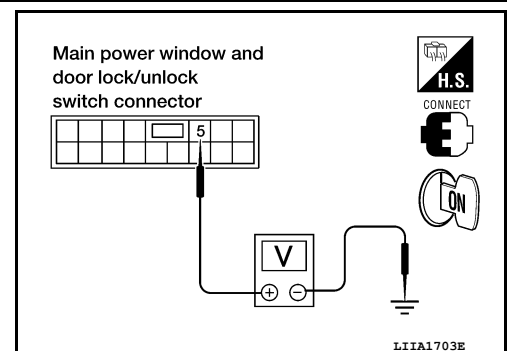

### 2. CHECK GROUND CIRCUIT

A  
B  
C  
D  
E  
F  
G  
H  
I  
J  
L  
M  
N  
O  
P

PWC

# POWER SUPPLY AND GROUND CIRCUIT

## < DTC/CIRCUIT DIAGNOSIS >

1. Turn ignition switch OFF.
2. Disconnect main power window and door lock/unlock switch.
3. Check continuity between main power window and door lock/unlock switch connector D7 terminal 14 and ground.

Connector	Terminals		Continuity
Main power window and door lock/unlock switch: D7	14	Ground	Yes

### Is the inspection result normal?

- YES >> Check main power window and door lock/unlock switch output signal (rear power window switch LH) GO TO 5
- YES >> Check main power window and door lock/unlock switch output signal (rear power window switch RH) GO TO 6
- YES >> Check main power window and door lock/unlock switch output signal (front power window switch RH) GO TO 7
- YES >> Check main power window and door lock/unlock switch output signal (front power window switch LH) GO TO 8
- NO >> Repair or replace harness.

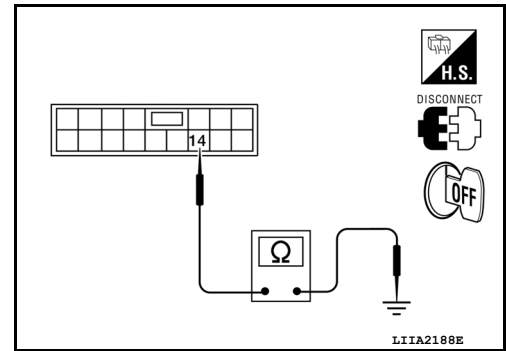

## 3. CHECK MAIN POWER WINDOW AND DOOR LOCK/UNLOCK SWITCH POWER SUPPLY CIRCUIT

1. Turn ignition switch OFF.
2. Disconnect BCM and main power window and door lock/unlock switch.
3. Check continuity between BCM and main power window and door lock/unlock switch.

A		B		Continuity
Connector	Terminal	Connector	Terminal	
BCM: M20	68	Main power window and door lock/unlock switch: D7	5	Yes

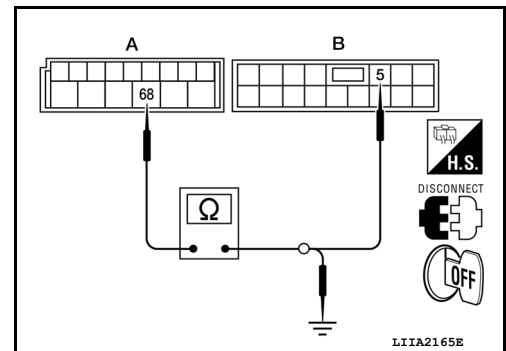

4. Check continuity between BCM and ground.

A		Ground	Continuity
Connector	Terminal		
BCM: M20	68		No

### Is the inspection result normal?

- YES >> GO TO 4
- NO >> Repair or replace harness.

## 4. CHECK BCM OUTPUT SIGNAL

1. Connect BCM.
2. Turn ignition switch ON.
3. Check voltage between BCM connector M20 terminal 68 and ground.

**68 - Ground : Battery voltage**

### Is the measurement value within the specification?

- YES >> Check intermittent incident. Refer to [GI-49. "Intermittent Incident"](#).
- NO >> Replace BCM. Refer to [BCS-49. "Removal and Installation"](#).

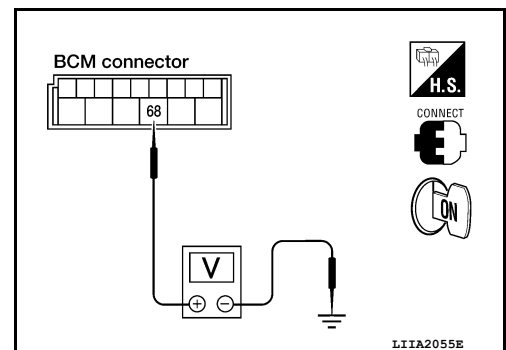

## 5. CHECK MAIN POWER WINDOW AND DOOR LOCK/UNLOCK SWITCH OUTPUT SIGNAL (REAR POW-

# POWER SUPPLY AND GROUND CIRCUIT

## < DTC/CIRCUIT DIAGNOSIS >

### ER WINDOW SWITCH LH)

1. Connect main power window and door lock/unlock switch.
2. Turn ignition switch ON.
3. Check voltage between main power window and door lock/unlock switch connector and ground.

Terminal		(-)	Window switch position (rear LH)	Voltage (V) (Approx.)
(+)	Terminal			
Main power window and door lock/unlock switch		Ground	UP	Battery voltage
	15		DOWN	0
	16		UP	0
			DOWN	Battery voltage

Is the measurement value within the specification?

YES >> Check intermittent incident. Refer to [GI-49. "Intermittent Incident"](#).

NO >> Replace main power window and door lock/unlock switch. Refer to [PWC-73. "Removal and Installation"](#).

### 6. CHECK MAIN POWER WINDOW AND DOOR LOCK/UNLOCK SWITCH OUTPUT SIGNAL (REAR POWER WINDOW SWITCH RH)

1. Connect main power window and door lock/unlock switch.
2. Turn ignition switch ON.
3. Check voltage between main power window and door lock/unlock switch connector and ground.

Terminal		(-)	Window switch position (rear RH)	Voltage (V) (Approx.)
(+)	Terminal			
Main power window and door lock/unlock switch connector		Ground	UP	Battery voltage
	8		DOWN	0
	9		UP	0
			DOWN	Battery voltage

Is the measurement value within the specification?

YES >> Check intermittent incident. Refer to [GI-49. "Intermittent Incident"](#).

NO >> Replace main power window and door lock/unlock switch. Refer to [PWC-73. "Removal and Installation"](#).

### 7. CHECK MAIN POWER WINDOW AND DOOR LOCK/UNLOCK SWITCH OUTPUT SIGNAL (FRONT POWER WINDOW SWITCH RH)

1. Connect main power window and door lock/unlock switch.
2. Turn ignition switch ON.
3. Check voltage between main power window and door lock/unlock switch connector and ground.

# POWER SUPPLY AND GROUND CIRCUIT

## < DTC/CIRCUIT DIAGNOSIS >

Terminal		(-)	Window switch position (front RH)	Voltage (V) (Approx.)
(+)	Terminal			
Main power window and door lock/unlock switch connector	Terminal			
D7	3	Ground	UP	Battery voltage
			DOWN	0
	2		UP	0
			DOWN	Battery voltage

Is the measurement value within the specification?

YES >> Check intermittent incident. Refer to [GI-49, "Intermittent Incident"](#).

NO >> Replace main power window and door lock/unlock switch. Refer to [PWC-73, "Removal and Installation"](#).

### 8. CHECK MAIN POWER WINDOW AND DOOR LOCK/UNLOCK SWITCH OUTPUT SIGNAL (FRONT POWER WINDOW SWITCH LH)

1. Connect main power window and door lock/unlock switch.
2. Turn ignition switch ON.
3. Check voltage between main power window and door lock/unlock switch connector and ground.

Terminal		(-)	Window switch position (front LH)	Voltage (V) (Approx.)
(+)	Terminal			
Main power window and door lock/unlock switch connector	Terminal			
D7	6	Ground	UP	Battery voltage
			DOWN	0
	7		UP	0
			DOWN	Battery voltage

Is the measurement value within the specification?

YES >> Check intermittent incident. Refer to [GI-49, "Intermittent Incident"](#).

NO >> Replace main power window and door lock/unlock switch. Refer to [PWC-73, "Removal and Installation"](#).

### POWER WINDOW MAIN SWITCH (CREW CAB) : Component Inspection INFOID:000000008789375

#### 1. CHECK MAIN POWER WINDOW AND DOOR LOCK/UNLOCK SWITCH

1. Check main power window and door lock/unlock switch.

# POWER SUPPLY AND GROUND CIRCUIT

## < DTC/CIRCUIT DIAGNOSIS >

Terminal		Main power window and door lock/unlock switch condition		Continuity
5	3	Front RH	UP	Yes
5	15	Rear LH		
5	8	Rear RH		
2	3	Front RH	NEUTRAL	
15	16	Rear LH		
8	9	Rear RH		
5	2	Front RH	DOWN	
5	16	Rear LH		
5	9	Rear RH		

2. Check continuity between main power window and door lock/unlock switch (power window lock switch). (Lock operation).

Terminal		Main power window and door lock/unlock switch condition		Continuity
2	14	Front RH	UP	No
16		Rear LH		
9		Rear RH		
2		Front RH	NEUTRAL	
3		Rear LH		
15		Rear RH		
16		Front RH	DOWN	
8		Rear LH		
9		Rear RH		
3		Front RH	DOWN	
15		Rear LH		
8		Rear RH		

3. Check continuity between main power window and door lock/unlock switch (power window lock switch). (Unlock operation).

Terminal		Main power window and door lock/unlock switch condition		Continuity
2	14	Front RH	UP	Yes
16		Rear LH		
9		Rear RH		
2		Front RH	NEUTRAL	
3		Rear LH		
15		Rear RH		
16		Front RH	DOWN	
8		Rear LH		
9		Rear RH		
3		Front RH	DOWN	
15		Rear LH		
8		Rear RH		

A  
B  
C  
D  
E  
F  
G  
H  
I  
J  
L  
M  
N  
O  
P

PWC

# POWER SUPPLY AND GROUND CIRCUIT

## < DTC/CIRCUIT DIAGNOSIS >

### Is the inspection result normal?

- YES >> Main power window and door lock/unlock switch is OK.
- NO >> Replace main power window and door lock/unlock switch. Refer to [PWC-73. "Removal and Installation"](#).

## POWER WINDOW MAIN SWITCH (KING CAB)

### POWER WINDOW MAIN SWITCH (KING CAB) : Description

INFOID:000000008789376

- BCM supplies power.
- It operates each power window motor via corresponding power window switch and makes window move up/down when main power window and door lock/unlock switch is operated.

### POWER WINDOW MAIN SWITCH (KING CAB) : Component Function Check

INFOID:000000008789377

#### Main Power Window And Door Lock/Unlock Switch

### 1. CHECK MAIN POWER WINDOW AND DOOR LOCK/UNLOCK SWITCH FUNCTION

Check power window motor operation with main power window and door lock/unlock switch.

#### Is the inspection result normal?

- YES >> Main power window and door lock/unlock switch power supply and ground circuit are OK.
- NO >> Refer to [PWC-16. "POWER WINDOW MAIN SWITCH \(KING CAB\) : Diagnosis Procedure"](#).

### POWER WINDOW MAIN SWITCH (KING CAB) : Diagnosis Procedure

INFOID:000000008789378

Regarding Wiring Diagram information, refer to [PWC-49. "Wiring Diagram - King Cab"](#).

### 1. CHECK POWER SUPPLY CIRCUIT

1. Turn ignition switch ON.
2. Check voltage between main power window and door lock/unlock switch connector D7 terminal 5 and ground.

**5 - Ground : Battery voltage**

#### Is the measurement value within the specification?

- YES >> GO TO 2
- NO >> GO TO 3

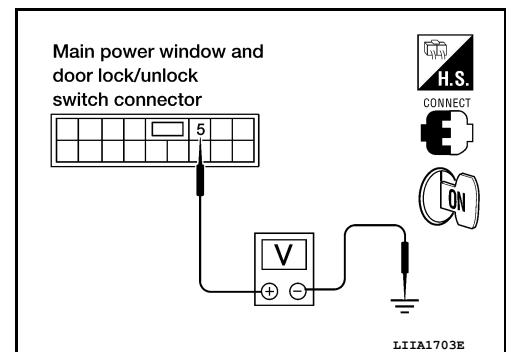

### 2. CHECK GROUND CIRCUIT

1. Turn ignition switch OFF.
2. Disconnect main power window and door lock/unlock switch.
3. Check continuity between main power window and door lock/unlock switch connector D7 terminal 14 and ground.

Connector	Terminals		Continuity
Main power window and door lock/unlock switch: D7	14	Ground	Yes

#### Is the inspection result normal?

- YES >> Check main power window and door lock/unlock switch output signal (front power window switch RH) GO TO 5
- YES >> Check main power window and door lock/unlock switch output signal (front power window switch LH) GO TO 6
- NO >> Repair or replace harness.

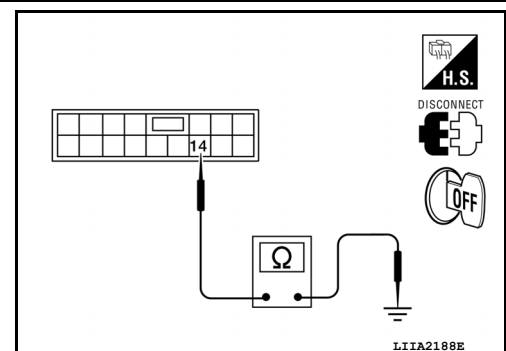



# POWER SUPPLY AND GROUND CIRCUIT

< DTC/CIRCUIT DIAGNOSIS >

## 3. CHECK MAIN POWER WINDOW AND DOOR LOCK/UNLOCK SWITCH POWER SUPPLY CIRCUIT

1. Turn ignition switch OFF.
2. Disconnect BCM and main power window and door lock/unlock switch.
3. Check continuity between BCM and main power window and door lock/unlock switch.

A		B		Continuity
Connector	Terminal	Connector	Terminal	
BCM: M20	68	Main power window and door lock/unlock switch: D7	5	Yes

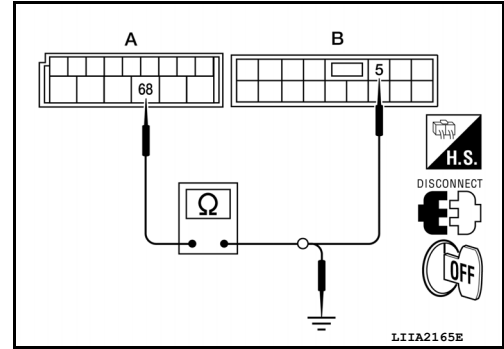

4. Check continuity between BCM and ground.

A		Ground	Continuity
Connector	Terminal		
BCM: M20	68		No

Is the inspection result normal?

- YES >> GO TO 4  
 NO >> Repair or replace harness.

## 4. CHECK BCM OUTPUT SIGNAL

1. Connect BCM.
2. Turn ignition switch ON.
3. Check voltage between BCM connector M20 terminal 68 and ground.

**68 - Ground : Battery voltage**

Is the measurement value within the specification?

- YES >> Check intermittent incident. Refer to [GI-49. "Intermittent Incident"](#).  
 NO >> Replace BCM. Refer to [BCS-49. "Removal and Installation"](#).

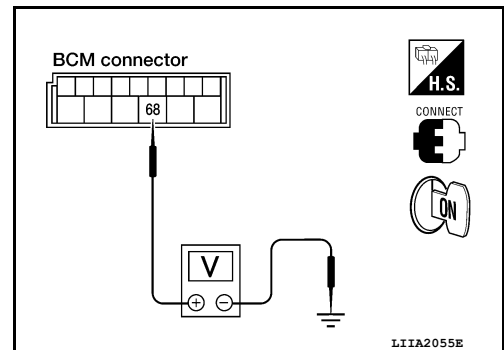

## 5. CHECK MAIN POWER WINDOW AND DOOR LOCK/UNLOCK SWITCH OUTPUT SIGNAL (FRONT POWER WINDOW SWITCH RH)

1. Connect main power window and door lock/unlock switch.
2. Turn ignition switch ON.
3. Check voltage between main power window and door lock/unlock switch connector and ground.

Terminal (+)		Terminal (-)	Window switch position (front RH)	Voltage (V) (Approx.)
Main power window and door lock/unlock switch connector	Terminal			
D7	3	Ground	UP	Battery voltage
			DOWN	0
	2		UP	0
			DOWN	Battery voltage

Is the measurement value within the specification?

A  
B  
C  
D  
E  
F  
G  
H  
I  
J  
L  
M  
N  
O  
P

PWC

# POWER SUPPLY AND GROUND CIRCUIT

## < DTC/CIRCUIT DIAGNOSIS >

- YES >> Check intermittent incident. Refer to [GI-49, "Intermittent Incident"](#).  
 NO >> Replace main power window and door lock/unlock switch. Refer to [PWC-73, "Removal and Installation"](#).

### 6. CHECK MAIN POWER WINDOW AND DOOR LOCK/UNLOCK SWITCH OUTPUT SIGNAL (FRONT POWER WINDOW SWITCH LH)

1. Connect main power window and door lock/unlock switch.
2. Turn ignition switch ON.
3. Check voltage between main power window and door lock/unlock switch connector and ground.

Terminal (+)		Terminal (-)	Window switch position (front LH)	Voltage (V) (Approx.)
Main power window and door lock/unlock switch connector	Terminal			
D7	6	Ground	UP	Battery voltage
			DOWN	0
	7		UP	0
			DOWN	Battery voltage

#### Is the measurement value within the specification?

- YES >> Check intermittent incident. Refer to [GI-49, "Intermittent Incident"](#).  
 NO >> Replace main power window and door lock/unlock switch. Refer to [PWC-73, "Removal and Installation"](#).

### POWER WINDOW MAIN SWITCH (KING CAB) : Component Inspection

INFOID:000000008789379

#### 1. CHECK MAIN POWER WINDOW AND DOOR LOCK/UNLOCK SWITCH

1. Turn ignition switch OFF.
2. Disconnect main power window and door lock/unlock switch.
3. Check main power window and door lock/unlock switch.

Terminal	Main power window and door lock/unlock switch condition	Continuity
5	3 Front RH UP	Yes
2	3 Front RH NEUTRAL	
5	2 Front RH DOWN	

4. Check continuity between main power window and door lock/unlock switch (power window lock switch).

Main power window and door lock/unlock switch	Terminals	Condition	Continuity
	14	2 Lock switch UNLOCK	Yes
		2 Lock switch LOCK	No
	3	3 Lock switch UNLOCK	Yes
		3 Lock switch LOCK	No

#### Is the inspection result normal?

- YES >> Main power window and door lock/unlock switch is OK.  
 NO >> Replace main power window and door lock/unlock switch. Refer to [PWC-73, "Removal and Installation"](#).

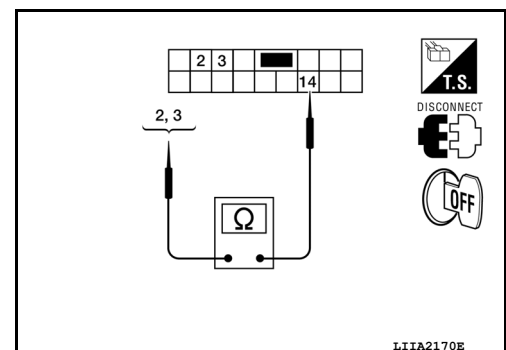

### FRONT POWER WINDOW SWITCH

#### FRONT POWER WINDOW SWITCH : Description

INFOID:000000008789380

- BCM supplies power.

# POWER SUPPLY AND GROUND CIRCUIT

## < DTC/CIRCUIT DIAGNOSIS >

- Front power window motor RH will be operated if power window and door lock/unlock switch RH is operated.

## FRONT POWER WINDOW SWITCH : Component Function Check

INFOID:000000008789381

### Power Window And Door Lock/Unlock Switch RH

#### 1. CHECK FRONT POWER WINDOW MOTOR RH FUNCTION

Check front power window motor RH operation with power window and door lock/unlock switch RH.

Is the inspection result normal?

- YES >> Power window and door lock/unlock switch RH power supply and ground circuit are OK.
- NO >> Refer to [PWC-19. "FRONT POWER WINDOW SWITCH : Diagnosis Procedure"](#).

## FRONT POWER WINDOW SWITCH : Diagnosis Procedure

INFOID:000000008789382

Regarding Wiring Diagram information, refer to [PWC-56. "Wiring Diagram - Crew Cab"](#), [PWC-49. "Wiring Diagram - King Cab"](#).

#### 1. CHECK POWER SUPPLY CIRCUIT

1. Turn ignition switch ON.
2. Check voltage between power window and door lock/unlock switch RH connector and ground.

Terminal (+)		Terminal (-)	Voltage (V) (Approx.)
Power window and door lock/unlock switch RH connector	Terminal		
D105	8	Ground	Battery voltage

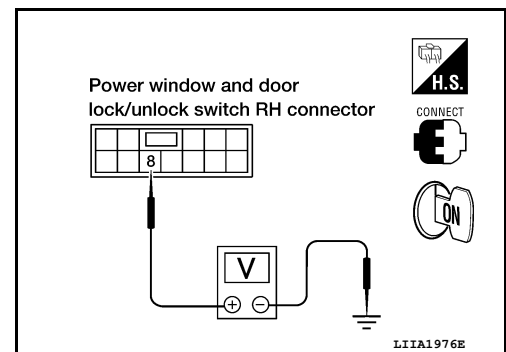

Is the measurement value within the specification?

- YES >> GO TO 3
- NO >> GO TO 2

#### 2. CHECK HARNESS CONTINUITY

1. Turn ignition switch OFF.
2. Disconnect BCM and power window and door lock/unlock switch RH.
3. Check continuity between BCM connector (A) and power window and door lock/unlock switch RH connector (B).

BCM connector	Terminal	Power window and door lock/unlock switch RH connector	Terminal	Continuity
M20 (A)	68	D105 (B)	8	Yes

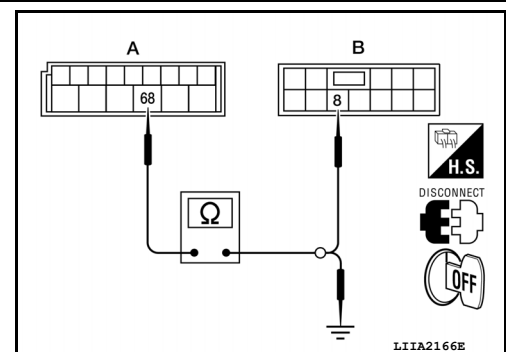

4. Check continuity between BCM connector (A) and ground.

BCM connector	Terminal	Ground	Continuity
M20 (A)	68		No

Is the inspection result normal?

- YES >> GO TO 4
- NO >> Repair or replace harness.

#### 3. CHECK GROUND CIRCUIT

1. Turn ignition switch OFF.

A  
B  
C  
D  
E  
F  
G  
H  
I  
J  
L  
M  
N  
O  
P

PWC

# POWER SUPPLY AND GROUND CIRCUIT

## < DTC/CIRCUIT DIAGNOSIS >

- Disconnect power window and door lock/unlock switch RH and main power window and door lock/unlock switch.
- Check continuity between main power window and door lock/unlock switch connector and front power window switch RH connector.

Main power window and door lock/unlock switch connector	Terminal	Front power window switch RH connector	Terminal	Continuity
D7	3	D105	12	Yes
	2		11	

- Check continuity between main power window and door lock/unlock switch connector and ground.

Main power window and door lock/unlock switch connector	Terminal	Ground	Continuity
D7	3	Ground	No
	2		

### Is the inspection result normal?

YES >> Replace power and door lock/unlock switch RH. Refer to [PWC-74, "Removal and Installation"](#).

NO >> Repair or replace harness.

## 4. CHECK BCM OUTPUT SIGNAL

- Connect BCM.
- Turn ignition switch ON.
- Check voltage between BCM connector and ground.

Terminals		Voltage (V) (Approx.)
(+)	(-)	
BCM connector	Terminal	
M20	68	Battery voltage

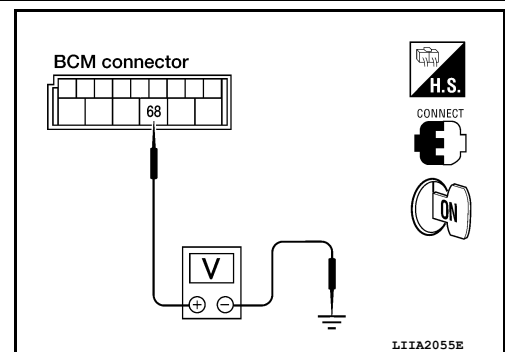

### Is the measurement value within the specification?

YES >> Check intermittent incident. Refer to [GI-49, "Intermittent Incident"](#).

NO >> Replace BCM. Refer to [BCS-49, "Removal and Installation"](#).

## REAR POWER WINDOW SWITCH

### REAR POWER WINDOW SWITCH : Description

INFOID:000000008789383

- BCM supplies power.
- Rear power window motor will be operated if rear power window switch is operated.

### REAR POWER WINDOW SWITCH : Component Function Check

INFOID:000000008789384

#### Rear Power Window Switch

## 1. CHECK REAR POWER WINDOW MOTOR FUNCTION

Check rear power window motor operation with rear power window switch.

### Is the inspection result normal?

YES >> Rear power window switch power supply and ground circuit are OK.

NO >> Refer to [PWC-20, "REAR POWER WINDOW SWITCH : Diagnosis Procedure"](#).

### REAR POWER WINDOW SWITCH : Diagnosis Procedure

INFOID:000000008789385

Regarding Wiring Diagram information, refer to [PWC-56, "Wiring Diagram - Crew Cab"](#).

# POWER SUPPLY AND GROUND CIRCUIT

< DTC/CIRCUIT DIAGNOSIS >

## 1. CHECK POWER SUPPLY CIRCUIT

- Turn ignition switch ON.
- Check voltage between rear power window switch connector and ground.

Terminal		Terminal	Condition	Voltage (V) (Approx.)
(+)	(-)			
Rear power window switch connector		8	Ignition switch ON	Battery voltage
LH	D203	Ground		
RH	D303			

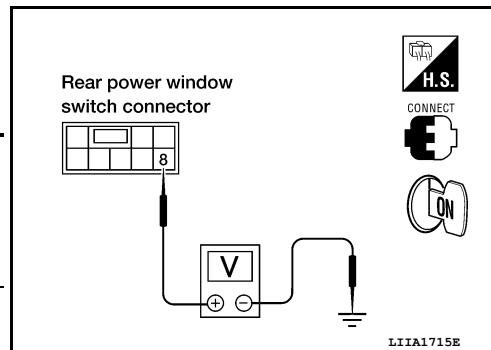

Is the measurement value within the specification?

- YES >> GO TO 2 (Rear power window switch LH)
- YES >> GO TO 3 (Rear power window switch RH)
- NO >> GO TO 4

## 2. CHECK HARNESS CONTINUITY (REAR POWER WINDOW SWITCH LH)

- Turn ignition switch OFF.
- Disconnect main power window and door lock/unlock switch and rear power window switch LH.
- Check continuity between main power window and door lock/unlock switch connector (A) and rear power window switch LH connector (B).

Main power window and door lock/unlock switch connector	Terminal	Rear power window switch LH connector	Terminal	Continuity
D7 (A)	15	D203 (B)	4	Yes
	16		5	

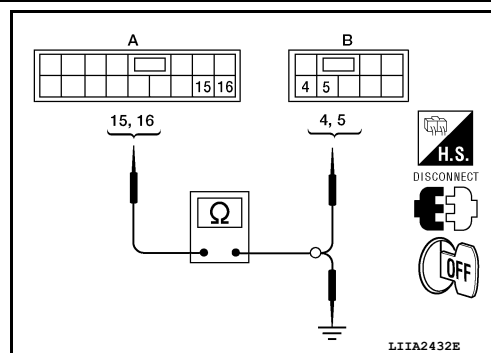

- Check continuity between main power window and door lock/unlock switch connector (A) and ground.

Main power window and door lock/unlock switch connector	Terminal	Ground	Continuity
D7 (A)	15	Ground	No
	16		

Is the inspection result normal?

- YES >> GO TO 5
- NO >> Repair or replace harness.

## 3. CHECK HARNESS CONTINUITY (REAR POWER WINDOW SWITCH RH)

- Turn ignition switch OFF.
- Disconnect main power window and door lock/unlock switch and rear power window switch RH.
- Check continuity between main power window and door lock/unlock switch connector (A) and rear power window switch RH connector (B).

Main power window and door lock/unlock switch connector	Terminal	Rear power window switch RH connector	Terminal	Continuity
D7 (A)	8	D303 (B)	4	Yes
	9		5	

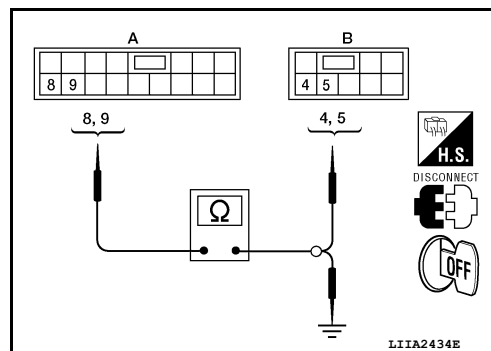

A  
B  
C  
D  
E  
F  
G  
H  
I  
J

PWC

L  
M  
N  
O  
P

# POWER SUPPLY AND GROUND CIRCUIT

## < DTC/CIRCUIT DIAGNOSIS >

4. Check continuity between main power window and door lock/unlock switch connector (A) and ground.

Main power window and door lock/unlock switch connector	Terminal	Ground	Continuity
D7 (A)	8		
	9		

Is the inspection result normal?

YES >> GO TO 5

NO >> Repair or replace harness.

### 4. CHECK HARNESS CONTINUITY

1. Disconnect BCM and rear power window switch.
2. Check continuity between BCM connector (A) and rear power window switch connector (B).

BCM connector	Terminal	Rear power window switch connector		Terminal	Continuity
M20 (A)	68	LH	D203 (B)	8	Yes
		RH	D303 (B)		

3. Check continuity between BCM connector (A) and ground.

BCM connector	Terminal	Ground	Continuity
M20 (A)	68		

Is the inspection result normal?

YES >> Replace BCM. Refer to [BCS-49. "Removal and Installation"](#).

NO >> Repair or replace harness.

### 5. CHECK REAR POWER WINDOW SWITCH

Check rear power window switch.

Refer to [PWC-22. "REAR POWER WINDOW SWITCH : Component Inspection"](#).

Is the inspection result normal?

YES >> Check intermittent incident. Refer to [GI-49. "Intermittent Incident"](#).

NO >> Replace rear power window switch. Refer to [PWC-75. "Removal and Installation - Rear Door Switch \(If Equipped\)"](#).

## REAR POWER WINDOW SWITCH : Component Inspection

INFOID:000000008789386

### COMPONENT INSPECTION

#### 1. CHECK REAR POWER WINDOW SWITCH

Check rear power window switch.

	Terminals		Condition	Continuity
	Rear power window switch LH or RH	6	5	DOWN
NEUTRAL or UP				Yes
8			NEUTRAL or UP	No
			DOWN	Yes
7		4	UP	No
			NEUTRAL or DOWN	Yes
		8	NEUTRAL or DOWN	No
8		2	UP	Yes
	-		Yes	

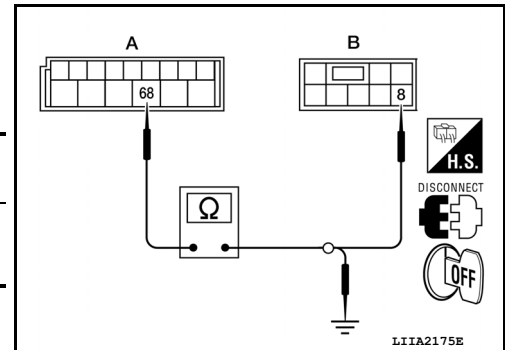

## POWER SUPPLY AND GROUND CIRCUIT

### < DTC/CIRCUIT DIAGNOSIS >

---

#### Is the inspection result normal?

YES >> Rear power window switch is OK.

NO >> Replace rear power window switch. Refer to [PWC-75. "Removal and Installation - Rear Door Switch \(If Equipped\)".](#)

A

B

C

D

E

F

G

H

I

J

PWC

L

M

N

O

P

# POWER WINDOW MOTOR

< DTC/CIRCUIT DIAGNOSIS >

## POWER WINDOW MOTOR DRIVER SIDE

### DRIVER SIDE : Description

INFOID:000000008789387

Door glass moves UP/DOWN by receiving the signal from main power window and door lock/unlock switch.

### DRIVER SIDE : Component Function Check

INFOID:000000008789388

#### 1. CHECK POWER WINDOW MOTOR CIRCUIT

Check front power window motor LH operation when operating main power window and door lock/unlock switch.

Is the inspection result normal?

YES >> Front power window motor LH is OK.

NO >> Refer to [PWC-24, "DRIVER SIDE : Diagnosis Procedure"](#).

### DRIVER SIDE : Diagnosis Procedure

INFOID:000000008789389

Regarding Wiring Diagram information, refer to [PWC-49, "Wiring Diagram - King Cab"](#), [PWC-56, "Wiring Diagram - Crew Cab"](#).

#### 1. CHECK MAIN POWER WINDOW AND DOOR LOCK/UNLOCK SWITCH OUTPUT SIGNAL

1. Disconnect front power window motor LH.
2. Turn ignition switch ON.
3. Check voltage between front power window motor LH connector and ground.

Terminal (+)		Terminal (-)	Main power window and door lock/unlock switch condition	Voltage (V) (Approx.)
Power window motor LH connector	Terminal			
D9	2	Ground	UP	Battery voltage
			DOWN	0
	1		UP	0
			DOWN	Battery voltage

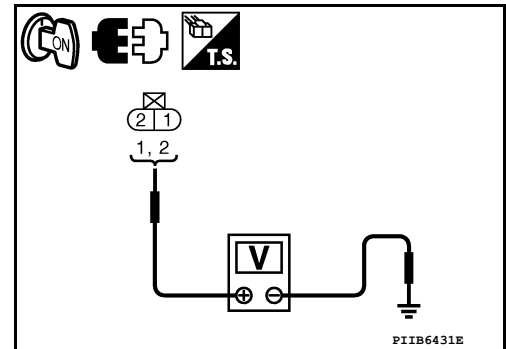

Is the measurement value within the specification?

YES >> GO TO 3

NO >> GO TO 2

#### 2. CHECK HARNESS CONTINUITY

1. Turn ignition switch OFF.
2. Disconnect main power window and door lock/unlock switch.
3. Check continuity between main power window and door lock/unlock switch connector D7 and front power window motor LH connector D9.

Main power window and door lock/unlock switch connector	Terminal	Front power window motor LH connector	Terminal	Continuity
D7	6	D9	2	Yes
	7		1	

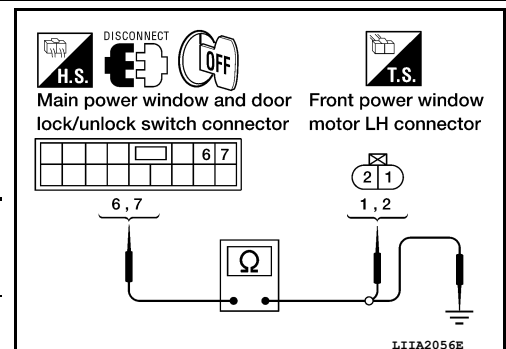



# POWER WINDOW MOTOR

## < DTC/CIRCUIT DIAGNOSIS >

4. Check continuity between main power window and door lock/unlock switch connector D7 and ground.

Main power window and door lock/unlock switch connector	Terminal		Continuity
		Ground	
D7	6	Ground	No
	7		

Is the inspection result normal?

YES >> Replace main power window and door lock/unlock switch. Refer to [PWC-73, "Removal and Installation"](#).

NO >> Repair or replace harness.

### 3. CHECK POWER WINDOW MOTOR

Check front power window motor LH.

Refer to [PWC-25, "DRIVER SIDE : Component Inspection"](#).

Is the inspection result normal?

YES >> Check intermittent incident. Refer to [GI-49, "Intermittent Incident"](#).

NO >> Replace power window motor LH. Refer to [GW-16, "Front Door Glass Regulator"](#).

### DRIVER SIDE : Component Inspection

INFOID:000000008789390

#### COMPONENT INSPECTION

##### 1. CHECK FRONT POWER WINDOW MOTOR LH

Check motor operation by connecting the battery voltage directly to power window motor.

Terminal		Motor condition
(+)	(-)	
1	2	DOWN
2	1	UP

Is the inspection result normal?

YES >> Front power window motor LH is OK.

NO >> Replace front power window motor LH. Refer to [GW-16, "Front Door Glass Regulator"](#).

### PASSENGER SIDE

#### PASSENGER SIDE : Description

INFOID:000000008789391

Door glass moves UP/DOWN by receiving the signal from main power window and door lock/unlock switch or power window and door lock/unlock switch RH.

#### PASSENGER SIDE : Component Function Check

INFOID:000000008789392

##### 1. CHECK POWER WINDOW MOTOR CIRCUIT

Check power window motor operation when operating main power window and door lock/unlock switch or power window and door lock/unlock switch RH.

Is the inspection result normal?

YES >> Front power window motor RH is OK.

NO >> Refer to [PWC-25, "PASSENGER SIDE : Diagnosis Procedure"](#).

#### PASSENGER SIDE : Diagnosis Procedure

INFOID:000000008789393

Regarding Wiring Diagram information, refer to [PWC-49, "Wiring Diagram - King Cab"](#), [PWC-56, "Wiring Diagram - Crew Cab"](#).

A  
B  
C  
D  
E  
F  
G  
H  
I  
J  
L  
M  
N  
O  
P

PWC

# POWER WINDOW MOTOR

## < DTC/CIRCUIT DIAGNOSIS >

### 1. CHECK FRONT POWER WINDOW SWITCH RH OUTPUT SIGNAL

1. Disconnect front power window motor RH.
2. Turn ignition switch ON.
3. Check voltage between front power window motor RH connector and ground.

Terminal (+)		Terminal (-)	Front power window motor RH condition	Voltage (V) (Approx.)
Front power window motor RH connector	Terminal			
D104	2	Ground	UP	Battery voltage
			DOWN	0
	1		UP	0
			DOWN	Battery voltage

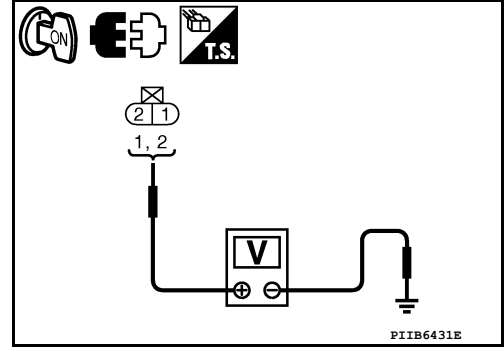

Is the measurement value within the specification?

- YES >> GO TO 3  
 NO >> GO TO 2

### 2. CHECK HARNESS CONTINUITY

1. Turn ignition switch OFF.
2. Disconnect power window and door lock/unlock switch RH.
3. Check continuity between power window and door lock/unlock switch RH connector and front power window motor RH connector.

Power window and door lock/unlock switch RH connector	Terminal	Front power window motor RH connector	Terminal	Continuity
D105	6	D104	1	Yes
	7		2	

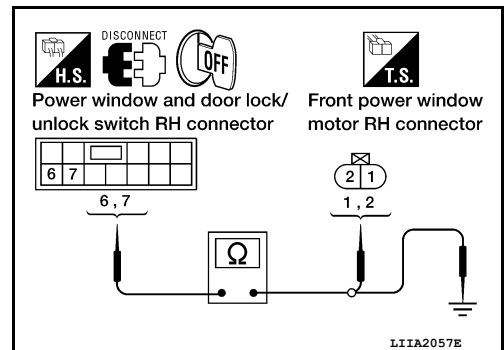

4. Check continuity between power window and door lock/unlock switch RH connector and ground.

Power window and door lock/unlock switch RH connector	Terminal	Ground	Continuity
D105	6	Ground	No
	7		

Is the inspection result normal?

- YES >> Replace power window and door lock/unlock switch RH. Refer to [PWC-74, "Removal and Installation"](#).  
 NO >> Repair or replace harness.

### 3. CHECK FRONT POWER WINDOW MOTOR RH

Check front power window motor RH.  
 Refer to [PWC-26, "PASSENGER SIDE : Component Inspection"](#).

Is the inspection result normal?

- YES >> Check intermittent incident. Refer to [GI-49, "Intermittent Incident"](#).  
 NO >> Replace front power window motor RH. Refer to [GW-16, "Front Door Glass Regulator"](#).

## PASSENGER SIDE : Component Inspection

INFOID:000000008789394

## COMPONENT INSPECTION

# POWER WINDOW MOTOR

## < DTC/CIRCUIT DIAGNOSIS >

### 1. CHECK FRONT POWER WINDOW MOTOR RH

Check motor operation by connecting the battery voltage directly to front power window motor RH.

Terminal		Motor condition
(+)	(-)	
1	2	DOWN
2	1	UP

Is the inspection result normal?

YES >> Front power window motor RH is OK.

NO >> Replace front power window motor RH. Refer to [GW-16, "Front Door Glass Regulator"](#).

### REAR LH

#### REAR LH : Description

INFOID:000000008789395

Door glass moves UP/DOWN by receiving the signal from power window main switch or rear power window switch LH.

#### REAR LH : Component Function Check

INFOID:000000008789396

### 1. CHECK REAR POWER WINDOW MOTOR LH CIRCUIT

Check rear power window motor LH operation with main power window and door lock/unlock switch or rear power window switch LH.

Is the inspection result normal?

YES >> Rear power window motor LH is OK.

NO >> Refer to [PWC-27, "REAR LH : Diagnosis Procedure"](#).

#### REAR LH : Diagnosis Procedure

INFOID:000000008789397

Regarding Wiring Diagram information, refer to [PWC-56, "Wiring Diagram - Crew Cab"](#).

### 1. CHECK REAR POWER WINDOW SWITCH OUTPUT SIGNAL

1. Disconnect rear power window motor LH.
2. Turn ignition switch ON.
3. Check voltage between rear power window motor LH connector and ground.

Terminal		Window condition	Voltage (V) (Approx.)
(+)	(-)		
Rear power window motor LH connector D204	2	UP	Battery voltage
		DOWN	0
	1	UP	0
		DOWN	Battery voltage

Is the measurement value within the specification?

YES >> GO TO 3

NO >> GO TO 2

### 2. CHECK HARNESS CONTINUITY

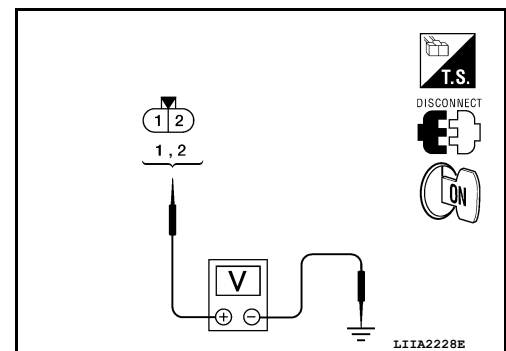

# POWER WINDOW MOTOR

## < DTC/CIRCUIT DIAGNOSIS >

1. Turn ignition switch OFF.
2. Disconnect rear power window switch LH.
3. Check continuity between rear power window switch LH connector (A) and rear power window motor LH connector (B).

Rear power window switch LH connector	Terminal	Rear power window motor LH connector	Terminal	Continuity
D203 (A)	6	D204 (B)	1	Yes
	7		2	

4. Check continuity between rear power window switch LH connector (A) and ground.

Rear power window switch LH connector	Terminal	Ground	Continuity
D203 (A)	6	Ground	No
	7		

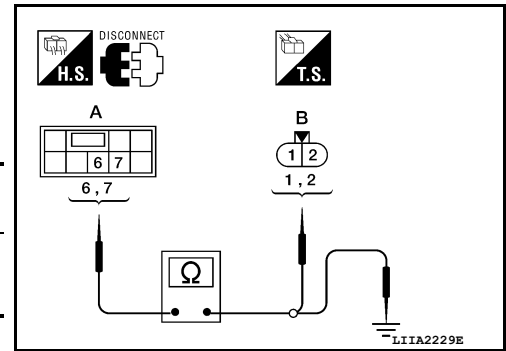

### Is the inspection result normal?

- YES >> Check rear power window switch LH. Refer to [PWC-20. "REAR POWER WINDOW SWITCH : Component Function Check"](#).
- NO >> Repair or replace harness.

## 3. CHECK REAR POWER WINDOW MOTOR LH

Check rear power window motor LH.

Refer to [PWC-28. "REAR LH : Component Inspection"](#).

### Is the inspection result normal?

- YES >> Check intermittent incident. Refer to [GI-49. "Intermittent Incident"](#).
- NO >> Replace rear power window motor LH. Refer to [GW-20. "Rear Door Glass Regulator"](#).

## REAR LH : Component Inspection

INFOID:000000008789398

### COMPONENT INSPECTION

## 1. CHECK REAR POWER WINDOW MOTOR LH

Check motor operation by connecting the battery voltage directly to rear power window motor LH.

Terminal		Motor condition
(+)	(-)	
2	1	UP
1	2	DOWN

### Is the inspection result normal?

- YES >> Rear power window motor LH is OK.
- NO >> Replace rear power window motor LH. Refer to [GW-20. "Rear Door Glass Regulator"](#).

## REAR RH

### REAR RH : Description

INFOID:000000008789399

Door glass moves UP/DOWN by receiving the signal from main power window and door lock/unlock switch or rear power window switch RH.

### REAR RH : Component Function Check

INFOID:000000008789400

## 1. CHECK REAR POWER WINDOW MOTOR RH CIRCUIT

Check rear power window motor RH operation with operating main power window and door lock/unlock switch or rear power window switch RH.

# POWER WINDOW MOTOR

## < DTC/CIRCUIT DIAGNOSIS >

### Is the inspection result normal?

- YES >> Rear power window motor RH is OK.
- NO >> Refer to [PWC-29. "REAR RH : Diagnosis Procedure"](#).

### REAR RH : Diagnosis Procedure

INFOID:000000008789401

Regarding Wiring Diagram information, refer to [PWC-56. "Wiring Diagram - Crew Cab"](#).

## 1. CHECK REAR POWER WINDOW SWITCH RH OUTPUT SIGNAL

1. Disconnect rear power window motor RH.
2. Turn ignition switch ON.
3. Check voltage between rear power window motor RH connector and ground.

Terminal (+)		Terminal (-)	Rear power window switch RH condition	Voltage (V) (Approx.)
Rear power window motor RH connector	Terminal			
D304	2	Ground	UP	Battery voltage
			DOWN	0
	1		UP	0
			DOWN	Battery voltage

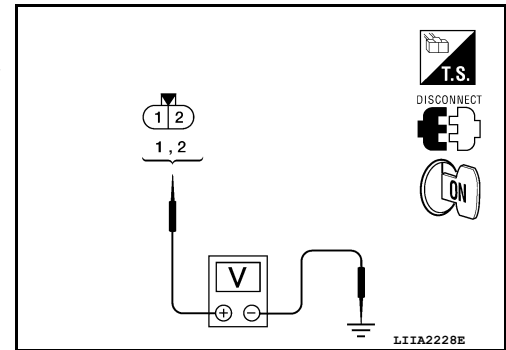

### Is the measurement value within the specification?

- YES >> GO TO 3
- NO >> GO TO 2

## 2. CHECK HARNESS CONTINUITY

1. Turn ignition switch OFF.
2. Disconnect rear power window switch RH.
3. Check continuity between rear power window switch RH connector (A) and rear power window motor RH connector (B).

Rear power window switch RH connector	Terminal	Rear power window motor RH connector	Terminal	Continuity
D303 (A)	6	D304 (B)	1	Yes
	7		2	

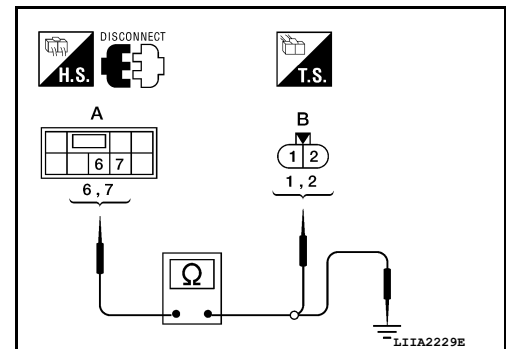

4. Check continuity between rear power window switch RH connector (A) and ground.

Rear power window switch RH connector	Terminal	Ground	Continuity
D303 (A)	6		Ground
	7		

### Is the inspection result normal?

- YES >> Check rear power window switch RH. Refer to [PWC-20. "REAR POWER WINDOW SWITCH : Component Function Check"](#).
- NO >> Repair or replace harness.

## 3. CHECK REAR POWER WINDOW MOTOR RH

Check rear power window motor RH.  
Refer to [PWC-30. "REAR RH : Component Inspection"](#).

# POWER WINDOW MOTOR

## < DTC/CIRCUIT DIAGNOSIS >

---

### Is the inspection result normal?

YES >> Check intermittent incident. Refer to [GI-49, "Intermittent Incident"](#).

NO >> Replace rear power window motor RH. Refer to [GW-20, "Rear Door Glass Regulator"](#).

## REAR RH : Component Inspection

INFOID:000000008789402

### COMPONENT INSPECTION

#### 1. CHECK REAR POWER WINDOW MOTOR RH

---

Check motor operation by connecting the battery voltage directly to rear power window motor RH.

Terminal		Motor condition
(+)	(-)	
2	1	UP
1	2	DOWN

### Is the inspection result normal?

YES >> Rear power window motor RH is OK.

NO >> Replace rear power window motor RH. Refer to [GW-20, "Rear Door Glass Regulator"](#).

# DOOR SWITCH

< DTC/CIRCUIT DIAGNOSIS >

## DOOR SWITCH

### KING CAB

#### KING CAB : Description

INFOID:000000009233146

Detects door open/close condition.

#### KING CAB : Component Function Check

INFOID:000000009233147

### 1.CHECK FUNCTION

#### With CONSULT

Check door switches in Data Monitor mode with CONSULT.

Monitor item	Condition
DOOR SW-DR	CLOSE → OPEN: OFF → ON
DOOR SW-AS	

Is the inspection result normal?

YES >> Door switch is OK.

NO >> Refer to [PWC-31, "KING CAB : Diagnosis Procedure"](#).

#### KING CAB : Diagnosis Procedure

INFOID:000000009233148

Regarding Wiring Diagram information, refer to [DLK-77, "Wiring Diagram - King Cab"](#).

### 1.CHECK DOOR SWITCHES INPUT SIGNAL

#### With CONSULT

Check door switches ("DOOR SW-DR", "DOOR SW-AS") in DATA MONITOR mode with CONSULT. Refer to [BCS-15, "DOOR LOCK : CONSULT Function \(BCM - DOOR LOCK\)"](#).

• When any doors are open:

**DOOR SW-DR :ON**

**DOOR SW-AS :ON**

• When any doors are closed:

**DOOR SW-DR :OFF**

**DOOR SW-AS :OFF**

#### Without CONSULT

Check voltage between BCM connector M18 or M19 terminals 12, 47 and ground.

Connector	Item	Terminals		Condition	Voltage (V) (Approx.)
		(+)	(-)		
M19	Door switches LH	47	Ground	Open	0
M18	Door switches RH	12		Closed	Battery voltage

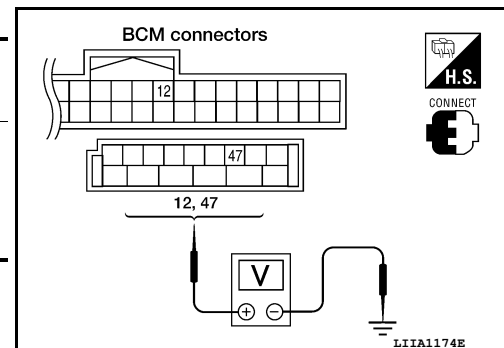

Is the inspection result normal?

YES >> Door switch circuit is OK.

NO >> GO TO 2

### 2.CHECK BCM OUTPUT VOLTAGE

A  
B  
C  
D  
E  
F  
G  
H  
I  
J  
L  
M  
N  
O  
P

PWC

# DOOR SWITCH

## < DTC/CIRCUIT DIAGNOSIS >

1. Turn ignition switch OFF.
2. Disconnect door switches.
3. Check voltage between BCM connector M18, M19 terminals 12, 47 and ground.

**12 - Ground : Battery voltage**  
**47 - Ground : Battery voltage**

Is the inspection result normal?

- YES >> GO TO 3  
 NO >> Replace BCM. Refer to [BCS-49, "Removal and Installation"](#).

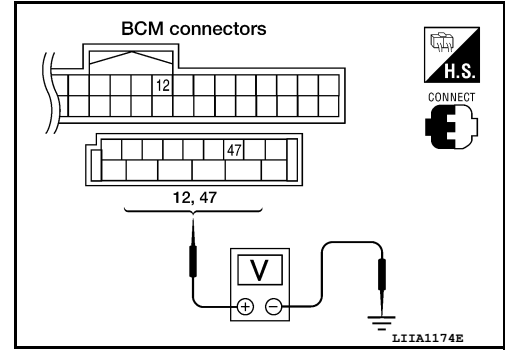

## 3. CHECK DOOR SWITCH CIRCUIT

1. Disconnect BCM.
2. Check continuity between door switch connector D213 (Front LH), D314 (Front RH) terminal 2, D211 (Rear upper LH), D312 (Rear upper RH), D212 (Rear lower LH), D313 (Rear lower RH) terminal 1 and BCM connector M18, M19 terminals 12, and 47.

**2 - 47 : Continuity should exist**  
**2 - 12 : Continuity should exist**  
**1 - 47 : Continuity should exist**  
**1 - 12 : Continuity should exist**

3. Check continuity between door switch connector D213 (Front LH), D314 (Front RH) terminal 2, D211 (Rear upper LH), D312 (Rear upper RH), D212 (Rear lower LH), D313 (Rear lower RH) terminal 1 and ground.

**2 - Ground : Continuity should not exist**  
**1 - Ground : Continuity should not exist**

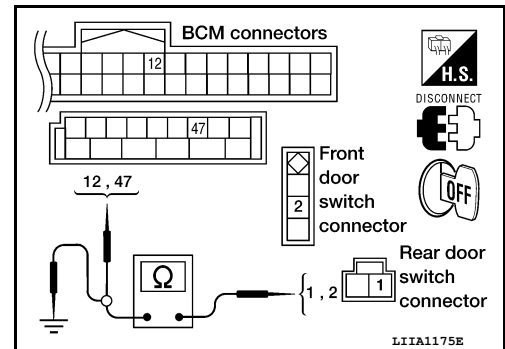

Is the inspection result normal?

- YES >> GO TO 4  
 NO >> Repair or replace harness.

## 4. CHECK DOOR SWITCHES GROUND CIRCUIT

Check continuity between door switch connector D213 (Front LH), D314 (Front RH) terminal 3, D211 (Rear upper LH), D312 (Rear upper RH), D212 (Rear lower LH), D313 (Rear lower RH) terminal 2 and ground.

**3 - Ground : Continuity should exist**  
**2 - Ground : Continuity should exist**

Is the inspection result normal?

- YES >> GO TO 5  
 NO >> Repair or replace harness.

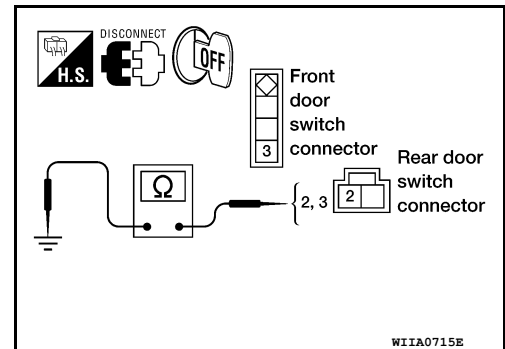

## 5. CHECK DOOR SWITCHES

Check continuity between door switch terminals.



# DOOR SWITCH

## < DTC/CIRCUIT DIAGNOSIS >

Item	Terminal	Condition	Continuity
Door switches (front)	2 - 3	Open	Yes
		Closed	No
Door switches (rear upper and lower)	1 - 2	Open	Yes
		Closed	No

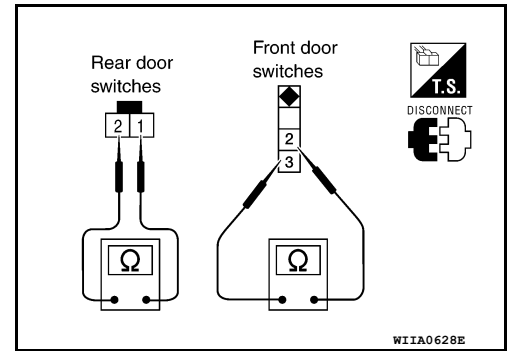

### Is the inspection result normal?

- YES >> Check condition of harness and connector.
- NO >> Replace door switch.

## CREW CAB

### CREW CAB : Description

INFOID:000000009233149

Detects door open/close condition.

### CREW CAB : Component Function Check

INFOID:000000009233150

## 1. CHECK FUNCTION

### With CONSULT

Check door switches in Data Monitor mode with CONSULT.

Monitor item	Condition
DOOR SW-DR	CLOSE → OPEN: OFF → ON
DOOR SW-AS	
DOOR SW-RL	
DOOR SW-RR	

### Is the inspection result normal?

- YES >> Door switch is OK.
- NO >> Refer to [PWC-33. "CREW CAB : Diagnosis Procedure"](#).

## CREW CAB : Diagnosis Procedure

INFOID:000000009233151

PWC

Regarding Wiring Diagram information, refer to [DLK-87. "Wiring Diagram - Crew Cab"](#).

## 1. CHECK DOOR SWITCHES INPUT SIGNAL

### With CONSULT

Check door switches ("DOOR SW-DR", "DOOR SW-AS", "DOOR SW-RL", "DOOR SW-RR") in DATA MONITOR mode with CONSULT. Refer to [BCS-15. "DOOR LOCK : CONSULT Function \(BCM - DOOR LOCK\)"](#).

• When any doors are open:

**DOOR SW-DR : ON**  
**DOOR SW-AS : ON**  
**DOOR SW-RL : ON**  
**DOOR SW-RR : ON**

• When any doors are closed:

**DOOR SW-DR : OFF**  
**DOOR SW-AS : OFF**  
**DOOR SW-RL : OFF**  
**DOOR SW-RR : OFF**

# DOOR SWITCH

## < DTC/CIRCUIT DIAGNOSIS >

Without CONSULT

Check voltage between BCM connector M18 or M19 terminals 12, 13, 47, 48 and ground.

Connector	Item	Terminals		Condition	Voltage (V) (Approx.)
		(+)	(-)		
M19	Front door switch LH	47	Ground	Open ↓ Closed	0 ↓ Battery voltage
	Rear door switch LH	48			
M18	Front door switch RH	12			
	Rear door switch RH	13			

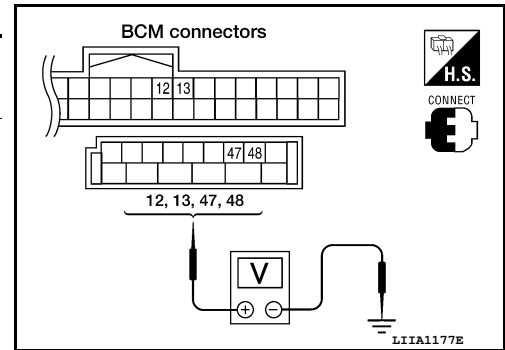

Is the inspection result normal?

- YES >> Door switch circuit is OK.  
NO >> GO TO 2

## 2. CHECK BCM OUTPUT VOLTAGE

- Turn ignition switch OFF.
- Disconnect door switches.
- Check voltage between BCM connector M18, M19 terminals 12, 13, 47, 48 and ground.

- 12 - Ground : Battery voltage**  
**13 - Ground : Battery voltage**  
**47 - Ground : Battery voltage**  
**48 - Ground : Battery voltage**

Is the inspection result normal?

- YES >> GO TO 3  
NO >> Replace BCM. Refer to [BCS-49, "Removal and Installation"](#).

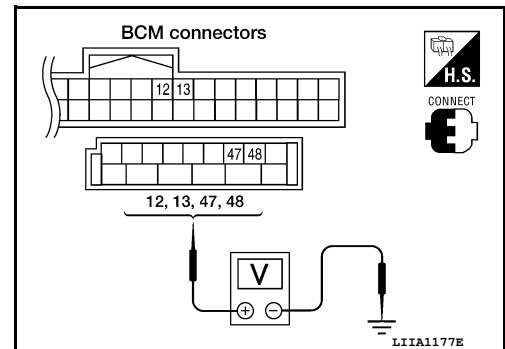

## 3. CHECK DOOR SWITCH CIRCUIT

- Disconnect door switch and BCM.
- Check continuity between door switch connector B8 (Front LH), B108 (Front RH), B18 (Rear LH), B116 (Rear RH) terminal 2 and BCM connector M18, M19 terminals 12, 13, 47 and 48.

- 2 - 47 : Continuity should exist.**  
**2 - 12 : Continuity should exist.**  
**2 - 48 : Continuity should exist.**  
**2 - 13 : Continuity should exist.**

- Check continuity between door switch connector B8 (Front LH), B108 (Front RH), B18 (Rear LH), B116 (Rear RH) terminal 2 and ground.

- 2 - Ground : Continuity should not exist.**

Is the inspection result normal?

- YES >> GO TO 4  
NO >> Repair or replace harness.

## 4. CHECK DOOR SWITCHES

- Disconnect door switch.
- Check continuity between door switch terminals.

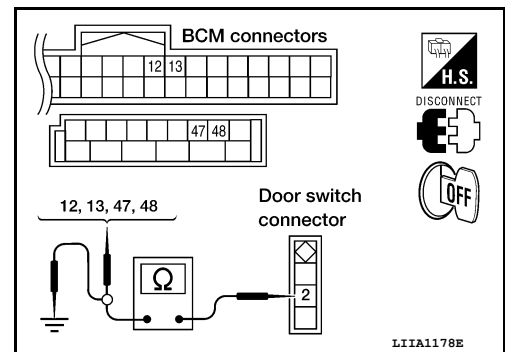

# DOOR SWITCH

## < DTC/CIRCUIT DIAGNOSIS >

	Terminal	Condition	Continuity
Door switch	2 – Ground	Open	Yes
		Closed	No

Is the inspection result normal?

YES >> Check switch case ground condition.

NO >> Replace door switch.

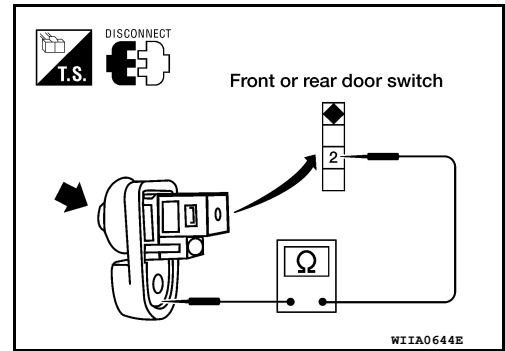

A  
B  
C  
D  
E  
F  
G  
H  
I  
J  
L  
M  
N  
O  
P

PWC

# POWER WINDOW LOCK SWITCH

< DTC/CIRCUIT DIAGNOSIS >

---

## POWER WINDOW LOCK SWITCH

### Description

INFOID:000000008789409

Ground circuit of main power window and door lock/unlock switch shuts off if power window lock switch of main power window and door lock/unlock switch is operated. This inhibits all operation, except for the main switch.

### Component Function Check

INFOID:000000008789410

#### 1. CHECK POWER WINDOW LOCK SIGNAL

---

Exchanges for a normal main power window and door lock/unlock switch, and operation is checked.

Does power window lock operate?

- YES >> Replace main power window and door lock/unlock switch. Refer to [PWC-73. "Removal and Installation"](#).
- NO >> Check condition of harness and connector.

# POWER WINDOW SYSTEM

< ECU DIAGNOSIS INFORMATION >

## ECU DIAGNOSIS INFORMATION

### POWER WINDOW SYSTEM

#### Terminal Layout for Power Window Main Switch

INFOID:000000008789411

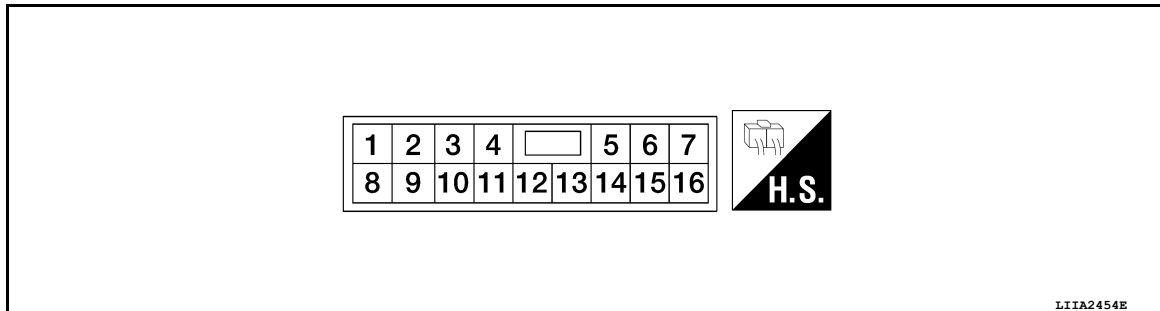

#### Physical Values for Power Window Main Switch

INFOID:000000008789412

Terminal	Wire Color	Item	Condition	Voltage (V) (Approx.)
2	G/Y	Front power window motor RH DOWN signal	When power window motor is operated DOWN	Battery voltage
3	L/W	Front power window motor RH UP signal	When power window motor is operated UP	Battery voltage
5	W/R	RAP signal	When ignition switch ON	Battery voltage
			Within 45 seconds after ignition switch is turned to OFF	Battery voltage
			More than 45 seconds after ignition switch is turned to OFF	0
			When front door LH or RH open or power window timer operates	0
6	G/R	Front power window motor LH UP signal	When power window motor is operated UP	Battery voltage
7	G/W	Front power window motor LH DOWN signal	When power window motor is operated DOWN	Battery voltage
8*	G/B	Rear power window RH UP signal	When rear RH switch in main power window and door lock/unlock switch is operated UP	Battery voltage
9*	R	Rear power window RH DOWN signal	When rear RH switch in main power window and door lock/unlock switch is operated DOWN	Battery voltage
14	B	Ground	—	0
15*	R/B	Rear power window LH UP signal	When rear LH switch in main power window and door lock/unlock switch is operated UP	Battery voltage
16*	R/Y	Rear power window LH DOWN signal	When rear LH switch in main power window and door lock/unlock switch is operated DOWN	Battery voltage

\*: Crew cab

# BCM (BODY CONTROL MODULE)

< ECU DIAGNOSIS INFORMATION >

## BCM (BODY CONTROL MODULE)

### Reference Value

INFOID:000000009233092

**NOTE:**

The Signal Tech II Tool (J-50190) can be used to perform the following functions. Refer to the Signal Tech II User Guide for additional information.

- Activate and display TPMS transmitter IDs
- Display tire pressure reported by the TPMS transmitter
- Read TPMS DTCs
- Register TPMS transmitter IDs
- Test remote keyless entry keyfob relative signal strength

### VALUES ON THE DIAGNOSIS TOOL

Monitor Item	Condition	Value/Status
ACC ON SW	Ignition switch OFF or ON	Off
	Ignition switch ACC	On
AIR COND SW	A/C switch OFF	Off
	A/C switch ON	On
AIR PRESS FL	Front left tire air pressure value	kPa, kg/cm <sup>2</sup> , psi
AIR PRESS FR	Front right tire air pressure value	kPa, kg/cm <sup>2</sup> , psi
AIR PRESS RL	Rear left tire air pressure value	kPa, kg/cm <sup>2</sup> , psi
AIR PRESS RR	Rear right tire air pressure value	kPa, kg/cm <sup>2</sup> , psi
BRAKE SW	Brake pedal released	Off
	Brake pedal applied	On
BUCKLE SW	Seat belt buckle unfastened	Off
	Seat belt buckle fastened	On
BUZZER	Buzzer in combination meter OFF	Off
	Buzzer in combination meter ON	On
CARGO LAMP SW	Cargo lamp switch OFF	Off
	Cargo lamp switch ON	On
CDL LOCK SW	Door lock/unlock switch does not operate	Off
	Press door lock/unlock switch to the LOCK side	On
CDL UNLOCK SW	Door lock/unlock switch does not operate	Off
	Press door lock/unlock switch to the UNLOCK side	On
DOOR SW-AS	Front door RH closed	Off
	Front door RH opened	On
DOOR SW-DR	Front door LH closed	Off
	Front door LH opened	On
DOOR SW-RL	Rear door LH closed	Off
	Rear door LH opened	On
DOOR SW-RR	Rear door RH closed	Off
	Rear door RH opened	On
FAN ON SIG	Blower motor fan switch OFF	Off
	Blower motor fan switch ON	On
FR FOG SW	Front fog lamp switch OFF	Off
	Front fog lamp switch ON	On

## BCM (BODY CONTROL MODULE)

### < ECU DIAGNOSIS INFORMATION >

Monitor Item	Condition	Value/Status	
FR WASHER SW	Front washer switch OFF	Off	A
	Front washer switch ON	On	
FR WIPER LOW	Front wiper switch OFF	Off	B
	Front wiper switch LO	On	
FR WIPER HI	Front wiper switch OFF	Off	C
	Front wiper switch HI	On	
FR WIPER INT	Front wiper switch OFF	Off	D
	Front wiper switch INT	On	
FR WIPER STOP	Any position other than front wiper stop position	Off	E
	Front wiper stop position	On	
HAZARD SW	When hazard switch is not pressed	Off	F
	When hazard switch is pressed	On	
HEAD LAMP SW 1	Headlamp switch OFF	Off	G
	Headlamp switch 1st	On	
HEAD LAMP SW 2	Headlamp switch OFF	Off	H
	Headlamp switch 1st	On	
HI BEAM SW	High beam switch OFF	Off	I
	High beam switch HI	On	
ID REGST FL1	ID registration of front left tire incomplete	YET	J
	ID registration of front left tire complete	DONE	
ID REGST FR1	ID registration of front right tire incomplete	YET	
	ID registration of front right tire complete	DONE	
ID REGST RL1	ID registration of rear left tire incomplete	YET	
	ID registration of rear left tire complete	DONE	
ID REGST RR1	ID registration of rear right tire incomplete	YET	
	ID registration of rear right tire complete	DONE	PWC
IGN ON SW	Ignition switch OFF or ACC	Off	
	Ignition switch ON	On	
IGN SW CAN	Ignition switch OFF or ACC	Off	L
	Ignition switch ON	On	
INT VOLUME	Wiper intermittent dial is in a dial position 1 - 7	1 - 7	M
KEY CYL LK-SW	Door key cylinder LOCK position	Off	
	Door key cylinder other than LOCK position	On	
KEY CYL UN-SW	Door key cylinder UNLOCK position	Off	N
	Door key cylinder other than UNLOCK position	On	
KEY ON SW	Mechanical key is removed from key cylinder	Off	O
	Mechanical key is inserted to key cylinder	On	
KEYLESS LOCK	LOCK button of key fob is not pressed	Off	
	LOCK button of key fob is pressed	On	P
KEYLESS PANIC	PANIC button of key fob is not pressed	Off	
	PANIC button of key fob is pressed	On	
KEYLESS UNLOCK	UNLOCK button of key fob is not pressed	Off	
	UNLOCK button of key fob is pressed	On	

## BCM (BODY CONTROL MODULE)

### < ECU DIAGNOSIS INFORMATION >

Monitor Item	Condition	Value/Status
LIGHT SW 1ST	Lighting switch OFF	Off
	Lighting switch 1st	On
OIL PRESS SW	<ul style="list-style-type: none"><li>Ignition switch OFF or ACC</li><li>Engine running</li></ul>	Off
	Ignition switch ON	On
PASSING SW	Other than lighting switch PASS	Off
	Lighting switch PASS	On
REAR DEF SW	Rear window defogger switch OFF	Off
	Rear window defogger switch ON	On
TURN SIGNAL L	Turn signal switch OFF	Off
	Turn signal switch LH	On
TURN SIGNAL R	Turn signal switch OFF	Off
	Turn signal switch RH	On
VEHICLE SPEED	While driving	Equivalent to speedometer reading
WARNING LAMP	Low tire pressure warning lamp in combination meter OFF	Off
	Low tire pressure warning lamp in combination meter ON	On



# BCM (BODY CONTROL MODULE)

< ECU DIAGNOSIS INFORMATION >

## Terminal Layout

INFOID:000000009233093

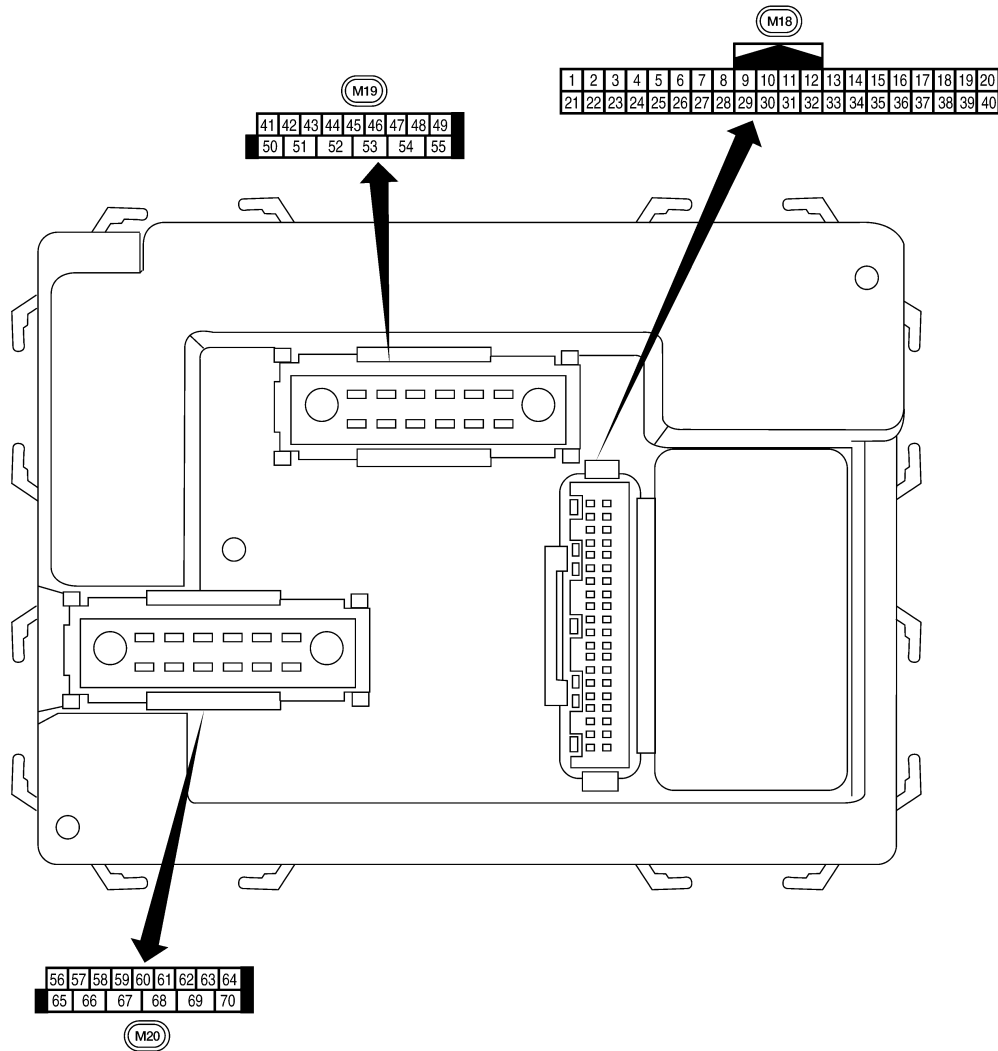

A  
B  
C  
D  
E  
F  
G  
H  
I  
J  
L  
M  
N  
O  
P

PWC



## Physical Values

LIIA2443E

INFOID:000000009233094

# BCM (BODY CONTROL MODULE)

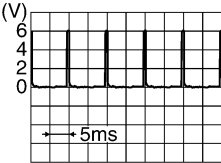
## < ECU DIAGNOSIS INFORMATION >

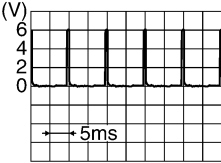
Terminal	Wire color	Item	Signal input/output	Measuring condition		Reference value or waveform (Approx.)
				Ignition switch	Operation or condition	
1	BR	Ignition keyhole illumination	Output	OFF	Door is locked (SW OFF)	Battery voltage
					Door is unlocked (SW ON)	0V
2	P	Combination switch input 5	Input	ON	Lighting, turn, wiper OFF Wiper dial position 4	 <p style="text-align: right; font-size: small;">SKIA5291E</p>
3	SB	Combination switch input 4	Input	ON	Lighting, turn, wiper OFF Wiper dial position 4	 <p style="text-align: right; font-size: small;">SKIA5292E</p>
4	V	Combination switch input 3	Input	ON	Lighting, turn, wiper OFF Wiper dial position 4	 <p style="text-align: right; font-size: small;">SKIA5291E</p>
5	L	Combination switch input 2	Input	ON	Lighting, turn, wiper OFF Wiper dial position 4	 <p style="text-align: right; font-size: small;">SKIA5292E</p>
6	R	Combination switch input 1				
7	GR	Front door lock assembly LH (key cylinder switch) unlock	Input	OFF	ON (open, 2nd turn)	Momentary 1.5V
8	SB	Front door lock assembly LH (key cylinder switch) lock			OFF (closed)	0V
			On (open)	Momentary 1.5V		
9	LG	Brake sw	Input	OFF	OFF (brake pedal is not depressed)	0V
					ON (brake pedal is depressed)	Battery voltage
11	G/B	Ignition switch (ACC or ON)	Input	ACC or ON	Ignition switch ACC or ON	Battery voltage
12	LG	Front door switch RH (All)	Input	OFF	ON (open)	0V
		Rear door switch upper RH (King Cab)			OFF (closed)	Battery voltage
		Rear door switch lower RH (King Cab)				

# BCM (BODY CONTROL MODULE)

## < ECU DIAGNOSIS INFORMATION >

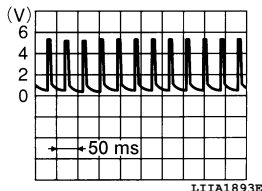
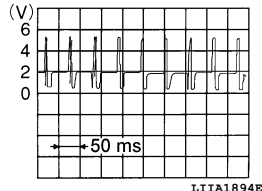
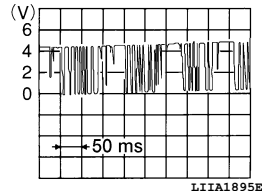
Terminal	Wire color	Item	Signal input/output	Measuring condition		Reference value or waveform (Approx.)
				Ignition switch	Operation or condition	
13	L	Rear door switch RH (Crew Cab)	Input	OFF	ON (open)	0V
					OFF (closed)	Battery voltage
15	W	Tire pressure warning check connector	Input	OFF	—	5V
18	BR	Remote keyless entry receiver (Ground)	Output	OFF	—	0V
19	V	Remote keyless entry receiver (power supply)	Output	OFF	Ignition switch OFF	
20	G	Remote keyless entry receiver signal (Signal)	Input	OFF	Stand-by (keyfob buttons released)	
					When remote keyless entry receiver receives signal from keyfob (keyfob buttons pressed)	
21	GR	NATS antenna amp.	Input	OFF → ON	Ignition switch (OFF → ON)	Just after turning ignition switch ON: Pointer of tester should move.
23	G	Security indicator lamp	Output	OFF	Goes OFF → illuminates (Every 2.4 seconds)	Battery voltage → 0V
25	BR	NATS antenna amp.	Input	OFF → ON	Ignition switch (OFF → ON)	Just after turning ignition switch ON: Pointer of tester should move.
27	W	Compressor ON signal	Input	ON	A/C switch OFF	5V
					A/C switch ON	0V
28	R	Front blower monitor	Input	ON	Front blower motor OFF	Battery voltage
					Front blower motor ON	0V
29	G	Hazard switch	Input	OFF	ON	0V
					OFF	5V
31	GR	Cargo lamp switch	Input	OFF	ON	0V
					OFF	Battery voltage

A  
B  
C  
D  
E  
F  
G  
H  
I  
J  
L  
M  
N  
O  
P

PWC

# BCM (BODY CONTROL MODULE)

## < ECU DIAGNOSIS INFORMATION >

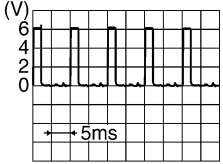
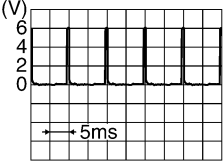
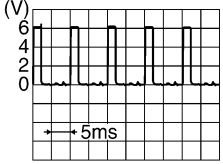
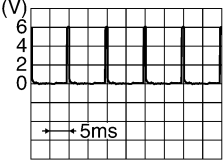
Terminal	Wire color	Item	Signal input/output	Measuring condition		Reference value or waveform (Approx.)
				Ignition switch	Operation or condition	
32	O	Combination switch output 5	Output	ON	Lighting, turn, wiper OFF Wiper dial position 4	 <p style="text-align: right; font-size: small;">SKIA5291E</p>
33	GR	Combination switch output 4	Output	ON	Lighting, turn, wiper OFF Wiper dial position 4	 <p style="text-align: right; font-size: small;">SKIA5292E</p>
34	G	Combination switch output 3	Output	ON	Lighting, turn, wiper OFF Wiper dial position 4	 <p style="text-align: right; font-size: small;">SKIA5291E</p>
35	BR	Combination switch output 2	Output	ON	Lighting, turn, wiper OFF Wiper dial position 4	 <p style="text-align: right; font-size: small;">SKIA5292E</p>
36	LG	Combination switch output 1				
37	B	Key switch	Input	OFF	Key inserted	Battery voltage
					Key removed	0V
38	W/R	Ignition switch (ON)	Input	ON	—	Battery voltage
39	L	CAN-H	—	—	—	—
40	P	CAN-L	—	—	—	—
41	Y	Rear window defogger switch	Input	ON	Rear window defogger switch ON	0V
					Rear window defogger switch OFF	5V
45	V	Lock switch	Input	OFF	ON (lock)	0V
					OFF	Battery voltage
46	LG	Unlock switch	Input	OFF	ON (unlock)	0V
					OFF	Battery voltage
47	GR	Front door switch LH (All)	Input	OFF	ON (open)	0V
		Rear door switch upper LH (King Cab)			OFF (closed)	Battery voltage
		Rear door switch lower LH (King Cab)				

# BCM (BODY CONTROL MODULE)

## < ECU DIAGNOSIS INFORMATION >

Terminal	Wire color	Item	Signal input/output	Measuring condition		Reference value or waveform (Approx.)	
				Ignition switch	Operation or condition		
48	P	Rear door switch LH (Crew Cab)	Input	OFF	ON (open)	0V	
					OFF (closed)	Battery voltage	
50	P	Cargo lamp	Output	OFF	Any door open (ON)	0V	
					All doors closed (OFF)	Battery voltage	
51	O	Trailer turn signal (right)	Output	ON	Turn right ON	<p style="text-align: right; font-size: small;">SKIA3009J</p>	
52	LG	Trailer turn signal (left)	Output	ON	Turn left ON	<p style="text-align: right; font-size: small;">SKIA3009J</p>	
56	R/Y	Battery saver output	Output	OFF	15 minutes after ignition switch is turned OFF	0V	
				ON	—	Battery voltage	
57	R/Y	Battery power supply	Input	—	—	Battery voltage	
58	W	Optical sensor	Input	ON	When optical sensor is illuminated	3.1V or more	
					When optical sensor is not illuminated	0.6V or less	
59	GR	Front door lock assembly LH (unlock)	Output	OFF	OFF (neutral)	0V	
					ON (unlock)	Battery voltage	
60	LG	Turn signal (left)	Output	ON	Turn left ON	<p style="text-align: right; font-size: small;">SKIA3009J</p>	
61	G	Turn signal (right)	Output	ON	Turn right ON	<p style="text-align: right; font-size: small;">SKIA3009J</p>	
63	BR	Interior room/map lamp	Output	OFF	Any door switch	ON (open)	0V
					OFF (closed)	Battery voltage	
65	V	All door lock actuators (lock)	Output	OFF	OFF (neutral)	0V	
					ON (lock)	Battery voltage	

A  
B  
C  
D  
E  
F  
G  
H  
I  
J  
L  
M  
N  
O  
P

PWC

# BCM (BODY CONTROL MODULE)

## < ECU DIAGNOSIS INFORMATION >

Terminal	Wire color	Item	Signal input/output	Measuring condition		Reference value or waveform (Approx.)
				Ignition switch	Operation or condition	
66	L	Front door lock actuator RH, rear door lock actuators LH/RH (unlock)	Output	OFF	OFF (neutral)	0V
					ON (unlock)	Battery voltage
67	B	Ground	Input	ON	—	0V
68 <sup>1</sup>	O	Power window power supply (RAP)	Output	—	Ignition switch ON	Battery voltage
					Within 45 seconds after ignition switch OFF	Battery voltage
					More than 45 seconds after ignition switch OFF	0V
					When front door LH or RH is open or power window timer operates	0V
68 <sup>2</sup>	SB	Power window power supply (RAP)	Output	—	Ignition switch ON	Battery voltage
					Within 45 seconds after ignition switch OFF	Battery voltage
					More than 45 seconds after ignition switch OFF	0V
					When front door LH or RH is open or power window timer operates	0V
69	P	Power window power supply (BAT)	Output	OFF	—	Battery voltage
70	W	Battery power supply	Input	OFF	—	Battery voltage

1: King cab (with power door lock system)

2: Crew cab (without power door lock system)

## Fail Safe

INFOID:000000009233095

### Fail-safe index

BCM performs fail-safe control when any DTC listed below is detected.

Display contents of CONSULT	Fail-safe	Cancellation
U1000: CAN COMM CIRCUIT	Inhibit engine cranking	When the BCM re-establishes communication with the other modules.

## DTC Inspection Priority Chart

INFOID:000000009233096

If some DTCs are displayed at the same time, perform inspections one by one based on the following priority chart.

Priority	DTC
1	<ul style="list-style-type: none"> <li>U1000: CAN COMM CIRCUIT</li> </ul>
2	<ul style="list-style-type: none"> <li>B2190: NATS ANTENNA AMP</li> <li>B2191: DIFFERENCE OF KEY</li> <li>B2192: ID DISCORD BCM-ECM</li> <li>B2193: CHAIN OF BCM-ECM</li> </ul>

# BCM (BODY CONTROL MODULE)

## < ECU DIAGNOSIS INFORMATION >

Priority	DTC
3	<ul style="list-style-type: none"> <li>• C1729: VHCL SPEED SIG ERR</li> <li>• C1735: IGNITION SIGNAL</li> </ul>
4	<ul style="list-style-type: none"> <li>• C1704: LOW PRESSURE FL</li> <li>• C1705: LOW PRESSURE FR</li> <li>• C1706: LOW PRESSURE RR</li> <li>• C1707: LOW PRESSURE RL</li> <li>• C1708: [NO DATA] FL</li> <li>• C1709: [NO DATA] FR</li> <li>• C1710: [NO DATA] RR</li> <li>• C1711: [NO DATA] RL</li> <li>• C1712: [CHECKSUM ERR] FL</li> <li>• C1713: [CHECKSUM ERR] FR</li> <li>• C1714: [CHECKSUM ERR] RR</li> <li>• C1715: [CHECKSUM ERR] RL</li> <li>• C1716: [PRESSDATA ERR] FL</li> <li>• C1717: [PRESSDATA ERR] FR</li> <li>• C1718: [PRESSDATA ERR] RR</li> <li>• C1719: [PRESSDATA ERR] RL</li> <li>• C1720: [CODE ERR] FL</li> <li>• C1721: [CODE ERR] FR</li> <li>• C1722: [CODE ERR] RR</li> <li>• C1723: [CODE ERR] RL</li> <li>• C1724: [BATT VOLT LOW] FL</li> <li>• C1725: [BATT VOLT LOW] FR</li> <li>• C1726: [BATT VOLT LOW] RR</li> <li>• C1727: [BATT VOLT LOW] RL</li> </ul>

## DTC Index

INFOID:000000009233097

### NOTE:

- Details of time display
- CRNT: Displays when there is a malfunction now or after returning to the normal condition until turning ignition switch OFF → ON again.
- 1 - 39: Displayed if any previous malfunction is present when current condition is normal. It increases like 1 → 2 → 3...38 → 39 after returning to the normal condition whenever ignition switch OFF → ON. The counter remains at 39 even if the number of cycles exceeds it. It is counted from 1 again when turning ignition switch OFF → ON after returning to the normal condition if the malfunction is detected again.

CONSULT display	Fail-safe	Low tire pressure warning lamp ON	Reference page
No DTC is detected. further testing may be required.	—	—	—
U1000: CAN COMM CIRCUIT	—	—	<a href="#">BCS-26</a>
B2190: NATS ANTENA AMP	—	—	<a href="#">SEC-18</a>
B2191: DIFFERENCE OF KEY	—	—	<a href="#">SEC-21</a>
B2192: ID DISCORD BCM-ECM	—	—	<a href="#">SEC-22</a>
B2193: CHAIN OF BCM-ECM	—	—	<a href="#">SEC-24</a>
C1708: [NO DATA] FL	—	X	<a href="#">WT-15</a>
C1709: [NO DATA] FR	—	X	<a href="#">WT-15</a>
C1710: [NO DATA] RR	—	X	<a href="#">WT-15</a>
C1711: [NO DATA] RL	—	X	<a href="#">WT-15</a>
C1712: [CHECKSUM ERR] FL	—	X	<a href="#">WT-17</a>
C1713: [CHECKSUM ERR] FR	—	X	<a href="#">WT-17</a>
C1714: [CHECKSUM ERR] RR	—	X	<a href="#">WT-17</a>
C1715: [CHECKSUM ERR] RL	—	X	<a href="#">WT-17</a>

## BCM (BODY CONTROL MODULE)

### < ECU DIAGNOSIS INFORMATION >

CONSULT display	Fail-safe	Low tire pressure warning lamp ON	Reference page
C1716: [PRESSDATA ERR] FL	—	X	<a href="#">WT-19</a>
C1717: [PRESSDATA ERR] FR	—	X	<a href="#">WT-19</a>
C1718: [PRESSDATA ERR] RR	—	X	<a href="#">WT-19</a>
C1719: [PRESSDATA ERR] RL	—	X	<a href="#">WT-19</a>
C1720: [CODE ERR] FL	—	X	<a href="#">WT-17</a>
C1721: [CODE ERR] FR	—	X	<a href="#">WT-17</a>
C1722: [CODE ERR] RR	—	X	<a href="#">WT-17</a>
C1723: [CODE ERR] RL	—	X	<a href="#">WT-17</a>
C1724: [BATT VOLT LOW] FL	—	X	<a href="#">WT-17</a>
C1725: [BATT VOLT LOW] FR	—	X	<a href="#">WT-17</a>
C1726: [BATT VOLT LOW] RR	—	X	<a href="#">WT-17</a>
C1727: [BATT VOLT LOW] RL	—	X	<a href="#">WT-17</a>
C1729: VHCL SPEED SIG ERR	—	X	<a href="#">WT-21</a>
C1735: IGNITION SIGNAL	—	X	<a href="#">WT-22</a>



# POWER WINDOW SYSTEM

< WIRING DIAGRAM >

## WIRING DIAGRAM

### POWER WINDOW SYSTEM

#### Wiring Diagram - King Cab

INFOID:000000008789419

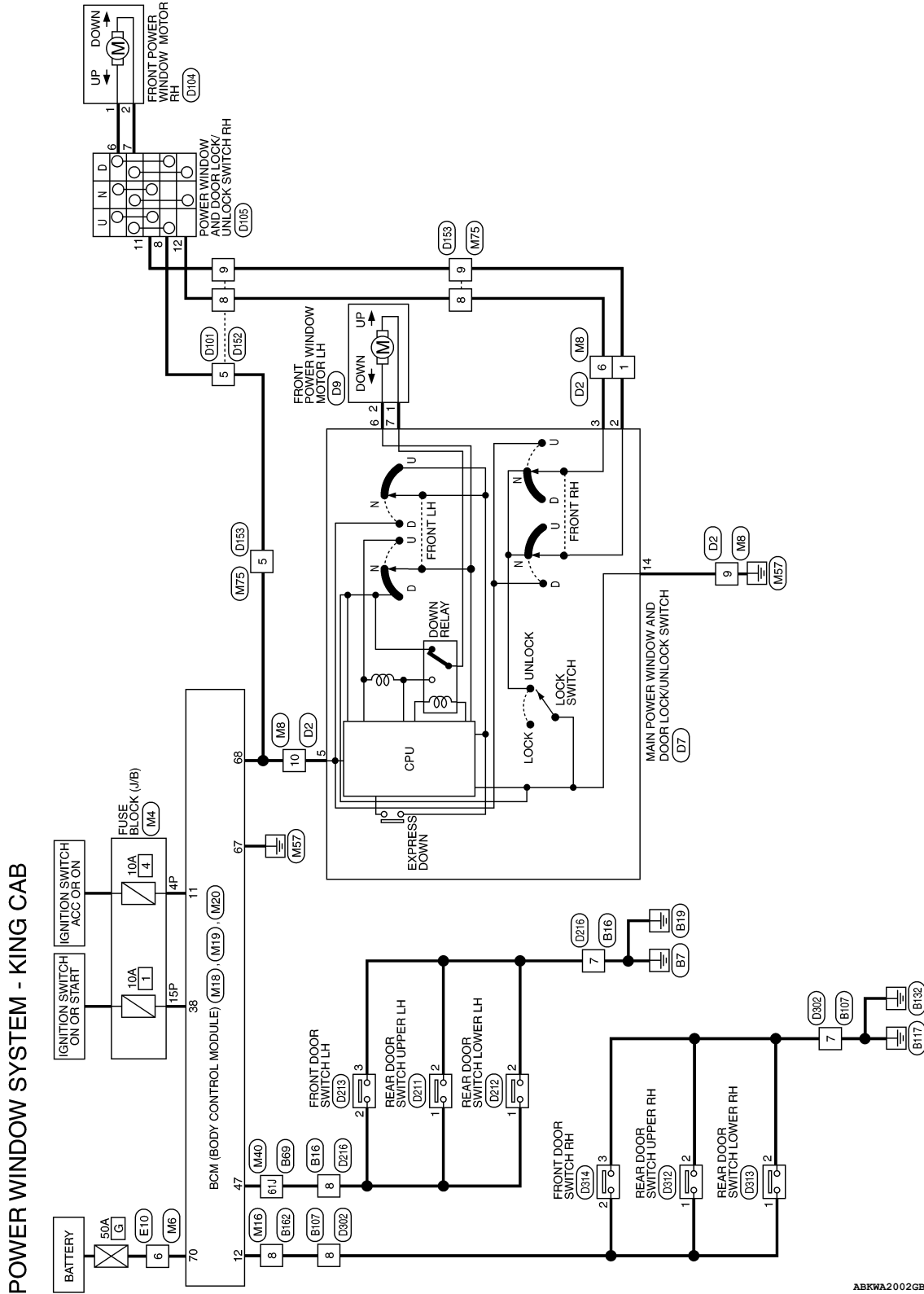

ABKWA2002GB

A  
B  
C  
D  
E  
F  
G  
H  
I  
J  
L  
M  
N  
O  
P

PWC

# POWER WINDOW SYSTEM

< WIRING DIAGRAM >

## POWER WINDOW SYSTEM CONNECTORS - KING CAB

Connector No.	M4
Connector Name	FUSE BLOCK (J/B)
Connector Color	WHITE



Terminal No.	Color of Wire	Signal Name
4P	G/B	-
15P	W/R	-

Connector No.	M6
Connector Name	WIRE TO WIRE
Connector Color	WHITE



Terminal No.	Color of Wire	Signal Name
6	W	-

Connector No.	M8
Connector Name	WIRE TO WIRE
Connector Color	BROWN

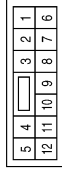

Terminal No.	Color of Wire	Signal Name
1	SB	-
6	P	-
9	B	-
10	O	-

Connector No.	M16
Connector Name	WIRE TO WIRE
Connector Color	WHITE

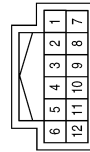

Terminal No.	Color of Wire	Signal Name
8	LG	-

Connector No.	M18
Connector Name	BCM (BODY CONTROL MODULE)
Connector Color	WHITE

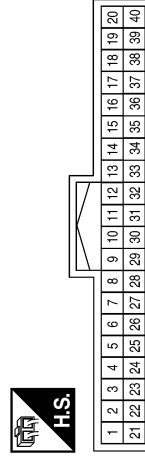

Terminal No.	Color of Wire	Signal Name
11	G/B	ACC SW
12	LG	DOOR SW (AS)
38	W/R	IGN SW

Connector No.	M19
Connector Name	BCM (BODY CONTROL MODULE)
Connector Color	WHITE

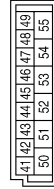

Terminal No.	Color of Wire	Signal Name
47	GR	DOOR SW (DR)

# POWER WINDOW SYSTEM

< WIRING DIAGRAM >

Connector No.	M75
Connector Name	WIRE TO WIRE
Connector Color	WHITE

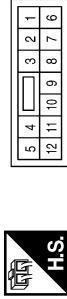

Terminal No.	Color of Wire	Signal Name
5	W	-
8	P	-
9	SB	-

Connector No.	M40
Connector Name	WIRE TO WIRE
Connector Color	WHITE

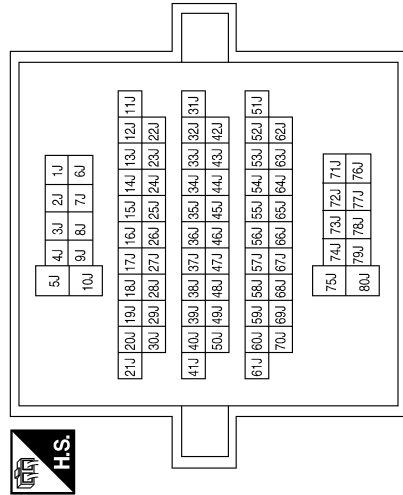

Terminal No.	Color of Wire	Signal Name
61J	GR	-

Connector No.	M20
Connector Name	BCM (BODY CONTROL MODULE)
Connector Color	BLACK



Terminal No.	Color of Wire	Signal Name
67	B	GND (POWER)
68	O	POWER WINDOW POWER SUPPLY OUTPUT (LINKED TO RAP) (WITH POWER DOOR LOCK SYSTEM)
70	W	BAT (F/L)

Connector No.	B16
Connector Name	WIRE TO WIRE
Connector Color	WHITE



Terminal No.	Color of Wire	Signal Name
7	B	-
8	GR	-

Connector No.	E10
Connector Name	WIRE TO WIRE
Connector Color	WHITE



Terminal No.	Color of Wire	Signal Name
6	W	-

ABKIA2909GB

A  
B  
C  
D  
E  
F  
G  
H  
I  
J  
K  
L  
M  
N  
O  
P

PWC

# POWER WINDOW SYSTEM

< WIRING DIAGRAM >

Connector No.	B69
Connector Name	WIRE TO WIRE
Connector Color	WHITE

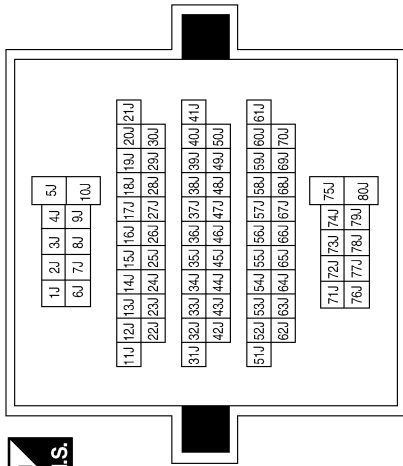

Terminal No.	Color of Wire	Signal Name
61J	GR	-

Connector No.	B107
Connector Name	WIRE TO WIRE
Connector Color	WHITE

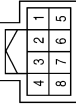

Terminal No.	Color of Wire	Signal Name
7	B	-
8	LG	-

Connector No.	B162
Connector Name	WIRE TO WIRE
Connector Color	WHITE

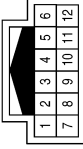

Terminal No.	Color of Wire	Signal Name
8	LG	-

Connector No.	D2
Connector Name	WIRE TO WIRE
Connector Color	BROWN

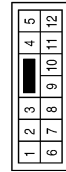

Terminal No.	Color of Wire	Signal Name
1	G/Y	-
6	L/W	-
9	B	-
10	W/R	-

Connector No.	D7
Connector Name	MAIN POWER WINDOW AND DOOR LOCK/UNLOCK SWITCH
Connector Color	WHITE

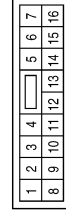

Terminal No.	Color of Wire	Signal Name
2	G/Y	-
3	L/W	-
5	W/R	-
6	G/R	-
7	G/W	-
14	B	-

Connector No.	D9
Connector Name	FRONT POWER WINDOW MOTOR LH
Connector Color	BROWN



Terminal No.	Color of Wire	Signal Name
1	G/W	-
2	G/R	-

ABKIA2910GB

# POWER WINDOW SYSTEM

< WIRING DIAGRAM >

Connector No.	D105
Connector Name	POWER WINDOW AND DOOR LOCK/UNLOCK SWITCH RH
Connector Color	WHITE

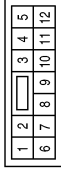

Terminal No.	Color of Wire	Signal Name
6	G	-
7	L	-
8	W/R	-
11	G/Y	-
12	L/W	-

Connector No.	D104
Connector Name	FRONT POWER WINDOW MOTOR RH
Connector Color	BROWN

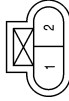

Terminal No.	Color of Wire	Signal Name
1	G	-
2	L	-

Connector No.	D101
Connector Name	WIRE TO WIRE
Connector Color	WHITE

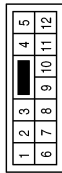

Terminal No.	Color of Wire	Signal Name
5	W/R	-
8	L/W	-
9	G/Y	-

Connector No.	D211
Connector Name	REAR DOOR SWITCH UPPER LH
Connector Color	BLACK



Terminal No.	Color of Wire	Signal Name
1	L	-
2	B	-

Connector No.	D153
Connector Name	WIRE TO WIRE
Connector Color	WHITE



Terminal No.	Color of Wire	Signal Name
5	W	-
8	P	-
9	SB	-

Connector No.	D152
Connector Name	WIRE TO WIRE
Connector Color	WHITE



Terminal No.	Color of Wire	Signal Name
5	W	-
8	P	-
9	SB	-

ABKIA4367GB

A  
B  
C  
D  
E  
F  
G  
H  
I  
J  
L  
M  
N  
O  
P

PWC

# POWER WINDOW SYSTEM

< WIRING DIAGRAM >

Connector No.	D216
Connector Name	WIRE TO WIRE
Connector Color	WHITE



Terminal No.	Color of Wire	Signal Name
7	B	-
8	LG	-

Connector No.	D213
Connector Name	FRONT DOOR SWITCH LH (KING CAB)
Connector Color	WHITE



Terminal No.	Color of Wire	Signal Name
2	LG	-
3	B	-

Connector No.	D212
Connector Name	REAR DOOR SWITCH LOWER LH
Connector Color	BLACK



Terminal No.	Color of Wire	Signal Name
1	L	-
2	B	-

Connector No.	D313
Connector Name	REAR DOOR SWITCH LOWER RH
Connector Color	BLACK



Terminal No.	Color of Wire	Signal Name
1	L	-
2	B	-

Connector No.	D312
Connector Name	REAR DOOR SWITCH UPPER RH
Connector Color	BLACK



Terminal No.	Color of Wire	Signal Name
1	L	-
2	B	-

Connector No.	D302
Connector Name	WIRE TO WIRE
Connector Color	WHITE

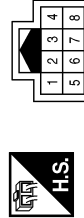

Terminal No.	Color of Wire	Signal Name
7	B	-
8	LG	-

ABKIA4368GB

# POWER WINDOW SYSTEM

< WIRING DIAGRAM >

A  
B  
C  
D  
E  
F  
G  
H  
I  
J  
L  
M  
N  
O  
P

PWC

Connector No.	D314
Connector Name	FRONT DOOR SWITCH RH (KING CAB)
Connector Color	WHITE

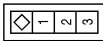

Terminal No.	Color of Wire	Signal Name
2	LG	-
3	B	-

ABKIA4369GB

# POWER WINDOW SYSTEM

< WIRING DIAGRAM >

## Wiring Diagram - Crew Cab

INFOID:000000008789420

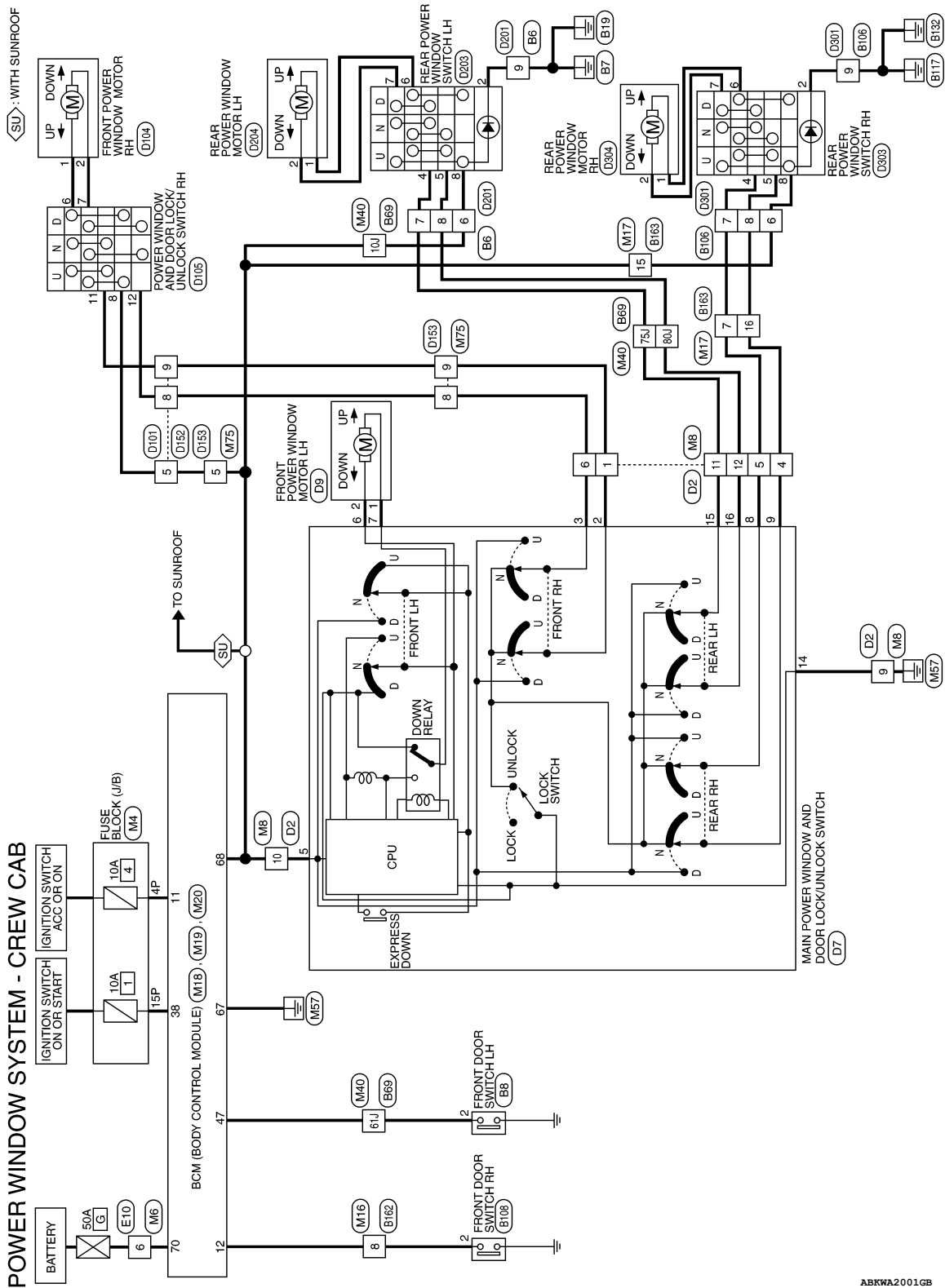

ABKWA2001GB



# POWER WINDOW SYSTEM

< WIRING DIAGRAM >

## POWER WINDOW SYSTEM CONNECTORS - CREW CAB

Connector No.	M4
Connector Name	FUSE BLOCK (J/B)
Connector Color	WHITE



Terminal No.	Color of Wire	Signal Name
4P	G/B	-
15P	W/R	-

Connector No.	M6
Connector Name	WIRE TO WIRE
Connector Color	WHITE



Terminal No.	Color of Wire	Signal Name
6	W	-

Connector No.	M8
Connector Name	WIRE TO WIRE
Connector Color	BROWN

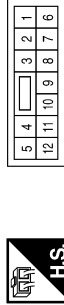

Terminal No.	Color of Wire	Signal Name
1	SB	-
4	P	-
5	Y	-
6	P	-
9	B	-
10	O	-
11	R	-
12	LG	-

Connector No.	M16
Connector Name	WIRE TO WIRE
Connector Color	WHITE

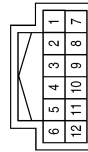

Terminal No.	Color of Wire	Signal Name
8	LG	-

Connector No.	M17
Connector Name	WIRE TO WIRE
Connector Color	WHITE

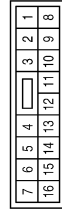

Terminal No.	Color of Wire	Signal Name
7	Y	-
15	W	-
16	P	-

Connector No.	M18
Connector Name	BCM (BODY CONTROL MODULE)
Connector Color	WHITE



1	2	3	4	5	6	7	8	9	10	11	12	13	14	15	16	17	18	19	20	21	22	23	24	25	26	27	28	29	30	31	32	33	34	35	36	37	38	39	40
---	---	---	---	---	---	---	---	---	----	----	----	----	----	----	----	----	----	----	----	----	----	----	----	----	----	----	----	----	----	----	----	----	----	----	----	----	----	----	----

Terminal No.	Color of Wire	Signal Name
11	G/B	ACC SW
12	LG	DOOR SW (AS)
38	W/R	IGN SW

ABKIA2901GB

A  
B  
C  
D  
E  
F  
G  
H  
I  
J  
L  
M  
N  
O  
P



# POWER WINDOW SYSTEM

< WIRING DIAGRAM >

Connector No.	M19
Connector Name	BCM (BODY CONTROL MODULE)
Connector Color	WHITE

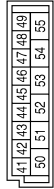

Terminal No.	Color of Wire	Signal Name
47	GR	DOOR SW (DR)

Connector No.	M20
Connector Name	BCM (BODY CONTROL MODULE)
Connector Color	BLACK



Terminal No.	Color of Wire	Signal Name
67	B	GND (POWER)
68	O	POWER WINDOW POWER SUPPLY OUTPUT (LINKED TO RAP) (WITH POWER DOOR LOCK SYSTEM)
70	W	BAT (F/L)

Connector No.	M40
Connector Name	WIRE TO WIRE
Connector Color	WHITE

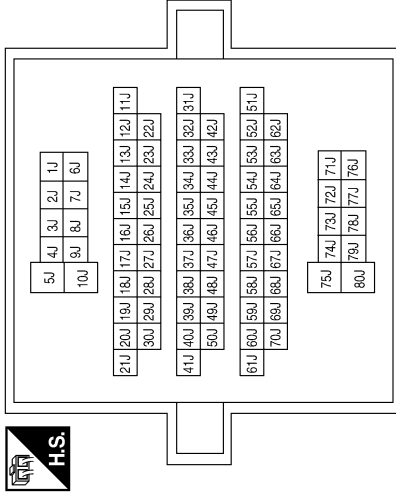

Terminal No.	Color of Wire	Signal Name
10J	W	-
61J	GR	-
75J	R	-
80J	LG	-

Connector No.	M75
Connector Name	WIRE TO WIRE
Connector Color	WHITE

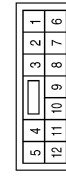

Terminal No.	Color of Wire	Signal Name
5	W	-
8	P	-
9	SB	-

Connector No.	E10
Connector Name	WIRE TO WIRE
Connector Color	WHITE



Terminal No.	Color of Wire	Signal Name
6	W	-

Connector No.	B6
Connector Name	WIRE TO WIRE
Connector Color	WHITE

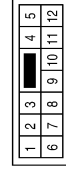

Terminal No.	Color of Wire	Signal Name
6	W	-
7	R	-
8	LG	-
9	B	-

ABKIA2902GB

# POWER WINDOW SYSTEM

< WIRING DIAGRAM >

Terminal No.	Color of Wire	Signal Name
10J	W	-
61J	GR	-
75J	R	-
80J	LG	-

Connector No.	B69
Connector Name	WIRE TO WIRE
Connector Color	WHITE

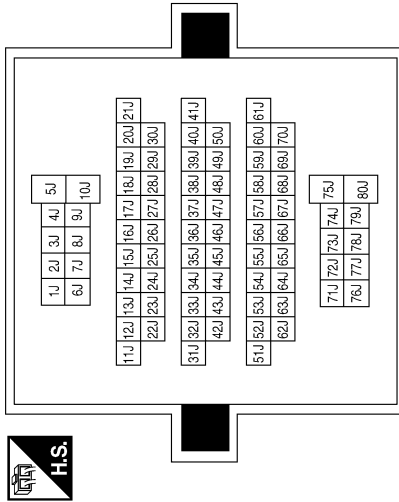

Connector No.	B8
Connector Name	FRONT DOOR SWITCH LH (CREW CAB)
Connector Color	WHITE

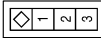

Terminal No.	Color of Wire	Signal Name
2	GR	-

Connector No.	B162
Connector Name	WIRE TO WIRE
Connector Color	WHITE

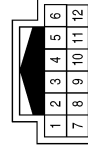

Terminal No.	Color of Wire	Signal Name
8	LG	-

Connector No.	B108
Connector Name	FRONT DOOR SWITCH RH (CREW CAB)
Connector Color	WHITE

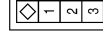

Terminal No.	Color of Wire	Signal Name
2	LG	-

Connector No.	B106
Connector Name	WIRE TO WIRE
Connector Color	WHITE



Terminal No.	Color of Wire	Signal Name
6	W	-
7	Y	-
8	P	-
9	B	-

ABKIA2903GB

A  
B  
C  
D  
E  
F  
G  
H  
I  
J  
L  
M  
N  
O  
P

PWC

# POWER WINDOW SYSTEM

< WIRING DIAGRAM >

Connector No.	D7
Connector Name	MAIN POWER WINDOW AND DOOR LOCK/UNLOCK SWITCH
Connector Color	WHITE

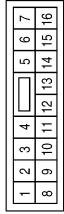

Terminal No.	Color of Wire	Signal Name
2	G/Y	-
3	L/W	-
5	W/R	-
6	G/R	-
7	G/W	-
8	G/B	-
9	R	-
14	B	-
15	R/B	-
16	R/Y	-

Connector No.	D2
Connector Name	WIRE TO WIRE
Connector Color	BROWN

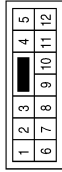

Terminal No.	Color of Wire	Signal Name
1	G/Y	-
4	R	-
5	G/B	-
6	L/W	-
9	B	-
10	W/R	-
11	R/B	-
12	R/Y	-

Connector No.	B163
Connector Name	WIRE TO WIRE
Connector Color	WHITE

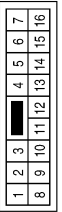

Terminal No.	Color of Wire	Signal Name
7	Y	-
15	W	-
16	P	-

Connector No.	D104
Connector Name	FRONT POWER WINDOW MOTOR RH
Connector Color	BROWN

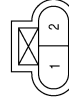

Terminal No.	Color of Wire	Signal Name
1	G	-
2	L	-

Connector No.	D101
Connector Name	WIRE TO WIRE
Connector Color	WHITE



Terminal No.	Color of Wire	Signal Name
5	W/R	-
8	L/W	-
9	G/Y	-

Connector No.	D9
Connector Name	FRONT POWER WINDOW MOTOR LH
Connector Color	BROWN

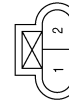

Terminal No.	Color of Wire	Signal Name
1	G/W	-
2	G/R	-

ABKIA2904GB

# POWER WINDOW SYSTEM

< WIRING DIAGRAM >

Connector No.	D105
Connector Name	POWER WINDOW AND DOOR LOCK/UNLOCK SWITCH RH
Connector Color	WHITE

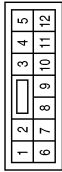

Terminal No.	Color of Wire	Signal Name
6	G	-
7	L	-
8	W/R	-
11	G/Y	-
12	L/W	-

Connector No.	D152
Connector Name	WIRE TO WIRE
Connector Color	WHITE

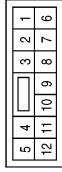

Terminal No.	Color of Wire	Signal Name
5	W	-
8	P	-
9	SB	-

Connector No.	D153
Connector Name	WIRE TO WIRE
Connector Color	WHITE

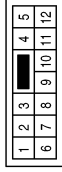

Terminal No.	Color of Wire	Signal Name
5	W	-
8	P	-
9	SB	-

Connector No.	D201
Connector Name	WIRE TO WIRE
Connector Color	WHITE

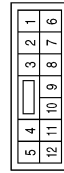

Terminal No.	Color of Wire	Signal Name
6	W	-
7	LG	-
8	R	-
9	B	-

Connector No.	D203
Connector Name	REAR POWER WINDOW SWITCH LH
Connector Color	WHITE

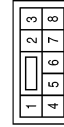

Terminal No.	Color of Wire	Signal Name
2	B	-
4	LG	-
5	R	-
6	Y	-
7	L	-
8	W	-

Connector No.	D204
Connector Name	REAR POWER WINDOW MOTOR LH
Connector Color	BLACK



Terminal No.	Color of Wire	Signal Name
1	Y	-
2	L	-

ABKIA4364GB

A  
B  
C  
D  
E  
F  
G  
H  
I  
J  
L  
M  
N  
O  
P

PWC

# POWER WINDOW SYSTEM

## < WIRING DIAGRAM >

Connector No.	D304
Connector Name	REAR POWER WINDOW MOTOR RH
Connector Color	BLACK



Terminal No.	Color of Wire	Signal Name
1	Y	-
2	L	-

Connector No.	D303
Connector Name	REAR POWER WINDOW SWITCH RH
Connector Color	WHITE



Terminal No.	Color of Wire	Signal Name
2	B	-
4	LG	-
5	R	-
6	Y	-
7	L	-
8	W	-

Connector No.	D301
Connector Name	WIRE TO WIRE
Connector Color	WHITE

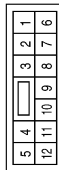

Terminal No.	Color of Wire	Signal Name
6	W	-
7	LG	-
8	R	-
9	B	-

ABKIA4365GB

# NONE OF THE POWER WINDOWS CAN BE OPERATED USING ANY SWITCH

< SYMPTOM DIAGNOSIS >

## SYMPTOM DIAGNOSIS

NONE OF THE POWER WINDOWS CAN BE OPERATED USING ANY SWITCH

### Diagnosis Procedure

INFOID:000000008789421

#### 1. CHECK BCM POWER SUPPLY AND GROUND CIRCUIT

Check BCM power supply and ground circuit.

Refer to [BCS-27, "Diagnosis Procedure"](#).

Is the inspection result normal?

YES >> GO TO 2

NO >> Repair or replace the malfunctioning parts.

#### 2. CHECK MAIN POWER WINDOW AND DOOR LOCK/UNLOCK SWITCH

Check main power window switch.

Refer to [PWC-14, "POWER WINDOW MAIN SWITCH \(CREW CAB\) : Component Inspection"](#) or [PWC-18, "POWER WINDOW MAIN SWITCH \(KING CAB\) : Component Inspection"](#).

Is the inspection result normal?

YES >> GO TO 3

NO >> Replace main power window and door lock/unlock switch. Refer to [PWC-73, "Removal and Installation"](#).

#### 3. CHECK MAIN POWER WINDOW AND DOOR LOCK/UNLOCK SWITCH POWER SUPPLY AND GROUND CIRCUIT

Check power window switch main power supply and ground circuit.

Refer to [PWC-11, "POWER WINDOW MAIN SWITCH \(CREW CAB\) : Component Function Check"](#) or [PWC-16, "POWER WINDOW MAIN SWITCH \(KING CAB\) : Component Function Check"](#).

Is the inspection result normal?

YES >> Check intermittent incident. Refer to [GI-49, "Intermittent Incident"](#).

NO >> Repair or replace the malfunctioning parts.

A  
B  
C  
D  
E  
F  
G  
H  
I  
J  
L  
M  
N  
O  
P

PWC

# DRIVER SIDE POWER WINDOW ALONE DOES NOT OPERATE

< SYMPTOM DIAGNOSIS >

---

## DRIVER SIDE POWER WINDOW ALONE DOES NOT OPERATE

### Diagnosis Procedure

INFOID:000000008789422

#### 1. CHECK MAIN POWER WINDOW AND DOOR LOCK/UNLOCK SWITCH

---

Check main power window switch.

Refer to [PWC-14. "POWER WINDOW MAIN SWITCH \(CREW CAB\) : Component Inspection"](#) or [PWC-18. "POWER WINDOW MAIN SWITCH \(KING CAB\) : Component Inspection"](#).

Is the inspection result normal?

YES >> GO TO 2

NO >> Replace main power window and door lock/unlock switch. Refer to [PWC-73. "Removal and Installation"](#).

#### 2. CHECK FRONT POWER WINDOW MOTOR LH

---

Check front power window motor LH.

Refer to [PWC-24. "DRIVER SIDE : Component Function Check"](#).

Is the inspection result normal?

YES >> Inspection End.

NO >> Check intermittent incident. Refer to [GI-49. "Intermittent Incident"](#).



# FRONT PASSENGER SIDE POWER WINDOW ALONE DOES NOT OPERATE

< SYMPTOM DIAGNOSIS >

## FRONT PASSENGER SIDE POWER WINDOW ALONE DOES NOT OPERATE

### Diagnosis Procedure

INFOID:000000008789423

#### 1. CHECK POWER WINDOW AND DOOR LOCK/UNLOCK SWITCH RH

Check power window and door lock/unlock switch RH.

Refer to [PWC-19, "FRONT POWER WINDOW SWITCH : Component Function Check"](#).

Is the inspection result normal?

YES >> GO TO 2

NO >> Repair or replace the malfunctioning parts.

#### 2. CHECK MAIN POWER WINDOW AND DOOR LOCK/UNLOCK SWITCH

Check main power window and door lock/unlock switch.

Refer to [PWC-14, "POWER WINDOW MAIN SWITCH \(CREW CAB\) : Component Inspection"](#) or [PWC-18, "POWER WINDOW MAIN SWITCH \(KING CAB\) : Component Inspection"](#).

Is the inspection result normal?

YES >> GO TO 3

NO >> Replace main power window and door lock/unlock switch. Refer to [PWC-73, "Removal and Installation"](#).

#### 3. CHECK FRONT POWER WINDOW MOTOR RH CIRCUIT

Check front power window motor RH circuit.

Refer to [PWC-25, "PASSENGER SIDE : Component Function Check"](#).

Is the inspection result normal?

YES >> Inspection End.

NO >> Check intermittent incident. Refer to [GI-49, "Intermittent Incident"](#).

A  
B  
C  
D  
E  
F  
G  
H  
I  
J  
L  
M  
N  
O  
P

PWC

# REAR LH SIDE POWER WINDOW ALONE DOES NOT OPERATE

< SYMPTOM DIAGNOSIS >

---

## REAR LH SIDE POWER WINDOW ALONE DOES NOT OPERATE

### Diagnosis Procedure

INFOID:000000008789424

#### 1. CHECK REAR POWER WINDOW SWITCH LH

---

Check rear power window switch LH.

Refer to [PWC-20, "REAR POWER WINDOW SWITCH : Component Function Check"](#).

Is the inspection result normal?

YES >> GO TO 2

NO >> Repair or replace the malfunctioning parts.

#### 2. CHECK MAIN POWER WINDOW AND DOOR LOCK/UNLOCK SWITCH

---

Check main power window and door lock/unlock switch.

Refer to [PWC-14, "POWER WINDOW MAIN SWITCH \(CREW CAB\) : Component Inspection"](#).

Is the inspection result normal?

YES >> GO TO 3

NO >> Replace main power window and door lock/unlock switch. Refer to [PWC-73, "Removal and Installation"](#).

#### 3. CHECK REAR POWER WINDOW MOTOR LH

---

Check rear power window motor LH.

Refer to [PWC-27, "REAR LH : Component Function Check"](#).

Is the inspection result normal?

YES >> Inspection End.

NO >> Check intermittent incident. Refer to [GI-49, "Intermittent Incident"](#).

# REAR RH SIDE POWER WINDOW ALONE DOES NOT OPERATE

< SYMPTOM DIAGNOSIS >

## REAR RH SIDE POWER WINDOW ALONE DOES NOT OPERATE

### Diagnosis Procedure

INFOID:000000008789425

#### 1. CHECK REAR POWER WINDOW SWITCH RH

Check rear power window switch RH.

Refer to [PWC-20, "REAR POWER WINDOW SWITCH : Component Function Check"](#).

Is the inspection result normal?

YES >> GO TO 2

NO >> Repair or replace the malfunctioning parts.

#### 2. CHECK MAIN POWER WINDOW AND DOOR LOCK/UNLOCK SWITCH

Check main power window and door lock/unlock switch.

Refer to [PWC-14, "POWER WINDOW MAIN SWITCH \(CREW CAB\) : Component Inspection"](#).

Is the inspection result normal?

YES >> GO TO 3

NO >> Replace main power window and door lock/unlock switch. Refer to [PWC-73, "Removal and Installation"](#).

#### 3. CHECK REAR POWER WINDOW MOTOR RH

Check rear power window motor RH.

Refer to [PWC-28, "REAR RH : Component Function Check"](#).

Is the inspection result normal?

YES >> Inspection End.

NO >> Check intermittent incident. Refer to [GI-49, "Intermittent Incident"](#).

A  
B  
C  
D  
E  
F  
G  
H  
I  
J  
L  
M  
N  
O  
P

PWC

# AUTO OPERATION DOES NOT OPERATE BUT MANUAL OPERATES NORMALLY (DRIVER SIDE)

< SYMPTOM DIAGNOSIS >

---

## AUTO OPERATION DOES NOT OPERATE BUT MANUAL OPERATES NORMALLY (DRIVER SIDE)

### Diagnosis Procedure

INFOID:000000008789426

#### 1. REPLACE MAIN POWER WINDOW AND DOOR LOCK/UNLOCK SWITCH

---

Replace main power window and door lock/unlock switch and check operation. Refer to [PWC-73, "Removal and Installation"](#).

Is the inspection result normal?

YES >> Inspection End.

NO >> Check intermittent incident. Refer to [GI-49, "Intermittent Incident"](#).

# POWER WINDOW RETAINED POWER OPERATION DOES NOT OPERATE PROPERLY

< SYMPTOM DIAGNOSIS >

## POWER WINDOW RETAINED POWER OPERATION DOES NOT OPERATE PROPERLY

### Diagnosis Procedure

INFOID:000000008789427

#### 1. CHECK FRONT DOOR SWITCH

Check front door switch.

Refer to [DLK-29. "CREW CAB : Component Function Check"](#) or [DLK-27. "KING CAB : Component Function Check"](#).

Is the inspection result normal?

YES >> Inspection End.

NO >> Check intermittent incident. Refer to [GI-49. "Intermittent Incident"](#).

A  
B  
C  
D  
E  
F  
G  
H  
I  
J  
L  
M  
N  
O  
P

PWC

## POWER WINDOW LOCK SWITCH DOES NOT FUNCTION

< SYMPTOM DIAGNOSIS >

---

### POWER WINDOW LOCK SWITCH DOES NOT FUNCTION

#### Diagnosis Procedure

INFOID:000000008789428

#### 1. REPLACE MAIN POWER WINDOW AND DOOR LOCK/UNLOCK SWITCH

---

Replace main power window and door lock/unlock switch and check operation.  
Refer to [PWC-73. "Removal and Installation"](#).

Is the inspection result normal?

YES >> Inspection End.

NO >> Check intermittent incident. Refer to [GI-49. "Intermittent Incident"](#).

# PRECAUTIONS

< PRECAUTION >

## PRECAUTION

### PRECAUTIONS

#### Precaution for Supplemental Restraint System (SRS) "AIR BAG" and "SEAT BELT PRE-TENSIONER"

INFOID:000000008789429

The Supplemental Restraint System such as "AIR BAG" and "SEAT BELT PRE-TENSIONER", used along with a front seat belt, helps to reduce the risk or severity of injury to the driver and front passenger for certain types of collision. This system includes seat belt switch inputs and dual stage front air bag modules. The SRS system uses the seat belt switches to determine the front air bag deployment, and may only deploy one front air bag, depending on the severity of a collision and whether the front occupants are belted or unbelted. Information necessary to service the system safely is included in the SR and SB section of this Service Manual.

#### **WARNING:**

- To avoid rendering the SRS inoperative, which could increase the risk of personal injury or death in the event of a collision which would result in air bag inflation, all maintenance must be performed by an authorized NISSAN/INFINITI dealer.
- Improper maintenance, including incorrect removal and installation of the SRS, can lead to personal injury caused by unintentional activation of the system. For removal of Spiral Cable and Air Bag Module, see the SR section.
- Do not use electrical test equipment on any circuit related to the SRS unless instructed to in this Service Manual. SRS wiring harnesses can be identified by yellow and/or orange harnesses or harness connectors.

#### PRECAUTIONS WHEN USING POWER TOOLS (AIR OR ELECTRIC) AND HAMMERS

#### **WARNING:**

- When working near the Airbag Diagnosis Sensor Unit or other Airbag System sensors with the Ignition ON or engine running, DO NOT use air or electric power tools or strike near the sensor(s) with a hammer. Heavy vibration could activate the sensor(s) and deploy the air bag(s), possibly causing serious injury.
- When using air or electric power tools or hammers, always switch the Ignition OFF, disconnect the battery, and wait at least 3 minutes before performing any service.

#### Precaution for Work

INFOID:000000009246703

- When removing or disassembling each component, be careful not to damage or deform it. If a component may be subject to interference, be sure to protect it with a shop cloth.
- When removing (disengaging) components with a screwdriver or similar tool, be sure to wrap the component with a shop cloth or vinyl tape to protect it.
- Protect the removed parts with a shop cloth and prevent them from being dropped.
- Replace a deformed or damaged clip.
- If a part is specified as a non-reusable part, always replace it with a new one.
- Be sure to tighten bolts and nuts securely to the specified torque.
- After installation is complete, be sure to check that each part works properly.
- Follow the steps below to clean components:
  - Water soluble dirt:
    - Dip a soft cloth into lukewarm water, wring the water out of the cloth and wipe the dirty area.
    - Then rub with a soft, dry cloth.
  - Oily dirt:
    - Dip a soft cloth into lukewarm water with mild detergent (concentration: within 2 to 3%) and wipe the dirty area.
    - Then dip a cloth into fresh water, wring the water out of the cloth and wipe the detergent off.
    - Then rub with a soft, dry cloth.
  - Do not use organic solvent such as thinner, benzene, alcohol or gasoline.
  - For genuine leather seats, use a genuine leather seat cleaner.

A  
B  
C  
D  
E  
F  
G  
H  
I  
J  
L  
M  
N  
O  
P

PWC

# PREPARATION

< PREPARATION >

## PREPARATION

### PREPARATION

#### Special Service Tool

INFOID:000000008789431

The actual shapes of Kent-Moore tools may differ from those of special service tools illustrated here.

Tool number (Kent-Moore No.) Tool name	Description
— ( J-46534 ) Trim Tool Set	Removing trim components

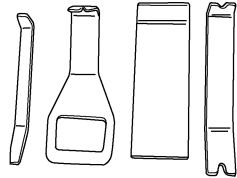

AWJIA0483ZZ



# POWER WINDOW MAIN SWITCH

< REMOVAL AND INSTALLATION >

## REMOVAL AND INSTALLATION

### POWER WINDOW MAIN SWITCH

#### Removal and Installation

INFOID:000000008789432

#### REMOVAL

1. Using a suitable tool, release the metal clip and pawls, then lift upward the main power window/door lock switch and finisher (2) as an assembly.

□: Metal clip

○: Pawl

**CAUTION:**

**Wrap a cloth around suitable tool to protect components from damage.**

2. Disconnect the harness connectors.
3. Remove the main power window/door lock switch and finisher (2) assembly from the front door finisher.
4. Remove the three screws (A) from the main power window/door lock switch (1).
5. Remove the main power window/door lock switch (1) from the main power window/door lock switch finisher (2).

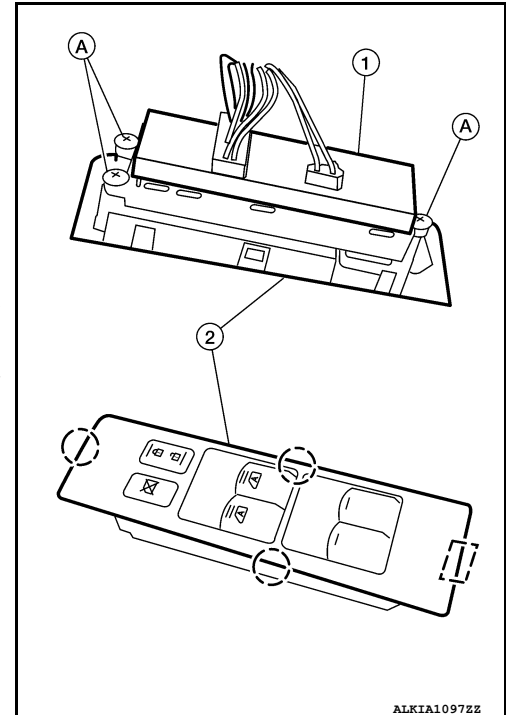

#### INSTALLATION

Installation is in the reverse order of removal.

A  
B  
C  
D  
E  
F  
G  
H  
I  
J

PWC

L  
M  
N  
O  
P

# FRONT POWER WINDOW SWITCH

< REMOVAL AND INSTALLATION >

## FRONT POWER WINDOW SWITCH

### Removal and Installation

INFOID:000000008789433

#### REMOVAL

1. Using a suitable tool, release the metal clip and pawls, then lift upward the front power window/door lock switch and finisher (2) as an assembly.

□: Metal clip

○: Pawl

#### CAUTION:

**Wrap a cloth around suitable tool to protect components from damage.**

2. Disconnect the harness connector.
3. Remove the front power window/door lock switch and finisher (2) assembly from the front door finisher.
4. Release the four tabs (A), two on each side, then separate the front power window/door lock switch (1) from the front power window/door lock switch finisher (2).

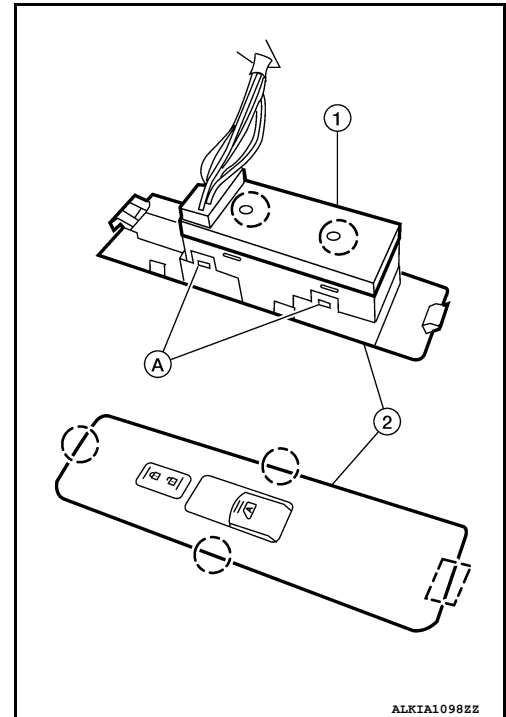

#### INSTALLATION

Installation is in the reverse order of removal.

# REAR POWER WINDOW SWITCH

< REMOVAL AND INSTALLATION >

## REAR POWER WINDOW SWITCH

### Removal and Installation - Rear Door Switch (If Equipped)

INFOID:000000008789434

#### REMOVAL

1. Using a suitable tool, release the metal clip and pawls, then lift upward the rear power window switch and finisher (2) as an assembly.

□: Metal clip

○: Pawl

**CAUTION:**

**Wrap a cloth around suitable tool to protect components from damage.**

2. Disconnect the harness connector.
3. Remove the rear power window switch and finisher (2) assembly from the rear door finisher.
4. Release the two tabs (A), one on each side, then separate the rear power window switch (1) from the rear power window switch finisher (2).

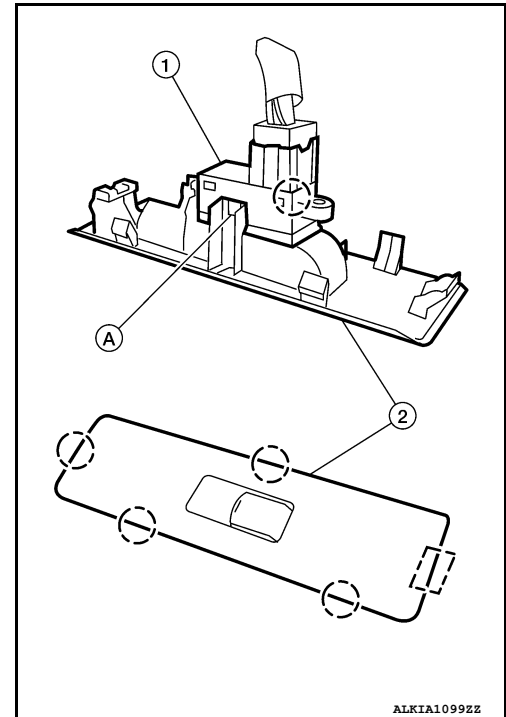

#### INSTALLATION

Installation is in the reverse order of removal.

A

B

C

D

E

F

G

H

I

J

PWC

L

M

N

O

P