

A
B
C

TM

SECTION

TRANSAXLE & TRANSMISSION

TM

CONTENTS

FS5R30A		
PRECAUTION	AIR BREATHER HOSE	19
	Removal and Installation	19
PRECAUTIONS	UNIT REMOVAL AND INSTALLATION	21
Precaution for Supplemental Restraint System (SRS) "AIR BAG" and "SEAT BELT PRE-TENSIONER"	TRANSMISSION ASSEMBLY	21
Precaution for Work	Removal and Installation from Vehicle	21
Service Notice or Precaution	UNIT DISASSEMBLY AND ASSEMBLY ...	23
PREPARATION	TRANSMISSION ASSEMBLY	23
	Overhaul	23
PREPARATION	CASE COMPONENTS	30
Special Service Tool	Disassembly	30
Commercial Service Tool	Assembly	32
SYMPTOM DIAGNOSIS	SHIFT CONTROL COMPONENTS	35
NOISE, VIBRATION AND HARSHNESS (NVH) TROUBLESHOOTING	Disassembly	35
NVH Troubleshooting Chart	Inspection	35
DESCRIPTION	Assembly	36
Description	GEAR COMPONENTS	37
PERIODIC MAINTENANCE	Disassembly	37
M/T OIL	Inspection	41
Changing	Assembly	43
Checking	SERVICE DATA AND SPECIFICATIONS (SDS)	53
REMOVAL AND INSTALLATION	SERVICE DATA AND SPECIFICATIONS (SDS)	53
REAR OIL SEAL	General Specification	53
Removal and Installation	Gear End Play	54
POSITION SWITCH	Baulk Ring Clearance	54
Checking	Available Snap Rings	54
SHIFT CONTROL	Available C-Rings	55
Removal and Installation	Available Thrust Washer	55
	Available Shims	55
	6MT: FS6R31A	
	PRECAUTION	56

PRECAUTIONS	56	GEAR COMPONENTS	102
Precaution for Supplemental Restraint System (SRS) "AIR BAG" and "SEAT BELT PRE-TENSIONER"	56	Disassembly	102
Precaution for Work	56	Inspection	108
Service Notice or Precaution	56	Assembly	111
PREPARATION	58	SERVICE DATA AND SPECIFICATIONS (SDS)	125
PREPARATION	58	SERVICE DATA AND SPECIFICATIONS (SDS)	125
Special Service Tool	58	General Specification	125
Commercial Service Tool	60	Gear End Play	126
SYMPTOM DIAGNOSIS	62	Snap Rings	126
NOISE, VIBRATION AND HARSHNESS (NVH) TROUBLESHOOTING	62	Baulk Ring Clearance	126
NVH Troubleshooting Chart	62	5AT: RE5R05A	
DESCRIPTION	63	BASIC INSPECTION	128
Cross-Sectional View	63	DIAGNOSIS AND REPAIR WORKFLOW	128
PERIODIC MAINTENANCE	65	How to Perform Trouble Diagnosis for Quick and Accurate Repair	128
M/T OIL	65	Diagnostic Work Sheet	129
Changing	65	SYSTEM DESCRIPTION	131
Checking	65	A/T CONTROL SYSTEM	131
REMOVAL AND INSTALLATION	66	Cross-Sectional View	131
REAR OIL SEAL	66	Shift Mechanism	132
Removal and Installation	66	TCM Function	143
POSITION SWITCH	68	CAN Communication	144
Checking	68	Input/Output Signal of TCM	145
SHIFT CONTROL	69	Line Pressure Control	145
Removal and Installation	69	Shift Control	147
AIR BREATHER HOSE	71	Lock-up Control	148
Removal and Installation	71	Engine Brake Control	149
UNIT REMOVAL AND INSTALLATION	72	Control Valve	149
TRANSMISSION ASSEMBLY	72	A/T Electrical Parts Location	151
Removal and Installation from Vehicle (For 2WD Models)	72	A/T SHIFT LOCK SYSTEM	153
Removal and Installation from Vehicle (For 4WD Models)	74	System Description	153
UNIT DISASSEMBLY AND ASSEMBLY ...	77	Component Parts Location	153
TRANSMISSION ASSEMBLY	77	ON BOARD DIAGNOSTIC (OBD) SYSTEM ...	154
Overhaul	77	Introduction	154
CASE COMPONENTS	83	OBD-II Function for A/T System	154
Disassembly	83	One or Two Trip Detection Logic of OBD-II	154
Assembly	87	OBD-II Diagnostic Trouble Code (DTC)	154
SHIFT CONTROL COMPONENTS	94	Malfunction Indicator Lamp (MIL)	155
Disassembly	94	DIAGNOSIS SYSTEM (TCM)	156
Inspection	97	CONSULT Function (TRANSMISSION)	156
Assembly	97	Diagnosis Procedure without CONSULT	161
		DTC/CIRCUIT DIAGNOSIS	164
		U0100 LOST COMMUNICATION (ECM A)	164
		Description	164
		On Board Diagnosis Logic	164
		Possible Cause	164
		DTC Confirmation Procedure	164
		Diagnosis Procedure	164

U1000 CAN COMM CIRCUIT	165	Description	178	
Description	165	On Board Diagnosis Logic	178	A
On Board Diagnosis Logic	165	Possible Cause	178	
Possible Cause	165	DTC Confirmation Procedure	178	
DTC Confirmation Procedure	165	Diagnosis Procedure	179	B
Diagnosis Procedure	165	P0732 2GR INCORRECT RATIO	180	
P0615 STARTER RELAY	166	Description	180	C
Description	166	On Board Diagnosis Logic	180	
CONSULT Reference Value in Data Monitor		Possible Cause	180	
Mode	166	DTC Confirmation Procedure	180	
On Board Diagnosis Logic	166	Diagnosis Procedure	181	TM
Possible Cause	166	P0733 3GR INCORRECT RATIO	182	
DTC Confirmation Procedure	166	Description	182	E
Diagnosis Procedure	166	On Board Diagnosis Logic	182	
P0700 TRANSMISSION CONTROL	168	Possible Cause	182	
Description	168	DTC Confirmation Procedure	182	F
On Board Diagnosis Logic	168	Diagnosis Procedure	183	
Possible Cause	168	P0734 4GR INCORRECT RATIO	184	
DTC Confirmation Procedure	168	Description	184	G
Diagnosis Procedure	168	On Board Diagnosis Logic	184	
P0705 TRANSMISSION RANGE SENSOR A	169	Possible Cause	184	
Description	169	DTC Confirmation Procedure	184	H
CONSULT Reference Value in Data Monitor		Diagnosis Procedure	185	
Mode	169	P0735 5GR INCORRECT RATIO	186	
On Board Diagnosis Logic	169	Description	186	I
Possible Cause	169	On Board Diagnosis Logic	186	
DTC Confirmation Procedure	169	Possible Cause	186	
Diagnosis Procedure	169	DTC Confirmation Procedure	186	J
P0717 INPUT SPEED SENSOR A	171	Diagnosis Procedure	187	
Description	171	P0740 TORQUE CONVERTER	188	
CONSULT Reference Value in Data Monitor		Description	188	K
Mode	171	CONSULT Reference Value in Data Monitor		
On Board Diagnosis Logic	171	Mode	188	
Possible Cause	171	On Board Diagnosis Logic	188	L
DTC Confirmation Procedure	171	Possible Cause	188	
Diagnosis Procedure	171	DTC Confirmation Procedure	188	
P0720 OUTPUT SPEED SENSOR	173	Diagnosis Procedure	188	M
Description	173	P0744 TORQUE CONVERTER	190	
CONSULT Reference Value in Data Monitor		Description	190	
Mode	173	CONSULT Reference Value in Data Monitor		N
On Board Diagnosis Logic	173	Mode	190	
Possible Cause	173	On Board Diagnosis Logic	190	
DTC Confirmation Procedure	173	Possible Cause	190	O
Diagnosis Procedure	174	DTC Confirmation Procedure	190	
P0725 ENGINE SPEED	176	Diagnosis Procedure	190	
Description	176	P0745 PRESSURE CONTROL SOLENOID A	192	
CONSULT Reference Value in Data Monitor		Description	192	P
Mode	176	CONSULT Reference Value in Data Monitor		
On Board Diagnosis Logic	176	Mode	192	
Possible Cause	176	On Board Diagnosis Logic	192	
DTC Confirmation Procedure	176	Possible Cause	192	
Diagnosis Procedure	176	DTC Confirmation Procedure	192	
P0731 1GR INCORRECT RATIO	178	Diagnosis Procedure	192	

P1705 TP SENSOR	194	Possible Cause	206
Description	194	DTC Confirmation Procedure	206
CONSULT Reference Value in Data Monitor		Diagnosis Procedure	206
Mode	194		
On Board Diagnosis Logic	194	P1762 DIRECT CLUTCH SOLENOID	208
Possible Cause	194	Description	208
DTC Confirmation Procedure	194	CONSULT Reference Value in Data Monitor	
Diagnosis Procedure	194	Mode	208
		On Board Diagnosis Logic	208
P1710 TRANSMISSION FLUID TEMPERATURE SENSOR	196	Possible Cause	208
Description	196	DTC Confirmation Procedure	208
CONSULT Reference Value in Data Monitor		Diagnosis Procedure	208
Mode	196		
On Board Diagnosis Logic	196	P1767 HIGH AND LOW REVERSE CLUTCH SOLENOID	210
Possible Cause	196	Description	210
DTC Confirmation Procedure	196	CONSULT Reference Value in Data Monitor	
Diagnosis Procedure	196	Mode	210
Component Inspection	197	On Board Diagnosis Logic	210
		Possible Cause	210
P1721 VEHICLE SPEED SIGNAL	198	DTC Confirmation Procedure	210
Description	198	Diagnosis Procedure	210
CONSULT Reference Value in Data Monitor			
Mode	198	P1772 LOW COAST BRAKE SOLENOID	212
On Board Diagnosis Logic	198	Description	212
Possible Cause	198	CONSULT Reference Value in Data Monitor	
DTC Confirmation Procedure	198	Mode	212
Diagnosis Procedure	198	On Board Diagnosis Logic	212
		Possible Cause	212
P1730 INTERLOCK	200	DTC Confirmation Procedure	212
Description	200	Diagnosis Procedure	212
On Board Diagnosis Logic	200		
Possible Cause	200	P1774 LOW COAST BRAKE SOLENOID	214
DTC Confirmation Procedure	200	Description	214
Judgment of Interlock	200	CONSULT Reference Value in Data Monitor	
Diagnosis Procedure	200	Mode	214
		On Board Diagnosis Logic	214
P1731 1ST ENGINE BRAKING	202	Possible Cause	214
Description	202	DTC Confirmation Procedure	214
CONSULT Reference Value in Data Monitor		Diagnosis Procedure	215
Mode	202		
On Board Diagnosis Logic	202	MAIN POWER SUPPLY AND GROUND CIRCUIT	216
Possible Cause	202	Diagnosis Procedure	216
DTC Confirmation Procedure	202		
Diagnosis Procedure	202	CLOSED THROTTLE POSITION AND WIDE OPEN THROTTLE POSITION CIRCUIT	218
		CONSULT Reference Value in Data Monitor	
P1752 INPUT CLUTCH SOLENOID	204	Mode	218
Description	204	Diagnosis Procedure	218
CONSULT Reference Value in Data Monitor			
Mode	204	BRAKE SIGNAL CIRCUIT	219
On Board Diagnosis Logic	204	CONSULT Reference Value in Data Monitor	
Possible Cause	204	Mode	219
DTC Confirmation Procedure	204	Diagnosis Procedure	219
Diagnosis Procedure	204		
		A/T SHIFT LOCK SYSTEM	220
P1757 FRONT BRAKE SOLENOID	206	Description	220
Description	206	Diagnosis Procedure	220
CONSULT Reference Value in Data Monitor			
Mode	206	OVERDRIVE CONTROL SWITCH	222
On Board Diagnosis Logic	206		

CONSULT Reference Value in Data Monitor	Description	277	
Mode	Check Before Engine Is Started	277	A
Diagnosis Procedure	Check at Idle	277	
1ST POSITION SWITCH	Cruise Test - Part 1	278	
CONSULT Reference Value in Data Monitor	Cruise Test - Part 2	280	B
Mode	Cruise Test - Part 3	280	
Diagnosis Procedure	REMOVAL AND INSTALLATION	282	C
ECU DIAGNOSIS INFORMATION	SHIFT CONTROL SYSTEM	282	
TCM	Exploded view	282	
Reference Value	Removal and Installation	282	TM
Fail-Safe	Inspection and Adjustment	283	
DTC Inspection Priority Chart	OIL PAN	284	
DTC No. Index	Removal and Installation	284	E
WIRING DIAGRAM	CONTROL VALVE WITH TCM	286	
A/T CONTROL SYSTEM	Removal and Installation	286	F
Wiring Diagram	REAR OIL SEAL	294	
A/T SHIFT LOCK SYSTEM	Removal and Installation	294	G
Wiring Diagram	KEY INTERLOCK CABLE	295	
SYMPTOM DIAGNOSIS	Component	295	H
SYSTEM SYMPTOM	Removal and Installation	295	
Symptom Chart	AIR BREATHER HOSE	298	
PRECAUTION	Removal and Installation for QR25DE Engine	298	I
PRECAUTIONS	Removal and Installation for VQ40DE Engine	298	
Precaution for Supplemental Restraint System (SRS) "AIR BAG" and "SEAT BELT PRE-TENSIONER"	A/T FLUID COOLER	301	J
Precaution for Work	Removal and Installation	301	
Precaution for On Board Diagnosis (OBD) System of A/T and Engine	UNIT REMOVAL AND INSTALLATION ...	302	K
Precaution	TRANSMISSION ASSEMBLY	302	
Service Notice or Precaution	Component	302	L
PREPARATION	Removal and Installation for QR25DE	304	
PREPARATION	Removal and Installation for VQ40DE 2WD Models	306	M
Special Service Tool	Removal and Installation for VQ40DE 4WD Models	308	
Commercial Service Tool	UNIT DISASSEMBLY AND ASSEMBLY .	311	N
PERIODIC MAINTENANCE	OVERHAUL	311	
A/T FLUID	Exploded View	311	O
Checking the A/T Fluid (ATF)	Oil Channel	318	
Changing the A/T Fluid (ATF)	Location of Adjusting Shims, Needle Bearings, Thrust Washers and Snap Rings	320	P
A/T Fluid Cooler Cleaning	DISASSEMBLY	322	
INSPECTIONS BEFORE TROUBLE DIAGNOSIS	Disassembly	322	
Fluid Condition Check	OIL PUMP	341	
Stall Test	Exploded View	341	
Line Pressure Test	Disassembly and Assembly	341	
ROAD TEST	FRONT SUN GEAR, 3RD ONE-WAY CLUTCH	344	
	Exploded View	344	

Disassembly and Assembly	344	Assembly (2)	377
FRONT CARRIER, INPUT CLUTCH, REAR INTERNAL GEAR	346	SERVICE DATA AND SPECIFICATIONS (SDS)	383
Front Carrier, Input Clutch, Rear Internal Gear	346	SERVICE DATA AND SPECIFICATIONS (SDS)	383
MID SUN GEAR, REAR SUN GEAR, HIGH AND LOW REVERSE CLUTCH HUB	351	General Specification	383
Mid Sun Gear, Rear Sun Gear, High and Low Re- verse Clutch Hub	351	Vehicle Speed at Which Gear Shifting Occurs	383
HIGH AND LOW REVERSE CLUTCH	356	Vehicle Speed at Which Lock-up Occurs/Releas- es	384
High and Low Reverse Clutch	356	Stall Speed	385
DIRECT CLUTCH	358	Line Pressure	385
Direct Clutch	358	A/T Fluid Temperature Sensor	385
ASSEMBLY	361	Input Speed Sensor	386
Assembly (1)	361	Output Speed Sensor	386
Adjustment	374	Reverse brake	386
		Total End Play	386

PRECAUTION

PRECAUTIONS

Precaution for Supplemental Restraint System (SRS) "AIR BAG" and "SEAT BELT PRE-TENSIONER"

INFOID:000000008790740

The Supplemental Restraint System such as "AIR BAG" and "SEAT BELT PRE-TENSIONER", used along with a front seat belt, helps to reduce the risk or severity of injury to the driver and front passenger for certain types of collision. This system includes seat belt switch inputs and dual stage front air bag modules. The SRS system uses the seat belt switches to determine the front air bag deployment, and may only deploy one front air bag, depending on the severity of a collision and whether the front occupants are belted or unbelted. Information necessary to service the system safely is included in the SR and SB section of this Service Manual.

WARNING:

- To avoid rendering the SRS inoperative, which could increase the risk of personal injury or death in the event of a collision which would result in air bag inflation, all maintenance must be performed by an authorized NISSAN/INFINITI dealer.
- Improper maintenance, including incorrect removal and installation of the SRS, can lead to personal injury caused by unintentional activation of the system. For removal of Spiral Cable and Air Bag Module, see the SR section.
- Do not use electrical test equipment on any circuit related to the SRS unless instructed to in this Service Manual. SRS wiring harnesses can be identified by yellow and/or orange harnesses or harness connectors.

PRECAUTIONS WHEN USING POWER TOOLS (AIR OR ELECTRIC) AND HAMMERS

WARNING:

- When working near the Airbag Diagnosis Sensor Unit or other Airbag System sensors with the Ignition ON or engine running, DO NOT use air or electric power tools or strike near the sensor(s) with a hammer. Heavy vibration could activate the sensor(s) and deploy the air bag(s), possibly causing serious injury.
- When using air or electric power tools or hammers, always switch the Ignition OFF, disconnect the battery, and wait at least 3 minutes before performing any service.

Precaution for Work

INFOID:000000009249564

- When removing or disassembling each component, be careful not to damage or deform it. If a component may be subject to interference, be sure to protect it with a shop cloth.
- When removing (disengaging) components with a screwdriver or similar tool, be sure to wrap the component with a shop cloth or vinyl tape to protect it.
- Protect the removed parts with a shop cloth and prevent them from being dropped.
- Replace a deformed or damaged clip.
- If a part is specified as a non-reusable part, always replace it with a new one.
- Be sure to tighten bolts and nuts securely to the specified torque.
- After installation is complete, be sure to check that each part works properly.
- Follow the steps below to clean components:
 - Water soluble dirt:
 - Dip a soft cloth into lukewarm water, wring the water out of the cloth and wipe the dirty area.
 - Then rub with a soft, dry cloth.
 - Oily dirt:
 - Dip a soft cloth into lukewarm water with mild detergent (concentration: within 2 to 3%) and wipe the dirty area.
 - Then dip a cloth into fresh water, wring the water out of the cloth and wipe the detergent off.
 - Then rub with a soft, dry cloth.
 - Do not use organic solvent such as thinner, benzene, alcohol or gasoline.
 - For genuine leather seats, use a genuine leather seat cleaner.

Service Notice or Precaution

INFOID:000000008790742

- Do not reuse transmission oil once it has been drained.
- Check oil level or replace oil with vehicle on level surface.

A
B
C
TM
E
F
G
H
I
J
K
L
M
N
O
P

PRECAUTIONS

[FS5R30A]

< PRECAUTION >

- During removal or installation, keep inside of transmission clear of dust or dirt.
- Check for the correct installation status prior to removal or disassembly. If matching marks are required, be certain they do not interfere with the function of the parts they are applied to.
- In principle, tighten nuts and bolts gradually in several steps working diagonally from inside to outside. If tightening sequence is specified, use it.
- Be careful not to damage sliding surfaces and mating surfaces.

PREPARATION

< PREPARATION >

[FS5R30A]

PREPARATION

PREPARATION

Special Service Tool

INFOID:000000008790743

The actual shapes of Kent-Moore tools may differ from those of special service tools illustrated here.

Tool number (Kent-Moore No.) Tool name	Description
ST23540000 (J-25689-A) Pin punch <div data-bbox="646 541 902 705" data-label="Image"> <p>NT442</p> </div>	Removing and installing retaining pin a: 2.3 mm (0.091 in) dia. b: 4 mm (0.16 in) dia.
ST30031000 (J-22912-01) Puller <div data-bbox="678 768 873 953" data-label="Image"> <p>NT411</p> </div>	<ul style="list-style-type: none"> Removing 1st and 2nd synchronizer assembly Removing counter gear rear thrust bearing Removing main drive bearing Inspecting baulk ring wear a: 90 mm (3.54 in) dia. b: 50 mm (1.97 in) dia.
ST33290001 (J-34286) Puller <div data-bbox="662 1016 880 1205" data-label="Image"> <p>WMT066</p> </div>	Removing rear oil seal
ST33230000 () Drift <div data-bbox="646 1283 906 1457" data-label="Image"> <p>NT084</p> </div>	Removing counter gear a: 51 mm (2.01 in) dia. b: 28.5 mm (1.122 in) dia.
ST22350000 (J-25678-01) Drift <div data-bbox="607 1503 857 1709" data-label="Image"> <p>NT065</p> </div>	Removing counter gear front bearing (Use with KV38100300) a: 34 mm (1.34 in) dia. b: 28 mm (1.10 in) dia.
KV38100300 (J-25523) Drift <div data-bbox="646 1787 906 1961" data-label="Image"> <p>NT084</p> </div>	<ul style="list-style-type: none"> Removing counter gear front bearing (Use with ST22350000) Installing counter gear rear bearing a: 54 mm (2.13 in) dia. b: 32 mm (1.26 in) dia.

PREPARATION

< PREPARATION >

[FS5R30A]

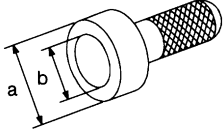
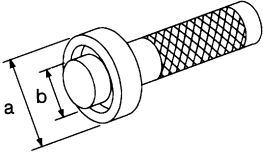
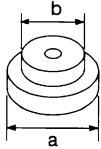
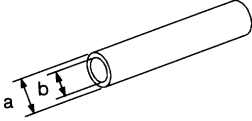
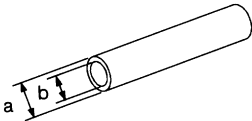
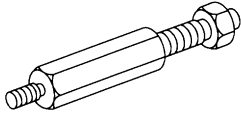
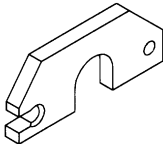
Tool number (Kent-Moore No.) Tool name	Description
ST30720000 1. (—) 2. (J-25405) Drift <div style="text-align: center;">  <p style="font-size: small;">NT115</p> </div>	<ul style="list-style-type: none"> • Removing and installing mainshaft front bearing • Installing rear oil seal a: 77 mm (3.03 in) dia. b: 55.5 mm (2.185 in) dia.
ST33210000 1. (J-25523) 2. (J-25803-01) Drift <div style="text-align: center;">  <p style="font-size: small;">NT084</p> </div>	<ul style="list-style-type: none"> • Installing counter gear front bearing • Installing front cover oil seal a: 44 mm (1.73 in) dia. b: 24.5 mm (0.965 in) dia.
ST30613000 (J-25742-3) Drift <div style="text-align: center;">  <p style="font-size: small;">NT073</p> </div>	Installing main drive gear bearing a: 72 mm (2.83 in) dia. b: 48 mm (1.89 in) dia.
ST37750000 1. (J-25863-01) 2. (J-34332) 3. (J-34334) 4. (J-25679-01) Drift <div style="text-align: center;">  <p style="font-size: small;">NT065</p> </div>	<ul style="list-style-type: none"> • Removing counter gear rear bearing • Installing OD gear bushing • Installing reverse cone • Installing reverse counter gear • Installing counter gear rear end bearing a: 40 mm (1.57 in) dia. b: 31 mm (1.22 in) dia.
ST22452000 (J-34337) Drift <div style="text-align: center;">  <p style="font-size: small;">NT065</p> </div>	Installing reverse synchronizer hub a: 45 mm (1.77 in) dia. b: 36 mm (1.42 in) dia.
— (J-26349-3) Puller leg <div style="text-align: center;">  <p style="font-size: small;">NT078</p> </div>	Installing mainshaft and counter gear (Use with J-34328)
— (J-34328) Puller <div style="text-align: center;">  <p style="font-size: small;">NT079</p> </div>	Installing mainshaft and counter gear (Use with J-26349-3)

PREPARATION

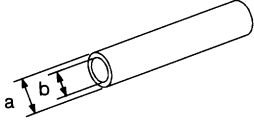
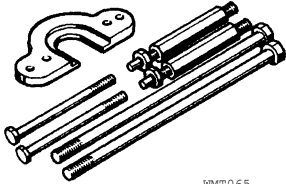
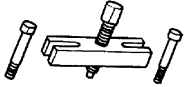
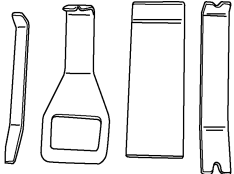

< PREPARATION >

[FS5R30A]

Tool number (Kent-Moore No.) Tool name	Description
<p>— (J-34342) Drift</p>  <p style="text-align: center;">NT065</p>	<ul style="list-style-type: none"> • Installing OD main gear • Installing reverse gear bushing <p>a: 44.5 mm (1.752 in) dia. b: 40.5 mm (1.594 in) dia.</p>
<p>— (J-26349-A) Bearing Remover and Installer Set</p>  <p style="text-align: center;">WMT065</p>	<p>Removing and installing mainshaft rear bearing (Use with J-25726-B)</p>
<p>— (J-25726-B) Puller</p>  <p style="text-align: center;">ZZA0010D</p>	<p>Removing and installing mainshaft rear bearing (Use with J-26349-A)</p>
<p>— (J-46534) Trim Tool Set</p>  <p style="text-align: center;">ANJIA0483ZZ</p>	<p>Removing trim components</p>

Commercial Service Tool

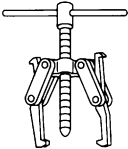
INFOID:000000008790744

Tool name	Description
<p>Puller</p>  <p style="text-align: center;">NT077</p>	<ul style="list-style-type: none"> • Removing counter gear rear end bearing • Removing reverse synchronizer hub • Removing reverse cone • Removing reverse gear bushing • Removing reverse counter gear
<p>Power tool</p>  <p style="text-align: center;">PIIB1407E</p>	<p>Loosening nuts, screws and bolts</p>

NOISE, VIBRATION AND HARSHNESS (NVH) TROUBLESHOOTING

< SYMPTOM DIAGNOSIS >

[FS5R30A]

SYMPTOM DIAGNOSIS

NOISE, VIBRATION AND HARSHNESS (NVH) TROUBLESHOOTING

NVH Troubleshooting Chart

INFOID:000000008790745

Use the chart below to help you find the cause of the problem. The numbers indicate the order of the inspection. If necessary, repair or replace these parts.

Reference page		TM-14			TM-23		TM-23			TM-23			
SUSPECTED PARTS (Possible cause)		OIL (Level low)	OIL (Wrong)	OIL (Level too high)	GASKET (Damaged)	OIL SEAL (Worn or damaged)	O-RING (Worn or damaged)	CHECK PLUG RETURN SPRING AND CHECK BALL (Worn or damaged)	SHIFT FORK (Worn)	GEAR (Worn or damaged)	BEARING (Worn or damaged)	BAULK RING (Worn or damaged)	INSERT SPRING (Damaged)
Symptom	Noise	1	2							3	3		
	Oil leakage		3	1	2	2	2						
	Hard to shift or will not shift		1	1								2	2
	Jumps out of gear							1	2	2			

DESCRIPTION

[FS5R30A]

< SYMPTOM DIAGNOSIS >

DESCRIPTION

Description

INFOID:000000008790746

CROSS-SECTIONAL VIEW

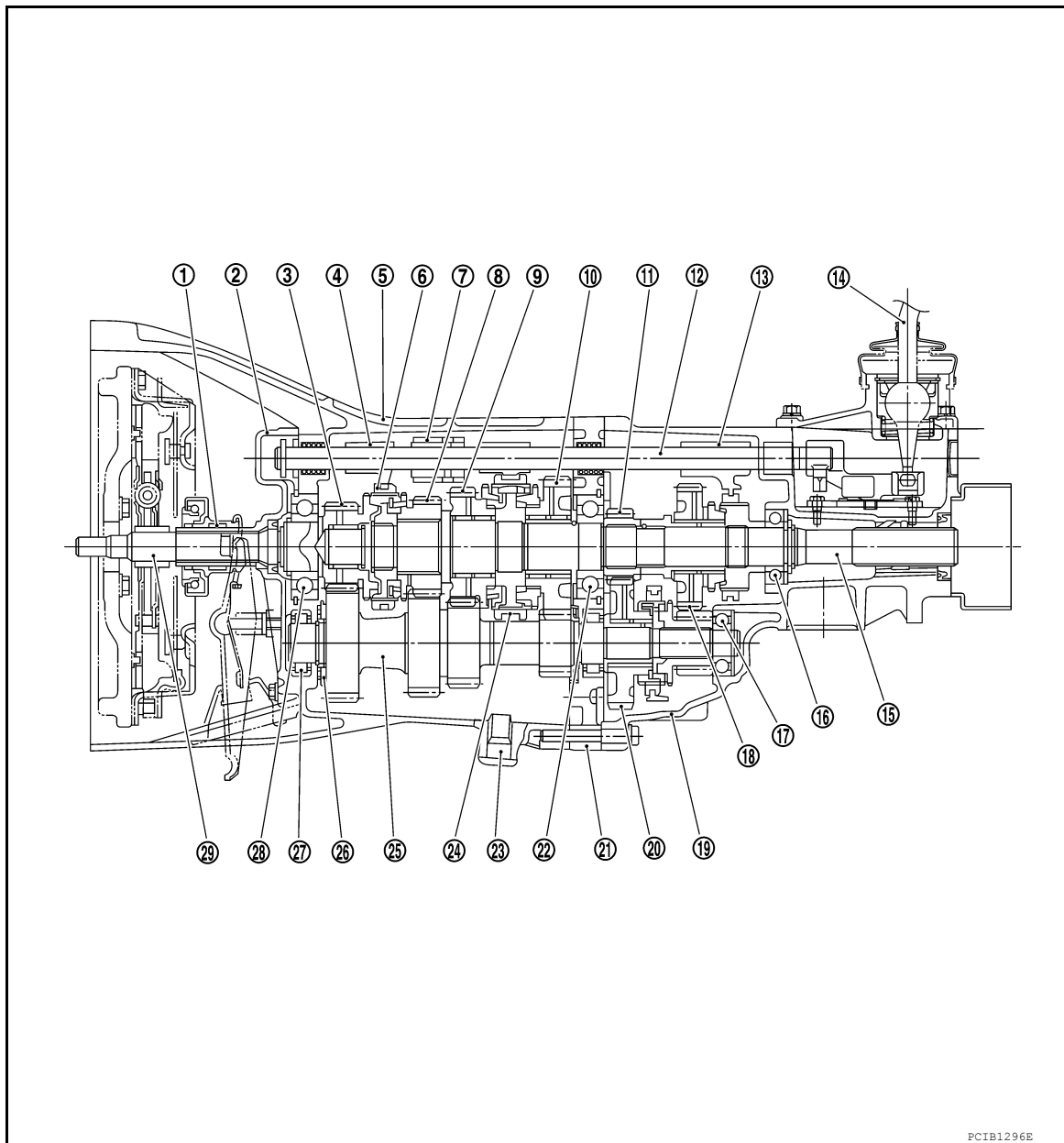

- | | | |
|-----------------------------|-----------------------------------|---------------------------------|
| 1. Release bearing sleeve | 2. Front cover | 3. Main drive gear |
| 4. 3rd and 4th shift fork | 5. Transmission case | 6. 3rd and 4th coupling sleeve |
| 7. Striking interlock | 8. 3rd main gear | 9. 2nd main gear |
| 10. 1st main gear | 11. OD main gear | 12. Striking rod |
| 13. Reverse shift fork | 14. Shift selector | 15. Mainshaft |
| 16. Mainshaft rear bearing | 17. Counter gear rear end bearing | 18. Reverse main gear |
| 19. Rear extension | 20. OD counter gear | 21. Adapter plate |
| 22. Mainshaft front bearing | 23. Drain plug | 24. 1st and 2nd coupling sleeve |
| 25. Counter gear | 26. Sub-gear bracket | 27. Counter gear front bearing |
| 28. Main drive gear bearing | 29. Main drive gear | |

A
B
C
TM
E
F
G
H
I
J
K
L
M
N
O
P

PERIODIC MAINTENANCE

M/T OIL

Changing

INFOID:000000008790747

DRAINING

1. Start the engine and let it run to warm up the transmission.
2. Stop the engine. Remove the transmission drain plug and drain the oil.
3. Set a gasket on the drain plug and install it to the transmission. Tighten the drain plug to the specified torque. Refer to [TM-23, "Overhaul"](#).

CAUTION:

Do no reuse gasket.

FILLING

1. Remove the filler plug. Fill with new oil until oil level reaches the specified limit near the filler plug hole.

Oil grade and Viscosity:

Refer to [MA-17, "FOR USA AND CANADA : Fluids and Lubricants"](#).

Oil capacity:

Refer to [MA-17, "FOR USA AND CANADA : Fluids and Lubricants"](#).

2. After refilling the oil, check oil level. Set a gasket to the filler plug, then install it to the transmission. Tighten the filler plug to the specified torque. Refer to [TM-23, "Overhaul"](#).

CAUTION:

Do not reuse gasket.

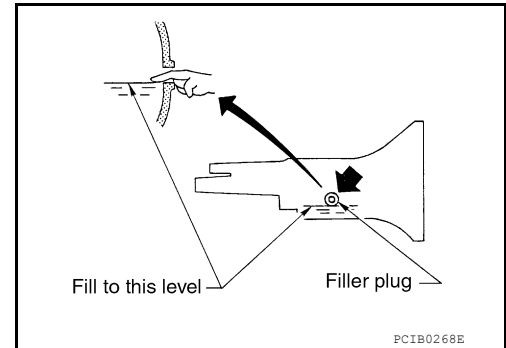

Checking

INFOID:000000008790748

OIL LEAKAGE AND OIL LEVEL

1. Make sure that oil is not leaking from the transmission or around it.
2. Check oil level from the filler plug hole as shown.

CAUTION:

Do not start engine while checking oil level.

3. Set a gasket on the filler plug and install it to the transmission. Tighten the filler plug to the specified torque. Refer to [TM-23, "Overhaul"](#).

CAUTION:

Do not reuse gasket.

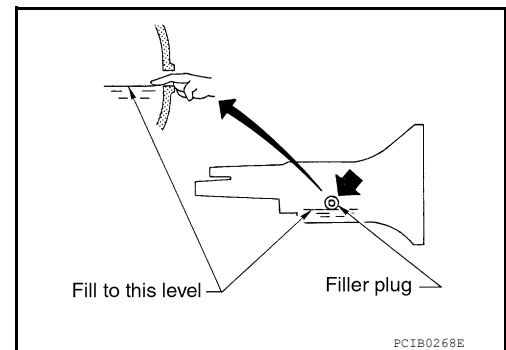

REMOVAL AND INSTALLATION

REAR OIL SEAL

Removal and Installation

INFOID:000000008790749

REMOVAL

1. Remove the rear propeller shaft. Refer to [DLN-144. "Removal and Installation"](#).
2. Remove the rear oil seal using Tool.

Tool number : ST33290001 (J-34286)

CAUTION:

Do not reuse rear oil seal.

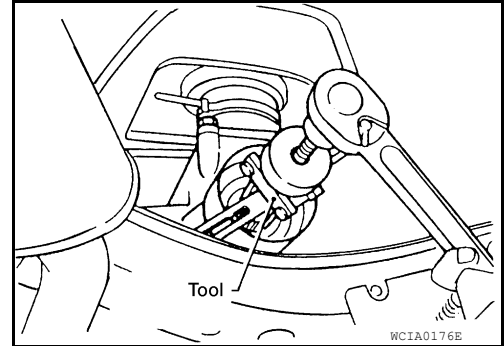

INSTALLATION

Installation is the reverse order of removal.

- Drive the new oil seal straight until it stops using Tool.

Tool number : ST30720000 (J-25405)

CAUTION:

- **Do not reuse rear oil seal.**
 - **Apply multi-purpose grease to oil seal lips before installing.**
 - **Do not incline rear oil seal during installation.**
- Check the transmission oil level after installation. Refer to [TM-14. "Checking"](#).

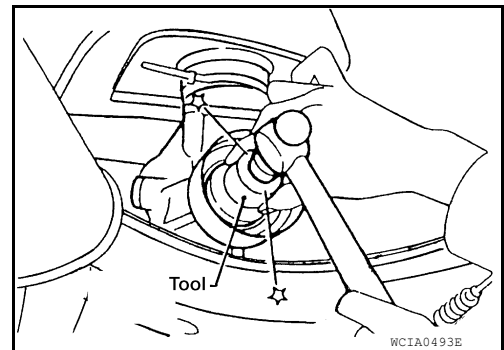

A
B
C
TM
E
F
G
H
I
J
K
L
M
N
O
P

POSITION SWITCH

< REMOVAL AND INSTALLATION >

[FS5R30A]

POSITION SWITCH

Checking

INFOID:000000008790750

BACK-UP LAMP SWITCH

- Check continuity.

Gear position	Continuity
Reverse	Yes
Except reverse	No

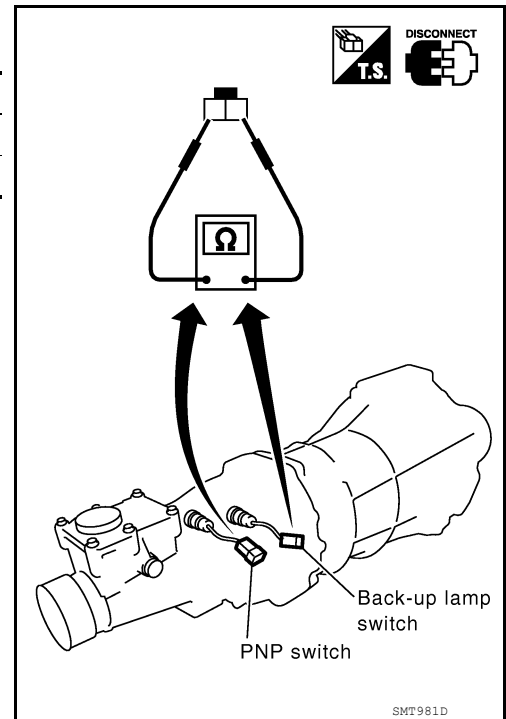

PARK/NEUTRAL POSITION SWITCH

- Check continuity.

Gear position	Continuity
Neutral	Yes
Except neutral	No

SHIFT CONTROL

< REMOVAL AND INSTALLATION >

[FS5R30A]

SHIFT CONTROL

Removal and Installation

INFOID:000000008790751

COMPONENTS

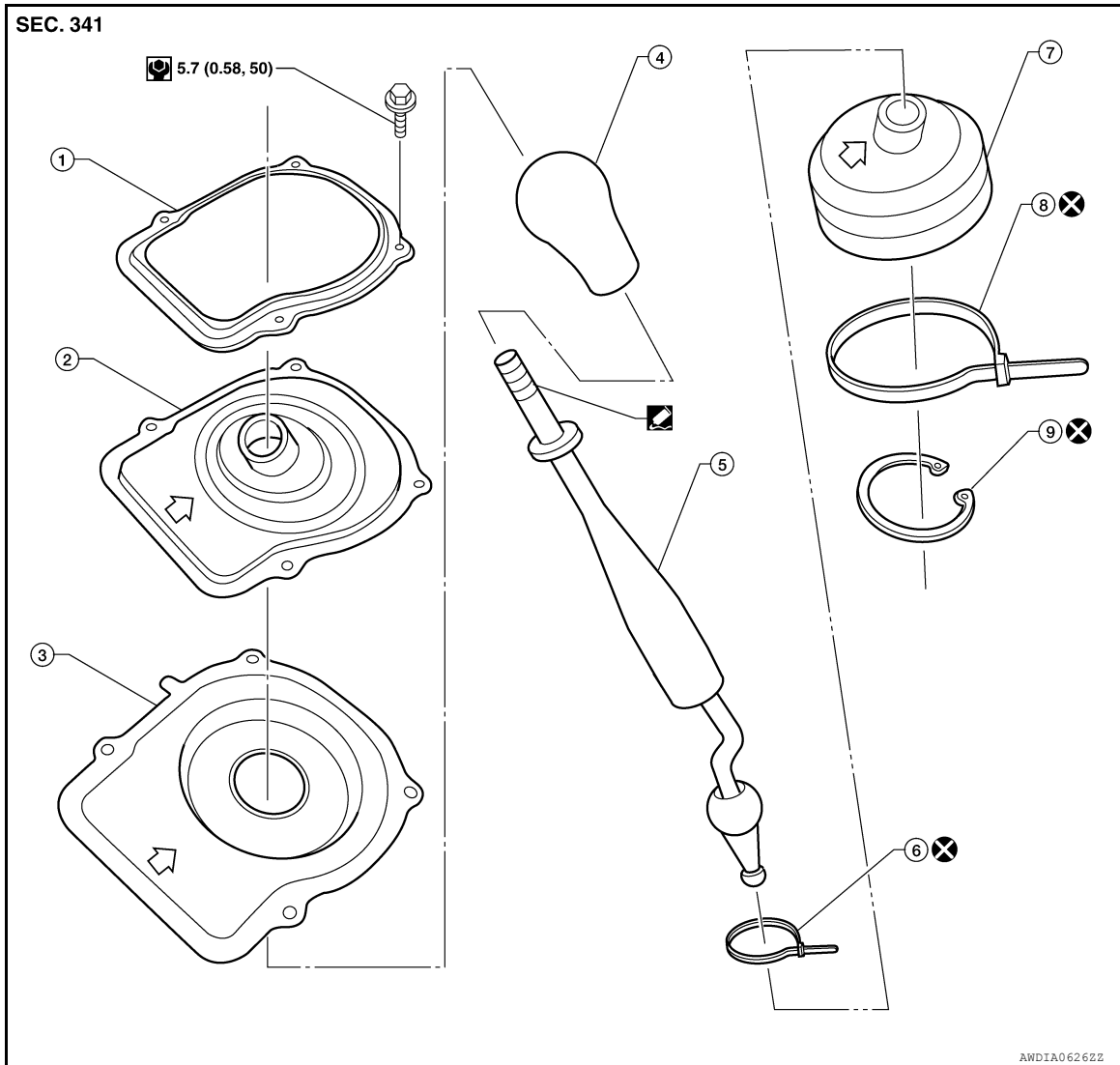

- | | | |
|--------------------------|----------------------------|----------------------------|
| 1. Retaining plate | 2. Dust boot cover (upper) | 3. Dust boot cover (lower) |
| 4. Shift selector handle | 5. Shift selector assembly | 6. Clip A |
| 7. Boot | 8. Clip B | 9. Snap ring |

REMOVAL

1. Remove the shift selector handle.
2. Remove the cup holder finisher and shift bezel. Refer to [IP-29, "Exploded View"](#).
3. Remove the retaining plate and dust boot covers.
4. Remove the clip B and then separate the boot from the control housing.
5. Remove the snap ring.
6. Remove the shift selector assembly from the transmission.

INSTALLATION

Installation is the reverse order of removal.

CAUTION:

- Do not reuse the clips and snap ring.

SHIFT CONTROL

< REMOVAL AND INSTALLATION >

[FS5R30A]

- **Apply cement to threads of the shift selector assembly.**
- **When shift selector assembly is moved to each position, make sure there is no binding or disconnection in either boot.**

AIR BREATHER HOSE

< REMOVAL AND INSTALLATION >

[FS5R30A]

AIR BREATHER HOSE

Removal and Installation

INFOID:000000008790752

COMPONENTS

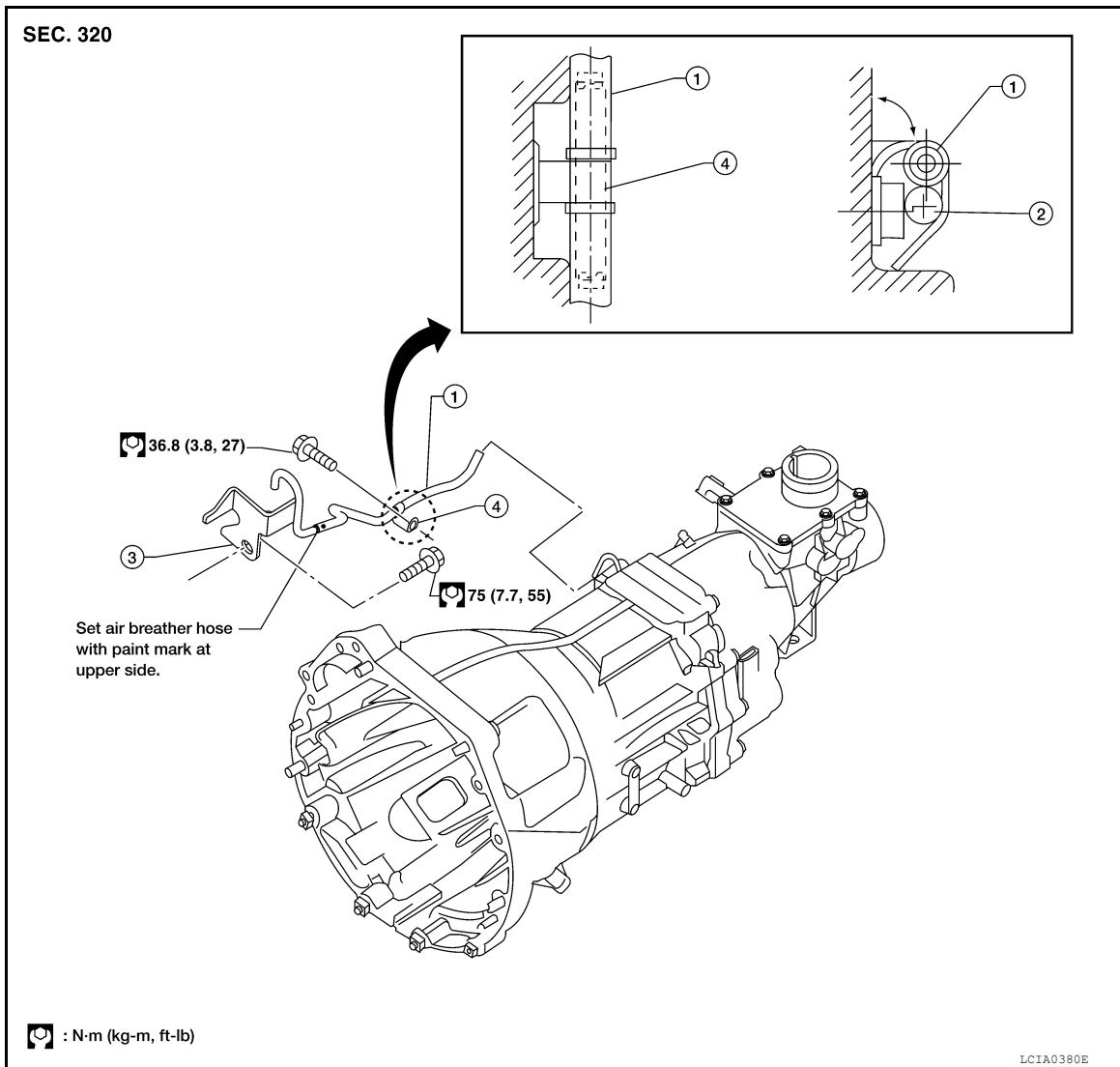

1. Air breather hose
2. Harness
3. Breather tube
4. Clip

REMOVAL

1. Disconnect air breather hose from breather tube and transmission harness connector.
2. Bend the clip away from the transmission housing and remove air breather hose.
3. Remove the clip bolt and remove the clip from the transmission housing, if necessary.
4. Remove the breather tube bolt and the breather tube.

INSTALLATION

Installation is in the reverse order of removal.

CAUTION:

- Make sure there are no pinched or blocked areas on the air breather hose after installation.
- When inserting the air breather hose, be sure to insert it fully until its end reaches the end of the tube radius.
- Install the air breather hose with the paint mark side up.
- Install the air breather hose and harness to the clip to prevent separation.

AIR BREATHER HOSE

< REMOVAL AND INSTALLATION >

[FS5R30A]

- Push the clip so that the harness contacts the clip bolt.

TRANSMISSION ASSEMBLY

< UNIT REMOVAL AND INSTALLATION >

[FS5R30A]

UNIT REMOVAL AND INSTALLATION

TRANSMISSION ASSEMBLY

Removal and Installation from Vehicle

INFOID:000000008790753

COMPONENTS

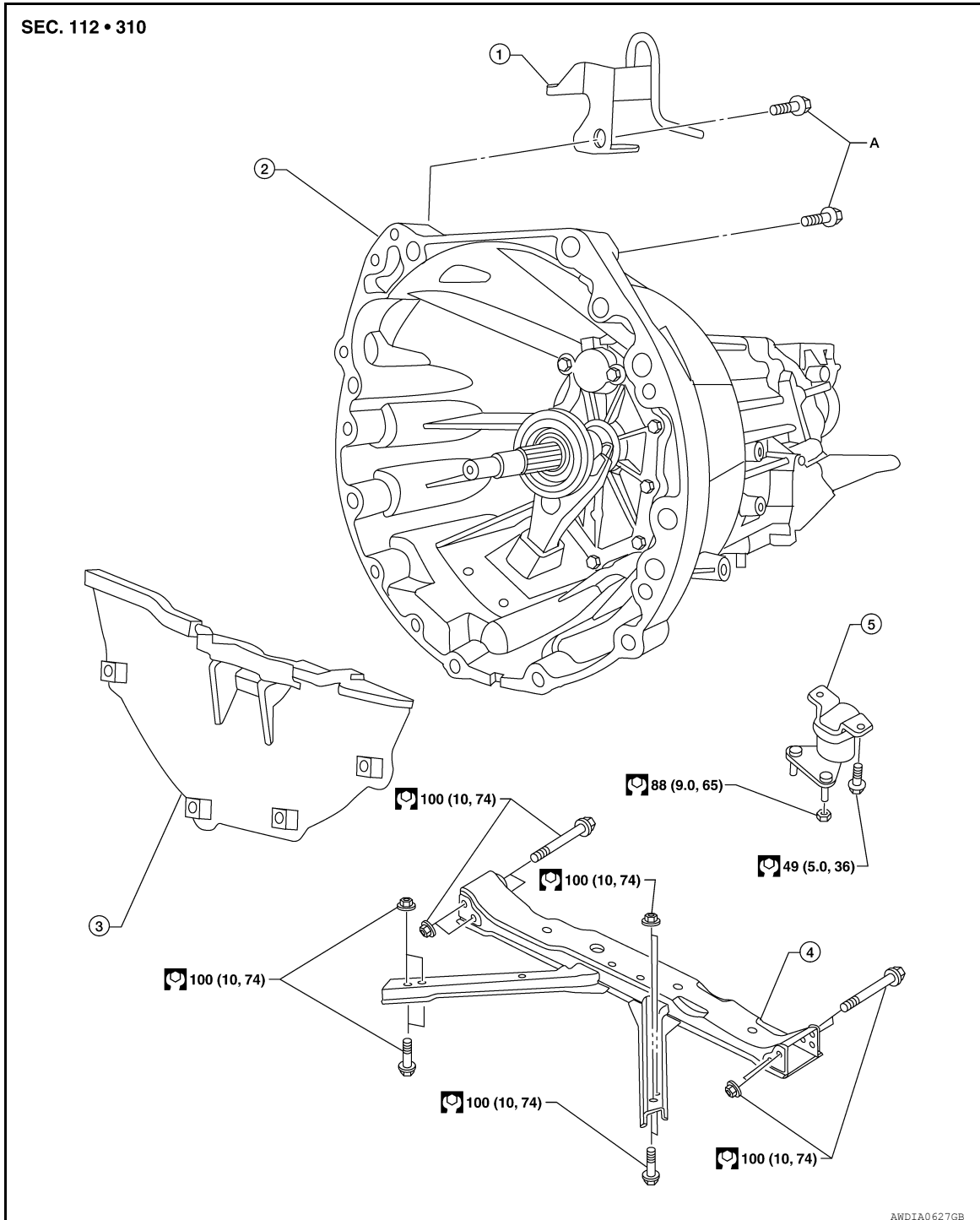

NOTE:

TRANSMISSION ASSEMBLY

[FS5R30A]

< UNIT REMOVAL AND INSTALLATION >

When removing components such as hoses, tubes/lines, etc., cap or plug openings to prevent fluid from spilling.

REMOVAL

1. Disconnect the battery cable from the negative terminal. Refer to [PG-82, "Removal and Installation"](#).
2. Remove the shift selector assembly. Refer to [TM-17, "Removal and Installation"](#).
3. Remove the rear propeller shaft. Refer to [DLN-175, "Removal and Installation"](#).
4. Remove the gusset.
5. Disconnect harness connector from the heated oxygen sensor and remove wire harness from transmission.
6. Disconnect harness connectors from the back-up lamp switch and park/neutral position (PNP) switch.
7. Remove the clutch operating cylinder from the transmission. Refer to [CL-14, "5M/T : Removal and Installation"](#).
8. Remove the starter motor. Refer to [STR-35, "Removal and Installation \(QR25DE\)"](#).
9. Support the transmission using a suitable jack.
10. Remove the transmission dust cover.
11. Remove the transmission to engine bolts.
12. Remove the nuts securing the insulator to the crossmember.
13. Remove the transmission crossmember using power tool.

WARNING:

Support the transmission using suitable jack.

14. Remove the air breather hose and breather tube. Refer to [TM-19, "Removal and Installation"](#).
15. Separate the transmission from the engine and remove it from the vehicle.

WARNING:

Support manual transmission while removing it using suitable jack.

INSTALLATION

Installation is in the reverse order of removal.

- When installing the transmission to the engine, install the bolts in accordance with the standard below.

Bolt No.	1	2	3
Quantity	4	1	6
Bolt length "ℓ" mm (in)	60 (2.36)		65 (2.56)
Tightening torque N·m (kg·m, ft·lb)	35 (3.6, 26)		75 (7.7, 55)

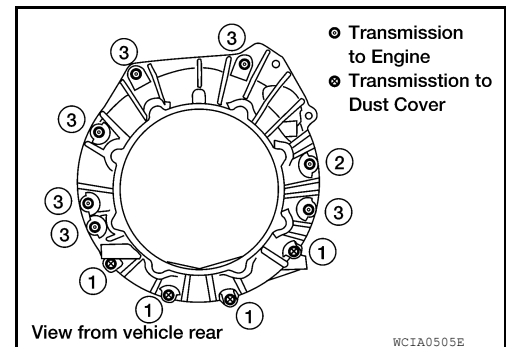

CAUTION:

- When installing be careful to avoid interference between transmission main drive gear and clutch cover.
- When replacing an engine or transmission you must make sure the dowels are installed correctly during re-assembly.
- Improper alignment caused by missing dowels may cause vibration oil leaks or breakage of drivetrain components.
- After installation, check for oil leakage and oil level. Refer to [TM-14, "Checking"](#).

TRANSMISSION ASSEMBLY

< UNIT DISASSEMBLY AND ASSEMBLY >

[FS5R30A]

UNIT DISASSEMBLY AND ASSEMBLY

TRANSMISSION ASSEMBLY

Overhaul

EXPLODED VIEW

INFOID:000000008790754

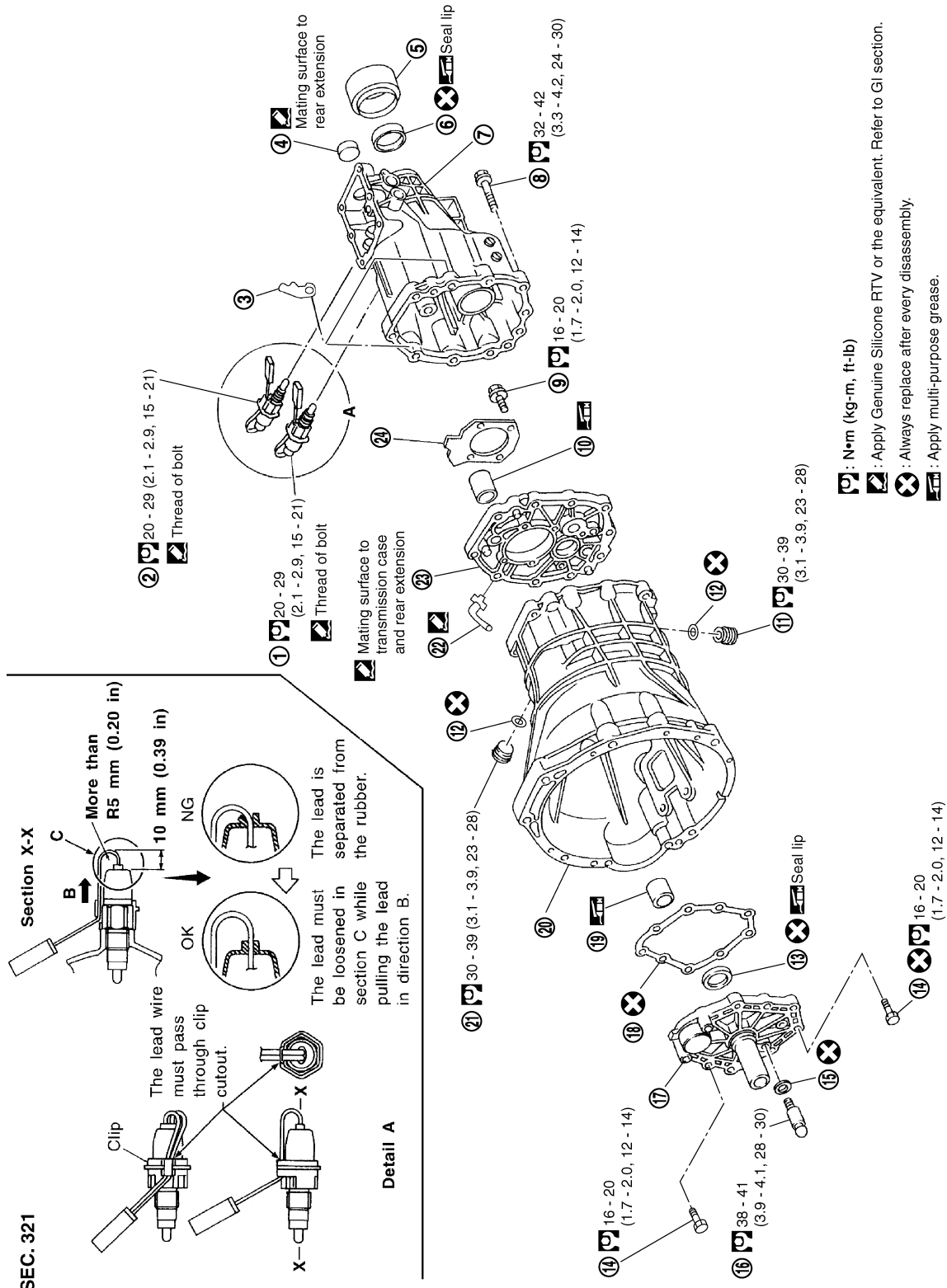

PCIB1281E

A
B
C
TM
E
F
G
H
I
J
K
L
M
N
O
P

TRANSMISSION ASSEMBLY

< UNIT DISASSEMBLY AND ASSEMBLY >

[FS5R30A]

- | | | |
|--------------------------|---------------------------------------|--------------------------|
| 1. Back-up lamp switch | 2. Park/neutral position (PNP) switch | 3. Clip |
| 4. Plug | 5. Dust cover | 6. Rear oil seal |
| 7. Rear extension | 8. Rear extension bolt | 9. Bearing retainer bolt |
| 10. Slide ball bearing | 11. Drain plug | 12. Gasket |
| 13. Front cover oil seal | 14. Front cover bolt | 15. Washer |
| 16. Ball pin | 17. Front cover | 18. Gasket |
| 19. Slide ball bearing | 20. Transmission case | 21. Filler plug |
| 22. Air breather | 23. Adapter plate | 24. Bearing retainer |

GEAR COMPONENTS

TRANSMISSION ASSEMBLY

< UNIT DISASSEMBLY AND ASSEMBLY >

[FS5R30A]

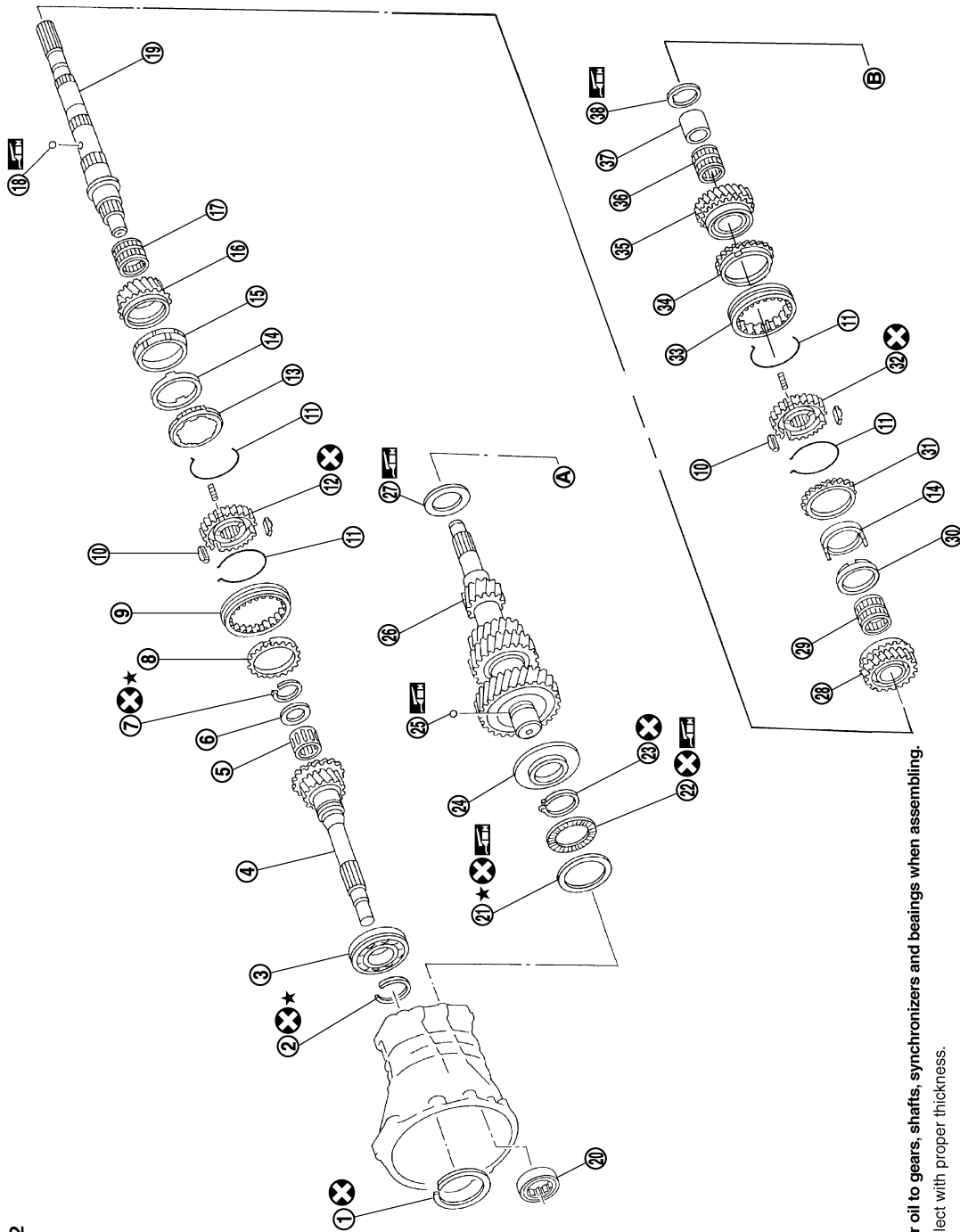

SEC. 322

Apply gear oil to gears, shafts, synchronizers and bearings when assembling.

★ : Select with proper thickness.

▣ : Apply multi-purpose grease.

⊗ : Always replace after every disassembly.

PCIB1282E

- | | | |
|--------------------------------------|------------------------------|--------------------------------------|
| 1. Main drive gear bearing snap ring | 2. Main drive gear snap ring | 3. Main drive gear bearing |
| 4. Main drive gear | 5. Pilot bearing | 6. Spacer |
| 7. Mainshaft front snap ring | 8. 4th baulk ring | 9. 3rd and 4th coupling sleeve |
| 10. Shifting insert | 11. Spread spring | 12. 3rd and 4th synchronizer hub |
| 13. 3rd outer baulk ring | 14. Synchronizer cone | 15. 3rd inner baulk ring |
| 16. 3rd main gear | 17. 3rd gear needle bearing | 18. Steel ball (For 1st gear washer) |

A
B
C
TM
E
F
G
H
I
J
K
L
M
N
O
P

TRANSMISSION ASSEMBLY

< UNIT DISASSEMBLY AND ASSEMBLY >

[FS5R30A]

-
- | | | |
|---------------------------------------|----------------------------------|--------------------------------------|
| 19. Mainshaft | 20. Counter gear front bearing | 21. Counter gear front bearing shim |
| 22. Counter gear front thrust bearing | 23. Sub-gear snap ring | 24. Sub-gear bracket |
| 25. Steel ball | 26. Counter gear | 27. Counter gear rear thrust bearing |
| 28. 2nd main gear | 29. 2nd gear needle bearing | 30. 2nd inner baulk ring |
| 31. 2nd outer baulk ring | 32. 1st and 2nd synchronizer hub | 33. 1st and 2nd coupling sleeve |
| 34. 1st baulk ring | 35. 1st main gear | 36. 1st gear needle bearing |
| 37. 1st gear bushing | 38. 1st gear washer | |

TRANSMISSION ASSEMBLY

< UNIT DISASSEMBLY AND ASSEMBLY >

[FS5R30A]

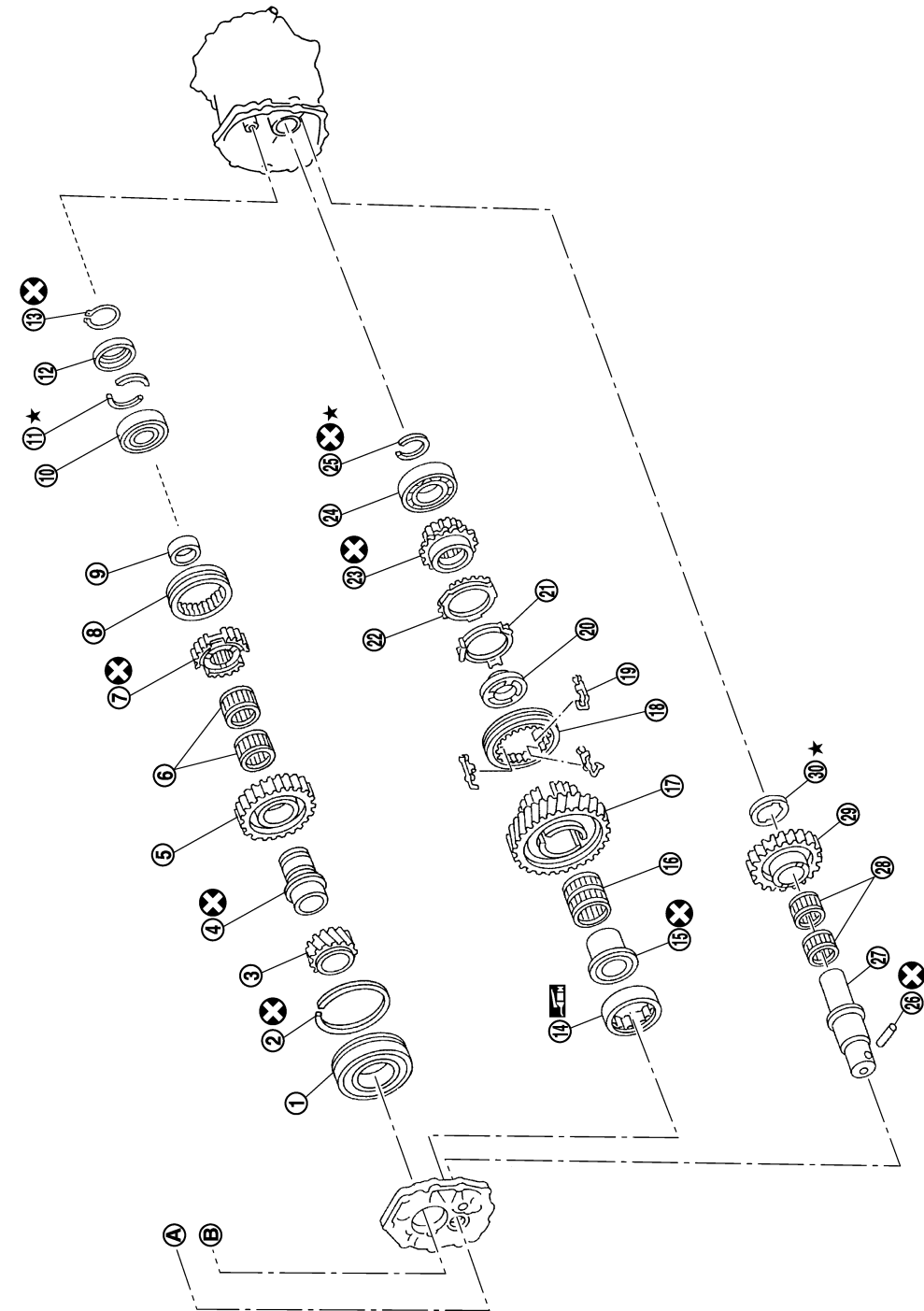

SEC. 322

Apply gear oil to gears, shafts, synchronizers and bearings when assembling.

- ★ : Select with proper thickness.
- ⊗ : Always replace after every disassembly.
- : Apply multi-purpose grease.

PCIB1283E

- | | | |
|------------------------------|--------------------------------------|---------------------------------|
| 1. Mainshaft front bearing | 2. Mainshaft front bearing snap ring | 3. OD main gear |
| 4. Reverse gear bushing | 5. Reverse main gear | 6. Reverse gear needle bearings |
| 7. Reverse synchronizer hub | 8. Reverse coupling sleeve | 9. Mainshaft spacer |
| 10. Mainshaft rear bearing | 11. Mainshaft C-ring | 12. C-ring holder |
| 13. Mainshaft rear snap ring | 14. Counter gear rear bearing | 15. OD gear bushing |
| 16. OD gear needle bearing | 17. OD counter gear | 18. OD coupling sleeve |

A
B
C
TM
E
F
G
H
I
J
K
L
M
N
O
P

TRANSMISSION ASSEMBLY

[FS5R30A]

< UNIT DISASSEMBLY AND ASSEMBLY >

- | | | |
|-----------------------------------|--------------------------|-----------------------------------|
| 19. Spring insert | 20. Reverse cone | 21. Reverse baulk ring |
| 22. OD baulk ring | 23. Reverse counter gear | 24. Counter gear rear end bearing |
| 25. Counter gear rear snap ring | 26. Retaining pin | 27. Reverse idler shaft |
| 28. Reverse idler needle bearings | 29. Reverse idler gear | 30. Reverse idler thrust washer |

SHIFT CONTROL COMPONENTS

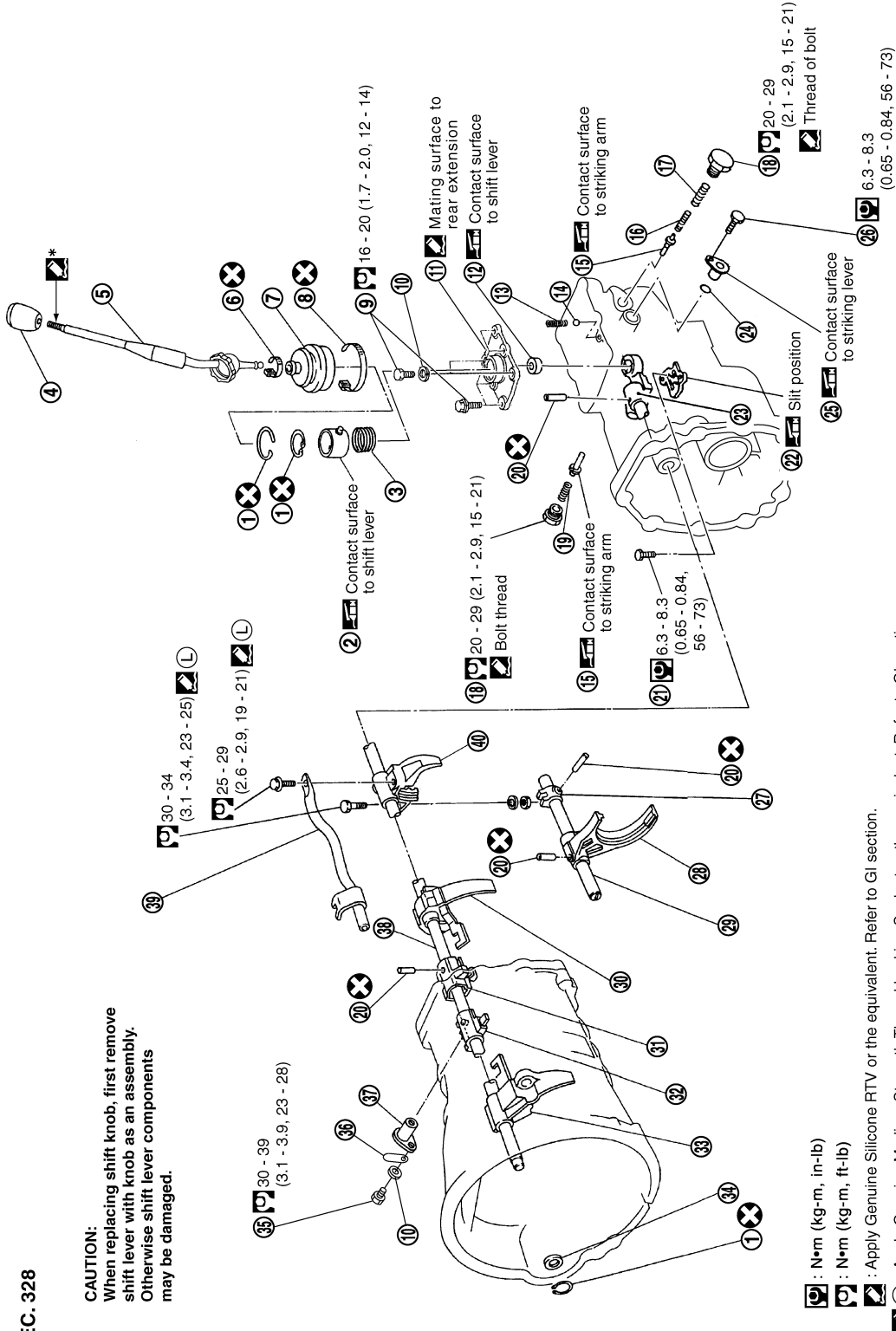

SEC. 328

CAUTION:
When replacing shift knob, first remove shift lever with knob as an assembly. Otherwise shift lever components may be damaged.

- : N*m (kg-m, in-lb)
- : N*m (kg-m, ft-lb)
- : Apply Genuine Silicone RTV or the equivalent. Refer to GI section.
- : Apply Genuine Medium Strength Thread Locking Sealant or the equivalent. Refer to GI section.
- : Always replace after every disassembly.
- : Apply cement.
- : Apply multi-purpose grease.

PCIB1284E

TRANSMISSION ASSEMBLY

< UNIT DISASSEMBLY AND ASSEMBLY >

[FS5R30A]

1. Snap ring	2. Socket	3. Spring	A
4. Shift selector handle	5. Shift selector	6. Upper boot retainer	
7. Boot	8. Lower boot retainer	9. Control housing bolt	
10. Washer	11. Control housing	12. Bushing	B
13. Return spring	14. Check ball	15. Select check plunger	
16. Select check spring (small)	17. Select check spring (large)	18. Select check plug	
19. Select check spring	20. Retaining pin	21. Guide plate bolt	C
22. Guide plate	23. Striking arm	24. O-ring	
25. Reverse check sleeve	26. Reverse check sleeve bolt	27. OD rod bracket	
28. OD shift fork	29. OD fork rod	30. 1st and 2nd shift fork	TM
31. Striking interlock	32. Striking lever	33. 3rd and 4th shift fork	
34. Stopper ring	35. Interlock stopper bolt	36. Clip	
37. Interlock stopper	38. Striking rod	39. OD and reverse fork rod	E
40. Reverse shift fork			

F

G

H

I

J

K

L

M

N

O

P

CASE COMPONENTS

< UNIT DISASSEMBLY AND ASSEMBLY >

[FS5R30A]

CASE COMPONENTS

Disassembly

INFOID:000000008790755

1. Remove interlock stopper bolt, washer and clip and then remove interlock stopper using suitable tool.

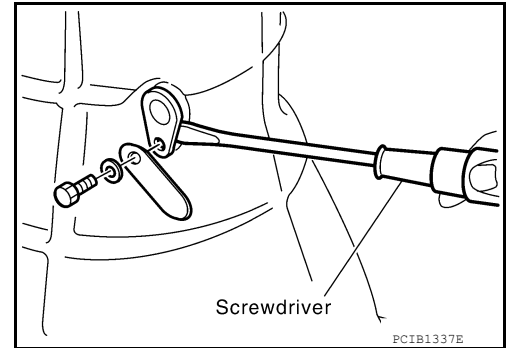

2. Remove control housing, return spring and check ball.
CAUTION:
Do not lose check ball.

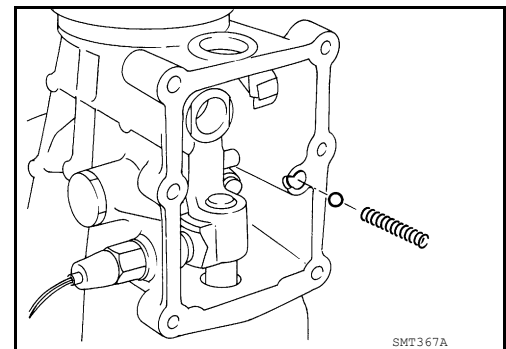

3. Drive out retaining pin from striking arm using Tool.

Tool number : ST23540000 (J-25689-A)

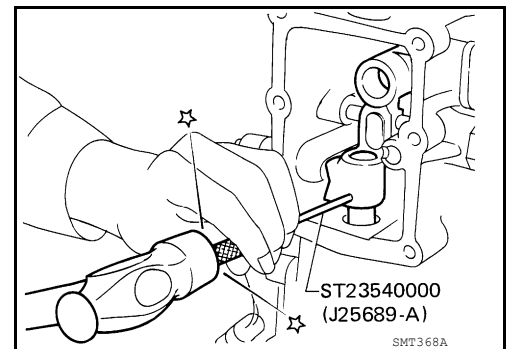

4. Remove rear extension together with striking arm by tapping lightly.

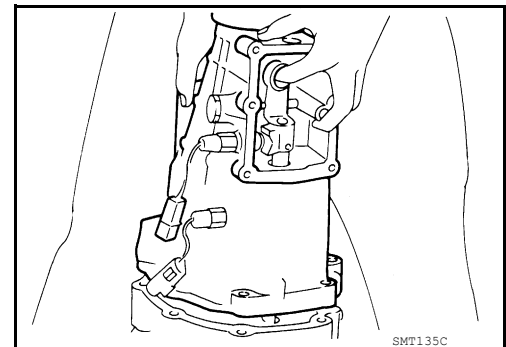

CASE COMPONENTS

< UNIT DISASSEMBLY AND ASSEMBLY >

[FS5R30A]

5. Remove front cover and gasket using suitable tool.

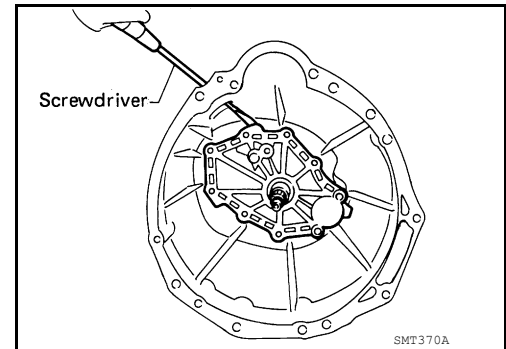

6. Remove stopper ring and main drive bearing snap ring using suitable tool.

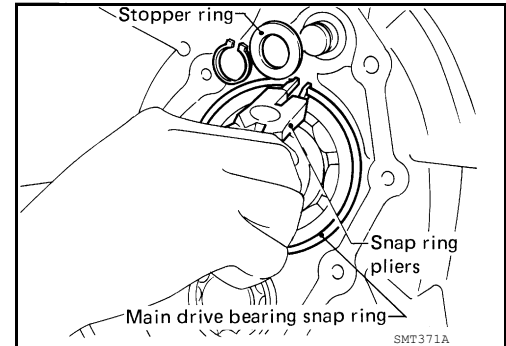

7. Remove transmission case by tapping lightly using suitable tool.
8. Remove counter gear front bearing shim and counter gear front bearing.

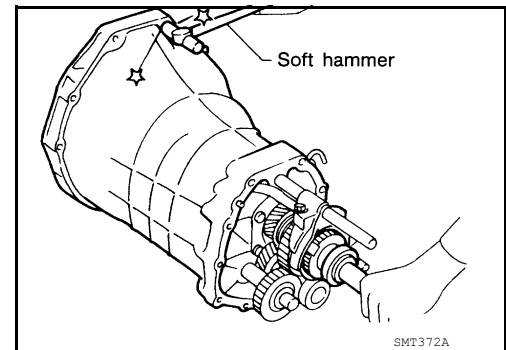

9. Remove front cover oil seal using suitable tool.
CAUTION:
Do not damage front cover.

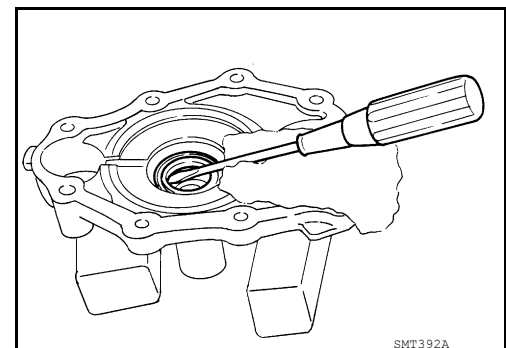

A
B
C
TM
E
F
G
H
I
J
K
L
M
N
O
P

CASE COMPONENTS

< UNIT DISASSEMBLY AND ASSEMBLY >

[FS5R30A]

INFOID:000000008790756

Assembly

1. Install new front cover oil seal using Tool.

Tool number : ST33210000 (J-25803-01)

CAUTION:

- Apply multi-purpose grease to seal lip.
- Do not reuse front cover oil seal.

2. Install selected counter gear new front bearing shim onto transmission case.

CAUTION:

- Apply multi-purpose grease to counter gear front bearing shim and counter gear front bearing.
- Do not reuse counter gear front bearing and counter gear front bearing shim.

3. Apply sealant to mating surface of transmission case.

- Use **Genuine Silicone RTV or the equivalent**. Refer to [GI-24, "Recommended Chemical Products and Sealants"](#).

4. Install gear assembly onto transmission case.

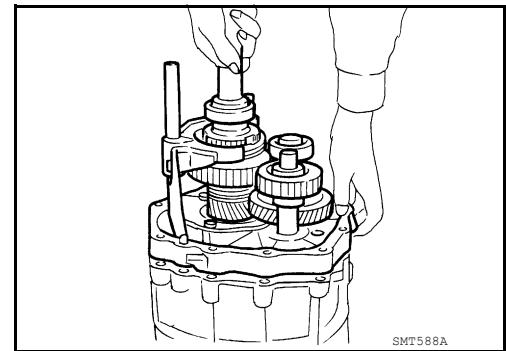
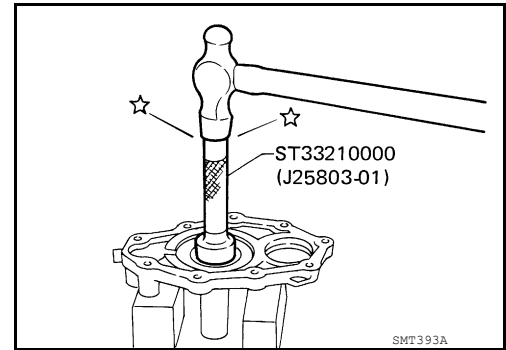

5. Install interlock stopper to transmission case.

6. Install clip and washer to interlock stopper bolt, and then install to transmission case. Tighten to the specified torque.

Interlock stopper bolt Refer to [TM-23, "Overhaul"](#)

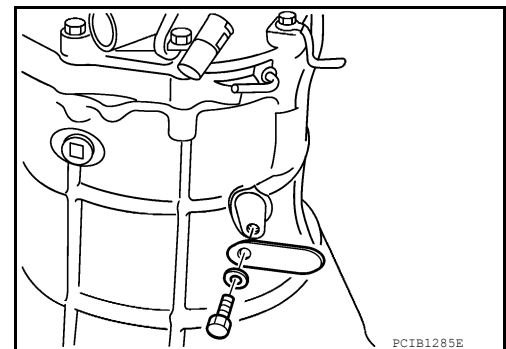

7. Install stopper ring, new snap ring and new main drive bearing snap ring using suitable tool.

CAUTION:

- Do not reuse the snap rings.

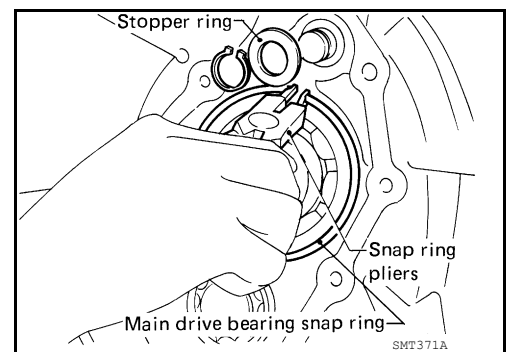

CASE COMPONENTS

< UNIT DISASSEMBLY AND ASSEMBLY >

[FS5R30A]

8. Install front cover and gasket.

CAUTION:

Do not reuse bolts indicated as (A) shown.

Bolt symbol	Bolt length "ℓ" mm (in)	Tightening torque N·m (kg-m, ft-lb)
(A)	35 (1.38)	16-20 (1.6-2.1, 12-15)
(B)	30 (1.18)	
(C)	50 (1.97)	

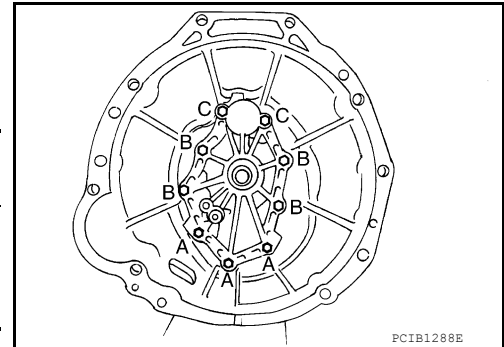

9. Apply sealant to mating surface of adapter plate.

- Use Genuine Silicone RTV or the equivalent. Refer to [GI-24, "Recommended Chemical Products and Sealants"](#).

10. Install rear extension together with striking arm.

Rear extension bolts Refer to [TM-23, "Overhaul"](#)

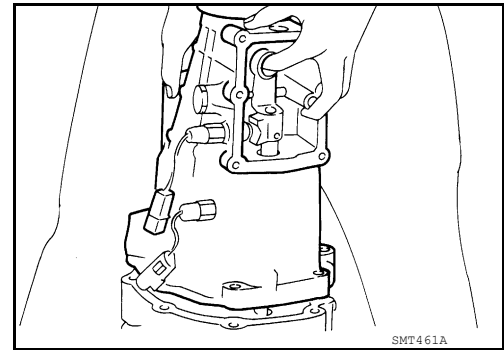

11. Install new retaining pin into striking arm using Tool.

Tool number : ST23540000 (J-25689-A)

CAUTION:

Do not reuse retaining pin.

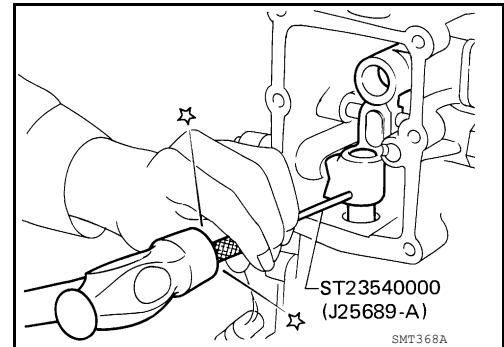

12. Install check ball and return spring.

13. Apply sealant to mating surface of rear extension, and then install control housing.

- Use Genuine Silicone RTV or the equivalent. Refer to [GI-24, "Recommended Chemical Products and Sealants"](#).

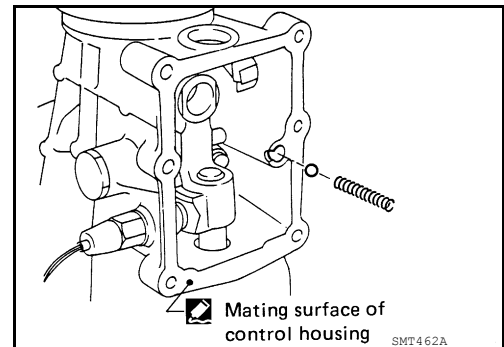

CASE COMPONENTS

< UNIT DISASSEMBLY AND ASSEMBLY >

[FS5R30A]

14. Tighten control housing bolts to the specified torque.

Bolt head size

(A) bolts : 12 mm (0.47 in)

(B) bolts : 13 mm (0.51 in)

Control housing bolts Refer to [TM-23, "Overhaul"](#)

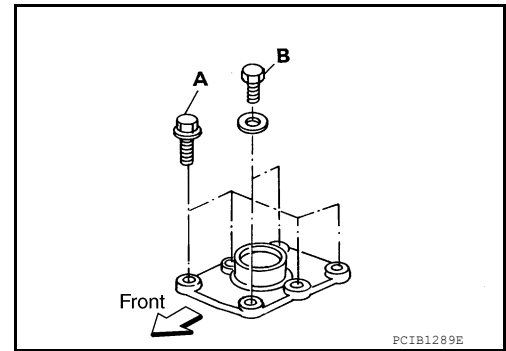

SHIFT CONTROL COMPONENTS

< UNIT DISASSEMBLY AND ASSEMBLY >

[FS5R30A]

SHIFT CONTROL COMPONENTS

Disassembly

INFOID:000000008790757

1. Mount adapter plate on vise using copper plates to protect adapter plate.
2. Remove OD and reverse fork rod.

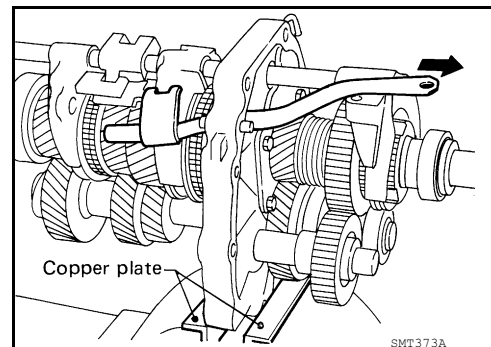

3. Drive out retaining pin from striking lever using Tool.

Tool number : ST23540000 (J-25689-A)

4. While pulling out striking rod, remove striking lever and striking interlock. Then remove 1st and 2nd, 3rd and 4th, and reverse shift forks.

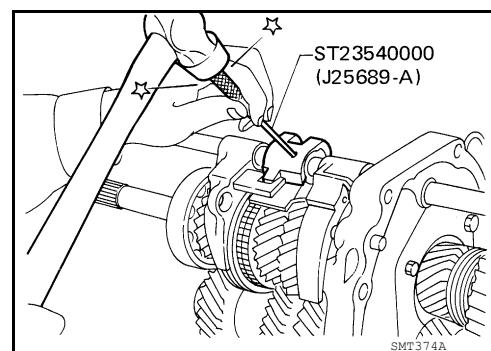

5. Drive out retaining pin from OD shift fork using Tool.

Tool number : ST23540000 (J-25689-A)

6. Pull out OD fork rod and then remove OD shift fork.

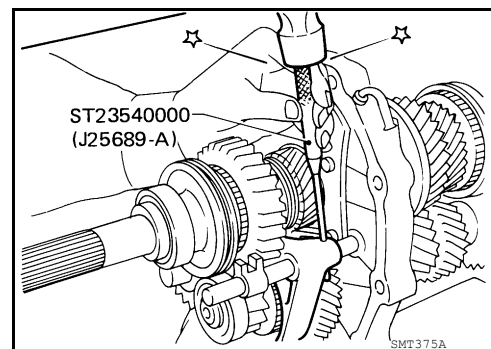

Inspection

INFOID:000000008790758

- Check contact surface and sliding surface for wear, scratches, projections or other damage.

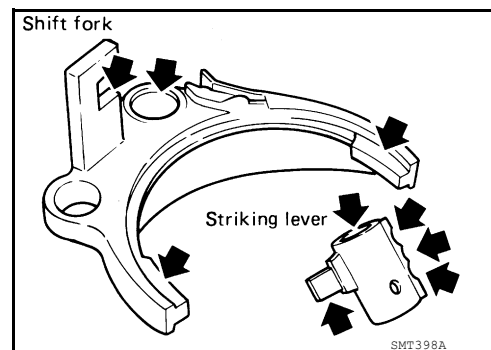

A
B
C
TM
E
F
G
H
I
J
K
L
M
N
O
P

SHIFT CONTROL COMPONENTS

< UNIT DISASSEMBLY AND ASSEMBLY >

[FS5R30A]

Assembly

INFOID:000000008790759

1. Install OD fork rod and OD shift fork. Then install new retaining pin into OD shift fork.

CAUTION:

Do not reuse retaining pin.

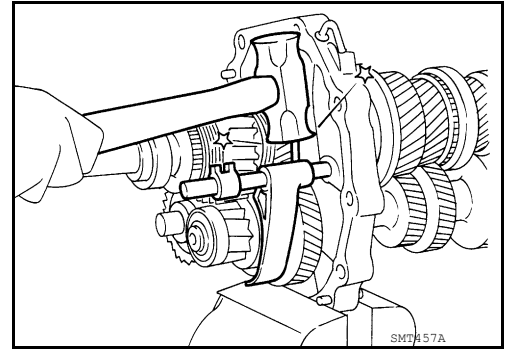

2. Install 1st and 2nd, 3rd and 4th, and reverse shift forks onto coupling sleeve.
3. Install striking rod into hole of shift forks, striking lever and interlock and then install new retaining pin into striking lever using Tool.

Tool number : ST23540000 (J-25689-A)

CAUTION:

- **Make sure that striking rod moves smoothly.**
- **Do not reuse retaining pin.**

4. Apply sealant to thread of OD and reverse fork rod bolt, and then install OD and reverse fork rod.

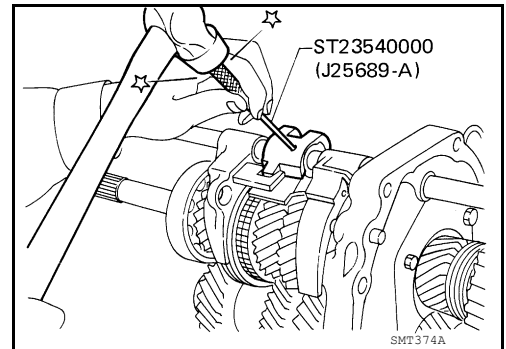

OD and reverse fork rod bolt Refer to [TM-23, "Overhaul"](#)

- **Use Genuine Medium Strength Thread Locking Sealant or the equivalent. Refer to [GI-24, "Recommended Chemical Products and Sealants"](#).**

GEAR COMPONENTS

Disassembly

INFOID:000000008790760

1. Before removing gears and shafts, measure each gear end play. Refer to [TM-54. "Gear End Play"](#).
 - If not within specification, disassemble and check contact surface of gear to hub, washer, bushing, needle bearing and shaft.

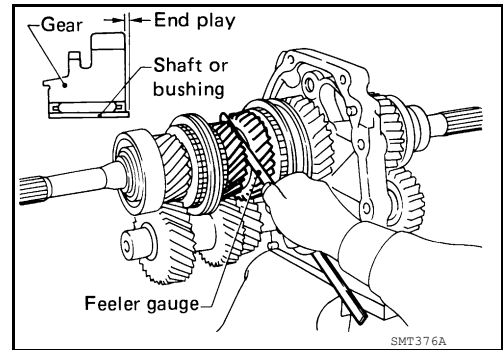

2. Remove rear side components on mainshaft and counter gear.
 - a. Remove reverse coupling sleeve.

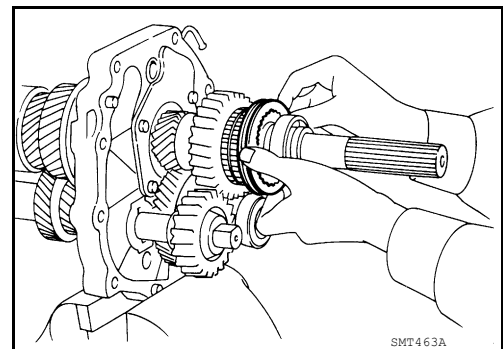

- b. Remove mainshaft rear snap ring and counter gear rear snap ring using suitable tool.
 - c. Remove C-ring holder and mainshaft C-rings from mainshaft using suitable tool.

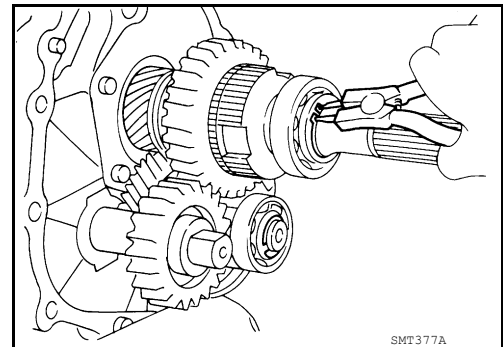

- d. Remove counter gear rear end bearing using suitable tool.
 - e. Remove reverse idler thrust washer, reverse idler gear and reverse idler needle bearings.
 - f. Remove mainshaft rear bearing using Tools.

Tool number : — (J-26349-A)
 : — (J-25726-B)

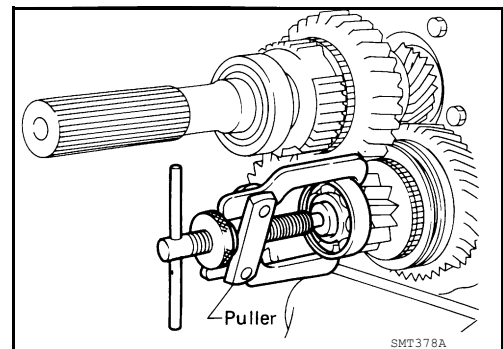

A
B
C
TM
E
F
G
H
I
J
K
L
M
N
O
P

GEAR COMPONENTS

< UNIT DISASSEMBLY AND ASSEMBLY >

[FS5R30A]

- g. Remove reverse main gear together with mainshaft spacer and reverse synchronizer hub using suitable tool. Then remove reverse gear needle bearings.

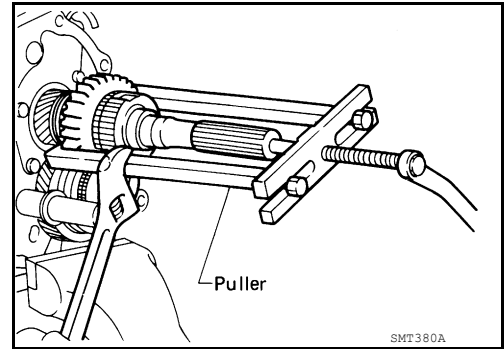

- h. Remove reverse counter gear using suitable tool.
i. Remove OD coupling sleeve together with OD baulk ring, reverse baulk ring and spring inserts.

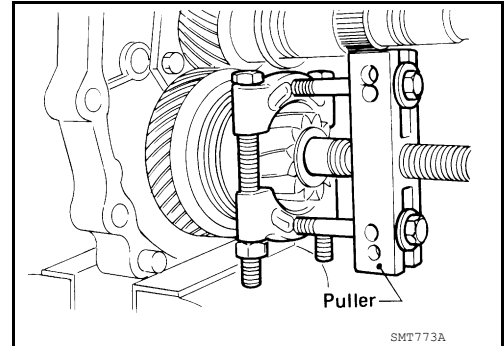

- j. Remove reverse gear bushing using suitable tool.

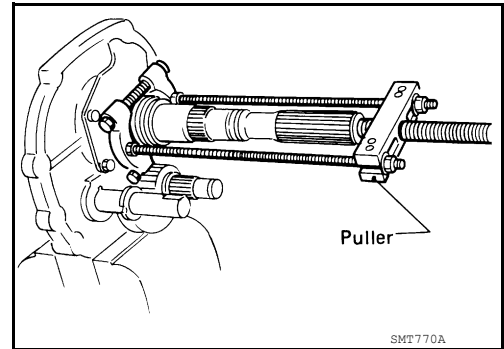

- k. Remove OD counter gear and reverse cone using suitable tool.
l. Remove OD gear needle bearing.
m. Remove reverse idler shaft.

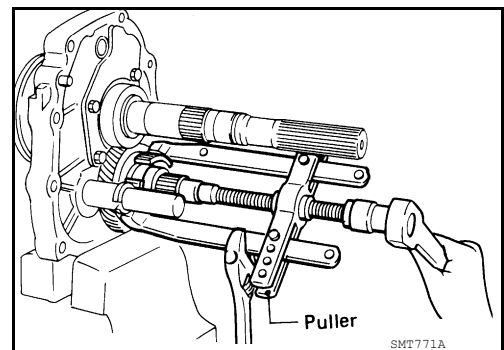

3. Press out mainshaft, OD main gear, OD gear bushing and counter gear alternately using Tool.

Tool number : ST33230000 (—)

GEAR COMPONENTS

< UNIT DISASSEMBLY AND ASSEMBLY >

[FS5R30A]

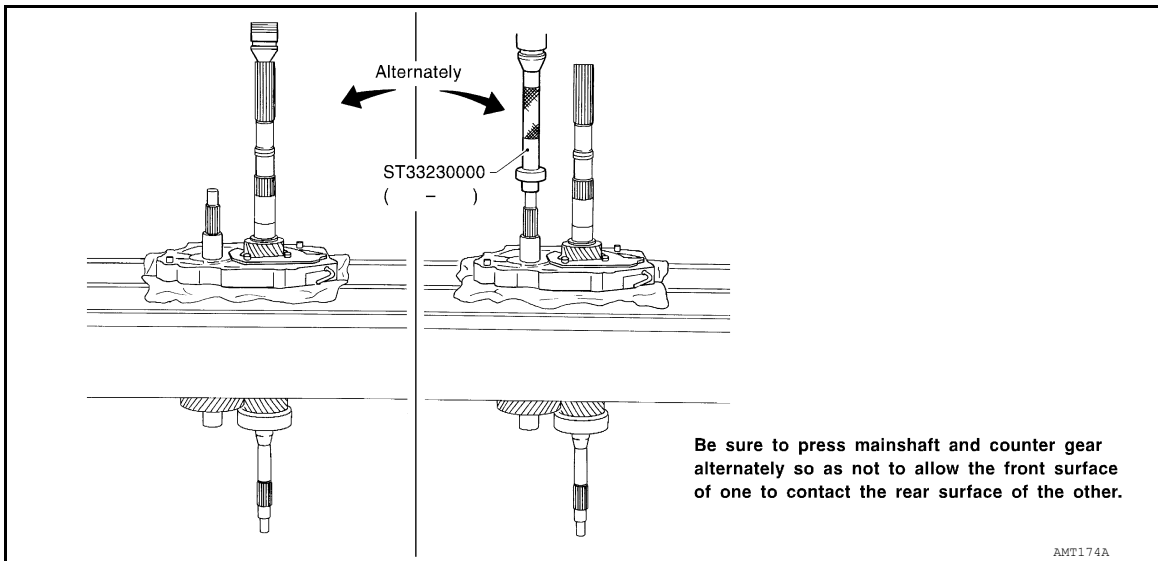

4. Remove front side components on mainshaft.
 - a. Remove 1st gear washer and steel ball using suitable tool.
CAUTION:
Be careful not to lose steel ball.
 - b. Remove 1st main gear and 1st gear needle bearing.

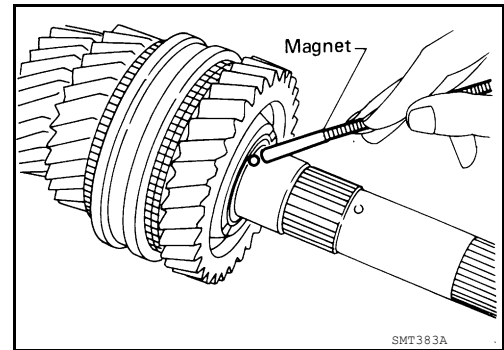

- c. Press out 2nd main gear together with 1st gear bushing and 1st and 2nd synchronizer assembly using Tool.

Tool number : ST30031000 (J-22912-01)

- d. Remove 2nd gear needle bearing.
 - e. Remove mainshaft front snap ring.

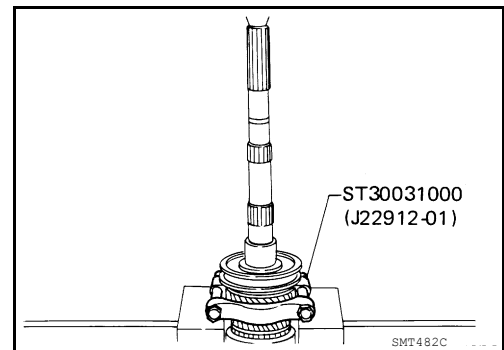

- f. Press out 3rd main gear together with 3rd and 4th synchronizer assembly.
 - g. Remove 3rd gear needle bearing.

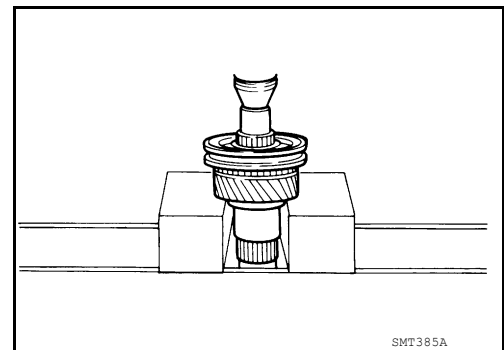

A
B
C
TM
E
F
G
H
I
J
K
L
M
N
O
P

GEAR COMPONENTS

< UNIT DISASSEMBLY AND ASSEMBLY >

[FS5R30A]

5. Remove front side components on counter gear.
 - a. Remove counter gear rear thrust bearing using Tool.

Tool number : ST30031000 (J-22912-01)

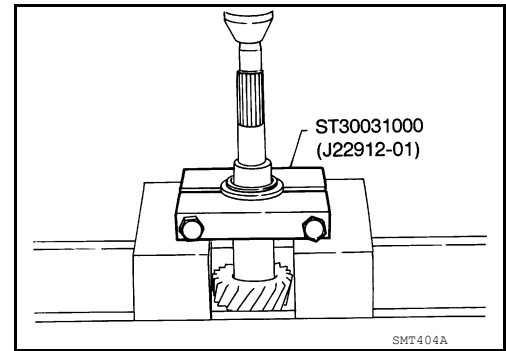

- b. Remove sub-gear snap ring, sub-gear bracket and steel ball using suitable tool.

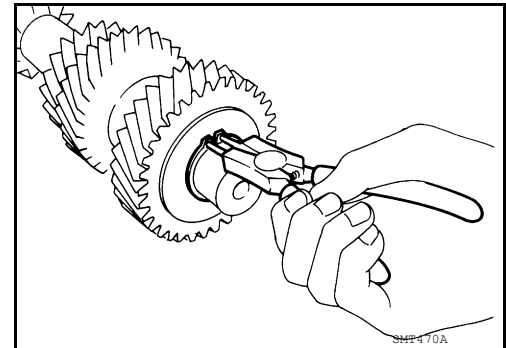

6. Remove main drive gear bearing.
 - a. Remove spacer and pilot bearing.
 - b. Remove main drive gear snap ring.
 - c. Press out main drive gear bearing using Tool.

Tool number : ST30031000 (J-22912-01)

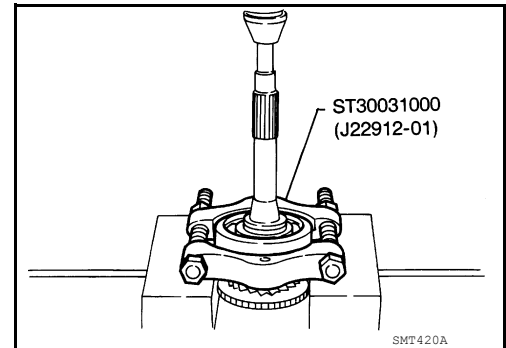

7. Remove bearing retainer.
8. Remove bearings from case components using Tools.

Tool number : ST22350000 (J-25678-01)
: KV38100300 (J-25523)
: ST30720000 (—)
: ST37750000 (J-5863-01)

GEAR COMPONENTS

< UNIT DISASSEMBLY AND ASSEMBLY >

[FS5R30A]

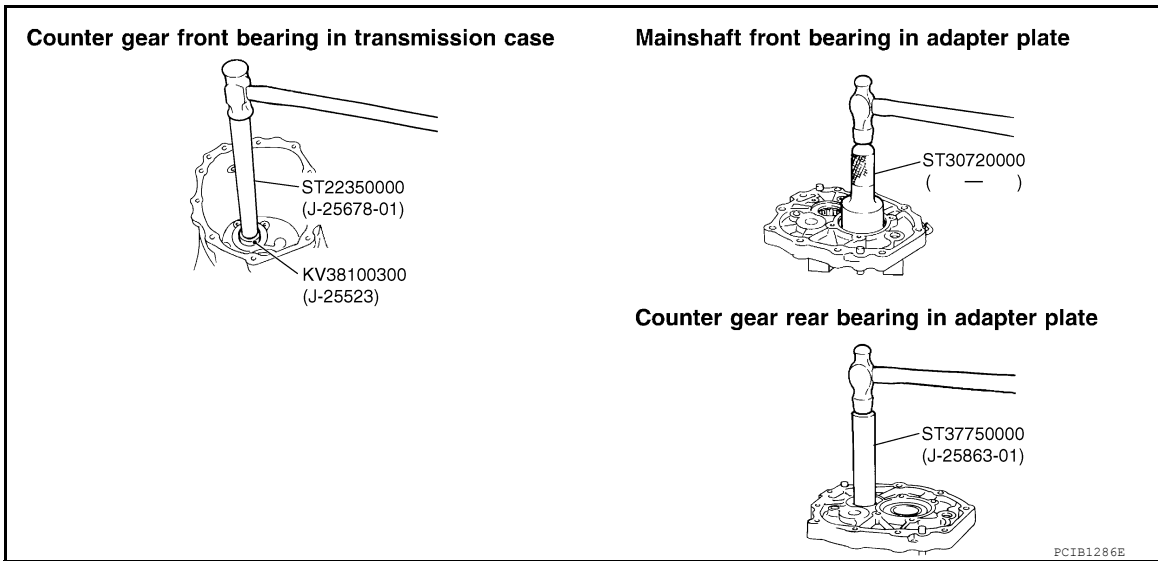

9. Remove mainshaft front bearing snap ring from mainshaft front bearing.

Inspection

INFOID:000000008790761

GEARS AND SHAFTS

- Check shafts for cracks, wear or bending.

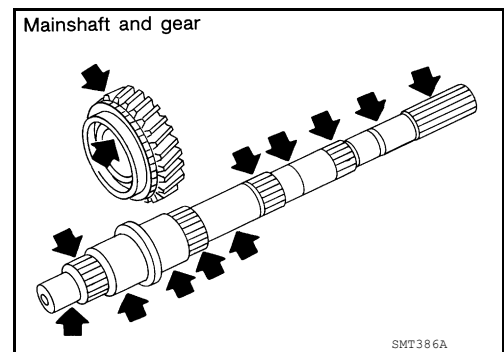

- Check gears for excessive wear, chips or cracks.

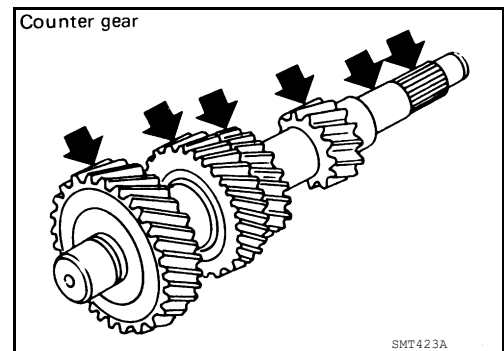

SYNCHRONIZERS

- Check spline portion of coupling sleeves, hubs, and gears for wear or cracks.
- Check baulk rings for cracks or deformation.
- Check shifting inserts for wear or deformation.
- Check insert springs for deformation.

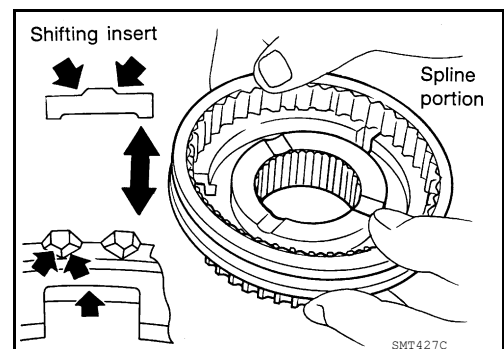

A
B
C
TM
E
F
G
H
I
J
K
L
M
N
O
P

GEAR COMPONENTS

< UNIT DISASSEMBLY AND ASSEMBLY >

[FS5R30A]

- Measure wear of main drive, 1st and OD baulk rings. Refer to [TM-54. "Baulk Ring Clearance"](#).
- If the clearance is smaller than the wear limit, replace baulk ring.

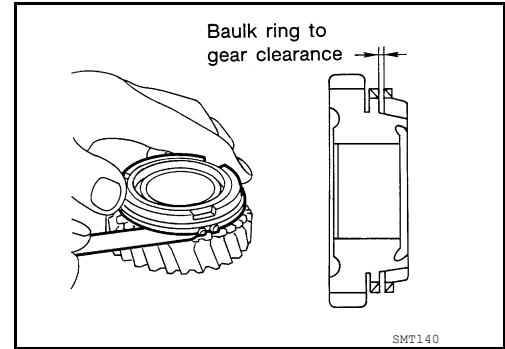

- Measure wear of 2nd and 3rd double baulk rings using Tool.

Tool number : ST30031000 (J-22912-01)

- Place baulk rings in position on synchronizer cone.
- While holding baulk rings against synchronizer cone as far as it will go, measure the dimensions (A) and (B).

Standard

Dimension (A) : 0.7 - 0.9 mm (0.028 - 0.035 in)

Dimension (B) : 0.6 - 1.1 mm (0.024 - 0.043 in)

Wear limit : 0.2 mm (0.008 in)

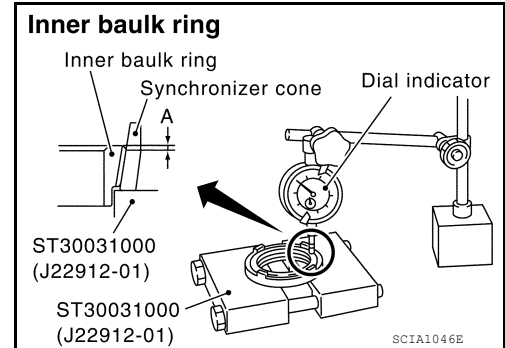

- If the dimension (A) or (B) is smaller than the wear limit, replace outer baulk ring, inner baulk ring and synchronizer cone as a set.

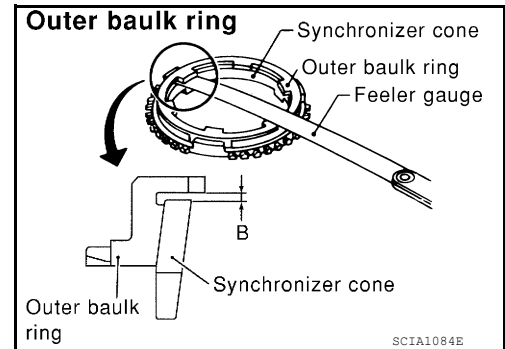

- Measure wear of reverse baulk ring.
- Place baulk ring in position on reverse cone.
- While holding baulk ring against reverse cone as far as it will go, measure the dimension (A) with dial indicator.

Standard

Dimension (A) : 0.35 - 0.95 mm (0.0138 - 0.0374 in)

Wear limit : 1.1 mm (0.043 in)

- If the dimension (A) is larger than the wear limit, replace baulk ring.

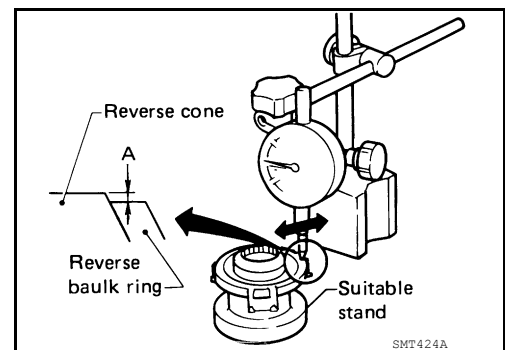

BEARINGS

GEAR COMPONENTS

< UNIT DISASSEMBLY AND ASSEMBLY >

[FS5R30A]

- Make sure bearings roll freely and are free from noise, crack, pitting or wear.

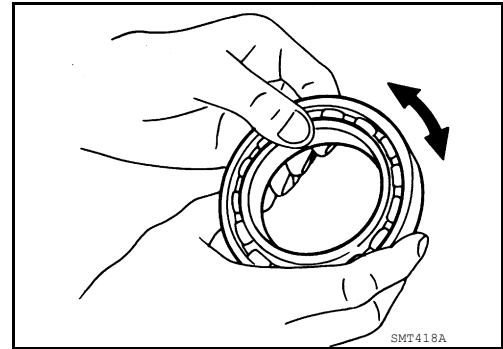

Assembly

INFOID:000000008790762

1. Install mainshaft front bearing snap ring to mainshaft front bearing.
2. Install bearings into case components using Tools.

Tool number : **ST33210000 (J-25523)**
: **ST30720000 (—)**
: **KV38100300 (J-25523)**

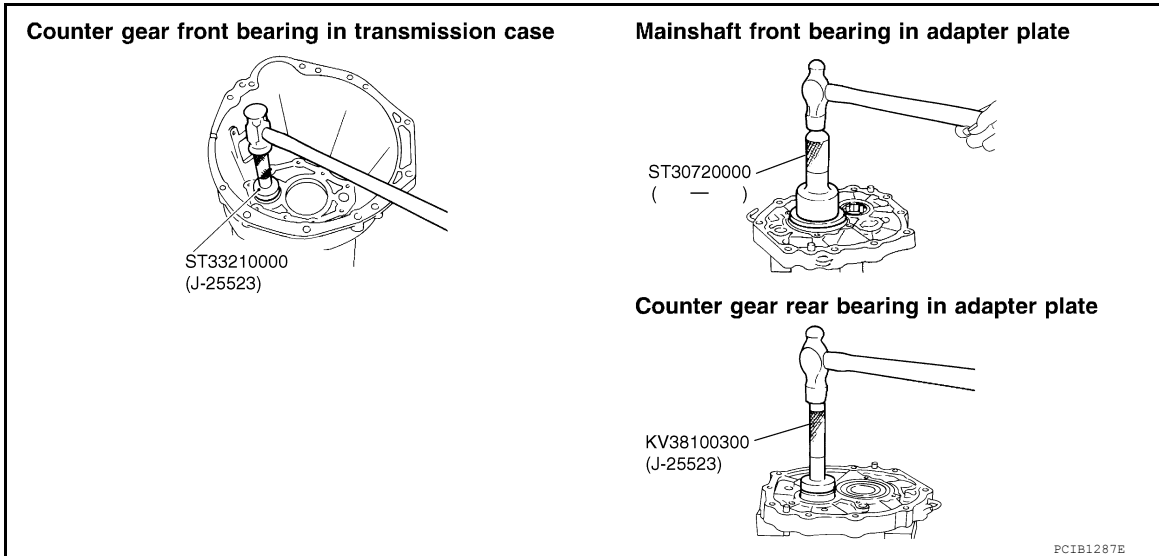

3. Install bearing retainer. Tighten bearing retainer bolts to the specified torque.

Bearing retainer bolts Refer to [TM-23, "Overhaul"](#)

4. Install main drive gear bearing.
 - a. Press main drive gear bearing using Tool.

Tool number : **ST30613000 (J-25742-3)**

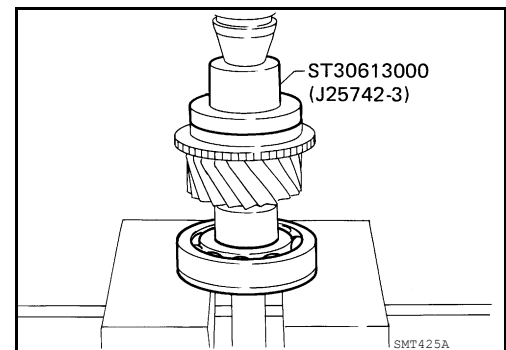

GEAR COMPONENTS

[FS5R30A]

< UNIT DISASSEMBLY AND ASSEMBLY >

- b. Select proper main drive gear snap ring to minimize clearance of groove. Refer to [TM-54, "Available Snap Rings"](#).

End play

Refer to [TM-54, "Gear End Play"](#)

CAUTION:

Do not reuse main drive gear snap ring.

- c. Install selected new main drive gear snap ring on main drive gear.

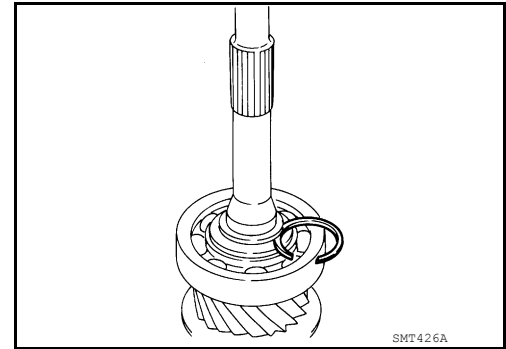

5. Install front side components on mainshaft.

- a. Assemble 1st and 2nd synchronizer.

CAUTION:

Do not reuse 1st and 2nd synchronizer hub.

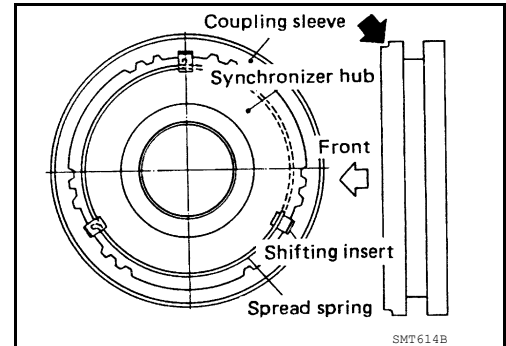

- b. Assemble 3rd and 4th synchronizer.

CAUTION:

Do not reuse 3rd and 4th synchronizer hub.

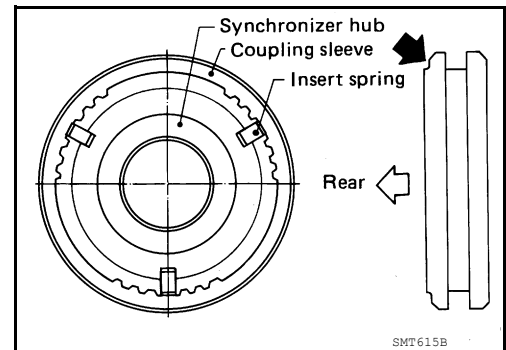

- c. Press on 3rd and 4th synchronizer assembly together with 3rd main gear and 3rd gear needle bearing.

CAUTION:

Pay attention to direction of synchronizer assembly.

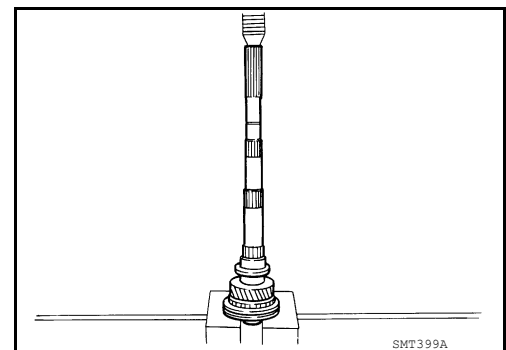

- d. Select proper mainshaft front snap ring to minimize clearance of groove. Refer to [TM-54, "Available Snap Rings"](#).

End play

: 0 - 0.1 mm (0 - 0.004 in)

CAUTION:

Do not reuse mainshaft front snap ring.

- e. Install selected new mainshaft front snap ring on mainshaft.

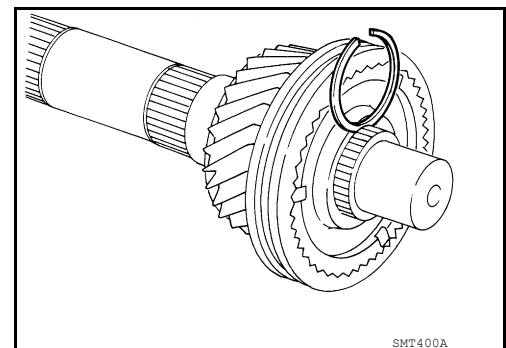

GEAR COMPONENTS

[FS5R30A]

< UNIT DISASSEMBLY AND ASSEMBLY >

- f. Press on 1st and 2nd synchronizer assembly together with 2nd main gear and 2nd gear needle bearing.

CAUTION:

Pay attention to direction of synchronizer assembly.

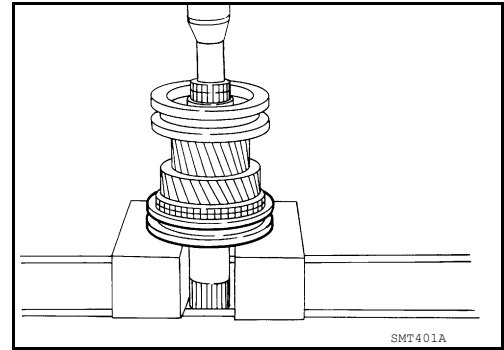

- g. Press on 1st gear bushing using 1st gear washer.

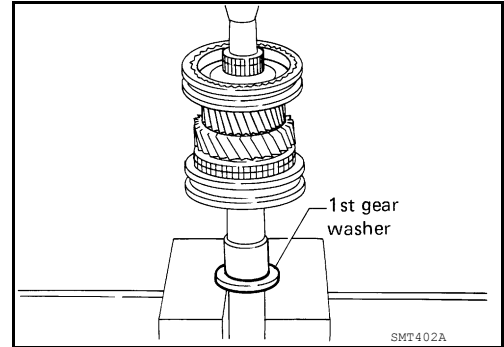

- h. Install 1st main gear and 1st gear needle bearing.

- i. Install steel ball and 1st gear washer.

CAUTION:

Apply multi-purpose grease to steel ball and 1st gear washer before installing.

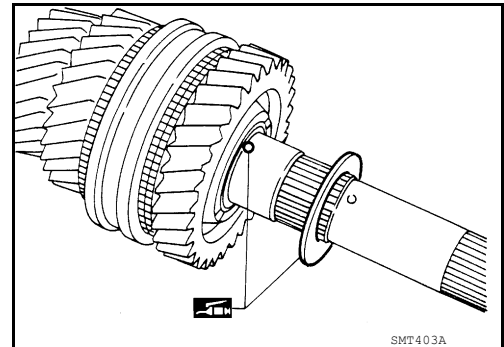

6. Install components on counter gear.

- a. Install steel ball, sub-gear bracket and new sub-gear snap ring.

CAUTION:

- **Apply multi-purpose grease to steel ball.**
- **Do not reuse sub-gear snap ring.**

- b. Install counter gear rear thrust bearing using a brass drift.

CAUTION:

Be careful not to damage counter gear rear thrust bearing.

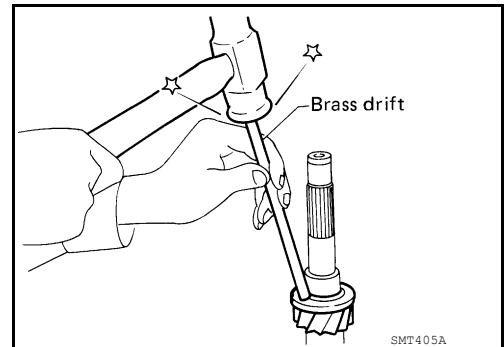

A
B
C
TM
E
F
G
H
I
J
K
L
M
N
O
P

GEAR COMPONENTS

[FS5R30A]

< UNIT DISASSEMBLY AND ASSEMBLY >

7. Select proper counter gear front bearing shim when replacing transmission case, counter gear, counter gear rear thrust bearing or sub-gear bracket.
 - a. Install counter gear, counter gear front thrust bearing and counter gear rear thrust bearing on adapter plate.
 - b. Place adapter plate and counter gear assembly in transmission case (case inverted).

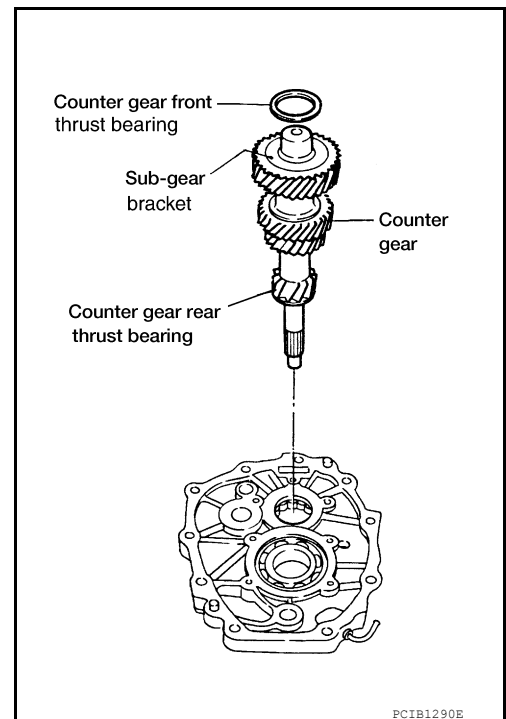

- c. Tighten adapter plate to transmission case using 2 bolts.
- d. Place dial indicator on rear end of counter gear.
- e. Move counter gear up and down and measure dial indicator deflection.
- f. Select proper counter gear front bearing shim using the table as a guide. Refer to [TM-55, "Available Shims"](#).

End play : 0.10 - 0.26 mm (0.0039 - 0.0102 in)

- g. Separate adapter plate and transmission case.
- h. Remove counter gear assembly.

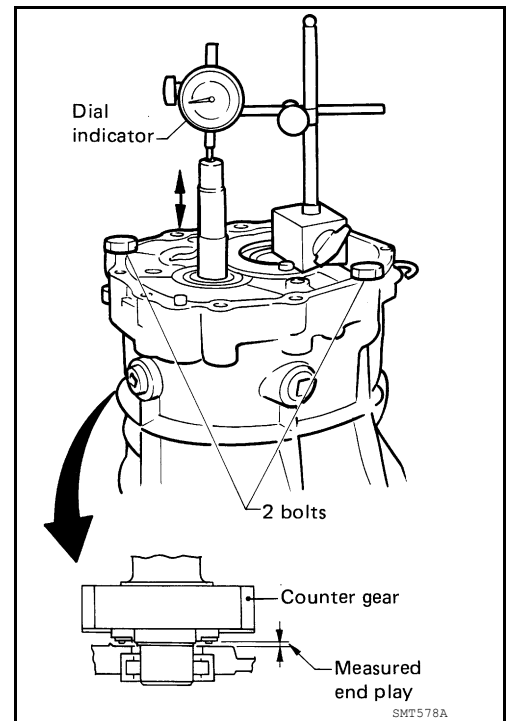

GEAR COMPONENTS

[FS5R30A]

< UNIT DISASSEMBLY AND ASSEMBLY >

8. Select proper reverse idler thrust washer when replacing rear extension, reverse idler gear or reverse idler shaft.
 - a. Install reverse idler thrust washer, reverse idler gear, reverse idler needle bearings and reverse idler shaft into rear extension.
 - **When replacing reverse idler thrust washer, install either (A or B). Refer to [TM-55, "Available Thrust Washer"](#).**

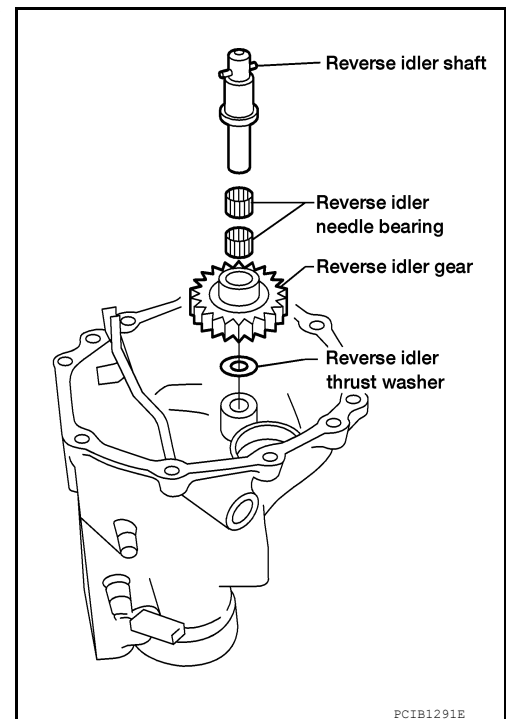

- b. Place dial indicator on front end of reverse idler shaft.
 - c. Put straightedge on front surface of rear extension as a stopper of reverse idler shaft.
 - d. Move reverse idler shaft up and down and measure end play.

End play Refer to [TM-55, "Available Thrust Washer"](#)

- e. If not within specification, replace reverse idler thrust washer with the other (A or B) and check again.

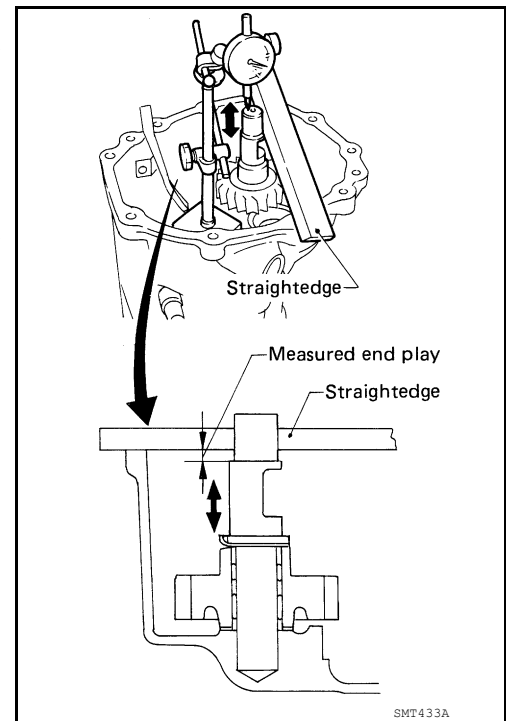

9. Install mainshaft and counter gear on adapter plate and main drive gear on mainshaft.
 - a. Mount adapter plate on vise and apply multi-purpose grease to counter gear rear bearing.

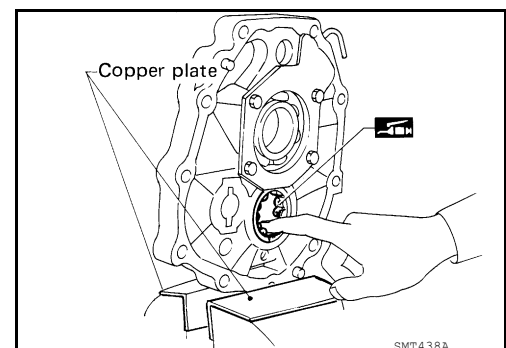

GEAR COMPONENTS

< UNIT DISASSEMBLY AND ASSEMBLY >

[FS5R30A]

- b. Partially install mainshaft on mainshaft front bearing using suitable tool.

CAUTION:

To allow for installation of counter gear, do not install mainshaft completely.

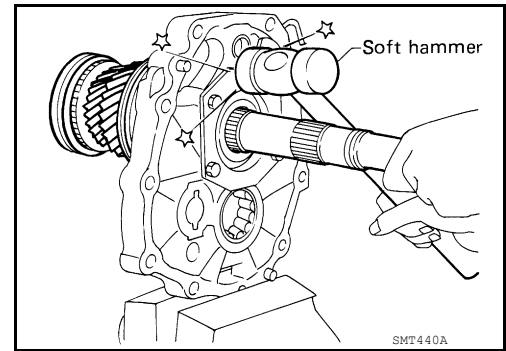

- c. Install counter gear in counter gear rear bearing and install main drive gear, pilot bearing and spacer on mainshaft.

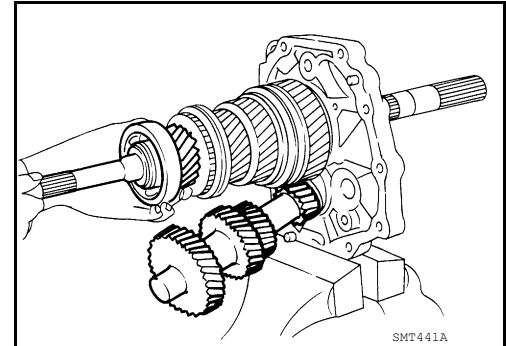

NOTE:

When installing counter gear into counter gear rear bearing, push up on upper roller of counter gear rear bearing using suitable tool.

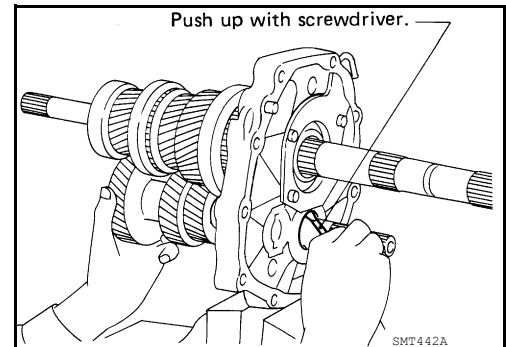

- d. Install Tool onto adapter plate and mainshaft C-ring and C-ring holder on mainshaft.

Tool number : — (J-26349-3)

- e. Install Tool on mainshaft.

Tool number : — (J-34328)

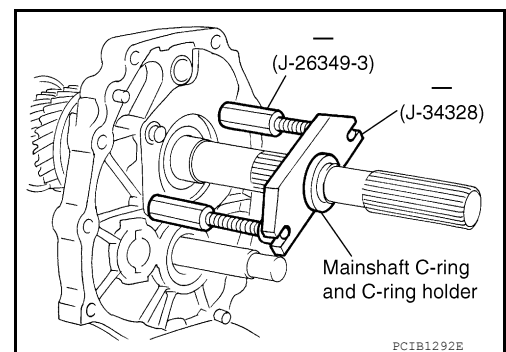

GEAR COMPONENTS

< UNIT DISASSEMBLY AND ASSEMBLY >

[FS5R30A]

- f. Install mainshaft and counter gear completely by extending length of Tool.

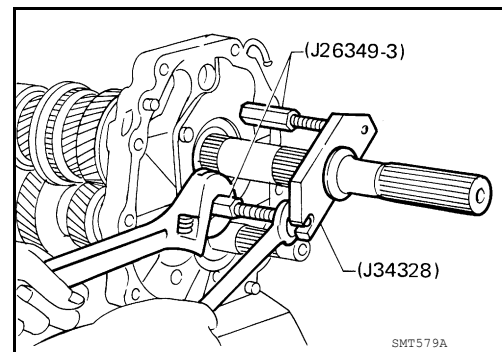

10. Install rear side components on mainshaft and counter gear.
a. Install new OD gear bushing using Tool while pushing on the front of counter gear.

Tool number : ST37750000 (J-34332)

CAUTION:
Do not reuse OD gear bushing.

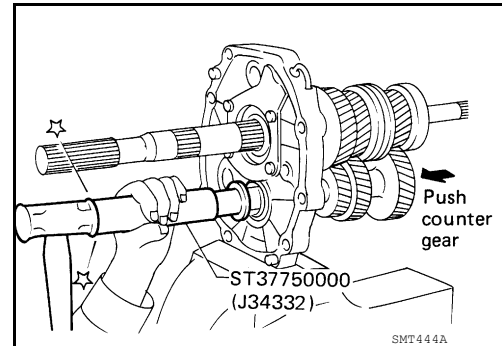

- b. Install OD main gear using Tool.

Tool number : — (J-34342)

CAUTION:
Pay attention to direction of OD main gear. [(B) is wider than (A) as shown].

- c. Install adapter plate with gear assembly onto transmission case.
d. Install OD gear needle bearing and then install OD counter gear and reverse idler shaft.

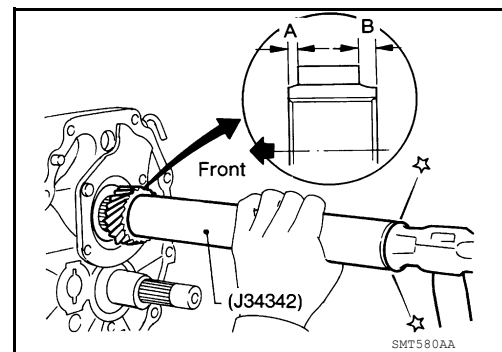

- e. Install new reverse gear bushing using Tool.

Tool number : — (J-34342)

CAUTION:
Do not reuse reverse gear bushing.

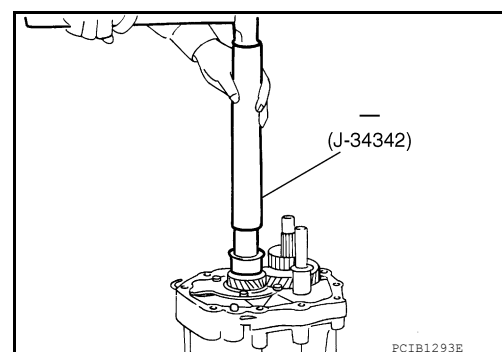

- f. Install reverse cone using Tool.

Tool number : ST37750000 (J-34332)

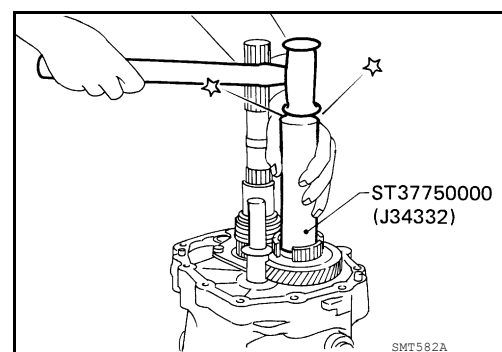

GEAR COMPONENTS

< UNIT DISASSEMBLY AND ASSEMBLY >

[FS5R30A]

- g. Install spring inserts and reverse baulk ring on OD coupling sleeve. Then install them and OD baulk ring on OD counter gear.

CAUTION:

Pay attention to direction of OD coupling sleeve.

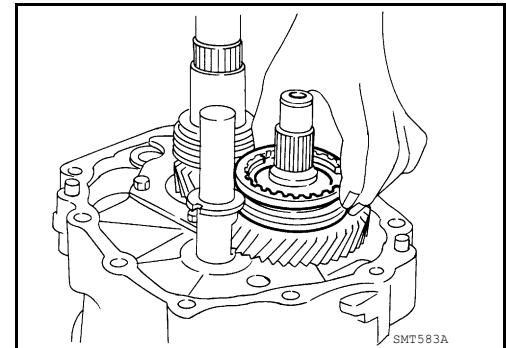
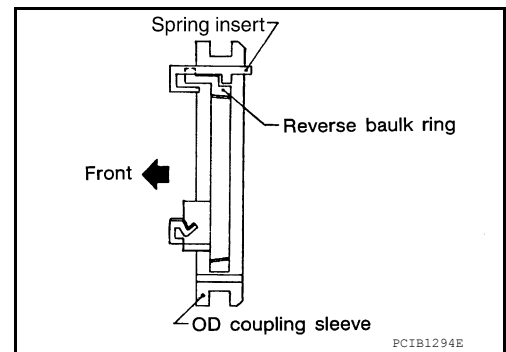

- h. Install reverse counter gear using Tool.

Tool number : ST37750000 (J-34334)

- i. Install reverse gear needle bearings, reverse idler needle bearings and then install reverse main gear, reverse idler gear and selected reverse idler thrust washer.

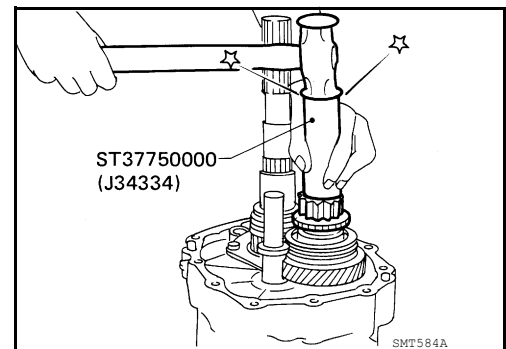

- j. Install new reverse synchronizer hub using Tool.

Tool number : ST22452000 (J-34337)

CAUTION:

- Pay attention to direction of reverse synchronizer hub.
- Do not reuse reverse synchronizer hub.

- k. Install mainshaft spacer and mainshaft rear bearing using Tools.

Tool number : — (J-26349-A)
: — (J-25726-B)

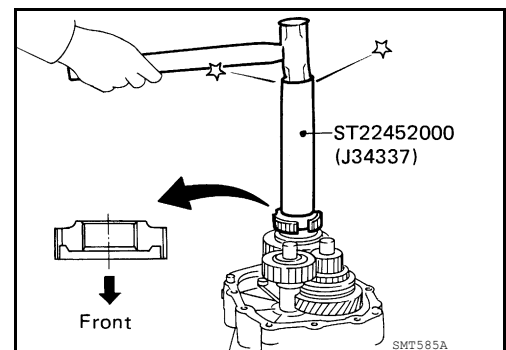

- l. Install counter gear rear end bearing using Tool.

Tool number : ST37750000 (J-25679-01)

- m. Separate adapter plate from transmission case and mount adapter plate on vise again.

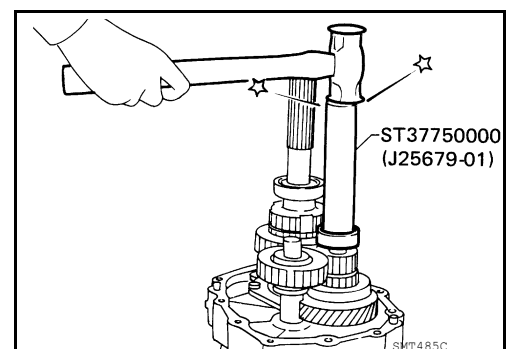

GEAR COMPONENTS

< UNIT DISASSEMBLY AND ASSEMBLY >

[FS5R30A]

- n. Select proper mainshaft C-ring to minimize clearance of groove.
Refer to [TM-55, "Available C-Rings"](#).

End play Refer to [TM-55, "Available C-Rings"](#)

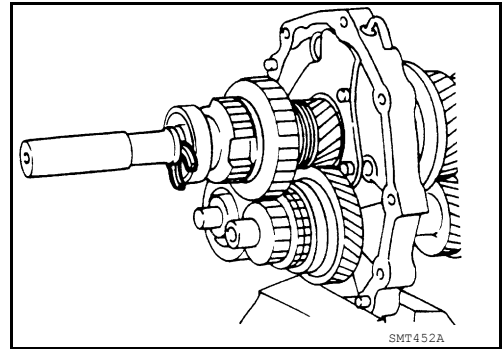

- o. Install selected mainshaft C-ring, C-ring holder and new mainshaft rear snap ring using suitable tool.

CAUTION:

Do not reuse mainshaft rear snap ring.

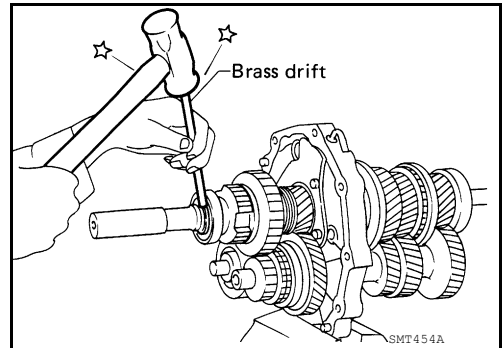

- p. Select proper counter gear rear snap ring to minimize clearance of groove. Refer to [TM-54, "Available Snap Rings"](#).

End play Refer to [TM-54, "Available Snap Rings"](#)

CAUTION:

Do not reuse counter gear rear snap ring.

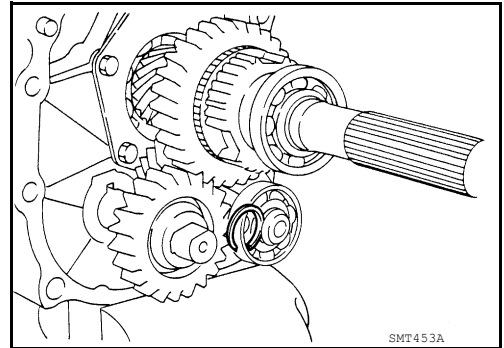

- q. Install selected new counter gear rear snap ring using suitable tool.

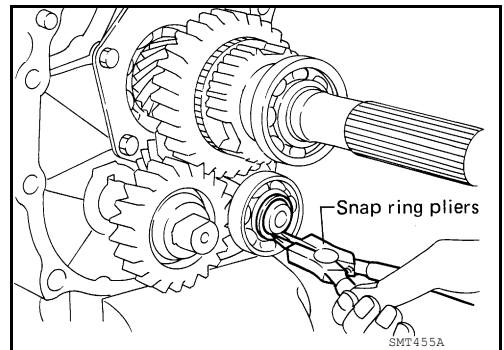

- r. Install reverse coupling sleeve.

CAUTION:

Pay attention to direction of reverse coupling sleeve.

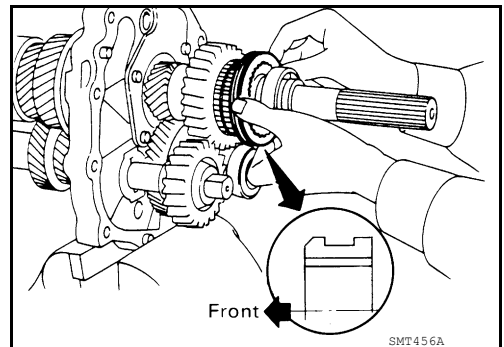

A
B
C
TM
E
F
G
H
I
J
K
L
M
N
O
P

GEAR COMPONENTS

< UNIT DISASSEMBLY AND ASSEMBLY >

[FS5R30A]

- s. Measure each gear end play as a final check. Refer to [TM-54](#).
["Gear End Play"](#).

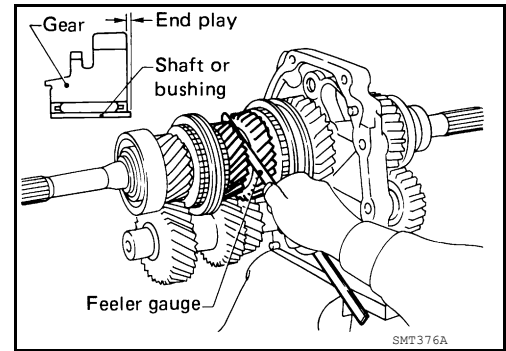

SERVICE DATA AND SPECIFICATIONS (SDS)

< SERVICE DATA AND SPECIFICATIONS (SDS)

[FS5R30A]

SERVICE DATA AND SPECIFICATIONS (SDS)

SERVICE DATA AND SPECIFICATIONS (SDS)

General Specification

INFOID:000000008790763

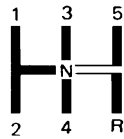
Engine		QR25DE	
Transmission model		FS5R30A	
Model code number		EA000	
Number of speed		5	
Synchronesh type		Warner	
Shift pattern		 <p style="text-align: center; font-size: small;">SCIA0821E</p>	
Gear ratio	1st	3.580	
	2nd	2.077	
	3rd	1.360	
	4th	1.000	
	OD	0.811	
	Reverse	3.636	
Number of teeth	Main gear	Drive	22
		1st	32
		2nd	30
		3rd	29
		4th	—
		OD	24
		Reverse	30
	Counter gear	Drive	32
		1st	13
		2nd	21
		3rd	31
		4th	—
		OD	43
		Reverse	12
Reverse idler gear		22	
Oil capacity (Approx.)		ℓ (US pt, Imp pt)	2.9 (6-1/8, 5-1/8)
Remarks	Reverse synchronizer		Installed
	Double-cone synchronizer		2nd and 3rd

SERVICE DATA AND SPECIFICATIONS (SDS)

< SERVICE DATA AND SPECIFICATIONS (SDS)

[FS5R30A]

Gear End Play

INFOID:000000008790764

Unit: mm (in)

Gear	End play
1st main gear	0.23 - 0.33 (0.0091 - 0.0130)
2nd main gear	0.23 - 0.33 (0.0091 - 0.0130)
3rd main gear	0.06 - 0.16 (0.0024 - 0.0063)
OD counter gear	0.23 - 0.33 (0.0091 - 0.0130)
Reverse main gear	0.33 - 0.43 (0.0130 - 0.0169)

Baulk Ring Clearance

INFOID:000000008790765

Unit: mm (in)

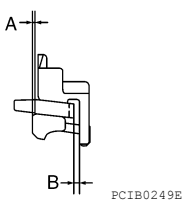
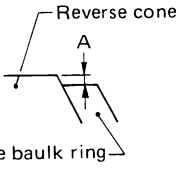
Measurement point		Standard value	Limit value
2nd and 3rd (Double-cone synchronizer)	Clearance between synchronizer cone and inner baulk ring end face (A)	0.7 - 0.9 (0.028 - 0.035)	0.2 (0.008)
	Clearance between outer baulk ring pawl and synchronizer cone (B)	0.6 - 1.1 (0.024 - 0.043)	0.2 (0.008)
 <p>PCIB0249E</p>			
1st		1.05 - 1.3 (0.041 - 0.051)	0.7 (0.028)
Main drive		1.05 - 1.3 (0.041 - 0.051)	0.7 (0.028)
OD		1.05 - 1.3 (0.041 - 0.051)	0.7 (0.028)
Reverse	Clearance between reverse cone and reverse baulk ring end face (A)	0.35 - 0.95 (0.0138 - 0.0374)	1.1 (0.043)
 <p>SMT428C</p>			

Available Snap Rings

INFOID:000000008790766

MAIN DRIVE GEAR SNAP RING

End play		0 - 0.1 mm (0 - 0.004 in)	
Thickness mm (in)	Part number*	Thickness mm (in)	Part number*
1.89 (0.0744)	32204 01G60	2.03 (0.0799)	32204 01G63
1.95 (0.0768)	32204 01G61	2.07 (0.0815)	32204 01G64
1.99 (0.0783)	32204 01G62	2.11 (0.0831)	32204 01G65

*: Always check with the Parts Department for the latest parts information.

MAINSHAFT FRONT SNAP RING

End play		0 - 0.1 mm (0 - 0.004 in)	
Thickness mm (in)	Part number*	Thickness mm (in)	Part number*
1.99 (0.0783)	32204 01G62	2.11 (0.0831)	32204 01G65
2.03 (0.0799)	32204 01G63	2.15 (0.0846)	32204 01G66
2.07 (0.0815)	32204 01G64	2.19 (0.0862)	32204 01G67

SERVICE DATA AND SPECIFICATIONS (SDS)

< SERVICE DATA AND SPECIFICATIONS (SDS)

[FS5R30A]

*: Always check with the Parts Department for the latest parts information.

COUNTER GEAR REAR SNAP RING

End play		0 - 0.1 mm (0 - 0.004 in)	
Thickness mm (in)	Part number*	Thickness mm (in)	Part number*
1.32 (0.0520)	32236 01G00	1.56 (0.0614)	32236 01G04
1.38 (0.0543)	32236 01G01	1.62 (0.0638)	32236 01G05
1.44 (0.0567)	32236 01G02	1.68 (0.0661)	32236 01G06
1.50 (0.0591)	32236 01G03	1.74 (0.0685)	32236 01G07

*: Always check with the Parts Department for the latest parts information.

Available C-Rings

INFOID:000000008790767

MAINSHAFT C-RING

End play		0 - 0.1 mm (0 - 0.004 in)	
Thickness mm (in)	Part number*	Thickness mm (in)	Part number*
2.63 (0.1035)	32348 01G15	3.19 (0.1256)	32348 01G07
2.70 (0.1063)	32348 01G00	3.26 (0.1283)	32348 01G08
2.77 (0.1091)	32348 01G01	3.33 (0.1311)	32348 01G09
2.84 (0.1118)	32348 01G02	3.40 (0.1339)	32348 01G10
2.91 (0.1146)	32348 01G03	3.47 (0.1366)	32348 01G11
2.98 (0.1173)	32348 01G04	3.54 (0.1394)	32348 01G12
3.05 (0.1201)	32348 01G05	3.61 (0.1421)	32348 01G13
3.12 (0.1228)	32348 01G06	3.68 (0.1449)	32348 01G14

*: Always check with the Parts Department for the latest parts information.

Available Thrust Washer

INFOID:000000008790768

REVERSE IDLER THRUST WASHER

End play		0.30 - 0.53 mm (0.0118 - 0.0209 in)	
	Thickness mm (in)	Part number*	
A	1.97 (0.0776)	32284 01G20	
B	2.07 (0.0815)	32284 01G21	

*: Always check with the Parts Department for the latest parts information.

Available Shims

INFOID:000000008790769

TABLE FOR SELECTING PROPER COUNTER GEAR FRONT BEARING SHIM

End play		0.10 - 0.26 mm (0.0039 - 0.0102 in)	
Dial indicator deflection mm (in)	Thickness of proper shim mm (in)	Part number*	
0.93 - 1.02 (0.0367 - 0.0401)	0.80 (0.0315)	32218 01G00	
1.01 - 1.10 (0.0398 - 0.0433)	0.88 (0.0346)	32218 01G11	
1.09 - 1.18 (0.0430 - 0.0464)	0.96 (0.0378)	32218 01G12	
1.17 - 1.26 (0.0461 - 0.0496)	1.04 (0.0409)	32218 01G13	
1.25 - 1.34 (0.0493 - 0.0527)	1.12 (0.0441)	32218 01G14	
1.33 - 1.42 (0.0524 - 0.0559)	1.20 (0.0472)	32218 01G04	
1.41 - 1.50 (0.0556 - 0.0590)	1.28 (0.0504)	32218 01G15	
1.49 - 1.58 (0.0587 - 0.0622)	1.36 (0.0535)	32218 01G16	
1.57 - 1.66 (0.0619 - 0.0653)	1.44 (0.0567)	32218 01G17	

*: Always check with the Parts Department for the latest parts information.

PRECAUTION

PRECAUTIONS

Precaution for Supplemental Restraint System (SRS) "AIR BAG" and "SEAT BELT PRE-TENSIONER"

INFOID:000000008790770

The Supplemental Restraint System such as "AIR BAG" and "SEAT BELT PRE-TENSIONER", used along with a front seat belt, helps to reduce the risk or severity of injury to the driver and front passenger for certain types of collision. This system includes seat belt switch inputs and dual stage front air bag modules. The SRS system uses the seat belt switches to determine the front air bag deployment, and may only deploy one front air bag, depending on the severity of a collision and whether the front occupants are belted or unbelted. Information necessary to service the system safely is included in the SR and SB section of this Service Manual.

WARNING:

- To avoid rendering the SRS inoperative, which could increase the risk of personal injury or death in the event of a collision which would result in air bag inflation, all maintenance must be performed by an authorized NISSAN/INFINITI dealer.
- Improper maintenance, including incorrect removal and installation of the SRS, can lead to personal injury caused by unintentional activation of the system. For removal of Spiral Cable and Air Bag Module, see the SR section.
- Do not use electrical test equipment on any circuit related to the SRS unless instructed to in this Service Manual. SRS wiring harnesses can be identified by yellow and/or orange harnesses or harness connectors.

PRECAUTIONS WHEN USING POWER TOOLS (AIR OR ELECTRIC) AND HAMMERS

WARNING:

- When working near the Airbag Diagnosis Sensor Unit or other Airbag System sensors with the Ignition ON or engine running, DO NOT use air or electric power tools or strike near the sensor(s) with a hammer. Heavy vibration could activate the sensor(s) and deploy the air bag(s), possibly causing serious injury.
- When using air or electric power tools or hammers, always switch the Ignition OFF, disconnect the battery, and wait at least 3 minutes before performing any service.

Precaution for Work

INFOID:000000009249567

- When removing or disassembling each component, be careful not to damage or deform it. If a component may be subject to interference, be sure to protect it with a shop cloth.
- When removing (disengaging) components with a screwdriver or similar tool, be sure to wrap the component with a shop cloth or vinyl tape to protect it.
- Protect the removed parts with a shop cloth and prevent them from being dropped.
- Replace a deformed or damaged clip.
- If a part is specified as a non-reusable part, always replace it with a new one.
- Be sure to tighten bolts and nuts securely to the specified torque.
- After installation is complete, be sure to check that each part works properly.
- Follow the steps below to clean components:
 - Water soluble dirt:
 - Dip a soft cloth into lukewarm water, wring the water out of the cloth and wipe the dirty area.
 - Then rub with a soft, dry cloth.
 - Oily dirt:
 - Dip a soft cloth into lukewarm water with mild detergent (concentration: within 2 to 3%) and wipe the dirty area.
 - Then dip a cloth into fresh water, wring the water out of the cloth and wipe the detergent off.
 - Then rub with a soft, dry cloth.
 - Do not use organic solvent such as thinner, benzene, alcohol or gasoline.
 - For genuine leather seats, use a genuine leather seat cleaner.

Service Notice or Precaution

INFOID:000000008790772

- Do not reuse transmission oil once it has been drained.
- Check oil level or replace oil with vehicle on level surface.

PRECAUTIONS

< PRECAUTION >

[6MT: FS6R31A]

- During removal or installation, keep inside of transmission clear of dust or dirt.
- Check for the correct installation status prior to removal or disassembly. If matching marks are required, be certain they do not interfere with the function of the parts they are applied to.
- In principle, tighten nuts and bolts gradually in several steps working diagonally from inside to outside. If tightening sequence is specified, use it.
- Be careful not to damage sliding surfaces and mating surfaces.

A

B

C

TM

E

F

G

H

I

J

K

L

M

N

O

P

PREPARATION

< PREPARATION >

[6MT: FS6R31A]



PREPARATION

PREPARATION

Special Service Tool

INFOID:000000008790773

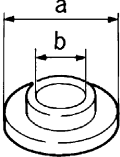
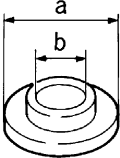
The actual shapes of Kent-Moore tools may differ from those of special service tools illustrated here.

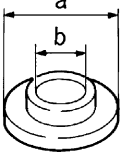
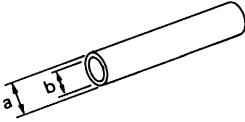
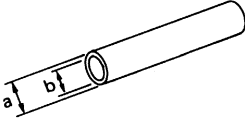
Tool number (Kent-Moore No.) Tool name	Description
ST30911000 (—) Inserter	 <p style="text-align: center;">ZZA0920D</p> <ul style="list-style-type: none"> • Installing mainshaft bearing • Installing 5th-6th synchronizer hub assembly • Installing reverse main gear bushing • Installing 3rd gear bushing • Installing 3rd-4th synchronizer hub assembly <p>a: 98 mm (3.86 in) dia. b: 40 mm (1.57 in) dia.</p>
ST30022000 (—) Inserter	 <p style="text-align: center;">ZZA0920D</p> <ul style="list-style-type: none"> • Installing 3rd main gear • Installing 4th main gear <p>a: 110 mm (4.33 in) dia. b: 46 mm (1.81 in) dia.</p>
ST27861000 (—) Support ring	 <p style="text-align: center;">ZZA0832D</p> <ul style="list-style-type: none"> • Installing 1st-2nd synchronizer hub assembly • Installing 1st gear bushing <p>a: 62 mm (2.44 in) dia. b: 52 mm (2.05 in) dia.</p>
ST30032000 (J-26010-01) Inserter	 <p style="text-align: center;">ZZA0920D</p> <p>Installing counter rear bearing inner race</p> <p>a: 80 mm (3.15 in) dia. b: 31 mm (1.22 in) dia.</p>
KV32102700 (—) Drift	 <p style="text-align: center;">ZZA0534D</p> <p>Installing main drive gear bearing</p> <p>a: 48 mm (1.89 in) dia. b: 41 mm (1.61 in) dia.</p>
ST23860000 (—) Drift	 <p style="text-align: center;">ZZA0534D</p> <p>Installing reverse counter gear</p> <p>a: 38 mm (1.50 in) dia. b: 33 mm (1.30 in) dia.</p>

PREPARATION

< PREPARATION >

[6MT: FS6R31A]

Tool number (Kent-Moore No.) Tool name	Description	
ST01530000 (—) Drift	Installing reverse synchronizer hub assembly a: 50 mm (1.97 in) dia. b: 41 mm (1.61 in) dia.	A B C
KV381054S0 (J-34286) Puller	Removing rear oil seal	TM E F
ST33200000 (J-26082) Drift	<ul style="list-style-type: none"> • Installing counter rear bearing • Installing rear oil seal a: 60 mm (2.36 in) dia. b: 44.5 mm (1.752 in) dia.	G H
KV40100630 (J-26092) Inserter	Installing 4th counter gear thrust washer a: 67 mm (2.64 in) dia. b: 38 mm (1.50 in) dia.	I J
KV38102100 (J-25803-01) Drift	Installing front cover oil seal a: 44 mm (1.73 in) dia. b: 28 mm (1.10 in) dia.	K L M
KV32103300 (J-46529) Press plate	Installing reverse synchronizer hub assembly a: 73 mm (2.87 in)	N O
ST30031000 (J-22912-01) Puller	Measuring wear of inner baulk ring	P

PREPARATION

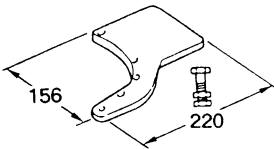
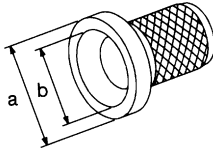
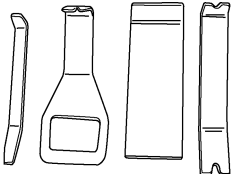

< PREPARATION >

[6MT: FS6R31A]

Tool number (Kent-Moore No.) Tool name	Description
ST22490000 (—) Adapter setting plate	Holding a adapter plate
 <p style="font-size: small; margin-top: 5px;">ZZC0465D</p>	
ST33400001 (J-26082) Drift	Installing oil seal a: 60 mm (2.36 in) dia. b: 47 mm (1.85 in) dia.
 <p style="font-size: small; margin-top: 5px;">NT086</p>	
— (J-46534) Trim Tool Set	Removing trim components
 <p style="font-size: small; margin-top: 5px;">AWJIA0483ZZ</p>	

Commercial Service Tool

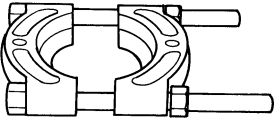
INFOID:000000008790774

Tool name	Description
Puller	Removing each bearing, gear and bushing
 <p style="font-size: small; margin-top: 5px;">ZZB0823D</p>	
Pin punch	Removing and installing each retaining pin Tip diameter: 6.0 mm (0.236 in) dia.
 <p style="font-size: small; margin-top: 5px;">ZZA0815D</p>	
Power tool	Loosening nuts, screws and bolts
 <p style="font-size: small; margin-top: 5px;">PIIB1407E</p>	

PREPARATION

< PREPARATION >

[6MT: FS6R31A]

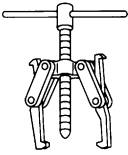
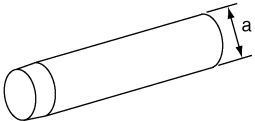
Tool name	Description
<p>Puller</p>  <p style="text-align: center;">NT077</p>	<ul style="list-style-type: none"> • Removing reverse synchronizer hub assembly • Removing reverse counter gear • Removing reverse main gear
<p>Drift</p>  <p style="text-align: center;">LC1A0362E</p>	<p>Removing counter end bearing a: 32 mm (1.26 in) dia.</p>

A
B
C
TM
E
F
G
H
I
J
K
L
M
N
O
P

NOISE, VIBRATION AND HARSHNESS (NVH) TROUBLESHOOTING

< SYMPTOM DIAGNOSIS >

[6MT: FS6R31A]

SYMPTOM DIAGNOSIS

NOISE, VIBRATION AND HARSHNESS (NVH) TROUBLESHOOTING

NVH Troubleshooting Chart

INFOID:000000008790775

Use the chart below to help you find the cause of the symptom. The numbers indicate the order of the inspection. If necessary, repair or replace these parts.

Reference page		TM-65			TM-77		TM-69	TM-69	TM-108				
SUSPECTED PARTS (Possible cause)		OIL (Oil level is low.)	OIL (Wrong oil.)	OIL (Oil level is high.)	GASKET (Damaged)	OIL SEAL (Worn or damaged)	SHIFT CONTROL LINKAGE (Worn)	CHECK PLUG RETURN SPRING AND CHECK BALL (Worn or damaged)	SHIFT FORK (Worn)	GEAR (Worn or damaged)	BEARING (Worn or damaged)	BAULK RING (Worn or damaged)	INSERT SPRING (Damaged)
Symptoms	Noise	1	2							3	3		
	Oil leakage		3	1	2	2							
	Hard to shift or will not shift		1	1			2					2	2
	Jumps out of gear						1	1	2	2			

DESCRIPTION

Cross-Sectional View

INFOID:000000008790776

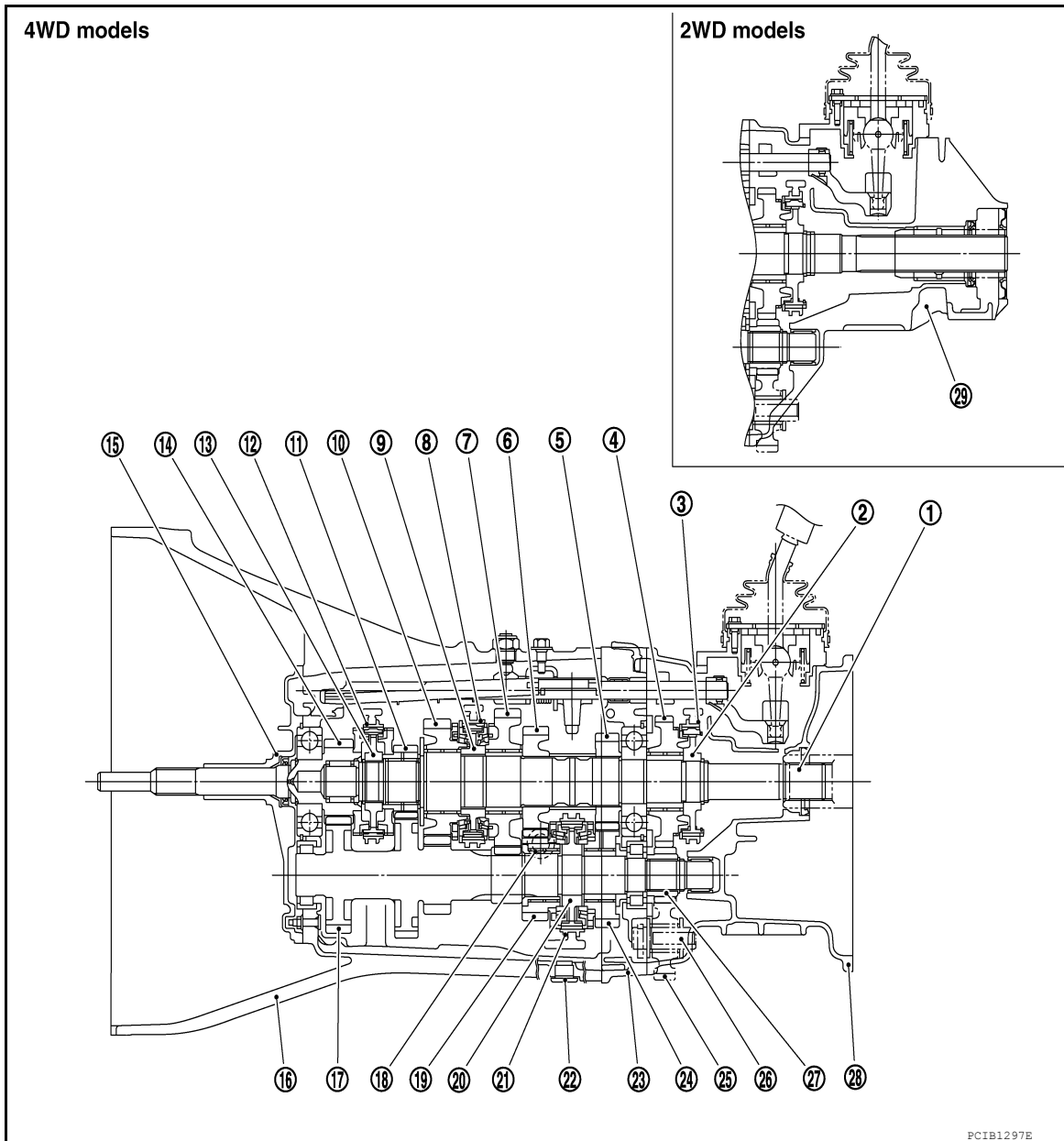

- | | | |
|------------------------------|------------------------------|-----------------------------|
| 1. Mainshaft | 2. Reverse synchronizer hub | 3. Reverse coupling sleeve |
| 4. Reverse main gear | 5. 4th main gear | 6. 3rd main gear |
| 7. 1st main gear | 8. 1st-2nd coupling sleeve | 9. 1st-2nd synchronizer hub |
| 10. 2nd main gear | 11. 6th main gear | 12. 5th-6th coupling sleeve |
| 13. 5th-6th synchronizer hub | 14. Main drive gear | 15. Front cover |
| 16. Transmission case | 17. Counter gear | 18. Filler plug |
| 19. 3rd counter gear | 20. 3rd-4th synchronizer hub | 21. 3rd-4th coupling sleeve |
| 22. Drain plug | 23. Adapter plate | 24. 4th counter gear |
| 25. Reverse idler gear | 26. Reverse idler shaft | 27. Reverse counter gear |
| 28. OD gear case | 29. Rear extension | |

DOUBLE-CONE SYNCHRONIZER

A
B
C
TM
E
F
G
H
I
J
K
L
M
N
O
P

DESCRIPTION

< SYMPTOM DIAGNOSIS >

[6MT: FS6R31A]

The 1st, 3rd and 4th gears are equipped with a double-cone synchronizer to reduce the operating force of the shift selector.

TRIPLE-CONE SYNCHRONIZER

The 2nd gear is equipped with a triple-cone synchronizer to reduce the operating force of the shift selector.

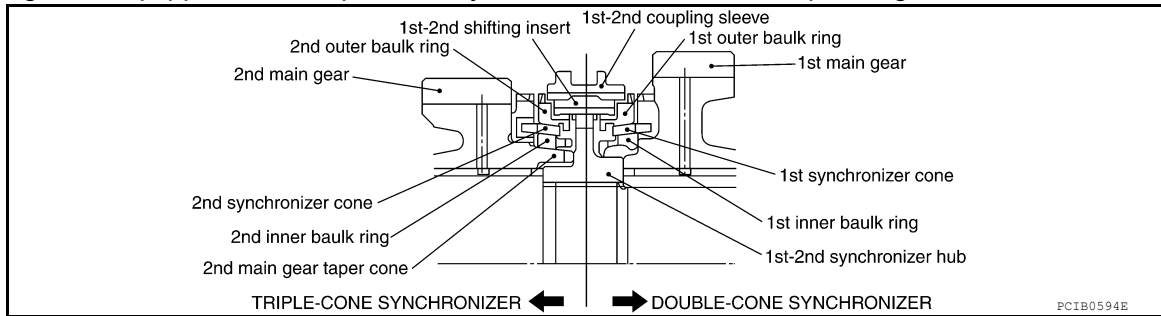

PERIODIC MAINTENANCE

M/T OIL

Changing

INFOID:000000008790777

DRAINING

1. Start the engine and let it run to warm up the transmission.
2. Stop the engine. Remove the transmission drain plug and drain the oil.
3. Set a gasket on the drain plug and install it to the transmission. Tighten the drain plug to the specified torque. Refer to [TM-77, "Overhaul"](#).

CAUTION:
Do not reuse gasket.

FILLING

1. Remove the filler plug. Fill with new oil until oil level reaches the specified limit near the filler plug hole as shown.

Oil grade and viscosity : Refer to [MA-17, "FOR USA AND CANADA : Fluids and Lubricants"](#).

Oil capacity : Refer to [MA-17, "FOR USA AND CANADA : Fluids and Lubricants"](#).

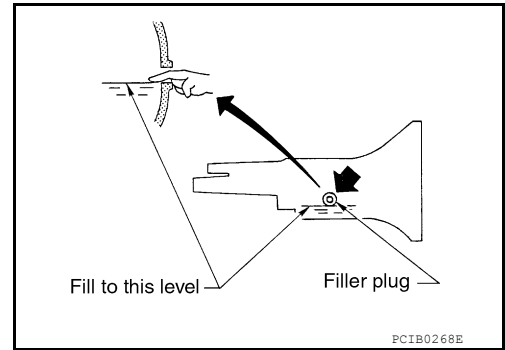

2. After refilling the oil, check oil level. Set a gasket to the filler plug, then install it to the transmission. Tighten the filler plug to the specified torque. Refer to [TM-77, "Overhaul"](#).

CAUTION:
Do not reuse gasket.

Checking

INFOID:000000008790778

OIL LEAKAGE AND OIL LEVEL

1. Make sure that oil is not leaking from the transmission or around it.
2. Check oil level from the filler plug hole as shown.

CAUTION:
Do not start engine while checking oil level.

3. Set a gasket on the filler plug and install it to the transmission. Tighten the filler plug to the specified torque. Refer to [TM-77, "Overhaul"](#).

CAUTION:
Do not reuse gasket.

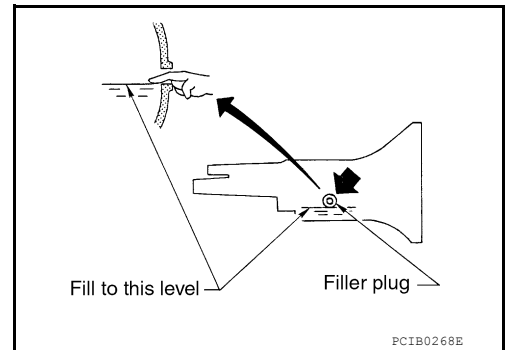

A
B
C
TM
E
F
G
H
I
J
K
L
M
N
O
P

REAR OIL SEAL

< REMOVAL AND INSTALLATION >

[6MT: FS6R31A]

REMOVAL AND INSTALLATION

REAR OIL SEAL

Removal and Installation

INFOID:000000008790779

REMOVAL

For 2WD Models

1. Remove rear propeller shaft. Refer to [DLN-153. "Removal and Installation"](#) (3S1310), [DLN-164. "Removal and Installation"](#) (3S1330), [DLN-175. "Removal and Installation"](#) (3S1330-2BJ100).
2. Remove dust seal and rear oil seal using suitable tool.
CAUTION:
Do not damage rear extension.

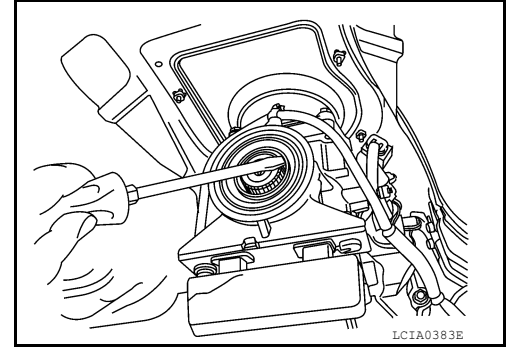

For 4WD Models

1. Remove front and rear propeller shafts. Refer to [DLN-135. "Removal and Installation"](#) (front) and [DLN-144. "Removal and Installation"](#) (2S1330), [DLN-175. "Removal and Installation"](#) (3S1330-2BJ100) (rear).
2. Remove transfer assembly. Refer to [DLN-102. "Removal and Installation"](#).
3. Remove rear oil seal using Tool.

Tool number : KV381054S0 (J-34286)

CAUTION:
Do not damage OD gear case.

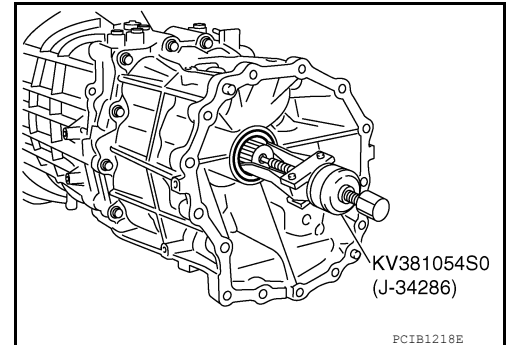

INSTALLATION

Installation is in the reverse order of removal.

For 2WD Models

REAR OIL SEAL

< REMOVAL AND INSTALLATION >

[6MT: FS6R31A]

- Drive the new rear oil seal (1) and new dust seal (2) using Tools.

Tool number : ST33200000 (J-26082)
: KV38100500 (—)

Dimension (H1) : 1.2 - 2.2 mm (0.047 - 0.087 in)

Dimension (H2) : 0.5 - 1.5 mm (0.020 - 0.059 in)

CAUTION:

- Do not reuse rear oil seal.
- Do not incline the dust seal and rear oil seal during installation.

(A): Seal lip

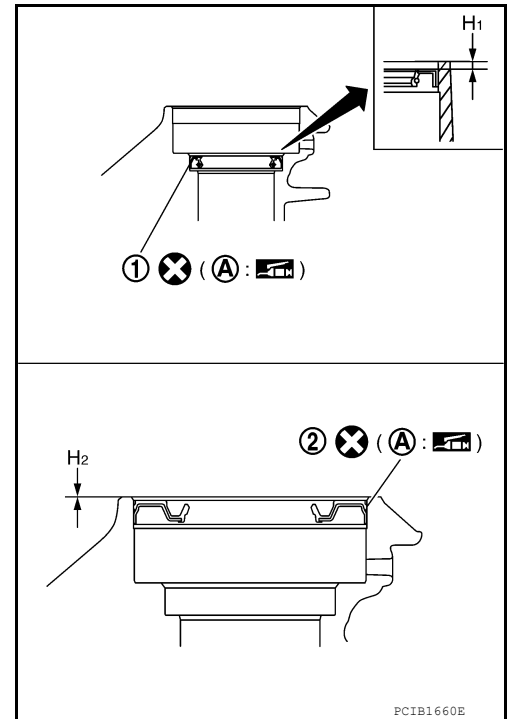

For 4WD Models

- Drive the rear oil seal using Tool.

Tool number : ST33200000 (J-26082)

Dimension (A) : -0.5 - 0.5 mm (-0.020 - 0.020 in)

CAUTION:

- Do not reuse rear oil seal.
- Do not incline the rear oil seal during installation.

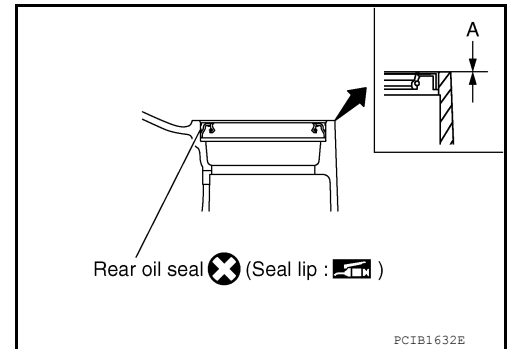

- Check the transmission oil level after installation. Refer to [TM-65, "Checking"](#).

POSITION SWITCH

< REMOVAL AND INSTALLATION >

[6MT: FS6R31A]

POSITION SWITCH

Checking

INFOID:000000008790780

BACK-UP LAMP SWITCH

- Check continuity.

Gear position	Continuity
Reverse	Yes
Except reverse	No

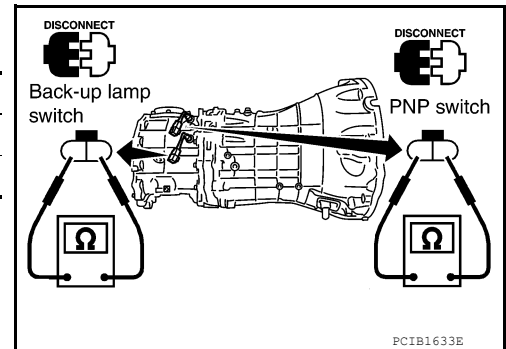

PARK/NEUTRAL POSITION SWITCH

- Check continuity.

Gear position	Continuity
Neutral	Yes
Except neutral	No

SHIFT CONTROL

< REMOVAL AND INSTALLATION >

[6MT: FS6R31A]

SHIFT CONTROL

Removal and Installation

INFOID:000000008790781

COMPONENTS

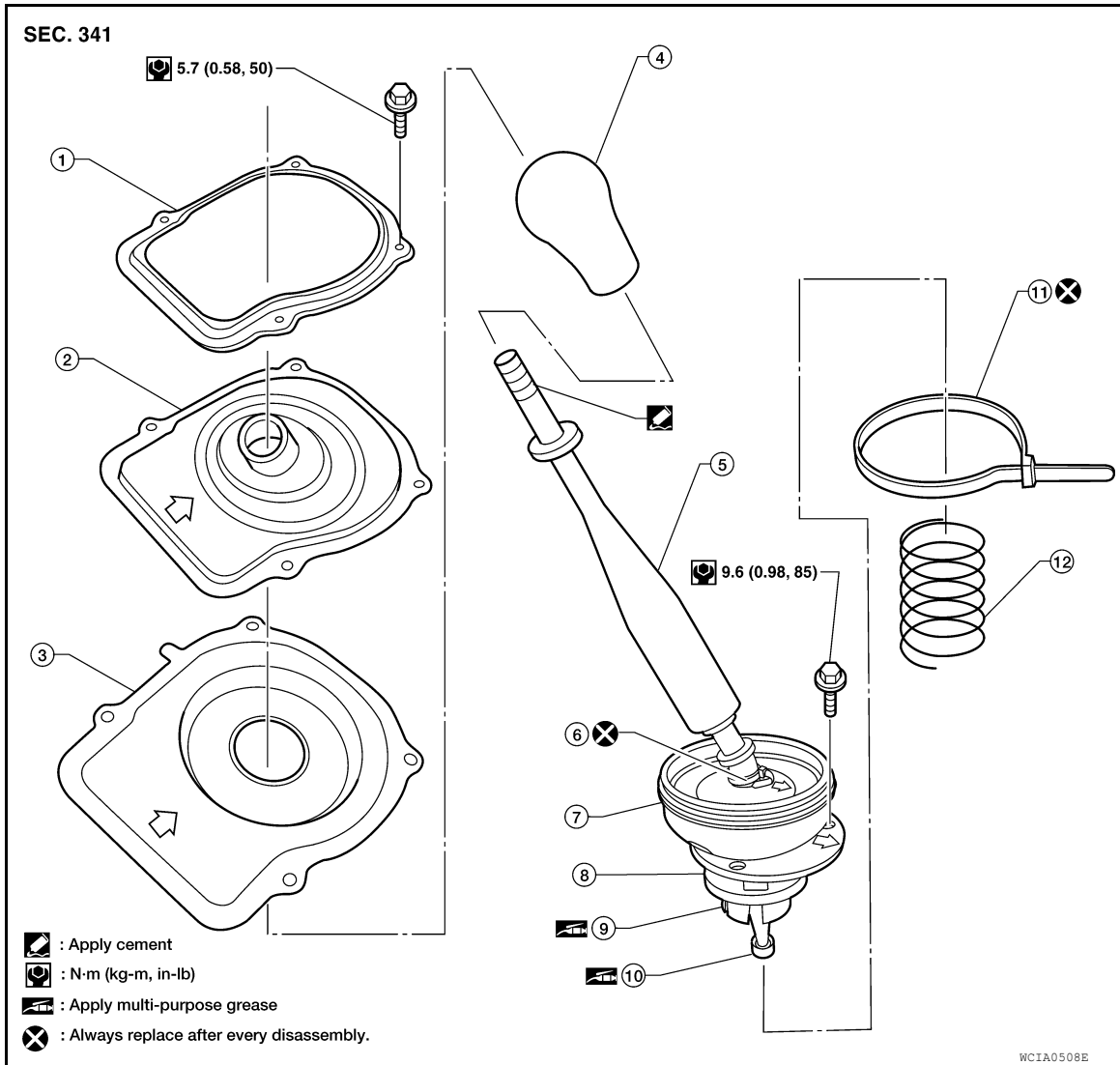

- | | | |
|--------------------------|----------------------------|----------------------------|
| 1. Retaining plate | 2. Dust boot cover (upper) | 3. Dust boot cover (lower) |
| 4. Shift selector handle | 5. Shift selector assembly | 6. Clip A |
| 7. Boot | 8. Guide plate | 9. Socket |
| 10. Bushing | 11. Clip B | 12. Spring |

REMOVAL

1. Remove the shift selector handle.
2. Remove the M/T finisher. Refer to [IP-29. "Exploded View"](#).
3. Remove the retaining plate and dust boot covers.
4. Remove the clip B and then separate the boot from the control housing.
5. Remove the guide plate bolts and then separate the guide plate.
6. Remove the shift selector assembly and spring from the transmission.

INSTALLATION

Installation is the reverse order of removal.

- Install shift selector handle according to the following.

SHIFT CONTROL

< REMOVAL AND INSTALLATION >

[6MT: FS6R31A]

- Apply cement to threads of shift selector assembly.
- Tighten shift selector handle until increased tension is felt. Then align shift selector handle to the position as shown within one turn.

CAUTION:

Do not adjust shift selector handle by loosening it.

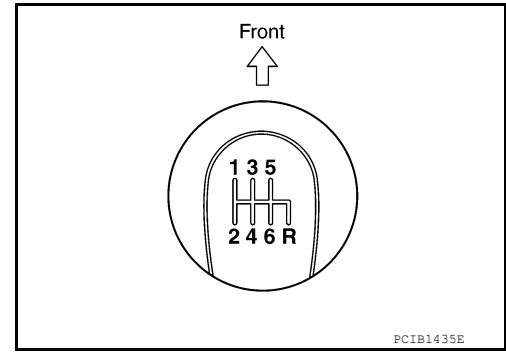

CAUTION:

- Apply multi-purpose grease to socket and bushing.
- Insert bushing of shift selector assembly as far as it will go into the hole of striking arm.
- Tighten guide plate (1) bolts to the specified torque in order as shown.
- ⇐: Front

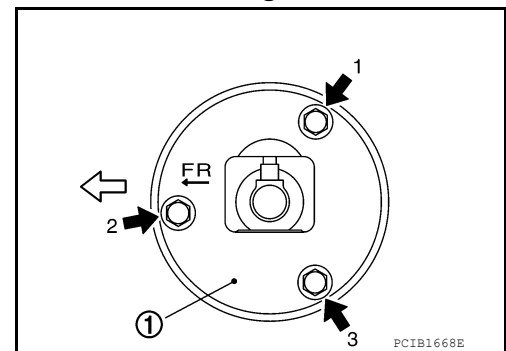

- Do not reuse clip.
- Position clip as shown.
- Be careful with the orientation of guide plate and boot.

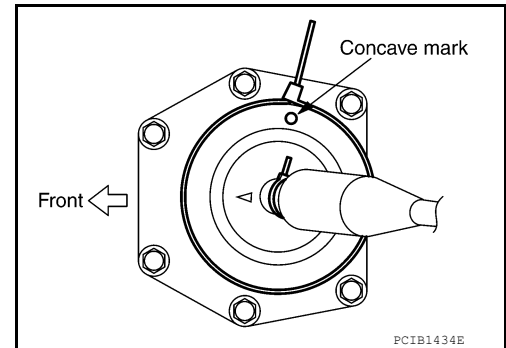

INSPECTION AFTER INSTALLATION

- Tighten guide plate bolts to the specified torque. Refer to [TM-77, "Overhaul"](#).
- When shift selector assembly is moved to each position, make sure there is no binding or disconnection in either boot.
- When moved to each position, make sure there is no noise, bending, and backlash. Especially when shift selector assembly is moved to 5th, 6th without pressing downward, check for bending.
- When shift selector assembly is moved to 1st, 2nd side and 5th, 6th side, confirm shift selector assembly returns to neutral position smoothly.
- In any position other than reverse, confirm that shift selector assembly can be pressed downward.
- With shift selector assembly pressed downward, confirm that it can be moved to reverse.
- When moved from reverse to neutral position, confirm shift selector assembly returns to neutral position smoothly with spring power.
- Without shift selector assembly pressed downward, confirm that it cannot be moved to reverse.

AIR BREATHER HOSE

< REMOVAL AND INSTALLATION >

[6MT: FS6R31A]

AIR BREATHER HOSE

Removal and Installation

INFOID:000000008790782

COMPONENTS

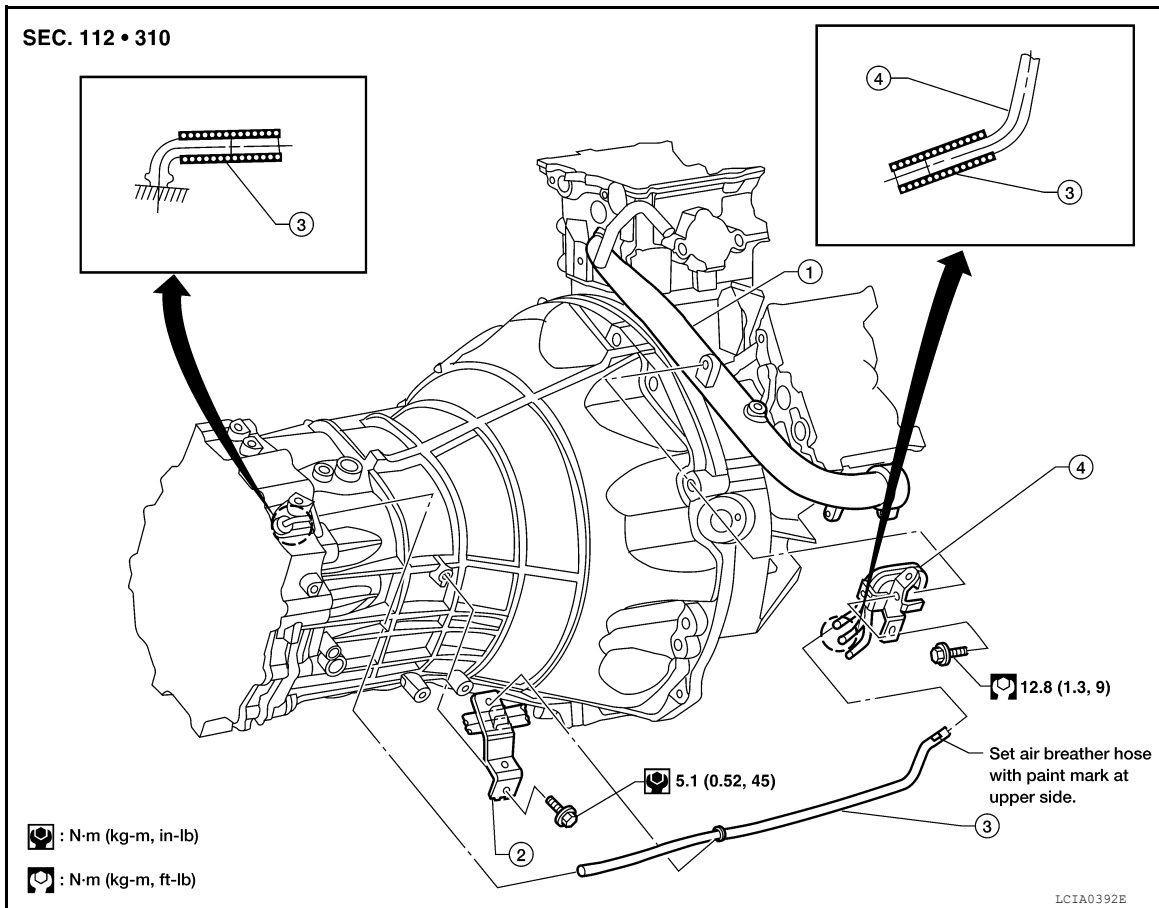

1. Water outlet
2. Bracket
3. Air breather hose
4. Breather tube

REMOVAL

1. Disconnect air breather hose from breather tube and transmission harness connector.
2. Disconnect air breather hose from the bracket.
3. Remove the bracket bolt and remove the bracket from the transmission housing, if necessary.
4. Remove the breather tube bolt and the breather tube.

INSTALLATION

Installation is in the reverse order of removal.

CAUTION:

- Make sure there are no pinched or blocked areas on the air breather hose after installation.
- When inserting the air breather hose, be sure to insert it fully until its end reaches the end of the tube radius.
- Install the air breather hose with the paint mark side up.

TRANSMISSION ASSEMBLY

< UNIT REMOVAL AND INSTALLATION >

[6MT: FS6R31A]

UNIT REMOVAL AND INSTALLATION

TRANSMISSION ASSEMBLY

Removal and Installation from Vehicle (For 2WD Models)

INFOID:000000008790783

COMPONENTS

SEC. 112 • 310

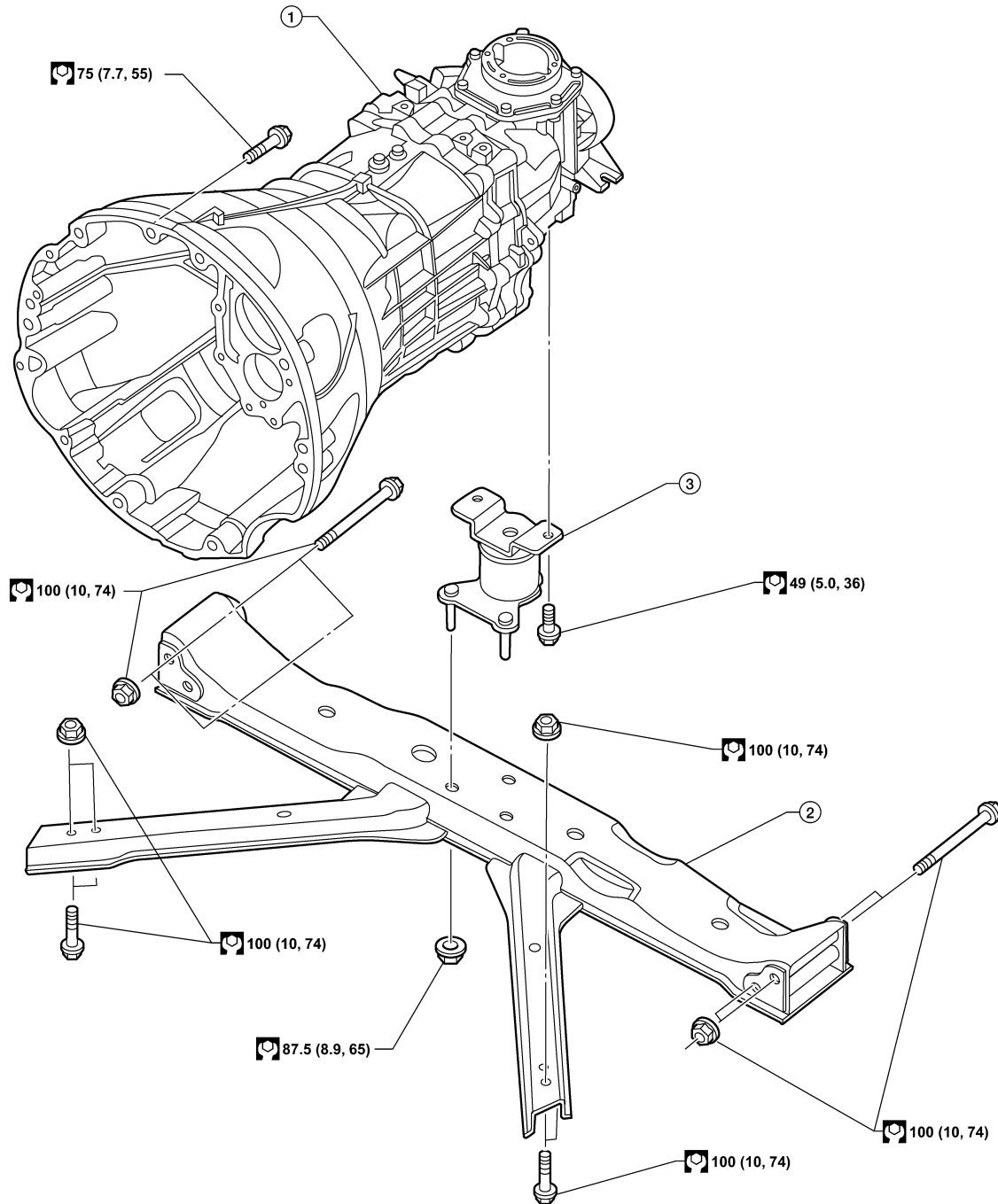

AMDIA0687GB

1. Transmission assembly

2. Crossmember

3. Insulator

NOTE:

When removing components such as hoses, tubes/lines, etc., cap or plug openings to prevent fluid from spilling.

TRANSMISSION ASSEMBLY

< UNIT REMOVAL AND INSTALLATION >

[6MT: FS6R31A]

REMOVAL

1. Disconnect the battery cable from the negative terminal. Refer to [PG-82, "Removal and Installation"](#).
2. Remove the shift selector assembly. Refer to [TM-69, "Removal and Installation"](#).
3. Remove the LH fender protector. Refer to [EXT-27, "Removal and Installation of Front Fender Protector"](#).
4. Remove the crankshaft position sensor (POS) from M/T assembly.
CAUTION:
Do not damage the sensor edge.
5. Remove the under cover(s) using power tool.
6. Remove the front crossmember using power tool.
7. Remove the starter motor. Refer to [STR-36, "Removal and Installation \(VQ40DE\)"](#).
8. Remove the rear propeller shaft. Refer to [DLN-144, "Removal and Installation" \(2S1330\)](#), [DLN-164, "Removal and Installation" \(3S1330\)](#), [DLN-175, "Removal and Installation" \(3S1330-2BJ100\)](#).
9. Remove the left and right front exhaust tubes. Refer to [EX-5, "Exploded View"](#).
10. Remove the clutch operating cylinder from the transmission. Refer to [CL-16, "6M/T : Removal and Installation"](#).
11. Support the transmission using a suitable jack.
12. Remove the nuts securing the insulator to the crossmember.
13. Remove the crossmember using power tool.
WARNING:
Support the transmission using suitable jack.
14. Tilt the transmission slightly to gain clearance between the body and the transmission, then disconnect the air breather hoses. Refer to [TM-71, "Removal and Installation"](#).
15. Disconnect the following:
 - Back-up lamp switch harness connector
 - Park/neutral position (PNP) switch harness connector
16. Remove the harness from the retainers.
17. Remove the transmission to engine bolts using power tool.
18. Separate the transmission from the engine and remove it from the vehicle.

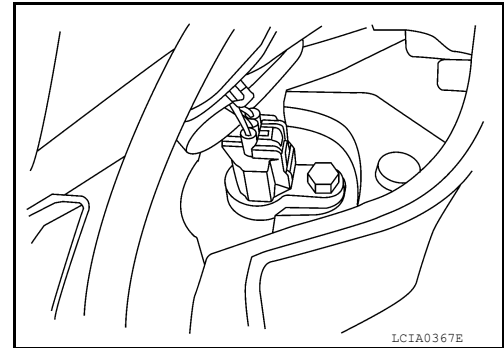

WARNING:
Support the transmission while removing it using suitable jack.

INSTALLATION

Installation is in the reverse order of removal.

- When installing the transmission to the engine, tighten the bolts to the specified torque.

Quantity	10
Bolt length "ℓ" mm (in)	65 (2.56)
Tightening torque N·m (kg-m, ft-lb)	75 (7.7, 55)

CAUTION:

- When installing be careful to avoid interference between transmission main drive gear and clutch cover.
- After installation, check for oil leakage and oil level. Refer to [TM-65, "Checking"](#).
- If flywheel is removed, align dowel pin with the smallest hole of flywheel.
- When replacing an engine or transmission you must make sure the dowels are installed correctly during re-assembly.
- Improper alignment caused by missing dowels may cause vibration, oil leaks or breakage of drive train components.

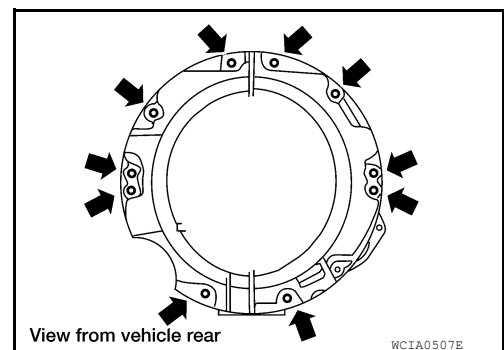

TRANSMISSION ASSEMBLY

< UNIT REMOVAL AND INSTALLATION >

[6MT: FS6R31A]

Removal and Installation from Vehicle (For 4WD Models)

INFOID:000000008790784

COMPONENTS

SEC. 112 • 310

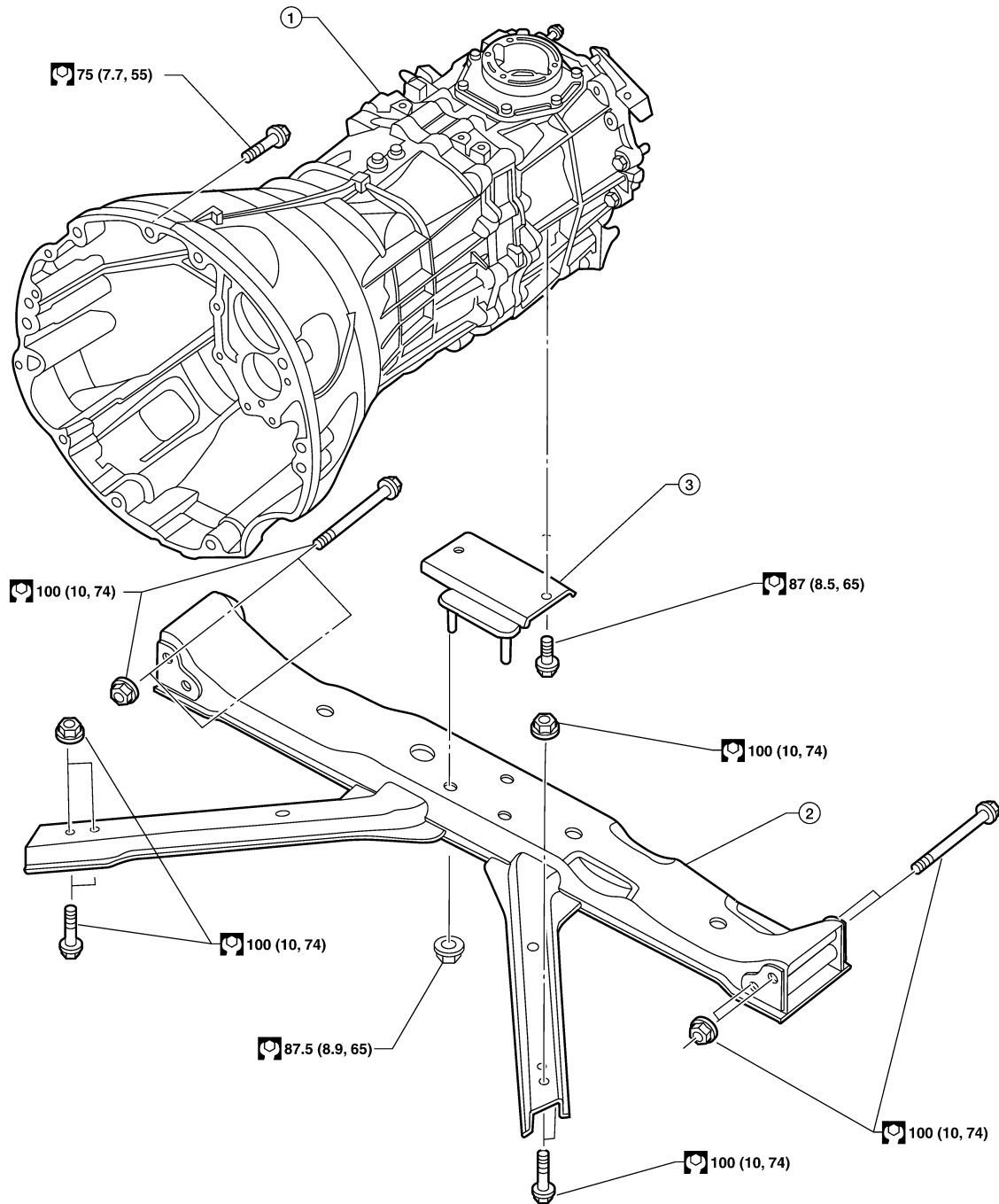

WCIA0577E

1. Transmission assembly

2. Crossmember

3. Insulator

NOTE:

When removing components such as hoses, tubes/lines, etc., cap or plug openings to prevent fluid from spilling.

REMOVAL

1. Disconnect the battery cable from the negative terminal. Refer to [PG-82. "Removal and Installation"](#).
2. Remove the shift selector assembly. Refer to [TM-69. "Removal and Installation"](#).

TRANSMISSION ASSEMBLY

[6MT: FS6R31A]

< UNIT REMOVAL AND INSTALLATION >

3. Remove the LH fender protector. Refer to [EXT-27, "Removal and Installation of Front Fender Protector"](#).
4. Remove the crankshaft position sensor (POS) from the M/T assembly.
CAUTION:
Do not damage the sensor edge.
5. Remove the under cover(s) using power tool.
6. Remove the front crossmember using power tool.
7. Remove the starter motor. Refer to [STR-36, "Removal and Installation \(VQ40DE\)"](#).
8. Remove the front and rear propeller shafts. Refer to [DLN-135, "Removal and Installation"](#) (front), [DLN-144, "Removal and Installation"](#) (2S1330) or [DLN-175, "Removal and Installation"](#) (3S1330-2BJ100) (rear).
9. Remove the left and right front exhaust tubes. Refer to [EX-6, "Removal and Installation"](#).
10. Remove the clutch operating cylinder from the transmission. Refer to [CL-16, "6M/T : Removal and Installation"](#).
11. Support the transmission using a suitable jack.
12. Remove the nuts securing the insulator to the crossmember.
13. Remove the crossmember using power tool.
WARNING:
Support the transmission using suitable jack.
14. Tilt the transmission slightly to gain clearance between the body and the transmission, then disconnect the air breather hoses. Refer to [TM-71, "Removal and Installation"](#).
15. Disconnect the following:
 - Back-up lamp switch harness connector
 - Park/neutral position (PNP) switch harness connector
 - ATP switch harness connector
 - Neutral 4LO switch harness connector
 - Wait detection switch harness connector
 - Transfer control device harness connector
16. Remove the harness from the retainers.
17. Remove the transmission to engine bolts using power tool.
18. Separate the transmission from the engine and remove it from the vehicle.
WARNING:
Support manual transmission while removing it.

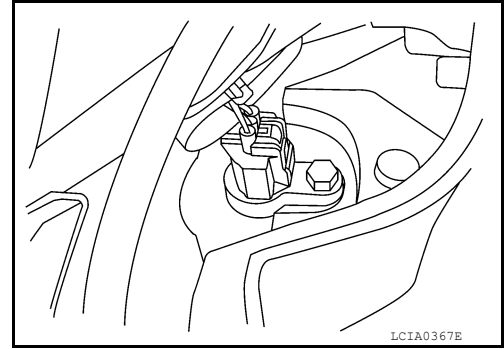

INSTALLATION

Installation is in the reverse order of removal.

- When installing the transmission to the engine, tighten the bolts to the specified torque.

Quantity	10
Bolt length "ℓ" mm (in)	65 (2.56)
Tightening torque N·m (kg-m, ft-lb)	75 (7.7, 55)

CAUTION:

- When installing be careful to avoid interference between transmission main drive gear and clutch cover.
- After installation, check for oil leakage and oil level. Refer to [TM-65, "Checking"](#).
- If flywheel is removed, align dowel pin with the smallest hole of flywheel. Refer to [EM-220, "Disassembly and Assembly"](#).
- When replacing an engine or transmission you must make sure the dowels are installed correctly during re-assembly.

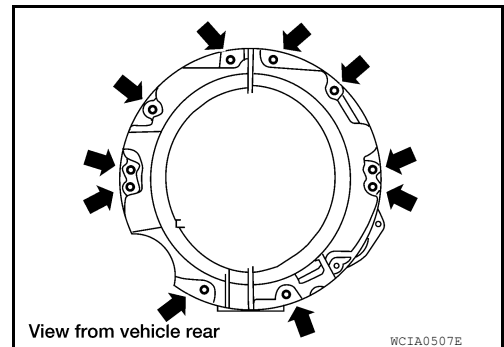

TRANSMISSION ASSEMBLY

< UNIT REMOVAL AND INSTALLATION >

[6MT: FS6R31A]

- **Improper alignment caused by missing dowels may cause vibration oil leaks or breakage of drivetrain components.**

TRANSMISSION ASSEMBLY

< UNIT DISASSEMBLY AND ASSEMBLY >

[6MT: FS6R31A]

UNIT DISASSEMBLY AND ASSEMBLY

TRANSMISSION ASSEMBLY

Overhaul

INFOID:000000008790785

EXPLODED VIEW

Case Components

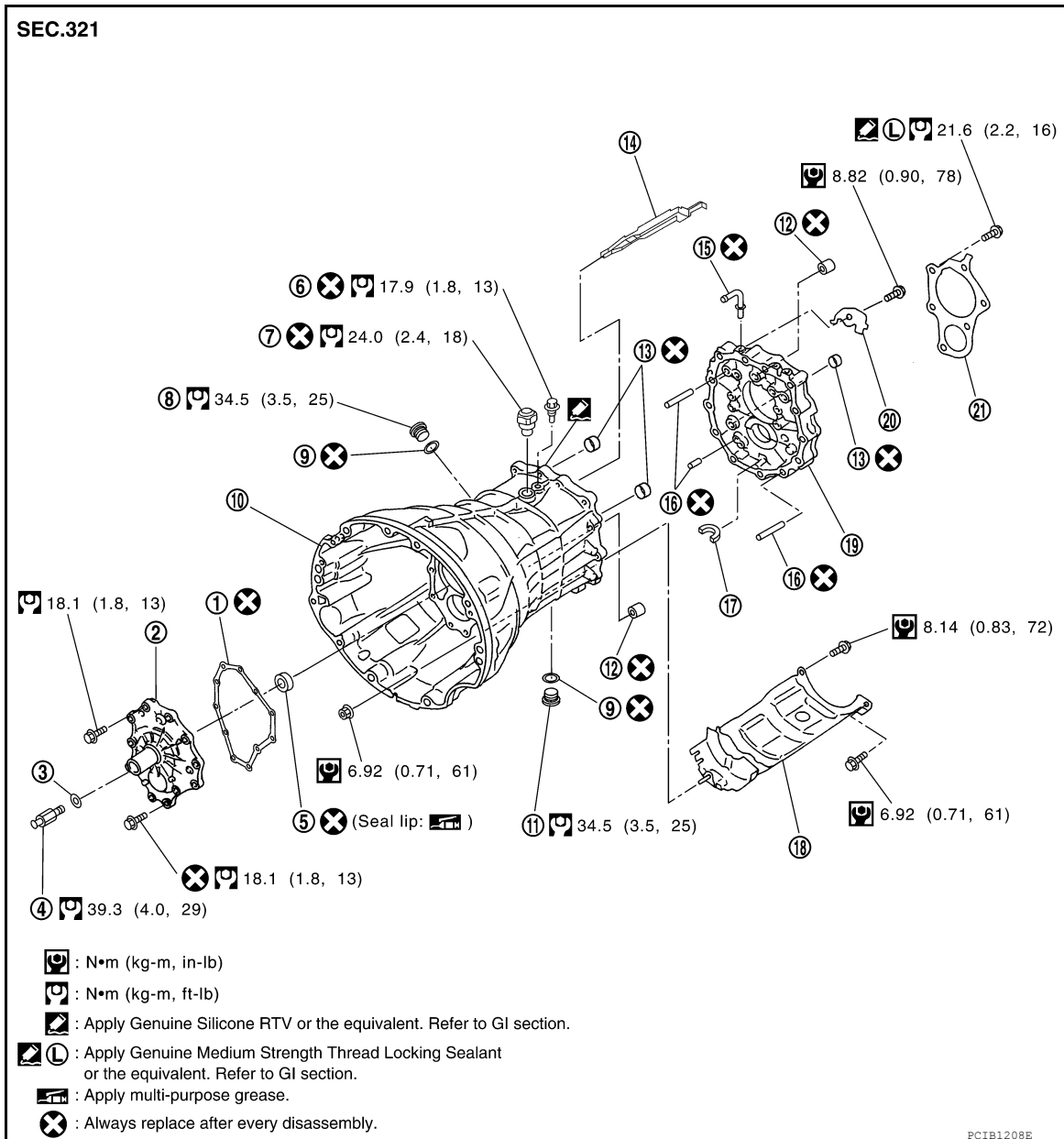

- | | | |
|------------------------------|-------------------------|--------------------------|
| 1. Front cover gasket | 2. Front cover | 3. Washer |
| 4. Withdrawal lever ball pin | 5. Front cover oil seal | 6. Pivot bolt |
| 7. Check shift pin | 8. Filler plug | 9. Gasket |
| 10. Transmission case | 11. Drain plug | 12. Sliding ball bearing |
| 13. Bushing | 14. Oil gutter | 15. Breather |
| 16. Dowel pin | 17. Magnet | 18. Baffle plate |
| 19. Adapter plate | 20. Baffle plate | 21. Bearing retainer |

TRANSMISSION ASSEMBLY

< UNIT DISASSEMBLY AND ASSEMBLY >

[6MT: FS6R31A]

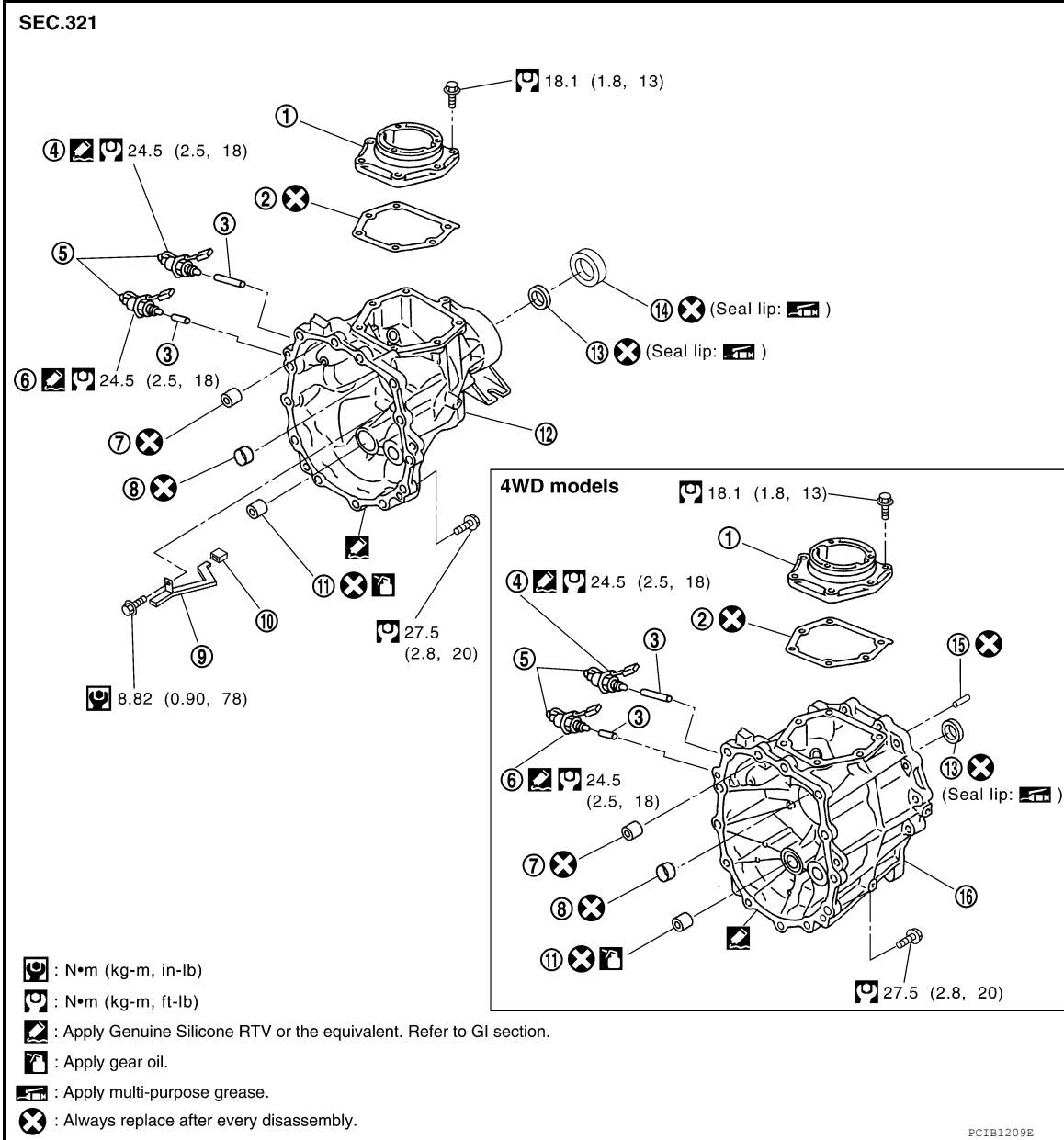

- | | | |
|---------------------------------------|-------------------------|------------------------------|
| 1. Control housing | 2. Gasket | 3. Plunger |
| 4. Park/neutral position (PNP) switch | 5. Clip | 6. Back-up lamp switch |
| 7. Sliding ball bearing | 8. Bushing | 9. Rear extension oil gutter |
| 10. Cap | 11. Counter end bearing | 12. Rear extension |
| 13. Rear oil seal | 14. Dust seal | 15. Dowel pin |
| 16. OD gear case | | |

Gear Components

TRANSMISSION ASSEMBLY

< UNIT DISASSEMBLY AND ASSEMBLY >

[6MT: FS6R31A]

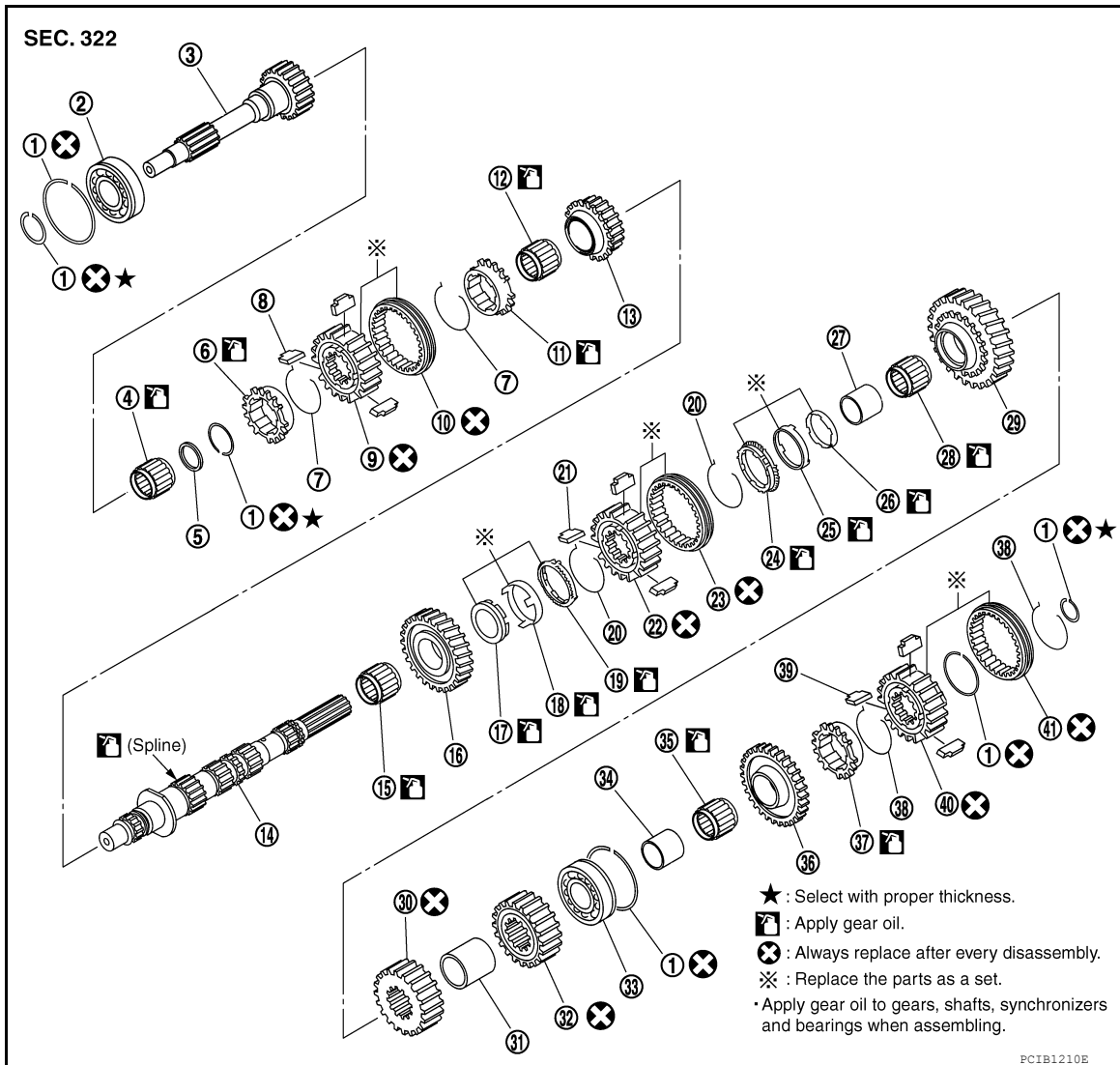

- | | | |
|-------------------------------|---------------------------------|-----------------------------|
| 1. Snap ring | 2. Main drive gear bearing | 3. Main drive gear |
| 4. Main pilot bearing | 5. Pilot bearing spacer | 6. 5th baulk ring |
| 7. 5th-6th spread spring | 8. 5th-6th shifting insert | 9. 5th-6th synchronizer hub |
| 10. 5th-6th coupling sleeve | 11. 6th baulk ring | 12. 6th needle bearing |
| 13. 6th main gear | 14. Mainshaft | 15. 2nd needle bearing |
| 16. 2nd main gear | 17. 2nd inner baulk ring | 18. 2nd synchronizer cone |
| 19. 2nd outer baulk ring | 20. 1st-2nd spread spring | 21. 1st-2nd shifting insert |
| 22. 1st-2nd synchronizer hub | 23. 1st-2nd coupling sleeve | 24. 1st outer baulk ring |
| 25. 1st synchronizer cone | 26. 1st inner baulk ring | 27. 1st gear bushing |
| 28. 1st needle bearing | 29. 1st main gear | 30. 3rd main gear |
| 31. 3rd-4th main spacer | 32. 4th main gear | 33. Mainshaft bearing |
| 34. Reverse main gear bushing | 35. Reverse main needle bearing | 36. Reverse main gear |
| 37. Reverse baulk ring | 38. Reverse spread spring | 39. Reverse shifting insert |
| 40. Reverse synchronizer hub | 41. Reverse coupling sleeve | |

TRANSMISSION ASSEMBLY

< UNIT DISASSEMBLY AND ASSEMBLY >

[6MT: FS6R31A]

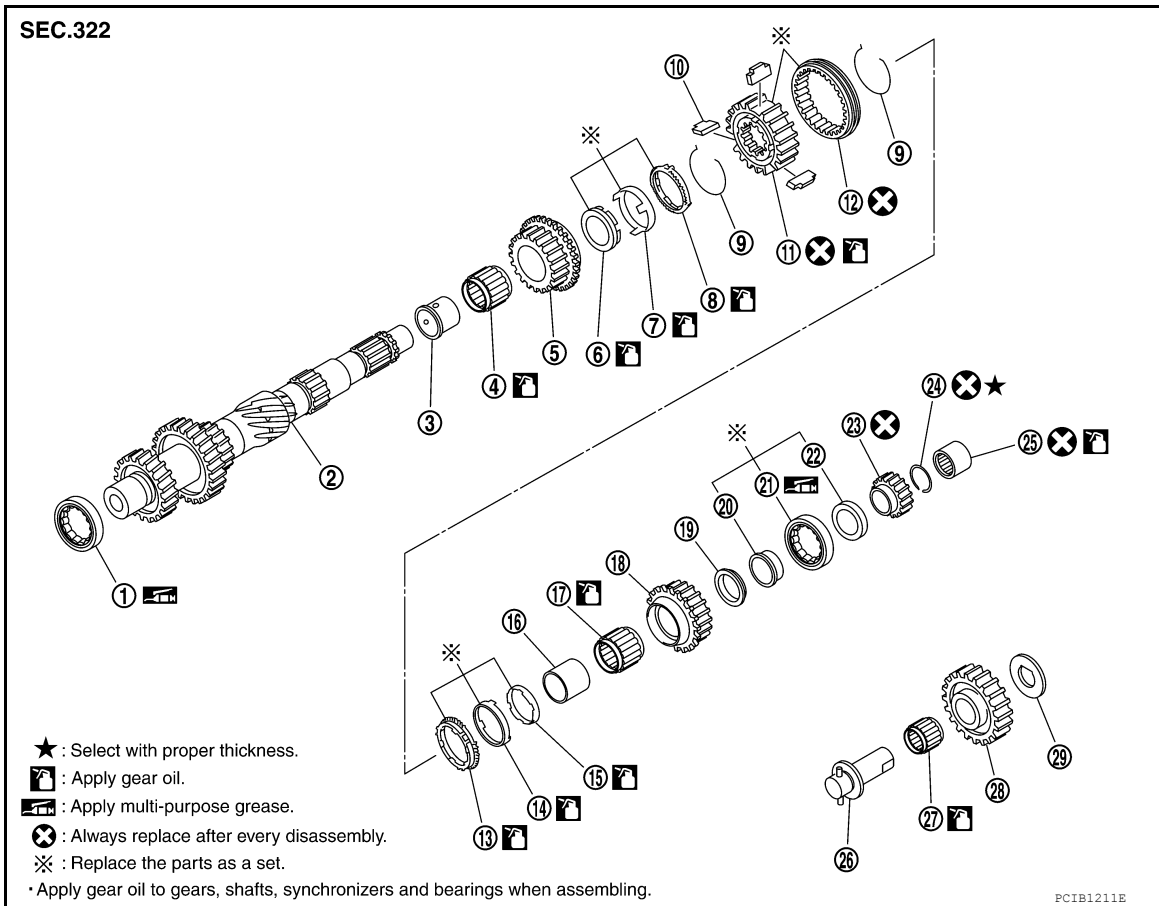

- | | | |
|------------------------------------|-------------------------------------|----------------------------------|
| 1. Counter front bearing | 2. Counter gear | 3. 3rd gear bushing |
| 4. 3rd needle bearing | 5. 3rd counter gear | 6. 3rd inner baulk ring |
| 7. 3rd synchronizer cone | 8. 3rd outer baulk ring | 9. 3rd-4th spread spring |
| 10. 3rd-4th shifting insert | 11. 3rd-4th synchronizer hub | 12. 3rd-4th coupling sleeve |
| 13. 4th outer baulk ring | 14. 4th synchronizer cone | 15. 4th inner baulk ring |
| 16. 4th gear bushing | 17. 4th needle bearing | 18. 4th counter gear |
| 19. 4th counter gear thrust washer | 20. Counter rear bearing inner race | 21. Counter rear bearing |
| 22. Counter rear bearing spacer | 23. Reverse counter gear | 24. Snap ring |
| 25. Counter end bearing | 26. Reverse idler shaft | 27. Reverse idler needle bearing |
| 28. Reverse idler gear | 29. Reverse idler thrust washer | |

Shift Control Components

TRANSMISSION ASSEMBLY

< UNIT DISASSEMBLY AND ASSEMBLY >

[6MT: FS6R31A]

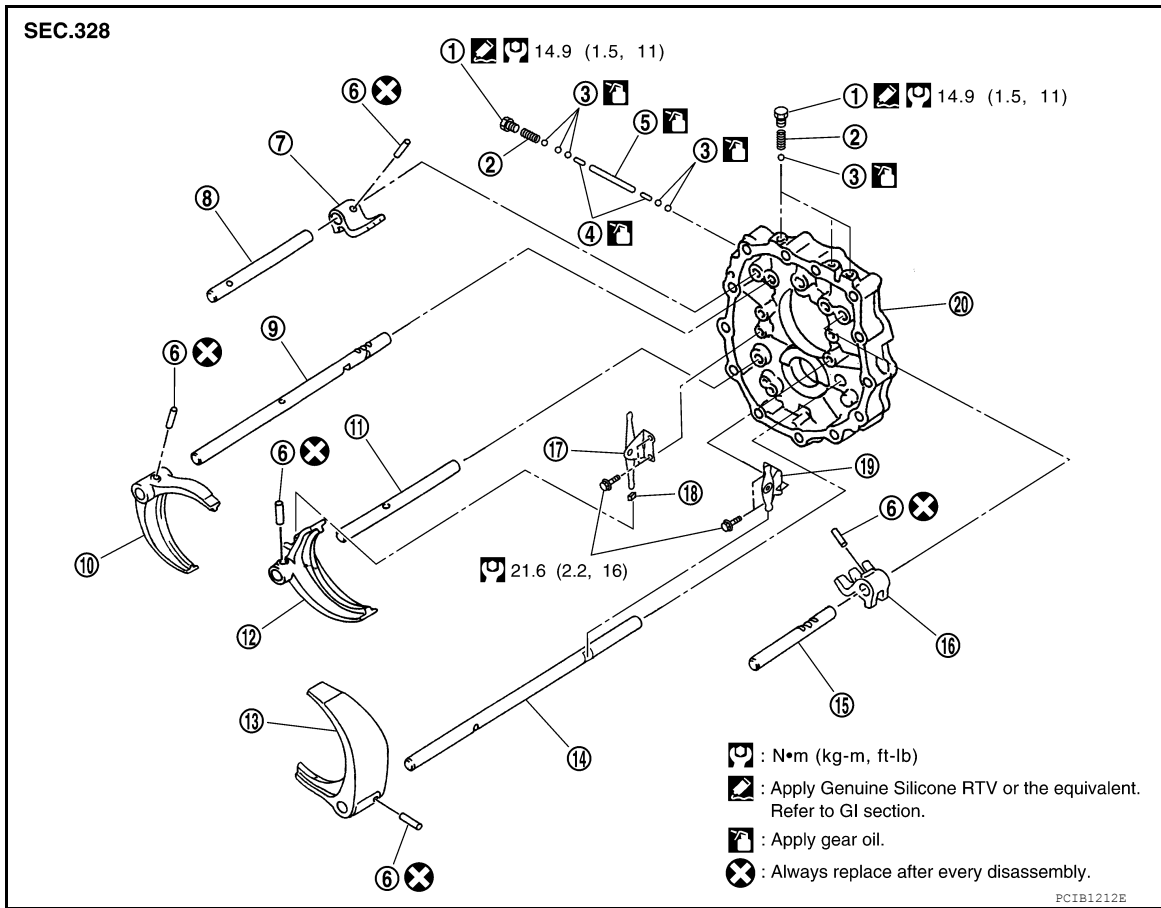

- | | | |
|------------------------------|--------------------------------------|------------------------|
| 1. Check ball plug | 2. Check ball spring | 3. Check ball |
| 4. Interlock pin | 5. Interlock plunger | 6. Retaining pin |
| 7. 3rd-4th fork rod bracket | 8. 3rd-4th fork rod | 9. 1st-2nd fork rod |
| 10. 1st-2nd shift fork | 11. 3rd-4th fork rod (reversal side) | 12. 3rd-4th shift fork |
| 13. 5th-6th shift fork | 14. 5th-6th fork rod (reversal side) | 15. 5th-6th fork rod |
| 16. 5th-6th fork rod bracket | 17. 3rd-4th control lever | 18. Shifter cap |
| 19. 5th-6th control lever | 20. Adapter plate | |

A
B
C
TM
E
F
G
H
I
J
K
L
M
N
O
P

TRANSMISSION ASSEMBLY

< UNIT DISASSEMBLY AND ASSEMBLY >

[6MT: FS6R31A]

SEC.328

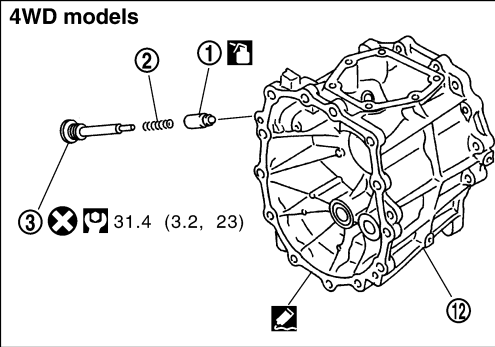
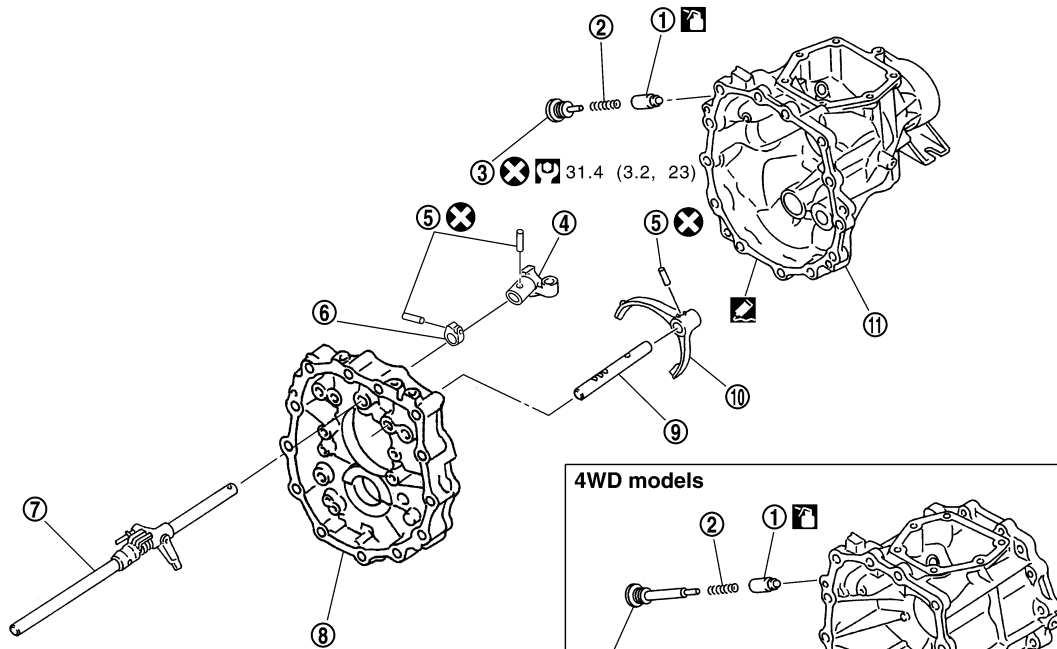

- : N•m (kg-m, ft-lb)
- : Apply Genuine Silicone RTV or the equivalent.
Refer to GI section.
- : Apply gear oil.
- : Always replace after every disassembly.

PCIB1213E

- | | | |
|--------------------------|--------------------|-----------------------|
| 1. Return spring plunger | 2. Return spring | 3. Return spring plug |
| 4. Striking arm | 5. Retaining pin | 6. Stopper ring |
| 7. Striking rod assembly | 8. Adapter plate | 9. Reverse fork rod |
| 10. Reverse shift fork | 11. Rear extension | 12. OD gear case |

CASE COMPONENTS

< UNIT DISASSEMBLY AND ASSEMBLY >

[6MT: FS6R31A]

CASE COMPONENTS

Disassembly

INFOID:000000008790786

Case Components

1. Remove clips from PNP switch and back-up lamp switch.
2. Remove PNP switch, back-up lamp switch and plungers from rear extension (or OD gear case).

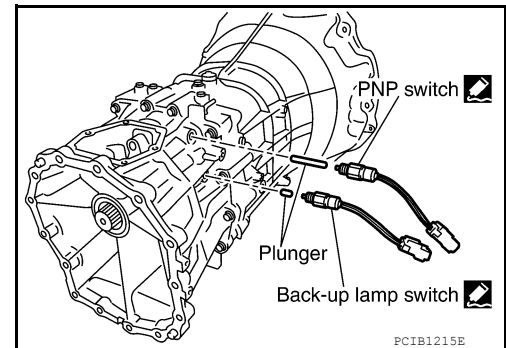

3. Remove control housing bolts, and then remove control housing and gasket from rear extension (or OD gear case).

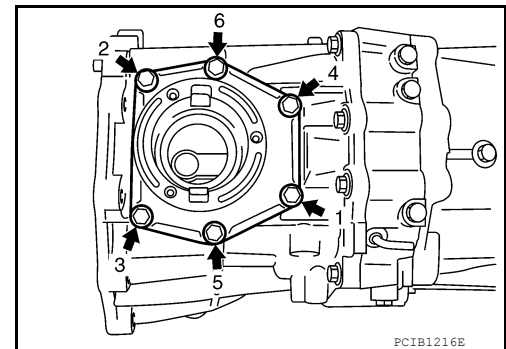

4. Remove return spring plug, return spring and return spring plunger from rear extension (or OD gear case).

CAUTION:

Do not reuse return spring plug.

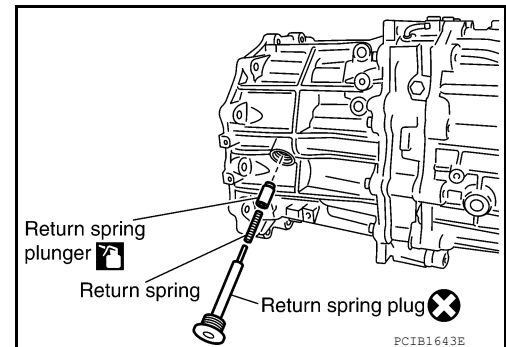

5. Remove rear oil seal from OD gear case using Tool (for 4WD models).

Tool number : KV381054S0 (J-34286)

CAUTION:

Do not damage OD gear case.

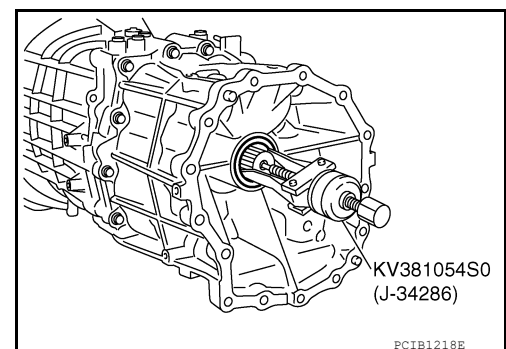

A
B
C
TM
E
F
G
H
I
J
K
L
M
N
O
P

CASE COMPONENTS

< UNIT DISASSEMBLY AND ASSEMBLY >

[6MT: FS6R31A]

6. Remove retaining pin using suitable tool, and then remove striking arm from striking rod assembly.

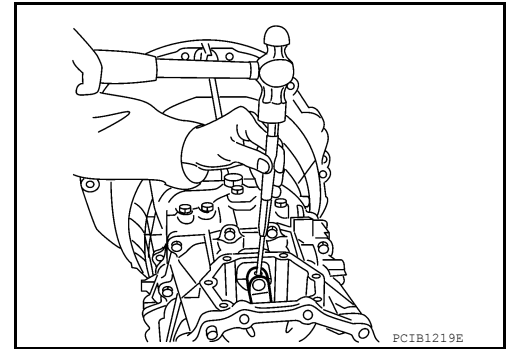

7. Remove rear extension (or OD gear case) bolts, and then remove rear extension (or OD gear case) from adapter plate using suitable tool.

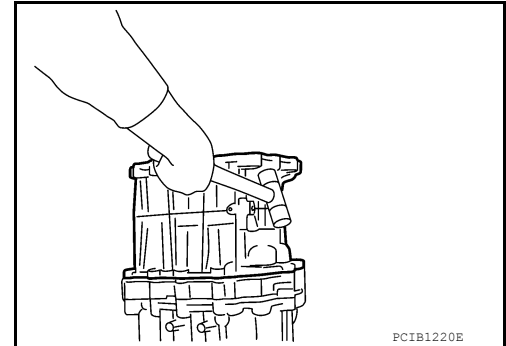

8. Remove rear extension oil gutter bolt, and then remove rear extension oil gutter and cap from rear extension. (For 2WD models)

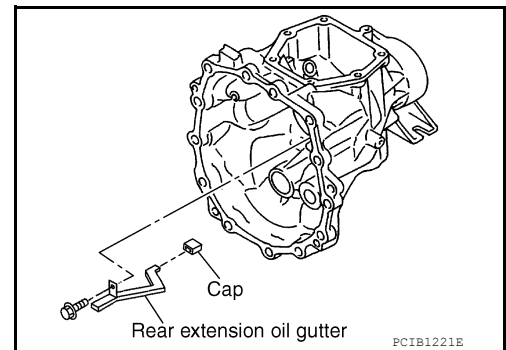

9. Remove dust seal and rear oil seal from rear extension using suitable tool. (For 2WD models)

CAUTION:

Be careful not to damage rear extension.

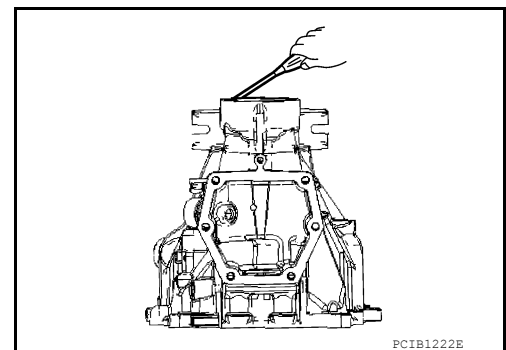

10. Remove counter end bearing from rear extension (or OD gear case) using suitable tool.

CAUTION:

Be careful not to damage rear extension (or OD gear case).

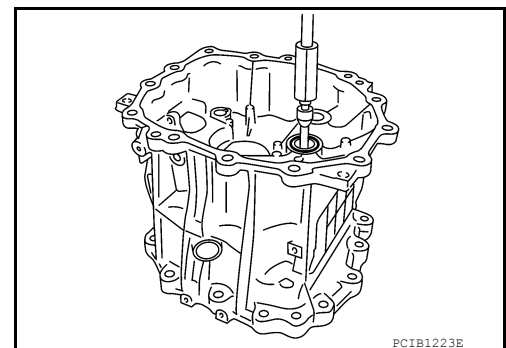

CASE COMPONENTS

< UNIT DISASSEMBLY AND ASSEMBLY >

[6MT: FS6R31A]

11. Remove withdrawal lever ball pin and washer from front cover.

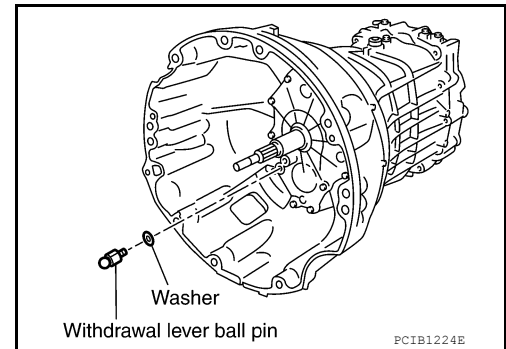

12. Remove front cover bolts, and then remove front cover and front cover gasket from transmission case.

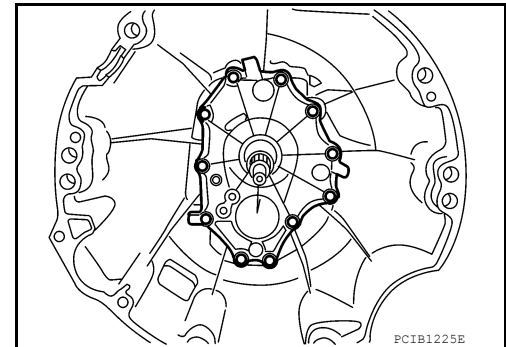

13. Remove front cover oil seal from front cover using suitable tool.
CAUTION:
Be careful not to damage front cover.

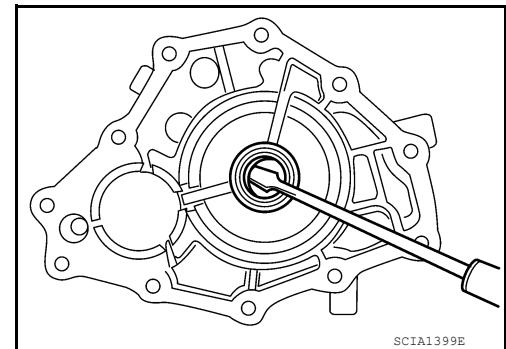

14. Remove baffle plate nut from transmission case.

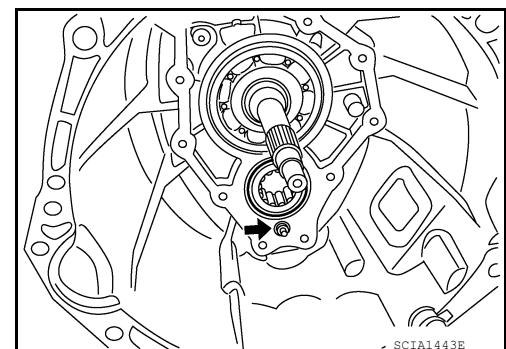

15. Remove snap ring from main drive gear bearing using suitable tool.

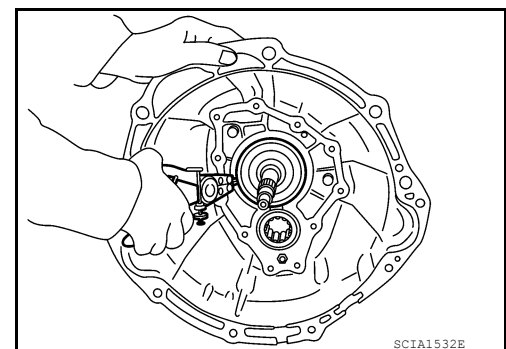

A
B
C
TM
E
F
G
H
I
J
K
L
M
N
O
P

CASE COMPONENTS

< UNIT DISASSEMBLY AND ASSEMBLY >

[6MT: FS6R31A]

16. Remove pivot bolt and check shift pin from transmission case.

CAUTION:

Do not reuse pivot bolt and check shift pin.

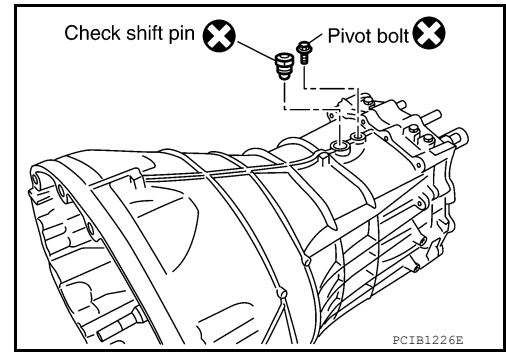

17. Remove transmission case from adapter plate.

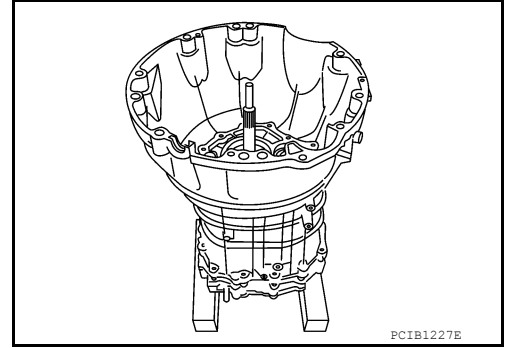

18. Remove counter front bearing from transmission case.

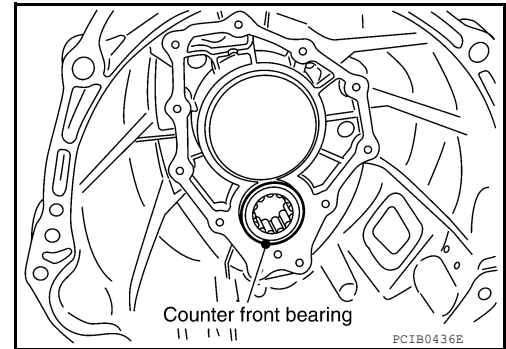

19. Remove oil gutter from transmission case.

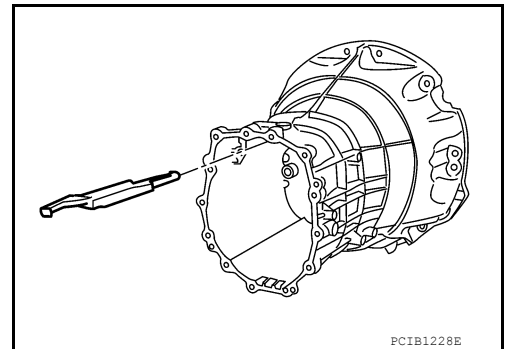

20. Remove filler plug and gasket from transmission case.

CAUTION:

Do not reuse gasket.

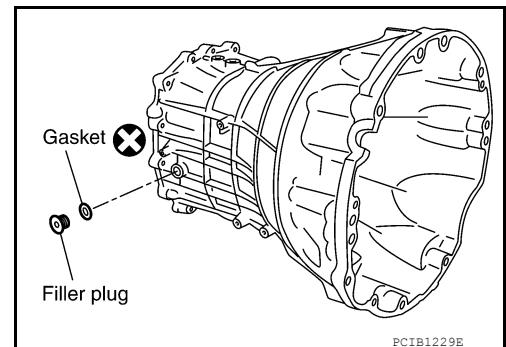

CASE COMPONENTS

< UNIT DISASSEMBLY AND ASSEMBLY >

[6MT: FS6R31A]

Assembly

INFOID:000000008790787

CASE COMPONENTS

1. Install main drive gear assembly, mainshaft assembly, counter gear assembly and reverse idler shaft assembly. Refer to [TM-77, "Overhaul"](#).
2. Install fork rods and shift forks. Refer to [TM-77, "Overhaul"](#).
3. Install oil gutter to transmission case.

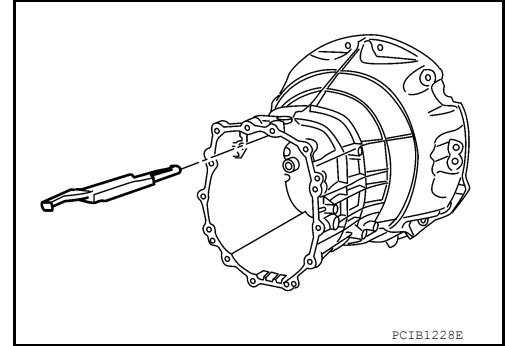

4. Install counter front bearing to transmission case.
CAUTION:
Apply multi-purpose grease to counter front bearing.

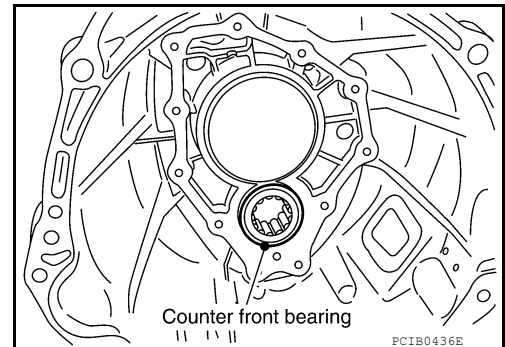

5. Apply recommended sealant to mating surface of transmission case as shown.
 - Use Genuine Silicone RTV or the equivalent. Refer to [GI-24, "Recommended Chemical Products and Sealants"](#).**CAUTION:**
Remove old sealant adhering to the mating surfaces. Also remove any moisture, oil, or foreign material adhering to both mating surfaces.

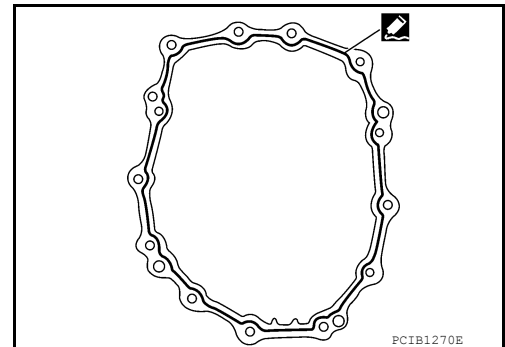

6. Install transmission case to adapter plate assembly.

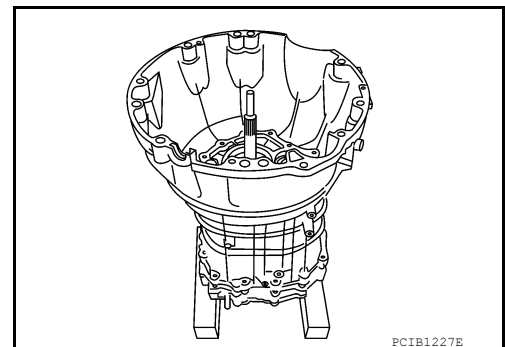

CASE COMPONENTS

< UNIT DISASSEMBLY AND ASSEMBLY >

[6MT: FS6R31A]

7. Install snap ring to main drive gear bearing using suitable tool.

CAUTION:
Do not reuse snap ring.

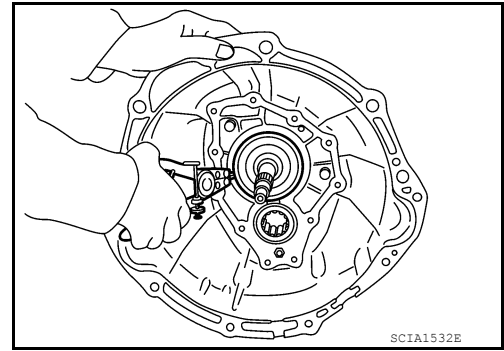

8. Tighten baffle plate nut to the specified torque. Refer to [TM-77](#), "[Overhaul](#)".

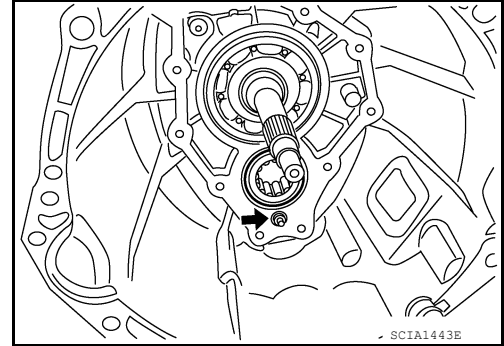

9. Tighten baffle plate bolt to the specified torque. Refer to [TM-77](#), "[Overhaul](#)".

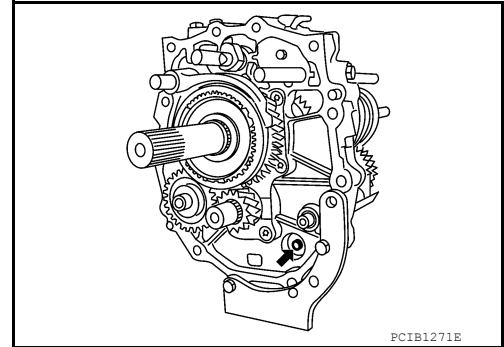

10. Install front cover oil seal to front cover using Tool.

Tool number : KV38102100 (J-25803-01)

Dimension (A) : 8.55 - 9.55 mm (0.336 - 0.376 in)

CAUTION:

- Do not reuse front cover oil seal.
- Apply multi-purpose grease onto oil seal lip.
- When installing, do not incline front cover oil seal.

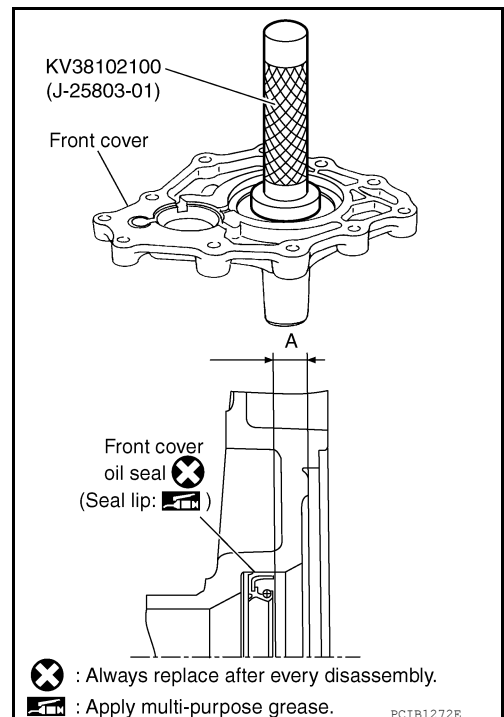

CASE COMPONENTS

< UNIT DISASSEMBLY AND ASSEMBLY >

[6MT: FS6R31A]

11. Install front cover according to the following.
 - a. Install front cover gasket and front cover to transmission case.
CAUTION:
Do not reuse front cover gasket.
 - b. Temporarily tighten 2 bolts in the positions shown.
 - c. Temporarily tighten remaining 9 bolts.

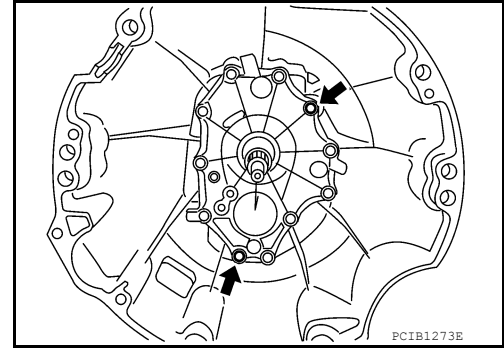

- d. Tighten bolts to the specified torque in order as shown. Refer to [TM-77. "Overhaul"](#).
CAUTION:
Do not reuse bolts indicated as (A) in the figure.

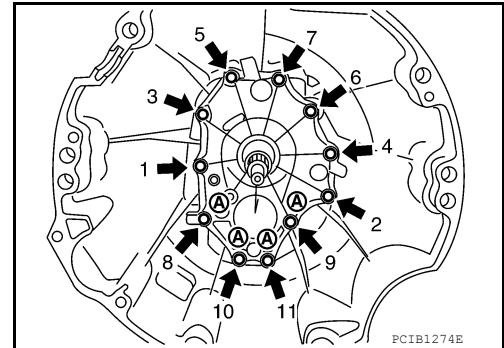

12. Install washer to withdrawal lever ball pin, and then install it to front cover. Tighten withdrawal lever ball pin to the specified torque. Refer to [TM-77. "Overhaul"](#).

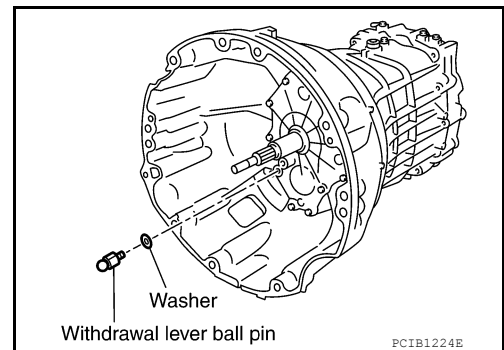

CASE COMPONENTS

< UNIT DISASSEMBLY AND ASSEMBLY >

[6MT: FS6R31A]

13. Install counter end bearing to rear extension (or OD gear case) using suitable tool [32 mm (1.26 in) dia.].

Dimension (A) : 0.5 - 1.5 mm (0.020 - 0.059 in)

CAUTION:

- Do not reuse counter end bearing.
- Apply gear oil to counter end bearing.
- Install counter end bearing with maker stamp at upper side.

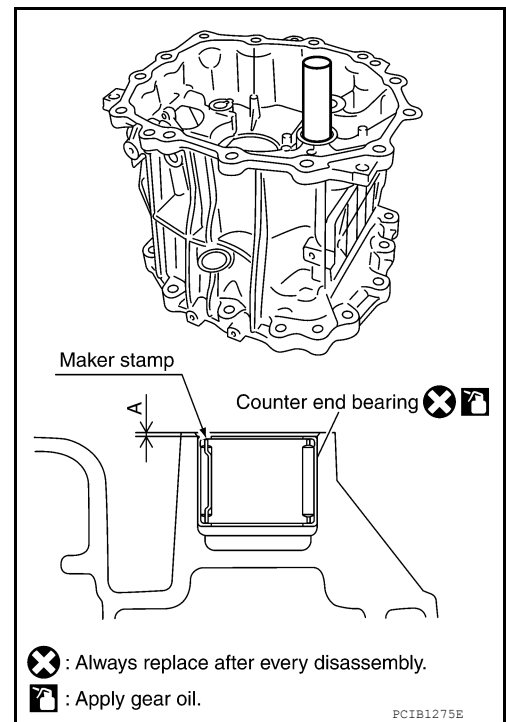

14. Install rear extension oil gutter according to the following. (For 2WD models)

- a. Install cap to rear extension oil gutter.
- b. Install rear extension oil gutter to rear extension, and then tighten bolt to specified torque. Refer to [TM-77. "Overhaul"](#).

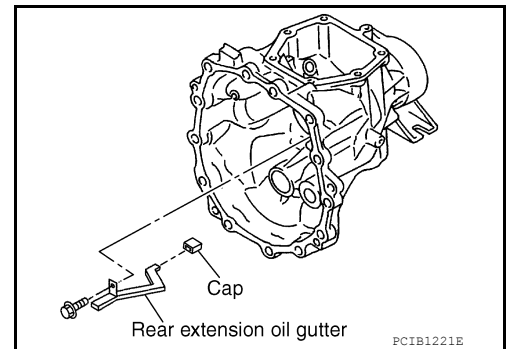

15. Install rear oil seal (1) to rear extension (or OD gear case) using Tool (A).

Tool number : ST33200000 (J-26082)

Dimension (H1)

2WD models : 1.2 - 2.2 mm (0.047 - 0.087 in)

4WD models : -0.5 - 0.5 mm (-0.020 - 0.020 in)

CAUTION:

- Do not reuse rear oil seal.
- When installing, do not incline rear oil seal.

(B): Seal lip

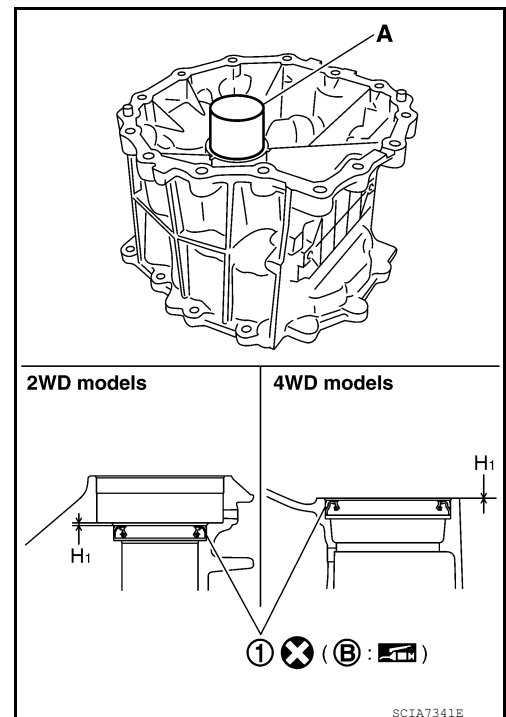

CASE COMPONENTS

< UNIT DISASSEMBLY AND ASSEMBLY >

[6MT: FS6R31A]

16. Install dust seal (1) to rear extension using Tool (A) (for 2WD models).

Tool number : KV38100500 (—)

Dimension (H2) : 0.5 - 1.5 mm (0.020 - 0.059 in)

CAUTION:

- Do not reuse dust seal.
 - When installing, do not incline dust seal.
- (B): Seal lip

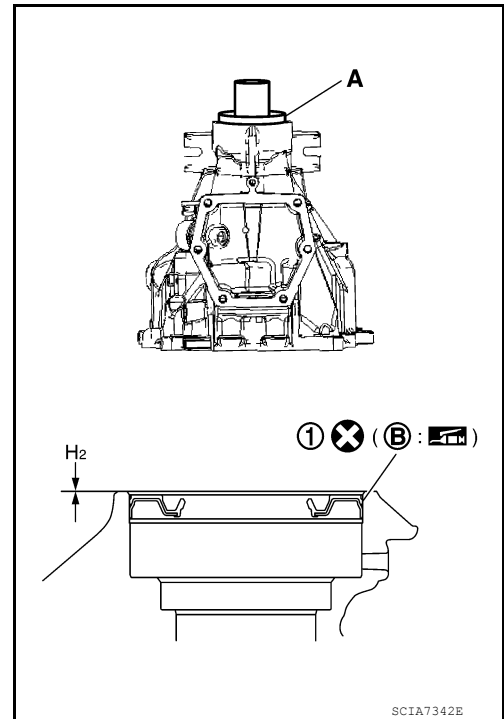

17. Apply recommended sealant to mating surface of rear extension as shown.

- Use Genuine Silicone RTV or the equivalent. Refer to [GI-24, "Recommended Chemical Products and Sealants"](#).

CAUTION:

Remove old sealant adhering to the mating surfaces. Also remove any moisture, oil, or foreign material adhering to both mating surfaces.

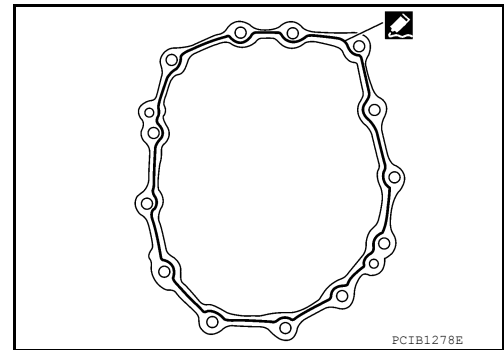

18. Install rear extension (or OD gear case) to adapter plate, and then tighten bolts to the specified torque in order as shown. Refer to [TM-77, "Overhaul"](#).

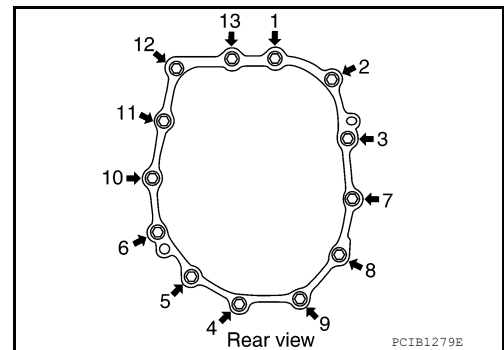

19. Install check shift pin and pivot bolt to transmission case, and then tighten them to the specified torque. Refer to [TM-77, "Overhaul"](#).

CAUTION:

Do not reuse check shift pin and pivot bolt.

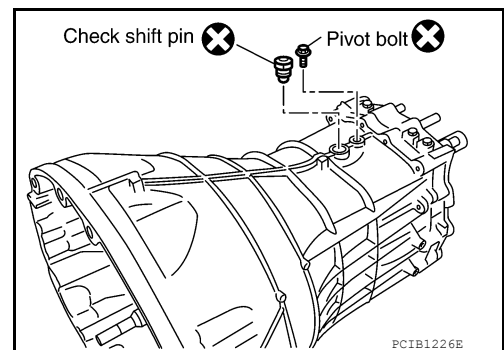

A
B
C
TM
E
F
G
H
I
J
K
L
M
N
O
P

CASE COMPONENTS

< UNIT DISASSEMBLY AND ASSEMBLY >

[6MT: FS6R31A]

20. Install return spring plunger, return spring and return spring plug to rear extension (or OD gear case), and then tighten return spring plug to the specified torque. Refer to [TM-77. "Overhaul"](#).

CAUTION:

- Do not reuse return spring plug.
- Apply gear oil to return spring plunger.

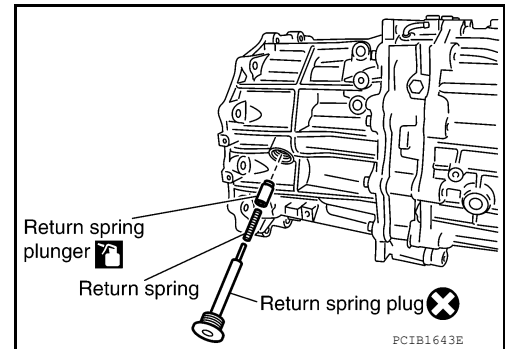

21. Install PNP switch and back-up lamp switch according to the following.

- Install plunger to rear extension (or OD gear case).
- Apply recommended sealant to threads of PNP switch and back-up lamp switch.
 - Use Genuine Silicone RTV or the equivalent. Refer to [GI-24. "Recommended Chemical Products and Sealants"](#).
- Install PNP switch and back-up lamp switch to rear extension (or OD gear case), and tighten them to the specified torque. Refer to [TM-77. "Overhaul"](#).

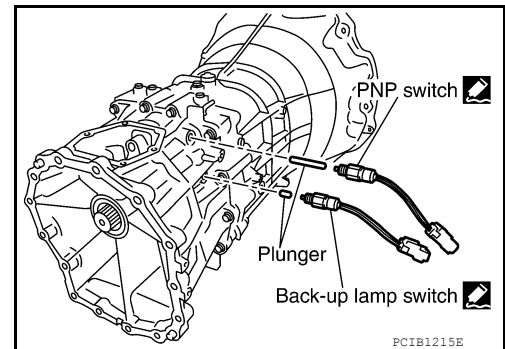

22. Install clips to PNP switch and back-up lamp switch.

CAUTION:

- Thread harness through the notch of clip.

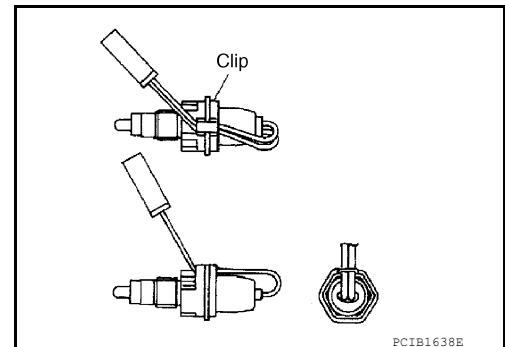

- Thread the harness as shown.

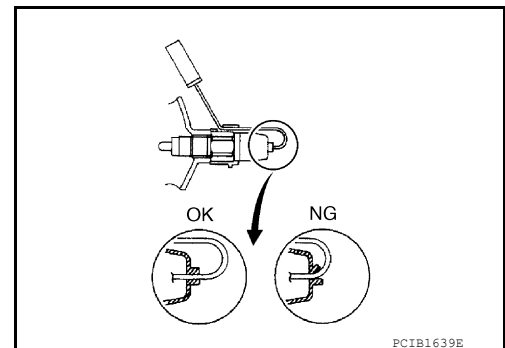

23. Install striking arm according to the following.

CASE COMPONENTS

< UNIT DISASSEMBLY AND ASSEMBLY >

[6MT: FS6R31A]

- a. Install striking arm to striking rod assembly.
- b. Install retaining pin to striking arm using suitable tool.
CAUTION:
Do not reuse retaining pin.

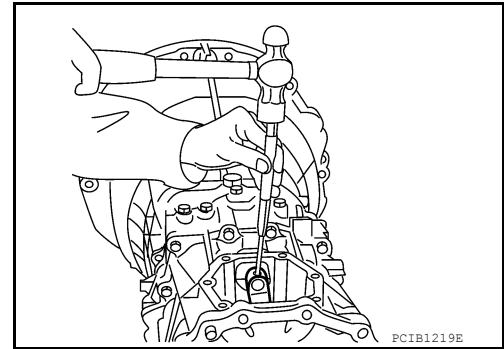

24. Install control housing according to the following.
 - a. Install gasket and control housing to rear extension (or OD gear case).
CAUTION:
Do not reuse gasket.
 - b. Tighten bolts to the specified torque in order as shown. Refer to [TM-77. "Overhaul"](#).

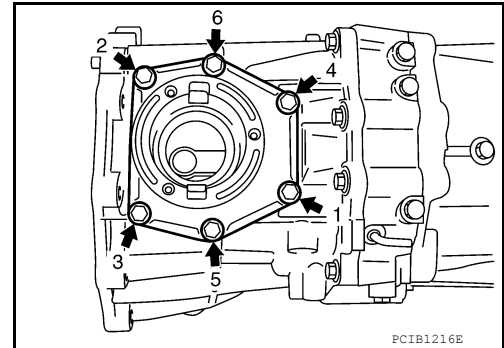

25. Install gasket to drain plug, and then install it to transmission case. Tighten drain plug to the specified torque. Refer to [TM-77. "Overhaul"](#).
CAUTION:
Do not reuse gasket.

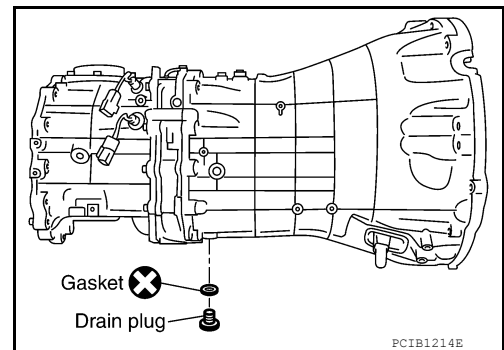

26. Install gasket to filler plug, and then install it to transmission case. Tighten filler plug to the specified torque. Refer to [TM-77. "Overhaul"](#).
CAUTION:
 - Do not reuse gasket.
 - After oil is filled, tighten filler plug to specified torque.

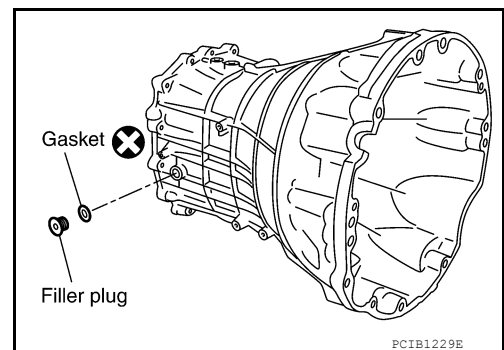

SHIFT CONTROL COMPONENTS

< UNIT DISASSEMBLY AND ASSEMBLY >

[6MT: FS6R31A]

SHIFT CONTROL COMPONENTS

Disassembly

INFOID:000000008790788

SHIFT CONTROL COMPONENTS

1. Remove rear extension (or OD gear case) and transmission case. Refer to [TM-77. "Overhaul"](#).
2. Install Tool to adapter plate, and then position in a vise.

Tool number : ST22490000 (—)

CAUTION:

Do not directly secure mating surface of adapter plate in a vise.

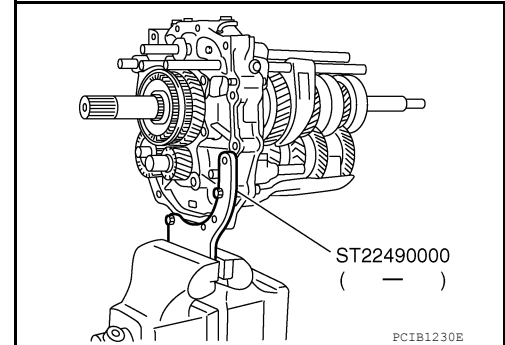

3. Remove baffle plate bolts, and then remove baffle plate from adapter plate.

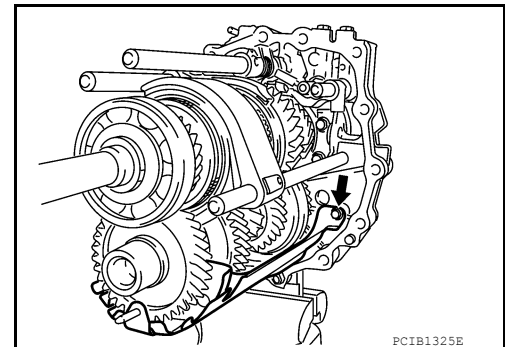

4. Remove check ball plugs, check ball springs and check balls from adapter plate.

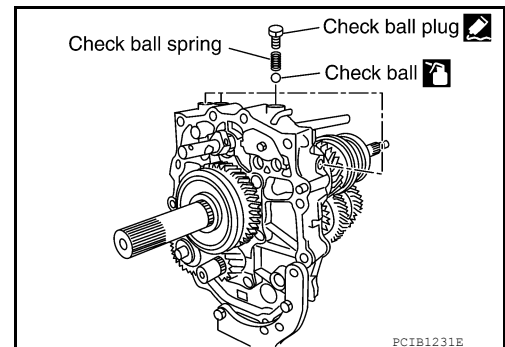

5. Remove 3rd-4th control lever bolts, and then remove 3rd-4th control lever and shifter cap from adapter plate.

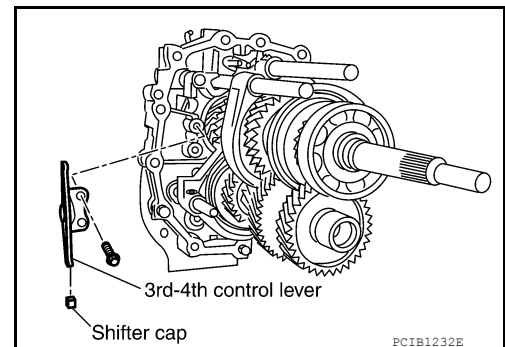

SHIFT CONTROL COMPONENTS

< UNIT DISASSEMBLY AND ASSEMBLY >

[6MT: FS6R31A]

6. Remove retaining pin using suitable tool, and then remove 3rd - 4th fork rod bracket and 3rd-4th fork rod from adapter plate.

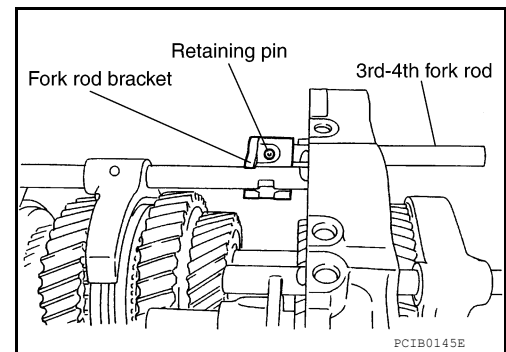

7. Remove check balls and interlock pin from adapter plate.

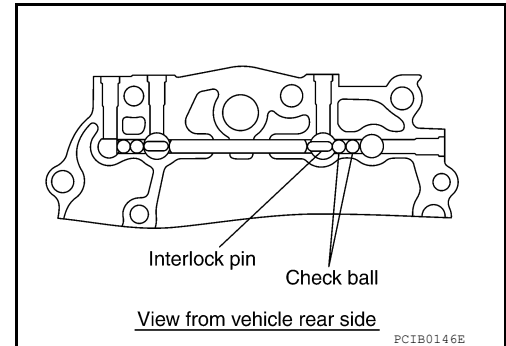

8. Remove retaining pin using a suitable tool, and then remove 3rd-4th shift fork and 3rd-4th fork rod (reversal side) from adapter plate.

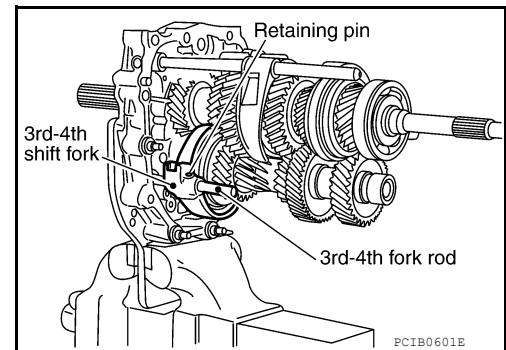

9. Remove retaining pin using a suitable tool, and then remove 1st-2nd shift fork and 1st-2nd fork rod from adapter plate.

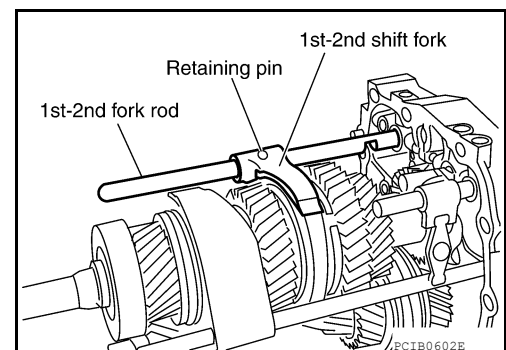

10. Remove interlock plunger and interlock pin from adapter plate.

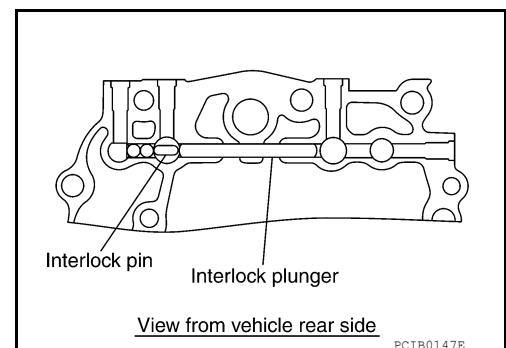

A
B
C
TM
E
F
G
H
I
J
K
L
M
N
O
P

SHIFT CONTROL COMPONENTS

< UNIT DISASSEMBLY AND ASSEMBLY >

[6MT: FS6R31A]

11. Remove retaining pin using suitable tool, and then remove reverse shift fork and reverse fork rod from adapter plate.

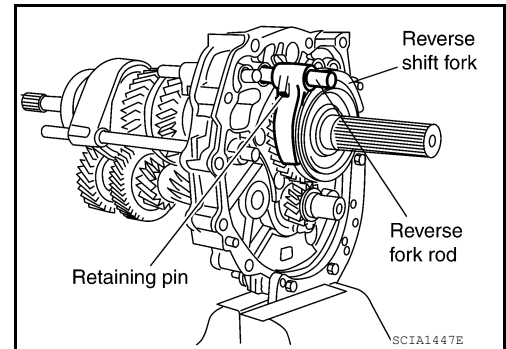

12. Remove check balls from adapter plate.

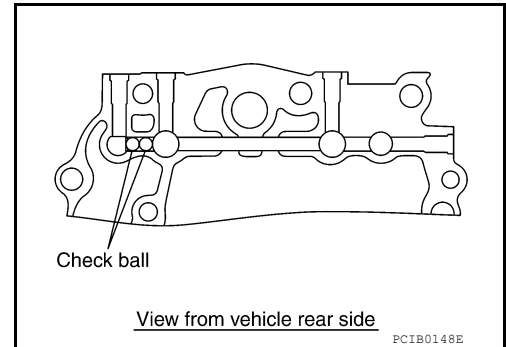

13. Remove retaining pin using suitable tool, and then remove 5th-6th fork rod bracket and 5th-6th fork rod from adapter plate.

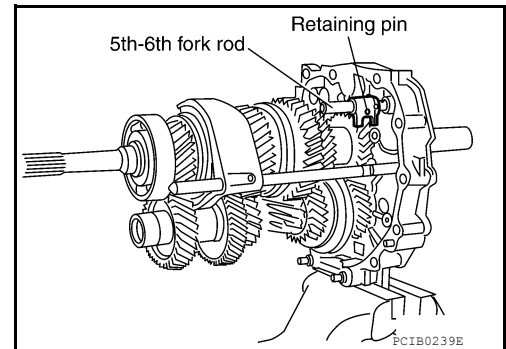

14. Remove 5th-6th control lever bolts, and then remove 5th-6th control lever from adapter plate.

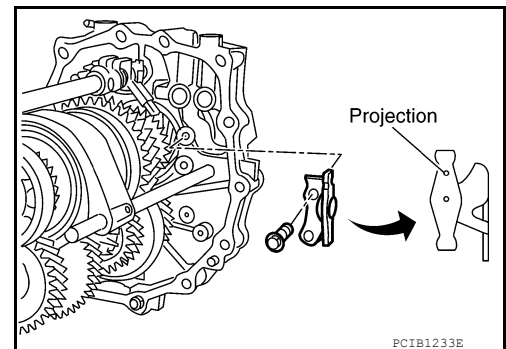

15. Remove retaining pin using suitable tool, and then remove 5th-6th shift fork and 5th-6th fork rod (reversal side) from adapter plate.

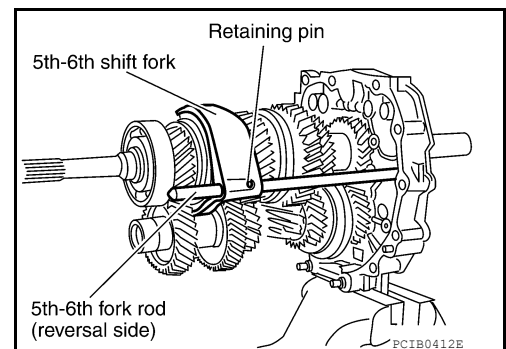

SHIFT CONTROL COMPONENTS

< UNIT DISASSEMBLY AND ASSEMBLY >

[6MT: FS6R31A]

16. Remove retaining pin using suitable tool, and then remove stopper ring from striking rod assembly.

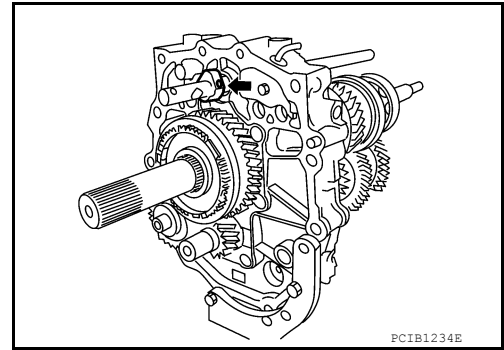

17. Remove striking rod assembly from adapter plate.

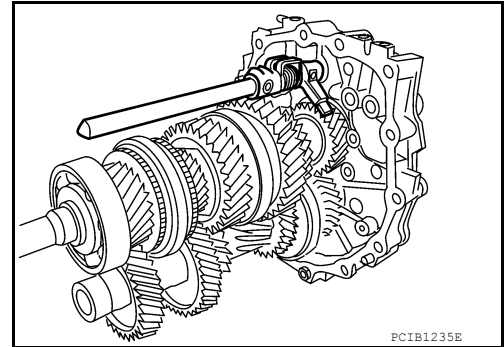

Inspection

INFOID:000000008790789

SHIFT CONTROL COMPONENTS

If the contact surface on striking lever, fork rod, shift fork, etc., has excessive wear, abrasion, bend, or any other damage, replace the components.

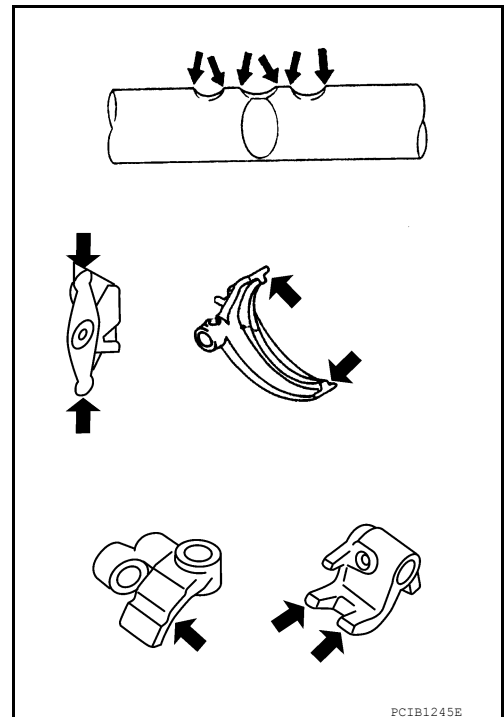

INFOID:000000008790790

Assembly

SHIFT CONTROL COMPONENTS

1. Install main drive gear assembly, mainshaft assembly, counter gear assembly and reverse idler shaft assembly. Refer to [TM-77, "Overhaul"](#).
2. Install striking rod assembly according to the following.

A
B
C
TM
E
F
G
H
I
J
K
L
M
N
O
P

SHIFT CONTROL COMPONENTS

< UNIT DISASSEMBLY AND ASSEMBLY >

[6MT: FS6R31A]

- a. Install striking rod assembly to adapter plate.

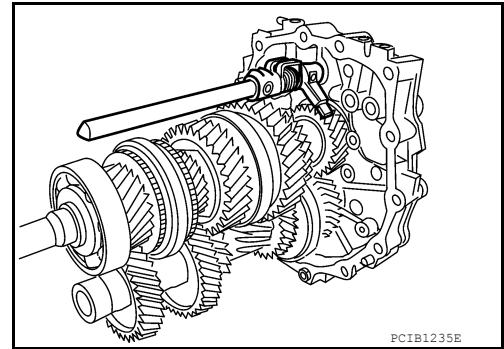

- b. Install stopper ring to striking rod assembly.
c. Install retaining pin onto stopper ring using suitable tool.

CAUTION:

Do not reuse retaining pin.

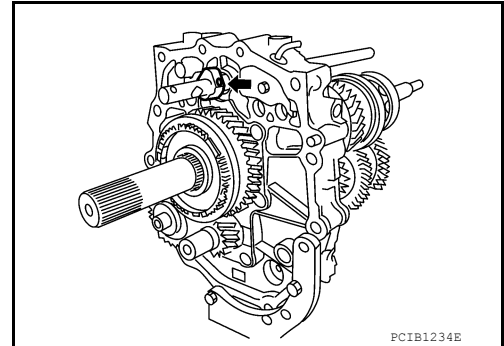

3. Install 5th-6th fork rod (reversal side) according to the following.

- a. Install 5th-6th shift fork to 5th-6th coupling sleeve.
b. Install 5th-6th fork rod (reversal side) to 5th-6th shift fork.
c. Install retaining pin onto 5th-6th shift fork using suitable tool.

CAUTION:

Do not reuse retaining pin.

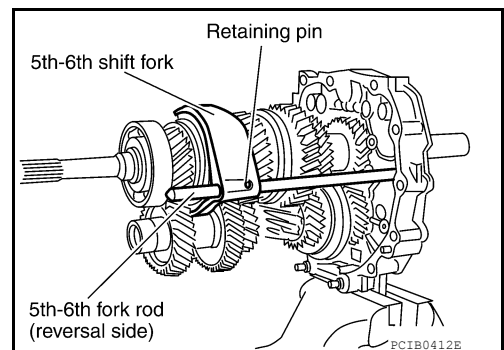

4. Install 5th-6th control lever to adapter plate, and then tighten bolts to the specified torque. Refer to [TM-77, "Overhaul"](#).

CAUTION:

Install 5th-6th control lever with projection side upward.

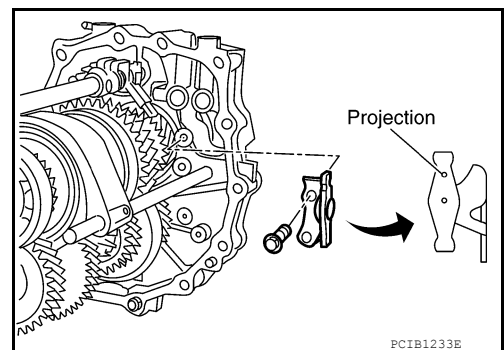

5. Install 5th-6th fork rod according to the following.

SHIFT CONTROL COMPONENTS

< UNIT DISASSEMBLY AND ASSEMBLY >

[6MT: FS6R31A]

- a. Install 5th-6th fork bracket and 5th-6th fork rod to adapter plate.
- b. Install retaining pin onto 5th-6th fork bracket using suitable tool.

CAUTION:

Do not reuse retaining pin.

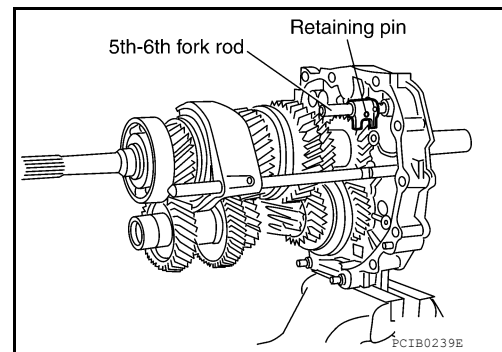

6. Install check balls to adapter plate.

CAUTION:

Apply gear oil to check balls.

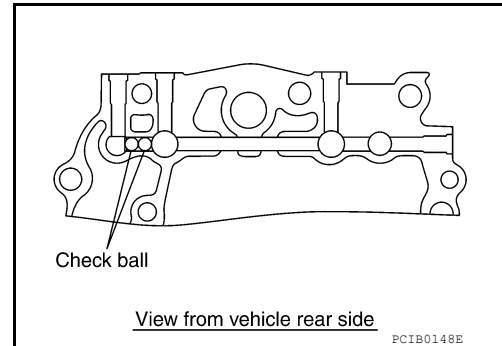

7. Install reverse fork rod according to the following.
 - a. Install reverse shift fork to reverse coupling sleeve.
 - b. Install reverse fork rod to reverse shift fork.
 - c. Install retaining pin onto reverse shift fork using suitable tool.

CAUTION:

Do not reuse retaining pin.

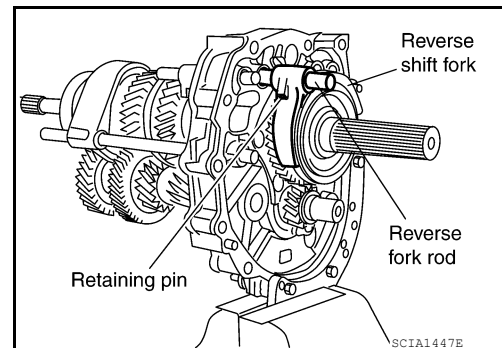

8. Install interlock pin and interlock plunger to adapter plate.

CAUTION:

Apply gear oil to interlock pin and interlock plunger.

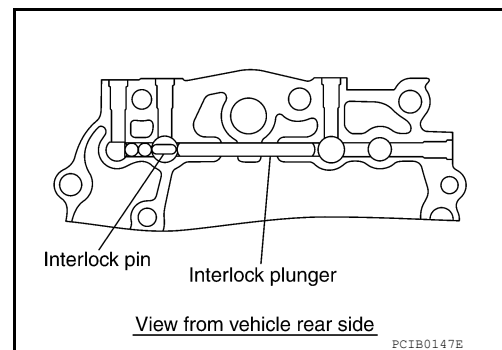

9. Install 1st-2nd fork rod according to the following.

A
B
C
TM
E
F
G
H
I
J
K
L
M
N
O
P

SHIFT CONTROL COMPONENTS

< UNIT DISASSEMBLY AND ASSEMBLY >

[6MT: FS6R31A]

- a. Install 1st-2nd shift fork to 1st-2nd coupling sleeve.
- b. Install 1st-2nd fork rod to 1st-2nd shift fork.
- c. Install retaining pin onto 1st-2nd shift fork using suitable tool.

CAUTION:

Do not reuse retaining pin.

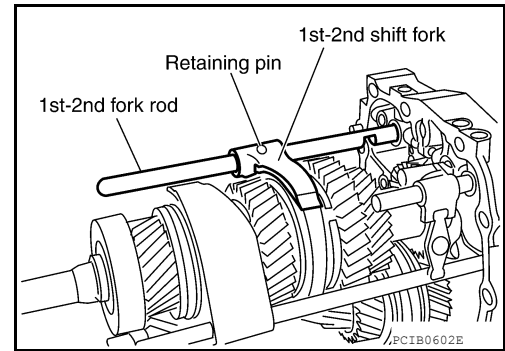

- 10. Install interlock pin and check balls to adapter plate.

CAUTION:

Apply gear oil to interlock pin and check balls.

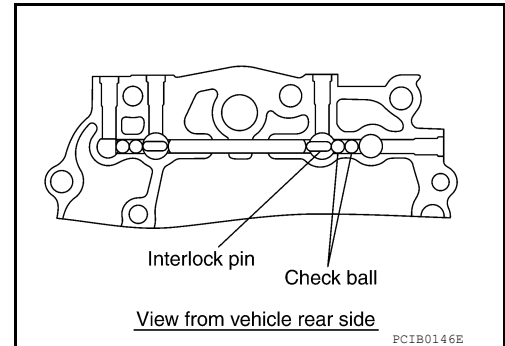

- 11. Install 3rd-4th fork rod (reversal side) according to the following.

- a. Install 3rd-4th shift fork to 3rd-4th coupling sleeve.
- b. Install 3rd-4th fork rod (reversal side) to 3rd-4th shift fork.
- c. Install retaining pin onto 3rd-4th shift fork using suitable tool.

CAUTION:

Do not reuse retaining pin.

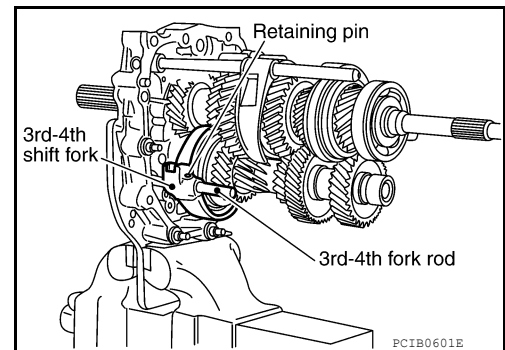

- 12. Install 3rd-4th fork rod according to the following.

- a. Install 3rd-4th fork rod to adapter plate.
- b. Install 3rd-4th fork rod bracket to 3rd-4th fork rod.
- c. Install retaining pin onto 3rd-4th fork rod bracket using suitable tool.

CAUTION:

Do not reuse retaining pin.

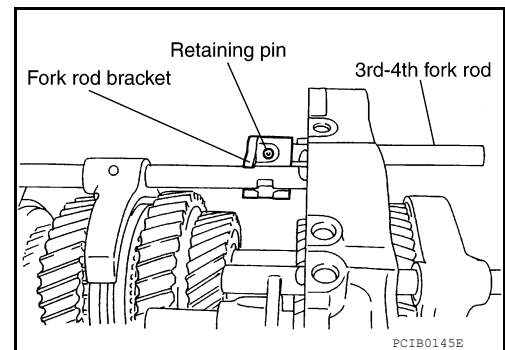

- 13. Install 3rd-4th control lever according to the following.

SHIFT CONTROL COMPONENTS

< UNIT DISASSEMBLY AND ASSEMBLY >

[6MT: FS6R31A]

- a. Install shifter cap to 3rd-4th control lever.
- b. Install 3rd-4th control lever to adapter plate, and then tighten bolts to the specified torque. Refer to [TM-77, "Overhaul"](#) "Shift Control Components".

CAUTION:

Be careful with the orientation 3rd-4th control lever.

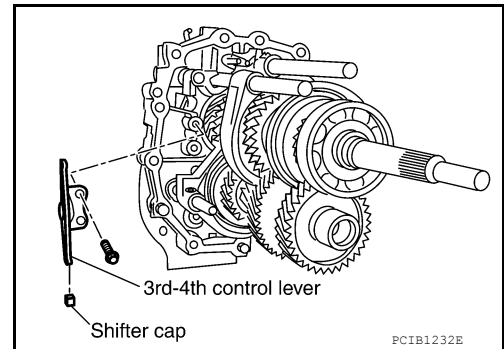

14. Install check ball plug according to the following.
 - a. Install check balls, check ball springs to adapter plate.

CAUTION:

Apply gear oil to check ball.

- b. Apply recommended sealant to threads of check ball plugs, and tighten check ball plugs to the specified torque. Refer to [TM-77, "Overhaul"](#).
 - Use Genuine Silicone RTV or the equivalent. Refer to [GI-24, "Recommended Chemical Products and Sealants"](#).

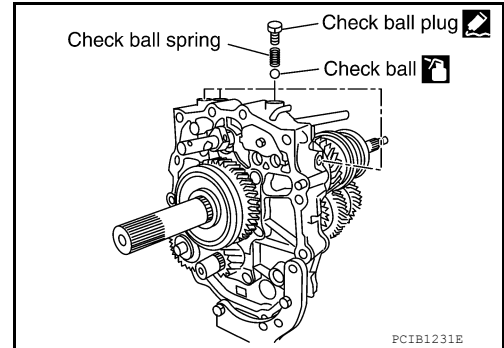

15. Install baffle plate to adapter plate, and then tighten bolt to the specified torque. Refer to [TM-77, "Overhaul"](#).

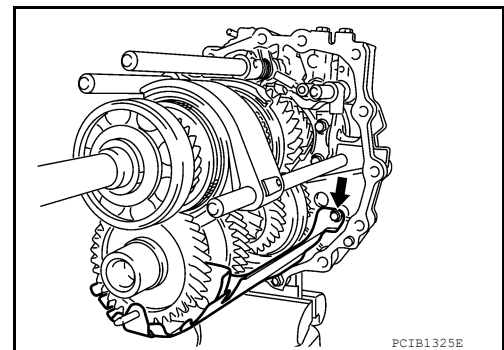

A
B
C
TM
E
F
G
H
I
J
K
L
M
N
O
P

GEAR COMPONENTS

Disassembly

INFOID:000000008790791

GEAR COMPONENTS

1. Remove rear extension (or OD gear case) and transmission case. Refer to [TM-77, "Overhaul"](#).
2. Remove shift forks and fork rods. Refer to [TM-77, "Overhaul"](#).
3. Before disassembling, measure the end play for each position. If the end play is outside the standards, disassemble and inspect.
 - Main drive gear

End play Refer to [TM-126, "Gear End Play"](#)

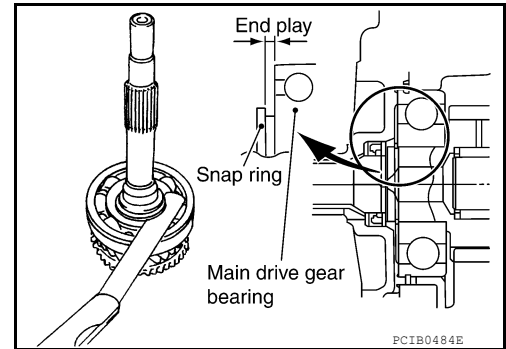

- Mainshaft (Rear side)

End play Refer to [TM-126, "Gear End Play"](#)

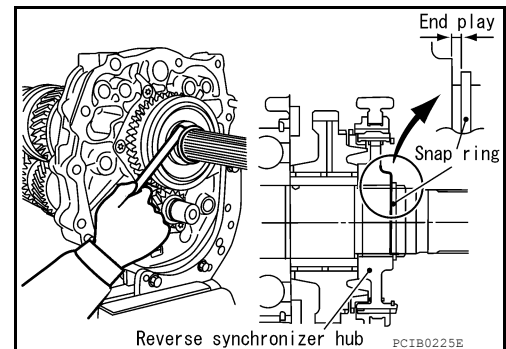

- Counter gear

End play Refer to [TM-126, "Gear End Play"](#)

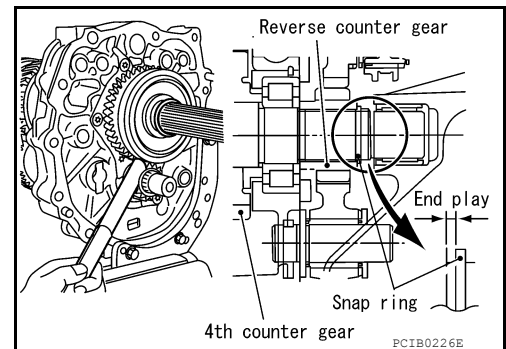

4. Remove reverse idler gear according to the following.
 - a. Remove reverse idler shaft assembly from adapter plate.
 - b. Remove reverse idler thrust washer, reverse idler gear and reverse idler needle bearing from reverse idler shaft.

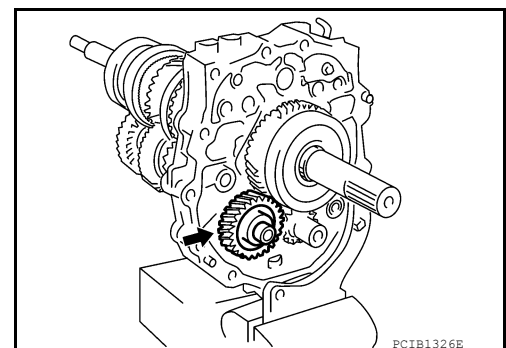

GEAR COMPONENTS

< UNIT DISASSEMBLY AND ASSEMBLY >

[6MT: FS6R31A]

5. Remove reverse main gear and reverse synchronizer hub assembly according to the following.
 - a. Remove snap ring from mainshaft using suitable tool.

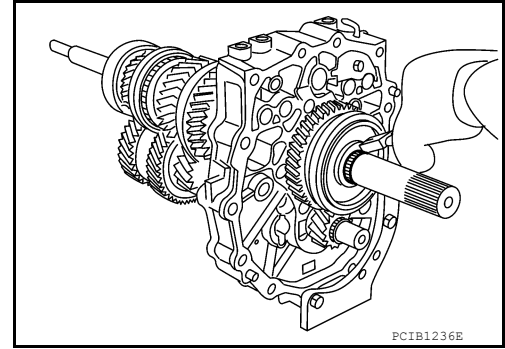

- b. Remove reverse main gear and reverse synchronizer hub assembly using suitable tool.
 - c. Remove reverse main needle bearing from mainshaft.

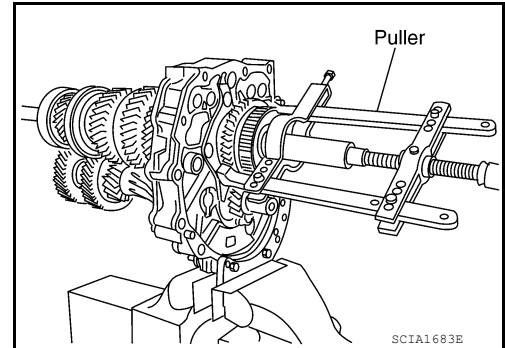

6. Remove reverse coupling sleeve according to the following.
 - a. Remove snap ring from reverse synchronizer hub.
 - b. Remove spread springs and shifting inserts from reverse synchronizer hub.
 - c. Remove reverse coupling sleeve from reverse synchronizer hub.

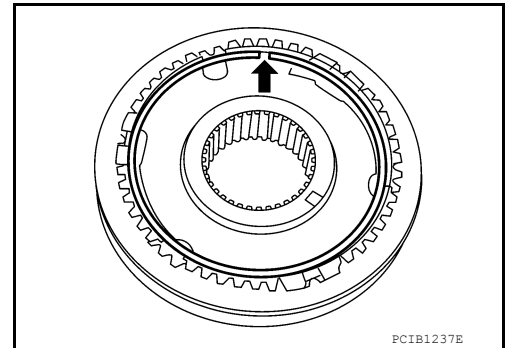

7. Remove reverse counter gear according to the following.
 - a. Remove snap ring from counter gear using suitable tool.

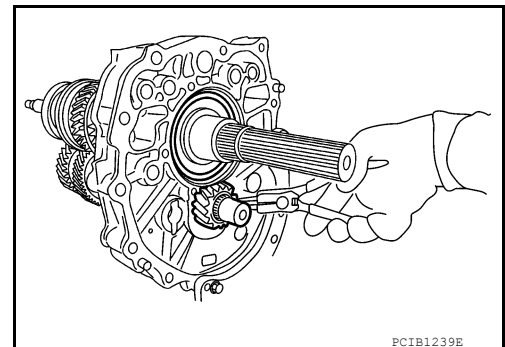

A
B
C
TM
E
F
G
H
I
J
K
L
M
N
O
P

GEAR COMPONENTS

< UNIT DISASSEMBLY AND ASSEMBLY >

[6MT: FS6R31A]

- b. Remove reverse counter gear using suitable tool.
8. Remove counter rear bearing spacer from counter gear.

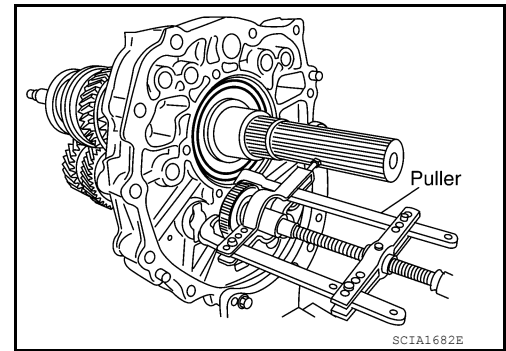

9. Remove bearing retainer bolts, and then remove bearing retainer.

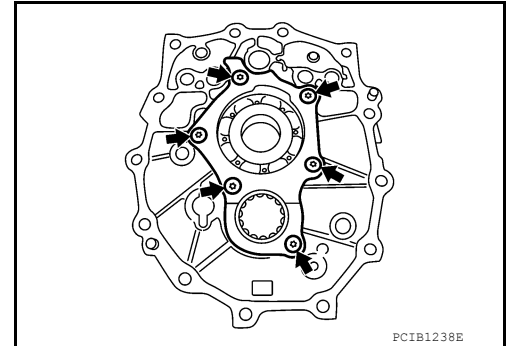

10. Remove main drive gear assembly, mainshaft assembly and counter gear assembly according to the following.

- a. Remove snap ring from mainshaft bearing using suitable tool.

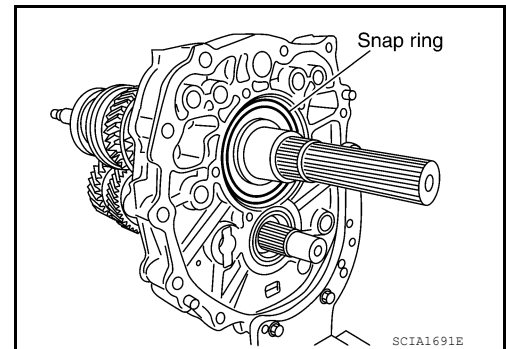

- b. Carefully tap mainshaft using suitable tool, and then remove main drive gear assembly, mainshaft assembly and counter gear assembly from adapter plate.
- c. Remove main pilot bearing, pilot bearing spacer from mainshaft.
- d. Remove 5th baulk ring from main drive gear.

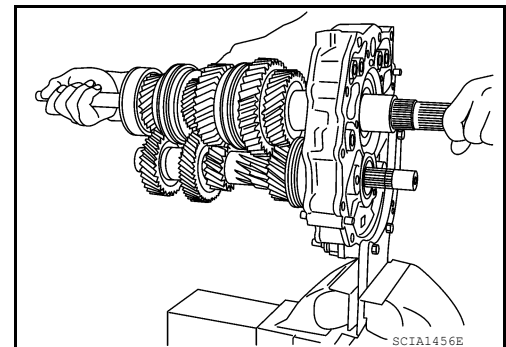

GEAR COMPONENTS

< UNIT DISASSEMBLY AND ASSEMBLY >

[6MT: FS6R31A]

11. Remove counter rear bearing from adapter plate.

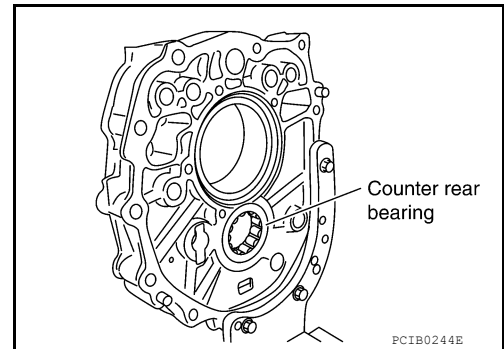

12. Remove magnet from adapter plate.

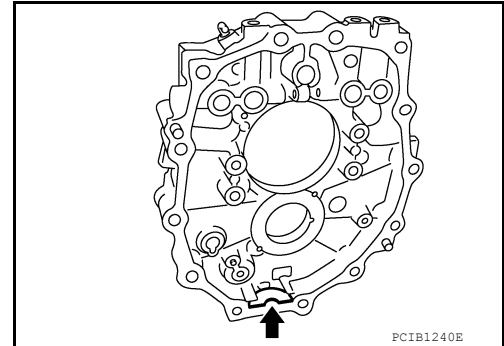

13. Remove baffle plate bolt, and then remove baffle plate from adapter plate.

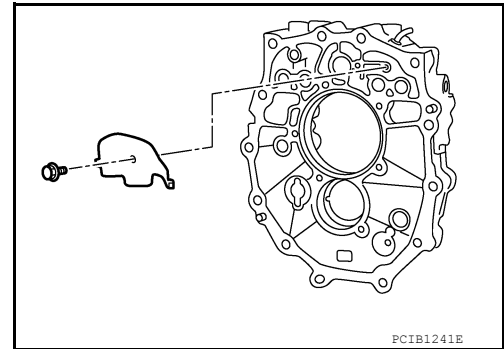

14. Remove breather from adapter plate.

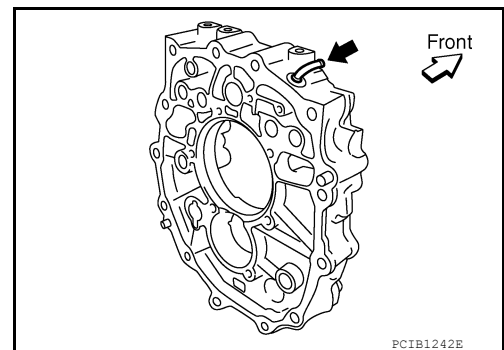

15. Remove main drive gear bearing according to the following.

A
B
C
TM
E
F
G
H
I
J
K
L
M
N
O
P

GEAR COMPONENTS

< UNIT DISASSEMBLY AND ASSEMBLY >

[6MT: FS6R31A]

a. Remove snap ring from main drive gear using suitable tool.

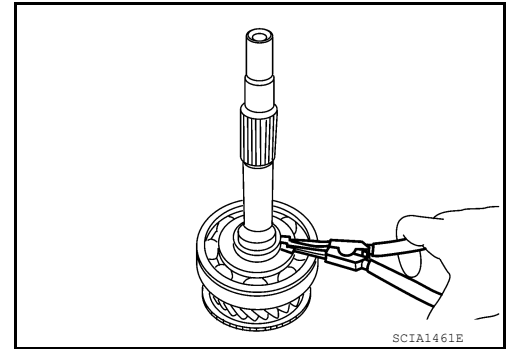

b. Press out main drive gear bearing using suitable tool.

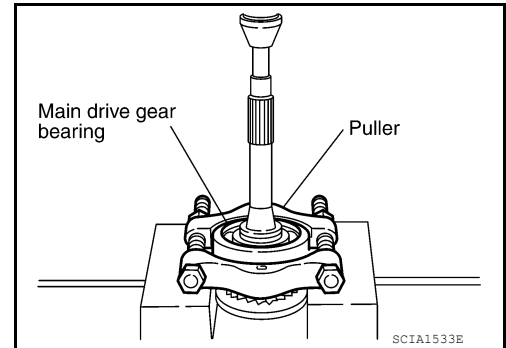

16. Before disassembling, measure the end play for mainshaft (Front side). If the end play is outside the standards, disassemble and inspect.

End play

Refer to [TM-126, "Gear End Play"](#)

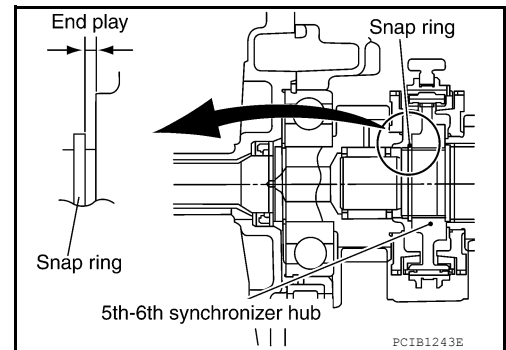

17. Press out reverse main gear bushing, mainshaft bearing and 4th main gear using suitable tool.

18. Remove 3rd-4th main spacer from mainshaft.

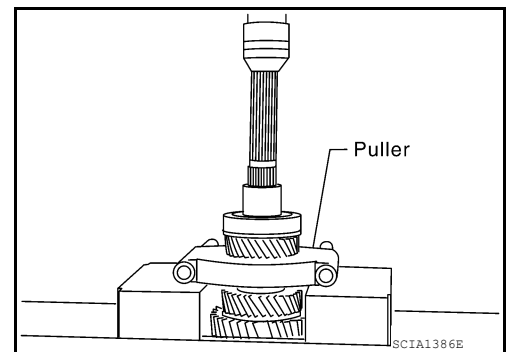

19. Remove 3rd main gear and 1st main gear according to the following.

GEAR COMPONENTS

< UNIT DISASSEMBLY AND ASSEMBLY >

[6MT: FS6R31A]

- a. Press out 3rd main gear and 1st main gear using suitable tool.
CAUTION:
Be careful not to damage 1st outer baulk ring.
- b. Remove 1st needle bearing from mainshaft.

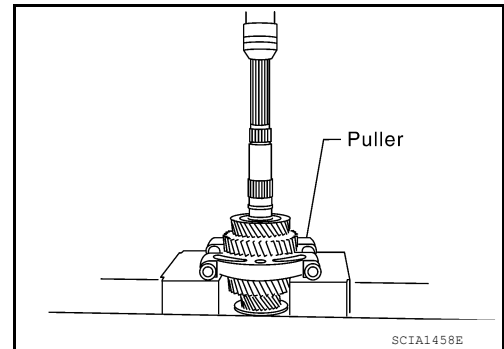

A
B
C

TM

20. Remove 1st-2nd synchronizer hub assembly and 2nd main gear according to the following.

- a. Press out 1st gear bushing, 1st-2nd synchronizer hub assembly and 2nd main gear using suitable tool.
CAUTION:
Be aware that when using the press, if mainshaft gear positioner catches on the V-block, etc., mainshaft could be damaged.

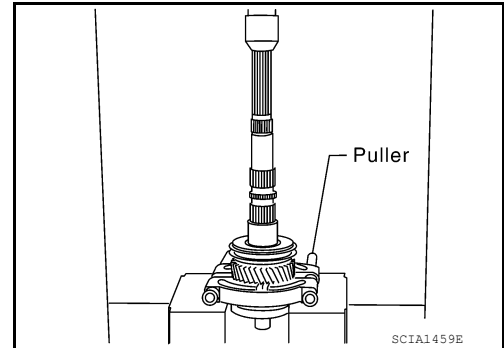

E
F
G

- b. Remove 2nd needle bearing from mainshaft.
- 21. Remove 1st-2nd coupling sleeve according to the following.
 - a. Remove spread springs and shifting inserts from 1st-2nd synchronizer hub.
 - b. Remove 1st-2nd coupling sleeve from 1st-2nd synchronizer hub.

H

22. Remove 6th main gear and 5th-6th synchronizer hub assembly according to the following.

- a. Remove snap ring from mainshaft using suitable tool.

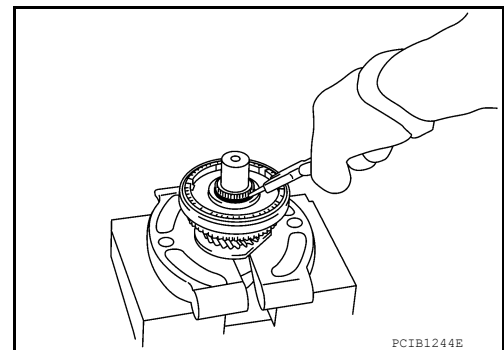

I
J
K
L

- b. Press out 6th main gear and 5th-6th synchronizer hub assembly using suitable tool.
- c. Remove 6th needle bearing from mainshaft.

23. Remove 5th-6th coupling sleeve according to the following.

- a. Remove spread springs and shifting inserts from 5th-6th synchronizer hub.
- b. Remove 5th-6th coupling sleeve from 5th-6th synchronizer hub.

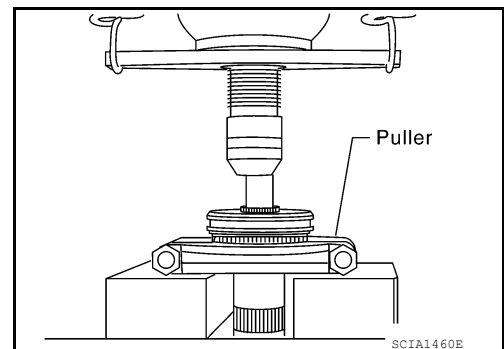

M
N
O
P

24. Remove 3rd counter gear, 3rd-4th synchronizer hub assembly, 4th counter gear according to the following.

GEAR COMPONENTS

< UNIT DISASSEMBLY AND ASSEMBLY >

[6MT: FS6R31A]

- a. Press out 3rd counter gear, 3rd-4th synchronizer hub assembly, 4th counter gear, 4th needle bearing, 4th gear bushing, 4th counter gear thrust washer, and counter rear bearing inner race using suitable tool.
 - b. Remove 3rd needle bearing from counter gear.
25. Remove 3rd-4th coupling sleeve according to the following.
- a. Remove spread springs and shifting inserts from 3rd-4th synchronizer hub.
 - b. Remove 3rd-4th coupling sleeve from 3rd-4th synchronizer hub.

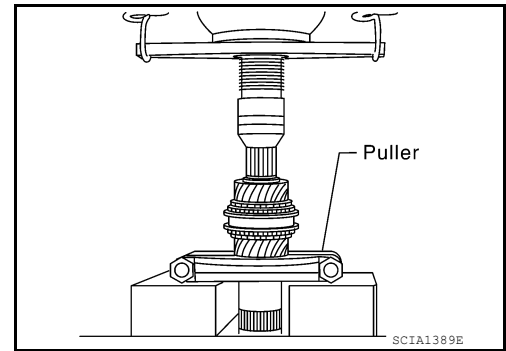

26. Press out 3rd gear bushing using suitable tool.
- CAUTION:**
Do not use oil hole of 3rd gear bushing when press out.

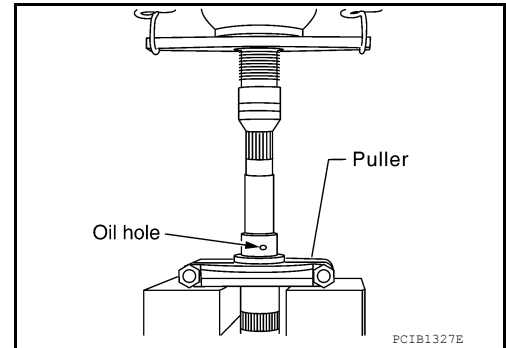

Inspection

GEAR AND SHAFT

If the contact surface on each gear, mainshaft, main drive gear, and counter gear, etc., has damage, peeling, abrasion, dent, bent, or any other damage, replace the components.

INFOID:000000008790792

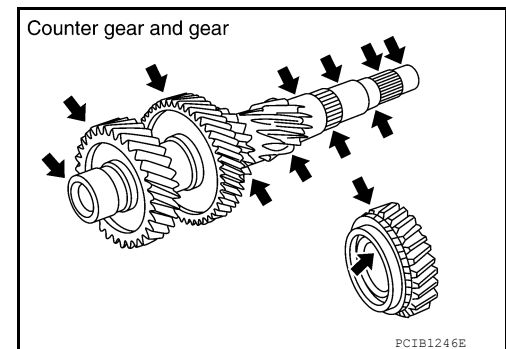
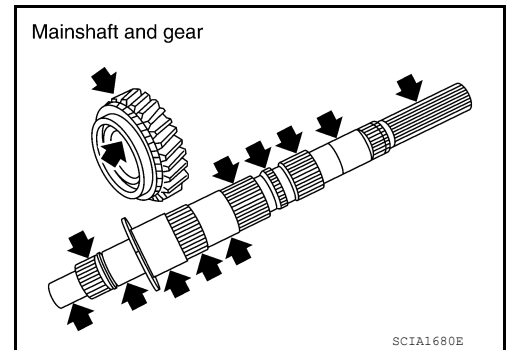

SYNCHRONIZERS

GEAR COMPONENTS

< UNIT DISASSEMBLY AND ASSEMBLY >

[6MT: FS6R31A]

- If the contact surface on coupling sleeve, synchronizer hub, and shifting insert has damage or abrasion, replace the components.
- Coupling sleeve and synchronizer hub shall move smoothly.

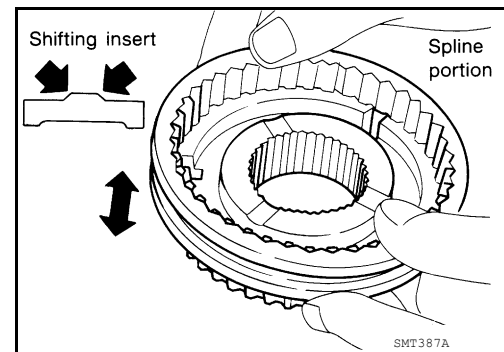

- If the cam surface on baulk ring or contact surface on insert has damage or excessive wear, replace with a new one.
- If spread spring damaged, replace with a new one.

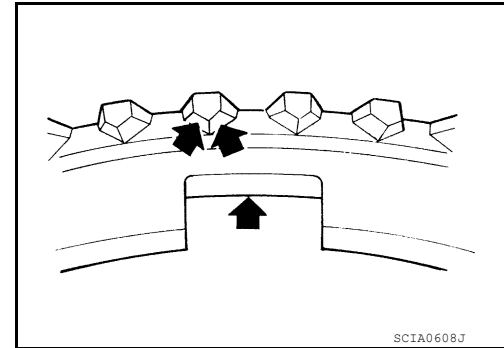

• Reverse Synchronizer

Push baulk ring on the cone, and measure the clearance between baulk ring and cone. If the measurement is below limit, replace it with a new one.

Clearance

Standard value Refer to [TM-126, "Baulk Ring Clearance"](#)

Limit value Refer to [TM-126, "Baulk Ring Clearance"](#)

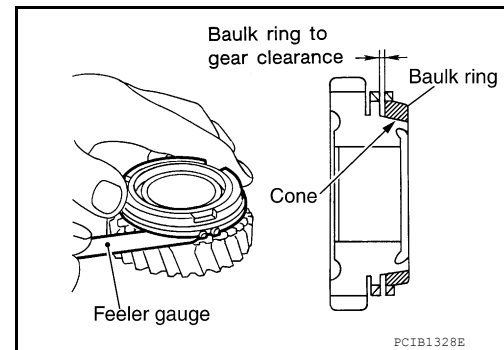

BAULK RING CLEARANCE

• Single Cone Synchronizer (5th and 6th)

Push baulk ring on the cone, and measure the clearance between baulk ring and cone. If the measurement is below limit, replace it with a new one.

Clearance

Standard value Refer to [TM-126, "Baulk Ring Clearance"](#)

Limit value Refer to [TM-126, "Baulk Ring Clearance"](#)

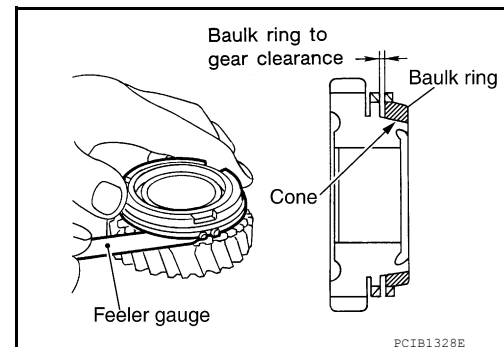

• Double Cone Synchronizer (1st, 3rd and 4th)

GEAR COMPONENTS

< UNIT DISASSEMBLY AND ASSEMBLY >

[6MT: FS6R31A]

Check the clearance between outer baulk ring, synchronizer cone, and inner baulk ring as follows.

CAUTION:

The clearances (A) and (B) are controlled with outer baulk ring, synchronizer cone, and inner baulk ring as a set. Replace them as a set if the clearances are outside the limit value.

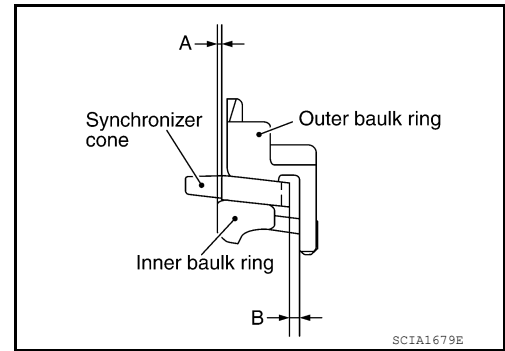

1. Measure the clearance (A) at 2 points or more diagonally opposite using a dial indicator and Tool. Then calculate the mean value.

Tool number : ST30031000 (J-22912-01)

Clearance (A)
Standard value Refer to [TM-126, "Baulk Ring Clearance"](#)

Limit value Refer to [TM-126, "Baulk Ring Clearance"](#)

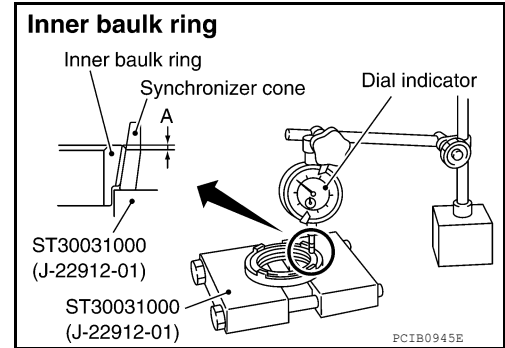

2. Measure the clearance (B) at 2 points or more diagonally opposite using a feeler gauge. Then calculate the mean value.

Clearance (B)
Standard value
 1st Refer to [TM-126, "Baulk Ring Clearance"](#)

3rd,4th Refer to [TM-126, "Baulk Ring Clearance"](#)

Limit value Refer to [TM-126, "Baulk Ring Clearance"](#)

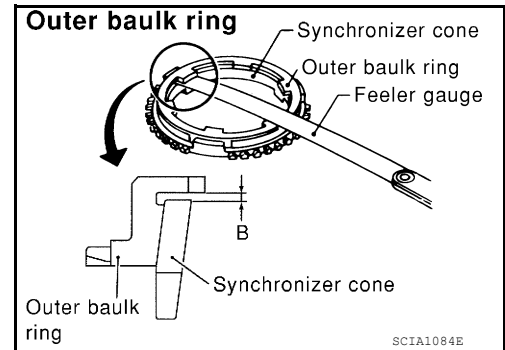

• **Triple Cone Synchronizer (2nd)**

Check the clearance between outer baulk ring, synchronizer cone, and inner baulk ring as follows.

CAUTION:

The clearances (A), (B) and (C) are controlled with outer baulk ring, synchronizer cone, and inner baulk ring as a set. Replace them as a set if the clearances are outside the limit value.

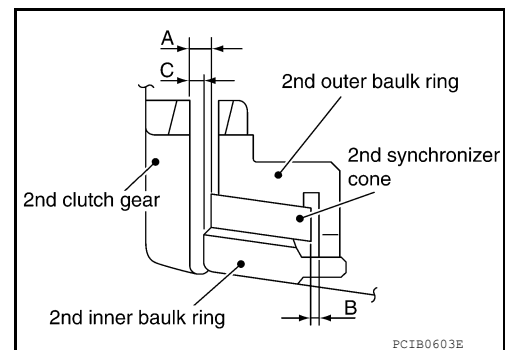

GEAR COMPONENTS

< UNIT DISASSEMBLY AND ASSEMBLY >

[6MT: FS6R31A]

1. Measure the clearance (A) at 2 points or more diagonally opposite using a feeler gauge when pressing baulk ring toward clutch gear taper cone. Then calculate the mean value.

Clearance (A)

Standard value Refer to [TM-126, "Baulk Ring Clearance"](#)

Limit value Refer to [TM-126, "Baulk Ring Clearance"](#)

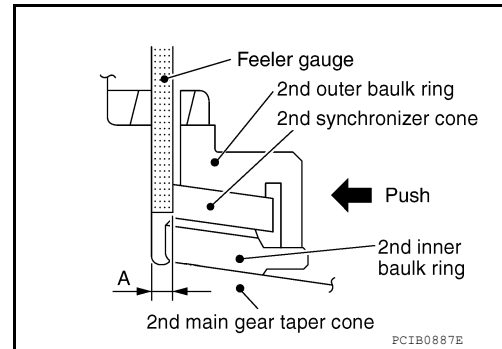

2. Measure the clearance (B) at 2 points or more diagonally opposite using a feeler gauge. Then calculate the mean value.

Clearance (B)

Standard value Refer to [TM-126, "Baulk Ring Clearance"](#)

Limit value Refer to [TM-126, "Baulk Ring Clearance"](#)

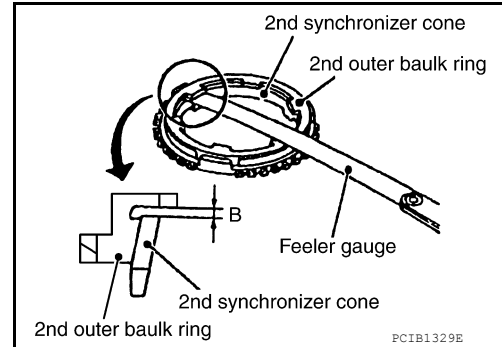

3. Measure the clearance (C) at 2 points or more diagonally opposite using a feeler gauge when pressing baulk ring toward clutch gear taper cone. Then calculate the mean value.

Clearance (C)

Standard value Refer to [TM-126, "Baulk Ring Clearance"](#)

Limit value Refer to [TM-126, "Baulk Ring Clearance"](#)

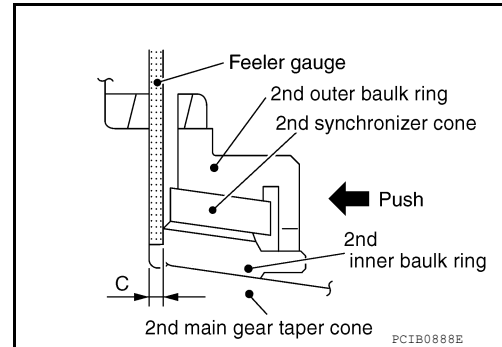

BEARINGS

If the bearing does not rotate smoothly or the contact surface on ball or race is damaged or peeled, replace with new ones.

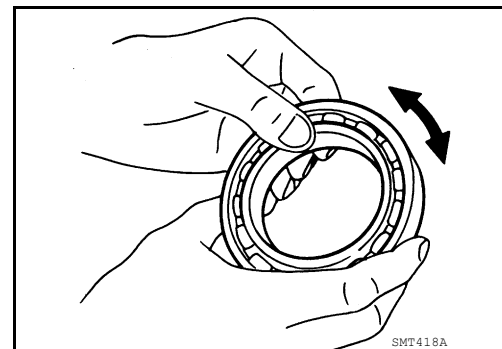

INFOID:000000008790793

Assembly

GEAR COMPONENTS

1. Install 5th-6th synchronizer hub assembly according to the following.
 - a. Install 5th-6th coupling sleeve to 5th-6th synchronizer hub.

CAUTION:

- Do not reuse 5th-6th synchronizer hub and 5th-6th coupling sleeve.
- Replace 5th-6th synchronizer hub and 5th-6th coupling sleeve as a set.

GEAR COMPONENTS

< UNIT DISASSEMBLY AND ASSEMBLY >

[6MT: FS6R31A]

- Be careful with the orientation 5th-6th coupling sleeve.

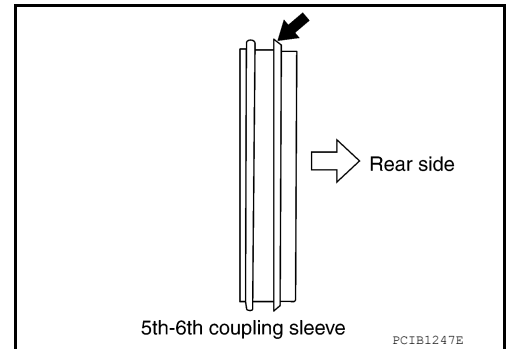

- Be careful with the orientation 5th-6th synchronizer hub.

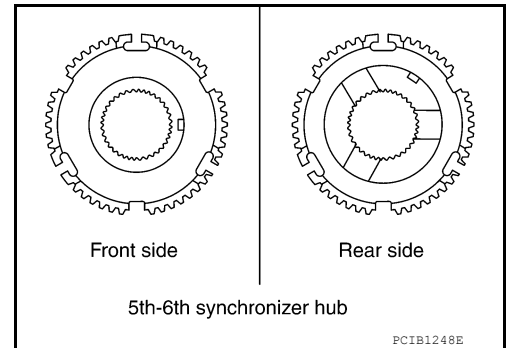

- b. Install shifting inserts and spread springs to 5th-6th synchronizer hub.

CAUTION:

- Do not install spread spring hook onto the same shifting insert.

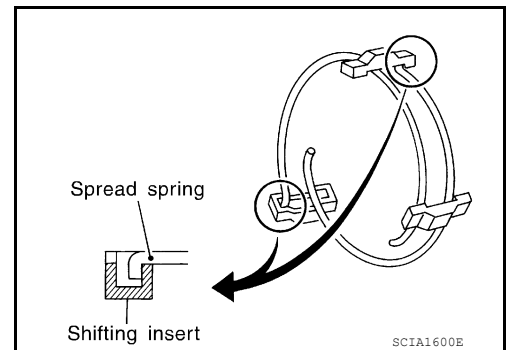

- Be careful with the shape of reserve shifting insert to avoid misemploy.

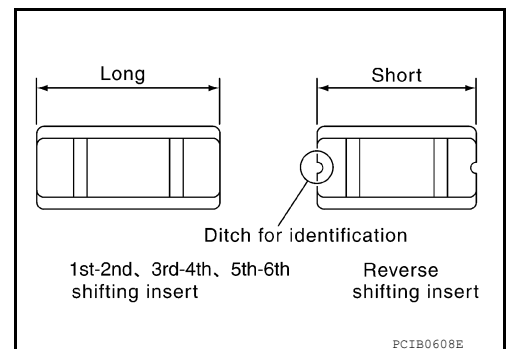

GEAR COMPONENTS

< UNIT DISASSEMBLY AND ASSEMBLY >

[6MT: FS6R31A]

- c. Press in 5th-6th synchronizer hub assembly, 6th baulk ring, 6th main gear and 6th needle bearing using Tool.

Tool number : ST30911000 (—)

CAUTION:

- Apply gear oil to 6th baulk ring and 6th needle bearing.
- Be careful with the orientation 5th-6th coupling sleeve.

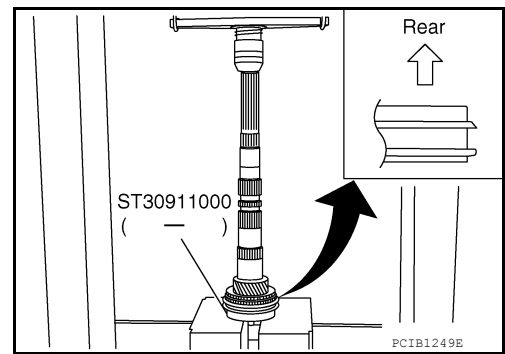

NOTE:

5th and 6th baulk rings have three spaces that four gear teeth are missing as shown.

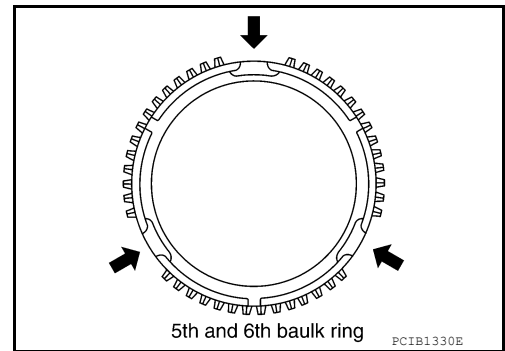

2. Select and install a snap ring so that the end play comes within the standard value. Refer to [TM-126. "Snap Rings"](#).

End play : 0 - 0.10 mm (0 - 0.004 in)

CAUTION:

Do not reuse snap ring.

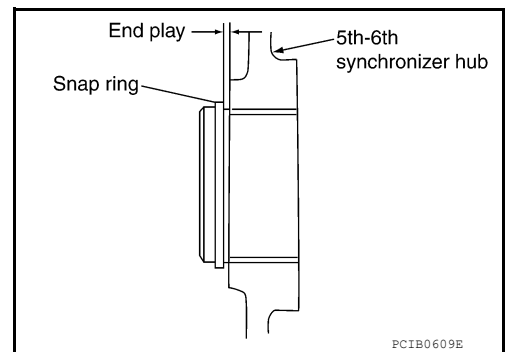

3. Install 1st-2nd synchronizer hub assembly according to the following.
 a. Install 1st-2nd coupling sleeve to 1st-2nd synchronizer hub.

CAUTION:

- Do not reuse 1st-2nd coupling sleeve and 1st-2nd synchronizer hub.
- Replace 1st-2nd synchronizer hub and 1st-2nd coupling sleeve as a set.
- Be careful with the orientation 1st-2nd coupling sleeve.

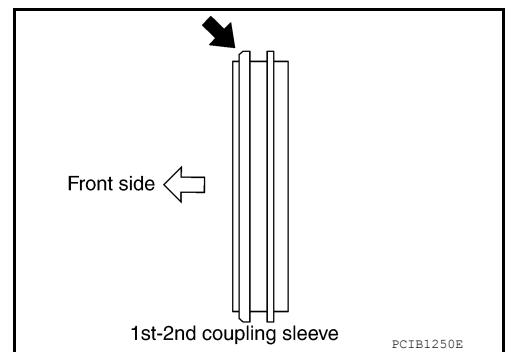

A
B
C
TM
E
F
G
H
I
J
K
L
M
N
O
P

GEAR COMPONENTS

< UNIT DISASSEMBLY AND ASSEMBLY >

[6MT: FS6R31A]

- Be careful with the orientation 1st-2nd synchronizer hub.

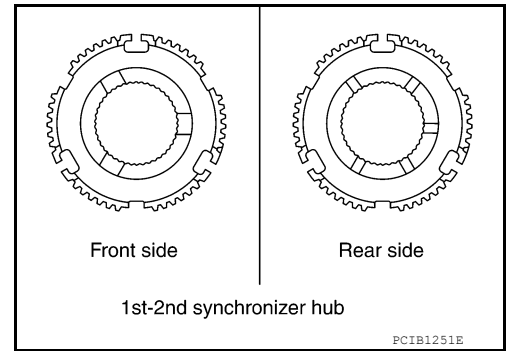

- b. Install spread springs and shifting inserts to 1st-2nd synchronizer hub.

CAUTION:

- Do not install spread spring hook onto the same shifting insert.

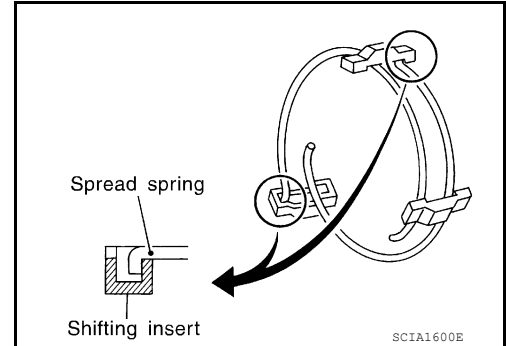

- Be careful with the shape of reverse shifting insert to avoid misassembly.

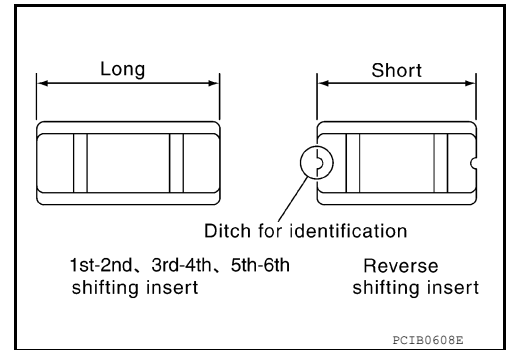

- c. Press in 1st-2nd synchronizer hub assembly, 2nd inner baulk ring, 2nd synchronizer cone and 2nd outer baulk ring, 2nd main gear and 2nd needle bearing using Tool.

Tool number : ST27861000 (—)

CAUTION:

- Apply gear oil to 2nd needle bearing, 2nd inner baulk ring, 2nd synchronizer cone and 2nd outer baulk ring, 1st-2nd synchronizer hub spline of mainshaft.
- Replace 2nd inner baulk ring, 2nd synchronizer cone and 2nd outer baulk ring as a set.
- Be careful with the orientation 1st-2nd coupling sleeve.

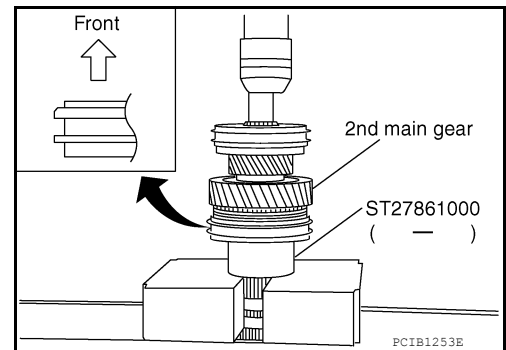

NOTE:

GEAR COMPONENTS

< UNIT DISASSEMBLY AND ASSEMBLY >

[6MT: FS6R31A]

1st outer baulk ring has three spaces that three gear tooth is missing and 2nd outer baulk ring has three spaces that two gear teeth are missing.

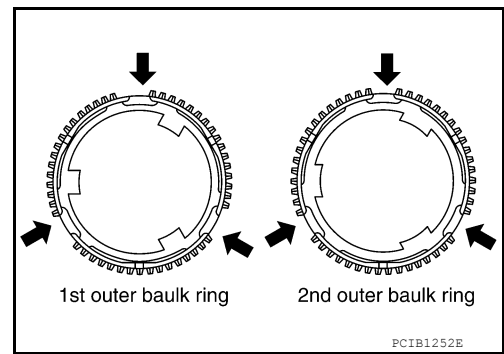

4. Press in 1st gear bushing using Tool.

Tool number : ST27861000 (—)

5. Install 1st outer baulk ring, 1st synchronizer cone, 1st inner baulk ring, 1st needle bearing and 1st main gear to mainshaft.

CAUTION:

- Apply gear oil to 1st outer baulk ring, 1st synchronizer cone, 1st inner baulk ring and 1st needle bearing.
- Replace 1st outer baulk ring, 1st synchronizer cone and 1st inner baulk ring as a set.

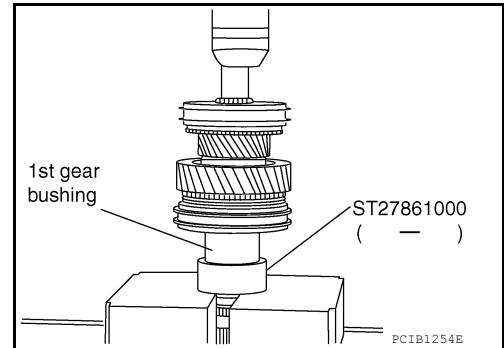

NOTE:

1st outer baulk ring has three spaces that three gear tooth is missing and 2nd outer baulk ring has three spaces that two gear teeth are missing.

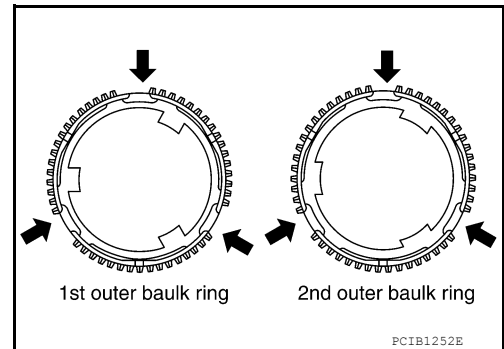

6. Press in 3rd main gear using Tool.

Tool number : ST30022000 (—)

CAUTION:

- Do not reuse 3rd main gear.
- Be careful with the orientation 3rd main gear.

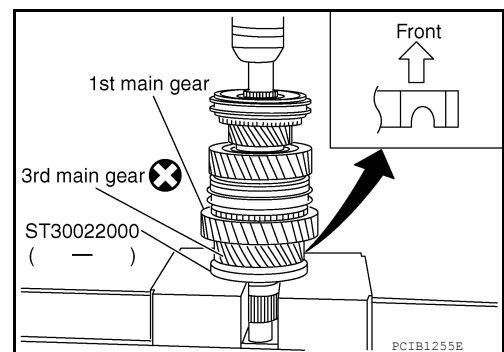

A
B
C
TM
E
F
G
H
I
J
K
L
M
N
O
P

GEAR COMPONENTS

< UNIT DISASSEMBLY AND ASSEMBLY >

[6MT: FS6R31A]

7. Install 3rd-4th main spacer to mainshaft.
8. Press in 4th main gear using Tool.

Tool number : ST30022000 (—)

CAUTION:

- Do not reuse 4th main gear.
- Be careful with the orientation 4th main gear.

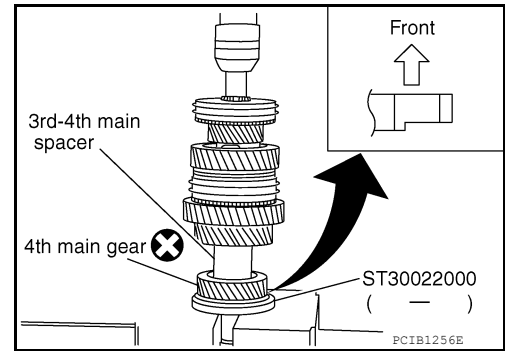

9. Press in mainshaft bearing using Tool.

Tool number : ST30911000 (—)

CAUTION:

Be careful with the orientation mainshaft bearing.

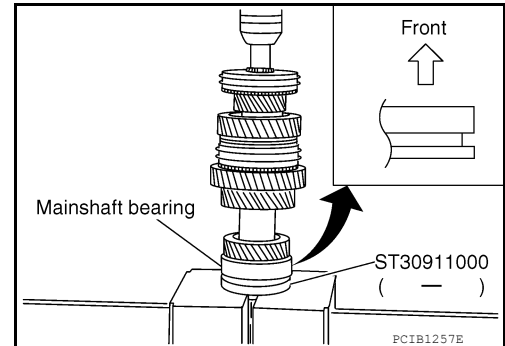

10. Press in reverse main gear bushing using Tool.

Tool number : ST30911000 (—)

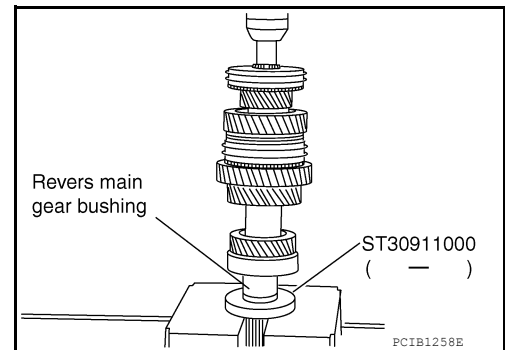

11. Press in 3rd gear bushing using Tool.

Tool number : ST30911000 (—)

12. Install 3rd-4th synchronizer hub assembly according to the following.

- a. Install 3rd-4th coupling sleeve to 3rd-4th synchronizer hub.

CAUTION:

- Do not reuse 3rd-4th synchronizer hub and 3rd-4th coupling sleeve.
- Replace 3rd-4th synchronizer hub and 3rd-4th coupling sleeve as a set.

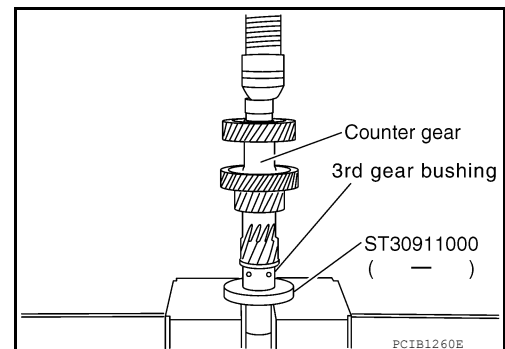

GEAR COMPONENTS

< UNIT DISASSEMBLY AND ASSEMBLY >

[6MT: FS6R31A]

- Be careful with the orientation 3rd-4th coupling sleeve.

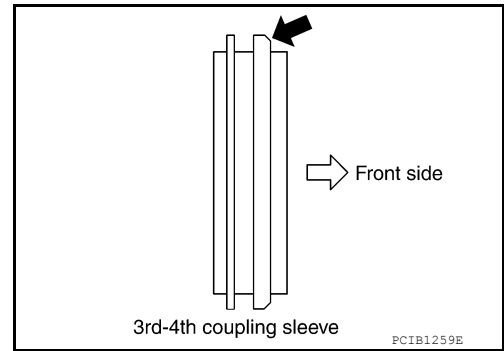

- b. Install spread springs and shifting inserts to 3rd-4th synchronizer hub.

CAUTION:

- Do not install spread spring hook onto the same shifting insert.

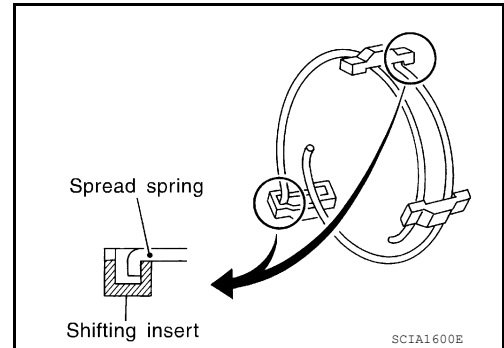

- Be careful with the shape of reverse shifting insert to avoid misassembly.

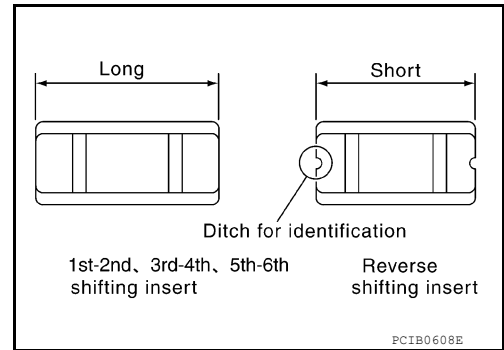

- c. Press in 3rd-4th synchronizer hub assembly, 3rd inner baulk ring, 3rd synchronizer cone, 3rd outer baulk ring, 3rd counter gear and 3rd needle bearing using Tool.

Tool number : ST30911000 (—)

CAUTION:

- Apply gear oil to 3rd inner baulk ring, 3rd synchronizer cone, 3rd outer baulk ring and 3rd needle bearing, hole spline of 3rd-4th synchronizer hub.
- Replace 3rd inner baulk ring, 3rd synchronizer cone and 3rd outer baulk ring as a set.
- Be careful with the orientation 3rd-4th coupling sleeve.

NOTE:

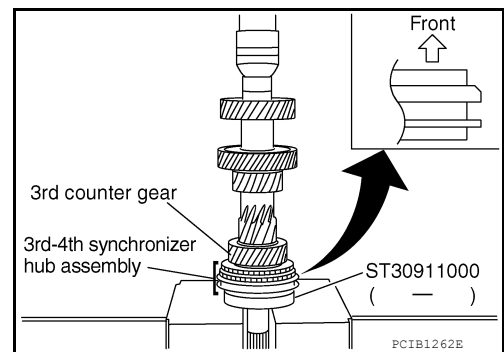

A
B
C
TM
E
F
G
H
I
J
K
L
M
N
O
P

GEAR COMPONENTS

< UNIT DISASSEMBLY AND ASSEMBLY >

[6MT: FS6R31A]

4th baulk ring has three spaces that one gear tooth is missing but 3rd baulk ring doesn't.

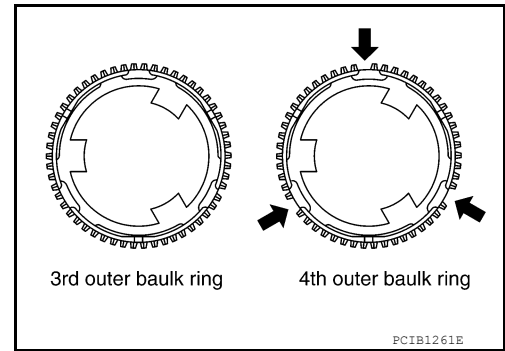

13. Press in 4th counter gear thrust washer, 4th gear bushing, 4th needle bearing, 4th counter gear, 4th outer baulk ring, 4th synchronizer cone and 4th inner baulk ring using Tool.

Tool number : KV40100630 (J-26092)

CAUTION:

- Apply gear oil to 4th needle bearing, 4th outer baulk ring, 4th synchronizer cone and 4th inner baulk ring.
- Replace 4th outer baulk ring, 4th synchronizer cone and 4th inner baulk ring as a set.
- Be careful with the orientation 4th counter gear thrust washer.

NOTE:

4th baulk ring has three spaces that one gear tooth is missing but 3rd baulk ring doesn't.

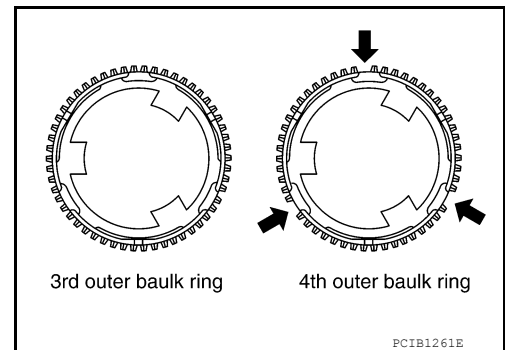
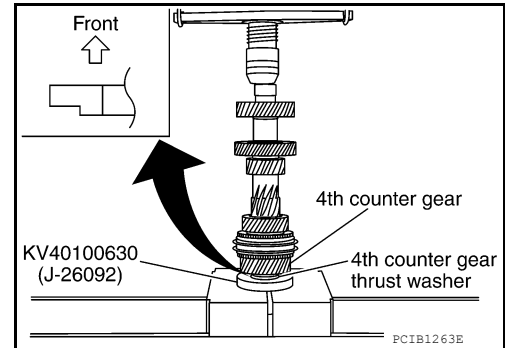

14. Press in counter rear bearing inner race using Tool.

Tool number : ST30032000 (J-26010-01)

CAUTION:

Be careful with the orientation counter rear bearing inner race.

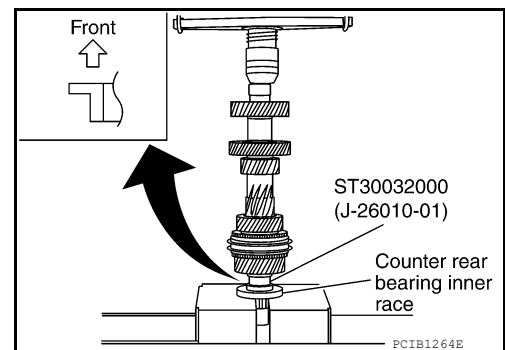

15. Install main drive gear bearing according to the following.

GEAR COMPONENTS

< UNIT DISASSEMBLY AND ASSEMBLY >

[6MT: FS6R31A]

- a. Press in main drive gear bearing using Tool.

Tool number : KV32102700 (—)

CAUTION:

Be careful with the orientation main drive gear bearing.

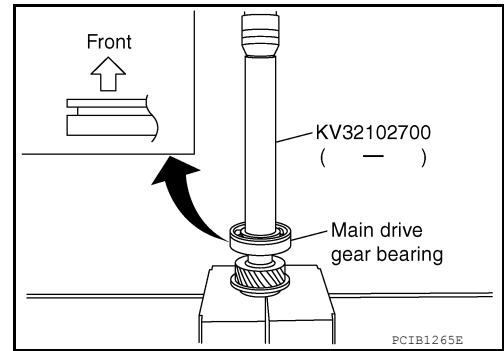

- b. Select and install a snap ring to main drive gear bearing so that the end play comes within the standard value. Refer to [TM-126. "Snap Rings"](#).

End play : 0 - 0.10 mm (0 - 0.004 in)

CAUTION:

Do not reuse snap ring.

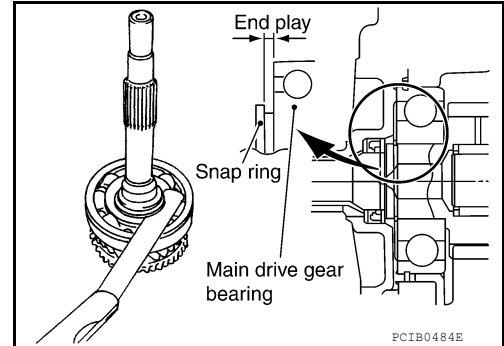

16. Install breather to adapter plate.

CAUTION:

- Do not reuse breather.
- Be careful with the orientation breather.

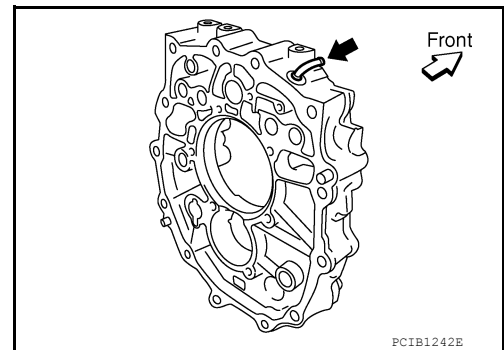

17. Install magnet to adapter plate.

CAUTION:

Be careful with the orientation magnet.

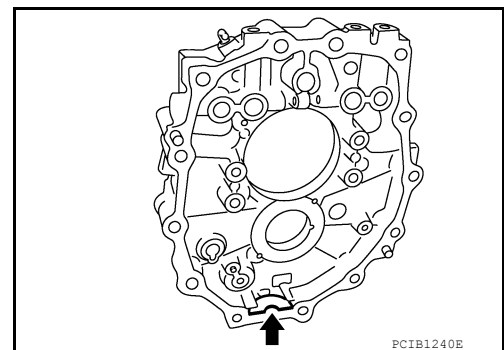

18. Install baffle plate to adapter plate, and then tighten bolt to the specified torque. Refer to [TM-77. "Overhaul"](#).

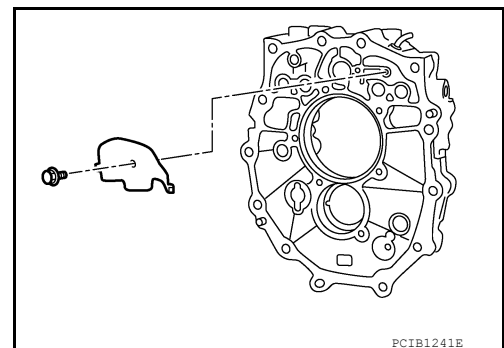

A
B
C
TM
E
F
G
H
I
J
K
L
M
N
O
P

GEAR COMPONENTS

< UNIT DISASSEMBLY AND ASSEMBLY >

[6MT: FS6R31A]

19. Install main drive gear assembly, mainshaft assembly and counter gear assembly according to the following.
- a. Install main pilot bearing, pilot bearing spacer and 5th baulk ring to main drive gear.
 - b. Install main drive gear assembly, mainshaft assembly and counter gear assembly combined in one unit to adapter plate using brass bar.

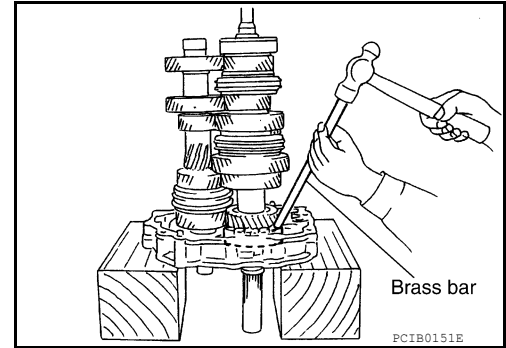

20. Install Tool to adapter plate, and then position in a vise.

Tool number : ST22490000 (—)

CAUTION:

Do not directly secure mating surface of adapter plate in a vise.

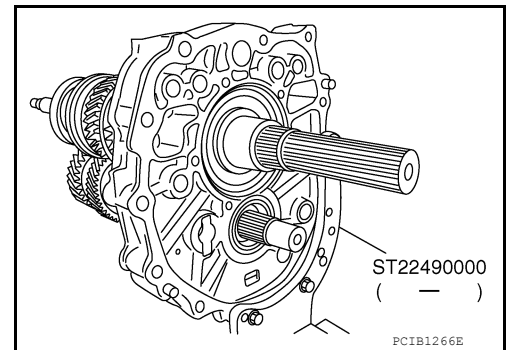

21. Install snap ring to mainshaft bearing.

CAUTION:

Do not reuse snap ring.

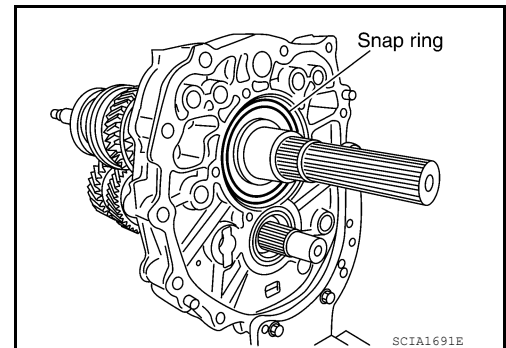

22. Install counter rear bearing to adapter plate using Tool.

Tool number : ST33200000 (J-26082)

23. Install counter rear bearing spacer to counter gear.

CAUTION:

When installing counter rear bearing spacer, groove should face to the rear side.

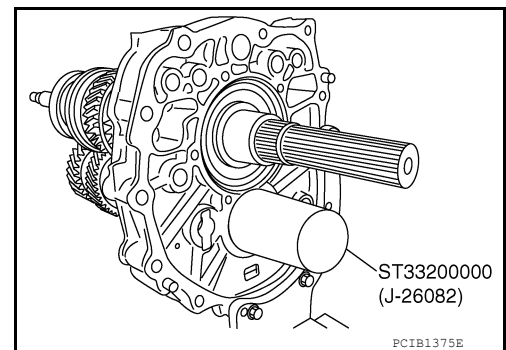

24. Install bearing retainer according to the following.

GEAR COMPONENTS

< UNIT DISASSEMBLY AND ASSEMBLY >

[6MT: FS6R31A]

- a. Install bearing retainer to adapter plate.
- b. Apply recommended thread locking sealant to threads of bolts, and then tighten bolts to the specified torque. Refer to [TM-77, "Overhaul"](#).
 - Use Genuine Medium Strength Thread Locking Sealant or the equivalent. Refer to [GI-24, "Recommended Chemical Products and Sealants"](#).

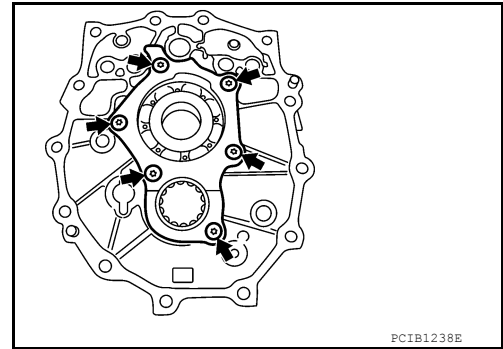

25. Install reverse synchronizer hub assembly according to the following.

- a. Install reverse coupling sleeve to reverse synchronizer hub.

CAUTION:

- Do not reuse reverse coupling sleeve and reverse synchronizer hub.
- Replace reuse reverse coupling sleeve and reverse synchronizer hub as a set.
- Be careful with the orientation reverse coupling sleeve.

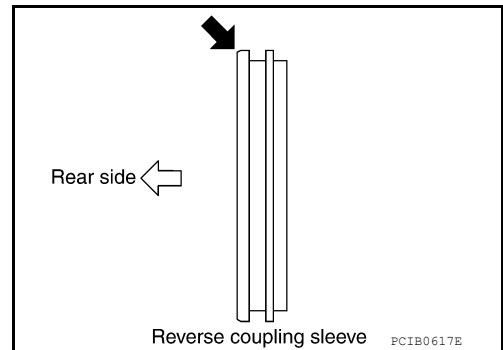

- Be careful with the orientation reverse synchronizer hub.

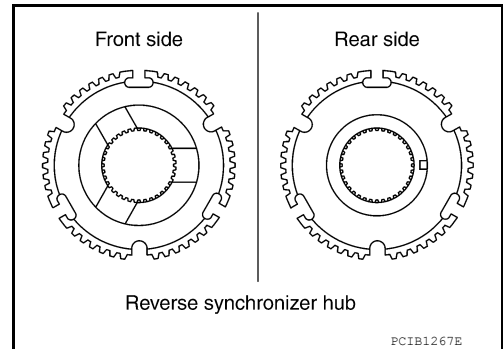

- b. Install spread springs to shifting inserts to reverse synchronizer hub.

CAUTION:

- Do not install spread spring hook onto the same shifting insert.

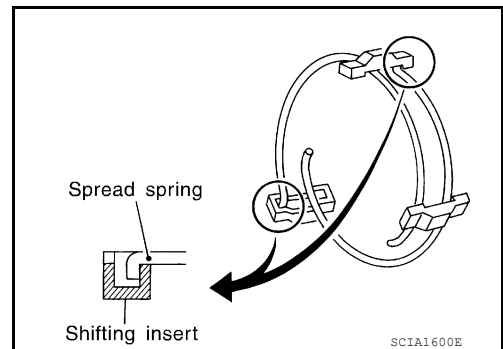

A
B
C
TM
E
F
G
H
I
J
K
L
M
N
O
P

GEAR COMPONENTS

< UNIT DISASSEMBLY AND ASSEMBLY >

[6MT: FS6R31A]

- Be careful with the shape of 1st-2nd, 3rd-4th and 5th-6th shifting insert to avoid misassembly.

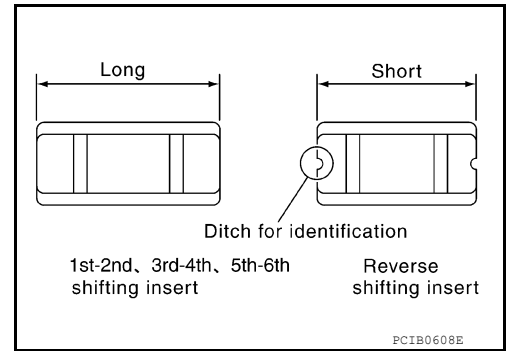

- c. Install snap ring to reverse synchronizer hub.

CAUTION:

- Do not reuse snap ring.
- Do not align the snap ring notch with synchronizer hub groove when assembling.

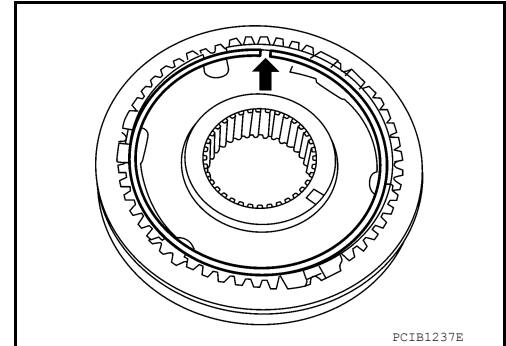

- d. Press in reverse synchronizer hub assembly, reverse baulk ring, reverse main gear and reverse main needle bearing using Tools.

Tool number : ST01530000 (—)
 : KV32103300 (J-46529)

CAUTION:

Apply gear oil to reverse baulk ring and reverse main needle bearing.

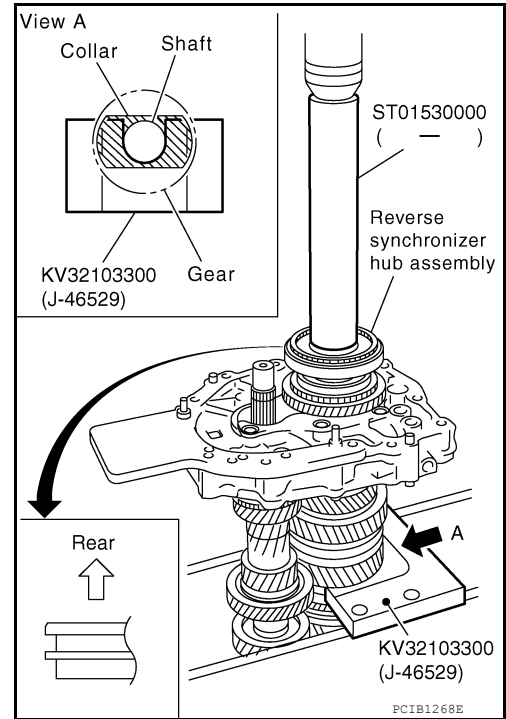

NOTE:

GEAR COMPONENTS

< UNIT DISASSEMBLY AND ASSEMBLY >

[6MT: FS6R31A]

Reverse baulk ring has three spaces that two gear teeth are missing, and each space has small ditch for identification as shown.

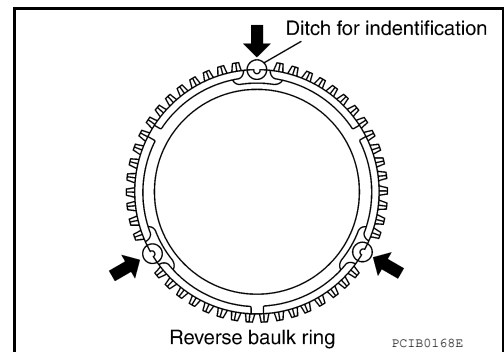

26. Select and install a snap ring so that the end play comes within the standard value. Refer to [TM-126, "Snap Rings"](#).

End play : 0 - 0.10 mm (0 - 0.004 in)

CAUTION:
Do not reuse snap ring.

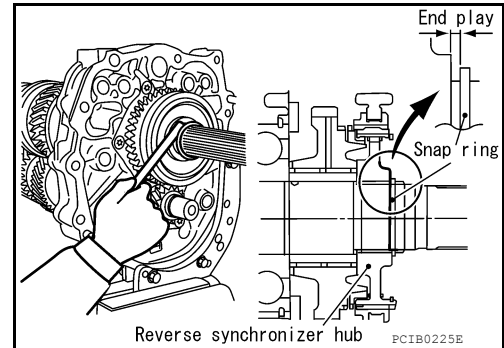

27. Press in reverse counter gear using Tool.

Tool number : ST23860000 (—)

CAUTION:
• Do not reverse counter gear.
• Be careful with the orientation counter gear.

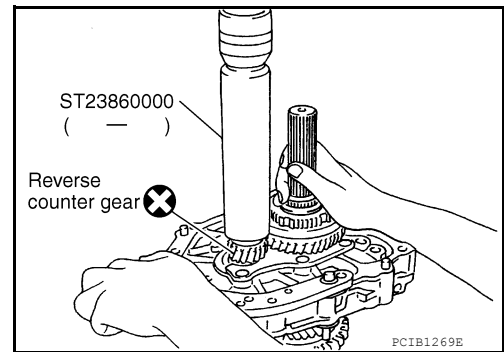

28. Select and install a snap ring so that the end play comes within the standard value. Refer to [TM-126, "Snap Rings"](#).

End play : 0 - 0.10 mm (0 - 0.004 in)

CAUTION:
Do not reuse snap ring.

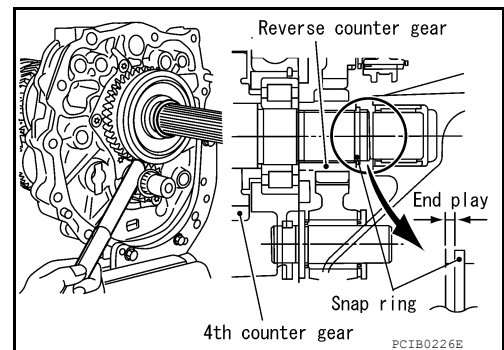

29. Install reverse idler shaft assembly according to the following.

a. Install reverse idler needle bearing, reverse idler gear and reverse idler thrust washer to reverse idler shaft.

CAUTION:
Apply gear oil to reverse idler needle bearing.

A
B
C
TM
E
F
G
H
I
J
K
L
M
N
O
P

GEAR COMPONENTS

< UNIT DISASSEMBLY AND ASSEMBLY >

[6MT: FS6R31A]

- b. Install reverse idler shaft assembly to adapter plate.

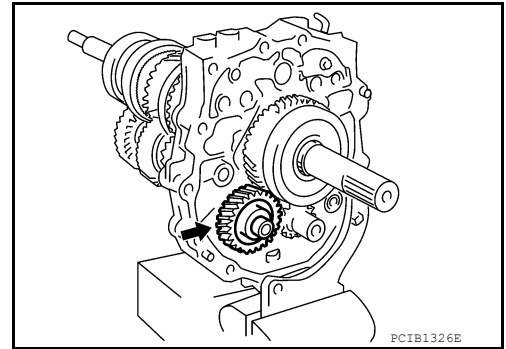

SERVICE DATA AND SPECIFICATIONS (SDS)

< SERVICE DATA AND SPECIFICATIONS (SDS)

[6MT: FS6R31A]

SERVICE DATA AND SPECIFICATIONS (SDS)

SERVICE DATA AND SPECIFICATIONS (SDS)

General Specification

INFOID:000000008790794

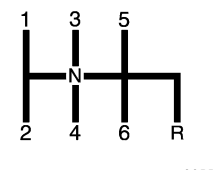
Engine		VQ40DE	
Transmission model		FS6R31A	
Axle type		2WD	4WD
Number of speed		6	
Synchronesh type		Warner	
Shift pattern		 <p style="text-align: center; font-size: small;">SCIA0955E</p>	
Gear ratio	1st	4.368	
	2nd	2.518	
	3rd	1.743	
	4th	1.283	
	5th	1.000	
	6th	0.769	
	Reverse	3.966	
Main gear (Number of teeth)	Drive	24	
	1st	37	
	2nd	32	
	3rd	32	
	4th	29	
	6th	25	
	Reverse	42	
Counter gear (Number of teeth)	Drive	34	
	1st	12	
	2nd	18	
	3rd	26	
	4th	32	
	6th	46	
	Reverse	15	
Reverse idler gear (Number of teeth)		26	
Oil capacity (Approximate)		<i>ℓ</i> (US pt, Imp pt)	4.0 (8-3/8, 7) 4.2 (8-7/8, 7-3/8)
Remarks	Reverse synchronizer	Installed	
	Double cone synchronizer	1st, 3rd and 4th	
	Triple cone synchronizer	2nd	

SERVICE DATA AND SPECIFICATIONS (SDS)

< SERVICE DATA AND SPECIFICATIONS (SDS)

[6MT: FS6R31A]

Gear End Play

INFOID:000000008790795

Unit: mm (in)

Item	Standard value
Counter gear	0 - 0.10 (0 - 0.004)
Main drive gear	0 - 0.10 (0 - 0.004)
Mainshaft (Front side)	0 - 0.10 (0 - 0.004)
Mainshaft (Rear side)	0 - 0.10 (0 - 0.004)

Snap Rings

INFOID:000000008790796

Unit: mm (in)

Selective parts	Thickness	Part number*
Main drive gear	1.89 (0.0744)	32204 01G60
	1.95 (0.0768)	32204 01G61
	1.99 (0.0783)	32204 01G62
	2.03 (0.0799)	32204 01G63
	2.07 (0.0815)	32204 01G64
	2.11 (0.0831)	32204 01G65
Counter gear	1.96 (0.0772)	32236 CD000
	2.02 (0.0795)	32236 CD001
	2.08 (0.0819)	32236 CD002
	2.14 (0.0843)	32236 CD003
	2.20 (0.0866)	32236 CD004
	2.26 (0.0890)	32236 CD005
	2.32 (0.0913)	32236 CD006
	2.38 (0.0937)	32236 CD007
	2.44 (0.0961)	32236 CD008
	2.50 (0.0984)	32236 CD009
	2.56 (0.1008)	32236 CD010
2.62 (0.1031)	32236 CD011	
Front side	2.08 (0.0819)	32204 CD000
	2.14 (0.0843)	32204 CD001
	2.20 (0.0866)	32204 CD002
	2.26 (0.0890)	32204 CD003
Rear side	2.08 (0.0819)	32204 CD000
	2.14 (0.0843)	32204 CD001
	2.20 (0.0866)	32204 CD002
	2.26 (0.0890)	32204 CD003
	2.32 (0.0913)	32204 CD004
	2.38 (0.0937)	32204 CD005
	2.44 (0.0961)	32204 CD006
	2.50 (0.0984)	32204 CD007
	2.56 (0.1008)	32204 CD008
	2.62 (0.1031)	32204 CD009
	2.68 (0.1055)	32204 CD010
	2.74 (0.1079)	32204 CD011
	2.80 (0.1102)	32204 CD012
	2.86 (0.1126)	32204 CD013
2.92 (0.1150)	32204 CD014	
2.98 (0.1173)	32204 CD015	

*: Always check with the Parts Department for the latest parts information.

Baulk Ring Clearance

INFOID:000000008790797

Unit: mm (in)

SERVICE DATA AND SPECIFICATIONS (SDS)

< SERVICE DATA AND SPECIFICATIONS (SDS)

[6MT: FS6R31A]

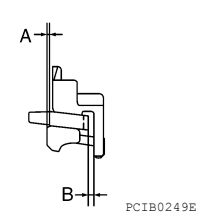
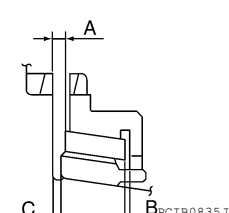
Measurement point	Standard value	Limit value
1st, 3rd and 4th (Double-cone synchronizer)	Clearance between synchronizer cone and inner baulk ring end face "A"	0.5 - 0.7 (0.020 - 0.028)
	Clearance between outer baulk ring pawl and synchronizer cone "B"	1st: 1.0 - 1.5 (0.039 - 0.059) 3rd, 4th: 0.85 - 1.35 (0.0335 - 0.0531)
		
2nd (Triple-cone synchronizer)	Clearance between synchronizer and clutch gear end face "A"	0.6 - 1.3 (0.024 - 0.051)
	Clearance between outer baulk ring pawl and synchronizer cone "B"	0.85 - 1.35 (0.0335 - 0.0531)
	Clearance between inner baulk ring and clutch gear end face "C"	0.7 - 1.25 (0.028 - 0.0492)
		
5th and 6th	0.7 - 1.35 (0.028 - 0.0531)	0.5 (0.020)
Reverse	0.75 - 1.2 (0.0295 - 0.047)	0.5 (0.020)

A
B
C
TM
E
F
G
H
I
J
K
L
M
N
O
P

BASIC INSPECTION

DIAGNOSIS AND REPAIR WORKFLOW

How to Perform Trouble Diagnosis for Quick and Accurate Repair

INFOID:000000008790798

INTRODUCTION

The TCM receives a signal from the output speed sensor, accelerator pedal position sensor (throttle position sensor) or transmission range switch. Then provides shift control or lock-up control via A/T solenoid valves.

The TCM also communicates with the ECM by means of a signal sent from sensing elements used with the OBD-related parts of the A/T system for malfunction-diagnostic purposes. The TCM is capable of diagnosing malfunctioning parts while the ECM can store malfunctions in its memory.

Input and output signals must always be correct and stable in the operation of the A/T system. The A/T system must be in good operating condition and be free of valve seizure, solenoid valve malfunction, etc.

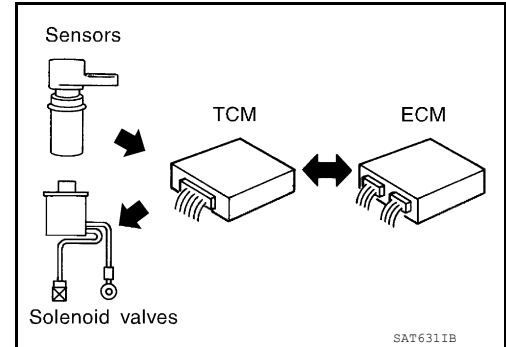

It is much more difficult to diagnose an error that occurs intermittently rather than continuously. Most intermittent errors are caused by poor electric connections or improper wiring. In this case, careful checking of suspected circuits may help prevent the replacement of good parts.

A visual check only may not find the cause of the errors. A road test with CONSULT (or GST) or a circuit tester connected should be performed. Follow the "DETAILED FLOW".

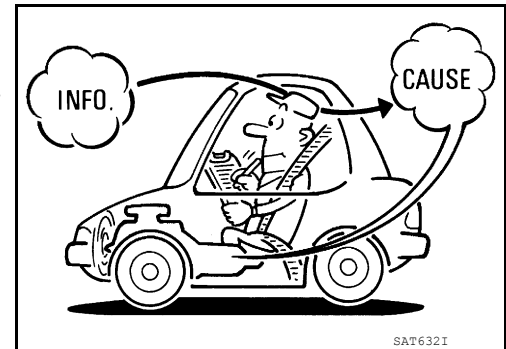

Before undertaking actual checks, take a few minutes to talk with a customer who approaches with a driveability complaint. The customer can supply good information about such errors, especially intermittent ones. Find out what symptoms are present and under what conditions they occur. A "Diagnostic work sheet" as shown on the example (Refer to [TM-129](#)) should be used.

Start your diagnosis by looking for "conventional" errors first. This will help troubleshoot driveability errors on an electronically controlled engine vehicle.

Also check related Service bulletins.

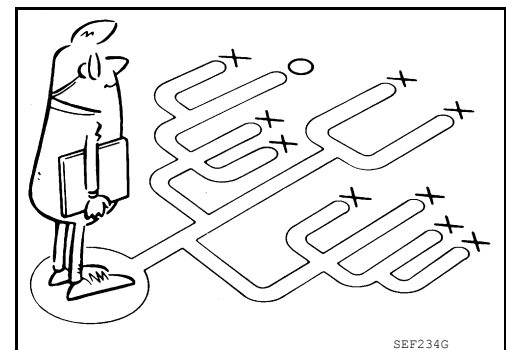

DETAILED FLOW

1. COLLECT THE INFORMATION FROM THE CUSTOMER

Get the detailed information from the customer about the symptom (the condition and the environment when the incident/malfunction occurred) using diagnosis worksheet. Refer to [TM-129, "Diagnostic Work Sheet"](#).

>> GO TO 2.

2. CHECK SYMPTOM 1

Check the following items based on the information obtained from the customer.

- Fail-safe. Refer to [TM-228, "Fail-Safe"](#).
- A/T fluid inspection. Refer to [TM-267, "Checking the A/T Fluid \(ATF\)"](#).
- Stall test. Refer to [TM-273, "Stall Test"](#).
- Line pressure test. Refer to [TM-274, "Line Pressure Test"](#).

DIAGNOSIS AND REPAIR WORKFLOW

< BASIC INSPECTION >

[5AT: RE5R05A]

>> GO TO 3.

3. CHECK DTC

1. Check DTC.
2. Perform the following procedure if DTC is detected.
 - Record DTC.
 - Erase DTC. Refer to [TM-154. "OBD-II Diagnostic Trouble Code \(DTC\)"](#).

Is any DTC detected?

YES >> GO TO 4.

NO >> GO TO 6.

4. PERFORM DIAGNOSTIC PROCEDURE

Perform "Diagnosis Procedure" for the displayed DTC.

>> GO TO 5.

5. PERFORM DTC CONFIRMATION PROCEDURE

Perform "DTC CONFIRMATION PROCEDURE".

Is DTC detected?

YES >> GO TO 4.

NO >> GO TO 6.

6. CHECK SYMPTOM 2

Try to confirm the symptom described by the customer.

Is any malfunction present?

YES >> GO TO 7.

NO >> Inspection End

7. ROAD TEST

Perform "ROAD TEST". Refer to [TM-277. "Check Before Engine Is Started"](#).

>> GO TO 8.

8. CHECK SYMPTOM 3

Try to confirm the symptom described by the customer.

Is any malfunction present?

YES >> GO TO 2.

NO >> Inspection End

Diagnostic Work Sheet

INFOID:000000008790799

INFORMATION FROM CUSTOMER

KEY POINTS

- **WHAT**..... Vehicle and A/T model
- **WHEN**..... Date, Frequencies
- **WHERE**..... Road conditions
- **HOW**..... Operating conditions, Symptoms

Customer name MR/MS	Model and Year	VIN
Trans. Model	Engine	Mileage
Malfunction Date	Manuf. Date	In Service Date
Frequency	<input type="checkbox"/> Continuous <input type="checkbox"/> Intermittent (times a day)	

DIAGNOSIS AND REPAIR WORKFLOW

< BASIC INSPECTION >

[5AT: RE5R05A]

Symptoms	<input type="checkbox"/> Vehicle does not move. (<input type="checkbox"/> Any position <input type="checkbox"/> Particular position)	
	<input type="checkbox"/> No up-shift (<input type="checkbox"/> 1st → 2nd <input type="checkbox"/> 2nd → 3rd <input type="checkbox"/> 3rd → 4th <input type="checkbox"/> 4th → 5th)	
	<input type="checkbox"/> No down-shift (<input type="checkbox"/> 5th → 4th <input type="checkbox"/> 4th → 3rd <input type="checkbox"/> 3rd → 2nd <input type="checkbox"/> 2nd → 1st)	
	<input type="checkbox"/> Lock-up malfunction	
	<input type="checkbox"/> Shift point too high or too low.	
	<input type="checkbox"/> Shift shock or slip (<input type="checkbox"/> N → D <input type="checkbox"/> N → R <input type="checkbox"/> Lock-up <input type="checkbox"/> Any drive position)	
	<input type="checkbox"/> Noise or vibration	
	<input type="checkbox"/> No kick down	
	<input type="checkbox"/> No pattern select	
	<input type="checkbox"/> Cannot be changed to manual mode	
	<input type="checkbox"/> Others ()	
O/D OFF indicator lamp	<input type="checkbox"/> Continuously lit	<input type="checkbox"/> Not lit
Malfunction indicator lamp (MIL)	<input type="checkbox"/> Continuously lit	<input type="checkbox"/> Not lit

DIAGNOSTIC WORK SHEET

1	<input type="checkbox"/> Read the item on cautions concerning fail-safe and understand the customer's complaint.		TM-228	
2	<input type="checkbox"/> A/T fluid inspection, stall test and line pressure test			
		<input type="checkbox"/> A/T fluid inspection <input type="checkbox"/> Leak (Repair leak location.) <input type="checkbox"/> State <input type="checkbox"/> Amount	TM-267	
		<input type="checkbox"/> Stall test <input type="checkbox"/> Torque converter one-way clutch <input type="checkbox"/> Front brake <input type="checkbox"/> High and low reverse clutch <input type="checkbox"/> Low coast brake <input type="checkbox"/> Forward brake <input type="checkbox"/> Reverse brake <input type="checkbox"/> Forward one-way clutch	TM-273	
		<input type="checkbox"/> 1st one-way clutch <input type="checkbox"/> 3rd one-way clutch <input type="checkbox"/> Engine <input type="checkbox"/> Line pressure low <input type="checkbox"/> Except for input clutch and direct clutch, clutches and brakes OK <input type="checkbox"/> Line pressure test - Suspected part:	TM-274	
3	<input type="checkbox"/> Perform self-diagnosis. — Check detected items to repair or replace malfunctioning part.		TM-156	
4	<input type="checkbox"/> Perform road test.			
	5-1	<input type="checkbox"/> Check before engine is started	TM-277	
	5-2	<input type="checkbox"/> Check at idle	TM-277	
	5-3	Cruise test	<input type="checkbox"/> Part 1	TM-278
			<input type="checkbox"/> Part 2	TM-280
<input type="checkbox"/> Part 3			TM-280	
<input type="checkbox"/> Check malfunction phenomena to repair or replace malfunctioning part after completing all road test. Refer to TM-240, "Symptom Chart" .				
5	<input type="checkbox"/> Drive vehicle to check that the malfunction phenomenon has been resolved.			
6	<input type="checkbox"/> Erase the results of the self-diagnosis from the TCM and the ECM.		TM-154	

SYSTEM DESCRIPTION

A/T CONTROL SYSTEM

Cross-Sectional View

INFOID:000000008790800

2WD models

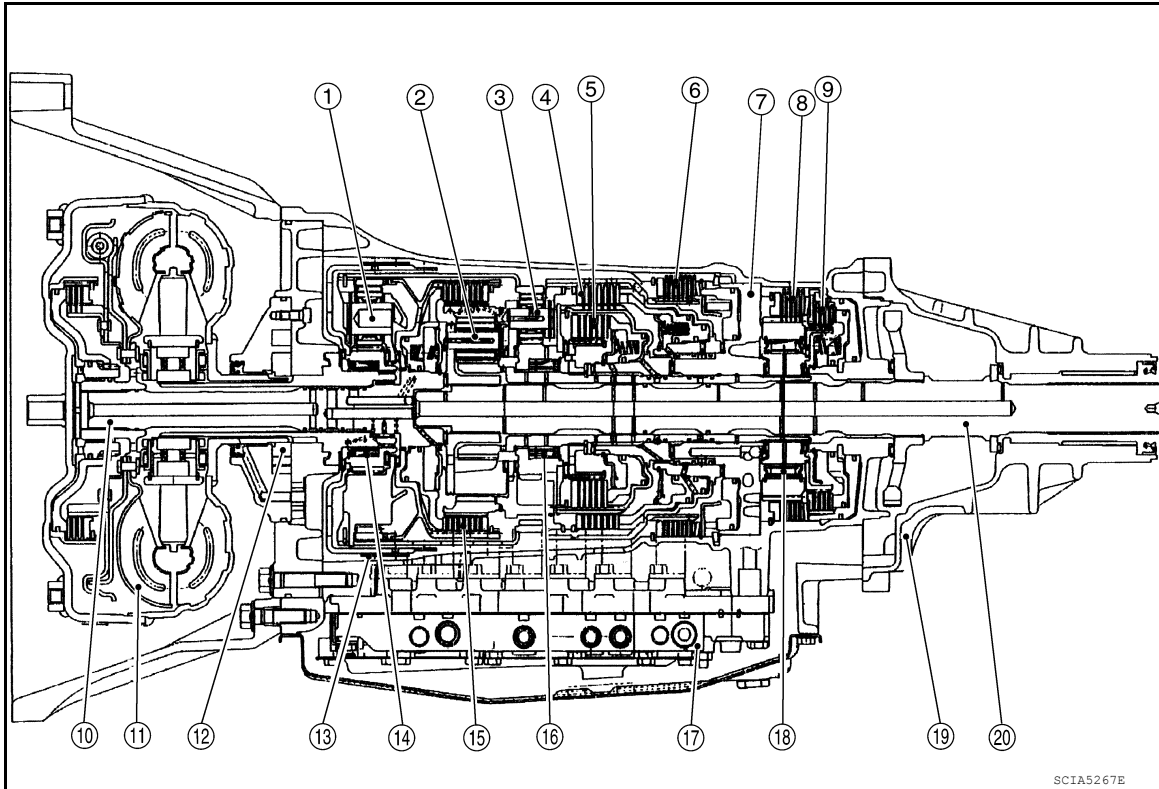

- | | | |
|-------------------------|--------------------------------|----------------------------|
| 1. Front planetary gear | 2. Mid planetary gear | 3. Rear planetary gear |
| 4. Direct clutch | 5. High and low reverse clutch | 6. Reverse brake |
| 7. Drum support | 8. Forward brake | 9. Low coast brake |
| 10. Input shaft | 11. Torque converter | 12. Oil pump |
| 13. Front brake | 14. 3rd one-way clutch | 15. Input clutch |
| 16. 1st one-way clutch | 17. Control valve with TCM | 18. Forward one-way clutch |
| 19. Rear extension | 20. Output shaft | |

A/T CONTROL SYSTEM

< SYSTEM DESCRIPTION >

[5AT: RE5R05A]

4WD models

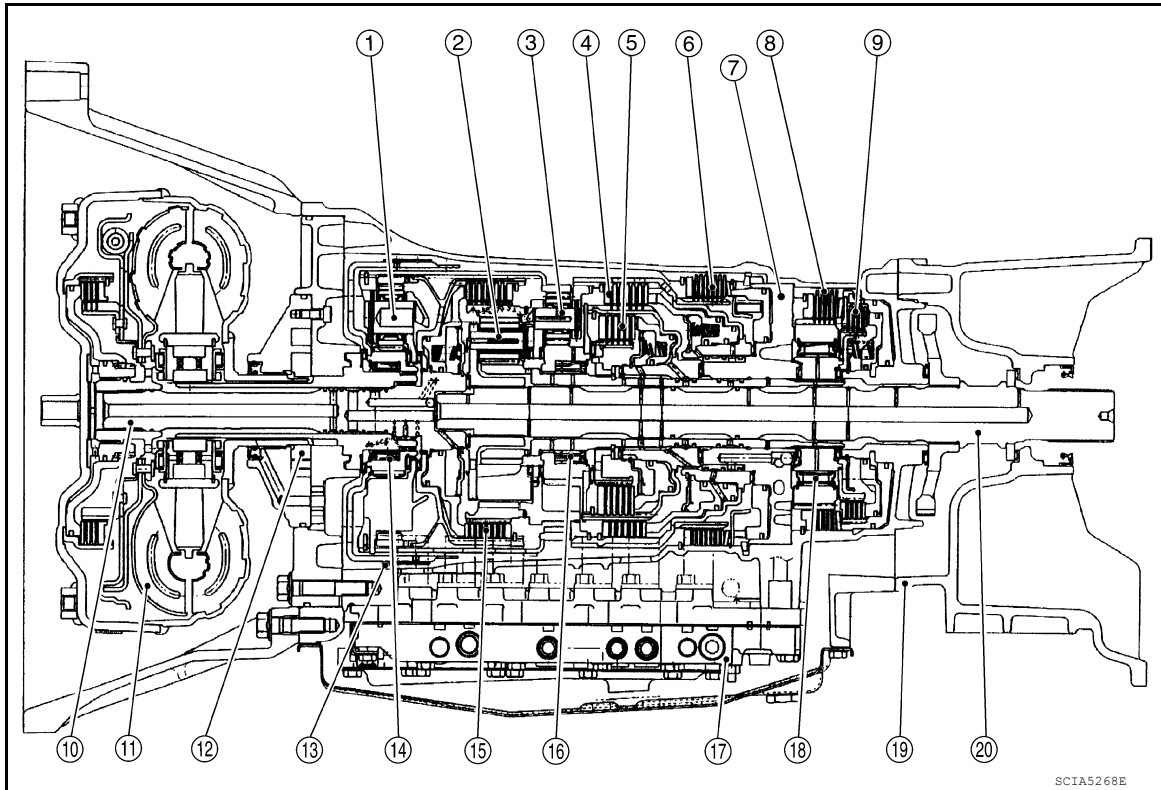

- | | | |
|-------------------------|--------------------------------|----------------------------|
| 1. Front planetary gear | 2. Mid planetary gear | 3. Rear planetary gear |
| 4. Direct clutch | 5. High and low reverse clutch | 6. Reverse brake |
| 7. Drum support | 8. Forward brake | 9. Low coast brake |
| 10. Input shaft | 11. Torque converter | 12. Oil pump |
| 13. Front brake | 14. 3rd one-way clutch | 15. Input clutch |
| 16. 1st one-way clutch | 17. Control valve with TCM | 18. Forward one-way clutch |
| 19. Adapter case | 20. Output shaft | |

Shift Mechanism

INFOID:000000008790801

The automatic transmission uses compact triple planetary gear systems to improve power-transmission efficiency, simplify construction and reduce weight.

It also employs an optimum shift control and super wide gear ratios. They improve starting performance and acceleration during medium and high-speed operation.

CONSTRUCTION

A/T CONTROL SYSTEM

< SYSTEM DESCRIPTION >

[5AT: RE5R05A]

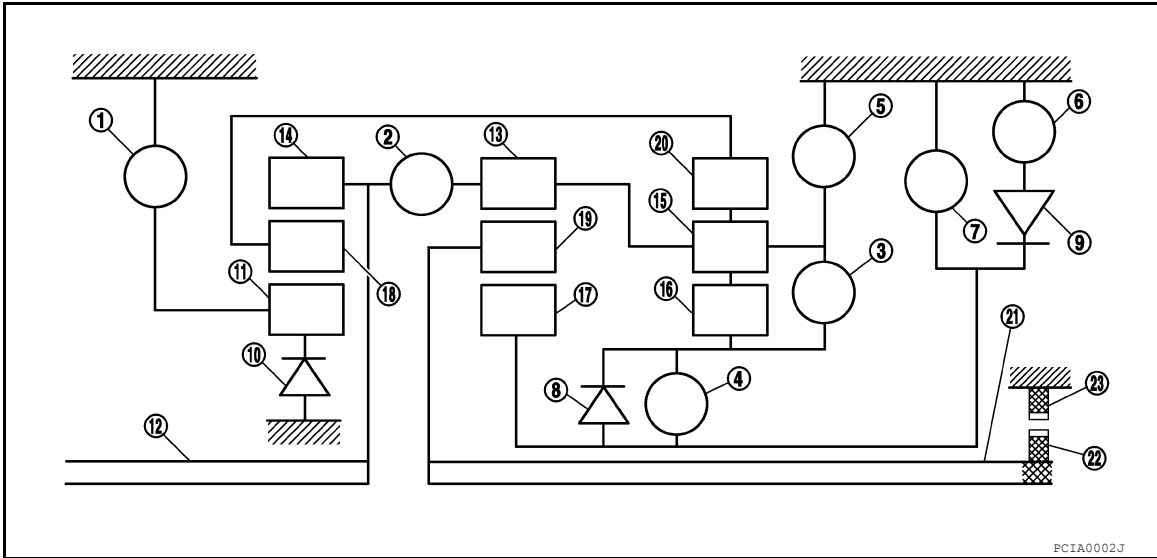

- | | | |
|--------------------------------|-------------------------|---------------------------|
| 1. Front brake | 2. Input clutch | 3. Direct clutch |
| 4. High and low reverse clutch | 5. Reverse brake | 6. Forward brake |
| 7. Low coast brake | 8. 1st one-way clutch | 9. Forward one-way clutch |
| 10. 3rd one-way clutch | 11. Front sun gear | 12. Input shaft |
| 13. Mid internal gear | 14. Front internal gear | 15. Rear carrier |
| 16. Rear sun gear | 17. Mid sun gear | 18. Front carrier |
| 19. Mid carrier | 20. Rear internal gear | 21. Output shaft |
| 22. Parking gear | 23. Parking pawl | |

FUNCTION OF CLUTCH AND BRAKE

Name of the Part	Abbreviation	Function
Front brake (1)	FR/B	Fastens the front sun gear (11).
Input clutch (2)	I/C	Connects the input shaft (12), the front internal gear (14) and the mid internal gear (13).
Direct clutch (3)	D/C	Connects the rear carrier (15) and the rear sun gear (16).
High and low reverse clutch (4)	HLR/C	Connects the mid sun gear (17) and the rear sun gear (16).
Reverse brake (5)	R/B	Fastens the rear carrier (15).
Forward brake (6)	Fwd/B	Fastens the mid sun gear (17).
Low coast brake (7)	LC/B	Fastens the mid sun gear (17).
1st one-way clutch (8)	1st WOC	Allows the rear sun gear (16) to turn freely forward relative to the mid sun gear (17) but fastens it for reverse rotation.
Forward one-way clutch (9)	Fwd OWC	Allows the mid sun gear (17) to turn freely in the forward direction but fastens it for reverse rotation.
3rd one-way clutch (10)	3rd OWC	Allows the front sun gear (11) to turn freely in the forward direction but fastens it for reverse rotation.

CLUTCH AND BAND CHART

Shift position	I/C	HLR/C	D/C	R/B	FR/B	LC/B	Fwd/B	1st OWC	Fwd OWC	3rd OWC	Remarks
P		△			△						PARK POSITION
R		○		○	○			☆		☆	REVERSE POSITION

A/T CONTROL SYSTEM

< SYSTEM DESCRIPTION >

[5AT: RE5R05A]

Shift position	I/C	HLR/C	D/C	R/B	FR/B	LC/B	Fwd/B	1st OWC	Fwd OWC	3rd OWC	Remarks
N		△			△						NEUTRAL POSITION
D*1	1st	△*			△	△**	○	☆	☆	☆	Automatic shift 1↔2↔3↔4↔5
	2nd		○		△		○		☆	☆	
	3rd	○	○		○		△	★		☆	
	4th	○	○	○			△	★			
	5th	○	○		○		△	★		★	
3	1st	△*			△	△**	○	☆	☆	☆	Automatic shift 1↔2↔3↔4
	2nd		○		△		○		☆	☆	
	3rd	○	○		○		△	★		☆	
	4th	○	○	○			△	★			
2	1st	△*			△	△**	○	☆	☆	☆	Automatic shift 1↔2↔3↔4
	2nd		○		○	○	○		☆	☆	
	3rd	○	○	○			△	★		☆	
	4th	○	○	○			△	★			
1	1st	○			○	○	○	☆	☆	☆	Locks (held stationary in 1GR) 1↔2↔3↔4
	2nd		○		○	○	○		☆	☆	
	3rd	○	○	○			△	★		☆	
	4th	○	○	○			△	★			

- ○—Operates
- ☆—Operates during “progressive” acceleration.
- ★—Operates and effects power transmission while coasting.
- △—Line pressure is applied but does not affect power transmission.
- △*—Operates under conditions shown in HLR/C Operating Condition
- △**—Operates under conditions shown in LC/B Operating Condition. Delay control is applied during D (4,3,2,1) ⇒N shift.
- *1: A/T will not shift to 5th when overdrive control switch is set in “OFF” position.

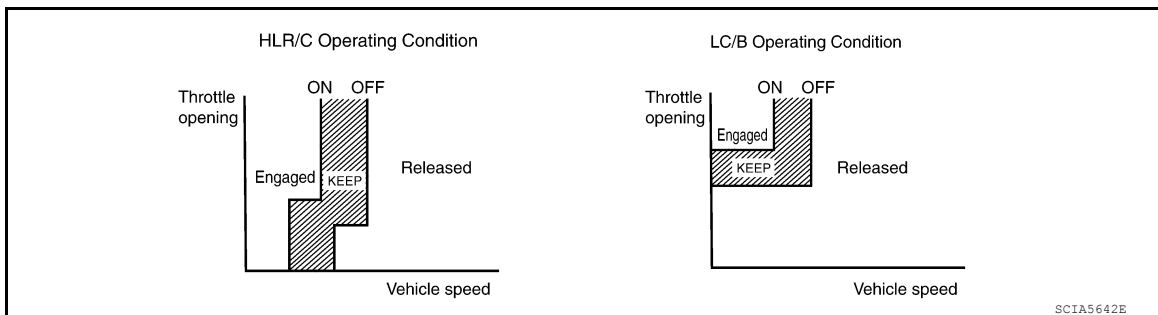

POWER TRANSMISSION

“N” Position

Since both the forward brake and the reverse brake are released, torque from the input shaft drive is not transmitted to the output shaft.

“P” Position

- The same as for the “N” position, both the forward brake and the reverse brake are released, so torque from the input shaft drive is not transmitted to the output shaft.

A/T CONTROL SYSTEM

< SYSTEM DESCRIPTION >

[5AT: RE5R05A]

- The parking pawl linked with the select lever meshes with the parking gear and fastens the output shaft mechanically.

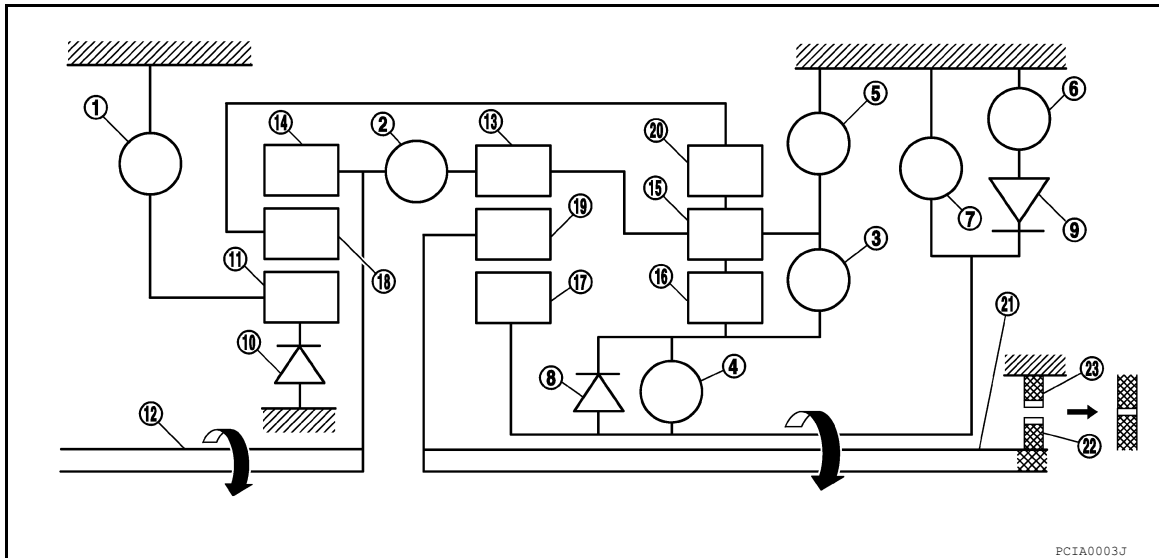

- | | | |
|--------------------------------|-------------------------|---------------------------|
| 1. Front brake | 2. Input clutch | 3. Direct clutch |
| 4. High and low reverse clutch | 5. Reverse brake | 6. Forward brake |
| 7. Low coast brake | 8. 1st one-way clutch | 9. Forward one-way clutch |
| 10. 3rd one-way clutch | 11. Front sun gear | 12. Input shaft |
| 13. Mid internal gear | 14. Front internal gear | 15. Rear carrier |
| 16. Rear sun gear | 17. Mid sun gear | 18. Front carrier |
| 19. Mid carrier | 20. Rear internal gear | 21. Output shaft |
| 22. Parking gear | 23. Parking pawl | |

"D1", "31" and "21" Positions

- The forward brake and the forward one-way clutch regulate reverse rotation of the mid sun gear.
- The 1st one-way clutch regulates reverse rotation of the rear sun gear.
- The 3rd one-way clutch regulates reverse rotation of the front sun gear.
- During deceleration, the mid sun gear turns forward, so the forward one-way clutch idles and the engine brake is not activated.

A/T CONTROL SYSTEM

< SYSTEM DESCRIPTION >

[5AT: RE5R05A]

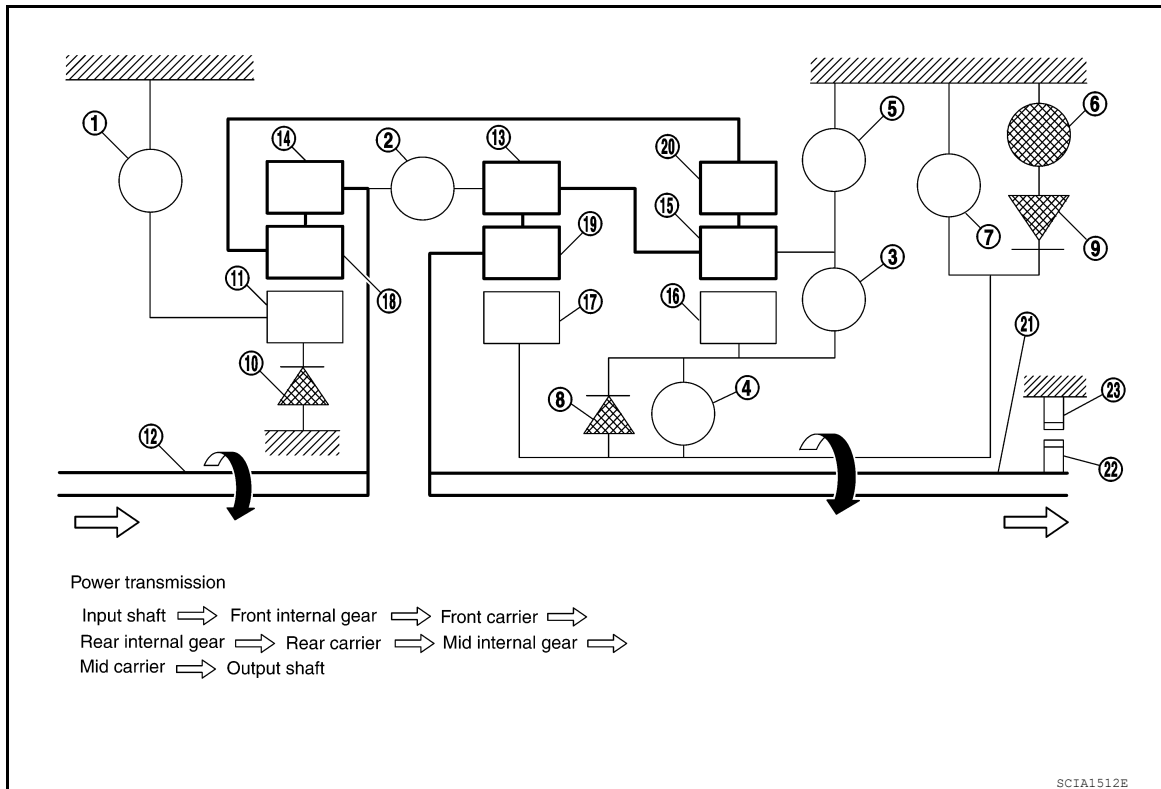

- | | | |
|--------------------------------|-------------------------|---------------------------|
| 1. Front brake | 2. Input clutch | 3. Direct clutch |
| 4. High and low reverse clutch | 5. Reverse brake | 6. Forward brake |
| 7. Low coast brake | 8. 1st one-way clutch | 9. Forward one-way clutch |
| 10. 3rd one-way clutch | 11. Front sun gear | 12. Input shaft |
| 13. Mid internal gear | 14. Front internal gear | 15. Rear carrier |
| 16. Rear sun gear | 17. Mid sun gear | 18. Front carrier |
| 19. Mid carrier | 20. Rear internal gear | 21. Output shaft |
| 22. Parking gear | 23. Parking pawl | |

"11" Position

- The front brake fastens the front sun gear.
- The forward brake and the forward one-way clutch regulate reverse rotation of the mid sun gear.
- High and low reverse clutch connects the rear sun gear and the mid sun gear.
- The low coast brake fastens the mid sun gear.
- During deceleration, the low coast brake regulates forward rotation of the mid sun gear and the engine brake functions.

A/T CONTROL SYSTEM

< SYSTEM DESCRIPTION >

[5AT: RE5R05A]

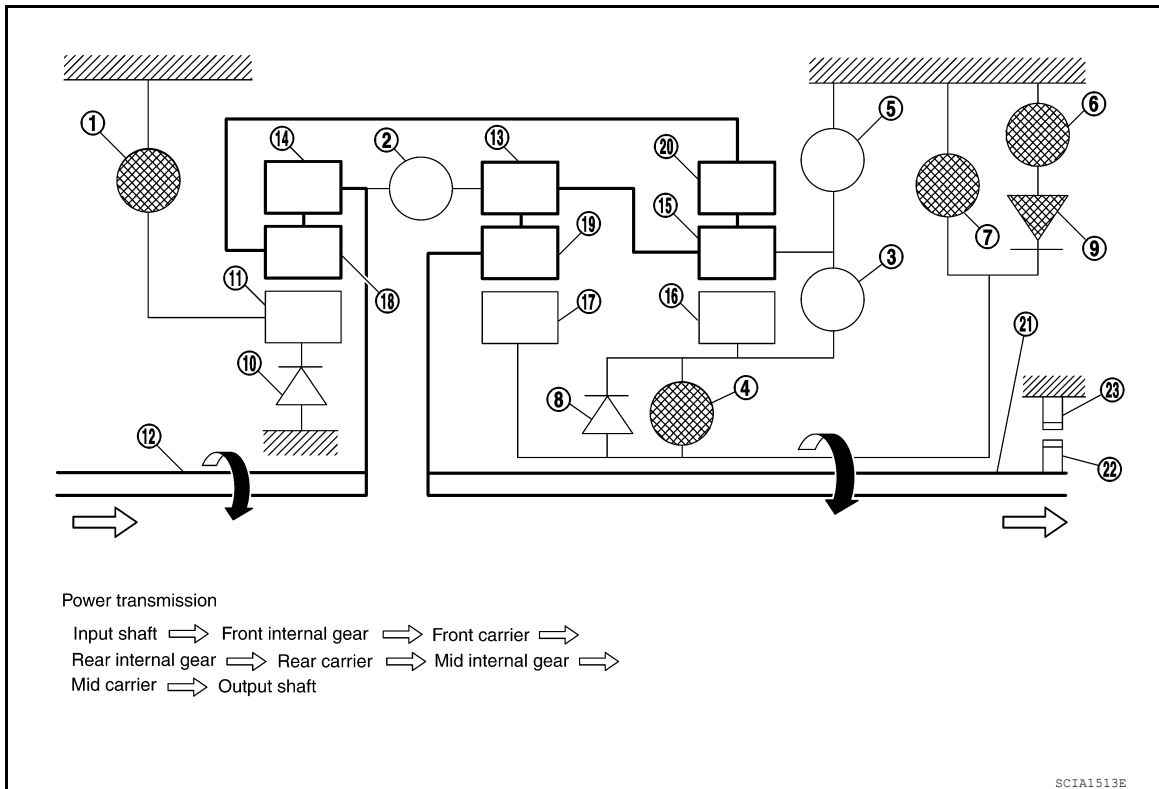

- | | | |
|--------------------------------|-------------------------|---------------------------|
| 1. Front brake | 2. Input clutch | 3. Direct clutch |
| 4. High and low reverse clutch | 5. Reverse brake | 6. Forward brake |
| 7. Low coast brake | 8. 1st one-way clutch | 9. Forward one-way clutch |
| 10. 3rd one-way clutch | 11. Front sun gear | 12. Input shaft |
| 13. Mid internal gear | 14. Front internal gear | 15. Rear carrier |
| 16. Rear sun gear | 17. Mid sun gear | 18. Front carrier |
| 19. Mid carrier | 20. Rear internal gear | 21. Output shaft |
| 22. Parking gear | 23. Parking pawl | |

"D2" and "32" Positions

- The forward brake and the forward one-way clutch regulate reverse rotation of the mid sun gear.
- The 3rd one-way clutch regulates reverse rotation of the front sun gear.
- The direct clutch is coupled and the rear carrier and rear sun gear are connected.
- During deceleration, the mid sun gear turns forward, so the forward one-way clutch idles and engine brake is not activated.

A/T CONTROL SYSTEM

< SYSTEM DESCRIPTION >

[5AT: RE5R05A]

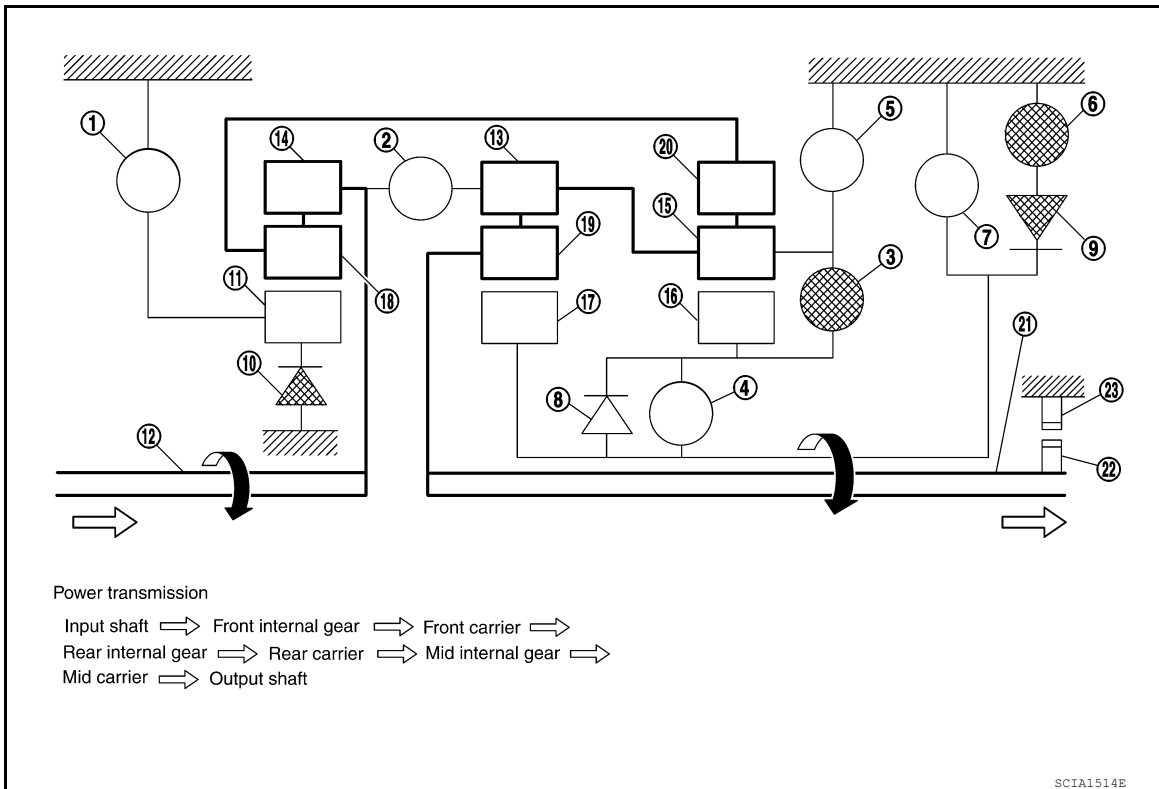

- | | | |
|--------------------------------|-------------------------|---------------------------|
| 1. Front brake | 2. Input clutch | 3. Direct clutch |
| 4. High and low reverse clutch | 5. Reverse brake | 6. Forward brake |
| 7. Low coast brake | 8. 1st one-way clutch | 9. Forward one-way clutch |
| 10. 3rd one-way clutch | 11. Front sun gear | 12. Input shaft |
| 13. Mid internal gear | 14. Front internal gear | 15. Rear carrier |
| 16. Rear sun gear | 17. Mid sun gear | 18. Front carrier |
| 19. Mid carrier | 20. Rear internal gear | 21. Output shaft |
| 22. Parking gear | 23. Parking pawl | |

"22" and "12" Positions

- The front brake fastens the front sun gear.
- The forward brake and the forward one-way clutch regulate reverse rotation of the mid sun gear.
- The direct clutch is coupled, and the rear carrier and rear sun gear are connected.
- The low coast brake fastens the mid sun gear.
- During deceleration, the low coast brake regulates forward rotation of the mid sun gear and the engine brake functions.

A/T CONTROL SYSTEM

< SYSTEM DESCRIPTION >

[5AT: RE5R05A]

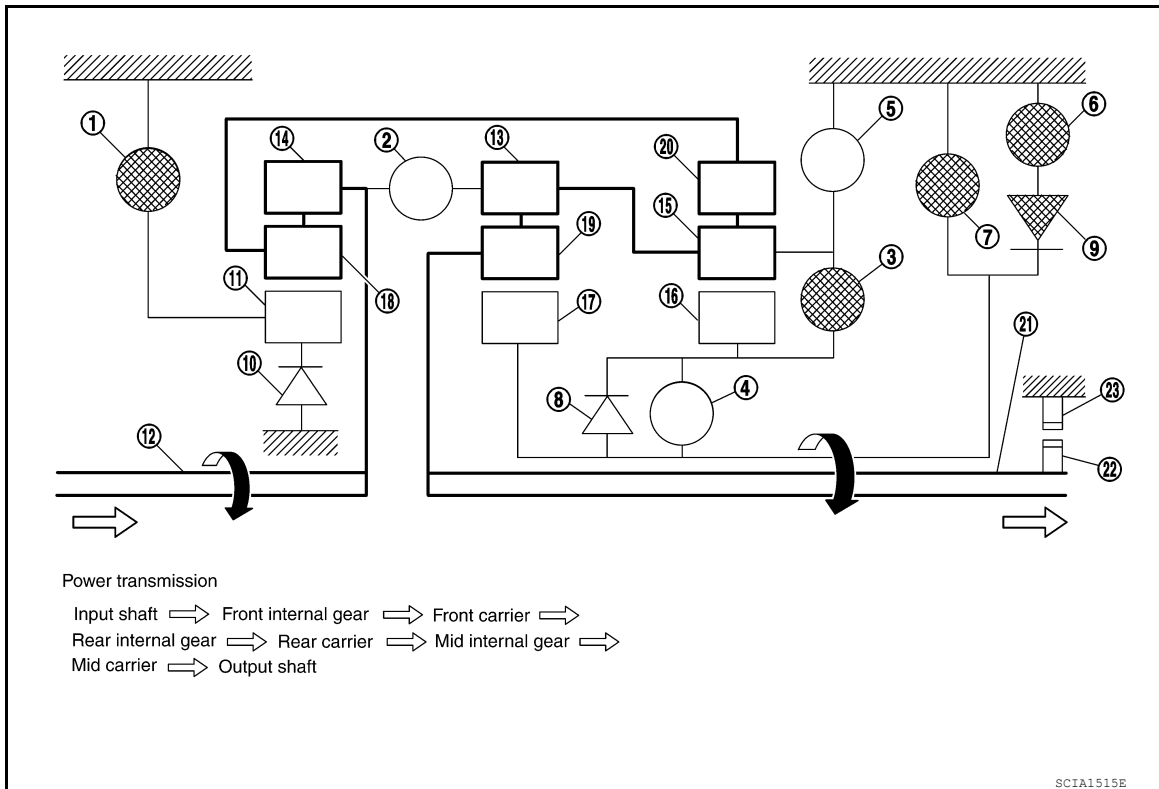

- | | | |
|--------------------------------|-------------------------|---------------------------|
| 1. Front brake | 2. Input clutch | 3. Direct clutch |
| 4. High and low reverse clutch | 5. Reverse brake | 6. Forward brake |
| 7. Low coast brake | 8. 1st one-way clutch | 9. Forward one-way clutch |
| 10. 3rd one-way clutch | 11. Front sun gear | 12. Input shaft |
| 13. Mid internal gear | 14. Front internal gear | 15. Rear carrier |
| 16. Rear sun gear | 17. Mid sun gear | 18. Front carrier |
| 19. Mid carrier | 20. Rear internal gear | 21. Output shaft |
| 22. Parking gear | 23. Parking pawl | |

"D3" and "33" Positions

- The front brake fastens the front sun gear.
- The direct clutch is coupled, and the rear carrier and rear sun gear are connected.
- The high and low reverse clutch is coupled and the mid sun gear and rear sun gear are connected.

A/T CONTROL SYSTEM

< SYSTEM DESCRIPTION >

[5AT: RE5R05A]

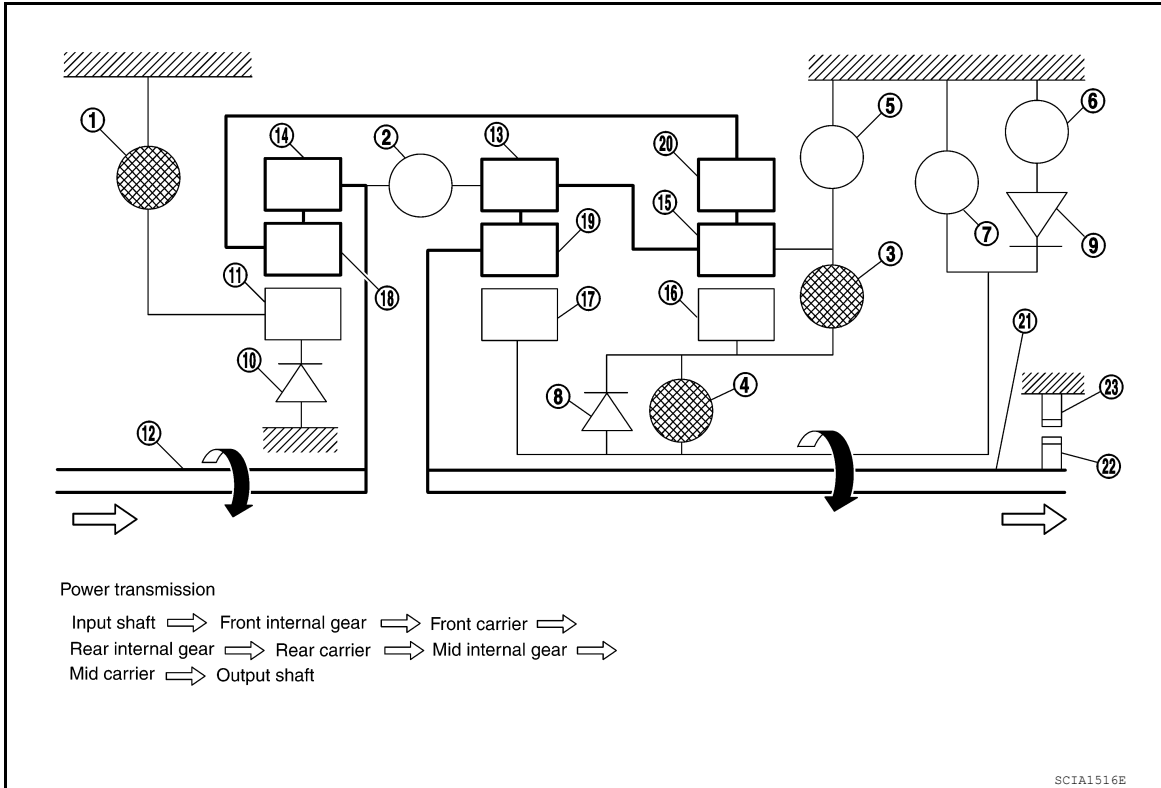

- | | | |
|--------------------------------|-------------------------|---------------------------|
| 1. Front brake | 2. Input clutch | 3. Direct clutch |
| 4. High and low reverse clutch | 5. Reverse brake | 6. Forward brake |
| 7. Low coast brake | 8. 1st one-way clutch | 9. Forward one-way clutch |
| 10. 3rd one-way clutch | 11. Front sun gear | 12. Input shaft |
| 13. Mid internal gear | 14. Front internal gear | 15. Rear carrier |
| 16. Rear sun gear | 17. Mid sun gear | 18. Front carrier |
| 19. Mid carrier | 20. Rear internal gear | 21. Output shaft |
| 22. Parking gear | 23. Parking pawl | |

"D4" Position

- The direct clutch is coupled, and the rear carrier and rear sun gear are connected.
- The high and low reverse clutch is coupled and the mid sun gear and rear sun gear are connected.
- The input clutch is coupled and the front internal gear and mid internal gear are connected.
- The drive power is conveyed to the front internal gear, mid internal gear, and rear carrier and the three planetary gears rotate forward as one unit.

A/T CONTROL SYSTEM

< SYSTEM DESCRIPTION >

[5AT: RE5R05A]

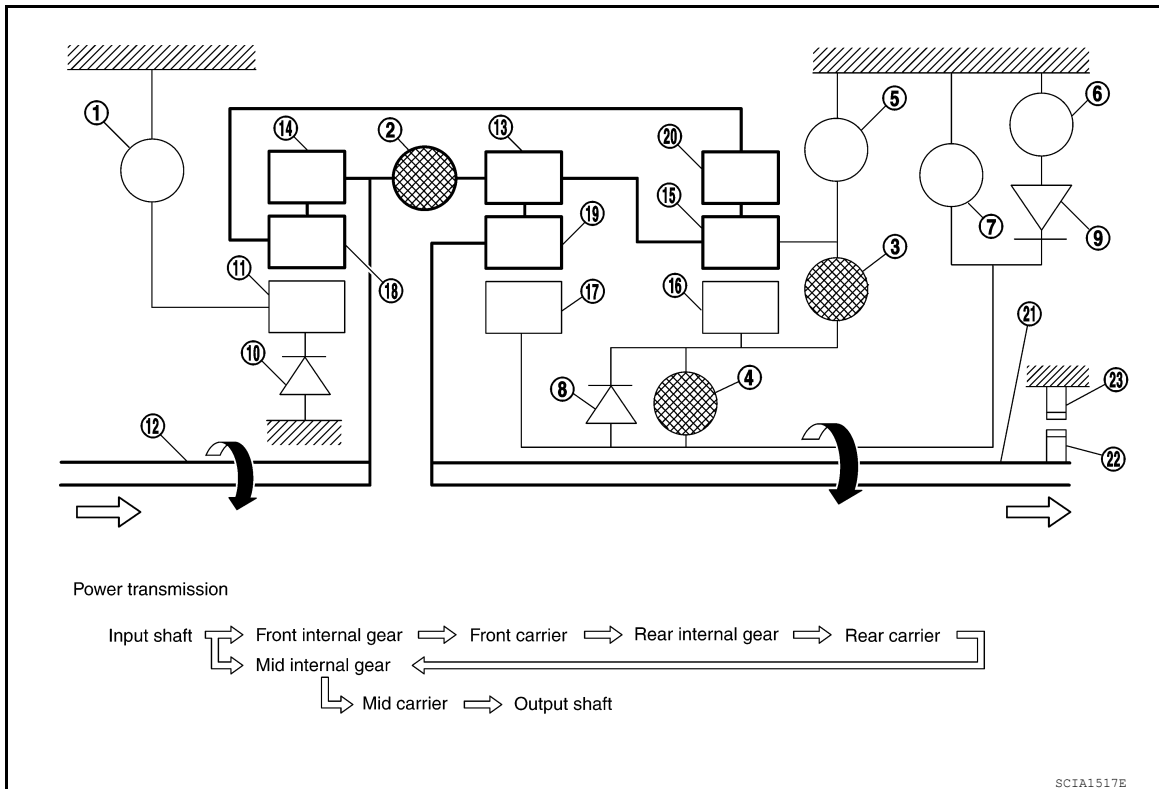

- | | | |
|--------------------------------|-------------------------|---------------------------|
| 1. Front brake | 2. Input clutch | 3. Direct clutch |
| 4. High and low reverse clutch | 5. Reverse brake | 6. Forward brake |
| 7. Low coast brake | 8. 1st one-way clutch | 9. Forward one-way clutch |
| 10. 3rd one-way clutch | 11. Front sun gear | 12. Input shaft |
| 13. Mid internal gear | 14. Front internal gear | 15. Rear carrier |
| 16. Rear sun gear | 17. Mid sun gear | 18. Front carrier |
| 19. Mid carrier | 20. Rear internal gear | 21. Output shaft |
| 22. Parking gear | 23. Parking pawl | |

"D5" Position

- The front brake fastens the front sun gear.
- The input clutch is coupled and the front internal gear and mid internal gear are connected.
- The high and low reverse clutch is coupled and the mid sun gear and rear sun gear are connected.

A/T CONTROL SYSTEM

< SYSTEM DESCRIPTION >

[5AT: RE5R05A]

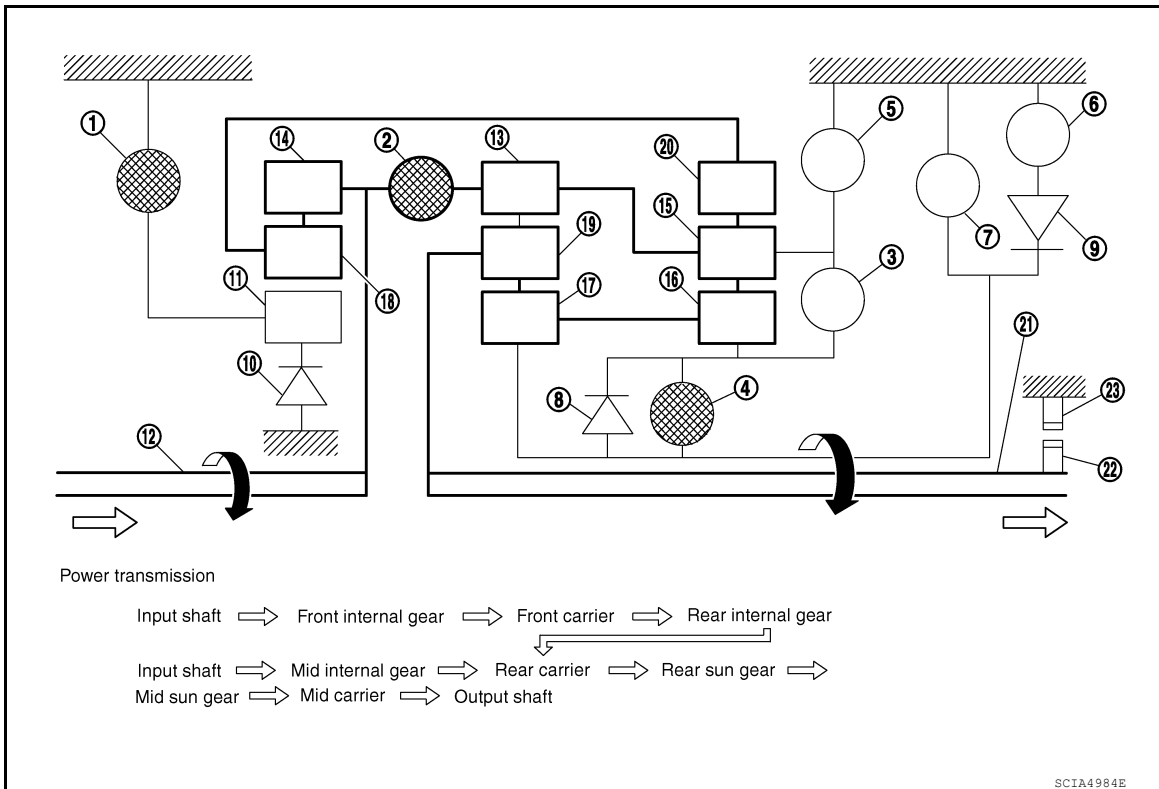

- | | | |
|--------------------------------|-------------------------|---------------------------|
| 1. Front brake | 2. Input clutch | 3. Direct clutch |
| 4. High and low reverse clutch | 5. Reverse brake | 6. Forward brake |
| 7. Low coast brake | 8. 1st one-way clutch | 9. Forward one-way clutch |
| 10. 3rd one-way clutch | 11. Front sun gear | 12. Input shaft |
| 13. Mid internal gear | 14. Front internal gear | 15. Rear carrier |
| 16. Rear sun gear | 17. Mid sun gear | 18. Front carrier |
| 19. Mid carrier | 20. Rear internal gear | 21. Output shaft |
| 22. Parking gear | 23. Parking pawl | |

"R" Position

- The front brake fastens the front sun gear.
- The high and low reverse clutch is coupled, and the mid sun gear and rear sun gear are connected.
- The reverse brake fastens the rear carrier.

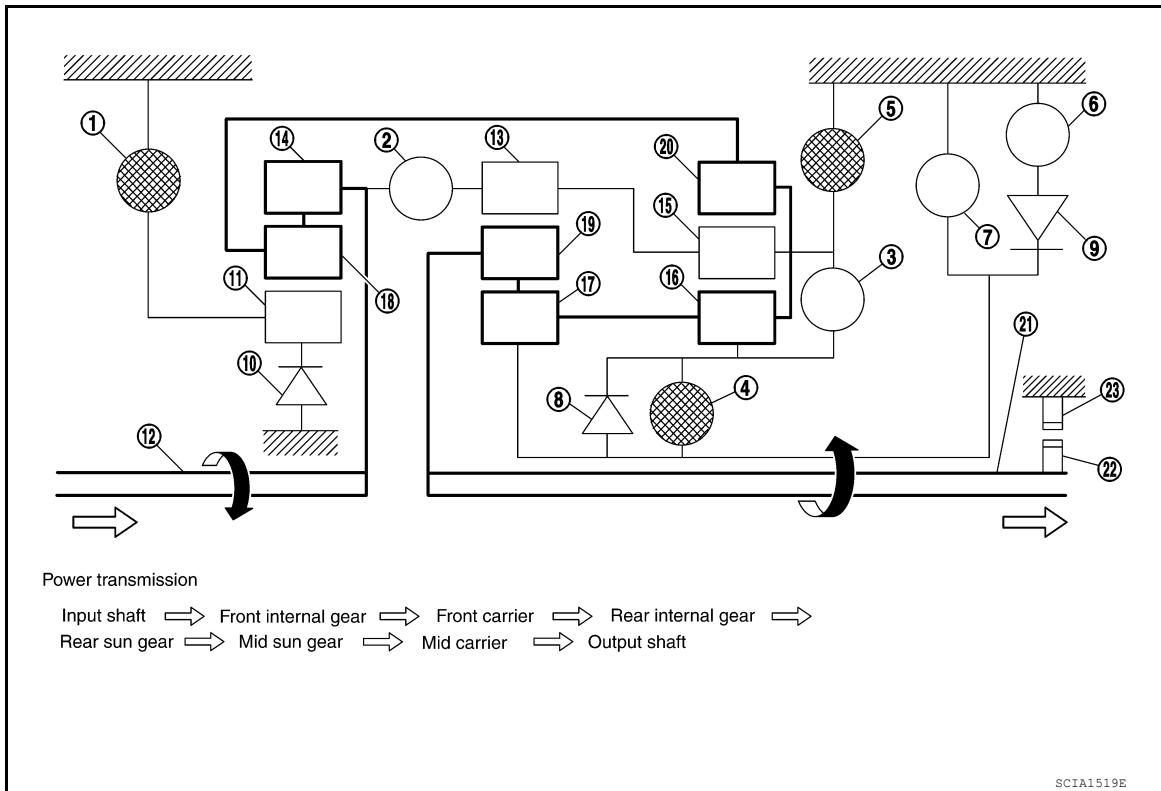

- | | | |
|--------------------------------|-------------------------|---------------------------|
| 1. Front brake | 2. Input clutch | 3. Direct clutch |
| 4. High and low reverse clutch | 5. Reverse brake | 6. Forward brake |
| 7. Low coast brake | 8. 1st one-way clutch | 9. Forward one-way clutch |
| 10. 3rd one-way clutch | 11. Front sun gear | 12. Input shaft |
| 13. Mid internal gear | 14. Front internal gear | 15. Rear carrier |
| 16. Rear sun gear | 17. Mid sun gear | 18. Front carrier |
| 19. Mid carrier | 20. Rear internal gear | 21. Output shaft |
| 22. Parking gear | 23. Parking pawl | |

TCM Function

INFOID:000000008790802

The function of the TCM is to:

- Receive input signals sent from various switches and sensors.
- Determine required line pressure, shifting point, lock-up operation, and engine brake operation.
- Send required output signals to the respective solenoids.

CONTROL SYSTEM OUTLINE

The A/T senses vehicle operating conditions through various sensors or signals. It always controls the optimum shift position and reduces shifting and lock-up shocks.

A/T CONTROL SYSTEM

< SYSTEM DESCRIPTION >

[5AT: RE5R05A]

SENSORS (or SIGNALS)		TCM		ACTUATORS
Transmission range switch Accelerator pedal position sensor Closed throttle position signal Wide open throttle position signal Engine speed signal A/T fluid temperature sensor Output speed sensor Vehicle speed signal Stop lamp switch signal Input speed sensor 1st position switch signal Overdrive control switch signal ATF pressure switch signal	⇒	Shift control Line pressure control Lock-up control Engine brake control Timing control Fail-safe control Self-diagnosis CONSULT communication line Duet-EA control CAN system	⇒	Input clutch solenoid valve Direct clutch solenoid valve Front brake solenoid valve High and low reverse clutch solenoid valve Low coast brake solenoid valve Torque converter clutch solenoid valve Line pressure solenoid valve O/D OFF indicator lamp Starter relay Back-up lamp relay

CONTROL SYSTEM DIAGRAM

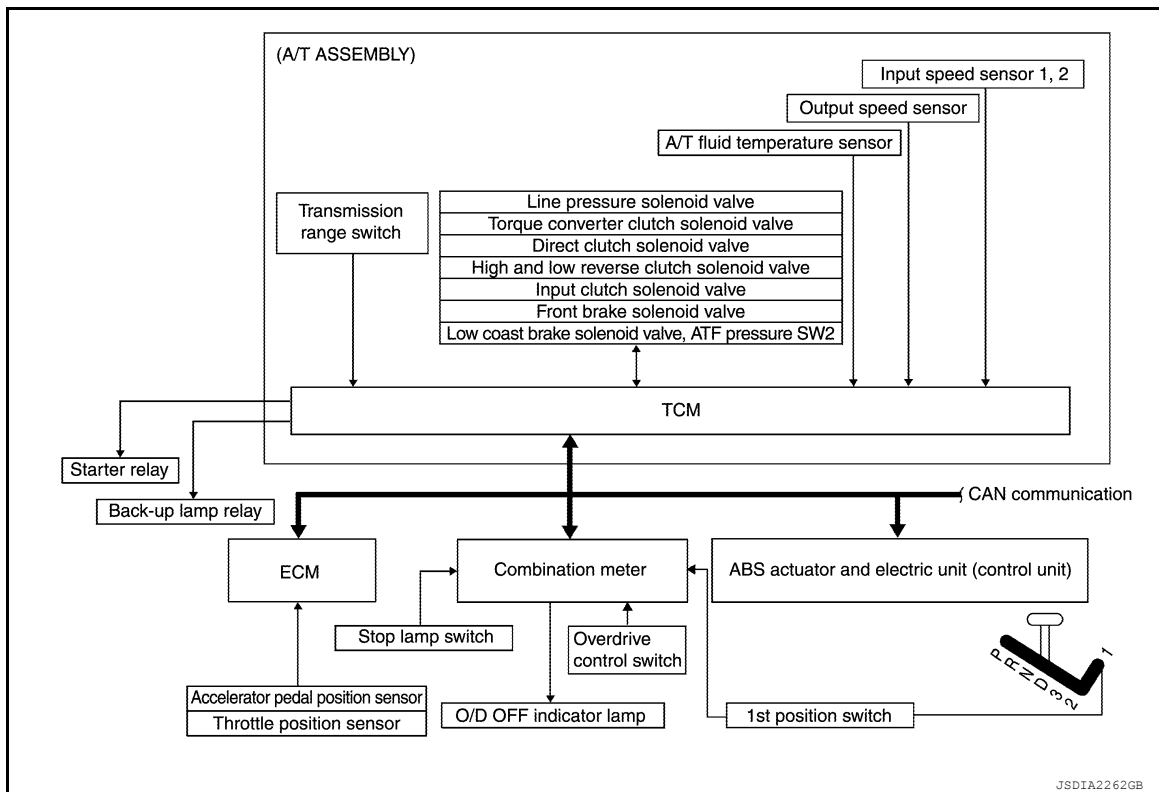

CAN Communication

INFOID:000000008790803

SYSTEM DESCRIPTION

CAN (Controller Area Network) is a serial communication line for real time application. It is an on-vehicle multiplex communication line with high data communication speed and excellent error detection ability. Many electronic control units are equipped onto a vehicle, and each control unit shares information and links with other control units during operation (not independent). In CAN communication, control units are connected with 2 communication lines (CAN H line, CAN L line) allowing a high rate of information transmission with less wiring. Each control unit transmits/receives data but selectively reads required data only. For details, refer to [LAN-57, "CAN System Specification Chart"](#).

A/T CONTROL SYSTEM

< SYSTEM DESCRIPTION >

[5AT: RE5R05A]

Input/Output Signal of TCM

INFOID:000000008790804

Control item		Line pressure control	Vehicle speed control	Shift control	Lock-up control	Engine brake control	Fail-safe function (*3)	Self-diagnostics function
Input	Accelerator pedal position signal (*5)	X	X	X	X	X	X	X
	Output speed sensor	X	X	X	X	X	X	X
	Vehicle speed signal(*1) (*5)						X	
	Closed throttle position signal(*5)		X(*2)	X	X		X	X(*4)
	Wide open throttle position signal(*5)						X	X(*4)
	Input speed sensor 1		X		X	X	X	X
	Input speed sensor 2 (for 4th speed only)		X		X	X	X	X
	Engine speed signals(*5)	X	X	X	X	X	X	X
	Stop lamp switch signal(*5)		X	X	X			X(*4)
	A/T fluid temperature sensor	X	X	X	X		X	X
	ASCD	Operation signal(*5)		X	X	X		
Overdrive cancel signal(*5)			X					
Output	Direct clutch solenoid		X	X			X	X
	Input clutch solenoid		X	X			X	X
	High and low reverse clutch solenoid		X	X			X	X
	Front brake solenoid		X	X			X	X
	Low coast brake solenoid (ATF pressure switch 2)		X	X		X	X	X
	Line pressure solenoid	X	X	X	X	X	X	X
	TCC solenoid				X		X	X
	O/D OFF indicator lamp(*6)							X(*4)
Starter relay						X	X	

*1: Spare for output speed sensor.

*2: Spare for accelerator pedal position signal.

*3: If these input and output signals are different, the TCM triggers the fail-safe function.

*4: Used as a condition for starting self-diagnosis; if self-diagnosis is not started, it is judged that there is some kind of error.

*5: Input by CAN communications.

*6: Output by CAN communications.

Line Pressure Control

INFOID:000000008790805

- When an input torque signal equivalent to the engine drive force is sent from the ECM to the TCM, the TCM controls the line pressure solenoid.

A/T CONTROL SYSTEM

< SYSTEM DESCRIPTION >

[5AT: RE5R05A]

- This line pressure solenoid controls the pressure regulator valve as the signal pressure and adjusts the pressure of the operating oil discharged from the oil pump to the line pressure most appropriate to the driving state.

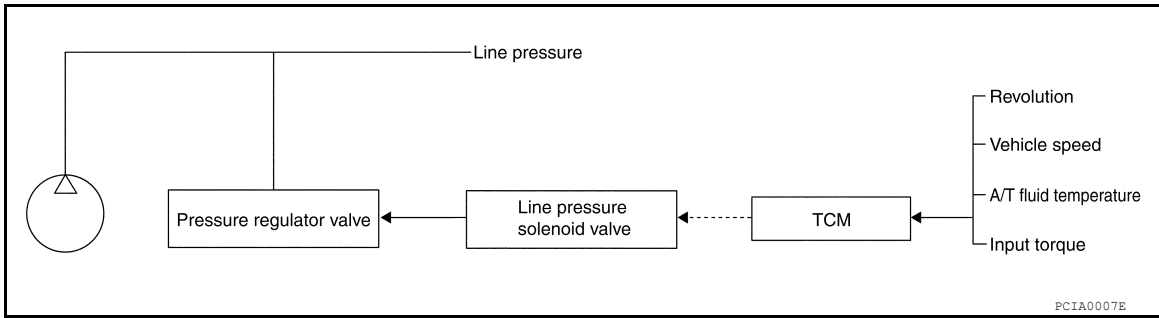

LINE PRESSURE CONTROL IS BASED ON THE TCM LINE PRESSURE CHARACTERISTIC PATTERN

- The TCM has stored in memory a number of patterns for the optimum line pressure characteristic for the driving state.
- In order to obtain the most appropriate line pressure characteristic to meet the current driving state, the TCM controls the line pressure solenoid current value and thus controls the line pressure.

Normal Control

Each clutch is adjusted to the necessary pressure to match the engine drive force.

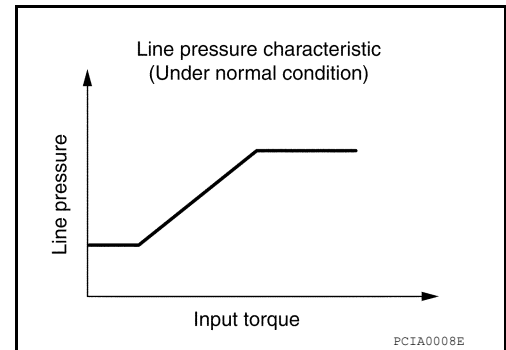

Back-up Control (Engine Brake)

When the select operation is performed during driving and the transmission is shifted down, the line pressure is set according to the vehicle speed.

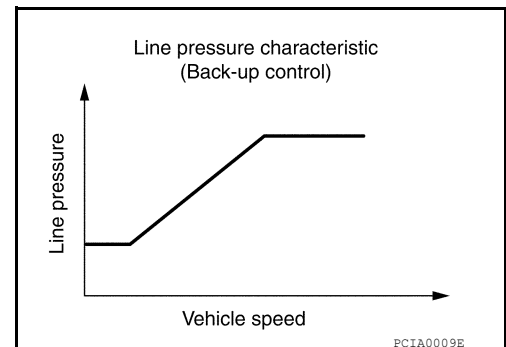

During Shift Change

A/T CONTROL SYSTEM

< SYSTEM DESCRIPTION >

[5AT: RE5R05A]

The necessary and adequate line pressure for shift change is set. For this reason, line pressure pattern setting corresponds to input torque and shift selector selection. Also, line pressure characteristic is set according to engine speed, during engine brake operation.

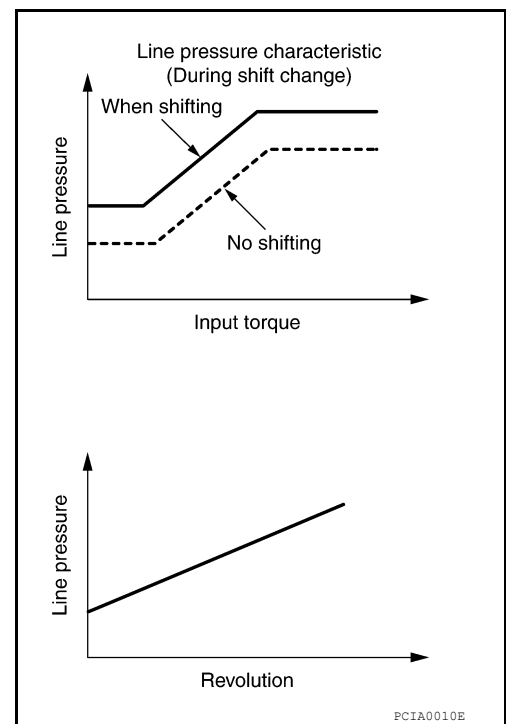

At Low Fluid Temperature

When the A/T fluid temperature drops below the prescribed temperature, in order to speed up the action of each friction element, the line pressure is set higher than the normal line pressure characteristic.

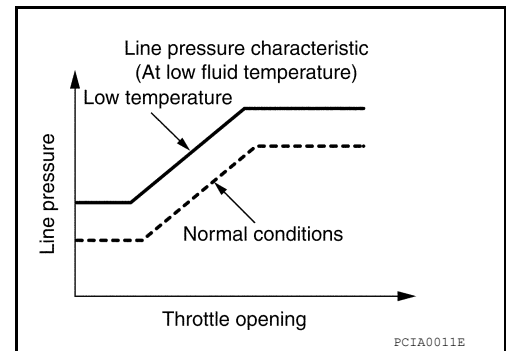

Shift Control

INFOID:000000008790806

The clutch pressure control solenoid is controlled by the signals from the switches and sensors. Thus, the clutch pressure is adjusted to be appropriate to the engine load state and vehicle driving state. It becomes possible to finely control the clutch hydraulic pressure with high precision and a smoother shift change characteristic is attained.

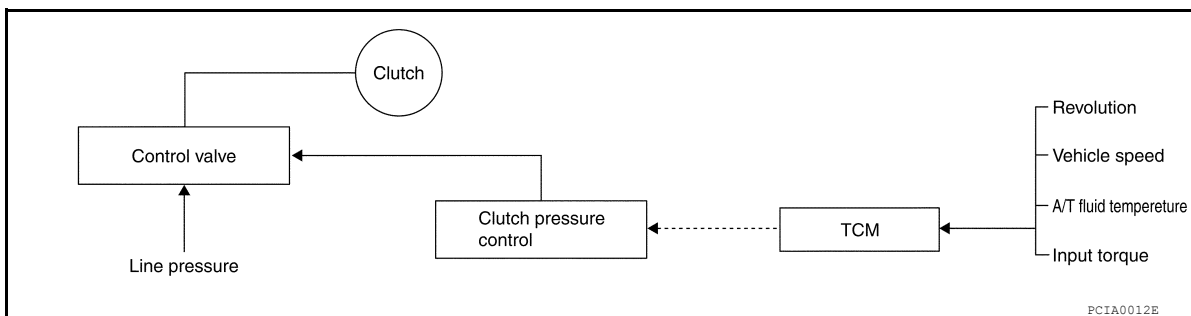

SHIFT CHANGE

The clutch is controlled with the optimum timing and oil pressure by the engine speed, engine torque information, etc.

Shift Change System Diagram

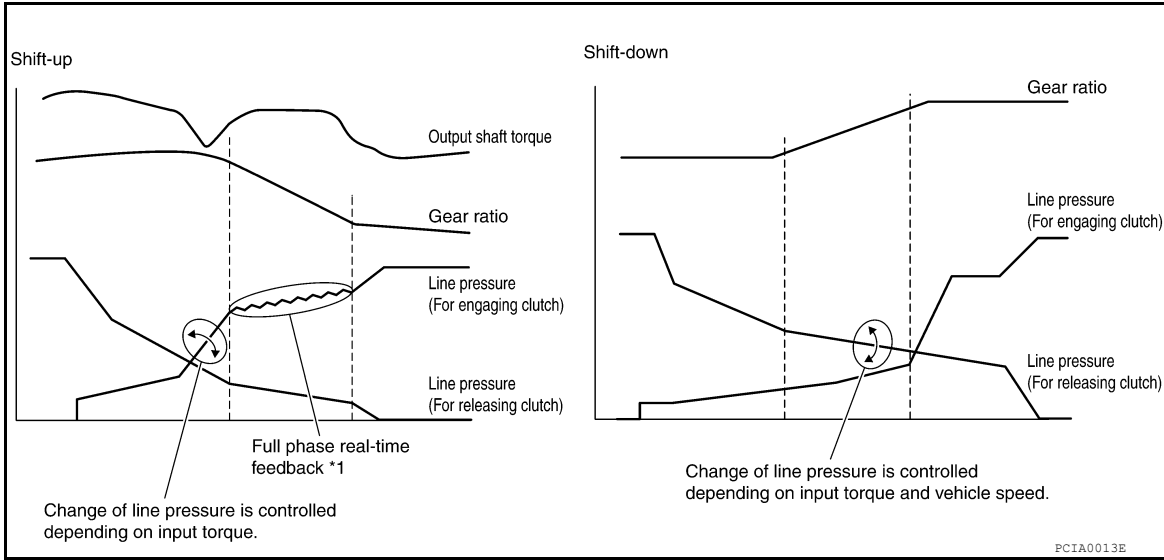

*1: Full phase real-time feedback control monitors movement of gear ratio at gear change, and controls oil pressure at real-time to achieve the best gear ratio.

Lock-up Control

INFOID:000000008790807

The torque converter clutch piston in the torque converter is engaged to eliminate torque converter slip to increase power transmission efficiency.

The torque converter clutch control valve operation is controlled by the torque converter clutch solenoid valve, which is controlled by a signal from TCM, and the torque converter clutch control valve engages or releases the torque converter clutch piston.

Lock-up Operation Condition Table (QR25DE Models)

Select lever	D position			3 position	2 position
Gear position	5	4	3	3	2
Lock-up	×	—	—	—	—
Slip lock-up	—	—	—	—	—

Lock-up Operation Condition Table (VQ40DE Models)

Select lever	D position			3 position	2 position
Gear position	5	4	3	3	2
Lock-up	×	×	—	—	—
Slip lock-up	—	—	×	—	—

TORQUE CONVERTER CLUTCH CONTROL VALVE CONTROL

Lock-up Control System Diagram

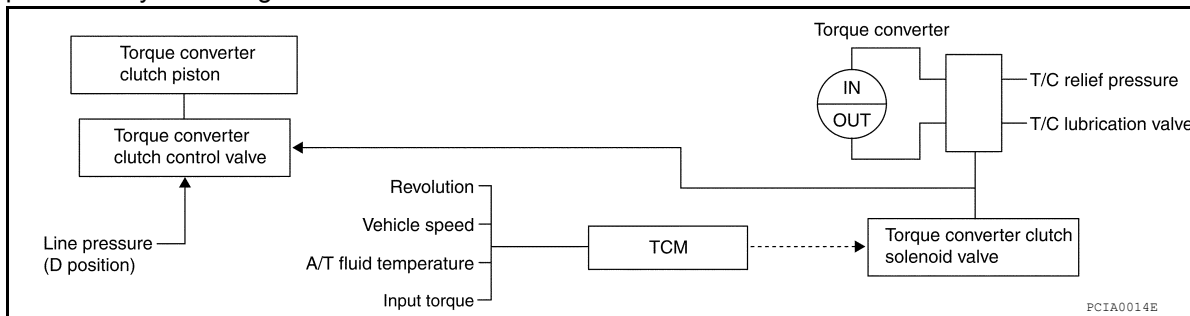

Lock-up Released

- In the lock-up released state, the torque converter clutch control valve is set into the unlocked state by the torque converter clutch solenoid and the lock-up apply pressure is drained. In this way, the torque converter clutch piston is not coupled.

Lock-up Applied

- In the lock-up applied state, the torque converter clutch control valve is set into the locked state by the torque converter clutch solenoid and lock-up apply pressure is generated. In this way, the torque converter clutch piston is pressed and coupled.

SMOOTH LOCK-UP CONTROL

When shifting from the lock-up released state to the lock-up applied state, the current output to the torque converter clutch solenoid is controlled with the TCM. In this way, when shifting to the lock-up applied state, the torque converter clutch is temporarily set to the half-clutched state to reduce the shock.

Half-clutched State

- The current output from the TCM to the torque converter clutch solenoid is varied to gradually increase the torque converter clutch solenoid pressure. In this way, the lock-up apply pressure gradually rises and while the torque converter clutch piston is put into half-clutched status, the torque converter clutch piston operating pressure is increased and the coupling is completed smoothly.

Slip Lock-up Control

- In the slip region, the torque converter clutch solenoid current is controlled with the TCM to put it into the half-clutched state. This absorbs the engine torque fluctuation and lock-up operates from low speed. This raises the fuel efficiency for 4GR and 5GR at both low speed and when the accelerator has a low degree of opening.

Engine Brake Control

INFOID:000000008790808

- The forward one-way clutch transmits the drive force from the engine to the rear wheels. But the reverse drive from the rear wheels is not transmitted to the engine because the one-way clutch is idling. Therefore, the low coast brake solenoid is operated to prevent the forward one-way clutch from idling and the engine brake is operated in the same manner as conventionally.

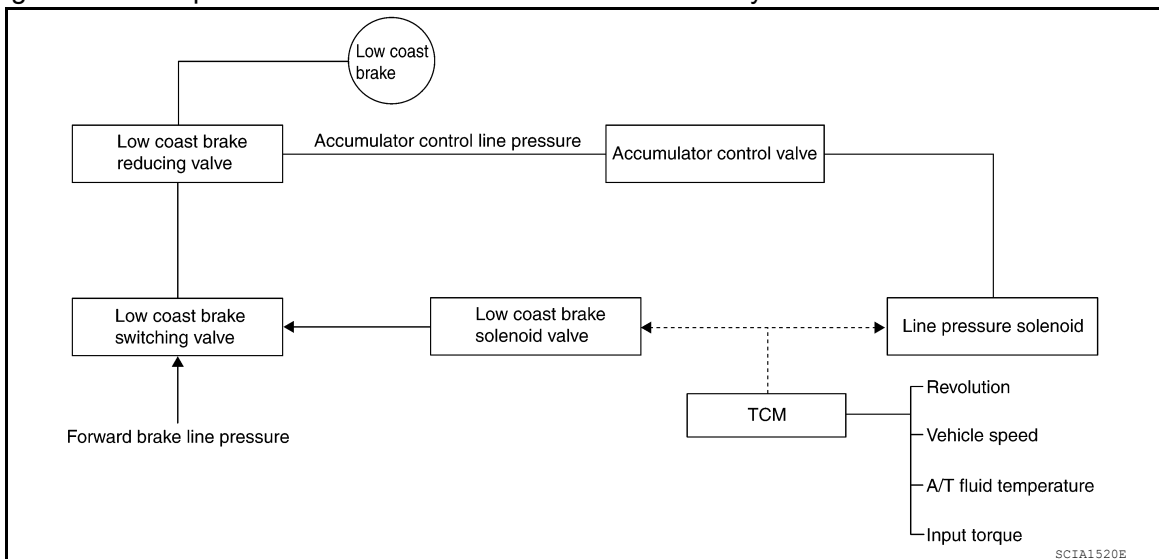

- The operation of the low coast brake solenoid switches the low coast brake switching valve and controls the coupling and releasing of the low coast brake. The low coast brake reducing valve controls the low coast brake coupling force.

Control Valve

INFOID:000000008790809

FUNCTION OF CONTROL VALVE

Name	Function
Torque converter regulator valve	In order to prevent the pressure supplied to the torque converter from being excessive, the line pressure is adjusted to the optimum pressure (torque converter operating pressure).
Pressure regulator valve Pressure regulator plug Pressure regulator sleeve	Adjusts the oil discharged from the oil pump to the optimum pressure (line pressure) for the driving state.

A/T CONTROL SYSTEM

< SYSTEM DESCRIPTION >

[5AT: RE5R05A]

Name	Function
Front brake control valve	When the front brake is coupled, adjusts the line pressure to the optimum pressure (front brake pressure) and supplies it to the front brake. (In 1GR, 2GR, 3GR, and 5GR, adjusts the clutch pressure.)
Accumulator control valve	Adjusts the pressure (accumulator control pressure) acting on the accumulator piston and low coast reducing valve to the pressure appropriate to the driving state.
Pilot valve A	Adjusts the line pressure and produces the constant pressure (pilot pressure) required for line pressure control, shift change control, and lock-up control.
Pilot valve B	Adjusts the line pressure and produces the constant pressure (pilot pressure) required for shift change control.
Low coast brake switching valve	During engine braking, supplies the line pressure to the low coast brake reducing valve.
Low coast brake reducing valve	When the low coast brake is coupled, adjusts the line pressure to the optimum pressure (low coast brake pressure) and supplies it to the low coast brake.
N-R accumulator	Produces the stabilizing pressure for when N-R is selected.
Direct clutch piston switching valve	Operates in 4GR and switches the direct clutch coupling capacity.
High and low reverse clutch control valve	When the high and low reverse clutch is coupled, adjusts the line pressure to the optimum pressure (high and low reverse clutch pressure) and supplies it to the high and low reverse clutch. (In 1GR, 3GR, 4GR and 5GR, adjusts the clutch pressure.)
Input clutch control valve	When the input clutch is coupled, adjusts the line pressure to the optimum pressure (input clutch pressure) and supplies it to the input clutch. (In 4GR and 5GR, adjusts the clutch pressure.)
Direct clutch control valve	When the direct clutch is coupled, adjusts the line pressure to the optimum pressure (direct clutch pressure) and supplies it to the direct clutch. (In 2GR, 3GR, and 4GR, adjusts the clutch pressure.)
TCC control valve TCC control plug TCC control sleeve	Switches the lock-up to operating or released. Also, by performing the lock-up operation transiently, lock-up smoothly.
Torque converter lubrication valve	Operates during lock-up to switch the torque converter, cooling, and lubrication system oil path.
Cool bypass valve	Allows excess oil to bypass cooler circuit without being fed into it.
Line pressure relief valve	Discharges excess oil from line pressure circuit.
N-D accumulator	Produces the stabilizing pressure for when N-D is selected.
Manual valve	Sends line pressure to each circuit according to the select position. The circuits to which the line pressure is not sent drain.

FUNCTION OF PRESSURE SWITCH

Name	Function
Pressure switch 2 (LC/B)	Detects any malfunction in the low coast brake hydraulic pressure. When it detects any malfunction, it puts the system into fail-safe mode.

A/T CONTROL SYSTEM

< SYSTEM DESCRIPTION >

[5AT: RE5R05A]

A/T Electrical Parts Location

INFOID:000000008790810

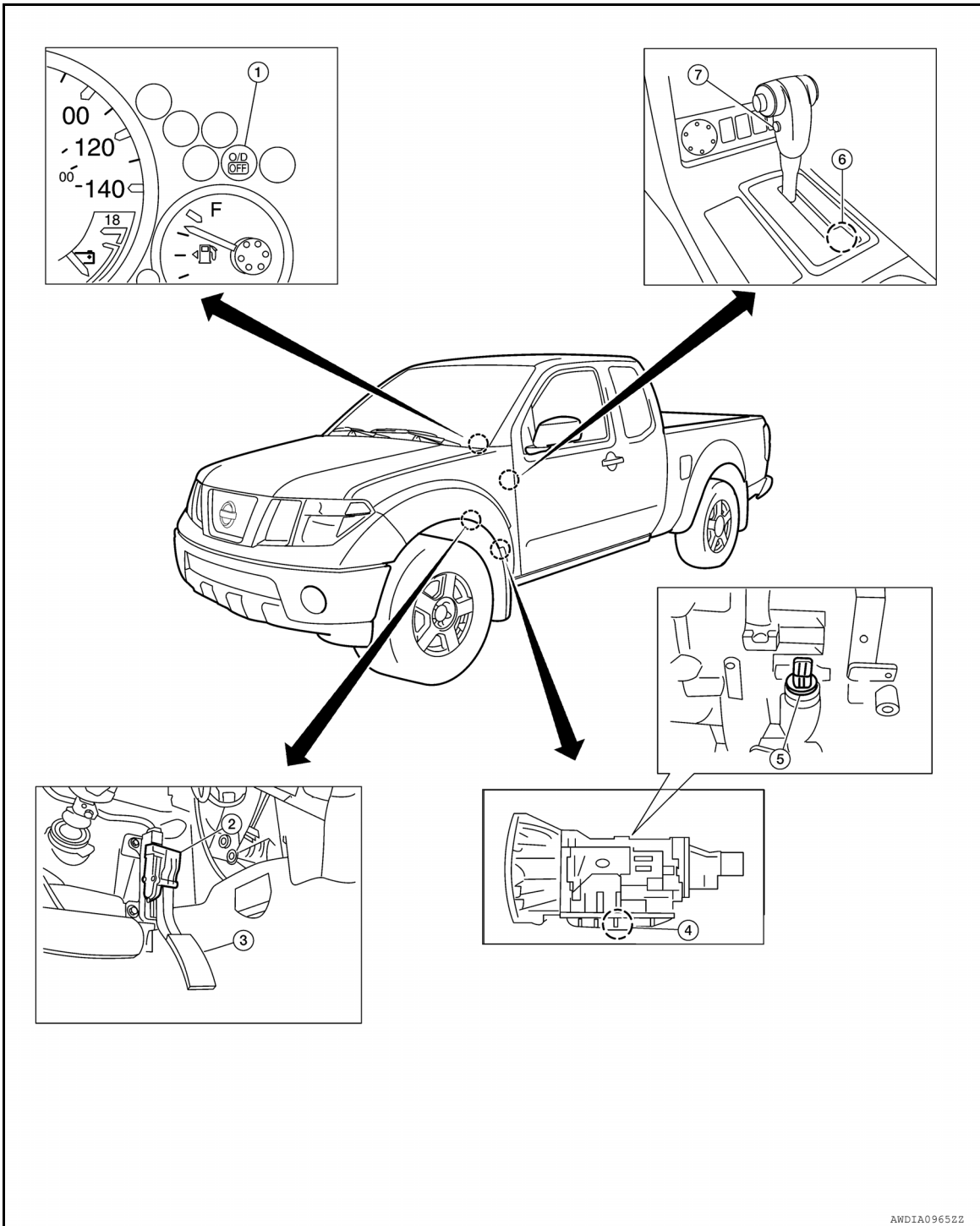

- | | | |
|-----------------------------|--------------------------------------|------------------------|
| 1. O/D OFF indicator lamp | 2. Accelerator pedal position sensor | 3. Accelerator pedal |
| 4. Control valve with TCM*1 | 5. A/T assembly harness connector | 6. 1st position switch |
| 7. Overdrive control switch | | |

*1: The following components are included in the control valve with TCM.

- TCM (transmission control module)
- Input speed sensor 1
- Input speed sensor 2
- Output speed sensor

A
B
C
TM
E
F
G
H
I
J
K
L
M
N
O
P

< SYSTEM DESCRIPTION >

- A/T fluid temperature sensor
- Transmission range switch
- Line pressure solenoid valve
- Torque converter clutch solenoid valve
- Direct clutch solenoid valve
- High and low reverse clutch solenoid valve
- Input clutch solenoid valve
- Front brake solenoid valve
- Low coast brake solenoid valve
- ATF pressure switch 2

A/T SHIFT LOCK SYSTEM

< SYSTEM DESCRIPTION >

[5AT: RE5R05A]

A/T SHIFT LOCK SYSTEM

System Description

INFOID:000000008790811

- The selector lever cannot be shifted from “P” (Park) unless the brake pedal is applied and the ignition switch is in the “ON” position.
- Battery voltage is supplied to the shift lock solenoid by the stop lamp switch.
- Ground is supplied to the shift lock solenoid by the park position switch (shift selector).
- With the the ignition switch “ON”, brake pedal applied and the A/T shift selector in “P” (Park), the shift lock solenoid is energized, allowing the selector lever to be shifted from Park.

Component Parts Location

INFOID:000000008790812

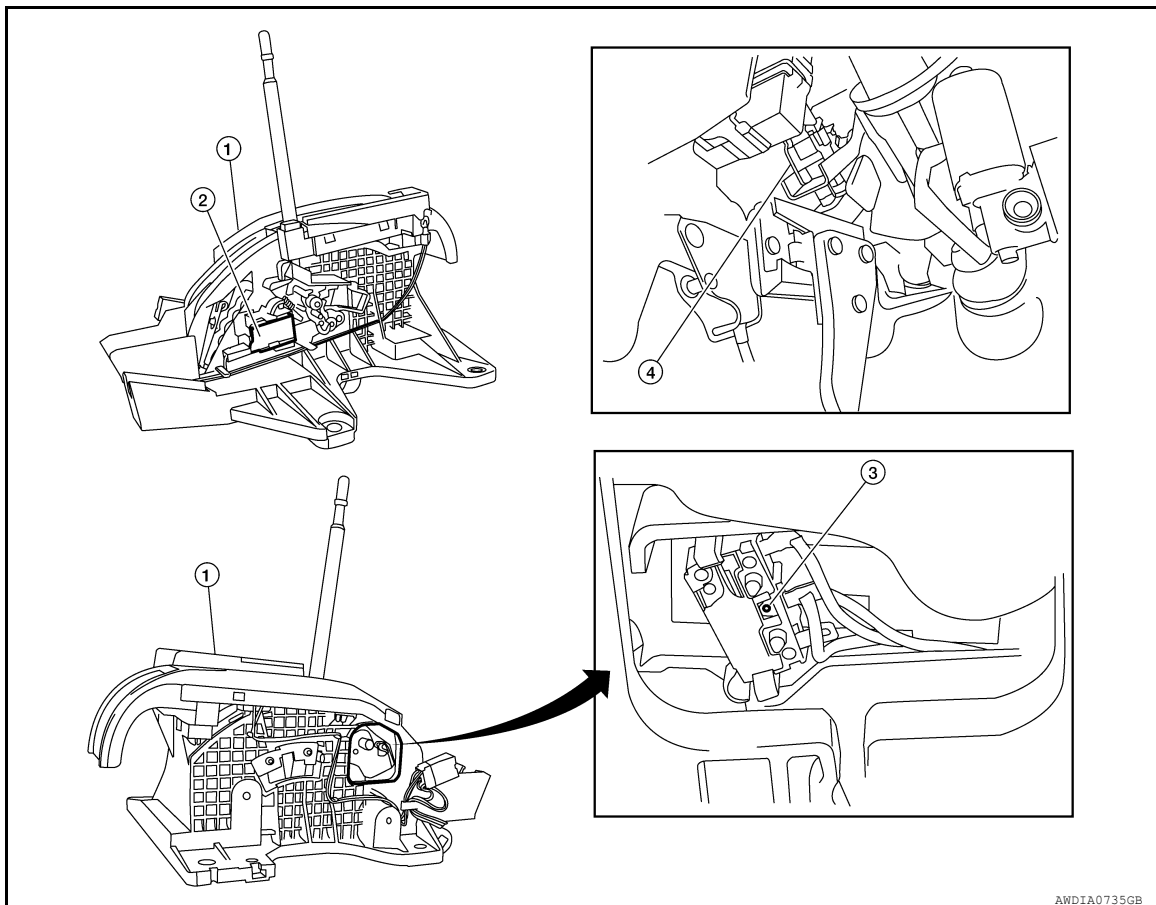

1. A/T shift selector
2. Shift lock solenoid
3. Park position switch (shift selector)
4. Stop lamp switch E39

ON BOARD DIAGNOSTIC (OBD) SYSTEM

Introduction

INFOID:000000008790813

The A/T system has two self-diagnostic systems.

The first is the emission-related on board diagnostic system (OBD-II) performed by the TCM in combination with the ECM. The malfunction is indicated by the MIL (malfunction indicator lamp) and is stored as a DTC in the ECM memory but not the TCM memory.

The second is the TCM original self-diagnosis indicated by the O/D OFF indicator lamp. The malfunction is stored in the TCM memory. The detected items are overlapped with OBD-II self-diagnostic items. For detail, refer to [TM-156. "CONSULT Function \(TRANSMISSION\)"](#).

OBD-II Function for A/T System

INFOID:000000008790814

The ECM provides emission-related on board diagnostic (OBD-II) functions for the A/T system. One function is to receive a signal from the TCM used with OBD-related parts of the A/T system. The signal is sent to the ECM when a malfunction occurs in the corresponding OBD-related part. The other function is to indicate a diagnostic result by means of the MIL (malfunction indicator lamp) on the instrument panel. Sensors, switches and solenoid valves are used as sensing elements.

The MIL automatically illuminates in One or Two Trip Detection Logic when a malfunction is sensed in relation to A/T system parts.

One or Two Trip Detection Logic of OBD-II

INFOID:000000008790815

ONE TRIP DETECTION LOGIC

If a malfunction is sensed during the first test drive, the MIL will illuminate and the malfunction will be stored in the ECM memory as a DTC. The TCM is not provided with such a memory function.

TWO TRIP DETECTION LOGIC

When a malfunction is sensed during the first test drive, it is stored in the ECM memory as a 1st trip DTC (diagnostic trouble code) or 1st trip freeze frame data. At this point, the MIL will not illuminate. — 1st Trip

If the same malfunction as that experienced during the first test drive is sensed during the second test drive, the MIL will illuminate. — 2nd Trip



The "Trip" in the "One or Two Trip Detection Logic" means a driving mode in which self-diagnosis is performed during vehicle operation.

OBD-II Diagnostic Trouble Code (DTC)

INFOID:000000008790816

HOW TO READ DTC AND 1ST TRIP DTC

DTC and 1st trip DTC can be read by the following methods.

( with **CONSULT** or ( **GST**) CONSULT or GST (Generic Scan Tool) Examples: P0705, P0720 etc.

These DTC are prescribed by SAE J2012.

(CONSULT also displays the malfunctioning component or system.)

- **1st trip DTC No. is the same as DTC No.**
 - **Output of the diagnostic trouble code indicates that the indicated circuit has a malfunction. However, in case of the Mode II and GST, they do not indicate whether the malfunction is still occurring or occurred in the past and returned to normal.**
- CONSULT can identify them as shown below, therefore, CONSULT (if available) is recommended.**

Freeze Frame Data and 1st Trip Freeze Frame Data

The ECM has a memory function, which stores the driving condition such as fuel system status, calculated load value, engine coolant temperature, short term fuel trim, long term fuel trim, engine speed and vehicle speed at the moment the ECM detects a malfunction.

Data which are stored in the ECM memory, along with the 1st trip DTC, are called 1st trip freeze frame data, and the data, stored together with the DTC data, are called freeze frame data and displayed on CONSULT or GST. The 1st trip freeze frame data can only be displayed on the CONSULT screen, not on the GST. For detail, refer to [TM-154](#).

Only one set of freeze frame data (either 1st trip freeze frame data or freeze frame data) can be stored in the ECM. 1st trip freeze frame data is stored in the ECM memory along with the 1st trip DTC. There is no priority for 1st trip freeze frame data and it is updated each time a different 1st trip DTC is detected. However, once freeze frame data (2nd trip detection/MIL on) is stored in the ECM memory, 1st trip freeze frame data is no

ON BOARD DIAGNOSTIC (OBD) SYSTEM

< SYSTEM DESCRIPTION >

[5AT: RE5R05A]

longer stored. Remember, only one set of freeze frame data can be stored in the ECM. The ECM has the following priorities to update the data.

Priority	Items	
1	Freeze frame data	Misfire — DTC: P0300 - P0306 Fuel Injection System Function — DTC: P0171, P0172, P0174, P0175
2		Except the above items (Includes A/T related items)
3	1st trip freeze frame data	

Both 1st trip freeze frame data and freeze frame data (along with the DTC) are cleared when the ECM memory is erased.

HOW TO ERASE DTC

The diagnostic trouble code can be erased by CONSULT, GST or ECM DIAGNOSTIC TEST MODE as described following.

- **If the battery cable is disconnected, the diagnostic trouble code will be lost within 24 hours.**
- **When you erase the DTC, using CONSULT or GST is easier and quicker than switching the mode selector on the ECM.**

The following emission-related diagnostic information is cleared from the ECM memory when erasing DTC related to OBD-II. For details, refer to [EC-55. "On Board Diagnosis Function"](#) (QR25DE) or [EC-515. "On Board Diagnosis Function"](#) (VQ40DE).

- **Diagnostic trouble codes (DTC)**
- **1st trip diagnostic trouble codes (1st trip DTC)**
- **Freeze frame data**
- **1st trip freeze frame data**
- **System readiness test (SRT) codes**
- **Test values**

Ⓟ HOW TO ERASE DTC (WITH CONSULT)

1. The emission related diagnostic information in the TCM and ECM can be erased by selecting "ALL Erase" in the "Description" of "FINAL CHECK" mode with CONSULT.

Ⓜ HOW TO ERASE DTC (WITH GST)

1. If the ignition switch stays "ON" after repair work, be sure to turn ignition switch "OFF" once. Wait at least 10 seconds and then turn it "ON" (engine stopped) again.
2. Select Mode 4 with the Generic Scan Tool (GST). For details refer to [EC-47. "GST \(Generic Scan Tool\)"](#) (QR25DE) or [EC-507. "GST \(Generic Scan Tool\)"](#) (VQ40DE).

Ⓝ HOW TO ERASE DTC (NO TOOLS)

1. Disconnect battery for 24 hours.
2. Reconnect battery.

Malfunction Indicator Lamp (MIL)

INFOID:000000008790817

DESCRIPTION

The MIL is located on the instrument panel.

1. The MIL will light up when the ignition switch is turned "ON" without the engine running. This is a bulb check.
 - If the MIL does not light up, refer to [MWI-4. "Work Flow"](#).
2. When the engine is started, the MIL should go off.
If the MIL remains on, the on board diagnostic system has detected an engine system malfunction.

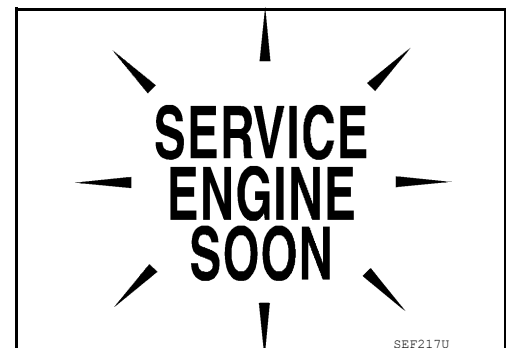

DIAGNOSIS SYSTEM (TCM)

< SYSTEM DESCRIPTION >

[5AT: RE5R05A]

DIAGNOSIS SYSTEM (TCM)

CONSULT Function (TRANSMISSION)

INFOID:000000008790818

FUNCTION

TCM diagnostic mode	Description
Self Diagnostic Result	Retrieve DTC from ECU and display diagnostic items.
Data Monitor	Monitor the input/output signal of the control unit in real time.
CAN Diagnosis	The condition of CAN communication can be indicated by a topology.
CAN Diagnosis Support Monitor	It monitors the status of CAN communication.
DTC work support	DTC reproduction procedure can be performed speedily and precisely.
ECU Identification	Display the ECU identification number (part number etc.) of the selected system.

SELF-DIAGNOSTIC RESULT MODE

Display Items List

X: Applicable, —: Not applicable

Items (CONSULT screen terms)	Malfunction is detected when...	TCM self-diagnosis	OBD-II (DTC)	Reference page
		"TRANSMISSION" with CONSULT	MIL indicator lamp*1, "ENGINE" with CONSULT or GST	
LOST COMM (ECM A)	<ul style="list-style-type: none"> When a malfunction is detected in CAN communications (ECM). 	U0100	U0100	TM-164
CAN COMM CIRCUIT	<ul style="list-style-type: none"> When TCM is not transmitting or receiving CAN communication signal for 2 seconds or more. 	U1000	U1000	TM-165
STARTER RELAY	<ul style="list-style-type: none"> If this signal is ON other than in "P" or "N" position, this is judged to be a malfunction. (And if it is OFF in "P" or "N" position, this too is judged to be a malfunction.) 	P0615	—	TM-166
TRANSMISSION CONT	<ul style="list-style-type: none"> TCM is malfunctioning. 	P0700	P0700	TM-168
T/M RANGE SENSOR A	<ul style="list-style-type: none"> Transmission range switch 1-4 signals input with impossible pattern "P" position is detected from "N" position without any other position being detected in between. 	P0705	P0705	TM-169
INPUT SPEED SENSOR A	<ul style="list-style-type: none"> TCM does not receive the proper voltage signal from the sensor. TCM detects an irregularity only at position of 4GR for input speed sensor 2. 	P0717	P0717	TM-171
OUTPUT SPEED SENSOR	<ul style="list-style-type: none"> Signal from output speed sensor not input due to cut line or the like Unexpected signal input during running After ignition switch is turned ON, unexpected signal input from vehicle speed signal before the vehicle starts moving 	P0720	P0720	TM-173
ENGINE SPEED	<ul style="list-style-type: none"> TCM does not receive the CAN communication signal from the ECM. 	P0725	—	TM-176
1GR INCORRECT RATIO	<ul style="list-style-type: none"> A/T cannot shift to 1GR 	P0731	P0731	TM-179
2GR INCORRECT RATIO	<ul style="list-style-type: none"> A/T cannot shift to 2GR 	P0732	P0732	TM-181
3GR INCORRECT RATIO	<ul style="list-style-type: none"> A/T cannot shift to 3GR 	P0733	P0733	TM-183

DIAGNOSIS SYSTEM (TCM)

< SYSTEM DESCRIPTION >

[5AT: RE5R05A]

Items (CONSULT screen terms)	Malfunction is detected when...	TCM self-diagnosis	OBD-II (DTC)	Reference page
		"TRANSMISSION" with CONSULT	MIL indicator lamp*1, "ENGINE" with CONSULT or GST	
4GR INCORRECT RATIO	<ul style="list-style-type: none"> A/T cannot shift to 4GR 	P0734	P0734	TM-185
5GR INCORRECT RATIO	<ul style="list-style-type: none"> A/T cannot shift to 5GR 	P0735	P0735	TM-187
TORQUE CONVERTER	<ul style="list-style-type: none"> Normal voltage not applied to solenoid due to cut line, short, or the like 	P0740	P0740	TM-188
TORQUE CONVERTER	<ul style="list-style-type: none"> A/T cannot perform lock-up even if electrical circuit is good. TCM detects as irregular by comparing difference value with slip rotation. 	P0744	P0744*2	TM-190
PC SOLENOID A	<ul style="list-style-type: none"> Normal voltage not applied to solenoid due to cut line, short, or the like TCM detects as irregular by comparing target value with monitor value. 	P0745	P0745	TM-192
TP SENSOR	<ul style="list-style-type: none"> TCM does not receive the proper accelerator pedal position signals (input by CAN communication) from ECM. 	P1705	—	TM-194
TRANS FLUID TEMP SEN	<ul style="list-style-type: none"> During running, the ATF temperature sensor signal voltage is excessively high or low 	P1710	P0710	TM-196
VEHICLE SPEED SIGNAL	<ul style="list-style-type: none"> Signal (CAN communication) from vehicle speed signal not input due to cut line or the like Unexpected signal input during running 	P1721	—	TM-198
INTERLOCK	<ul style="list-style-type: none"> Except during shift change, the gear position and ATF pressure switch states are monitored and comparative judgment made. 	P1730	P1730	TM-200
1ST E/BRAKING	<ul style="list-style-type: none"> Each ATF pressure switch and solenoid current is monitored and if a pattern is detected having engine braking 1GR other than in the "1" position, a malfunction is detected. 	P1731	—	TM-202
INPUT CLUTCH SOL	<ul style="list-style-type: none"> Normal voltage not applied to solenoid due to functional malfunction, cut line, short, or the like TCM detects as irregular by comparing target value with monitor value. 	P1752	P1752	TM-204
FR BRAKE SOLENOID	<ul style="list-style-type: none"> Normal voltage not applied to solenoid due to functional malfunction, cut line, short, or the like TCM detects as irregular by comparing target value with monitor value. 	P1757	P1757	TM-206
DRCT CLUTCH SOL	<ul style="list-style-type: none"> Normal voltage not applied to solenoid due to cut line, short, or the like TCM detects as irregular by comparing target value with monitor value. 	P1762	P1762	TM-208
HLR CLUTCH SOLENOID	<ul style="list-style-type: none"> Normal voltage not applied to solenoid due to functional malfunction, cut line, short, or the like TCM detects as irregular by comparing target value with monitor value. 	P1767	P1767	TM-210
L C BRAKE SOLENOID	<ul style="list-style-type: none"> Normal voltage not applied to solenoid due to functional malfunction, cut line, short, or the like 	P1772	P1772	TM-212

A
B
C
TM
E
F
G
H
I
J
K
L
M
N
O
P

DIAGNOSIS SYSTEM (TCM)

< SYSTEM DESCRIPTION >

[5AT: RE5R05A]

Items (CONSULT screen terms)	Malfunction is detected when...	TCM self-diagnosis	OBD-II (DTC)	Reference page
		"TRANSMISSION" with CONSULT	MIL indicator lamp*1, "ENGINE" with CONSULT or GST	
L C BRAKE SOLENOID	<ul style="list-style-type: none"> TCM detects an improper voltage drop when it tries to operate the solenoid valve. Condition of ATF pressure switch 2 is different from monitor value, and relation between gear position and actual gear ratio is irregular. 	P1774	P1774*2	TM-214
NO DTC IS DETECTED FURTHER TESTING MAY BE REQUIRED	<ul style="list-style-type: none"> No NG item has been detected. 	X	X	—

*1: Refer to [TM-155. "Malfunction Indicator Lamp \(MIL\)"](#).

*2: These malfunctions cannot be displayed MIL if another malfunction is assigned to MIL.

DATA MONITOR MODE

Display Items List

NOTE:

The following table includes information (items) inapplicable to this vehicle. For information (items) applicable to this vehicle, refer to CONSULT display items.

X: Standard, —: Not applicable, ▼: Option

Monitored item (Unit)	Monitor Item Selection			Remarks
	ECU INPUT SIGNALS	MAIN SIGNALS	SELECTION FROM MENU	
VHCL/S SE-A/T (km/h or mph)	X	X	▼	Output speed sensor
VHCL/S SE-MTR (km/h or mph)	X	—	▼	
ACCELE POSI (0.0/8)	X	—	▼	Accelerator pedal position signal
THROTTLE POSI (0.0/8)	X	X	▼	Degree of opening for accelerator recognized by the TCM For fail-safe operation, the specific value used for control is displayed.
CLSD THL POS (ON-OFF display)	X	—	▼	Signal input with CAN communications
W/O THL POS (ON-OFF display)	X	—	▼	
BRAKESW (ON-OFF display)	X	—	▼	Stop lamp switch
GEAR	—	X	▼	Gear position recognized by the TCM updated after gear-shifting
ENGINE SPEED (rpm)	X	X	▼	
INPUT SPEED (rpm)	X	X	▼	
OUTPUT REV (rpm)	X	X	▼	
GEAR RATIO	—	X	▼	
TC SLIP SPEED (rpm)	—	X	▼	Difference between engine speed and torque converter input shaft speed
F SUN GR REV (rpm)	—	—	▼	
F CARR GR REV (rpm)	—	—	▼	
ATF TEMP SE 1 (V)	X	—	▼	

DIAGNOSIS SYSTEM (TCM)

< SYSTEM DESCRIPTION >

[5AT: RE5R05A]

Monitored item (Unit)	Monitor Item Selection			Remarks
	ECU IN-PUT SIG-NALS	MAIN SIG-NALS	SELEC-TION FROM MENU	
ATF TEMP 1 (°C or °F)	—	X	▼	
ATF TEMP 2 (°C or °F)	—	X	▼	
BATTERY VOLT (V)	X	—	▼	
ATF PRES SW 1 (ON-OFF display)	X	X	▼	
ATF PRES SW 2 (ON-OFF display)	X	X	▼	(for LC/B solenoid)
ATF PRES SW 3 (ON-OFF display)	X	X	▼	
ATF PRES SW 5 (ON-OFF display)	X	X	▼	
ATF PRES SW 6 (ON-OFF display)	X	X	▼	
RANGE SW 1 (ON-OFF display)	X	—	▼	
RANGE SW 2 (ON-OFF display)	X	—	▼	
RANGE SW 3 (ON-OFF display)	X	—	▼	
RANGE SW 4 (ON-OFF display)	X	—	▼	
1 POSITION SW (ON-OFF display)	X	—	▼	1st position switch
SLCT LVR POSI	—	X	▼	Selector lever position is recognized by the TCM. For fail-safe operation, the specific value used for control is displayed.
OD CONT SW (ON-OFF display)	X	—	▼	
POWERSHIFT SW (ON-OFF display)	X	—	▼	
HOLD SW (ON-OFF display)	X	—	▼	
DS RANGE (ON-OFF display)	—	—	▼	
MANU MODE SW (ON-OFF display)	X	—	▼	
NON M-MODE SW (ON-OFF display)	X	—	▼	Not mounted but displayed.
UP SW LEVER (ON-OFF display)	X	—	▼	
DOWN SW LEVER (ON-OFF display)	X	—	▼	
SFT UP ST SW (ON-OFF display)	—	—	▼	
SFT DWN ST SW (ON-OFF display)	—	—	▼	
ASCD-OD CUT (ON-OFF display)	—	—	▼	
ASCD-CRUISE (ON-OFF display)	—	—	▼	
ABS SIGNAL (ON-OFF display)	—	—	▼	
ACC OD CUT (ON-OFF display)	—	—	▼	
ACC SIGNAL (ON-OFF display)	—	—	▼	Not mounted but displayed.
TCS GR/P KEEP (ON-OFF display)	—	—	▼	
TCS SIGNAL 2 (ON-OFF display)	—	—	▼	
TCS SIGNAL 1 (ON-OFF display)	—	—	▼	
TCC SOLENOID (A)	—	X	▼	
LINE PRES SOL (A)	—	X	▼	

A
B
C
TM
E
F
G
H
I
J
K
L
M
N
O
P

DIAGNOSIS SYSTEM (TCM)

< SYSTEM DESCRIPTION >

[5AT: RE5R05A]

Monitored item (Unit)	Monitor Item Selection			Remarks
	ECU INPUT SIGNALS	MAIN SIGNALS	SELECTION FROM MENU	
I/C SOLENOID (A)	—	X	▼	
FR/B SOLENOID (A)	—	X	▼	
D/C SOLENOID (A)	—	X	▼	
HLR/C SOL (A)	—	X	▼	
ON OFF SOL (ON-OFF display)	—	—	▼	LC/B solenoid
TCC SOL MON (A)	—	—	▼	
L/P SOL MON (A)	—	—	▼	
I/C SOL MON (A)	—	—	▼	
FR/B SOL MON (A)	—	—	▼	
D/C SOL MON (A)	—	—	▼	
HLR/C SOL MON (A)	—	—	▼	
ON OFF SOL MON (ON-OFF display)	—	—	▼	LC/B solenoid
P POSI IND (ON-OFF display)	—	—	▼	
R POSI IND (ON-OFF display)	—	—	▼	
N POSI IND (ON-OFF display)	—	—	▼	
D POSI IND (ON-OFF display)	—	—	▼	
4TH POSI IND (ON-OFF display)	—	—	▼	
3RD POSI IND (ON-OFF display)	—	—	▼	
2ND POSI IND (ON-OFF display)	—	—	▼	
1ST POSI IND (ON-OFF display)	—	—	▼	
MANU MODE IND (ON-OFF display)	—	—	▼	Not mounted but displayed.
POWER M LAMP (ON-OFF display)	—	—	▼	
F-SAFE IND/L (ON-OFF display)	—	—	▼	
ATF WARN LAMP (ON-OFF display)	—	—	▼	
BACK-UP LAMP (ON-OFF display)	—	—	▼	
STARTER RELAY (ON-OFF display)	—	—	▼	
RANGE SW 3M (ON-OFF display)	—	—	▼	
C/V CLB ID1	—	—	▼	
C/V CLB ID2	—	—	▼	
C/V CLB ID3	—	—	▼	
UNIT CLB ID1	—	—	▼	
UNIT CLB ID2	—	—	▼	
UNIT CLB ID3	—	—	▼	
TRGT GR RATIO	—	—	▼	
TRGT PRES TCC (kPa, kg/cm ² or psi)	—	—	▼	

DIAGNOSIS SYSTEM (TCM)

< SYSTEM DESCRIPTION >

[5AT: RE5R05A]

Monitored item (Unit)	Monitor Item Selection			Remarks
	ECU IN-PUT SIGNALS	MAIN SIGNALS	SELECTION FROM MENU	
TRGT PRES L/P (kPa, kg/cm ² or psi)	—	—	▼	
TRGT PRES I/C (kPa, kg/cm ² or psi)	—	—	▼	
TRGT PRE FR/B (kPa, kg/cm ² or psi)	—	—	▼	
TRGT PRES D/C (kPa, kg/cm ² or psi)	—	—	▼	
TRG PRE HLR/C (kPa, kg/cm ² or psi)	—	—	▼	
SHIFT PATTERN	—	—	▼	
DRV CST JUDGE	—	—	▼	
START RLY MON (ON-OFF display)	—	—	▼	
NEXT GR POSI	—	—	▼	
SHIFT MODE	—	—	▼	
MANU GR POSI	—	—	▼	
VEHICLE SPEED (km/h or mph)	—	X	▼	Vehicle speed recognized by the TCM.

DTC WORK SUPPORT

Display Items List

DTC work support item	Description	Check item
1ST GR FNCTN P0731	Following items for "1GR incorrect ratio" can be confirmed. • Self-diagnosis status (whether the diagnosis is being performed or not) • Self-diagnostic results (OK or NG)	
2ND GR FNCTN P0732	Following items for "2GR incorrect ratio" can be confirmed. • Self-diagnosis status (whether the diagnosis is being performed or not) • Self-diagnostic results (OK or NG)	
3RD GR FNCTN P0733	Following items for "3GR incorrect ratio" can be confirmed. • Self-diagnosis status (whether the diagnosis is being performed or not) • Self-diagnostic results (OK or NG)	
4TH GR FNCTN P0734	Following items for "4GR incorrect ratio" can be confirmed. • Self-diagnosis status (whether the diagnosis is being performed or not) • Self-diagnostic results (OK or NG)	
5TH GR FNCTN P0735	Following items for "5GR incorrect ratio" can be confirmed. • Self-diagnosis status (whether the diagnosis is being performed or not) • Self-diagnostic results (OK or NG)	<ul style="list-style-type: none"> • Input clutch solenoid valve • Front brake solenoid valve • Direct clutch solenoid valve • High and low reverse clutch solenoid valve • Each clutch and brake • Hydraulic control circuit

Diagnosis Procedure without CONSULT

INFOID:000000008790819

OBD-II SELF-DIAGNOSTIC PROCEDURE (NO TOOLS)

Refer to [TM-155, "Malfunction Indicator Lamp \(MIL\)"](#).

TCM SELF-DIAGNOSTIC PROCEDURE (NO TOOLS)

Description

DIAGNOSIS SYSTEM (TCM)

< SYSTEM DESCRIPTION >

[5AT: RE5R05A]

When the ignition switch is switched "ON", the O/D OFF indicator lamp lights up for 2 seconds. As a method for locating the suspect circuit, when the self-diagnostics start signal is input, the memory for the malfunction location is output and the O/D OFF indicator lamp flashes to display the corresponding DTC.

Diagnostic Procedure

1. CHECK O/D OFF INDICATOR LAMP

1. Start the engine with selector lever in "P" position. Warm engine to normal operating temperature.
2. Turn ignition switch ON and OFF at least twice, then leave it in the OFF position.
3. Wait 10 seconds.
4. Turn ignition switch ON. (Do not start engine.)

Does O/D OFF indicator lamp come on for about 2 seconds?

YES >> GO TO 2.

NO >> Go to [TM-240, "Symptom Chart"](#).

2. JUDGMENT PROCEDURE STEP 1

1. Turn ignition switch OFF.
2. Keep pressing shift lock release button.
3. Move selector lever from "P" to "D" position.
4. Release accelerator pedal. (Set the closed throttle position signal "ON".)
5. Depress brake pedal. (Stop lamp switch signal "ON".)
6. Turn ignition switch ON. (Do not start engine.)
7. Wait 3 seconds.
8. Move the selector lever from "D" to "3" position.
9. Release brake pedal. (Stop lamp switch signal "OFF".)
10. Move the selector lever from "3" to "2" position.
11. Depress brake pedal. (Stop lamp switch signal "ON".)
12. Release brake pedal. (Stop lamp switch signal "OFF".)
13. Depress accelerator pedal fully and release it.

>> GO TO 3.

3. CHECK SELF-DIAGNOSIS CODE

Check O/D OFF indicator lamp.

Refer to "Judgment Self-diagnosis Code".

If the system does not go into self-diagnostics. Refer to [TM-169, "Diagnosis Procedure"](#), [TM-218, "Diagnosis Procedure"](#), [TM-219, "Diagnosis Procedure"](#).

>> **DIAGNOSIS END**

Judgment Self-diagnosis Code

DIAGNOSIS SYSTEM (TCM)

< SYSTEM DESCRIPTION >

[5AT: RE5R05A]

If there is a malfunction, the lamp lights up for the time corresponding to the suspect circuit.

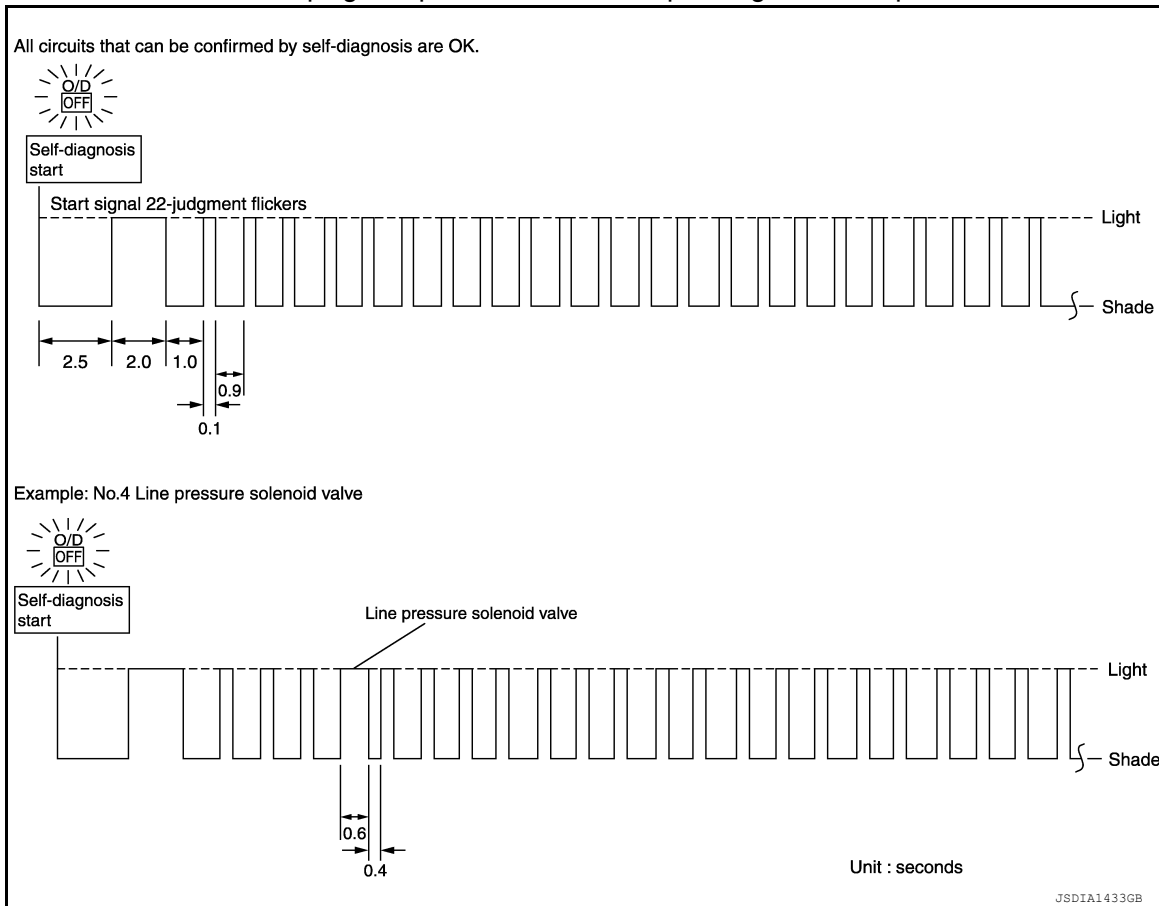

No.	Malfunctioning item	No.	Malfunctioning item
1	Output speed sensor TM-173	12	Interlock TM-200
2	Direct clutch solenoid TM-208	13	1st engine braking TM-202
3	Torque converter TM-188 , TM-190	14	Starter relay TM-166
4	Line pressure solenoid TM-192	15	TP sensor TM-194
5	Input clutch solenoid TM-204	16	Engine speed TM-176
6	Front brake solenoid TM-206	17	CAN communication line TM-165
7	Low coast brake solenoid TM-212 , TM-214	18	1GR incorrect ratio TM-178
8	High and low reverse clutch solenoid TM-210	19	2GR incorrect ratio TM-180
9	Transmission range switch TM-169	20	3GR incorrect ratio TM-182
10	Transmission fluid temperature sensor TM-196	21	4GR incorrect ratio TM-184
11	Input speed sensor TM-171	22	5GR incorrect ratio TM-186

Erase Self-diagnosis

- In order to make it easier to find the cause of hard-to-duplicate malfunctions, malfunction information is stored into the control unit as necessary during use by the user. This memory is not erased no matter how many times the ignition switch is turned ON and OFF.
- However, this information is erased by turning ignition switch OFF after executing self-diagnostics or by erasing the memory using the CONSULT.

DTC/CIRCUIT DIAGNOSIS

U0100 LOST COMMUNICATION (ECM A)

Description

INFOID:000000009241403

CAN (Controller Area Network) is a serial communication line for real time application. It is an on-vehicle multiplex communication line with high data communication speed and excellent malfunction detection ability. Many electronic control units are equipped onto a vehicle, and each control unit shares information and links with other control units during operation (not independent). In CAN communication, control units are connected with 2 communication lines (CAN H line, CAN L line) allowing a high rate of information transmission with less wiring. Each control unit transmits/receives data but selectively reads required data only.

On Board Diagnosis Logic

INFOID:000000009241404

- This is an OBD-II self-diagnostic item.
- Diagnostic trouble code "U0100" with CONSULT is detected when TCM is unable to receive the CAN communications signal from ECM.

Possible Cause

INFOID:000000009241405

- ECM
- Harness or connectors
(CAN communication line is open or shorted.)

DTC Confirmation Procedure

INFOID:000000009241406

NOTE:

If "DTC Confirmation Procedure" has been previously performed, always turn ignition switch "OFF" and wait at least 10 seconds before performing the next test.

After the repair, perform the following procedure to confirm the malfunction is eliminated.

WITH CONSULT

1. Turn ignition switch "ON". (Do not start engine.)
2. Select "DATA MONITOR" mode for "TRANSMISSION" with CONSULT.
3. Start engine and wait for at least 6 seconds.
4. If DTC is detected, go to [TM-164, "Diagnosis Procedure"](#).

WITH GST

Follow the procedure "WITH CONSULT".

Diagnosis Procedure

INFOID:000000009241407

1. CHECK CAN COMMUNICATION CIRCUIT

With CONSULT

1. Turn ignition switch "ON" and start engine.
2. Select "SELF-DIAG RESULTS" mode for "TRANSMISSION" with CONSULT.

Is "U0100" detected?

- YES >> Go to LAN section. Refer to [LAN-14, "Trouble Diagnosis Flow Chart"](#).
 NO >> **INSPECTION END**

U1000 CAN COMM CIRCUIT

Description

INFOID:000000008790820

CAN (Controller Area Network) is a serial communication line for real time application. It is an on-vehicle multiplex communication line with high data communication speed and excellent malfunction detection ability. Many electronic control units are equipped onto a vehicle, and each control unit shares information and links with other control units during operation (not independent). In CAN communication, control units are connected with 2 communication lines (CAN H line, CAN L line) allowing a high rate of information transmission with less wiring. Each control unit transmits/receives data but selectively reads required data only.

On Board Diagnosis Logic

INFOID:000000008790821

- This is an OBD-II self-diagnostic item.
- Diagnostic trouble code "U1000" with CONSULT or 17th judgment flicker without CONSULT is detected when TCM cannot communicate to other control units.

Possible Cause

INFOID:000000008790822

Harness or connectors
(CAN communication line is open or shorted.)

DTC Confirmation Procedure

INFOID:000000008790823

NOTE:

If "DTC Confirmation Procedure" has been previously performed, always turn ignition switch "OFF" and wait at least 10 seconds before performing the next test.

After the repair, perform the following procedure to confirm the malfunction is eliminated.

ⓐ WITH CONSULT

1. Turn ignition switch "ON". (Do not start engine.)
2. Select "DATA MONITOR" mode for "TRANSMISSION" with CONSULT.
3. Start engine and wait for at least 6 seconds.
4. If DTC is detected, go to [TM-165, "Diagnosis Procedure"](#).

ⓑ WITH GST

Follow the procedure "WITH CONSULT".

Diagnosis Procedure

INFOID:000000008790824

1. CHECK CAN COMMUNICATION CIRCUIT

ⓐ With CONSULT

1. Turn ignition switch "ON" and start engine.
2. Select "SELF-DIAG RESULTS" mode for "TRANSMISSION" with CONSULT.

Is any malfunction of the "U1000" indicated?

- YES >> Go to LAN section. Refer to [LAN-14, "Trouble Diagnosis Flow Chart"](#).
 NO >> **INSPECTION END**

P0615 STARTER RELAY

< DTC/CIRCUIT DIAGNOSIS >

[5AT: RE5R05A]

P0615 STARTER RELAY

Description

INFOID:000000008790825

TCM prohibits cranking other than at "P" or "N" position.

CONSULT Reference Value in Data Monitor Mode

INFOID:000000008790826

Item name	Condition	Display value
STARTER RELAY	Selector lever in "N", "P" positions.	ON
	Selector lever in other position.	OFF

On Board Diagnosis Logic

INFOID:000000008790827

- This is not an OBD-II self-diagnostic item.
- Diagnostic trouble code "P0615" with CONSULT or 14th judgment flicker without CONSULT is detected when starter relay is switched "ON" other than at "P" or "N" position. (Or when switched "OFF" at "P" or "N" position).

Possible Cause

INFOID:000000008790828

- Harness or connectors
(The starter relay and TCM circuit is open or shorted.)
- Starter relay

DTC Confirmation Procedure

INFOID:000000008790829

NOTE:

If "DTC Confirmation Procedure" has been previously performed, always turn ignition switch "OFF" and wait at least 10 seconds before performing the next test.

After the repair, perform the following procedure to confirm the malfunction is eliminated.

Ⓟ WITH CONSULT

1. Shift selector lever to "P" or "N" position.
2. Turn ignition switch ON and wait for at least 2 seconds.
3. Select "SELF-DIAG RESULTS" mode for "TRANSMISSION" with CONSULT.
4. If DTC is detected, go to [TM-166, "Diagnosis Procedure"](#).

Diagnosis Procedure

INFOID:000000008790830

1. CHECK STARTER RELAY

Ⓟ With CONSULT

1. Turn ignition switch ON. (Do not start engine.)
2. Select "SELECTION FROM MENU" in "DATA MONITOR" mode for "TRANSMISSION" with CONSULT and check monitor "STARTER RELAY" ON/OFF.

⊗ Without CONSULT

1. Turn ignition switch ON. (Do not start engine.)
2. Check voltage between the IPDM E/R connector and ground.

Item	Connector	Terminal	Shift position	Voltage (Approx.)	
Starter relay	E122	48	Ground	"N" and "P"	Battery voltage
				"R" and "D"	0 V

OK or NG

- OK >> GO TO 5.
NG >> GO TO 2.

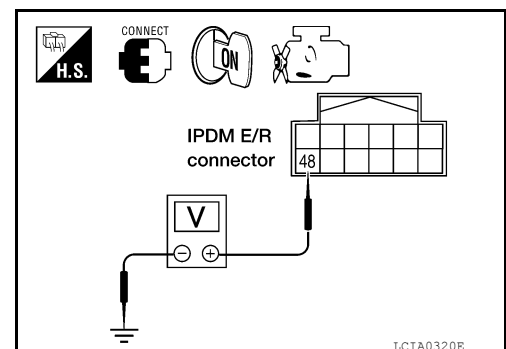

LCIA0320E

P0615 STARTER RELAY

< DTC/CIRCUIT DIAGNOSIS >

[5AT: RE5R05A]

2. CHECK HARNESS BETWEEN A/T ASSEMBLY HARNESS CONNECTOR AND IPDM E/R CONNECTOR

1. Turn ignition switch OFF.
2. Disconnect A/T assembly harness connector and IPDM E/R connector.
3. Check continuity between A/T assembly harness connector and IPDM E/R connector.

Item	Connector	Terminal	Continuity
A/T assembly harness connector	F9	9	Yes
IPDM E/R connector	E122	48	

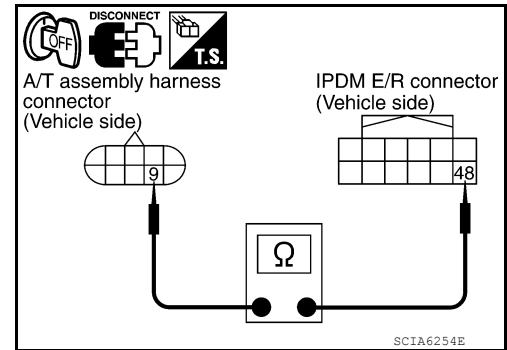

4. If OK, check harness for short to ground and short to power.
5. Reinstall any part removed.

OK or NG

OK >> GO TO 3.

NG >> Repair open circuit or short to ground or short to power in harness or connectors.

3. CHECK TERMINAL CORD ASSEMBLY

1. Remove control valve with TCM. Refer to [TM-286, "Removal and Installation"](#).
2. Disconnect A/T assembly harness connector and TCM connector.
3. Check continuity between A/T assembly harness connector terminal and TCM connector terminal.

Item	Connector	Terminal	Continuity
A/T assembly harness connector	F9	9	Yes
TCM connector	F502	8	

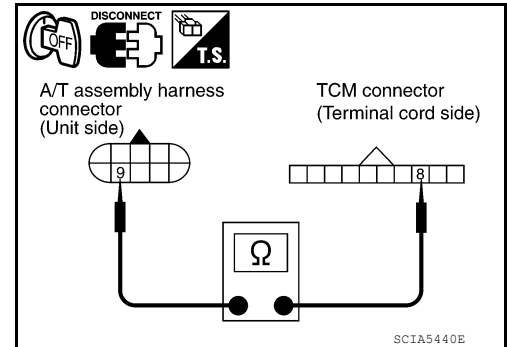

4. If OK, check harness for short to ground and short to power.
5. Reinstall any part removed.

OK or NG

OK >> GO TO 4.

NG >> Replace open circuit or short to ground and short to power in harness or connectors.

4. DETECT MALFUNCTIONING ITEM

Check the following.

- Starter relay, Refer to [STR-12](#).
- IPDM E/R, Refer to [PCS-3, "System Description"](#).

OK or NG

OK >> Replace the control valve with TCM. Refer to [TM-286, "Removal and Installation"](#).

NG >> Repair or replace damaged parts.

5. CHECK DTC

Perform [TM-166, "DTC Confirmation Procedure"](#).

OK or NG

OK >> **INSPECTION END**

NG >> GO TO 2.

P0700 TRANSMISSION CONTROL

< DTC/CIRCUIT DIAGNOSIS >

[5AT: RE5R05A]

P0700 TRANSMISSION CONTROL

Description

INFOID:000000008790831

The TCM consists of a microcomputer and connectors for signal input and output and for power supply. The TCM controls the A/T.

On Board Diagnosis Logic

INFOID:000000008790832

- This is an OBD-II self-diagnostic item.
- Diagnostic trouble code "P0700" with CONSULT is detected when the TCM is malfunctioning.

Possible Cause

INFOID:000000008790833

TCM.

DTC Confirmation Procedure

INFOID:000000008790834

NOTE:

If "DTC Confirmation Procedure" has been previously performed, always turn ignition switch "OFF" and wait at least 10 seconds before performing the next test.

After the repair, perform the following procedure to confirm the malfunction is eliminated.

④ WITH CONSULT

1. Turn ignition switch "ON". (Do not start engine.)
2. Select "DATA MONITOR" mode for "TRANSMISSION" with CONSULT.
3. Start engine.
4. Run engine for at least 2 consecutive seconds at idle speed.
5. If DTC is detected, go to [TM-168, "Diagnosis Procedure"](#).

④ WITH GST

Follow the procedure "WITH CONSULT".

Diagnosis Procedure

INFOID:000000008790835

1. CHECK DTC

④ With CONSULT

1. Turn ignition switch "ON". (Do not start engine.)
2. Select "SELF DIAG RESULTS" mode for "TRANSMISSION" with CONSULT.
3. Touch "ERASE".
4. Turn ignition switch "OFF" and wait at least 10 seconds.
5. Perform [TM-168, "DTC Confirmation Procedure"](#).

Is the "P0700" displayed again?

- YES >> Replace the control valve with TCM. Refer to [TM-286, "Removal and Installation"](#).
NO >> **INSPECTION END**

P0705 TRANSMISSION RANGE SENSOR A

< DTC/CIRCUIT DIAGNOSIS >

[5AT: RE5R05A]

P0705 TRANSMISSION RANGE SENSOR A

Description

INFOID:000000008790836

The transmission range switch detects the selector lever position and sends a signal to the TCM.

CONSULT Reference Value in Data Monitor Mode

INFOID:000000008790837

Item name	Condition	Display value
SLCTLVR POSI	Selector lever in "N","P" positions.	N/P
	Selector lever in "R" position.	R
	Selector lever in "D" position.	D
	Selector lever in "3" position.	3
	Selector lever in "2" position.	2
	Selector lever in "1" position.	1

On Board Diagnosis Logic

INFOID:000000008790838

- This is an OBD-II self-diagnostic item.
- Diagnostic trouble code "P0705" with CONSULT or 9th judgment flicker without CONSULT is detected under the following conditions.
 - When TCM does not receive the correct voltage signal from the transmission range switch 1, 2, 3, 4 based on the gear position.
 - When no other position but "P" position is detected from "N" positions.

Possible Cause

INFOID:000000008790839

- Harness or connectors
(The transmission range switch 1, 2, 3, 4 and TCM circuit is open or shorted.)
- Transmission range switch 1, 2, 3, 4

DTC Confirmation Procedure

INFOID:000000008790840

CAUTION:

Always drive vehicle at a safe speed.

NOTE:

If "DTC Confirmation Procedure" has been previously performed, always turn ignition switch "OFF" and wait at least 10 seconds before performing the next test.

After the repair, perform the following procedure to confirm the malfunction is eliminated.

Ⓟ WITH CONSULT

1. Turn ignition switch "ON". (Do not start engine.)
2. Select "DATA MONITOR" mode for "TRANSMISSION" with CONSULT.
3. Start engine.
4. Drive vehicle and maintain the following conditions for at least 2 consecutive seconds.
ACCELE POSI: More than 1.0/8
5. If DTC is detected, go to [TM-169, "Diagnosis Procedure"](#).

Ⓟ WITH GST

Follow the procedure "WITH CONSULT".

Diagnosis Procedure

INFOID:000000008790841

1. CHECK TRANSMISSION RANGE SWITCH CIRCUIT

Ⓟ With CONSULT

1. Turn ignition switch ON. (Do not start engine.)
2. Select "SELECTION FROM MENU" in "DATA MONITOR" mode for "TRANSMISSION" with CONSULT.
3. Check if correct selector lever position (N/P, R, D, 3, 2 or 1) is displayed as selector lever is moved into each position.

P0705 TRANSMISSION RANGE SENSOR A

< DTC/CIRCUIT DIAGNOSIS >

[5AT: RE5R05A]

OK or NG

- OK >> GO TO 5.
- NG >> GO TO 2.

2. CHECK TCM POWER SUPPLY AND GROUND CIRCUIT

Check TCM power supply and ground circuit. Refer to [TM-216, "Diagnosis Procedure"](#).

OK or NG

- OK >> GO TO 3.
- NG >> Repair or replace damaged parts.

3. DETECT MALFUNCTIONING ITEM

Check the following.

- A/T assembly harness connector pin terminals for damage or loose connection with harness connector.

OK or NG

- OK >> GO TO 4.
- NG >> Repair or replace damaged parts.

4. CHECK SUB-HARNESS

1. Remove control valve with TCM. Refer to [TM-286, "Removal and Installation"](#).
2. Disconnect transmission range switch connector and TCM connector.
3. Check continuity between transmission range switch connector (A) terminals and TCM connector (B) terminals.

Item	Connector	Terminal	Continuity
Transmission range switch connector	F505	1	Yes
TCM connector	F503	13	
Transmission range switch connector	F505	2	Yes
TCM connector	F503	11	
Transmission range switch connector	F505	3	Yes
TCM connector	F503	12	
Transmission range switch connector	F505	5	Yes
TCM connector	F503	14	

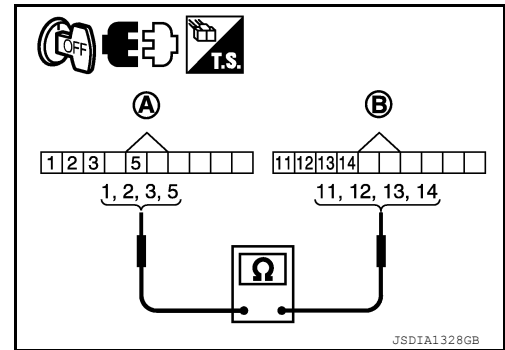

4. If OK, check harness for short to ground and short to power.
5. Reinstall any part removed.

OK or NG

- OK >> Replace the control valve with TCM. Refer to [TM-286, "Removal and Installation"](#).
- NG >> Replace open circuit or short to ground and short to power in harness or connectors.

5. CHECK DTC

Perform "DTC Confirmation Procedure".

- Refer to [TM-169, "DTC Confirmation Procedure"](#).

OK or NG

- OK >> **INSPECTION END**
- NG >> GO TO 2.

P0717 INPUT SPEED SENSOR A

< DTC/CIRCUIT DIAGNOSIS >

[5AT: RE5R05A]

P0717 INPUT SPEED SENSOR A

Description

INFOID:000000008790842

The input speed sensor detects input shaft rpm (revolutions per minute). It is located on the input side of the automatic transmission. Monitors revolution of sensor 1 and sensor 2 for non-standard conditions.

CONSULT Reference Value in Data Monitor Mode

INFOID:000000008790843

Item name	Condition	Display value (rpm)
INPUT SPEED	During driving (lock-up ON)	Approximately matches the engine speed.

On Board Diagnosis Logic

INFOID:000000008790844

- This is an OBD-II self-diagnostic item.
- Diagnostic trouble code “P0717” with CONSULT or 11th judgment flicker without CONSULT is detected under the following conditions.
 - When TCM does not receive the proper voltage signal from the sensor.
 - When TCM detects an irregularity only at position of 4GR for input speed sensor 2.

Possible Cause

INFOID:000000008790845

- Harness or connectors
(The sensor circuit is open or shorted.)
- Input speed sensor 1, 2

DTC Confirmation Procedure

INFOID:000000008790846

CAUTION:

- **Always drive vehicle at a safe speed.**
- **Be careful not to rev engine into the red zone on the tachometer.**

NOTE:

If “DTC Confirmation Procedure” has been previously performed, always turn ignition switch “OFF” and wait at least 10 seconds before performing the next test.

After the repair, perform the following procedure to confirm the malfunction is eliminated.

Ⓟ WITH CONSULT

1. Turn ignition switch “ON”. (Do not start engine.)
2. Select “DATA MONITOR” mode for “TRANSMISSION” with CONSULT.
3. Start engine and maintain the following conditions for at least 5 consecutive seconds.
 - VHCL/S SE-A/T: 40 km/h (25 MPH) or more**
 - ENGINE SPEED: 1,500 rpm or more**
 - ACCELE POSI: 0.5/8 or more**
 - SLCT LVR POSI: “D” position**
 - GEAR (Input speed sensor 1): 4th or 5th position**
 - GEAR (Input speed sensor 2): All position**
 - Driving location: Driving the vehicle uphill (increased engine load) will help maintain the driving conditions required for this test.**
4. If DTC is detected, go to [TM-171, "Diagnosis Procedure"](#).

Ⓢ WITH GST

Follow the procedure “WITH CONSULT”.

Diagnosis Procedure

INFOID:000000008790847

1. CHECK INPUT SIGNAL

Ⓟ With CONSULT

1. Start engine.
2. Select “ECU INPUT SIGNALS” in “DATA MONITOR” mode for “TRANSMISSION” with CONSULT.
3. Drive vehicle and read out the value of “INPUT SPEED”.

P0717 INPUT SPEED SENSOR A

< DTC/CIRCUIT DIAGNOSIS >

[5AT: RE5R05A]

OK or NG

- OK >> GO TO 4.
- NG >> GO TO 2.

2. CHECK TCM POWER SUPPLY AND GROUND CIRCUIT

Check TCM power supply and ground circuit. Refer to [TM-216, "Diagnosis Procedure"](#).

OK or NG

- OK >> GO TO 3.
- NG >> Repair or replace damaged parts.

3. DETECT MALFUNCTIONING ITEM

Check the following.

- The A/T assembly harness connector pin terminals for damage or loose connection with harness connector.

OK or NG

- OK >> Replace the control valve with TCM. Refer to [TM-286, "Removal and Installation"](#).
- NG >> Repair or replace damaged parts.

4. CHECK DTC

Perform "DTC Confirmation Procedure".

- Refer to [TM-171, "DTC Confirmation Procedure"](#).

OK or NG

- OK >> **INSPECTION END**
- NG >> GO TO 2.

P0720 OUTPUT SPEED SENSOR

< DTC/CIRCUIT DIAGNOSIS >

[5AT: RE5R05A]

P0720 OUTPUT SPEED SENSOR

Description

INFOID:000000008790848

The output speed sensor detects the revolution of the parking gear and emits a pulse signal. The pulse signal is sent to the TCM which converts it into vehicle speed.

CONSULT Reference Value in Data Monitor Mode

INFOID:000000008790849

Item name	Condition	Display value (km/h)
VHCL/S SE-A/T	During driving	Approximately matches the speedometer reading.

On Board Diagnosis Logic

INFOID:000000008790850

- This is an OBD-II self-diagnostic item.
- Diagnostic trouble code “P0720” with CONSULT or 1st judgment flicker without CONSULT is detected under the following conditions.
 - When TCM does not receive the proper voltage signal from the sensor.
 - After ignition switch is turned “ON”, irregular signal input from vehicle speed signal before the vehicle starts moving.

Possible Cause

INFOID:000000008790851

- Harness or connectors
(The sensor circuit is open or shorted.)
- Output speed sensor
- Vehicle speed signal

DTC Confirmation Procedure

INFOID:000000008790852

CAUTION:

- Always drive vehicle at a safe speed.
- Be careful not to rev engine into the red zone on the tachometer.

NOTE:

If “DTC Confirmation Procedure” has been previously performed, always turn ignition switch “OFF” and wait at least 10 seconds before performing the next test.

After the repair, perform the following procedure to confirm the malfunction is eliminated.

Ⓟ WITH CONSULT

1. Turn ignition switch “ON”. (Do not start engine.)
2. Select “DATA MONITOR” mode for “TRANSMISSION” with CONSULT.
3. Drive vehicle and check for an increase of “VHCL/S SE-A/T” value in response to “VHCL/S SE-MTR” value.
If the check result is NG, go to [TM-174. "Diagnosis Procedure"](#).
If the check result is OK, go to following step.
4. Select “DATA MONITOR” mode for “TRANSMISSION” with CONSULT.
5. Start engine and maintain the following conditions for at least 5 consecutive seconds.
VHCL/S SE-A/T: 30 km/h (19 MPH) or more
ACCELE POSI: More than 1.0/8
SLCT LVR POSI: “D” position
Driving location: Driving the vehicle uphill (increased engine load) will help maintain the driving conditions required for this test.
If the check result is NG, go to [TM-174. "Diagnosis Procedure"](#).
If the check result is OK, go to following step.
6. Maintain the following conditions for at least 5 consecutive seconds.
ENGINE SPEED: 3,500 rpm or more
ACCELE POSI: More than 1.0/8
SLCT LVR POSI: “D” position
Driving location: Driving the vehicle uphill (increased engine load) will help maintain the driving conditions required for this test.
If the check result is NG, go to [TM-174. "Diagnosis Procedure"](#).

P0720 OUTPUT SPEED SENSOR

< DTC/CIRCUIT DIAGNOSIS >

[5AT: RE5R05A]

 WITH GST

Follow the procedure "WITH CONSULT".

Diagnosis Procedure

INFOID:000000008790853

1. CHECK INPUT SIGNAL

 With CONSULT

1. Turn ignition switch ON.
2. Select "ECU INPUT SIGNALS" in "DATA MONITOR" mode for "TRANSMISSION" with CONSULT.
3. Start the engine.
4. Read out the value of "VHCL/S SE-A/T" while driving.
Check the value changes according to driving speed.

OK or NG

- OK >> GO TO 6.
NG >> GO TO 2.

2. CHECK TCM POWER SUPPLY AND GROUND CIRCUIT

Check TCM power supply and ground circuit. Refer to [TM-216, "Diagnosis Procedure"](#).

OK or NG

- OK >> GO TO 3.
NG >> Repair or replace damaged parts.

3. DETECT MALFUNCTIONING ITEM

Check the following.

- The A/T assembly harness connector pin terminals for damage or loose connection with harness connector.

OK or NG

- OK >> GO TO 4.
NG >> Repair or replace damaged parts.

4. CHECK SUB-HARNESS

1. Remove control valve with TCM. Refer to [TM-286, "Removal and Installation"](#).
2. Disconnect transmission range switch connector and TCM connector.
3. Check continuity between transmission range switch connector (A) terminals and TCM connector (B) terminals.

Item	Connector	Terminal	Continuity
Transmission range switch connector	F505	8	Yes
TCM connector	F503	20	
Transmission range switch connector	F505	9	Yes
TCM connector	F503	17	
Transmission range switch connector	F505	10	Yes
TCM connector	F503	16	

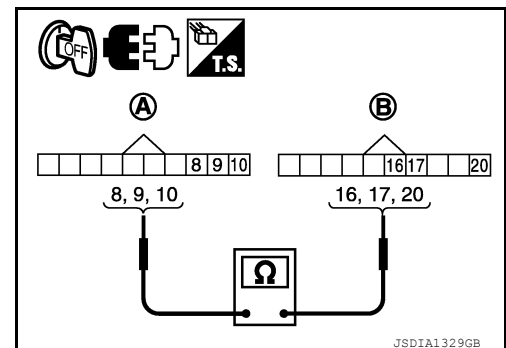

4. If OK, check harness for short to ground and short to power.
5. Reinstall any part removed.

OK or NG

- OK >> GO TO 5.
NG >> Replace open circuit or short to ground and short to power in harness or connectors.

5. REPLACE THE OUTPUT SPEED SENSOR AND CHECK DTC

1. Replace the output speed sensor. Refer to [TM-311](#).
2. Perform "DTC Confirmation Procedure". Refer to [TM-173, "DTC Confirmation Procedure"](#).

OK or NG

P0720 OUTPUT SPEED SENSOR

< DTC/CIRCUIT DIAGNOSIS >

[5AT: RE5R05A]

OK >> **INSPECTION END**

NG >> Replace the control valve with TCM. Refer to [TM-286, "Removal and Installation"](#).

6. CHECK DTC

Perform "DTC Confirmation Procedure".

• Refer to [TM-173, "DTC Confirmation Procedure"](#).

OK or NG

OK >> **INSPECTION END**

NG >> GO TO 2.

A

B

C

TM

E

F

G

H

I

J

K

L

M

N

O

P

P0725 ENGINE SPEED

< DTC/CIRCUIT DIAGNOSIS >

[5AT: RE5R05A]

P0725 ENGINE SPEED

Description

INFOID:000000008790854

The engine speed signal is sent from the ECM to the TCM.

CONSULT Reference Value in Data Monitor Mode

INFOID:000000008790855

Item name	Condition	Display value (rpm)
ENGINE SPEED	Engine running	Closely matches the tachometer reading.

On Board Diagnosis Logic

INFOID:000000008790856

- This is not an OBD-II self-diagnostic item.
- Diagnostic trouble code “P0725” with CONSULT or 16th judgment flicker without CONSULT is detected when TCM does not receive the ignition signal from ECM during engine cranking or running.

Possible Cause

INFOID:000000008790857

Harness or connectors
(The ECM to the TCM circuit is open or shorted.)

DTC Confirmation Procedure

INFOID:000000008790858

CAUTION:

Always drive vehicle at a safe speed.

NOTE:

If “DTC Confirmation Procedure” has been previously performed, always turn ignition switch “OFF” and wait at least 10 seconds before performing the next test.

After the repair, perform the following procedure to confirm the malfunction is eliminated.

④ WITH CONSULT

1. Turn ignition switch “ON” and select “DATA MONITOR” mode for “TRANSMISSION” with CONSULT.
2. Start engine and maintain the following conditions for at least 10 consecutive seconds.
VHCL/S SE-A/T: 10 km/h (6 MPH) or more
ACCELE POSI: More than 1/8
SLCT LVR POSI: “D” position
3. If DTC is detected, go to [TM-176, "Diagnosis Procedure"](#).

Diagnosis Procedure

INFOID:000000008790859

1. CHECK CAN COMMUNICATION LINE

Perform the self-diagnosis. Refer to [TM-156, "CONSULT Function \(TRANSMISSION\)"](#).

Is a malfunction in the CAN communication indicated in the results?

- YES >> Check CAN communication line. Refer to [TM-165](#).
NO >> GO TO 2.

2. CHECK DTC WITH TCM

④ With CONSULT

1. Start engine.
2. Select “ECU INPUT SIGNALS” in “DATA MONITOR” mode for “TRANSMISSION” with CONSULT.
3. While monitoring engine speed, check for engine speed change corresponding to wide-open throttle position signal.

Is the inspection result normal?

- YES >> GO TO 3.
NO >> Check the ignition signal circuit.
 - Refer to [EC-446, "Diagnosis Procedure"](#) (QR25DE) or [EC-932, "Diagnosis Procedure"](#) (VQ40DE).

P0725 ENGINE SPEED

< DTC/CIRCUIT DIAGNOSIS >

[5AT: RE5R05A]

3.CHECK DTC

Perform "DTC Confirmation Procedure".

- Refer to [TM-176, "DTC Confirmation Procedure"](#).

Is the inspection result normal?

YES >> **INSPECTION END**

NO >> GO TO 4.

4.CHECK TCM POWER SUPPLY AND GROUND CIRCUIT

Check TCM power supply and ground circuit. Refer to [TM-216, "Diagnosis Procedure"](#).

Is the inspection result normal?

YES >> GO TO 5.

NO >> Repair or replace damaged parts.

5.DETECT MALFUNCTIONING ITEM

Check the following.

- The A/T assembly harness connector pin terminals for damage or loose connection with harness connector.

Is the inspection result normal?

YES >> Replace the control valve with TCM. Refer to [TM-286, "Removal and Installation"](#).

NO >> Repair or replace damaged parts.

A
B
C
TM
E
F
G
H
I
J
K
L
M
N
O
P

P0731 1GR INCORRECT RATIO

< DTC/CIRCUIT DIAGNOSIS >

[5AT: RE5R05A]

P0731 1GR INCORRECT RATIO

Description

INFOID:000000008790860

This malfunction is detected when the A/T does not shift into 1GR position as instructed by TCM. This is not only caused by electrical malfunction (circuits open or shorted) but mechanical malfunction such as control valve sticking, improper solenoid valve operation.

On Board Diagnosis Logic

INFOID:000000008790861

- This is an OBD-II self-diagnostic item.
- Diagnostic trouble code "P0731" with CONSULT or 18th judgment flicker without CONSULT is detected when TCM detects any inconsistency in the actual gear ratio.

Possible Cause

INFOID:000000008790862

- Input clutch solenoid valve
- Front brake solenoid valve
- Direct clutch solenoid valve
- High and low reverse clutch solenoid valve
- Each clutch
- Hydraulic control circuit

DTC Confirmation Procedure

INFOID:000000008790863

CAUTION:

Always drive vehicle at a safe speed.

NOTE:

If "DTC Confirmation Procedure" has been previously performed, always turn ignition switch OFF and wait at least 10 seconds before performing the next test.

After the repair, perform the following procedure to confirm the malfunction is eliminated.

WITH CONSULT

1. Start the engine and select "DATA MONITOR" mode for "TRANSMISSION" with CONSULT.
2. Make sure that "ATF TEMP 1" is within the following range.
ATF TEMP 1: 20°C – 180°C (68°F – 356°F)
If out of range, drive vehicle to warm ATF or stop engine to cool ATF.
3. Select "1ST GR FNCTN P0731" of "DTC & SRT CONFIRMATION" mode for "TRANSMISSION" with CONSULT.
4. Drive vehicle and maintain the following conditions.
SLCT LVR POSI: "1" position
GEAR: "1" position
ACCELE POSI: 0.6/8 or more
VEHICLE SPEED: 10 km/h (6 MPH) or more
ENGINE SPEED: INPUT SPEED – 50 rpm or more
INPUT SPEED: 300 rpm or more
5. Keep the current driving status for at least 5 consecutive seconds if CONSULT screen changes from "OUT OF CONDITION" to "TESTING".
CAUTION:
If "TESTING" does not appear on CONSULT for a long time, select "SELF-DIAG RESULTS". In case a 1st trip DTC other than P0731 is shown, refer to [TM-156, "CONSULT Function \(TRANSMISSION\)"](#). If "COMPLETED RESULT NG" is detected, go to [TM-179, "Diagnosis Procedure"](#). If "STOP VEHICLE" is detected, go to the following step.
6. Stop vehicle.
7. Drive vehicle in "D" position allowing it to shift from 1GR to 5GR and check shift timing and shift shock.
 - Touch "OK" to complete the inspection when normally shifted from the 1GR to 5GR.
 - Touch "NG" when an unusual shift shock, etc. occurs in spite of shifting from the 1GR to 5GR. Go to [TM-277, "Check Before Engine Is Started"](#).
 - Perform [TM-156, "CONSULT Function \(TRANSMISSION\)"](#) when not shifted from the 1GR to 5GR. (Neither "OK" nor "NG" are indicated.)

WITH GST

1. Start the engine.

P0731 1GR INCORRECT RATIO

[5AT: RE5R05A]

< DTC/CIRCUIT DIAGNOSIS >

2. Drive vehicle for approximately 5 minutes in urban areas.
3. Drive vehicle and maintain the following conditions for at least 5 consecutive seconds.
Selector lever: "1" position
Gear position: "1" position
Accelerator opening: 0.6/8 or more
Vehicle speed: 10 km/h (6 MPH) or more
4. Check DTC.
5. If DTC is detected, go to [TM-179, "Diagnosis Procedure"](#).

Diagnosis Procedure

INFOID:000000008790864

1. CHECK CAN COMMUNICATION LINE

Perform self-diagnosis. Refer to [TM-156, "CONSULT Function \(TRANSMISSION\)"](#), [TM-161, "Diagnosis Procedure without CONSULT"](#).

Is a malfunction in the CAN communication indicated in the results?

- YES >> Check CAN communication line. Refer to [TM-165, "Diagnosis Procedure"](#).
NO >> GO TO 2.

2. CHECK TCM POWER SUPPLY AND GROUND CIRCUIT

Check TCM power supply and ground circuit. Refer to [TM-216, "Diagnosis Procedure"](#).

OK or NG

- OK >> GO TO 3.
NG >> Repair or replace damaged parts.

3. DETECT MALFUNCTION ITEM

Check A/T assembly harness connector pin terminals for damage or loose connection with harness connector.

OK or NG

- OK >> GO TO 4.
NG >> Repair or replace damaged parts.

4. REPLACE CONTROL VALVE WITH TCM

1. Replace control valve with TCM. Refer to [TM-286, "Removal and Installation"](#).
2. Perform [TM-178, "DTC Confirmation Procedure"](#).

OK or NG

- OK >> **INSPECTION END**
NG >> Confirm malfunction phenomena by "ROAD TEST" to repair malfunctioning part. Refer to [TM-277, "Check Before Engine Is Started"](#).

P0732 2GR INCORRECT RATIO

Description

INFOID:000000008790865

This malfunction is detected when the A/T does not shift into 2GR position as instructed by TCM. This is not only caused by electrical malfunction (circuits open or shorted) but mechanical malfunction such as control valve sticking, improper solenoid valve operation.

On Board Diagnosis Logic

INFOID:000000008790866

- This is an OBD-II self-diagnostic item.
- Diagnostic trouble code “P0732” with CONSULT or 19th judgment flicker without CONSULT is detected when TCM detects any inconsistency in the actual gear ratio.

Possible Cause

INFOID:000000008790867

- Input clutch solenoid valve
- Front brake solenoid valve
- Direct clutch solenoid valve
- High and low reverse clutch solenoid valve
- Each clutch
- Hydraulic control circuit

DTC Confirmation Procedure

INFOID:000000008790868

CAUTION:

Always drive vehicle at a safe speed.

NOTE:

If “DTC Confirmation Procedure” has been previously performed, always turn ignition switch OFF and wait at least 10 seconds before performing the next test.

After the repair, perform the following procedure to confirm the malfunction is eliminated.

 WITH CONSULT

1. Start the engine and select “DATA MONITOR” mode for “TRANSMISSION” with CONSULT.
2. Make sure that “ATF TEMP 1” is within the following range.
ATF TEMP 1: 20°C – 180°C (68°F – 356°F)
 If out of range, drive vehicle to warm ATF or stop engine to cool ATF.
3. Select “2ND GR FNCTN P0732” of “DTC & SRT CONFIRMATION” mode for “TRANSMISSION” with CONSULT.
4. Drive vehicle and maintain the following conditions.
SLCT LVR POSI: “2” position
GEAR: “2” position
ACCELE POSI: 0.6/8 or more
VEHICLE SPEED: 10 km/h (6 MPH) or more
ENGINE SPEED: INPUT SPEED – 50 rpm or more
INPUT SPEED: 300 rpm or more
5. Keep the current driving status for at least 5 consecutive seconds if CONSULT screen changes from “OUT OF CONDITION” to “TESTING”.
CAUTION:
If “TESTING” does not appear on CONSULT for a long time, select “SELF-DIAG RESULTS”. In case a 1st trip DTC other than P0732 is shown, refer to “[TM-156, “CONSULT Function \(TRANSMISSION\)”](#)”.
 If “COMPLETED RESULT NG” is detected, go to [TM-181, “Diagnosis Procedure”](#).
 If “STOP VEHICLE” is detected, go to the following step.
6. Stop vehicle.
7. Drive vehicle in “D” position allowing it to shift from 1GR to 5GR and check shift timing and shift shock.
 - Touch “OK” to complete the inspection when normally shifted from the 1GR to 5GR.
 - Touch “NG” when an unusual shift shock, etc. occurs in spite of shifting from the 1GR to 5GR. Go to [TM-277, “Check Before Engine Is Started”](#).
 - Perform [TM-156, “CONSULT Function \(TRANSMISSION\)”](#) when not shifted from the 1GR to 5GR. (Neither “OK” nor “NG” are indicated.)

 WITH GST

P0732 2GR INCORRECT RATIO

< DTC/CIRCUIT DIAGNOSIS >

[5AT: RE5R05A]

1. Start the engine.
2. Drive vehicle for approximately 5 minutes in urban areas.
3. Drive vehicle and maintain the following conditions for at least 5 consecutive seconds.
Selector lever: "2" position
Gear position: "2" position
Accelerator opening: 0.6/8 or more
Vehicle speed: 10 km/h (6 MPH) or more
4. Check DTC.
5. If DTC is detected, go to [TM-181, "Diagnosis Procedure"](#).

Diagnosis Procedure

INFOID:000000008790869

1. CHECK CAN COMMUNICATION LINE

Perform self-diagnosis. Refer to [TM-156, "CONSULT Function \(TRANSMISSION\)"](#), [TM-161, "Diagnosis Procedure without CONSULT"](#).

Is a malfunction in the CAN communication indicated in the results?

- YES >> Check CAN communication line. Refer to [TM-165, "Diagnosis Procedure"](#).
NO >> GO TO 2.

2. CHECK TCM POWER SUPPLY AND GROUND CIRCUIT

Check TCM power supply and ground circuit. Refer to [TM-216, "Diagnosis Procedure"](#).

OK or NG

- OK >> GO TO 3.
NG >> Repair or replace damaged parts.

3. DETECT MALFUNCTION ITEM

Check A/T assembly harness connector pin terminals for damage or loose connection with harness connector.

OK or NG

- OK >> GO TO 4.
NG >> Repair or replace damaged parts.

4. REPLACE CONTROL VALVE WITH TCM

1. Replace control valve with TCM. Refer to [TM-286, "Removal and Installation"](#).
2. Perform [TM-180, "DTC Confirmation Procedure"](#).

OK or NG

- OK >> **INSPECTION END**
NG >> Confirm malfunction phenomena by "ROAD TEST" to repair malfunctioning part. Refer to [TM-277, "Check Before Engine Is Started"](#).

P0733 3GR INCORRECT RATIO

< DTC/CIRCUIT DIAGNOSIS >

[5AT: RE5R05A]

P0733 3GR INCORRECT RATIO

Description

INFOID:000000008790870

This malfunction is detected when the A/T does not shift into 3GR position as instructed by TCM. This is not only caused by electrical malfunction (circuits open or shorted) but mechanical malfunction such as control valve sticking, improper solenoid valve operation.

On Board Diagnosis Logic

INFOID:000000008790871

- This is an OBD-II self-diagnostic item.
- Diagnostic trouble code “P0733” with CONSULT or 20th judgment flicker without CONSULT is detected when TCM detects any inconsistency in the actual gear ratio.

Possible Cause

INFOID:000000008790872

- Input clutch solenoid valve
- Front brake solenoid valve
- Direct clutch solenoid valve
- High and low reverse clutch solenoid valve
- Each clutch
- Hydraulic control circuit

DTC Confirmation Procedure

INFOID:000000008790873

CAUTION:

Always drive vehicle at a safe speed.

NOTE:

If “DTC Confirmation Procedure” has been previously performed, always turn ignition switch OFF and wait at least 10 seconds before performing the next test.

After the repair, perform the following procedure to confirm the malfunction is eliminated.

WITH CONSULT

1. Start the engine and select “DATA MONITOR” mode for “TRANSMISSION” with CONSULT.
2. Make sure that “ATF TEMP 1” is within the following range.
ATF TEMP 1: 20°C – 180°C (68°F – 356°F)
If out of range, drive vehicle to warm ATF or stop engine to cool ATF.
3. Select “3RD GR FNCTN P0733” of “DTC & SRT CONFIRMATION” mode for “TRANSMISSION” with CONSULT.
4. Drive vehicle and maintain the following conditions.
SLCT LVR POSI: “3” position
GEAR: “3” position
ACCELE POSI: 0.6/8 or more
VEHICLE SPEED: 10 km/h (6 MPH) or more
ENGINE SPEED: INPUT SPEED – 50 rpm or more
INPUT SPEED: 300 rpm or more
5. Keep the current driving status for at least 5 consecutive seconds if CONSULT screen changes from “OUT OF CONDITION” to “TESTING”.
CAUTION:
If “TESTING” does not appear on CONSULT for a long time, select “SELF-DIAG RESULTS”. In case a 1st trip DTC other than P0733 is shown, refer to “[TM-156, “CONSULT Function \(TRANSMISSION\)”](#)”.
If “COMPLETED RESULT NG” is detected, go to [TM-183, “Diagnosis Procedure”](#).
If “STOP VEHICLE” is detected, go to the following step.
6. Stop vehicle.
7. Drive vehicle in “D” position allowing it to shift from 1GR to 5GR and check shift timing and shift shock.
 - Touch “OK” to complete the inspection when normally shifted from the 1GR to 5GR.
 - Touch “NG” when an unusual shift shock, etc. occurs in spite of shifting from the 1GR to 5GR. Go to [TM-277, “Check Before Engine Is Started”](#).
 - Perform [TM-156, “CONSULT Function \(TRANSMISSION\)”](#) when not shifted from the 1GR to 5GR. (Neither “OK” nor “NG” are indicated.)

WITH GST

P0733 3GR INCORRECT RATIO

< DTC/CIRCUIT DIAGNOSIS >

[5AT: RE5R05A]

1. Start the engine.
2. Drive vehicle for approximately 5 minutes in urban areas.
3. Drive vehicle and maintain the following conditions for at least 5 consecutive seconds.
Selector lever: "3" position
Gear position: "3" position
Accelerator opening: 0.6/8 or more
Vehicle speed: 10 km/h (6 MPH) or more
4. Check DTC.
5. If DTC is detected, go to [TM-183. "Diagnosis Procedure"](#).

Diagnosis Procedure

INFOID:000000008790874

1. CHECK CAN COMMUNICATION LINE

Perform self-diagnosis. Refer to [TM-156. "CONSULT Function \(TRANSMISSION\)"](#), [TM-161. "Diagnosis Procedure without CONSULT"](#).

Is a malfunction in the CAN communication indicated in the results?

- YES >> Check CAN communication line. Refer to [TM-165. "Diagnosis Procedure"](#).
NO >> GO TO 2.

2. CHECK TCM POWER SUPPLY AND GROUND CIRCUIT

Check TCM power supply and ground circuit. Refer to [TM-216. "Diagnosis Procedure"](#).

OK or NG

- OK >> GO TO 3.
NG >> Repair or replace damaged parts.

3. DETECT MALFUNCTION ITEM

Check A/T assembly harness connector pin terminals for damage or loose connection with harness connector.

OK or NG

- OK >> GO TO 4.
NG >> Repair or replace damaged parts.

4. REPLACE CONTROL VALVE WITH TCM

1. Replace control valve with TCM. Refer to [TM-286. "Removal and Installation"](#).
2. Perform [TM-182. "DTC Confirmation Procedure"](#).

OK or NG

- OK >> **INSPECTION END**
NG >> Confirm malfunction phenomena by "ROAD TEST" to repair malfunctioning part. Refer to [TM-277. "Check Before Engine Is Started"](#).

P0734 4GR INCORRECT RATIO

< DTC/CIRCUIT DIAGNOSIS >

[5AT: RE5R05A]

P0734 4GR INCORRECT RATIO

Description

INFOID:000000008790875

This malfunction is detected when the A/T does not shift into 4GR position as instructed by TCM. This is not only caused by electrical malfunction (circuits open or shorted) but mechanical malfunction such as control valve sticking, improper solenoid valve operation.

On Board Diagnosis Logic

INFOID:000000008790876

- This is an OBD-II self-diagnostic item.
- Diagnostic trouble code "P0734" with CONSULT or 21st judgment flicker without CONSULT is detected when TCM detects any inconsistency in the actual gear ratio.

Possible Cause

INFOID:000000008790877

- Input clutch solenoid valve
- Front brake solenoid valve
- Direct clutch solenoid valve
- High and low reverse clutch solenoid valve
- Each clutch
- Hydraulic control circuit

DTC Confirmation Procedure

INFOID:000000008790878

CAUTION:

Always drive vehicle at a safe speed.

NOTE:

If "DTC Confirmation Procedure" has been previously performed, always turn ignition switch OFF and wait at least 10 seconds before performing the next test.

After the repair, perform the following procedure to confirm the malfunction is eliminated.

WITH CONSULT

1. Start the engine and select "DATA MONITOR" mode for "TRANSMISSION" with CONSULT.
2. Make sure that "ATF TEMP 1" is within the following range.
ATF TEMP 1: 20°C – 180°C (68°F – 356°F)
If out of range, drive vehicle to warm ATF or stop engine to cool ATF.
3. Select "4TH GR FNCTN P0734" of "DTC & SRT CONFIRMATION" mode for "TRANSMISSION" with CONSULT.
4. Drive vehicle and maintain the following conditions.
SLCT LVR POSI: "D" position
GEAR: "4" position
ACCELE POSI: 0.6/8 or more
VEHICLE SPEED: 10 km/h (6 MPH) or more
ENGINE SPEED: INPUT SPEED – 50 rpm or more
INPUT SPEED: 300 rpm or more
5. Keep the current driving status for at least 5 consecutive seconds if CONSULT screen changes from "OUT OF CONDITION" to "TESTING".
CAUTION:
If "TESTING" does not appear on CONSULT for a long time, select "SELF-DIAG RESULTS". In case a 1st trip DTC other than P0734 is shown, refer to "[TM-156, "CONSULT Function \(TRANSMISSION\)"](#)".
If "COMPLETED RESULT NG" is detected, go to [TM-185, "Diagnosis Procedure"](#).
If "STOP VEHICLE" is detected, go to the following step.
6. Stop vehicle.
7. Drive vehicle in "D" position allowing it to shift from 1GR to 5GR and check shift timing and shift shock.
 - Touch "OK" to complete the inspection when normally shifted from the 1GR to 5GR.
 - Touch "NG" when an unusual shift shock, etc. occurs in spite of shifting from the 1GR to 5GR. Go to [TM-277, "Check Before Engine Is Started"](#).
 - Perform [TM-156, "CONSULT Function \(TRANSMISSION\)"](#) when not shifted from the 1GR to 5GR. (Neither "OK" nor "NG" are indicated.)

WITH GST

P0734 4GR INCORRECT RATIO

< DTC/CIRCUIT DIAGNOSIS >

[5AT: RE5R05A]

1. Start the engine.
2. Drive vehicle for approximately 5 minutes in urban areas.
3. Drive vehicle and maintain the following conditions for at least 5 consecutive seconds.
Selector lever: "D" position
Gear position: "4" position
Accelerator opening: 0.6/8 or more
Vehicle speed: 10 km/h (6 MPH) or more
4. Check DTC.
5. If DTC is detected, go to [TM-185. "Diagnosis Procedure"](#).

Diagnosis Procedure

INFOID:000000008790879

1. CHECK CAN COMMUNICATION LINE

Perform self-diagnosis. Refer to [TM-156. "CONSULT Function \(TRANSMISSION\)"](#), [TM-161. "Diagnosis Procedure without CONSULT"](#).

Is a malfunction in the CAN communication indicated in the results?

- YES >> Check CAN communication line. Refer to [TM-165. "Diagnosis Procedure"](#).
NO >> GO TO 2.

2. CHECK TCM POWER SUPPLY AND GROUND CIRCUIT

Check TCM power supply and ground circuit. Refer to [TM-216. "Diagnosis Procedure"](#).

OK or NG

- OK >> GO TO 3.
NG >> Repair or replace damaged parts.

3. DETECT MALFUNCTION ITEM

Check A/T assembly harness connector pin terminals for damage or loose connection with harness connector.

OK or NG

- OK >> GO TO 4.
NG >> Repair or replace damaged parts.

4. REPLACE CONTROL VALVE WITH TCM

1. Replace control valve with TCM. Refer to [TM-286. "Removal and Installation"](#).
2. Perform [TM-184. "DTC Confirmation Procedure"](#).

OK or NG

- OK >> **INSPECTION END**
NG >> Confirm malfunction phenomena by "ROAD TEST" to repair malfunctioning part. Refer to [TM-277. "Check Before Engine Is Started"](#).

P0735 5GR INCORRECT RATIO

< DTC/CIRCUIT DIAGNOSIS >

[5AT: RE5R05A]

P0735 5GR INCORRECT RATIO

Description

INFOID:000000008790880

This malfunction is detected when the A/T does not shift into 5GR position as instructed by TCM. This is not only caused by electrical malfunction (circuits open or shorted) but mechanical malfunction such as control valve sticking, improper solenoid valve operation.

On Board Diagnosis Logic

INFOID:000000008790881

- This is an OBD-II self-diagnostic item.
- Diagnostic trouble code “P0735” with CONSULT or 22nd judgment flicker without CONSULT is detected when TCM detects any inconsistency in the actual gear ratio.

Possible Cause

INFOID:000000008790882

- Input clutch solenoid valve
- Front brake solenoid valve
- Direct clutch solenoid valve
- High and low reverse clutch solenoid valve
- Each clutch
- Hydraulic control circuit

DTC Confirmation Procedure

INFOID:000000008790883

CAUTION:

Always drive vehicle at a safe speed.

NOTE:

If “DTC Confirmation Procedure” has been previously performed, always turn ignition switch OFF and wait at least 10 seconds before performing the next test.

After the repair, perform the following procedure to confirm the malfunction is eliminated.

WITH CONSULT

1. Start the engine and select “DATA MONITOR” mode for “TRANSMISSION” with CONSULT.
2. Make sure that “ATF TEMP 1” is within the following range.
ATF TEMP 1: 20°C – 180°C (68°F – 356°F)
If out of range, drive vehicle to warm ATF or stop engine to cool ATF.
3. Select “5TH GR FNCTN P0735” of “DTC & SRT CONFIRMATION” mode for “TRANSMISSION” with CONSULT.
4. Drive vehicle and maintain the following conditions.
SLCT LVR POSI: “D” position
GEAR: “5” position
ACCELE POSI: 0.6/8 or more
VEHICLE SPEED: 10 km/h (6 MPH) or more
ENGINE SPEED: INPUT SPEED – 50 rpm or more
INPUT SPEED: 300 rpm or more
5. Keep the current driving status for at least 5 consecutive seconds if CONSULT screen changes from “OUT OF CONDITION” to “TESTING”.
CAUTION:
If “TESTING” does not appear on CONSULT for a long time, select “SELF-DIAG RESULTS”. In case a 1st trip DTC other than P0735 is shown, refer to “[TM-156, “CONSULT Function \(TRANSMISSION\)”](#)”.
If “COMPLETED RESULT NG” is detected, go to [TM-187, “Diagnosis Procedure”](#).
If “STOP VEHICLE” is detected, go to the following step.
6. Stop vehicle.
7. Drive vehicle in “D” position allowing it to shift from 1GR to 5GR and check shift timing and shift shock.
 - Touch “OK” to complete the inspection when normally shifted from the 1GR to 5GR.
 - Touch “NG” when an unusual shift shock, etc. occurs in spite of shifting from the 1GR to 5GR. Go to [TM-277, “Check Before Engine Is Started”](#).
 - Perform [TM-156, “CONSULT Function \(TRANSMISSION\)”](#) when not shifted from the 1GR to 5GR. (Neither “OK” nor “NG” are indicated.)

WITH GST

P0735 5GR INCORRECT RATIO

< DTC/CIRCUIT DIAGNOSIS >

[5AT: RE5R05A]

1. Start the engine.
2. Drive vehicle for approximately 5 minutes in urban areas.
3. Drive vehicle and maintain the following conditions for at least 5 consecutive seconds.
Selector lever: "D" position
Gear position: "5" position
Accelerator opening: 0.6/8 or more
Vehicle speed: 10 km/h (6 MPH) or more
4. Check DTC.
5. If DTC is detected, go to [TM-187, "Diagnosis Procedure"](#).

Diagnosis Procedure

INFOID:000000008790884

1. CHECK CAN COMMUNICATION LINE

Perform self-diagnosis. Refer to [TM-156, "CONSULT Function \(TRANSMISSION\)"](#), [TM-161, "Diagnosis Procedure without CONSULT"](#).

Is a malfunction in the CAN communication indicated in the results?

- YES >> Check CAN communication line. Refer to [TM-165, "Diagnosis Procedure"](#).
NO >> GO TO 2.

2. CHECK TCM POWER SUPPLY AND GROUND CIRCUIT

Check TCM power supply and ground circuit. Refer to [TM-216, "Diagnosis Procedure"](#).

OK or NG

- OK >> GO TO 3.
NG >> Repair or replace damaged parts.

3. DETECT MALFUNCTION ITEM

Check A/T assembly harness connector pin terminals for damage or loose connection with harness connector.

OK or NG

- OK >> GO TO 4.
NG >> Repair or replace damaged parts.

4. REPLACE CONTROL VALVE WITH TCM

1. Replace control valve with TCM. Refer to [TM-286, "Removal and Installation"](#).
2. Perform [TM-186, "DTC Confirmation Procedure"](#).

OK or NG

- OK >> **INSPECTION END**
NG >> Confirm malfunction phenomena by "ROAD TEST" to repair malfunctioning part. Refer to [TM-277, "Check Before Engine Is Started"](#).

P0740 TORQUE CONVERTER

< DTC/CIRCUIT DIAGNOSIS >

[5AT: RE5R05A]

P0740 TORQUE CONVERTER

Description

INFOID:000000008790885

- The torque converter clutch solenoid valve is activated, with the gear in D4, D5 by the TCM in response to signals sent from the output speed sensor and accelerator pedal position sensor (throttle position sensor). Torque converter clutch piston operation will then be controlled.
- Lock-up operation, however, is prohibited when A/T fluid temperature is too low.
- When the accelerator pedal is depressed (less than 1/8) in lock-up condition, the engine speed should not change abruptly. If there is a big jump in engine speed, there is no lock-up.

CONSULT Reference Value in Data Monitor Mode

INFOID:000000008790886

Item name	Condition	Display value (Approx.)
TCC SOLENOID	When performing slip lock-up	0.2 - 0.4 A
	When performing lock-up	0.4 - 0.6 A

On Board Diagnosis Logic

INFOID:000000008790887

- This is an OBD-II self-diagnostic item.
- Diagnostic trouble code “P0740” with CONSULT or 3rd judgment flicker without CONSULT is detected under the following conditions.
 - When TCM detects an improper voltage drop when it tries to operate the solenoid valve.
 - When TCM detects as irregular by comparing target value with monitor value.

Possible Cause

INFOID:000000008790888

- Torque converter clutch solenoid valve
- Harness or connectors
(The solenoid circuit is open or shorted.)

DTC Confirmation Procedure

INFOID:000000008790889

CAUTION:

Always drive vehicle at a safe speed.

NOTE:

If “DTC Confirmation Procedure” has been previously performed, always turn ignition switch “OFF” and wait at least 10 seconds before performing the next test.

After the repair, perform the following procedure to confirm the malfunction is eliminated.

④ WITH CONSULT

1. Turn ignition switch “ON”. (Do not start engine.)
2. Select “DATA MONITOR” mode for “TRANSMISSION” with CONSULT.
3. Start engine and maintain the following conditions for at least 5 consecutive seconds.
VHCL/S SE-A/T: 80 km/h (50 MPH) or more
ACCELE POSI: 0.5/8 - 1.0/8
SLCT LVR POSI: “D” position
Driving location: Driving the vehicle uphill (increased engine load) will help maintain the driving conditions required for this test.
4. If DTC is detected go to [TM-188, "Diagnosis Procedure"](#).

④ WITH GST

Follow the procedure “WITH CONSULT”.

Diagnosis Procedure

INFOID:000000008790890

1. CHECK INPUT SIGNAL

④ With CONSULT

1. Turn ignition switch ON.
2. Select “MAIN SIGNALS” in “DATA MONITOR” mode for “TRANSMISSION” with CONSULT.

P0740 TORQUE CONVERTER

[5AT: RE5R05A]

< DTC/CIRCUIT DIAGNOSIS >

3. Start engine.
4. Read out the value of "TCC SOLENOID" while driving.

OK or NG

- OK >> GO TO 4.
- NG >> GO TO 2.

2.CHECK TCM POWER SUPPLY AND GROUND CIRCUIT

Check TCM power supply and ground circuit. Refer to [TM-216. "Diagnosis Procedure"](#).

OK or NG

- OK >> GO TO 3.
- NG >> Repair or replace damaged parts.

3.DETECT MALFUNCTIONING ITEM

Check the following.

- The A/T assembly harness connector pin terminals for damage or loose connection with harness connector.

OK or NG

- OK >> Replace the control valve with TCM. Refer to [TM-286. "Removal and Installation"](#).
- NG >> Repair or replace damaged parts.

4.CHECK DTC

Perform "DTC Confirmation Procedure".

- Refer to [TM-188. "DTC Confirmation Procedure"](#).

OK or NG

- OK >> **INSPECTION END**
- NG >> GO TO 2.

A
B
C
TM
E
F
G
H
I
J
K
L
M
N
O
P

P0744 TORQUE CONVERTER

< DTC/CIRCUIT DIAGNOSIS >

[5AT: RE5R05A]

P0744 TORQUE CONVERTER

Description

INFOID:000000008790891

This malfunction is detected when the A/T does not lock-up. This is not only caused by electrical malfunction (circuits open or shorted) but also by mechanical malfunction such as control valve sticking, improper solenoid valve operation, etc.

CONSULT Reference Value in Data Monitor Mode

INFOID:000000008790892

Item name	Condition	Display value (Approx.)
TCC SOLENOID	When performing slip lock-up	0.2 - 0.4 A
	When performing lock-up	0.4 - 0.6 A

On Board Diagnosis Logic

INFOID:000000008790893

- This is an OBD-II self-diagnostic item.
- Diagnostic trouble code "P0744" with CONSULT or 3rd judgment flicker without CONSULT is detected under the following conditions.
 - When A/T cannot perform lock-up even if electrical circuit is good.
 - When TCM detects as irregular by comparing difference value with slip rotation.

Possible Cause

INFOID:000000008790894

- Harness or connectors
(The solenoid circuit is open or shorted.)
- Torque converter clutch solenoid valve
- Hydraulic control circuit

DTC Confirmation Procedure

INFOID:000000008790895

CAUTION:

Always drive vehicle at a safe speed.

NOTE:

If "DTC Confirmation Procedure" has been previously performed, always turn ignition switch "OFF" and wait at least 10 seconds before performing the next test.

After the repair, perform the following procedure to confirm the malfunction is eliminated.

④ WITH CONSULT

1. Start engine.
2. Select "DATA MONITOR" mode for "TRANSMISSION" with CONSULT.
3. Drive vehicle and maintain the following conditions for at least 30 consecutive seconds.
 - ACCELE POSI: More than 1.0/8**
 - SLCT LVR POSI: "D" position**
 - TCC SOLENOID: 0.4 - 0.6 A**
 - VEHICLE SPEED: 80 km/h (50 MPH) or more**
 - Driving locations: Driving the vehicle uphill (increased engine load) will help maintain the driving conditions required for this test.**
4. If DTC is detected, go to [TM-190, "Diagnosis Procedure"](#).

④ WITH GST

Follow the procedure "WITH CONSULT".

Diagnosis Procedure

INFOID:000000008790896

1. CHECK INPUT SIGNAL

④ With CONSULT

1. Turn ignition switch ON.
2. Select "MAIN SIGNALS" in "DATA MONITOR" mode for "TRANSMISSION" with CONSULT.
3. Start the engine.

P0744 TORQUE CONVERTER

< DTC/CIRCUIT DIAGNOSIS >

[5AT: RE5R05A]

4. Read out the value of "TCC SOLENOID" while driving.

OK or NG

- OK >> GO TO 4.
- NG >> GO TO 2.

2.CHECK TCM POWER SUPPLY AND GROUND CIRCUIT

Check TCM power supply and ground circuit. Refer to [TM-216, "Diagnosis Procedure"](#).

OK or NG

- OK >> GO TO 3.
- NG >> Repair or replace damaged parts.

3.DETECT MALFUNCTIONING ITEM

Check the following.

- The A/T assembly harness connector pin terminals for damage or loose connection with harness connector.

OK or NG

- OK >> Replace the control valve with TCM. Refer to [TM-286, "Removal and Installation"](#).
- NG >> Repair or replace damaged parts.

4.CHECK DTC

Perform "DTC Confirmation Procedure".

- Refer to [TM-190, "DTC Confirmation Procedure"](#).

OK or NG

- OK >> **INSPECTION END**
- NG >> GO TO 2.

A
B
C
TM
E
F
G
H
I
J
K
L
M
N
O
P

P0745 PRESSURE CONTROL SOLENOID A

< DTC/CIRCUIT DIAGNOSIS >

[5AT: RE5R05A]

P0745 PRESSURE CONTROL SOLENOID A

Description

INFOID:000000008790897

The line pressure solenoid valve regulates the oil pump discharge pressure to suit the driving condition in response to a signal sent from the TCM.

CONSULT Reference Value in Data Monitor Mode

INFOID:000000008790898

Item name	Condition	Display value (Approx.)
LINE PRES SOL	During driving	0.2 - 0.6 A

On Board Diagnosis Logic

INFOID:000000008790899

- This is an OBD-II self-diagnostic item.
- Diagnostic trouble code "P0745" with CONSULT or 4th judgment flicker without CONSULT is detected under the following conditions.
 - When TCM detects an improper voltage drop when it tries to operate the solenoid valve.
 - When TCM detects as irregular by comparing target value with monitor value.

Possible Cause

INFOID:000000008790900

- Harness or connectors
(The solenoid circuit is open or shorted.)
- Line pressure solenoid valve

DTC Confirmation Procedure

INFOID:000000008790901

NOTE:

If "DTC Confirmation Procedure" has been previously performed, always turn ignition switch "OFF" and wait at least 10 seconds before performing the next test.

After the repair, perform the following procedure to confirm the malfunction is eliminated.

④ WITH CONSULT

1. Turn ignition switch "ON" and select "DATA MONITOR" mode for "TRANSMISSION" with CONSULT.
2. Engine start and wait at least 5 second.
3. If DTC is detected, go to [TM-192, "Diagnosis Procedure"](#).

④ WITH GST

Follow the procedure "WITH CONSULT".

Diagnosis Procedure

INFOID:000000008790902

1.CHECK INPUT SIGNAL

④ With CONSULT

1. Turn ignition switch ON.
2. Select "MAIN SIGNALS" in "DATA MONITOR" mode for "TRANSMISSION" with CONSULT.
3. Start the engine.
4. Read out the value of "LINE PRES SOL" while driving.

OK or NG

- OK >> GO TO 4.
- NG >> GO TO 2.

2.CHECK TCM POWER SUPPLY AND GROUND CIRCUIT

Check TCM power supply and ground circuit. Refer to [TM-216, "Diagnosis Procedure"](#).

OK or NG

- OK >> GO TO 3.
- NG >> Repair or replace damaged parts.

3.DETECT MALFUNCTIONING ITEM

P0745 PRESSURE CONTROL SOLENOID A

< DTC/CIRCUIT DIAGNOSIS >

[5AT: RE5R05A]

Check the following.

- The A/T assembly harness connector pin terminals for damage or loose connection with harness connector.

OK or NG

OK >> Replace the control valve with TCM. Refer to [TM-286. "Removal and Installation"](#).

NG >> Repair or replace damaged parts.

4. CHECK DTC

Perform "DTC Confirmation Procedure".

- Refer to [TM-192. "DTC Confirmation Procedure"](#).

OK or NG

OK >> **INSPECTION END**

NG >> GO TO 2.

A
B
C
TM
E
F
G
H
I
J
K
L
M
N
O
P

P1705 TP SENSOR

< DTC/CIRCUIT DIAGNOSIS >

[5AT: RE5R05A]

P1705 TP SENSOR

Description

INFOID:000000008790903

Electric throttle control actuator consists of throttle control motor, accelerator pedal position sensor, throttle position sensor, etc. The actuator sends a signal to the ECM, and ECM sends signals to TCM with CAN communication.

CONSULT Reference Value in Data Monitor Mode

INFOID:000000008790904

Item name	Condition	Display value (Approx.)
ACCELE POSI	Released accelerator pedal.	0.0/8
	Fully depressed accelerator pedal.	8/8

On Board Diagnosis Logic

INFOID:000000008790905

- This is not an OBD-II self-diagnostic item.
- Diagnostic trouble code "P1705" with CONSULT or 15th judgment flicker without CONSULT is detected when TCM does not receive the proper accelerator pedal position signals (input by CAN communication) from ECM.

Possible Cause

INFOID:000000008790906

Harness or connectors
(The sensor circuit is open or shorted.)

DTC Confirmation Procedure

INFOID:000000008790907

NOTE:

If "DTC Confirmation Procedure" has been previously performed, always turn ignition switch "OFF" and wait at least 10 seconds before performing the next test.

After the repair, perform the following procedure to confirm the malfunction is eliminated.

Ⓟ WITH CONSULT

1. Turn ignition switch "ON". (Do not start engine.)
2. Select "DATA MONITOR" mode for "TRANSMISSION" with CONSULT.
3. Start engine and let it idle for 1 second.
4. If DTC is detected, go to [TM-194, "Diagnosis Procedure"](#).

Diagnosis Procedure

INFOID:000000008790908

1.CHECK CAN COMMUNICATION LINE

Perform the self-diagnosis. Refer to [TM-156, "CONSULT Function \(TRANSMISSION\)"](#).

Is a malfunction in the CAN communication indicated in the results?

- YES >> Check CAN communication line. Refer to [TM-165](#).
NO >> GO TO 2.

2.CHECK DTC WITH TCM

Ⓟ With CONSULT

1. Turn ignition switch ON. (Do not start engine.)
2. Select "ECU INPUT SIGNALS" in "DATA MONITOR" mode for "TRANSMISSION" with CONSULT.
3. Depress accelerator pedal and read out the value of "ACCELE POSI".
4. Select "SELF-DIAG RESULTS" mode for "TRANSMISSION" with CONSULT. Refer to [TM-156, "CONSULT Function \(TRANSMISSION\)"](#).

Is the inspection result normal?

- YES >> GO TO 4.
NO >> GO TO 3.

3.CHECK DTC WITH ECM

P1705 TP SENSOR

< DTC/CIRCUIT DIAGNOSIS >

[5AT: RE5R05A]

With CONSULT

1. Turn ignition switch ON. (Do not start engine.)
2. Select "SELF-DIAG RESULTS" mode for "ENGINE" with CONSULT. Refer to [EC-58, "CONSULT Function"](#) (QR25DE) or [EC-518, "CONSULT Function"](#) (VQ40DE).

Is the inspection result normal?

YES >> GO TO 4.

NO >> Check the DTC detected item. Refer to [EC-58, "CONSULT Function"](#) (QR25DE) or [EC-518, "CONSULT Function"](#) (VQ40DE).

- If CAN communication line is detected, go to [TM-165, "Diagnosis Procedure"](#).

4. CHECK DTC

Perform "DTC Confirmation Procedure".

- Refer to [TM-194, "DTC Confirmation Procedure"](#).

Is the inspection result normal?

YES >> **INSPECTION END**

NO >> GO TO 5.

5. CHECK TCM POWER SUPPLY AND GROUND CIRCUIT

Check TCM power supply and ground circuit. Refer to [TM-216, "Diagnosis Procedure"](#).

Is the inspection result normal?

YES >> GO TO 6.

NO >> Repair or replace damaged parts.

6. DETECT MALFUNCTIONING ITEM

Check the following.

- The A/T assembly harness connector pin terminals for damage or loose connection with harness connector.

Is the inspection result normal?

YES >> Replace the control valve with TCM. Refer to [TM-286, "Removal and Installation"](#).

NO >> Repair or replace damaged parts.

A
B
C
TM
E
F
G
H
I
J
K
L
M
N
O
P

P1710 TRANSMISSION FLUID TEMPERATURE SENSOR

< DTC/CIRCUIT DIAGNOSIS >

[5AT: RE5R05A]

P1710 TRANSMISSION FLUID TEMPERATURE SENSOR

Description

INFOID:000000008790909

The A/T fluid temperature sensor detects the A/T fluid temperature and sends a signal to the TCM.

CONSULT Reference Value in Data Monitor Mode

INFOID:000000008790910

Item name	Condition °C (°F)	Display value (Approx.)
ATF TEMP SE 1	0 (32) - 20 (68) - 80 (176)	3.3 - 2.7 - 0.9 V

On Board Diagnosis Logic

INFOID:000000008790911

- This is an OBD-II self-diagnostic item.
- Diagnostic trouble code “P1710 (A/T), P0710 (ENGINE)” with CONSULT or 10th judgment flicker without CONSULT is detected when TCM receives an excessively low or high voltage from the sensor.

Possible Cause

INFOID:000000008790912

- Harness or connectors
(The sensor circuit is open or shorted.)
- A/T fluid temperature sensor

DTC Confirmation Procedure

INFOID:000000008790913

CAUTION:

Always drive vehicle at a safe speed.

NOTE:

If “DTC Confirmation Procedure” has been previously performed, always turn ignition switch “OFF” and wait at least 10 seconds before performing the next test.

After the repair, perform the following procedure to confirm the malfunction is eliminated.

④ WITH CONSULT

1. Turn ignition switch “ON”. (Do not start engine.)
2. Select “DATA MONITOR” mode for “TRANSMISSION” with CONSULT.
3. Start engine and maintain the following conditions for at least 10 minutes (Total). (It is not necessary to maintain continuously.)
VHCL/S SE-AT: 10 km/h (6 MPH) or more
ACCELE POSI: More than 1.0/8
SLCT LVR POSI: “D” position
4. If DTC is detected, go to [TM-196, "Diagnosis Procedure"](#).

④ WITH GST

Follow the procedure “WITH CONSULT”.

Diagnosis Procedure

INFOID:000000008790914

1. CHECK A/T FLUID TEMPERATURE SENSOR SIGNAL

④ With CONSULT

1. Start engine.
2. Select “ECU INPUT SIGNALS” in “DATA MONITOR” mode for “TRANSMISSION” with CONSULT.
3. Read out the value of “ATF TEMP SE 1”.

OK or NG

- OK >> GO TO 5.
NG >> GO TO 2.

2. CHECK A/T FLUID TEMPERATURE SENSOR

Check A/T fluid temperature sensor 1. Refer to [TM-197, "Component Inspection"](#).

OK or NG

- OK >> GO TO 3.

P1710 TRANSMISSION FLUID TEMPERATURE SENSOR

< DTC/CIRCUIT DIAGNOSIS >

[5AT: RE5R05A]

NG >> Replace the control valve with TCM. Refer to [TM-286, "Removal and Installation"](#).

3. CHECK SUB-HARNESS

1. Disconnect transmission range switch connector and TCM connector.
2. Check continuity between transmission range switch connector (A) terminals and TCM connector (B) terminals.

Item	Connector	Terminal	Continuity
Transmission range switch connector	F505	6	Yes
TCM connector	F503	19	
Transmission range switch connector	F505	7	Yes
TCM connector	F503	18	

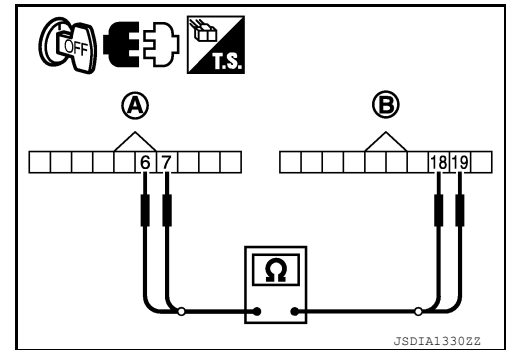

3. If OK, check harness for short to ground and short to power.

OK or NG

OK >> GO TO 4.

NG >> Replace open circuit or short to ground and short to power in harness or connectors.

4. CHECK TCM POWER SUPPLY AND GROUND CIRCUIT

1. Check TCM power supply and ground circuit. Refer to [TM-216, "Diagnosis Procedure"](#).
2. Reinstall any part removed.

OK or NG

OK >> Replace the control valve with TCM. Refer to [TM-286, "Removal and Installation"](#).

NG >> Repair or replace damaged parts.

5. CHECK DTC

Perform "DTC Confirmation Procedure".

- Refer to [TM-196, "DTC Confirmation Procedure"](#).

OK or NG

OK >> **INSPECTION END**

NG >> GO TO 1.

Component Inspection

INFOID:000000008790915

A/T FLUID TEMPERATURE SENSOR

1. Remove control valve with TCM. Refer to [TM-286, "Removal and Installation"](#).
2. Check resistance between transmission range switch connector (A) terminals.

Name	Terminal	Temperature °C (°F)	Resistance (Approx.)
A/T fluid temperature sensor	6 - 7	TM-385, "A/T Fluid Temperature Sensor"	

3. If NG, replace the control valve with TCM. Refer to [TM-286, "Removal and Installation"](#).

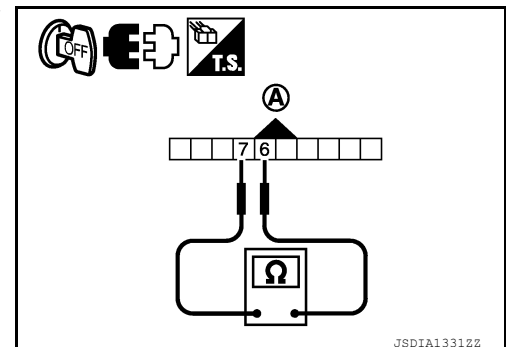

P1721 VEHICLE SPEED SIGNAL

< DTC/CIRCUIT DIAGNOSIS >

[5AT: RE5R05A]

P1721 VEHICLE SPEED SIGNAL

Description

INFOID:000000008790916

The vehicle speed signal is transmitted from combination meter to TCM by CAN communication line. The signal functions as an auxiliary device to the output speed sensor when it is malfunctioning. The TCM will then use the vehicle speed signal.

CONSULT Reference Value in Data Monitor Mode

INFOID:000000008790917

Item name	Condition	Display value (km/h)
VHCL/S SE-MTR	During driving	Approximately matches the speedometer reading.

On Board Diagnosis Logic

INFOID:000000008790918

- This is not an OBD-II self-diagnostic item.
- Diagnostic trouble code "P1721" with CONSULT is detected when TCM does not receive the proper vehicle speed signal (input by CAN communication) from combination meter.

Possible Cause

INFOID:000000008790919

Harness or connectors
(The sensor circuit is open or shorted.)

DTC Confirmation Procedure

INFOID:000000008790920

CAUTION:

Always drive vehicle at a safe speed.

NOTE:

If "DTC Confirmation Procedure" has been previously performed, always turn ignition switch "OFF" and wait at least 10 seconds before performing the next test.

After the repair, perform the following procedure to confirm the malfunction is eliminated.

Ⓟ WITH CONSULT

1. Turn ignition switch "ON". (Do not start engine.)
2. Select "DATA MONITOR" mode for "TRANSMISSION" with CONSULT.
3. Start engine and maintain the following conditions for at least 5 consecutive seconds.
ACCELE POSI: 1/8 or less
VHCL/S SE-A/T: 30 km/h (19 MPH) or more
4. If DTC is detected, go to [TM-198, "Diagnosis Procedure"](#).

Diagnosis Procedure

INFOID:000000008790921

1. CHECK CAN COMMUNICATION LINE

Perform the self-diagnosis. Refer to [TM-156, "CONSULT Function \(TRANSMISSION\)"](#).

Is malfunction in the CAN communication indicated in the result?

- YES >> Check CAN communication line. Refer to [TM-165](#).
NO >> GO TO 2.

2. CHECK INPUT SIGNAL

Ⓟ With CONSULT

1. Start engine.
2. Select "ECU INPUT SIGNALS" in "DATA MONITOR" mode for "TRANSMISSION" with CONSULT.
3. Drive vehicle and read out the value of "VHCL/S SE-MTR".

OK or NG

- OK >> GO TO 4.
NG >> GO TO 3.

3. CHECK COMBINATION METERS

Check combination meters. Refer to [MWI-5, "METER SYSTEM : System Description"](#).

P1721 VEHICLE SPEED SIGNAL

< DTC/CIRCUIT DIAGNOSIS >

[5AT: RE5R05A]

OK or NG

OK >> GO TO 4.

NG >> Repair or replace damaged parts.

4.CHECK DTC

Perform "DTC Confirmation Procedure".

- Refer to [TM-198, "DTC Confirmation Procedure"](#).

OK or NG

OK >> **INSPECTION END**

NG >> GO TO 5.

5.CHECK TCM POWER SUPPLY AND GROUND CIRCUIT

Check TCM power supply and ground circuit. Refer to [TM-216, "Diagnosis Procedure"](#).

OK or NG

OK >> GO TO 6.

NG >> Repair or replace damaged parts.

6.DETECT MALFUNCTIONING ITEM

Check the following.

- The A/T assembly harness connector pin terminals for damage or loose connection with harness connector.

OK or NG

OK >> Replace the control valve with TCM. Refer to [TM-286, "Removal and Installation"](#).

NG >> Repair or replace damaged parts.

A
B
C
TM
E
F
G
H
I
J
K
L
M
N
O
P

P1730 INTERLOCK

Description

INFOID:000000008790922

Fail-safe function to detect interlock conditions.

On Board Diagnosis Logic

INFOID:000000008790923

- This is an OBD-II self-diagnostic item.
- Diagnostic trouble code “P1730” with CONSULT or 12th judgment flicker without CONSULT is detected when TCM does not receive the proper voltage signal from the sensor and switch.
- TCM monitors and compares gear position and conditions of each ATF pressure switch when gear is steady.

Possible Cause

INFOID:000000008790924

- Harness or connectors
(The solenoid and switch circuit is open or shorted.)
- Low coast brake solenoid valve
- ATF pressure switch 2

DTC Confirmation Procedure

INFOID:000000008790925

NOTE:

If “DTC Confirmation Procedure” has been previously performed, always turn ignition switch “OFF” and wait at least 10 seconds before performing the next test.

After the repair, perform the following procedure to confirm the malfunction is eliminated.

Ⓟ WITH CONSULT

1. Turn ignition switch “ON”. (Do not start engine.)
2. Select “DATA MONITOR” mode for “TRANSMISSION” with CONSULT.
3. Start engine.
4. Drive vehicle and maintain the following conditions for at least 2 consecutive seconds.
SLCT LVR POSI: “D” position
5. If DTC is detected, go to [TM-200, "Diagnosis Procedure"](#).

Ⓟ WITH GST

Follow the procedure “WITH CONSULT”.

Judgment of Interlock

INFOID:000000008790926

When interlock is judged to be malfunctioning, the vehicle should be fixed in 2GR, and should be set in a condition in which it can travel.

When one of the following fastening patterns is detected, the fail-safe function in correspondence with the individual pattern should be performed.

NOTE:

When the vehicle is driven in 2GR, an input speed sensor malfunction is displayed, but this is not an input speed sensor malfunction.

When interlock is detected at the 3GR or more, it is locked at the 2GR.

Diagnosis Procedure

INFOID:000000008790927

1. SELF-DIAGNOSIS

Ⓟ With CONSULT

1. Drive vehicle.
2. Stop vehicle and turn ignition switch OFF.
3. Turn ignition switch ON.
4. Select “SELF-DIAG RESULTS” mode for “TRANSMISSION” with CONSULT.

Ⓟ Without CONSULT

1. Drive vehicle.
2. Stop vehicle and turn ignition switch OFF.
3. Turn ignition switch ON.

P1730 INTERLOCK

< DTC/CIRCUIT DIAGNOSIS >

[5AT: RE5R05A]

4. Perform self-diagnosis. Refer to [TM-161, "Diagnosis Procedure without CONSULT"](#).

OK or NG

OK >> GO TO 2.

NG >> Check low coast brake solenoid valve circuit and function. Refer to [TM-212](#), [TM-214](#).

2.CHECK DTC

Perform "DTC Confirmation Procedure".

• Refer to [TM-200, "DTC Confirmation Procedure"](#).

OK or NG

OK >> **INSPECTION END**

NG >> GO TO 3.

3.CHECK TCM POWER SUPPLY AND GROUND CIRCUIT

Check TCM power supply and ground circuit. Refer to [TM-216, "Diagnosis Procedure"](#).

OK or NG

OK >> GO TO 4.

NG >> Repair or replace damaged parts.

4.DETECT MALFUNCTIONING ITEM

Check the following.

• The A/T assembly harness connector pin terminals for damage or loose connection with harness connector.

OK or NG

OK >> Replace the control valve with TCM. Refer to [TM-286, "Removal and Installation"](#).

NG >> Repair or replace damaged parts.

A
B
C
TM
E
F
G
H
I
J
K
L
M
N
O
P

P1731 1ST ENGINE BRAKING

< DTC/CIRCUIT DIAGNOSIS >

[5AT: RE5R05A]

P1731 1ST ENGINE BRAKING

Description

INFOID:000000008790928

Fail-safe function to prevent sudden decrease in speed by engine brake other than at “1” position.

CONSULT Reference Value in Data Monitor Mode

INFOID:000000008790929

Item name	Condition	Display value
ON OFF SOL	Low coast brake engaged. Refer to TM-132 .	ON
	Low coast brake disengaged. Refer to TM-132 .	OFF
ATF PRES SW 2	Low coast brake engaged. Refer to TM-132 .	ON
	Low coast brake disengaged. Refer to TM-132 .	OFF

On Board Diagnosis Logic

INFOID:000000008790930

- This is not an OBD-II self-diagnostic item.
- Diagnostic trouble code “P1731” with CONSULT or 13th judgment flicker without CONSULT is detected under the following conditions.
 - When TCM does not receive the proper voltage signal from the sensor.
 - When TCM monitors each ATF pressure switch and solenoid monitor value, and detects as irregular when engine brake of 1GR acts other than at “1” position.

Possible Cause

INFOID:000000008790931

- Harness or connectors
(The sensor circuit is open or shorted.)
- Low coast brake solenoid valve
- ATF pressure switch 2

DTC Confirmation Procedure

INFOID:000000008790932

NOTE:

If “DTC Confirmation Procedure” has been previously preformed, always turn ignition switch “OFF” and wait at least 10 seconds before performing the next test.

After the repair, perform the following procedure to confirm the malfunction is eliminated.

④ WITH CONSULT

1. Turn ignition switch “ON”. (Do not start engine.)
2. Select “DATA MONITOR” mode for “TRANSMISSION” with CONSULT.
3. Start engine.
4. Drive vehicle and maintain the following conditions for at least 2 consecutive seconds.
ENGINE SPEED: 1,200 rpm
SLCT LVR POSI: “1” position
GEAR: 1st
5. If DTC is detected, go to [TM-202. "Diagnosis Procedure"](#).

Diagnosis Procedure

INFOID:000000008790933

1. CHECK INPUT SIGNALS

④ With CONSULT

1. Start the engine.
2. Select “SELECTION FROM MENU” in “DATA MONITOR” mode for “TRANSMISSION” with CONSULT.
3. Drive vehicle in the “1” position (1GR), and confirm the ON/OFF actuation of “ATF PRES SW 2” and “ON OFF SOL”.

OK or NG

- OK >> GO TO 4.
- NG >> GO TO 2.

P1731 1ST ENGINE BRAKING

< DTC/CIRCUIT DIAGNOSIS >

[5AT: RE5R05A]

2.CHECK TCM POWER SUPPLY AND GROUND CIRCUIT

Check TCM power supply and ground circuit. Refer to [TM-216, "Diagnosis Procedure"](#).

OK or NG

OK >> GO TO 3.

NG >> Repair or replace damaged parts.

3.DETECT MALFUNCTIONING ITEM

Check the following.

- The A/T assembly harness connector pin terminals for damage or loose connection with harness connector.

OK or NG

OK >> Replace the control valve with TCM. Refer to [TM-286, "Removal and Installation"](#).

NG >> Repair or replace damaged parts.

4.CHECK DTC

Perform "DTC Confirmation Procedure".

- Refer to [TM-202, "DTC Confirmation Procedure"](#).

OK or NG

OK >> **INSPECTION END**

NG >> GO TO 2.

A
B
C
TM
E
F
G
H
I
J
K
L
M
N
O
P

P1752 INPUT CLUTCH SOLENOID

< DTC/CIRCUIT DIAGNOSIS >

[5AT: RE5R05A]

P1752 INPUT CLUTCH SOLENOID

Description

INFOID:000000008790934

Input clutch solenoid valve is controlled by the TCM in response to signals sent from the transmission range switch, output speed sensor and accelerator pedal position sensor (throttle position sensor). Gears will then be shifted to the optimum position.

CONSULT Reference Value in Data Monitor Mode

INFOID:000000008790935

Item name	Condition	Display value (Approx.)
I/C SOLENOID	Input clutch disengaged. Refer to TM-132 .	0.6 - 0.8 A
	Input clutch engaged. Refer to TM-132 .	0 - 0.05 A

On Board Diagnosis Logic

INFOID:000000008790936

- This is an OBD-II self-diagnostic item.
- Diagnostic trouble code “P1752” with CONSULT or 5th judgment flicker without CONSULT is detected under the following conditions.
 - When TCM detects an improper voltage drop when it tries to operate the solenoid valve.
 - When TCM detects as irregular by comparing target value with monitor value.

Possible Cause

INFOID:000000008790937

- Harness or connectors
(The solenoid circuit is open or shorted.)
- Input clutch solenoid valve

DTC Confirmation Procedure

INFOID:000000008790938

CAUTION:

Always drive vehicle at a safe speed.

NOTE:

If “DTC Confirmation Procedure” has been previously performed, always turn ignition switch “OFF” and wait at least 10 seconds before performing the next test.

After the repair, perform the following procedure to confirm the malfunction is eliminated.

④ WITH CONSULT

1. Turn ignition switch “ON”. (Do not start engine.)
2. Select “DATA MONITOR” mode for “TRANSMISSION” with CONSULT.
3. Start engine.
4. Drive vehicle and maintain the following conditions for at least 5 consecutive seconds.
 - ACCELE POSI: 1.5/8 - 2.0/8**
 - SLCT LVR POSI: “D” position**
 - GEAR: 3rd ⇒ 4th (I/C ON/OFF)**
 - Driving location: Driving the vehicle uphill (increased engine load) will help maintain the driving conditions required for this test.**
5. If DTC is detected go to [TM-204, "Diagnosis Procedure"](#).

④ WITH GST

Follow the procedure “WITH CONSULT”.

Diagnosis Procedure

INFOID:000000008790939

1. CHECK INPUT SIGNAL

④ With CONSULT

1. Turn ignition switch ON.
2. Select “MAIN SIGNALS” in “DATA MONITOR” mode for “TRANSMISSION” with CONSULT.
3. Start the engine.
4. Read out the value of “I/C SOLENOID” while driving.

P1752 INPUT CLUTCH SOLENOID

< DTC/CIRCUIT DIAGNOSIS >

[5AT: RE5R05A]

OK or NG

OK >> GO TO 4.

NG >> GO TO 2.

2.CHECK TCM POWER SUPPLY AND GROUND CIRCUIT

Check TCM power supply and ground circuit. Refer to [TM-216. "Diagnosis Procedure"](#).

OK or NG

OK >> GO TO 3.

NG >> Repair or replace damaged parts.

3.DETECT MALFUNCTIONING ITEM

Check the following.

- The A/T assembly harness connector pin terminals for damage or loose connection with harness connector.

OK or NG

OK >> Replace the control valve with TCM. Refer to [TM-286. "Removal and Installation"](#).

NG >> Repair or replace damaged parts.

4.CHECK DTC

Perform "DTC Confirmation Procedure".

- Refer to [TM-204. "DTC Confirmation Procedure"](#).

OK or NG

OK >> **INSPECTION END**

NG >> GO TO 2.

A
B
C
TM
E
F
G
H
I
J
K
L
M
N
O
P

P1757 FRONT BRAKE SOLENOID

< DTC/CIRCUIT DIAGNOSIS >

[5AT: RE5R05A]

P1757 FRONT BRAKE SOLENOID

Description

INFOID:000000008790940

Front brake solenoid valve is controlled by the TCM in response to signals sent from the transmission range switch, output speed sensor and accelerator pedal position sensor (throttle position sensor). Gears will then be shifted to the optimum position.

CONSULT Reference Value in Data Monitor Mode

INFOID:000000008790941

Item name	Condition	Display value (Approx.)
FR/B SOLENOID	Front brake engaged. Refer to TM-132 .	0.6 - 0.8 A
	Front brake disengaged. Refer to TM-132 .	0 - 0.05 A

On Board Diagnosis Logic

INFOID:000000008790942

- This is an OBD-II self-diagnostic item.
- Diagnostic trouble code “P1757” with CONSULT or 6th judgment flicker without CONSULT is detected under the following conditions.
 - When TCM detects an improper voltage drop when it tries to operate the solenoid valve.
 - When TCM detects as irregular by comparing target value with monitor value.

Possible Cause

INFOID:000000008790943

- Harness or connectors
(The solenoid circuit is open or shorted.)
- Front brake solenoid valve

DTC Confirmation Procedure

INFOID:000000008790944

CAUTION:

Always drive vehicle at a safe speed.

NOTE:

If “DTC Confirmation Procedure” has been previously performed, always turn ignition switch “OFF” and wait at least 10 seconds before performing the next test.

After the repair, perform the following procedure to confirm the malfunction is eliminated.

WITH CONSULT

1. Turn ignition switch “ON”. (Do not start engine.)
2. Select “DATA MONITOR” mode for “TRANSMISSION” with CONSULT.
3. Start engine.
4. Drive vehicle and maintain the following conditions for at least 5 consecutive seconds.
 - ACCELE POSI: 1.5/8 - 2.0/8**
 - SLCT LVR POSI: “D” position**
 - GEAR: 3rd ⇒ 4th (FR/B ON/OFF)**
 - Driving location: Driving the vehicle uphill (increased engine load) will help maintain the driving conditions required for this test.**
5. If DTC is detected go to [TM-206, "Diagnosis Procedure"](#).

WITH GST

Follow the procedure “WITH CONSULT”.

Diagnosis Procedure

INFOID:000000008790945

1. CHECK INPUT SIGNAL

With CONSULT

1. Turn ignition switch ON.
2. Select “MAIN SIGNALS” in “DATA MONITOR” mode for “TRANSMISSION” with CONSULT.
3. Start engine.
4. Read out the value of “FR/B SOLENOID” while driving.

P1757 FRONT BRAKE SOLENOID

< DTC/CIRCUIT DIAGNOSIS >

[5AT: RE5R05A]

OK or NG

- OK >> GO TO 4.
- NG >> GO TO 2.

A

2.CHECK TCM POWER SUPPLY AND GROUND CIRCUIT

Check TCM power supply and ground circuit. Refer to [TM-216. "Diagnosis Procedure"](#).

B

OK or NG

- OK >> GO TO 3.
- NG >> Repair or replace damaged parts.

C

3.DETECT MALFUNCTIONING ITEM

Check the following.

- The A/T assembly harness connector pin terminals for damage or loose connection with harness connector.

TM

OK or NG

- OK >> Replace the control valve with TCM. Refer to [TM-286. "Removal and Installation"](#).
- NG >> Repair or replace damaged parts.

E

4.CHECK DTC

Perform "DTC Confirmation Procedure".

- Refer to [TM-206. "DTC Confirmation Procedure"](#).

F

OK or NG

- OK >> **INSPECTION END**
- NG >> GO TO 2.

G

H

I

J

K

L

M

N

O

P

P1762 DIRECT CLUTCH SOLENOID

< DTC/CIRCUIT DIAGNOSIS >

[5AT: RE5R05A]

P1762 DIRECT CLUTCH SOLENOID

Description

INFOID:000000008790946

Direct clutch solenoid valve is controlled by the TCM in response to signals sent from the transmission range switch, output speed sensor and accelerator pedal position sensor (throttle position sensor). Gears will then be shifted to the optimum position.

CONSULT Reference Value in Data Monitor Mode

INFOID:000000008790947

Item name	Condition	Display value (Approx.)
D/C SOLENOID	Direct clutch disengaged. Refer to TM-132 .	0.6 - 0.8 A
	Direct clutch engaged. Refer to TM-132 .	0 - 0.05 A

On Board Diagnosis Logic

INFOID:000000008790948

- This is an OBD-II self-diagnostic item.
- Diagnostic trouble code "P1762" with CONSULT or 2nd judgment flicker without CONSULT is detected under the following conditions.
 - When TCM detects an improper voltage drop when it tries to operate the solenoid valve.
 - When TCM detects as irregular by comparing target value with monitor value.

Possible Cause

INFOID:000000008790949

- Harness or connectors
(The solenoid circuit is open or shorted.)
- Direct clutch solenoid valve

DTC Confirmation Procedure

INFOID:000000008790950

NOTE:

If "DTC Confirmation Procedure" has been previously performed, always turn ignition switch "OFF" and wait at least 10 seconds before performing the next test.

After the repair, perform the following procedure to confirm the malfunction is eliminated.

Ⓜ WITH CONSULT

1. Turn ignition switch "ON". (Do not start engine.)
2. Select "DATA MONITOR" mode for "TRANSMISSION" with CONSULT.
3. Start engine.
4. Drive vehicle and maintain the following conditions for at least 5 consecutive seconds.
ACCELE POSI: 1.5/8 - 2.0/8
SLCT LVR POSI: "D" position
GEAR: 1st ⇒ 2nd (D/C ON/OFF)
Driving location: Driving the vehicle uphill (increased engine load) will help maintain the driving conditions required for this test.
5. If DTC is detected, go to [TM-208](#). "[Diagnosis Procedure](#)".

Ⓜ WITH GST

Follow the procedure "WITH CONSULT".

Diagnosis Procedure

INFOID:000000008790951

1. CHECK INPUT SIGNAL

Ⓜ With CONSULT

1. Turn ignition switch ON.
2. Select "MAIN SIGNALS" in "DATA MONITOR" mode for "TRANSMISSION" with CONSULT.
3. Start the engine.
4. Read out the value of "D/C SOLENOID" while driving.

OK or NG

OK >> GO TO 4.

P1762 DIRECT CLUTCH SOLENOID

< DTC/CIRCUIT DIAGNOSIS >

[5AT: RE5R05A]

NG >> GO TO 2.

2.CHECK TCM POWER SUPPLY AND GROUND CIRCUIT

Check TCM power supply and ground circuit. Refer to [TM-216, "Diagnosis Procedure"](#).

OK or NG

OK >> GO TO 3.

NG >> Repair or replace damaged parts.

3.DETECT MALFUNCTIONING ITEM

Check the following.

- The A/T assembly harness connector pin terminals for damage or loose connection with harness connector.

OK or NG

OK >> Replace the control valve with TCM. Refer to [TM-286, "Removal and Installation"](#).

NG >> Repair or replace damaged parts.

4.CHECK DTC

Perform "DTC Confirmation Procedure".

- Refer to [TM-208, "DTC Confirmation Procedure"](#).

OK or NG

OK >> **INSPECTION END**

NG >> GO TO 2.

A
B
C
TM
E
F
G
H
I
J
K
L
M
N
O
P

P1767 HIGH AND LOW REVERSE CLUTCH SOLENOID

< DTC/CIRCUIT DIAGNOSIS >

[5AT: RE5R05A]

P1767 HIGH AND LOW REVERSE CLUTCH SOLENOID

Description

INFOID:000000008790952

High and low reverse clutch solenoid valve is controlled by the TCM in response to signals sent from the transmission range switch, output speed sensor and accelerator pedal position sensor (throttle position sensor). Gears will then be shifted to the optimum position.

CONSULT Reference Value in Data Monitor Mode

INFOID:000000008790953

Item name	Condition	Display value (Approx.)
HLR/C SOL	High and low reverse clutch disengaged. Refer to TM-132 .	0.6 - 0.8 A
	High and low reverse clutch engaged. Refer to TM-132 .	0 - 0.05 A

On Board Diagnosis Logic

INFOID:000000008790954

- This is an OBD-II self-diagnostic item.
- Diagnostic trouble code “P1767” with CONSULT or 8th judgment flicker without CONSULT is detected under the following conditions.
 - When TCM detects an improper voltage drop when it tries to operate the solenoid valve.
 - When TCM detects as irregular by comparing target value with monitor value.

Possible Cause

INFOID:000000008790955

- Harness or connectors
(The solenoid circuit is open or shorted.)
- High and low reverse clutch solenoid valve

DTC Confirmation Procedure

INFOID:000000008790956

CAUTION:

Always drive vehicle at a safe speed.

NOTE:

If “DTC Confirmation Procedure” has been previously performed, always turn ignition switch “OFF” and wait at least 10 seconds before performing the next test.

After the repair, perform the following procedure to confirm the malfunction is eliminated.

WITH CONSULT

1. Turn ignition switch “ON”. (Do not start engine.)
2. Select “DATA MONITOR” mode for “TRANSMISSION” with CONSULT.
3. Start engine.
4. Drive vehicle and maintain the following conditions for at least 5 consecutive seconds.
 - ACCELE POSI: 1.5/8 - 2.0/8**
 - SLCT LVR POSI: “D” position**
 - GEAR: 2nd ⇒ 3rd (HLR/C ON/OFF)**
 - Driving location: Driving the vehicle uphill (increased engine load) will help maintain the driving conditions required for this test.**
5. If DTC is detected, go to [TM-210, "Diagnosis Procedure"](#).

WITH GST

Follow the procedure “WITH CONSULT”.

Diagnosis Procedure

INFOID:000000008790957

1. CHECK INPUT SIGNAL

With CONSULT

1. Turn ignition switch ON.
2. Select “MAIN SIGNALS” in “DATA MONITOR” mode for “TRANSMISSION” with CONSULT.
3. Start the engine.
4. Read out the value of “HLR/C SOLENOID” while driving.

P1767 HIGH AND LOW REVERSE CLUTCH SOLENOID

< DTC/CIRCUIT DIAGNOSIS >

[5AT: RE5R05A]

OK or NG

- OK >> GO TO 4.
- NG >> GO TO 2.

A

2.CHECK TCM POWER SUPPLY AND GROUND CIRCUIT

Check TCM power supply and ground circuit. Refer to [TM-216. "Diagnosis Procedure"](#).

B

OK or NG

- OK >> GO TO 3.
- NG >> Repair or replace damaged parts.

C

3.DETECT MALFUNCTIONING ITEM

Check the following.

- The A/T assembly harness connector pin terminals for damage or loose connection with harness connector.

TM

OK or NG

- OK >> Replace the control valve with TCM. Refer to [TM-286. "Removal and Installation"](#).
- NG >> Repair or replace damaged parts.

E

4.CHECK DTC

Perform "DTC Confirmation Procedure".

- Refer to [TM-210. "DTC Confirmation Procedure"](#).

F

OK or NG

- OK >> **INSPECTION END**
- NG >> GO TO 2.

G

H

I

J

K

L

M

N

O

P

P1772 LOW COAST BRAKE SOLENOID

< DTC/CIRCUIT DIAGNOSIS >

[5AT: RE5R05A]

P1772 LOW COAST BRAKE SOLENOID

Description

INFOID:000000008790958

Low coast brake solenoid valve is turned “ON” or “OFF” by the TCM in response to signals sent from the transmission range switch, output speed sensor and accelerator pedal position sensor (throttle position sensor). Gears will then be shifted to the optimum position.

CONSULT Reference Value in Data Monitor Mode

INFOID:000000008790959

Item name	Condition	Display value
ON OFF SOL	Low coast brake engaged. Refer to TM-132 .	ON
	Low coast brake disengaged. Refer to TM-132 .	OFF

On Board Diagnosis Logic

INFOID:000000008790960

- This is an OBD-II self-diagnostic item.
- Diagnostic trouble code “P1772” with CONSULT or 7th judgment flicker without CONSULT is detected when TCM detects an improper voltage drop when it tries to operate the solenoid valve.

Possible Cause

INFOID:000000008790961

- Harness or connectors
(The solenoid circuit is open or shorted.)
- Low coast brake solenoid valve

DTC Confirmation Procedure

INFOID:000000008790962

NOTE:

If “DTC Confirmation Procedure” has been previously performed, always turn ignition switch “OFF” and wait at least 10 seconds before performing the next test.

After the repair, perform the following procedure to confirm the malfunction is eliminated.

Ⓟ WITH CONSULT

1. Turn ignition switch “ON”. (Do not start engine.)
2. Select “DATA MONITOR” mode for “ENGINE” with CONSULT.
3. Start engine.
4. Drive vehicle and maintain the following conditions for at least 5 consecutive seconds.
SLCT LVR POSI: “1” or “2”
GEAR: “1st” or “2nd” (LC/B ON/OFF)
5. If DTC is detected, go to [TM-212, "Diagnosis Procedure"](#).

Ⓟ WITH GST

Follow the procedure “WITH CONSULT”.

Diagnosis Procedure

INFOID:000000008790963

1. CHECK INPUT SIGNAL

Ⓟ With CONSULT

1. Turn ignition switch ON.
2. Select “SELECTION FROM MENU” in “DATA MONITOR” mode for “TRANSMISSION” with CONSULT.
3. Start the engine.
4. Read out the value of “ON OFF SOL” while driving.

OK or NG

- OK >> GO TO 4.
- NG >> GO TO 2.

2. CHECK TCM POWER SUPPLY AND GROUND CIRCUIT

Check TCM power supply and ground circuit. Refer to [TM-216, "Diagnosis Procedure"](#).

P1772 LOW COAST BRAKE SOLENOID

< DTC/CIRCUIT DIAGNOSIS >

[5AT: RE5R05A]

OK or NG

OK >> GO TO 3.

NG >> Repair or replace damaged parts.

3.DETECT MALFUNCTIONING ITEM

Check the following.

- The A/T assembly harness connector pin terminals for damage or loose connection with harness connector.

OK or NG

OK >> Replace the control valve with TCM. Refer to [TM-286. "Removal and Installation"](#).

NG >> Repair or replace damaged parts.

4.CHECK DTC

Perform "DTC Confirmation Procedure".

- Refer to [TM-212. "DTC Confirmation Procedure"](#).

OK or NG

OK >> **INSPECTION END**

NG >> GO TO 2.

A
B
C
TM
E
F
G
H
I
J
K
L
M
N
O
P

P1774 LOW COAST BRAKE SOLENOID

< DTC/CIRCUIT DIAGNOSIS >

[5AT: RE5R05A]

P1774 LOW COAST BRAKE SOLENOID

Description

INFOID:000000008790964

- Low coast brake solenoid valve is turned “ON” or “OFF” by the TCM in response to signals sent from the transmission range switch, output speed sensor and accelerator pedal position sensor (throttle position sensor). Gears will then be shifted to the optimum position.
- This is not only caused by electrical malfunction (circuits open or shorted) but also by mechanical malfunction such as control valve sticking, improper solenoid valve operation.

CONSULT Reference Value in Data Monitor Mode

INFOID:000000008790965

Item name	Condition	Display value
ON OFF SOL	Low coast brake engaged. Refer to TM-132 .	ON
	Low coast brake disengaged. Refer to TM-132 .	OFF
ATF PRES SW 2	Low coast brake engaged. Refer to TM-132 .	ON
	Low coast brake disengaged. Refer to TM-132 .	OFF

On Board Diagnosis Logic

INFOID:000000008790966

- This is an OBD-II self-diagnostic item.
- Diagnostic trouble code “P1774” with CONSULT or 7th judgment flicker without CONSULT is detected under the following conditions.
 - When TCM detects that actual gear ratio is irregular, and relation between gear position and condition of ATF pressure switch 2 is irregular during depressing accelerator pedal. (Other than during shift change)
 - When TCM detects that relation between gear position and condition of ATF pressure switch 2 is irregular during releasing accelerator pedal. (Other than during shift change)

Possible Cause

INFOID:000000008790967

- Harness or connectors
(The solenoid and switch circuits are open or shorted.)
- Low coast brake solenoid valve
- ATF pressure switch 2

DTC Confirmation Procedure

INFOID:000000008790968

CAUTION:

Always drive vehicle at a safe speed.

NOTE:

If “DTC Confirmation Procedure” has been previously performed, always turn ignition switch “OFF” and wait at least 10 seconds before performing the next test.

After the repair, perform the following procedure to confirm the malfunction is eliminated.

WITH CONSULT

1. Start engine.
2. Accelerate vehicle to maintain the following conditions.
SLCT LVR POSI: “1” or “2” position
GEAR: “1st” or “2nd” (LC/B ON/OFF)
3. Perform step “2” again.
4. Turn ignition switch “OFF”, then perform step “1” to “3” again.
5. Check “SELF-DIAG RESULTS” mode for “TRANSMISSION” with CONSULT. If DTC (P1774) is detected, refer to [TM-215, "Diagnosis Procedure"](#).
If DTC (P1772) is detected, go to [TM-212, "Diagnosis Procedure"](#).

WITH GST

Follow the procedure “WITH CONSULT”.

P1774 LOW COAST BRAKE SOLENOID

< DTC/CIRCUIT DIAGNOSIS >

[5AT: RE5R05A]

Diagnosis Procedure

INFOID:000000008790969

1. CHECK INPUT SIGNALS

Ⓜ With CONSULT

1. Start the engine.
2. Select "SELECTION FROM MENU" in "DATA MONITOR" mode for "TRANSMISSION" with CONSULT.
3. Drive vehicle in the "1" or "2" position ("11" or "22" gear), and confirm the ON/OFF actuation of the "ATF PRES SW 2" and "ON OFF SOL".

OK or NG

- OK >> GO TO 4.
NG >> GO TO 2.

2. CHECK TCM POWER SUPPLY AND GROUND CIRCUIT

Check TCM power supply and ground circuit. Refer to [TM-216, "Diagnosis Procedure"](#).

OK or NG

- OK >> GO TO 3.
NG >> Repair or replace damaged parts.

3. DETECT MALFUNCTIONING ITEM

Check the following.

- The A/T assembly harness connector pin terminals for damage or loose connection with harness connector.

OK or NG

- OK >> Replace the control valve with TCM. Refer to [TM-286, "Removal and Installation"](#).
NG >> Repair or replace damaged parts.

4. CHECK DTC

Perform "DTC Confirmation Procedure".

- Refer to [TM-214, "DTC Confirmation Procedure"](#).

OK or NG

- OK >> **INSPECTION END**
NG >> GO TO 2.

A
B
C
TM
E
F
G
H
I
J
K
L
M
N
O
P

MAIN POWER SUPPLY AND GROUND CIRCUIT

< DTC/CIRCUIT DIAGNOSIS >

[5AT: RE5R05A]

MAIN POWER SUPPLY AND GROUND CIRCUIT

Diagnosis Procedure

INFOID:000000008790970

1. CHECK TCM POWER SOURCE STEP 1

1. Turn ignition switch OFF.
2. Disconnect A/T assembly harness connector.
3. Check voltage between A/T assembly harness connector terminals and ground.

Item	Connector	Terminal	Voltage
TCM	F9	1 - Ground	Battery voltage
		2 - Ground	
		6 - Ground	0 V

OK or NG

- OK >> GO TO 2.
NG >> GO TO 3.

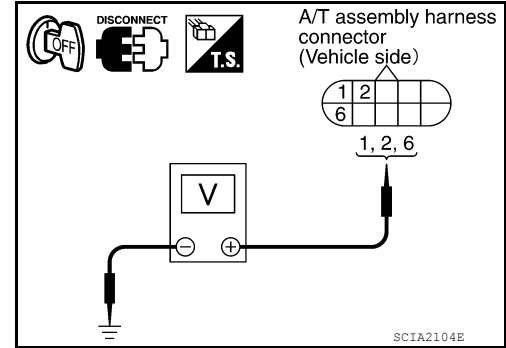

2. CHECK TCM POWER SOURCE STEP 2

1. Disconnect A/T assembly harness connector.
2. Turn ignition switch ON. (Do not start engine.)
3. Check voltage between A/T assembly harness connector terminals and ground.

Item	Connector	Terminal	Voltage
TCM	F9	1 - Ground	Battery voltage
		2 - Ground	
		6 - Ground	

OK or NG

- OK >> GO TO 4.
NG >> GO TO 3.

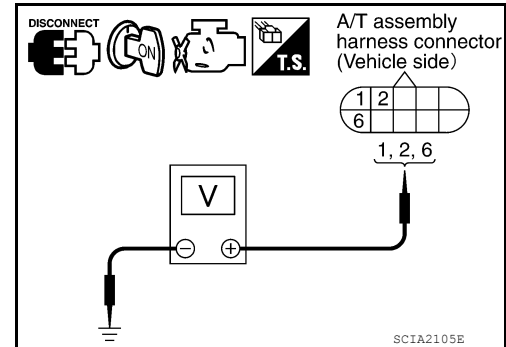

3. DETECT MALFUNCTIONING ITEM

Check the following.

- Harness for short or open between battery and A/T assembly harness connector terminals 1, 2
- Harness for short or open between ignition switch and A/T assembly harness connector terminal 6
- 10A fuse (No. 22, located in the fuse and fusible link block) and 10A fuse (No. 49, located in the IPDM E/R)
- Ignition switch. Refer to [PG-20, "Wiring Diagram—Ignition Power Supply"](#).

OK or NG

- OK >> GO TO 4.
NG >> Repair or replace damaged parts.

4. CHECK TCM GROUND CIRCUIT

1. Turn ignition switch OFF.
2. Disconnect A/T assembly harness connector.

MAIN POWER SUPPLY AND GROUND CIRCUIT

[5AT: RE5R05A]

< DTC/CIRCUIT DIAGNOSIS >

- Check continuity between A/T assembly harness connector terminals and ground.

Item	Connector	Terminal	Continuity
TCM	F9	5, 10 - Ground	Yes

If OK, check harness for short to ground and short to power.

OK or NG

- OK >> GO TO 5.
- NG >> Repair open circuit or short to ground or short to power in harness or connectors.

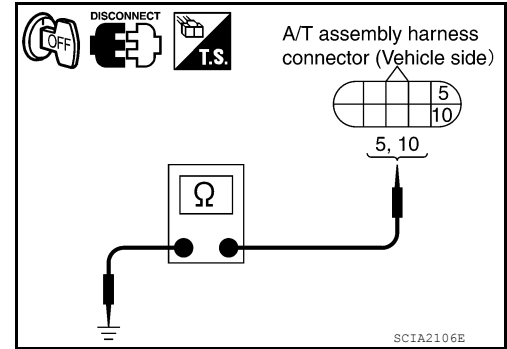

5. DETECT MALFUNCTIONING ITEM

Check the following.

- The A/T assembly harness connector terminals for damage or loose connection with harness connector.

OK or NG

- OK >> GO TO 6.
- NG >> Repair or replace damaged parts.

6. PERFORM SELF-DIAGNOSIS

Perform self-diagnosis. Refer to [TM-156, "CONSULT Function \(TRANSMISSION\)"](#).

OK or NG

- OK >> **INSPECTION END**
- NG-1 >> Self-diagnosis does not activate: GO TO 7.
- NG-2 >> DTC is displayed: Check the malfunctioning system. Refer to [TM-156, "CONSULT Function \(TRANSMISSION\)"](#).

7. CHECK TERMINAL CORD ASSEMBLY

- Remove control valve with TCM. Refer to [TM-286, "Removal and Installation"](#).
- Disconnect A/T assembly harness connector and TCM connector.
- Check continuity between A/T assembly harness connector terminals and TCM connector terminals.

Item	Connector	Terminal	Continuity
A/T assembly harness connector	F9	1	Yes
TCM connector	F502	9	
A/T assembly harness connector	F9	2	Yes
TCM connector	F502	10	
A/T assembly harness connector	F9	6	Yes
TCM connector	F502	4	

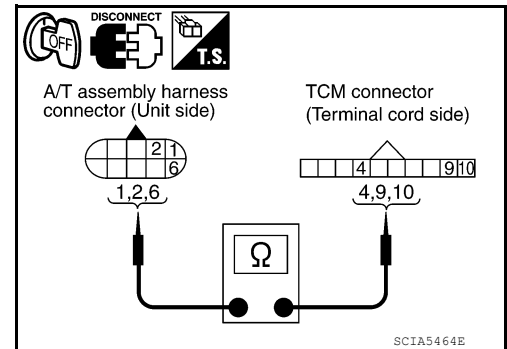

- Check continuity between A/T assembly harness connector terminals and TCM connector terminals.

Item	Connector	Terminal	Continuity
A/T assembly harness connector	F9	5	Yes
TCM connector	F504	21	
A/T assembly harness connector	F9	10	Yes
TCM connector	F504	22	

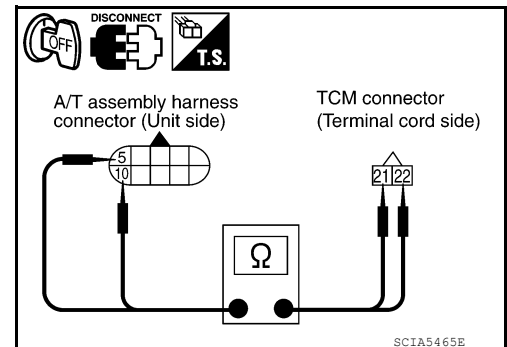

- If OK, check harness for short to ground and short to power.

OK or NG

- OK >> Replace the control valve with TCM. Refer to [TM-286, "Removal and Installation"](#).
- NG >> Replace open circuit or short to ground and short to power in harness or connectors.

CLOSED THROTTLE POSITION AND WIDE OPEN THROTTLE POSITION CIRCUIT

< DTC/CIRCUIT DIAGNOSIS >

[5AT: RE5R05A]

CLOSED THROTTLE POSITION AND WIDE OPEN THROTTLE POSITION CIRCUIT

CONSULT Reference Value in Data Monitor Mode

INFOID:000000008790971

Item name	Condition	Display value
CLSD THL POS	Released accelerator pedal.	ON
	Fully depressed accelerator pedal.	OFF
W/O THL POS	Fully depressed accelerator pedal.	ON
	Released accelerator pedal.	OFF

Diagnosis Procedure

INFOID:000000008790972

1. CHECK CAN COMMUNICATION LINE

Perform the self-diagnosis. Refer to [TM-156. "CONSULT Function \(TRANSMISSION\)"](#).

Is a malfunction in the CAN communication indicated in the results?

- YES >> Check CAN communication line. Refer to [TM-165](#).
NO >> GO TO 2.

2. CHECK THROTTLE POSITION SIGNAL CIRCUIT

With CONSULT

1. Turn ignition switch "ON". (Do not start engine.)
2. Select "ECU INPUT SIGNALS" in "DATA MONITOR" mode for "TRANSMISSION" with CONSULT.
3. Depress accelerator pedal and read out the value of "CLSD THL POS" and "W/O THL POS".

OK or NG

- OK >> **INSPECTION END**
NG >> Check the following. If NG, repair or replace damaged parts.
- Perform the self-diagnosis for "ENGINE" with CONSULT.
 - Open circuit or short to ground or short to power in harness or connectors.
 - Pin terminals for damage or loose connection with harness connector.

BRAKE SIGNAL CIRCUIT

< DTC/CIRCUIT DIAGNOSIS >

[5AT: RE5R05A]

BRAKE SIGNAL CIRCUIT

CONSULT Reference Value in Data Monitor Mode

INFOID:000000008790973

Item name	Condition	Display value
BRAKE SW	Depressed brake pedal.	ON
	Released brake pedal.	OFF

Diagnosis Procedure

INFOID:000000008790974

1. CHECK CAN COMMUNICATION LINE

Perform the self-diagnosis. Refer to [TM-156. "CONSULT Function \(TRANSMISSION\)"](#).

Is a malfunction in the CAN communication indicated in the results?

- YES >> Check CAN communication line. Refer to [TM-165](#).
 NO >> GO TO 2.

2. CHECK STOP LAMP SWITCH CIRCUIT

With CONSULT

- Turn ignition switch "ON". (Do not start engine.)
- Select "ECU INPUT SIGNALS" in "DATA MONITOR" mode for "TRANSMISSION" with CONSULT.
- Read out ON/OFF switching action of the "BRAKE SW".

OK or NG

- OK >> **INSPECTION END**
 NG >> GO TO 3.

3. CHECK STOP LAMP SWITCH

Check continuity between stop lamp switch harness connector terminals 1 and 2.

Item	Condition	Terminal	Continuity
Stop lamp switch harness connector	When brake pedal is depressed	1 - 2	Yes
	When brake pedal is released		No

Check stop lamp switch after adjusting brake pedal — refer to [BR-16. "Inspection and Adjustment"](#).

OK or NG

- OK >> Check the following. If NG, repair or replace damaged parts.
- Harness for short or open between battery and stop lamp switch.
 - Harness for short or open between stop lamp switch and combination meter.
- NG >> Repair or replace the stop lamp switch.

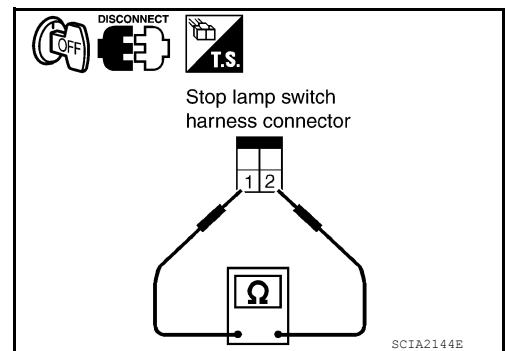

A/T SHIFT LOCK SYSTEM

Description

INFOID:000000008790975

Refer to [TM-153, "System Description"](#).

Diagnosis Procedure

INFOID:000000008790976

Regarding Wiring Diagram information, refer to [TM-238, "Wiring Diagram"](#).

1. CHECK KEY INTERLOCK CABLE

Check key interlock cable for damage.

Is the inspection result normal?

YES >> GO TO 2.

NO >> Repair key interlock cable. Refer to [TM-295, "Removal and Installation"](#).

2. CHECK SELECTOR LEVER

Check selector lever for damage. Refer to [TM-283, "Inspection and Adjustment"](#).

Is the inspection result normal?

YES >> GO TO 3.

NO >> Repair selector lever. Refer to [TM-282, "Exploded view"](#).

3. CHECK INPUT SIGNAL

1. Turn ignition switch ON.
2. Check voltage between A/T shift selector connector M156 terminal 1 and ground.

Brake pedal depressed : Battery voltage

Brake pedal released : 0V

Is the inspection result normal?

YES >> GO TO 5.

NO >> GO TO 4.

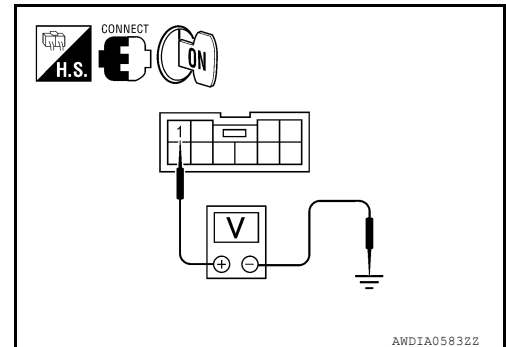

4. CHECK STOP LAMP SWITCH

1. Turn ignition switch OFF.
2. Disconnect stop lamp switch connector.
3. Check continuity between stop lamp switch terminals 3 and 4.

Brake pedal depressed : Continuity should exist

Brake pedal released : Continuity should not exist

Is the inspection result normal?

YES >> GO TO 5.

NO >> Repair or replace damaged parts.

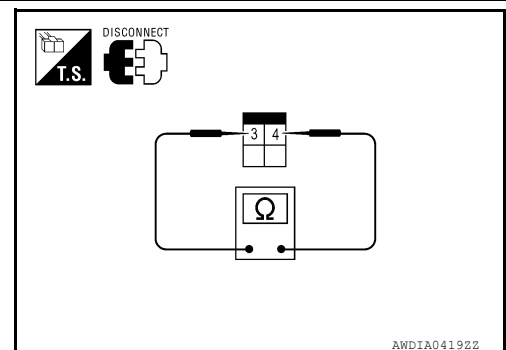

5. CHECK GROUND CIRCUIT

A/T SHIFT LOCK SYSTEM

[5AT: RE5R05A]

< DTC/CIRCUIT DIAGNOSIS >

1. Turn ignition switch OFF.
2. Disconnect A/T shift selector connector.
3. Check continuity between A/T shift selector connector M156 terminal 2 and ground.

Continuity should exist.

Is the inspection result normal?

- YES >> GO TO 6.
NO >> Repair harness or connectors.

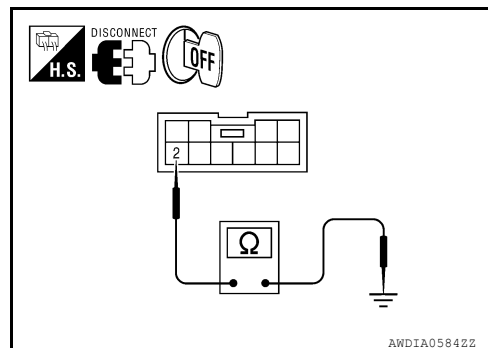

6. CHECK PARK POSITION SWITCH AND SHIFT LOCK SOLENOID

Check continuity between A/T shift selector terminals 1 and 2.

Selector lever in "P" position : Continuity should exist

Except above : Continuity should not exist

Is the inspection result normal?

- YES >> Inspection End
NO >> Replace A/T shift selector. Refer to [TM-282, "Removal and Installation"](#).

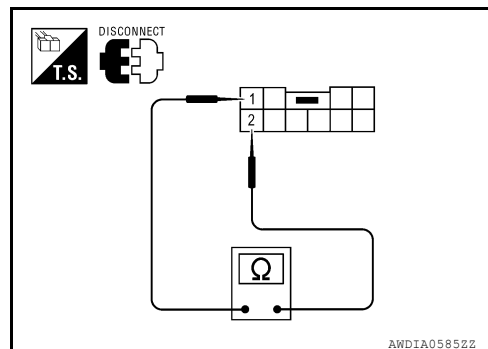

A
B
C
TM
E
F
G
H
I
J
K
L
M
N
O
P

OVERDRIVE CONTROL SWITCH

< DTC/CIRCUIT DIAGNOSIS >

[5AT: RE5R05A]

OVERDRIVE CONTROL SWITCH

CONSULT Reference Value in Data Monitor Mode

INFOID:000000008790977

Item name	Condition	Display value
OD CONT SW	Releasing overdrive control switch	OFF
	Holding overdrive control switch	ON

Diagnosis Procedure

INFOID:000000008790978

1. CHECK CAN COMMUNICATION LINE

Perform the self-diagnosis. Refer to [TM-156. "CONSULT Function \(TRANSMISSION\)"](#).

Is any malfunction in the CAN communication indicated in the results?

- YES >> Check CAN communication line. Refer to [TM-165](#).
- NO >> GO TO 2.

2. CHECK OVERDRIVE CONTROL SWITCH CIRCUIT

With CONSULT

1. Turn ignition switch "ON".
2. Select "ECU INPUT SIGNALS" in "DATA MONITOR" mode for "TRANSMISSION" with CONSULT.
3. Read out "OD CONT SW".
Check the signal of the overdrive control switch is indicated properly.

Monitor item	Condition	Display value
OD CONT SW	Releasing overdrive control switch	OFF
	Holding overdrive control switch	ON

Without CONSULT

1. Turn ignition switch "ON". (Do not start engine)
2. Check voltage between A/T shift selector connector terminal and ground.

Item	Connector	Terminal	Condition	Data (Approx.)
Overdrive control switch	M156	7 - Ground	Releasing overdrive control switch	Battery voltage
			Holding overdrive control switch	0 V

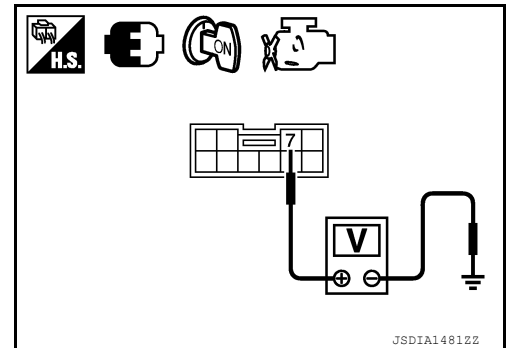

OK or NG

- OK >> GO TO 5.
- NG >> GO TO 3.

3. CHECK OVERDRIVE CONTROL SWITCH

1. Turn ignition switch "OFF".
2. Disconnect A/T shift selector connector.

OVERDRIVE CONTROL SWITCH

< DTC/CIRCUIT DIAGNOSIS >

[5AT: RE5R05A]

3. Check continuity between A/T shift selector connector terminals.

Item	Connector	Terminal	Condition	Continuity
Overdrive control switch	M156	7 - 8	Releasing overdrive control switch	No
			Holding overdrive control switch	Yes

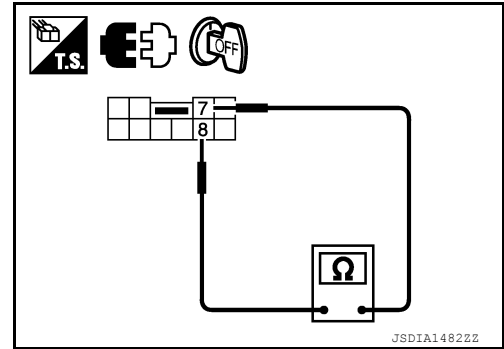

OK or NG

OK >> GO TO 4.

NG >> Repair or replace overdrive control switch.

4. DETECT MALFUNCTIONING ITEM

Check the following. If any items are damaged, repair or replace damaged parts.

- Harness for short or open between combination meter connector terminal 20 and A/T shift selector connector terminal 7.
- Harness for short or open between A/T shift selector connector terminal 8 and ground.

OK or NG

OK >> GO TO 5.

NG >> Repair or replace damaged parts.

5. CHECK COMBINATION METER

Check the combination meter. Refer to [MWI-5, "METER SYSTEM : System Description"](#).

OK or NG

OK >> **INSPECTION END**

NO >> Repair or replace damaged parts.

A
B
C
TM
E
F
G
H
I
J
K
L
M
N
O
P

1ST POSITION SWITCH

< DTC/CIRCUIT DIAGNOSIS >

[5AT: RE5R05A]

1ST POSITION SWITCH

CONSULT Reference Value in Data Monitor Mode

INFOID:000000008790979

Item name	Condition	Display value
1 POSITION SW	When setting selector lever to "1" position.	ON
	When setting selector lever to other positions.	OFF

Diagnosis Procedure

INFOID:000000008790980

1. CHECK CAN COMMUNICATION LINE

Perform the self-diagnosis. Refer to [TM-156. "CONSULT Function \(TRANSMISSION\)"](#).

Is any malfunction in the CAN communication indicated in the results?

- YES >> Check CAN communication line. Refer to [TM-165](#).
- NO >> GO TO 2.

2. CHECK 1ST POSITION SWITCH CIRCUIT

With CONSULT

1. Turn ignition switch "ON".
2. Select "ECU INPUT SIGNALS" in "DATA MONITOR" mode for "TRANSMISSION" with CONSULT.
3. Read out "1 POSITION SW".
Check the signal of the 1st position switch is indicated properly.

Monitor item	Condition	Display value
1 POSITION SW	When setting selector lever to "1" position.	ON
	When setting selector lever to other positions.	OFF

Without CONSULT

1. Turn ignition switch "ON". (Do not start engine)
2. Check voltage between A/T shift selector connector terminal and ground.

Item	Connector	Terminal	Condition	Data (Approx.)
1st position switch	M156	9 - Ground	When setting selector lever to "1" position.	0 V
			When setting selector lever to other positions.	Battery voltage

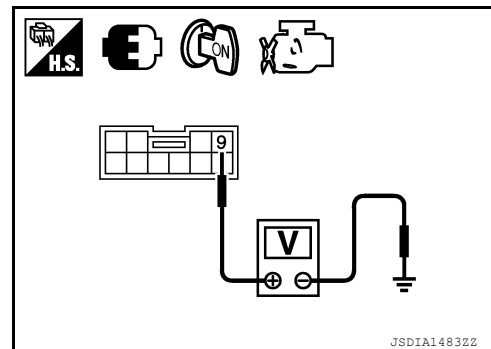

OK or NG

- OK >> GO TO 5.
- NG >> GO TO 3.

3. CHECK 1ST POSITION SWITCH

1. Turn ignition switch "OFF".
2. Disconnect A/T shift selector connector.

1ST POSITION SWITCH

[5AT: RE5R05A]

< DTC/CIRCUIT DIAGNOSIS >

3. Check continuity between A/T shift selector connector terminals.

Item	Connector	Terminal	Condition	Continuity
1st position switch	M156	9 - 10	When setting selector lever to "1" position.	Yes
			When setting selector lever to other positions.	No

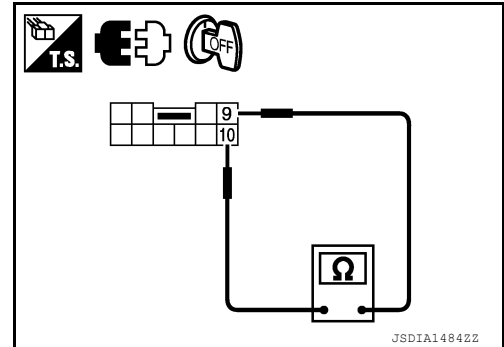

OK or NG

OK >> GO TO 4.

NG >> Repair or replace A/T shift selector assembly.

4. DETECT MALFUNCTIONING ITEM

Check the following. If any items are damaged, repair or replace damaged parts.

- Harness for short or open between combination meter connector terminal 18 and A/T shift selector connector terminal 9.
- Harness for short or open between A/T shift selector connector terminal 10 and ground.

OK or NG

OK >> GO TO 5.

NG >> Repair or replace damaged parts.

5. CHECK COMBINATION METER

Check the combination meter. Refer to [MWI-24, "Diagnosis Description"](#).

OK or NG

OK >> **INSPECTION END**

NO >> Repair or replace damaged parts.

A
B
C
TM
E
F
G
H
I
J
K
L
M
N
O
P

ECU DIAGNOSIS INFORMATION

TCM

Reference Value

INFOID:000000008790981

VALUES ON THE DIAGNOSIS TOOL

- The CONSULT electrically displays shift timing and lock-up timing (that is, operation timing of each solenoid).
Check for time difference between actual shift timing and the CONSULT display. If the difference is noticeable, mechanical parts (except solenoids, sensors, etc.) may be malfunctioning. Check mechanical parts using applicable diagnostic procedures.
- Shift schedule (which implies gear position) displayed on CONSULT and that indicated in Service Manual may differ slightly. This occurs because of the following reasons:
 - Actual shift schedule has more or less tolerance or allowance,
 - Shift schedule indicated in Service Manual refers to the point where shifts start, and
 - Gear position displayed on CONSULT indicates the point where shifts are completed.
- Display of solenoid valves on CONSULT changes at the start of shifting, while gear position is displayed upon completion of shifting (which is computed by TCM).

NOTE:

The following table includes information (items) inapplicable to this vehicle. For information (items) applicable to this vehicle, refer to CONSULT display items.

Item name	Condition	Display value (Approx.)
ATF TEMP SE 1	0°C (32° F) - 20°C (68°F) - 80°C (176°F)	3.3 - 2.7 - 0.9 V
TCC SOLENOID	When perform slip lock-up	0.2 - 0.4 A
	When perform lock-up	0.4 - 0.6 A
SLCT LVR POSI	Selector lever in "N", "P" positions.	N/P
	Selector lever in "R" position.	R
	Selector lever in "D" position.	D
	Selector lever in "3" position.	3
	Selector lever in "2" position.	2
SLCT LVR POSI	Selector lever in "1" position.	1
VHCL/S SE-A/T	During driving	Approximately matches the speedometer reading.
ENGINE SPEED	Engine running	Closely matches the tachometer reading.
LINE PRES SOL	During driving	0.2 - 0.6 A
INPUT SPEED	During driving (lock-up ON)	Approximately matches the engine speed.
VHCL/S SE-MTR	During driving	Approximately matches the speedometer reading.
ATF PRES SW 2	Low coast brake engaged. Refer to TM-132	ON
	Low coast brake disengaged. Refer to TM-132	OFF
I/C SOLENOID	Input clutch disengaged. Refer to TM-132	0.6 - 0.8 A
	Input clutch engaged. Refer to TM-132	0 - 0.05 A
FR/B SOLENOID	Front brake engaged. Refer to TM-132	0.6 - 0.8 A
	Front brake disengaged. Refer to TM-132	0 - 0.05 A
D/C SOLENOID	Direct clutch disengaged. Refer to TM-132	0.6 - 0.8 A
	Direct clutch engaged. Refer to TM-132	0 - 0.05 A
HLR/C SOL	High and low reverse clutch disengaged. Refer to TM-132	0.6 - 0.8 A
	High and low reverse clutch engaged. Refer to TM-132	0 - 0.05 A

TCM

< ECU DIAGNOSIS INFORMATION >

[5AT: RE5R05A]

Item name	Condition	Display value (Approx.)
ON OFF SOL	Low coast brake engaged. Refer to TM-132	ON
	Low coast brake disengaged. Refer to TM-132	OFF
STARTER RELAY	Selector lever in "N","P" positions.	ON
	Selector lever in other position.	OFF
ACCELE POSI	Released accelerator pedal.	0.0/8
	Fully depressed accelerator pedal.	8/8
CLSD THL POS	Released accelerator pedal.	ON
	Fully depressed accelerator pedal.	OFF
W/O THL POS	Fully depressed accelerator pedal.	ON
	Released accelerator pedal.	OFF
OD CONT SW	Releasing overdrive control switch	OFF
	Holding overdrive control switch	ON
1 POSITION SW	When setting selector lever to "1" position.	ON
	When setting selector lever to other positions.	OFF
BRAKESW	Depressed brake pedal.	ON
	Released brake pedal.	OFF

TERMINAL LAYOUT

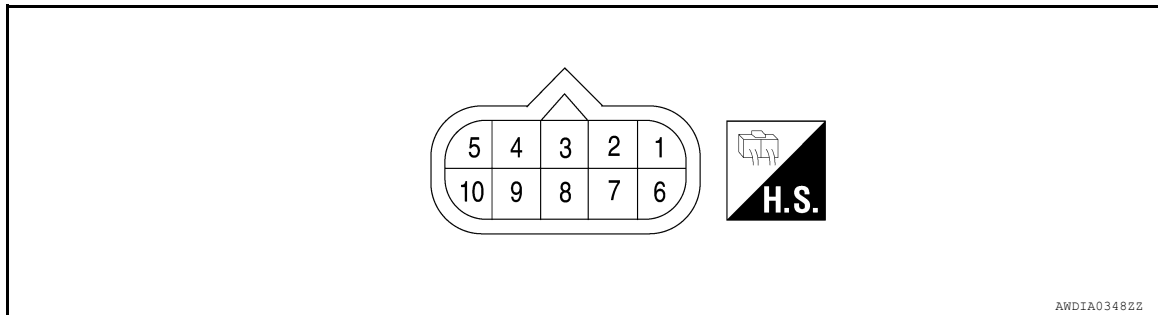

PHYSICAL VALUES

Data are reference value and are measured between each terminal and ground.

Terminal No.	Wire color	Item	Condition	Data (Approx.)
1	R/B	Power supply (Memory back-up)	Always	Battery voltage
2	R/B	Power supply (Memory back-up)	Always	Battery voltage
3	L	CAN H	—	—
4	V	K-line (CONSULT signal)	The terminal is connected to the data link connector for CONSULT.	—
5	B	Ground	Always	0 V
6	W/G	Power supply		—
				—
7	LG	Back-up lamp relay		Selector lever in "R" position.
				Selector lever in other positions.
8	P	CAN L	—	—

Terminal No.	Wire color	Item	Condition	Data (Approx.)	
9	R	Starter relay		Selector lever in "N", "P" positions.	Battery voltage
				Selector lever in other positions.	0 V
10	B	Ground	Always	0 V	

Fail-Safe

INFOID:000000008790982

The TCM has an electrical fail-safe mode. This mode makes it possible to operate even if there is an error in a main electronic control input/output signal circuit. In fail-safe mode the transmission is fixed in 2GR, 4GR or 5GR (depending on the breakdown position), so the customer should feel "slipping" or "poor acceleration". Even when the electronic circuits are normal, under special conditions (for example, when slamming on the brake with the wheels spinning drastically and stopping the tire rotation), the transmission can go into fail-safe mode. If this happens, switch "OFF" the ignition switch for 10 seconds, then switch it "ON" again to return to the normal shift pattern. Therefore, the customer's vehicle has returned to normal, so handle according to the "diagnostics flow" (Refer to [TM-129. "Diagnostic Work Sheet"](#)).

FAIL-SAFE FUNCTION

If any malfunction occurs in a sensor or solenoid, this function controls the A/T to mark driving possible.

Output Speed Sensor

- Signals are input from two systems - from output speed sensor installed on the transmission and from combination meter so normal driving is possible even if there is a malfunction in one of the systems. And if output speed has unusual cases, 5GR is prohibited.

Accelerator Pedal Position Sensor

- If there is a malfunction in one of the systems, the accelerator opening angle is controlled by ECM according to a pre-determined accelerator angle to make driving possible. And if there are malfunctions in tow systems, the engine speed is fixed by ECM to a pre-determined engine speed to make driving possible.

Throttle Position Sensor

- If there is a malfunction in one of the systems, the accelerator opening angle is controlled by ECM according to a pre-determined accelerator angle to make driving possible. And if there are malfunctions in tow systems, the accelerator opening angle is controlled by the idle signal sent from the ECM which is based on input indicating either idle condition or off-idle condition (pre-determined accelerator opening) in order to make driving possible.

Transmission Range Switch

- In the unlikely event that a malfunction signal enters the TCM, the position indicator is switched "OFF", the starter relay is switched "OFF" (starter starting is disabled), the back-up lamp relay switched "OFF" (back-up lamp is OFF) and the position is fixed to the "D" range to make driving possible.

Starter Relay

- The starter relay is switched "OFF". (Starter starting is disabled.)

Interlock

- If there is an interlock judgment malfunction, the transmission is fixed in 2GR to make driving possible.

NOTE:

When the vehicle is driven fixed in 2GR, an input speed sensor malfunction is displayed, but this is not an input speed sensor malfunction.

- When interlock is detected at the 3GR or more, it is locked at the 2GR.

1st Engine Braking

- When there is an 1st engine brake judgment malfunction, the low coast brake solenoid is switched "OFF" to avoid the engine brake operation.

Line Pressure Solenoid

- The solenoid is switched "OFF" and the line pressure is set to the maximum hydraulic pressure to make driving possible.

Torque Converter Clutch Solenoid

- The solenoid is switched "OFF" to release the lock-up.

Low Coast Brake Solenoid

- When a (electrical or functional) malfunction occurs, in order to make driving possible, the engine brake is not applied in 1GR and 2GR.

Input Clutch Solenoid

- If a (electrical or functional) malfunction occurs with the solenoid either “ON” or “OFF”, the transmission is held in 4GR to make driving possible.

Direct Clutch Solenoid

- If a (electrical or functional) malfunction occurs with the solenoid either “ON” or “OFF”, the transmission is held in 4GR to make driving possible.

Front Brake Solenoid

- If a (electrical or functional) malfunction occurs with the solenoid “ON”, in order to make driving possible, the A/T is held in 5GR; if the solenoid is OFF, 4GR.

High and Low Reverse Clutch Solenoid

- If a (electrical or functional) malfunction occurs with the solenoid either “ON” or “OFF”, the transmission is held in 4GR to make driving possible.

Input Speed Sensor 1 or 2

- The control is the same as if there were no input speed sensors, 5GR is prohibited.

DTC Inspection Priority Chart

INFOID:000000008790983

If some DTCs are displayed at the same time, perform inspections one by one based on the following priority chart.

NOTE:

If DTC U0100/U1000 is displayed with other DTCs, first perform the trouble diagnosis for DTC U0100/U1000. Refer to [TM-164](#) (U0100), [TM-165](#) (U1000).

Priority	Detected items (DTC)
1	<ul style="list-style-type: none"> • U0100 LOST COMM (ECM A) • U1000 CANCOMM CIRCUIT
2	Except above

DTC No. Index

INFOID:000000008790984

NOTE:

If DTC U0100/U1000 is displayed with other DTCs, first perform the trouble diagnosis for DTC U0100/U1000. Refer to [TM-164](#) (U0100), [TM-165](#) (U1000).

DTC		Items (CONSULT screen terms)	Reference page
OBD-II	Except OBD-II		
CONSULT GST (*1)	CONSULT only "TRANSMISSION"		
—	P0615	STARTER RELAY	TM-166
P0700	P0700	TRANSMISSION CONT	TM-168
P0705	P0705	T/M RANGE SENSOR A	TM-169
P0710	P1710	FLUID TEMP SENSOR A	TM-196
P0717	P0717	INPUT SPEED SENSOR A	TM-171
P0720	P0720	OUTPUT SPEED SENSOR	TM-173
—	P0725	ENGINE SPEED	TM-176
P0731	P0731	1GR INCORRECT RATIO	TM-188
P0732	P0732	2GR INCORRECT RATIO	TM-188
P0733	P0733	3GR INCORRECT RATIO	TM-188
P0734	P0734	4GR INCORRECT RATIO	TM-188
P0735	P0735	5GR INCORRECT RATIO	TM-188
P0740	P0740	TORQUE CONVERTER	TM-188

TCM

< ECU DIAGNOSIS INFORMATION >

[5AT: RE5R05A]

DTC		Items (CONSULT screen terms)	Reference page
OBD-II	Except OBD-II		
CONSULT GST (*1)	CONSULT only "TRANSMISSION"		
P0744 (*2)	P0744	TORQUE CONVERTER	TM-190
P0745	P0745	PC SOLENOID A	TM-192
—	P1705	TP SENSOR	TM-194
—	P1721	VEHICLE SPEED SIGNAL	TM-198
P1730	P1730	INTERLOCK	TM-200
—	P1731	1ST E/BRAKING	TM-202
P1752	P1752	INPUT CLUTCH SOL	TM-204
P1757	P1757	FR BRAKE SOLENOID	TM-206
P1762	P1762	DRCT CLUTCH SOL	TM-208
P1767	P1767	HLR CLUTCH SOLENOID	TM-210
P1772	P1772	L C BRAKE SOLENOID	TM-212
P1774 (*2)	P1774	L C BRAKE SOLENOID	TM-214
U0100	U0100	LOST COMM (ECM A)	TM-164
U1000	U1000	CAN COMM CIRCUIT	TM-165

*1: These numbers are prescribed by SAE J2012.

*2: These malfunctions cannot be displayed MIL if another malfunction is assigned to MIL.

WIRING DIAGRAM

A/T CONTROL SYSTEM

Wiring Diagram

INFOID:000000008790985

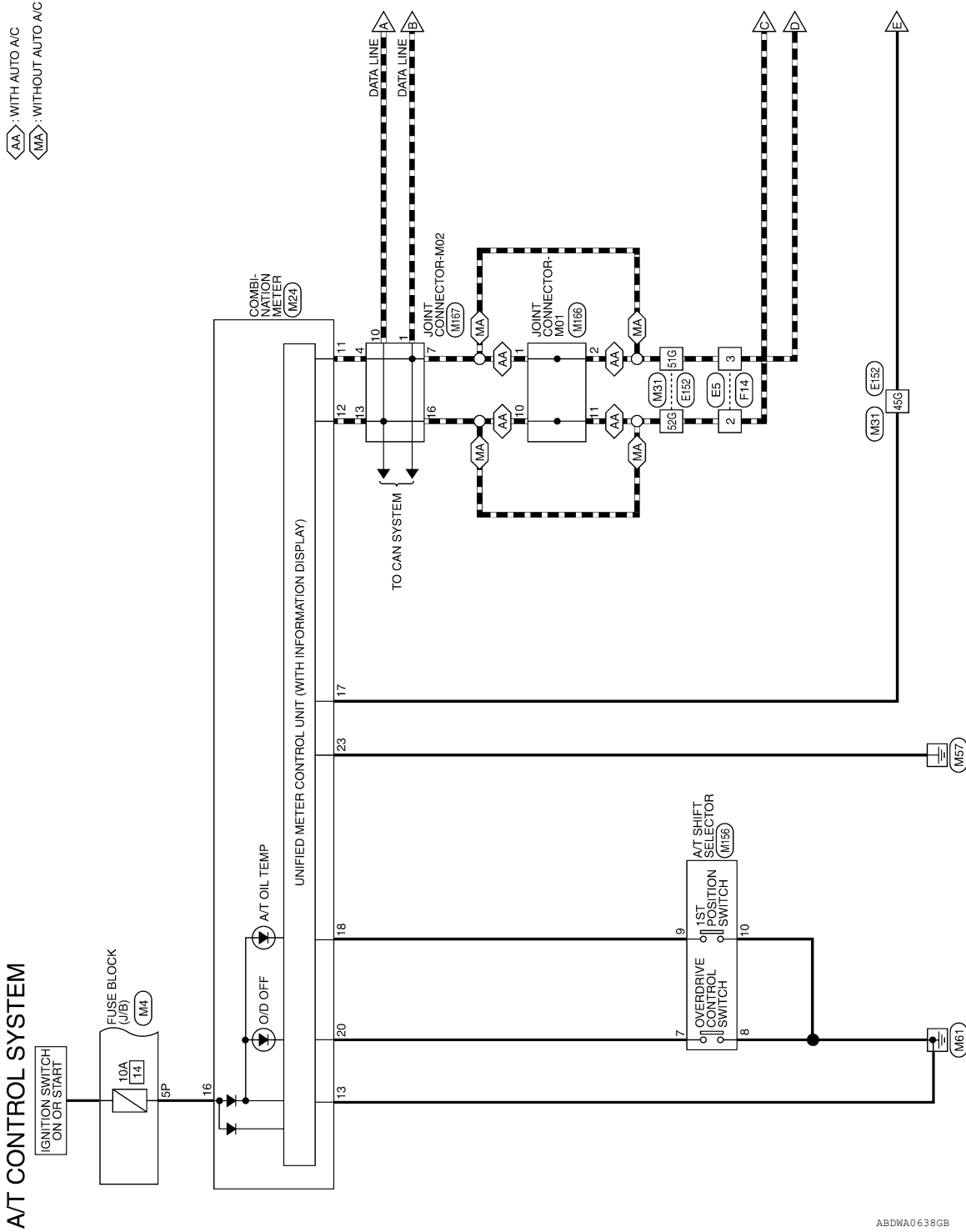

A/T CONTROL SYSTEM

AA: WITH AUTO A/C
MA: WITHOUT AUTO A/C

ABDWA0638GB

A
B
C
TM
E
F
G
H
I
J
K
L
M
N
O
P

A/T CONTROL SYSTEM

< WIRING DIAGRAM >

[5AT: RE5R05A]

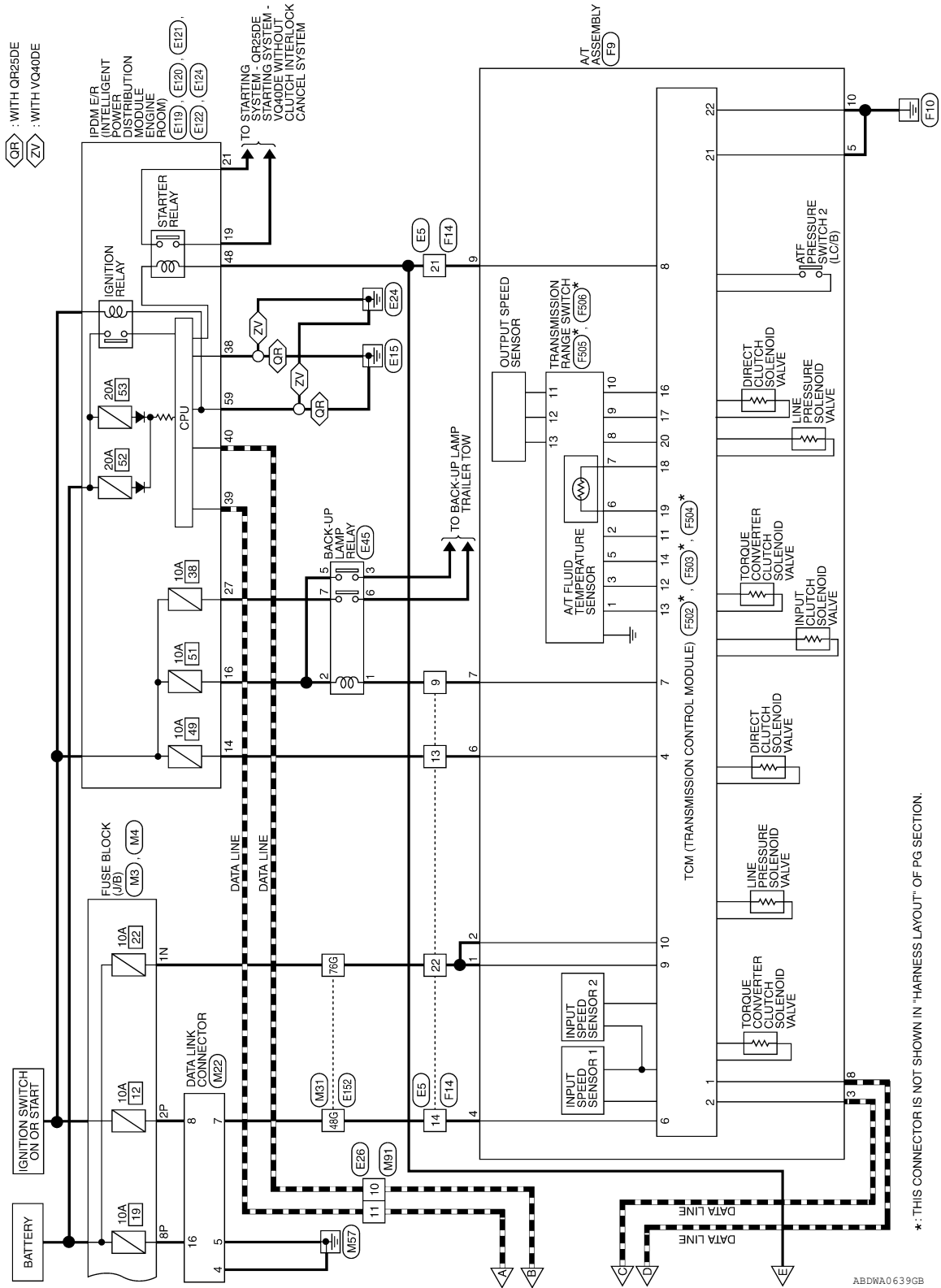

ABDWA0639GB

A/T CONTROL SYSTEM CONNECTORS

Connector No.	M3
Connector Name	FUSE BLOCK (J/B)
Connector Color	WHITE

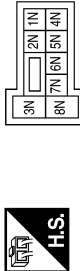

Terminal No.	Color of Wire	Signal Name
1N	R/B	-

Connector No.	M4
Connector Name	FUSE BLOCK (J/B)
Connector Color	WHITE



Terminal No.	Color of Wire	Signal Name
2P	W/G	-
5P	W/G	-
8P	R/Y	-

Connector No.	M22
Connector Name	DATA LINK CONNECTOR
Connector Color	WHITE

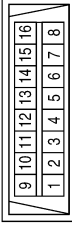

Terminal No.	Color of Wire	Signal Name
4	B	-
5	B	-
7	W	-(FOR MEXICO)
7	V	-(EXCEPT FOR MEXICO)
8	W/G	-
16	R/Y	-

Connector No.	M24
Connector Name	COMBINATION METER
Connector Color	WHITE

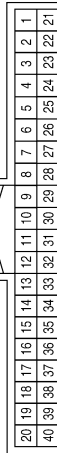

Terminal No.	Color of Wire	Signal Name
11	P	CAN-L
12	L	CAN-H
13	GR	GROUND
16	W/G	RUN START
17	B	AT-PN SWITCH
18	L	AT 1 RANGE SWITCH
20	Y	O/D OFF SWITCH
23	B	POWER GND

Connector No.	M31
Connector Name	WIRE TO WIRE
Connector Color	WHITE

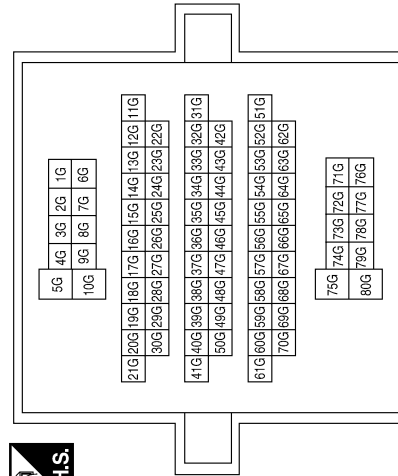

Terminal No.	Color of Wire	Signal Name
45G	B	-
48G	W	-(FOR MEXICO)
48G	V	-(EXCEPT FOR MEXICO)
51G	P	-
52G	L	-
76G	R/B	-

ABDIA0996GB

A/T CONTROL SYSTEM

< WIRING DIAGRAM >

[5AT: RE5R05A]

Connector No.	M166
Connector Name	JOINT CONNECTOR-M01
Connector Color	BLUE

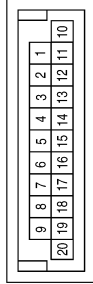

Terminal No.	Color of Wire	Signal Name
1	P	-
2	P	-
10	L	-
11	L	-

Connector No.	M156
Connector Name	A/T SHIFT SELECTOR
Connector Color	WHITE

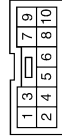

Terminal No.	Color of Wire	Signal Name
7	Y	-
8	B	-
9	L	-
10	B	-

Connector No.	M91
Connector Name	WIRE TO WIRE
Connector Color	WHITE

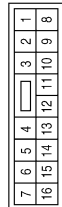

Terminal No.	Color of Wire	Signal Name
10	P	-
11	L	-

Connector No.	E26
Connector Name	WIRE TO WIRE
Connector Color	WHITE



Terminal No.	Color of Wire	Signal Name
10	P	-
11	L	-

Connector No.	E5
Connector Name	WIRE TO WIRE
Connector Color	WHITE



Terminal No.	Color of Wire	Signal Name
2	L	-
3	P	-
9	LG	-
13	W/G	-
14	V	-
21	R	-
22	R/B	-

Connector No.	M167
Connector Name	JOINT CONNECTOR-M02
Connector Color	BLUE

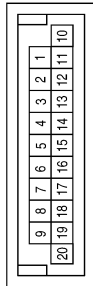

Terminal No.	Color of Wire	Signal Name
1	P	-
4	P	-
7	P	-
10	L	-
13	L	-
16	L	-

ABDIA0997GB

A/T CONTROL SYSTEM

< WIRING DIAGRAM >

[5AT: RE5R05A]

Connector No.	E120
Connector Name	IPDM E/R (INTELLIGENT POWER DISTRIBUTION MODULE ENGINE ROOM)
Connector Color	WHITE



21	20	19
24	23	22

Terminal No.	Color of Wire	Signal Name
19	W	STARTER MTR
21	GR	IGN SW (ST)

Connector No.	E119
Connector Name	IPDM E/R (INTELLIGENT POWER DISTRIBUTION MODULE ENGINE ROOM)
Connector Color	WHITE



9	8	7	6	5	4	3
18	17	16	15	14	13	12
11	10					

Terminal No.	Color of Wire	Signal Name
14	W/G	A/T ECU IGN SUPPLY
16	W/G	REVERSE LAMP

Connector No.	E45
Connector Name	BACK-UP LAMP RELAY
Connector Color	BROWN



Terminal No.	Color of Wire	Signal Name
1	LG	-
2	W/G	-
3	SB	-
5	W/G	-
6	Y	-
7	W/G	-

Connector No.	E124
Connector Name	IPDM E/R (INTELLIGENT POWER DISTRIBUTION MODULE ENGINE ROOM)
Connector Color	BLACK



59	58	57
62	61	60

Terminal No.	Color of Wire	Signal Name
59	B	GND (POWER)

Connector No.	E122
Connector Name	IPDM E/R (INTELLIGENT POWER DISTRIBUTION MODULE ENGINE ROOM)
Connector Color	WHITE



42	41	40	39	38	37
48	47	46	45	44	43

Terminal No.	Color of Wire	Signal Name
38	B	GND (SIGNAL)
39	L	CAN-H
40	P	CAN-L
48	R	RANGE SW

Connector No.	E121
Connector Name	IPDM E/R (INTELLIGENT POWER DISTRIBUTION MODULE ENGINE ROOM)
Connector Color	BROWN



29	28	27	26	25
36	35	34	33	32
31	30			

Terminal No.	Color of Wire	Signal Name
27	W/G	T TOW REV LAMP

ABDIA0817GB

A
B
C
TM
E
F
G
H
I
J
K
L
M
N
O
P

A/T CONTROL SYSTEM

< WIRING DIAGRAM >

[5AT: RE5R05A]

Connector No.	E152
Connector Name	WIRE TO WIRE
Connector Color	WHITE

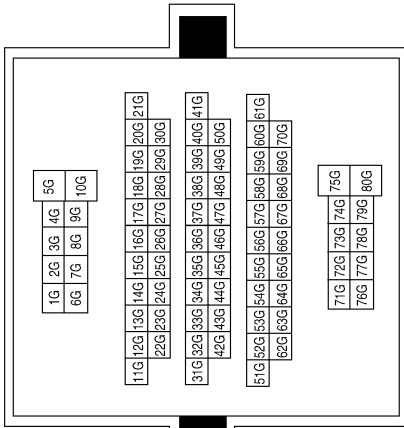

Terminal No.	Color of Wire	Signal Name
45G	B	-
48G	W	-(FOR MEXICO)
48G	V	-(EXCEPT FOR MEXICO)
51G	P	-
52G	L	-
76G	R/B	-

Connector No.	F9
Connector Name	A/T ASSEMBLY
Connector Color	GREEN

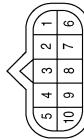

Terminal No.	Color of Wire	Signal Name
1	R/B	-
2	R/B	-
3	L	-
4	V	-
5	B	-
6	W/G	-
7	LG	-
8	P	-
9	R	-
10	B	-

Connector No.	F14
Connector Name	WIRE TO WIRE
Connector Color	WHITE

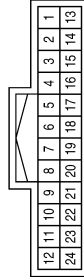

Terminal No.	Color of Wire	Signal Name
2	L	-
3	P	-
9	LG	-
13	W/G	-
14	V	-
21	R	-
22	R/B	-

Connector No.	F502
Connector Name	TCM (TRANSMISSION CONTROL MODULE)
Connector Color	GRAY

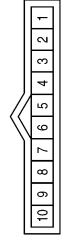

Terminal No.	Color of Wire	Signal Name
1	BR	CAN-H
2	L/Y	CAN-L
3	-	-
4	R	VIGN
5	-	-
6	L	K-LINE
7	O	REV LAMP RLY
8	G	START-RLY
9	W	STAND BY SUPPLY-1
10	GR	STAND BY SUPPLY-2

ABDIA0999GB

A/T CONTROL SYSTEM

< WIRING DIAGRAM >

[5AT: RE5R05A]

Connector No.	F505
Connector Name	TRANSMISSION RANGE SWITCH
Connector Color	GRAY

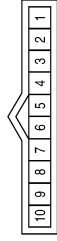

Terminal No.	Color of Wire	Signal Name
1	BR	-
2	W	-
3	GR	-
4	-	-
5	L	-
6	G	-
7	O	-
8	Y	-
9	R	-
10	B	-

Connector No.	F504
Connector Name	TCM (TRANSMISSION CONTROL MODULE)
Connector Color	WHITE



Terminal No.	Color of Wire	Signal Name
21	B	POWER GND-1
22	Y	POWER GND-2

Connector No.	F503
Connector Name	TCM (TRANSMISSION CONTROL MODULE)
Connector Color	GREEN

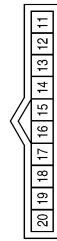

Terminal No.	Color of Wire	Signal Name
11	W	TR SW 4
12	GR	TR SW 2
13	BR	TR SW 1
14	L	TR SW 3
15	-	-
16	B	OUT SPD SEN GND
17	R	OUT SPD SEN
18	O	ATF SENS
19	G	ATF SENS
20	Y	OUT SPD SEN POWER

Connector No.	F506
Connector Name	TRANSMISSION RANGE SWITCH
Connector Color	GREEN



Terminal No.	Color of Wire	Signal Name
11	L	-
12	W	-
13	R	-

ABDIA1000GB

A
B
C
TM
E
F
G
H
I
J
K
L
M
N
O
P

A/T SHIFT LOCK SYSTEM

< WIRING DIAGRAM >

[5AT: RE5R05A]

A/T SHIFT LOCK SYSTEM

Wiring Diagram

INFOID:000000008790986

A/T SHIFT LOCK SYSTEM

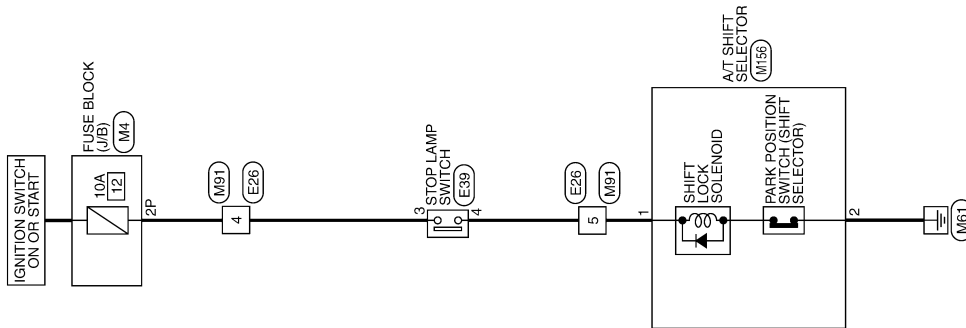

ABDWA0553GB

A/T SHIFT LOCK SYSTEM CONNECTORS

Connector No.	M4
Connector Name	FUSE BLOCK (J/B)
Connector Color	WHITE



Terminal No.	Color of Wire	Signal Name
2P	W/G	-

Connector No.	M91
Connector Name	WIRE TO WIRE
Connector Color	WHITE

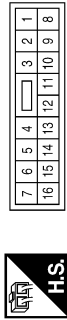

Terminal No.	Color of Wire	Signal Name
4	W/G	-
5	R	-

Connector No.	M156
Connector Name	A/T SHIFT SELECTOR
Connector Color	WHITE

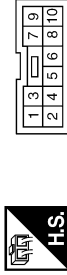

Terminal No.	Color of Wire	Signal Name
1	R	-
2	B	-

Connector No.	E26
Connector Name	WIRE TO WIRE
Connector Color	WHITE

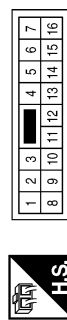

Terminal No.	Color of Wire	Signal Name
4	W/G	-
5	R	-

Connector No.	E39
Connector Name	STOP LAMP SWITCH (WITH A/T)
Connector Color	WHITE



Terminal No.	Color of Wire	Signal Name
3	W/G	-
4	R	-

SYSTEM SYMPTOM

< SYMPTOM DIAGNOSIS >

[5AT: RE5R05A]

SYMPTOM DIAGNOSIS

SYSTEM SYMPTOM

Symptom Chart

INFOID:000000008790987

- The diagnostics item numbers show the sequence for inspection. Inspect in order from item 1.
- Overhaul and inspect inside the A/T only if A/T fluid condition is NG. Refer to [TM-267](#). "Checking the A/T Fluid (ATF)".

No.	Items	Symptom	Condition	Diagnostic Item	Reference page
1		Large shock. ("N"→"D" position)	ON vehicle	1. Engine idle speed	EC-121 (QR25DE), EC-588 (VQ40DE)
				2. Engine speed signal	TM-176
				3. Accelerator pedal position sensor	TM-194
				4. Control cable adjustment	TM-283
				5. ATF temperature sensor	TM-196
				6. Front brake solenoid valve	TM-206
				7. CAN communication line	TM-165
				8. Fluid level and state	TM-267
				9. Line pressure test	TM-274
				10. Control valve with TCM	TM-286
			OFF vehicle	11. Forward brake (Parts behind drum support is impossible to perform inspection by disassembly. Refer to TM-131 .)	TM-311
2	Shift Shock	Shock is too large when changing D1→D2.	ON vehicle	1. Accelerator pedal position sensor	TM-194
				2. Control cable adjustment	TM-283
				3. Direct clutch solenoid valve	TM-208
				4. CAN communication line	TM-165
				5. Engine speed signal	TM-176
				6. Input speed sensor	TM-171
				7. Output speed sensor and vehicle speed signal	TM-173 , TM-198
				8. Fluid level and state	TM-267
				9. Control valve with TCM	TM-286
			OFF vehicle	10. Direct clutch	TM-358
3		Shock is too large when changing D2→D3.	ON vehicle	1. Accelerator pedal position sensor	TM-194
				2. Control cable adjustment	TM-283
				3. High and low reverse clutch solenoid valve	TM-210
				4. CAN communication line	TM-165
				5. Engine speed signal	TM-176
				6. Input speed sensor	TM-171
				7. Output speed sensor and vehicle speed signal	TM-173 , TM-198
				8. Fluid level and state	TM-267
				9. Control valve with TCM	TM-286
			OFF vehicle	10. High and low reverse clutch	TM-356

SYSTEM SYMPTOM

< SYMPTOM DIAGNOSIS >

[5AT: RE5R05A]

No.	Items	Symptom	Condition	Diagnostic Item	Reference page
4		Shock is too large when changing D3→D4.	ON vehicle	1. Accelerator pedal position sensor	TM-194
				2. Control cable adjustment	TM-283
				3. Input clutch solenoid valve	TM-204
				4. CAN communication line	TM-165
				5. Engine speed signal	TM-176
				6. Input speed sensor	TM-171
				7. Output speed sensor and vehicle speed signal	TM-173, TM-198
				8. Fluid level and state	TM-267
				9. Control valve with TCM	TM-286
			OFF vehicle	10. Input clutch	TM-346
5	Shift Shock	Shock is too large when changing D4→D5.	ON vehicle	1. Accelerator pedal position sensor	TM-194
				2. Control cable adjustment	TM-283
				3. Front brake solenoid valve	TM-206
				4. CAN communication line	TM-165
				5. Engine speed signal	TM-176
				6. Input speed sensor	TM-171
				7. Output speed sensor and vehicle speed signal	TM-173, TM-198
				8. Fluid level and state	TM-267
				9. Control valve with TCM	TM-286
			OFF vehicle	10. Front brake (brake band)	TM-311
				11. Input clutch	TM-346
6		Shock is too large for downshift when accelerator pedal is pressed.	ON vehicle	1. Accelerator pedal position sensor	TM-194
				2. Control cable adjustment	TM-283
				3. CAN communication line	TM-165
				4. Engine speed signal	TM-176
				5. Input speed sensor	TM-171
				6. Output speed sensor and vehicle speed signal	TM-173, TM-198
				7. Fluid level and state	TM-267
				8. Control valve with TCM	TM-286
			OFF vehicle	9. Front brake (brake band)	TM-311
				10. Input clutch	TM-346
				11. High and low reverse clutch	TM-356
				12. Direct clutch	TM-358

A
B
C
TM
E
F
G
H
I
J
K
L
M
N
O
P

SYSTEM SYMPTOM

< SYMPTOM DIAGNOSIS >

[5AT: RE5R05A]

No.	Items	Symptom	Condition	Diagnostic Item	Reference page
7		Shock is too large for upshift when accelerator pedal is released.	ON vehicle	1. Accelerator pedal position sensor	TM-194
				2. Control cable adjustment	TM-283
				3. Engine speed signal	TM-176
				4. CAN communication line	TM-165
				5. Input speed sensor	TM-171
				6. Output speed sensor and vehicle speed signal	TM-173 , TM-198
				7. Fluid level and state	TM-267
				8. Control valve with TCM	TM-286
			OFF vehicle	9. Front brake (brake band)	TM-311
				10. Input clutch	TM-346
				11. High and low reverse clutch	TM-356
				12. Direct clutch	TM-358
8	Shift Shock	Shock is too large for lock-up.	ON vehicle	1. Accelerator pedal position sensor	TM-194
				2. Control cable adjustment	TM-283
				3. Engine speed signal	TM-176
				4. CAN communication line	TM-165
				5. Input speed sensor	TM-171
				6. Output speed sensor and vehicle speed signal	TM-173 , TM-198
				7. Torque converter clutch solenoid valve	TM-188
				8. Fluid level and state	TM-267
				9. Control valve with TCM	TM-286
			OFF vehicle	10. Torque converter	TM-311
9		Shock is too large during engine brake.	ON vehicle	1. Accelerator pedal position sensor	TM-194
				2. Control cable adjustment	TM-283
				3. CAN communication line	TM-165
				4. Fluid level and state	TM-267
				5. Control valve with TCM	TM-286
			OFF vehicle	6. Front brake (brake band)	TM-311
				7. Input clutch	TM-346
				8. High and low reverse clutch	TM-356
				9. Direct clutch	TM-358

SYSTEM SYMPTOM

< SYMPTOM DIAGNOSIS >

[5AT: RE5R05A]

No.	Items	Symptom	Condition	Diagnostic Item	Reference page
10		Gear does not change from D1 → D2.	ON vehicle	1. Fluid level and state	TM-267
				2. Output speed sensor and vehicle speed signal	TM-173 , TM-198
				3. Direct clutch solenoid valve	TM-208
				4. Line pressure test	TM-274
				5. CAN communication line	TM-165
				6. Control valve with TCM	TM-286
			OFF vehicle	7. Direct clutch	TM-358
11		Gear does not change from D2 → D3.	ON vehicle	1. Fluid level and state	TM-267
				2. Output speed sensor and vehicle speed signal	TM-173 , TM-198
				3. High and low reverse clutch solenoid valve	TM-210
				4. Line pressure test	TM-274
				5. CAN communication line	TM-165
				6. Control valve with TCM	TM-286
			OFF vehicle	7. High and low reverse clutch	TM-356
12	No Up Shift	Gear does not change from D3 → D4.	ON vehicle	1. Fluid level and state	TM-267
				2. Output speed sensor and vehicle speed signal	TM-173 , TM-198
				3. Input clutch solenoid valve	TM-204
				4. Front brake solenoid valve	TM-206
				5. Line pressure test	TM-274
				6. CAN communication line	TM-165
				7. Control valve with TCM	TM-286
			OFF vehicle	8. Input clutch	TM-346
13		Gear does not change from D4 → D5.	ON vehicle	1. Fluid level and state	TM-267
				2. Output speed sensor and vehicle speed signal	TM-173 , TM-198
				3. Front brake solenoid valve	TM-206
				4. Direct clutch solenoid valve	TM-208
				5. Input speed sensor	TM-171
				6. Line pressure test	TM-274
				7. CAN communication line	TM-165
				8. Control valve with TCM	TM-286
			OFF vehicle	9. Front brake (brake band)	TM-311
				10. Input clutch	TM-346

A
B
C
TM
E
F
G
H
I
J
K
L
M
N
O
P

SYSTEM SYMPTOM

< SYMPTOM DIAGNOSIS >

[5AT: RE5R05A]

No.	Items	Symptom	Condition	Diagnostic Item	Reference page			
14	No Down Shift	In "D" range, does not downshift to 4GR.	ON vehicle	1. Fluid level and state	TM-267			
				2. Output speed sensor and vehicle speed signal	TM-173 , TM-198			
				3. Front brake solenoid valve	TM-206			
				4. Direct clutch solenoid valve	TM-208			
				5. CAN communication line	TM-165			
				6. Line pressure test	TM-274			
				7. Control valve with TCM	TM-286			
			OFF vehicle	8. Front brake (brake band)	TM-311			
				9. Input clutch	TM-346			
15	No Down Shift	In "D" or "3" range, does not downshift to 3GR.	ON vehicle	1. Fluid level and state	TM-267			
				2. Output speed sensor and vehicle speed signal	TM-173 , TM-198			
				3. Input clutch solenoid valve	TM-204			
				4. Front brake solenoid valve	TM-206			
				5. CAN communication line	TM-165			
				6. Line pressure test	TM-274			
				7. Control valve with TCM	TM-286			
			OFF vehicle	8. Input clutch	TM-346			
			16	No Down Shift	In "D" or "2" range, does not downshift to 2GR.	ON vehicle	1. Fluid level and state	TM-267
2. Output speed sensor and vehicle speed signal	TM-173 , TM-198							
3. High and low reverse clutch solenoid valve	TM-210							
4. CAN communication line	TM-165							
5. Line pressure test	TM-274							
6. Control valve with TCM	TM-286							
OFF vehicle	7. High and low reverse clutch	TM-356						
17	No Down Shift	In "D" or "1" range, does not downshift to 1GR.				ON vehicle	1. Fluid level and state	TM-267
							2. Output speed sensor and vehicle speed signal	TM-173 , TM-198
			3. Direct clutch solenoid valve	TM-208				
			4. CAN communication line	TM-165				
			5. Line pressure test	TM-274				
			6. Control valve with TCM	TM-286				
			OFF vehicle	7. Direct clutch	TM-358			

SYSTEM SYMPTOM

< SYMPTOM DIAGNOSIS >

[5AT: RE5R05A]

No.	Items	Symptom	Condition	Diagnostic Item	Reference page
18	Slips/Will Not engage	When "D" position, remains in 1GR.	ON vehicle	1. Fluid level and state	TM-267
				2. Output speed sensor and vehicle speed signal	TM-173 , TM-198
				3. Direct clutch solenoid valve	TM-208
				4. Line pressure test	TM-274
				5. CAN communication line	TM-165
				6. Control valve with TCM	TM-286
			OFF vehicle	7. 3rd one-way clutch	TM-344
				8. 1st one-way clutch	TM-311
				9. Gear system	TM-311
				10. Reverse brake	TM-311
				11. Forward one-way clutch (Parts behind drum support is impossible to perform inspection by disassembly. Refer to TM-131 .)	TM-311
				12. Forward brake (Parts behind drum support is impossible to perform inspection by disassembly. Refer to TM-131 .)	TM-311
19		When "D" position, remains in 2GR.	ON vehicle	1. Fluid level and state	TM-267
				2. Output speed sensor and vehicle speed signal	TM-173 , TM-198
				3. Low coast brake solenoid valve	TM-212
				4. Line pressure test	TM-274
				5. CAN communication line	TM-165
				6. Control valve with TCM	TM-286
			OFF vehicle	7. 3rd one-way clutch	TM-344
				8. Gear system	TM-311
				9. Direct clutch	TM-358
				10. Forward brake (Parts behind drum support is impossible to perform inspection by disassembly. Refer to TM-131 .)	TM-311

A
B
C
TM
E
F
G
H
I
J
K
L
M
N
O
P

SYSTEM SYMPTOM

< SYMPTOM DIAGNOSIS >

[5AT: RE5R05A]

No.	Items	Symptom	Condition	Diagnostic Item	Reference page
20		When "D" position, re- mains in 3GR.	ON vehicle	1. Fluid level and state	TM-267
				2. Output speed sensor and vehicle speed signal	TM-173 , TM-198
				3. Line pressure test	TM-274
				4. CAN communication line	TM-165
				5. Control valve with TCM	TM-286
			OFF vehicle	6. 3rd one-way clutch	TM-344
				7. Gear system	TM-311
				8. High and low reverse clutch	TM-356
				9. Forward one-way clutch (Parts behind drum support is impossible to perform inspection by disassembly. Refer to TM-131 .)	TM-311
				10. Forward brake (Parts behind drum support is impossible to perform inspection by disassembly. Refer to TM-131 .)	TM-311
21	Slips/Will Not en- gage	When "D" position, re- mains in 4GR.	ON vehicle	1. Fluid level and state	TM-267
				2. Output speed sensor and vehicle speed signal	TM-173 , TM-198
				3. Input clutch solenoid valve	TM-204
				4. Direct clutch solenoid valve	TM-208
				5. High and low reverse clutch solenoid valve	TM-210
				6. Low coast brake solenoid valve	TM-212
				7. Front brake solenoid valve	TM-206
				8. Line pressure test	TM-274
				9. CAN communication line	TM-165
				10. Control valve with TCM	TM-286
			OFF vehicle	11. Input clutch	TM-346
				12. Gear system	TM-311
				13. High and low reverse clutch	TM-356
				14. Direct clutch	TM-358

SYSTEM SYMPTOM

< SYMPTOM DIAGNOSIS >

[5AT: RE5R05A]

No.	Items	Symptom	Condition	Diagnostic Item	Reference page
22		When "D" position, remains in 5GR.	ON vehicle	1. Fluid level and state	TM-267
				2. Output speed sensor and vehicle speed signal	TM-173 , TM-198
				3. Front brake solenoid valve	TM-206
				4. Line pressure test	TM-274
				5. CAN communication line	TM-165
				6. Control valve with TCM	TM-286
			OFF vehicle	7. Front brake (brake band)	TM-311
				8. Input clutch	TM-346
				9. Gear system	TM-311
				10. High and low reverse clutch	TM-356
23	Slips/Will Not Engage	Vehicle cannot be started from D1.	ON vehicle	1. Fluid level and state	TM-267
				2. Accelerator pedal position sensor	TM-194
				3. Line pressure test	TM-274
				4. CAN communication line	TM-165
				5. Control valve with TCM	TM-286
			OFF vehicle	6. Torque converter	TM-311
				7. Oil pump assembly	TM-341
				8. 3rd one-way clutch	TM-344
				9. 1st one-way clutch	TM-311
				10. Gear system	TM-311
				11. Reverse brake	TM-311
				12. Forward one-way clutch (Parts behind drum support is impossible to perform inspection by disassembly. Refer to TM-131 .)	TM-311
				13. Forward brake (Parts behind drum support is impossible to perform inspection by disassembly. Refer to TM-131 .)	TM-311
24		Does not lock-up.	ON vehicle	1. Fluid level and state	TM-267
				2. Line pressure test	TM-274
				3. Engine speed signal	TM-176
				4. Input speed sensor	TM-171
				5. Torque converter clutch solenoid valve	TM-188
				6. CAN communication line	TM-165
				7. Control valve with TCM	TM-286
			OFF vehicle	8. Torque converter	TM-311
				9. Oil pump assembly	TM-341

A
B
C
TM
E
F
G
H
I
J
K
L
M
N
O
P

SYSTEM SYMPTOM

< SYMPTOM DIAGNOSIS >

[5AT: RE5R05A]

No.	Items	Symptom	Condition	Diagnostic Item	Reference page	
25	Slips/Will Not engage	Does not hold lock-up condition.	ON vehicle	1. Fluid level and state	TM-267	
				2. Line pressure test	TM-274	
				3. Engine speed signal	TM-176	
				4. Input speed sensor	TM-171	
				5. Torque converter clutch solenoid valve	TM-188	
				6. CAN communication line	TM-165	
				7. Control valve with TCM	TM-286	
			OFF vehicle	8. Torque converter	TM-311	
				9. Oil pump assembly	TM-341	
26		Slips/Will Not engage	Lock-up is not released.	ON vehicle	1. Fluid level and state	TM-267
					2. Line pressure test	TM-274
					3. Engine speed signal	TM-176
					4. Input speed sensor	TM-171
					5. Torque converter clutch solenoid valve	TM-188
					6. CAN communication line	TM-165
					7. Control valve with TCM	TM-286
				OFF vehicle	8. Torque converter	TM-311
					9. Oil pump assembly	TM-341
27	Slips/Will Not engage		No shock at all or the clutch slips when vehicle changes speed D1 → D2.	ON vehicle	1. Fluid level and state	TM-267
					2. Output speed sensor and vehicle speed signal	TM-173 , TM-198
					3. Direct clutch solenoid valve	TM-208
					4. CAN communication line	TM-165
					5. Line pressure test	TM-274
					6. Control valve with TCM	TM-286
				OFF vehicle	7. Torque converter	TM-311
					8. Oil pump assembly	TM-341
					9. 3rd one-way clutch	TM-344
		10. Gear system			TM-311	
		11. Direct clutch			TM-358	
		12. Forward brake (Parts behind drum support is impossible to perform inspection by disassembly. Refer to TM-131 .)			TM-311	

SYSTEM SYMPTOM

< SYMPTOM DIAGNOSIS >

[5AT: RE5R05A]

No.	Items	Symptom	Condition	Diagnostic Item	Reference page
28	Slips/Will Not engage	No shock at all or the clutch slips when vehicle changes speed D2 → D3.	ON vehicle	1. Fluid level and state	TM-267
				2. Output speed sensor and vehicle speed signal	TM-173, TM-198
				3. High and low reverse clutch solenoid valve	TM-210
				4. CAN communication line	TM-165
				5. Line pressure test	TM-274
				6. Control valve with TCM	TM-286
			OFF vehicle	7. Torque converter	TM-311
				8. Oil pump assembly	TM-341
				9. 3rd one-way clutch	TM-344
				10. Gear system	TM-311
				11. High and low reverse clutch	TM-356
				12. Forward one-way clutch (Parts behind drum support is impossible to perform inspection by disassembly. Refer to TM-131.)	TM-311
				13. Forward brake (Parts behind drum support is impossible to perform inspection by disassembly. Refer to TM-131.)	TM-311
29	No shock at all or the clutch slips when vehicle changes speed D3 → D4.	ON vehicle	1. Fluid level and state	TM-267	
			2. Output speed sensor and vehicle speed signal	TM-173, TM-198	
			3. Input clutch solenoid valve	TM-204	
			4. Front brake solenoid valve	TM-206	
			5. CAN communication line	TM-165	
			6. Line pressure test	TM-274	
			7. Control valve with TCM	TM-286	
		OFF vehicle	8. Torque converter	TM-311	
			9. Oil pump assembly	TM-341	
			10. Input clutch	TM-346	
			11. Gear system	TM-311	
			12. High and low reverse clutch	TM-356	
			13. Direct clutch	TM-358	

A
B
C
TM
E
F
G
H
I
J
K
L
M
N
O
P

SYSTEM SYMPTOM

< SYMPTOM DIAGNOSIS >

[5AT: RE5R05A]

No.	Items	Symptom	Condition	Diagnostic Item	Reference page
30	Slips/Will Not engage	No shock at all or the clutch slips when vehicle changes speed D4 → D5.	ON vehicle	1. Fluid level and state	TM-267
				2. Output speed sensor and vehicle speed signal	TM-173 , TM-198
				3. Front brake solenoid valve	TM-206
				4. Direct clutch solenoid valve	TM-208
				5. CAN communication line	TM-165
				6. Line pressure test	TM-274
				7. Control valve with TCM	TM-286
			OFF vehicle	8. Torque converter	TM-311
				9. Oil pump assembly	TM-341
				10. Front brake (brake band)	TM-311
				11. Input clutch	TM-346
				12. Gear system	TM-311
				13. High and low reverse clutch	TM-356
31	Slips/Will Not engage	When you press the accelerator pedal and shift speed D5 → D4, the engine idles or the transmission slips.	ON vehicle	1. Fluid level and state	TM-267
				2. Output speed sensor and vehicle speed signal	TM-173 , TM-198
				3. Front brake solenoid valve	TM-206
				4. Direct clutch solenoid valve	TM-208
				5. CAN communication line	TM-165
				6. Line pressure test	TM-274
				7. Control valve with TCM	TM-286
			OFF vehicle	8. Torque converter	TM-311
				9. Oil pump assembly	TM-341
				10. Input clutch	TM-346
				11. Gear system	TM-311
				12. High and low reverse clutch	TM-356
				13. Direct clutch	TM-358

SYSTEM SYMPTOM

< SYMPTOM DIAGNOSIS >

[5AT: RE5R05A]

No.	Items	Symptom	Condition	Diagnostic Item	Reference page
32	Slips/Will Not engage	When you press the accelerator pedal and shift speed D4→ D3, the engine idles or the transmission slips.	ON vehicle	1. Fluid level and state	TM-267
				2. Output speed sensor and vehicle speed signal	TM-173 , TM-198
				3. Input clutch solenoid valve	TM-204
				4. Front brake solenoid valve	TM-206
				5. CAN communication line	TM-165
				6. Line pressure test	TM-274
				7. Control valve with TCM	TM-286
			OFF vehicle	8. Torque converter	TM-311
				9. Oil pump assembly	TM-341
				10. 3rd one-way clutch	TM-344
				11. Gear system	TM-311
				12. High and low reverse clutch	TM-356
				13. Forward one- way clutch (Parts behind drum support is impossible to perform inspection by disassembly. Refer to TM-131 .)	TM-311
				14. Forward brake (Parts behind drum support is impossible to perform inspection by disassembly. Refer to TM-131 .)	TM-311
33		When you press the accelerator pedal and shift speed D3→ D2, the engine idles or the transmission slips.	ON vehicle	1. Fluid level and state	TM-267
				2. Output speed sensor and vehicle speed signal	TM-173 , TM-198
				3. High and low reverse clutch solenoid valve	TM-210
				4. Direct clutch solenoid valve	TM-208
				5. CAN communication line	TM-165
				6. Line pressure test	TM-274
				7. Control valve with TCM	TM-286
			OFF vehicle	8. Torque converter	TM-311
				9. Oil pump assembly	TM-341
				10. 3rd one-way clutch	TM-344
				11. Gear system	TM-311
				12. Direct clutch	TM-358
				13. Forward brake (Parts behind drum support is impossible to perform inspection by disassembly. Refer to TM-131 .)	TM-311

A
B
C
TM
E
F
G
H
I
J
K
L
M
N
O
P

SYSTEM SYMPTOM

< SYMPTOM DIAGNOSIS >

[5AT: RE5R05A]

No.	Items	Symptom	Condition	Diagnostic Item	Reference page
34	Slips/Will Not Engage	When you press the accelerator pedal and shift speed D2→ D1, the engine idles or the transmission slips.	ON vehicle	1. Fluid level and state	TM-267
				2. Output speed sensor and vehicle speed signal	TM-173 , TM-198
				3. Direct clutch solenoid valve	TM-208
				4. CAN communication line	TM-165
				5. Line pressure test	TM-274
				6. Control valve with TCM	TM-286
			OFF vehicle	7. Torque converter	TM-311
				8. Oil pump assembly	TM-341
				9. 3rd one-way clutch	TM-344
				10. 1st one-way clutch	TM-311
				11. Gear system	TM-311
				12. Reverse brake	TM-311
				13. Forward one- way clutch (Parts behind drum support is impossible to perform inspection by disassembly. Refer to TM-131 .)	TM-311
				14. Forward brake (Parts behind drum support is impossible to perform inspection by disassembly. Refer to TM-131 .)	TM-311
35		With selector lever in "D" position, acceleration is extremely poor.	ON vehicle	1. Fluid level and state	TM-267
				2. Line pressure test	TM-274
				3. Accelerator pedal position sensor	TM-194
				4. CAN communication line	TM-165
				5. Transmission range switch	TM-169
				6. Control cable adjustment	TM-283
				7. Control valve with TCM	TM-286
			OFF vehicle	8. Torque converter	TM-311
				9. Oil pump assembly	TM-341
				10. 1st one-way clutch	TM-311
				11. Gear system	TM-311
				12. Reverse brake	TM-311
				13. Forward one- way clutch (Parts behind drum support is impossible to perform inspection by disassembly. Refer to TM-131 .)	TM-311
				14. Forward brake (Parts behind drum support is impossible to perform inspection by disassembly. Refer to TM-131 .)	TM-311

SYSTEM SYMPTOM

< SYMPTOM DIAGNOSIS >

[5AT: RE5R05A]

No.	Items	Symptom	Condition	Diagnostic Item	Reference page
36		With selector lever in "R" position, acceleration is extremely poor.	ON vehicle	1. Fluid level and state	TM-267
				2. Line pressure test	TM-274
				3. Accelerator pedal position sensor	TM-194
				4. High and low reverse clutch solenoid valve	TM-210
				5. CAN communication line	TM-165
				6. Transmission range switch	TM-169
				7. Control cable adjustment	TM-283
				8. Control valve with TCM	TM-286
			OFF vehicle	9. Gear system	TM-311
				10. Output shaft	TM-311
				11. Reverse brake	TM-311
37	Slips/Will Not Engage	While starting off by accelerating in 1GR, engine races or slippage occurs.	ON vehicle	1. Fluid level and state	TM-267
				2. Line pressure test	TM-274
				3. Accelerator pedal position sensor	TM-194
				4. CAN communication line	TM-165
				5. Control valve with TCM	TM-286
			OFF vehicle	6. Torque converter	TM-341
				7. Oil pump assembly	TM-341
				8. 3rd one-way clutch	TM-344
				9. 1st one-way clutch	TM-311
				10. Gear system	TM-311
				11. Reverse brake	TM-311
				12. Forward one- way clutch (Parts behind drum support is impossible to perform inspection by disassembly. Refer to TM-131.)	TM-311
				13. Forward brake (Parts behind drum support is impossible to perform inspection by disassembly. Refer to TM-131.)	TM-311
38		While accelerating in 2GR, engine races or slippage occurs.	ON vehicle	1. Fluid level and state	TM-267
				2. Line pressure test	TM-274
				3. Accelerator pedal position sensor	TM-194
				4. CAN communication line	TM-165
				5. Direct clutch solenoid valve	TM-208
				6. Control valve with TCM	TM-286
			OFF vehicle	7. Torque converter	TM-311
				8. Oil pump assembly	TM-341
				9. 3rd one-way clutch	TM-344
				10. Gear system	TM-311
				11. Direct clutch	TM-358
				12. Forward brake (Parts behind drum support is impossible to perform inspection by disassembly. Refer to TM-131.)	TM-311

A
B
C
TM
E
F
G
H
I
J
K
L
M
N
O
P

SYSTEM SYMPTOM

< SYMPTOM DIAGNOSIS >

[5AT: RE5R05A]

No.	Items	Symptom	Condition	Diagnostic Item	Reference page
39	Slips/Will Not Engage	While accelerating in 3GR, engine races or slippage occurs.	ON vehicle	1. Fluid level and state	TM-267
				2. Line pressure test	TM-274
				3. Accelerator pedal position sensor	TM-194
				4. CAN communication line	TM-165
				5. High and low reverse clutch solenoid valve	TM-210
				6. Control valve with TCM	TM-286
			OFF vehicle	7. Torque converter	TM-311
				8. Oil pump assembly	TM-341
				9. 3rd one-way clutch	TM-344
				10. Gear system	TM-311
				11. High and low reverse clutch	TM-356
				12. Forward one- way clutch (Parts behind drum support is impossible to perform inspection by disassembly. Refer to TM-131 .)	TM-311
				13. Forward brake (Parts behind drum support is impossible to perform inspection by disassembly. Refer to TM-131 .)	TM-311
40		While accelerating in 4GR, engine races or slippage occurs.	ON vehicle	1. Fluid level and state	TM-267
				2. Line pressure test	TM-274
				3. Accelerator pedal position sensor	TM-194
				4. CAN communication line	TM-165
				5. Input clutch solenoid valve	TM-204
				6. Control valve with TCM	TM-286
			OFF vehicle	7. Torque converter	TM-311
				8. Oil pump assembly	TM-341
				9. Input clutch	TM-346
				10. Gear system	TM-311
				11. High and low reverse clutch	TM-356
				12. Direct clutch	TM-358

SYSTEM SYMPTOM

< SYMPTOM DIAGNOSIS >

[5AT: RE5R05A]

No.	Items	Symptom	Condition	Diagnostic Item	Reference page				
41		While accelerating in 5GR, engine races or slippage occurs.	ON vehicle	1. Fluid level and state	TM-267				
				2. Line pressure test	TM-274				
				3. Accelerator pedal position sensor	TM-194				
				4. CAN communication line	TM-165				
				5. Front brake solenoid valve	TM-206				
				6. Control valve with TCM	TM-286				
			OFF vehicle	7. Torque converter	TM-311				
				8. Oil pump assembly	TM-341				
				9. Front brake (brake band)	TM-311				
				10. Input clutch	TM-346				
				11. Gear system	TM-311				
				12. High and low reverse clutch	TM-356				
42	Slips/Will Not Engage	Slips at lock-up.	ON vehicle	1. Fluid level and state	TM-267				
				2. Line pressure test	TM-274				
				3. Engine speed signal	TM-176				
				4. Input speed sensor	TM-171				
				5. Torque converter clutch solenoid valve	TM-188				
				6. CAN communication line	TM-165				
				7. Control valve with TCM	TM-286				
			OFF vehicle	8. Torque converter	TM-311				
				9. Oil pump assembly	TM-341				
				43		No creep at all.	ON vehicle	1. Fluid level and state	TM-267
								2. Line pressure test	TM-274
								3. Accelerator pedal position sensor	TM-194
4. Direct clutch solenoid valve	TM-208								
5. Transmission range switch	TM-169								
6. CAN communication line	TM-165								
7. Control cable adjustment	TM-283								
8. Control valve with TCM	TM-286								
OFF vehicle	9. Torque converter	TM-311							
	10. Oil pump assembly	TM-341							
	11. 1st one-way clutch	TM-311							
	12. Gear system	TM-311							
	13. Reverse brake	TM-311							
	14. Direct clutch	TM-358							
	15. Forward one- way clutch (Parts behind drum support is impossible to perform inspection by disassembly. Refer to TM-131.)	TM-311							
	16. Forward brake (Parts behind drum support is impossible to perform inspection by disassembly. Refer to TM-131.)	TM-311							

A
B
C
TM
E
F
G
H
I
J
K
L
M
N
O
P

SYSTEM SYMPTOM

< SYMPTOM DIAGNOSIS >

[5AT: RE5R05A]

No.	Items	Symptom	Condition	Diagnostic Item	Reference page
44		Vehicle cannot run in all positions.	ON vehicle	1. Fluid level and state	TM-267
				2. Line pressure test	TM-274
				3. Transmission range switch	TM-169
				4. Control cable adjustment	TM-283
				5. Control valve with TCM	TM-286
			OFF vehicle	6. Oil pump assembly	TM-341
				7. Gear system	TM-311
				8. Output shaft	TM-311
45	Slips/Will Not Engage	With selector lever in "D" position, driving is not possible.	ON vehicle	1. Fluid level and state	TM-267
				2. Line pressure test	TM-274
				3. Transmission range switch	TM-169
				4. Control cable adjustment	TM-283
				5. Control valve with TCM	TM-286
			OFF vehicle	6. Torque converter	TM-311
				7. Oil pump assembly	TM-341
				8. 1st one-way clutch	TM-311
				9. Gear system	TM-311
				10. Reverse brake	TM-311
				11. Forward one- way clutch (Parts behind drum support is impossible to perform inspection by disassembly. Refer to TM-131 .)	TM-311
				12. Forward brake (Parts behind drum support is impossible to perform inspection by disassembly. Refer to TM-131 .)	TM-311
46		With selector lever in "R" position, driving is not possible.	ON vehicle	1. Fluid level and state	TM-267
				2. Line pressure test	TM-274
				3. Transmission range switch	TM-169
				4. Control cable adjustment	TM-283
				5. Control valve with TCM	TM-286
			OFF vehicle	6. Gear system	TM-311
				7. Output shaft	TM-311
				8. Reverse brake	TM-311
47	Others	Shift point is high in "D" position.	ON vehicle	1. Output speed sensor and vehicle speed signal	TM-173 , TM-198
				2. Accelerator pedal position sensor	TM-194
				3. CAN communication line	TM-165
				4. ATF temperature sensor	TM-196
				5. Control valve with TCM	TM-286

SYSTEM SYMPTOM

< SYMPTOM DIAGNOSIS >

[5AT: RE5R05A]

No.	Items	Symptom	Condition	Diagnostic Item	Reference page
48		Shift point is low in "D" position.	ON vehicle	1. Output speed sensor and vehicle speed signal	TM-173 , TM-198
				2. Accelerator pedal position sensor	TM-194
				3. CAN communication line	TM-165
				4. Control valve with TCM	TM-286
49		Judder occurs during lock-up.	ON vehicle	1. Fluid level and state	TM-267
				2. Engine speed signal	TM-176
				3. Input speed sensor	TM-171
				4. Output speed sensor and vehicle speed signal	TM-173 , TM-198
			OFF vehicle	5. Accelerator pedal position sensor	TM-194
				6. CAN communication line	TM-165
				7. Torque converter clutch solenoid valve	TM-188
				8. Control valve with TCM	TM-286
50	Others	Strange noise in "R" position.	ON vehicle	1. Fluid level and state	TM-267
				2. Engine speed signal	TM-176
				3. CAN communication line	TM-165
				4. Control valve with TCM	TM-286
			OFF vehicle	5. Torque converter	TM-311
				6. Oil pump assembly	TM-341
				7. Gear system	TM-311
				8. High and low reverse clutch	TM-356
				9. Reverse brake	TM-311
51		Strange noise in "N" position.	ON vehicle	1. Fluid level and state	TM-267
				2. Engine speed signal	TM-176
				3. CAN communication line	TM-165
				4. Control valve with TCM	TM-286
			OFF vehicle	5. Torque converter	TM-311
				6. Oil pump assembly	TM-341
				7. Gear system	TM-311
52		Strange noise in "D" position.	ON vehicle	1. Fluid level and state	TM-267
				2. Engine speed signal	TM-176
				3. CAN communication line	TM-165
				4. Control valve with TCM	TM-286
			OFF vehicle	5. Torque converter	TM-311
				6. Oil pump assembly	TM-341
				7. Gear system	TM-311
				8. Forward brake (Parts behind drum support is impossible to perform inspection by disassembly. Refer to TM-131 .)	TM-311

A
B
C
TM
E
F
G
H
I
J
K
L
M
N
O
P

SYSTEM SYMPTOM

< SYMPTOM DIAGNOSIS >

[5AT: RE5R05A]

No.	Items	Symptom	Condition	Diagnostic Item	Reference page
53		Vehicle does not decelerate by engine brake.	ON vehicle	1. Transmission range switch	TM-169
				2. Fluid level and state	TM-267
				3. Control cable adjustment	TM-283
				4. 1st position switch	TM-224
				5. CAN communication line	TM-165
				6. Control valve with TCM	TM-286
			OFF vehicle	7. Input clutch	TM-346
				8. High and low reverse clutch	TM-356
				9. Direct clutch	TM-358
54	Others	Engine brake does not operate in "2" position.	ON vehicle	1. Transmission range switch	TM-169
				2. Fluid level and state	TM-267
				3. Control cable adjustment	TM-283
				4. CAN communication line	TM-165
				5. Control valve with TCM	TM-286
			OFF vehicle	6. Front brake (brake band)	TM-311
				7. Input clutch	TM-346
				8. High and low reverse clutch	TM-356
55		Engine brake does not operate in "1" position.	ON vehicle	1. Transmission range switch	TM-169
				2. Fluid level and state	TM-267
				3. Control cable adjustment	TM-283
				4. 1st position switch	TM-224
				5. CAN communication line	TM-165
				6. Control valve with TCM	TM-286
			OFF vehicle	7. Input clutch	TM-346
				8. High and low reverse clutch	TM-356
				9. Direct clutch	TM-358

SYSTEM SYMPTOM

< SYMPTOM DIAGNOSIS >

[5AT: RE5R05A]

No.	Items	Symptom	Condition	Diagnostic Item	Reference page
56	Others	Maximum speed low.	ON vehicle	1. Fluid level and state	TM-267
				2. Line pressure test	TM-274
				3. Accelerator pedal position sensor	TM-194
				4. CAN communication line	TM-165
				5. Direct clutch solenoid valve	TM-208
				6. Control valve with TCM	TM-286
			OFF vehicle	7. Torque converter	TM-311
				8. Oil pump assembly	TM-341
				9. Input clutch	TM-346
				10. Gear system	TM-311
				11. High and low reverse clutch	TM-356
				12. Direct clutch	TM-358
				13. Forward one- way clutch (Parts behind drum support is impossible to perform inspection by disassembly. Refer to TM-131 .)	TM-311
				14 Forward brake (Parts behind drum support is impossible to perform inspection by disassembly. Refer to TM-131 .)	TM-311
57	Others	Extremely large creep.	ON vehicle	1. Engine idle speed	EC-121 (QR25DE), EC-588 (VQ40DE)
				2. CAN communication line	TM-165
			OFF vehicle	3. Torque converter	TM-311
58	Others	With selector lever in "P" position, vehicle does not enter parking condition or, with selector lever in another position, parking condition is not cancelled.	ON vehicle	1. Transmission range switch	TM-169
				2. Control cable adjustment	TM-283
			OFF vehicle	3. Parking pawl components	TM-311
59	Others	Vehicle runs with transmission in "P" position.	ON vehicle	1. Transmission range switch	TM-169
				2. Fluid level and state	TM-267
				3. Control cable adjustment	TM-283
				4. Control valve with TCM	TM-286
				5. Parking pawl components	TM-311
			OFF vehicle	6. Gear system	TM-311

A
B
C
TM
E
F
G
H
I
J
K
L
M
N
O
P

SYSTEM SYMPTOM

< SYMPTOM DIAGNOSIS >

[5AT: RE5R05A]

No.	Items	Symptom	Condition	Diagnostic Item	Reference page
60		Vehicle runs with transmission in "N" position.	ON vehicle	1. Transmission range switch	TM-169
				2. Fluid level and state	TM-267
				3. Control cable adjustment	TM-283
				4. Control valve with TCM	TM-286
			OFF vehicle	5. Input clutch	TM-346
				6. Gear system	TM-311
				7. Direct clutch	TM-358
				8. Reverse brake	TM-311
				9. Forward one- way clutch (Parts behind drum support is impossible to perform inspection by disassembly. Refer to TM-131 .)	TM-311
				10. Forward brake (Parts behind drum support is impossible to perform inspection by disassembly. Refer to TM-131 .)	TM-311
61		Engine does not start in "N" or "P" position.	ON vehicle	1. Ignition switch and starter	PG-20 , STR-12
				2. Control cable adjustment	TM-283
				3. Transmission range switch	TM-169
62	Others	Engine starts in positions other than "N" or "P".	ON vehicle	1. Ignition switch and starter	PG-20 , STR-12
				2. Control cable adjustment	TM-283
				3. Transmission range switch	TM-169
63		Engine stall.	ON vehicle	1. Fluid level and state	TM-267
				2. Engine speed signal	TM-176
				3. Input speed sensor	TM-171
				4. Torque converter clutch solenoid valve	TM-188
				5. CAN communication line	TM-165
				6. Control valve with TCM	TM-286
			OFF vehicle	7. Torque converter	TM-311
64		Engine stalls when select lever shifted "N" → "D", "R".	ON vehicle	1. Fluid level and state	TM-267
				2. Engine speed signal	TM-176
				3. Input speed sensor	TM-171
				4. Torque converter clutch solenoid valve	TM-188
				5. CAN communication line	TM-165
				6. Control valve with TCM	TM-286
			OFF vehicle	7. Torque converter	TM-311

SYSTEM SYMPTOM

< SYMPTOM DIAGNOSIS >

[5AT: RE5R05A]

No.	Items	Symptom	Condition	Diagnostic Item	Reference page
65	Others	Engine speed does not return to idle.	ON vehicle	1. Fluid level and state	TM-267
				2. Direct clutch solenoid valve	TM-208
				3. Front brake solenoid valve	TM-206
				4. Accelerator pedal position sensor	TM-194
				5. Output speed sensor and vehicle speed signal	TM-173 , TM-198
				6. CAN communication line	TM-165
				7. Control valve with TCM	TM-286
			OFF vehicle	8. Front brake (brake band)	TM-311
				9. Direct clutch	TM-358
66		O/D OFF indicator lamp does not come on.	ON vehicle	1. CAN communication line	TM-165
				2. Combination meter	MWI-24
				3. TCM power supply	TM-216

A
B
C
TM
E
F
G
H
I
J
K
L
M
N
O
P

PRECAUTION

PRECAUTIONS

Precaution for Supplemental Restraint System (SRS) "AIR BAG" and "SEAT BELT PRE-TENSIONER"

INFOID:000000008790988

The Supplemental Restraint System such as "AIR BAG" and "SEAT BELT PRE-TENSIONER", used along with a front seat belt, helps to reduce the risk or severity of injury to the driver and front passenger for certain types of collision. This system includes seat belt switch inputs and dual stage front air bag modules. The SRS system uses the seat belt switches to determine the front air bag deployment, and may only deploy one front air bag, depending on the severity of a collision and whether the front occupants are belted or unbelted. Information necessary to service the system safely is included in the SR and SB section of this Service Manual.

WARNING:

- To avoid rendering the SRS inoperative, which could increase the risk of personal injury or death in the event of a collision which would result in air bag inflation, all maintenance must be performed by an authorized NISSAN/INFINITI dealer.
- Improper maintenance, including incorrect removal and installation of the SRS can lead to personal injury caused by unintentional activation of the system. For removal of Spiral Cable and Air Bag Module, see the SRS section.
- Do not use electrical test equipment on any circuit related to the SRS unless instructed to in this Service Manual. SRS wiring harnesses can be identified by yellow and/or orange harnesses or harness connectors.

PRECAUTIONS WHEN USING POWER TOOLS (AIR OR ELECTRIC) AND HAMMERS

WARNING:

- When working near the Airbag Diagnosis Sensor Unit or other Airbag System sensors with the Ignition ON or engine running, DO NOT use air or electric power tools or strike near the sensor(s) with a hammer. Heavy vibration could activate the sensor(s) and deploy the air bag(s), possibly causing serious injury.
- When using air or electric power tools or hammers, always switch the Ignition OFF, disconnect the battery, and wait at least 3 minutes before performing any service.

Precaution for Work

INFOID:000000009249569

- When removing or disassembling each component, be careful not to damage or deform it. If a component may be subject to interference, be sure to protect it with a shop cloth.
- When removing (disengaging) components with a screwdriver or similar tool, be sure to wrap the component with a shop cloth or vinyl tape to protect it.
- Protect the removed parts with a shop cloth and prevent them from being dropped.
- Replace a deformed or damaged clip.
- If a part is specified as a non-reusable part, always replace it with a new one.
- Be sure to tighten bolts and nuts securely to the specified torque.
- After installation is complete, be sure to check that each part works properly.
- Follow the steps below to clean components:
 - Water soluble dirt:
 - Dip a soft cloth into lukewarm water, wring the water out of the cloth and wipe the dirty area.
 - Then rub with a soft, dry cloth.
 - Oily dirt:
 - Dip a soft cloth into lukewarm water with mild detergent (concentration: within 2 to 3%) and wipe the dirty area.
 - Then dip a cloth into fresh water, wring the water out of the cloth and wipe the detergent off.
 - Then rub with a soft, dry cloth.
 - Do not use organic solvent such as thinner, benzene, alcohol or gasoline.
 - For genuine leather seats, use a genuine leather seat cleaner.

Precaution for On Board Diagnosis (OBD) System of A/T and Engine

INFOID:000000008790990

The ECM has an on board diagnostic system. It will light up the malfunction indicator lamp (MIL) to warn the driver of a malfunction causing emission deterioration.

PRECAUTIONS

< PRECAUTION >

[5AT: RE5R05A]

CAUTION:

- Be sure to turn the ignition switch “OFF” and disconnect the negative battery cable before any repair or inspection work. The open/short circuit of related switches, sensors, solenoid valves, etc. Will cause the MIL to light up.
- Be sure to connect and lock the connectors securely after work. A loose (unlocked) connector will cause the MIL to light up due to an open circuit. (Be sure the connector is free from water, grease, dirt, bent terminals, etc.)
- Be sure to route and secure the harnesses properly after work. Interference of the harness with a bracket, etc. May cause the MIL to light up due to a short circuit.
- Be sure to connect rubber tubes properly after work. A mis-connected or disconnected rubber tube may cause the MIL to light up due to a malfunction of the EGR system or fuel injection system, etc.
- Be sure to erase the unnecessary malfunction information (repairs completed) from the TCM and ECM before returning the vehicle to the customer.

Precaution

INFOID:000000008790991

- Before connecting or disconnecting the A/T assembly harness connector, turn ignition switch “OFF” and disconnect negative battery cable. Because battery voltage is applied to TCM even if ignition switch is turned “OFF”.

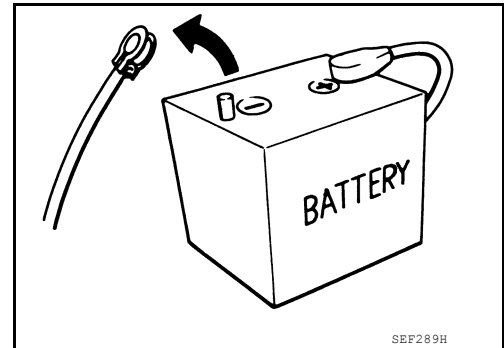

- After performing each TROUBLE DIAGNOSIS, perform “DTC (Diagnostic Trouble Code) CONFIRMATION PROCEDURE”. If the repair is completed the DTC should not be displayed in the “DTC CONFIRMATION PROCEDURE”.

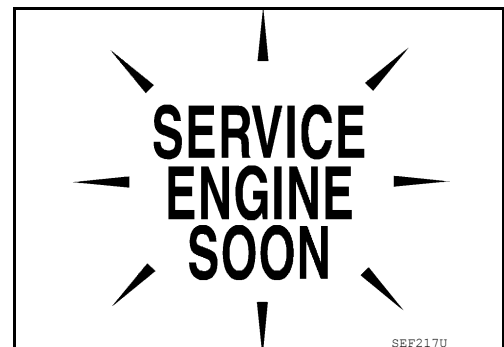

- Always use the specified brand of ATF. Refer to [MA-17. "FOR USA AND CANADA : Fluids and Lubricants"](#) (United States and Canada) and [MA-19. "FOR MEXICO : Fluids and Lubricants"](#) (Mexico).
- Use lint-free paper not cloth rags during work.
- After replacing the ATF, dispose of the waste oil using the methods prescribed by law, ordinance, etc.
- Before proceeding with disassembly, thoroughly clean the outside of the transmission. It is important to prevent the internal parts from becoming contaminated by dirt or other foreign matter.
- Disassembly should be done in a clean work area.
- Use lint-free paper or towels for wiping parts clean. Common shop rags can leave fibers that could interfere with the operation of the transmission.
- Place disassembled parts in order for easier and proper assembly.
- All parts should be carefully cleaned with a general purpose, non-flammable solvent before inspection or reassembly.
- Gaskets, seals and O-rings should be replaced any time the transmission is disassembled.
- It is very important to perform functional tests whenever they are indicated.
- The valve body contains precision parts and requires extreme care when parts are removed and serviced. Place disassembled valve body parts in order for easier and proper assembly. Care will also prevent springs and small parts from becoming scattered or lost.
- Properly installed valves, sleeves, plugs, etc. will slide along bores in valve body under their own weight.
- Before assembly, apply a coat of recommended ATF to all parts. Apply petroleum jelly to protect O-rings and seals, or hold bearings and washers in place during assembly. Do not use grease.

PRECAUTIONS

< PRECAUTION >

[5AT: RE5R05A]

- Extreme care should be taken to avoid damage to O-rings, seals and gaskets when assembling.
- Clean or replace ATF cooler if excessive foreign material is found in oil pan or clogging strainer. Refer to [TM-270, "A/T Fluid Cooler Cleaning"](#).
- After overhaul, refill the transmission with new ATF.
- When the A/T drain plug is removed, only some of the fluid is drained. Old A/T fluid will remain in torque converter and ATF cooling system.

Always follow the procedures under "Changing A/T Fluid" in the AT section when changing A/T fluid. Refer to [TM-269, "Changing the A/T Fluid \(ATF\)"](#), [TM-267, "Checking the A/T Fluid \(ATF\)"](#).

Service Notice or Precaution

INFOID:000000008790992

ATF COOLER SERVICE

If A/T fluid contains frictional material (clutches, bands, etc.), or if an A/T is repaired, overhauled, or replaced, inspect and clean the A/T fluid cooler mounted in the radiator or replace the radiator. Flush cooler lines using cleaning solvent and compressed air after repair. For A/T fluid cooler cleaning procedure, refer to [TM-270, "A/T Fluid Cooler Cleaning"](#). For radiator replacement, refer to [CO-16, "Removal and Installation"](#) (QR25DE), [CO-44, "Removal and Installation"](#) (VQ40DE).

OBD-II SELF-DIAGNOSIS

- A/T self-diagnosis is performed by the TCM in combination with the ECM. Refer to the table on [TM-156, "CONSULT Function \(TRANSMISSION\)"](#) for the indicator used to display each self-diagnostic result.
- The self-diagnostic results indicated by the MIL are automatically stored in both the ECM and TCM memories.

Always perform the procedure on [TM-156, "CONSULT Function \(TRANSMISSION\)"](#) to complete the repair and avoid unnecessary blinking of the MIL.

For details of OBD-II, refer to [TM-154, "Introduction"](#).

- **Certain systems and components, especially those related to OBD, may use the new style slide-locking type harness connector. For description and how to disconnect, refer to [PG-73, "Description"](#).**

PREPARATION

< PREPARATION >

[5AT: RE5R05A]

PREPARATION

PREPARATION

Special Service Tool

INFOID:000000008790993

The actual shapes of Kent-Moore tools may differ from those of special service tools illustrated here.

Tool number (Kent-Moore No.) Tool name	Description
ST2505S001 (J-34301-C) Oil pressure gauge set 1 ST25051001 (—) Oil pressure gauge 2 ST25052000 (—) Hose 3 ST25053000 (—) Joint pipe 4 ST25054000 (—) Adapter 5 ST25055000 (—) Adapter	Measuring line pressure
KV31103600 (J-45674) Joint pipe adapter (With ST25054000)	Measuring line pressure
ST33400001 (J-26082) Drift	<ul style="list-style-type: none"> • Installing rear oil seal (2WD models) • Installing oil pump housing oil seal a: 60 mm (2.36 in) dia. b: 47 mm (1.85 in) dia.
KV31102400 (J-34285 and J-34285-87) Clutch spring compressor	Installing reverse brake return spring retainer a: 320 mm (12.60 in) b: 174 mm (6.85 in)
ST25850000 (J-25721-A) Sliding hammer	Remove oil pump assembly a: 179 mm (7.05 in) b: 70 mm (2.76 in) c: 40 mm (1.57 in) d: M12X1.75P

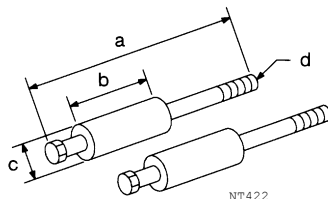
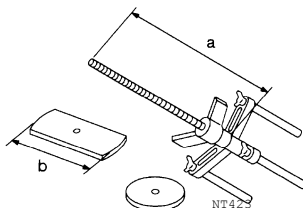
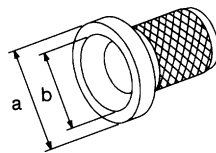
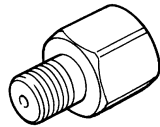
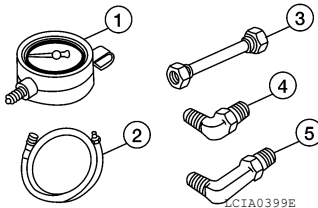

PREPARATION

< PREPARATION >

[5AT: RE5R05A]

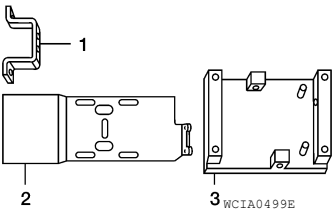
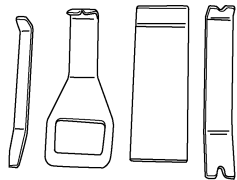
Tool number (Kent-Moore No.) Tool name		Description
<p>— (J-47002) Transmission jack adapter kit</p> <p>1. — (J-47002-1) Center bracket</p> <p>2. — (J-47002-3) Adapter plate</p> <p>3. — (J-47002-4) Adapter block</p>		<p>Assist in removal of transmission and transfer case as one assembly using only one transmission jack.</p>
<p>— (J-46534) Trim Tool Set</p>		<p>Removing and installing trim parts</p>

Commercial Service Tool

INFOID:000000008790994

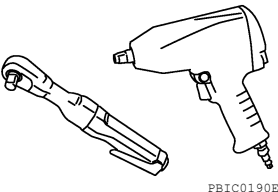
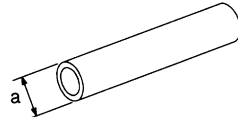
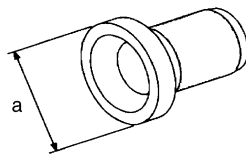
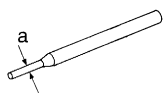
Tool name		Description
<p>Power tool</p>		<p>Loosening bolts and nuts</p>
<p>Drift</p>		<p>Installing manual shaft seals a: 22 mm (0.87 in) dia.</p>
<p>Drift</p>		<p>Installing rear oil seal (4WD models) a: 64 mm (2.52 in) dia.</p>
<p>Pin punch</p>		<ul style="list-style-type: none"> • Removing retaining pin • Installing retaining pin <p>a: 4 mm (0.16 in) dia.</p>

PERIODIC MAINTENANCE

A/T FLUID

Checking the A/T Fluid (ATF)

INFOID:000000008790995

CAUTION:

If using the vehicle for towing, the A/T fluid must be replaced as specified. Refer to [MA-10, "FOR USA AND CANADA : Periodic Maintenance"](#) (United States and Canada) and [MA-14, "FOR MEXICO : Periodic Maintenance"](#) (Mexico).

1. Before driving, the A/T fluid level can be checked at A/T fluid temperatures of 30° to 50° C (86° to 122° F) using the "COLD" range on the A/T fluid level gauge as follows:
 - a. Park the vehicle on a level surface and set the parking brake.
 - b. Start the engine and move the selector lever through each gear position. Shift the selector lever into the "P" position.
 - c. Check the A/T fluid level with the engine idling.
 - d. Remove the A/T fluid level gauge and wipe it clean with a lint-free paper.

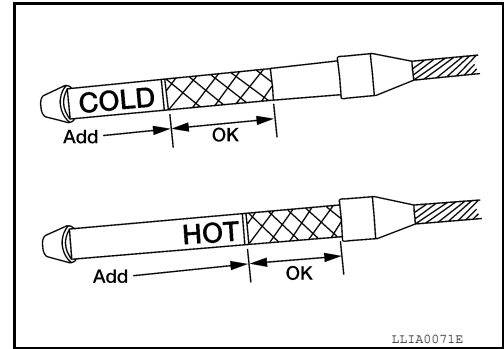

CAUTION:

When wiping the A/T fluid from the A/T fluid level gauge, always use a lint-free paper, not a cloth.

- e. Re-insert the A/T fluid level gauge into the A/T fluid charging pipe until the cap contacts the top of the A/T fluid charging pipe as shown.

CAUTION:

To check A/T fluid level, insert the A/T fluid level gauge until the cap contacts the top of the A/T fluid charging pipe, with the gauge reversed from the normal inserted position.

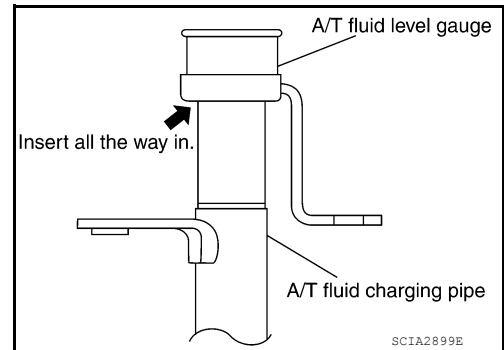

- f. Remove the A/T fluid level gauge and note the A/T fluid level. If the A/T fluid level is at low side of range, add A/T fluid to the transmission through the A/T fluid charging pipe.

CAUTION:

Do not overfill the transmission with A/T fluid.

- g. Install the A/T fluid level gauge and the A/T fluid level gauge bolt.

A/T fluid level gauge bolt : Refer to [TM-302, "Component"](#).

2. Warm up the engine and transmission.
3. Check for any A/T fluid leaks.
4. Drive the vehicle to increase the A/T fluid temperature to 80° C (176° F).

A/T FLUID

< PERIODIC MAINTENANCE >

[5AT: RE5R05A]

- Allow the A/T fluid temperature to fall to approximately 65°C (149°F). Use the CONSULT to monitor the A/T fluid temperature as follows:

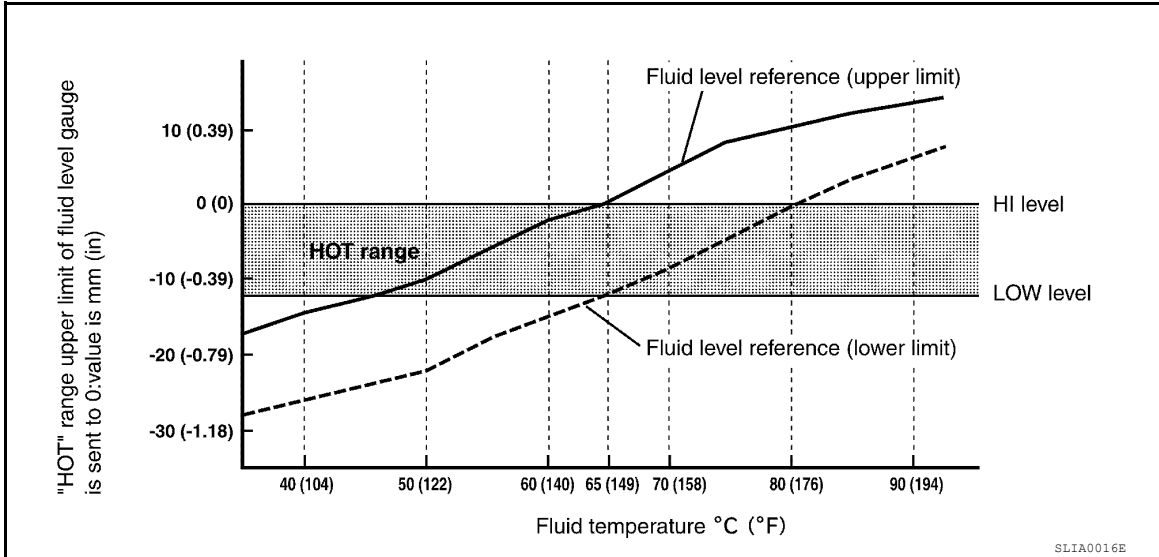

NOTE:

The A/T fluid level will be significantly affected by the A/T fluid temperature as shown. Therefore monitor the A/T fluid temperature data using the CONSULT.

- Connect CONSULT to data link connector.
 - Select "MAIN SIGNALS" in "DATA MONITOR" mode for "A/T" with CONSULT.
 - Read out the value of "ATF TEMP 1".
- Re-check the A/T fluid level at A/T fluid temperatures of approximately 65°C (149°F) using the "HOT" range on the A/T fluid level gauge as shown. The HOT range is between 50° - 80° C (122° - 176° F).

CAUTION:

- When wiping the A/T fluid from the A/T fluid level gauge, always use lint-free paper, not a cloth.

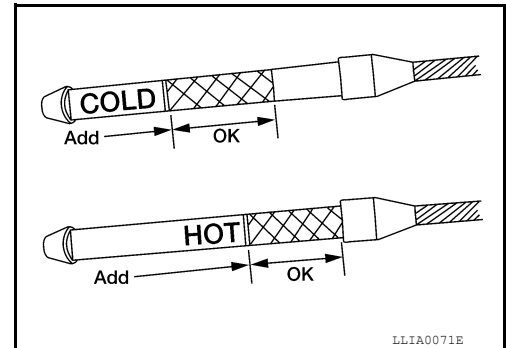

- To check the A/T fluid level, insert the A/T fluid level gauge until the cap contacts the top of the A/T fluid charging pipe, with the gauge reversed from the normal inserted position as shown.

- Check the A/T fluid condition.
 - If the A/T fluid is very dark or has some burned smell, there may be an internal problem with the transmission. Flush the transmission cooling system after repairing the transmission.
 - If the A/T fluid contains frictional material (clutches, bands, etc.), replace the radiator and flush the transmission cooler lines using cleaning solvent and compressed air after repairing the transmission.
- Install the A/T fluid level gauge in the A/T fluid charging pipe.
- Tighten the A/T fluid level gauge bolt to specification.

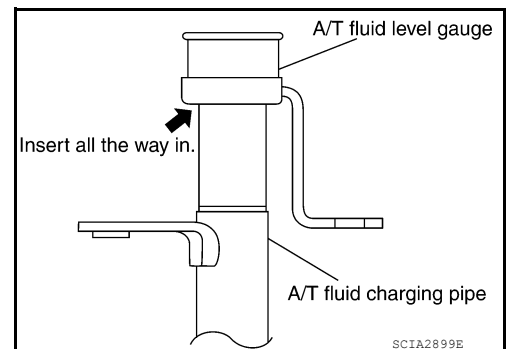

A/T fluid level gauge bolt : Refer to [TM-302, "Component"](#).

Changing the A/T Fluid (ATF)

CAUTION:

If using the vehicle for towing, the A/T fluid must be replaced as specified. Refer to [MA-10, "FOR USA AND CANADA : Periodic Maintenance"](#) (United States) or [MA-14, "FOR MEXICO : Periodic Maintenance"](#) (Mexico).

1. Drive the vehicle to warm up the A/T fluid to approximately 80° C (176° F).
2. Stop the engine.
3. Remove the A/T fluid level gauge.
4. Drain the A/T fluid from the drain plug hole, then install the drain plug with a new gasket. Refill the transmission with new A/T fluid. Always refill with the same volume as the drained A/T fluid. Use the A/T fluid level gauge to check the A/T fluid level as shown. Add A/T fluid as necessary.

Drain plug : Refer to [TM-302, "Component"](#).

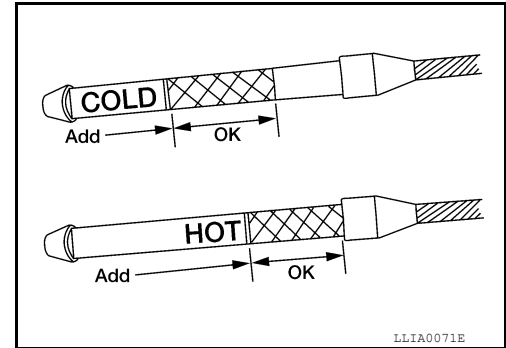

- To flush out the old A/T fluid from the transmission oil coolers, pour new A/T fluid into the A/T fluid charging pipe with the engine idling and at the same time drain the old A/T fluid from the auxiliary transmission oil cooler hose return line.
- When the color of the A/T fluid coming out of the auxiliary transmission oil cooler hose return line is about the same as the color of the new A/T fluid, flushing out the old A/T fluid is complete. The amount of new A/T fluid used for flushing should be 30% to 50% increase of the specified capacity.

A/T fluid grade and capacity : Refer to [MA-17, "FOR USA AND CANADA : Fluids and Lubricants"](#) (United States and Canada) and [MA-19, "FOR MEXICO : Fluids and Lubricants"](#) (Mexico).

CAUTION:

- If genuine NISSAN Matic S ATF is not available, Genuine NISSAN Matic J ATF may also be used. Using automatic transmission fluid other than Genuine NISSAN Matic S ATF or Matic J ATF will cause deterioration in driveability and automatic transmission durability, and may damage the automatic transmission, which is not covered by the NISSAN new vehicle limited warranty
 - When filling the transmission with A/T fluid, do not spill the A/T fluid on any heat generating parts such as the exhaust manifold.
 - Do not reuse the drain plug gasket.
5. Install the A/T fluid level gauge and tighten the A/T fluid level gauge bolt to specification.

A/T fluid level gauge bolt : Refer to [TM-302, "Component"](#).

6. Drive the vehicle to warm up the A/T fluid to approximately 80° C (176° F).
7. Check the fluid level and condition. If the A/T fluid is still dirty, repeat steps 2 through 6.

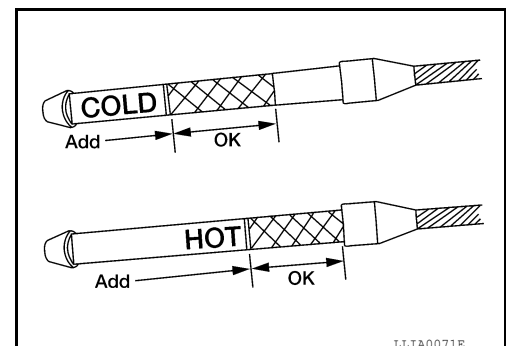

8. Install the A/T fluid level gauge in the A/T fluid charging pipe and install the A/T fluid level gauge bolt.
9. Tighten the A/T fluid level gauge bolt to specification.

A/T fluid level gauge bolt : Refer to [TM-302, "Component"](#).

A/T Fluid Cooler Cleaning

INFOID:000000008790997

Whenever an A/T is repaired, overhauled, or replaced, the A/T fluid cooler mounted in the radiator must be inspected and cleaned.

Metal debris and friction material, if present, can become trapped in the A/T fluid cooler. This debris can contaminate the newly serviced A/T or, in severe cases, can block or restrict the flow of A/T fluid. In either case, malfunction of the newly serviced A/T may result.

Debris, if present, may build up as A/T fluid enters the cooler inlet. It will be necessary to back flush the cooler through the cooler outlet in order to flush out any built up debris.

A/T FLUID COOLER CLEANING PROCEDURE

1. Position a drain pan under the A/T inlet and outlet fluid cooler tube to cooler hose connection.
2. Put a different color matching mark on each cooler tube to cooler hose connection to aid in assembly.

CAUTION:

Use paint to make the matching mark. Do not damage the tubes or hose.

3. Disconnect the fluid cooler inlet and outlet rubber hoses from the steel cooler tubes.

NOTE:

Replace the cooler hoses if rubber material from the hose remains on the tube fitting.

4. Drain any A/T fluid from the cooler hose.

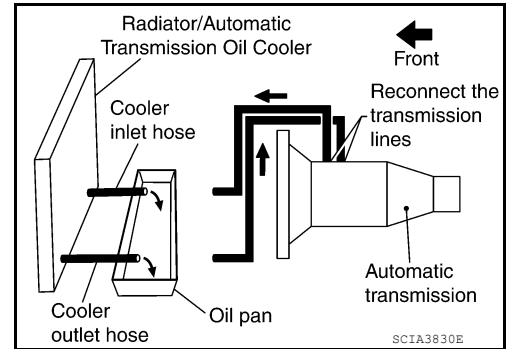

5. Insert the extension adapter hose of a can of Transmission Cooler Cleaner (Nissan P/N 999MP-AM006) into the cooler outlet hose.

CAUTION:

- Wear safety glasses and rubber gloves when spraying the Transmission Cooler Cleaner.
- Spray cooler cleaner only with adequate ventilation.
- Avoid contact with eyes and skin.
- Do not breath vapors or spray mist.

6. Hold the hose and can as high as possible and spray Transmission Cooler Cleaner in a continuous stream into the cooler outlet hose until fluid flows out of the cooler inlet hose for 5 seconds.

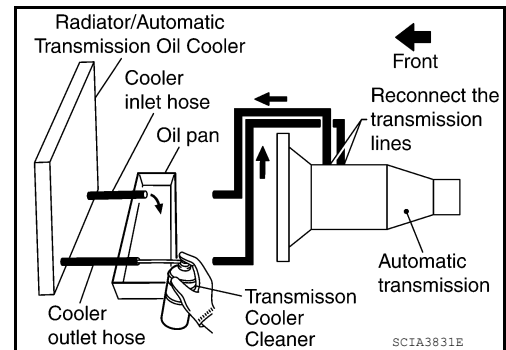

7. Insert the tip of an air gun into the end of the cooler outlet hose.
8. Wrap a shop rag around the tip of the air gun and the cooler outlet hose.

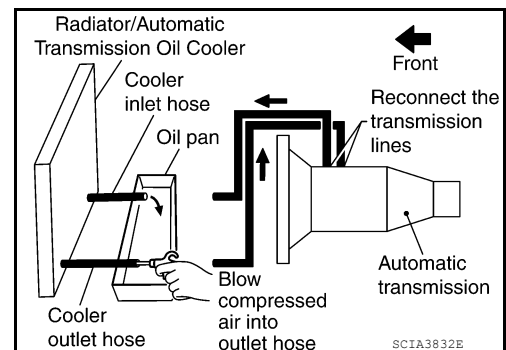

9. Blow compressed air regulated to 5 - 9 kg/cm² (70 - 130 psi) through the cooler outlet hose for 10 seconds to force out any remaining fluid.
10. Repeat steps 5 through 9 three additional times.
11. Position an oil pan under the banjo bolts that connect the fluid cooler tubes to the A/T.

12. Remove the banjo bolts.
13. Flush each steel line from the cooler side back toward the A/T by spraying Transmission Cooler Cleaner in a continuous stream for 5 seconds.
14. Blow compressed air regulated to 5 - 9 kg/cm² (70 - 130 psi) through each steel line from the cooler side back toward the A/T for 10 seconds to force out any remaining fluid.
15. Ensure all debris is removed from the steel cooler lines.
16. Ensure all debris is removed from the banjo bolts and fittings.
17. Perform "A/T FLUID COOLER DIAGNOSIS PROCEDURE".

A/T FLUID COOLER DIAGNOSIS PROCEDURE

NOTE:

Insufficient cleaning of the cooler inlet hose exterior may lead to inaccurate debris identification.

1. Position a drain pan under the A/T inlet and outlet fluid cooler tube to cooler hose connection.
2. Clean the exterior and tip of the cooler inlet hose.
3. Put a different color matching mark on each cooler tube to cooler hose connection to aid in assembly.

CAUTION:

Use paint to make the matching mark. Do not damage the tubes or hose.

4. Disconnect the fluid cooler inlet and outlet rubber hoses from the steel cooler tubes.

NOTE:

Replace the cooler hoses if rubber material from the hose remains on the tube fitting.

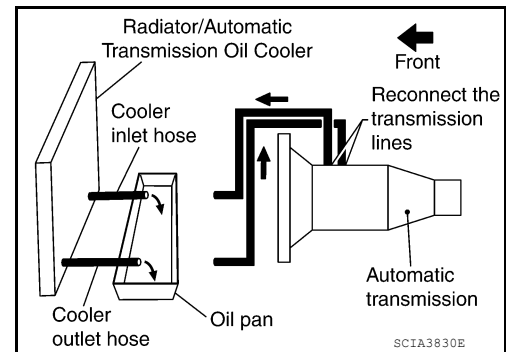

5. Insert the extension adapter hose of a can of Transmission Cooler Cleaner (Nissan P/N 999MP-AM006) into the cooler outlet hose.

CAUTION:

- **Wear safety glasses and rubber gloves when spraying the Transmission Cooler Cleaner.**
- **Spray cooler cleaner only with adequate ventilation.**
- **Avoid contact with eyes and skin.**
- **Do not breath vapors or spray mist.**

6. Hold the hose and can as high as possible and spray Transmission Cooler Cleaner in a continuous stream into the cooler outlet hose until fluid flows out of the cooler inlet hose for 5 seconds.

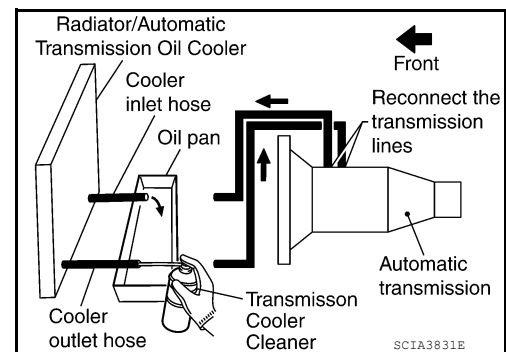

7. Tie a common white, basket-type coffee filter to the end of the cooler inlet hose.

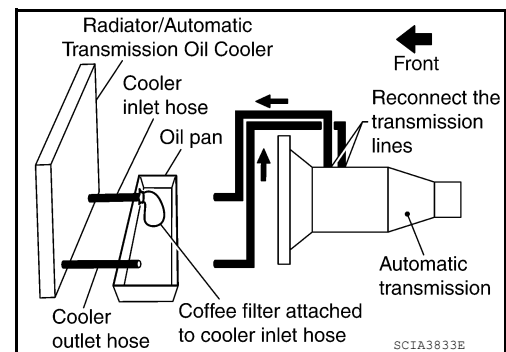

A/T FLUID

< PERIODIC MAINTENANCE >

[5AT: RE5R05A]

8. Insert the tip of an air gun into the end of the cooler outlet hose.
9. Wrap a shop rag around the air gun tip and end of cooler outlet hose.
10. Blow compressed air regulated to 5 - 9 kg/cm² (70 - 130 psi) through the cooler outlet hose to force any remaining A/T fluid into the coffee filter.
11. Remove the coffee filter from the end of the cooler inlet hose.
12. Perform A/T fluid cooler inspection. Refer to [TM-267, "Checking the A/T Fluid \(ATF\)"](#).

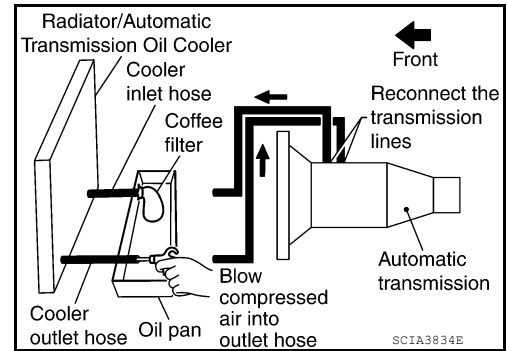

A/T FLUID COOLER INSPECTION PROCEDURE

1. Inspect the coffee filter for debris.
 - a. If small metal debris less than 1mm (0.040 in) in size or metal powder is found in the coffee filter, this is normal. If normal debris is found, the A/T fluid cooler/radiator can be re-used and the procedure is ended.
 - b. If one or more pieces of debris are found that are over 1mm (0.040 in) in size and/or peeled clutch facing material is found in the coffee filter, the fluid cooler is not serviceable. The A/T fluid cooler/radiator must be replaced and the inspection procedure is ended. Refer to [CO-16, "Removal and Installation"](#) for (QR25DE) [CO-44, "Removal and Installation"](#) for (VQ40DE).

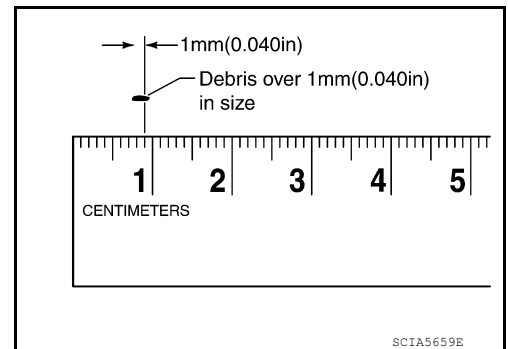
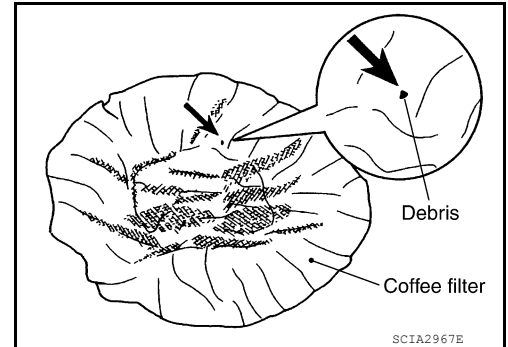

A/T FLUID COOLER FINAL INSPECTION

After performing all procedures, ensure that all remaining oil is cleaned from all components.

INSPECTIONS BEFORE TROUBLE DIAGNOSIS

< PERIODIC MAINTENANCE >

[5AT: RE5R05A]

INSPECTIONS BEFORE TROUBLE DIAGNOSIS

Fluid Condition Check

INFOID:000000008790998

A/T FLUID CHECK

Fluid Leakage and Fluid Level Check

- Inspect for fluid leakage and check the fluid level. Refer to [TM-269. "Changing the A/T Fluid \(ATF\)".](#)

Fluid Condition Check

Inspect the fluid condition.

Fluid condition	Conceivable Cause	Required Operation
Varnished (viscous varnish state)	Clutch, brake scorched	Replace the ATF and check the A/T main unit and the vehicle for malfunctions (wire harnesses, cooler pipes, etc.)
Milky white or cloudy	Water in the fluid	Replace the ATF and check for places where water is getting in.
Large amount of metal powder mixed in	Unusual wear of sliding parts within A/T	Replace the ATF and check for improper operation of the A/T.

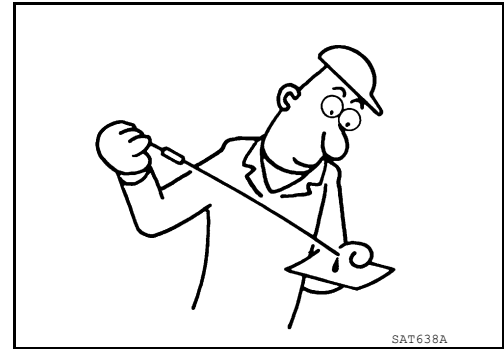

Stall Test

INFOID:000000008790999

STALL TEST

Stall Test Procedure

1. Inspect the amount of engine oil. Replenish the engine oil if necessary.
2. Drive for about 10 minutes to warm up the vehicle so that the A/T fluid temperature is 50 to 80°C (122 to 176°F). Inspect the amount of ATF. Replenish if necessary.

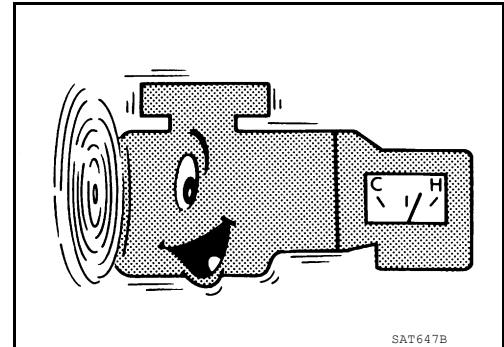

3. Securely engage the parking brake so that the tires do not turn.

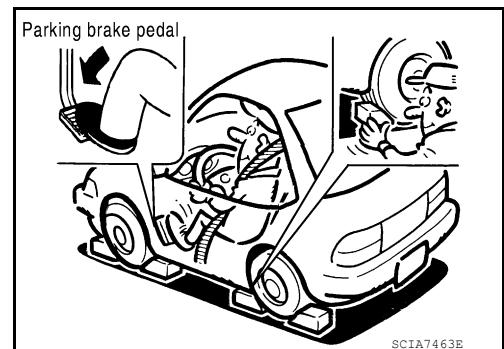

A
B
C
TM
E
F
G
H
I
J
K
L
M
N
O
P

INSPECTIONS BEFORE TROUBLE DIAGNOSIS

< PERIODIC MAINTENANCE >

[5AT: RE5R05A]

4. Engine start, apply foot brake, and place shift selector in "D" position.
5. While holding down the foot brake, gradually press down the accelerator pedal.
6. Quickly read off the stall speed, then quickly remove your foot from the accelerator pedal.

CAUTION:

Do not hold down the accelerator pedal for more than 5 seconds during this test.

Stall speed: [TM-385, "Stall Speed"](#)

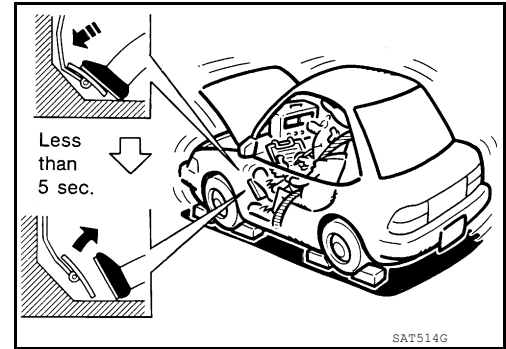

7. Move the shift selector to the "N" position.
8. Cool down the ATF.
CAUTION:
Run the engine at idle for at least one minute.
9. Repeat steps 5 through 8 with selector lever in "R" position.

Judgment of Stall Test

	Shift selector position		Expected problem location
	D	R	
Stall rotation	H	O	<ul style="list-style-type: none"> • Forward brake • Forward one-way clutch • 1st one-way clutch • 3rd one-way clutch
	O	H	<ul style="list-style-type: none"> • Reverse brake
	L	L	<ul style="list-style-type: none"> • Engine and torque converter one-way clutch
	H	H	<ul style="list-style-type: none"> • Line pressure low

O: Stall speed within standard value position

H: Stall speed higher than standard value

L: Stall speed lower than standard value

Stall test standard value position

Does not shift-up D position 1 → 2	Slipping in 2GR, 3GR, 4GR	Direct clutch slippage
Does not shift-up D position 2 → 3	Slipping in 3GR, 4GR, 5GR	High and low reverse clutch slippage
Does not shift-up D position 3 → 4	Slipping in 4GR, 5GR	Input clutch slippage
Does not shift-up D position 4 → 5	Slipping in 5GR	Front brake slippage

Line Pressure Test

INFOID:000000008791000

LINE PRESSURE TEST

Line Pressure Test Port

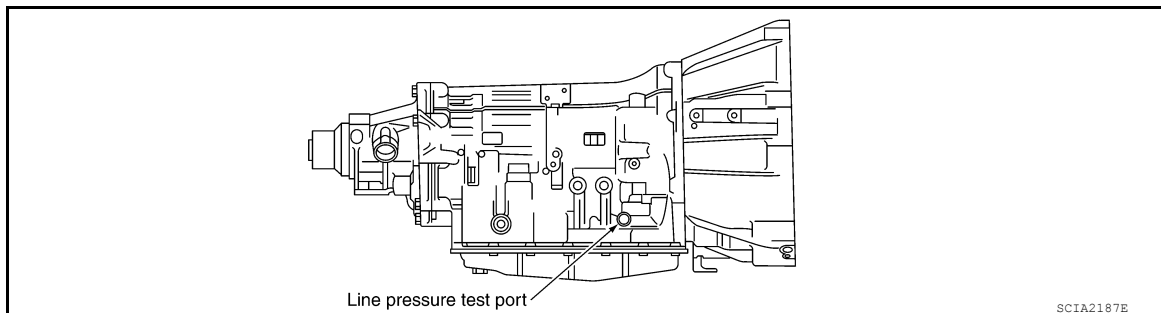

Line Pressure Test Procedure

1. Inspect the amount of engine oil and replenish if necessary.

INSPECTIONS BEFORE TROUBLE DIAGNOSIS

< PERIODIC MAINTENANCE >

[5AT: RE5R05A]

- Drive the car for about 10 minutes to warm it up so that the ATF reaches in range of 50 to 80°C (122 to 176°F), then inspect the amount of ATF and replenish if necessary.

NOTE:

The automatic fluid temperature rises in range of 50 to 80°C (122 to 176°F) during 10 minutes of driving.

- After warming up remove the oil pressure detection plug and install the oil pressure gauge [ST2505S001(J-34301-C)].

CAUTION:

When using the oil pressure gauge, be sure to use the O-ring attached to the oil pressure detection plug.

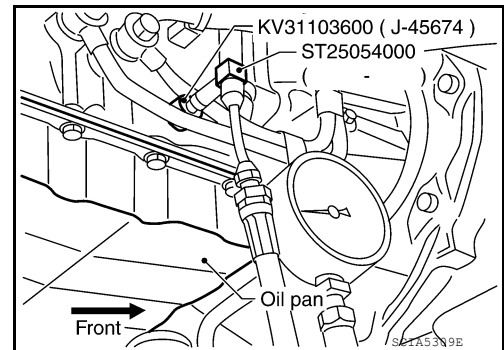

- Securely engage the parking brake so that the tires do not turn.

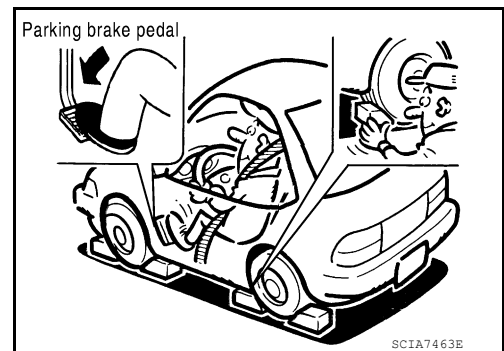

- Start the engine, then measure the line pressure at both idle and the stall speed.

CAUTION:

- Keep the brake pedal pressed all the way down during measurement.
- When measuring the line pressure at the stall speed, refer to "STALL TEST".

- After the measurements are complete, install the oil pressure detection plug and tighten to the regulation torque below.

Oil pressure detection plug :7.3 N·m (0.74 kg-m, 65 in-lb)

CAUTION:

- Do not reuse the O-ring.
- Apply ATF to O-ring.

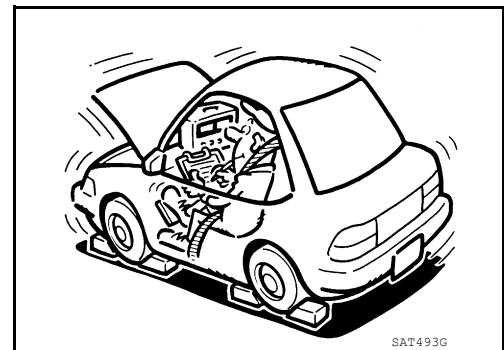

Line Pressure

Engine speed	Line pressure [kPa (kg/cm ² , psi)]	
	"R" position	"D" position
At idle speed	TM-385. "Line Pressure"	
At stall speed		

Judgment of Line Pressure Test

A
B
C
TM
E
F
G
H
I
J
K
L
M
N
O
P

INSPECTIONS BEFORE TROUBLE DIAGNOSIS

< PERIODIC MAINTENANCE >

[5AT: RE5R05A]

Judgment		Possible cause
Idle speed	Low for all positions (P, R, N, D)	Possible causes include malfunctions in the pressure supply system and low oil pump output. For example <ul style="list-style-type: none"> • Oil pump wear • Pressure regulator valve or plug sticking or spring fatigue • Oil strainer ⇒ oil pump ⇒ pressure regulator valve passage oil leak • Engine idle speed too low
	Only low for a specific position	Possible causes include an oil pressure leak in a passage or device related to the position after the pressure is distributed by the manual valve.
	High	Possible causes include a sensor malfunction or malfunction in the line pressure adjustment function. For example <ul style="list-style-type: none"> • Accelerator pedal position signal malfunction • ATF temperature sensor malfunction • Line pressure solenoid malfunction (sticking in "OFF" state, filter clog, cut line) • Pressure regulator valve or plug sticking
Stall speed	Oil pressure does not rise higher than the oil pressure for idle.	Possible causes include a sensor malfunction or malfunction in the pressure adjustment function. For example <ul style="list-style-type: none"> • Accelerator pedal position signal malfunction • TCM breakdown • Line pressure solenoid malfunction (shorting, sticking in "ON" state) • Pressure regulator valve or plug sticking • Pilot valve sticking or pilot filter clogged
	The pressure rises, but does not enter the standard position.	Possible causes include malfunctions in the pressure supply system and malfunction in the pressure adjustment function. For example <ul style="list-style-type: none"> • Accelerator pedal position signal malfunction • Line pressure solenoid malfunction (sticking, filter clog) • Pressure regulator valve or plug sticking • Pilot valve sticking or pilot filter clogged
	Only low for a specific position	Possible causes include an oil pressure leak in a passage or device related to the position after the pressure is distributed by the manual valve.

ROAD TEST

Description

INFOID:000000008791001

ROAD TEST

- The road test inspects overall performance of the A/T and analyzes possible malfunction causes.
- The road test is carried out in the following three stages.

1. Check before engine is started. Refer to [TM-277](#).
2. Check at idle. Refer to [TM-277](#).
3. Cruise test
 - Inspect all the items from Part 1 to Part 3. Refer to [TM-278](#), [TM-280](#), [TM-280](#).
- Before beginning the road test, check the test procedure and inspection items.
- Test all inspection items until the symptom is uncovered. Diagnose NG items when all road tests are complete.

Check Before Engine Is Started

INFOID:000000008791002

1.CHECK O/D OFF INDICATOR LAMP

1. Park vehicle on level surface.
2. Move shift selector to "P" position.
3. Turn ignition switch to "OFF" position and wait at least 10 seconds.
4. Turn ignition switch to "ON" position. (Do not start engine.)

Does O/D OFF indicator lamp light up for about 2 seconds?

- YES >> 1. Turn ignition switch "OFF".
2. Perform self-diagnostics and record all NG items on the [TM-129, "Diagnostic Work Sheet"](#). Refer to [TM-156, "CONSULT Function \(TRANSMISSION\)"](#), [TM-161, "Diagnosis Procedure without CONSULT"](#).
3. Go to [TM-277, "Check at Idle"](#).
- NO >> Stop the test and go to [TM-240, "Symptom Chart"](#).

Check at Idle

INFOID:000000008791003

1.CHECK STARTING THE ENGINE

1. Park vehicle on level surface.
2. Move shift selector to "P" or "N" position.
3. Turn ignition switch to "OFF" position.
4. Turn ignition switch to "START" position.

Does the engine start?

- YES >> GO TO 2.
- NO >> Stop the road test and go to [TM-240, "Symptom Chart"](#).

2.CHECK STARTING THE ENGINE

1. Turn ignition switch to "ON" position.
2. Move shift selector in "D", "3", "2", "1" or "R" position.
3. Turn ignition switch to "START" position.

Does the engine start in either position?

- YES >> Stop the road test and go to [TM-240, "Symptom Chart"](#).
- NO >> GO TO 3.

3.CHECK "P" POSITION FUNCTIONS

1. Move shift selector to "P" position.
2. Turn ignition switch to "OFF" position.
3. Release the parking brake.
4. Push the vehicle forward or backward.
5. Engage the parking brake.

ROAD TEST

< PERIODIC MAINTENANCE >

[5AT: RE5R05A]

When you push the vehicle with disengaging the parking brake, does it move?

- YES >> Record the malfunction, GO TO 4.
- NO >> GO TO 4.

4.CHECK "N" POSITION FUNCTIONS

1. Start the engine.
2. Move shift selector to "N" position.
3. Release the parking brake.

Does vehicle move forward or backward?

- YES >> Record the malfunction, GO TO 5.
- NO >> GO TO 5.

5.CHECK SHIFT SHOCK

1. Engage the brake.
2. Move shift selector to "D" position.

When the transmission is shifted from "N" to "D", is there an excessive shock?

- YES >> Record the malfunction, GO TO 6.
- NO >> GO TO 6.

6.CHECK "R" POSITION FUNCTIONS

1. Engage the brake.
2. Move shift selector to "R" position.
3. Release the brake for 4 to 5 seconds.

Does the vehicle creep backward?

- YES >> GO TO 7.
- NO >> Record the malfunction, GO TO 7.

7.CHECK "D" POSITION FUNCTIONS

Inspect whether the vehicle creep forward when the transmission is put into the "D" position.

Does the vehicle creep forward in the "D" positions?

- YES >> Go to [TM-278, "Cruise Test - Part 1"](#).
- NO >> Record the malfunction and go to [TM-278, "Cruise Test - Part 1"](#).

Cruise Test - Part 1

INFOID:000000008791004

1.CHECK STARTING OUT FROM D1

1. Drive the vehicle for about 10 minutes to warm up the engine oil and ATF.
Appropriate temperature for the ATF: 50 - 80°C (122 - 176°F)
2. Park the vehicle on a level surface.
3. Move shift selector to "P" position.
4. Start the engine.
5. Set overdrive control switch to ON position (without manual mode).
6. Move shift selector to "D" position.
7. Press the accelerator pedal about half way down to accelerate the vehicle.

With CONSULT

Read off the gear positions.

Starts from D1?

- YES >> GO TO 2.
- NO >> Record the malfunction, GO TO 2.

2.CHECK SHIFT-UP D1 → D2

Press down the accelerator pedal about half way and inspect if the vehicle shifts up (D1 → D2) at the appropriate speed.

- Refer to [TM-383, "Vehicle Speed at Which Gear Shifting Occurs"](#).

With CONSULT

Read the gear position, throttle degree of opening, and vehicle speed.

Does the A/T shift-up D1 → D2 at the correct speed?

ROAD TEST

< PERIODIC MAINTENANCE >

[5AT: RE5R05A]

- YES >> GO TO 3.
NO >> Record the malfunction, GO TO 3.

3. CHECK SHIFT-UP D2 → D3

Press down the accelerator pedal about half way and inspect if the vehicle shifts up (D2 → D3) at the appropriate speed.

- Refer to [TM-383. "Vehicle Speed at Which Gear Shifting Occurs"](#).

With CONSULT

Read the gear position, throttle degree of opening, and vehicle speed.

Does the A/T shift-up D2 → D3 at the correct speed?

- YES >> GO TO 4.
NO >> Record the malfunction, GO TO 4.

4. CHECK SHIFT-UP D3 → D4

Press down the accelerator pedal about half way and inspect if the vehicle shifts up (D3 → D4) at the appropriate speed.

- Refer to [TM-383. "Vehicle Speed at Which Gear Shifting Occurs"](#).

With CONSULT

Read the gear position, throttle degree of opening, and vehicle speed.

Does the A/T shift-up D3 → D4 at the correct speed?

- YES >> GO TO 5.
NO >> Record the malfunction, GO TO 5.

5. CHECK SHIFT-UP D4 → D5

Press down the accelerator pedal about half way and inspect if the vehicle shifts up (D4 → D5) at the appropriate speed.

- Refer to [TM-383. "Vehicle Speed at Which Gear Shifting Occurs"](#).

With CONSULT

Read the gear position, throttle degree of opening, and vehicle speed.

Does the A/T shift-up D4 → D5 at the correct speed?

- YES >> GO TO 6.
NO >> Record the malfunction, GO TO 6.

6. CHECK LOCK-UP

When releasing accelerator pedal from D5 (closed throttle position signal: OFF), check lock-up from D5 to L/U.

- Refer to [TM-383. "Vehicle Speed at Which Gear Shifting Occurs"](#).

With CONSULT

Select "TCC SOLENOID" with the "MAIN SIGNAL" mode for "TRANSMISSION".

Does it lock-up?

- YES >> GO TO 7.
NO >> Record the malfunction, GO TO 7.

7. CHECK LOCK-UP HOLD

Check hold lock-up.

With CONSULT

Select "TCC SOLENOID" with the "MAIN SIGNAL" mode for "TRANSMISSION".

Does it maintain lock-up status?

- YES >> GO TO 8.
NO >> Record the malfunction, GO TO 8.

8. CHECK LOCK-UP RELEASE

Check lock-up cancellation by depressing brake pedal lightly to decelerate.

With CONSULT

Select "TCC SOLENOID" with the "MAIN SIGNAL" mode for "TRANSMISSION".

Does lock-up cancel?

- YES >> GO TO 9.

A
B
C
TM
E
F
G
H
I
J
K
L
M
N
O
P

ROAD TEST

< PERIODIC MAINTENANCE >

[5AT: RE5R05A]

NO >> Record the malfunction, GO TO 9.

9. CHECK SHIFT-DOWN D5 → D4

Decelerate by pressing lightly on the brake pedal.

With CONSULT

Read the gear position and engine speed.

When the A/T shift-down D5 → D4, does the engine speed drop smoothly back to idle?

YES >> 1. Stop the vehicle.

2. Go to [TM-280, "Cruise Test - Part 2"](#).

NO >> Record the malfunction and go to [TM-280, "Cruise Test - Part 2"](#).

Cruise Test - Part 2

INFOID:000000008791005

1. CHECK SHIFT-UP D1 → D2

Press the accelerator pedal down all the way and inspect whether or not the transmission shifts up (D1 → D2) at the correct speed.

• Refer to [TM-383, "Vehicle Speed at Which Gear Shifting Occurs"](#).

With CONSULT

Read the gear position, throttle position and vehicle speed.

Does the A/T shift-up D1 → D2 at the correct speed?

YES >> GO TO 2.

NO >> Record the malfunction, GO TO 2.

2. CHECK SHIFT-UP D2 → D3

Press the accelerator pedal down all the way and inspect whether or not the transmission shifts up (D2 → D3) at the correct speed.

• Refer to [TM-383, "Vehicle Speed at Which Gear Shifting Occurs"](#).

With CONSULT

Read the gear position, throttle position and vehicle speed.

Does the A/T shift-up D2 → D3 at the correct speed?

YES >> GO TO 3.

NO >> Record the malfunction, GO TO 3.

3. CHECK SHIFT-UP D3 → D4

When the transmission changes speed D3 → D4, return the accelerator pedal.

Does the A/T shift-up D3 → D4 and apply the engine brake?

YES >> 1. Stop the vehicle.

2. Go to [TM-280, "Cruise Test - Part 3"](#).

NO >> Record the malfunction and go to [TM-280, "Cruise Test - Part 3"](#).

Cruise Test - Part 3

INFOID:000000008791006

1. CHECK SHIFT-DOWN

1. Confirm overdrive control switch is ON position.

2. Confirm gear shift selector is in "D" position.

3. Accelerate vehicle using half-throttle to D5.

4. Release accelerator pedal.

5. Set overdrive control switch to OFF position while driving in D5.

With CONSULT

Read the gear position.

Does A/T shift from D5 to D4 (O/D OFF)?

YES >> GO TO 2.

NO >> Record the malfunction, GO TO 2.

2. CHECK SHIFT-DOWN

During D4 driving, move gear selector from D → 3 → 2 → 1.

ROAD TEST

< PERIODIC MAINTENANCE >

[5AT: RE5R05A]

④ **With CONSULT**

Read the gear position.

Is downshifting correctly performed?

YES >> GO TO 3.

NO >> Record the malfunction, GO TO 3.

3.CHECK ENGINE BRAKE

Check engine brake.

Does engine braking effectively reduce speed in 11 position?

YES >> 1. Stop the vehicle.

2. Carry out the self-diagnostics. Refer to [TM-156, "CONSULT Function \(TRANSMISSION\)"](#).

NO >> Record the malfunction, then continue the trouble diagnosis.

A
B
C
TM
E
F
G
H
I
J
K
L
M
N
O
P

SHIFT CONTROL SYSTEM

< REMOVAL AND INSTALLATION >

[5AT: RE5R05A]

REMOVAL AND INSTALLATION

SHIFT CONTROL SYSTEM

Exploded view

INFOID:000000008791007

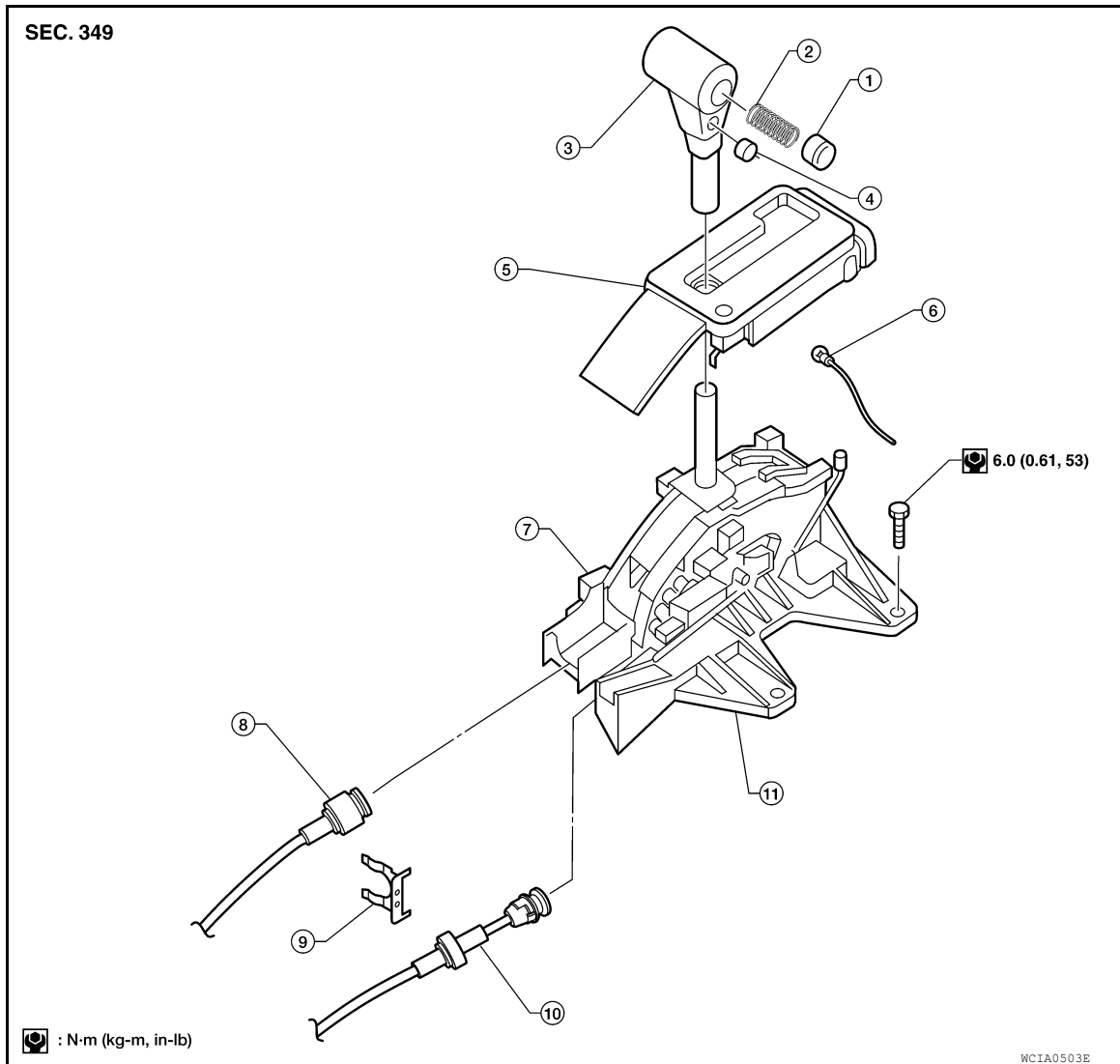

- | | | |
|-------------------------------------|---------------------------------|--------------------------|
| 1. Shift selector handle button | 2. Shift selector handle spring | 3. Shift selector handle |
| 4. Overdrive control switch | 5. Position indicator | 6. Position lamp |
| 7. Shift selector harness connector | 8. Shift selector control cable | 9. Lock plate |
| 10. Key interlock cable | 11. Shift selector assembly | |

Removal and Installation

INFOID:000000008791008

REMOVAL

1. Remove instrument lower panel RH and glove box. Refer to [IP-24, "Removal and Installation"](#).
2. Remove the center console. Refer to [IP-29, "Exploded View"](#).
3. Disconnect the following from the shift selector assembly.
 - Shift selector control cable
 - Key interlock cable
 - Shift selector harness connector
4. Remove the shift selector assembly.

SHIFT CONTROL SYSTEM

< REMOVAL AND INSTALLATION >

[5AT: RE5R05A]

5. Remove the shift selector handle, if necessary.
6. Remove the position indicator, if necessary.

INSTALLATION

Installation is in the reverse order of removal.

- Install and adjust the shift selector control cable. Refer to [TM-283, "Inspection and Adjustment"](#).
- Install and adjust the key interlock cable. Refer to [TM-295, "Removal and Installation"](#).

Inspection and Adjustment

INFOID:000000008791009

ADJUSTMENT

1. Loosen nut of shift selector control cable (A).
2. Place the manual lever (B) and shift selector handle in "P" position.
3. Push the shift selector control cable in the direction shown with a force of 9.8 N (1kg, 2.2 lb), and release it. This is in the natural state, tighten shift selector control cable nut (A) to specifications.

Shift selector control cable nut (A) : 14.7 N·m (1.5 kg·m, 11 ft·lb)

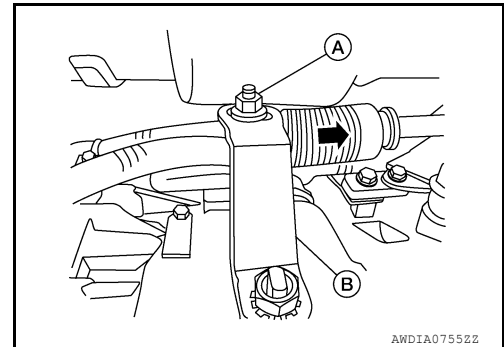

INSPECTION

With the shift selector handle in the "P" position, turn the ignition switch to the ON position with the engine OFF.

Confirm that the following conditions apply.

- The shift selector handle can be moved from the "P" position only when the brake pedal is depressed.
- The shift selector handle stops at each position with the feel of engagement when it is moved through all the positions.
- There is no excessive effort, sticking, noise or rattle.
- The actual position of the shift selector handle matches the position shown by the shift position indicator and the A/T body.
- The back-up lamps illuminate only when the shift selector handle is placed in the "R" position.
- The back-up lamps do not illuminate when the shift selector handle is pushed against the "R" position when in the "P" or "N" position.
- The engine can only be started with the shift selector handle in the "P" and "N" positions.
- The A/T is locked completely when shift selector handle is in the "P" position.

OIL PAN

< REMOVAL AND INSTALLATION >

[5AT: RE5R05A]

OIL PAN

Removal and Installation

INFOID:000000008791010

REMOVAL AND INSTALLATION

Removal

1. Drain A/T fluid. Refer to [TM-269, "Changing the A/T Fluid \(ATF\)"](#).
2. Remove oil pan bolts.
3. Remove oil pan and gasket.

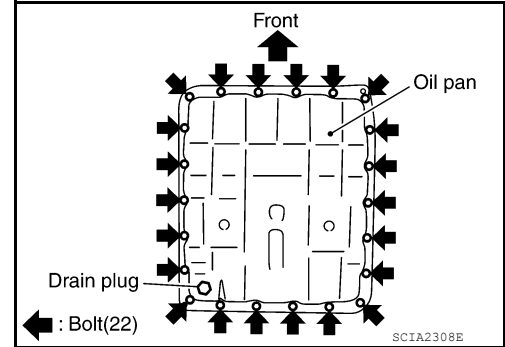

4. Check for foreign materials in oil pan to help determine cause of malfunction. If the A/T fluid is very dark, has some burned smell, or contains foreign particles then friction material (clutches, band) may need replacement. A tacky film that will not wipe clean indicates varnish build up. Varnish can cause valves, servo, and clutches to stick and can inhibit pump pressure.

CAUTION:

If friction material is detected, flush the transmission cooler after repair. Refer to [TM-270, "A/T Fluid Cooler Cleaning"](#).

5. Remove magnets from oil pan.

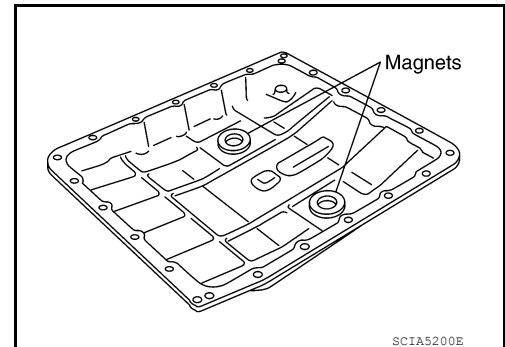

Installation

1. Install the oil pan magnets as shown.

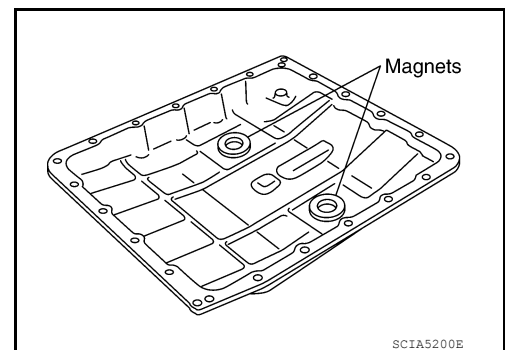

OIL PAN

< REMOVAL AND INSTALLATION >

[5AT: RE5R05A]

2. Install the oil pan with new oil pan gasket.

CAUTION:

- Be sure the oil drain plug is located to the rear of the transmission assembly.
- Before installing oil pan bolts, remove any traces of old sealant from the sealing surfaces and threaded holes.
- Do not reuse old gasket, replace with a new one.
- Always replace the oil pan bolts as they are self-sealing.
- Partially install the oil pan bolts in a criss-cross pattern to prevent dislocation of the gasket.

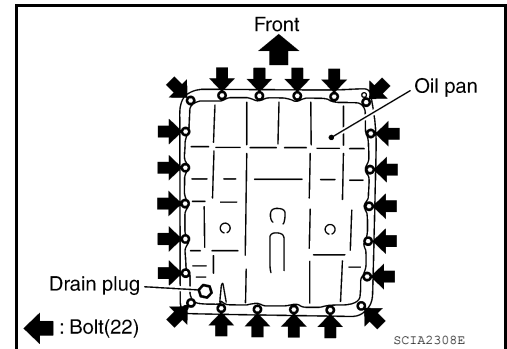

3. Tighten oil pan bolts in numerical order as shown.

Oil pan bolts : 7.9 N·m (0.81 kg-m, 70 in-lb)

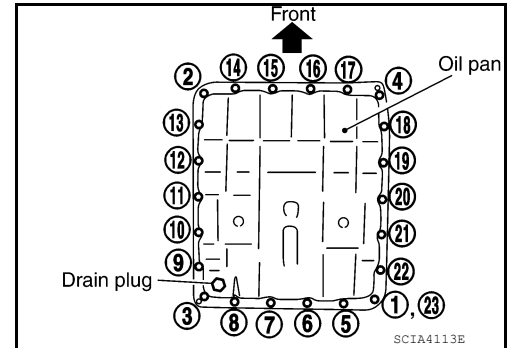

4. Refill the A/T with fluid and check for fluid leaks. Refer to [TM-267. "Checking the A/T Fluid \(ATF\)".](#)

A
B
C
TM
E
F
G
H
I
J
K
L
M
N
O
P

CONTROL VALVE WITH TCM

< REMOVAL AND INSTALLATION >

[5AT: RE5R05A]

CONTROL VALVE WITH TCM

Removal and Installation

INFOID:000000008791011

COMPONENTS

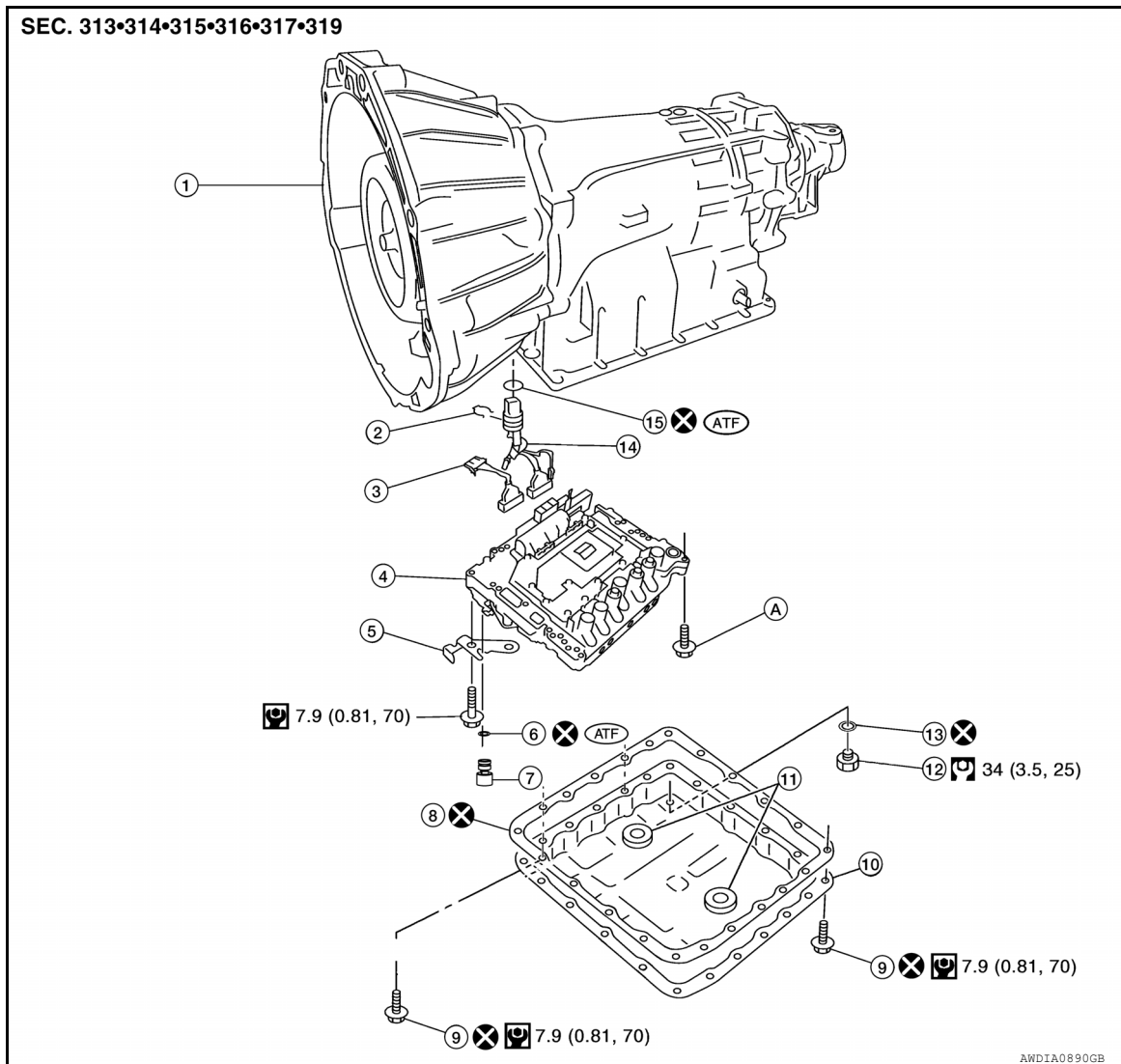

- | | | |
|---|----------------------------|------------------|
| 1. Transmission | 2. Snap ring | 3. Sub-harness |
| 4. Control valve with TCM | 5. Bracket | 6. O-ring |
| 7. Plug | 8. Oil pan gasket | 9. Oil pan bolts |
| 10. Oil pan | 11. Magnet | 12. Drain plug |
| 13. Drain plug gasket | 14. Terminal cord assembly | 15. O-ring |
| A. Refer to GI-4. "Component" | | |

REMOVAL AND INSTALLATION OF CONTROL VALVE WITH TCM

Removal

1. Disconnect negative battery terminal. Refer to [PG-82. "Removal and Installation"](#).
2. Drain A/T fluid. Refer to [TM-269. "Changing the A/T Fluid \(ATF\)"](#).
3. Disconnect A/T assembly harness connector.

CONTROL VALVE WITH TCM

< REMOVAL AND INSTALLATION >

[5AT: RE5R05A]

- Remove snap ring from A/T assembly harness connector.

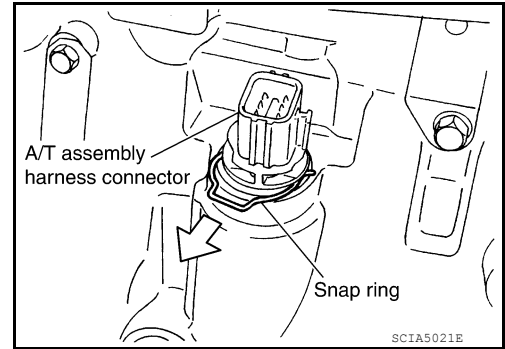

- Push A/T assembly harness connector.
CAUTION:
Do not damage harness connector.

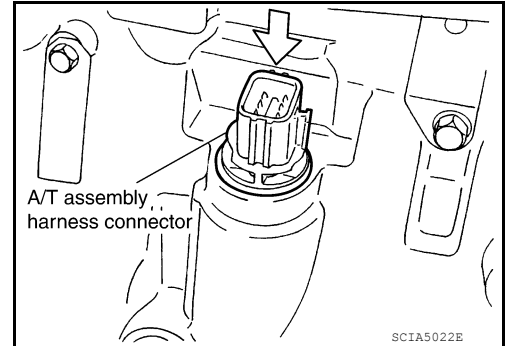

- Remove oil pan and oil pan gasket. Refer to [TM-284, "Removal and Installation"](#).
- Straighten terminal clip (←) to free the output speed sensor harness.
- Disconnect output speed sensor harness connector (1).
CAUTION:
Do not damage harness connector.

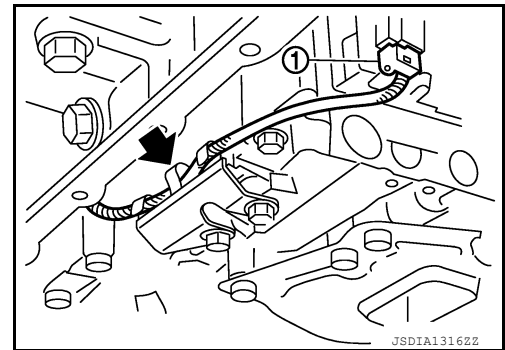

- Remove bolts (A), (B) and (C) from control valve with TCM.

← : Front

Bolt symbol	Length mm (in)	Number of bolts
A	42 (1.65)	5
B	55 (2.17)	6
C	40 (1.57)	1

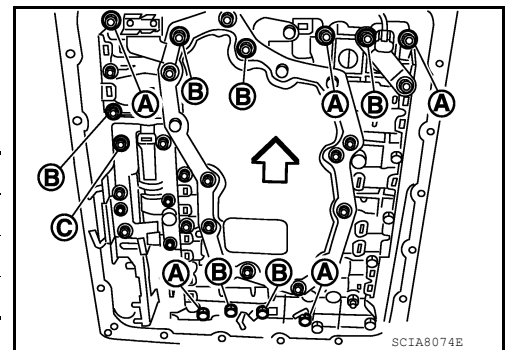

CONTROL VALVE WITH TCM

< REMOVAL AND INSTALLATION >

[5AT: RE5R05A]

10. Remove control valve with TCM from transmission case.

CAUTION:

When removing, be careful with the manual valve notch and manual plate height. Remove it vertically.

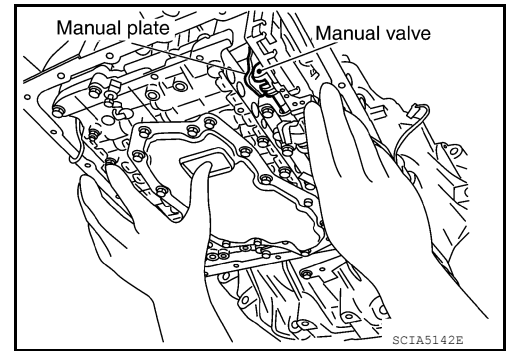

11. Remove plug (1) with bracket (2) from control valve with TCM.

- ◀ :Bolt

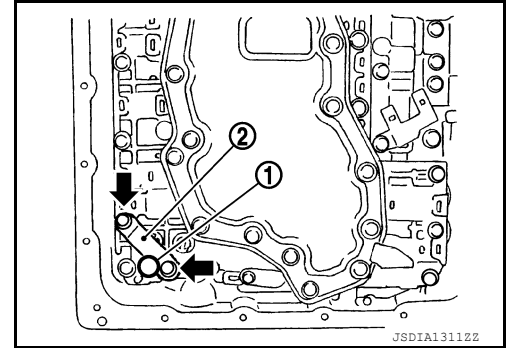

12. Remove the bracket (1) from plug (2).

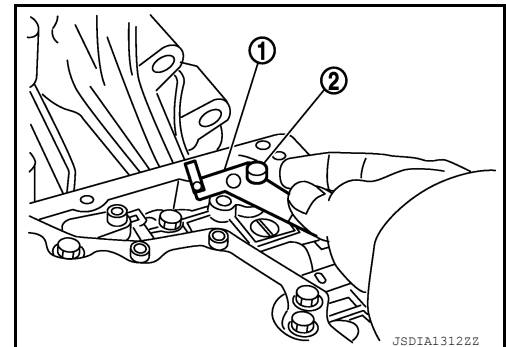

13. Remove O-ring (1) from plug (2).

CAUTION:

Do not reuse O-ring.

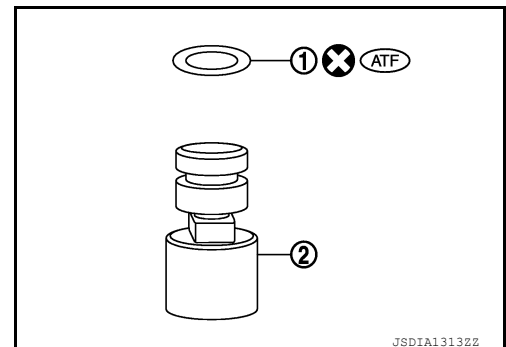

CONTROL VALVE WITH TCM

< REMOVAL AND INSTALLATION >

[5AT: RE5R05A]

14. Remove O-ring from A/T assembly harness connector.

CAUTION:
Do not reuse O-ring.

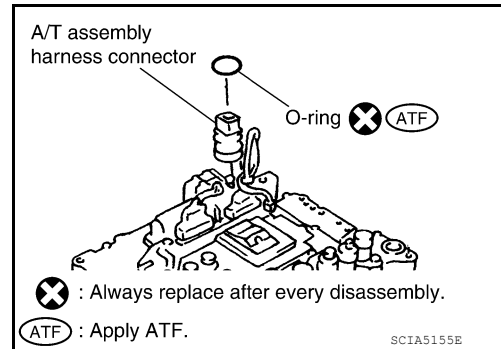

15. Disconnect TCM connectors.

CAUTION:
Do not damage harness connectors.

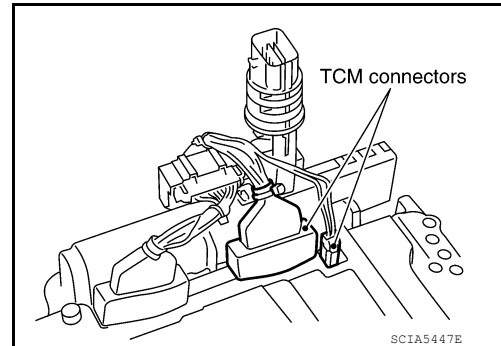

16. Remove A/T assembly harness connector from control valve with TCM using suitable tool.

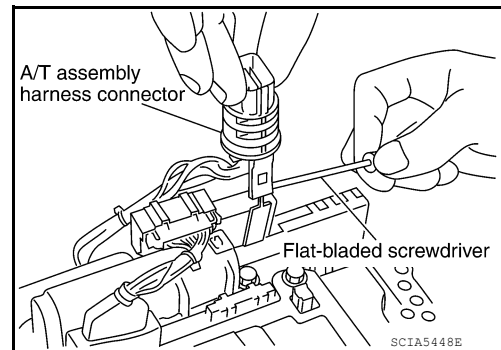

17. Disconnect harness connector (1) and (2) from TCM connector and transmission range switch.

CAUTION:
Do not damage harness connectors.

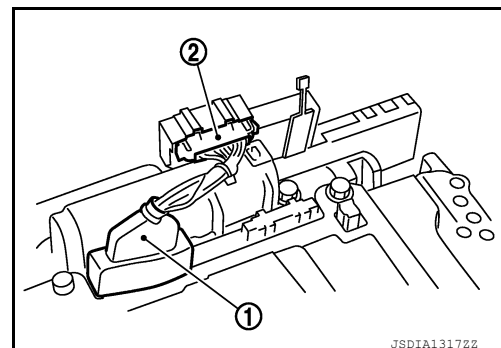

Installation

CAUTION:
After completing installation, check A/T fluid leakage and fluid level. Refer to [TM-267, "Checking the A/T Fluid \(ATF\)"](#).

A
B
C
TM
E
F
G
H
I
J
K
L
M
N
O
P

CONTROL VALVE WITH TCM

< REMOVAL AND INSTALLATION >

[5AT: RE5R05A]

1. Connect TCM connector (1) and transmission range switch harness connector (2).

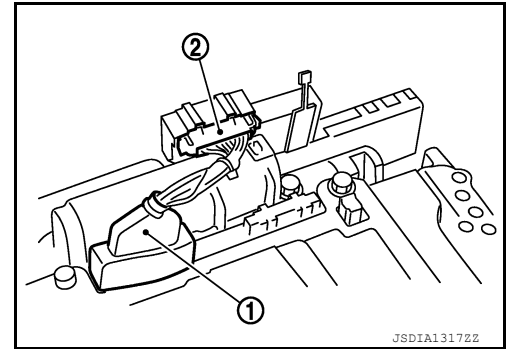

2. Install A/T assembly harness connector to control valve with TCM.

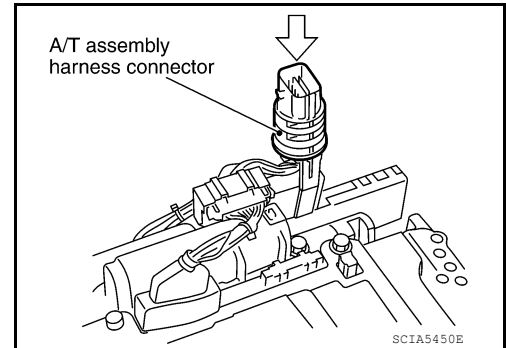

3. Connect TCM connector.

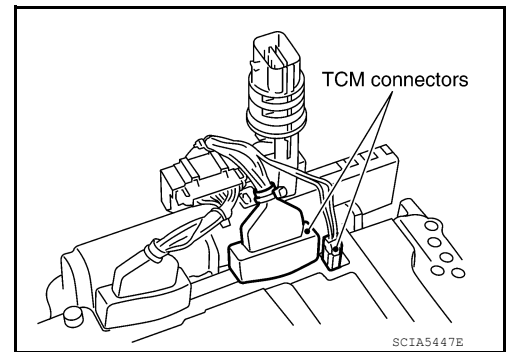

4. Install new O-ring in A/T assembly harness connector.

CAUTION:

- Do not reuse O-ring.
- Apply ATF to O-ring.

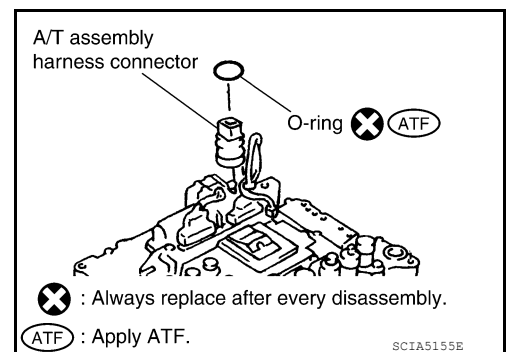

5. Install new O-ring (1) in plug (2).

CAUTION:

- Do not reuse O-ring.
- Apply ATF to O-ring.
- O-ring should be free of contamination.

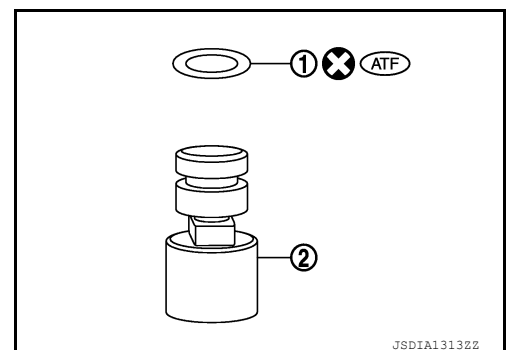

CONTROL VALVE WITH TCM

< REMOVAL AND INSTALLATION >

[5AT: RE5R05A]

6. Install plug (2) to bracket (1).

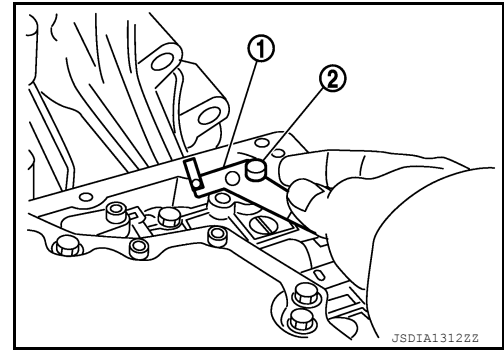

7. Install plug (1) [with bracket (2)] to control valve with TCM. Tighten plug bolt (⬅) to the specified torque.

CAUTION:

Adjust bolt hole of bracket to bolt hole of control valve with TCM.

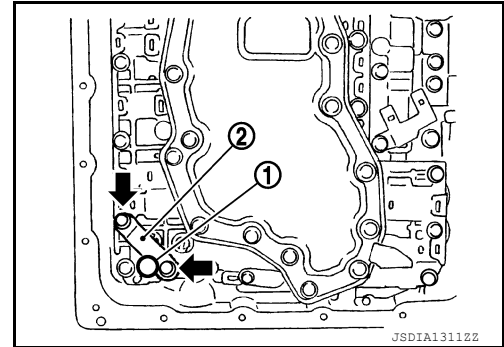

8. Install control valve with TCM in transmission case.

(1) : Brake band

CAUTION:

- Make sure that input speed sensor is securely installed into input speed sensor hole (A).
- Hang down output speed sensor harness toward outside so as not to disturb installation of control valve with TCM.
- Adjust A/T assembly harness connector of control valve with TCM to terminal hole of transmission case.

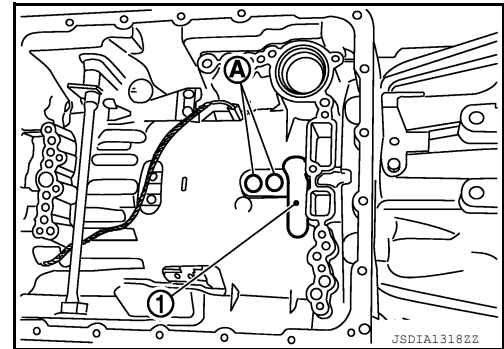

- Assemble it so that manual valve cutout is engaged with manual plate projection.

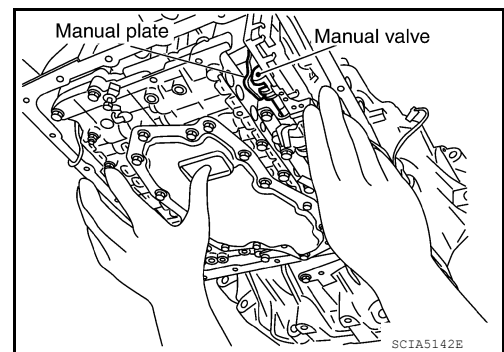

9. Install bolts (A), (B) and (C) in control valve with TCM.

⬅ : Front

Bolt symbol	Length mm (in)	Number of bolts
A	42 (1.65)	5
B	55 (2.17)	6
C	40 (1.57)	1

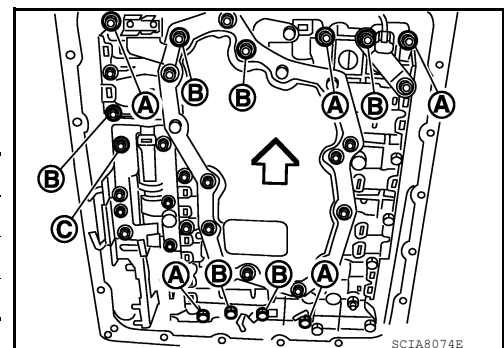

A
B
C
TM
E
F
G
H
I
J
K
L
M
N
O
P

CONTROL VALVE WITH TCM

< REMOVAL AND INSTALLATION >

[5AT: RE5R05A]

10. Tighten bolt (1A), (2B) and (3A) temporarily to prevent dislocation. After that tighten them in order (1 → 2 → 3). Then tighten other bolts. Tighten control valve with TCM bolts to the specified torque.

⇐ : Front

Bolt symbol	A	B	C
Number of bolts	5	6	1
Length mm (in)	42 (1.65)	55 (2.17)	40 (1.57)
Tightening torque N·m (kg·m, in·lb)	7.9 (0.81, 70)		With ATF applied 7.9 (0.81, 70)

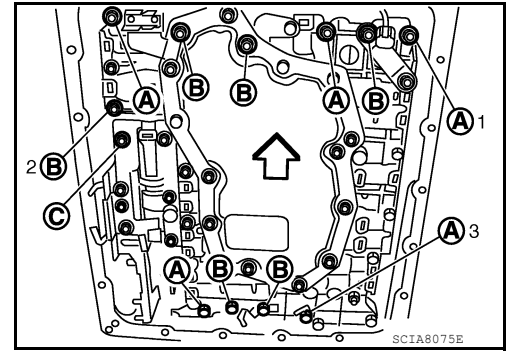

11. Connect output speed sensor harness connector (1).

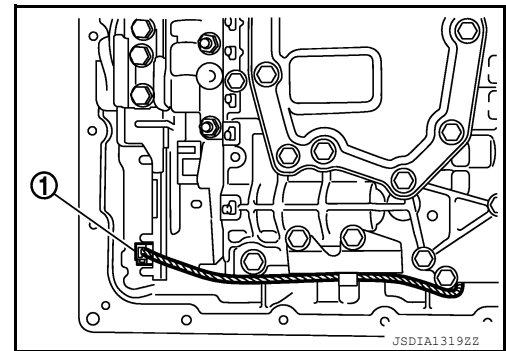

12. Securely fasten output speed sensor (1) harness with terminal clip (⇐).

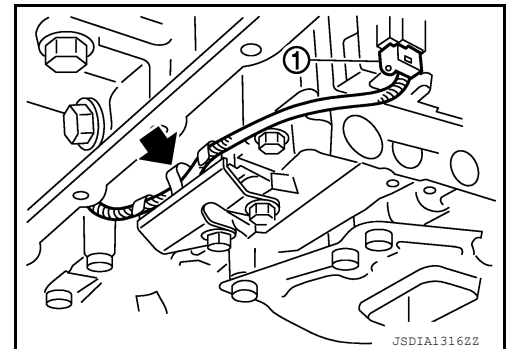

13. Install oil pan to transmission case. Refer to [TM-284, "Removal and Installation"](#).

14. Pull up A/T assembly harness connector.

CAUTION:

Do not damage harness connector.

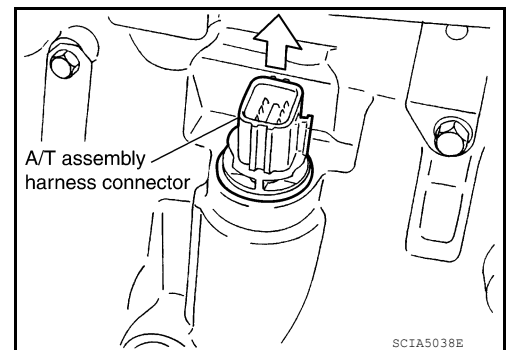

CONTROL VALVE WITH TCM

< REMOVAL AND INSTALLATION >

[5AT: RE5R05A]

15. Install snap ring to A/T assembly harness connector.
16. Connect A/T assembly harness connector.
17. Connect the negative battery terminal.
18. Refill the A/T with fluid and check the fluid level and for fluid leakage. Refer to [TM-267, "Checking the A/T Fluid \(ATF\)"](#).

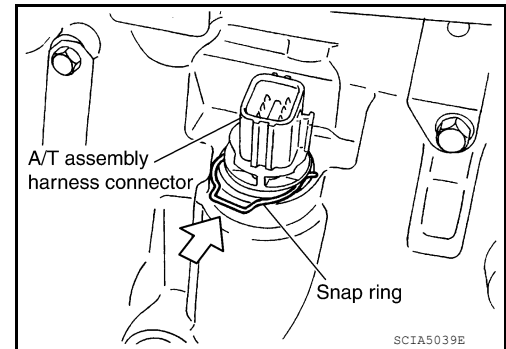

A
B
C

TM

E

F

G

H

I

J

K

L

M

N

O

P

REAR OIL SEAL

< REMOVAL AND INSTALLATION >

[5AT: RE5R05A]

REAR OIL SEAL

Removal and Installation

INFOID:000000008791012

REMOVAL

1. Remove rear propeller shaft. Refer to [DLN-144. "Removal and Installation"](#) (2S1330), [DLN-153. "Removal and Installation"](#) (3S1310), [DLN-164. "Removal and Installation"](#) (3S1330), [DLN-175. "Removal and Installation"](#) (3S1330-2BJ100).
2. Remove transfer from transmission (4WD models). Refer to [DLN-102. "Removal and Installation"](#) (TX15B).
3. Remove rear oil seal using a suitable tool.

CAUTION:

Do not scratch rear extension assembly (2WD models) or adapter case assembly (4WD models).

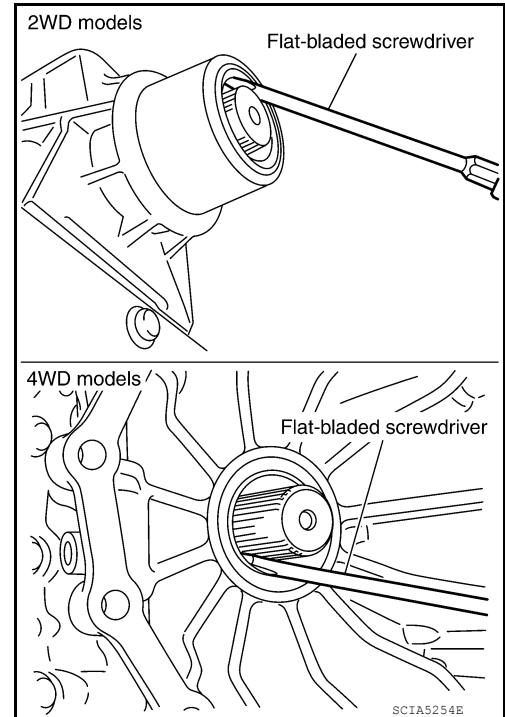

INSTALLATION

1. Install new rear oil seal until it is flush into the rear extension case (2WD models) using Tool or adapter case (4WD models) using suitable tool.

Tool number : ST33400001 (J-26082)

CAUTION:

- Apply ATF to rear oil seal.
- Do not reuse rear oil seal.

2. Install transfer to transmission (4WD models). Refer to [DLN-102. "Removal and Installation"](#) (TX15B).
3. Install rear propeller shaft. Refer to [DLN-144. "Removal and Installation"](#) (2S1330), [DLN-153. "Removal and Installation"](#) (3S1310), [DLN-164. "Removal and Installation"](#) (3S1330), [DLN-175. "Removal and Installation"](#) (3S1330-2BJ100).
4. Check the A/T fluid level and for fluid leaks. Refer to [TM-267. "Checking the A/T Fluid \(ATF\)"](#).

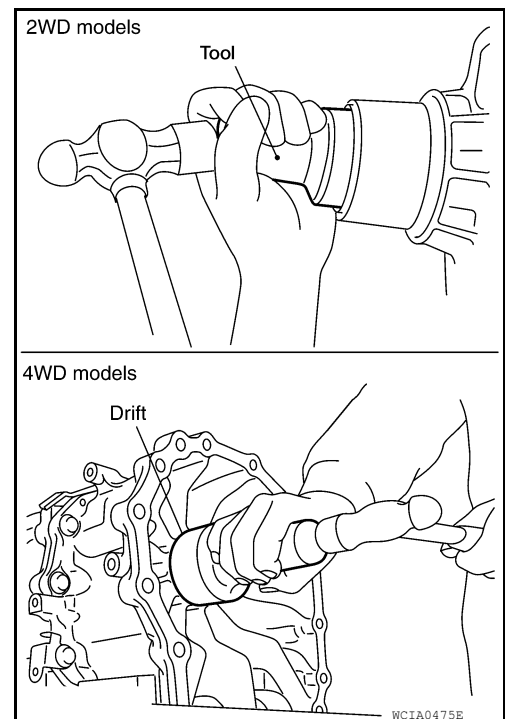

KEY INTERLOCK CABLE

< REMOVAL AND INSTALLATION >

[5AT: RE5R05A]

KEY INTERLOCK CABLE

Component

INFOID:000000008791013

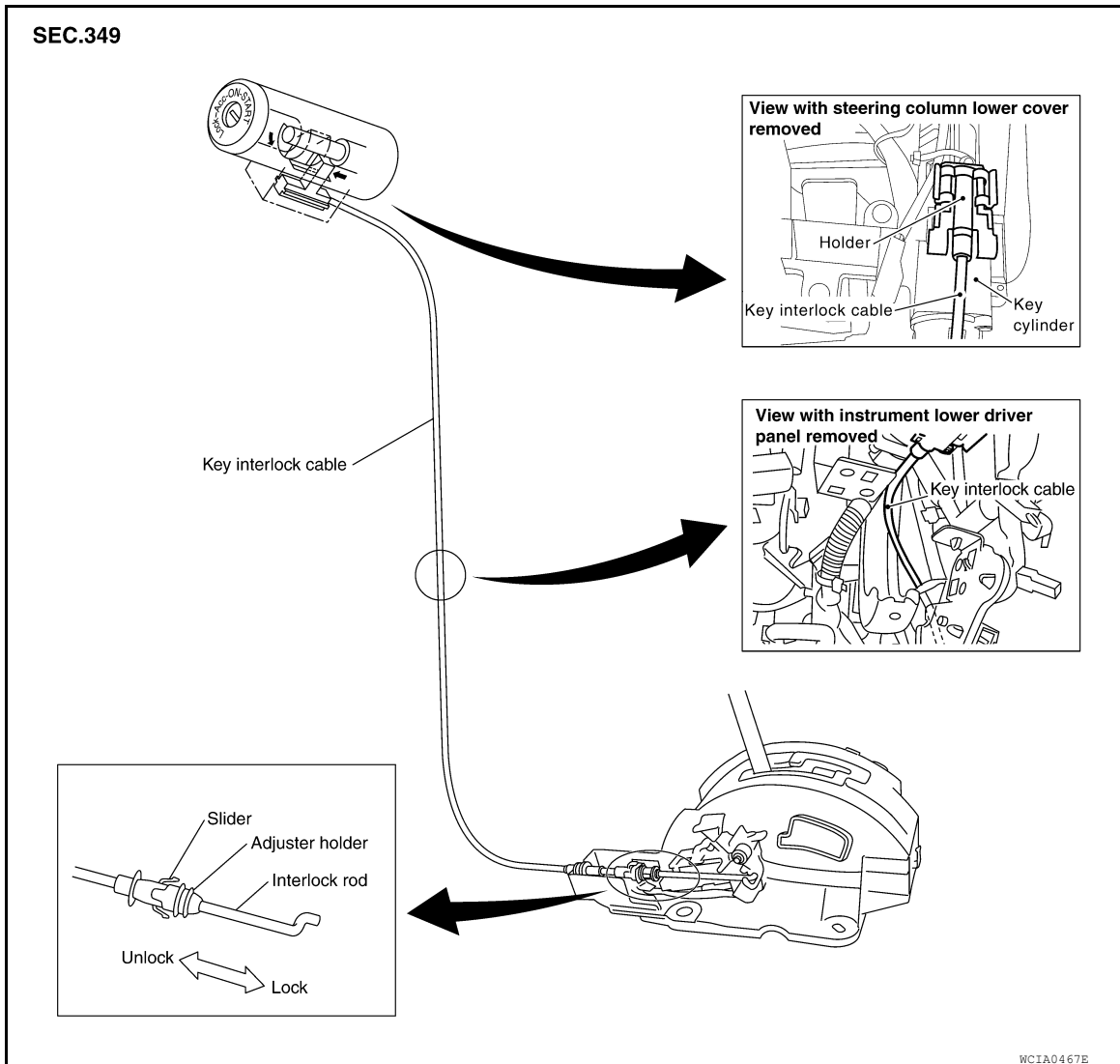

CAUTION:

- Install key interlock cable in such a way that it will not be damaged by sharp bends, twists or interference with adjacent parts.
- After installing key interlock cable to shift selector, make sure that casing cap and bracket are firmly secured in their positions. If casing cap can be removed with an external load of less than 39 N (4.0 kg, 8.8 lb), replace key interlock cable with new one.

Removal and Installation

INFOID:000000008791014

REMOVAL

1. Remove the A/T finisher. Refer to [IP-29, "Exploded View"](#).
2. Remove the lower glove box. Refer to [IP-23, "Removal and Installation"](#).
3. Remove instrument lower panel LH. Refer to [IP-18, "Removal and Installation"](#).

A
B
C
TM
E
F
G
H
I
J
K
L
M
N
O
P

KEY INTERLOCK CABLE

[5AT: RE5R05A]

< REMOVAL AND INSTALLATION >

4. Unlock slider from adjuster holder by squeezing lock tabs.
5. Remove casing cap from bracket of shift selector assembly and remove interlock rod from adjuster holder.
6. Remove holder from key cylinder and remove key interlock cable.

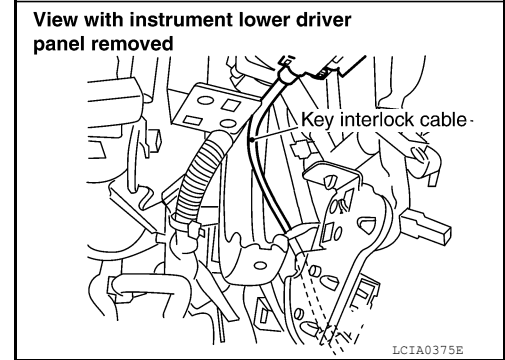
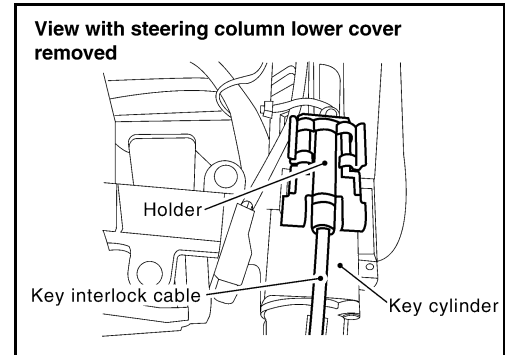
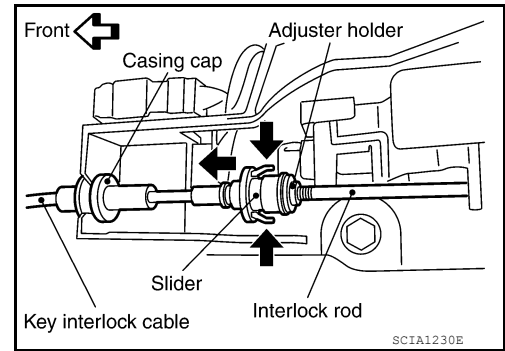

INSTALLATION

1. Set key interlock cable to key cylinder and install holder.
2. Set shift selector handle to "P" position.
3. Turn ignition key to "LOCK" position.

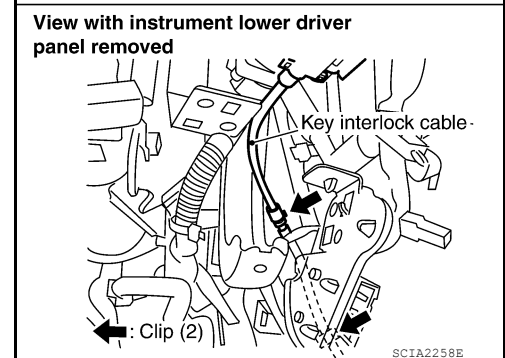
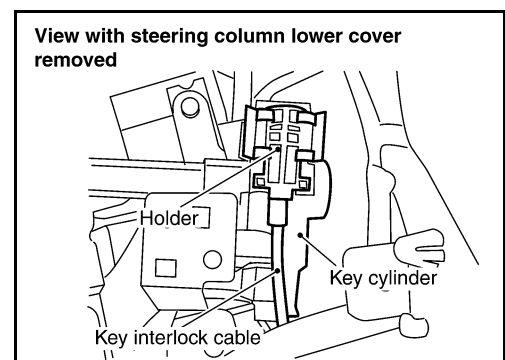

KEY INTERLOCK CABLE

< REMOVAL AND INSTALLATION >

[5AT: RE5R05A]

4. Insert key interlock rod (A) into adjuster holder (B).
5. Install casing cap (C) to bracket (D).
6. Move slider (E) toward key interlock rod (A) to secure adjuster holder (B) to key interlock rod (A).

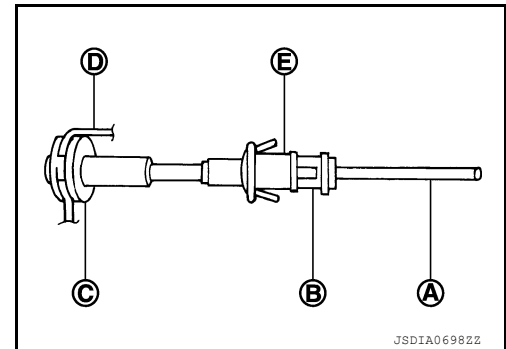

7. Install instrument lower panel LH. Refer to [IP-14, "Exploded View"](#).
8. Install lower glove box. Refer to [IP-14, "Exploded View"](#).
9. Install A/T finisher. Refer to [IP-14, "Exploded View"](#).

AIR BREATHER HOSE

< REMOVAL AND INSTALLATION >

[5AT: RE5R05A]

AIR BREATHER HOSE

Removal and Installation for QR25DE Engine

INFOID:000000008791015

COMPONENTS

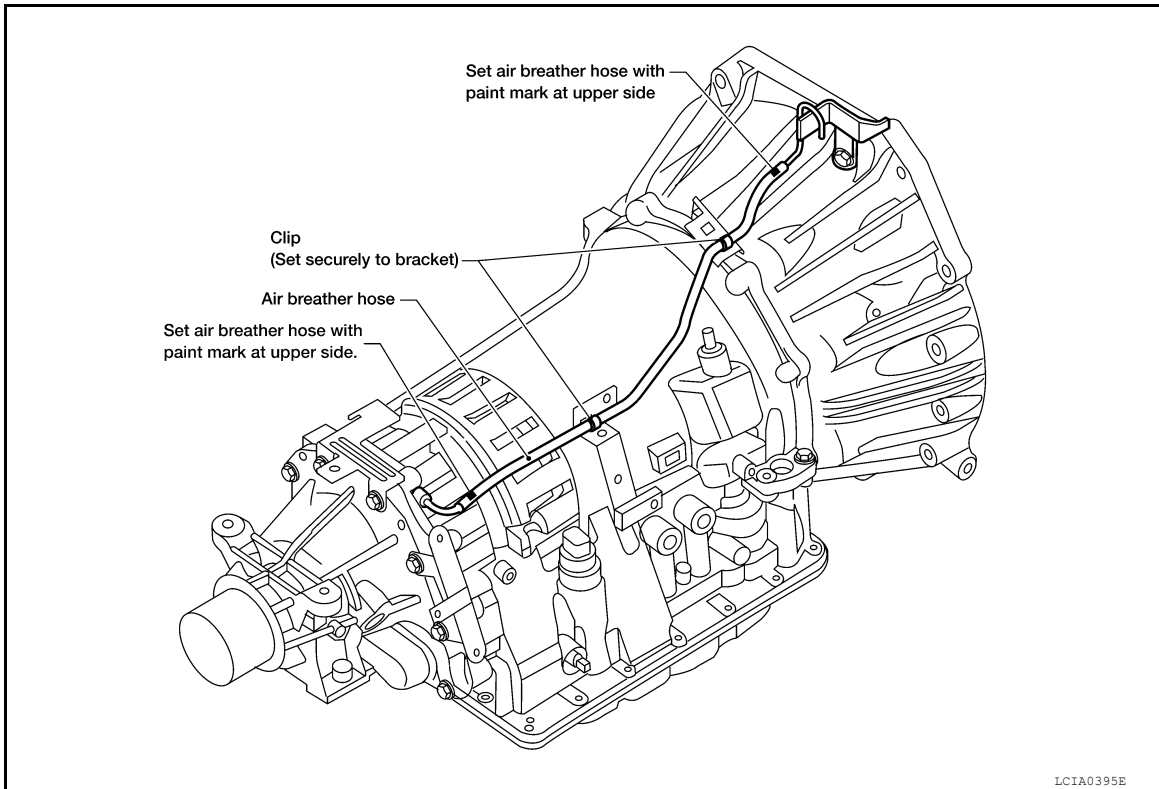

REMOVAL

1. Release air breather hose from clip.
2. Disconnect air breather hose from transmission tube.
3. Disconnect air breather hose from air breather tube.

INSTALLATION

Installation is in the reverse order of removal.

CAUTION:

- Install air breather hose with paint mark at upper side.
- When installing the air breather hose, do not crush or block by folding or bending the hose.
- When inserting the hose to the transmission tube, be sure to insert it fully until its end reaches the tube bend portion.
- Make sure clip is securely installed to bracket.

Removal and Installation for VQ40DE Engine

INFOID:000000008791016

COMPONENTS (2WD MODELS)

AIR BREATHER HOSE

< REMOVAL AND INSTALLATION >

[5AT: RE5R05A]

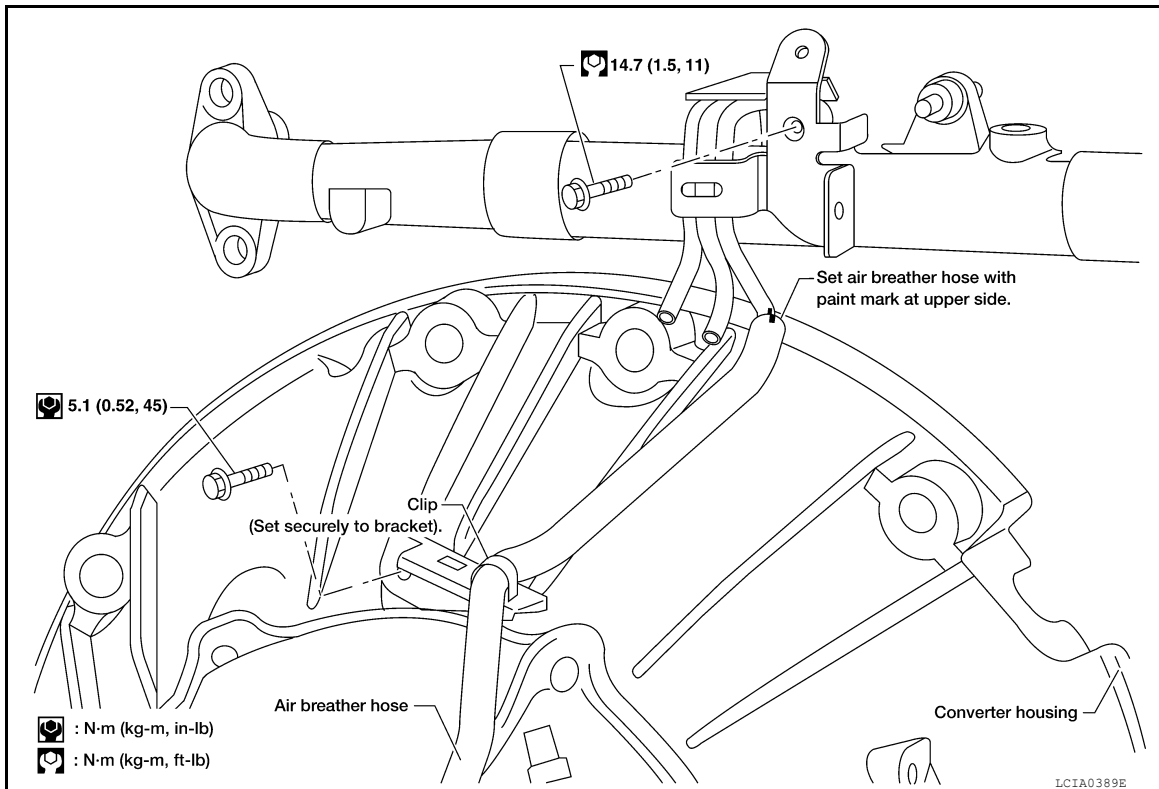

REMOVAL (2WD MODELS)

1. Release air breather hose from clip.
2. Disconnect air breather hose from transmission tube.
3. Disconnect air breather hose from air breather tube.

INSTALLATION (2WD MODELS)

Installation is in the reverse order of removal.

CAUTION:

- Install air breather hose with paint mark at upper side.
- When installing the air breather hose, do not crush or block by folding or bending the hose.
- When inserting the hose to the transmission tube, be sure to insert it fully until its end reaches the tube bend portion.
- Make sure clip is securely installed to bracket.

COMPONENTS (4WD)

A
B
C
TM
E
F
G
H
I
J
K
L
M
N
O
P

AIR BREATHER HOSE

< REMOVAL AND INSTALLATION >

[5AT: RE5R05A]

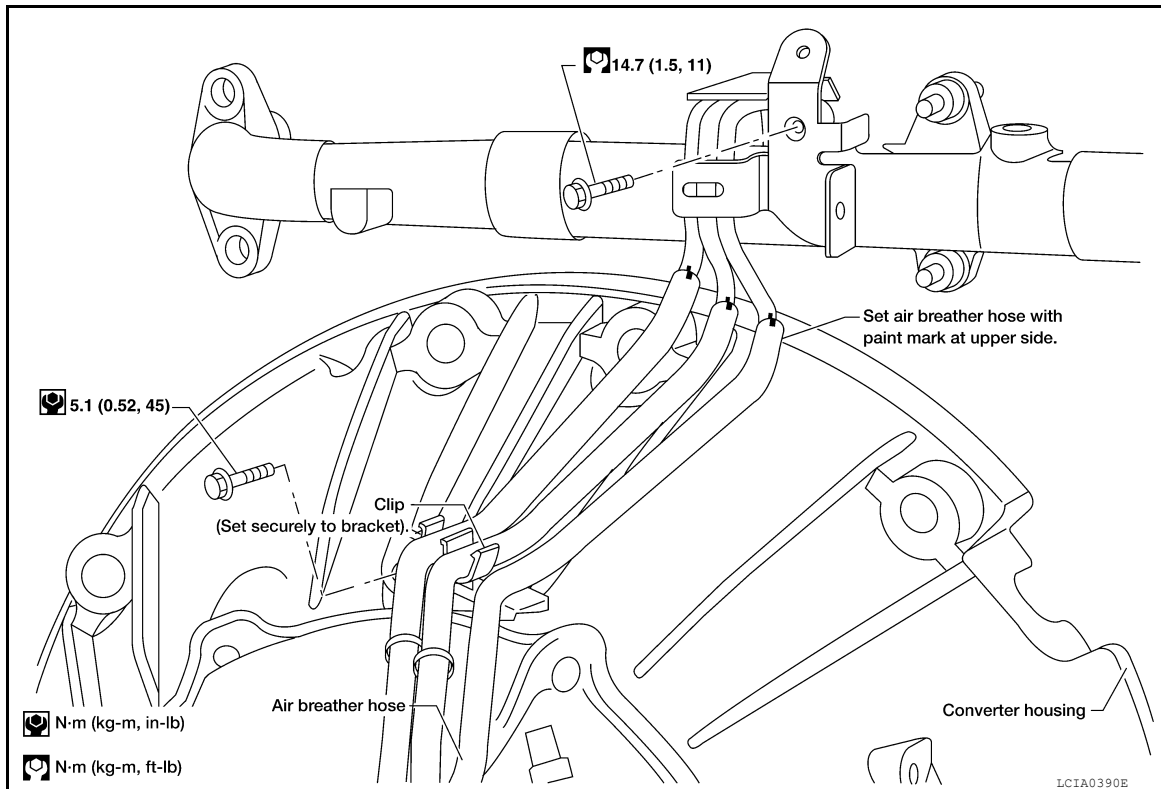

REMOVAL (4WD MODELS)

1. Release air breather hose from clip.
2. Disconnect air breather hose from transmission tube.
3. Disconnect air breather hose from air breather tube.

INSTALLATION (4WD MODELS)

Installation is in the reverse order of removal.

CAUTION:

- Install air breather hose with paint mark at upper side.
- When installing the air breather hose, do not crush or block by folding or bending the hose.
- When inserting the hose to the transmission tube, be sure to insert it fully until its end reaches the tube bend portion.
- Make sure clip is securely installed to bracket.

A/T FLUID COOLER

< REMOVAL AND INSTALLATION >

[5AT: RE5R05A]

A/T FLUID COOLER

Removal and Installation

INFOID:000000008791017

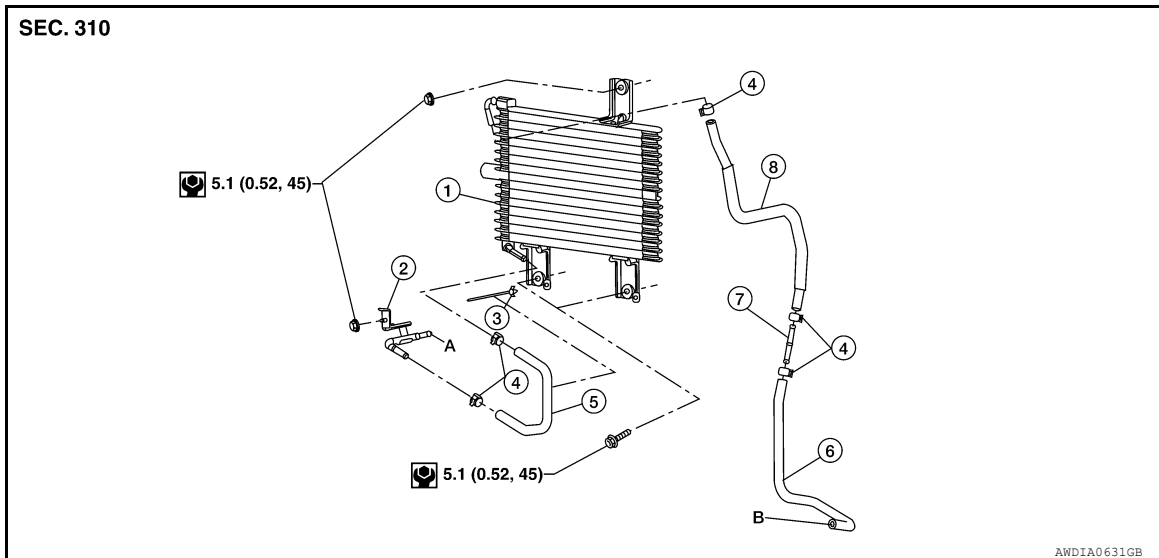

- | | | |
|---------------------|------------------------|--------------------|
| 1. A/T fluid cooler | 2. Fluid cooler tube | 3. Clip |
| 4. Hose clamp | 5. Cooler hose (lower) | 6. Cooler hose |
| 7. Tube joint | 8. Cooler hose (upper) | A. To transmission |
| B. From radiator | | |

NOTE:

When removing components such as hoses, tubes/lines, etc., cap or plug openings to prevent fluid from spilling.

REMOVAL

1. Remove front grille. Refer to [EXT-23, "Removal and Installation"](#).
2. Remove A/T fluid cooler hoses from fluid cooler.
3. Remove A/T fluid cooler.

INSTALLATION

Installation is in the reverse order of removal.

- After completing installation, check fluid level and check for fluid leaks. Refer to [TM-267, "Checking the A/T Fluid \(ATF\)"](#).

TRANSMISSION ASSEMBLY

< UNIT REMOVAL AND INSTALLATION >

[5AT: RE5R05A]

UNIT REMOVAL AND INSTALLATION

TRANSMISSION ASSEMBLY

Component

INFOID:000000008791018

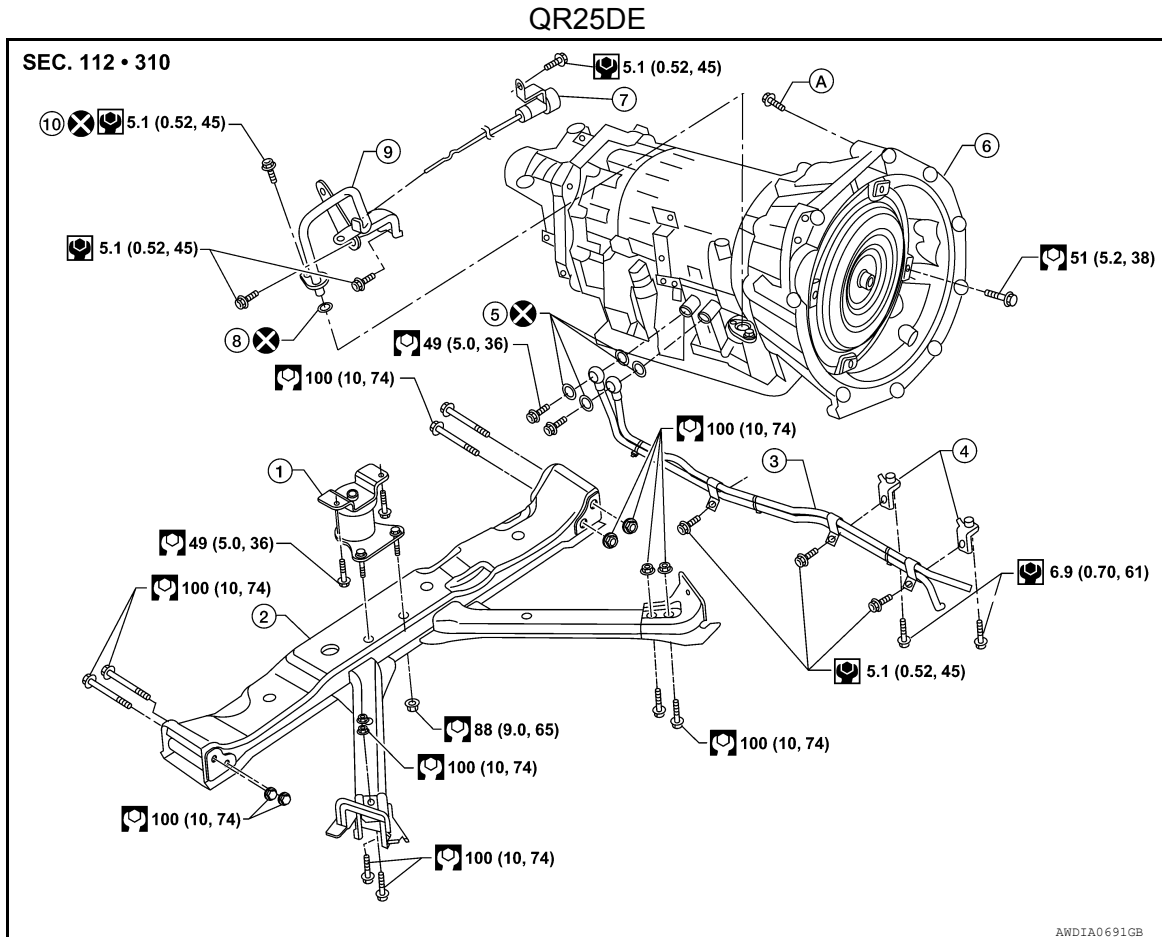

- | | | |
|----------------------------------|---------------------------|-----------------------------|
| 1. Insulator | 2. A/T cross member | 3. A/T fluid cooler tube |
| 4. A/T fluid cooler tube bracket | 5. Copper sealing washers | 6. Transmission assembly |
| 7. A/T fluid indicator | 8. O-ring | 9. A/T fluid indicator pipe |
| 10. Self-sealing bolt | A. Refer to installation | |

TRANSMISSION ASSEMBLY

< UNIT REMOVAL AND INSTALLATION >

[5AT: RE5R05A]

VQ40DE 2WD Models

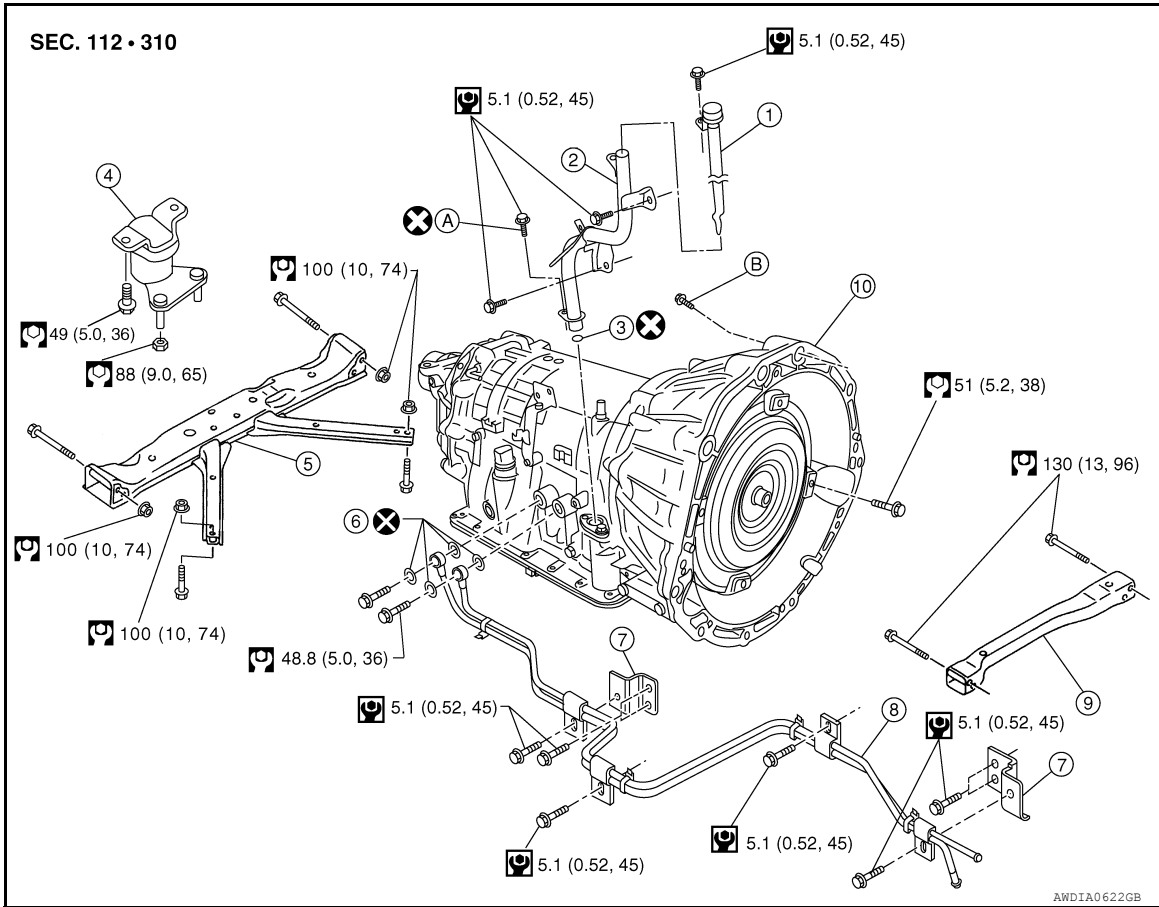

- 1. A/T fluid indicator
- 4. Insulator
- 7. Bracket
- 10. Transmission assembly

- 2. A/T fluid indicator pipe
- 5. A/T crossmember
- 8. A/T fluid cooler tube
- A. Self-sealing bolt

- 3. O-ring
- 6. Copper sealing washers
- 9. Front crossmember
- B. Refer to installation.

A
B
C
TM
E
F
G
H
I
J
K
L
M
N
O
P

TRANSMISSION ASSEMBLY

< UNIT REMOVAL AND INSTALLATION >

[5AT: RE5R05A]

VQ40DE 4WD Models

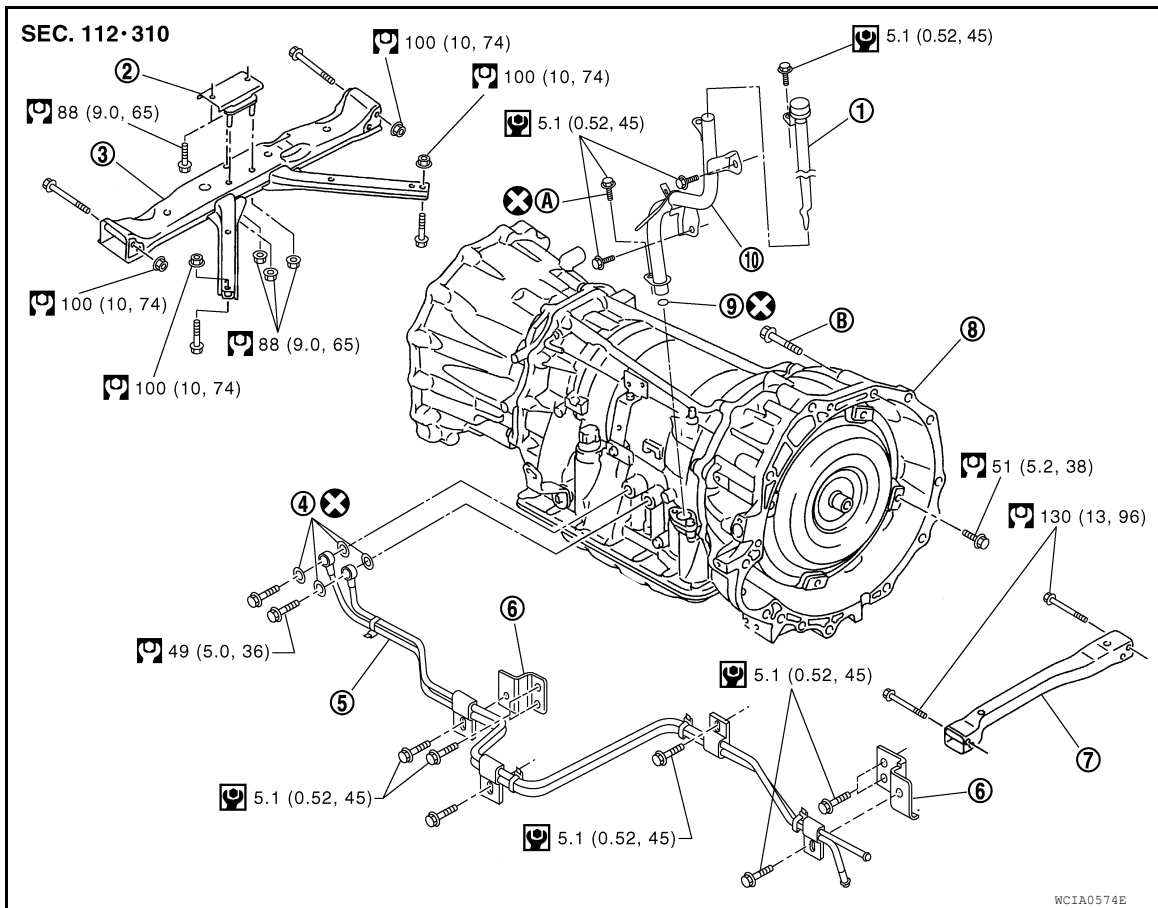

- | | | |
|------------------------------|--------------------------|---------------------------|
| 1. A/T fluid indicator | 2. Insulator | 3. A/T crossmember |
| 4. Copper sealing washers | 5. A/T fluid cooler tube | 6. Bracket |
| 7. Front crossmember | 8. Transmission assembly | 9. O-ring |
| 10. A/T fluid indicator pipe | A. Self-sealing bolt | B. Refer to installation. |

Removal and Installation for QR25DE

INFOID:000000008791019

CAUTION:

When removing the A/T assembly from engine, first remove the crankshaft position sensor (POS) from the A/T assembly.

NOTE:

When removing components such as hoses, tubes/lines, etc., cap or plug openings to prevent fluid from spilling.

REMOVAL

1. Disconnect the negative battery terminal. Refer to [PG-82, "Removal and Installation"](#).
2. Remove the A/T fluid indicator.
3. Remove the front LH wheel and tire assembly Refer to [WT-48, "Adjustment"](#).
4. Remove the front LH mud flap. Refer to [EXT-29, "Removal and Installation"](#).
5. Remove the LH fender protector. Refer to [EXT-27, "Removal and Installation of Front Fender Protector"](#).

TRANSMISSION ASSEMBLY

< UNIT REMOVAL AND INSTALLATION >

[5AT: RE5R05A]

6. Remove the crankshaft position sensor (POS) from the A/T assembly.

CAUTION:

- Do not subject it to impact by dropping or hitting it.
- Do not disassemble.
- Do not allow metal filings or debris to get on the sensor's front edge magnetic area.
- Do not place in an area affected by magnetism.

7. Remove the under cover using power tool.
8. Remove the front crossmember using power tool.
9. Remove the starter.

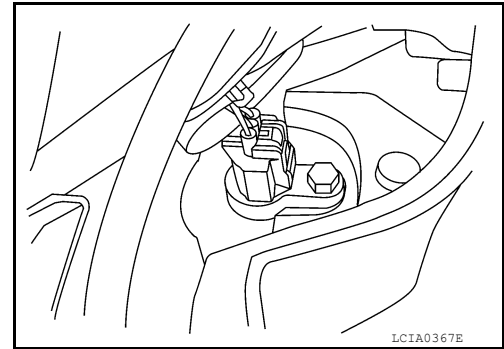

10. Remove the rear propeller shaft. Refer to [DLN-153, "Removal and Installation"](#).
11. Remove the shift selector control cable and bracket from the A/T.
12. Disconnect the A/T fluid cooler tubes from the A/T assembly.

CAUTION:

Do not reuse copper sealing washers.

13. Remove the dust cover from the converter housing.
14. Turn the crankshaft to access and remove the four bolts for the drive plate and torque converter.

CAUTION:

When turning the crankshaft, turn it clockwise as viewed from the front of the engine.

15. Support the A/T assembly using a transmission jack.

CAUTION:

When setting the transmission jack, be careful not to allow it to collide against the drain plug.

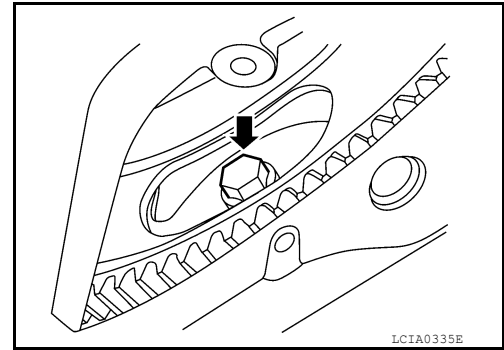

16. Remove the nuts securing the insulator to the crossmember.
17. Remove the crossmember using power tool.

WARNING:

Support the transmission using suitable jack.

18. Tilt the transmission slightly to gain clearance between the body and the transmission, then disconnect the air breather hose.
19. Disconnect the A/T assembly harness connector.
20. Remove the harness from the retainers.
21. Remove the A/T fluid indicator pipe.
22. Remove the A/T assembly to engine bolts using power tool.
23. Remove A/T assembly from the vehicle using Tool.

Tool number : — (J-47002)

CAUTION:

- Secure the torque converter to prevent it from dropping.
- Secure the A/T assembly to a transmission jack.

NOTE:

The actual special service Tool may differ from Tool shown.

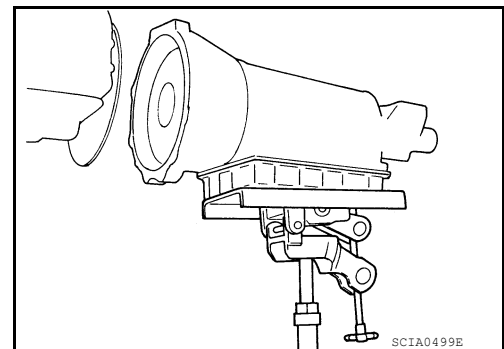

INSPECTION

Installation and Inspection of Torque Converter

A
B
C
TM
E
F
G
H
I
J
K
L
M
N
O
P

TRANSMISSION ASSEMBLY

< UNIT REMOVAL AND INSTALLATION >

[5AT: RE5R05A]

- After inserting a torque converter to a transmission, be sure to check dimension (A) to ensure it is within the reference value limit.

Dimension (A) : 25.0 mm (0.98 in) or more

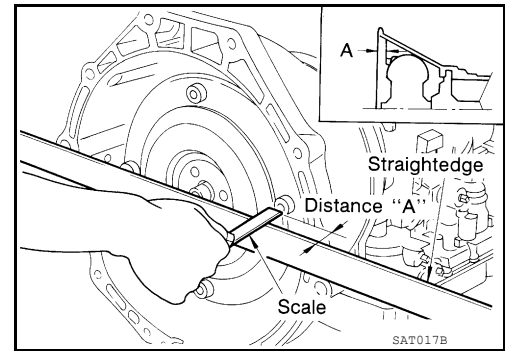

INSTALLATION

Installation of the remaining components is in the reverse order of the removal, while paying attention to the following.

- When installing the transmission to the engine, install the bolts in accordance with the standard below.

Bolt No.	1	2	3
Quantity	4	1	6
Bolt length "ℓ" mm (in)	60 (2.36)		65 (2.56)
Tightening torque N·m (kg·m, ft·lb)	35 (3.6, 26)		75 (7.7, 55)

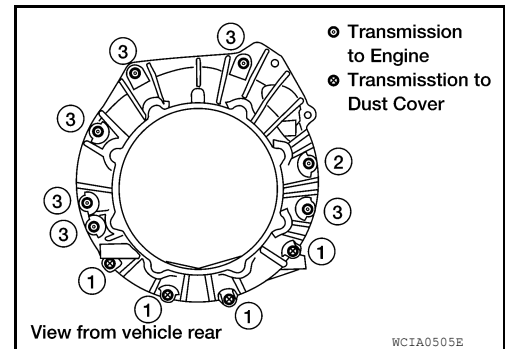

- Align the positions of bolts for drive plate with those of the torque converter, and temporarily tighten the bolts. Then, tighten the bolts with the specified torque.

CAUTION:

- When turning crankshaft, turn it clockwise as viewed from the front of the engine.
- After converter is installed to drive plate, rotate crankshaft several turns and check to be sure that transmission rotates freely without binding.
- When replacing an engine or transmission you must make sure the dowels are installed correctly during re-assembly.
- Improper alignment caused by missing dowels may cause vibration, oil leaks or breakage of drive train components.
- Install crankshaft position sensor (POS).

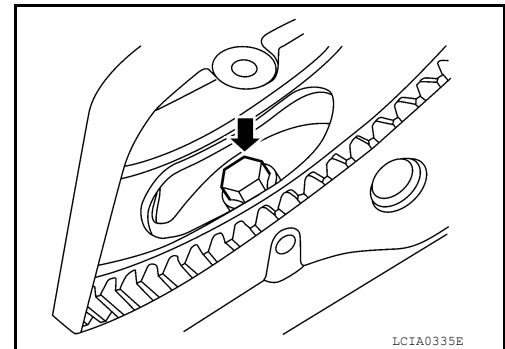

- After completing installation, check fluid leakage, fluid level, and the positions of A/T. Refer to [TM-267, "Checking the A/T Fluid \(ATF\)"](#), [TM-283, "Inspection and Adjustment"](#).

Removal and Installation for VQ40DE 2WD Models

INFOID:000000008791020

CAUTION:

When removing the A/T assembly from engine, first remove the crankshaft position sensor (POS) from the A/T assembly.

NOTE:

When removing components such as hoses, tubes/lines, etc., cap or plug openings to prevent fluid from spilling.

REMOVAL

1. Disconnect the negative battery terminal. Refer to [PG-82, "Removal and Installation"](#).
2. Remove the A/T fluid indicator.
3. Remove the front LH wheel and tire assembly. Refer to [WT-48, "Adjustment"](#).
4. Remove the front LH mud flap. Refer to [EXT-29, "Removal and Installation"](#).
5. Remove the LH fender protector. Refer to [EXT-27, "Removal and Installation of Front Fender Protector"](#).

TRANSMISSION ASSEMBLY

< UNIT REMOVAL AND INSTALLATION >

[5AT: RE5R05A]

6. Remove the crankshaft position sensor (POS) from the A/T assembly.

CAUTION:

- Do not subject it to impact by dropping or hitting it.
- Do not disassemble.
- Do not allow metal filings or debris to get on the sensor's front edge magnetic area.
- Do not place in an area affected by magnetism.

7. Remove the under cover(s) using power tool.
8. Remove the front crossmember using power tool.
9. Remove the starter.

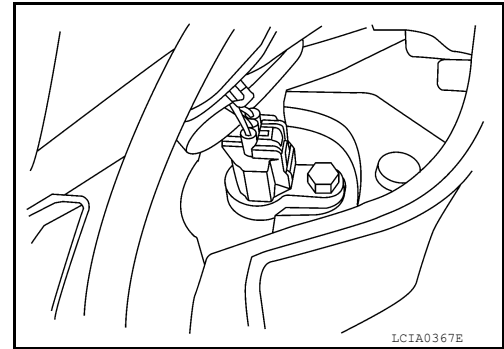

10. Remove the rear propeller shaft. Refer to [DLN-164, "Removal and Installation"](#) (3S1330), [DLN-175, "Removal and Installation"](#) (3S1330-2BJ100).
11. Remove the left and right front exhaust tubes. Refer to [EX-6, "Removal and Installation"](#).
12. Remove the shift selector control cable and bracket from the A/T.

13. Disconnect the A/T fluid cooler tubes from the A/T assembly.

CAUTION:

Do not reuse copper sealing washers.

14. Remove the dust cover from the converter housing.
15. Turn the crankshaft to access and remove the four bolts for the drive plate and torque converter.

CAUTION:

When turning the crankshaft, turn it clockwise as viewed from the front of the engine.

16. Support the A/T assembly using a transmission jack.

CAUTION:

When setting the transmission jack, be careful not to allow it to collide against the drain plug.

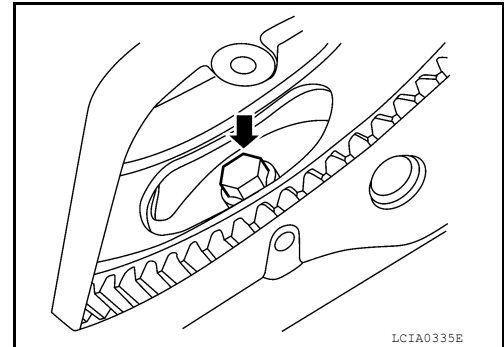

17. Remove the nuts securing the insulator to the crossmember.
18. Remove the crossmember using power tool.
19. Tilt the transmission slightly to gain clearance between the body and the transmission, then disconnect the air breather hose.
20. Disconnect the A/T assembly harness connector.
21. Remove the wiring harness from the retainers.
22. Remove the A/T fluid indicator pipe.
23. Remove the A/T assembly to engine bolts using power tool.
24. Remove A/T assembly from the vehicle using Tool.

Tool number : — (J-47002)

CAUTION:

- Secure the torque converter to prevent it from dropping.
- Secure the A/T assembly to a transmission jack.

NOTE:

The actual special service Tool may differ from Tool shown.

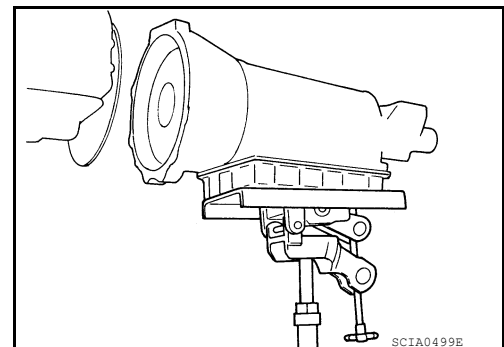

INSPECTION

Installation and Inspection of Torque Converter

TRANSMISSION ASSEMBLY

< UNIT REMOVAL AND INSTALLATION >

[5AT: RE5R05A]

- After inserting a torque converter to a transmission, be sure to check dimension (A) to ensure it is within the reference value limit.

Dimension (A) : 25.0 mm (0.98 in) or more

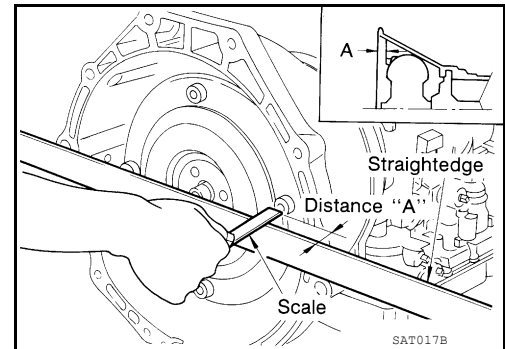

INSTALLATION

Installation of the remaining components is in the reverse order of the removal, while paying attention to the following.

- When installing transmission to the engine, tighten the bolts to the specified torque using sequence shown.

Transmission bolts : 75 N·m (7.6 kg-m, 55 ft-lb)

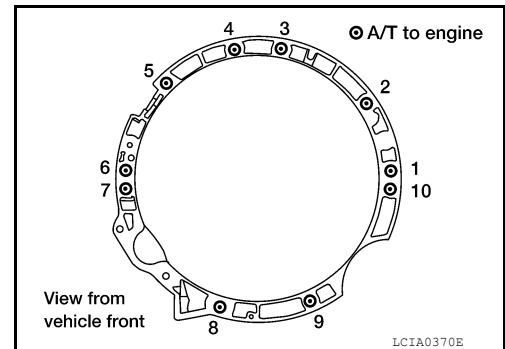

- Align the positions of bolts for drive plate with those of the torque converter, and temporarily tighten the bolts. Then, tighten the bolts with the specified torque.

CAUTION:

- **When turning crankshaft, turn it clockwise as viewed from the front of the engine.**
- **After converter is installed to drive plate, rotate crankshaft several turns and check to be sure that transmission rotates freely without binding.**
- **When replacing an engine or transmission you must make sure the dowels are installed correctly during re-assembly.**
- **Improper alignment caused by missing dowels may cause vibration, oil leaks or breakage of drive train components.**
- Install crankshaft position sensor (POS).

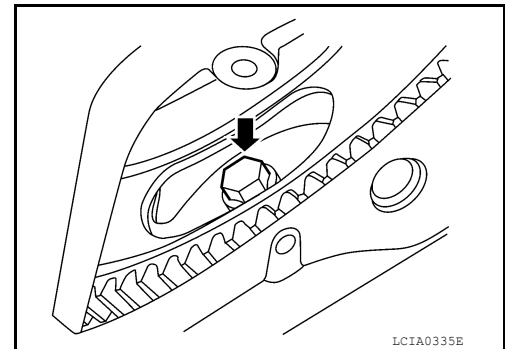

- After completing installation, check fluid leakage, fluid level, and the positions of A/T. Refer to [TM-267, "Checking the A/T Fluid \(ATF\)"](#), [TM-283, "Inspection and Adjustment"](#).

Removal and Installation for VQ40DE 4WD Models

INFOID:000000008791021

CAUTION:

When removing the A/T assembly from engine, first remove the crankshaft position sensor (POS) from the A/T assembly.

NOTE:

When removing components such as hoses, tubes/lines, etc., cap or plug openings to prevent fluid from spilling.

REMOVAL

1. Disconnect the negative battery terminal. Refer to [PG-82, "Removal and Installation"](#).
2. Remove the A/T fluid indicator.
3. Remove the front LH wheel and tire assembly. Refer to [WT-48, "Adjustment"](#).
4. Remove the front LH mud flap. Refer to [EXT-29, "Removal and Installation"](#).
5. Remove the LH fender protector. Refer to [EXT-27, "Removal and Installation of Front Fender Protector"](#).

TRANSMISSION ASSEMBLY

< UNIT REMOVAL AND INSTALLATION >

[5AT: RE5R05A]

6. Remove the crankshaft position sensor (POS) from the A/T assembly.

CAUTION:

- Do not subject it to impact by dropping or hitting it.
- Do not disassemble.
- Do not allow metal filings or debris to get on the sensor's front edge magnetic area.
- Do not place in an area affected by magnetism.

7. Remove the air dam.
8. Remove the front and rear engine under cover using power tool.
9. Remove the front crossmember using power tool.
10. Remove the starter motor.

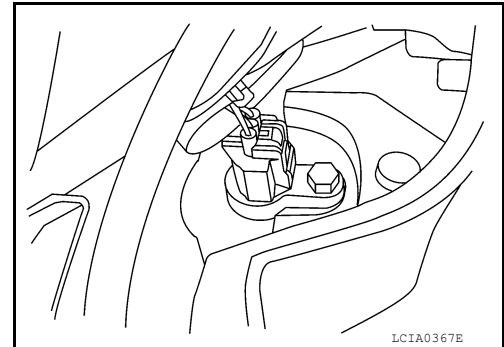

11. Remove the front and rear propeller shafts. Refer to [DLN-135, "Removal and Installation"](#) (2F1310), [DLN-144, "Removal and Installation"](#) (2S1330) or (3S1330-2BJ100) [DLN-175, "Removal and Installation"](#).
12. Remove the left and right front exhaust tubes. Refer to [EX-6, "Removal and Installation"](#).
13. Remove the shift selector control cable and bracket from the A/T.
14. Disconnect the fluid cooler tubes from the A/T assembly.

CAUTION:

Do not reuse copper sealing washers.

15. Remove the dust cover from the converter housing.
16. Turn the crankshaft to access and remove the four bolts for the drive plate and torque converter.

CAUTION:

When turning the crankshaft, turn it clockwise as viewed from the front of the engine.

17. Support the A/T assembly using a transmission jack.

CAUTION:

When setting the transmission jack, be careful not to allow it to collide against the drain plug.

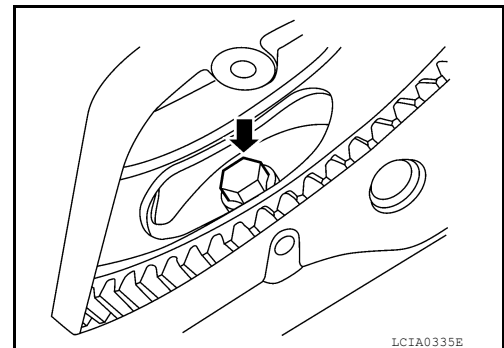

18. Remove the nuts securing the insulator to the crossmember.
19. Remove the crossmember using power tool.
20. Tilt the transmission slightly to gain clearance between the body and the transmission, then disconnect the air breather hose.
21. Disconnect the following:
 - A/T assembly harness connector
 - 4LO switch harness connector
 - Wait detection switch harness connector
 - ATP switch harness connector
 - Transfer control device harness connector
22. Remove the wiring harness from the retainers.
23. Remove the A/T fluid indicator pipe.
24. Remove the A/T assembly to engine bolts using power tool.
25. Remove A/T assembly with transfer from the vehicle using Tool.

Tool number : — (J-47002)

CAUTION:

- Secure the torque converter to prevent it from dropping.
- Secure the A/T assembly to a transmission jack.

NOTE:

The actual special service Tool may differ from Tool shown.

26. Remove the transfer from the A/T assembly. Refer to [DLN-102, "Removal and Installation"](#).

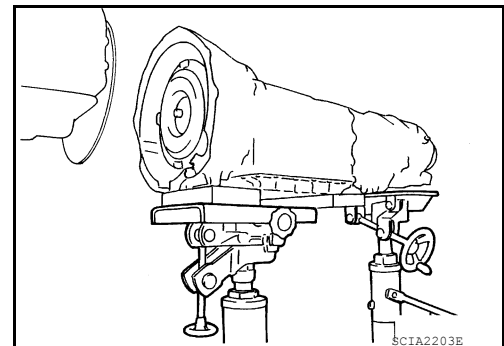

INSPECTION

Installation and Inspection of Torque Converter

A
B
C
TM
E
F
G
H
I
J
K
L
M
N
O
P

TRANSMISSION ASSEMBLY

< UNIT REMOVAL AND INSTALLATION >

[5AT: RE5R05A]

- After inserting a torque converter to a transmission, be sure to check dimension (A) to ensure it is within the reference value limit.

Dimension (A) : 25.0 mm (0.98 in) or more

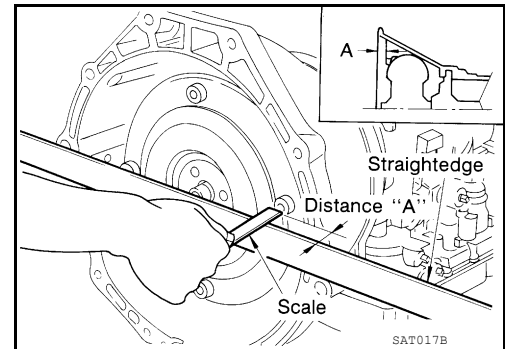

INSTALLATION

Installation of the remaining components is in the reverse order of removal, while paying attention to the following.

- When installing transmission to the engine, tighten the bolts to the specified torque using sequence shown.

Transmission bolts : 75 N·m (7.6 kg-m, 55 ft-lb)

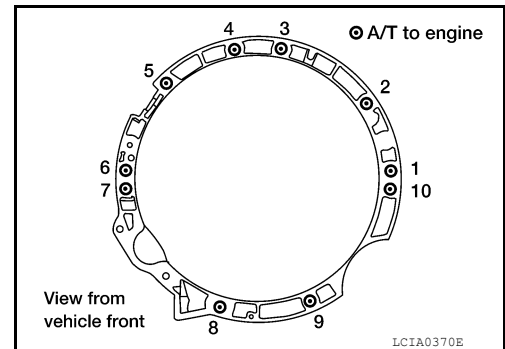

- Align the positions of bolts for drive plate with those of the torque converter, and temporarily tighten the bolts. Then, tighten the bolts with the specified torque.

CAUTION:

- **When turning crankshaft, turn it clockwise as viewed from the front of the engine.**
- **After converter is installed to drive plate, rotate crankshaft several turns and check to be sure that transmission rotates freely without binding.**
- **When replacing an engine or transmission you must make sure the dowels are installed correctly during re-assembly.**
- **Improper alignment caused by missing dowels may cause vibration, oil leaks or breakage of drive train components.**
- Install crankshaft position sensor (POS).

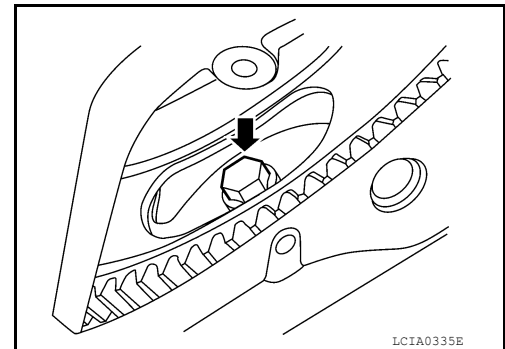

- After completing installation, check fluid leakage, fluid level, and the positions of A/T. Refer to [TM-267, "Checking the A/T Fluid \(ATF\)"](#), [TM-283, "Inspection and Adjustment"](#).

OVERHAUL

< UNIT DISASSEMBLY AND ASSEMBLY >

[5AT: RE5R05A]

UNIT DISASSEMBLY AND ASSEMBLY

OVERHAUL

Exploded View

INFOID:000000008791022

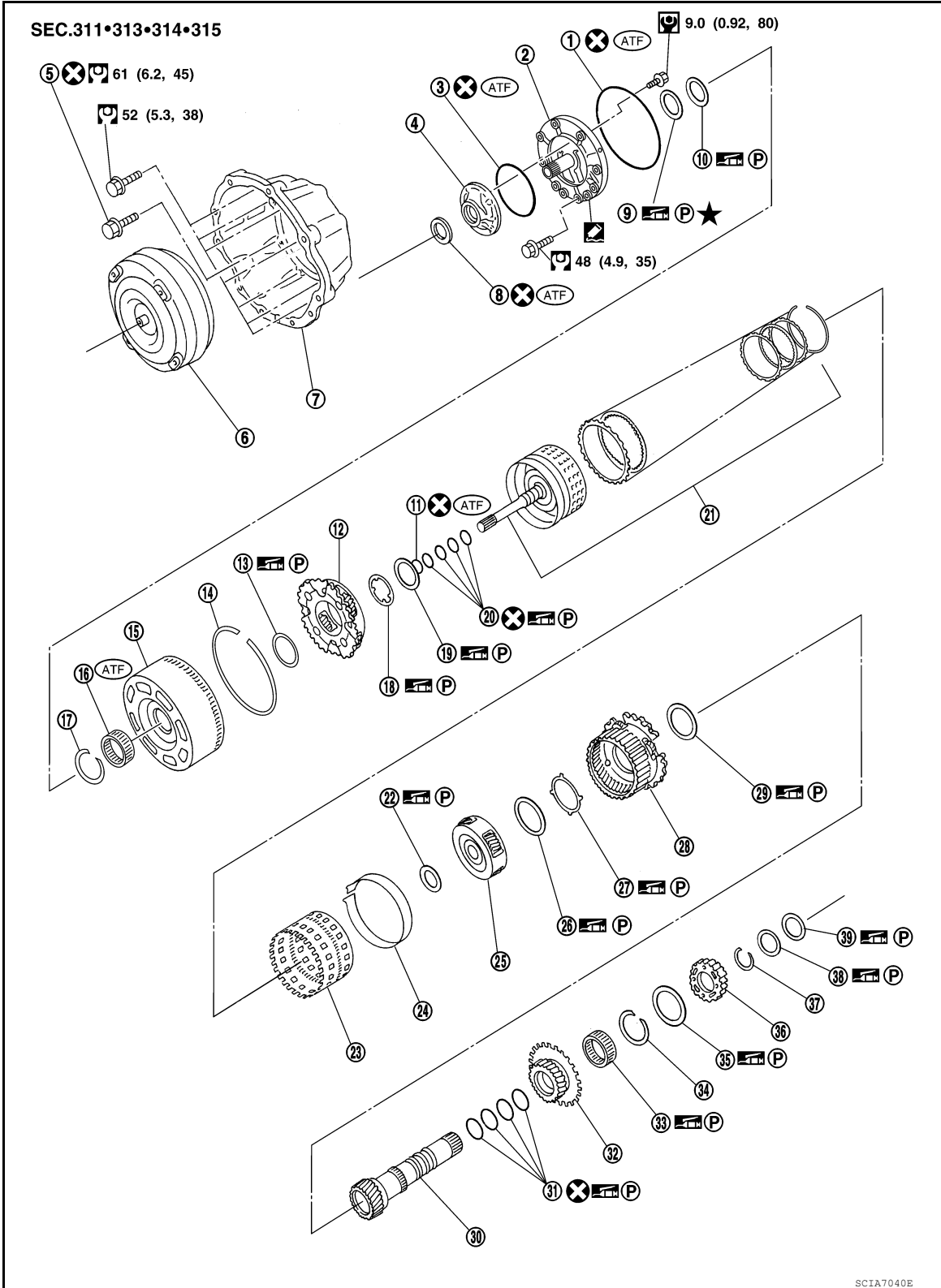

A
B
C
TM
E
F
G
H
I
J
K
L
M
N
O
P

OVERHAUL

< UNIT DISASSEMBLY AND ASSEMBLY >

[5AT: RE5R05A]

- | | | |
|---------------------------|------------------------------|-------------------------------------|
| 1. O-ring | 2. Oil pump cover | 3. O-ring |
| 4. Oil pump housing | 5. Self-sealing bolt | 6. Torque converter |
| 7. Converter housing | 8. Oil pump housing oil seal | 9. Bearing race |
| 10. Needle bearing | 11. O-ring | 12. Front carrier assembly |
| 13. Needle bearing | 14. Snap ring | 15. Front sun gear |
| 16. 3rd one-way clutch | 17. Snap ring | 18. Bearing race |
| 19. Needle bearing | 20. Seal ring | 21. Input clutch assembly |
| 22. Needle bearing | 23. Rear internal gear | 24. Brake band |
| 25. Mid carrier assembly | 26. Needle bearing | 27. Bearing race |
| 28. Rear carrier assembly | 29. Needle bearing | 30. Mid sun gear |
| 31. Seal ring | 32. Rear sun gear | 33. 1st one-way clutch |
| 34. Snap ring | 35. Needle bearing | 36. High and low reverse clutch hub |
| 37. Snap ring | 38. Bearing race | 39. Needle bearing |

: Apply Genuine RTV silicone sealant or equivalent. Refer to [GI-24. "Recommended Chemical Products and Sealants"](#).

Refer to [GI-4. "Component"](#) for symbols not described on the above.

OVERHAUL

< UNIT DISASSEMBLY AND ASSEMBLY >

[5AT: RE5R05A]

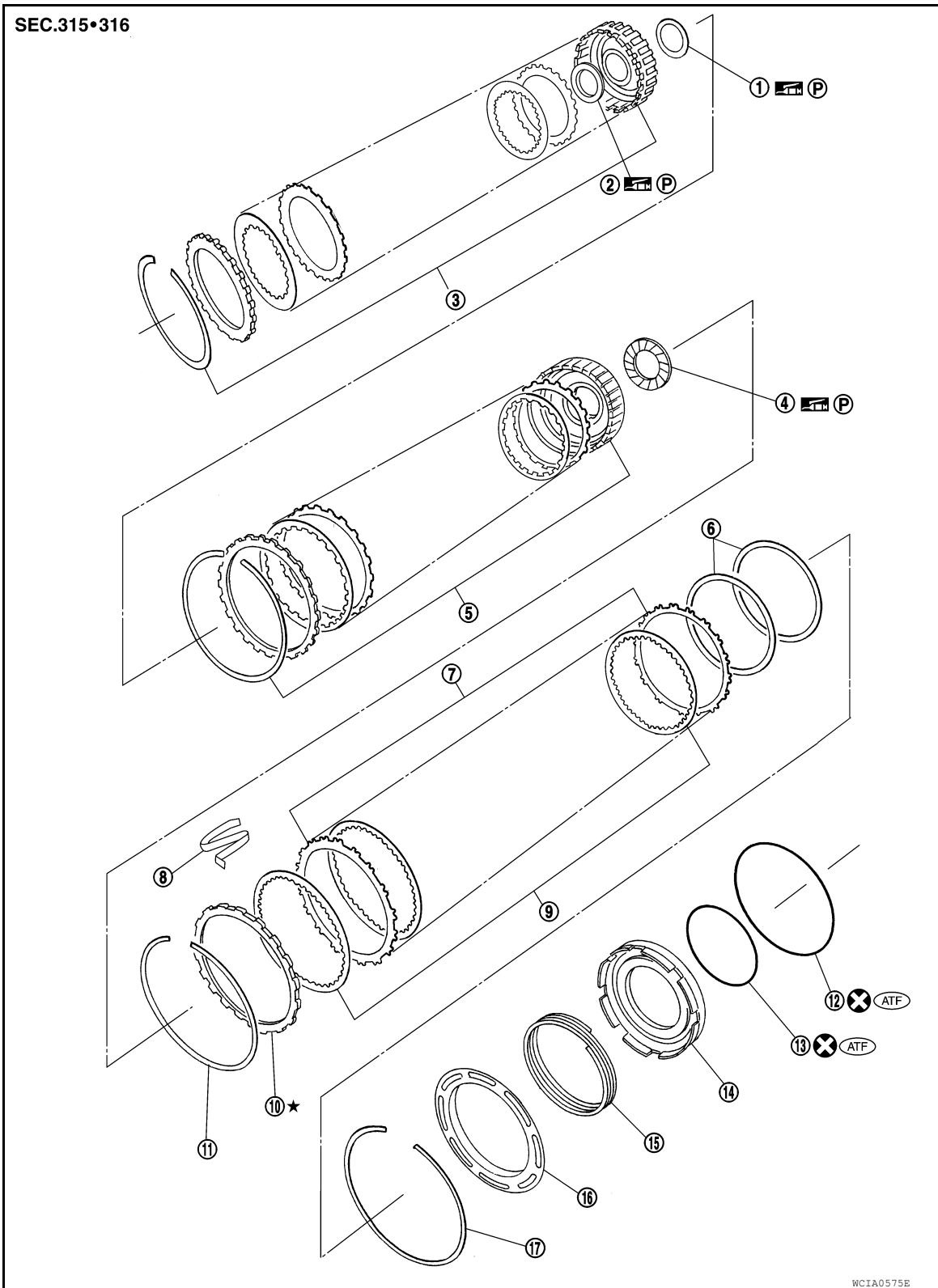

- | | | |
|-----------------------------------|---------------------------|---|
| 1. Needle bearing | 2. Bearing race | 3. High and low reverse clutch assembly |
| 4. Needle bearing | 5. Direct clutch assembly | 6. Reverse brake dish plate |
| 7. Reverse brake driven plate | 8. N-spring | 9. Reverse brake drive plate |
| 10. Reverse brake retaining plate | 11. Snap ring | 12. D-ring |
| 13. D-ring | 14. Reverse brake piston | 15. Return spring |

A
B
C
TM
E
F
G
H
I
J
K
L
M
N
O
P

OVERHAUL

< UNIT DISASSEMBLY AND ASSEMBLY >

[5AT: RE5R05A]

16. Spring retainer

17. Snap ring

Refer to [GI-4, "Component"](#) for symbols in the figure.

2WD Models

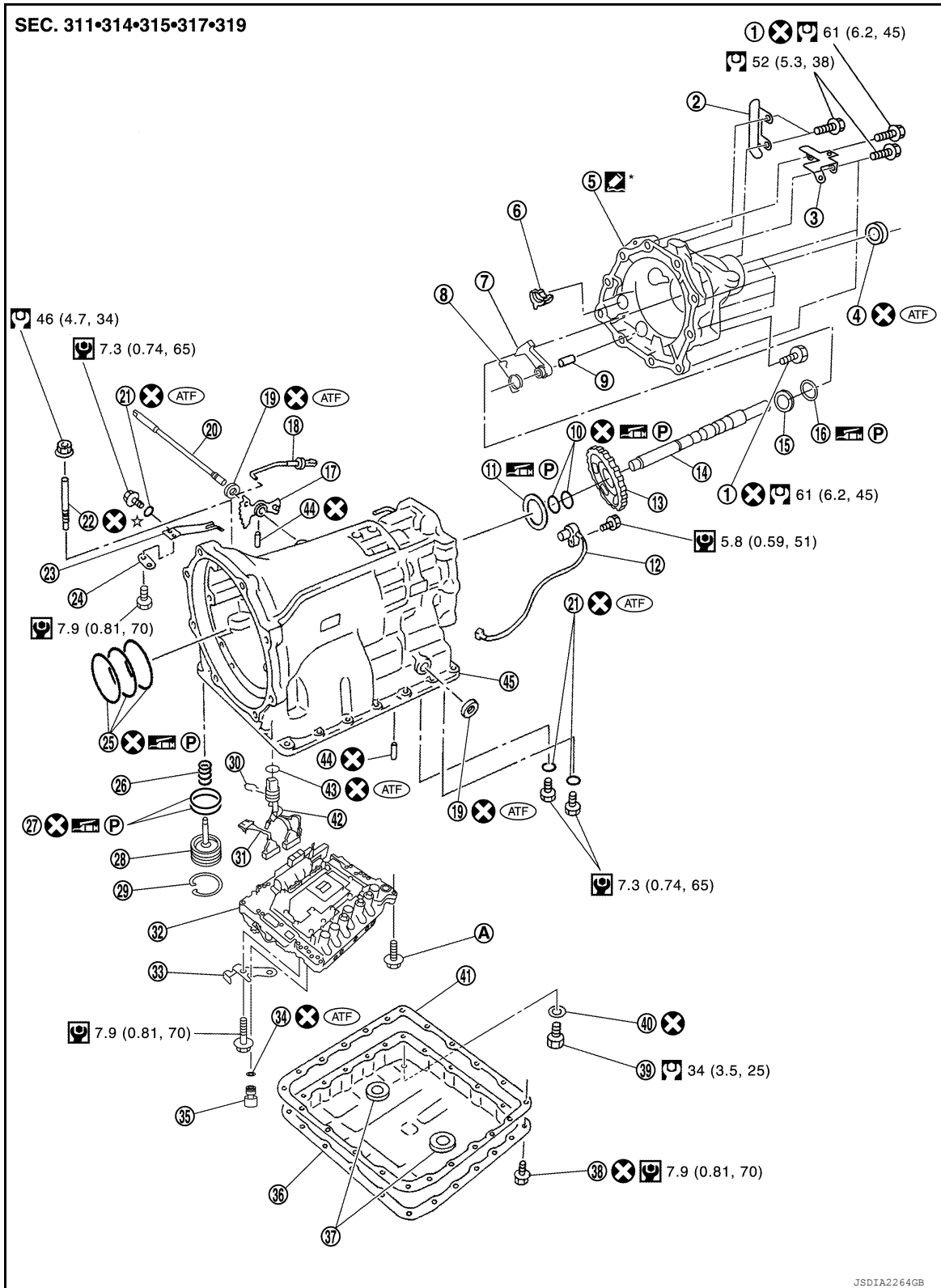

1. Self-sealing bolt

2. Bracket

3. Bracket

4. Rear oil seal

5. Rear extension

6. Parking actuator support

7. Parking pawl

8. Return spring

9. Pawl shaft

10. Seal ring

11. Needle bearing

12. Output speed sensor

OVERHAUL

< UNIT DISASSEMBLY AND ASSEMBLY >

[5AT: RE5R05A]

- | | | |
|-------------------------------|----------------------------|----------------------------|
| 13. Parking gear | 14. Output shaft | 15. Bearing race |
| 16. Needle bearing | 17. Manual plate | 18. Parking rod |
| 19. Manual shaft oil seal | 20. Manual shaft | 21. O-ring |
| 22. Band servo anchor end pin | 23. Detent spring | 24. Spacer |
| 25. Seal ring | 26. Return spring | 27. O-ring |
| 28. Servo assembly | 29. Snap ring | 30. Snap ring |
| 31. Sub-harness | 32. Control valve with TCM | 33. Bracket |
| 34. O-ring | 35. Plug | 36. Oil pan |
| 37. Magnet | 38. Oil pan bolt | 39. Drain plug |
| 40. Drain plug gasket | 41. Oil pan gasket | 42. Terminal cord assembly |
| 43. O-ring | 44. Retaining pin | 45. Transmission case |

A. Tightening must be done following the assembly procedure. Refer to [TM-377, "Assembly \(2\)"](#).

*: Apply Genuine Anaerobic Liquid Gasket or equivalent.

A
B
C
TM
E
F
G
H
I
J
K
L
M
N
O
P

OVERHAUL

< UNIT DISASSEMBLY AND ASSEMBLY >

[5AT: RE5R05A]

4WD Models

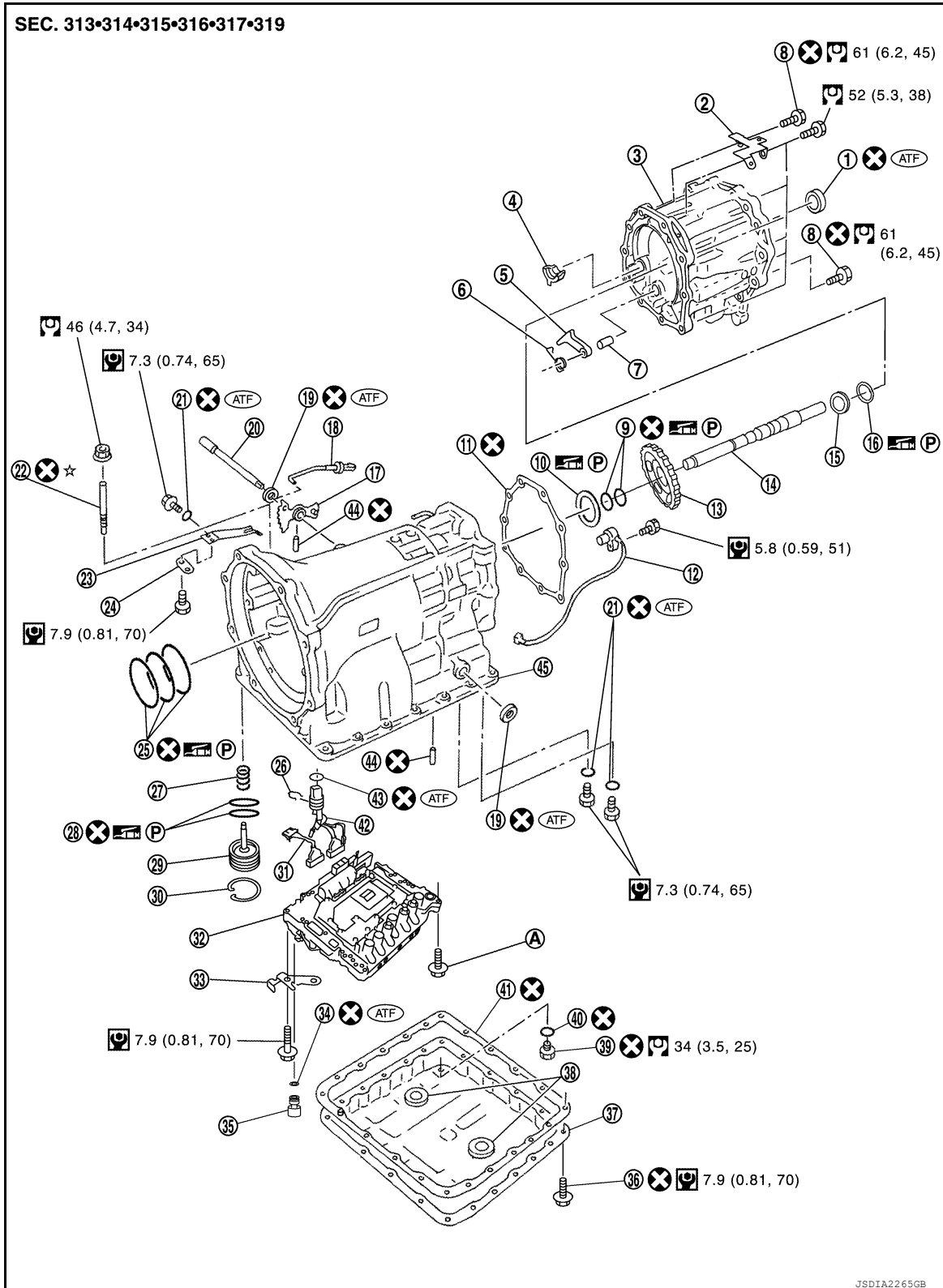

- | | | |
|-----------------------------|----------------------|-------------------------|
| 1. Rear oil seal | 2. Bracket | 3. Adapter case |
| 4. Parking actuator support | 5. Parking pawl | 6. Return spring |
| 7. Pawl shaft | 8. Self-sealing bolt | 9. Seal ring |
| 10. Needle bearing | 11. Gasket | 12. Output speed sensor |
| 13. Parking gear | 14. Output shaft | 15. Bearing race |
| 16. Needle bearing | 17. Manual plate | 18. Parking rod |

OVERHAUL

< UNIT DISASSEMBLY AND ASSEMBLY >

[5AT: RE5R05A]

- | | | |
|-------------------------------|----------------------------|----------------------------|
| 19. Manual shaft oil seal | 20. Manual shaft | 21. O-ring |
| 22. Band servo anchor end pin | 23. Detent spring | 24. Spacer |
| 25. Seal ring | 26. Snap ring | 27. Return spring |
| 28. O-ring | 29. Servo assembly | 30. Snap ring |
| 31. Sub-harness | 32. Control valve with TCM | 33. Bracket |
| 34. O-ring | 35. Plug | 36. Oil pan |
| 37. Magnet | 38. Oil pan bolt | 39. Drain plug |
| 40. Drain plug gasket | 41. Oil pan gasket | 42. Terminal cord assembly |
| 43. O-ring | 44. Retaining pin | 45. Transmission case |

A. Tightening must be done following the assembly procedure. Refer to [TM-377, "Assembly \(2\)"](#).

Refer to [GI-4, "Component"](#) for symbols in the figure.

A
B
C

TM

E
F
G
H
I
J
K
L
M
N
O
P

OVERHAUL

< UNIT DISASSEMBLY AND ASSEMBLY >

[5AT: RE5R05A]

INFOID:00000008791023

Oil Channel

2WD Models

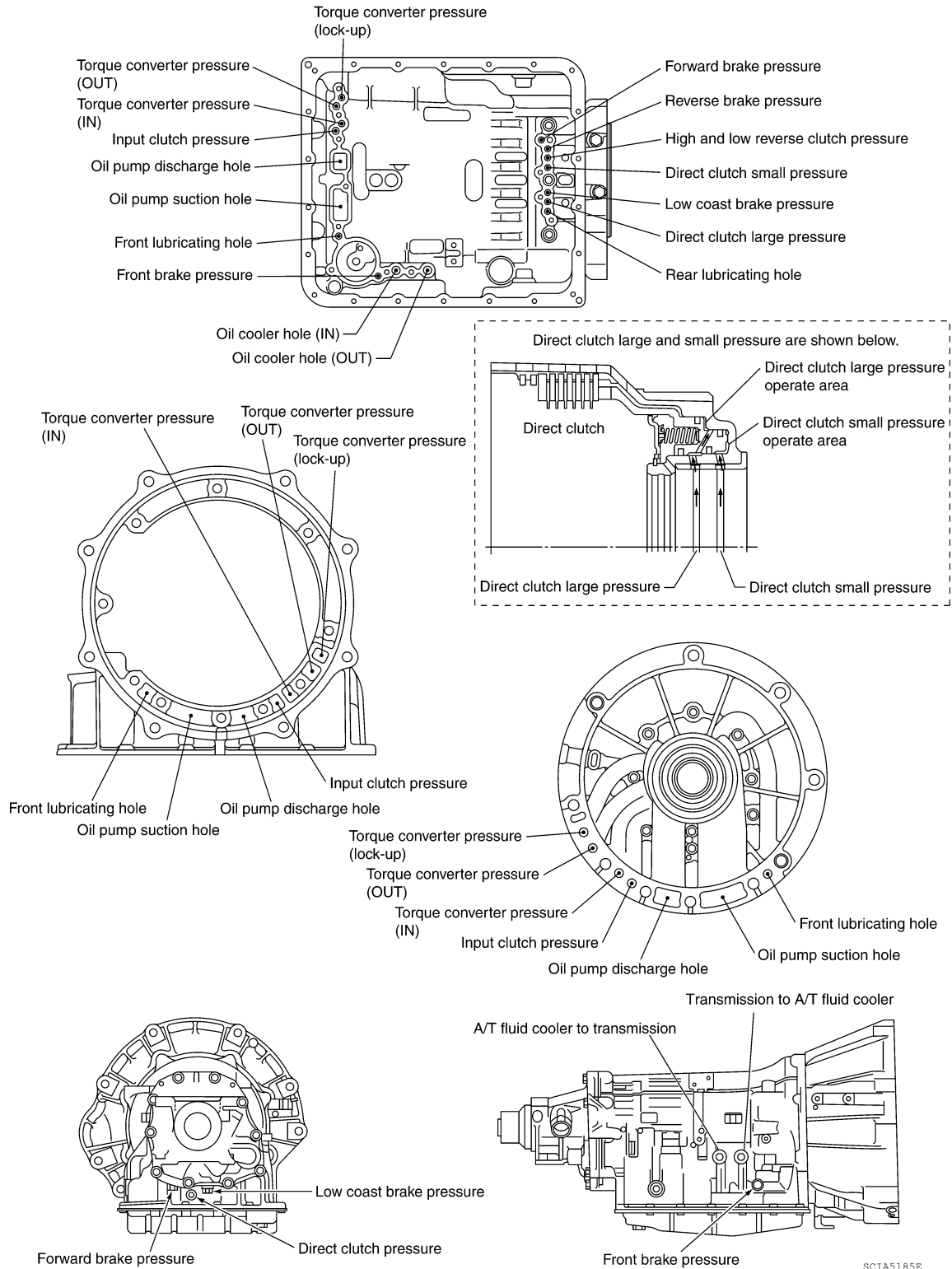

SCIA5185E

OVERHAUL

< UNIT DISASSEMBLY AND ASSEMBLY >

[5AT: RE5R05A]

4WD Models

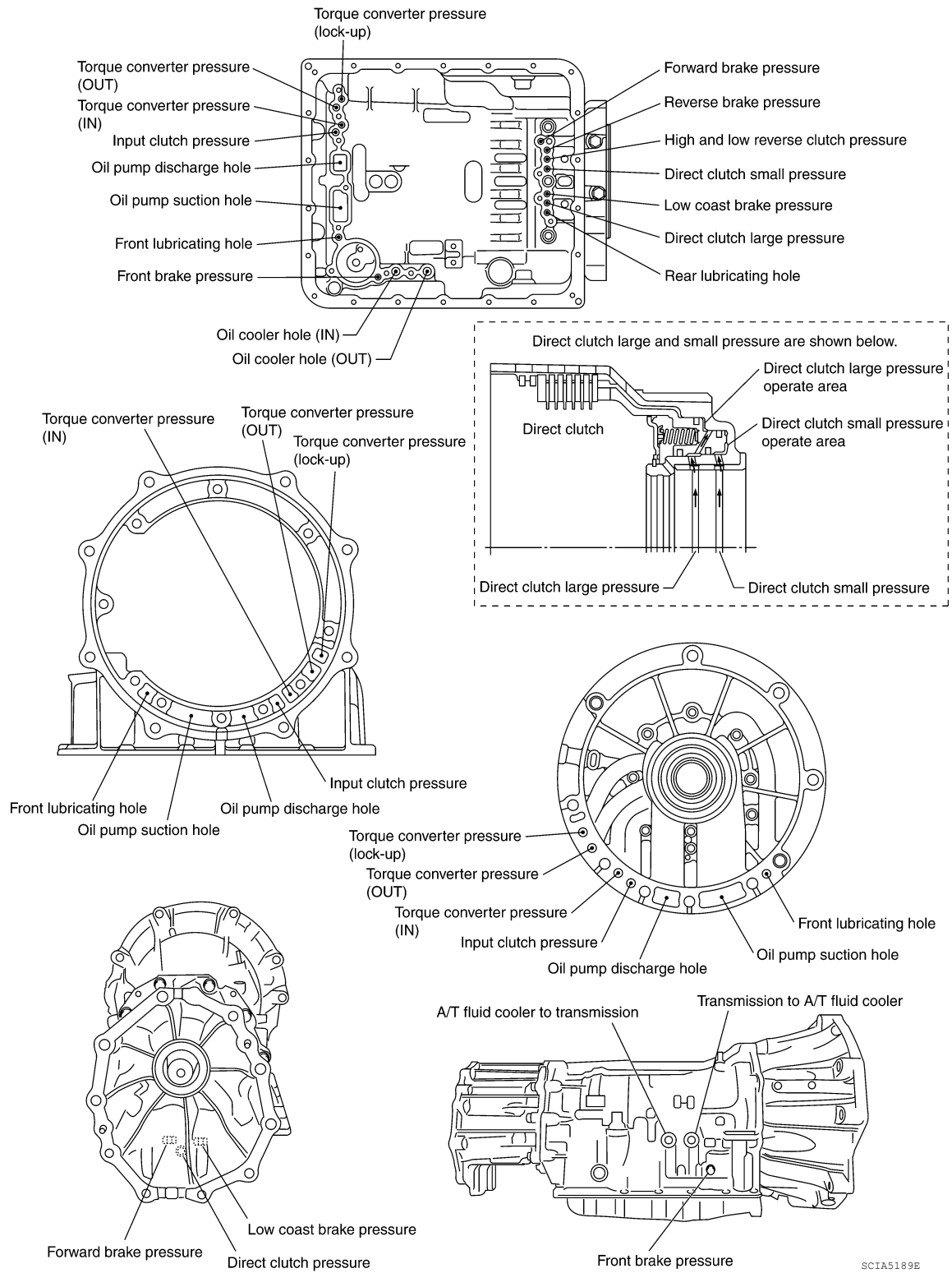

A
B
C
TM
E
F
G
H
I
J
K
L
M
N
O
P

OVERHAUL

< UNIT DISASSEMBLY AND ASSEMBLY >

[5AT: RE5R05A]

Location of Adjusting Shims, Needle Bearings, Thrust Washers and Snap Rings

INFOID:000000008791024

2WD Models

Outer diameter of snap rings

Item number	Outer diameter mm (in)
①	63 (2.48)
②	183 (7.20)
③	173 (6.81)
④	70 (2.76)
⑤	170 (6.69)
⑥	135 (5.31)
⑦	180 (7.09)
⑧	185 (7.28)
⑨	48 (1.89)

Outer diameter of needle bearings

Item number	Outer diameter mm (in)
⑩	80 (3.15)
⑪	77 (3.03)
⑫	77 (3.03)
⑬	47 (1.85)
⑭	84 (3.31)
⑮	80 (3.15)
⑯	92 (3.62)
⑰	60 (2.36)
⑱	63 (2.48)
⑲	92 (3.62)
⑳	65 (2.56)
㉑	60 (2.36)

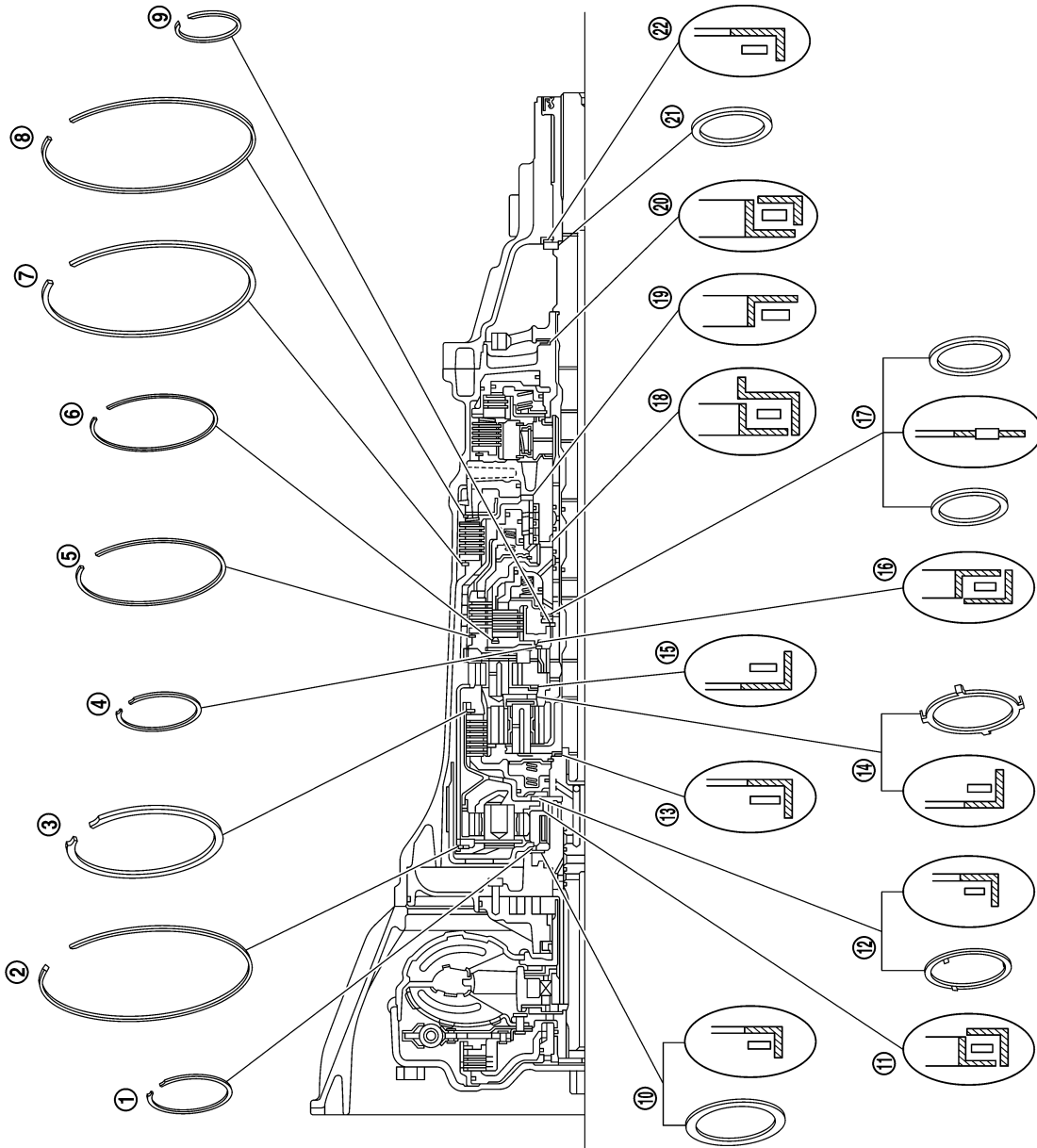

SCIA7019E

OVERHAUL

< UNIT DISASSEMBLY AND ASSEMBLY >

[5AT: RE5R05A]

4WD Models

Outer diameter of snap rings

Item number	Outer diameter mm (in)
①	63 (2.48)
②	183 (7.20)
③	173 (6.81)
④	70 (2.76)
⑤	170 (6.69)
⑥	135 (5.31)
⑦	180 (7.09)
⑧	185 (7.28)
⑨	48 (1.89)

Outer diameter of needle bearings

Item number	Outer diameter mm (in)
⑩	80 (3.15)
⑪	77 (3.03)
⑫	77 (3.03)
⑬	47 (1.85)
⑭	84 (3.31)
⑮	80 (3.15)
⑯	92 (3.62)
⑰	60 (2.36)
⑱	63 (2.48)
⑲	92 (3.62)
⑳	65 (2.56)
㉑	60 (2.36)

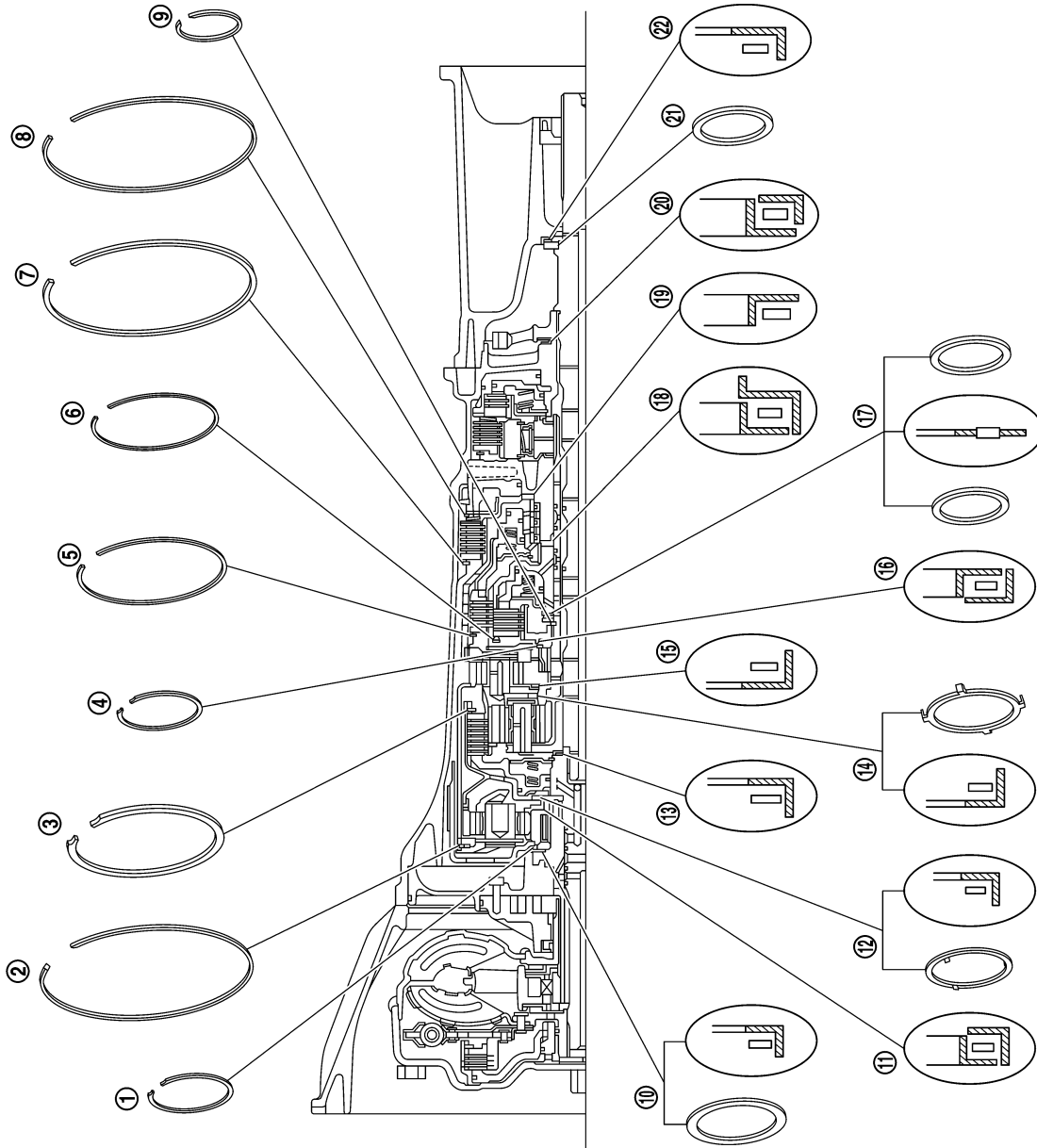

SCIA7020E

A
B
C
TM
E
F
G
H
I
J
K
L
M
N
O
P

DISASSEMBLY

< UNIT DISASSEMBLY AND ASSEMBLY >

[5AT: RE5R05A]

DISASSEMBLY

Disassembly

INFOID:000000008791025

CAUTION:

Do not disassemble parts behind Drum Support. Refer to [TM-131, "Cross-Sectional View"](#).

1. Drain A/T fluid through drain plug.
2. Remove torque converter by holding it firmly and turning while pulling straight out.

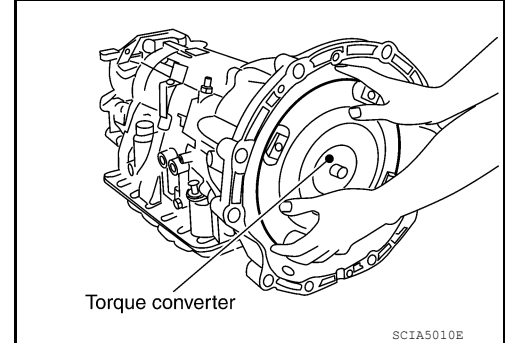

3. Check torque converter one-way clutch using a check tool as shown.
 - a. Insert a check tool into the groove of bearing support built into one-way clutch outer race.
 - b. While holding bearing support with a check tool, rotate one-way clutch spline using suitable tool.
 - c. Make sure that inner race rotates clockwise only. If not, replace torque converter assembly.

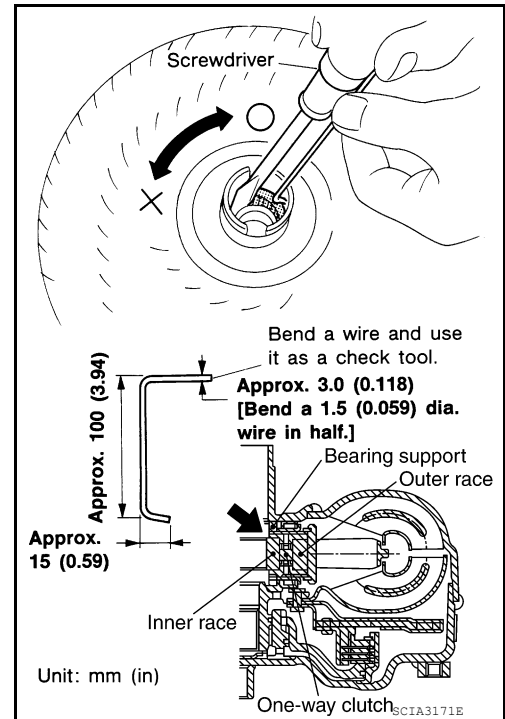

4. Remove bolts and converter housing from transmission case.

CAUTION:

Do not scratch converter housing.

- Self-sealing bolt (A)

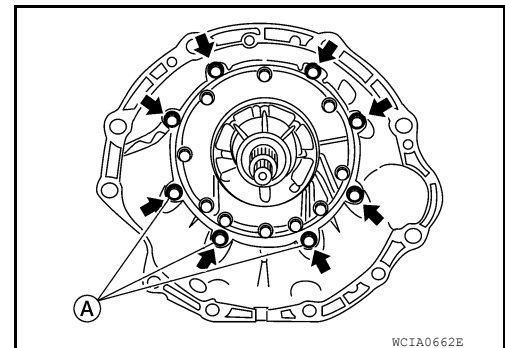

DISASSEMBLY

< UNIT DISASSEMBLY AND ASSEMBLY >

[5AT: RE5R05A]

5. Remove O-ring from input clutch assembly.

CAUTION:
Do not reuse O-ring.

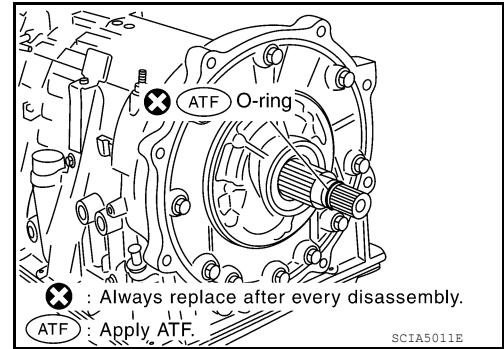

6. Remove oil pump assembly to transmission case bolts.

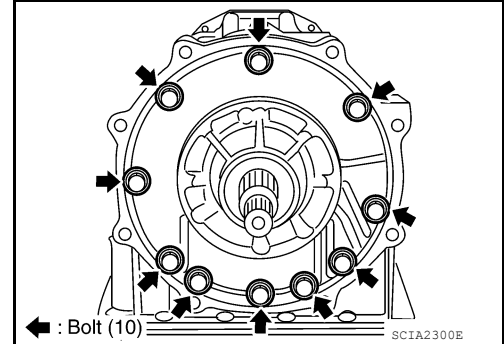

7. Remove the oil pump assembly evenly from the transmission case using Tools.

Tool number : ST25850000 (J-25721-A)

CAUTION:

- Fully tighten the sliding hammer screws.
- Make sure that bearing race is installed to the oil pump assembly edge surface.

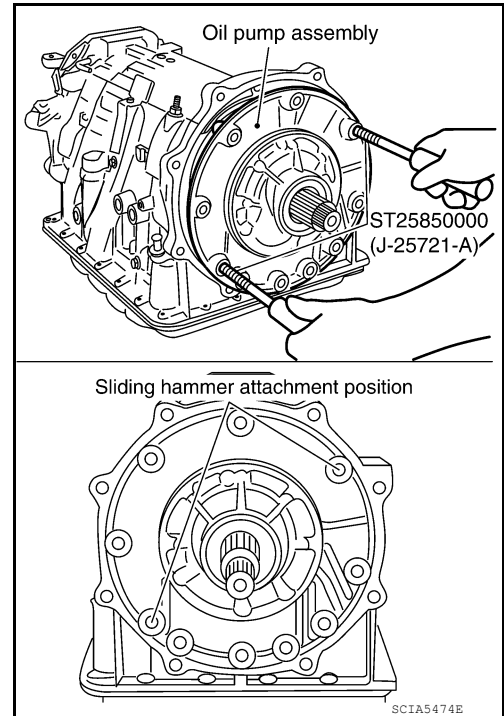

8. Remove O-ring from oil pump assembly.

CAUTION:
Do not reuse O-ring.

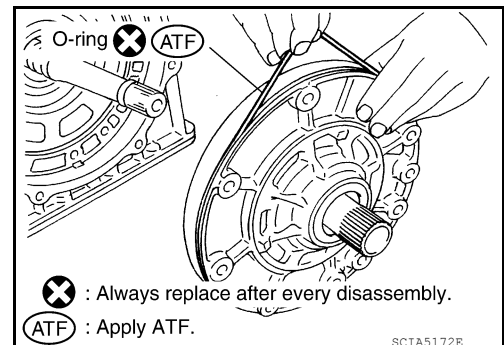

A
B
C
TM
E
F
G
H
I
J
K
L
M
N
O
P

DISASSEMBLY

< UNIT DISASSEMBLY AND ASSEMBLY >

[5AT: RE5R05A]

9. Remove bearing race from oil pump assembly.

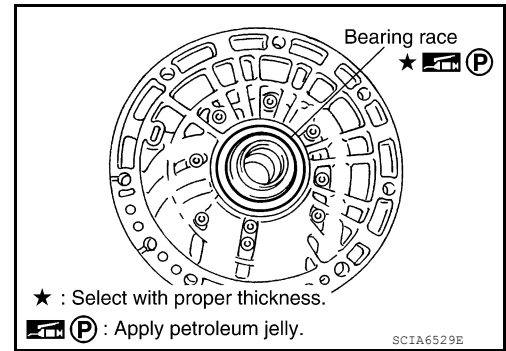

10. Remove needle bearing from front sun gear.

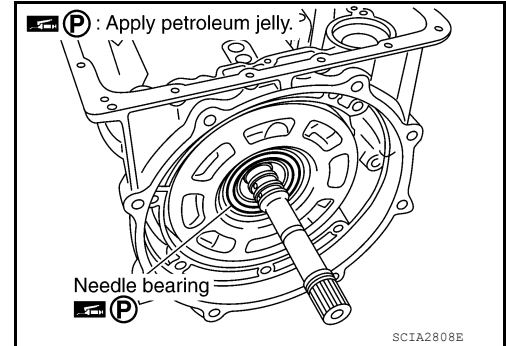

11. Remove front sun gear assembly from front carrier assembly.

NOTE:

Remove front sun gear by rotating it left and right.

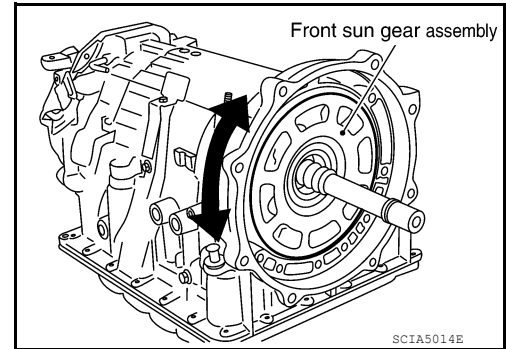

12. Remove seal rings from input clutch assembly.

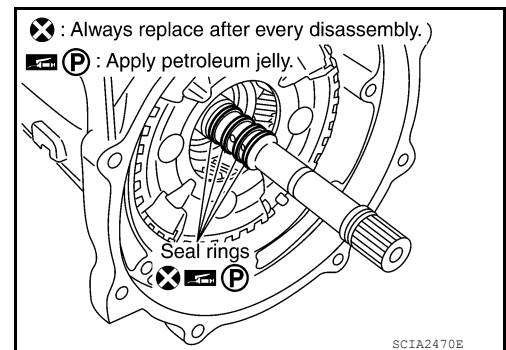

13. Remove front carrier assembly (with input clutch assembly and rear internal gear) from rear carrier assembly.

CAUTION:

Do not remove it with needle bearing.

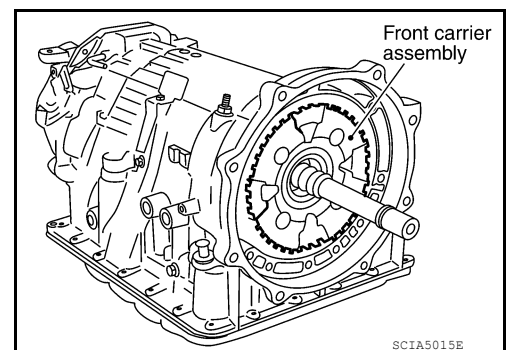

DISASSEMBLY

< UNIT DISASSEMBLY AND ASSEMBLY >

[5AT: RE5R05A]

14. Loosen lock nut and remove band servo anchor end pin from transmission case.

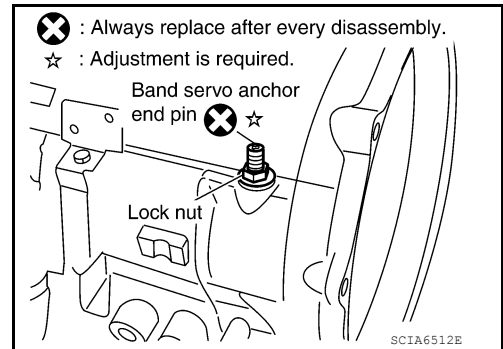

15. Remove brake band from transmission case.

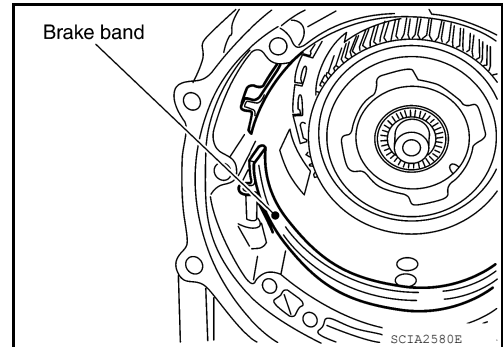

CAUTION:

- To prevent brake linings from cracking or peeling, do not stretch the flexible band unnecessarily. When removing the brake band, always secure it with a clip as shown.
- Check brake band facing for damage, cracks, wear or burns.

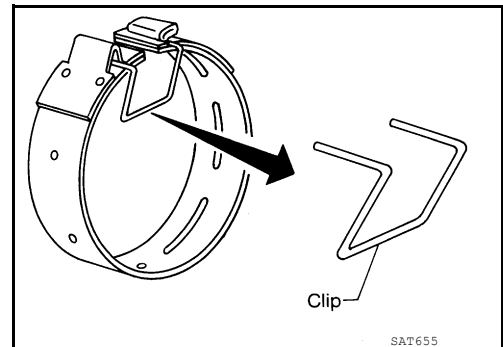

16. Remove mid carrier assembly and rear carrier assembly as a unit.

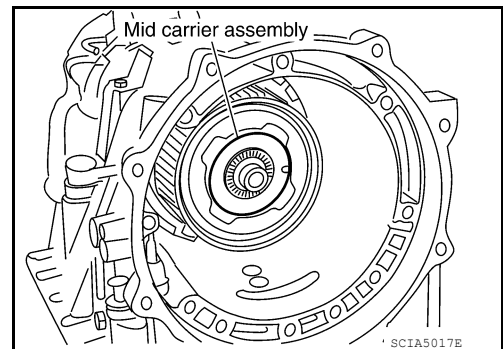

A
B
C
TM
E
F
G
H
I
J
K
L
M
N
O
P

DISASSEMBLY

< UNIT DISASSEMBLY AND ASSEMBLY >

[5AT: RE5R05A]

17. Remove mid carrier assembly from rear carrier assembly.

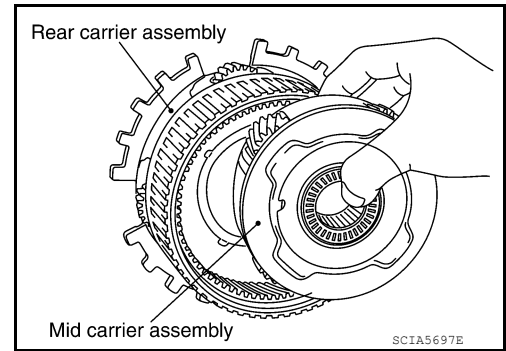

18. Remove needle bearing (front side) from mid carrier assembly.

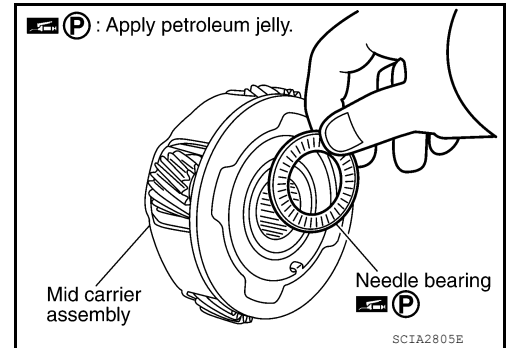

19. Remove needle bearing (rear side) from mid carrier assembly.

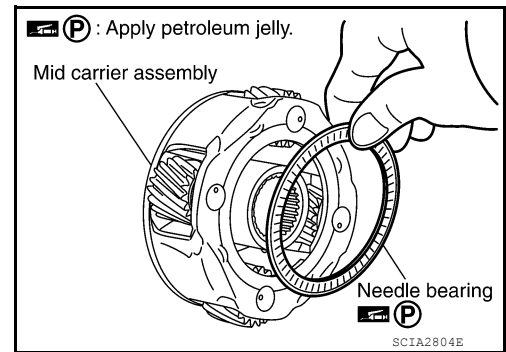

20. Remove bearing race from rear carrier assembly.

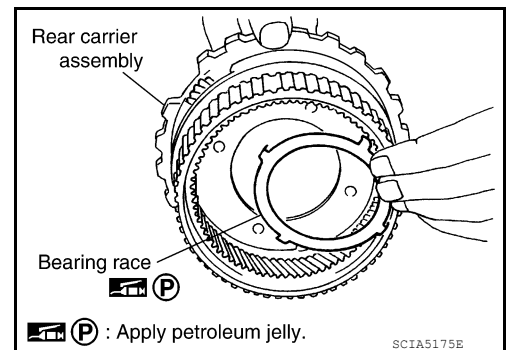

21. Remove needle bearing from rear carrier assembly.

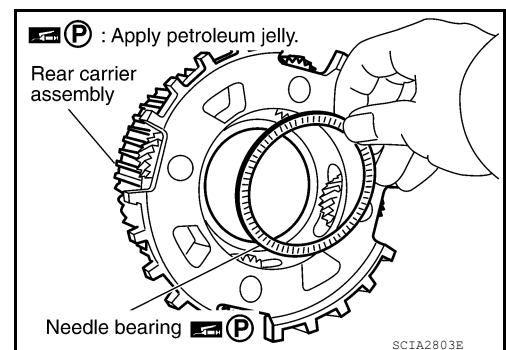

DISASSEMBLY

< UNIT DISASSEMBLY AND ASSEMBLY >

[5AT: RE5R05A]

22. Remove mid sun gear assembly, rear sun gear assembly and high and low reverse clutch hub as a unit.

CAUTION:

Remove them with bearing race and needle bearing.

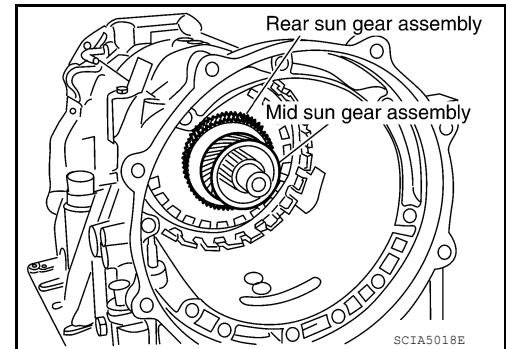

23. Remove high and low reverse clutch assembly from direct clutch assembly.

CAUTION:

Make sure that needle bearing is installed to the high and low reverse clutch assembly edge surface.

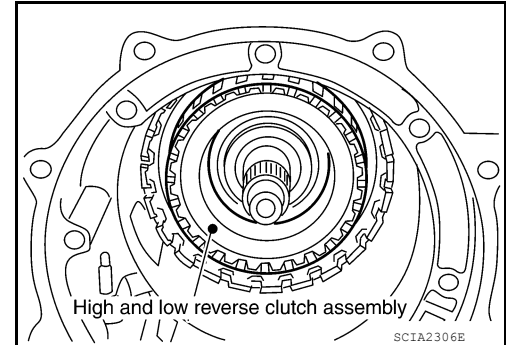

24. Remove needle bearing from drum support.

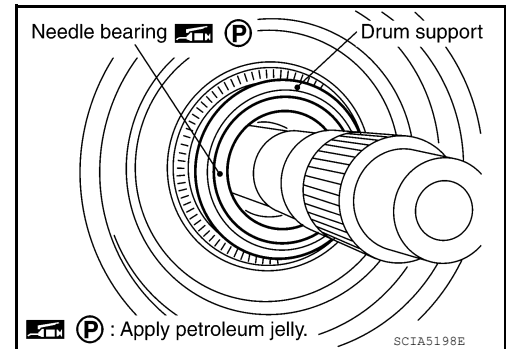

25. Remove direct clutch assembly from reverse brake.

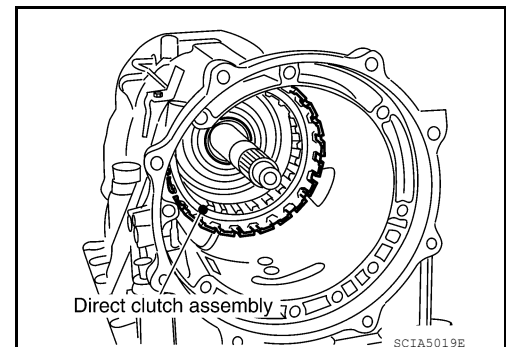

26. Remove snap ring from A/T assembly harness connector.

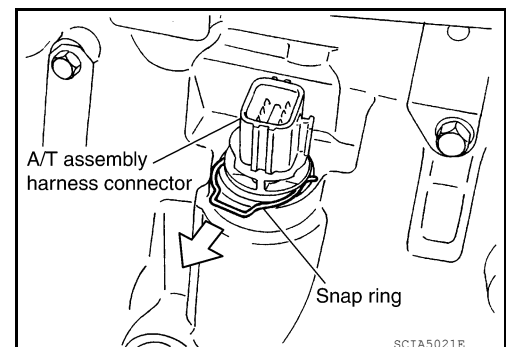

A
B
C
TM
E
F
G
H
I
J
K
L
M
N
O
P

DISASSEMBLY

< UNIT DISASSEMBLY AND ASSEMBLY >

[5AT: RE5R05A]

27. Push A/T assembly harness connector.

CAUTION:

Do not damage connector.

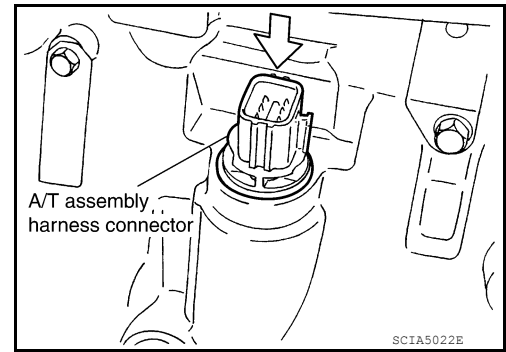

28. Remove oil pan and oil pan gasket. Refer to [TM-284, "Removal and Installation"](#).

29. Check foreign materials in oil pan to help determine causes of malfunction. If the A/T fluid is very dark, smells burned, or contains foreign particles, the frictional material (clutches, band) may need replacement. A tacky film that will not wipe clean indicates varnish build up. Varnish can cause valves, servo, and clutches to stick and can inhibit pump pressure.

• If frictional material is detected, perform A/T fluid cooler cleaning. Refer to [TM-270, "A/T Fluid Cooler Cleaning"](#).

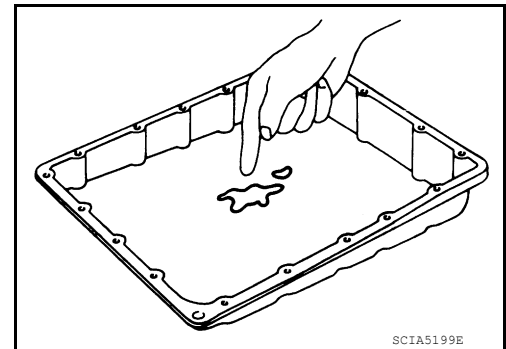

30. Remove magnets from oil pan.

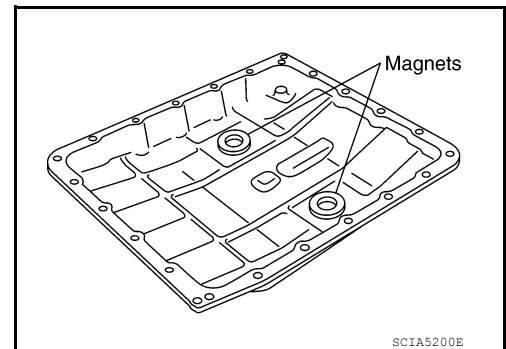

31. If an A/T fluid temperature sensor 2 is attached, disconnect the A/T fluid temperature sensor 2 connector as shown below.

a. Disconnect A/T fluid temperature sensor 2 connector (A).

CAUTION:

Do not damage connector.

b. Straighten terminal clips (➡) to free terminal cord assembly and A/T fluid temperature sensor 2 harness.

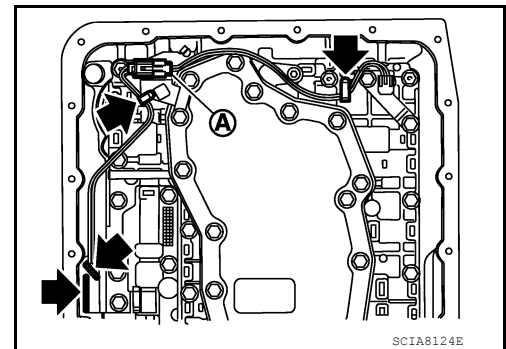

DISASSEMBLY

< UNIT DISASSEMBLY AND ASSEMBLY >

[5AT: RE5R05A]

32. Disconnect output speed sensor connector (1).

CAUTION:

Do not damage connector.

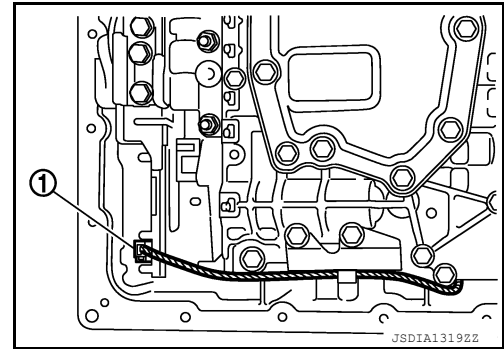

33. Straighten terminal clip (←) to free output speed sensor harness.

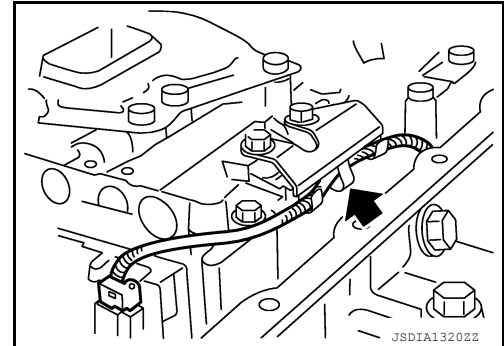

34. Remove bolts (A), (B) and (C) from control valve with TCM.

Bolt symbol	Length mm (in)	Number of bolts
A	42 (1.65)	5
B	55 (2.17)	6
C	40 (1.57)	1

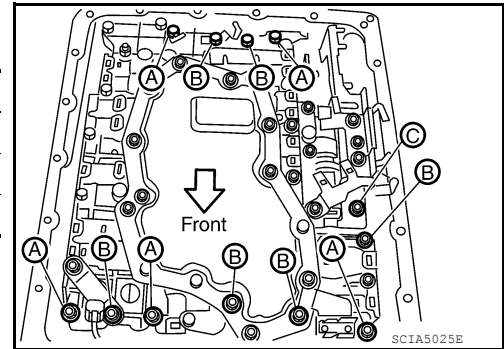

35. Remove control valve with TCM from transmission case.

CAUTION:

When removing, be careful with the manual valve notch and manual plate height. Remove it vertically.

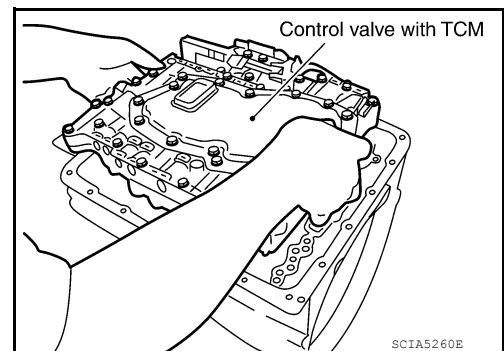

36. Remove the A/T fluid temperature sensor 2 or plug as shown below.

- a. **A/T fluid temperature sensor 2**

A
B
C
TM
E
F
G
H
I
J
K
L
M
N
O
P

DISASSEMBLY

< UNIT DISASSEMBLY AND ASSEMBLY >

[5AT: RE5R05A]

- i. Remove A/T fluid temperature sensor 2 with bracket from control valve with TCM.

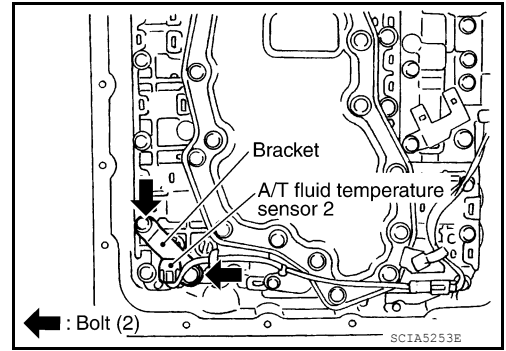

- ii. Remove bracket from A/T fluid temperature sensor 2.

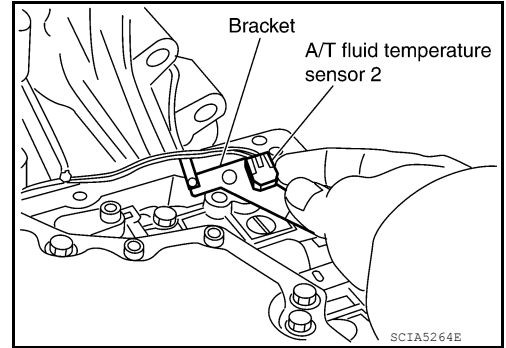

b. Plug

- i. Remove plug (1) with bracket (2) from control valve with TCM.

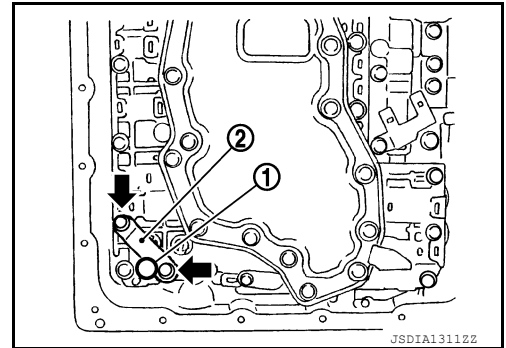

- ii. Remove bracket (1) from plug (2).

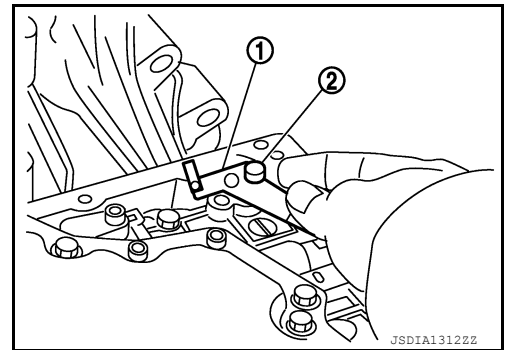

DISASSEMBLY

< UNIT DISASSEMBLY AND ASSEMBLY >

[5AT: RE5R05A]

- iii. Remove O-ring (1) from plug (2).

CAUTION:
Do not reuse O-ring.

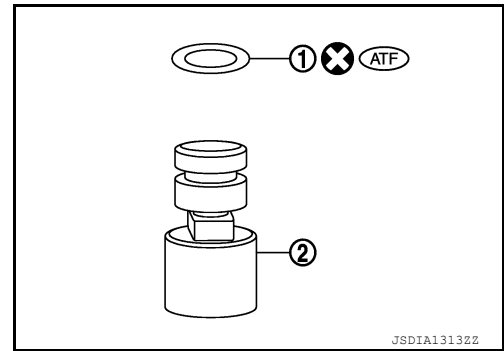

37. Remove O-ring from A/T assembly harness connector.

CAUTION:
Do not reuse O-ring.

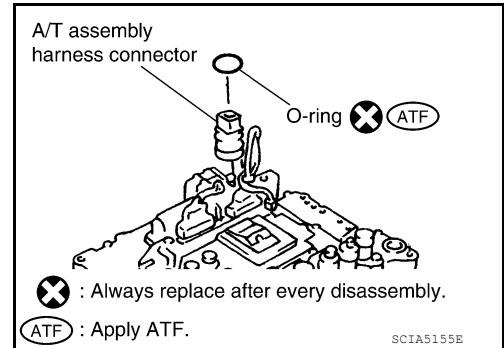

38. Disconnect TCM connectors.

CAUTION:
Do not damage connectors.

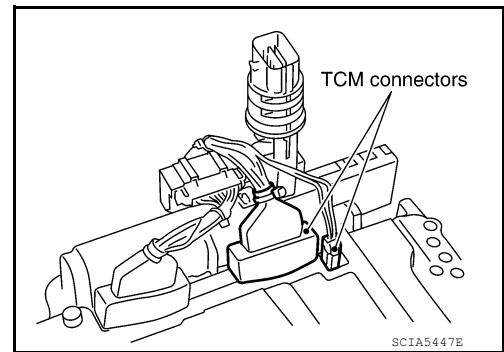

39. Remove A/T assembly harness connector from control valve with TCM using suitable tool.

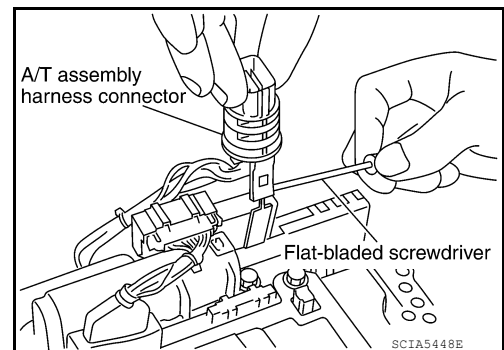

40. Disconnect TCM connector (1) and transmission range switch connector (2).

CAUTION:
Do not damage connectors.

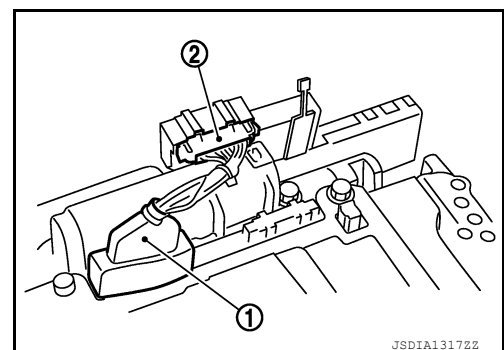

A
B
C
TM
E
F
G
H
I
J
K
L
M
N
O
P

DISASSEMBLY

< UNIT DISASSEMBLY AND ASSEMBLY >

[5AT: RE5R05A]

41. Remove rear extension assembly (2WD models) or adapter case assembly (4WD models) according to the following procedures.

a. **2WD models**

- i. Remove tightening bolts for rear extension assembly and transmission case.
- Bracket (1)
 - Bracket (2)
 - Self-sealing bolts (3)
 - Bolt (A)

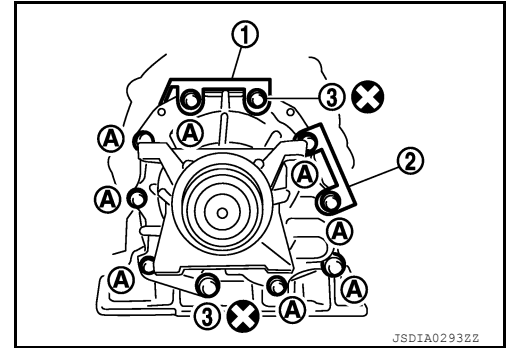

ii. Tap rear extension assembly with soft hammer.

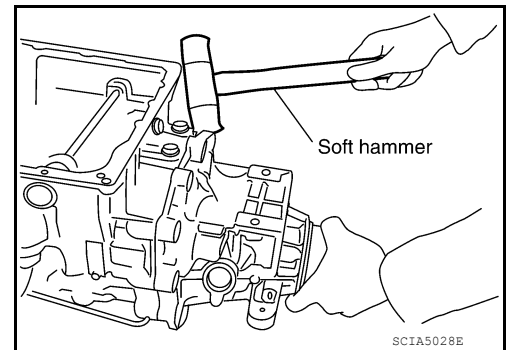

iii. Remove rear extension assembly (with needle bearing) from transmission case.

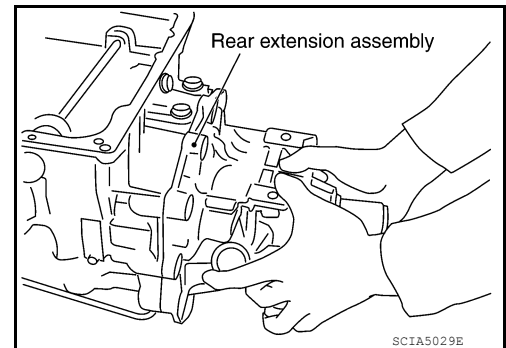

DISASSEMBLY

< UNIT DISASSEMBLY AND ASSEMBLY >

[5AT: RE5R05A]

b. 4WD models

- i. Remove adapter case to transmission case bolts and terminal bracket (2).
 - ←; Front (1)
 - Self-sealing bolt (3)

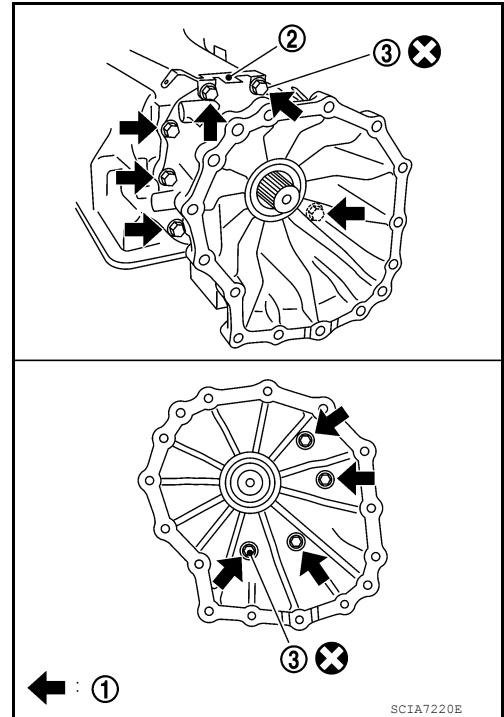

- ii. Tap adapter case assembly using suitable tool.

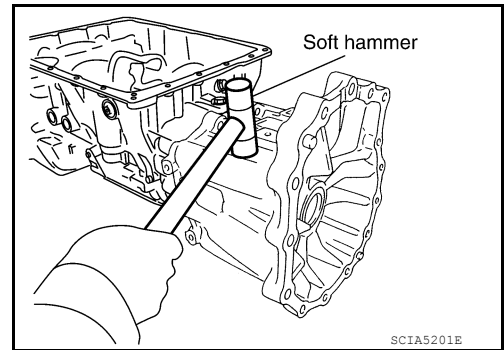

- iii. Remove adapter case assembly (with needle bearing) from transmission case.

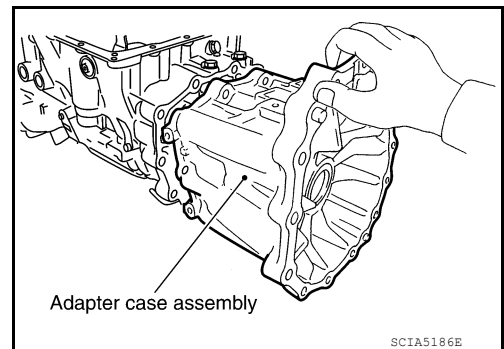

- iv. Remove gasket from transmission case.

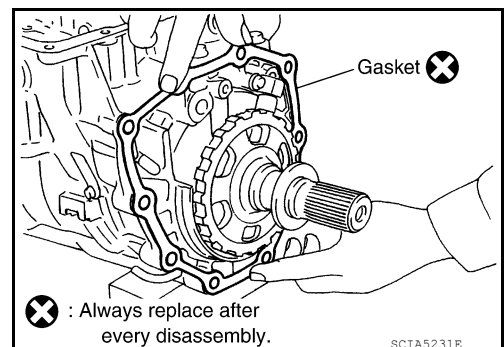

A
B
C
TM
E
F
G
H
I
J
K
L
M
N
O
P

DISASSEMBLY

< UNIT DISASSEMBLY AND ASSEMBLY >

[5AT: RE5R05A]

42. Remove bearing race from output shaft.

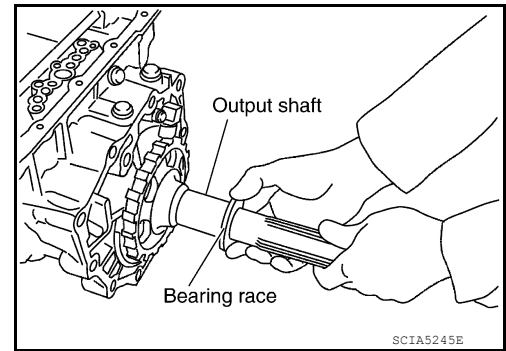

43. Remove output shaft from transmission case by rotating left and right.

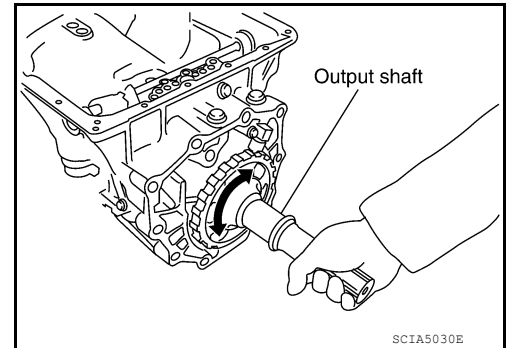

44. Remove parking gear from output shaft.

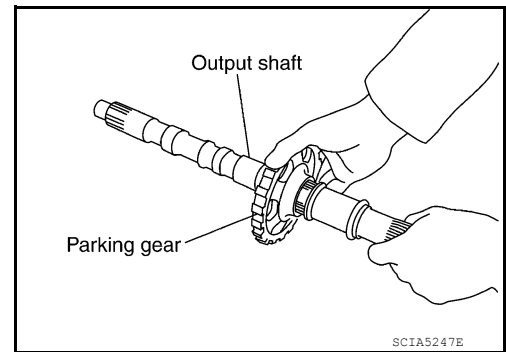

45. Remove seal rings from output shaft.

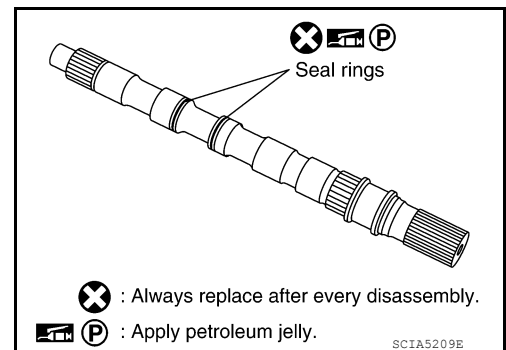

46. Remove needle bearing from transmission case.

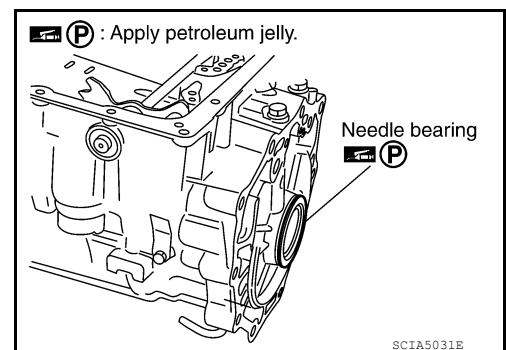

DISASSEMBLY

< UNIT DISASSEMBLY AND ASSEMBLY >

[5AT: RE5R05A]

47. Remove output speed sensor (1) from transmission case.

← : Bolt

CAUTION:

- Do not subject it to impact by dropping or hitting it.
- Do not disassemble.
- Do not allow metal filings or any foreign material to get on the sensor's front edge magnetic area.
- Do not place in an area affected by magnetism.

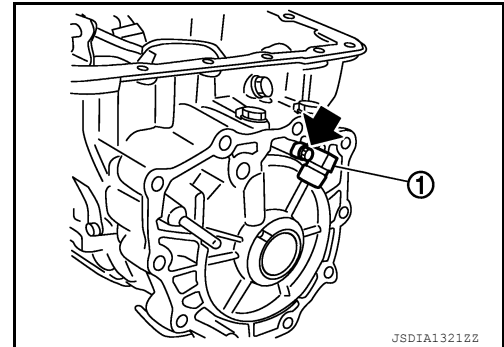

48. Remove reverse brake snap ring using two flat-bladed screwdrivers.

NOTE:

Press out snap ring from the transmission case oil pan side gap using a flat-bladed screwdriver, and remove it using a another screwdriver.

49. Remove reverse brake retaining plate from transmission case.

- Check facing for burns, cracks or damage. If necessary, replace the plate.

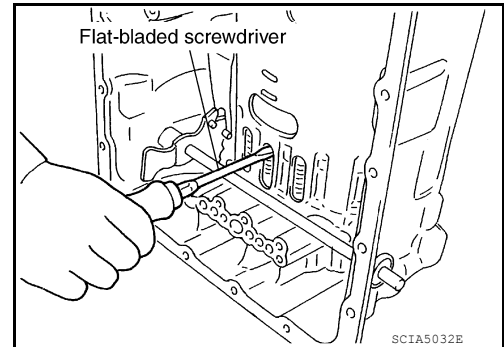

50. Remove N-spring from transmission case.

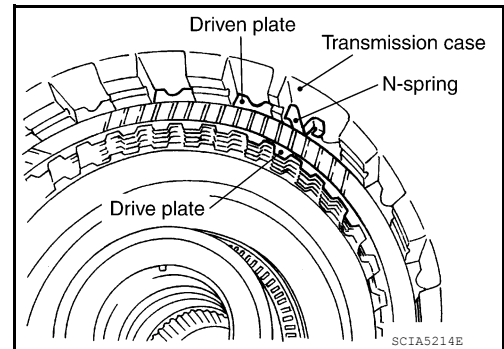

51. Remove reverse brake drive plates, driven plates and dish plate from transmission case.

- Check facing for burns, cracks or damage. If necessary, replace the plate.

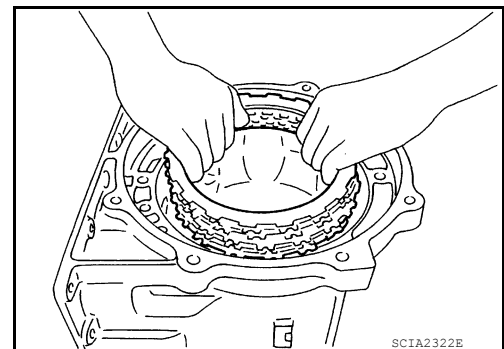

52. Remove snap ring using suitable tool.

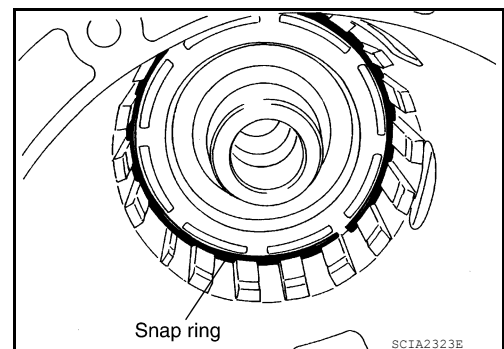

A
B
C
TM
E
F
G
H
I
J
K
L
M
N
O
P

DISASSEMBLY

< UNIT DISASSEMBLY AND ASSEMBLY >

[5AT: RE5R05A]

53. Remove spring retainer and return spring from transmission case.

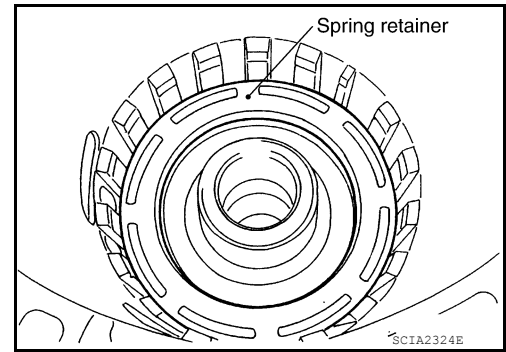

54. Remove seal rings from drum support.

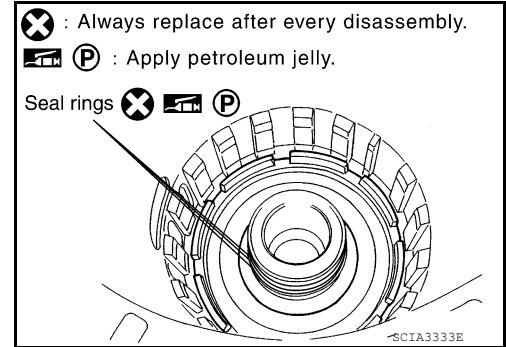

55. Remove needle bearing from drum support edge surface.

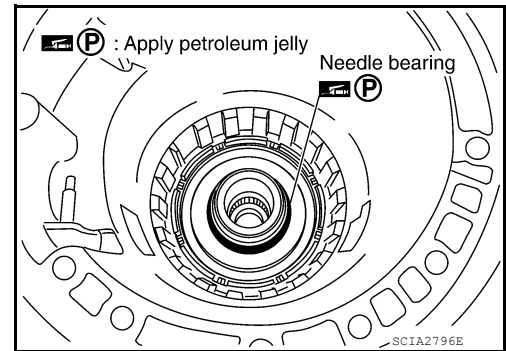

56. Remove reverse brake piston from transmission case using compressed air. Refer to [TM-322](#). "Disassembly".

CAUTION:

Care should be taken not to abruptly blow air. It makes the piston incline, and as a result, it becomes hard to disassemble the pistons.

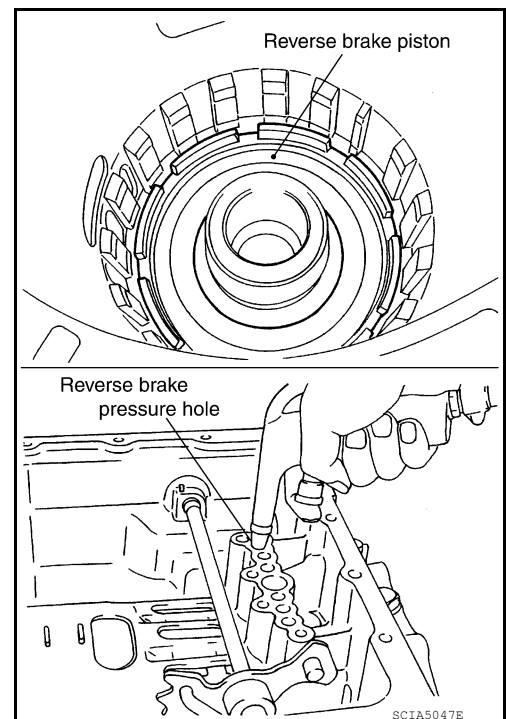

DISASSEMBLY

< UNIT DISASSEMBLY AND ASSEMBLY >

[5AT: RE5R05A]

57. Remove D-rings from reverse brake piston.

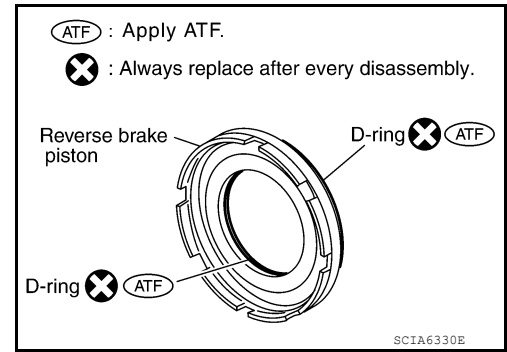

58. Knock out retaining pin using suitable tool.

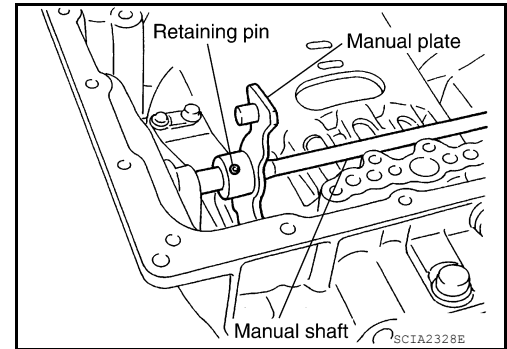

59. Remove manual shaft retaining pin using suitable tool.

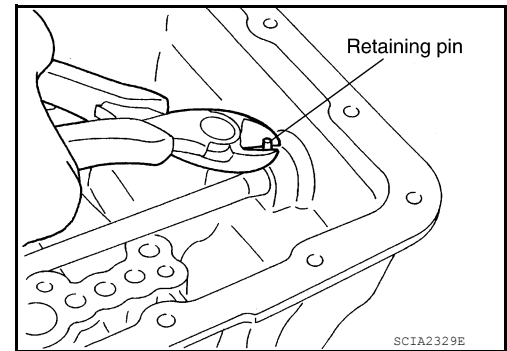

60. Remove manual plate (with parking rod) from manual shaft.

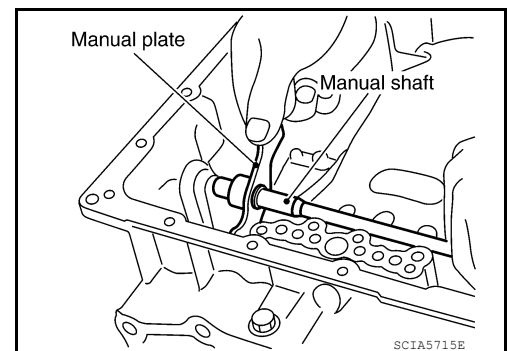

61. Remove parking rod from manual plate.

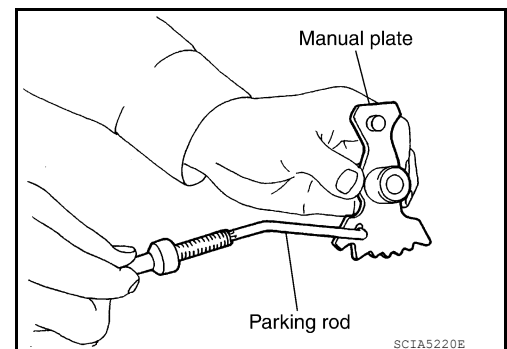

A
B
C
TM
E
F
G
H
I
J
K
L
M
N
O
P

DISASSEMBLY

< UNIT DISASSEMBLY AND ASSEMBLY >

[5AT: RE5R05A]

62. Remove manual shaft from transmission case.

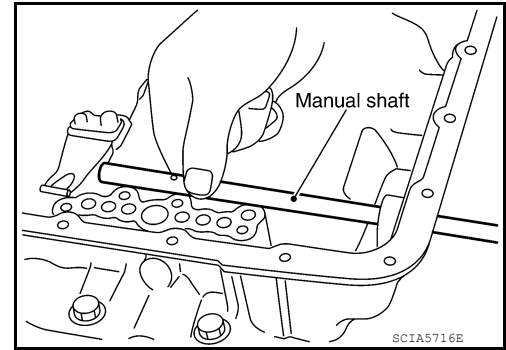

63. Remove manual shaft oil seals using suitable tool.

CAUTION:

Do not scratch transmission case.

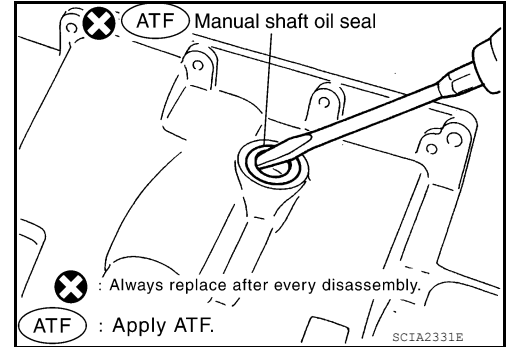

64. Remove detent spring and spacer from transmission case.

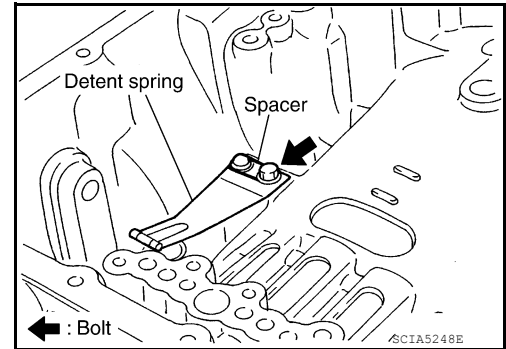

65. Remove snap ring from transmission case using suitable tool.

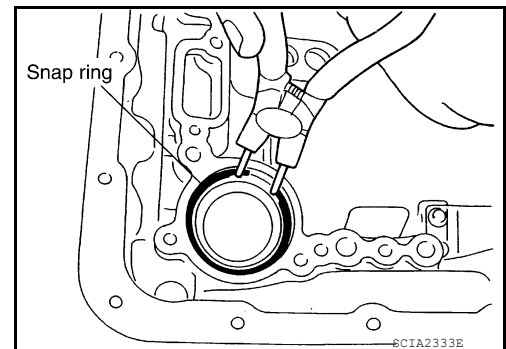

66. Remove servo assembly (with return spring) from transmission case.

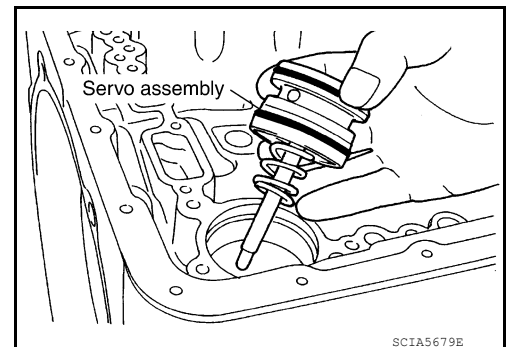

DISASSEMBLY

< UNIT DISASSEMBLY AND ASSEMBLY >

[5AT: RE5R05A]

67. Remove return spring from servo assembly.

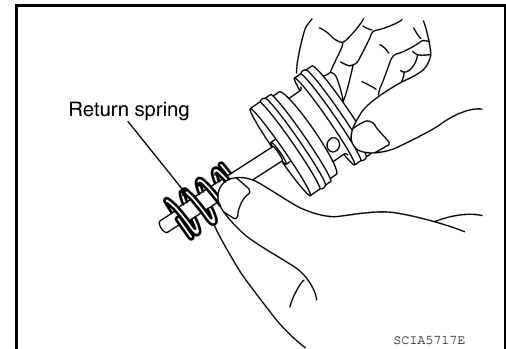

68. Remove O-rings from servo assembly.

CAUTION:
Do not reuse O-rings.

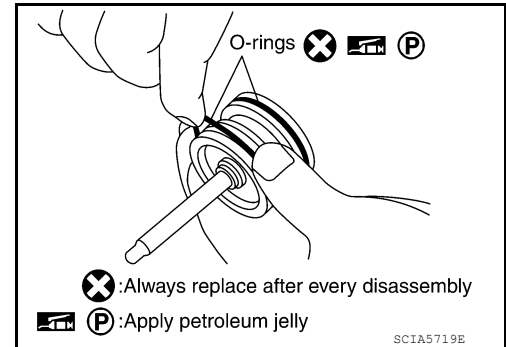

69. Remove needle bearing (1) from rear extension (2WD models) or adapter case (4WD models).

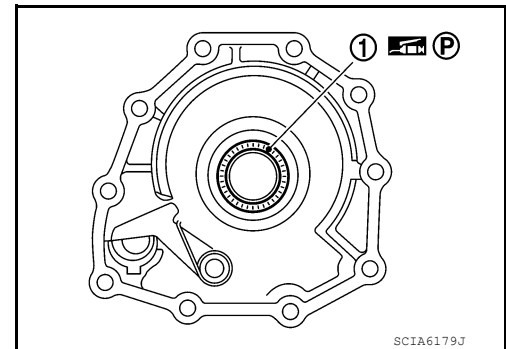

70. Remove parking actuator support from rear extension (2WD models) or adapter case (4WD models).

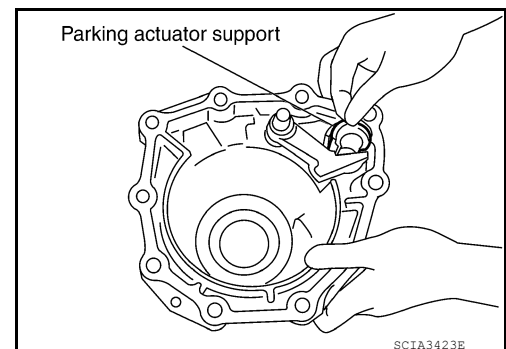

71. Remove parking pawl (with return spring) and pawl shaft from rear extension (2WD models) or adapter case (4WD models).

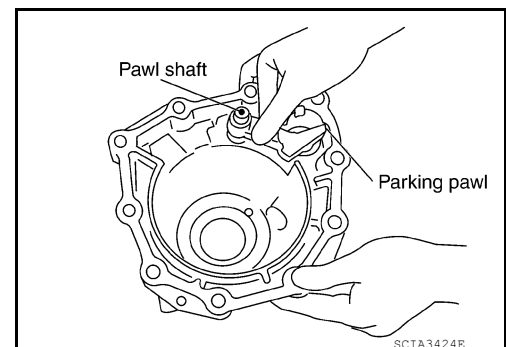

DISASSEMBLY

< UNIT DISASSEMBLY AND ASSEMBLY >

[5AT: RE5R05A]

72. Remove return spring (1) from parking pawl (2).

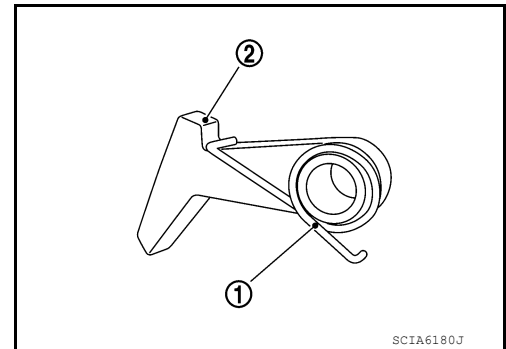

73. Remove rear oil seal from rear extension (2WD models) or adapter case (4WD models) using suitable tool.

CAUTION:

Do not scratch rear extension (2WD models) or adapter case (4WD models).

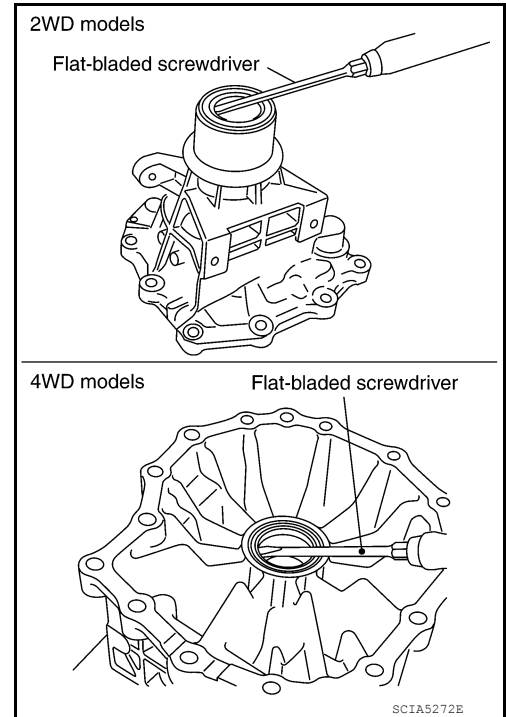

OIL PUMP

< UNIT DISASSEMBLY AND ASSEMBLY >

[5AT: RE5R05A]

OIL PUMP

Exploded View

INFOID:000000008791026

Oil Pump

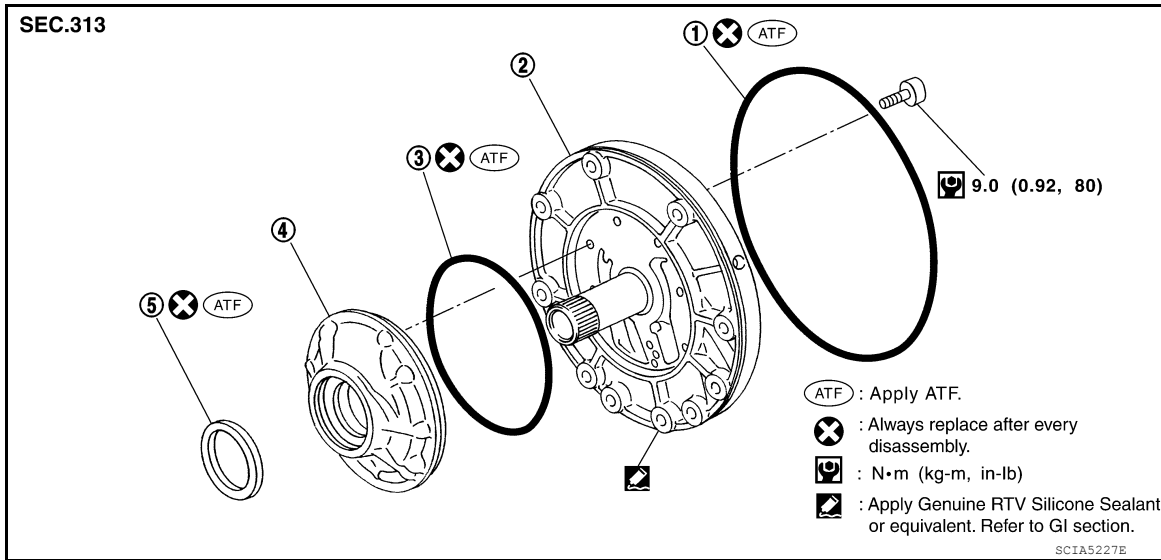

- | | | |
|---------------------|------------------------------|-----------|
| 1. O-ring | 2. Oil pump cover | 3. O-ring |
| 4. Oil pump housing | 5. Oil pump housing oil seal | |

Disassembly and Assembly

INFOID:000000008791027

DISASSEMBLY

1. Remove oil pump housing from oil pump cover.

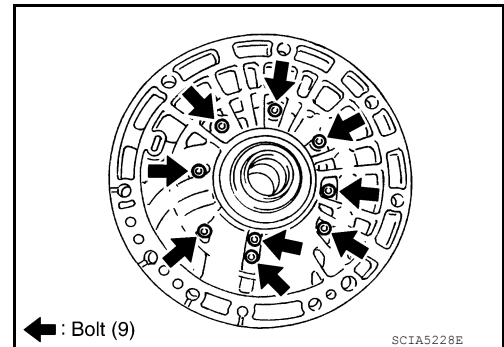

2. Remove oil pump housing oil seal using suitable tool.

CAUTION:
Do not scratch oil pump housing.

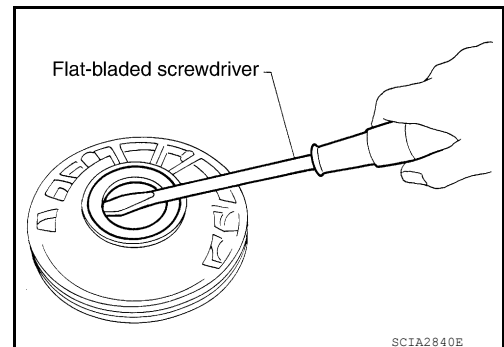

OIL PUMP

< UNIT DISASSEMBLY AND ASSEMBLY >

[5AT: RE5R05A]

3. Remove O-ring from oil pump housing.

CAUTION:
Do not reuse O-ring.

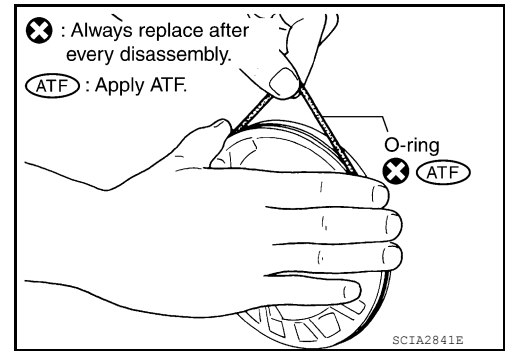

4. Remove O-ring from oil pump cover.

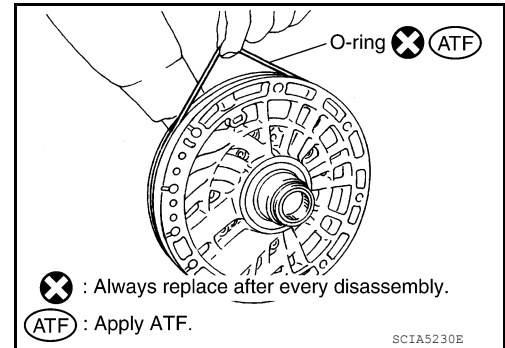

ASSEMBLY

1. Install O-ring to oil pump cover.

CAUTION:
• Do not reuse O-ring.
• Apply ATF to O-ring.

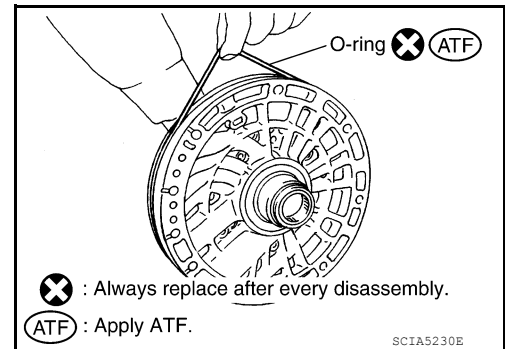

2. Install O-ring to oil pump housing.

CAUTION:
• Do not reuse O-ring.
• Apply ATF to O-ring.

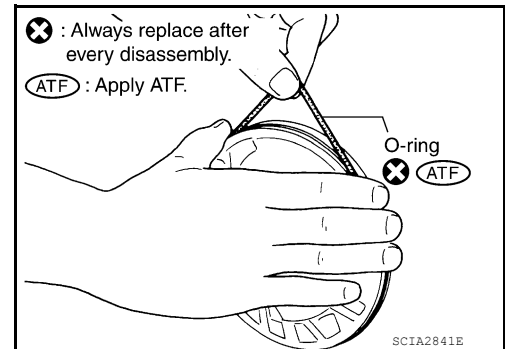

OIL PUMP

< UNIT DISASSEMBLY AND ASSEMBLY >

[5AT: RE5R05A]

3. Install oil pump housing oil seal to the oil pump housing until it is flush using Tool.

Tool number : ST33400001 (J-26082)

CAUTION:

- Do not reuse oil seal.
- Apply ATF to oil seal.

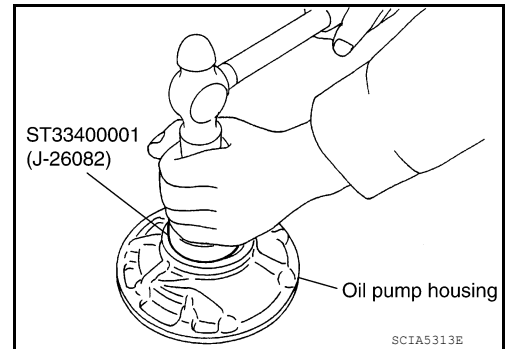

4. After temporarily tightening the bolts for the oil pump housing to the oil pump cover, tighten them to the specified torque in the sequence shown.

Oil pump housing bolts : 9.0 N·m (0.92 kg·m, 80 in-lb.)

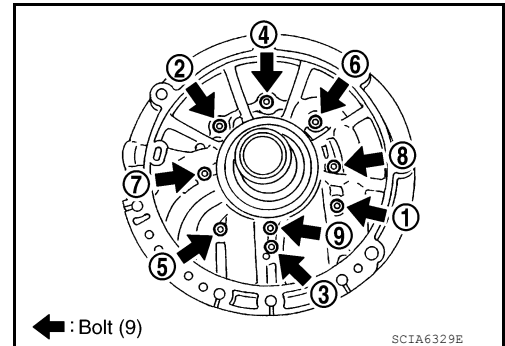

A
B
C
TM
E
F
G
H
I
J
K
L
M
N
O
P

FRONT SUN GEAR, 3RD ONE-WAY CLUTCH

< UNIT DISASSEMBLY AND ASSEMBLY >

[5AT: RE5R05A]

FRONT SUN GEAR, 3RD ONE-WAY CLUTCH

Exploded View

INFOID:000000008791028

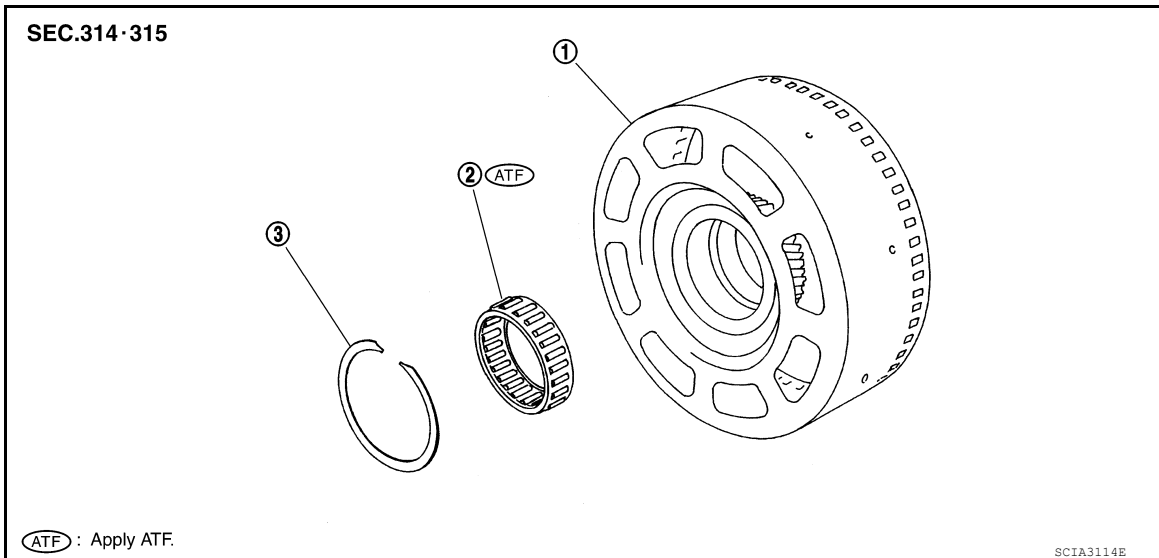

1. Front sun gear

2. 3rd one-way clutch

3. Snap ring

Disassembly and Assembly

INFOID:000000008791029

DISASSEMBLY

1. Remove snap ring from front sun gear using suitable tool.

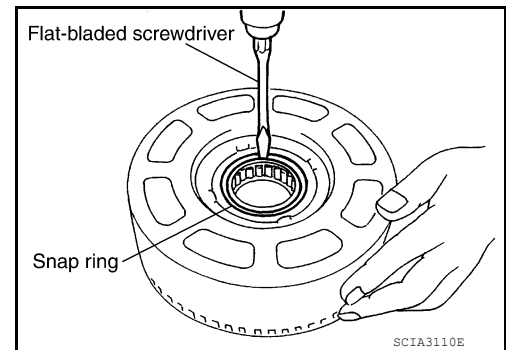

2. Remove 3rd one-way clutch from front sun gear.

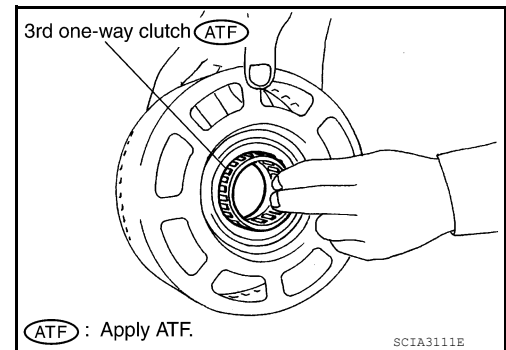

INSPECTION

3rd One-way Clutch

- Check frictional surface for wear or damage.

CAUTION:

If necessary, replace the 3rd one-way clutch.

FRONT SUN GEAR, 3RD ONE-WAY CLUTCH

< UNIT DISASSEMBLY AND ASSEMBLY >

[5AT: RE5R05A]

Front Sun Gear Snap Ring

- Check for deformation, fatigue or damage.

CAUTION:

If necessary, replace the snap ring.

Front Sun Gear

- Check for deformation, fatigue or damage.

CAUTION:

If necessary, replace the front sun gear.

ASSEMBLY

1. Install 3rd one-way clutch in front sun gear.

CAUTION:

Apply ATF to 3rd one-way clutch.

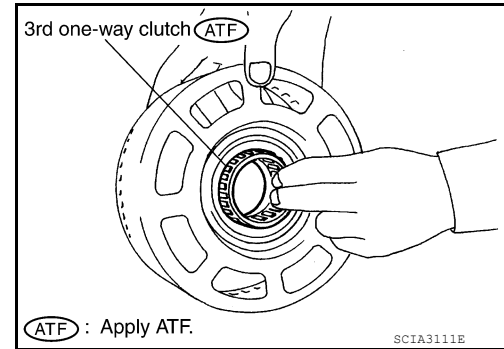

2. Install snap ring in front sun gear using suitable tool.

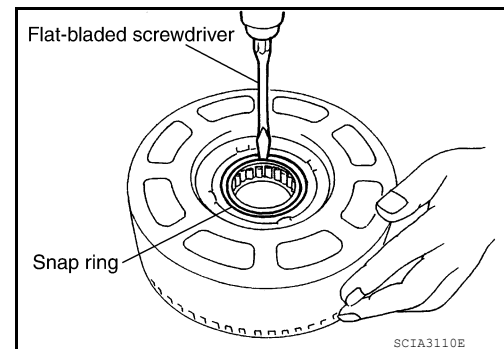

3. Check operation of 3rd one-way clutch.

- a. Hold oil pump assembly and turn front sun gear.

- b. Check 3rd one-way clutch for correct locking and unlocking directions.

CAUTION:

If not as shown, check installation direction of 3rd one-way clutch.

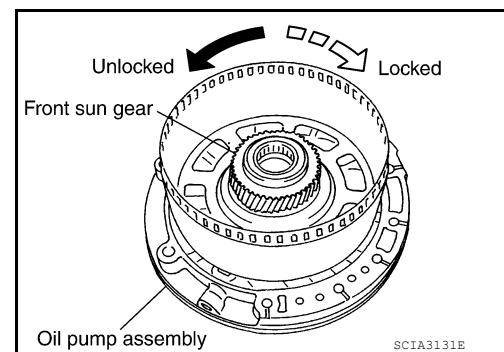

A
B
C
TM
E
F
G
H
I
J
K
L
M
N
O
P

FRONT CARRIER, INPUT CLUTCH, REAR INTERNAL GEAR

< UNIT DISASSEMBLY AND ASSEMBLY >

[5AT: RE5R05A]

FRONT CARRIER, INPUT CLUTCH, REAR INTERNAL GEAR

Front Carrier, Input Clutch, Rear Internal Gear

INFOID:000000008791030

COMPONENTS

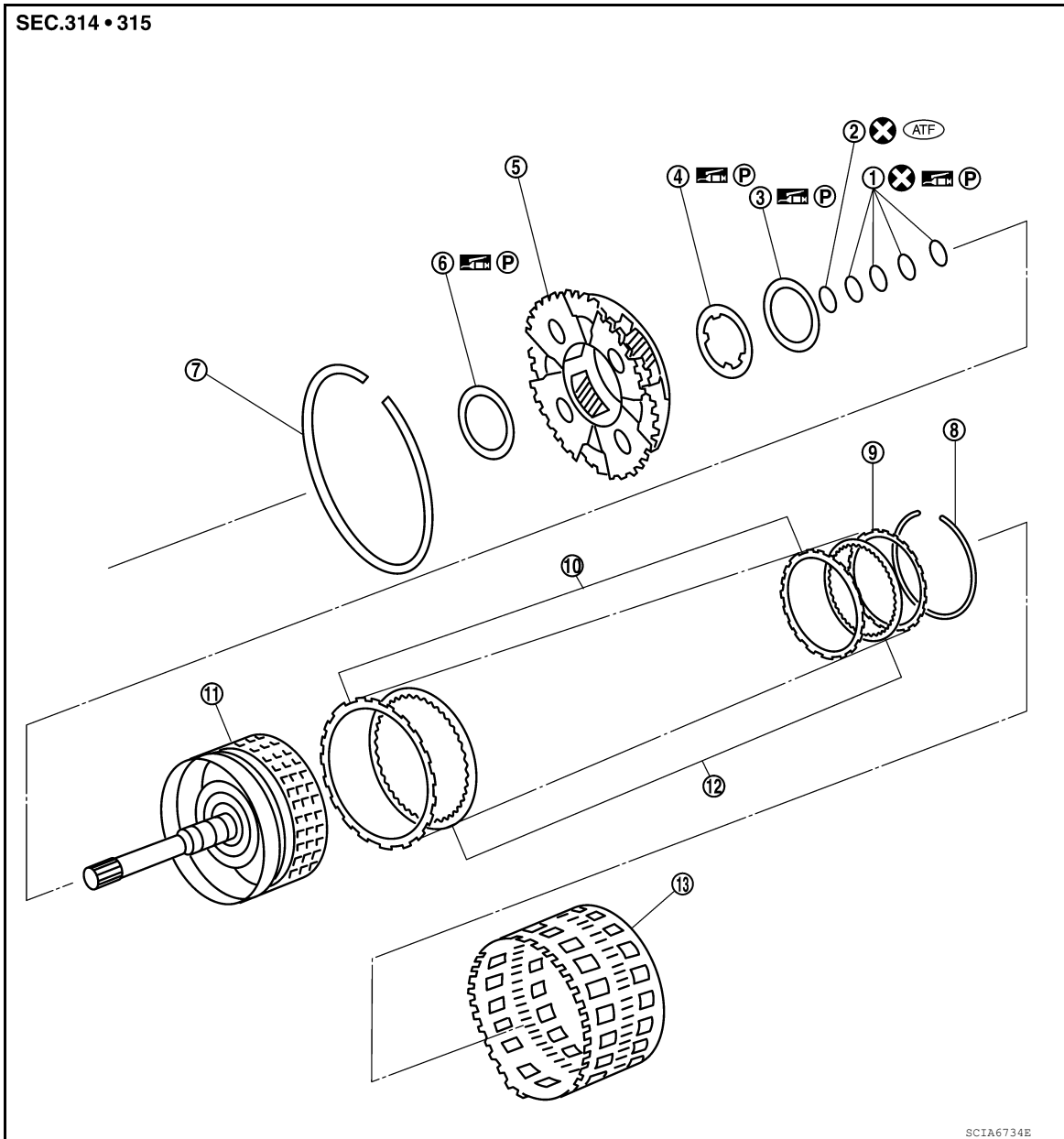

- | | | |
|------------------|---------------------------|--------------------|
| 1. Seal ring | 2. O-ring | 3. Needle bearing |
| 4. Bearing race | 5. Front carrier assembly | 6. Needle bearing |
| 7. Snap ring | 8. Snap ring | 9. Retaining plate |
| 10. Driven plate | 11. Input clutch drum | 12. Drive plate |

Refer to [GI-4, "Component"](#) for symbols in the figure.

DISASSEMBLY

FRONT CARRIER, INPUT CLUTCH, REAR INTERNAL GEAR

< UNIT DISASSEMBLY AND ASSEMBLY >

[5AT: RE5R05A]

1. Compress snap ring using suitable tools.
2. Remove front carrier assembly and input clutch assembly from rear internal gear.
3. Remove front carrier assembly from input clutch assembly.

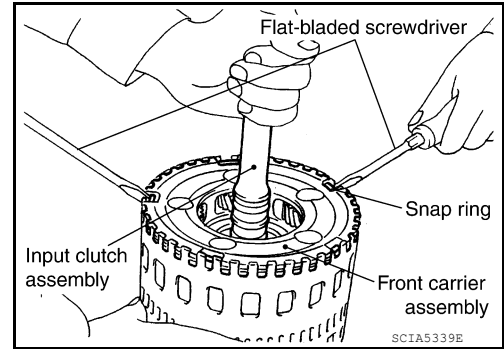

- a. Remove bearing race from front carrier assembly.

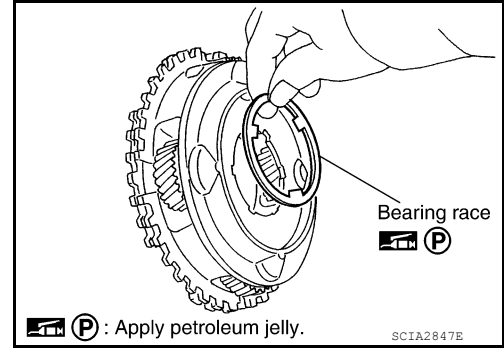

- b. Remove needle bearing from front carrier assembly.

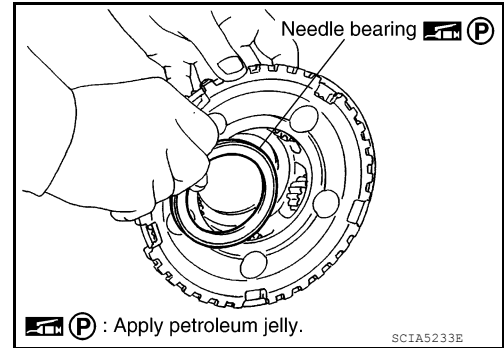

- c. Remove snap ring from front carrier assembly.
CAUTION:
Do not expand snap ring excessively.

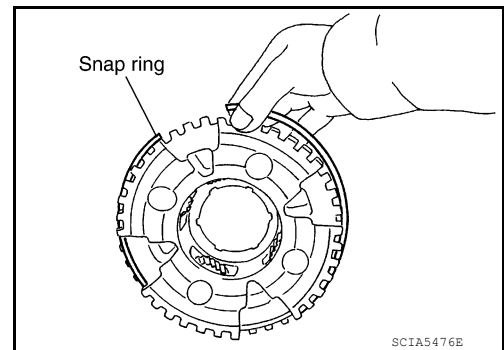

4. Disassemble input clutch assembly.
- a. Remove O-ring and seal rings from input clutch assembly.

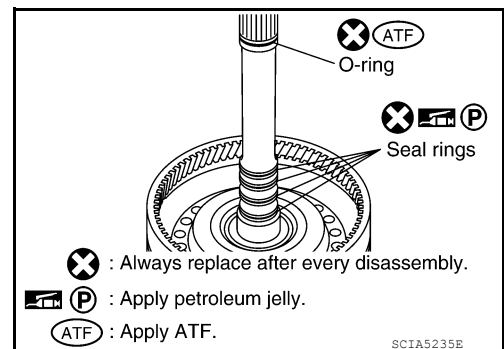

⊗ : Always replace after every disassembly.
 ⊗ P : Apply petroleum jelly.
 ATF : Apply ATF.

A
B
C
TM
E
F
G
H
I
J
K
L
M
N
O
P

FRONT CARRIER, INPUT CLUTCH, REAR INTERNAL GEAR

< UNIT DISASSEMBLY AND ASSEMBLY >

[5AT: RE5R05A]

b. Remove needle bearing from input clutch assembly.

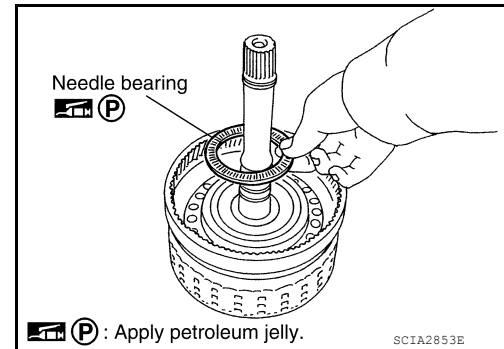

c. Remove snap ring from input clutch drum using suitable tools.
d. Remove drive plates, driven plates and retaining plate from input clutch drum.

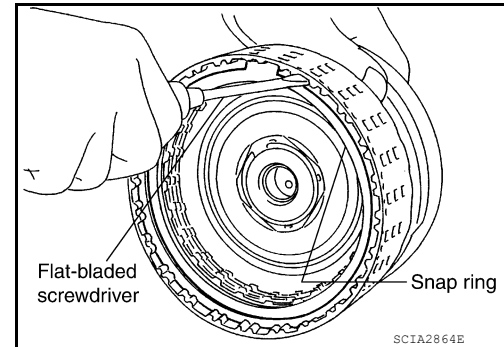

INSPECTION

Front Carrier Snap Ring

- Check for deformation, fatigue or damage.

CAUTION:

If necessary, replace the snap ring.

Input Clutch Snap Ring

- Check for deformation, fatigue or damage.

CAUTION:

If necessary, replace the input clutch assembly.

Input Clutch Drum

- Check for deformation, fatigue or damage or burns.

CAUTION:

If necessary, replace the input clutch assembly.

Input Clutch Drive Plates

- Check facing for burns, cracks or damage.

CAUTION:

If necessary, replace the input clutch assembly.

Input Clutch Retaining Plate and Driven Plates

- Check facing for burns, cracks or damage.

CAUTION:

If necessary, replace the input clutch assembly.

Front Carrier

- Check for deformation, fatigue or damage.

CAUTION:

If necessary, replace the front carrier assembly.

Rear Internal Gear

- Check for deformation, fatigue or damage.

CAUTION:

If necessary, replace the rear internal gear assembly.

ASSEMBLY

1. Install input clutch.

FRONT CARRIER, INPUT CLUTCH, REAR INTERNAL GEAR

< UNIT DISASSEMBLY AND ASSEMBLY >

[5AT: RE5R05A]

a. Install drive plates, driven plates and retaining plate in input clutch drum.

CAUTION:

Take care with order of plates.

- QR25DE models
 - Snap ring (1)
 - Retaining plate (2)
 - Drive plate (3)
 - Driven plate (4)
 - Drive plate/Driven plate: 5/5

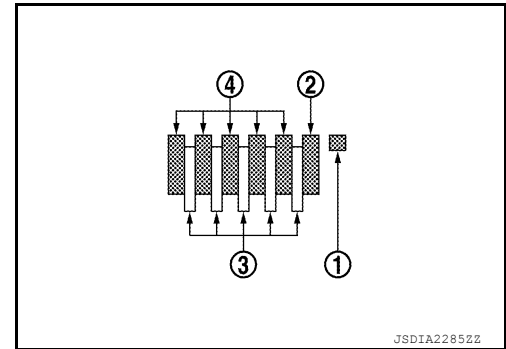

- VQ40DE models
 - Snap ring (1)
 - Retaining plate (2)
 - Drive plate (3)
 - Driven plate (4)
 - Drive plate/Driven plate: 7/7

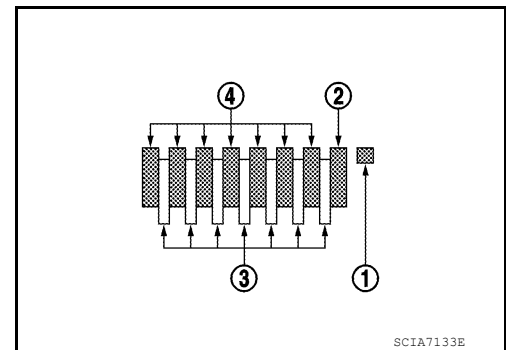

b. Install snap ring in input clutch drum using suitable tool.

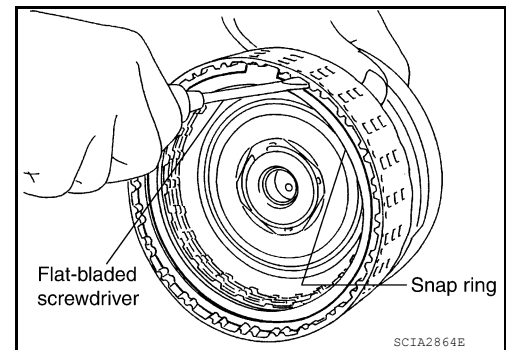

c. Install needle bearing in input clutch assembly.

CAUTION:

Apply petroleum jelly to needle bearing.

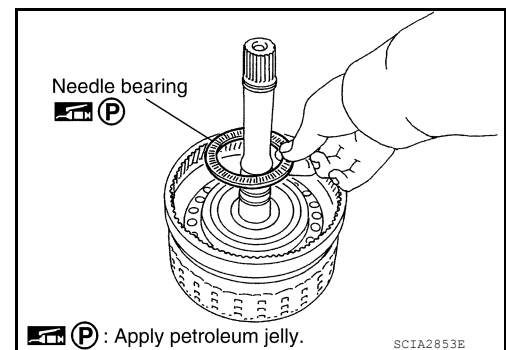

A
B
C
TM
E
F
G
H
I
J
K
L
M
N
O
P

FRONT CARRIER, INPUT CLUTCH, REAR INTERNAL GEAR

< UNIT DISASSEMBLY AND ASSEMBLY >

[5AT: RE5R05A]

d. Install O-ring and seal rings in input clutch assembly.

CAUTION:

- Do not reuse O-ring and seal rings.
- Apply ATF to O-ring.
- Apply petroleum jelly to seal rings.

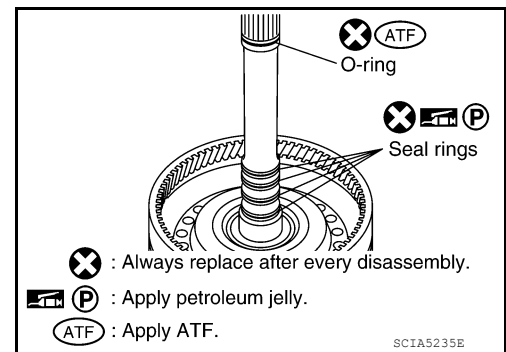

2. Install front carrier assembly.

a. Install snap ring to front carrier assembly.

CAUTION:

Do not expand snap ring excessively.

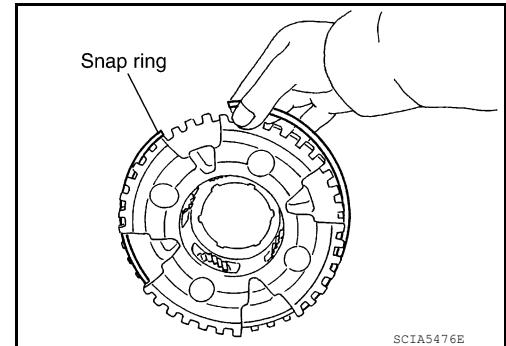

b. Install needle bearing in front carrier assembly.

CAUTION:

- Take care with the direction of needle bearing. Refer to [TM-320, "Location of Adjusting Shims, Needle Bearings, Thrust Washers and Snap Rings"](#).
- Apply petroleum jelly to bearing race.

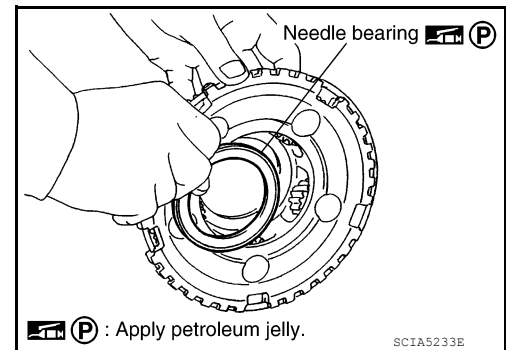

c. Install bearing race in front carrier assembly.

CAUTION:

Apply petroleum jelly to bearing race.

d. Install front carrier assembly to input clutch assembly.

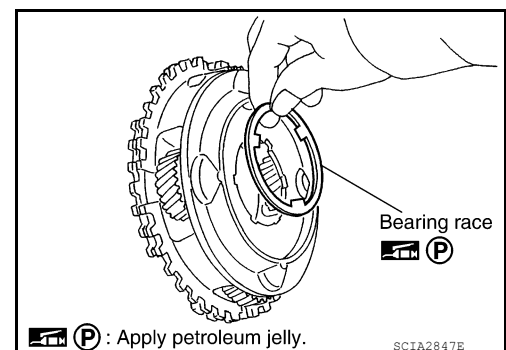

3. Compress snap ring using suitable tools.

4. Install front carrier assembly and input clutch assembly to rear internal gear.

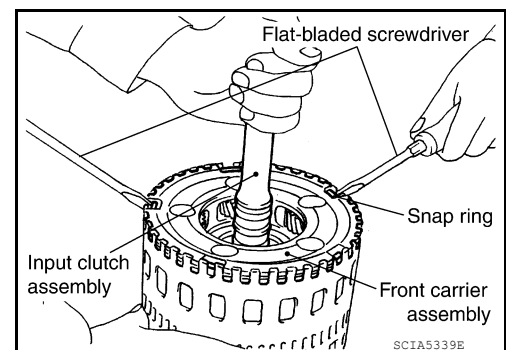

MID SUN GEAR, REAR SUN GEAR, HIGH AND LOW REVERSE CLUTCH HUB
 < UNIT DISASSEMBLY AND ASSEMBLY > [5AT: RE5R05A]

MID SUN GEAR, REAR SUN GEAR, HIGH AND LOW REVERSE CLUTCH HUB

Mid Sun Gear, Rear Sun Gear, High and Low Reverse Clutch Hub

INFOID:000000008791031

COMPONENTS

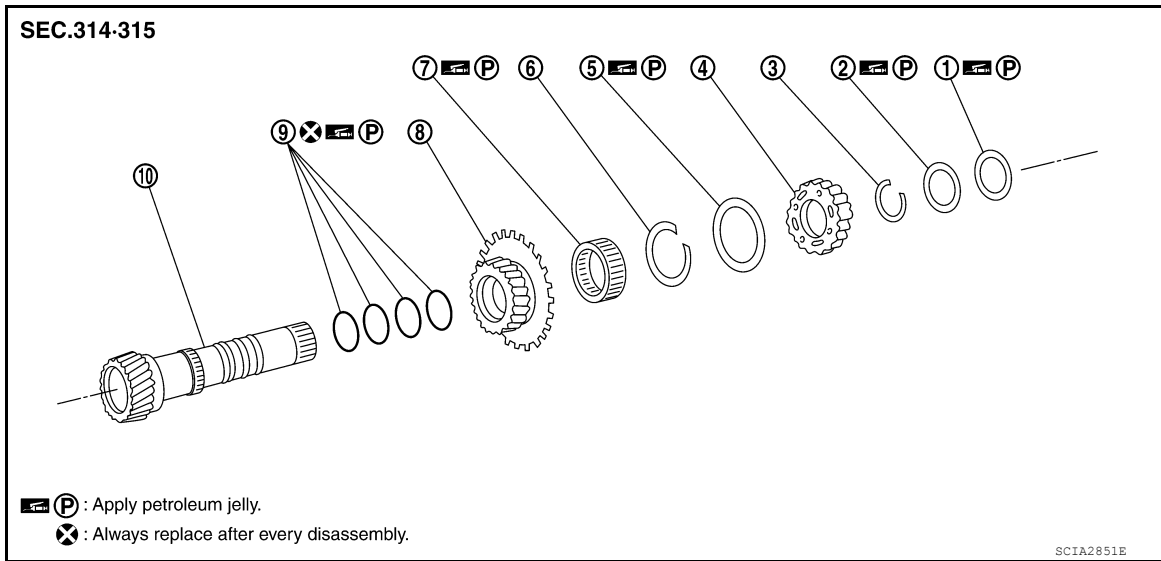

- | | | |
|------------------------------------|-------------------|--------------|
| 1. Needle bearing | 2. Bearing race | 3. Snap ring |
| 4. High and low reverse clutch hub | 5. Needle bearing | 6. Snap ring |
| 7. 1st one-way clutch | 8. Rear sun gear | 9. Seal ring |
| 10. Mid sun gear | | |

DISASSEMBLY

1. Remove needle bearing and bearing race from high and low reverse clutch hub.

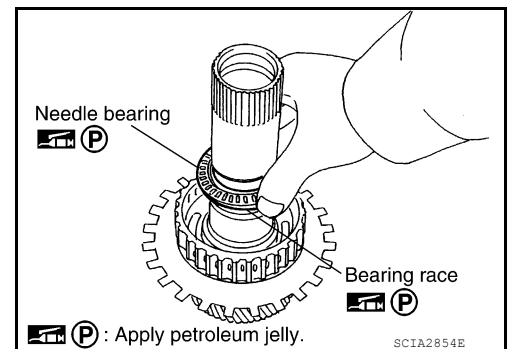

2. Remove snap ring from mid sun gear assembly using suitable tool.

CAUTION:
 Do not expand snap ring excessively.

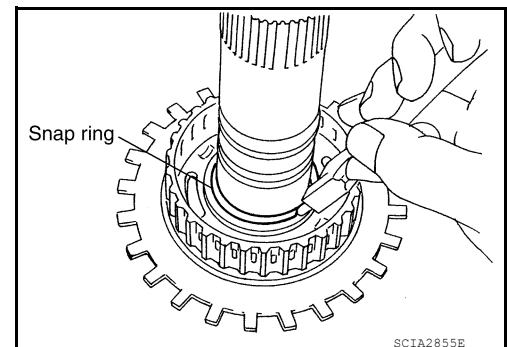

MID SUN GEAR, REAR SUN GEAR, HIGH AND LOW REVERSE CLUTCH HUB

< UNIT DISASSEMBLY AND ASSEMBLY >

[5AT: RE5R05A]

3. Remove high and low reverse clutch hub from mid sun gear assembly.

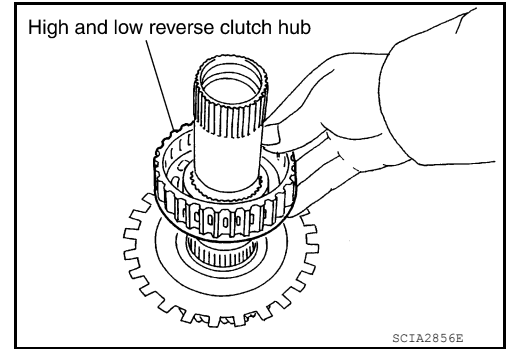

- a. Remove needle bearing from high and low reverse clutch hub.

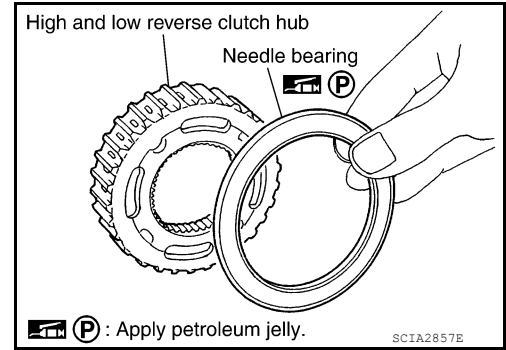

4. Remove rear sun gear assembly from mid sun gear assembly.

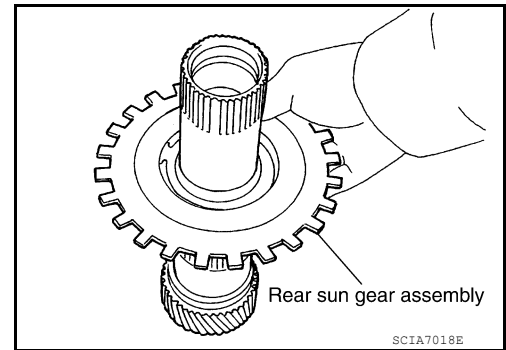

- a. Remove snap ring from rear sun gear using suitable tool.

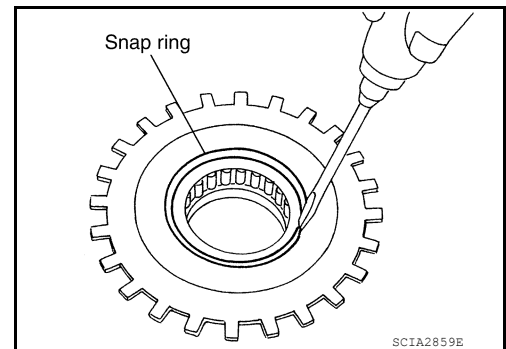

MID SUN GEAR, REAR SUN GEAR, HIGH AND LOW REVERSE CLUTCH HUB

< UNIT DISASSEMBLY AND ASSEMBLY >

[5AT: RE5R05A]

- b. Remove 1st one-way clutch from rear sun gear.

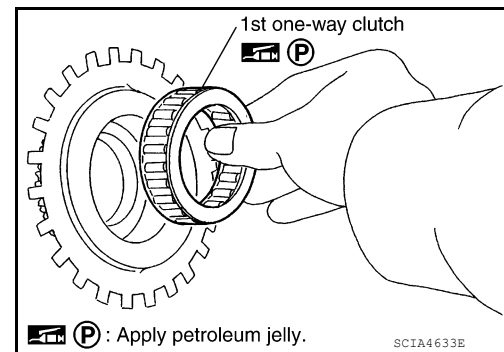

5. Remove seal rings from mid sun gear.

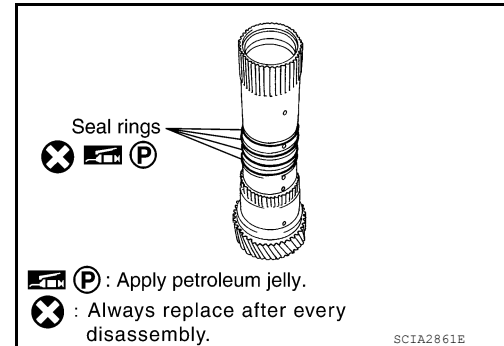

INSPECTION

High and Low Reverse Clutch Hub Snap Ring, Rear Sun Gear Snap Ring

- Check for deformation, fatigue or damage.

CAUTION:

If necessary, replace the snap ring.

1st One-way Clutch

- Check frictional surface for wear or damage.

CAUTION:

If necessary, replace the 1st one-way clutch.

Mid Sun Gear

- Check for deformation, fatigue or damage.

CAUTION:

If necessary, replace the mid sun gear.

Rear Sun Gear

- Check for deformation, fatigue or damage.

CAUTION:

If necessary, replace the rear sun gear.

High and Low Reverse Clutch Hub

- Check for deformation, fatigue or damage.

CAUTION:

If necessary, replace the high and low reverse clutch hub.

ASSEMBLY

A
B
C
TM
E
F
G
H
I
J
K
L
M
N
O
P

MID SUN GEAR, REAR SUN GEAR, HIGH AND LOW REVERSE CLUTCH HUB

< UNIT DISASSEMBLY AND ASSEMBLY >

[5AT: RE5R05A]

1. Install seal rings to mid sun gear.

CAUTION:

- Do not reuse seal rings.
- Apply petroleum jelly to seal rings.

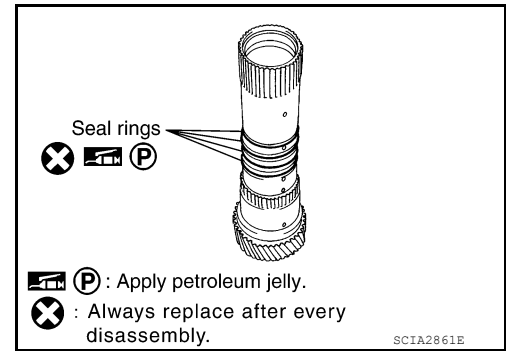

2. Install 1st one-way clutch to rear sun gear.

CAUTION:

- Apply petroleum jelly to 1st one-way clutch.

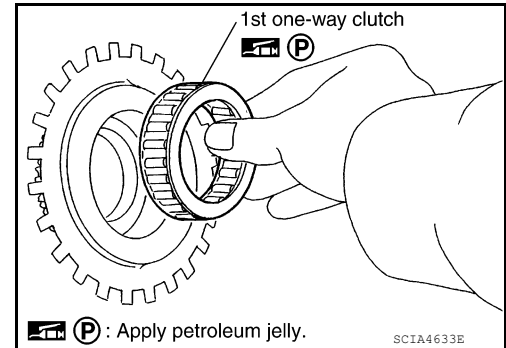

3. Install snap ring to rear sun gear using suitable tool.

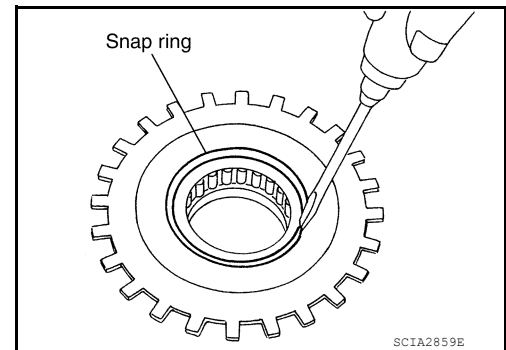

4. Install rear sun gear assembly to mid sun gear assembly.

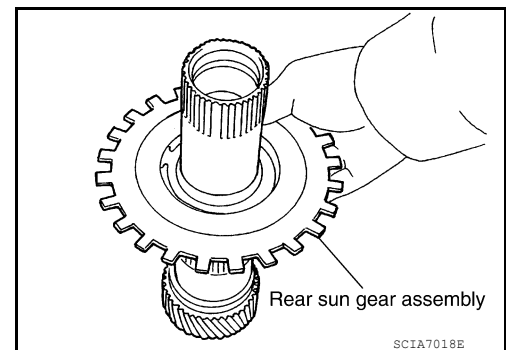

5. Install needle bearing to high and low reverse clutch hub.

CAUTION:

- Apply petroleum jelly to needle bearing.

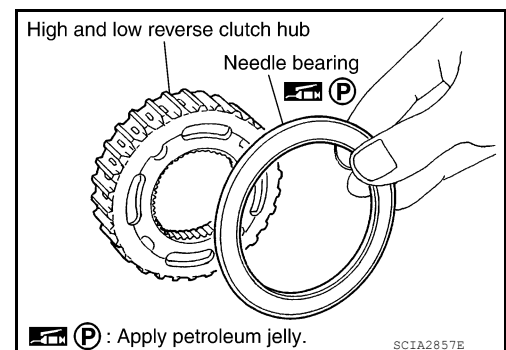

MID SUN GEAR, REAR SUN GEAR, HIGH AND LOW REVERSE CLUTCH HUB

< UNIT DISASSEMBLY AND ASSEMBLY >

[5AT: RE5R05A]

6. Install high and low reverse clutch hub to mid sun gear assembly.

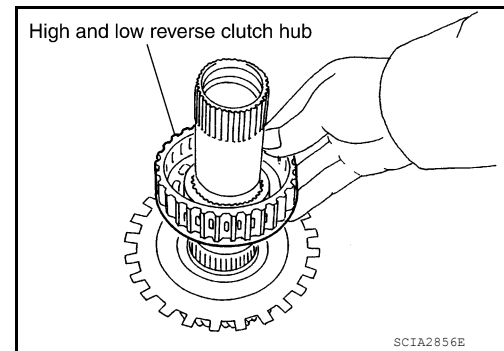

7. Install snap ring to mid sun gear assembly using suitable tool.

CAUTION:

Do not expand snap ring excessively.

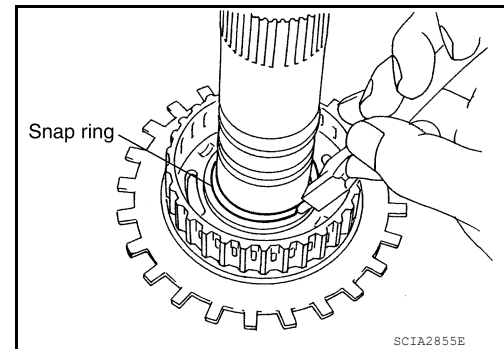

8. Check operation of 1st one-way clutch.

a. Hold mid sun gear and turn rear sun gear.

- b. Check 1st one-way clutch for correct locking and unlocking directions.

CAUTION:

If not as shown, check installation direction of 1st one-way clutch.

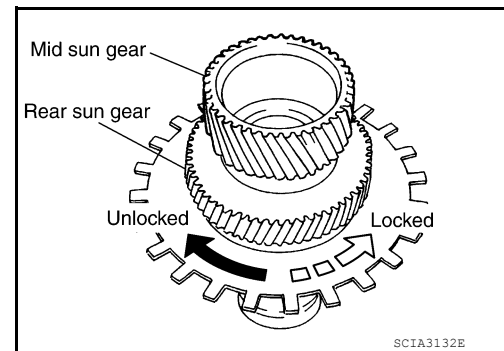

9. Install needle bearing and bearing race to high and low reverse clutch hub.

CAUTION:

Apply petroleum jelly to needle bearing and bearing race.

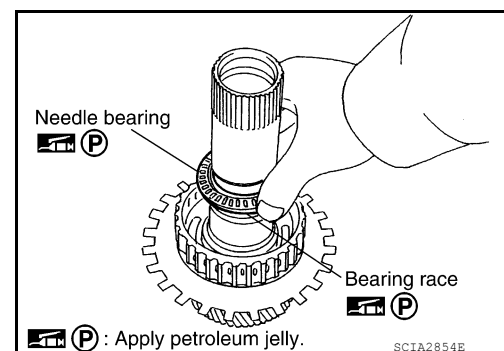

HIGH AND LOW REVERSE CLUTCH

< UNIT DISASSEMBLY AND ASSEMBLY >

[5AT: RE5R05A]

HIGH AND LOW REVERSE CLUTCH

High and Low Reverse Clutch

INFOID:000000008791032

COMPONENTS

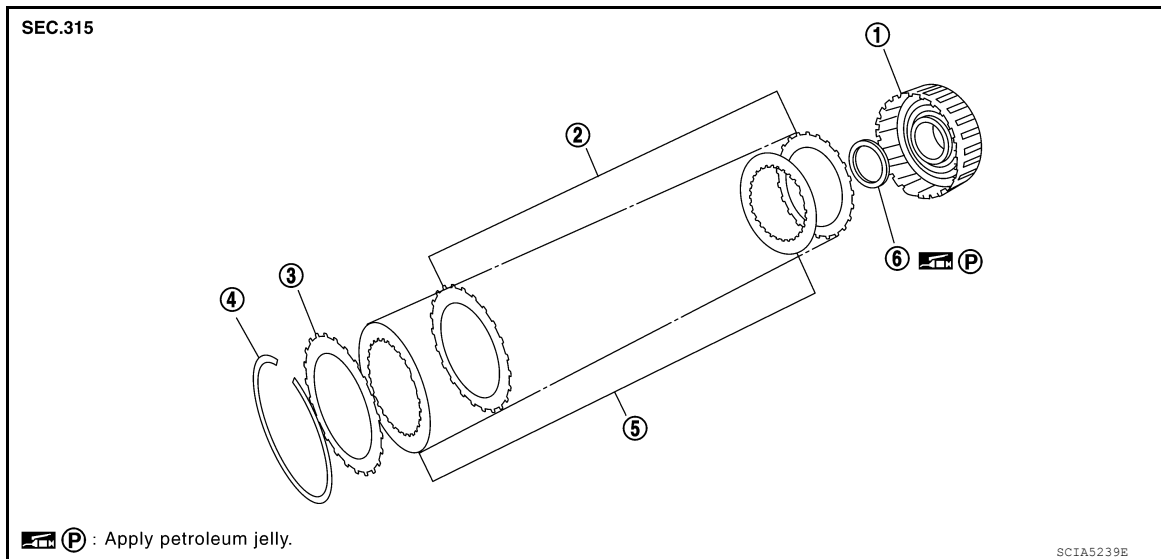

- | | | |
|-------------------------------------|-----------------|--------------------|
| 1. High and low reverse clutch drum | 2. Driven plate | 3. Retaining plate |
| 4. Snap ring | 5. Drive plate | 6. Bearing race |

DISASSEMBLY

1. Remove bearing race from high and low reverse clutch drum.

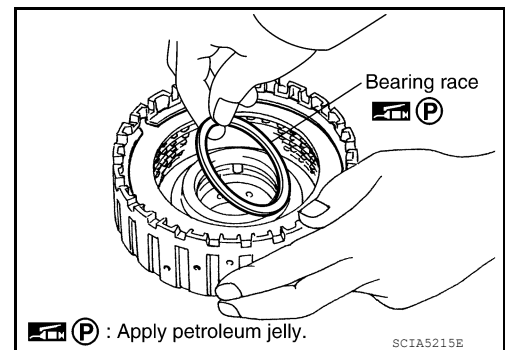

2. Remove snap ring from high and low reverse clutch drum using suitable tool.
3. Remove drive plates, driven plates and retaining plate from high and low reverse clutch drum.

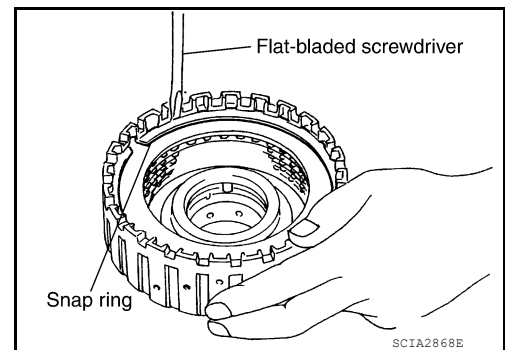

INSPECTION

- Check the following, and replace high and low reverse clutch assembly if necessary.

High and Low Reverse Clutch Snap Ring

- Check for deformation, fatigue or damage.

High and Low Reverse Clutch Drive Plates

HIGH AND LOW REVERSE CLUTCH

< UNIT DISASSEMBLY AND ASSEMBLY >

[5AT: RE5R05A]

- Check facing for burns, cracks or damage.

High and Low Reverse Clutch Retaining Plate and Driven Plates

- Check facing for burns, cracks or damage.

ASSEMBLY

1. Install drive plates, driven plates and retaining plate in high and low reverse clutch drum.

CAUTION:

Take care with the order of plates.

- QR25DE models

- Snap ring (1)
- Retaining plate (2)
- Drive plate (3)
- Driven plate (4)
- Drive plate/Driven plate: 4/4

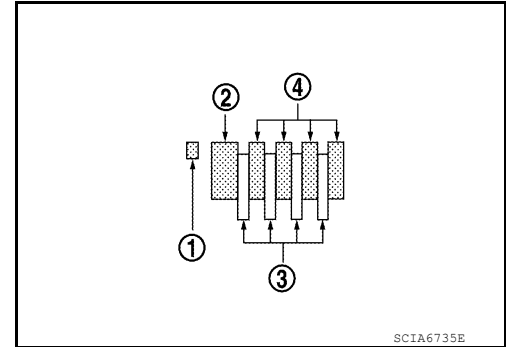

- VQ40DE models

- Snap ring (1)
- Retaining plate (2)
- Drive plate (3)
- Driven plate (4)
- Drive plate/Driven plate: 5/5

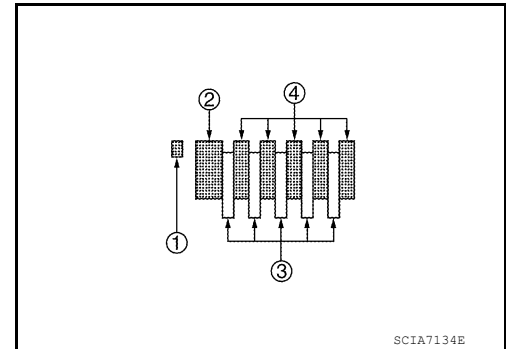

2. Install snap ring in high and low reverse clutch drum using suitable tool.

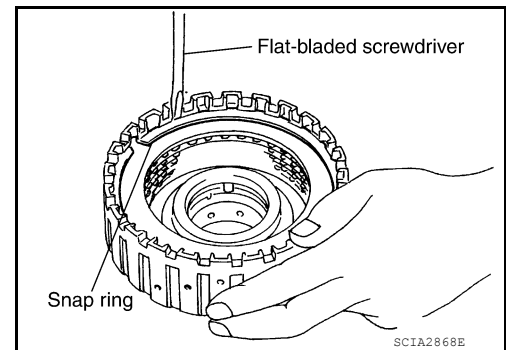

3. Install bearing race to high and low reverse clutch drum.

CAUTION:

Apply petroleum jelly to bearing race.

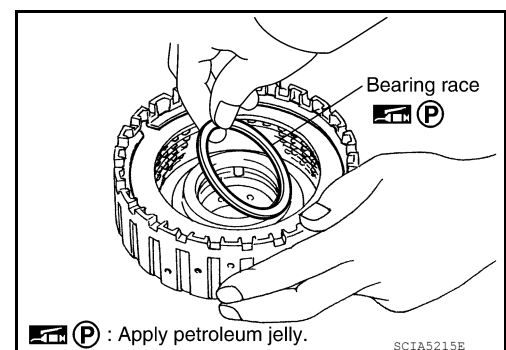

A
B
C
TM
E
F
G
H
I
J
K
L
M
N
O
P

DIRECT CLUTCH

< UNIT DISASSEMBLY AND ASSEMBLY >

[5AT: RE5R05A]

DIRECT CLUTCH

Direct Clutch

INFOID:000000008791033

COMPONENTS

QR25DE Models

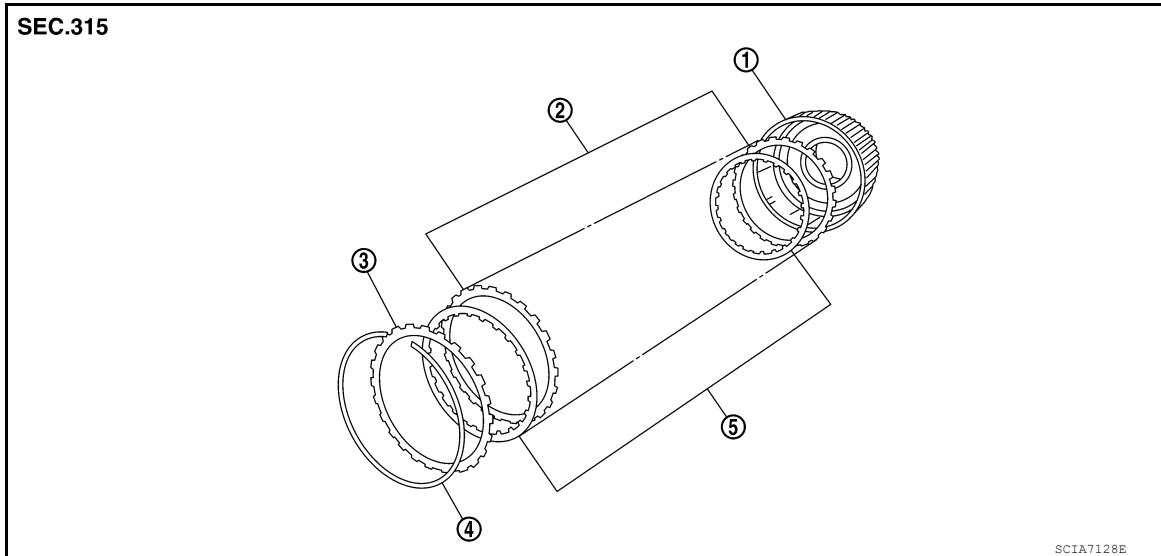

- 1. Direct clutch drum
- 4. Snap ring

- 2. Driven plate
- 5. Drive plate

- 3. Retaining plate

VQ40DE Models

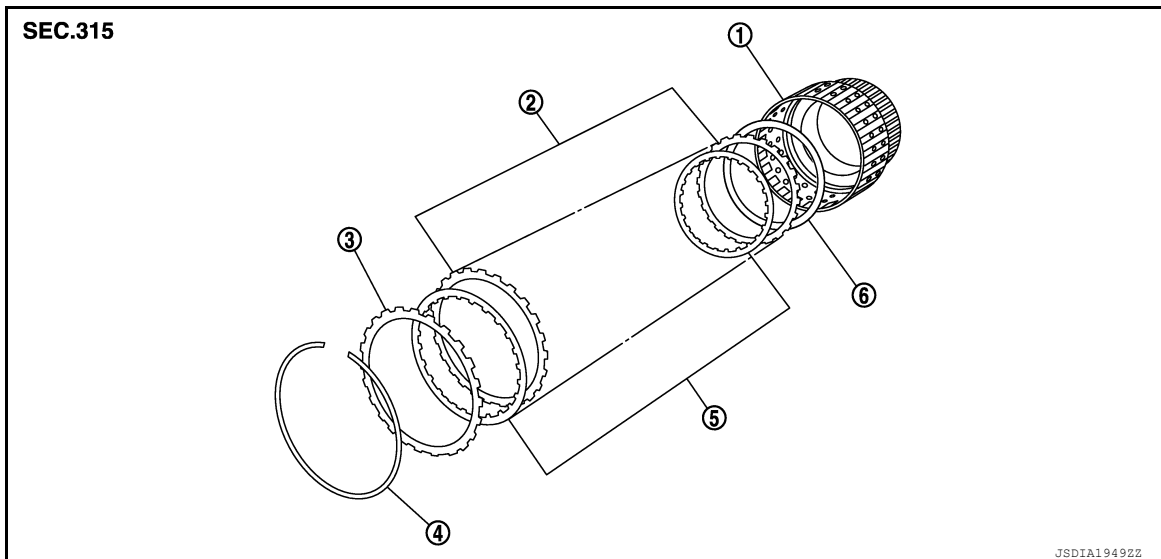

- 1. Direct clutch drum
- 4. Snap ring

- 2. Driven plate
- 5. Drive plate

- 3. Retaining plate
- 6. Dish plate

DISASSEMBLY

DIRECT CLUTCH

< UNIT DISASSEMBLY AND ASSEMBLY >

[5AT: RE5R05A]

1. Remove snap ring from direct clutch drum using suitable tool.
2. Remove retaining plate, drive plates, driven plates and dish plate* from direct clutch drum.
*: VQ40DE models only

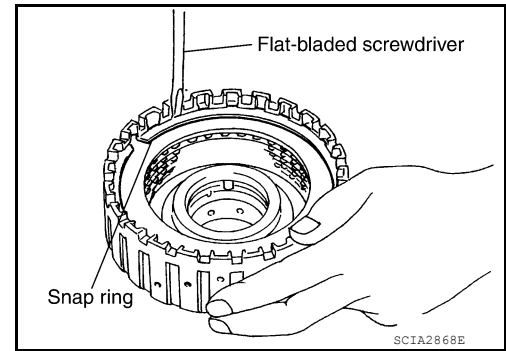

INSPECTION

- Check the following, and replace direct clutch assembly if necessary.

Direct Clutch Snap Ring

- Check for deformation, fatigue or damage.

Direct Clutch Drive Plates

- Check facing for burns, cracks or damage.

Direct Clutch Retaining Plate and Driven Plates

- Check facing for burns, cracks or damage.

Direct Clutch Dish Plate (VQ40DE Models)

- Check facing for burns, cracks or damage.

ASSEMBLY

1. Install retaining plate, drive plates, driven plates and dish plate* in direct clutch drum.
*: VQ40DE models only

CAUTION:

Take care with order of plates.

- QR25DE Models

- Snap ring (1)
- Retaining plate (2)
- Drive plate (3)
- Driven plate (4)
- Drive plate/Driven plate: 5/5

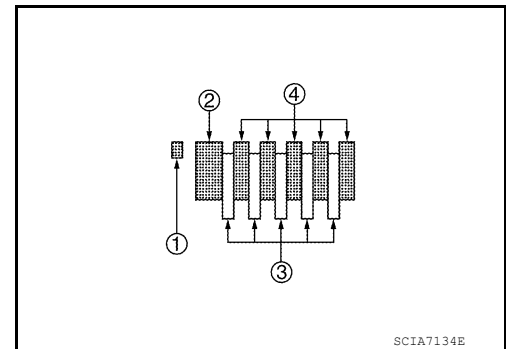

- VQ40DE Models

- Snap ring (1)
- Retaining plate (2)
- Drive plate (3)
- Driven plate (4)
- Dish plate (5)
- Drive plate/Driven plate: 5/5

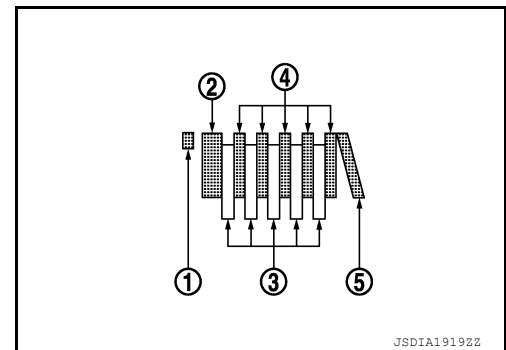

DIRECT CLUTCH

< UNIT DISASSEMBLY AND ASSEMBLY >

[5AT: RE5R05A]

2. Install snap ring in direct clutch drum using suitable tool.

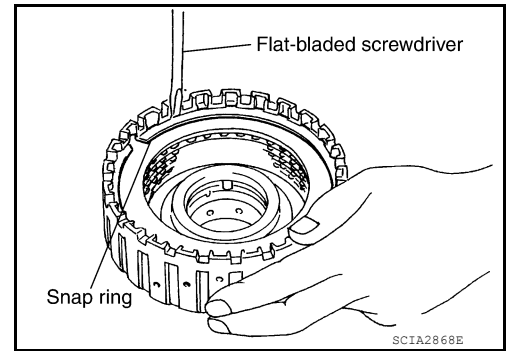

ASSEMBLY

Assembly (1)

INFOID:000000008791034

1. Drive manual shaft oil seals into the transmission case until they are flush using suitable tool.

CAUTION:

- Apply ATF to manual shaft oil seals.
- Do not reuse manual shaft oil seals.

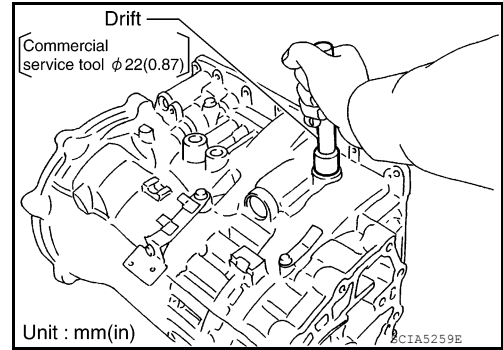

2. Install detent spring and spacer in transmission case and secure with the bolt.

Bolt : 7.9 N·m (0.81 kg-m, 70 in-lb)

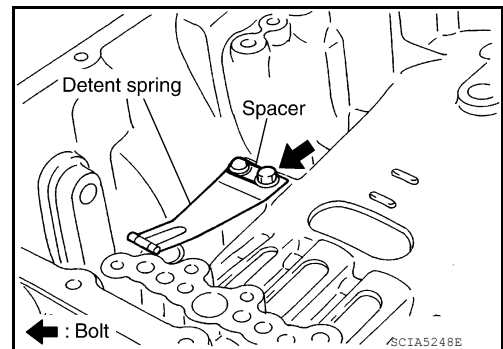

3. Install manual shaft to transmission case.

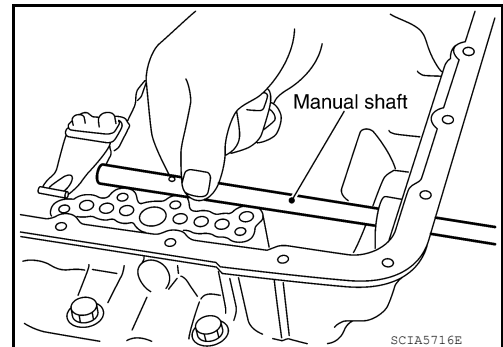

4. Install parking rod to manual plate.

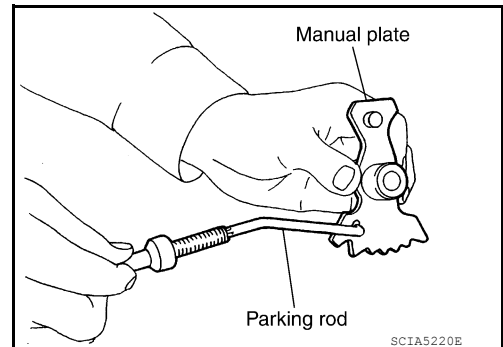

A
B
C
TM
E
F
G
H
I
J
K
L
M
N
O
P

ASSEMBLY

< UNIT DISASSEMBLY AND ASSEMBLY >

[5AT: RE5R05A]

5. Install manual plate (with parking rod) to manual shaft.

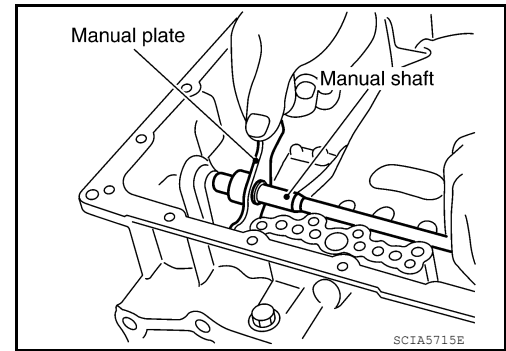

6. Install retaining pin into the manual plate and manual shaft.

- a. Align pinhole of the manual plate to pinhole of the manual shaft using suitable tool.
- b. Tap the retaining pin into the manual plate using suitable tool.

CAUTION:

- Drive retaining pin to 2 ± 0.5 mm (0.08 ± 0.020 in) over the manual plate.
- Do not reuse retaining pin.

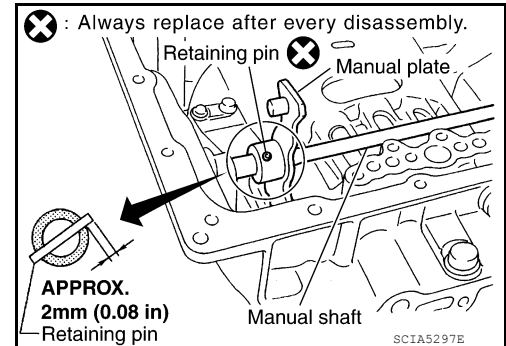

7. Install retaining pin into the transmission case and manual shaft.

- a. Align pinhole of the transmission case to pinhole of the manual shaft using suitable tool.
- b. Tap the retaining pin into the transmission case using suitable tool.

CAUTION:

- Drive retaining pin to 5 ± 1 mm (0.20 ± 0.04 in) over the transmission case.
- Do not reuse retaining pin.

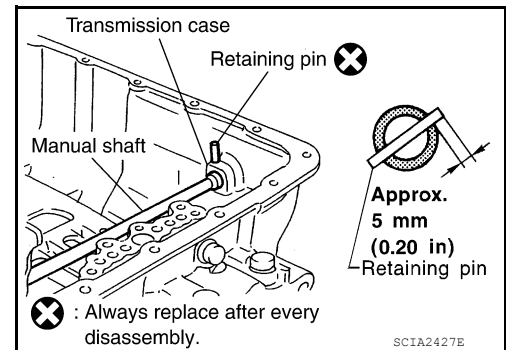

8. Install O-rings to servo assembly.

CAUTION:

- Do not reuse O-rings.
- Apply petroleum jelly to O-rings.

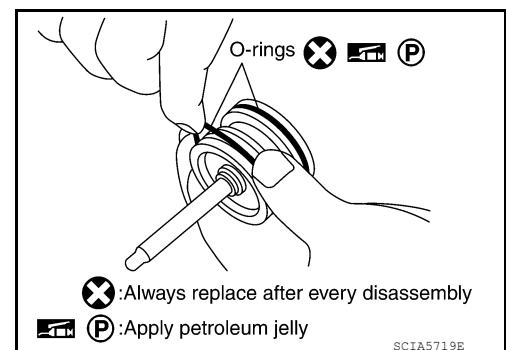

9. Install return spring to servo assembly.

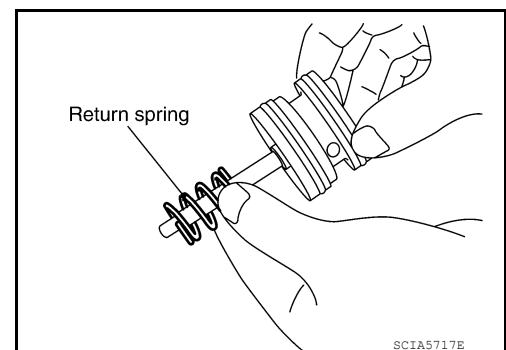

ASSEMBLY

< UNIT DISASSEMBLY AND ASSEMBLY >

[5AT: RE5R05A]

10. Install servo assembly in transmission case.

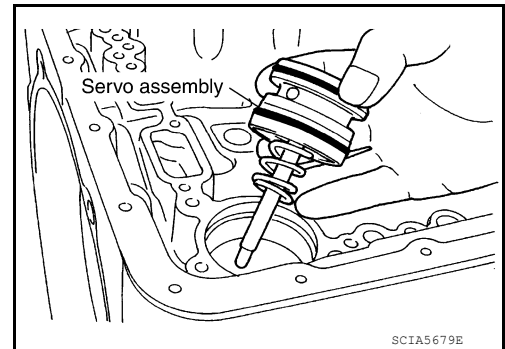

11. Install snap ring to transmission case using suitable tool.

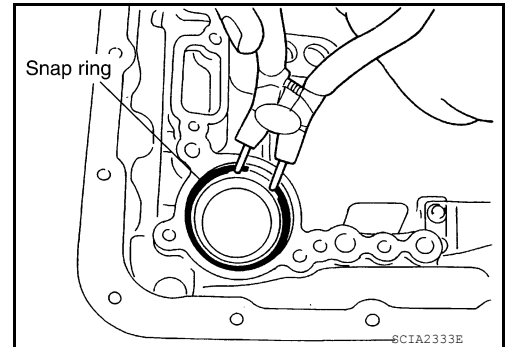

12. Install D-rings in reverse brake piston.

CAUTION:

- Do not reuse D-rings.
- Apply ATF to D-rings.

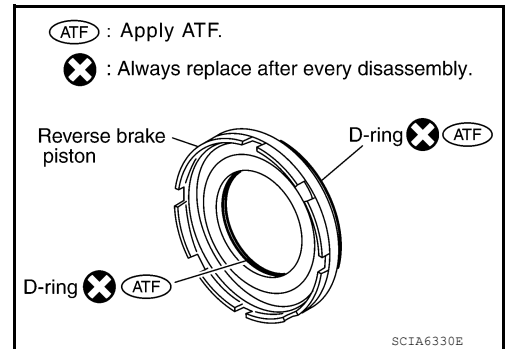

13. Install reverse brake piston in transmission case.

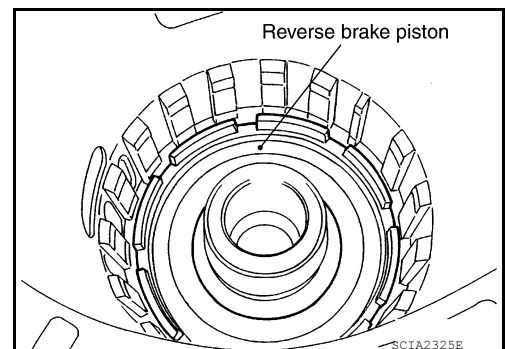

14. Install needle bearing to drum support edge surface.

CAUTION:

- Apply petroleum jelly to needle bearing.

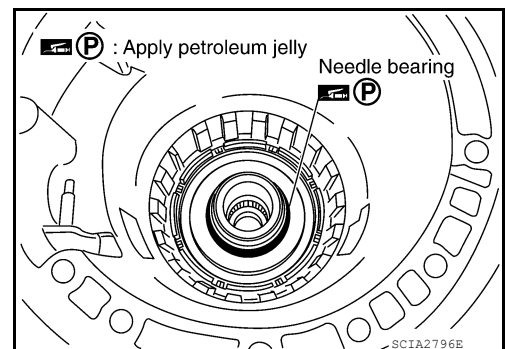

A
B
C
TM
E
F
G
H
I
J
K
L
M
N
O
P

ASSEMBLY

< UNIT DISASSEMBLY AND ASSEMBLY >

[5AT: RE5R05A]

15. Install seal rings to drum support.

CAUTION:

- Do not reuse seal rings.
- Apply petroleum jelly to seal rings.

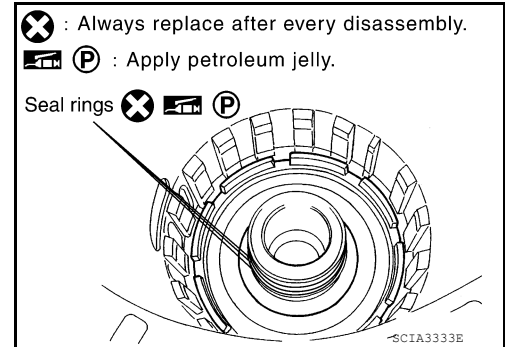

16. Install spring retainer and return spring in transmission case.

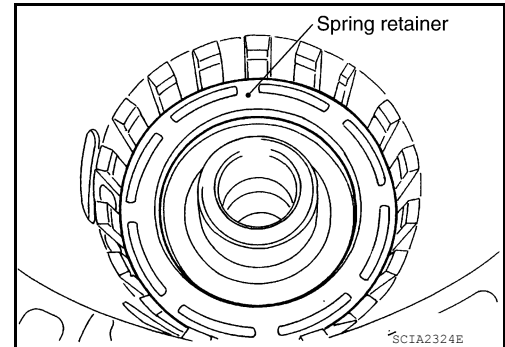

17. Install snap ring in transmission case while compressing return spring using Tool.

Tool number : KV31102400 (J-34285 and J-34285-87)

CAUTION:

Securely assemble them using a flat-bladed screwdriver so that snap ring tension is slightly weak.

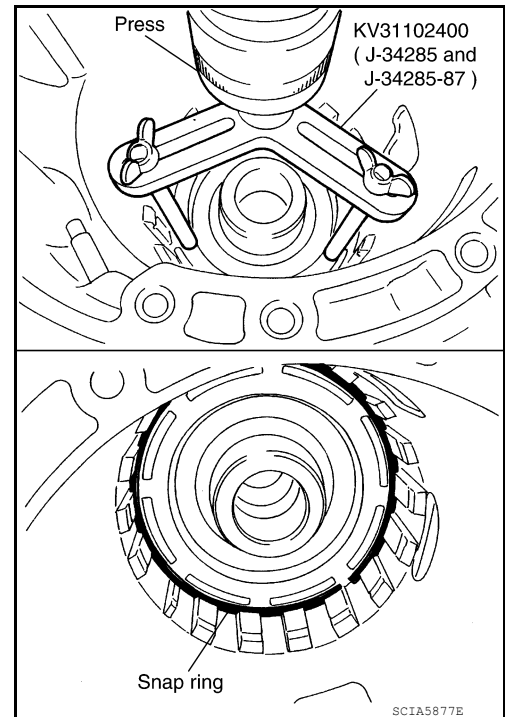

18. Install reverse brake drive plates driven plates and dish plates in transmission case.

CAUTION:

Take care with order of plates.

ASSEMBLY

< UNIT DISASSEMBLY AND ASSEMBLY >

[5AT: RE5R05A]

- QR25DE models
- Snap ring (1)
- Retaining plate (2)
- Drive plate (3)
- Driven plate (4)
- Dish plate (5)
- Drive plate/Driven plate:5/6

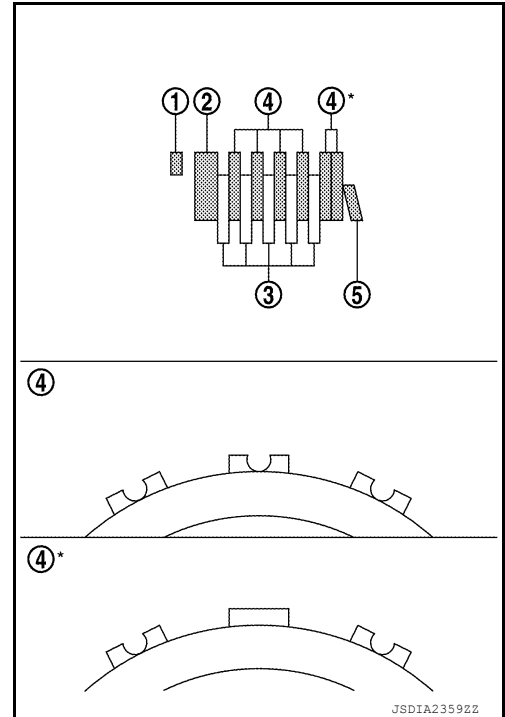

- VQ40DE models
- Snap ring (1)
- Retaining plate (2)
- Drive plate (3)
- Driven plate (4)
- Dish plate (5)
- Drive plate/Driven plate:6/6

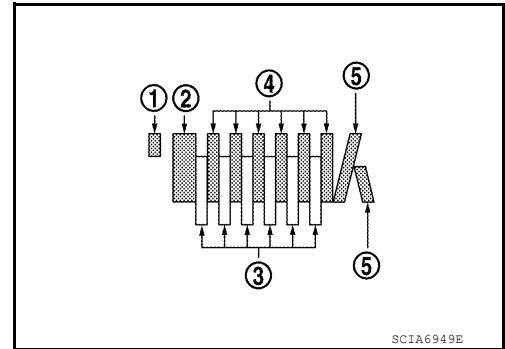

19. Assemble N-spring.
20. Install reverse brake retaining plate in transmission case.

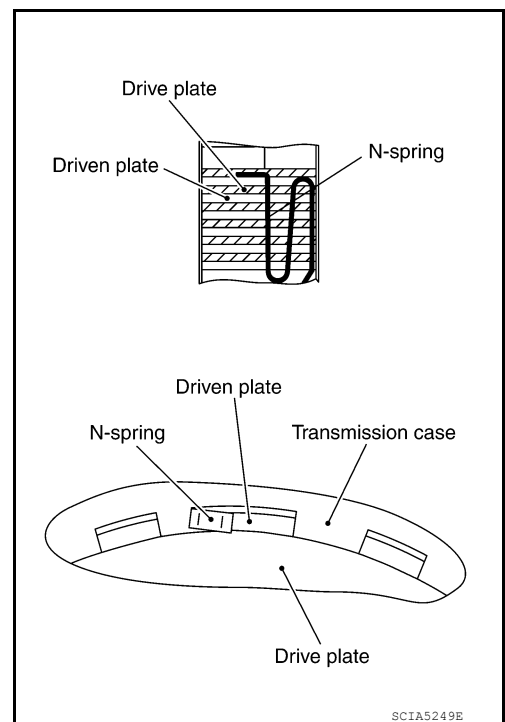

A
B
C
TM
E
F
G
H
I
J
K
L
M
N
O
P

ASSEMBLY

< UNIT DISASSEMBLY AND ASSEMBLY >

[5AT: RE5R05A]

21. Install snap ring in transmission case.

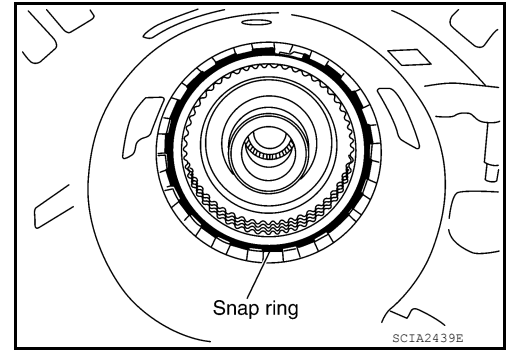

22. Measure clearance (A) between retaining plate and snap ring. If not within specified clearance, select proper retaining plate.

Clearance "A" : 0.7 - 1.1mm (0.028 - 0.043 in)
Retaining plate : Refer to [TM-386, "Reverse brake"](#).

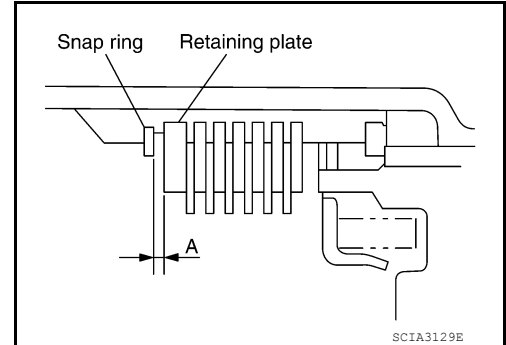

23. Install needle bearing to transmission case.

CAUTION:

- Take care with the direction of needle bearing. Refer to [TM-320, "Location of Adjusting Shims, Needle Bearings, Thrust Washers and Snap Rings"](#).
- Apply petroleum jelly to needle bearing.

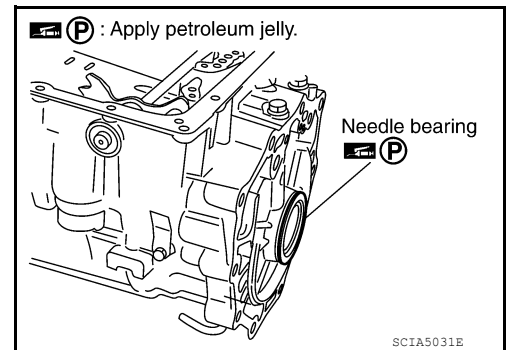

24. Install output speed sensor (1) to transmission case and tighten bolt to specified torque.

← : Bolt

Output speed sensor bolt : 5.8 N·m (0.59 kg-m, 51 in-lb)

CAUTION:

- Do not subject sensor to impact by dropping or hitting it.
- Do not disassemble sensor.
- Do not allow metal filings or any foreign material to get on the sensor's front edge magnetic area.
- Do not place sensor in an area affected by magnetism.

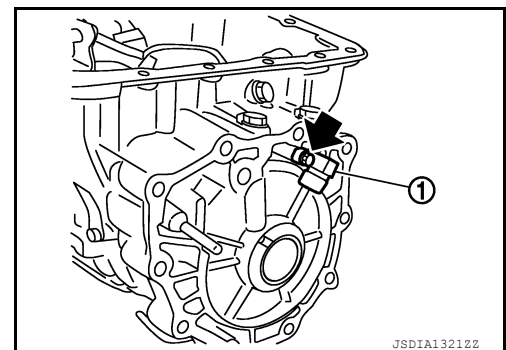

ASSEMBLY

< UNIT DISASSEMBLY AND ASSEMBLY >

[5AT: RE5R05A]

25. Install new rear oil seal until it is flush into the rear extension case (2WD models) using Tool or adapter case (4WD models) using suitable tool.

Tool number : ST33400001 (J-26082)

CAUTION:

- Apply ATF to rear oil seal.
- Do not reuse rear oil seal.

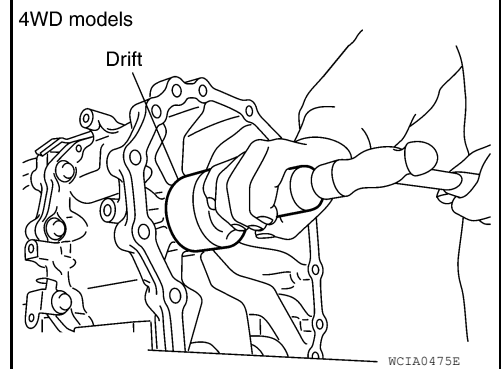
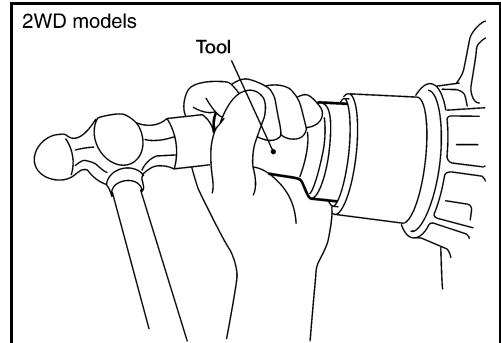

26. Install return spring (1) to parking pawl (2).

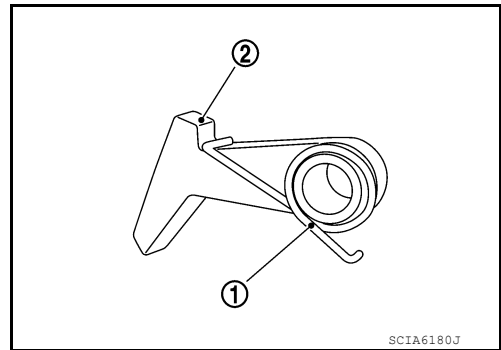

27. Install parking pawl (with return spring) and pawl shaft to rear extension (2WD models) or adapter case (4WD models).

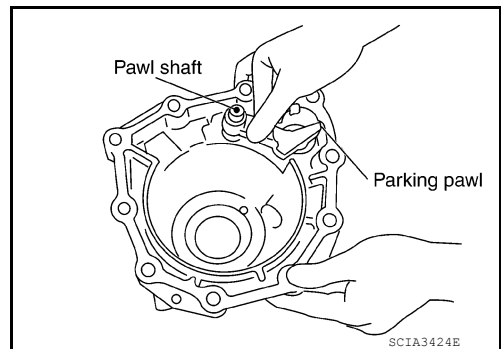

28. Install parking actuator support to rear extension (2WD models) or adapter case (4WD models).

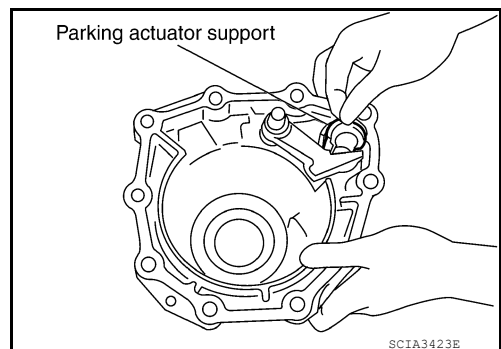

A
B
C
TM
E
F
G
H
I
J
K
L
M
N
O
P

ASSEMBLY

< UNIT DISASSEMBLY AND ASSEMBLY >

[5AT: RE5R05A]

29. Install needle bearing (1) to rear extension (2WD models) or adapter case (4WD models).

CAUTION:

Apply petroleum jelly to needle bearing.

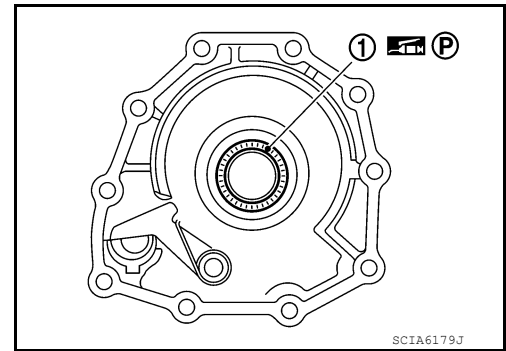

30. Install seal rings to output shaft.

CAUTION:

- Do not reuse seal rings.
- Apply petroleum jelly to seal rings.

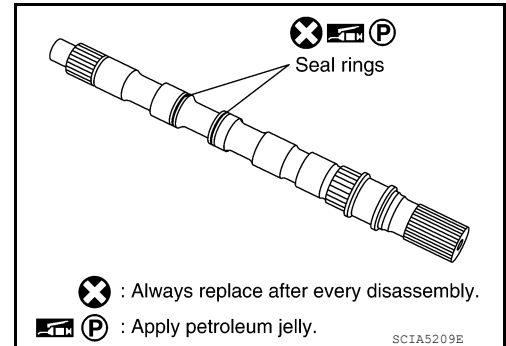

31. Install parking gear to output shaft.

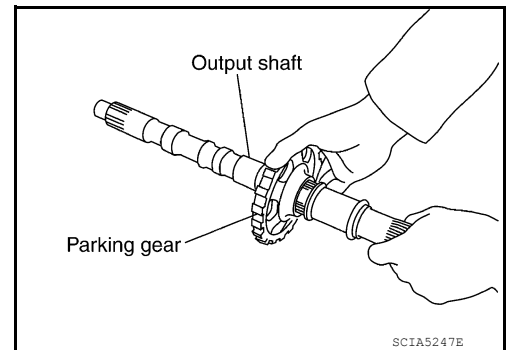

32. Install output shaft in transmission case.

CAUTION:

Do not mistake front of shaft for rear because both sides look similar (thinner end is front side).

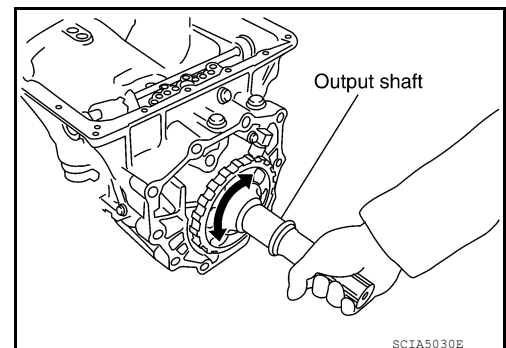

33. Install bearing race to output shaft.

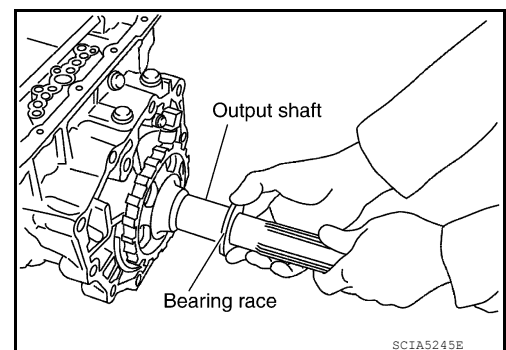

ASSEMBLY

< UNIT DISASSEMBLY AND ASSEMBLY >

[5AT: RE5R05A]

34. Install rear extension assembly (2WD models) or adapter case assembly (4WD models) according to the following procedures.

a. **2WD models**

i. Apply recommended sealant (Genuine Anaerobic Liquid Gasket or equivalent. Refer to [GI-24, "Recommended Chemical Products and Sealants"](#).) to rear extension assembly as shown.

CAUTION:

Completely remove all moisture, oil, old sealant and any foreign material from the transmission case and rear extension assembly mating surfaces.

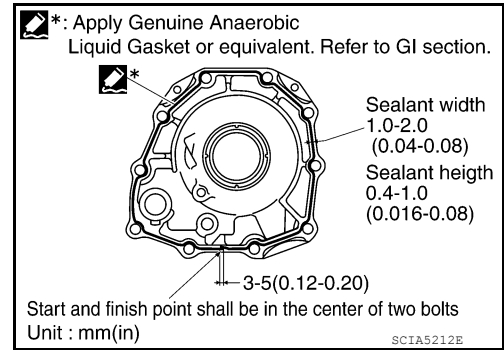

ii. Install rear extension assembly to transmission case.

CAUTION:

Insert the tip of parking rod between the parking pawl and the parking actuator support when assembling the rear extension assembly.

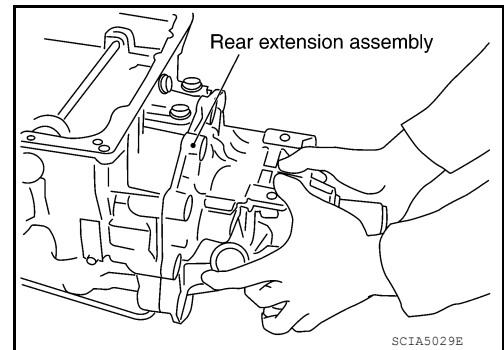

iii. Install the bracket (1), (2) and rear extension assembly bolts and tighten to the specified torque.

- Self sealing bolt (3)
- Bolt (A)

Rear extension assembly bolt : 52 N·m (5.3 kg-m, 38 ft-lb)

Self-sealing bolt : 61 N·m (6.2 kg-m, 45 ft-lb)

CAUTION:

Do not reuse self-sealing bolt.

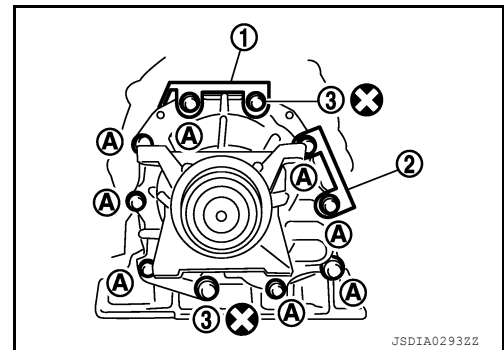

b. **4WD models**

i. Install gasket onto transmission case.

CAUTION:

- Completely remove all moisture, oil, old gasket and any foreign material from the transmission case and adapter case assembly mating surfaces.
- Do not reuse gasket.

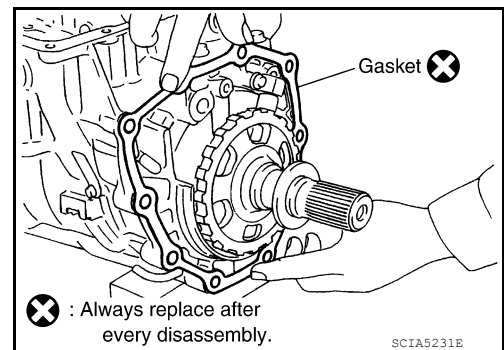

⊗ : Always replace after every disassembly.

A
B
C
TM
E
F
G
H
I
J
K
L
M
N
O
P

ASSEMBLY

< UNIT DISASSEMBLY AND ASSEMBLY >

[5AT: RE5R05A]

- ii. Install adapter case assembly to transmission case.

CAUTION:

Insert the tip of parking rod between the parking pawl and the parking actuator support when assembling the rear extension assembly.

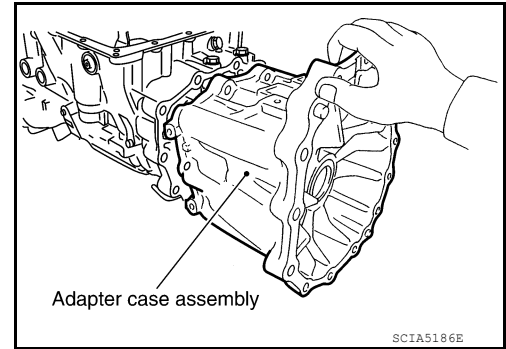

- iii. Tighten adapter case assembly to specified torque.

- 1: ➡
- 2: Brackets
- 3: Self-sealing bolts

CAUTION:

Do not reuse self-sealing bolt (2).

Adapter case : 52 N·m (5.3 kg-m, 38 ft-lb)
assembly bolt

Self-sealing bolt : 61 N·m (6.2 kg-m, 45 ft-lb)

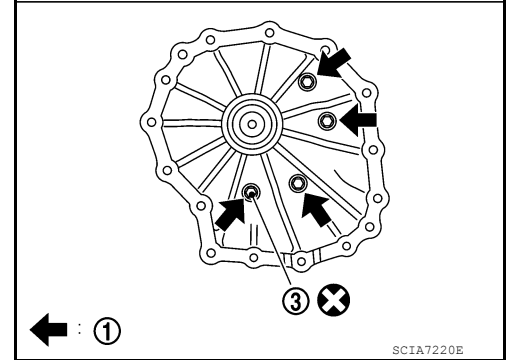
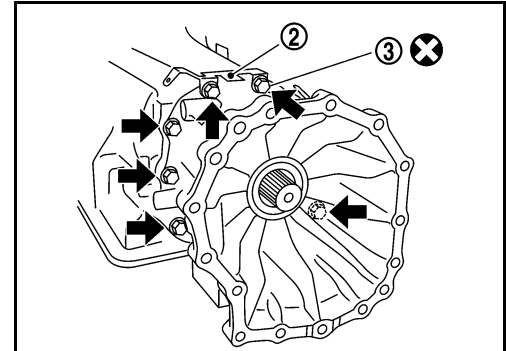

35. Install direct clutch assembly in reverse brake.

CAUTION:

Make sure that drum support edge surface and direct clutch inner boss edge surface come to almost same place.

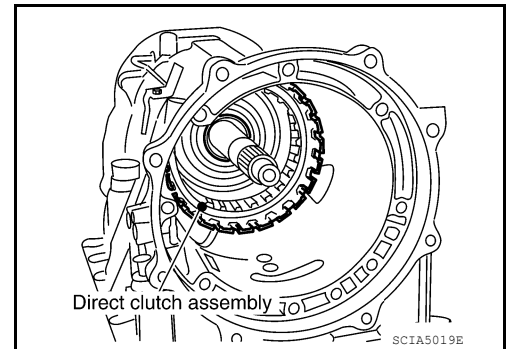

36. Install needle bearing in drum support.

CAUTION:

Apply petroleum jelly to needle bearing.

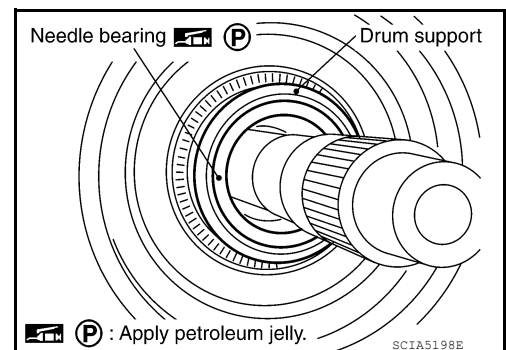

ASSEMBLY

< UNIT DISASSEMBLY AND ASSEMBLY >

[5AT: RE5R05A]

37. Install high and low reverse clutch assembly in direct clutch.

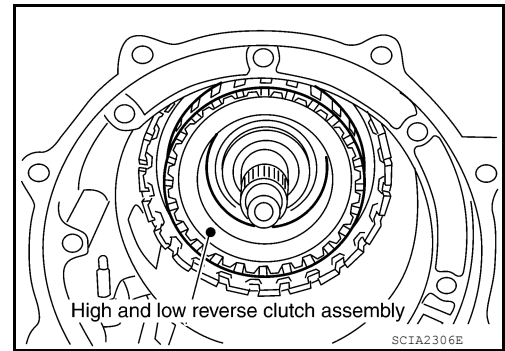

38. Align the drive plate using suitable tool.

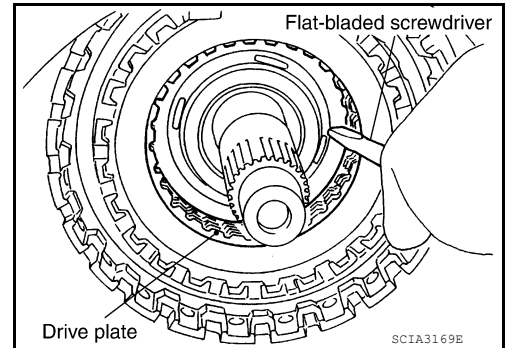

39. Install high and low reverse clutch hub, mid sun gear assembly and rear sun gear assembly as a unit.

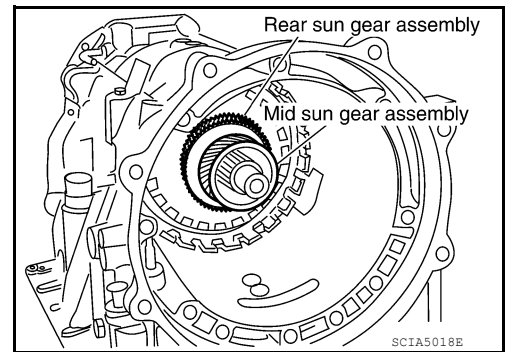

CAUTION:

Make sure that portion "A" of high and low reverse clutch drum protrudes approximately 2 mm (0.08 in) beyond portion "B" of rear sun gear.

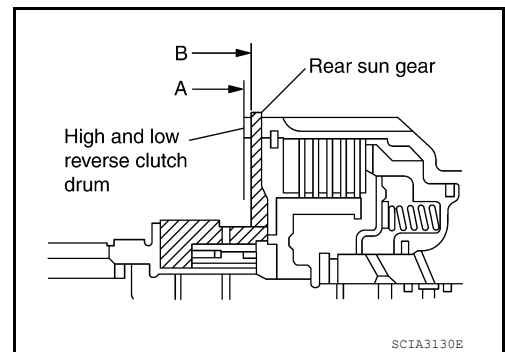

ASSEMBLY

< UNIT DISASSEMBLY AND ASSEMBLY >

[5AT: RE5R05A]

40. Install needle bearing in rear carrier assembly.

CAUTION:

Apply petroleum jelly to needle bearing.

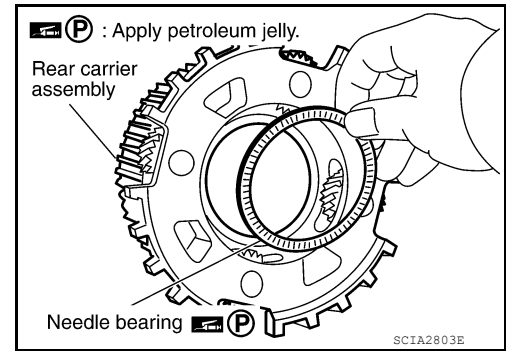

41. Install bearing race in rear carrier assembly.

CAUTION:

Apply petroleum jelly to bearing race.

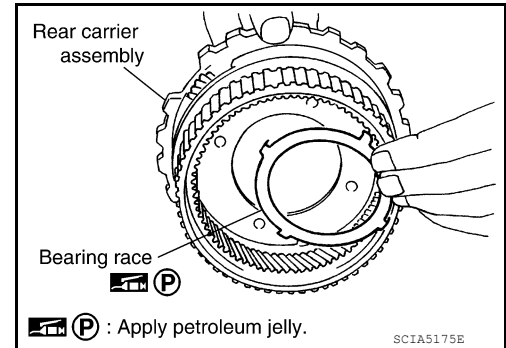

42. Install rear carrier assembly in direct clutch drum.

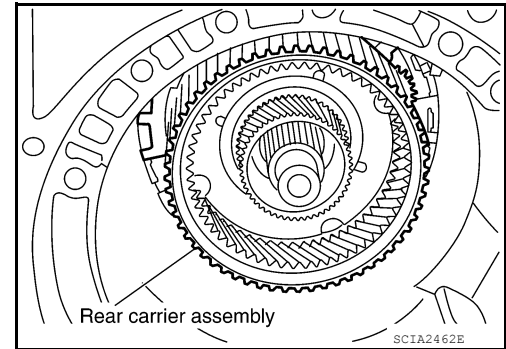

43. Install needle bearing (rear side) to mid carrier assembly.

CAUTION:

Apply petroleum jelly to needle bearing.

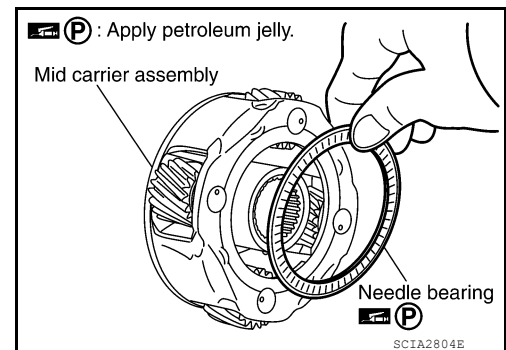

44. Install needle bearing (front side) to mid carrier assembly.

CAUTION:

Apply petroleum jelly to needle bearing.

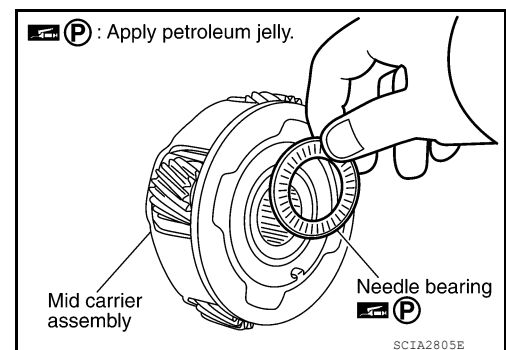

ASSEMBLY

< UNIT DISASSEMBLY AND ASSEMBLY >

[5AT: RE5R05A]

45. Install mid carrier assembly in rear carrier assembly.

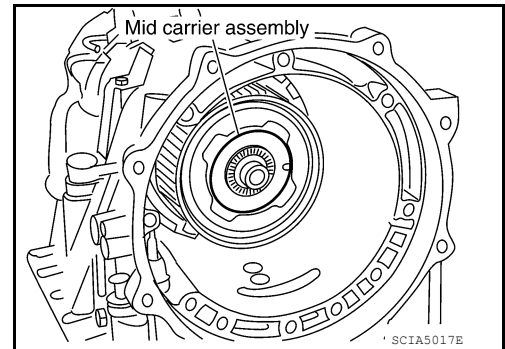

46. Install front carrier assembly, input clutch assembly and rear internal gear as a unit.

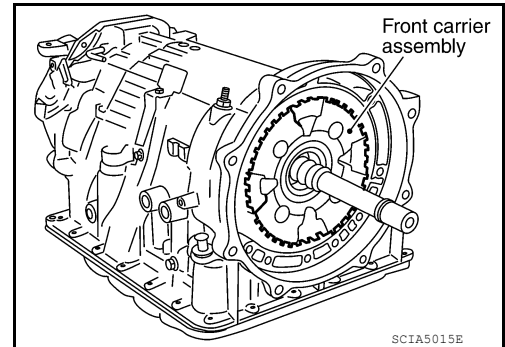

47. Install seal rings in input clutch assembly.

CAUTION:

- Do not reuse seal rings.
- Apply petroleum jelly to seal rings.

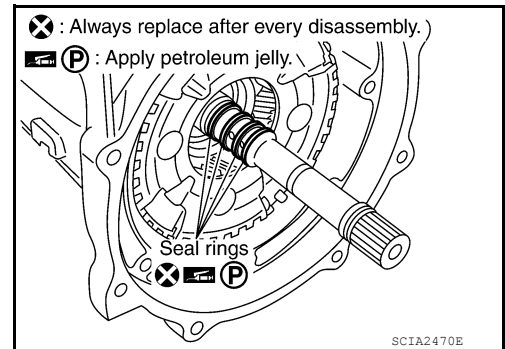

48. Install band servo anchor end pin and lock nut in transmission case.

CAUTION:

Do not reuse band servo anchor end pin.

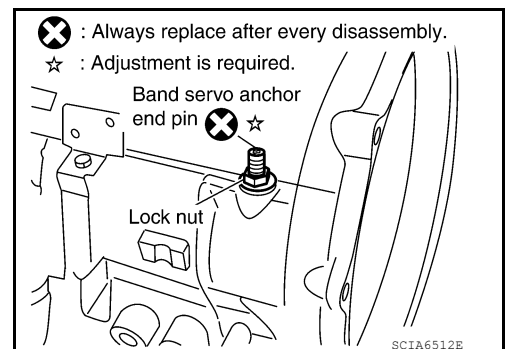

49. Install brake band in transmission case.

CAUTION:

Install it so that the identification to avoid incorrect installation faces the servo side.

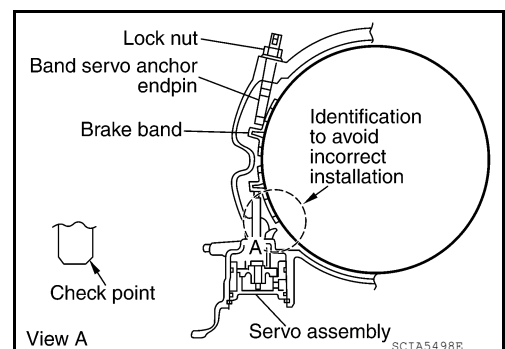

A
B
C
TM
E
F
G
H
I
J
K
L
M
N
O
P

ASSEMBLY

< UNIT DISASSEMBLY AND ASSEMBLY >

[5AT: RE5R05A]

50. Install front sun gear to front carrier assembly.

CAUTION:

Apply ATF to front sun gear bearing and 3rd one-way clutch end bearing.

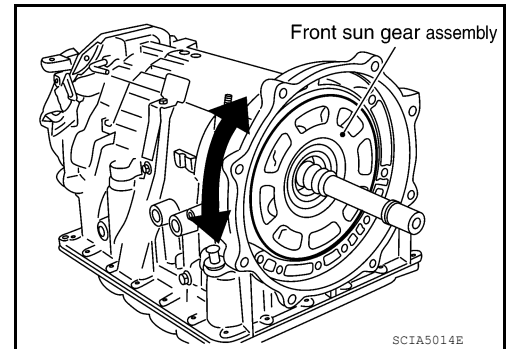

51. Install needle bearing to front sun gear.

CAUTION:

Apply petroleum jelly to needle bearing.

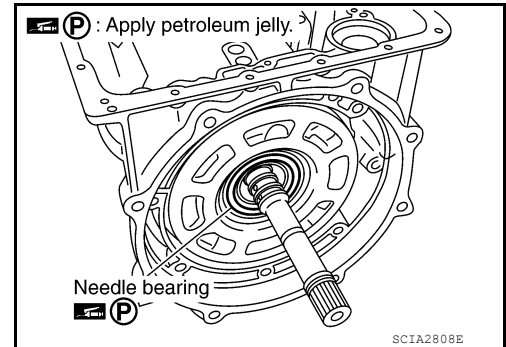

52. Adjust brake band tilting using a clip so that brake band contacts front sun gear drum evenly.

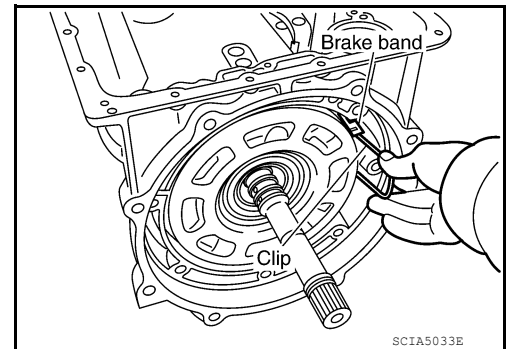

53. Adjust brake band.

- Loosen lock nut.
- Tighten band servo anchor end pin to specified torque.

Anchor end pin : 5.0 N·m (0.51 kg-m, 44 in-lb)

- Back off band servo anchor end pin three turns.
- Holding band servo anchor end pin, tighten lock nut to specified torque.

Lock nut : 46 N·m (4.7 kg-m, 34 ft-lb)

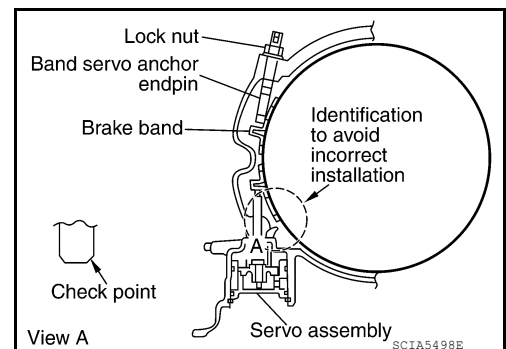

Adjustment

INFOID:000000008791035

TOTAL END PLAY

ASSEMBLY

< UNIT DISASSEMBLY AND ASSEMBLY >

[5AT: RE5R05A]

- Measure clearance between front sun gear and bearing race for oil pump cover.
- Select proper thickness of bearing race so that end play is within specifications.

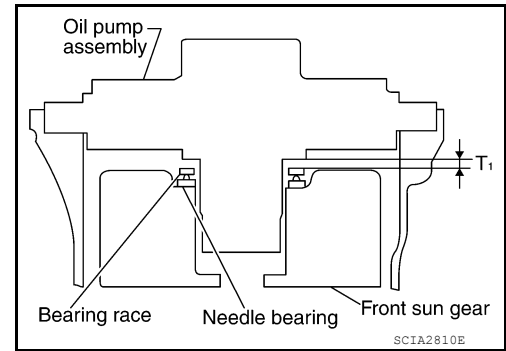

1. Measure dimensions “K” and “L” and then calculate dimension “J”.

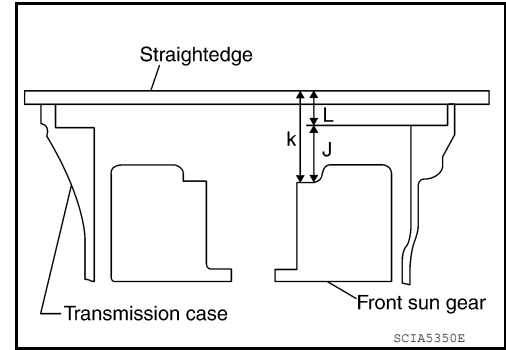

- a. Measure dimension “K”.

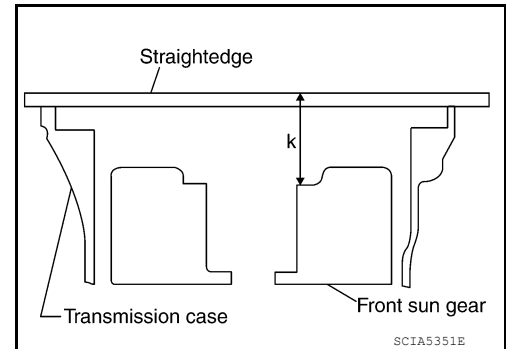

- b. Measure dimension “L”.
- c. Calculate dimension “J”.

“J”: Distance between oil pump fitting surface of transmission case and needle bearing mating surface of front sun gear.

$$J = K - L$$

2. Measure dimensions “M1” and “M2” and then calculate dimension “M”.

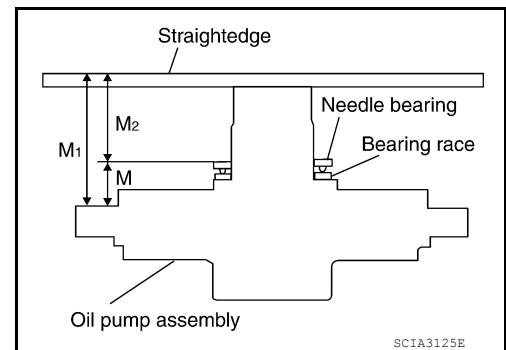
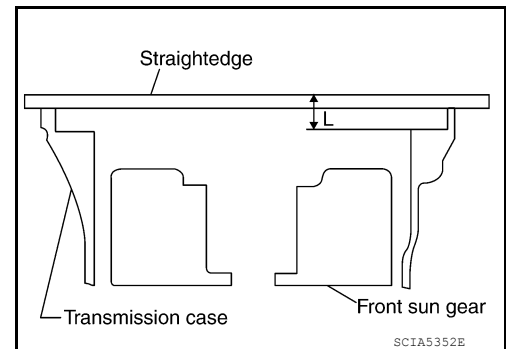

A
B
C
TM
E
F
G
H
I
J
K
L
M
N
O
P

ASSEMBLY

< UNIT DISASSEMBLY AND ASSEMBLY >

[5AT: RE5R05A]

- a. Place bearing race and needle bearing on oil pump assembly.

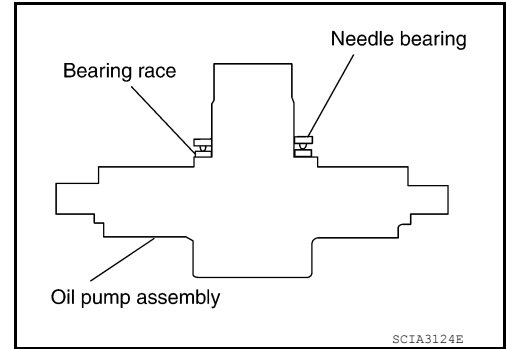

- b. Measure dimension "M1".

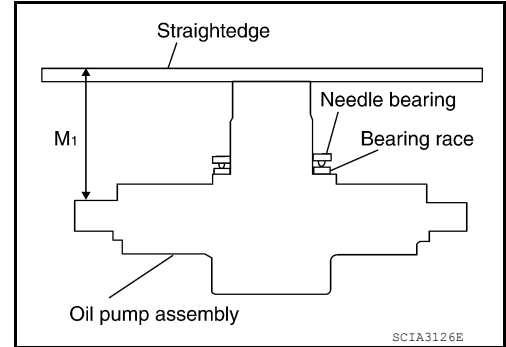

- c. Measure dimension "M2".

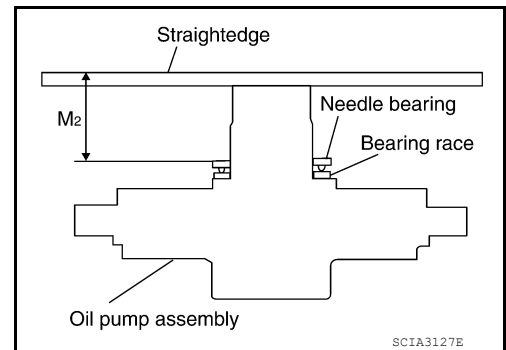

- d. Calculate dimension "M".

"M": Distance between transmission case fitting surface of oil pump and needle bearing on oil pump.

$$M = M_1 - M_2$$

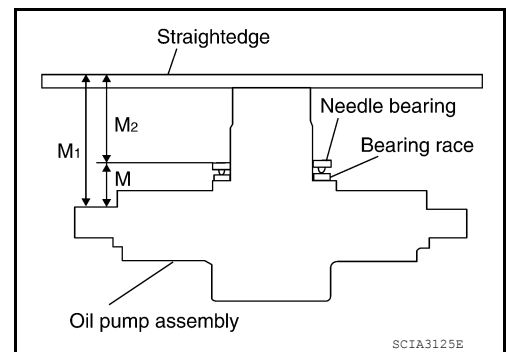

3. Adjust total end play "T1".

$$T_1 = J - M$$

Total end play "T1" : 0.25 - 0.55 mm (0.0098 - 0.0217 in)

- Select proper thickness of bearing race so that total end play is within specifications.

Bearing races :Refer to [TM-386, "Total End Play"](#).

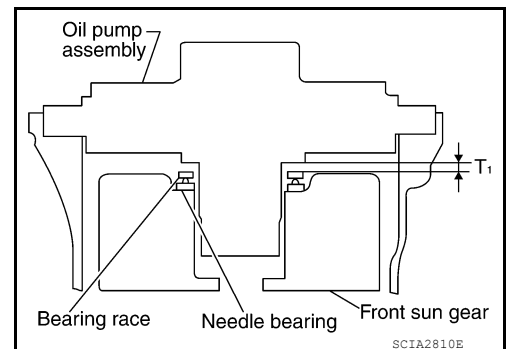

ASSEMBLY

< UNIT DISASSEMBLY AND ASSEMBLY >

[5AT: RE5R05A]

INFOID:000000008791036

Assembly (2)

1. Install O-ring to oil pump assembly.

CAUTION:

- Do not reuse O-ring.
- Apply ATF to O-ring.

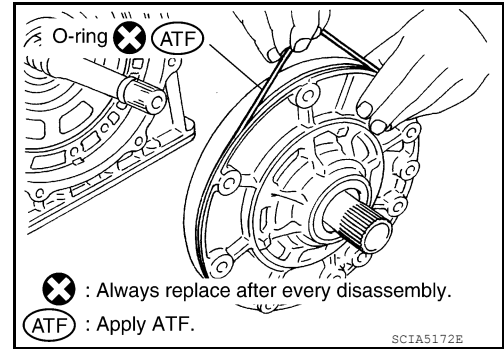

2. Install bearing race to oil pump assembly.

CAUTION:

Apply petroleum jelly to bearing race.

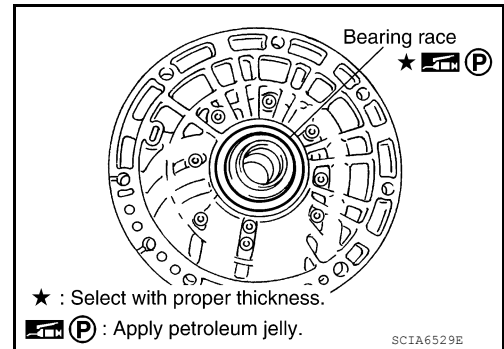

3. Install oil pump assembly in transmission case.

CAUTION:

Apply ATF to oil pump bearing.

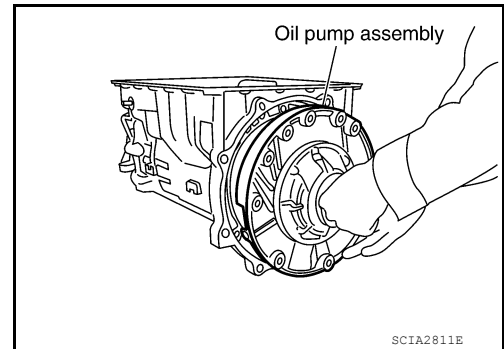

4. Apply recommended sealant (Genuine RTV Silicone Sealant or equivalent. Refer to [GI-24. "Recommended Chemical Products and Sealants"](#).) to oil pump assembly as shown.

CAUTION:

Completely remove all moisture, oil, old sealant and any foreign material from the oil pump bolts and oil pump bolt mating surfaces.

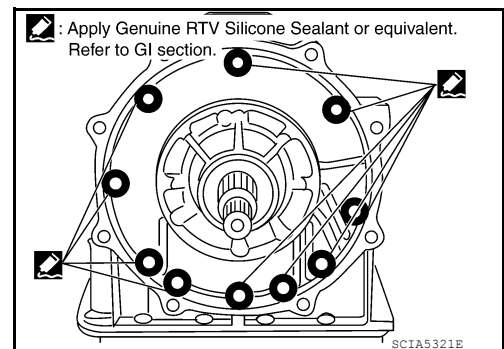

A
B
C
TM
E
F
G
H
I
J
K
L
M
N
O
P

ASSEMBLY

< UNIT DISASSEMBLY AND ASSEMBLY >

[5AT: RE5R05A]

5. Tighten oil pump bolts to specified torque.

Oil pump bolts : 48 N·m (4.9 kg-m, 35 ft-lb)

CAUTION:
Apply ATF to oil pump bushing.

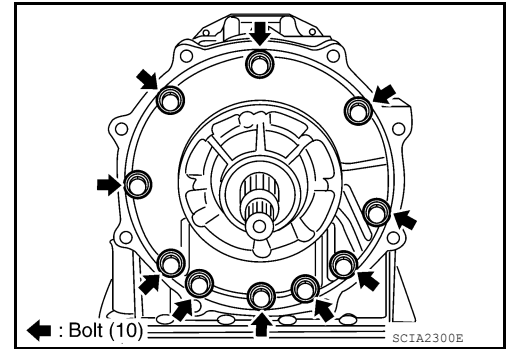

6. Install O-ring to input clutch assembly.

CAUTION:
• Do not reuse O-ring.
• Apply ATF to O-ring.

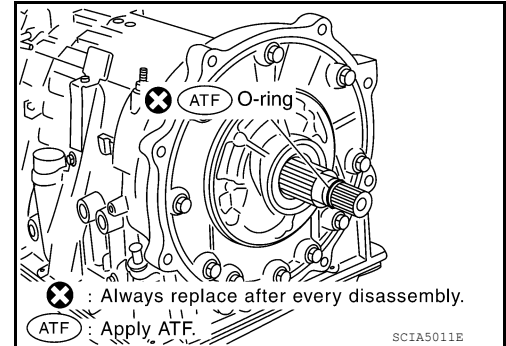

7. Install converter housing to transmission case and tighten bolts to specified torque.

Converter housing bolt : 52 N·m (5.3 kg-m, 38 ft-lb)

Self-sealing bolt (A) : 61 N·m (6.2 kg-m, 45 ft-lb)

CAUTION:
Do not reuse self-sealing bolt (A).

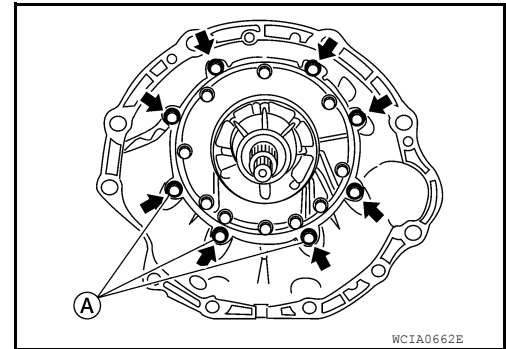

8. Make sure that brake band (1) does not close input speed sensor hole (A).

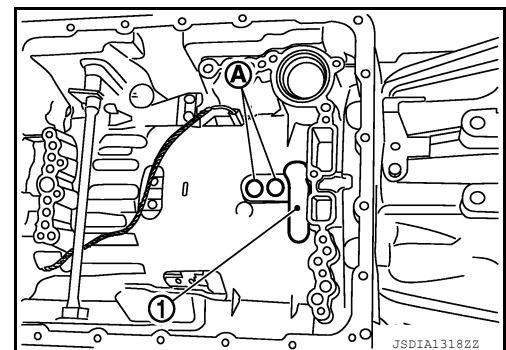

9. Connect TCM connector (1) and transmission range switch connector (2).

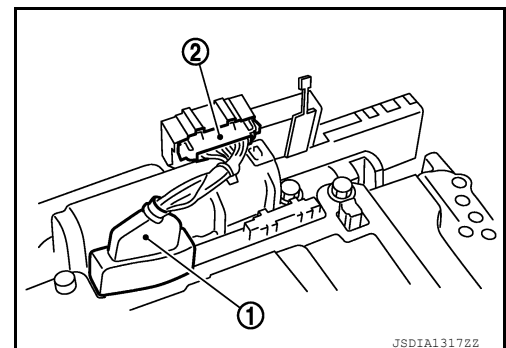

ASSEMBLY

< UNIT DISASSEMBLY AND ASSEMBLY >

[5AT: RE5R05A]

10. Install A/T assembly harness connector to control valve with TCM.

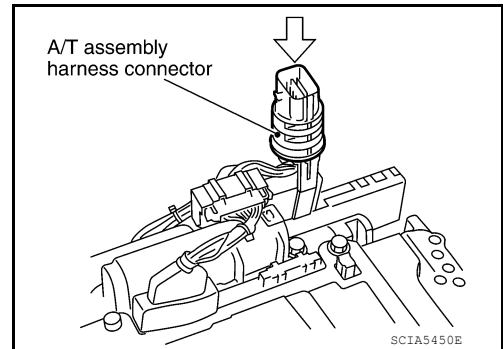

11. Connect TCM connectors.

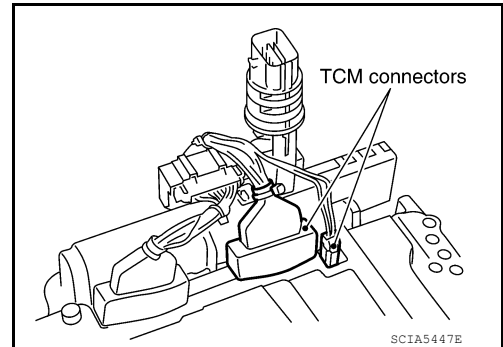

12. Install O-ring to A/T assembly harness connector.

CAUTION:

- Do not reuse O-ring.
- Apply ATF to O-ring.

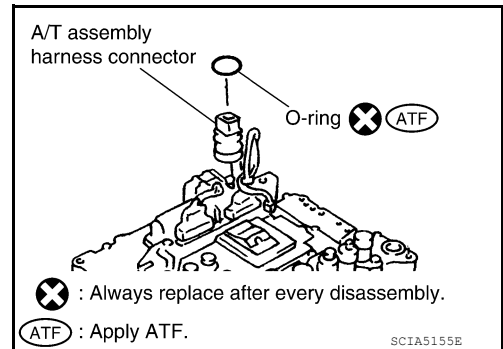

13. Install new O-ring (1) in plug (2).

CAUTION:

- Do not reuse O-ring.
- Apply ATF to O-ring.
- O-ring should be free of contamination.

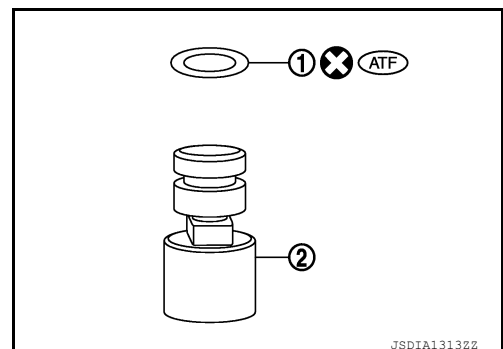

14. Install plug (2) to bracket (1).

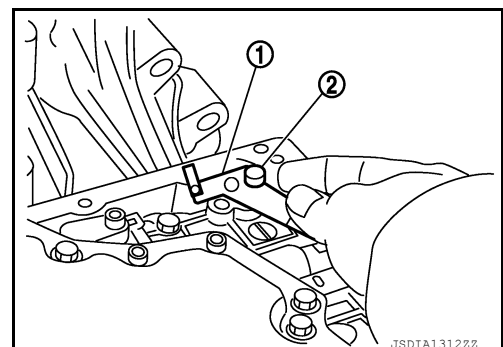

A
B
C
TM
E
F
G
H
I
J
K
L
M
N
O
P

ASSEMBLY

< UNIT DISASSEMBLY AND ASSEMBLY >

[5AT: RE5R05A]

15. Install plug (1) [with bracket (2)] to control valve with TCM and tighten bolt (←) to specified torque.

Bracket bolt : 7.9 N·m (0.81 kg-m, 70 in-lb)

CAUTION:
Adjust bolt hole of bracket to bolt hole of control valve.

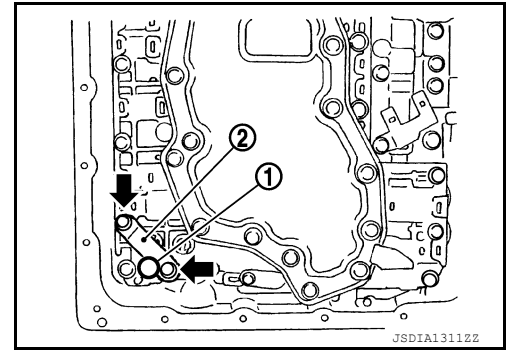

16. Install control valve with TCM in transmission case.

1 : Brake band

CAUTION:

- Make sure that input speed sensor is securely installed into input speed sensor hole (A).
- Hang down output speed sensor harness toward outside so as not to disturb installation of control valve with TCM.
- Adjust A/T assembly harness connector of control valve with TCM to terminal hole of transmission case.

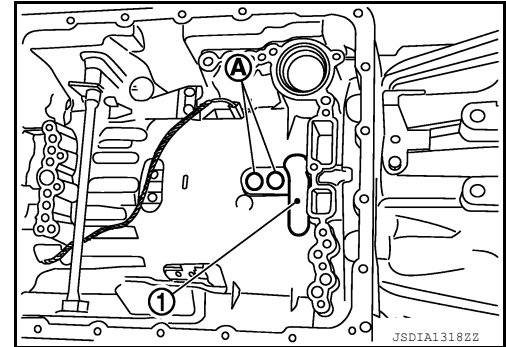

- Assemble it so that manual valve cutout is engaged with manual plate projection.

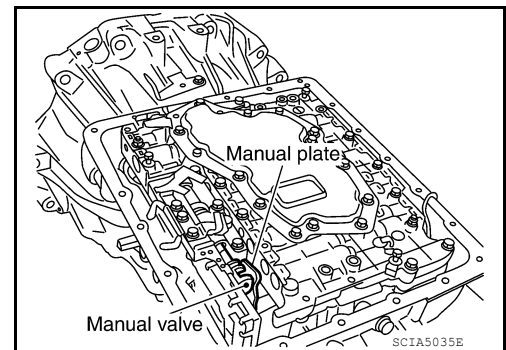

17. Install bolts (A), (B) and (C) to control valve with TCM.

← : Front

Bolt symbol	Length mm (in)	Number of bolts
A	42 (1.65)	5
B	55 (2.17)	6
C	40 (1.57)	1

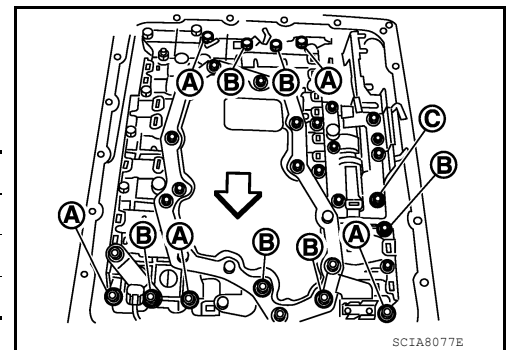

18. Tighten bolt (A), (B) and (C) temporarily to prevent dislocation. After that tighten them in order (A → B → C), and then tighten other bolts.

← : Front

Bolt symbol	A	B	C
Number of bolts	5	6	1
Length mm (in)	42 (1.65)	55 (2.17)	40 (1.57)

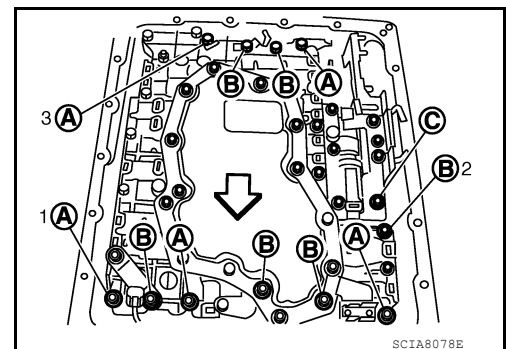

ASSEMBLY

< UNIT DISASSEMBLY AND ASSEMBLY >

[5AT: RE5R05A]

Tightening torque N·m (km-g, in-lb)	7.9 (0.81, 70)	With ATF applied
		7.9 (0.81, 70)

19. Connect output speed sensor connector (1).

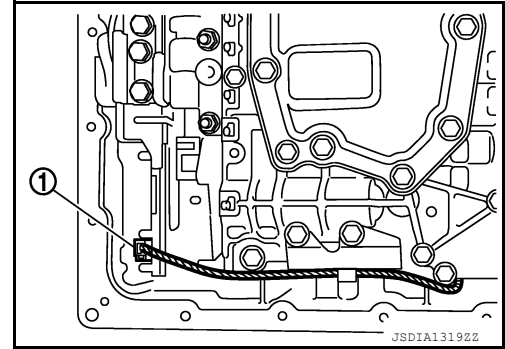

20. Securely fasten output speed sensor harness with terminal clip (←).

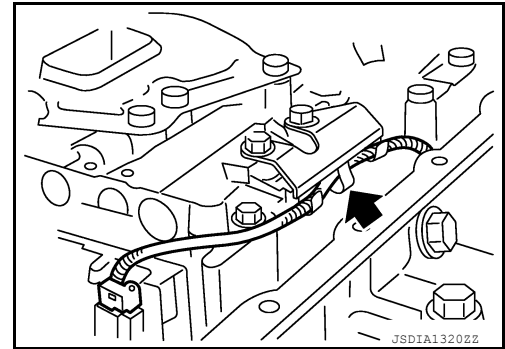

21. Pull down A/T assembly harness connector.

CAUTION:
Do not damage connector.

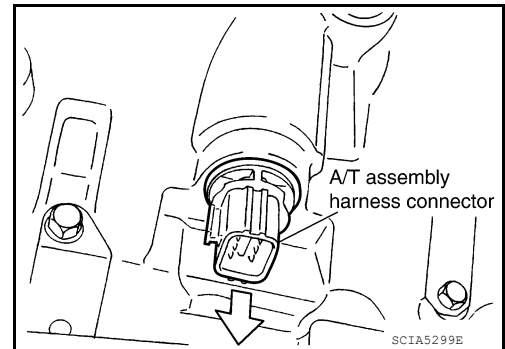

22. Install snap ring to A/T assembly harness connector.

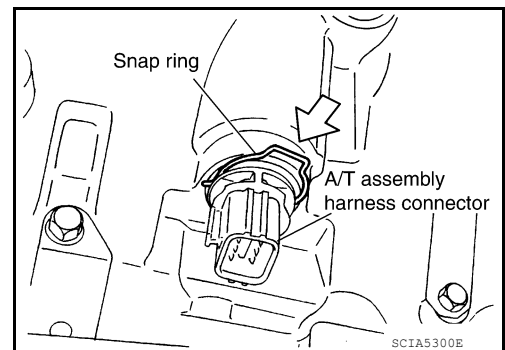

A
B
C
TM
E
F
G
H
I
J
K
L
M
N
O
P

ASSEMBLY

< UNIT DISASSEMBLY AND ASSEMBLY >

[5AT: RE5R05A]

23. Install magnets in oil pan.

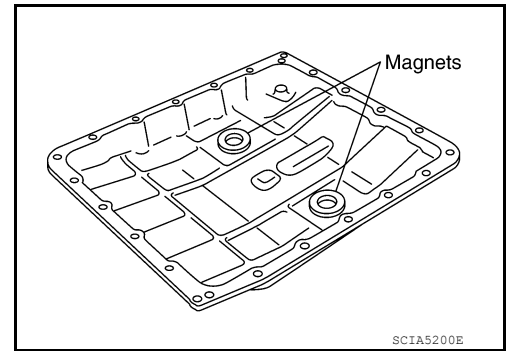

24. Install oil pan to transmission case. Refer to [TM-284. "Removal and Installation"](#).

25. Install torque converter.

a. Pour ATF into torque converter.

NOTE:

- Approximately 2 liters (2-1/8 US qt. 1-3/4 Imp qt) of fluid is required for a new torque converter.
- When reusing old torque converter, add the same amount of fluid as was drained.

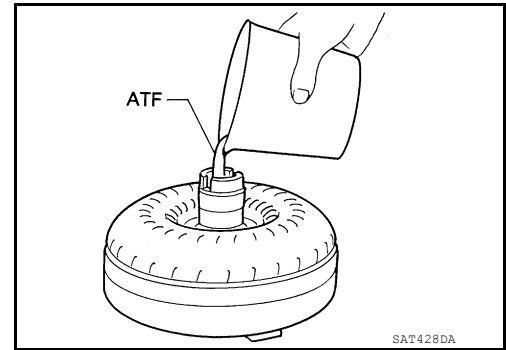

b. Install torque converter while aligning notches of torque converter with notches of oil pump.

CAUTION:

Install torque converter while rotating it.

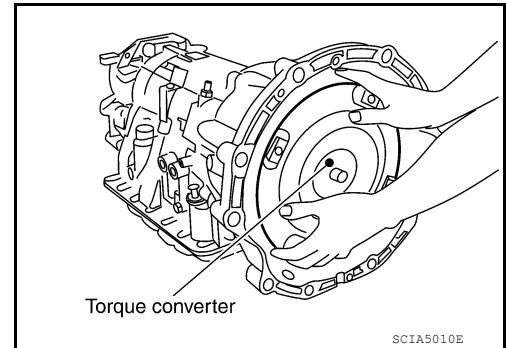

c. Measure distance "A" to make sure that torque converter is in proper position.

Distance "A" : 25.0 mm (0.98 in) or more

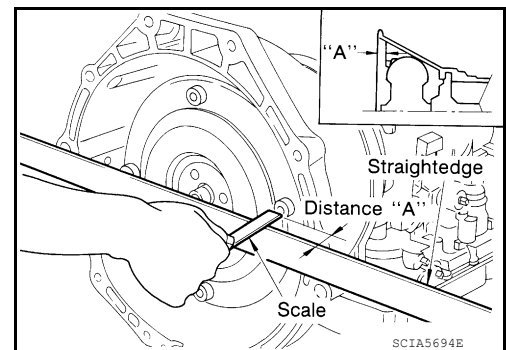

SERVICE DATA AND SPECIFICATIONS (SDS)

< SERVICE DATA AND SPECIFICATIONS (SDS)

[5AT: RE5R05A]

SERVICE DATA AND SPECIFICATIONS (SDS)

SERVICE DATA AND SPECIFICATIONS (SDS)

General Specification

INFOID:000000008791037

Applied model		QR25DE	VQ40DE	
		2WD		4WD
Automatic transmission model		RE5R05A		
Transmission model code number		3GX4D	3GX4C	3GX4B
Stall torque ratio		1.84 : 1	1.76 : 1	
Transmission gear ratio	1st	3.842		
	2nd	2.353		
	3rd	1.529		
	4th	1.000		
	5th	0.839		
	Reverse	2.765		
Recommended fluid		Genuine NISSAN Matic S ATF*1		
Fluid capacity		10.3 liter (10-7/8 US qt, 9-1/8 Imp qt)		

CAUTION:

If Genuine NISSAN Matic S ATF is not available, Genuine NISSAN Matic J ATF may also be used, Using automatic transmission fluid other than Genuine NISSAN Matic S ATF or Matic J ATF will cause deterioration in driveability and automatic transmission durability, and may damage automatic transmission, which is not covered by the NISSAN new vehicle limited warranty.

*1: Refer to [MA-17, "FOR USA AND CANADA : Fluids and Lubricants"](#) (United States and Canada) and [MA-19, "FOR MEXICO : Fluids and Lubricants"](#) (Mexico).

Vehicle Speed at Which Gear Shifting Occurs

INFOID:000000008791038

QR25DE MODELS

Throttle position	Vehicle speed km/h (MPH)							
	D1→D2	D2→D3	D3→D4	D4→D5	D5→D4	D4→D3	D3→D2	D2→D1
Full throttle	49 - 53 (30 - 33)	80 - 88 (50 - 55)	125-135 (78 - 84)	194 - 204 (121 - 127)	190 - 200 (118 - 124)	115 - 125 (72 - 77)	69 - 77 (43 - 48)	32 - 36 (20 - 23)
Half throttle	36 - 40 (23 - 25)	59 - 65 (37 - 44)	91 - 99 (57 - 62)	127 - 135 (79 - 83)	99 - 107 (62 - 66)	63 - 71 (39 - 44)	44 - 50 (27 - 30)	11 - 15 (7 - 9)

• At half throttle, the accelerator opening is 1/2 of the full opening.

VQ40DE MODELS FOR 2WD

Final gear ratio	Tire size	Throttle position	Vehicle speed km/h (MPH)							
			D1→D2	D2→D3	D3→D4	D4→D5	D5→D4	D4→D3	D3→D2	D2→D1
2.937	P265/70R16	Full throttle	68 - 72 (43 - 44)	109 - 117 (68 - 72)	169 - 179 (106 - 111)	249 - 259 (156 - 162)	245 - 255 (153 - 158)	157 - 167 (98 - 103)	95 - 103 (60 - 64)	43 - 47 (27 - 29)
		Half throttle	54 - 58 (34 - 36)	88 - 94 (55 - 58)	137 - 145 (86 - 90)	165 - 175 (103 - 108)	137 - 145 (86 - 90)	77 - 85 (48 - 52)	54 - 60 (34 - 38)	11 - 15 (7 - 9)

SERVICE DATA AND SPECIFICATIONS (SDS)

< SERVICE DATA AND SPECIFICATIONS (SDS)

[5AT: RE5R05A]

3.133	P265/75R16	Full throttle	68 - 72 (43 - 44)	109 - 117 (68 - 72)	169 - 179 (106 - 111)	249 - 259 (156 - 162)	245 - 255 (153 - 158)	157 - 167 (98 - 103)	95 - 103 (60 - 64)	43 - 47 (27 - 29)
		Half throttle	54 - 58 (34 - 36)	88 - 94 (55 - 58)	137 - 145 (86 - 90)	165 - 175 (103 - 108)	137 - 145 (86 - 90)	77 - 85 (48 - 52)	54 - 60 (34 - 38)	11 - 15 (7 - 9)
	P265/70R16 P265/60R18	Full throttle	62 - 66 (39 - 41)	100 - 108 (63 - 67)	156 - 166 (97 - 103)	241 - 251 (150 - 155)	237 - 247 (148 - 153)	145 - 155 (91 - 96)	88 - 96 (55 - 59)	42 - 46 (27 - 28)
		Half throttle	50 - 54 (32 - 33)	82 - 88 (51 - 54)	126 - 134 (79 - 83)	155 - 163 (97 - 101)	126 - 134 (79 - 83)	71 - 79 (45 - 49)	50 - 56 (32 - 34)	11 - 15 (7 - 9)

- At half throttle, the accelerator opening is 1/2 of the full opening.

VQ40DE MODELS FOR 4WD

Final gear ratio	Tire size	Throttle position	Vehicle speed km/h (MPH)							
			D1→D2	D2→D3	D3→D4	D4→D5	D5→D4	D4→D3	D3→D2	D2→D1
3.133	P265/70R16	Full throttle	62 - 66 (39 - 41)	100 - 108 (63 - 67)	156 - 166 (97 - 103)	241 - 251 (150 - 155)	237 - 247 (148 - 153)	145 - 155 (91 - 96)	88 - 96 (55 - 59)	42 - 46 (27 - 28)
		Half throttle	50 - 54 (32 - 33)	82 - 88 (51 - 54)	126 - 134 (79 - 83)	155 - 163 (97 - 101)	126 - 134 (79 - 83)	71 - 79 (45 - 49)	50 - 56 (32 - 34)	11 - 15 (7 - 9)
3.357	P265/75R16	Full throttle	62 - 66 (39 - 41)	100 - 108 (63 - 67)	156 - 166 (97 - 103)	241 - 251 (150 - 155)	237 - 247 (148 - 153)	145 - 155 (91 - 96)	88 - 96 (55 - 59)	42 - 46 (27 - 28)
		Half throttle	50 - 54 (32 - 33)	82 - 88 (51 - 54)	126 - 134 (79 - 83)	155 - 163 (97 - 101)	126 - 134 (79 - 83)	71 - 79 (45 - 49)	50 - 56 (32 - 34)	11 - 15 (7 - 9)
	P265/70R16 P265/60R18	Full throttle	59 - 63 (37 - 39)	95 - 103 (59 - 64)	147 - 157 (92 - 98)	228 - 238 (143 - 149)	224 - 234 (140 - 146)	137 - 147 (86 - 92)	83 - 91 (52 - 57)	40 - 44 (25 - 27)
		Half throttle	47 - 51 (30 - 31)	77 - 83 (48 - 51)	119 - 127 (74 - 78)	147 - 155 (92 - 96)	119 - 127 (74 - 78)	67 - 75 (42 - 46)	48 - 54 (30 - 33)	11 - 15 (7 - 9)

- At half throttle, the accelerator opening is 1/2 of the full opening.

Vehicle Speed at Which Lock-up Occurs/Releases

INFOID:000000008791039

QR25DE MODELS

Tire size	Throttle position	Vehicle speed km/h (MPH)	
		Lock-up "ON"	Lock-up "OFF"
P 235/75R15	Closed throttle	76 - 84 (47 - 52)	73 - 81 (45 - 50)
	Half throttle	161 - 169 (100 - 105)	127 - 135 (80 - 84)
P265/70R16	Closed throttle	56 - 64 (35 - 40)	50 - 58 (31 - 36)
	Half throttle	161 - 169 (100 - 105)	99 - 107 (62 - 66)

- At closed throttle, the accelerator opening is less than 1/8 condition. (Closed throttle position signal: OFF)
- At half throttle, the accelerator opening is 1/2 of the full opening.

VQ40DE MODELS FOR 2WD

Final gear ratio	Tire size	Throttle position	Vehicle speed km/h (MPH)	
			Lock-up "ON"	Lock-up "OFF"
2.937	P265/70R16	Closed throttle	57 - 65 (36 - 40)	53 - 61 (33 - 37)
		Half throttle	182 - 190 (114 - 118)	137 - 145 (86 - 90)

SERVICE DATA AND SPECIFICATIONS (SDS)

< SERVICE DATA AND SPECIFICATIONS (SDS)

[5AT: RE5R05A]

Final gear ratio	Tire size	Throttle position	Vehicle speed km/h (MPH)	
			Lock-up "ON"	Lock-up "OFF"
3.133	P265/75R16	Closed throttle	57 - 65 (36 - 40)	53 - 61 (33 - 37)
		Half throttle	182 - 190 (114 - 118)	137 - 145 (86 - 90)
	P265/70R16 P265/60R18	Closed throttle	52 - 60 (33 - 37)	49 - 57 (31 - 35)
		Half throttle	172 - 180 (107 - 111)	126 - 134 (79 - 83)

- At closed throttle, the accelerator opening is less than 1/8 condition. (Closed throttle position signal: OFF)
- At half throttle, the accelerator opening is 1/2 of the full opening.

VQ40DE MODELS FOR 4WD

Final gear ratio	Tire size	Throttle position	Vehicle speed km/h (MPH)	
			Lock-up "ON"	Lock-up "OFF"
3.133	P265/70R16	Closed throttle	52 - 60 (33 - 37)	49 - 57 (31 - 35)
		Half throttle	172 - 180 (107 - 111)	126 - 134 (79 - 83)
3.357	P265/75R16	Closed throttle	52 - 60 (33 - 37)	49 - 57 (31 - 35)
		Half throttle	172 - 180 (107 - 111)	126 - 134 (79 - 83)
	P265/70R16 P265/60R18	Closed throttle	49 - 57 (31 - 35)	46 - 54 (29 - 33)
		Half throttle	163 - 171 (102 - 106)	119 - 127 (74 - 78)

- At closed throttle, the accelerator opening is less than 1/8 condition. (Closed throttle position signal: OFF)
- At half throttle, the accelerator opening is 1/2 of the full opening.

Stall Speed

INFOID:000000008791040

Engine model	QR25DE	VQ40DE
Stall speed	2,350 - 2,650 rpm	2,600 - 2,900 rpm

Line Pressure

INFOID:000000008791041

Engine speed	Line pressure [kPa (kg/cm ² , psi)]	
	"R" position	"D" position
At idle speed	425 - 465 (4.3 - 4.7, 62 - 67)	379 - 428 (3.9 - 4.4, 55 - 62)
At stall speed	1,605 - 1,950 (16.4 - 19.9, 233 - 283)	1,310 - 1,500 (13.4 - 15.3, 190 - 218)

A/T Fluid Temperature Sensor

INFOID:000000008791042

Name	Condition	CONSULT "DATA MONITOR" (Approx.) (V)	Resistance (Approx.) (kΩ)
A/T fluid temperature sensor 1	0°C (32°F)	3.3	15
	20°C (68°F)	2.7	6.5
	80°C (176°F)	0.9	0.9

SERVICE DATA AND SPECIFICATIONS (SDS)

< SERVICE DATA AND SPECIFICATIONS (SDS)

[5AT: RE5R05A]

Input Speed Sensor

INFOID:000000008791043

Name	Condition	Data (Approx.)
Input speed sensor 1	When running at 50 km/h (31 MPH) in 4th speed with the closed throttle position switch "OFF".	1.3 (kHz)
Input speed sensor 2	When moving at 20 km/h (12 MPH) in 1st speed with the closed throttle position switch "OFF".	

Output Speed Sensor

INFOID:000000008791044

Name	Condition	Data (Approx.)
Output speed sensor	When moving at 20 km/h (12 MPH).	185 (Hz)

Reverse brake

INFOID:000000008791045

QR25DE

Number of drive plates	5	
Number of driven plates	6 (5+1)	
Clearance [mm (in)]	Standard	0.7 - 1.1 (0.028 - 0.043)
Thickness of retaining plates	Thickness mm (in)	Part number*
	4.2 (0.165)	31667 90X14
	4.4 (0.173)	31667 90X15
	4.6 (0.181)	31667 90X16
	4.8 (0.189)	31667 90X17
	5.0 (0.197)	31667 90X18
5.2 (0.205)	31667 90X19	

*: Always check with the Parts Department for the latest parts information.

VQ40DE

Number of drive plates	6	
Number of driven plates	6	
Clearance [mm (in)]	Standard	0.7 - 1.1 (0.028 - 0.043)
Thickness of retaining plates	Thickness mm (in)	Part number*
	4.2 (0.165)	31667 90X14
	4.4 (0.173)	31667 90X15
	4.6 (0.181)	31667 90X16
	4.8 (0.189)	31667 90X17
	5.0 (0.197)	31667 90X18
5.2 (0.205)	31667 90X19	

*: Always check with the Parts Department for the latest parts information.

Total End Play

INFOID:000000008791046

Total end play mm (in)	0.25 - 0.55 (0.0098 - 0.0217)
------------------------	-------------------------------

BEARING RACE FOR ADJUSTING TOTAL END PLAY

SERVICE DATA AND SPECIFICATIONS (SDS)

< SERVICE DATA AND SPECIFICATIONS (SDS)

[5AT: RE5R05A]

Thickness mm (in)	Part number*
0.8 (0.031)	31435 95X00
1.0 (0.039)	31435 95X01
1.2 (0.047)	31435 95X02
1.4 (0.055)	31435 95X03
1.6 (0.063)	31435 95X04
1.8 (0.071)	31435 95X05

*: Always check with the Parts Department for the latest parts information.

A
B
C
E
F
G
H
I
J
K
L
M
N
O
P

TM