

SECTION **PB**
PARKING BRAKE SYSTEM

A
B
C
D
E
PB
G
H
I
J
K
L
M
N
O
P

CONTENTS

PRECAUTION	2	UNIT REMOVAL AND INSTALLATION	5
PRECAUTIONS	2	PARKING BRAKE CONTROL	5
Precaution for Supplemental Restraint System (SRS) "AIR BAG" and "SEAT BELT PRE-TEN- SIONER"	2	Component	5
PREPARATION	3	Removal and Installation	6
PREPARATION	3	PARKING BRAKE SHOE	7
Commercial Service Tool	3	Component	7
REMOVAL AND INSTALLATION	4	Removal and Installation	7
PARKING BRAKE SYSTEM	4	SERVICE DATA AND SPECIFICATIONS (SDS)	10
On-Vehicle Service	4	SERVICE DATA AND SPECIFICATIONS (SDS)	10
		Parking Drum Brake	10
		Parking Brake Control	10

PRECAUTIONS

< PRECAUTION >

PRECAUTION

PRECAUTIONS

Precaution for Supplemental Restraint System (SRS) "AIR BAG" and "SEAT BELT PRE-TENSIONER"

INFOID:000000010115227

The Supplemental Restraint System such as "AIR BAG" and "SEAT BELT PRE-TENSIONER", used along with a front seat belt, helps to reduce the risk or severity of injury to the driver and front passenger for certain types of collision. This system includes seat belt switch inputs and dual stage front air bag modules. The SRS system uses the seat belt switches to determine the front air bag deployment, and may only deploy one front air bag, depending on the severity of a collision and whether the front occupants are belted or unbelted. Information necessary to service the system safely is included in the SR and SB section of this Service Manual.

WARNING:

- To avoid rendering the SRS inoperative, which could increase the risk of personal injury or death in the event of a collision which would result in air bag inflation, all maintenance must be performed by an authorized NISSAN/INFINITI dealer.
- Improper maintenance, including incorrect removal and installation of the SRS, can lead to personal injury caused by unintentional activation of the system. For removal of Spiral Cable and Air Bag Module, see the SR section.
- Do not use electrical test equipment on any circuit related to the SRS unless instructed to in this Service Manual. SRS wiring harnesses can be identified by yellow and/or orange harnesses or harness connectors.

PRECAUTIONS WHEN USING POWER TOOLS (AIR OR ELECTRIC) AND HAMMERS

WARNING:

- When working near the Airbag Diagnosis Sensor Unit or other Airbag System sensors with the Ignition ON or engine running, DO NOT use air or electric power tools or strike near the sensor(s) with a hammer. Heavy vibration could activate the sensor(s) and deploy the air bag(s), possibly causing serious injury.
- When using air or electric power tools or hammers, always switch the Ignition OFF, disconnect the battery and wait at least three minutes before performing any service.

PREPARATION



< PREPARATION >

PREPARATION

PREPARATION

Commercial Service Tool

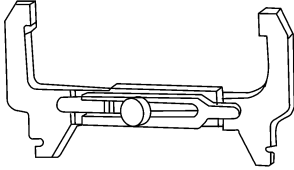
INFOID:000000009478981

Tool name	Description
<p data-bbox="167 415 456 443">Brake drum clearance gauge</p>  <p data-bbox="867 632 943 646">WFIA0167E</p>	<p data-bbox="1062 415 1458 464">Measuring rear rotor drum inner diameter</p>
<p data-bbox="167 665 277 693">Power tool</p>  <p data-bbox="867 884 943 898">PIIB1407E</p>	<p data-bbox="1062 665 1398 693">Loosening nuts, screws and bolts</p>

A
B
C
D
E
PB
G
H
I
J
K
L
M
N
O
P

PARKING BRAKE SYSTEM

< REMOVAL AND INSTALLATION >

REMOVAL AND INSTALLATION

PARKING BRAKE SYSTEM

On-Vehicle Service

INFOID:000000009478982

LEVER STROKE

- When parking brake lever is operated with the specified force, make sure the stroke is within the specified number of notches. Check by listening and counting the ratchet clicks.

Lever stroke : 6 – 8 notches [under force of 196 N (20.0 kg-f, 44.1 lb-f)]

INSPECTION

- Make sure the components are attached properly, check for looseness or backlash.
- Check parking brake lever assembly for bends, damage and cracks, and replace if necessary.
- Check cable for wear and damage, and replace if necessary.
- Check parking brake warning lamp switch for malfunction, and replace if necessary. Refer to [MWI-19, "WARNING LAMPS/INDICATOR LAMPS : System Description"](#).

ADJUSTMENT

1. Remove rear half of the center console. Refer to [IP-29, "Disassembly and Assembly"](#).
2. Rotate adjusting nut and loosen cable until tension is sufficiently released.

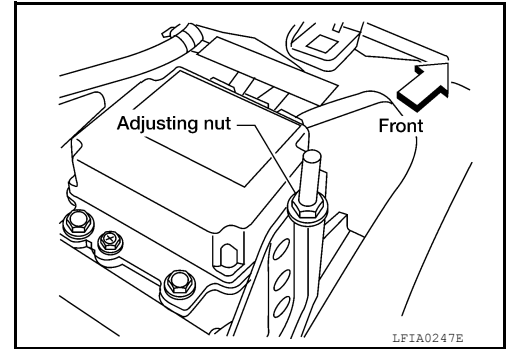

3. Remove the rear wheels and tires. Refer to [MA-53, "WHEELS : Rotation"](#).
4. Using wheel nuts, secure the disc to the hub to prevent it from tilting.
5. Remove the adjuster hole plug installed on the disc rotor. Turn the adjuster in direction (A) using a suitable tool as shown, until disc rotor is locked. Turn the adjuster in the opposite direction by 5 or 6 notches after locking.
6. Rotate disc rotor to make sure there is no drag.

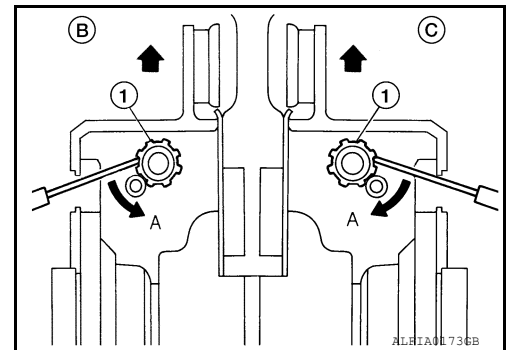

B: Left **C: Right**
←: Front

7. Adjust cable as follows:
 - a. Rotate the adjusting nut to adjust the parking brake lever operating force to 294N (29.9 Kg, 66.0 lb-ft) just before a full lever stroke 229.0 mm (9.0 in).
CAUTION:
Do not reuse the adjusting nut after removing it.
 - b. When replacing brake cable, operate parking brake lever 10 or more times with a full stroke of 229.0mm (9.0 in).
 - c. Release the parking brake lever and rotate the disc rotor to make sure there is no drag.
 - d. Rotate adjusting nut to adjust lever stroke to specification.

Lever stroke : 6 – 8 notches [under force of 196 N (20.0 kg-f, 44.1 lb-f)]

- e. With parking brake lever completely disengaged, make sure there is no drag on the parking brake.

PARKING BRAKE CONTROL

< UNIT REMOVAL AND INSTALLATION >

UNIT REMOVAL AND INSTALLATION

PARKING BRAKE CONTROL

Component

INFOID:000000009478983

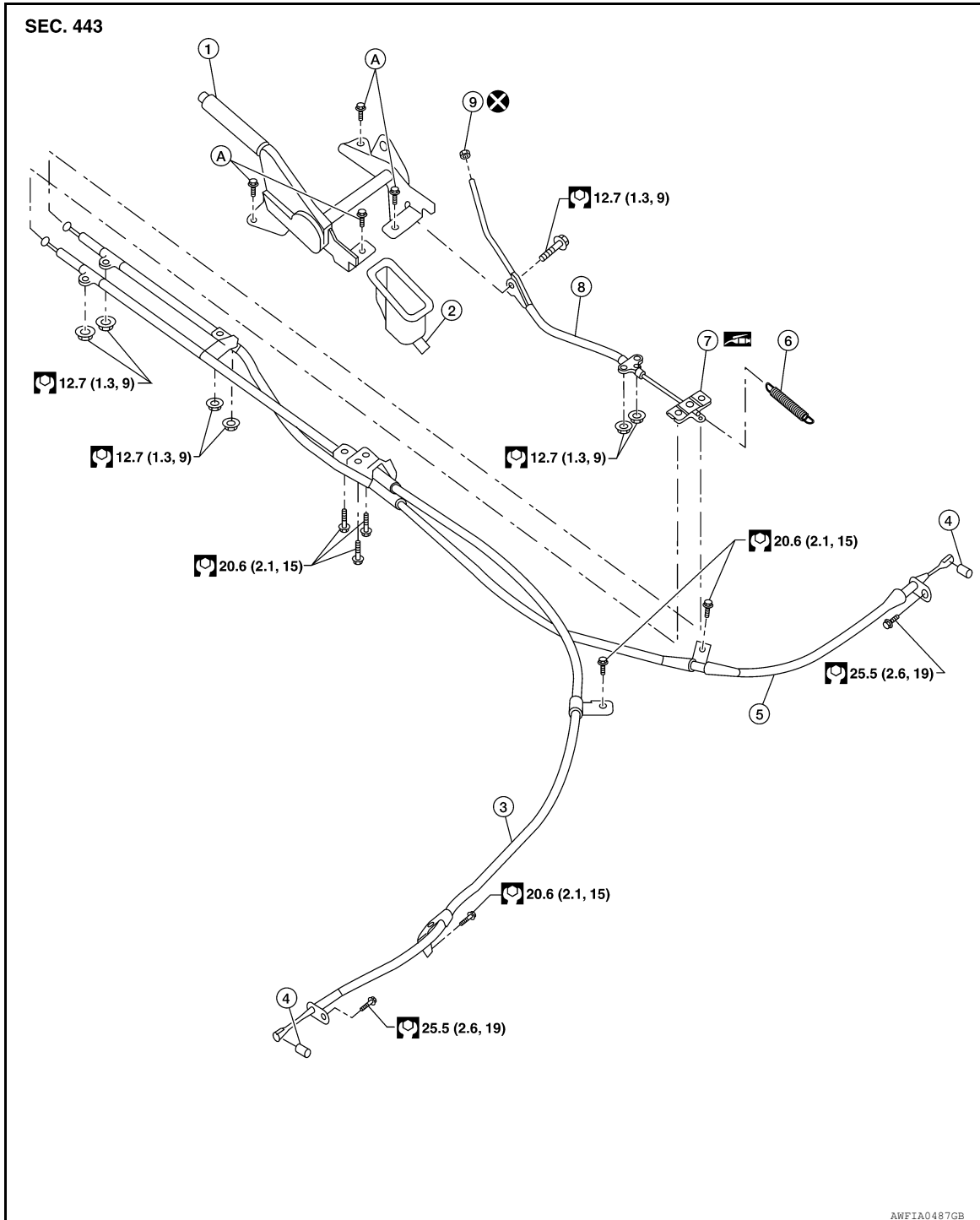

- | | | |
|---|------------------------|--------------------|
| 1. Control lever assembly | 2. Front cable grommet | 3. Left rear cable |
| 4. Pin | 5. Right rear cable | 6. Return spring |
| 7. Equalizer | 8. Front cable | 9. Adjusting nut |
| A. Refer to installation for tightening order | | |

PARKING BRAKE CONTROL

< UNIT REMOVAL AND INSTALLATION >

Removal and Installation

INFOID:000000009478984

REMOVAL

1. Disconnect the return spring from the equalizer.
2. Remove the right and left rear cables from the equalizer.
3. Remove the front cable nuts from underneath the vehicle.
4. Remove the rear half of the center console. Refer to [IP-29, "Disassembly and Assembly"](#).
5. Remove the four control lever assembly bolts, then remove the control lever assembly.
6. Remove the front cable grommet from the control lever assembly.
7. Remove the front cable to control lever assembly bolt.
8. Remove the adjusting nut and discard, then remove the front cable.
CAUTION:
Do not reuse the adjusting nut, use a new adjusting nut for installation.
9. Remove the rear disc rotors. Refer to [BR-40, "Removal and Installation of Brake Caliper and Disc Rotor"](#).
10. Remove the left and right parking brake shoes, then disconnect the rear cables from the toggle levers.
11. Remove the left and right rear cable bolts and nuts, then remove the left and right rear cables.

INSTALLATION

Installation is in the reverse order of removal.

- The control lever assembly bolts must be installed in the following order:

Control lever assembly bolt : 12.7 N·m (1.3 kg-m, 9 ft-lb)

1. Install and temporarily tighten the control lever assembly bolts (A), (B) and (D).
2. Install and tighten the control lever assembly bolt (C) to specification.
3. Install and tighten the control lever assembly bolt (D) to specification.
4. Install and tighten the control lever assembly bolt (A) to specification.
5. Install and tighten the control lever assembly bolt (B) to specification.

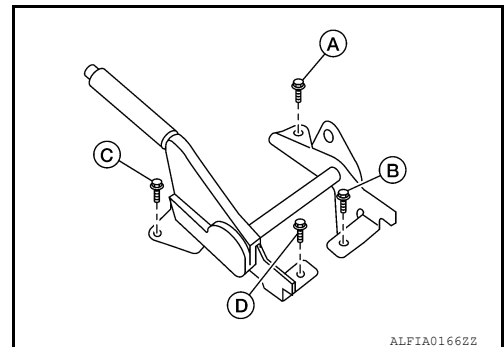

ALFPA0166ZZ

- Adjust the parking brake. Refer to [PB-10, "Parking Brake Control"](#).

CAUTION:

- **Do not reuse the adjusting nut, use a new adjusting nut for installation.**
- **Install the control lever assembly bolts in the specified order and pattern.**

PARKING BRAKE SHOE

< UNIT REMOVAL AND INSTALLATION >

PARKING BRAKE SHOE

Component

INFOID:000000009478985

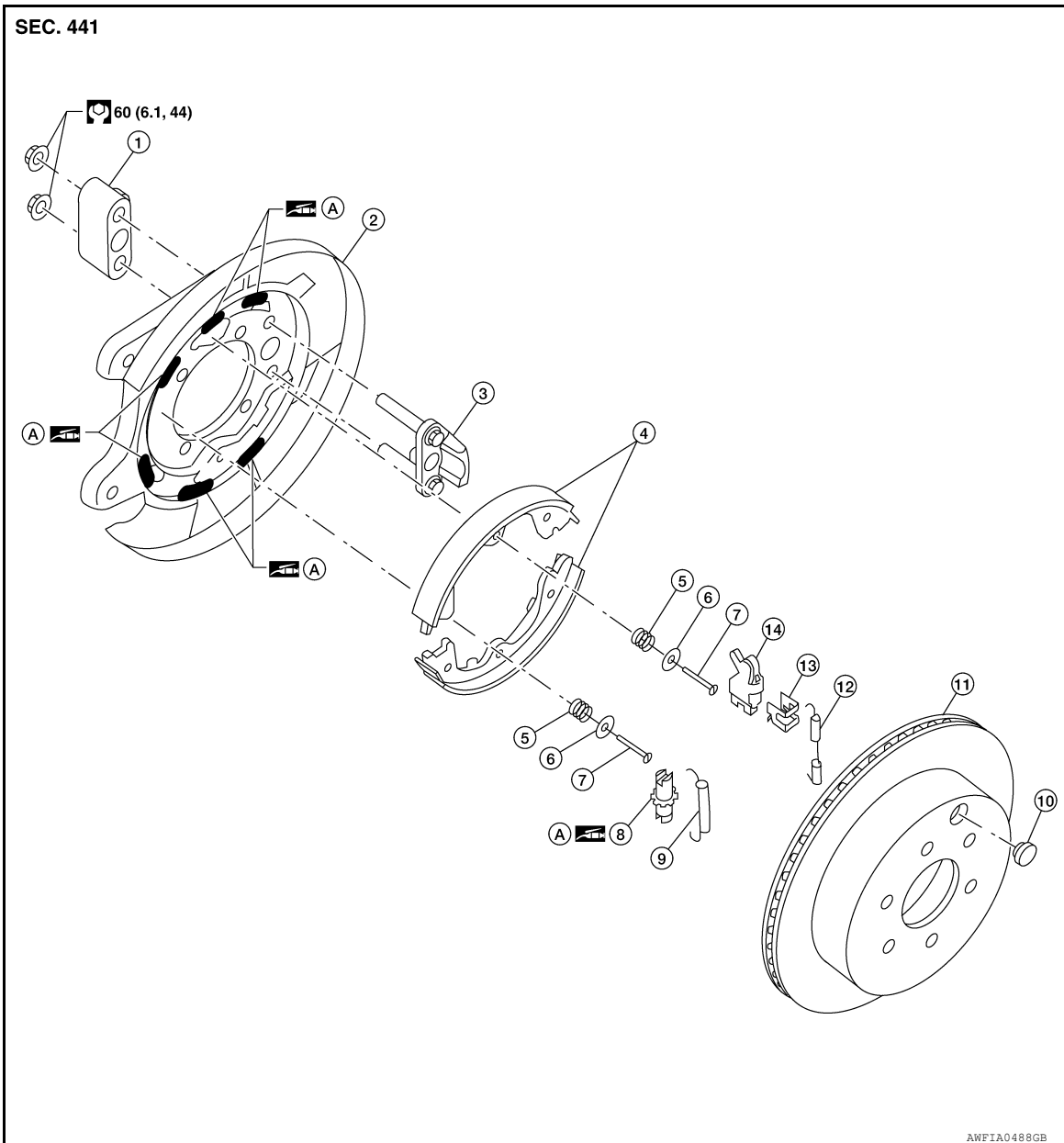

- | | | |
|--------------------------|--------------------------|---|
| 1. Anchor block | 2. Back plate | 3. Anchor |
| 4. Shoes | 5. Shoe hold-down spring | 6. Retainer |
| 7. Shoe hold-down pin | 8. Adjuster | 9. Adjuster spring |
| 10. Adjuster access plug | 11. Disc rotor | 12. Return spring |
| 13. Pin retainer | 14. Toggle lever | A. PBC (Poly Butyl Cuprysil) grease or equivalent |

Removal and Installation

INFOID:000000009478986

REMOVAL

WARNING:

Clean the brakes with a vacuum dust collector to minimize the hazard of airborne particles or other materials.

A
B
C
D
E
PB
G
H
I
J
K
L
M
N
O
P

PARKING BRAKE SHOE

< UNIT REMOVAL AND INSTALLATION >

NOTE:

Remove the disc rotor only with the parking brake lever completely disengaged.

1. Remove the rear disc rotor. Refer to [BR-40, "Removal and Installation of Brake Caliper and Disc Rotor"](#).
2. Remove the adjuster and return springs.
3. Remove the adjuster.
4. Remove the shoe hold-down pins, retainers, shoe hold-down springs and shoes.
5. Remove pin retainer, then disconnect the parking brake cable from the toggle lever.
6. Remove back plate. Refer to [RAX-7, "Removal and Installation"](#) (C200) or [RAX-19, "Removal and Installation"](#) (M226).

INSPECTION AFTER REMOVAL

Lining Thickness Inspection

- Check thickness of lining.

Standard thickness (A)

Refer to [PB-10, "Parking Drum Brake"](#)

Wear limit thickness (A)

Refer to [PB-10, "Parking Drum Brake"](#)

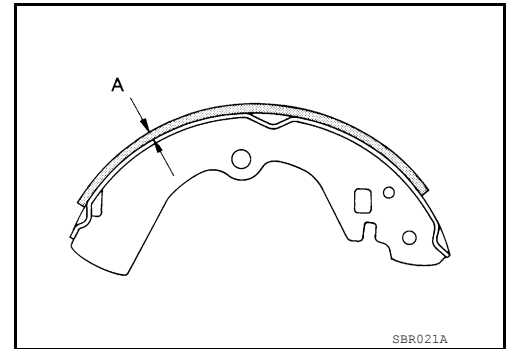

Drum Inner Diameter Inspection

- Check visually for cracks, corrosion, or damage inside drum.
- Measure drum inner diameter using suitable tool.

Standard inner diameter

Refer to [PB-10, "Parking Drum Brake"](#)

Wear limit of inner diameter

Refer to [PB-10, "Parking Drum Brake"](#)

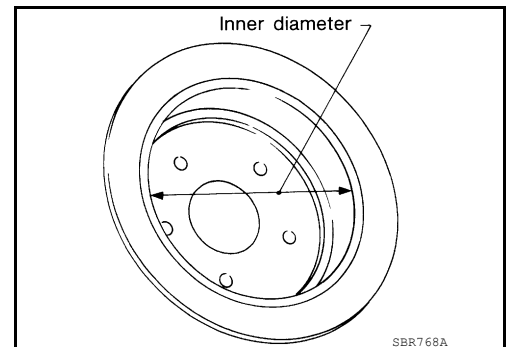

Other Inspections

- Check shoe sliding surface for excessive wear and damage.
- Check shoe hold-down pins for excessive wear and corrosion.
- Check adjuster and return springs for sagging.
- Check adjuster for rough operation.
- When disassembling adjuster, apply PBC (Poly Butyl Cuprysil) grease or equivalent to the adjuster threads.

INSTALLATION

Installation is in the reverse order of removal.

- Apply brake grease to the specified points during assembly. Refer to [PB-7, "Component"](#).
- Install adjuster (1) so that threaded part expands when rotating it in the direction shown (A) using a suitable tool.
- Shorten adjuster by rotating it in the opposite direction as shown (A).

B: Left

C: Right

←: Front

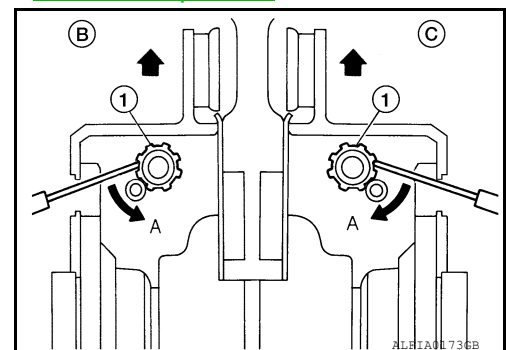

NOTE:

After replacing brake shoes or disc rotors, or if parking brake does not function well, perform break-in operation as follows.

PARKING BRAKE SHOE

< UNIT REMOVAL AND INSTALLATION >

1. Adjust parking brake lever stroke. Refer to [PB-4. "On-Vehicle Service"](#).
 2. Perform parking brake burnishing operation by driving the vehicle forward under the following conditions:
 - **Vehicle speed 40 +10, -0 km/h (25 +6, -0 MPH) set (forward)**
 - **Parking brake operating force 196 +49, -0 N (20.0 +5.0, -0 kg-f, 44.1 +11.0, -0 lb-ft) set**
 - **Apply time 10 +5, -0 sec.**
- CAUTION:**
- **To prevent lining from getting too hot, allow a cool off period of approximately 5 minutes after every break-in operation.**
 - **Do not perform excessive break-in operations, because it may cause uneven or early wear of lining.**
3. After burnishing operation, check parking brake lever stroke. Readjust if it is now longer than the specified stroke. Refer to [PB-4. "On-Vehicle Service"](#).

A
B
C
D
E
G
H
I
J
K
L
M
N
O
P

PB

SERVICE DATA AND SPECIFICATIONS (SDS)

< SERVICE DATA AND SPECIFICATIONS (SDS)

SERVICE DATA AND SPECIFICATIONS (SDS)

SERVICE DATA AND SPECIFICATIONS (SDS)

Parking Drum Brake

INFOID:000000009478987

Unit: mm (in)

Type		Drum
Brake lining	Standard thickness (new)	3.8 ± 0.15 (0.150 ± 0.006)
	Wear limit thickness	0.5 (0.020)
Drum inner diameter (disc)	Standard inner diameter (new)	190 +0.15, -0.00 (7.480 + 0.006, - 0.000)
	Wear limit of inner diameter	190.7 (7.508)

Parking Brake Control

INFOID:000000009478988

Control type	Control lever
Number of notches [under force of 196 N (20.0 kg-f, 44.1 lb-f)]	6 – 8 notches
Number of notches when warning lamp switch comes on	1 notch