

SECTION **RSU**
 REAR SUSPENSION

A
 B
 C
 D
 F
 G
 H
 I
 J
 K
 L
 M
 N
 O
 P

RSU

CONTENTS

PRECAUTION	2	REMOVAL AND INSTALLATION	6
PRECAUTIONS	2	REAR SUSPENSION ASSEMBLY	6
Precaution for Supplemental Restraint System (SRS) "AIR BAG" and "SEAT BELT PRE-TENSIONER"	2	Component	6
Precaution for Rear Suspension	2	UNIT REMOVAL AND INSTALLATION	8
PREPARATION	3	SHOCK ABSORBER	8
PREPARATION	3	Removal and Installation	8
Commercial Service Tool	3	Disposal	8
SYMPTOM DIAGNOSIS	4	LEAF SPRING	9
NOISE, VIBRATION, AND HARSHNESS (NVH) TROUBLESHOOTING	4	Removal and Installation	9
NVH Troubleshooting Chart	4	SERVICE DATA AND SPECIFICATIONS (SDS)	12
PERIODIC MAINTENANCE	5	SERVICE DATA AND SPECIFICATIONS (SDS)	12
REAR SUSPENSION ASSEMBLY	5	General Specification (Rear)	12
On-Vehicle Inspection and Service	5	Wheelarch Height (Unladen*1)	12

PRECAUTIONS

< PRECAUTION >

PRECAUTION

PRECAUTIONS

Precaution for Supplemental Restraint System (SRS) "AIR BAG" and "SEAT BELT PRE-TENSIONER"

INFOID:000000010136163

The Supplemental Restraint System such as "AIR BAG" and "SEAT BELT PRE-TENSIONER", used along with a front seat belt, helps to reduce the risk or severity of injury to the driver and front passenger for certain types of collision. This system includes seat belt switch inputs and dual stage front air bag modules. The SRS system uses the seat belt switches to determine the front air bag deployment, and may only deploy one front air bag, depending on the severity of a collision and whether the front occupants are belted or unbelted. Information necessary to service the system safely is included in the SR and SB section of this Service Manual.

WARNING:

- To avoid rendering the SRS inoperative, which could increase the risk of personal injury or death in the event of a collision which would result in air bag inflation, all maintenance must be performed by an authorized NISSAN/INFINITI dealer.
- Improper maintenance, including incorrect removal and installation of the SRS, can lead to personal injury caused by unintentional activation of the system. For removal of Spiral Cable and Air Bag Module, see the SR section.
- Do not use electrical test equipment on any circuit related to the SRS unless instructed to in this Service Manual. SRS wiring harnesses can be identified by yellow and/or orange harnesses or harness connectors.

PRECAUTIONS WHEN USING POWER TOOLS (AIR OR ELECTRIC) AND HAMMERS

WARNING:

- When working near the Airbag Diagnosis Sensor Unit or other Airbag System sensors with the Ignition ON or engine running, DO NOT use air or electric power tools or strike near the sensor(s) with a hammer. Heavy vibration could activate the sensor(s) and deploy the air bag(s), possibly causing serious injury.
- When using air or electric power tools or hammers, always switch the Ignition OFF, disconnect the battery and wait at least three minutes before performing any service.

Precaution for Rear Suspension

INFOID:000000009478692

- When installing the rubber bushings, the final tightening must be done under unladen condition and with the tires on level ground. Oil will shorten the life of the rubber bushings, so wipe off any spilled oil immediately.
- Unladen condition means the fuel tank, engine coolant and lubricants are at the full specification. The spare tire, jack, hand tools, and mats are in their designated positions. There are no passengers in the vehicle.
- After installing suspension components, check the wheel alignment.
- Caulking nuts are not reusable. Always use new caulking nuts for installation. New caulking nuts are pre-oiled, do not apply any additional lubrication.

PREPARATION

< PREPARATION >

PREPARATION

PREPARATION

Commercial Service Tool

INFOID:000000009478693

Tool name	Description
Power tool  PIIB1407E	Loosening nuts, screws and bolts

A

B

C

D

RSU

F

G

H

I

J

K

L

M

N

O

P

REAR SUSPENSION ASSEMBLY

< PERIODIC MAINTENANCE >

PERIODIC MAINTENANCE

REAR SUSPENSION ASSEMBLY

On-Vehicle Inspection and Service

INFOID:000000009478695

- Check the rear suspension parts for any excessive play, cracks, wear, and other damage.
- Shake each rear wheel to check for any excessive play as shown.
- Tighten all of the nuts and bolts to the specified torque.

CAUTION:

When installing the components with rubber bushings, the final tightening of the nuts and bolts must be done with the vehicle in an unladen condition (the fuel, engine coolant, and engine oil full; the spare tire, jack, hand tools and mats in their designated positions) with the tires on the ground.

- Check the shock absorbers for oil leaks, deformation, and other damage.
- Check the shock absorber bushings for excessive wear and other damage.

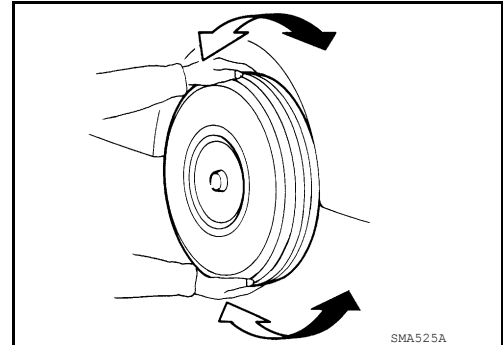

A

B

C

D

RSU

F

G

H

I

J

K

L

M

N

O

P

REAR SUSPENSION ASSEMBLY

< REMOVAL AND INSTALLATION >

REMOVAL AND INSTALLATION

REAR SUSPENSION ASSEMBLY

Component

INFOID:000000009478696

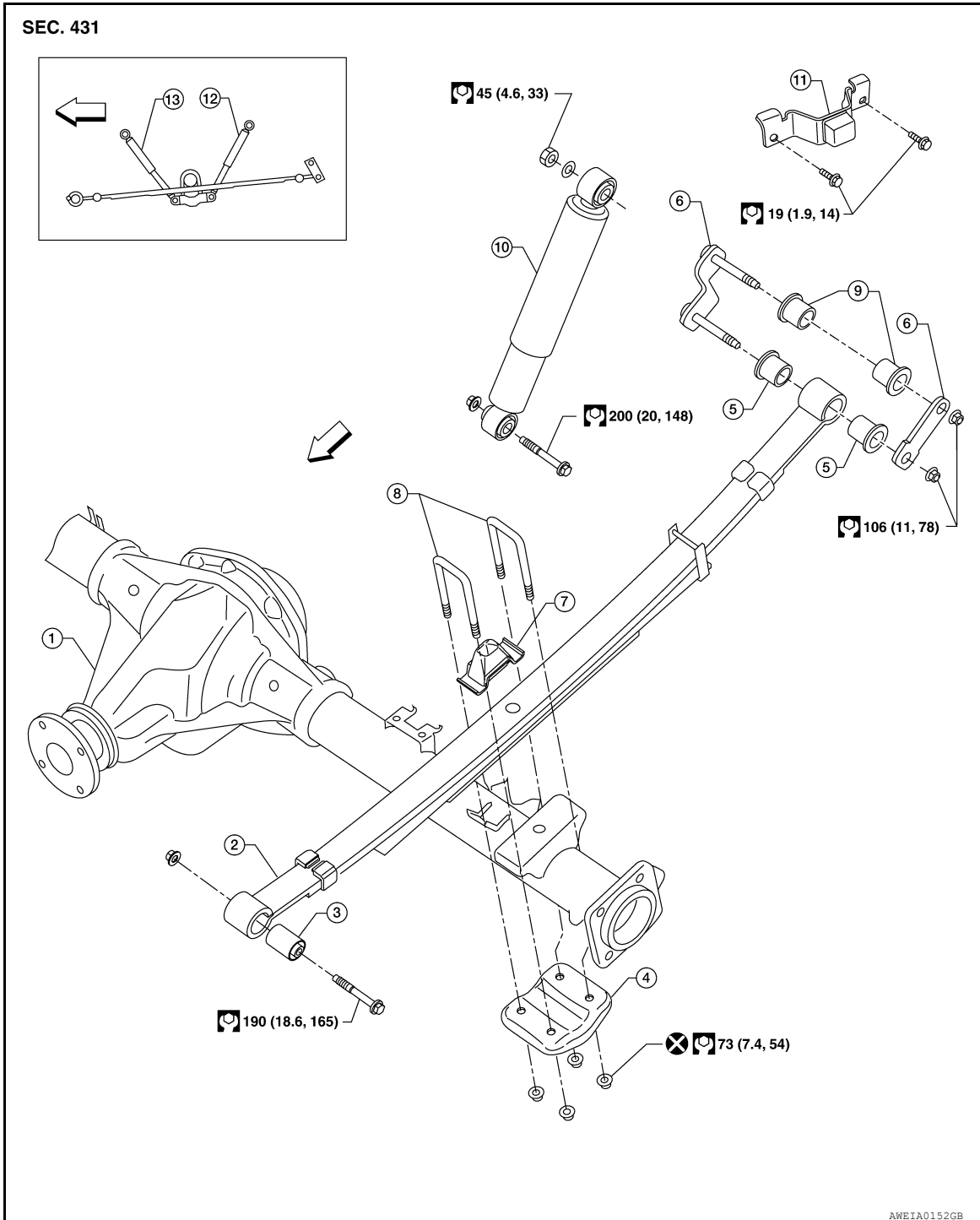

AWEIA0152GB

- | | | |
|-------------------------|-------------------------------|--------------------------------|
| 1. Rear final drive | 2. Rear leaf spring | 3. Rear spring bushing (front) |
| 4. Rear spring pad | 5. Rear spring bushing (rear) | 6. Rear spring shackle |
| 7. Bumper | 8. Rear spring clip U-bolts | 9. Rear spring shackle bushing |
| 10. Shock absorber | 11. Bumper | 12. Shock absorber (LH) |
| 13. Shock absorber (RH) | ← Front | |

REAR SUSPENSION ASSEMBLY

< REMOVAL AND INSTALLATION >

CAUTION:

When installing the components with rubber bushings, the final tightening of the nuts and bolts must be done with the vehicle in an unladen condition (the fuel, engine coolant, and engine oil full; the spare tire, jack, hand tools and mats in their designated positions) with the tires on the ground.

A
B
C
D
F
G
H
I
J
K
L
M
N
O
P

RSU

SHOCK ABSORBER

< UNIT REMOVAL AND INSTALLATION >

UNIT REMOVAL AND INSTALLATION

SHOCK ABSORBER

Removal and Installation

INFOID:000000009478697

REMOVAL

1. Support the rear final drive and suspension assembly using a suitable jack.
2. Remove the shock absorber upper and lower nuts and bolts using power tool.

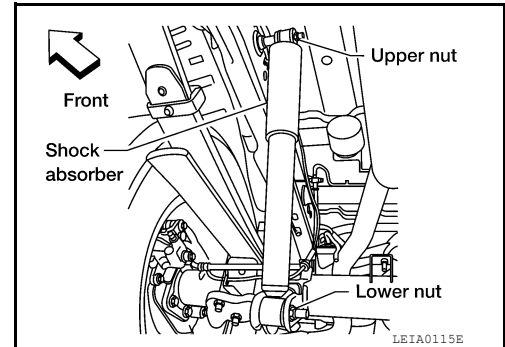

3. Remove the shock absorber.

INSPECTION AFTER REMOVAL

Inspect the shock absorber for any oil leaks, cracks, or deformations. Replace the shock absorber as necessary.

INSTALLATION

Installation is in the reverse order of removal.

Shock absorber upper and lower nuts : Refer to [RSU-6, "Component"](#).

Disposal

INFOID:000000009478698

1. Set shock absorber horizontally with the piston rod fully extended.
2. Drill 2 – 3 mm (0.08 – 0.12 in) hole at the position (●) from top as shown to release gas gradually.

CAUTION:

- Wear eye protection (safety glasses).
- Wear gloves.
- Be careful with metal chips or oil blown out by the compressed gas.

NOTE:

- Drill vertically in this direction (←).
- Directly to the outer tube avoiding brackets.
- The gas is clear, colorless, odorless, and harmless.

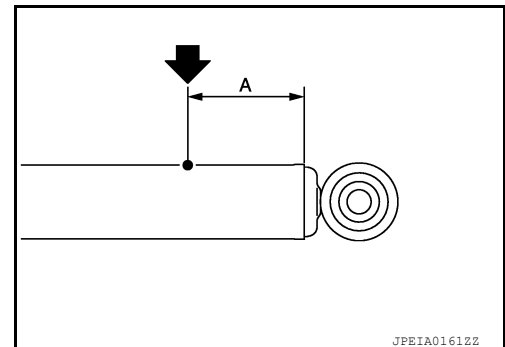

(A) : 20 – 30 mm (0.79 – 1.18 in)

3. Position the drilled hole downward and drain oil by moving the piston rod several times.

CAUTION:

Dispose of drained oil according to the law and local regulations.

LEAF SPRING

< UNIT REMOVAL AND INSTALLATION >

LEAF SPRING

Removal and Installation

INFOID:000000009478699

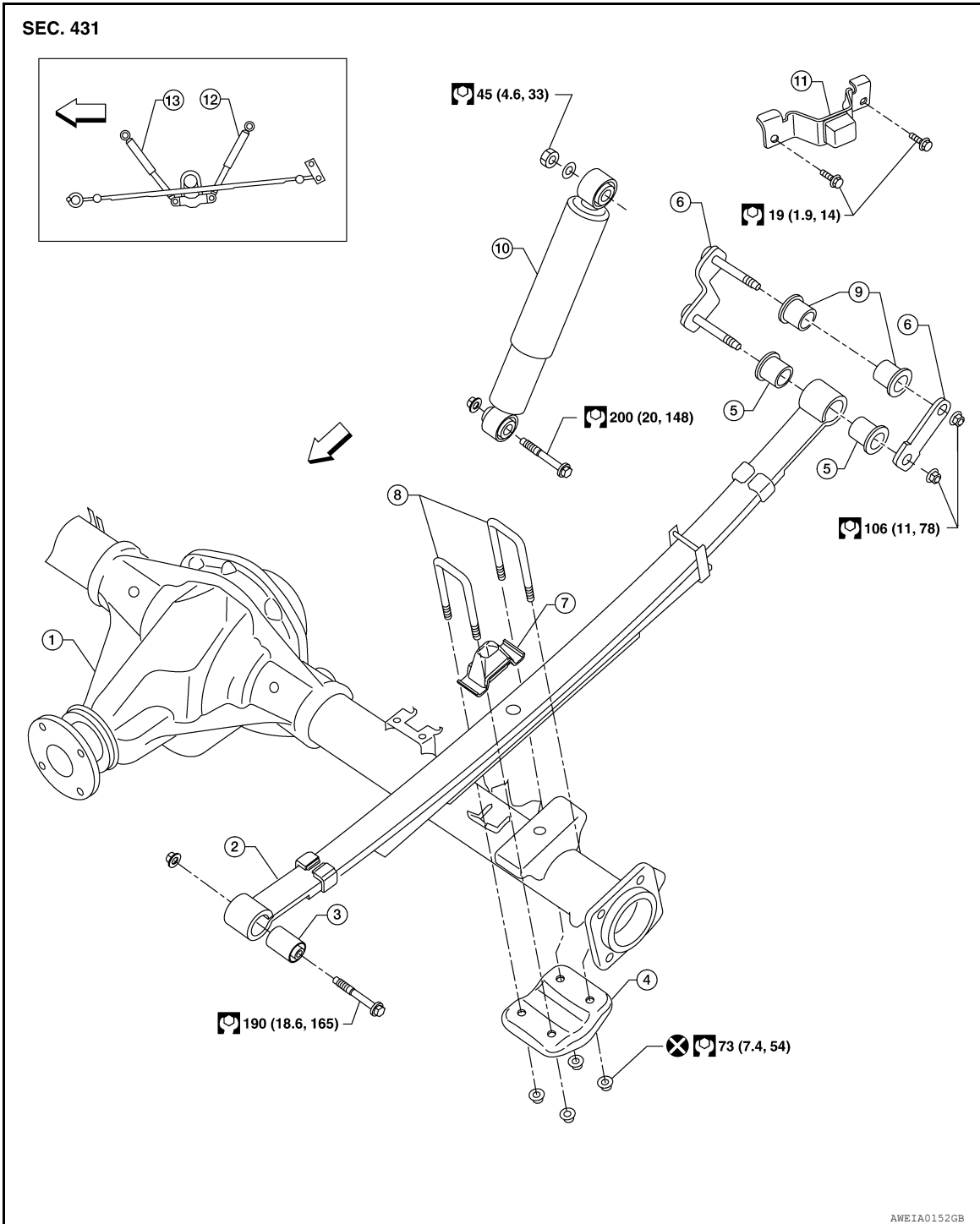

- | | | |
|-------------------------|-------------------------------|--------------------------------|
| 1. Rear final drive | 2. Rear leaf spring | 3. Rear spring bushing (front) |
| 4. Rear spring pad | 5. Rear spring bushing (rear) | 6. Rear spring shackle |
| 7. Bumper | 8. Rear spring clip U-bolts | 9. Rear spring shackle bushing |
| 10. Shock absorber | 11. Bumper | 12. Shock absorber (LH) |
| 13. Shock absorber (RH) | ← Front | |

CAUTION:

A
B
C
D
RSU
F
G
H
I
J
K
L
M
N
O
P

LEAF SPRING

< UNIT REMOVAL AND INSTALLATION >

When installing the components with rubber bushings, the final tightening of the nuts and bolts must be done with the vehicle in an unladen condition (the fuel, engine coolant, and engine oil full; the spare tire, jack, hand tools and mats in their designated positions) with the tires on the ground.

REMOVAL

1. Remove the wheel and tire from the vehicle using power tool. Refer to [WT-48. "Adjustment"](#).
2. Support the rear final drive assembly with a suitable jack to relieve the tension from the rear leaf spring.
 - The axle weight should be supported, but there should be no compression in the rear leaf spring.
3. Remove the four rear spring clip U-bolt nuts using power tool, then remove the rear spring pad and bumper.

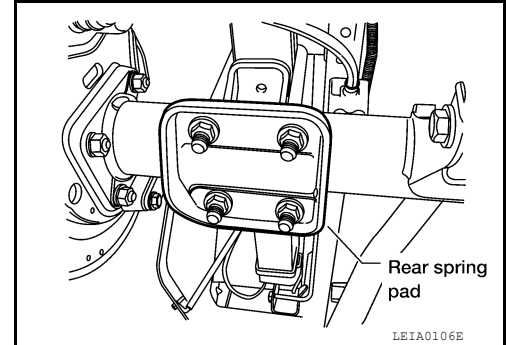

4. Remove the rear spring shackle and bushings using power tool.

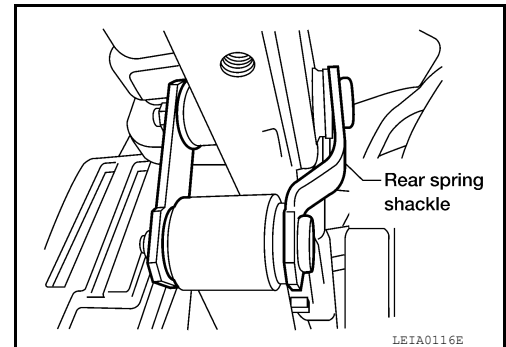

5. Remove the rear leaf spring front nut and bolt using power tool.
6. Remove the rear leaf spring.

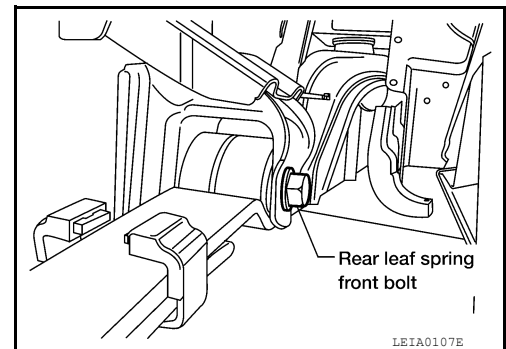

INSPECTION AFTER REMOVAL

- Check the rear leaf spring for any cracks or damage. Replace the rear leaf spring if necessary.
- Check the rear spring shackle, rear spring clip U-bolts, bumper, and rear spring pad for excessive wear, cracks, straightness, and damage. Replace any components if necessary.
- Check all bushings for deformation and cracks. Replace any bushings if necessary.

INSTALLATION

1. Apply soapsuds to all of the rubber bushings.
2. Install the rear spring shackle and rear leaf spring front nut and bolt. Finger-tighten the nuts.
3. Install the rear spring clip U-bolts and bumper on top of the rear leaf spring.
4. Install the bumper and rear spring pad, then finger-tighten nuts under the axle case.

LEAF SPRING

< UNIT REMOVAL AND INSTALLATION >

5. Tighten the rear spring clip U-bolt nuts diagonally and evenly to specification.
 - Tighten the rear spring clip U-bolt nuts so the lengths of all the exposed rear spring clip U-bolt threads under spring pad are equal in length within a tolerance of 3 mm (0.12 in), as shown.

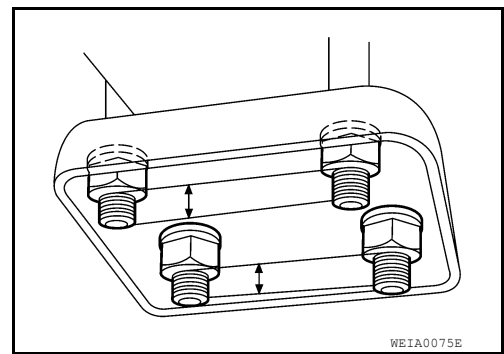

6. Remove the jack supporting the rear final drive assembly and bounce the rear of the vehicle to stabilize the suspension.

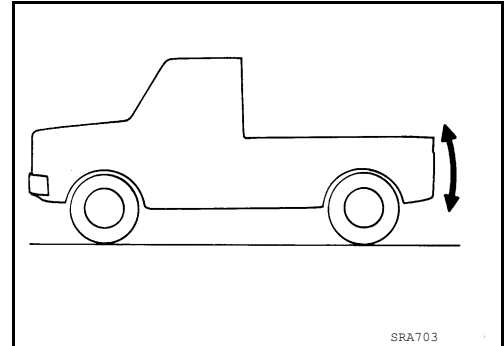

7. Tighten the rear spring shackle nuts, rear leaf spring front nut, and shock absorber nuts to specification.
 - When installing the components with rubber bushings, the final nut tightening must be carried out under unladen* conditions with the tires on level ground.
 - * (Fuel, radiator coolant and engine oil full. Spare tire, jack, hand tools and mats in designated positions.)
8. Install the wheel and tire. Refer to [WT-48. "Adjustment"](#).

A
B
C
D
RSU
F
G
H
I
J
K
L
M
N
O
P

SERVICE DATA AND SPECIFICATIONS (SDS)

< SERVICE DATA AND SPECIFICATIONS (SDS)

SERVICE DATA AND SPECIFICATIONS (SDS)

SERVICE DATA AND SPECIFICATIONS (SDS)

General Specification (Rear)

INFOID:000000009478700

Suspension type	Rigid axle with semi-elliptic leaf springs
Shock absorber type	Double-acting hydraulic

Wheelarch Height (Unladen*¹)

INFOID:000000009478701

King Cab

Unit: mm (in)

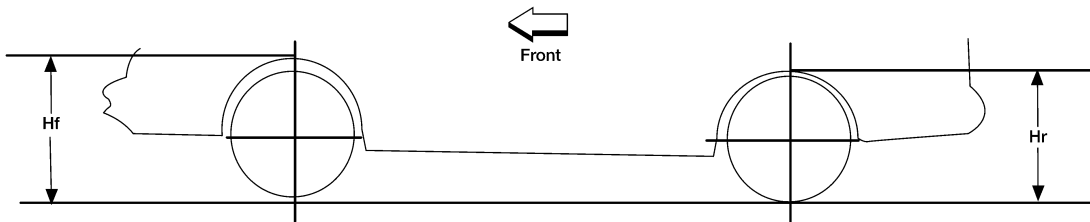

LEIA0085E

Drive type	2WD				4WD	
Engine type	QR25DE		VQ40DE			
Tire size	P235/75R15	P265/70R16	P265/70R16	P265/75R16	P265/70R16	P265/75R16
Front wheelarch height (Hf)	850 (33.46)	865 (34.06)	868 (34.17)	880 (34.65)	881 (34.68)	893 (35.16)
Rear wheelarch height (Hr)	878 (34.57)	887 (34.92)	895 (35.24)	907 (35.71)	904 (35.59)	917 (36.10)

*1: Fuel, radiator coolant and engine oil full. Spare tire, jack, hand tools and mats in designated positions.

Crew Cab

Unit: mm (in)

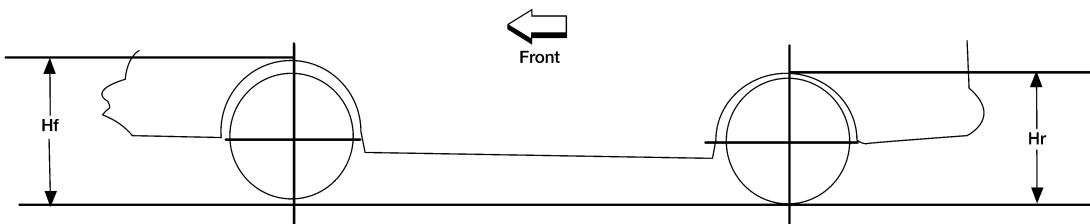

LEIA0085E

Engine type	VQ40DE									
Drive type	2WD					4WD				
Tire size	P265/70R16		P265/75R16		P265/60R18	P265/70R16		P265/75R16		P265/60R18
Wheel base	Short	Long	Short	Short	Long	Short	Long	Short	Short	Long

SERVICE DATA AND SPECIFICATIONS (SDS)

< SERVICE DATA AND SPECIFICATIONS (SDS)

Front wheelarch height (Hf)	867 (34.13)	870 (34.25)	879 (34.61)	866 (34.09)	869 (34.21)	879 (34.61)	882 (34.72)	891 (35.08)	879 (34.61)	882 (34.72)
Rear wheelarch height (Hr)	892 (35.12)	892 (35.12)	904 (35.59)	892 (35.12)	892 (35.12)	905 (35.63)	902 (35.51)	918 (36.14)	905 (35.63)	902 (35.51)

*1: Fuel, radiator coolant and engine oil full. Spare tire, jack, hand tools and mats in designated positions.

A

B

C

D

RSU

F

G

H

I

J

K

L

M

N

O

P