

SECTION **MA**
 MAINTENANCE

A
B
C
D
E
F
G
H
I
J
K
L
M
N
O

CONTENTS

PRECAUTION	3	FOR MEXICO : SAE Viscosity Number	21
PRECAUTIONS	3	FOR MEXICO : Engine Coolant Mixture Ratio	22
Precaution for Supplemental Restraint System (SRS) "AIR BAG" and "SEAT BELT PRE-TENSIONER"	3	ENGINE MAINTENANCE (QR25DE ENGINE)...	23
PREPARATION	4	DRIVE BELTS	23
PREPARATION	4	DRIVE BELTS : Exploded View	23
Special Service Tool	4	DRIVE BELTS : Checking Drive Belts	23
Commercial Service Tool	4	DRIVE BELTS : Tension Adjustment	23
PERIODIC MAINTENANCE	6	ENGINE COOLANT	23
GENERAL MAINTENANCE	6	ENGINE COOLANT : System Inspection	23
FOR USA AND CANADA	6	ENGINE COOLANT : Changing Engine Coolant	24
FOR USA AND CANADA : Explanation of General Maintenance	6	FUEL LINES	26
FOR MEXICO	8	FUEL LINES : Checking Fuel Line	26
FOR MEXICO : General Maintenance	8	AIR CLEANER FILTER	26
PERIODIC MAINTENANCE	10	AIR CLEANER FILTER : Removal and Installation	26
FOR USA AND CANADA	10	ENGINE OIL	27
FOR USA AND CANADA : Periodic Maintenance... ..	10	ENGINE OIL : Inspection	27
FOR MEXICO	13	ENGINE OIL : Changing Engine Oil	27
FOR MEXICO : Periodic Maintenance	13	OIL FILTER	28
RECOMMENDED FLUIDS AND LUBRICANTS	16	OIL FILTER : Removal and Installation	28
FOR USA AND CANADA	16	SPARK PLUG	29
FOR USA AND CANADA : Fluids and Lubricants... ..	16	SPARK PLUG : Exploded View	29
FOR USA AND CANADA : SAE Viscosity Number	18	SPARK PLUG : Removal and Installation	29
FOR USA AND CANADA : Anti-Freeze Coolant Mixture Ratio	19	EVAP VAPOR LINES	30
FOR MEXICO	19	EVAP VAPOR LINES : Checking EVAP Vapor Line	31
FOR MEXICO : Fluids and Lubricants	19	ENGINE MAINTENANCE (VQ40DE)	32
		DRIVE BELT	32
		DRIVE BELT : Exploded View	32
		DRIVE BELT : Checking Drive Belts	32
		DRIVE BELT : Adjustment	32
		ENGINE COOLANT	32

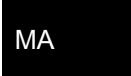

ENGINE COOLANT : System Inspection	32	DIFFERENTIAL GEAR OIL : Changing Differential Gear Oil	49
ENGINE COOLANT : Changing Engine Coolant ...	33	DIFFERENTIAL GEAR OIL : Checking Differential Gear Oil	49
FUEL LINES	36	DIFFERENTIAL GEAR OIL : Rear Final Drive - C200	49
FUEL LINES : Checking Fuel Line	36	DIFFERENTIAL GEAR OIL : Changing Differential Gear Oil	49
FUEL FILTER	36	DIFFERENTIAL GEAR OIL : Checking Differential Gear Oil	50
FUEL FILTER : Changing Fuel Filter	36	DIFFERENTIAL GEAR OIL : Rear Final Drive - M226	50
AIR CLEANER FILTER	36	DIFFERENTIAL GEAR OIL : Changing Differential Gear Oil	50
AIR CLEANER FILTER : Exploded View	37	DIFFERENTIAL GEAR OIL : Checking Differential Gear Oil	51
AIR CLEANER FILTER : Removal and Installation ...	37	DIFFERENTIAL GEAR OIL : Rear Final Drive - M226 (ELD)	51
ENGINE OIL	37	DIFFERENTIAL GEAR OIL : Changing Differential Gear Oil	51
ENGINE OIL : Inspection	37	DIFFERENTIAL GEAR OIL : Checking Differential Gear Oil	52
ENGINE OIL : Changing Engine Oil	38	WHEELS	52
OIL FILTER	38	WHEELS : Balancing Wheels	52
OIL FILTER : Removal and Installation	38	WHEELS : Rotation	54
SPARK PLUG	39	BRAKE FLUID LEVEL AND LEAKS	54
SPARK PLUG : Exploded View	40	BRAKE FLUID LEVEL AND LEAKS : On Board Inspection	54
SPARK PLUG : Removal and Installation	40	BRAKE LINES AND CABLES	54
EVAP VAPOR LINES	41	BRAKE LINES AND CABLES : Checking Brake Line and Cables	55
EVAP VAPOR LINES : Checking EVAP Vapor Line	41	DISC BRAKE	55
CHASSIS AND BODY MAINTENANCE	42	DISC BRAKE : Checking Disc Brake	55
IN-CABIN MICROFILTER	42	STEERING GEAR AND LINKAGE	55
IN-CABIN MICROFILTER : Removal and Installation	42	STEERING GEAR AND LINKAGE : Checking Steering Gear and Linkage	56
EXHAUST SYSTEM	42	POWER STEERING FLUID AND LINES	56
EXHAUST SYSTEM : Checking Exhaust System...	43	POWER STEERING FLUID AND LINES : Checking Power Steering Fluid and Line	56
TRANSMISSION OIL	43	AXLE AND SUSPENSION PARTS	56
TRANSMISSION OIL : Checking the A/T Fluid (ATF)	43	AXLE AND SUSPENSION PARTS : Checking Axle and Suspension Parts	56
TRANSMISSION OIL : Changing the A/T Fluid (ATF)	45	LOCKS, HINGES AND HOOD LATCH	57
M/T OIL	46	LOCKS, HINGES AND HOOD LATCH : Lubricating Locks, Hinges and Hood Latches	58
M/T OIL : FS6R31A	46	SEAT BELT, BUCKLES, RETRACTORS, ANCHORS AND ADJUSTERS	58
M/T OIL : Changing	46	SEAT BELT, BUCKLES, RETRACTORS, ANCHORS AND ADJUSTERS : Checking Seat Belts, Buckles, Retractors, Anchors and Adjusters ...	58
M/T OIL : Checking	46		
M/T OIL : FS5R30A	46		
M/T OIL : Changing	46		
M/T OIL : Checking	47		
TRANSFER FLUID	47		
TRANSFER FLUID : Replacement	47		
TRANSFER FLUID : Inspection	48		
PROPELLER SHAFT	48		
PROPELLER SHAFT : Checking Propeller Shaft...	48		
DIFFERENTIAL GEAR OIL	48		
DIFFERENTIAL GEAR OIL : Front Final Drive - R180A	49		

PRECAUTIONS

< PRECAUTION >

PRECAUTION

PRECAUTIONS

Precaution for Supplemental Restraint System (SRS) "AIR BAG" and "SEAT BELT PRE-TENSIONER"

INFOID:000000010710180

The Supplemental Restraint System such as "AIR BAG" and "SEAT BELT PRE-TENSIONER", used along with a front seat belt, helps to reduce the risk or severity of injury to the driver and front passenger for certain types of collision. This system includes seat belt switch inputs and dual stage front air bag modules. The SRS system uses the seat belt switches to determine the front air bag deployment, and may only deploy one front air bag, depending on the severity of a collision and whether the front occupants are belted or unbelted. Information necessary to service the system safely is included in the SR and SB section of this Service Manual.

WARNING:

- To avoid rendering the SRS inoperative, which could increase the risk of personal injury or death in the event of a collision which would result in air bag inflation, all maintenance must be performed by an authorized NISSAN/INFINITI dealer.
- Improper maintenance, including incorrect removal and installation of the SRS, can lead to personal injury caused by unintentional activation of the system. For removal of Spiral Cable and Air Bag Module, see the SR section.
- Do not use electrical test equipment on any circuit related to the SRS unless instructed to in this Service Manual. SRS wiring harnesses can be identified by yellow and/or orange harnesses or harness connectors.

PRECAUTIONS WHEN USING POWER TOOLS (AIR OR ELECTRIC) AND HAMMERS

WARNING:

- When working near the Airbag Diagnosis Sensor Unit or other Airbag System sensors with the Ignition ON or engine running, DO NOT use air or electric power tools or strike near the sensor(s) with a hammer. Heavy vibration could activate the sensor(s) and deploy the air bag(s), possibly causing serious injury.
- When using air or electric power tools or hammers, always switch the Ignition OFF, disconnect the battery, and wait at least three minutes before performing any service.

A
B
C
D
E
F
G
H
I
J
K
L
M
N
O

MA

PREPARATION

< PREPARATION >

PREPARATION

PREPARATION

Special Service Tool

INFOID:000000010710181

The actual shape of the tools may differ from those illustrated here.

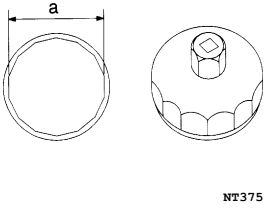
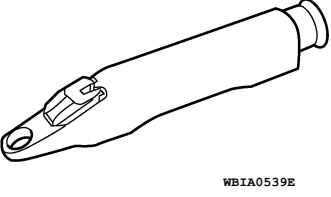
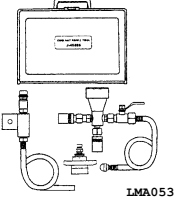
Tool number (TechMate No.) Tool name	Description
KV10115801 (J-38956) Oil filter cap wrench <div data-bbox="609 499 873 709" style="text-align: center;">  <p>NI375</p> </div>	Removing and installing oil filter a: 64.3 mm (2.531 in)
KV991J0010 (J-23688) Engine coolant refractometer <div data-bbox="609 766 938 961" style="text-align: center;">  <p>WBIA0539E</p> </div>	Checking concentration of ethylene glycol in engine coolant
KV991J0070 (J-45695) Coolant refill tool <div data-bbox="706 1008 885 1207" style="text-align: center;">  <p>LMA053</p> </div>	Filling cooling system

Commercial Service Tool

INFOID:000000010710182

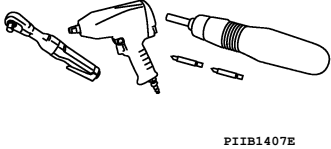
Tool name	Description
Power tool <div data-bbox="609 1459 938 1606" style="text-align: center;">  <p>PIIB1407E</p> </div>	Loosening nuts, screws and bolts

PREPARATION

< PREPARATION >

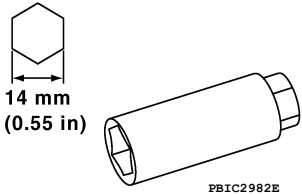
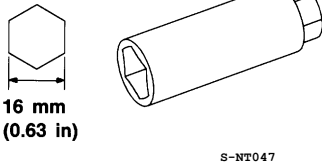
Tool name	Description
<p>Spark plug wrench</p>  <p>14 mm (0.55 in)</p> <p>PBIC2982E</p>	<p>Removing and installing spark plug for QR25DE engine</p>
<p>Spark plug wrench</p>  <p>16 mm (0.63 in)</p> <p>S-NT047</p>	<p>Removing and installing spark plug for VQ40DE engine</p>

A
B
C
D
E
F
G
H
I
J
K
L
M
N
O

MA

GENERAL MAINTENANCE

< PERIODIC MAINTENANCE >

PERIODIC MAINTENANCE

GENERAL MAINTENANCE FOR USA AND CANADA

FOR USA AND CANADA : Explanation of General Maintenance

INFOID:0000000010710183

EXPLANATION OF GENERAL MAINTENANCE

General maintenance includes those items which should be checked during the normal day-to-day operation of the vehicle. They are essential if the vehicle is to continue operating properly. The owners can perform these checks and inspections themselves or have their NISSAN dealers do them.

OUTSIDE THE VEHICLE

The maintenance items listed here should be performed from time to time, unless otherwise specified.

Item		Reference page
Tires	Check the pressure with a gauge often and always prior to long distance trips. Adjust the pressure in all tires, including the spare, to the pressure specified. Check carefully for damage, cuts or excessive wear.	WT-53, "Tire"
Wheel lug nuts	When checking the tires, make sure no nuts are missing, and check for any loose nuts. Tighten if necessary.	MA-54
Tire rotation	Tires should be rotated every 5,000 miles (8,000 km).	MA-54, "WHEELS : Rotation"
Tire Pressure Monitoring System (TPMS) transmitter components	Replace the TPMS transmitter grommet seal, valve core and cap when the tires are replaced due to wear or age.	WT-50
Wheel alignment and balance	If the vehicle should pull to either side while driving on a straight and level road, or if you detect uneven or abnormal tire wear, there may be a need for wheel alignment. If the steering wheel or seat vibrates at normal highway speeds, wheel balancing may be needed. For additional information regarding tires, refer to "Important Tire Safety Information" (US) or "Tire Safety Information" (Canada) in the NISSAN Warranty Information Booklet.	MA-52, FSU-6, "Front Wheel Alignment"
Windshield	Clean the windshield on a regular basis. Check the windshield at least every six months for cracks or other damage. Repair as necessary.	—
Windshield wiper blades	Check for cracks or wear if they do not wipe properly.	—
Doors and engine hood	Check that all doors and the engine hood operate smoothly as well as the back tail gate. Also make sure that all latches lock securely. Lubricate if necessary. Make sure that the secondary latch keeps the hood from opening when the primary latch is released. When driving in areas using road salt or other corrosive materials, check for lubrication frequently.	MA-58
Lamps	Make sure that the head lamps, stop lamps, tail lamps, turn signal lamps, and other lamps are all operating properly and installed securely. Also check head lamp aim. Clean the head lamps on a regular basis.	EXL-136, "Aiming Adjustment"

INSIDE THE VEHICLE

The maintenance items listed here should be checked on a regular basis, such as when performing periodic maintenance, cleaning the vehicle, etc.

Item		Reference page
Warning lamps and chimes	Make sure that all warning lamps and chimes are operating properly.	WCS-4, "WARNING CHIME SYSTEM : System Description"
Windshield wiper and washer	Check that the wipers and washer operate properly and that the wipers do not streak.	—
Windshield defroster	Check that the air comes out of the defroster outlets properly and in sufficient quantity when operating the heater or air conditioner.	—

GENERAL MAINTENANCE

< PERIODIC MAINTENANCE >

Item		Reference page	
Steering wheel	Check that it has the specified play. Check for changes in the steering condition, such as excessive play, hard steering or strange noises. Free play: Less than 35mm (1.38in)	ST-31, "Steering Wheel"	A
Seats	Check seat position controls such as seat adjusters, seat back recliner, etc. to make sure they operate smoothly and that all latches lock securely in every position. Check that the head restraints move up and down smoothly and that the locks (if equipped) hold securely in all latched positions. Check that the latches lock securely for folding-down rear seat backs.	—	B C
Seat belts	Check that all parts of the seat belt system (e.g. buckles, anchors, adjusters and retractors) operate properly and smoothly and are installed securely. Check the belt webbing for cuts, fraying, wear or damage.	SB-3	D
Accelerator pedal	Check the pedal for smooth operation and make sure the pedal does not catch or require uneven effort. Keep the floor mats away from the pedal.	—	E
Brakes	Check that the brake does not pull the vehicle to one side when applied.	—	F
Brake pedal and booster	Check the pedal for smooth operation and make sure it has the proper distance under it when depressed fully. Check the brake booster function. Keep the floor mats away from the pedal.	BR-10, "Inspection" , BR-17, "Inspection and Adjustment"	G
Clutch Pedal	Make sure the pedal operates smoothly and check that it has proper free play.	CL-26, "Clutch Pedal"	H
Parking brake	Check that the lever or the pedal has the proper travel and make sure that the vehicle is held securely on a fairly steep hill when only the parking brake is applied.	PB-4, "On-Vehicle Service"	
Automatic transmission "Park" mechanism	Check that the lock release button on the selector lever operates properly and smoothly. On a fairly steep hill check that the vehicle is held securely with the selector lever in the P (Park) position without applying any brakes.	—	

UNDER THE HOOD AND VEHICLE

The maintenance items listed here should be checked periodically (e.g. each time you check the engine oil or refuel).

Item		Reference page	
Windshield washer fluid	Check that there is adequate fluid in the tank.	—	I
Engine coolant level	Check the coolant level when the engine is cold.	MA-23 (QR) , MA-32 (VQ)	J
Radiator and hoses	Check the front of the radiator and clean off any dirt, insects, leaves, etc., that may have accumulated. Make sure the hoses have no cracks, deformation, deterioration or loose connections.	—	K
Brake and clutch fluid levels	Make sure that the brake and clutch fluid levels are between the "MAX" and "MIN" lines on the reservoirs	MA-54 CL-8, "Bleeding"	L
Battery	Check the fluid level in each cell. It should be between the "MAX" and "MIN" lines. Vehicles operated in high temperatures or under severe conditions require frequent checks of the battery fluid level.	—	M
Engine drive belt	Make sure that no belt is frayed, worn, cracked or oily.	MA-23 (QR) , MA-32 (VQ)	N
Engine oil level	Check the level on the oil level gauge after parking the vehicle on a level spot and turning off the engine.	MA-27 (QR) , MA-37 (VQ)	O
Power steering fluid level and lines	Check the level when the fluid is cold, with the engine off. Check the lines for proper attachment, leaks, cracks, etc.	MA-56	
Automatic transmission fluid level	Check the level on the dipstick after putting the shift selector in P (Park) with the engine idling.	MA-43	
Exhaust system	Make sure there are no loose supports, cracks or holes. If the sound of the exhaust seems unusual or there is a smell of exhaust fumes, immediately locate the trouble and correct it.	MA-43	MA

GENERAL MAINTENANCE

< PERIODIC MAINTENANCE >

Item		Reference page
Underbody	The underbody is frequently exposed to corrosive substances such as those used on icy roads or to control dust. It is very important to remove these substances, otherwise rust will form on the floor pan, frame, fuel lines and around the exhaust system. At the end of winter, the underbody should be thoroughly flushed with plain water, being careful to clean those areas where mud and dirt can easily accumulate.	—
Fluid leaks	Check under the vehicle for fuel, oil, water or other fluid leaks after the vehicle has been parked for a while. Water dripping from the air conditioner after use is normal. If you should notice any leaks or gasoline fumes are evident, check for the cause and correct it immediately.	—

FOR MEXICO

FOR MEXICO : General Maintenance

INFOID:000000010710184

OUTSIDE THE VEHICLE

The maintenance items listed here should be performed from time to time, unless otherwise specified.

Item		Reference page
Doors and hood	Check that all doors and the hood operate smoothly as well as the rear door, trunk lid and hatch. Also make sure that all latches lock securely. Lubricate if necessary. Make sure that the secondary latch keeps the hood from opening when the primary latch is released. When driving in areas using road salt or other corrosive materials, check lubrication frequently.	MA-58
Lamps	Clean the headlamps on a regular basis. Make sure that the headlamps, stop lamps, tail lamps, turn signal lamps, and other lamps are all operating properly and installed securely. Also check the aim of the headlamps.	—
Tires	Check the pressure with a gauge often and always prior to long distance trips. Adjust the pressure in all tires, including the spare, to the pressure specified. Check carefully for damage, cuts or excessive wear.	WT-53, "Tire"
Tire rotation	In the case that Two-Wheel Drive (2WD) and front & rear tires are same size; Tires should be rotated every 10,000 km (6,000 miles). Tires marked with directional indicators can only be rotated between front and rear. Make sure that the directional indicators point in the direction of wheel rotation after the tire rotation is completed. In the case that Four-Wheel Drive (4WD) and front & rear tires are same size; Tires should be rotated every 5,000 km (3,000 miles). Tires marked with directional indicators can only be rotated between front and rear. Make sure that the directional indicators point in the direction of wheel rotation after the tire rotation is completed. In the case that front tires are different size from rear tires; Tires cannot be rotated. However, the timing for tire rotation may vary according to your driving habits and the road surface conditions.	MA-54, "WHEELS : Rotation"
Tire Pressure Monitoring System (TPMS) transmitter components	Replace the TPMS transmitter grommet seal, valve core and cap when the tires are replaced due to wear or age.	WT-50, "Transmitter (Pressure Sensor)"
Wheel alignment and balance	If the vehicle should pull to either side while driving on a straight and level road, or if you detect uneven or abnormal tire wear, there may be a need for wheel alignment. If the steering wheel or seat vibrates at normal highway speeds, wheel balancing may be needed.	MA-52, FSU-6, "Front Wheel Alignment"
Windshield	Clean the windshield on a regular basis. Check the windshield at least every six months for cracks or other damage. Repair as necessary.	—
Wiper blades	Check for cracks or wear if not functioning correctly.	—

INSIDE THE VEHICLE

GENERAL MAINTENANCE

< PERIODIC MAINTENANCE >

The maintenance items listed here should be checked on a regular basis, such as when performing periodic maintenance, cleaning the vehicle, etc.

	Item	Reference page
Accelerator pedal	Check the pedal for smooth operation and make sure that the pedal does not catch or require uneven effort. Keep the floor mats away from the pedal.	—
Brake pedal	Check the pedal for smooth operation and make sure that it is the proper distance from the floor mat when depressed fully. Check the brake booster function. Be sure to keep the floor mats away from the pedal.	BR-10, "Inspection"
Parking brake	Check the parking brake operation regularly. Check that the lever (if equipped) or the pedal (if equipped) has the proper travel. Also make sure that the vehicle is held securely on a fairly steep hill when only the parking brake is applied.	PB-4, "On-Vehicle Service"
Seat belts	Check that all parts of the seat belt system (for example, buckles, anchors, adjusters and retractors) operate properly and smoothly, and are installed securely. Check the belt webbing for cuts, fraying, wear or damage.	SB-3
Steering wheel	Check for changes in the steering condition, such as excessive play, hard steering or strange noises. Check that it has the specified play. Free play: Less than 35 mm (1.38 in)	—
Warning lamps and chimes	Make sure that all warning lamps and chimes are operating properly.	—
Windshield defogger	Check that the air comes out of the defogger outlets properly and in good quantity when operating the heater or air conditioner.	—
Windshield wiper and washer	Check that the wipers and washer operate properly and that the wipers do not streak.	—

UNDER THE HOOD AND VEHICLE

The maintenance items listed here should be checked periodically (for example, each time you check the engine oil or refuel.)

	Item	Reference page
Battery	Except for maintenance free battery; Check the fluid level in each cell. It should be between the "UPPER" and "LOWER" lines. Vehicles operated in high temperatures or under severe conditions require frequent checks of the battery fluid level.	—
Brake (and clutch) fluid level(s)	For Manual Transmission (MT) model; Make sure that the brake and clutch fluid levels are between the "MAX" and "MIN" lines on the reservoir(s). Except for Manual Transmission (MT) model; Make sure that the brake fluid level is between the "MAX" and "MIN" lines on the reservoir.	MA-54
Coolant level	Check the coolant level when the coolant is cold. Make sure that the coolant level is between the "MAX" and "MIN" lines on the reservoir.	MA-23 (QR) , MA-32 (VQ)
Engine drive belt(s)	Make sure that drive belt(s) is/are not frayed, worn, cracked or oily.	MA-23 (QR) , MA-32 (VQ)
Engine oil level	Check the level after parking the vehicle (on a level ground) and turning off the engine.	MA-27 (QR) , MA-37 (VQ)
Fluid leaks	Check under the vehicle for fuel, oil, water or other fluid leaks after the vehicle has been parked for a while. Water dripping from the air conditioner after use is normal. If you should notice any leaks or if fuel fumes are evident, check for cause and have it corrected immediately.	—
Power steering fluid level and lines	Check the level when the fluid is cold with the engine off. Check the lines for proper attachment, leaks, cracks, etc.	MA-56
Windshield washer fluid	Check that there is adequate fluid in the reservoir.	—

A
B
C
D
E
F
G
H
I
J
K
L
M
N
O

MA

PERIODIC MAINTENANCE

< PERIODIC MAINTENANCE >

PERIODIC MAINTENANCE FOR USA AND CANADA

FOR USA AND CANADA : Periodic Maintenance

INFOID:000000010710185

The following tables show the normal maintenance schedule. Depending upon weather and atmospheric conditions, varying road surfaces, individual driving habits and vehicle usage, additional or more frequent maintenance may be required.

Periodic maintenance beyond the last period shown on the tables requires similar maintenance.

Emission Control System Maintenance

Abbreviations: R = Replace. I = Inspect. Correct or replace if necessary.

MAINTENANCE OPERATION		MAINTENANCE INTERVAL								
Perform at number of miles, kilometers or months, whichever comes first.	Miles x 1,000 (km x 1,000)	5 (8)	10 (16)	15 (24)	20 (32)	25 (40)	30 (48)	35 (56)	40 (64)	45 (72)
	Months	6	12	18	24	30	36	42	48	54
Drive belt	NOTE (1)								I*	
Air cleaner filter	NOTE (2)						R			
EVAP vapor lines					I*				I*	
Fuel lines					I*				I*	
Fuel filter	NOTE (3)									
Engine coolant*	NOTE (4)(5)									
Engine oil		R	R	R	R	R	R	R	R	R
Engine oil filter		R	R	R	R	R	R	R	R	R
Spark plugs (Platinum-tipped type for QR engine and iridium-tipped type for VQ engine)		Replace every 105,000 miles (168,000 km)								
Intake and exhaust valve clearance*	NOTE (6)									

MAINTENANCE OPERATION		MAINTENANCE INTERVAL								
Perform at number of miles, kilometers or months, whichever comes first.	Miles x 1,000 (km x 1,000)	50 (80)	55 (88)	60 (96)	65 (104)	70 (112)	75 (120)	80 (128)	85 (136)	90 (144)
	Months	60	66	72	78	84	90	96	102	108
Drive belt	NOTE (1)	I*		I*		I*		I*		I*
Air cleaner filter	NOTE (2)			R						R
EVAP vapor lines				I*				I*		
Fuel lines				I*				I*		
Fuel filter	NOTE (3)									
Engine coolant*	NOTE (4)(5)									
Engine oil		R	R	R	R	R	R	R	R	R
Engine oil filter		R	R	R	R	R	R	R	R	R
Spark plugs (Platinum-tipped type for QR engine and iridium-tipped type for VQ engine)		Replace every 105,000 miles (168,000 km)								
Intake and exhaust valve clearance*	NOTE (6)									

PERIODIC MAINTENANCE

< PERIODIC MAINTENANCE >

MAINTENANCE OPERATION		MAINTENANCE INTERVAL						Reference Page
		Miles x 1,000 (km x 1,000) Months	95 (152) 114	100 (160) 120	105 (168) 126	110 (176) 132	115 (184) 138	
Perform at number of miles, kilometers or months, whichever comes first.								
Drive belt	NOTE (1)		I*			I*		MA-23 (QR) MA-32 (VQ)
Air cleaner filter	NOTE (2)						R	MA-26 (QR) MA-37 (VQ)
EVAP vapor lines			I*				I*	MA-31 (QR) MA-41 (VQ)
Fuel lines			I*				I*	MA-26 (QR) MA-36 (VQ)
Fuel filter	NOTE (3)							—
Engine coolant*	NOTE (4)(5)							MA-23 (QR) MA-32 (VQ)
Engine oil		R	R	R	R	R	R	MA-27 (QR) MA-37 (VQ)
Engine oil filter		R	R	R	R	R	R	MA-28 (QR) MA-38 (VQ)
Spark plugs (Platinum-tipped type for QR engine and iridium-tipped type for VQ engine)		Replace every 105,000 miles (168,000 km)						MA-29 (QR) MA-40 (VQ)
Intake and exhaust valve clearance*	NOTE (6)							EM-23 (QR) EM-138 (VQ)

NOTE:

- (1) After 40,000 miles (64,000 km) or 48 months, inspect every 10,000 miles (16,000 km) or 12 months. Replace the drive belts if found damaged.
- (2) If operating mainly in dusty conditions, more frequent maintenance may be required.
- (3) Maintenance-free item. For service procedures, refer to the FL section.
- (4) First replacement interval is 105,000 miles (168,000 km) or 84 months. After first replacement, replace every 75,000 miles (120,000 km) or 60 months.
- (5) Use only Genuine NISSAN Long Life Antifreeze/Coolant (blue) or equivalent with proper mixture ratio of 50% anti-freeze and 50% demineralized or distilled water. Mixing any other type of coolant or the use of non-distilled water will reduce the life expectancy of the factory fill coolant.
- (6) Periodic maintenance is not required. However, if valve noise increases, inspect valve clearance.

* Maintenance items and intervals with "*" are recommended by NISSAN for reliable vehicle operation. The owner need not perform such maintenance in order to maintain the emission warranty or manufacturer recall liability. Other maintenance items and intervals are required.

Chassis and Body Maintenance

Abbreviations: R = Replace. I = Inspect. Correct or replace if necessary.

MAINTENANCE OPERATION		MAINTENANCE INTERVAL								
		Miles x 1,000 (km x 1,000) Months	5 (8) 6	10 (16) 12	15 (24) 18	20 (32) 24	25 (40) 30	30 (48) 36	35 (56) 42	40 (64) 48
Perform at number of miles, kilometers or months, whichever comes first.										
Brake lines & cables			I			I		I		I
Brake pads & rotors★			I			I		I		I
Brake fluid★						R				R
Automatic transmission fluid	NOTE (1)		I			I		I		I
Manual transmission gear oil, transfer fluid & differential gear oil	NOTE (2)		I			I		I		I
Steering gear & linkage, axle & suspension parts★						I				I

PERIODIC MAINTENANCE

< PERIODIC MAINTENANCE >

MAINTENANCE OPERATION		MAINTENANCE INTERVAL								
Perform at number of miles, kilometers or months, whichever comes first.	Miles x 1,000 (km x 1,000)	5 (8)	10 (16)	15 (24)	20 (32)	25 (40)	30 (48)	35 (56)	40 (64)	45 (72)
	Months	6	12	18	24	30	36	42	48	54
Tire rotation	NOTE (3)									
Propeller shaft & drive shaft boots (AWD models)★			I		I		I		I	
Exhaust system★					I				I	
In-cabin microfilter				R			R			R

MAINTENANCE OPERATION		MAINTENANCE INTERVAL								
Perform at number of miles, kilometers or months, whichever comes first.	Miles x 1,000 (km x 1,000)	50 (80)	55 (88)	60 (96)	65 (104)	70 (112)	75 (120)	80 (128)	85 (136)	90 (144)
	Months	60	66	72	78	84	90	96	102	108
Brake lines & cables		I		I		I		I		I
Brake pads & rotors★		I		I		I		I		I
Brake fluid★				R				R		
Automatic transmission fluid	NOTE (1)	I		I		I		I		I
Manual transmission gear oil, transfer fluid & differential gear oil	NOTE (2)	I		I		I		I		I
Steering gear & linkage, axle & suspension parts★				I				I		
Tire rotation	NOTE (3)									
Propeller shaft & drive shaft boots (AWD models)★		I		I		I		I		I
Exhaust system★				I				I		
In-cabin microfilter				R			R			R

MAINTENANCE OPERATION		MAINTENANCE INTERVAL						Reference Page
Perform at number of miles, kilometers or months, whichever comes first.	Miles x 1,000 (km x 1,000)	95 (152)	100 (160)	105 (168)	110 (176)	115 (184)	120 (192)	
	Months	114	120	126	132	138	144	
Brake lines & cables			I		I		I	MA-55
Brake pads & rotors★			I		I		I	MA-55
Brake fluid★			R				R	MA-54
Automatic transmission fluid	NOTE (1)		I		I		I	MA-43
Manual transmission gear oil, transfer fluid & differential gear oil	NOTE (2)		I		I		I	MA-46 MA-46 MA-48
Steering gear & linkage, axle & suspension parts★			I				I	MA-56 MA-58
Tire rotation	NOTE (3)							MA-54
Propeller shaft & drive shaft boots (AWD models)★			I		I		I	MA-48
Exhaust system★			I				I	MA-43
In-cabin microfilter				R			R	MA-42

NOTE:

- Maintenance items with “★” should be performed more frequently according to “Maintenance Under Severe Driving Conditions”.

PERIODIC MAINTENANCE

< PERIODIC MAINTENANCE >

- (1) If towing a trailer, using a car-top carrier, or driving on rough or muddy roads, change (not just inspect) oil at every 30,000 miles (48,000 km) or 24 months. Using automatic transmission fluid other than Genuine NISSAN Matic S ATF or Matic J ATF will cause deterioration in driveability and automatic transmission durability, and may damage the automatic transmission, which is not covered by the NISSAN new vehicle limited warranty.
- (2) If towing a trailer, using a camper or car-top carrier, or driving on rough or muddy roads, change (not just inspect) oil at every 20,000 miles (32,000 km) or 24 months.
- (3) Refer to "Tire rotation" under the "GENERAL MAINTENANCE" heading earlier in this section.

MAINTENANCE UNDER SEVERE DRIVING CONDITIONS

The maintenance intervals shown on the preceding pages are for normal operating conditions. If the vehicle is mainly operated under severe driving conditions as shown below, more frequent maintenance must be performed on the following items as shown in the table.

Severe driving conditions

- Repeated short trips of less than 5 miles (8 km).
- Repeated short trips of less than 10 miles (16 km) with outside temperatures remaining below freezing.
- Operating in hot weather in stop-and-go "rush hour" traffic.
- Extensive idling and/or low speed driving for long distances, such as police, taxi or door-to-door delivery use.
- Driving in dusty conditions.
- Driving on rough, muddy, or salt spread roads.
- Towing a trailer, using a camper or a car-top carrier.

Maintenance operation: Inspect = Inspect and correct or replace as necessary.

Maintenance item	Maintenance operation	Maintenance interval	Reference page
Brake fluid	Replace	Every 10,000 miles (16,000 km) or 12 months	MA-54
Brake pads & rotors	Inspect	Every 5,000 miles (8,000 km) or 6 months	MA-55
Steering gear & linkage, axle & suspension parts	Inspect	Every 5,000 miles (8,000 km) or 6 months	MA-56 MA-58
Propeller shaft & drive shaft boots (AWD models)	Inspect	Every 5,000 miles (8,000 km) or 6 months	MA-48
Exhaust system	Inspect	Every 5,000 miles (8,000 km) or 6 months	MA-43

FOR MEXICO

FOR MEXICO : Periodic Maintenance

INFOID:000000010710186

The following tables show the normal maintenance schedule. Depending upon weather and atmospheric conditions, varying road surfaces, individual driving habits and vehicle usage, additional or more frequent maintenance may be required.

Periodic maintenance beyond the last period shown on the tables requires similar maintenance.

ENGINE AND EMISSION CONTROL MAINTENANCE

Abbreviations: I = Inspect and correct or replace as necessary, R = Replace, E = Check and correct the engine coolant mixture ratio

MAINTENANCE OPERATION	km x 1,000 (Miles x 1,000) Months	MAINTENANCE INTERVAL								Refer- ence page
		10 (6)	20 (12)	30 (18)	40 (24)	50 (30)	60 (36)	70 (42)	80 (48)	
Perform either at number of kilometers (miles) or months, whichever comes first.		6	12	18	24	30	36	42	48	

Engine compartment and under vehicle

Intake & exhaust valve clearance	NOTE (1)									EM-248
Drive belts	NOTE (2)				I				I	MA-32
Engine oil (Use recommended oil)★		R	R	R	R	R	R	R	R	MA-38
Engine oil filter (Use Genuine NISSAN engine oil filter or equivalent) ★		R	R	R	R	R	R	R	R	MA-38
Engine coolant	NOTE (3)				E				E	MA-33

PERIODIC MAINTENANCE

< PERIODIC MAINTENANCE >

MAINTENANCE OPERATION		MAINTENANCE INTERVAL								Reference page
	km x 1,000 (Miles x 1,000) Months	10 (6) 6	20 (12) 12	30 (18) 18	40 (24) 24	50 (30) 30	60 (36) 36	70 (42) 42	80 (48) 48	
Perform either at number of kilometers (miles) or months, whichever comes first.										
Cooling system					I				I	MA-32
Fuel lines and EVAP vapor lines					I				I	MA-36
Air cleaner filter (Viscous paper type)★					R				R	MA-37
Fuel filter	NOTE (4)									—
Spark plugs (Iridium-tipped type)		Replace every 100,000 km (60,000 miles)								MA-40

NOTE:

★ Maintenance items with “★” should be performed more frequently according to “Maintenance Under Severe Driving Conditions”.

(1) Periodic maintenance is not required. However, if valve noise increases, check valve clearance.

(2) Replace the drive belts if found damaged or if the auto belt tensioner reading reaches the maximum limit.

(3) Use Genuine NISSAN Engine Coolant (blue) or equivalent in its quality, in order to avoid possible aluminum corrosion within the engine cooling system caused by the use of non-genuine engine coolant. Check and correct the engine coolant mixture ratio every 40,000 km (24,000 miles) or 24 months. First replacement interval is 160,000 km (96,000 miles) or 96 months. After first replacement, replace every 80,000 km (48,000 miles) or 48 months.

(4) Fuel filter is maintenance-free. For service procedures, refer to FL section.

CHASSIS AND BODY MAINTENANCE

Abbreviations: I = Inspect and correct or replace as necessary, R = Replace

MAINTENANCE OPERATION		MAINTENANCE INTERVAL								Reference page
	km x 1,000 (Miles x 1,000) Months	10 (6) 6	20 (12) 12	30 (18) 18	40 (24) 24	50 (30) 30	60 (36) 36	70 (42) 42	80 (48) 48	
Underhood and under vehicle										
Brake line & cable			I		I		I		I	MA-55
Brake fluid (For level & leaks)			I		I		I		I	MA-54
Brake fluid ★					R				R	MA-54
Automatic transmission fluid (For level & leaks)			I		I		I		I	BR-12
Power steering fluid & lines (For level & leaks)			I		I		I		I	MA-56
Exhaust system					I				I	MA-43
Transfer gear fluid (For level & leaks)			I		I		I		I	MA-47
Differential gear oil (For level & leaks) ★			I		I		I		I	MA-50, MA-51
Steering gear & linkage, axle & suspension parts ★					I				I	MA-56 MA-48
Propeller shaft and drive shafts ★			I		I		I		I	—
Outside and inside										
Wheel alignment (If necessary, rotate & balance wheels)			I		I		I		I	MA-54 MA-52,
Brake pads, rotors, drums & linings ★			I		I		I		I	MA-55
Foot brake & parking brake (For free play, stroke & operation)			I		I		I		I	PB-4,
Air conditioner filter ★			R		R		R		R	MA-42

★ : Maintenance items with “★” should be performed more frequently according to “Maintenance Under Severe Driving Conditions”.

PERIODIC MAINTENANCE

< PERIODIC MAINTENANCE >

MAINTENANCE UNDER SEVERE DRIVING CONDITIONS

The maintenance intervals shown on the preceding pages are for normal operating conditions. If the vehicle is mainly operated under severe driving conditions as shown below, more frequent maintenance must be performed on the following items as shown in the table.

Severe driving conditions

- A — Driving under dusty conditions
- B — Driving repeatedly short distances
- C — Towing a trailer or caravan
- D — Extensive idling
- E — Driving in extremely adverse weather conditions or in areas where ambient temperatures are either extremely low or extremely high
- F — Driving in high humidity or mountainous areas
- G — Driving in areas using salt or other corrosive materials
- H — Driving on rough and/or muddy roads or in the desert
- I — Driving with frequent use of braking or in mountainous areas

Driving condition										Maintenance item		Maintenance operation	Maintenance interval	Reference page
A	Air cleaner filter	Viscous paper filter	Replace	More frequently	MA-37 MA-42
A	B	C	D	Engine oil and engine oil filter		Replace	Every 5,000 km (3,000 miles) or 3 months	MA-38 MA-38
.	F	Brake fluid		Replace	Every 20,000 km (12,000 miles) or 12 months	MA-54
.	.	C	H	.	Automatic transmission fluid		Replace	Every 40,000 km (24,000 miles) or 24 months	MA-45
.	.	C	H	.	Differential gear oil		Replace	Every 40,000 km (24,000 miles) or 24 months	MA-50 MA-51
.	G	H	.	Steering gear & linkage, axle & suspension parts		Inspect	Every 20,000 km (12,000 miles) or 12 months	MA-56 , MA-56
.	G	H	.	Propeller shaft & drive shafts		Inspect	Every 10,000 km (6,000 miles) or 6 months	MA-56
A	.	C	G	H	I	Brake pads, rotors, drums & linings		Inspect	Every 10,000 km (6,000 miles) or 6 months	MA-55
A	Air conditioner filter		Replace	More frequently	MA-42

MAINTENANCE FOR OFF-ROAD DRIVING (4WD ONLY)

Whenever you drive off-road through sand, mud or water, more frequent maintenance may be required of the following items.

- Brake pads and rotors
- Brake lines and hoses
- Differential gear oil, transfer fluid and automatic transmission fluid
- Steering linkage
- Propeller shafts and front drive shafts
- Air cleaner filter

A
B
C
D
E
F
G
H
I
J
K
L
M
N
O

MA

RECOMMENDED FLUIDS AND LUBRICANTS

< PERIODIC MAINTENANCE >

RECOMMENDED FLUIDS AND LUBRICANTS FOR USA AND CANADA

FOR USA AND CANADA : Fluids and Lubricants

INFOID:000000010710187

QR25DE

NOTE:

The following are approximate capacities. The actual capacities may be slightly different. When refilling, follow the procedures described elsewhere in this manual.

Description		Capacity (Approximate)			Recommended Fluids/Lubricants
		Metric	US measure	Imp measure	
Fuel		80 ℓ	21-1/8 gal	17-5/8 gal	Unleaded gasoline with an octane rating of at least 87 AKI (RON 91) • For further details. Refer to GI-31, "Fuel (Regular Unleaded Gasoline Recommended) QR25DE and VQ40DE" .
Engine oil Drain and refill	With oil filter change	4.6 ℓ	4-7/8 qt	4 qt	• Genuine NISSAN engine oil or equivalent • Engine oil with API Certification Mark - For further details. Refer to MA-18, "FOR USA AND CANADA : SAE Viscosity Number" .
	Without oil filter change	4.3 ℓ	4-1/2 qt	3-3/4 qt	
Dry engine (engine overhaul)		5.0 ℓ	5-1/4 qt	4-3/8 qt	Viscosity SAE 5W-30 • As an alternative to this recommended oil, SAE 5W-30 or SAE 10W-30 conventional petroleum based oils may be used and meet all specifications and requirements necessary to maintain the New Vehicle Limited Warranty.
Cooling system	With reservoir at MAX level	9.4 ℓ	10 qt	8-1/4 qt	Pre-diluted Genuine NISSAN Long Life Antifreeze/ Coolant (blue) or equivalent
Automatic transmission fluid (ATF)		10.3 ℓ	10-7/8 qt	9-1/8 qt	Genuine NISSAN Matic S ATF • If Genuine NISSAN Matic S ATF is not available, Genuine NISSAN Matic J ATF may also be used. Using automatic transmission fluid other than Genuine NISSAN Matic S ATF or Genuine NISSAN Matic J ATF will cause deterioration in driveability and automatic transmission durability, and may damage the automatic transmission, which is not covered by the NISSAN new vehicle limited warranty.
Manual transmission fluid (MTF) (5 M/T)		2.9 ℓ	6-1/8 pt	5-1/8 pt	Genuine NISSAN Manual Transmission Fluid (MTF) HQ Multi 75W-85 • API GL-4 Viscosity SAE 75W-85 may be used as a temporary replacement for Genuine NISSAN Manual Transmission Fluid (MTF) HQ Multi 75W-85. However, NISSAN recommends the use of Genuine NISSAN gear oil, available at NISSAN dealer.
Rear final drive oil	C200	1.6 ℓ	3-3/8 pt	2-7/8 pt	API GL-5 synthetic gear oil, Viscosity SAE 75W-90 • See a NISSAN dealer for service for synthetic oil.
Power steering fluid (PSF)		1.0 ℓ	2-1/8 pt	1-3/4 pt	Genuine NISSAN PSF or equivalent • DEXRON™ VI type ATF may also be used.

RECOMMENDED FLUIDS AND LUBRICANTS

< PERIODIC MAINTENANCE >

Description	Capacity (Approximate)			Recommended Fluids/Lubricants
	Metric	US measure	Imp measure	
Brake and clutch fluids	—	—	—	Genuine NISSAN Super Heavy Duty Brake Fluid or equivalent, DOT 3 (US FMVSS No. 116) • Available in mainland U.S.A. through a NISSAN dealer.
Multi-purpose grease	—	—	—	NLGI No. 2 (Lithium soap base)
Windshield washer fluid	4.5 ℓ	1-1/4 gal	1 gal	Genuine NISSAN Windshield Washer Concentrate Cleaner & Anti-freeze or equivalent
Air conditioning system refrigerant	0.70 ± 0.05 kg	1.54 ± 0.11 lb	1.54 ± 0.11 lb	HFC-134a (R-134a) • For further details, see "Air conditioner specification label".
Air conditioning system oil	180 m ℓ	6.1 fl oz	6.3 fl oz	A/C System Oil Type R (DH-PR) • For further details, see "Air conditioner specification label".

VQ40DE

NOTE:

The following are approximate capacities. The actual capacities may be slightly different. When refilling, follow the procedures described elsewhere in this manual.

Description		Capacity (Approximate)			Recommended Fluids/Lubricants
		Metric	US measure	Imp measure	
Fuel		80 ℓ	21-1/8 gal	17-5/8 gal	Unleaded gasoline with an octane rating of at least 87 AKI (RON 91) • For further details. Refer to GI-31, "Fuel (Regular Unleaded Gasoline Recommended) QR25DE and VQ40DE" .
Engine oil Drain and refill	With oil filter change	5.1 ℓ	5-3/8 qt	4-1/2 qt	• Genuine NISSAN engine oil or equivalent - NISSAN recommends Genuine NISSAN Ester Oil available at a NISSAN dealer. • Engine oil with API Certification Mark - For further details. Refer to MA-18, "FOR USA AND CANADA : SAE Viscosity Number" . Viscosity SAE 5W-30
	Without oil filter change	4.8 ℓ	5-1/8 qt	4-1/4 qt	
Dry engine (engine overhaul)		6.3 ℓ	6 5/8 qt	5-1/2 qt	
Cooling system	With reservoir at MAX level	10.2 ℓ	10-3/4 qt	9 qt	Pre-diluted Genuine NISSAN Long Life Antifreeze/ Coolant (blue) or equivalent
Automatic transmission fluid (ATF)		10.3 ℓ	10-7/8 qt	9-1/8 qt	Genuine NISSAN Matic S ATF • If Genuine NISSAN Matic S ATF is not available, Genuine NISSAN Matic J ATF may also be used. Using automatic transmission fluid other than Genuine NISSAN Matic S ATF or Genuine NISSAN Matic J ATF will cause deterioration in driveability and automatic transmission durability, and may damage the automatic transmission, which is not covered by the NISSAN new vehicle limited warranty.

RECOMMENDED FLUIDS AND LUBRICANTS

< PERIODIC MAINTENANCE >

Description		Capacity (Approximate)			Recommended Fluids/Lubricants
		Metric	US measure	Imp measure	
Manual transmission fluid (MTF) (6 M/T)	2WD	4.0 ℓ	8-3/8 pt	7 pt	Genuine NISSAN Manual Transmission Fluid (MTF) HQ Multi 75W-85 <ul style="list-style-type: none"> API GL-4 Viscosity SAE 75W-85 may be used as a temporary replacement for Genuine NISSAN Manual Transmission Fluid (MTF) HQ Multi 75W-85. However, NISSAN recommends the use of Genuine NISSAN gear oil, available at NISSAN dealer.
	4WD	4.2 ℓ	8-7/8 pt	7-3/8 pt	
Rear final drive oil	C200	1.6 ℓ	3-3/8 pt	2-7/8 pt	API GL-5 synthetic gear oil, Viscosity SAE 75W-90 <ul style="list-style-type: none"> See a NISSAN dealer for service for synthetic oil.
	M226	2.01 ℓ	4-1/4 pt	3-1/2 pt	
Transfer fluid	TX15B	2.0 ℓ	2-1/8 qt	1-3/4 qt	Genuine NISSAN Matic D ATF recommended. <ul style="list-style-type: none"> Using fluid other than Genuine NISSAN Matic D ATF will cause deterioration in driveability and transfer durability, and may damage the transfer, which is not covered by the NISSAN new vehicle limited warranty.
Front final drive oil		0.85 ℓ	1-3/4 pt	1-1/2 pt	Genuine NISSAN Differential Oil Hypoid Super GL-5 80W-90 or API GL-5 Viscosity SAE 80W-90 <ul style="list-style-type: none"> For hot climates, viscosity SAE 90 is suitable for ambient temperatures above 0° C (32° F).
Power steering fluid (PSF)		1.0 ℓ	2-1/8 pt	1-3/4 pt	Genuine NISSAN PSF or equivalent <ul style="list-style-type: none"> DEXRON™ VI type ATF may also be used.
Brake and clutch fluid		—	—	—	Genuine NISSAN Super Heavy Duty Brake Fluid or equivalent, DOT 3 (US FMVSS No. 116) <ul style="list-style-type: none"> Available in mainland U.S.A. through a NISSAN dealer.
Multi-purpose grease		—	—	—	NLGI No. 2 (Lithium soap base)
Windshield washer fluid		4.5 ℓ	1-1/4 gal	1 gal	Genuine NISSAN Windshield Washer Concentrate Cleaner & Anti-freeze or equivalent
A/C system refrigerant		0.70 ± 0.05 kg	1.54 ± 0.11 lb	1.54 ± 0.11 lb	HFC-134a (R134a) <ul style="list-style-type: none"> For further details, see "Air conditioner Specification Label".
A/C system oil		180 m ℓ	6.1 fl oz	6.3 fl oz	A/C System Oil Type R (DH-PR) <ul style="list-style-type: none"> For further details, see "Air conditioner Specification Label".

FOR USA AND CANADA : SAE Viscosity Number

INFOID:000000010710188

NISSAN recommends the use of an energy conserving oil in order to improve fuel economy. Select only engine oils that meet the American Petroleum Institute (API) certification and International Lubricant Standardization and Approval Committee (ILSAC) certification and SAE viscosity standard (2). These oils have the API

RECOMMENDED FLUIDS AND LUBRICANTS

< PERIODIC MAINTENANCE >

certification mark (1) on the front of the container. Oils which do not have the specified quality label should not be used as they could cause engine damage.



1. API certification mark 2. API service symbol

FOR USA AND CANADA : Anti-Freeze Coolant Mixture Ratio

INFOID:000000010710189

The engine cooling system is filled at the factory with a pre-diluted mixture of 50% Genuine NISSAN Long Life Antifreeze/Coolant (blue) and 50% water to provide year-round anti-freeze and coolant protection. The anti-freeze solution contains rust and corrosion inhibitors. Additional engine cooling system additives are not necessary.

WARNING:

- Do not remove the radiator or coolant reservoir cap when the engine is hot. Wait until the engine and radiator cool down. Serious burns could be caused by high pressure fluid escaping from the radiator.
- The radiator is equipped with a pressure type radiator cap. To prevent engine damage, use only a genuine NISSAN radiator cap.

CAUTION:

- When adding or replacing coolant, be sure to use only Genuine NISSAN Long Life Antifreeze/Coolant (blue) or equivalent. Genuine NISSAN Long Life Antifreeze/Coolant (blue) is pre-diluted to provide antifreeze protection to -34°F (-37°C). If additional freeze protection is needed due to weather where the vehicle is operated, add Genuine NISSAN long life Antifreeze/Coolant (blue) concentrate following the directions on the container. If an equivalent coolant other than Genuine NISSAN Long Life Antifreeze/Coolant (blue) is used, follow the coolant manufacturer's instructions to maintain minimum antifreeze protection to -34°F (-37°C). The use of other types of coolant solutions other than Genuine NISSAN Long Life Antifreeze/Coolant (blue) or equivalent may damage the engine cooling system.
- Mixing any other type of coolant other than Genuine NISSAN Long Life Antifreeze/Coolant (blue), including Genuine NISSAN Long Life Antifreeze/Coolant (green), or the use of non-distilled water will reduce the life expectancy of the factory filled coolant.

FOR MEXICO

FOR MEXICO : Fluids and Lubricants

INFOID:000000010710190

VQ40DE

NOTE:

The following are approximate capacities. The actual capacities may be slightly different. When refilling, follow the procedures described elsewhere in this manual.

Description	Capacity (Approximate)			Recommended Fluids/Lubricants
	Metric	US measure	Imp measure	
Fuel	80 ℓ	21-1/8 gal	17-5/8 gal	Unleaded gasoline with an octane rating of at least 87 AKI (RON 91)

A
B
C
D
E
F
G
H
I
J
K
L
M
N
O

MA

RECOMMENDED FLUIDS AND LUBRICANTS

< PERIODIC MAINTENANCE >

Description		Capacity (Approximate)			Recommended Fluids/Lubricants
		Metric	US measure	Imp measure	
Engine oil Drain and refill	With oil filter change	5.1 ℓ	5-3/8 qt	4-1/2 qt	Genuine NISSAN engine oil • For further details. Refer to MA-21 , "FOR MEXICO : SAE Viscosity Number" .
	Without oil filter change	4.8 ℓ	5-1/8 qt	4-1/4 qt	
Dry engine (engine overhaul)		6.3 ℓ	6-5/8 qt	5-1/2 qt	API grade SL, SM or SN • For further details. Refer to MA-21 , "FOR MEXICO : SAE Viscosity Number" . ILSAC grade GF-3, GF-4 or GF-5 • For further details. Refer to MA-21 , "FOR MEXICO : SAE Viscosity Number" .
Cooling system (with reservoir at "MAX" level)		10.2 ℓ	10-3/4 qt	9 qt	Genuine NISSAN Engine Coolant (blue) or equivalent • Use Genuine NISSAN Engine Coolant (blue) or equivalent in quality, in order to avoid possible aluminium corrosion within the engine cooling system caused by the use of non-genuine engine coolant.
Automatic transmission fluid (ATF)		10.3 ℓ	10-7/8 qt	9-1/8 qt	Genuine NISSAN Matic S ATF • If Genuine NISSAN Matic S ATF is not available, Genuine NISSAN Matic J ATF may also be used. Using automatic transmission fluid other than Genuine NISSAN Matic S ATF or Matic J ATF will cause deterioration in driveability and automatic transmission durability, and may damage the automatic transmission, which is not covered by the warranty.
Rear final drive oil		2.01 ℓ	4-1/4 pt	3-1/2 pt	Genuine NISSAN Differential Oil Hypoid Super-S GL-5 synthetic, 75W-90 or equivalent • See a NISSAN dealer for service for synthetic oil.
Transfer fluid		2.0 ℓ	2-1/8 qt	1-3/4 qt	Genuine NISSAN Matic D ATF recommended • Using fluid other than Genuine NISSAN Matic D ATF will cause deterioration in driveability and transfer durability, and may damage the transfer, which is not covered by the warranty.
Front final drive oil		0.85 ℓ	1-3/4 pt	1-1/2 pt	Genuine NISSAN Differential Oil Hypoid Super GL-5 80W-90 or API GL-5 Viscosity SAE 80W-90
Power steering fluid (PSF)		1.0 ℓ	2-1/8 pt	1-3/4 pt	Genuine NISSAN PSF or equivalent • DEXRON™ VI type ATF may also be used.
Brake fluid		—	—	—	Genuine NISSAN Brake Fluid or equivalent DOT 3 (US FMVSS No. 116)
Multi-purpose grease		—	—	—	NLGI No. 2 (Lithium soap base)
Windshield washer fluid		4.5 ℓ	1 1/4 gal	1 gal	Windshield Washer Concentrate Cleaner & Anti-freeze or equivalent

RECOMMENDED FLUIDS AND LUBRICANTS

< PERIODIC MAINTENANCE >

Description	Capacity (Approximate)			Recommended Fluids/Lubricants
	Metric	US measure	Imp measure	
A/C system refrigerant	0.70 ± 0.05 kg	1.54 ± 0.11 lb	1.54 ± 0.11 lb	HFC-134a (R134a) • For further details, see "Air conditioner specification label".
A/C system oil	180 mℓ	6.1 fl oz	6.3 fl oz	A/C System Oil Type R (DH-PR) • For further details, see "Air conditioner specification label".

FOR MEXICO : SAE Viscosity Number

INFOID:000000010710191

GASOLINE ENGINE

- 10W-30 is preferable.
- 5W-30 is also preferable and will improve fuel economy.
- If 10W-30 or 5W-30 is not available, select the viscosity, from the chart, that is suitable for the outside temperature range.

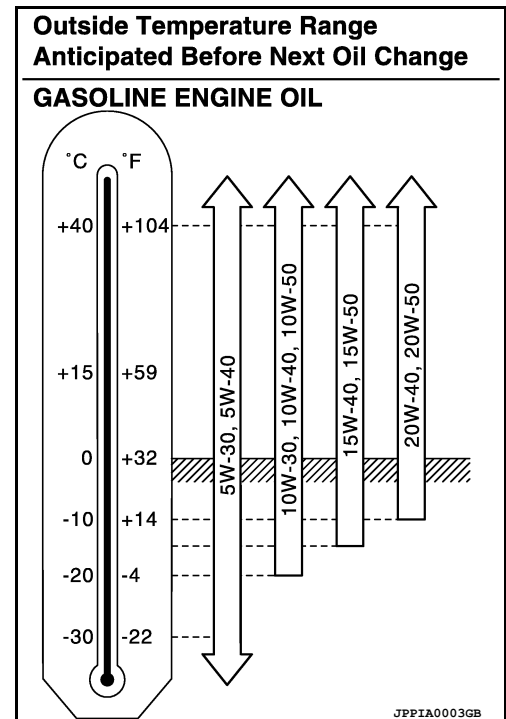

DIFFERENTIAL GEAR OIL

RECOMMENDED FLUIDS AND LUBRICANTS

< PERIODIC MAINTENANCE >

- 80W-90 for the front final drive is preferable.

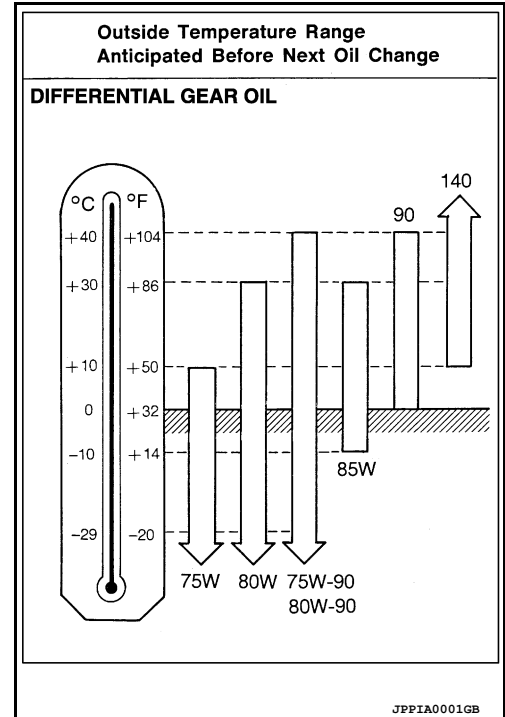

FOR MEXICO : Engine Coolant Mixture Ratio

INFOID:000000010710192

The engine cooling system is filled at the factory with a high-quality, year-round and extended life engine coolant. The high quality engine coolant contains the specific solutions effective for the anti-corrosion and the anti-freeze function. Therefore, additional cooling system additives are not necessary.

WARNING:

Do not remove the radiator cap when the engine is hot. Serious burns could be caused by high pressure fluid escaping from the radiator. Wait until the engine and radiator cool down.

Coolant Mixture Ratio

Outside temperature down to		Composition	
°C	°F	Engine coolant (concentrated)	Demineralized water or distilled water
- 15	5	30%	70%
- 35	- 30	50%	50%

CAUTION:

- When adding or replacing coolant, be sure to use only Genuine NISSAN Engine Coolant, or equivalent in quality with the proper mixture ratio.
- The use of other types of engine coolant may damage the engine cooling system.

When checking the engine coolant mixture ratio by the coolant hydrometer, use the chart below to correct your hydrometer reading (specific gravity) according to coolant temperature.

Mixed coolant specific gravity

Unit: specific gravity

Engine coolant mixture ratio	Coolant temperature °C (°F)			
	15 (59)	25 (77)	35 (95)	45 (113)
30%	1.046 - 1.050	1.042 - 1.046	1.038 - 1.042	1.033 - 1.038
50%	1.076 - 1.080	1.070 - 1.076	1.065 - 1.071	1.059 - 1.065

ENGINE MAINTENANCE (QR25DE ENGINE)

< PERIODIC MAINTENANCE >

ENGINE MAINTENANCE (QR25DE ENGINE)

DRIVE BELTS

DRIVE BELTS : Exploded View

INFOID:000000010710193

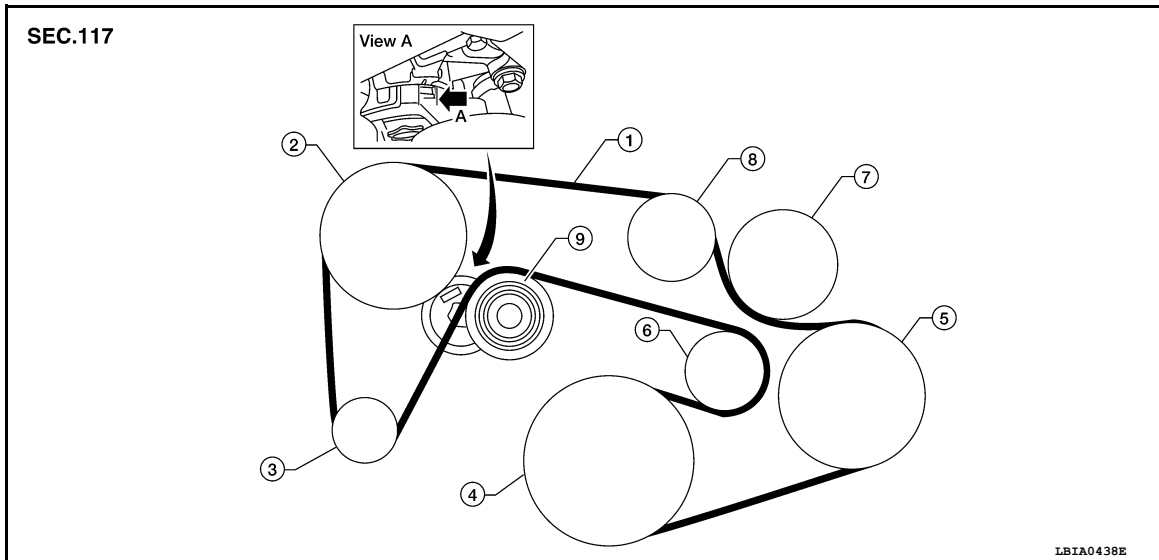

- | | | |
|----------------------------|-----------------------------------|------------------------------|
| 1. Drive belt | 2. Power steering oil pump pulley | 3. Generator pulley |
| 4. Crankshaft pulley | 5. A/C compressor or idler pulley | 6. Idler pulley |
| 7. Water pump | 8. Idler pulley | 9. Drive belt auto-tensioner |
| A. Allowable working range | | |

DRIVE BELTS : Checking Drive Belts

INFOID:000000010710194

WARNING:

Be sure to perform when the engine is stopped.

1. Remove air duct and resonator assembly when inspecting drive belt. Refer to [EM-141. "Removal and Installation"](#).
2. Make sure that the auto-tensioner indicator is within the allowable working range.
3. Visually check entire belt for wear, damage or cracks.
4. If the indicator is out of allowable working range or drive belt is damaged, replace the drive belt. Refer to [EM-129. "Removal and Installation"](#).

DRIVE BELTS : Tension Adjustment

INFOID:000000010710195

There is no manual drive belt tension adjustment. The drive belt tension is automatically adjusted by the drive belt auto-tensioner.

ENGINE COOLANT

ENGINE COOLANT : System Inspection

INFOID:000000010710196

WARNING:

- Do not remove the radiator cap or reservoir tank cap when the engine is hot. Serious burns could occur from high pressure fluid escaping from the radiator or reservoir.
- Wrap a thick cloth around the cap. Slowly push down and turn it a quarter turn to allow built-up pressure to escape. Carefully remove the cap by pushing down and turning it all the way.

CHECKING COOLING SYSTEM HOSES

Check hoses for the following:

- Improper attachment
- Leaks

A
B
C
D
E
F
G
H
I
J
K
L
M
N
O

MA

ENGINE MAINTENANCE (QR25DE ENGINE)

< PERIODIC MAINTENANCE >

- Cracks
- Damage
- Loose connections
- Chafing
- Deterioration

CHECKING RESERVOIR LEVEL

- Check if the engine coolant reservoir tank level is within MIN to MAX when the engine is cool.
- Adjust engine coolant level as necessary.

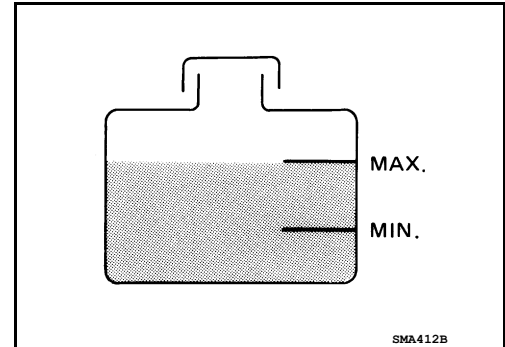

ENGINE COOLANT : Changing Engine Coolant

INFOID:0000000010710197

WARNING:

- To avoid being scalded, do not change the coolant when the engine is hot.
- Wrap a thick cloth around the cap to carefully remove the cap. First, turn the cap a quarter of a turn to release any built-up pressure, then push down and turn the cap all the way to remove it.
- Avoid direct skin contact with used coolant. If skin contact is made, wash thoroughly with soap or hand cleaner as soon as possible.
- Keep coolant out of the reach of children and pets.

DRAINING ENGINE COOLANT

1. Turn ignition switch ON and set temperature control lever all the way to HOT position or the highest temperature position. Wait 10 seconds and turn ignition switch OFF.
2. Open the radiator drain plug at the bottom of the radiator, and remove the reservoir cap. This is the only step required when partially draining the cooling system (radiator only).

CAUTION:

- Do not allow the coolant to contact the drive belts.
- Perform this step when engine is cold.

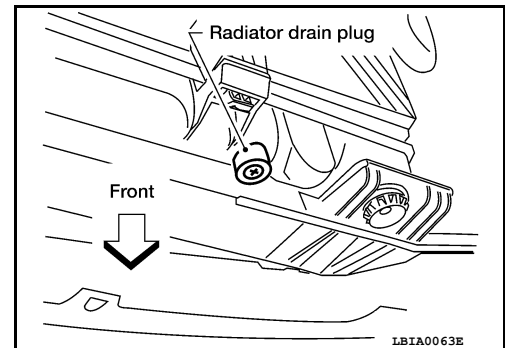

3. Follow this step for heater core removal/replacement only. Disconnect the upper heater hose at the engine side and apply moderate air pressure [103.46 kPa (15 psi, 1.055 kg/cm²) maximum air pressure] into the hose for 30 seconds to blow the excess coolant out of the heater core.
4. When draining all of the coolant in the system for engine removal or repair, it is necessary to drain the cylinder block. Remove the cylinder block drain plug to drain the cylinder block as shown.

CAUTION:

Do not reuse copper sealing washers.

NOTE:

For Canada, the cylinder block drain plug as shown, is not a cylinder block drain plug but a block heater.

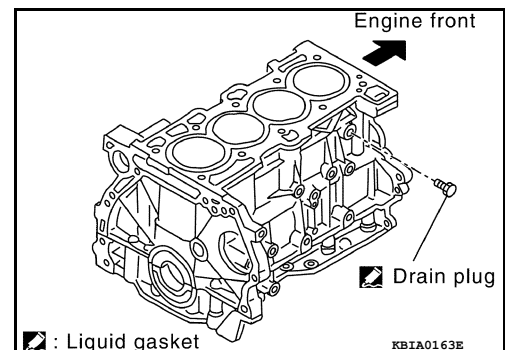

5. Remove the reservoir tank to drain the engine coolant, then clean the reservoir tank before installing it.

ENGINE MAINTENANCE (QR25DE ENGINE)

< PERIODIC MAINTENANCE >

6. Check the drained coolant for contaminants such as rust, corrosion or discoloration. If the coolant is contaminated, flush the engine cooling system. Follow the "Flushing Cooling System" procedure.

REFILLING ENGINE COOLANT

1. Close the radiator drain plug. Install the reservoir tank and cylinder block drain plug and block heater (if equipped).

CAUTION:

Do not reuse copper sealing washers.

- The radiator must be completely empty of coolant and water.
- Apply sealant to the threads of the cylinder block drain plugs.
- **Use Genuine High Performance Thread Sealant or equivalent. Refer to [GI-21, "Recommended Chemical Products and Sealants"](#).**
- Tighten each plug to the specified torque.

Radiator drain plug : Refer to [CO-16](#).

Cylinder block drain plug : Refer to [EM-80](#).

2. Set the vehicle heater controls to the full HOT and heater ON position. Turn the vehicle ignition ON with the engine OFF as necessary to activate the heater mode.
3. Remove the vented reservoir cap and replace it with a non-vented reservoir cap before filling the cooling system.
4. Install the Tool by installing the radiator cap adapter onto the radiator neck opening. Then attach the gauge body assembly with the refill tube and the venturi assembly to the radiator cap adapter.

Tool number : [KV991J0070 \(J-45695\)](#)

5. Insert the refill hose into the coolant mixture container that is placed at floor level. Make sure the ball valve is in the closed position.

CAUTION:

Do not use any cooling system additives such as radiator sealer. Additives may clog the cooling system and cause damage to the engine, transmission and/or cooling system.

NOTE:

Use recommended coolant or equivalent. Refer to [MA-16, "FOR USA AND CANADA : Fluids and Lubricants"](#).

Cooling system capacity (with reservoir) : Refer to [MA-16, "FOR USA AND CANADA : Fluids and Lubricants"](#).

6. Install an air hose to the venturi assembly, the air pressure must be within specification.

Compressed air supply pressure : 549 - 824 kPa (5.6 - 8.4 kg/cm², 80 - 119 psi)

CAUTION:

The compressed air supply must be equipped with an air dryer.

7. The vacuum gauge will begin to rise and there will be an audible hissing noise. During this process open the ball valve on the refill hose slightly. Coolant will be visible rising in the refill hose. Once the refill hose is full of coolant, close the ball valve. This will purge any air trapped in the refill hose.

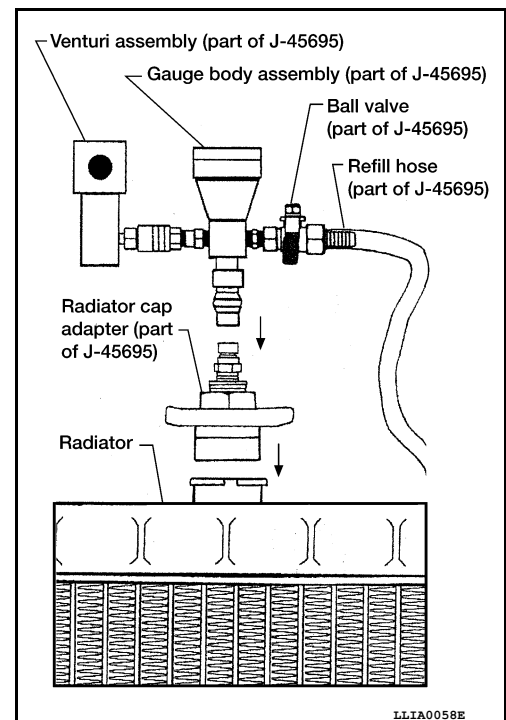
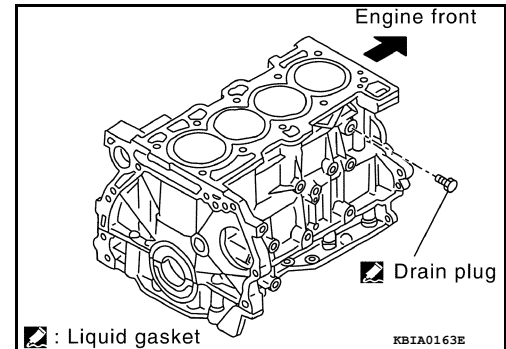

ENGINE MAINTENANCE (QR25DE ENGINE)

< PERIODIC MAINTENANCE >

8. Continue to draw the vacuum until the gauge reaches 28 inches of vacuum. The gauge may not reach 28 inches in high altitude locations, use the vacuum specifications below based on the altitude above sea level.

Altitude above sea level	Vacuum gauge reading
0 - 100 m (328 ft)	: 28 inches of vacuum
300 m (984 ft)	: 27 inches of vacuum
500 m (1,641 ft)	: 26 inches of vacuum
1,000 m (3,281 ft)	: 24 - 25 inches of vacuum

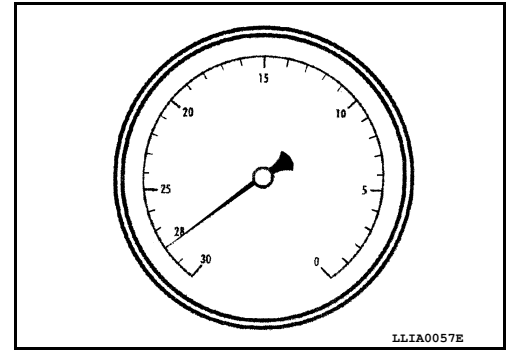

9. When the vacuum gauge has reached the specified amount, disconnect the air hose and wait 20 seconds to see if the system loses any vacuum. If the vacuum level drops, perform any necessary repairs to the system and repeat steps 6 - 8 to bring the vacuum to the specified amount. Recheck for any leaks.
10. Place the coolant container (with the refill hose inserted) at the same level as the top of the radiator. Then open the ball valve on the refill hose so the coolant will be drawn up to fill the cooling system. The cooling system is full when the vacuum gauge reads zero.

CAUTION:

Do not allow the coolant container to get too low when filling, to avoid air from being drawn into the cooling system.

11. Remove the Tool from the radiator neck opening and install the radiator cap.
12. Remove the non-vented reservoir cap.
13. Fill the cooling system reservoir tank to the specified level. Run the engine to warm up the cooling system and top up the system as necessary before installing the vented reservoir cap.

FLUSHING COOLING SYSTEM

1. Drain the engine coolant from the engine cooling system. Refer to [CO-12, "Changing Engine Coolant"](#).
2. Fill the radiator and the reservoir tank (to the "MAX" line) with water. Reinstall the radiator cap and leave the vented reservoir cap off.
3. Run the engine until it reaches normal operating temperature.
4. Press the engine accelerator two or three times under no-load.
5. Stop the engine and wait until it cools down.
6. Drain the water from the engine cooling system. Refer to [CO-12, "Changing Engine Coolant"](#).
7. Repeat steps 2 through 6 until clear water begins to drain from the radiator.

FUEL LINES

FUEL LINES : Checking Fuel Line

INFOID:000000010710198

Inspect the fuel lines and fuel tank for improperly attached hoses, leaks, cracks, damage, loose connections, chafing, or deterioration. If necessary, repair or replace any damaged parts.

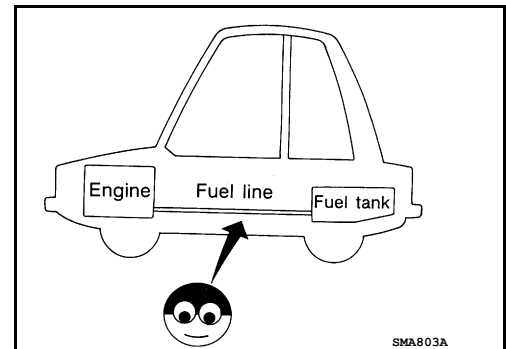

AIR CLEANER FILTER

AIR CLEANER FILTER : Removal and Installation

INFOID:000000010710199

REMOVAL

ENGINE MAINTENANCE (QR25DE ENGINE)

< PERIODIC MAINTENANCE >

1. Unfasten clips and lift up air cleaner case (upper).
2. Remove air cleaner filter.

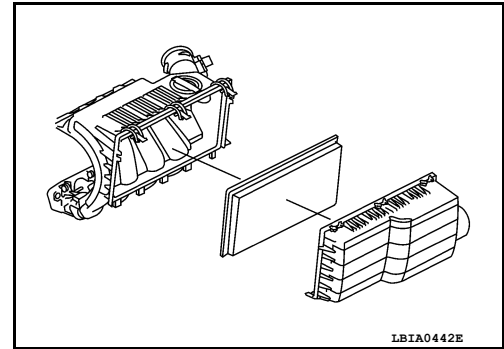

INSTALLATION

Installation is in the reverse order of removal.

ENGINE OIL

ENGINE OIL : Inspection

INFOID:000000010710200

OIL LEVEL

- Before starting the engine make sure the vehicle is parked on a flat and level surface, then check the oil level. If the engine is already running, turn it off and allow 10 minutes before checking.
- Pull out oil level gauge and wipe clean.
- Insert oil level gauge.
- Check that the oil level is within the low (L) and high (H) range as indicated on the dipstick.
- If the engine oil level is out of range, add oil as necessary. Refer to [MA-16, "FOR USA AND CANADA : Fluids and Lubricants"](#).

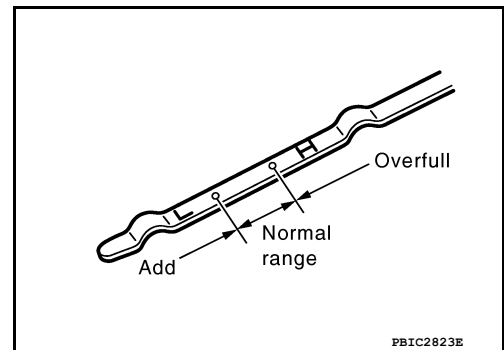

CAUTION:

Do not overfill the engine with oil.

NOTE:

It is normal to add some oil between oil maintenance intervals or during the break-in period, depending on the severity of the operating conditions.

ENGINE OIL : Changing Engine Oil

INFOID:000000010710201

WARNING:

- **Be careful not to burn yourself, as the engine and engine oil may be hot.**
- **Prolonged and repeated contact with used engine oil may cause skin cancer; try to avoid direct skin contact with used oil. If skin contact is made, wash thoroughly with soap or hand cleaner as soon as possible.**

1. Warm up the engine and check for any oil leaks
2. Stop the engine and wait for at least 10 minutes.
3. Remove the oil drain plug and oil filler cap to drain the old oil.
4. Install a new washer on the oil drain plug, then install the oil drain plug in the oil pan.

CAUTION:

- **Clean the drain plug and install with new washer.**
- **Do not reuse copper sealing washers.**

Oil pan drain plug: : Refer to [EM-33, "Exploded View"](#).

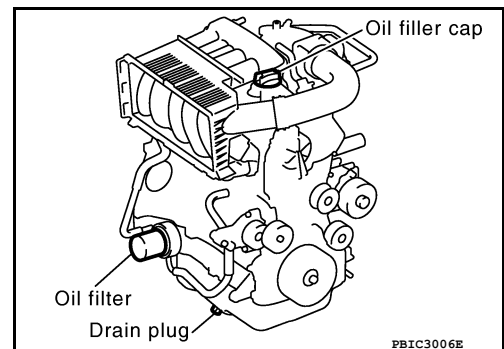

5. Refill the engine with new specified engine oil.

A
B
C
D
E
F
G
H
I
J
K
L
M
N
O
MA

ENGINE MAINTENANCE (QR25DE ENGINE)

< PERIODIC MAINTENANCE >

Oil grade and viscosity : Refer to [MA-18, "FOR USA AND CANADA : SAE Viscosity Number"](#) (United States and Canada).

Oil capacity : Refer to [MA-16, "FOR USA AND CANADA : Fluids and Lubricants"](#).

CAUTION:

The refill capacity depends on the oil temperature and drain time. Use the "Refill oil capacity" values as a reference and check the oil level using the dipstick when filling the engine with oil.

6. Warm up the engine and check the area around the drain plug and oil filter for any oil leaks.
7. Stop the engine and wait for more than 10 minutes.
8. Check the oil level using the dipstick as shown. Add oil as necessary and install the oil filler cap. Refer to [LU-9, "Inspection"](#).

CAUTION:

Do not overfill the engine with oil.

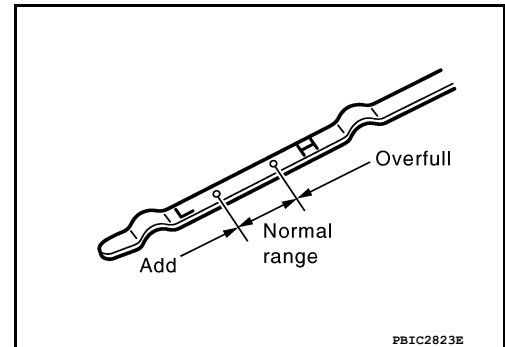

OIL FILTER

OIL FILTER : Removal and Installation

INFOID:000000010710202

REMOVAL

1. Remove the engine under cover. Refer to [EXT-15, "Removal and Installation"](#).
2. Drain the engine oil. Refer to [LU-10, "Changing Engine Oil"](#).
3. Remove the oil filter using Tool as shown.

Tool number : KV10115801 (J-38956)

WARNING:

Be careful not to burn yourself, as the engine and engine oil may be hot.

CAUTION:

- Oil filter is equipped with a pressure relief valve.
- Use Genuine NISSAN Oil Filter or equivalent.
- When removing, position a shop cloth to absorb any engine oil leaks or spills.
- Do not allow engine oil to adhere to drive belts.
- Completely wipe off any engine oil that adheres to the engine and the vehicle.

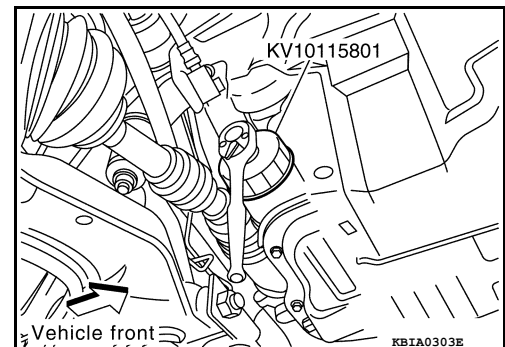

INSTALLATION

1. Remove foreign materials adhering to the oil filter seal mating surface.
2. Apply clean engine oil to the oil filter seal circumference of the new oil filter as shown.

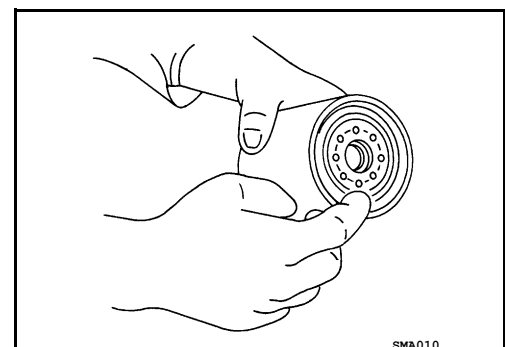

ENGINE MAINTENANCE (QR25DE ENGINE)

< PERIODIC MAINTENANCE >

3. Screw on the oil filter manually until it touches the installation surface, then tighten it by 2/3 turn as shown. Or tighten to specification.

Oil filter : 17.7 N·m (1.8 kg-m, 13 ft-lb)

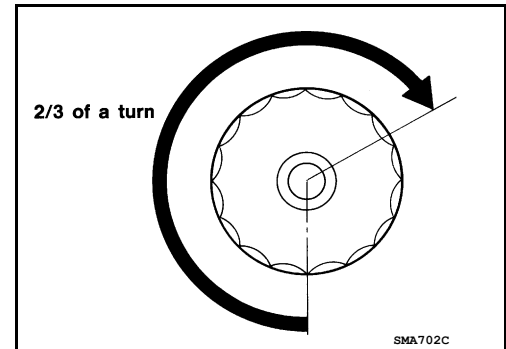

4. Refill the engine with new engine oil. Refer to [LU-10, "Changing Engine Oil"](#).
5. Inspect the engine for oil leaks. Refer to [LU-9, "Inspection"](#).
6. Install the engine under cover. Refer to [EXT-15, "Removal and Installation"](#).

INSPECTION AFTER INSTALLATION

1. Check the engine oil level. Refer to [LU-9, "Inspection"](#).
2. Start the engine and check for engine oil leaks.
3. Stop the engine and wait for 10 minutes.
4. Check the engine oil level and add engine oil as required.

SPARK PLUG

SPARK PLUG : Exploded View

INFOID:0000000010710203

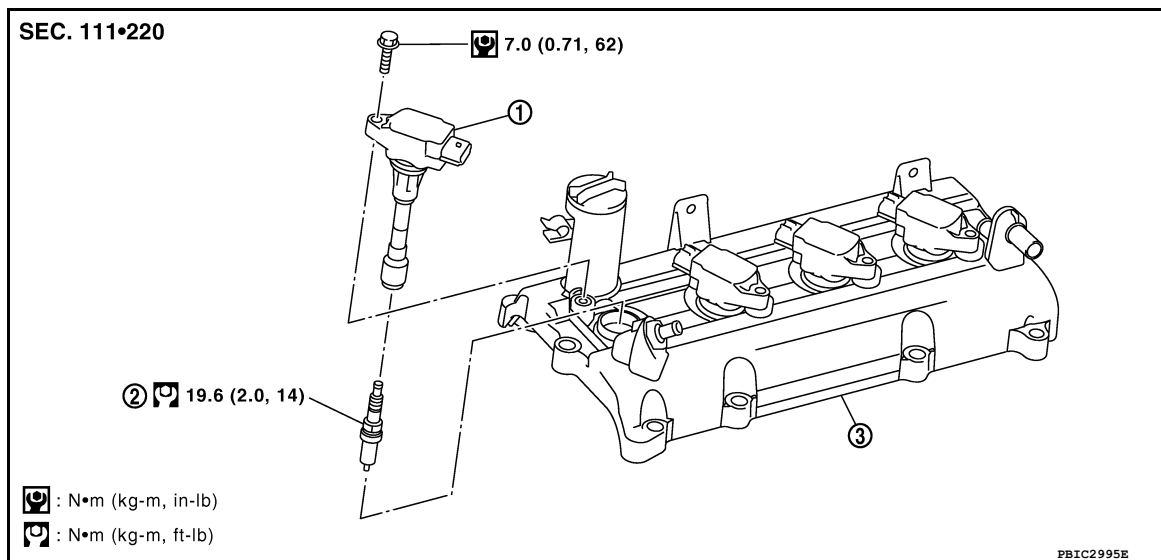

1. Ignition coil

2. Spark plug

3. Rocker cover

SPARK PLUG : Removal and Installation

INFOID:0000000010710204

WARNING:

Be sure the engine and ignition switch are off and that the parking brake is engaged securely.

CAUTION:

Be sure to use the correct socket to remove the spark plugs. An incorrect socket can damage the spark plugs.

REMOVAL

1. Remove the ignition coil. Refer to [EM-36](#).

ENGINE MAINTENANCE (QR25DE ENGINE)

< PERIODIC MAINTENANCE >

2. Remove the spark plug using a suitable tool.

CAUTION:

Do not drop or shock it.

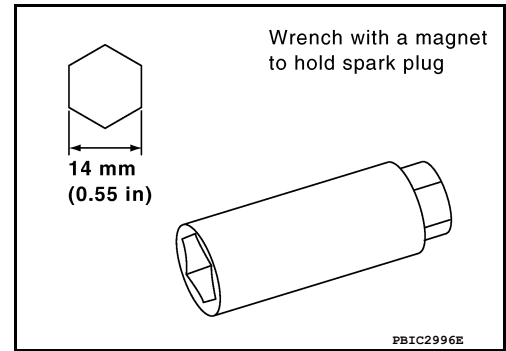

INSPECTION AFTER REMOVAL

- Do not use a wire brush for cleaning.

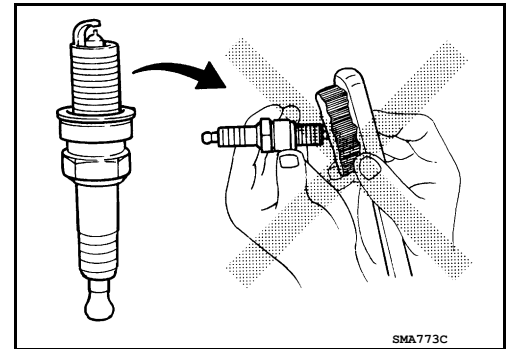

- If the spark plug tip is covered with carbon, spark plug cleaner may be used.

Cleaner air pressure : Less than 588 kPa (5.9 bar, 6 kg/cm², 85 psi)

Cleaning time : Less than 20 seconds

- Checking and adjusting spark plug gap is not required between change intervals.

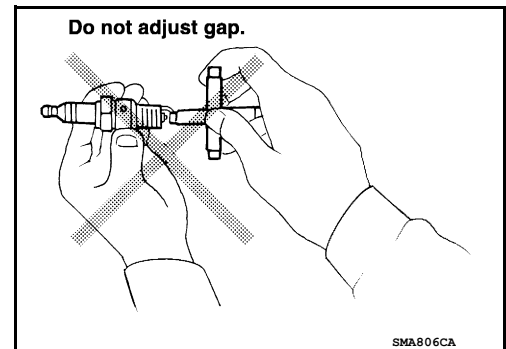

INSTALLATION

Installation is in the reverse order of removal.

CAUTION:

Do not drop or shock the spark plug.

Make	NGK
Standard type *	PLZKAR6A-11
Gap (nominal)	1.1 mm (0.043 in)

*: Always check with the Parts Department for the latest parts information.

EVAP VAPOR LINES

ENGINE MAINTENANCE (QR25DE ENGINE)

< PERIODIC MAINTENANCE >

EVAP VAPOR LINES : Checking EVAP Vapor Line

INFOID:000000010710205

1. Visually inspect EVAP vapor lines for improper attachment and for cracks, damage, loose connections, chafing and deterioration.
2. Inspect fuel tank filler cap vacuum relief valve for clogging and sticking.

A
B
C
D
E
F
G
H
I
J
K
L
M
N
O

MA

ENGINE MAINTENANCE (VQ40DE)

< PERIODIC MAINTENANCE >

ENGINE MAINTENANCE (VQ40DE)

DRIVE BELT

DRIVE BELT : Exploded View

INFOID:0000000010710206

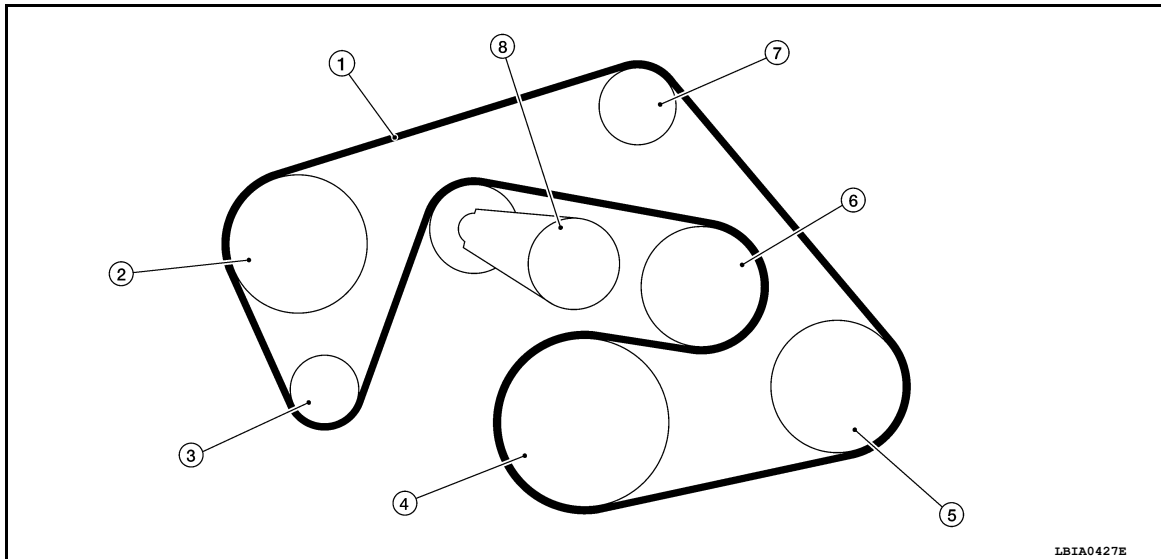

- | | | |
|----------------------|-----------------------------------|-----------------------|
| 1. Drive belt | 2. Power steering oil pump pulley | 3. Generator pulley |
| 4. Crankshaft pulley | 5. A/C compressor | 6. Cooling fan pulley |
| 7. Idler pulley | 8. Drive belt tensioner | |

DRIVE BELT : Checking Drive Belts

INFOID:0000000010710207

WARNING:

Be sure to perform when the engine is stopped.

1. Remove air duct and resonator assembly when inspecting drive belt. Refer to [EM-141, "Removal and Installation"](#).
2. Make sure that the drive belt tensioner indicator is within the allowable working range (A) as shown.
3. Visually check entire belt for wear, damage or cracks.
4. If the indicator is out of allowable working range or drive belt is damaged, replace the drive belt. Refer to [EM-129, "Removal and Installation"](#).

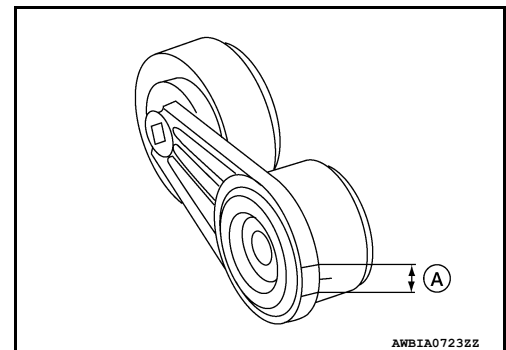

DRIVE BELT : Adjustment

INFOID:0000000010710208

There is no manual drive belt tension adjustment. The drive belt tension is automatically adjusted by the drive belt auto-tensioner.

ENGINE COOLANT

ENGINE COOLANT : System Inspection

INFOID:0000000010710209

WARNING:

- Do not remove the radiator/reservoir cap when the engine is hot. Serious burns could occur from high pressure fluid escaping from the radiator or reservoir.
- Wrap a thick cloth around the cap. Slowly push down and turn it a quarter turn to allow built-up pressure to escape. Carefully remove the cap by pushing down and turning it all the way.

ENGINE MAINTENANCE (VQ40DE)

< PERIODIC MAINTENANCE >

CHECKING COOLING SYSTEM HOSES

Check hoses for the following:

- Improper attachment
- Leaks
- Cracks
- Damage
- Loose connections
- Chafing
- Deterioration

CHECKING RESERVOIR LEVEL

- Check if the engine coolant reservoir tank level is within MIN to MAX when the engine is cool.
- Adjust engine coolant level as necessary.

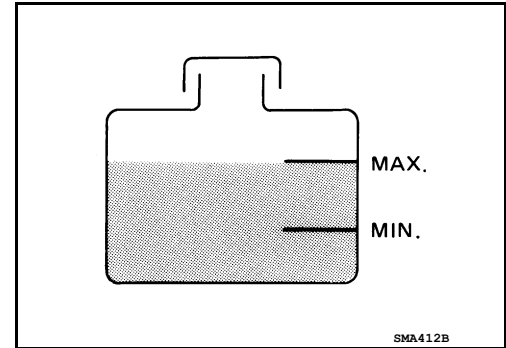

ENGINE COOLANT : Changing Engine Coolant

INFOID:0000000010710210

WARNING:

- To avoid being scalded, do not change the coolant when the engine is hot.
- Wrap a thick cloth around the cap to carefully remove the cap. First, turn the cap a quarter of a turn to release any built-up pressure, then push down and turn the cap all the way to remove it.
- Avoid direct skin contact with used coolant. If skin contact is made, wash thoroughly with soap or hand cleaner as soon as possible. When removing components such as hoses, tubes/lines, etc., cap or plug openings to prevent fluid from spilling.
- Keep coolant out of the reach of children and pets.

DRAINING ENGINE COOLANT

1. Turn ignition switch ON and set temperature control lever all the way to HOT position or the highest temperature position. Wait 10 seconds and turn ignition switch OFF.
2. Remove the engine under cover (if equipped). Refer to [EXT-15, "Removal and Installation"](#).
3. Open the radiator drain plug at the bottom of the radiator, and remove the reservoir cap. This is the only step required when partially draining the cooling system (radiator only).

CAUTION:

- Do not allow the coolant to contact the drive belts.
- Perform this step when engine is cold.

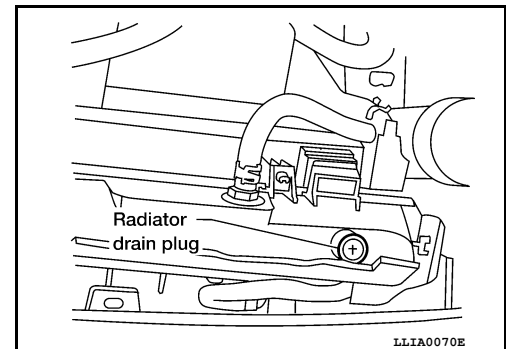

ENGINE MAINTENANCE (VQ40DE)

< PERIODIC MAINTENANCE >

4. When draining all of the coolant in the system for engine removal or repair, it is necessary to drain the cylinder block. Remove the cylinder block drain plugs (A), (B), (C), (D) and block heater (if equipped), to drain the cylinder block as shown.

CAUTION:

Do not reuse copper sealing washers.

NOTE:

For Canada, the (D) cylinder block drain plug as shown, is not a cylinder block drain plug but a block heater.

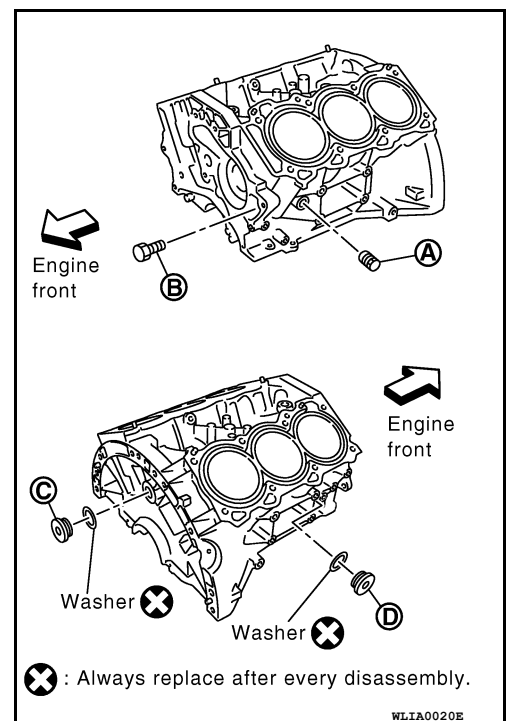

5. Remove the reservoir tank to drain the engine coolant, then clean the reservoir tank before installing it.
6. Check the drained coolant for contaminants such as rust, corrosion or discoloration. If the coolant is contaminated, flush the engine cooling system. Follow the "Flushing Cooling System" procedure.

REFILLING ENGINE COOLANT

1. Close the radiator drain plug. Install the reservoir tank, cylinder block drain plugs (A), (B), (C), (D) and block heater (if equipped), if removed for a total system drain or for engine removal or repair.
- The radiator must be completely empty of coolant and water.
 - Apply sealant to the threads of the cylinder block drain plugs (A), (B), (C), (D). Use Genuine High Performance Thread Sealant or equivalent. Refer to [GI-21, "Recommended Chemical Products and Sealants"](#).
 - Tighten each plug to the specified torque. Refer to [EM-220, "Disassembly and Assembly"](#).

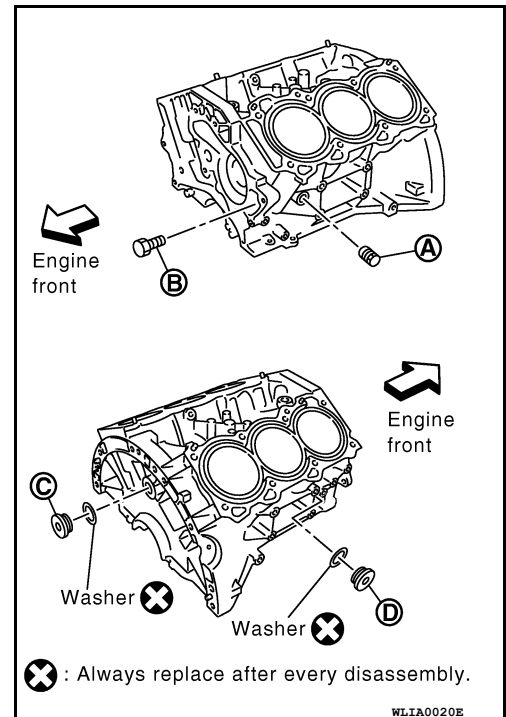

2. Set the vehicle heater controls to the full HOT and heater ON position. Turn the vehicle ignition ON with the engine OFF as necessary to activate the heater mode.
3. Remove the vented reservoir cap and replace it with a non-vented reservoir cap before filling the cooling system.

ENGINE MAINTENANCE (VQ40DE)

< PERIODIC MAINTENANCE >

4. Install the Tool by installing the radiator cap adapter onto the radiator neck opening. Then attach the gauge body assembly with the refill tube and the venturi assembly to the radiator cap adapter.

Tool number : KV991J0070 (J-45695)

5. Insert the refill hose into the coolant mixture container that is placed at floor level. Make sure the ball valve is in the closed position.

CAUTION:

Do not use any cooling system additives such as radiator sealer. Additives may clog the cooling system and cause damage to the engine, transmission and/or cooling system.

NOTE:

Use recommended coolant or equivalent. Refer to [MA-16, "FOR USA AND CANADA : Fluids and Lubricants"](#) (United States and Canada) or [MA-19, "FOR MEXICO : Fluids and Lubricants"](#) (Mexico).

Cooling system capacity (with reservoir) : Refer to [MA-16 \(United States and Canada\)](#), [MA-19 \(Mexico\)](#).

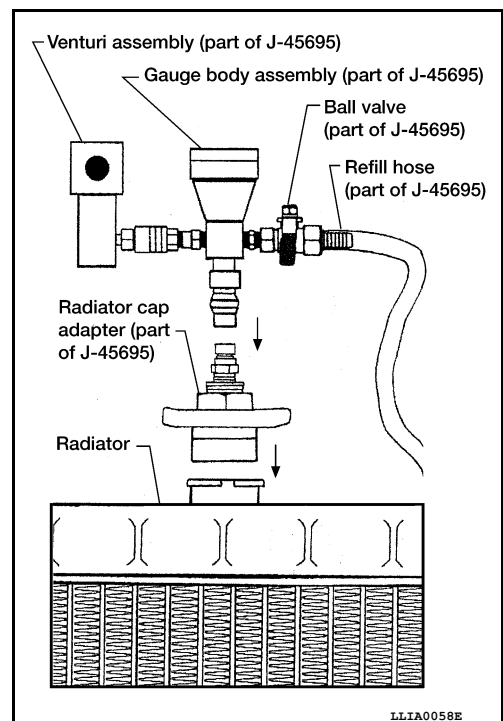

6. Install an air hose to the venturi assembly, the air pressure must be within specification.

Compressed air supply pressure : 549 - 824 kPa (5.6 - 8.4 kg/cm², 80 - 120 psi)

CAUTION:

The compressed air supply must be equipped with an air dryer.

7. The vacuum gauge will begin to rise and there will be an audible hissing noise. During this process open the ball valve on the refill hose slightly. Coolant will be visible rising in the refill hose. Once the refill hose is full of coolant, close the ball valve. This will purge any air trapped in the refill hose.
8. Continue to draw the vacuum until the gauge reaches 28 inches of vacuum. The gauge may not reach 28 inches in high altitude locations, use the vacuum specifications based on the altitude above sea level.

Altitude above sea level	Vacuum gauge reading
0 - 100 m (328 ft)	: 28 inches of vacuum
300 m (984 ft)	: 27 inches of vacuum
500 m (1,641 ft)	: 26 inches of vacuum
1,000 m (3,281 ft)	: 24 - 25 inches of vacuum

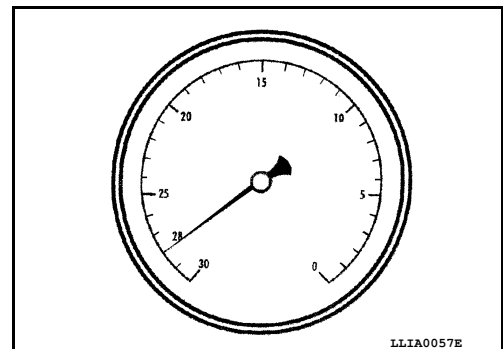

9. When the vacuum gauge has reached the specified amount, disconnect the air hose and wait 20 seconds to see if the system loses any vacuum. If the vacuum level drops, perform any necessary repairs to the system and repeat steps 6 - 8 to bring the vacuum to the specified amount. Recheck for any leaks.
10. Place the coolant container (with the refill hose inserted) at the same level as the top of the radiator. Then open the ball valve on the refill hose so the coolant will be drawn up to fill the cooling system. The cooling system is full when the vacuum gauge reads zero.

CAUTION:

Do not allow the coolant container to get too low when filling, to avoid air from being drawn into the cooling system.

11. Remove the Tool from the radiator neck opening and install the radiator cap.
12. Remove the non-vented reservoir cap.
13. Fill the cooling system reservoir tank to the specified level. Run the engine to warm up the cooling system and top up the system as necessary before installing the vented reservoir cap.

A
B
C
D
E
F
G
H
I
J
K
L
M
N
O

MA

ENGINE MAINTENANCE (VQ40DE)

< PERIODIC MAINTENANCE >

14. Install the engine under cover (if equipped). Refer to [EXT-15, "Removal and Installation"](#).

FLUSHING COOLING SYSTEM

1. Drain the water from the engine cooling system. Refer to [MA-33, "ENGINE COOLANT : Changing Engine Coolant"](#).
2. Fill the radiator and the reservoir tank (to the "MAX" line), with water. Reinstall the radiator cap and leave the vented reservoir cap off.
3. Run the engine until it reaches normal operating temperature.
4. Press the engine accelerator two or three times under no-load.
5. Stop the engine and wait until it cools down.
6. Drain the water from the engine cooling system. Refer to [MA-33, "ENGINE COOLANT : Changing Engine Coolant"](#).
7. Repeat steps 2 through 6 until clear water begins to drain from the radiator.

FUEL LINES

FUEL LINES : Checking Fuel Line

INFOID:000000010710211

Inspect the fuel lines and fuel tank for improper mounting, leaks, cracks, damage, loose connections, chafing, or deterioration. As necessary, repair or replace any faulty parts.

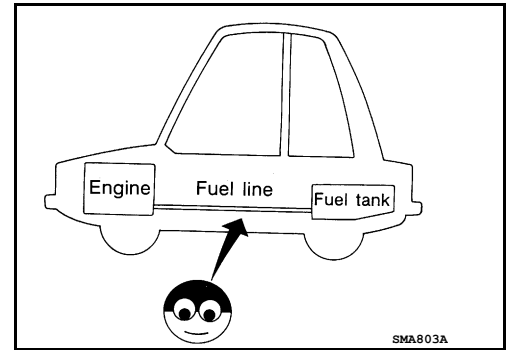

FUEL FILTER

FUEL FILTER : Changing Fuel Filter

INFOID:000000010710212

The fuel filter is part of the fuel level sensor unit, fuel filter and fuel pump assembly. Refer to [FL-11, "Removal and Installation"](#).

WARNING:

Before replacing the fuel filter, release the fuel pressure from the fuel system. Refer to [EC-968, "Fuel Pressure Check"](#).

AIR CLEANER FILTER

ENGINE MAINTENANCE (VQ40DE)

< PERIODIC MAINTENANCE >

AIR CLEANER FILTER : Exploded View

INFOID:000000010710213

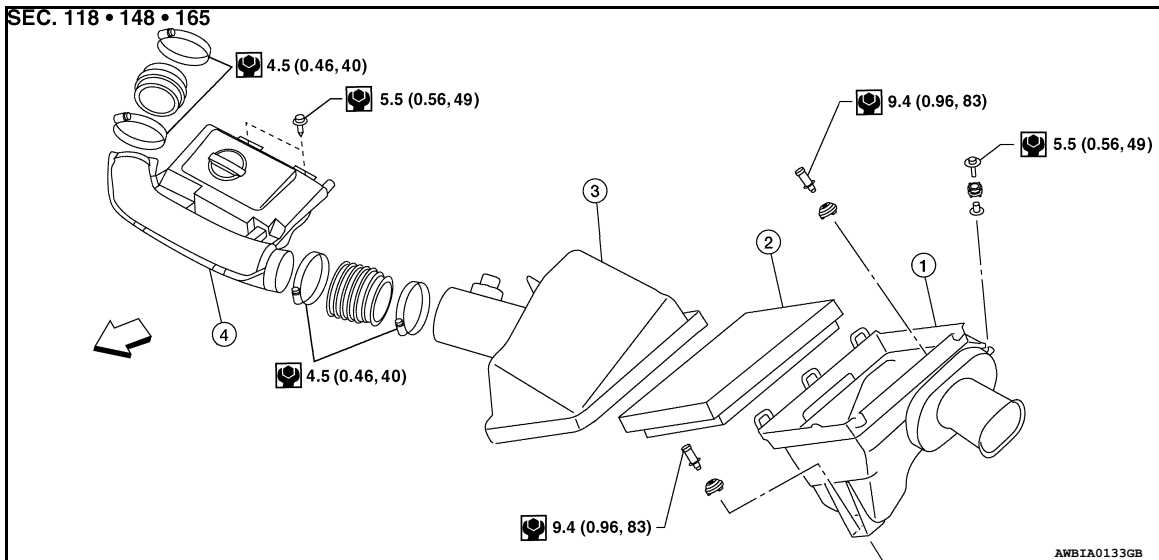

1. Air cleaner case (lower)
 2. Air cleaner filter
 3. Air cleaner case (upper)
 4. Air duct and resonator
- ⇐ Front

AIR CLEANER FILTER : Removal and Installation

INFOID:000000010710214

REMOVAL

1. Disconnect air duct and resonator assembly from the air cleaner case (upper).
2. Disconnect MAF/IAT sensor.
3. Unhook clips, and lift air cleaner case (upper).
4. Remove air cleaner filter.

INSTALLATION

Installation is in the reverse order of removal.

ENGINE OIL

ENGINE OIL : Inspection

INFOID:000000010710215

OIL LEVEL

- Before starting the engine make sure the vehicle is parked on a flat and level surface, then check the oil level. If the engine is already running, turn it off and allow 10 minutes before checking.
- Pull out oil level gauge and wipe clean.
- Insert oil level gauge.
- Check that the oil level is within the low (L) and high (H) range as indicated on the dipstick.
- If the engine oil level is out of range, add oil as necessary. Refer to [MA-16. "FOR USA AND CANADA : Fluids and Lubricants"](#) (United States and Canada) or [MA-19. "FOR MEXICO : Fluids and Lubricants"](#) (Mexico).

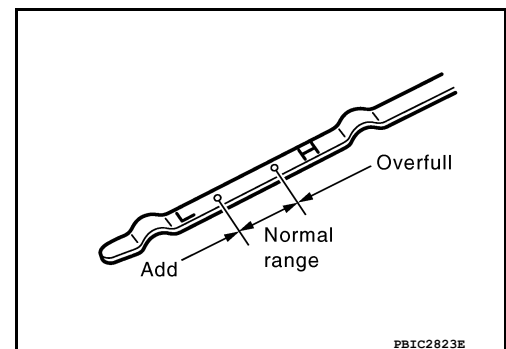

CAUTION:

Do not overfill the engine with oil.

NOTE:

It is normal to add some oil between oil maintenance intervals or during the break-in period, depending on the severity of the operating conditions.

A
B
C
D
E
F
G
H
I
J
K
L
M
N
O

MA

ENGINE MAINTENANCE (VQ40DE)

< PERIODIC MAINTENANCE >

ENGINE OIL : Changing Engine Oil

INFOID:000000010710216

WARNING:

- Be careful not to burn yourself, as the engine and engine oil may be hot.
- Prolonged and repeated contact with used engine oil may cause skin cancer; try to avoid direct skin contact with used oil. If skin contact is made, wash thoroughly with soap or hand cleaner as soon as possible.

1. Warm up the engine, and check for any oil leaks.
2. Stop the engine and wait for at least 10 minutes.
3. Remove the oil drain plug and oil filler cap to drain the old oil.
4. Install a new washer on the oil drain plug, then install the oil drain plug in the oil pan.

CAUTION:

- Clean the drain plug and install with a new washer.
- Do not reuse copper sealing washers.

Oil drain plug : Refer to [EM-151, "Removal and Installation"](#).

5. Refill the engine with new specified engine oil.

Oil grade and viscosity : Refer to [MA-16 \(United States and Canada\)](#), [MA-19 \(Mexico\)](#).

Oil capacity : Refer to [MA-16 \(United States and Canada\)](#), [MA-19 \(Mexico\)](#).

CAUTION:

The refill capacity depends on the oil temperature and drain time. Use the "Refill oil capacity" values as a reference and check the oil level using the dipstick when filling the engine with oil.

6. Warm up the engine and check the area around the drain plug and oil filter for any oil leaks.
7. Stop the engine and wait for more than 10 minutes.
8. Check the oil level using the dipstick as shown. Add oil as necessary and install the oil filler cap. Refer to [MA-37, "ENGINE OIL : Inspection"](#).

CAUTION:

Do not overfill the engine with oil.

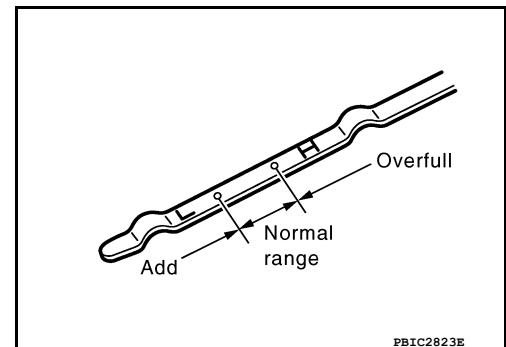

OIL FILTER

OIL FILTER : Removal and Installation

INFOID:000000010710217

REMOVAL

1. Remove the engine under cover. Refer to [EXT-15, "Removal and Installation"](#).
2. Drain engine oil. Refer to [MA-38, "ENGINE OIL : Changing Engine Oil"](#).
3. Remove the oil filter using Tool as shown.

Tool number : KV10115801 (J-38956)

WARNING:

Be careful not to burn yourself, as the engine and engine oil may be hot.

CAUTION:

- Oil filter is equipped with a pressure relief valve.
- Use Genuine NISSAN Oil Filter or equivalent.
- When removing, prepare a shop cloth to absorb any engine oil leaks or spills.

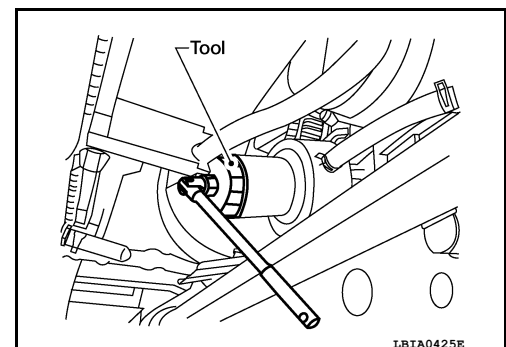

ENGINE MAINTENANCE (VQ40DE)

< PERIODIC MAINTENANCE >

- Do not allow engine oil to adhere to drive belts.
- Completely wipe off any engine oil that adheres to the engine and the vehicle.

INSTALLATION

1. Remove foreign materials adhering to the oil filter seal mating surface.
2. Apply clean engine oil to the oil filter seal circumference of the new oil filter as shown.

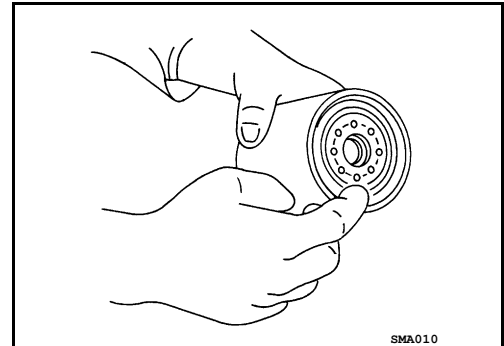

3. Screw on the oil filter manually until it touches the installation surface, then tighten it by 2/3 turn as shown. Or tighten to specification.

Oil filter : 17.7 N·m (1.8 kg·m, 13 ft·lb)

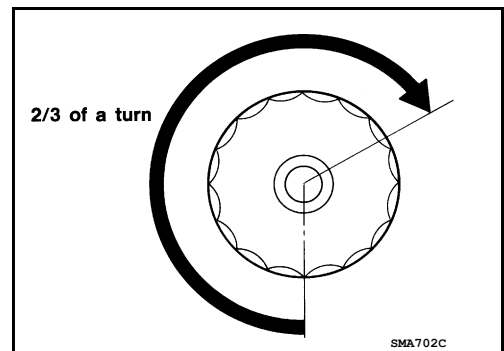

4. Refill engine with new engine oil. Refer to [LU-23. "Changing Engine Oil"](#).
5. Inspect the engine for oil leaks. Refer to [MA-38. "OIL FILTER : Removal and Installation"](#).
6. Install the engine under cover. Refer to [EXT-15. "Removal and Installation"](#).

INSPECTION AFTER INSTALLATION

1. Check the engine oil level. Refer to [MA-37. "ENGINE OIL : Inspection"](#).
2. Start the engine and check for engine oil leaks.
3. Stop the engine and wait for 10 minutes.
4. Check the engine oil level and add engine oil as required.

SPARK PLUG

ENGINE MAINTENANCE (VQ40DE)

< PERIODIC MAINTENANCE >

SPARK PLUG : Exploded View

INFOID:000000010710218

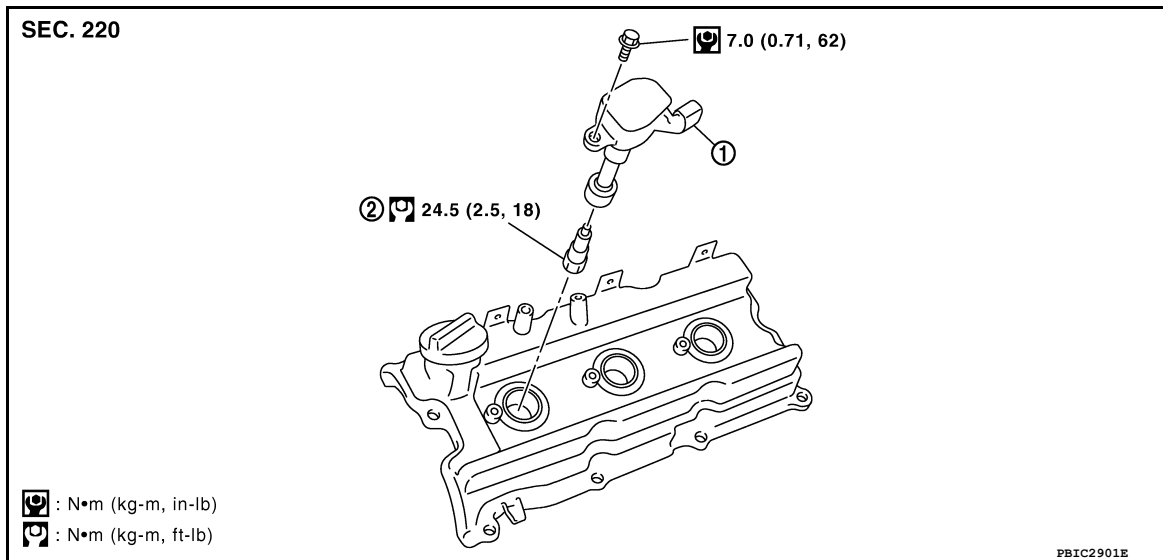

1. Ignition coil

2. Spark plug

SPARK PLUG : Removal and Installation

INFOID:000000010710219

REMOVAL

1. Remove the ignition coil. Refer to [EM-157, "Removal and Installation"](#).
2. Remove the spark plug using a suitable tool.

CAUTION:

Do not drop or shock it.

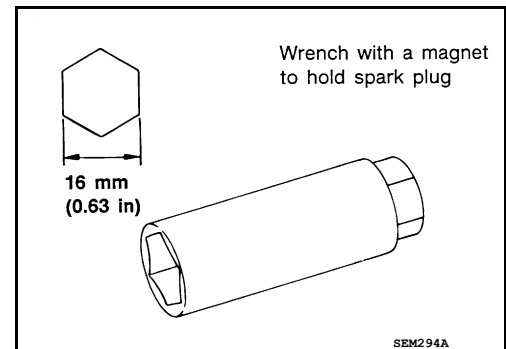

INSPECTION AFTER REMOVAL

- Do not use a wire brush for cleaning.

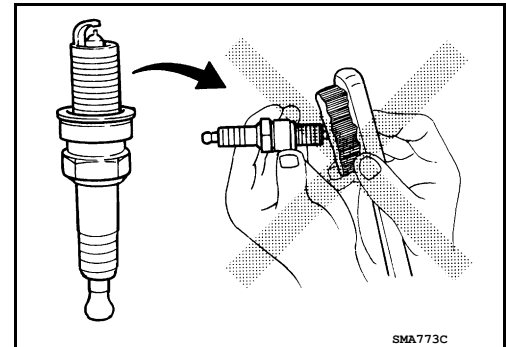

- If the spark plug tip is covered with carbon, spark plug cleaner may be used.

Cleaner air pressure : Less than 588 kPa (5.9 bar, 6 kg/cm², 85 psi)

Cleaning time : Less than 20 seconds

ENGINE MAINTENANCE (VQ40DE)

< PERIODIC MAINTENANCE >

- Checking and adjusting spark plug gap is not required between change intervals.

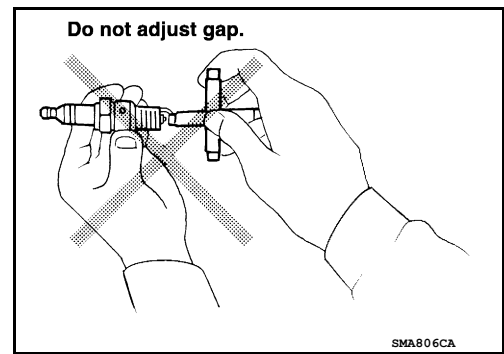

INSTALLATION

Installation is in the reverse order of removal.

CAUTION:

Do not drop or shock the spark plug.

Make	NGK
Standard type *	DILFR5A-11
Gap (nominal)	1.1 mm (0.043 in)

*: Always check with the Parts Department for the latest parts information.

EVAP VAPOR LINES

EVAP VAPOR LINES : Checking EVAP Vapor Line

INFOID:000000010710220

1. Visually inspect EVAP vapor lines for improper attachment, cracks, damage, loose connections, chafing or deterioration.
2. Inspect vacuum relief valve of fuel tank filler cap for clogging and sticking.
Refer to [EC-970. "How to Detect Fuel Vapor Leakage"](#).

CHASSIS AND BODY MAINTENANCE

< PERIODIC MAINTENANCE >

CHASSIS AND BODY MAINTENANCE

IN-CABIN MICROFILTER

IN-CABIN MICROFILTER : Removal and Installation

INFOID:000000010710221

REPLACEMENT PROCEDURE

1. Open the lower glove box and press in on the sides so that it will open completely allowing it to hang by the cord.

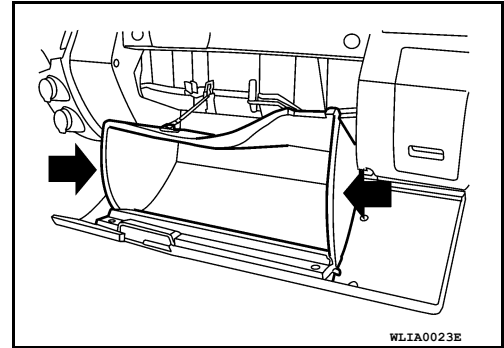

2. Gently lift up on the tab (1) then pull the in-cabin microfilter cover down (2) to remove the cover (3).

CAUTION:

Use care when lifting up on the tab to avoid damaging it.

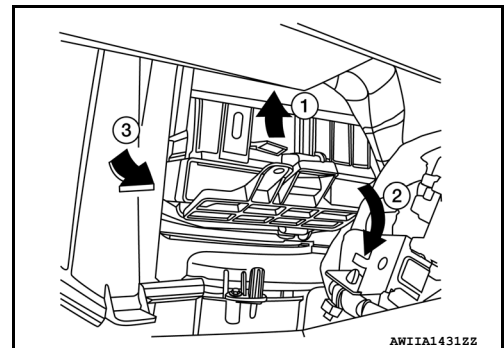

3. Remove the in-cabin microfilters from the heater and cooling unit housing.

4. Insert the first new in-cabin microfilter into the heater and cooling unit housing and slide it over to the right. Insert the second new in-cabin microfilter into the heater and cooling unit housing as shown.

NOTE:

The in-cabin microfilters are marked with air flow arrows. The end of the microfilter with the arrow should face the rear of the vehicle. The arrows should point downward.

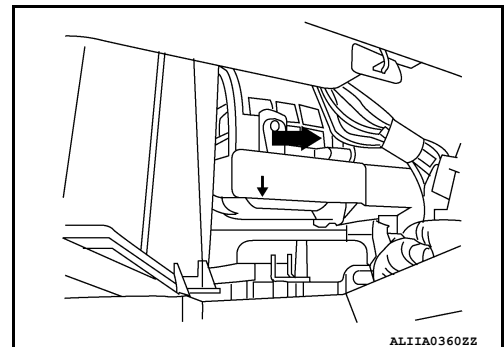

5. Install the in-cabin microfilter cover, make sure the tab is locked in place as shown.

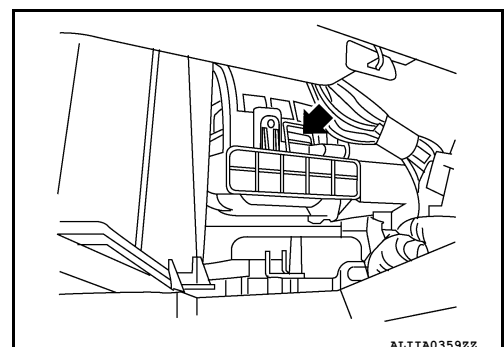

6. Close the lower glove box completely.

EXHAUST SYSTEM

CHASSIS AND BODY MAINTENANCE

< PERIODIC MAINTENANCE >

EXHAUST SYSTEM : Checking Exhaust System

INFOID:0000000110710223

Check exhaust pipes, muffler and mounting for improper attachment, leaks, cracks, damage or deterioration.

- If anything is found, repair or replace damaged parts.

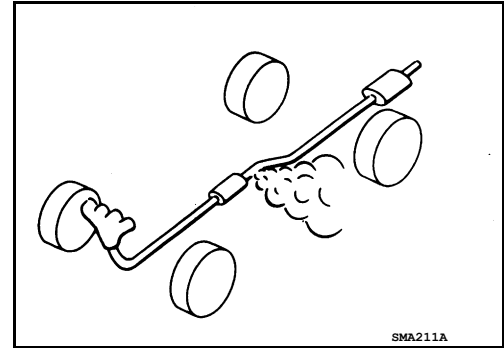

TRANSMISSION OIL

TRANSMISSION OIL : Checking the A/T Fluid (ATF)

INFOID:0000000110710223

CAUTION:

If using the vehicle for towing, the A/T fluid must be replaced as specified. Refer to [MA-10, "FOR USA AND CANADA : Periodic Maintenance"](#) (United States and Canada), [MA-13, "FOR MEXICO : Periodic Maintenance"](#) (Mexico).

1. Before driving, the A/T fluid level can be checked at A/T fluid temperatures of 30° to 50° C (86° to 122° F) using the "COLD" range on the A/T fluid level gauge as follows:
 - a. Park the vehicle on a level surface and set the parking brake.
 - b. Start the engine and move the shift selector through each gear position. Move the shift selector into the "P" position.
 - c. Check the A/T fluid level with the engine idling.
 - d. Remove the A/T fluid level gauge and wipe it clean with a lint-free paper.

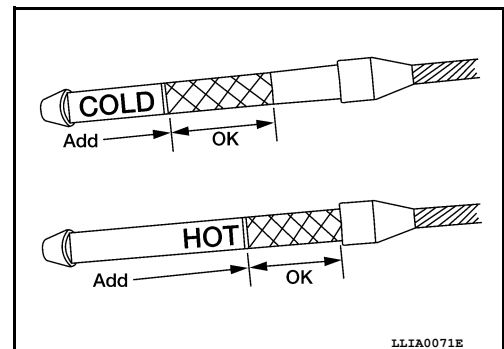

CAUTION:

When wiping the A/T fluid from the A/T fluid level gauge, always use a lint-free paper, not a cloth.

- e. Re-insert the A/T fluid level gauge into the A/T fluid charging pipe until the cap contacts the top of the A/T fluid charging pipe as shown.

CAUTION:

To check A/T fluid level, insert the A/T fluid level gauge until the cap contacts the top of the A/T fluid charging pipe, with the gauge reversed from the normal inserted position.

- f. Remove the A/T fluid level gauge and note the A/T fluid level. If the A/T fluid level is at low side of range, add A/T fluid to the transmission through the A/T fluid charging pipe.

CAUTION:

Do not overfill the transmission with A/T fluid.

- g. Install the A/T fluid level gauge and the A/T fluid level gauge bolt.

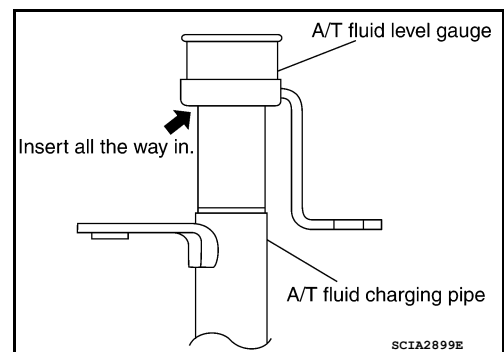

A/T fluid level gauge bolt : Refer to [TM-304, "Component"](#).

2. Warm up the engine and transmission.
3. Check for any A/T fluid leaks.
4. Drive the vehicle to increase the A/T fluid temperature to 80° C (176° F).

CHASSIS AND BODY MAINTENANCE

< PERIODIC MAINTENANCE >

- Allow the A/T fluid temperature to fall to approximately 65°C (149°F). Use the CONSULT to monitor the A/T fluid temperature as follows:

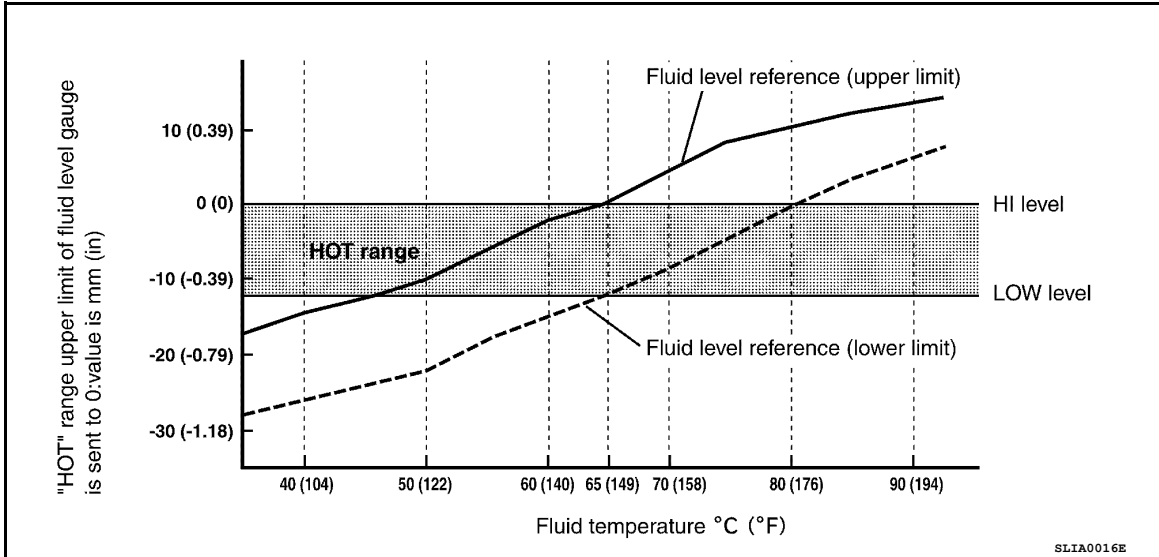

NOTE:

The A/T fluid level will be significantly affected by the A/T fluid temperature as shown. Therefore monitor the A/T fluid temperature data using the CONSULT.

- Connect CONSULT to data link connector.
 - Select "MAIN SIGNALS" in "DATA MONITOR" mode for "A/T" with CONSULT.
 - Read out the value of "ATF TEMP 1".
- Re-check the A/T fluid level at A/T fluid temperatures of approximately 65°C (149°F) using the "HOT" range on the A/T fluid level gauge as shown. The HOT range is between 50° - 80° C (122° - 176° F).

CAUTION:

- When wiping the A/T fluid from the A/T fluid level gauge, always use lint-free paper, not a cloth.

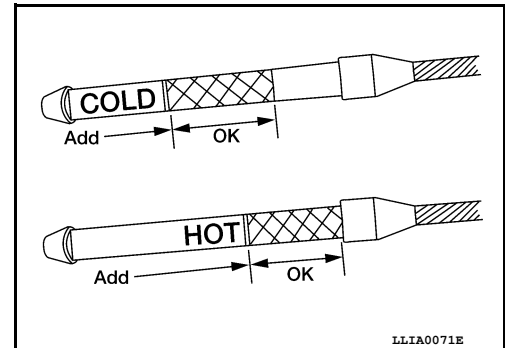

- To check the A/T fluid level, insert the A/T fluid level gauge until the cap contacts the top of the A/T fluid charging pipe, with the gauge reversed from the normal inserted position as shown.

- Check the A/T fluid condition.
 - If the A/T fluid is very dark or has some burned smell, there may be an internal problem with the transmission. Flush the transmission cooling system after repairing the transmission.
 - If the A/T fluid contains frictional material (clutches, bands, etc.), replace the radiator and flush the transmission cooler lines using cleaning solvent and compressed air after repairing the transmission.
- Install the A/T fluid level gauge in the A/T fluid charging pipe.
- Tighten the A/T fluid level gauge bolt to specification.

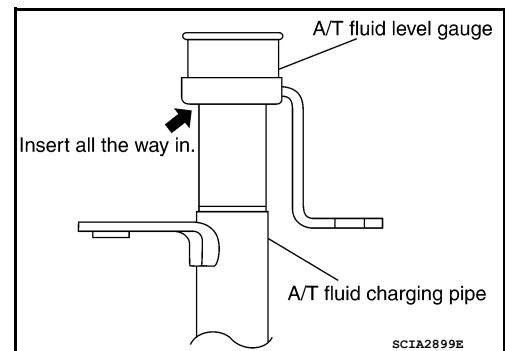

A/T fluid level gauge bolt : Refer to [TM-304, "Component"](#).

CHASSIS AND BODY MAINTENANCE

< PERIODIC MAINTENANCE >

TRANSMISSION OIL : Changing the A/T Fluid (ATF)

INFOID:000000010710224

CAUTION:

If using the vehicle for towing, the A/T fluid must be replaced as specified.

Refer to [MA-16, "FOR USA AND CANADA : Fluids and Lubricants"](#) (United States and Canada), [MA-19, "FOR MEXICO : Fluids and Lubricants"](#) (Mexico).

1. Drive the vehicle to warm up the A/T fluid to approximately 80° C (176° F).
2. Stop the engine.
3. Remove the A/T fluid level gauge.
4. Drain the A/T fluid from the drain plug hole, then install the drain plug with a new gasket. Refill the transmission with new A/T fluid. Always refill with the same volume as the drained A/T fluid. Use the A/T fluid level gauge to check the A/T fluid level as shown. Add A/T fluid as necessary.

Drain plug : Refer to [TM-304, "Component"](#).

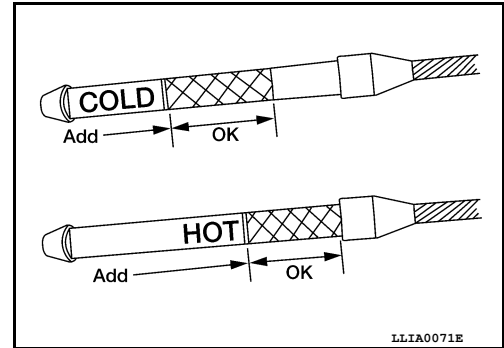

- To flush out the old A/T fluid from the transmission oil coolers, pour new A/T fluid into the A/T fluid charging pipe with the engine idling and at the same time drain the old A/T fluid from the auxiliary transmission oil cooler hose return line.
- When the color of the A/T fluid coming out of the auxiliary transmission oil cooler hose return line is about the same as the color of the new A/T fluid, flushing out the old A/T fluid is complete. The amount of new A/T fluid used for flushing should be 30% to 50% increase of the specified capacity.

A/T fluid grade and capacity : Refer to [MA-16, "FOR USA AND CANADA : Fluids and Lubricants"](#) (United States and Canada), [MA-19, "FOR MEXICO : Fluids and Lubricants"](#) (Mexico).

CAUTION:

- If genuine NISSAN Matic S ATF is not available, Genuine NISSAN Matic J ATF may also be used. Using automatic transmission fluid other than Genuine NISSAN Matic S ATF or Matic J ATF will cause deterioration in driveability and automatic transmission durability, and may damage the automatic transmission, which is not covered by the NISSAN new vehicle limited warranty
 - When filling the transmission with A/T fluid, do not spill the A/T fluid on any heat generating parts such as the exhaust manifold.
 - Do not reuse the drain plug gasket.
5. Install the A/T fluid level gauge and tighten the A/T fluid level gauge bolt to specification.

A/T fluid level gauge bolt : Refer to [TM-304, "Component"](#).

6. Drive the vehicle to warm up the A/T fluid to approximately 80° C (176° F).
7. Check the fluid level and condition. If the A/T fluid is still dirty, repeat steps 2 through 6.

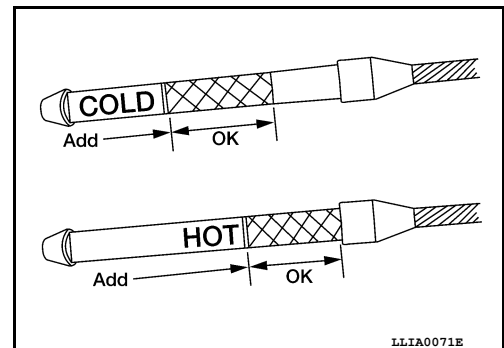

8. Install the A/T fluid level gauge in the A/T fluid charging pipe and install the A/T fluid level gauge bolt.

A
B
C
D
E
F
G
H
I
J
K
L
M
N
O

MA

CHASSIS AND BODY MAINTENANCE

< PERIODIC MAINTENANCE >

9. Tighten the A/T fluid level gauge bolt to specification.

A/T fluid level gauge bolt : Refer to [TM-304, "Component"](#).

M/T OIL

M/T OIL : FS6R31A

INFOID:000000010710225

M/T OIL : Changing

INFOID:000000010710226

DRAINING

1. Start the engine and let it run to warm up the transmission.
2. Stop the engine. Remove the transmission drain plug and drain the oil.
3. Set a gasket on the drain plug and install it to the transmission. Tighten the drain plug to the specified torque. Refer to [TM-77, "Overhaul"](#).

CAUTION:

Do not reuse gasket.

FILLING

1. Remove the filler plug. Fill with new oil until oil level reaches the specified limit near the filler plug hole as shown.

Oil grade and viscosity Refer to [MA-16, "FOR USA AND CANADA : Fluids and Lubricants"](#).

Oil capacity Refer to [MA-16, "FOR USA AND CANADA : Fluids and Lubricants"](#).

2. After refilling the oil, check oil level. Set a gasket to the filler plug, then install it to the transmission. Tighten the filler plug to the specified torque. Refer to [TM-77, "Overhaul"](#).

CAUTION:

Do not reuse gasket.

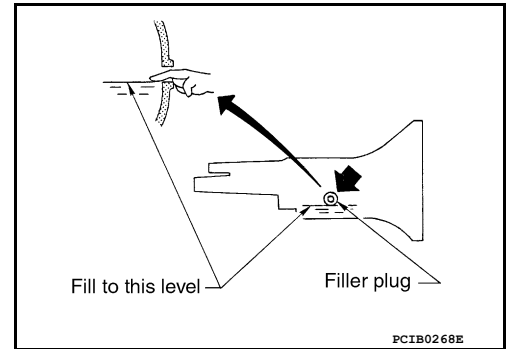

M/T OIL : Checking

INFOID:000000010710227

OIL LEAKAGE AND OIL LEVEL

1. Make sure that oil is not leaking from the transmission or around it.
2. Check oil level from the filler plug hole as shown.

CAUTION:

Do not start engine while checking oil level.

3. Set a gasket on the filler plug and install it to the transmission. Tighten the filler plug to the specified torque. Refer to [TM-77, "Overhaul"](#).

CAUTION:

Do not reuse gasket.

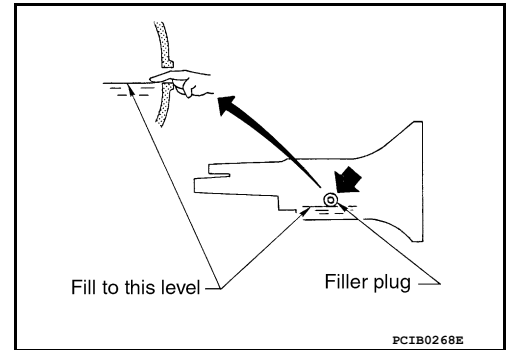

M/T OIL : FS5R30A

INFOID:000000010710228

M/T OIL : Changing

INFOID:000000010710229

DRAINING

1. Start the engine and let it run to warm up the transmission.

CHASSIS AND BODY MAINTENANCE

< PERIODIC MAINTENANCE >

2. Stop the engine. Remove the transmission drain plug and drain the oil.
3. Set a gasket on the drain plug and install it to the transmission. Tighten the drain plug to the specified torque. Refer to [TM-23, "Overhaul"](#).

CAUTION:

Do no reuse gasket.

FILLING

1. Remove the filler plug. Fill with new oil until oil level reaches the specified limit near the filler plug hole.

Oil grade and Viscosity Refer to [MA-16, "FOR USA AND CANADA : Fluids and Lubricants"](#).

Oil capacity Refer to [MA-16, "FOR USA AND CANADA : Fluids and Lubricants"](#).

2. After refilling the oil, check oil level. Set a gasket to the filler plug, then install it to the transmission. Tighten the filler plug to the specified torque. Refer to [TM-23, "Overhaul"](#).

CAUTION:

Do not reuse gasket.

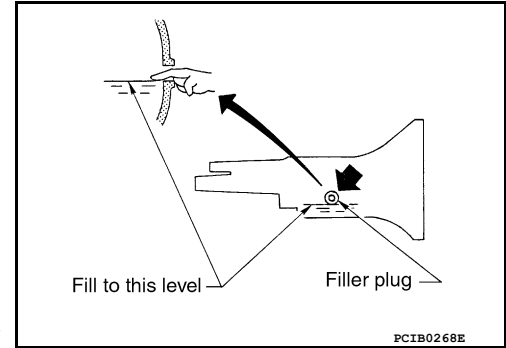

M/T OIL : Checking

INFOID:000000010710230

OIL LEAKAGE AND OIL LEVEL

1. Make sure that oil is not leaking from the transmission or around it.
2. Check oil level from the filler hole as shown.

CAUTION:

Do not start engine while checking oil level.

3. Set a gasket on the filler plug and install it to the transmission. Tighten the filler plug to the specified torque. Refer to [TM-23, "Overhaul"](#).

CAUTION:

Do not reuse gasket.

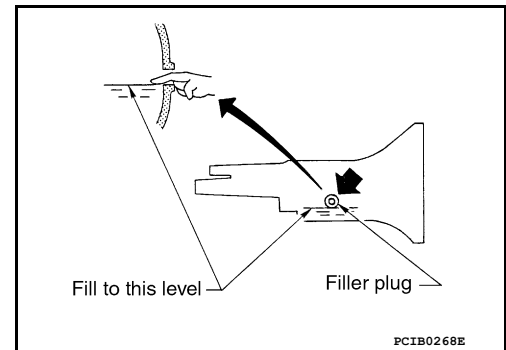

TRANSFER FLUID

TRANSFER FLUID : Replacement

INFOID:000000010710231

CAUTION:

If using the vehicle for towing, the transfer fluid must be replaced as specified.

Refer to [MA-10, "FOR USA AND CANADA : Periodic Maintenance"](#) (United States and Canada), [MA-13, "FOR MEXICO : Periodic Maintenance"](#) (Mexico).

DRAINING

1. Stop engine.

CHASSIS AND BODY MAINTENANCE

< PERIODIC MAINTENANCE >

2. Remove the drain plug and gasket and drain the fluid.
3. Install the drain plug with a new gasket to the transfer. Tighten to the specified torque. Refer to [DLN-103, "Exploded View"](#).

CAUTION:

Do not reuse gasket.

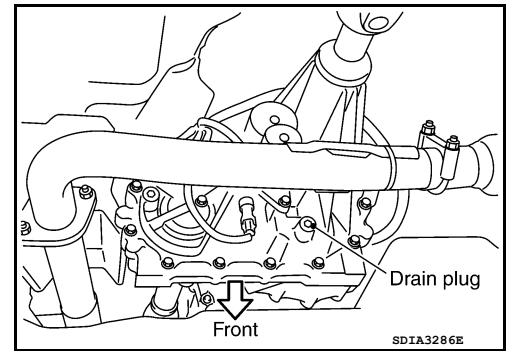

FILLING

1. Remove the filler plug and gasket.
2. Fill the transfer with new fluid until the fluid level reaches the specified limit near the filler plug hole.

Fluid grade and capacity : Refer to [MA-16, "FOR USA AND CANADA : Fluids and Lubricants"](#) (United States and Canada), [MA-19, "FOR MEXICO : Fluids and Lubricants"](#) (Mexico).

CAUTION:

Carefully fill fluid. (Fill up for approx. 3 minutes.)

3. Leave the vehicle for 3 minutes, and check fluid level again.
4. Install the filler plug with a new gasket to the transfer. Tighten to the specified torque. Refer to [DLN-103, "Exploded View"](#).

CAUTION:

Do not reuse gasket.

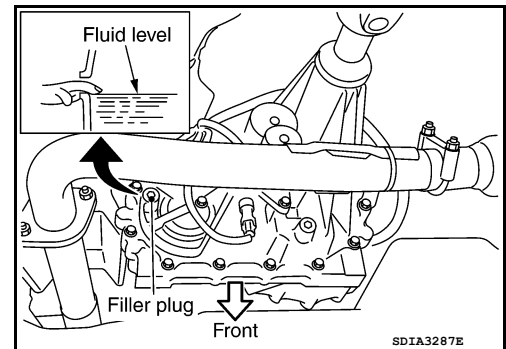

TRANSFER FLUID : Inspection

INFOID:000000010710232

CAUTION:

If using the vehicle for towing, the transfer fluid must be replaced as specified.

Refer to [MA-10, "FOR USA AND CANADA : Periodic Maintenance"](#) (United States and Canada), [MA-13, "FOR MEXICO : Periodic Maintenance"](#) (Mexico).

FLUID LEAKAGE AND FLUID LEVEL

1. Make sure that fluid is not leaking from the transfer assembly or around it.
2. Check fluid level from the filler plug hole as shown.

CAUTION:

Do not start engine while checking fluid level.

3. Install the filler plug with a new gasket to the transfer. Tighten to the specified torque. Refer to [DLN-103, "Exploded View"](#).

CAUTION:

Do not reuse gasket.

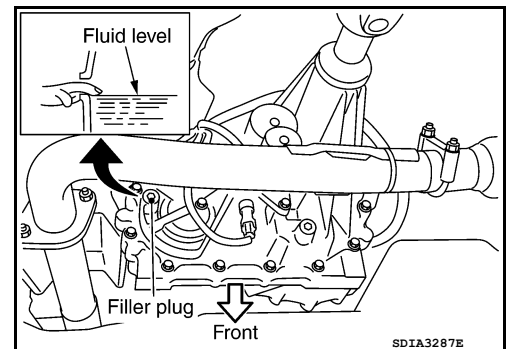

PROPELLER SHAFT

PROPELLER SHAFT : Checking Propeller Shaft

INFOID:000000010710233

Check the front and rear propeller shafts for damage, dents, and cracks. Check the joints for looseness and any damage. Repair or replace as necessary. Refer to [FAX-4, "NVH Troubleshooting Chart"](#).

DIFFERENTIAL GEAR OIL

CHASSIS AND BODY MAINTENANCE

< PERIODIC MAINTENANCE >

DIFFERENTIAL GEAR OIL : Front Final Drive - R180A

INFOID:000000010710234

DIFFERENTIAL GEAR OIL : Changing Differential Gear Oil

INFOID:000000010710235

DRAINING

1. Stop the engine.
2. Remove the drain plug and gasket from the front final drive assembly to drain the differential gear oil.
3. Install the drain plug with a new gasket to the front final drive assembly. Tighten to the specified torque. Refer to [DLN-193, "Disassembly and Assembly"](#).

CAUTION:

Do not reuse gasket.

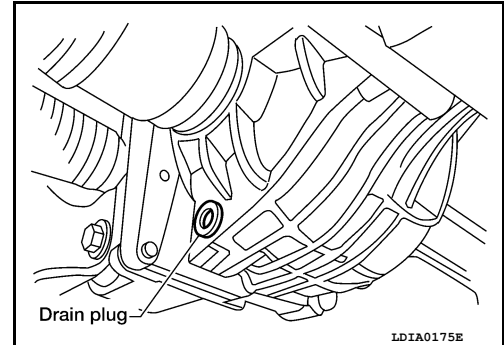

FILLING

1. Remove the filler plug and gasket from the front final drive assembly.
2. Fill the front final drive assembly with new differential gear oil until the level reaches the specified level near the filler plug hole.

Differential gear oil grade and capacity

: Refer to [MA-16, "FOR USA AND CANADA : Fluids and Lubricants" \(United States and Canada\), MA-19, "FOR MEXICO : Fluids and Lubricants" \(Mexico\).](#)

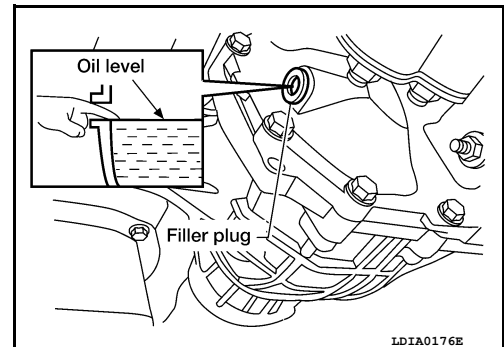

3. Install the filler plug with a new gasket on it to the front final drive assembly. Tighten to the specified torque. Refer to [DLN-193, "Disassembly and Assembly"](#).

CAUTION:

Do not reuse gasket.

DIFFERENTIAL GEAR OIL : Checking Differential Gear Oil

INFOID:000000010710236

DIFFERENTIAL GEAR OIL LEAKAGE AND LEVEL

1. Make sure that differential gear oil is not leaking from the front final drive assembly or around it.
2. Check the differential gear oil level from the filler plug hole as shown.

CAUTION:

Do not start engine while checking differential gear oil level.

3. Install the filler plug with a new gasket on it to the front final drive assembly. Tighten to the specified torque. Refer to [DLN-193, "Disassembly and Assembly"](#).

CAUTION:

Do not reuse gasket.

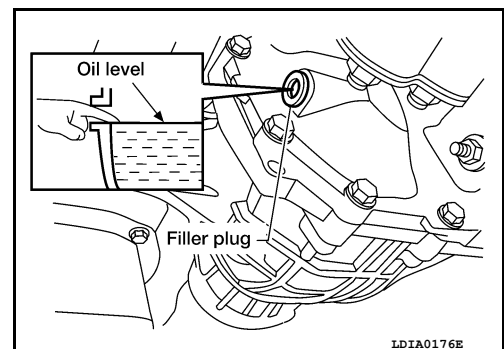

DIFFERENTIAL GEAR OIL : Rear Final Drive - C200

INFOID:000000010710237

DIFFERENTIAL GEAR OIL : Changing Differential Gear Oil

INFOID:000000010710238

DRAINING

A
B
C
D
E
F
G
H
I
J
K
L
M
N
O

MA

CHASSIS AND BODY MAINTENANCE

< PERIODIC MAINTENANCE >

1. Stop engine.
2. Remove the drain plug from the rear final drive assembly to drain the differential gear oil.
3. Install the drain plug with a new gasket to the rear final drive assembly. Tighten to the specified torque. Refer to [DLN-225, "Disassembly and Assembly"](#).

CAUTION:

Do not reuse gasket.

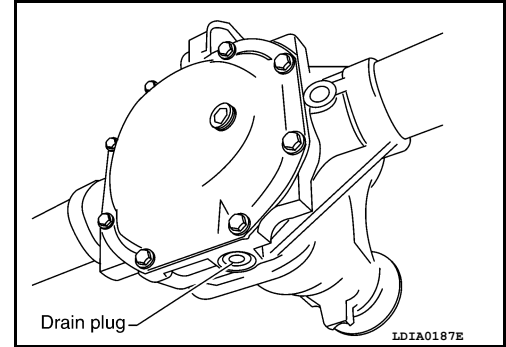

FILLING

1. Remove the filler plug from the rear final drive assembly.
2. Fill the rear final drive assembly with new differential gear oil until the level reaches the specified level near the filler plug hole.

Differential gear oil grade and capacity

: Refer to [MA-16, "FOR USA AND CANADA : Fluids and Lubricants"](#).

3. Install the filler plug with sealant applied on the threads to the rear final drive assembly. Tighten to the specified torque. Refer to [DLN-225, "Disassembly and Assembly"](#).
 - Use High Performance Thread Sealant or equivalent. Refer to [GI-21, "Recommended Chemical Products and Sealants"](#).

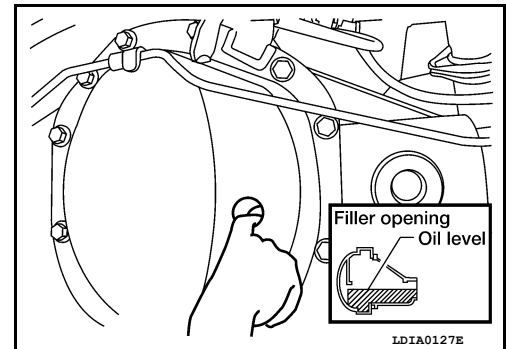

DIFFERENTIAL GEAR OIL : Checking Differential Gear Oil

INFOID:0000000010710239

DIFFERENTIAL GEAR OIL LEAKAGE AND LEVEL

1. Make sure that differential gear oil is not leaking from the rear final drive assembly or around it.
2. Check the differential gear oil level from the filler plug hole as shown.

CAUTION:

Do not start engine while checking differential gear oil level.

3. Install the filler plug with sealant applied on the threads to the rear final drive assembly. Tighten to the specified torque. Refer to [DLN-225, "Disassembly and Assembly"](#).
 - Use High Performance Thread Sealant or equivalent. Refer to [GI-21, "Recommended Chemical Products and Sealants"](#).

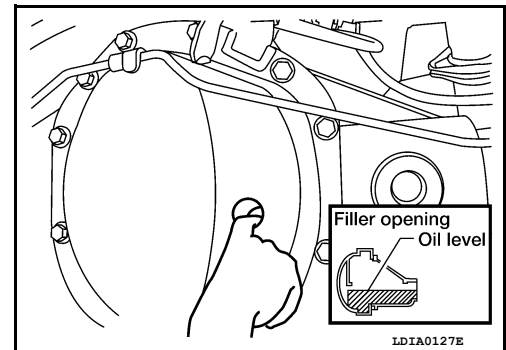

DIFFERENTIAL GEAR OIL : Rear Final Drive - M226

INFOID:0000000010710240

DIFFERENTIAL GEAR OIL : Changing Differential Gear Oil

INFOID:0000000010710241

DRAINING

1. Stop engine.

CHASSIS AND BODY MAINTENANCE

< PERIODIC MAINTENANCE >

2. Remove the drain plug from the rear final drive assembly to drain the differential gear oil.
3. Install the drain plug with sealant applied on the threads to the rear final drive assembly. Tighten to the specified torque. Refer to [DLN-256, "Disassembly and Assembly"](#).
 - Use High Performance Thread Sealant or equivalent. Refer to [GI-21, "Recommended Chemical Products and Sealants"](#).

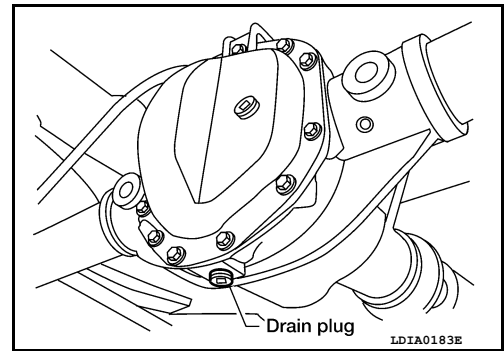

FILLING

1. Remove the filler plug from the rear final drive assembly.
2. Fill the rear final drive assembly with new differential gear oil until the level reaches the specified level near the filler plug hole.

Differential gear oil grade and capacity

: Refer to [MA-16, "FOR USA AND CANADA : Fluids and Lubricants"](#) (United States and Canada), [MA-19, "FOR MEXICO : Fluids and Lubricants"](#) (Mexico).

3. Install the filler plug with sealant applied on the threads to the rear final drive assembly. Tighten to the specified torque. Refer to [DLN-256, "Disassembly and Assembly"](#).
 - Use High Performance Thread Sealant or equivalent. Refer to [GI-21, "Recommended Chemical Products and Sealants"](#).

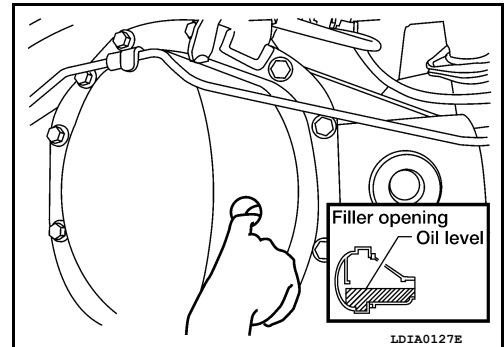

DIFFERENTIAL GEAR OIL : Checking Differential Gear Oil

INFOID:000000010710242

DIFFERENTIAL GEAR OIL LEAKAGE AND LEVEL

1. Make sure that differential gear oil is not leaking from the rear final drive assembly or around it.
2. Check the differential gear oil level from the filler plug hole as shown.

CAUTION:

Do not start engine while checking differential gear oil level.

3. Install the filler plug with sealant applied on the threads to the rear final drive assembly. Tighten to the specified torque. Refer to [DLN-256, "Disassembly and Assembly"](#).
 - Use High Performance Thread Sealant or equivalent. Refer to [GI-21, "Recommended Chemical Products and Sealants"](#).

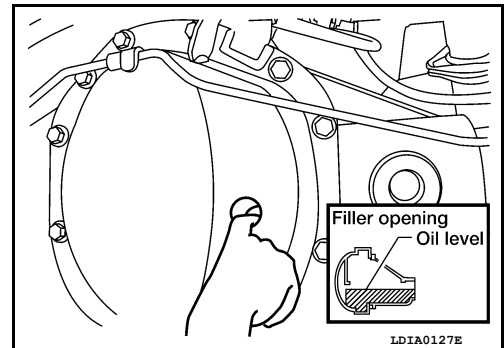

DIFFERENTIAL GEAR OIL : Rear Final Drive - M226 (ELD)

INFOID:000000010710243

DIFFERENTIAL GEAR OIL : Changing Differential Gear Oil

INFOID:000000010710244

DRAINING

1. Stop engine.

MA

CHASSIS AND BODY MAINTENANCE

< PERIODIC MAINTENANCE >

2. Remove the drain plug from the rear final drive assembly to drain the differential gear oil.
3. Install the drain plug with sealant applied on the threads to the rear final drive assembly. Tighten to the specified torque. Refer to [DLN-321, "Disassembly and Assembly"](#).
 - Use High Performance Thread Sealant or equivalent. Refer to [GI-21, "Recommended Chemical Products and Sealants"](#)

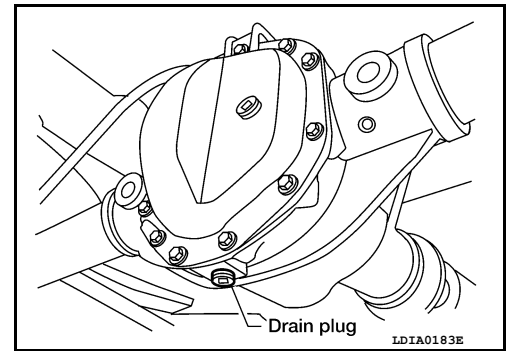

FILLING

1. Remove the filler plug from the rear final drive assembly.
2. Fill the rear final drive assembly with new differential gear oil until the level reaches the specified level near the filler plug hole.

Differential gear oil grade and capacity

: Refer to [MA-16, "FOR USA AND CANADA : Fluids and Lubricants" \(United States and Canada\), MA-19, "FOR MEXICO : Fluids and Lubricants" \(Mexico\).](#)

3. Install the filler plug with sealant applied on the threads to the rear final drive assembly. Tighten to the specified torque. Refer to [DLN-321, "Disassembly and Assembly"](#).
 - Use High Performance Thread Sealant or equivalent. Refer to [GI-21, "Recommended Chemical Products and Sealants"](#).

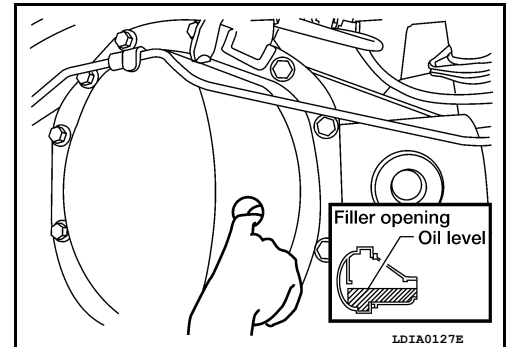

DIFFERENTIAL GEAR OIL : Checking Differential Gear Oil

INFOID:000000010710245

DIFFERENTIAL GEAR OIL LEAKAGE AND LEVEL

1. Make sure that differential gear oil is not leaking from the rear final drive assembly or around it.
2. Check the differential gear oil level from the filler plug hole as shown.

CAUTION:

Do not start engine while checking differential gear oil level.

3. Install the filler plug with sealant applied on the threads to the rear final drive assembly. Tighten to the specified torque. Refer to [DLN-321, "Disassembly and Assembly"](#).
 - Use High Performance Thread Sealant or equivalent. Refer to [GI-21, "Recommended Chemical Products and Sealants"](#).

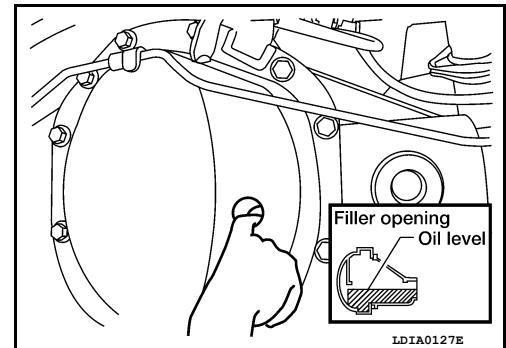

WHEELS

WHEELS : Balancing Wheels

INFOID:000000010710246

BALANCING WHEELS (ADHESIVE WEIGHT TYPE)

Preparation Before Adjustment

Remove inner and outer balance weights from the road wheel. Using releasing agent, remove double-faced adhesive tape from the road wheel.

CAUTION:

- **Be careful not to scratch the road wheel during removal.**
- **After removing double-faced adhesive tape, wipe clean all traces of releasing agent from the road wheel.**

CHASSIS AND BODY MAINTENANCE

< PERIODIC MAINTENANCE >

Wheel Balance Adjustment

- If a balancer machine has an adhesive weight mode setting, select the adhesive weight mode setting and skip Step 2. below. If a balancer machine only has the clip-on (rim flange) weight mode setting, follow Step 2. to calculate the correct size adhesive weight.

1. Set road wheel on balancer machine using the center hole as a guide. Start the balancer machine.
2. For balancer machines that only have a clip-on (rim flange) weight mode setting, follow this step to calculate the correct size adhesive weight to use. When inner and outer imbalance values are shown on the balancer machine indicator, multiply outer imbalance value by 5/3 (1.67) to determine balance weight that should be used. Select the outer balance weight with a value closest to the calculated value above and install in to the designated outer position of, or at the designated angle in relation to the road wheel.

- a. Indicated imbalance value $\times 5/3 =$ balance weight to be installed

Calculation example:

23 g (0.81 oz) $\times 5/3$ (1.67) = 38.33 g (1.35 oz) \Rightarrow 40 g (1.41 oz)
balance weight (closer to calculated balance weight value)

NOTE:

Note that balance weight value must be closer to the calculated balance weight value.

Example:

37.4 \Rightarrow 35 g (1.23 oz)

37.5 \Rightarrow 40 g (1.41 oz)

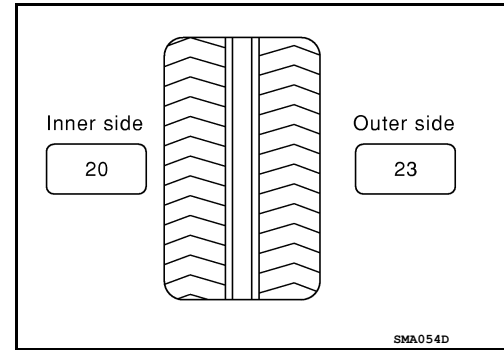

3. Install balance weight in the position shown.

CAUTION:

- Do not install the inner balance weight before installing the outer balance weight.
- Before installing the balance weight, be sure to clean the mating surface of the road wheel.
- When installing balance weight (1) to road wheel, set it into the grooved area (A) on the inner wall of the road wheel as shown so that the balance weight center (B) is aligned with the balancer machine indication position (angle) (C).

CAUTION:

- Always use Genuine NISSAN adhesive balance weights.
- Balance weights are non-reusable; always replace with new ones.
- Do not install more than three sheets of balance weight.

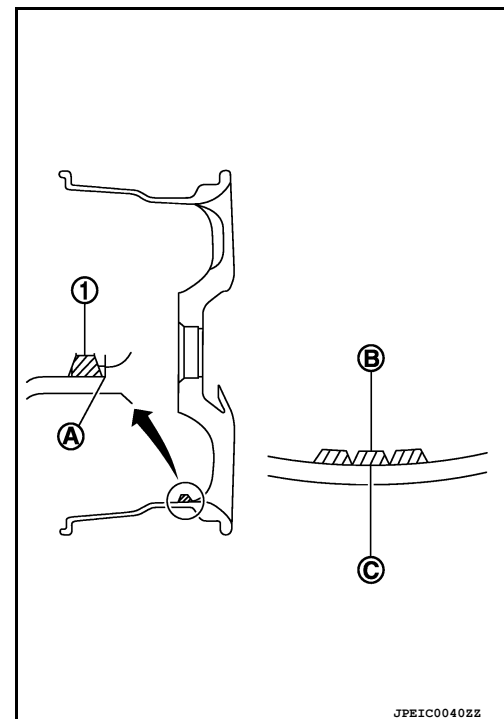

4. If calculated balance weight value exceeds 50 g (1.76 oz), install two balance weight sheets in line with each other as shown.

CAUTION:

Do not install one balance weight sheet on top another.

5. Start balancer machine again.
6. Install balance weight on inner side of road wheel in the balancer machine indication position (angle).

CAUTION:

Do not install more than two balance weights.

7. Start balancer machine. Make sure that inner and outer residual imbalance values are 5 g (0.17 oz) each or below.

8. If either residual imbalance value exceeds 5 g (0.17 oz), repeat installation procedures.

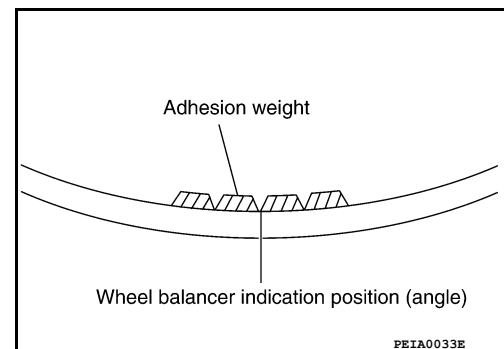

A
B
C
D
E
F
G
H
I
J
K
L
M
N
O

MA

CHASSIS AND BODY MAINTENANCE

< PERIODIC MAINTENANCE >

Wheel balance	Dynamic (At flange)	Static (At flange)
Maximum allowable imbalance	Refer to WT-53. "Road Wheel" .	

WHEELS : Rotation

INFOID:0000000010710247

TIRE ROTATION

- Follow the maintenance schedule for tire rotation service intervals. Refer to [MA-6. "FOR USA AND CANADA : Explanation of General Maintenance"](#) (United States and Canada), or [MA-8. "FOR MEXICO : General Maintenance"](#) (Mexico).

- When installing the wheel, tighten wheel nuts to the specified torque.

CAUTION:

- Do not include the spare tire when rotating the tires.
- When installing wheels, tighten them diagonally by dividing the work two to three times in order to prevent the wheels from developing any distortion.
- Be careful not to tighten wheel nut at torque exceeding the criteria for preventing strain of disc rotor.
- Use NISSAN Genuine wheel nuts for aluminum wheels.

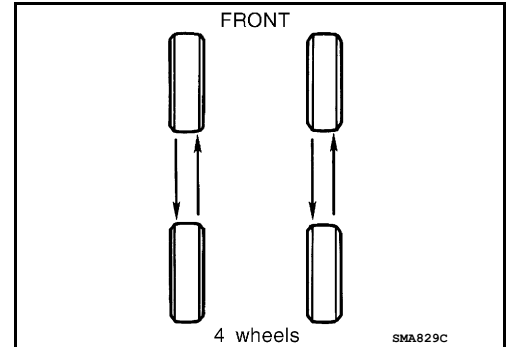

Wheel nut tightening torque : 133 N·m (14 kg-m, 98 ft-lb)

- Perform the ID registration, after tire rotation. Refer to [WT-6. "Work Procedure"](#).

BRAKE FLUID LEVEL AND LEAKS

BRAKE FLUID LEVEL AND LEAKS : On Board Inspection

INFOID:0000000010710248

LEVEL CHECK

- Check that the brake fluid level in the reservoir tank is within specification, between the MAX and MIN lines as shown.
- Visually check around reservoir tank for fluid leaks.
- If fluid level is excessively low, check brake system for leaks.
- If brake warning lamp remains illuminated after the parking brake pedal is released, check the brake system for any brake fluid leaks.

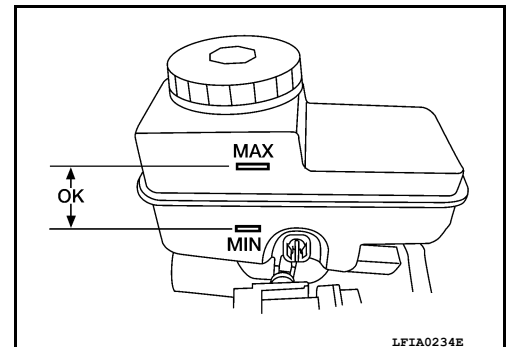

BRAKE LINES AND CABLES

CHASSIS AND BODY MAINTENANCE

< PERIODIC MAINTENANCE >

BRAKE LINES AND CABLES : Checking Brake Line and Cables

INFOID:000000010710249

1. Check the brake lines and hoses for cracks, deterioration, and other damage. Replace any damaged parts.

CAUTION:

If brake fluid leaks are visible around the brake line joints, retighten the joint, or replace damaged parts as necessary.

2. Check for brake fluid leaks by fully depressing brake pedal while engine is running.

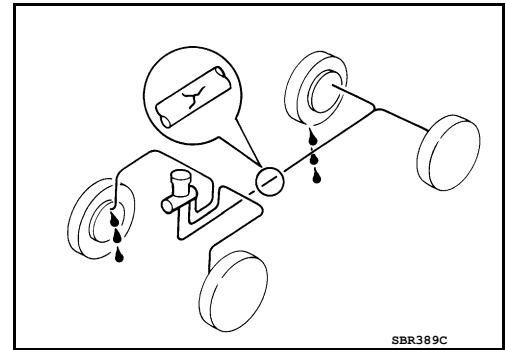

DISC BRAKE

DISC BRAKE : Checking Disc Brake

INFOID:000000010710250

ROTOR

Check the condition of the rotor, and for any wear or damage. Measure the rotor thickness using a suitable tool as shown. Repair or replace as necessary.

Standard thickness : Refer to [BR-53, "Front Disc Brake" \(front\)](#), [BR-53, "Rear Disc Brake" \(rear\)](#).

Repair limit thickness : Refer to [BR-53, "Front Disc Brake" \(front\)](#), [BR-53, "Rear Disc Brake" \(rear\)](#).

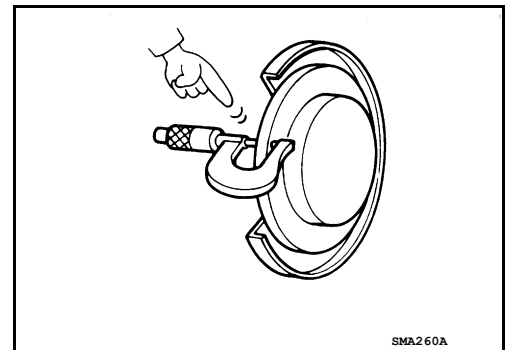

CALIPER

Check for any fluid leakage. Repair as necessary.

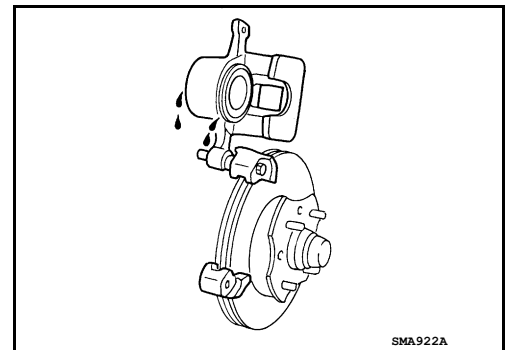

PAD

Check for any wear or damage. Measure the pad thickness. Replace as necessary.

NOTE:

Front brake shown, rear brake similar.

Standard thickness : Refer to [BR-53, "Front Disc Brake" \(front\)](#), [BR-53, "Rear Disc Brake" \(rear\)](#).

Repair limit thickness : Refer to [BR-53, "Front Disc Brake" \(front\)](#), [BR-53, "Rear Disc Brake" \(rear\)](#).

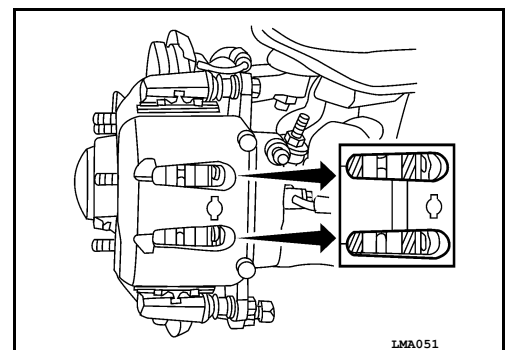

STEERING GEAR AND LINKAGE

A
B
C
D
E
F
G
H
I
J
K
L
M
N
O

MA

CHASSIS AND BODY MAINTENANCE

< PERIODIC MAINTENANCE >

STEERING GEAR AND LINKAGE : Checking Steering Gear and Linkage

INFOID:000000010710251

STEERING GEAR

- Check the steering gear housing for looseness, damage and oil leakage as shown.
- Check the steering column connections for looseness.

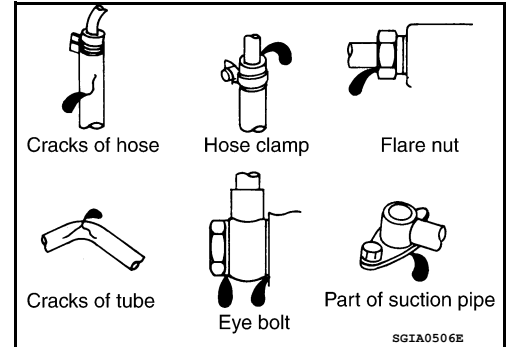

STEERING LINKAGE

- Check the ball joint, dust cover and other component parts for looseness, wear, damage and grease leakage.

POWER STEERING FLUID AND LINES

POWER STEERING FLUID AND LINES : Checking Power Steering Fluid and Line

INFOID:000000010710252

CHECKING FLUID LEVEL

Check fluid level, referring to the scale on the reservoir tank.

Use HOT range for fluid temperatures of 50° – 80°C (122° – 176°F).

Use COLD range for fluid temperatures of 0° – 30°C (32° – 86°F).

CAUTION:

- Do not overfill.
- Do not reuse any power steering fluid.
- Recommended fluid is Genuine NISSAN PSF or equivalent. Refer to [MA-16, "FOR USA AND CANADA : Fluids and Lubricants"](#) (United States and Canada), [MA-19, "FOR MEXICO : Fluids and Lubricants"](#) (Mexico).

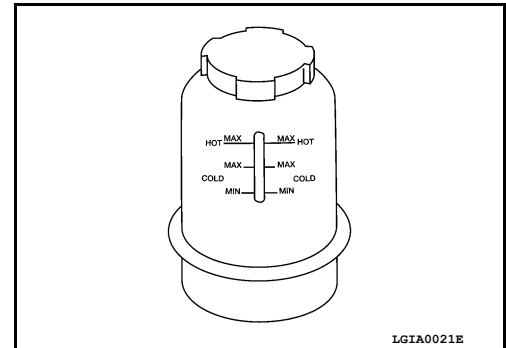

CHECKING LINES

- Check lines for improper attachment, leaks, cracks, damage, loose connections, chafing and deterioration.

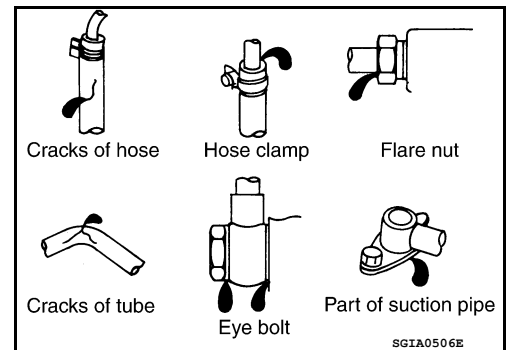

AXLE AND SUSPENSION PARTS

AXLE AND SUSPENSION PARTS : Checking Axle and Suspension Parts

INFOID:000000010710253

FRONT AND REAR AXLE AND SUSPENSION PARTS

Check front and rear axle and suspension parts for excessive play, cracks, wear or other damage.

CHASSIS AND BODY MAINTENANCE

< PERIODIC MAINTENANCE >

- Shake each wheel to check for excessive play.
- Rotate each wheel to check for abnormal noise.
- Check axle and suspension nuts and bolts for looseness.

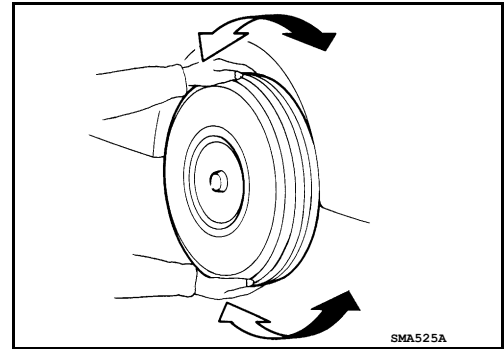

- Check the strut and shock absorber for oil leakage or other damage.
- Check suspension ball joints for grease leakage and ball joint dust cover for cracks or other damage.

FRONT DRIVE SHAFT

Check the boots and drive shaft for cracks, wear, damage, and grease leakage.

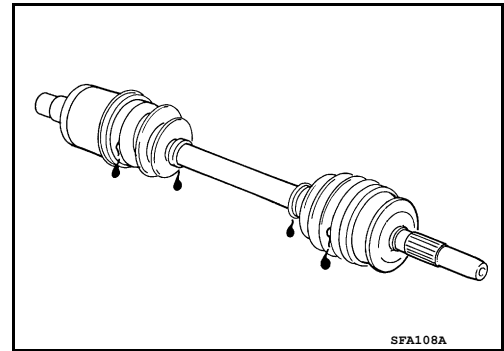

LOCKS, HINGES AND HOOD LATCH

A
B
C
D
E
F
G
H
I
J
K
L
M
N
O

MA

CHASSIS AND BODY MAINTENANCE

< PERIODIC MAINTENANCE >

LOCKS, HINGES AND HOOD LATCH : Lubricating Locks, Hinges and Hood Latches

INFOID:000000010710254

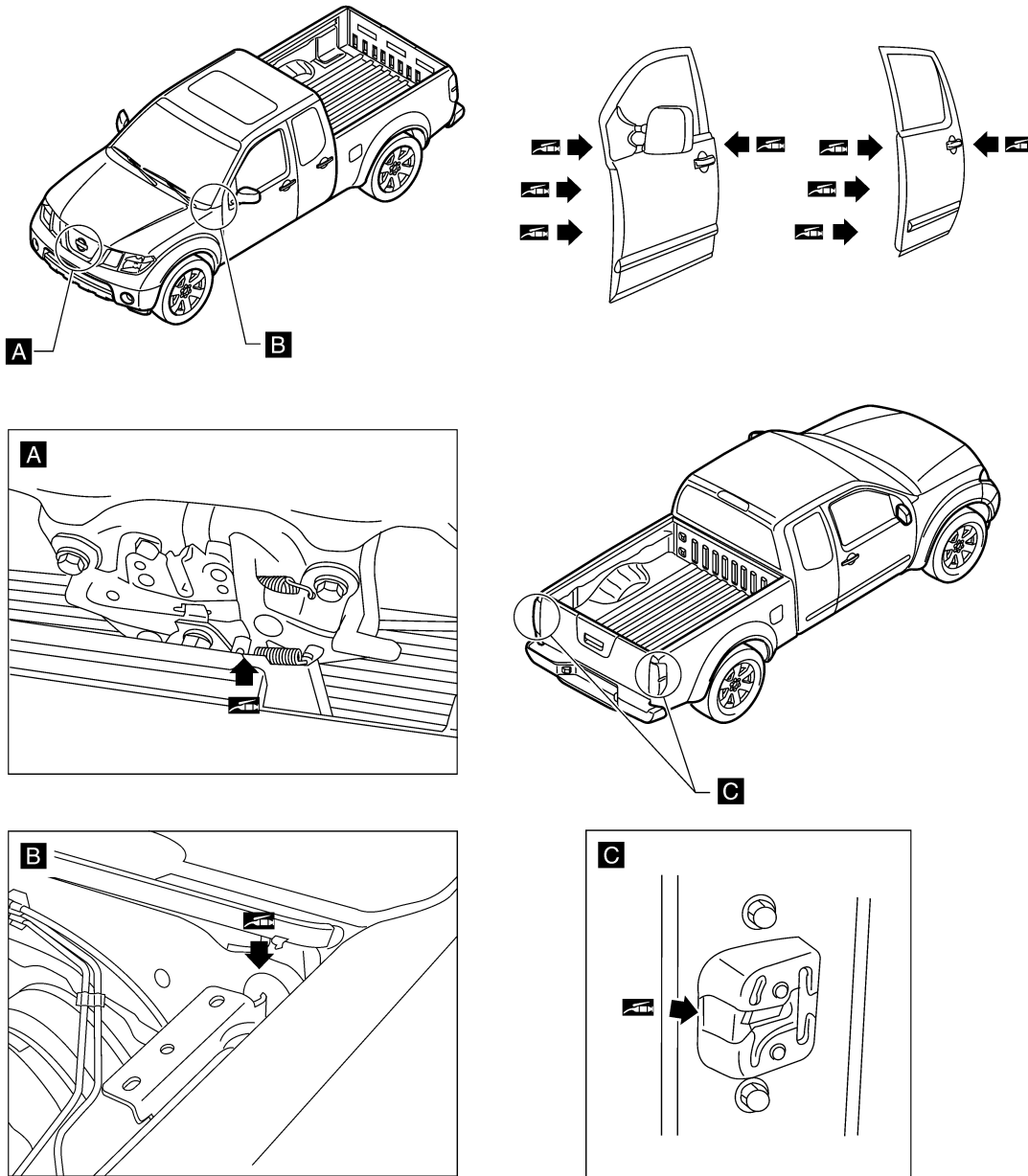

 : Multi-purpose grease

WLIA0025E

- Lubricate the locations shown.

Refer to [MA-16. "FOR USA AND CANADA : Fluids and Lubricants"](#) (United States and Canada), [MA-19. "FOR MEXICO : Fluids and Lubricants"](#) (Mexico).

SEAT BELT, BUCKLES, RETRACTORS, ANCHORS AND ADJUSTERS

SEAT BELT, BUCKLES, RETRACTORS, ANCHORS AND ADJUSTERS : Checking Seat Belts, Buckles, Retractors, Anchors and Adjusters

INFOID:000000010710255

Check the seat belt buckles, webbing, retractors, anchors and adjusters. Replace any seat belt assembly as necessary. Refer to [SB-3. "Inspection"](#).

- Check the seat belt anchors for loose mounting bolts, damage, or excessive wear.

CHASSIS AND BODY MAINTENANCE

< PERIODIC MAINTENANCE >

- Check the seat belt webbing for any damage, cuts, fraying, or excessive wear.
- Check the retractor for smooth operation.
- Check the function of the buckles by inserting the seat belt tongue and checking for proper engagement of the buckle and press the button on the buckle to check for proper release of the seat belt tongue.

CAUTION:

- **After any collision, inspect all seat belt assemblies, including retractors and other attached components, such as the guide rail set. NISSAN recommends replacing all seat belt assemblies in use during a collision, unless they are not damaged and are inspected to confirm they are operating properly after a minor collision.**
Also inspect all seat belt assemblies that are not in use during a collision, and replace any components if damaged or not operating properly. The seat belt pre-tensioner should be replaced even if the seat belts are not in use during a frontal collision where the driver and passenger air bags have been deployed.
- **If any component of the seat belt assembly is suspected of being damaged or not operating properly, do not repair the component. Replace the components as an assembly.**
- **If the seat belt webbing is cut, frayed, or damaged then replace the seat belt assembly.**
- **Do not lubricate the seat belt buckle or tongue.**
- **When replacing any seat belt assembly always use a Genuine NISSAN seat belt assembly.**

A

B

C

D

E

F

G

H

I

J

K

L

M

N

O

MA