

SECTION **SN**
SONAR SYSTEM

A
B
C
D
E
F
G
H
I
J
K
L
M
SN
O
P

CONTENTS

BASIC INSPECTION	2	Component Inspection	13
DIAGNOSIS AND REPAIR WORKFLOW	2	ECU DIAGNOSIS INFORMATION	14
Work Flow	2	SONAR CONTROL UNIT	14
INSPECTION AND ADJUSTMENT	4	Reference Value	14
Preliminary Check	4	DTC Index	15
SYSTEM DESCRIPTION	5	WIRING DIAGRAM	16
REAR SONAR SYSTEM	5	SONAR SYSTEM	16
System Diagram	5	Wiring Diagram	16
System Description	5	SYMPTOM DIAGNOSIS	22
Component Parts Location	6	SONAR SYSTEM SYMPTOMS	22
Component Description	6	Symptom Table	22
Self-Diagnosis Function	7	PRECAUTION	24
DTC/CIRCUIT DIAGNOSIS	9	PRECAUTION	24
POWER SUPPLY AND GROUND CIRCUIT	9	Precaution for Supplemental Restraint System (SRS) "AIR BAG" and "SEAT BELT PRE-TENSIONER"	24
Diagnosis Procedure	9	UNIT REMOVAL AND INSTALLATION	25
SONAR SENSOR CIRCUIT INSPECTION	10	SONAR SENSOR	25
Description	10	Removal and Installation	25
Diagnosis Procedure	10	SONAR CONTROL UNIT	26
SONAR BUZZER CIRCUIT INSPECTION	11	Removal and Installation	26
Description	11	BUZZER	27
Diagnosis Procedure	11	Removal and Installation	27
Component Inspection	11		
SONAR SYSTEM OFF SWITCH CIRCUIT INSPECTION	12		
Description	12		
Diagnosis Procedure	12		

DIAGNOSIS AND REPAIR WORKFLOW

< BASIC INSPECTION >

BASIC INSPECTION

DIAGNOSIS AND REPAIR WORKFLOW

Work Flow

INFOID:000000010711391

WORK FLOW

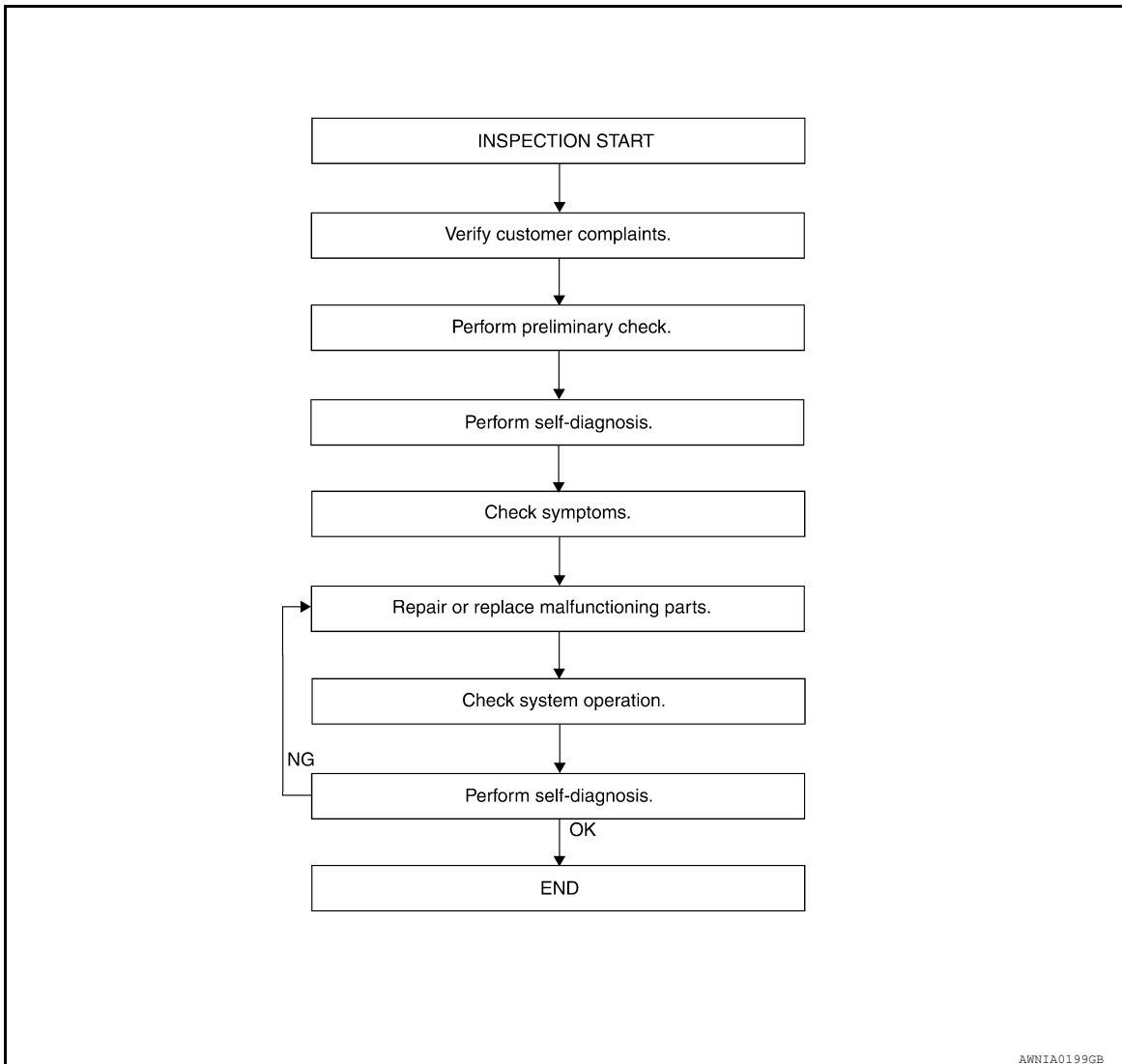

DETAILED FLOW

1. CUSTOMER INFORMATION

Interview the customer to obtain detailed information about the symptom.

>> GO TO 2.

2. PRELIMINARY CHECK

Perform preliminary check. Refer to [SN-4. "Preliminary Check"](#).

>> GO TO 3.

3. SELF-DIAGNOSIS

Perform self-diagnosis. Refer to [SN-7. "Self-Diagnosis Function"](#).

DIAGNOSIS AND REPAIR WORKFLOW

< BASIC INSPECTION >

>> GO TO 4.

4.SYMPTOM

Check for symptoms. Refer to [SN-22. "Symptom Table"](#).

>> GO TO 5.

5.MALFUNCTIONING PARTS

Repair or replace the applicable parts.

>> GO TO 6.

6.SYSTEM OPERATION

Check system operation.

>> GO TO 7.

7.SELF-DIAGNOSIS

Perform self-diagnosis.

Are any fault codes displayed?

YES >> GO TO 5.

NO >> Inspection End.

A

B

C

D

E

F

G

H

I

J

K

L

M

SN

O

P

INSPECTION AND ADJUSTMENT

< BASIC INSPECTION >

INSPECTION AND ADJUSTMENT

Preliminary Check

INFOID:000000010711392

DESCRIPTION

The purpose of the sonar sensor preliminary check is to confirm that there are no outside factors affecting the sonar system.

CONDITIONS

- Ignition switch ON
- No obstructions within 3.0 m (10 ft.) of sonar sensors

SONAR SENSOR STATUS CHECK

- Check that the sonar sensors are properly aligned (no deformation in sensor mounting areas).
- Check that snow, mud or other foreign objects are not adhering to the sonar sensors.
- Check that there is no deformation, scratches or other damage to the sonar sensors.
- Check that water has not accumulated in the sonar sensors.

CAUTION:

Use water, cotton swab, or other soft material for cleaning the sensors.

1. Inspect for the following:
 - Physical damage to wiring
 - Physical damage to harness connectors
 - Loose or disconnected harness connectors
 - Physical damage to system components
2. Check that there are no obstacles within each sonar sensor's detection range.

Sonar sensors	Detection range
Rear	Approx. 1.8 m (5.9 ft.) maximum

3. Check that there are no nearby ultrasound sources such as the sounds of vehicle horns, motorcycle engines or truck air brakes.
4. Check that the vehicle is on a level surface.

REAR SONAR SYSTEM

< SYSTEM DESCRIPTION >

SYSTEM DESCRIPTION

REAR SONAR SYSTEM

System Diagram

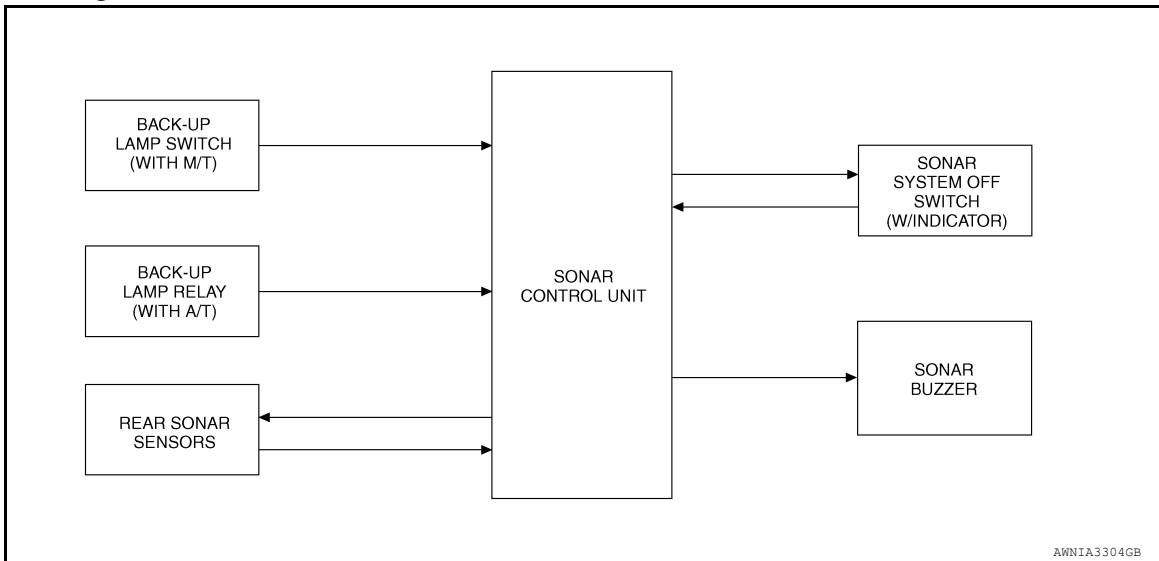

System Description

INFOID:0000000010711394

FUNCTION

With power and ground supplied, transmission gear selector lever in R position, and the sonar system OFF switch ON, the rear sonar system will detect obstacles within 1.8 m (5.9 ft.) of the rear sonar sensors. The vehicle operator is notified of obstacles by varied rate of tone from the rear sonar buzzer depending on distance of obstacle being sensed.

SONAR SYSTEM OFF SWITCH

With power and ground supplied to the sonar control unit, transmission gear selector lever in R position, the sonar system can be disabled and the sonar buzzer silenced by momentarily pressing the sonar system OFF switch. The sonar system OFF indicator lamp will be illuminated in the sonar system OFF switch.

The rear sonar system and buzzer will be disabled and the sonar system OFF indicator will be illuminated until the ignition switch is turned OFF. When the ignition switch is turned ON, the rear sonar system will be enabled. Depressing the sonar system OFF switch again will enable the rear sonar system also. Enabling the rear sonar system will cause the rear sonar system OFF indicator to go out. If the sonar control unit detects a malfunction in the system it will turn off the sonar system and the indicator lamp will turn on.

REAR SONAR BUZZER

With power and ground supplied to the sonar control unit and the A/T selector lever in R position, a stationary object that is at least 7.0 cm (2.8 in.) wide and 1.0 m (39.0 in.) tall and that is closer than 1.8 m (5.9 ft.) will be detected by the rear sonar sensors, causing the rear sonar buzzer to sound a tone. As the vehicle moves closer to the object, the rate of the tone will increase. When the object is less than 25.0 cm (10 in.) from the rear bumper, the tone will sound continuously.

REAR SONAR SENSORS

With power and ground supplied to the rear sonar sensors, the sonar sensors transmit an ultrasonic signal. This signal is reflected back to the sensor by objects large enough and close enough to be detected. The rear sonar sensors measure the time from the transmitted signal to the time the signal is reflected back and sends this information to the sonar control unit.

BACK-UP LAMP RELAY (WITH A/T)

The back-up lamp relay provides a reverse signal to the sonar control unit.

BACK-UP LAMP SWITCH (WITH M/T)

The back-up lamp switch provides a reverse signal to the sonar control unit.

REAR SONAR SYSTEM

< SYSTEM DESCRIPTION >

Component Parts Location

INFOID:000000010711395

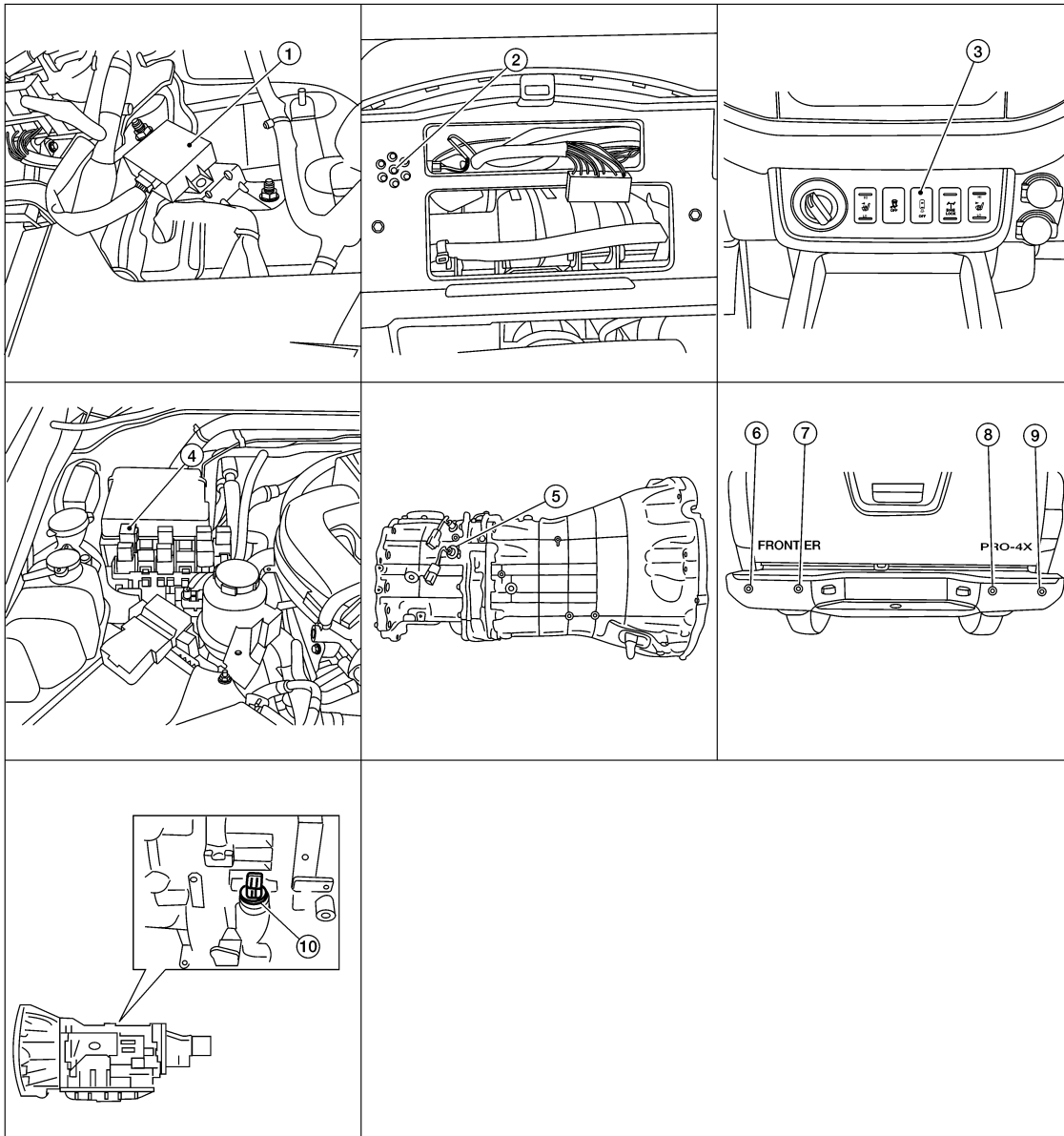

ALNIA15002Z

- | | | |
|---|--|------------------------------------|
| 1. Sonar control unit M93 (above left lower dash side finisher) | 2. Rear sonar buzzer M92 (view with combination meter removed) | 3. Sonar system OFF switch M94 |
| 4. Back-up lamp relay E45 (with A/T) | 5. Back-up lamp switch F69 (with M/T) | 6. Rear sonar sensor LH outer C227 |
| 7. Rear sonar sensor LH inner C228 | 8. Rear sonar sensor RH inner C229 | 9. Rear sonar sensor RH outer C230 |
| 10. A/T assembly F9 (with A/T) | | |

Component Description

INFOID:000000010711396

Component	Function
Sonar control unit	Controls sonar system and provides self-diagnosis
Back-up lamp relay (with A/T)	Provides reverse signal for sonar control unit
Back-up lamp switch (with M/T)	Provides reverse signal for sonar control unit
A/T assembly	Controls back-up lamp relay

REAR SONAR SYSTEM

< SYSTEM DESCRIPTION >

Component	Function
Rear sonar buzzer	Sounds a signal when objects are detected in the rear of the vehicle
Sonar system OFF switch	Enables the driver to turn system off and signals a system malfunction
Sonar sensor	Senses objects in the rear of the vehicle

Self-Diagnosis Function

INFOID:000000010711397

NOTE:

Always perform Preliminary Check before running Self-Diagnosis Function. Refer to [SN-4. "Preliminary Check"](#).

There are four modes of self-diagnosis. These modes must be followed in the following order:

1. Entering diagnostics mode
2. Requesting number of fault codes mode
3. Requesting fault codes mode
4. Clearing fault codes mode

Self-diagnosis can be manually exited by turning the ignition OFF or selecting reverse gear. Self-diagnosis will exit unless a fault code request occurs before a message is repeated five times without acknowledgement.

ENTERING DIAGNOSTICS MODE

1. Turn ignition switch ON. Sonar system OFF switch indicator lamp illuminates for three seconds and then turns off.
2. Immediately push sonar system OFF switch ten times within five seconds.
3. The rear sonar buzzer will sound once and the sonar system OFF indicator will flash once.

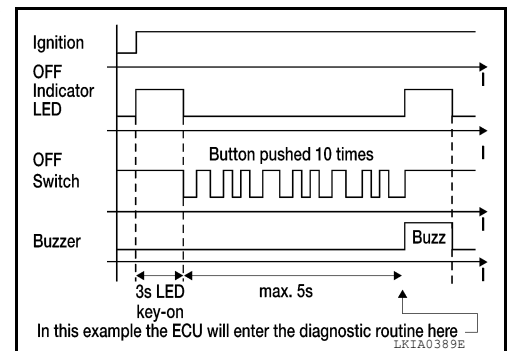

REQUESTING NUMBER OF FAULT CODES MODE

1. While in "entering diagnostic mode", push sonar system OFF switch once within 30 seconds of entering diagnostic mode.

NOTE:

If the number of fault codes is not requested within 30 seconds after entering diagnostic mode, the system will return to regular operation mode.

2. The rear sonar buzzer will sound once.
3. Sonar system OFF indicator will flash once and rear sonar buzzer will sound once for each fault code detected.
4. There will be a four second pause.
5. The number of fault codes will repeat five times then pause.

NOTE:

Self-diagnosis will exit unless "requesting fault codes mode" occurs before five repeats ends.

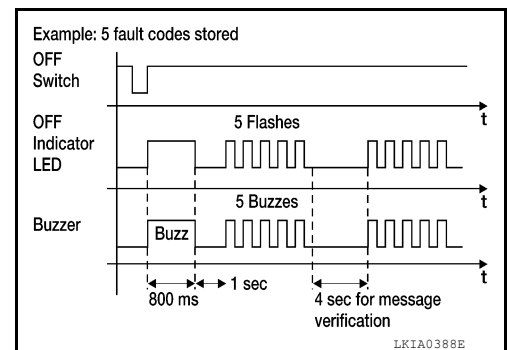

REQUESTING FAULT CODES MODE

REAR SONAR SYSTEM

< SYSTEM DESCRIPTION >

1. While in "requesting number of fault codes" mode, push sonar system OFF switch once.
2. The rear sonar buzzer will sound once.
3. Sonar system OFF indicator will flash and rear sonar buzzer will sound the first digit of the fault code followed by a one second pause.
4. Sonar system OFF indicator will flash and rear sonar buzzer will sound the second digit of the fault code followed by a four second pause.
5. Each fault code will repeat five times then pause.
6. Write down each fault code. Then, acknowledge the fault code by pushing the sonar system OFF switch once (the rear sonar buzzer may sound).

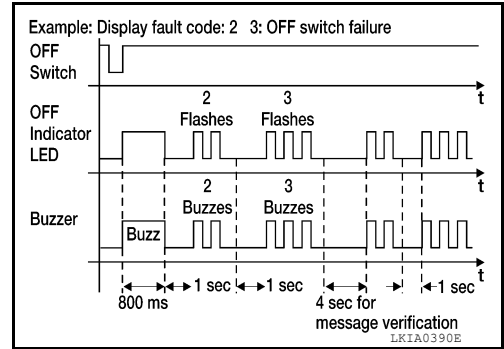

NOTE:

"Requesting fault codes mode" will exit unless the fault code is acknowledged before it is repeated five times. When all fault codes have been indicated, "clearing fault codes mode" will be entered. Refer to [SN-15. "DTC Index"](#).

CLEARING FAULT CODES MODE

NOTE:

While in "clearing fault codes mode", self-diagnosis will automatically exit if no activity occurs for 30 seconds.

1. Push and hold sonar system OFF switch for three seconds to reset time-out counter.
2. Push and hold sonar system OFF switch for three seconds to clear codes.

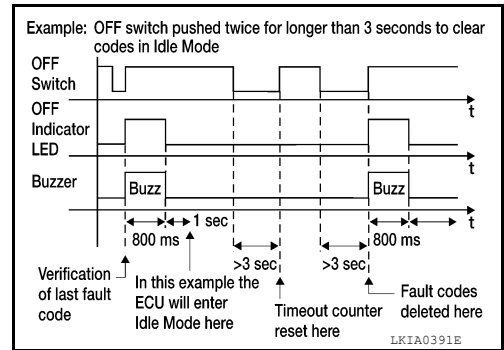

POWER SUPPLY AND GROUND CIRCUIT

< DTC/CIRCUIT DIAGNOSIS >

DTC/CIRCUIT DIAGNOSIS

POWER SUPPLY AND GROUND CIRCUIT

Diagnosis Procedure

INFOID:0000000010711398

Regarding Wiring Diagram information, refer to [SN-16. "Wiring Diagram"](#).

1. CHECK FUSE

Check that the following fuse is not blown.

Terminal No.	Signal name	Fuse No.
8	Ignition power supply	12 (10A)

Is the fuse blown?

- YES >> Replace the blown fuse after repairing the affected circuit.
NO >> GO TO 2.

2. CHECK POWER SUPPLY CIRCUIT

1. Turn ignition switch OFF.
2. Disconnect sonar control unit connector.
3. Check voltage between sonar control unit connector M93 and ground.

Sonar control unit		Ground	Condition	Voltage (Approx.)
Connector	Terminal			
M93	8	—	Ignition switch: ON	Battery voltage

Is the inspection result normal?

- YES >> GO TO 3.
NO >> Repair or replace harness or connectors.

3. CHECK GROUND CIRCUIT

1. Turn ignition switch OFF.
2. Check continuity between sonar control unit connector M93 and ground.

Sonar control unit		Ground	Continuity
Connector	Terminal		
M93	6	—	Yes

Is the inspection result normal?

- YES >> Inspection End.
NO >> Repair or replace harness or connectors.

A
B
C
D
E
F
G
H
I
J
K
L
M
O
P

SN

SONAR SENSOR CIRCUIT INSPECTION

< DTC/CIRCUIT DIAGNOSIS >

SONAR SENSOR CIRCUIT INSPECTION

Description

INFOID:000000010711399

With power and ground supplied to the sonar sensors, the sonar sensors transmit an ultrasonic signal. This signal is reflected back to the sensor by objects large enough and close enough to be detected. The sonar sensors measure the time from the transmitted signal to the time the signal is reflected back and send this information to the sonar control unit. Refer to [SN-5, "System Description"](#) for more details.

Diagnosis Procedure

INFOID:000000010711400

Regarding Wiring Diagram information, refer to [SN-16, "Wiring Diagram"](#).

1. CHECK REAR SONAR SENSOR CIRCUITS

1. Turn ignition switch OFF.
2. Disconnect sonar control unit and rear sonar sensor connectors.
3. Check continuity between sonar control unit connector M93 and rear sonar sensor connectors.

Sonar control unit		Rear sonar sensor		Continuity
Connector	Terminal	Connector	Terminal	
M93	10	C227 (LH outer)	2	Yes
	15		3	
	16		1	
	11	C228 (LH inner)	2	
	15		3	
	16		1	
	12	C229 (RH inner)	2	
	15		3	
	16		1	
	9	C230 (RH outer)	2	
	15		3	
	16		1	

4. Check continuity between sonar control unit connector M93 and ground.

Sonar control unit		Ground	Continuity
Connector	Terminal		
M93	9	—	No
	10		
	11		
	12		
	15		
	16		

Is the inspection result normal?

- YES >> Inspection End.
 NO >> Repair or replace harness or connectors.

SONAR BUZZER CIRCUIT INSPECTION

< DTC/CIRCUIT DIAGNOSIS >

SONAR BUZZER CIRCUIT INSPECTION

Description

INFOID:0000000010711401

When the A/T selector lever is not in park or neutral, a stationary object will be detected by the sonar sensors causing the rear sonar buzzer to sound a tone. As the vehicle moves closer to the object, the rate of the tone will increase. When the object is very close to the vehicle, the tone will sound continuously.

Diagnosis Procedure

INFOID:0000000010711402

Regarding Wiring Diagram information, refer to [SN-16, "Wiring Diagram"](#).

1. CHECK REAR SONAR BUZZER

Perform the rear sonar buzzer component inspection. Refer to [SN-11, "Component Inspection"](#).

Is the inspection result normal?

YES >> GO TO 2.

NO >> Replace rear sonar buzzer. Refer to [SN-27, "Removal and Installation"](#).

2. CHECK REAR SONAR BUZZER CIRCUIT

1. Turn ignition switch OFF.
2. Disconnect sonar control unit and rear sonar buzzer connectors.
3. Check continuity between sonar control unit connector M93 and rear sonar buzzer connector M92.

Sonar control unit		Rear sonar buzzer		Continuity
Connector	Terminal	Connector	Terminal	
M93	3	M92	3	Yes
	7		2	

4. Check continuity between sonar control unit connector M93 and ground.

Sonar control unit		Ground	Continuity
Connector	Terminal		
M93	3	—	No
	7		

Is the inspection result normal?

YES >> Inspection End.

NO >> Repair or replace harness or connectors.

Component Inspection

INFOID:0000000010711403

1. CHECK REAR SONAR BUZZER

1. Turn ignition switch OFF.
2. Disconnect rear sonar buzzer connector.
3. Check resistance between rear sonar buzzer terminals.

Rear sonar buzzer terminals		Value
2	3	50Ω ± 10Ω

Is the inspection result normal?

YES >> Inspection End.

NO >> Replace the rear sonar buzzer. Refer to [SN-27, "Removal and Installation"](#).

A
B
C
D
E
F
G
H
I
J
K
L
M
O
P

SN

SONAR SYSTEM OFF SWITCH CIRCUIT INSPECTION

< DTC/CIRCUIT DIAGNOSIS >

SONAR SYSTEM OFF SWITCH CIRCUIT INSPECTION

Description

INFOID:000000010711404

The sonar system can be disabled by momentarily pressing the rear sonar system OFF switch. The sonar system OFF indicator lamp will be illuminated when the sonar system is OFF. Enabling the sonar system will cause the sonar system OFF indicator to go out. The indicator will flash if a malfunction exists in the system.

Diagnosis Procedure

INFOID:000000010711405

Regarding Wiring Diagram information, refer to [SN-16, "Wiring Diagram"](#).

1. CHECK SONAR SYSTEM OFF SWITCH

Perform the sonar system OFF switch component inspection. Refer to [SN-13, "Component Inspection"](#).

Is the inspection result normal?

- YES >> GO TO 2.
- NO >> Replace sonar system OFF switch.

2. CHECK SONAR SYSTEM OFF SWITCH ON/OFF AND STATUS LED CIRCUITS

1. Turn ignition switch OFF.
2. Disconnect sonar control unit and sonar system OFF switch connectors.
3. Check continuity between sonar control unit connector M93 and sonar system OFF switch connector M94.

Sonar control unit		Sonar system OFF switch		Continuity
Connector	Terminal	Connector	Terminal	
M93	4	M94	5	Yes
	13		1	

4. Check continuity between sonar system OFF switch connector and ground.

Sonar control unit		Ground	Continuity
Connector	Terminal		
M93	4	—	No
	13		

Is the inspection result normal?

- YES >> GO TO 3.
- NO >> Repair or replace harness or connectors.

3. CHECK SONAR SYSTEM OFF SWITCH GROUND CIRCUITS

Check continuity between sonar system OFF switch connector and ground.

Sonar control unit		Ground	Continuity
Connector	Terminal		
M93	2	—	Yes
	6		

Is the inspection result normal?

- YES >> Inspection End.
- NO >> Repair or replace harness or connectors.

SONAR SYSTEM OFF SWITCH CIRCUIT INSPECTION

< DTC/CIRCUIT DIAGNOSIS >

Component Inspection

INFOID:0000000010711406

1. SONAR SYSTEM OFF SWITCH

1. Turn ignition switch OFF.
2. Disconnect sonar system OFF switch connector.
3. Check continuity between sonar system OFF switch terminals.

Sonar system OFF switch terminals		Condition	Continuity
1	2	Switch pressed	Yes
		Switch released	No

Is the inspection result normal?

- YES >> GO TO 2.
NO >> Replace sonar system OFF switch.

2. SONAR SYSTEM OFF INDICATOR

Apply battery voltage to terminal 5 and ground to terminal 6 of sonar system OFF switch.

Sonar system OFF switch		Condition	Result
Terminal	5	Battery voltage applied	Indicator ON
	6	Ground applied	

Is the inspection result normal?

- YES >> Inspection End.
NO >> Replace sonar system OFF switch.

A
B
C
D
E
F
G
H
I
J
K
L
M
O
P

SN

SONAR CONTROL UNIT

< ECU DIAGNOSIS INFORMATION >

ECU DIAGNOSIS INFORMATION

SONAR CONTROL UNIT

Reference Value

INFOID:000000010711407

SONAR CONTROL UNIT TERMINAL LAYOUT

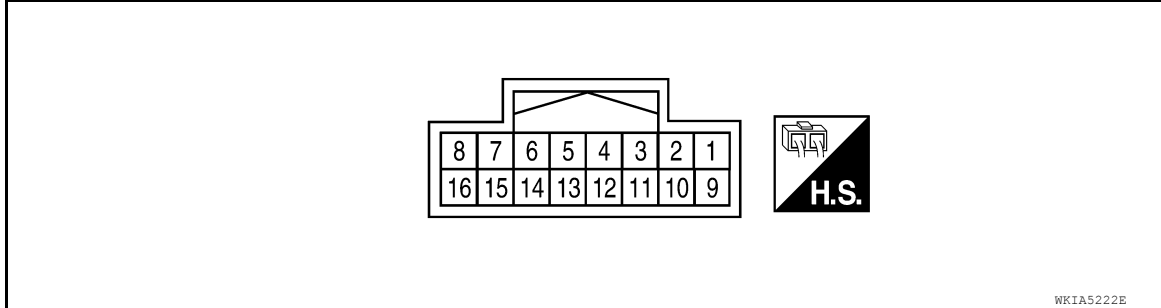

TERMINALS AND REFERENCE VALUES FOR SONAR CONTROL UNIT

Terminal (wire color)		Description		Condition		Reference value (Approx.)
+	-	Signal name	Input/Output	Ignition switch	Operation	
3 (R)	Ground	Rear sonar buzzer return signal	Input	ON	Obstacle detected	0 – 12 V (variable)
4 (V)	Ground	Sonar system OFF indicator signal	Output	ON	Sonar system OFF switch ON	0 V
					Sonar system OFF switch OFF	Battery voltage
5 (SB)	Ground	Reverse signal	Input	ON	Selector lever in R (reverse) position	Battery voltage
					Selector lever in any position except R (reverse)	0 V
6 (B)	Ground	Sonar control unit ground	Input	OFF	—	0 V
7 (L)	Ground	Rear sonar buzzer drive signal	Output	ON	Obstacle detected	Battery voltage
8 (W/G)	Ground	Sonar control unit power	Input	ON	—	Battery voltage
9 (GR)	Ground	RH outer sensor signal	Input	ON	Selector lever in R (reverse) position	 SKIB8942E
10 (P)	Ground	LH outer sensor signal	Input	ON	Selector lever in R (reverse) position	 SKIB8942E

SONAR CONTROL UNIT

< ECU DIAGNOSIS INFORMATION >

Terminal (wire color)		Description		Condition		Reference value (Approx.)
+	-	Signal name	Input/ Output	Ignition switch	Operation	
11 (BG)	Ground	LH inner sensor signal	Input	ON	Selector lever in R (re-verse) position	<p style="text-align: right; font-size: small;">SKIB8942E</p>
12 (LG)	Ground	RH inner sensor signal	Input	ON	Selector lever in R (re-verse) position	<p style="text-align: right; font-size: small;">SKIB8942E</p>
13 (G)	Ground	Sonar system OFF switch ON/OFF signal	Output	ON	Sonar system OFF switch ON	0 V
					Sonar system OFF switch OFF	Battery voltage
15 (Y)	Ground	Rear sensor ground	Output	ON	—	0 V
16 (W)	Ground	Rear sensor power	Output	ON	—	Battery voltage

DTC Index

INFOID:000000010711408

Fault Code	Malfunction	Service Procedure
11	Rear sonar sensor LH outer	1. Check harness for open or short. 2. Replace sonar sensor. Refer to SN-25, "Removal and Installation" .
12	Rear sonar sensor LH inner	
13	Rear sonar sensor RH inner	
14	Rear sonar sensor RH outer	
21	Rear sonar buzzer	1. Refer to SN-11, "Diagnosis Procedure" . 2. Check harness for open or short. 3. Refer to SN-22, "Symptom Table" .
22	Sonar system OFF indicator	1. Refer to SN-12, "Diagnosis Procedure" . 2. Check harness for open or short. 3. Refer to symptom table.
23	Sonar system OFF switch	
24	Sonar control unit	Replace sonar control unit. Refer to SN-26, "Removal and Installation" .

SONAR SYSTEM

< WIRING DIAGRAM >

WIRING DIAGRAM

SONAR SYSTEM

Wiring Diagram

INFOID:0000000010711409

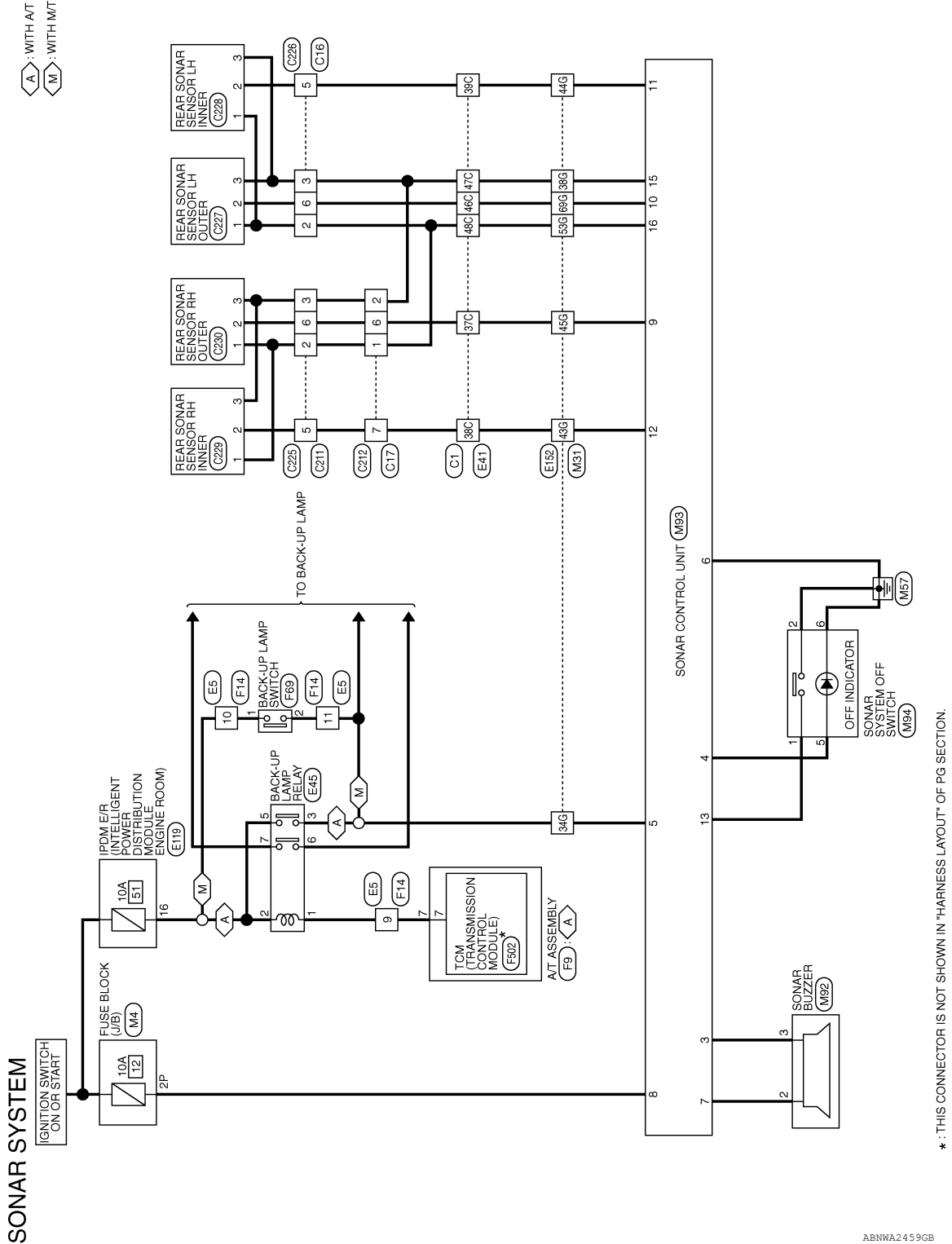

SONAR SYSTEM CONNECTORS

Connector No.	M4
Connector Name	FUSE BLOCK (J/B)
Connector Color	WHITE



Terminal No.	Color of Wire	Signal Name
2P	W/G	-

Connector No.	M31
Connector Name	WIRE TO WIRE
Connector Color	WHITE

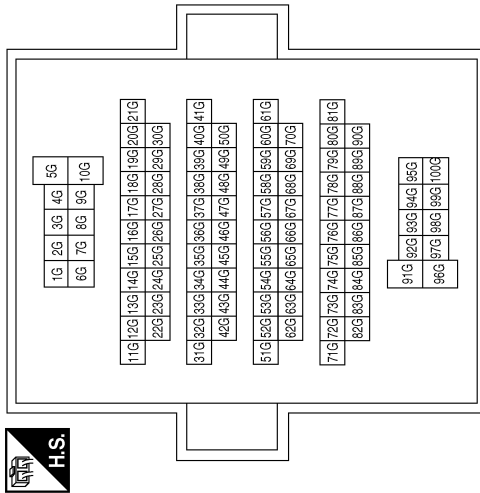

Connector No.	M92
Connector Name	SONAR BUZZER
Connector Color	WHITE



Terminal No.	Color of Wire	Signal Name
2	L	-
3	R	-

Connector No.	M93
Connector Name	SONAR CONTROL UNIT
Connector Color	WHITE

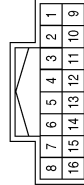

Terminal No.	Color of Wire	Signal Name
1	-	-
2	-	-
3	R	SOUNDER -
4	V	STATUS LED
5	SB	REVERSE LAMP SIGNAL

Terminal No.	Color of Wire	Signal Name
34G	SB	-
38G	Y	-
43G	LG	-
44G	BG	-
45G	GR	-
53G	W	-
69G	P	-

Terminal No.	Color of Wire	Signal Name
6	B	GND
7	L	SOUNDER +
8	W/G	PWR
9	GR	SENSOR SIGNAL FOR
10	P	SENSOR SIGNAL ROL
11	BG	SENSOR SIGNAL RIL
12	LG	SENSOR SIGNAL RIR
13	G	ON/OFF SWITCH
14	-	-
15	Y	REAR SENSOR GND
16	W	REAR SENSOR PWR

SONAR SYSTEM

< WIRING DIAGRAM >

Connector No.	M94
Connector Name	SONAR SYSTEM OFF SWITCH
Connector Color	GRAY



Terminal No.	Color of Wire	Signal Name
1	G	-
2	B	-
5	V	-
6	B	-

Connector No.	E5
Connector Name	WIRE TO WIRE
Connector Color	WHITE

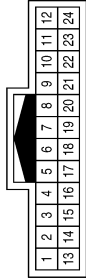

Terminal No.	Color of Wire	Signal Name
9	LG	-
10	W/G	-
11	SB	-

Connector No.	E41
Connector Name	WIRE TO WIRE
Connector Color	BLACK

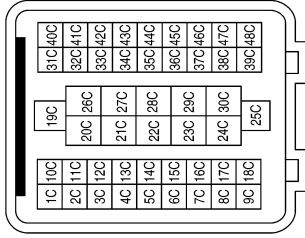

Terminal No.	Color of Wire	Signal Name
37C	GR	-
38C	LG	-
39C	BG	-
46C	P	-
47C	Y	-
48C	W	-

Connector No.	E45
Connector Name	BACK-UP LAMP RELAY (WITH A/T)
Connector Color	BROWN



Terminal No.	Color of Wire	Signal Name
1	LG	-
2	W/G	-
3	SB	-
5	W/G	-
6	Y	-
7	W/G	-

Connector No.	E119
Connector Name	IPDM E/R (INTELLIGENT POWER DISTRIBUTION MODULE ENGINE ROOM)
Connector Color	WHITE

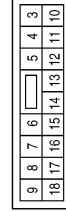

Terminal No.	Color of Wire	Signal Name
16	W/G	REVERSE LAMP

ABNIA5562GB

SONAR SYSTEM

< WIRING DIAGRAM >

Connector No.	F9
Connector Name	A/T ASSEMBLY
Connector Color	GREEN

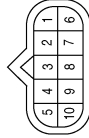

Terminal No.	Color of Wire	Signal Name
7	LG	-

Terminal No.	Color of Wire	Signal Name
34G	SB	-
38G	Y	-
43G	LG	-
44G	BG	-
45G	GR	-
53G	W	-
69G	P	-

Connector No.	E152
Connector Name	WIRE TO WIRE
Connector Color	WHITE

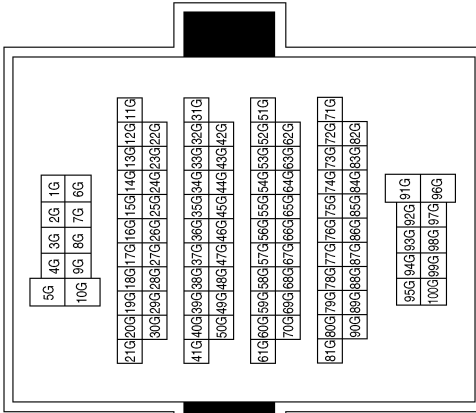

Connector No.	F502
Connector Name	TCM (TRANSMISSION CONTROL MODULE)
Connector Color	GRAY

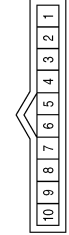

Terminal No.	Color of Wire	Signal Name
7	O	REV LAMP RLY

Connector No.	F69
Connector Name	BACK-UP LAMP SWITCH
Connector Color	WHITE



Terminal No.	Color of Wire	Signal Name
1	W/G	-
2	SB	-

Connector No.	F14
Connector Name	WIRE TO WIRE
Connector Color	WHITE

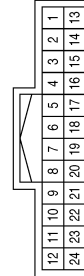

Terminal No.	Color of Wire	Signal Name
9	LG	-
10	W/G	-
11	SB	-

ABNIA5563GB

A
B
C
D
E
F
G
H
I
J
K
L
M
N
O
P



SONAR SYSTEM

< WIRING DIAGRAM >

Connector No.	C1
Connector Name	WIRE TO WIRE
Connector Color	BLACK

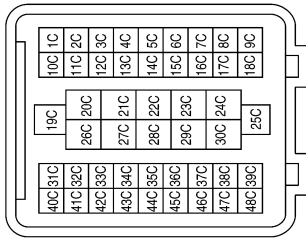

Terminal No.	Color of Wire	Signal Name
37C	GR	-
38C	LG	-
39C	O	-
46C	P	-
47C	Y	-
48C	W	-

Connector No.	C16
Connector Name	WIRE TO WIRE
Connector Color	BLACK



Terminal No.	Color of Wire	Signal Name
2	W	-
3	Y	-
5	O	-
6	P	-

Connector No.	C17
Connector Name	WIRE TO WIRE
Connector Color	GRAY

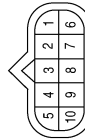

Terminal No.	Color of Wire	Signal Name
1	W	-
2	Y	-
6	GR	-
7	LG	-

Connector No.	C211
Connector Name	WIRE TO WIRE
Connector Color	BLACK



Terminal No.	Color of Wire	Signal Name
2	W	-
3	Y	-
5	LG	-
6	GR	-

Connector No.	C212
Connector Name	WIRE TO WIRE
Connector Color	GRAY

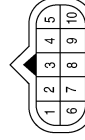

Terminal No.	Color of Wire	Signal Name
1	W	-
2	Y	-
6	GR	-
7	LG	-

ABNIA5564GB

SONAR SYSTEM

< WIRING DIAGRAM >

Connector No.	C225
Connector Name	WIRE TO WIRE
Connector Color	BLACK



Terminal No.	Color of Wire	Signal Name
2	W	-
3	Y	-
5	LG	-
6	GR	-

Connector No.	C226
Connector Name	WIRE TO WIRE
Connector Color	BLACK



Terminal No.	Color of Wire	Signal Name
2	W	-
3	Y	-
5	LG	-
6	GR	-

Connector No.	C227
Connector Name	REAR SONAR SENSOR LH OUTER
Connector Color	BLACK

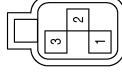

Terminal No.	Color of Wire	Signal Name
1	W	-
2	GR	-
3	Y	-

Connector No.	C228
Connector Name	REAR SONAR SENSOR LH INNER
Connector Color	BLACK

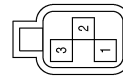

Terminal No.	Color of Wire	Signal Name
1	W	-
2	LG	-
3	Y	-

Connector No.	C229
Connector Name	REAR SONAR SENSOR RH INNER
Connector Color	BLACK

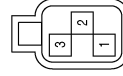

Terminal No.	Color of Wire	Signal Name
1	W	-
2	LG	-
3	Y	-

Connector No.	C230
Connector Name	REAR SONAR SENSOR RH OUTER
Connector Color	BLACK

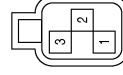

Terminal No.	Color of Wire	Signal Name
1	W	-
2	GR	-
3	Y	-

ABNIA5565GB

A
B
C
D
E
F
G
H
I
J
K
L
M
N
O
P



SONAR SYSTEM SYMPTOMS

< SYMPTOM DIAGNOSIS >

SYMPTOM DIAGNOSIS

SONAR SYSTEM SYMPTOMS

Symptom Table

INFOID:000000010711410

NOTE:

Always perform Preliminary Check and Self-Diagnosis Function before diagnosing vehicle by symptom. Refer to [SN-4, "Preliminary Check"](#) and [SN-7, "Self-Diagnosis Function"](#).

Symptom	Repair order
When the transmission gear selector lever is in the R position and the sonar system is ON, the rear sonar system does not operate.	<ol style="list-style-type: none"> 1. Check sonar control unit power and ground circuits. Refer to SN-9, "Diagnosis Procedure". 2. Check transmission range switch. Refer to TM-170, "Diagnosis Procedure". 3. Check back-up lamp relay. 4. Check related harness and connections for back-up lamp relay. 5. Check rear sonar buzzer. Refer to SN-11, "Diagnosis Procedure". 6. Replace sonar control unit. Refer to SN-26, "Removal and Installation".
Sonar Control Unit will not enter Diagnostic Mode.	<ol style="list-style-type: none"> 1. Check sonar control unit power and ground circuits. Refer to SN-9, "Diagnosis Procedure". 2. Check harness and connections for sonar system OFF switch. Refer to SN-12, "Diagnosis Procedure". 3. Replace sonar control unit. Refer to SN-26, "Removal and Installation".
Buzzer sounds although there are no obstacles within the detection range (false detection).	<ol style="list-style-type: none"> 1. Check all sonar sensors for misalignment or damage (including bumper and fascia). Refer to SN-4, "Preliminary Check". 2. Check all sonar sensors for dirt or ice buildup. Refer to SN-4, "Preliminary Check". 3. Check sonar sensors. Refer to SN-10, "Diagnosis Procedure". 4. Replace sonar control unit. Refer to SN-26, "Removal and Installation".
When sonar system is ON, the sonar system OFF indicator lamp lights up and the sonar buzzer sounds intermittently (for about 4 seconds).	<ol style="list-style-type: none"> 1. Check sonar sensors. Refer to SN-4, "Preliminary Check". 2. Check harnesses between sonar sensors and sonar control unit for an open condition. Refer to SN-10, "Diagnosis Procedure". 3. Replace sonar control unit. Refer to SN-26, "Removal and Installation".
The sonar system still operates when the sonar system OFF indicator lamp is ON.	<ol style="list-style-type: none"> 1. Check sonar system OFF indicator lamp. Refer to SN-12, "Diagnosis Procedure". 2. Replace sonar control unit. Refer to SN-26, "Removal and Installation".
The sonar sensors do not detect objects within the detectable range (intermittent operation).	<ol style="list-style-type: none"> 1. Check sonar sensors. Refer to SN-4, "Preliminary Check". 2. Replace sonar control unit. Refer to SN-26, "Removal and Installation".
When the sonar system is OFF, the OFF indicator does not light and the rear sonar buzzer does not sound.	<ol style="list-style-type: none"> 1. Check sonar system OFF switch. Refer to SN-13, "Component Inspection". 2. Check harness and connections for sonar system OFF switch. Refer to SN-12, "Diagnosis Procedure". 3. Replace sonar control unit. Refer to SN-26, "Removal and Installation".

SONAR SYSTEM SYMPTOMS

< SYMPTOM DIAGNOSIS >

Symptom	Repair order
When the sonar system is OFF, the OFF indicator lamp does not light but the rear sonar buzzer does sound.	<ol style="list-style-type: none"> 1. Check sonar system OFF indicator lamp. Refer to SN-13. "Component Inspection". 2. Check harness and connections for sonar system OFF indicator lamp. Refer to SN-12. "Diagnosis Procedure". 3. Replace sonar control unit. Refer to SN-26. "Removal and Installation".
When the sonar system is OFF, the rear sonar buzzer does not sound but the OFF indicator lamp lights.	<ol style="list-style-type: none"> 1. Check sonar buzzer. Refer to SN-11. "Component Inspection". 2. Check harness and connections between sonar buzzer and sonar control unit. Refer to SN-11. "Diagnosis Procedure". 3. Replace sonar control unit. Refer to SN-26. "Removal and Installation".

A
B
C
D
E
F
G
H
I
J
K
L
M
N
O
P

SN

PRECAUTION

< PRECAUTION >

PRECAUTION

PRECAUTION

Precaution for Supplemental Restraint System (SRS) "AIR BAG" and "SEAT BELT PRE-TENSIONER"

INFOID:000000010711411

The Supplemental Restraint System such as "AIR BAG" and "SEAT BELT PRE-TENSIONER", used along with a front seat belt, helps to reduce the risk or severity of injury to the driver and front passenger for certain types of collision. This system includes seat belt switch inputs and dual stage front air bag modules. The SRS system uses the seat belt switches to determine the front air bag deployment, and may only deploy one front air bag, depending on the severity of a collision and whether the front occupants are belted or unbelted. Information necessary to service the system safely is included in the SR and SB section of this Service Manual.

WARNING:

- To avoid rendering the SRS inoperative, which could increase the risk of personal injury or death in the event of a collision which would result in air bag inflation, all maintenance must be performed by an authorized NISSAN/INFINITI dealer.
- Improper maintenance, including incorrect removal and installation of the SRS, can lead to personal injury caused by unintentional activation of the system. For removal of Spiral Cable and Air Bag Module, see the SR section.
- Do not use electrical test equipment on any circuit related to the SRS unless instructed to in this Service Manual. SRS wiring harnesses can be identified by yellow and/or orange harnesses or harness connectors.

PRECAUTIONS WHEN USING POWER TOOLS (AIR OR ELECTRIC) AND HAMMERS

WARNING:

- When working near the Airbag Diagnosis Sensor Unit or other Airbag System sensors with the Ignition ON or engine running, DO NOT use air or electric power tools or strike near the sensor(s) with a hammer. Heavy vibration could activate the sensor(s) and deploy the air bag(s), possibly causing serious injury.
- When using air or electric power tools or hammers, always switch the Ignition OFF, disconnect the battery and wait at least three minutes before performing any service.

SONAR SENSOR

< UNIT REMOVAL AND INSTALLATION >

UNIT REMOVAL AND INSTALLATION

SONAR SENSOR

Removal and Installation

INFOID:0000000010711412

REMOVAL

1. Disconnect the harness connector from the sonar sensor.
2. Disconnect the sonar sensor retainers from the rear bumper (2).
3. Remove the rear sonar sensor (1) from the rear bumper (2).

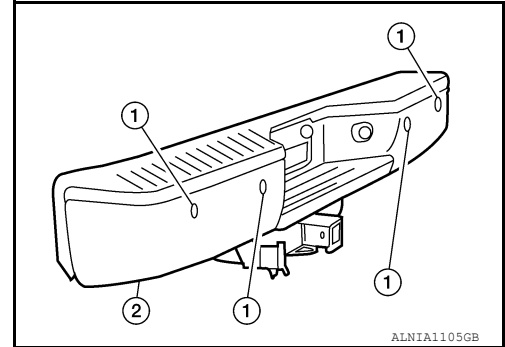

INSTALLATION

Installation is in the reverse order of removal.

A
B
C
D
E
F
G
H
I
J
K
L
M
SN
O
P

SONAR CONTROL UNIT

< UNIT REMOVAL AND INSTALLATION >

SONAR CONTROL UNIT

Removal and Installation

INFOID:000000010711413

REMOVAL

1. Remove instrument lower panel LH. Refer to [IP-18. "Removal and Installation"](#).
2. Remove the sonar control unit nuts.
3. Disconnect the harness connector (A) from the sonar control unit (1) and remove.

↶: Front

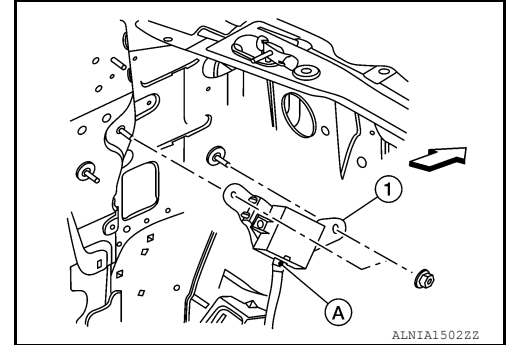

INSTALLATION

Installation is in the reverse order of removal.

BUZZER

< UNIT REMOVAL AND INSTALLATION >

BUZZER

Removal and Installation

INFOID:0000000010711414

REMOVAL

1. Remove the combination meter. Refer to [MWI-91. "Removal and Installation"](#).
2. Remove the two screws.
3. Disconnect the harness connector (A) from the rear sonar buzzer (1) and remove.

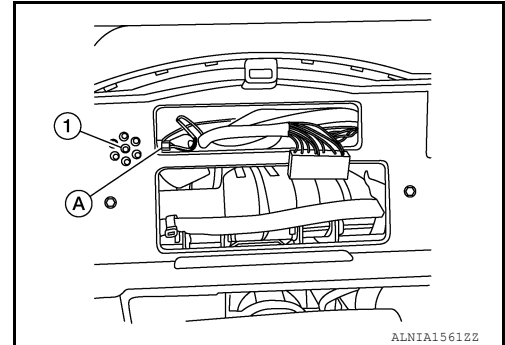

INSTALLATION

Installation is in the reverse order of removal.

A
B
C
D
E
F
G
H
I
J
K
L
M
O
P

SN