

EXL

SECTION EXL

EXTERIOR LIGHTING SYSTEM

A
B
C
D
E
F
G
H
I
J
K
EXL
M
N
O
P

CONTENTS

PRECAUTION	4	Component Parts Location	18
PRECAUTIONS	4	Component Description	18
Precaution for Supplemental Restraint System (SRS) "AIR BAG" and "SEAT BELT PRE-TENSIONER"	4	TURN SIGNAL AND HAZARD WARNING LAMPS	19
Precaution for Work	4	System Diagram	19
General precautions for service operations	4	System Description	19
PREPARATION	6	Component Parts Location	19
PREPARATION	6	Component Description	19
Special Service Tool	6	PARKING, LICENSE PLATE AND TAIL LAMPS	21
BASIC INSPECTION	7	System Diagram	21
DIAGNOSIS AND REPAIR WORKFLOW	7	System Description	21
Work Flow	7	Component Parts Location	21
SYSTEM DESCRIPTION	10	Component Description	22
HEADLAMP	10	TRAILER TOW	23
System Diagram	10	System Diagram	23
System Description	10	System Description	23
Component Parts Location	10	Component Parts Location	24
Component Description	11	Component Description	24
DAYTIME LIGHT SYSTEM	12	COMBINATION SWITCH READING SYSTEM	25
System Diagram	12	System Diagram	25
System Description	12	System Description	25
Component Parts Location	13	Component Parts Location	28
Component Description	13	DIAGNOSIS SYSTEM (BCM)	29
AUTO LIGHT SYSTEM	15	COMMON ITEM	29
System Diagram	15	COMMON ITEM : CONSULT Function (BCM - COMMON ITEM)	29
System Description	15	HEADLAMP	29
Component Parts Location	16	HEADLAMP : CONSULT Function (BCM - HEADLAMP)	30
Component Description	17	FLASHER	31
FRONT FOG LAMP	18	FLASHER : CONSULT Function (BCM - FLASHER)	31
System Diagram	18		
System Description	18		

COMB SW	31	Terminal Layout	60
COMB SW : CONSULT Function (BCM - COMB SW)	31	Physical Values	60
DIAGNOSIS SYSTEM (IPDM E/R)	32	Fail Safe	65
Diagnosis Description	32	DTC Inspection Priority Chart	65
CONSULT Function (IPDM E/R)	34	DTC Index	66
DTC/CIRCUIT DIAGNOSIS	36	IPDM E/R (INTELLIGENT POWER DISTRIBUTION MODULE ENGINE ROOM)	68
POWER SUPPLY AND GROUND CIRCUIT	36	Reference Value	68
BCM (BODY CONTROL MODULE)	36	Terminal Layout	69
BCM (BODY CONTROL MODULE) : Diagnosis Procedure	36	Physical Values	69
IPDM E/R (INTELLIGENT POWER DISTRIBUTION MODULE ENGINE ROOM)	37	Fail Safe	73
IPDM E/R (INTELLIGENT POWER DISTRIBUTION MODULE ENGINE ROOM) : Diagnosis Procedure	37	DTC Index	74
HEADLAMP (HI) CIRCUIT	39	WIRING DIAGRAM	75
Description	39	HEADLAMP	75
Component Function Check	39	Wiring Diagram	75
Diagnosis Procedure	39	DAYTIME LIGHT SYSTEM	79
HEADLAMP (LO) CIRCUIT	42	Wiring Diagram	79
Description	42	AUTO LIGHT SYSTEM	86
Component Function Check	42	Wiring Diagram	86
Diagnosis Procedure	42	FRONT FOG LAMP	94
Component Inspection	45	Wiring Diagram	94
DAYTIME LIGHT RELAY CIRCUIT	46	TURN SIGNAL AND HAZARD WARNING LAMP SYSTEM	98
Description	46	Wiring Diagram	98
Diagnosis Procedure	46	PARKING, LICENSE PLATE AND TAIL LAMPS SYSTEM	104
Component Inspection	47	Wiring Diagram	104
FRONT FOG LAMP CIRCUIT	48	STOP LAMP	110
Description	48	Wiring Diagram	110
Component Function Check	48	BACK-UP LAMP	115
Diagnosis Procedure	48	Wiring Diagram	115
PARKING LAMP CIRCUIT	50	TRAILER TOW	119
Description	50	Wiring Diagram	119
Component Function Check	50	SYMPTOM DIAGNOSIS	128
Diagnosis Procedure	50	EXTERIOR LIGHTING SYSTEM SYMPTOMS	128
TURN SIGNAL LAMP CIRCUIT	53	Symptom Table	128
Description	53	NORMAL OPERATING CONDITION	130
Component Function Check	53	Description	130
Diagnosis Procedure	53	BOTH SIDE HEADLAMPS DO NOT SWITCH TO HIGH BEAM	131
OPTICAL SENSOR	56	Description	131
Description	56	Diagnosis Procedure	131
Diagnosis Procedure	56	DAYTIME LIGHT SYSTEM INOPERATIVE	132
ECU DIAGNOSIS INFORMATION	57	Description	132
BCM (BODY CONTROL MODULE)	57	Diagnosis Procedure	132
Reference Value	57		

BOTH SIDE HEADLAMPS (LO) ARE NOT TURNED ON	133	STOP LAMP	143	
Description	133	Bulb Replacement	143	A
Diagnosis Procedure	133	Removal and Installation	143	
PARKING, LICENSE PLATE AND TAIL LAMPS ARE NOT TURNED ON	134	LICENSE PLATE LAMP	144	B
Description	134	Bulb Replacement	144	
Diagnosis Procedure	134	Removal and Installation	144	
BOTH SIDE FRONT FOG LAMPS ARE NOT TURNED ON	135	REAR COMBINATION LAMP	145	C
Description	135	Bulb Replacement	145	
Diagnosis Procedure	135	Removal and Installation	145	
PERIODIC MAINTENANCE	136	LIGHTING & TURN SIGNAL SWITCH	146	D
HEADLAMP	136	Removal and Installation	146	
Aiming Adjustment	136	HAZARD SWITCH	147	E
FRONT FOG LAMP	138	Removal and Installation	147	
Aiming Adjustment	138	OPTICAL SENSOR	148	F
REMOVAL AND INSTALLATION	140	Removal and Installation	148	
HEADLAMP	140	UNIT DISASSEMBLY AND ASSEMBLY .	149	G
Bulb Replacement	140	FRONT COMBINATION LAMP	149	
Removal and Installation	140	Disassembly and Assembly	149	
FRONT FOG LAMP	142	SERVICE DATA AND SPECIFICATIONS (SDS)	150	H
Bulb Replacement	142	SERVICE DATA AND SPECIFICATIONS (SDS)	150	I
Removal and Installation	142	Bulb Specifications	150	J

EXL

M
N
O
P

PRECAUTIONS

< PRECAUTION >

PRECAUTION

PRECAUTIONS

Precaution for Supplemental Restraint System (SRS) "AIR BAG" and "SEAT BELT PRE-TENSIONER"

INFOID:000000012563605

The Supplemental Restraint System such as "AIR BAG" and "SEAT BELT PRE-TENSIONER", used along with a front seat belt, helps to reduce the risk or severity of injury to the driver and front passenger for certain types of collision. This system includes seat belt switch inputs and dual stage front air bag modules. The SRS system uses the seat belt switches to determine the front air bag deployment, and may only deploy one front air bag, depending on the severity of a collision and whether the front occupants are belted or unbelted. Information necessary to service the system safely is included in the SR and SB section of this Service Manual.

WARNING:

- To avoid rendering the SRS inoperative, which could increase the risk of personal injury or death in the event of a collision which would result in air bag inflation, all maintenance must be performed by an authorized NISSAN/INFINITI dealer.
- Improper maintenance, including incorrect removal and installation of the SRS, can lead to personal injury caused by unintentional activation of the system. For removal of Spiral Cable and Air Bag Module, see the SR section.
- Do not use electrical test equipment on any circuit related to the SRS unless instructed to in this Service Manual. SRS wiring harnesses can be identified by yellow and/or orange harnesses or harness connectors.

PRECAUTIONS WHEN USING POWER TOOLS (AIR OR ELECTRIC) AND HAMMERS

WARNING:

- When working near the Airbag Diagnosis Sensor Unit or other Airbag System sensors with the Ignition ON or engine running, DO NOT use air or electric power tools or strike near the sensor(s) with a hammer. Heavy vibration could activate the sensor(s) and deploy the air bag(s), possibly causing serious injury.
- When using air or electric power tools or hammers, always switch the Ignition OFF, disconnect the battery and wait at least three minutes before performing any service.

Precaution for Work

INFOID:000000012563606

- When removing or disassembling each component, be careful not to damage or deform it. If a component may be subject to interference, be sure to protect it with a shop cloth.
- When removing (disengaging) components with a screwdriver or similar tool, be sure to wrap the component with a shop cloth or vinyl tape to protect it.
- Protect the removed parts with a shop cloth and prevent them from being dropped.
- Replace a deformed or damaged clip.
- If a part is specified as a non-reusable part, always replace it with a new one.
- Be sure to tighten bolts and nuts securely to the specified torque.
- After installation is complete, be sure to check that each part works properly.
- Follow the steps below to clean components:
 - Water soluble dirt:
 - Dip a soft cloth into lukewarm water, wring the water out of the cloth and wipe the dirty area.
 - Then rub with a soft, dry cloth.
 - Oily dirt:
 - Dip a soft cloth into lukewarm water with mild detergent (concentration: within 2 to 3%) and wipe the dirty area.
 - Then dip a cloth into fresh water, wring the water out of the cloth and wipe the detergent off.
 - Then rub with a soft, dry cloth.
 - Do not use organic solvent such as thinner, benzene, alcohol or gasoline.
 - For genuine leather seats, use a genuine leather seat cleaner.

General precautions for service operations

INFOID:000000012563607

- Do not work with wet hands.
- Turn the lighting switch OFF before disconnecting and connecting the connector.

PRECAUTIONS

< PRECAUTION >

- When checking the headlamp on/off operation, check it on vehicle and with the power connected to the vehicle-side connector. A
- Do not touch the headlamp bulb glass surface with bare hands or allow oil or grease to get on it. Do not touch the headlamp bulb just after the headlamp is turned off, because it is very hot.
- When the bulb has burned out, wrap it in a thick vinyl bag and discard. Do not break the bulb. B
- Leaving the bulb removed from the headlamp housing for a long period of time can deteriorate the performance of the lens and reflector (dirt, clouding). Always prepare a new bulb and have it on hand when replacing the bulb.
- Do not use organic solvent (paint thinner or gasoline) to clean lamps and to remove old sealant. C

D

E

F

G

H

I

J

K

EXL

M

N

O

P

PREPARATION

< PREPARATION >

PREPARATION

PREPARATION

Special Service Tool

INFOID:0000000012563608

The actual shape of the tools may differ from those illustrated here.

Tool number (TechMate No.) Tool name	Description
— (J-46534) Trim Tool Set	Removing trim components

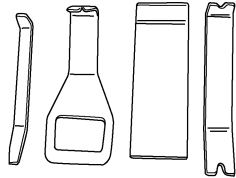

AWJIA0483ZZ

DIAGNOSIS AND REPAIR WORKFLOW

< BASIC INSPECTION >

BASIC INSPECTION

DIAGNOSIS AND REPAIR WORKFLOW

Work Flow

INFOID:0000000012563609

OVERALL SEQUENCE

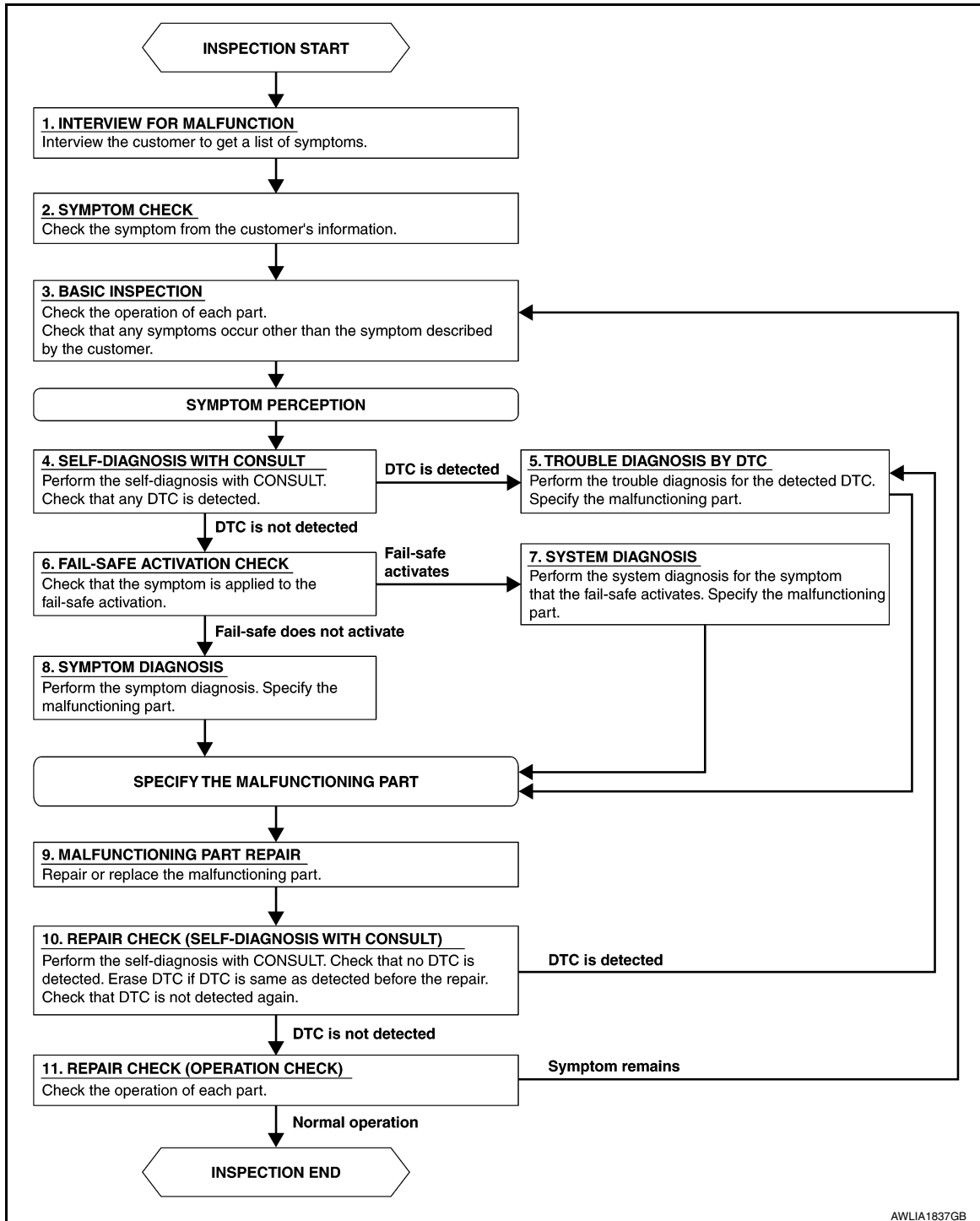

AWLJA1837GB

A
B
C
D
E
F
G
H
I
J
K
EXL
M
N
O
P

DIAGNOSIS AND REPAIR WORKFLOW

< BASIC INSPECTION >

DETAILED FLOW

1. INTERVIEW FOR MALFUNCTION

Find out what the customer's concerns are.

>> GO TO 2.

2. SYMPTOM CHECK

Verify the symptom from the customer's information.

>> GO TO 3.

3. BASIC INSPECTION

Check the operation of each part. Check that any concerns occur other than those mentioned in the customer interview.

>> GO TO 4.

4. SELF-DIAGNOSIS WITH CONSULT

Perform the self diagnosis with CONSULT. Check that any DTC is detected.

Is any DTC detected?

YES >> GO TO 5.

NO >> GO TO 6.

5. TROUBLE DIAGNOSIS BY DTC

Perform the trouble diagnosis for the detected DTC. Specify the malfunctioning part.

>> GO TO 9.

6. FAIL-SAFE ACTIVATION CHECK

Determine if the customer's concern is related to fail-safe activation.

Does the fail-safe activate?

YES >> GO TO 7.

NO >> GO TO 8.

7. SYSTEM DIAGNOSIS

Perform the system diagnosis for the system in which the fail-safe activates. Specify the malfunctioning part.

>> GO TO 9.

8. SYMPTOM DIAGNOSIS

Perform the symptom diagnosis. Specify the malfunctioning part.

>> GO TO 9.

9. MALFUNCTION PART REPAIR

Repair or replace the malfunctioning part.

>> GO TO 10.

10. REPAIR CHECK (SELF-DIAGNOSIS WITH CONSULT)

Perform the self diagnosis with CONSULT. Verify that no DTCs are detected. Erase all DTCs detected prior to the repair. Verify that DTC is not detected again.

Is any DTC detected?

DIAGNOSIS AND REPAIR WORKFLOW

< BASIC INSPECTION >

YES >> GO TO 5.

NO >> GO TO 11.

11. REPAIR CHECK (OPERATION CHECK)

Check the operation of each part.

Does it operate normally?

YES >> Inspection End.

NO >> GO TO 3.

A

B

C

D

E

F

G

H

I

J

K

EXL

M

N

O

P

HEADLAMP

< SYSTEM DESCRIPTION >

SYSTEM DESCRIPTION

HEADLAMP

System Diagram

INFOID:000000012563610

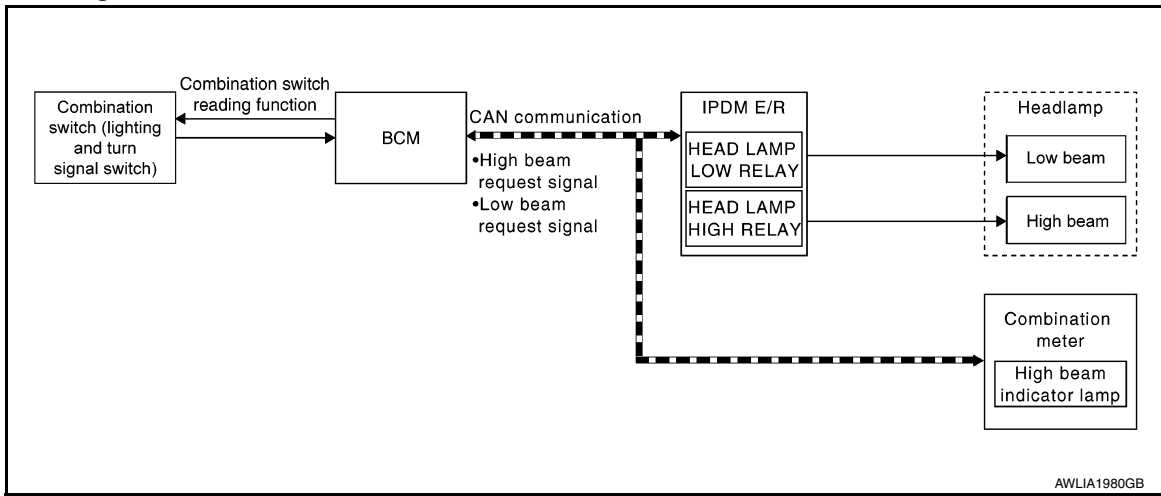

System Description

INFOID:000000012563611

Control of the headlamp system operation is dependent upon the position of the combination switch (lighting and turn signal switch). When the combination switch (lighting and turn signal switch) is placed in the 2nd position, the BCM (body control module) receives input requesting the headlamps and park lamps to illuminate. This input is communicated to the IPDM E/R (intelligent power distribution module engine room) via the CAN communication lines. The CPU (central processing unit) of the IPDM E/R controls the headlamp high and headlamp low relay coils. When energized, these relays direct power to the respective headlamps, which then illuminate.

HIGH BEAM OPERATION/FLASH-TO-PASS OPERATION

With the combination switch (lighting and turn signal switch) in the 2ND position and placed in HIGH position, the BCM receives input requesting the headlamp high beams to illuminate. The flash to pass feature can be used any time and also sends a signal to the BCM. This input is communicated to the IPDM E/R via the CAN communication lines. The CPU of the combination meter controls the ON/OFF status off the HIGH BEAM indicator. The CPU of the IPDM E/R controls the headlamp high relay coil which supplies power to the high beam headlamps.

The combination meter receives a high beam request signal (ON) via the CAN communication lines and turns the high beam indicator lamp ON.

Component Parts Location

INFOID:000000012563612

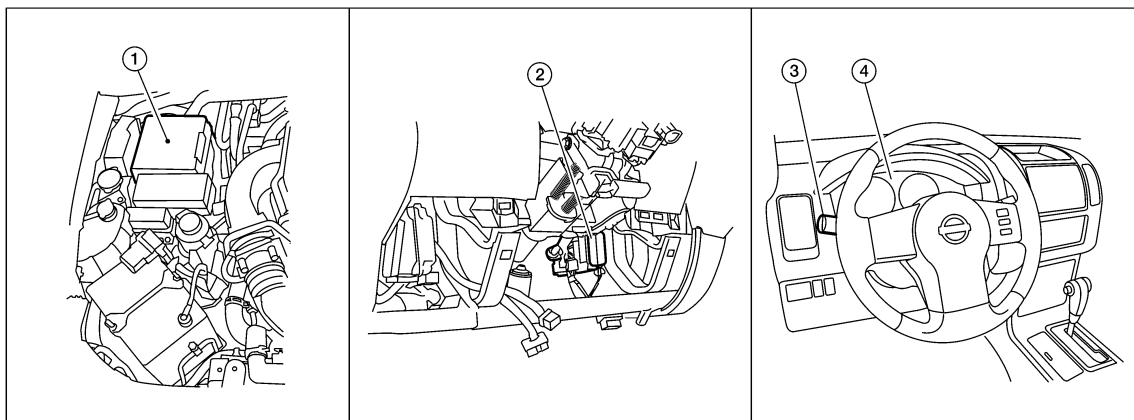

WKIA4957E

HEADLAMP

< SYSTEM DESCRIPTION >

1. IPDM E/R E122, E123, E124
2. BCM M18, M20 (view with lower instrument panel LH removed)
3. Combination switch (lighting and turn signal switch) M28
4. Combination meter M24

Component Description

INFOID:000000012563613

Part name	Description
BCM	<ul style="list-style-type: none">• Receives combination switch (lighting and turn signal switch) request via BCM combination switch reading function.• Sends headlamp high/low request signal to the IPDM E/R.
IPDM E/R	Activates the headlamp high and headlamp low relays upon request from the BCM.
Combination switch (lighting and turn signal switch)	Outputs lighting requests to the BCM.

A
B
C
D
E
F
G
H
I
J
K
EXL
M
N
O
P

DAYTIME LIGHT SYSTEM

< SYSTEM DESCRIPTION >

DAYTIME LIGHT SYSTEM

System Diagram

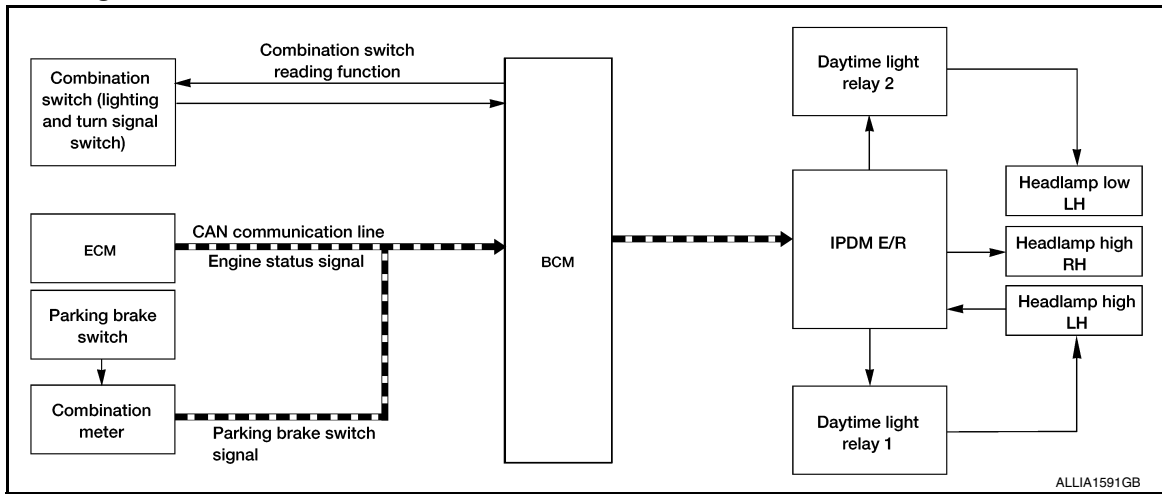

System Description

INFOID:000000012563615

The headlamp system for Canada vehicles is equipped with a daytime light control that activates the high beam headlamps at approximately half illumination whenever the engine is operating. If the parking brake is applied before the engine is started the daytime lights will not be illuminated. The daytime lights will illuminate once the parking brake is released. Thereafter, the daytime lights will continue to operate when the parking brake is applied.

OPERATION

The BCM monitors inputs from the parking brake switch and the combination switch (lighting and turn signal switch) to determine when to activate the daytime light system. The BCM sends a daytime light request to the IPDM E/R via the CAN communication lines. The IPDM E/R grounds the daytime light relay 1 which in turn, provides power to the ground side of the LH high beam lamp. Power flows backward through the LH high beam lamp to the IPDM E/R, through the high beam fuses, through the RH high beam lamp circuit to the RH high beam lamp and on to ground. The high beam lamps are wired in series which causes them to illuminate at a reduced intensity. When daytime light relay 2 is open, it prevents headlamp low beam from turning on while daytime lights are operating.

DAYTIME LIGHT SYSTEM

< SYSTEM DESCRIPTION >

Component Parts Location

INFOID:000000012563616

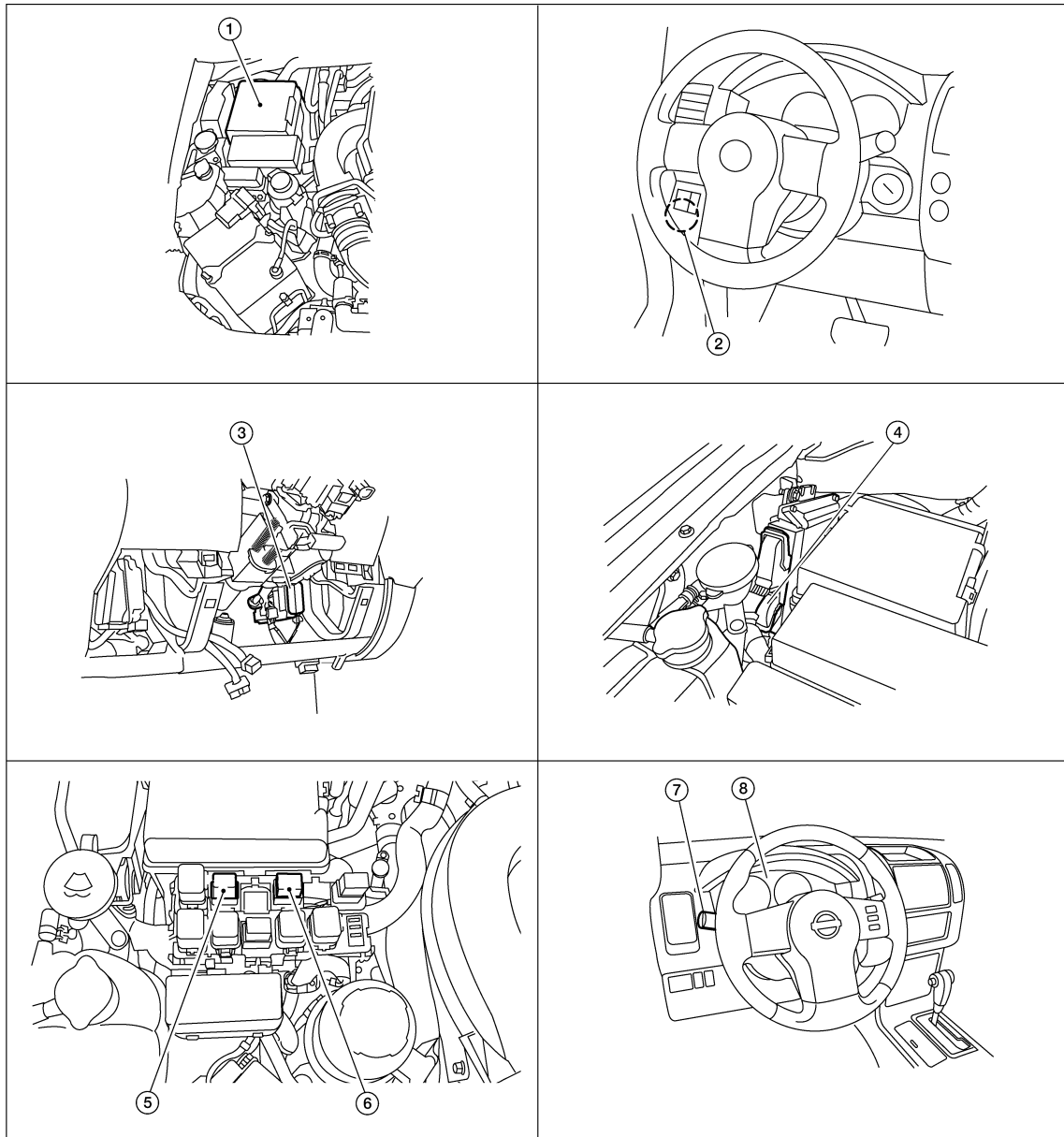

AVNIA0928ZZ

- | | | |
|---|-------------------------------|---|
| 1. IPDM E/R E119, E122, E123, E124 | 2. Parking brake switch B84 | 3. BCM M18, M20 (view with lower instrument panel LH removed) |
| 4. ECM (view with ECM cover removed) | 5. Daytime light relay 1 E103 | 6. Daytime light relay 2 E104 |
| 7. Combination switch (lighting and turn signal switch) M28 | 8. Combination meter M24 | |

Component Description

INFOID:000000012563617

Part name	Description
BCM	<ul style="list-style-type: none"> Receives combination switch (lighting and turn signal switch) inputs via BCM combination switch reading function. Receives park brake applied input from the park brake switch. Receives engine running status from the ECM via CAN communication.

DAYTIME LIGHT SYSTEM

< SYSTEM DESCRIPTION >

IPDM E/R	Receives daytime light request from the BCM and activates the daytime light relay.
Combination switch (lighting and turn signal switch)	Outputs lighting requests to the BCM.
Parking brake switch	Outputs parking brake status to the combination meter which forwards that information to the BCM via CAN communication.
ECM	Outputs engine running status to the BCM.

AUTO LIGHT SYSTEM

< SYSTEM DESCRIPTION >

AUTO LIGHT SYSTEM

System Diagram

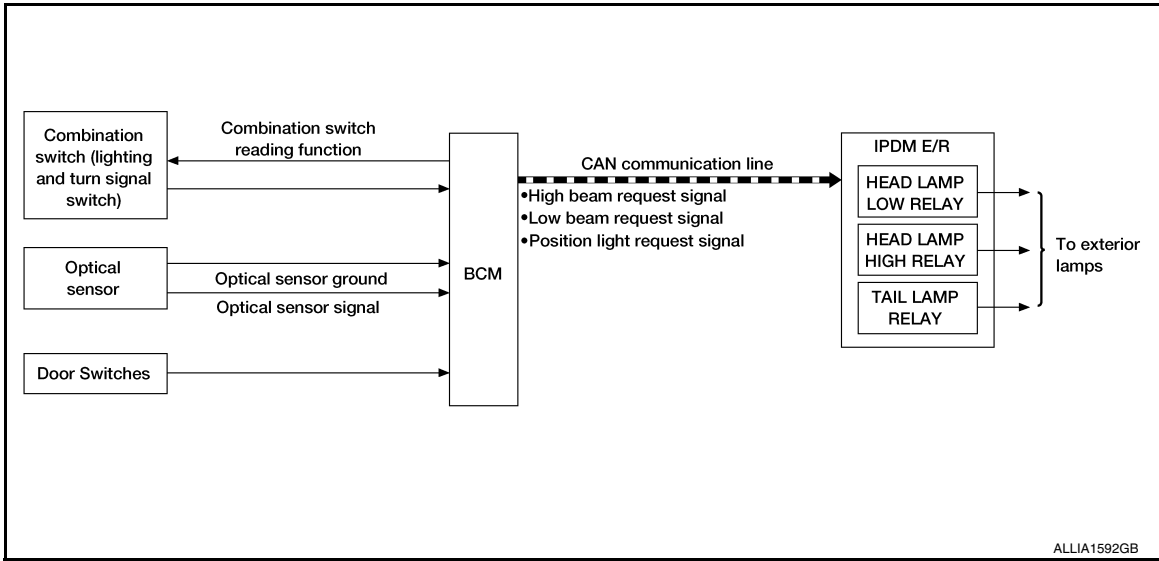

System Description

INFOID:000000012563619

The auto light control system has an optical sensor that detects outside brightness.

When the combination switch (lighting and turn signal switch) is in AUTO position, it automatically turns ON/OFF the parking, license plate, tail and headlamps in accordance with the ambient light. Sensitivity can be adjusted in four steps. For the details, refer to [BCS-23, "HEADLAMP : CONSULT Function \(BCM - HEAD-LAMP\)"](#).

AUTO LIGHT OPERATION

The auto light system operates the low beam and high beam headlamps, parking lamps, tail lamps and license plate lamps. The BCM monitors the combination switch (lighting and turn signal switch) position as a part of the BCM combination switch reading function. When the combination switch (lighting and turn signal switch) is in the AUTO position, the BCM automatically turns the lamps ON/OFF according to ambient light brightness. When the key is turned OFF and all doors are closed, the auto light system keeps the headlamps ON for 45 seconds.

NOTE:

Timing for when lamps turn ON/OFF can be changed by the CONSULT. Refer to [BCS-23, "HEADLAMP : CONSULT Function \(BCM - HEADLAMP\)"](#).

AUTO LIGHT SYSTEM

< SYSTEM DESCRIPTION >

Component Parts Location

INFOID:000000012563620

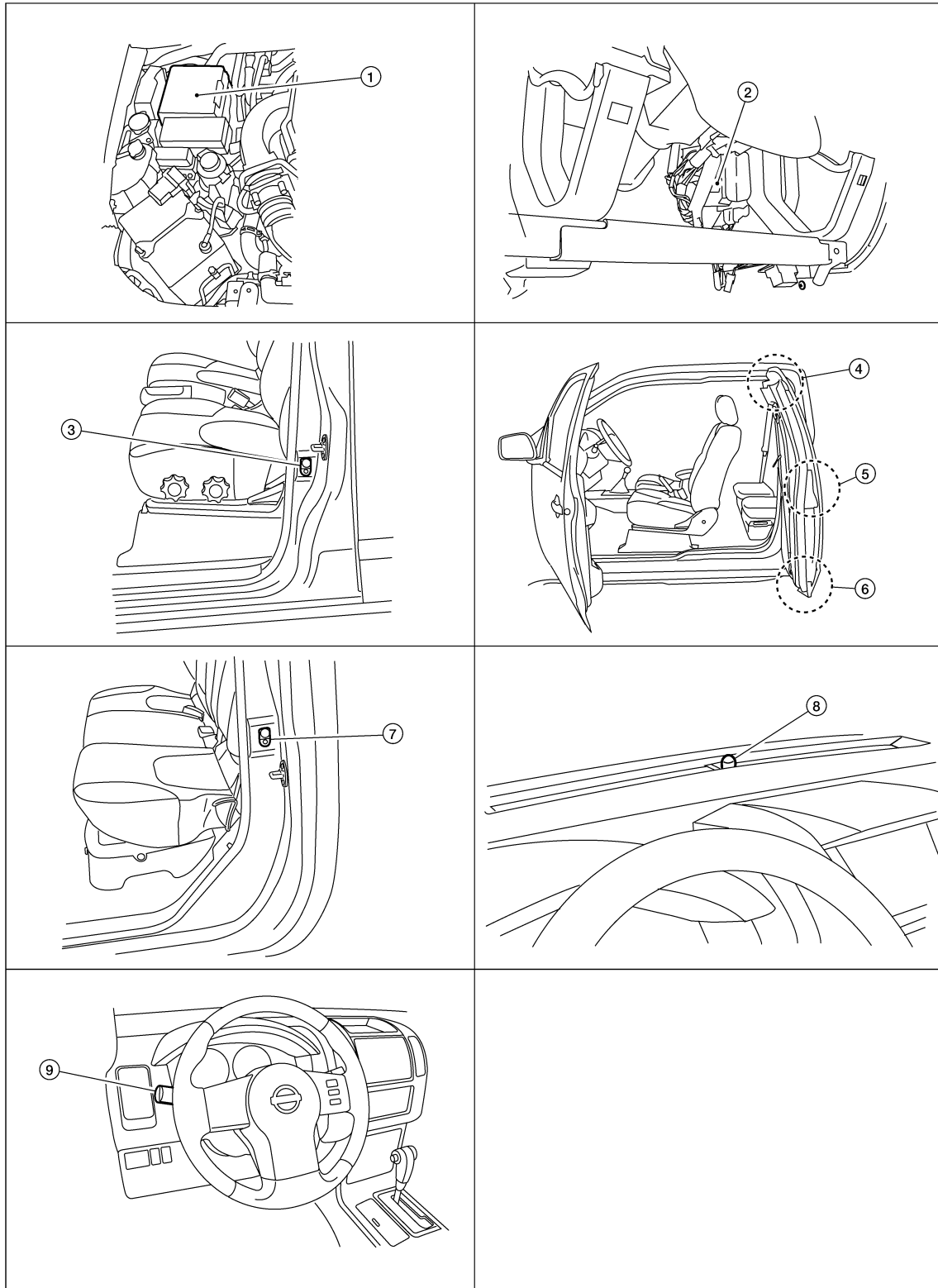

ALLIA1235ZZ

1. IPDM E/R E122, E123, E124

2. BCM (view with lower instrument panel LH removed) M18, M19, M20

3. Front door switch LH (Crew Cab) (RH similar) B8

AUTO LIGHT SYSTEM

< SYSTEM DESCRIPTION >

- | | | |
|---|--|--|
| 4. Rear door switch upper LH (King Cab) (RH similar) D211 | 5. Front door switch LH (King Cab) (RH similar) D213 | 6. Rear door switch lower LH (King Cab) D212 |
| 7. Rear door switch LH (Crew Cab) (RH similar) B18 | 8. Optical Sensor M14 | 9. Combination switch M28 |

Component Description

INFOID:000000012563621

Part name	Description
BCM	BCM (Body Control Module) controls auto light operation according to signals from optical sensor, lighting switch and ignition switch.
IPDM E/R	IPDM E/R (Intelligent Power Distribution Module Engine Room) operates parking, license plate, tail and headlamps according to CAN communication signals from BCM.
Combination switch (lighting and turn signal switch)	The lighting switch outputs lighting requests to the BCM.
Optical sensor	Optical sensor detects ambient brightness and converts light (lux) to voltage, then sends the optical sensor signal to BCM.
Door switches	Detects door open/closed status and forwards that status to the BCM.

A
B
C
D
E
F
G
H
I
J
K
EXL
M
N
O
P

EXL

FRONT FOG LAMP

< SYSTEM DESCRIPTION >

FRONT FOG LAMP

System Diagram

INFOID:000000012563622

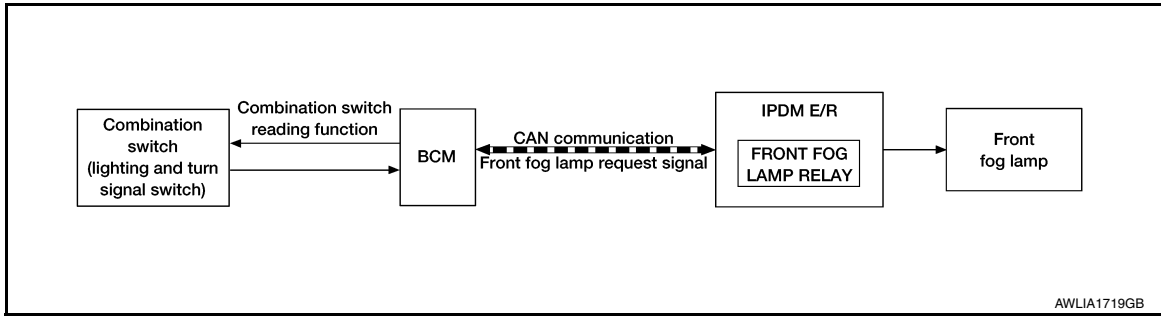

AWLIA1719GB

System Description

INFOID:000000012563623

The front fog lamps are activated with the combination switch (lighting and turn signal switch). The combination switch (lighting and turn signal switch) signal to the BCM is monitored with the BCM combination switch reading function. When the fog lamps are turned ON with the combination switch (lighting and turn signal switch), the BCM sends a front fog lamp request signal via CAN communication lines to the IPDM E/R. The IPDM E/R grounds the front fog lamp relay coil to activate the front fog lamps.

FRONT FOG LAMP OPERATION

When the combination switch (lighting and turn signal switch) is in front fog lamp ON position and also in 1ST or 2ND position or AUTO (if equipped) position (headlamp is ON), the BCM detects FR FOG ON and the HEAD LAMP1 or 2 ON. The BCM sends a front fog lamp request ON signal via the CAN communication lines to the IPDM E/R. The IPDM E/R then turns ON the front fog lamp relay sending power to the front fog lamps.

Component Parts Location

INFOID:000000012563624

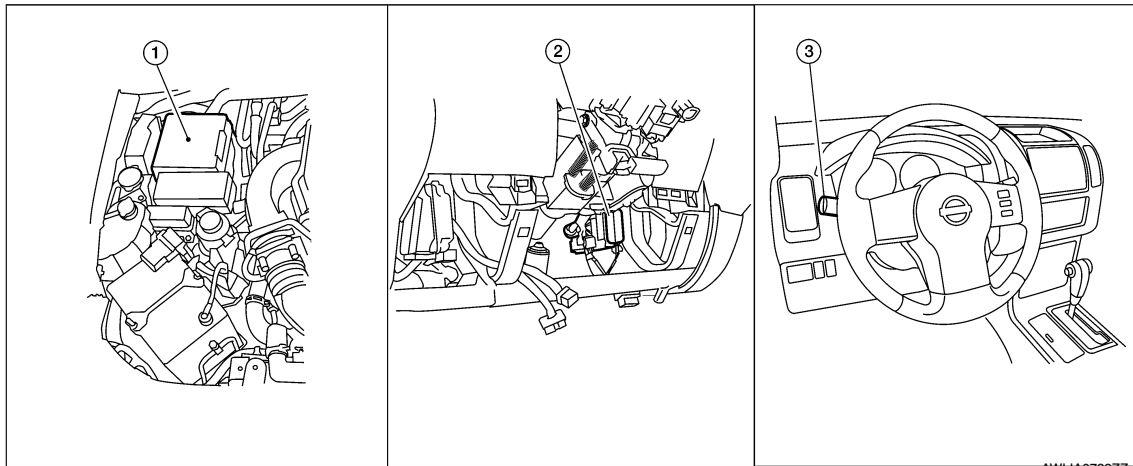

AWLIA0732ZZ

1. IPDM E/R E122, E123, E124
2. BCM M18, M20 (view with lower instrument panel LH removed)
3. Combination switch (lighting and turn signal switch) M28

Component Description

INFOID:000000012563625

Part name	Description
BCM	<ul style="list-style-type: none"> Receives lighting switch requests via BCM combination switch reading function. Sends headlamp high/low request signal to the IPDM E/R.
IPDM E/R	Activates the front fog lamp relay upon request from the BCM.
Combination switch (lighting and turn signal switch)	Outputs lighting requests to the BCM.

TURN SIGNAL AND HAZARD WARNING LAMPS

< SYSTEM DESCRIPTION >

TURN SIGNAL AND HAZARD WARNING LAMPS

System Diagram

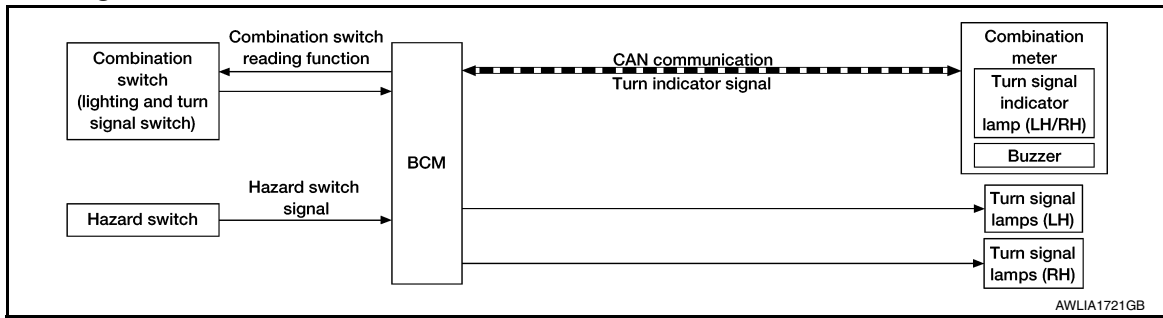

INFOID:0000000012563626

System Description

INFOID:0000000012563627

TURN SIGNAL OPERATION

When the combination switch (lighting and turn signal switch) is in LH or RH position with the ignition switch in ON position, the BCM detects the TURN RH or TURN LH ON request. The BCM outputs the flasher signal to the respective turn signal lamp. The BCM also sends a turn indicator signal ON request via the CAN communication lines to the combination meter. The combination meter then activates the appropriate turn signal indicator and audible buzzer.

HAZARD LAMP OPERATION

When the hazard switch is in ON position, the BCM detects the hazard switch signal ON. The BCM outputs the flasher signal (right and left). The BCM sends a hazard indicator signal ON request via the CAN communication lines to the combination meter. The combination meter then activates the hazard indicator and audible buzzer.

Component Parts Location

INFOID:0000000012563628

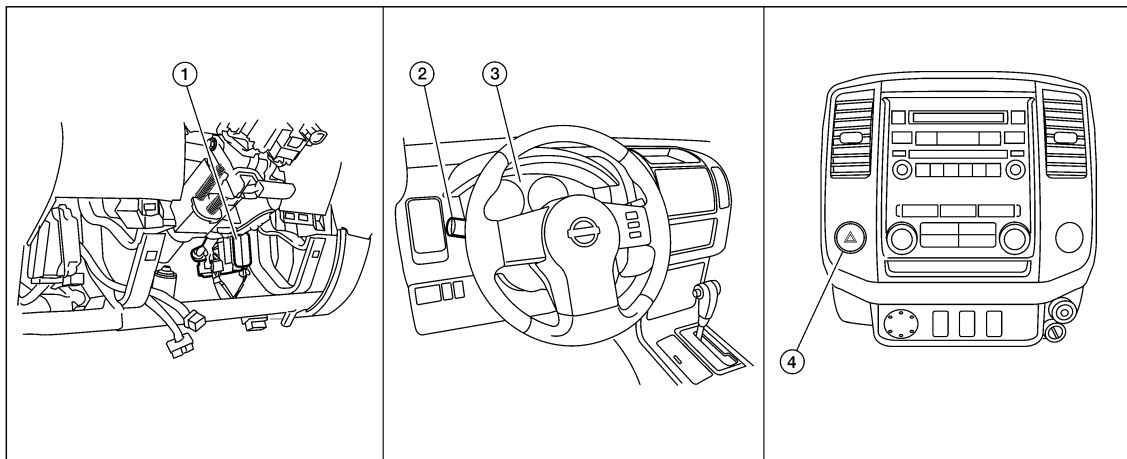

1. BCM M18, M20 (view with lower instrument panel LH removed)
2. Combination switch (lighting and turn signal switch) M28
3. Combination meter M24
4. Hazard switch M55

Component Description

INFOID:0000000012563629

Part name	Description
BCM	Controls turn signal and hazard flasher operation.

A
B
C
D
E
F
G
H
I
J
K
EXL
M
N
O
P

TURN SIGNAL AND HAZARD WARNING LAMPS

< SYSTEM DESCRIPTION >

Combination switch (lighting and turn signal switch)	Lighting and turn signal switch requests are output to the BCM.
Hazard switch	Hazard flasher request signal is output to the BCM.
Combination meter	Outputs turn and hazard indicator as requested by the BCM.

PARKING, LICENSE PLATE AND TAIL LAMPS

< SYSTEM DESCRIPTION >

PARKING, LICENSE PLATE AND TAIL LAMPS

System Diagram

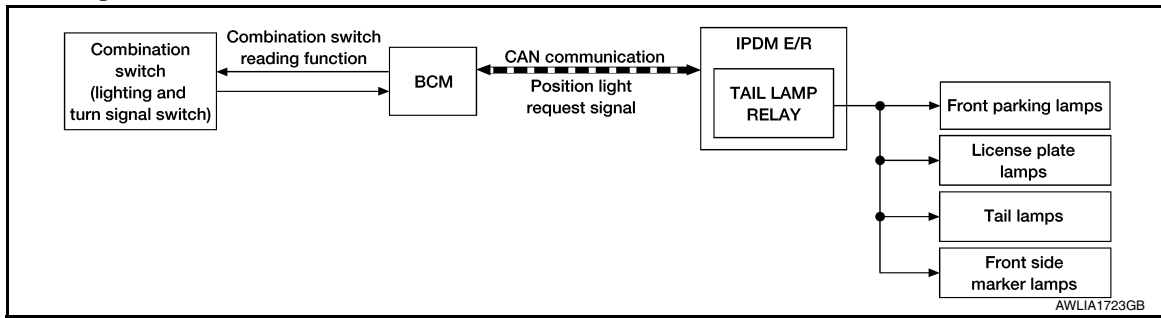

INFOID:000000012563630

System Description

INFOID:000000012563631

PARKING, LICENCE PLATE AND TAIL LAMPS OPERATION

When the combination switch (lighting and turn signal switch) is in 1ST position, BCM detects the LIGHTING SWITCH 1ST POSITION ON. The BCM sends a parking light ON request via the CAN communication lines to the IPDM E/R. The IPDM E/R then activates the tail lamp relay which sends power to the parking and instrument illumination circuits.

EXTERIOR LAMP BATTERY SAVER CONTROL

With the combination switch (lighting and turn signal switch) in the 2ND position and the ignition switch is turned from ON or ACC to OFF, the battery saver feature is activated.

Under this condition, the headlamps remain illuminated for 5 minutes unless the combination switch (lighting and turn signal switch) position is changed. If the combination switch (lighting and turn signal switch) position is changed, then the headlamps are turned off.

This setting can be changed by CONSULT. Refer to [BCS-23. "HEADLAMP : CONSULT Function \(BCM - HEADLAMP\)".](#)

Component Parts Location

INFOID:000000012563632

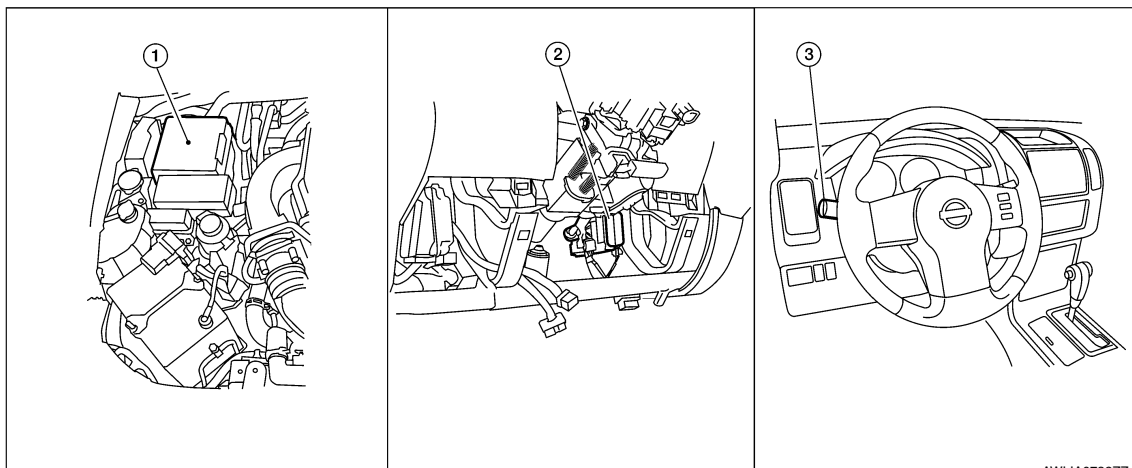

AWLIA0732ZZ

1. IPDM E/R E121, E122, E123, E124
2. BCM M18, M20 (view with lower instrument panel LH removed)
3. Combination switch (lighting and turn signal switch) M28

PARKING, LICENSE PLATE AND TAIL LAMPS

< SYSTEM DESCRIPTION >

Component Description

INFOID:000000012563633

Part name	Description
BCM	<ul style="list-style-type: none">• Receives combination switch (lighting and turn signal switch) requests via BCM combination switch reading function.• Sends parking light request signal to the IPDM E/R.
IPDM E/R	Activates the tail lamp relay upon request of the BCM.
Combination switch (lighting and turn signal switch)	Outputs lighting requests to the BCM.

TRAILER TOW

< SYSTEM DESCRIPTION >

TRAILER TOW

System Diagram

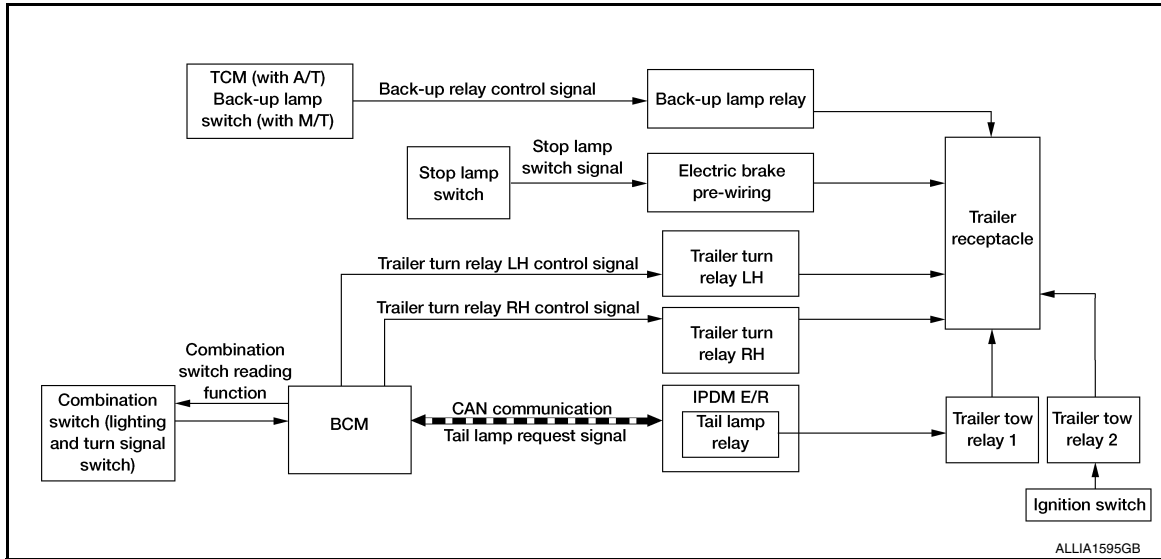

INFOID:000000012563634

System Description

INFOID:000000012563635

TRAILER TAIL LAMP OPERATION

The trailer tail lamps are controlled by the trailer tow relay 1 that is located on the front of the IPDM E/R. With the combination switch (lighting and turn signal switch) in the 1st position, the BCM detects the LIGHTING SWITCH 1ST POSITION ON. The BCM sends a parking light ON request via the CAN communication lines to the IPDM E/R. The IPDM E/R then activates the tail lamp relay which activates the trailer tow relay 1 and sends power to the trailer receptacle.

TRAILER TURN SIGNAL LAMP OPERATION

The trailer turn signal lamps are controlled by the BCM. When the combination switch (lighting and turn signal switch) is in the LH or RH position with the ignition switch ON, the combination switch (lighting and turn signal switch) sends a signal to the BCM. The BCM detects the TURN RH or TURN LH ON request. The BCM sends a control signal to the respective trailer turn relay which sends power to the trailer receptacle.

TRAILER HAZARD LAMP OPERATION

The trailer hazard lamps are controlled by the BCM. When the hazard switch is pressed, the BCM detects the the hazard ON request. The BCM then sends a control signal to both trailer turn relays which sends power to the trailer receptacle.

TRAILER BRAKE LAMP OPERATION

The trailer brake lamps operate when the brake pedal is pressed sending the stop lamp switch signal to the trailer receptacle.

A
B
C
D
E
F
G
H
I
J
K
EXL
M
N
O
P

TRAILER TOW

< SYSTEM DESCRIPTION >

Component Parts Location

INFOID:000000012563636

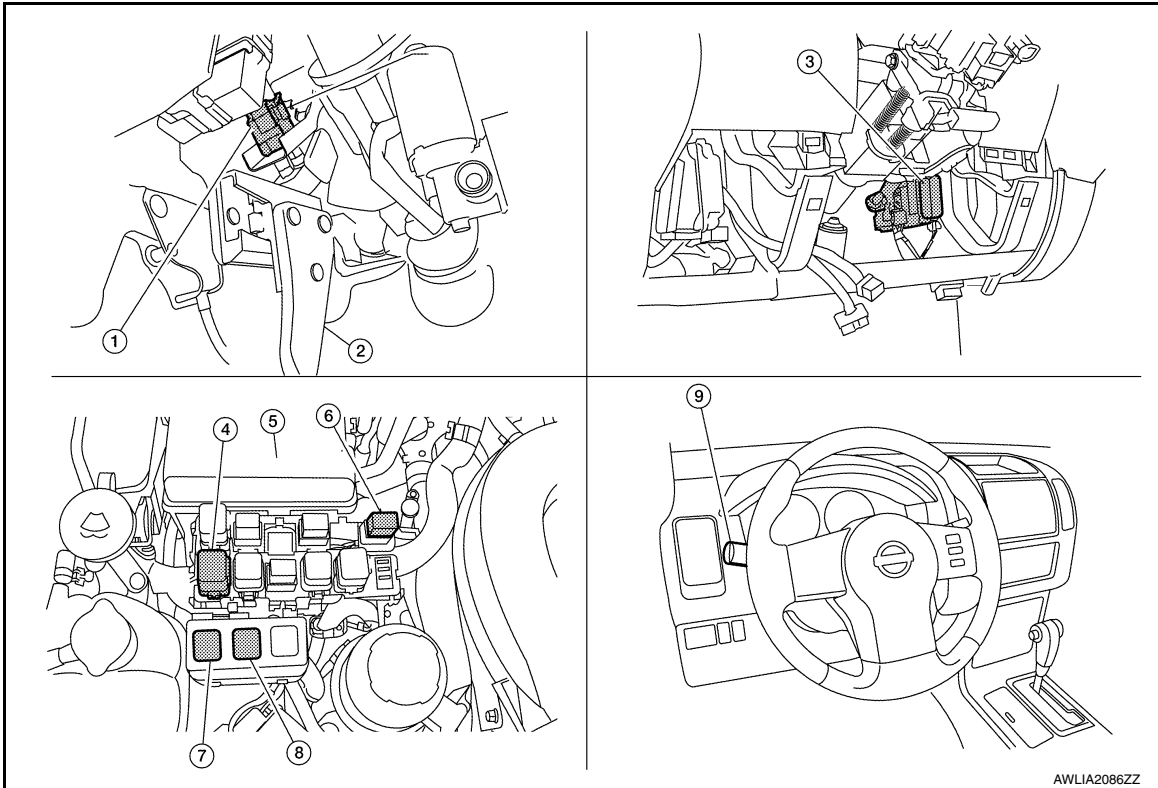

- | | | |
|--|------------------------------|---|
| 1. Stop lamp switch E38 (with M/T) or E39 (with A/T) (view with lower instrument panel LH removed) | 2. Brake pedal | 3. BCM, M18, M19, M20 (view with lower instrument panel LH removed) |
| 4. Trailer turn relay LH E164 | 5. IPDM E/R E121, E122, E124 | 6. Trailer turn relay RH E165 |
| 7. Trailer tow relay 2 E228 | 8. Trailer tow relay 1 E227 | 9. Combination switch (lighting and turn signal switch) M28 |

Component Description

INFOID:000000012563637

Part name	Description
BCM	<ul style="list-style-type: none"> Receives lighting and turn signal requests from combination switch (lighting and turn signal switch). Sends lighting signal request to the IPDM E/R to control the tail lamp relay via CAN communication. Sends turn/hazard/brake control signal to the trailer turn relays.
IPDM E/R	Activates the tail lamp relay upon request from the BCM via CAN communication.
Combination switch (lighting and turn signal switch)	Outputs lighting and turn signal requests to the BCM.

COMBINATION SWITCH READING SYSTEM

< SYSTEM DESCRIPTION >

COMBINATION SWITCH READING SYSTEM

System Diagram

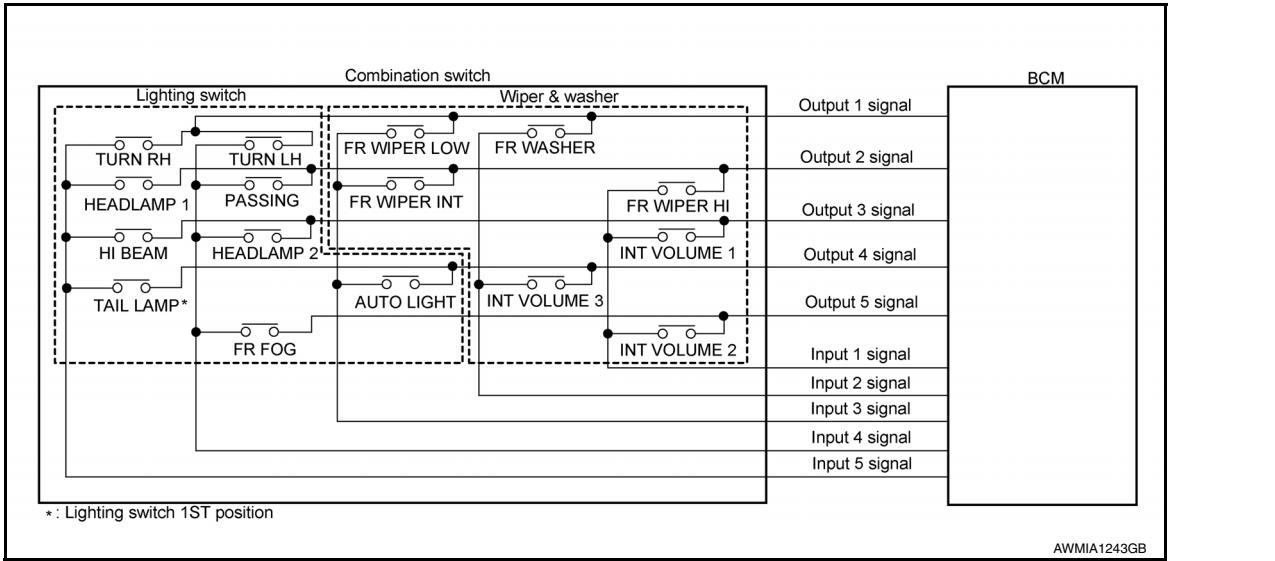

System Description

INFOID:000000012563639

OUTLINE

- BCM reads the status of the combination switch (light, turn signal, wiper and washer) and recognizes the status of each switch.
- BCM has a combination of 5 output terminals (OUTPUT 1 - 5) and 5 input terminals (INPUT 1 - 5) and reads a maximum of 20 switch states.

COMBINATION SWITCH MATRIX

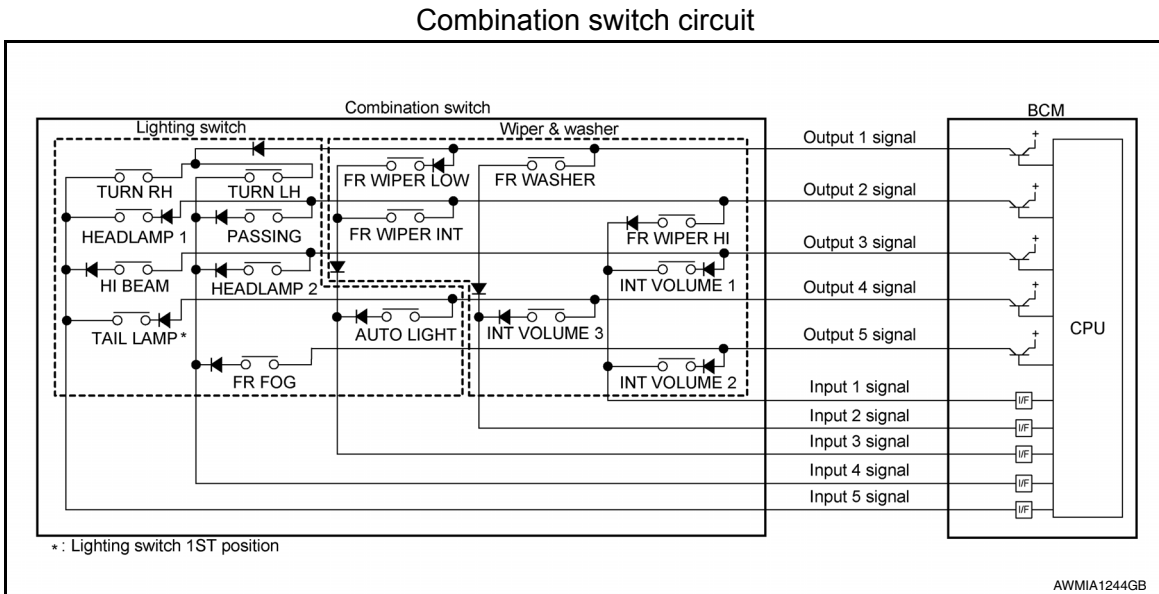

Combination switch INPUT-OUTPUT system list

System	INPUT 1	INPUT 2	INPUT 3	INPUT 4	INPUT 5
OUTPUT 1	—	FR WASHER	FR WIPER LOW	TURN LH	TURN RH
OUTPUT 2	FR WIPER HI	—	FR WIPER INT	PASSING	HEADLAMP 1
OUTPUT 3	INT VOLUME 1	—	—	HEADLAMP 2	HI BEAM

COMBINATION SWITCH READING SYSTEM

< SYSTEM DESCRIPTION >

System	INPUT 1	INPUT 2	INPUT 3	INPUT 4	INPUT 5
OUTPUT 4	—	INT VOLUME 3	AUTO LIGHT	—	TAIL LAMP
OUTPUT 5	INT VOLUME 2	—	—	FR FOG	—

COMBINATION SWITCH READING FUNCTION

Description

- BCM reads the status of the combination switch at 10 ms intervals normally.

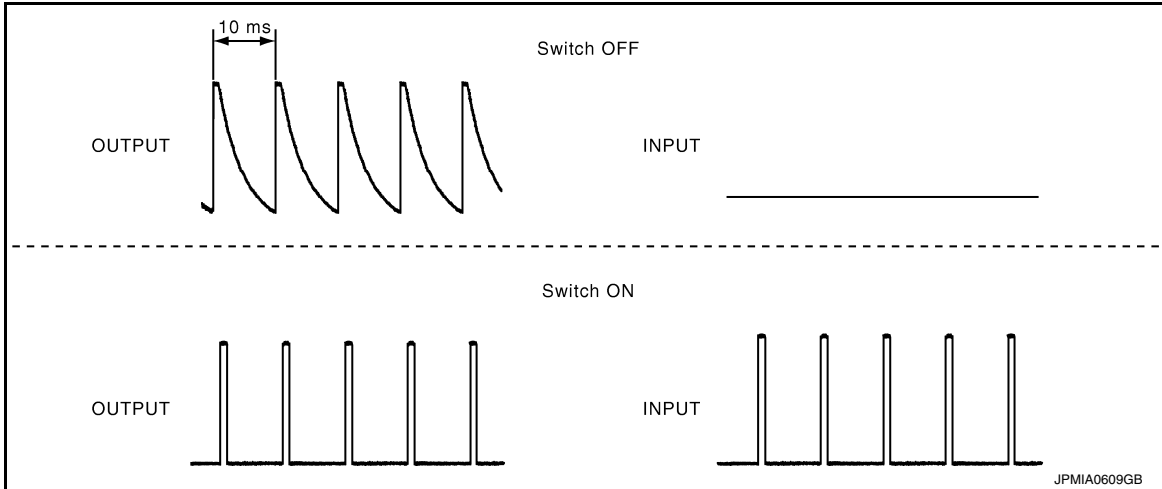

NOTE:

BCM reads the status of the combination switch at 60 ms intervals when BCM is controlled at low power consumption control mode.

- BCM operates as follows and judges the status of the combination switch.
- It operates the transistor on OUTPUT side in the following order: OUTPUT 1 → 2 → 3 → 4 → 5, and outputs voltage waveform.
- The voltage waveform of OUTPUT corresponding to the formed circuit is input into the interface on INPUT side if any (1 or more) switches are ON.
- It reads this change of the voltage as the status signal of the combination switch.

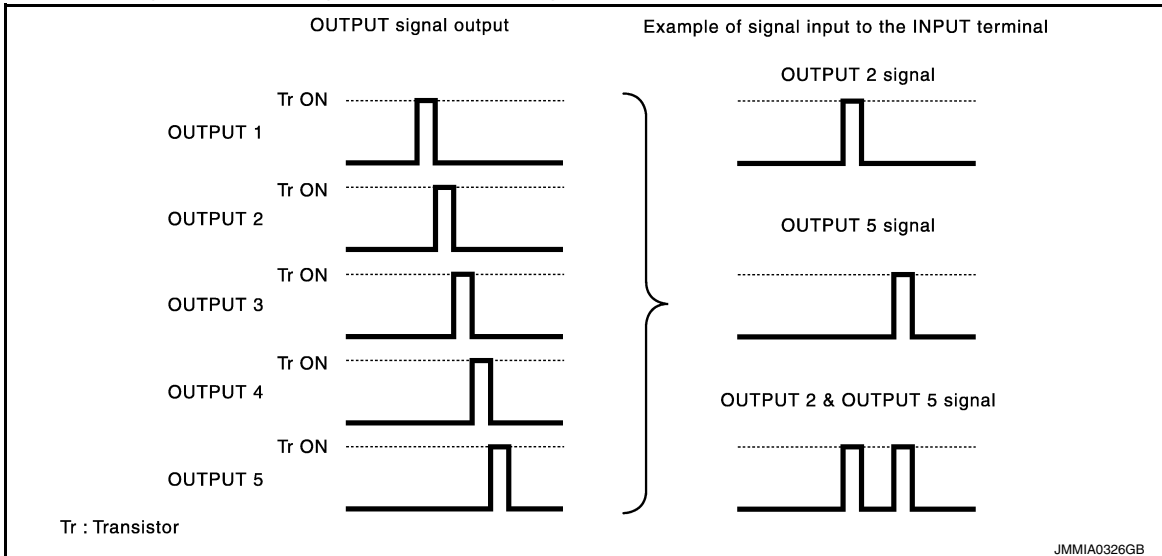

Operation Example

In the following operation example, the combination of the status signals of the combination switch is replaced as follows: INPUT 1 - 5 to "1 - 5" and OUTPUT 1 - 5 to "A - E".

Example 1: When a switch (TAIL LAMP) is turned ON

COMBINATION SWITCH READING SYSTEM

< SYSTEM DESCRIPTION >

- The circuit between OUTPUT 4 and INPUT 5 is formed when the TAIL LAMP switch is turned ON.

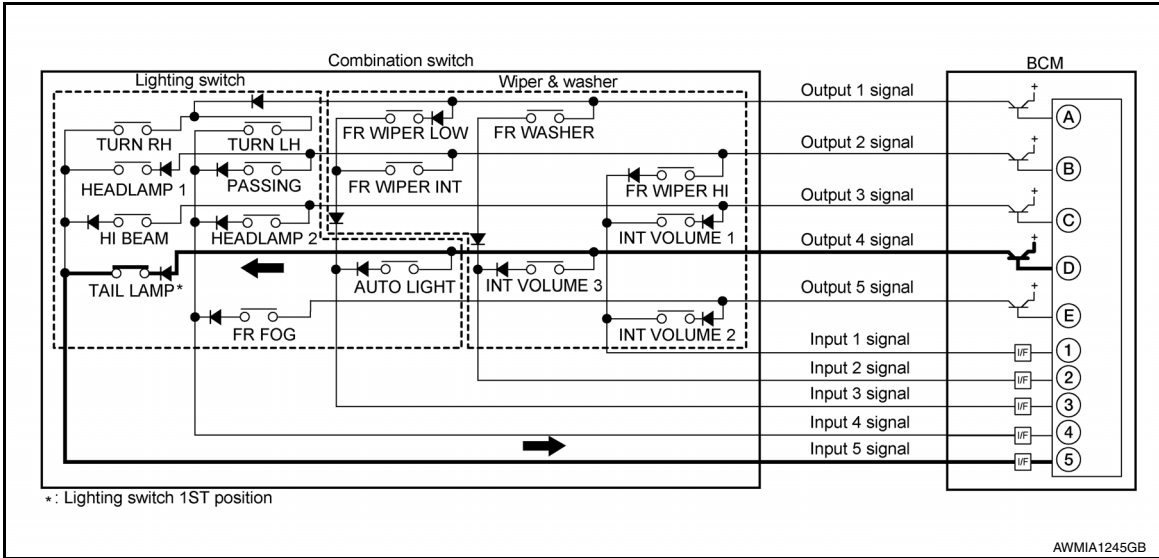

- BCM detects the combination switch status signal “5D” when the signal of OUTPUT 4 is input to INPUT 5.
- BCM judges that the TAIL LAMP switch is ON when the signal “5D” is detected.

Example 2: When some switches (TURN RH, TAIL LAMP) are turned ON

- The circuits between OUTPUT 1 and INPUT 5 and between OUTPUT 4 and INPUT 5 are formed when the TURN RH switch and TAIL LAMP switch are turned ON.

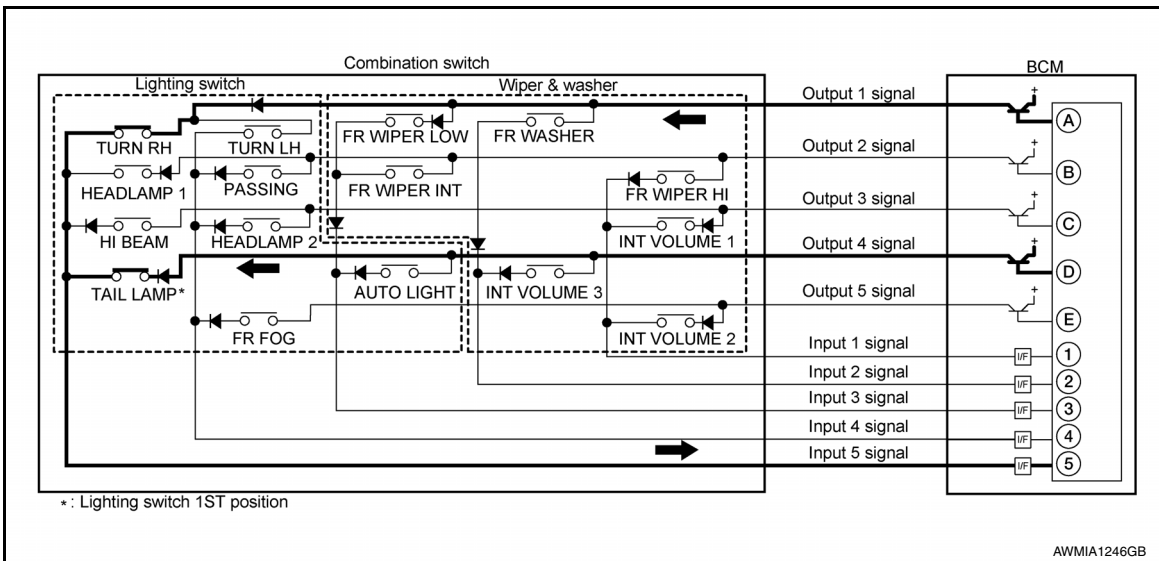

- BCM detects the combination switch status signal “5AD” when the signals of OUTPUT 1 and OUTPUT 4 are input to INPUT 5.
- BCM judges that the TURN RH switch and TAIL LAMP switch are ON when the signal “5AD” is detected.

WIPER INTERMITTENT DIAL POSITION SETTING (FRONT WIPER INTERMITTENT OPERATION)

BCM judges the wiper intermittent dial 1 - 7 by the status of INT VOLUME 1, 2, and 3 switches.

COMBINATION SWITCH READING SYSTEM

< SYSTEM DESCRIPTION >

Wiper intermittent dial position	Intermittent operation delay interval	INT VOLUME switch ON/OFF status		
		INT VOLUME 1	INT VOLUME 2	INT VOLUME 3
1	Short ↑	ON	ON	ON
2		ON	ON	OFF
3		ON	OFF	OFF
4		OFF	OFF	OFF
5	↓ Long	OFF	OFF	ON
6		OFF	ON	ON
7		OFF	ON	OFF

Component Parts Location

INFOID:000000012563640

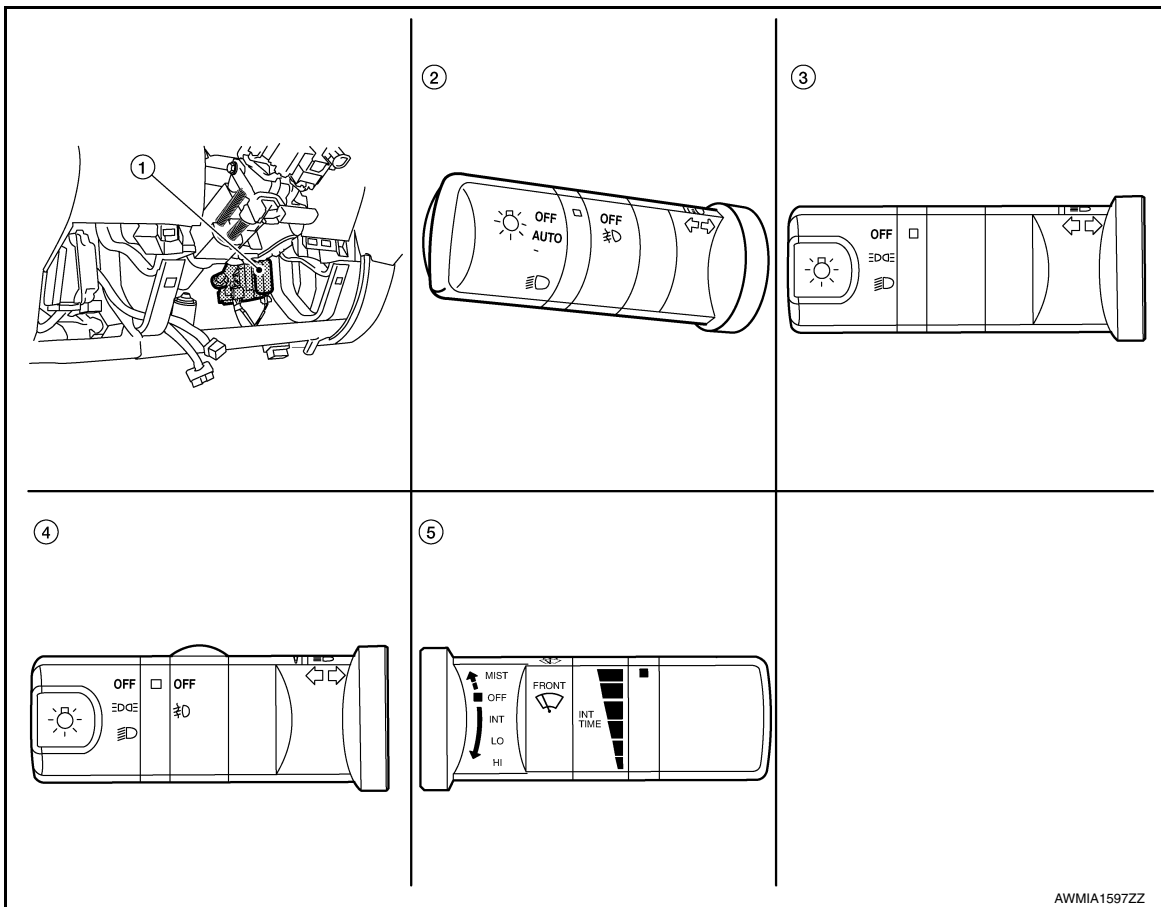

AWMIA159ZZ

1. BCM M18, M19, M20 (view with lower instrument panel LH removed)
2. Combination switch (lighting and turn signal switch with auto lights and fog lights) M28
3. Combination switch (lighting and turn signal switch without auto lights and fog lights) M28
4. Combination switch (lighting and turn signal switch with fog lights without auto lights) M28
5. Combination switch (wiper and washer switch) M28

DIAGNOSIS SYSTEM (BCM)

< SYSTEM DESCRIPTION >

DIAGNOSIS SYSTEM (BCM) COMMON ITEM

COMMON ITEM : CONSULT Function (BCM - COMMON ITEM)

INFOID:000000012563641

APPLICATION ITEM

CONSULT performs the following functions via CAN communication with BCM.

Direct Diagnostic Mode	Description
ECU Identification	The BCM part number is displayed.
Self Diagnostic Result	The BCM self diagnostic results are displayed.
Data Monitor	The BCM input/output data is displayed in real time.
Active Test	The BCM activates outputs to test components.
Work support	The settings for BCM functions can be changed.
Configuration	<ul style="list-style-type: none"> The vehicle specification can be read and saved. The vehicle specification can be written when replacing BCM.
CAN Diag Support Mntr	The result of transmit/receive diagnosis of CAN communication is displayed.

SYSTEM APPLICATION

BCM can perform the following functions.

System	Sub System	Direct Diagnostic Mode						
		ECU Identification	Self Diagnostic Result	Data Monitor	Active Test	Work support	Configuration	CAN Diag Support Mntr
Door lock	DOOR LOCK			x	x	x		
Rear window defogger	REAR DEFOGGER			x	x			
Warning chime	BUZZER			x	x			
Interior room lamp timer	INT LAMP			x	x	x		
Remote keyless entry system	MULTI REMOTE ENT			x	x	x		
Exterior lamp	HEAD LAMP			x	x	x		
Wiper and washer	WIPER			x	x	x		
Turn signal and hazard warning lamps	FLASHER			x	x			
Air conditioner	AIR CONDITIONER			x				
Combination switch	COMB SW			x				
BCM	BCM	x	x			x	x	x
Immobilizer	IMMU		x	x	x			
Interior room lamp battery saver	BATTERY SAVER			x	x	x		
Vehicle security system	THEFT ALM			x	x	x		
RAP system	RETAINED PWR			x	x	x		
Signal buffer system	SIGNAL BUFFER			x	x			
TPMS	AIR PRESSURE MONITOR		x	x	x	x		
Panic alarm system	PANIC ALARM				x			

HEADLAMP

DIAGNOSIS SYSTEM (BCM)

< SYSTEM DESCRIPTION >

HEADLAMP : CONSULT Function (BCM - HEADLAMP)

INFOID:000000012563642

DATA MONITOR

Monitor Item [Unit]	Description
IGN ON SW [On/Off]	Indicates condition of ignition switch ON position.
ACC ON SW [On/Off]	Indicates condition of ignition switch ACC position.
HI BEAM SW [On/Off]	Indicates condition of combination switch.
HEAD LAMP SW 1 [On/Off]	
HEAD LAMP SW 2 [On/Off]	
LIGHT SW 1ST [On/Off]	
AUTO LIGHT SW [On/Off]	
PASSING SW [On/Off]	
FR FOG SW [On/Off]	
DOOR SW-DR [On/Off]	Indicates condition of front door switch LH.
DOOR SW-AS [On/Off]	Indicates condition of front door switch RH.
DOOR SW-RR [On/Off]	Indicates condition of rear door switch RH.
DOOR SW-RL [On/Off]	Indicates condition of rear door switch LH.
TURN SIGNAL R [On/Off]	Indicates condition of combination switch.
TURN SIGNAL L [On/Off]	
CARGO LAMP SW [On/Off]	Indicates condition of cargo lamp switch.
OPTICAL SENSOR [V]	Indicates voltage signal from optical sensor.

ACTIVE TEST

Test Item	Description
TAIL LAMP	This test is able to check tail lamp operation [Off/On].
HEAD LAMP	This test is able to check head lamp operation [Off/Lo/Hi].
FR FOG LAMP	This test is able to check front fog lamp operation [Off/On].
CARGO LAMP	This test is able to check cargo lamp operation [Off/On].

WORK SUPPORT

Support Item	Setting	Description
BATTERY SAVER SET	Off	Exterior lamp battery saver function OFF.
	On*	Exterior lamp battery saver function ON.
CUSTOM A/LIGHT SETTING	MODE4	Less sensitive setting than normal setting (Turns ON later than normal operation).
	MODE3	More sensitive setting than MODE 2 (Turns ON earlier than MODE 2).
	MODE2	More sensitive setting than normal setting (Turns ON earlier than normal operation).
	MODE1*	Normal.

DIAGNOSIS SYSTEM (BCM)

< SYSTEM DESCRIPTION >

Support Item	Setting	Description		
ILL DELAY SET	MODE8	180 sec	Sets delay timer function operation time (All doors closed).	A
	MODE7	150 sec		B
	MODE6	120 sec		C
	MODE5	90 sec		D
	MODE4	60 sec		
	MODE3	30 sec		
	MODE2	OFF		
	MODE1*	45 sec		

*: Initial setting

FLASHER

FLASHER : CONSULT Function (BCM - FLASHER)

INFOID:0000000012563643

DATA MONITOR

Monitor Item [Unit]	Description	
IGN ON SW [On/Off]	Indicates condition of ignition switch ON position.	G
HAZARD SW [On/Off]	Indicates condition of hazard switch.	H
TURN SIGNAL R [On/Off]	Indicates condition of turn signal function of combination switch.	I
TURN SIGNAL L [On/Off]		J
BRAKE SW [On/Off]	Indicates condition of brake switch.	K

ACTIVE TEST

Test Item	Description	
FLASHER	This test is able to check turn signal lamp operation [Off/LH/RH].	EXL

COMB SW

COMB SW : CONSULT Function (BCM - COMB SW)

INFOID:0000000012563644

DATA MONITOR

Monitor Item [Unit]	Description	
TURN SIGNAL R [On/Off]	Indicates condition of turn signal operation of combination switch.	M
TURN SIGNAL L [On/Off]		N
HI BEAM SW [On/Off]	Indicates condition of hi beam operation of combination switch.	O
HEAD LAMP SW 1 [On/Off]	Indicates condition of headlamp operation of combination switch.	P
HEAD LAMP SW 2 [On/Off]		
LIGHT SW 1ST [On/Off]	Indicates condition of lighting operation of combination switch.	
PASSING SW [On/Off]	Indicates condition of passing switch operation of combination switch.	
AUTO LIGHT SW [On/Off]	Indicates condition of auto light operation of combination switch.	
FR FOG SW [On/Off]	Indicates condition of front fog light operation of combination switch.	
FR WIPER HI [On/Off]	Indicates condition of front wiper operation of combination switch.	
FR WIPER LOW [On/Off]		
FR WIPER INT [On/Off]		
FR WASHER SW [On/Off]	Indicates condition of front washer operation of combination switch.	
INT VOLUME [1 - 7]	Indicates condition of intermittent wiper operation of combination switch.	

DIAGNOSIS SYSTEM (IPDM E/R)

< SYSTEM DESCRIPTION >

DIAGNOSIS SYSTEM (IPDM E/R)

Diagnosis Description

INFOID:000000012563645

AUTO ACTIVE TEST

Description

In auto active test mode, the IPDM E/R sends a drive signal to the following systems to check their operation.

- Oil pressure low warning indicator
- Oil pressure gauge (if equipped)
- Rear window defogger (if equipped)
- Front wipers
- Tail, license and parking lamps
- Front fog lamps (if equipped)
- Headlamps (Hi, Lo)
- A/C compressor (magnetic clutch)
- Cooling fan (if equipped)

Operation Procedure

1. Close the hood and front door RH, and lift the wiper arms from the windshield (to prevent windshield damage due to wiper operation).
NOTE:
When auto active test is performed with hood opened, sprinkle water on windshield before hand.
2. Turn ignition switch OFF.
3. Turn the ignition switch ON and, within 20 seconds, press the front door switch LH 10 times. Then turn the ignition switch OFF.
4. Turn the ignition switch ON within 10 seconds. After that the horn sounds once and the auto active test starts.
5. After a series of the following operations is repeated 3 times, auto active test is completed.

NOTE:

When auto active test mode has to be cancelled halfway through test, turn ignition switch OFF.

CAUTION:

- If auto active test mode cannot be actuated, check door switch system. Refer to [DLK-27, "KING CAB : Description"](#) (king cab) or [DLK-29, "CREW CAB : Description"](#) (crew cab).
- Do not start the engine.

Inspection in Auto Active Test Mode

When auto active test mode is actuated, the following 7 steps are repeated 3 times.

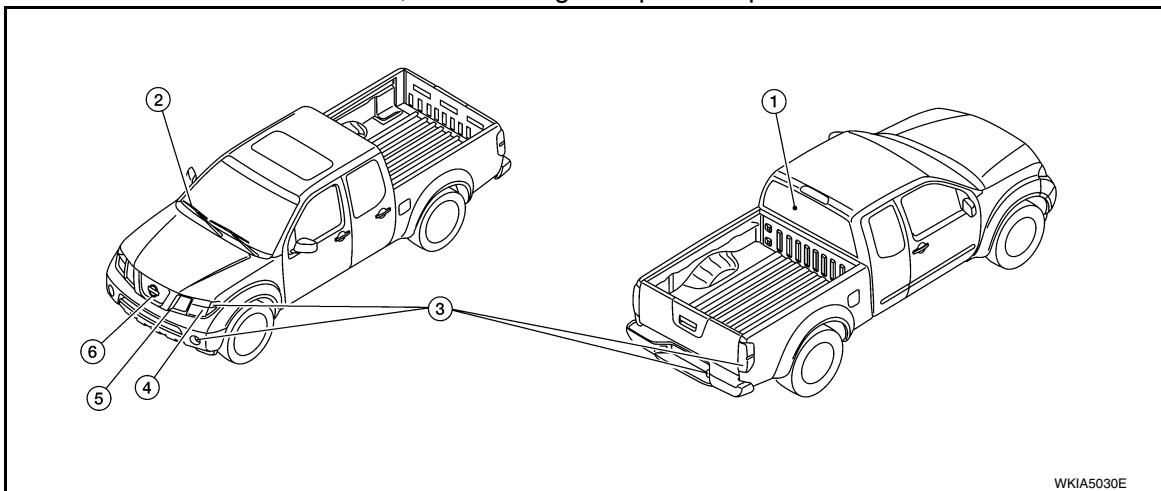

Item Number	Test Item	Operation Time/Frequency
1	Rear window defogger (if equipped)	10 seconds
2	Front wipers	LOW 5 seconds then HIGH 5 seconds
3	Tail, license plate, front fog and parking lamps	10 seconds

DIAGNOSIS SYSTEM (IPDM E/R)

< SYSTEM DESCRIPTION >

Item Number	Test Item	Operation Time/Frequency
4	Headlamps	Low ON for 10 seconds, then High ON-OFF five times.
5	A/C compressor (magnet clutch)	ON-OFF 5 times
6	Cooling fan (if equipped)	LOW 5 seconds then HIGH 5 seconds

Concept of auto active test

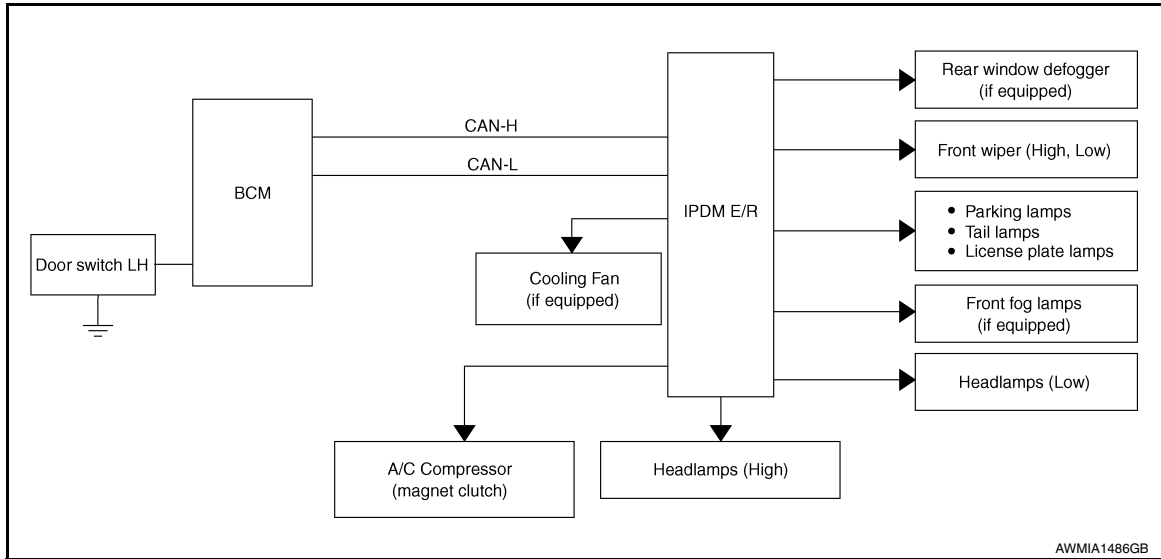

- IPDM E/R starts the auto active test with the door switch signals transmitted by BCM via CAN communication. Therefore, the CAN communication line between IPDM E/R and BCM is considered normal if the auto active test starts successfully.
- The auto active test facilitates troubleshooting if any systems controlled by IPDM E/R cannot be operated.

Diagnosis chart in auto active test mode

Symptom	Inspection contents	Possible cause
Oil pressure low warning indicator does not operate	Perform auto active test. Does the oil pressure low warning indicator operate?	YES • IPDM E/R signal input circuit • ECM signal input circuit • CAN communication signal between ECM and combination meter
		NO • CAN communication signal between IPDM E/R, BCM and combination meter
Oil pressure gauge does not operate	Perform auto active test. Does the oil pressure gauge operate?	YES IPDM E/R signal input circuit
		NO • CAN communication signal between IPDM E/R, BCM and combination meter
Rear window defogger does not operate	Perform auto active test. Does the rear window defogger operate?	YES BCM signal input circuit
		NO • Harness or connector between front air control and BCM • CAN communication signal between BCM and IPDM E/R

DIAGNOSIS SYSTEM (IPDM E/R)

< SYSTEM DESCRIPTION >

Symptom	Inspection contents	Possible cause
Any of the following components do not operate <ul style="list-style-type: none"> • Front wipers • Tail lamps • License plate lamps • Parking lamps • Front fog lamps (if equipped) • Headlamps (Hi, Lo) 	Perform auto active test. Does the applicable system operate?	YES BCM signal input system
		NO <ul style="list-style-type: none"> • Lamp or front wiper motor malfunction • Lamp or front wiper motor ground circuit • Harness or connector between IPDM E/R and applicable system • IPDM E/R (integrated relay malfunction)
A/C compressor does not operate	Perform auto active test. Does the A/C compressor operate?	YES <ul style="list-style-type: none"> • BCM signal input circuit • CAN communication signal between BCM and ECM • CAN communication signal between ECM and IPDM E/R
		NO <ul style="list-style-type: none"> • Magnetic clutch malfunction • Harness or connector between IPDM E/R and magnetic clutch • IPDM E/R (integrated relay malfunction)
Cooling fan does not operate (if equipped)	Perform auto active test. Does the cooling fan operate?	YES <ul style="list-style-type: none"> • ECM signal input circuit • CAN communication signal between ECM and IPDM E/R
		NO <ul style="list-style-type: none"> • Cooling fan motor malfunction • Harness or connector between IPDM E/R and cooling fan • IPDM E/R (integrated relay malfunction)

CONSULT Function (IPDM E/R)

INFOID:000000012563646

APPLICATION ITEM

CONSULT performs the following functions via CAN communication with IPDM E/R.

Direct Diagnostic Mode	Description
Self Diagnostic Result	The IPDM E/R self diagnostic results are displayed.
Data Monitor	The IPDM E/R input/output data is displayed in real time.
Active Test	The IPDM E/R activates outputs to test components.
CAN Diag Support Mntr	The result of transmit/receive diagnosis of CAN communication is displayed.

SELF DIAGNOSTIC RESULT

Refer to [PCS-21, "DTC Index"](#).

DATA MONITOR

Monitor Item [Unit]	Main Signals	Description
MOTOR FAN REQ [1/2/3/4]	×	Indicates cooling fan speed signal received from ECM on CAN communication line
AC COMP REQ [On/Off]	×	Indicates A/C compressor request signal received from ECM on CAN communication line

DIAGNOSIS SYSTEM (IPDM E/R)

< SYSTEM DESCRIPTION >

Monitor Item [Unit]	Main Signals	Description	A
TAIL&CLR REQ [On/Off]	×	Indicates position light request signal received from BCM on CAN communication line	A
HL LO REQ [On/Off]	×	Indicates low beam request signal received from BCM on CAN communication line	B
HL HI REQ [On/Off]	×	Indicates high beam request signal received from BCM on CAN communication line	C
FR FOG REQ [On/Off]	×	Indicates front fog light request signal received from BCM on CAN communication line	D
FR WIP REQ [Stop/1LOW/Low/Hi]	×	Indicates front wiper request signal received from BCM on CAN communication line	D
WIP AUTO STOP [STOP P/ACT P]	×	Indicates condition of front wiper auto stop signal	E
WIP PROT [Off/BLOCK]	×	Indicates condition of front wiper fail-safe operation	E
ST RLY REQ [On/Off]		Indicates starter request signal received from ECM on CAN communication line	F
IGN RLY [On/Off]	×	Indicates condition of ignition relay	F
RR DEF REQ [On/Off]	×	Indicates rear defogger request signal received from BCM on CAN communication line	G
OIL P SW [Open/Close]		Indicates condition of oil pressure switch	G
DTRL REQ [Off]		Indicates daytime light request signal received from BCM on CAN communication line	H
THFT HRN REQ [On/Off]		Indicates theft warning horn request signal received from BCM on CAN communication line	H
HORN CHIRP [On/Off]		Indicates horn reminder signal received from BCM on CAN communication line	I

ACTIVE TEST

Test item	Description	J
REAR DEFOGGER	This test is able to check rear defogger operation [On/Off].	J
FRONT WIPER	This test is able to check wiper motor operation [Hi/Lo/Off].	K
MOTOR FAN	This test is able to check cooling fan operation [4/3/2/1].	K
EXTERNAL LAMPS	This test is able to check external lamp operation [Fog/Hi/Lo/TAIL/Off].	EXL
HORN	This test is able to check horn operation [On].	EXL

POWER SUPPLY AND GROUND CIRCUIT

< DTC/CIRCUIT DIAGNOSIS >

DTC/CIRCUIT DIAGNOSIS

POWER SUPPLY AND GROUND CIRCUIT

BCM (BODY CONTROL MODULE)

BCM (BODY CONTROL MODULE) : Diagnosis Procedure

INFOID:000000012563647

Regarding Wiring Diagram information, refer to [BCS-49, "Wiring Diagram"](#).

1. CHECK FUSES AND FUSIBLE LINK

Check that the following fuses and fusible link are not blown.

Terminal No.	Signal name	Fuses and fusible link No.
57	Battery power supply	21 (10A)
70		G (50A)
11	Ignition ACC or ON	4 (10A)
38	Ignition ON or START	1 (10A)

Is the fuse blown?

YES >> Replace the blown fuse or fusible link after repairing the affected circuit.

NO >> GO TO 2

2. CHECK POWER SUPPLY CIRCUIT

1. Turn ignition switch OFF.
2. Disconnect BCM.
3. Check voltage between BCM harness connector and ground.

Connector	Terminals		Power source	Condition	Voltage (V) (Approx.)
	(+)	(-)			
M18	11	Ground	ACC power supply	Ignition switch ACC or ON	Battery voltage
	38	Ground	Ignition power supply	Ignition switch ON or START	Battery voltage
M20	57	Ground	Battery power supply	Ignition switch OFF	Battery voltage
	70	Ground	Battery power supply	Ignition switch OFF	Battery voltage

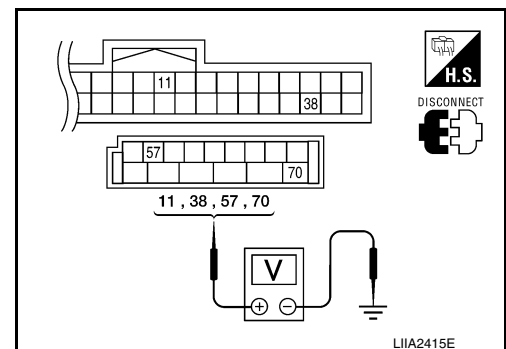

Is the measurement value normal?

YES >> GO TO 3

NO >> Repair or replace harness.

3. CHECK GROUND CIRCUIT

POWER SUPPLY AND GROUND CIRCUIT

< DTC/CIRCUIT DIAGNOSIS >

Check continuity between BCM harness connector and ground.

BCM		Ground	Continuity
Connector	Terminal		
M20	67		Yes

Does continuity exist?

- YES >> Inspection End.
- NO >> Repair or replace harness.

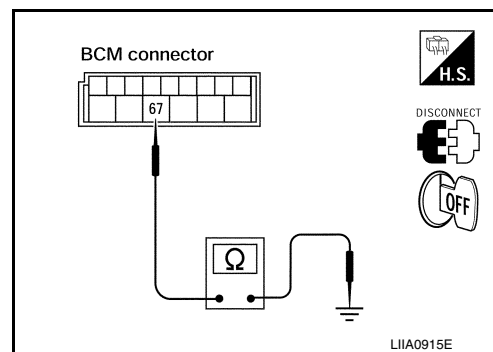

IPDM E/R (INTELLIGENT POWER DISTRIBUTION MODULE ENGINE ROOM)

IPDM E/R (INTELLIGENT POWER DISTRIBUTION MODULE ENGINE ROOM) : Diagnosis Procedure

INFOID:000000012563648

Regarding Wiring Diagram information, refer to [PCS-22, "Wiring Diagram"](#).

1. CHECK FUSIBLE LINKS

Check that the following IPDM E/R fusible links are not blown.

Terminal No.	Signal name	Fusible link No.
1	Battery	A, D
2		C
22		A, E, I

Is the fusible link blown?

- YES >> Replace the blown fusible link after repairing the affected circuit.
- NO >> GO TO 2

2. CHECK BATTERY POWER SUPPLY CIRCUIT

1. Turn ignition switch OFF.
2. Disconnect IPDM E/R.
3. Check voltage between IPDM E/R harness connectors and ground.

Terminals		Ignition switch position	Voltage (V) (Approx.)	
(+)	(-)			
Connector	Terminal	Ground	OFF	Battery voltage
E118 (A)	1			
	2			
E120 (B)	22			

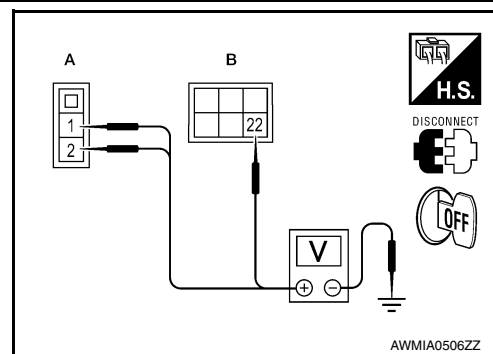

Is there voltage on all pins?

- YES >> GO TO 3
- NO >> Repair or replace harness.

3. CHECK GROUND CIRCUIT

1. Turn ignition switch OFF.

POWER SUPPLY AND GROUND CIRCUIT

< DTC/CIRCUIT DIAGNOSIS >

2. Check continuity between IPDM E/R harness connectors and ground.

IPDM E/R		Ground	Continuity
Connector	Terminal		
E122 (A)	38		Yes
E124 (B)	59		

Does continuity exist?

- YES >> Inspection End.
 NO >> Repair or replace harness.

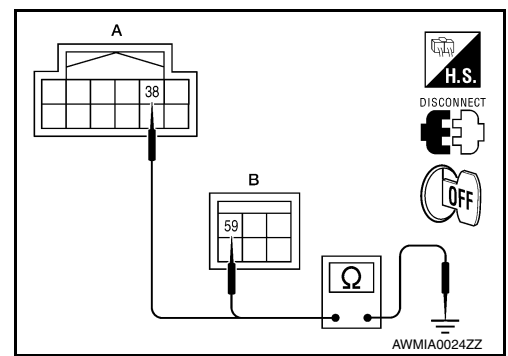

HEADLAMP (HI) CIRCUIT

< DTC/CIRCUIT DIAGNOSIS >

HEADLAMP (HI) CIRCUIT

Description

INFOID:0000000012563649

The IPDM E/R (intelligent power distribution module engine room) controls the headlamp high relay based on inputs from the BCM via the CAN communication lines. When the headlamp high relay is energized, power flows through fuses 34 and 35, located in the IPDM E/R. Power then flows to the front combination lamps to the headlamp high beam.

Component Function Check

INFOID:0000000012563650

1. CHECK HEADLAMP (HI) OPERATION

⊗ WITHOUT CONSULT

1. Start IPDM E/R auto active test. Refer to [PCS-9, "Diagnosis Description"](#).
2. Check that the headlamp switches to the high beam.

NOTE:

HI/LO is repeated 1 second each when using the IPDM E/R auto active test.

Ⓜ WITH CONSULT

1. Select "EXTERNAL LAMPS" of IPDM E/R active test item.
2. With the test item operating, check that the headlamp switches to high beam.

HI : Headlamp switches to the high beam.

OFF : Headlamp OFF

Does the headlamp switch to high beam?

YES >> Headlamp (HI) circuit is normal.

NO >> Refer to [EXL-39, "Diagnosis Procedure"](#).

Diagnosis Procedure

INFOID:0000000012563651

Regarding Wiring Diagram information, refer to [EXL-75, "Wiring Diagram"](#)(without Daytime light system) or [EXL-79, "Wiring Diagram"](#)(with Daytime light system).

1. CHECK HEADLAMP (HI) FUSES

1. Turn the ignition switch OFF.
2. Check that the following fuses are not open:

Unit	Location	Fuse No.	Capacity
Headlamp HI (LH)	IPDM E/R	35	10A
Headlamp HI (RH)	IPDM E/R	34	10A

Is the fuse open?

YES >> Replace the blown fuse after repairing the affected circuit.

NO >> GO TO 2.

2. CHECK HEADLAMP (HI) OUTPUT VOLTAGE

HEADLAMP (HI) CIRCUIT

< DTC/CIRCUIT DIAGNOSIS >

1. Disconnect the front combination lamp connector E7 (with Daytime light system), E11 (without Daytime light system) or E107.
2. Turn the ignition switch ON.
3. Turn the high beam headlamps ON.
4. With the high beam headlamps ON, check the voltage between the front combination lamp connector and ground.

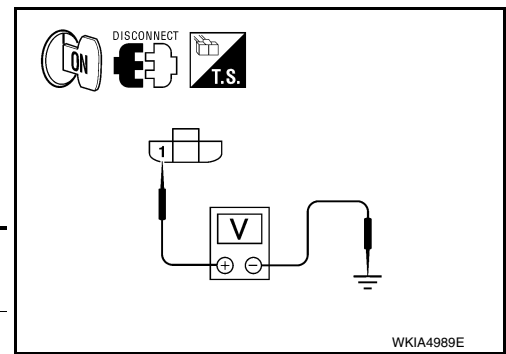

		(+)		(-)	Voltage
		Connector	Terminal		
LH	E7 (with Daytime light system)	E11 (without Daytime light system)	1	Ground	Battery voltage
	E11 (without Daytime light system)				
RH	E107				

Is battery voltage present?

- YES >> GO TO 4.
NO >> GO TO 3.

3. CHECK HEADLAMP (HI) CIRCUIT FOR OPEN

1. Turn the ignition switch OFF.
2. Disconnect IPDM E/R connector E123.
3. Check continuity between the IPDM E/R harness connector (A) and the front headlamp harness connector (B).

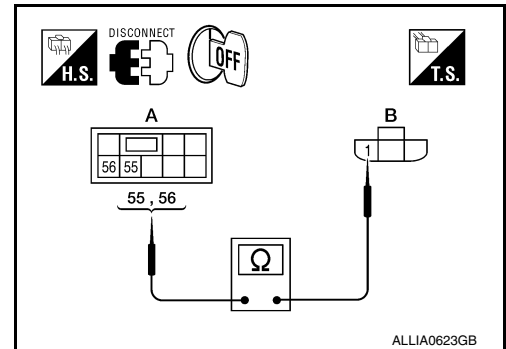

		A		B		Continuity
		Connector	Terminal	Connector	Terminal	
LH	E123	55, 56	55	E7 (with Daytime light system)	1	Yes
				E11 (without Daytime light system)		
RH				E107		

Does continuity exist?

- YES >> Replace IPDM E/R. Refer to [PCS-28. "Removal and Installation of IPDM E/R"](#).
NO >> Repair the harnesses or connectors.

4. CHECK FRONT HEADLAMP (HI) GROUND CIRCUIT

Check continuity between the front headlamp harness connector terminal and ground.

		Connector	Terminal	-	Continuity
LH	E7 (with Daytime light system)	E11 (without Daytime light system)	2	Ground	Yes
	E11 (without Daytime light system)				
RH	E107				

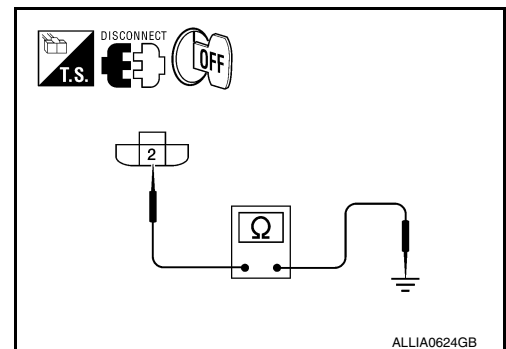

Does continuity exist?

- YES >> Inspect the headlamp bulb.
NO (Except LH with Daytime light system) >> Repair the harness.
NO (LH with Daytime light system) >> GO TO 5.

5. CHECK CONTINUITY BETWEEN FRONT HEADLAMP LH (HI) AND DAYTIME LIGHT RELAY 1

1. Disconnect daytime light relay 1 connector.
2. Check continuity between front headlamp LH harness connector and daytime light relay 1 harness connector.

HEADLAMP (HI) CIRCUIT

< DTC/CIRCUIT DIAGNOSIS >

Front headlamp LH		Daytime light relay 1		Continuity
Connector	Terminal	Connector	Terminal	
E7	2	E103	3	Yes

Does continuity exist?

YES >> GO TO 6.

NO >> Repair the harness or connector.

6.CHECK DAYTIME LIGHT RELAY 1 GROUND CIRCUIT

Check continuity between daytime light relay 1 harness connector and ground.

Daytime light relay 1		Ground	Continuity
Connector	Terminal		
E103	4		Yes

Does continuity exist?

YES >> GO TO 7.

NO >> Repair the harness or connector.

7.CHECK DAYTIME LIGHT RELAY 1

Check daytime light relay 1. Refer to [EXL-47. "Component Inspection"](#)

Is the inspection result normal?

YES >> Inspect the headlamp bulb.

NO >> Replace daytime light relay 1.

A
B
C
D
E
F
G
H
I
J
K
L
M
N
O
P

EXL

HEADLAMP (LO) CIRCUIT

< DTC/CIRCUIT DIAGNOSIS >

HEADLAMP (LO) CIRCUIT

Description

INFOID:0000000012563652

The IPDM E/R (intelligent power distribution module engine room) controls the headlamp low relay based on inputs from the BCM via the CAN communication lines. When the headlamp low relay is energized, power flows through fuses 40 and 41, located in the IPDM E/R. Power then flows to the front combination lamps to the headlamp low beam.

Component Function Check

INFOID:0000000012563653

1. CHECK HEADLAMP (LO) OPERATION

⊗ WITHOUT CONSULT

1. Start IPDM E/R auto active test. Refer to [PCS-9, "Diagnosis Description"](#).
2. Check that the headlamp is turned ON.

NOTE:

HI/LO is repeated 1 second each when using the IPDM E/R auto active test.

Ⓟ WITH CONSULT

1. Select "EXTERNAL LAMPS" of IPDM E/R active test item.
2. With the test items operating, check that the headlamp is turned ON.

LO : Headlamp ON
OFF : Headlamp OFF

Is the headlamp turned ON?

- YES >> Headlamp (LO) is normal.
NO >> Refer to [EXL-42, "Diagnosis Procedure"](#).

Diagnosis Procedure

INFOID:0000000012563654

Regarding Wiring Diagram information, refer to [EXL-75, "Wiring Diagram"](#) (without Daytime light system) or [EXL-79, "Wiring Diagram"](#) (with Daytime light system).

1. CHECK HEADLAMP (LO) FUSES

1. Turn the ignition switch OFF.
2. Check that the following fuses are not open:

Unit	Location	Fuse No.	Capacity
Headlamp LO (LH)	IPDM E/R	40	15A
Headlamp LO (RH)	IPDM E/R	41	15A

Is the fuse open?

- YES >> Replace the blown fuse after repairing the affected circuit.
NO >> GO TO 2.

2. CHECK HEADLAMP (LO) OUTPUT VOLTAGE

HEADLAMP (LO) CIRCUIT

< DTC/CIRCUIT DIAGNOSIS >

1. Disconnect the front headlamp connector.
2. Turn the ignition switch ON.
3. Turn the low beam headlamps ON.
4. With the low beam headlamps ON, check the voltage between the headlamp connector and ground.

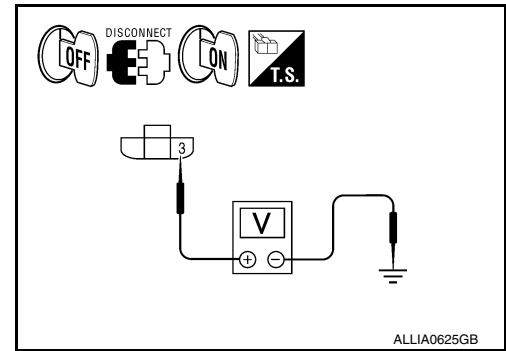

(+)		Terminal	(-)	Voltage
Connector				
LH	E7 (with Daytime light system)	3	Ground	Battery voltage
	E11 (without Daytime light system)			
RH	E107			

Is battery voltage present?

YES >> GO TO 8.

NO (Except LH with Daytime light system)>>Check headlamp (LO) circuit for open GO TO 3.

NO (LH with Daytime light system)>>Check headlamp (LO) circuit for open (LH WITH Daytime light system) GO TO 4.

3.CHECK HEADLAMP (LO) CIRCUIT FOR OPEN (EXCEPT LH WITH DAYTIME LIGHT SYSTEM)

1. Turn the ignition switch OFF.
2. Disconnect IPDM E/R connector E123.
3. Check continuity between the IPDM E/R harness connector (A) and the front headlamp harness connector (B).

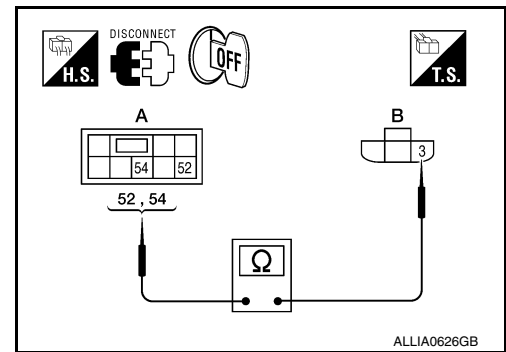

A		Terminal	B		Continuity
Connector			Connector	Terminal	
LH	E123	52	E11	3	Yes
RH		54	E107		

Does continuity exist?

YES >> Replace IPDM E/R. Refer to [PCS-28, "Removal and Installation of IPDM E/R"](#).

NO >> Repair the harnesses or connectors.

4.CHECK HEADLAMP (LO) CIRCUIT FOR OPEN (LH WITH DAYTIME LIGHT SYSTEM)

1. Turn the ignition switch OFF.
2. Disconnect IPDM E/R connector E123 and daytime light relay 2 connector.
3. Check continuity between the IPDM E/R harness connector and the daytime light relay 2 harness connector.

IPDM E/R		Daytime light relay 2		Continuity
Connector	Terminal	Connector	Terminal	
E123	52	E104	5	Yes
			2	

Does continuity exist?

YES >> GO TO 5.

NO >> Repair the harnesses or connectors.

5.CHECK DAYTIME LIGHT RELAY 2 CIRCUIT (LH WITH DAYTIME LIGHT SYSTEM)

1. Check continuity between the daytime light relay 2 harness connector and the front headlamp LH harness connector.

HEADLAMP (LO) CIRCUIT

< DTC/CIRCUIT DIAGNOSIS >

Daytime light relay 2		Front headlamp LH		Continuity
Connector	Terminal	Connector	Terminal	
E104	3	E7	3	Yes

2. Check continuity between the daytime light relay 2 harness connector and ground.

Daytime light relay 2		Ground	Continuity
Connector	Terminal		
E104	3		No

Is the measurement value normal?

YES >> GO TO 6.

NO >> Repair the harnesses or connectors.

6. CHECK DAYTIME LIGHT RELAY 2 GROUND CIRCUIT

Check continuity between daytime light relay 2 harness connector and ground.

Daytime light relay 2		Ground	Continuity
Connector	Terminal		
E104	1		Yes

Does continuity exist?

YES >> GO TO 7.

NO >> Repair the harness or connector.

7. CHECK DAYTIME LIGHT RELAY 2

Check daytime light relay 2. Refer to [EXL-45, "Component Inspection"](#).

Is the inspection result normal?

YES >> Replace IPDM E/R. Refer to [PCS-28, "Removal and Installation of IPDM E/R"](#).

NO >> Replace daytime light relay 2.

8. CHECK FRONT HEADLAMP (LO) GROUND CIRCUIT

Check continuity between the front headlamp harness connector terminal 2 and ground.

	Connector	Terminal	-	Continuity
LH	E7 (with Daytime light system)	2	Ground	Yes
	E11 (without Daytime light system)			
RH	E107			

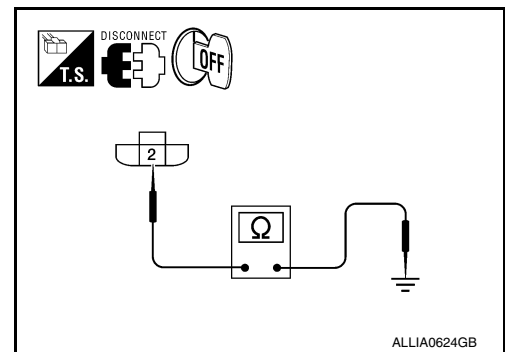

Does continuity exist?

YES >> Inspect the headlamp bulb.

NO (Except LH with Daytime light system)>> Repair the harness.

NO (LH with Daytime light system)>> GO TO 9.

9. CHECK CONTINUITY BETWEEN FRONT HEADLAMP LH (HI) AND DAYTIME LIGHT RELAY 1

1. Disconnect daytime light relay 1 connector.

2. Check continuity between front headlamp LH harness connector and daytime light relay 1 harness connector.

Front headlamp LH		Daytime light relay 1		Continuity
Connector	Terminal	Connector	Terminal	
E7	2	E103	3	Yes

HEADLAMP (LO) CIRCUIT

< DTC/CIRCUIT DIAGNOSIS >

Does continuity exist?

- YES >> GO TO 10.
NO >> Repair the harness or connector.

10. CHECK DAYTIME LIGHT RELAY 1 GROUND CIRCUIT

Check continuity between daytime light relay 1 harness connector and ground.

Daytime light relay 1		Ground	Continuity
Connector	Terminal		
E103	4		Yes

Does continuity exist?

- YES >> GO TO 11.
NO >> Repair the harness or connector.

11. CHECK DAYTIME LIGHT RELAY 1

Check daytime light relay 1. Refer to [EXL-47, "Component Inspection"](#)

Is the inspection result normal?

- YES >> Replace IPDM E/R. Refer to [PCS-28, "Removal and Installation of IPDM E/R"](#).
NO >> Replace daytime light relay 1.

Component Inspection

INFOID:0000000012563655

1. CHECK DAYTIME LIGHT RELAY 2

1. Turn ignition switch OFF.
2. Remove daytime light relay 2.
3. Check the continuity between daytime light relay 2 terminals under the following conditions:

Terminals	Condition	Continuity
3 and 5	12V direct current supply between terminals 1 and 2	Yes
	No current supply	No

Is the inspection result normal?

- YES >> Inspection End.
NO >> Replace daytime light relay 2.

A
B
C
D
E
F
G
H
I
J
K
M
N
O
P

EXL

DAYTIME LIGHT RELAY CIRCUIT

< DTC/CIRCUIT DIAGNOSIS >

DAYTIME LIGHT RELAY CIRCUIT

Description

INFOID:000000012563656

The BCM sends a daytime light request to the IPDM E/R via the CAN communication lines. The power flows backward through fuse 45 located in IPDM E/R to daytime light relay 1 and LH high beam lamp to IPDM E/R, through the high beam fuses, through the RH high beam lamp and on to ground. The high beam lamps are wired in series which causes them to illuminate at a reduced intensity. When daytime light relay 2 is open, it prevents headlamp low beam from turning on while daytime lights are operating.

Diagnosis Procedure

INFOID:000000012563657

Regarding Wiring Diagram information, refer to [EXL-79, "Wiring Diagram"](#).

1. CHECK DAYTIME LIGHT RELAY 1 FUSE

1. Turn the ignition switch OFF.
2. Check that the following fuse is not open:

Unit	Location	Fuse No.	Capacity
Daytime light relay 1	IPDM E/R	45	10A

Is the fuse open?

- YES >> Replace the blown fuse after repairing the affected circuit.
NO >> GO TO 2.

2. CHECK IPDM E/R OUTPUT SIGNAL

1. Disconnect the daytime light relay 1 connector.
2. Turn the ignition switch ON.
3. Check the voltage between the daytime light relay 1 harness connector and ground.

(+)		(-)	Voltage
Connector	Terminal		
E103	2	Ground	Battery voltage
	5		

Is battery voltage present?

- YES >> GO TO 3.
NO >> GO TO 5.

3. CHECK DAYTIME LIGHT RELAY 1 CIRCUIT

1. Turn the ignition switch OFF.
2. Disconnect IPDM E/R connector E122.
3. Check continuity between the IPDM E/R harness connector and the daytime light relay 1 harness connector.

IPDM E/R		Daytime light relay 1		Continuity
Connector	Terminal	Connector	Terminal	
E122	44	E103	1	Yes

4. Check continuity between the daytime light relay 1 harness connector and ground.

Connector	Terminal	-	Continuity
E103	1	Ground	No

Is the measurement value normal?

DAYTIME LIGHT RELAY CIRCUIT

< DTC/CIRCUIT DIAGNOSIS >

- YES >> GO TO 4.
 NO >> Repair the harnesses or connectors.

4. CHECK DAYTIME LIGHT RELAY 1

Check daytime light relay 1. Refer to [EXL-47. "Component Inspection"](#).

Is the inspection result normal?

- YES >> Check headlamp (HI) circuit. If OK, replace IPDM E/R. Refer to [PCS-28. "Removal and Installation of IPDM E/R"](#). If NG, refer to [EXL-39. "Diagnosis Procedure"](#).
 NO >> Replace daytime light relay1.

5. CHECK DAYTIME LIGHT RELAY CIRCUIT FOR OPEN

- Turn the ignition switch OFF.
- Disconnect IPDM E/R connector E119.
- Check continuity between the IPDM E/R harness connector and the daytime light relay 1 harness connector.

IPDM E/R		Daytime light relay 1		Continuity
Connector	Terminal	Connector	Terminal	
E119	10	E103	2	Yes
			5	

Does continuity exist?

- YES >> Replace IPDM E/R. Refer to [PCS-28. "Removal and Installation of IPDM E/R"](#).
 NO >> Repair the harnesses or connectors.

Component Inspection

INFOID:000000012563658

1. CHECK DAYTIME LIGHT RELAY 1

- Turn ignition switch OFF.
- Remove daytime light relay 1.
- Check the continuity between daytime light relay 1 terminals under the following conditions:

Terminals	Condition	Continuity
3 and 5	12V direct current supply between terminals 1 and 2	Yes
	No current supply	No
3 and 4	12V direct current supply between terminals 1 and 2	No
	No current supply	Yes

Is the inspection result normal?

- YES >> Inspection End.
 NO >> Replace daytime light relay 1.

FRONT FOG LAMP CIRCUIT

< DTC/CIRCUIT DIAGNOSIS >

FRONT FOG LAMP CIRCUIT

Description

INFOID:000000012563659

The IPDM E/R (intelligent power distribution module engine room) controls the front fog lamp relay based on inputs from the BCM via the CAN communication lines. When the front fog lamp relay is energized, power flows from the front fog lamp relay in the IPDM E/R to the front fog lamps.

Component Function Check

INFOID:000000012563660

1. CHECK FRONT FOG LAMP OPERATION

⊗ WITHOUT CONSULT

1. Activate IPDM E/R auto active test. Refer to [PCS-9, "Diagnosis Description"](#).
2. Check that the front fog lamp is turned ON.

Ⓟ WITH CONSULT

1. Select "EXTERNAL LAMPS" of IPDM E/R active test item.
2. With operating the test items, Check that the front fog lamp is turned ON.

FOG : Front fog lamp ON
OFF : Front fog lamp OFF

Is the front fog lamp turned ON?

- YES >> Front fog lamp circuit is normal.
NO >> Refer to [EXL-48, "Diagnosis Procedure"](#).

Diagnosis Procedure

INFOID:000000012563661

Regarding Wiring Diagram information, refer to [EXL-94, "Wiring Diagram"](#).

1. CHECK FRONT FOG LAMP FUSE

1. Turn the ignition switch OFF.
2. Check that the following fuses are not open:

Unit	Location	Fuse No.	Capacity
Front fog lamp	IPDM E/R	56	20A

Is the fuse open?

- YES >> Replace the blown fuse after repairing the affected circuit.
NO >> GO TO 2.

2. CHECK FRONT FOG LAMP OUTPUT VOLTAGE

1. Disconnect the front fog lamp connector.
2. Turn the ignition switch ON.
3. Turn the front fog lamps ON.
4. Check the voltage between the fog lamp connector and ground.

(+)		Terminal	(-)	Voltage
Connector				
LH	E101	1	Ground	Battery voltage
RH	E102	1		

Is battery voltage present?

- YES >> GO TO 4.
NO >> GO TO 3.

3. CHECK FRONT FOG LAMP OPEN CIRCUIT

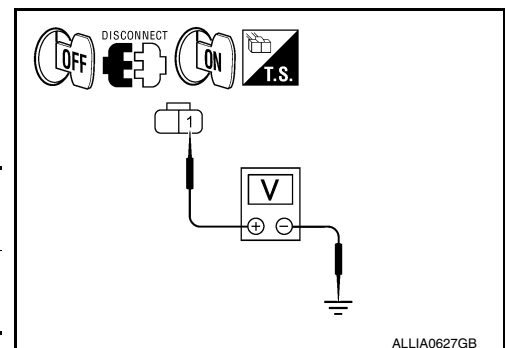

FRONT FOG LAMP CIRCUIT

< DTC/CIRCUIT DIAGNOSIS >

1. Turn the ignition switch OFF.
2. Disconnect IPDM E/R connector E123.
3. Check continuity between the IPDM E/R harness connector (A) and the front fog lamp harness connector (B).

A		B		Continuity
Connector	Terminal	Connector	Terminal	
LH	E123	50	E101	Yes
RH		51	E102	

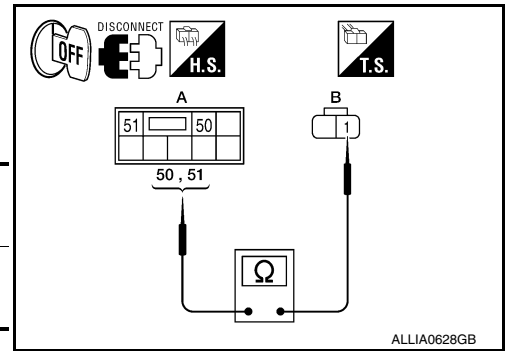

Does continuity exist?

- YES >> Replace IPDM E/R. Refer to [PCS-28, "Removal and Installation of IPDM E/R"](#).
 NO >> Repair the harnesses or connectors.

4. CHECK FRONT FOG LAMP GROUND CIRCUIT

1. Disconnect the front fog lamp connector.
2. Check continuity between the front fog lamp harness connector terminal and ground.

Connector	Terminal	-	Continuity
LH	E101	Ground	Yes
RH	E102		

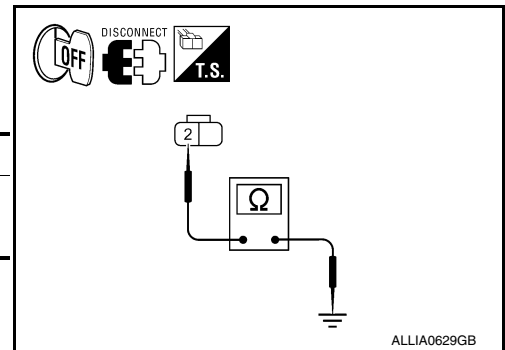

Does continuity exist?

- YES >> Inspect the fog lamp bulb.
 NO >> Repair the harness.

A
B
C
D
E
F
G
H
I
J
K
L
M
N
O
P

EXL

PARKING LAMP CIRCUIT

< DTC/CIRCUIT DIAGNOSIS >

PARKING LAMP CIRCUIT

Description

INFOID:000000012563662

The IPDM E/R (intelligent power distribution module engine room) controls the tail lamp relay based on inputs from the BCM via the CAN communication lines. When the tail lamp relay is energized, power flows through fuse 36 and 37, located in the IPDM E/R. Power then flows to the front and rear combination lamps, license plate lamps.

Component Function Check

INFOID:000000012563663

1. CHECK PARKING LAMP OPERATION

⊗ WITHOUT CONSULT

1. Activate IPDM E/R auto active test. Refer to [PCS-9, "Diagnosis Description"](#).
2. Check that the parking lamp is turned ON.

Ⓟ WITH CONSULT

1. Select "EXTERNAL LAMPS" of IPDM E/R active test item.
2. With operating the test items, check that the parking lamp is turned ON.

TAIL : Parking lamp ON
OFF : Parking lamp OFF

Is the parking lamp turned ON?

- YES >> Parking lamp circuit is normal.
NO >> Refer to [EXL-50, "Diagnosis Procedure"](#).

Diagnosis Procedure

INFOID:000000012563664

Regarding Wiring Diagram information, refer to [EXL-104, "Wiring Diagram"](#).

1. CHECK PARKING LAMP FUSES

1. Turn the ignition switch OFF.
2. Check that the following fuses are not open:

Unit	Location	Fuse No.	Capacity
Parking lamps	IPDM E/R	36	10A
		37	10A

Is the fuse open?

- YES >> Replace the blown fuse after repairing the affected circuit.
NO >> GO TO 2.

2. CHECK TAIL LAMP RELAY OUTPUT (VOLTAGE)

1. Disconnect the front combination lamp connectors, front side marker lamp connectors, rear combination lamp connectors and license plate lamp connectors.
2. Turn the ignition switch ON.
3. Turn the parking lamps ON.
4. With the parking lamps ON, check voltage between the front combination lamp connector and ground.

(+)		Terminal	(-)	Voltage
Connector				
LH	E27	5	Ground	Battery voltage
RH	E111			

5. With the parking lamps ON, check voltage between the front side marker lamp connector and ground.

PARKING LAMP CIRCUIT

< DTC/CIRCUIT DIAGNOSIS >

(+)		Terminal	(-)	Voltage
Connector				
LH	E17	7	Ground	Battery voltage
RH	E108			

6. With the parking lamps ON, check voltage between the rear combination lamp connector and ground.

(+)		Terminal	(-)	Voltage
Connector				
LH	C201	3	Ground	Battery voltage
RH	C202			

7. With the parking lamps ON, check voltage between the license plate lamp connector and ground

(+)		Terminal	(-)	Voltage
Connector				
LH	C203	1	Ground	Battery voltage
RH	C204			

Are voltage readings as specified?

YES >> GO TO 4.

NO >> GO TO 3.

3. CHECK PARKING, LICENSE PLATE AND TAIL LAMP CIRCUIT (OPEN)

1. Turn the ignition switch OFF.
2. Disconnect IPDM E/R connector E121, E123 and E124.
3. Check continuity between the IPDM E/R harness connector and the front combination lamp harness connector.

Connector		Terminal	Connector		Terminal	Continuity
LH	E121	28	E27	5	Yes	
RH	E123	49	E111			

4. Check continuity between the IPDM E/R harness connector and the front side marker lamp harness connector.

Connector		Terminal	Connector		Terminal	Continuity
LH	E121	28	E17	7	Yes	
RH	E123	49	E108			

5. Check continuity between the IPDM E/R harness connector and the rear combination lamp harness connector.

IPDM E/R			Rear combination lamp		Continuity
Connector		Terminal	Connector	Terminal	
LH	E124	57	C201	3	Yes
RH			C202		

6. Check continuity between the IPDM E/R harness connector and license plate lamp connector.

PARKING LAMP CIRCUIT

< DTC/CIRCUIT DIAGNOSIS >

IPDM E/R			License plate lamp		Continuity
Connector		Terminal	Connector	Terminal	
LH	E124	57	C203	1	Yes
RH			C204		

Are continuity results as specified?

YES >> Replace IPDM E/R. Refer to [PCS-28, "Removal and Installation of IPDM E/R"](#).

NO >> Repair the harnesses or connectors.

4. CHECK PARKING, LICENSE AND TAIL LAMP GROUND CIRCUITS

1. Check continuity between the front combination lamp harness connector and ground.

Connector		Terminal	-	Continuity
LH	E27	4	Ground	Yes
RH	E111			

2. Check continuity between the front side marker lamp harness connector and ground.

Connector		Terminal	-	Continuity
LH	E17	8	Ground	Yes
RH	E108			

3. Check continuity between the rear combination lamp harness connector and ground.

Connector		Terminal	-	Continuity
LH	C201	2	Ground	Yes
RH	C202			

4. Check continuity between the license plate lamp harness connector and ground.

Connector		Terminal	-	Continuity
LH	C203	2	Ground	Yes
RH	C204			

Are continuity results as specified?

YES >> Inspect the parking lamp bulb.

NO >> Repair the harness.

TURN SIGNAL LAMP CIRCUIT

< DTC/CIRCUIT DIAGNOSIS >

TURN SIGNAL LAMP CIRCUIT

Description

INFOID:000000012563665

The BCM monitors inputs from the combination switch (lighting and turn signal switch) to determine when to activate the turn signals. The BCM outputs voltage direction to the left and right turn signals during turn signal operation or both during hazard warning operation. The BCM sends a turn signal indicator request to the combination meter via the CAN communication lines.

The BCM performs the fast flasher operation (fail-safe) if any bulb or harness of the turn signal lamp circuit is open.

NOTE:

Turn signal lamp blinks at normal speed when using the hazard warning lamp.

Component Function Check

INFOID:000000012563666

1. CHECK TURN SIGNAL LAMP

WITH CONSULT

1. Select "FLASHER" of BCM (FLASHER) active test item.
2. With operating the test items, check that the turn signal lamp blinks.

LH : Turn signal lamp LH blinking

RH : Turn signal lamp RH blinking

OFF : The turn signal lamp OFF

Does the turn signal lamp blink?

- YES >> Turn signal lamp circuit is normal.
 NO >> Refer to [EXL-53, "Diagnosis Procedure"](#).

Diagnosis Procedure

INFOID:000000012563667

Regarding Wiring Diagram information, refer to [EXL-98, "Wiring Diagram"](#).

1. CHECK TURN SIGNAL LAMP BULB

Check the applicable lamp bulb to be sure the proper bulb standard is in use and the bulb is not open.

Is the bulb OK?

- YES >> GO TO 2.
 NO >> Replace the bulb.

2. CHECK TURN SIGNAL LAMP OUTPUT VOLTAGE

1. Turn the ignition switch OFF.
2. Disconnect the front combination lamp connector and the rear combination lamp connector.
3. Turn the ignition switch ON.
4. With turn signal switch operating, check the voltage between the front combination lamp harness connector and ground.

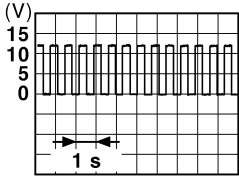
(+)		Terminal	(-)	Voltage
Connector				
E27	LH	6	Ground	
E111	RH			

PKID0926E

TURN SIGNAL LAMP CIRCUIT

< DTC/CIRCUIT DIAGNOSIS >

- With turn signal switch operating, check the voltage between the rear combination lamp harness connector and ground.

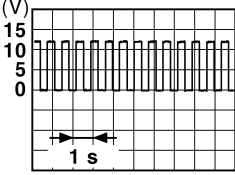
(+)		Terminal	(-)	Voltage
Connector				
C207	LH	4	Ground	
C208	RH			

PKID0926E

Is voltage reading as specified?

- YES >> GO TO 5.
 NO >> GO TO 3.

3. CHECK TURN SIGNAL LAMP CIRCUIT FOR OPEN

- Turn the ignition switch OFF.
- Disconnect BCM connector M20.
- Check continuity between the BCM harness connector and the front combination lamps harness connector.

BCM			Front combination lamp		Continuity
Connector		Terminal	Connector	Terminal	
LH	M20	60	E27	6	Yes
RH		61	E111		

- Check continuity between the BCM harness connector and the rear combination lamp harness connector.

BCM			Rear combination lamp		Continuity
Connector		Terminal	Connector	Terminal	
LH	M20	60	C207	4	Yes
RH		61	C208	4	

Are continuity results as specified?

- YES >> GO TO 4.
 NO >> Repair the harnesses or connectors.

4. CHECK TURN SIGNAL LAMP SHORT CIRCUIT

Check continuity between the BCM harness connector and ground.

Connector		Terminal	-	Continuity
LH	M20	60	Ground	No
RH		61		

Does continuity exist?

- YES >> Repair the harnesses or connectors.
 NO >> Replace BCM. Refer to [BCS-56, "Removal and Installation"](#).

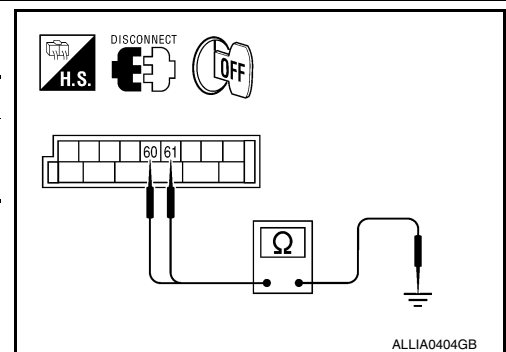

5. CHECK TURN SIGNAL LAMP GROUND CIRCUIT

- Check continuity between the front combination lamp harness connector and ground.

TURN SIGNAL LAMP CIRCUIT

< DTC/CIRCUIT DIAGNOSIS >

Connector		Terminal	-	Continuity
LH	E27	4	Ground	Yes
RH	E111			

2. Check continuity between the rear combination lamp harness connector and ground.

Connector		Terminal	-	Continuity
LH	C207	5	Ground	Yes
RH	C208			

Are continuity results as specified?

- YES >> Replace the malfunctioning lamp.
- NO >> Repair the harnesses or connectors.

A
B
C
D
E
F
G
H
I
J
K
M
N
O
P

EXL

OPTICAL SENSOR

< DTC/CIRCUIT DIAGNOSIS >

OPTICAL SENSOR

Description

INFOID:000000012563668

The optical sensor converts the outside brightness (lux) to voltage and transmits the optical sensor signal to the BCM.

Diagnosis Procedure

INFOID:000000012563669

Regarding Wiring Diagram information, refer to [EXL-86, "Wiring Diagram"](#).

1. CHECK OPTICAL SENSOR GROUND CIRCUIT

1. Turn the ignition switch OFF.
2. Disconnect BCM connector M18 and optical sensor connector M14.
3. Check continuity between BCM harness connector and optical sensor harness connector.

BCM		Optical sensor		Continuity
Connector	Terminal	Connector	Terminal	
M18	18	M14	3	Yes

4. Check continuity between BCM harness connector and ground.

BCM		-	Continuity
Connector	Terminal		
M18	18	Ground	No

Are continuity results as specified?

- YES >> GO TO 2.
NO >> Repair harness or connector.

2. CHECK OPTICAL SENSOR SIGNAL CIRCUIT

1. Check continuity between BCM harness connector and optical sensor harness connector.

BCM		Optical sensor		Continuity
Connector	Terminal	Connector	Terminal	
M20	58	M14	4	Yes

2. Check continuity between BCM harness connector and ground.

BCM		—	Continuity
Connector	Terminal		
M20	58	Ground	No

Are the continuity results as specified?

- YES >> Replace the optical sensor. Refer to [EXL-148, "Removal and Installation"](#).
NO >> Repair harness or connector.

BCM (BODY CONTROL MODULE)

< ECU DIAGNOSIS INFORMATION >

ECU DIAGNOSIS INFORMATION

BCM (BODY CONTROL MODULE)

Reference Value

INFOID:0000000012563670

NOTE:

The Signal Tech II Tool [– (J-50190)] can be used to perform the following functions. Refer to the Signal Tech II User Guide for additional information.

- Activate and display TPMS transmitter IDs
- Display tire pressure reported by the TPMS transmitter
- Read TPMS DTCs
- Register TPMS transmitter IDs
- Test remote keyless entry keyfob relative signal strength

VALUES ON THE DIAGNOSIS TOOL

Monitor Item	Condition	Value/Status
ACC ON SW	Ignition switch OFF or ON	Off
	Ignition switch ACC	On
AIR COND SW	A/C switch OFF	Off
	A/C switch ON	On
AIR PRESS FL	Front left tire air pressure value	kPa, kg/cm ² , psi
AIR PRESS FR	Front right tire air pressure value	kPa, kg/cm ² , psi
AIR PRESS RL	Rear left tire air pressure value	kPa, kg/cm ² , psi
AIR PRESS RR	Rear right tire air pressure value	kPa, kg/cm ² , psi
AUTO LIGHT SW	Lighting switch OFF	Off
	Lighting switch AUTO	On
BRAKE SW	Brake pedal released	Off
	Brake pedal applied	On
BUCKLE SW	Seat belt buckle unfastened	Off
	Seat belt buckle fastened	On
BUZZER	Buzzer in combination meter OFF	Off
	Buzzer in combination meter ON	On
CARGO LAMP SW	Cargo lamp switch OFF	Off
	Cargo lamp switch ON	On
CDL LOCK SW	Door lock/unlock switch does not operate	Off
	Press door lock/unlock switch to the LOCK side	On
CDL UNLOCK SW	Door lock/unlock switch does not operate	Off
	Press door lock/unlock switch to the UNLOCK side	On
DOOR SW-AS	Front door RH closed	Off
	Front door RH opened	On
DOOR SW-DR	Front door LH closed	Off
	Front door LH opened	On
DOOR SW-RL	Rear door LH closed	Off
	Rear door LH opened	On
DOOR SW-RR	Rear door RH closed	Off
	Rear door RH opened	On

BCM (BODY CONTROL MODULE)

< ECU DIAGNOSIS INFORMATION >

Monitor Item	Condition	Value/Status
FAN ON SIG	Blower motor fan switch OFF	Off
	Blower motor fan switch ON	On
FR FOG SW	Front fog lamp switch OFF	Off
	Front fog lamp switch ON	On
FR WASHER SW	Front washer switch OFF	Off
	Front washer switch ON	On
FR WIPER LOW	Front wiper switch OFF	Off
	Front wiper switch LO	On
FR WIPER HI	Front wiper switch OFF	Off
	Front wiper switch HI	On
FR WIPER INT	Front wiper switch OFF	Off
	Front wiper switch INT	On
FR WIPER STOP	Any position other than front wiper stop position	Off
	Front wiper stop position	On
HAZARD SW	When hazard switch is not pressed	Off
	When hazard switch is pressed	On
HEAD LAMP SW 1	Headlamp switch OFF	Off
	Headlamp switch 1st	On
HEAD LAMP SW 2	Headlamp switch OFF	Off
	Headlamp switch 1st	On
HI BEAM SW	High beam switch OFF	Off
	High beam switch HI	On
ID REGST FL1	ID registration of front left tire incomplete	YET
	ID registration of front left tire complete	DONE
ID REGST FR1	ID registration of front right tire incomplete	YET
	ID registration of front right tire complete	DONE
ID REGST RL1	ID registration of rear left tire incomplete	YET
	ID registration of rear left tire complete	DONE
ID REGST RR1	ID registration of rear right tire incomplete	YET
	ID registration of rear right tire complete	DONE
IGN ON SW	Ignition switch OFF or ACC	Off
	Ignition switch ON	On
IGN SW CAN	Ignition switch OFF or ACC	Off
	Ignition switch ON	On
INT VOLUME	Wiper intermittent dial is in a dial position 1 - 7	1 - 7
KEY CYL LK-SW	Door key cylinder LOCK position	Off
	Door key cylinder other than LOCK position	On
KEY CYL UN-SW	Door key cylinder UNLOCK position	Off
	Door key cylinder other than UNLOCK position	On
KEY ON SW	Mechanical key is removed from key cylinder	Off
	Mechanical key is inserted to key cylinder	On
KEYLESS LOCK	LOCK button of key fob is not pressed	Off
	LOCK button of key fob is pressed	On

BCM (BODY CONTROL MODULE)

< ECU DIAGNOSIS INFORMATION >

Monitor Item	Condition	Value/Status	
KEYLESS PANIC	PANIC button of key fob is not pressed	Off	A
	PANIC button of key fob is pressed	On	
KEYLESS UNLOCK	UNLOCK button of key fob is not pressed	Off	B
	UNLOCK button of key fob is pressed	On	
LIGHT SW 1ST	Lighting switch OFF	Off	C
	Lighting switch 1st	On	
OIL PRESS SW	<ul style="list-style-type: none"> • Ignition switch OFF or ACC • Engine running 	Off	D
	Ignition switch ON	On	
OPTICAL SENSOR	Bright outside of the vehicle	Close to 5V	E
	Dark outside of the vehicle	Close to 0V	
PASSING SW	Other than lighting switch PASS	Off	F
	Lighting switch PASS	On	
REAR DEF SW	Rear window defogger switch OFF	Off	G
	Rear window defogger switch ON	On	
TURN SIGNAL L	Turn signal switch OFF	Off	H
	Turn signal switch LH	On	
TURN SIGNAL R	Turn signal switch OFF	Off	I
	Turn signal switch RH	On	
VEHICLE SPEED	While driving	Equivalent to speedometer reading	J
WARNING LAMP	Low tire pressure warning lamp in combination meter OFF	Off	K
	Low tire pressure warning lamp in combination meter ON	On	

EXL

M

N

O

P

BCM (BODY CONTROL MODULE)

< ECU DIAGNOSIS INFORMATION >

Terminal Layout

INFOID:000000012563671

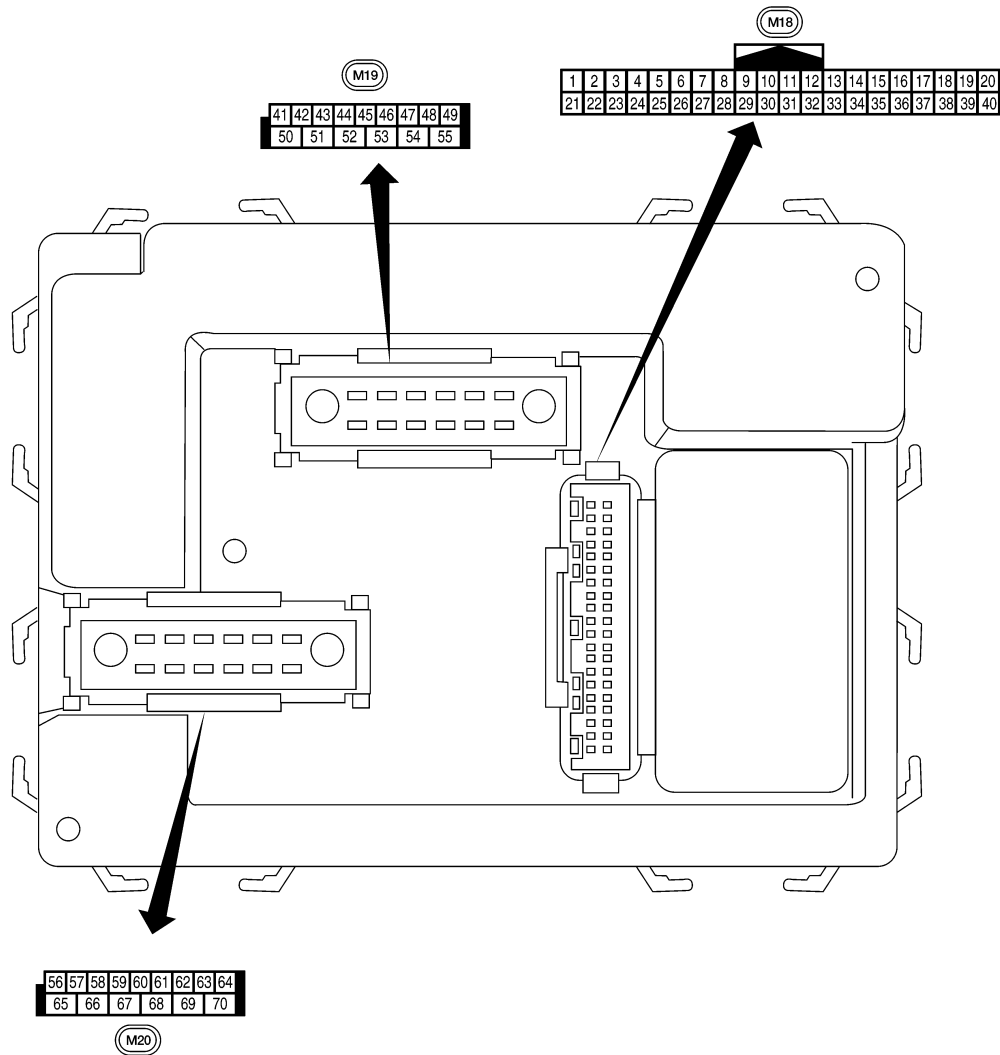



AWMIA1598ZZ

Physical Values

INFOID:000000012563672

BCM (BODY CONTROL MODULE)

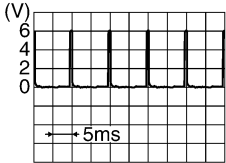
< ECU DIAGNOSIS INFORMATION >

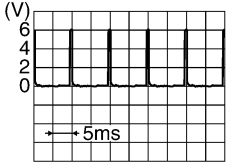
Terminal	Wire color	Item	Signal input/output	Measuring condition		Reference value or waveform (Approx.)
				Ignition switch	Operation or condition	
1	BR	Ignition keyhole illumination	Output	OFF	Door is locked (SW OFF)	Battery voltage
					Door is unlocked (SW ON)	0V
2	P	Combination switch input 5	Input	ON	Lighting, turn, wiper OFF Wiper dial position 4	 SKIA5291E
3	SB	Combination switch input 4	Input	ON	Lighting, turn, wiper OFF Wiper dial position 4	 SKIA5292E
4	V	Combination switch input 3	Input	ON	Lighting, turn, wiper OFF Wiper dial position 4	 SKIA5291E
5	L	Combination switch input 2	Input	ON	Lighting, turn, wiper OFF Wiper dial position 4	 SKIA5292E
6	R	Combination switch input 1				
7	GR	Front door lock assembly LH (key cylinder switch) unlock	Input	OFF	ON (open, 2nd turn)	Momentary 1.5V
8	SB	Front door lock assembly LH (key cylinder switch) lock	Input		On (open)	Momentary 1.5V
				OFF (closed)	0V	
9	LG	Brake sw	Input	OFF	OFF (brake pedal is not depressed)	0V
					ON (brake pedal is depressed)	Battery voltage
11	G/B	Ignition switch (ACC or ON)	Input	ACC or ON	Ignition switch ACC or ON	Battery voltage
12	LG	Front door switch RH (All)	Input	OFF	ON (open)	0V
		Rear door switch upper RH (King Cab)			OFF (closed)	Battery voltage
		Rear door switch lower RH (King Cab)				

A
B
C
D
E
F
G
H
I
J
K
L
M
N
O
P

EXL

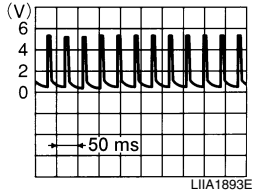
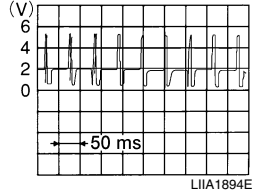
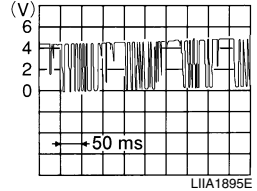

BCM (BODY CONTROL MODULE)

< ECU DIAGNOSIS INFORMATION >

Terminal	Wire color	Item	Signal input/output	Measuring condition		Reference value or waveform (Approx.)
				Ignition switch	Operation or condition	
13	L	Rear door switch RH (Crew Cab)	Input	OFF	ON (open)	0V
					OFF (closed)	Battery voltage
15	W	Tire pressure warning check connector	Input	OFF	—	5V
18	BR	Remote keyless entry receiver and optical sensor (Ground)	Output	OFF	—	0V
19	V	Remote keyless entry receiver (power supply)	Output	OFF	Ignition switch OFF	 <small>LIIA1893E</small>
20	G	Remote keyless entry receiver signal (Signal)	Input	OFF	Stand-by (keyfob buttons released)	 <small>LIIA1894E</small>
					When remote keyless entry receiver receives signal from keyfob (keyfob buttons pressed)	 <small>LIIA1895E</small>
21	GR	NATS antenna amp.	Input	OFF → ON	Ignition switch (OFF → ON)	Just after turning ignition switch ON: Pointer of tester should move.
23	G	Security indicator lamp	Output	OFF	Goes OFF → illuminates (Every 2.4 seconds)	Battery voltage → 0V
25	BR	NATS antenna amp.	Input	OFF → ON	Ignition switch (OFF → ON)	Just after turning ignition switch ON: Pointer of tester should move.
27	W	Compressor ON signal	Input	ON	A/C switch OFF	5V
					A/C switch ON	0V
28	R	Front blower monitor	Input	ON	Front blower motor OFF	Battery voltage
					Front blower motor ON	0V
29	G	Hazard switch	Input	OFF	ON	0V
					OFF	5V
31	GR	Cargo lamp switch	Input	OFF	ON	0V
					OFF	Battery voltage

BCM (BODY CONTROL MODULE)

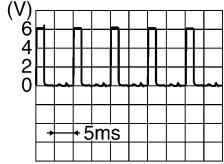
< ECU DIAGNOSIS INFORMATION >

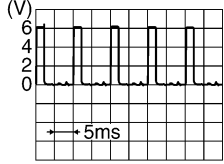
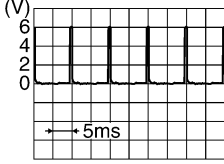
Terminal	Wire color	Item	Signal input/output	Measuring condition		Reference value or waveform (Approx.)
				Ignition switch	Operation or condition	
32	BG	Combination switch output 5	Output	ON	Lighting, turn, wiper OFF Wiper dial position 4	 <p style="text-align: right; font-size: small;">SKIA5291E</p>
33	GR	Combination switch output 4	Output	ON	Lighting, turn, wiper OFF Wiper dial position 4	 <p style="text-align: right; font-size: small;">SKIA5292E</p>
34	G	Combination switch output 3	Output	ON	Lighting, turn, wiper OFF Wiper dial position 4	 <p style="text-align: right; font-size: small;">SKIA5291E</p>
35	BR	Combination switch output 2	Output	ON	Lighting, turn, wiper OFF Wiper dial position 4	 <p style="text-align: right; font-size: small;">SKIA5292E</p>
36	LG	Combination switch output 1				
37	B	Key switch	Input	OFF	Key inserted	Battery voltage
					Key removed	0V
38	W/R	Ignition switch (ON)	Input	ON	—	Battery voltage
39	L	CAN high	—	—	—	—
40	P	CAN low	—	—	—	—
41	Y	Rear window defogger switch	Input	ON	Rear window defogger switch ON	0V
					Rear window defogger switch OFF	5V
45	V	Lock switch	Input	OFF	ON (lock)	0V
					OFF	Battery voltage
46	LG	Unlock switch	Input	OFF	ON (unlock)	0V
					OFF	Battery voltage
47	GR	Front door switch LH (All)	Input	OFF	ON (open)	0V
		Rear door switch upper LH (King Cab)			OFF (closed)	Battery voltage
		Rear door switch lower LH (King Cab)				

A
B
C
D
E
F
G
H
I
J
K
M
N
O
P

EXL

BCM (BODY CONTROL MODULE)

< ECU DIAGNOSIS INFORMATION >

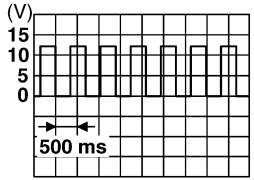
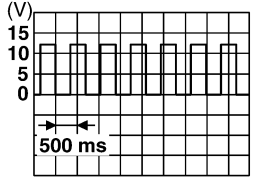
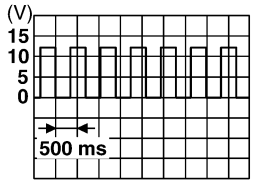
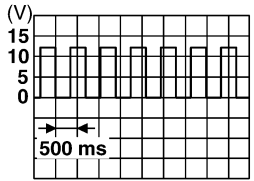
Terminal	Wire color	Item	Signal input/output	Measuring condition		Reference value or waveform (Approx.)	
				Ignition switch	Operation or condition		
48	P	Rear door switch LH (Crew Cab)	Input	OFF	ON (open)	0V	
					OFF (closed)	Battery voltage	
50	P	Cargo lamp	Output	OFF	Any door open (ON)	0V	
					All doors closed (OFF)	Battery voltage	
51	BG	Trailer turn signal (right)	Output	ON	Turn right ON	 <p style="text-align: right; font-size: small;">SKIA3009J</p>	
52	LG	Trailer turn signal (left)	Output	ON	Turn left ON	 <p style="text-align: right; font-size: small;">SKIA3009J</p>	
56	R/Y	Battery saver output	Output	OFF	10 minutes after ignition switch is turned OFF	0V	
				ON	—	Battery voltage	
57	R/Y	Battery power supply	Input	—	—	Battery voltage	
58	W	Optical sensor	Input	ON	When optical sensor is illuminated	3.1V or more	
					When optical sensor is not illuminated	0.6V or less	
59	GR	Front door lock assembly LH (unlock)	Output	OFF	OFF (neutral)	0V	
					ON (unlock)	Battery voltage	
60	LG	Turn signal (left)	Output	ON	Turn left ON	 <p style="text-align: right; font-size: small;">SKIA3009J</p>	
61	G	Turn signal (right)	Output	ON	Turn right ON	 <p style="text-align: right; font-size: small;">SKIA3009J</p>	
63	BR	Interior room/map lamp	Output	OFF	Any door switch	ON (open)	0V
					OFF (closed)	Battery voltage	
65	V	All door lock actuators (lock)	Output	OFF	OFF (neutral)	0V	
					ON (lock)	Battery voltage	

BCM (BODY CONTROL MODULE)

< ECU DIAGNOSIS INFORMATION >

Terminal	Wire color	Item	Signal input/output	Measuring condition		Reference value or waveform (Approx.)
				Ignition switch	Operation or condition	
66	L	Front door lock actuator RH, rear door lock actuators LH/RH (unlock)	Output	OFF	OFF (neutral)	0V
					ON (unlock)	Battery voltage
67	B	Ground	Input	ON	—	0V
68 ¹	O	Power window power supply (RAP)	Output	—	Ignition switch ON	Battery voltage
					Within 45 seconds after ignition switch OFF	Battery voltage
					More than 45 seconds after ignition switch OFF	0V
					When front door LH or RH is open or power window timer operates	0V
68 ²	SB	Power window power supply (RAP)	Output	—	Ignition switch ON	Battery voltage
					Within 45 seconds after ignition switch OFF	Battery voltage
					More than 45 seconds after ignition switch OFF	0V
					When front door LH or RH is open or power window timer operates	0V
69	P	Power window power supply (BAT)	Output	OFF	—	Battery voltage
70	W	Battery power supply	Input	OFF	—	Battery voltage

1: King cab

2: Crew cab

Fail Safe

INFOID:000000012563673

Fail-safe index

BCM performs fail-safe control when any DTC listed below is detected.

Display contents of CONSULT	Fail-safe	Cancellation
U1000: CAN COMM CIRCUIT	Inhibit engine cranking	When the BCM re-establishes communication with the other modules.

DTC Inspection Priority Chart

INFOID:000000012563674

If some DTCs are displayed at the same time, perform inspections one by one based on the following priority chart.

Priority	DTC
1	<ul style="list-style-type: none"> U1000: CAN COMM CIRCUIT
2	<ul style="list-style-type: none"> B2190: NATS ANTENNA AMP B2191: DIFFERENCE OF KEY B2192: ID DISCORD BCM-ECM B2193: CHAIN OF BCM-ECM

BCM (BODY CONTROL MODULE)

< ECU DIAGNOSIS INFORMATION >

Priority	DTC
3	<ul style="list-style-type: none"> • C1729: VHCL SPEED SIG ERR • C1735: IGNITION SIGNAL
4	<ul style="list-style-type: none"> • C1704: LOW PRESSURE FL • C1705: LOW PRESSURE FR • C1706: LOW PRESSURE RR • C1707: LOW PRESSURE RL • C1708: [NO DATA] FL • C1709: [NO DATA] FR • C1710: [NO DATA] RR • C1711: [NO DATA] RL • C1712: [CHECKSUM ERR] FL • C1713: [CHECKSUM ERR] FR • C1714: [CHECKSUM ERR] RR • C1715: [CHECKSUM ERR] RL • C1716: [PRESSDATA ERR] FL • C1717: [PRESSDATA ERR] FR • C1718: [PRESSDATA ERR] RR • C1719: [PRESSDATA ERR] RL • C1720: [CODE ERR] FL • C1721: [CODE ERR] FR • C1722: [CODE ERR] RR • C1723: [CODE ERR] RL • C1724: [BATT VOLT LOW] FL • C1725: [BATT VOLT LOW] FR • C1726: [BATT VOLT LOW] RR • C1727: [BATT VOLT LOW] RL

DTC Index

INFOID:000000012563675

NOTE:

Details of time display

- CRNT: Displays when there is a malfunction now or after returning to the normal condition until turning ignition switch OFF → ON again.
- 1 - 39: Displayed if any previous malfunction is present when current condition is normal. It increases like 1 → 2 → 3...38 → 39 after returning to the normal condition whenever ignition switch OFF → ON. The counter remains at 39 even if the number of cycles exceeds it. It is counted from 1 again when turning ignition switch OFF → ON after returning to the normal condition if the malfunction is detected again.

CONSULT display	Fail-safe	Low tire pressure warning lamp ON	Reference page
No DTC is detected. further testing may be required.	—	—	—
U1000: CAN COMM CIRCUIT	—	—	BCS-31
B2190: NATS ANTENA AMP	—	—	SEC-18
B2191: DIFFERENCE OF KEY	—	—	SEC-21
B2192: ID DISCORD BCM-ECM	—	—	SEC-22
B2193: CHAIN OF BCM-ECM	—	—	SEC-24
C1708: [NO DATA] FL	—	X	WT-15
C1709: [NO DATA] FR	—	X	WT-15
C1710: [NO DATA] RR	—	X	WT-15
C1711: [NO DATA] RL	—	X	WT-15
C1712: [CHECKSUM ERR] FL	—	X	WT-17
C1713: [CHECKSUM ERR] FR	—	X	WT-17
C1714: [CHECKSUM ERR] RR	—	X	WT-17
C1715: [CHECKSUM ERR] RL	—	X	WT-17

BCM (BODY CONTROL MODULE)

< ECU DIAGNOSIS INFORMATION >

CONSULT display	Fail-safe	Low tire pressure warning lamp ON	Reference page
C1716: [PRESSDATA ERR] FL	—	X	WT-19
C1717: [PRESSDATA ERR] FR	—	X	WT-19
C1718: [PRESSDATA ERR] RR	—	X	WT-19
C1719: [PRESSDATA ERR] RL	—	X	WT-19
C1720: [CODE ERR] FL	—	X	WT-17
C1721: [CODE ERR] FR	—	X	WT-17
C1722: [CODE ERR] RR	—	X	WT-17
C1723: [CODE ERR] RL	—	X	WT-17
C1724: [BATT VOLT LOW] FL	—	X	WT-17
C1725: [BATT VOLT LOW] FR	—	X	WT-17
C1726: [BATT VOLT LOW] RR	—	X	WT-17
C1727: [BATT VOLT LOW] RL	—	X	WT-17
C1729: VHCL SPEED SIG ERR	—	X	WT-21
C1735: IGNITION SIGNAL	—	X	WT-22

A
B
C
D
E
F
G
H
I
J
K
EXL
M
N
O
P

IPDM E/R (INTELLIGENT POWER DISTRIBUTION MODULE ENGINE ROOM)

< ECU DIAGNOSIS INFORMATION >

IPDM E/R (INTELLIGENT POWER DISTRIBUTION MODULE ENGINE ROOM)

Reference Value

INFOID:000000012563676

VALUES ON THE DIAGNOSIS TOOL

Monitor Item	Condition		Value/Status
MOTOR FAN REQ	Engine idle speed	Changes depending on engine coolant temperature, air conditioner operation status, vehicle speed, etc.	1, 2, 3, 4
A/C COMP REQ	A/C switch OFF		Off
	A/C switch ON		On
TAIL&CLR REQ	Lighting switch OFF		Off
	Lighting switch 1ST, 2ND, HI or AUTO (Light is illuminated)		On
HL LO REQ	Lighting switch OFF		Off
	Lighting switch 2ND HI or AUTO (Light is illuminated)		On
HL HI REQ	Lighting switch OFF		Off
	Lighting switch HI		On
FR FOG REQ	Lighting switch 2ND	Front fog lamp switch OFF	Off
		Front fog lamp switch ON	On
FR WIP REQ	Ignition switch ON	Front wiper switch OFF	Stop
		Front wiper switch INT	1LOW
		Front wiper switch LO	Low
		Front wiper switch HI	HI
WIP AUTO STOP	Ignition switch ON	Front wiper stop position	STOP P
		Any position other than front wiper stop position	ACT P
WIP PROT	Ignition switch ON	Front wiper operates normally	Off
		Front wiper stops at fail-safe operation	BLOCK
ST RLY REQ	Ignition switch OFF or ACC		Off
	Ignition switch START		On
IGN RLY	Ignition switch OFF or ACC		Off
	Ignition switch ON		On
RR DEF REQ	Rear defogger switch OFF		Off
	Rear defogger switch ON		On
OIL P SW	Ignition switch OFF, ACC or engine running		Open
	Ignition switch ON		Close
DTRL REQ	Daytime light system requested OFF with CONSULT.		Off
	Daytime light system requested ON with CONSULT.		On
THFT HRN REQ	Not operated		Off
	<ul style="list-style-type: none"> Panic alarm is activated Horn is activated with VEHICLE SECURITY (THEFT WARNING) SYSTEM 		On
HORN CHIRP	Not operated		Off
	Door locking with keyfob (horn chirp mode)		On

IPDM E/R (INTELLIGENT POWER DISTRIBUTION MODULE ENGINE ROOM)

< ECU DIAGNOSIS INFORMATION >

Terminal Layout

INFOID:000000012563677

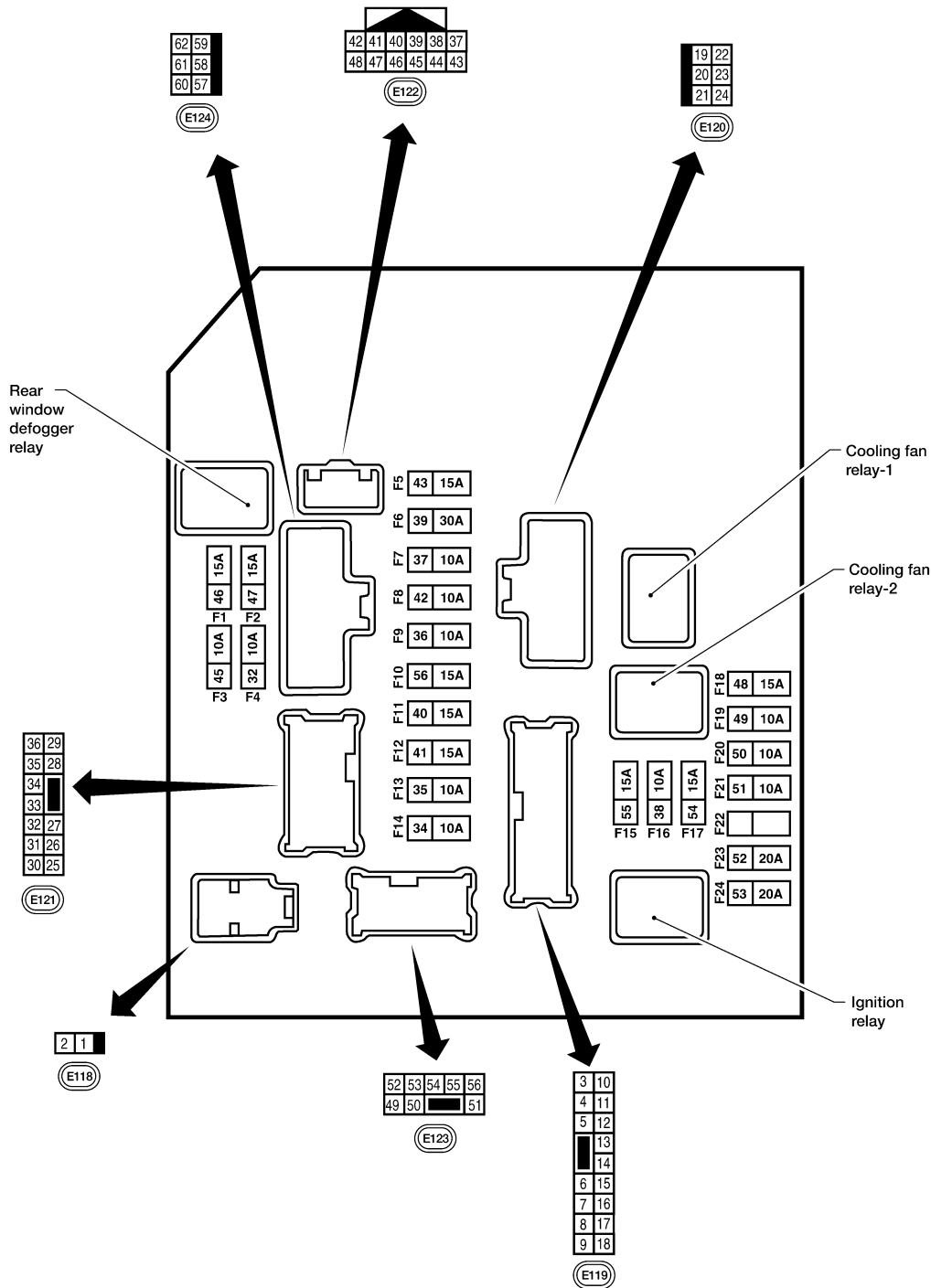

A
B
C
D
E
F
G
H
I
J
K
EXL
M
N
O
P

Physical Values

PHYSICAL VALUES

AAMIA0386GB

INFOID:000000012563678

IPDM E/R (INTELLIGENT POWER DISTRIBUTION MODULE ENGINE ROOM)

< ECU DIAGNOSIS INFORMATION >

Terminal	Wire color	Signal name	Signal input/output	Measuring condition		Reference value (Approx.)
				Ignition switch	Operation or condition	
1	W	Battery power supply	Input	OFF	—	Battery voltage
2	R	Battery power supply	Input	OFF	—	Battery voltage
3	G	ECM relay	Output	—	Ignition switch ON or START	Battery voltage
					Ignition switch OFF or ACC	0V
4	P ¹ R ²	ECM relay	Output	—	Ignition switch ON or START	Battery voltage
					Ignition switch OFF or ACC	0V
6	V	Throttle control motor relay	Output	—	Ignition switch ON or START	Battery voltage
					Ignition switch OFF or ACC	0V
7	BR	ECM relay control	Input	—	Ignition switch ON or START	0V
					Ignition switch OFF or ACC	Battery voltage
8	W/R	Fuse 54-Air fuel ratio sensor 1, Heated oxygen sensor 2	Output	—	Ignition switch ON or START	Battery voltage
					Ignition switch OFF or ACC	0V
10	R/B	Fuse 45-Daytime light relay 1	Output	ON	Daytime light system active	0V
					Daytime light system inactive	Battery voltage
11	Y	A/C compressor	Output	ON or START	A/C switch ON or defrost A/C switch	Battery voltage
					A/C switch OFF or defrost A/C switch	0V
12	W/G	Ignition switch supplied power	Input	—	OFF or ACC	0V
					ON or START	Battery voltage
13	R	Fuel pump relay	Output	—	Ignition switch ON or START	Battery voltage
					Ignition switch OFF or ACC	0V
14	W/G	Fuse 49- Clutch interlock switch, clutch interlock cancel switch, clutch interlock cancel relay 2, TCM	Output	—	Ignition switch ON or START	Battery voltage
					Ignition switch OFF or ACC	0V
15	W/R	Fuse 50-ABS actuator, steering angle sensor	Output	—	Ignition switch ON or START	Battery voltage
					Ignition switch OFF or ACC	0V
16	W/G	Fuse 51-Backup lamp switch, back up lamp relay	Output	—	Ignition switch ON or START	Battery voltage
					Ignition switch OFF or ACC	0V
17	W/G	Fuse 55-Fuel injectors	Output	—	Ignition switch ON or START	Battery voltage
					Ignition switch OFF or ACC	0V
19	W	Starter motor	Output	START	—	Battery voltage
20	BR	Cooling fan motor (low)	Output	ON or START	—	Battery voltage
21	GR	Ignition switch supplied power	Input	—	OFF or ACC	0V
					START	Battery voltage
22	G	Battery power supply	Output	OFF	—	Battery voltage
23	LG	Door mirror defogger output signal	Output	—	When rear defogger switch is ON	Battery voltage
					When raker defogger switch is OFF	0V

IPDM E/R (INTELLIGENT POWER DISTRIBUTION MODULE ENGINE ROOM)

< ECU DIAGNOSIS INFORMATION >

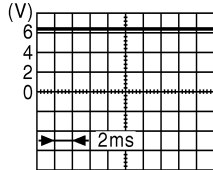
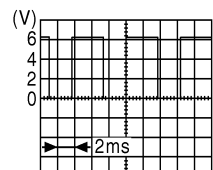
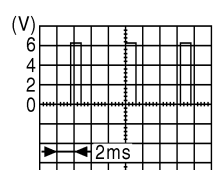
Terminal	Wire color	Signal name	Signal input/output	Measuring condition		Reference value (Approx.)
				Ignition switch	Operation or condition	
24	P	Cooling fan motor (high)	Output	—	Conditions correct for cooling fan operation	Battery voltage
					Conditions not correct for cooling fan operation	0V
27	W/G	Fuse 38-Back up lamp relay, back up lamp switch	Output	—	Ignition switch ON or START	Battery voltage
					Ignition switch OFF or ACC	0V
28	R	LH front parking and front side marker lamp	Output	OFF	Lighting switch 1st position OFF	0V
					Lighting switch 1st position ON	Battery voltage
29	G	Trailer tow relay	Output	ON	Lighting switch 1st position OFF	0V
					Lighting switch 1st position ON	Battery voltage
30	R/B	Fuse 53-ECM, NATS antenna amp.	Output	—	Ignition switch ON or START	Battery voltage
					Ignition switch OFF or ACC	0V
32	GR	Wiper low speed signal	Output	ON or START	Wiper switch OFF	Battery voltage
					Wiper switch LO or INT	0V
35	L	Wiper high speed signal	Output	ON or START	Wiper switch OFF, LO, INT	Battery voltage
					Wiper switch HI	0V
37	Y	Power generation command signal	Output	—	Ignition switch ON	 <p style="text-align: right;">JPMIA0001GB 6.3 V</p>
					40% is set on "Active test," "ALTERNATOR DUTY" of "ENGINE"	 <p style="text-align: right;">JPMIA0002GB 3.8 V</p>
					40% is set on "Active test," "ALTERNATOR DUTY" of "ENGINE"	 <p style="text-align: right;">JPMIA0003GB 1.4 V</p>
38	B	Ground	Input	—	—	0V
39	L	CAN-H	—	ON	—	—
40	P	CAN-L	—	ON	—	—

A
B
C
D
E
F
G
H
I
J
K
L
M
N
O
P

EXL

IPDM E/R (INTELLIGENT POWER DISTRIBUTION MODULE ENGINE ROOM)

< ECU DIAGNOSIS INFORMATION >

Terminal	Wire color	Signal name	Signal input/output	Measuring condition		Reference value (Approx.)
				Ignition switch	Operation or condition	
42	GR	Oil pressure switch	Input	—	Engine running	Battery voltage
					Engine stopped	0V
43	G	Wiper auto stop signal	Input	ON or START	Wiper switch OFF, LO, INT	Battery voltage
44	R	Daytime light relay control (Canada only)	Input	ON	Daytime light system active	0V
					Daytime light system inactive	Battery voltage
45	LG	Horn relay control	Input	ON	When door locks are operated using keyfob (OFF → ON) ³	Battery voltage → 0V
46	V	Fuel pump relay control	Input	—	Ignition switch ON or START	0V
					Ignition switch OFF or ACC	Battery voltage
47	W ¹ BG ²	Throttle control motor relay control	Input	—	Ignition switch ON or START	0V
					Ignition switch OFF or ACC	Battery voltage
48	R	Starter relay (inhibit switch)	Input	ON or START	Selector lever in "P" or "N"	0V
					Selector lever any other position	Battery voltage
49	GR	Front RH parking and front side marker lamp	Output	OFF	Lighting switch 1st position OFF	0V
					ON	Battery voltage
50	W	Front fog lamp (LH)	Output	ON or START	Lighting switch must be in the 2nd position (LOW beam is ON) and the front fog lamp switch OFF	0V
					ON	Battery voltage
51	V	Front fog lamp (RH)	Output	ON or START	Lighting switch must be in the 2nd position (LOW beam is ON) and the front fog lamp switch OFF	0V
					ON	Battery voltage
52	P	LH low beam headlamp	Output	—	Lighting switch in 2nd position	Battery voltage
54	R	RH low beam headlamp	Output	—	Lighting switch in 2nd position	Battery voltage
55	G	LH high beam headlamp	Output	—	Lighting switch in 2nd position and placed in HIGH or PASS position	Battery voltage
56	L	RH high beam headlamp	Output	—	Lighting switch in 2nd position and placed in HIGH or PASS position	Battery voltage
57	GR	Parking, license, and tail lamp	Output	ON	Lighting switch 1st position OFF	0V
					ON	Battery voltage
59	B	Ground	Input	—	—	0V

IPDM E/R (INTELLIGENT POWER DISTRIBUTION MODULE ENGINE ROOM)

< ECU DIAGNOSIS INFORMATION >

Terminal	Wire color	Signal name	Signal input/output	Measuring condition		Reference value (Approx.)
				Ignition switch	Operation or condition	
60	GR	Rear window defogger relay	Output	ON or START	Rear defogger switch ON	Battery voltage
					Rear defogger switch OFF	0V
61	R/B	Fuse 32-Trailer tow relay 1	Output	OFF	—	Battery voltage

1: For Mexico

2: Except for Mexico

3: When horn reminder is ON

Fail Safe

INFOID:0000000012563679

CAN COMMUNICATION CONTROL

When CAN communication with ECM and BCM is impossible, IPDM E/R performs fail-safe control. After CAN communication recovers normally, it also returns to normal control.

If No CAN Communication Is Available With ECM

Control part	Fail-safe in operation
Cooling fan (if equipped)	<ul style="list-style-type: none"> Turns ON the cooling fan relay when the ignition switch is turned ON Turns OFF the cooling fan relay when the ignition switch is turned OFF

If No CAN Communication Is Available With BCM

Control part	Fail-safe in operation
Headlamp	<ul style="list-style-type: none"> Turns ON the headlamp low relay when the ignition switch is turned ON Turns OFF the headlamp low relay when the ignition switch is turned OFF Headlamp (LH/RH) high relays OFF
<ul style="list-style-type: none"> Parking lamps License plate lamps Tail lamps 	<ul style="list-style-type: none"> Turns ON the tail lamp relay when the ignition switch is turned ON Turns OFF the tail lamp relay when the ignition switch is turned OFF
Front wiper	<ul style="list-style-type: none"> The status just before activation of fail-safe control is maintained until the ignition switch is turned OFF while the front wiper is operating at LO or HI speed. The wiper is operated at LO speed until the ignition switch is turned OFF if the fail-safe control is activated while the front wiper is set in the INT mode and the front wiper motor is operating.
Rear window defogger	Rear window defogger relay OFF
A/C compressor	A/C relay OFF
Front fog lamps (if equipped)	Front fog lamp relay OFF

IGNITION RELAY MALFUNCTION DETECTION FUNCTION

- IPDM E/R monitors the voltage at the contact circuit and excitation coil circuit of the ignition relay inside it.
- IPDM E/R judges the ignition relay error if the voltage differs between the contact circuit and the excitation coil circuit.
- If the ignition relay cannot turn OFF due to contact seizure, it activates the tail lamp relay for 10 minutes to alert the user to the ignition relay malfunction when the ignition switch is turned OFF.

Ignition switch	Ignition relay	Tail lamp relay
ON	ON	—
OFF	OFF	—

NOTE:

The tail lamp turns OFF when the ignition switch is turned ON.

IPDM E/R (INTELLIGENT POWER DISTRIBUTION MODULE ENGINE ROOM)

< ECU DIAGNOSIS INFORMATION >

FRONT WIPER CONTROL

IPDM E/R detects front wiper stop position by a front wiper auto stop signal.

When a front wiper auto stop signal is in the conditions listed below, IPDM E/R stops power supply to wiper after repeating a front wiper 10 second activation and 20 second stop five times.

Ignition switch	Front wiper switch	Auto stop signal
ON	OFF	Front wiper stop position signal cannot be input 10 seconds.
	ON	The signal does not change for 10 seconds.

NOTE:

This operation status can be confirmed on the IPDM E/R “DATA MONITOR” that displays “Block” for the item “WIP PROT” while the wiper is stopped.

STARTER MOTOR PROTECTION FUNCTION

IPDM E/R turns OFF the starter control relay to protect the starter motor when the starter control relay remains active for 90 seconds.

DTC Index

INFOID:0000000012563680

CONSULT display	Fail-safe	TIME ^{NOTE}		Refer to
No DTC is detected. further testing may be required.	—	—	—	—
U1000: CAN COMM CIRCUIT	×	CRNT	1 – 39	PCS-13

NOTE:

The details of TIME display are as follows.

- CRNT: The malfunctions that are detected now
- 1 - 39: The number is indicated when it is normal at present and a malfunction was detected in the past. It increases like 0 → 1 → 2 ··· 38 → 39 after returning to the normal condition whenever IGN OFF → ON. It is fixed to 39 until the self-diagnosis results are erased if it is over 39. It returns to 0 when a malfunction is detected again in the process.

HEADLAMP

< WIRING DIAGRAM >

WIRING DIAGRAM

HEADLAMP

Wiring Diagram

INFOID:000000012563681

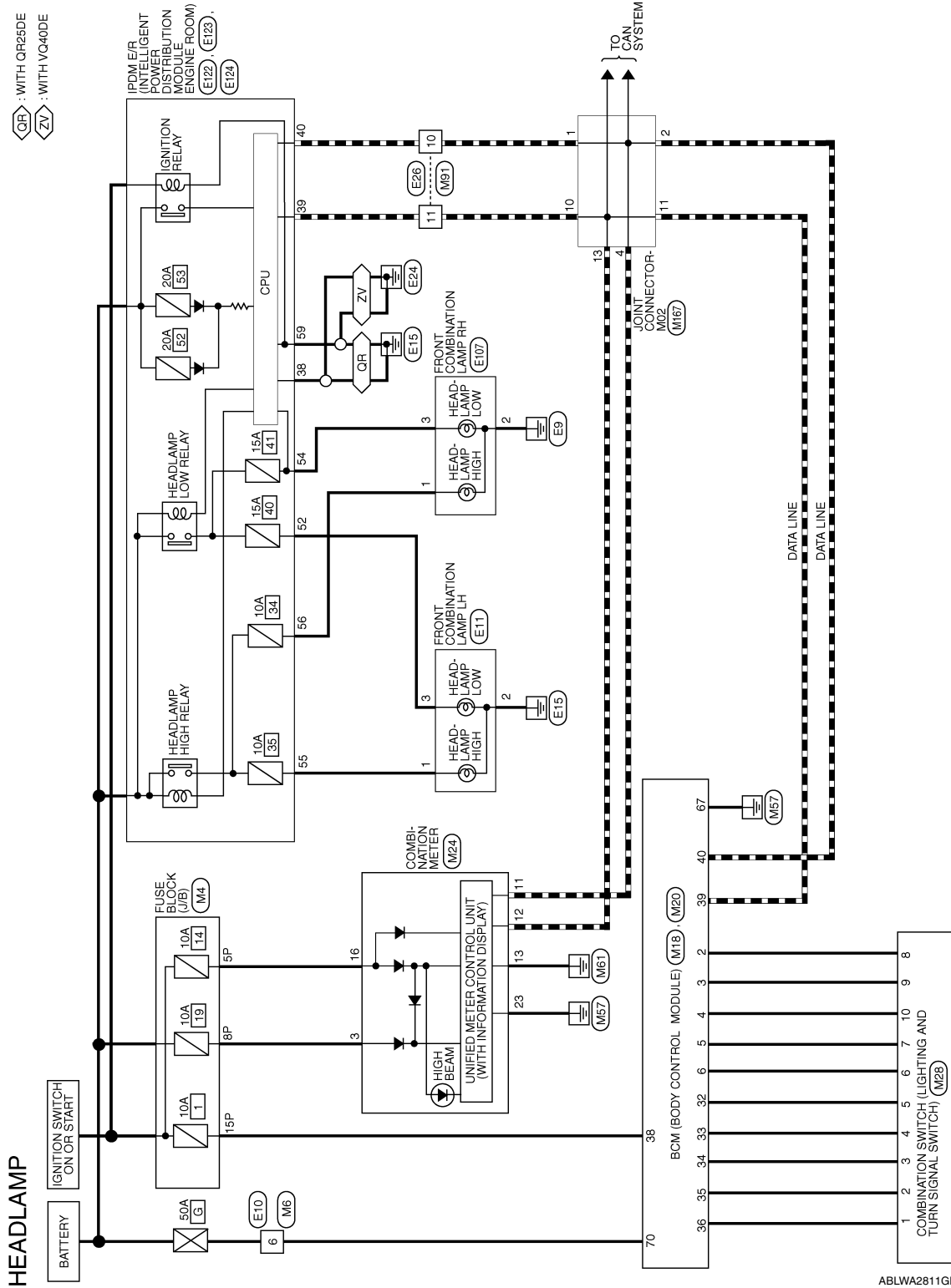

HEADLAMP

< WIRING DIAGRAM >

HEADLAMP CONNECTORS

Connector No.	M4
Connector Name	FUSE BLOCK (J/B)
Connector Color	WHITE



7P	8P	9P	4P	3P	2P	1P
16P	13P	14P	12P	11P	10P	9P
8P						

Terminal No.	Color of Wire	Signal Name
5P	W/G	-
8P	R/Y	-
15P	W/R	-

Connector No.	M6
Connector Name	WIRE TO WIRE
Connector Color	WHITE



3	2	1
6	5	4

Terminal No.	Color of Wire	Signal Name
6	W	-

Connector No.	M18
Connector Name	BCM (BODY CONTROL MODULE)
Connector Color	WHITE



1	2	3	4	5	6	7	8	9	10	11	12	13	14	15	16	17	18	19	20
21	22	23	24	25	26	27	28	29	30	31	32	33	34	35	36	37	38	39	40

Terminal No.	Color of Wire	Signal Name
2	P	INPUT 5
3	SB	INPUT 4
4	V	INPUT 3

Terminal No.	Color of Wire	Signal Name
5	L	INPUT 2
6	R	INPUT 1
32	BG	OUTPUT 5
33	GR	OUTPUT 4
34	G	OUTPUT 3
35	BR	OUTPUT 2
36	LG	OUTPUT 1
38	W/R	IGN SW
39	L	CAN-H
40	P	CAN-L

Connector No.	M20
Connector Name	BCM (BODY CONTROL MODULE)
Connector Color	BLACK



66	67	68	69	70	63	64
65	66	67	68	69	70	

Terminal No.	Color of Wire	Signal Name
67	B	GND (POWER)
70	W	BAT (F/L)

HEADLAMP

< WIRING DIAGRAM >

Terminal No.	Color of Wire	Signal Name
4	GR	-
5	BG	-
6	R	-
7	L	-
8	P	-
9	SB	-
10	V	-

Connector No.	M28
Connector Name	COMBINATION SWITCH
Connector Color	WHITE

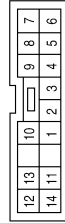

Terminal No.	Color of Wire	Signal Name
1	LG	-
2	BR	-
3	G	-

Connector No.	M24
Connector Name	COMBINATION METER
Connector Color	WHITE

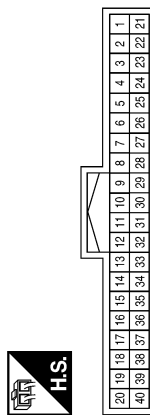

Terminal No.	Color of Wire	Signal Name
3	R/Y	BATTERY
11	P	CAN-L
12	L	CAN-H
13	GR	GROUND
16	W/G	RUN START
23	B	POWER GND

Connector No.	E10
Connector Name	WIRE TO WIRE
Connector Color	WHITE



Terminal No.	Color of Wire	Signal Name
6	W	-

Connector No.	M167
Connector Name	JOINT CONNECTOR-M02
Connector Color	BLUE

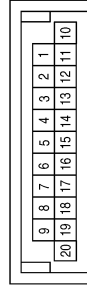

Terminal No.	Color of Wire	Signal Name
1	P	-
2	P	-
4	P	-
10	L	-
11	L	-
13	L	-

Connector No.	M91
Connector Name	WIRE TO WIRE
Connector Color	WHITE

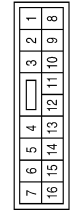

Terminal No.	Color of Wire	Signal Name
10	P	-
11	L	-

ABLIA5604GB

A
B
C
D
E
F
G
H
I
J
K
EXL
M
N
O
P

HEADLAMP

< WIRING DIAGRAM >

Connector No.	E107
Connector Name	FRONT COMBINATION LAMP RH
Connector Color	BLACK



Terminal No.	Color of Wire	Signal Name
1	L	-
2	B	-
3	R	-

Connector No.	E26
Connector Name	WIRE TO WIRE
Connector Color	WHITE

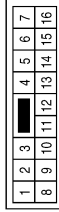

Terminal No.	Color of Wire	Signal Name
10	P	-
11	L	-

Connector No.	E11
Connector Name	FRONT COMBINATION LAMP LH (WITHOUT DAYTIME LIGHT SYSTEM)
Connector Color	BLACK



Terminal No.	Color of Wire	Signal Name
1	G	-
2	B	-
3	P	-

Connector No.	E124
Connector Name	IPDM E/R (INTELLIGENT POWER DISTRIBUTION MODULE ENGINE ROOM)
Connector Color	BLACK



Terminal No.	Color of Wire	Signal Name
59	B	GND (POWER)

Connector No.	E123
Connector Name	IPDM E/R (INTELLIGENT POWER DISTRIBUTION MODULE ENGINE ROOM)
Connector Color	BROWN



Terminal No.	Color of Wire	Signal Name
52	P	H/LAMP LO LH
54	R	H/LAMP LO RH
55	G	H/LAMP HI LH
56	L	H/LAMP HI RH

Connector No.	E122
Connector Name	IPDM E/R (INTELLIGENT POWER DISTRIBUTION MODULE ENGINE ROOM)
Connector Color	WHITE



Terminal No.	Color of Wire	Signal Name
38	B	GND (SIGNAL)
39	L	CAN-H
40	P	CAN-L

ABLIA3317GB

DAYTIME LIGHT SYSTEM

< WIRING DIAGRAM >

DAYTIME LIGHT SYSTEM

Wiring Diagram

INFOID:000000012563682

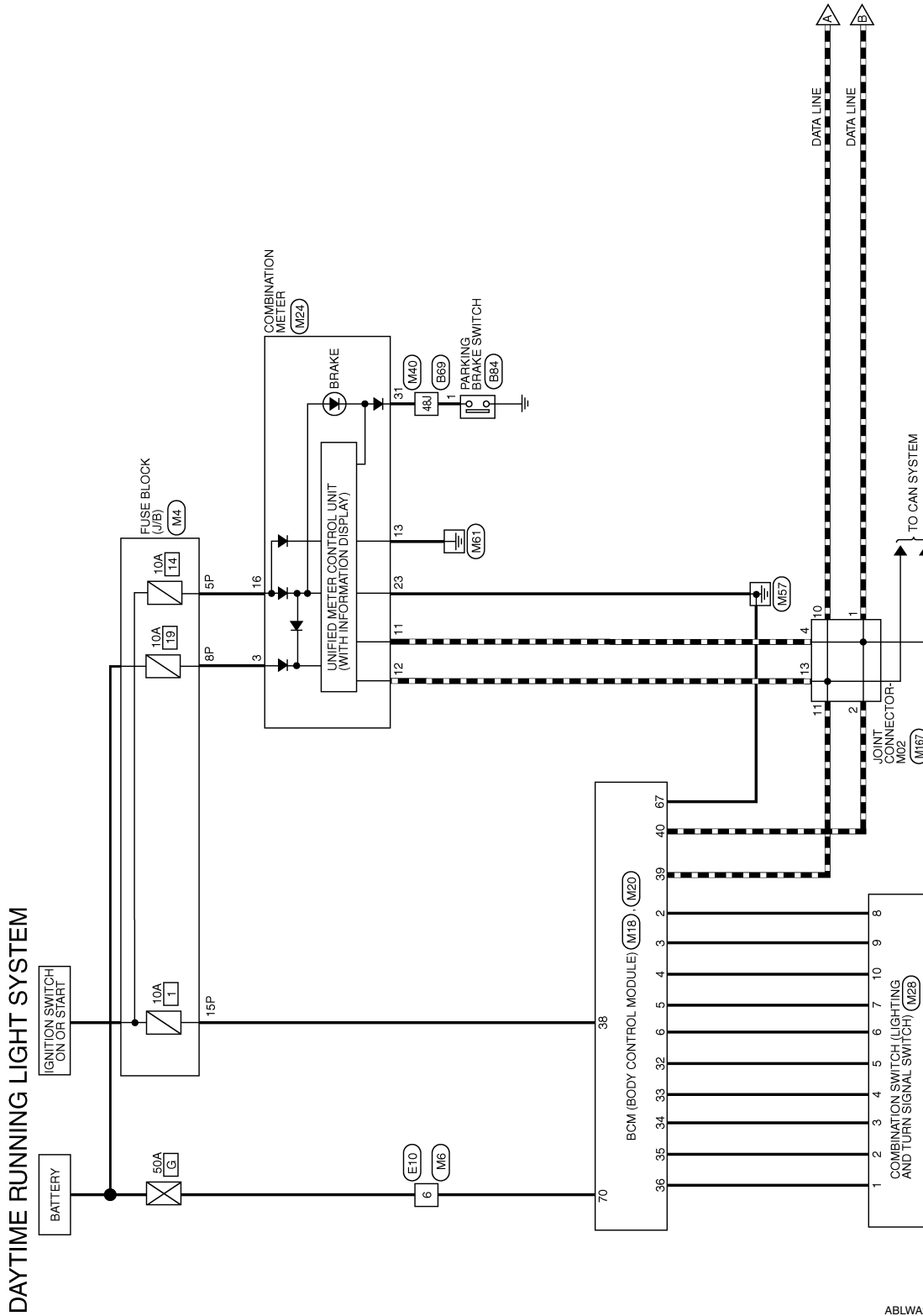

ABLWA2812GB

A
B
C
D
E
F
G
H
I
J
K
EXL
M
N
O
P

DAYTIME LIGHT SYSTEM

< WIRING DIAGRAM >

QR : WITH QR25DE
ZV : WITH VQ40DE

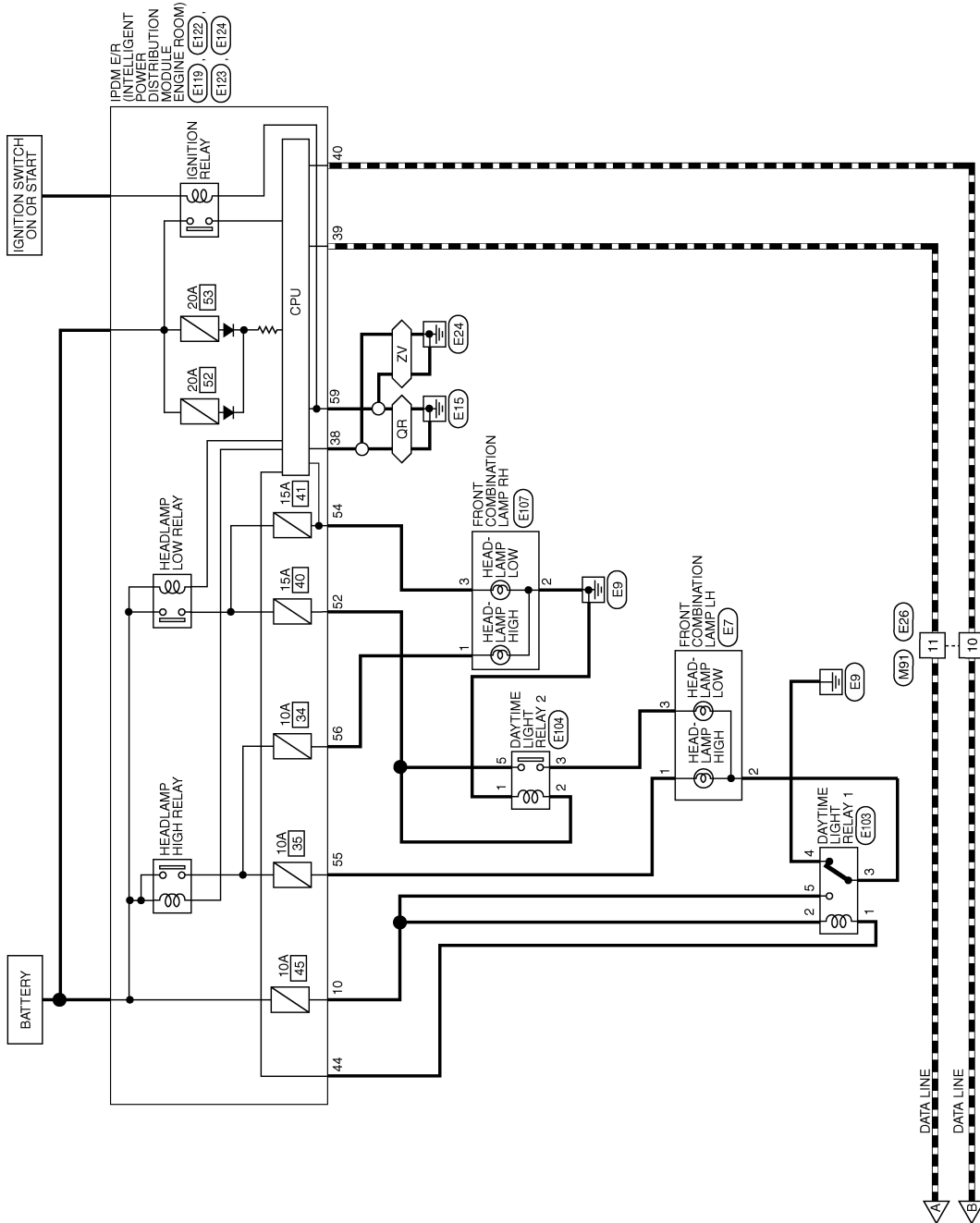

ABLWA2813GB

DAYTIME LIGHT SYSTEM

< WIRING DIAGRAM >

DAYTIME RUNNING LIGHT SYSTEM CONNECTORS

Connector No.	M4
Connector Name	FUSE BLOCK (J/B)
Connector Color	WHITE



7P	8P	9P	4P	3P	2P	1P
16P	13P	14P	13P	12P	11P	10P
9P	8P					

Terminal No.	Color of Wire	Signal Name
5P	W/G	-
8P	R/Y	-
15P	W/R	-

Connector No.	M6
Connector Name	WIRE TO WIRE
Connector Color	WHITE



3	2	1
6	5	4

Terminal No.	Color of Wire	Signal Name
6	W	-

Connector No.	M18
Connector Name	BCM (BODY CONTROL MODULE)
Connector Color	WHITE



1	2	3	4	5	6	7	8	9	10	11	12	13	14	15	16	17	18	19	20
21	22	23	24	25	26	27	28	29	30	31	32	33	34	35	36	37	38	39	40

Terminal No.	Color of Wire	Signal Name
2	P	INPUT 5
3	SB	INPUT 4
4	V	INPUT 3

Terminal No.	Color of Wire	Signal Name
5	L	INPUT 2
6	R	INPUT 1
32	BG	OUTPUT 5
33	GR	OUTPUT 4
34	G	OUTPUT 3
35	BR	OUTPUT 2
36	LG	OUTPUT 1
38	W/R	IGN SW
39	L	CAN-H
40	P	CAN-L

Connector No.	M20
Connector Name	BCM (BODY CONTROL MODULE)
Connector Color	BLACK



56	57	58	59	60	61	62	63	64
65	66	67	68	69	70			

Terminal No.	Color of Wire	Signal Name
67	B	GND (POWER)
70	W	BAT (F/L)

ABLIA6844GB

A
B
C
D
E
F
G
H
I
J
K
L
M
N
O
P

EXL

DAYTIME LIGHT SYSTEM

< WIRING DIAGRAM >

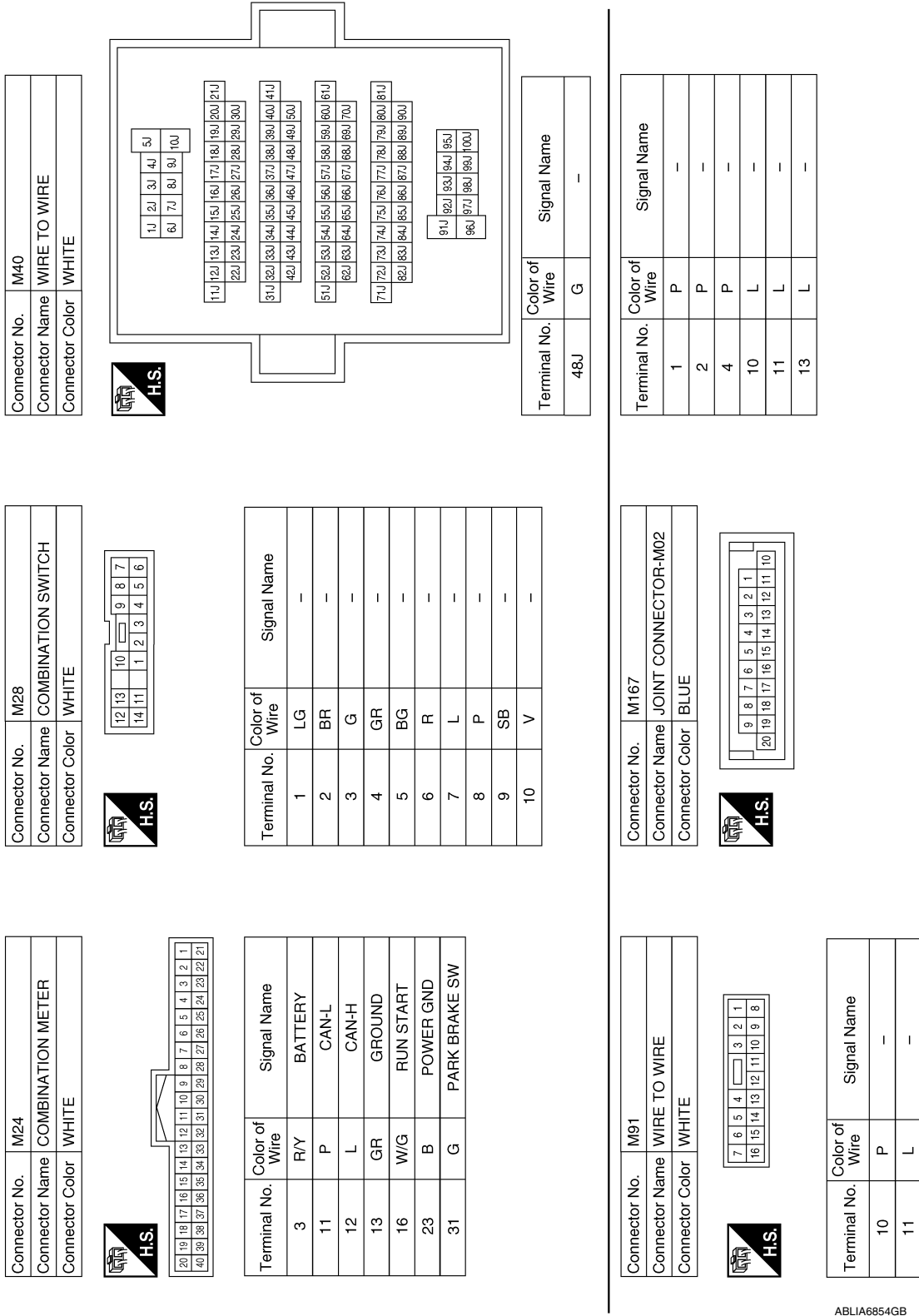

Connector No.	M24
Connector Name	COMBINATION METER
Connector Color	WHITE

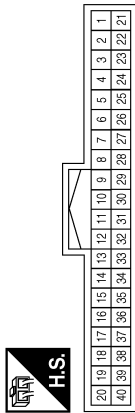

Connector No.	M28
Connector Name	COMBINATION SWITCH
Connector Color	WHITE

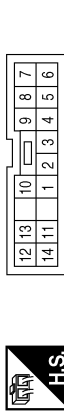

Connector No.	M40
Connector Name	WIRE TO WIRE
Connector Color	WHITE

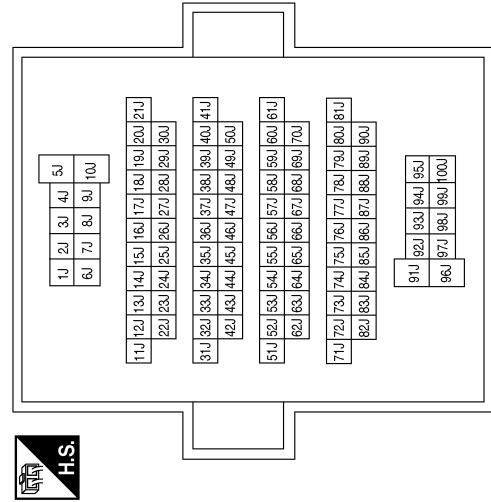

Terminal No.	Color of Wire	Signal Name
48J	G	-

Connector No.	M91
Connector Name	WIRE TO WIRE
Connector Color	WHITE

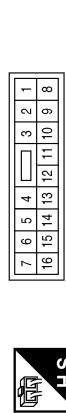

Connector No.	M167
Connector Name	JOINT CONNECTOR-M02
Connector Color	BLUE

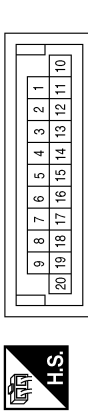

Terminal No.	Color of Wire	Signal Name
1	P	-
2	P	-
4	P	-
10	L	-
11	L	-
13	L	-

Terminal No.	Color of Wire	Signal Name
10	P	-
11	L	-

ABLIA6854GB

DAYTIME LIGHT SYSTEM

< WIRING DIAGRAM >

Connector No.	E26
Connector Name	WIRE TO WIRE
Connector Color	WHITE

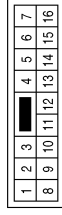

Terminal No.	Color of Wire	Signal Name
10	P	-
11	L	-

Connector No.	E10
Connector Name	WIRE TO WIRE
Connector Color	WHITE



Terminal No.	Color of Wire	Signal Name
6	W	-

Connector No.	E7
Connector Name	FRONT COMBINATION LAMP LH (WITH DAYTIME LIGHT SYSTEM)
Connector Color	BLACK



Terminal No.	Color of Wire	Signal Name
1	G	-
2	B	-
3	SB	-

Connector No.	E107
Connector Name	FRONT COMBINATION LAMP RH
Connector Color	BLACK



Terminal No.	Color of Wire	Signal Name
1	L	-
2	B	-
3	R	-

Connector No.	E104
Connector Name	DAYTIME LIGHT RELAY 2
Connector Color	BLUE



Terminal No.	Color of Wire	Signal Name
1	B	-
2	G	-
3	SB	-
5	P	-

Connector No.	E103
Connector Name	DAYTIME LIGHT RELAY 1
Connector Color	BLACK



Terminal No.	Color of Wire	Signal Name
1	R	-
2	R/B	-
3	B	-
4	GR	-
5	R/B	-

ABLIA6855GB

A
B
C
D
E
F
G
H
I
J
K
EXL
M
N
O
P

DAYTIME LIGHT SYSTEM

< WIRING DIAGRAM >

Connector No.	E123
Connector Name	IPDM E/R (INTELLIGENT POWER DISTRIBUTION MODULE ENGINE ROOM)
Connector Color	BROWN

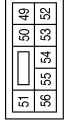

Terminal No.	Color of Wire	Signal Name
52	P	H/LAMP LO LH
54	R	H/LAMP LO RH
55	G	H/LAMP HI LH
56	L	H/LAMP HI RH

Connector No.	E122
Connector Name	IPDM E/R (INTELLIGENT POWER DISTRIBUTION MODULE ENGINE ROOM)
Connector Color	WHITE

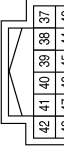

Terminal No.	Color of Wire	Signal Name
38	B	GND (SIGNAL)
39	L	CAN-H
40	P	CAN-L
44	R	DTRL RLY CONT

Connector No.	E119
Connector Name	IPDM E/R (INTELLIGENT POWER DISTRIBUTION MODULE ENGINE ROOM)
Connector Color	WHITE

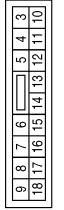

Terminal No.	Color of Wire	Signal Name
10	R/B	DTRL RLY SUPPLY

Terminal No.	48J	Color of Wire	G	Signal Name	-
--------------	-----	---------------	---	-------------	---

Connector No.	B69
Connector Name	WIRE TO WIRE
Connector Color	WHITE

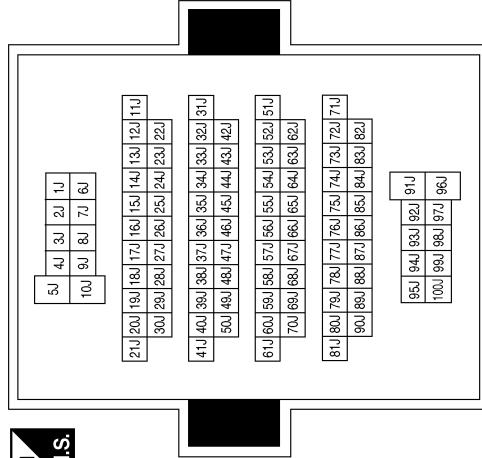

Connector No.	E124
Connector Name	IPDM E/R (INTELLIGENT POWER DISTRIBUTION MODULE ENGINE ROOM)
Connector Color	BLACK



Terminal No.	Color of Wire	Signal Name
59	B	GND (POWER)

ABLIA6856GB

DAYTIME LIGHT SYSTEM

< WIRING DIAGRAM >

A
B
C
D
E
F
G
H
I
J
K
EXL
M
N
O
P

Connector No.	B84
Connector Name	PARKING BRAKE SWITCH
Connector Color	BLACK



Terminal No.	1	Color of Wire	G	Signal Name	-
--------------	---	---------------	---	-------------	---

ABLIA6857GB

AUTO LIGHT SYSTEM

< WIRING DIAGRAM >

AUTO LIGHT SYSTEM

Wiring Diagram

INFOID:000000012563683

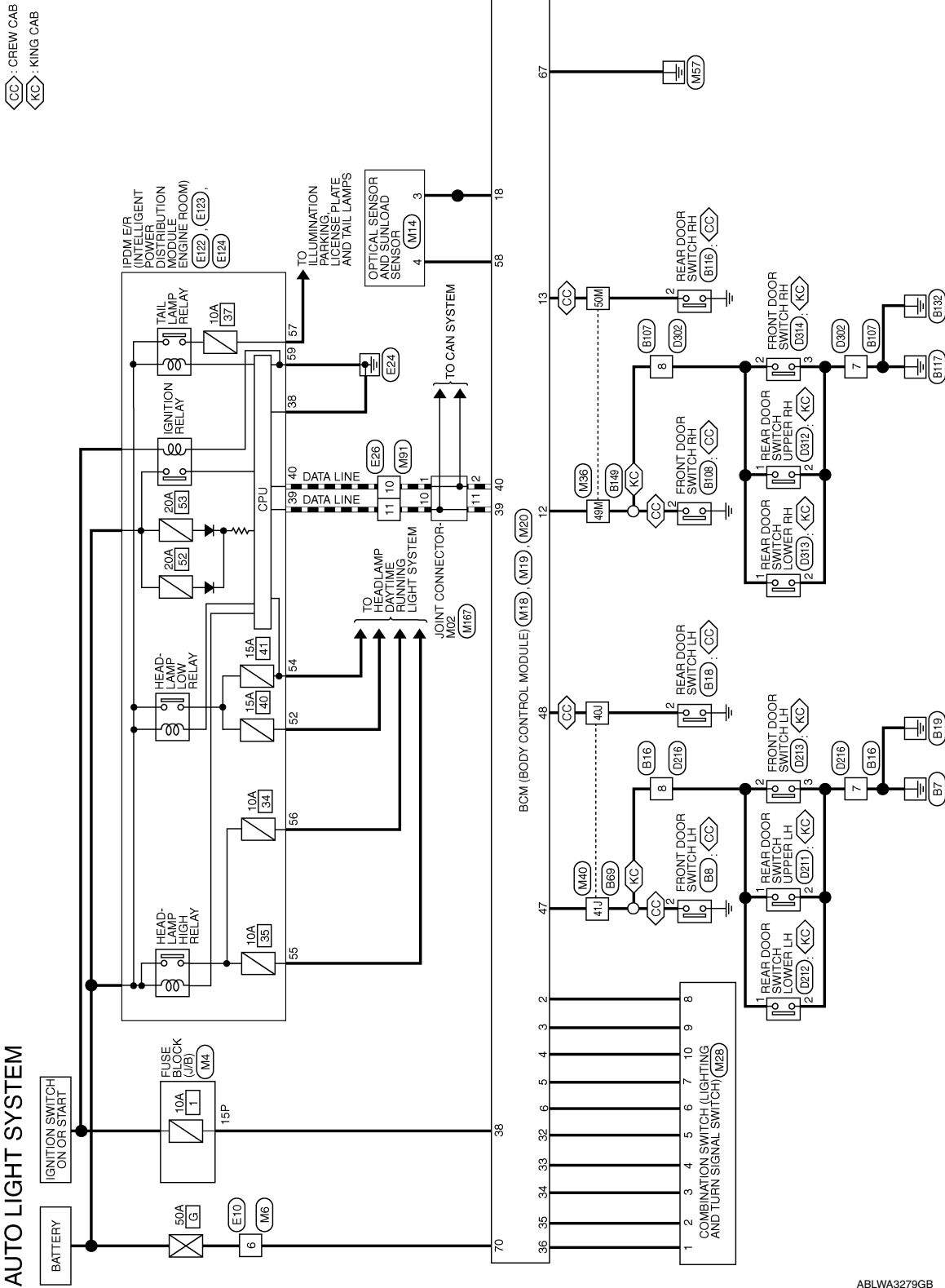

ABLWA3279GB

AUTO LIGHT SYSTEM

< WIRING DIAGRAM >

AUTO LIGHT SYSTEM CONNECTORS

Connector No.	M4
Connector Name	FUSE BLOCK (J/B)
Connector Color	WHITE



Terminal No.	15P	Color of Wire	W/R	Signal Name	-
--------------	-----	---------------	-----	-------------	---

Connector No.	M6
Connector Name	WIRE TO WIRE
Connector Color	WHITE



Terminal No.	6	Color of Wire	W	Signal Name	-
--------------	---	---------------	---	-------------	---

Connector No.	M14
Connector Name	OPTICAL SENSOR AND SUNLOAD SENSOR
Connector Color	BLACK



Terminal No.	3	Color of Wire	P	Signal Name	-
Terminal No.	4	Color of Wire	W	Signal Name	-

Connector No.	M18
Connector Name	BCM (BODY CONTROL MODULE)
Connector Color	WHITE

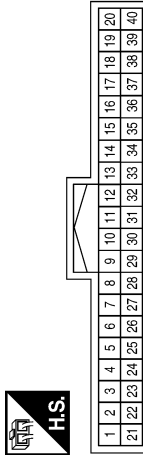

Terminal No.	2	Color of Wire	P	Signal Name	INPUT 5
Terminal No.	3	Color of Wire	SB	Signal Name	INPUT 4
Terminal No.	4	Color of Wire	V	Signal Name	INPUT 3

Terminal No.	5	Color of Wire	L	Signal Name	INPUT 2
Terminal No.	6	Color of Wire	R	Signal Name	INPUT 1
Terminal No.	12	Color of Wire	LG	Signal Name	DOOR SW (AS)
Terminal No.	13	Color of Wire	L	Signal Name	DOOR SW (RR)
Terminal No.	18	Color of Wire	BR	Signal Name	KEYLESS & AUTO LIGHT SENSOR GND
Terminal No.	32	Color of Wire	BG	Signal Name	OUTPUT 5
Terminal No.	33	Color of Wire	GR	Signal Name	OUTPUT 4
Terminal No.	34	Color of Wire	G	Signal Name	OUTPUT 3
Terminal No.	35	Color of Wire	BR	Signal Name	OUTPUT 2
Terminal No.	36	Color of Wire	LG	Signal Name	OUTPUT 1
Terminal No.	38	Color of Wire	W/R	Signal Name	IGN SW
Terminal No.	39	Color of Wire	L	Signal Name	CAN-H
Terminal No.	40	Color of Wire	P	Signal Name	CAN-L

Connector No.	M19
Connector Name	BCM (BODY CONTROL MODULE)
Connector Color	WHITE

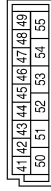

Terminal No.	47	Color of Wire	GR	Signal Name	DOOR SW (DR)
Terminal No.	48	Color of Wire	P	Signal Name	DOOR SW (RL)

ABLIA5606GB

A
B
C
D
E
F
G
H
I
J
K
L
M
N
O
P

EXL

AUTO LIGHT SYSTEM

< WIRING DIAGRAM >

Connector No.	M36
Connector Name	WIRE TO WIRE
Connector Color	WHITE

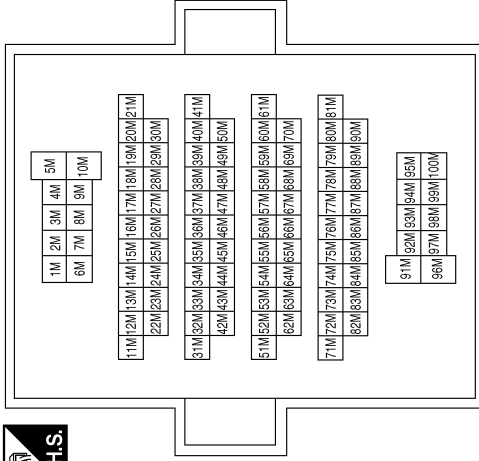

Terminal No.	Color of Wire	Signal Name
49M	LG	-
50M	L	-

Connector No.	M28
Connector Name	COMBINATION SWITCH
Connector Color	WHITE

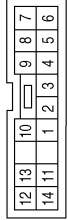

Terminal No.	Color of Wire	Signal Name
1	LG	-
2	BR	-
3	G	-
4	GR	-
5	BG	-
6	R	-
7	L	-
8	P	-
9	SB	-
10	V	-

Connector No.	M20
Connector Name	BCM (BODY CONTROL MODULE)
Connector Color	BLACK



Terminal No.	Color of Wire	Signal Name
58	W	AUTO LIGHT SENSOR INPUT 2
67	B	GND (POWER)
70	W	BAT (F/L)

ABLIA6845GB

AUTO LIGHT SYSTEM

< WIRING DIAGRAM >

Connector No.	M40
Connector Name	WIRE TO WIRE
Connector Color	WHITE

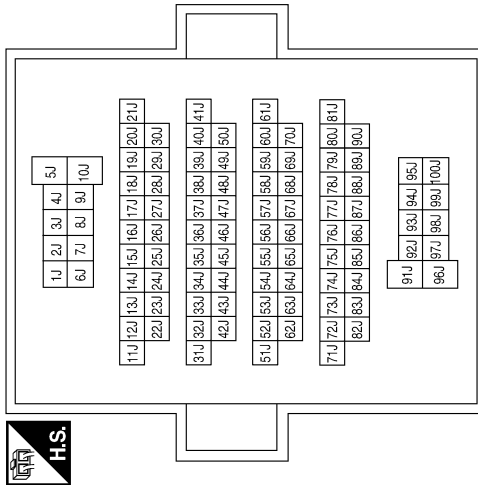

Terminal No.	Color of Wire	Signal Name
40J	P	-
41J	GR	-

Connector No.	M91
Connector Name	WIRE TO WIRE
Connector Color	WHITE

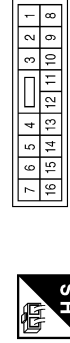

Terminal No.	Color of Wire	Signal Name
10	P	-
11	L	-

Connector No.	M167
Connector Name	JOINT CONNECTOR-M02
Connector Color	BLUE

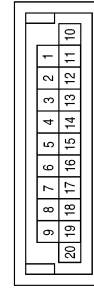

Terminal No.	Color of Wire	Signal Name
1	P	-
2	P	-
10	L	-
11	L	-

Connector No.	E10
Connector Name	WIRE TO WIRE
Connector Color	WHITE



Terminal No.	Color of Wire	Signal Name
6	W	-

Connector No.	E26
Connector Name	WIRE TO WIRE
Connector Color	WHITE

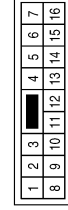

Terminal No.	Color of Wire	Signal Name
10	P	-
11	L	-

ABLIA5608GB

A B C D E F G H I J K EXL M N O P

AUTO LIGHT SYSTEM

< WIRING DIAGRAM >

Connector No.	E124
Connector Name	IPDM E/R (INTELLIGENT POWER DISTRIBUTION MODULE ENGINE ROOM)
Connector Color	BLACK



Terminal No.	Color of Wire	Signal Name
57	GR	TAIL LAMP
59	B	GND (POWER)

Connector No.	E123
Connector Name	IPDM E/R (INTELLIGENT POWER DISTRIBUTION MODULE ENGINE ROOM)
Connector Color	BROWN

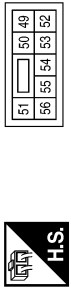

Terminal No.	Color of Wire	Signal Name
52	P	H/LAMP LO LH
54	R	H/LAMP LO RH
55	G	H/LAMP HI LH
56	L	H/LAMP HI RH

Connector No.	E122
Connector Name	IPDM E/R (INTELLIGENT POWER DISTRIBUTION MODULE ENGINE ROOM)
Connector Color	WHITE



Terminal No.	Color of Wire	Signal Name
38	B	GND (SIGNAL)
39	L	CAN-H
40	P	CAN-L

Connector No.	B18
Connector Name	REAR DOOR SWITCH LH
Connector Color	WHITE



Terminal No.	Color of Wire	Signal Name
2	P	-

Connector No.	B16
Connector Name	WIRE TO WIRE
Connector Color	WHITE



Terminal No.	Color of Wire	Signal Name
7	B	-
8	GR	-

Connector No.	B8
Connector Name	FRONT DOOR SWITCH LH (CREW CAB)
Connector Color	WHITE



Terminal No.	Color of Wire	Signal Name
2	GR	-

ABLIA5609GB

AUTO LIGHT SYSTEM

< WIRING DIAGRAM >

Connector No.	B107
Connector Name	WIRE TO WIRE
Connector Color	WHITE

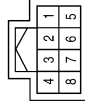

Terminal No.	Color of Wire	Signal Name
7	B	-
8	LG	-

Terminal No.	Color of Wire	Signal Name
40J	P	-
41J	GR	-

Connector No.	B69
Connector Name	WIRE TO WIRE
Connector Color	WHITE

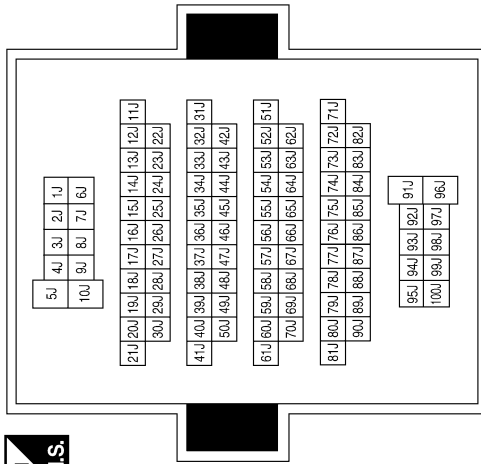

Connector No.	B116
Connector Name	REAR DOOR SWITCH RH
Connector Color	WHITE

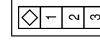

Terminal No.	Color of Wire	Signal Name
2	L	-

Connector No.	B108
Connector Name	FRONT DOOR SWITCH RH (CREW CAB)
Connector Color	WHITE

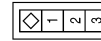

Terminal No.	Color of Wire	Signal Name
2	LG	-

ABLIA5610GB

A
B
C
D
E
F
G
H
I
J
K
EXL
M
N
O
P

AUTO LIGHT SYSTEM

< WIRING DIAGRAM >

Connector No.	D211
Connector Name	REAR DOOR SWITCH UPPER LH
Connector Color	BLACK



Terminal No.	Color of Wire	Signal Name
1	L	-
2	B	-

Terminal No.	Color of Wire	Signal Name
49M	LG	-
50M	L	-

Connector No.	B149
Connector Name	WIRE TO WIRE
Connector Color	WHITE

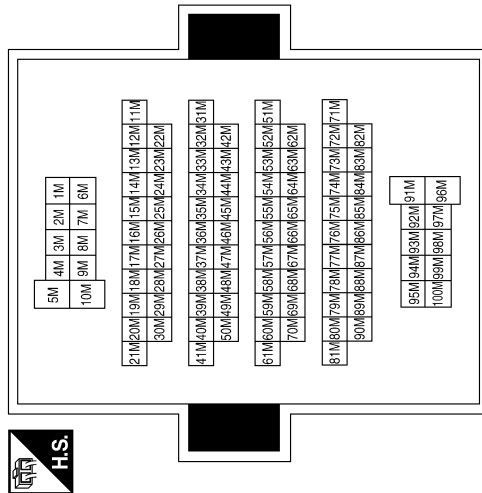

Connector No.	D216
Connector Name	WIRE TO WIRE
Connector Color	WHITE

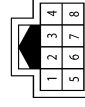

Terminal No.	Color of Wire	Signal Name
7	B	-
8	LG	-

Connector No.	D213
Connector Name	FRONT DOOR SWITCH LH (KING CAB)
Connector Color	WHITE

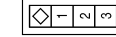

Terminal No.	Color of Wire	Signal Name
2	LG	-
3	B	-

Connector No.	D212
Connector Name	REAR DOOR SWITCH LOWER LH
Connector Color	BLACK



Terminal No.	Color of Wire	Signal Name
1	L	-
2	B	-

ABLIA5611GB

AUTO LIGHT SYSTEM

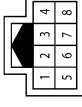

< WIRING DIAGRAM >

Connector No.	D302
Connector Name	WIRE TO WIRE
Connector Color	WHITE



Terminal No.	Color of Wire	Signal Name
7	B	-
8	LG	-

Connector No.	D312
Connector Name	REAR DOOR SWITCH UPPER RH
Connector Color	BLACK



Terminal No.	Color of Wire	Signal Name
1	L	-
2	B	-

Connector No.	D313
Connector Name	REAR DOOR SWITCH LOWER RH
Connector Color	BLACK

Terminal No.	Color of Wire	Signal Name
1	L	-
2	B	-

Connector No.	D314
Connector Name	FRONT DOOR SWITCH RH (KING CAB)
Connector Color	WHITE

Terminal No.	Color of Wire	Signal Name
2	LG	-
3	B	-

A
B
C
D
E
F
G
H
I
J
K
EXL
M
N
O
P

ABLIA5673GB

FRONT FOG LAMP

< WIRING DIAGRAM >

FRONT FOG LAMP

Wiring Diagram

INFOID:000000012563684

FRONT FOG LAMP

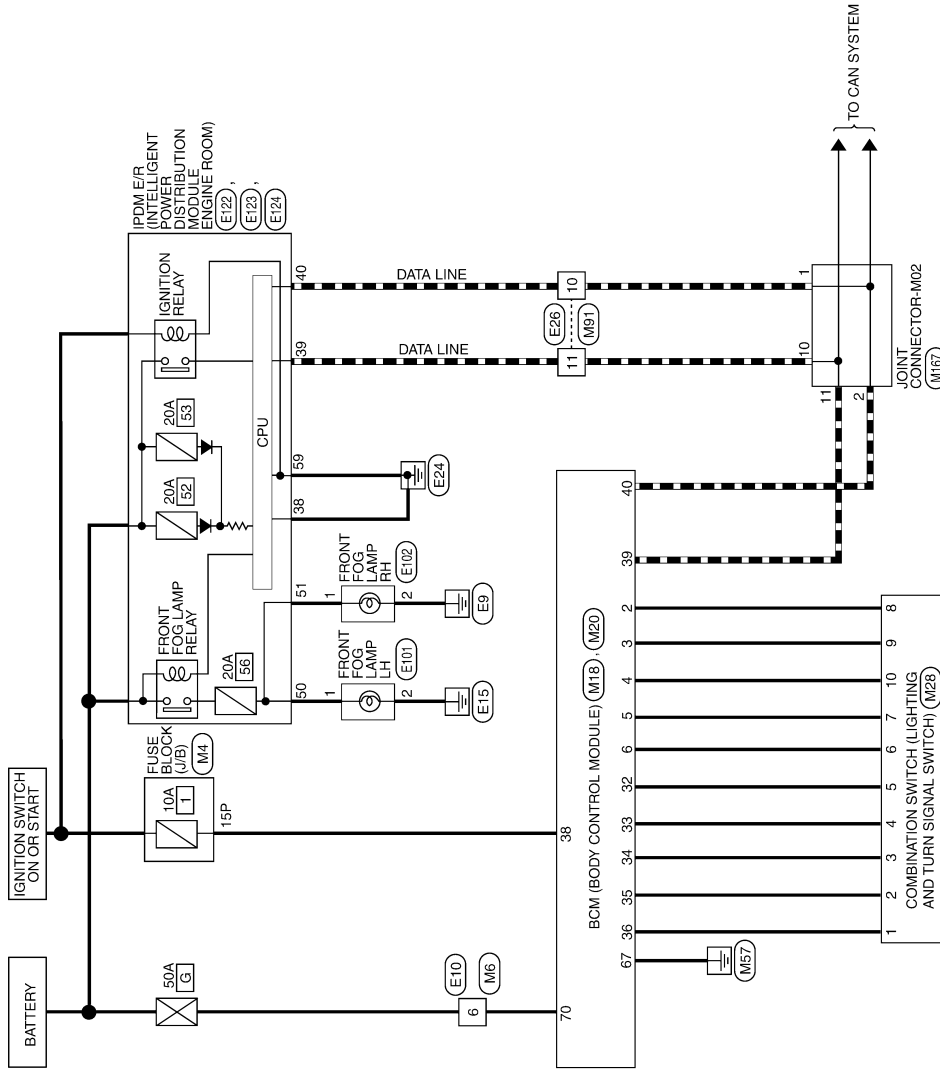

ABLWA2020GB

FRONT FOG LAMP

< WIRING DIAGRAM >

FRONT FOG LAMP CONNECTORS

Connector No.	M4
Connector Name	FUSE BLOCK (J/B)
Connector Color	WHITE



Terminal No.	15P	Color of Wire	W/R	Signal Name	-
--------------	-----	---------------	-----	-------------	---

Connector No.	M6
Connector Name	WIRE TO WIRE
Connector Color	WHITE



Terminal No.	6	Color of Wire	W	Signal Name	-
--------------	---	---------------	---	-------------	---

Connector No.	M18
Connector Name	BCM (BODY CONTROL MODULE)
Connector Color	WHITE

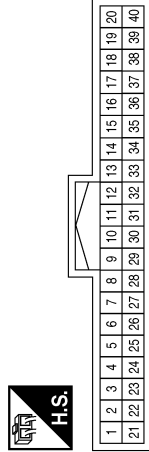

Terminal No.	2	Color of Wire	P	Signal Name	INPUT 5
	3		SB		INPUT 4
	4		V		INPUT 3
	5		L		INPUT 2
	6		R		INPUT 1

Terminal No.	32	Color of Wire	BG	Signal Name	OUTPUT 5
	33		GR		OUTPUT 4
	34		G		OUTPUT 3
	35		BR		OUTPUT 2
	36		LG		OUTPUT 1
	38		W/R		IGN SW
	39		L		CAN-H
	40		P		CAN-L

Connector No.	M20
Connector Name	BCM (BODY CONTROL MODULE)
Connector Color	BLACK

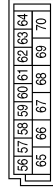

Terminal No.	67	Color of Wire	B	Signal Name	GND (POWER)
	70		W		BAT (F/L)

ABLIA6848GB

A
B
C
D
E
F
G
H
I
J
K
EXL
M
N
O
P

FRONT FOG LAMP

< WIRING DIAGRAM >

Connector No.	M91
Connector Name	WIRE TO WIRE
Connector Color	WHITE

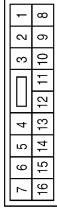

Terminal No.	Color of Wire	Signal Name
10	P	-
11	L	-

Terminal No.	Color of Wire	Signal Name
9	SB	-
10	V	-

Connector No.	M28
Connector Name	COMBINATION SWITCH
Connector Color	WHITE

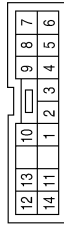

Terminal No.	Color of Wire	Signal Name
1	LG	-
2	BR	-
3	G	-
4	GR	-
5	BG	-
6	R	-
7	L	-
8	P	-

Connector No.	E26
Connector Name	WIRE TO WIRE
Connector Color	WHITE

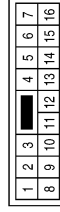

Terminal No.	Color of Wire	Signal Name
10	P	-
11	L	-

Connector No.	E10
Connector Name	WIRE TO WIRE
Connector Color	WHITE



Terminal No.	Color of Wire	Signal Name
6	W	-

Connector No.	M167
Connector Name	JOINT CONNECTOR-M02
Connector Color	BLUE

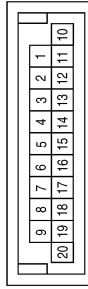

Terminal No.	Color of Wire	Signal Name
1	P	-
2	P	-
10	L	-
11	L	-

ABLIA5618GB

FRONT FOG LAMP

< WIRING DIAGRAM >

Connector No.	E122
Connector Name	IPDM E/R (INTELLIGENT POWER DISTRIBUTION MODULE ENGINE ROOM)
Connector Color	WHITE

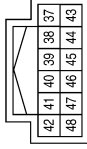

Terminal No.	Color of Wire	Signal Name
38	B	GND (SIGNAL)
39	L	CAN-H
40	P	CAN-L

Connector No.	E102
Connector Name	FRONT FOG LAMP RH
Connector Color	BLACK



Terminal No.	Color of Wire	Signal Name
1	V	-
2	B	-

Connector No.	E101
Connector Name	FRONT FOG LAMP LH
Connector Color	BLACK



Terminal No.	Color of Wire	Signal Name
1	W	-
2	B	-

Connector No.	E124
Connector Name	IPDM E/R (INTELLIGENT POWER DISTRIBUTION MODULE ENGINE ROOM)
Connector Color	BLACK



Terminal No.	Color of Wire	Signal Name
59	B	GND (POWER)

Connector No.	E123
Connector Name	IPDM E/R (INTELLIGENT POWER DISTRIBUTION MODULE ENGINE ROOM)
Connector Color	BROWN



Terminal No.	Color of Wire	Signal Name
50	W	FR FOG LAMP LH
51	V	FR FOG LAMP RH

ABLIA3309GB

A
B
C
D
E
F
G
H
I
J
K
L
M
N
O
P

EXL

TURN SIGNAL AND HAZARD WARNING LAMP SYSTEM

< WIRING DIAGRAM >

TURN SIGNAL AND HAZARD WARNING LAMP SYSTEM

Wiring Diagram

INFOID:000000012563685

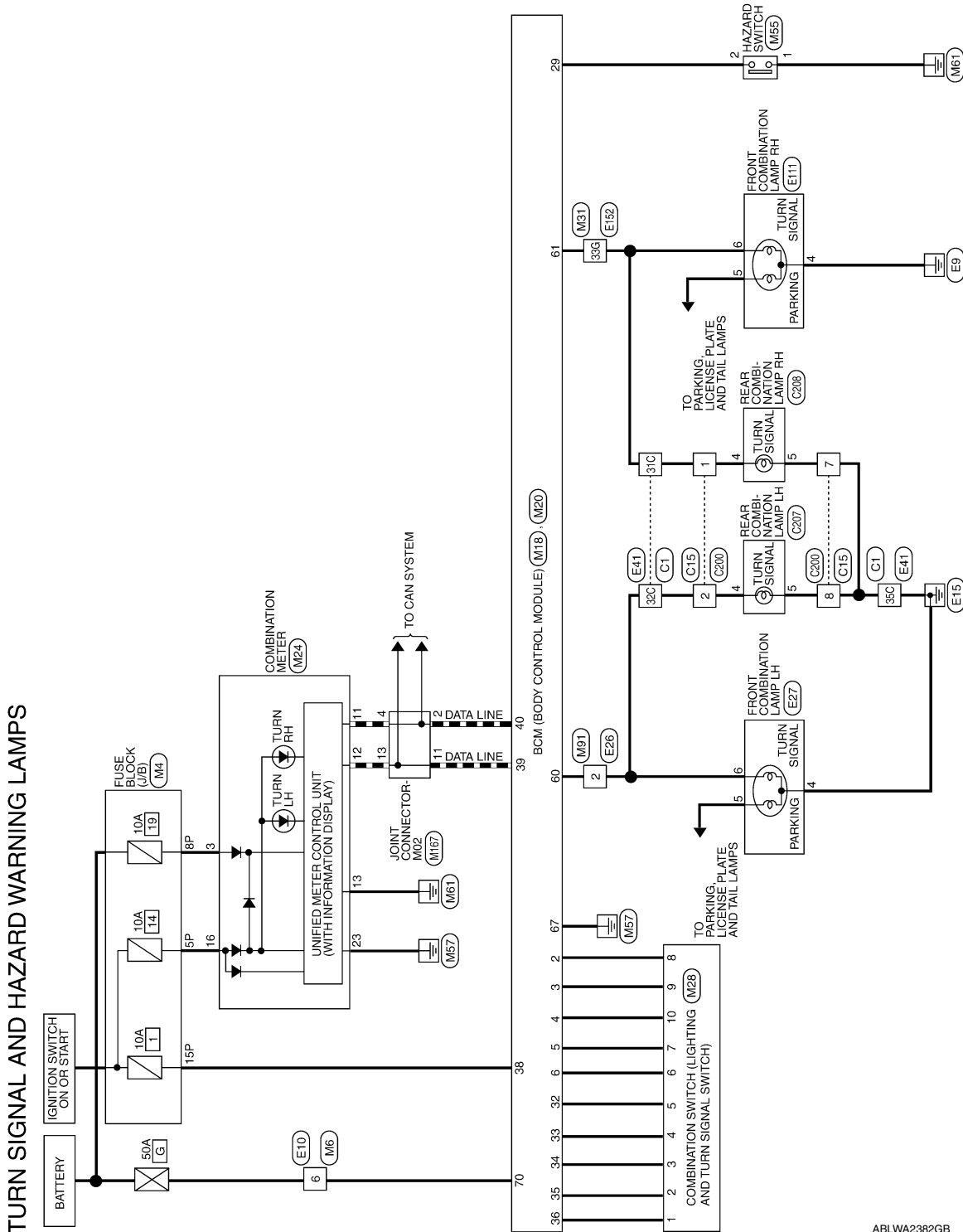

ABLWA2382GB

TURN SIGNAL AND HAZARD WARNING LAMP SYSTEM

< WIRING DIAGRAM >

TURN SIGNAL AND HAZARD WARNING LAMPS CONNECTORS

Connector No.	M4
Connector Name	FUSE BLOCK (J/B)
Connector Color	WHITE



7P	8P	9P	4P	15P	3P	2P	1P	
16P	13P	14P	13P	12P	11P	10P	9P	8P

Terminal No.	Color of Wire	Signal Name
5P	W/G	-
8P	R/Y	-
15P	W/R	-

Connector No.	M6
Connector Name	WIRE TO WIRE
Connector Color	WHITE



3	2	1
6	5	4

Terminal No.	Color of Wire	Signal Name
6	W	-

Connector No.	M18
Connector Name	BCM (BODY CONTROL MODULE)
Connector Color	WHITE



1	2	3	4	5	6	7	8	9	10	11	12	13	14	15	16	17	18	19	20
21	22	23	24	25	26	27	28	29	30	31	32	33	34	35	36	37	38	39	40

Terminal No.	Color of Wire	Signal Name
2	P	INPUT 5
3	SB	INPUT 4
4	V	INPUT 3
5	L	INPUT 2
6	R	INPUT 1
29	G	HAZARD SW

Terminal No.	Color of Wire	Signal Name
32	BG	OUTPUT 5
33	GR	OUTPUT 4
34	G	OUTPUT 3
35	BR	OUTPUT 2
36	LG	OUTPUT 1
38	W/R	IGN SW
39	L	CAN-H
40	P	CAN-L

Connector No.	M20
Connector Name	BCM (BODY CONTROL MODULE)
Connector Color	BLACK



56	57	58	59	60	61	62	63	64
65	66	67	68	69	70			

Terminal No.	Color of Wire	Signal Name
60	LG	FLASHER OUTPUT (LEFT)
61	G	FLASHER OUTPUT (RIGHT)
67	B	GND (POWER)
70	W	BAT (F/L)

ABLIA6847GB

A
B
C
D
E
F
G
H
I
J
K
L
M
N
O
P

EXL

TURN SIGNAL AND HAZARD WARNING LAMP SYSTEM

< WIRING DIAGRAM >

Connector No.	M24
Connector Name	COMBINATION METER
Connector Color	WHITE

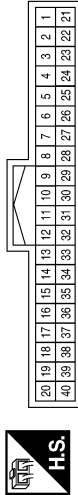

Terminal No.	Color of Wire	Signal Name
3	R/Y	BATTERY
11	P	CAN-L
12	L	CAN-H
13	GR	GROUND
16	W/G	RUN START
23	B	POWER GND

Connector No.	M28
Connector Name	COMBINATION SWITCH
Connector Color	WHITE

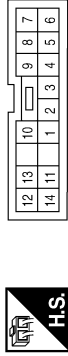

Terminal No.	Color of Wire	Signal Name
1	LG	-
2	BR	-
3	G	-
4	GR	-
5	BG	-
6	R	-

Terminal No.	Color of Wire	Signal Name
7	L	-
8	P	-
9	SB	-
10	V	-

Connector No.	M31
Connector Name	WIRE TO WIRE
Connector Color	WHITE

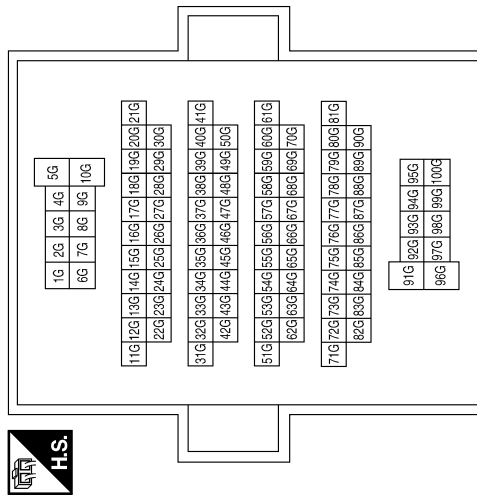

Terminal No.	Color of Wire	Signal Name
33G	G	-

Connector No.	M55
Connector Name	HAZARD SWITCH
Connector Color	WHITE

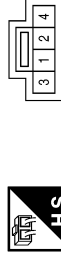

Terminal No.	Color of Wire	Signal Name
1	B	-
2	G	-

ABLIA5620GB

TURN SIGNAL AND HAZARD WARNING LAMP SYSTEM

< WIRING DIAGRAM >

Connector No.	M91
Connector Name	WIRE TO WIRE
Connector Color	WHITE

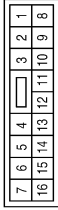

Terminal No.	Color of Wire	Signal Name
2	LG	-

Connector No.	M167
Connector Name	JOINT CONNECTOR-M02
Connector Color	BLUE

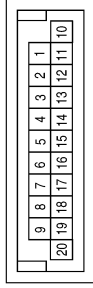

Terminal No.	Color of Wire	Signal Name
2	P	-
4	P	-
11	L	-
13	L	-

Connector No.	E10
Connector Name	WIRE TO WIRE
Connector Color	WHITE



Terminal No.	Color of Wire	Signal Name
6	W	-

Connector No.	E26
Connector Name	WIRE TO WIRE
Connector Color	WHITE

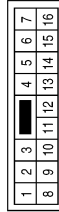

Terminal No.	Color of Wire	Signal Name
2	LG	-

Connector No.	E27
Connector Name	FRONT COMBINATION LAMP LH
Connector Color	GRAY



Terminal No.	Color of Wire	Signal Name
4	B	-
5	R	-
6	LG	-

Connector No.	E41
Connector Name	WIRE TO WIRE
Connector Color	BLACK

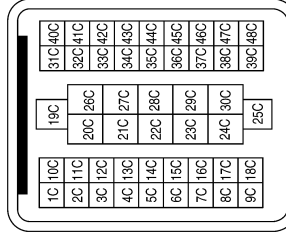

Terminal No.	Color of Wire	Signal Name
31C	L	-
32C	G	-
35C	B	-

ABLIA5657GB

A
B
C
D
E
F
G
H
I
J
K
EXL
M
N
O
P

TURN SIGNAL AND HAZARD WARNING LAMP SYSTEM

< WIRING DIAGRAM >

Connector No.	C1
Connector Name	WIRE TO WIRE
Connector Color	BLACK

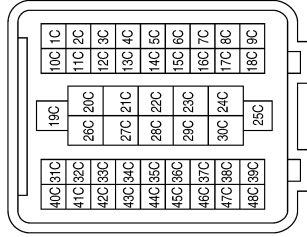

Terminal No.	Color of Wire	Signal Name
31C	L	-
32C	G	-
35C	B	-

Connector No.	E152
Connector Name	WIRE TO WIRE
Connector Color	WHITE

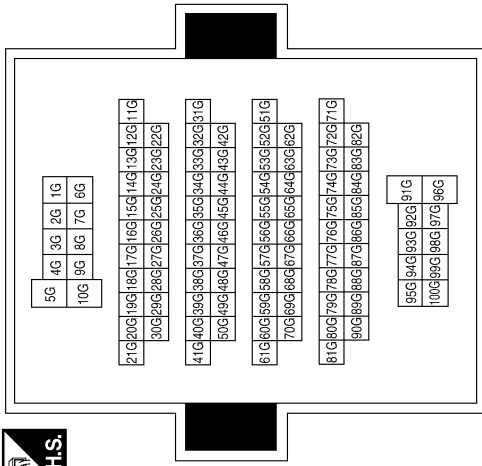

Terminal No.	Color of Wire	Signal Name
33G	G	-

Connector No.	E111
Connector Name	FRONT COMBINATION LAMP RH
Connector Color	GRAY



Terminal No.	Color of Wire	Signal Name
4	B	-
5	GR	-
6	G	-

Connector No.	C207
Connector Name	REAR COMBINATION LAMP LH
Connector Color	GRAY

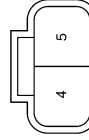

Terminal No.	Color of Wire	Signal Name
4	G	-
5	B/Y	-

Connector No.	C200
Connector Name	WIRE TO WIRE
Connector Color	GRAY

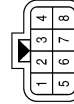

Terminal No.	Color of Wire	Signal Name
1	L	-
2	G	-
7	BR	-
8	B/Y	-

Connector No.	C15
Connector Name	WIRE TO WIRE
Connector Color	GRAY

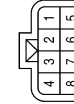

Terminal No.	Color of Wire	Signal Name
1	L	-
2	G	-
7	BR	-
8	B/Y	-

ABLIA5621GB

TURN SIGNAL AND HAZARD WARNING LAMP SYSTEM

< WIRING DIAGRAM >

A
B
C
D
E
F
G
H
I
J
K
EXL
M
N
O
P

Connector No.	C208
Connector Name	REAR COMBINATION LAMP RH
Connector Color	GRAY

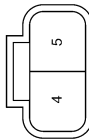

Terminal No.	Color of Wire	Signal Name
4	L	-
5	BR	-

ABLIA3304GB

PARKING, LICENSE PLATE AND TAIL LAMPS SYSTEM

< WIRING DIAGRAM >

PARKING, LICENSE PLATE AND TAIL LAMPS SYSTEM

Wiring Diagram

INFOID:000000012563686

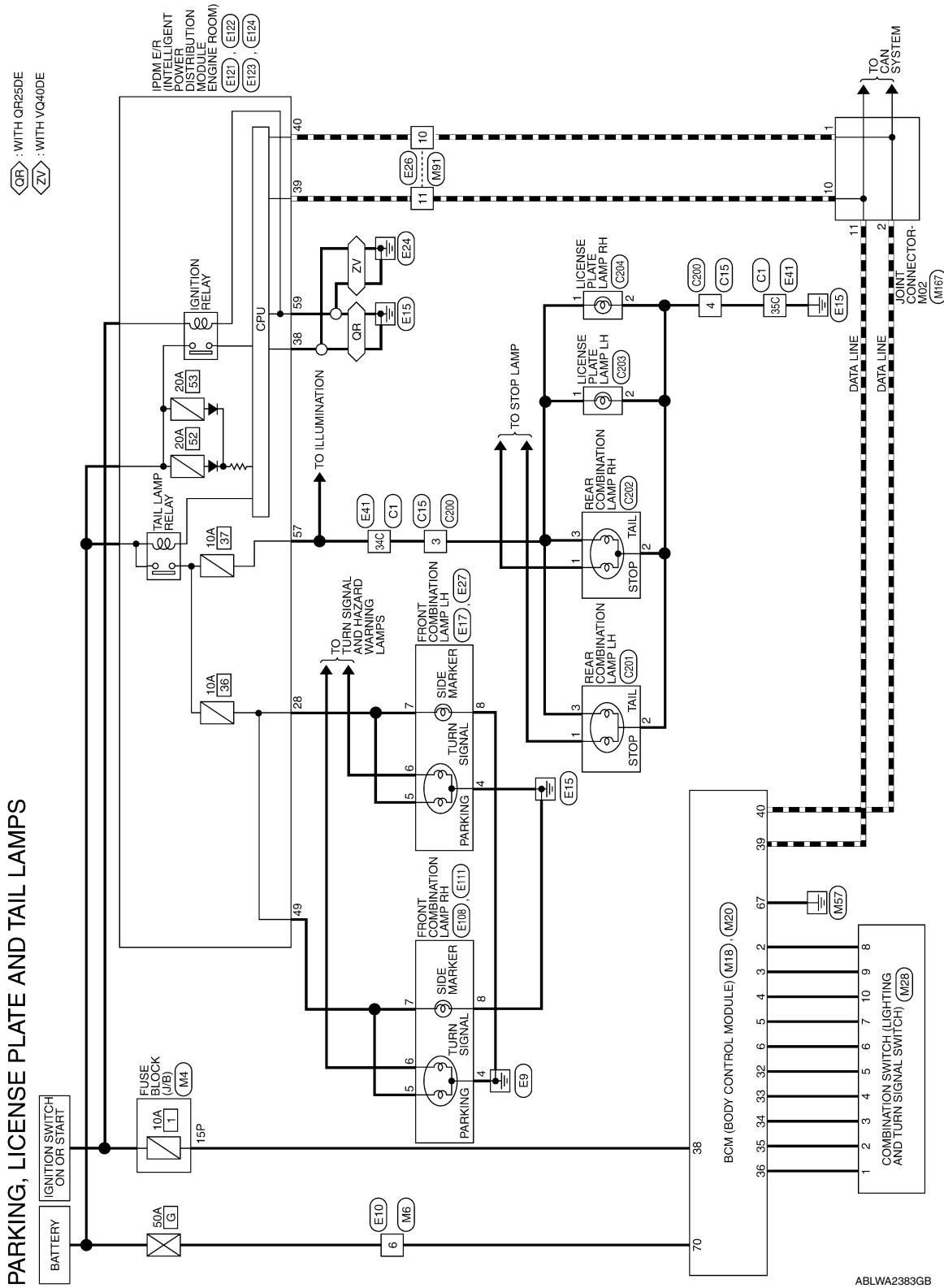

ABLWA2383GB

PARKING, LICENSE PLATE AND TAIL LAMPS SYSTEM

< WIRING DIAGRAM >

PARKING, LICENSE PLATE AND TAIL LAMPS CONNECTORS

Connector No.	M4
Connector Name	FUSE BLOCK (J/B)
Connector Color	WHITE



Terminal No.	Color of Wire	Signal Name
15P	W/R	-

Connector No.	M6
Connector Name	WIRE TO WIRE
Connector Color	WHITE



Terminal No.	Color of Wire	Signal Name
6	W	-

Connector No.	M18
Connector Name	BCM (BODY CONTROL MODULE)
Connector Color	WHITE

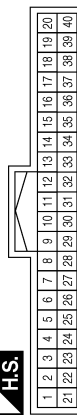

Terminal No.	Color of Wire	Signal Name
2	P	INPUT 5
3	SB	INPUT 4
4	V	INPUT 3
5	L	INPUT 2
6	R	INPUT 1

Terminal No.	Color of Wire	Signal Name
32	BG	OUTPUT 5
33	GR	OUTPUT 4
34	G	OUTPUT 3
35	BR	OUTPUT 2
36	LG	OUTPUT 1
38	W/R	IGN SW
39	L	CAN-H
40	P	CAN-L

Connector No.	M20
Connector Name	BCM (BODY CONTROL MODULE)
Connector Color	BLACK

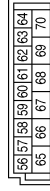

Terminal No.	Color of Wire	Signal Name
67	B	GND (POWER)
70	W	BAT (F/L)

ABLIA6846GB

A
B
C
D
E
F
G
H
I
J
K
L
M
N
O
P

EXL

PARKING, LICENSE PLATE AND TAIL LAMPS SYSTEM

< WIRING DIAGRAM >

Connector No.	M91
Connector Name	WIRE TO WIRE
Connector Color	WHITE

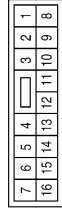

Terminal No.	Color of Wire	Signal Name
10	P	-
11	L	-

Terminal No.	Color of Wire	Signal Name
9	SB	-
10	V	-

Connector No.	M28
Connector Name	COMBINATION SWITCH
Connector Color	WHITE

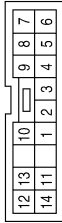

Terminal No.	Color of Wire	Signal Name
1	LG	-
2	BR	-
3	G	-
4	GR	-
5	BG	-
6	R	-
7	L	-
8	P	-

Connector No.	E17
Connector Name	FRONT COMBINATION LAMP LH
Connector Color	GRAY



Terminal No.	Color of Wire	Signal Name
7	R	-
8	B	-

Connector No.	E10
Connector Name	WIRE TO WIRE
Connector Color	WHITE



Terminal No.	Color of Wire	Signal Name
6	W	-

Connector No.	M167
Connector Name	JOINT CONNECTOR-M02
Connector Color	BLUE

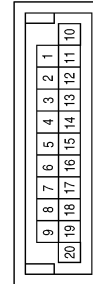

Terminal No.	Color of Wire	Signal Name
1	P	-
2	P	-
10	L	-
11	L	-

ABLIA5623GB

PARKING, LICENSE PLATE AND TAIL LAMPS SYSTEM

< WIRING DIAGRAM >

Connector No.	E41
Connector Name	WIRE TO WIRE
Connector Color	BLACK

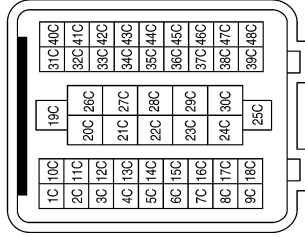

Terminal No.	Color of Wire	Signal Name
34C	GR	-
35C	B	-

Connector No.	E27
Connector Name	FRONT COMBINATION LAMP LH
Connector Color	GRAY



Terminal No.	Color of Wire	Signal Name
4	B	-
5	R	-
6	LG	-

Connector No.	E26
Connector Name	WIRE TO WIRE
Connector Color	WHITE

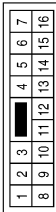

Terminal No.	Color of Wire	Signal Name
10	P	-
11	L	-

Connector No.	E121
Connector Name	IPDM E/R (INTELLIGENT POWER DISTRIBUTION MODULE ENGINE ROOM)
Connector Color	BROWN



Terminal No.	Color of Wire	Signal Name
28	R	CLEARANCE FRONT LH

Connector No.	E111
Connector Name	FRONT COMBINATION LAMP RH
Connector Color	GRAY



Terminal No.	Color of Wire	Signal Name
4	B	-
5	GR	-
6	G	-

Connector No.	E108
Connector Name	FRONT COMBINATION LAMP RH
Connector Color	GRAY



Terminal No.	Color of Wire	Signal Name
7	R	-
8	B	-

ABLIA5653GB

A
B
C
D
E
F
G
H
I
J
K
L
M
N
O
P

EXL

PARKING, LICENSE PLATE AND TAIL LAMPS SYSTEM

< WIRING DIAGRAM >

Connector No.	E124
Connector Name	IPDM E/R (INTELLIGENT POWER DISTRIBUTION MODULE ENGINE ROOM)
Connector Color	BLACK



59	58	57
62	61	60

Terminal No.	Color of Wire	Signal Name
57	GR	TAIL LAMP
59	B	GND (POWER)

Connector No.	E123
Connector Name	IPDM E/R (INTELLIGENT POWER DISTRIBUTION MODULE ENGINE ROOM)
Connector Color	BROWN



51	50	49
56	55	54
53	52	

Terminal No.	Color of Wire	Signal Name
49	GR	CLEARANCE FRONT RH

Connector No.	E122
Connector Name	IPDM E/R (INTELLIGENT POWER DISTRIBUTION MODULE ENGINE ROOM)
Connector Color	WHITE



42	41	40	39	38	37
48	47	46	45	44	43

Terminal No.	Color of Wire	Signal Name
38	B	GND (SIGNAL)
39	L	CAN-H
40	P	CAN-L

Connector No.	C200
Connector Name	WIRE TO WIRE
Connector Color	GRAY



1	2	3	4
5	6	7	8

Terminal No.	Color of Wire	Signal Name
3	GR	-
4	B	-

Connector No.	C15
Connector Name	WIRE TO WIRE
Connector Color	GRAY



4	3	2	1
8	7	6	5

Terminal No.	Color of Wire	Signal Name
3	GR	-
4	B	-

Connector No.	C1
Connector Name	WIRE TO WIRE
Connector Color	BLACK

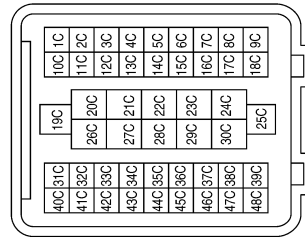

Terminal No.	Color of Wire	Signal Name
34C	GR	-
35C	B	-

ABLIA5654GB

PARKING, LICENSE PLATE AND TAIL LAMPS SYSTEM

< WIRING DIAGRAM >

Connector No.	C203
Connector Name	LICENSE PLATE LAMP LH
Connector Color	GRAY



Terminal No.	Color of Wire	Signal Name
1	V	-
2	B	-

Connector No.	C202
Connector Name	REAR COMBINATION LAMP RH
Connector Color	BROWN



Terminal No.	Color of Wire	Signal Name
1	R	-
2	B	-
3	V	-

Connector No.	C201
Connector Name	REAR COMBINATION LAMP LH
Connector Color	BROWN



Terminal No.	Color of Wire	Signal Name
1	Y	-
2	B	-
3	GR	-

Connector No.	C204
Connector Name	LICENSE PLATE LAMP RH
Connector Color	GRAY



Terminal No.	Color of Wire	Signal Name
1	V	-
2	B	-

ABLIA3301GB

A
B
C
D
E
F
G
H
I
J
K
EXL
M
N
O
P

STOP LAMP

< WIRING DIAGRAM >

STOP LAMP CONNECTORS

Connector No.	M31
Connector Name	WIRE TO WIRE
Connector Color	WHITE

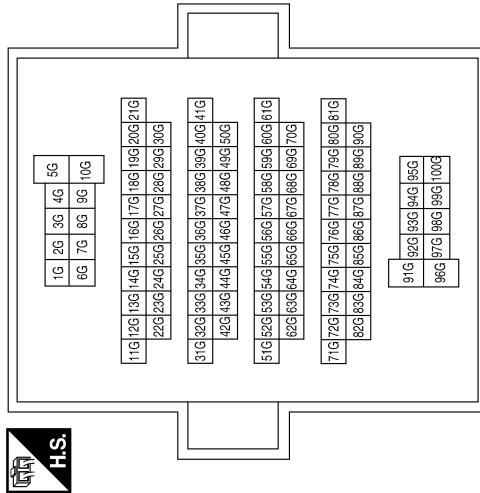

Terminal No.	Color of Wire	Signal Name
60G	L	-

Connector No.	E38
Connector Name	STOP LAMP SWITCH (WITH M/T)
Connector Color	BLACK



Terminal No.	Color of Wire	Signal Name
1	R/B	-
2	Y	-

Connector No.	M36
Connector Name	WIRE TO WIRE
Connector Color	WHITE

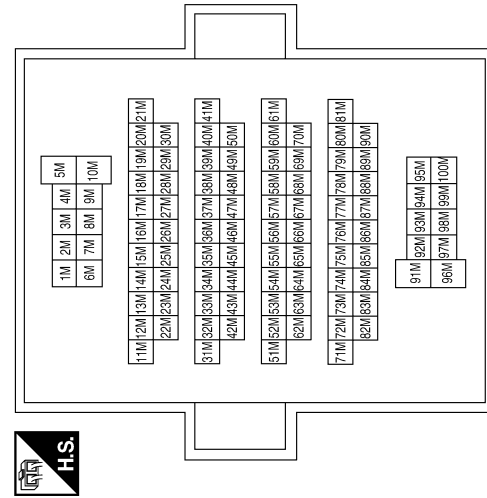

Terminal No.	Color of Wire	Signal Name
46M	L	-

Connector No.	E39
Connector Name	STOP LAMP SWITCH (WITH A/T)
Connector Color	WHITE



Terminal No.	Color of Wire	Signal Name
1	R/B	-
2	Y	-

Connector No.	E12
Connector Name	STOP LAMP RELAY
Connector Color	BLUE



Terminal No.	Color of Wire	Signal Name
1	V	-
2	R/B	-
3	R/B	-
5	G	-

A
B
C
D
E
F
G
H
I
J
K
EXL
M
N
O
P

STOP LAMP

< WIRING DIAGRAM >

Connector No.	E127
Connector Name	ABS ACTUATOR AND ELECTRIC UNIT (CONTROL UNIT)
Connector Color	BLACK



47	46	45	44	43	42	41	40	39	38	37	36	35	34	33	32
16	31	30	29	28	27	26	25	24	23	22	21	20	19	18	17
	15	14	13	12	11	10	9	8	7	6	5	4	3	2	1

Terminal No.	Color of Wire	Signal Name
35	V	STOP LAMP SW ON
39	SB	STOP LAMP SW

Terminal No.	Color of Wire	Signal Name
30C	Y	-
35C	B	-

Connector No.	E41
Connector Name	WIRE TO WIRE
Connector Color	BLACK



1C	10C	19C	31C	40C
2C	11C	20C	32C	41C
3C	12C	21C	33C	42C
4C	13C	22C	34C	43C
5C	14C	23C	35C	44C
6C	15C	24C	36C	45C
7C	16C	25C	37C	46C
8C	17C	26C	38C	47C
9C	18C	27C	39C	48C

Connector No.	E152
Connector Name	WIRE TO WIRE
Connector Color	WHITE

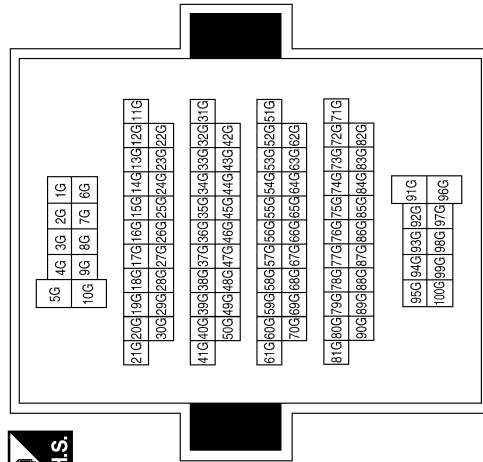

Connector No.	E160
Connector Name	FUSE BLOCK (J/B)
Connector Color	WHITE



5Q	2Q	1Q
8Q	7Q	6Q
5Q	4Q	3Q

Terminal No.	Color of Wire	Signal Name
8Q	R/B	-

ABLIA5600GB

STOP LAMP

< WIRING DIAGRAM >

Connector No.	C1
Connector Name	WIRE TO WIRE
Connector Color	BLACK

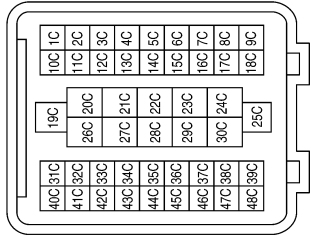

Terminal No.	Color of Wire	Signal Name
30C	Y	-
35C	B	-

Connector No.	C15
Connector Name	WIRE TO WIRE
Connector Color	GRAY

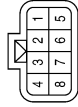

Terminal No.	Color of Wire	Signal Name
4	B	-
5	Y	-

Connector No.	C200
Connector Name	WIRE TO WIRE
Connector Color	GRAY

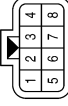

Terminal No.	Color of Wire	Signal Name
4	B	-
5	Y	-

Connector No.	C201
Connector Name	REAR COMBINATION LAMP LH
Connector Color	BROWN



Terminal No.	Color of Wire	Signal Name
1	Y	-
2	B	-
3	GR	-

Connector No.	C202
Connector Name	REAR COMBINATION LAMP RH
Connector Color	BROWN



Terminal No.	Color of Wire	Signal Name
1	R	-
2	B	-
3	V	-

ABLIA5601GB

A B C D E F G H I J K L M N O P

EXL

STOP LAMP

< WIRING DIAGRAM >

Connector No.	B161
Connector Name	HIGH-MOUNTED STOP LAMP ASSEMBLY
Connector Color	WHITE

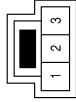

Terminal No.	Color of Wire	Signal Name
1	L	-
2	B	-

Connector No.	B149
Connector Name	WIRE TO WIRE
Connector Color	WHITE

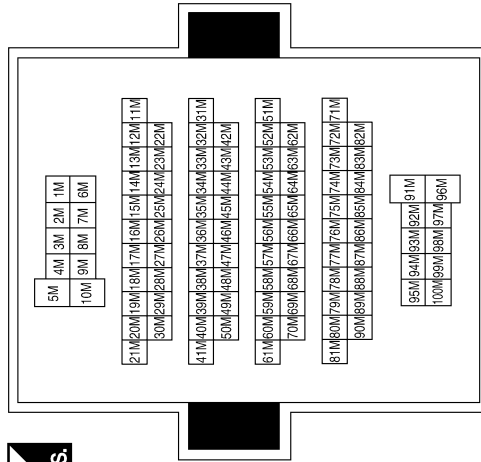

Terminal No.	Color of Wire	Signal Name
46M	L	

ABLIA5602GB

BACK-UP LAMP

< WIRING DIAGRAM >

BACK-UP LAMP

Wiring Diagram

INFOID:000000012563688

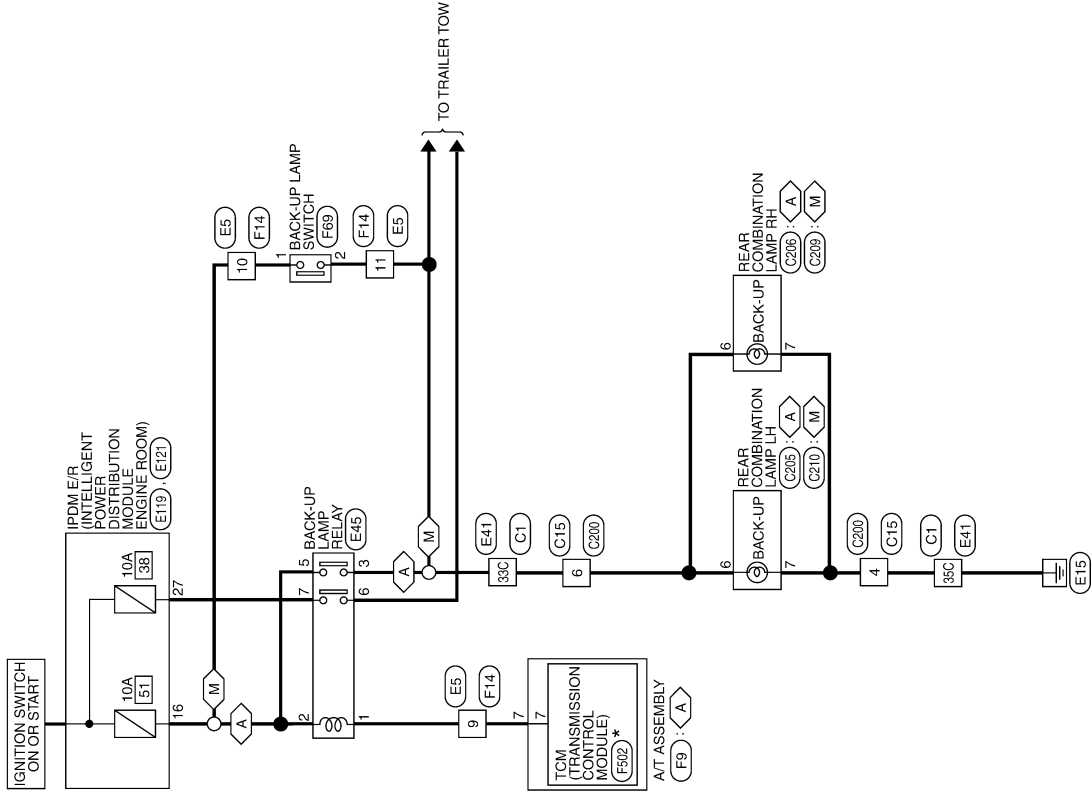
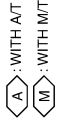

* : THIS CONNECTOR IS NOT SHOWN IN "HARNES LAYOUT" OF PG SECTION.

ABLWA1581GB

BACK-UP LAMP

A
B
C
D
E
F
G
H
I
J
K
L
M
N
O
P

EXL

BACK-UP LAMP

< WIRING DIAGRAM >

BACK-UP LAMP CONNECTORS

Connector No.	E5
Connector Name	WIRE TO WIRE
Connector Color	WHITE

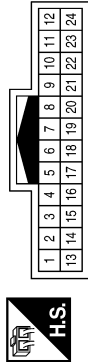

Terminal No.	Color of Wire	Signal Name
9	LG	-
10	W/G	-
11	SB	-

Connector No.	E41
Connector Name	WIRE TO WIRE
Connector Color	BLACK

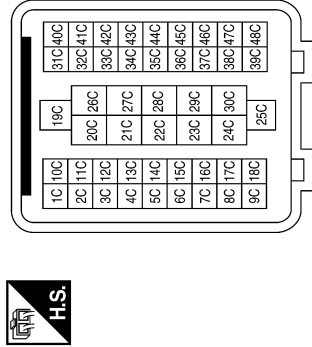

Terminal No.	Color of Wire	Signal Name
33C	SB	-
35C	B	-

Connector No.	E45
Connector Name	BACK-UP LAMP RELAY (WITH A/T)
Connector Color	BROWN



Terminal No.	Color of Wire	Signal Name
1	LG	-
2	W/G	-
3	SB	-
5	W/G	-
6	Y	-
7	W/G	-

Connector No.	E119
Connector Name	IPDM E/R (INTELLIGENT POWER DISTRIBUTION MODULE ENGINE ROOM)
Connector Color	WHITE



Terminal No.	Color of Wire	Signal Name
16	W/G	REVERSE LAMP

Connector No.	E121
Connector Name	IPDM E/R (INTELLIGENT POWER DISTRIBUTION MODULE ENGINE ROOM)
Connector Color	BROWN

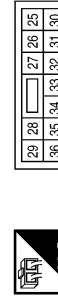

Terminal No.	Color of Wire	Signal Name
27	W/G	T TOW REV LAMP

Connector No.	F9
Connector Name	A/T ASSEMBLY
Connector Color	GREEN



Terminal No.	Color of Wire	Signal Name
7	LG	-

BACK-UP LAMP

< WIRING DIAGRAM >

Connector No.	F502
Connector Name	TCM (TRANSMISSION CONTROL MODULE)
Connector Color	GRAY

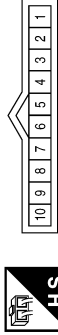

Terminal No.	Color of Wire	Signal Name
7	O	REV LAMP RLY

Connector No.	F69
Connector Name	BACK-UP LAMP SWITCH
Connector Color	WHITE



Terminal No.	Color of Wire	Signal Name
1	W/G	-
2	SB	-

Connector No.	F14
Connector Name	WIRE TO WIRE
Connector Color	WHITE

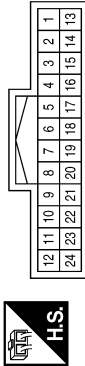

Terminal No.	Color of Wire	Signal Name
9	LG	-
10	W/G	-
11	SB	-

Connector No.	C200
Connector Name	WIRE TO WIRE
Connector Color	GRAY



Terminal No.	Color of Wire	Signal Name
4	B	-
6	SB	-

Connector No.	C15
Connector Name	WIRE TO WIRE
Connector Color	GRAY



Terminal No.	Color of Wire	Signal Name
4	B	-
6	SB	-

Connector No.	C1
Connector Name	WIRE TO WIRE
Connector Color	BLACK

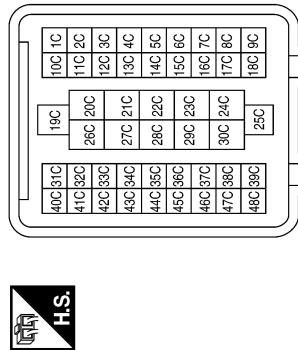

Terminal No.	Color of Wire	Signal Name
33C	SB	-
35C	B	-

ABLIA5652GB

A
B
C
D
E
F
G
H
I
J
K
EXL
M
N
O
P

BACK-UP LAMP

< WIRING DIAGRAM >

Connector No.	C209
Connector Name	REAR COMBINATION LAMP RH (WITH M/T)
Connector Color	GRAY



Terminal No.	Color of Wire	Signal Name
6	O	-
7	B	-

Connector No.	C206
Connector Name	REAR COMBINATION LAMP RH (WITH A/T)
Connector Color	GRAY



Terminal No.	Color of Wire	Signal Name
6	O	-
7	B	-

Connector No.	C205
Connector Name	REAR COMBINATION LAMP LH (WITH A/T)
Connector Color	GRAY



Terminal No.	Color of Wire	Signal Name
6	SB	-
7	B	-

Connector No.	C210
Connector Name	REAR COMBINATION LAMP LH (WITH M/T)
Connector Color	GRAY



Terminal No.	Color of Wire	Signal Name
6	SB	-
7	B	-

ABLIA1896GB

TRAILER TOW

< WIRING DIAGRAM >

TRAILER TOW CONNECTORS

Connector No.	M4
Connector Name	FUSE BLOCK (J/B)
Connector Color	WHITE



Terminal No.	15P	Color of Wire	W/R	Signal Name	-
--------------	-----	---------------	-----	-------------	---

Connector No.	M6
Connector Name	WIRE TO WIRE
Connector Color	WHITE



Terminal No.	6	Color of Wire	W	Signal Name	-
--------------	---	---------------	---	-------------	---

Connector No.	M18
Connector Name	BCM (BODY CONTROL MODULE)
Connector Color	WHITE

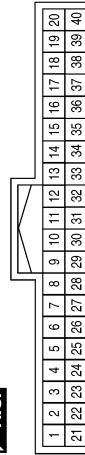

Terminal No.	Color of Wire	Signal Name
2	P	INPUT 5
3	SB	INPUT 4
4	V	INPUT 3
5	L	INPUT 2
6	R	INPUT 1

Terminal No.	Color of Wire	Signal Name
32	BG	OUTPUT 5
33	GR	OUTPUT 4
34	G	OUTPUT 3
35	BR	OUTPUT 2
36	LG	OUTPUT 1
38	W/R	IGN SW
39	L	CAN-H
40	P	CAN-L

Connector No.	M19
Connector Name	BCM (BODY CONTROL MODULE)
Connector Color	WHITE

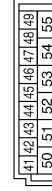

Terminal No.	Color of Wire	Signal Name
51	BG	TRAILER FLASHER OUTPUT (RIGHT)
52	LG	TRAILER FLASHER OUTPUT (LEFT)

TRAILER TOW

< WIRING DIAGRAM >

Terminal No.	Color of Wire	Signal Name
7	L	-
8	P	-
9	SB	-
10	V	-

Connector No.	M28
Connector Name	COMBINATION SWITCH
Connector Color	WHITE

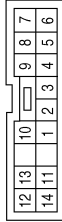

Terminal No.	Color of Wire	Signal Name
1	LG	-
2	BR	-
3	G	-
4	GR	-
5	BG	-
6	R	-

Connector No.	M20
Connector Name	BCM (BODY CONTROL MODULE)
Connector Color	BLACK

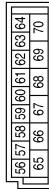

Terminal No.	Color of Wire	Signal Name
67	B	GND (POWER)
70	W	BAT (F/L)

Connector No.	M76
Connector Name	ELECTRIC BRAKE (PRE-WIRING)
Connector Color	WHITE



Terminal No.	Color of Wire	Signal Name
1	B	-
2	LG	-
3	BR	-
4	R	-
5	Y	-

Terminal No.	Color of Wire	Signal Name
42G	R	-
51G	BG	-
52G	LG	-
60G	L	-
94G	BR	-
95G	Y	-

Connector No.	M31
Connector Name	WIRE TO WIRE
Connector Color	WHITE

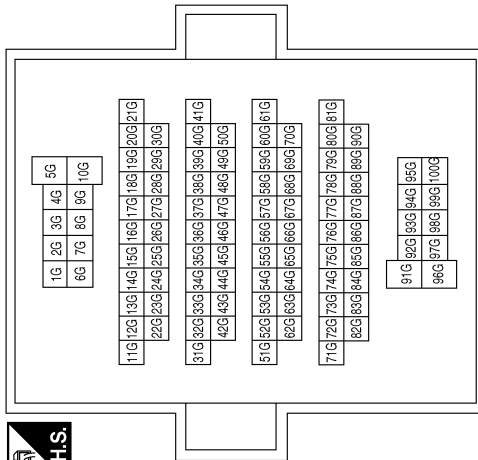

ABLIA6841GB

A
B
C
D
E
F
G
H
I
J
K
EXL
M
N
O
P

TRAILER TOW

< WIRING DIAGRAM >

Connector No.	M91
Connector Name	WIRE TO WIRE
Connector Color	WHITE

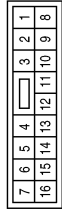

Terminal No.	Color of Wire	Signal Name
10	P	-
11	L	-

Connector No.	M167
Connector Name	JOINT CONNECTOR-M02
Connector Color	BLUE

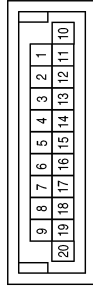

Terminal No.	Color of Wire	Signal Name
1	P	-
2	P	-
10	L	-
11	L	-

Connector No.	E10
Connector Name	WIRE TO WIRE
Connector Color	WHITE



Terminal No.	Color of Wire	Signal Name
6	W	-

Connector No.	E26
Connector Name	WIRE TO WIRE
Connector Color	WHITE

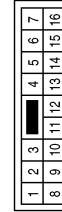

Terminal No.	Color of Wire	Signal Name
10	P	-
11	L	-

Connector No.	E38
Connector Name	STOP LAMP SWITCH (WITH M/T)
Connector Color	BLACK



Terminal No.	Color of Wire	Signal Name
1	R/B	-
2	Y	-

Connector No.	E39
Connector Name	STOP LAMP SWITCH (WITH A/T)
Connector Color	WHITE



Terminal No.	Color of Wire	Signal Name
1	R/B	-
2	Y	-

TRAILER TOW

< WIRING DIAGRAM >

Connector No.	E41
Connector Name	WIRE TO WIRE
Connector Color	BLACK

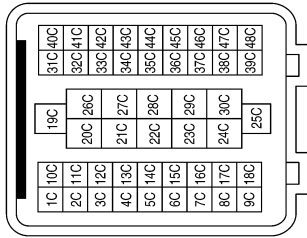

Terminal No.	Color of Wire	Signal Name
2C	G	-
3C	V	-
4C	Y	-
19C	V	-
20C	B	-
21C	R	-
22C	BR	-

Connector No.	E121
Connector Name	IPDM E/R (INTELLIGENT POWER DISTRIBUTION MODULE ENGINE ROOM)
Connector Color	BROWN

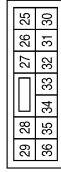

Terminal No.	Color of Wire	Signal Name
27	W/G	T TOW REV LAMP
29	G	TRAILER RLY CONT

Connector No.	E122
Connector Name	IPDM E/R (INTELLIGENT POWER DISTRIBUTION MODULE ENGINE ROOM)
Connector Color	WHITE



Terminal No.	Color of Wire	Signal Name
38	B	GND (SIGNAL)
39	L	CAN-H
40	P	CAN-L

Connector No.	E124
Connector Name	IPDM E/R (INTELLIGENT POWER DISTRIBUTION MODULE ENGINE ROOM)
Connector Color	BLACK



Terminal No.	Color of Wire	Signal Name
57	GR	TAIL LAMP
59	B	GND (POWER)
61	R/B	TRAIL RLY SUPPLY

ABLIA5655GB

A
B
C
D
E
F
G
H
I
J
K
EXL
M
N
O
P

TRAILER TOW

< WIRING DIAGRAM >

Connector No.	E160
Connector Name	FUSE BLOCK (J/B)
Connector Color	WHITE



Terminal No.	Color of Wire	Signal Name
8Q	R/B	-

Terminal No.	Color of Wire	Signal Name
42G	R	-
51G	BG	-
52G	LG	-
60G	L	-
94G	BR	-
95G	Y	-

Connector No.	E152
Connector Name	WIRE TO WIRE
Connector Color	WHITE

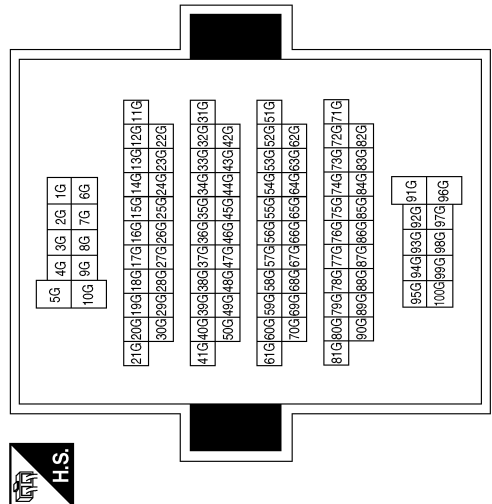

Connector No.	E165
Connector Name	TRAILER TURN RELAY RH
Connector Color	BLUE



Terminal No.	Color of Wire	Signal Name
1	BG	-
2	B	-
3	G	-
5	L	-

Connector No.	E164
Connector Name	TRAILER TURN RELAY LH
Connector Color	BLUE



Terminal No.	Color of Wire	Signal Name
1	LG	-
2	B	-
3	V	-
5	L	-

ABLIA6842GB

TRAILER TOW

< WIRING DIAGRAM >

Connector No.	E168
Connector Name	WIRE TO WIRE
Connector Color	WHITE



Terminal No.	Color of Wire	Signal Name
1	B	-
2	W/G	-
3	R/B	-
4	GR	-
5	Y	-
6	P	-
7	W/G	-
8	Y	-
9	V	-
10	R	-
11	V	-
12	G	-

Connector No.	E225
Connector Name	WIRE TO WIRE
Connector Color	WHITE

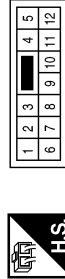

Terminal No.	Color of Wire	Signal Name
1	B	-
2	W/G	-
3	R/B	-
4	GR	-
5	W	-
6	BR	-
7	W/G	-
8	SB	-
9	L	-
10	R	-
11	O	-
12	G	-

Connector No.	E226
Connector Name	BACK-UP LAMP RELAY (WITH M/T)
Connector Color	BLUE

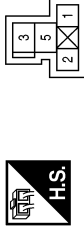

Terminal No.	Color of Wire	Signal Name
1	B	-
2	BR	-
3	W/G	-
5	SB	-

Connector No.	E227
Connector Name	TRAILER TOW RELAY 1
Connector Color	BLUE

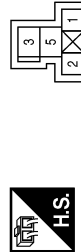

Terminal No.	Color of Wire	Signal Name
1	G	-
2	B	-
3	R/B	-
5	R	-

Connector No.	E228
Connector Name	TRAILER TOW RELAY 2
Connector Color	BROWN



Terminal No.	Color of Wire	Signal Name
1	W/G	-
2	B	-
3	GR	-
5	L	-
6	W	-
7	O	-

ABLIA4505GB

A
B
C
D
E
F
G
H
I
J
K
L
M
N
O
P

EXL

TRAILER TOW

< WIRING DIAGRAM >

Connector No.	C1
Connector Name	WIRE TO WIRE
Connector Color	BLACK

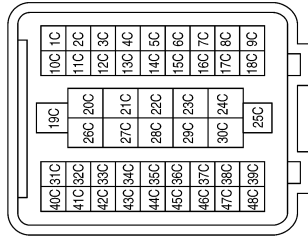

Terminal No.	Color of Wire	Signal Name
2C	G	-
3C	V	-
4C	Y	-
19C	V	-
20C	B	-
21C	R	-
22C	BR	-

Connector No.	C51
Connector Name	WIRE TO WIRE
Connector Color	GRAY

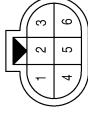

Terminal No.	Color of Wire	Signal Name
1	B	-
2	G	-
3	V	-
5	Y	-
6	R	-

Connector No.	C52
Connector Name	WIRE TO WIRE
Connector Color	BLACK



Terminal No.	Color of Wire	Signal Name
1	BR	-
2	V	-

Connector No.	C125
Connector Name	WIRE TO WIRE
Connector Color	GRAY

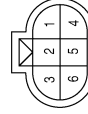

Terminal No.	Color of Wire	Signal Name
1	W	-
2	G	-
3	V	-
5	B	-
6	BR	-

Connector No.	C126
Connector Name	TRAILER
Connector Color	BLACK

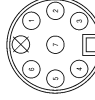

Terminal No.	Color of Wire	Signal Name
1	R	-
2	W	-
3	V	-
4	BR	-
5	L	-
6	G	-
7	B	-

TRAILER TOW

< WIRING DIAGRAM >

A
B
C
D
E
F
G
H
I
J
K
EXL
M
N
O
P

Connector No.	C150
Connector Name	WIRE TO WIRE
Connector Color	BLACK



Terminal No.	Color of Wire	Signal Name
1	R	-
2	L	-

Connector No.	C129
Connector Name	TRAILER RECEPTACLE
Connector Color	BLACK

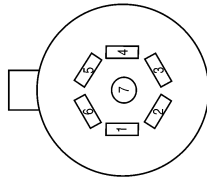

Terminal No.	Color of Wire	Signal Name
1	-	STOP/TURN LH
2	-	GROUND
3	-	ELECTRIC BRAKE
4	-	STOP/TURN RH
5	-	BATTERY
6	-	RUNNING LAMPS
7	-	BACK-UP LAMPS

ABLIA5658GB

EXTERIOR LIGHTING SYSTEM SYMPTOMS

< SYMPTOM DIAGNOSIS >

SYMPTOM DIAGNOSIS

EXTERIOR LIGHTING SYSTEM SYMPTOMS

Symptom Table

INFOID:000000012563690

CAUTION:

Perform the self-diagnosis with CONSULT before the symptom diagnosis. Perform the trouble diagnosis if any DTC is detected.

Symptom		Possible cause	Inspection item
Headlamp does not switch to the high beam.	One side	<ul style="list-style-type: none"> • Fuse • Harness between IPDM E/R and the front combination lamp • Front combination lamp • IPDM E/R 	Headlamp (HI) circuit Refer to EXL-39 .
	Both sides	Symptom diagnosis "BOTH SIDE HEADLAMPS DO NOT SWITCH TO HIGH BEAM" Refer to EXL-131 , "Diagnosis Procedure".	
High beam indicator lamp is not turned ON. (Headlamp switches to the high beam.)		<ul style="list-style-type: none"> • Combination meter • BCM 	<ul style="list-style-type: none"> • Combination meter. Data monitor "HI-BEAM IND" • BCM (HEAD LAMP) Active test "HEADLAMP"
Headlamp does not switch to the low beam.	One side	<ul style="list-style-type: none"> • Daytime light relay 2 • Harness between IPDM, daytime light relay 2 and front combination lamp LH. • Front combination lamp (Low beam) 	Headlamp (LO) circuit Refer to EXL-42 .
	Both sides	<ul style="list-style-type: none"> • Combination switch (lighting and turn signal switch) • Harness between the combination switch (lighting and turn signal switch) and BCM • BCM 	Combination switch (lighting and turn signal switch) Refer to BCS-53 .
		High beam request signal	IPDM E/R Data monitor "HL HI REQ"
		IPDM E/R	—
Headlamp does not turn ON.	One side	<ul style="list-style-type: none"> • Fuse • Bulb • Harness between IPDM E/R and the front combination lamp • Front combination lamp • IPDM E/R 	Headlamp (LO) circuit Refer to EXL-42 .
	Both sides	Symptom diagnosis "BOTH SIDE HEADLAMPS (LO) ARE NOT TURNED ON" Refer to EXL-133 , "Diagnosis Procedure".	
Headlamp does not turn OFF.	When the ignition switch is turned ON	<ul style="list-style-type: none"> • BCM • Combination switch (lighting and turn signal switch) 	Combination switch (lighting and turn signal switch) Refer to BCS-53 .

EXTERIOR LIGHTING SYSTEM SYMPTOMS

< SYMPTOM DIAGNOSIS >

Symptom	Possible cause	Inspection item	
Headlamp is not turned ON/OFF with the lighting switch AUTO.	<ul style="list-style-type: none"> • Combination switch (lighting and turn signal switch) • Harness between the combination switch (lighting and turn signal switch) and BCM • BCM • IPDM E/R 	Combination switch (lighting and turn signal switch) Refer to BCS-53 .	
	<ul style="list-style-type: none"> • Optical sensor • Harness between the optical sensor and BCM • BCM 	Optical sensor Refer to EXL-56 .	
Daytime light system does not activate.	<ul style="list-style-type: none"> • Either high beam bulb • Parking brake switch • Combination switch (lighting and turn signal switch) • BCM • IPDM E/R • Daytime light relay 1 • Harness between IPDM E/R and daytime light relay 1. 	Daytime light system description. Refer to EXL-12 , " System Description ".	
Front fog lamp is not turned ON.	One side	<ul style="list-style-type: none"> • Front fog lamp bulb • Harness between IPDM E/R and the front combination lamp • Front combination lamp • IPDM E/R 	Front fog lamp circuit Refer to EXL-48 .
	Both side	Symptom diagnosis "BOTH SIDE FRONT FOG LAMPS ARE NOT TURNED ON" Refer to EXL-135 , " Diagnosis Procedure ".	
Parking lamp is not turned ON.	One side	<ul style="list-style-type: none"> • Fuse • Parking lamp bulb • Harness between IPDM E/R and the front/rear combination lamp • Front/rear combination lamp • IPDM E/R 	Parking lamp circuit Refer to EXL-50 .
	Both sides	Symptom diagnosis "PARKING, LICENSE PLATE AND TAIL LAMPS ARE NOT TURNED ON" Refer to EXL-134 , " Diagnosis Procedure ".	
Turn signal lamp does not blink.	Indicator lamp is normal. (The applicable side performs the high flasher activation).	<ul style="list-style-type: none"> • Harness between BCM and each turn signal lamp • Turn signal lamp bulb 	Turn signal lamp circuit Refer to EXL-53 .
Turn signal indicator lamp does not blink.	One side	Combination meter	—
	Both sides (Always)	<ul style="list-style-type: none"> • Turn signal indicator lamp signal • Combination meter • BCM 	<ul style="list-style-type: none"> • Combination meter. • Data monitor "TURN IND" • BCM (FLASHER) • Active test "FLASHER"
	Both sides (Does blink when activating the hazard warning lamp with the ignition switch OFF)	<ul style="list-style-type: none"> • The combination meter power supply and the ground circuit • Combination meter 	Power supply and the ground circuit Refer to MWI-31 .

A
B
C
D
E
F
G
H
I
J
K
EXL
M
N
O
P

NORMAL OPERATING CONDITION

< SYMPTOM DIAGNOSIS >

NORMAL OPERATING CONDITION

Description

INFOID:000000012563691

AUTO LIGHT SYSTEM

The auto light system may not turn the headlamp ON/OFF immediately after passing a dark area or a bright area (short tunnel, sky bridge, shadowed area etc.). This is normal.

BOTH SIDE HEADLAMPS DO NOT SWITCH TO HIGH BEAM

< SYMPTOM DIAGNOSIS >

BOTH SIDE HEADLAMPS DO NOT SWITCH TO HIGH BEAM

Description

INFOID:000000012563692

The headlamps (both sides) do not switch to high beam when the combination switch (lighting and turn signal switch) is in the HI or PASS setting.

Diagnosis Procedure

INFOID:000000012563693

1.COMBINATION SWITCH (LIGHTING AND TURN SIGNAL SWITCH) INSPECTION

Check the combination switch (lighting and turn signal switch). Refer to [BCS-53. "Symptom Table"](#).

Is the combination switch (lighting and turn signal switch) normal?

YES >> GO TO 2.

NO >> Repair or replace the malfunctioning part.

2.CHECK HEADLAMP (HI) REQUEST SIGNAL INPUT

 WITH CONSULT DATA MONITOR

1. Select "HL HI REQ" of IPDM E/R DATA MONITOR item.

2. With operating the combination switch (lighting and turn signal switch), check the monitor status.

Monitor item	Condition	Monitor status	
HL HI REQ	Combination switch (lighting and turn signal switch) (2ND position)	HI or PASS	ON
		Except for HI or PASS	OFF

Is the item status normal?

YES >> GO TO 3.

NO >> Replace BCM. Refer to [BCS-56. "Removal and Installation"](#).

3.HEADLAMP (HI) CIRCUIT INSPECTION

Check the headlamp (HI) circuit. Refer to [EXL-39. "Description"](#).

Is the headlamp (HI) circuit normal?

YES >> Replace IPDM E/R. Refer to [PCS-28. "Removal and Installation of IPDM E/R"](#).

NO >> Repair or replace the malfunctioning part.

A
B
C
D
E
F
G
H
I
J
K
M
N
O
P

EXL

DAYTIME LIGHT SYSTEM INOPERATIVE

< SYMPTOM DIAGNOSIS >

DAYTIME LIGHT SYSTEM INOPERATIVE

Description

INFOID:000000012563694

The daytime light system is inoperative even though the combination switch (lighting and turn signal switch) and parking brake switch are in the normal setting, also whenever engine is operating.

Diagnosis Procedure

INFOID:000000012563695

NOTE:

Before performing the diagnosis, check that the following is normal:

- High beam lamp function
- Parking brake warning lamp
- Engine operation status

1.COMBINATION SWITCH (LIGHTING AND TURN SIGNAL SWITCH) INSPECTION

Check the combination switch (lighting and turn signal switch). Refer to [BCS-53. "Symptom Table"](#).

Is the combination switch (lighting and turn signal switch) normal?

YES >> GO TO 2.

NO >> Repair or replace the malfunctioning part.

2.CHECK DAYTIME LIGHT REQUEST SIGNAL INPUT

Ⓔ WITH CONSULT DATA MONITOR

1. Parking brake switch is released.
2. Start engine.
3. Select "DTRL REQ" of IPDM E/R DATA MONITOR item.
4. While operating the combination switch (lighting and turn signal switch), check the monitor status.

Monitor item	Condition	Monitor status	
DTRL REQ	combination switch (lighting and turn signal switch)	1ST or OFF	ON
		Except for 1ST or OFF	OFF

Is the item status normal?

YES >> GO TO 3.

NO >> Replace BCM. Refer to [BCS-56. "Removal and Installation"](#).

3.DAYTIME LIGHT RELAY CIRCUIT INSPECTION

Check the daytime light relay circuit. Refer to [EXL-46. "Diagnosis Procedure"](#).

Is the daytime light relay circuit normal?

YES >> Replace IPDM E/R. Refer to [PCS-28. "Removal and Installation of IPDM E/R"](#).

NO >> Repair or replace the malfunctioning part.

BOTH SIDE HEADLAMPS (LO) ARE NOT TURNED ON

< SYMPTOM DIAGNOSIS >

BOTH SIDE HEADLAMPS (LO) ARE NOT TURNED ON

Description

INFOID:000000012563696

The headlamps (both sides) do not turn ON in any combination switch (lighting and turn signal switch) setting.

Diagnosis Procedure

INFOID:000000012563697

1.COMBINATION SWITCH (LIGHTING AND TURN SIGNAL SWITCH) INSPECTION

Check the combination switch (lighting and turn signal switch). Refer to [BCS-53, "Symptom Table"](#).

Is the combination switch (lighting and turn signal switch) normal?

YES >> GO TO 2.

NO >> Repair or replace the malfunctioning part.

2.CHECK HEADLAMP (LO) REQUEST SIGNAL INPUT

Ⓜ WITH CONSULT DATA MONITOR

1. Select "HL LO REQ" of IPDM E/R DATA MONITOR item.

2. With operating the combination switch (lighting and turn signal switch), check the monitor status.

Monitor item	Condition	Monitor status	
HL LO REQ	Combination switch (lighting and turn signal switch)	2ND	ON
		OFF	OFF

Is the item status normal?

YES >> GO TO 3.

NO >> Replace BCM. Refer to [BCS-56, "Removal and Installation"](#).

3.HEADLAMP (LO) CIRCUIT INSPECTION

Check the headlamp (LO) circuit. Refer to [EXL-42, "Description"](#).

Is the headlamp (LO) circuit normal?

YES >> Replace IPDM E/R. Refer to [PCS-28, "Removal and Installation of IPDM E/R"](#).

NO >> Repair or replace the malfunctioning part.

A
B
C
D
E
F
G
H
I
J
K
L
M
N
O
P

EXL

PARKING, LICENSE PLATE AND TAIL LAMPS ARE NOT TURNED ON

< SYMPTOM DIAGNOSIS >

PARKING, LICENSE PLATE AND TAIL LAMPS ARE NOT TURNED ON

Description

INFOID:000000012563698

The parking, license plate and tail lamps do not turn ON in with any combination switch (lighting and turn signal switch) setting.

Diagnosis Procedure

INFOID:000000012563699

1.COMBINATION SWITCH (LIGHTING AND TURN SIGNAL SWITCH) INSPECTION

Check the combination switch (lighting and turn signal switch). Refer to [BCS-53. "Symptom Table"](#).

Is the combination switch (lighting and turn signal switch) normal?

YES >> GO TO 2.

NO >> Repair or replace the malfunctioning part.

2.CHECK TAIL LAMP RELAY REQUEST SIGNAL INPUT

 WITH CONSULT DATA MONITOR

1. Select "TAIL & CLR REQ" of IPDM E/R DATA MONITOR item.

2. With operating the combination switch (lighting and turn signal switch), check the monitor status.

Monitor item	Condition	Monitor status	
TAIL & CLR REQ	Combination switch (lighting and turn signal switch)	1ST	ON
		OFF	OFF

Is the item status normal?

YES >> GO TO 3.

NO >> Replace BCM. Refer to [BCS-56. "Removal and Installation"](#).

3.PARK LAMP CIRCUIT INSPECTION

Check the parking lamp circuit. Refer to [EXL-50. "Description"](#).

Is the tail lamp circuit normal?

YES >> Replace IPDM E/R. Refer to [PCS-28. "Removal and Installation of IPDM E/R"](#).

NO >> Repair or replace the malfunctioning part.

BOTH SIDE FRONT FOG LAMPS ARE NOT TURNED ON

< SYMPTOM DIAGNOSIS >

BOTH SIDE FRONT FOG LAMPS ARE NOT TURNED ON

Description

INFOID:000000012563700

The front fog lamps do not turn ON in any combination switch (lighting and turn signal switch) setting.

Diagnosis Procedure

INFOID:000000012563701

1.COMBINATION SWITCH (LIGHTING AND TURN SIGNAL SWITCH) INSPECTION

Check the combination switch (lighting and turn signal switch). Refer to [BCS-53, "Symptom Table"](#).

Is the combination switch (lighting and turn signal switch) normal?

YES >> GO TO 2.

NO >> Repair or replace the malfunctioning part.

2.CHECK FRONT FOG LAMP REQUEST SIGNAL INPUT

Ⓜ WITH CONSULT DATA MONITOR

1. Select "FR FOG REQ" of IPDM E/R DATA MONITOR item.

2. With operating the combination switch (lighting and turn signal switch), check the monitor status.

Monitor item	Condition	Monitor status	
FR FOG REQ	Combination switch (lighting and turn signal switch) (2ND)	ON	ON
		OFF	OFF

Is the item status normal?

YES >> GO TO 3.

NO >> Replace BCM. Refer to [BCS-56, "Removal and Installation"](#).

3.FRONT FOG LAMP CIRCUIT INSPECTION

Check the front fog lamp circuit. Refer to [EXL-48, "Description"](#).

Is the front fog lamp circuit normal?

YES >> Replace IPDM E/R. Refer to [PCS-28, "Removal and Installation of IPDM E/R"](#).

NO >> Repair or replace the malfunctioning part.

A
B
C
D
E
F
G
H
I
J
K
M
N
O
P

EXL

HEADLAMP

< PERIODIC MAINTENANCE >

PERIODIC MAINTENANCE

HEADLAMP

Aiming Adjustment

INFOID:0000000012563702

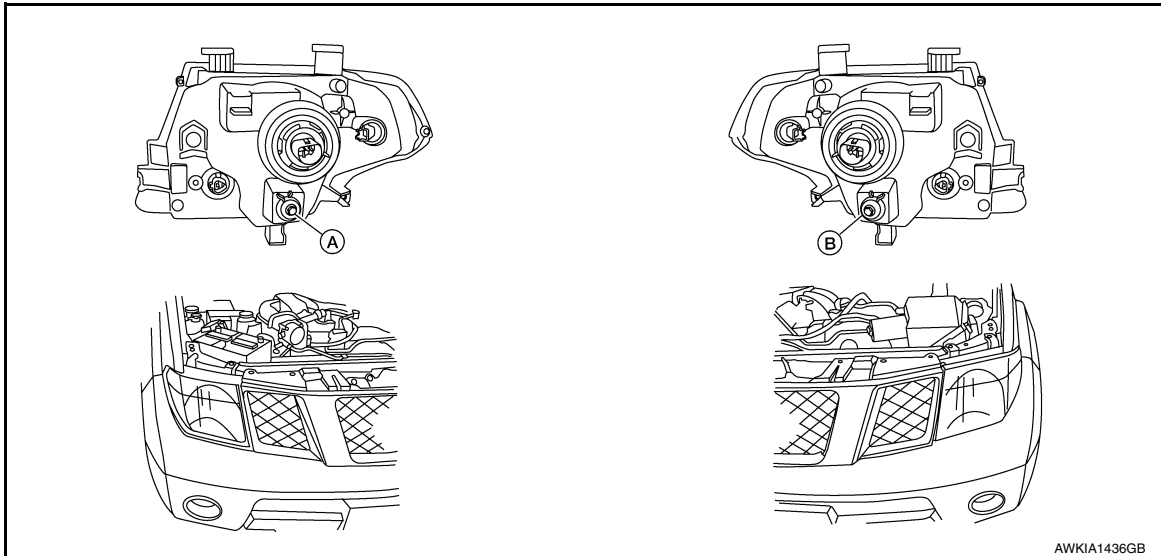

A. Headlamp (RH) adjustment screw

B. Headlamp (LH) adjustment screw

NOTE:

- For headlamp aiming details, refer to the regulations in your area.
- If vehicle front body has been repaired or the front combination lamp has been replaced, check headlamp aiming.
- Before performing aiming adjustment, check the following:
 - Confirm headlamp aiming switch is set to "0" (zero) position.
 - Ensure all tires are inflated to correct pressure.
 - Place vehicle and screen on level surface.
 - Ensure there is no load in vehicle other than the driver (or equivalent weight placed in driver's position). Coolant and engine oil filled to correct level, and fuel tank full.
 - Confirm spare tire, jack and tools are properly stowed.
 - Aim each headlamp individually and ensure other headlamp beam pattern is blocked from screen.
 - Use adjusting screw to perform aiming adjustment

LOW BEAM AND HIGH BEAM

CAUTION:

Do not tighten adjustment screw beyond a torque of 1.67 N·m (17 kg-cm, 15 in-lb) or damage may occur.

NOTE:

By regulation, no means for horizontal aim adjustment is provided from the factory; only vertical aim is adjustable.

1. Turn headlamp low beam on.
2. Use adjustment screw to perform aiming adjustment.
3. Adjust beam pattern until cut-off line (top edge of illumination area) is positioned at same height off ground as bulb center (on H-line). Measure cut-off line within distance A on H-line. See aiming chart below.
 - Basic illuminating area for adjustment should be within the range shown on the aiming chart. Adjust headlamps accordingly.

Headlamp Aiming

HEADLAMP

< PERIODIC MAINTENANCE >

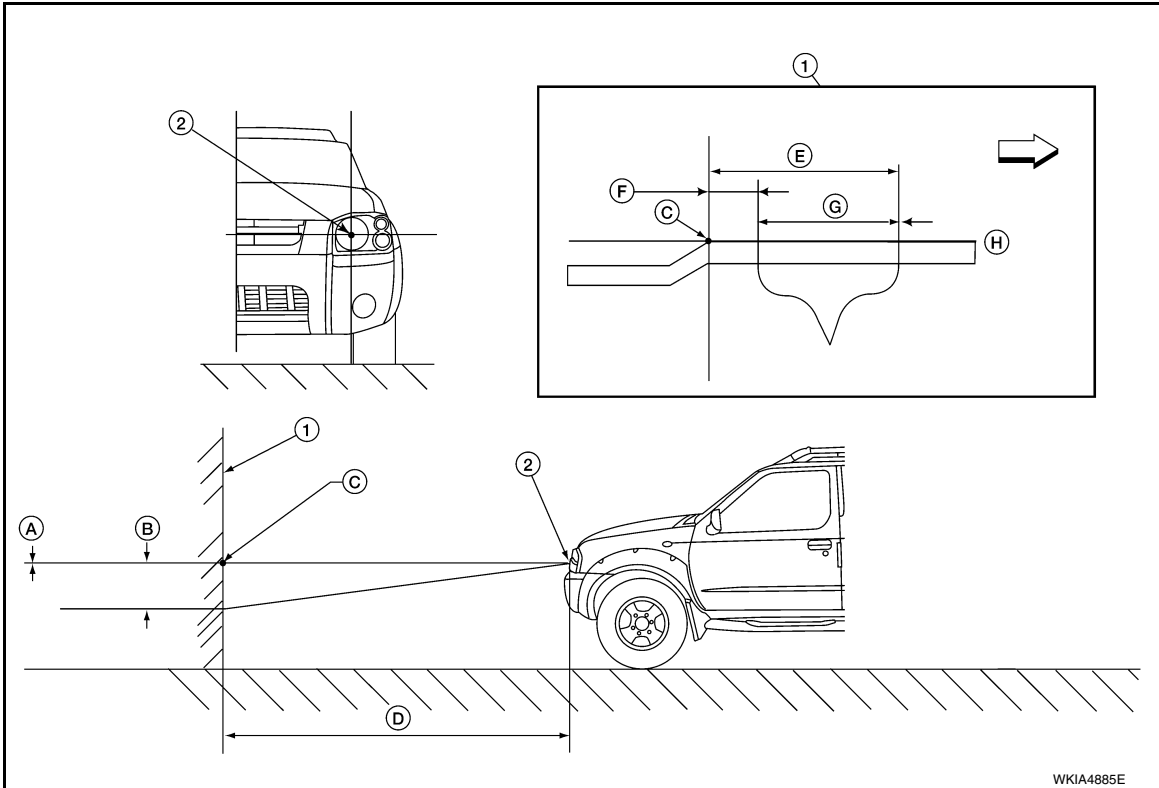

- | | | | | | |
|---|--|---|---|---|--|
| 1 | Adjustment screen | 2 | Headlamp bulb center (HV point) | A | Minimum acceptable vertical aim dimension (see aiming chart) |
| B | Maximum acceptable vertical aim dimension (see aiming chart) | C | H-V point | D | Distance of headlamp aiming screen from vehicle 7.62 m (25 ft) |
| E | Maximum aim evaluation distance from vertical center on aiming screen 399 mm (3° R). | F | Minimum aim evaluation distance from vertical center on aiming screen 133 mm (1° R) | G | Aim evaluation area |
| H | Horizontal aiming evaluation line | ↔ | Right | | |

Aiming Chart

A (Minimum acceptable vertical aim dimension)	-3.3 mm (0.13 in)	0.025° up
B (Maximum acceptable vertical aim dimension)	36.6 mm (1.44 in)	0.275° down

A
B
C
D
E
F
G
H
I
J
K
L
M
N
O
P

EXL

FRONT FOG LAMP

< PERIODIC MAINTENANCE >

FRONT FOG LAMP

Aiming Adjustment

INFOID:000000012563703

The fog lamp is a semi-sealed beam type which uses a replaceable halogen bulb. Before performing aiming adjustment, make sure of the following.

- Keep all tires inflated to correct pressure.
- Place vehicle on level ground.
- See that vehicle is unloaded (except for full levels of coolant, engine oil and fuel, and spare tire, jack, and tools). Have the driver or equivalent weight placed in driver seat.

Adjust aiming in the vertical direction by turning the adjustment screw.

NOTE:

Use a Phillips screwdriver to adjust. Turn screw clockwise to raise pattern and counterclockwise to lower pattern.

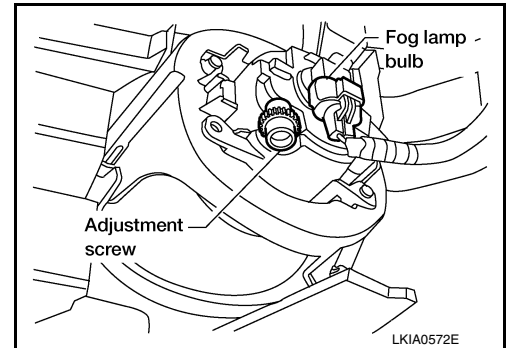

1. Set the distance between the screen and the center of the fog lamp lens as shown.

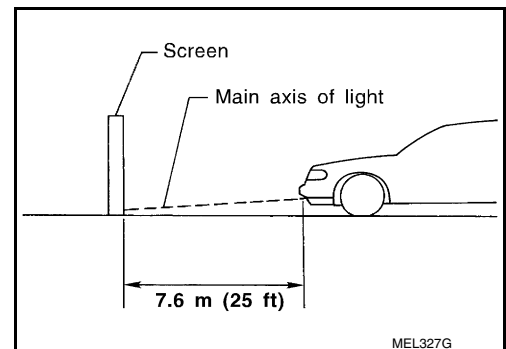

2. Turn front fog lamps ON.
3. Remove front portion of fender protector(s) for adjustment screw access. Refer to [EXT-25. "Removal and Installation"](#).

FRONT FOG LAMP

< PERIODIC MAINTENANCE >

- Adjust front fog lamps using adjustment screw so that the top edge of the high intensity zone is 100 mm (4 in) below the height of the fog lamp centers as shown.
 - When performing adjustment, if necessary, cover the headlamps and opposite fog lamp.

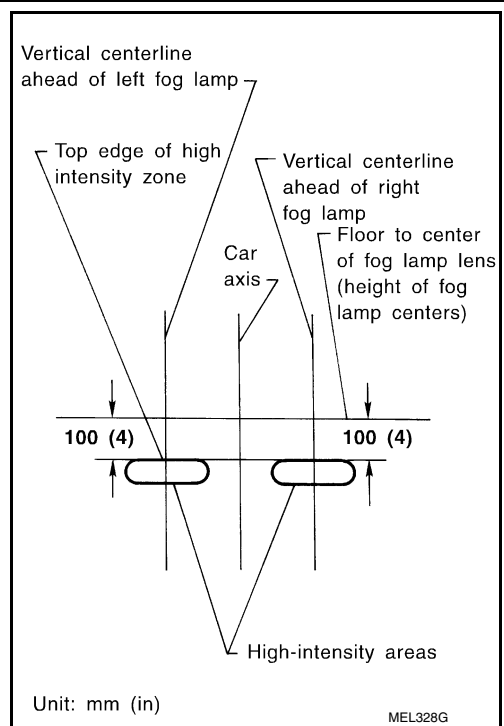

A
B
C
D
E
F
G
H
I
J
K
L
M
N
O
P

EXL

HEADLAMP

< REMOVAL AND INSTALLATION >

REMOVAL AND INSTALLATION

HEADLAMP

Bulb Replacement

INFOID:0000000012563704

WARNING:

Do not touch bulb with your hand while it is on or right after being turned off. Burning may result.

CAUTION:

Do not touch the glass surface of the bulb with bare hands or allow oil or grease to get on it to prevent damage to the bulb. Do not leave bulb out of lamp reflector for a long time because dust, moisture, smoke, etc. may affect the performance of lamp. When replacing bulb, be sure to replace it with new one.

HEADLAMP

Removal

1. Turn front headlamp switch OFF.
2. Disconnect the harness connector from the headlamp.
3. Rotate the headlamp bulb retaining ring counterclockwise and remove.
4. Pull the headlamp bulb straight out from the headlamp assembly.

CAUTION:

Grasp only the plastic base when handling headlamp bulb. Do not touch the glass envelope.

Installation

Installation is in the reverse order of removal.

CAUTION:

After installing bulb, be sure to install the bulb socket and plastic cap securely to ensure watertightness.

FRONT TURN SIGNAL/PARKING LAMP

Removal

1. Turn the bulb socket counterclockwise and remove.
2. Pull the bulb to remove it from the socket.

Installation

Installation is in the reverse order of removal.

CAUTION:

After installing bulb, be sure to install the bulb socket and plastic cap securely to ensure watertightness.

FRONT SIDE MARKER LAMP

Removal

1. Turn the bulb socket counterclockwise and remove.
2. Pull the bulb to remove it from the socket.

Installation

Installation is in the reverse order of removal.

CAUTION:

After installing bulb, be sure to install the bulb socket securely for watertightness.

Removal and Installation

INFOID:0000000012563705

FRONT COMBINATION LAMP

Removal

1. Position front fender protector aside. Refer to [EXT-27. "Removal and Installation of Front Fender Protector"](#).
2. For steel bumper, remove the front bumper upper valance. Refer to [EXT-15. "Removal and Installation"](#).
3. For plastic bumper, remove the front bumper assembly. Refer to [EXT-15. "Removal and Installation"](#).

HEADLAMP

< REMOVAL AND INSTALLATION >

4. Remove the front combination lamp bolts.
5. Disconnect the harness connector from the front combination lamp and remove.

Installation

Installation is in the reverse order of removal.

NOTE:

After installation, perform headlamp aiming adjustment. Refer to [EXL-136, "Aiming Adjustment"](#).

Front combination lamp bolt : 6.0 N·m (0.61 kg-m, 53 in-lb)

A
B
C
D
E
F
G
H
I
J
K
EXL
M
N
O
P

FRONT FOG LAMP

< REMOVAL AND INSTALLATION >

FRONT FOG LAMP

Bulb Replacement

INFOID:000000012563706

REMOVAL

1. Position front fender protector aside. Refer to [EXT-27, "Removal and Installation of Front Fender Protector"](#).
2. Disconnect the harness connector from the fog lamp.
3. Turn the bulb counterclockwise to remove it.

WARNING:

Do not touch bulb by hand while it is lit or right after being turned off. Burning may result.

CAUTION:

- Do not touch the glass of bulb directly by hand. Keep grease and other oily substances away from it.
- Do not leave bulb out of fog lamp reflector for a long time because dust, moisture smoke, etc. may affect the performance of fog lamp. When replacing bulb, be sure to replace it with new one.

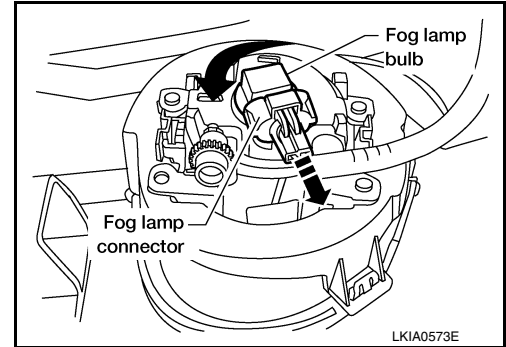

INSTALLATION

Installation is in the reverse order of removal.

Removal and Installation

INFOID:000000012563707

REMOVAL

Note:

The fog lamp is a semi-sealed beam type which uses a replaceable halogen bulb.

1. Position front fender protector aside. Refer to [EXT-27, "Removal and Installation of Front Fender Protector"](#)
2. Disconnect the harness connector from the fog lamp.
3. Remove fog lamp screws and pull fog lamp rearward out of front bumper.

CAUTION:

- Do not leave fog lamp assembly without bulb for a long period of time. Dust, moisture, smoke, etc. entering the fog lamp body may affect the performance. Remove the bulb from the headlamp assembly just before replacement bulb is installed.
- Grasp only the plastic base when handling the bulb. Do not touch the glass envelope. Touching the glass could significantly affect the bulb life and/or fog lamp performance.

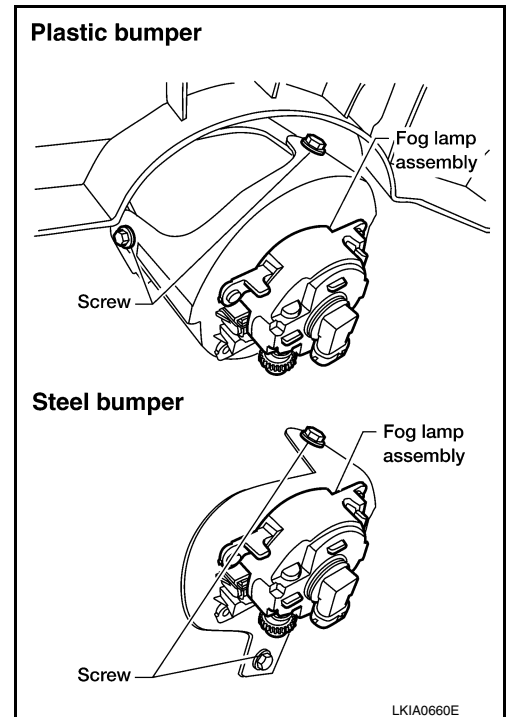

INSTALLATION

Installation is in the reverse order of removal.

NOTE:

After installation, perform front fog lamp aiming adjustment. Refer to [EXL-138, "Aiming Adjustment"](#).

STOP LAMP

< REMOVAL AND INSTALLATION >

STOP LAMP

Bulb Replacement

INFOID:000000012563708

HIGH-MOUNTED STOP LAMP

Removal

1. Remove high-mounted stop lamp. Refer to [EXL-143, "Removal and Installation"](#).
2. Rotate the center bulb socket counterclockwise and remove.
3. Pull bulb straight out from bulb socket.

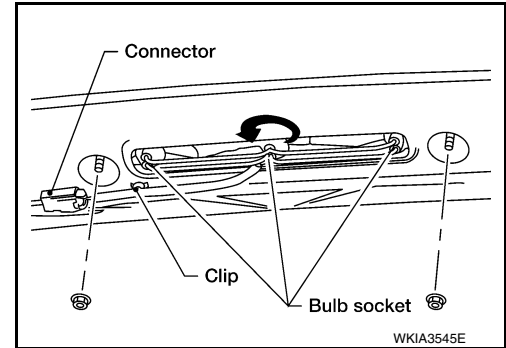

Installation

Installation is in the reverse order of removal.

Removal and Installation

INFOID:000000012563709

HIGH-MOUNTED STOP LAMP

Removal

1. Remove plugs on headlining.
2. Remove the nuts and remove high-mounted stop lamp from outside of roof outer panel.
3. Rotate the bulb sockets counterclockwise and remove the high-mounted stop lamp assembly.

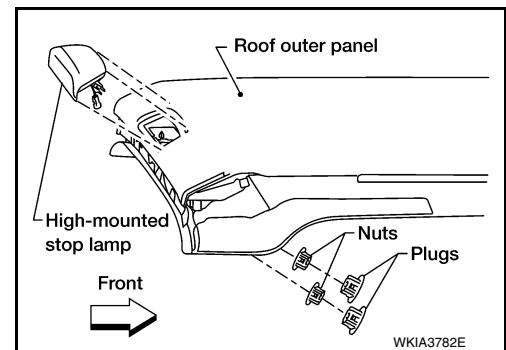

Installation

Installation is in the reverse order of removal.

High-mounted stop lamp nuts : 3.38 N-m (0.34 kg-m, 30 in-lb)

A
B
C
D
E
F
G
H
I
J
K
EXL
M
N
O
P

LICENSE PLATE LAMP

< REMOVAL AND INSTALLATION >

LICENSE PLATE LAMP

Bulb Replacement

INFOID:000000012563710

REMOVAL

1. Turn bulb socket counterclockwise to unlock bulb socket.
2. Pull bulb to remove from bulb socket.

INSTALLATION

Installation is in the reverse order of removal.

Removal and Installation

INFOID:000000012563711

REMOVAL

1. Disconnect the harness connector from the license plate lamp.
2. Depress tab to remove license plate lamp from rear bumper.

INSTALLATION

Installation is in the reverse order of removal.

REAR COMBINATION LAMP

< REMOVAL AND INSTALLATION >

REAR COMBINATION LAMP

Bulb Replacement

INFOID:000000012563712

REMOVAL

1. Remove rear combination lamp. Refer to [EXL-145. "Removal and Installation"](#).
2. Turn bulb socket counterclockwise to remove.
3. Pull bulb straight out away from socket.

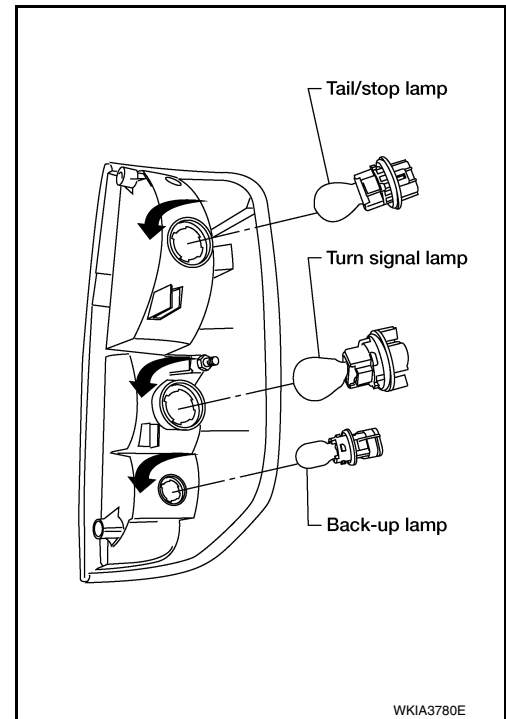

INSTALLATION

Installation is in the reverse order of removal.

Removal and Installation

INFOID:000000012563713

REMOVAL

1. Open tail gate and remove rear combination lamp bolts.
2. Pull combination lamp housing rearward to release locating snap.
3. Rotate each bulb socket counterclockwise and remove.

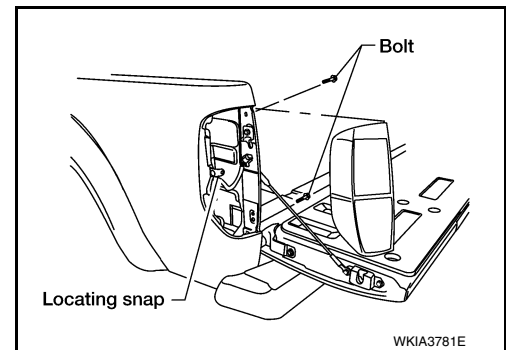

INSTALLATION

Installation is in the reverse order of removal.

NOTE:

During installation, align locating snap on body prior to installing bolts.

Rear combination lamp bolts : 5.5 Nm (0.56 kg-m, 49 in-lb)

LIGHTING & TURN SIGNAL SWITCH

< REMOVAL AND INSTALLATION >

LIGHTING & TURN SIGNAL SWITCH

Removal and Installation

INFOID:000000012563714

REMOVAL

1. Remove instrument lower panel LH. Refer to [IP-18. "Removal and Installation"](#).
2. Remove steering column covers.
3. Disconnect the harness connector from the lighting and turn signal switch.
4. While pressing tabs, pull lighting and turn signal switch toward driver door and release from the steering column.

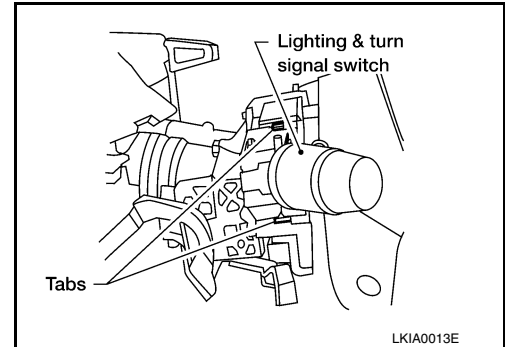

INSTALLATION

Installation is in the reverse order of removal.

HAZARD SWITCH

< REMOVAL AND INSTALLATION >

HAZARD SWITCH

Removal and Installation

INFOID:0000000012563715

REMOVAL

1. Remove cluster lid C. Refer to [IP-19. "Removal and Installation"](#).
2. Remove the screws and the hazard switch.

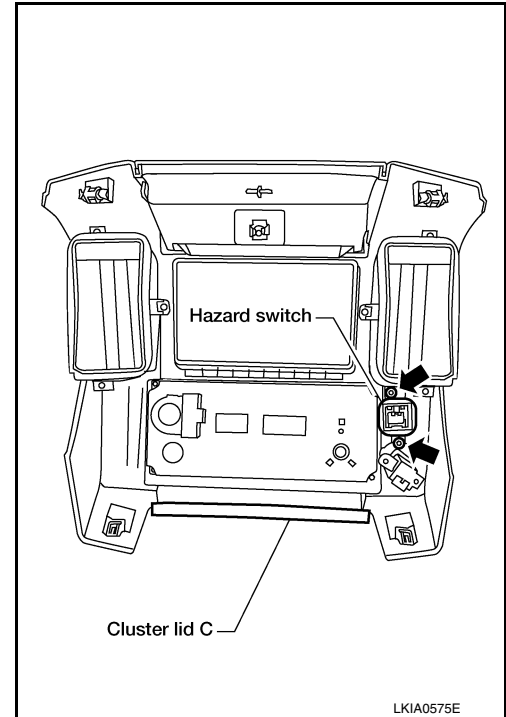

INSTALLATION

Installation is in the reverse order of removal.

A
B
C
D
E
F
G
H
I
J
K
L
M
N
O
P

EXL

OPTICAL SENSOR

< REMOVAL AND INSTALLATION >

OPTICAL SENSOR

Removal and Installation

INFOID:000000012563716

REMOVAL

1. Insert a suitable tool between the optical sensor and the instrument panel, then lift the optical sensor upward.
2. Disconnect the harness connector from the optical sensor and remove.

INSTALLATION

Installation is in the reverse order of removal.

FRONT COMBINATION LAMP

< UNIT DISASSEMBLY AND ASSEMBLY >

UNIT DISASSEMBLY AND ASSEMBLY

FRONT COMBINATION LAMP

Disassembly and Assembly

INFOID:0000000012563717

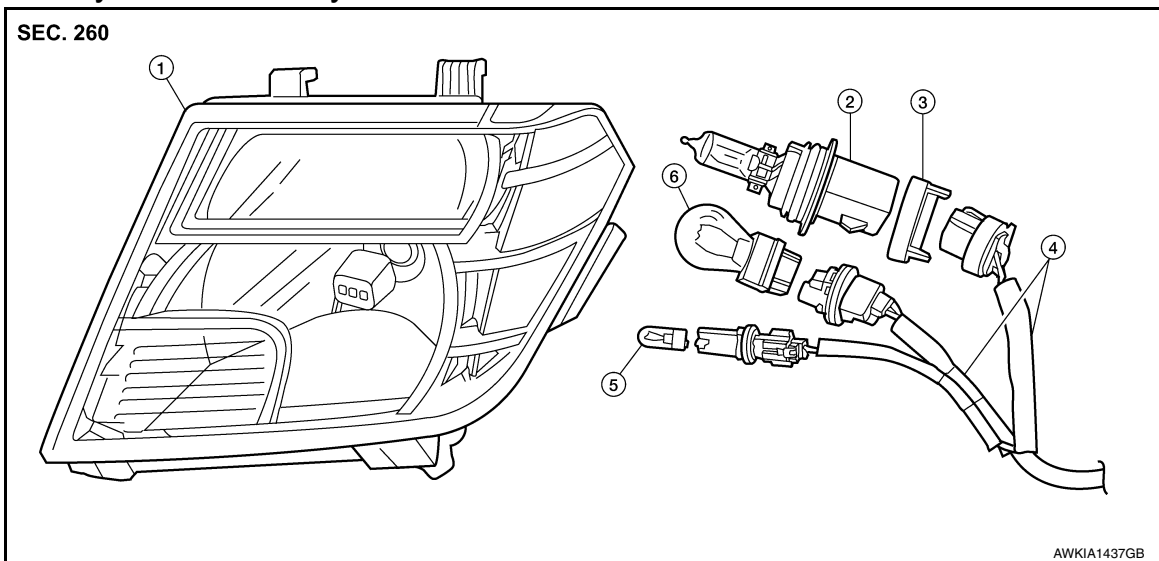

- | | | |
|---------------------------|--------------------------------|--|
| 1. Front combination lamp | 2. Headlamp bulb | 3. Headlamp bulb retaining ring |
| 4. Harness assembly | 5. Front side marker lamp bulb | 6. Front turn signal/parking lamp bulb |

DISASSEMBLY

WARNING:

Do not touch bulb with your hand while it is on or right after being turned off. Burning may result.

CAUTION:

Do not touch the glass surface of the bulb with bare hands or allow oil or grease to get on it to prevent damage to the bulb. Do not leave bulb out of lamp reflector for a long time because dust, moisture, smoke, etc. may affect the performance of lamp. When replacing bulb, be sure to replace it with new one.

1. Rotate headlamp bulb retaining ring counterclockwise and remove.
2. Turn front turn signal/parking lamp bulb socket counterclockwise to unlock and remove.
3. Turn front side marker lamp bulb socket counterclockwise to unlock and remove.

ASSEMBLY

Installation is in the reverse order of removal.

CAUTION:

After installing bulb, be sure to install the bulb socket and plastic cap securely to ensure watertightness.

SERVICE DATA AND SPECIFICATIONS (SDS)

< SERVICE DATA AND SPECIFICATIONS (SDS)

SERVICE DATA AND SPECIFICATIONS (SDS)

SERVICE DATA AND SPECIFICATIONS (SDS)

Bulb Specifications

INFOID:0000000012563718

	Item	Wattage (W)*
Front combination lamp	Headlamp (Halogen low beam)	55
	Headlamp (Halogen high beam)	60
	Park/Turn lamp	8/28
	Front side marker lamp	3.8
Rear combination lamp	Stop/Tail lamp	27/8
	Rear turn signal lamp	27
	Back-up lamp	18
Fog lamp		55
License plate lamp		5
High-mounted stop lamp		12.8
Cargo lamp (in high-mounted stop lamp)		12.8

*: Always check with the Parts Department for the latest parts information.