

SECTION **WCS**

WARNING CHIME SYSTEM

A
B
C
D
E
F
G
H
I
J
K
L
M
O
P

CONTENTS

<p>BASIC INSPECTION 3</p> <p>DIAGNOSIS AND REPAIR WORKFLOW 3</p> <p style="padding-left: 20px;">Work Flow3</p> <p>SYSTEM DESCRIPTION 4</p> <p>WARNING CHIME SYSTEM 4</p> <p>WARNING CHIME SYSTEM4</p> <p style="padding-left: 20px;">WARNING CHIME SYSTEM : System Diagram4</p> <p style="padding-left: 20px;">WARNING CHIME SYSTEM : System Description4</p> <p style="padding-left: 20px;">WARNING CHIME SYSTEM : Component Parts Location5</p> <p style="padding-left: 20px;">WARNING CHIME SYSTEM : Component Description5</p> <p>LIGHT REMINDER WARNING CHIME5</p> <p style="padding-left: 20px;">LIGHT REMINDER WARNING CHIME : System Diagram6</p> <p style="padding-left: 20px;">LIGHT REMINDER WARNING CHIME : System Description6</p> <p style="padding-left: 20px;">LIGHT REMINDER WARNING CHIME : Component Parts Location7</p> <p style="padding-left: 20px;">LIGHT REMINDER WARNING CHIME : Component Description7</p> <p>SEAT BELT WARNING CHIME7</p> <p style="padding-left: 20px;">SEAT BELT WARNING CHIME : System Diagram7</p> <p style="padding-left: 20px;">SEAT BELT WARNING CHIME : System Description8</p> <p style="padding-left: 20px;">SEAT BELT WARNING CHIME : Component Parts Location8</p> <p style="padding-left: 20px;">SEAT BELT WARNING CHIME : Component Description9</p> <p>KEY WARNING CHIME9</p> <p style="padding-left: 20px;">KEY WARNING CHIME : System Diagram9</p> <p style="padding-left: 20px;">KEY WARNING CHIME : System Description9</p>	<p style="padding-left: 20px;">KEY WARNING CHIME : Component Parts Location10</p> <p style="padding-left: 20px;">KEY WARNING CHIME : Component Description...10</p> <p>DIAGNOSIS SYSTEM (METER) 11</p> <p style="padding-left: 20px;">Diagnosis Description11</p> <p style="padding-left: 20px;">CONSULT Function (METER/M&A)13</p> <p>DIAGNOSIS SYSTEM (BCM) 15</p> <p>COMMON ITEM15</p> <p style="padding-left: 20px;">COMMON ITEM : CONSULT Function (BCM - COMMON ITEM)15</p> <p>BUZZER15</p> <p style="padding-left: 20px;">BUZZER : CONSULT Function (BCM - BUZZER)...16</p> <p>DTC/CIRCUIT DIAGNOSIS17</p> <p>POWER SUPPLY AND GROUND CIRCUIT17</p> <p>COMBINATION METER17</p> <p style="padding-left: 20px;">COMBINATION METER : Diagnosis Procedure17</p> <p>BCM (BODY CONTROL MODULE)17</p> <p style="padding-left: 20px;">BCM (BODY CONTROL MODULE) : Diagnosis Procedure18</p> <p>METER BUZZER CIRCUIT 19</p> <p style="padding-left: 20px;">Description19</p> <p style="padding-left: 20px;">Component Function Check19</p> <p style="padding-left: 20px;">Diagnosis Procedure19</p> <p>SEAT BELT BUCKLE SWITCH SIGNAL CIRCUIT20</p> <p style="padding-left: 20px;">Description20</p> <p style="padding-left: 20px;">Component Function Check20</p> <p style="padding-left: 20px;">Diagnosis Procedure20</p> <p style="padding-left: 20px;">Component Inspection21</p> <p>KEY SWITCH SIGNAL CIRCUIT22</p> <p style="padding-left: 20px;">Description22</p> <p style="padding-left: 20px;">Component Function Check22</p>
---	--

WCS

Diagnosis Procedure	22	SYMPTOM DIAGNOSIS	44
Component Inspection	23		
ECU DIAGNOSIS INFORMATION	24	THE LIGHT REMINDER WARNING DOES	
		NOT SOUND	44
COMBINATION METER	24	Description	44
Reference Value	24	Diagnosis Procedure	44
Fail Safe	25	THE SEAT BELT WARNING CONTINUES	
DTC Index	26	SOUNDING, OR DOES NOT SOUND	45
BCM (BODY CONTROL MODULE)	27	Description	45
Reference Value	27	Diagnosis Procedure	45
Terminal Layout	30	THE KEY WARNING DOES NOT SOUND	46
Physical Values	30	Description	46
Fail Safe	35	Diagnosis Procedure	46
DTC Inspection Priority Chart	35	PRECAUTION	47
DTC Index	36		
WIRING DIAGRAM	38	PRECAUTIONS	47
		Precaution for Supplemental Restraint System	
WARNING CHIME SYSTEM	38	(SRS) "AIR BAG" and "SEAT BELT PRE-TEN-	
Wiring Diagram	38	SIONER"	47

DIAGNOSIS AND REPAIR WORKFLOW

< BASIC INSPECTION >

BASIC INSPECTION

DIAGNOSIS AND REPAIR WORKFLOW

Work Flow

INFOID:0000000012563049

DETAILED FLOW

1.OBTAIN INFORMATION ABOUT SYMPTOM

Interview the customer to obtain as much information as possible about the conditions and environment under which the malfunction occurred.

>> GO TO 2

2.CHECK SYMPTOM

- Check the symptom based on the information obtained from the customer.
- Check to see if any other malfunctions are present.

>> GO TO 3

3.CHECK CONSULT SELF-DIAGNOSIS RESULTS

Connect CONSULT and perform "SELF-DIAGNOSIS". Refer to [MWI-27, "CONSULT Function \(METER/M&A\)"](#).

Are self-diagnosis results normal?

YES >> GO TO 4

NO >> Repair or replace the malfunctioning parts, GO TO 5

4.NARROW DOWN MALFUNCTIONING PARTS THROUGH SYMPTOM DIAGNOSIS

Perform symptom diagnosis and repair or replace the identified malfunctioning parts.

>> GO TO 5

5.FINAL CHECK

Check that the warning buzzer in the combination meter operates normally.

Does it operate normally?

YES >> Inspection End.

NO >> GO TO 1

A
B
C
D
E
F
G
H
I
J
K
L
M
O
P

WCS

WARNING CHIME SYSTEM

< SYSTEM DESCRIPTION >

SYSTEM DESCRIPTION

WARNING CHIME SYSTEM

WARNING CHIME SYSTEM

WARNING CHIME SYSTEM : System Diagram

INFOID:0000000012563050

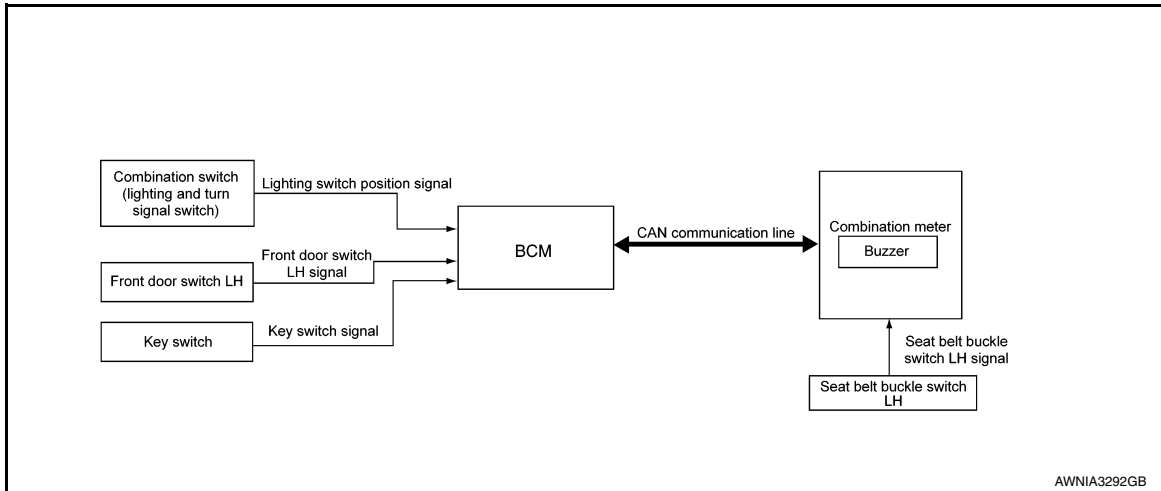

WARNING CHIME SYSTEM : System Description

INFOID:0000000012563051

COMBINATION METER

- The buzzer for warning chime system is installed in the combination meter.
- The buzzer sounds when the combination meter receives a buzzer output signal from each unit.

BCM

BCM receives signals from various units and transmits a buzzer output signal to the combination meter with CAN communication line if it judges that the warning buzzer should be activated.

BCM warning function list

Warning functions	Signal name
Light reminder warning chime	<ul style="list-style-type: none"> • Lighting switch position signal • Front door switch LH signal
Seat belt warning chime	Seat belt buckle switch LH signal
Key warning chime	<ul style="list-style-type: none"> • Key switch signal • Door switch signal

WARNING CHIME SYSTEM

< SYSTEM DESCRIPTION >

WARNING CHIME SYSTEM : Component Parts Location

INFOID:000000012563052

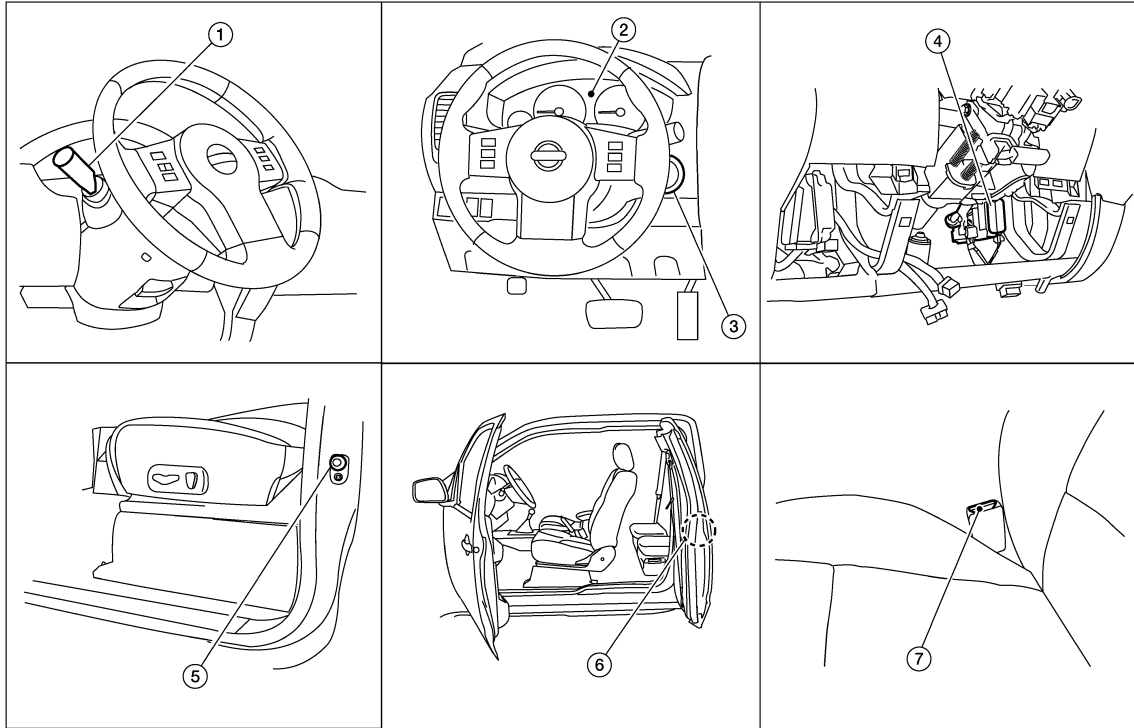

WKIA4988E

- | | | |
|--|---------------------------------------|---|
| 1. Combination switch (lighting and turn signal switch) M28 | 2. Combination meter M24 | 3. Key switch M27 |
| 4. BCM M18, M19, M20 (view with instrument lower panel LH removed) | 5. Front door switch LH B8 (crew cab) | 6. Front door switch LH D213 (king cab) |
| 7. Seat belt buckle switch LH B12 | | |

WARNING CHIME SYSTEM : Component Description

INFOID:000000012563053

Unit	Description
Combination meter	<ul style="list-style-type: none"> Receives the seat belt buckle switch LH signal from the seat belt buckle switch LH and transmits it to BCM with CAN communication line. Receives a buzzer output signal from BCM with CAN communication line.
BCM	Transmits signals provided by various units to the combination meter with CAN communication line.
Key switch	Transmits key switch signal to BCM.
Seat belt buckle switch LH	Transmits a seat belt buckle switch LH signal to the combination meter.
Combination switch (lighting and turn signal switch)	Transmits the lighting switch position signal to BCM.
Front door switch LH	Transmits the door switch signal to BCM.

LIGHT REMINDER WARNING CHIME

A
B
C
D
E
F
G
H
I
J
K
L
M
WCS
O
P

WARNING CHIME SYSTEM

< SYSTEM DESCRIPTION >

LIGHT REMINDER WARNING CHIME : System Diagram

INFOID:000000012563054

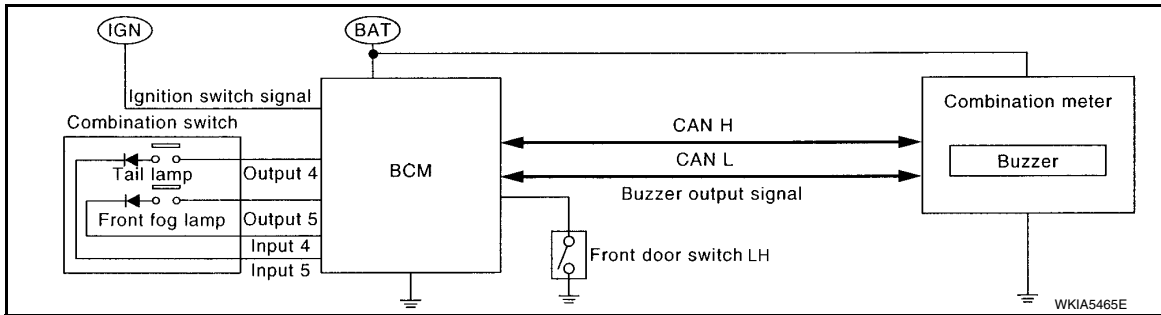

LIGHT REMINDER WARNING CHIME : System Description

INFOID:000000012563055

DESCRIPTION

With ignition switch in OFF or ACC position, driver door open, and lighting switch in 1ST or 2ND position, the light warning chime will sound.

- BCM detects ignition switch in OFF or ACC position, front door switch LH ON, and lighting switch in 1ST or 2ND position. And then transmits buzzer output signal (light reminder warning chime) to combination meter with CAN communication line.
- When combination meter receives buzzer output signal (light reminder warning chime), it sounds the buzzer.

WARNING OPERATION CONDITIONS

If all of the following conditions are fulfilled

- Lighting switch is at 1st or 2nd position
- Ignition switch is at OFF or ACC
- Front door switch LH is ON

WARNING CANCEL CONDITIONS

Warning is canceled if any of the following conditions is fulfilled.

- Lighting switch OFF
- Ignition switch ON
- Front door switch LH is OFF

WARNING CHIME SYSTEM

< SYSTEM DESCRIPTION >

LIGHT REMINDER WARNING CHIME : Component Parts Location

INFOID:000000012563056

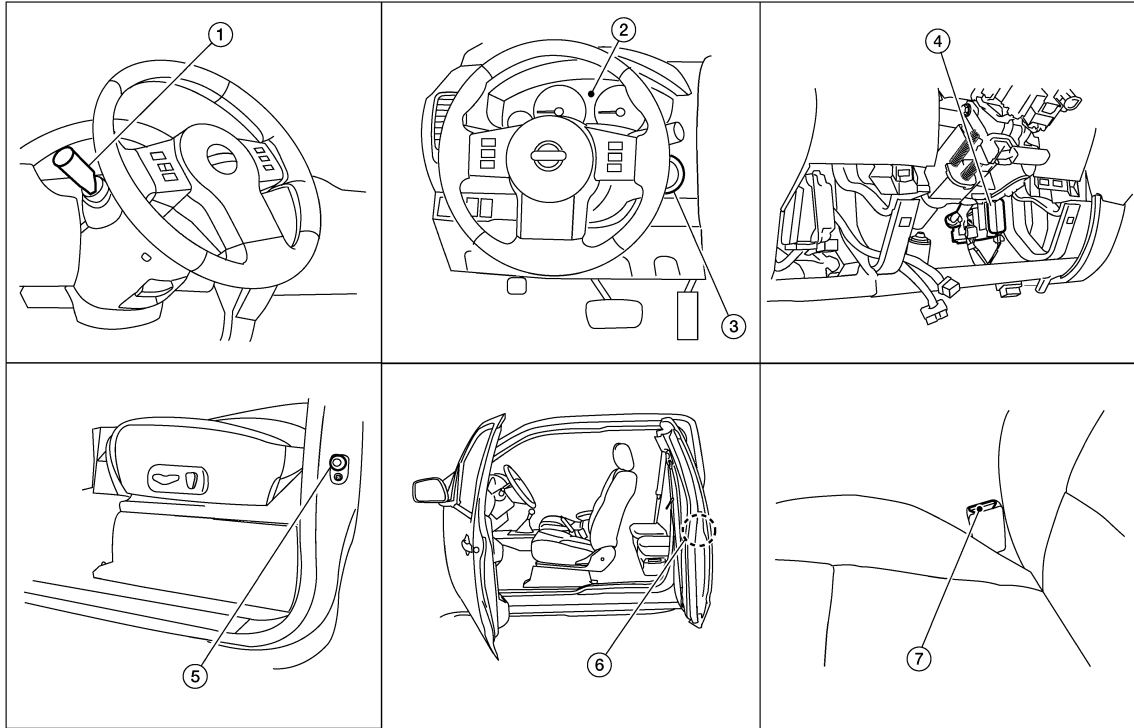

WKIA4988E

- | | | |
|--|---------------------------------------|---|
| 1. Combination switch (lighting and turn signal switch) M28 | 2. Combination meter M24 | 3. Key switch M27 |
| 4. BCM M18, M19, M20 (view with instrument lower panel LH removed) | 5. Front door switch LH B8 (crew cab) | 6. Front door switch LH D213 (king cab) |
| 7. Seat belt buckle switch LH B12 | | |

LIGHT REMINDER WARNING CHIME : Component Description

INFOID:000000012563057

Unit	Description
Combination meter	Receives a buzzer output signal from BCM via CAN communication line and sounds the buzzer.
BCM	Judges the light warning conditions from the signals provided by various switches and transmits a buzzer output signal to the combination meter via CAN communication line if necessary.
Combination switch (lighting and turn signal switch)	Transmits the lighting switch position signal to BCM.
Front door switch LH	Transmits the door switch signal to BCM.

SEAT BELT WARNING CHIME

WCS

SEAT BELT WARNING CHIME : System Diagram

INFOID:000000012563058

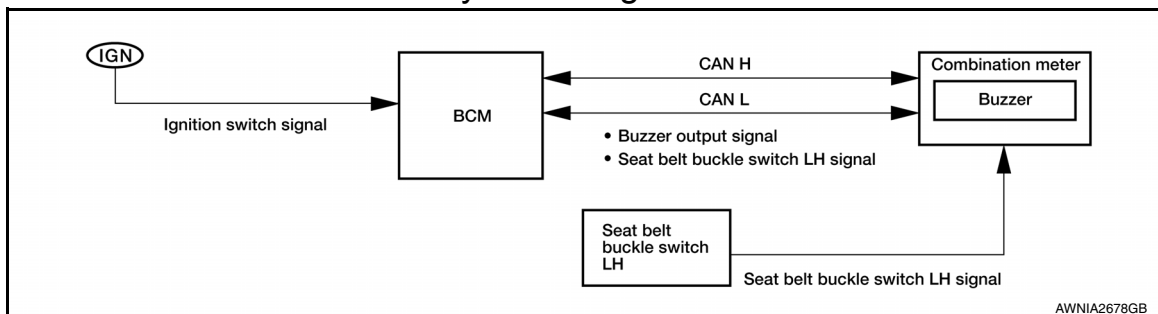

AWNIA2678GB

WARNING CHIME SYSTEM

< SYSTEM DESCRIPTION >

SEAT BELT WARNING CHIME : System Description

INFOID:000000012563059

DESCRIPTION

With ignition switch turned ON and driver seat belt unfastened, seat belt warning chime will sound for approximately 6 seconds.

- BCM receives seat belt buckle switch LH signal from combination meter with CAN communication line.
- BCM detects ignition switch turned ON and seat belt buckle switch LH ON. And then transmits buzzer output signal (seat belt warning chime) to combination meter with CAN communication line.
- When combination meter receives buzzer output signal (seat belt warning chime), it sounds the buzzer.

WARNING OPERATION CONDITIONS

If all of the following conditions are fulfilled

- Ignition switch OFF→ON
- Seat belt buckle switch LH is ON (driver seat belt not fastened)

WARNING CANCEL CONDITIONS

Cancels the warning if any of the following conditions is fulfilled.

- Ignition switch OFF
- Seat belt buckle switch LH is OFF (driver seat belt fastened)

SEAT BELT WARNING CHIME : Component Parts Location

INFOID:000000012563060

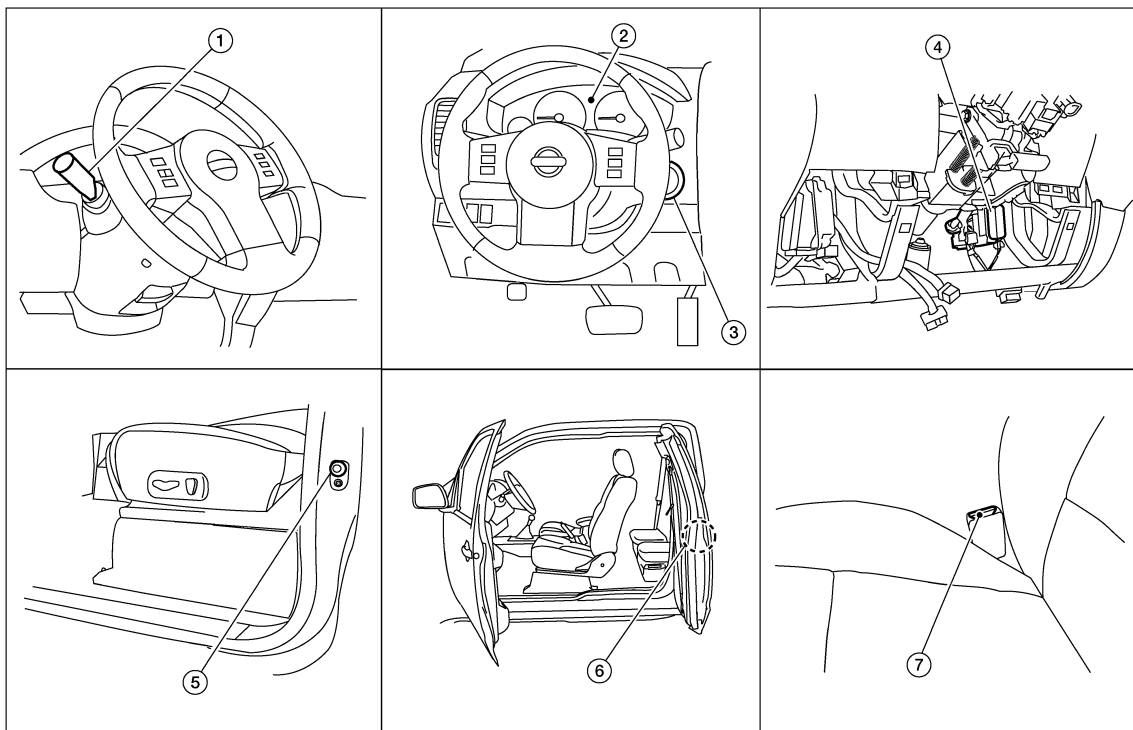

WKIA4988E

- | | | |
|--|---------------------------------------|---|
| 1. Combination switch (lighting and turn signal switch) M28 | 2. Combination meter M24 | 3. Key switch M27 |
| 4. BCM M18, M19, M20 (view with instrument lower panel LH removed) | 5. Front door switch LH B8 (crew cab) | 6. Front door switch LH D213 (king cab) |
| 7. Seat belt buckle switch LH B12 | | |

WARNING CHIME SYSTEM

< SYSTEM DESCRIPTION >

SEAT BELT WARNING CHIME : Component Description

INFOID:000000012563061

Unit	Description
Combination meter	<ul style="list-style-type: none"> Receives the seat belt buckle switch LH signal from the seat belt buckle switch LH and transmits it to BCM via CAN communication line. Receives a buzzer output signal from BCM via CAN communication line and sounds the buzzer.
BCM	Judges the seat belt warning condition from the seat belt buckle switch LH signal received from the combination meter and transmits a buzzer output signal to the combination meter via CAN communication line if necessary.
Seat belt buckle switch LH	Transmits seat belt buckle switch LH signal to combination meter.

KEY WARNING CHIME

KEY WARNING CHIME : System Diagram

INFOID:000000012563062

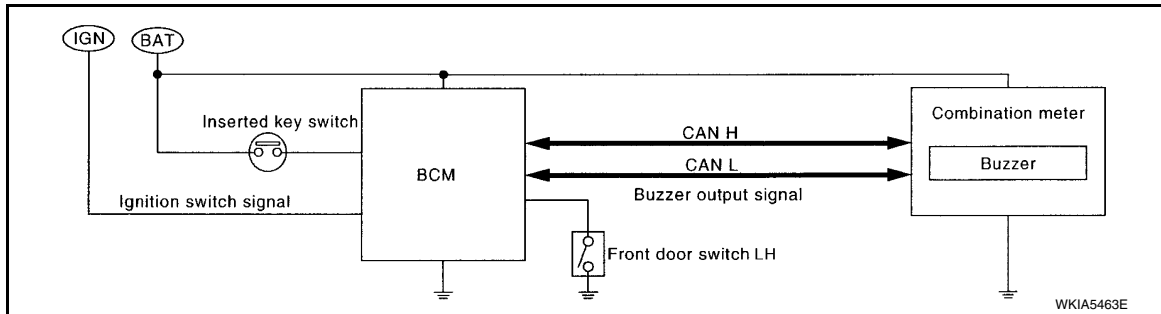

KEY WARNING CHIME : System Description

INFOID:000000012563063

With the key inserted into the key switch, and the ignition switch in the OFF or ACC position, when driver's door is opened, the warning chime will sound.

- BCM detects key inserted into the ignition switch, and sends key warning signal to combination meter with CAN communication line.
- When combination meter receives key warning signal, it sounds warning chime.

A
B
C
D
E
F
G
H
I
J
K
L
M

WCS

O
P

WARNING CHIME SYSTEM

< SYSTEM DESCRIPTION >

KEY WARNING CHIME : Component Parts Location

INFOID:000000012563064

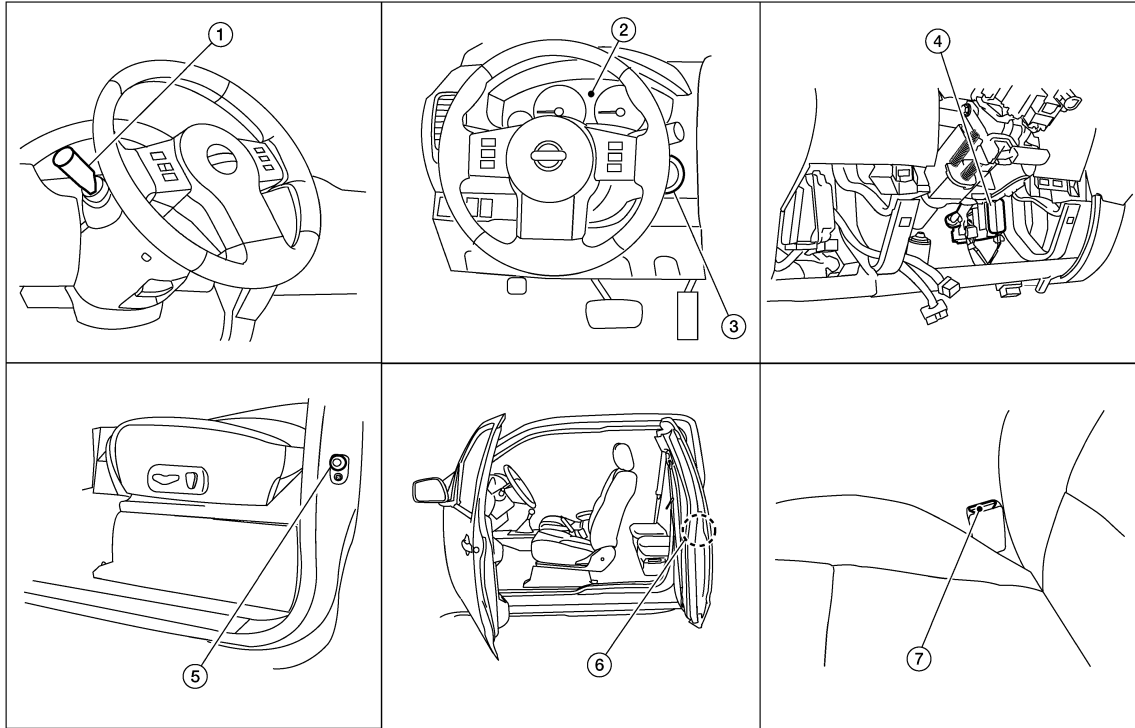

WKIA4988E

- | | | |
|--|---------------------------------------|---|
| 1. Combination switch (lighting and turn signal switch) M28 | 2. Combination meter M24 | 3. Key switch M27 |
| 4. BCM M18, M19, M20 (view with instrument lower panel LH removed) | 5. Front door switch LH B8 (crew cab) | 6. Front door switch LH D213 (king cab) |
| 7. Seat belt buckle switch LH B12 | | |

KEY WARNING CHIME : Component Description

INFOID:000000012563065

Unit	Description
Combination meter	Receives key warning signal from BCM via CAN communication line and sounds the buzzer.
BCM	Judges the key warning condition from the door switch signal received from the front door switch LH, and the key switch signal received from the key switch. It then transmits a buzzer output signal to the combination meter via CAN communication line if necessary.
Front door switch LH	Transmits door switch signal to BCM.
Key switch	Transmits key switch signal to BCM.

DIAGNOSIS SYSTEM (METER)

< SYSTEM DESCRIPTION >

DIAGNOSIS SYSTEM (METER)

Diagnosis Description

INFOID:000000012797948

SELF-DIAGNOSIS MODE

The following items can be checked during Combination Meter Self-Diagnosis Mode.

- Gauge sweep and present gauge values.
- Illuminates all odometer/trip meters and A/T indicator segments.
- Illuminates all micro controlled lamps/LEDs regardless of switch position.
- Displays estimated present battery voltage.
- Displays seat belt buckle switch LH status.

OPERATION PROCEDURE

NOTE:

- Once entered, combination meter self-diagnosis mode will function with the ignition switch in ON or START. Combination meter self-diagnosis mode will exit upon turning the ignition switch to OFF or ACC.
- If the diagnosis function is activated with trip A displayed, the mileage on trip A is reset to 0000.0. (Trip B operates the same way.)

To initiate combination meter self-diagnosis mode, refer to the following procedure.

1. Turn the ignition switch ON, while pressing the odometer/trip meter switch for 5 - 8 seconds. When the diagnosis function is activated, the odometer/trip meter will display tEst.

NOTE:

Check combination meter power supply and ground circuit when self-diagnosis mode of combination meter does not start. Refer to [MWI-31, "COMBINATION METER : Diagnosis Procedure"](#). Replace combination meter if normal. Refer to [MWI-91, "Removal and Installation"](#).

COMBINATION METER SELF-DIAGNOSIS MODE FUNCTIONS

To interpret combination meter self-diagnosis mode functions, refer to the following table.

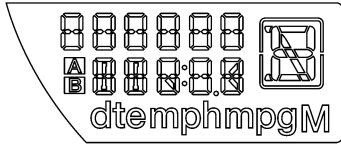
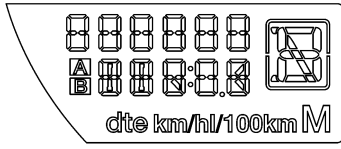
Event	Odometer Display	Description of Test/Data	Notes:
Odometer/trip meter A/B switch held from 5 to 8 seconds (or until released)	tEst		Initiating self-diagnosis mode
Switch released	GAGE	Performs sweep of all gauges, then displays present gauge values.	Gauges sweep within 10 seconds
Switch pressed	(All segments illuminated)	Lights all LCD segments. Compare with picture.	<p>USA</p>  <p>AWNIA3686ZZ</p> <p>Except USA</p>  <p>AWNIA3687ZZ</p>
Switch pressed	bulb	Illuminates all micro-controlled lamps/LEDs.	Part may not be configured for all lamps (functions) that turn on during test. This is normal.
Switch pressed	r XXXX, FAIL	Return to normal operation of all lamps/LEDs and displays "r XXXX".	If a malfunction exists, "FAIL" will flash.

DIAGNOSIS SYSTEM (METER)

< SYSTEM DESCRIPTION >

Event	Odometer Display	Description of Test/Data	Notes:
Switch pressed	nrXXXX	Displays Hex ROM rev as stored in NVM.	
Switch pressed	EE XX, FAIL	Displays "EE XX".	If a malfunction exists, "FAIL" will flash.
Switch pressed	dtXXXX	Hex coding of final manufacturing test date.	
Switch pressed (3 times)	Sc1 XX through Epr XX	Displays 8 bit software configuration value in Hex format	
Switch pressed	1nF XX	Displays 8-bit market info value in Hex format.	\$31 = USA \$2A = Canada \$23 = EUR-R \$1C = EUR-L \$38 = Japan \$15 = Australia \$0E = Middle East \$FF = Other
Switch pressed (3 times)	cYL XX through tF	N/A	
Switch pressed	ot1 XX	Displays oil pressure tell-tale "" in Hex format.	
Switch pressed	ot0 XX	Displays oil pressure tell-tale "" in Hex format.	
Switch pressed	XXXXXX	"Corrected" speed value in hundredths of MPH. Gauge indication may be slightly higher. This is normal.	Will display "----" if message is not received. Will display "99999" if data received is invalid.
Switch pressed	XXXXXX	"Corrected" speed value in hundredths of KPH. Gauge indication may be slightly different. This is normal.	Will display "----" if message is not received. Will display "99999" if data received is invalid.
Switch pressed	t XXXX	Tachometer value in RPM. Gauge indication may be higher at higher RPM. This is normal.	Will display "----" if message is not received.
Switch pressed	F1XXXX	Present fuel level A/D input. This input represents fuel sender input.	000-009 = Short circuit 010-254 = Normal range 255 = Open circuit
Switch pressed	XXXXC	Last temperature gauge input value in degrees C. Temperature gauge indicates present temperature per indication standard.	Will display "---"C if message is not received. Will display "999" if data received is invalid. High = 130 deg C Normal = 70 - 105 deg C Low = less than 50 deg C
Switch pressed	BAtXX.X	Estimated present battery voltage.	
Switch pressed	rES -X	Seat belt buckle switch LH status.	1= Buckled 0 = Unbuckled
Switch pressed (30 times)	PA -XX through PA1-XX	N/A	
Switch pressed	GAGE		Return to beginning of self-diagnosis cycle.

DIAGNOSIS SYSTEM (METER)

< SYSTEM DESCRIPTION >

CONSULT Function (METER/M&A)

INFOID:000000012797949

CONSULT can display each diagnostic item using the diagnostic test modes shown following.

METER/M&A diagnosis mode	Description
SELF DIAGNOSTIC RESULT	Displays combination meter self-diagnosis results.
DATA MONITOR	Displays combination meter input/output data in real time.
WORK SUPPORT	Displays diagnosis procedure of each work item.
CAN DIAG SUPPORT MNTR	The result of transmit/receive diagnosis of CAN communication can be read.

SELF-DIAG RESULTS

Display Item List

Refer to [MWI-41, "DTC Index"](#).

DATA MONITOR

Display Item List

X: Applicable

Display item [Unit]	MAIN SIGNALS	SELECTION FROM MENU	Description
SPEED METER [km/h] or [mph]	X	X	Displays the value of vehicle speed signal.
SPEED OUTPUT [km/h] or [mph]	X	X	Displays the value of vehicle speed signal, which is transmitted to each unit with CAN communication.
TACHO METER [rpm]	X	X	Displays the value of engine speed signal, which is input from ECM.
W TEMP METER [°C] or [°F]	X	X	Displays the value of engine coolant temperature signal, which is input from ECM.
FUEL METER [lit.]	X	X	Displays the value, which processes a resistance signal from fuel gauge.
DISTANCE [km] or [mile]	X	X	Displays the value, which is calculated by vehicle speed signal, fuel gauge and fuel consumption from ECM.
FUEL W/L [ON/OFF]	X	X	Displays [ON/OFF] condition of low-fuel warning lamp.
C-ENG W/L [ON/OFF]		X	Displays [ON/OFF] condition of malfunction indicator lamp.
AIR PRES W/L [ON/OFF]		X	Displays [ON/OFF] condition of tire pressure warning lamp.
SEAT BELT W/L [ON/OFF]		X	Indicates [ON/OFF] condition of seat belt warning lamp.
BUZZER [ON/OFF]	X	X	Displays [ON/OFF] condition of buzzer.
DOOR W/L [ON/OFF]		X	Displays [ON/OFF] condition of door warning lamp.
HI-BEAM IND [ON/OFF]		X	Displays [ON/OFF] condition of high beam indicator.
TURN IND [ON/OFF]		X	Displays [ON/OFF] condition of turn indicator.
OIL W/L [ON/OFF]		X	Displays [ON/OFF] condition of oil pressure warning lamp.
VDC/TCS IND [ON/OFF]		X	Displays [ON/OFF] condition of VDC OFF indicator lamp.
ABS W/L [ON/OFF]		X	Displays [ON/OFF] condition of ABS warning lamp.
SLIP IND [ON/OFF]		X	Displays [ON/OFF] condition of SLIP indicator lamp.
BRAKE W/L [ON/OFF]		X	Displays [ON/OFF] condition of brake warning lamp.*
O/D OFF SW [ON/OFF]		X	Indicates [ON/OFF] condition of O/D OFF switch.
P RANGE IND [ON/OFF]	X	X	Indicates [ON/OFF] condition of A/T shift P range indicator.
R RANGE IND [ON/OFF]	X	X	Indicates [ON/OFF] condition of A/T shift R range indicator.
N RANGE IND [ON/OFF]	X	X	Indicates [ON/OFF] condition of A/T shift N range indicator.
4 RANGE IND [ON/OFF]	X	X	Indicates [ON/OFF] condition of A/T shift 4 range indicator.
3 RANGE IND [ON/OFF]	X	X	Indicates [ON/OFF] condition of A/T shift 3 range indicator.
2 RANGE IND [ON/OFF]	X	X	Indicates [ON/OFF] condition of A/T shift 2 range indicator.

DIAGNOSIS SYSTEM (METER)

< SYSTEM DESCRIPTION >

Display item [Unit]	MAIN SIGNALS	SELECTION FROM MENU	Description
1 RANGE IND [ON/OFF]	X	X	Indicates [ON/OFF] condition of A/T shift 1 range indicator.
O/D OFF W/L [ON/OFF]		X	Displays [ON/OFF] condition of AT CHECK (with manual mode) or O/D OFF (without manual mode) warning lamp.
CRUISE IND [ON/OFF]		X	Displays [ON/OFF] condition of CRUISE indicator.
4WD W/L [ON/OFF]		X	Displays [ON/OFF] condition of tire 4WD warning lamp.
SET IND [ON/OFF]		X	Displays [ON/OFF] condition of SET indicator.
4WD LOCK SW [ON/OFF]		X	Indicates [ON/OFF] condition of 4WD lock switch.
4WD LOCK IND [ON/OFF]		X	Indicates [ON/OFF] condition of 4WD lock indicator.
FUEL CAP W/L [ON/OFF]		X	Displays [ON/OFF] condition of loose fuel cap indicator.
TPMS PRESS L [ON/OFF]		X	Displays [ON/OFF] condition of check tire pressure indicator.

NOTE:

Some items are not available due to vehicle specification.

*: The monitor will indicate "OFF" even though the brake warning lamp is on if either of the following conditions exist.

- The parking brake is engaged
- The brake fluid level is low

WORK SUPPORT

Work support item	Description
Turn signal buzzer diagnosis	A possible malfunction can be narrowed down by following displayed instructions.
Fuel meter diagnosis (Analog pointer)	

DIAGNOSIS SYSTEM (BCM)

< SYSTEM DESCRIPTION >

DIAGNOSIS SYSTEM (BCM) COMMON ITEM

COMMON ITEM : CONSULT Function (BCM - COMMON ITEM)

INFOID:0000000012797950

APPLICATION ITEM

CONSULT performs the following functions via CAN communication with BCM.

Direct Diagnostic Mode	Description
ECU Identification	The BCM part number is displayed.
Self Diagnostic Result	The BCM self diagnostic results are displayed.
Data Monitor	The BCM input/output data is displayed in real time.
Active Test	The BCM activates outputs to test components.
Work support	The settings for BCM functions can be changed.
Configuration	<ul style="list-style-type: none"> The vehicle specification can be read and saved. The vehicle specification can be written when replacing BCM.
CAN Diag Support Mntr	The result of transmit/receive diagnosis of CAN communication is displayed.

SYSTEM APPLICATION

BCM can perform the following functions.

System	Sub System	Direct Diagnostic Mode						
		ECU Identification	Self Diagnostic Result	Data Monitor	Active Test	Work support	Configuration	CAN Diag Support Mntr
Door lock	DOOR LOCK			x	x	x		
Rear window defogger	REAR DEFOGGER			x	x			
Warning chime	BUZZER			x	x			
Interior room lamp timer	INT LAMP			x	x	x		
Remote keyless entry system	MULTI REMOTE ENT			x	x	x		
Exterior lamp	HEAD LAMP			x	x	x		
Wiper and washer	WIPER			x	x	x		
Turn signal and hazard warning lamps	FLASHER			x	x			
Air conditioner	AIR CONDITIONER			x				
Combination switch	COMB SW			x				
BCM	BCM	x	x			x	x	x
Immobilizer	IMMU		x	x	x			
Interior room lamp battery saver	BATTERY SAVER			x	x	x		
Vehicle security system	THEFT ALM			x	x	x		
RAP system	RETAINED PWR			x	x	x		
Signal buffer system	SIGNAL BUFFER			x	x			
TPMS	AIR PRESSURE MONITOR		x	x	x	x		
Panic alarm system	PANIC ALARM				x			

BUZZER

DIAGNOSIS SYSTEM (BCM)

< SYSTEM DESCRIPTION >

BUZZER : CONSULT Function (BCM - BUZZER)

INFOID:000000012797951

DATA MONITOR

Monitor Item [Unit]	Description
DOOR SW-DR [On/Off]	Indicates condition of front door switch LH.
IGN ON SW [On/Off]	Indicates condition of ignition switch ON position.
KEY ON SW [On/Off]	Indicates condition of key switch.
LIGHT SW 1ST [On/Off]	Indicates condition of combination switch.
BUCKLE SW [On/Off]	Indicates condition of seat belt buckle switch.

ACTIVE TEST

Test Item	Description
SEAT BELT WARN TEST	This test is able to check seat belt warning operation [Off/On].
LIGHT WARN ALM	This test is able to check light reminder warning operation [Off/On].
IGN KEY WARN ALM	This test is able to check key warning chime operation [Off/On].

POWER SUPPLY AND GROUND CIRCUIT

< DTC/CIRCUIT DIAGNOSIS >

DTC/CIRCUIT DIAGNOSIS

POWER SUPPLY AND GROUND CIRCUIT COMBINATION METER

COMBINATION METER : Diagnosis Procedure

INFOID:000000012797952

Regarding Wiring Diagram information, refer to [MWI-66, "Wiring Diagram"](#).

1. CHECK FUSES

Check for blown combination meter fuses.

Unit	Power source	Fuse No.
Combination meter	Battery	19
	Ignition switch ON or START	14

Is the inspection result normal?

YES >> GO TO 2

NO >> If fuse is blown, be sure to eliminate cause of malfunction before installing new fuse.

2. POWER SUPPLY CIRCUIT CHECK

1. Disconnect combination meter connector M24.
2. Check voltage between combination meter harness connector M24 terminals 3, 16 and ground.

Terminals		(-)	Ignition switch position		
(+)			OFF	ACC	ON
Connector	Terminal	Ground			
M24	3			Battery voltage	Battery voltage
	16		0V	0V	Battery voltage

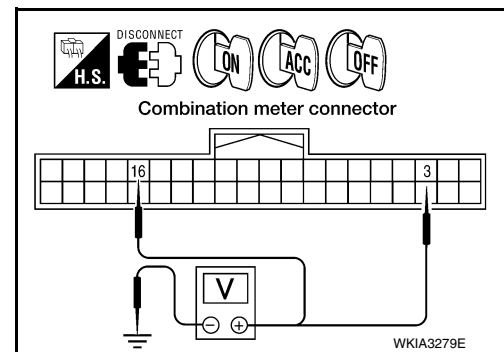

Is the inspection result normal?

YES >> GO TO 3

NO >> Check harness for open between combination meter and fuse.

3. GROUND CIRCUIT CHECK

1. Turn ignition switch OFF.
2. Check continuity between combination meter harness connector M24 terminals 13, 23 and ground.

Terminals		(-)	Continuity
(+)			
Connector	Terminal	Ground	Yes
M24	13		
	23		

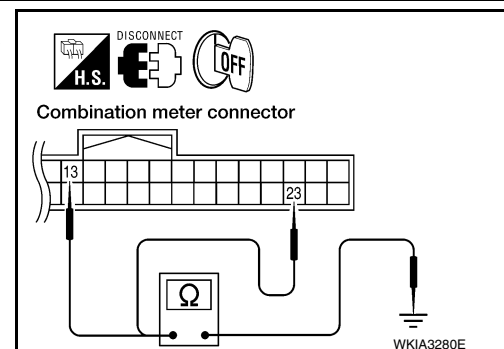

Is the inspection result normal?

YES >> Inspection End.

NO >> Check ground harness.

BCM (BODY CONTROL MODULE)

A
B
C
D
E
F
G
H
I
J
K
L
M

WCS

O
P

POWER SUPPLY AND GROUND CIRCUIT

< DTC/CIRCUIT DIAGNOSIS >

BCM (BODY CONTROL MODULE) : Diagnosis Procedure

INFOID:000000012797953

Regarding Wiring Diagram information, refer to [BCS-49. "Wiring Diagram"](#).

1. CHECK FUSES AND FUSIBLE LINK

Check that the following fuses and fusible link are not blown.

Terminal No.	Signal name	Fuses and fusible link No.
57	Battery power supply	21 (10A)
70		G (50A)
11	Ignition ACC or ON	4 (10A)
38	Ignition ON or START	1 (10A)

Is the fuse blown?

YES >> Replace the blown fuse or fusible link after repairing the affected circuit.

NO >> GO TO 2

2. CHECK POWER SUPPLY CIRCUIT

1. Turn ignition switch OFF.
2. Disconnect BCM.
3. Check voltage between BCM harness connector and ground.

Connector	Terminals		Power source	Condition	Voltage (V) (Approx.)
	(+)	(-)			
M18	11	Ground	ACC power supply	Ignition switch ACC or ON	Battery voltage
	38	Ground	Ignition power supply	Ignition switch ON or START	Battery voltage
M20	57	Ground	Battery power supply	Ignition switch OFF	Battery voltage
	70	Ground	Battery power supply	Ignition switch OFF	Battery voltage

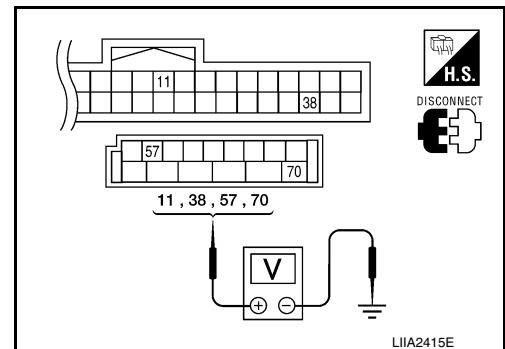

Is the measurement value normal?

YES >> GO TO 3

NO >> Repair or replace harness.

3. CHECK GROUND CIRCUIT

Check continuity between BCM harness connector and ground.

BCM		Ground	Continuity
Connector	Terminal		
M20	67		Yes

Does continuity exist?

YES >> Inspection End.

NO >> Repair or replace harness.

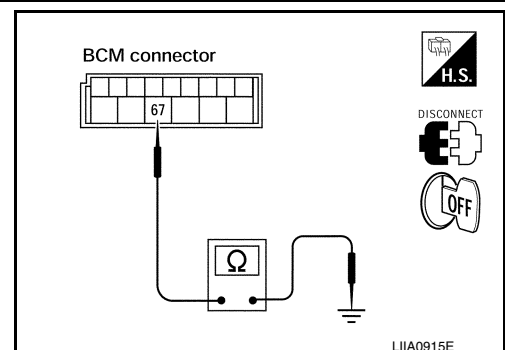

METER BUZZER CIRCUIT

< DTC/CIRCUIT DIAGNOSIS >

METER BUZZER CIRCUIT

Description

INFOID:000000012563072

- The buzzer for warning chime system is installed in the combination meter.
- The combination meter sounds the alarm buzzer based on the signals transmitted from various units.

Component Function Check

INFOID:000000012563073

1. CHECK OPERATION OF METER BUZZER

1. Select "BUZZER" of "BCM" on CONSULT.
2. Perform "LIGHT WARN ALM" of "ACTIVE TEST".

Does meter buzzer activate?

- YES >> Inspection End.
NO >> Replace combination meter. Refer to [MWI-91, "Removal and Installation"](#).

Diagnosis Procedure

INFOID:000000012563074

1. CHECK POWER SUPPLY OF COMBINATION METER

Check power supply of combination meter. Refer to [MWI-31, "COMBINATION METER : Diagnosis Procedure"](#).

Is the inspection result normal?

- YES >> Inspection End.
NO >> Repair or replace harness.

A
B
C
D
E
F
G
H
I
J
K
L
M
O
P

WCS

SEAT BELT BUCKLE SWITCH SIGNAL CIRCUIT

< DTC/CIRCUIT DIAGNOSIS >

SEAT BELT BUCKLE SWITCH SIGNAL CIRCUIT

Description

INFOID:000000012563075

Transmits a seat belt buckle switch LH signal to the combination meter.

Component Function Check

INFOID:000000012563076

1. CHECK COMBINATION METER INPUT SIGNAL

Select "DATA MONITOR" for "METER/M&A" and check the "SEAT BELT W/L" monitor value.

SEAT BELT W/L

When seat belt is fastened : OFF

When seat belt is unfastened : ON

Is the inspection result normal?

YES >> Inspection End.

NO >> Refer to [WCS-20, "Diagnosis Procedure"](#).

Diagnosis Procedure

INFOID:000000012563077

Regarding Wiring Diagram information, refer to [WCS-38, "Wiring Diagram"](#).

1. CHECK COMBINATION METER INPUT SIGNAL

1. Turn ignition switch ON.
2. Check voltage between combination meter harness connector M24 terminal 24 and ground.

24 - Ground

When driver seat belt is fastened : Approx. 12V

When driver seat belt is unfastened : Approx. 0V

Is the inspection result normal?

YES >> Replace combination meter. Refer to [MWI-91, "Removal and Installation"](#).

NO >> GO TO 2

2. CHECK SEAT BELT BUCKLE SWITCH LH CIRCUIT

1. Turn ignition switch OFF.
2. Disconnect combination meter connector and seat belt buckle switch LH connector.
3. Check continuity between combination meter harness connector M24 terminal 24 and seat belt buckle switch LH harness connector B12 terminal 1.

24 - 1 : Continuity should exist.

4. Check continuity between combination meter harness connector M24 terminal 24 and ground.

24 - Ground : Continuity should not exist.

Is the inspection result normal?

YES >> GO TO 3

NO >> Repair or replace harness.

3. CHECK SEAT BELT BUCKLE SWITCH LH GROUND CIRCUIT

Check continuity between seat belt buckle switch LH harness connector B12 terminal 2 and ground.

2 - Ground : Continuity should exist.

Is the inspection result normal?

SEAT BELT BUCKLE SWITCH SIGNAL CIRCUIT

< DTC/CIRCUIT DIAGNOSIS >

- YES >> Inspection End.
NO >> Repair or replace harness.

A

Component Inspection

INFOID:0000000012563078

1. CHECK SEAT BELT BUCKLE SWITCH LH

B

1. Turn ignition switch OFF.
2. Disconnect the seat belt buckle switch LH connector.
3. Check continuity between the seat belt buckle switch LH terminals 1 and 2.

C

1-2

When seat belt is fastened : Continuity should not exist.

D

When seat belt is unfastened : Continuity should exist.

E

Is the inspection result normal?

- YES >> Inspection End.
NO >> Replace the seat belt buckle switch LH. Refer to [SB-7, "Removal and Installation"](#).

F

G

H

I

J

K

L

M

WCS

O

P

KEY SWITCH SIGNAL CIRCUIT

< DTC/CIRCUIT DIAGNOSIS >

KEY SWITCH SIGNAL CIRCUIT

Description

INFOID:000000012563079

Transmits a key switch signal to the BCM.

Component Function Check

INFOID:000000012563080

1. CHECK BCM INPUT SIGNAL

Select "DATA MONITOR" for "BCM" and check the "KEY ON SW" monitor value.

KEY ON SW

When key is inserted into key cylinder : ON

When key is removed from key cylinder : OFF

Is the inspection result normal?

YES >> Inspection End.

NO >> Refer to [WCS-22, "Diagnosis Procedure"](#).

Diagnosis Procedure

INFOID:000000012563081

Regarding Wiring Diagram information, refer to [WCS-38, "Wiring Diagram"](#).

1. CHECK FUSE

Check if the key switch 10A fuse [No. 25, located in the fuse and fusible link box] is blown.

Is the fuse blown?

YES >> Be sure to repair the cause of malfunction before installing new fuse.

NO >> GO TO 2

2. CHECK BCM INPUT SIGNAL

Check voltage between BCM harness connector M18 terminal 37 and ground.

Terminals		(-)	Condition	Voltage (Approx.)
(+)	BCM connector			
	Terminal			
M18	37	Ground	Key is inserted	Battery voltage
			Key is removed	0

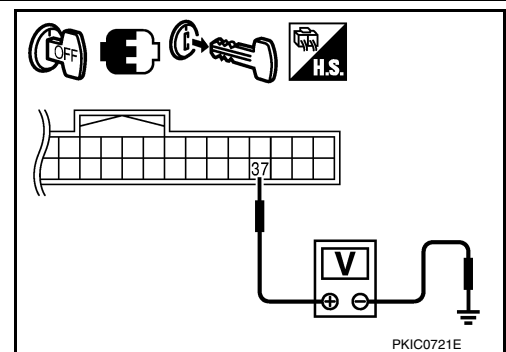

Is the inspection result normal?

YES >> Inspection End.

NO >> GO TO 3

3. CHECK KEY SWITCH CIRCUIT

KEY SWITCH SIGNAL CIRCUIT

< DTC/CIRCUIT DIAGNOSIS >

1. Disconnect BCM connector M18 and key switch connector.
2. Check continuity between BCM harness connector M18 (A) terminal 37 and key switch harness connector M27 (B) terminal 1.

BCM		Key switch		Continuity
Connector	Terminal	Connector	Terminal	
M18 (A)	37	M27 (B)	1	Yes

3. Check continuity between BCM harness connector M18 (A) terminal 37 and ground.

BCM		Ground	Continuity
Connector	Terminal		
M18 (A)	37		No

Is the inspection result normal?

YES >> GO TO 4

NO >> Repair or replace harness.

4. CHECK KEY SWITCH POWER SUPPLY CIRCUIT

Check voltage between key switch harness connector M27 terminal 2 and ground.

Terminals			Voltage (Approx.)
(+)		(-)	
Key switch	Terminal		
M27	2	Ground	Battery voltage

Is the inspection result normal?

YES >> Replace key switch.

NO >> Repair or replace harness.

Component Inspection

1. CHECK KEY SWITCH

1. Turn ignition switch OFF.
2. Disconnect key switch.
3. Check continuity between key switch terminals 1 and 2.

1 – 2

When key is inserted into key cylinder : Continuity should exist.

When key is removed from key cylinder : Continuity should not exist.

Is the inspection result normal?

YES >> Inspection End.

NO >> Replace key switch.

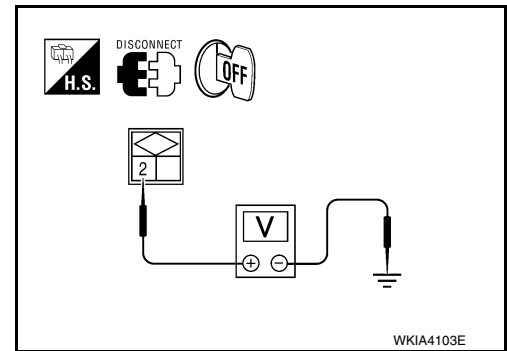
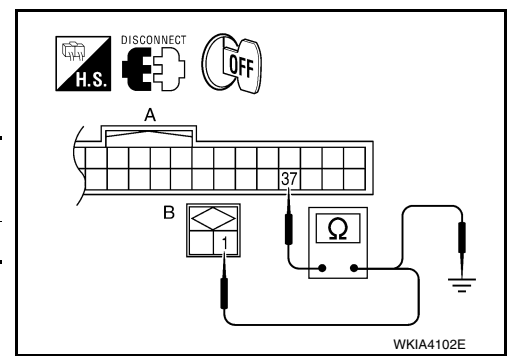

INFOID:000000012563082

A
B
C
D
E
F
G
H
I
J
K
L
M
O
P

WCS

COMBINATION METER

< ECU DIAGNOSIS INFORMATION >

ECU DIAGNOSIS INFORMATION

COMBINATION METER

Reference Value

INFOID:000000012990873

TERMINAL LAYOUT

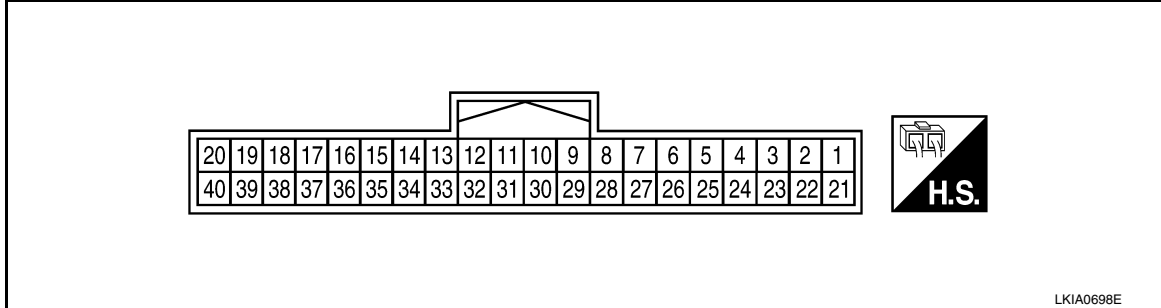

PHYSICAL VALUES

Terminal	Wire color	Item	Condition		Reference value (V) (Approx.)
			Ignition switch	Operation or condition	
2	P	Generator	ON	Generator voltage low	0
				Generator voltage normal	Battery voltage
3	R/Y	Battery power supply	—	—	Battery voltage
4	B/Y	Fuel level sensor ground	ON	—	0
5	W	Vehicle speed signal output (2-pulse)	ON	Speedometer operated [When vehicle speed is approx. 20 km/h (12 MPH)]	240 Hz
6	SB	Vehicle speed signal output (8-pulse)	ON	Speedometer operated [When vehicle speed is approx. 40 km/h (25 MPH)]	<p>NOTE: Maximum voltage may be 12V due to specifications (connected units).</p>
7	G	Transmission range signal	ON	Shift lever: P or N	0
				Shift lever: Except above	Battery voltage
9	BR	Fuel level sensor signal	—	—	Refer to MWI-12. "FUEL GAUGE : System Description" .
11	P	CAN low	—	—	—
12	L	CAN high	—	—	—
13	GR	Ground	—	—	0
16	W/G	Ignition switch ON or START	ON	—	Battery voltage
17	B	AT-PN switch	—	—	—
18	L	AT 1 Range switch	—	—	—
20	Y	O/D off switch	ON	O/D off switch ON	0
				O/D off switch OFF	Battery voltage
22	BR	Illumination control switch	—	—	Refer to INL-74. "System Description" .

COMBINATION METER

< ECU DIAGNOSIS INFORMATION >

Terminal	Wire color	Item	Condition		Reference value (V) (Approx.)
			Ignition switch	Operation or condition	
23	B	Ground	—	—	0
24	V	Seat belt buckle switch LH	ON	Unfastened (ON)	0
				Fastened (OFF)	Battery voltage
25	SB	DIFF LOCK indicator input	ON	DIFF LOCK indicator ON	0
				DIFF LOCK indicator OFF	Battery voltage
31	G	Parking brake switch	ON	Parking brake applied	0
				Parking brake released	Battery voltage
32	SB	Brake fluid level switch	ON	Brake fluid level low	0
				Brake fluid level normal	Battery voltage
34	L	Washer fluid level switch	ON	Washer fluid level low	0
				Washer fluid level normal	Battery voltage
37	SB	Air bag warning lamp input	ON	Air bag warning lamp ON	4
				Air bag warning lamp OFF	0
39	G	Security indicator input	OFF	Security indicator ON	0
				Security indicator OFF	Battery voltage
40	LG	Seat belt buckle switch RH	ON	Unfastened (ON)	0
				Fastened (OFF)	Battery voltage

Fail Safe

INFOID:0000000012990874

The combination meter performs a fail-safe operation for the functions listed below when communication is lost.

Function	Specifications	
Speedometer	Zero indication.	
Tachometer		
Fuel gauge		
Engine coolant temperature gauge		
Engine oil pressure gauge (with 6 gauge combination meter)		
Voltage gauge (with 6 gauge combination meter)		
Illumination control	Meter illumination	Change to nighttime mode when communication is lost.
Segment LCD	Odometer	Freeze current indication.
	A/T position	Display turns off.
Buzzer		Buzzer turns off.

COMBINATION METER

< ECU DIAGNOSIS INFORMATION >

	Function	Specifications
Warning lamp/indicator lamp	ABS warning lamp	Lamp turns on when communication is lost.
	Brake warning lamp	
	VDC OFF indicator lamp	
	Malfunction indicator lamp	
	SLIP indicator lamp	
	AT oil temp warning lamp	Lamp turns off when communication is lost.
	Low washer fluid warning lamp	
	Hill descent control indicator lamp	
	Door open warning lamp	
	CRUISE indicator lamp	
	SET indicator lamp	
	O/D OFF indicator lamp	
	Oil pressure warning lamp	
	Air bag warning lamp	
	High beam indicator	
	Turn signal indicator lamp	Lamp turns off when disconnected.
	Driver and passenger seat belt warning lamp	
	Charge warning lamp	
	Security indicator lamp	
	4WD indicator lamp	
ATP indicator lamp		
Differential lock indicator lamp	Lamp will flash every second for 1 minute and then stay on continuously thereafter.	
Low tire pressure warning lamp		

DTC Index

INFOID:000000012990875

CONSULT display	Malfunction	Reference page
CAN COMM CIRC [U1000]	Malfunction is detected in CAN communication. CAUTION: Even when there is no malfunction on CAN communication system, malfunction may be misinterpreted when battery has low voltage (when maintaining 7 - 8 V for about 2 seconds) or 10A fuse [No. 19, located in the fuse block (J/B)] is disconnected.	MWI-29
VEHICLE SPEED CIRC [B2205]	Malfunction is detected when an erroneous speed signal is input. CAUTION: Even when there is no malfunction on speed signal system, malfunction may be misinterpreted when battery has low voltage (when maintaining 7 - 8 V for about 2 seconds).	MWI-30

NOTE:

“TIME” indicates the following.

- 0: Indicates that a malfunction is detected at present.
- 1-63: Indicates that a malfunction was detected in the past. (Displays number of ignition switch OFF → ON cycles after malfunction is detected. Self-diagnosis result is erased when “63” is exceeded.)

BCM (BODY CONTROL MODULE)

< ECU DIAGNOSIS INFORMATION >

BCM (BODY CONTROL MODULE)

Reference Value

INFOID:000000012848073

NOTE:

The Signal Tech II Tool [– (J-50190)] can be used to perform the following functions. Refer to the Signal Tech II User Guide for additional information.

- Activate and display TPMS transmitter IDs
- Display tire pressure reported by the TPMS transmitter
- Read TPMS DTCs
- Register TPMS transmitter IDs
- Test remote keyless entry keyfob relative signal strength

VALUES ON THE DIAGNOSIS TOOL

Monitor Item	Condition	Value/Status
ACC ON SW	Ignition switch OFF or ON	Off
	Ignition switch ACC	On
AIR COND SW	A/C switch OFF	Off
	A/C switch ON	On
AIR PRESS FL	Front left tire air pressure value	kPa, kg/cm ² , psi
AIR PRESS FR	Front right tire air pressure value	kPa, kg/cm ² , psi
AIR PRESS RL	Rear left tire air pressure value	kPa, kg/cm ² , psi
AIR PRESS RR	Rear right tire air pressure value	kPa, kg/cm ² , psi
AUTO LIGHT SW	Lighting switch OFF	Off
	Lighting switch AUTO	On
BRAKE SW	Brake pedal released	Off
	Brake pedal applied	On
BUCKLE SW	Seat belt buckle unfastened	Off
	Seat belt buckle fastened	On
BUZZER	Buzzer in combination meter OFF	Off
	Buzzer in combination meter ON	On
CARGO LAMP SW	Cargo lamp switch OFF	Off
	Cargo lamp switch ON	On
CDL LOCK SW	Door lock/unlock switch does not operate	Off
	Press door lock/unlock switch to the LOCK side	On
CDL UNLOCK SW	Door lock/unlock switch does not operate	Off
	Press door lock/unlock switch to the UNLOCK side	On
DOOR SW-AS	Front door RH closed	Off
	Front door RH opened	On
DOOR SW-DR	Front door LH closed	Off
	Front door LH opened	On
DOOR SW-RL	Rear door LH closed	Off
	Rear door LH opened	On
DOOR SW-RR	Rear door RH closed	Off
	Rear door RH opened	On
FAN ON SIG	Blower motor fan switch OFF	Off
	Blower motor fan switch ON	On

A
B
C
D
E
F
G
H
I
J
K
L
M
O
P

WCS

BCM (BODY CONTROL MODULE)

< ECU DIAGNOSIS INFORMATION >

Monitor Item	Condition	Value/Status
FR FOG SW	Front fog lamp switch OFF	Off
	Front fog lamp switch ON	On
FR WASHER SW	Front washer switch OFF	Off
	Front washer switch ON	On
FR WIPER LOW	Front wiper switch OFF	Off
	Front wiper switch LO	On
FR WIPER HI	Front wiper switch OFF	Off
	Front wiper switch HI	On
FR WIPER INT	Front wiper switch OFF	Off
	Front wiper switch INT	On
FR WIPER STOP	Any position other than front wiper stop position	Off
	Front wiper stop position	On
HAZARD SW	When hazard switch is not pressed	Off
	When hazard switch is pressed	On
HEAD LAMP SW 1	Headlamp switch OFF	Off
	Headlamp switch 1st	On
HEAD LAMP SW 2	Headlamp switch OFF	Off
	Headlamp switch 1st	On
HI BEAM SW	High beam switch OFF	Off
	High beam switch HI	On
ID REGST FL1	ID registration of front left tire incomplete	YET
	ID registration of front left tire complete	DONE
ID REGST FR1	ID registration of front right tire incomplete	YET
	ID registration of front right tire complete	DONE
ID REGST RL1	ID registration of rear left tire incomplete	YET
	ID registration of rear left tire complete	DONE
ID REGST RR1	ID registration of rear right tire incomplete	YET
	ID registration of rear right tire complete	DONE
IGN ON SW	Ignition switch OFF or ACC	Off
	Ignition switch ON	On
IGN SW CAN	Ignition switch OFF or ACC	Off
	Ignition switch ON	On
INT VOLUME	Wiper intermittent dial is in a dial position 1 - 7	1 - 7
KEY CYL LK-SW	Door key cylinder LOCK position	Off
	Door key cylinder other than LOCK position	On
KEY CYL UN-SW	Door key cylinder UNLOCK position	Off
	Door key cylinder other than UNLOCK position	On
KEY ON SW	Mechanical key is removed from key cylinder	Off
	Mechanical key is inserted to key cylinder	On
KEYLESS LOCK	LOCK button of key fob is not pressed	Off
	LOCK button of key fob is pressed	On
KEYLESS PANIC	PANIC button of key fob is not pressed	Off
	PANIC button of key fob is pressed	On

BCM (BODY CONTROL MODULE)

< ECU DIAGNOSIS INFORMATION >

Monitor Item	Condition	Value/Status	
KEYLESS UNLOCK	UNLOCK button of key fob is not pressed	Off	A
	UNLOCK button of key fob is pressed	On	
LIGHT SW 1ST	Lighting switch OFF	Off	B
	Lighting switch 1st	On	
OIL PRESS SW	<ul style="list-style-type: none"> • Ignition switch OFF or ACC • Engine running 	Off	C
	Ignition switch ON	On	
OPTICAL SENSOR	Bright outside of the vehicle	Close to 5V	D
	Dark outside of the vehicle	Close to 0V	
PASSING SW	Other than lighting switch PASS	Off	E
	Lighting switch PASS	On	
REAR DEF SW	Rear window defogger switch OFF	Off	F
	Rear window defogger switch ON	On	
TURN SIGNAL L	Turn signal switch OFF	Off	G
	Turn signal switch LH	On	
TURN SIGNAL R	Turn signal switch OFF	Off	H
	Turn signal switch RH	On	
VEHICLE SPEED	While driving	Equivalent to speedometer reading	I
WARNING LAMP	Low tire pressure warning lamp in combination meter OFF	Off	J
	Low tire pressure warning lamp in combination meter ON	On	

WCS

BCM (BODY CONTROL MODULE)

< ECU DIAGNOSIS INFORMATION >

Terminal Layout

INFOID:000000012848074

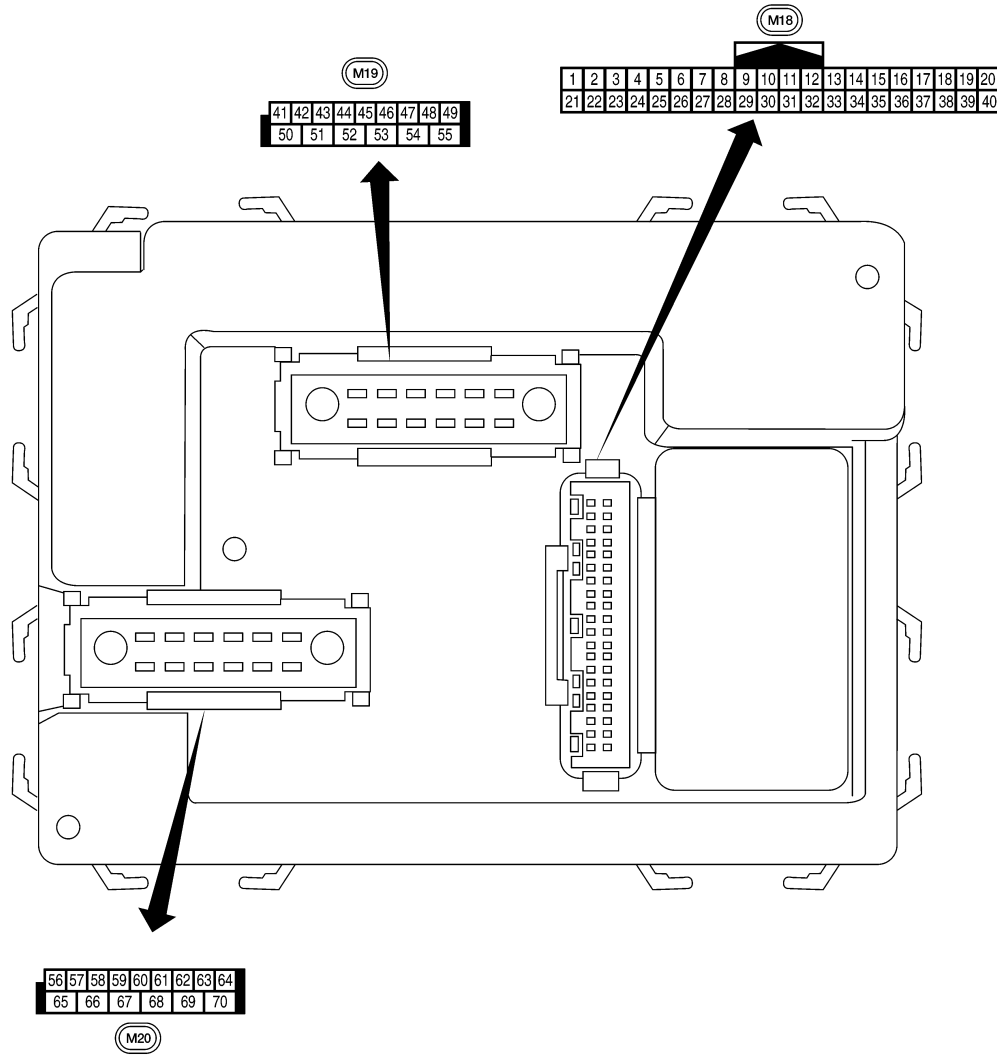



Physical Values

AWMIA1598ZZ

INFOID:000000012848075

BCM (BODY CONTROL MODULE)

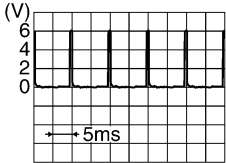
< ECU DIAGNOSIS INFORMATION >

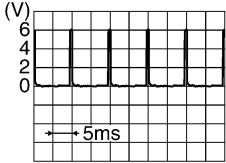
Terminal	Wire color	Item	Signal input/output	Measuring condition		Reference value or waveform (Approx.)
				Ignition switch	Operation or condition	
1	BR	Ignition keyhole illumination	Output	OFF	Door is locked (SW OFF)	Battery voltage
					Door is unlocked (SW ON)	0V
2	P	Combination switch input 5	Input	ON	Lighting, turn, wiper OFF Wiper dial position 4	 <p style="text-align: right; font-size: small;">SKIA5291E</p>
3	SB	Combination switch input 4	Input	ON	Lighting, turn, wiper OFF Wiper dial position 4	 <p style="text-align: right; font-size: small;">SKIA5292E</p>
4	V	Combination switch input 3	Input	ON	Lighting, turn, wiper OFF Wiper dial position 4	 <p style="text-align: right; font-size: small;">SKIA5291E</p>
5	L	Combination switch input 2	Input	ON	Lighting, turn, wiper OFF Wiper dial position 4	 <p style="text-align: right; font-size: small;">SKIA5292E</p>
6	R	Combination switch input 1				
7	GR	Front door lock assembly LH (key cylinder switch) unlock	Input	OFF	ON (open, 2nd turn)	Momentary 1.5V
8	SB	Front door lock assembly LH (key cylinder switch) lock			OFF (closed)	0V
			On (open)	Momentary 1.5V		
9	LG	Brake sw	Input	OFF	OFF (brake pedal is not depressed)	0V
					ON (brake pedal is depressed)	Battery voltage
11	G/B	Ignition switch (ACC or ON)	Input	ACC or ON	Ignition switch ACC or ON	Battery voltage
12	LG	Front door switch RH (All)	Input	OFF	ON (open)	0V
		Rear door switch upper RH (King Cab)			OFF (closed)	Battery voltage
		Rear door switch lower RH (King Cab)				

A
B
C
D
E
F
G
H
I
J
K
L
M
O
P

WCS

BCM (BODY CONTROL MODULE)

< ECU DIAGNOSIS INFORMATION >

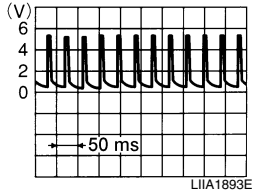
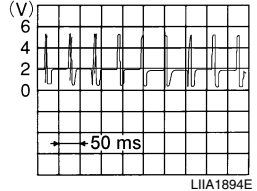
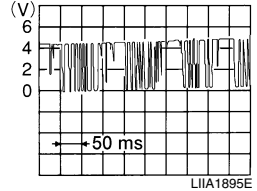
Terminal	Wire color	Item	Signal input/output	Measuring condition		Reference value or waveform (Approx.)
				Ignition switch	Operation or condition	
13	L	Rear door switch RH (Crew Cab)	Input	OFF	ON (open)	0V
					OFF (closed)	Battery voltage
15	W	Tire pressure warning check connector	Input	OFF	—	5V
18	BR	Remote keyless entry receiver and optical sensor (Ground)	Output	OFF	—	0V
19	V	Remote keyless entry receiver (power supply)	Output	OFF	Ignition switch OFF	
20	G	Remote keyless entry receiver signal (Signal)	Input	OFF	Stand-by (keyfob buttons released)	
					When remote keyless entry receiver receives signal from keyfob (keyfob buttons pressed)	
21	GR	NATS antenna amp.	Input	OFF → ON	Ignition switch (OFF → ON)	Just after turning ignition switch ON: Pointer of tester should move.
23	G	Security indicator lamp	Output	OFF	Goes OFF → illuminates (Every 2.4 seconds)	Battery voltage → 0V
25	BR	NATS antenna amp.	Input	OFF → ON	Ignition switch (OFF → ON)	Just after turning ignition switch ON: Pointer of tester should move.
27	W	Compressor ON signal	Input	ON	A/C switch OFF	5V
					A/C switch ON	0V
28	R	Front blower monitor	Input	ON	Front blower motor OFF	Battery voltage
					Front blower motor ON	0V
29	G	Hazard switch	Input	OFF	ON	0V
					OFF	5V
31	GR	Cargo lamp switch	Input	OFF	ON	0V
					OFF	Battery voltage

BCM (BODY CONTROL MODULE)

< ECU DIAGNOSIS INFORMATION >

Terminal	Wire color	Item	Signal input/output	Measuring condition		Reference value or waveform (Approx.)
				Ignition switch	Operation or condition	
32	BG	Combination switch output 5	Output	ON	Lighting, turn, wiper OFF Wiper dial position 4	<p style="text-align: right; font-size: small;">SKIA5291E</p>
33	GR	Combination switch output 4	Output	ON	Lighting, turn, wiper OFF Wiper dial position 4	<p style="text-align: right; font-size: small;">SKIA5292E</p>
34	G	Combination switch output 3	Output	ON	Lighting, turn, wiper OFF Wiper dial position 4	<p style="text-align: right; font-size: small;">SKIA5291E</p>
35	BR	Combination switch output 2	Output	ON	Lighting, turn, wiper OFF Wiper dial position 4	<p style="text-align: right; font-size: small;">SKIA5292E</p>
36	LG	Combination switch output 1				
37	B	Key switch	Input	OFF	Key inserted	Battery voltage
					Key removed	0V
38	W/R	Ignition switch (ON)	Input	ON	—	Battery voltage
39	L	CAN high	—	—	—	—
40	P	CAN low	—	—	—	—
41	Y	Rear window defogger switch	Input	ON	Rear window defogger switch ON	0V
					Rear window defogger switch OFF	5V
45	V	Lock switch	Input	OFF	ON (lock)	0V
					OFF	Battery voltage
46	LG	Unlock switch	Input	OFF	ON (unlock)	0V
					OFF	Battery voltage
47	GR	Front door switch LH (All)	Input	OFF	ON (open)	0V
		Rear door switch upper LH (King Cab)			OFF (closed)	Battery voltage
		Rear door switch lower LH (King Cab)				

A
B
C
D
E
F
G
H
I
J
K
L
M
O
P

WCS

BCM (BODY CONTROL MODULE)

< ECU DIAGNOSIS INFORMATION >

Terminal	Wire color	Item	Signal input/output	Measuring condition		Reference value or waveform (Approx.)	
				Ignition switch	Operation or condition		
48	P	Rear door switch LH (Crew Cab)	Input	OFF	ON (open)	0V	
					OFF (closed)	Battery voltage	
50	P	Cargo lamp	Output	OFF	Any door open (ON)	0V	
					All doors closed (OFF)	Battery voltage	
51	BG	Trailer turn signal (right)	Output	ON	Turn right ON	<p style="text-align: right; font-size: small;">SKIA3009J</p>	
52	LG	Trailer turn signal (left)	Output	ON	Turn left ON	<p style="text-align: right; font-size: small;">SKIA3009J</p>	
56	R/Y	Battery saver output	Output	OFF	10 minutes after ignition switch is turned OFF	0V	
				ON	—	Battery voltage	
57	R/Y	Battery power supply	Input	—	—	Battery voltage	
58	W	Optical sensor	Input	ON	When optical sensor is illuminated	3.1V or more	
					When optical sensor is not illuminated	0.6V or less	
59	GR	Front door lock assembly LH (unlock)	Output	OFF	OFF (neutral)	0V	
					ON (unlock)	Battery voltage	
60	LG	Turn signal (left)	Output	ON	Turn left ON	<p style="text-align: right; font-size: small;">SKIA3009J</p>	
61	G	Turn signal (right)	Output	ON	Turn right ON	<p style="text-align: right; font-size: small;">SKIA3009J</p>	
63	BR	Interior room/map lamp	Output	OFF	Any door switch	ON (open)	0V
					OFF (closed)	Battery voltage	
65	V	All door lock actuators (lock)	Output	OFF	OFF (neutral)	0V	
					ON (lock)	Battery voltage	

BCM (BODY CONTROL MODULE)

< ECU DIAGNOSIS INFORMATION >

Terminal	Wire color	Item	Signal input/output	Measuring condition		Reference value or waveform (Approx.)
				Ignition switch	Operation or condition	
66	L	Front door lock actuator RH, rear door lock actuators LH/RH (unlock)	Output	OFF	OFF (neutral)	0V
					ON (unlock)	Battery voltage
67	B	Ground	Input	ON	—	0V
68 ¹	O	Power window power supply (RAP)	Output	—	Ignition switch ON	Battery voltage
					Within 45 seconds after ignition switch OFF	Battery voltage
					More than 45 seconds after ignition switch OFF	0V
					When front door LH or RH is open or power window timer operates	0V
68 ²	SB	Power window power supply (RAP)	Output	—	Ignition switch ON	Battery voltage
					Within 45 seconds after ignition switch OFF	Battery voltage
					More than 45 seconds after ignition switch OFF	0V
					When front door LH or RH is open or power window timer operates	0V
69	P	Power window power supply (BAT)	Output	OFF	—	Battery voltage
70	W	Battery power supply	Input	OFF	—	Battery voltage

1: King cab

2: Crew cab

Fail Safe

INFOID:000000012848076

Fail-safe index

BCM performs fail-safe control when any DTC listed below is detected.

Display contents of CONSULT	Fail-safe	Cancellation
U1000: CAN COMM CIRCUIT	Inhibit engine cranking	When the BCM re-establishes communication with the other modules.

DTC Inspection Priority Chart

INFOID:000000012848077

If some DTCs are displayed at the same time, perform inspections one by one based on the following priority chart.

Priority	DTC
1	<ul style="list-style-type: none"> U1000: CAN COMM CIRCUIT
2	<ul style="list-style-type: none"> B2190: NATS ANTENNA AMP B2191: DIFFERENCE OF KEY B2192: ID DISCORD BCM-ECM B2193: CHAIN OF BCM-ECM

BCM (BODY CONTROL MODULE)

< ECU DIAGNOSIS INFORMATION >

Priority	DTC
3	<ul style="list-style-type: none"> • C1729: VHCL SPEED SIG ERR • C1735: IGNITION SIGNAL
4	<ul style="list-style-type: none"> • C1704: LOW PRESSURE FL • C1705: LOW PRESSURE FR • C1706: LOW PRESSURE RR • C1707: LOW PRESSURE RL • C1708: [NO DATA] FL • C1709: [NO DATA] FR • C1710: [NO DATA] RR • C1711: [NO DATA] RL • C1712: [CHECKSUM ERR] FL • C1713: [CHECKSUM ERR] FR • C1714: [CHECKSUM ERR] RR • C1715: [CHECKSUM ERR] RL • C1716: [PRESSDATA ERR] FL • C1717: [PRESSDATA ERR] FR • C1718: [PRESSDATA ERR] RR • C1719: [PRESSDATA ERR] RL • C1720: [CODE ERR] FL • C1721: [CODE ERR] FR • C1722: [CODE ERR] RR • C1723: [CODE ERR] RL • C1724: [BATT VOLT LOW] FL • C1725: [BATT VOLT LOW] FR • C1726: [BATT VOLT LOW] RR • C1727: [BATT VOLT LOW] RL

DTC Index

INFOID:000000012848078

NOTE:

Details of time display

- CRNT: Displays when there is a malfunction now or after returning to the normal condition until turning ignition switch OFF → ON again.
- 1 - 39: Displayed if any previous malfunction is present when current condition is normal. It increases like 1 → 2 → 3...38 → 39 after returning to the normal condition whenever ignition switch OFF → ON. The counter remains at 39 even if the number of cycles exceeds it. It is counted from 1 again when turning ignition switch OFF → ON after returning to the normal condition if the malfunction is detected again.

CONSULT display	Fail-safe	Low tire pressure warning lamp ON	Reference page
No DTC is detected. further testing may be required.	—	—	—
U1000: CAN COMM CIRCUIT	—	—	BCS-31
B2190: NATS ANTENA AMP	—	—	SEC-18
B2191: DIFFERENCE OF KEY	—	—	SEC-21
B2192: ID DISCORD BCM-ECM	—	—	SEC-22
B2193: CHAIN OF BCM-ECM	—	—	SEC-24
C1708: [NO DATA] FL	—	X	WT-15
C1709: [NO DATA] FR	—	X	WT-15
C1710: [NO DATA] RR	—	X	WT-15
C1711: [NO DATA] RL	—	X	WT-15
C1712: [CHECKSUM ERR] FL	—	X	WT-17
C1713: [CHECKSUM ERR] FR	—	X	WT-17
C1714: [CHECKSUM ERR] RR	—	X	WT-17
C1715: [CHECKSUM ERR] RL	—	X	WT-17

BCM (BODY CONTROL MODULE)

< ECU DIAGNOSIS INFORMATION >

CONSULT display	Fail-safe	Low tire pressure warning lamp ON	Reference page
C1716: [PRESSDATA ERR] FL	—	X	WT-19
C1717: [PRESSDATA ERR] FR	—	X	WT-19
C1718: [PRESSDATA ERR] RR	—	X	WT-19
C1719: [PRESSDATA ERR] RL	—	X	WT-19
C1720: [CODE ERR] FL	—	X	WT-17
C1721: [CODE ERR] FR	—	X	WT-17
C1722: [CODE ERR] RR	—	X	WT-17
C1723: [CODE ERR] RL	—	X	WT-17
C1724: [BATT VOLT LOW] FL	—	X	WT-17
C1725: [BATT VOLT LOW] FR	—	X	WT-17
C1726: [BATT VOLT LOW] RR	—	X	WT-17
C1727: [BATT VOLT LOW] RL	—	X	WT-17
C1729: VHCL SPEED SIG ERR	—	X	WT-21
C1735: IGNITION SIGNAL	—	X	WT-22

A
B
C
D
E
F
G
H
I
J
K
L
M
O
P

WCS

WARNING CHIME SYSTEM

< WIRING DIAGRAM >

WIRING DIAGRAM

WARNING CHIME SYSTEM

Wiring Diagram

INFOID:000000012563092

◁ CC ▷ : CREW CAB
 ▷ KC ▷ : KING CAB

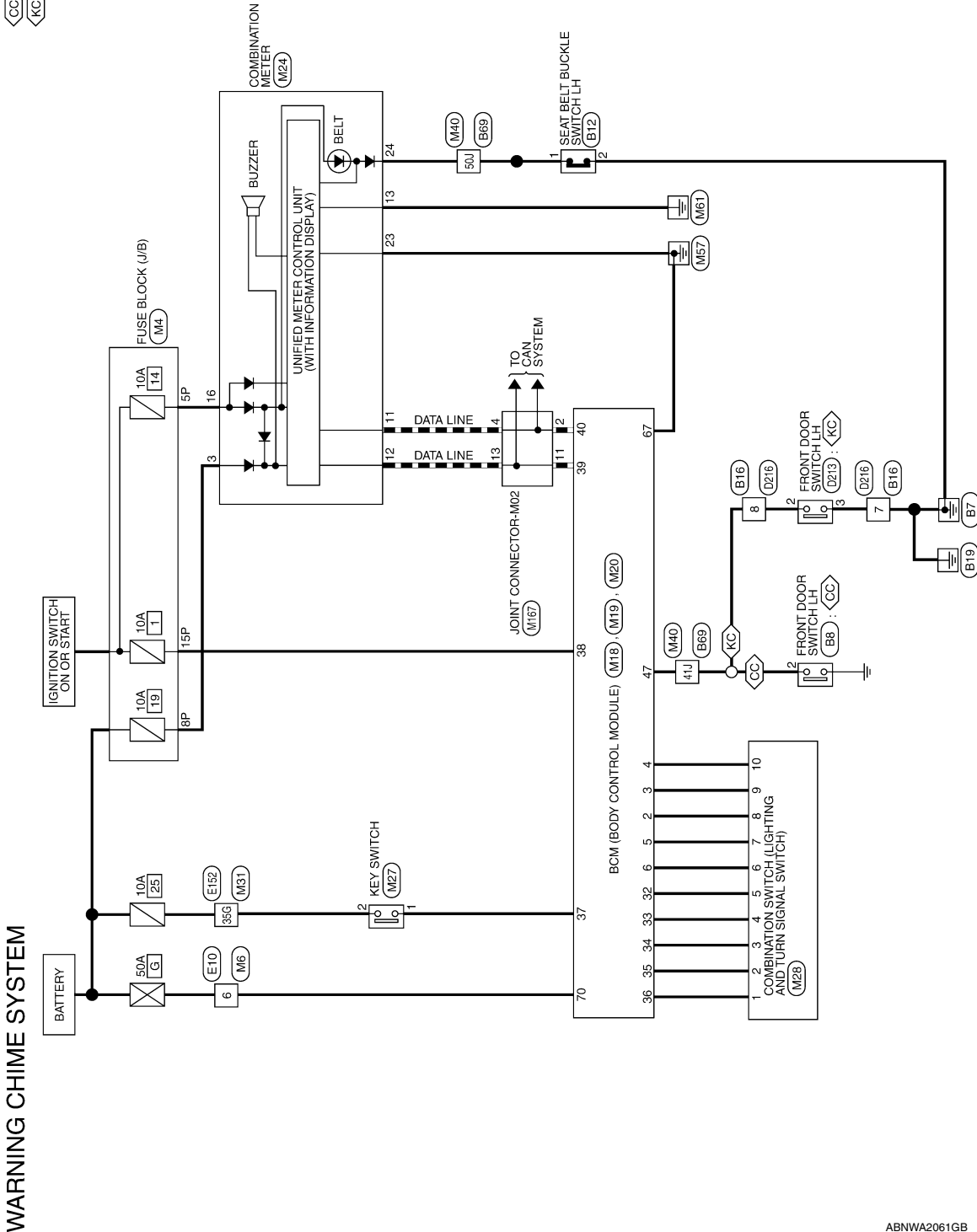

ABNWA2061GB

WARNING CHIME SYSTEM

< WIRING DIAGRAM >

WARNING CHIME SYSTEM CONNECTORS

Connector No.	M4
Connector Name	FUSE BLOCK (J/B)
Connector Color	WHITE



Terminal No.	Color of Wire	Signal Name
5P	W/G	-
8P	R/Y	-
15P	W/R	-

Connector No.	M6
Connector Name	WIRE TO WIRE
Connector Color	WHITE



Terminal No.	Color of Wire	Signal Name
6	W	-

Connector No.	M18
Connector Name	BCM (BODY CONTROL MODULE)
Connector Color	WHITE

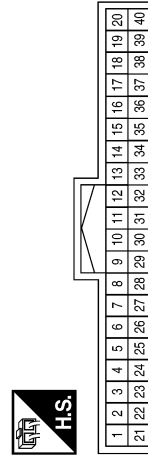

Terminal No.	Color of Wire	Signal Name
2	P	INPUT 5
3	SB	INPUT 4

Terminal No.	Color of Wire	Signal Name
4	V	INPUT 3
5	L	INPUT 2
6	R	INPUT 1
32	BG	OUTPUT 5
33	GR	OUTPUT 4
34	G	OUTPUT 3
35	BR	OUTPUT 2
36	LG	OUTPUT 1
37	B	KEY SW
38	W/R	IGN SW
39	L	CAN-H
40	P	CAN-L

Connector No.	M19
Connector Name	BCM (BODY CONTROL MODULE)
Connector Color	WHITE

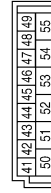

Terminal No.	Color of Wire	Signal Name
47	GR	DOOR SW (DR)

ABNIA5549GB

A
B
C
D
E
F
G
H
I
J
K
L
M
O
P



WARNING CHIME SYSTEM

< WIRING DIAGRAM >

Connector No.	M27
Connector Name	KEY SWITCH
Connector Color	WHITE



Terminal No.	Color of Wire	Signal Name
1	B	-
2	Y	-

Connector No.	M24
Connector Name	COMBINATION METER
Connector Color	WHITE



Terminal No.	Color of Wire	Signal Name
3	R/Y	BATTERY
11	P	CAN-L
12	L	CAN-H
13	GR	GROUND
16	W/G	RUN START
23	B	POWER GND
24	V	BUCKLE (SEATBELT) SW

Connector No.	M20
Connector Name	BCM (BODY CONTROL MODULE)
Connector Color	BLACK

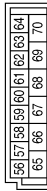

Terminal No.	Color of Wire	Signal Name
67	B	GND (POWER)
70	W	BAT (F/L)

Connector No.	M28
Connector Name	COMBINATION SWITCH
Connector Color	WHITE



Terminal No.	Color of Wire	Signal Name
1	LG	-

Terminal No.	Color of Wire	Signal Name
2	BR	-
3	G	-
4	GR	-
5	BG	-
6	R	-
7	L	-
8	P	-
9	SB	-
10	V	-

ABNIA6674GB

WARNING CHIME SYSTEM

< WIRING DIAGRAM >

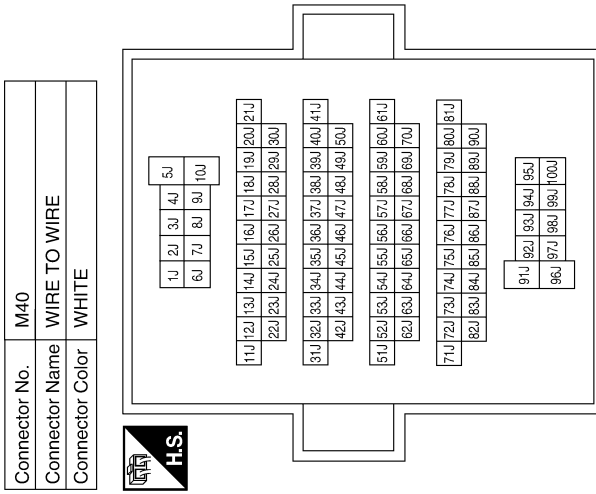

Terminal No.	Color of Wire	Signal Name
35G	Y	-

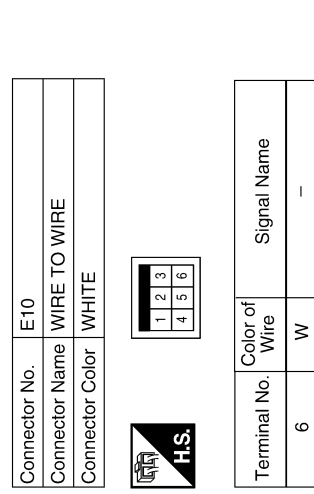

Terminal No.	Color of Wire	Signal Name
2	P	-
4	P	-
11	L	-
13	L	-



ABNIA5551GB

A
B
C
D
E
F
G
H
I
J
K
L
M
N
O
P

WCS

WARNING CHIME SYSTEM

< WIRING DIAGRAM >

Connector No.	B8
Connector Name	FRONT DOOR SWITCH LH (CREW CAB)
Connector Color	WHITE

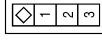

Terminal No.	Color of Wire	Signal Name
2	GR	-

Terminal No.	Color of Wire	Signal Name
35G	Y	-

Connector No.	E152
Connector Name	WIRE TO WIRE
Connector Color	WHITE

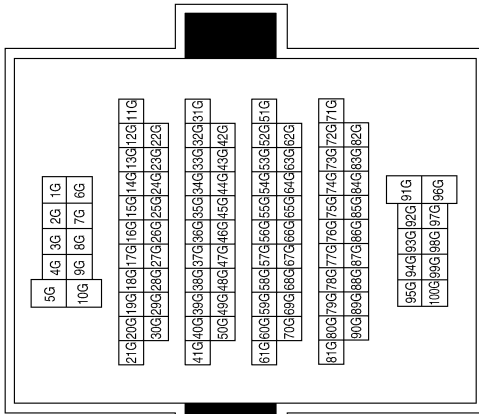

Connector No.	B16
Connector Name	WIRE TO WIRE
Connector Color	WHITE

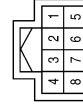

Terminal No.	Color of Wire	Signal Name
7	B	-
8	GR	-

Connector No.	B12
Connector Name	SEAT BELT BUCKLE SWITCH LH
Connector Color	WHITE

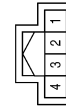

Terminal No.	Color of Wire	Signal Name
1	BG	-
2	B	-

ABNIA5552GB

WARNING CHIME SYSTEM

< WIRING DIAGRAM >

Connector No.	D213
Connector Name	FRONT DOOR SWITCH LH (KING CAB)
Connector Color	WHITE

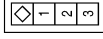

Terminal No.	Color of Wire	Signal Name
2	LG	-
3	B	-

Terminal No.	Color of Wire	Signal Name
41J	GR	-
50J	V	-

Connector No.	B69
Connector Name	WIRE TO WIRE
Connector Color	WHITE

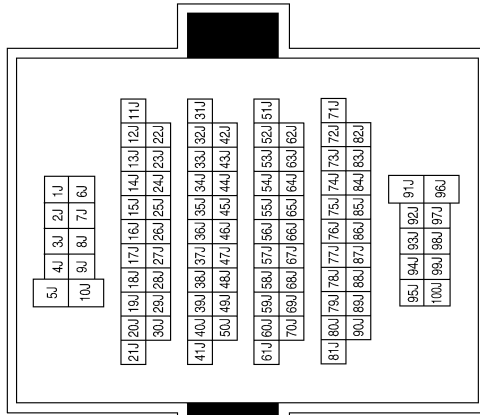

Connector No.	D216
Connector Name	WIRE TO WIRE
Connector Color	WHITE

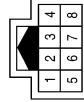

Terminal No.	Color of Wire	Signal Name
7	B	-
8	LG	-

ABNIA5553GB

A
B
C
D
E
F
G
H
I
J
K
L
M
N
O
P

WCS

THE LIGHT REMINDER WARNING DOES NOT SOUND

< SYMPTOM DIAGNOSIS >

SYMPTOM DIAGNOSIS

THE LIGHT REMINDER WARNING DOES NOT SOUND

Description

INFOID:0000000012563093

Light reminder warning does not sound even though headlamp is illuminated.

Diagnosis Procedure

INFOID:0000000012563094

1. CHECK COMBINATION SWITCH (LIGHTING AND TURN SIGNAL SWITCH) OPERATION

Check that the headlamps operate normally by operating the combination switch (lighting and turn signal switch).

Do they operate normally?

YES >> GO TO 2

NO >> Refer to [EXL-7, "Work Flow"](#).

2. CHECK FRONT DOOR SWITCH LH SIGNAL CIRCUIT

Perform a unit inspection for the front door switch LH. Refer to [DLK-29, "CREW CAB : Component Function Check"](#) (Crew Cab) or [DLK-27, "KING CAB : Component Function Check"](#) (King Cab).

Is the inspection result normal?

YES >> Replace the BCM. Refer to [BCS-56, "Removal and Installation"](#).

NO >> Refer to [DLK-29, "CREW CAB : Diagnosis Procedure"](#) (Crew Cab) or [DLK-27, "KING CAB : Diagnosis Procedure"](#) (King Cab).

THE SEAT BELT WARNING CONTINUES SOUNDING, OR DOES NOT SOUND

< SYMPTOM DIAGNOSIS >

THE SEAT BELT WARNING CONTINUES SOUNDING, OR DOES NOT SOUND

Description

INFOID:000000012563095

- Seat belt warning does not sound even though driver seat belt is not fastened.
- Seat belt warning sounds even though driver seat belt is fastened.

Diagnosis Procedure

INFOID:000000012563096

1. CHECK WARNING CHIME OPERATION

1. With key removed from key switch and the front door LH open, turn lighting switch to 1st or 2nd position.
2. Return lighting switch to off position, and insert key into key switch.

Does warning chime sound for both steps?

YES >> GO TO 2

- NO >> • If both light reminder warning and key warning do not sound, replace combination meter. Refer to [MWI-91, "Removal and Installation"](#).
- If the light reminder warning does not sound only, refer to [WCS-44, "Diagnosis Procedure"](#).
 - If the key warning does not sound only, refer to [WCS-46, "Diagnosis Procedure"](#).

2. CHECK SEAT BELT WARNING LAMP

1. Turn ignition switch ON.
2. Check the operation of the seat belt warning lamp in the combination meter.

Seat belt fastened : OFF

Seat belt not fastened : ON

Is the inspection result normal?

YES >> Replace BCM. Refer to [BCS-56, "Removal and Installation"](#).

NO >> GO TO 3

3. CHECK SEAT BELT BUCKLE SWITCH LH CIRCUIT

Perform inspection of the seat belt buckle switch LH circuit. Refer to [WCS-20, "Diagnosis Procedure"](#).

Is the inspection result normal?

YES >> GO TO 4

NO >> Repair harness or connector.

4. CHECK SEAT BELT BUCKLE SWITCH LH

Perform a unit inspection for the seat belt buckle switch LH. Refer to [WCS-21, "Component Inspection"](#).

Is the inspection result normal?

YES >> Replace the combination meter. Refer to [MWI-91, "Removal and Installation"](#).

NO >> Replace the seat belt buckle switch LH. Refer to [SB-7, "Removal and Installation"](#).

A
B
C
D
E
F
G
H
I
J
K
L
M

WCS

THE KEY WARNING DOES NOT SOUND

< SYMPTOM DIAGNOSIS >

THE KEY WARNING DOES NOT SOUND

Description

INFOID:000000012563097

Key warning does not sound even though key is in ignition and front door LH is opened.

Diagnosis Procedure

INFOID:000000012563098

1.CHECK WARNING CHIME OPERATION

With key removed from the ignition and the front door LH open, turn the lighting switch to 1st or 2nd position.

Does warning chime sound?

YES >> GO TO 2

NO >> Replace combination meter. Refer to [MWI-91, "Removal and Installation"](#).

2.CHECK KEY SWITCH CIRCUIT

Perform inspection of the key switch circuit. Refer to [WCS-22, "Diagnosis Procedure"](#).

Is the inspection result normal?

YES >> GO TO 3

NO >> Repair harness or connector.

3.CHECK KEY SWITCH

Perform a unit inspection for the key switch. Refer to [WCS-23, "Component Inspection"](#).

Is the inspection result normal?

YES >> Replace the BCM. Refer to [BCS-56, "Removal and Installation"](#).

NO >> Replace the key switch.

PRECAUTIONS

< PRECAUTION >

PRECAUTION

PRECAUTIONS

Precaution for Supplemental Restraint System (SRS) "AIR BAG" and "SEAT BELT PRE-TENSIONER"

INFOID:000000012563099

The Supplemental Restraint System such as "AIR BAG" and "SEAT BELT PRE-TENSIONER", used along with a front seat belt, helps to reduce the risk or severity of injury to the driver and front passenger for certain types of collision. This system includes seat belt switch inputs and dual stage front air bag modules. The SRS system uses the seat belt switches to determine the front air bag deployment, and may only deploy one front air bag, depending on the severity of a collision and whether the front occupants are belted or unbelted. Information necessary to service the system safely is included in the SR and SB section of this Service Manual.

WARNING:

- To avoid rendering the SRS inoperative, which could increase the risk of personal injury or death in the event of a collision which would result in air bag inflation, all maintenance must be performed by an authorized NISSAN/INFINITI dealer.
- Improper maintenance, including incorrect removal and installation of the SRS, can lead to personal injury caused by unintentional activation of the system. For removal of Spiral Cable and Air Bag Module, see the SR section.
- Do not use electrical test equipment on any circuit related to the SRS unless instructed to in this Service Manual. SRS wiring harnesses can be identified by yellow and/or orange harnesses or harness connectors.

PRECAUTIONS WHEN USING POWER TOOLS (AIR OR ELECTRIC) AND HAMMERS

WARNING:

- When working near the Airbag Diagnosis Sensor Unit or other Airbag System sensors with the Ignition ON or engine running, DO NOT use air or electric power tools or strike near the sensor(s) with a hammer. Heavy vibration could activate the sensor(s) and deploy the air bag(s), possibly causing serious injury.
- When using air or electric power tools or hammers, always switch the Ignition OFF, disconnect the battery and wait at least three minutes before performing any service.

A
B
C
D
E
F
G
H
I
J
K
L
M
O
P

WCS