

# RESTRAINT SYSTEM

# SECTION RS

GI  
MA  
EM  
LC  
EC  
FE  
CL  
MT  
AT  
AX  
SU  
BR  
ST  
**RS**  
BT  
HA  
SC  
EL  
IDX

## CONTENTS

<b>SEAT BELTS</b> .....3	Front Passenger Air Bag Module .....23
Precautions .....3	REMOVAL.....23
SUPPLEMENTAL RESTRAINT SYSTEM (SRS)	INSTALLATION.....23
"Air Bag" AND "SEAT BELT PRE-TENSIONER" .....3	Side Air Bag Module.....24
PRECAUTION FOR SEAT BELT SERVICE.....3	REMOVAL.....24
Front Seat Belt.....5	INSTALLATION.....25
REMOVAL AND INSTALLATION.....5	Disposal of Air Bag Module and Seat Belt Pre-
Rear Seat Belt .....7	tensioner .....26
REMOVAL AND INSTALLATION.....7	CHECKING DEPLOYMENT TOOL.....26
Seat Belt Inspection.....9	DEPLOYMENT PROCEDURES FOR AIR BAG
AFTER A COLLISION.....9	MODULE (OUTSIDE OF VEHICLE).....27
PRELIMINARY CHECKS .....9	DEPLOYMENT PROCEDURES FOR SEAT BELT
SEAT BELT RETRACTOR ON-VEHICLE CHECK.....10	PRE-TENSIONER (OUTSIDE OF VEHICLE) .....30
SEAT BELT RETRACTOR OFF-VEHICLE CHECK .....10	DEPLOYMENT OF AIR BAG MODULE AND SEAT
Tether Anchor Plate .....12	BELT PRE-TENSIONER WHILE MOUNTED IN
REMOVAL AND INSTALLATION.....12	VEHICLE .....30
<b>SUPPLEMENTAL RESTRAINT SYSTEM (SRS)</b> .....13	DISPOSING OF AIR BAG MODULE AND SEAT
Precautions .....13	BELT PRE-TENSIONER.....31
SUPPLEMENTAL RESTRAINT SYSTEM (SRS)	Trouble Diagnoses Introduction.....32
"Air Bag" AND "SEAT BELT PRE-TENSIONER" .....13	DIAGNOSIS FUNCTION.....32
PRECAUTIONS FOR SRS "Air Bag" AND "SEAT	DIAGNOSIS MODE FOR CONSULT-II .....32
BELT PRE-TENSIONER" SERVICE.....13	Ⓜ HOW TO CHANGE SELF-DIAGNOSIS MODE
WIRING DIAGRAMS AND TROUBLE DIAGNOSIS .....13	WITH CONSULT-II .....33
Preparation .....14	ⓧ HOW TO CHANGE SELF-DIAGNOSIS MODE
SPECIAL SERVICE TOOLS .....14	WITHOUT CONSULT-II .....33
SRS Configuration.....15	HOW TO ERASE SELF-DIAGNOSIS RESULTS .....33
Seat Belt Pre-tensioner with Load Limiter.....16	How to Perform Trouble Diagnoses for Quick
Built-in Type Side Air Bag.....16	and Accurate Repair.....35
SRS Component Parts Location .....17	INFORMATION FROM CUSTOMER.....35
Maintenance Items .....17	PRELIMINARY CHECK .....35
Diagnosis Sensor Unit.....18	WORK FLOW .....36
REMOVAL AND INSTALLATION.....18	Schematic .....37
Seat Belt Pre-tensioner .....19	Wiring Diagram - SRS - .....38
REMOVAL AND INSTALLATION.....19	SRS Operation Check .....41
Satellite Sensor.....19	DIAGNOSTIC PROCEDURE 1 .....41
REMOVAL AND INSTALLATION.....19	Ⓜ Trouble Diagnoses with CONSULT-II.....43
Driver Air Bag Module and Spiral Cable .....20	DIAGNOSTIC PROCEDURE 2 .....43
REMOVAL AND INSTALLATION.....20	DIAGNOSTIC PROCEDURE 3.....46
REMOVAL.....20	DIAGNOSTIC PROCEDURE 4 (CONTINUED
INSTALLATION.....22	FROM DIAGNOSTIC PROCEDURE 2) .....48
	DIAGNOSTIC PROCEDURE 5 .....48

# CONTENTS (Cont'd)

⊗ Trouble Diagnoses without CONSULT-II.....52	DIAGNOSTIC PROCEDURE 11 .....61
DIAGNOSTIC PROCEDURE 6.....52	Trouble Diagnoses: "SEAT BELT" Warning Lamp
DIAGNOSTIC PROCEDURE 7.....55	Does Not Turn Off .....62
DIAGNOSTIC PROCEDURE 8 (CONTINUED	DIAGNOSTIC PROCEDURE 12 .....62
FROM DIAGNOSTIC PROCEDURE 6) .....57	Trouble Diagnoses: "SEAT BELT" Warning Lamp
Trouble Diagnoses: "AIR BAG" Warning Lamp	Does Not Turn On .....64
Does Not Turn Off .....58	DIAGNOSTIC PROCEDURE 13 .....64
DIAGNOSTIC PROCEDURE 9.....58	Collision Diagnosis .....65
Trouble Diagnoses: "AIR BAG" Warning Lamp	FOR FRONTAL COLLISION .....65
Does Not Turn On .....60	FOR SIDE COLLISION.....67
DIAGNOSTIC PROCEDURE 10 .....60	
Trouble Diagnoses: SRS Does Not Enter	
Diagnosis Mode Using Door Switch.....61	

## Precautions

**SUPPLEMENTAL RESTRAINT SYSTEM (SRS) “AIR BAG” AND “SEAT BELT PRE-TENSIONER”**

NCRS0001

The Supplemental Restraint System such as “AIR BAG” and “SEAT BELT PRE-TENSIONER” used along with a seat belt, helps to reduce the risk or severity of injury to the driver and front passenger for certain types of collision. The SRS composition which is available to INFINITI G20 is as follows:

- For a frontal collision  
The Supplemental Restraint System consists of driver air bag module (located in the center of the steering wheel), front passenger air bag module (located on the instrument panel on passenger side), seat belt pre-tensioners, a diagnosis sensor unit, warning lamp, wiring harness and spiral cable.
- For a side collision  
The Supplemental Restraint System consists of side air bag module (located in the outer side of front seat), satellite sensor, diagnosis sensor unit (one of components of air bags for a frontal collision), wiring harness, warning lamp (one of components of air bags for a frontal collision).

**WARNING:**

- To avoid rendering the SRS inoperative, which could increase the risk of personal injury or death in the event of a collision which would result in air bag inflation, all maintenance must be performed by an authorized INFINITI dealer.
- Improper maintenance, including incorrect removal and installation of the SRS, can lead to personal injury caused by unintentional activation of the system.
- Do not use electrical test equipment on any circuit related to the SRS unless instructed to in this Service Manual. Spiral cable and wiring harnesses (except “SEAT BELT PRE-TENSIONER”) covered with yellow insulation tape either just before the harness connectors or for the complete harness are related to the SRS.

**PRECAUTION FOR SEAT BELT SERVICE**

NCRS0002

**CAUTION:**

- Before removing the seat belt pre-tensioner assembly, turn the ignition switch off, disconnect both battery cables and wait at least 3 minutes.
- Do not use electrical test equipment for seat belt pre-tensioner connector.
- After replacing or reinstalling seat belt pre-tensioner assembly, or reconnecting seat belt pre-tensioner connector, check the system function. Refer to “Checking Seat Belt Pre-tensioner Operation by Using “SEAT BELT” Warning Lamp — User Mode”, “SRS Operation Check” (RS-42) for details.
- Do not use disassemble buckle or seat belt assembly.
- Replace anchor bolts if they are deformed or worn out.
- Never oil tongue and buckle.
- If any component of seat belt assembly is questionable, do not repair. Replace the whole seat belt assembly.
- If webbing is cut, frayed, or damaged, replace seat belt assembly.
- When replacing seat belt assembly, use a genuine seat belt assembly.

**After A Collision**

NCRS0002S01

**WARNING:**

Inspect all seat belt assemblies including retractors and attaching hardware after any collision. NISSAN recommends that all seat belt assemblies in use during a collision be replaced unless the collision was minor and the belts show no damage and continue to operate properly. Failure to do so could result in serious personal injury in an accident. Seat belt assemblies not in use during a collision should also be replaced if either damage or improper operation is noted. Seat belt pre-tensioner should be replaced even if the seat belts are not in use during a frontal collision in which the air bags are deployed.

Replace any seat belt assembly if:

- The seat belt was in use at the time of a collision (except for minor collisions and the belts, retractors and buckles show no damage and continue to operate properly).
- The seat belt was damaged in an accident. (i.e. torn webbing, bent retractor or guide, etc.)
- The seat belt attaching point was damaged in an accident. Inspect the seat belt attaching area for damage or distortion and repair as necessary before installing a new seat belt assembly.

## SEAT BELTS

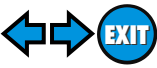

### *Precautions (Cont'd)*

---

- Anchor bolts are deformed or worn out.
- The seat belt pre-tensioner should be replaced even if the seat belts are not in use during the collision in which the air bags are deployed.

## Front Seat Belt

### REMOVAL AND INSTALLATION

=NCRS0003

1. Slide the seat all the way forward and tilt the seatback toward the front.
2. Remove adjuster cover. **A**
3. Slide floor anchor cover.
4. Remove floor anchor bolt. **B**
5. Remove shoulder anchor bolt. **C**
6. Remove center pillar upper and lower garnish. Refer to BT-26, "SIDE AND FLOOR TRIM" for details.
7. Disconnect seat belt pre-tensioner connector.
8. Remove second sash guide.
9. Remove the screw securing seat belt pre-tensioner retractor, then remove seat belt and seat belt pre-tensioner retractor.
10. Remove bolts securing seat belt adjuster, then remove seat belt adjuster.

GI  
MA  
EM  
LC  
EC  
FE  
CL  
MT  
AT  
AX  
SU  
BR  
ST  
**RS**  
BT  
HA  
SC  
EL  
IDX

SEC. 769•868

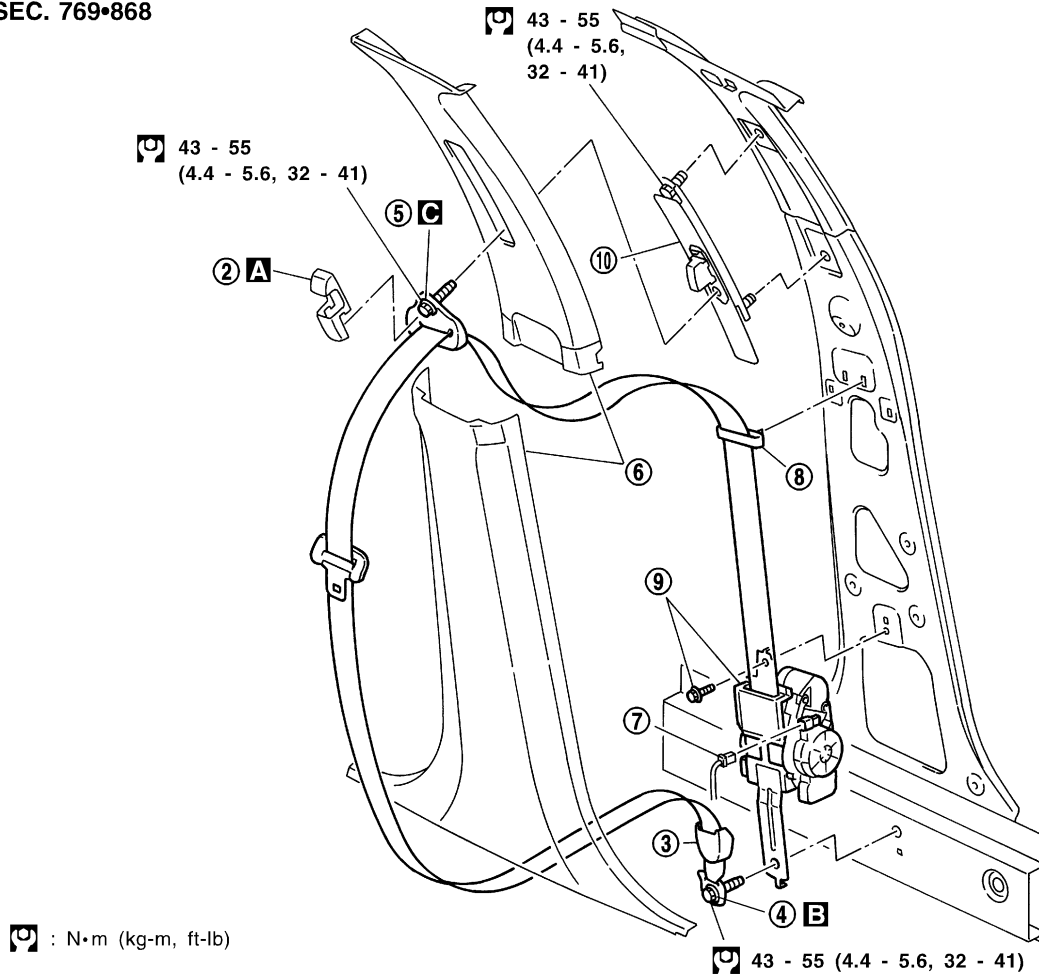

: N•m (kg-m, ft-lb)

SRS556-A

# SEAT BELTS

## Front Seat Belt (Cont'd)

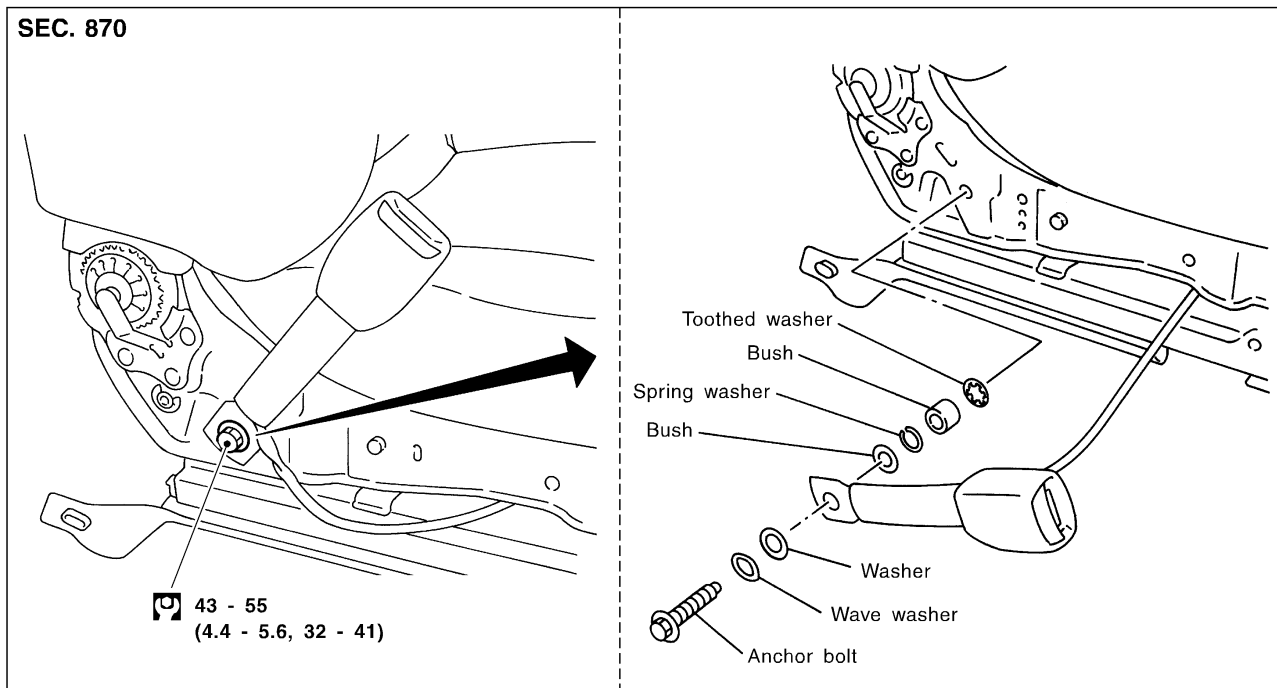
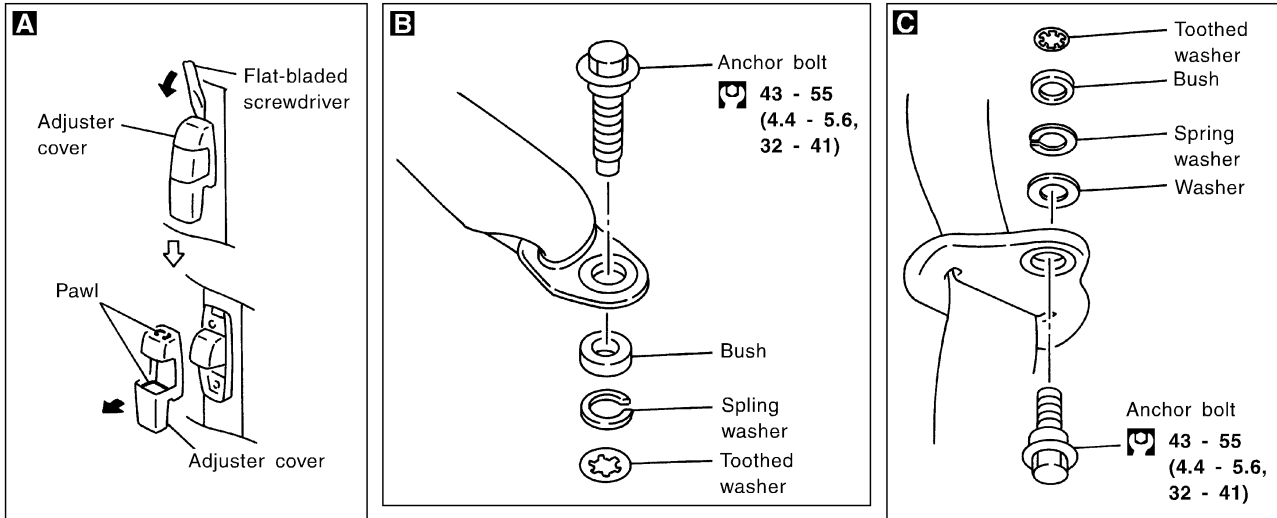

: N•m (kg-m, ft-lb)

## Rear Seat Belt

### REMOVAL AND INSTALLATION

=NCRS0004

1. Remove rear seat. Refer to BT-42, "REAR SEAT" for details.
2. Remove outer and floor anchor bolt. **A B**
3. Remove rear side garnish. Refer to BT-26, "SIDE AND FLOOR TRIM" for details.
4. Remove rear parcel shelf finisher. Refer to BT-26, "SIDE AND FLOOR TRIM" for details.
5. Remove bolts securing rear seat belt retractor, then remove seat belt and seat belt retractor. **C D**

SEC. 869

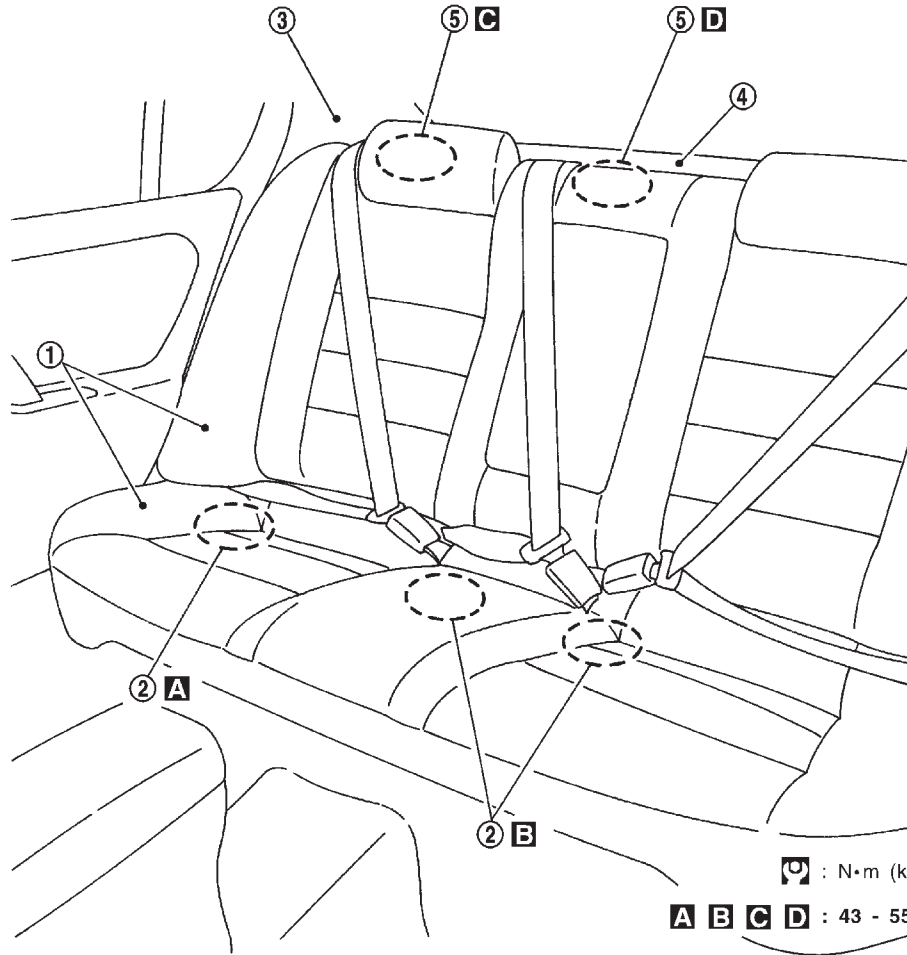

: N·m (kg-m, ft-lb)

**A B C D** : 43 - 55 (4.4 - 5.6, 32 - 41)

SRS558

GI  
MA  
EM  
LC  
EC  
FE  
CL  
MT  
AT  
AX  
SU  
BR  
ST  
RS  
BT  
HA  
SC  
EL  
IDX

# SEAT BELTS

Rear Seat Belt (Cont'd)

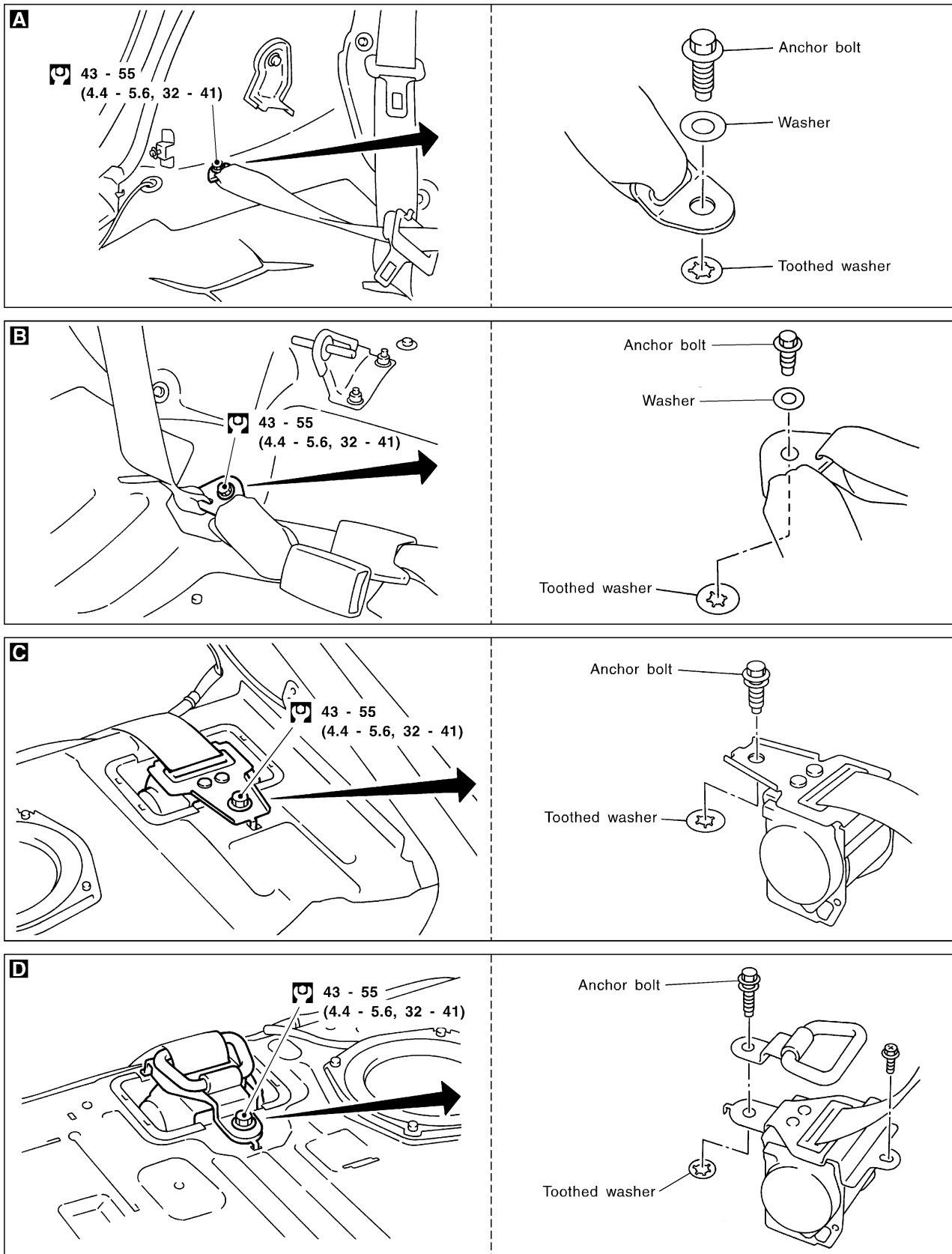

: N•m (kg-m, ft-lb)

SRS559-A



## Seat Belt Inspection

=NCRS0005

NCRS0005S01

## AFTER A COLLISION

**WARNING:**

Inspect all seat belt assemblies including retractors and attaching hardware after any collision. NISSAN recommends that all seat belt assemblies in use during a collision be replaced unless the collision was minor and the belts show no damage and continue to operate properly. Failure to do so could result in serious personal injury in an accident. Seat belt assemblies not in use during a collision should also be replaced if either damage or improper operation is noted. Seat belt pre-tensioner should be replaced even if the seat belts are not in use during a frontal collision in which the air bags are deployed.

Replace any seat belt assembly if:

- The seat belt was in use at the time of a collision (except for minor collisions and the belts, retractors and buckles show no damage and continue to operate properly).
- The seat belt was damaged in an accident. (i.e. torn webbing, bent retractor or guide, etc.)
- The seat belt attaching point was damaged in an accident. Inspect the seat belt attaching area for damage or distortion and repair as necessary before installing a new seat belt assembly.
- Anchor bolts are deformed or worn out.
- The seat belt pre-tensioner should be replaced even if the seat belts are not in use during the collision in which the air bags are deployed.

## PRELIMINARY CHECKS

NCRS0005S02

1. Check the seat belt warning lamp/chime for proper operation as follows:
  - a. Switch ignition ON. The seat belt warning lamp should illuminate. Also, the seat belt warning chime should sound for about seven seconds.
  - b. Fasten driver's seat belt. The seat belt warning lamp should go out and the chime (if sounding) should stop.
  - c. If the seat belt warning lamp is blinking, conduct self-diagnosis using CONSULT-II, and seat belt warning lamp. Refer to "Checking Seat Belt Pre-tensioner Operation by Using "SEAT BELT" Warning Lamp — User Mode", "SRS Operation Check", RS-42.
2. Check that the seat belt retractor, seat belt anchor and buckle bolts are securely attached.
3. Check the shoulder seat belt guide and shoulder belt height adjuster for front seats. Ensure guide swivels freely and that belt lays flat and does not bind in guide. Ensure height adjuster operates properly and holds securely.
4. Check retractor operation:
  - a. Fully extend the seat belt webbing and check for twists, tears or other damage.
  - b. Allow the seat belt to retract. Ensure that belt returns smoothly and completely into the retractor. If the seat belt does not return smoothly, wipe the inside of the loops with a clean paper cloth etc. because dirt built up in the loops of the upper anchors can cause the seat belts to retract slowly.
  - c. Fasten the seat belt. Pull firmly on belt and buckle to ensure belt remains latched. Unfasten seat belt. Ensure belt releases freely and buckle button returns to original position.

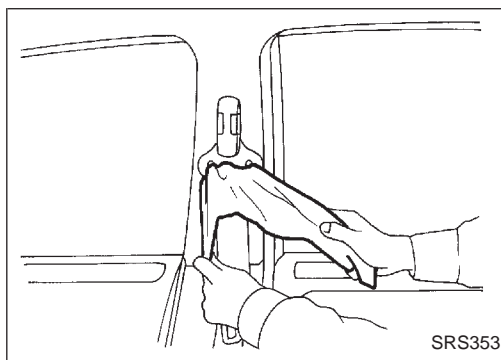

5. Repeat steps above as necessary to check the other seat belts.

GI

MA

EM

LC

EC

FE

CL

MT

AT

AX

SU

BR

ST

RS

BT

HA

SC

EL

IDX

# SEAT BELTS

Seat Belt Inspection (Cont'd)

## SEAT BELT RETRACTOR ON-VEHICLE CHECK

NCRS0005S03

### Emergency Locking Retractors (ELR) and Automatic Locking Retractors (ALR)

NCRS0005S0301

#### NOTE:

All seat belt retractors are of the Emergency Locking Retractors (ELR) type. In an emergency (sudden stop) the retractor will lock and prevent the belt from extending any further. All 3-point type seat belt retractors except the driver's seat belt also have an Automatic Locking Retractors (ALR) mode. The ALR mode (also called child restraint mode) is used when installing child seats. The ALR mode is activated when the seat belt is fully extended. When the belt is then retracted partially, the ALR mode automatically locks the seat belt in a specific position so the belt cannot be extended any further. To cancel the ALR mode, allow the seat belt to fully wind back into the retractor.

Check the seat belt retractors using the following test(s) to determine if a retractor assembly is operating properly.

#### ELR Function Stationary Check

NCRS0005S0302

Grasp the shoulder belt and pull forward quickly. The retractor should lock and prevent the belt from extending further.

#### ALR Function Stationary Check

NCRS0005S0303

1. Pull out entire length of seat belt from retractor until a click is heard.
2. Retract the belt partially. A clicking noise should be heard as the belt retracts indicating that the retractor is in the Automatic Locking Retractors (ALR) mode.
3. Grasp the seat belt and try to pull out the retractor. The belt must lock and not extend any further. If NG, replace the retractor assembly.
4. Allow the entire length of the belt to retract to cancel the automatic locking mode.

#### ELR Function Moving Check

NCRS0005S0304

#### WARNING:

Perform the following test in a safe, open area clear of other vehicles and obstructions (for example, a large, empty parking lot). Road surface must be paved and dry. DO NOT perform the following test on wet or gravel roads or on public streets and highways. This could result in an accident and serious personal injury. The driver and passenger must be prepared to brace themselves in the event the retractor does not lock.

1. Fasten driver's seat belt. Buckle a passenger into the seat for the belt that is to be tested.
2. Proceed to the designated safe area.
3. Drive the vehicle at approximately 16 km/h (10 MPH). Notify any passengers of a pending sudden stop and the driver and passenger must be prepared to brace themselves in the event the retractor does not lock, apply brakes firmly and make a very hard stop.

During stop, seat belts should lock and not be extended. If the seat belt retractor assembly does not lock, perform the retractor off-vehicle check.

## SEAT BELT RETRACTOR OFF-VEHICLE CHECK

NCRS0005S04

1. Remove the seat belt retractor assembly.
2. Slowly pull out belt while tilting the retractor assembly forward from the mounted position without twisting the retractor assembly as shown in the illustration.

**15 degrees or less tilt: Belt can be pulled out.**

**35 degrees or more tilt: Belt locks and cannot be pulled out.**

# SEAT BELTS

Seat Belt Inspection (Cont'd)

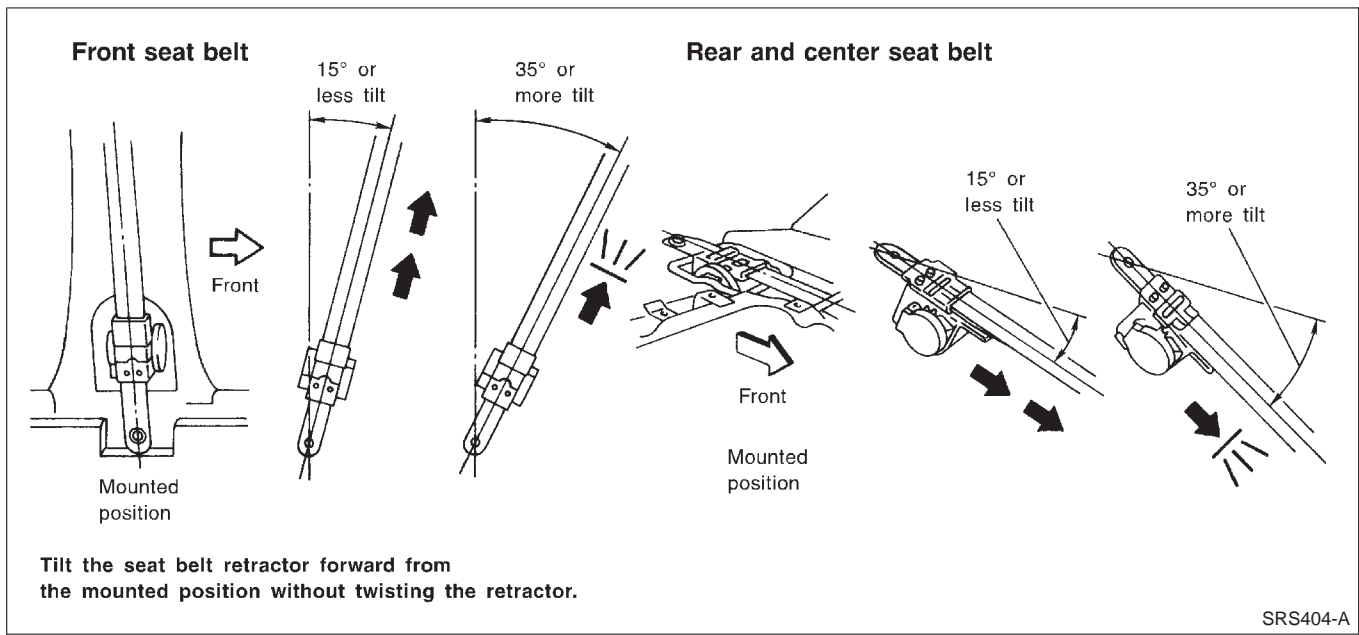

If NG, replace the retractor assembly.

GI

MA

EM

LC

EC

FE

CL

MT

AT

AX

SU

BR

ST

**RS**

BT

HA

SC

EL

IDX

# SEAT BELTS

Tether Anchor Plate

## Tether Anchor Plate

### REMOVAL AND INSTALLATION

=NCRS0039

**CAUTION:**

Replace anchor bolts if they are deformed or worn out.

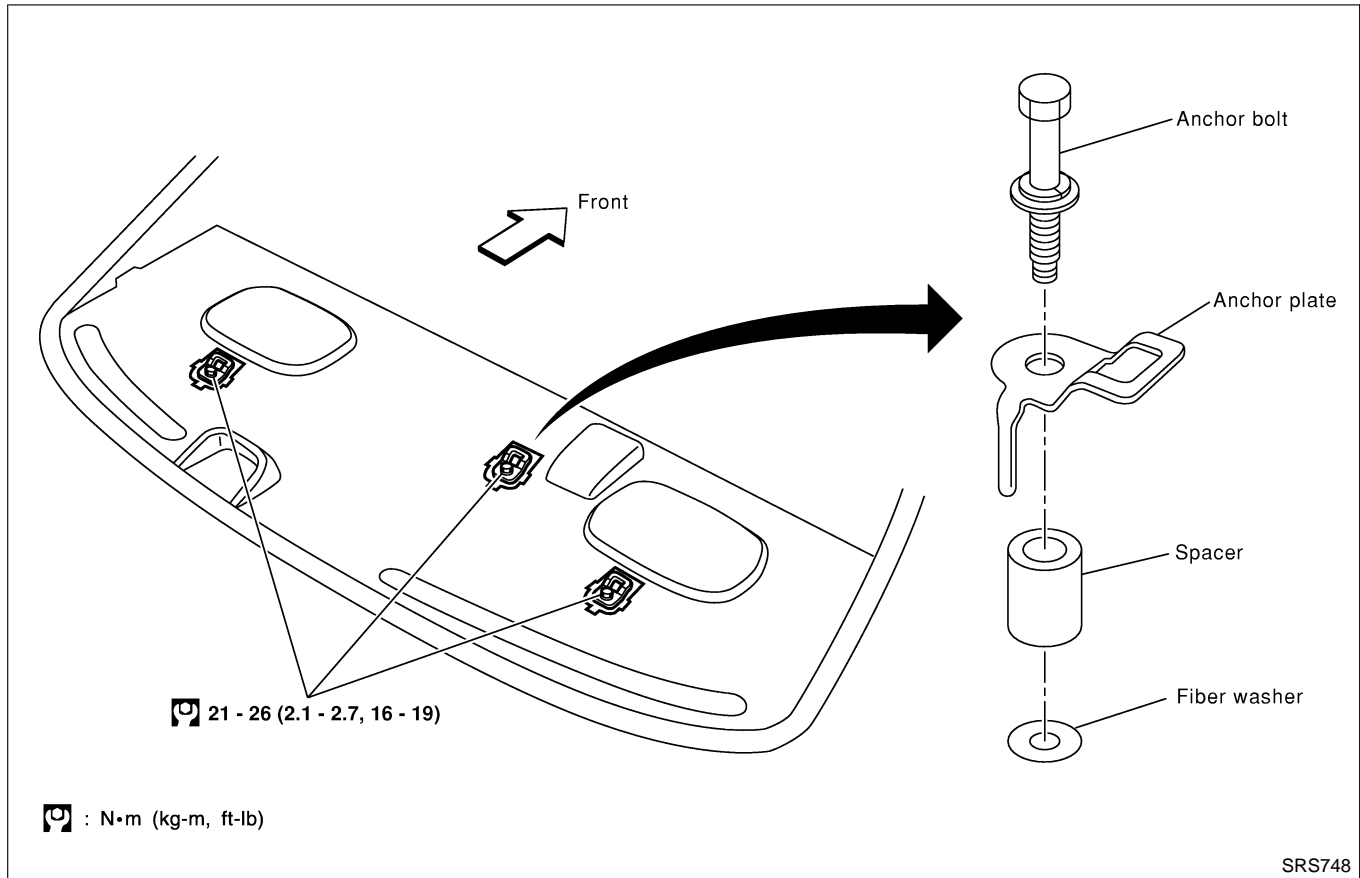

1. Remove tether anchor plate cover. Refer to BT-26, "SIDE AND FLOOR TRIM" for details.
2. Remove tether anchor plate.

**NOTE:**

- To install, reverse the removal procedure sequence.

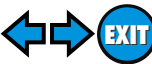

## Precautions

### SUPPLEMENTAL RESTRAINT SYSTEM (SRS) “AIR BAG” AND “SEAT BELT PRE-TENSIONER”

The Supplemental Restraint System such as “AIR BAG” and “SEAT BELT PRE-TENSIONER” used along with a seat belt, helps to reduce the risk or severity of injury to the driver and front passenger for certain types of collision. The SRS composition which is available to INFINITI G20 is as follows:

- For a frontal collision  
The Supplemental Restraint System consists of driver air bag module (located in the center of the steering wheel), front passenger air bag module (located on the instrument panel on passenger side), seat belt pre-tensioners, a diagnosis sensor unit, warning lamp, wiring harness and spiral cable.
- For a side collision  
The Supplemental Restraint System consists of side air bag module (located in the outer side of front seat), satellite sensor, diagnosis sensor unit (one of components of air bags for a frontal collision), wiring harness, warning lamp (one of components of air bags for a frontal collision).

#### WARNING:

- To avoid rendering the SRS inoperative, which could increase the risk of personal injury or death in the event of a collision which would result in air bag inflation, all maintenance must be performed by an authorized INFINITI dealer.
- Improper maintenance, including incorrect removal and installation of the SRS, can lead to personal injury caused by unintentional activation of the system.
- Do not use electrical test equipment on any circuit related to the SRS unless instructed to in this Service Manual. Spiral cable and wiring harnesses (except “SEAT BELT PRE-TENSIONER”) covered with yellow insulation tape either just before the harness connectors or for the complete harness are related to the SRS.

### PRECAUTIONS FOR SRS “AIR BAG” AND “SEAT BELT PRE-TENSIONER” SERVICE

- Do not use electrical test equipment to check SRS circuits unless instructed to in this Service Manual.
- Before servicing the SRS, turn ignition switch “OFF”, disconnect both battery cables and wait at least 3 minutes.  
For approximately 3 minutes after the cables are removed, it is still possible for the air bag and seat belt pre-tensioner to deploy. Therefore, do not work on any SRS connectors or wires until at least 3 minutes have passed.
- Diagnosis sensor unit must always be installed with their arrow marks “⇐” pointing towards the front of the vehicle for proper operation. Also check diagnosis sensor unit for cracks, deformities or rust before installation and replace as required.
- The spiral cable must be aligned with the neutral position since its rotations are limited. Do not attempt to turn steering wheel or column after removal of steering gear.
- Handle air bag module carefully. Always place driver and passenger air bag modules with the pad side facing upward and side air bag module (built-in type) with the stud bolt side facing down.
- Conduct self-diagnosis to check entire SRS for proper function after replacing any components.
- After air bag inflates, the front instrument panel assembly should be replaced if damaged.

### WIRING DIAGRAMS AND TROUBLE DIAGNOSIS

When you read wiring diagrams, refer to the following:

- GI-11, “HOW TO READ WIRING DIAGRAMS”
- EL-9, “POWER SUPPLY ROUTING” for power distribution circuit

When you perform trouble diagnosis, refer to the following:

- GI-36, “HOW TO FOLLOW TEST GROUP IN TROUBLE DIAGNOSIS”
- GI-25, “HOW TO PERFORM EFFICIENT DIAGNOSIS FOR AN ELECTRICAL INCIDENT”

GI

NCRS0006

MA

EM

LC

EC

FE

CL

MT

AT

NCRS0007

AX

SU

BR

ST

RS

BT

NCRS0008

HA

SC

EL

IDX

## Preparation

### SPECIAL SERVICE TOOLS

=NCRS0009

The actual shapes of Kent-Moore tools may differ from those of special service tools illustrated here.

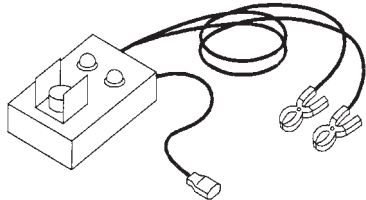
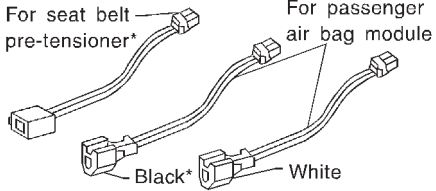
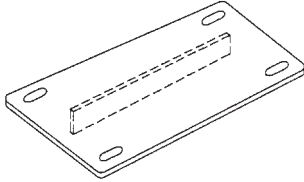
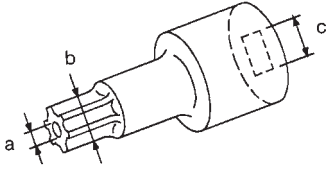
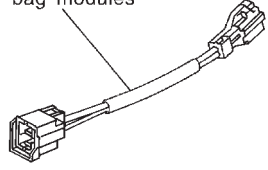
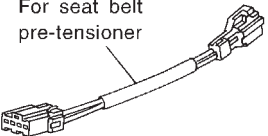
Tool number (Kent-Moore No.) Tool name	Description	
KV991072S0 (J38381-KIT) Air bag deployment kit KV99106400 (J38381) Deployment tool		Disposing of air bag module
	NT357	
KV991065S0 (J38381-30) Deployment tool adapters	 <p>For seat belt pre-tensioner*</p> <p>For passenger air bag module</p> <p>Black* White</p>	* Deployment tool adapters for seat belt pre-tensioner and for passenger air bag module with black connector are not necessary for servicing INFINITI G20.
	NT762	
KV99105300 (J41246) Air bag module bracket		Anchoring air bag module
	NT354	
HT61961000 and HT62152000 combined (J38219) *Special torx bit		Use for special bolts [TAMPER RESISTANT TORX (Size T50)] <b>a: 3.5 (0.138) dia.</b> <b>b: 8.5 - 8.6 (0.335 - 0.339) dia.</b> <b>c: approx. 10 (0.39) sq.</b> Unit: mm (in)
	NT361	
KV99108300 (J38381-35) Deployment tool adapter for built-in type side air bags	 <p>For built-in type side air bag modules</p>	
	NT763	
KV99108200 (J38381-50) Deployment tool adapter for seat belt pre-tensioner	 <p>For seat belt pre-tensioner</p>	
	NT721	

\*: Special tool or commercial equivalent

## SRS Configuration

NCRS0010

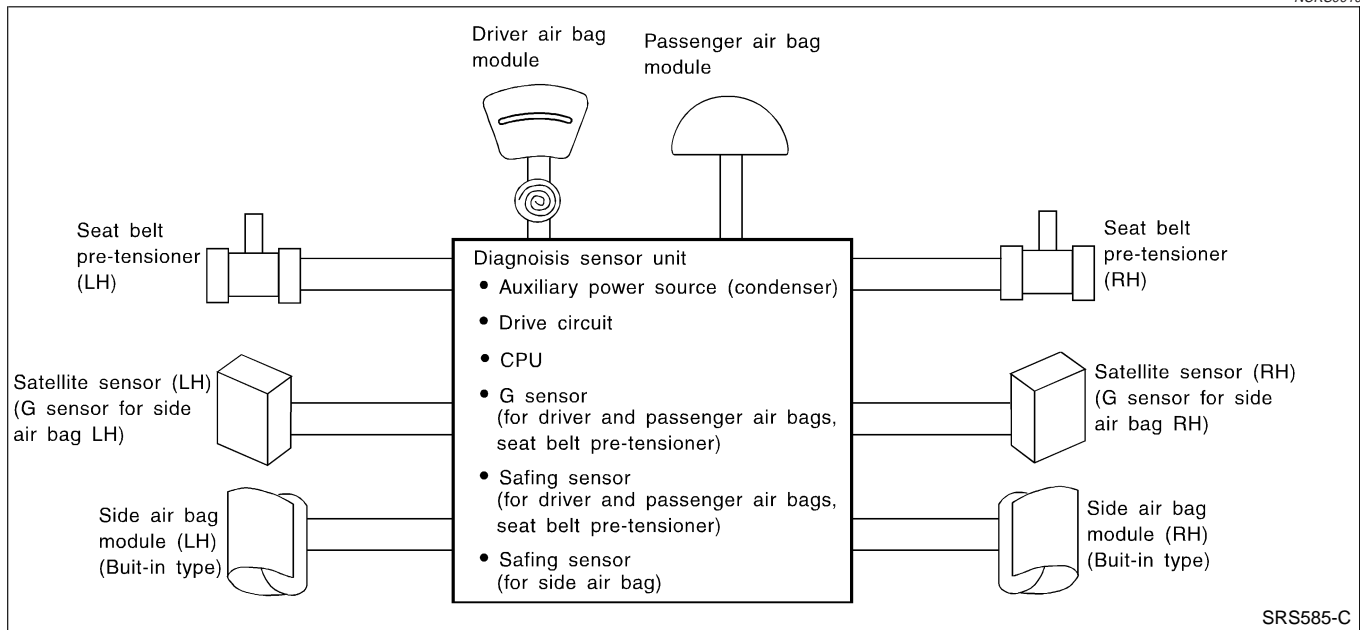

The air bag deploys if the diagnosis sensor unit activates while the ignition switch is in the “ON” or “START” position.

The collision modes for which supplemental restraint systems are activated are different among the SRS systems. For example, the driver air bag module and passenger air bag module are activated in a frontal collision but not in a side collision.

SRS configurations which are activated for some collision modes are as follows;

SRS configuration	Frontal collision	Left side collision	Right side collision
Driver air bag module	○	—	—
Passenger air bag module	○	—	—
Seat belt pre-tensioner (LH)	○	—	—
Seat belt pre-tensioner (RH)	○	—	—
Side air bag module (LH)	—	○	—
Side air bag module (RH)	—	—	○

GI  
MA  
EM  
LC  
EC  
FE  
CL  
MT  
AT  
AX  
SU  
BR  
ST  
RS  
BT  
HA  
SC  
EL  
IDX

## Seat Belt Pre-tensioner with Load Limiter

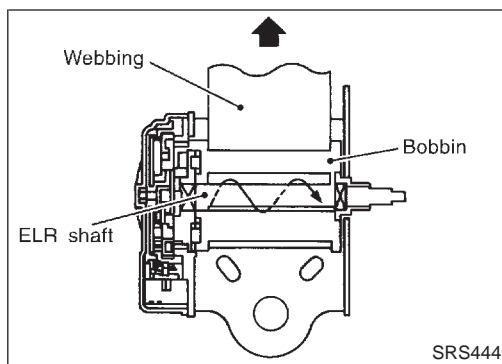

### Seat Belt Pre-tensioner with Load Limiter

=NCRS0034

The seat belt pre-tensioner system with load limiter is installed to both the driver's seat and the front passenger's seat. It operates simultaneously with the SRS air bag system in the event of a frontal collision with an impact exceeding a specified level.

When the frontal collision with an impact exceeding a specified level occurs, seat belt slack resulting from clothing or other factors is immediately taken up by the pre-tensioner. Vehicle passengers are securely restrained.

When passengers in a vehicle are thrown forward in a collision and the restraining force of the seat belt exceeds a specified level, the load limiter permits the specified extension of the seat belt by the twisting of the ELR shaft, and a relaxation of the chest-area seat belt web tension while maintaining force.

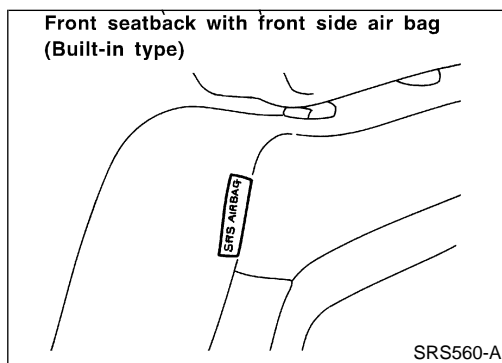

Front seatback with front side air bag (Built-in type)

### Built-in Type Side Air Bag

NCRS0035

Front side air bag is built-in type.

The front seatbacks with built-in type side air bag have the labels shown in figures at left.



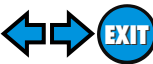

## SRS Component Parts Location

NCRS0011

SEC. 240•251•253•484•680•868•870

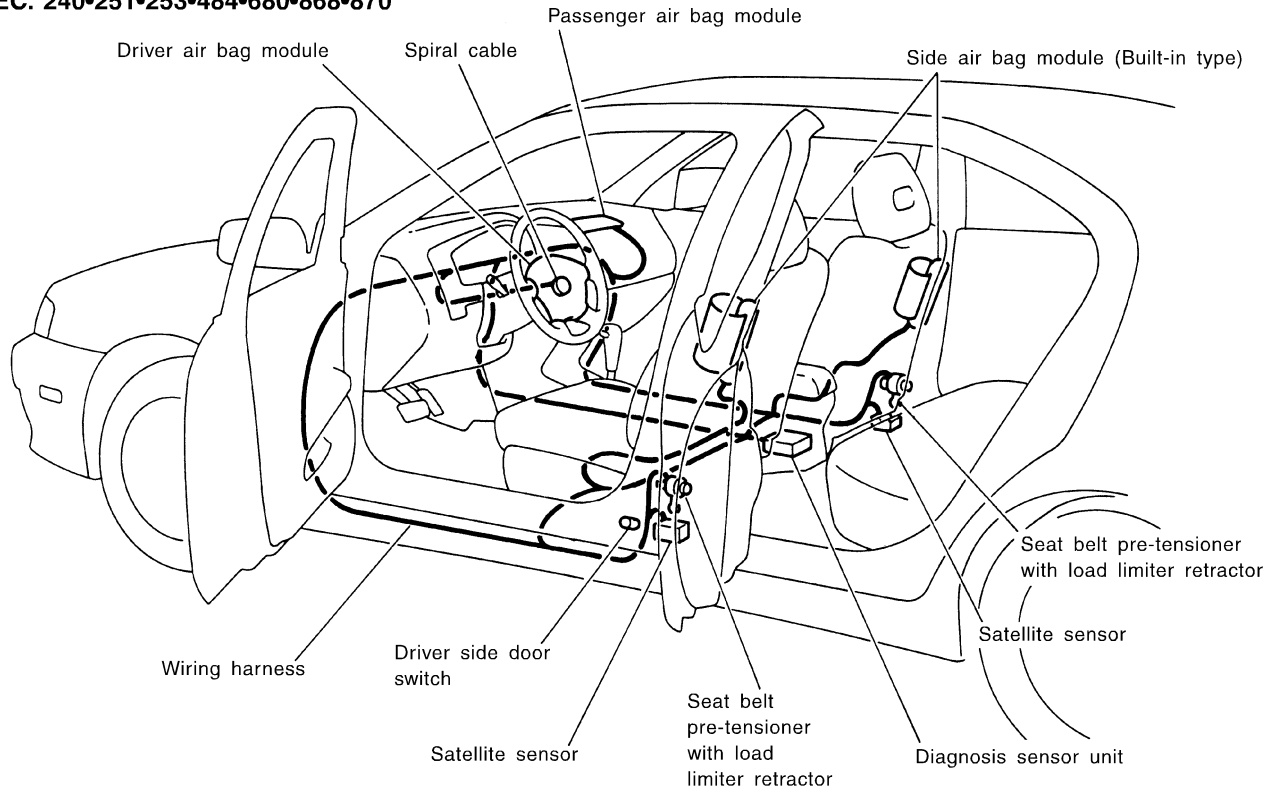

SRS750

GI  
MA  
EM  
LC  
EC  
FE  
CL  
MT  
AT  
AX



SRS222

### Maintenance Items

NCRS0012

#### CAUTION:

**Do not use a circuit tester to check SRS circuit.**

1. Check operation of "AIR BAG" and "SEAT BELT" warning lamps.

After turning ignition key to "ON" position, both warning lamps illuminate. The "AIR BAG" warning lamp will go off after about 7 seconds if no malfunction is detected. The "SEAT BELT" warning lamp will also go off after about 7 seconds after seat belt has been fastened and no malfunction is detected. (When seat belt has not been fastened, the warning lamp continues to illuminate until seat belt is fastened.) If any of the following warning lamp conditions occur, immediately check the air bag or seat belt pre-tensioner system. Refer to RS-41 or RS-42 for details.

- The "AIR BAG" or "SEAT BELT" warning lamp does not illuminate when the ignition switch is turned "ON".
- The "AIR BAG" or "SEAT BELT" (with seat belt fastened) warning lamp does not go off about 7 seconds after the ignition switch is turned "ON".
- The "AIR BAG" or "SEAT BELT" (with seat belt fastened) warning lamp blinks after about 7 seconds after the ignition switch is turned "ON".

RS  
BT  
HA  
SC  
EL  
IDX

2. Visually check SRS components.
  - 1) Diagnosis sensor unit
    - Check diagnosis sensor unit and bracket for dents, cracks and deformities.
    - Check connectors for damage, and terminals for deformities.
  - 2) Air bag module and steering wheel
    - Remove air bag module from steering wheel, instrument panel or seatback. Check harness cover and connectors for damage, terminals for deformities, and harness for binding.
    - Install driver air bag module to steering wheel to check fit or alignment with the wheel.
    - Check steering wheel for excessive free play.
    - Install passenger air bag module to instrument panel to check fit or alignment with the instrument panel.
    - Install side air bag module to seatback to check fit and alignment with the seat.
  - 3) Spiral cable
    - Check spiral cable for dents, cracks, or deformities.
    - Check connectors and protective tape for damage.
    - Check steering wheel for noise, binding or heavy operation.
  - 4) Main harness, air bag harness, body harness, side air bag module sub-harness
    - Check connectors for poor connections, damage, and terminals for deformities.
    - Check harnesses for binding, chafing or cut.
  - 5) Seat belt pre-tensioner
    - Check harness cover and connectors for damage, terminals for deformities, and harness for binding.
    - Check belts for damage and anchors for loose mounting.
    - Check retractor for smooth operation.
    - Perform self-diagnosis for seat belt pre-tensioner using seat belt warning lamp or CONSULT-II. Refer to "SRS Operation Check" for details. (RS-42)
  - 6) Satellite sensor
    - Check satellite sensor (including bracket portion) for dents, cracks or deformities.
    - Check connectors for damage, and terminals for deformities.

**CAUTION:**

Replace previously used special bolts and ground bolt with new ones.

## Diagnosis Sensor Unit

### REMOVAL AND INSTALLATION

NCRS0013

**CAUTION:**

- Before servicing SRS, turn the ignition switch off, disconnect both battery cables and wait for at least 3 minutes.
- The special bolts are coated with bonding agent while the other bolt is for ground. Do not use old bolts after removal; replace with new ones.
- Check diagnosis sensor unit for proper installation.
- Check diagnosis sensor unit to ensure it is free of deformities, dents, cracks or rust. If they show any visible

signs of damage, replace them with new ones.

- Check diagnosis sensor unit brackets to ensure they are free of deformities or rust.
- Replace diagnosis sensor unit if it has been dropped or sustained an impact.
- After replacement of diagnosis sensor unit, perform self-diagnosis for SRS. Refer to “DIAGNOSTIC PROCEDURE 1” for details (RS-41).

GI

MA

EM

LC

EC

FE

CL

MT

AT

AX

SU

BR

ST

RS

BT

HA

SC

EL

IDX

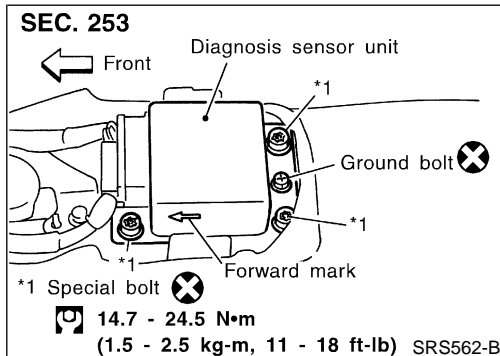

1. Disconnect driver, passenger and side air bag module connectors. Also, disconnect seat belt pre-tensioner connector.
2. Remove console box. Refer to BT-22, “INSTRUMENT PANEL ASSEMBLY”.
3. Disconnect diagnosis sensor unit connector.
4. Remove bolt and also remove special bolts using the TAMPER RESISTANT TORX (Size T50), from diagnosis sensor unit. Then remove the diagnosis sensor unit.

**NOTE:**

- To install, reverse the removal procedure sequence.

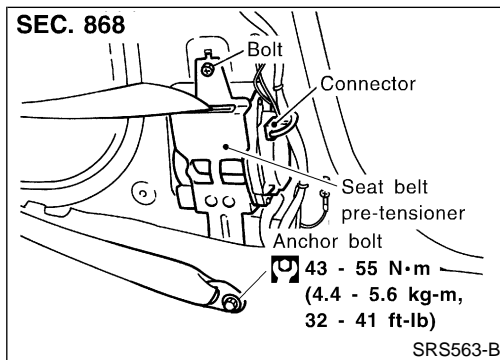

## Seat Belt Pre-tensioner REMOVAL AND INSTALLATION

NCRS0036

**CAUTION:**

- Before servicing SRS, turn the ignition switch off, disconnect both battery cables and wait at least 3 minutes.
- Check seat belt pre-tensioner with load limiter for proper installation.
- After replacement of seat belt pre-tensioner, check SRS function and perform self-diagnosis for SRS. Refer to “Checking Seat Belt Pre-tensioner Operation by Using “Seat Belt” Warning Lamp — User Mode”, “SRS Operation Check” for details. (RS-42)
- Do not attempt to disassemble seat belt pre-tensioner with load limiter.
- Replace seat belt pre-tensioner if it has been dropped or sustained an impact.
- Do not expose seat belt pre-tensioner to temperatures exceeding 80°C (176°F).

For removal of seat belt pre-tensioner, refer to “Front Seat Belt” for details. (RS-5)

**NOTE:**

- To install, reverse the removal procedure sequence.

## Satellite Sensor

### REMOVAL AND INSTALLATION

NCRS0014

**CAUTION:**

- Before servicing SRS, turn the ignition switch off, disconnect both battery cables and wait at least 3 minutes.
- Do not use old bolts coated with bonding agent after removal; replace with new ones.
- Check satellite sensor for proper installation.
- Check satellite sensor to ensure they are free of deformities, dents, cracks or rust. If it shows any visible signs of damage, replace it with new one.

# SUPPLEMENTAL RESTRAINT SYSTEM (SRS)

Satellite Sensor (Cont'd)

- After replacement of satellite sensor, check SRS function and perform self-diagnosis for SRS. Refer to “SRS Operation Check” for details. (RS-41)
- Do not attempt to disassemble satellite sensor.
- Replace satellite sensor if it has been dropped or sustained an impact.

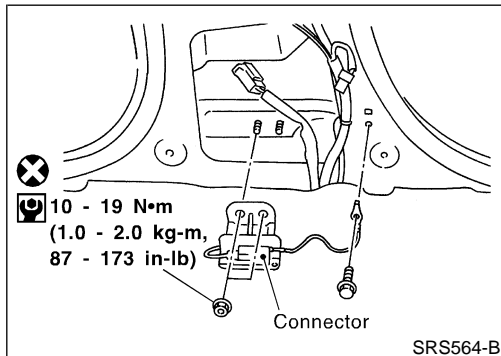

1. Remove seat belt pre-tensioner. Refer to “Front Seat Belt” for details. (RS-5)
2. Disconnect satellite sensor connector.
3. Remove bolt and nuts from satellite sensor unit. Then remove the satellite sensor.

**NOTE:**

- To install, reverse the removal procedure sequence.

## Driver Air Bag Module and Spiral Cable

### REMOVAL AND INSTALLATION

NCRS0015

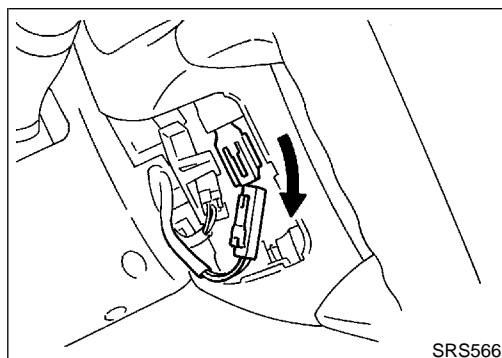
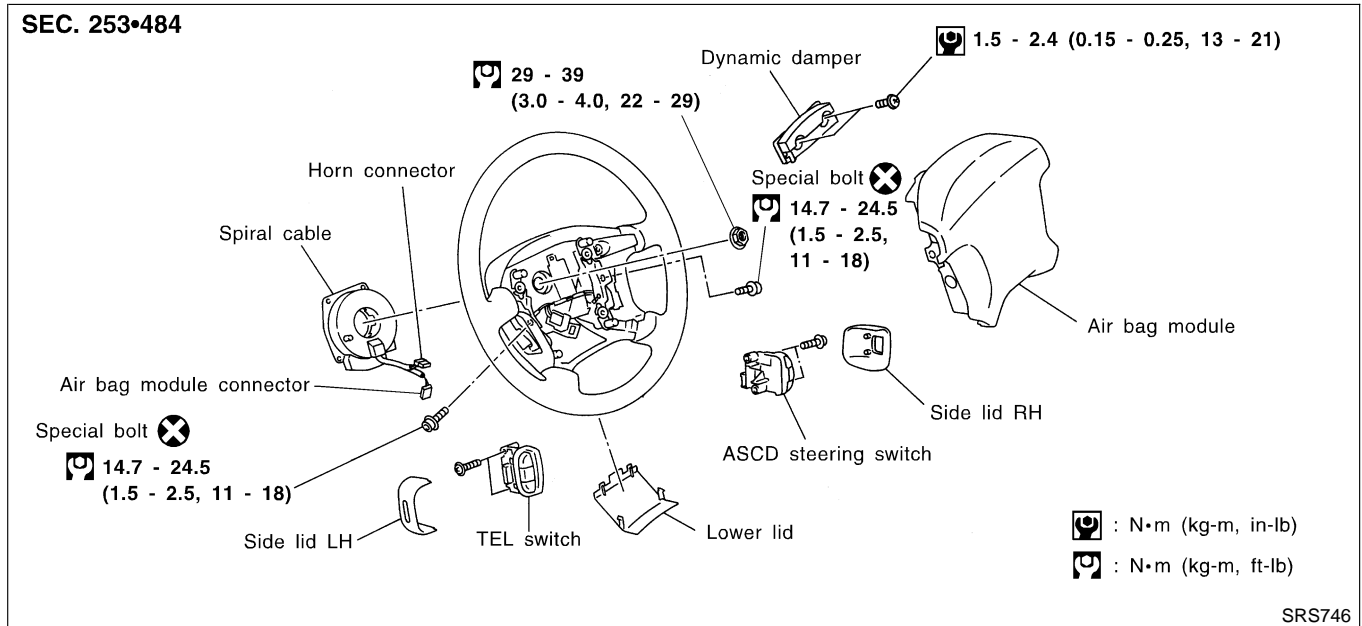

### REMOVAL

**CAUTION:**

- Before servicing SRS, turn the ignition switch off, disconnect both battery cables and wait at least 3 minutes.
  - Always work from the side of air bag module.
1. Remove lower lid from steering wheel, and disconnect air bag module connector.

NCRS0016

# SUPPLEMENTAL RESTRAINT SYSTEM (SRS)



Driver Air Bag Module and Spiral Cable (Cont'd)

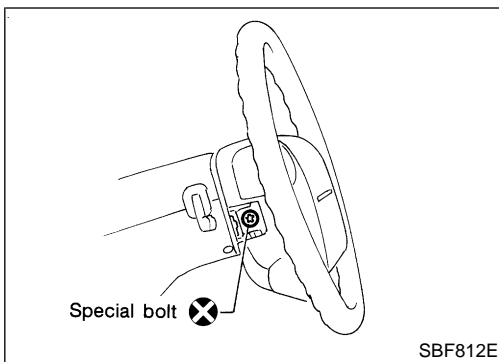

2. Remove side lids, ASCD switch and TEL switch. Using the TAMPER RESISTANT TORX (Size T50), remove left and right special bolts. Air bag module can then be removed.

GI

MA

EM

LC

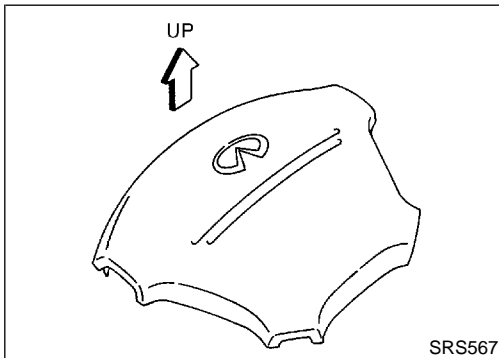

### CAUTION:

- Always place air bag module with pad side facing upward.
- Do not attempt to disassemble air bag module.
- The special bolts are coated with bonding agent. Do not use old bolts after removal; replace with new ones.
- Do not insert any foreign objects (screwdriver, etc.) into air bag module connector.

EC

FE

CL

MT



- Replace air bag module if it has been dropped or sustained an impact.
- Do not expose the air bag module to temperatures exceeding 90°C (194°F).
- Do not allow oil, grease or water to come in contact with the air bag module.

AT

AX

SU

BR

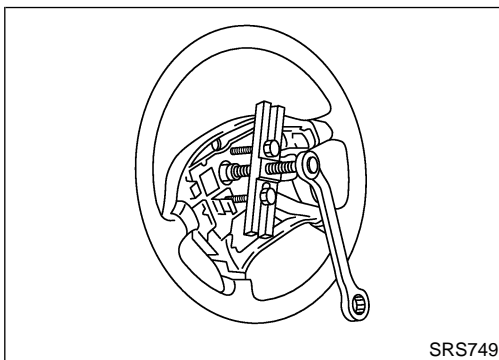

3. Set steering wheel in the neutral position.
4. Disconnect horn connector and remove nuts.
5. Remove dynamic damper. Then using steering wheel puller, remove steering wheel. Be careful not to over-tighten puller bolt on steering wheel.

ST

RS

### CAUTION:

- Do not tap or bump the steering wheel.
6. Remove steering column cover.

BT

HA

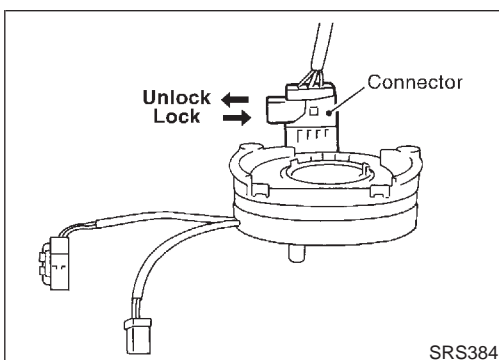

7. Unlock the spiral cable connector. Then disconnect connectors and remove the four screws. The spiral cable can then be removed.

SC

EL

### CAUTION:

- Do not attempt to disassemble spiral cable.
- Do not apply lubricant to the spiral cable.

IDX

# SUPPLEMENTAL RESTRAINT SYSTEM (SRS)

Driver Air Bag Module and Spiral Cable (Cont'd)

NCRS0017

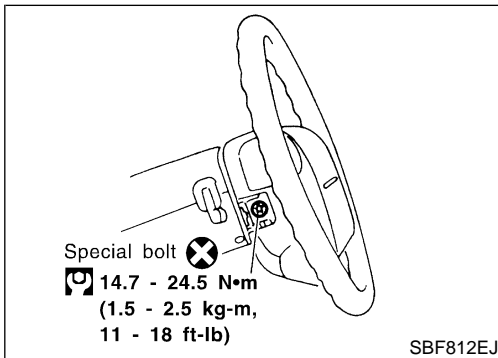
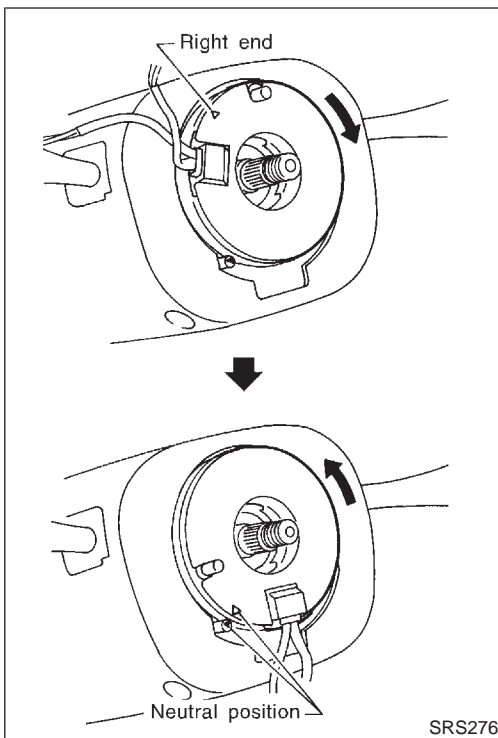

## INSTALLATION

1. Set the front wheels in the straight-ahead position.
2. Make sure that the spiral cable is in the neutral position. The neutral position is detected by turning left about 2.5 revolutions from the right end position. Align the two marks (X).

### CAUTION:

- The spiral cable may snap due to steering operation if the cable is installed in an improper position.
- Also, with the steering linkage disconnected, the cable may snap by turning the steering wheel beyond the limited number of turns. The spiral cable can be turned to the left about 2.5 turns from the right end position.

3. Connect spiral cable connector and tighten with screws. Install steering column cover.
4. Install steering wheel, aligning with spiral cable pin guides, and pull spiral cable through.
5. Connect horn connector and engage spiral cable with pawls in steering wheel. Move air bag module connector away from steering wheel lower lid opening.
6. Tighten nut.
  - : 29 - 39 N·m (3.0 - 4.0 kg-m, 22 - 29 ft-lb)
7. Install dynamic damper.
8. Position air bag module and tighten with new special bolts.
9. Connect air bag module connector.
10. Install steering switches and all lids.
11. Conduct self-diagnosis to ensure entire SRS operates properly. (Use CONSULT-II or warning lamp check.) Before performing self-diagnosis, connect both battery cables.
12. Turn steering wheel to the left end and then to the right end fully to make sure that spiral cable is set in the neutral position. If air bag warning lamp blinks or stays ON (at the user mode), it shows the spiral cable may be snapped due to its improper position. Perform self-diagnosis again (use CONSULT-II or warning lamp). If a malfunction is detected, replace the spiral cable with a new one.
13. Perform self-diagnosis again to check that no malfunction is detected.

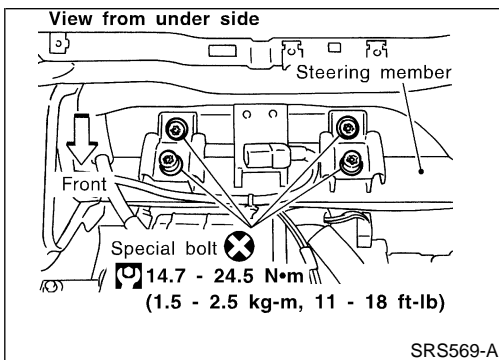
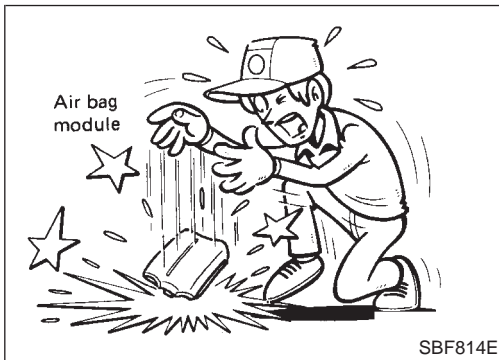
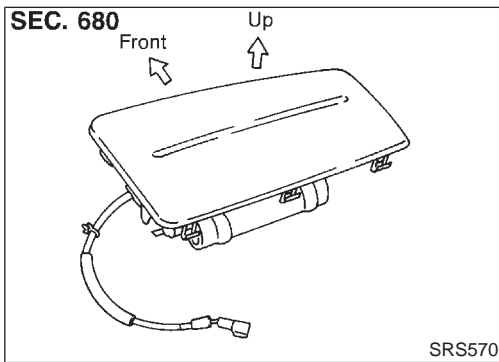
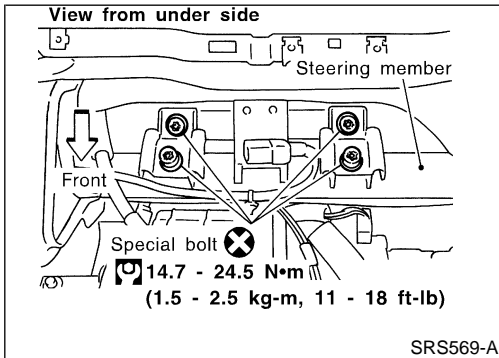
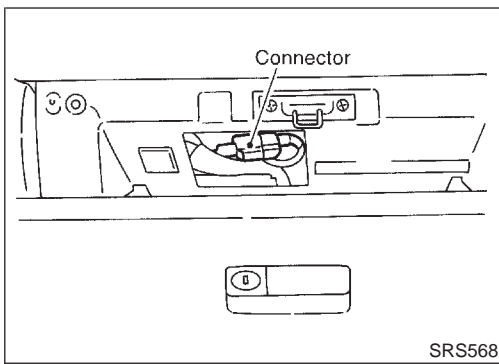

## Front Passenger Air Bag Module

### REMOVAL

NCRS0018

#### CAUTION:

- Before servicing SRS, turn the ignition switch off, disconnect both battery cables and wait for at least 3 minutes.
  - Always work from the side of or under air bag module.
1. Open the glove box lid.
  2. Disconnect front passenger air bag module connector from air bag harness connector.
  3. Remove glove box assembly. Refer to BT-22, "INSTRUMENT PANEL ASSEMBLY" for details.
  4. Remove the nuts and special bolts using the TAMPER RESISTANT TORX (Size T50) from front passenger air bag module. Take out the air bag module from the instrument panel.
- The air bag module is heavy and should be supported using both hands during removal.

GI

MA

EM

LC

EC

FE

CL

MT

#### CAUTION:

- Always place air bag module with pad side facing upward.
- Do not attempt to disassemble air bag module.
- The special bolts are coated with bonding agent. Do not use old bolts after removal; replace with new coated bolts.
- Do not insert any foreign objects (screwdriver, etc.) into air bag module connector.

AT

AX

SU

BR

- Replace air bag module if it has been dropped or sustained an impact.
- Do not expose the air bag module to temperatures exceeding 90°C (194°F).
- Do not allow oil, grease or water to come in contact with the air bag module.
- After air bag inflates, the front instrument panel assembly should be replaced if damaged.

ST

RS

BT

HA

### INSTALLATION

NCRS0019

#### CAUTION:

- Always work from the side of or under air bag module.
1. Install front passenger air bag module on steering member.
  - Ensure harness is not caught between rear of air bag module and steering member.
  2. Install glove box assembly. (Glove box lid is open.)

SC

EL

IDX

# SUPPLEMENTAL RESTRAINT SYSTEM (SRS)

## Front Passenger Air Bag Module (Cont'd)

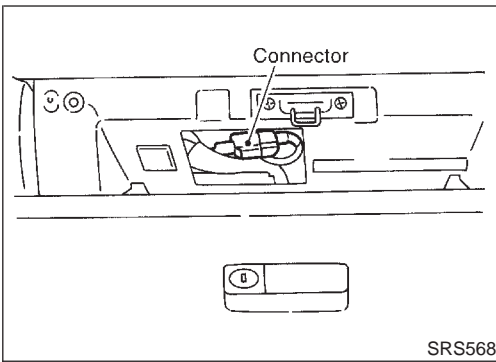

3. Connect air bag module connector to air bag harness connector.
4. Close the glove box lid.
5. Connect both battery cables.
6. Conduct self-diagnosis to ensure entire SRS operates properly. (Use CONSULT-II or warning lamp check.)

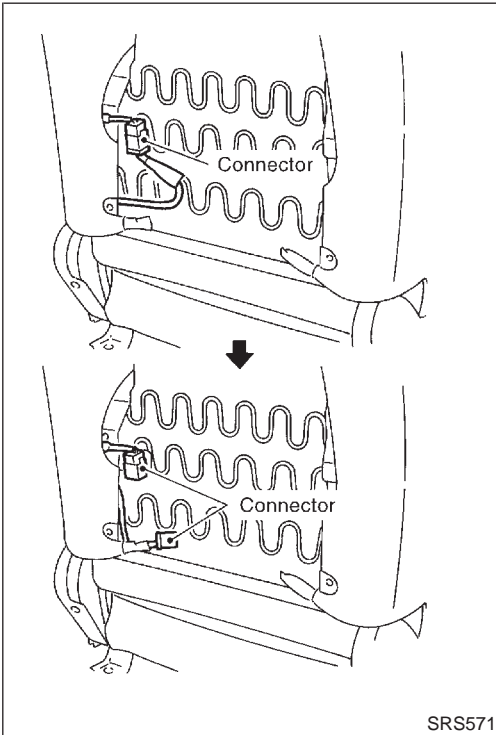

## Side Air Bag Module

### REMOVAL

NCRS0020

#### CAUTION:

- Before servicing SRS, turn the ignition switch off, disconnect both battery cables and wait at least 3 minutes.
  - Always work from the rear of air bag module.
1. Remove seatback board.
  - When using a clip removal tool to remove the seatback finisher, take care not to damage the air bag harness.
  2. Disconnect side air bag module connector.

### SEC. 985

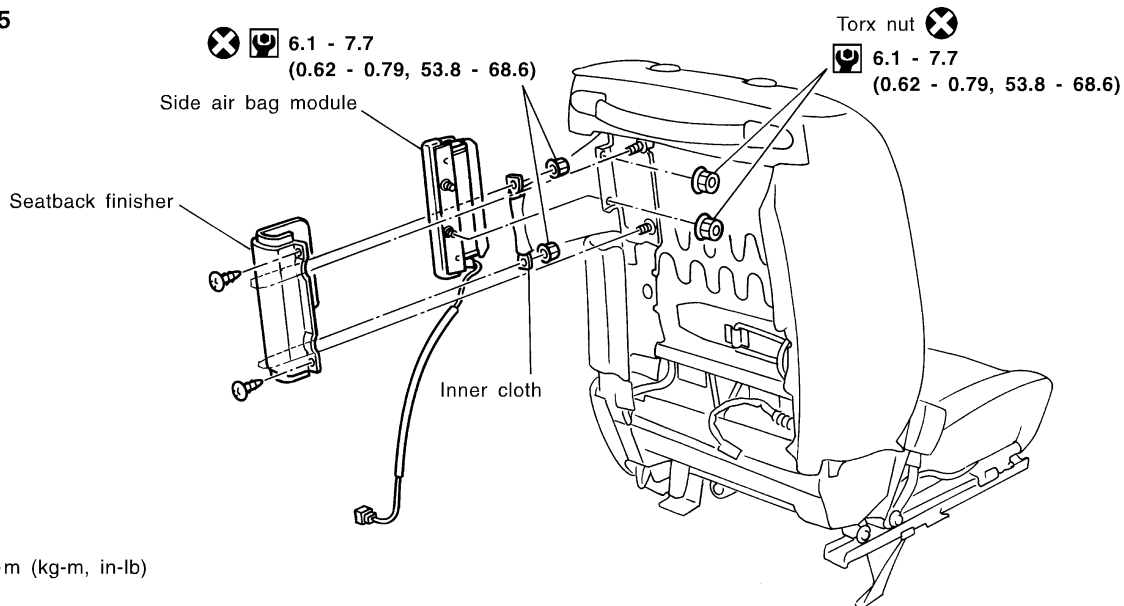

SRS572-A

3. Pull up the seatback trim.
4. Remove the nuts securing the inner cloth which covers side air



- bag module. Then pull up the inner cloth.
5. Remove the screws securing the seatback finisher. Then remove the seatback finisher.
6. Remove the torx nuts coated with bonding agent from side air bag module.
7. Remove harness clips. Side air bag module can then be removed.

GI

MA

EM

LC

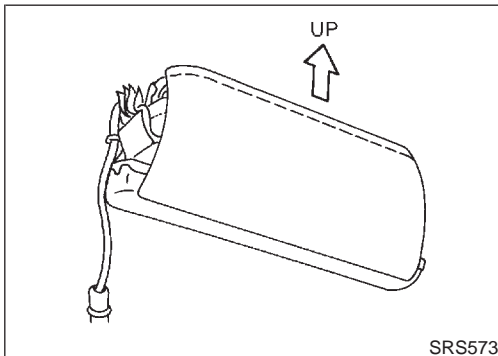

SRS573

### CAUTION:

- Always place air bag module with the stud bolt side facing down.
- Do not attempt to disassemble air bag module.
- The torx nuts are coated with bonding agent. Do not use old nuts after removal; replace with new coated nuts.
- Do not insert any foreign objects (screwdriver, etc.) into air bag module connector.

EC

FE

CL

MT



SBF814E

- Replace air bag module if it has been dropped or sustained an impact.
- Do not expose the air bag module to temperatures exceeding 90°C (194°F).
- Do not allow oil, grease or water to come in contact with the air bag module.
- After air bag inflates, the front seat should be replaced if damaged.

AT

AX

SU

BR

### INSTALLATION

NCRS0021

1. Install side air bag module on front seat with new torx nuts coated with bonding agent.
2. Secure the side air bag module harness with new harness clips.
3. Install the seatback finisher with screws.
4. Secure the inner cloth which covers the side air bag module and seatback finisher with nuts.
5. Connect side air bag module connector.
6. Install seatback board with new clips.
  - Ensure harness is not caught between seatback board and seatback.
7. Connect both battery cables.
8. Go to "SRS Operation Check", RS-41 and perform self-diagnosis to ensure entire SRS operates properly. (Use CONSULT-II or air bag warning lamp.)

ST

RS

BT

HA

SC

EL

IDX

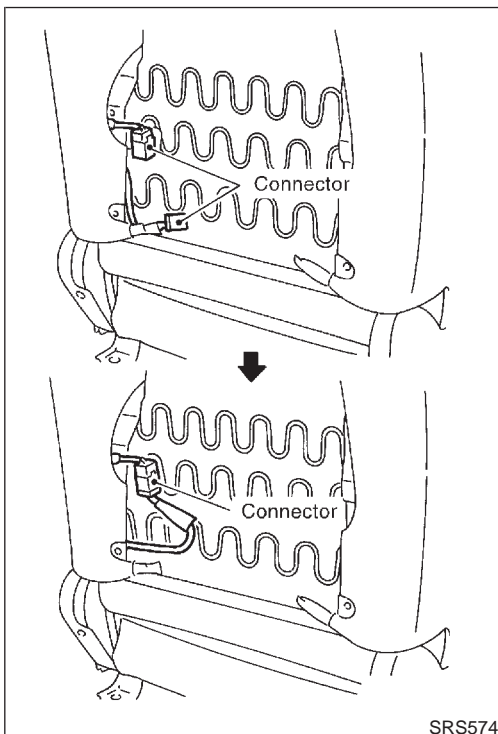

SRS574

## Disposal of Air Bag Module and Seat Belt Pre-tensioner

NCRS0022

- Before disposing of air bag module and seat belt pre-tensioner, or vehicles equipped with such systems, deploy the systems. If such systems have already been deployed due to an accident, dispose of them as indicated in “DISPOSING OF AIR BAG MODULE AND SEAT BELT PRE-TENSIONER” (RS-31).
- When deploying the air bag module and seat belt pre-tensioner, always use the Special Service Tool; Deployment tool KV99106400 (Kent-Moore No. J38381).
- When deploying the air bag module and seat belt pre-tensioner, stand at least 5 m (16 ft) away from the deployment component.
- When deploying air bag module and seat belt pre-tensioner, a fairly loud noise is made, followed by smoke being released. The smoke is not poisonous, however, be careful not to inhale smoke since it irritates the throat and can cause choking.
- Always activate one air bag module at a time.
- Due to heat, leave air bag module unattended for more than 30 minutes after deployment. Also leave seat belt pre-tensioner unattended for more than 10 minutes after deployment.
- Be sure to wear gloves when handling a deployed air bag module and seat belt pre-tensioner.
- Never apply water to the deployed air bag module and seat belt pre-tensioner.
- Wash your hands clean after finishing work.
- Place the vehicle outdoors with an open space of at least 6 m (20 ft) on all sides when deploying air bag module and seat belt pre-tensioner while mounted in vehicle.
- Use a voltmeter to make sure the vehicle battery is fully charged.
- Do not dispose of the air bag module and seat belt pre-tensioner un-deployed.

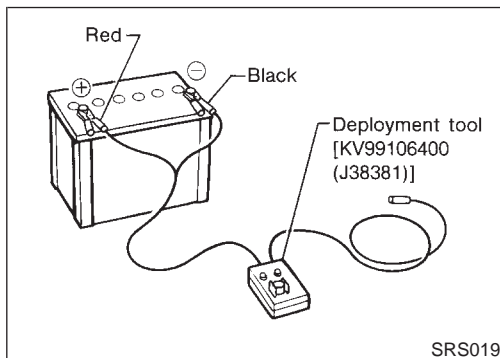

## CHECKING DEPLOYMENT TOOL

NCRS0022S01

### Connecting to Battery

NCRS0022S0101

#### CAUTION:

**The battery must show voltage of 9.6V or more.**

Remove the battery from the vehicle and place it on dry wood blocks approximately 5 m (16 ft) away from the vehicle.

- Wait 3 minutes after the vehicle battery is disconnected before proceeding.
- Connect red clip of deployment tool to battery positive terminal and black clip to negative terminal.

**Make sure the polarity is correct. The right side lamp in the tool, marked “deployment tool power”, should glow with a green light. If the right side lamp glows red, reverse the connections to the battery.**

# SUPPLEMENTAL RESTRAINT SYSTEM (SRS)

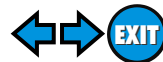

Disposal of Air Bag Module and Seat Belt Pre-tensioner (Cont'd)

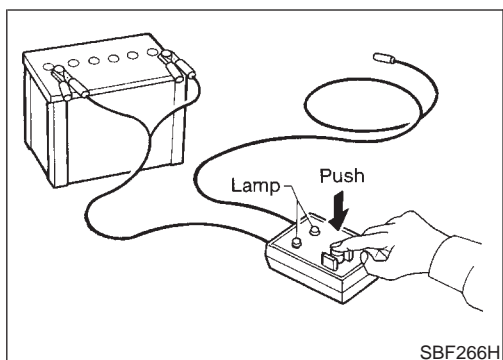

## Deployment Tool Check

Press the deployment tool switch to the "ON" position. The left side lamp in the tool, marked "air bag connector voltage" should illuminate. If it does not illuminate, replace the tool.

NCRS0022S0102

GI

MA

EM

LC

## Air Bag Deployment Tool Lamp Illumination Chart (Battery connected)

NCRS0022S0103

Switch operation	Left side lamp, green* "AIR BAG CONNECTOR VOLTAGE"	Right side lamp, green* "DEPLOYMENT TOOL POWER"
OFF	OFF	ON
ON	ON	ON

EC

FE

CL

\*: If this lamp glows red, the tool is connected to the battery incorrectly. Reverse the connections and make sure the lamp glows green.

MT

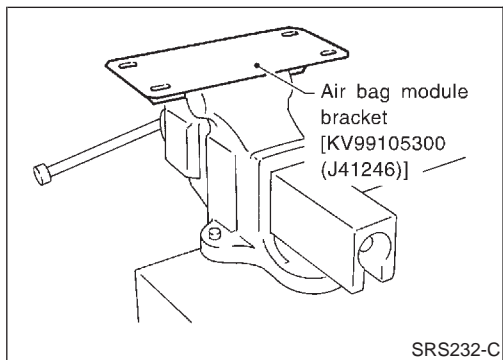

## DEPLOYMENT PROCEDURES FOR AIR BAG MODULE (OUTSIDE OF VEHICLE)

NCRS0022S02

Unless the vehicle is being scrapped, deploying the air bag in the vehicle is not recommended. This may cause damage to the vehicle interior.

AT

AX

Anchor air bag module bracket [KV99105300 (J41246)] in a vise secured to a firm foundation during deployment.

SU

### Deployment of Driver's Air Bag Module (Outside of vehicle)

NCRS0022S0201

- Using wire, secure air bag module to air bag module bracket [SST: KV99105300 (J41246)] at two places.

BR

### CAUTION:

Use wire of at least 1 mm (0.04 in) diameter.

ST

- Firmly secure air bag module bracket [SST: KV99105300 (J41246)] with air bag module attached, in a vise.

RS

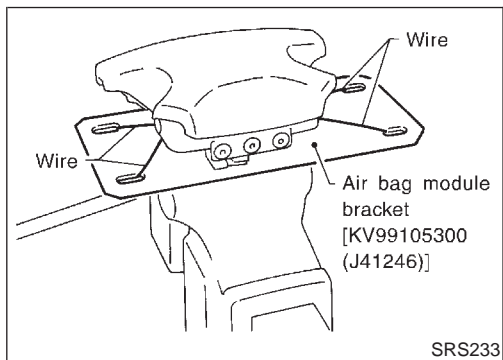

BT

HA

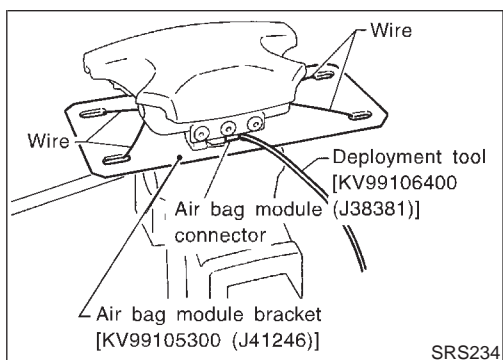

SC

EL

IDX

# SUPPLEMENTAL RESTRAINT SYSTEM (SRS)

Disposal of Air Bag Module and Seat Belt Pre-tensioner (Cont'd)

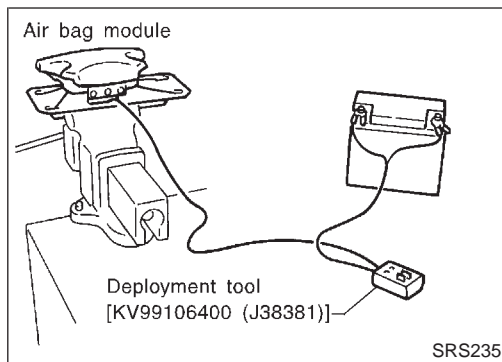

4. Connect red clip of deployment tool to battery positive terminal and black clip to negative terminal.
5. The lamp on the right side of the tool, marked "deployment tool power", should glow green, not red.
6. Press the button on the deployment tool. The left side lamp on the tool, marked "air bag connector voltage", will illuminate and the air bag module will deploy.

**CAUTION:**

**When deploying the air bag module, stand at least 5 m (16 ft) away from the air bag module.**

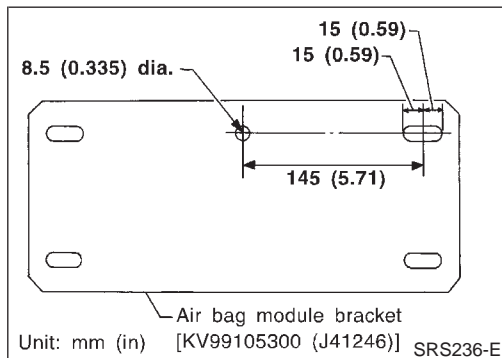

## Deployment of Passenger Air Bag Module (Outside of vehicle)

NCRS0022S0202

1. Make an 8.5 mm (0.335 in) diameter hole in air bag module bracket [SST: KV99105300 (J41246)] at the position shown in figure at left.

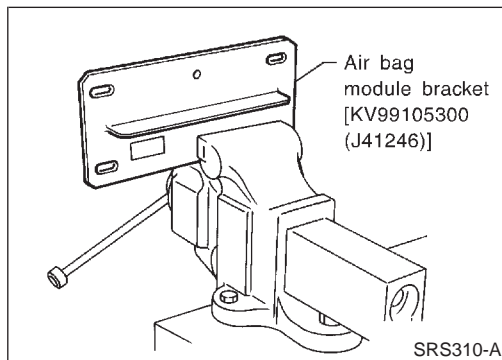

2. Firmly secure air bag module bracket [SST: KV99105300 (J41246)] in a vise.

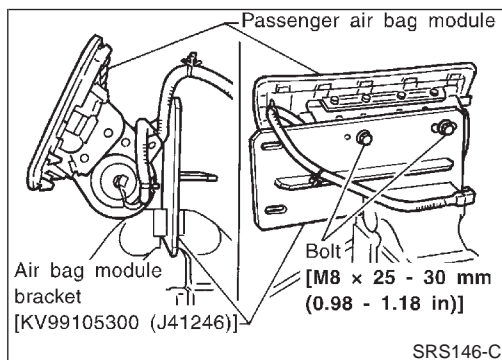

3. Match the two holes in air bag module bracket (held in vise) and passenger air bag module and fix them with two bolts [M8 x 25 - 30 mm (0.98 - 1.18 in)].

**CAUTION:**

**If a gap exists between passenger air bag module and air bag module bracket, use a piece of wood inserted in the gap to stabilize the air bag module.**

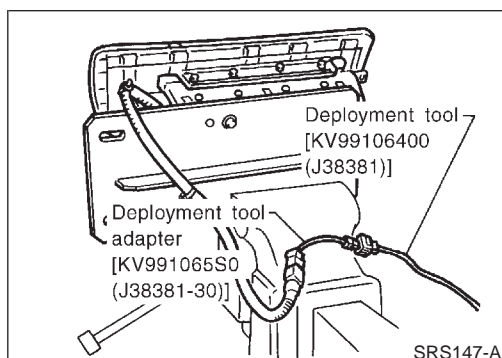

4. Connect deployment tool adapter [SST: KV991065S0 (J38381-30)] to deployment tool [SST: KV99106400 (J38381)] connector and air bag module connector.
5. Connect red clip of deployment tool to battery positive terminal and black clip to negative terminal.
6. The lamp on the right side of the tool, marked "deployment tool power", should glow green, not red.
7. Press the button on the deployment tool. The left side lamp on the tool, marked "air bag connector voltage", will illuminate and the air bag module will deploy.

# SUPPLEMENTAL RESTRAINT SYSTEM (SRS)

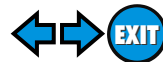

Disposal of Air Bag Module and Seat Belt Pre-tensioner (Cont'd)

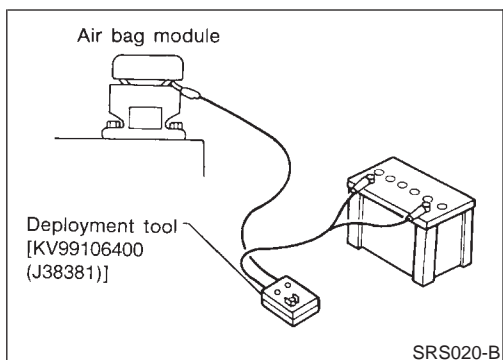

## CAUTION:

- When deploying the air bag module, do not stand on the deploying side.
- Stand at least 5 m (16 ft) away from the air bag module.

GI

MA

EM

LC

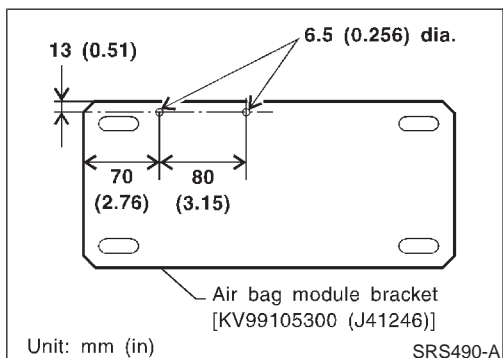

## Deployment of Side Air Bag Module (Built-in type) (Outside of vehicle)

NCRS0022S0203

1. Make 6.5 mm (0.256 in) diameter holes in air bag module bracket [SST: KV99105300 (J41246)] at the position shown in figure at left.

EC

FE

CL

MT

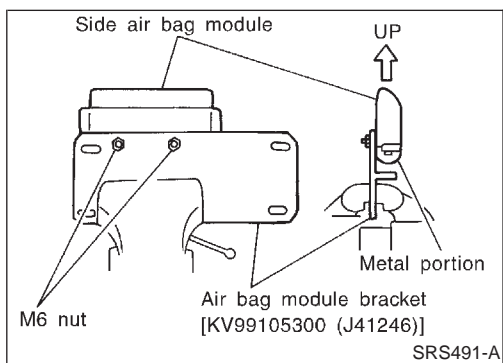

2. Firmly secure air bag module bracket [SST: KV99105300 (J41246)] in a vise.
3. Insert the stud bolts of side air bag module (built-in type) into the two holes in air bag module bracket (held in vise) and fix them with two M6 nuts.

AT

AX

SU

BR

## CAUTION:

Side air bag module should be secured to air bag module bracket [SST: KV99105300 (J41246)] in a vise with metal portion facing down.

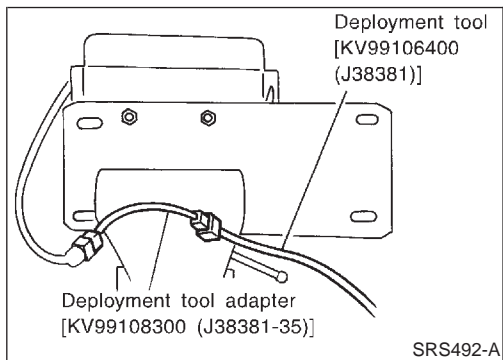

4. Connect deployment tool adapter [SST: KV99108300 (J38381-35)] to deployment tool [SST: KV99106400 (J38381)] connector and connector on air bag module.

ST

RS

BT

HA

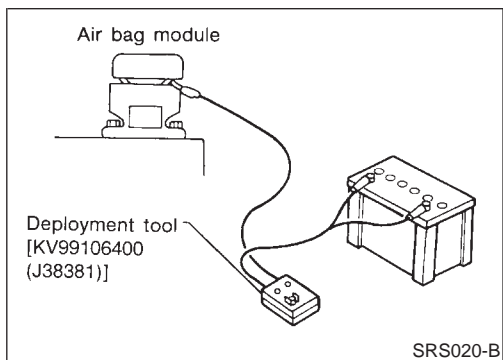

5. Connect red clip of deployment tool to battery positive terminal and black clip to negative terminal.
6. The lamp on the right side of the tool, marked "deployment tool power", should glow green, not red.
7. Press the button on the deployment tool. The left side lamp on the tool, marked "air bag connector voltage", will illuminate and the air bag module will deploy.

SC

EL

IDX

## CAUTION:

When deploying the air bag module, stand at least 5 m (16 ft) away from the air bag module.

# SUPPLEMENTAL RESTRAINT SYSTEM (SRS)

Disposal of Air Bag Module and Seat Belt Pre-tensioner (Cont'd)

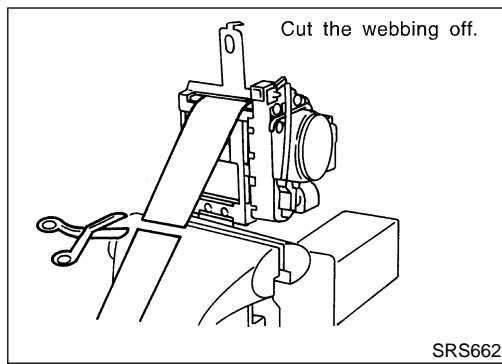

## DEPLOYMENT PROCEDURES FOR SEAT BELT PRE-TENSIONER (OUTSIDE OF VEHICLE)

NCRS0022S05

1. Firmly grip pre-tensioner in a vise and cut the webbing off.

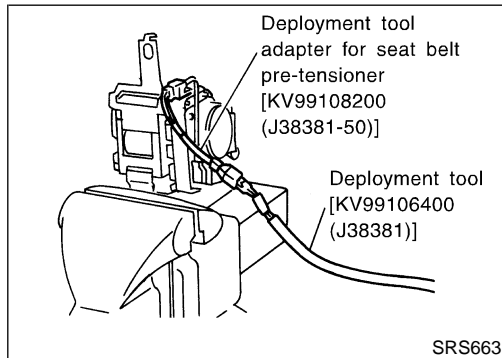

2. Connect deployment tool adapter [SST: KV99108200 (J38381-50)] to deployment tool [SST: KV99106400 (J38381)] connector and seat belt pre-tensioner connector.

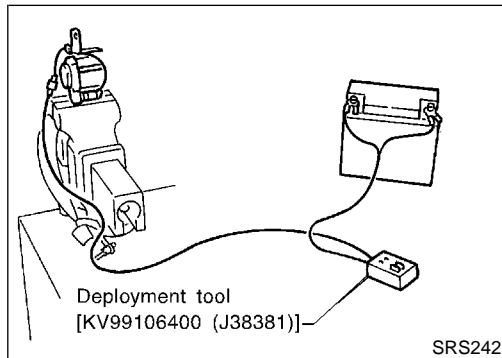

3. Connect red clip of deployment tool to battery positive terminal and black clip to negative terminal.
4. The lamp on the right side of the tool, marked "deployment tool power", should glow green, not red.
5. Press the button on the deployment tool. The left side lamp on the tool, marked "seat belt pre-tensioner connector voltage", will illuminate and the seat belt pre-tensioner will deploy.

**CAUTION:**

When deploying the seat belt pre-tensioner, stand at least 5 m (16 ft) away from the seat belt pre-tensioner.

## DEPLOYMENT OF AIR BAG MODULE AND SEAT BELT PRE-TENSIONER WHILE MOUNTED IN VEHICLE

NCRS0022S03

When disposing of a vehicle, deploy air bag module and seat belt pre-tensioners while they are mounted in vehicle.

**CAUTION:**

When deploying air bag module or seat belt pre-tensioner, ensure vehicle is empty.

1. Disconnect both the vehicle battery cables and wait 3 minutes.
2. Disconnect air bag module and seat belt pre-tensioner connector.
3. Connect deployment tool [SST: KV99106400 (J38381)] to air bag module or seat belt pre-tensioner.  
For front passenger air bag module, attach deployment tool adapter [SST: KV991065S0 (J38381-30)] to the tool connector. For side air bag module (built-in type), attach deployment tool adapter [SST: KV99108300 (J38381-35)]. For seat belt pre-tensioner, attach deployment tool adapter [SST: KV99108200 (J38381-50)] to the tool connector.

# SUPPLEMENTAL RESTRAINT SYSTEM (SRS)

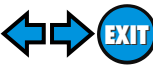

## Disposal of Air Bag Module and Seat Belt Pre-tensioner (Cont'd)

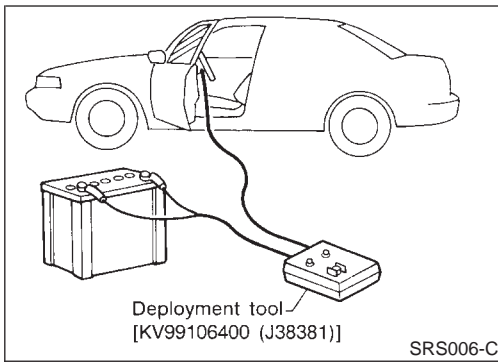

SRS006-C

4. Connect red clip of deployment tool to battery positive terminal and black clip to negative terminal.
5. The lamp on the right side of the tool, marked "deployment tool power", should glow green, not red.
6. Press the button on the deployment tool. The left side lamp on the tool, marked "air bag connector voltage", will illuminate and the air bag module or seat belt pre-tensioner will deploy.

GI

MA

EM

### CAUTION:

Activate only one air bag module or seat belt pre-tensioner at a time.

LC

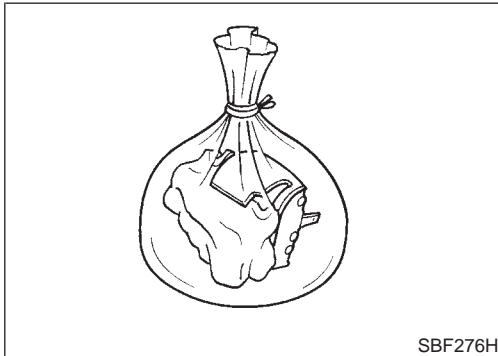

SBF276H

## DISPOSING OF AIR BAG MODULE AND SEAT BELT PRE-TENSIONER

NCRS0022S04

Deployed air bag module and seat belt pre-tensioner are very hot. Before disposing of air bag module, and seat belt pre-tensioner wait at least 30 minutes, and 10 minutes, respectively. Seal them in a plastic bag before disposal.

EC

FE

### CAUTION:

- Never apply water to a deployed air bag module and seat belt pre-tensioner.
- Be sure to wear gloves when handling a deployed air bag module and seat belt pre-tensioner.
- No poisonous gas is produced upon air bag module deployment. However, be careful not to inhale gas since it irritates throat and can cause choking.
- Do not attempt to disassemble air bag module and seat belt pre-tensioner.
- Air bag module and seat belt pre-tensioner cannot be reused.
- Wash your hands clean after finishing work.

CL

MT

AT

AX

SU

BR

ST

RS

BT

HA

SC

EL

IDX

## Trouble Diagnoses Introduction

=NCRS0023

### CAUTION:

- Do not use electrical test equipment on any circuit related to the SRS unless instructed to in this Service Manual. SRS wiring harnesses (except “SEAT BELT PRE-TENSIONER” connector) are covered with yellow insulation either just before the harness connectors or for the complete harness, for easy identification.
- Do not attempt to repair, splice or modify the SRS wiring harness. If the harness is damaged, replace it with a new one.
- Keep ground portion clean.

### DIAGNOSIS FUNCTION

NCRS0023S01

The SRS self-diagnosis results can be read by using “AIR BAG” warning lamp, “SEAT BELT” warning lamp and/or CONSULT-II. The reading of these results is accomplished using one of two modes — “User mode” and “Diagnosis mode”.

The User mode is exclusively prepared for the customer (driver). This mode warns the driver of a system malfunction through the operation of the “AIR BAG” warning lamp and/or “SEAT BELT” warning lamp.

The Diagnosis mode allows the technician to locate and inspect the malfunctioning part.

The mode applications for the “AIR BAG” warning lamp, “SEAT BELT” warning lamp and CONSULT-II are as follows:

	User mode	Diagnosis mode	Display type
“AIR BAG” warning lamp	X	X	ON-OFF operation
“SEAT BELT” warning lamp	X	—	ON-OFF operation
CONSULT-II	—	X	Monitoring

### DIAGNOSIS MODE FOR CONSULT-II

NCRS0023S02

- “SELF-DIAG [CURRENT]”  
A current Self-diagnosis result (also indicated by the number of warning lamp flashes in the Diagnosis mode) is displayed on the CONSULT-II screen in real time. This refers to a malfunctioning part requiring repairs.
- “SELF-DIAG [PAST]”  
Diagnosis results previously stored in the memory are displayed on the CONSULT-II screen. The stored results are not erased until memory erasing is executed.
- “TROUBLE DIAG RECORD”  
With TROUBLE DIAG RECORD, diagnosis results previously erased by a reset operation can be displayed on the CONSULT-II screen.
- “ECU DISCRIMINATED NO.”  
The diagnosis sensor unit for each vehicle model is assigned with its own, individual classification number. This number will be displayed on the CONSULT-II screen, as shown below. When replacing the diagnosis sensor unit, refer to the part number for the compatibility. After installation, replacement with a correct unit can be checked by confirming this classification number on the CONSULT-II screen.

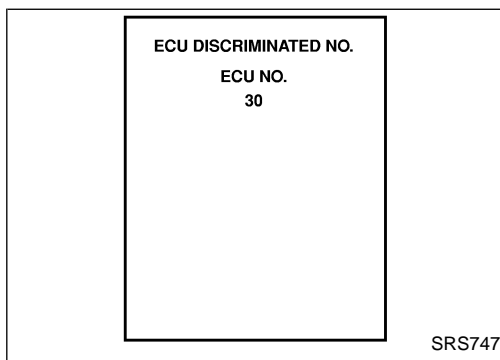

For INFINITI G20, the diagnosis sensor unit classification number assigned is 30.



## Ⓟ HOW TO CHANGE SELF-DIAGNOSIS MODE WITH CONSULT-II

=NCRS0023S03

### From User Mode to Diagnosis Mode

NCRS0023S0301

After selecting "AIR BAG" on the "SELECT SYSTEM" screen, User mode automatically changes to Diagnosis mode.

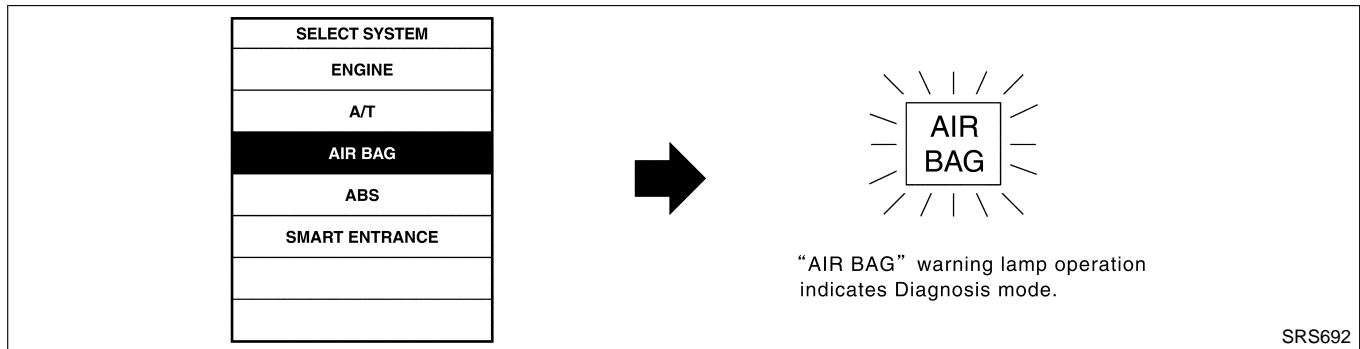

GI  
MA  
EM  
LC  
EC  
FE

### From Diagnosis Mode to User Mode

NCRS0023S0302

To return to User mode from Diagnosis mode, touch "BACK" key of CONSULT-II until "SELECT SYSTEM" appears, Diagnosis mode automatically changes to User mode.

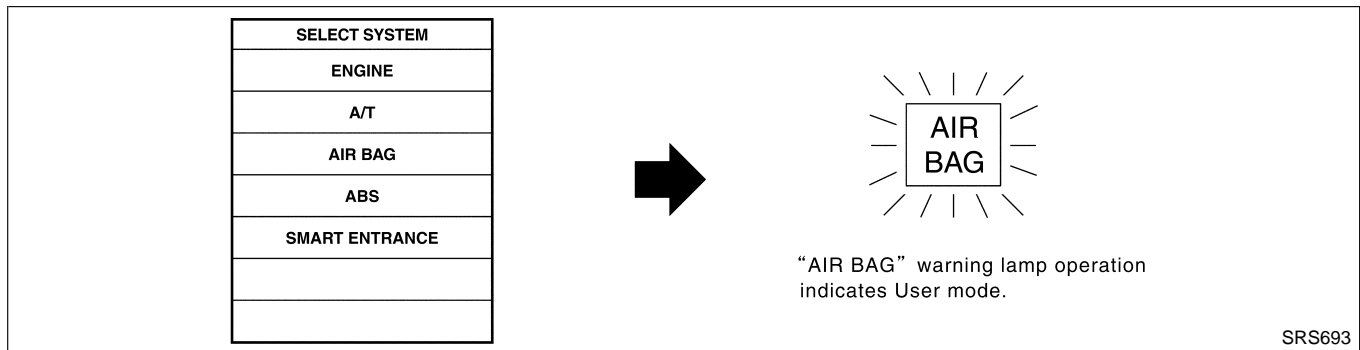

CL  
MT  
AT  
AX  
SU

## ⊗ HOW TO CHANGE SELF-DIAGNOSIS MODE WITHOUT CONSULT-II

NCRS0023S04

### From User Mode to Diagnosis Mode

NCRS0023S0401

Diagnosis mode activates only when a malfunction is detected, by pressing the driver's door switch at least 5 times within 7 seconds after turning the ignition "ON". SRS will not enter Diagnosis mode, if no malfunction is detected.

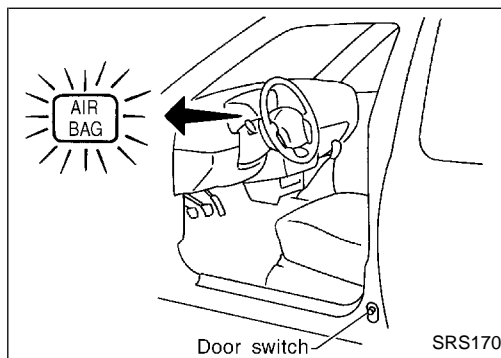

BR  
ST  
RS  
BT  
HA  
SC

### From Diagnosis Mode to User Mode

NCRS0023S0402

After a malfunction is repaired, switch the ignition "OFF" for at least one second, then back "ON". Diagnosis mode is returned to User mode. If switching Diagnosis mode to User mode is required while malfunction is being detected, switch the ignition "OFF", then back "ON" and press the driver's door switch at least 5 times within 7 seconds.

EL  
IDX

## HOW TO ERASE SELF-DIAGNOSIS RESULTS

NCRS0023S05

### Ⓟ With CONSULT-II

NCRS0023S0501

- "SELF-DIAG [CURRENT]"

# SUPPLEMENTAL RESTRAINT SYSTEM (SRS)

## Trouble Diagnoses Introduction (Cont'd)

A current Self-diagnosis result is displayed on the CONSULT-II screen in real time.

After the malfunction is repaired completely, no malfunction is detected on "SELF-DIAG [CURRENT]".

- "SELF-DIAG [PAST]"

Return to the "SELF-DIAG [CURRENT]" CONSULT-II screen by pushing "BACK" key of CONSULT-II and select "SELF-DIAG [CURRENT]" in SELECT DIAG MODE. Touch "ERASE" in "SELF-DIAG [CURRENT]" mode.

**NOTE:**

If the memory of the malfunction in "SELF-DIAG [PAST]" is not erased, the User mode shows the system malfunction by the operation of the warning lamp even if the malfunction is repaired completely.

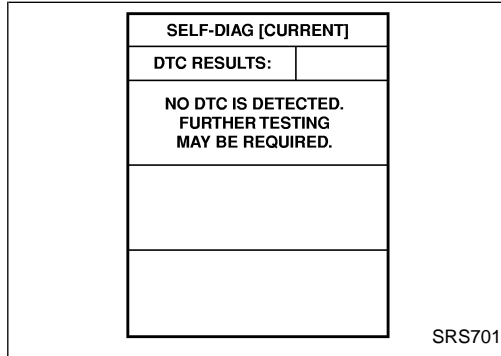

- "TROUBLE DIAG RECORD"

The memory of "TROUBLE DIAG RECORD" cannot be erased.

⊗ **Without CONSULT-II**

After a malfunction is repaired, switch the ignition "OFF" for at least one second, then back "ON". Diagnosis mode returns to the User mode. At that time, the self-diagnostic result is cleared.

NCRS0023S0502

## How to Perform Trouble Diagnoses for Quick and Accurate Repair

A good understanding of the malfunction conditions can make troubleshooting faster and more accurate. In general, each customer feels differently about a malfunction. It is important to fully understand the symptoms or conditions for a customer complaint.

=NCRS0024

GI

### INFORMATION FROM CUSTOMER

WHAT ..... Vehicle model

WHEN ..... Date, Frequencies

WHERE ..... Road conditions

HOW ..... Operating conditions, Symptoms

NCRS0024S01

MA

EM

LC

### PRELIMINARY CHECK

Check that the following parts are in good order.

- Battery [Refer to SC-3, "BATTERY".]
- Fuse [Refer to EL-17, "Fuse", "POWER SUPPLY ROUTING".]
- System component-to-harness connections

NCRS0024S02

EC

FE

CL

MT

AT

AX

SU

BR

ST

**RS**

BT

HA

SC

EL

IDX

# SUPPLEMENTAL RESTRAINT SYSTEM (SRS)

How to Perform Trouble Diagnoses for Quick and Accurate Repair (Cont'd)

## WORK FLOW

NCRS0024S03

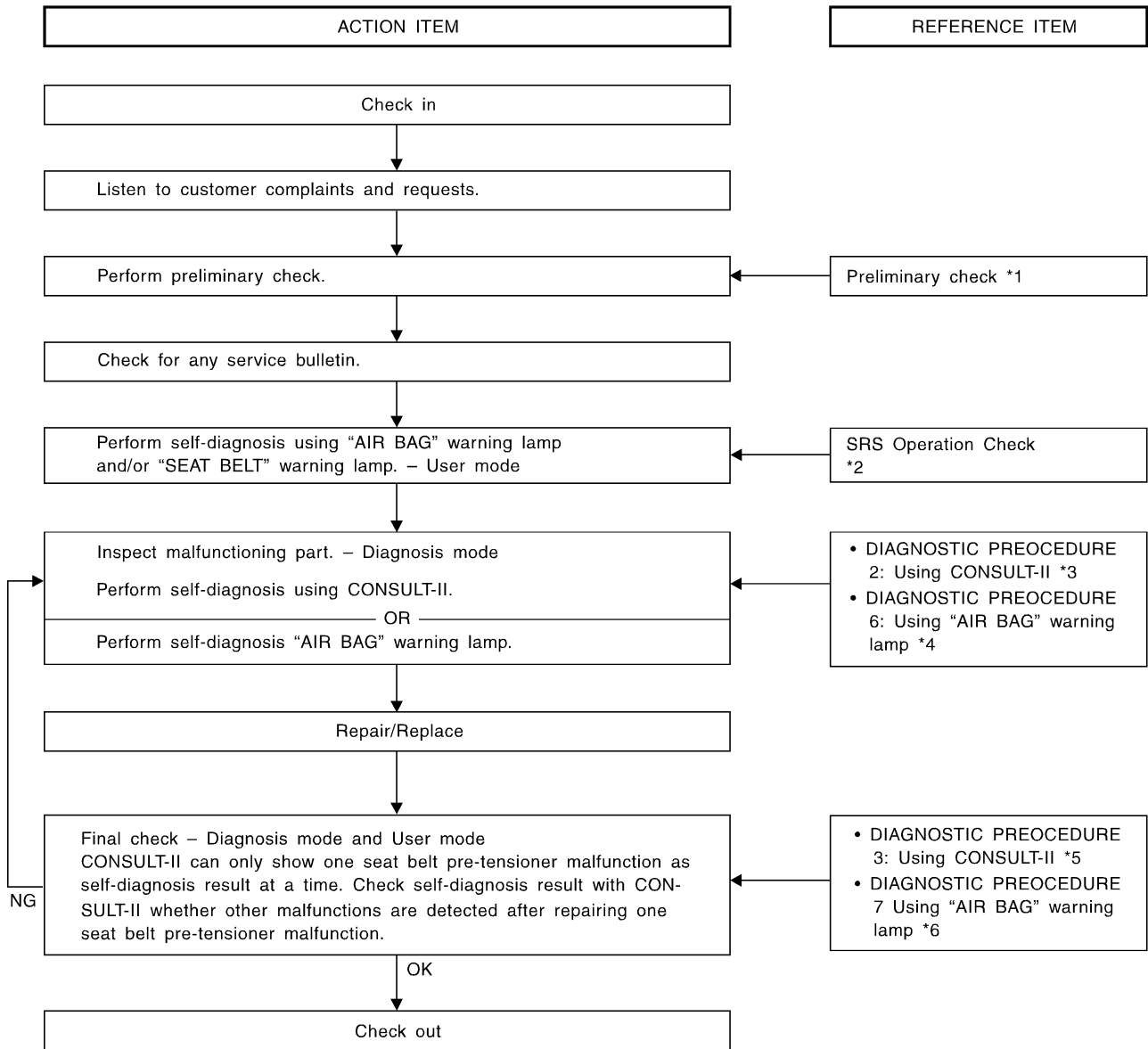

SRS586-A

\*1: RS-35  
\*2: RS-41

\*3: RS-43  
\*4: RS-52

\*5: RS-46  
\*6: RS-55

## Schematic

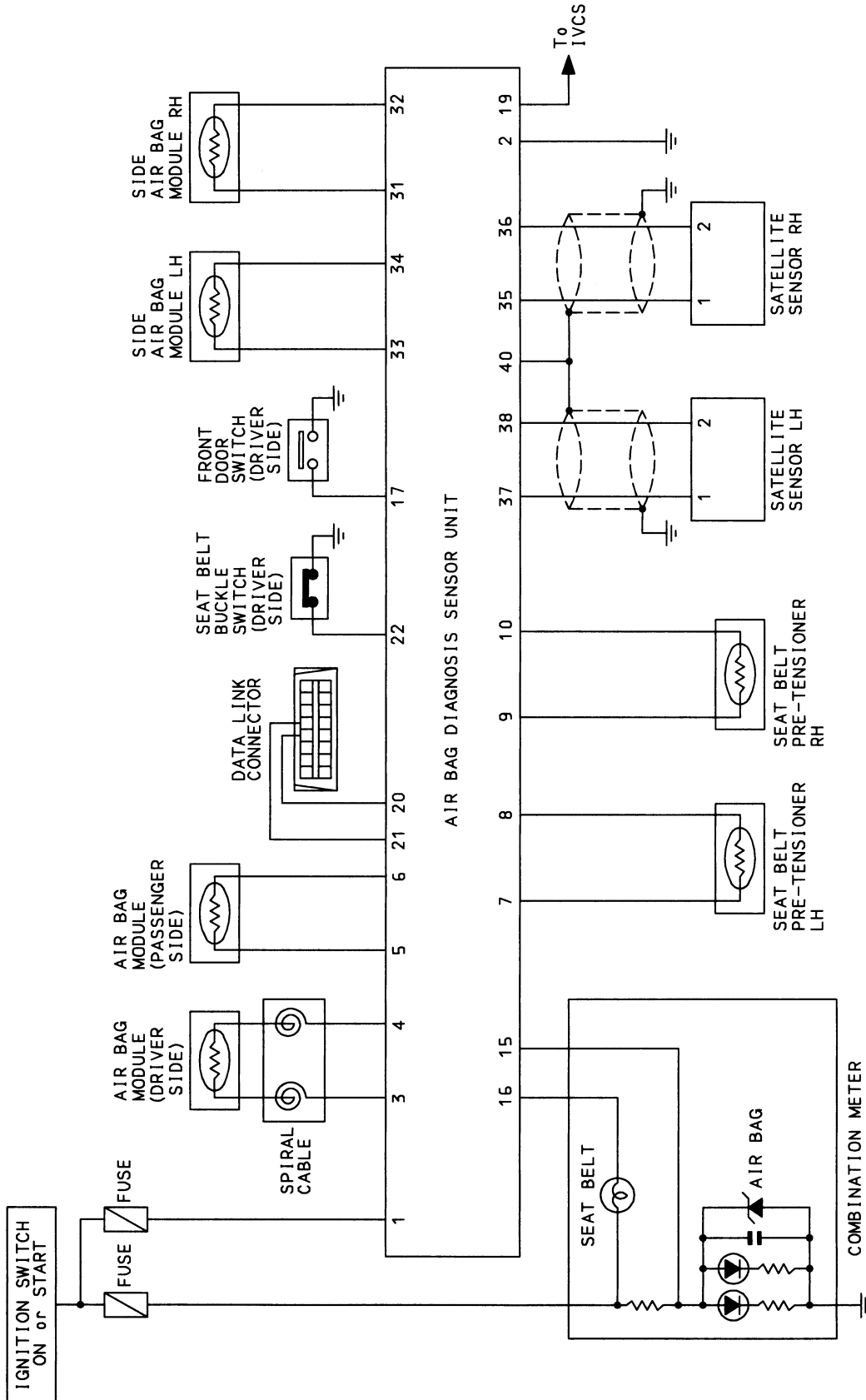

- GI
- MA
- EM
- LC
- EC
- FE
- CL
- MT
- AT
- AX
- SU
- BR
- ST
- RS**
- BT
- HA
- SC
- EL
- IDX

# SUPPLEMENTAL RESTRAINT SYSTEM (SRS)

Wiring Diagram — SRS —

## Wiring Diagram — SRS —

NCRS0026

RS-SRS-01

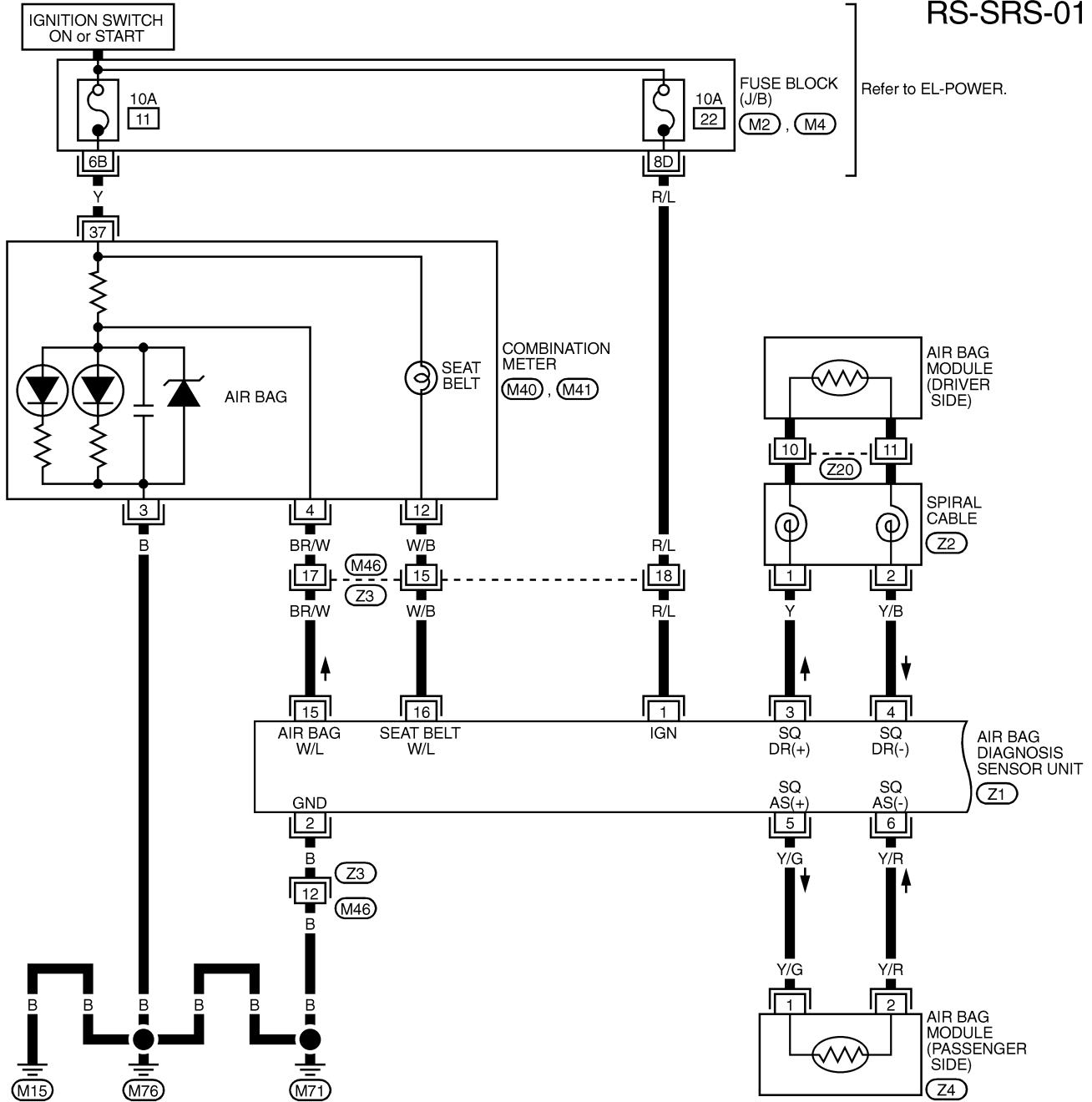

Refer to EL-POWER.

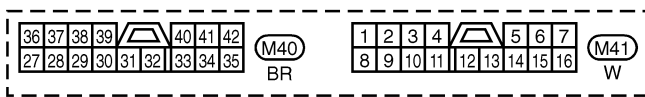

REFER TO THE FOLLOWING.  
 (M2), (M4) - FUSE BLOCK-JUNCTION BOX (J/B)

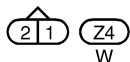
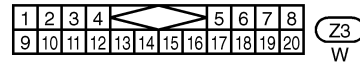
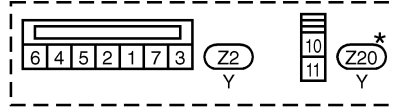
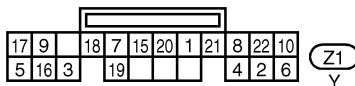

\*: This connector is not shown in "HARNESS LAYOUT", EL section.

# SUPPLEMENTAL RESTRAINT SYSTEM (SRS)

Wiring Diagram — SRS — (Cont'd)

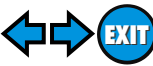

RS-SRS-02

GI  
MA  
EM  
LC  
EC  
FE  
CL  
MT  
AT  
AX  
SU  
BR  
ST  
RS  
BT  
HA  
SC  
EL  
IDX

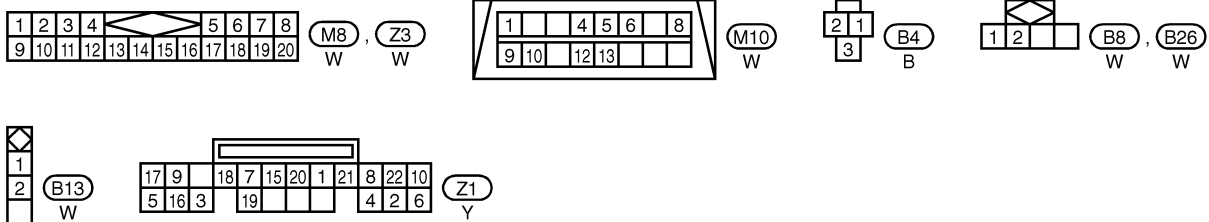
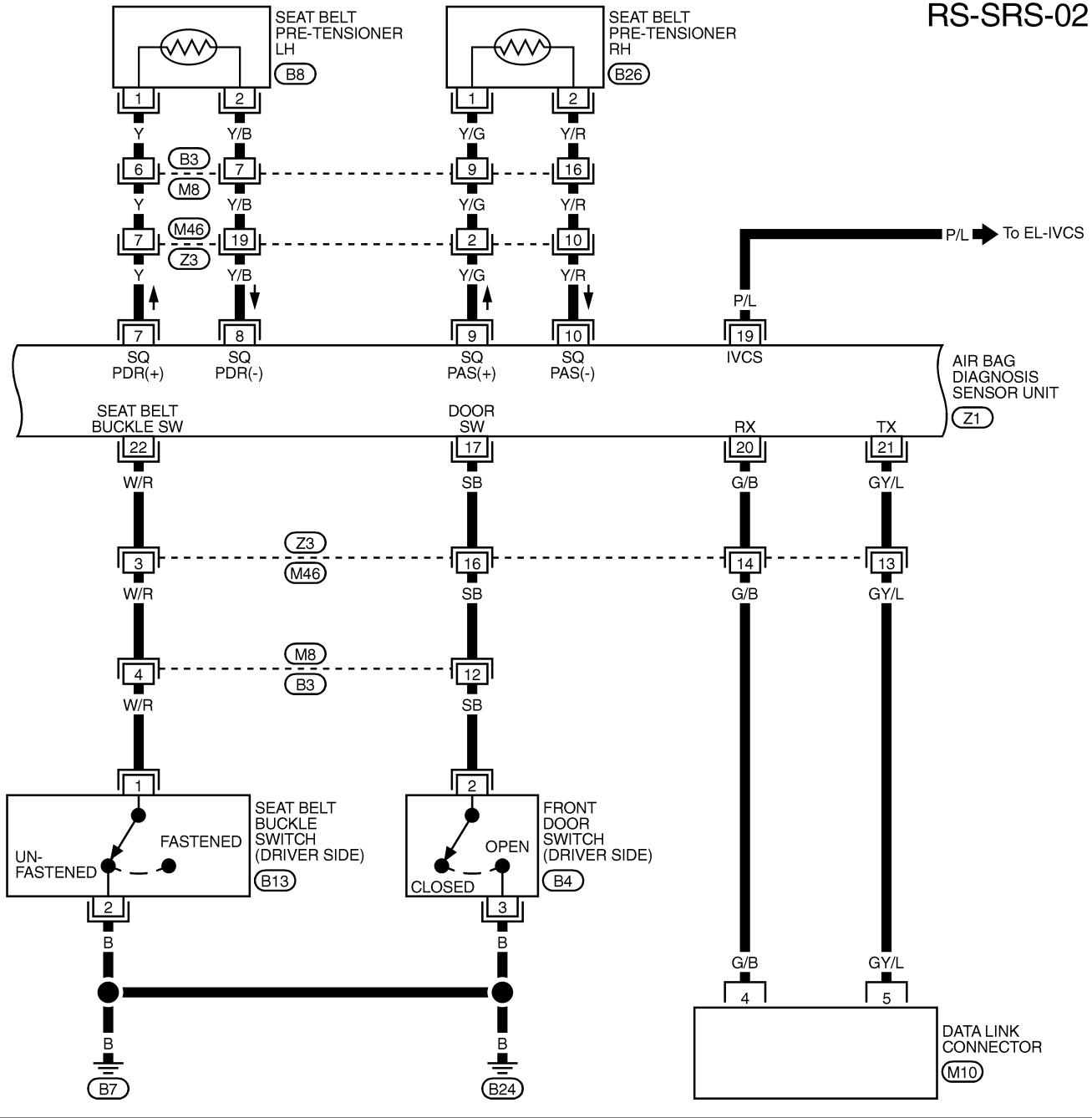

# SUPPLEMENTAL RESTRAINT SYSTEM (SRS)

Wiring Diagram — SRS — (Cont'd)

RS-SRS-03

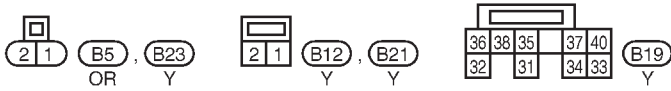
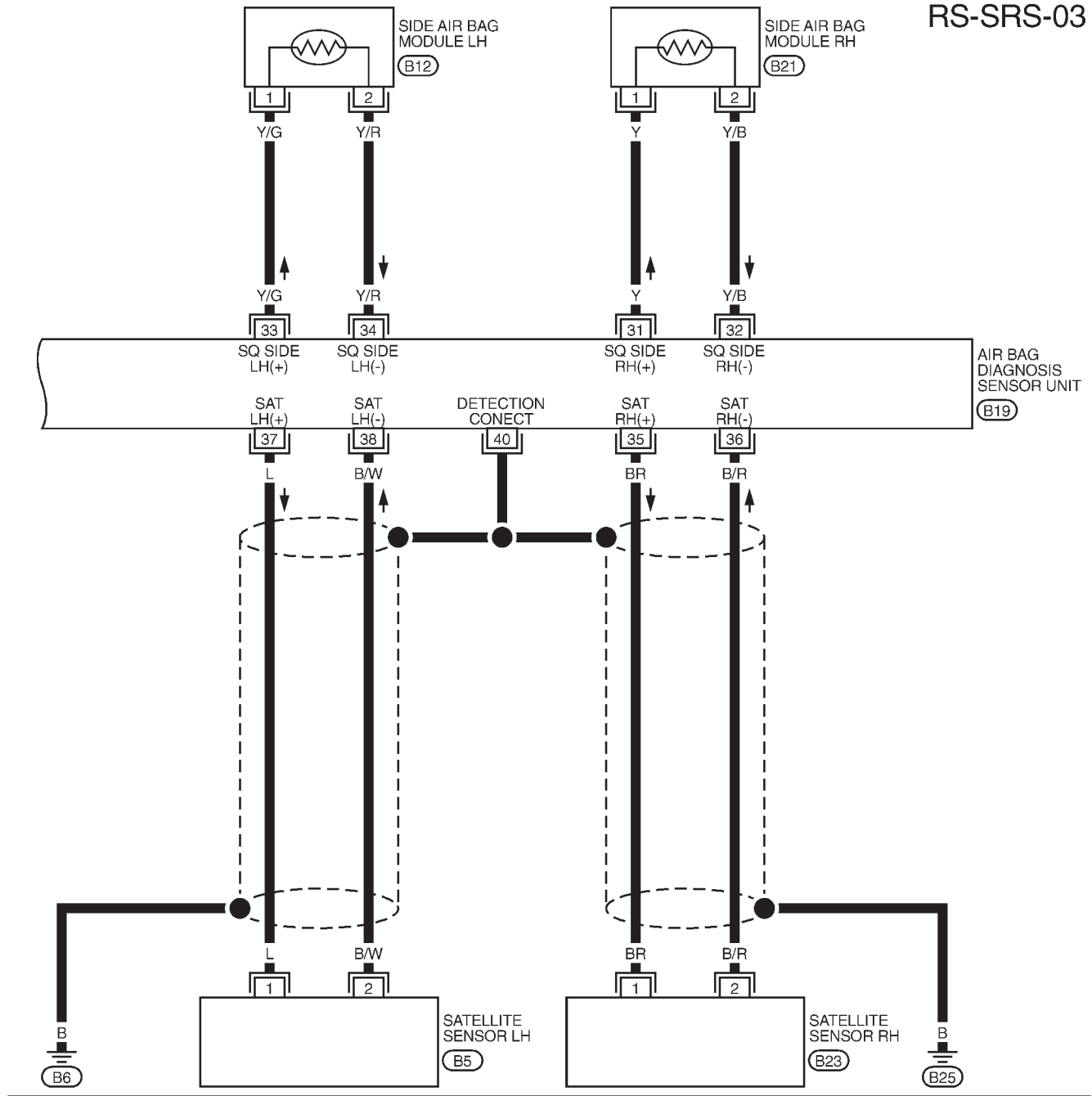





## SRS Operation Check DIAGNOSTIC PROCEDURE 1 Checking Air Bag Operation by Using "AIR BAG" Warning Lamp — User Mode

NCRS0027

NCRS0027S01

NCRS0027S0101

1. After turning ignition switch from "OFF" to "ON", "AIR BAG" warning lamp operates.
2. Compare "AIR BAG" warning lamp operation to the chart below.

"AIR BAG" warning lamp operation — User mode —	SRS condition	Reference item
<p>MRS095A</p>	No malfunction is detected. No further action is necessary.	—
<p>MRS096A</p>	The system is malfunctioning and needs to be repaired as indicated.	Go to DIAGNOSTIC PROCEDURE 2 or 6 (RS-43 or RS-52).
<p>MRS097A</p>	Air bag is deployed.	Go to COLLISION DIAGNOSIS (RS-65).
<p>MRS097A</p>	Air bag fuse, diagnosis sensor unit or harness is malfunctioning and needs to be repaired.	Go to DIAGNOSTIC PROCEDURE 9 (RS-58).
<p>MRS098A</p>	One of the following has occurred and needs to be repaired. <ul style="list-style-type: none"> <li>• Meter fuse is blown.</li> <li>• "AIR BAG" warning lamp circuit has open or short.</li> <li>• Diagnosis sensor unit is malfunctioning.</li> </ul>	Go to DIAGNOSTIC PROCEDURE 10 (RS-60).

**NOTE:**

If "AIR BAG" warning lamp operates differently from the operations shown above, refer to "AIR BAG" warning lamp operation — Diagnosis mode —, DIAGNOSTIC PROCEDURE 6 (step 4), RS-52.

GI  
MA  
EM  
LC  
EC  
FE  
CL  
MT  
AT  
AX  
SU  
BR  
ST  
RS  
BT  
HA  
SC  
EL  
IDX

# SUPPLEMENTAL RESTRAINT SYSTEM (SRS)

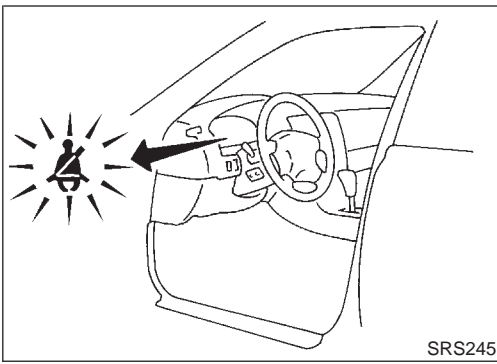

## SRS Operation Check (Cont'd)



### Checking Seat Belt Pre-tensioner Operation by Using "Seat Belt" Warning Lamp — User Mode

=NCRS0027S0102

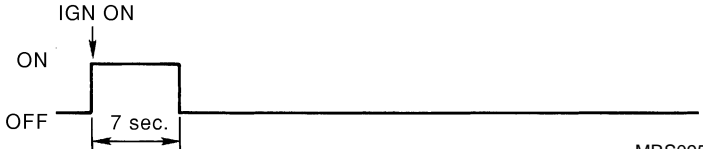
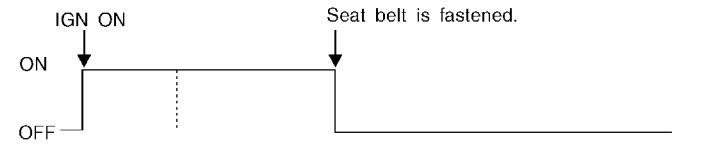
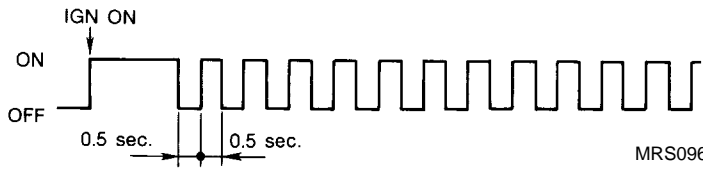
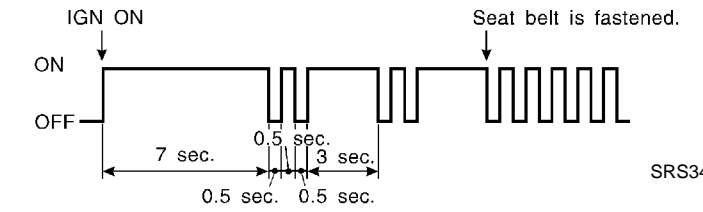
1. After turning ignition switch from "OFF" to "ON", "SEAT BELT" warning lamp operates.
2. Compare "SEAT BELT" warning lamp operation to the chart below.

"SEAT BELT" warning lamp operation	SRS condition	Reference item
<ul style="list-style-type: none"> <li>● After driver's seat belt has been fastened.</li> </ul>  <p>MRS095A</p>	No malfunction is detected. No further action is necessary.	—
<ul style="list-style-type: none"> <li>● When driver's seat belt has not been fastened.</li> </ul>  <p>SRS086</p>		
<ul style="list-style-type: none"> <li>● After driver's seat belt has been fastened.</li> </ul>  <p>MRS096A</p>	<ul style="list-style-type: none"> <li>● Seat belt pre-tensioner circuit is opened, or</li> <li>● Seat belt pre-tensioner power supply or ground circuit is shorted.</li> </ul>	<ul style="list-style-type: none"> <li>● If CONSULT-II is available, go to DIAGNOSTIC PROCEDURE 2 (RS-43).</li> <li>● If CONSULT-II is not available, repair the system as follows.*</li> </ul> <ol style="list-style-type: none"> <li>1. Visually check the wiring harness connections.</li> <li>2. Replace driver's and front passenger seat belt assemblies. (Before disposing, they must be deactivated.)</li> <li>3. Replace diagnosis sensor unit.</li> <li>4. Replace the related harness.</li> </ol>
<ul style="list-style-type: none"> <li>● When driver's seat belt has not been fastened.</li> </ul>  <p>SRS344</p>		
<ul style="list-style-type: none"> <li>● When driver's seat belt is fastened.</li> </ul>  <p>MRS097A</p>	Seat belt pre-tensioner (and air bag) is deployed.  Seat belt buckle switch, harness, combination meter assembly, diagnosis sensor unit are malfunctioning and need to be repaired.	Go to COLLISION DIAGNOSIS (RS-65).  Go to DIAGNOSTIC PROCEDURE 12 (RS-62).

"SEAT BELT" warning lamp operation	SRS condition	Reference item
<p>MRS098A</p>	Meter fuse, diagnosis sensor unit or "SEAT BELT" warning lamp circuit is shorted or open and needs to be repaired.	Go to DIAGNOSTIC PROCEDURE 13 (RS-64).

\* Follow the procedures in numerical order when repairing malfunctioning parts. Confirm whether malfunction is eliminated using the seat belt warning lamp each time repair is finished. If malfunction is still observed, proceed to the next step. When malfunction is eliminated, further repair work is not required.

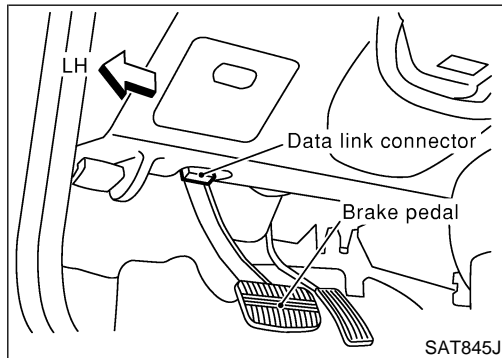

## Ⓜ Trouble Diagnoses with CONSULT-II

NCRS0028

### DIAGNOSTIC PROCEDURE 2

NCRS0028S01

#### Inspecting SRS malfunctioning parts by using CONSULT-II — Diagnosis mode

1. Turn ignition switch "OFF".
2. Connect CONSULT-II to data link connector.
3. Turn ignition switch "ON".
4. Touch "START".

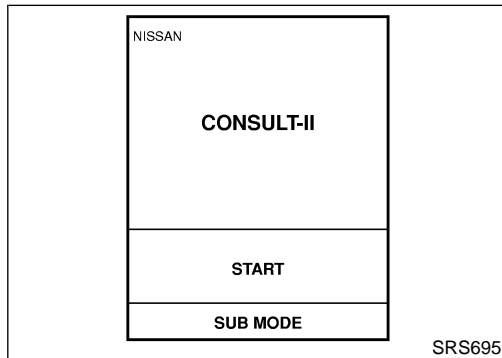

5. Touch "AIR BAG".

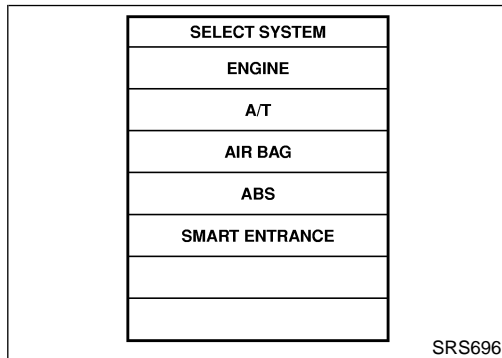

6. Touch "SELF-DIAG [CURRENT]".

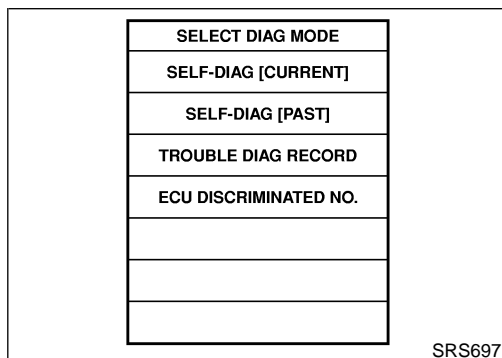

GI  
MA  
EM  
LC  
EC  
FE  
CL  
MT  
AT  
AX  
SU  
BR  
ST  
RS  
BT  
HA  
SC  
EL  
IDX

# SUPPLEMENTAL RESTRAINT SYSTEM (SRS)

Trouble Diagnoses with CONSULT-II (Cont'd)

SELF-DIAG [CURRENT]	
DTC RESULTS:	
AIR BAG MODULE [OPEN]	

SRS772

SELF-DIAG [CURRENT]	
DTC RESULTS:	
NO DTC IS DETECTED. FURTHER TESTING MAY BE REQUIRED.	

SRS701

7. Diagnostic codes are displayed on “SELF-DIAG [CURRENT]”.

If no malfunction is detected on “SELF-DIAG [CURRENT]” even though malfunction is detected in “SRS Operation Check”, go to DIAGNOSTIC PROCEDURE 4, page RS-48, to diagnose the following cases:

- Self-diagnostic result “SELF-DIAG [PAST]” (previously stored in the memory) might not be erased after repair.
- The SRS system malfunctions intermittently.

8. Touch “PRINT”.
9. Compare diagnostic codes to “CONSULT-II Diagnostic Code Chart”, page RS-44.
10. Touch “BACK” key of CONSULT-II until “SELECT SYSTEM” appears in order to return to User mode from Diagnosis mode.
11. Turn ignition switch “OFF”, then turn off and disconnect CONSULT-II and disconnect both battery cables.
12. Repair the system as outlined by the “Repair order” in “CONSULT-II Diagnostic Code Chart”, that corresponds to the self-diagnostic result. For replacement procedure of component parts, refer to RS-18.
13. After repairing the system, go to DIAGNOSTIC PROCEDURE 3, page RS-46 for final checking.  
CONSULT-II can only show one seat belt pre-tensioner malfunction as self-diagnosis result at a time. Check self-diagnosis result with CONSULT-II whether other malfunctions are detected after repairing one seat belt pre-tensioner malfunction.

## CONSULT-II Diagnostic Code Chart (“SELF-DIAG [CURRENT]”)

NCRS0028S0101

Diagnostic item	Explanation		Repair order <b>Recheck SRS at each replacement.</b>
NO DTC IS DETECTED.	When malfunction is indicated by the “AIR BAG” warning lamp in User mode	<ul style="list-style-type: none"> <li>• Self-diagnostic result “SELF-DIAG [PAST]” (previously stored in the memory) might not be erased after repair.</li> <li>• Intermittent malfunction has been detected in the past.</li> </ul>	<ul style="list-style-type: none"> <li>• Go to DIAGNOSTIC PROCEDURE 4 (RS-48).</li> </ul>
		<ul style="list-style-type: none"> <li>• No malfunction is detected.</li> </ul>	<ul style="list-style-type: none"> <li>• Go to DIAGNOSTIC PROCEDURE 3 (RS-46).</li> </ul>

# SUPPLEMENTAL RESTRAINT SYSTEM (SRS)

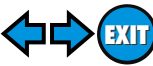

Trouble Diagnoses with CONSULT-II (Cont'd)

Diagnostic item	Explanation	Repair order <b>Recheck SRS at each replacement.</b>	
AIRBAG MODULE [OPEN]	● Driver's air bag module circuit is open. (including the spiral cable)	1. Visually check the wiring harness connection.	GI
AIRBAG MODULE [VB-SHORT]	● Driver's air bag module circuit is shorted to some power supply circuit. (including the spiral cable)	2. Replace the harness if it has visible damage.	MA
AIRBAG MODULE [GND-SHORT]	● Driver's air bag module circuit is shorted to ground. (including the spiral cable)	3. Replace the spiral cable.	EM
AIRBAG MODULE [SHORT]	● Driver's air bag module circuits are shorted to each other.	4. Replace driver's air bag module. (Before disposal of it, it must be deployed.)	LC
ASSIST A/B MODULE [VB-SHORT]	● Front passenger air bag module circuit is shorted to some power supply circuit.	5. Replace the diagnosis sensor unit.	EC
ASSIST A/B MODULE [OPEN]	● Front passenger air bag module circuit is open.	6. Replace the related harness.	FE
ASSIST A/B MODULE [GND-SHORT]	● Front passenger air bag module circuit is shorted to ground.	1. Visually check the wiring harness connection.	CL
ASSIST A/B MODULE [SHORT]	● Front passenger air bag module circuits are shorted to each other.	2. Replace the harness if it has visible damage.	MT
SIDE MODULE LH [OPEN]	● Side air bag module (LH) circuit is open.	3. Replace front passenger air bag module. (Before disposal of it, it must be deployed.)	AT
SIDE MODULE LH [VB-SHORT]	● Side air bag module (LH) circuit is shorted to some power supply circuits.	4. Replace the diagnosis sensor unit.	AX
SIDE MODULE LH [GND-SHORT]	● Side air bag module (LH) circuit is shorted to ground.	5. Replace the related harness.	SU
SIDE MODULE LH [SHORT]	● Side air bag module (LH) circuits are shorted to each other.	1. Visually check the wiring harness connection.	BR
SIDE MODULE RH [OPEN]	● Side air bag module (RH) circuit is open.	2. Replace the harness if it has visible damage.	ST
SIDE MODULE RH [VB-SHORT]	● Side air bag module (RH) circuit is shorted to some power supply circuits.	3. Replace side air bag module (RH). (Before disposal, it must be deployed.)	RS
SIDE MODULE RH [GND-SHORT]	● Side air bag module (RH) circuit is shorted to ground.	4. Replace the diagnosis sensor unit.	BT
SIDE MODULE RH [SHORT]	● Side air bag module (RH) circuits are shorted to each other.	5. Replace the related harness.	HA
SATELLITE SENS LH [UNIT FAIL] SATELLITE SENS LH [COMM FAIL]	● Satellite sensor (LH)	1. Visually check the wiring harness connection.	SC
SATELLITE SENS RH [UNIT FAIL] SATELLITE SENS RH [COMM FAIL]	● Satellite sensor (RH)	2. Replace the harness if it has visible damage.	EL
		3. Replace the satellite sensor (LH).	IDX
		4. Replace the diagnosis sensor unit.	
		5. Replace the related harness.	

# SUPPLEMENTAL RESTRAINT SYSTEM (SRS)

Trouble Diagnoses with CONSULT-II (Cont'd)

Diagnostic item	Explanation	Repair order <b>Recheck SRS at each replacement.</b>
DRIVE PRE-TENSIONER [OPEN/VB-SHORT]	<ul style="list-style-type: none"> <li>The circuit for the driver's pre-tensioner is open or shorted to some power supply circuit.</li> </ul>	<ol style="list-style-type: none"> <li>1. Visually check the wiring harness connections.</li> <li>2. Replace the harness if it has visible damage.</li> <li>3. Replace the driver's seat belt. (Before disposing, it must be deactivated.)</li> </ol>
DRIVE PRE-TENSIONER [GND-SHORT]	<ul style="list-style-type: none"> <li>The circuit for the driver's pre-tensioner is shorted to ground.</li> </ul>	<ol style="list-style-type: none"> <li>4. Replace the diagnosis sensor unit.</li> <li>5. Replace the related harness.</li> </ol>
ASSIST PRE-TENSIONER [OPEN/VB-SHORT]	<ul style="list-style-type: none"> <li>The circuit for the front passenger pre-tensioner is open or shorted to some power supply circuit.</li> </ul>	<ol style="list-style-type: none"> <li>1. Visually check the wiring harness connections.</li> <li>2. Replace the harness if it has visible damage.</li> <li>3. Replace the front passenger seat belt. (Before disposing, it must be deactivated.)</li> </ol>
ASSIST PRE-TENSIONER [GND-SHORT]	<ul style="list-style-type: none"> <li>The circuit for the front passenger pre-tensioner is shorted to ground.</li> </ul>	<ol style="list-style-type: none"> <li>4. Replace the diagnosis sensor unit.</li> <li>5. Replace the related harness.</li> </ol>
CONTROL UNIT	<ul style="list-style-type: none"> <li>Low battery voltage (Less than 9V)</li> </ul>	<ul style="list-style-type: none"> <li>Go to DIAGNOSTIC PROCEDURE 3 (RS-46) after charging battery.</li> </ul>
	<ul style="list-style-type: none"> <li>Diagnosis sensor unit is malfunctioning.</li> </ul>	<ol style="list-style-type: none"> <li>1. Visually check wiring harness connections.</li> <li>2. Replace the harness if it has visible damage.</li> <li>3. Replace diagnosis sensor unit.</li> <li>4. Replace the related harness.</li> </ol>

\* Follow the procedures in numerical order when repairing malfunctioning parts. Confirm whether malfunction is eliminated using the air bag or seat belt warning lamp or CONSULT-II each time repair is finished. If malfunction is still observed, proceed to the next step. When malfunction is eliminated, further repair work is not required.

CONSULT-II can only show one seat belt pre-tensioner malfunction as self-diagnosis result at a time. Check self-diagnosis result with CONSULT-II whether other malfunctions are detected after repairing one seat belt pre-tensioner malfunction.

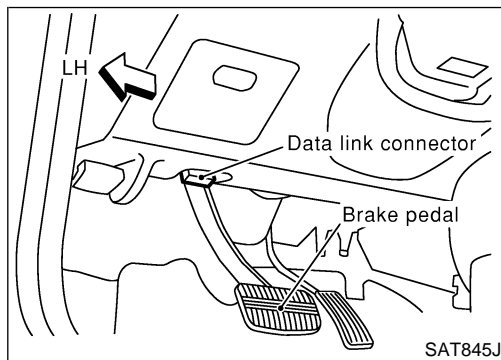

## DIAGNOSTIC PROCEDURE 3

NCRS0028S02

### Final checking after repairing SRS by using CONSULT-II — Diagnosis mode

1. After repairing SRS, connect both battery cables.
2. Connect CONSULT-II to data link connector.
3. Turn ignition switch from "OFF" to "ON".
4. Touch "START".

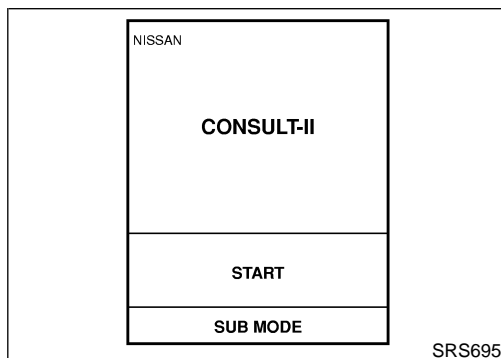

# SUPPLEMENTAL RESTRAINT SYSTEM (SRS)

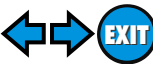

Trouble Diagnoses with CONSULT-II (Cont'd)

SELECT SYSTEM
ENGINE
A/T
AIR BAG
ABS
SMART ENTRANCE

SRS696

5. Touch "AIR BAG".

GI

MA

EM

LC

SELECT DIAG MODE
SELF-DIAG [CURRENT]
SELF-DIAG [PAST]
TROUBLE DIAG RECORD
ECU DISCRIMINATED NO.

SRS697

6. Touch "SELF-DIAG [CURRENT]".

EC

FE

CL

MT

SELF-DIAG [CURRENT]
DTC RESULTS:
NO DTC IS DETECTED. FURTHER TESTING MAY BE REQUIRED.

SRS701

7. If no malfunction is detected on "SELF-DIAG [CURRENT]", repair of SRS is completed. Go to step 8.

AT

(When the malfunction was only in seat belt pre-tensioner system, go to step 11.)

If any malfunction is detected on "SELF-DIAG [CURRENT]", the malfunctioning part is not repaired completely or another malfunctioning part is detected. Go to DIAGNOSTIC PROCEDURE 2, page RS-43, and repair malfunctioning part completely.

AX

SU

BR

SELF-DIAG [CURRENT]
DTC RESULTS:
AIR BAG MODULE [OPEN]
ERASE

SRS773

8. Touch "ERASE".

**NOTE:**

Touch "ERASE" to clear the memory of the malfunction ("SELF-DIAG [PAST]").

If the memory of the malfunction in "SELF-DIAG [PAST]" is not erased, the User mode shows the system malfunction by the operation of the warning lamp even if the malfunction is repaired completely.

ST

RS

BT

HA

SELECT DIAG MODE
SELF-DIAG [CURRENT]
SELF-DIAG [PAST]
TROUBLE DIAG RECORD
ECU DISCRIMINATED NO.

SRS697

9. Touch "BACK" key of CONSULT-II to "SELECT DIAG MODE" screen. Touch "SELF-DIAG [PAST]".

SC

EL

IDX

# SUPPLEMENTAL RESTRAINT SYSTEM (SRS)

Trouble Diagnoses with CONSULT-II (Cont'd)

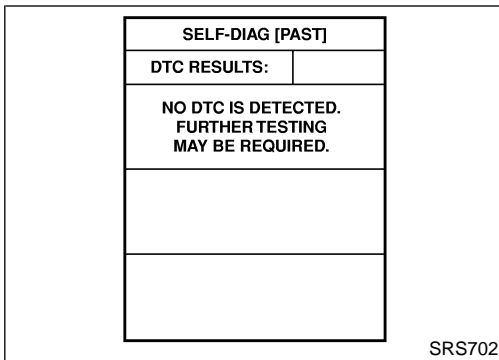

SRS702

10. Check that no malfunction is detected on “SELF-DIAG [PAST]”.

**NOTE:**

Past malfunction for seat belt pre-tensioner system will not be displayed on “SELF-DIAG [PAST]”.

11. Touch “BACK” key of CONSULT-II until “SELECT SYSTEM” appears in order to return to User mode from Diagnosis mode.
12. Turn ignition switch “OFF” then turn off and disconnect CONSULT-II.
13. Go to “SRS Operation Check”, page RS-41 to check SRS operation by using “AIR BAG” warning lamp with User mode.

## DIAGNOSTIC PROCEDURE 4 (CONTINUED FROM DIAGNOSTIC PROCEDURE 2)

NCRS0028S03

### Inspecting SRS malfunctioning record

<b>1</b>	<b>CONSIDER POSSIBILITY OF NOT ERASING SELF-DIAGNOSTIC RESULT AFTER REPAIRING</b>	
Is it the first time for maintenance of SRS?		
Yes or No		
Yes	▶	Go to DIAGNOSTIC PROCEDURE 5 (RS-48).
No	▶	Self-diagnostic result “SELF-DIAG [PAST]” (previously stored in the memory) might not be erased after repair. Go to DIAGNOSTIC PROCEDURE 3, step 8 (RS-46).

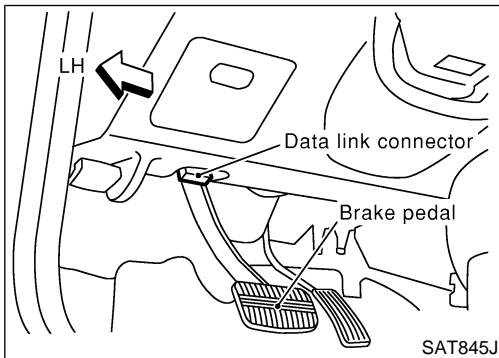

## DIAGNOSTIC PROCEDURE 5

NCRS0028S04

### Inspecting SRS intermittent malfunction by using CONSULT-II — Diagnosis mode

1. Turn ignition switch “OFF”.
2. Connect CONSULT-II to data link connector.

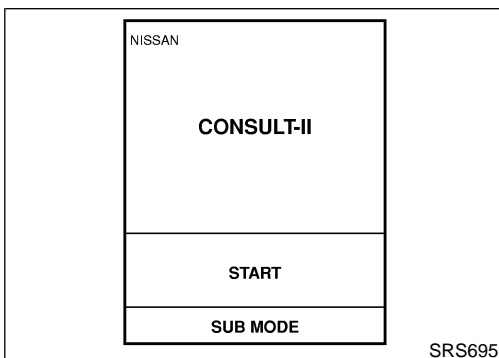

SRS695

3. Turn ignition switch “ON”.
4. Touch “START”.



# SUPPLEMENTAL RESTRAINT SYSTEM (SRS)

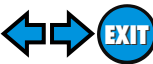

Trouble Diagnoses with CONSULT-II (Cont'd)

SELECT SYSTEM
ENGINE
A/T
AIR BAG
ABS
SMART ENTRANCE

SRS696

5. Touch "AIR BAG".

SELECT DIAG MODE
SELF-DIAG [CURRENT]
SELF-DIAG [PAST]
TROUBLE DIAG RECORD
ECU DISCRIMINATED NO.

SRS697

6. Touch "SELF-DIAG [PAST]".

SELF-DIAG [PAST]
DTC RESULTS:
AIR BAG MODULE [OPEN]

SRS700

7. If diagnostic codes are displayed on "SELF-DIAG [PAST]", go to step 10.

SELF-DIAG [PAST]
DTC RESULTS:
NO DTC IS DETECTED. FURTHER TESTING MAY BE REQUIRED.

SRS702

If no malfunction is detected on "SELF-DIAG [PAST]", touch "BACK" and go back to "SELECT DIAG MODE".

**NOTE:**  
Past malfunction for seat belt pre-tensioner system will not be displayed on "SELF-DIAG [PAST]".

SELECT DIAG MODE
SELF-DIAG [CURRENT]
SELF-DIAG [PAST]
TROUBLE DIAG RECORD
ECU DISCRIMINATED NO.

SRS697

8. Touch "TROUBLE DIAG RECORD".

**NOTE:**  
With "TROUBLE DIAG RECORD", diagnosis results previously erased by a reset operation can be displayed.

GI  
MA  
EM  
LC  
EC  
FE  
CL  
MT  
AT  
AX  
SU  
BR  
ST  
RS  
BT  
HA  
SC  
EL  
IDX

# SUPPLEMENTAL RESTRAINT SYSTEM (SRS)

Trouble Diagnoses with CONSULT-II (Cont'd)

TROUBLE DIAG RECORD	
DTC RESULTS:	
AIR BAG MODULE [OPEN]	

SRS704

9. Diagnostic code is displayed on "TROUBLE DIAG RECORD".
10. Touch "PRINT".
11. Compare diagnostic codes to "Intermittent Malfunction Diagnostic Code Chart", page RS-50.
12. Touch "BACK" key of CONSULT-II until "SELECT SYSTEM" appears.
13. Turn ignition switch "OFF", then turn off and disconnect CONSULT-II, and both battery cables.
14. Repair the system as outlined by the "Repair order" in "Intermittent Malfunction Diagnostic Code Chart", that corresponds to the self-diagnostic result. For replacement procedure of component parts, refer to RS-18.
15. Go to DIAGNOSTIC PROCEDURE 3, page RS-46, for final checking.

## Intermittent Malfunction Diagnostic Code Chart ("SELF-DIAG [PAST]" or "TROUBLE DIAG RECORD")

NCRS0028S0401

Diagnostic item	Explanation	Repair order
NO DTC IS DETECTED.	<ul style="list-style-type: none"> <li>● No malfunction is detected.</li> </ul>	<ul style="list-style-type: none"> <li>● Go to DIAGNOSTIC PROCEDURE 3 (RS-46).</li> </ul>
AIRBAG MODULE [OPEN]	<ul style="list-style-type: none"> <li>● Driver's air bag module circuit is open. (including the spiral cable)</li> </ul>	<ol style="list-style-type: none"> <li>1. Visually check the wiring harness connection.</li> <li>2. Replace the harness if it has visible damage.</li> <li>3. If the harness check is OK, replace the spiral cable, diagnosis sensor unit and driver air bag module. (Before disposing the driver air bag module, it must be deployed.)</li> </ol>
AIRBAG MODULE [VB-SHORT]	<ul style="list-style-type: none"> <li>● Driver's air bag module circuit is shorted to some power supply circuit. (including the spiral cable)</li> </ul>	
AIRBAG MODULE [GND-SHORT]	<ul style="list-style-type: none"> <li>● Driver's air bag module circuit is shorted to ground. (including the spiral cable)</li> </ul>	
AIRBAG MODULE [SHORT]	<ul style="list-style-type: none"> <li>● Driver's air bag module circuits are shorted to each other.</li> </ul>	
ASSIST A/B MODULE [VB-SHORT]	<ul style="list-style-type: none"> <li>● Front passenger air bag module circuit is shorted to some power supply circuit.</li> </ul>	<ol style="list-style-type: none"> <li>1. Visually check the wiring harness connection.</li> <li>2. Replace the harness if it has visible damage.</li> <li>3. If the harness check is OK, replace the diagnosis sensor unit and passenger air bag module. (Before disposing the passenger air bag module, it must be deployed.)</li> </ol>
ASSIST A/B MODULE [OPEN]	<ul style="list-style-type: none"> <li>● Front passenger air bag module circuit is open.</li> </ul>	
ASSIST A/B MODULE [GND-SHORT]	<ul style="list-style-type: none"> <li>● Front passenger air bag module circuit is shorted to ground.</li> </ul>	
ASSIST A/B MODULE [SHORT]	<ul style="list-style-type: none"> <li>● Front passenger air bag module circuits are shorted to each other.</li> </ul>	

# SUPPLEMENTAL RESTRAINT SYSTEM (SRS)

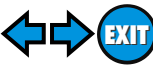

Trouble Diagnoses with CONSULT-II (Cont'd)

Diagnostic item	Explanation	Repair order	
SIDE MODULE LH [OPEN]	● Side air bag module (LH) circuit is open.	1. Visually check the wiring harness connection.	GI
SIDE MODULE LH [VB-SHORT]	● Side air bag module (LH) circuit is shorted to some power supply circuits.	2. Replace the harness if it has visible damage.	MA
SIDE MODULE LH [GND-SHORT]	● Side air bag module (LH) circuit is shorted to ground.	3. If the harness check is OK, replace the diagnosis sensor unit and side air bag module (LH). (Before disposing the side air bag module (LH), it must be deployed.)	EM
SIDE MODULE LH [SHORT]	● Side air bag module (LH) circuits are shorted to each other.		LC
SIDE MODULE RH [OPEN]	● Side air bag module (RH) circuit is open.	1. Visually check the wiring harness connection.	EC
SIDE MODULE RH [VB-SHORT]	● Side air bag module (RH) circuit is shorted to some power supply circuits.	2. Replace the harness if it has visible damage.	FE
SIDE MODULE RH [GND-SHORT]	● Side air bag module (RH) circuit is shorted to ground.	3. If the harness check is OK, replace the diagnosis sensor unit and side air bag module (RH). (Before disposing the side air bag module (RH), it must be deployed.)	CL
SIDE MODULE RH [SHORT]	● Side air bag module (RH) circuits are shorted to each other.		GL
SATELLITE SENS LH [UNIT FAIL] SATELLITE SENS LH [COMM FAIL]	● Satellite sensor (LH)	1. Visually check the wiring harness connection. 2. Replace the harness if it has visible damage. 3. If the harness check is OK, replace the diagnosis sensor unit and satellite sensor (LH).	MT AT
SATELLITE SENS RH [UNIT FAIL] SATELLITE SENS RH [COMM FAIL]	● Satellite sensor (RH)	1. Visually check the wiring harness connection. 2. Replace the harness if it has visible damage. 3. If the harness check is OK, replace the diagnosis sensor unit and satellite sensor (RH).	AX SU BR
CONTROL UNIT	● Diagnosis sensor unit is malfunctioning.	1. Visually check the wiring harness connection. 2. Replace the harness if it has visible damage. 3. If the harness check is OK, replace the diagnosis sensor unit.	ST <b>RS</b>

\* Follow the procedures in numerical order when repairing malfunctioning parts, then make the final system check.

BT

HA

SC

EL

IDX

# SUPPLEMENTAL RESTRAINT SYSTEM (SRS)

Trouble Diagnoses without CONSULT-II

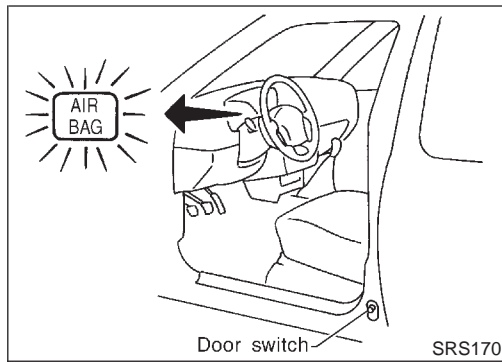

## Trouble Diagnoses without CONSULT-II

=NCRS0029

### DIAGNOSTIC PROCEDURE 6

NCRS0029S01

#### Inspecting SRS malfunctioning parts by using "AIR BAG" warning lamp — Diagnosis mode

##### NOTE:

SRS will not enter Diagnosis mode if no malfunction is detected in User mode.

1. Open driver's door.
2. Turn ignition switch from "OFF" to "ON".
3. Press driver's door switch at least 5 times within 7 seconds after turning ignition switch "ON".  
SRS is now in Diagnosis mode.
4. "AIR BAG" warning lamp operates in Diagnosis mode as follows:

##### NOTE:

If SRS does not enter Diagnosis mode even though malfunction is detected in User mode, go to DIAGNOSTIC PROCEDURE 11, page RS-61.

No.	"AIR BAG" warning lamp flash pattern — Diagnosis mode —	SRS condition
1		<p>a through b are repeated.</p> <ul style="list-style-type: none"> <li>• Diagnosis results (previously stored in the memory) might not be erased after repair.</li> <li>• Intermittent malfunction has been detected in the past. Go to DIAGNOSTIC PROCEDURE 8 (RS-57).</li> </ul>
2		<p>a through d are repeated. b — Driver and passenger air bag marker (For identifying driver and/or passenger air bag malfunctioning) d — Indicates malfunctioning part. The number of flash varies with malfunctioning part (0.5 sec. ON and 0.5 sec. OFF is counted as one flash.)</p> <p>The system is malfunctioning and needs to be repaired.</p>
3		<p>a through f are repeated. b, c, d — Side air bag marker (For identifying side air bag malfunctioning) f — Indicates malfunctioning part. The number of flash varies with malfunctioning part (0.5 sec. ON and 0.5 sec. OFF is counted as one flash.)</p>

5. Malfunctioning part is indicated by the number of flashes (part d or f). Compare the number of flashes to "Air Bag Warning Lamp Flash Code Chart", page RS-53, and locate malfunctioning part.

# SUPPLEMENTAL RESTRAINT SYSTEM (SRS)



⊗ Trouble Diagnoses without CONSULT-II (Cont'd)

6. Turn ignition switch "OFF", and disconnect both battery cables.
7. Repair the system as outlined by the "Repair order" in "Warning Lamp Flash Code Chart" that corresponds to the flash code. For replacement procedure of component parts, refer to RS-18.
8. After repairing the system, go to DIAGNOSTIC PROCEDURE 7, page RS-55.

## Air Bag Warning Lamp Flash Code Chart (Diagnosis mode)

NCRS0029S0101

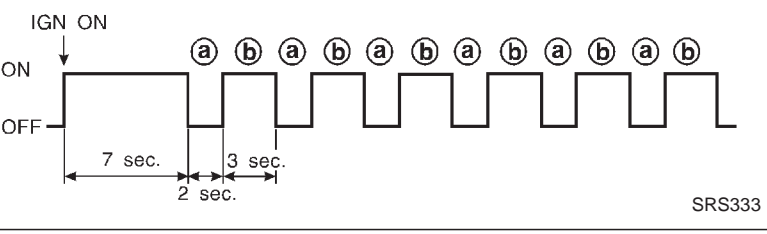
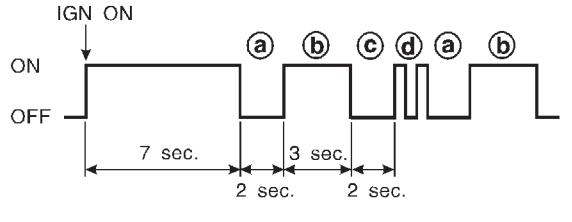
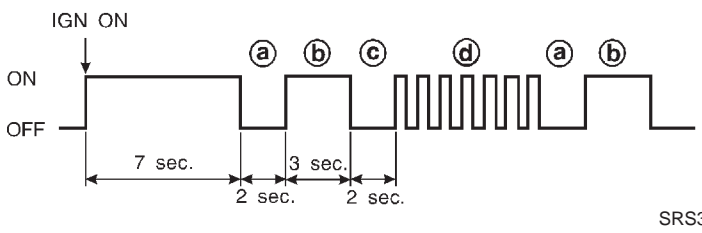
<ul style="list-style-type: none"> <li>● Diagnosis results (previously stored in the memory) might not be erased after repair.</li> <li>● Intermittent malfunction has been detected in the past.</li> </ul>	<p style="text-align: center;">Flash pattern</p>  <p>a through b are repeated.</p> <p>Repair order</p> <ul style="list-style-type: none"> <li>● Go to DIAGNOSTIC PROCEDURE 8 (RS-57).</li> </ul>
<p>The driver's air bag module circuit is malfunctioning. (d: 2 flashes)</p>	<p style="text-align: center;">Flash pattern</p>  <p>a through d are repeated. d — Two flashes indicate malfunctioning driver's air bag module circuit.</p> <p>Repair order ("Recheck SRS at each replacement.")</p> <ol style="list-style-type: none"> <li>1. Visually check the wiring harness connection.</li> <li>2. Replace the harness if it has visible damage.</li> <li>3. Replace the spiral cable.</li> <li>4. Replace driver's air bag module. (Before disposal, it must be deployed.)</li> <li>5. Replace the diagnosis sensor unit.</li> <li>6. Replace the related harness.</li> </ol>
<p>The diagnosis sensor unit is malfunctioning. (d: 7 flashes)</p>	<p style="text-align: center;">Flash pattern</p>  <p>a through d are repeated. d — Seven flashes indicate malfunctioning diagnosis sensor unit.</p> <p>Repair order ("Recheck SRS at each replacement.")</p> <ol style="list-style-type: none"> <li>1. Visually check the wiring harness connections.</li> <li>2. Replace the harness if it has visible damage.</li> <li>3. Replace the diagnosis sensor unit.</li> <li>4. Replace the related harness.</li> </ol>

# SUPPLEMENTAL RESTRAINT SYSTEM (SRS)

Trouble Diagnoses without CONSULT-II (Cont'd)

<p>The front passenger air bag module circuit is malfunctioning. (d: 8 flashes)</p>	<p style="text-align: center;">Flash pattern</p> <p style="text-align: right;">SRS336</p> <p>a through d are repeated. d — Eight flashes indicate malfunctioning front passenger air bag module circuit.</p>
	<p>Repair order ("Recheck SRS at each replacement.")</p>
	<ol style="list-style-type: none"> <li>1. Visually check the wiring harness connection.</li> <li>2. Replace the harness if it has visible damage.</li> <li>3. Replace front passenger air bag module. (Before disposal, it must be deployed.)</li> <li>4. Replace the diagnosis sensor unit.</li> <li>5. Replace the related harness.</li> </ol>
<p>The side air bag module (RH) circuit is malfunctioning. (f: 1 flash)</p>	<p style="text-align: center;">Flash pattern</p> <p style="text-align: right;">SRS338</p> <p>a through f are repeated. f — One flash indicates malfunctioning side air bag module (RH) circuit.</p>
	<p>Repair order ("Recheck SRS at each replacement.")</p>
	<ol style="list-style-type: none"> <li>1. Visually check the wiring harness connection.</li> <li>2. Replace the harness if it has visible damage.</li> <li>3. Replace side air bag module (RH). (Before disposal, it must be deployed.)</li> <li>4. Replace the diagnosis sensor unit.</li> <li>5. Replace the related harness.</li> </ol>
<p>The side air bag module (LH) circuit is malfunctioning. (f: 2 flashes)</p>	<p style="text-align: center;">Flash pattern</p> <p style="text-align: right;">SRS337</p> <p>a through f are repeated. f — Two flashes indicate malfunctioning side air bag module (LH) circuit.</p>
	<p>Repair order ("Recheck SRS at each replacement.")</p>
	<ol style="list-style-type: none"> <li>1. Visually check the wiring harness connection.</li> <li>2. Replace the harness if it has visible damage.</li> <li>3. Replace side air bag module (LH). (Before disposal, it must be deployed.)</li> <li>4. Replace the diagnosis sensor unit.</li> <li>5. Replace the related harness.</li> </ol>

# SUPPLEMENTAL RESTRAINT SYSTEM (SRS)

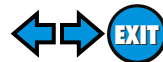

⊗ Trouble Diagnoses without CONSULT-II (Cont'd)

<p>The satellite sensor (RH) is malfunctioning. (f: 3 flashes)</p>	<p style="text-align: center;">Flash pattern</p> <p style="text-align: right;">SRS340</p>	<p>a through f are repeated. f — Three flashes indicate malfunctioning satellite sensor (RH) circuit.</p>	GI
	<p>Repair order ("Recheck SRS at each replacement.")</p>	MA	
<ol style="list-style-type: none"> <li>1. Visually check the wiring harness connection.</li> <li>2. Replace the harness if it has visible damage.</li> <li>3. Replace the satellite sensor (RH).</li> <li>4. Replace the diagnosis sensor unit.</li> <li>5. Replace the related harness.</li> </ol>	EM	LC	
<p>The satellite sensor (LH) is malfunctioning. (f: 4 flashes)</p>	<p style="text-align: center;">Flash pattern</p> <p style="text-align: right;">SRS339-A</p>	<p>a through f are repeated. f — Four flashes indicate malfunctioning satellite sensor (LH) circuit.</p>	FE
	<p>Repair order ("Recheck SRS at each replacement.")</p>	CL	
<ol style="list-style-type: none"> <li>1. Visually check the wiring harness connection.</li> <li>2. Replace the harness if it has visible damage.</li> <li>3. Replace the satellite sensor (LH).</li> <li>4. Replace the diagnosis sensor unit.</li> <li>5. Replace the related harness.</li> </ol>	MT	AT	

\* Follow the procedures in numerical order when repairing malfunctioning parts. Confirm whether malfunction is eliminated using the air bag warning lamp or CONSULT-II each time repair is finished. If malfunction is still observed, proceed to the next step. When malfunction is eliminated, further repair work is not required.

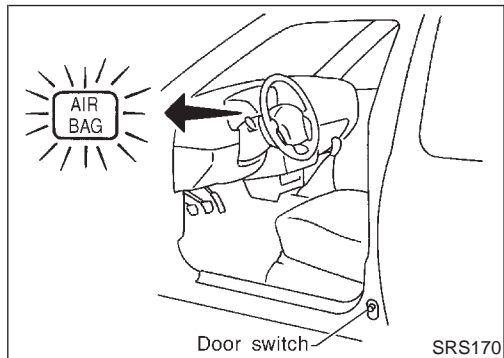

## DIAGNOSTIC PROCEDURE 7

Final checking after repairing SRS by using "AIR BAG" warning lamp — Diagnosis mode and User mode NCRS0029S02

1. After repairing SRS connect both battery cables.
2. Open driver's door.
3. Turn ignition switch from "OFF" to "ON".
4. "AIR BAG" warning lamp operates in Diagnosis mode as follows:

RS

BT

HA

SC

EL

IDX

# SUPPLEMENTAL RESTRAINT SYSTEM (SRS)

⊗ Trouble Diagnoses without CONSULT-II (Cont'd)

No.	"AIR BAG" warning lamp flash pattern — Diagnosis mode —	SRS condition
1	<p style="text-align: right;">SRS333</p>	<p>a through b are repeated.</p> <p>No malfunction is detected or repair is completed. No further action is necessary.</p>
2	<p style="text-align: right;">SRS341</p>	<p>a through d are repeated.</p> <p><b>b</b> — Driver and passenger air bag marker (For identifying driver and/or passenger air bag malfunctioning)</p> <p><b>d</b> — Indicates malfunctioning part. The number of flashes varies with malfunctioning part (0.5 sec. ON and 0.5 sec. OFF is counted as one flash.)</p> <p>The system is malfunctioning and needs to be repaired.</p>
3	<p style="text-align: right;">SRS342-A</p>	<p>a through f are repeated.</p> <p><b>b, c, d</b> — Side air bag marker (For identifying side air bag malfunctioning)</p> <p><b>f</b> — Indicates malfunctioning part. The number of flashes varies with malfunctioning part (0.5 sec. ON and 0.5 sec. OFF is counted as one flash.)</p>

**NOTE:**

When diagnosis sensor unit is replaced with new one, "AIR BAG" warning lamp will operate in User mode. Checking "AIR BAG" warning lamp operation in Diagnosis mode is not required. Go to step 6.

5. If "AIR BAG" warning lamp operates as shown in No. 1 in chart above, turn ignition switch "OFF" to reset from Diagnosis mode to User mode and to erase the memory of the malfunction. Then go to step 6.

If "AIR BAG" warning lamp operates as shown in No. 2 or No. 3 in chart above, the malfunctioning part is not repaired completely, or another malfunctioning part is detected. Go to DIAGNOSTIC PROCEDURE 6, page RS-52, and repair malfunctioning part completely.

6. Turn ignition switch "ON". "AIR BAG" warning lamp operates in User mode. Compare "AIR BAG" warning lamp operation to the chart below.

**NOTE:**

If switching Diagnosis mode to User mode is required while malfunction is being detected, turn ignition switch from "OFF" to "ON". Then press driver's door switch at least 5 times within 7 seconds after turning ignition switch "ON". SRS is now in User mode.

"AIR BAG" warning lamp operation — User mode —	SRS condition	Reference item
<p style="text-align: right;">MRS095A</p>	<p>No malfunction is detected. No further action is necessary.</p>	—



# SUPPLEMENTAL RESTRAINT SYSTEM (SRS)

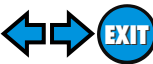

⊗ Trouble Diagnoses without CONSULT-II (Cont'd)

"AIR BAG" warning lamp operation — User mode —	SRS condition	Reference item	
<p>MRS096A</p>	The system is malfunctioning and needs to be repaired as indicated.	Go to DIAGNOSTIC PROCEDURE 6 (RS-52).	GI MA EM
<p>MRS097A</p>	Air bag is deployed.	Go to COLLISION DIAGNOSIS (RS-65).	EM
<p>MRS097A</p>	Air bag fuse, diagnosis sensor unit or harness is malfunctioning and needs to be repaired.	Go to DIAGNOSTIC PROCEDURE 9 (RS-58).	LC EC
<p>MRS098A</p>	One of the following has occurred and needs to be repaired. <ul style="list-style-type: none"> <li>• Meter fuse is blown.</li> <li>• "AIR BAG" warning lamp circuit has open or short.</li> <li>• Diagnosis sensor unit is malfunctioning.</li> </ul>	Go to DIAGNOSTIC PROCEDURE 10 (RS-60).	FE CL MT

## DIAGNOSTIC PROCEDURE 8 (CONTINUED FROM DIAGNOSTIC PROCEDURE 6)

NCRS0029S03

### Inspecting SRS malfunctioning record

<b>1</b>	<b>CONSIDER POSSIBILITY OF NOT ERASING SELF-DIAGNOSTIC RESULT AFTER REPAIRING</b>		AT
Is it the first time for maintenance of SRS?			AX
Yes or No			SU
Yes	▶	Go to DIAGNOSTIC PROCEDURE 5 (RS-48). (Further inspection cannot be performed without CONSULT-II.)	BR
No	▶	Diagnosis results (previously stored in the memory) might not be erased after repair. Go to DIAGNOSTIC PROCEDURE 7, step 5 (RS-55).	ST

**RS**

BT

HA

SC

EL

IDX

# SUPPLEMENTAL RESTRAINT SYSTEM (SRS)

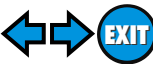

Trouble Diagnoses: "AIR BAG" Warning Lamp Does Not Turn Off

## Trouble Diagnoses: "AIR BAG" Warning Lamp Does Not Turn Off

### DIAGNOSTIC PROCEDURE 9

=NCRS0030

NCRS0030S01

<b>1</b>	<b>SEE THE DEPLOYMENT OF AIR BAG MODULE</b>	
Is air bag module deployed?		
<b>Yes or No</b>		
Yes	▶	Refer to COLLISION DIAGNOSIS (RS-65).
No	▶	GO TO 2.

<b>2</b>	<b>CHECK "AIR BAG" FUSE</b>	
Is SRS "Air Bag" fuse OK?		
<b>OK or NG</b>		
OK	▶	GO TO 4.
NG	▶	GO TO 3.

SRS577

<b>3</b>	<b>CHECK "AIR BAG" FUSE AGAIN</b>	
Replace "AIR BAG" fuse and turn ignition switch ON.		
<b>Is "AIR BAG" fuse blown again?</b>		
Yes	▶	Repair main harness and/or replace air bag harness.
No	▶	INSPECTION END

# SUPPLEMENTAL RESTRAINT SYSTEM (SRS)

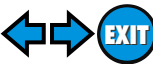

Trouble Diagnoses: "AIR BAG" Warning Lamp Does Not Turn Off (Cont'd)

<b>4</b>	<b>CHECK DIAGNOSIS SENSOR UNIT</b>									
<p>Ⓟ Connect CONSULT-II and touch "START".</p> <ul style="list-style-type: none"> <li>● Is "AIR BAG" displayed on CONSULT-II?</li> </ul>										
<table border="1" style="margin: auto;"> <tr><td>SELECT SYSTEM</td></tr> <tr><td>ENGINE</td></tr> <tr><td>A/T</td></tr> <tr><td>AIR BAG</td></tr> <tr><td>ABS</td></tr> <tr><td>SMART ENTRANCE</td></tr> <tr><td> </td></tr> <tr><td> </td></tr> </table>			SELECT SYSTEM	ENGINE	A/T	AIR BAG	ABS	SMART ENTRANCE		
SELECT SYSTEM										
ENGINE										
A/T										
AIR BAG										
ABS										
SMART ENTRANCE										
SRS696										
<b>Yes or No</b>										
Yes	▶	GO TO 5.								
No	▶	Visually check the wiring harness connection of diagnosis sensor unit. If the harness connection check result is OK, replace diagnosis sensor unit.								

GI  
MA  
EM  
LC  
EC  
FE  
CL  
MT  
AT  
AX  
SU  
BR  
ST  
RS  
BT  
HA  
SC  
EL  
IDX

<b>5</b>	<b>CHECK HARNESS CONNECTION</b>	
Is harness connection between warning lamp and diagnosis sensor unit OK?		
<b>OK or NG</b>		
OK	▶	Replace diagnosis sensor unit.
NG	▶	Connect "AIR BAG" warning lamp and diagnosis sensor unit connector properly. If "AIR BAG" warning lamp still does not go off, replace harness.

# SUPPLEMENTAL RESTRAINT SYSTEM (SRS)

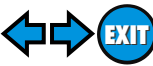

Trouble Diagnoses: "AIR BAG" Warning Lamp Does Not Turn On

## Trouble Diagnoses: "AIR BAG" Warning Lamp Does Not Turn On

### DIAGNOSTIC PROCEDURE 10

=NCRS0031

NCRS0031S01

<b>1</b>	<b>CHECK "METER" FUSE</b>	
Is meter fuse OK?		
SRS578		
<b>OK or NG</b>		
OK	▶	GO TO 3.
NG	▶	GO TO 2.

<b>2</b>	<b>CHECK "METER" FUSE AGAIN</b>	
Replace meter fuse and turn ignition switch ON.		
<b>Is meter fuse blown again?</b>		
Yes	▶	Repair main harness.
No	▶	INSPECTION END

<b>3</b>	<b>CHECK "AIR BAG" WARNING LAMP LED</b>	
Is "AIR BAG" warning lamp LED OK?		
<b>OK or NG</b>		
OK	▶	GO TO 4.
NG	▶	Replace "AIR BAG" warning lamp LED.

<b>4</b>	<b>CHECK HARNESS CONNECTION BETWEEN DIAGNOSIS SENSOR UNIT AND "AIR BAG" WARNING LAMP</b>	
Disconnect diagnosis sensor unit connector and turn ignition switch "ON".		
● Does "AIR BAG" warning lamp turn on?		
<b>Yes or No</b>		
Yes	▶	Replace diagnosis sensor unit.
No	▶	Check the ground circuit of "AIR BAG" warning lamp.

# SUPPLEMENTAL RESTRAINT SYSTEM (SRS)

Trouble Diagnoses: SRS Does Not Enter Diagnosis Mode Using Door Switch

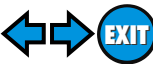

## Trouble Diagnoses: SRS Does Not Enter Diagnosis Mode Using Door Switch

### DIAGNOSTIC PROCEDURE 11

=NCRS0032

NCRS0032S01

<b>1</b>	<b>CHECK BATTERY VOLTAGE</b>	
Disconnect both battery cables and check battery voltage using circuit tester. ● Is battery voltage more than 9V?		
Yes or No		
Yes	▶	GO TO 2.
No	▶	Charge battery.

<b>2</b>	<b>CHECK DRIVER'S DOOR SWITCH</b>	
Remove driver's door switch and check continuity between driver's door switch connector terminals 2 and 3 under the following conditions.		
<p>Front door switch LH connector (B4)</p>		
<p><b>Continuity:</b>                  Door switch is depressed (Door is closed).                  NO                  Door switch is released (Door is open).                  YES</p>		
OK or NG		
OK	▶	GO TO 3.
NG	▶	Replace driver's door switch.

GI  
MA  
EM  
LC  
EC  
FE  
CL  
MT  
AT  
AX  
SU  
BR  
ST  
RS  
BT  
HA  
SC  
EL  
IDX

# SUPPLEMENTAL RESTRAINT SYSTEM (SRS)

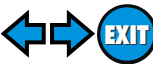

Trouble Diagnoses: SRS Does Not Enter Diagnosis Mode Using Door Switch (Cont'd)

<b>3</b>	<b>CHECK GROUND CIRCUIT FOR DRIVER'S DOOR SWITCH</b>	
<p>Check harness continuity between driver's door switch connector terminal 3 and body ground.</p> <ul style="list-style-type: none"> <li>Does continuity exist?</li> </ul>		
<p>Front door switch LH connector (B4)</p>		
SRS583		
<b>Yes or No</b>		
Yes	▶	Replace diagnosis sensor unit. Go to "SRS Operation Check" (RS-41).
No	▶	Replace or repair harness.

## Trouble Diagnoses: "SEAT BELT" Warning Lamp Does Not Turn Off DIAGNOSTIC PROCEDURE 12

NCRS0037

NCRS0037S01

<b>1</b>	<b>SEE THE DEPLOYMENT OF SEAT BELT PRE-TENSIONER</b>	
<p>Is seat belt pre-tensioner (and driver's and front passenger's air bags) deployed?</p>		
<b>Yes or No</b>		
Yes	▶	Refer to COLLISION DIAGNOSIS (RS-65).
No	▶	GO TO 2.

<b>2</b>	<b>CHECK THE STATUS OF SEAT BELT</b>	
<p>Is driver's seat belt fastened?</p>		
<b>Yes or No</b>		
Yes	▶	GO TO 3.
No	▶	Check "SEAT BELT" warning lamp operation after the seat belt is fastened.

# SUPPLEMENTAL RESTRAINT SYSTEM (SRS)

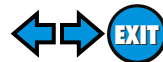

Trouble Diagnoses: "SEAT BELT" Warning Lamp Does Not Turn Off (Cont'd)

<b>3</b>	<b>CHECK DRIVER'S SEAT BELT BUCKLE SWITCH</b>
<p>1. Disconnect the seat belt buckle switch connector. 2. Check continuity between terminals 1 and 2.</p> <div style="text-align: center;"> <p>Seat belt buckle switch connector (B13)</p> </div> <p><b>Continuity</b>  <b>Seat belt is unfastened.</b>  <b>YES</b>  <b>Seat belt is fastened.</b>  <b>NO</b></p> <p><b>WARNING:</b>  <b>Do not measure resistance with harness side connector.</b></p> <p style="text-align: center;"><b>OK or NG</b></p>	
OK	▶ GO TO 4.
NG	▶ Replace the seat belt buckle switch.

<b>4</b>	<b>REPLACE DIAGNOSIS UNIT</b>
<p>1. Visually check the wiring harness connection. 2. Replace the diagnosis unit. 3. Fasten the seat belt. 4. Turn ignition switch to ON position. Does the "SEAT BELT" warning lamp illuminate for about 7 seconds and then turn off?</p> <p style="text-align: center;"><b>Yes or No</b></p>	
Yes	▶ System is OK.
No	▶ GO TO 5.

<b>5</b>	<b>REPLACE METER ASSEMBLY</b>
<p>1. Replace combination meter assembly. 2. Fasten the seat belt. 3. Turn ignition switch to ON position. Does the "SEAT BELT" warning lamp illuminate for about 7 seconds and then turn off?</p> <p style="text-align: center;"><b>Yes or No</b></p>	
Yes	▶ System is OK.
No	▶ Replace the main harness and air bag harness.

GI  
MA  
EM  
LC  
EC  
FE  
CL  
MT  
AT  
AX  
SU  
BR  
ST  
RS  
BT  
HA  
SC  
EL  
IDX

# SUPPLEMENTAL RESTRAINT SYSTEM (SRS)

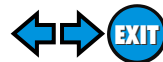

Trouble Diagnoses: "SEAT BELT" Warning Lamp Does Not Turn On

## Trouble Diagnoses: "SEAT BELT" Warning Lamp Does Not Turn On DIAGNOSTIC PROCEDURE 13

NCRS0038

NCRS0038S01

<b>1</b>	<b>CHECK "METER" FUSE</b>	
Is meter fuse OK?		
SRS578		
<b>OK or NG</b>		
OK	▶	GO TO 3.
NG	▶	GO TO 2.

<b>2</b>	<b>CHECK "METER" FUSE AGAIN</b>	
Replace meter fuse and turn ignition switch ON.		
<b>Is meter fuse blown again?</b>		
Yes	▶	Repair main harness.
No	▶	INSPECTION END

<b>3</b>	<b>CHECK WARNING LAMP BULB</b>	
Is warning lamp bulb OK?		
<b>OK or NG</b>		
OK	▶	GO TO 4.
NG	▶	Replace warning lamp bulb.

<b>4</b>	<b>REPLACE DIAGNOSIS UNIT</b>	
<ol style="list-style-type: none"> <li>1. Visually check the wiring harness connection.</li> <li>2. Replace the diagnosis unit.</li> <li>3. Fasten the seat belt.</li> <li>4. Turn ignition switch to ON position.</li> </ol> Does the "SEAT BELT" warning lamp illuminate for about 7 seconds and then turn off?		
<b>Yes or No</b>		
Yes	▶	System is OK.
No	▶	GO TO 5.



# SUPPLEMENTAL RESTRAINT SYSTEM (SRS)

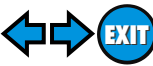

Trouble Diagnoses: "SEAT BELT" Warning Lamp Does Not Turn On (Cont'd)

<b>5</b>	<b>REPLACE METER ASSEMBLY</b>	
1. Replace combination meter assembly. 2. Fasten the seat belt. 3. Turn ignition switch to ON position. Does the "SEAT BELT" warning lamp illuminate for about 7 seconds and then turn off? <p style="text-align: center;"><b>Yes or No</b></p>		
Yes	▶	System is OK.
No	▶	Replace the main harness and air bag harness.

GI  
MA  
EM  
LC  
EC  
FE  
CL  
MT  
AT  
AX  
SU  
BR  
ST  
BT  
HA  
SC  
EL  
IDX

## Collision Diagnosis

NCRS0033

NCRS0033S01

### FOR FRONTAL COLLISION

To repair the SRS, perform the following steps.

#### When SRS (except the side air bag) is activated in a collision:

- 1) Replace the diagnosis sensor unit.
- 2) Remove the air bag modules (except the side air bag module) and seat belt pre-tensioner assemblies.
- 3) Check the SRS components using the table shown below:
  - Replace any SRS components showing visible signs of damage (dents, cracks and deformation).
- 4) Install new air bag modules (except the side air bag module) and seat belt pre-tensioner assemblies.
- 5) Conduct self-diagnosis using CONSULT-II or "AIR BAG" and "SEAT BELT" warning lamp. Refer to "SRS Operation Check" for details (RS-41). Ensure entire SRS operates properly.

#### When SRS is not activated in a collision:

- 1) Check the SRS components using the table shown below:
  - Replace any SRS components showing visible signs of damage (dents, cracks and deformation).
- 2) Conduct self-diagnosis using CONSULT-II or "AIR BAG" and "SEAT BELT" warning lamp. Refer to "SRS Operation Check" for details (RS-41). Ensure entire SRS operates properly.

### SRS Inspection (For frontal collision)

NCRS0033S0101

Part	SRS is activated	SRS is NOT activated
Air bag module (driver and passenger side)	REPLACE Install with new special bolts coated with bonding agent.	1. Remove air bag module. Check harness cover and connectors for damage, terminals for deformities, and harness for binding. 2. a. Install driver air bag module into the steering wheel to check fit and alignment with the wheel. b. Install passenger air bag module into the instrument panel to check fit with the instrument panel. 3. No damage found, reinstall with new bolts coated with bonding agent. 4. If damaged—REPLACE. Install air bag modules with new special bolts coated with bonding agent. Air bag must be deployed before discarding.
Seat belt pre-tensioner assembly	REPLACE Install seat belt pre-tensioner with new bolts.	1. Remove seat belt pre-tensioners. Check harness cover and connectors for damage, terminals for deformities, and harness for binding. 2. Check belts for damage and anchors for loose mounting. 3. Check retractor for smooth operation. 4. If no damage is found, reinstall with new bolts coated with bonding agent. 5. If damaged—REPLACE. Install the seat belt pre-tensioners with new bolts coated with bonding agent. Seat belt pre-tensioners must be deployed before discarding.
Diagnosis sensor unit	REPLACE Install with new bolts coated with bonding agent.	1. Check case for dents, cracks or deformities. 2. Check connectors for damage, and terminals for deformities. 3. If no damage is found, reinstall with new special bolts and ground bolt coated with bonding agent. 4. If damaged—REPLACE. Install diagnosis sensor unit with new special bolts and ground bolt coated with bonding agent.

# SUPPLEMENTAL RESTRAINT SYSTEM (SRS)

Collision Diagnosis (Cont'd)

Part	SRS is activated	SRS is NOT activated
Steering wheel	<ol style="list-style-type: none"> <li>1. Visually check steering wheel for deformities.</li> <li>2. Check harness (built into steering wheel) and connectors for damage, and terminals for deformities.</li> <li>3. Install air bag module to check fit or alignment with steering wheel.</li> <li>4. Check steering wheel for excessive free play.</li> <li>5. If no damage is found, reinstall with bolts.</li> <li>6. If damaged—REPLACE.</li> </ol>	
Spiral cable	<ol style="list-style-type: none"> <li>1. Visually check spiral cable and combination switch for damage.</li> <li>2. Check connectors and protective tape for damage.</li> <li>3. Check steering wheel for noise, binding or heavy operation.</li> <li>4. If no damage is found, reinstall with bolts.</li> <li>5. If damaged—REPLACE.</li> </ol>	
Harness and Connectors	<ol style="list-style-type: none"> <li>1. Check connectors for poor connection, damage, and terminals for deformities.</li> <li>2. Check harness for binding, chafing, cuts, or deformities.</li> <li>3. If no damage is found, reinstall the harness and connectors.</li> <li>4. Damaged—REPLACE damaged section of harness. Do not attempt to repair, splice or modify any SRS harness.</li> </ol>	
Instrument panel	<ol style="list-style-type: none"> <li>1. When passenger air bag inflates, check the following points for bending, deformities or cracks. <ul style="list-style-type: none"> <li>● Opening portion for passenger air bag <div data-bbox="711 768 1166 1031"> <p>● : Check points</p> </div> </li> <li>● Passenger air bag module brackets <div data-bbox="786 1104 1110 1377"> <p>● : Check points</p> </div> </li> <li>● The portions securing the instrument panel <div data-bbox="695 1436 1198 1692"> <p>● : Check points</p> </div> </li> </ul> </li> <li>2. If no damage is found, reinstall the instrument panel.</li> <li>3. If damaged—REPLACE the instrument panel with bolts.</li> </ol>	

SRS579

SRS580

SRS581

## FOR SIDE COLLISION

=NCRS0033S02

To repair the SRS for a side collision, perform the following steps.

### When the side air bag is activated in the side collision:

- 1) Replace the following component:
  - All parts of front seatback (including front seatback frame) with side air bag module (on the side on which side air bag is activated)
  - Diagnosis sensor unit
  - Satellite sensor (on the side on which side air bag is activated)
- 2) Check the SRS components and the related parts using the table shown below.
  - Replace any SRS components and the related parts showing visible signs of damage (dents, cracks, deformation).
- 3) Conduct self-diagnosis using CONSULT-II, and “AIR BAG” and “SEAT BELT” warning lamp. Refer to “SRS Operation Check” for details (RS-41). Ensure entire SRS operates properly.

GI

MA

EM

LC

EC

### When SRS is not activated in the side collision:

- 1) Check the SRS components and the related parts using the table shown below.
  - Replace any SRS components and the related parts showing visible signs of damage (dents, cracks, deformation).
- 2) Conduct self-diagnosis using CONSULT-II, and “AIR BAG” and “SEAT BELT” warning lamp. Refer to “SRS Operation Check” for details (RS-41). Ensure entire SRS operates properly.

FE

CL

### SRS Inspection (For side collision)

NCRS0033S0201

Part	Side air bag is activated	SRS is NOT activated
Built-in side air bags module (LH or RH)	REPLACE all parts of front seatback with deployed side air bag module.	<ol style="list-style-type: none"> <li>1. Check for visible signs of damage (dents, tears, deformation) of the seatback on the collision side.</li> <li>2. If damaged—REPLACE the damaged seat parts with new bolts and remove the side air bag module.</li> <li>3. Check for visible signs of damaged (tesrs etc.) of the side air bag module.</li> <li>4. Check harness and connectors for damage, and terminals for deformities.</li> <li>5. If no damaged is found, reinstall the side air bag module with new torx nuts coated with bonding agent.</li> <li>6. If damaged—REPLACE the side air bag module with new torx nuts coated with bonding agent. Air bag must be deployed before disposing of it.</li> </ol>
Satellite sensor (LH or RH)	REPLACE the satellite sensor on the collision side with new nuts coated with bonding agent. (Repair the center pillar inner, etc. before installing new one if damaged.)	<ol style="list-style-type: none"> <li>1. Remove the satellite sensor on the collision side. Check harness connectors for damage, terminals for deformities, and harness for binding.</li> <li>2. Check for visible signs of damage (dents, cracks, deformation) of the satellite sensor.</li> <li>3. Install the satellite sensor to check fit.</li> <li>4. If no damage is found, reinstall the satellite sensor with new nuts coated with bonding agent.</li> <li>5. If damaged—REPLACE the satellite sensor with new nuts coated with bonding agent.</li> </ol>
Diagnosis sensor unit	REPLACE the diagnosis sensor unit with the new bolts.	<ol style="list-style-type: none"> <li>1. Check case and bracket for dents, cracks or deformities.</li> <li>2. Check connectors for damage, and terminals for deformities.</li> <li>3. If no damage is found, reinstall the diagnosis sensor unit with new special bolts and ground bolt.</li> <li>4. If damaged—REPLACE. Install the diagnosis sensor unit with new special bolts and ground bolt.</li> </ol>

MT

AT

AX

SU

BR

ST

RS

BT

HA

SC

EL

IDX

## SUPPLEMENTAL RESTRAINT SYSTEM (SRS)

### Collision Diagnosis (Cont'd)

Part	Side air bag is activated	SRS is NOT activated
Seat belt pre-tensioner assembly	<ol style="list-style-type: none"> <li>1. Check if the seat belt can be extended smoothly. If the seat belt cannot be extended smoothly.               <ul style="list-style-type: none"> <li>– Check for deformities of the center pillar inner.</li> <li>– If the center pillar inner has no damage, REPLACE the seat belt pre-tensioner assembly.</li> </ul> </li> <li>2. Remove the seat belt pre-tensioner assembly on the collision side. Check harness cover and connectors for damage, terminals for deformities, and harness for binding.</li> <li>3. Check for visible signs of damage (dents, cracks, deformation) of the seat belt pre-tensioner assembly.</li> <li>4. If no damage is found, reinstall the seat belt pre-tensioner assembly with new bolts coated with bonding agent.</li> <li>5. If damaged—REPLACE the seat belt pre-tensioner assembly with new bolts coated with bonding agent. The seat belt pre-tensioner assembly must be deployed before disposing of it.</li> </ol>	
Seat with built-in side air bag	REPLACE all parts of front seatback (including front seatback frame)	<ol style="list-style-type: none"> <li>1. Visually check the seat on the collision side.</li> <li>2. Remove the seat on the collision side and check the following for damage and deformities.               <ul style="list-style-type: none"> <li>● Harness, connectors and terminals</li> <li>● Frame and recliner (for front and rear seat), and also adjuster and slides (for front seat)</li> </ul> </li> <li>3. If no damage is found, reinstall the seat.</li> <li>4. If damaged—REPLACE the damaged seat parts with new bolts.</li> </ol>
Center pillar inner	<ol style="list-style-type: none"> <li>1. Check the center pillar inner on the collision side for damage (dents, cracks, deformation).</li> <li>2. If damaged—REPAIR the center pillar inner.</li> </ol>	
Trim	<ol style="list-style-type: none"> <li>1. Check for visible signs of damage (dents, cracks, deformation) of the interior trim on the collision side.</li> <li>2. If damaged—REPLACE the damaged trim parts.</li> </ol>	