

LT
SECTION
LIGHTING SYSTEM

A
B
C
D
E
F
G
H
I
J
LT
L
M

CONTENTS

<p>PRECAUTIONS 5</p> <p> Precautions for Supplemental Restraint System (SRS) "AIR BAG" and "SEAT BELT PRE-TENSIONER" 5</p> <p> Precautions for Battery Service 5</p> <p> General Precautions for Service Operations 5</p> <p> Wiring Diagrams and Trouble Diagnosis 6</p> <p>HEADLAMP (FOR USA) 7</p> <p> Component Parts and Harness Connector Location... 7</p> <p> System Description 7</p> <p> OUTLINE 7</p> <p> HEADLAMP OPERATION 8</p> <p> COMBINATION SWITCH READING FUNCTION... 9</p> <p> EXTERIOR LAMP BATTERY SAVER CONTROL... 9</p> <p> AUTO LIGHT OPERATION 9</p> <p> VEHICLE SECURITY SYSTEM 9</p> <p> XENON HEADLAMP 9</p> <p> CAN Communication System Description 9</p> <p> CAN Communication Unit 9</p> <p> Schematic 10</p> <p> Wiring Diagram — H/LAMP — 11</p> <p> Terminals and Reference Values for BCM 15</p> <p> Terminals and Reference Values for IPDM E/R 16</p> <p> How to Proceed With Trouble Diagnosis 16</p> <p> Preliminary Check 17</p> <p> CHECK POWER SUPPLY AND GROUND CIRCUIT 17</p> <p> CONSULT-II Functions (BCM) 18</p> <p> CONSULT-II BASIC OPERATION 18</p> <p> WORK SUPPORT 19</p> <p> DATA MONITOR 19</p> <p> ACTIVE TEST 20</p> <p> CONSULT-II Functions (IPDM E/R) 21</p> <p> CONSULT-II OPERATION 21</p> <p> SELF-DIAGNOSTIC RESULTS 22</p> <p> DATA MONITOR 22</p> <p> ACTIVE TEST 23</p> <p> Headlamp High Beam Does Not Illuminate (Both Sides) 23</p> <p> Headlamp High Beam Does Not Illuminate (One</p>	<p>Side) 25</p> <p> High Beam Indicator Lamp Does Not Illuminate 27</p> <p> Headlamp Low Beam Does Not Illuminate (Both Sides) 27</p> <p> Headlamp Low Beam Does Not Illuminate (One Side) 29</p> <p> Headlamps Does Not Turn OFF 30</p> <p> CAUTION: 32</p> <p> Xenon Headlamp Trouble Diagnosis 32</p> <p> Aiming Adjustment 33</p> <p> PREPARATION BEFORE ADJUSTING 33</p> <p> LOW BEAM AND HIGH BEAM 33</p> <p> ADJUSTMENT USING AN ADJUSTMENT SCREEN (LIGHT/DARK BORDERLINE) 34</p> <p> Bulb Replacement 34</p> <p> HEADLAMP (UPPER) LOW BEAM 34</p> <p> HEADLAMP (LOWER) HIGH BEAM/FOG LAMP.. 34</p> <p> PARKING LAMP (CLEARANCE LAMP) 35</p> <p> FRONT TURN SIGNAL AND PARKING LAMP... 35</p> <p> Removal and Installation 35</p> <p> REMOVAL 35</p> <p> INSTALLATION 35</p> <p> Disassembly 36</p> <p> Assembly 36</p> <p> Servicing to Replace Headlamps When Damaged.. 37</p> <p> REMOVAL AND INSTALLATION 37</p> <p>HEADLAMP (FOR CANADA) - DAYTIME LIGHT SYSTEM - 38</p> <p> Component Parts and Harness Connector Location.. 38</p> <p> System Description 38</p> <p> HEADLAMP OPERATION 39</p> <p> COMBINATION SWITCH READING FUNCTION.. 40</p> <p> EXTERIOR LAMP BATTERY SAVER CONTROL.. 40</p> <p> AUTO LIGHT OPERATION 40</p> <p> DAYTIME LIGHT OPERATION 41</p> <p> OPERATION 41</p> <p> XENON HEADLAMP 42</p> <p> CAN Communication System Description 42</p> <p> CAN Communication Unit 42</p> <p> Schematic 43</p>
---	---

Wiring Diagram — DTRL —	44	ACTIVE TEST	83
Terminals and Reference Values for Daytime Light Control Unit	50	CONSULT-II Functions (IPDM E/R)	84
Terminals and Reference Values for BCM	51	CONSULT-II OPERATION	84
Terminals and Reference Values for IPDM E/R	52	SELF-DIAGNOSTIC RESULTS	85
How to Proceed With Trouble Diagnosis	52	DATA MONITOR	85
Preliminary Check	53	ACTIVE TEST	85
CHECK POWER SUPPLY AND GROUND CIRCUIT	53	Trouble Diagnosis Chart by Symptom	86
CONSULT-II Functions (BCM)	54	Lighting Switch Inspection	86
CONSULT-II BASIC OPERATION	54	Optical Sensor System Inspection	87
WORK SUPPORT	55	Removal and Installation for Optical Sensor	88
DATA MONITOR	55	REMOVAL	88
ACTIVE TEST	56	INSTALLATION	88
CONSULT-II Functions (IPDM E/R)	57	FRONT FOG LAMP	89
CONSULT-II OPERATION	57	Component Parts and Harness Connector Location	89
SELF-DIAGNOSTIC RESULTS	58	System Description	89
DATA MONITOR	58	OUTLINE	89
ACTIVE TEST	58	COMBINATION SWITCH READING FUNCTION	91
Daytime Light Control Does Not Operate Properly	59	EXTERIOR LAMP BATTERY SAVER CONTROL	91
Headlamp High Beam Does Not Illuminate (Both Sides)	61	CAN Communication System Description	91
RH High Beam Does Not Illuminate But RH Low Beam Illuminates	63	CAN Communication Unit	91
LH High Beam Does Not Illuminate But LH Low Beam Illuminates	65	Wiring Diagram — F/FOG —	92
Headlamp Low Beam Does Not Illuminate (Both Sides)	67	FOR USA	92
RH Low Beam Does Not Illuminate But RH High Beam Illuminates	69	FOR CANADA	94
LH Low Beam Does Not Illuminate But LH High Beam Illuminates	70	Terminals and Reference Values for BCM	96
Aiming Adjustment	70	Terminals and Reference Values for IPDM E/R	97
Bulb Replacement	70	How to Proceed With Trouble Diagnosis	97
Removal and Installation	70	Preliminary Check	97
Disassembly and Assembly	70	CHECK POWER SUPPLY AND GROUND CIRCUIT	97
AUTO LIGHT SYSTEM	71	CONSULT-II Functions	98
Component Parts and Harness Connector Location	71	Front Fog lamps Does Not Illuminate (Both Sides) (FOR USA)	99
System Description	71	Front Fog Lamp Does Not Illuminate (One Side) (FOR USA)	101
OUTLINE	71	Front Fog lamps Does Not Illuminate (Both Sides) (For CANADA)	102
COMBINATION SWITCH READING FUNCTION	72	LH Front Fog Lamp Does Not Illuminate (FOR CANADA)	103
EXTERIOR LAMP BATTERY SAVER CONTROL	72	RH Front Fog Lamp Does Not Illuminate (FOR CANADA)	105
DELAY TIMER FUNCTION	72	Bulb Replacement	106
CAN Communication System Description	72	TURN SIGNAL AND HAZARD WARNING LAMPS.107	
CAN Communication Unit	72	Component Parts and Harness Connector Location	107
Major Components and Functions	72	System Description	107
Schematic	73	TURN SIGNAL OPERATION	107
Wiring Diagram — AUTO/L —	74	HAZARD LAMP OPERATION	108
Terminals and Reference Values for BCM	77	REMOTE KEYLESS ENTRY SYSTEM OPERATION	108
Terminals and Reference Values for IPDM E/R	78	COMBINATION SWITCH READING FUNCTION	109
How to Proceed With Trouble Diagnosis	79	CAN Communication System Description	109
Preliminary Check	79	CAN Communication Unit	109
SETTING CHANGE FUNCTIONS	79	Schematic	110
CHECK POWER SUPPLY AND GROUND CIRCUIT	79	Wiring Diagram — TURN —	111
CONSULT-II Functions (BCM)	81	Terminals and Reference Value for BCM	114
CONSULT-II BASIC OPERATION	81	How to Proceed With Trouble Diagnosis	115
WORK SUPPORT	82	Preliminary Check	116
DATA MONITOR	82	CHECK POWER SUPPLY AND GROUND CIRCUIT	116
		CONSULT-II Functions	117

CONSULT-II BASIC OPERATION	117	Schematic	140
DATA MONITOR	118	Wiring Diagram — TAIL/L —	141
ACTIVE TEST	118	Terminals and Reference Value for BCM	145
Turn Signal Lamp Does Not Operate	119	Terminals and Reference Values for IPDM E/R ...	146
Hazard Warning Lamp Does Not Operate But Turn		How to Proceed With Trouble Diagnosis	146
Signal Lamp Operates	120	Preliminary Check	146
Turn Signal Indicator Lamp Does Not Operate ...	121	CHECK POWER SUPPLY AND GROUND CIR-	
Bulb Replacement (Front Turn Signal Lamp)	121	CUIT	146
Bulb Replacement (Rear Turn Signal Lamp)	121	CONSULT-II Functions	147
Removal and Installation of Front Turn Signal Lamp	122	Parking, License Plate and Tail Lamps Do Not Illu-	
Removal and Installation of Rear Turn Signal Lamp	122	minate	148
LIGHTING AND TURN SIGNAL SWITCH	123	Parking, License Plate and Tail Lamps Do Not Turn	
Removal and Installation	123	OFF (After Approx. 10 Minutes)	153
REMOVAL	123	Bulb Replacement	153
INSTALLATION	123	FRONT SIDE MARKER LAMP	153
HAZARD SWITCH	124	LICENSE PLATE LAMP	153
Removal and Installation (M/T)	124	FRONT TURN SIGNAL (PARKING) LAMP	153
REMOVAL	124	TAIL LAMP	153
INSTALLATION	124	Removal and Installation	153
Removal and Installation (A/T)	124	FRONT SIDE MARKER LAMP	153
REMOVAL	124	LICENSE PLATE LAMP	154
INSTALLATION	124	FRONT TURN SIGNAL (PARKING) LAMP	154
COMBINATION SWITCH	125	TAIL LAMP	154
Wiring Diagram — COMBSW —	125	REAR COMBINATION LAMP	155
Combination Switch Reading Function	126	Bulb Replacement	155
CONSULT-II Function	126	REAR FENDER SIDE (REAR TURN SIGNAL	
CONSULT-II BASIC OPERATION	126	LAMP BULB)	155
DATA MONITOR	127	Removal and Installation	155
Combination Switch Inspection	128	REMOVAL	155
Removal and Installation	130	INSTALLATION	155
STOP LAMP	131	VANITY MIRROR LAMP	156
Wiring Diagram — STOP/L —	131	Bulb Replacement	156
Bulb Replacement of High-mounted Stop Lamp .	133	MAP LAMP	157
WITH REAR SPOILER	133	Bulb Replacement of Map Lamp	157
WITHOUT REAR SPOILER	133	Removal and Installation of Map Lamp	157
Bulb Replacement of Rear Combination Lamp (Stop		REMOVAL	157
Lamp)	133	INSTALLATION	157
Removal and Installation of High-mounted Stop		TRUNK ROOM LAMP	158
Lamp	133	Bulb Replacement, Removal and Installation of	
REMOVAL (WITH REAR SPOILER)	133	Trunk Room Lamp	158
INSTALLATION	133	IGNITION KEY HOLE ILLUMINATION	159
REMOVAL (WITHOUT REAR SPOILER)	133	Removal and Installation	159
INSTALLATION	133	REMOVAL	159
Removal and Installation of Rear Combination		INSTALLATION	159
Lamp (Stop Lamp)	133	GLOVE BOX LAMP	160
BACK-UP LAMP	134	Removal and Installation	160
Wiring Diagram — BACK/L —	134	REMOVAL	160
A/T MODELS	134	INSTALLATION	160
M/T MODELS	135	ASHTRAY ILLUMINATION	161
Bulb Replacement	136	Bulb Replacement, Removal and Installation (M/T)	161
Removal and Installation	136	Bulb Replacement, Removal and Installation (A/T)	161
PARKING, LICENSE PLATE AND TAIL LAMPS ..	137	CIGARETTE LIGHTER ILLUMINATION	162
Component Parts and Harness Connector Location	137	Removal and Installation	162
System Description	137	INTERIOR ROOM LAMP	163
OPERATION BY LIGHTING SWITCH	138	Component Parts and Harness Connector Location	163
COMBINATION SWITCH READING FUNCTION	138	System Description	163
EXTERIOR LAMP BATTERY SAVER CONTROL	139	POWER SUPPLY AND GROUND	163
CAN Communication System Description	139	SWITCH OPERATION	164
CAN Communication Unit	139	ROOM LAMP TIMER OPERATION	164

A
B
C
D
E
F
G
H
I
J
LT
L
M

INTERIOR LAMP BATTERY SAVER CONTROL	165	All Interior Room Lamps Do Not Operate	180
Schematic	166	Removal and Installation	181
Wiring Diagram — ROOM/L —	167	MAP LAMP	181
Terminals and Reference Values for BCM	172	STEP LAMP	181
How to Proceed With Trouble Diagnosis	172	ILLUMINATION	182
Preliminary Check	173	System Description	182
CHECK FOR POWER SUPPLY AND GROUND		ILLUMINATION OPERATION BY LIGHTING	
CIRCUIT	173	SWITCH	182
CONSULT-II Functions	174	EXTERIOR LAMP BATTERY SAVER CONTROL	183
CONSULT-II BASIC OPERATION	174	CAN Communication System Description	183
WORK SUPPORT	175	CAN Communication Unit	183
DATA MONITOR	175	Schematic	184
ACTIVE TEST	176	Wiring Diagram — ILL —	185
Map Lamp Control Does Not Operate	176	Removal and Installation	193
Ignition Key Hole Illumination Control Does Not Operate	178	GLOVE BOX LAMP	193
All Step Lamps Do Not Operate	179	BULB SPECIFICATIONS	194
		Headlamp	194
		Exterior Lamp	194
		Interior Lamp/Illumination	194

PRECAUTIONS

PRECAUTIONS

PF0:00011

Precautions for Supplemental Restraint System (SRS) “AIR BAG” and “SEAT BELT PRE-TENSIONER”

AKS00AIG

The Supplemental Restraint System such as “AIR BAG” and “SEAT BELT PRE-TENSIONER”, used along with a front seat belt, helps to reduce the risk or severity of injury to the driver and front passenger for certain types of collision. This system includes seat belt switch inputs and dual stage front air bag modules. The SRS system uses the seat belt switches to determine the front air bag deployment, and may only deploy one front air bag, depending on the severity of a collision and whether the front occupants are belted or unbelted. Information necessary to service the system safely is included in the SRS and SB section of this Service Manual.

WARNING:

- To avoid rendering the SRS inoperative, which could increase the risk of personal injury or death in the event of a collision which would result in air bag inflation, all maintenance must be performed by an authorized NISSAN/INFINITI dealer.
- Improper maintenance, including incorrect removal and installation of the SRS, can lead to personal injury caused by unintentional activation of the system. For removal of Spiral Cable and Air Bag Module, see the SRS section.
- Do not use electrical test equipment on any circuit related to the SRS unless instructed to in this Service Manual. SRS wiring harnesses can be identified by yellow and/or orange harnesses or harness connectors.

Precautions for Battery Service

AKS00B6E

Before disconnecting the battery, lower both the driver and passenger windows. This will prevent any interference between the window edge and the vehicle when the door is opened/closed. During normal operation, the window slightly raises and lowers automatically to prevent any window to vehicle interference. The automatic window function will not work with the battery disconnected.

General Precautions for Service Operations

AKS00AII

- Never work with wet hands.
- Xenon headlamp includes high voltage generating part. Be sure to disconnect battery negative cable (negative terminal) or power fuse before removing, installing, or touching the xenon headlamp (including lamp bulb).
- Turn the lighting switch OFF before disconnecting and connecting the connector.
- When turning the xenon headlamp on and while it is illuminated, never touch the harness, bulb, and socket of the headlamp.
- When checking the headlamp on/off operation, check it on vehicle and with the power connected to the vehicle-side connector.
- Do not touch the headlamp bulb glass surface with bare hands or allow oil or grease to get on it. Do not touch the headlamp bulb just after the headlamp is turned off, because it is very hot.
- Install the xenon headlamp bulb socket correctly. If it is installed improperly, high-voltage leak or corona discharge may occur that can melt the bulb, connector, and housing. Do not illuminate the xenon headlamp bulb out of the headlamp housing. Doing so can cause fire and harm your eyes.
- When the bulb has burned out, wrap it in a thick vinyl bag and discard. Do not break the bulb.
- Leaving the bulb removed from the headlamp housing for a long period of time can deteriorate the performance of the lens and reflector (dirt, clouding). Always prepare a new bulb and have it on hand when replacing the bulb.
- When adjusting the headlamp aiming, turn the aiming adjustment screw only in the tightening direction. (If it is necessary to loosen the screw, first fully loosen the screw, and then turn it in the tightening direction.)
- Do not use organic solvent (paint thinner or gasoline) to clean lamps and to remove old sealant.

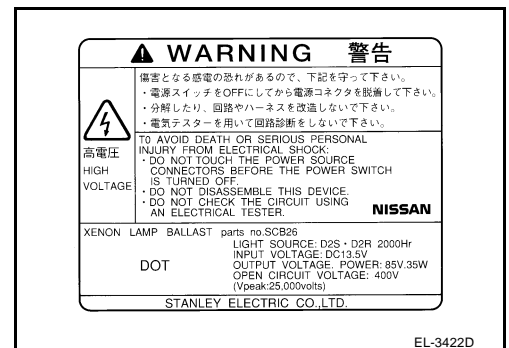
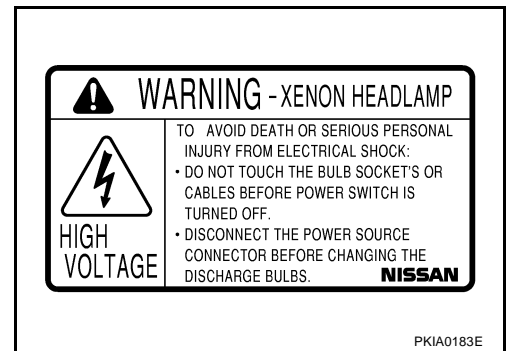

PRECAUTIONS

Wiring Diagrams and Trouble Diagnosis

AKS00AJ

When you read wiring diagrams, refer to the following:

- Refer to [GI-15, "How to Read Wiring Diagrams"](#) in GI section.
- Refer to [PG-4, "POWER SUPPLY ROUTING CIRCUIT"](#) for power distribution in PG section.

When you perform trouble diagnosis, refer to the following:

- Refer to [GI-11, "HOW TO FOLLOW TEST GROUPS IN TROUBLE DIAGNOSES"](#) in GI section.
- Refer to [GI-27, "How to Perform Efficient Diagnosis for an Electrical Incident"](#) in GI section.

HEADLAMP (FOR USA)

HEADLAMP (FOR USA)

PFP:26010

Component Parts and Harness Connector Location

AKS00AC6

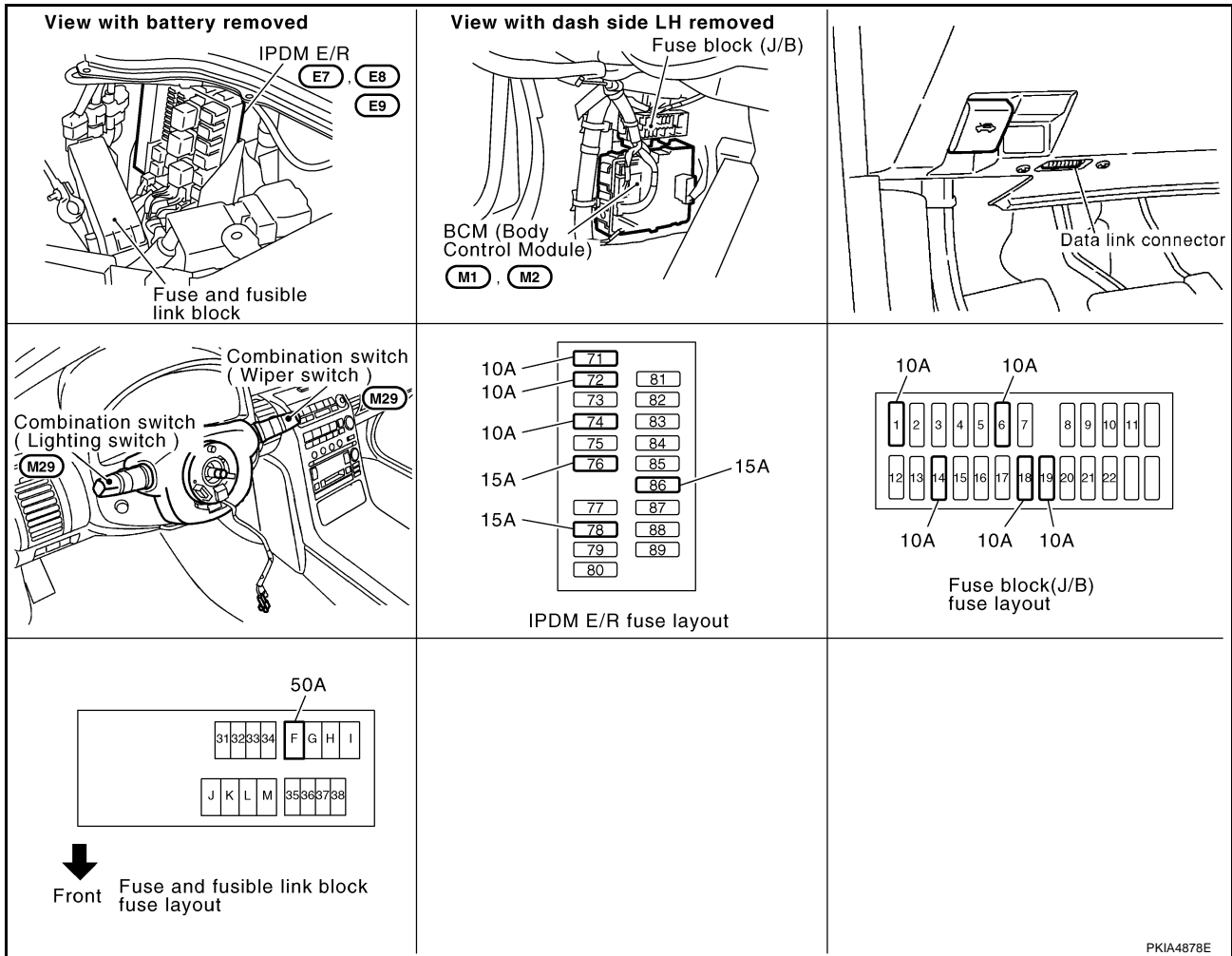

PKIA4878E

System Description

AKS00AC7

Control of the headlamp system operation is dependent upon the position of the combination switch (lighting switch). When the lighting switch is placed in the 2ND position, the BCM (body control module) receives input signal requesting the headlamps (and tail lamps) illuminate. This input signal is communicated to the IPDM E/R (intelligent power distribution module engine room) across the CAN communication lines. The CPU (central processing unit) of the IPDM E/R (intelligent power distribution module engine room) controls the headlamp high and headlamp low relay coils. These relays, when energized, direct power to the respective headlamps, which then illuminate.

If voltage is applied to a high beam solenoid, the bulb shade will move, even a xenon head lamp bulb comes out, and a high beam and a low beam are changed.

OUTLINE

Power is supplied at all times

- to headlamp high relay, [located in IPDM E/R (intelligent power distribution module engine room)],
- to headlamp low relay, [located in IPDM E/R (intelligent power distribution module engine room)], and
- to ignition relay, [located in IPDM E/R (intelligent power distribution module engine room)]
- through 10A fuse [No. 71 located in IPDM E/R (intelligent power distribution module engine room)]
- to CPU (central processing unit) [located in IPDM E/R (intelligent power distribution module engine room)]
- through 15A fuse [No. 78 located in IPDM E/R (intelligent power distribution module engine room)]
- to CPU (central processing unit) [located in IPDM E/R (intelligent power distribution module engine room)]
- through 50A fusible link (letter F, located in fuse and fusible link block)
- to BCM (body control module) terminal 55

A
B
C
D
E
F
G
H
I
J

LT

L
M

HEADLAMP (FOR USA)

- through 10A fuse [No. 18 located in fuse block (J/B)]
- to BCM (body control module) terminal 42
- through 10A fuse [No. 19, located in fuse block (J/B)]
- to combination meter terminal 43.

With the ignition switch in the ON or START position, power is supplied

- to ignition relay, [located in IPDM E/R (intelligent power distribution module engine room)]
- through 10A fuse [No. 1, located in fuse block (J/B)]
- to BCM (body control module) terminal 38
- through 10A fuse [No. 14, located in fuse block (J/B)]
- to combination meter terminals 41 and 42.

With the ignition switch in the ACC or ON position, power is supplied

- through 10A fuse [No. 6, located in fuse block (J/B)]
- to BCM (body control module) terminal 11.

Ground is supplied

- to BCM (body control module) terminal 52
- through grounds M30 and M66
- to IPDM E/R (intelligent power distribution module engine room) terminals 38 and 60
- through grounds E17 and E43
- to combination meter terminals 45 and 46
- through grounds M30 and M66.

HEADLAMP OPERATION

Low Beam Operation

With the lighting switch in 2ND position, the BCM receives input signal requesting the headlamps to illuminate. This input signal is communicated to the IPDM E/R across the CAN communication lines. The CPU in the IPDM E/R controls the headlamp low relay coil, which when energized, directs power

- to 15A fuse [No. 76, located in IPDM E/R]
- through IPDM E/R terminal 20
- to headlamp RH terminal 3, and
- to 15A fuse [No. 86, located in IPDM E/R]
- through IPDM E/R terminal 30
- to headlamp LH terminal 3.

Ground is supplied

- to headlamp RH terminal 4
- through grounds E17 and E43
- to headlamp LH terminal 4
- through grounds E17 and E43.

With power and ground supplied, low beam headlamps illuminate.

High Beam Operation/Flash-to-Pass Operation

With the lighting switch in 2ND position and placed in HIGH or PASS position, the BCM receives input signal requesting the headlamp high beams to illuminate. This input signal is communicated to the IPDM E/R across the CAN communication lines. The CPU in the IPDM E/R controls the headlamp high relay coil and low relay coil, which when energized, directs power

- to 15A fuse [No. 76, located in IPDM E/R]
- through IPDM E/R terminal 20
- to headlamp RH terminal 3, and
- to 15A fuse [No. 86, located in IPDM E/R]
- through IPDM E/R terminal 30
- to headlamp LH terminal 3
- to 10A fuse [No. 72, located in IPDM E/R]

HEADLAMP (FOR USA)

- through IPDM E/R terminal 27
- to headlamp RH terminal 2, and
- to 10A fuse [No. 74, located in IPDM E/R]
- through IPDM E/R terminal 28
- to headlamp LH terminal 2.

Ground is supplied

- to headlamp RH terminals 4 and 8
- through grounds E17 and E43
- to headlamp LH terminals 4 and 8
- through grounds E17 and E43.

With power and ground supplied, the high beam headlamps illuminate.

If voltage is applied to a high beam solenoid, the bulb shade will move, even a xenon head lamp bulb comes out, and a high beam and a low beam are changed.

The unified meter and A/C amp that received the high beam request signal by BCM across the CAN communication makes a high beam indicator lamp turn on in combination meter.

COMBINATION SWITCH READING FUNCTION

Refer to [BCS-3, "COMBINATION SWITCH READING FUNCTION"](#) .

EXTERIOR LAMP BATTERY SAVER CONTROL

When the combination switch (lighting switch) is in the 2ND position (ON), and the ignition switch is turned from ON or ACC to OFF, the battery saver control function is activated.

Under this condition, the headlamps remain illuminated for 5 minutes, then the headlamps are turned off.

Exterior lamp battery saver control mode can be changed by the function setting of CONSULT-II.

AUTO LIGHT OPERATION

Refer to [LT-71, "System Description"](#) in "AUTO LIGHT SYSTEM".

VEHICLE SECURITY SYSTEM

The vehicle security system will flash the high beams if the system is triggered. Refer to [BL-93, "VEHICLE SECURITY \(THEFT WARNING\) SYSTEM"](#) .

XENON HEADLAMP

Xenon type headlamp is adopted to the low beam headlamps. Xenon bulbs do not use a filament. Instead, they produce light when a high voltage current is passed between two tungsten electrodes through a mixture of xenon (an inert gas) and certain other metal halides. In addition to added lighting power, electronic control of the power supply gives the headlamps stable quality and tone color.

Following are some of the many advantages of the xenon type headlamp.

- The light produced by the headlamps is a white color comparable to sunlight that is easy on the eyes.
- Light output is nearly double that of halogen headlamps, affording increased area of illumination.
- The light features a high relative spectral distribution at wavelengths to which the human eye is most sensitive. This means that even in the rain, more light is reflected back from the road surface toward the vehicle, for added visibility.
- Power consumption is approximately 25 percent less than halogen headlamps, reducing battery load.

CAN Communication System Description

AKS00AC8

CAN (Controller Area Network) is a serial communication line for real time application. It is an on-vehicle multiplex communication line with high data communication speed and excellent error detection ability. Many electronic control units are equipped onto a vehicle, and each control unit shares information and links with other control units during operation (not independent). In CAN communication, control units are connected with 2 communication lines (CAN H line, CAN L line) allowing a high rate of information transmission with less wiring. Each control unit transmits/receives data but selectively reads required data only.

CAN Communication Unit

AKS00AC9

Refer to [LAN-4, "CAN Communication Unit"](#) .

HEADLAMP (FOR USA)

Schematic

AKS00ACA

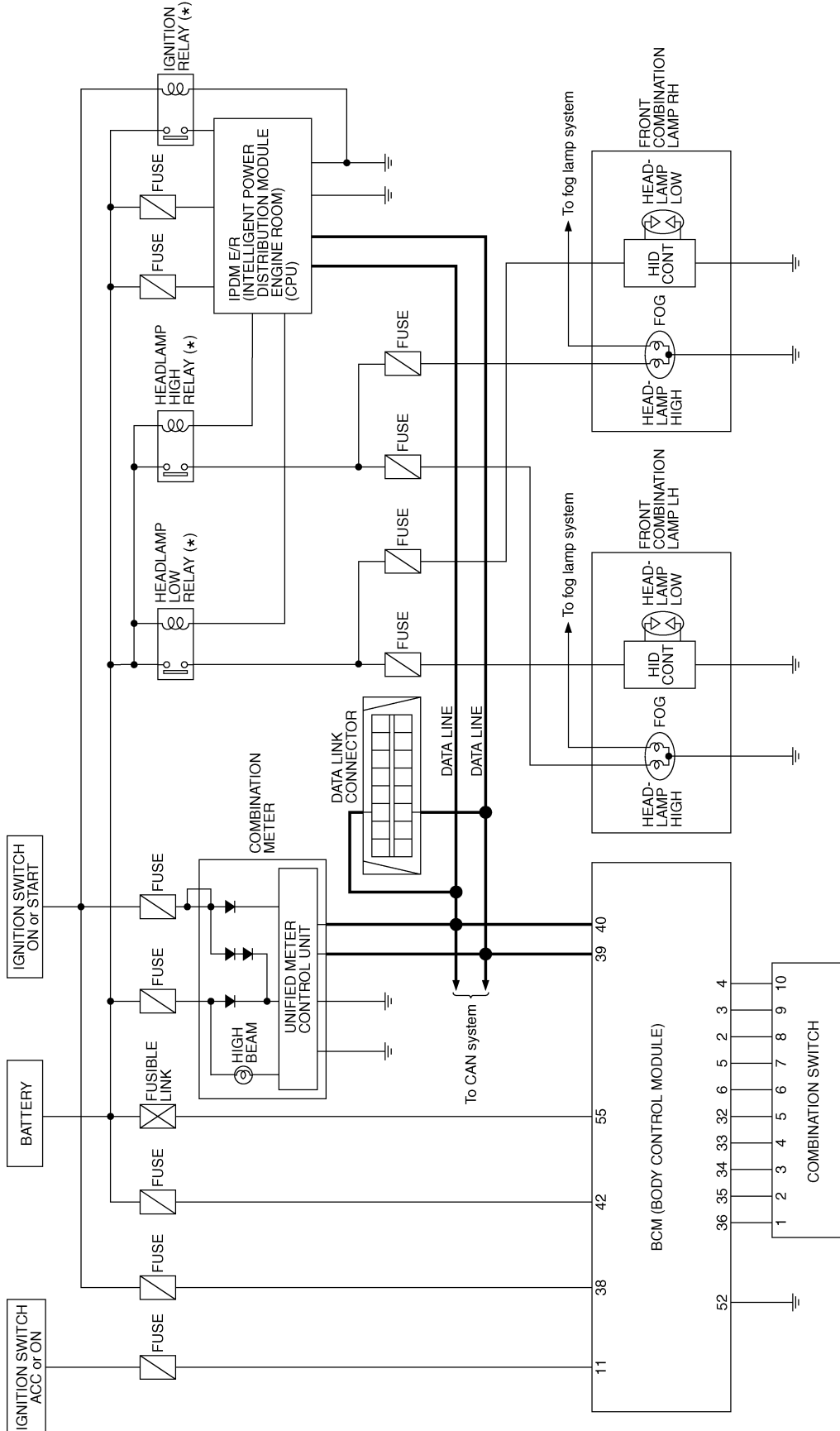

* : This relay is built into the IPDM E/R (Intelligent power distribution module engine room).

TKWM0847E

HEADLAMP (FOR USA)

Wiring Diagram — H/LAMP —

AKS00ACB

LT-H/LAMP-01

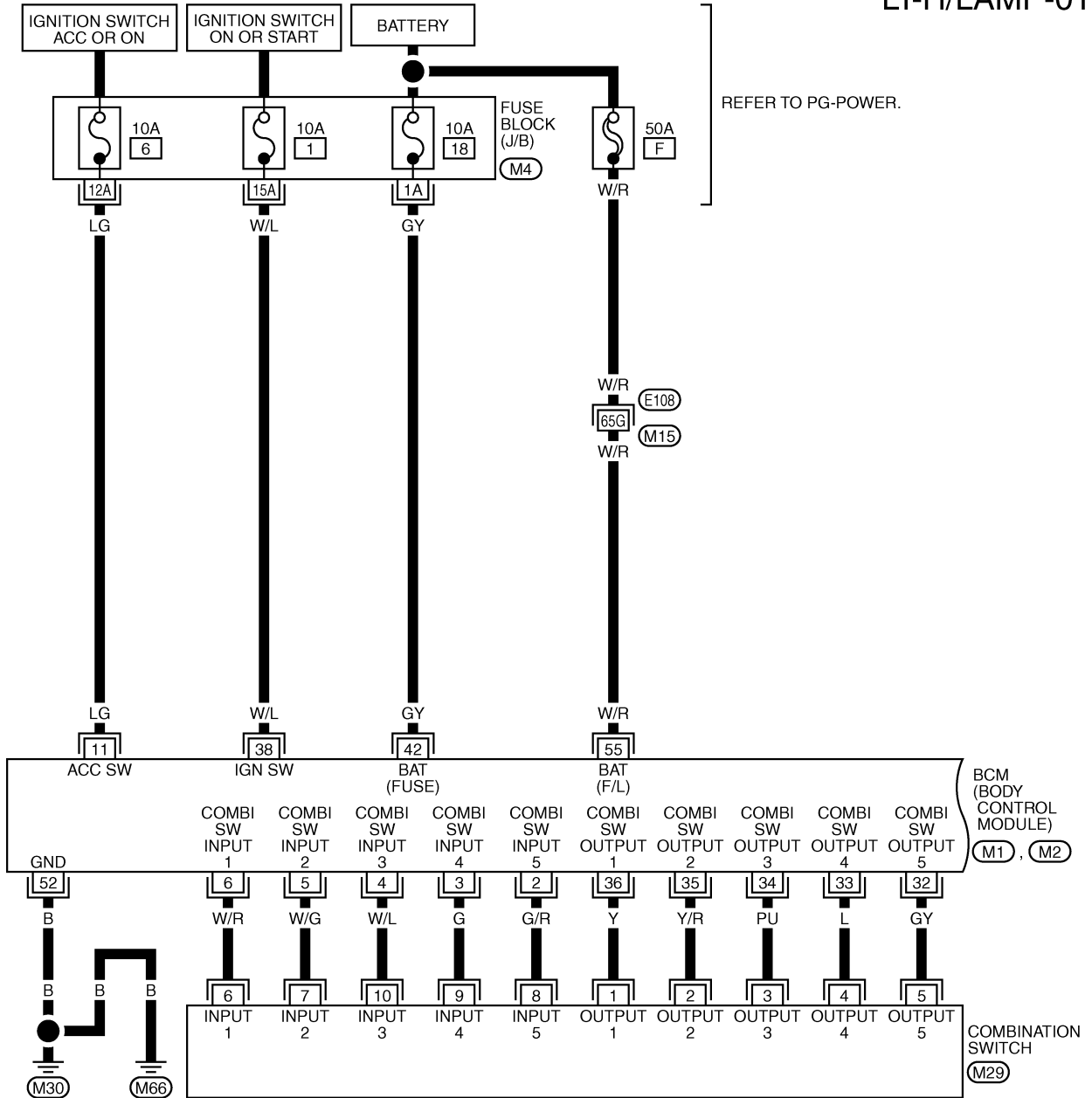

7	8	9	10	13	12
6	5	4	3	2	1

(M29) W

REFER TO THE FOLLOWING.

(E108) -SUPER MULTIPLE JUNCTION (SMJ)

(M4) -FUSE BLOCK-JUNCTION BOX (J/B)

(M1), (M2) -ELECTRICAL UNITS

TKWM0848E

HEADLAMP (FOR USA)

LT-H/LAMP-02

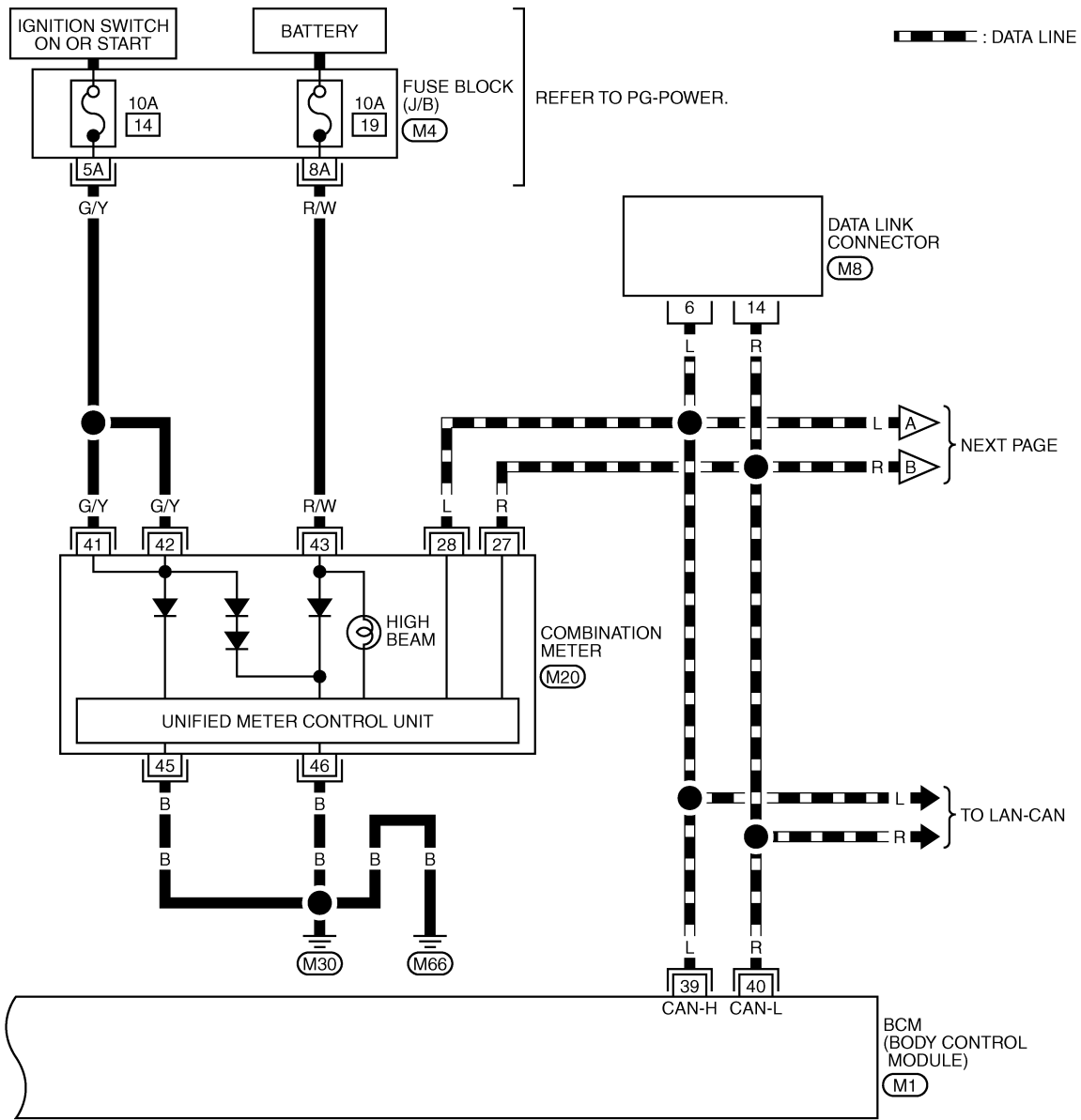

16	15	14	13	12	11	10	9
8	7	6	5	4	3	2	1

(M8)
W

25	26	27	28	29	30	31	32	33	34	35		
36	37	38	39	40	41	42	43	44	45	46	47	48

(M20)
W

REFER TO THE FOLLOWING.

(M4) - FUSE BLOCK-JUNCTION BOX (J/B)

(M1) - ELECTRICAL UNITS

HEADLAMP (FOR USA)

LT-H/LAMP-03

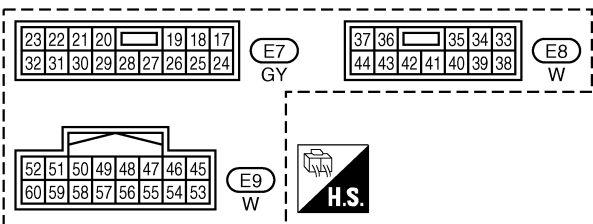
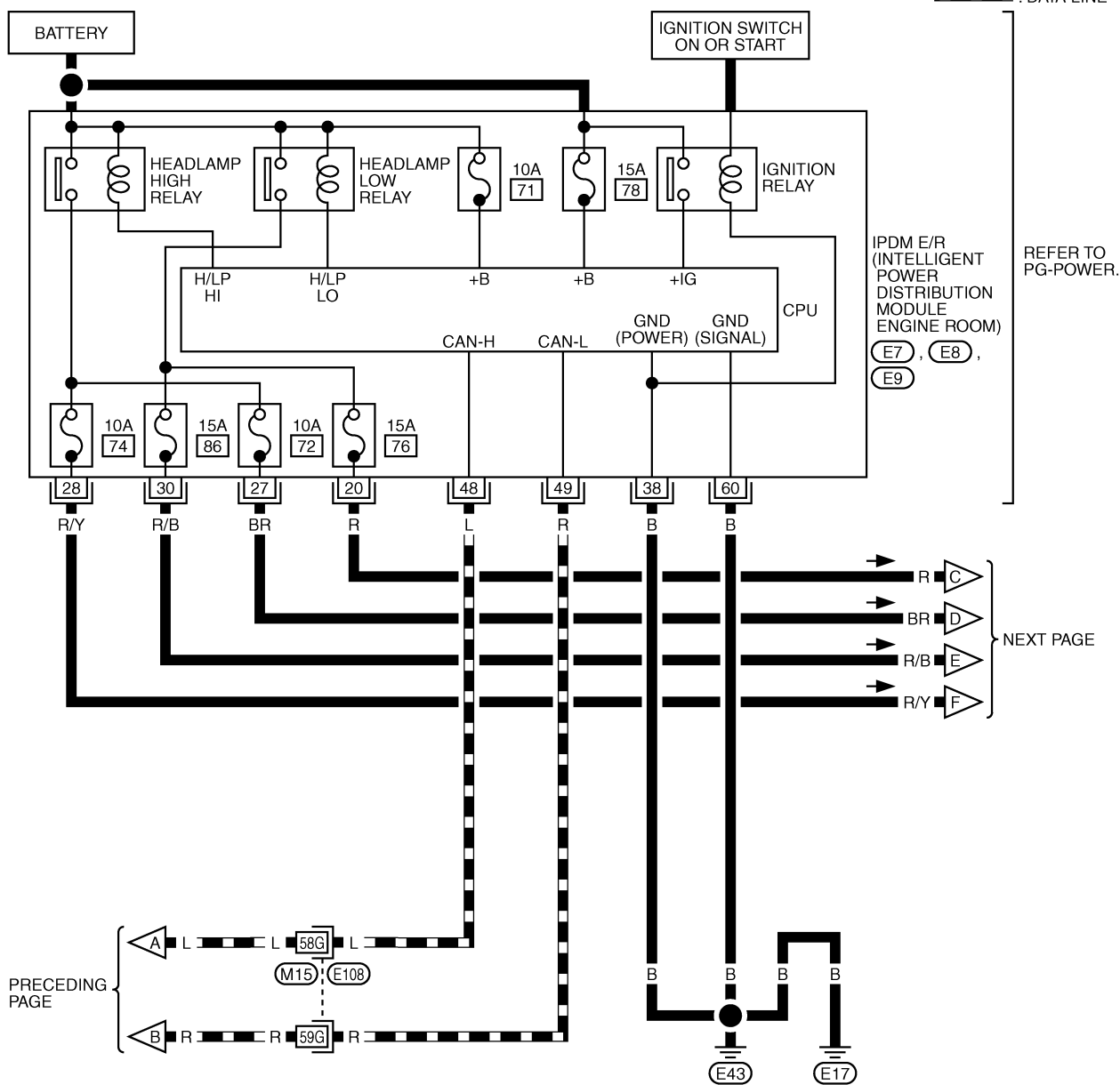

REFER TO THE FOLLOWING.
E108 -SUPER MULTIPLE JUNCTION (SMJ)

TKWM0850E

HEADLAMP (FOR USA)

LT-H/LAMP-04

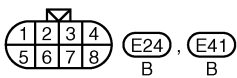
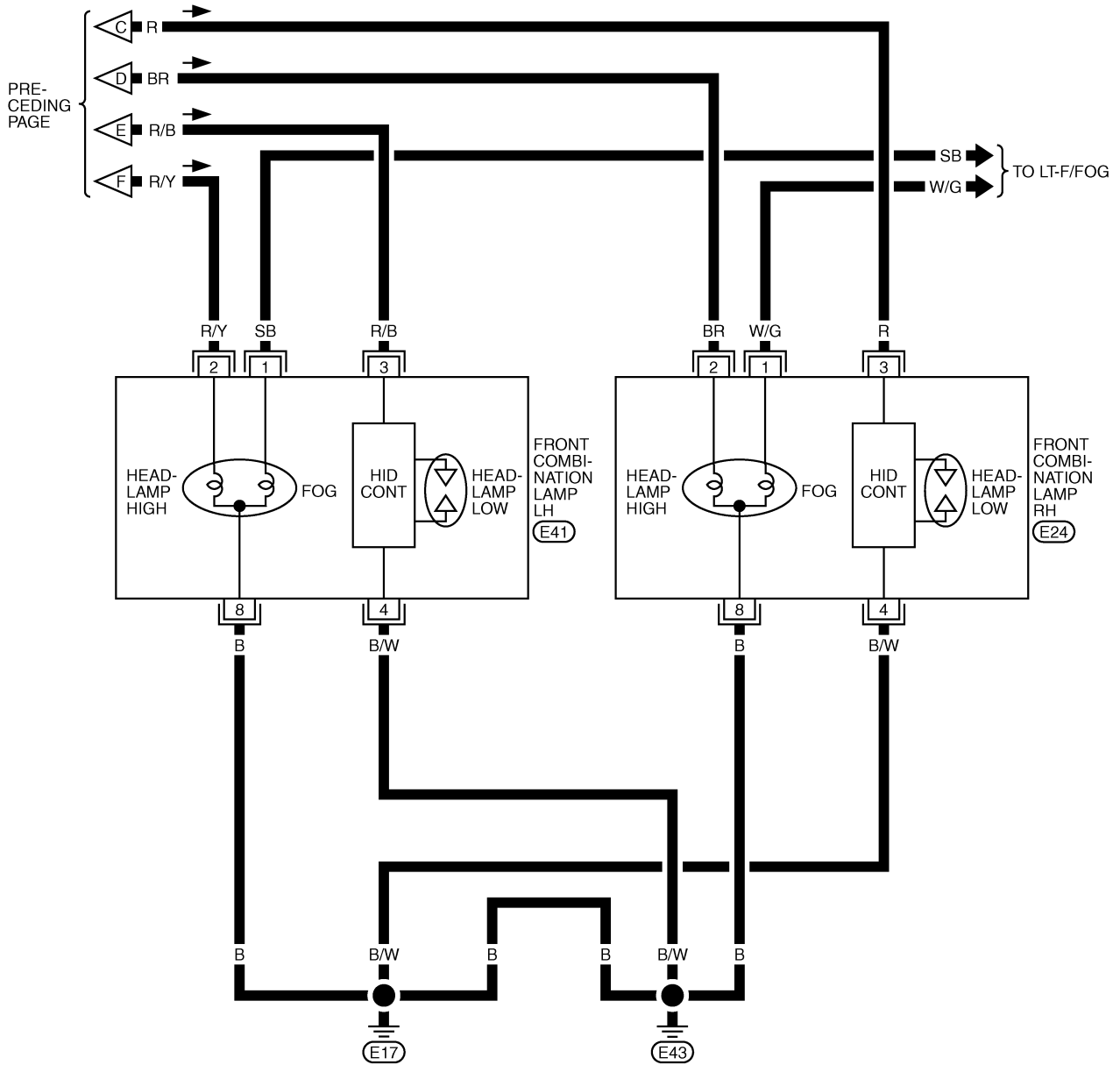





TKWM0851E

HEADLAMP (FOR USA)

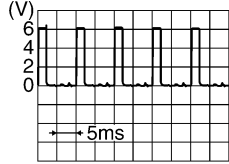
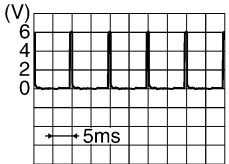
Terminals and Reference Values for BCM

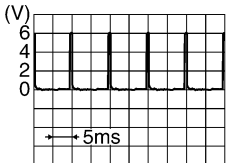
AKS00ACC

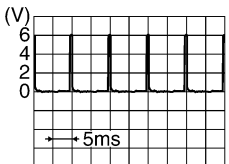
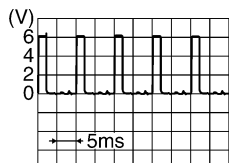
Terminal No.	Wire color	Signal name	Measuring condition		Reference value
			Ignition switch	Operation or condition	
2	G/R	Combination switch input 5	ON	Lighting, turn, wiper OFF Wiper dial position 4	 <p style="text-align: right;">SKIA5291E</p>
3	G	Combination switch input 4	ON	Lighting, turn, wiper OFF Wiper dial position 4	 <p style="text-align: right;">SKIA5292E</p>
4	W/L	Combination switch input 3	ON	Lighting, turn, wiper OFF Wiper dial position 4	 <p style="text-align: right;">SKIA5291E</p>
5	W/G	Combination switch input 2	ON	Lighting, turn, wiper OFF Wiper dial position 4	 <p style="text-align: right;">SKIA5292E</p>
6	W/R	Combination switch input 1			
11	LG	Ignition switch (ACC)	ACC	—	Battery voltage
32	GY	Combination switch output 5	ON	Lighting, turn, wiper OFF Wiper dial position 4	 <p style="text-align: right;">SKIA5291E</p>
33	L	Combination switch output 4	ON	Lighting, turn, wiper OFF Wiper dial position 4	 <p style="text-align: right;">SKIA5292E</p>
34	PU	Combination switch output 3	ON	Lighting, turn, wiper OFF Wiper dial position 4	 <p style="text-align: right;">SKIA5291E</p>

A
B
C
D
E
F
G
H
I
J
LT
L
M

HEADLAMP (FOR USA)

Terminal No.	Wire color	Signal name	Measuring condition		Reference value
			Ignition switch	Operation or condition	
35	Y/R	Combination switch output 2	ON	Lighting, turn, wiper OFF Wiper dial position 4	
36	Y	Combination switch output 1			
38	W/L	Ignition switch (ON)	ON	—	Battery voltage
39	L	CAN- H	—	—	—
40	R	CAN- L	—	—	—
42	GY	Battery power supply	OFF	—	Battery voltage
52	B	Ground	ON	—	Approx. 0V
55	W/R	Battery power supply	OFF	—	Battery voltage

Terminals and Reference Values for IPDM E/R

AKS00ACD

Terminal No.	Wire color	Signal name	Measuring condition		Reference value
			Ignition switch	Operation or condition	
20	R	Headlamp low (RH)	ON	Lighting switch 2ND position OFF	Approx. 0V
				ON	Battery voltage
27	BR	Headlamp high (RH)	ON	Lighting switch HIGH or PASS position OFF	Approx. 0V
				ON	Battery voltage
28	R/Y	Headlamp high (LH)	ON	Lighting switch HIGH or PASS position OFF	Approx. 0V
				ON	Battery voltage
30	R/B	Headlamp low (LH)	ON	Lighting switch 2ND position OFF	Approx. 0V
				ON	Battery voltage
38	B	Ground	ON	—	Approx. 0V
48	L	CAN- H	—	—	—
49	R	CAN- L	—	—	—
60	B	Ground	ON	—	Approx. 0V

How to Proceed With Trouble Diagnosis

AKS00ACE

1. Confirm the symptom or customer complaint.
2. Understand operation description and function description. Refer to [LT-7, "System Description"](#) .
3. Perform the preliminary check. Refer to [LT-17, "Preliminary Check"](#) .
4. Check symptom and repair or replace the cause of malfunction.
5. Does the headlamp operate normally? If YES: GO TO 6. If NO: GO TO 4.
6. INSPECTION END

HEADLAMP (FOR USA)

AKS00ACF

Preliminary Check CHECK POWER SUPPLY AND GROUND CIRCUIT

1. CHECK FUSES

- Check fuses for blown-out.

Unit	Power source	Fuse and fusible link No.
BCM	Battery	F
		18
	Ignition switch ON or START position	1
	Ignition switch ACC or ON position	6
IPDM E/R	Battery	72
		74
		76
		86

Refer to [LT-11, "Wiring Diagram — H/LAMP —"](#).

OK or NG

OK >> GO TO 2.

NG >> If fuse is blown, be sure to eliminate cause of malfunction before installing new fuse. Refer to [PG-4, "POWER SUPPLY ROUTING CIRCUIT"](#).

2. CHECK POWER SUPPLY CIRCUIT

1. Turn ignition switch OFF.
2. Disconnect BCM connector.
3. Check voltage between BCM harness connector and ground.

Terminals		(-)	Ignition switch position		
(+)	Terminal (Wire color)		OFF	ACC	ON
M1	11 (LG)	Ground	0V	Battery voltage	Battery voltage
	38 (W/L)		0V	0V	Battery voltage
M2	42 (GY)		Battery voltage	Battery voltage	Battery voltage
	55 (W/R)		Battery voltage	Battery voltage	Battery voltage

OK or NG

OK >> GO TO 3.

NG >> Check harness for open or short between BCM and fuse.

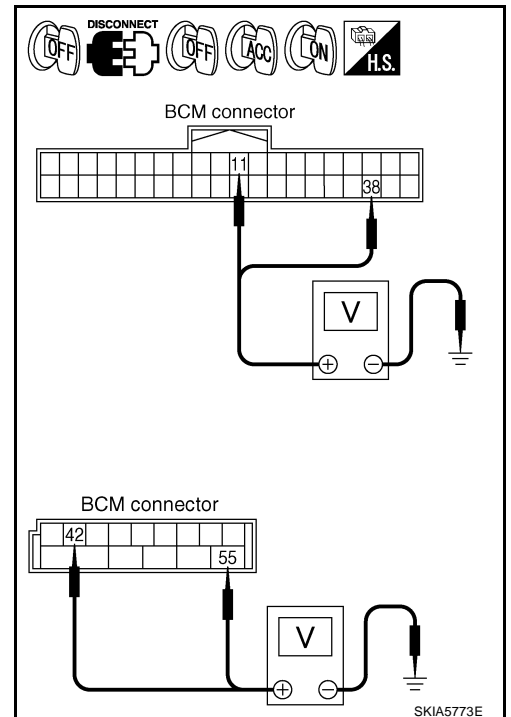

HEADLAMP (FOR USA)

3. CHECK GROUND CIRCUIT

Check continuity between BCM harness connector and ground.

Terminals		Continuity
Connector	Terminal (Wire color)	
M2	52 (B)	Ground Yes

OK or NG

- OK >> INSPECTION END
- NG >> Check ground circuit harness.

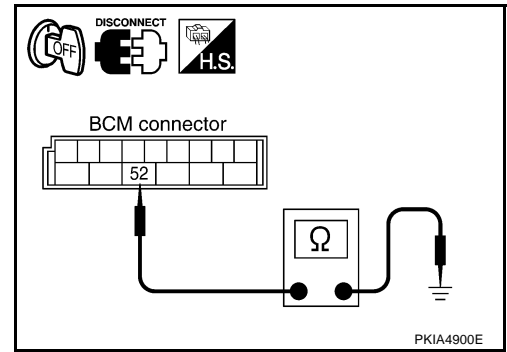

CONSULT-II Functions (BCM)

- CONSULT-II performs the following functions communicating with BCM.

BCM diagnosis part	Check item, diagnosis mode	Description
HEAD LAMP	WORK SUPPORT	Changes the setting for each function.
	DATA MONITOR	Displays BCM input data in real time.
	ACTIVE TEST	Operation of electrical loads can be checked by sending drive signal to them.
BCM	CAN DIAG SUPPORT MNTR	The result of transmit/receive diagnosis of CAN communication can be read.

CONSULT-II BASIC OPERATION

CAUTION:

If CONSULT-II is used with no connection of CONSULT-II CONVERTER, malfunctions might be detected in self-diagnosis depending on control unit which carry out CAN communication.

1. With the ignition switch OFF, connect CONSULT-II and CONSULT-II CONVERTER to the data link connector, then turn ignition switch ON.

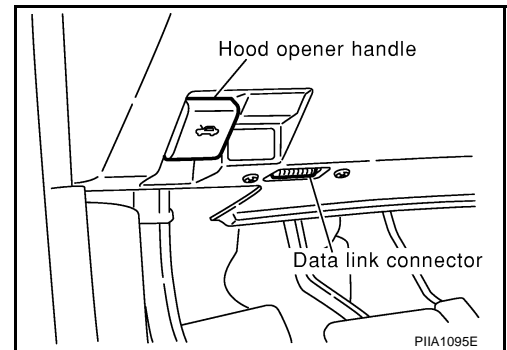

2. Touch "START (NISSAN BASED VHCL)".

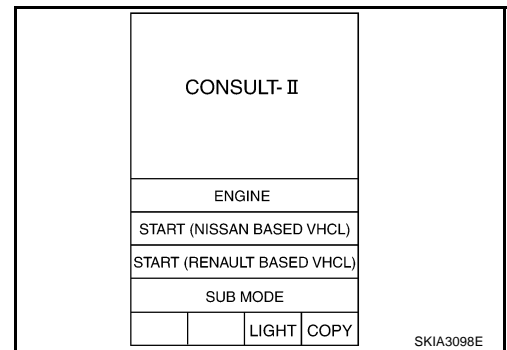

HEADLAMP (FOR USA)

3. Touch "BCM" on "SELECT SYSTEM" screen.
If "BCM" is not indicated, refer to [GI-39, "CONSULT-II Data Link Connector \(DLC\) Circuit"](#).

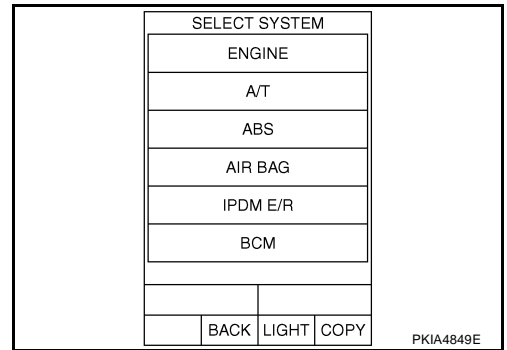

4. Touch "HEAD LAMP" on "SELECT TEST ITEM" screen.

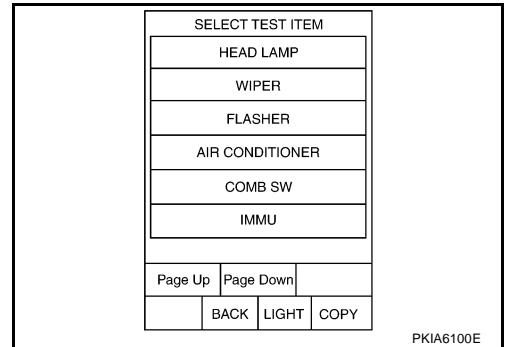

WORK SUPPORT

Operation Procedure

1. Touch "HEAD LAMP" on "SELECT TEST ITEM" screen.
2. Touch "WORK SUPPORT" on "SELECT DIAG MODE" screen.
3. Touch item on "SELECT WORK ITEM" screen.
4. Touch "START".
5. Touch "CHANGE SET".
6. The setting will be changed and "CUSTOMIZING COMPLETED" will be displayed.
7. Touch "END".

Display Item List

Item	Description	CONSULT-II	Factory setting
BATTERY SAVER SET	Exterior lamp battery saver control mode can be changed in this mode. Selects exterior lamp battery saver control mode between two ON/OFF.	ON	×
		OFF	—

DATA MONITOR

Operation Procedure

1. Touch "HEAD LAMP" on "SELECT TEST ITEM" screen.
2. Touch "DATA MONITOR" on "SELECT DIAG MODE" screen.
3. Touch either "ALL SIGNALS" or "SELECTION FROM MENU" on "DATA MONITOR" screen.

ALL SIGNALS	Monitors all the signals.
SELECTION FROM MENU	Selects and monitors individual signal.

4. Touch "START".
5. When "SELECTION FROM MENU" is selected, touch individual items to be monitored. When "ALL SIGNALS" is selected, all the items will be monitored.
6. Touch "RECORD" while monitoring, then the status of the monitored item can be recorded. To stop recording, touch "STOP".

HEADLAMP (FOR USA)

Display Item List

Monitor item		Contents
IGN ON SW	"ON/OFF"	Displays "IGN position (ON)/OFF, ACC position (OFF)" judged from the ignition switch signal.
ACC ON SW	"ON/OFF"	Displays "ACC (ON)/OFF, Ignition OFF (OFF)" status judged from ignition switch signal.
HI BEAM SW	"ON/OFF"	Displays status (high beam switch: ON/Others: OFF) of high beam switch judged from lighting switch signal.
HEAD LAMP SW 1	"ON/OFF"	Displays status (headlamp switch 1: ON/Others: OFF) of headlamp switch 2 judged from lighting switch signal.
HEAD LAMP SW 2	"ON/OFF"	Displays status (headlamp switch 2: ON/Others: OFF) of headlamp switch 2 judged from lighting switch signal.
LIGH SW 1 ST	"ON/OFF"	Displays status (lighting switch 1st position: ON/Others: OFF) of lighting switch judged from lighting switch signal.
AUTO LIGHT SW	"ON/OFF"	Displays status of the lighting switch as judged from the lighting switch signal. (AUTO position: ON/Other than AUTO position: OFF)
PASSING SW	"ON/OFF"	Displays status (flash-to-pass switch: ON/Others: OFF) of flash-to-pass switch judged from lighting switch signal.
FR FOG SW	"ON/OFF"	Displays status (front fog lamp switch: ON/Others: OFF) of front fog lamp switch judged from lighting switch signal.
DOOR SW - DR	"ON/OFF"	Displays status of the driver door as judged from the driver door switch signal. (Door is open: ON/Door is closed: OFF)
DOOR SW - AS	"ON/OFF"	Displays status of the passenger door as judged from the passenger door switch signal. (Door is open: ON/Door is closed: OFF)
DOOR SW - RR ^{NOTE}	"OFF"	—
DOOR SW - RL ^{NOTE}	"OFF"	—
BACK DOOR SW ^{NOTE}	"OFF"	—
TURN SIGNAL R	"ON/OFF"	Displays status (Turn right: ON/Others: OFF) as judged from lighting switch signal.
TURN SIGNAL L	"ON/OFF"	Displays status (Turn left: ON/Others: OFF) as judged from lighting switch signal.
CARGO LAMP SW ^{NOTE}	"OFF"	—
OPTICAL SENSOR	[0 - 5V]	Displays "ambient light (close to 5V when light/close to 0V when dark)" judged from optical sensor signal.

NOTE:

This item is displayed, but cannot monitor it.

ACTIVE TEST

Operation Procedure

1. Touch "HEAD LAMP" on "SELECT TEST ITEM" screen.
2. Touch "ACTIVE TEST" on "SELECT DIAG MODE" screen.
3. Touch item to be tested and check operation of the selected item.
4. During the operation check, touching "BACK" deactivates the operation.

Display Item List

Test item	Description
TAIL LAMP	Allows tail lamp relay to operate by switching ON-OFF.
HEAD LAMP	Allows headlamp relay to operate by switching ON-OFF.
FR FOG LAMP	Allows fog lamp relay to operate by switching ON-OFF.
CORNERING LAMP ^{NOTE}	—
CARGO LAMP	Allows cargolamp operate by switching ON-OFF.

NOTE:

This item is displayed, but cannot monitor it.

HEADLAMP (FOR USA)

CONSULT-II Functions (IPDM E/R)

AKS000ACH

CONSULT-II performs the following functions communicating with IPDM E/R.

Check Item, Diagnosis Mode	Description
SELF-DIAGNOSTIC RESULTS	The IPDM E/R performs self-diagnosis of CAN communication.
DATA MONITOR	The input/output data of the IPDM E/R is displayed in real time.
CAN DIAG SUPPORT MNTR	The result of transmit/receive diagnosis of CAN communication can be read.
ACTIVE TEST	The IPDM E/R sends a drive signal to electronic components to check their operation.

CONSULT-II OPERATION

CAUTION:

If CONSULT-II is used with no connection of CONSULT-II CONVERTER, malfunctions might be detected in self-diagnosis depending on control unit which carry out CAN communication.

1. With the ignition switch OFF, connect CONSULT-II and CONSULT-II CONVERTER to the data link connector, then turn the ignition switch ON.

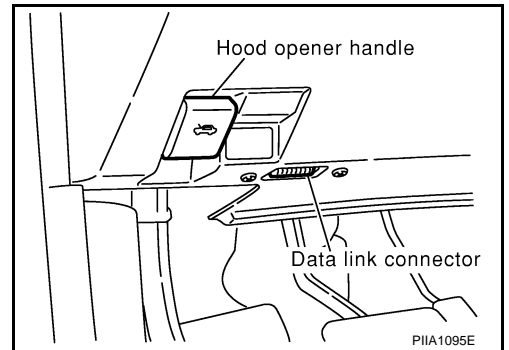

2. Touch "START (NISSAN BASED VHCL)".

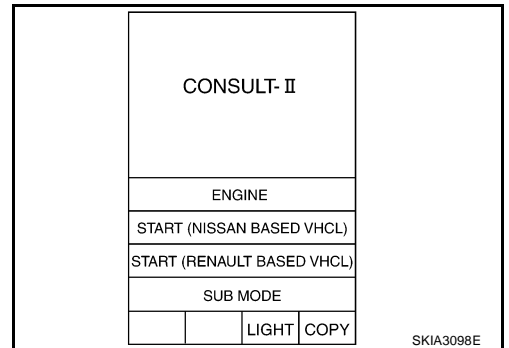

3. Touch "IPDM E/R" on "SELECT SYSTEM" screen. If "IPDM E/R" is not displayed, print "SELECT SYSTEM" screen, then refer to [GI-39, "CONSULT-II Data Link Connector \(DLC\) Circuit"](#).

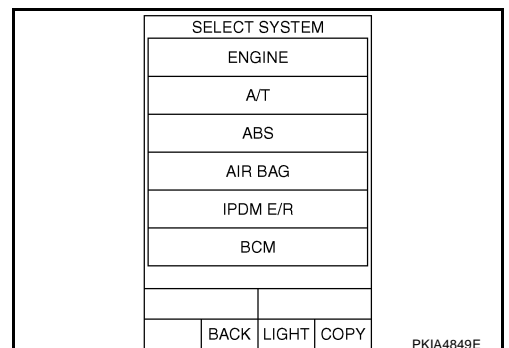

HEADLAMP (FOR USA)

- Select the desired part to be diagnosed on the “SELECT DIAG MODE” screen.

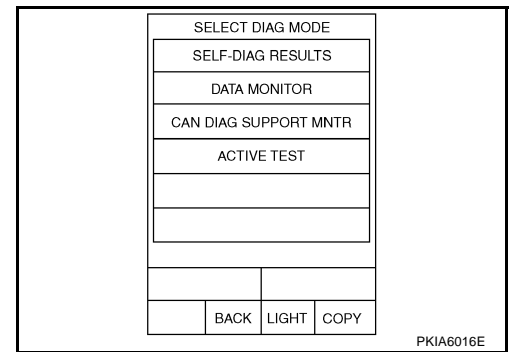

SELF-DIAGNOSTIC RESULTS

Refer to [PG-20, "SELF-DIAG RESULTS"](#) .

DATA MONITOR

Operation Procedure

- Touch “DATA MONITOR” on “SELECT DIAG MODE ” screen.
- Touch “ALL SIGNALS”, “MAIN SIGNALS” or “SELECTION FROM MENU” on “DATA MONITOR” screen.

ALL SIGNALS	All items will be monitored.
MAIN SIGNALS	Monitor the predetermined item.
SELECTION FROM MENU	Select any item for monitoring.

- Touch “START”.
- Touch the required monitoring item on “SELECTION FROM MENU”. In “ALL SIGNALS”, all items are monitored. In “MAIN SIGNALS”, predetermined items are monitored.
- Touch “RECORD” while monitoring to record the status of the item being monitored. To stop recording, touch “STOP”.

All Signals, Main Signals, Selection From Menu

Item name	CONSULT-II screen display	Display or unit	Monitor item selection			Description
			ALL SIGNALS	MAIN SIGNALS	SELECTION FROM MENU	
Position lights request	TAIL & CLR REQ	ON/OFF	×	×	×	Signal status input from BCM
Headlamp low beam request	HL LO REQ	ON/OFF	×	×	×	Signal status input from BCM
Headlamp high beam request	HL HI REQ	ON/OFF	×	×	×	Signal status input from BCM
Font fog lights request	FR FOG REQ	ON/OFF	×	×	×	Signal status input from BCM

NOTE:

Perform monitoring of IPDM E/R data with the ignition switch ON. When the ignition switch is at ACC, the display may not be correct.

HEADLAMP (FOR USA)

ACTIVE TEST

Operation Procedure

1. Touch "ACTIVE TEST" on "SELECT DIAG MODE" screen.
2. Touch item to be tested, and check operation.
3. Touch "START".
4. Touch "STOP" while testing to stop the operation.

Test item	CONSULT-II screen display	Description
Headlamp relay (HI, LO) output	LAMPS	Allows headlamp relay (HI, LO) to operate by switching operation (OFF, HI ON, LO ON) at your option.
Front fog lamp relay output		Allows fog lamp relay to operate by switching operation ON-OFF at your option.
Tail lamp relay output	TAIL LAMP	Allows tail lamp relay to operate by switching operation ON-OFF at your option.

Headlamp High Beam Does Not Illuminate (Both Sides)

AKS00AC1

1. CHECK COMBINATION SWITCH INPUT SIGNAL

☑ With CONSULT-II

Select "BCM" on CONSULT-II. With "HEAD LAMP" data monitor, make sure "HI BEAM SW" turns ON-OFF linked with operation of lighting switch.

**When lighting switch is : HI BEAM SW ON
HIGH BEAM position**

DATA MONITOR	
MONITOR	
HI BEAM SW	ON

SKIA4193E

☒ Without CONSULT-II

Refer to [LT-128, "Combination Switch Inspection"](#).

OK or NG

OK >> GO TO 2.

NG >> Check lighting switch. Refer to [LT-128, "Combination Switch Inspection"](#).

2. HEADLAMP ACTIVE TEST

☑ With CONSULT-II

1. Select "IPDM E/R" on CONSULT-II, and select "ACTIVE TEST" on "SELECT DIAG MODE" screen.
2. Select "LAMPS" on "SELECT TEST ITEM" screen.
3. Touch "HI" screen.
4. Make sure headlamp high beam operates.

Headlamp high beam should operate.

☒ Without CONSULT-II

1. Start auto active test. Refer to [PG-23, "Auto Active Test"](#).
2. Make sure headlamp high beam operates.

Headlamp high beam should operate.

OK or NG

OK >> GO TO 3.

NG >> GO TO 4.

ACTIVE TEST			
LAMPS		OFF	
		HI	
	LO	FOG	
MODE	BACK	LIGHT	COPY

SKIA5774E

HEADLAMP (FOR USA)

3. CHECK IPDM E/R

1. Select "IPDM E/R" on CONSULT-II, and select "DATA MONITOR" on "SELECT DIAG MODE" screen.
2. Make sure "HL LO REQ" and "HL HI REQ" turns ON when lighting switch is in HI position.

**When lighting switch is HIGH BEAM position : HL LO REQ ON
: HL HI REQ ON**

DATA MONITOR			
MONITOR			
HL LO REQ		ON	
HL HI REQ		ON	
			Page Down
			RECORD
MODE	BACK	LIGHT	COPY

SKIA5775E

OK or NG

- OK >> Replace IPDM E/R.
 NG >> Replace BCM. Refer to [BCS-15, "Removal and Installation of BCM"](#).

4. CHECK HEADLAMP INPUT SIGNAL

 With CONSULT-II

1. Turn ignition switch OFF.
2. Disconnect front combination lamp RH and LH connector.
3. Select "IPDM E/R" on CONSULT-II, and select "ACTIVE TEST" on "SELECT DIAG MODE" screen.
4. Select "LAMPS" on "SELECT TEST ITEM" screen.
5. Touch "HI" screen.
6. When headlamp high beam is operating, check voltage between front combination lamp RH and LH harness connector and ground (Headlamp high beam repeats ON-OFF every 1 second).

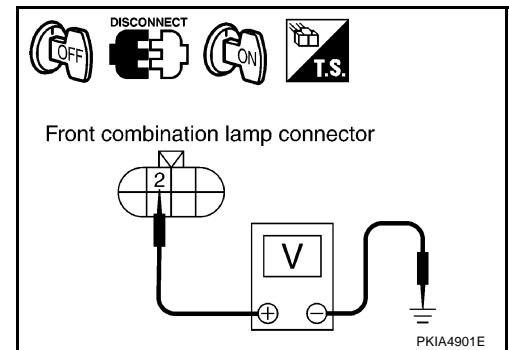

Terminals			(-)	Voltage
(+)				
Connector	Terminal (Wire color)		Ground	Battery voltage
RH	E24	2 (BR)		
LH	E41	2 (R/Y)		

 Without CONSULT-II

1. Turn ignition switch OFF.
2. Disconnect front combination lamp RH and LH connector.
3. Start auto active test. Refer to [PG-23, "Auto Active Test"](#).
4. When headlamp high beam is operating, check voltage between front combination lamp RH and LH harness connector and ground.

Terminals			(-)	Voltage
(+)				
Connector	Terminal (Wire color)		Ground	Battery voltage
RH	E24	2 (BR)		
LH	E41	2 (R/Y)		

OK or NG

- OK >> GO TO 6.
 NG >> GO TO 5.

HEADLAMP (FOR USA)

5. CHECK HEADLAMP CIRCUIT

1. Turn ignition switch OFF.
2. Disconnect IPDM E/R connector.
3. Check continuity between IPDM E/R harness connector E7 terminal 27 (BR) and front combination lamp RH harness connector E24 terminal 2 (BR).

27 (BR) – 2 (BR) : Continuity should exist.

4. Check continuity between IPDM E/R harness connector E7 terminal 28 (R/Y) and front combination lamp LH harness connector E41 terminal 2 (R/Y).

28 (R/Y) – 2 (R/Y) : Continuity should exist.

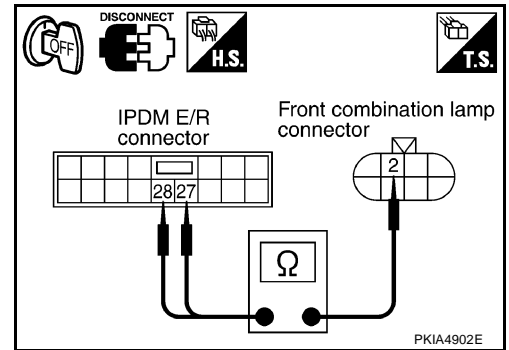

OK or NG

- OK >> Replace IPDM E/R.
NG >> Repair harness or connector.

6. CHECK HEADLAMP GROUND

1. Check continuity between front combination lamp RH harness connector E24 terminal 8 (B) and ground.

8 (B) – Ground : Continuity should exist.

2. Check continuity between front combination lamp LH harness connector E44 terminal 8 (B) and ground.

8 (B) – Ground : Continuity should exist.

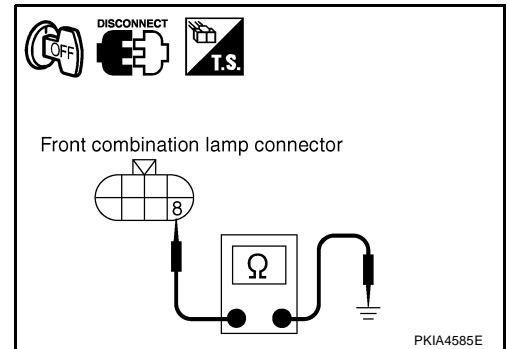

OK or NG

- OK >> Check headlamp bulb.
NG >> Repair harness or connector.

Headlamp High Beam Does Not Illuminate (One Side)

AKS00ACJ

1. CHECK BULB

Check bulbs of lamps which do not illuminate.

OK or NG

- OK >> GO TO 2.
NG >> Replace headlamp bulb.

A
B
C
D
E
F
G
H
I
J
L
M

LT

HEADLAMP (FOR USA)

2. CHECK HEADLAMP INPUT SIGNAL

1. Turn ignition switch OFF.
2. Disconnect front combination lamp RH or LH connector.
3. Turn ignition switch ON.
4. Lighting switch is turned HIGH BEAM position.
5. Check voltage between front combination lamp RH or LH harness connector and ground.

Terminals			(-)	Voltage
(+) Connector		Terminal (Wire color)		
RH	E24	2 (BR)	Ground	Battery voltage
LH	E41	2 (R/Y)		

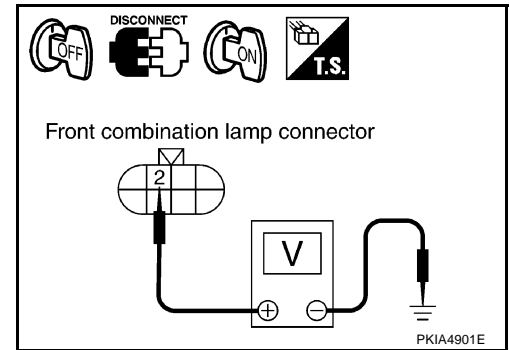

OK or NG

- OK >> GO TO 4.
 NG >> GO TO 3.

3. CHECK HEADLAMP CIRCUIT

1. Turn ignition switch OFF.
2. Disconnect IPDM E/R connector.
3. Check continuity between IPDM E/R harness connector E7 terminal 27 (BR) and front combination lamp RH harness connector E24 terminal 2 (BR).

27 (BR) – 2 (BR) : Continuity should exist.

4. Check continuity between IPDM E/R harness connector E7 terminal 28 (R/Y) and front combination lamp LH harness connector E41 terminal 2 (R/Y).

28 (R/Y) – 2 (R/Y) : Continuity should exist.

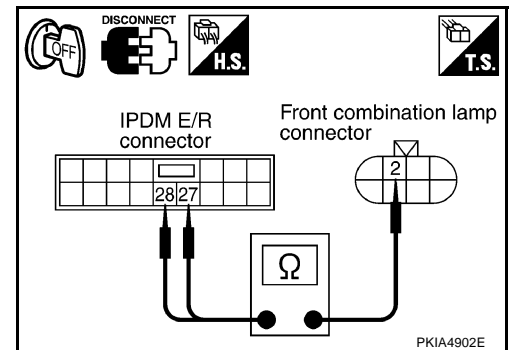

OK or NG

- OK >> Replace IPDM E/R.
 NG >> Repair harness or connector.

4. CHECK HEADLAMP GROUND

1. Check continuity between front combination lamp RH harness connector E24 terminal 8 (B) and ground.

8 (B) – Ground : Continuity should exist.

2. Check continuity between front combination lamp LH harness connector E41 terminal 8 (B) and ground.

8 (B) – Ground : Continuity should exist.

OK or NG

- OK >> Check headlamp harness and connector.
 NG >> Repair harness or connector.

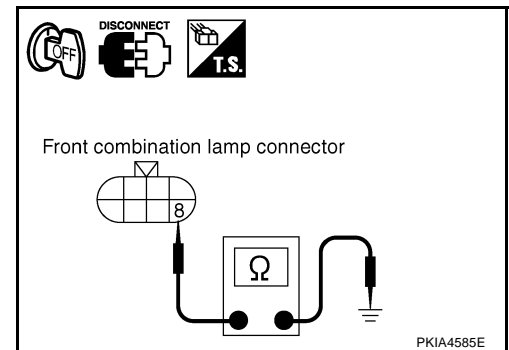

HEADLAMP (FOR USA)

High Beam Indicator Lamp Does Not Illuminate

AKS00ACK

1. CHECK BULB

Check bulb of high beam indicator lamp.

OK or NG

- OK >> Replace combination meter.
- NG >> Replace indicator bulb.

Headlamp Low Beam Does Not Illuminate (Both Sides)

AKS00ACL

1. CHECK COMBINATION SWITCH INPUT SIGNAL

Ⓟ With CONSULT-II

Select "BCM" on CONSULT-II. With "HEAD LAMP" data monitor, make sure "HEAD LAMP SW 1" and "HEAD LAMP SW 2" turns ON-OFF linked with operation of lighting switch.

**When lighting switch is 2ND position : HEAD LAMP SW 1 ON
: HEAD LAMP SW 2 ON**

ⓧ Without CONSULT-II

Refer to [LT-128, "Combination Switch Inspection"](#).

OK or NG

- OK >> GO TO 2.
- NG >> Check lighting switch. Refer to [LT-128, "Combination Switch Inspection"](#).

DATA MONITOR	
MONITOR	
HEAD LAMP SW1	ON
HEAD LAMP SW2	ON

SKIA4194E

2. HEADLAMP ACTIVE TEST

Ⓟ With CONSULT-II

1. Select "IPDM E/R" on CONSULT-II, and select "ACTIVE TEST" on "SELECT DIAG MODE" screen.
2. Select "LAMPS" on "SELECT TEST" ITEM screen.
3. Touch "LO" screen.
4. Make sure headlamp low beam operates.

Headlamp low beam should operate.

ⓧ Without CONSULT-II

1. Start auto active test. Refer to [PG-23, "Auto Active Test"](#).
2. Make sure headlamp low beam operates.

Headlamp low beam should operate.

OK or NG

- OK >> GO TO 3.
- NG >> GO TO 4.

ACTIVE TEST			
LAMPS		OFF	
		HI	
LO		FOG	
MODE	BACK	LIGHT	COPY

SKIA5774E

HEADLAMP (FOR USA)

3. CHECK IPDM E/R

1. Select "IPDM E/R" on CONSULT-II, and select "DATA MONITOR" on "SELECT DIAG MODE" screen.
2. Make sure "HL LO REQ" turns ON when lighting switch is in 2ND position.

When lighting switch is 2ND : HL LO REQ ON position

DATA MONITOR			
MONITOR			
HL LO REQ		ON	
			Page Down
			RECORD
MODE	BACK	LIGHT	COPY

SKIA5780E

OK or NG

- OK >> Replace IPDM E/R.
 NG >> Replace BCM. Refer to [BCS-15, "Removal and Installation of BCM"](#).

4. CHECK HEADLAMP INPUT SIGNAL

With CONSULT-II

1. Turn ignition switch OFF.
2. Disconnect front combination lamp RH and LH connector.
3. Select "IPDM E/R" on CONSULT-II, and select "ACTIVE TEST" on "SELECT DIAG MODE" screen.
4. Select "LAMPS" on "SELECT TEST ITEM" screen.
5. Touch "LO" screen.
6. When headlamp low beam is operating, check voltage between front combination lamp RH and LH harness connector and ground.

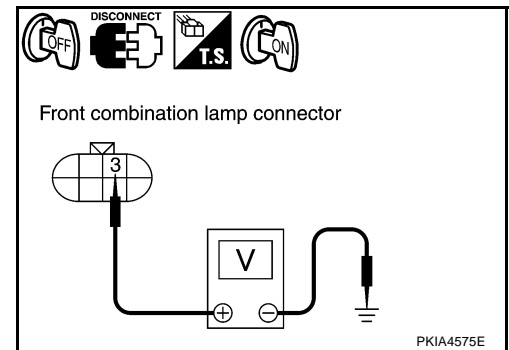

Terminals			(-)	Voltage
(+)				
Connector	Terminal (Wire color)		Ground	Battery voltage
RH	E24	3 (R)		
LH	E41	3 (R/B)		

Without CONSULT-II

1. Turn ignition switch OFF.
2. Disconnect front combination lamp RH and LH connector.
3. Start auto active test. Refer to [PG-23, "Auto Active Test"](#).
4. When headlamp low beam is operating, check voltage between front combination lamp RH and LH harness connector and ground.

Terminals			(-)	Voltage
(+)				
Connector	Terminal (Wire color)		Ground	Battery voltage
RH	E24	3 (R)		
LH	E41	3 (R/B)		

OK or NG

- OK >> GO TO 6.
 NG >> GO TO 5.

HEADLAMP (FOR USA)

5. CHECK HEADLAMP CIRCUIT

1. Turn ignition switch OFF.
2. Disconnect IPDM E/R connector.
3. Check continuity between IPDM E/R harness connector E7 terminal 20 (R) and front combination lamp RH harness connector E24 terminal 3 (R).

20 (R) – 3 (R) : Continuity should exist.

4. Check continuity between IPDM E/R harness connector E7 terminal 30 (R/B) and front combination lamp LH harness connector E41 terminal 3 (R/B).

30 (R/B) – 3 (R/B) : Continuity should exist.

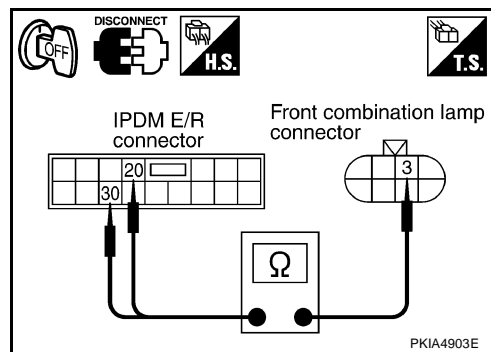

OK or NG

- OK >> Replace IPDM E/R.
- NG >> Repair harness or connector.

6. CHECK HEADLAMP GROUND

1. Turn ignition switch OFF.
2. Check continuity between front combination lamp RH harness connector E24 terminal 4 (B/W) and ground.

4 (B/W) – Ground : Continuity should exist.

3. Check continuity between front combination lamp LH harness connector E41 terminal 4 (B/W) and ground.

4 (B/W) – Ground : Continuity should exist.

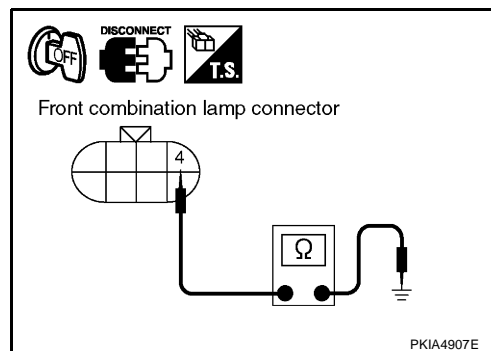

OK or NG

- OK >> Check headlamp harness and connectors, ballasts (HID control unit), and xenon bulbs. Refer to [LT-32, "Xenon Headlamp Trouble Diagnosis"](#).
- NG >> Repair harness or connector.

Headlamp Low Beam Does Not Illuminate (One Side)

AKS00ACM

LT

1. CHECK BULB

Check ballasts (HID control unit) and xenon bulb of lamp which does not illuminate. Refer to [LT-32, "Xenon Headlamp Trouble Diagnosis"](#).

OK or NG

- OK >> GO TO 2.
- NG >> Repair malfunctioning part.

HEADLAMP (FOR USA)

2. CHECK HEADLAMP CIRCUIT

1. Turn ignition switch OFF.
2. Disconnect IPDM E/R connector and front combination lamp RH or LH connector.
3. Check continuity between IPDM E/R harness connector E7 terminal 20 (R) and front combination lamp RH harness connector E24 terminal 3 (R).

20 (R) – 3 (R) : Continuity should exist.

4. Check continuity between IPDM E/R harness connector E7 terminal 30 (R/B) and front combination lamp LH harness connector E41 terminal 3 (R/B).

30 (R/B) – 3 (R/B) : Continuity should exist.

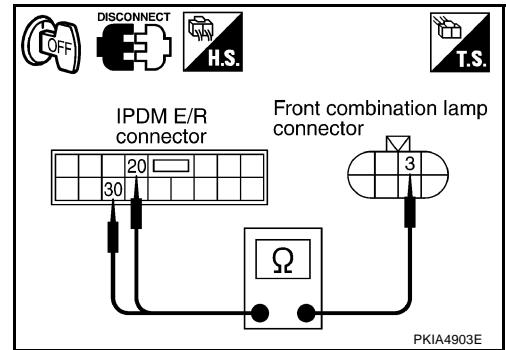

OK or NG

- OK >> GOTO 3.
- NG >> Repair harness or connector.

3. CHECK HEADLAMP GROUND

1. Check continuity between front combination lamp RH harness connector E24 terminal 4 (B/W) and ground.

4 (B/W) – Ground : Continuity should exist.

2. Check continuity between front combination lamp LH harness connector E41 terminal 4 (B/W) and ground.

4 (B/W) – Ground : Continuity should exist.

OK or NG

- OK >> Replace IPDM E/R.
- NG >> Repair harness or connector.

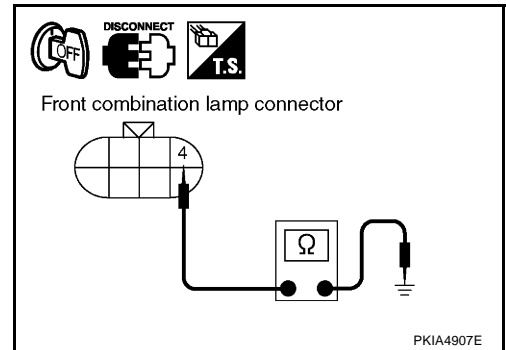

Headlamps Does Not Turn OFF

1. CHECK HEADLAMP TURN OFF

Make sure that lighting switch is OFF. And make sure is headlamp turns off when ignition switch is turned OFF.

OK or NG

- OK >> GO TO 3.
- NG >> GO TO 2.

2. CHECK COMBINATION SWITCH INPUT SIGNAL

Select "BCM" on CONSULT-II. With "HEAD LAMP" data monitor, make sure "HEAD LAMP SW 1" and "HEAD LAMP SW 2" turns ON-OFF linked with operation of lighting switch.

When lighting switch is OFF : HEAD LAMP SW 1 OFF position : HEAD LAMP SW 2 OFF

OK or NG

- OK >> Replace IPDM E/R.
- NG >> Check lighting switch. Refer to [LT-128, "Combination Switch Inspection"](#).

DATA MONITOR	
MONITOR	
HEAD LAMP SW 1	OFF
HEAD LAMP SW 2	OFF

HEADLAMP (FOR USA)

3. CHECKING CAN COMMUNICATIONS BETWEEN BCM AND IPDM E/R

Select "BCM" on CONSULT-II, and perform self-diagnosis for "BCM".

Display of self-diagnosis results

NO DTC>> Replace IPDM E/R.

CAN COMM CIRCUIT>> Refer to [BCS-14, "CAN Communication Inspection Using CONSULT-II \(Self-Diagnosis\)"](#).

SELF-DIAG RESULTS			
DTC RESULTS		TIME	
CAN COMM CIRCUIT [U1000]		PAST	
ERASE		PRINT	
MODE	BACK	LIGHT	COPY

SKIA1039E

A
B
C
D
E
F
G
H
I
J
LT
L
M

HEADLAMP (FOR USA)

CAUTION:

AKS00ACO

- Installation or removal of the connector must be done with the lighting switch OFF.
- When the lamp is illuminated (when the lighting switch is ON), do not touch the harness, HID control unit, inside of the lamp, or the lamp metal parts.
- To check illumination, temporarily install lamp in the vehicle. Be sure to connect power at the vehicle-side connector.
- If the error can be traced directly to the electrical system, first check for items such as burned-out fuses and fusible links, broken wires or loose connectors, pulled-out terminals, and improper connections.
- Do not work with wet hands.
- Using a tester for HID control unit circuit trouble diagnosis is prohibited.
- Disassembling the HID control unit or harnesses (bulb socket harness, ECM harness) is prohibited.
- Immediately after illumination, the light intensity and color will fluctuate, but there is nothing wrong.
- When the bulb has reached the end of its lifetime, the brightness may drop significantly, it may flash repeatedly, or the light may turn a reddish color.

Xenon Headlamp Trouble Diagnosis

AKS00ACP

1. CHECK 1: XENON HEADLAMP LIGHTING

Install normal xenon bulb to corresponding xenon bulb headlamp, and check if lamp lights up.

OK or NG

- OK >> Replace xenon bulb.
- NG >> GO TO 2.

2. CHECK 2: XENON HEADLAMP LIGHTING

Install normal HID control unit to corresponding xenon headlamp, and check if lamp lights up.

OK or NG

- OK >> Replace HID control unit.
- NG >> GO TO 3.

3. CHECK 3: XENON HEADLAMP LIGHTING

Install normal xenon lamp housing assembly to corresponding xenon headlamp, and check if lamp lights up.

OK or NG

- OK >> Malfunction in starter (boosting circuit) in xenon headlamp housing. (Replace xenon headlamp housing assembly.)
- NG >> INSPECTION END

HEADLAMP (FOR USA)

Aiming Adjustment

AKS00ACQ

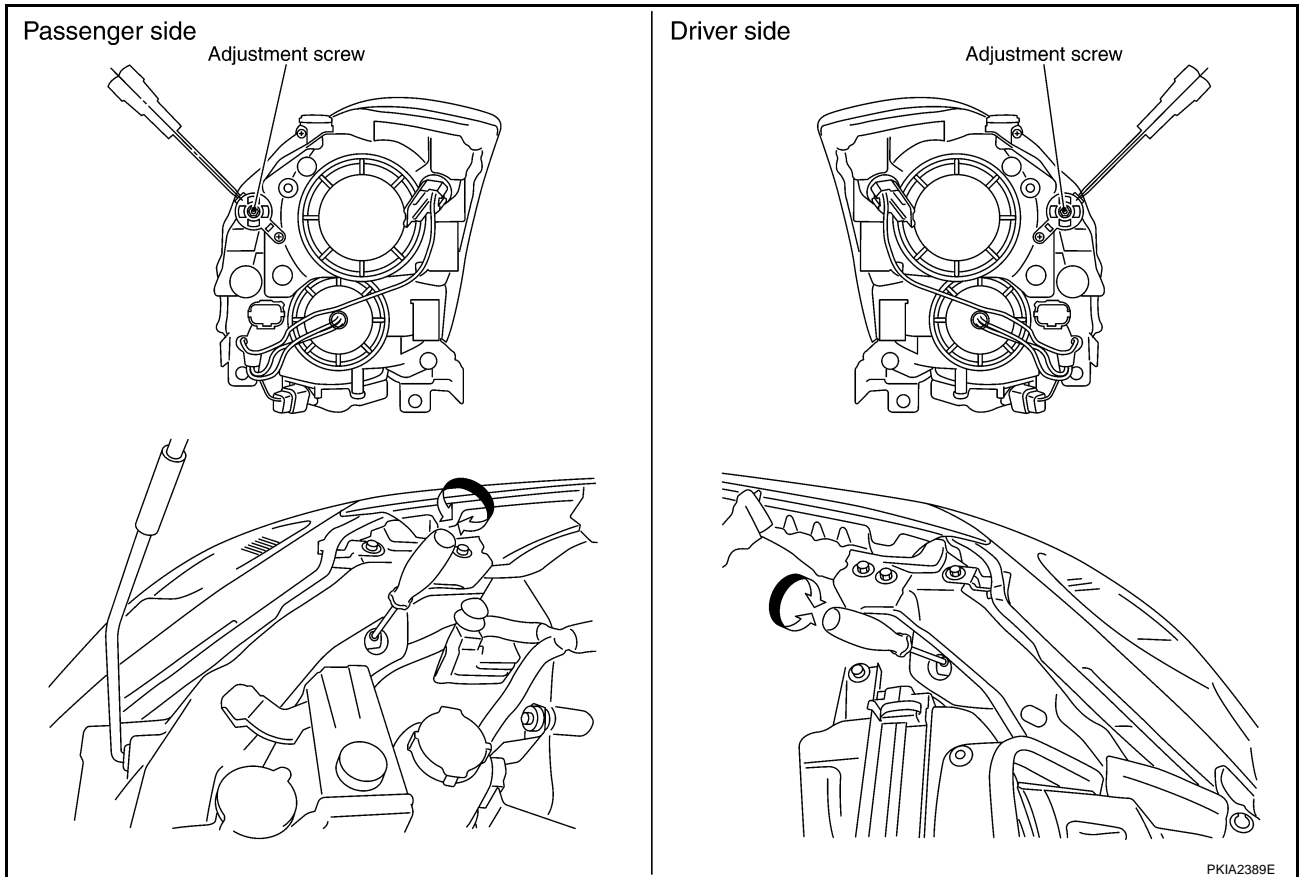

PREPARATION BEFORE ADJUSTING

For details, refer to the regulations in your own country.
Before performing aiming adjustment, check the following.

1. Keep all tires inflated to correct pressures.
2. Place vehicle on flat surface.
3. Set that there is no-load in vehicle other than the driver (or equivalent weight placed in driver's position).
Coolant, engine oil filled up to correct level and full fuel tank.

LOW BEAM AND HIGH BEAM

1. Turn headlamp low beam on.
2. Use adjusting screws to perform aiming adjustment.

A
B
C
D
E
F
G
H
I
J
LT
L
M

HEADLAMP (FOR USA)

ADJUSTMENT USING AN ADJUSTMENT SCREEN (LIGHT/DARK BORDERLINE)

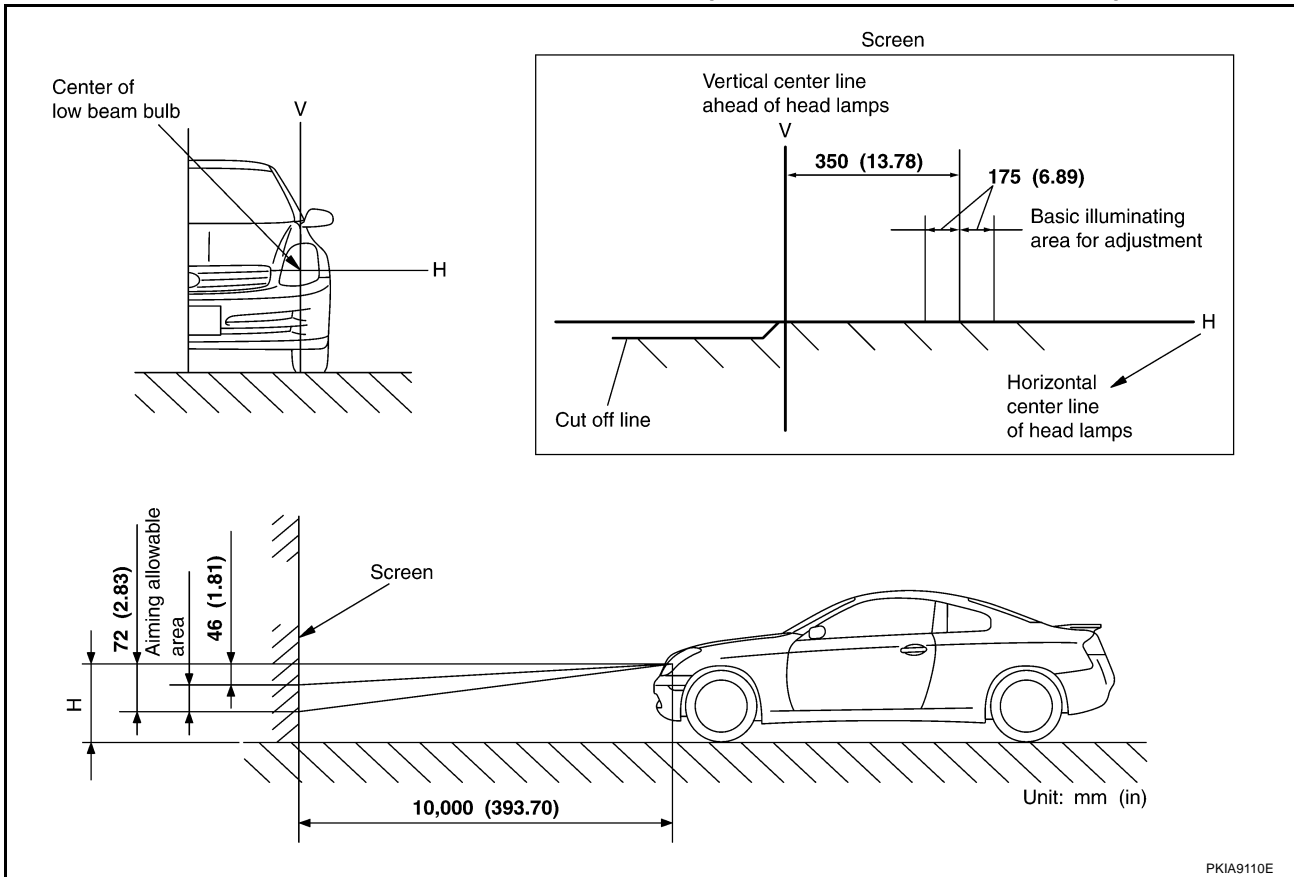

If the vehicle front body has been repaired and/or the headlamp assembly has been replaced, check aiming. Use the aiming chart shown in the figure.

- Basic illumination area for adjustment should be within the range shown on the aiming chart. Adjust headlamp accordingly.

Bulb Replacement HEADLAMP (UPPER) LOW BEAM

AKS00ACR

1. Turn lighting switch OFF.
2. Remove headlamp. Refer to [LT-35, "Removal and Installation"](#).
3. Turn plastic cap counterclockwise and unlock it.
4. Turn bulb socket counterclockwise and unlock it.
5. Unlock retaining spring and remove bulb from headlamp.
6. Install in reverse order of removal.

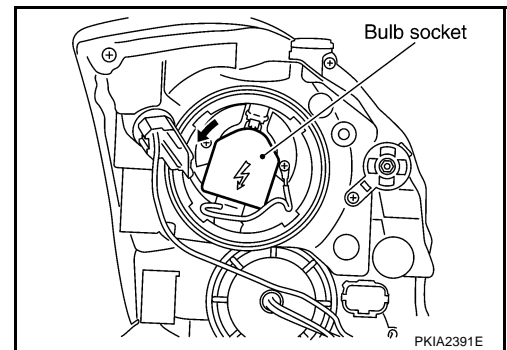

HEADLAMP (LOWER) HIGH BEAM/FOG LAMP

1. Turn lighting switch OFF.
2. Disconnect battery negative cable or remove power fuse.
3. Remove fender protector (front). Refer to [EI-21, "FENDER PROTECTOR"](#) in "EI" section.
4. Turn plastic cap counterclockwise and unlock it.
5. Disconnect bulb terminal.
6. Unlock retaining spring and remove bulb from headlamp.
7. Install in the reverse order of removal.

HEADLAMP (FOR USA)

PARKING LAMP (CLEARANCE LAMP)

1. Turn lighting switch OFF.
2. Remove fender protector (front). Refer to [EI-21, "FENDER PROTECTOR"](#) in "EI" section.
3. Turn bulb socket counterclockwise and unlock it.
4. Remove bulb from its socket.
5. Install in the reverse order of removal.

FRONT TURN SIGNAL AND PARKING LAMP

1. Turn lighting switch OFF.
2. Remove fender protector (front). Refer to [EI-21, "FENDER PROTECTOR"](#) in "EI" section.
3. Turn bulb socket counterclockwise and unlock it.
4. Remove bulb from its socket.
5. Install in the reverse order of removal.

Headlamp (upper) low beam (Xenon) : 12V - 35W (D2R)

Headlamp (lower) high beam/Fog lamp : 12V - 60/55W (HB2)

Parking lamp (Clearance lamp) : 12V - 5W

Front turn signal and parking lamp : 12V - 21/5W

CAUTION:

After installing bulb, be sure to install plastic cap and bulb socket securely to insure watertightness.

Removal and Installation

REMOVAL

1. Disconnect battery negative cable or remove power fuse.
2. Remove front bumper. Refer to [EI-14, "FRONT BUMPER"](#) in "EI" section.

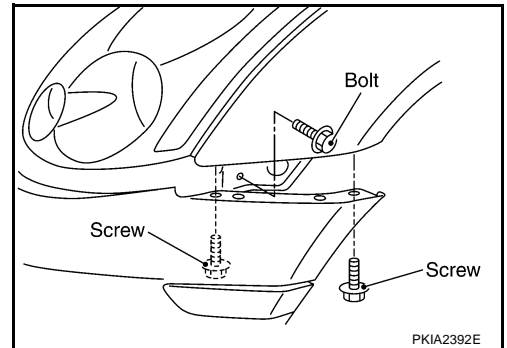

3. Remove headlamp mounting bolts.
4. Pull headlamp toward vehicle front, disconnect connector, and remove headlamp.

CAUTION:

When removing headlamps, put a shop cloth or something similar between headlamps and bumper to protect bumper.

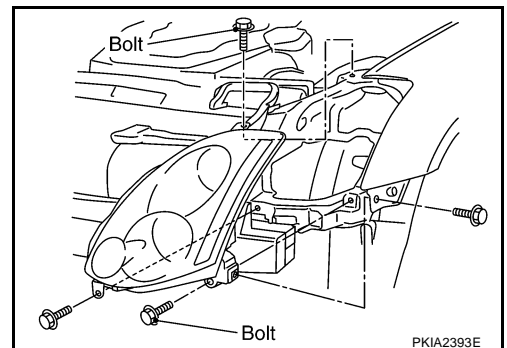

INSTALLATION

Install in the reverse order of removal. Be careful of the following:

Headlamp mounting bolt  : 5.0 N·m (0.51 kg·m, 44 in·lb)

A
B
C
D
E
F
G
H
I
J
LT
L
M

HEADLAMP (FOR USA)

Disassembly

AKS00ACT

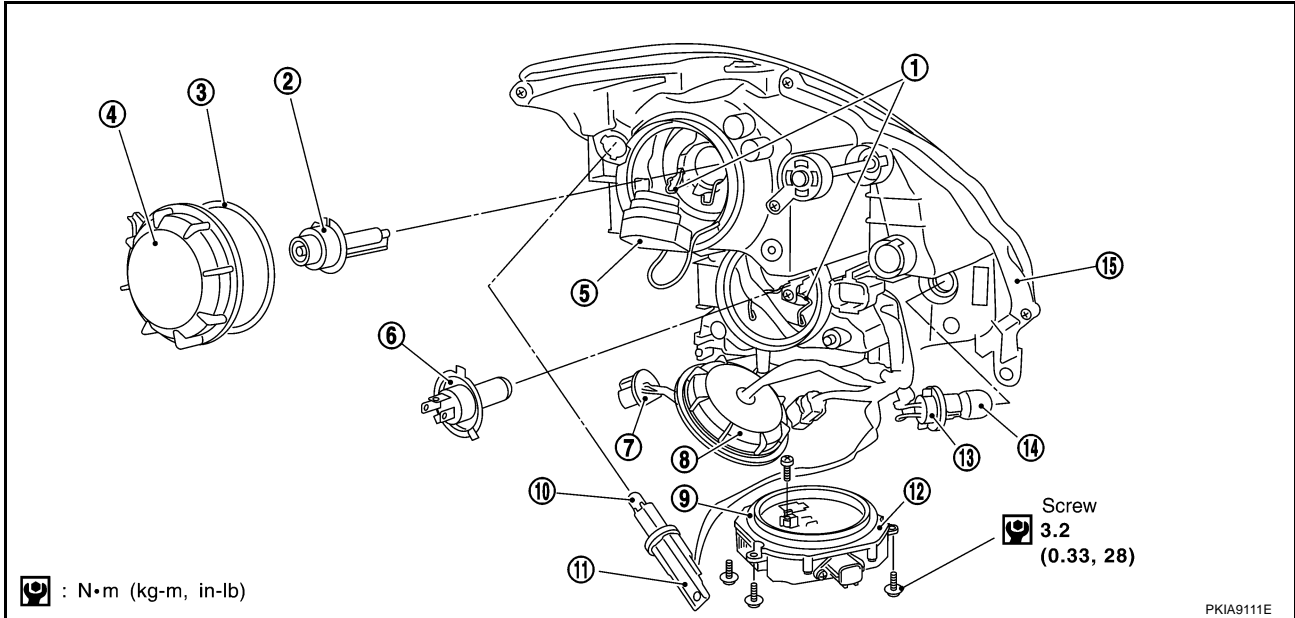

- | | | |
|--|---|-------------------------------|
| 1. Retaining spring | 2. Xenon bulb | 3. Seal rubber |
| 4. Plastic cap (low) | 5. Xenon bulb socket | 6. Halogen bulb (high/fog) |
| 7. Halogen bulb socket | 8. Plastic cap (high/fog) | 9. Seal packing |
| 10. Parking lamp (Clearance lamp) bulb | 11. Parking lamp (Clearance lamp) bulb socket | 12. HID C/U |
| 13. Front turn signal and parking lamp bulb socket | 14. Front turn signal and parking lamp bulb | 15. Headlamp housing assembly |

1. Turn plastic cap (low) counterclockwise and unlock it.
2. Turn xenon bulb socket counterclockwise, and unlock it. (Xenon)
3. Unlock retaining spring, and remove xenon bulb (low). (Xenon)
4. Unlock retaining spring, and remove halogen bulb (low). (Halogen)
5. Disconnect HID control unit connector, and remove HID control unit screws. (Xenon)
6. Turn plastic cap (high/fog) counterclockwise, and unlock it.
7. Disconnect the terminal connected to the halogen bulb.
8. Unlock retaining spring, and remove halogen bulb (high/fog).
9. Turn clearance lamp bulb socket counterclockwise and unlock it.
10. Remove clearance lamp bulb from its socket.
11. Turn front turn signal lamp bulb socket counterclockwise and unlock it.
12. Remove front turn signal lamp bulb from its socket.

Assembly

AKS00ACU

Assemble in reverse order of disassembly. Be careful of the following:

HID control unit  : **3.2 N-m (0.33 kg-m, 28 in-lb)**

CAUTION:

- When HID control unit is removed, reinstall it securely and avoid any looseness.
- After installing bulb, be sure to install plastic cap and bulb socket securely to insure watertightness.

HEADLAMP (FOR USA)

Servicing to Replace Headlamps When Damaged

If only installation part as shown in the figure is damaged, and headlamp housing itself is not damaged, repair can be completed easily by installing correction brackets.

AKS00ACV

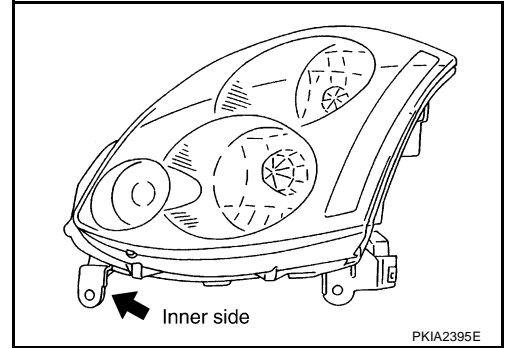

REMOVAL AND INSTALLATION

1. Remove headlamps. Refer to [LT-35, "Removal and Installation"](#).
2. Cut damaged section of installation part, then shape with sandpaper.
3. Attach Inner side bracket to headlamp housing boss with 2 screws.

RH headlamp	Inner side	26040 AM800
LH headlamp	Inner side	26090 AM800

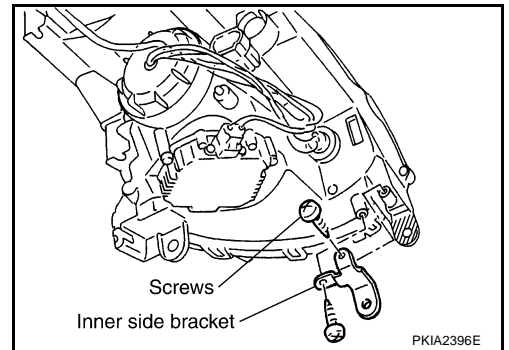

A
B
C
D
E
F
G
H
I
J
LT
L
M

HEADLAMP (FOR CANADA) - DAYTIME LIGHT SYSTEM -

HEADLAMP (FOR CANADA) - DAYTIME LIGHT SYSTEM -

PFP:26010

Component Parts and Harness Connector Location

AKS00ACW

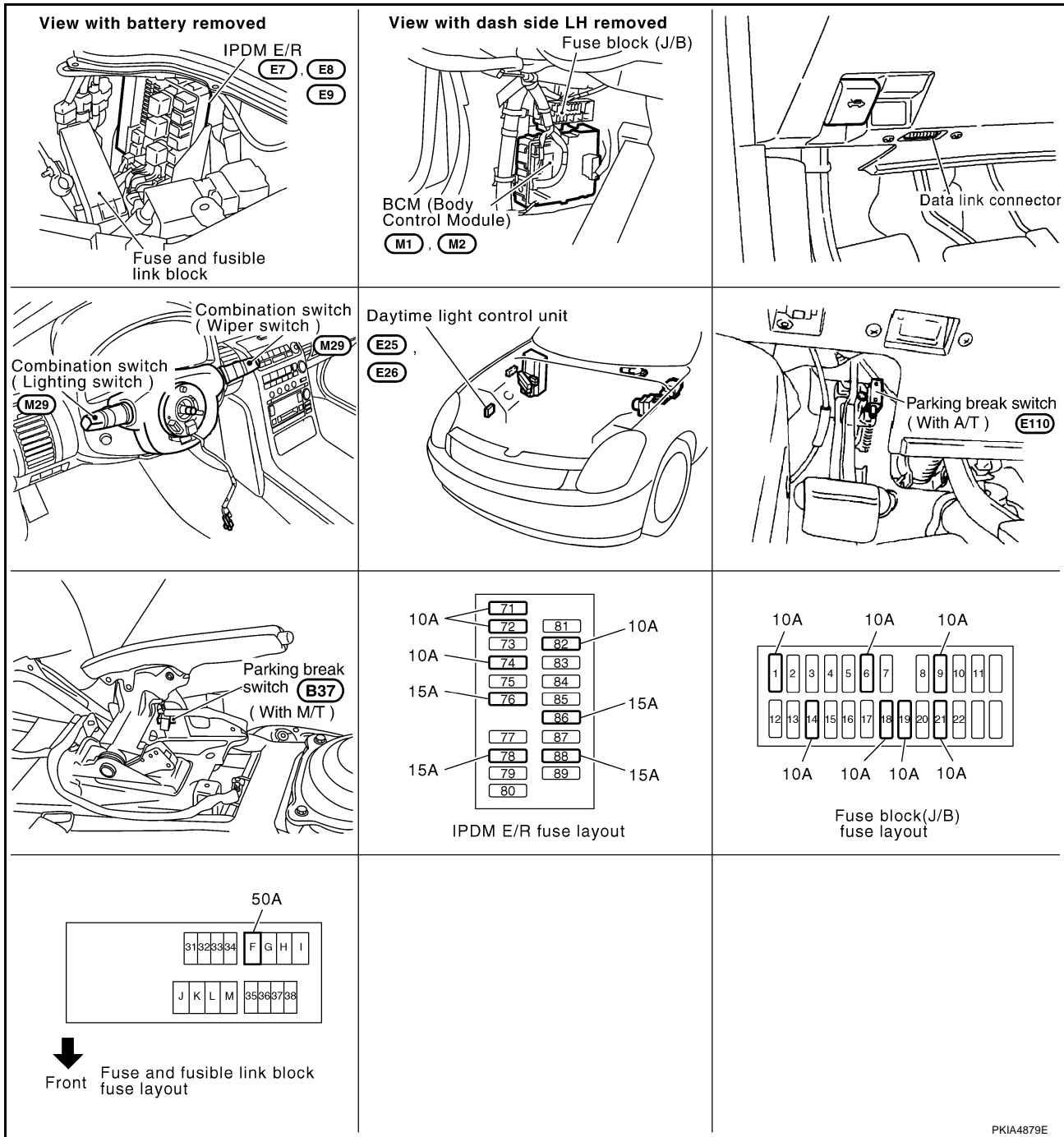

PKIA4879E

System Description

AKS00ACX

The headlamp system for Canada vehicles is equipped with a daytime light control unit that activates the high beam headlamps at approximately half illumination whenever the engine is running. If the parking brake is applied before the engine is started the daytime lights will not be illuminated. The daytime lights will illuminate once the parking brake is released. Thereafter, the daytime lights will continue to operate when the parking brake is applied.

And battery saver system is controlled by the BCM (body control module).

Power is supplied at all times

- to ignition relay [located in IPDM E/R (intelligent power distribution module engine room)]
- to headlamp high relay [located in IPDM E/R (intelligent power distribution module engine room)]
- to headlamp low relay [located in IPDM E/R (intelligent power distribution module engine room)]

HEADLAMP (FOR CANADA) - DAYTIME LIGHT SYSTEM -

- to CPU (central processing unit) [located in IPDM E/R (intelligent power distribution module engine room)]
- through 15A fuse [No. 78, located in IPDM E/R (intelligent power distribution module engine room)]
- through 10A fuse [No. 71, located in IPDM E/R (intelligent power distribution module engine room)]
- to combination meter terminal 43
- through 10A fuse [No. 19, located in IPDM E/R (intelligent power distribution module engine room)]
- to daytime light control unit terminals 2 and 3
- through 10A fuse [No. 21, located in fuse block (J/B)].

Power is also supplied at all times

- to BCM (body control module) terminal 55
- through 50A fusible link [letter F, located in fuse and fusible link block].

With the ignition switch in the ON or START position, power is supplied

- to ignition relay [located in IPDM E/R (intelligent power distribution module engine room)]
- to daytime light control unit terminal 12
- through 10A fuse [No. 82, located in IPDM E/R (intelligent power distribution module engine room)]
- to BCM (body control module) terminal 38
- through 10A fuse [No. 1, located in fuse block (J/B)]
- to combination meter terminals 41 and 42
- through 10A fuse [No. 14, located in fuse block (J/B)].

With the ignition switch in the ACC or ON position, power is supplied

- to BCM (body control module) terminal 11
- through 10A fuse [No. 6, located in fuse block (J/B)].

With the ignition switch in the START position, power is supplied

- to daytime light control unit terminal 1
- through 10A fuse [No. 9, located in fuse block (J/B)].

Ground is supplied

- to daytime light control unit terminal 9
- through grounds E17 and E43
- to BCM (body control module) terminal 52
- through grounds M30 and M66
- to IPDM E/R (intelligent power distribution module engine room) terminals 38 and 60
- through grounds E17 and E43
- to combination meter terminals 45 and 46
- through grounds M30 and M66.

HEADLAMP OPERATION

Low Beam Operation

With the lighting switch in 2ND position, the BCM receives input signal requesting the headlamps to illuminate. This input signal is communicated to the IPDM E/R across the CAN communication lines. The CPU in the IPDM E/R controls the headlamp low relay coil, which when energized, directs power

- to 15A fuse [No. 76, located in IPDM E/R]
- through IPDM E/R terminal 20
- to headlamp RH terminal 3 and
- to 15A fuse [No. 86, located in IPDM E/R]
- through IPDM E/R terminal 30
- to headlamp LH terminal 3.

Ground is supplied at all times

- to headlamp RH terminal 4
- through grounds E17 and E43
- to headlamp LH terminal 4
- through grounds E17 and E43.

A
B
C
D
E
F
G
H
I
J
LT
L
M

HEADLAMP (FOR CANADA) - DAYTIME LIGHT SYSTEM -

With power and ground supplied, low beam headlamps illuminate.

High Beam Operation (When engine stopped)/Flash-to-Pass Operation

With the lighting switch in 2ND position and placed in HIGH or PASS position, the BCM receives input signal requesting the headlamp high beams to illuminate. This input signal is communicated to the IPDM E/R across the CAN communication lines. The CPU in the IPDM E/R controls the headlamp high relay coil and daytime light relay-2 turned on, which when energized, directs power

- to 10A fuse [No. 74, located in IPDM E/R]
- through IPDM E/R terminal 28
- to IPDM E/R terminal 28
- through daytime light control unit terminal 5
- to daytime light control unit terminal 6
- through headlamp LH terminal 2
- to 10A fuse [No. 72, located in IPDM E/R]
- through IPDM E/R terminal 27
- to IPDM E/R terminal 27
- through daytime light relay-2 terminal 2 and
- through daytime light control unit terminal 1
- to 10A fuse [No. 72, located in IPDM E/R]
- through IPDM E/R terminal 27
- to IPDM E/R terminal 27
- through daytime light relay-2 terminal 5
- to daytime light relay-2 terminal 3
- through headlamp RH terminal 2.

Ground is supplied

- to daytime light relay-2 terminal 1
- through grounds E17 and E43
- to headlamp RH terminal 8
- through grounds E17 and E43
- to headlamp LH terminal 8
- through daytime light control unit terminal 7
- to headlamp RH terminal 4
- through grounds E17 and E43
- to headlamp LH terminal 4
- through grounds E17 and E43
- to daytime light control unit terminal 9
- through grounds E17 and E43.

When power and ground supplied, the high beam headlamps illuminate.

High beam indicator illuminates when combination meter receives input signal requesting high beam indicator to illuminate. This is communicated to BCM across the CAN communication lines.

COMBINATION SWITCH READING FUNCTION

Refer to [BCS-3, "COMBINATION SWITCH READING FUNCTION"](#) .

EXTERIOR LAMP BATTERY SAVER CONTROL

With the combination switch (lighting switch) is in the 2ND position (ON), and the ignition switch is turned from ON or ACC to OFF, the battery saver control function is activated.

Under this condition, the headlamps remain illuminated for 5 minutes, then the headlamps are turned off. Exterior lamp battery saver control made can be changed by the function setting of CONSULT-II.

AUTO LIGHT OPERATION

For auto light operation, refer to [LT-71, "System Description"](#) in "AUTO LIGHT SYSTEM".

HEADLAMP (FOR CANADA) - DAYTIME LIGHT SYSTEM -

DAYTIME LIGHT OPERATION

With the engine running, the lighting switch in the OFF or 1ST position and parking brake released, power is supplied

- through daytime light control unit terminal 6
- to headlamp LH terminal 2
- through headlamp LH terminal 8
- to daytime light control unit terminal 7
- through daytime light control unit terminal 8
- to headlamp RH terminal 2.

Ground is supplied

- to headlamp RH terminal 8
- through grounds E17 and E43
- to daytime light control unit terminal 9
- through grounds E17 and E43.

Because the high beam headlamps are now wired in series, they operate at half illumination.

If the lighting switch is in the HIGH position, daytime light operation is canceled. On this occasion, power is supplied

- through IPDM E/R terminal 24
- to daytime light control unit terminal 1.

Daytime light control unit is canceled power supplying from headlamp RH terminal 8 to terminal 2 (series power supplying is canceled). And then high beam is ON.

OPERATION

After starting the engine with the lighting switch in the "OFF" or 1ST position, the headlamp high beam automatically turns on. Lighting switch operations other than the above are the same as conventional light systems.

Engine		With engine stopped												With engine running											
Lighting switch		OFF				1ST				2ND				OFF				1ST				2ND			
		Hi	Lo	P	F	Hi	Lo	P	F	Hi	Lo	P	F	Hi	Lo	P	F	Hi	Lo	P	F	Hi	Lo	P	F
Head-lamp	High beam	-	-	x	-	-	-	x	-	x	-	x	-	● *	● *	x	-	● *	● *	x	-	x	-	x	-
	Low beam	-	-	x	-	-	-	x	-	x	x	x	x	-	-	x	-	-	-	x	-	x	x	x	x
Tail lamp		-	-	-	-	x	x	x	x	x	x	x	x	-	-	-	-	x	x	x	x	x	x	x	x
License plate and instrument illumination lamp		-	-	-	-	x	x	x	x	x	x	x	x	-	-	-	-	x	x	x	x	x	x	x	x

- Hi: "HIGH BEAM" position
- Lo: "LOW BEAM" position
- P: "FLASH TO PASS" position
- F: "FOG LAMP" SW is ON
- x: Lamp "ON"
- -: Lamp "OFF"
- ●: Lamp dims. (Added functions)
- *: When starting the engine with the parking brake released, the daytime light will come ON.
When starting the engine with the parking brake pulled, the daytime light will not come ON.

HEADLAMP (FOR CANADA) - DAYTIME LIGHT SYSTEM -

XENON HEADLAMP

Xenon type headlamp is adopted to the low beam headlamps. Xenon bulbs do not use a filament. Instead, they produce light when a high voltage current is passed between two tungsten electrodes through a mixture of xenon (an inert gas) and certain other metal halides. In addition to added lighting power, electronic control of the power supply gives the headlamps stable quality and tone color.

Following are some of the many advantages of the xenon type headlamp.

- The light produced by the headlamps is a white color comparable to sunlight that is easy on the eyes.
- Light output is nearly double that of halogen headlamps, affording increased area of illumination.
- The light features a high relative spectral distribution at wavelengths to which the human eye is most sensitive. This means that even in the rain, more light is reflected back from the road surface toward the vehicle, for added visibility.
- Power consumption is approximately 25 percent less than halogen headlamps, reducing battery load.

CAN Communication System Description

AKS00ACY

CAN (Controller Area Network) is a serial communication line for real time application. It is an on-vehicle multiplex communication line with high data communication speed and excellent error detection ability. Many electronic control units are equipped onto a vehicle, and each control unit shares information and links with other control units during operation (not independent). In CAN communication, control units are connected with 2 communication lines (CAN H line, CAN L line) allowing a high rate of information transmission with less wiring. Each control unit transmits/receives data but selectively reads required data only.

CAN Communication Unit

AKS00ACZ

Refer to [LAN-4, "CAN Communication Unit"](#) .

HEADLAMP (FOR CANADA) - DAYTIME LIGHT SYSTEM -

Schematic

AKS00ADO

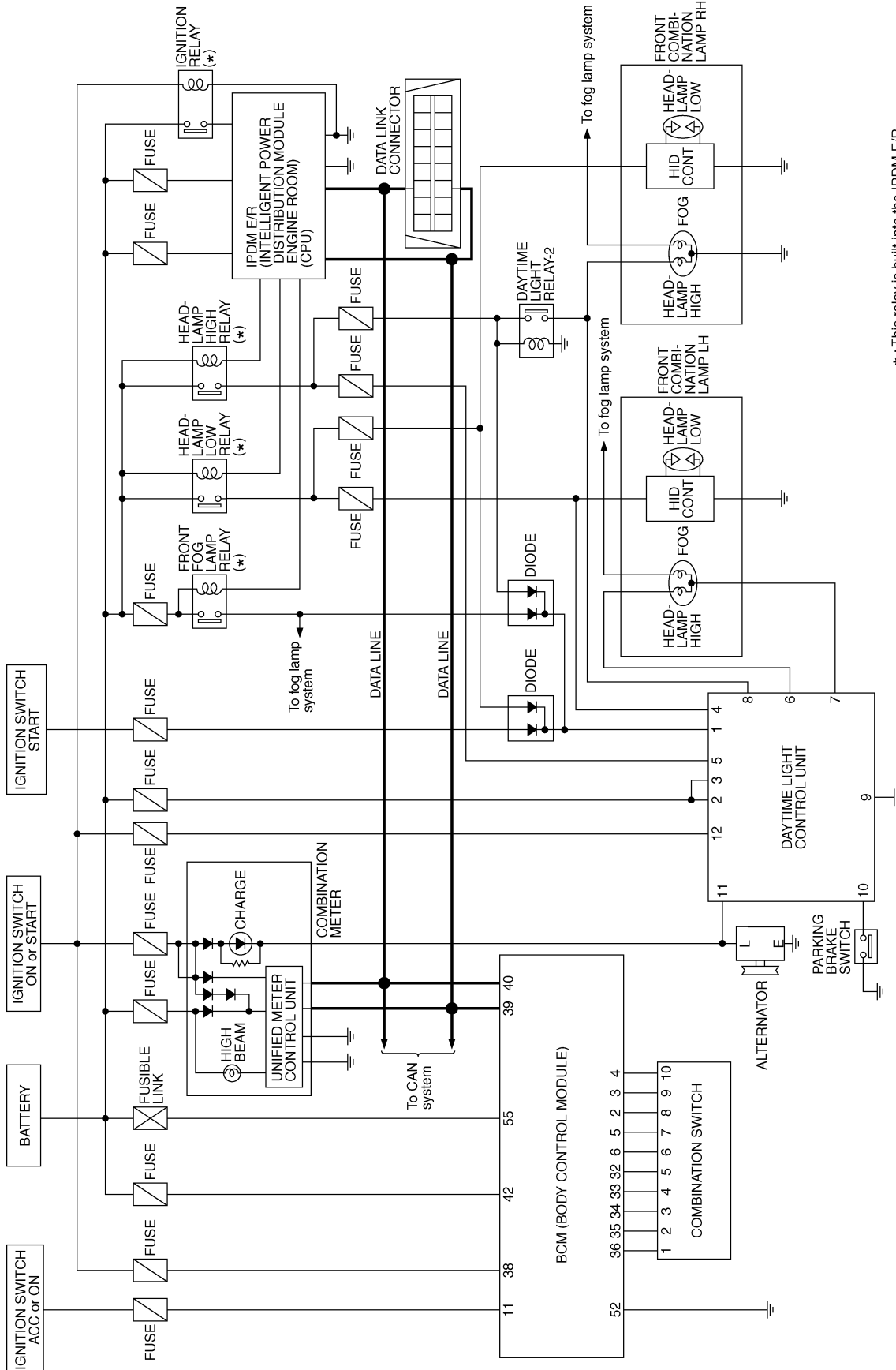

* : This relay is built into the IPDM E/R (intelligent power distribution module engine room).

A
B
C
D
E
F
G
H
I
J
K
L
M

LT

HEADLAMP (FOR CANADA) - DAYTIME LIGHT SYSTEM -

AKS00AD1

LT-DTRL-01

Wiring Diagram — DTRL —

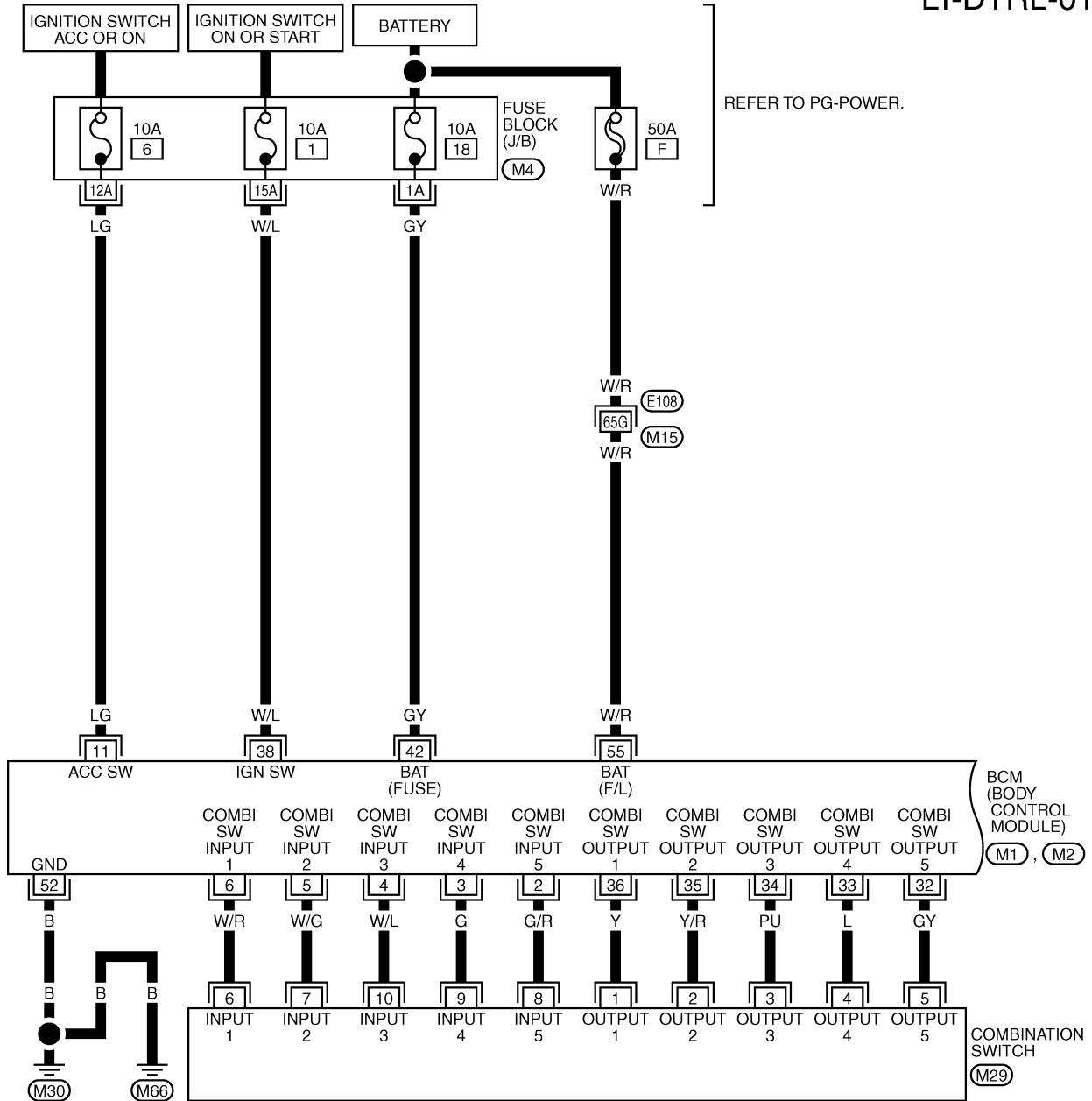

REFER TO PG-POWER.

BCM
(BODY
CONTROL
MODULE)

(M1) , (M2)

COMBINATION
SWITCH

(M29)

7	8	9	10	13	12
6	5	4	3	2	1

(M29)
W

REFER TO THE FOLLOWING.

(E108) -SUPER MULTIPLE
JUNCTION (SMJ)

(M4) -FUSE BLOCK-JUNCTION
BOX (J/B)

(M1) , (M2) -ELECTRICAL
UNITS

TKWM0855E

HEADLAMP (FOR CANADA) - DAYTIME LIGHT SYSTEM -

LT-DTRL-02

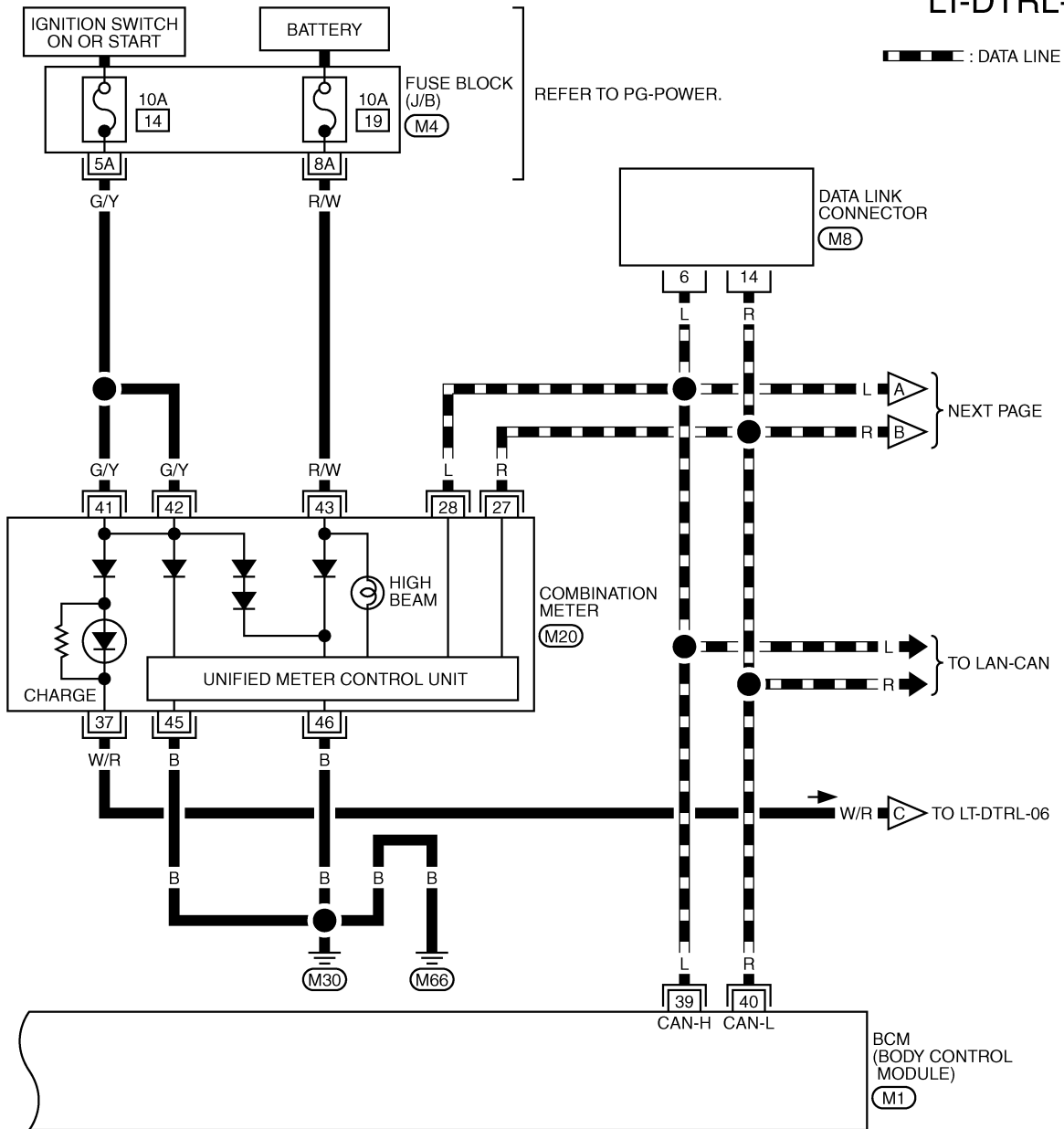

A
B
C
D
E
F
G
H
I
J
LT
L
M

16	15	14	13	12	11	10	9
8	7	6	5	4	3	2	1

(M8)
W

25	26	27	28	29	30	31	32	33	34	35		
36	37	38	39	40	41	42	43	44	45	46	47	48

(M20)
W

REFER TO THE FOLLOWING.
 (M4) - FUSE BLOCK-JUNCTION BOX (J/B)
 (M1) - ELECTRICAL UNITS

TKWM0856E

HEADLAMP (FOR CANADA) - DAYTIME LIGHT SYSTEM -

LT-DTRL-03

▬ : DATA LINE

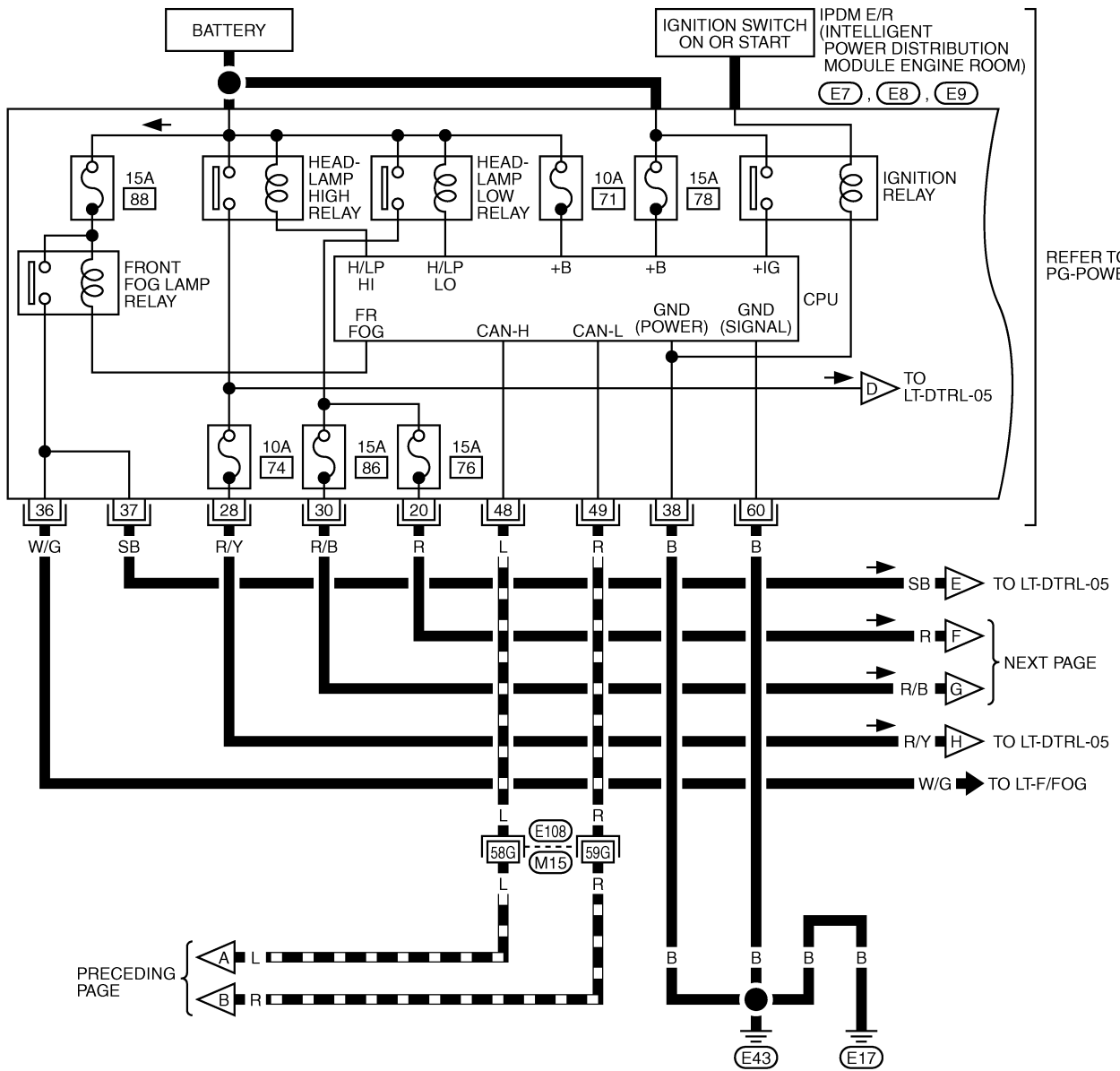

REFER TO PG-POWER.

REFER TO THE FOLLOWING.

(E108) -SUPER MULTIPLE JUNCTION (SMJ)

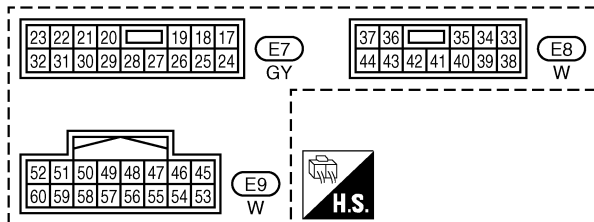

HEADLAMP (FOR CANADA) - DAYTIME LIGHT SYSTEM -

LT-DTRL-04

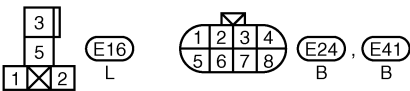
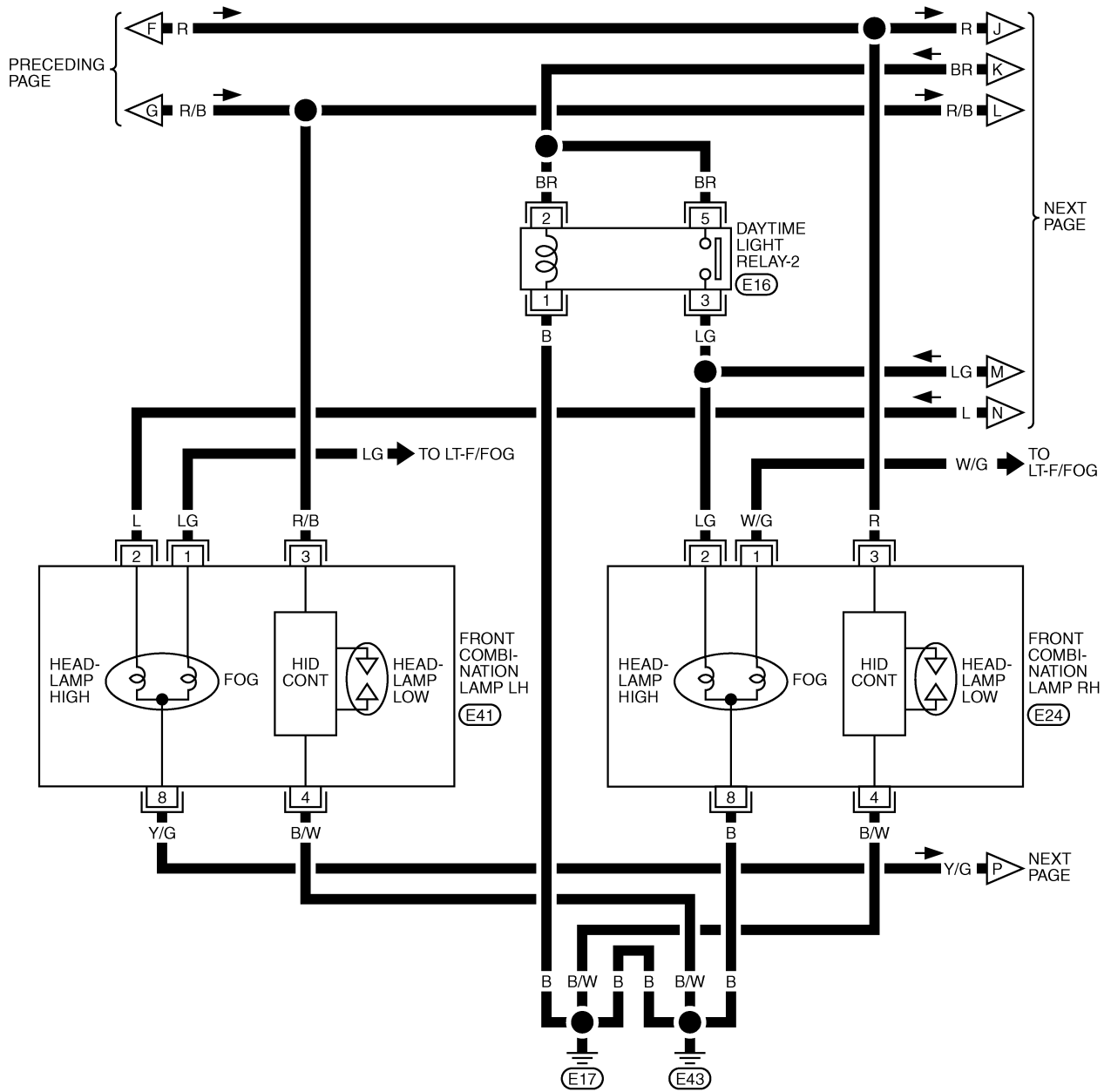

TKWM0858E

HEADLAMP (FOR CANADA) - DAYTIME LIGHT SYSTEM -

LT-DTRL-05

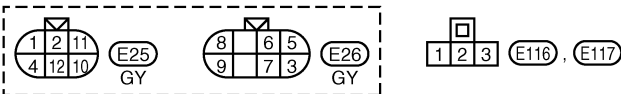
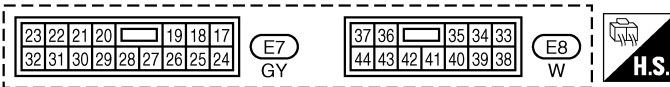
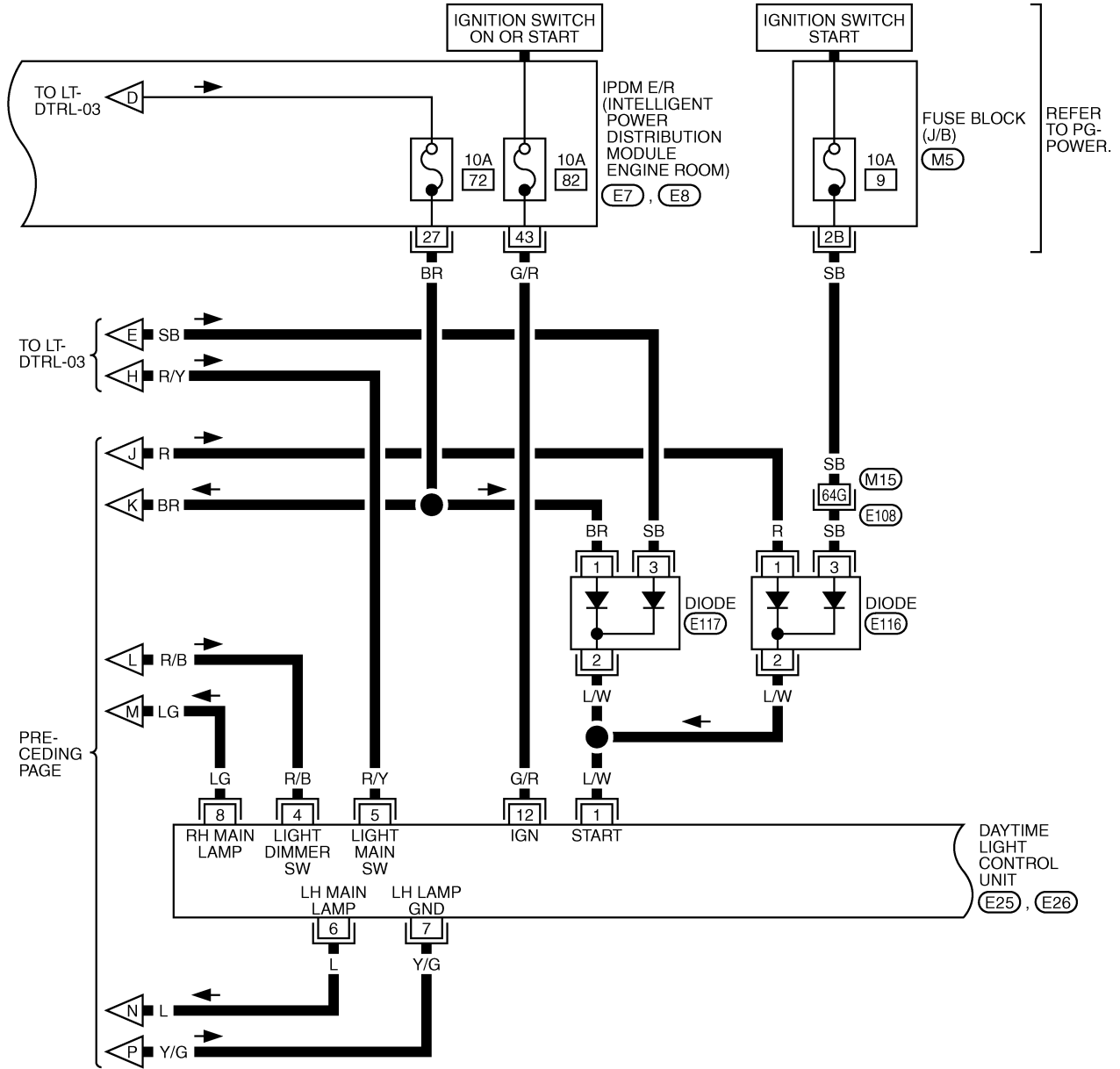

REFER TO THE FOLLOWING.

- (E108) -SUPER MULTIPLE JUNCTION (SMJ)
- (M5) -FUSE BLOCK-JUNCTION BOX (J/B)

TKWM0859E

HEADLAMP (FOR CANADA) - DAYTIME LIGHT SYSTEM -

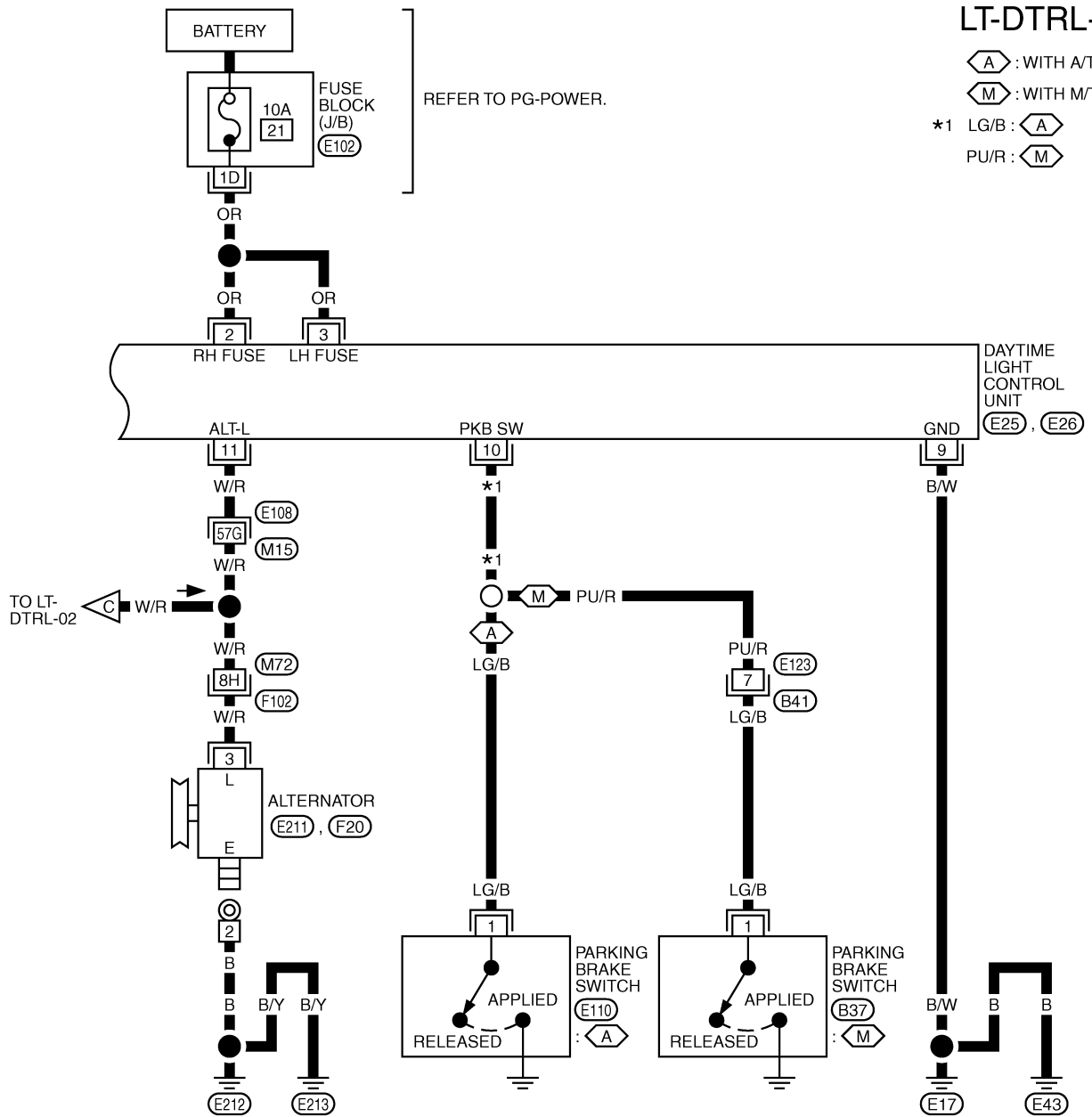

A
B
C
D
E
F
G
H
I
J
K
L
M

LT

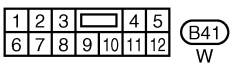
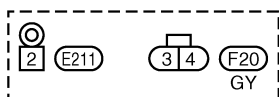
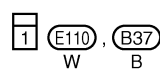
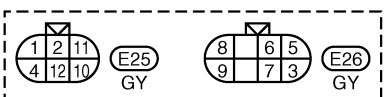

REFER TO THE FOLLOWING.

(E108), (F102) -SUPER MULTIPLE JUNCTION (SMJ)

(E102) -FUSE BLOCK-JUNCTION BOX (J/B)

HEADLAMP (FOR CANADA) - DAYTIME LIGHT SYSTEM -

Terminals and Reference Values for Daytime Light Control Unit



AKS00AD2

Terminal No.	Wire color	Item	Condition	Reference value
1	L/W	Start signal	When turning ignition switch to "START"	Battery voltage
			When turning ignition switch to "ON" from "START"	Approx. 0V
			When turning ignition switch to "OFF"	Approx. 0V
2	OR	RH light fuse	—	Battery voltage
3	OR	LH light fuse	—	Battery voltage
4	R/B	Light dimmer switch	When turning lighting switch to "LOW BEAM"	Battery voltage
5	R/Y	Light main switch	When turning lighting switch to "HI BEAM"	Battery voltage
6	L	LH main lamp	When lighting switch is turned to the 2ND position with "HI BEAM" or "FLASH TO PASS" position	Battery voltage
			When releasing parking brake with engine running and turning lighting switch to "OFF" (daytime light operation) CAUTION: Block wheels and ensure selector lever is in N or P position.	Battery voltage
7	Y/G	LH lamp (Ground)	When turning lighting switch to the 2ND position with "HI BEAM" or "FLASH TO PASS" position	Approx. 0V
			When releasing parking brake with engine running and turning lighting switch to "OFF" (daytime light operation) CAUTION: Block wheels and ensure selector lever is in N or P position.	Approx. 0V
8	LG	RH main lamp	When lighting switch is turned to the 2ND position with "HI BEAM" or "FLASH TO PASS" position	Battery voltage
			When releasing parking brake with engine running and turning lighting switch to "OFF" (daytime light operation) CAUTION: Block wheels and ensure selector lever is in N or P position.	Battery voltage
9	B/W	Ground	—	—
10	LG/B (A/T)	Parking brake switch	When parking brake is released	Battery voltage
			When parking brake is applied	Approx. 0V
	PU/R (M/T)	Parking brake switch	When parking brake is released	Battery voltage
			When parking brake is applied	Approx. 0V
11	W/R	Alternator	When turning ignition switch to "ON"	Approx. 0V
			When engine is running	Battery voltage
			When turning ignition switch to "OFF"	Approx. 0V
12	G/R	Ignition power supply	When turning ignition switch to "ON"	Battery voltage

HEADLAMP (FOR CANADA) - DAYTIME LIGHT SYSTEM -

Terminals and Reference Values for BCM

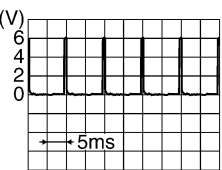
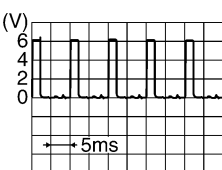
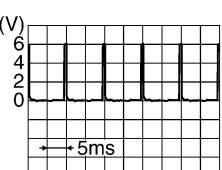
AKS00AD3

Terminal No.	Wire color	Signal name	Measuring condition		Reference value
			Ignition switch	Operation or condition	
2	G/R	Combination switch input 5	ON	Lighting, turn, wiper OFF Wiper dial position 4	 <p style="text-align: right;">SKIA5291E</p>
3	G	Combination switch input 4	ON	Lighting, turn, wiper OFF Wiper dial position 4	 <p style="text-align: right;">SKIA5292E</p>
4	W/L	Combination switch input 3	ON	Lighting, turn, wiper OFF Wiper dial position 4	 <p style="text-align: right;">SKIA5291E</p>
5	W/G	Combination switch input 2	ON	Lighting, turn, wiper OFF Wiper dial position 4	 <p style="text-align: right;">SKIA5292E</p>
6	W/R	Combination switch input 1			
11	LG	Ignition switch (ACC)	ACC	—	Battery voltage
32	GY	Combination switch output 5	ON	Lighting, turn, wiper OFF Wiper dial position 4	 <p style="text-align: right;">SKIA5291E</p>
33	L	Combination switch output 4	ON	Lighting, turn, wiper OFF Wiper dial position 4	 <p style="text-align: right;">SKIA5292E</p>

A
B
C
D
E
F
G
H
I
J
LT
L
M

HEADLAMP (FOR CANADA) - DAYTIME LIGHT SYSTEM -

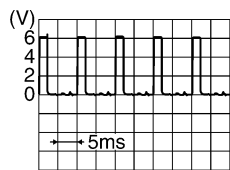
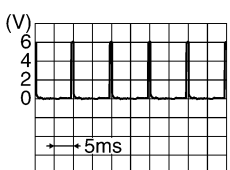
Terminal No.	Wire color	Signal name	Measuring condition		Reference value
			Ignition switch	Operation or condition	
34	PU	Combination switch output 3	ON	Lighting, turn, wiper OFF Wiper dial position 4	 SKIA5291E
35	Y/R	Combination switch output 2	ON	Lighting, turn, wiper OFF Wiper dial position 4	 SKIA5292E
36	Y	Combination switch output 1			
38	W/L	Ignition switch (ON)	ON	—	Battery voltage
39	L	CAN- H	—	—	—
40	R	CAN- L	—	—	—
42	G/Y	Battery power supply	OFF	—	Battery voltage
52	B	Ground	ON	—	Approx. 0V
55	WR	Battery power supply	OFF	—	Battery voltage

Terminals and Reference Values for IPDM E/R

AKS00AD4

Terminal No.	Wire color	Signal name	Measuring condition		Reference value	
			Ignition switch	Operation or condition		
20	R	Headlamp low (RH)	ON	Lighting switch 2ND position	OFF	Approx. 0V
					ON	Battery voltage
27	BR	Headlamp high (LH)	ON	Lighting switch HIGH or PASS position	OFF	Approx. 0V
					ON	Battery voltage
28	RY	Headlamp high (RH)	ON	Lighting switch HIGH or PASS position	OFF	Approx. 0V
					ON	Battery voltage
30	R/B	Headlamp low (LH)	ON	Lighting switch 2ND position	OFF	Approx. 0V
					ON	Battery voltage
36	W/G	Front fog lamp	ON	Lighting switch must be in the 2ND position or AUTO position (LOW beam is ON) and the front fog lamp switch must be ON.	OFF	Approx. 0V
					ON	Battery voltage
37	SB	Front fog lamp	ON	Lighting switch must be in the 2ND position or AUTO position (LOW beam is ON) and the front fog lamp switch must be ON.	OFF	Approx. 0V
					ON	Battery voltage
38	B	Ground	ON	—	Approx. 0V	
43	G/R	Ignition power supply	ON	When turning ignition switch to "ON"	Battery voltage	
48	L	CAN- H	—	—	—	
49	R	CAN- L	—	—	—	
60	B	Ground	ON	—	Approx. 0V	

How to Proceed With Trouble Diagnosis

AKS00AD5

1. Confirm the symptom or customer complaint.
2. Understand operation description and function description. Refer to [LT-38, "System Description"](#).

HEADLAMP (FOR CANADA) - DAYTIME LIGHT SYSTEM -

3. Perform the preliminary check. Refer to [LT-53, "Preliminary Check"](#).
4. Check symptom and repair or replace the cause of malfunction.
5. Does the headlamp operate normally? If YES: GO TO 6. If NO: GO TO 4.
6. INSPECTION END

Preliminary Check CHECK POWER SUPPLY AND GROUND CIRCUIT

AKS00AD6

1. CHECK FUSES

- Check for blown fuses.

Unit	Power source	Fuse and fusible link No.
BCM	Battery	F
		18
	Ignition switch ON or START position	1
	Ignition switch ACC or ON position	6
IPDM E/R	Battery	72
		74
		76
		86
	Ignition switch ON or START	82
DAYTIME LIGHT CONTROL UNIT	Battery	21
	Ignition switch START position	9

Refer to [LT-44, "Wiring Diagram — DTRL —"](#).

OK or NG

OK >> GO TO 2.

NG >> If fuse is blown, be sure to eliminate cause of malfunction before installing new fuse. Refer to [PG-4, "POWER SUPPLY ROUTING CIRCUIT"](#).

2. CHECK POWER SUPPLY CIRCUIT

1. Turn ignition switch OFF.
2. Disconnect BCM connector.
3. Check voltage between BCM harness connector and ground.

Terminals		(-)	Ignition switch position		
(+)	Terminal (Wire color)		OFF	ACC	ON
M1	11 (LG)	Ground	0V	Battery voltage	Battery voltage
	38 (W/L)		0V	0V	Battery voltage
M2	42 (GY)		Battery voltage	Battery voltage	Battery voltage
	55 (W/R)		Battery voltage	Battery voltage	Battery voltage

OK or NG

OK >> GO TO 3.

NG >> Check harness for open or short between BCM and fuse.

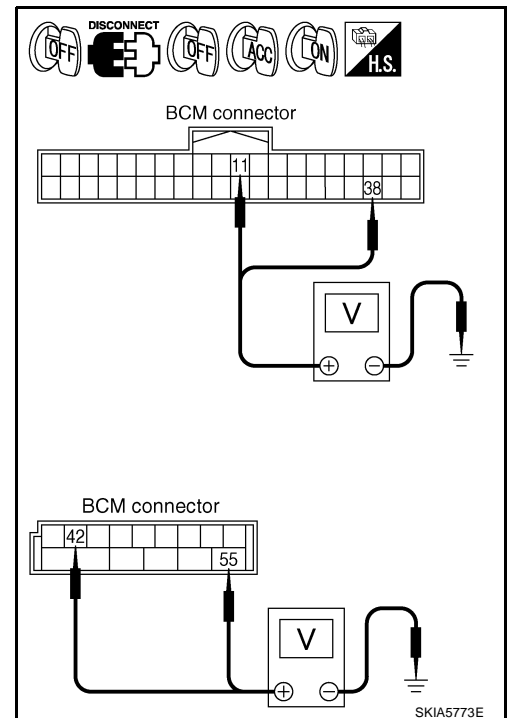

HEADLAMP (FOR CANADA) - DAYTIME LIGHT SYSTEM -

3. CHECK GROUND CIRCUIT

Check continuity between BCM harness connector and ground.

Terminals			Continuity
Connector	Terminal (Wire color)	Ground	
M2	52 (B)	Ground	Yes

OK or NG

- OK >> INSPECTION END
- NG >> Check ground circuit harness.

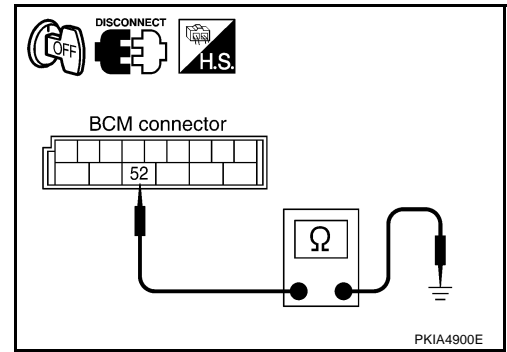

CONSULT-II Functions (BCM)

AKS00AD7

- CONSULT-II performs the following functions communicating with BCM.

BCM diagnosis part	Check item, diagnosis mode	Description
HEAD LAMP	DATA MONITOR	Displays BCM input data in real time.
	ACTIVE TEST	Operation of electrical loads can be checked by sending drive signal to them.
BCM	CAN DIAG SUPPORT MNTR	The result of transmit/receive diagnosis of CAN communication can be read.

CONSULT-II BASIC OPERATION

CAUTION:

If CONSULT-II is used with no connection of CONSULT-II CONVERTER, malfunctions might be detected in self-diagnosis depending on control unit which carry out CAN communication.

1. With the ignition switch OFF, connect CONSULT-II and CONSULT-II CONVERTER to the data link connector, then turn ignition switch ON.

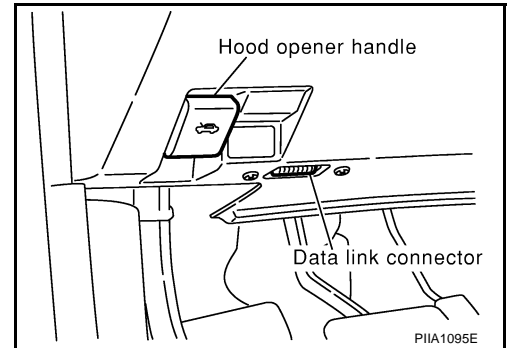

2. Touch "START (NISSAN BASED VHCL)".

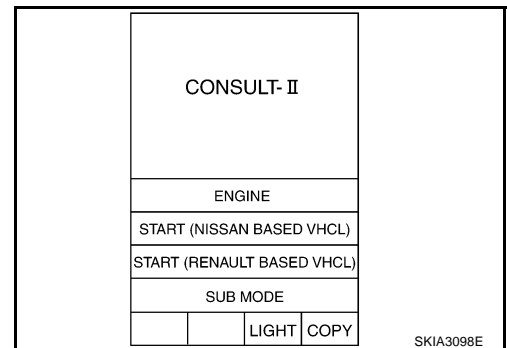

HEADLAMP (FOR CANADA) - DAYTIME LIGHT SYSTEM -

3. Touch "BCM" on "SELECT SYSTEM" screen.
If "BCM" is not indicated, refer to [GI-39, "CONSULT-II Data Link Connector \(DLC\) Circuit"](#)

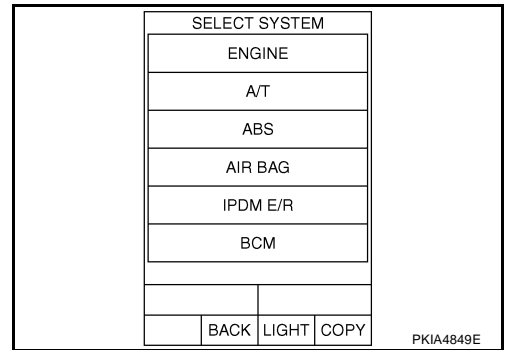

4. Touch "HEAD LAMP" on "SELECT TEST ITEM" screen.

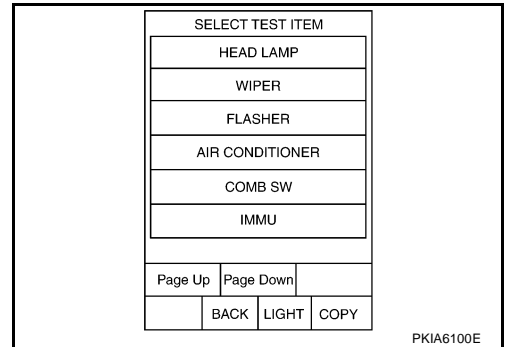

WORK SUPPORT

Operation Procedure

1. Touch "HEAD LAMP" on "SELECT TEST ITEM" screen.
2. Touch "WORK SUPPORT" on "SELECT DIAG MODE" screen.
3. Touch item on "SELECT WORK ITEM" screen.
4. Touch "START".
5. Touch "CHANGE SET".
6. The setting will be changed and "CUSTOMIZING COMPLETED" will be displayed.
7. Touch "END".

Display Item List

Item	Description	CONSULT-II	Factory setting
BATTERY SAVER SET	Exterior lamp battery saver control mode can be changed in this mode. Selects exterior lamp battery saver control mode between two ON/OFF.	ON	×
		OFF	—

DATA MONITOR

Operation Procedure

1. Touch "HEAD LAMP" on "SELECT TEST ITEM" screen.
2. Touch "DATA MONITOR" on "SELECT DIAG MODE" screen.
3. Touch either "ALL SIGNALS" or "SELECTION FROM MENU" on the "DATA MONITOR" screen.

ALL SIGNALS	Monitors all the signals.
SELECTION FROM MENU	Selects and monitors individual signal.

4. Touch "START".
5. When "SELECTION FROM MENU" is selected, touch individual items to be monitored. When "ALL SIGNALS" is selected, all the items will be monitored.
6. Touch "RECORD" while monitoring, then the status of the monitored item can be recorded. To stop recording, touch "STOP".

HEADLAMP (FOR CANADA) - DAYTIME LIGHT SYSTEM -

Display Item List

Monitor item		Contents
IGN ON SW	"ON/OFF"	Displays "IGN position (ON)/OFF, ACC position (OFF)" judged from the ignition switch signal.
ACC ON SW	"ON/OFF"	Displays "ACC (ON)/OFF, Ignition OFF (OFF)" status judged from ignition switch signal.
HI BEAM SW	"ON/OFF"	Displays status (high beam switch: ON/Others: OFF) of high beam switch judged from lighting switch signal.
HEAD LAMP SW 1	"ON/OFF"	Displays status (headlamp switch 1: ON/Others: OFF) of headlamp switch 2 judged from lighting switch signal.
HEAD LAMP SW 2	"ON/OFF"	Displays status (headlamp switch 2: ON/Others: OFF) of headlamp switch 2 judged from lighting switch signal.
LIGH SW 1 ST	"ON/OFF"	Displays status (lighting switch 1st position: ON/Others: OFF) of lighting switch judged from lighting switch signal.
AUTO LIGHT SW	"ON/OFF"	Displays status of the lighting switch as judged from the lighting switch signal. (AUTO position: ON/Other than AUTO position: OFF)
PASSING SW	"ON/OFF"	Displays status (flash-to-pass switch: ON/Others: OFF) of flash-to-pass switch judged from lighting switch signal.
FR FOG SW	"ON/OFF"	Displays status (front fog lamp switch: ON/Others: OFF) of front fog lamp switch judged from lighting switch signal.
DOOR SW - DR	"ON/OFF"	Displays status of the driver door as judged from the driver door switch signal. (Door is open: ON/Door is closed: OFF)
DOOR SW - AS	"ON/OFF"	Displays status of the passenger door as judged from the passenger door switch signal. (Door is open: ON/Door is closed: OFF)
DOOR SW - RR ^{NOTE}	"OFF"	—
DOOR SW - RL ^{NOTE}	"OFF"	—
BACK DOOR SW ^{NOTE}	"OFF"	—
TURN SIGNAL R	"ON/OFF"	Displays status (Turn right: ON/Others: OFF) as judged from lighting switch signal.
TURN SIGNAL L	"ON/OFF"	Displays status (Turn left: ON/Others: OFF) as judged from lighting switch signal.
CARGO LAMP SW ^{NOTE}	"OFF"	—
OPTICAL SENSOR	[0 - 5V]	Displays "ambient light (close to 5V when light/close to 0V when dark)" judged from optical sensor signal.

NOTE:

This item is displayed, but cannot monitor it.

ACTIVE TEST

Operation Procedure

1. Touch "HEAD LAMP" on "SELECT TEST ITEM" screen.
2. Touch "ACTIVE TEST" on "SELECT DIAG MODE" screen.
3. Touch item to be tested and check operation of the selected item.
4. During the operation check, touching "BACK" deactivates the operation.

Display Item List

Test item	Description
TAIL LAMP	Allows tail lamp relay to operate by switching ON-OFF.
HEAD LAMP	Allows headlamp relay to operate by switching ON-OFF.
FR FOG LAMP	Allows fog lamp relay to operate by switching ON-OFF.
CORNERING LAMP ^{NOTE}	—
CARGO LAMP	Allows cargolamp operate by switching ON-OFF.

NOTE:

This item is displayed, but cannot monitor it.

HEADLAMP (FOR CANADA) - DAYTIME LIGHT SYSTEM -

CONSULT-II Functions (IPDM E/R)

AKS00AD8

CONSULT-II perform the following functions communicating with IPDM E/R.

Check Item, Diagnosis Mode	Description
SELF-DIAGNOSTIC RESULTS	The IPDM E/R performs self-diagnosis of CAN communication.
DATA MONITOR	The input/output data of the IPDM E/R is displayed in real time.
CAN DIAG SUPPORT MNTR	The result of transmit/receive diagnosis of CAN communication can be read.
ACTIVE TEST	The IPDM E/R sends a drive signal to electronic components to check their operation.

CONSULT-II OPERATION

CAUTION:

If CONSULT-II is used with no connection of CONSULT-II CONVERTER, malfunctions might be detected in self-diagnosis depending on control unit which carry out CAN communication.

1. With the ignition switch OFF, connect CONSULT-II and CONSULT-II CONVERTER to the data link connector, then turn the ignition switch ON.

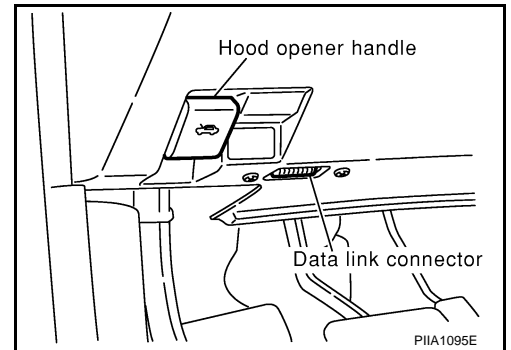

2. Touch "START (NISSAN BASED VHCL)".

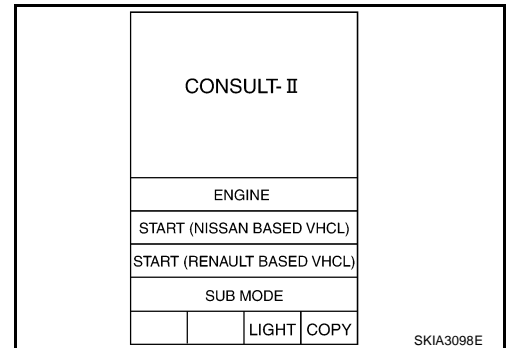

3. Touch "IPDM E/R" on "SELECT SYSTEM" screen. If "IPDM E/R" is not displayed, print "SELECT SYSTEM" screen, then refer to [GI-39, "CONSULT-II Data Link Connector \(DLC\) Circuit"](#).

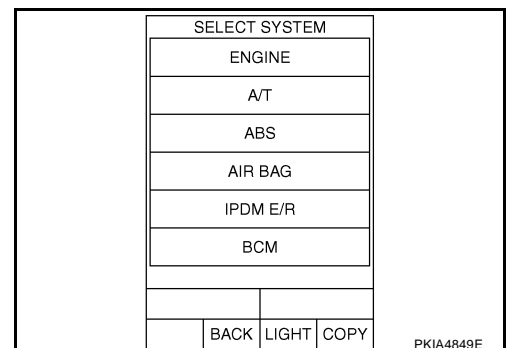

HEADLAMP (FOR CANADA) - DAYTIME LIGHT SYSTEM -

- Select the desired part to be diagnosed on the “SELECT DIAG MODE” screen.

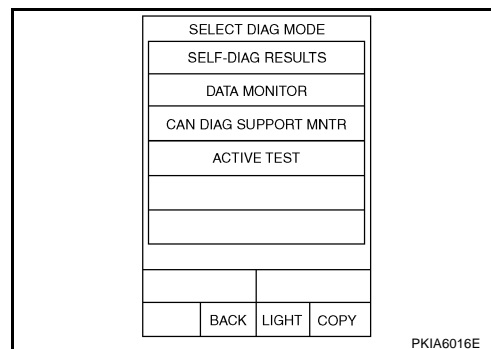

SELF-DIAGNOSTIC RESULTS

Refer to [PG-20, "SELF-DIAG RESULTS"](#) .

DATA MONITOR

Operation Procedure

- Touch “DATA MONITOR” on “SELECT DIAG MODE ” screen.
- Touch “ALL SIGNALS”, “MAIN SIGNALS” or “SELECTION FROM MENU” on “DATA MONITOR” screen.

ALL SIGNALS	All items will be monitored.
MAIN SIGNALS	Monitor the predetermined item.
SELECTION FROM MENU	Select any item for monitoring.

- Touch “START”.
- Touch the required monitoring item on “SELECTION FROM MENU”. In “ALL SIGNALS”, all items are monitored. In “MAIN SIGNALS”, predetermined items are monitored.
- Touch “RECORD” while monitoring to record the status of the item being monitored. To stop recording, touch “STOP”.

All Signals, Main Signals, Selection From Menu

Item name	CONSULT-II screen display	Display or unit	Monitor item selection			Description
			ALL SIGNALS	MAIN SIGNALS	SELECTION FROM MENU	
Position lights request	TAIL & CLR REQ	ON/OFF	×	×	×	Signal status input from BCM
Headlamp low beam request	HL LO REQ	ON/OFF	×	×	×	Signal status input from BCM
Headlamp high beam request	HL HI REQ	ON/OFF	×	×	×	Signal status input from BCM
Font fog lights request	FR FOG REQ	ON/OFF	×	×	×	Signal status input from BCM

NOTE:

Perform monitoring of IPDM E/R data with the ignition switch ON. When the ignition switch is at ACC, the display may not be correct.

ACTIVE TEST

Operation Procedure

- Touch “ACTIVE TEST” on “SELECT DIAG MODE” screen.
- Touch item to be tested, and check operation.
- Touch “START”.
- Touch “STOP” while testing to stop the operation.

Test item	CONSULT-II screen display	Description
Headlamp relay (HI, LO) output	LAMPS	Allows headlamp relay (HI, LO) to operate by switching operation (OFF, HI ON, LO ON) at your option.
Front fog lamp relay output		Allows fog lamp relay to operate by switching operation ON-OFF at your option
Tail lamp relay output	TAIL LAMP	Allows tail lamp relay to operate by switching operation ON-OFF at your option

HEADLAMP (FOR CANADA) - DAYTIME LIGHT SYSTEM -

AKS00AD9

Daytime Light Control Does Not Operate Properly

1. CHECK DAYTIME LIGHT CONTROL UNIT

1. Turn ignition switch OFF.
2. Disconnect daytime light control unit connector.
3. Check voltage between daytime light control unit harness connector and ground.

Terminals		Voltage
Daytime light control unit (+)		
Connector	Terminal (Wire color)	Ground
E25	2 (OR)	
E26	3 (OR)	Battery voltage

OK or NG

OK >> GO TO 2.

NG >> Repair or replace daytime light control unit power supply circuit harness.

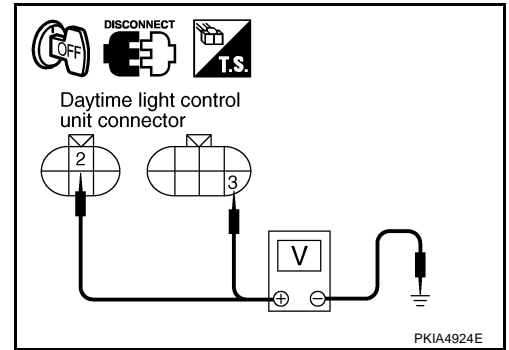

2. CHECK GROUND FOR DAYTIME LIGHT CONTROL UNIT

Check continuity between daytime light control unit harness connector and ground.

9 (B/W) – Ground : Continuity should exist.

OK or NG

OK >> GO TO 3.

NG >> Repair harness or connector.

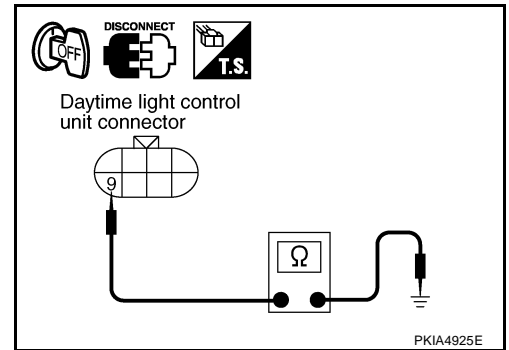

3. CHECK PARKING BRAKE SWITCH CIRCUIT

1. Disconnect parking brake switch connector.
2. Check continuity between daytime light control unit harness connector E25 terminal 10 (PU/R^{*1}, LG/B^{*2}) and parking brake switch harness connector B37^{*1} or E110^{*2} terminal 1 (LG/B).

10 (PU/R^{*1}, LG/B^{*2}) – 1 (LG/B) : Continuity should exist.

*1: M/T, *2: A/T

OK or NG

OK >> GO TO 4.

NG >> Repair harness or connector.

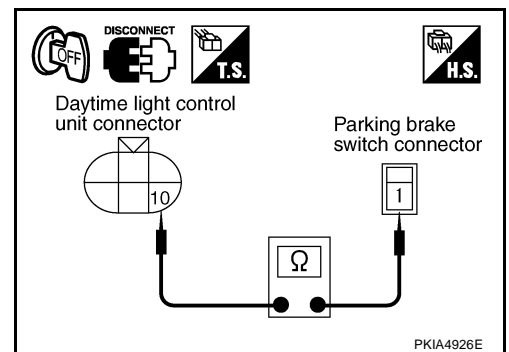

HEADLAMP (FOR CANADA) - DAYTIME LIGHT SYSTEM -

4. CHECK PARKING BRAKE SWITCH

1. Connect daytime light control unit connector and parking brake switch connector.
2. Turn ignition switch ON.
3. Check voltage between parking brake switch harness connector B37*1 or E110*2 terminal 1 (LG/B) and ground, when parking brake is released.

1 (LG/B) – Ground : Battery voltage should exist.

*1: M/T, *2: A/T

OK or NG

OK >> GO TO 5.

NG >> Replace parking brake switch.

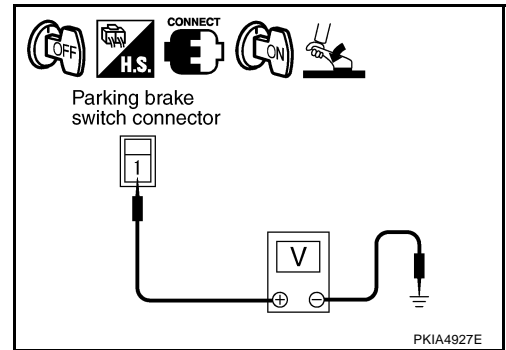

5. CHECK ALTERNATOR CIRCUIT

1. Turn ignition switch OFF.
2. Disconnect daytime light control unit connector.
3. Start engine running.
4. Check voltage between daytime light control unit harness connector E25 terminal 11 (W/R) and ground.

11 (W/R) – Ground : Battery voltage should exist.

OK or NG

OK >> GO TO 6.

NG >> Repair harness or connector.

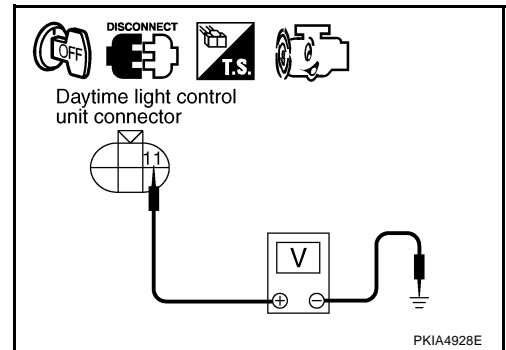

6. CHECK POWER CIRCUIT BETWEEN DAYTIME LIGHT CONTROL UNIT AND HEADLAMP LH

1. Turn ignition switch OFF.
2. Disconnect daytime light control unit connector and LH front combination lamp connector.
3. Check continuity between daytime light control unit harness connector E26 terminal 6 (L) and front combination lamp harness connector E41 terminal 2 (L).

6 (L) – 2 (L) : Continuity should exist.

OK or NG

OK >> GO TO 7.

NG >> Repair harness or connector.

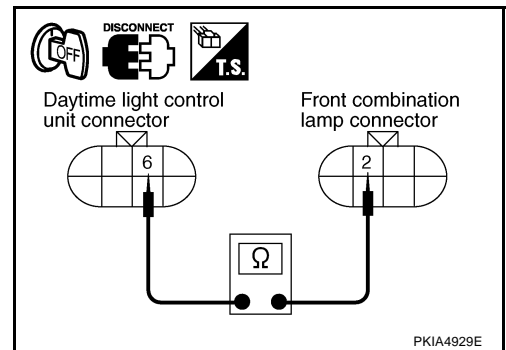

7. CHECK GROUND CIRCUIT BETWEEN DAYTIME LIGHT CONTROL UNIT AND HEADLAMP LH

Check continuity between daytime light control unit harness connector E26 terminal 7 (Y/G) and harness connector of LH front combination lamp harness connector E41 terminal 8 (Y/G).

7 (Y/G) – 8 (Y/G) : Continuity should exist.

OK or NG

OK >> GO TO 8.

NG >> Repair harness or connector.

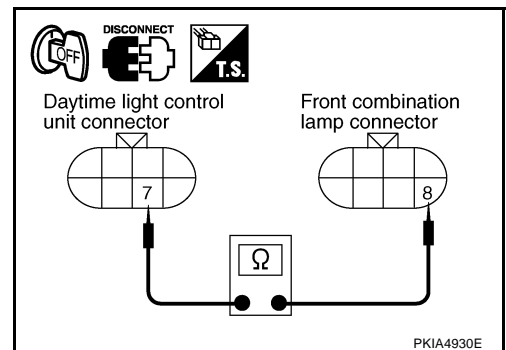

HEADLAMP (FOR CANADA) - DAYTIME LIGHT SYSTEM -

8. CHECK POWER CIRCUIT BETWEEN DAYTIME LIGHT CONTROL UNIT AND HEADLAMP RH

1. Turn ignition switch OFF.
2. Disconnect RH front combination lamp connector.
3. Check continuity between daytime light control unit harness connector E26 terminal 8 (LG) and front combination lamp RH harness connector E24 terminal 2 (LG).

8 (LG) – 2 (LG) : Continuity should exist.

OK or NG

- OK >> GO TO 9.
 NG >> Repair harness or connector.

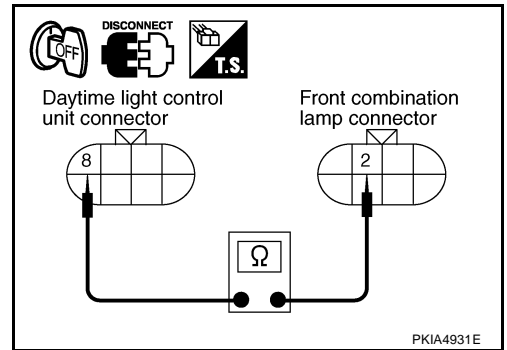

9. CHECK DAYTIME LIGHT CONTROL UNIT

1. Connect daytime light control unit connector and LH front combination lamp connector.
2. Check voltage between front combination lamp RH harness connector E24 terminal 2 (LG) and ground, when releasing parking brake with engine running and turning lighting switch to "OFF".

2 (LG) - Ground : Battery voltage should exist.

OK or NG

- OK >> Check headlamp bulb.
 NG >> Replace daytime light control unit.

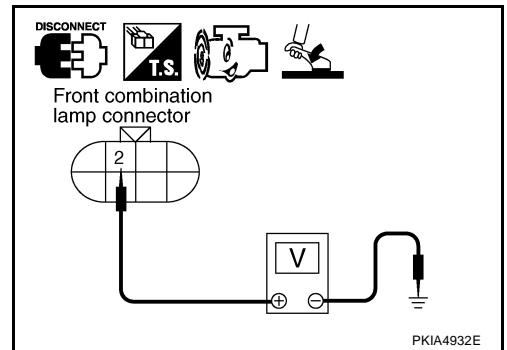

Headlamp High Beam Does Not Illuminate (Both Sides)

AKS00ADA

1. CHECK COMBINATION SWITCH INPUT SIGNAL

Ⓟ With CONSULT-II

Select "BCM" on CONSULT-II, With "HEAD LAMP" data monitor, make sure "HI BEAM SW" turns ON-OFF linked with operation of lighting switch.

**When lighting switch is : HI BEAM SW ON
 HIGH BEAM position**

ⓧ Without CONSULT-II

Refer to [LT-128, "Combination Switch Inspection"](#).

OK or NG

- OK >> GO TO 2.
 NG >> Check lighting switch. Refer to [LT-128, "Combination Switch Inspection"](#).

DATA MONITOR			
MONITOR		NO DTC	
HI BEAM SW		ON	
RECORD			
MODE	BACK	LIGHT	COPY

PKIA7743E

HEADLAMP (FOR CANADA) - DAYTIME LIGHT SYSTEM -

2. HEADLAMP ACTIVE TEST

☑ With CONSULT-II

1. Select "IPDM E/R" on CONSULT-II, and select "ACTIVE TEST" on "SELECT DIAG MODE" screen.
2. Select "LAMPS" on "SELECT TEST ITEM" screen.
3. Touch "HI" screen.
4. Make sure headlamp high beam operates.

Headlamp high beam should operate.

☒ Without CONSULT-II

1. Start auto active test. Refer to [PG-23, "Auto Active Test"](#).
2. Make sure headlamp high beam operates.

Headlamp high beam should operate.

ACTIVE TEST			
LAMPS		HI	
OFF			
LO		FOG	
MODE	BACK	LIGHT	COPY

PKIA7741E

OK or NG

- OK >> GO TO 3.
 NG >> GO TO 4.

3. CHECK IPDM E/R

1. Select "IPDM E/R" on CONSULT-II, and select "DATA MONITOR" on "SELECT DIAG MODE" screen.
2. Make sure "HL LO REQ" and "HL HI REQ" turns ON when lighting switch is in HIGH BEAM position.

**When lighting switch is HIGH BEAM position : HL LO REQ ON
 : HL HI REQ ON**

OK or NG

- OK >> Replace IPDM E/R.
 NG >> Replace BCM. Refer to [BCS-15, "Removal and Installation of BCM"](#).

DATA MONITOR			
MONITOR			
HL LO REQ		ON	
HL HI REQ		ON	
RECORD			
MODE	BACK	LIGHT	COPY

PKIA7638E

HEADLAMP (FOR CANADA) - DAYTIME LIGHT SYSTEM -

4. CHECK HEADLAMP INPUT SIGNAL

 With CONSULT-II

1. Select "IPDM E/R" on CONSULT-II, and select "ACTIVE TEST" on "SELECT DIAG MODE" screen.
2. Select "LAMPS" on "SELECT TEST ITEM" screen.
3. Touch "HI" screen.
4. When headlamp high beam is operating, check voltage between front combination lamp RH and LH harness connector and ground.

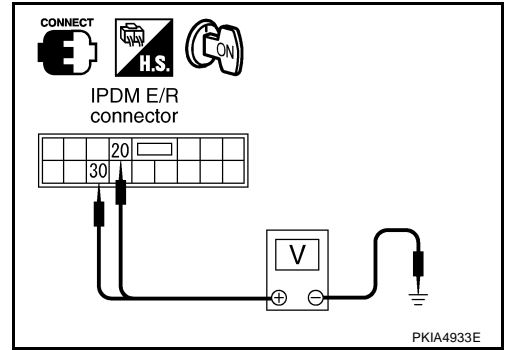

Terminals		(-)	Voltage
(+) Connector			
Connector	Terminal (Wire color)		
E7	20 (R)	Ground	Battery voltage
	30 (R/B)		

 Without CONSULT-II

1. Start auto active test. Refer to [PG-23, "Auto Active Test"](#).
2. When headlamp high beam is operating, check voltage between front combination lamp RH and LH harness connector and ground.

Terminals		(-)	Voltage
(+) Connector			
Connector	Terminal (Wire color)		
E7	20 (R)	Ground	Battery voltage
	30 (R/B)		

OK or NG

- OK >> Check headlamp bulbs.
- NG >> Replace IPDM E/R.

RH High Beam Does Not Illuminate But RH Low Beam Illuminates

AKS00ADB

1. CHECK BULB

Check bulb of lamp.

OK or NG

- OK >> GO TO 2.
- NG >> Replace bulb of lamp.

HEADLAMP (FOR CANADA) - DAYTIME LIGHT SYSTEM -

2. CHECK CIRCUIT BETWEEN IPDM E/R AND DAYTIME LIGHT RELAY-2

1. Turn ignition switch OFF.
2. Disconnect IPDM E/R connector and daytime light relay-2.
3. Check continuity between IPDM E/R harness connector E7 terminal 27 (BR) and daytime light relay-2 harness connector E16 terminal 2 (BR).

27 (BR) – 2 (BR) : Continuity should exist.

4. Check continuity between IPDM E/R harness connector E7 terminal 27 (BR) and daytime light relay-2 harness connector E16 terminal 5 (BR).

27 (BR) – 5 (BR) : Continuity should exist.

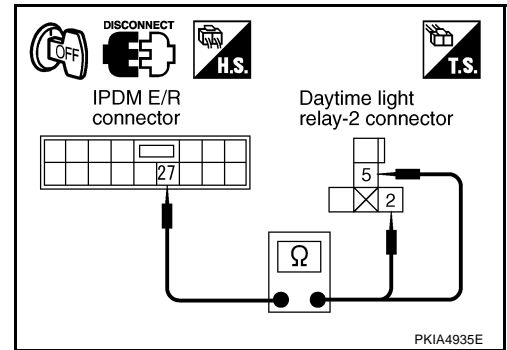

OK or NG

OK >> GO TO 3.

NG >> Repair harness or connector.

3. CHECK DAYTIME LIGHT RELAY-2 AND GROUND

Check continuity between daytime light relay-2 harness connector E16 terminal 1 (B) and ground.

1 (B) – Ground : Continuity should exist.

OK or NG

OK >> GO TO 4.

NG >> Repair harness or connector.

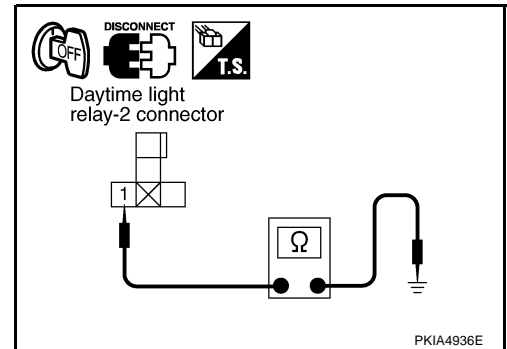

4. CHECK CIRCUIT BETWEEN DAYTIME LIGHT RELAY-2 AND HEADLAMP RH

1. Disconnect RH front combination lamp connector.
2. Check continuity between daytime light relay-2 harness connector E16 terminal 3 (LG) and front combination lamp RH harness connector E24 terminal 2 (LG).

3 (LG) – 2 (LG) : Continuity should exist.

OK or NG

OK >> GO TO 5.

NG >> Repair harness or connector.

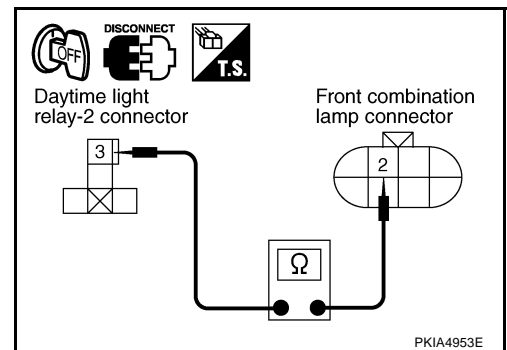

5. CHECK HEADLAMP RH GROUND CIRCUIT

Check continuity between RH front combination lamp harness connector E24 terminal 8 (B) and ground.

8 (B) – Ground : Continuity should exist.

OK or NG

OK >> GO TO 6.

NG >> Repair harness or connector.

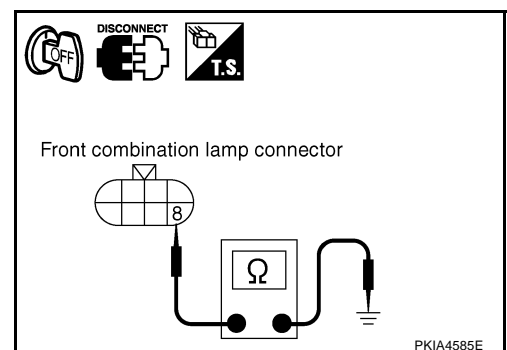

HEADLAMP (FOR CANADA) - DAYTIME LIGHT SYSTEM -

6. CHECK IPDM E/R

1. Connect IPDM E/R connector.
2. Turn ignition switch ON.
3. Lighting switch turned HIGH BEAM position.
4. Check voltage between daytime light relay-2 harness connector E16 terminal 2 (BR) and ground.

2 (BR) - Ground : Battery voltage should exist.

5. Check voltage between daytime light relay-2 harness connector E16 terminal 5 (BR) and ground.

5 (BR) - Ground : Battery voltage should exist.

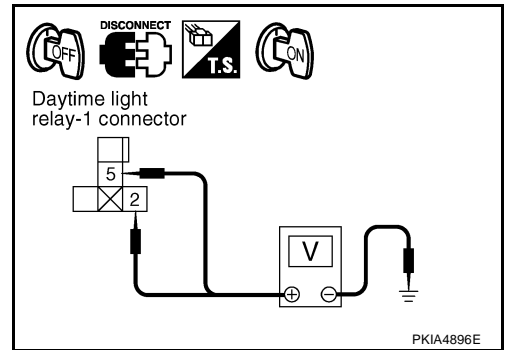

OK or NG

- OK >> Replace daytime light relay-2.
- NG >> Replace IPDM E/R.

LH High Beam Does Not Illuminate But LH Low Beam Illuminates

AKS00ADC

1. CHECK CIRCUIT IPDM E/R AND DAYTIME LIGHT CONTROL UNIT

1. Turn ignition switch OFF.
2. Disconnect IPDM E/R connector and daytime light control unit connector.
3. Check continuity between IPDM E/R harness connector E7 terminal 28 (R/Y) and daytime light control unit harness connector E26 terminal 5 (R/Y).

28 (R/Y) - 5 (R/Y) : Continuity should exist.

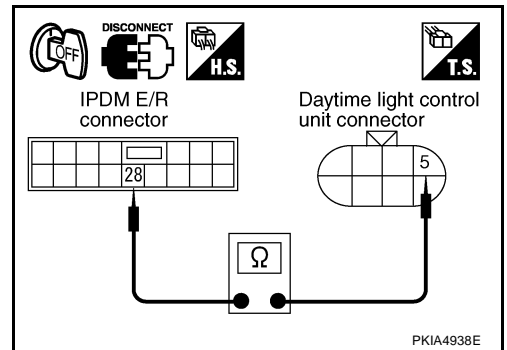

OK or NG

- OK >> GO TO 2.
- NG >> Repair harness or connector.

2. CHECK IPDM E/R

1. Connect IPDM E/R connector.
2. Turn ignition switch ON.
3. Lighting switch turned HIGH BEAM position.
4. Check voltage between daytime light control unit harness connector E26 terminal 5 (R/Y) and ground.

5 (R/Y) - Ground : Battery voltage should exist.

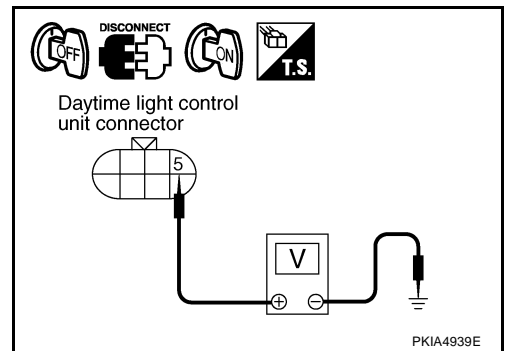

OK or NG

- OK >> GO TO 3.
- NG >> Replace IPDM E/R.

HEADLAMP (FOR CANADA) - DAYTIME LIGHT SYSTEM -

3. CHECK POWER CIRCUIT BETWEEN DAYTIME LIGHT CONTROL UNIT AND HEADLAMP LH

1. Turn ignition switch OFF.
2. Disconnect daytime light control unit connector and LH front combination lamp connector.
3. Check continuity between daytime light control unit of harness connector E26 terminal 6 (L) and LH front combination lamp of harness connector LH E41 terminal 2 (L).

6 (L) - 2 (L) : Continuity should exist.

OK or NG

- OK >> GO TO 4.
NG >> Repair harness or connector.

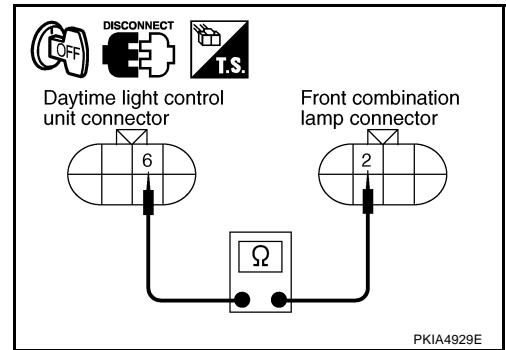

4. CHECK CIRCUIT BETWEEN DAYTIME LIGHT CONTROL UNIT AND HEADLAMP LH

Check continuity between daytime light control unit harness connector E26 terminal 7 (Y/G) and front combination lamp LH harness connector E41 terminal 8 (Y/G).

7 (Y/G) - 8 (Y/G) : Continuity should exist.

OK or NG

- OK >> GO TO 5.
NG >> Repair harness or connector.

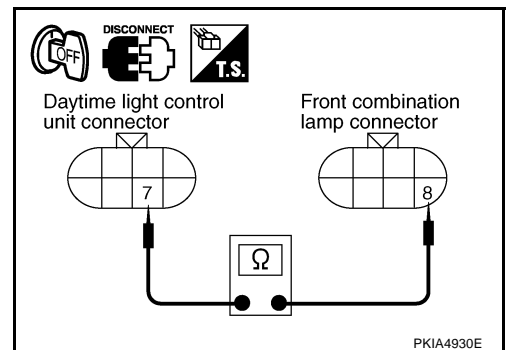

5. CHECK DAYTIME LIGHT CONTROL UNIT AND GROUND

Check continuity between daytime light control unit harness connector E26 terminal 9 (B/W) and ground.

9 (B/W) - Ground : Continuity should exist.

OK or NG

- OK >> GO TO 6.
NG >> Repair harness or connector.

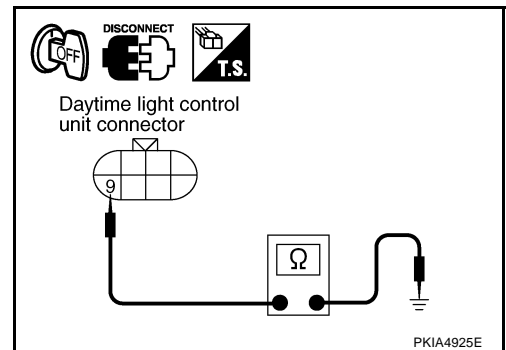

6. CHECK DAYTIME LIGHT CONTROL UNIT

1. Connect daytime light control unit connector.
2. Turn ignition switch ON.
3. Lighting switch is turned HIGH BEAM position.
4. Check voltage between front combination lamp LH harness connector E41 terminal 2 (L) and ground.

2 (L) - Ground : Battery voltage should exist.

OK or NG

- OK >> Check headlamp bulb.
NG >> Replace daytime light control unit.

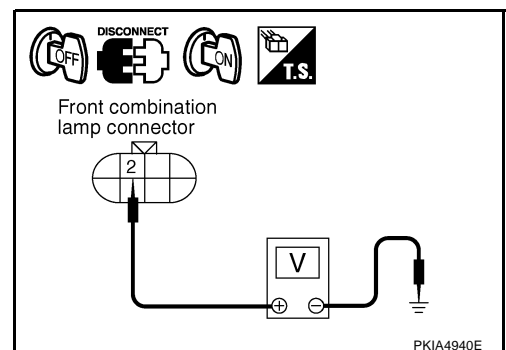

HEADLAMP (FOR CANADA) - DAYTIME LIGHT SYSTEM -

Headlamp Low Beam Does Not Illuminate (Both Sides)

AKS00ADD

1. CHECK COMBINATION SWITCH INPUT SIGNAL

④ With CONSULT-II

Select "BCM" on CONSULT-II. With "HEAD LAMP" data monitor, make sure "HEAD LAMP SW 1" and "HEAD LAMP SW 2" turns ON-OFF linked with operation of lighting switch.

**When lighting switch is 2ND position : HEAD LAMP SW 1 ON
: HEAD LAMP SW 2 ON**

⊗ Without CONSULT-II

Refer to [LT-128, "Combination Switch Inspection"](#).

OK or NG

OK >> GO TO 2.

NG >> Check lighting switch. Refer to [LT-128, "Combination Switch Inspection"](#).

DATA MONITOR			
MONITOR		NO DTC	
HEAD LAMP SW1	ON		
HEAD LAMP SW2	ON		
RECORD			
MODE	BACK	LIGHT	COPY

PKIA7744E

2. HEADLAMP ACTIVE TEST

④ With CONSULT-II

1. Select "IPDM E/R" on CONSULT-II, and select "ACTIVE TEST" on "SELECT DIAG MODE" screen.
2. Select "LAMPS" on "SELECT TEST" ITEM screen.
3. Touch "LO" screen.
4. Make sure headlamp low beam operates.

Headlamp low beam should operate.

⊗ Without CONSULT-II

1. Start auto active test. Refer to [PG-23, "Auto Active Test"](#).
2. Make sure headlamp low beam operates.

Headlamp low beam should operate.

OK or NG

OK >> GO TO 3.

NG >> GO TO 4.

3. CHECK IPDM E/R

1. Select "IPDM E/R" on CONSULT-II, and select "DATA MONITOR" on "SELECT DIAG MODE" screen.
2. Make sure "HL LO REQ" turns ON when lighting switch is in 2ND position.

When lighting switch is 2ND position : HL LO REQ ON

OK or NG

OK >> Replace IPDM E/R.

NG >> Replace BCM. Refer to [BCS-15, "Removal and Installation of BCM"](#).

ACTIVE TEST			
LAMPS		LO	
OFF	HI		
	FOG		
MODE	BACK	LIGHT	COPY

PKIA7742E

DATA MONITOR			
MONITOR		NO DTC	
HL LO REQ	ON		
RECORD			
MODE	BACK	LIGHT	COPY

PKIA7644E

HEADLAMP (FOR CANADA) - DAYTIME LIGHT SYSTEM -

4. CHECK HEADLAMP INPUT SIGNAL

④ With CONSULT-II

1. Turn ignition switch OFF.
2. Disconnect front combination lamp RH and LH connector.
3. Select "IPDM E/R" on CONSULT-II, and select "ACTIVE TEST" on "SELECT DIAG MODE" screen.
4. Select "LAMPS" on "SELECT TEST ITEM" screen.
5. Touch "LO" screen.
6. When headlamp low beam is operating, check voltage between front combination lamp RH and LH harness connector and ground.

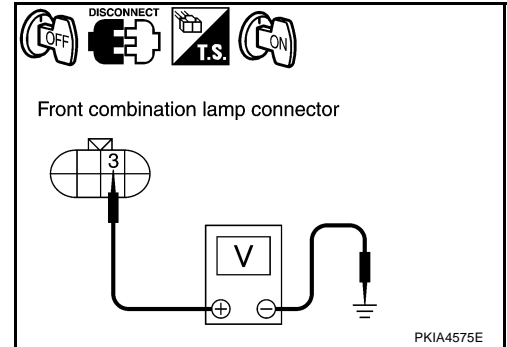

Terminals			(-)	Voltage
(+)				
Connector		Terminal (Wire color)	Ground	Battery voltage
RH	E24	3 (R)		
LH	E41	3 (R/B)		

⊗ Without CONSULT-II

1. Turn ignition switch OFF.
2. Disconnect front combination lamp RH and LH connector.
3. Start auto active test. Refer to [PG-23, "Auto Active Test"](#).
4. When headlamp low beam is operating, check voltage between front combination lamp RH and LH harness connector and ground.

Terminals			(-)	Voltage
(+)				
Connector		Terminal (Wire color)	Ground	Battery voltage
RH	E24	3 (R)		
LH	E41	3 (R/B)		

OK or NG

- OK >> GO TO 6.
 NG >> GO TO 5.

5. CHECK HEADLAMP CIRCUIT

1. Turn ignition switch OFF.
2. Disconnect IPDM E/R connector.
3. Check continuity between IPDM E/R harness connector E7 terminal 20 (R) and front combination lamp RH harness connector E24 terminal 3 (R).

20 (R) – 3 (R) : Continuity should exist.

4. Check continuity between IPDM E/R harness connector E7 terminal 30 (R/B) and front combination lamp LH harness connector E41 terminal 3 (R/B).

30 (R/B) – 3 (R/B) : Continuity should exist.

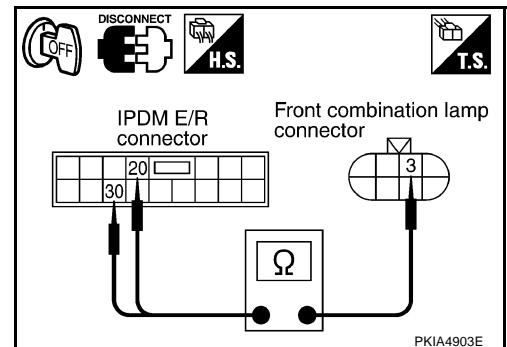

OK or NG

- OK >> Replace IPDM E/R.
 NG >> Repair harness or connector.

HEADLAMP (FOR CANADA) - DAYTIME LIGHT SYSTEM -

6. CHECK HEADLAMP GROUND

1. Turn ignition switch OFF.
2. Check continuity between front combination lamp RH harness connector E24 terminal 4 (B/W) and ground.

4 (B/W) – Ground : Continuity should exist.

3. Check continuity between front combination lamp LH harness connector E41 terminal 4 (B/W) and ground.

4 (B/W) – Ground : Continuity should exist.

OK or NG

- OK >> Check headlamp harness and connectors, ballasts (HID control unit), and xenon bulbs. Refer to [LT-32, "Xenon Headlamp Trouble Diagnosis"](#).
- NG >> Repair harness or connector.

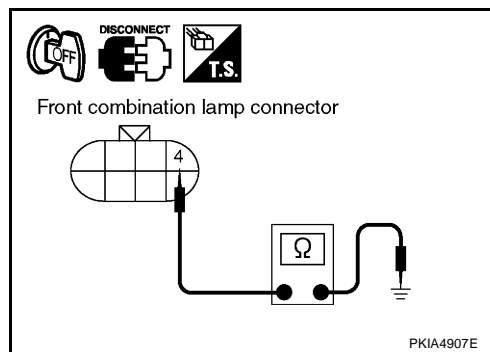

RH Low Beam Does Not Illuminate But RH High Beam Illuminates

AKS00ADE

1. CHECK BULB

Check ballasts (HID control unit) and xenon bulb of lamp which does not illuminate. (Xenon models)

OK or NG

- OK >> GO TO 2.
- NG >> Check headlamp harness and connectors, ballasts (HID control unit), and xenon bulbs. Refer to [LT-32, "Xenon Headlamp Trouble Diagnosis"](#).

2. CHECK CIRCUIT BETWEEN IPDM E/R AND HEADLAMP RH

1. Turn ignition switch OFF.
2. Disconnect IPDM E/R connector and RH front combination lamp connector.
3. Check continuity between IPDM E/R harness connector E7 terminal 20 (R) and front combination lamp RH harness connector E24 terminal 3 (R).

20 (R) - 3 (R) : Continuity should exist.

OK or NG

- OK >> GO TO 3.
- NG >> Repair harness or connector.

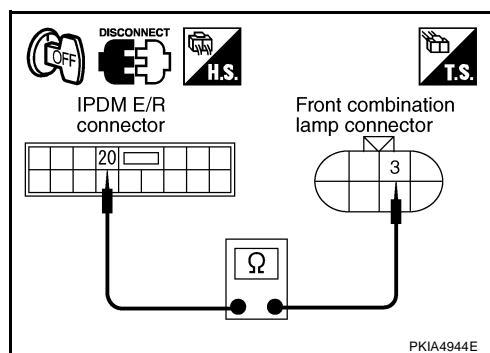

3. CHECK HEADLAMP RH GROUND CIRCUIT

Check continuity between front combination lamp RH harness connector E24 terminal 4 (B/W) and ground.

4 (B/W) - Ground : Continuity should exist.

OK or NG

- OK >> Replace IPDM E/R.
- NG >> Repair harness or connector.

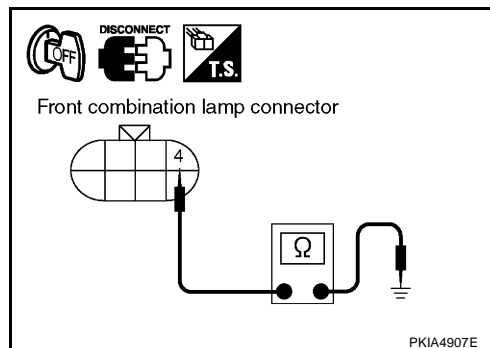

HEADLAMP (FOR CANADA) - DAYTIME LIGHT SYSTEM -

LH Low Beam Does Not Illuminate But LH High Beam Illuminates

AKS00ADF

1. CHECK BULB

Check ballasts (HID control unit) and xenon bulb of lamp which does not illuminate.

OK or NG

OK >> GO TO 2.

NG >> Check headlamp harness and connectors, ballasts (HID control unit), and xenon bulbs. Refer to [LT-32, "Xenon Headlamp Trouble Diagnosis"](#).

2. CHECK CIRCUIT BETWEEN IPDM E/R AND HEADLAMP LH

1. Disconnect IPDM E/R connector and LH front combination lamp LH connector.
2. Check continuity between IPDM E/R harness connector E7 terminal 30 (R/B) and front combination lamp harness connector LH E41 terminal 3 (R/B).

30 (R/B) - 3 (R/B) : Continuity should exist.

OK or NG

OK >> GO TO 3.

NG >> Repair harness or connector.

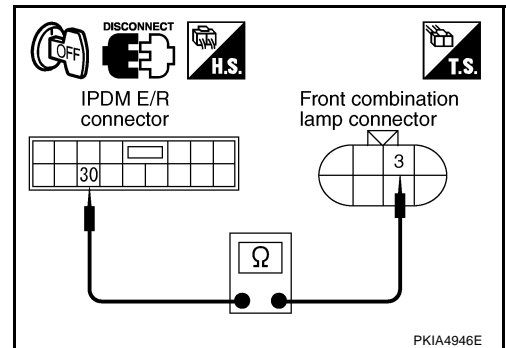

3. CHECK HEADLAMP LH AND GROUND

Check continuity between front combination lamp LH harness connector and ground.

4 (B/W) - Ground : Continuity should exist.

OK or NG

OK >> Replace IPDM E/R.

NG >> Repair harness or connector.

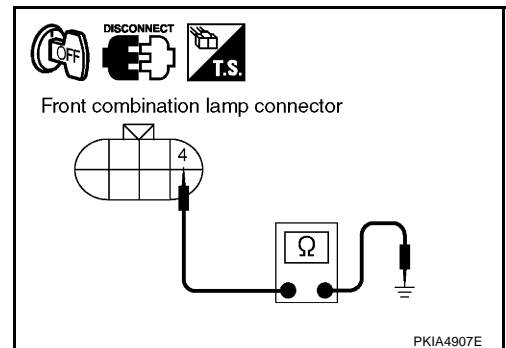

Aiming Adjustment

Refer to [LT-33, "Aiming Adjustment"](#) in "HEAD LAMP (FOR USA)".

AKS00ADG

Bulb Replacement

Refer to [LT-34, "Bulb Replacement"](#) in "HEAD LAMP (FOR USA)".

AKS00ADH

Removal and Installation

Refer to [LT-35, "Removal and Installation"](#) in "HEAD LAMP (FOR USA)".

AKS00ADI

Disassembly and Assembly

Refer to [LT-36, "Disassembly"](#), [LT-36, "Assembly"](#) in "HEAD LAMP (FOR USA)".

AKS00ADJ

AUTO LIGHT SYSTEM

PPF:28491

AUTO LIGHT SYSTEM

Component Parts and Harness Connector Location

AKS009UL

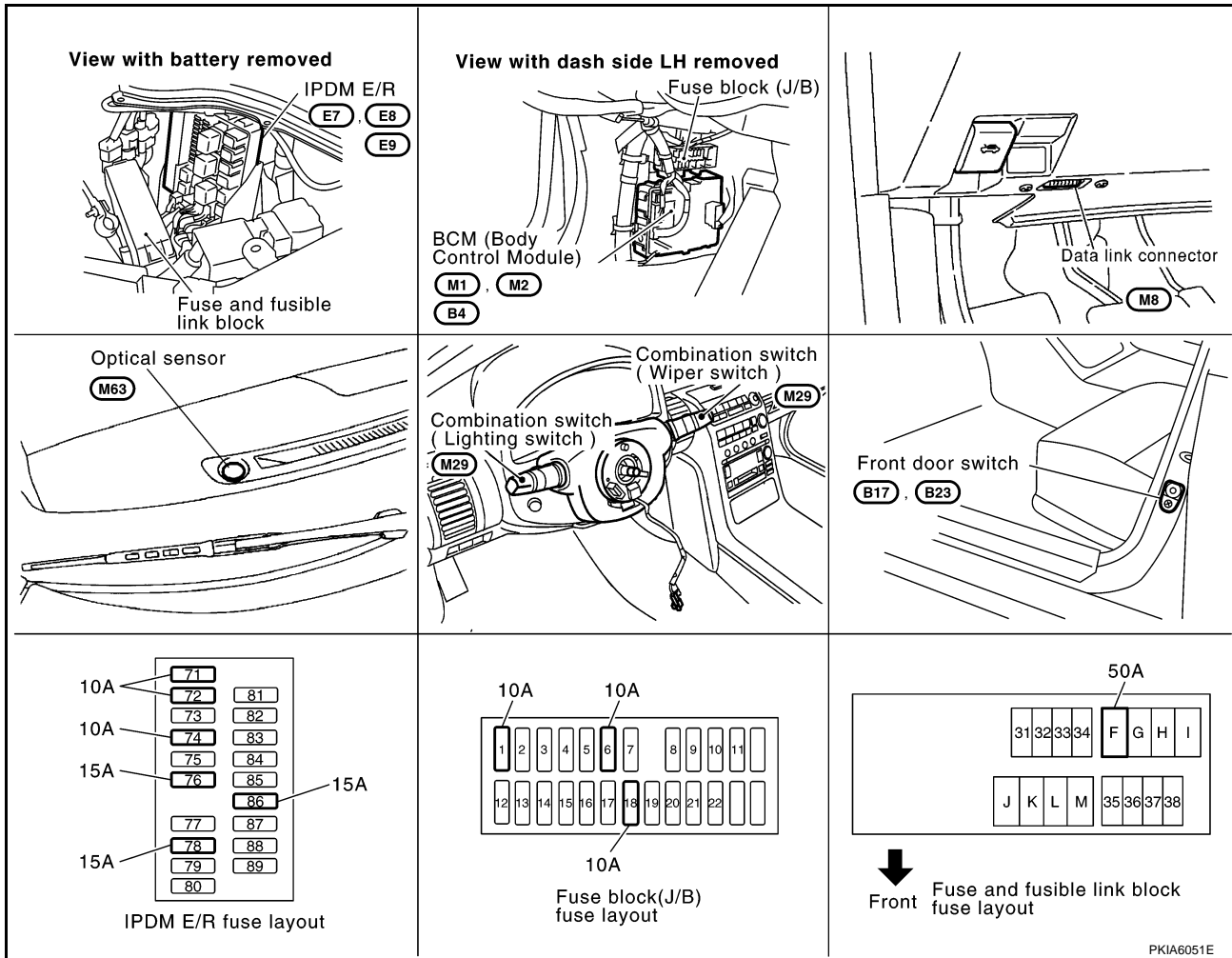

System Description

AKS009UM

Automatically turns on/off the parking lamps and the headlamps in accordance with ambient light. Timing for when the lamps turn on/off can be selected using four modes.

OUTLINE

The auto light control system has an optical sensor inside it that detects outside brightness.

When the lighting switch is in "AUTO" position, it automatically turns on/off the parking lamps and the headlamps in accordance with the ambient light. Sensitivity can be adjusted in four steps. For the details of the setting, refer to [LT-79, "SETTING CHANGE FUNCTIONS"](#).

Optical sensor, power is supplied

- from BCM (body control module) terminal 17
- to optical sensor terminal 1.

Optical sensor, ground is supplied

- from BCM (body control module) terminal 18
- to optical sensor terminal 3.

When ignition switch is turn to "ON" position, and

When outside brightness is darker than prescribed level, input is supplied

- to BCM (body control module) terminal 14
- from optical sensor terminal 2.

The headlamps will then illuminate. For a description of headlamp operation, refer to [LT-71, "System Description"](#).

AUTO LIGHT SYSTEM

COMBINATION SWITCH READING FUNCTION

Refer to [BCS-3, "COMBINATION SWITCH READING FUNCTION"](#) .

EXTERIOR LAMP BATTERY SAVER CONTROL

When the combination switch (lighting switch) is in the AUTO position, and the ignition switch is turned from ON or ACC to OFF, and one of the front door is opened, the battery saver control feature is activated. Under this condition, the headlamp remain illuminated for 5minutes, then the headlamp are turned off. Exterior lamp battery saver control mode can be changed by the function setting of CONSULT-II.

DELAY TIMER FUNCTION

When ignition switch ON and ACC are OFF while auto light switch is ON, BCM turn on/off headlamp. In delay timer function, auto timer sensor power source is OFF and BCM is not turned on/off by auto sensor signal. On condition that:

- when the states ignition switch ON or ACC is ON and output judgment by auto light function is headlamp ON turn to ignition switch ON or ACC are OFF and door switch (driver side), door switch (passenger side) is ON, output judgment by auto light function should be headlamp ON for 5 minutes by tamer. After time out, output judgment by auto light function should be headlamp OFF.
- when the state is door switch (driver side), door switch (passenger side) is turner to ON from OFF 45 seconds or 5 minutes while timer is counting, timer stops, and re-start counting for 5 minutes, then auto light function judges output as headlamp ON. After time out, auto light function judges output as headlamp OFF.
- when the states door witch (driver side), door switch (passenger side), is ON turns to door witch (driver side), front door switch (passenger side), are OFF 45seconds or 5minute while is counting, Timer stops, and re-start counting for 45 seconds, then auto light function judges output as head lamp ON. After timer out, auto light function judges output as head lamp OFF.
- when the state is ignition switch ON or ACC is ON or auto light switch OFF while timer is counting, timer stops counting and BCM turns on/off lamps according to headlamp function, front fog lamp function, auto light function and headlamp battery save function.

Delay timer control mode can be changed by the function setting of CONSULT-II.

CAN Communication System Description

AKS009UN

CAN (Controller Area Network) is a serial communication line for real time application. It is an on-vehicle multiplex communication line with high data communication speed and excellent error detection ability. Many electronic control units are equipped onto a vehicle, and each control unit shares information and links with other control units during operation (not independent). In CAN communication, control units are connected with 2 communication lines (CAN H line, CAN L line) allowing a high rate of information transmission with less wiring. Each control unit transmits/receives data but selectively reads required data only.

CAN Communication Unit

AKS009UO

Refer to [LAN-4, "CAN Communication Unit"](#) .

Major Components and Functions

AKS009UP

Components	Functions
BCM	● Turns on/off circuits of tail light and headlamp according to signals from light sensor, lighting switch (AUTO), driver door switch, passenger door switch, rear door switch, and ignition switch (ON, OFF).
Optical sensor	● Converts ambient light (lux) to voltage, and sends it to BCM. (Detects lightness of 50 to 1,300 lux)

AUTO LIGHT SYSTEM

Schematic

AKS009UQ

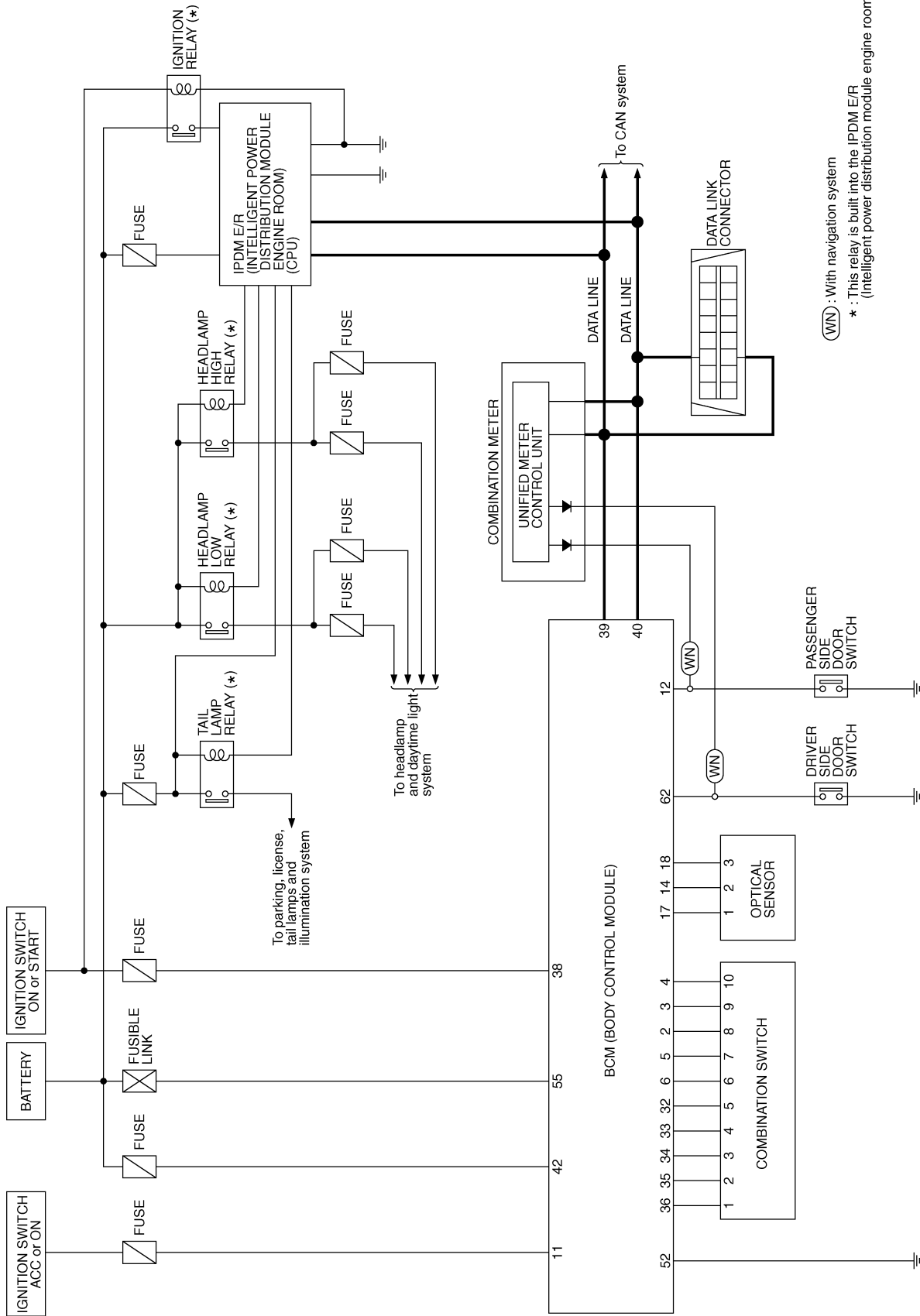

(W/N) : With navigation system
 * : This relay is built into the IPDM E/R (Intelligent power distribution module engine room).

TKWM0861E

A
B
C
D
E
F
G
H
I
J
LT
L
M

AUTO LIGHT SYSTEM

Wiring Diagram — AUTO/L —

AKS009UR

LT-AUTO/L-01

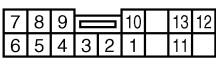
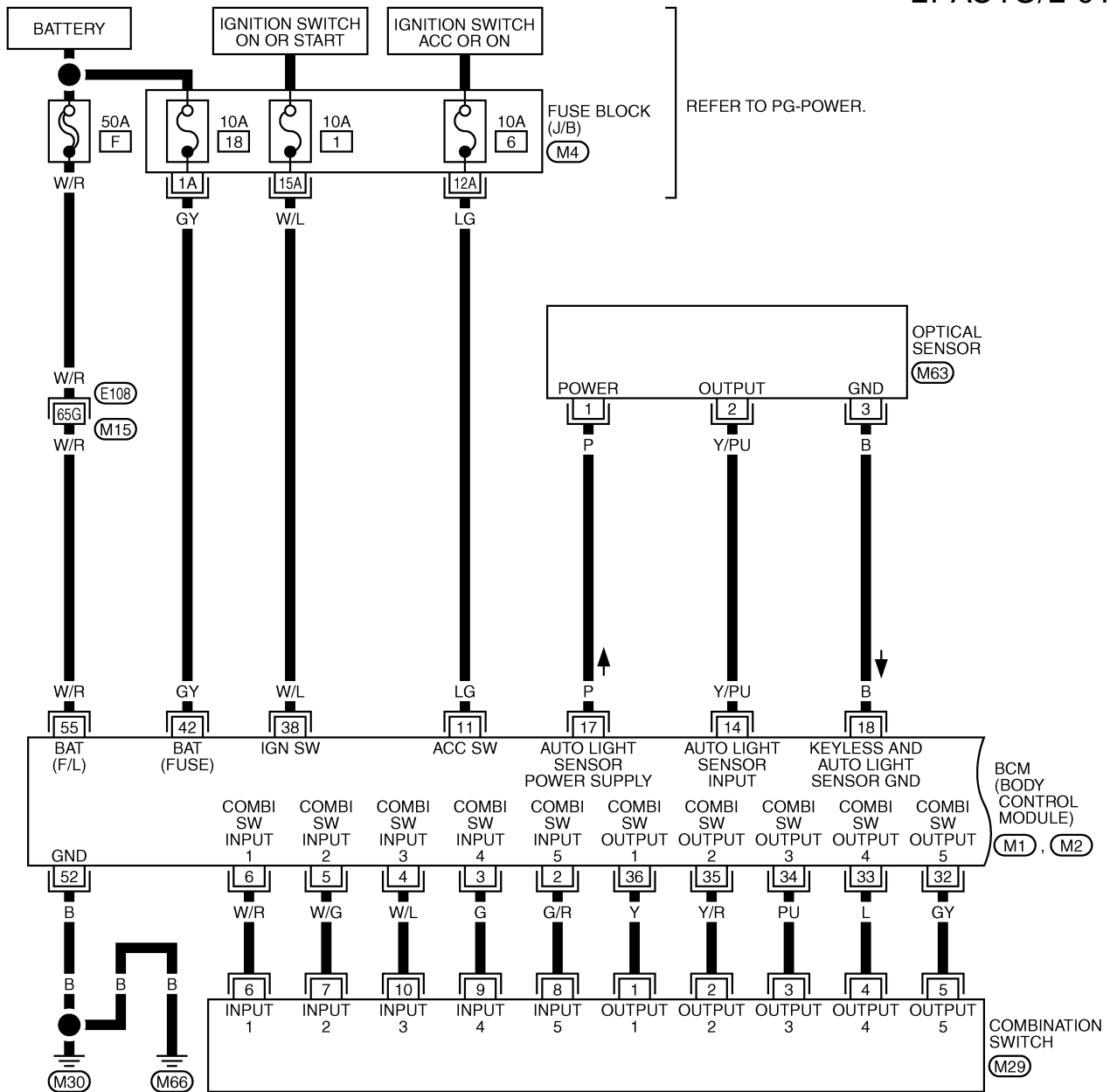

(M29)
W

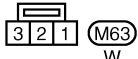

(M63)
W

REFER TO THE FOLLOWING.

(E108) -SUPER MULTIPLE JUNCTION (SMJ)

(M4) -FUSE BLOCK-JUNCTION BOX (J/B)

(M1), (M2) -ELECTRICAL UNITS

TKWM0862E

AUTO LIGHT SYSTEM

LT-AUTO/L-02

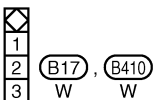
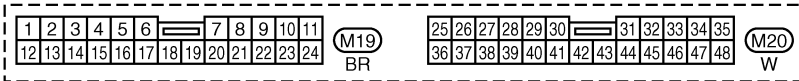
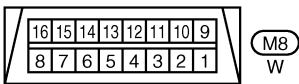
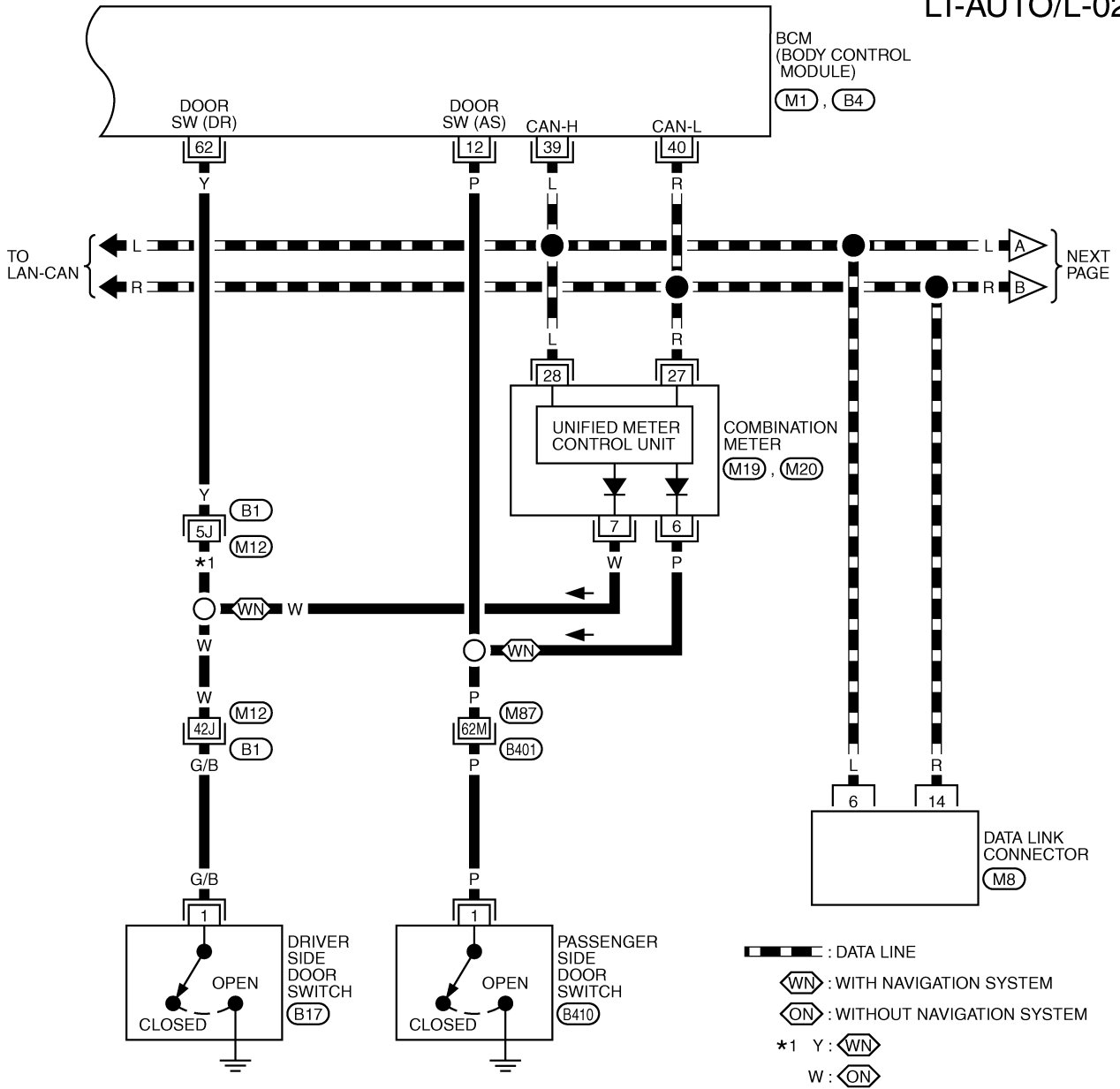

REFER TO THE FOLLOWING.
 (B1), (B401) -SUPER MULTIPLE JUNCTION (SMJ)
 (M1), (B4) -ELECTRICAL UNITS

AUTO LIGHT SYSTEM

LT-AUTO/L-03

▬▬▬ : DATA LINE

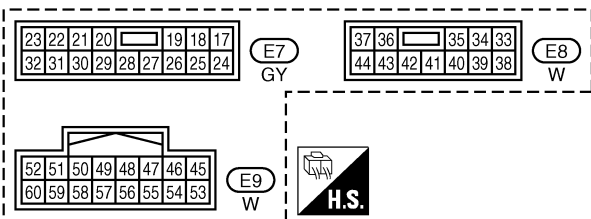
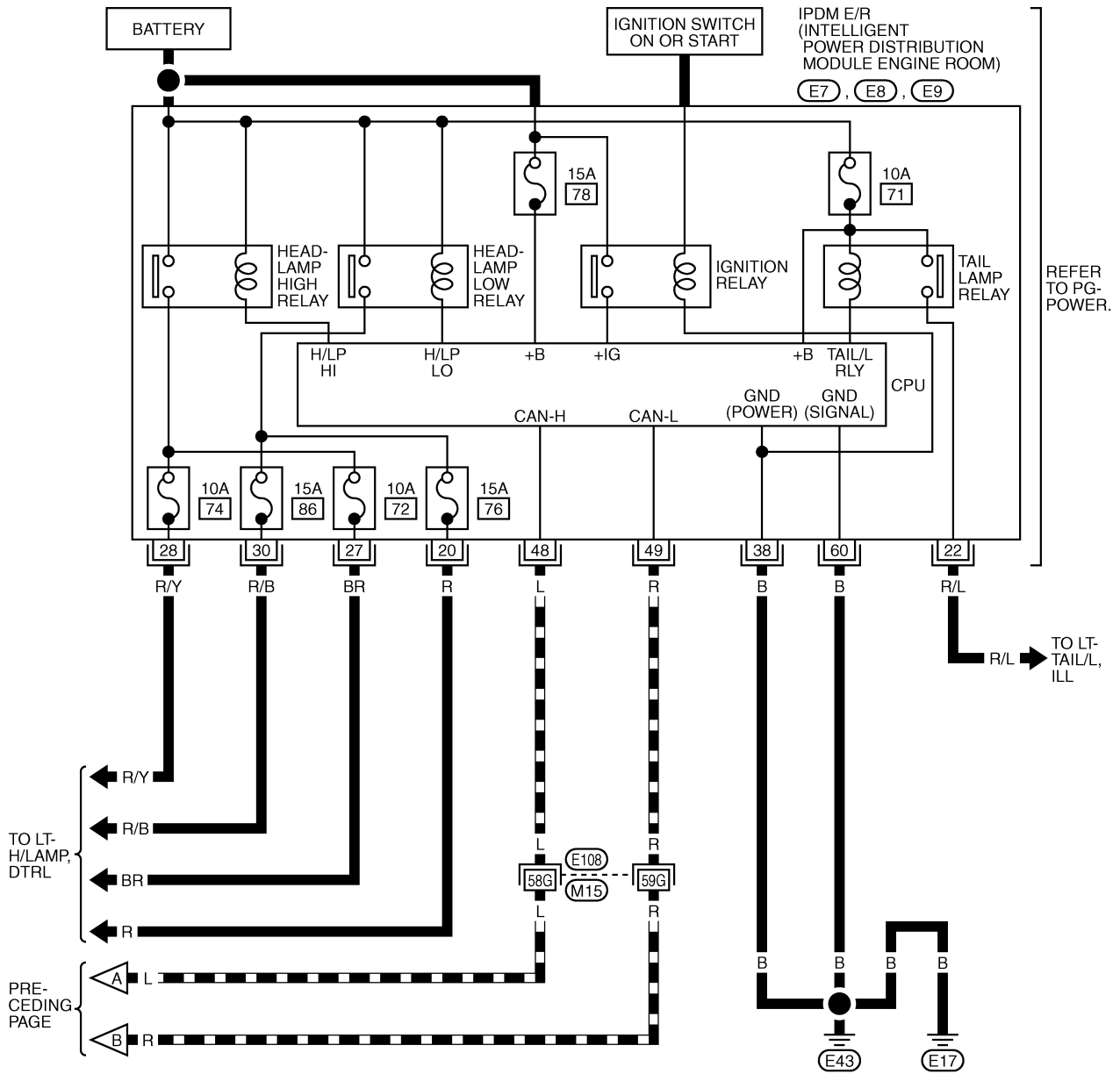



REFER TO THE FOLLOWING.

(E108) -SUPER MULTIPLE JUNCTION (SMJ)

AUTO LIGHT SYSTEM

Terminals and Reference Values for BCM

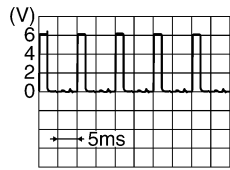
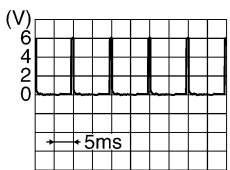
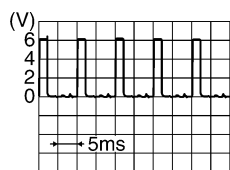
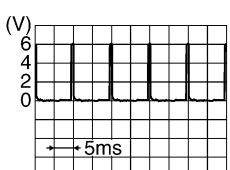
AKS009US

Terminal No.	Wire color	Signal name	Measuring condition		Reference value	
			Ignition switch	Operation or condition		
2	G/R	Combination switch input 5	ON	Lighting, turn, wiper OFF Wiper dial position 4	 <p style="text-align: right;">SKIA5291E</p>	
3	G	Combination switch input 4	ON	Lighting, turn, wiper OFF Wiper dial position 4	 <p style="text-align: right;">SKIA5292E</p>	
4	W/L	Combination switch input 3	ON	Lighting, turn, wiper OFF Wiper dial position 4	 <p style="text-align: right;">SKIA5291E</p>	
5	W/G	Combination switch input 2	ON	Lighting, turn, wiper OFF Wiper dial position 4	 <p style="text-align: right;">SKIA5292E</p>	
6	W/R	Combination switch input 1				
11	LG	Ignition switch (ACC)	ACC	—	Battery voltage	
12	P	Front door switch (Passenger side) signal	OFF	Front door switch (Passenger side)	ON (open)	Approx. 0V
					OFF (closed)	Battery voltage
14	Y/PU	Optical sensor signal	ON	When optical sensor is illuminated	3.1 V or more ^{NOTE}	
				When optical sensor is not illuminated	0.6 V or less	
17	P	Optical sensor power supply	ON	—	Approx. 5V	
18	B	Keyless and auto light sensor ground	ON	—	Approx. 0V	
32	GY	Combination switch output 5	ON	Lighting, turn, wiper OFF Wiper dial position 4	 <p style="text-align: right;">SKIA5291E</p>	

A
B
C
D
E
F
G
H
I
J
LT
L
M

AUTO LIGHT SYSTEM

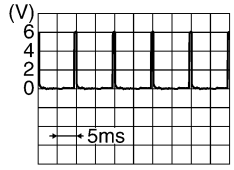
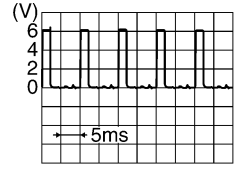
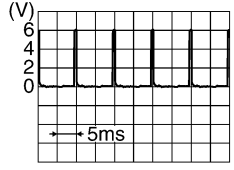
Terminal No.	Wire color	Signal name	Measuring condition		Reference value	
			Ignition switch	Operation or condition		
33	L	Combination switch output 4	ON	Lighting, turn, wiper OFF Wiper dial position 4	 SKIA5292E	
34	PU	Combination switch output 3	ON	Lighting, turn, wiper OFF Wiper dial position 4	 SKIA5291E	
35	Y/R	Combination switch output 2	ON	Lighting, turn, wiper OFF Wiper dial position 4	 SKIA5292E	
36	Y	Combination switch output 1				
38	W/L	Ignition switch (ON)	ON	—	Battery voltage	
39	L	CAN- H	—	—	—	
40	R	CAN- L	—	—	—	
42	GY	Battery power supply	OFF	—	Battery voltage	
52	B	Ground	ON	—	Approx. 0V	
55	W/R	Battery power supply	OFF	—	Battery voltage	
62	Y	Front door switch (Driver side) signal	OFF	Front door switch (Driver side)	ON (open)	Approx. 0V
					OFF (closed)	Battery voltage

NOTE:

Optical sensor must be securely subjected to work lamp light. If the optical sensor is insufficiently illuminated, the measured value may not satisfy standard.

Terminals and Reference Values for IPDM E/R

AKS009UT

Terminal No.	Wire color	Signal name	Measuring condition		Reference value	
			Ignition switch	Operation or condition		
20	R	Headlamp low (RH)	ON	Lighting switch 2ND position	OFF	Approx. 0V
					ON	Battery voltage
22	R/L	Parking, license, and tail lamp	ON	Lighting switch 1ST position	OFF	Approx. 0V
					ON	Battery voltage
27	BR	Headlamp high (RH)	ON	Lighting switch HIGH or PASS position	OFF	Approx. 0V
					ON	Battery voltage
28	R/Y	Headlamp high (LH)	ON	Lighting switch HIGH or PASS position	OFF	Approx. 0V
					ON	Battery voltage
30	R/B	Headlamp low (LH)	ON	Lighting switch 2ND position	OFF	Approx. 0V
					ON	Battery voltage

AUTO LIGHT SYSTEM

Terminal No.	Wire color	Signal name	Measuring condition		Reference value
			Ignition switch	Operation or condition	
38	B	Ground	ON	—	Approx. 0V
48	L	CAN- H	—	—	—
49	R	CAN- L	—	—	—
60	B	Ground	ON	—	Approx. 0V

How to Proceed With Trouble Diagnosis

AKS009UU

1. Confirm the symptom or customer complaint.
2. Understand operation description and function description. Refer to [LT-71, "System Description"](#) .
3. Perform the preliminary check. Refer to [LT-79, "Preliminary Check"](#) .
4. Check symptom and repair or replace the cause of malfunction. Refer to [LT-86, "Trouble Diagnosis Chart by Symptom"](#) .
5. Does the auto light system operate normally? If YES: GO TO 6. If NO: GO TO 4.
6. INSPECTION END

Preliminary Check

AKS009UV

SETTING CHANGE FUNCTIONS

- Sensitivity of auto light system can be adjusted using CONSULT-II. Refer to [LT-82, "WORK SUPPORT"](#) .

CHECK POWER SUPPLY AND GROUND CIRCUIT

1. CHECK FUSES

- Check fuses for blown-out.

Unit	Power source	Fuse and fusible link No.
BCM	Battery	F
		18
	Ignition switch ON or START position	1
	Ignition switch ACC or ON position	6
IPDM E/R	Battery	72
		74
		76
		86

Refer to [LT-74, "Wiring Diagram — AUTO/L —"](#) .

OK or NG

OK >> GO TO 2.

NG >> If fuse is blown, be sure to eliminate cause of malfunction before installing new fuse. Refer to [PG-4, "POWER SUPPLY ROUTING CIRCUIT"](#) .

AUTO LIGHT SYSTEM

2. CHECK POWER SUPPLY CIRCUIT

1. Turn ignition switch OFF.
2. Disconnect BCM connector.
3. Check voltage between BCM harness connector and ground.

Terminals		Ignition switch position			
(+)		(-)	OFF	ACC	ON
Connector	Terminal (Wire color)		OFF	ACC	ON
M1	11 (LG)	Ground	0V	Battery voltage	Battery voltage
	38 (W/L)		0V	0V	Battery voltage
M2	42 (GY)		Battery voltage	Battery voltage	Battery voltage
	55 (W/R)		Battery voltage	Battery voltage	Battery voltage

OK or NG

OK >> GO TO 3.

NG >> Check harness for open or short between BCM and fuse.

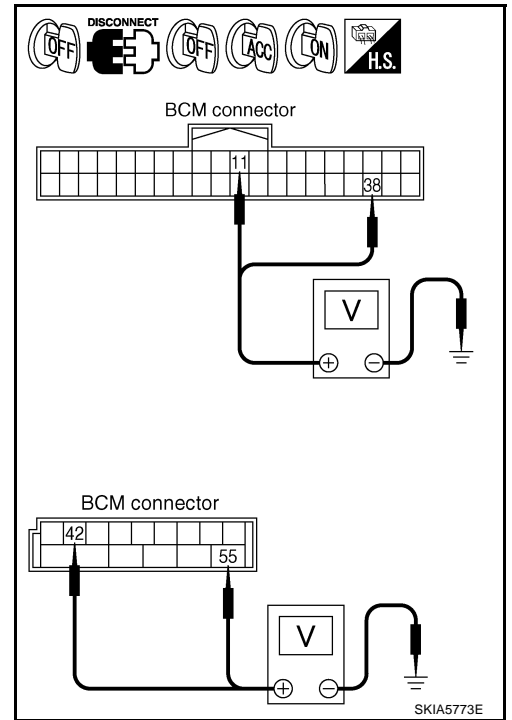

3. CHECK GROUND CIRCUIT

Check continuity between BCM harness connector and ground.

Terminals			Continuity
Connector	Terminal (Wire color)	Ground	
M2	52 (B)	Ground	Yes

OK or NG

OK >> INSPECTION END

NG >> Check ground circuit harness.

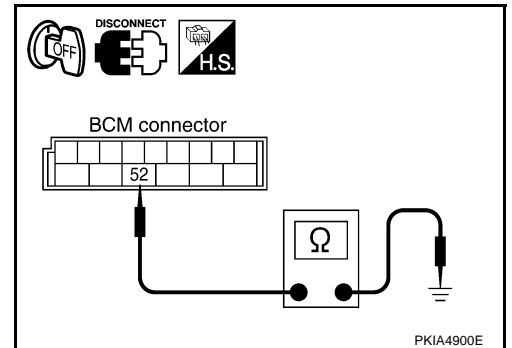

AUTO LIGHT SYSTEM

CONSULT-II Functions (BCM)

AKS009UW

- CONSULT-II performs the following functions communicating with BCM.

BCM diagnosis part	Check item, diagnosis mode	Description
HEAD LAMP	WORK SUPPORT	Changes the setting for each function.
	DATA MONITOR	Displays BCM input data in real time.
	ACTIVE TEST	Operation of electrical loads can be checked by sending drive signal to them.
BCM	CAN DIAG SUPPORT MNTR	The result of transmit/receive diagnosis of CAN communication can be read.

CONSULT-II BASIC OPERATION

CAUTION:

If CONSULT-II is used with no connection of CONSULT-II CONVERTER, malfunctions might be detected in self-diagnosis depending on control unit which carry out CAN communication.

1. With the ignition switch OFF, connect CONSULT-II and CONSULT-II CONVERTER to the data link connector, then turn ignition switch ON.

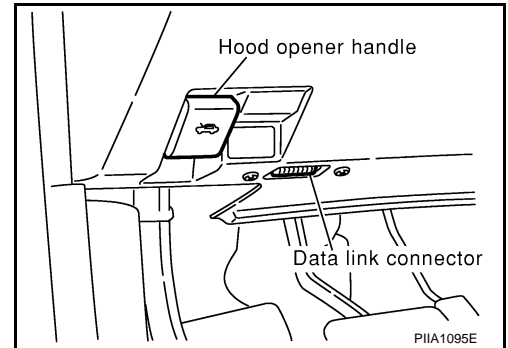

2. Touch "START (NISSAN BASED VHCL)".

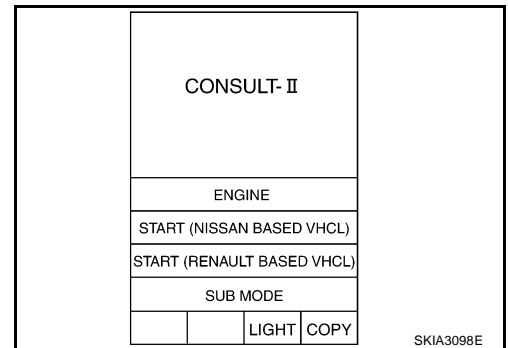

3. Touch "BCM" on "SELECT SYSTEM" screen. If "BCM" is not indicated, refer to [GI-39, "CONSULT-II Data Link Connector \(DLC\) Circuit"](#).

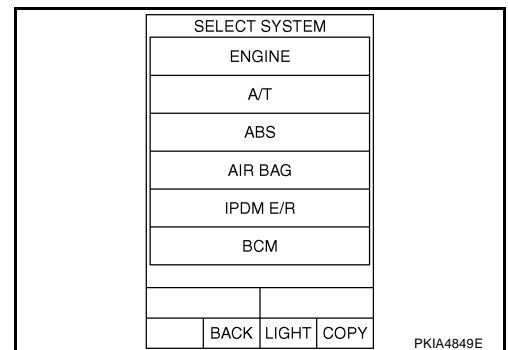

AUTO LIGHT SYSTEM

4. Touch "HEAD LAMP" on "SELECT TEST ITEM" screen.

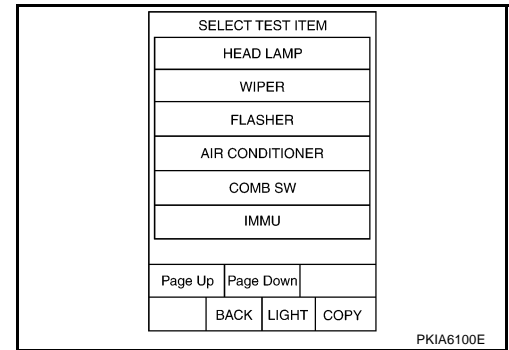

WORK SUPPORT

Operation Procedure

1. Touch "HEAD LAMP" on "SELECT TEST ITEM" screen.
2. Touch "WORK SUPPORT" on "SELECT DIAG MODE" screen.
3. Touch "CUSTOM A/LIGHT SETTING" or "ILL DELAY SET" on "SELECT WORK ITEM" screen.
4. Touch "START".
5. Touch "NORMAL" or "MODE 2 - 4" of setting to be changed (CUSTOM A/LIGHT SETTING). Touch "MODE1-8" of setting to be changed. (ILL DELAY SET)
6. Touch "SETTING CHANGE".
7. The setting will be changed and "CUSTOMIZING COMPLETED" will be displayed.
8. Touch "END".

Work Support Setting Item

- Sensitivity of auto light can be selected and set from four modes.

Work item	Description
CUSTOM A/LIGHT SETTING	Auto light sensitivity can be changed in this mode. Sensitivity can be adjusted in four modes. ● MODE 1 (Normal)/ MODE 2 (sensitive)/MODE 3 (Desensitized)/MODE4 (Insensitive)
ILL DELAY SET	Auto light delay off timer period can be changed in this mode. Selects auto light delay off timer period among eight modes. ● MODE 1 (45 sec.)/MODE 2 (OFF)/MODE 3 (30 sec.)/MODE 4 (60 sec.)/MODE 5 (90 sec.)/MODE 6 (120 sec.)/MODE 7 (150 sec.)/MODE 8 (180 sec.)

DATA MONITOR

Operation Procedure

1. Touch "HEAD LAMP" on "SELECT TEST ITEM" screen.
2. Touch "DATA MONITOR" on "SELECT DIAG MODE" screen.
3. Touch either "ALL SIGNALS" or "SELECTION FROM MENU" on the "DATA MONITOR" screen.

ALL SIGNALS	Monitors all the signals.
SELECTION FROM MENU	Selects and monitors individual signal.

4. Touch "START".
5. When "SELECTION FROM MENU" is selected, touch individual items to be monitored. When "ALL SIGNALS" is selected, all the items will be monitored.
6. Touch "RECORD" while monitoring, then the status of the monitored item can be recorded. To stop recording, touch "STOP".

Display Item List

Monitor item	Contents
IGN ON SW "ON/OFF"	Displays "IGN position (ON)/OFF, ACC position (OFF)" judged from the ignition switch signal.
ACC ON SW "ON/OFF"	Displays "ACC (ON)/OFF, Ignition OFF (OFF)" status judged from ignition switch signal.
HI BEAM SW "ON/OFF"	Displays status (high beam switch: ON/Others: OFF) of high beam switch judged from lighting switch signal.

AUTO LIGHT SYSTEM

Monitor item	Contents
HEAD LAMP SW 1	"ON/OFF" Displays status (headlamp switch 1: ON/Others: OFF) of headlamp switch 2 judged from lighting switch signal.
HEAD LAMP SW 2	"ON/OFF" Displays status (headlamp switch 2: ON/Others: OFF) of headlamp switch 2 judged from lighting switch signal.
LIGHT SW 1 ST	"ON/OFF" Displays status (lighting switch 1st position: ON/Others: OFF) of lighting switch judged from lighting switch signal.
AUTO LIGHT SW	"ON/OFF" Displays status of the lighting switch as judged from the lighting switch signal. (AUTO position: ON/Other than AUTO position: OFF)
PASSING SW	"ON/OFF" Displays status (flash-to-pass switch: ON/Others: OFF) of flash-to-pass switch judged from lighting switch signal.
FR FOG SW	"ON/OFF" Displays status (front fog lamp switch: ON/Others: OFF) of front fog lamp switch judged from lighting switch signal.
DOOR SW - DR	"ON/OFF" Displays status of the driver door as judged from the driver door switch signal. (Door is open: ON/Door is closed: OFF)
DOOR SW - AS	"ON/OFF" Displays status of the passenger door as judged from the passenger door switch signal. (Door is open: ON/Door is closed: OFF)
DOOR SW - RR ^{NOTE}	—
DOOR SW - RL ^{NOTE}	—
BACK DOOR SW ^{NOTE}	—
TURN SIGNAL R	"ON/OFF" Displays status (Turn right: ON/Others: OFF) as judged from lighting switch signal.
TURN SIGNAL L	"ON/OFF" Displays status (Turn left: ON/Others: OFF) as judged from lighting switch signal.
CARGO LAMP SW ^{NOTE}	—
OPTICAL SENSOR	[0 - 5V] Displays "ambient light (close to 5V when light/close to 0V when dark)" judged from optical sensor signal.

NOTE:

This item is displayed, but cannot monitor it.

ACTIVE TEST

Operation Procedure

1. Touch "HEAD LAMP" on "SELECT TEST ITEM" screen.
2. Touch "ACTIVE TEST" on "SELECT DIAG MODE" screen.
3. Touch item to be tested and check operation of the selected item.
4. During the operation check, touching "BACK" deactivates the operation.

Display Item List

Test item	Description
TAIL LAMP	Allows tail lamp relay to operate by switching ON-OFF.
HEAD LAMP (LOW)	Allows headlamp relay to operate by switching ON-OFF.
HEAD LAMP (HI)	Allows headlamp relay to operate by switching ON-OFF.
FR FOG LAMP	Allows fog lamp relay to operate by switching ON-OFF.
CORNERING LAMP ^{NOTE}	—
CARGO LAMP	Allow cargo lamp operate by switching ON-OFF.

NOTE:

This item is displayed, but cannot monitor it.

AUTO LIGHT SYSTEM

CONSULT-II Functions (IPDM E/R)

AKS009UX

CONSULT-II performs the following functions communicating with IPDM E/R.

Check Item, Diagnosis Mode	Description
SELF-DIAGNOSTIC RESULTS	The IPDM E/R performs self-diagnosis of CAN communication.
DATA MONITOR	The input/output data of the IPDM E/R is displayed in real time.
ACTIVE TEST	The IPDM E/R sends a drive signal to electronic components to check their operation.
CAN DIAG SUPPORT MNTR	The result of transmit/receive diagnosis of CAN communication can be read.

CONSULT-II OPERATION

CAUTION:

If CONSULT-II is used with no connection of CONSULT-II CONVERTER, malfunctions might be detected in self-diagnosis depending on control unit which carry out CAN communication.

1. With the ignition switch OFF, connect CONSULT-II and CONSULT-II CONVERTER to the data link connector, then turn the ignition switch ON.

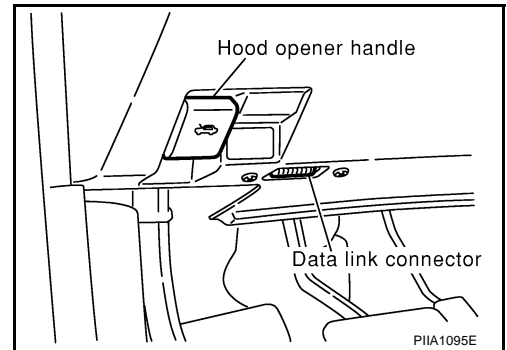

2. Touch "START (NISSAN BASED VHCL)".

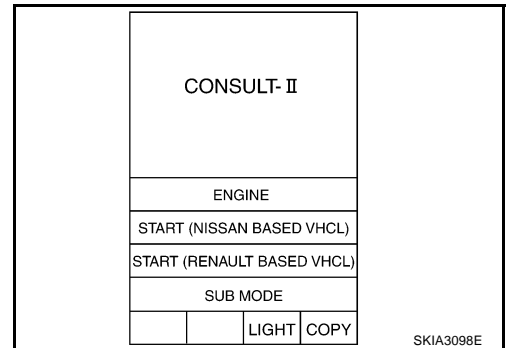

3. Touch "IPDM E/R" on "SELECT SYSTEM" screen. If "IPDM E/R" is not displayed, print "SELECT SYSTEM" screen, then refer to [GI-39, "CONSULT-II Data Link Connector \(DLC\) Circuit"](#).

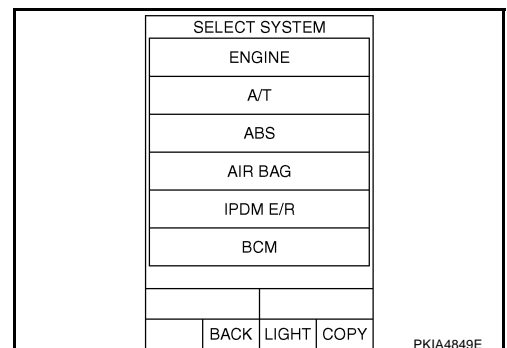

AUTO LIGHT SYSTEM

- Select the desired part to be diagnosed on the “SELECT DIAG MODE” screen.

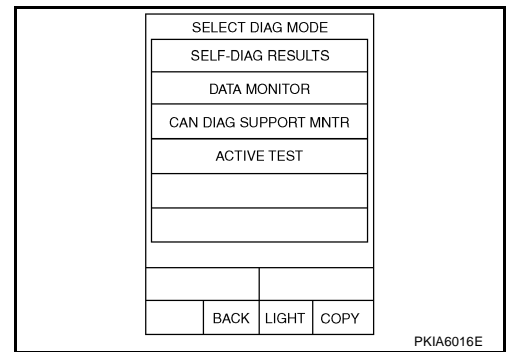

SELF-DIAGNOSTIC RESULTS

Refer to [PG-20, "SELF-DIAG RESULTS"](#) .

DATA MONITOR

Operation Procedure

- Touch “DATA MONITOR” on “SELECT DIAG MODE ” screen.
- Touch “ALL SIGNALS”, “MAIN SIGNALS” or “SELECT FROM MENU” on the “DATA MONITOR” screen.

ALL SIGNALS	All items will be monitored.
MAIN SIGNALS	Monitor the predetermined item.
SELECTION FROM MENU	Select any item for monitoring.

- Touch “START”.
- Touch the required monitoring item on “SELECTION FROM MENU”. In “ALL SIGNALS”, all items are monitored. In “MAIN SIGNALS”, predetermined items are monitored.
- Touch “RECORD” while monitoring to record the status of the item being monitored. To stop recording, touch “STOP”.

All Signals, Main Signals, Selection From Menu

Item name	CONSULT-II screen display	Display or unit	Monitor item selection			Description
			ALL SIGNALS	MAIN SIGNALS	SELECTION FROM MENU	
Position lights request	TAIL & CLR REQ	ON/OFF	×	×	×	Signal status input from BCM
Headlamp low beam request	HL LO REQ	ON/OFF	×	×	×	Signal status input from BCM
Headlamp high beam request	HL HI REQ	ON/OFF	×	×	×	Signal status input from BCM
Font fog lights request	FR FOG REQ	ON/OFF	×	×	×	Signal status input from BCM

NOTE:

Perform monitoring of IPDM E/R data with the ignition switch ON. When the ignition switch is at ACC, the display may not be correct.

ACTIVE TEST

Operation Procedure

- Touch “ACTIVE TEST” on “SELECT DIAG MODE” screen.
- Touch item to be tested, and check operation.
- Touch “START”.
- Touch “STOP” while testing to stop the operation.

Test item	CONSULT-II screen display	Description
Headlamp relay (HI, LO) output	LAMPS	Allows headlamp relay (HI, LO) to operate by switching operation (OFF, HI ON, LO ON) at your option.
Front fog lamp relay output		Allows fog lamp relay to operate by switching operation ON-OFF at your option.
Tail lamp relay output	TAIL LAMP	Allows tail lamp relay to operate by switching operation ON-OFF at your option.

AUTO LIGHT SYSTEM

Trouble Diagnosis Chart by Symptom

AKS009UY

Trouble phenomenon	Malfunction system and reference
<ul style="list-style-type: none"> ● Parking lamps and headlamps will not illuminate when outside of the vehicle becomes dark. (Lighting switch 1st position and 2nd position operate normally.) ● Parking lamps and headlamp will not go out when outside of the vehicle becomes light. (Lighting switch 1st position and 2nd position operate normally.) ● Headlamps go out when outside of the vehicle becomes light, but parking lamps stay on. 	<ul style="list-style-type: none"> ● Refer to LT-82, "WORK SUPPORT" . ● Refer to LT-86, "Lighting Switch Inspection" . ● Refer to LT-87, "Optical Sensor System Inspection" . <p>If above systems are normal, replace BCM.</p>
<p>Parking lamps illuminate when outside of the vehicle becomes dark, but headlamps stay off. (Lighting switch 1st position and 2nd position operate normally.)</p>	<ul style="list-style-type: none"> ● Refer to LT-82, "WORK SUPPORT" . ● Refer to LT-87, "Optical Sensor System Inspection" . <p>If above systems are normal, replace BCM.</p>
<p>Auto light adjustment system will not operate. (Lighting switch AUTO, 1st position and 2nd position operate normally.)</p>	<ul style="list-style-type: none"> ● Refer to LT-87, "Optical Sensor System Inspection" . <p>If above system is normal, replace BCM.</p>
<p>Auto light adjustment system of combination meter will not operate.</p>	<ul style="list-style-type: none"> ● CAN communication line inspection between BCM and combination meter. Refer to BCS-14, "CAN Communication Inspection Using CONSULT-II (Self-Diagnosis)" .
<p>Shut off delay feature will not operate.</p>	<ul style="list-style-type: none"> ● CAN communication line inspection between BCM and combination meter. Refer to BCS-14, "CAN Communication Inspection Using CONSULT-II (Self-Diagnosis)" . ● Refer to BL-33, "Check Door Switch (With Navigation System)" , BL-35, "Check Door Switch (Without Navigation System)" . <p>If above system is normal, replace BCM.</p>

Lighting Switch Inspection

AKS009UZ

1. CHECK LIGHTING SWITCH INPUT SIGNAL

 With CONSULT-II

Select "BCM" on CONSULT-II. With "HEAD LAMP" data monitor, make sure "AUTO LIGHT SW" turns ON-OFF linked with operation of lighting switch.

When lighting switch is AUTO : AUTO LIGHT SW ON position

 Without CONSULT-II

Refer to [LT-128, "Combination Switch Inspection"](#) .

OK or NG

OK >> INSPECTION END

NG >> Check lighting switch. Refer to [LT-128, "Combination Switch Inspection"](#) .

DATA MONITOR			
MONITOR		NO DTC	
AUTO LIGHT SW		ON	
RECORD			
MODE	BACK	LIGHT	COPY

PKIA7745E

AUTO LIGHT SYSTEM

Optical Sensor System Inspection

AKS009V0

1. CHECK OPTICAL SENSOR INPUT SIGNAL

① With CONSULT-II

Select "BCM" on CONSULT-II. With "HEAD LAMP" data monitor, make sure "OPTICAL SENSOR". Check difference in the voltage when the auto light sensor is illuminated and not illuminated.

Illuminated

OPTICAL SENSOR : 3.1V or more

Not illuminated

OPTICAL SENSOR : 0.6V or less

CAUTION:

Optical sensor must be securely subjected to work lamp light. If the optical sensor is insufficiently illuminated, the measured value may not satisfy the standard.

DATA MONITOR			
MONITOR		NO DTC	
OPTICAL SENSOR		0.75V	
RECORD			
MODE	BACK	LIGHT	COPY

PKIA7746E

⊗ Without CONSULT-II

GO TO 2.

OK or NG

OK >> INSPECTION END

NG >> GO TO 2.

2. CHECK OPTICAL SENSOR POWER SUPPLY CIRCUIT

1. Turn ignition switch OFF.
2. Disconnect BCM connector and optical sensor connector.
3. Check continuity (open circuit) between BCM harness connector M1 terminal 17 (P) and optical sensor harness connector M63 terminal 1 (P).

17 (P) – 1 (P) : Continuity should exist.

4. Check continuity (short circuit) between BCM harness connector M1 terminal 17 (P) and ground.

17 (P) – Ground : Continuity should not exist.

OK or NG

OK >> GO TO 3.

NG >> Repair harness or connector.

3. CHECK OPTICAL SENSOR POWER SUPPLY CIRCUIT

1. Check continuity (open circuit) between BCM harness connector M1 terminal 14 (Y/PU) and optical sensor harness connector M63 terminal 2 (Y/PU).

14 (Y/PU) – 2 (Y/PU) : Continuity should exist.

2. Check continuity (short circuit) between BCM harness connector M63 terminal 14 (Y/PU) and ground.

14 (Y/PU) – Ground : Continuity should not exist.

OK or NG

OK >> GO TO 4.

NG >> Repair harness or connector.

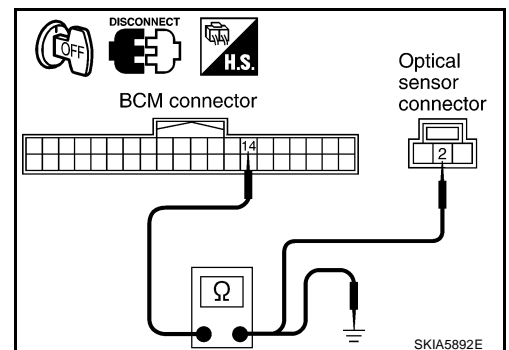
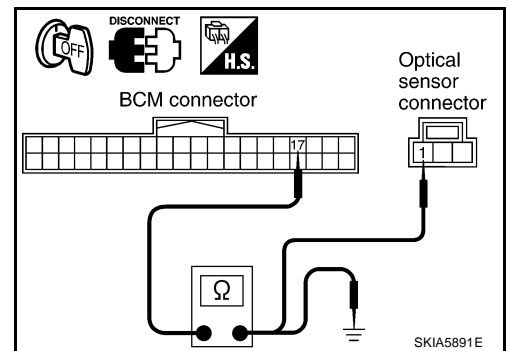

AUTO LIGHT SYSTEM

4. CHECK OPTICAL SENSOR POWER SUPPLY CIRCUIT

1. Check continuity (open circuit) between BCM harness connector M1 terminal 18 (B) and optical sensor harness connector M63 terminal 3 (B).

18 (B) – 3 (B) : Continuity should exist.

2. Check continuity (short circuit) between BCM harness connector M63 terminal 18 (B) and ground.

18 (B) – Ground : Continuity should not exist.

OK or NG

OK >> GO TO 5.

NG >> Repair harness or connector.

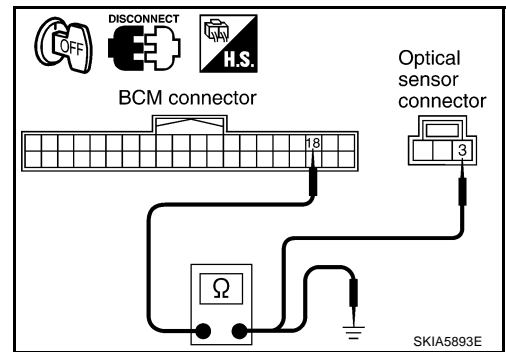

5. CHECK OPTICAL SENSOR VOLTAGE

1. Connect BCM connector.
2. Turn ignition switch ON.
3. Check voltage between BCM harness connector M1 terminal 17 (P) and ground.

17 (P) – Ground : Approx. 5V should exist.

OK or NG

OK >> Replace the optical sensor.

NG >> Replace BCM. Refer to [BCS-15, "Removal and Installation of BCM"](#) .

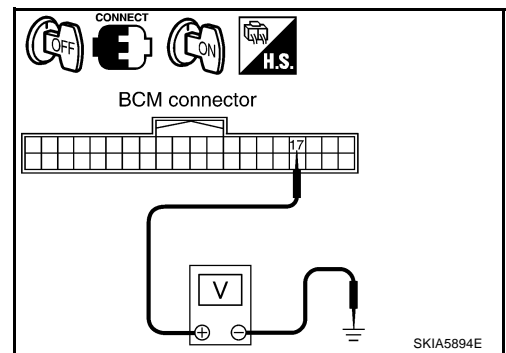

Removal and Installation for Optical Sensor

REMOVAL

1. Insert a screwdriver or similar tool and remove front defroster grill (LH). Refer to [IP-15, "\(W\) Front Defroster Grille \(RH/LH\)"](#) in "IP" section.
2. Disconnect optical sensor connector.
3. Remove optical sensor.

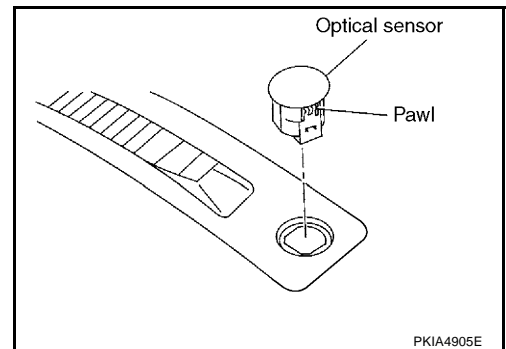

INSTALLATION

Install in the reverse order of removal.

FRONT FOG LAMP

FRONT FOG LAMP

PPF:26150

Component Parts and Harness Connector Location

AKS009V6

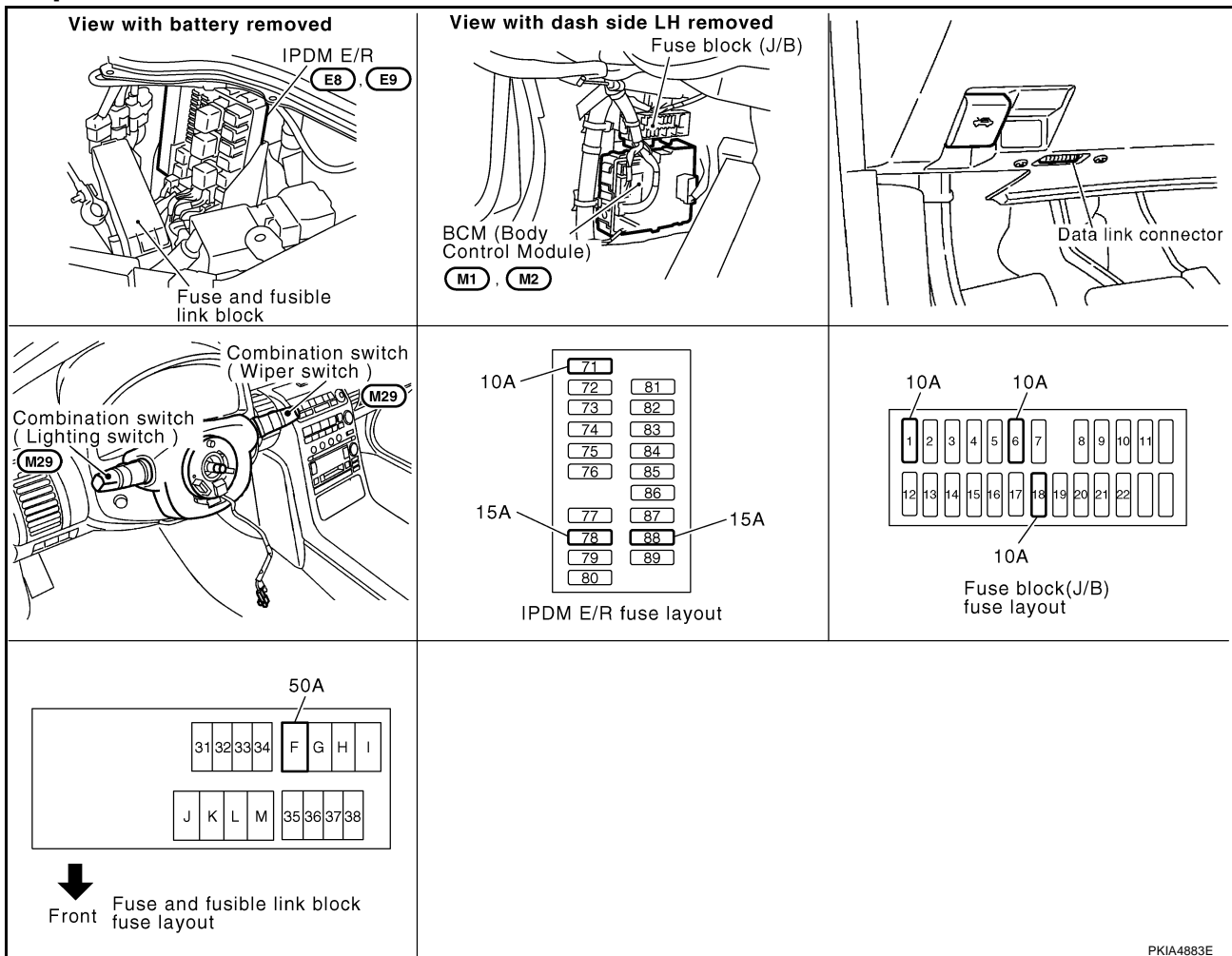

PKIA4883E

System Description

AKS009V7

Control of the fog lamps is dependent upon the position of the combination switch (lighting switch). The lighting switch must be in the 2ND position or AUTO position (LOW beam is ON) for front fog lamp operation. When the lighting switch is placed in the fog lamp position the BCM (body control module) receives input signal requesting the fog lamps to illuminate. When the headlamps are illuminated, this input signal is communicated to the IPDM E/R (intelligent power distribution module engine room) across the CAN communication lines. The CPU (central processing unit) of the IPDM E/R (intelligent power distribution module engine room) controls the front fog lamp relay coil. When activated, this relay directs power to the front fog lamps.

OUTLINE

Power is supplied at all times

- to ignition relay, [located in IPDM E/R (intelligent power distribution module engine room)]
- through 15A fuse [No. 88, located in IPDM E/R (intelligent power distribution module engine room)]
- to front fog lamp relay, [located in IPDM E/R (intelligent power distribution module engine room)]
- through 15A fuse [No. 78, [located in IPDM E/R (intelligent power distribution module engine room)]
- to CPU (central processing unit) [located in IPDM E/R (intelligent power distribution module engine room)]
- through 10A fuse [No. 71, [located in IPDM E/R (intelligent power distribution module engine room)]
- to CPU (central processing unit) [located in IPDM E/R (intelligent power distribution module engine room)].

Power is also supplied at all times

- through 50A fusible link (letter F, located in fuse and fusible link block)
- to BCM (body control module) terminal 55

A
B
C
D
E
F
G
H
I
J

LT

L
M

FRONT FOG LAMP

- through 10A fuse [No. 18, located in fuse block (J/B)]
- to BCM (body control module) terminal 42.

When the ignition switch is in ON or START position, power is supplied

- to ignition relay, [located in IPDM E/R (intelligent power distribution module engine room)]
- through 10A fuse [No. 1 located in fuse block (J/B)]
- to BCM (body control module) terminal 38.

When the ignition switch is in ACC or ON position, power is supplied

- through 10A fuse [No. 6, located in fuse block (J/B)]
- to BCM (body control module) terminal 11.

Ground is supplied

- to BCM (body control module) terminal 52
- through grounds M30 and M60
- to IPDM E/R (intelligent power distribution module engine room) terminals 38 and 60
- through grounds E17 and E43.

Fog Lamp Operation (For USA)

The fog lamp switch is built into the combination switch. The lighting switch must be in the 2ND position or AUTO position (LOW beam is ON) and the fog lamp switch must be ON for fog lamp operation.

With the fog lamp switch in the ON position, the CPU of the IPDM E/R grounds the coil side of the fog lamp relay. The fog lamp relay then directs power

- through IPDM E/R terminal 37
- to front fog lamp LH terminal 1
- through IPDM E/R terminal 36
- to front fog lamp RH terminal 1.

Ground is supplied

- to front fog lamp LH terminal 8
- through grounds E17 and E43
- to front fog lamp RH terminal 8
- through grounds E17 and E43.

With power and grounds supplied, the front fog lamps illuminate.

Fog Lamp Operation (For CANADA)

The fog lamp switch is built into the combination switch. The lighting switch must be in the 2ND position or AUTO position (LOW beam is ON) and the fog lamp switch must be ON for fog lamp operation.

With the fog lamp switch in the ON position, the CPU of the IPDM E/R grounds the coil side of the fog lamp relay. The fog lamp relay then directs power

- to front combination lamp LH terminal 1
- through daytime light relay-1 terminal 3
- to daytime light relay-1 terminals 2 and 5
- through IPDM E/R terminal 37
- to front combination lamp RH terminal 1
- through IPDM E/R terminal 36.

Ground is supplied

- to front combination lamp LH terminal 8
- through daytime light control unit terminal 7
- to daytime light control unit terminal 9
- through grounds E17 and E43
- to front combination lamp RH terminal 8
- through grounds E17 and E43.

With power and grounds supplied, the front fog lamps illuminate.

FRONT FOG LAMP

COMBINATION SWITCH READING FUNCTION

Refer to [BCS-3, "COMBINATION SWITCH READING FUNCTION"](#) .

A

EXTERIOR LAMP BATTERY SAVER CONTROL

When the combination switch (lighting switch) is in the 2ND position (ON), the fog lamp switch is ON, and the ignition switch is turned from ON or ACC to OFF, the battery saver control feature is activated.

B

Under this condition, the fog lamps (and headlamps) remain illuminated for 5 minutes, then the fog lamps (and headlamps) are turned off.

Exterior lamp battery saver control mode can be changed by the function setting of CONSULT-II.

C

CAN Communication System Description

AKS009V8

CAN (Controller Area Network) is a serial communication line for real time application. It is an on-vehicle multiplex communication line with high data communication speed and excellent error detection ability. Many electronic control units are equipped onto a vehicle, and each control unit shares information and links with other control units during operation (not independent). In CAN communication, control units are connected with 2 communication lines (CAN H line, CAN L line) allowing a high rate of information transmission with less wiring. Each control unit transmits/receives data but selectively reads required data only.

D

E

CAN Communication Unit

AKS009V9

Refer to [LAN-4, "CAN Communication Unit"](#) .

F

G

H

I

J

LT

L

M

FRONT FOG LAMP

Wiring Diagram — F/FOG — FOR USA

AKS009VA

LT-F/FOG-01

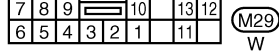
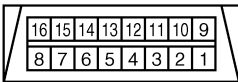
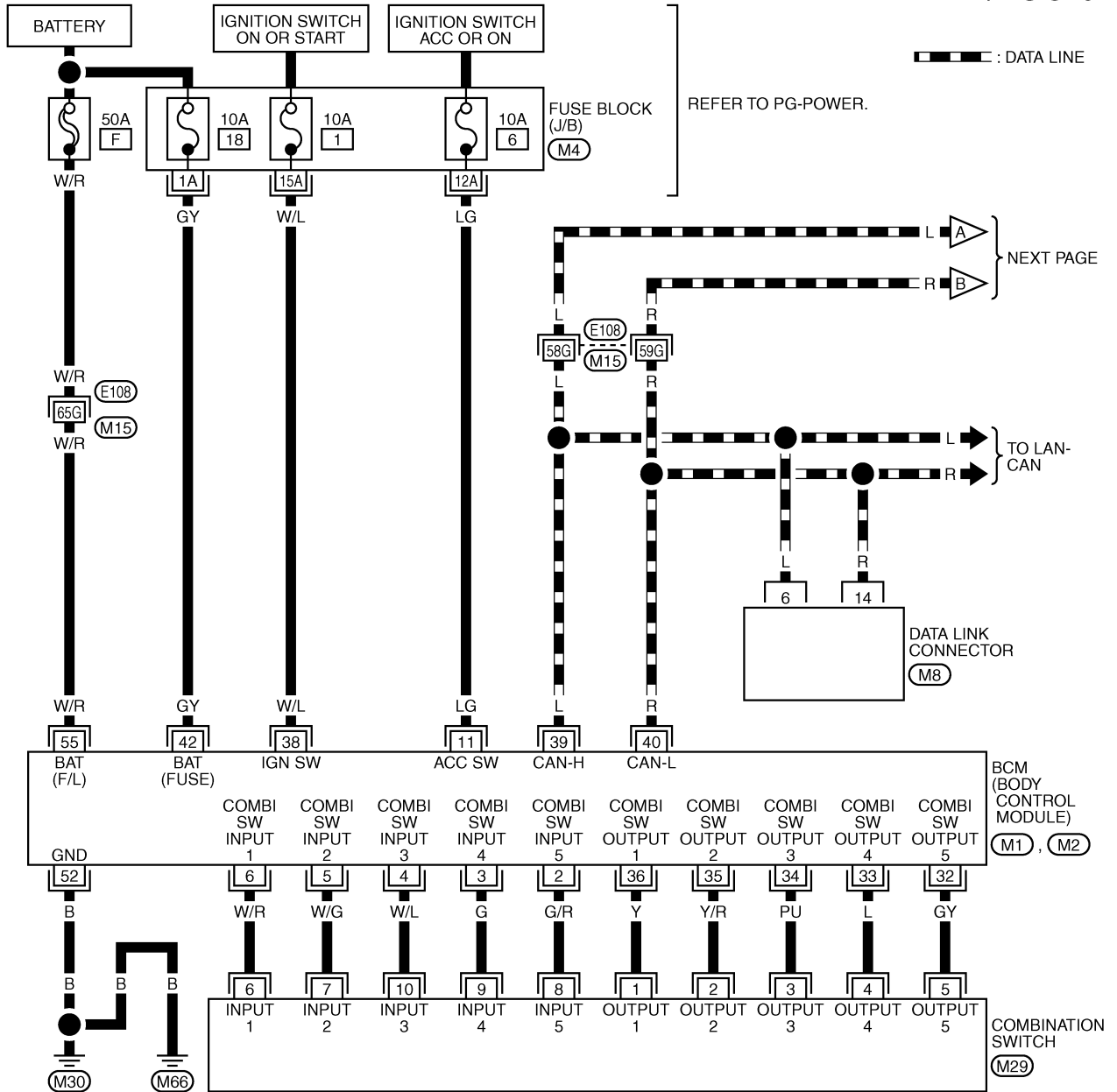

REFER TO THE FOLLOWING.

(E108) -SUPER MULTIPLE JUNCTION (SMJ)

(M4) -FUSE BLOCK-JUNCTION BOX (J/B)

(M1), (M2) -ELECTRICAL UNITS

TKWM0865E

FRONT FOG LAMP

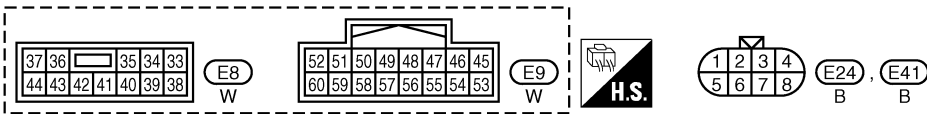
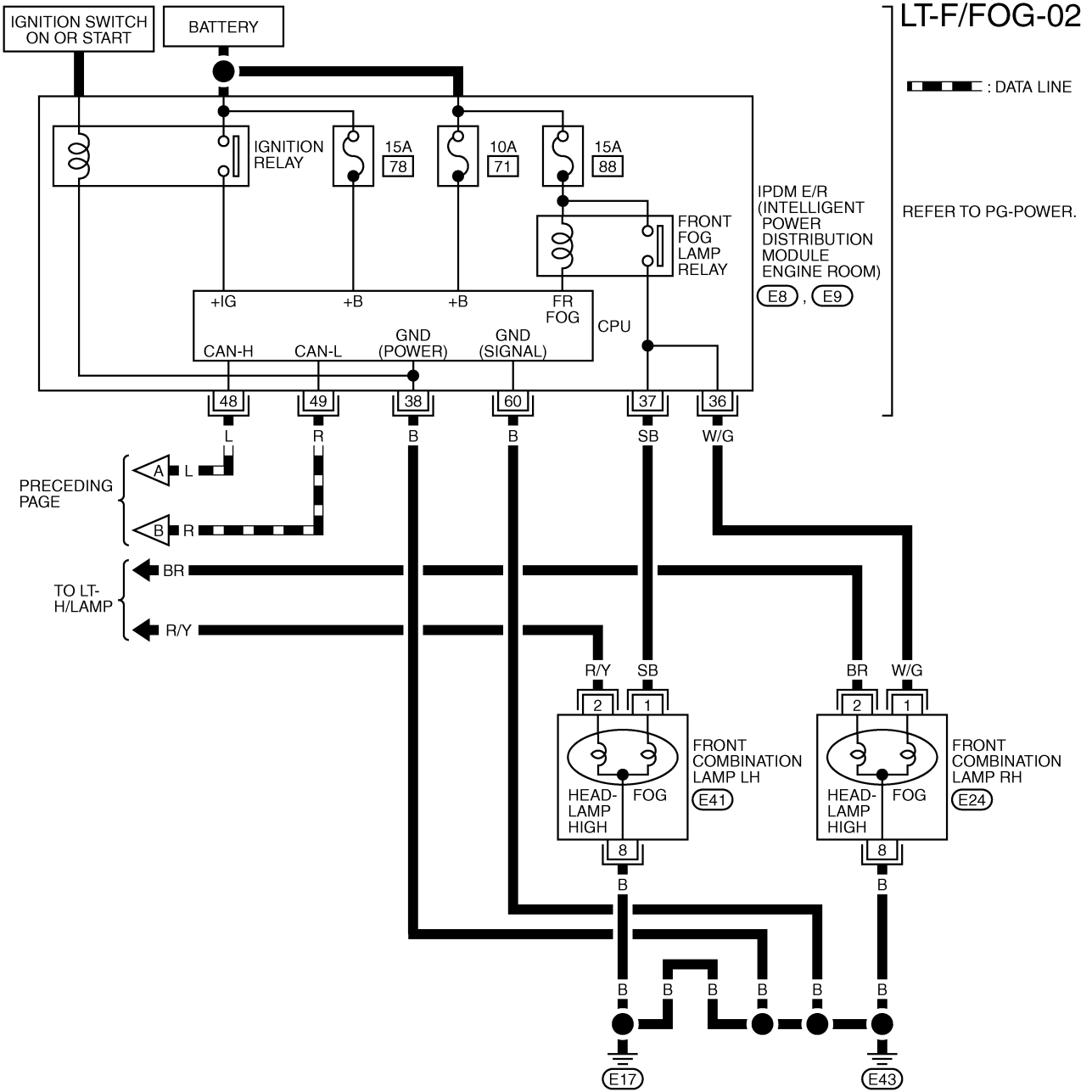

FRONT FOG LAMP

FOR CANADA

LT-F/FOG-03

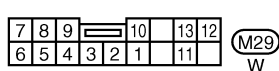
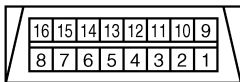
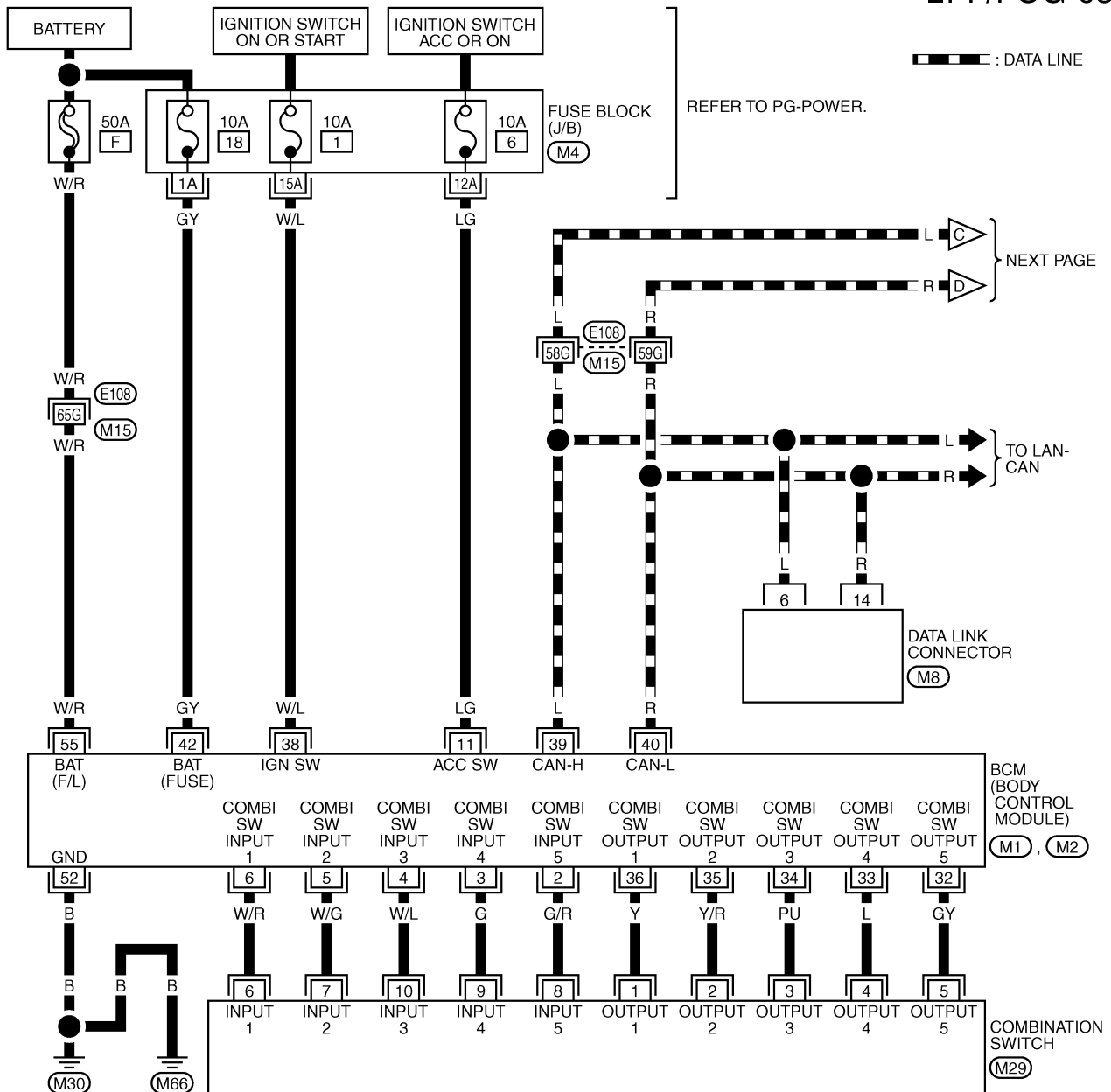

REFER TO THE FOLLOWING.

- (E108) -SUPER MULTIPLE JUNCTION (SMJ)
- (M4) -FUSE BLOCK-JUNCTION BOX (J/B)
- (M1) , (M2) -ELECTRICAL UNITS

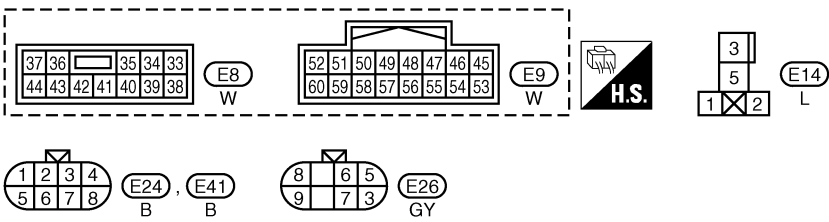
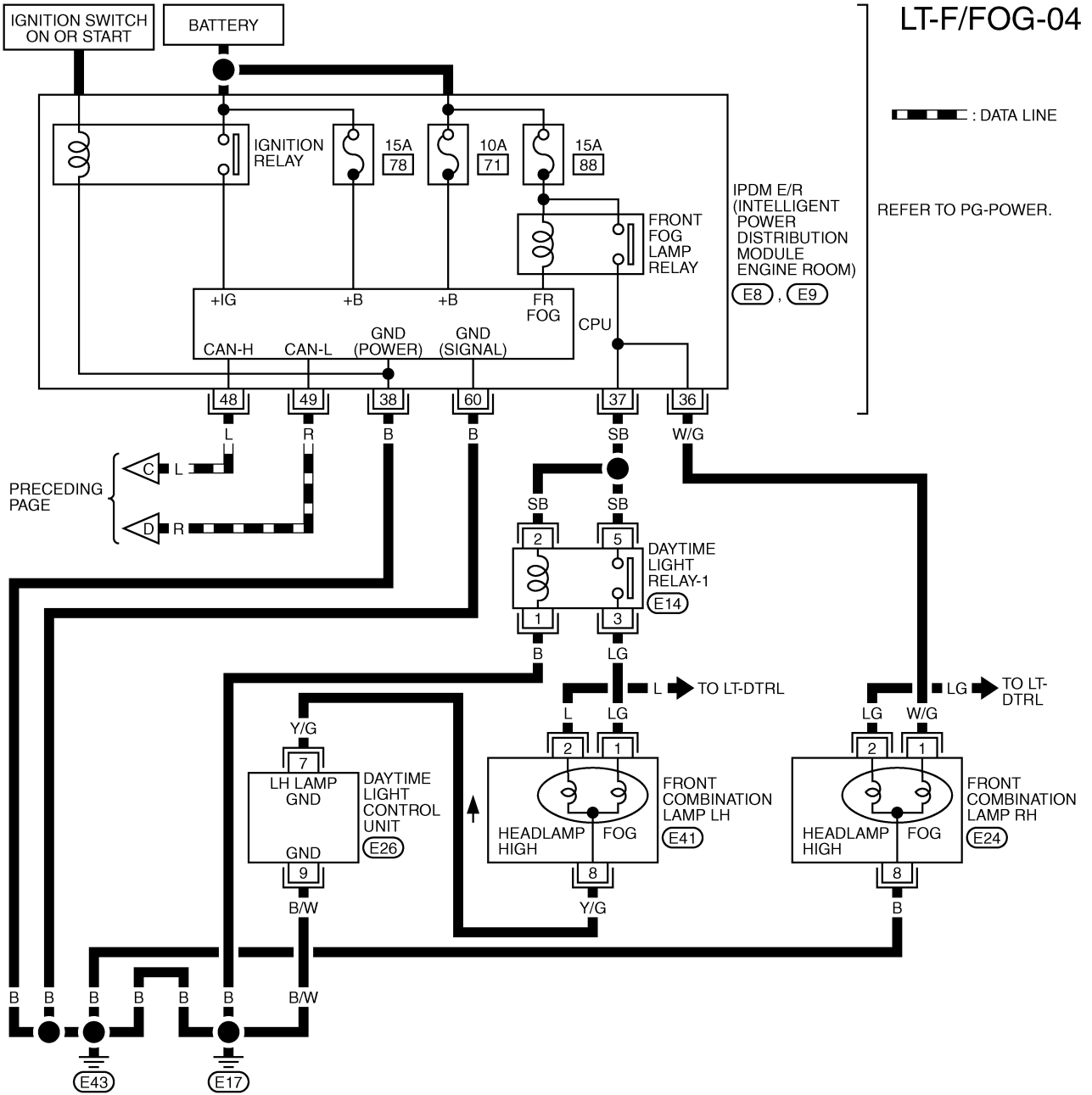

FRONT FOG LAMP



FRONT FOG LAMP

Terminals and Reference Values for BCM

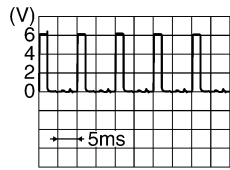
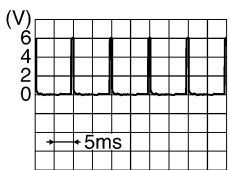
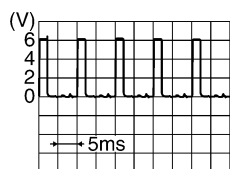
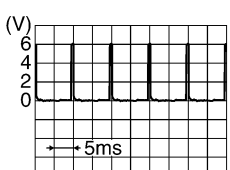
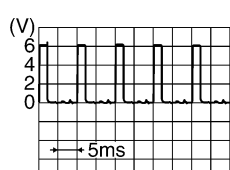
AKS009VB

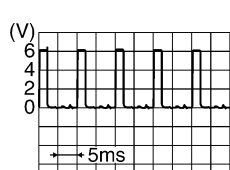
Terminal No.	Wire color	Signal name	Measuring condition		Reference value
			Ignition switch	Operation or condition	
2	G/R	Combination switch input 5	ON	Lighting, turn, wiper OFF Wiper dial position 4	 <p style="text-align: right;">SKIA5291E</p>
3	G	Combination switch input 4	ON	Lighting, turn, wiper OFF Wiper dial position 4	 <p style="text-align: right;">SKIA5292E</p>
4	W/L	Combination switch input 3	ON	Lighting, turn, wiper OFF Wiper dial position 4	 <p style="text-align: right;">SKIA5291E</p>
5	W/G	Combination switch input 2	ON	Lighting, turn, wiper OFF Wiper dial position 4	 <p style="text-align: right;">SKIA5292E</p>
6	W/R	Combination switch input 1			
11	LG	Ignition switch (ACC)	ACC	—	Battery voltage
32	GY	Combination switch output 5	ON	Lighting, turn, wiper OFF Wiper dial position 4	 <p style="text-align: right;">SKIA5291E</p>
33	L	Combination switch output 4	ON	Lighting, turn, wiper OFF Wiper dial position 4	 <p style="text-align: right;">SKIA5292E</p>
34	PU	Combination switch output 3	ON	Lighting, turn, wiper OFF Wiper dial position 4	 <p style="text-align: right;">SKIA5291E</p>

FRONT FOG LAMP

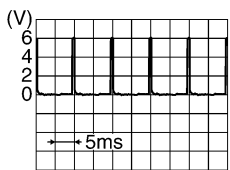
Terminal No.	Wire color	Signal name	Measuring condition		Reference value
			Ignition switch	Operation or condition	
35	Y/R	Combination switch output 2	ON	Lighting, turn, wiper OFF Wiper dial position 4	 SKIA5292E
36	Y	Combination switch output 1			
38	W/L	Ignition switch (ON)	ON	—	Battery voltage
39	L	CAN- H	—	—	—
40	R	CAN- L	—	—	—
42	GY	Battery power supply	OFF	—	Battery voltage
52	B	Ground	ON	—	Approx. 0V
55	W/R	Battery power supply	OFF	—	Battery voltage

Terminals and Reference Values for IPDM E/R

AKS009VC

Terminal No.	Wire color	Signal name	Measuring condition			Reference value
			Ignition switch	Operation or condition		
36	W/G	Front fog lamp (RH)	ON	Lighting switch must be in the 2ND position or AUTO position (LOW beam is ON) and the front fog lamp switch must be ON.	OFF	Approx. 0V
					ON	Battery voltage
37	SB	Front fog lamp (LH)	ON	Lighting switch must be in the 2ND position or AUTO position (LOW beam is ON) and the front fog lamp switch must be ON.	OFF	Approx. 0V
					ON	Battery voltage
38	B	Ground	ON	—	Approx. 0V	
48	L	CAN- H	—	—	—	
49	R	CAN- L	—	—	—	
60	B	Ground	ON	—	Approx. 0V	

How to Proceed With Trouble Diagnosis

AKS009VD

1. Confirm the symptom or customer complaint.
2. Understand operation description and function description. Refer to [LT-89, "System Description"](#) .
3. Perform the preliminary check. Refer to [LT-97, "Preliminary Check"](#) .
4. Check symptom and repair or replace the cause of malfunction.
5. Does the front fog lamp operate normally? If YES: GO TO 6. If NO: GO TO 4.
6. INSPECTION END

Preliminary Check

AKS009VE

CHECK POWER SUPPLY AND GROUND CIRCUIT

1. CHECK FUSES

- Check fuses for blown-out.

Unit	Power source	Fuse and fusible link No.
BCM	Battery	F
	Battery	18
	Ignition switch ON or START position	1
	Ignition switch ACC or ON position	6

FRONT FOG LAMP

Unit	Power source	Fuse and fusible link No.
IPDM E/R	Battery	71
		78
		88

Refer to [LT-92, "Wiring Diagram — F/FOG —"](#) .

OK or NG

OK >> GO TO 2.

NG >> If fuse is blown, be sure to eliminate cause of malfunction before installing new fuse. Refer to [PG-4, "POWER SUPPLY ROUTING CIRCUIT"](#) .

2. CHECK POWER SUPPLY CIRCUIT

1. Turn ignition switch OFF.
2. Disconnect BCM connector.
3. Check voltage between BCM harness connector and ground.

Terminals		(-)	Ignition switch position		
(+)			OFF	ACC	ON
Connector	Terminal (Wire color)	Ground	0V	Battery voltage	Battery voltage
	M1		11 (LG)	0V	0V
	38 (W/L)		Battery voltage	Battery voltage	Battery voltage
M2	42 (GY)		Battery voltage	Battery voltage	Battery voltage
	55 (W/R)		Battery voltage	Battery voltage	Battery voltage

OK or NG

OK >> GO TO 3.

NG >> Check harness for open or short between BCM and fuse.

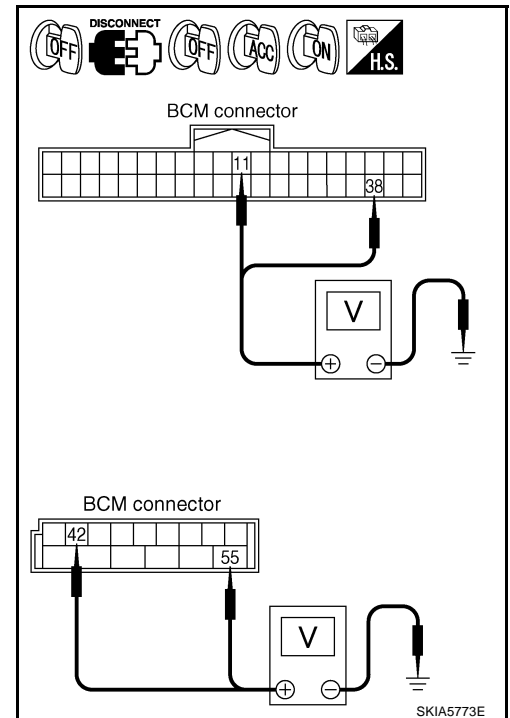

3. CHECK GROUND CIRCUIT

Check continuity between BCM harness connector and ground.

Terminals		Continuity
Connector	Terminal (Wire color)	
M2	52 (B)	Ground
		Yes

OK or NG

OK >> INSPECTION END

NG >> Check ground circuit harness.

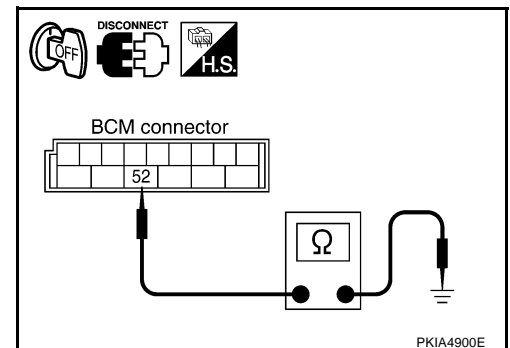

CONSULT-II Functions

Refer to [LT-18, "CONSULT-II Functions \(BCM\)"](#) in HEADLAMP.

Refer to [LT-21, "CONSULT-II Functions \(IPDM E/R\)"](#) in HEADLAMP.

Refer to [LT-54, "CONSULT-II Functions \(BCM\)"](#) in HEADLAMP (FOR CANADA).

Refer to [LT-57, "CONSULT-II Functions \(IPDM E/R\)"](#) in HEADLAMP (FOR CANADA).

FRONT FOG LAMP

Front Fog lamps Does Not Illuminate (Both Sides) (FOR USA)

AKS009VG

1. CHECK COMBINATION SWITCH INPUT SIGNAL

④ With CONSULT-II

Select "BCM" on CONSULT-II. With "HEAD LAMP" data monitor, make sure "FR FOG SW" turns ON-OFF linked with operation of lighting switch.

When lighting switch is FOG : FR FOG SW ON position

⊗ Without CONSULT-II

Refer to [LT-128, "Combination Switch Inspection"](#) .

OK or NG

OK >> GO TO 2.

NG >> Check lighting switch. Refer to [LT-128, "Combination Switch Inspection"](#) .

DATA MONITOR			
MONITOR		NO DTC	
FR FOG SW		ON	
RECORD			
MODE	BACK	LIGHT	COPY

PKIA7747E

2. FOG LAMP ACTIVE TEST

④ With CONSULT-II

1. Select "IPDM E/R" on CONSULT-II. and select "ACTIVE TEST" on "SELECT DIAG MODE" screen.
2. Select "LAMPS" on "SELECT TEST ITEM" screen.
3. Touch "FOG" screen.
4. Make sure fog lamp operates.

Fog lamp should operate.

⊗ Without CONSULT-II

1. Start auto active test. Refer to [PG-23, "Auto Active Test"](#) .
2. Make sure fog lamp operates.

Fog lamp should operate.

OK or NG

OK >> GO TO 3.

NG >> GO TO 4.

ACTIVE TEST			
LAMPS		FOG	
OFF		HI	
LO			
MODE	BACK	LIGHT	COPY

PKIA7748E

3. CHECK IPDM E/R

1. Select "IPDM E/R" on CONSULT-II, and select "DATA MONITOR" on "SELECT DIAG MODE" screen.
2. Make sure "FR FOG REQ" turns ON when lighting switch is in FOG position.

When lighting switch is FOG : FR FOG REQ ON position

OK or NG

OK >> Replace IPDM E/R.

NG >> Replace BCM. Refer to [BCS-15, "Removal and Installation of BCM"](#) .

DATA MONITOR			
MONITOR			
FR FOG REQ		ON	
Page Down			
RECORD			
MODE	BACK	LIGHT	COPY

SKIA5898E

FRONT FOG LAMP

4. CHECK FOG LAMP INPUT SIGNAL

☑ With CONSULT-II

1. Turn ignition switch OFF.
2. Disconnect front combination lamp RH and LH connectors.
3. Select "IPDM E/R" on CONSULT-II. and select "ACTIVE TEST" on "SELECT DIAG MODE" screen.
4. Select "TAIL LAMP" on "SELECT TEST ITEM" screen.
5. Touch "FOG" screen.
6. When fog lamp is operating, check voltage between front combination lamp RH and LH harness connector and ground.

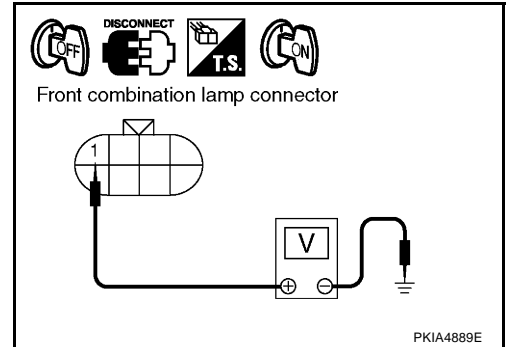

Terminals			(-)	Voltage
(+) Connector		Terminal (Wire color)		
RH	E24	1 (W/G)	Ground	Battery voltage
LH	E41	1 (SB)		

☒ Without CONSULT-II

1. Turn ignition switch OFF.
2. Disconnect front combination lamp RH and LH connectors.
3. Start auto active test. Refer to [PG-23, "Auto Active Test"](#).
4. When fog lamp is operating, check voltage between front combination lamp RH and LH harness connectors and ground.

Terminals			(-)	Voltage
(+) Connector		Terminal (Wire color)		
RH	E24	1 (W/G)	Ground	Battery voltage
LH	E41	1 (SB)		

OK or NG

- OK >> GO TO 6.
 NG >> GO TO 5.

5. CHECK FOG LAMP CIRCUIT

1. Turn ignition switch OFF.
2. Disconnect IPDM E/R connector.
3. Check continuity between IPDM E/R harness connector E8 terminal 36 (W/G) and front combination lamp RH harness connector E24 terminal 1 (W/G).

36 (W/G) – 1 (W/G) : Continuity should exist.

4. Check continuity between IPDM E/R harness connector E8 terminal 37 (SB) and front combination lamp LH harness connector E41 terminal 1 (SB).

37 (SB) – 1(SB) : Continuity should exist.

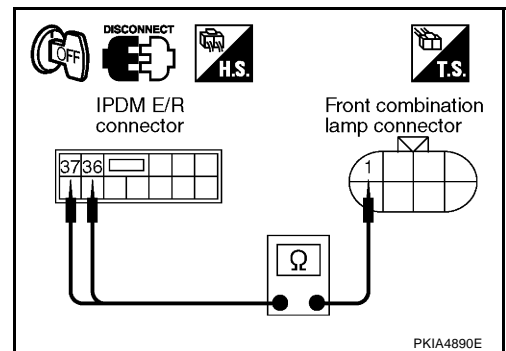

OK or NG

- OK >> Replace IPDM E/R.
 NG >> Repair harness or connector.

FRONT FOG LAMP

6. CHECK FOG LAMP GROUND

1. Check continuity between front combination lamp RH harness connector E24 terminal 8 (B) and ground.

8 (B) – Ground : Continuity should exist.

2. Check continuity between front combination lamp LH harness connector E41 terminal 8 (B) and ground.

8 (B) – Ground : Continuity should exist.

OK or NG

- OK >> Check front combination lamp bulbs.
NG >> Repair harness or connector.

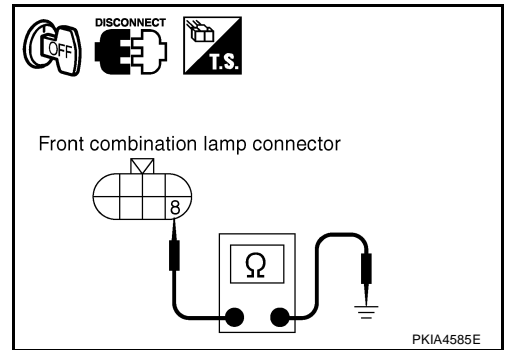

Front Fog Lamp Does Not Illuminate (One Side) (FOR USA)

AKS009VH

1. CHECK BULB

Check bulb of lamp which do not illuminate.

OK or NG

- OK >> GO TO 2.
NG >> Replace front combination lamp bulb.

2. CHECK FOG LAMP CIRCUIT

1. Disconnect IPDM E/R connector and front combination lamp RH or LH connectors.

2. Check continuity between IPDM E/R harness connector E8 terminal 36 (W/G) and front combination lamp RH harness connector E24 terminal 1 (W/G).

36 (W/G) – 1 (W/G) : Continuity should exist.

3. Check continuity between IPDM E/R harness connector E8 terminal 37 (SB) and front combination lamp LH harness connector E41 terminal 1 (SB).

37 (SB) – 1 (SB) : Continuity should exist.

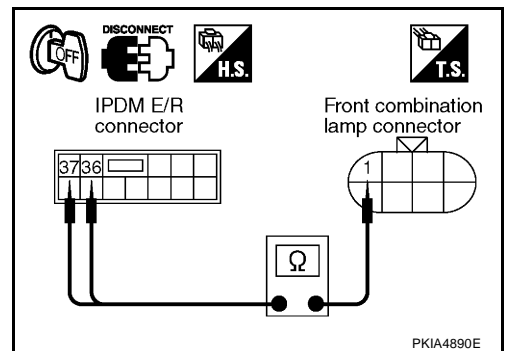

OK or NG

- OK >> GO TO 3.
NG >> Repair harness or connector.

3. CHECK FOG LAMP GROUND

1. Check continuity between front combination lamp RH harness connector E24 terminal 8 (B) and ground.

8 (B) – Ground : Continuity should exist.

2. Check continuity between front combination lamp LH harness connector E41 terminal 8 (B) and ground.

8 (B) – Ground : Continuity should exist.

OK or NG

- OK >> Replace IPDM E/R.
NG >> Repair harness or connector.

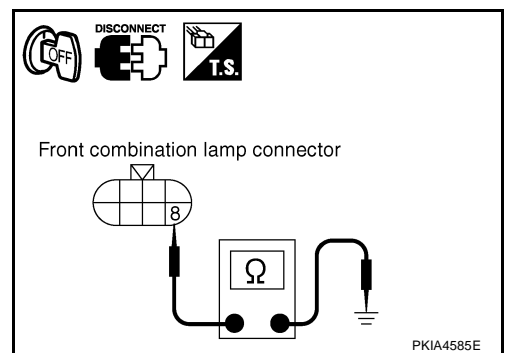

FRONT FOG LAMP

Front Fog lamps Does Not Illuminate (Both Sides) (For CANADA)

AKS00A0H

1. CHECK COMBINATION SWITCH INPUT SIGNAL

④ With CONSULT-II

Select "BCM" on CONSULT-II. With "HEAD LAMP" data monitor, make sure "FR FOG SW" turns ON-OFF linked with operation of lighting switch.

When lighting switch is FOG : FR FOG SW ON position

⊗ Without CONSULT-II

Refer to [LT-128, "Combination Switch Inspection"](#) .

OK or NG

OK >> GO TO 2.

NG >> Check lighting switch. Refer to [LT-128, "Combination Switch Inspection"](#) .

DATA MONITOR			
MONITOR		NO DTC	
FR FOG SW		ON	
MODE	BACK	LIGHT	COPY

PKIA6346E

2. FOG LAMP ACTIVE TEST

④ With CONSULT-II

1. Select "IPDM E/R" on CONSULT-II. and select "ACTIVE TEST" on "SELECT DIAG MODE" screen.
2. Select "LAMPS" on "SELECT TEST ITEM" screen.
3. Touch "FOG" screen.
4. Make sure fog lamp operates.

Fog lamp should operate.

⊗ Without CONSULT-II

1. Start auto active test. Refer to [PG-23, "Auto Active Test"](#) .
2. Make sure fog lamp operates.

Fog lamp should operate.

OK or NG

OK >> GO TO 3.

NG >> GO TO 4.

3. CHECK IPDM E/R

1. Select "IPDM E/R" on CONSULT-II, and select "DATA MONITOR" on "SELECT DIAG MODE" screen.
2. Make sure "FR FOG REQ" turns ON when lighting switch is in FOG position.

When lighting switch is FOG : FR FOG REQ ON position

OK or NG

OK >> Replace IPDM E/R.

NG >> Replace BCM. Refer to [BCS-15, "Removal and Installation of BCM"](#) .

ACTIVE TEST			
LAMPS		OFF	
MODE	BACK	LIGHT	COPY

SKIA5774E

DATA MONITOR			
MONITOR		NO DTC	
FR FOG REQ		ON	
MODE	BACK	LIGHT	COPY

SKIA5898E

FRONT FOG LAMP

4. CHECK IPDM E/R

With CONSULT-II

1. Select "IPDM E/R" on CONSULT-II. and select "ACTIVE TEST" on "SELECT DIAG MODE" screen.
2. Select "TAIL LAMP" on "SELECT TEST ITEM" screen.
3. Touch "FOG" screen.
4. When fog lamp is operating, check voltage between IPDM E/R and LH harness connector and ground.

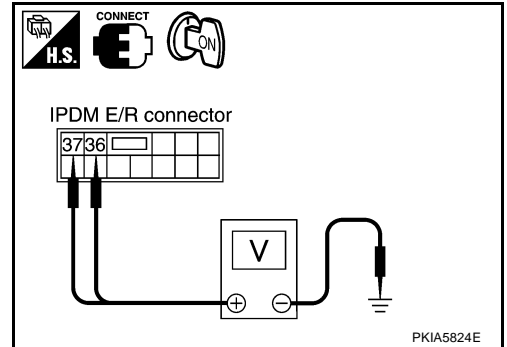

Terminals				Voltage	
(+)		(-)			
Connector	Terminal (Wire color)				
RH	E8	36 (W/G)		Ground	Battery voltage
LH		37 (SB)			

With out CONSULT-II

1. Start auto active test. Refer to [PG-23, "Auto Active Test"](#) .
2. When fog lamp is operating, check voltage between IPDM E/R harness connector and ground.

Terminals				Voltage	
(+)		(-)			
Connector	Terminal (Wire color)				
RH	E8	36 (W/G)		Ground	Battery voltage
LH		37 (SB)			

OK or NG

- OK >> Check front fog lamp bulbs.
 NG >> Replace IPDM E/R.

LH Front Fog Lamp Does Not Illuminate (FOR CANADA)

AKS00ADK

1. CHECK BULB

Check bulb of lamps which do not illuminate.

OK or NG

- OK >> GO TO 2.
 NG >> Replace front fog lamp bulb.

2. CHECK CIRCUIT BETWEEN IPDM E/R AND DAYTIME LIGHT RELAY-1

1. Turn ignition switch OFF.
2. Disconnect IPDM E/R connector and daytime light relay-1.
3. Check continuity between harness connector of IPDM E/R and harness connector of daytime light relay-1.

Terminals				Continuity
IPDM E/R		Daytime light relay-1		
Connector	Terminal (Wire color)	Connector	Terminal (Wire color)	
E8	37 (SB)	E14	2 (SB)	Yes
			5 (SB)	

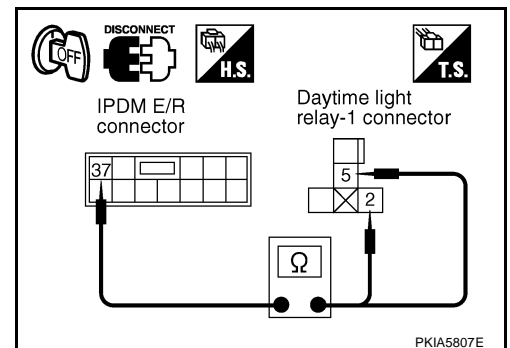

OK or NG

- OK >> GO TO 3.
 NG >> Repair harness or connector.

FRONT FOG LAMP

3. CHECK DAYTIME LIGHT RELAY-1 AND GROUND

Check continuity between daytime light relay-1 harness connector E14 terminal 1 (B) and ground.

1 (B) – Ground : Continuity should exist.

OK or NG

- OK >> GO TO 4.
- NG >> Repair harness or connector.

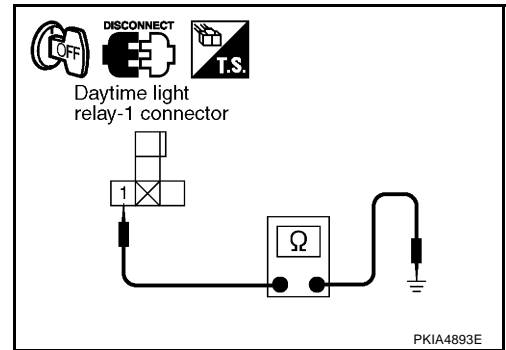

4. CHECK CIRCUIT DAYTIME LIGHT RELAY-1 AND HEADLAMP

1. Disconnect LH front combination lamp connector.
2. Check continuity between daytime light relay-1 harness connector E14 terminal 3 (LG) and LH front combination lamp harness connector E41 terminal 1 (LG).

3 (LG) – 1 (LG) : Continuity should exist.

OK or NG

- OK >> GO TO 5.
- NG >> Repair harness or connector.

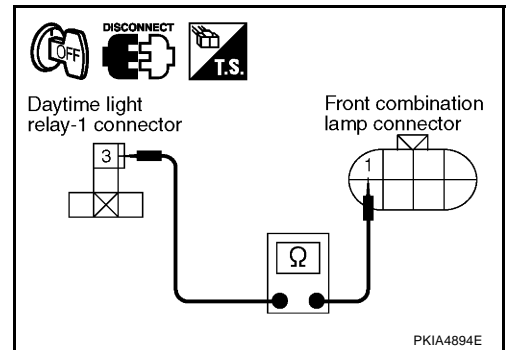

5. CHECK IPDM E/R

1. Connect IPDM E/R connector.
2. Turn ignition switch ON.
3. Lighting switch is turned 2ND and FOG ON position.
4. Check voltage between daytime light relay-1 harness connector E14 terminal 2 (SB) and 5 (SB) and ground.

2 (SB), 5 (SB) – Ground : Battery voltage should exist.

OK or NG

- OK >> GO TO 6.
- NG >> Replace IPDM E/R.

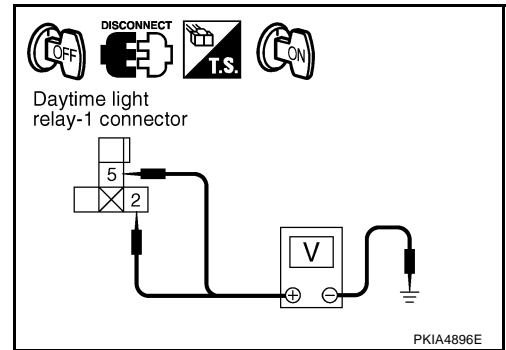

6. CHECK DAYTIME LIGHT RELAY-1

1. Turn ignition switch OFF.
2. Connect daytime light relay-1.
3. Turn ignition switch ON.
4. Lighting switch is turned 2 ND and FOG ON position.
5. Check voltage between front combination lamp LH harness connector E41 terminal 1 (LG) and ground.

1 (LG) – Ground : Battery voltage should exist.

OK or NG

- OK >> GO TO 7.
- NG >> Replace daytime light relay-1.

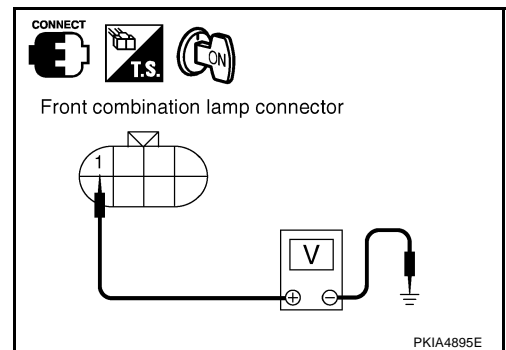

FRONT FOG LAMP

7. CHECK CIRCUIT BETWEEN HEADLAMP AND DAYTIME LIGHT CONTROL UNIT

1. Turn ignition switch OFF.
2. Disconnect daytime light control unit connector.
3. Check continuity between front combination lamp LH harness connector E41 terminal 8 (Y/G) and daytime light control unit harness connector E26 terminal 7 (Y/G).

8 (Y/G) – 7 (Y/G) : Continuity should exist.

OK or NG

- OK >> GO TO 8.
NG >> Repair harness or connector.

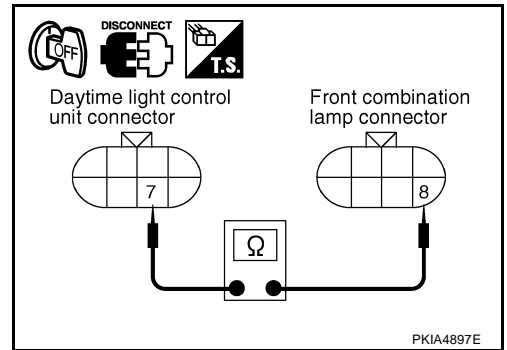

8. CHECK CIRCUIT BETWEEN HEADLAMP AND DAYTIME LIGHT CONTROL UNIT

Check continuity between daytime light control unit harness connector E26 terminal 9 (B/W) and ground.

9 (B/W) – Ground : Continuity should exist.

OK or NG

- OK >> Replace daytime light control unit.
NG >> Repair harness or connector.

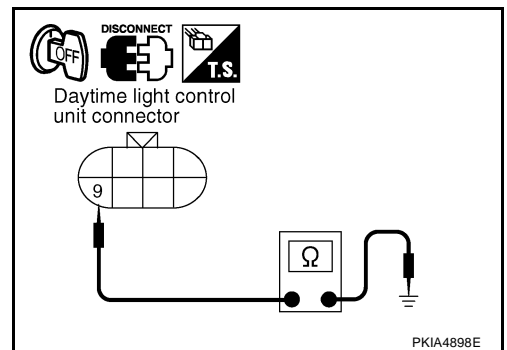

RH Front Fog Lamp Does Not Illuminate (FOR CANADA)

1. CHECK BULB

Check bulbs of lamps which do not illuminate.

OK or NG

- OK >> GO TO 2.
NG >> Replace front fog lamp bulb.

2. CHECK CIRCUIT BETWEEN IPDM E/R AND FRONT FOG LAMP

1. Turn ignition switch OFF.
2. Disconnect IPDM E/R connector and RH front combination lamp connector.
3. Check continuity between harness IPDM E/R harness connector E8 terminal 36 (W/G) and front combination lamp RH harness connector E24 terminal 1 (W/G).

36 (W/G) – 1 (W/G) : Continuity should exist.

OK or NG

- OK >> GO TO 3.
NG >> Repair harness or connector.

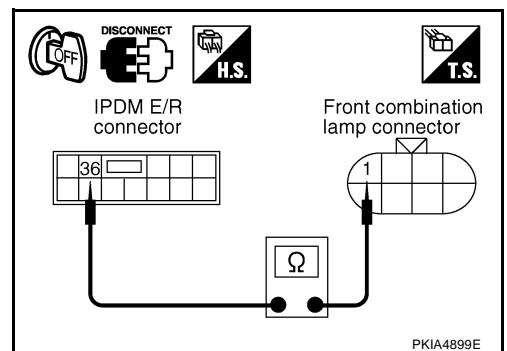

FRONT FOG LAMP

3. CHECK FRONT FOG LAMP GROUND

Check continuity between front combination lamp RH harness connector E24 terminal 8 (B) and ground.

8 (B) – Ground : Continuity should exist.

OK or NG

- OK >> Replace IPDM E/R.
- NG >> Repair harness or connector.

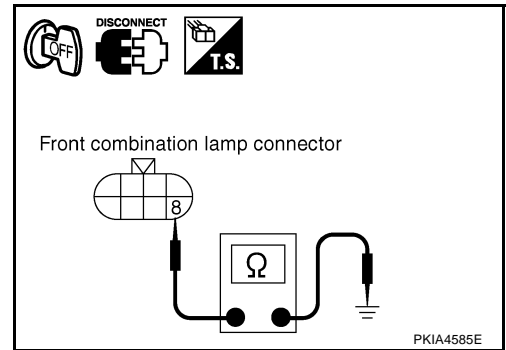

Bulb Replacement

Refer to [LT-34, "Bulb Replacement"](#) in "HEADLAMP".

AKS00ADM

TURN SIGNAL AND HAZARD WARNING LAMPS

TURN SIGNAL AND HAZARD WARNING LAMPS

PPF:26120

Component Parts and Harness Connector Location

AKS009VL

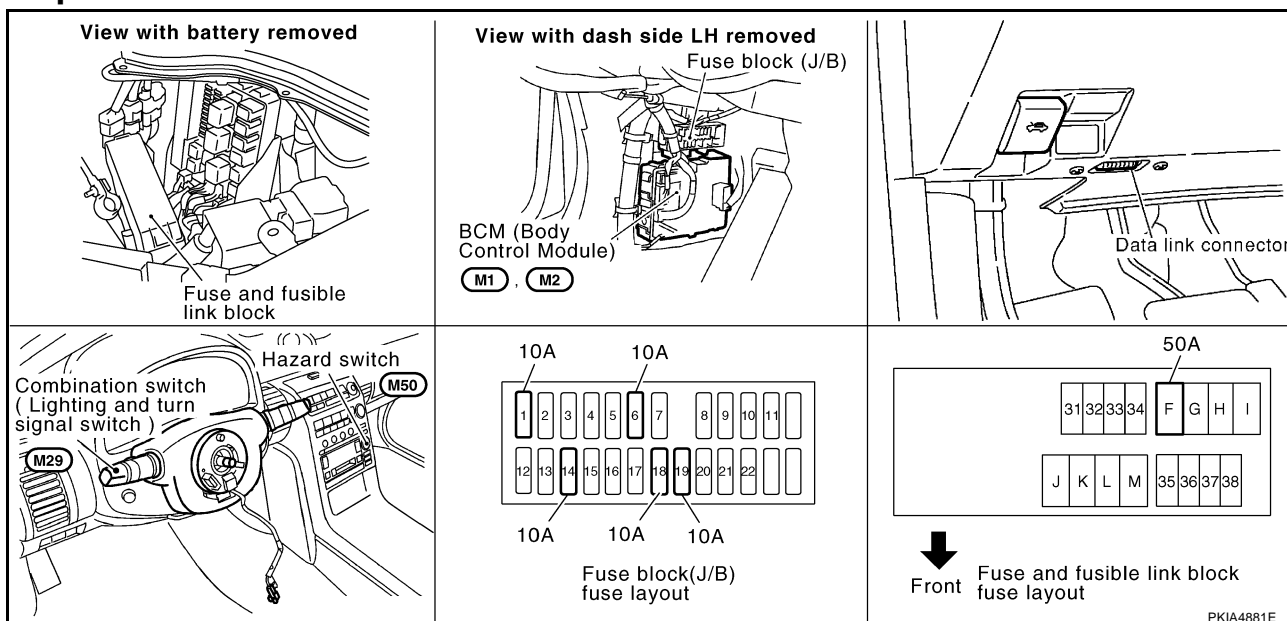

System Description

TURN SIGNAL OPERATION

AKS00A11

When the ignition switch is in the ON or START position, power is supplied

- to BCM (body control module) terminal 38
- through 10A fuse [No. 1, located in the fuse block (J/B)]
- to combination meter terminals 41 and 42
- through 10A fuse [No. 14, located in the fuse block (J/B)].

Ground is supplied

- to BCM (body control module) terminal 52
- through grounds M30 and M66, and
- to combination meter terminals 45 and 46
- through grounds M30 and M66.

LH Turn

When the turn signal switch (combination switch) is moved to the left position, the BCM (body control module) receives input signal requesting the left turn signals to flash. The BCM then supplies power

- through BCM (body control module) terminal 45
- to front combination lamp LH terminal 6, and
- to rear combination lamp LH terminal 5.

Ground is supplied to the front combination lamp LH terminal 4 through grounds E17 and E43.

Ground is supplied to the rear combination lamp LH terminal 4 through grounds B5 and B103.

The BCM also supplies input to combination meter terminals 27 and 28 across the CAN communication lines. This input is processed by the unified meter control unit in the combination meter, which in turn supplies ground to the left turn signal indicator lamp.

With power and input supplied, the BCM (body control module) controls the flashing of the LH turn signal lamps.

RH Turn

When the turn signal switch (combination switch) is moved to the right position, the BCM (body control module) receives input signal requesting the right turn signals to flash. The BCM then supplies power

- through BCM (body control module) terminal 46
- to front combination lamp RH terminal 6, and
- to rear combination lamp RH terminal 5.

TURN SIGNAL AND HAZARD WARNING LAMPS

Ground is supplied to the front combination lamp RH terminal 4 through grounds E17 and E43.

Ground is supplied to the rear combination lamp RH terminal 4 through grounds B5 and B103.

The BCM also supplies input to combination meter terminals 27 and 28 across the CAN communication lines. This input is processed by the unified meter control unit in the combination meter, which in turn supplies ground to the right turn signal indicator lamp.

With power and input supplied, the BCM (body control module) controls the flashing of the RH turn signal lamps.

HAZARD LAMP OPERATION

Power is supplied at all times

- to BCM terminal 55
- through 50A fusible link [letter F, located in fuse and fusible link block], and
- to combination meter terminal 43
- through 10A fuse [No. 19, located in fuse block (J/B)].

Ground is supplied

- to hazard switch terminal 3
- through grounds M30 and M66,
- to BCM terminal 52
- through grounds M30 and M66, and
- to combination meter terminals 45 and 46
- through grounds M30 and M66.

When the hazard switch is depressed, ground is supplied

- to BCM terminal 29
- through hazard switch terminal 1.

The BCM then supplies power

- through BCM terminal 45
- to front combination lamp LH terminal 6
- to rear combination lamp LH terminal 5
- through BCM terminal 46
- to front combination lamp RH terminal 6
- to rear combination lamp RH terminal 5.

Ground is supplied

- to the front combination lamp LH terminal 4 through grounds E17 and E43
- to the front combination lamp RH terminal 4 through grounds E17 and E43
- to the rear combination lamp LH terminal 4 through grounds B5 and B103
- to the rear combination lamp RH terminal 4 through grounds B5 and B103.

The BCM also supplies input to combination meter terminals 27 and 28 across the CAN communication lines. This input is processed by the unified meter control unit in the combination meter, which in turn supplies ground to the left and right turn signal indicator lamps.

With power and input supplied, the BCM controls the flashing of the hazard warning lamps.

REMOTE KEYLESS ENTRY SYSTEM OPERATION

Power is supplied at all times

- to BCM (body control module) terminal 55
- through 50A fusible link [letter F, located in fuse and fusible link block], and
- to combination meter terminal 43
- through 10A fuse [No. 19, located in fuse block (J/B)].

Ground is supplied

- to BCM terminal 52,
- through grounds M30 and M66, and
- to combination meter terminals 45 and 46
- through grounds M30 and M66.

TURN SIGNAL AND HAZARD WARNING LAMPS

When the remote keyless entry system is triggered by input from the keyfob, the BCM supplies power

- through BCM terminal 45
- to front combination lamp LH terminal 6
- to rear combination lamp LH terminal 5
- through BCM terminal 46
- to front combination lamp RH terminal 6
- to rear combination lamp RH terminal 5.

Ground is supplied

- to the front combination lamp LH terminal 4 through grounds E17 and E43
- to the front combination lamp RH terminal 4 through grounds E17 and E43
- to the rear combination lamp LH terminal 4 through grounds B5 and B103
- to the rear combination lamp RH terminal 4 through grounds B5 and B103.

The BCM also supplies input to combination meter terminals 27 and 28 across the CAN communication lines. This input is processed by the unified meter control unit in the combination meter, which in turn supplies ground to the left and right turn signal indicator lamps.

With power and ground supplied, the BCM controls the flashing of the hazard warning lamps when key fob is used to activate the remote keyless entry system.

COMBINATION SWITCH READING FUNCTION

Refer to [BCS-3, "COMBINATION SWITCH READING FUNCTION"](#) .

CAN Communication System Description

AKS009VN

CAN (Controller Area Network) is a serial communication line for real time application. It is an on-vehicle multiplex communication line with high data communication speed and excellent error detection ability. Many electronic control units are equipped onto a vehicle, and each control unit shares information and links with other control units during operation (not independent). In CAN communication, control units are connected with 2 communication lines (CAN H line, CAN L line) allowing a high rate of information transmission with less wiring. Each control unit transmits/receives data but selectively reads required data only.

CAN Communication Unit

AKS009VO

Refer to [LAN-4, "CAN Communication Unit"](#) .

A

B

C

D

E

F

G

H

I

J

LT

L

M

TURN SIGNAL AND HAZARD WARNING LAMPS

Schematic

AKS009VP

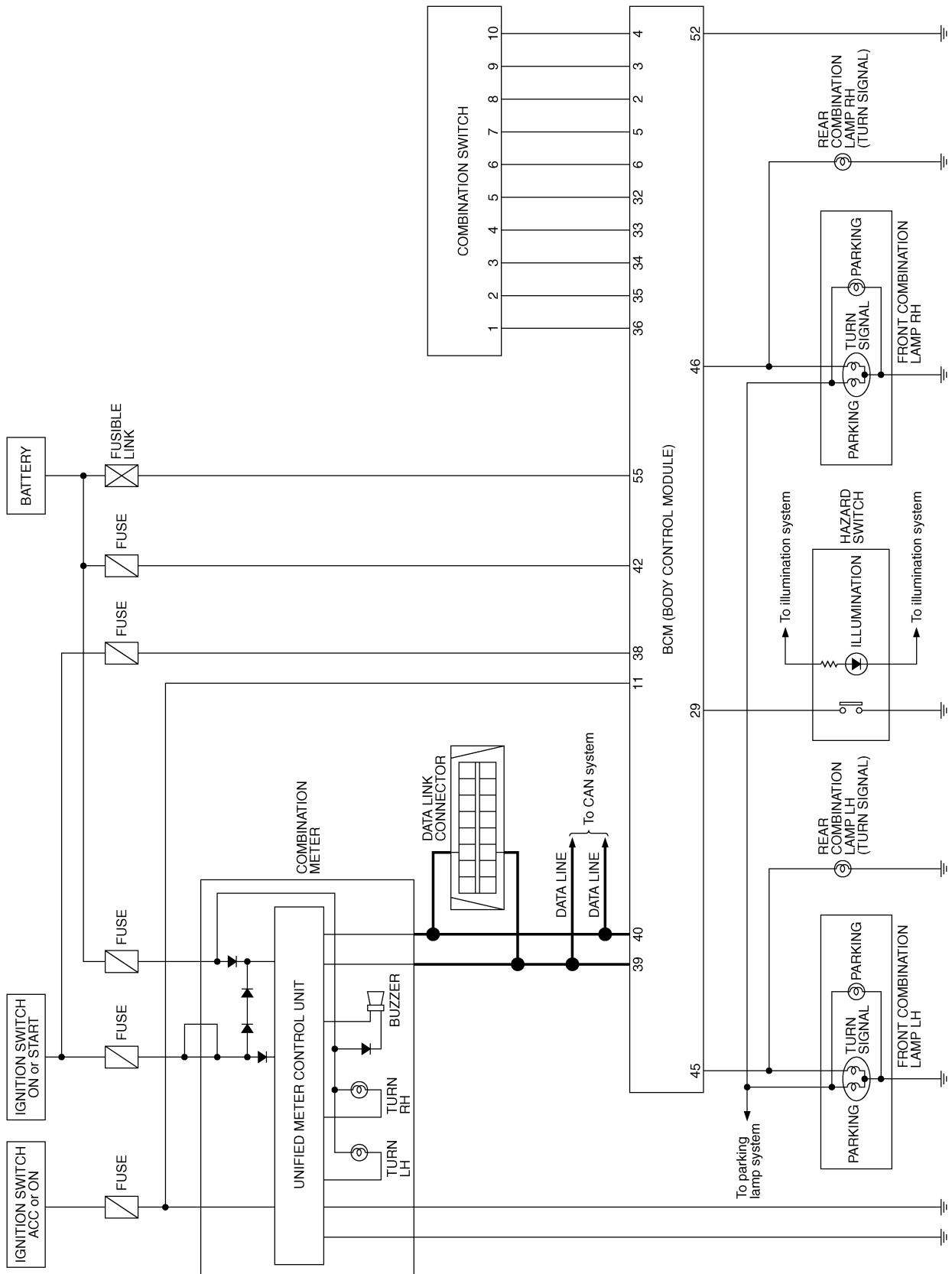

TKWM0869E

TURN SIGNAL AND HAZARD WARNING LAMPS

Wiring Diagram — TURN —

AKS009VQ

LT-TURN-01

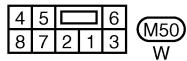
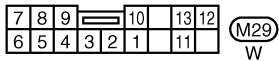
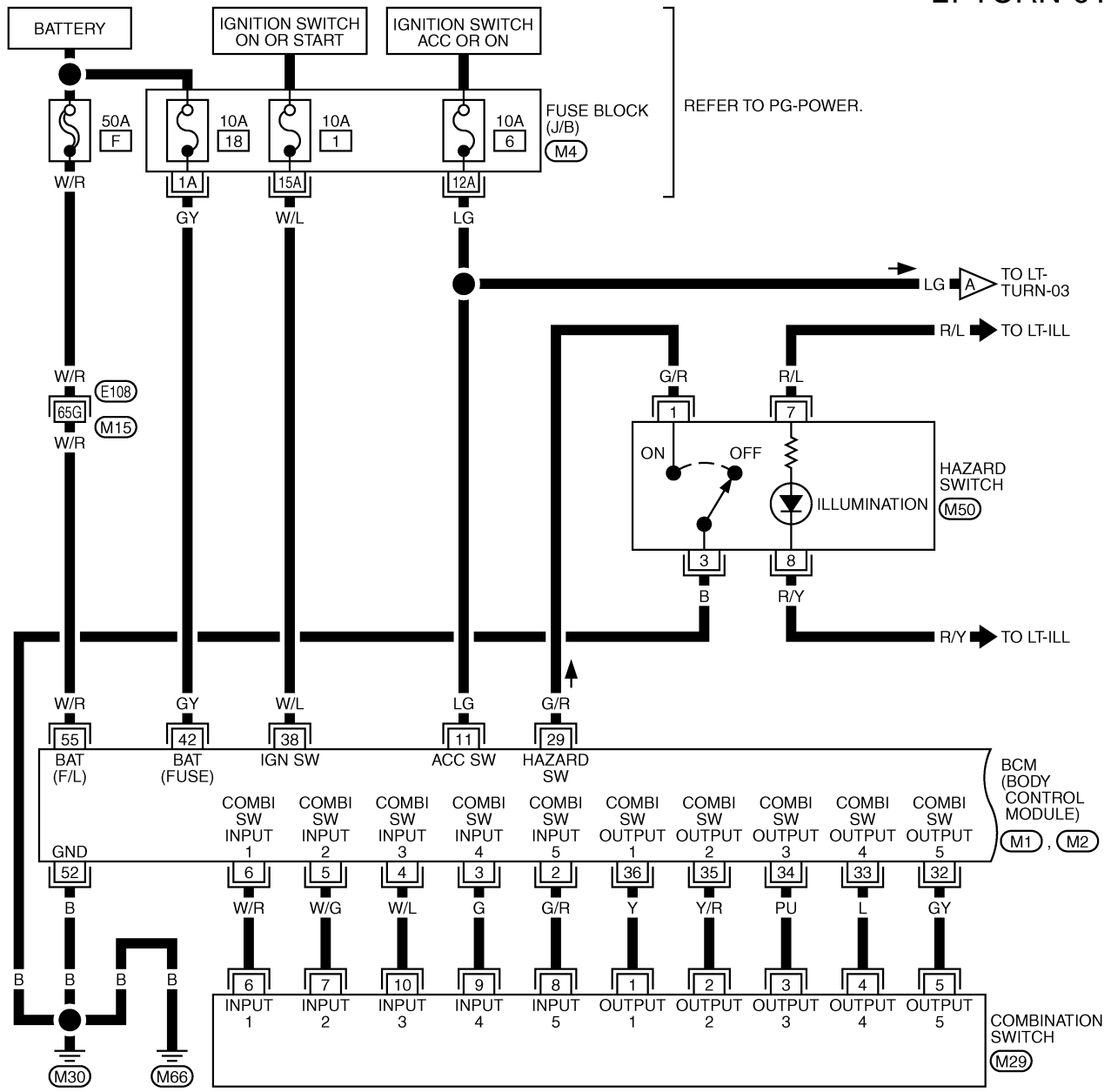

REFER TO THE FOLLOWING.

(E108) -SUPER MULTIPLE JUNCTION (SMJ)

(M4) -FUSE BLOCK-JUNCTION BOX (J/B)

(M1), (M2) -ELECTRICAL UNITS

TKWM0870E

TURN SIGNAL AND HAZARD WARNING LAMPS

LT-TURN-02

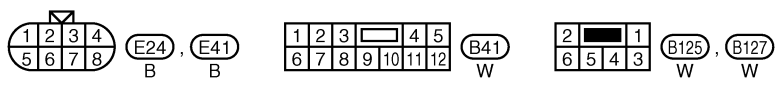
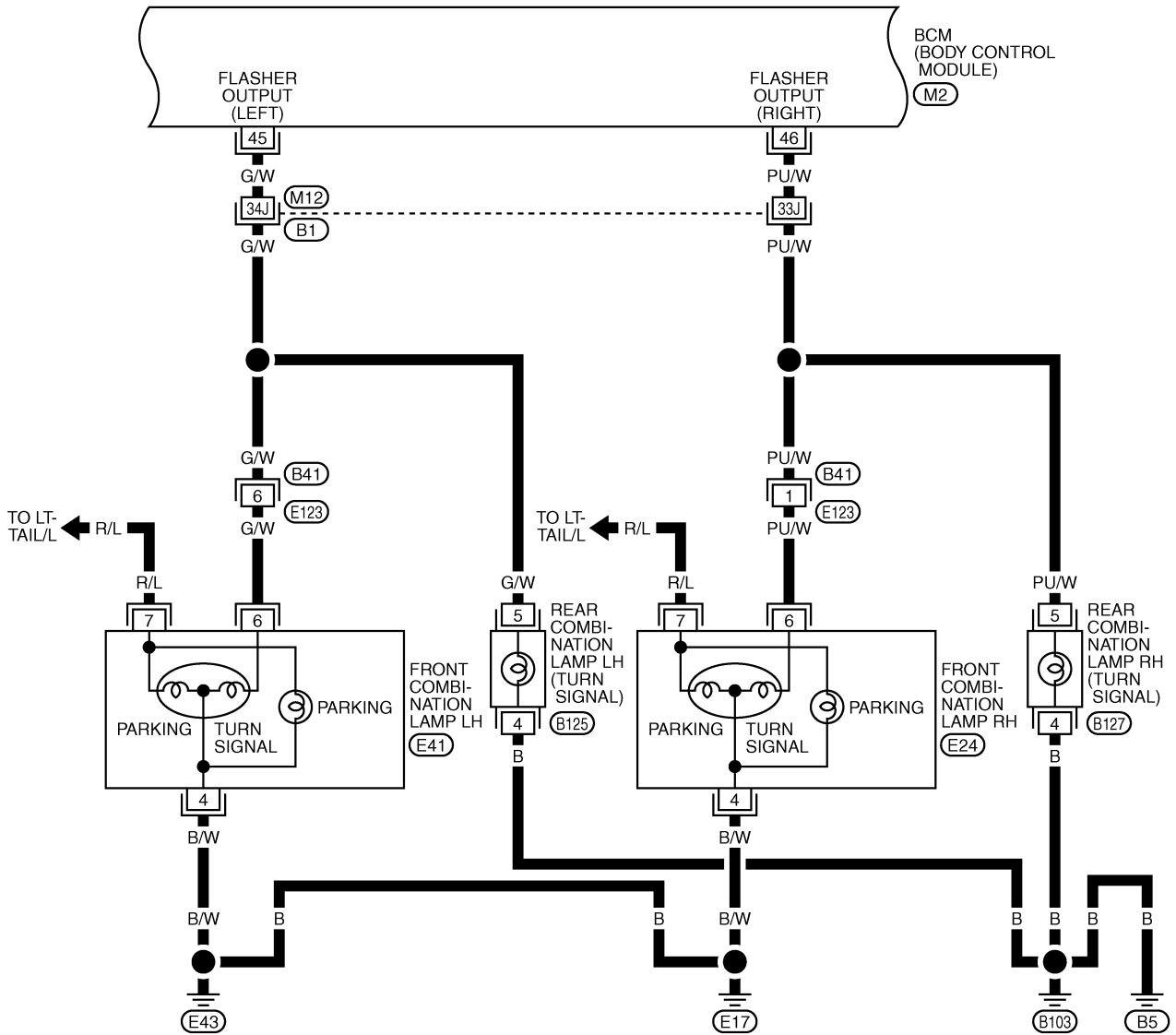

REFER TO THE FOLLOWING.
 (B1) -SUPER MULTIPLE JUNCTION (SMJ)
 (M2) -ELECTRICAL UNITS

TURN SIGNAL AND HAZARD WARNING LAMPS

LT-TURN-03

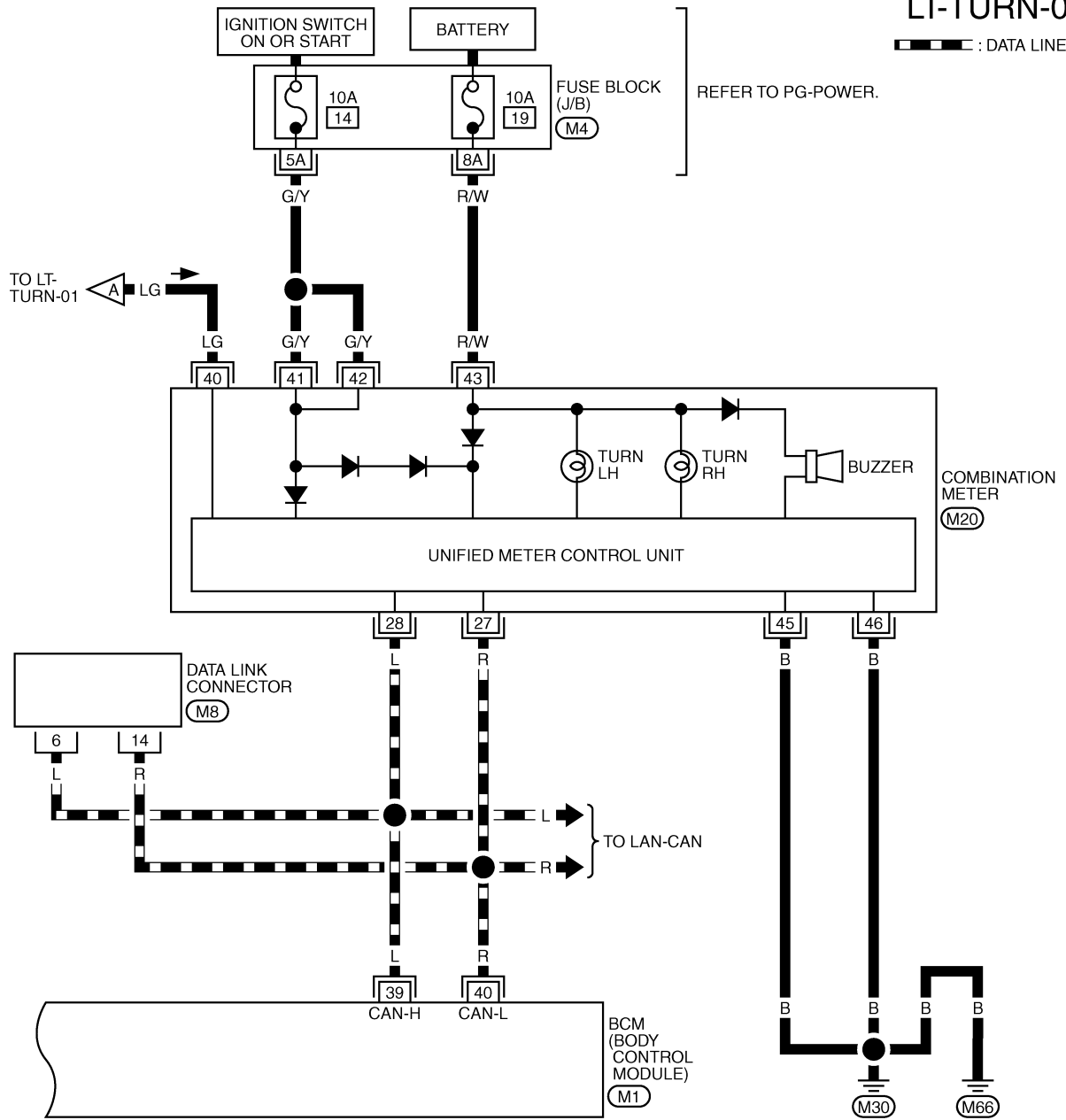

16	15	14	13	12	11	10	9
8	7	6	5	4	3	2	1

(M8)
W

25	26	27	28	29	30	31	32	33	34	35		
36	37	38	39	40	41	42	43	44	45	46	47	48

(M20)
W

REFER TO THE FOLLOWING.

(M4) - FUSE BLOCK-JUNCTION BOX (J/B)



(M1) - ELECTRICAL UNITS

TKWM0872E

TURN SIGNAL AND HAZARD WARNING LAMPS

Terminals and Reference Value for BCM

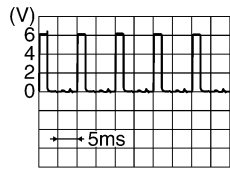
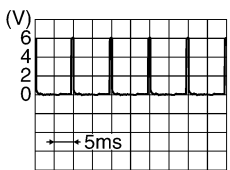
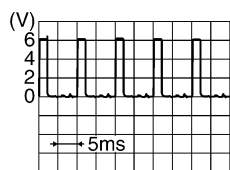
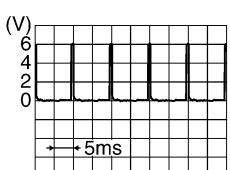
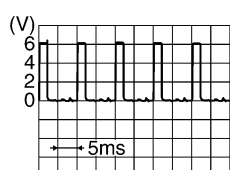
AKS009VR

Terminal No.	Wire color	Signal name	Measuring condition		Reference value	
			Ignition switch	Operation or condition		
2	G/R	Combination switch input 5	ON	Lighting, turn, wiper OFF Wiper dial position 4	 <p style="text-align: right;">SKIA5291E</p>	
3	G	Combination switch input 4	ON	Lighting, turn, wiper OFF Wiper dial position 4	 <p style="text-align: right;">SKIA5292E</p>	
4	W/L	Combination switch input 3	ON	Lighting, turn, wiper OFF Wiper dial position 4	 <p style="text-align: right;">SKIA5291E</p>	
5	W/G	Combination switch input 2	ON	Lighting, turn, wiper OFF Wiper dial position 4	 <p style="text-align: right;">SKIA5292E</p>	
6	W/R	Combination switch input 1				
11	LG	Ignition switch (ACC)	ACC	—	Battery voltage	
29	G/R	Hazard switch signal	OFF	Hazard switch	ON	Approx. 0V
					OFF	Approx. 5V
32	GY	Combination switch output 5	ON	Lighting, turn, wiper OFF Wiper dial position 4	 <p style="text-align: right;">SKIA5291E</p>	
33	L	Combination switch output 4	ON	Lighting, turn, wiper OFF Wiper dial position 4	 <p style="text-align: right;">SKIA5292E</p>	

TURN SIGNAL AND HAZARD WARNING LAMPS

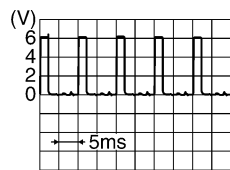
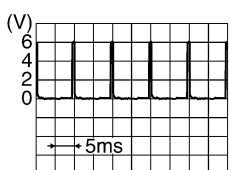
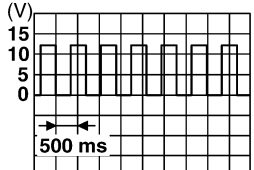
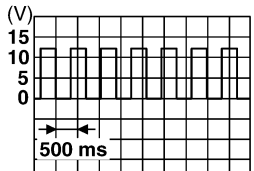
Terminal No.	Wire color	Signal name	Measuring condition		Reference value	
			Ignition switch	Operation or condition		
34	PU	Combination switch output 3	ON	Lighting, turn, wiper OFF Wiper dial position 4	 SKIA5291E	
35	Y/R	Combination switch output 2	ON	Lighting, turn, wiper OFF Wiper dial position 4	 SKIA5292E	
36	Y	Combination switch output 1				
38	W/L	Ignition switch (ON)	ON	—	Battery voltage	
39	L	CAN-H	—	—	—	
40	R	CAN-L	—	—	—	
42	GY	Battery power supply	OFF	—	Battery voltage	
45	G/W	Turn signal (left)	ON	Combina- tion switch	Turn left ON	 SKIA3009J
46	PU/W	Turn signal (right)	ON	Combina- tion switch	Turn right ON	 SKIA3009J
52	B	Ground	ON	—	Approx. 0V	
55	W/R	Battery power supply	OFF	—	Battery voltage	

How to Proceed With Trouble Diagnosis

AKS009VS

1. Confirm the symptom or customer complaint.
2. Understand operation description and function description. Refer to [LT-107, "System Description"](#) .
3. Perform preliminary check. Refer to [LT-116, "Preliminary Check"](#) .
4. Check symptom and repair or replace the cause of malfunction.
5. Do turn signal and hazard warning lamps operate normally? If YES: GO TO 6. If NO: GO TO 4.
6. INSPECTION END

TURN SIGNAL AND HAZARD WARNING LAMPS

AKS009VT

Preliminary Check CHECK POWER SUPPLY AND GROUND CIRCUIT

1. CHECK FUSES

- Check fuses for blown-out.

Unit	Power source	Fuse and fusible link No.
BCM	Battery	F
		18
	Ignition switch ON or START position	1
	Ignition switch ACC or ON position	6
Combination meter	Battery	19
	Ignition switch ON or START position	14

Refer to [LT-111, "Wiring Diagram — TURN —"](#).

OK or NG

OK >> GO TO 2.

NG >> If fuse is blown, be sure to eliminate cause of malfunction before installing new fuse. Refer to [PG-4, "POWER SUPPLY ROUTING CIRCUIT"](#).

2. CHECK POWER SUPPLY CIRCUIT

1. Turn ignition switch OFF.
2. Disconnect BCM connector.
3. Check voltage between BCM harness connector and ground.

Terminals		(-)	Ignition switch position		
Connector	(+) Terminal (Wire color)		OFF	ACC	ON
M1	11 (LG)	Ground	0V	Battery voltage	Battery voltage
	38 (W/L)		0V	0V	Battery voltage
M2	42 (GY)		Battery voltage	Battery voltage	Battery voltage
	55 (W/R)		Battery voltage	Battery voltage	Battery voltage

OK or NG

OK >> GO TO 3.

NG >> Check harness for open or short between BCM and fuse.

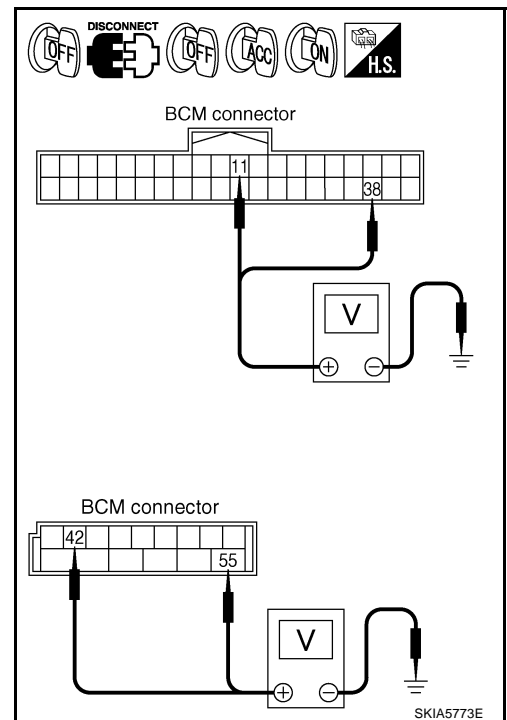

TURN SIGNAL AND HAZARD WARNING LAMPS

3. CHECK GROUND CIRCUIT

Check continuity between BCM harness connector and ground.

Terminals			Continuity
Connector	Terminal (Wire color)	Ground	
M2	52 (B)	Ground	Yes

OK or NG

- OK >> INSPECTION END
- NG >> Check ground circuit harness.

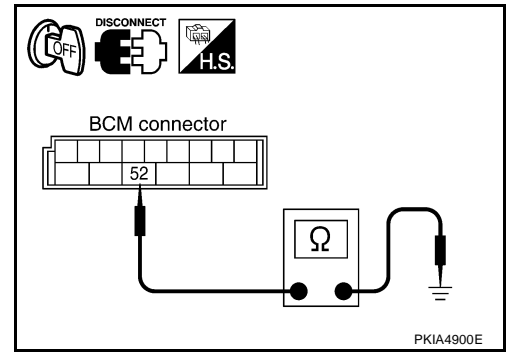

AKS009VU

CONSULT-II Functions

CONSULT-II performs the following functions communicating with BCM.

BCM diagnosis part	Check item, diagnosis mode	Description
FLASHER	DATA MONITOR	Displays BCM input data in real time.
	ACTIVE TEST	Operation of electrical loads can be checked by sending driving signal to them.

CONSULT-II BASIC OPERATION

CAUTION:

If CONSULT-II is used with no connection of CONSULT-II CONVERTER, malfunctions might be detected in self-diagnosis depending on control unit which carry out CAN communication.

- With the ignition switch OFF, connect CONSULT-II and CONSULT-II CONVERTER to the data link connector, then turn ignition switch ON.

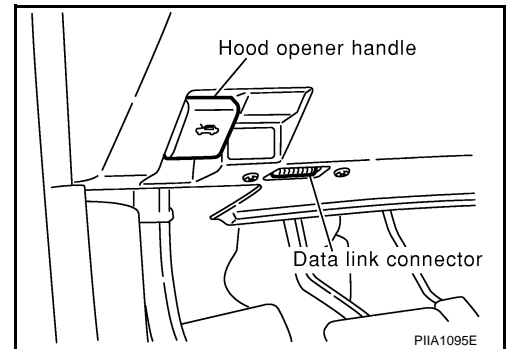

- Touch "START (NISSAN BASED VHCL)".

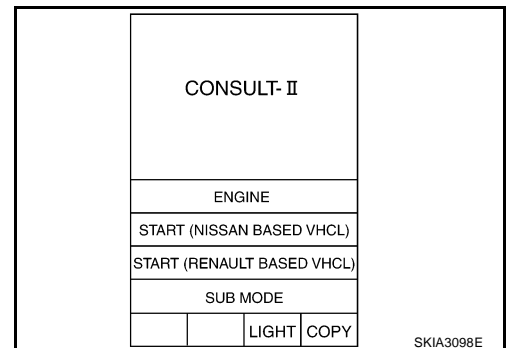

TURN SIGNAL AND HAZARD WARNING LAMPS

3. Touch "BCM" on "SELECT SYSTEM" screen.
If "BCM" is not indicated, refer to [GI-39, "CONSULT-II Data Link Connector \(DLC\) Circuit"](#).

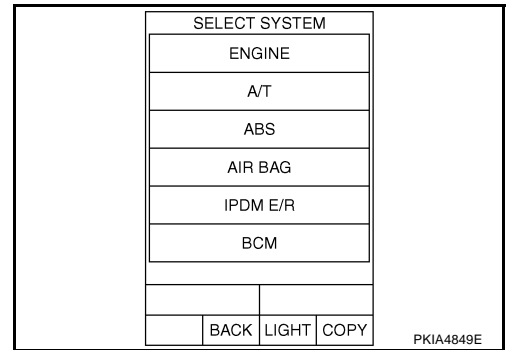

4. Touch "FLASHER" on "SELECT TEST ITEM" screen.

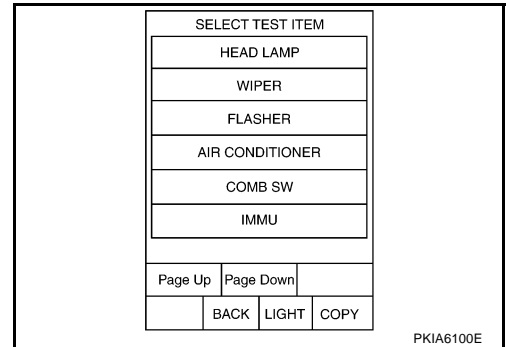

DATA MONITOR

Operation Procedure

1. Touch "FLASHER" on "SELECT TEST ITEM" screen.
2. Touch "DATA MONITOR" on "SELECT DIAG MODE" screen.
3. Touch either "ALL SIGNALS" or "SELECTION FROM MENU" on the "DATA MONITOR" screen.

ALL SIGNALS	Monitors all the signals.
SELECTION FROM MENU	Selects and monitors the individual signal.

4. Touch "START".
5. When "SELECTION FROM MENU" is selected, touch items to be monitored. When "ALL SIGNALS" is selected, all the items will be monitored.
6. Touch "RECORD" while monitoring, then the status of the monitored item can be recorded. To stop recording, touch "STOP".

Display Item List

Monitor item	Contents
IGN ON SW "ON/OFF"	Displays "IGN position (ON)/OFF, ACC position (OFF)" judged from the ignition switch signal.
HAZARD SW "ON/OFF"	Displays "Hazard ON (ON)/Hazard OFF (OFF)" status, determined from hazard switch signal.
TURN SIGNAL R "ON/OFF"	Displays "Turn right (ON)/Other (OFF)" status, determined from lighting switch signal.
TURN SIGNAL L "ON/OFF"	Displays "Turn left (ON)/Other (OFF)" status, determined from lighting switch signal.
BRAKE SW ^{NOTE} "OFF"	—

NOTE:

This item is displayed, but cannot monitor it.

ACTIVE TEST

Operation Procedure

1. Touch "FLASHER" on "SELECT TEST ITEM" screen.
2. Touch "ACTIVE TEST" on "SELECT DIAG MODE" screen.
3. Touch item to be tested and check operation of the selected item.
4. During the operation check, touching "BACK" deactivates the operation.

TURN SIGNAL AND HAZARD WARNING LAMPS

Display Item List

Test item	Description
FLASHER	With a certain operation (OFF, RH, LH), turn signal lamp can be operated.

Turn Signal Lamp Does Not Operate

AKS00ADN

1. CHECK BULB

Check bulb standard of each turn signal lamp is correct.

OK or NG

- OK >> GO TO 2.
- NG >> Replace turn signal lamp bulb.

2. CHECK COMBINATION SWITCH INPUT SIGNAL

Ⓟ With CONSULT-II

Select "BCM" on CONSULT-II. With "FLASHER" data monitor, make sure "TURN SIGNAL R" and "TURN SIGNAL L" turns ON-OFF linked with operation of lighting switch.

**When lighting switch is : TURN SIGNAL R ON
TURN RH position**

**When lighting switch is : TURN SIGNAL L ON
TURN LH position**

ⓧ Without CONSULT-II

Refer to [LT-128, "Combination Switch Inspection"](#).

OK or NG

- OK >> GO TO 3.
- NG >> Check lighting switch. Refer to [LT-128, "Combination Switch Inspection"](#).

DATA MONITOR			
MONITOR			
TURN SIGNAL R	ON		
TURN SIGNAL L	ON		
RECORD			
MODE	BACK	LIGHT	COPY

PKIA7600E

3. ACTIVE TEST

Ⓟ With CONSULT-II

1. Select "FLASHER" during active test. Refer to [LT-118, "ACTIVE TEST"](#).
2. Make sure "FLASHER RIGHT" and "FLASHER LEFT" operates.

Turn signal lamp should operate.

ⓧ Without CONSULT-II

GO TO 4.

OK or NG

- OK >> Replace BCM. Refer to [BCS-15, "Removal and Installation of BCM"](#).
- NG >> GO TO 4.

ACTIVE TEST			
FLASHER	OFF		
RH			
LH			
OFF			
MODE	BACK	LIGHT	COPY

PKIA5276E

TURN SIGNAL AND HAZARD WARNING LAMPS

4. CHECK SHORT CIRCUIT

1. Turn ignition switch OFF.
2. Disconnect BCM connector and all turn signal lamp connectors.
3. Check continuity (short circuit) between harness connector of BCM and ground.

Terminals			Ground	Continuity
BCM		Terminal (Wire color)		
Connector				
RH	M2	46 (PU/W)	Ground	No
LH		45 (G/W)		

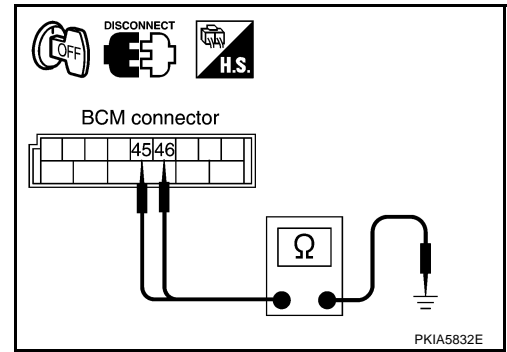

OK or NG

- OK >> Replace BCM if turn signal lamps does not work after setting the connector again. Refer to [BCS-15, "Removal and Installation of BCM"](#).
- NG >> Repair harness or connector.

Hazard Warning Lamp Does Not Operate But Turn Signal Lamp Operates

AKS00ADO

1. CHECK BULB

Make sure bulb standard of each turn signal lamp is correct.

OK or NG

- OK >> GO TO 2.
- NG >> Replace bulb.

2. CHECK HAZARD SWITCH INPUT SIGNAL

Ⓜ With CONSULT-II

Select "BCM" on CONSULT-II. With "FLASHER" data monitor, make sure "HAZARD SW" turns ON-OFF linked with operation of hazard switch.

When hazard switch is ON : HAZARD SW ON position

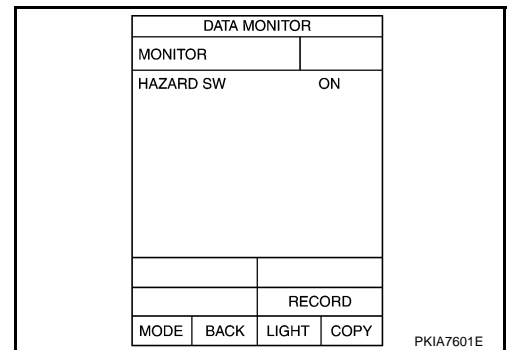

⊗ Without CONSULT-II

Check voltage between BCM harness connector M50 terminal 1 (G/R) and ground.

Terminals			Condition	Voltage
(+)		(-)		
Connector	Terminal (Wire color)			
M50	1 (G/R)	Ground	Hazard switch is ON.	Approx. 0V
			Hazard switch is OFF.	Approx. 5V

OK or NG

- OK >> Replace BCM. Refer to [BCS-15, "Removal and Installation of BCM"](#).
- NG >> GO TO 3.

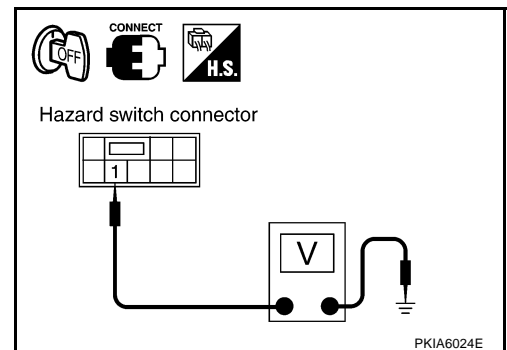

TURN SIGNAL AND HAZARD WARNING LAMPS

3. CHECK HAZARD SWITCH CIRCUIT

1. Turn ignition switch OFF.
2. Disconnect BCM connector and hazard switch connector.
3. Check continuity BCM harness connector M1 terminal 29 (G/R) and hazard switch harness connector M50 terminal 1 (G/R).

29 (G/R) – 1 (G/R) : Continuity should exist.

OK or NG

- OK >> GO TO 4.
 NG >> Repair harness or connector.

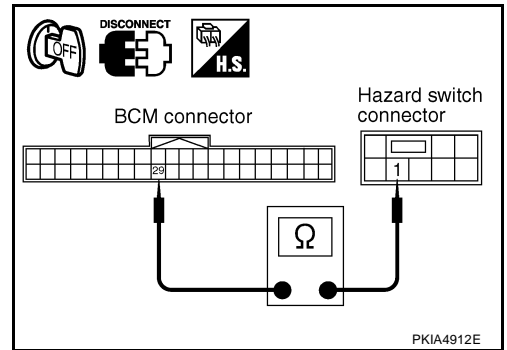

4. CHECK GROUND

- Check continuity hazard switch harness connector M50 terminal 3 (B) and ground.

3 (B) – Ground : Continuity should exist.

OK or NG

- OK >> GO TO 5.
 NG >> Repair harness or connector.

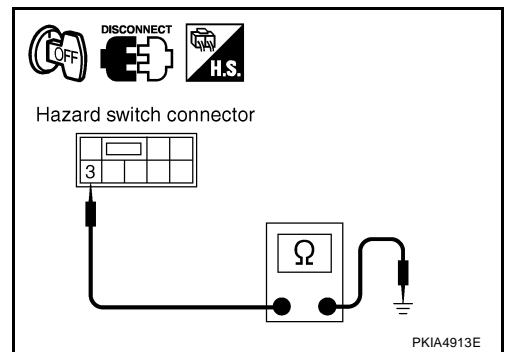

5. CHECK HAZARD SWITCH

1. Disconnect hazard switch connector.
2. Check continuity hazard switch.

Terminal		Condition	Continuity
Hazard switch			
1	3	Hazard switch is ON.	Yes
		Hazard switch is OFF.	No

OK or NG

- OK >> Replace BCM if turn signal lamps does not work after setting the connector again. Refer to [BCS-15, "Removal and Installation of BCM"](#) .
 NG >> Replace hazard switch.

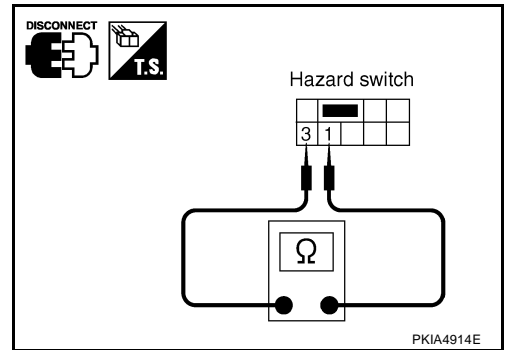

Turn Signal Indicator Lamp Does Not Operate

AKS009VY

1. CHECK BULB

- Check bulb of turn signal indicator lamp in combination meter.

OK or NG

- OK >> Replace combination meter.
 NG >> Replace indicator bulb.

Bulb Replacement (Front Turn Signal Lamp)

AKS00A1A

Refer to [LT-34, "Bulb Replacement"](#) in "HEADLAMP (FOR USA)".

Bulb Replacement (Rear Turn Signal Lamp)

AKS00A1B

Refer to [LT-155, "Bulb Replacement"](#) in "REAR COMBINATION LAMP".

TURN SIGNAL AND HAZARD WARNING LAMPS

Removal and Installation of Front Turn Signal Lamp

AKS00A1C

Refer to [LT-35, "Removal and Installation"](#) in "HEADLAMP (FOR USA)".

Removal and Installation of Rear Turn Signal Lamp

AKS00A1D

Refer to [LT-155, "Removal and Installation"](#) in "REAR COMBINATION LAMP".

LIGHTING AND TURN SIGNAL SWITCH

LIGHTING AND TURN SIGNAL SWITCH

PFP:25540

Removal and Installation

AKS00A1E

REMOVAL

1. Remove steering column cover. Refer to [IP-10, "INSTRUMENT PANEL ASSEMBLY"](#) in "IP" section.
2. Remove mounting bolts of cluster lid A and combination meter. Refer to [IP-10, "INSTRUMENT PANEL ASSEMBLY"](#) in "IP" section.
3. While pressing pawls in direction as shown in the figure, pull lighting and turn signal switch toward driver door and disconnect from the base.
4. Disconnect lighting and turn signal switch connector.

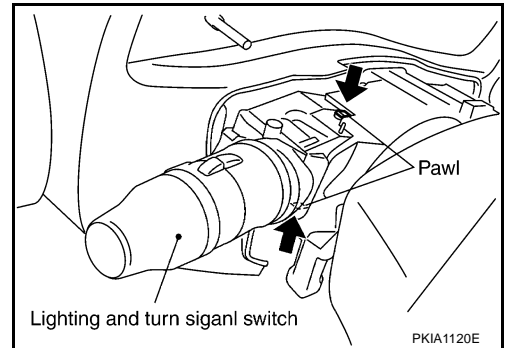

INSTALLATION

Install in the reverse order of removal.

A
B
C
D
E
F
G
H
I
J
LT
L
M

HAZARD SWITCH

HAZARD SWITCH

PFP:25290

Removal and Installation (M/T)

AKS00A1F

REMOVAL

1. Remove console boot (M/T). Refer to [IP-10, "INSTRUMENT PANEL ASSEMBLY"](#) in "IP" section.
2. Remove connector.
3. Remove screws and remove bracket from console finisher (M/T).
4. Press pawl on reverse side and remove the hazard switch.

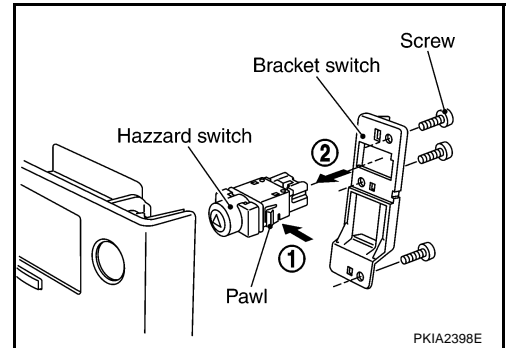

INSTALLATION

Install in the reverse order of removal.

Removal and Installation (A/T)

AKS00A1G

REMOVAL

1. Remove console finisher (A/T). Refer to [IP-10, "INSTRUMENT PANEL ASSEMBLY"](#) in "IP" section.
2. Remove connector.
3. Remove screws and remove ashtray assembly from console finisher (A/T).
4. Press pawl on reverse side and remove the hazard switch.

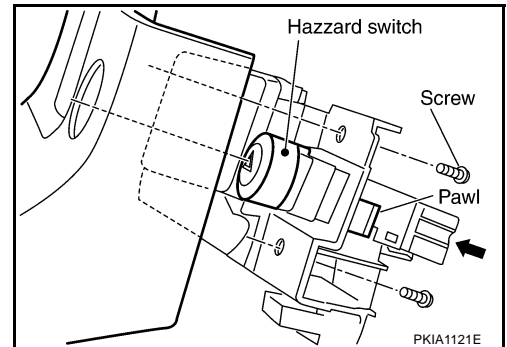

INSTALLATION

Install in the reverse order of removal.

COMBINATION SWITCH

PPF:25567

COMBINATION SWITCH

Wiring Diagram — COMBSW —

AKS009W6

LT-COMBSW-01

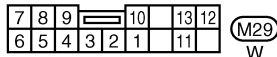
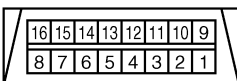
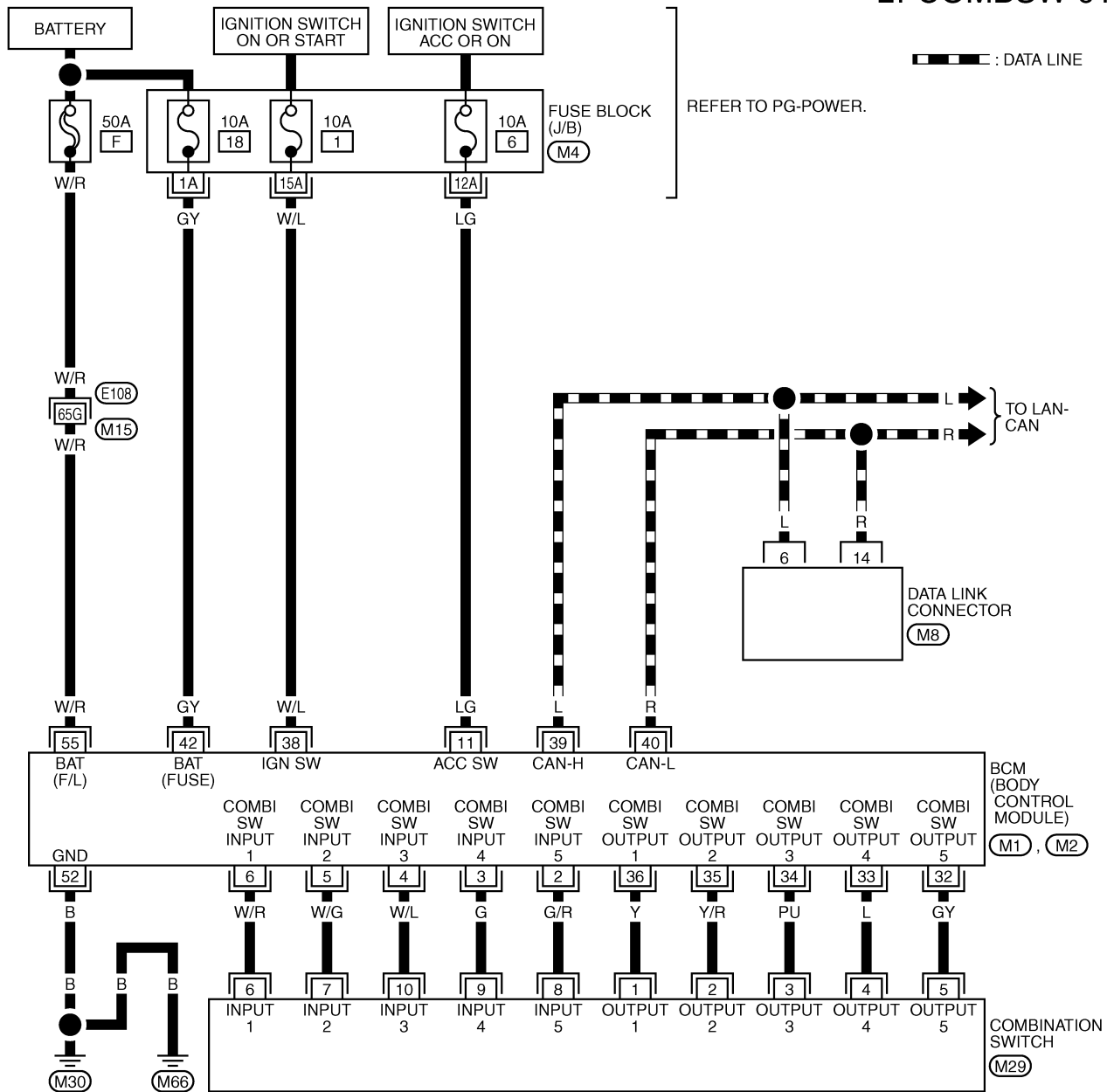

REFER TO THE FOLLOWING.

- (E108) -SUPER MULTIPLE JUNCTION (SMJ)
- (M4) -FUSE BLOCK-JUNCTION BOX (J/B)
- (M1), (M2) -ELECTRICAL UNITS

TKWM0846E

COMBINATION SWITCH

Combination Switch Reading Function

AKS009W7

For details, refer to [BCS-3, "COMBINATION SWITCH READING FUNCTION"](#) in "BCS" section.

CONSULT-II Function

AKS009W8

CONSULT-II performs the following functions communicating with the BCM.

BCM diagnosis part	Check item, diagnosis mode	Description
Combination switch	DATA MONITOR	Displays BCM input data in real time.

CONSULT-II BASIC OPERATION

CAUTION:

If CONSULT-II is used with no connection of CONSULT-II CONVERTER, malfunctions might be detected in self-diagnosis depending on control unit which carry out CAN communication.

1. With the ignition switch OFF, connect CONSULT-II and CONSULT-II CONVERTER to the data link connector, then turn ignition switch ON.

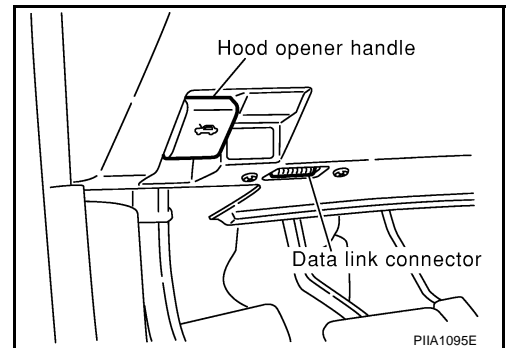

2. Touch "START (NISSAN BASED VHCL)".

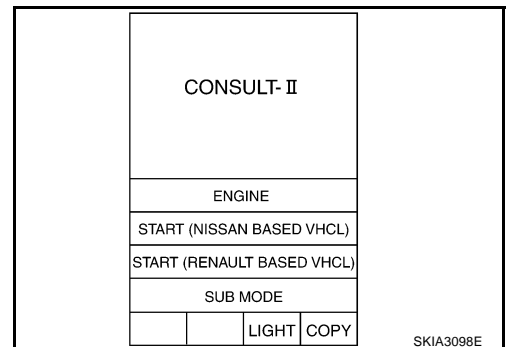

3. Touch "BCM" on "SELECT SYSTEM" screen. If "BCM" is not indicated, refer to [GI-39, "CONSULT-II Data Link Connector \(DLC\) Circuit"](#).

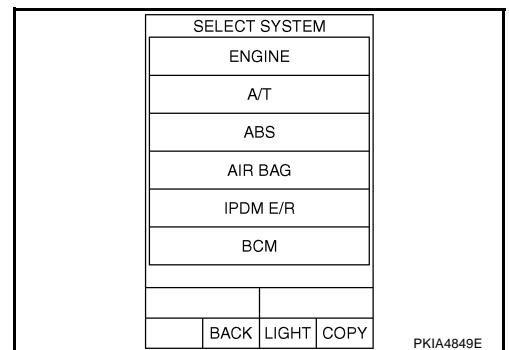

COMBINATION SWITCH

4. Touch "COMB SW".

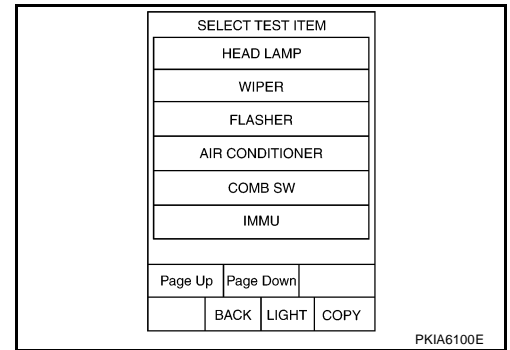

DATA MONITOR

Operation Procedure

1. Touch "COMB SW" on "SELECT TEST ITEM" screen.
2. Touch "DATA MONITOR" on "SELECT DIAG MODE" screen.
3. Touch either "ALL SIGNALS" or "SELECTION FROM MENU" on "DATA MONITOR" screen.

ALL SIGNALS	Monitors all the signals.
SELECTION FROM MENU	Selects and monitors individual signal.

4. Touch "START".
5. When "SELECTION FROM MENU" is selected, touch items to be monitored. When "ALL SIGNALS" is selected, all the signals will be monitored.
6. Touch "RECORD" while monitoring, then the status of the monitored item can be recorded. To stop recording, touch "STOP".

Display Item List

Monitor item name "OPERATION OR UNIT"	Contents
TURN SIGNAL R "ON/OFF"	Displays "Turn Right (ON)/Other (OFF)" status, determined from lighting switch signal.
TURN SIGNAL L "ON/OFF"	Displays "Turn Left (ON)/Other (OFF)" status, determined from lighting switch signal.
HI BEAM SW "ON/OFF"	Displays status (high beam switch: ON/Others: OFF) of high beam switch judged from lighting switch signal.
HEAD LAMP SW 1 "ON/OFF"	Displays "Headlamp switch 1 (ON)/Other (OFF)" status, determined from lighting switch signal.
HEAD LAMP SW 2 "ON/OFF"	Displays status (headlamp switch 2: ON/Others: OFF) of headlamp switch 2 judged from lighting switch signal.
TAIL LAMP SW "ON/OFF"	Displays status (lighting switch 1st position: ON/Others: OFF) of lighting switch judged from lighting switch signal.
PASSING SW "ON/OFF"	Displays status (flash-to-pass switch: ON/Others: OFF) of flash-to-pass switch judged from lighting switch signal.
AUTO LIGHT SW "ON/OFF"	Displays "Auto light switch (ON)/Other (OFF)" status, determined from lighting switch signal.
FR FOG SW "ON/OFF"	Displays "Front fog lamp switch (ON)/Other (OFF)" status, determined from lighting switch signal.
FR WIPER HI "ON/OFF"	Displays "Front Wiper HI (ON)/Other (OFF)" status, determined from wiper switch signal.
FR WIPER LOW "ON/OFF"	Displays "Front Wiper LOW (ON)/Other (OFF)" status, determined from wiper switch signal.
FR WIPER INT "ON/OFF"	Displays "Front Wiper INT (ON)/Other (OFF)" status, determined from wiper switch signal.
FR WASHER SW "ON/OFF"	Displays "Front Washer Switch (ON)/Other (OFF)" status, determined from wiper switch signal.
INT VOLUME [1 - 7]	Displays intermittent operation knob setting (1 - 7), determined from wiper switch signal.
RR WIPER ON "ON/OFF"	Displays "rear Wiper (ON)/Other (OFF)" status as judged from wiper switch signal.
RR WIPER INT "ON/OFF"	Displays "rear Wiper INT (ON)/Other (OFF)" status as judged from wiper switch signal.
RR WASHER SW "ON/OFF"	Displays "rear Washer Switch (ON)/Other (OFF)" status as judged from wiper switch signal.

NOTE:

This item is displayed, but cannot monitor it.

COMBINATION SWITCH

AKS009W9

Combination Switch Inspection

1. SYSTEM CHECK

1. Referring to table below, check which system malfunctioning switch belongs to.

System 1	System 2	System 3	System 4	System 5
—	FR WASHER	FR WIPER LO	TURN LH	TURN RH
FR WIPER HI	—	FR WIPER INT	PASSING	HEAD LAMP1
INT VOLUME 1	—	—	HEAD LAMP2	HI BEAM
—	INT VOLUME 3	AUTO LIGHT	—	LIGHT SW 1ST
INT VOLUME 2	—	—	FR FOG	—

>> Check the system to which malfunctioning switch belongs, and GO TO 2.

2. SYSTEM CHECK

 With CONSULT-II

CAUTION:

If CONSULT-II is used with no connection of CONSULT-II CONVERTER, malfunctions might be detected in self-diagnosis depending on control unit which carry out CAN communication.

1. Connect CONSULT-II, and select "COMB SW" on "SELECT TEST ITEM" screen.
2. Select "DATA MONITOR".
3. Select "START", and confirm that other switches in malfunctioning system operate normally.

Example: When auto light switch is malfunctioning, confirm that "FRONT WIPER LOW" and "FRONT WIPER INT" in System 3, to which the auto light switch belongs, turn ON-OFF normally.

DATA MONITOR	
MONITOR	
TURN SIGNAL R	OFF
TURN SIGNAL L	OFF
HIBEAM SW	OFF
HEAD LAMP SW1	OFF
HEAD LAMP SW2	OFF
LIGHT SW 1ST	OFF
PASSING SW	OFF
AUTO LIGHT SW	OFF
FR FOG SW	OFF
	Page Down
	RECORD
MODE	BACK LIGHT COPY

PKIA7602E

 Without CONSULT-II

Operating combination switch, and confirm that other switches in malfunctioning system operate normally.
Example: When auto light switch is malfunctioning, confirm that FRONT WIPER LOW and FRONT WIPER INT in System 3, to which the auto light switch belongs, operate normally.

Check results

- Other switches in malfunctioning system operate normally.>>Replace lighting switch or wiper switch.
- Other switches in malfunctioning system do not operate normally.>>GO TO 3.

COMBINATION SWITCH

3. HARNESS INSPECTION

1. Disconnect BCM and combination switch connectors.
2. Check for continuity between BCM harness connector of the suspect system and the corresponding combination switch connector terminals.

Suspect system	Terminals				Continuity	
	BCM		Combination switch			
	Connector	Terminal (Wire color)	Connector	Terminal (Wire color)		
1	M1	Input 1	6 (W/R)	M29	6 (W/R)	Yes
		Output 1	36 (Y)		1 (Y)	
2		Input 2	5 (W/G)		7 (W/G)	
		Output 2	35 (Y/R)		2 (Y/R)	
3		Input 3	4 (W/L)		10 (W/L)	
		Output 3	34 (PU)		3 (PU)	
4		Input 4	3 (G)		9 (G)	
		Output 4	33 (L)		4 (L)	
5		Input 5	2 (G/R)		8 (G/R)	
		Output 5	32 (GY)		5 (GY)	

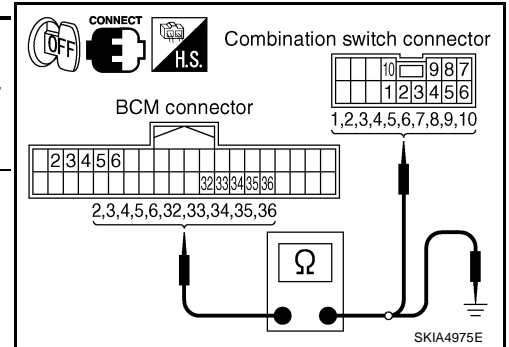

3. Check for continuity between each terminal of BCM harness connector in suspect malfunctioning system and ground.

Suspect system	Terminals			Continuity
	BCM		Ground	
	Connector	Terminal (Wire color)		
1	M1	Input 1	6 (W/R)	No
		Output 1	36 (Y)	
2		Input 2	5 (W/G)	
		Output 2	35 (W/R)	
3		Input 3	4 (W/L)	
		Output 3	34 (PU)	
4		Input 4	3 (G)	
		Output 4	33 (L)	
5		Input 5	2 (G/R)	
		Output 5	32 (GY)	

OK or NG

OK >> GO TO 4.

NG >> Check harness between BCM and combination switch for open or short circuit.

COMBINATION SWITCH

4. BCM OUTPUT TERMINAL INSPECTION

1. Turn lighting switch and wiper switch into OFF.
2. Set wiper dial position 4.
3. Connect BCM and combination switch connectors, and check BCM output terminal voltage waveform of suspect malfunctioning system.

Suspect system	Terminals	
	Combination switch(+)	
	Connector	Terminal (Wire color)
1	M29	1 (Y)
2		2 (Y/R)
3		3 (PU)
4		4 (L)
5		5 (GY)

OK or NG

OK >> Open circuit in combination switch, GO TO 5.

NG >> Replace BCM.

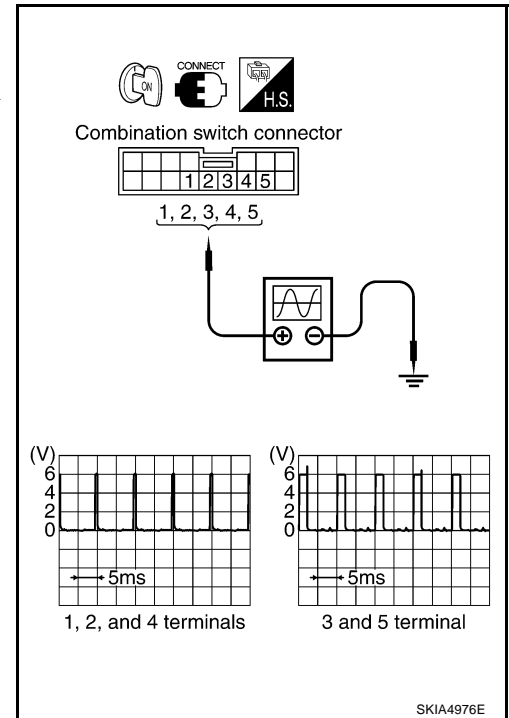

5. COMBINATION SWITCH INSPECTION

Referring to table below, perform combination switch inspection.

Procedure									
1	2		3	4		5	6		7
Replace lighting switch.	Confirm check results.	OK	INSPECTION END	Confirm check results.	OK	INSPECTION END	Confirm check results.	OK	INSPECTION END
		NG	Replace wiper switch.		NG	Replace switch base.		NG	Confirm symptom again.

>> INSPECTION END

Removal and Installation

For details, refer to [LT-123, "LIGHTING AND TURN SIGNAL SWITCH"](#) .

AKS009WA

STOP LAMP

STOP LAMP

PFP:26550

Wiring Diagram — STOP/L —

AKS009WE

LT-STOP/L-01

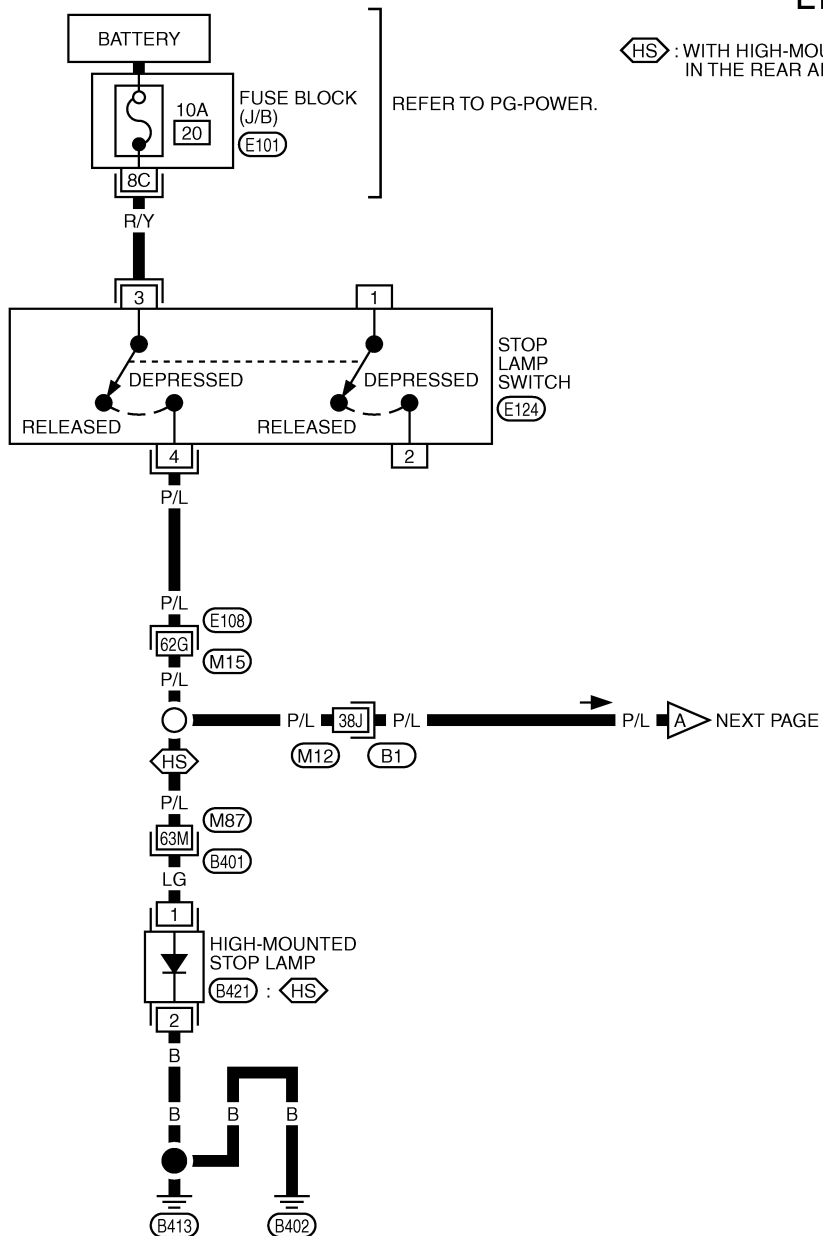

HS : WITH HIGH-MOUNTED STOP LAMP
 IN THE REAR AIR SPOILER

A
B
C
D
E
F
G
H
I
J
LT
L
M

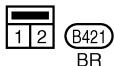
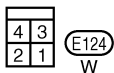

REFER TO THE FOLLOWING.
 (E108), (B1), (B401) -SUPER
 MULTIPLE JUNCTION (SMJ)
 (E101) -FUSE BLOCK-JUNCTION
 BOX (J/B)

TKWM0873E

STOP LAMP

LT-STOP/L-02

⬡HP⬡ : WITH HIGH-MOUNTED STOP LAMP ON THE REAR PARCEL SHELF

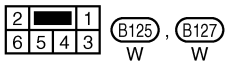
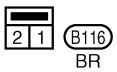
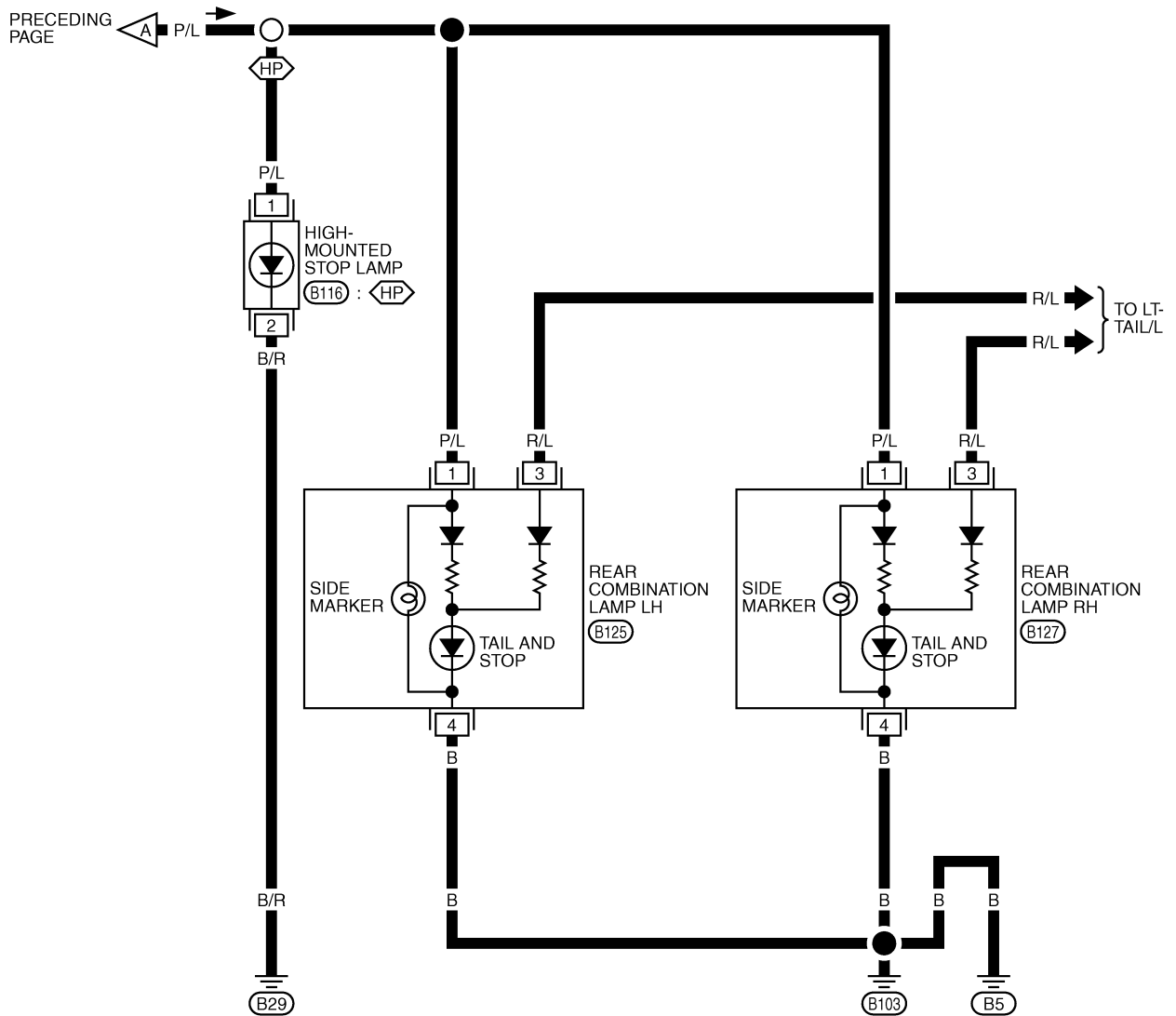

TKWM0874E

STOP LAMP

Bulb Replacement of High-mounted Stop Lamp WITH REAR SPOILER

AKS00A1H

1. Remove high-mounted stop lamp. Refer to [LT-133, "Bulb Replacement of Rear Combination Lamp \(Stop Lamp\)"](#) .
2. Replace together with high-mounted stop lamp.

High-mounted stop lamp : LED

WITHOUT REAR SPOILER

1. Remove high-mounted stop lamp. Refer to [LT-133, "Bulb Replacement of Rear Combination Lamp \(Stop Lamp\)"](#) .
2. Replace together with high-mounted stop lamp.

High-mounted stop lamp : LED

Bulb Replacement of Rear Combination Lamp (Stop Lamp)

AKS00A1I

Refer to [LT-155, "Bulb Replacement"](#) in "REAR COMBINATION LAMP".

Removal and Installation of High-mounted Stop Lamp REMOVAL (WITH REAR SPOILER)

AKS00A1J

1. Remove rear spoiler. Refer to [EI-28, "REAR SPOILER"](#) in "EI" section.
2. Remove screws and remove high-mounted stop lamp from rear spoiler.
3. Disconnect high-mounted stop lamp connector.

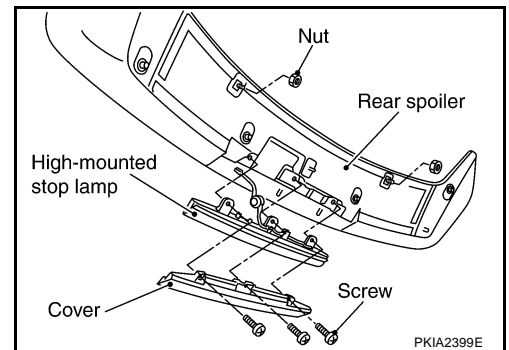

INSTALLATION

Install in the reverse order of removal.

REMOVAL (WITHOUT REAR SPOILER)

1. Remove rear parcel shelf finisher. Refer to [EI-35, "REAR PARCEL SHELF FINISHER"](#) in "EI" section.
2. Remove screws and remove high-mounted stop lamp from rear parcel shelf finisher.
3. Disconnect high-mounted stop lamp connector.

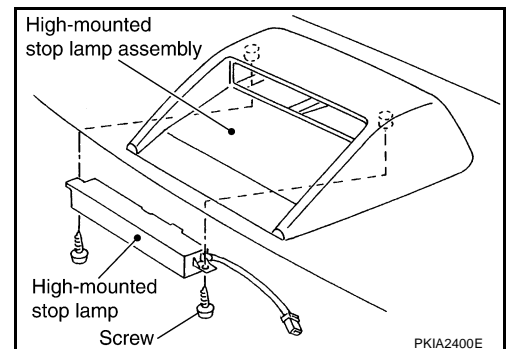

INSTALLATION

Install in the reverse order of removal.

Removal and Installation of Rear Combination Lamp (Stop Lamp)

AKS00A1K

Refer to [LT-155, "Removal and Installation"](#) in "REAR COMBINATION LAMP".

BACK-UP LAMP

PFP:26550

AKS009WL

BACK-UP LAMP

Wiring Diagram — BACK/L — A/T MODELS

LT-BACK/L-01

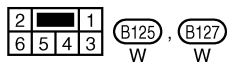
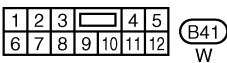
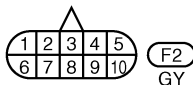
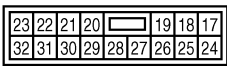
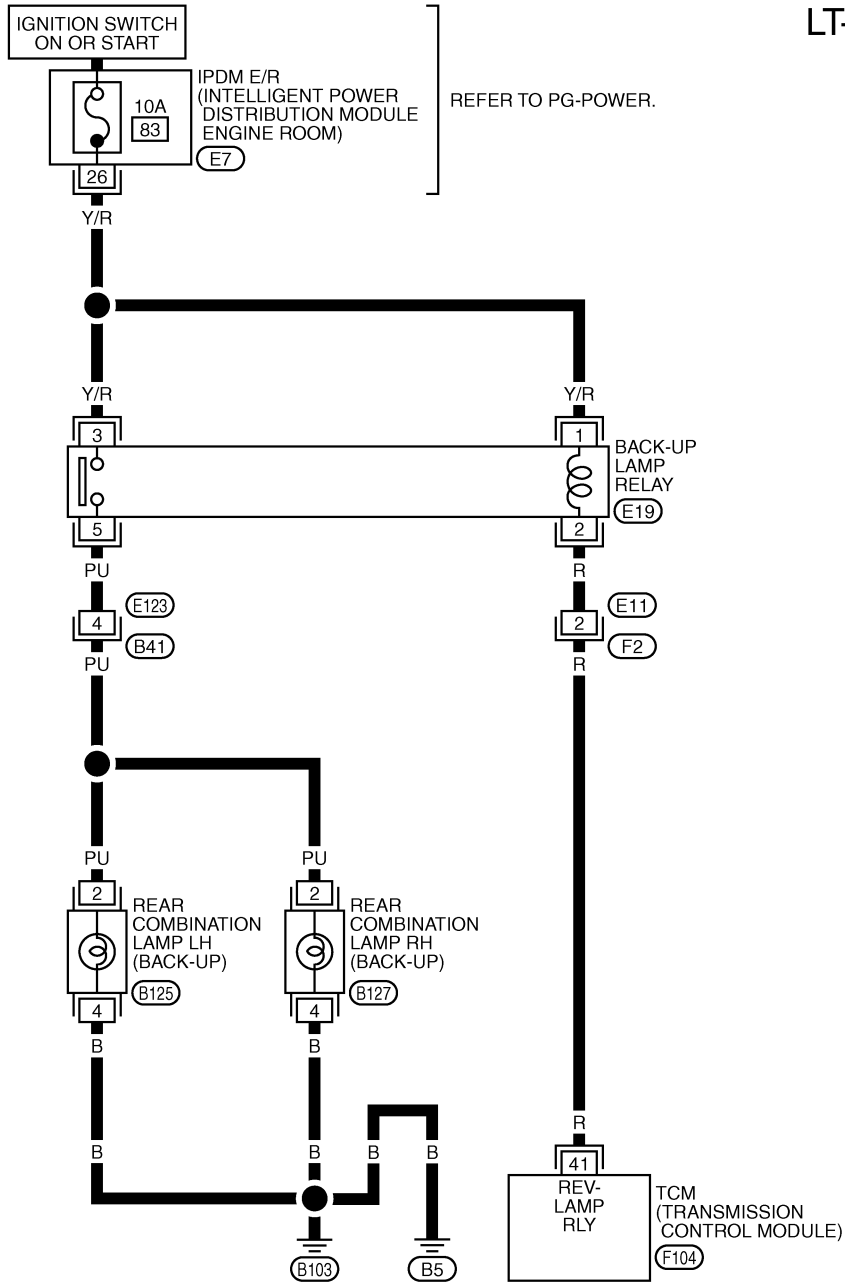

REFER TO THE FOLLOWING.
F104 -ELECTRICAL UNITS

BACK-UP LAMP

M/T MODELS

LT-BACK/L-02

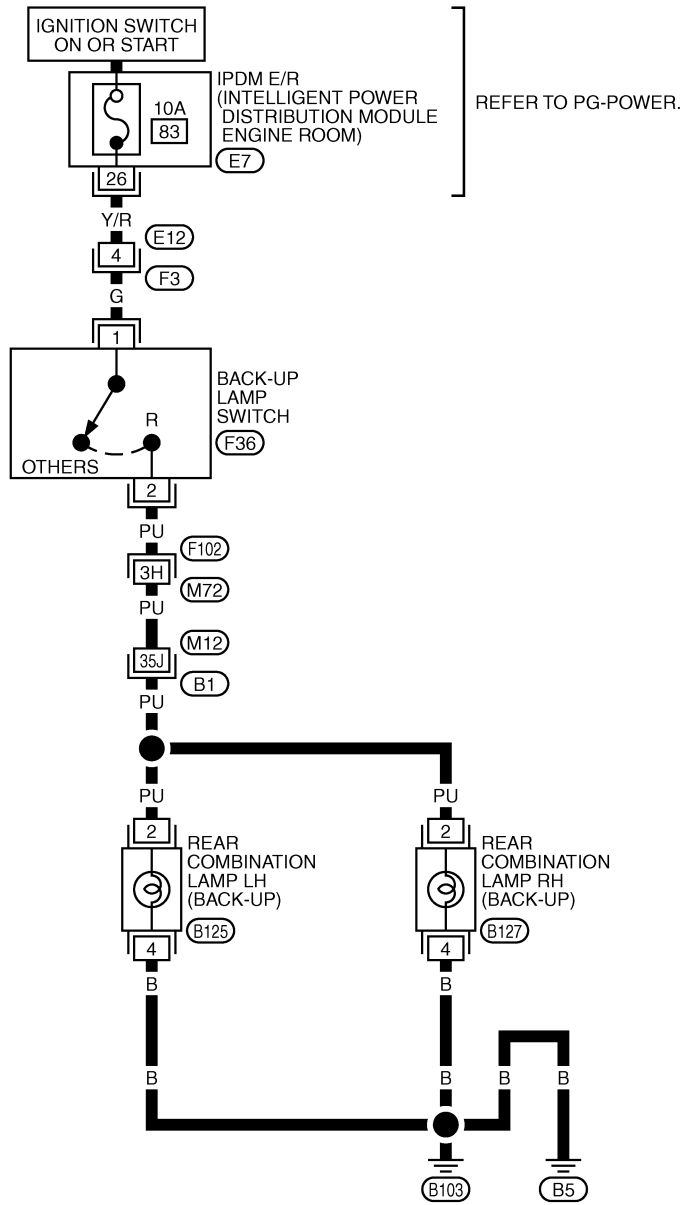

REFER TO PG-POWER.

A
B
C
D
E
F
G
H
I
J
LT
L
M

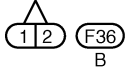
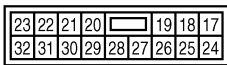

REFER TO THE FOLLOWING.
 (F102), (B1) -SUPER MULTIPLE JUNCTION (SMJ)

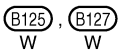
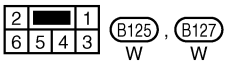

BACK-UP LAMP

Bulb Replacement

AKS009WM

Refer to [LT-155, "Bulb Replacement"](#) in "REAR COMBINATION LAMP".

Removal and Installation

AKS009WN

Refer to [LT-155, "Removal and Installation"](#) in "REAR COMBINATION LAMP".

PARKING, LICENSE PLATE AND TAIL LAMPS

PARKING, LICENSE PLATE AND TAIL LAMPS

PF26550

Component Parts and Harness Connector Location

AKS009WO

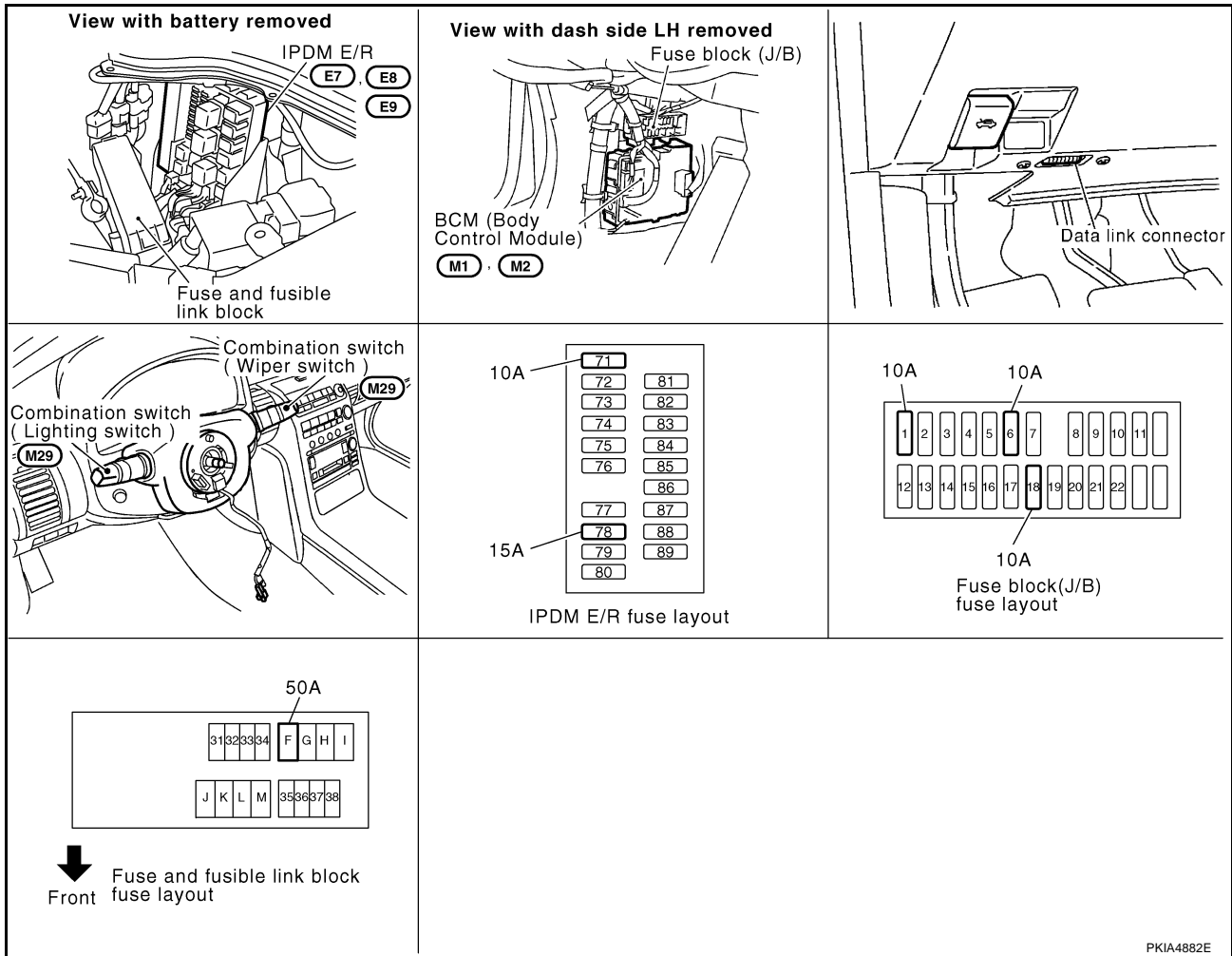

PKIA4882E

System Description

AKS009WP

Control of the parking, license plate, and tail lamp operation is dependent upon the position of the lighting switch (combination switch). When the lighting switch is placed in the 1ST position, the BCM (body control module) receives input signal requesting the parking, license plate, side marker and tail lamps to illuminate. This input signal is communicated to the IPDM E/R (intelligent power distribution module engine room) across the CAN communication lines. The CPU (central processing unit) of the IPDM E/R (intelligent power distribution module engine room) controls the tail lamp relay coil. This relay, when energized, directs power to the parking, license plate, side marker and tail lamps, which then illuminate.

The current that flows by Rear combination lamp unit is controlled, and a tail lamp (LED) is made to turn on. Power is supplied at all times

- to ignition relay, [located in IPDM E/R (intelligent power distribution module engine room)]
- through 10A fuse [No. 71, located in IPDM E/R (intelligent power distribution module engine room)]
- to tail lamp relay, [located in IPDM E/R (intelligent power distribution module engine room)]
- through 15A fuse [No. 78, located in IPDM E/R (intelligent power distribution module engine room)]
- to CPU (central processing unit) [located in IPDM E/R (intelligent power distribution module engine room)].

Power is also supplied at all times

- through 50A fusible link (letter F, located in fuse and fusible link block)
- to BCM (body control module) terminal 55
- through 10A fuse [No. 18, located in fuse block (J/B)]
- to BCM (body control module) terminal 42.

A
B
C
D
E
F
G
H
I
J
LT

PARKING, LICENSE PLATE AND TAIL LAMPS

With the ignition switch in the ON or START position, power is supplied

- through 10A fuse [No. 1, located in fuse block (J/B)]
- to BCM (body control module) terminal 38
- through ignition relay, [located in IPDM E/R (intelligent power distribution module engine room)]
- to CPU (central processing unit) [located in IPDM E/R (intelligent power distribution module engine room)].

With the ignition switch in the ACC or ON position, power is supplied

- through 10A fuse [No. 6, located in fuse block (J/B)]
- to BCM (body control module) terminal 11.

Ground is supplied

- to BCM (body control module) terminal 52
- through grounds M30 and M66
- to IPDM E/R (intelligent power distribution module engine room) terminals 38 and 60
- through grounds E17 and E43.

OPERATION BY LIGHTING SWITCH

With the lighting switch in the 1ST or 2ND position (or if the auto light system is activated), the BCM receives input signal requesting the parking, license plate, side marker and tail lamps to illuminate. This input signal is communicated to the IPDM E/R across the CAN communication lines. The CPU in the IPDM E/R controls the tail lamp relay coil, which when energized, directs power

- through IPDM E/R terminal 22
- to front side marker lamp LH terminal 1
- to front combination lamp LH terminal 7
- to license plate lamp LH terminal 1
- to rear combination lamp LH terminal 3
- to front side marker lamp RH terminal 1
- to front combination lamp RH terminal 7
- to license plate lamp RH terminal 1
- to rear combination lamp RH terminal 3.

Ground is supplied at all times

- to front side marker lamp LH terminal 2
- through grounds E17 and E43
- to front combination lamp LH terminal 4
- through grounds E17 and E43
- to license plate lamp LH terminal 2
- through grounds B5 and B103
- to rear combination lamp LH terminal 4
- through grounds B5 and B103
- to front side marker lamp RH terminal 2
- through grounds E17 and E43
- to front combination lamp RH terminal 4
- through grounds E17 and E43
- to license plate lamp RH terminal 2
- through grounds B5 and B103
- to rear combination lamp RH terminal 4
- through grounds B5 and B103.

With power and ground supplied, the parking, license plate, side marker and tail lamps illuminate.

COMBINATION SWITCH READING FUNCTION

Refer to [BCS-3, "COMBINATION SWITCH READING FUNCTION"](#) .

PARKING, LICENSE PLATE AND TAIL LAMPS

EXTERIOR LAMP BATTERY SAVER CONTROL

When the combination switch (lighting switch) is in the 1ST (or 2ND) position, and the ignition switch is turned from ON or ACC to OFF, the battery saver control feature is activated.

Under this condition, the parking, license, side marker and tail lamps remain illuminated for 5 minutes, then the parking, license plate, side marker and tail lamps are turned off.

Exterior lamp battery saver control mode can be changed by the function setting of CONSULT-II.

CAN Communication System Description

AKS009WQ

CAN (Controller Area Network) is a serial communication line for real time application. It is an on-vehicle multiplex communication line with high data communication speed and excellent error detection ability. Many electronic control units are equipped onto a vehicle, and each control unit shares information and links with other control units during operation (not independent). In CAN communication, control units are connected with 2 communication lines (CAN H line, CAN L line) allowing a high rate of information transmission with less wiring. Each control unit transmits/receives data but selectively reads required data only.

CAN Communication Unit

AKS009WR

Refer to [LAN-4. "CAN Communication Unit"](#) .

A

B

C

D

E

F

G

H

I

J

LT

L

M

PARKING, LICENSE PLATE AND TAIL LAMPS

Schematic

AKS009WS

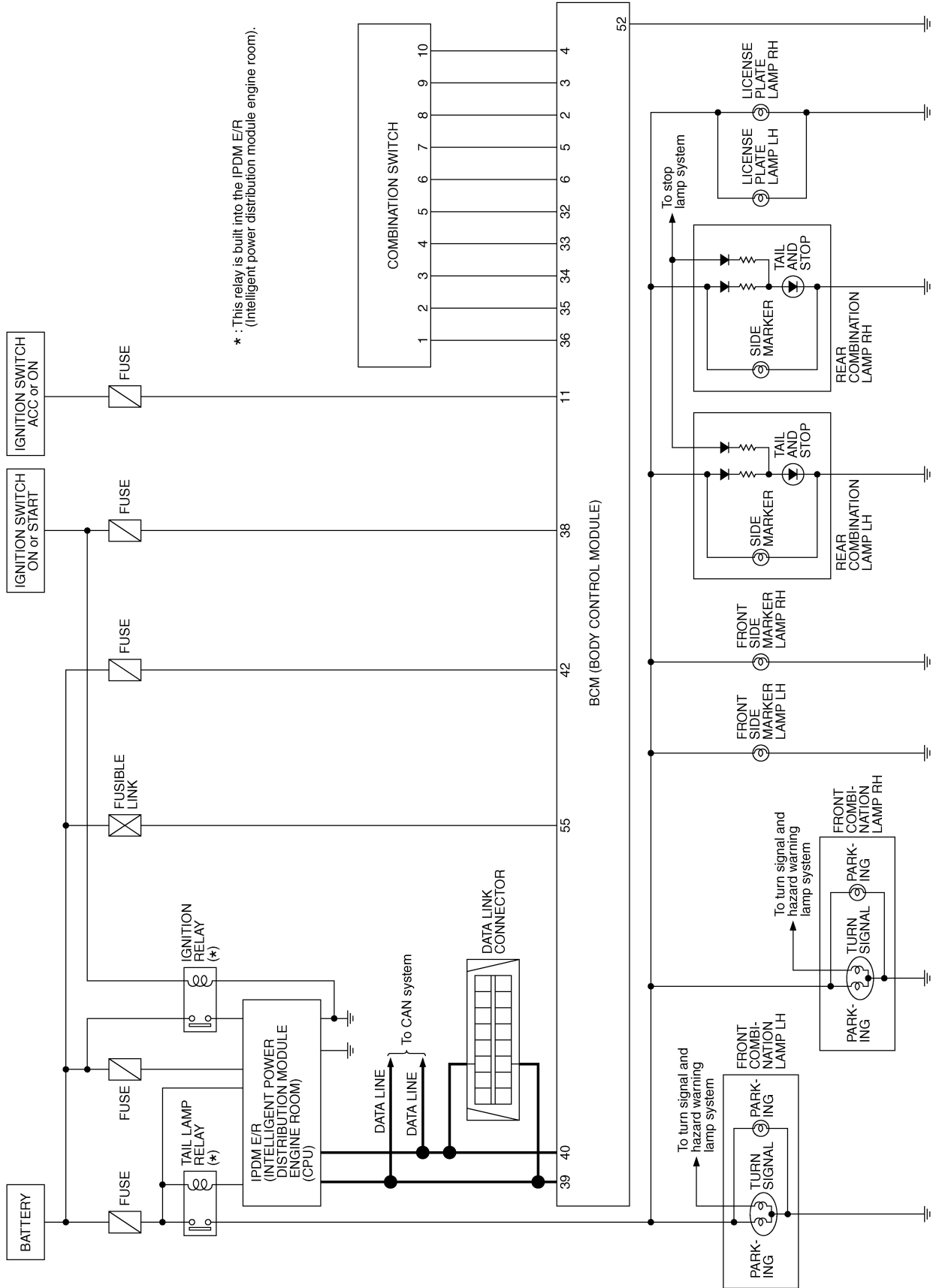

TKWM0877E

PARKING, LICENSE PLATE AND TAIL LAMPS

Wiring Diagram — TAIL/L —

AKS009WT

LT-TAIL/L-01

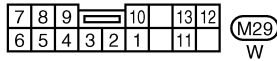
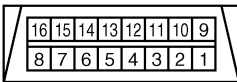
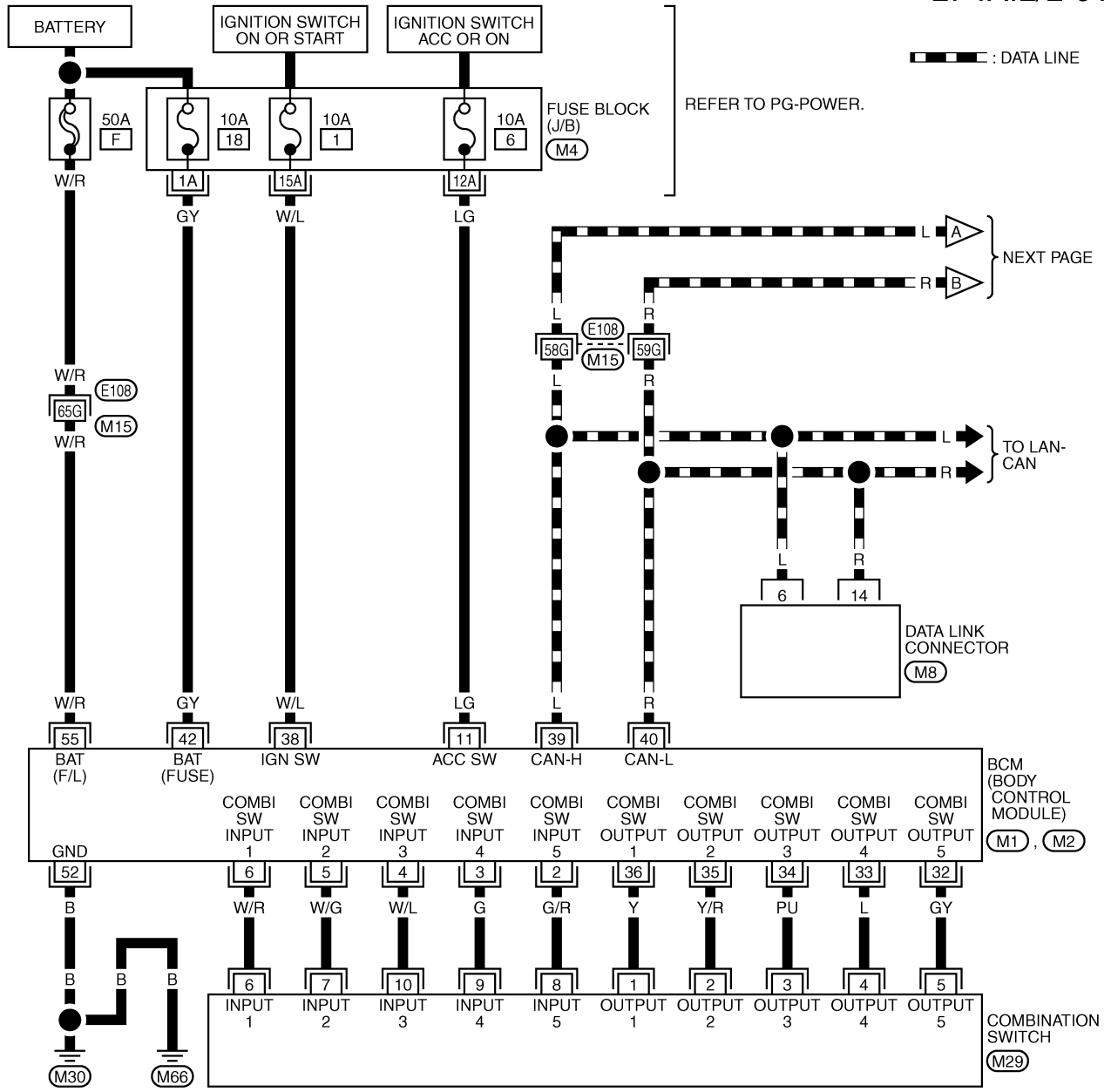

REFER TO THE FOLLOWING.

(E108) -SUPER MULTIPLE JUNCTION (SMJ)

(M4) -FUSE BLOCK-JUNCTION BOX (J/B)

(M1), (M2) -ELECTRICAL UNITS

TKWM0878E

PARKING, LICENSE PLATE AND TAIL LAMPS

LT-TAIL/L-02

▬ : DATA LINE

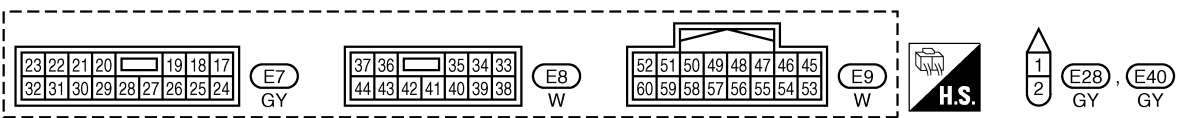
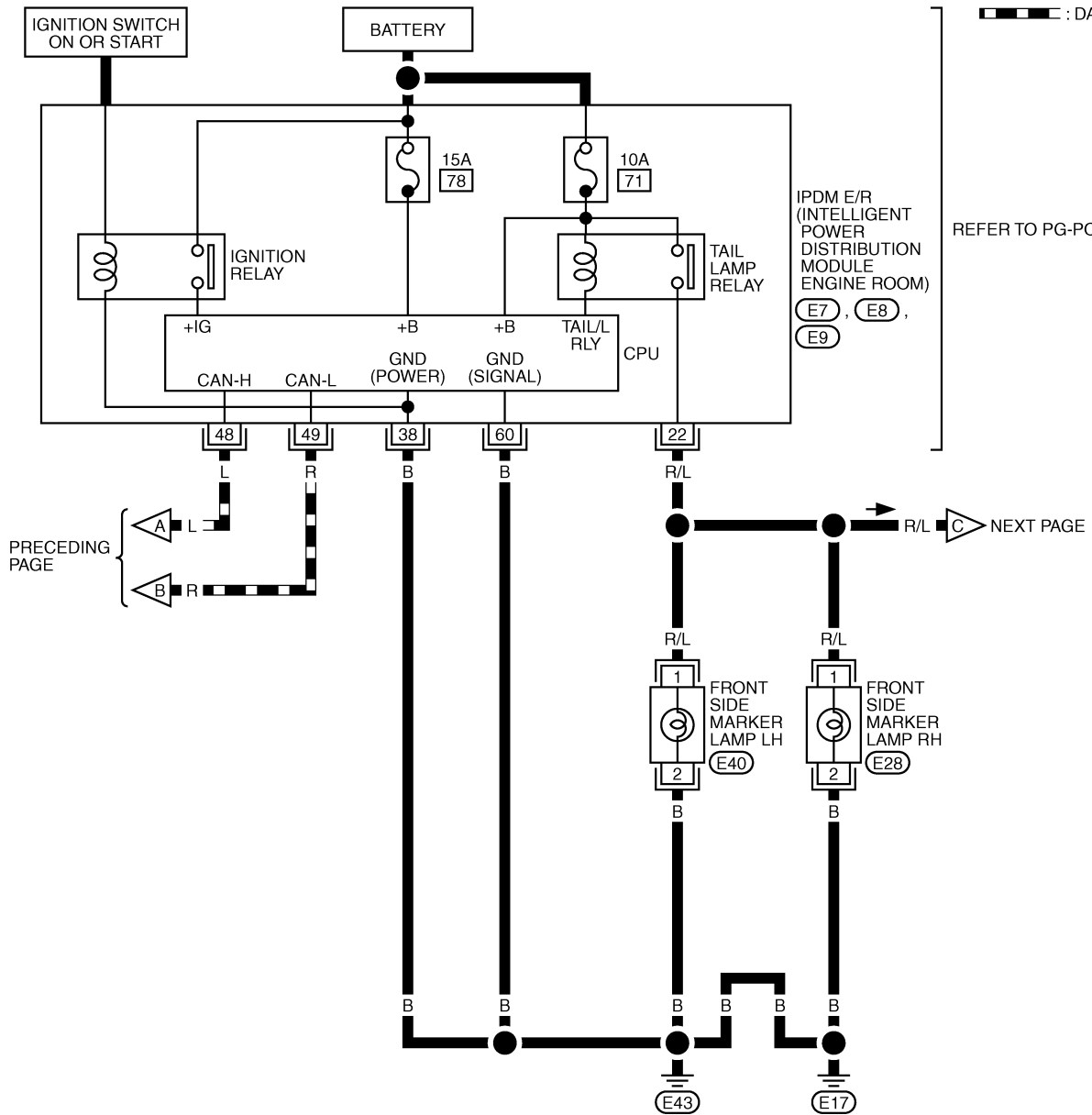

PARKING, LICENSE PLATE AND TAIL LAMPS

LT-TAIL/L-03

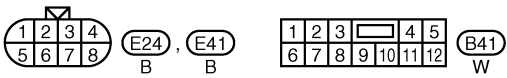
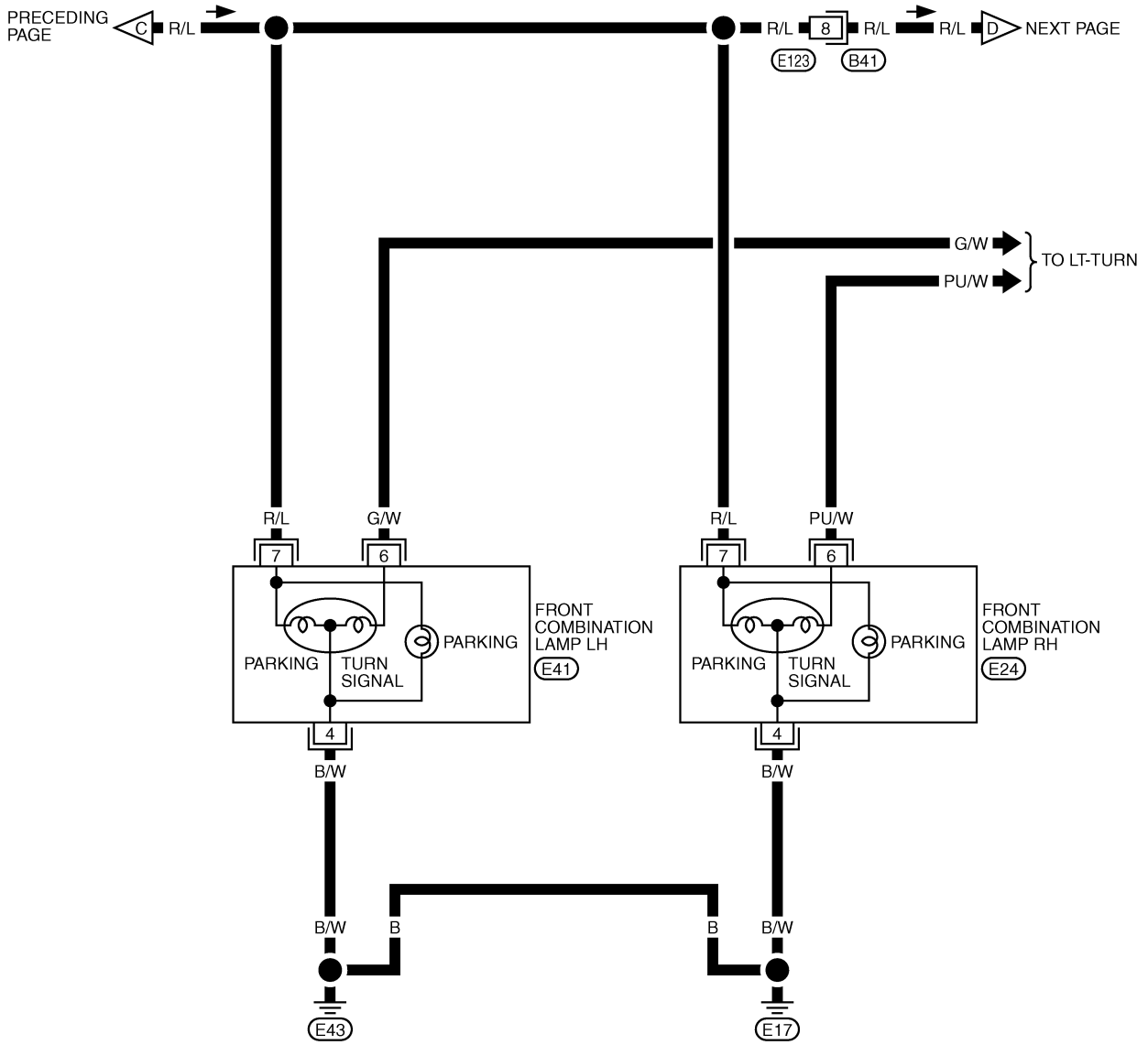

A
B
C
D
E
F
G
H
I
J
LT
L
M

PARKING, LICENSE PLATE AND TAIL LAMPS

LT-TAIL/L-04

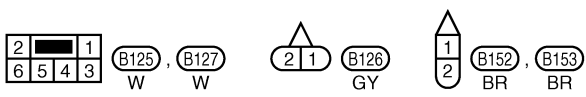
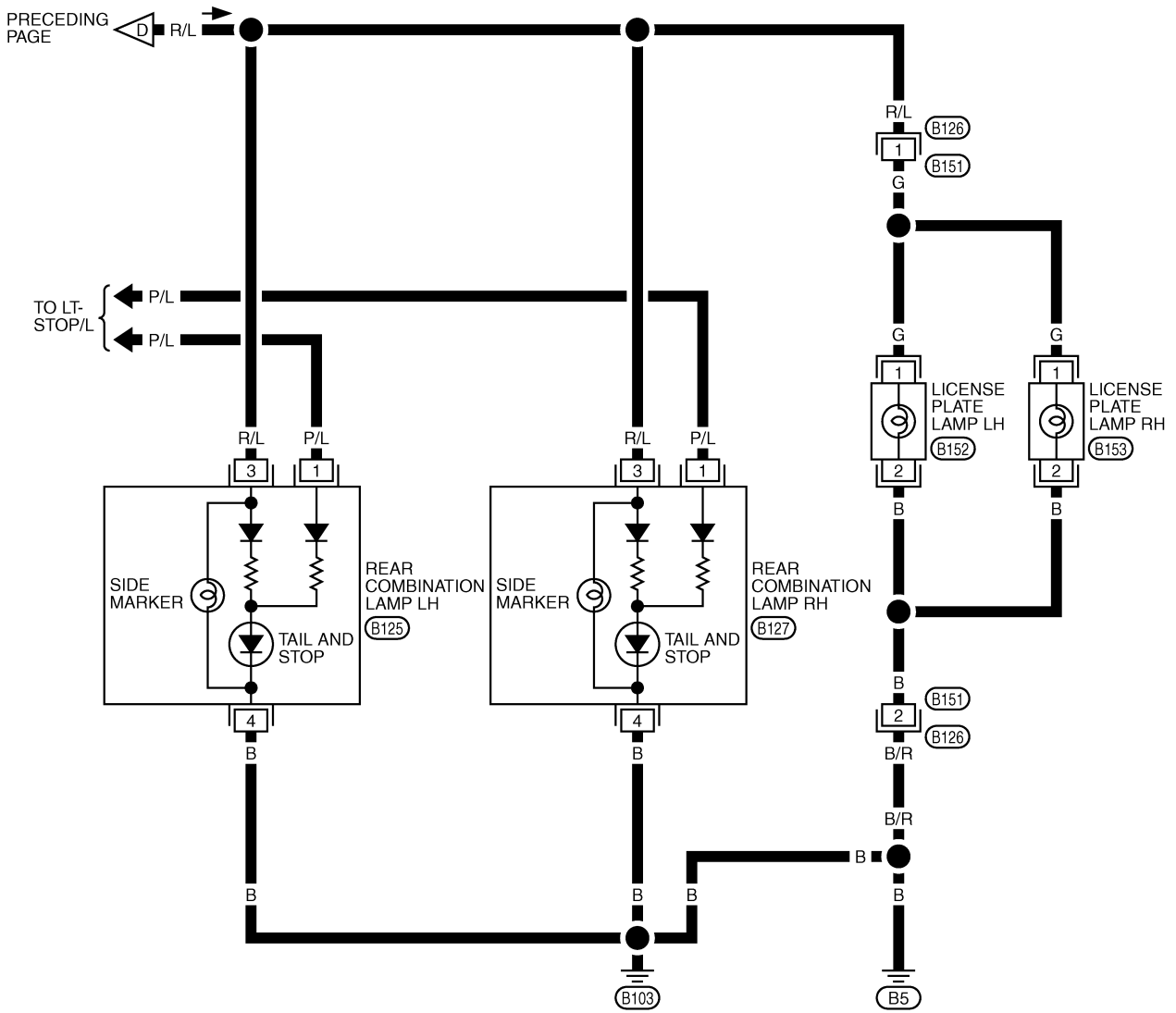





TKWM0881E

PARKING, LICENSE PLATE AND TAIL LAMPS

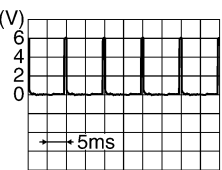
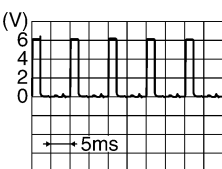
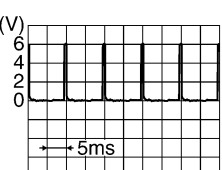
Terminals and Reference Value for BCM

AKS009WU

Terminal No.	Wire color	Signal name	Measuring condition		Reference value
			Ignition switch	Operation or condition	
2	G/R	Combination switch input 5	ON	Lighting, turn, wiper OFF Wiper dial position 4	 <p style="text-align: right;">SKIA5291E</p>
3	G	Combination switch input 4	ON	Lighting, turn, wiper OFF Wiper dial position 4	 <p style="text-align: right;">SKIA5292E</p>
4	W/L	Combination switch input 3	ON	Lighting, turn, wiper OFF Wiper dial position 4	 <p style="text-align: right;">SKIA5291E</p>
5	W/G	Combination switch input 2	ON	Lighting, turn, wiper OFF Wiper dial position 4	 <p style="text-align: right;">SKIA5292E</p>
6	W/R	Combination switch input 1			
11	LG	Ignition switch (ACC)	ACC	—	Battery voltage
32	GY	Combination switch output 5	ON	Lighting, turn, wiper OFF Wiper dial position 4	 <p style="text-align: right;">SKIA5291E</p>
33	L	Combination switch output 4	ON	Lighting, turn, wiper OFF Wiper dial position 4	 <p style="text-align: right;">SKIA5292E</p>
34	PU	Combination switch output 3	ON	Lighting, turn, wiper OFF Wiper dial position 4	 <p style="text-align: right;">SKIA5291E</p>

A
B
C
D
E
F
G
H
I
J
LT
L
M

PARKING, LICENSE PLATE AND TAIL LAMPS

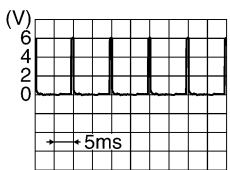
Terminal No.	Wire color	Signal name	Measuring condition		Reference value
			Ignition switch	Operation or condition	
35	Y/R	Combination switch output 2	ON	Lighting, turn, wiper OFF Wiper dial position 4	
36	Y	Combination switch output 1			
38	W/L	Ignition switch (ON)	ON	—	Battery voltage
39	L	CAN- H	—	—	—
40	R	CAN- L	—	—	—
42	GY	Battery power supply	OFF	—	Battery voltage
52	B	Ground	ON	—	Approx. 0V
55	W/R	Battery power supply	OFF	—	Battery voltage

Terminals and Reference Values for IPDM E/R

AKS009WW

Terminal No.	Wire color	Signal name	Measuring condition		Reference value
			Ignition switch	Operation or condition	
22	R/L	Parking, license, and tail lamp	ON	Lighting switch 1ST position	OFF Approx. 0V
					ON Battery voltage
38	B	Ground	ON	—	Approx. 0V
48	L	CAN- H	—	—	—
49	R	CAN- L	—	—	—
60	B	Ground	ON	—	Approx. 0V

How to Proceed With Trouble Diagnosis

AKS009WW

1. Confirm the symptom or customer complaint.
2. Understand operation description and function description. Refer to [LT-137, "System Description"](#) .
3. Perform the preliminary check. Refer to [LT-146, "Preliminary Check"](#) .
4. Check symptom and repair or replace the cause of malfunction.
5. Do the parking, license and tail lamps operate normally? If YES: GO TO 6. If NO: GO TO 4.
6. INSPECTION END

Preliminary Check

AKS009WX

CHECK POWER SUPPLY AND GROUND CIRCUIT

1. CHECK FUSES

- Check fuses for blown-out.

Unit	Power source	Fuse and fusible link No.
BCM	Battery	F
		18
	Ignition switch ON or START position	1
	Ignition switch ACC or ON position	6
IPDM E/R	Battery	71
		78

PARKING, LICENSE PLATE AND TAIL LAMPS

Refer to [LT-141, "Wiring Diagram — TAIL/L —"](#).

OK or NG

OK >> GO TO 2.

NG >> If fuse is blown, be sure to eliminate cause of malfunction before installing new fuse. Refer to [PG-4, "POWER SUPPLY ROUTING CIRCUIT"](#).

2. CHECK POWER SUPPLY CIRCUIT

1. Turn ignition switch OFF.
2. Disconnect BCM connector.
3. Check voltage between BCM harness connector and ground.

Terminals		(-)	Ignition switch position		
Connector	Terminal (Wire color)		OFF	ACC	ON
M1	11 (LG)	Ground	0V	Battery voltage	Battery voltage
	38 (W/L)		0V	0V	Battery voltage
M2	42 (GY)		Battery voltage	Battery voltage	Battery voltage
	55 (W/R)		Battery voltage	Battery voltage	Battery voltage

OK or NG

OK >> GO TO 3.

NG >> Check harness for open or short between BCM and fuse.

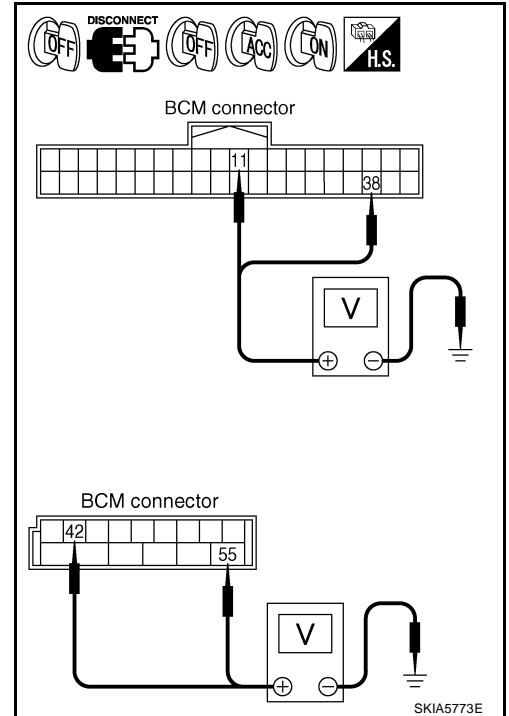

3. CHECK GROUND CIRCUIT

Check continuity between BCM harness connector and ground.

Terminals			Continuity
Connector	Terminal (Wire color)	Ground	
M2	52 (B)	Ground	Yes

OK or NG

OK >> INSPECTION END

NG >> Check ground circuit harness.

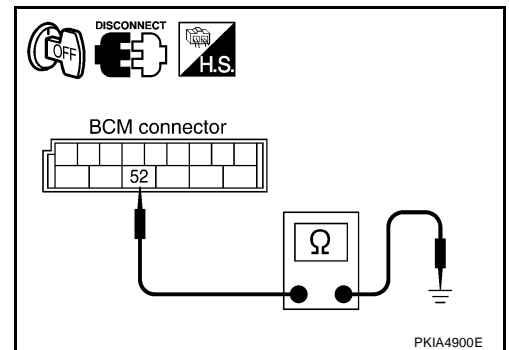

CONSULT-II Functions

Refer to [LT-18, "CONSULT-II Functions \(BCM\)"](#) in HEADLAMP (USA).

Refer to [LT-21, "CONSULT-II Functions \(IPDM E/R\)"](#) in HEADLAMP (USA).

Refer to [LT-54, "CONSULT-II Functions \(BCM\)"](#) in HEADLAMP (FOR CANADA).

Refer to [LT-57, "CONSULT-II Functions \(IPDM E/R\)"](#) in HEADLAMP (FOR CANADA).

PARKING, LICENSE PLATE AND TAIL LAMPS

AKS009WZ

Parking, License Plate and Tail Lamps Do Not Illuminate

1. CHECK COMBINATION SWITCH INPUT SIGNAL

④ With CONSULT-II

Select "BCM" on CONSULT-II. With "HEAD LAMP" data monitor, make sure "LIGHT SW 1 ST" turns ON-OFF linked with operation of lighting switch.

When lighting switch is 1ST : LIGHT SW 1 ST ON position

⊗ Without CONSULT-II

Refer to [LT-128, "Combination Switch Inspection"](#) .

OK or NG

OK >> GO TO 2.

NG >> Check lighting switch. Refer to [LT-128, "Combination Switch Inspection"](#) .

DATA MONITOR			
MONITOR		NO DTC	
LIGHT SW 1ST		ON	
RECORD			
MODE	BACK	LIGHT	COPY

PKIA7752E

2. ACTIVE TEST

④ With CONSULT-II

1. Select "IPDM E/R" on CONSULT-II, and select "ACTIVE TEST" on "SELECT DIAG MODE" screen.
2. Select "TAIL LAMP" on "SELECT TEST ITEM" screen.
3. Touch "ON" screen.
4. Make sure parking, license plate, side marker and tail lamp operation.

Parking, license plate, side marker and tail lamps should operate.

⊗ Without CONSULT-II

1. Start auto active test. Refer to [PG-23, "Auto Active Test"](#) .
2. Make sure parking, license plate, side marker and tail lamp operation.

Parking, license plate, side marker and tail lamps should operate.

OK or NG

OK >> GO TO 3.

NG >> GO TO 4.

3. CHECK IPDM E/R

1. Select "IPDM E/R" on CONSULT-II, and select "DATA MONITOR" on "SELECT DIAG MODE" screen.
2. Make sure "TAIL & CLR REQ" turns ON when lighting switch is in 1ST position.

When lighting switch is 1ST : TAIL & CLR REQ ON position

OK or NG

OK >> Replace IPDM E/R.

NG >> Replace BCM. Refer to [BCS-15, "Removal and Installation of BCM"](#) .

ACTIVE TEST			
TAIL LAMP		ON	
OFF			
MODE	BACK	LIGHT	COPY

PKIA7753E

DATA MONITOR			
MONITOR		NO DTC	
TAIL&CLR REQ		ON	
RECORD			
MODE	BACK	LIGHT	COPY

SKIA5958E

PARKING, LICENSE PLATE AND TAIL LAMPS

4. CHECK INPUT SIGNAL

 With CONSULT-II

1. Turn ignition switch OFF.
2. Disconnect front side marker, front combination lamp, license plate lamp and rear combination lamp connectors.
3. Select "IPDM E/R" on CONSULT-II, and select "ACTIVE TEST" on "SELECT DIAG MODE" screen.
4. Select "TAIL LAMP" on "SELECT TEST ITEM" screen.
5. Touch "ON" screen.
6. When tail lamp is operating, check voltage between front side marker lamp, front combination lamp, license plate lamp, rear combination lamp harness connector and ground.

 Without CONSULT-II

1. Turn ignition switch OFF.
2. Disconnect front combination lamp RH and LH connectors.
3. Start auto active test. Refer to [PG-23, "Auto Active Test"](#).
4. When tail lamp is operating, check voltage between front side marker lamp, front combination lamp, license plate lamp, rear combination lamp harness connector and ground.

Terminals				Voltage
Front side marker lamp (+)			(-)	
Connector		Terminal (Wire color)		Ground
RH	E28	1 (R/L)	Ground	
LH	E40			

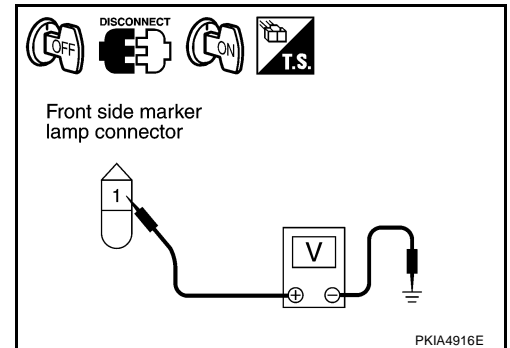

Terminals				Voltage
Front combination lamp (+) (Parking)			(-)	
Connector		Terminal (Wire color)		Ground
RH	E24	7 (R/L)	Ground	
LH	E41			

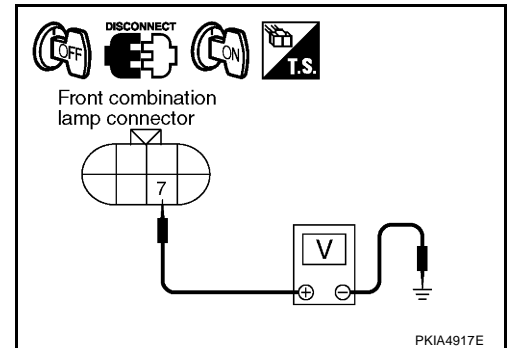

Terminals				Voltage
License plate lamp (+)			(-)	
Connector		Terminal (Wire color)		Ground
RH	B153	1 (G)	Ground	
LH	B152			

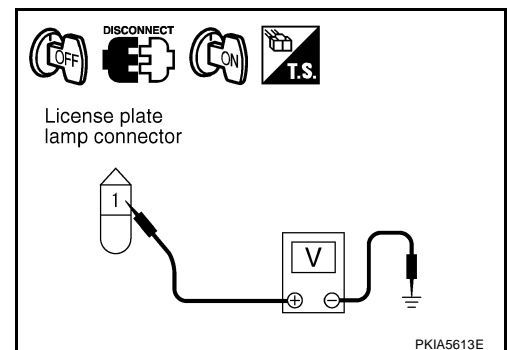

PARKING, LICENSE PLATE AND TAIL LAMPS

Terminals			(-)	Voltage
Rear combination lamp (+) (Tail and side marker)				
Connector	Terminal (Wire color)			
RH	B127	3 (R/L)	Ground	Battery voltage
LH	B125			

OK or NG

OK >> GO TO 6.
 NG >> GO TO 5.

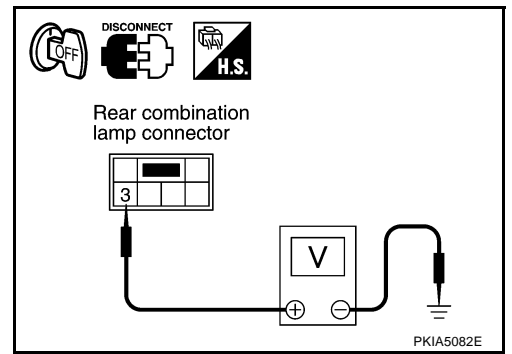

PARKING, LICENSE PLATE AND TAIL LAMPS

5. CHECK PARKING, LICENSE PLATE AND TAIL LAMPS CIRCUIT

1. Turn ignition switch OFF.
2. Disconnect IPDM E/R connector.
3. Check continuity between IPDM E/R harness connector and front side marker lamp harness connector.

Terminals					Continuity
IPDM E/R		Front side marker lamp			
Connector	Terminal (Wire color)	Connector	Terminal (Wire color)		
E7	22 (R/L)	RH	E28	1 (R/L)	Yes
		LH	E40		

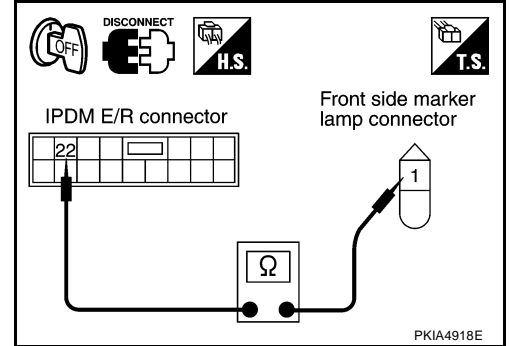

4. Check continuity between IPDM E/R harness connector and front combination lamp harness connector.

Terminals					Continuity
IPDM E/R		Front combination lamp (Parking)			
Connector	Terminal (Wire color)	Connector	Terminal (Wire color)		
E7	22 (R/L)	RH	E24	7 (R/L)	Yes
		LH	E41		

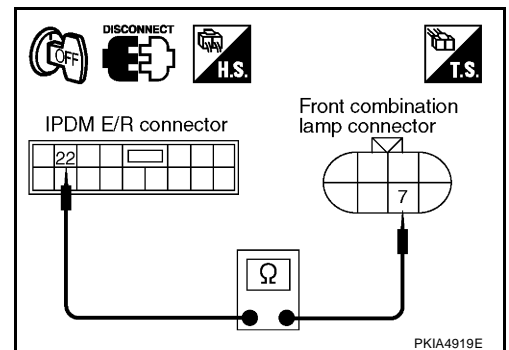

5. Check continuity between IPDM E/R harness connector and license plate lamp harness connector.

Terminals					Continuity
IPDM E/R		License plate lamp			
Connector	Terminal (Wire color)	Connector	Terminal (Wire color)		
E7	22 (B/L)	RH	B153	1 (G)	Yes
		LH	B152		

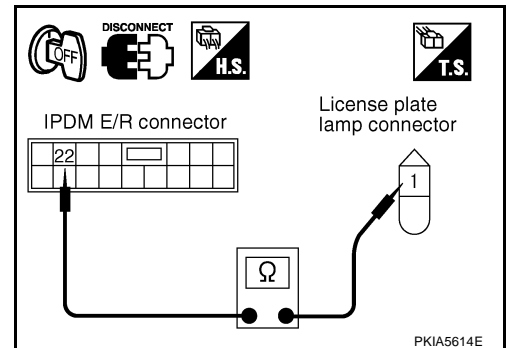

6. Check continuity between IPDM E/R harness connector and rear combination lamp harness connector.

Terminals					Continuity
IPDM E/R		Rear combination lamp (Tail and side marker)			
Connector	Terminal (Wire color)	Connector	Terminal (Wire color)		
E7	22 (R/L)	RH	B127	3 (R/L)	Yes
		LH	B125		

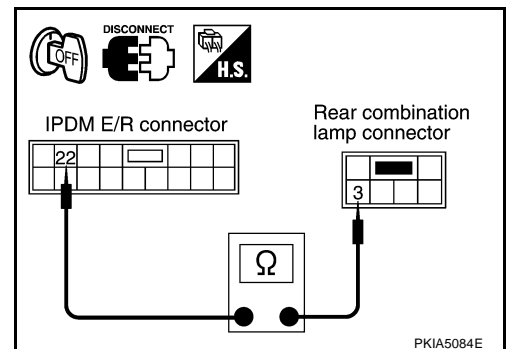

OK or NG

- OK >> Replace IPDM E/R.
 NG >> Repair harness or connector.

PARKING, LICENSE PLATE AND TAIL LAMPS

6. CHECK GROUND

1. Check continuity between front side marker lamp harness connector and ground.

Terminals				Ground	Continuity
Front side marker lamp					
Connector		Terminal (Wire color)		Ground	Yes
RH	E28	2 (B)			
LH	E40				

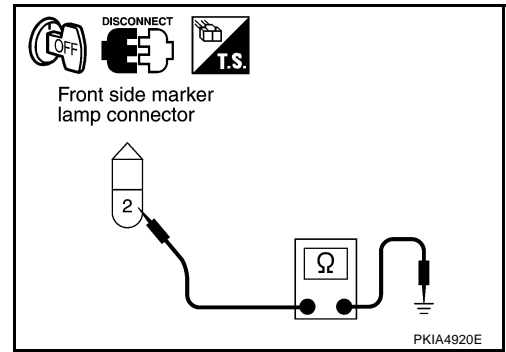

2. Check continuity between front combination lamp harness connector and ground.

Terminals				Ground	Continuity
Front combination lamp (Parking)					
Connector		Terminal (Wire color)		Ground	Yes
RH	E24	4 (B/W)			
LH	E41				

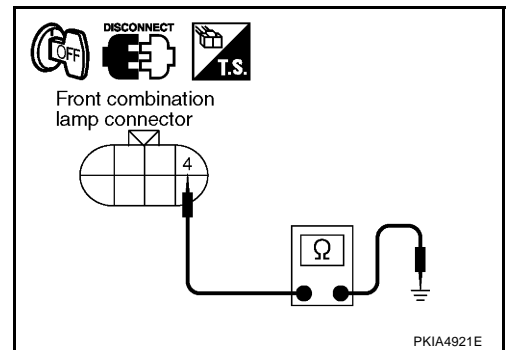

3. Check continuity between license plate lamp harness connector and ground.

Terminals				Ground	Continuity
License plate lamp					
Connector		Terminal (Wire color)		Ground	Yes
RH	B153	2 (B)			
LH	B152				

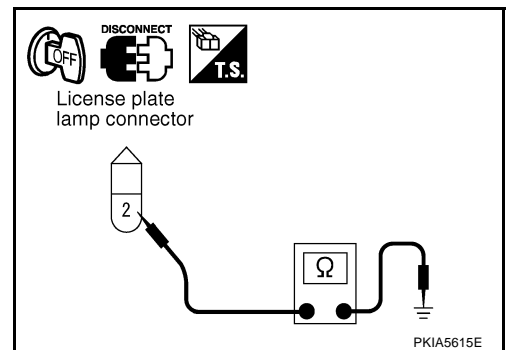

4. Check continuity between rear combination lamp harness connector and ground.

Terminals				Ground	Continuity
Rear combination lamp (Tail and side marker)					
Connector		Terminal (Wire color)		Ground	Yes
RH	B127	4 (B)			
LH	B125				

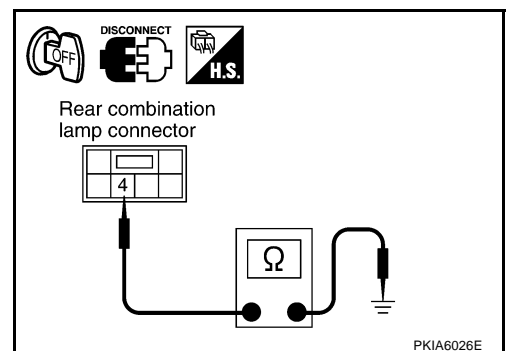

OK or NG

- OK >> Check bulb or replace rear combination lamp.
 NG >> Repair harness or connector.

PARKING, LICENSE PLATE AND TAIL LAMPS

Parking, License Plate and Tail Lamps Do Not Turn OFF (After Approx. 10 Minutes)

AKS00AM0

1. CHECK IPDM E/R

1. Turn the ignition switch ON. Place the combination switch (lighting switch) in the ON position. Turn the ignition switch OFF.
2. make sure the parking, license plate, and tail lamps turn OFF after approximately 10 minutes.

OK or NG

OK >> INSPECTION END.

NG >> Ignition relay malfunction. Refer to [PG-18, "Function of Detecting Ignition Relay Malfunction"](#).

Bulb Replacement FRONT SIDE MARKER LAMP

AKS00A1X

1. Remove front side marker lamp. Refer to [LT-153, "FRONT SIDE MARKER LAMP"](#).
2. Turn bulb socket counterclockwise and unlock it.
3. Remove bulb from it's socket.

Front side marker lamp : 12V - 3.8W

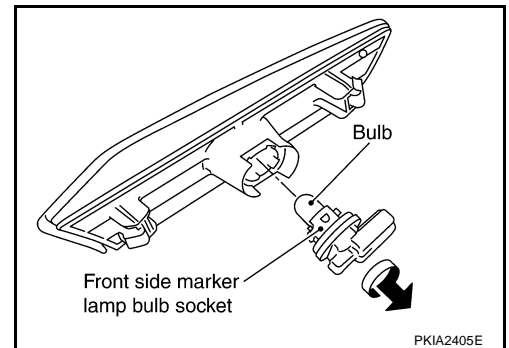

LICENSE PLATE LAMP

1. Remove license plate lamp. Refer to [LT-154, "LICENSE PLATE LAMP"](#).
2. Turn bulb socket counter click wise and unlock it.
3. Remove bulb from its socket.

License plate lamp : 12V - 5W

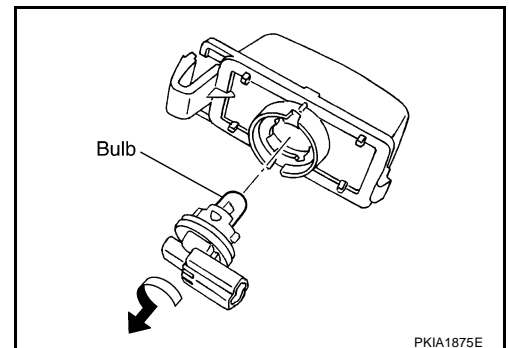

FRONT TURN SIGNAL (PARKING) LAMP

For bulb replacement, refer to [LT-34, "Bulb Replacement"](#) in "HEADLAMP (FOR USA)".

TAIL LAMP

For bulb replacement, refer to [LT-155, "Bulb Replacement"](#) in "REAR COMBINATION LAMP".

Removal and Installation FRONT SIDE MARKER LAMP

AKS00A1Y

1. Insert a slotted screwdriver or similar tool into fender protector gap to push front side marker lamp metal clip in direction 1 (see figure) while pulling in direction 2. Remove from vehicle.
2. Disconnect connectors of front side marker lamp.
3. Install in the reverse order of removal.

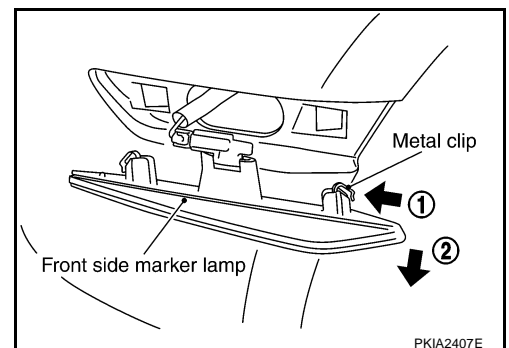

PARKING, LICENSE PLATE AND TAIL LAMPS

LICENSE PLATE LAMP

1. While pressing pawl on reverse side, push license plate towards you to remove.
2. Disconnect the license plate lamp connector.
3. Install in the reverse order of removal.

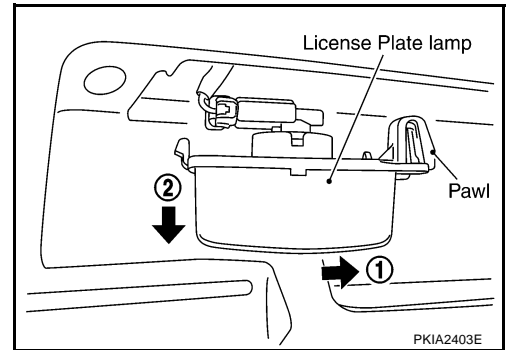

FRONT TURN SIGNAL (PARKING) LAMP

For front turn signal (parking) lamp removal and installation procedures, refer to [LT-35, "Removal and Installation"](#) in "HEADLAMP (FOR USA)".

TAIL LAMP

For tail lamp removal and installation procedures, refer to [LT-155, "Removal and Installation"](#) in "REAR COMBINATION LAMP".

REAR COMBINATION LAMP

REAR COMBINATION LAMP

PFP:26554

Bulb Replacement

REAR FENDER SIDE (REAR TURN SIGNAL LAMP BULB)

AKS00A1Z

1. Remove rear combination lamp. Refer to [LT-155, "Removal and Installation"](#) in REAR COMBINATION LAMP.
2. Turn bulb socket counterclockwise and unlock it.
3. Remove bulb.

Stop/tail lamp : LED (Replace together with rear combination lamp assembly.)

Rear turn signal lamp : 12V - 21W

Back-up lamp : 12V - 18W

Rear side marker lamp : 12V - 3.8W

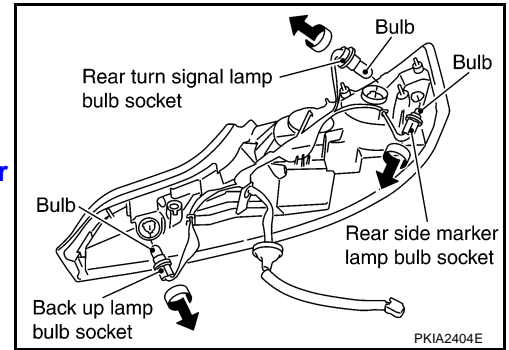

Removal and Installation

REMOVAL

AKS00A20

Rear Fender Side

1. Open trunk lid and remove trunk rear finisher (end). Refer to [EI-40, "TRUNK ROOM TRIM & TRUNK LID FINISHER"](#) in "EI" section.
2. Disconnect rear combination lamp connector.
3. Remove rear combination lamp installation nuts.
4. Pull the rear combination lamp toward rear of the vehicle and remove from the vehicle.
5. Remove seal packing from the vehicle.

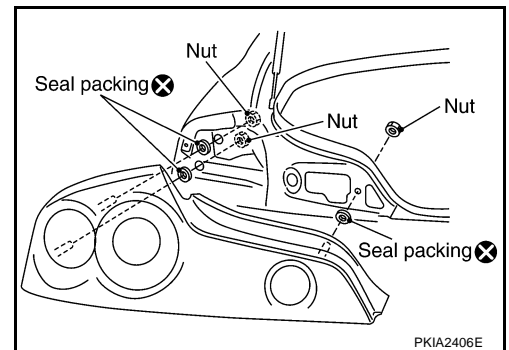

INSTALLATION

Install in the reverse order of removal. Be careful of the following:

- Install a new seal packing to the rear combination lamp.

CAUTION:

Seal packing cannot be reused.

Rear combination lamp mounting nut  : 3.2 N·m (0.33 kg·m, 28 in·lb)

A
B
C
D
E
F
G
H
I
J
L
M

LT

VANITY MIRROR LAMP

VANITY MIRROR LAMP

PFP:96400

Bulb Replacement

AKS00A16

1. Insert a thin screwdriver in the lens end and remove lens.
2. Remove bulb together with substrate.

Vanity mirror lamp : 12V - 1.32W

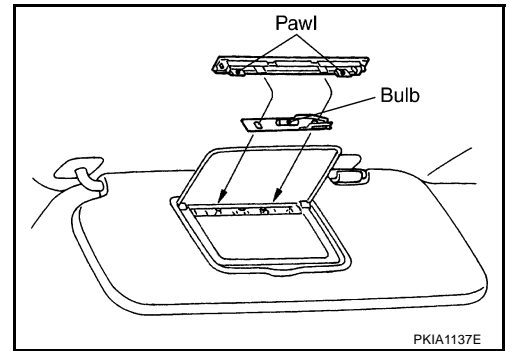

MAP LAMP

MAP LAMP

PFP:26430

Bulb Replacement of Map Lamp

AKS00A12

1. Insert a small screwdriver into the lens hinge gap and remove lens.
2. Remove bulb.

Map lamp : 12V - 8W

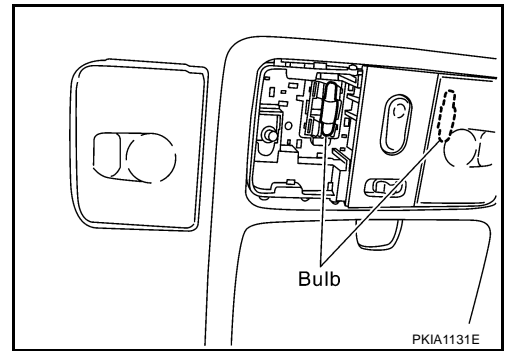

Removal and Installation of Map Lamp

REMOVAL

AKS00A13

1. Insert a clip driver or a suitable tool and disengage the pawl fittings of the map lamp.
2. Disconnect connector and remove map lamp.

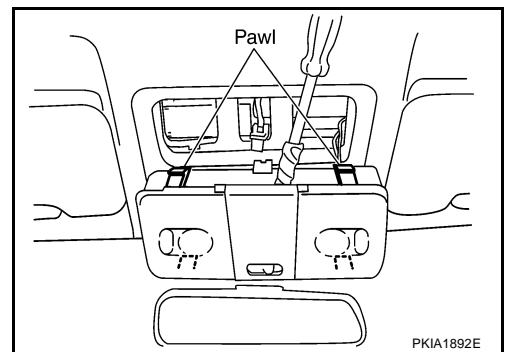

INSTALLATION

Install in the reverse order of removal.

A
B
C
D
E
F
G
H
I
J
LT
L
M

TRUNK ROOM LAMP

TRUNK ROOM LAMP

PFP:26470

Bulb Replacement, Removal and Installation of Trunk Room Lamp

AKS00A26

1. Unfold pawl A and remove lens.
2. Remove trunk room lamp while pressing pawl B in the direction of the arrow.
3. Disconnect trunk room lamp connector.

Trunk room lamp : 12V - 3.4W

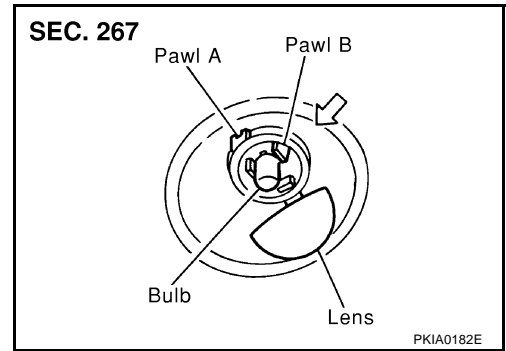

IGNITION KEY HOLE ILLUMINATION

IGNITION KEY HOLE ILLUMINATION

PFP:48476

Removal and Installation

AKS00A17

REMOVAL

1. Remove cluster lid A and steering lock escutcheon. Refer to [IP-10, "INSTRUMENT PANEL ASSEMBLY"](#) in "IP" section.
2. Pull out ring and turn bulb socket to left to release lock.

Key cylinder illumination : 12V - 1.4W

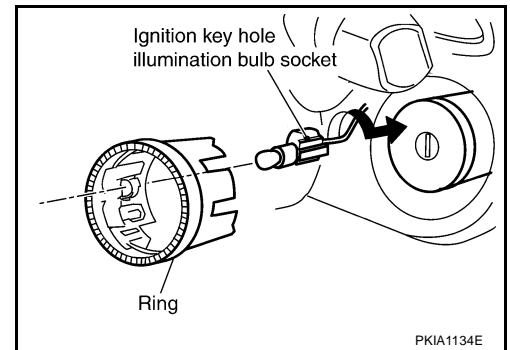

INSTALLATION

Install in the reverse order of removal.

A
B
C
D
E
F
G
H
I
J
LT
L
M

GLOVE BOX LAMP

GLOVE BOX LAMP

PFP:68520

Removal and Installation

AKS00A21

REMOVAL

1. Remove instrument lower passenger panel. Refer to [IP-10](#), "[INSTRUMENT PANEL ASSEMBLY](#)" in "IP" section.
2. Turn bulb socket left to release lock and remove it.

Glove box lamp : 12V - 1.4W

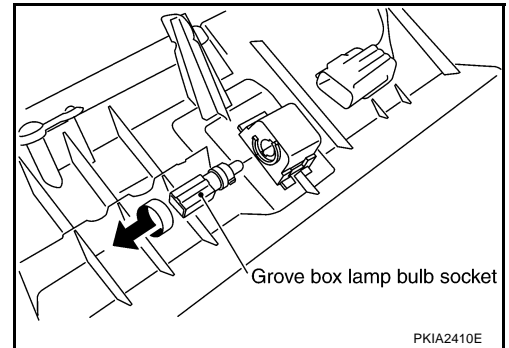

INSTALLATION

Install in the reverse order of removal.

ASHTRAY ILLUMINATION

ASHTRAY ILLUMINATION

PF2:25860

Bulb Replacement, Removal and Installation (M/T)

AKS00A22

1. Remove center console assembly. Refer to [IP-10, "INSTRUMENT PANEL ASSEMBLY"](#) in "IP" section.
2. Turn bulb socket counterclockwise to undo lock and remove bulb socket.

Ashtray illumination : 12V - 1.4W

3. Install in the reverse order of removal.

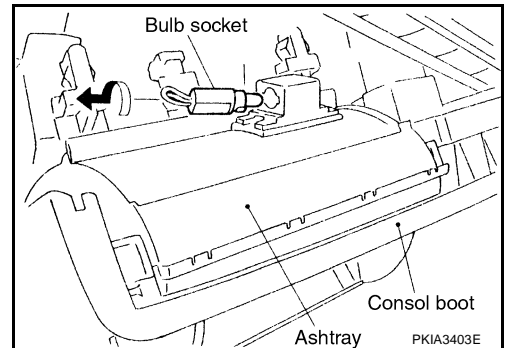

Bulb Replacement, Removal and Installation (A/T)

AKS00A23

1. Remove console finisher (A/T). Refer to [IP-10, "INSTRUMENT PANEL ASSEMBLY"](#) in "IP" section.
2. Remove instrument panel ashtray. Refer to [IP-10, "INSTRUMENT PANEL ASSEMBLY"](#) in "IP" section.
3. Use a screwdriver to undo ashtray finisher hooks.
4. Turn bulb socket on circuit board to left to undo lock. Remove bulb socket.

Ashtray illumination : 12V - 1.4W

5. Install in the reverse order of removal.

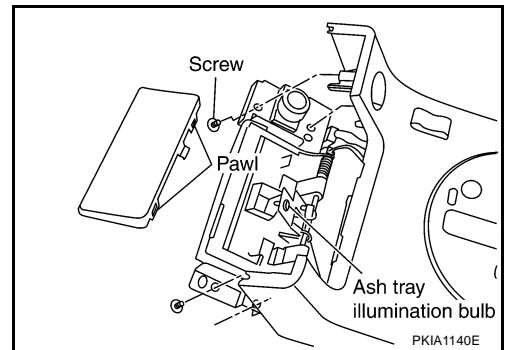
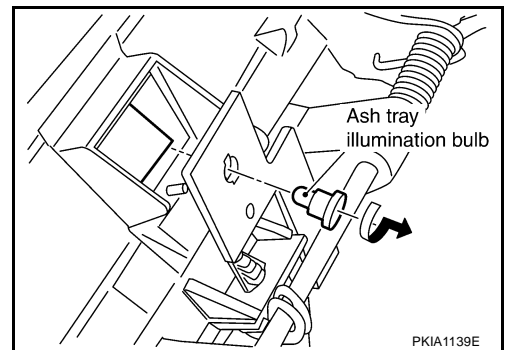

CIGARETTE LIGHTER ILLUMINATION

CIGARETTE LIGHTER ILLUMINATION

PFP:25331

Removal and Installation

AKS00A24

1. Remove instrument side panel. Refer to [IP-10, "INSTRUMENT PANEL ASSEMBLY"](#) in "IP" section.
2. Open hooks and remove bulb socket.

Cigarette lighter illumination : 12V - 1.4W

CAUTION:

When replacing bulb, replace assembly together with illumination ring.

3. Install in the reverse order of removal.

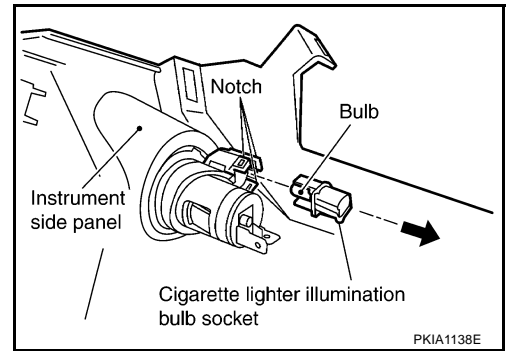

INTERIOR ROOM LAMP

INTERIOR ROOM LAMP

PFP:26410

Component Parts and Harness Connector Location

AKS009XL

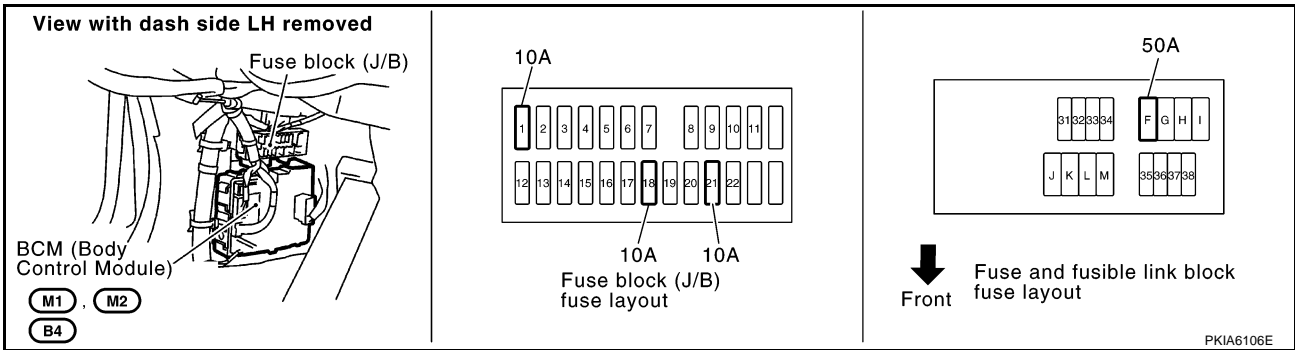

System Description

AKS009XM

When map lamp switch is in DOOR position, map lamp ON/OFF is controlled by timer according to signals from switches including key switch, front door switch driver side, unlock signal from keyfob, door lock and unlock switch, key cylinder lock and unlock switch, ignition switch.

When map lamp turns ON, there is a gradual brightening over 1 second. When map lamp turns OFF, there is a gradual dimming over 1 second.

The map lamp timer is controlled by the BCM (body control module).

Map lamp timer control settings can be changed with CONSULT-II.

Ignition keyhole illumination turns ON at time when driver door is opened (door switch ON) or removed keyfob from key cylinder. Illumination turns OFF when driver door is closed (door switch OFF).

Step lamp turns ON at time when driver door or passenger door is opened (door switch ON). Lamp turns OFF when driver, passenger doors are closed (all door switches OFF).

POWER SUPPLY AND GROUND

Power is supplied at all times

- through 10A fuse [No. 21, located in fuse block (J/B)]
- to key switch terminal 2
- through 10A fuse [No. 18, located in fuse block (J/B)]
- to BCM (body control module) terminal 42
- through 50A fusible link [letter F, located in fuse and fusible link block]
- to BCM (body control module) terminal 55.

When the key plate inserted to key switch, power is supplied

- through the key switch terminal 1
- to BCM (body control module) terminal 37.

With the ignition switch in the ON or START position, power is supplied

- through 10A fuse [No. 1, located in fuse block (J/B)]
- to BCM (body control module) terminal 38.

Ground is supplied

- to BCM (body control module) terminal 52
- through grounds terminals M30 and M66.

When the driver side door is opened, ground is supplied

- through case ground of driver side door switch
- to BCM (body control module) terminal 62 and
- to combination meter terminal 7 (with navigation system).

When the passenger side door is opened, ground is supplied

- through case ground of passenger side door switch
- to BCM (body control module) terminal 12 and
- to combination meter terminal 6 (with navigation system).

When the driver side door is unlocked by the door lock and unlock switch, BCM (body control module) receives a ground signal

A
B
C
D
E
F
G
H
I
J
LT
L
M

INTERIOR ROOM LAMP

- through grounds terminals M30 and M66
- to power window main switch (door lock and unlock switch) terminal 15 or power window sub-switch (door lock and unlock switch) terminal 11
- from power window main switch (door lock and unlock switch) terminal 12 or power window sub-switch (door lock and unlock switch) terminal 16
- to BCM (body control module) terminal 22.

When the front driver side door is unlocked by the driver side door lock assembly (door key cylinder switch), BCM (body control module) receives a ground signal

- through grounds M30 and M66
- to driver side door lock assembly (door key cylinder switch) terminal 5
- from driver side door lock assembly (door key cylinder switch) terminal 6
- to power window main switch (door lock and unlock switch) terminal 7
- from power window main switch (door lock and unlock switch) terminal 12
- to BCM (body control module) terminal 22.

When a signal, or combination of signals is received by BCM (body control module), ground is supplied

- through BCM (body control module) terminal 48
- to map lamp terminal 2.

With power and supplied, the interior lamp illuminates.

SWITCH OPERATION

When driver door switch is ON (door is opened), ground is supplied

- through BCM terminal 1
- to ignition keyhole illumination terminal 2.

And power is supplied

- from BCM terminal 41
- to ignition keyhole illumination terminal 1.

When any door switch is ON (door is opened), ground is supplied

- through BCM terminal 47
- to step lamp (driver side) and step lamp (passenger side) terminal 2.

And power is supplied

- from BCM terminal 41
- to step lamp (driver side) and step lamp (passenger side) terminal 1.

When map lamp switch is ON, ground is supplied

- through grounds M30 and M66
- to map lamp terminal 1.

And power is supplied

- from BCM terminal 41
- to map lamp terminal 3.

When vanity mirror lamp (driver side and passenger side) is ON, ground is supplied

- through grounds M30 and M66
- to vanity mirror lamp (driver side and passenger side) terminal 2.

And power is supplied

- from BCM terminal 41
- to vanity mirror lamp (driver side and passenger side) terminal 1.

ROOM LAMP TIMER OPERATION

When map lamp switch is in DOOR position, and when all conditions below are met, BCM performs timer control (maximum 30 seconds) for interior room lamp and map lamp ON/OFF.

In addition, when spot turns ON or OFF there is gradual brightening or dimming over 1 second.

Power is supplied

- to 10A fuse [No. 21, located in fuse block (J/B)]

INTERIOR ROOM LAMP

- through key switch terminal 2.

Key is removed from ignition key cylinder (key switch OFF), power will not be supplied to BCM terminal 37.
Ground is supplied

- from BCM terminal 22
- to power window main switch (door lock and unlock switch) terminal 12.

At the time that driver door are opened, BCM detects that driver door is unlocked. It determines that map lamp timer operation conditions are met, and turns the lamp ON for 30 seconds.

Key is in ignition key cylinder (key switch ON),
Power is supplied

- through key switch terminal 1
- to BCM terminal 37.

When key is removed from key switch (key switch OFF), power supply to BCM terminal 37 is terminated. BCM detects that key has been removed, determines that map lamp timer conditions are met, and turns map lamp ON for 30 seconds.

When driver door opens → closes, and the key is not inserted in the key switch (key switch OFF), BCM terminal 62 changes between 0V (door open) → 12V (door closed). The BCM determines that conditions for map lamp operation is met and turns the map lamp ON for 30 seconds.

Timer control is canceled under the following conditions.

- Driver door is locked [when locked power window main switch (door lock and unlock switch), door key cylinder switch].
- Driver door is opened (driver door switch turns ON).
- Ignition switch ON.

INTERIOR LAMP BATTERY SAVER CONTROL

If interior lamp is left "ON", it will not be turned out even when door is closed.

BCM turns off interior lamp automatically to save battery 30 minutes after ignition switch is turned off.

BCM controls interior lamps listed below

- Trunk room lamp
- Vanity mirror lamp
- Map lamp
- Step lamp

After lamps turn OFF by the battery saver system, the lamps illuminate again when

- signal from power window main switch (door lock and unlock switch) or key cylinder is locked or unlocked,
- door is opened or closed,
- key is removed from ignition key cylinder or inserted in ignition key cylinder.

Interior lamp battery saver control period can be changed by the function setting of CONSULT-II.

A
B
C
D
E
F
G
H
I
J
LT
L
M

INTERIOR ROOM LAMP

Schematic

AKS009XN

(WN) : With navigation system
 (VN) : With vanity mirror lamp

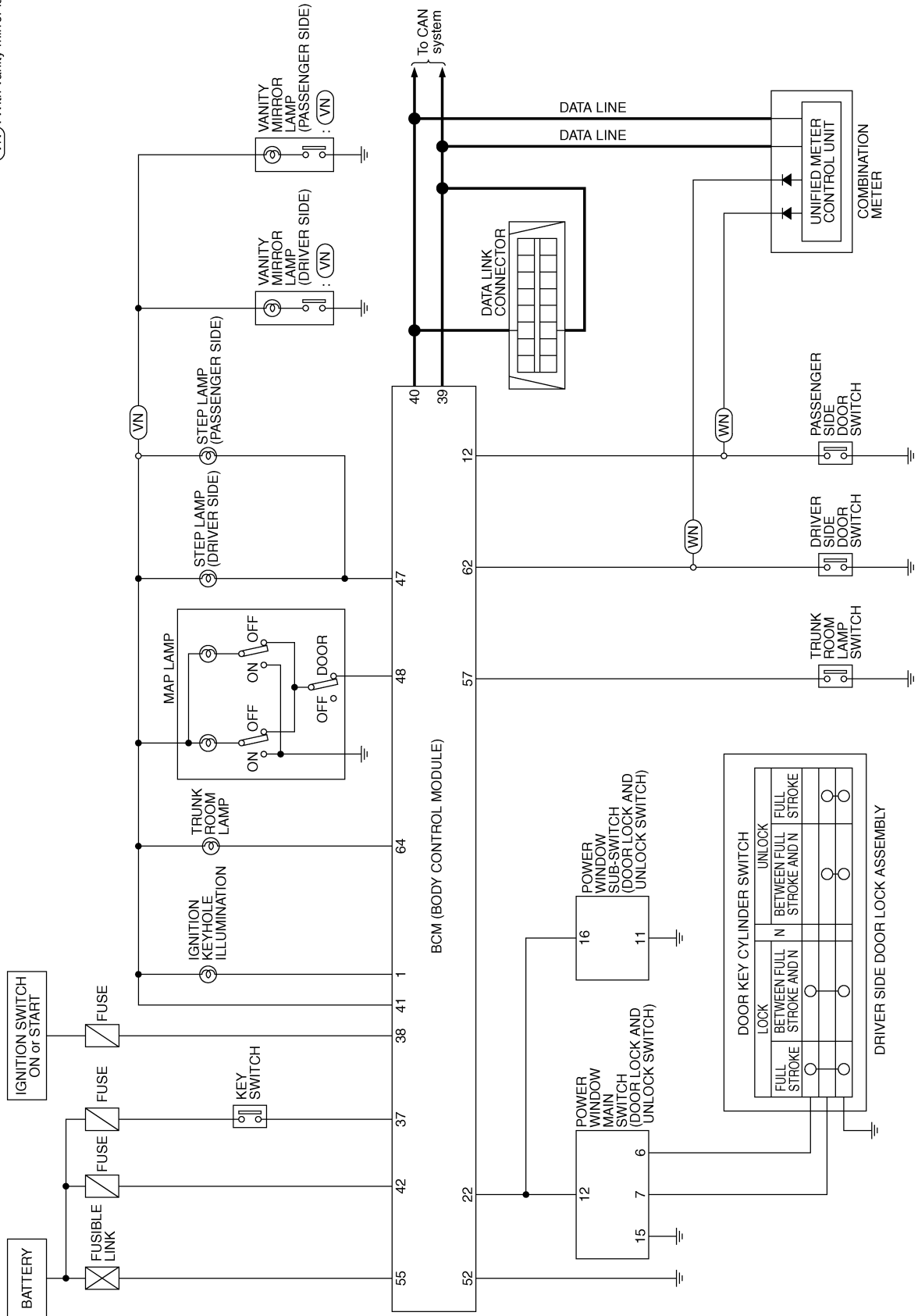

TKWM0882E

INTERIOR ROOM LAMP

Wiring Diagram — ROOM/L —

AKS009XO

LT-ROOM/L-01

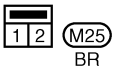
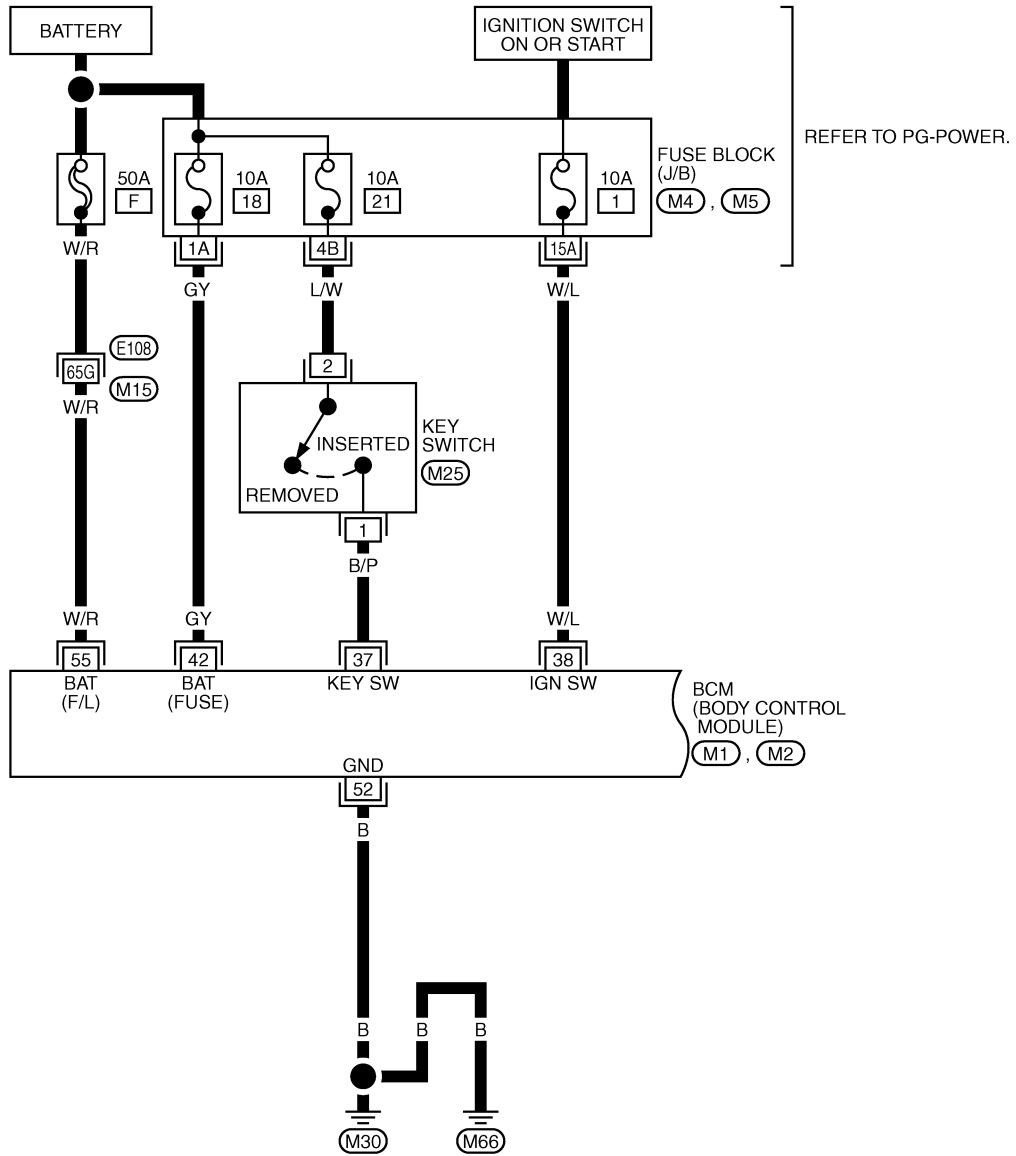

REFER TO THE FOLLOWING.

- (E108) -SUPER MULTIPLE JUNCTION (SMJ)
- (M4), (M5) -FUSE BLOCK-JUNCTION BOX (J/B)
- (M1), (M2) -ELECTRICAL UNITS

A
B
C
D
E
F
G
H
I
J
LT
L
M

TKWM0883E

INTERIOR ROOM LAMP

LT-ROOM/L-02

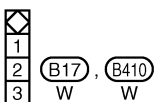
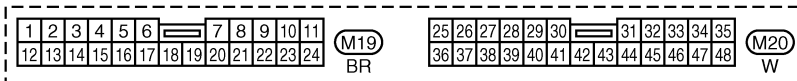
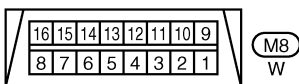
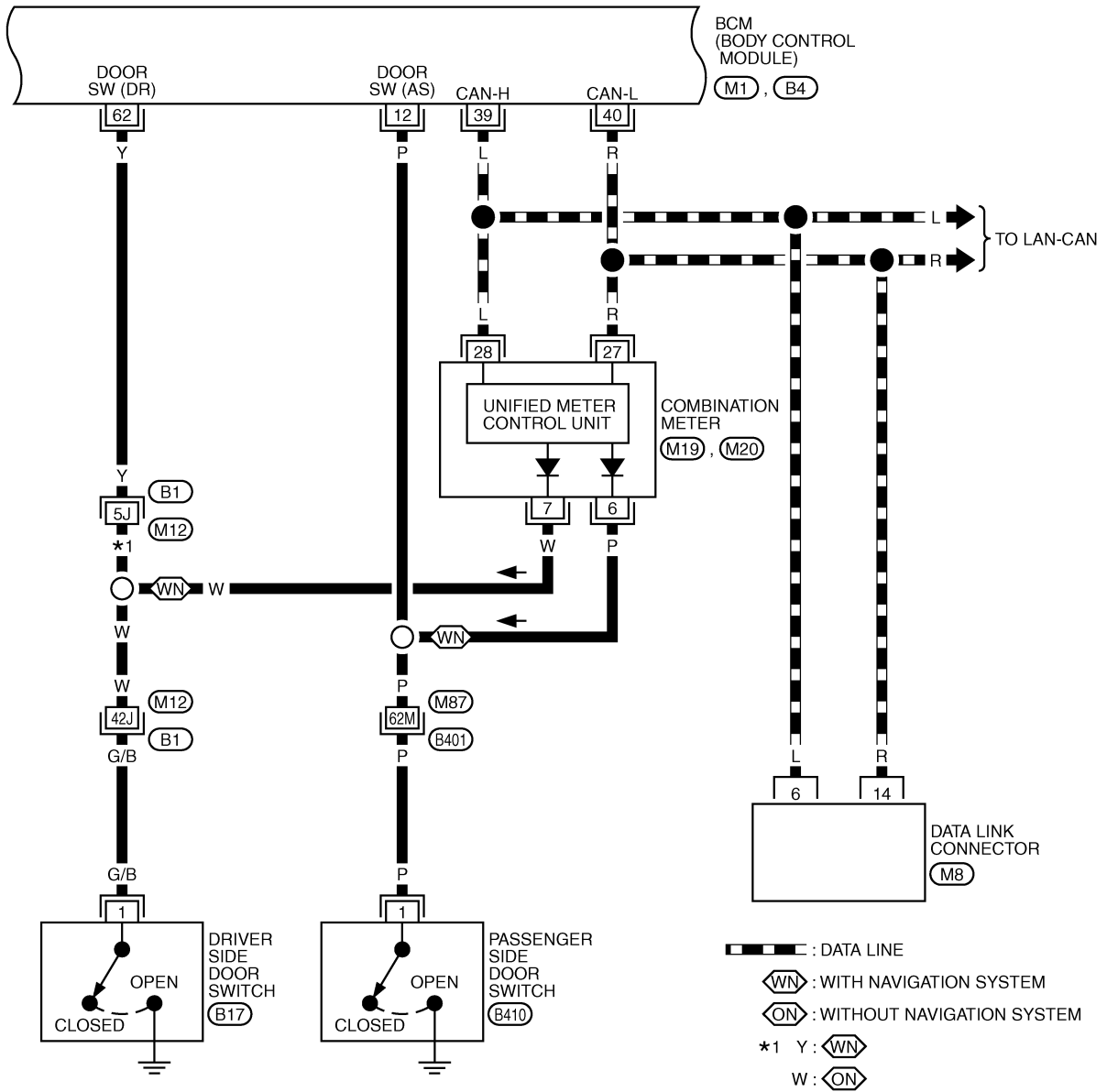

REFER TO THE FOLLOWING.
 (B1), (B401) -SUPER MULTIPLE JUNCTION (SMJ)
 (M1), (B4) -ELECTRICAL UNITS

INTERIOR ROOM LAMP

LT-ROOM/L-03

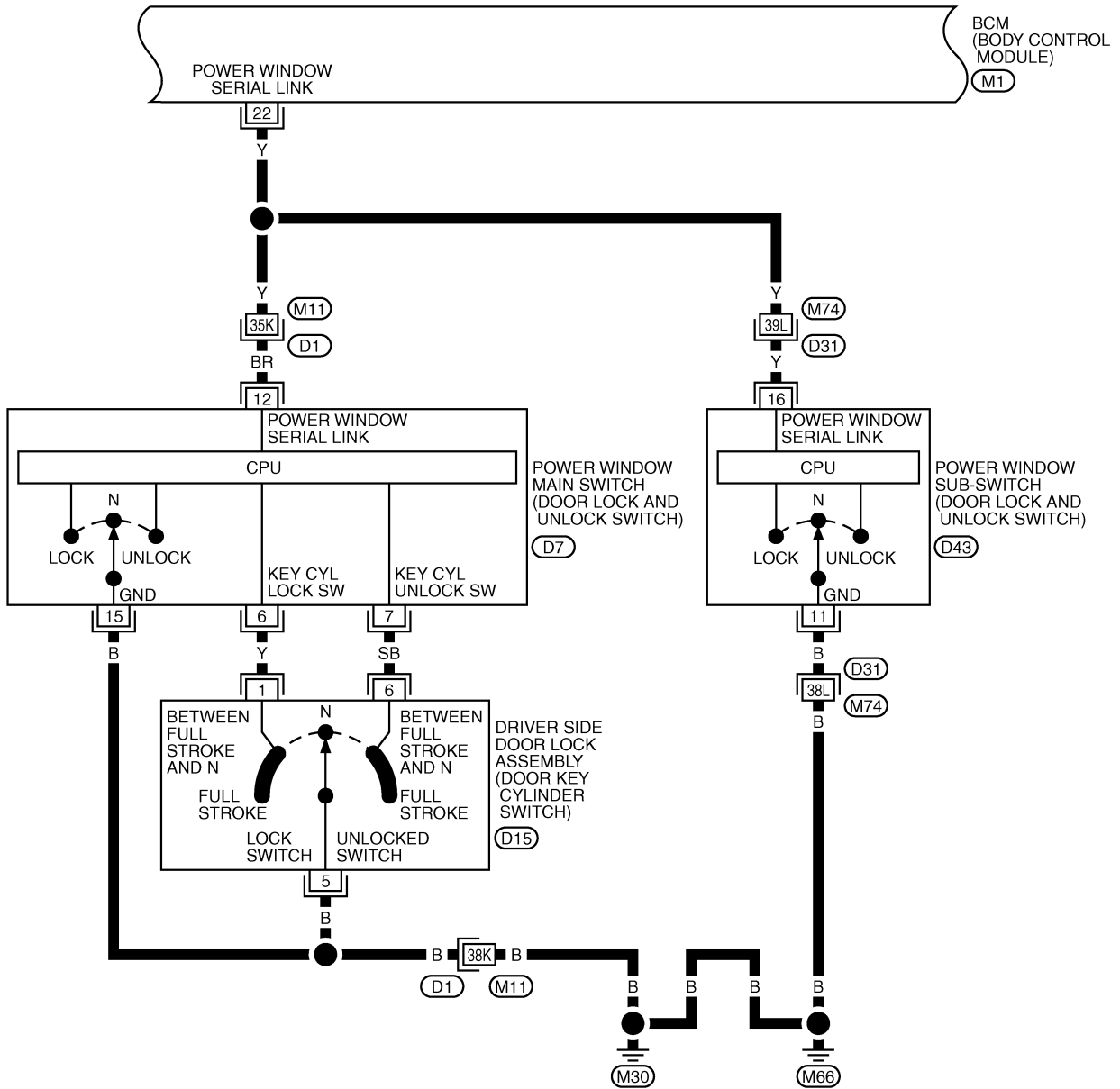

7	6	5	4	3	2	1
16	15	14	13	12	11	10

(D7), (D43) W W
 (6 5 4 3 2 1) (D15) B

REFER TO THE FOLLOWING.
 (D1), (D31) -SUPER MULTIPLE JUNCTION (SMJ)
 (M1) -ELECTRICAL UNITS

INTERIOR ROOM LAMP

LT-ROOM/L-04

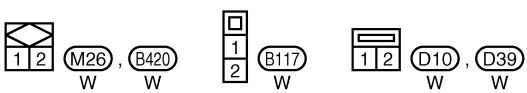
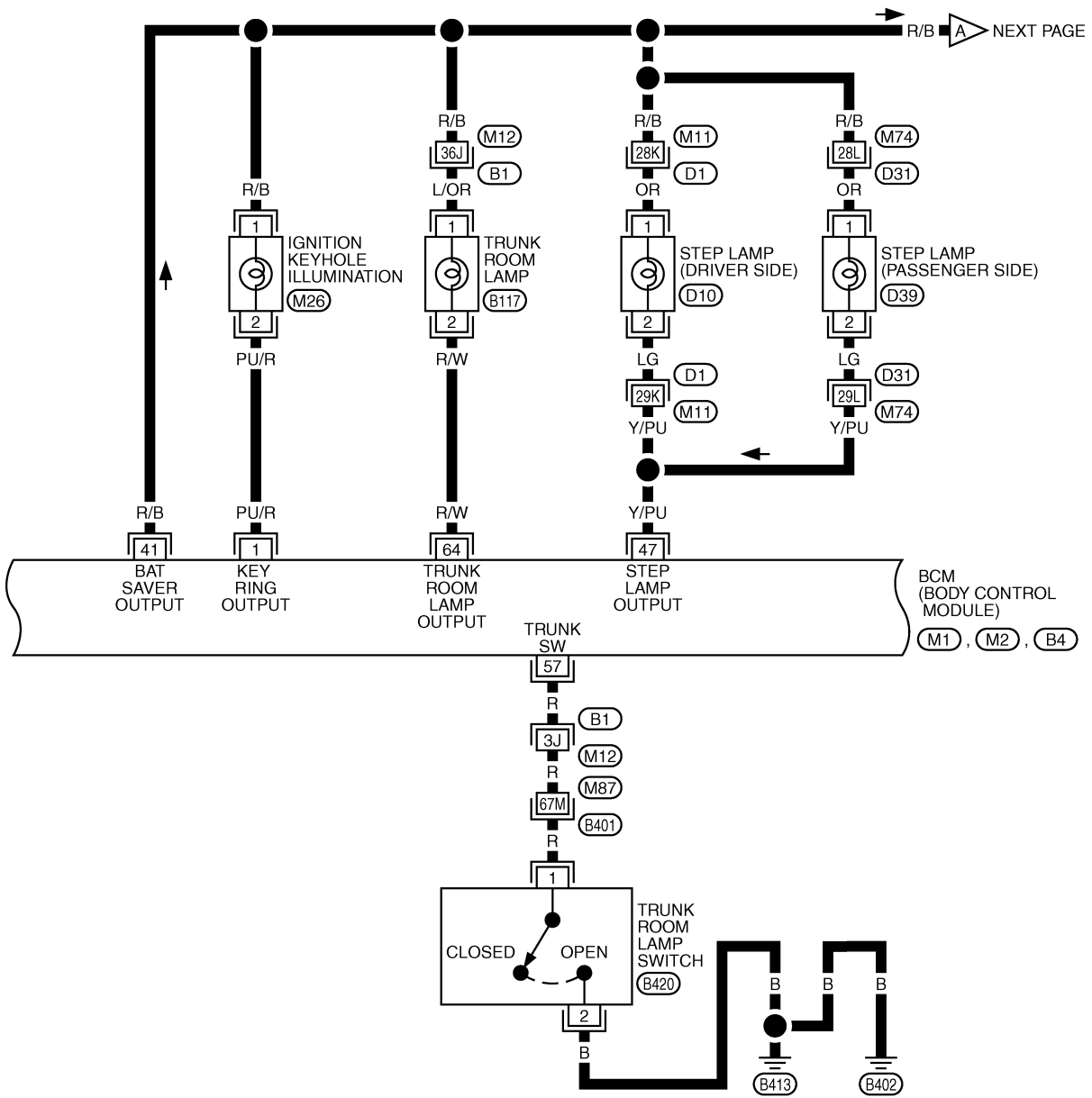

REFER TO THE FOLLOWING.

(B1), (B401), (D1), (D31)
 -SUPER MULTIPLE JUNCTION (SMJ)

(M1), (M2), (B4)
 -ELECTRICAL UNITS

INTERIOR ROOM LAMP

LT-ROOM/L-05

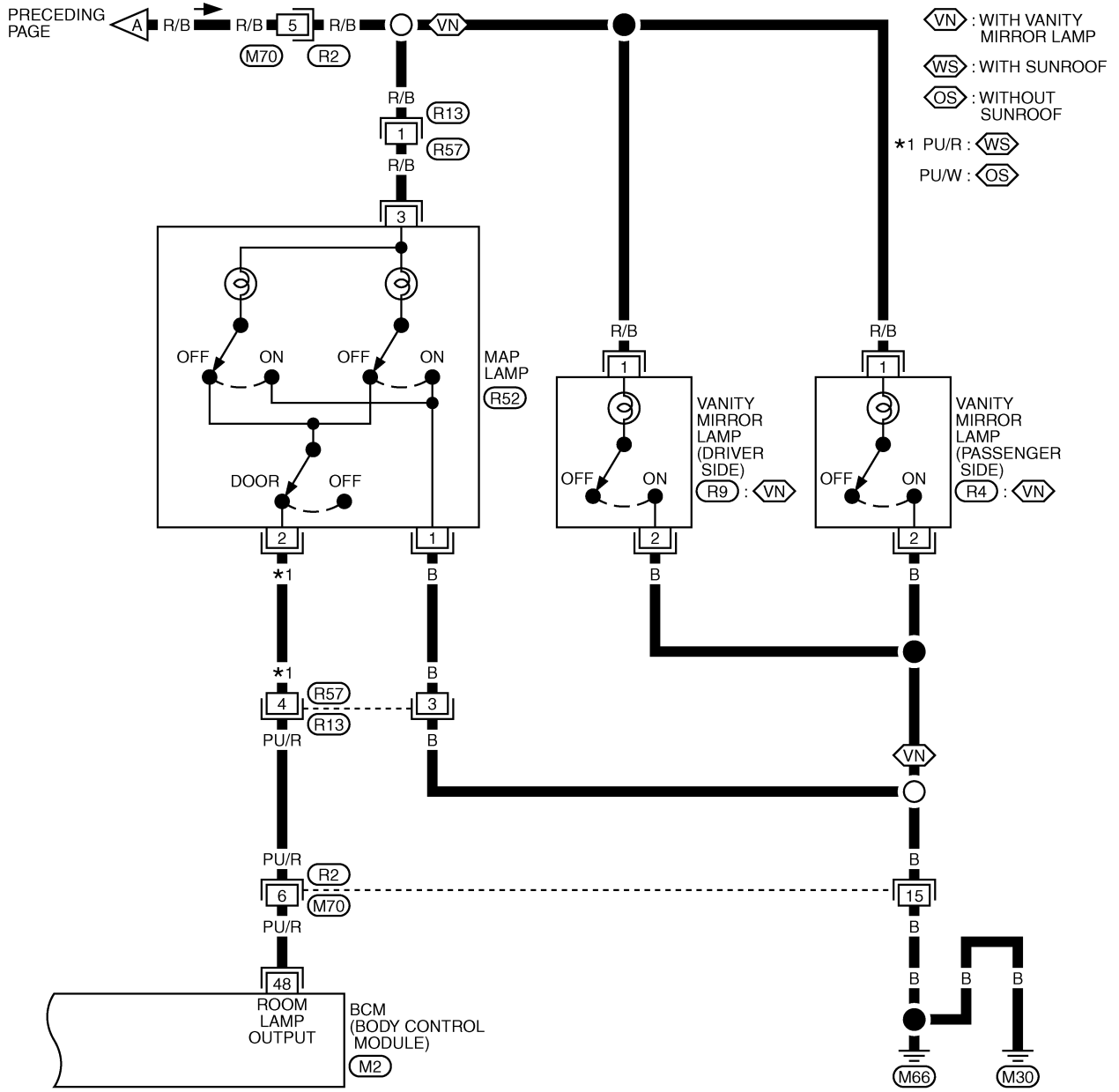

A
B
C
D
E
F
G
H
I
J
K
L
M

LT

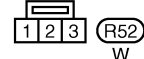
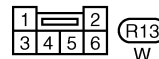
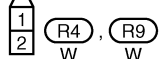
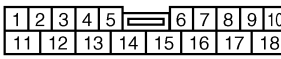

REFER TO THE FOLLOWING.
⬡M2 -ELECTRICAL UNITS

INTERIOR ROOM LAMP

Terminals and Reference Values for BCM

AKS009XP

Terminal No.	Wire color	Signal name	Measuring condition			Reference value
			Ignition switch	Operation or condition		
1	PU/R	Ignition keyhole illumination signal	OFF	Door is locked. (SW OFF)		Battery voltage
				Door is unlocked. (SW ON)		Approx. 0V
12	P	Front door switch AS signal	OFF	Front door switch AS	ON (open)	Approx. 0V
					OFF (closed)	Battery voltage
22	Y	Power window switch serial link	—	—		<p style="text-align: right; font-size: small;">P1IA2344J</p>
37	B/P	Key-in detection switch signal	OFF	Vehicle key is removed.		Approx. 0V
				Vehicle key is inserted.		Battery voltage
38	W/L	Ignition power supply	ON	—		Battery voltage
39	L	CAN-H	—	—		—
40	R	CAN-L	—	—		—
41	R/B	Battery saver output signal	OFF	30 minutes after ignition switch is turned to OFF.		Approx. 0V
			ON	—		Battery voltage
42	GY	Battery power supply	OFF	—		Battery voltage
47	Y/PU	Step lamp signal	OFF	Any door is open. (ON)		Approx. 0V
				All doors are closed. (OFF)		Battery voltage
48	PU/R	Interior room lamp, map lamp and front door inside handle illumination output signal	OFF	Interior door switch: DOOR position	Any door switch ON (open)	Approx. 0V
					Any door switch OFF (closed)	Battery voltage
52	B	Ground	ON	—		Approx. 0V
55	W/R	Battery power supply	OFF	—		Battery voltage
57	R	Trunk room lamp switch signal	OFF	Trunk room lamp switch	ON (open)	Approx. 0V
					OFF (closed)	Battery voltage
62	Y	Front door switch DR signal	OFF	Front door switch DR	ON (open)	Approx. 0V
					OFF (closed)	Battery voltage
64	R/W	Trunk room lamp switch signal	OFF	Trunk room lamp switch	ON (open)	Approx. 0V
					OFF (closed)	Battery voltage

How to Proceed With Trouble Diagnosis

AKS009XQ

1. Confirm the symptom or customer complaint.
2. Understand operation description and function description. Refer to [LT-163, "System Description"](#) .
3. Perform the preliminary check. Refer to [LT-173, "Preliminary Check"](#) .
4. Check symptom and repair or replace the cause of malfunction.
5. Does the interior room lamp operate normally? If YES: GO TO 6. If NO: GO TO 4.
6. INSPECTION END

INTERIOR ROOM LAMP

AKS009XR

Preliminary Check CHECK FOR POWER SUPPLY AND GROUND CIRCUIT

1. CHECK FUSES

- Check for blown BCM fuses.

Unit	Power source	Fuse and fusible link No.
BCM	Battery	F
		18
		21
	Ignition switch ON or START position	1

Refer to [LT-167, "Wiring Diagram — ROOM/L —"](#).

OK or NG

OK >> GO TO 2.

NG >> If fuse is blown, be sure to eliminate cause of malfunction before installing new fuse. Refer to [PG-4, "POWER SUPPLY ROUTING CIRCUIT"](#).

2. CHECK POWER SUPPLY CIRCUIT

1. Turn ignition switch OFF.
2. Disconnect BCM connector.
3. Check voltage between BCM connector and ground.

Terminals		(-)	Ignition switch position	
(+) Connector Terminal (Wire color)			OFF	ON
M2	42 (GY)	Ground	Battery voltage	Battery voltage
	55 (W/R)		Battery voltage	Battery voltage
M1	38 (W/L)		0V	Battery voltage

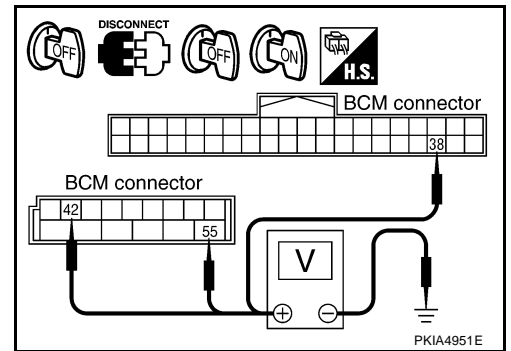

OK or NG

OK >> GO TO 3.

NG >> Check harness for open or short between BCM and fuse.

3. CHECK GROUND CIRCUIT

Check continuity between BCM and ground.

Terminals		Ground	Continuity
Connector	Terminal (Wire color)		
M2	52 (B)	Ground	Yes

OK or NG

OK >> INSPECTION END

NG >> Check harness ground circuit.

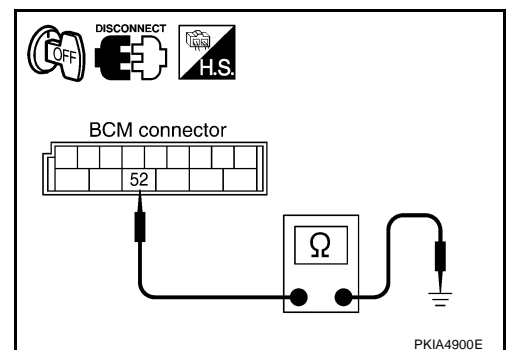

INTERIOR ROOM LAMP

CONSULT-II Functions

AKS009XS

CONSULT-II performs the following function communicating with BCM.

BCM diagnosis part	Check item, diagnosis mode	Description
INTERIOR LAMP	WORK SUPPORT	Changes the setting for each function.
	DATA MONITOR	Displays BCM input data in real time.
	ACTIVE TEST	Operation of electrical loads can be checked by sending driving signal to them.

CONSULT-II BASIC OPERATION

CAUTION:

If CONSULT-II is used with no connection of CONSULT-II CONVERTER, malfunctions might be detected in self-diagnosis depending on control unit which carry out CAN communication.

1. With the ignition switch OFF, connect CONSULT-II and CONSULT-II CONVERTER to the data link connector, then turn ignition switch ON.

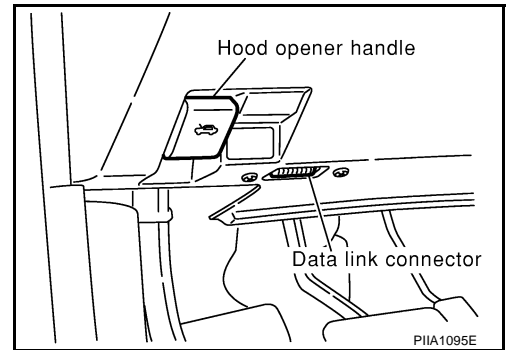

2. Touch "START (NISSAN BASED VHCL)".

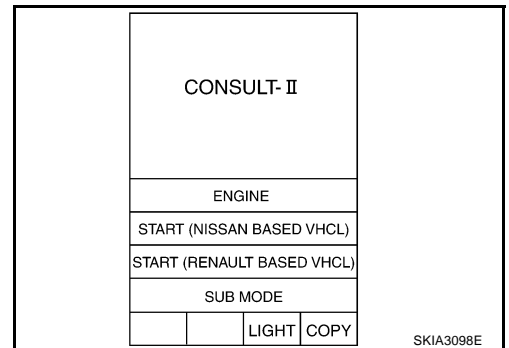

3. Touch "BCM" on "SELECT SYSTEM" screen. If "BCM" is not indicated, refer to [GI-39, "CONSULT-II Data Link Connector \(DLC\) Circuit"](#).

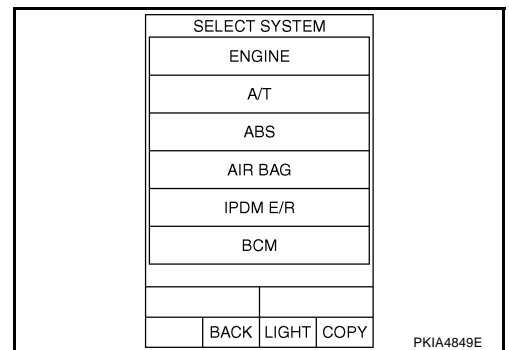

INTERIOR ROOM LAMP

4. Touch "INT LAMP" on "SELECT TEST ITEM" screen.

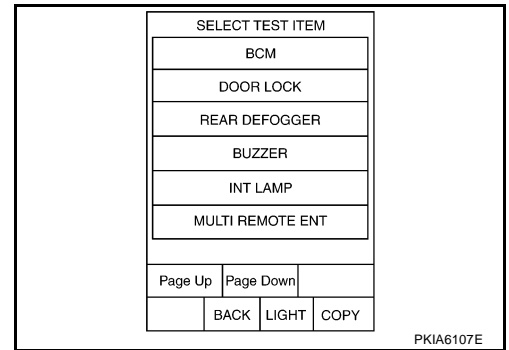

A
B
C
D
E
F
G
H
I
J
LT
L
M

WORK SUPPORT

Operation Procedure

1. Touch "INT LAMP" on "SELECT TEST ITEM" screen.
2. Touch "WORK SUPPORT" on "SELECT DIAG MODE" screen.
3. Touch "SET I/L D- UNLCK INTCON" on "SELECT WORK ITEM" screen.
4. Touch "START".
5. Touch "CHANGE SETT".
6. The setting will be changed and "CUSTOMIZING COMPLETED " will be displayed.
7. Touch "END".

Display Item List

Item	Description	CONSULT-II
SET I/L D-UNLCK INTCON	The 30 seconds glowing function the interior room lamps and the ignition keyhole illumination can be selected when driver door is released (unlocked).	ON/OFF
ROOM LAMP ON TIME SET	The time in order to escalate illumination can be adjusted when the interior room lamps and the ignition keyhole illumination is turned on.	MODE 1 - 7
ROOM LAMP OFF TIME SET	The time in order to diminish illumination can be adjusted when the interior room lamps and the ignition keyhole illumination is turned off.	MODE 1 - 7

Reference between "MODE" and "TIME" for "TURN ON/OFF"

MODE	1	2	3	4	5	6	7
Time (sec.)	0.5	1	2	3	4	5	0

DATA MONITOR

Operation Procedure

1. Touch "INT LAMP" on "SELECT TEST ITEM" screen.
2. Touch "DATA MONITOR" on "SELECT DIAG MODE" screen.
3. Touch either "ALL SIGNALS" or "SELECTION FROM MENU" on "DATA MONITOR" screen.

ALL SIGNALS	Monitors all the signals.
SELECTION FROM MENU	Selects and monitors the individual signal.

4. Touch "START".
5. When "SELECTION FROM MENU" is selected, touch items to be monitored. When "ALL SIGNALS" is selected, all the items will be monitored.
6. Touch "RECORD" while monitoring, then the status of the monitored item can be recorded. To stop recording, touch "STOP".

Display Item List

Monitor item	Contents
IGN ON SW "ON/OFF"	Displays "IGN position (ON)/OFF, ACC position (OFF)" judged from the ignition switch signal.
KEY ON SW "ON/OFF"	Displays "Key inserted (ON)/key removed (OFF)" status judged from the key switch signal.

INTERIOR ROOM LAMP

Monitor item	Contents
DOOR SW - DR "ON/OFF"	Displays status of the driver door as judged from the driver door switch signal. (Door is open: ON/Door is closed: OFF)
DOOR SW - AS "ON/OFF"	Displays "Door open (ON)/Door closed (OFF)" status, determined from passenger door switch signal.
DOOR SW - RR ^{NOTE} "OFF"	—
DOOR SW - RL ^{NOTE} "OFF"	—
BACK DOOR SW ^{NOTE} "OFF"	—
KEY CYL LK - SW "ON/OFF"	Displays "Door locked (ON) status, determined from key cylinder lock switch in driver door.
KEY CYL UN - SW "ON/OFF"	Displays "Door unlocked (OFF) status, determined from key cylinder lock switch in driver door.
CDL LOCK SW "ON/OFF"	Displays "Door locked (ON)/Door unlocked (OFF) status, determined from locking detection switch in driver door.
CDL UNLOCK SW "ON/OFF"	Displays "Door unlocked (OFF)" status, determined from locking detection switch in passenger door.
KEYLESS LOCK "ON/OFF"	Displays "Locked (ON)/Other (OFF)" status, determined from lock signal.
KEYLESS UNLOCK "ON/OFF"	Displays "Unlocked (ON)/Other (OFF)" status, determined from unlock signal.

NOTE:

This item is displayed, but cannot monitor it.

ACTIVE TEST

Operation Procedure

1. Touch "INT LAMP" on "SELECT TEST ITEM" screen.
2. Touch "ACTIVE TEST" on "SELECT DIAG MODE" screen.
3. Touch item to be tested and check operation of the selected item.
4. During the operation check, touching "BACK" deactivates the operation.

Display Item List

Test item	Description
INT LAMP	Map lamp can be operated by any ON-OFF operations.
IGN ILLUM	Ignition key hole illumination can be operated by ON- OFF operation.

Map Lamp Control Does Not Operate

AKS009XU

1. CHECK EACH SWITCH

Select "BCM" on CONSULT-II. With "INT LAMP" data monitor, make sure switches listed in display item list turn ON-OFF linked with switch operation. Refer to [LT-175, "Display Item List"](#) for switches and their functions.

OK or NG

- OK >> GO TO 2.
 NG >> Inspect malfunctioning switch system.

DATA MONITOR			
MONITOR		NO DTC	
IGN ON SW		ON	
KEY ON SW		ON	
DOOR SW-DR		ON	
DOOR SW-AS		OFF	
DOOR SW-RR		OFF	
DOOR SW-RL		OFF	
BACK DOOR SW		OFF	
KEY CYL LK-SW		OFF	
KEY CYL UN-SW		OFF	
		Page Down	
RECORD			
MODE	BACK	LIGHT	COPY

PKIA6365E

INTERIOR ROOM LAMP

2. ACTIVE TEST

1. Select "BCM" on CONSULT-II. Select "INT LAMP" active test.
2. When map lamp switch is in "DOOR" position, use active test to make sure map lamp operates.

Map lamp should operate.

OK or NG

- OK >> Replace BCM. Refer to [BCS-15, "Removal and Installation of BCM"](#).
- NG >> GO TO 3.

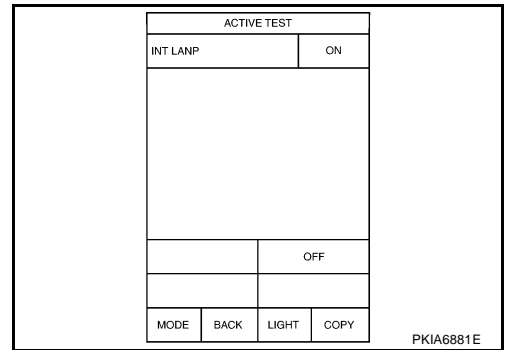

3. CHECK MAP LAMP INPUT

1. Turn ignition switch OFF.
2. Check voltage between map lamp harness connector R52 terminal 2 (PU/R)*1 or (PU/W)*2 and ground.

2 (PU/R)*1 or (PU/W)*2 – Ground

: Battery voltage should exist.

*1: with sunroof, *2: without sunroof

OK or NG

- OK >> GO TO 6.
- NG >> GO TO 4.

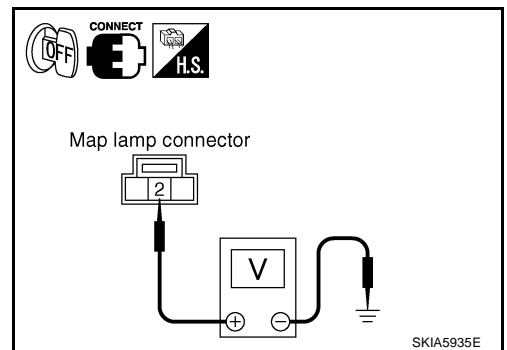

4. CHECK MAP LAMP

1. Disconnect map lamp connector.
2. Check continuity between map lamp.

Terminal		Condition	Continuity
Map lamp			
2	3	Map lamp switch is DOOR.	Yes
		Map lamp switch is ON.	No

OK or NG

- OK >> GO TO 5.
- NG >> Replace Map lamp.

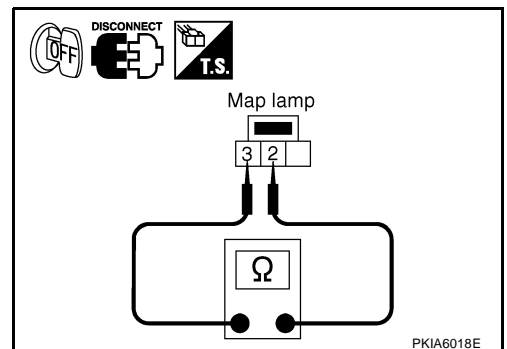

5. CHECK MAP LAMP CIRCUIT

1. Disconnect BCM connector and map lamp connector.
2. Check continuity between BCM harness connector M2 terminal 41 (R/B) and map lamp harness connector R52 terminal 3 (R/B).

41 (R/B) – 3 (R/B) : Continuity should exist.

OK or NG

- OK >> Replace BCM if map lamp does not work after setting the connector again. Refer to [BCS-15, "Removal and Installation of BCM"](#).
- NG >> Repair harness or connector.

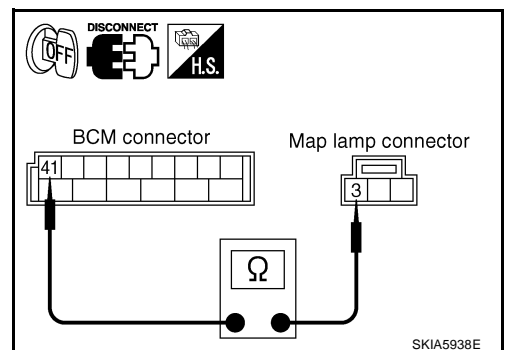

INTERIOR ROOM LAMP

6. CHECK MAP LAMP CIRCUIT

1. Disconnect BCM connector.
2. Check continuity between BCM harness connector M2 terminal 48 (PU/R) and map lamp harness connector R52 terminal 2 (PU/R)*¹ or (PU/W)*².

48 (PU/R) – 2 (PU/R)*¹ or (PU/W)*²
: Continuity should exist.

*1: with sunroof, *2: without sunroof

OK or NG

- OK >> Replace BCM if map lamp does not work after setting the connector again. Refer to [BCS-15, "Removal and Installation of BCM"](#).
- NG >> Repair harness or connector.

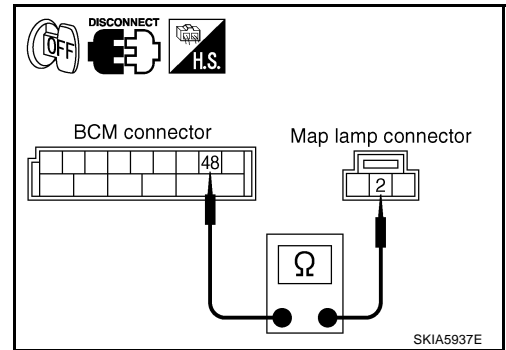

Ignition Key Hole Illumination Control Does Not Operate

AKS009XW

1. CHECK EACH SWITCH

Select "BCM" on CONSULT-II. With "INT LAMP" data monitor, make sure switches listed in display item list turn ON-OFF linked with switch operation. Refer to [LT-175, "Display Item List"](#) for switches and their functions.

OK or NG

- OK >> GO TO 2.
- NG >> Inspect malfunctioning switch system.

DATA MONITOR			
MONITOR		NO DTC	
IGN ON SW		ON	
KEY ON SW		ON	
DOOR SW-DR		ON	
DOOR SW-AS		OFF	
DOOR SW-RR		OFF	
DOOR SW-RL		OFF	
BACK DOOR SW		OFF	
KEY CYL LK-SW		OFF	
KEY CYL UN-SW		OFF	
Page Down			
RECORD			
MODE	BACK	LIGHT	COPY

PKIA6365E

2. ACTIVE TEST

1. Select "BCM" on CONSULT-II. Select "INT LAMP".
2. Select "IGN ILLUM" active test to make sure lamp operates.

Ignition key hole illumination should operate.

OK or NG

- OK >> Replace BCM. Refer to [BCS-15, "Removal and Installation of BCM"](#).
- NG >> GO TO 3.

ACTIVE TEST	
IGN ILLUM	ON
OFF	
MODE	BACK
LIGHT	COPY

PKIA6375E

3. CHECK IGNITION KEY HOLE ILLUMINATION INPUT

1. Turn ignition switch OFF.
2. Check voltage between ignition key hole illumination harness connector M26 terminal 1 (R/B) and ground.

1 (R/B) – Ground : Battery voltage should exist.

OK or NG

- OK >> GO TO 4.
- NG >> GO TO 6.

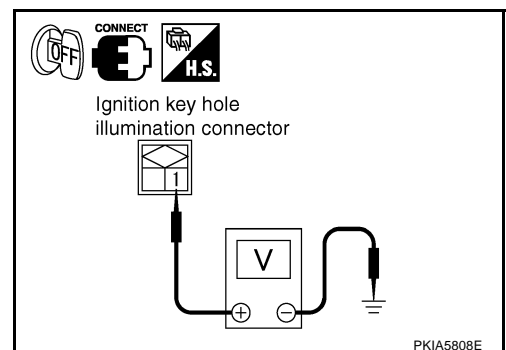

INTERIOR ROOM LAMP

4. CHECK IGNITION KEY HOLE ILLUMINATION BULB

1. Disconnect ignition key hole illumination connector.
2. Check continuity between ignition key hole illumination terminal 1 and 2.

1 – 2 : Continuity should exist.

OK or NG

OK >> GO TO 5.

NG >> Replace ignition key hole illumination. Refer to [LT-159, "Removal and Installation"](#) .

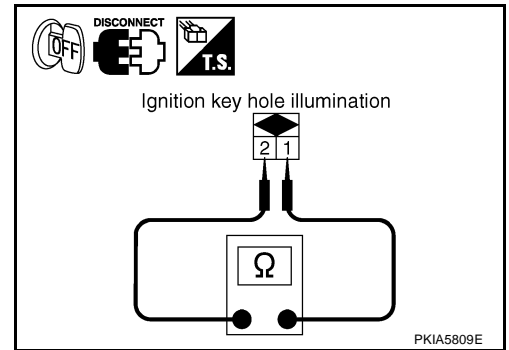

5. CHECK IGNITION KEY HOLE ILLUMINATION CIRCUIT

1. Disconnect BCM connector and key hole illumination connector.
2. Check continuity between BCM harness connector M1 terminal 1 (PU/R) and key hole illumination harness connector M26 terminal 2 (PU/R).

1 (PU/R) – 2 (PU/R) : Continuity should exist.

OK or NG

OK >> Replace BCM if ignition key hole illumination lamp does not work after setting the connector again. Refer to [BCS-15, "Removal and Installation of BCM"](#) .

NG >> Repair harness or connector.

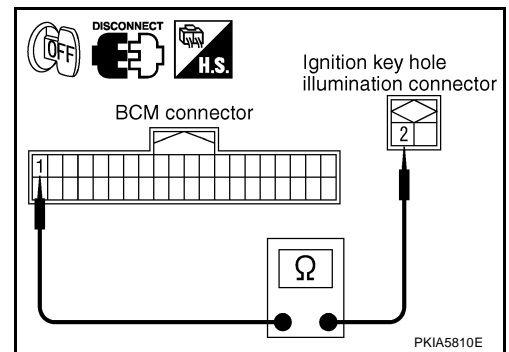

6. CHECK IGNITION KEY HOLE ILLUMINATION CIRCUIT

1. Disconnect BCM connector and key hole illumination connector.
2. Check continuity between BCM harness connector M2 terminal 41 (R/B) and key hole illumination harness connector M26 terminal 1 (R/B).

41 (R/B) – 1 (R/B) : Continuity should exist.

OK or NG

OK >> Replace BCM if ignition key hole illumination lamp does not work after setting the connector again. Refer to [BCS-15, "Removal and Installation of BCM"](#) .

NG >> Repair harness or connector.

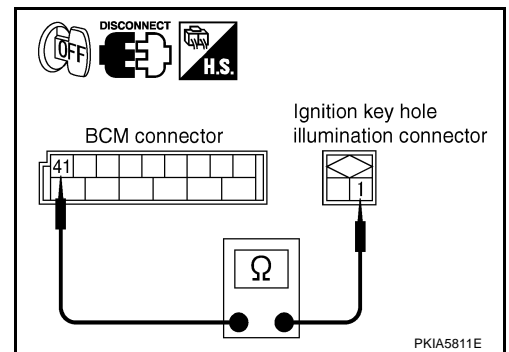

All Step Lamps Do Not Operate

1. CHECK EACH DOOR SWITCH

Select "BCM" on CONSULT-II. With "INT LAMP" data monitor, make sure switches listed below turn ON-OFF linked with switch operates.

Switch name	CONSULT screen
Driver side door switch	DOOR SW - DR
Passenger side door switch	DOOR SW - AS

OK or NG

OK >> GO TO 2.

NG >> Inspect malfunctioning switch system.

DATA MONITOR	
MONITOR	NO DTC
IGN ON SW	ON
KEY ON SW	ON
DOOR SW-DR	ON
DOOR SW-AS	OFF
DOOR SW-RR	OFF
DOOR SW-RL	OFF
BACK DOOR SW	OFF
KEY CYL LK-SW	OFF
KEY CYL UN-SW	OFF
Page Down	
RECORD	
MODE	BACK LIGHT COPY

INTERIOR ROOM LAMP

2. CHECK STEP LAMP INPUT

1. Turn ignition switch OFF.
2. Check voltage between front door driver side step lamp harness connector D10 terminal 1 (OR) and ground.

1 (OR) – Ground : Battery voltage should exist.

OK or NG

- OK >> GO TO 3.
NG >> GO TO 4.

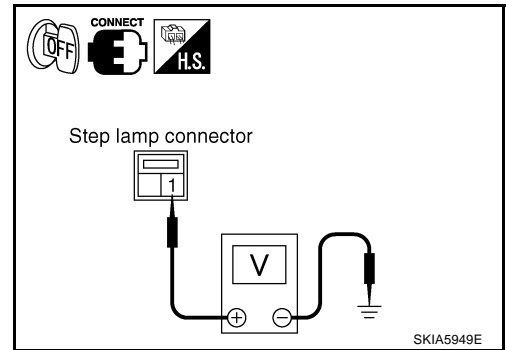

3. CHECK STEP LAMP CIRCUIT

1. Disconnect BCM connector and front door driver side step lamp connector.
2. Check continuity between BCM harness connector M2 terminal 47 (Y/PU) and front door driver side step lamp harness connector D10 terminal 2 (LG).

47 (Y/PU) – 2 (LG) : Continuity should exist.

OK or NG

- OK >> Replace BCM if step lamps does not work after setting the connector again. Refer to [BCS-15, "Removal and Installation of BCM"](#) .
- NG >> Repair harness or connector.

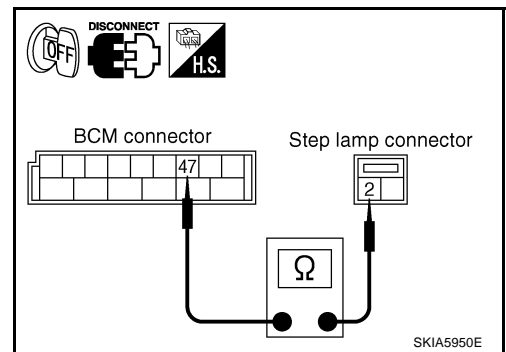

4. CHECK STEP LAMP CIRCUIT

1. Disconnect BCM connector and step lamp connector.
2. Check continuity between BCM harness connector M2 terminal 41 (R/B) and front door driver side step lamp harness connector D10 terminal 1 (OR).

41 (R/B) – 1 (OR) : Continuity should exist.

OK or NG

- OK >> Replace BCM if step lamps does not work after setting the connector again. Refer to [BCS-15, "Removal and Installation of BCM"](#) .
- NG >> Repair harness or connector.

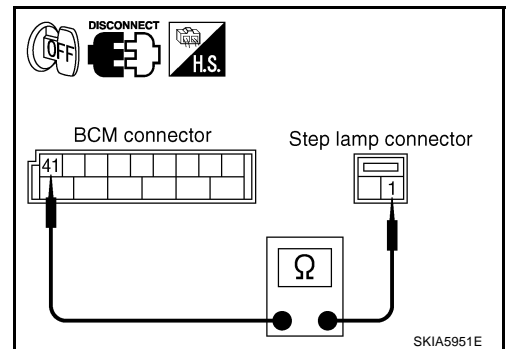

All Interior Room Lamps Do Not Operate

AKS009XY

1. CHECK POWER SUPPLY CIRCUIT

1. All interior room lamps switch are OFF.
2. Turn ignition switch ON.
3. Check voltage between BCM harness connector M2 terminal 41 (R/B) and ground.

41 (R/B) – Ground : Battery voltage should exist.

OK or NG

- OK >> Repair harness or connector. In a case of making a short circuit, be sure to disconnect battery negative cable after repairing harness, and then reconnect.
- NG >> Replace BCM. Refer to [BCS-15, "Removal and Installation of BCM"](#) .

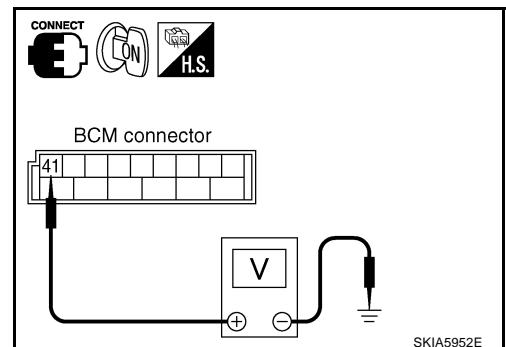

INTERIOR ROOM LAMP

Removal and Installation

MAP LAMP

AKS009Y0

Refer to [LT-157, "Removal and Installation of Map Lamp"](#) in "MAP LAMP".

STEP LAMP

Bulb Replacement

1. Remove step lamp.
2. Remove bulb.

Step lamp : 12V - 5W

Removal and Installation

1. Undo clips on lower part of front door finisher and lift finisher up.
2. Disconnect step lamp connector.
3. Press pawl on reverse side and remove the step lamp.

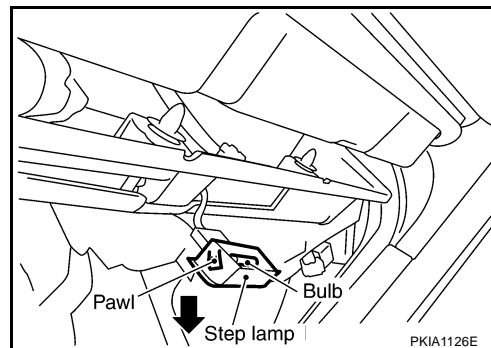

A
B
C
D
E
F
G
H
I
J
LT
L
M

ILLUMINATION

PFP:27545

System Description

AKS009Y1

Control of the illumination lamps operation is dependent upon the position of the lighting switch (combination switch). When the lighting switch is placed in the 1ST or 2ND position (or if the auto light system is activated) the BCM (body control module) receives input signal requesting the illumination lamps to illuminate. This input signal is communicated to the IPDM E/R (intelligent power distribution module engine room) across the CAN communication lines. The CPU (central processing unit) of the IPDM E/R (intelligent power distribution module engine room) controls the tail lamp relay coil. This relay, when energized, directs power to the illumination lamps, which then illuminate.

Power is supplied at all times

- to ignition relay [located in IPDM E/R (intelligent power distribution module engine room)]
- to tail lamp relay, [located in IPDM E/R (intelligent power distribution module engine room)]
- through 10A fuse [No. 71, located in IPDM E/R (intelligent power distribution module engine room)].

Power is also supplied at all times

- to BCM (body control module) terminal 55
- through 50A fusible link (letter F, located in fuse and fusible link block)
- to BCM (body control module) terminal 42
- through 10A fuse [No. 18 located in fuse block (J/B)]
- to CPU (central processing unit) [located in IPDM E/R (intelligent power distribution module engine room)]
- through 15A fuse [No. 78 located in IPDM E/R (intelligent power distribution module engine room)].

With the ignition switch in the ON or START position, power is supplied

- to BCM (body control module) terminal 38
- through 10A fuse [No. 1, located in fuse block (J/B)]
- to ignition relay [located in IPDM E/R (intelligent power distribution module engine room)]
- from ignition switch
- to combination meter terminals 41 and 42
- through 10A fuse [No. 14 located in fuse block (J/B)]
- to display and auto A/C amp. terminal 27
- to NAVI control unit terminal 27 (with NAVI)
- through 10A fuse [No. 12, located in fuse block (J/B)].

With the ignition switch in the ACC or ON position, power is supplied

- to BCM (body control module) terminal 11
- to combination meter terminal 40
- to NAVI control unit terminal 6 (with NAVI)
- to display unit terminal 19 (with NAVI)
- through 10A fuse [No. 6, located in fuse block (J/B)].

Ground is supplied

- to BCM (body control module) terminal 52
- to display and auto A/C amp. terminal 24
- to combination meter terminals 45, 46, and 47
- through grounds M30, and M66
- to IPDM E/R (intelligent power distribution module engine room) terminals 38 and 60
- through grounds E17, and E43.

ILLUMINATION OPERATION BY LIGHTING SWITCH

With the lighting switch in the 1ST or 2ND position (or if the auto light system is activated), the BCM receives input signal requesting the illumination lamps to illuminate. This input signal is communicated to the IPDM E/R across the CAN communication lines. The CPU (central processing unit) of the IPDM E/R controls the tail lamp relay coil, which, when energized, directs power

- through IPDM E/R terminal 22
- to glove box lamp terminal 1

ILLUMINATION

- to upper glove box lamp terminal 1 (with NAVI)
- to A/T device (illumination) terminal 1
- to illumination control switch (illumination) terminal 1
- to VDC off switch (illumination) terminal 3 (with VDC)
- to clock (illumination) terminal 4
- to hazard switch (illumination) terminal 7
- to heated seat switch (driver side) (illumination) terminal 5 (with heater seat)
- to heated seat switch (passenger side) (illumination) terminal 5 (with heater seat)
- to A/C and audio controller (illumination) terminal 9
- to audio unit terminal 8
- to display and A/C auto amp. (illumination) terminal 28
- to front cigarette lighter socket terminal 3
- to ashtray (illumination) terminal 1
- to NAVI control unit (illumination) terminal 9
- to NAVI switch (illumination) terminal 2 (with NAVI).

Ground is supplied at all times

- to glove box lamp terminal 2
- to upper glove box lamp terminal 2 (with NAVI)
- to ashtray (illumination) terminal 2
- to illumination control switch terminal 3
- through grounds M30 and M66.

With power and ground supplied, illumination lamps illuminate.

EXTERIOR LAMP BATTERY SAVER CONTROL

When the combination switch (lighting switch) is in the 1ST or 2ND position (or if auto light system is activated), and the ignition switch is turned from ON or ACC to OFF, the battery saver control function is activated. Under this condition, the illumination lamps remain illuminated for 5 minutes, then the illumination lamps are turned off.

When the lighting switch is turned from OFF to 1ST or 2ND position (or if auto light system is activated) after illumination lamps are turned off by the battery saver control, and illumination lamps illuminate again.

Exterior lamp battery saver control mode can be changed by the function setting of CONSULT-II.

CAN Communication System Description

AKS009Y2

CAN (Controller Area Network) is a serial communication line for real time application. It is an on-vehicle multiplex communication line with high data communication speed and excellent error detection ability. Many electronic control units are equipped onto a vehicle, and each control unit shares information and links with other control units during operation (not independent). In CAN communication, control units are connected with 2 communication lines (CAN H line, CAN L line) allowing a high rate of information transmission with less wiring. Each control unit transmits/receives data but selectively reads required data only.

CAN Communication Unit

AKS009Y3

Refer to [LAN-4, "CAN Communication Unit"](#) .

ILLUMINATION

Schematic

AKS009Y4

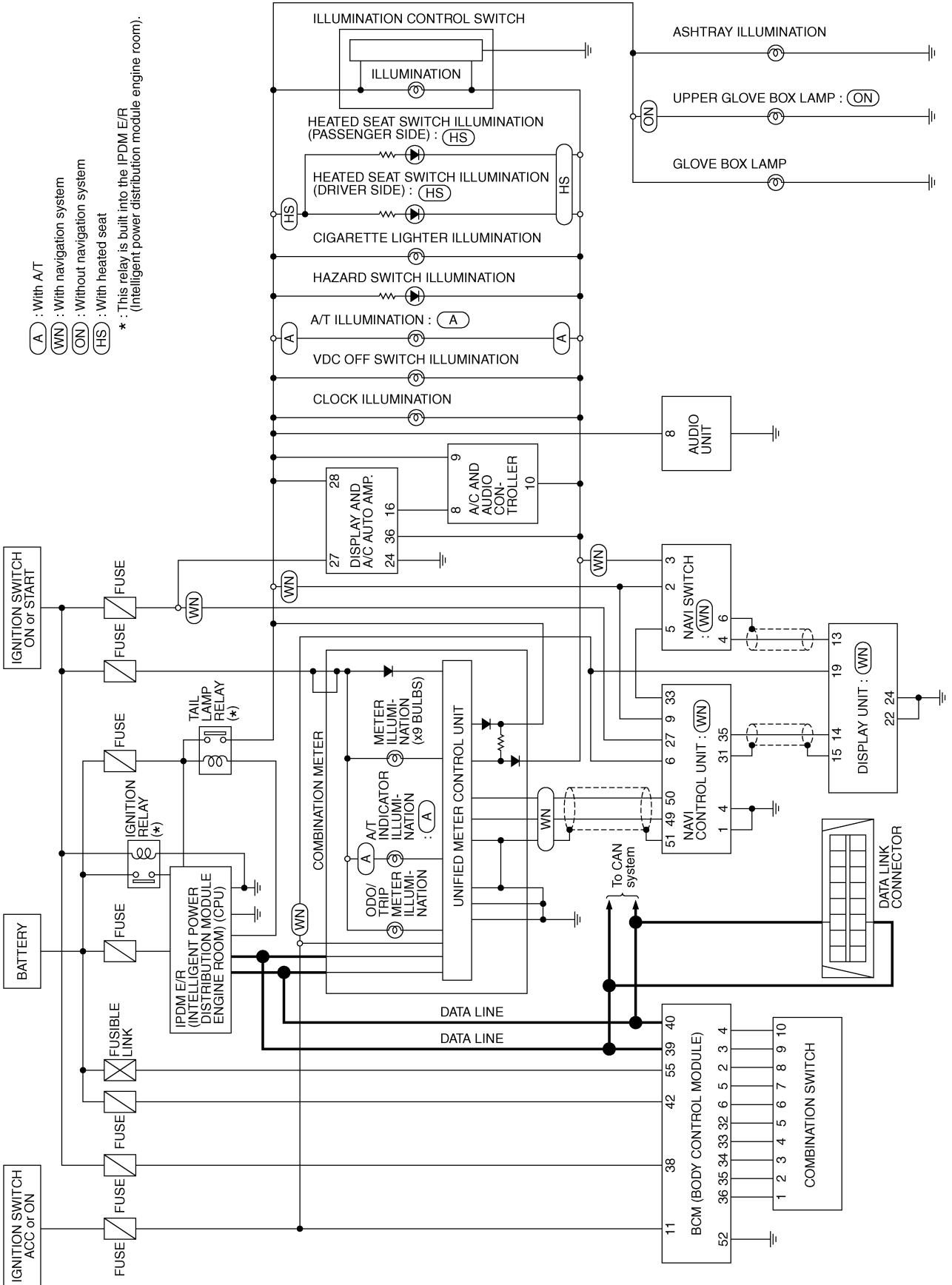

TKWM0888E

ILLUMINATION

Wiring Diagram — ILL —

AKS009Y5

LT-ILL-01

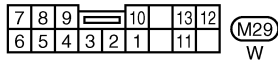
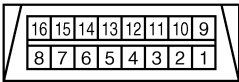
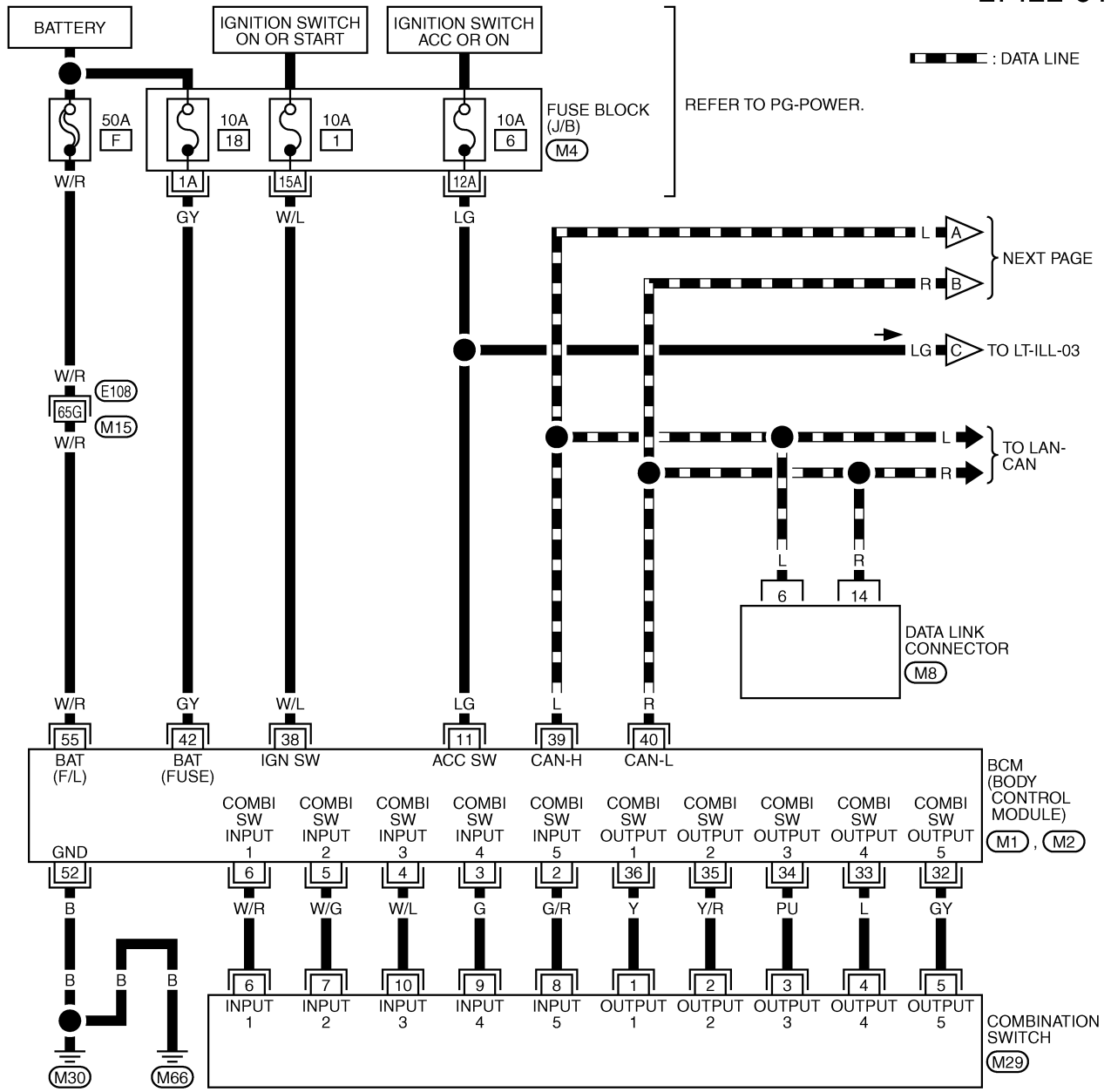

REFER TO THE FOLLOWING.

- (E108) -SUPER MULTIPLE JUNCTION (SMJ)
- (M4) -FUSE BLOCK-JUNCTION BOX (J/B)
- (M1), (M2) -ELECTRICAL UNITS

TKWM0889E

ILLUMINATION

LT-ILL-02

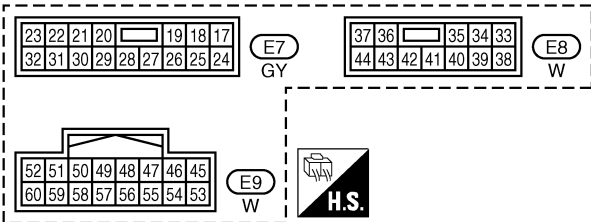
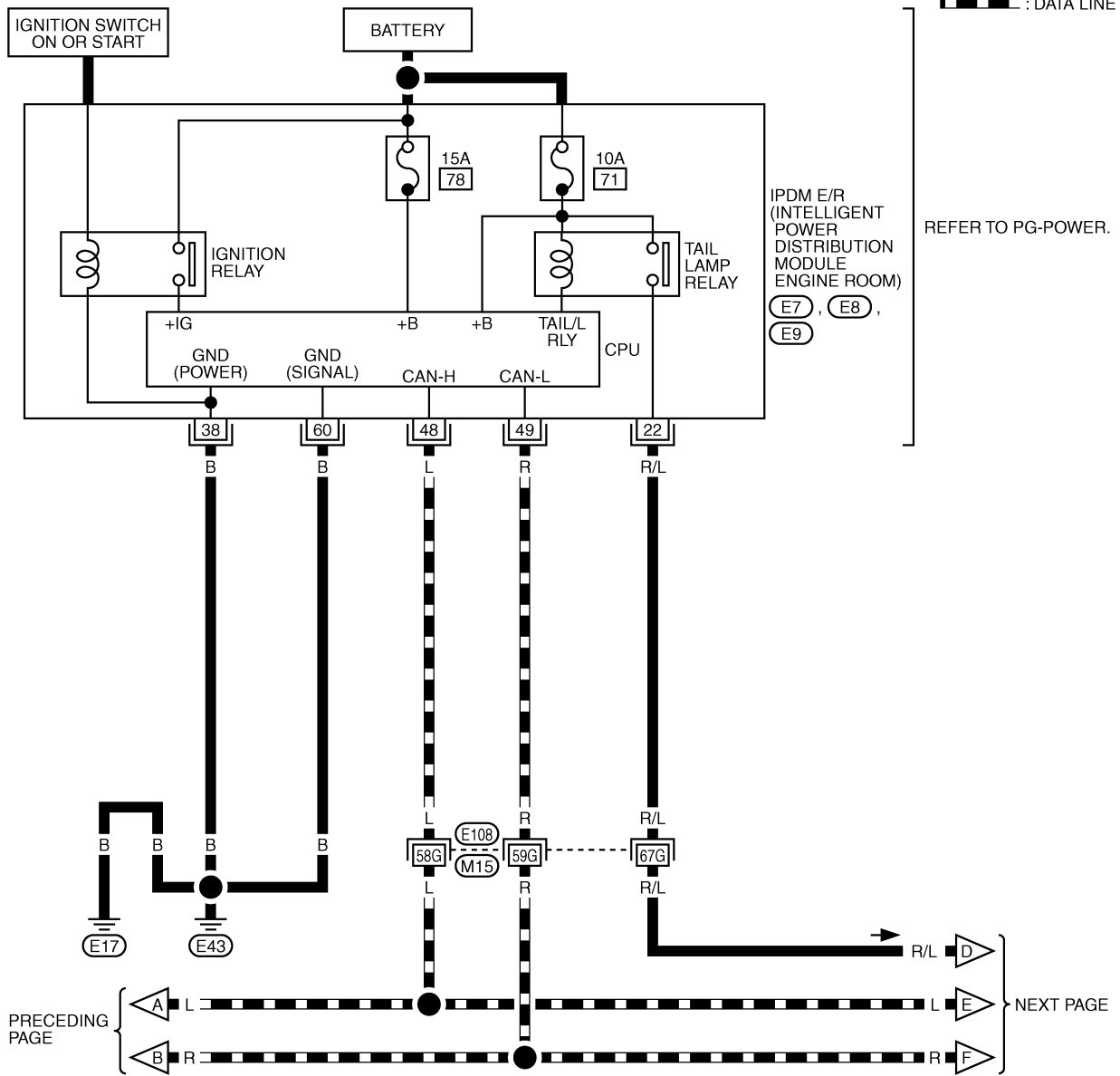

REFER TO THE FOLLOWING.
 E108 -SUPER MULTIPLE JUNCTION (SMJ)

ILLUMINATION

LT-ILL-03

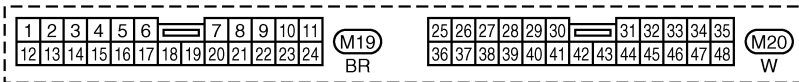
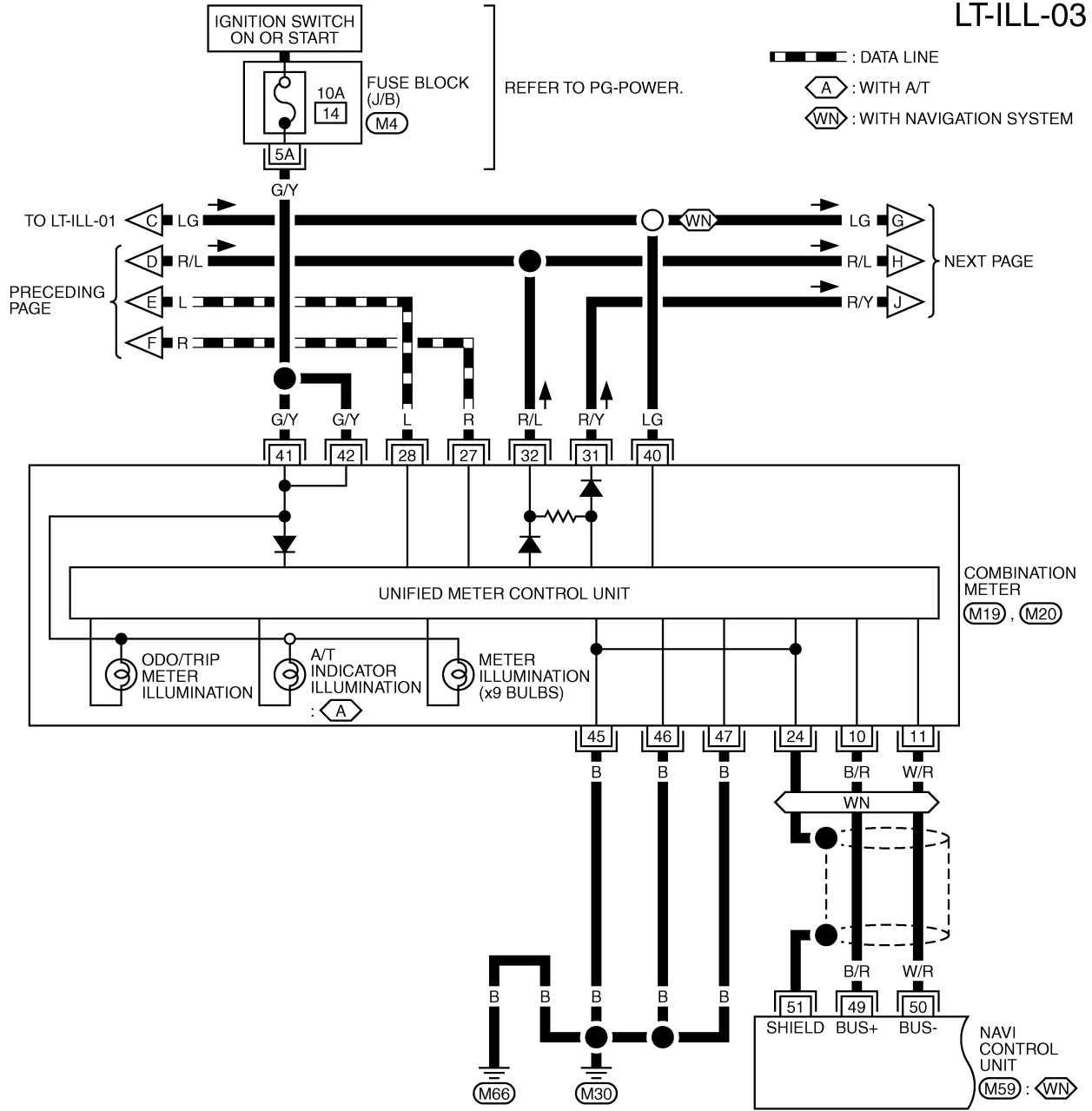

REFER TO THE FOLLOWING.

(M4) - FUSE BLOCK-JUNCTION BOX (J/B)

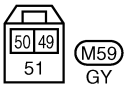

ILLUMINATION

LT-ILL-04

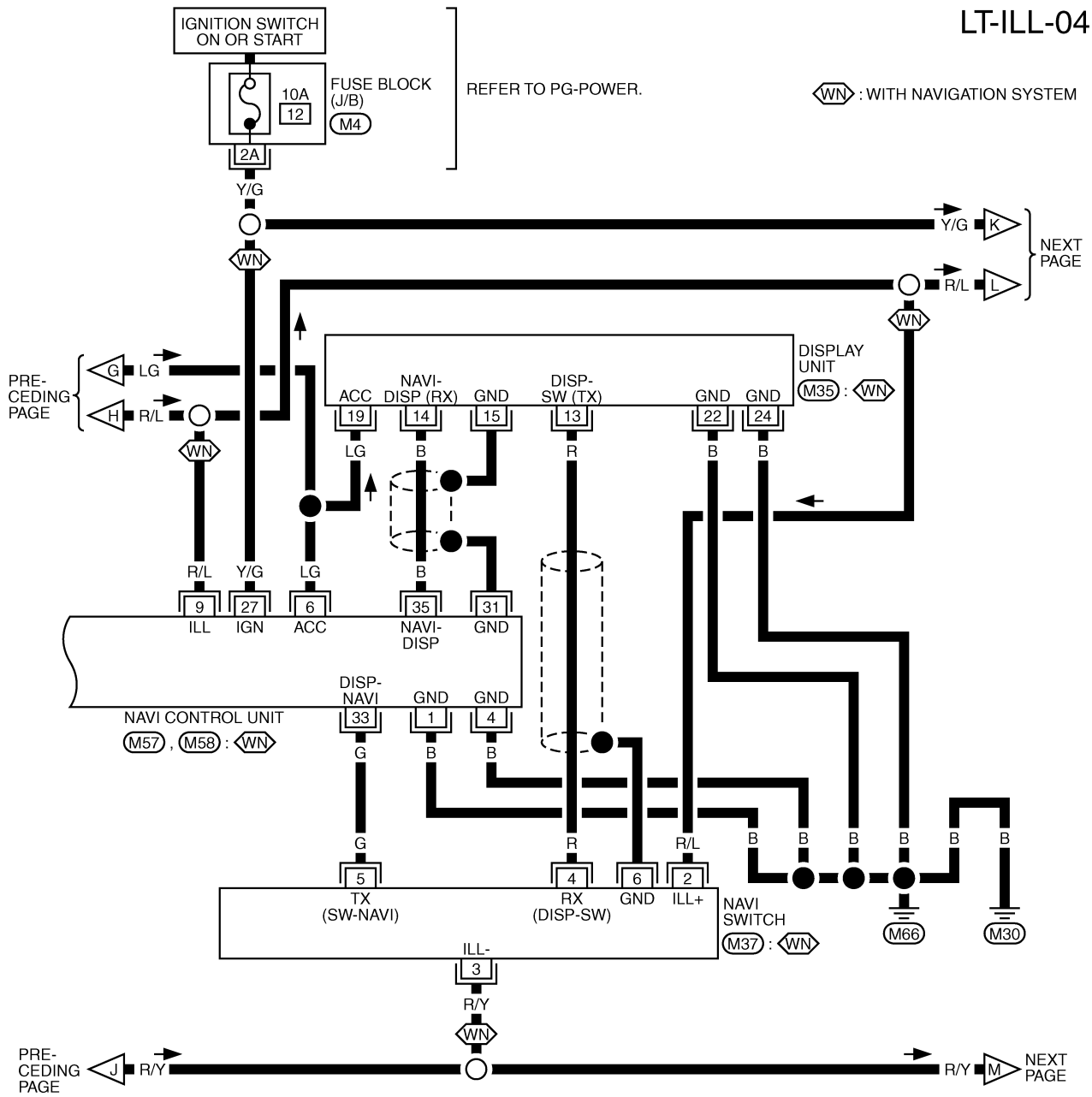

24	22	20	18	16	14	10	8	6	4	2		
23	21	19	17	15	13	12	11	9	7	5	3	1

(M35) W

3	2	1		
8	7	6	5	4

(M37) W

24	21	18	15	13	11	9	6	3
23	20	17	14	12	10	8	5	2
22	19	16	7	4	1			

(M57) W

48	45	42	39	37	35	33	30	27
47	44	41	38	36	34	32	29	26
46	43	40	31	28	25			

(M58) GY

REFER TO THE FOLLOWING.
 (M4) - FUSE BLOCK-JUNCTION BOX (J/B)

ILLUMINATION

LT-ILL-05

A
B
C
D
E
F
G
H
I
J
LT
L
M

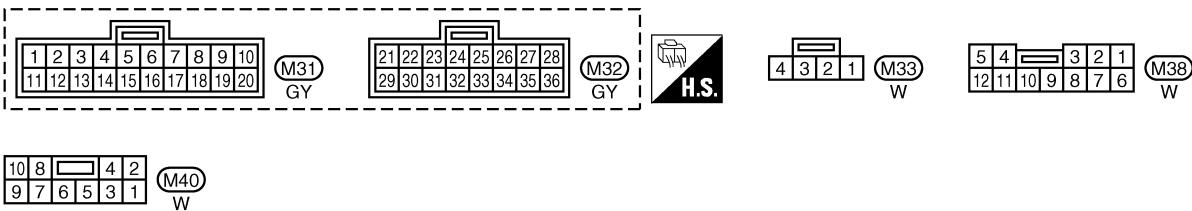
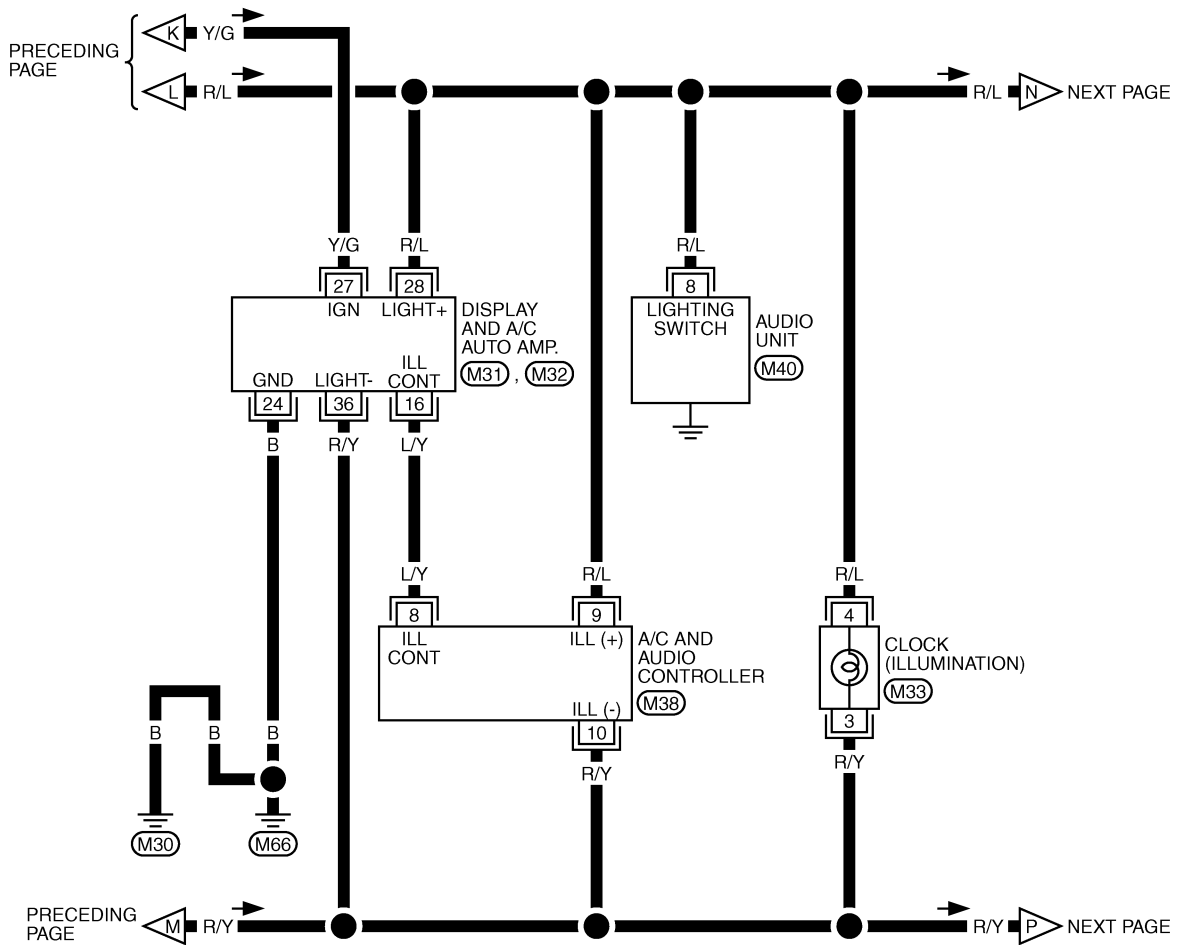

TKWT0632E

ILLUMINATION

LT-ILL-06

: WITH A/T

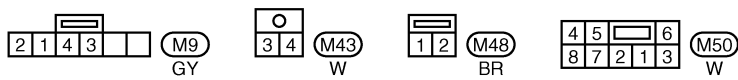
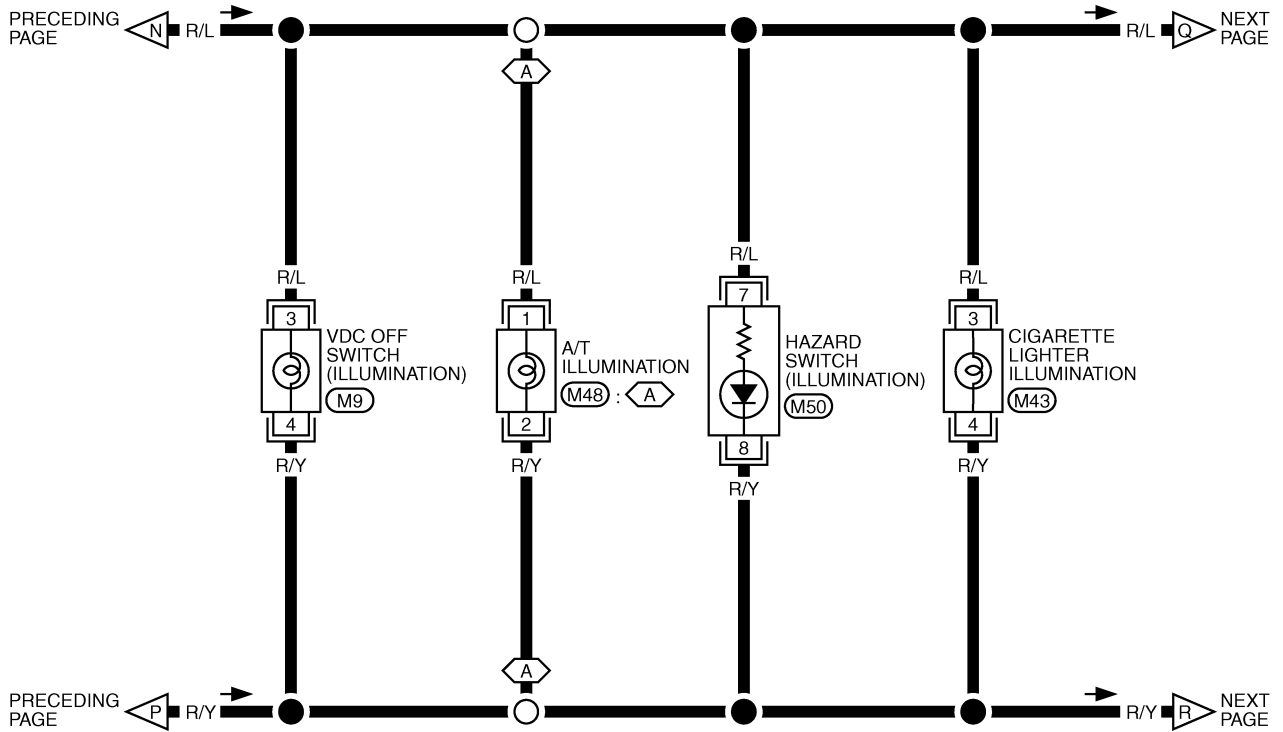

TKWT0633E

ILLUMINATION

LT-ILL-07

AH : WITH A/T WITH HEATED SEAT

MH : WITH M/T WITH HEATED SEAT

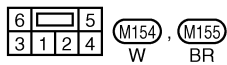
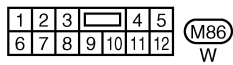
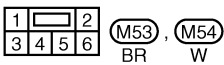
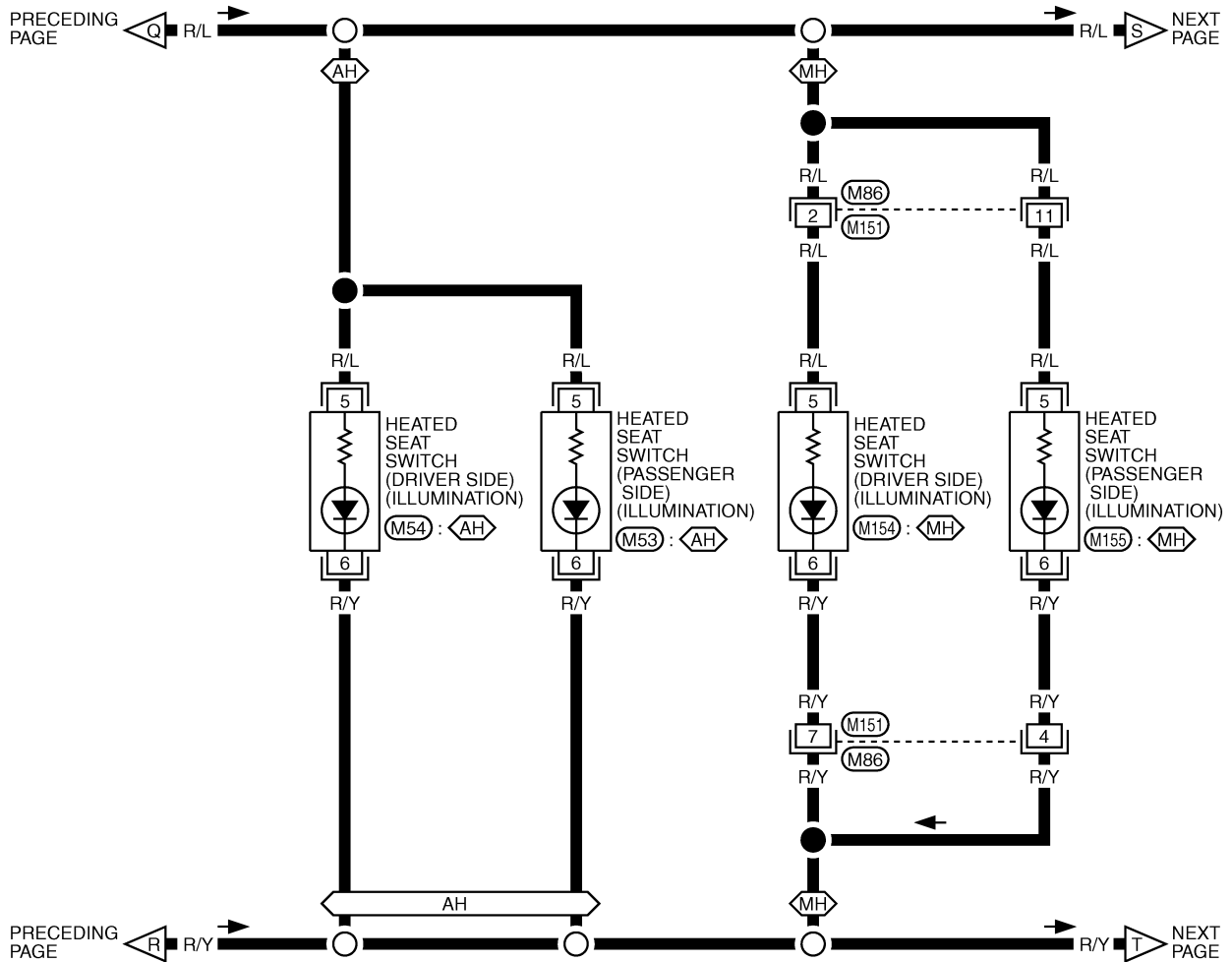

TKWM0892E

ILLUMINATION

LT-ILL-08

ON : WITHOUT NAVIGATION SYSTEM

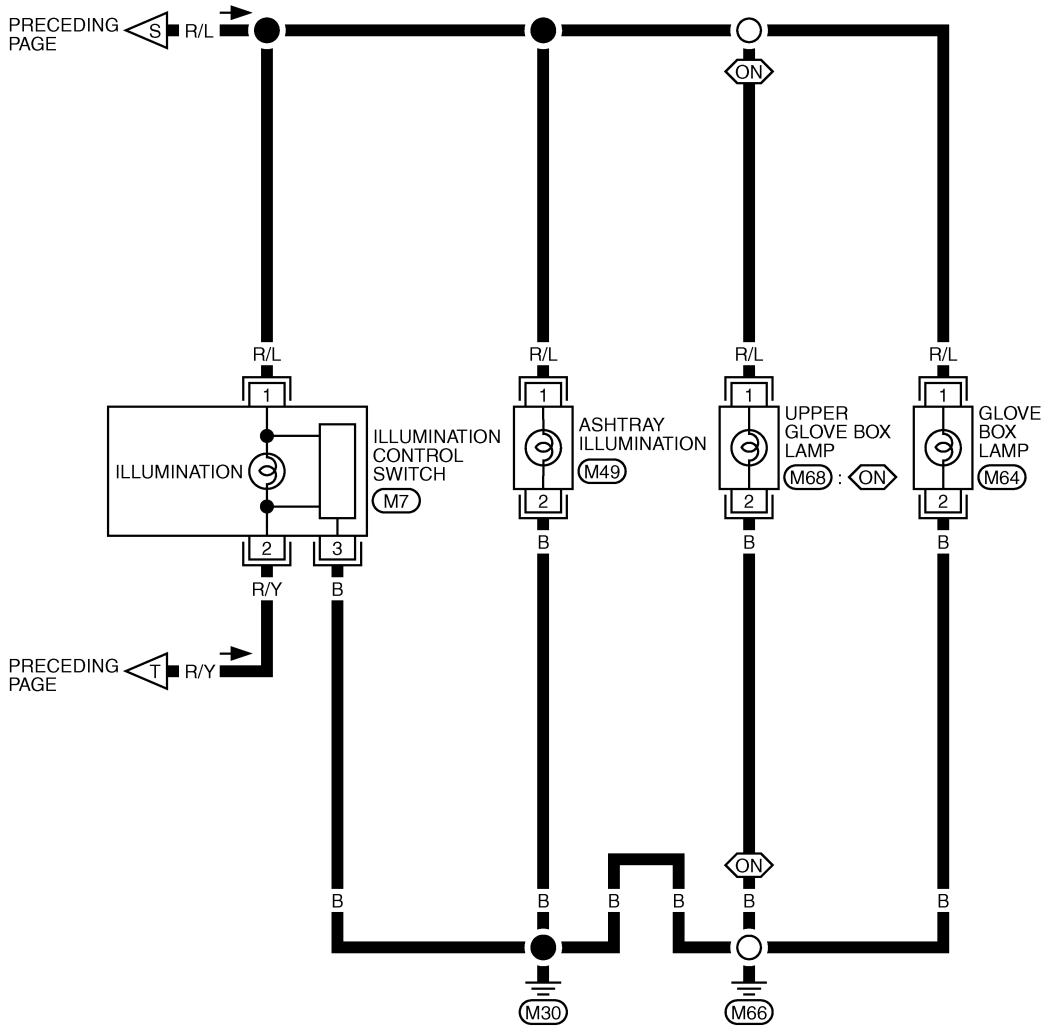

TKWM0893E

ILLUMINATION

Removal and Installation GLOVE BOX LAMP

AKS009Y6

Refer to [LT-160, "Removal and Installation"](#) .

A

B

C

D

E

F

G

H

I

J

LT

L

M

BULB SPECIFICATIONS

BULB SPECIFICATIONS

PFP:26297

Headlamp

AKS00A27

Item	Wattage (W)
Low (Xenon)	35 (D2R)
High/FOG	60/55 (HB2)

Exterior Lamp

AKS00A28

Item	Wattage (W)	
Front combination lamp	Turn signal and parking lamp	21/5
	Parking lamp	5
Rear combination lamp	Stop/Tail lamp	LED
	Turn signal lamp	21
	Back-up lamp	18
	Rear side marker lamp	3.8
Front side marker lamp	3.8	
License plate lamp	5	
High-mounted stop lamp	LED	

Interior Lamp/Illumination

AKS00A29

Item	Wattage (W)
Glove box lamp	1.4
Ignition key hole illumination lamp	1.4
Ashtray illumination lamp	1.4
Cigarette lighter illumination lamp	1.4
Map lamp	8
Step lamp	5
Trunk room lamp	3.4
Vanity mirror lamp	1.32