

SECTION **SE**  
SEAT

A  
B  
C  
D  
E  
F  
G  
H  
I  
J  
K  
L  
M

CONTENTS

<b>PRECAUTIONS</b> .....	<b>3</b>	<b>WORK-IN SYSTEM</b> .....	<b>14</b>
Precautions for Supplemental Restraint System (SRS) "AIR BAG" and "SEAT BELT PRE-TENSIONER" .....	3	<b>DRIVER SIDE OPERATION</b> .....	14
Service Notice .....	3	<b>PASSENGER SIDE OPERATION</b> .....	15
Precautions for Battery Service .....	3	Schematic .....	17
Precautions for Work .....	3	Wiring Diagram–SEAT– /For Driver Seat .....	18
<b>PREPARATION</b> .....	<b>5</b>	Wiring Diagram–SEAT– /For Passenger Seat .....	22
Special Service Tools .....	5	Terminal and Reference Value for Driver Side Seat Control Unit .....	24
Commercial Service Tools .....	5	Terminal and Reference Value for Passenger Side Seat Control Unit .....	25
<b>SQUEAK AND RATTLE TROUBLE DIAGNOSES</b> .....	<b>6</b>	Work Flow .....	26
Work Flow .....	6	Trouble Diagnoses Symptom Chart .....	26
CUSTOMER INTERVIEW .....	6	BCM Power Supply and Ground Circuit Check .....	27
DUPLICATE THE NOISE AND TEST DRIVE .....	7	Check Driver Seat Control Unit Power Supply and Ground Circuit .....	28
CHECK RELATED SERVICE BULLETINS .....	7	Check Passenger Seat Control Unit Power Supply and Ground Circuit .....	28
LOCATE THE NOISE AND IDENTIFY THE ROOT CAUSE .....	7	Check Power Seat Switch .....	30
REPAIR THE CAUSE .....	7	Check Sliding Motor .....	32
CONFIRM THE REPAIR .....	8	Check Sliding Sensor .....	32
Generic Squeak and Rattle Troubleshooting .....	8	Check Door Switch .....	33
INSTRUMENT PANEL .....	8	Check Seat Belt Buckle Switch .....	34
CENTER CONSOLE .....	8	Check Door Switch and Seat Belt Buckle Switch ...	36
DOORS .....	8	Check A/T Shift Lever P Position Signal (with A/T Models) .....	40
TRUNK .....	9	Check Parking Brake Signal (with M/T Models) ....	41
SUNROOF/HEADLINING .....	9	Check Vehicle Speed Signal .....	43
SEATS .....	9	Check Reclining Forward Switch .....	43
UNDERHOOD .....	9	Check Sliding Limit Switch (Forward) .....	44
Diagnostic Worksheet .....	10	Check Reclining Backward Switch .....	45
<b>CLIP AND FASTENER</b> .....	<b>12</b>	Check Reclining Limit Switch (Backward) .....	45
Description .....	12	<b>HEATED SEAT</b> .....	<b>47</b>
<b>POWER SEAT</b> .....	<b>13</b>	Description .....	47
Component Parts and Harness Connector Location. ....	13	Schematic .....	48
System Description .....	14	Wiring Diagram – HSEAT – / With A/T Models .....	49
<b>POWER WORK-IN SYSTEM</b> .....	14	Wiring Diagram – HSEAT – / With M/T Models .....	52
<b>FORWARD OPERATION</b> .....	14	<b>FRONT SEAT</b> .....	<b>55</b>
<b>BACKWARD OPERATION</b> .....	14	Removal and Installation .....	55
<b>CONDITION OF POWER WALK-IN SYSTEM OPERATING PERMISSION</b> .....	14	<b>REMOVAL</b> .....	56
<b>OPERATION STOP CONDITION OF POWER</b> .....			

---

INSTALLATION .....	56	<b>REAR SEAT .....</b>	<b>60</b>
Disassembly and Assembly .....	57	Removal and Installation .....	60
SEATBACK TRIM AND PAD .....	57	REMOVAL .....	60
REMOVAL OF SEATBACK ASSEMBLY .....	58	INSTALLATION .....	60
INSTALLATION OF SEATBACK ASSEMBLY .....	58		
SEAT CUSHION TRIM AND PAD .....	58		

# PRECAUTIONS

## PRECAUTIONS

PPF:00001

### Precautions for Supplemental Restraint System (SRS) “AIR BAG” and “SEAT BELT PRE-TENSIONER”

AIS001C5

The Supplemental Restraint System such as “AIR BAG” and “SEAT BELT PRE-TENSIONER”, used along with a front seat belt, helps to reduce the risk or severity of injury to the driver and front passenger for certain types of collision. This system includes seat belt switch inputs and dual stage front air bag modules. The SRS system uses the seat belt switches to determine the front air bag deployment, and may only deploy one front air bag, depending on the severity of a collision and whether the front occupants are belted or unbelted. Information necessary to service the system safely is included in the SRS and SB section of this Service Manual.

#### **WARNING:**

- To avoid rendering the SRS inoperative, which could increase the risk of personal injury or death in the event of a collision which would result in air bag inflation, all maintenance must be performed by an authorized NISSAN/INFINITI dealer.
- Improper maintenance, including incorrect removal and installation of the SRS, can lead to personal injury caused by unintentional activation of the system. For removal of Spiral Cable and Air Bag Module, see the SRS section.
- Do not use electrical test equipment on any circuit related to the SRS unless instructed to in this Service Manual. SRS wiring harnesses can be identified by yellow and/or orange harnesses or harness connectors.

#### **Service Notice**

AIS001C4

- When removing or installing various parts, place a cloth or padding onto the vehicle body to prevent scratches.
- Handle trim, molding, instruments, grille, etc. carefully during removing or installing. Be careful not to oil or damage them.
- Apply sealing compound where necessary when installing parts.
- When applying sealing compound, be careful that the sealing compound does not protrude from parts.
- When replacing any metal parts (for example body outer panel, members, etc.), be sure to take rust prevention measures.

#### **Precautions for Battery Service**

AIS005F7

Before disconnecting the battery, lower both the driver and passenger windows. This will prevent any interference between the window edge and the vehicle when the door is opened/closed. During normal operation, the window slightly raises and lowers automatically to prevent any window to vehicle interference. The automatic window function will not work with the battery disconnected.

#### **Precautions for Work**

AIS001C6

- When removing or disassembling each component, be careful not to damage or deform it. If a component may be subject to interference, be sure to protect it with a cloth.
- When removing (disengaging) components with a screwdriver or similar tool, be sure to wrap the component with a cloth or vinyl tape to protect it.
- Protect the removed parts with a cloth and keep them.
- Replace a deformed or damaged clip.
- If a part is specified as a non-reusable part, always replace it with new one.
- Be sure to tighten bolts and nuts securely to the specified torque.
- After re-installation is completed, be sure to check that each part works normally.
- Follow the steps below to clean components.
  - Water soluble foul: Dip a soft cloth into lukewarm water, and wring the water out of the cloth to wipe the fouled area.  
Then rub with a soft and dry cloth.
  - Oily foul: Dip a soft cloth into lukewarm water with mild detergent (concentration: within 2 to 3%), and wipe the fouled area.  
Then dip a cloth into fresh water, and wring the water out of the cloth to wipe the detergent off. Then rub with a soft and dry cloth.

## PRECAUTIONS

---

- Do not use organic solvent such as thinner, benzene, alcohol, and gasoline.
- For genuine leather seats, use a genuine leather seat cleaner.

# PREPARATION

## PREPARATION

PFP:00002

### Special Service Tools

AIS001C7

The actual shapes of Kent-Moore tools may differ from those of special service tools illustrated here.

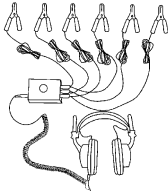
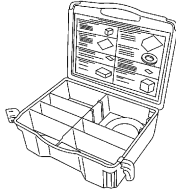
Tool number (Kent-Moore No.) Tool name	Description
(J39570) Chassis ear   SIIA0993E	Locating the noise
(J43980) NISSAN Squeak and Rattle Kit   SIIA0994E	Repairing the cause of noise

### Commercial Service Tools

AIS001C8

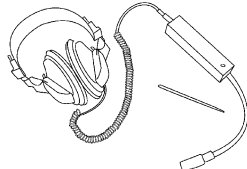
Tool name	Description
Engine ear   SIIA0995E	Locating the noise

A  
B  
C  
D  
E  
F  
G  
H  
SE  
J  
K  
L  
M

# SQUEAK AND RATTLE TROUBLE DIAGNOSES

## SQUEAK AND RATTLE TROUBLE DIAGNOSES

PFP:00000

### Work Flow

AIS001C9

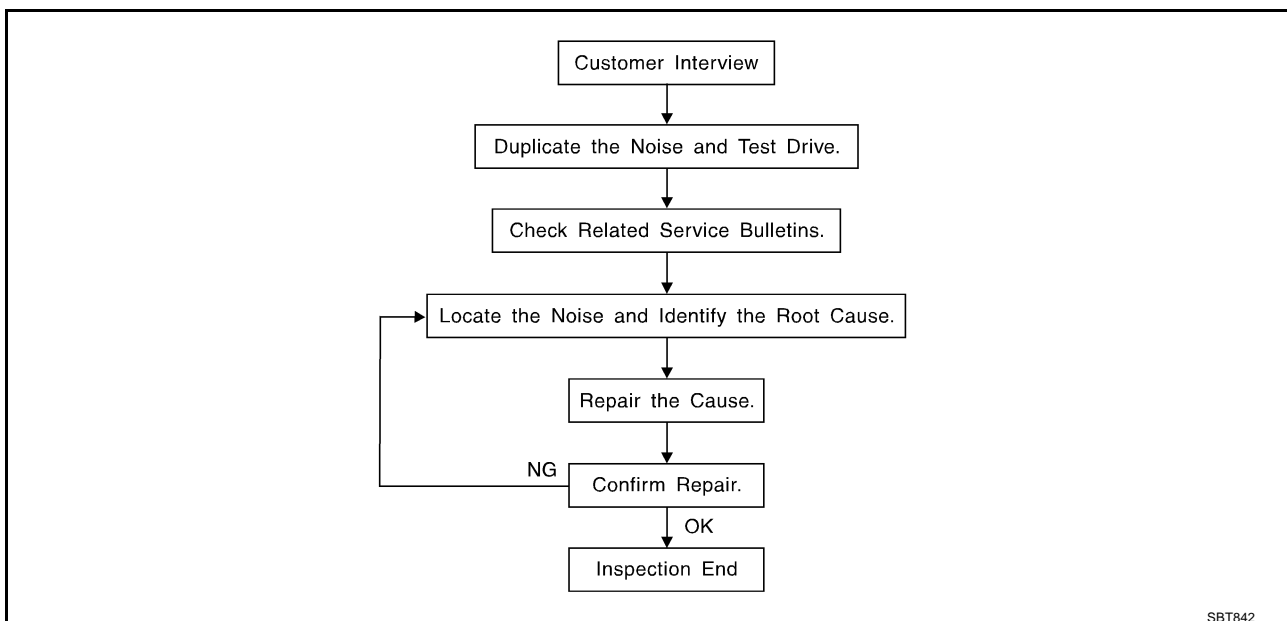

### CUSTOMER INTERVIEW

Interview the customer if possible, to determine the conditions that exist when the noise occurs. Use the Diagnostic Worksheet during the interview to document the facts and conditions when the noise occurs and any customer's comments; refer to [SE-10, "Diagnostic Worksheet"](#). This information is necessary to duplicate the conditions that exist when the noise occurs.

- The customer may not be able to provide a detailed description or the location of the noise. Attempt to obtain all the facts and conditions that exist when the noise occurs (or does not occur).
- If there is more than one noise in the vehicle, be sure to diagnose and repair the noise that the customer is concerned about. This can be accomplished by test driving the vehicle with the customer.
- After identifying the type of noise, isolate the noise in terms of its characteristics. The noise characteristics are provided so the customer, service adviser and technician are all speaking the same language when defining the noise.
- Squeak —(Like tennis shoes on a clean floor)  
Squeak characteristics include the light contact/fast movement/brought on by road conditions/hard surfaces=higher pitch noise/softer surfaces=lower pitch noises/edge to surface=chirping
- Creak—(Like walking on an old wooden floor)  
Creak characteristics include firm contact/slow movement/twisting with a rotational movement/pitch dependent on materials/often brought on by activity.
- Rattle—(Like shaking a baby rattle)  
Rattle characteristics include the fast repeated contact/vibration or similar movement/loose parts/missing clip or fastener/incorrect clearance.
- Knock —(Like a knock on a door)  
Knock characteristics include hollow sounding/sometimes repeating/often brought on by driver action.
- Tick—(Like a clock second hand)  
Tick characteristics include gentle contacting of light materials/loose components/can be caused by driver action or road conditions.
- Thump—(Heavy, muffled knock noise)  
Thump characteristics include softer knock/dead sound often brought on by activity.
- Buzz—(Like a bumble bee)  
Buzz characteristics include high frequency rattle/firm contact.
- Often the degree of acceptable noise level will vary depending upon the person. A noise that you may judge as acceptable may be very irritating to the customer.
- Weather conditions, especially humidity and temperature, may have a great effect on noise level.

# SQUEAK AND RATTLE TROUBLE DIAGNOSES

## DUPLICATE THE NOISE AND TEST DRIVE

If possible, drive the vehicle with the customer until the noise is duplicated. Note any additional information on the Diagnostic Worksheet regarding the conditions or location of the noise. This information can be used to duplicate the same conditions when you confirm the repair.

If the noise can be duplicated easily during the test drive, to help identify the source of the noise, try to duplicate the noise with the vehicle stopped by doing one or all of the following:

- 1) Close a door.
  - 2) Tap or push/pull around the area where the noise appears to be coming from.
  - 3) Rev the engine.
  - 4) Use a floor jack to recreate vehicle "twist".
  - 5) At idle, apply engine load (electrical load, half-clutch on M/T model, drive position on A/T model).
  - 6) Raise the vehicle on a hoist and hit a tire with a rubber hammer.
- Drive the vehicle and attempt to duplicate the conditions the customer states exist when the noise occurs.
  - If it is difficult to duplicate the noise, drive the vehicle slowly on an undulating or rough road to stress the vehicle body.

## CHECK RELATED SERVICE BULLETINS

After verifying the customer concern or symptom, check ASIST for Technical Service Bulletins (TSBs) related to that concern or symptom.

If a TSB relates to the symptom, follow the procedure to repair the noise.

## LOCATE THE NOISE AND IDENTIFY THE ROOT CAUSE

1. Narrow down the noise to a general area. To help pinpoint the source of the noise, use a listening tool (Chassis Ear: J39570, Engine Ear and mechanics stethoscope).
2. Narrow down the noise to a more specific area and identify the cause of the noise by:
  - removing the components in the area that you suspect the noise is coming from.  
Do not use too much force when removing clips and fasteners, otherwise clips and fastener can be broken or lost during the repair, resulting in the creation of new noise.
  - tapping or pushing/pulling the component that you suspect is causing the noise.  
Do not tap or push/pull the component with excessive force, otherwise the noise will be eliminated only temporarily.
  - feeling for a vibration with your hand by touching the component(s) that you suspect is (are) causing the noise.
  - placing a piece of paper between components that you suspect are causing the noise.
  - looking for loose components and contact marks.  
Refer to [SE-8, "Generic Squeak and Rattle Troubleshooting"](#).

## REPAIR THE CAUSE

- If the cause is a loose component, tighten the component securely.
- If the cause is insufficient clearance between components:
  - separate components by repositioning or loosening and retightening the component, if possible.
  - insulate components with a suitable insulator such as urethane pads, foam blocks, felt cloth tape or urethane tape. A Nissan Squeak and Rattle Kit (J43980) is available through your authorized Nissan Parts Department.

### CAUTION:

**Do not use excessive force as many components are constructed of plastic and may be damaged.**

**Always check with the Parts Department for the latest parts information.**

**The following materials are contained in the Nissan Squeak and Rattle Kit (J43980). Each item can be ordered separately as needed.**

**URETHANE PADS [1.5 mm (0.059 in) thick]**

**Insulates connectors, harness, etc.**

**76268-9E005: 100 × 135 mm (3.94 × 5.31 in)/76884-71L01: 60 × 85 mm (2.36 × 3.35 in)/76884-71L02: 15 × 25 mm (0.59 × 0.98 in)**

**INSULATOR (Foam blocks)**

**Insulates components from contact. Can be used to fill space behind a panel.**

**73982-9E000: 45 mm (1.77 in) thick, 50 × 50 mm (1.97 × 1.97 in)/73982-50Y00: 10 mm (0.39 in) thick, 50 × 50 mm (1.97 × 1.97 in)**

# SQUEAK AND RATTLE TROUBLE DIAGNOSES

---

## **INSULATOR (Light foam block)**

80845-71L00: 30 mm (1.18 in) thick, 30 × 50 mm (1.18 × 1.97 in)

## **FELT CLOTHTAPE**

Used to insulate where movement does not occur. Ideal for instrument panel applications.

68370-4B000: 15 × 25 mm (0.59 × 0.98 in) pad/68239-13E00: 5 mm (0.20 in) wide tape roll The following materials, not found in the kit, can also be used to repair squeaks and rattles.

## **UHMW (TEFLON) TAPE**

Insulates where slight movement is present. Ideal for instrument panel applications.

## **SILICONE GREASE**

Used in place of UHMW tape that will be visible or not fit.

Note: Will only last a few months.

## **SILICONE SPRAY**

Use when grease cannot be applied.

## **DUCT TAPE**

Use to eliminate movement.

## **CONFIRM THE REPAIR**

Confirm that the cause of a noise is repaired by test driving the vehicle. Operate the vehicle under the same conditions as when the noise originally occurred. Refer to the notes on the Diagnostic Worksheet.

## **Generic Squeak and Rattle Troubleshooting**

AIS001CA

Refer to Table of Contents for specific component removal and installation information.

## **INSTRUMENT PANEL**

Most incidents are caused by contact and movement between:

1. The cluster lid A and instrument panel
2. Acrylic lens and combination meter housing
3. Instrument panel to front pillar garnish
4. Instrument panel to windshield
5. Instrument panel mounting pins
6. Wiring harnesses behind the combination meter
7. A/C defroster duct and duct joint

These incidents can usually be located by tapping or moving the components to duplicate the noise or by pressing on the components while driving to stop the noise. Most of these incidents can be repaired by applying felt cloth tape or silicon spray (in hard to reach areas). Urethane pads can be used to insulate wiring harness.

### **CAUTION:**

**Do not use silicone spray to isolate a squeak or rattle. If you saturate the area with silicone, you will not be able to recheck the repair.**

## **CENTER CONSOLE**

Components to pay attention to include:

1. Shifter assembly cover to finisher
2. A/C control unit and cluster lid C
3. Wiring harnesses behind audio and A/C control unit

The instrument panel repair and isolation procedures also apply to the center console.

## **DOORS**

Pay attention to the:

1. Finisher and inner panel making a slapping noise
2. Inside handle escutcheon to door finisher
3. Wiring harnesses tapping
4. Door striker out of alignment causing a popping noise on starts and stops

Tapping or moving the components or pressing on them while driving to duplicate the conditions can isolate many of these incidents. You can usually insulate the areas with felt cloth tape or insulator foam blocks from the Nissan Squeak and Rattle Kit (J-43980) to repair the noise.



# SQUEAK AND RATTLE TROUBLE DIAGNOSES

## TRUNK

Trunk noises are often caused by a loose jack or loose items put into the trunk by the owner. In addition look for:

1. Trunk lid dumpers out of adjustment
2. Trunk lid striker out of adjustment
3. The trunk lid torsion bars knocking together
4. A loose license plate or bracket

Most of these incidents can be repaired by adjusting, securing or insulating the item(s) or component(s) causing the noise.

## SUNROOF/HEADLINING

Noises in the sunroof/headlining area can often be traced to one of the following:

1. Sunroof lid, rail, linkage or seals making a rattle or light knocking noise
2. Sunvisor shaft shaking in the holder
3. Front or rear windshield touching headlining and squeaking

Again, pressing on the components to stop the noise while duplicating the conditions can isolate most of these incidents. Repairs usually consist of insulating with felt cloth tape.

## SEATS

When isolating seat noise it's important to note the position the seat is in and the load placed on the seat when the noise is present. These conditions should be duplicated when verifying and isolating the cause of the noise.

Cause of seat noise include:

1. Headrest rods and holder
2. A squeak between the seat pad cushion and frame
3. The rear seatback lock and bracket

These noises can be isolated by moving or pressing on the suspected components while duplicating the conditions under which the noise occurs. Most of these incidents can be repaired by repositioning the component or applying urethane tape to the contact area.

## UNDERHOOD

Some interior noise may be caused by components under the hood or on the engine wall. The noise is then transmitted into the passenger compartment.

Causes of transmitted underhood noise include:

1. Any component mounted to the engine wall
2. Components that pass through the engine wall
3. Engine wall mounts and connectors
4. Loose radiator mounting pins
5. Hood bumpers out of adjustment
6. Hood striker out of adjustment

These noises can be difficult to isolate since they cannot be reached from the interior of the vehicle. The best method is to secure, move or insulate one component at a time and test drive the vehicle. Also, engine RPM or load can be changed to isolate the noise. Repairs can usually be made by moving, adjusting, securing, or insulating the component causing the noise.

A

B

C

D

E

F

G

H

SE

J

K

L

M

# SQUEAK AND RATTLE TROUBLE DIAGNOSES

## Diagnostic Worksheet

AIS001CB



### SQUEAK & RATTLE DIAGNOSTIC WORKSHEET

Dear Infiniti Customer:

We are concerned about your satisfaction with your Infiniti vehicle. Repairing a squeak or rattle sometimes can be very difficult. To help us fix your Infiniti right the first time, please take a moment to note the area of the vehicle where the squeak or rattle occurs and under what conditions. You may be asked to take a test drive with a service advisor or technician to ensure we confirm the noise you are hearing.

#### I. WHERE DOES THE NOISE COME FROM? (circle the area of the vehicle)

The illustrations are for reference only, and may not reflect the actual configuration of your vehicle.

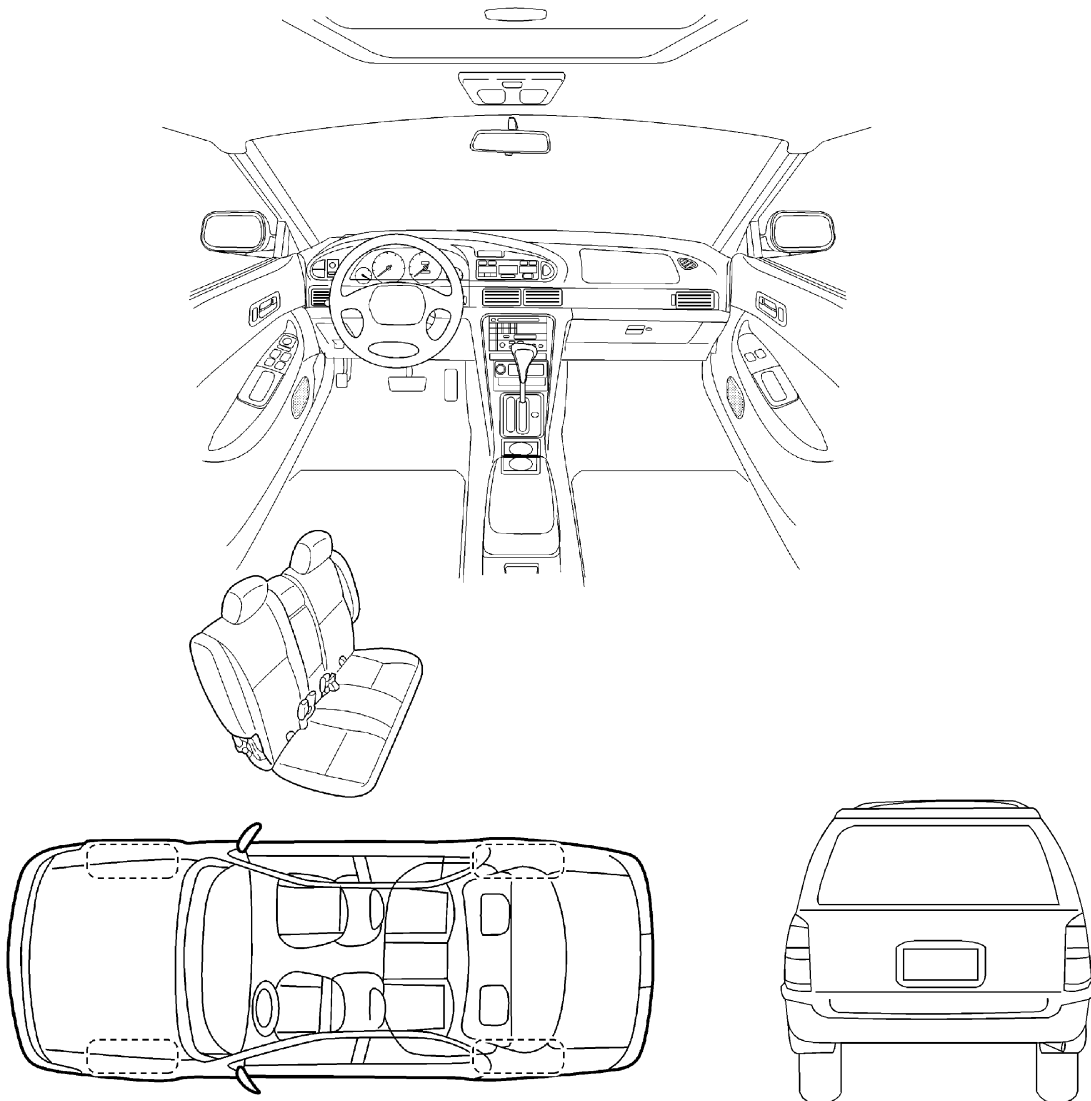

Continue to the back of the worksheet and briefly describe the location of the noise or rattle. In addition, please indicate the conditions which are present when the noise occurs.

SBT860

# SQUEAK AND RATTLE TROUBLE DIAGNOSES

## SQUEAK & RATTLE DIAGNOSTIC WORKSHEET- page 2

Briefly describe the location where the noise occurs:

---

---

---

### II. WHEN DOES IT OCCUR? (check the boxes that apply)

- |  |   |
|--|---|
| <input type="checkbox"/> anytime                             | <input type="checkbox"/> after sitting out in the sun |
| <input type="checkbox"/> 1 <sup>st</sup> time in the morning | <input type="checkbox"/> when it is raining or wet    |
| <input type="checkbox"/> only when it is cold outside        | <input type="checkbox"/> dry or dusty conditions      |
| <input type="checkbox"/> only when it is hot outside         | <input type="checkbox"/> other: _____                 |

### III. WHEN DRIVING:

- through driveways
- over rough roads
- over speed bumps
- only at about \_\_\_\_ mph
- on acceleration
- coming to a stop
- on turns : left, right or either (circle)
- with passengers or cargo
- other: \_\_\_\_\_
- after driving \_\_\_\_ miles or \_\_\_\_ minutes

### IV. WHAT TYPE OF NOISE?

- squeak (like tennis shoes on a clean floor)
- creak (like walking on an old wooden floor)
- rattle (like shaking a baby rattle)
- knock (like a knock on a door)
- tick (like a clock second hand)
- thump (heavy, muffled knock noise)
- buzz (like a bumble bee)

### TO BE COMPLETED BY DEALERSHIP PERSONNEL

#### Test Drive Notes:

---

---

	YES	NO	Initials of person performing
Vehicle test driven with customer	<input type="checkbox"/>	<input type="checkbox"/>	_____
- Noise verified on test drive	<input type="checkbox"/>	<input type="checkbox"/>	_____
- Noise source located and repaired	<input type="checkbox"/>	<input type="checkbox"/>	_____
- Follow up test drive performed to confirm repair	<input type="checkbox"/>	<input type="checkbox"/>	_____

VIN: \_\_\_\_\_ Customer Name: \_\_\_\_\_

W.O. #: \_\_\_\_\_ Date: \_\_\_\_\_

**This form must be attached to Work Order**

# CLIP AND FASTENER



PFP:76906

## CLIP AND FASTENER

### Description

AI500270

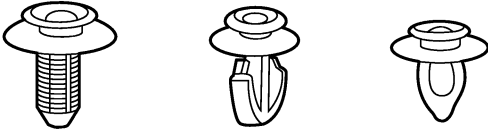
- Clips and fasteners in SE section correspond to the following numbers and symbols.
- Replace any clips and/or fasteners which are damaged during removal or installation.

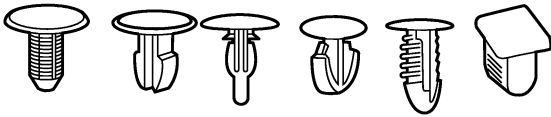
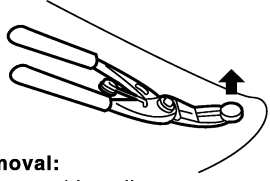
Symbol No.	Shapes	Removal & Installation
<p>C101</p> 		<p><b>Removal:</b> Remove by bending up with flat-bladed screwdrivers or clip remover.</p> 
<p>C103</p> 		 <p><b>Removal:</b> Remove with a clip remover.</p>

PIIA3432E

# POWER SEAT

PFP:87016

## POWER SEAT

### Component Parts and Harness Connector Location

AIS0028R

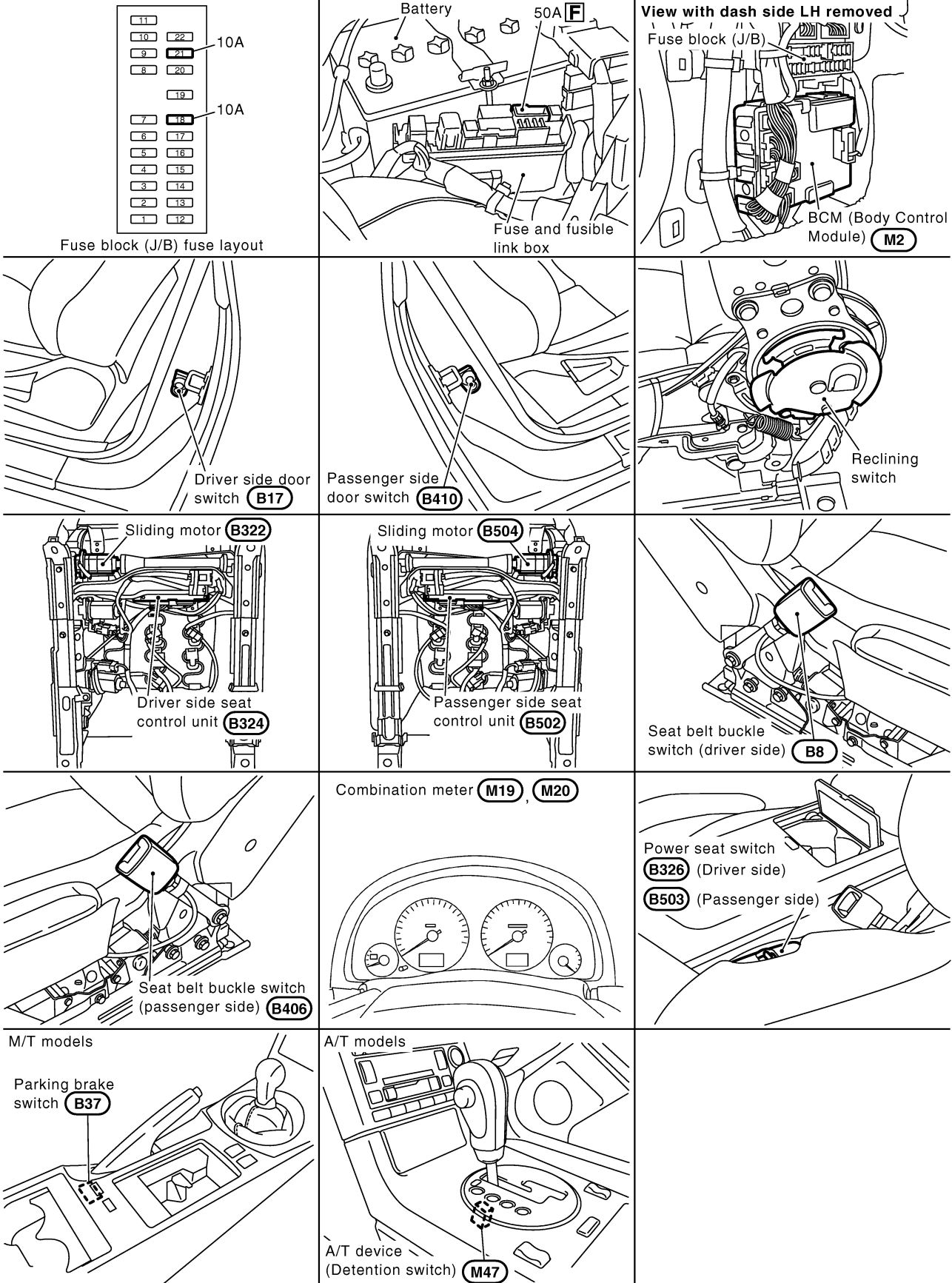

A  
B  
C  
D  
E  
F  
G  
H  
SE  
J  
K  
L  
M

PIIB0133E

# POWER SEAT

AIS002HE

## System Description POWER WORK-IN SYSTEM

This system is a mechanism on the benefit and convenience inclination when the rear seat gotten on and off. The seat is made to advance when the seat back of front seat is folded down. The seat is made to retreat to former position when the seat back of front seat is folded up. After forward movement has been operated, seat does not move backward when reclining the seat back for more than 26° from first locking position.

### FORWARD OPERATION

When condition of power walk-in system operating permission consists, the seat advances to the front most at the following condition.

- the seat back is fold down when the door is open
- the door is closed and when the seat is fold down, and the door is opened.

### BACKWARD OPERATION

When condition of power walk-in system operating permission consists, the seat retreats to former position at the following condition.

- Return based on the fold down seat back within 60 seconds after door is opened.

The backward distance of the passenger seat is different according to the seat position of beginning of the power walk-in system.

- Return to former position when the seat position of beginning of the power walk-in system is from the front most position to within 175mm (6.89in).
- Return to 175mm (6.89in) position when the seat position of beginning of the power walk-in system exceeds 175mm (6.89in) from the front most position.

### CONDITION OF POWER WALK-IN SYSTEM OPERATING PERMISSION

Common of driver side and passenger side condition

- When seat belt is unfastened
- When vehicle speed is less than 7km/h (4MPH)
- When does not operates slide sw

Condition only of driver side

- When shift lever to P position. (with A/T models)
- When pull the parking brake. (with M/T models)

### OPERATION STOP CONDITION OF POWER WORK-IN SYSTEM

Common of driver side and passenger side condition

- When vehicle speed is more than 7km/h (4MPH)
- When does operates slide sw
- When the slide motor locks
- When the operation time is consecutive and 60 seconds or more pass
- When reclining behind the seat back

Condition only of driver side

- When shift lever besides P position. (with A/T models)
- When release the parking brake. (with M/T modes)

Condition only of passenger side

- When seat belt is fastened.

### DRIVER SIDE OPERATION

Power is supplied at all time

- through 50A fusible link (letter **F** , located in the fuse and fusible link box)
- to driver seat control unit terminal 1.
- through 10A fuse [No.21, located in the fuse block (J/B)]
- to driver seat control unit terminal 8.

# POWER SEAT

## Forward Operation

When folding the seat back of driver side to more than 32° from first lock position.

Ground is supplied

- to driver seat control unit terminal 2
- through body ground B5 and B29.

Then driver seat control unit recognizes the forward signal.

Power is supplied

- through driver seat control unit terminal 10
- to sliding motor terminal 3.

Ground is supplied

- to sliding motor terminal 10
- through driver seat control unit terminal 11
- through driver seat control unit terminal 6
- through body ground B5 and B29.

The driver side seat advances to front most position.

## Backward Operation

When return based on the fold down seat back of driver side seat

Ground is supplied

- to driver seat control unit terminal 4
- through body ground B5 and B29.

Then driver seat control unit recognizes the backward signal.

Power is supplied

- through driver seat control unit terminal 11
- to sliding motor terminal 10.

Ground is supplied

- to sliding motor terminal 3
- through driver seat control unit terminal 10
- through driver seat control unit terminal 6
- through body ground B5 and B29.

The driver side seat retreats to former position.

## PASSENGER SIDE OPERATION

Power is supplied at all time

- through 50A fusible link (letter **F** , located in the fuse and fusible link box)
- through BCM terminal 7
- through BCM terminal 28
- to passenger seat control unit terminal 1.
- through 10A fuse [No.21, located in the fuse block (J/B)]
- to passenger seat control unit terminal 8.

## Forward Operation

When folding the seat back to more than 32° from first lock position.

Ground is supplied

- to passenger seat control unit terminal 2
- through body ground B402 and B413.

Then passenger seat control unit recognizes the forward signal.

Power is supplied

- through passenger seat control unit terminal 10
- to sliding motor terminal 3.

Ground is supplied

- to sliding motor terminal 10

A

B

C

D

E

F

G

H

SE

J

K

L

M

## POWER SEAT

---

- through passenger seat control unit terminal 11
- through passenger seat control unit terminal 6
- through body ground B402 and B413.

The passenger side seat advances to front most position.

### **Backward Operation**

When return based on the fold down seat back of passenger side seat

Ground is supplied

- to passenger seat control unit terminal 4
- through body ground B402 and B413.

Then passenger seat control unit recognizes the backward signal.

Power is supplied

- through passenger seat control unit terminal 11
- to sliding motor terminal 10.

Ground is supplied

- to sliding motor terminal 3
- through passenger seat control unit terminal 10
- through passenger seat control unit terminal 6
- through body ground B402 and B413.

The driver side seat retreats to former position.



# POWER SEAT

## Schematic

AIS0028T

(A) : With A/T  
(M) : With M/T

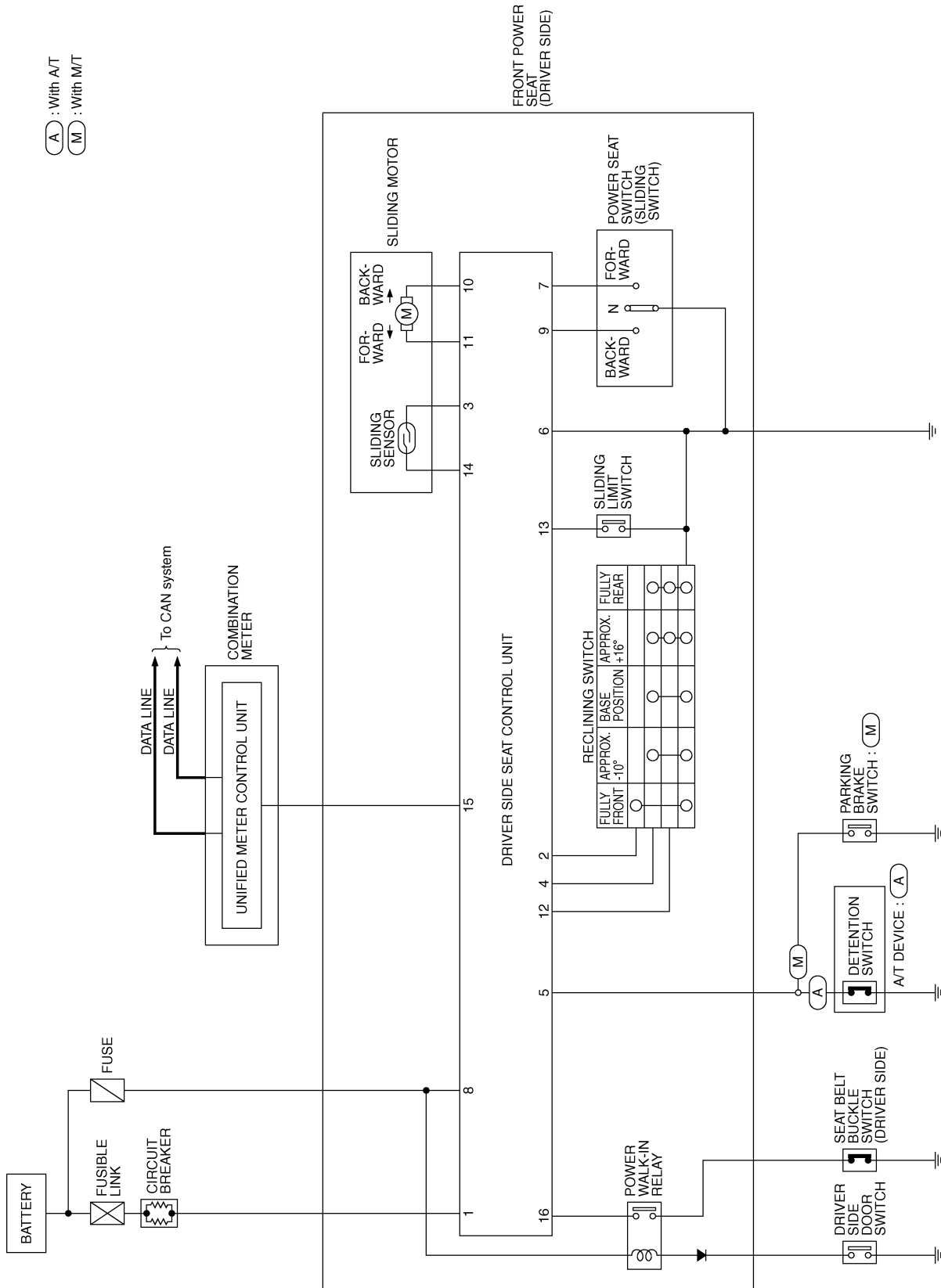

A  
B  
C  
D  
E  
F  
G  
H  
SE  
J  
K  
L  
M

# POWER SEAT

## Wiring Diagram-SEAT- /For Driver Seat

AIS001CI

### SE-SEAT-01

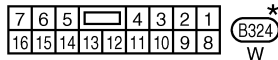
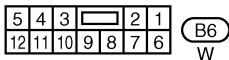
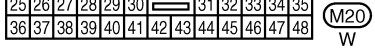
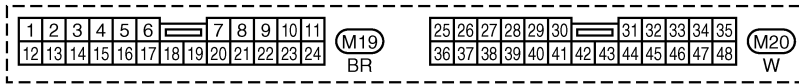
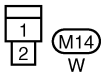
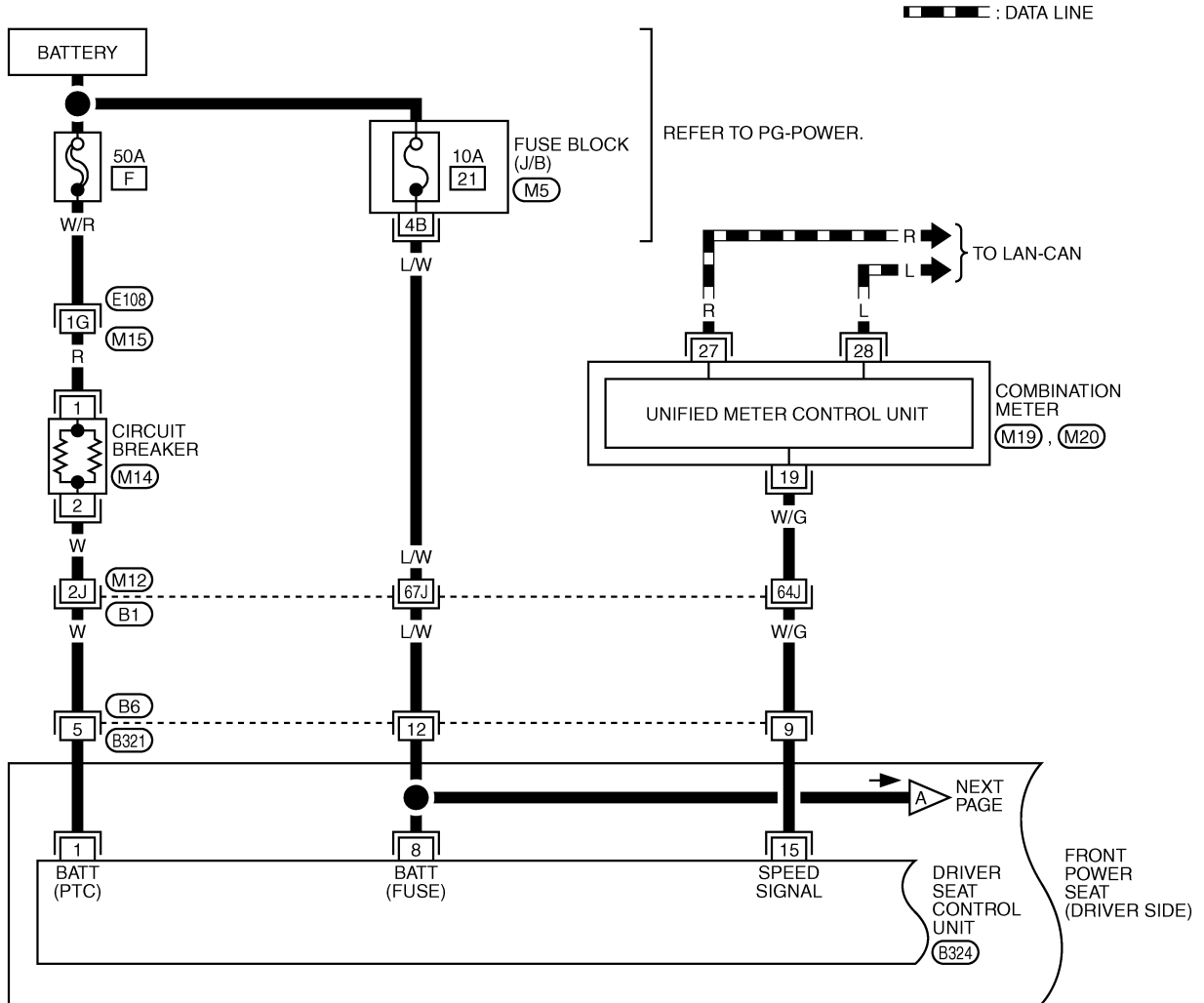

\*: THIS CONNECTOR IS NOT SHOWN IN "HARNESS LAYOUT", PG SECTION.

REFER TO THE FOLLOWING.

(E108), (B1) -SUPER MULTIPLE JUNCTION (SMJ)

(M5) -FUSE BLOCK-JUNCTION BOX (J/B)

TIWT0338E

# POWER SEAT

SE-SEAT-02

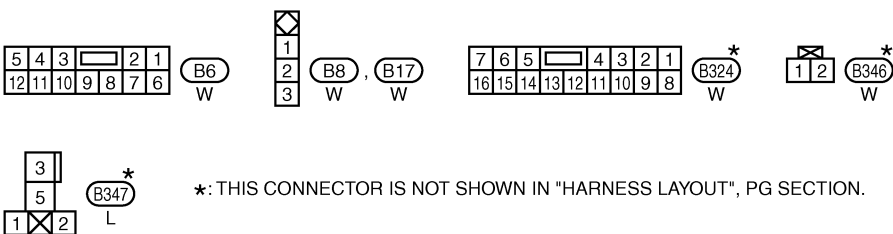
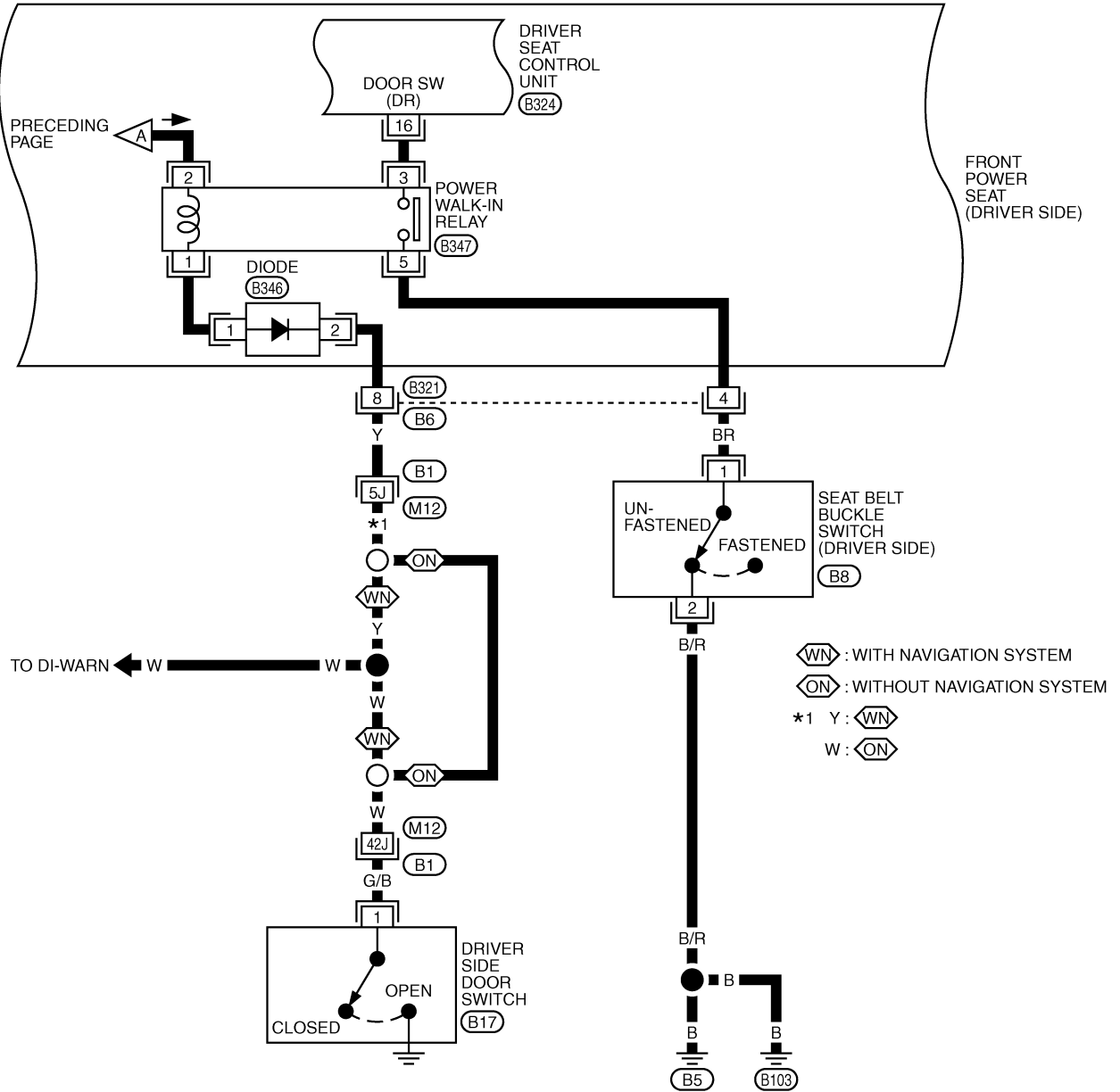

REFER TO THE FOLLOWING.  
 (B1) -SUPER MULTIPLE JUNCTION (SMJ)

# POWER SEAT

## SE-SEAT-03

A : WITH A/T  
M : WITH M/T

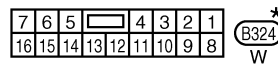
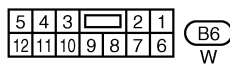
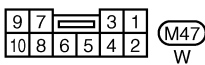
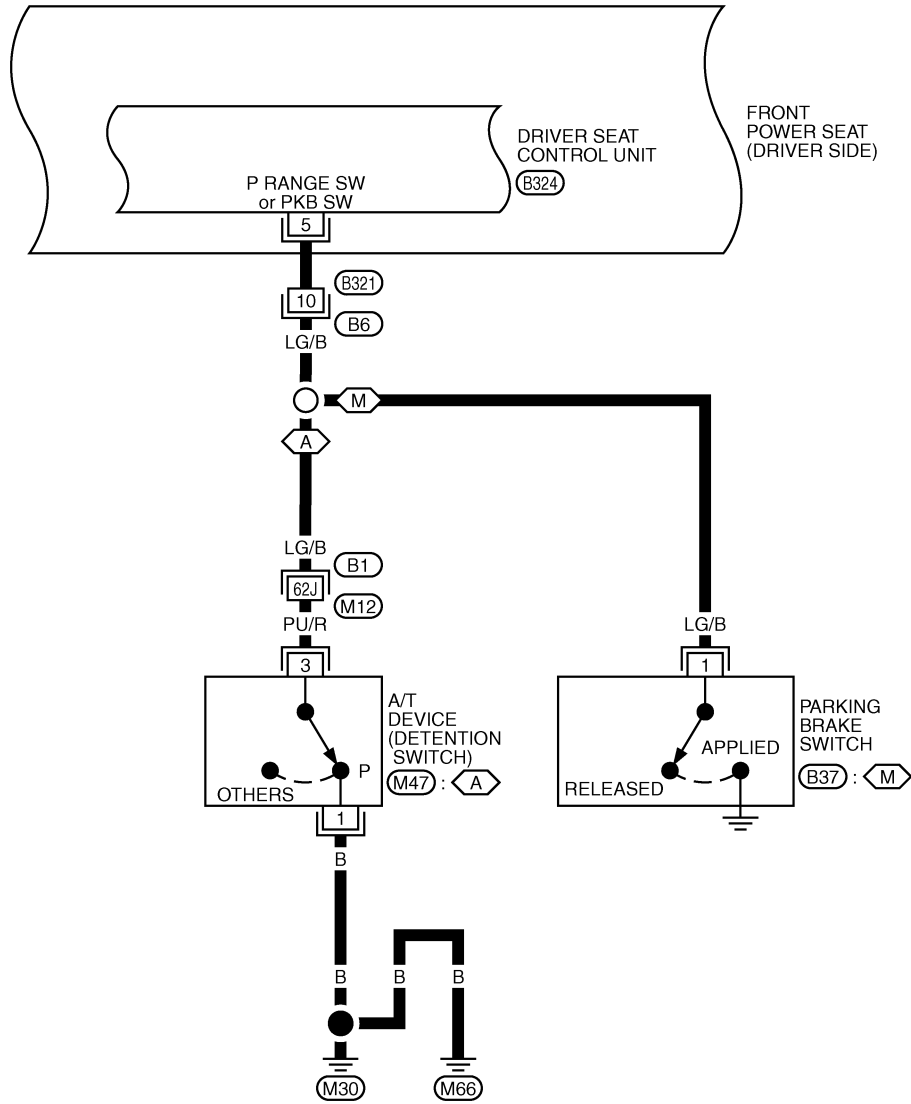

REFER TO THE FOLLOWING.  
B1 -SUPER MULTIPLE JUNCTION (SMJ)

\*: THIS CONNECTOR IS NOT SHOWN IN "HARNESS LAYOUT", PG SECTION.

# POWER SEAT

SE-SEAT-04

A  
B  
C  
D  
E  
F  
G  
H  
I  
J  
K  
L  
M

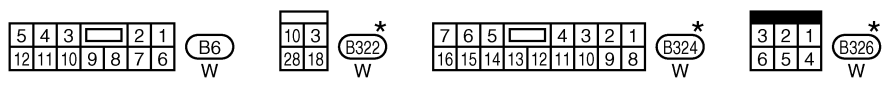
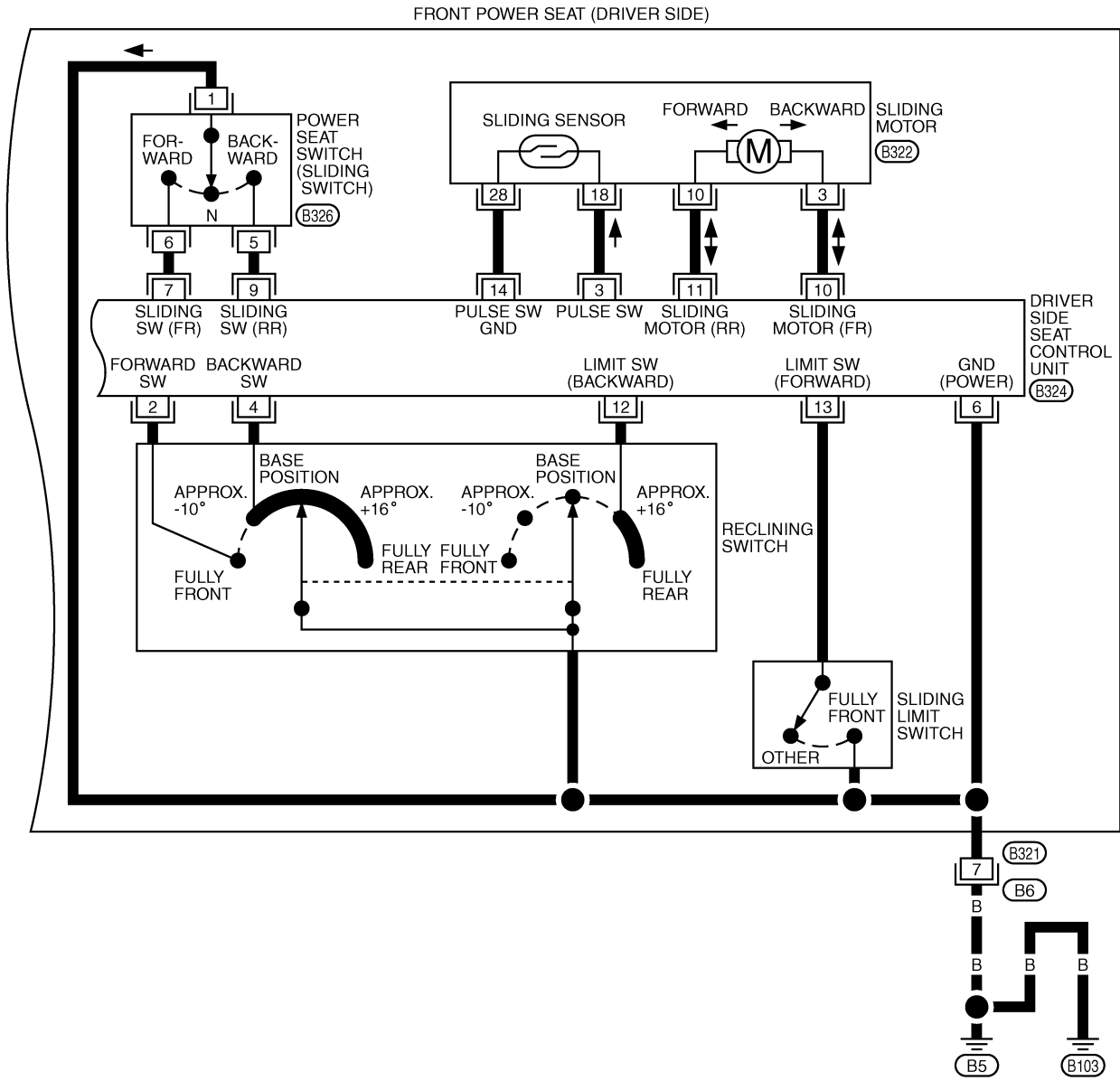

\*: THIS CONNECTOR IS NOT SHOWN IN "HARNESS LAYOUT", PG SECTION.

TIWM0483E

# POWER SEAT

## Wiring Diagram-SEAT- /For Passenger Seat

AIS001CJ

SE-SEAT-05

▬ : DATA LINE

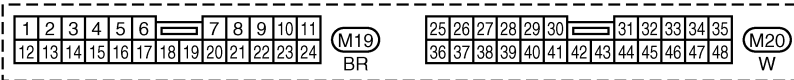
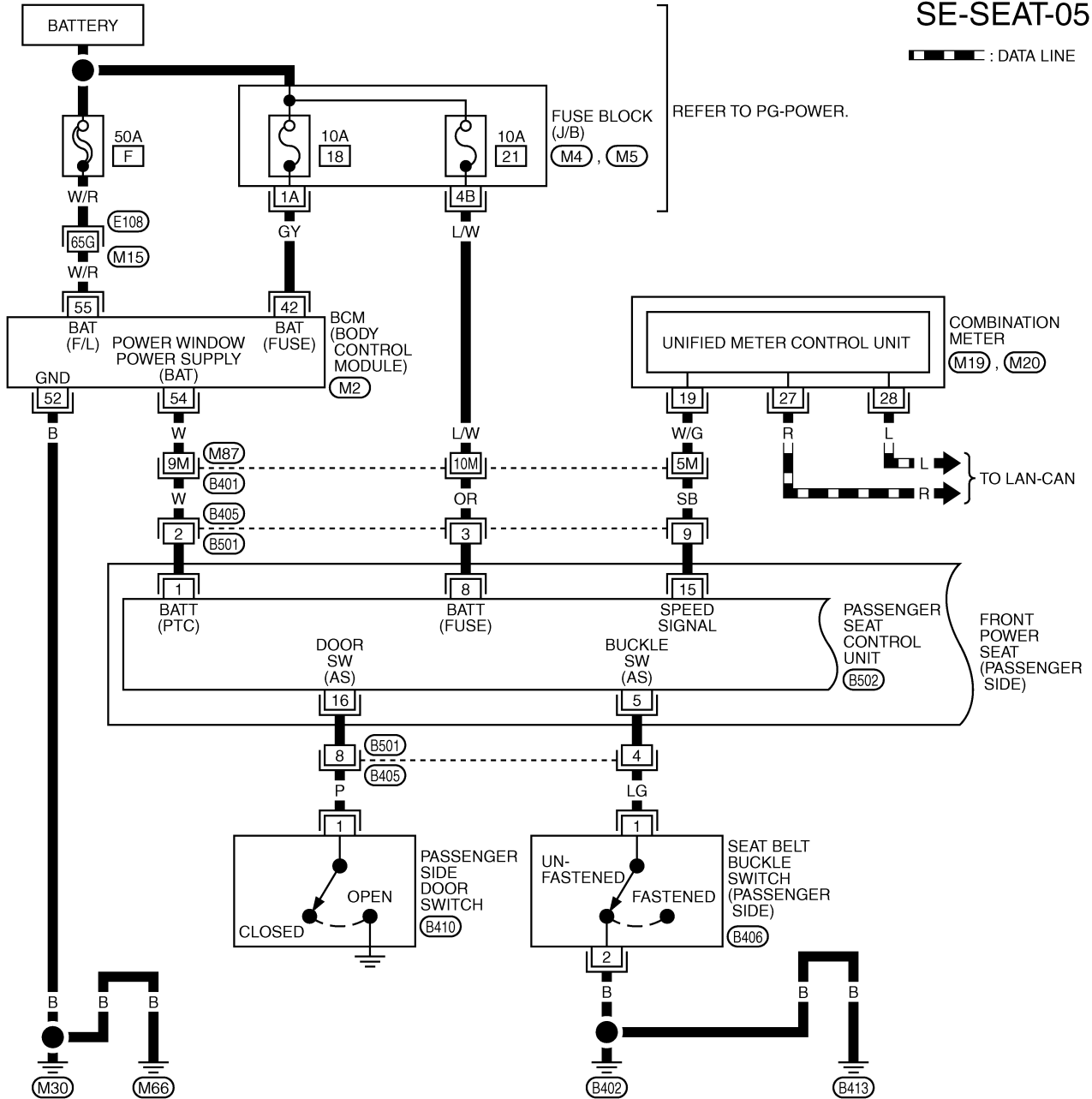

REFER TO THE FOLLOWING.  
 (E108), (B401) -SUPER MULTIPLE JUNCTION (SMJ)  
 (M4), (M5) -FUSE BLOCK-JUNCTION BOX (J/B)  
 (M2) -ELECTRICAL UNITS

\*: THIS CONNECTOR IS NOT SHOWN IN "HARNESS LAYOUT", PG SECTION.

TIWM0484E

# POWER SEAT

SE-SEAT-06

FRONT POWER SEAT (PASSENGER SIDE)

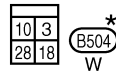
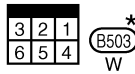
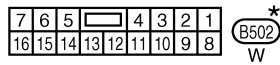
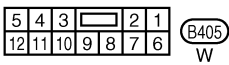
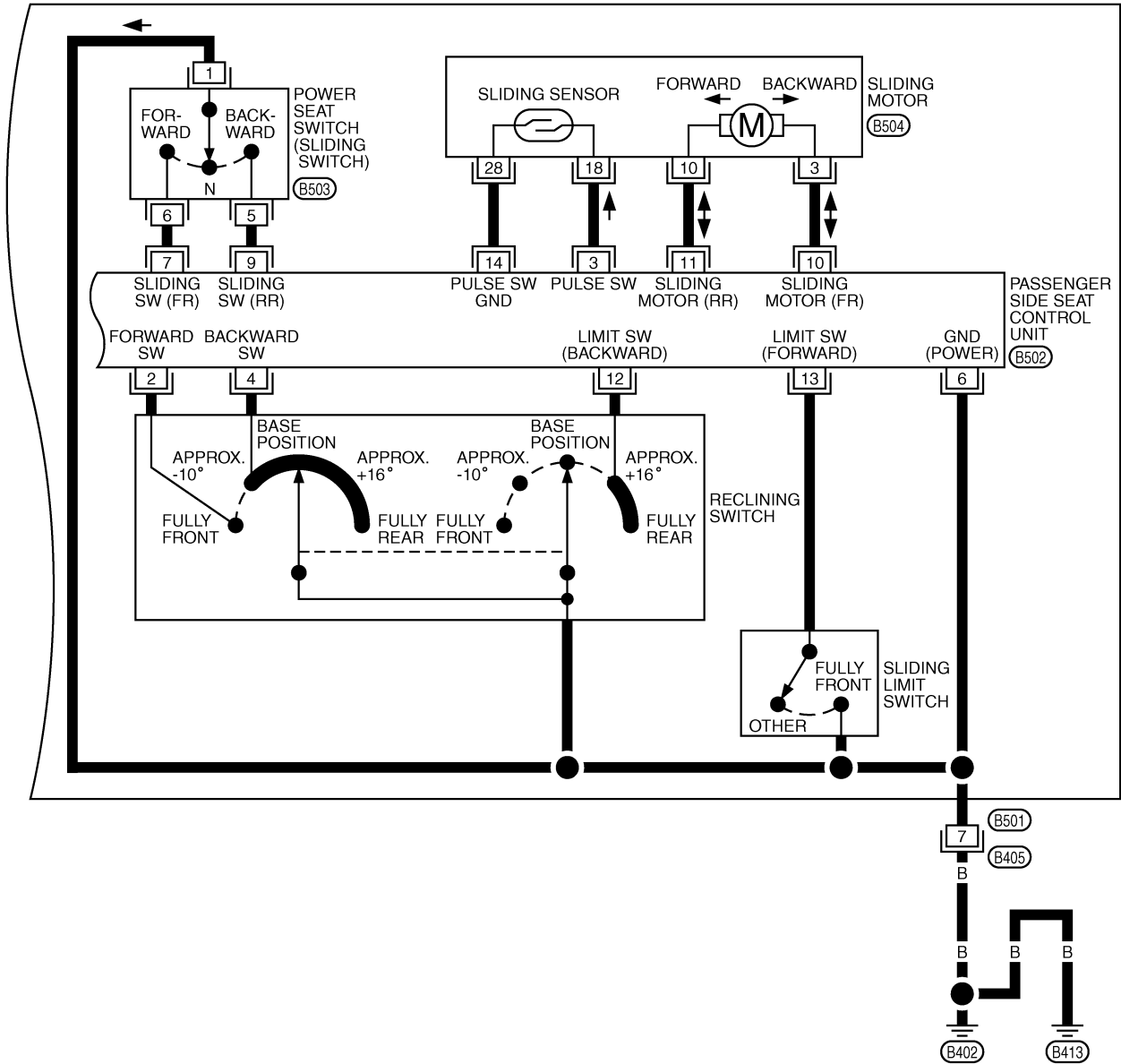

\*: THIS CONNECTOR IS NOT SHOWN IN "HARNESS LAYOUT", PG SECTION.

TIWT0342E

# POWER SEAT

## Terminal and Reference Value for Driver Side Seat Control Unit

AIS0028U

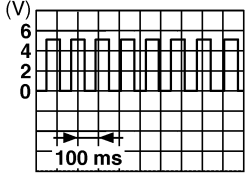
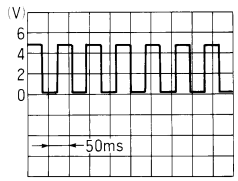
TERMI- NAL	ITEM	CONDITION	VOLTAGE (V) (Approx.)
1	BAT power supply	—	Battery voltage
2*	Forward switch signal	When folding the seat back of driver side to more than 32° from first locking position.	0
		Other than above	5
3*	Sliding motor pulse signal	When sliding motor operates	 <p style="text-align: right; font-size: small;">PIIA4079E</p>
4	Backward switch signal	When you return based on the fold down seat back	0
		Other than above	5
5	A/T shift lever P position signal (with A/T models)	When shift lever P position	0
		Other than above	5
	Parking brake signal (with M/T models)	When pull the parking brake	0
		Other than above	5
6	Ground	—	0
7	Forward sliding switch signal	Forward sliding switch: ON	0
		Other than above	Battery voltage
8	BAT power supply	—	Battery voltage
9	Backward sliding switch signal	Backward sliding switch: ON	0
		Other than above	Battery voltage
10	Sliding motor forward signal	When sliding motor forward operates	Battery voltage
		Other than above	0
11	Sliding motor backward signal	When sliding motor backward operates	Battery voltage
		Other than above	0
12*	Limit switch (backward)	When reclining the seat back of driver side to more than 26° from first locking position	0
		Other than above	5
13*	Limit switch (forward)	The seat slide front most part	0
		Other than above	5
14	Sliding motor pulse ground	—	0
15*	Vehicle speed signal (2-pulse)	Speedometer operated [When vehicle speed is approx. 40 km/h (25 MPH)]	 <p style="text-align: right; font-size: small;">ELF1080D</p>
16	Door switch and seat belt switch signal	When seat belt is unfastened and door is open	0
		Other than above	Battery voltage

\*: When operation condition consists.



# POWER SEAT

## Terminal and Reference Value for Passenger Side Seat Control Unit

AIS002HF

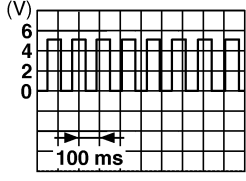
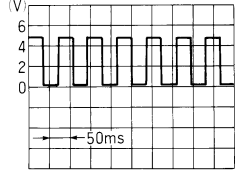
TERMI-NAL	ITEM	CONDITION	VOLTAGE (V) (Approx.)
1	BAT power supply	—	Battery voltage
2*	Forward switch signal	When folding the seat back of passenger side to more than 32° from first locking position	0
		Other than above	5
3*	Sliding motor pulse signal	When sliding motor operates	 <p style="text-align: right; font-size: small;">PIIA4079E</p>
4	Backward switch signal	When you return based on the fold down seat back	0
		Other than above	5
5	Seat belt buckle switch	When seat belt is fastened	5
		Other than above	0
6	Ground	—	0
7	Forward sliding switch signal	Forward sliding switch: ON	0
		Other than above	Battery voltage
8	BAT power supply	—	Battery voltage
9	Backward sliding switch signal	Backward sliding switch: ON	0
		Other than above	Battery voltage
10	Sliding motor forward signal	When sliding motor forward operates	Battery voltage
		Other than above	0
11	Sliding motor backward signal	When sliding motor backward operates	Battery voltage
		Other than above	0
12*	Limit switch (backward)	When reclining the seat back of passenger side to more than 26° from first locking position	0
		Other than above	5
13*	Limit switch (forward)	The seat slide front most part	0
		Other than above	5
14	Sliding motor pulse ground	—	0
15*	Vehicle speed signal (2-pulse)	Speedometer operated [When vehicle speed is approx. 40 km/h (25 MPH)]	 <p style="text-align: right; font-size: small;">ELF1080D</p>
16	Passenger side door switch signal	Open passenger side door (ON)	0
		Close passenger side door (OFF)	Battery voltage

\*: When operation condition consists.

# POWER SEAT

AIS0028V

## Work Flow

1. Check the symptom and customer's requests.
2. Understand the outline of system. Refer to [SE-14, "System Description"](#) .
3. According to the trouble diagnosis chart, repair or replace the cause of the malfunction. Refer to [SE-26, "Trouble Diagnoses Symptom Chart"](#) .
4. Does power seat system operate normally? If Yes, GO TO 5, If No, GO TO 3.
5. INSPECTION END.

## Trouble Diagnoses Symptom Chart

AIS0028W

- Check that other systems using the signal of the following systems operate normally.

Symptom	Diagnoses / service procedure	Refer to page
Driver side power seat cannot be operated.	1. Check driver seat control unit power supply and ground circuit.	<a href="#">SE-28</a>
	2. Check power seat switch.	<a href="#">SE-30</a>
	3. Check sliding motor.	<a href="#">SE-32</a>
Passenger side power seat cannot be operated.	1. Check BCM power supply and ground.	<a href="#">SE-27</a>
	2. Check passenger seat control unit power supply and ground circuit.	<a href="#">SE-28</a>
	4. Check power seat switch.	<a href="#">SE-30</a>
	5. Check sliding motor.	<a href="#">SE-32</a>
Power walk in system does not operated, but power seat can be operated (drive side)	1. Check door switch and seat belt buckle switch.	<a href="#">SE-36</a>
	2. Check A/T shift lever P position signal (with A/T models)	<a href="#">SE-40</a>
	2. Check parking brake signal (with M/T models)	<a href="#">SE-41</a>
	3. Check vehicle speed signal.	<a href="#">SE-43</a>
	4. Check reclining forward switch.	<a href="#">SE-43</a>
	5. Check sliding limit switch (forward)	<a href="#">SE-44</a>
	6. Check reclining backward switch.	<a href="#">SE-45</a>
Power walk in system does not operated, but power seat can be operated (passenger side)	7. Check sliding sensor.	<a href="#">SE-32</a>
	1. Check door switch.	<a href="#">SE-33</a>
	2. Check seat belt buckle switch.	<a href="#">SE-34</a>
	3. Check vehicle speed signal.	<a href="#">SE-43</a>
	4. Check reclining forward switch.	<a href="#">SE-43</a>
	5. Check sliding limit switch (forward)	<a href="#">SE-44</a>
	6. Check reclining backward switch.	<a href="#">SE-45</a>
After forward movement has been operated, seat will move backward even, when reclining the seat back for more than 26° from first locking position.	7. Check sliding sensor.	<a href="#">SE-32</a>
	1. Check reclining limit switch (backward)	<a href="#">SE-45</a>

# POWER SEAT

AIS004SE

## BCM Power Supply and Ground Circuit Check

### 1. FUSE INSPECTION

- Check 10A fuse [No.18, located in fuse block (J/B)]
- Check 50A fusible link (letter **F** located in the fuse and fusible link box).

**NOTE:**

Refer to [RF-10, "Component Parts and Harness Connector Location"](#) .

OK or NG

OK >> GO TO 2

NG >> If fuse is blown out, be sure to eliminate cause of malfunction before installing new fuse. Refer to [PG-4, "POWER SUPPLY ROUTING CIRCUIT"](#) .

### 2. CHECK POWER SUPPLY CIRCUIT

1. Turn ignition switch ON.
2. Check voltage between BCM connector M2 terminal 42, 55 and ground.

**42 (GY) – Ground : Battery voltage.**

**55 (W/R) – Ground : Battery voltage.**

OK or NG

OK >> GO TO 3.

NG >> Check BCM power supply circuit for open or short.

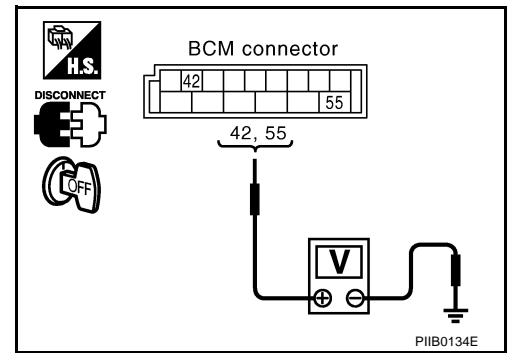

### 3. CHECK GROUND CIRCUIT

1. Turn ignition switch OFF.
2. Disconnect BCM connector.
3. Check continuity between BCM connector M2 terminal 52 and ground.

**52 (B) – Ground : Continuity should exist.**

OK or NG

OK >> Power supply and ground circuit is OK.

NG >> Check BCM ground circuit for open or short.

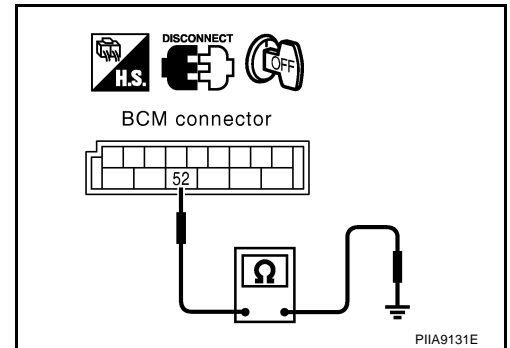

# POWER SEAT

## Check Driver Seat Control Unit Power Supply and Ground Circuit

AIS0028X

### 1. CHECK POWER SUPPLY CIRCUIT

1. Turn ignition switch OFF.
2. Check voltage between driver seat control unit B324 terminal 1, 8 and ground.

**1 – Ground : Battery voltage**  
**8 – Ground : Battery voltage**

#### OK or NG

OK >> GO TO 2.

NG >> Check the following.

- 50A fusible link (letter **F**, located in fuse and fusible link box.)
- 10A fuse [No.21, located in fuse block (J/B)]
- Harness for open or short between driver seat control unit and fuse.

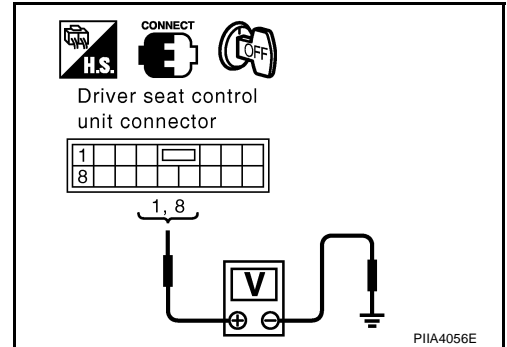

### 2. CHECK GROUND CIRCUIT

1. Disconnect driver side control unit connector.
2. Check continuity between driver side control unit B324 terminal 6 and ground.

**6 – Ground : Continuity should exist.**

#### OK or NG

OK >> Driver seat control unit power supply and ground circuit are OK. Further inspection is necessary, Refer to symptom chart.

NG >> Repair or replace harness.

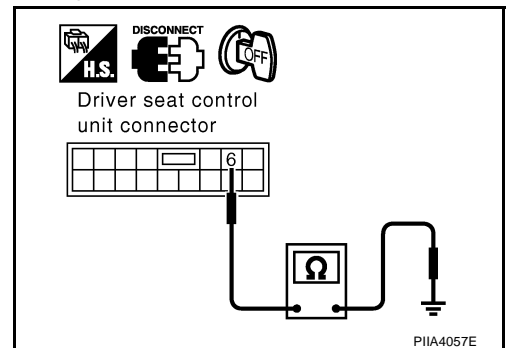

## Check Passenger Seat Control Unit Power Supply and Ground Circuit

AIS0028Y

### 1. CHECK FUSE

Check 10A fuse [No. 21, located in fuse block (J/B)].

#### NOTE:

Refer to

#### OK or NG

OK >> GO TO 2.

NG >> If fuse blown, be sure to eliminate cause of malfunction before installing new fuse. Refer to

# POWER SEAT

## 2. CHECK POWER SUPPLY CIRCUIT

1. Turn ignition switch OFF.
2. Check voltage between passenger seat control unit connector B502 terminals 1, 8 and ground.

**1 – Ground : Battery voltage**  
**8 – Ground : Battery voltage**

OK or NG

- OK >> GO TO 3.  
NG >> GO TO 4.

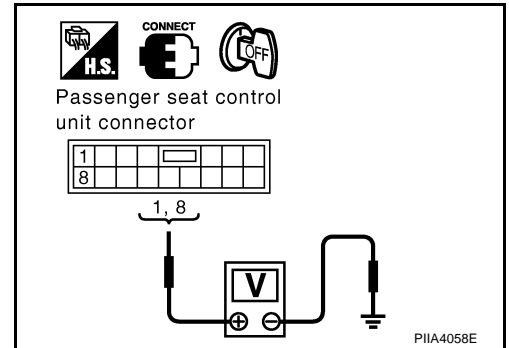

## 3. CHECK GROUND CIRCUIT

1. Disconnect passenger seat control unit connector.
2. Check continuity between passenger seat control unit connector B502 terminal 6 and ground.

**6 – Ground : Continuity should exist.**

OK or NG

- OK >> Passenger seat control unit power supply and ground circuit are OK, Further inspection is necessary. Refer to symptom chart.  
NG >> Repair or replace harness.

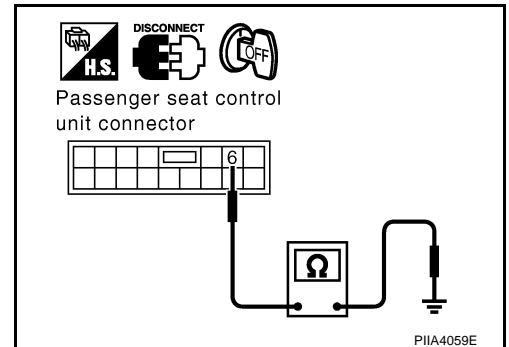

## 4. CHECK POWER SUPPLY CIRCUIT

1. Disconnect BCM and passenger seat control unit connector.
2. Check continuity between BCM connector M2 terminal 54 and passenger seat control unit connector B502 terminal 1.

**54 (W) – 1 : Continuity should exist.**

OK or NG

- OK >> GO TO 5.  
NG >> Repair or replace harness between BCM and passenger seat control unit.

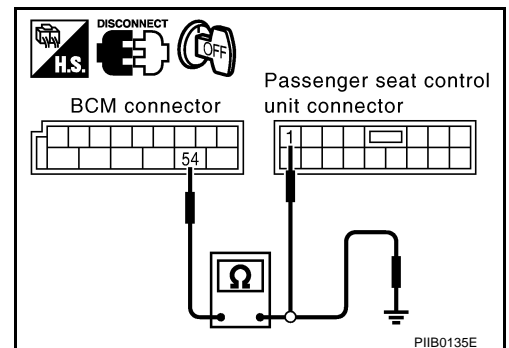

# POWER SEAT

## 5. CHECK BCM OUTPUT SIGNAL

1. Connect BCM connector.
2. Check voltage between BCM connector M2 terminal 54 and ground.

**54 (W) – Ground : Battery voltage**

OK or NG

- OK >> Check the condition of the harness and the connector.  
 NG >> Replace BCM.

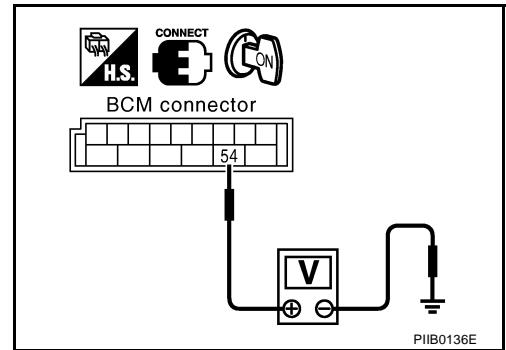

PIIB0136E

AIS0028Z

## Check Power Seat Switch

### 1. CHECK POWER SEAT SWITCH INPUT SIGNAL

1. Turn ignition switch ON.
2. Check voltage between seat control unit connector B324 (driver side), B502 (passenger side) terminals 7, 9 and ground.

Connector	Terminals		Condition	Voltage (V) (Approx.)
	(+)	(-)		
B302 B502	7	Ground	Forward SW: ON	0
			Other than above	Battery voltage
	9		Backward SW: ON	0
			Other than above	Battery voltage

OK or NG

- OK >> Power seat switch is OK.  
 NG >> GO TO 2.

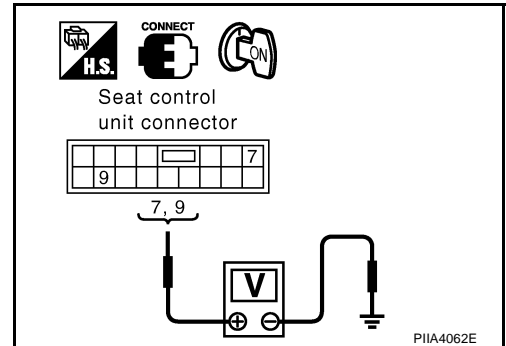

PIIA4062E

### 2. CHECK POWER SEAT SWITCH CIRCUIT

1. Turn ignition switch OFF.
2. Disconnect seat control unit and power seat switch connector.
3. Check continuity between seat control unit connector B324 (driver side), B502 (passenger side) terminals 7, 9 and power seat switch connector B326 (driver side), B503 (passenger side) terminal 5, 6.

**7 – 6 : Continuity should exist.**

**9 – 5 : Continuity should exist.**

OK or NG

- OK >> GO TO 3.  
 NG >> Repair or replace harness between seat control unit and power seat switch.

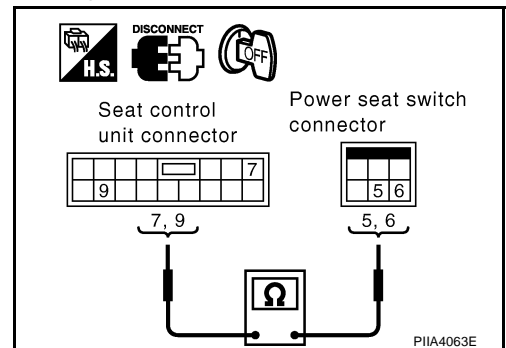

PIIA4063E

# POWER SEAT

## 3. CHECK SEAT CONTROL UNIT OUTPUT SIGNAL

1. Connect seat control unit connector.
2. Check voltage between seat control unit connector B324 (driver side), B503 (passenger side) terminal 7, 9 and ground.

**7 – Ground : Battery voltage.**  
**9 – Ground : Battery voltage.**

OK or NG

- OK >> GO TO 4.  
 NG >> Replace seat control unit.

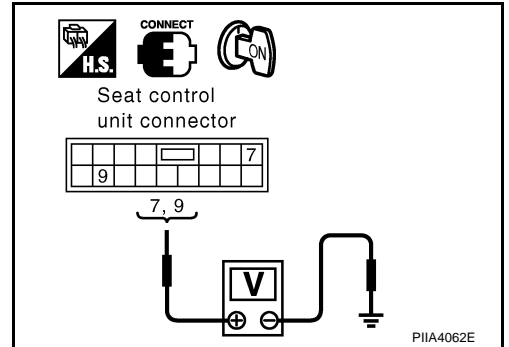

## 4. CHECK POWER SEAT SWITCH

Check continuity between power seat switch connector B326 (driver side), B503 (passenger side) terminals 5, 6 and 1.

Terminals	Power seat switch	Continuity
5	Backward SW: ON	Yes
	Other than above	No
6	Forward SW: ON	Yes
	Other than above	No

OK or NG

- OK >> GO TO 5.  
 NG >> Replace power seat switch.

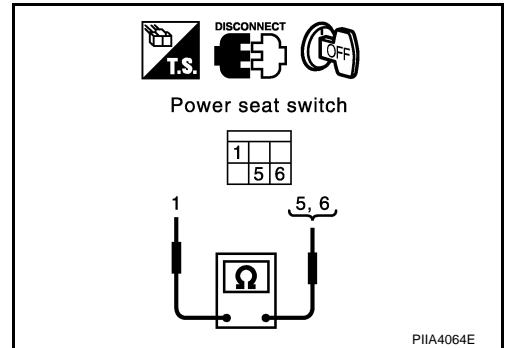

## 5. CHECK POWER SEAT SWITCH GROUND CIRCUIT

Check continuity between power seat switch connector B326 (driver side), B503 (passenger side) terminal 1 and ground.

**1 – Ground : Continuity should exist.**

OK or NG

- OK >> Check the condition of the harness and the connector.  
 NG >> Repair or replace harness.

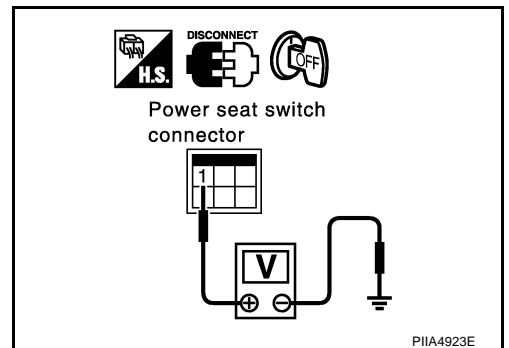

# POWER SEAT

AIS00290

## Check Sliding Motor

### 1. CHECK POWER SEAT MOTOR SIGNAL

Check voltage between seat control unit connector B324 (driver side), B502 (passenger side) terminals 10, 11 and ground.

Connector	Terminals		Condition	Voltage (V) (Approx.)
	(+)	(-)		
B324 B502	10	Ground	Forward sw: ON	Battery voltage
			Other than above	0
	11		Backward sw: OFF	Battery voltage
			Other than above	0

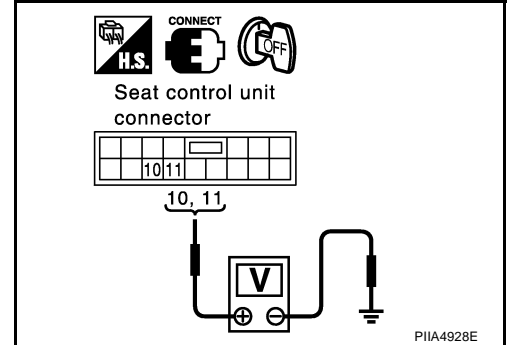

OK or NG

OK >> GO TO 2.

NG >> Replace seat control unit driver side or passenger side.

### 2. CHECK SLIDING MOTOR CIRCUIT

1. Disconnect seat control unit and sliding motor connector.
2. Check continuity between seat control unit connector B324 (driver side), B502 (passenger side) terminals 10, 11 and sliding motor connector B322 (driver side), B504 (passenger side) terminal 3, 10.

**10 – 3 : Continuity should exist.**

**11 – 10 : Continuity should exist.**

OK or NG

OK >> Replace sliding motor

NG >> Repair or replace harness between seat control unit and sliding motor.

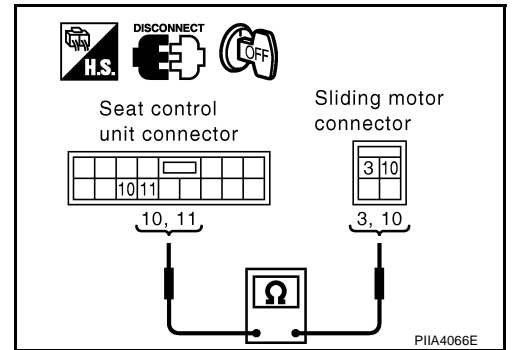

## Check Sliding Sensor

### 1. CHECK SLIDING SENSOR SIGNAL

AIS00202

Check the signal between seat control unit connector B324 (driver side), B502 (passenger side) and ground with oscilloscope.

Connector	Terminals		Condition	Signal (Reference valve)
	(+)	(-)		
B324 B502	3	Ground	Motor is operating	<p>(V)</p> <p>6 4 2 0</p> <p>100 ms</p> <p>PIIA4079E</p>

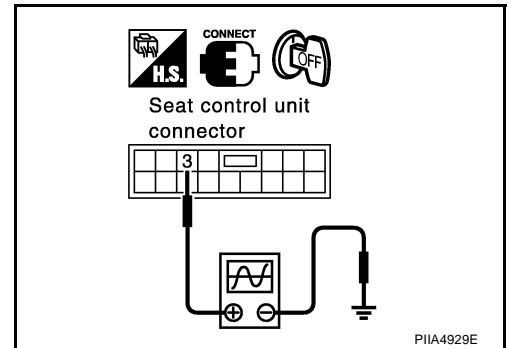

OK or NG

OK >> Sliding sensor is OK.

NG >> GO TO 2.



# POWER SEAT

## 2. CHECK SLIDING SENSOR GROUND CIRCUIT

1. Disconnect sliding motor connector.
2. Check continuity seat control unit connector B324 (driver side), B502 (passenger side) terminal 14 and ground.

**14 – Ground : Continuity should exist.**

OK or NG

- OK >> GO TO 3.  
 NG >> Repair or replace harness.

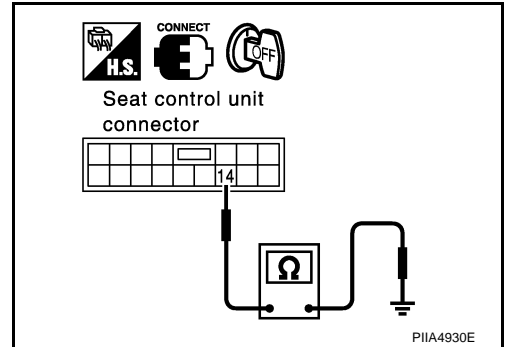

## 3. CHECK HARNESS CONTINUITY

1. Disconnect seat control unit connector.
2. Check continuity between seat control unit connector B324 (driver side), B502 (passenger side) terminal 3, 14 and sliding motor connector B322 (driver side), B504 (passenger side) terminal 18, 28.

**3 – 18 : Continuity should exist.**

**14 – 28 : Continuity should exist.**

3. Check continuity between seat control unit connector B324 (driver side), B504 (passenger side) terminal 3, 14 and ground.

**3 – Ground : Continuity should not exist.**

**14 – Ground : Continuity should not exist.**

OK or NG

- OK >> Replace sliding motor.  
 NG >> Repair or replace harness.

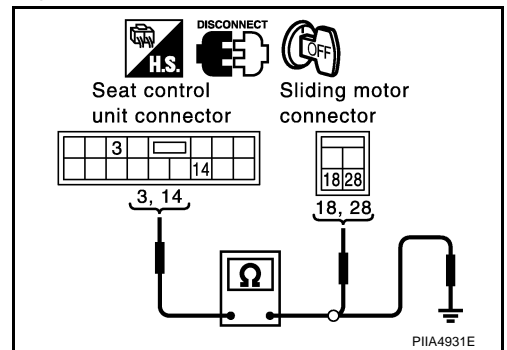

## Check Door Switch

### 1. CHECK DOOR SWITCH SIGNAL

Check voltage between seat control unit connector B502 (passenger side) terminal 16 and ground.

Terminals		Condition	Voltage (V) (Approx.)
(+)	(-)		
16	Ground	OPEN	0
		CLOSE	Battery voltage

OK or NG

- OK >> Door switch is OK  
 NG >> GO TO 2.

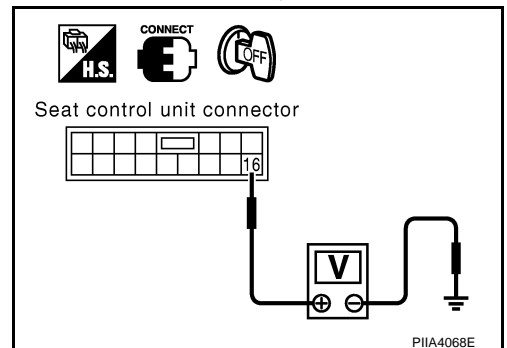

# POWER SEAT

## 2. CHECK DOOR SWITCH CIRCUIT

1. Turn ignition switch OFF.
2. Disconnect seat control unit and door switch connector.
3. Check continuity between seat control unit connector B502 (passenger side) terminal 16 and door switch connector B410 (passenger side) terminal 1.

**16 – 1 (P) : Continuity should exist.**

OK or NG

OK >> GO TO 3.

NG >> Repair or replace harness between seat control unit and door switch.

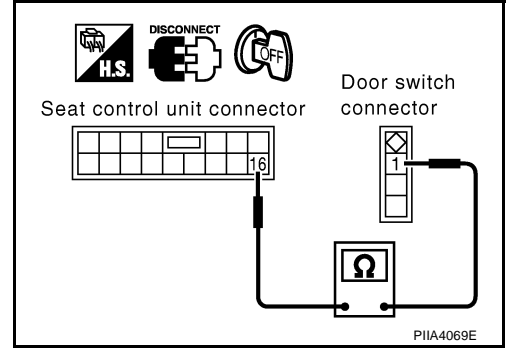

## 3. CHECK DOOR SWITCH

Check continuity between door switch B410 (passenger side) terminal 1 and ground part of door switch.

Terminals		Door switch	Continuity
1	Ground part of door switch	Pushed	No
		Released	Yes

OK or NG

OK >> Check the condition of the harness and the connector.

NG >> Replace malfunction door switch.

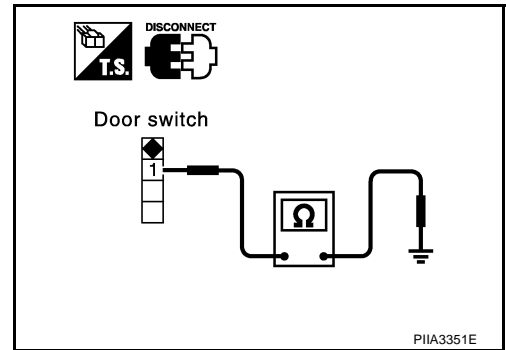

## Check Seat Belt Buckle Switch

### 1. CHECK SEAT BELT BUCKLE SWITCH SIGNAL

1. Turn ignition switch ON.
2. Check voltage between seat control unit connector B502 (passenger side) terminal 5 and ground.

Terminals		Condition	Voltage (V) (Approx.)
(+)	(-)		
5	Ground	When seat belt is fastened	5
		Other than above	0

OK or NG

OK >> Seat belt buckle switch is OK.

NG >> GO TO 2.

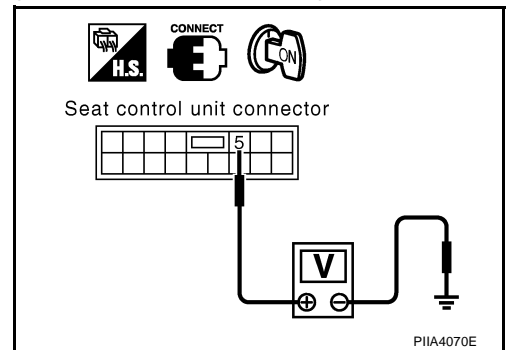

# POWER SEAT

## 2. CHECK SEAT BELT BUCKLE SWITCH CIRCUIT

1. Turn ignition switch OFF.
2. Disconnect seat control unit and seat belt buckle switch connector.
3. Check continuity between seat control unit (passenger side) connector B502 terminal 5 and seat belt buckle switch (passenger side) connector B406 terminal 1.

**5 – 1 (LG) : Continuity should exist.**

OK or NG

- OK >> GO TO 3.  
 NG >> Repair or replace harness between seat control unit and seat belt buckle switch.

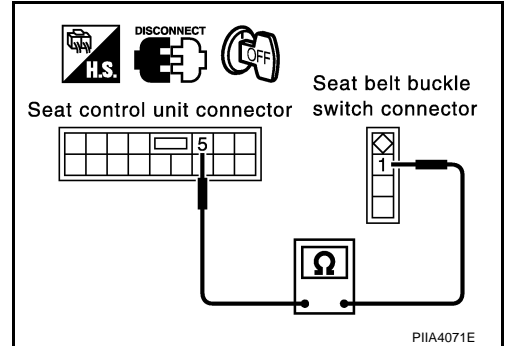

## 3. CHECK SEAT BELT BUCKLE SWITCH

Check continuity between seat belt buckle switch (passenger side) terminal 1 and 2.

Terminals		Condition	Continuity
1	2	When seat belt is fastened	No
		Other than above	Yes

OK or NG

- OK >> GO TO 4.  
 NG >> Replace seat belt buckle switch.

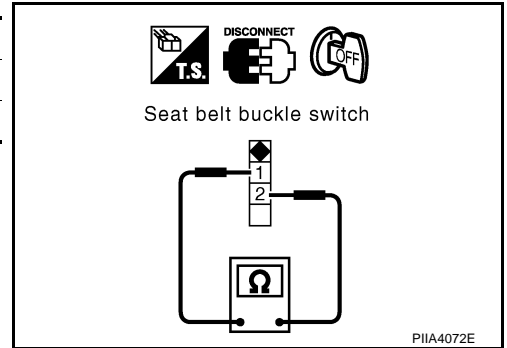

## 4. CHECK SEAT BELT BUCKLE SWITCH GROUND CIRCUIT

Check continuity between seat belt buckle switch (passenger side) connector B406 terminal 2 and ground.

**2 (B) – Ground : Continuity should exist.**

OK or NG

- OK >> Check the condition of the harness and the connector  
 NG >> Repair or replace harness

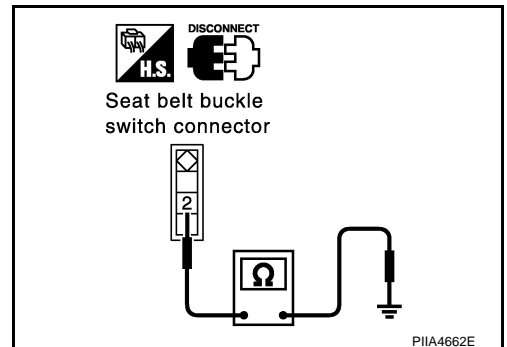

# POWER SEAT

AIS002L6

## Check Door Switch and Seat Belt Buckle Switch

### 1. CHECK DOOR SWITCH AND SEAT BELT SWITCH SIGNAL

Check voltage between driver side seat control unit connector and ground.

Connector	Terminals		Condition	Voltage (V) (Approx.)
	(+)	(-)		
B324	16	Ground	When seat belt is unfastened and door is open	0
			Other than above	Battery voltage

OK or NG

- OK >> Door switch and seat belt buckle switch is OK.  
 NG >> GO TO 2.

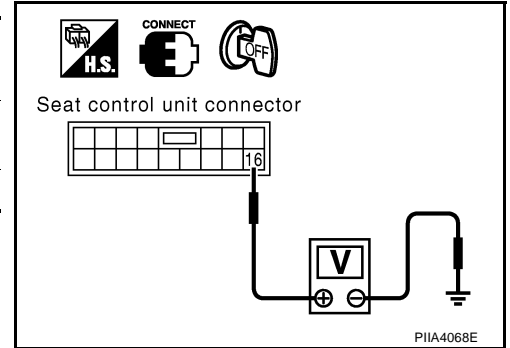

### 2. CHECK POWER WALK-IN RELAY POWER SUPPLY CIRCUIT

1. Turn ignition switch OFF.
2. Disconnect power walk-in relay.
3. Check voltage between power walk-in relay connector B347 terminal 3 and ground.

**3 – Ground : Battery voltage.**

OK or NG

- OK >> GO TO 5.  
 NG >> GO TO 3.

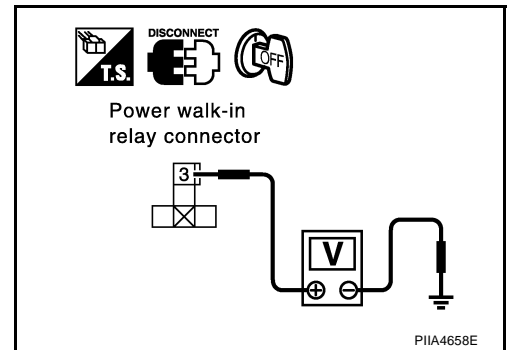

### 3. CHECK HARNESS CONTINUITY 1

1. Disconnect driver seat control unit.
2. Check continuity between driver seat control unit connector B324 terminal 16 and power walk-in relay connector B347 terminal 3.

**16 – 3 : Continuity should exist.**

OK or NG

- OK >> GO TO 4  
 NG >> Repair or replace harness between driver seat control unit and power walk-in relay.

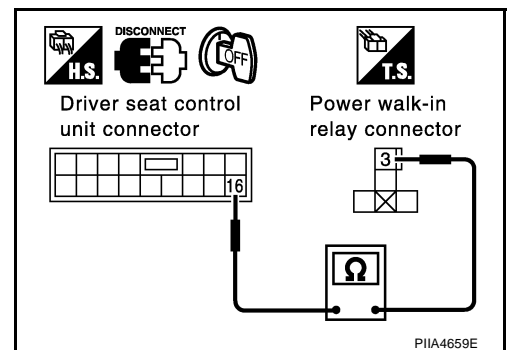

# POWER SEAT

## 4. CHECK DRIVER SEAT CONTROL UNIT OUTPUT SIGNAL

1. Connect driver seat control unit connector.
2. Check voltage between driver seat control unit connector B324 terminal 16 and ground.

**16 – Ground : Battery voltage.**

OK or NG

- OK >> Check the condition of the harness and the connector.  
 NG >> Replace driver seat control unit.

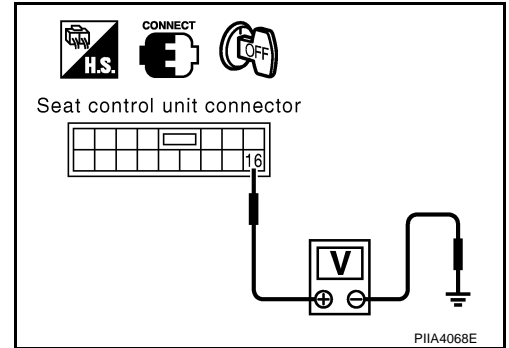

## 5. CHECK POWER WALK-IN RELAY GROUND CIRCUIT

Check continuity between power walk-in relay connector B347 terminal 5 and ground.

Terminals		Condition	Continuity
5	Ground	When seat belt is fastened	No
		Other than above	Yes

OK or NG

- OK >> GO TO 9.  
 NG >> GO TO 6.

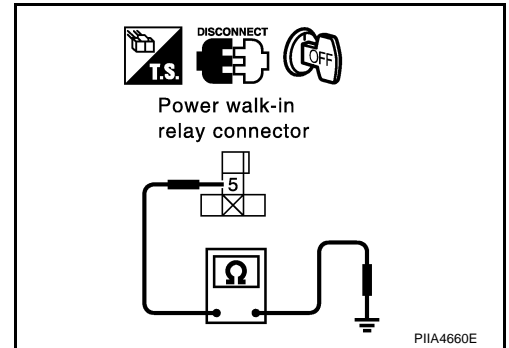

## 6. CHECK HARNESS CONTINUITY 2

1. Disconnect seat belt buckle switch connector.
2. Check continuity between power walk-in relay connector B347 terminal 5 and seat belt buckle switch (driver side) connector B8 terminal 1.

**5 – 1 (BR) : Continuity should exist.**

OK or NG

- OK >> GO TO 7.  
 NG >> Repair or replace harness power walk-in relay and seat belt buckle switch (driver side)

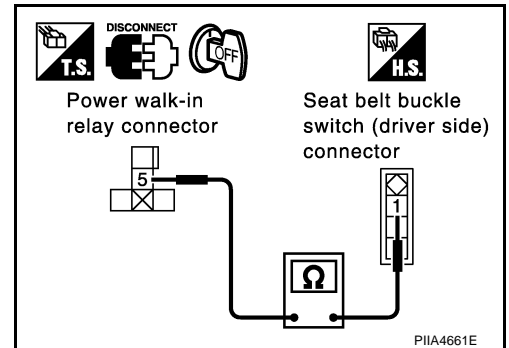

# POWER SEAT

## 7. CHECK SEAT BELT BUCKLE SWITCH

Check continuity between seat belt buckle switch (driver side) terminal 1 and 2.

Terminals		Condition	Continuity
1	2	When seat belt is fastened	No
		Other than above	Yes

OK or NG

OK >> GO TO 8.

NG >> Replace seat belt buckle switch (driver side).

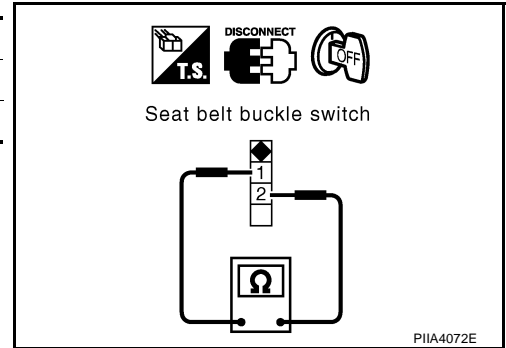

## 8. CHECK SEAT BELT BUCKLE SWITCH GROUND CIRCUIT

Check continuity between seat belt buckle switch (driver side) connector B8 terminal 2 and ground.

**2 (B/R) – Ground : Continuity should exist.**

OK or NG

OK >> Check the condition of the harness and the connector

NG >> Repair or replace harness

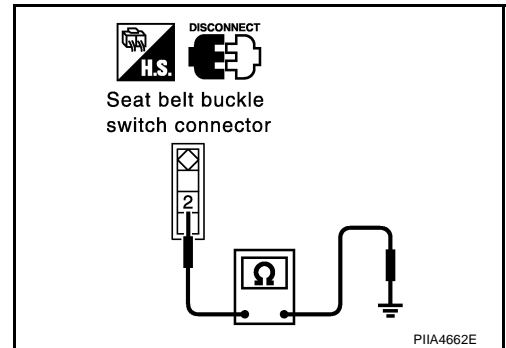

## 9. CHECK POWER WALK-IN RELAY

Check continuity between power walk-in relay terminals 3 and 5.

Terminals		Condition	Continuity
3	5	12V direct current supply between terminal 1 and 2	Yes
		Other than above	No

OK or NG

OK >> GO TO 10

NG >> Replace power walk-in relay.

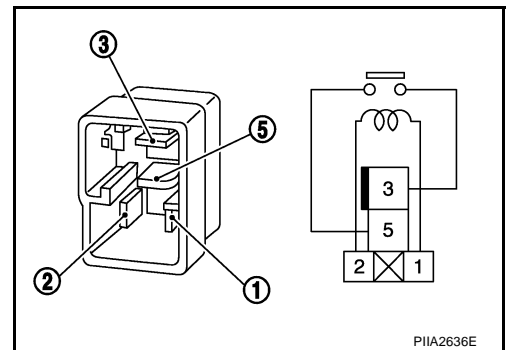

## 10. CHECK POWER WALK-IN RELAY POWER SUPPLY

Check voltage between power walk-in relay connector B347 terminal 2 and ground.

**2 – Ground : Battery voltage.**

OK or NG

OK >> GO TO 11.

NG >> Check the following

- 10A fuse [No.21, located in fuse block (J/B)]
- Harness for open or short between power walk-in relay and fuse.

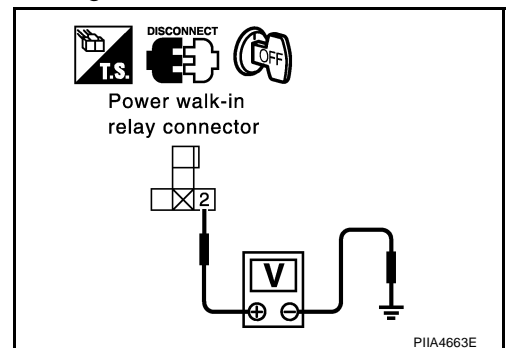

# POWER SEAT

## 11. CHECK DOOR SWITCH

Check continuity between power walk-in relay connector B347 terminal 1 and ground.

Connector	Terminal		Condition	Continuity
B347	1	Ground	Driver side door is open	Yes
			Driver side door is close	No

OK or NG

- OK >> Check the condition of the harness and the connector  
 NG >> GO TO 12.

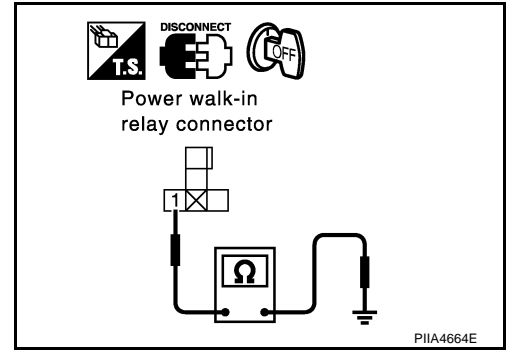

## 12. CHECK HARNESS CONTINUITY 3

1. Disconnect driver side door switch connector.
2. Check continuity between power walk-in relay connector B347 terminal 1 and driver side door switch connector B17 terminal 1.

**1 – 1 (G/B)**

**: Continuity should exist.**

OK or NG

- OK >> GO TO 13.  
 NG >> Repair or replace harness between power walk-in relay and driver side door switch.

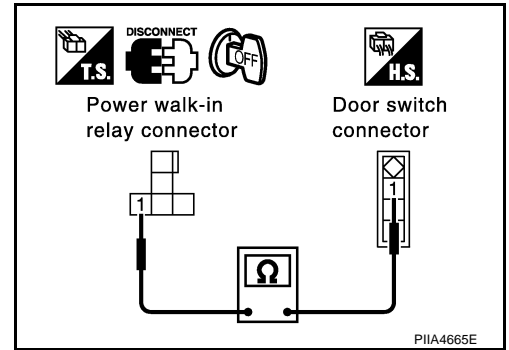

## 13. CHECK DOOR SWITCH

Check continuity between driver side door switch B17 terminal 1 and body ground part of door switch.

Terminals		Door switch	Continuity
1	Body ground part of door switch	Pushed	No
		Released	Yes

OK or NG

- OK >> Check ground condition of door switch.  
 NG >> Replace driver side door switch.

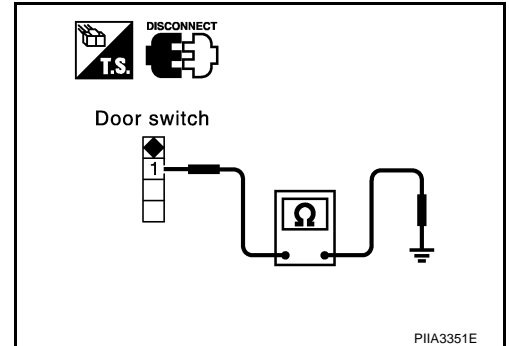

# POWER SEAT

AI5002MD

## Check A/T Shift Lever P Position Signal (with A/T Models)

### 1. CHECK A/T SHIFT LEVER P POSITION SIGNAL

Check voltage between driver seat control unit connector and ground.

Connector	Terminals		Condition	Voltage (V) (Approx.)
	(+)	(-)		
B324	5	Ground	When shift lever P position	0
			Other than above	5

OK or NG

- OK >> A/T shift lever P position signal is OK.  
 NG >> GO TO 2.

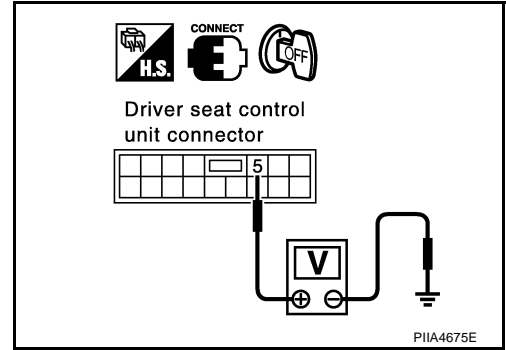

### 2. CHECK HARNESS CONTINUITY

1. Turn ignition switch OFF.
2. Disconnect driver seat control unit and A/T device connector.
3. Check continuity between driver seat control unit connector B324 terminal 5 and A/T device connector M47 terminal 3.

**5 – 3 (PU/R) : Continuity should exist.**

OK or NG

- OK >> GO TO 3.  
 NG >> Repair or replace harness between driver seat control unit and A/T device.

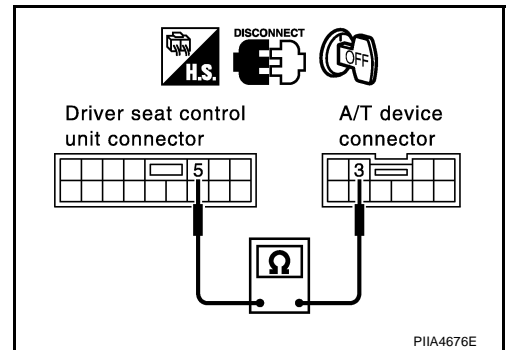

### 3. CHECK A/T DEVICE GROUND CIRCUIT

Check continuity between A/T device connector M47 terminal 1 and ground.

**1 (B) – Ground : Continuity should exist.**

OK or NG

- OK >> GO TO 4.  
 NG >> Repair or replace harness.

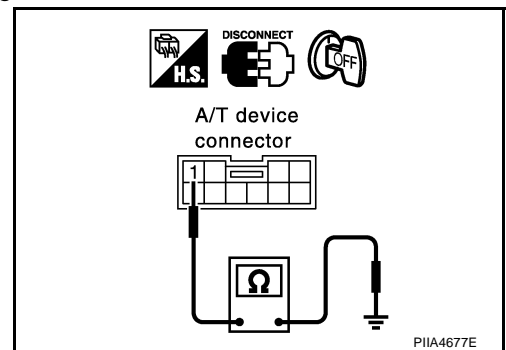



# POWER SEAT

## 4. CHECK A/T DEVICE

Check continuity between A/T device terminals 1 and 3.

Terminals		Condition	Continuity
1	3	When shift lever P position	Yes
		Other than above	No

OK or NG

- OK >> GO TO 5.
- NG >> Replace A/T device.

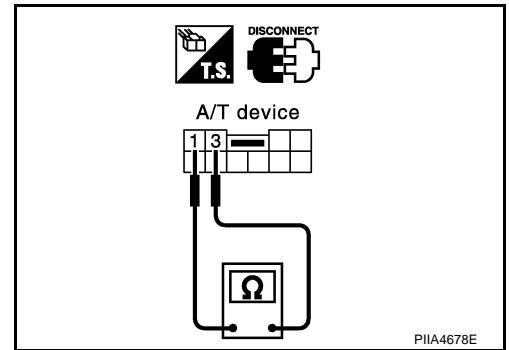

## 5. CHECK DRIVER SEAT CONTROL UNIT OUTPUT SIGNAL

- Connect driver seat control unit connector.
- Check voltage between driver seat control unit connector B324 terminal 5 and ground.

**5 – Ground : Approx. 5V**

OK or NG

- OK >> Check the condition of the harness and the connector.
- NG >> Replace driver control unit.

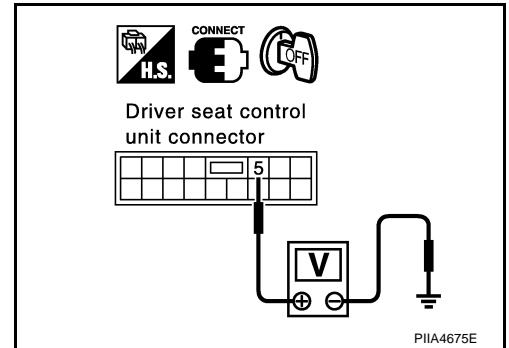

## Check Parking Brake Signal (with M/T Models)

### 1. CHECK PARKING BRAKE SIGNAL

Check voltage between driver seat control unit connector and ground.

Connector	Terminals		Condition	Voltage (V) (Approx.)
	(+)	(-)		
B324	5	Ground	When pull the parking brake	0
			Other than above	5

OK or NG

- OK >> Parking brake signal is OK.
- NG >> GO TO 2.

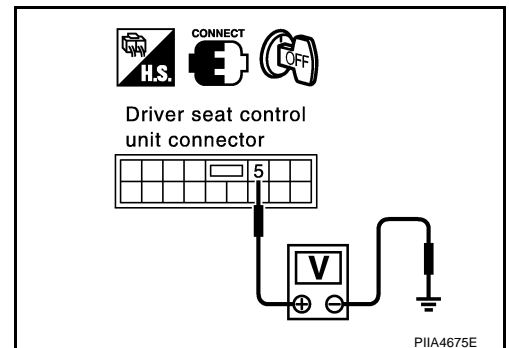

# POWER SEAT

## 2. CHECK HARNESS CONTINUITY

1. Turn ignition switch OFF.
2. Disconnect driver seat control unit and parking brake switch connector.
3. Check continuity between driver seat control unit connector M324 terminal 5 and parking brake switch connector B37 terminal 1.

**5 – 1 (LG/B) : Continuity should exist.**

OK or NG

- OK >> GO TO 3.  
 NG >> Repair or replace harness between driver seat control unit and parking brake switch.

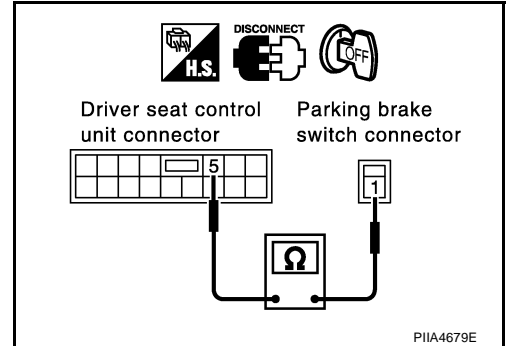

## 3. CHECK PARKING BRAKE SWITCH

Check continuity between parking brake switch terminal 1 and ground.

Terminals		Condition	Continuity
1	Ground	When pull the parking brake	Yes
		Other than above	No

OK or NG

- OK >> GO TO 4.  
 NG >> Check ground condition of parking brake switch.

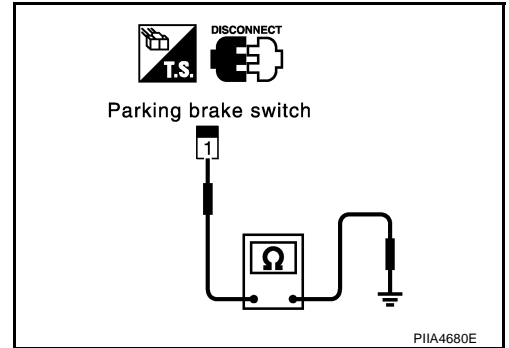

## 4. CHECK DRIVER SEAT CONTROL UNIT OUTPUT SIGNAL

1. Connect driver seat control unit connector.
2. Check voltage between driver seat control unit connector B324 terminal 5 and ground.

**5 – Ground : Approx. 5V**

OK or NG

- OK >> Check the condition of the harness and the connector.  
 NG >> Replace driver control unit.

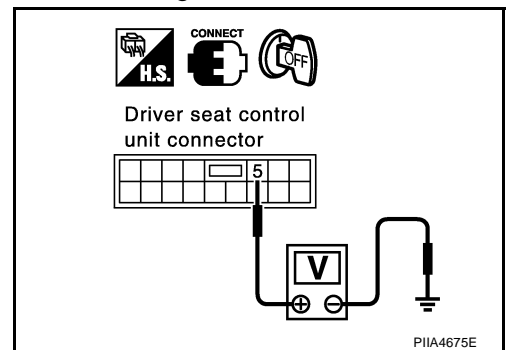

# POWER SEAT

AIS00296

## Check Vehicle Speed Signal

### 1. CHECK VEHICLE SPEED INPUT SIGNAL

Check the signal between seat control unit connector B324 (driver side), B502 (passenger side) terminal 15 and ground with oscilloscope.

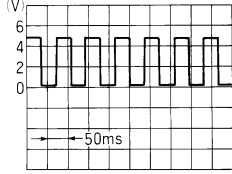
Connector	Terminals		Condition	Signal (Reference valve)
	(+)	(-)		
B324 B502	15	Ground	when vehicle speed is approx.40 km/h (25 MPH)	 <p>ELF1080D</p>

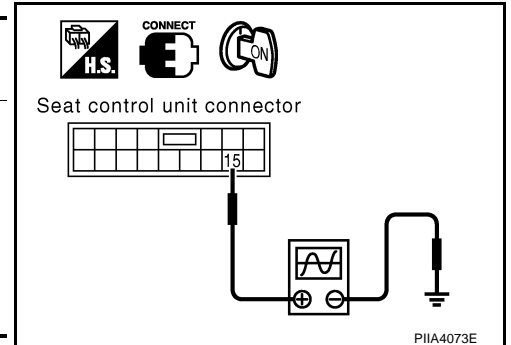

OK or NG

- OK >> Vehicle speed signal is OK.
- NG >> GO TO 2.

### 2. CHECK VEHICLE SPEED SIGNAL CIRCUIT

1. Turn ignition switch OFF.
2. Disconnect combination meter and seat control unit connector.
3. Check continuity between combination meter connector M19 terminal 19 and seat control unit connector B324 (driver side), B502 (passenger side) terminal 15.

**19 (G/R) – 15 : Continuity should exist.**

OK or NG

- OK >> Check combination meter. Refer to [DI-15](#)
- NG >> Repair or replace harness between combination meter and seat control unit.

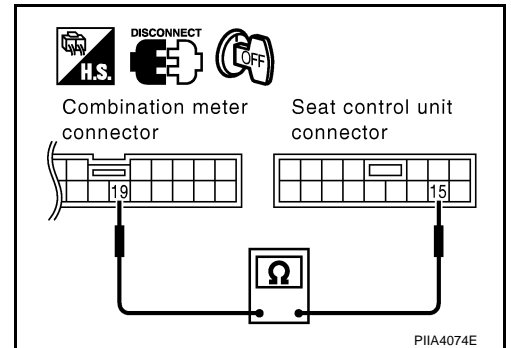

## Check Reclining Forward Switch

### 1. CHECK RECLINING FORWARD SWITCH SIGNAL

When operation condition consists, check voltage between seat control unit connector B324 (driver side), B502 (passenger side) terminal 2 and ground.

Connector	Terminals		Condition	Voltage (V) (Approx.)
	(+)	(-)		
B324 B502	2	Ground	When folding the seat back to more than 32° from first locking position	0
			Other than above	5

OK or NG

- OK >> Reclining forward switch is OK.
- NG >> GO TO 2.

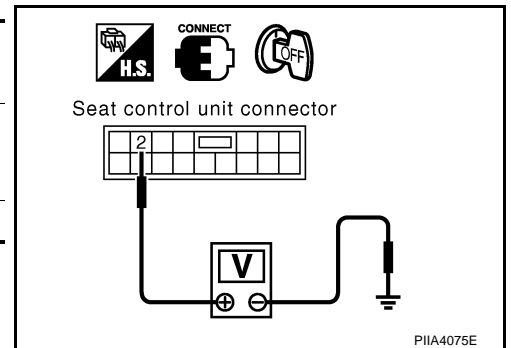

# POWER SEAT

## 2. CHECK SEAT CONTROL UNIT OUTPUT SIGNAL

Check voltage between seat control unit connector B324 (driver side), B502 (passenger side) terminal 2 and ground.

**2 – Ground : Approx. 5V**

OK or NG

- OK >> Reclining forward switch is NG. Replace seat adjuster assembly, Refer to [SE-57](#)
- NG >> Replace seat control unit.

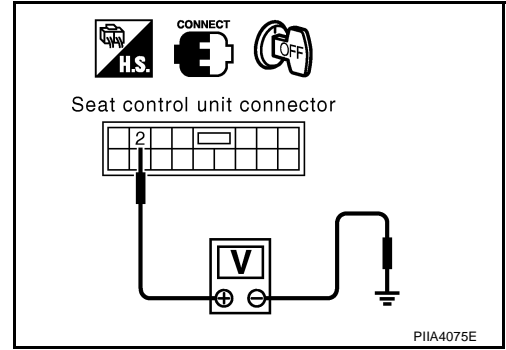

## Check Sliding Limit Switch (Forward)

### 1. CHECK SLIDING LIMIT SWITCH (FORWARD) SIGNAL

When operation condition consists, check voltage between seat control unit connector B324 (driver side), B502 (passenger side) terminal 13 and ground.

Connector	Terminals		Condition	Voltage (V) (Approx.)
	(+)	(-)		
B324 B502	13	Ground	The seat slide front most part	0
			Other than above	5

OK or NG

- OK >> Sliding limit switch (forward) is OK.
- NG >> GO TO 2.

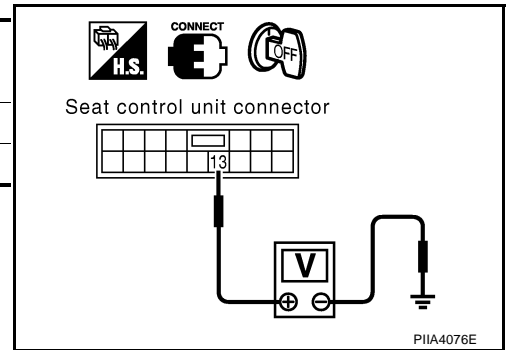

## 2. CHECK SEAT CONTROL UNIT OUTPUT SIGNAL

Check voltage between seat control unit connector B324 (driver side), B502 (passenger side) terminal 13 and ground.

**13 – Ground : Approx. 5V**

OK or NG

- OK >> Sliding limit switch (forward) is NG. Replace reclining device assembly, Refer to [SE-57](#).
- NG >> Replace seat control unit.

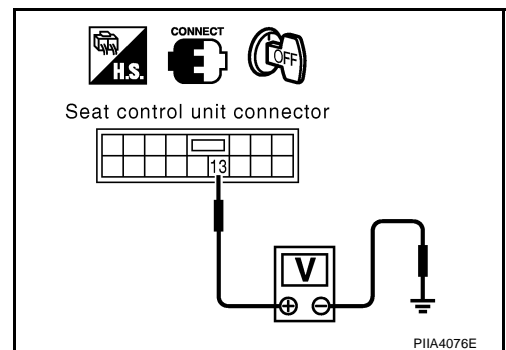

# POWER SEAT

AIS00299

## Check Reclining Backward Switch

### 1. CHECK RECLINING BACKWARD SWITCH SIGNAL

When operation condition consists, check voltage between seat control unit connector B324 (driver side), B502 (passenger side) terminal 4 and ground.

Connector	Terminals		Condition	Voltage (V) (Approx.)
	(+)	(-)		
B324 B502	4	Ground	When you return based on the fold down seat back	0
			Other than above	5

#### OK or NG

OK >> Reclining backward switch is OK.

NG >> GO TO 2.

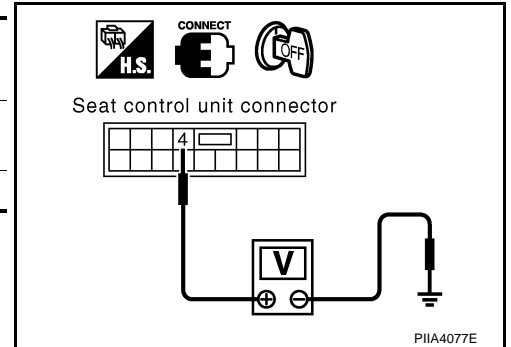

### 2. CHECK SEAT CONTROL UNIT OUTPUT SIGNAL

Check voltage between seat control unit connector B324 (driver side), B502 (passenger side) terminal 4 and ground.

**4 – Ground : Approx. 5V**

#### OK or NG

OK >> Reclining backward switch is NG. Replace reclining device assembly, Refer to [SE-57](#).

NG >> Replace seat control unit.

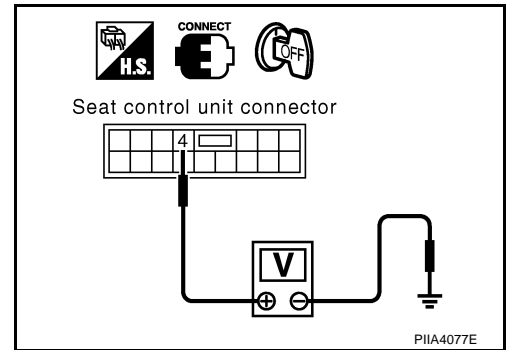

## Check Reclining Limit Switch (Backward)

### 1. CHECK RECLINING LIMIT SWITCH (BACKWARD) SIGNAL

When operation condition consists, check voltage between seat control unit connector B324 (driver side), B502 (passenger side) terminal 12 and ground.

Connector	Terminals		Condition	Voltage (V) (Approx.)
	(+)	(-)		
B324 B502	12	Ground	When reclining the seat back to more than 26° from first locking position	0
			Other than above	5

#### OK or NG

OK >> Reclining limit switch (backward) is OK.

NG >> GO TO 2.

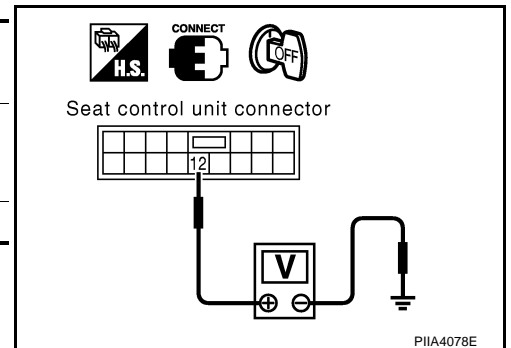

# POWER SEAT

## 2. CHECK SEAT CONTROL UNIT OUTPUT SIGNAL

Check voltage between seat control unit connector B324 (driver side), B502 (passenger side) terminal 12 and ground.

**12 – Ground : Approx. 5V**

OK or NG

- OK >> Reclining limit switch (backward) is NG. Replace reclining device assembly, Refer to [SE-57](#) .
- NG >> Replace seat control unit.

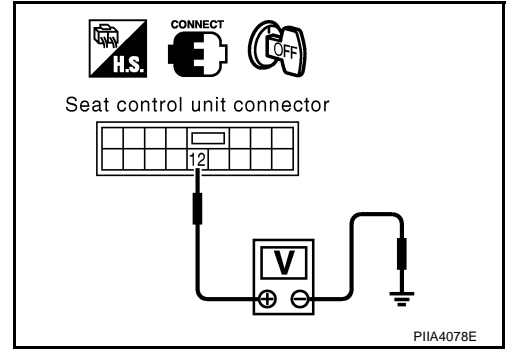

# HEATED SEAT

## HEATED SEAT

PFP:87335

### Description

AIS001CK

- When handling seat, be extremely careful not to scratch heating unit.
- To replace heating unit, seat trim and pad should be separated.
- Do not use any organic solvent, such as thinner, benzene, alcohol, etc. to clean trims.

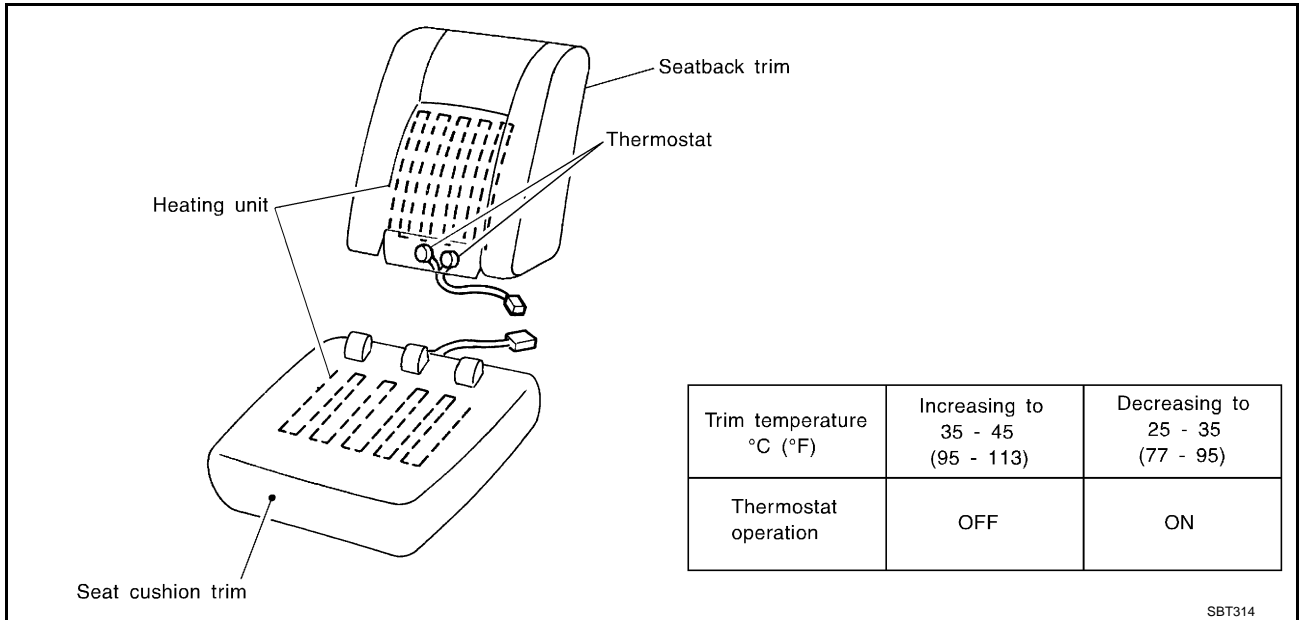

A  
B  
C  
D  
E  
F  
G  
H  
SE  
J  
K  
L  
M

# HEATED SEAT

## Schematic

AIS001CL

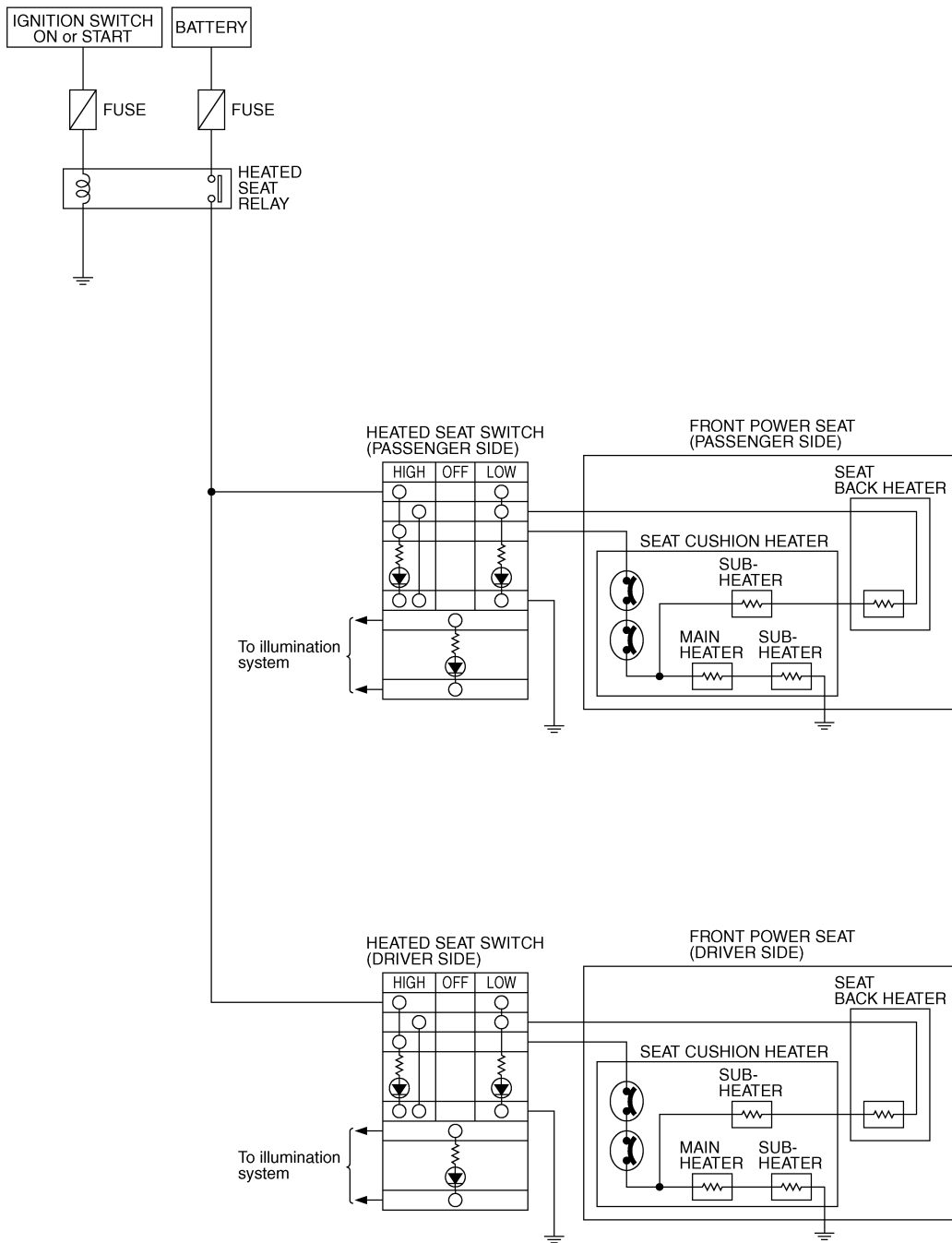

TIWT0343E



# HEATED SEAT

## Wiring Diagram – HSEAT – / With A/T Models

AIS001CM

SE-HSEAT-01

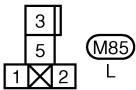
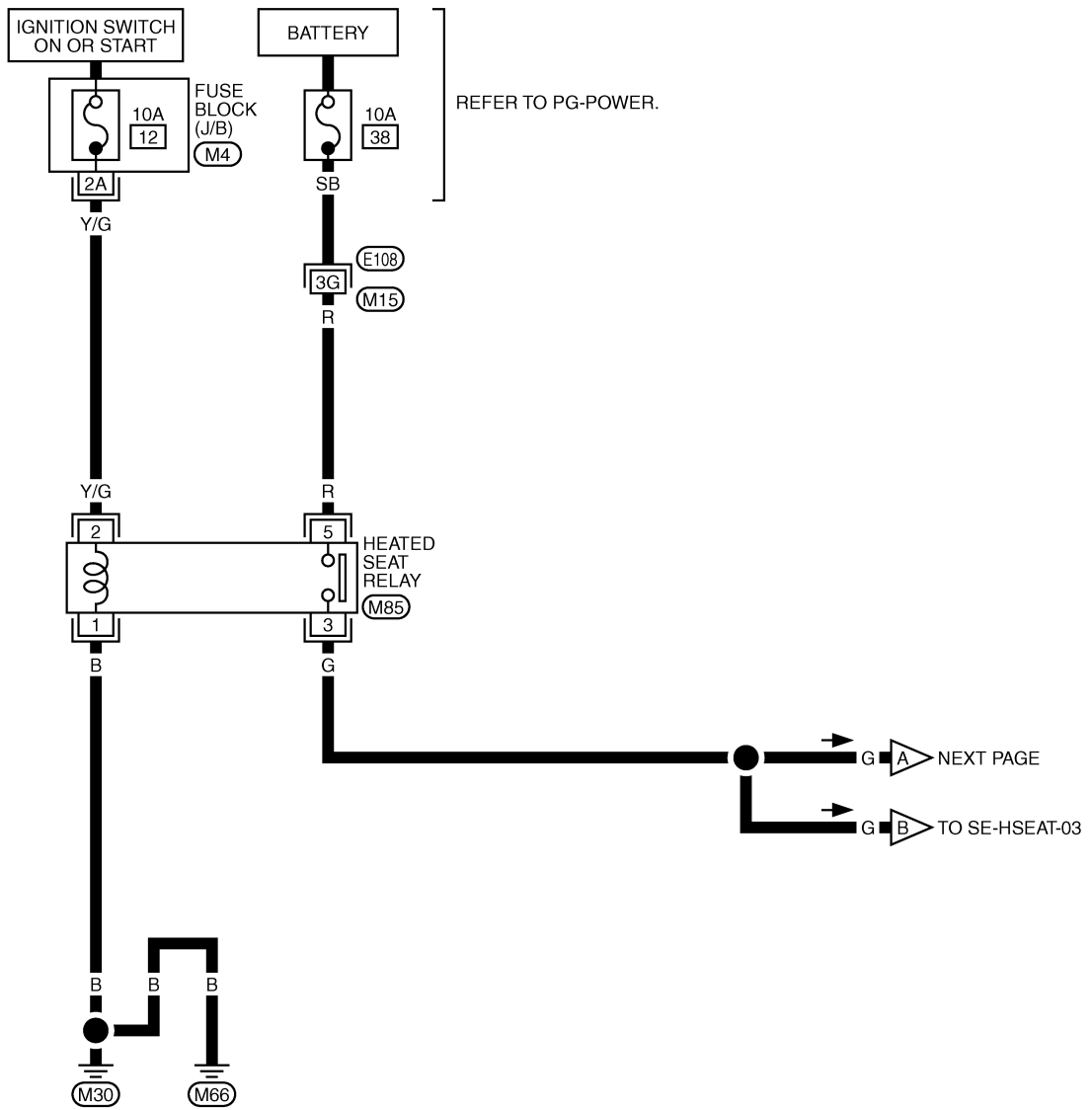

REFER TO THE FOLLOWING.

(E108) -SUPER MULTIPLE JUNCTION (SMJ)

(M4) -FUSE BLOCK-JUNCTION BOX (J/B)

TIWT0344E

# HEATED SEAT

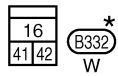
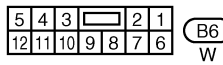
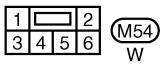
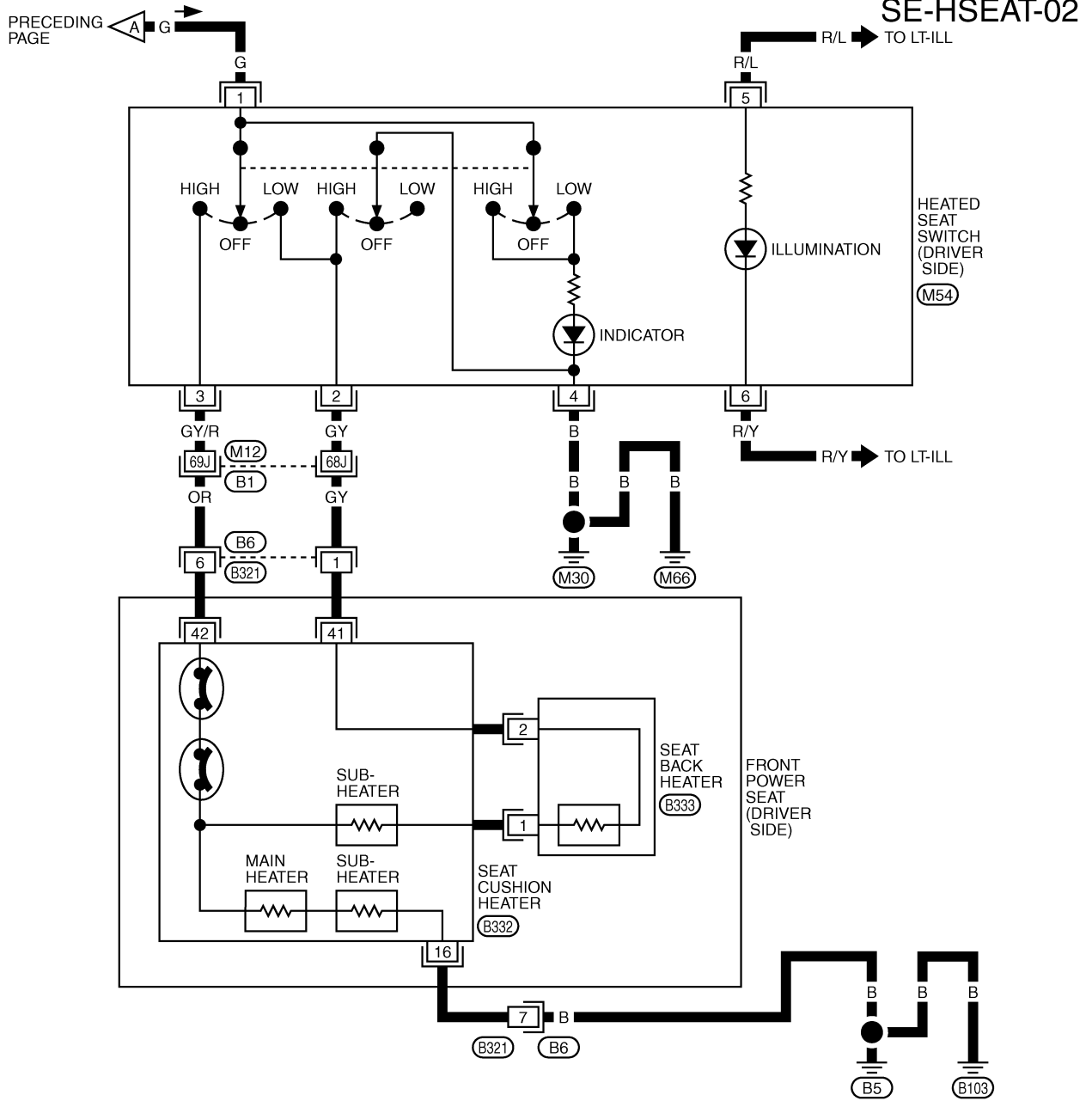

REFER TO THE FOLLOWING.  
 (B1) -SUPER MULTIPLE JUNCTION (SMJ)

\*: THIS CONNECTOR IS NOT SHOWN IN "HARNESS LAYOUT", PG SECTION.

# HEATED SEAT

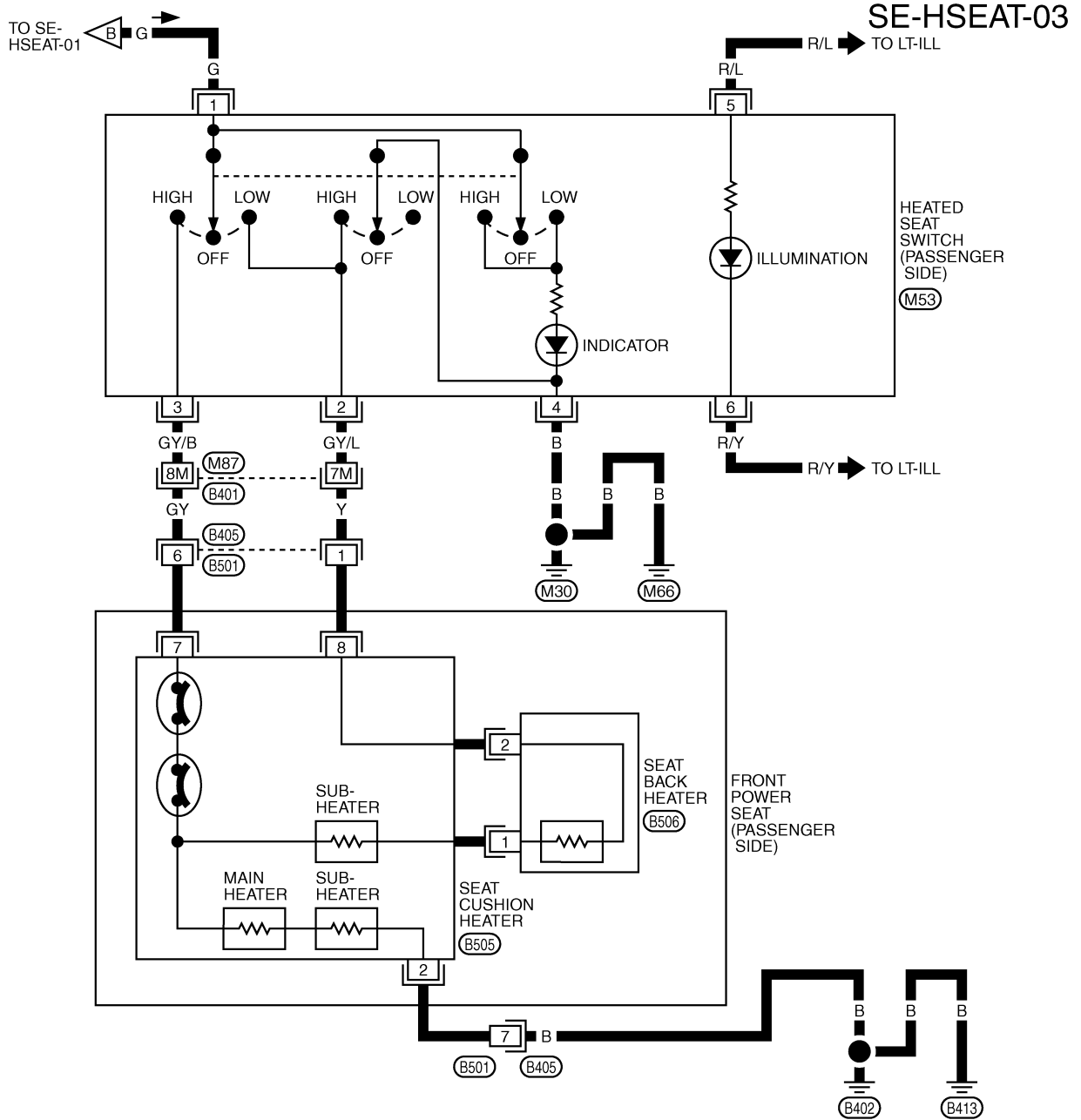

A  
B  
C  
D  
E  
F  
G  
H  
SE  
J  
K  
L  
M

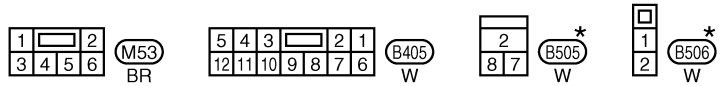

REFER TO THE FOLLOWING.  
(B401) -SUPER MULTIPLE JUNCTION (SMJ)

\*: THIS CONNECTOR IS NOT SHOWN IN "HARNESS LAYOUT", PG SECTION.

# HEATED SEAT

## Wiring Diagram – HSEAT – / With M/T Models

AIS00278

### SE-HSEAT-04

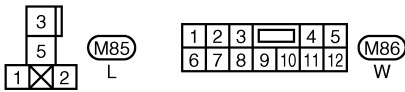
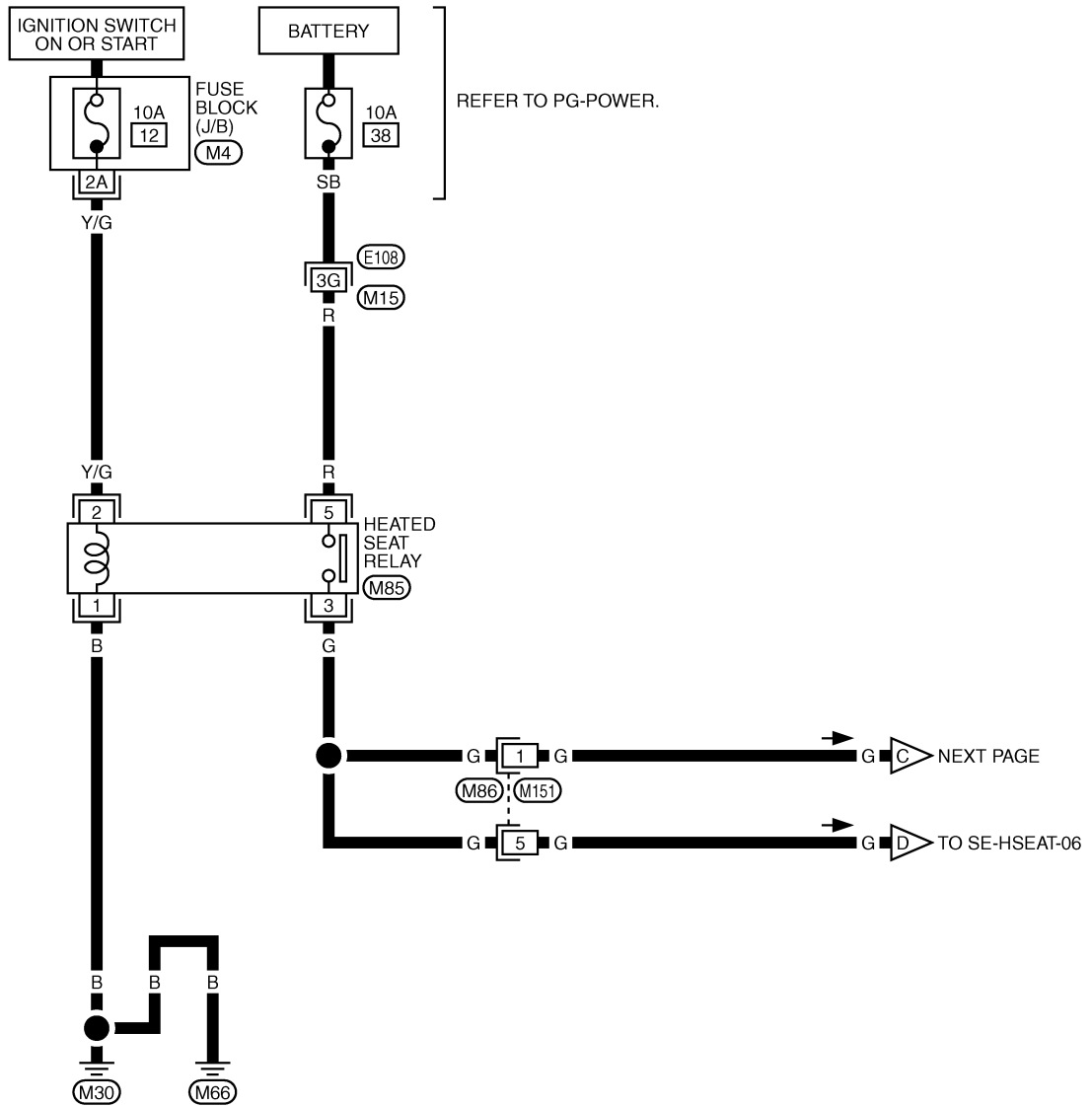

REFER TO THE FOLLOWING.  
 (E108) -SUPER MULTIPLE JUNCTION (SMJ)  
 (M4) -FUSE BLOCK-JUNCTION BOX (J/B)

TIWM0486E

# HEATED SEAT

SE-HSEAT-05

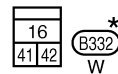
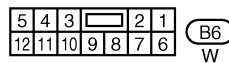
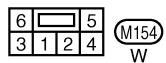
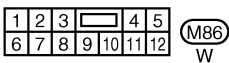
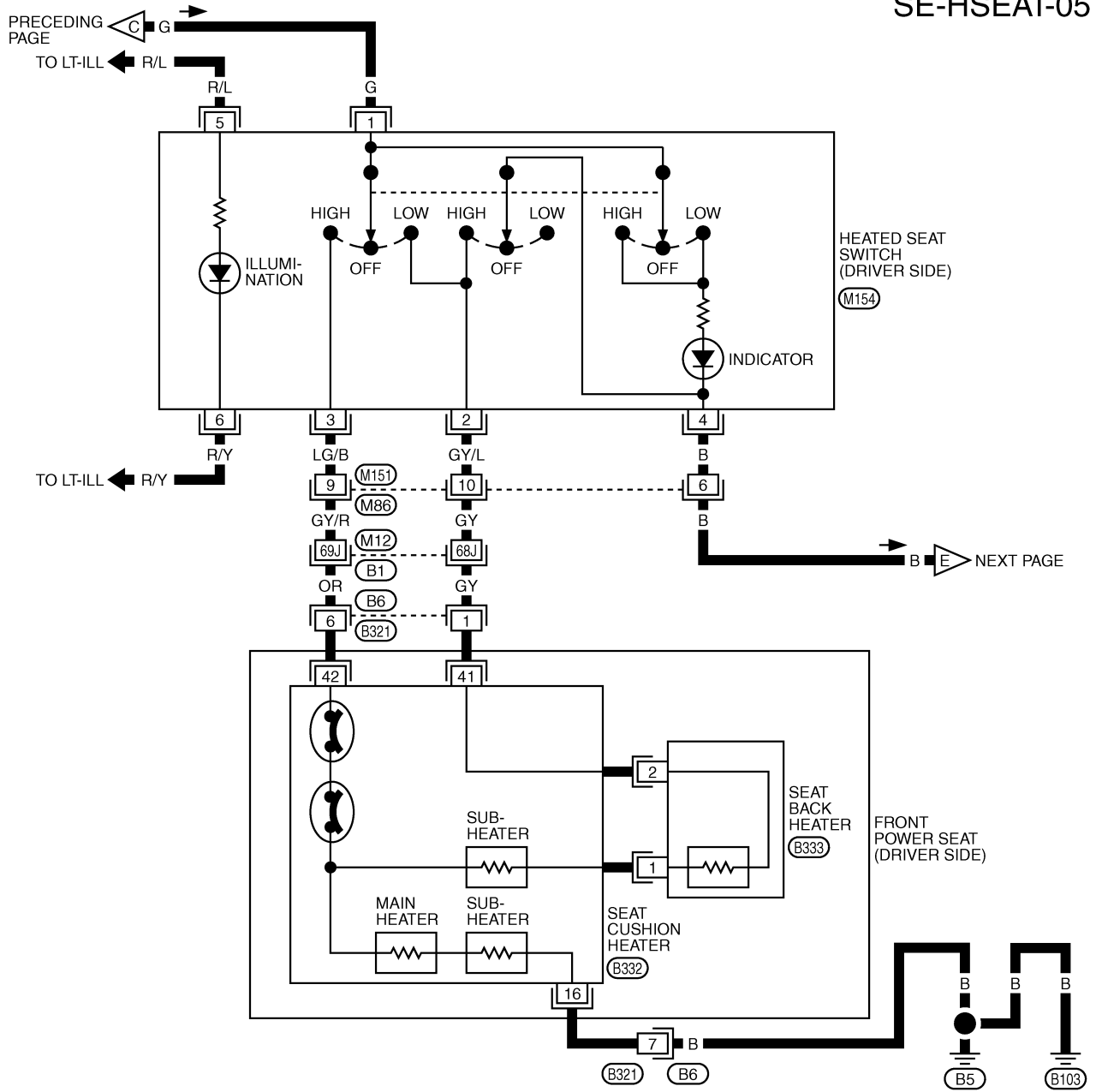

\*: THIS CONNECTOR IS NOT SHOWN IN "HARNESS LAYOUT", PG SECTION.

REFER TO THE FOLLOWING.

(B1) -SUPER MULTIPLE JUNCTION (SMJ)

# HEATED SEAT

SE-HSEAT-06

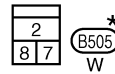
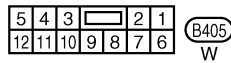
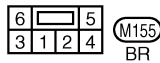
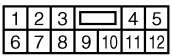
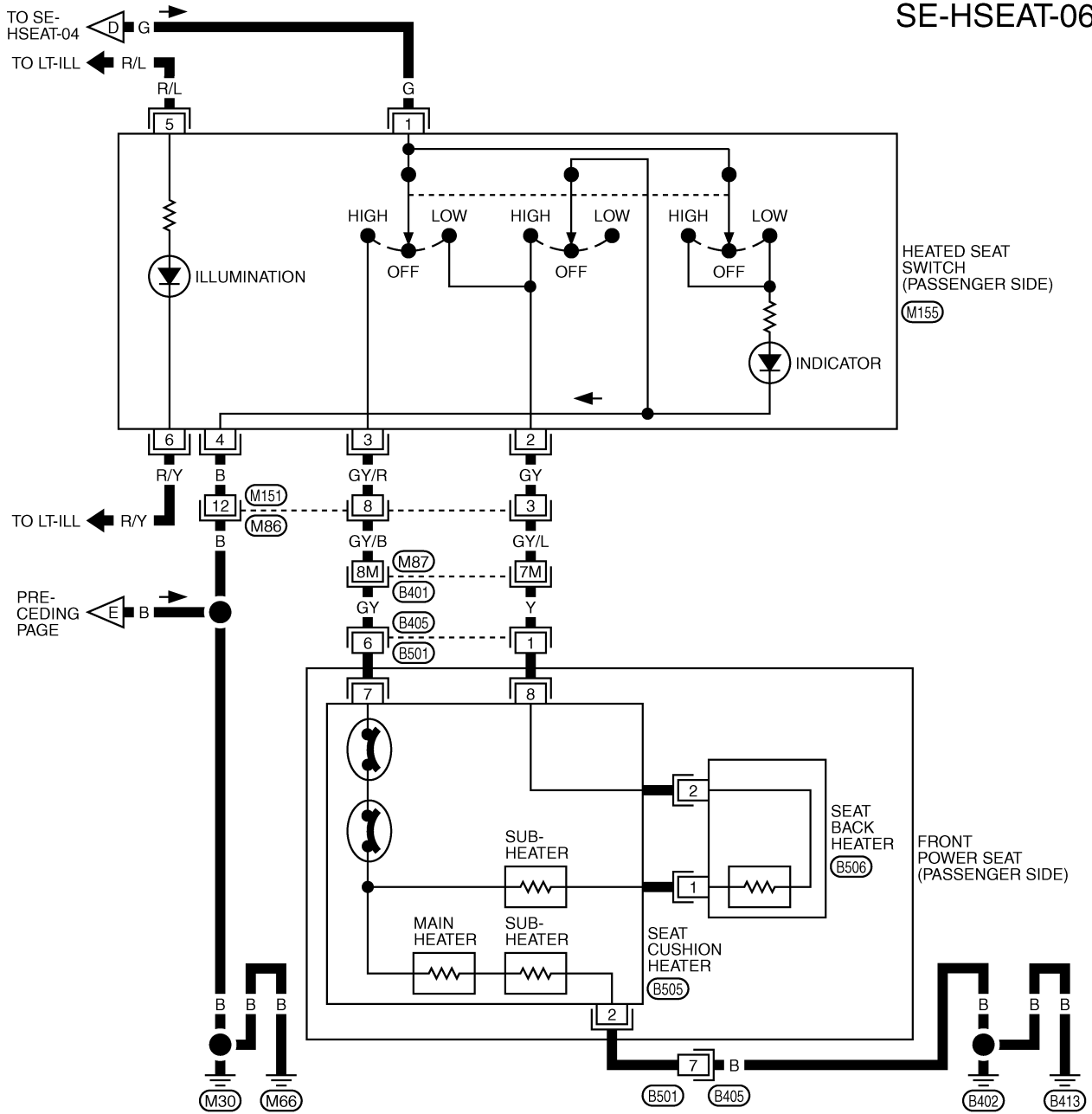

\*: THIS CONNECTOR IS NOT SHOWN IN "HARNESS LAYOUT", PG SECTION.

REFER TO THE FOLLOWING.  
(B401) -SUPER MULTIPLE JUNCTION (SMJ)

# FRONT SEAT

## FRONT SEAT

### Removal and Installation

SEC. 870

PF87000

AIS001CN

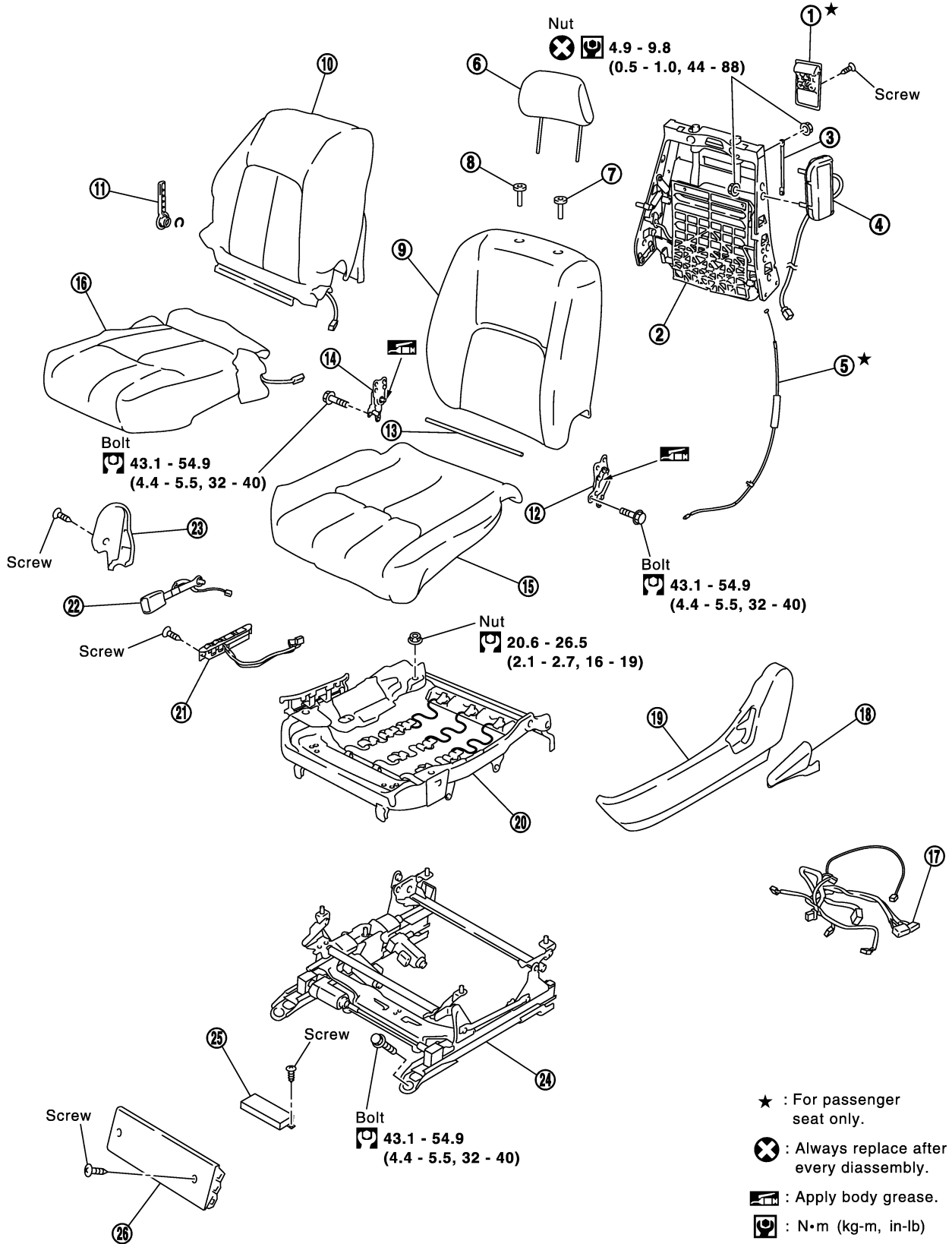

A  
B  
C  
D  
E  
F  
G  
H  
SE  
J  
K  
L  
M

PIIA3633E

# FRONT SEAT

- |                                  |                                 |                                |
|----------------------------------|---------------------------------|--------------------------------|
| 1. Walk-in lever                 | 2. Seatback frame assembly      | 3. Inner cloth stay            |
| 4. Side air bag module           | 5. Walk-in control cable        | 6. Headrest                    |
| 7. Headrest holder (locked)      | 8. Headrest holder (free)       | 9. Seatback pad                |
| 10. Seatback trim and heater     | 11. Lumber support lever knob   | 12. Reclining device (LH)      |
| 13. Reclining device rod         | 14. Reclining device (RH)       | 15. Seat cushion pad           |
| 16. Seat cushion trim and heater | 17. Power seat harness          | 18. Reclining lever            |
| 19. Seat cushion outer finisher  | 20. Seat cushion frame          | 21. Power seat switch          |
| 22. Seat belt buckle             | 23. Seat cushion inner finisher | 24. Seat cushion rail assembly |
| 25. Power seat control unit      | 26. Seat cushion front finisher |                                |

## REMOVAL

When removing or installing the seat trim, carefully handle it to keep dirt out and avoid damage.

### CAUTION:

- Before removing the front seat, turn the ignition switch off, disconnect both battery cables and wait at least 3 minutes.
  - When checking the power seat circuit for continuity using a circuit tester, do not confuse its connector with the side air bag module connector. Such an error may cause the air bag to deploy.
  - Do not drop, tilt, or bump the side air bag module installing in the seat. Always handle it with care.
1. Remove the front leg cover and rear leg cover. (LH/RH)

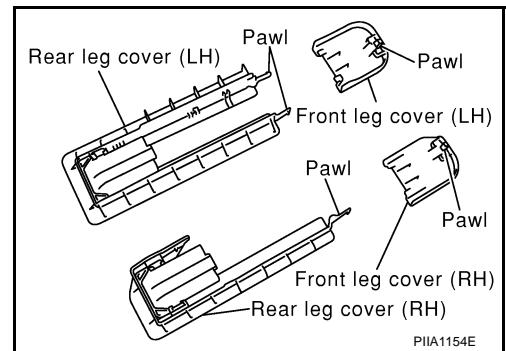

### NOTE:

1. Slide the seat backward, and disconnect the front tabs on the front leg cover. Then move the cover toward the rear of the vehicle, and pull up to remove.
  2. Slide the seat forward, then disengage the tabs on the front LH/RH of the rear leg cover and tabs engaged into the rail. Then pull the cover toward the rear of the vehicle.
2. Slide the seat until the body mounting bolts are visible and a tool can be inserted.

### NOTE:

When disassembling the driver seat after removal, set the front/rear cushion lifter to the top position.

3. Remove the body mounting bolts.
4. Disconnect both battery cables.
5. Remove the harness connector for the side air bag module.
6. Remove the power seat harness connector and vehicle harness fixing clip out of the vehicle.

### NOTE:

When removing and installing, using clothes, protect the parts from damage where it may interfere with others.

## INSTALLATION

Install in the reverse order of removal.

### NOTE:

Be sure to insert the rear end tab of the rear leg cover under the rail.



# FRONT SEAT

## Disassembly and Assembly SEATBACK TRIM AND PAD

AI5001CO

### NOTE:

Be sure to set the front/rear cushion lifter to the top position.

### Disassembly

1. Remove the walk-in lever (for passenger seat).

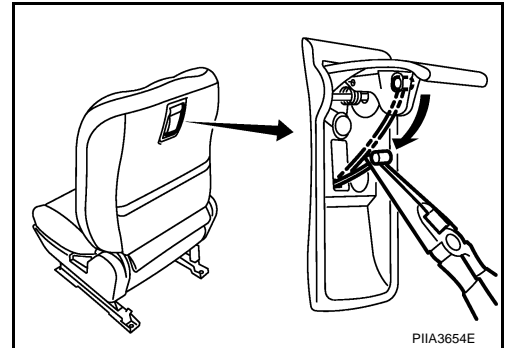

2. Open fastener on back of seatback, and remove retainer from seatback frame.

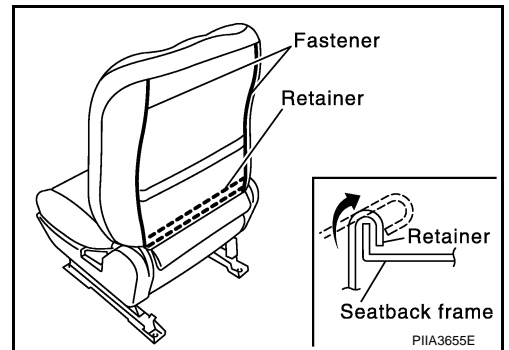

3. Pull snap ring upward, and remove lumbar support lever knob from seatback frame.

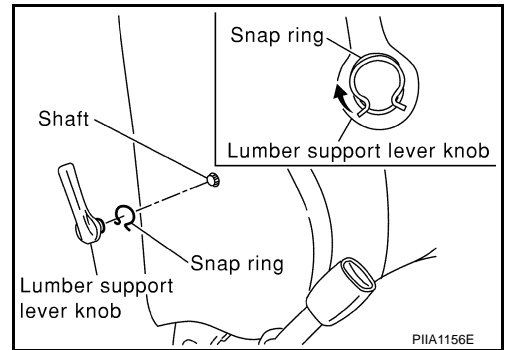

4. Remove the stay securing the inner cloth.

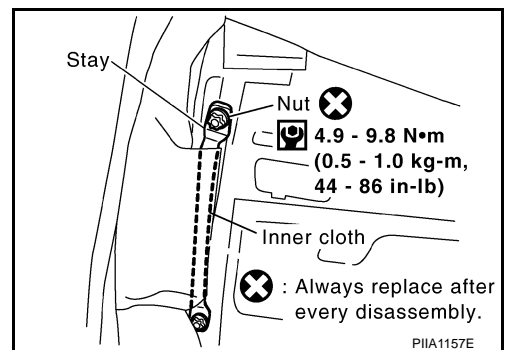

A  
B  
C  
D  
E  
F  
G  
H  
SE  
J  
K  
L  
M

## FRONT SEAT

- From the back of the seatback, press the headrest holder tab of the stay pipe hole to disengage. Then pull the headrest holder up to remove.

**NOTE:**

Before installing the headrest holder, check its orientation (front/rear and right/left).

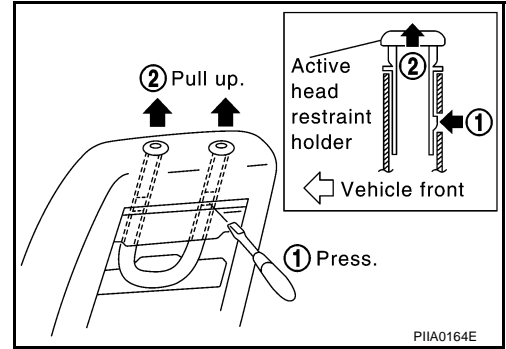

- Remove the seat heater harness connector. After removing the seatback trim and pad, remove the hog ring to separate the trim, pad and seatback heater unit.

### Assembly

Assembly in the reverse order of disassembly.

### REMOVAL OF SEATBACK ASSEMBLY

- After completing the steps 1, 2 and 3 of "SEATBACK TRIM AND PAD", remove the harness connectors for the side air bag from the seat cushion.
- Remove the reclining device mounting bolts on the seatback frame, and remove the seatback assembly.

**NOTE:**

When assembling the seatback frame, make sure that the reclining device are locked on both sides, and be sure to temporarily tighten the bolts, then tighten them finally.

### INSTALLATION OF SEATBACK ASSEMBLY

Install in the reverse order of removal.

### SEAT CUSHION TRIM AND PAD

#### Disassembly

- Pull up tabs of reclining lever knob inside. Slide knob forward to remove.

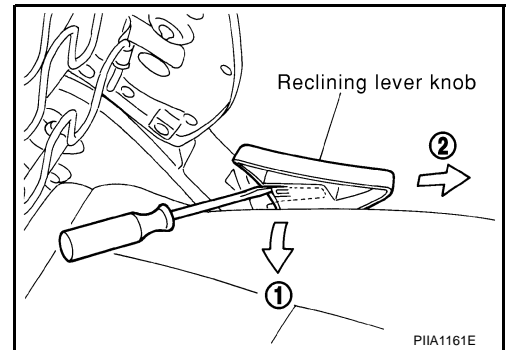

- Remove the seat cushion front finisher and seat cushion outer finisher.

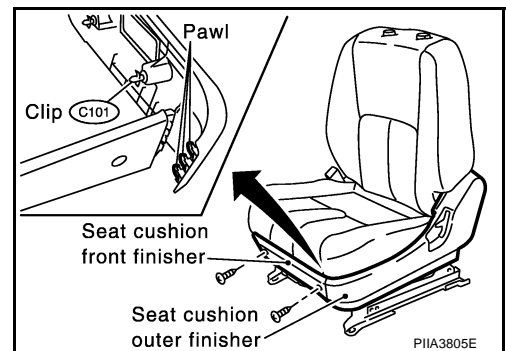

## FRONT SEAT

3. Remove the power seat switch assembly.

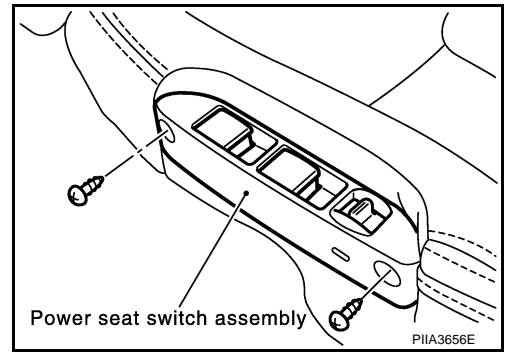

4. Remove the retainer on the seat cushion frame, then remove the harness connector for the seat heater.
5. After removing the seat cushion trim and pad, remove the hog rings to separate the trim and pad and the seat cushion heater unit.

### Assembly

Assembly in the reverse order of disassembly.

A

B

C

D

E

F

G

H

SE

J

K

L

M

# REAR SEAT

PFP:88300

AIS001CP

## REAR SEAT

### Removal and Installation

SEC. 880

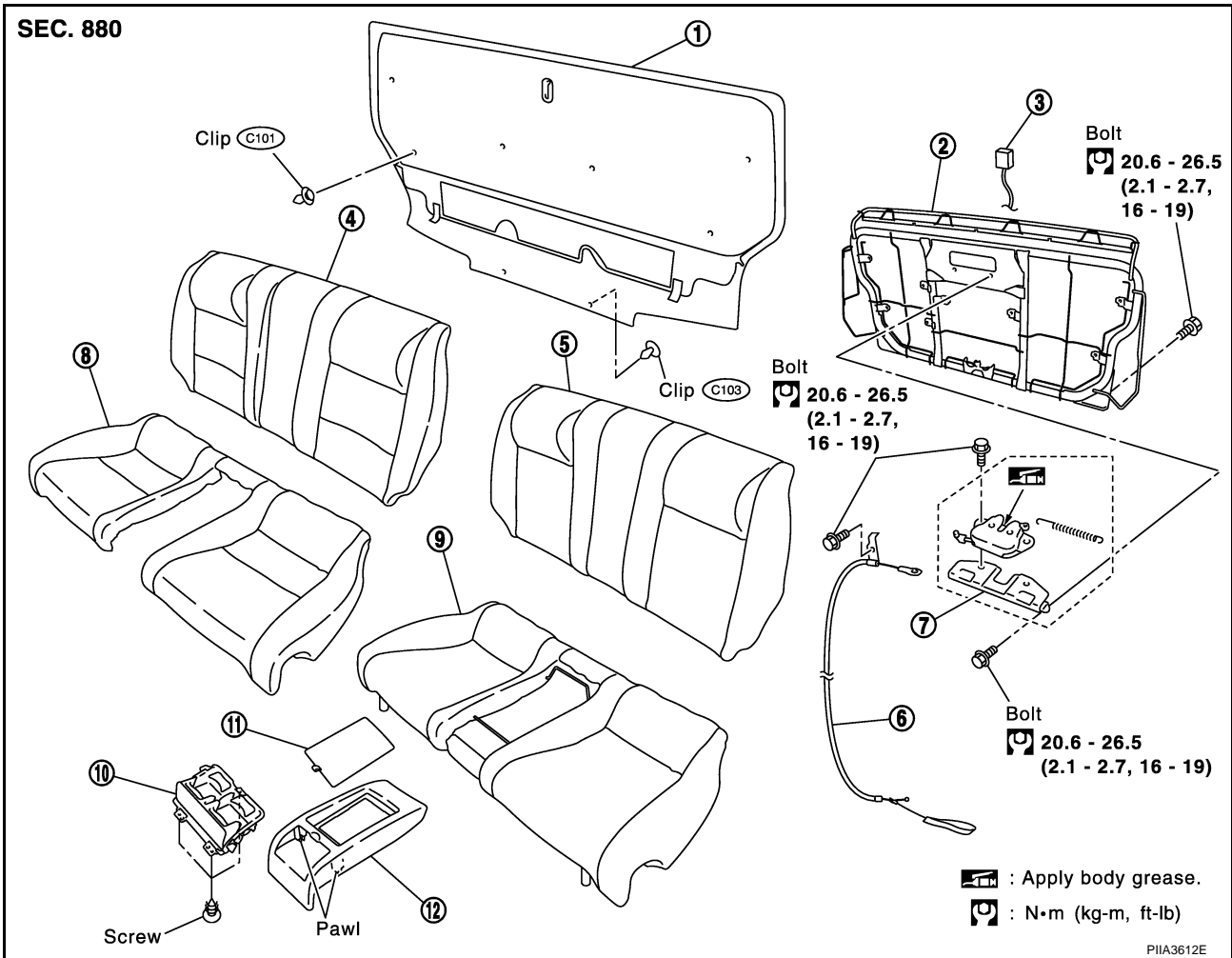

- |                            |                         |                                   |
|----------------------------|-------------------------|-----------------------------------|
| 1. Seatback board          | 2. Seatback frame       | 3. Seatback device lock indicator |
| 4. Seatback trim           | 5. Seat cushion pad     | 6. Seatback device cable          |
| 7. Seatback device lock    | 8. Seat cushion trim    | 9. Seat cushion pad               |
| 10. Center tray cup holder | 11. Center tray box lid | 12. Center tray box               |

### REMOVAL

1. Raise the bottom of the seat cushion to release the wire from the plastic hook, then pull the seat cushion forward to remove.

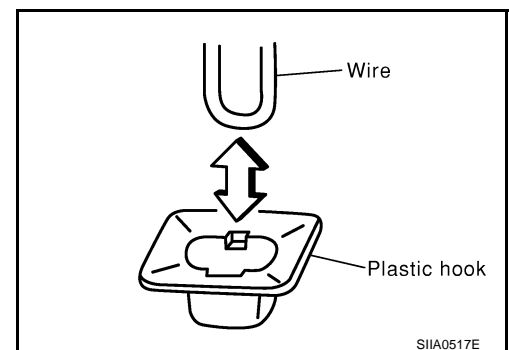

### INSTALLATION

Install in the reverse order of removal.