

SECTION **LAN**
LAN SYSTEM

A
B
C

CONTENTS

D
E

CAN

PRECAUTIONS	3	IPDM E/R Ignition Relay Circuit Check	38
Precautions for Supplemental Restraint System (SRS) "AIR BAG" and "SEAT BELT PRE-TENSIONER"	3	Component Inspection	38
Precautions When Using CONSULT-II	3	ECM/IPDM E/R INTERNAL CIRCUIT INSPECTION	38
CHECK POINTS FOR USING CONSULT-II	3	CAN SYSTEM (TYPE 2)	39
Precautions For Trouble Diagnosis	3	System Description	39
CAN SYSTEM	3	Component Parts and Harness Connector Location..	39
Precautions For Harness Repair	4	Schematic	40
CAN SYSTEM	4	Wiring Diagram - CAN -	41
CAN COMMUNICATION	5	Work Flow	44
System Description	5	CHECK SHEET	45
CAN Communication Unit	5	CHECK SHEET RESULTS (EXAMPLE)	47
TYPE 1	5	Circuit Check Between Data Link Connector and VDC/TCS/ABS Control Unit	56
TYPE 2	7	ECM Circuit Check	57
TYPE 3	9	Data Link Connector Circuit Check	57
CAN SYSTEM (TYPE 1)	11	Combination Meter Circuit Check	58
System Description	11	BCM Circuit Check	58
Component Parts and Harness Connector Location..	11	Steering Angle Sensor Circuit Check	59
Schematic	12	VDC/TCS/ABS Control Unit Circuit Check	59
Wiring Diagram - CAN -	13	IPDM E/R Circuit Check	60
Work Flow	16	CAN Communication Circuit Check	61
CHECK SHEET	17	IPDM E/R Ignition Relay Circuit Check	63
CHECK SHEET RESULTS (EXAMPLE)	19	Component Inspection	63
Circuit Check Between TCM and Data Link Connector	30	ECM/IPDM E/R INTERNAL CIRCUIT INSPECTION	63
Circuit Check Between Data Link Connector and VDC/TCS/ABS Control Unit	31	CAN SYSTEM (TYPE 3)	64
ECM Circuit Check	32	System Description	64
TCM Circuit Check	32	Component Parts and Harness Connector Location..	64
Data Link Connector Circuit Check	33	Schematic	65
Combination Meter Circuit Check	33	Wiring Diagram - CAN -	66
BCM Circuit Check	34	Work Flow	69
Steering Angle Sensor Circuit Check	34	CHECK SHEET	70
VDC/TCS/ABS Control Unit Circuit Check	35	CHECK SHEET RESULTS (EXAMPLE)	72
IPDM E/R Circuit Check	35	Circuit Check Between TCM and Data Link Connector	84
CAN Communication Circuit Check	36	Circuit Check Between Data Link Connector and VDC/TCS/ABS Control Unit	85
		ECM Circuit Check	86
		AWD Control Unit Circuit Check	86

F
G
H
I
J
L
M

LAN

TCM Circuit Check	87	IPDM E/R Circuit Check	90
Data Link Connector Circuit Check	87	CAN Communication Circuit Check	90
Combination Meter Circuit Check	88	IPDM E/R Ignition Relay Circuit Check	93
BCM Circuit Check	88	Component Inspection	93
Steering Angle Sensor Circuit Check	89	ECM/IPDM E/R INTERNAL CIRCUIT INSPEC-	
VDC/TCS/ABS Control Unit Circuit Check	89	TION	93

PRECAUTIONS

PFP:00001

Precautions for Supplemental Restraint System (SRS) “AIR BAG” and “SEAT BELT PRE-TENSIONER”

AKS00AAG

The Supplemental Restraint System such as “AIR BAG” and “SEAT BELT PRE-TENSIONER”, used along with a front seat belt, helps to reduce the risk or severity of injury to the driver and front passenger for certain types of collision. This system includes seat belt switch inputs and dual stage front air bag modules. The SRS system uses the seat belt switches to determine the front air bag deployment, and may only deploy one front air bag, depending on the severity of a collision and whether the front occupants are belted or unbelted. Information necessary to service the system safely is included in the SRS and SB section of this Service Manual.

WARNING:

- To avoid rendering the SRS inoperative, which could increase the risk of personal injury or death in the event of a collision which would result in air bag inflation, all maintenance must be performed by an authorized NISSAN/INFINITI dealer.
- Improper maintenance, including incorrect removal and installation of the SRS, can lead to personal injury caused by unintentional activation of the system. For removal of Spiral Cable and Air Bag Module, see the SRS section.
- Do not use electrical test equipment on any circuit related to the SRS unless instructed to in this Service Manual. SRS wiring harnesses can be identified by yellow and/or orange harnesses or harness connectors.

Precautions When Using CONSULT-II

AKS00ABN

When connecting CONSULT-II to data link connector, connect them through CONSULT-II CONVERTER.

CAUTION:

If CONSULT-II is used with no connection of CONSULT-II CONVERTER, malfunctions might be detected in self-diagnosis depending on control unit which carry out CAN communication.

CHECK POINTS FOR USING CONSULT-II

1. Has CONSULT-II been used without connecting CONSULT-II CONVERTER on this vehicle?
 - If YES, GO TO 2.
 - If NO, GO TO 5.
2. Is there any indication other than indications relating to CAN communication system in the self-diagnosis results?
 - If YES, GO TO 3.
 - If NO, GO TO 4.
3. Based on self-diagnosis results unrelated to CAN communication, carry out the inspection.
4. Malfunctions may be detected in self-diagnosis depending on control units carrying out CAN communication. Therefore, erase the self-diagnosis results.
5. Diagnose CAN communication system. Refer to [LAN-5, "CAN Communication Unit"](#) .

**Precautions For Trouble Diagnosis
CAN SYSTEM**

AKS000BF

- Do not apply voltage of 7.0 V or higher to the measurement terminals.
- Use the tester with its open terminal voltage being 7.0 V or less.
- Be sure to turn ignition switch off and disconnect negative battery terminal before checking the circuit.

Precautions For Harness Repair CAN SYSTEM

- Solder the repaired parts, and wrap with tape. [Frays of twisted line must be within 110 mm (4.33 in)]

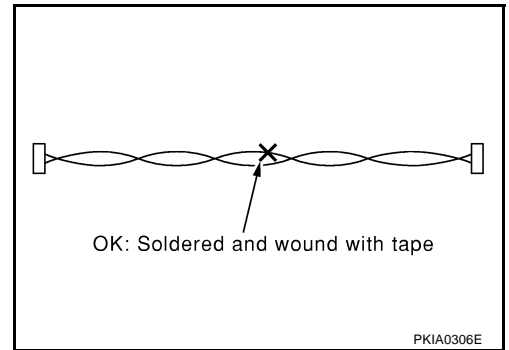

- Do not perform bypass wire connections for the repair parts. (The spliced wire will become separated and the characteristics of twisted line will be lost.)

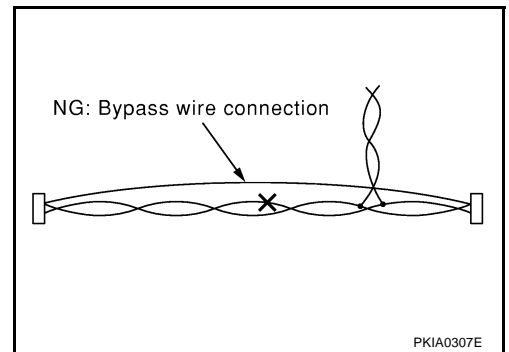

CAN COMMUNICATION

PFP:23710

System Description

AKS000D9

CAN (Controller Area Network) is a serial communication line for real time application. It is an on-vehicle multiplex communication line with high data communication speed and excellent error detection ability. Many electronic control units are equipped onto a vehicle, and each control unit shares information and links with other control units during operation (not independent). In CAN communication, control units are connected with 2 communication lines (CAN H line, CAN L line) allowing a high rate of information transmission with less wiring. Each control unit transmits/receives data but selectively reads required data only.

CAN Communication Unit

AKS000DA

Go to CAN system, when selecting your CAN system type from the following table.

Body type	Sedan		
Axle	2WD	4WD	
Engine	VQ35DE		
Transmission	A/T	M/T	A/T
Brake control	VDC		
CAN system type	1	2	3
CAN system trouble diagnosis	LAN-11	LAN-39	LAN-64

TYPE 1

System Diagram

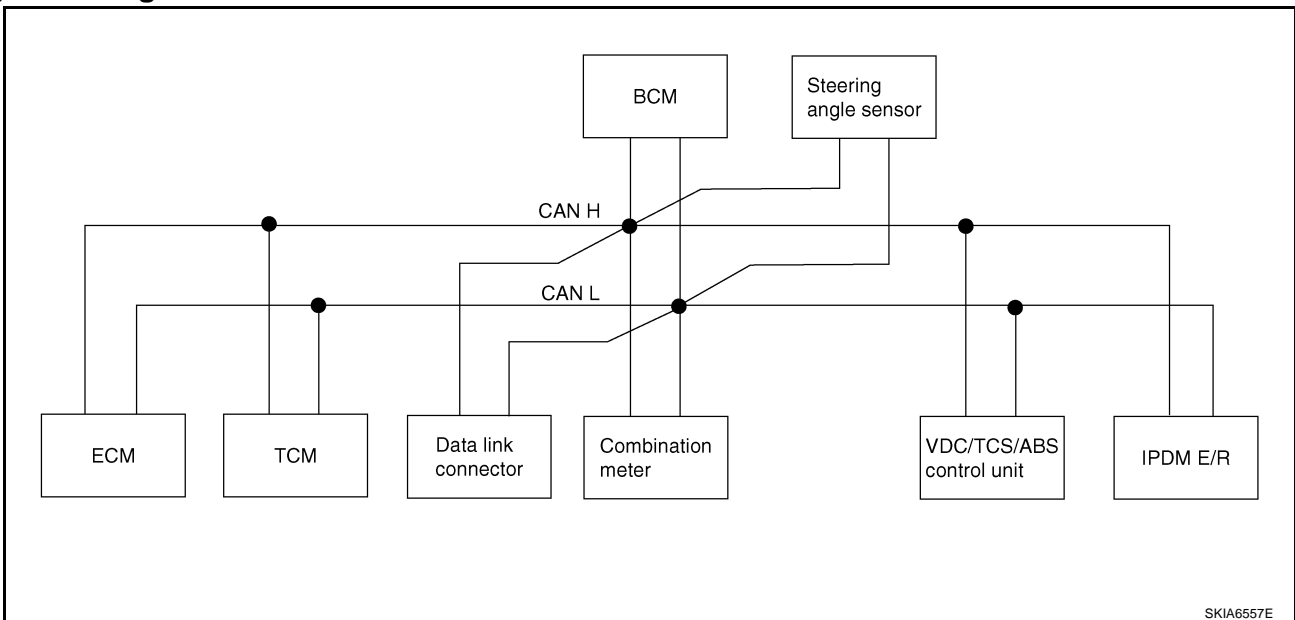

Input/output Signal Chart

T: Transmit R: Receive

Signals	ECM	TCM	Combina- tion meter	BCM	Steering angle sensor	VDC/TCS/ ABS control unit	IPDM E/R
Engine speed signal	T	R	R			R	
Engine coolant temperature signal	T		R				
Accelerator pedal position signal	T	R				R	
Closed throttle position signal	T	R					
Wide open throttle position signal	T	R					
Battery voltage signal	T	R					
Stop lamp switch signal		R	T				

CAN COMMUNICATION

[CAN]

Signals	ECM	TCM	Combina- tion meter	BCM	Steering angle sensor	VDC/TCS/ ABS control unit	IPDM E/R
Fuel consumption monitor signal	T		R				
A/T self-diagnosis signal	R	T					
A/T CHECK indicator lamp signal		T	R				
A/T position indicator signal		T	R			R	
ABS operation signal		R				T	
A/T shift schedule change demand signal		R				T	
A/C switch signal	R			T			
A/C compressor request signal	T						R
A/C compressor feedback signal	T		R				
Blower fan motor switch signal	R			T			
Cooling fan motor operation signal	T						R
Position lights request signal			R	T			R
Low beam request signal				T			R
Low beam status signal	R						T
High beam request signal			R	T			R
High beam status signal	R						T
Front fog lights request signal				T			R
Vehicle speed signal			R			T	
	R	R	T	R			
Sleep request 1 signal			R	T			
Sleep request 2 signal				T			R
Wake up request 1 signal				T			R
Wake up request 2 signal				T			R
Door switch signal (without navigation system)			R	T			R
Door switch signal (with navigation system)			T	R			
Turn indicator signal			R	T			
Seat belt buckle switch signal			T	R			
Oil pressure switch signal			R				T
Buzzer output signal			R	T			
ASCD SET lamp signal	T		R				
ASCD CRUISE lamp signal	T		R				
ASCD OD cancel request signal	T	R					
ASCD operation signal	T	R					
Output shaft revolution signal	R	T					
Front wiper request signal				T			R
Front wiper stop position signal				R			T
Rear window defogger switch signal				T			R
Rear window defogger control sig- nal	R						T
Manual mode signal		R	T				
Not manual mode signal		R	T				

CAN COMMUNICATION

[CAN]

Signals	ECM	TCM	Combina- tion meter	BCM	Steering angle sensor	VDC/TCS/ ABS control unit	IPDM E/R
Manual mode shift up signal		R	T				
Manual mode shift down signal		R	T				
Manual mode indicator signal		T	R				
Hood switch signal				R			T
Theft warning horn request signal				T			R
Horn chirp signal				T			R
Steering angle sensor signal					T	R	
Malfunction indicator lamp signal	T		R				
Fuel level sensor signal	R		T				
Turbine revolution signal	R	T					
Tire pressure signal			R	T			

TYPE 2

System Diagram

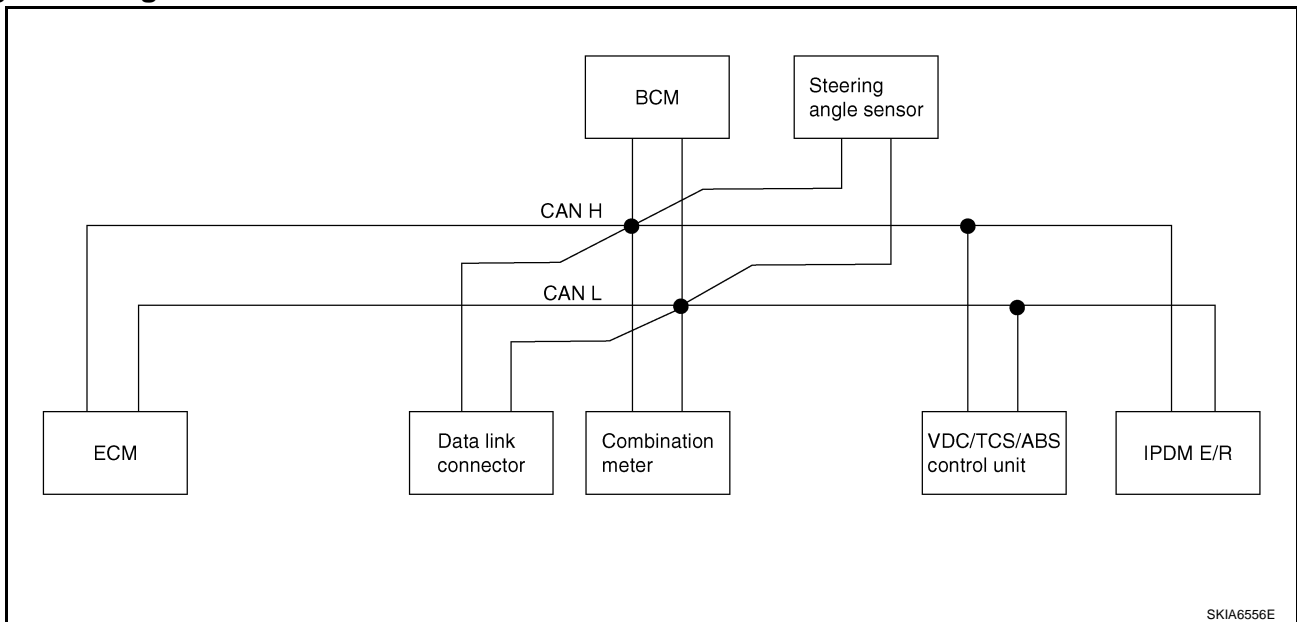

Input/output Signal Chart

T: Transmit R: Receive

Signals	ECM	Combina- tion meter	BCM	Steering angle sensor	VDC/TCS/ ABS control unit	IPDM E/R
Engine speed signal	T	R			R	
Engine coolant temperature signal	T	R				
Accelerator pedal position signal	T				R	
Fuel consumption monitor signal	T	R				
A/C switch signal	R		T			
A/C compressor request signal	T					R
A/C compressor feedback signal	T	R				
Blower fan motor switch signal	R		T			
Cooling fan motor operation signal	T					R
Position lights request signal		R	T			R

CAN COMMUNICATION

[CAN]

Signals	ECM	Combina- tion meter	BCM	Steering angle sensor	VDC/TCS/ ABS control unit	IPDM E/R
Low beam request signal			T			R
Low beam status signal	R		R			T
High beam request signal		R	T			R
High beam status signal	R		R			T
Front fog lights request signal			T			R
Vehicle speed signal		R			T	
	R	T	R			
Sleep request 1 signal		R	T			
Sleep request 2 signal			T			R
Door switch signal (without navigation system)		R	T			R
Door switch signal (with navigation system)		T	R			
Turn indicator signal		R	T			
Seat belt buckle switch signal		T	R			
Oil pressure switch signal		R				T
Buzzer output signal		R	T			
Malfunction indicator lamp signal	T	R				
ASCD SET lamp signal	T	R				
ASCD CRUISE lamp signal	T	R				
Fuel level sensor signal	R	T				
Front wiper request signal			T			R
Front wiper stop position signal			R			T
Rear window defogger switch signal			T			R
Rear window defogger control signal	R		R			T
Hood switch signal			R			T
Theft warning horn request signal			T			R
Horn chirp signal			T			R
Steering angle sensor signal				T	R	
Tire pressure signal		R	T			

CAN COMMUNICATION

[CAN]

TYPE 3

System Diagram

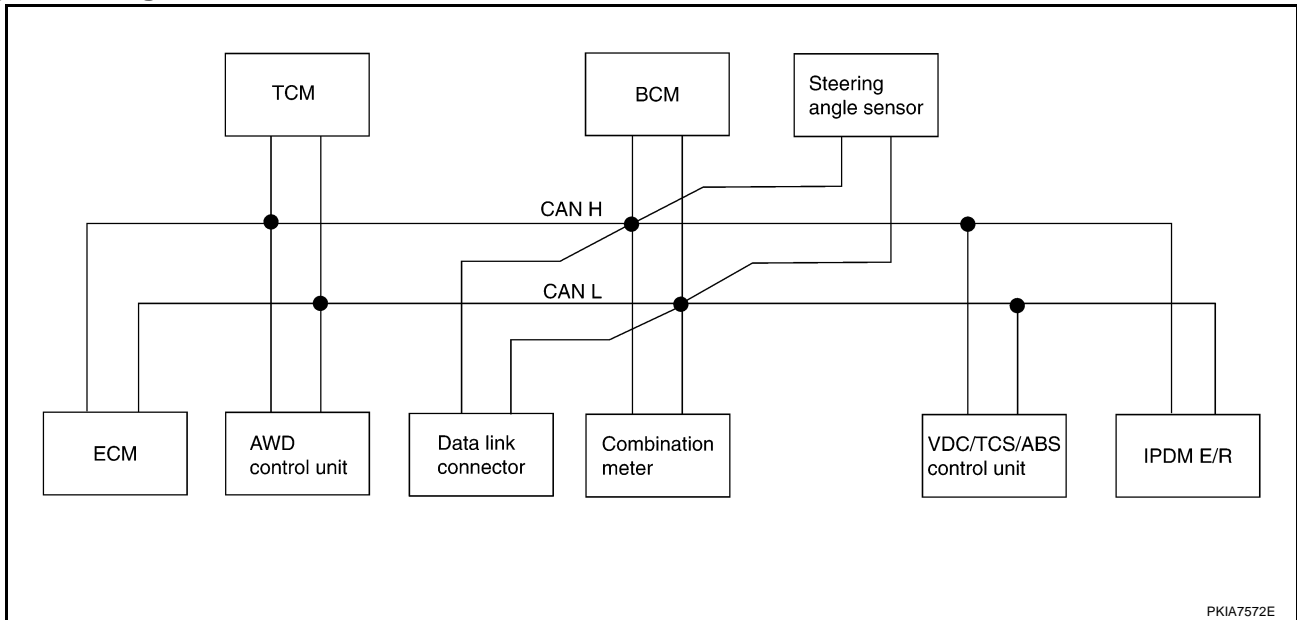

Input/output Signal Chart

T: Transmit R: Receive

Signals	ECM	AWD control unit	TCM	Combina- tion meter	BCM	Steering angle sensor	VDC/ TCS/ABS control unit	IPDM E/R
Engine speed signal	T	R	R	R			R	
Engine coolant temperature signal	T			R				
Accelerator pedal position signal	T	R	R				R	
Closed throttle position signal	T		R					
Wide open throttle position signal	T		R					
Battery voltage signal	T		R					
Stop lamp switch signal			R	T				
Stop lamp switch signal		R					T	
Fuel consumption monitor signal	T			R				
A/T self-diagnosis signal	R		T					
A/T CHECK indicator lamp signal			T	R				
A/T position indicator signal			T	R			R	
ABS operation signal			R				T	
A/T shift schedule change demand signal			R				T	
A/C switch signal	R				T			
A/C compressor request signal	T							R
A/C compressor feedback signal	T			R				
Blower fan motor switch signal	R				T			
Cooling fan motor operation signal	T							R
Position lights request signal				R	T			R
Low beam request signal					T			R
Low beam status signal	R							T
High beam request signal				R	T			R

CAN COMMUNICATION

[CAN]

Signals	ECM	AWD control unit	TCM	Combina-tion meter	BCM	Steering angle sensor	VDC/TCS/ABS control unit	IPDM E/R
High beam status signal	R							T
Front fog lights request signal					T			R
Vehicle speed signal		R		R			T	
	R		R	T	R			
Sleep request 1 signal				R	T			
Sleep request 2 signal					T			R
Wake up request 1 signal					T			R
Wake up request 2 signal					T			R
Door switch signal (without navigation system)				R	T			R
Door switch signal (with navigation system)				T	R			
Turn indicator signal				R	T			
Seat belt buckle switch signal				T	R			
Oil pressure switch signal				R				T
Buzzer output signal				R	T			
ASCD SET lamp signal	T			R				
ASCD CRUISE lamp signal	T			R				
ASCD OD cancel request signal	T		R					
ASCD operation signal	T		R					
Output shaft revolution signal	R		T					
Front wiper request signal					T			R
Front wiper stop position signal					R			T
Rear window defogger switch signal					T			R
Rear window defogger control signal	R							T
Manual mode signal			R	T				
Not manual mode signal			R	T				
Manual mode shift up signal			R	T				
Manual mode shift down signal			R	T				
Manual mode indicator signal			T	R				
Hood switch signal					R			T
Theft warning horn request signal					T			R
Horn chirp signal					T			R
Steering angle sensor signal						T	R	
Malfunction indicator lamp signal	T			R				
Fuel level sensor signal	R			T				
Turbine revolution signal	R		T					
Tire pressure signal				R	T			
Parking brake switch signal		R		T				
SNOW mode switch signal	R	R		T				
AWD warning lamp signal		T		R				

CAN SYSTEM (TYPE 1)

System Description

AKS0092B

CAN (Controller Area Network) is a serial communication line for real time application. It is an on-vehicle multiplex communication line with high data communication speed and excellent error detection ability. Many electronic control units are equipped onto a vehicle, and each control unit shares information and links with other control units during operation (not independent). In CAN communication, control units are connected with 2 communication lines (CAN H line, CAN L line) allowing a high rate of information transmission with less wiring. Each control unit transmits/receives data but selectively reads required data only.

Component Parts and Harness Connector Location

AKS0092C

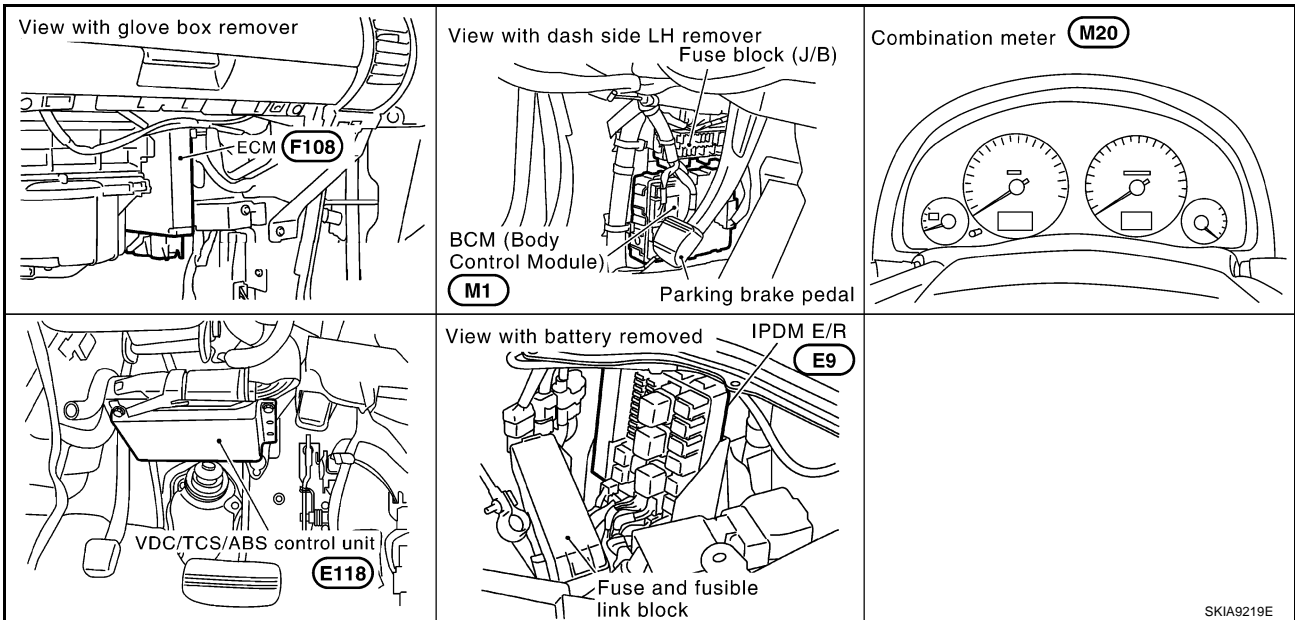

A
B
C
D
E
F
G
H
I
J
L
M

LAN

CAN SYSTEM (TYPE 1)

[CAN]

Schematic

AKS0092D

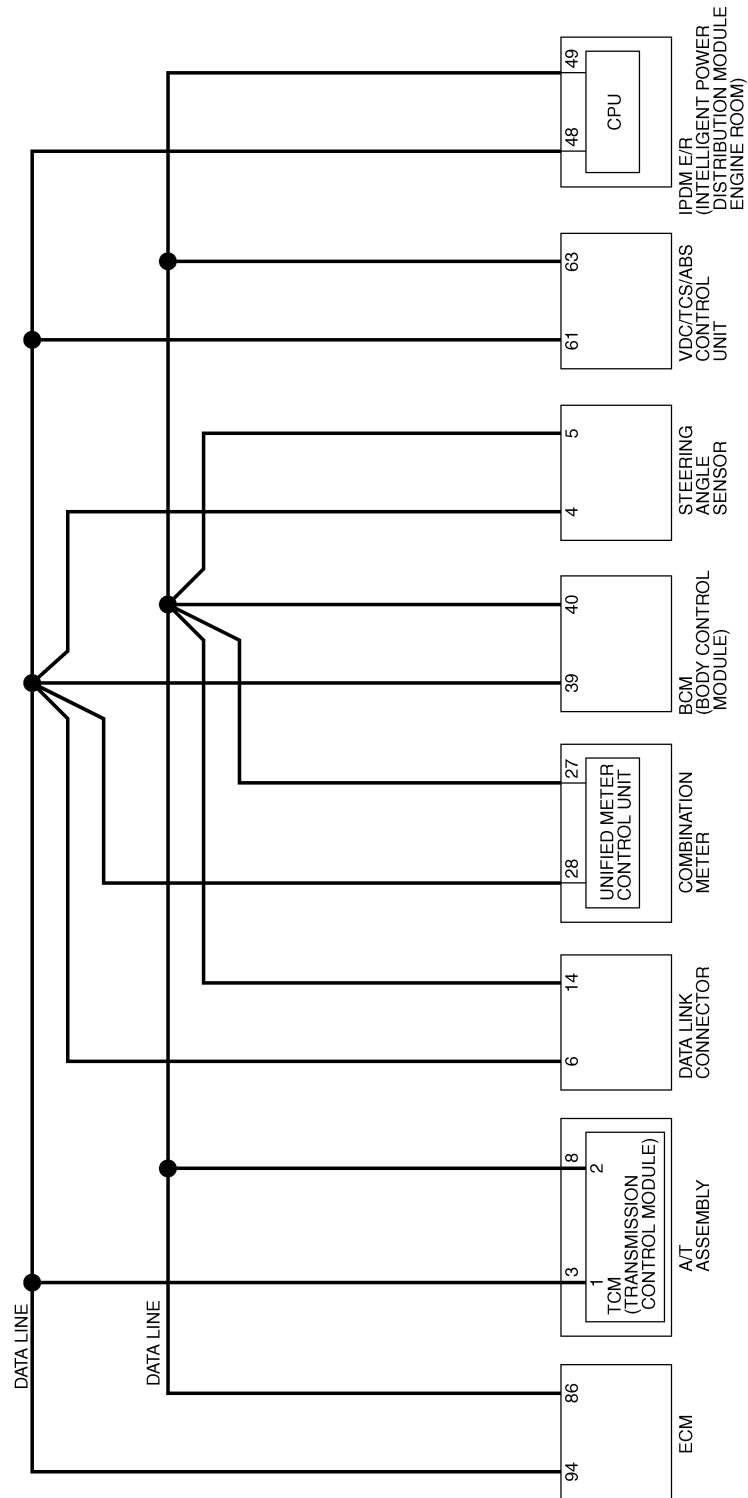

TKWM1419E

CAN SYSTEM (TYPE 1)

[CAN]

Wiring Diagram - CAN -

AKS0092E

LAN-CAN-01

▬ : DATA LINE

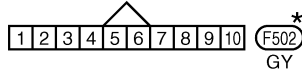
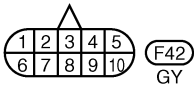
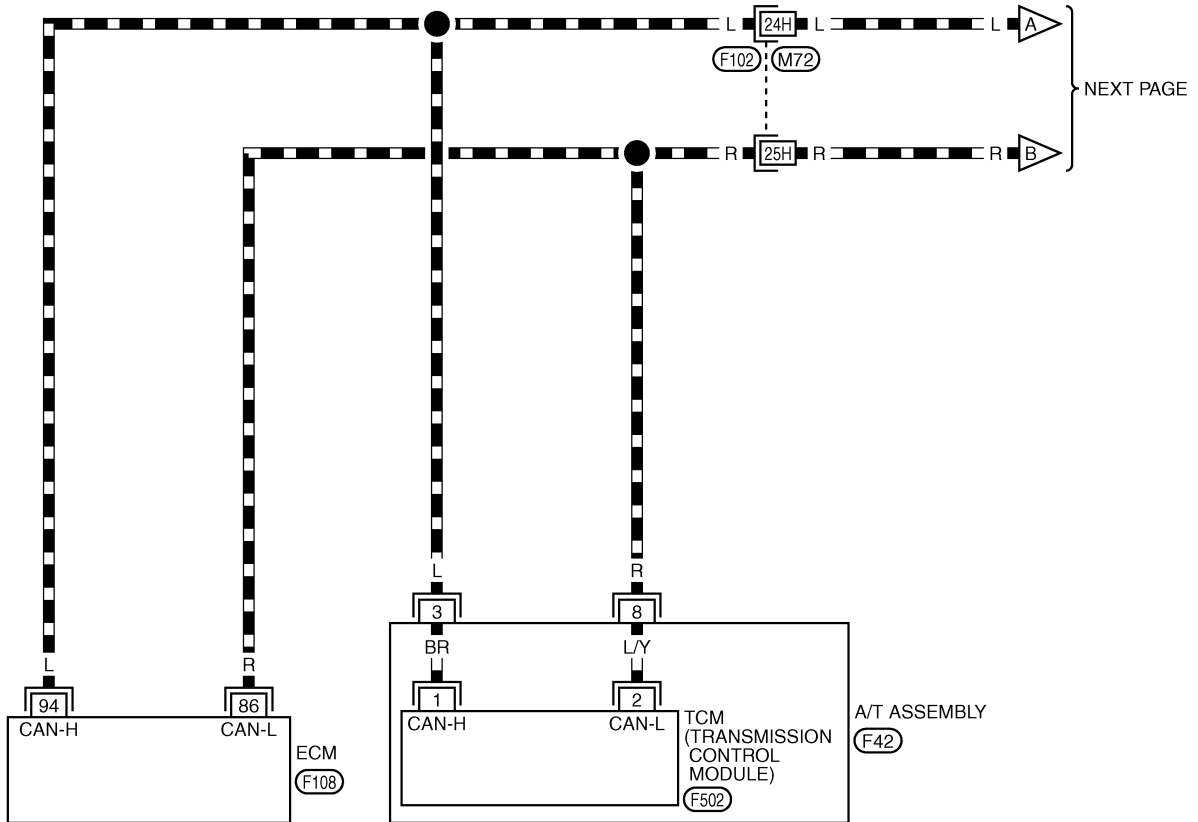

*: THIS CONNECTOR IS NOT SHOWN IN "HARNESS LAYOUT", PG SECTION.

REFER TO THE FOLLOWING.

(F102) -SUPER MULTIPLE JUNCTION (SMJ)

(F108) -ELECTRICAL UNITS

TKWM1420E

LAN-CAN-02

▬ : DATA LINE

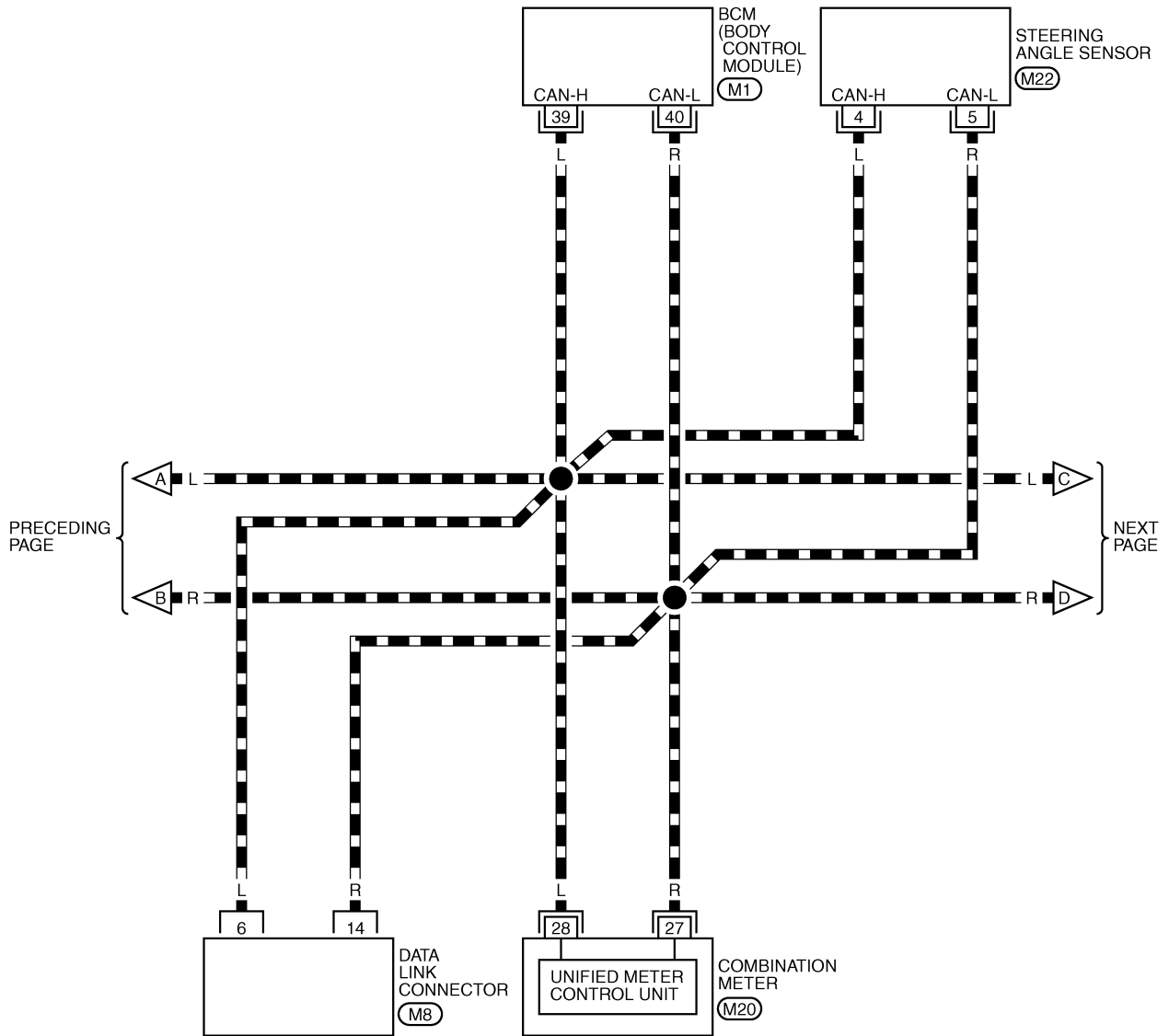

16	15	14	13	12	11	10	9
8	7	6	5	4	3	2	1

(M8)
W

25	26	27	28	29	30	31	32	33	34	35		
36	37	38	39	40	41	42	43	44	45	46	47	48

(M20)
W

3	2	1		
8	7	6	5	4

(M22)
W

REFER TO THE FOLLOWING.
(M1) -ELECTRICAL UNITS

TKWT1489E

CAN SYSTEM (TYPE 1)

[CAN]

LAN-CAN-03

▬ : DATA LINE

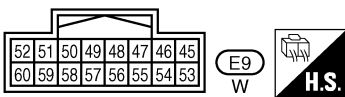
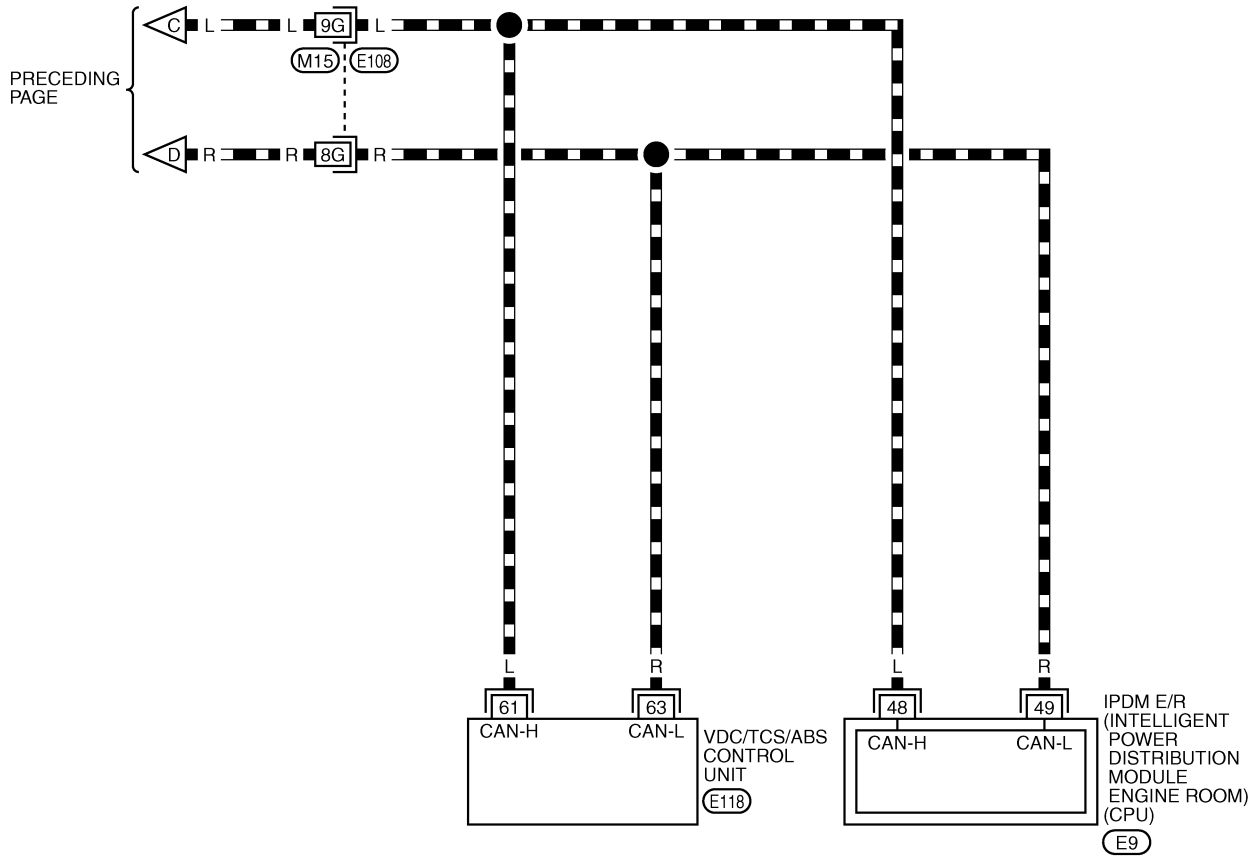

REFER TO THE FOLLOWING.

(E108) -SUPER MULTIPLE JUNCTION (SMJ)

(E118) -ELECTRICAL UNITS

TKWT1490E

Work Flow

- When there are no indications of "BCM" or "IPDM E/R" on "SELECT SYSTEM" display of CONSULT-II, print the "SELECT SYSTEM".

(Example)	NISSAN CONSULT- II ENGINE START (NISSAN BASED VHCL) START (RENAULT BASED VHCL) SUB MODE LIGHT COPY	➔	SELECT SYSTEM ENGINE A/T ABS AIR BAG BCM METER A/C AMP BACK LIGHT COPY	PKIA2093E
-----------	--	---	---	-----------

- Print all the data of "SELF-DIAG RESULTS" for "ENGINE", "A/T", "BCM", "ABS" and "IPDM E/R" displayed on CONSULT-II.

(Example)	SELECT DIAG MODE WORK SUPPORT SELF-DIAG RESULTS DATA MONITOR DATA MONITOR (SPEC) CAN DIAG SUPPORT MNTR ACTIVE TEST Scroll Down BACK LIGHT COPY	➔	SELF-DIAG RESULTS DTC RESULTS TIME CAN COMM CIRCUIT [U1000] 0 F.F.DATA ERASE PRINT MODE BACK LIGHT COPY	PKIA8260E
-----------	--	---	---	-----------

- Print all the data of "CAN DIAG SUPPORT MNTR" for "ENGINE", "A/T", "BCM", "ABS" and "IPDM E/R" displayed on CONSULT-II.

(Example)	SELECT DIAG MODE WORK SUPPORT SELF-DIAG RESULTS DATA MONITOR DATA MONITOR (SPEC) CAN DIAG SUPPORT MNTR ACTIVE TEST Scroll Down BACK LIGHT COPY	➔	CAN DIAG SUPPORT MNTR ENGINE INITIAL DIAG OK TRANSMIT DIAG OK TCM OK VDC/TCS/ABS OK METER/M&A OK ICC UNKWN BCM/SEC OK IPDM E/R OK AWD/4WD/e4WD UNKWN PRINT Scroll Down MODE BACK LIGHT COPY	PKIA8343E
-----------	--	---	---	-----------

- Attach the printed sheet of "SELECT SYSTEM", "SELF-DIAG RESULTS" and "CAN DIAG SUPPORT MNTR" onto the check sheet. Refer to [LAN-17, "CHECK SHEET"](#) .
- Based on the indications of "SELECT SYSTEM" and the results of "CAN DIAG SUPPORT MNTR", put marks "v" onto the items with "No indication", "NG", or "UNKWN" in the check sheet table. Refer to [LAN-17, "CHECK SHEET"](#) .

NOTE:

- If "NG" is displayed on "INITIAL DIAG (Initial diagnosis)" as "CAN DIAG SUPPORT MNTR" for the diagnosed control unit, replace the control unit.
- The "CAN DIAG SUPPORT MNTR" items, which are not in check sheet table, are not related to diagnostic procedure on service manual. So it is not necessary to check the status of the "CAN DIAG SUPPORT MNTR" items not in check sheet table.

- According to the check sheet results (example), start inspection. Refer to [LAN-19, "CHECK SHEET RESULTS \(EXAMPLE\)"](#) .

CAN SYSTEM (TYPE 1)

[CAN]

CHECK SHEET

NOTE:

If "NG" is displayed on "INITIAL DIAG (Initial diagnosis)" as "CAN DIAG SUPPORT MNTR" for the diagnosed control unit, replace the control unit.

Check sheet table

SELECT SYSTEM screen		CAN DIAG SUPPORT MNTR								
		Initial diagnosis	Transmit diagnosis	Receive diagnosis						
				ECM	TCM	METER /M&A	BCM/SEC	STRG	VDC/TCS /ABS	IPDM E/R
ENGINE	—	NG	UNKWN	—	UNKWN	UNKWN	UNKWN	—	UNKWN	UNKWN
A/T	—	NG	UNKWN	UNKWN	—	UNKWN	—	—	UNKWN	—
BCM	No indication	NG	UNKWN	UNKWN	—	UNKWN	—	—	—	UNKWN
ABS	—	NG	UNKWN	UNKWN	UNKWN	UNKWN	—	UNKWN	—	—
IPDM E/R	No indication	—	UNKWN	UNKWN	—	—	UNKWN	—	—	—

Symptoms :

Attach copy of
SELECT SYSTEM

Attach copy of
SELECT SYSTEM

PKIA7898E

A
B
C
D
E
F
G
H
I
J
LAN
L
M

CAN SYSTEM (TYPE 1)

[CAN]

Attach copy of
ENGINE
SELF-DIAG RESULTS

Attach copy of
A/T
SELF-DIAG RESULTS

Attach copy of
BCM
SELF-DIAG RESULTS

Attach copy of
ABS
SELF-DIAG RESULTS

Attach copy of
IPDM E/R
SELF-DIAG RESULTS

Attach copy of
ENGINE
CAN DIAG SUPPORT
MNTR

Attach copy of
A/T
CAN DIAG SUPPORT
MNTR

Attach copy of
BCM
CAN DIAG SUPPORT
MNTR

Attach copy of
ABS
CAN DIAG SUPPORT
MNTR

Attach copy of
IPDM E/R
CAN DIAG SUPPORT
MNTR

PKIA7899E

CHECK SHEET RESULTS (EXAMPLE)

NOTE:

If "NG" is displayed on "INITIAL DIAG (Initial diagnosis)" as "CAN DIAG SUPPORT MNTR" for the diagnosed control unit, replace the control unit.

Case1

Check harness between TCM and data link connector. Refer to [LAN-30, "Circuit Check Between TCM and Data Link Connector"](#) .

SELECT SYSTEM screen		CAN DIAG SUPPORT MNTR								
		Initial diagnosis	Transmit diagnosis	Receive diagnosis						IPDM E/R
				ECM	TCM	METER /M&A	BCM/SEC	STRG	VDC/TCS /ABS	
ENGINE	—	NG	UNKWN	—	UNKWN	UN KN W N ✓	UN KN W N ✓	—	UN KN W N ✓	UN KN W N ✓
A/T	—	NG	UNKWN	UNKWN	—	UN KN W N ✓	—	—	UN KN W N ✓	—
BCM	No indication	NG	UNKWN	UN KN W N ✓	—	UNKWN	—	—	—	UNKWN
ABS	—	NG	UNKWN	UN KN W N ✓	UN KN W N ✓	UNKWN	—	UNKWN	—	—
IPDM E/R	No indication	—	UNKWN	UN KN W N ✓	—	—	UNKWN	—	—	—

PKIA7900E

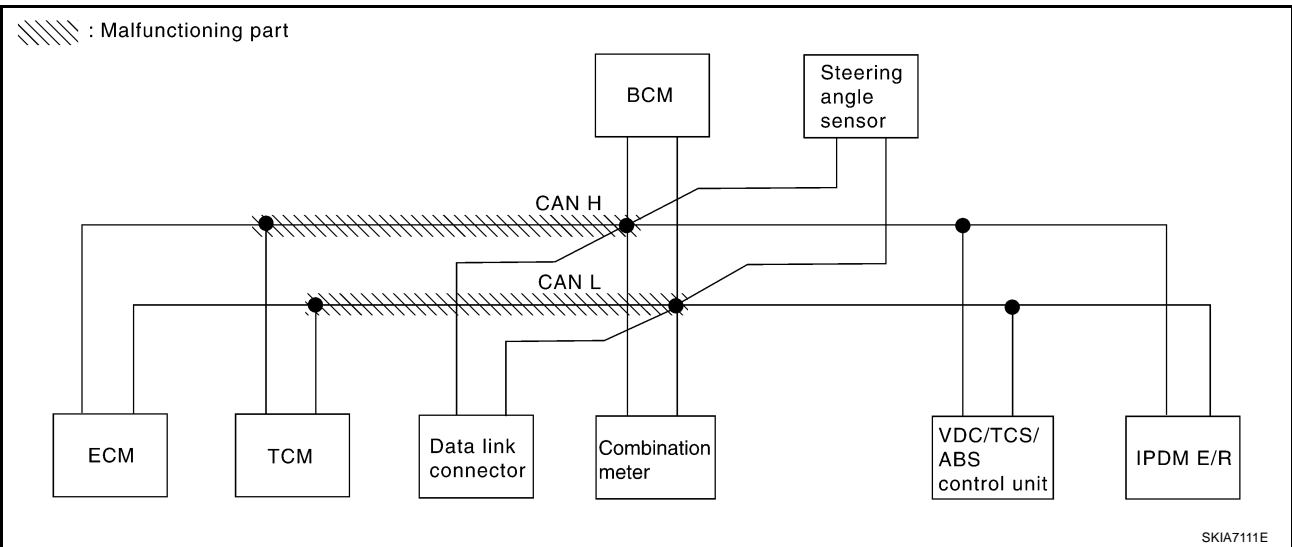

A
B
C
D
E
F
G
H
I
J
LAN
L
M

CAN SYSTEM (TYPE 1)

[CAN]

Case2

Check harness between data link connector and VDC/TCS/ABS control unit. Refer to [LAN-31, "Circuit Check Between Data Link Connector and VDC/TCS/ABS Control Unit"](#) .

SELECT SYSTEM screen		CAN DIAG SUPPORT MNTR								
		Initial diagnosis	Transmit diagnosis	Receive diagnosis						
				ECM	TCM	METER /M&A	BCM/SEC	STRG	VDC/TCS /ABS	IPDM E/R
ENGINE	—	NG	UNKWN	—	UNKWN	UNKWN	UNKWN	—	UNKWN	UNKWN
A/T	—	NG	UNKWN	UNKWN	—	UNKWN	—	—	UNKWN	—
BCM	No indication	NG	UNKWN	UNKWN	—	UNKWN	—	—	—	UNKWN
ABS	—	NG	UNKWN	UNKWN	UNKWN	UNKWN	—	UNKWN	—	—
IPDM E/R	No indication	—	UNKWN	UNKWN	—	—	UNKWN	—	—	—

PKIA7901E

//// : Malfunctioning part

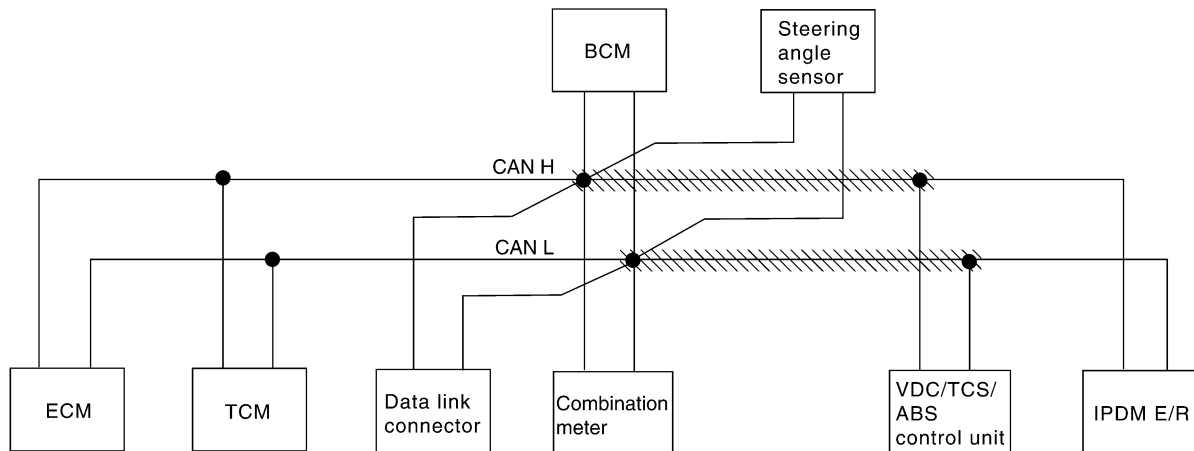

SKIA7112E

CAN SYSTEM (TYPE 1)

[CAN]

Case3

Check ECM circuit. Refer to [LAN-32. "ECM Circuit Check"](#) .

SELECT SYSTEM screen		CAN DIAG SUPPORT MNTR								
		Initial diagnosis	Transmit diagnosis	Receive diagnosis						
				ECM	TCM	METER /M&A	BCM/SEC	STRG	VDC/TCS /ABS	IPDM E/R
ENGINE	—	NG	UNKW [✓] N	—	UNKW [✓] N	UNKW [✓] N	UNKW [✓] N	—	UNKW [✓] N	UNKW [✓] N
A/T	—	NG	UNKW [✓] N	UNKW [✓] N	—	UNKW [✓] N	—	—	UNKW [✓] N	—
BCM	No indication	NG	UNKW [✓] N	UNKW [✓] N	—	UNKW [✓] N	—	—	—	UNKW [✓] N
ABS	—	NG	UNKW [✓] N	UNKW [✓] N	UNKW [✓] N	UNKW [✓] N	—	UNKW [✓] N	—	—
IPDM E/R	No indication	—	UNKW [✓] N	UNKW [✓] N	—	—	UNKW [✓] N	—	—	—

PKIA7902E

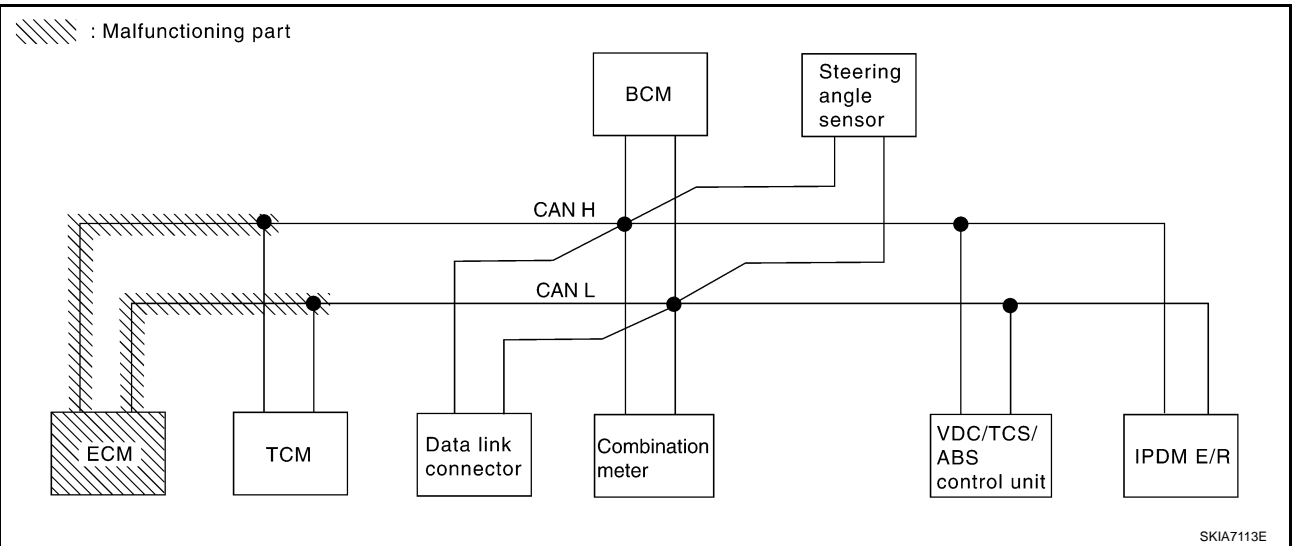

A
B
C
D
E
F
G
H
I
J
LAN
L
M

CAN SYSTEM (TYPE 1)

[CAN]

Case4

Check TCM circuit. Refer to [LAN-32, "TCM Circuit Check"](#) .

SELECT SYSTEM screen		CAN DIAG SUPPORT MNTR									
		Initial diagnosis	Transmit diagnosis	Receive diagnosis							
				ECM	TCM	METER /M&A	BCM/SEC	STRG	VDC/TCS /ABS	IPDM E/R	
ENGINE	—	NG	UNKWN	—	UNKWN ✓	UNKWN	UNKWN	—	UNKWN	UNKWN	
A/T	—	NG	UNKWN	UNKWN ✓	—	UNKWN ✓	—	—	UNKWN ✓	—	
BCM	No indication	NG	UNKWN	UNKWN	—	UNKWN	—	—	—	UNKWN	
ABS	—	NG	UNKWN	UNKWN	UNKWN ✓	UNKWN	—	UNKWN	—	—	
IPDM E/R	No indication	—	UNKWN	UNKWN	—	—	UNKWN	—	—	—	

PKIA7903E

//// : Malfunctioning part

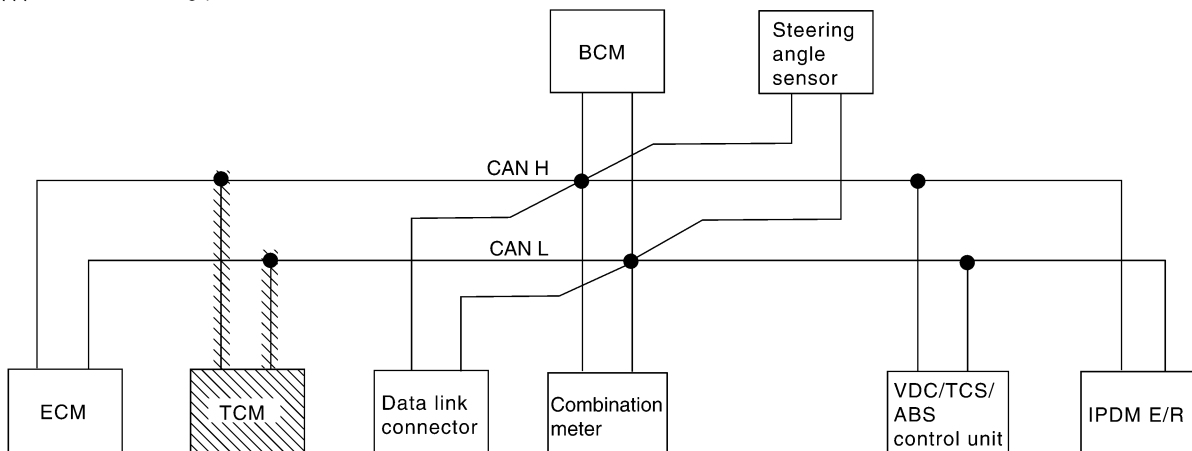

SKIA7114E

CAN SYSTEM (TYPE 1)

[CAN]

Case5

Check data link connector circuit. Refer to [LAN-33, "Data Link Connector Circuit Check"](#) .

SELECT SYSTEM screen		CAN DIAG SUPPORT MNTR								
		Initial diagnosis	Transmit diagnosis	Receive diagnosis						
				ECM	TCM	METER /M&A	BCM/SEC	STRG	VDC/TCS /ABS	IPDM E/R
ENGINE	—	NG	UNKWN	—	UNKWN	UNKWN	UNKWN	—	UNKWN	UNKWN
A/T	—	NG	UNKWN	UNKWN	—	UNKWN	—	—	UNKWN	—
BCM	No indication ✓	NG	UNKWN	UNKWN	—	UNKWN	—	—	—	UNKWN
ABS	—	NG	UNKWN	UNKWN	UNKWN	UNKWN	—	UNKWN	—	—
IPDM E/R	No indication ✓	—	UNKWN	UNKWN	—	—	UNKWN	—	—	—

PKIA7904E

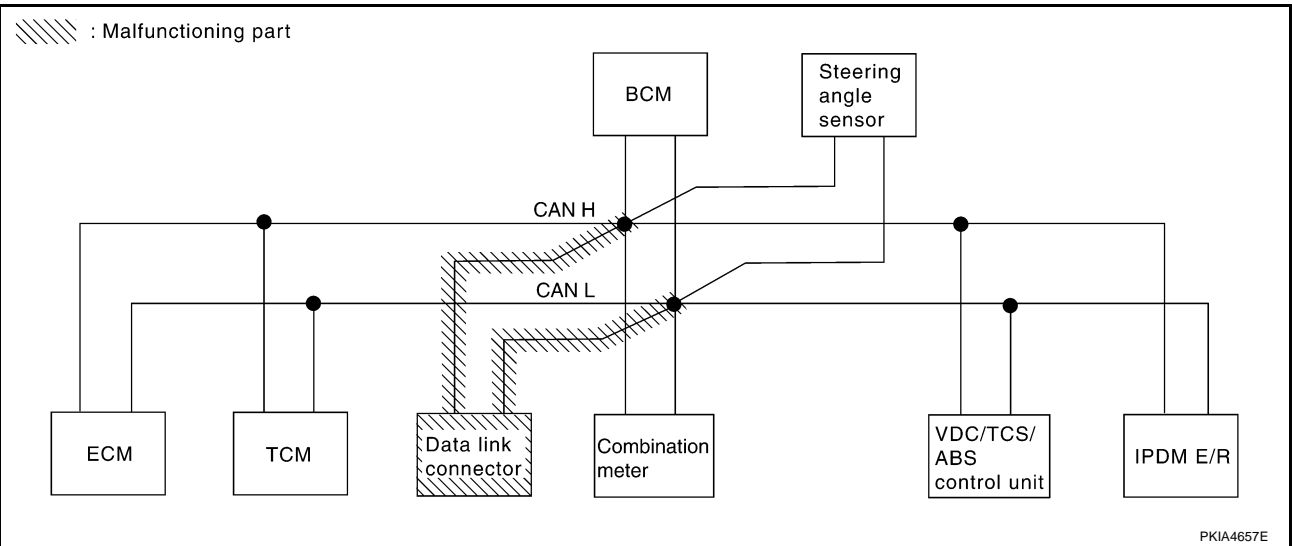

PKIA4657E

A
B
C
D
E
F
G
H
I
J
LAN
L
M

CAN SYSTEM (TYPE 1)

[CAN]

Case6

Check combination meter circuit. Refer to [LAN-33, "Combination Meter Circuit Check"](#) .

SELECT SYSTEM screen		CAN DIAG SUPPORT MNTR									
		Initial diagnosis	Transmit diagnosis	Receive diagnosis							
				ECM	TCM	METER /M&A	BCM/SEC	STRG	VDC/TCS /ABS	IPDM E/R	
ENGINE	—	NG	UNKWN	—	UNKWN	UNKWN ✓	UNKWN	—	UNKWN	UNKWN	
A/T	—	NG	UNKWN	UNKWN	—	UNKWN ✓	—	—	UNKWN	—	
BCM	No indication	NG	UNKWN	UNKWN	—	UNKWN ✓	—	—	—	UNKWN	
ABS	—	NG	UNKWN	UNKWN	UNKWN	UNKWN ✓	—	UNKWN	—	—	
IPDM E/R	No indication	—	UNKWN	UNKWN	—	—	UNKWN	—	—	—	

PKIA7905E

//// : Malfunctioning part

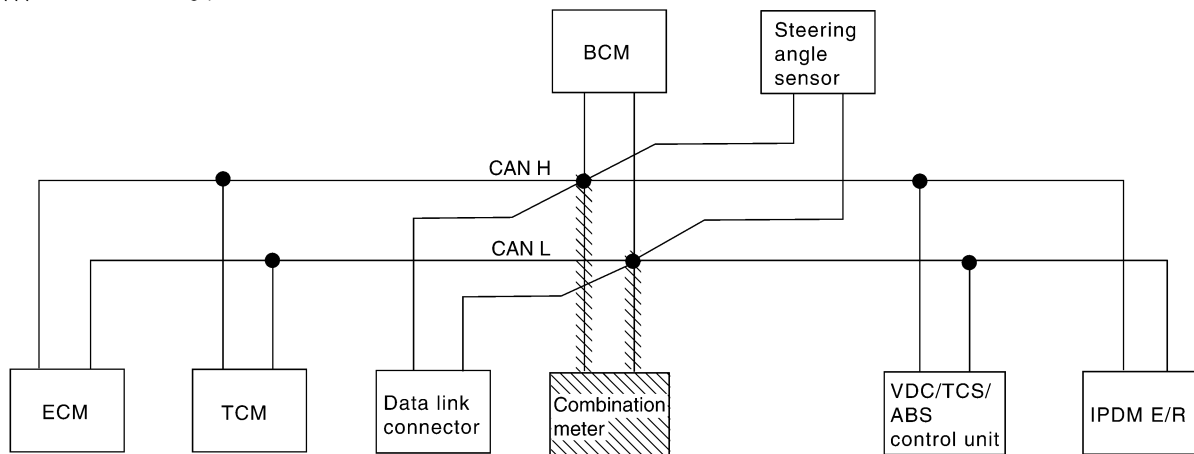

SKIA7115E

CAN SYSTEM (TYPE 1)

[CAN]

Case7

Check BCM circuit. Refer to [LAN-34, "BCM Circuit Check"](#) .

SELECT SYSTEM screen		CAN DIAG SUPPORT MNTR								
		Initial diagnosis	Transmit diagnosis	Receive diagnosis						IPDM E/R
				ECM	TCM	METER /M&A	BCM/SEC	STRG	VDC/TCS /ABS	
ENGINE	—	NG	UNKWN	—	UNKWN	UNKWN	UNKWN ✓	—	UNKWN	UNKWN
A/T	—	NG	UNKWN	UNKWN	—	UNKWN	—	—	UNKWN	—
BCM	No indication ✓	NG	UNKWN	UNKWN	—	UNKWN	—	—	—	UNKWN
ABS	—	NG	UNKWN	UNKWN	UNKWN	UNKWN	—	UNKWN	—	—
IPDM E/R	No indication	—	UNKWN	UNKWN	—	—	UNKWN ✓	—	—	—

PKIA7906E

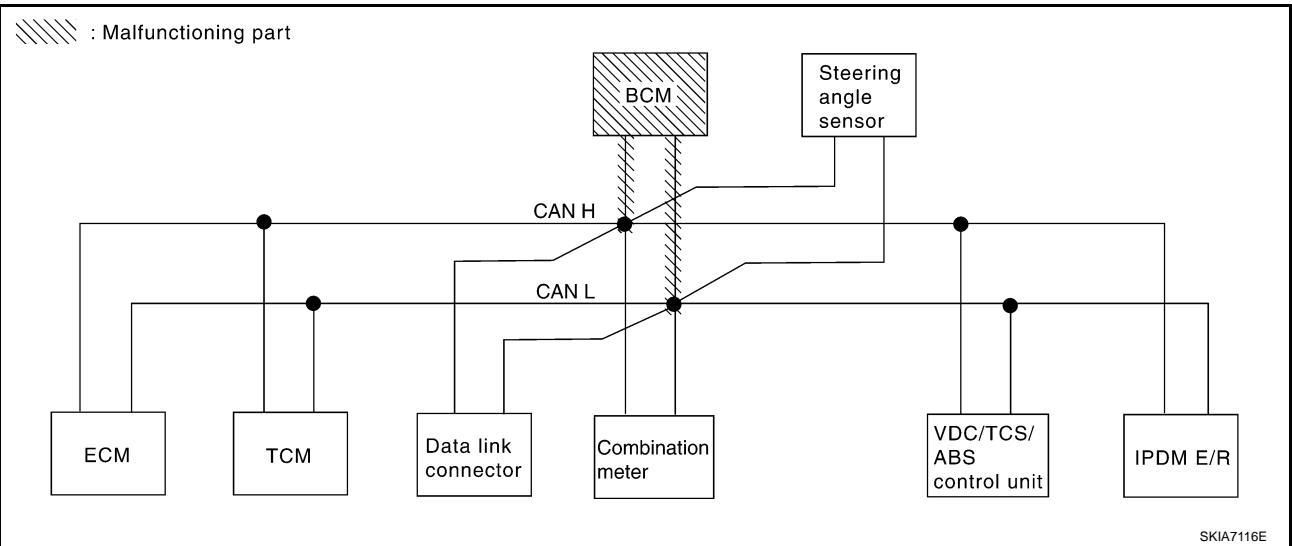

A
B
C
D
E
F
G
H
I
J
LAN
L
M

CAN SYSTEM (TYPE 1)

[CAN]

Case8

Check steering angle sensor circuit. Refer to [LAN-34, "Steering Angle Sensor Circuit Check"](#) .

SELECT SYSTEM screen		CAN DIAG SUPPORT MNTR									
		Initial diagnosis	Transmit diagnosis	Receive diagnosis							
				ECM	TCM	METER /M&A	BCM/SEC	STRG	VDC/TCS /ABS	IPDM E/R	
ENGINE	—	NG	UNKWN	—	UNKWN	UNKWN	UNKWN	—	UNKWN	UNKWN	
A/T	—	NG	UNKWN	UNKWN	—	UNKWN	—	—	UNKWN	—	
BCM	No indication	NG	UNKWN	UNKWN	—	UNKWN	—	—	—	UNKWN	
ABS	—	NG	UNKWN	UNKWN	UNKWN	UNKWN	—	UNKWN	—	—	
IPDM E/R	No indication	—	UNKWN	UNKWN	—	—	UNKWN	—	—	—	

PKIA7907E

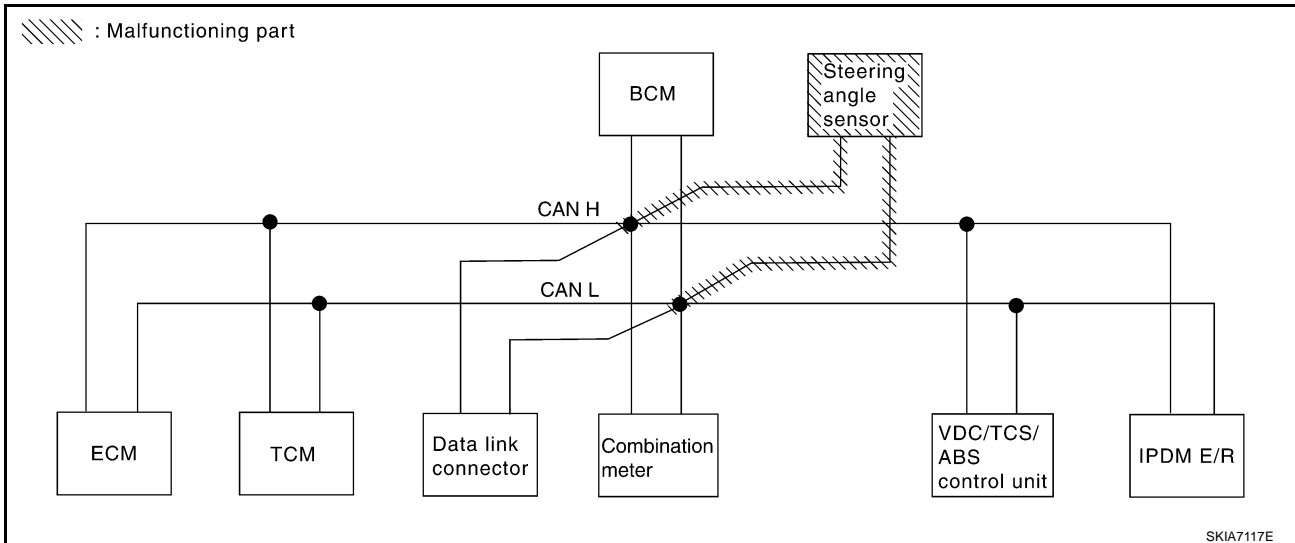

SKIA7117E

CAN SYSTEM (TYPE 1)

[CAN]

Case9

Check VDC/TCS/ABS control unit circuit. Refer to [LAN-35, "VDC/TCS/ABS Control Unit Circuit Check"](#) .

SELECT SYSTEM screen		CAN DIAG SUPPORT MNTR								
		Initial diagnosis	Transmit diagnosis	Receive diagnosis						
				ECM	TCM	METER /M&A	BCM/SEC	STRG	VDC/TCS /ABS	IPDM E/R
ENGINE	—	NG	UNKWN	—	UNKWN	UNKWN	UNKWN	—	UNKWN	UNKWN
A/T	—	NG	UNKWN	UNKWN	—	UNKWN	—	—	UNKWN	—
BCM	No indication	NG	UNKWN	UNKWN	—	UNKWN	—	—	—	UNKWN
ABS	—	NG	UNKWN	UNKWN	UNKWN	UNKWN	—	UNKWN	—	—
IPDM E/R	No indication	—	UNKWN	UNKWN	—	—	UNKWN	—	—	—

PKIA7908E

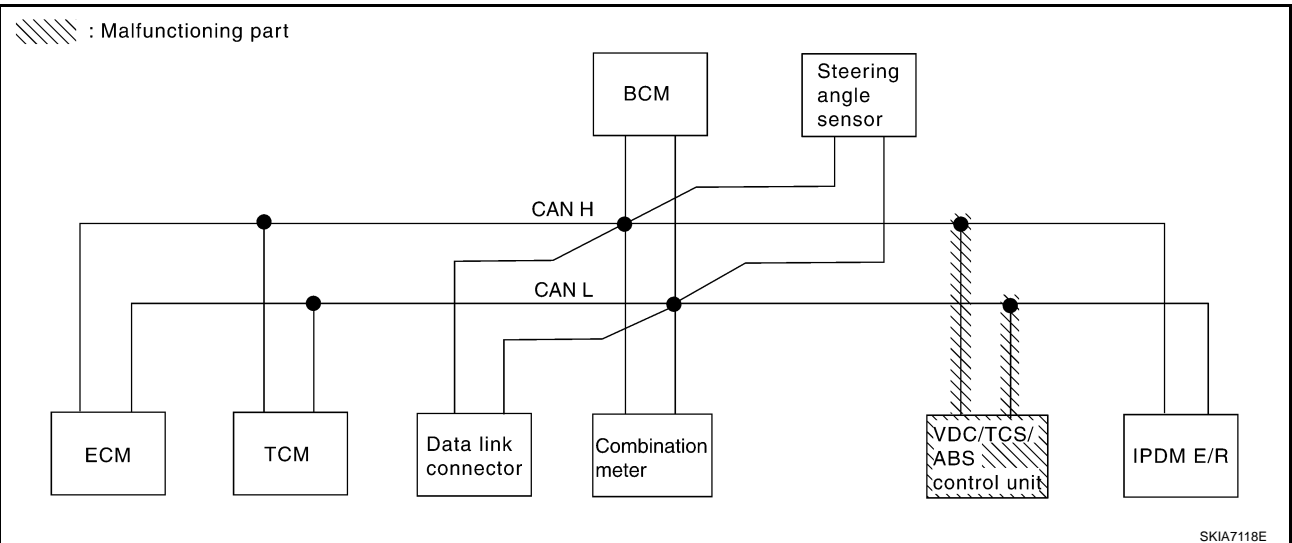

SKIA7118E

A
B
C
D
E
F
G
H
I
J
LAN
L
M

CAN SYSTEM (TYPE 1)

[CAN]

Case10

Check IPDM E/R circuit. Refer to [LAN-35, "IPDM E/R Circuit Check"](#) .

SELECT SYSTEM screen		CAN DIAG SUPPORT MNTR								
		Initial diagnosis	Transmit diagnosis	Receive diagnosis						
				ECM	TCM	METER /M&A	BCM/SEC	STRG	VDC/TCS /ABS	IPDM E/R
ENGINE	—	NG	UNKWN	—	UNKWN	UNKWN	UNKWN	—	UNKWN	UNKWN ✓
A/T	—	NG	UNKWN	UNKWN	—	UNKWN	—	—	UNKWN	—
BCM	No indication	NG	UNKWN	UNKWN	—	UNKWN	—	—	—	UNKWN ✓
ABS	—	NG	UNKWN	UNKWN	UNKWN	UNKWN	—	UNKWN	—	—
IPDM E/R	No indication ✓	—	UNKWN	UNKWN	—	—	UNKWN	—	—	—

PKIA7909E

▨ : Malfunctioning part

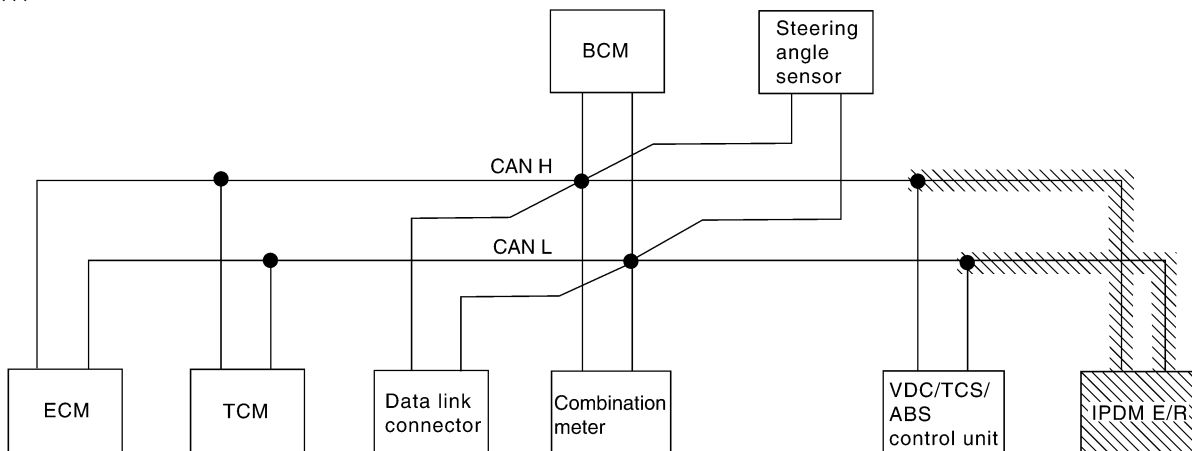

SKIA7119E

CAN SYSTEM (TYPE 1)

[CAN]

Case11

Check CAN communication circuit. Refer to [LAN-36, "CAN Communication Circuit Check"](#) .

SELECT SYSTEM screen		CAN DIAG SUPPORT MNTR								
		Initial diagnosis	Transmit diagnosis	Receive diagnosis						
				ECM	TCM	METER /M&A	BCM/SEC	STRG	VDC/TCS /ABS	IPDM E/R
ENGINE	—	NG	UNKW N	—	UNKW N	UNKW N	UNKW N	—	UNKW N	UNKW N
A/T	—	NG	UNKW N	UNKW N	—	UNKW N	—	—	UNKW N	—
BCM	No indication ✓	NG	UNKW N	UNKW N	—	UNKW N	—	—	—	UNKW N
ABS	—	NG ✓	UNKW N	UNKW N	UNKW N	UNKW N	—	UNKW N	—	—
IPDM E/R	No indication ✓	—	UNKW N	UNKW N	—	—	UNKW N	—	—	—

PKIA7910E

Case12

Check IPDM E/R ignition relay circuit continuously sticks "OFF". Refer to [LAN-38, "IPDM E/R Ignition Relay Circuit Check"](#) .

SELECT SYSTEM screen		CAN DIAG SUPPORT MNTR								
		Initial diagnosis	Transmit diagnosis	Receive diagnosis						
				ECM	TCM	METER /M&A	BCM/SEC	STRG	VDC/TCS /ABS	IPDM E/R
ENGINE	—	NG	UNKW N	—	UNKW N	UNKW N	UNKW N	—	UNKW N	UNKW N
A/T	—	NG	UNKW N	UNKW N	—	UNKW N	—	—	UNKW N	—
BCM	No indication ✓	NG	UNKW N	UNKW N	—	UNKW N	—	—	—	UNKW N
ABS	—	NG	UNKW N	UNKW N	UNKW N	UNKW N	—	UNKW N	—	—
IPDM E/R	No indication ✓	—	UNKW N	UNKW N	—	—	UNKW N	—	—	—

PKIA7911E

A
B
C
D
E
F
G
H
I
J
L
M

LAN

Case13

Check IPDM E/R ignition relay circuit continuously sticks "ON". Refer to [LAN-38, "IPDM E/R Ignition Relay Circuit Check"](#) .

SELECT SYSTEM screen		CAN DIAG SUPPORT MNTR								
		Initial diagnosis	Transmit diagnosis	Receive diagnosis						
				ECM	TCM	METER /M&A	BCM/SEC	STRG	VDC/TCS /ABS	IPDM E/R
ENGINE	—	NG	UNKWVN	—	UNKWVN ✓	UNKWVN ✓	UNKWVN	—	UNKWVN ✓	UNKWVN
A/T	—	NG	UNKWVN	UNKWVN	—	UNKWVN	—	—	UNKWVN	—
BCM	No indication	NG	UNKWVN	UNKWVN	—	UNKWVN ✓	—	—	—	UNKWVN
ABS	—	NG	UNKWVN	UNKWVN	UNKWVN	UNKWVN	—	UNKWVN	—	—
IPDM E/R	No indication	—	UNKWVN	UNKWVN	—	—	UNKWVN	—	—	—

PKIA7912E

Circuit Check Between TCM and Data Link Connector

AKS0092G

1. CHECK CONNECTOR

1. Turn ignition switch OFF.
2. Disconnect the negative battery terminal.
3. Check following terminals and connectors for damage, bend and loose connection (connector side and harness side).
 - Harness connector F102
 - Harness connector M72

OK or NG

- OK >> GO TO 2.
 NG >> Repair terminal or connector.

2. CHECK HARNESS FOR OPEN CIRCUIT

1. Disconnect A/T assembly connector and harness connector F102.
2. Check continuity between A/T assembly harness connector F42 terminals 3 (L), 8 (R) and harness connector F102 terminals 24H (L), 25H (R).

3 (L) - 24H (L) : Continuity should exist.
8 (R) - 25H (R) : Continuity should exist.

OK or NG

- OK >> GO TO 3.
 NG >> Repair harness.

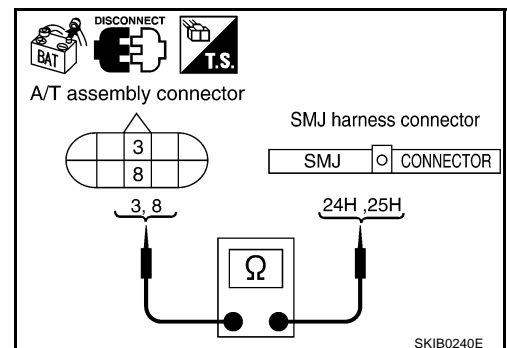

3. CHECK HARNESS FOR OPEN CIRCUIT

Check continuity between harness connector M72 terminals 24H (L), 25H (R) and data link connector M8 terminals 6 (L), 14 (R).

24H (L) - 6 (L) : Continuity should exist.

25H (R) - 14 (R) : Continuity should exist.

OK or NG

OK >> Connect all the connectors and diagnose again. Refer to

[LAN-16. "Work Flow"](#) .

NG >> Repair harness.

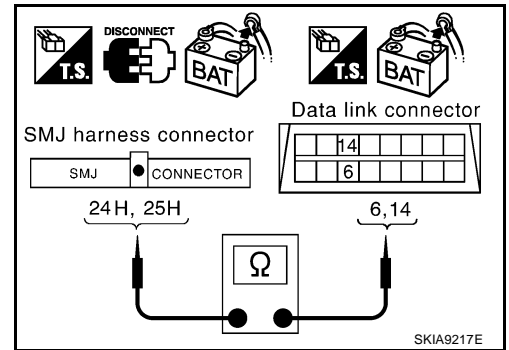

Circuit Check Between Data Link Connector and VDC/TCS/ABS Control Unit

AKS0092H

1. CHECK CONNECTOR

1. Turn ignition switch OFF.
2. Disconnect the negative battery terminal.
3. Check following terminals and connectors for damage, bend and loose connection (connector side and harness side).
 - Harness connector M15
 - Harness connector E108

OK or NG

OK >> GO TO 2.

NG >> Repair terminal or connector.

2. CHECK HARNESS FOR OPEN CIRCUIT

1. Disconnect harness connector M15.
2. Check continuity between data link connector M8 terminals 6 (L), 14 (R) and harness connector M15 terminals 9G (L), 8G (R).

6 (L) - 9G (L) : Continuity should exist.

14 (R) - 8G (R) : Continuity should exist.

OK or NG

OK >> GO TO 3.

NG >> Repair harness.

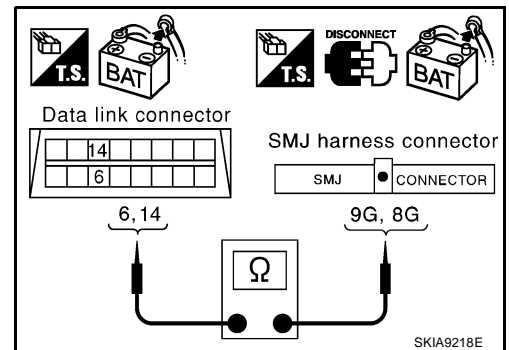

3. CHECK HARNESS FOR OPEN CIRCUIT

1. Disconnect VDC/TCS/ABS control unit connector.
2. Check continuity between harness connector E108 terminals 9G (L), 8G (R) and VDC/TCS/ABS control unit harness connector E118 terminals 61 (L), 63 (R).

9G (L) - 61 (L) : Continuity should exist.

8G (R) - 63 (R) : Continuity should exist.

OK or NG

OK >> Connect all the connectors and diagnose again. Refer to

[LAN-16. "Work Flow"](#) .

NG >> Repair harness.

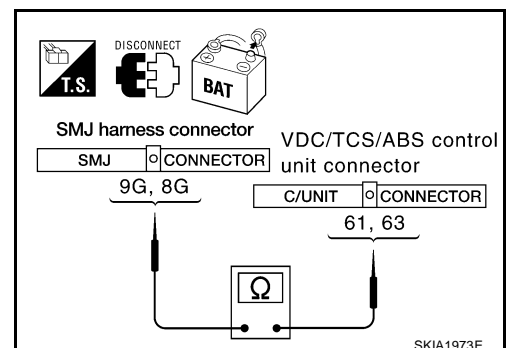

ECM Circuit Check**1. CHECK CONNECTOR**

1. Turn ignition switch OFF.
2. Disconnect the negative battery terminal.
3. Check terminals and connector of ECM for damage, bend and loose connection (control module side and harness side).

OK or NG

- OK >> GO TO 2.
 NG >> Repair terminal or connector.

2. CHECK HARNESS FOR OPEN CIRCUIT

1. Disconnect ECM connector.
2. Check resistance between ECM harness connector F108 terminals 94 (L) and 86 (R).

94 (L) - 86 (R) : Approx. 108 - 132Ω

OK or NG

- OK >> Replace ECM.
 NG >> Repair harness between harness connector F102 and ECM.

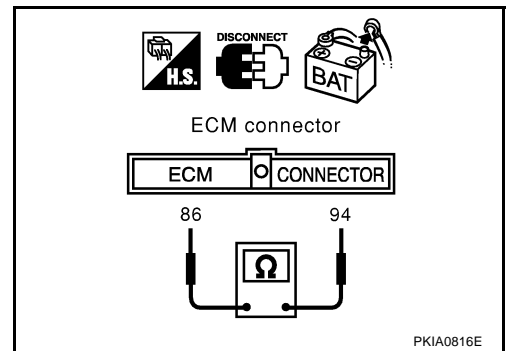
**TCM Circuit Check****1. CHECK CONNECTOR**

1. Turn ignition switch OFF.
2. Disconnect the negative battery terminal.
3. Check terminals and connector of A/T assembly for damage, bend and loose connection (control module side and harness side).

OK or NG

- OK >> GO TO 2.
 NG >> Repair terminal or connector.

2. CHECK HARNESS FOR OPEN CIRCUIT

1. Disconnect A/T assembly connector.
2. Check resistance between A/T assembly harness connector F42 terminals 3 (L) and 8 (R).

3 (L) - 8 (R) : Approx. 54 - 66Ω

OK or NG

- OK >> Replace control valve with TCM.
 NG >> Repair harness between harness connector F102 and A/T assembly.

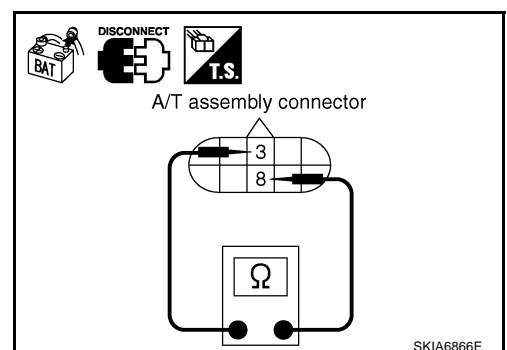

Data Link Connector Circuit Check**1. CHECK CONNECTOR**

1. Turn ignition switch OFF.
2. Disconnect the negative battery terminal.
3. Check terminals and connector of data link connector for damage, bend and loose connection (connector side and harness side).

OK or NG

- OK >> GO TO 2.
 NG >> Repair terminal or connector.

2. CHECK HARNESS FOR OPEN CIRCUIT

Check resistance between data link connector M8 terminals 6 (L) and 14 (R).

6 (L) - 14 (R) : Approx. 54 - 66Ω

OK or NG

- OK >> Diagnose again. Refer to [LAN-16, "Work Flow"](#) .
 NG >> Repair harness between data link connector and combination meter.

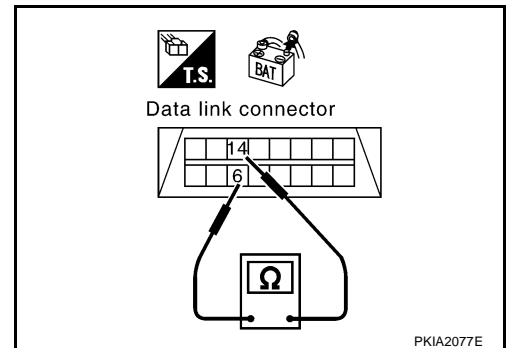
**Combination Meter Circuit Check****1. CHECK CONNECTOR**

1. Turn ignition switch OFF.
2. Disconnect the negative battery terminal.
3. Check terminals and connector of combination meter for damage, bend and loose connection (meter side and harness side).

OK or NG

- OK >> GO TO 2.
 NG >> Repair terminal or connector.

2. CHECK HARNESS FOR OPEN CIRCUIT

1. Disconnect combination meter connector.
2. Check resistance between combination meter harness connector M20 terminals 28 (L) and 27 (R).

28 (L) - 27 (R) : Approx. 54 - 66Ω

OK or NG

- OK >> Replace combination meter.
 NG >> Repair harness between data link connector and combination meter.

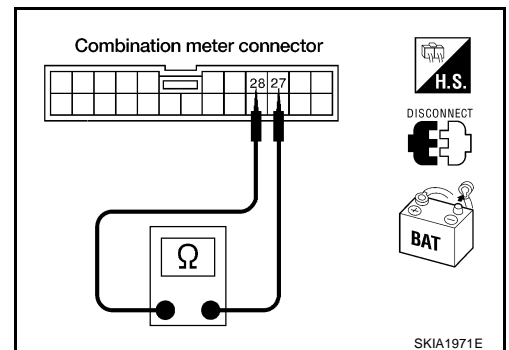

BCM Circuit Check**1. CHECK CONNECTOR**

1. Turn ignition switch OFF.
2. Disconnect the negative battery terminal.
3. Check terminals and connector of BCM for damage, bend and loose connection (control module side and harness side).

OK or NG

- OK >> GO TO 2.
 NG >> Repair terminal or connector.

2. CHECK HARNESS FOR OPEN CIRCUIT

1. Disconnect BCM connector.
2. Check resistance between BCM harness connector M1 terminals 39 (L) and 40 (R).

39 (L) - 40 (R) : Approx. 54 - 66Ω

OK or NG

- OK >> Replace BCM. Refer to [BCS-15. "Removal and Installation of BCM"](#) .
 NG >> Repair harness between data link connector and BCM.

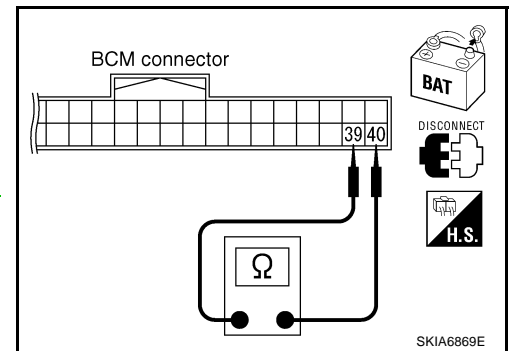
**Steering Angle Sensor Circuit Check****1. CHECK CONNECTOR**

1. Turn ignition switch OFF.
2. Disconnect the negative battery terminal.
3. Check terminals and connector of steering angle sensor for damage, bend and loose connection (sensor side and harness side).

OK or NG

- OK >> GO TO 2.
 NG >> Repair terminal or connector.

2. CHECK HARNESS FOR OPEN CIRCUIT

1. Disconnect steering angle sensor connector.
2. Check resistance between steering angle sensor harness connector M22 terminals 4 (L) and 5 (R).

4 (L) - 5 (R) : Approx. 54 - 66Ω

OK or NG

- OK >> Replace steering angle sensor.
 NG >> Repair harness between data link connector and steering angle sensor.

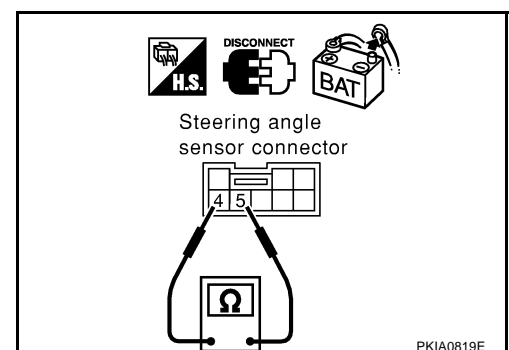

VDC/TCS/ABS Control Unit Circuit Check

1. CHECK CONNECTOR

1. Turn ignition switch OFF.
2. Disconnect the negative battery terminal.
3. Check terminals and connector of VDC/TCS/ABS control unit for damage, bend and loose connection (control unit side and harness side).

OK or NG

- OK >> GO TO 2.
 NG >> Repair terminal or connector.

2. CHECK HARNESS FOR OPEN CIRCUIT

1. Disconnect VDC/TCS/ABS control unit connector.
2. Check resistance between VDC/TCS/ABS control unit harness connector E118 terminals 61 (L) and 63 (R).

61 (L) - 63 (R) : Approx. 54 - 66Ω

OK or NG

- OK >> Replace VDC/TCS/ABS control unit.
 NG >> Repair harness between harness connector E108 and VDC/TCS/ABS control unit.

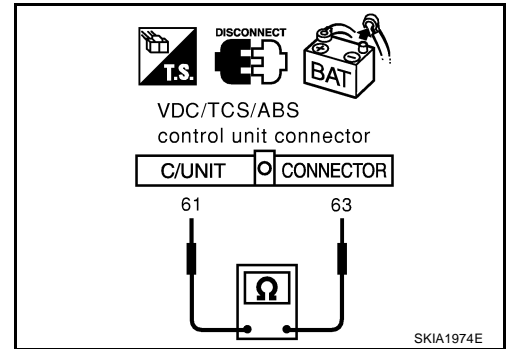

IPDM E/R Circuit Check

1. CHECK CONNECTOR

1. Turn ignition switch OFF.
2. Disconnect the negative battery terminal.
3. Check terminals and connector of IPDM E/R for damage, bend and loose connection (control module side and harness side).

OK or NG

- OK >> GO TO 2.
 NG >> Repair terminal or connector.

2. CHECK HARNESS FOR OPEN CIRCUIT

1. Disconnect IPDM E/R connector.
2. Check resistance between IPDM E/R harness connector E9 terminals 48 (L) and 49 (R).

48 (L) - 49 (R) : Approx. 108 - 132Ω

OK or NG

- OK >> Replace IPDM E/R.
 NG >> Repair harness between harness connector E108 and IPDM E/R.

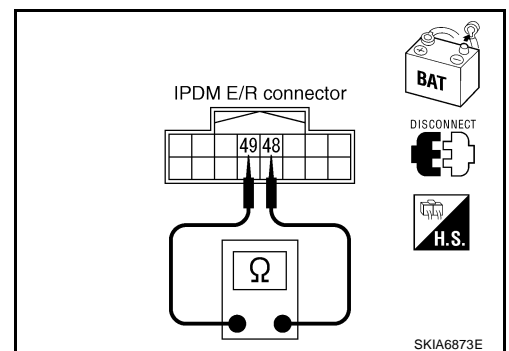

CAN Communication Circuit Check

AKS0092P

1. CHECK CONNECTOR

1. Turn ignition switch OFF.
2. Disconnect the negative battery terminal.
3. Check following terminals and connectors for damage, bend and loose connection (control module side, control unit side, meter side, sensor side and harness side).
 - ECM
 - A/T assembly
 - Combination meter
 - BCM
 - Steering angle sensor
 - VDC/TCS/ABS control unit
 - IPDM E/R
 - Between ECM and IPDM E/R

OK or NG

OK >> GO TO 2.

NG >> Repair terminal or connector.

2. CHECK HARNESS FOR SHORT CIRCUIT

1. Disconnect following connectors.
 - ECM connector
 - A/T assembly connector
 - Harness connector F102
2. Check continuity between ECM harness connector F108 terminals 94 (L) and 86 (R).

94 (L) - 86 (R) : Continuity should not exist.

OK or NG

OK >> GO TO 3.

NG >> Check the following harnesses. If any harness is damaged, repair the harness.

- Harness between ECM and harness connector F102
- Harness between A/T assembly and harness connector F102

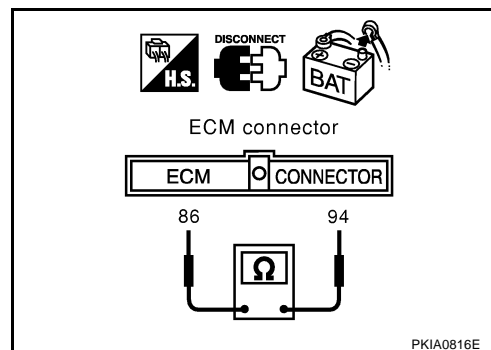

3. CHECK HARNESS FOR SHORT CIRCUIT

Check continuity between ECM harness connector F108 terminals 94 (L), 86 (R) and ground.

94 (L) - Ground : Continuity should not exist.

86 (R) - Ground : Continuity should not exist.

OK or NG

OK >> GO TO 4.

NG >> Check the following harnesses. If any harness is damaged, repair the harness.

- Harness between ECM and harness connector F102
- Harness between A/T assembly and harness connector F102

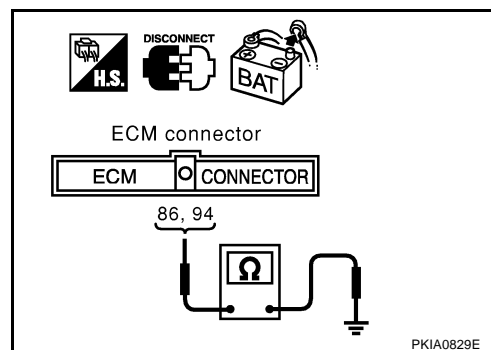

4. CHECK HARNESS FOR SHORT CIRCUIT

1. Disconnect following connectors.
 - Combination meter connector
 - BCM connector
 - Steering angle sensor connector
 - Harness connector M15
2. Check continuity between data link connector M8 terminals 6 (L) and 14 (R).

6 (L) - 14 (R) : Continuity should not exist.

OK or NG

OK >> GO TO 5.

NG >> Check the following harnesses. If any harness is damaged, repair the harness.

- Harness between harness connector M72 and harness connector M15
- Harness between harness connector M72 and combination meter
- Harness between harness connector M72 and data link connector
- Harness between harness connector M72 and BCM
- Harness between harness connector M72 and steering angle sensor

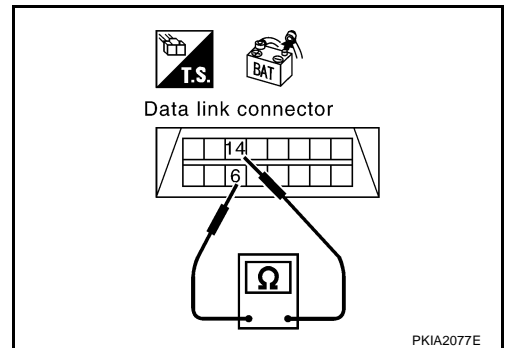

5. CHECK HARNESS FOR SHORT CIRCUIT

Check continuity between data link connector M8 terminals 6 (L), 14 (R) and ground.

6 (L) - Ground : Continuity should not exist.

14 (R) - Ground : Continuity should not exist.

OK or NG

OK >> GO TO 6.

NG >> Check the following harnesses. If any harness is damaged, repair the harness.

- Harness between harness connector M72 and harness connector M15
- Harness between harness connector M72 and combination meter
- Harness between harness connector M72 and data link connector
- Harness between harness connector M72 and BCM
- Harness between harness connector M72 and steering angle sensor

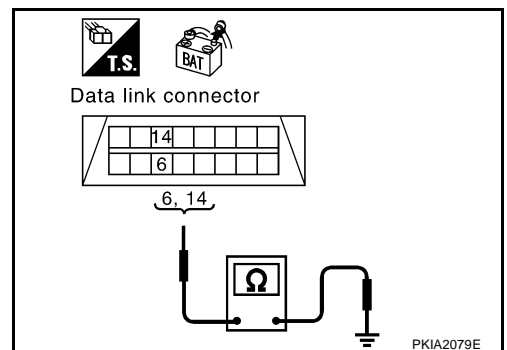

6. CHECK HARNESS FOR SHORT CIRCUIT

1. Disconnect VDC/TCS/ABS control unit connector and IPDM E/R connector.
2. Check continuity between IPDM E/R harness connector E9 terminals 48 (L) and 49 (R).

48 (L) - 49 (R) : Continuity should not exist.

OK or NG

OK >> GO TO 7.

NG >> Check the following harnesses. If any harness is damaged, repair the harness.

- Harness between harness connector E108 and VDC/TCS/ABS control unit
- Harness between harness connector E108 and IPDM E/R

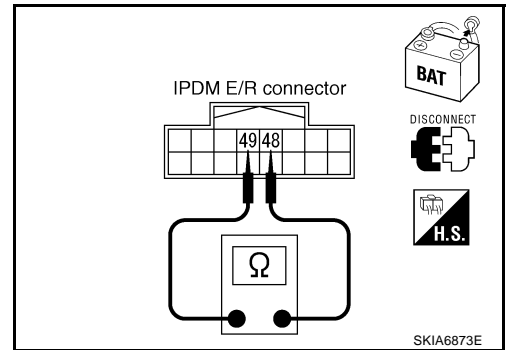

7. CHECK HARNESS FOR SHORT CIRCUIT

Check continuity between IPDM E/R harness connector E9 terminals 48 (L), 49 (R) and ground.

48 (L) - Ground : Continuity should not exist.

49 (R) - Ground : Continuity should not exist.

OK or NG

OK >> GO TO 8.

NG >> Check the following harnesses. If any harness is damaged, repair the harness.

- Harness between harness connector E108 and VDC/TCS/ABS control unit
- Harness between harness connector E108 and IPDM E/R

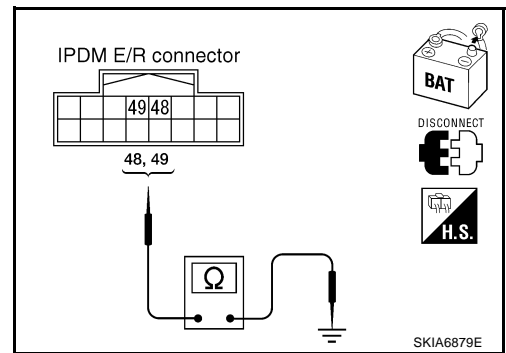

8. ECM/IPDM E/R INTERNAL CIRCUIT INSPECTION

Check components inspection. Refer to [LAN-38, "ECM/IPDM E/R INTERNAL CIRCUIT INSPECTION"](#).

OK or NG

OK >> Connect all the connectors and diagnose again. Refer to [LAN-16, "Work Flow"](#).

NG >> Replace ECM and/or IPDM E/R.

IPDM E/R Ignition Relay Circuit Check

AKS0092Q

Check the following. If no malfunction is found, replace the IPDM E/R.

- IPDM E/R power supply circuit. Refer to [PG-26, "IPDM E/R Power/Ground Circuit Inspection"](#).
- Ignition power supply circuit. Refer to [PG-10, "IGNITION POWER SUPPLY - IGNITION SW. IN "ON" AND/OR "START" "](#).

Component Inspection

ECM/IPDM E/R INTERNAL CIRCUIT INSPECTION

AKS0092R

- Remove ECM and IPDM E/R from vehicle.
- Check resistance between ECM terminals 94 and 86.
- Check resistance between IPDM E/R terminals 48 and 49.

Unit	Terminal	Resistance value (Ω) (Approx.)
ECM	94 - 86	108 - 132
IPDM E/R	48 - 49	

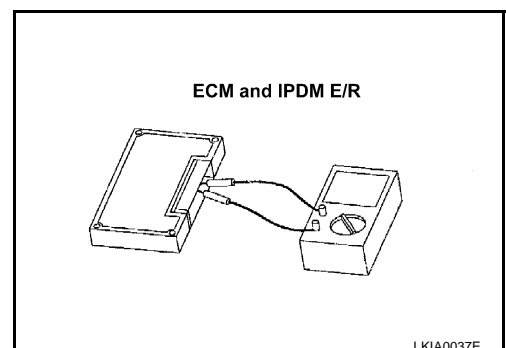

CAN SYSTEM (TYPE 2)

PFP:23710

System Description

AKS007V0

CAN (Controller Area Network) is a serial communication line for real time application. It is an on-vehicle multiplex communication line with high data communication speed and excellent error detection ability. Many electronic control units are equipped onto a vehicle, and each control unit shares information and links with other control units during operation (not independent). In CAN communication, control units are connected with 2 communication lines (CAN H line, CAN L line) allowing a high rate of information transmission with less wiring. Each control unit transmits/receives data but selectively reads required data only.

Component Parts and Harness Connector Location

AKS007V1

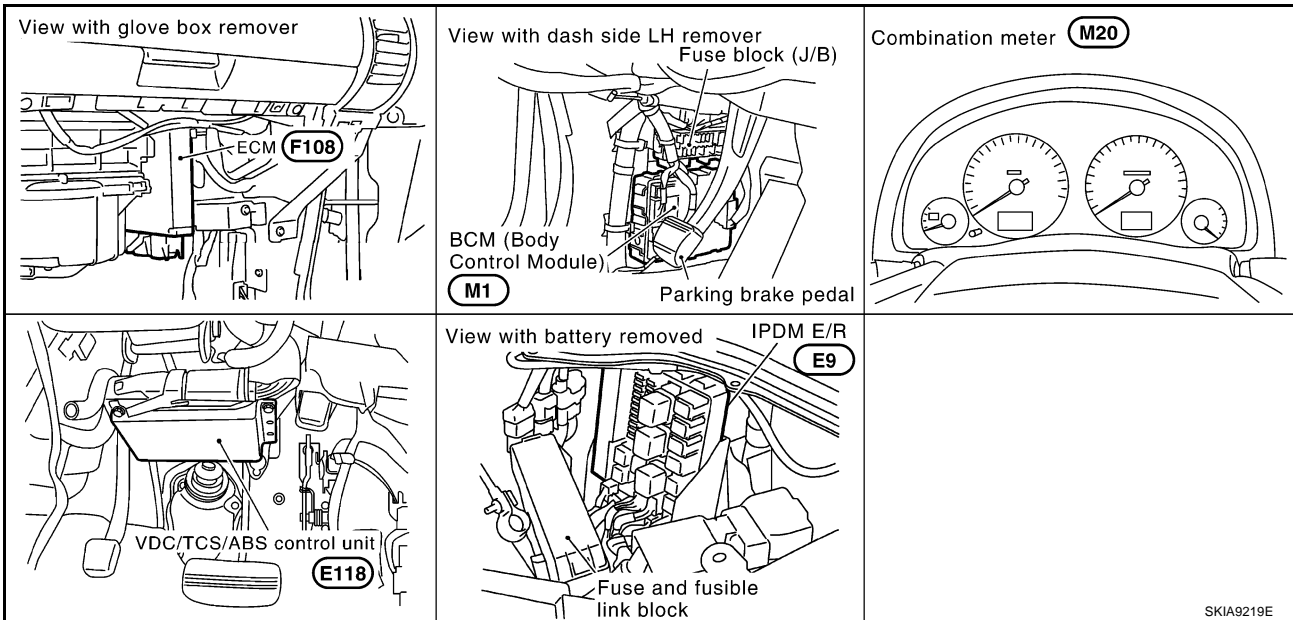

A
B
C
D
E
F
G
H
I
J
L
M

LAN

CAN SYSTEM (TYPE 2)

[CAN]

Schematic

AKS007V2

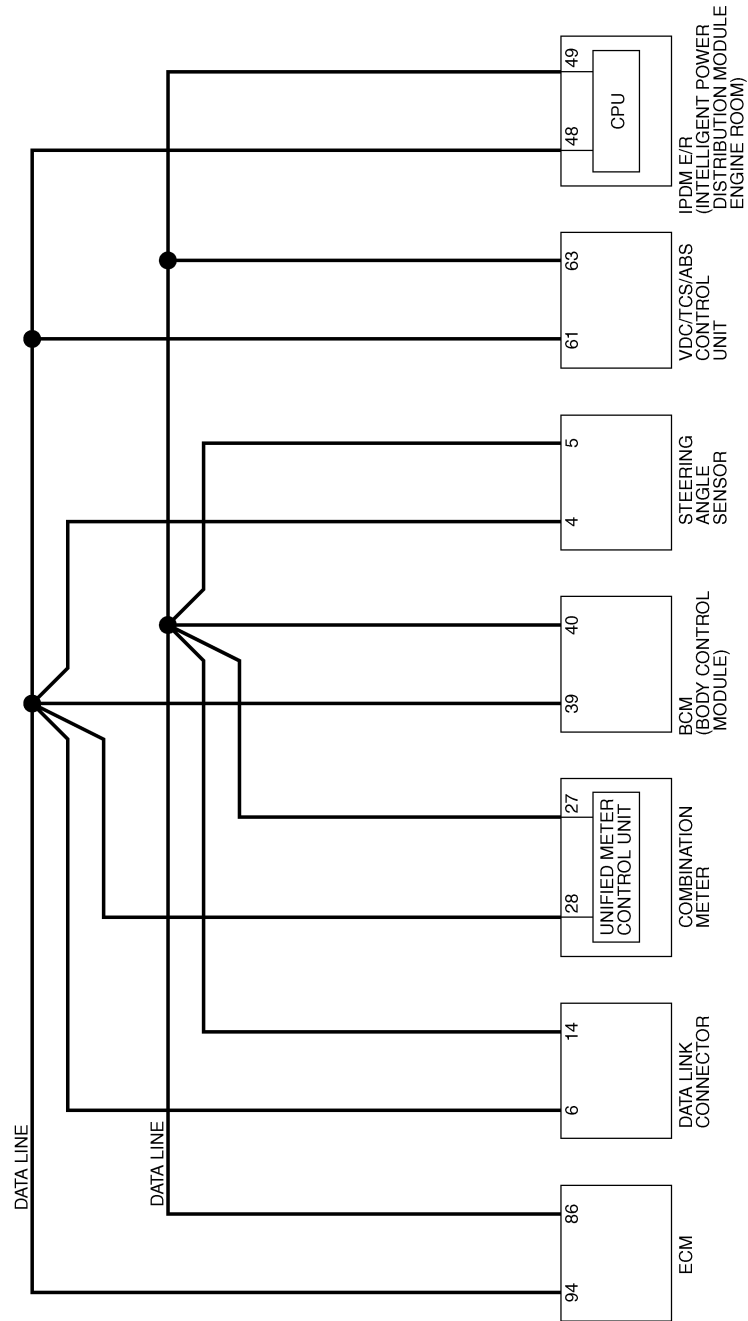

TKWT1491E

CAN SYSTEM (TYPE 2)

[CAN]

Wiring Diagram - CAN -

AKS00AAI

LAN-CAN-04

▬ : DATA LINE

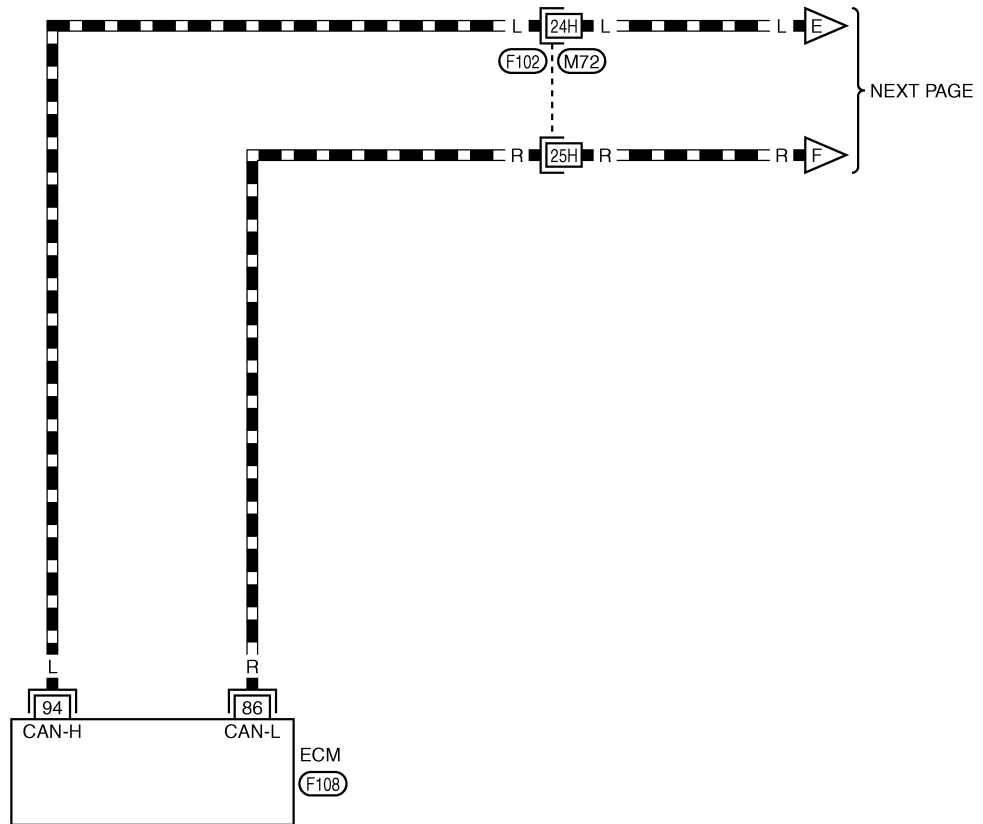

REFER TO THE FOLLOWING.

(F102) -SUPER MULTIPLE JUNCTION (SMJ)

(F108) -ELECTRICAL UNITS

TKWT2217E

LAN-CAN-05

▬ : DATA LINE

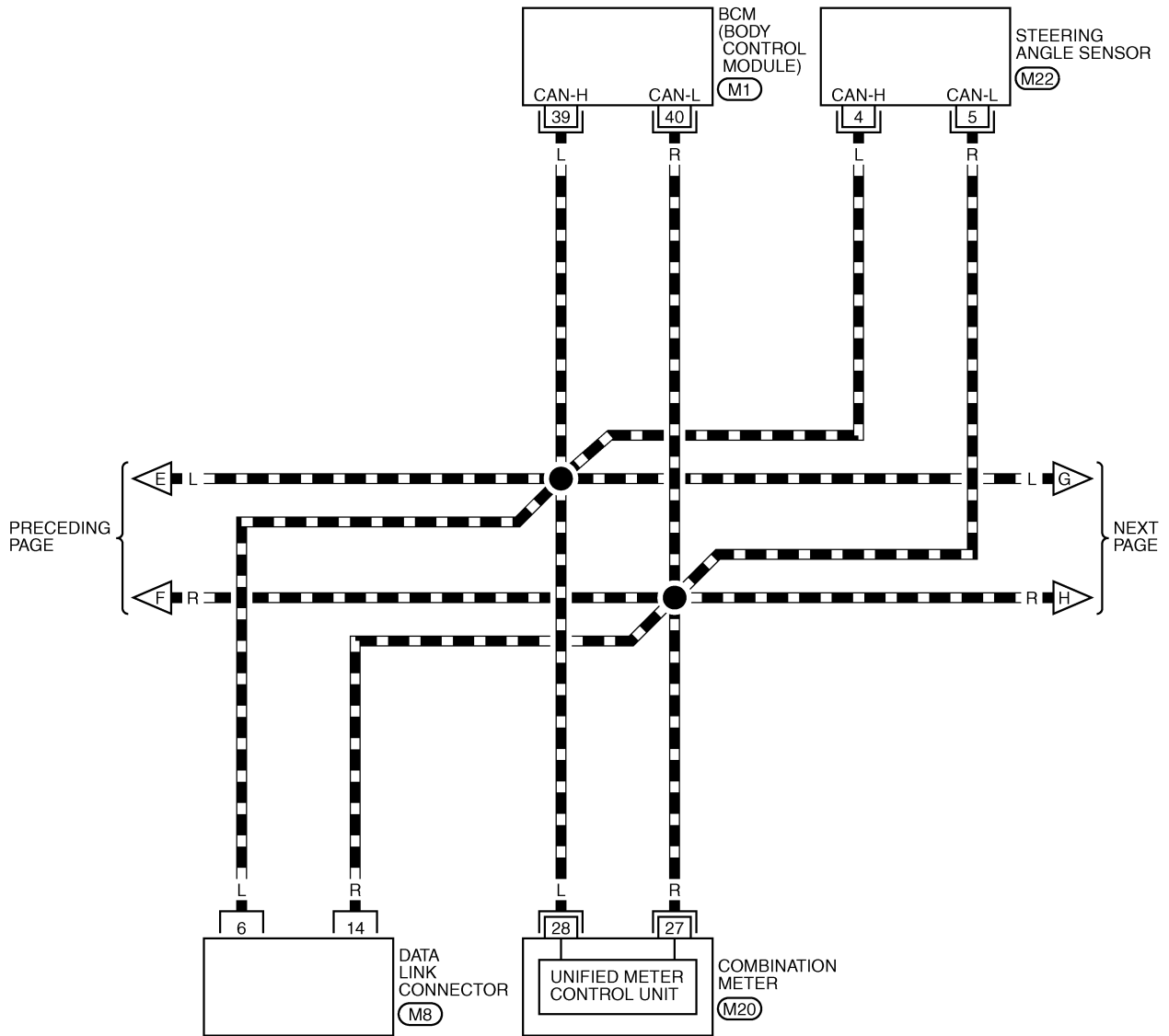

16	15	14	13	12	11	10	9
8	7	6	5	4	3	2	1

(M8)
W

25	26	27	28	29	30	31	32	33	34	35		
36	37	38	39	40	41	42	43	44	45	46	47	48

(M20)
W

3	2	1		
8	7	6	5	4

(M22)
W

REFER TO THE FOLLOWING.
(M1) -ELECTRICAL UNITS

CAN SYSTEM (TYPE 2)

[CAN]

LAN-CAN-06

DATA LINE

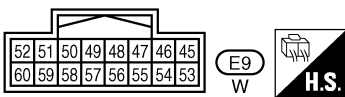
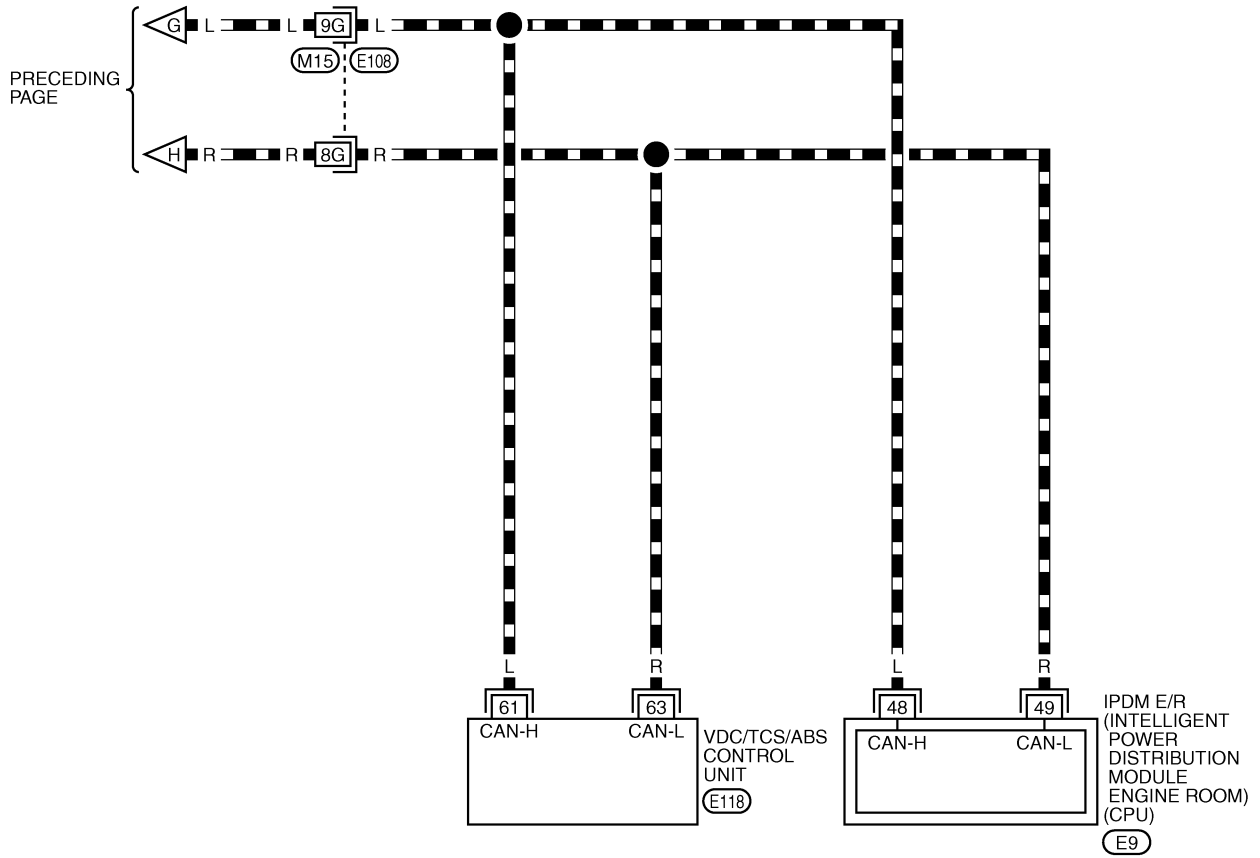

REFER TO THE FOLLOWING.

E108 -SUPER MULTIPLE JUNCTION (SMJ)

E118 -ELECTRICAL UNITS

TKWT2219E

Work Flow

- When there are no indications of "BCM" or "IPDM E/R" on "SELECT SYSTEM" display of CONSULT-II, print the "SELECT SYSTEM".

(Example)	<table border="1" style="width: 100%; border-collapse: collapse;"> <tr><td colspan="4" style="text-align: center;">NISSAN</td></tr> <tr><td colspan="4" style="text-align: center;">CONSULT- II</td></tr> <tr><td colspan="4" style="text-align: center;">ENGINE</td></tr> <tr><td colspan="4" style="text-align: center;">START (NISSAN BASED VHCL)</td></tr> <tr><td colspan="4" style="text-align: center;">START (RENAULT BASED VHCL)</td></tr> <tr><td colspan="4" style="text-align: center;">SUB MODE</td></tr> <tr> <td style="width: 25%;"></td> <td style="width: 25%;"></td> <td style="width: 25%;">LIGHT</td> <td style="width: 25%;">COPY</td> </tr> </table>	NISSAN				CONSULT- II				ENGINE				START (NISSAN BASED VHCL)				START (RENAULT BASED VHCL)				SUB MODE						LIGHT	COPY	➔	<table border="1" style="width: 100%; border-collapse: collapse;"> <tr><td colspan="4" style="text-align: center;">SELECT SYSTEM</td></tr> <tr><td colspan="4" style="text-align: center;">ENGINE</td></tr> <tr><td colspan="4" style="text-align: center;">A/T</td></tr> <tr><td colspan="4" style="text-align: center;">ABS</td></tr> <tr><td colspan="4" style="text-align: center;">AIR BAG</td></tr> <tr><td colspan="4" style="text-align: center;">BCM</td></tr> <tr><td colspan="4" style="text-align: center;">METER A/C AMP</td></tr> <tr><td colspan="4" style="text-align: center;"> </td></tr> <tr> <td style="width: 25%;"></td> <td style="width: 25%;"></td> <td style="width: 25%;">BACK</td> <td style="width: 25%;">LIGHT COPY</td> </tr> </table>	SELECT SYSTEM				ENGINE				A/T				ABS				AIR BAG				BCM				METER A/C AMP										BACK	LIGHT COPY
NISSAN																																																																			
CONSULT- II																																																																			
ENGINE																																																																			
START (NISSAN BASED VHCL)																																																																			
START (RENAULT BASED VHCL)																																																																			
SUB MODE																																																																			
		LIGHT	COPY																																																																
SELECT SYSTEM																																																																			
ENGINE																																																																			
A/T																																																																			
ABS																																																																			
AIR BAG																																																																			
BCM																																																																			
METER A/C AMP																																																																			
		BACK	LIGHT COPY																																																																

PKIA2093E

- Print all the data of "SELF-DIAG RESULTS" for "ENGINE", "BCM", "ABS" and "IPDM E/R" displayed on CONSULT-II.

(Example)	<table border="1" style="width: 100%; border-collapse: collapse;"> <tr><td colspan="4" style="text-align: center;">SELECT DIAG MODE</td></tr> <tr><td colspan="4" style="text-align: center;">WORK SUPPORT</td></tr> <tr><td colspan="4" style="text-align: center;">SELF-DIAG RESULTS</td></tr> <tr><td colspan="4" style="text-align: center;">DATA MONITOR</td></tr> <tr><td colspan="4" style="text-align: center;">DATA MONITOR (SPEC)</td></tr> <tr><td colspan="4" style="text-align: center;">CAN DIAG SUPPORT MNTR</td></tr> <tr><td colspan="4" style="text-align: center;">ACTIVE TEST</td></tr> <tr><td colspan="4" style="text-align: center;"> </td></tr> <tr> <td style="width: 25%;"></td> <td style="width: 25%;"></td> <td style="width: 25%;">Scroll Down</td> <td style="width: 25%;"></td> </tr> <tr> <td></td> <td></td> <td>BACK</td> <td>LIGHT COPY</td> </tr> </table>	SELECT DIAG MODE				WORK SUPPORT				SELF-DIAG RESULTS				DATA MONITOR				DATA MONITOR (SPEC)				CAN DIAG SUPPORT MNTR				ACTIVE TEST										Scroll Down				BACK	LIGHT COPY	➔	<table border="1" style="width: 100%; border-collapse: collapse;"> <tr><td colspan="4" style="text-align: center;">SELF-DIAG RESULTS</td></tr> <tr><td colspan="2" style="text-align: center;">DTC RESULTS</td><td colspan="2" style="text-align: center;">TIME</td></tr> <tr> <td style="width: 50%;">CAN COMM CIRCUIT [U1000]</td> <td style="width: 50%; text-align: center;">0</td> <td colspan="2"></td> </tr> <tr><td colspan="4" style="text-align: center;"> </td></tr> <tr><td colspan="4" style="text-align: center;"> </td></tr> <tr><td colspan="4" style="text-align: center;"> </td></tr> <tr> <td style="width: 25%;"></td> <td style="width: 25%;"></td> <td style="width: 25%;">F.F.DATA</td> <td style="width: 25%;"></td> </tr> <tr> <td>ERASE</td> <td>PRINT</td> <td colspan="2"></td> </tr> <tr> <td>MODE</td> <td>BACK</td> <td>LIGHT</td> <td>COPY</td> </tr> </table>	SELF-DIAG RESULTS				DTC RESULTS		TIME		CAN COMM CIRCUIT [U1000]	0																	F.F.DATA		ERASE	PRINT			MODE	BACK	LIGHT	COPY
SELECT DIAG MODE																																																																															
WORK SUPPORT																																																																															
SELF-DIAG RESULTS																																																																															
DATA MONITOR																																																																															
DATA MONITOR (SPEC)																																																																															
CAN DIAG SUPPORT MNTR																																																																															
ACTIVE TEST																																																																															
		Scroll Down																																																																													
		BACK	LIGHT COPY																																																																												
SELF-DIAG RESULTS																																																																															
DTC RESULTS		TIME																																																																													
CAN COMM CIRCUIT [U1000]	0																																																																														
		F.F.DATA																																																																													
ERASE	PRINT																																																																														
MODE	BACK	LIGHT	COPY																																																																												

PKIA8260E

- Print all the data of "CAN DIAG SUPPORT MNTR" for "ENGINE", "BCM", "ABS" and "IPDM E/R" displayed on CONSULT-II.

(Example)	<table border="1" style="width: 100%; border-collapse: collapse;"> <tr><td colspan="4" style="text-align: center;">SELECT DIAG MODE</td></tr> <tr><td colspan="4" style="text-align: center;">WORK SUPPORT</td></tr> <tr><td colspan="4" style="text-align: center;">SELF-DIAG RESULTS</td></tr> <tr><td colspan="4" style="text-align: center;">DATA MONITOR</td></tr> <tr><td colspan="4" style="text-align: center;">DATA MONITOR (SPEC)</td></tr> <tr><td colspan="4" style="text-align: center;">CAN DIAG SUPPORT MNTR</td></tr> <tr><td colspan="4" style="text-align: center;">ACTIVE TEST</td></tr> <tr><td colspan="4" style="text-align: center;"> </td></tr> <tr> <td style="width: 25%;"></td> <td style="width: 25%;"></td> <td style="width: 25%;">Scroll Down</td> <td style="width: 25%;"></td> </tr> <tr> <td></td> <td></td> <td>BACK</td> <td>LIGHT COPY</td> </tr> </table>	SELECT DIAG MODE				WORK SUPPORT				SELF-DIAG RESULTS				DATA MONITOR				DATA MONITOR (SPEC)				CAN DIAG SUPPORT MNTR				ACTIVE TEST										Scroll Down				BACK	LIGHT COPY	➔	<table border="1" style="width: 100%; border-collapse: collapse;"> <tr><td colspan="4" style="text-align: center;">CAN DIAG SUPPORT MNTR</td></tr> <tr><td colspan="4" style="text-align: center;">ENGINE</td></tr> <tr> <td style="width: 50%;"></td> <td style="width: 50%;"></td> <td colspan="2"></td> </tr> <tr> <td>INITIAL DIAG</td> <td>OK</td> <td colspan="2"></td> </tr> <tr> <td>TRANSMIT DIAG</td> <td>OK</td> <td colspan="2"></td> </tr> <tr> <td>TCM</td> <td>OK</td> <td colspan="2"></td> </tr> <tr> <td>VDC/TCS/ABS</td> <td>OK</td> <td colspan="2"></td> </tr> <tr> <td>METER/M&A</td> <td>OK</td> <td colspan="2"></td> </tr> <tr> <td>ICC</td> <td>UNKWKN</td> <td colspan="2"></td> </tr> <tr> <td>BCM/SEC</td> <td>OK</td> <td colspan="2"></td> </tr> <tr> <td>IPDM E/R</td> <td>OK</td> <td colspan="2"></td> </tr> <tr> <td>AWD/4WD/e4WD</td> <td>UNKWKN</td> <td colspan="2"></td> </tr> <tr> <td>PRINT</td> <td></td> <td>Scroll Down</td> <td></td> </tr> <tr> <td>MODE</td> <td>BACK</td> <td>LIGHT</td> <td>COPY</td> </tr> </table>	CAN DIAG SUPPORT MNTR				ENGINE								INITIAL DIAG	OK			TRANSMIT DIAG	OK			TCM	OK			VDC/TCS/ABS	OK			METER/M&A	OK			ICC	UNKWKN			BCM/SEC	OK			IPDM E/R	OK			AWD/4WD/e4WD	UNKWKN			PRINT		Scroll Down		MODE	BACK	LIGHT	COPY
SELECT DIAG MODE																																																																																																			
WORK SUPPORT																																																																																																			
SELF-DIAG RESULTS																																																																																																			
DATA MONITOR																																																																																																			
DATA MONITOR (SPEC)																																																																																																			
CAN DIAG SUPPORT MNTR																																																																																																			
ACTIVE TEST																																																																																																			
		Scroll Down																																																																																																	
		BACK	LIGHT COPY																																																																																																
CAN DIAG SUPPORT MNTR																																																																																																			
ENGINE																																																																																																			
INITIAL DIAG	OK																																																																																																		
TRANSMIT DIAG	OK																																																																																																		
TCM	OK																																																																																																		
VDC/TCS/ABS	OK																																																																																																		
METER/M&A	OK																																																																																																		
ICC	UNKWKN																																																																																																		
BCM/SEC	OK																																																																																																		
IPDM E/R	OK																																																																																																		
AWD/4WD/e4WD	UNKWKN																																																																																																		
PRINT		Scroll Down																																																																																																	
MODE	BACK	LIGHT	COPY																																																																																																

PKIA8343E

- Attach the printed sheet of "SELECT SYSTEM", "SELF-DIAG RESULTS" and "CAN DIAG SUPPORT MNTR" onto the check sheet. Refer to [LAN-45. "CHECK SHEET"](#) .
- Based on the indications of "SELECT SYSTEM" and the results of "CAN DIAG SUPPORT MNTR", put marks "v" onto the items with "No indication", "NG", or "UNKWKN" in the check sheet table. Refer to [LAN-45. "CHECK SHEET"](#) .

NOTE:

- If "NG" is displayed on "INITIAL DIAG (Initial diagnosis)" as "CAN DIAG SUPPORT MNTR" for the diagnosed control unit, replace the control unit.
- The "CAN DIAG SUPPORT MNTR" items, which are not in check sheet table, are not related to diagnostic procedure on service manual. So it is not necessary to check the status of the "CAN DIAG SUPPORT MNTR" items not in check sheet table.

- According to the check sheet results (example), start inspection. Refer to [LAN-47. "CHECK SHEET RESULTS \(EXAMPLE\)"](#) .

CAN SYSTEM (TYPE 2)

[CAN]

CHECK SHEET

NOTE:

If "NG" is displayed on "INITIAL DIAG (Initial diagnosis)" as "CAN DIAG SUPPORT MNTR" for the diagnosed control unit, replace the control unit.

Check sheet table

SELECT SYSTEM screen		CAN DIAG SUPPORT MNTR							
		Initial diagnosis	Transmit diagnosis	Receive diagnosis					
				ECM	METER /M&A	BCM/SEC	STRG	VDC/TCS /ABS	IPDM E/R
ENGINE	—	NG	UNKWN	—	UNKWN	UNKWN	—	UNKWN	UNKWN
BCM	No indication	NG	UNKWN	UNKWN	UNKWN	—	—	—	UNKWN
ABS	—	NG	UNKWN	UNKWN	UNKWN	—	UNKWN	—	—
IPDM E/R	No indication	—	UNKWN	UNKWN	—	UNKWN	—	—	—

Symptoms :

Attach copy of
SELECT SYSTEM

Attach copy of
SELECT SYSTEM

PKIA7913E

A
B
C
D
E
F
G
H
I
J
LAN
L
M

CAN SYSTEM (TYPE 2)

[CAN]

Attach copy of
ENGINE
SELF-DIAG RESULTS

Attach copy of
BCM
SELF-DIAG RESULTS

Attach copy of
ABS
SELF-DIAG RESULTS

Attach copy of
IPDM E/R
SELF-DIAG RESULTS

Attach copy of
ENGINE
CAN DIAG SUPPORT
MNTR

Attach copy of
BCM
CAN DIAG SUPPORT
MNTR

Attach copy of
ABS
CAN DIAG SUPPORT
MNTR

Attach copy of
IPDM E/R
CAN DIAG SUPPORT
MNTR

PKIA7914E

CHECK SHEET RESULTS (EXAMPLE)

NOTE:

If "NG" is displayed on "INITIAL DIAG (Initial diagnosis)" as "CAN DIAG SUPPORT MNTR" for the diagnosed control unit, replace the control unit.

Case1

Check harness between data link connector and VDC/TCS/ABS control unit. Refer to [LAN-56, "Circuit Check Between Data Link Connector and VDC/TCS/ABS Control Unit"](#).

SELECT SYSTEM screen		CAN DIAG SUPPORT MNTR							
		Initial diagnosis	Transmit diagnosis	Receive diagnosis					
				ECM	METER /M&A	BCM/SEC	STRG	VDC/TCS /ABS	IPDM E/R
ENGINE	—	NG	UNKWN	—	UNKWN	UNKWN	—	UNKWN ✓	UNKWN ✓
BCM	No indication	NG	UNKWN	UNKWN	UNKWN	—	—	—	UNKWN ✓
ABS	—	NG	UNKWN	UNKWN ✓	UNKWN ✓	—	UNKWN ✓	—	—
IPDM E/R	No indication ✓	—	UNKWN	UNKWN	—	UNKWN	—	—	—

PKIA7915E

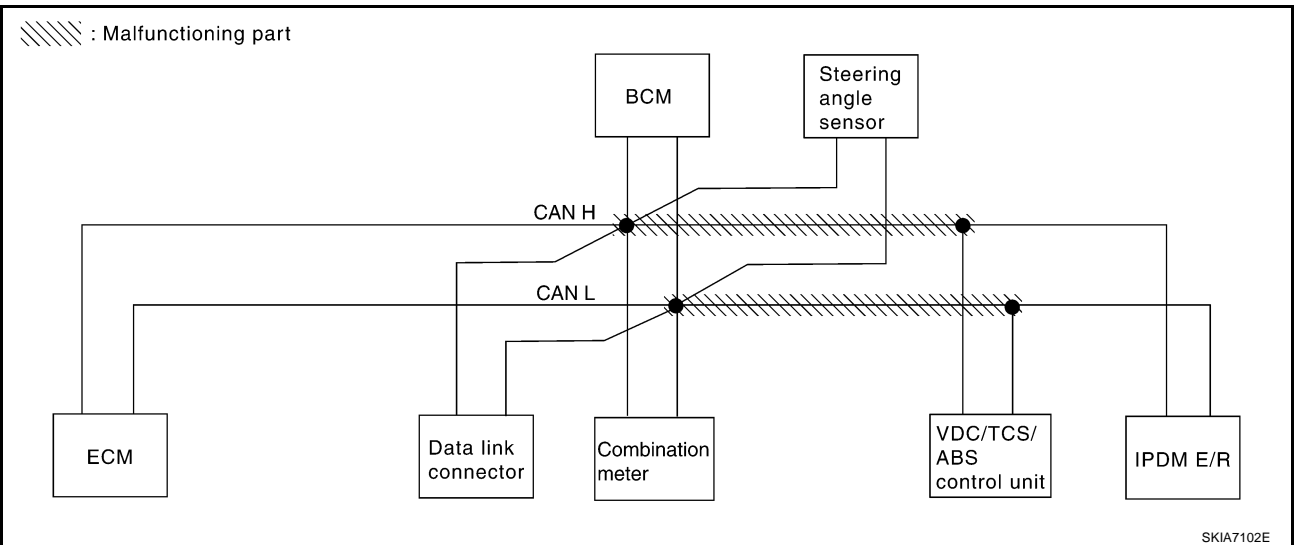

CAN SYSTEM (TYPE 2)

[CAN]

Case2

Check ECM circuit. Refer to [LAN-57, "ECM Circuit Check"](#) .

SELECT SYSTEM screen		CAN DIAG SUPPORT MNTR							
		Initial diagnosis	Transmit diagnosis	Receive diagnosis					
				ECM	METER /M&A	BCM/SEC	STRG	VDC/TCS /ABS	IPDM E/R
ENGINE	—	NG	UNKW ^N	—	UNKW ^N	UNKW ^N	—	UNKW ^N	UNKW ^N
BCM	No indication	NG	UNKW ^N	UNKW ^N	UNKW ^N	—	—	—	UNKW ^N
ABS	—	NG	UNKW ^N	UNKW ^N	UNKW ^N	—	UNKW ^N	—	—
IPDM E/R	No indication	—	UNKW ^N	UNKW ^N	—	UNKW ^N	—	—	—

PKIA7916E

▨ : Malfunctioning part

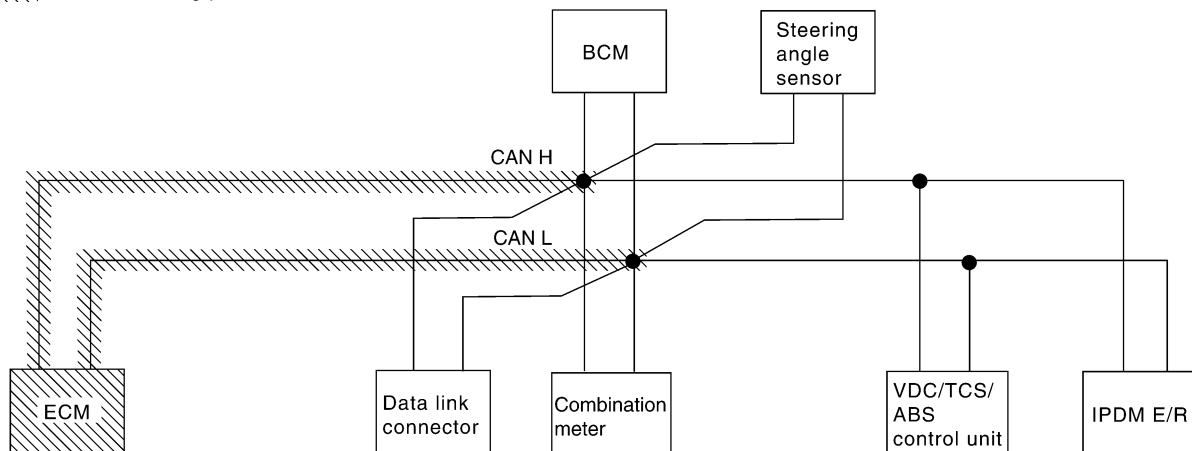

SKIA7103E

CAN SYSTEM (TYPE 2)

[CAN]

Case3

Check data link connector circuit. Refer to [LAN-57, "Data Link Connector Circuit Check"](#) .

SELECT SYSTEM screen		CAN DIAG SUPPORT MNTR							
		Initial diagnosis	Transmit diagnosis	Receive diagnosis					
				ECM	METER /M&A	BCM/SEC	STRG	VDC/TCS /ABS	IPDM E/R
ENGINE	—	NG	UNKWN	—	UNKWN	UNKWN	—	UNKWN	UNKWN
BCM	No indication ✓	NG	UNKWN	UNKWN	UNKWN	—	—	—	UNKWN
ABS	—	NG	UNKWN	UNKWN	UNKWN	—	UNKWN	—	—
IPDM E/R	No indication ✓	—	UNKWN	UNKWN	—	UNKWN	—	—	—

PKIA7917E

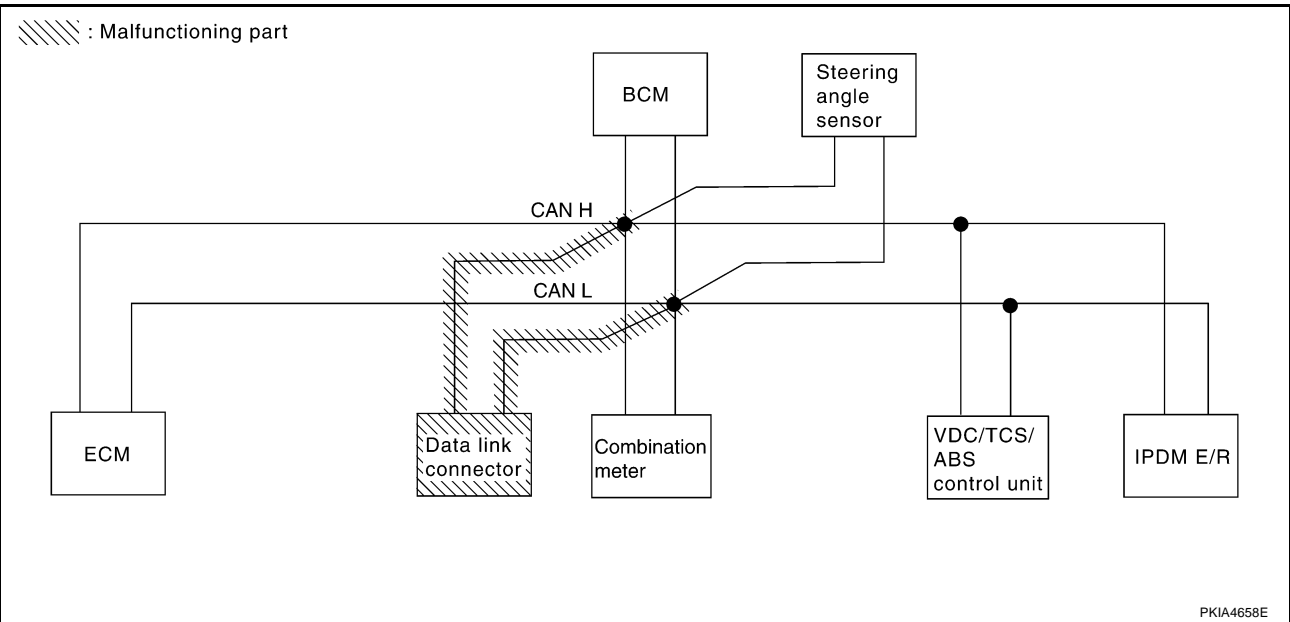

A
B
C
D
E
F
G
H
I
J
LAN
L
M

CAN SYSTEM (TYPE 2)

[CAN]

Case4

Check combination meter circuit. Refer to [LAN-58, "Combination Meter Circuit Check"](#) .

SELECT SYSTEM screen		CAN DIAG SUPPORT MNTR							
		Initial diagnosis	Transmit diagnosis	Receive diagnosis					
				ECM	METER /M&A	BCM/SEC	STRG	VDC/TCS /ABS	IPDM E/R
ENGINE	—	NG	UNKWN	—	UNKWN ✓	UNKWN	—	UNKWN	UNKWN
BCM	No indication	NG	UNKWN	UNKWN	UNKWN ✓	—	—	—	UNKWN
ABS	—	NG	UNKWN	UNKWN	UNKWN ✓	—	UNKWN	—	—
IPDM E/R	No indication	—	UNKWN	UNKWN	—	UNKWN	—	—	—

PKIA7918E

//// : Malfunctioning part

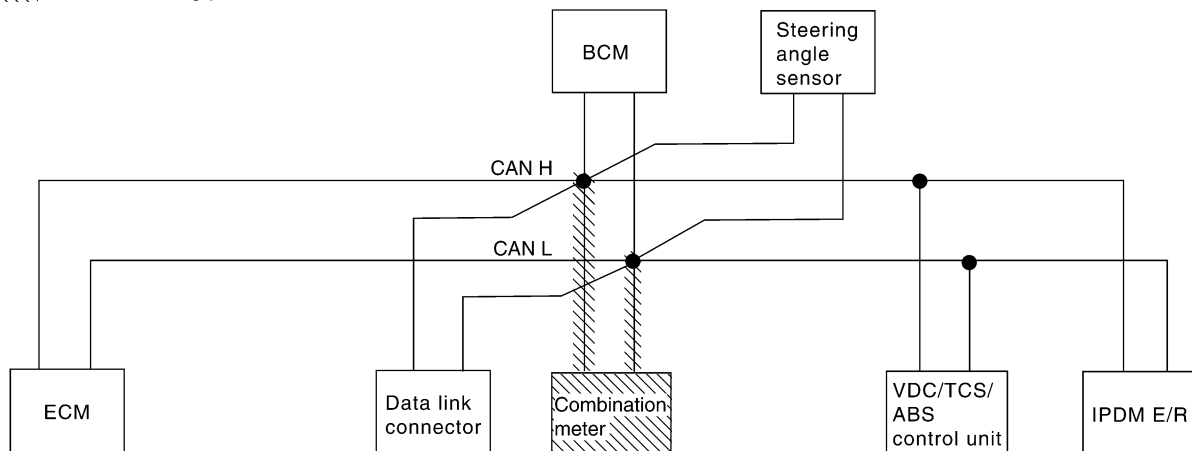

SKIA7104E

CAN SYSTEM (TYPE 2)

[CAN]

Case5

Check BCM circuit. Refer to [LAN-58. "BCM Circuit Check"](#) .

SELECT SYSTEM screen		CAN DIAG SUPPORT MNTR							
		Initial diagnosis	Transmit diagnosis	Receive diagnosis					
				ECM	METER /M&A	BCM/SEC	STRG	VDC/TCS /ABS	IPDM E/R
ENGINE	—	NG	UNKWN	—	UNKWN	UNKWN ✓	—	UNKWN	UNKWN
BCM	No indication ✓	NG	UNKWN	UNKWN	UNKWN	—	—	—	UNKWN
ABS	—	NG	UNKWN	UNKWN	UNKWN	—	UNKWN	—	—
IPDM E/R	No indication	—	UNKWN	UNKWN	—	UNKWN ✓	—	—	—

PKIA7919E

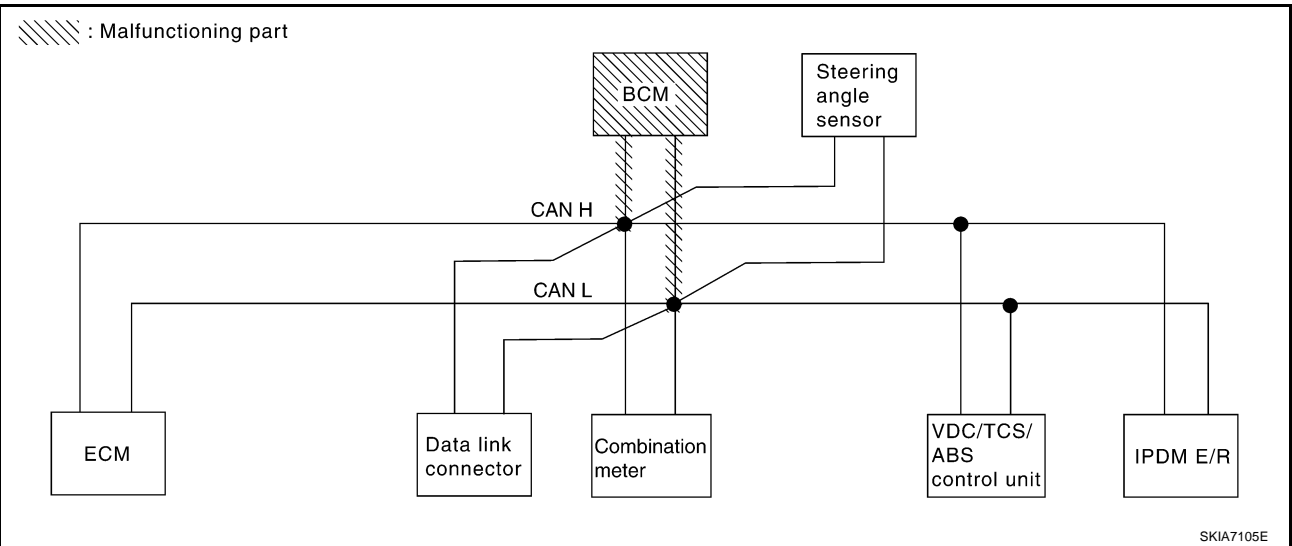

A
B
C
D
E
F
G
H
I
J
LAN
L
M

CAN SYSTEM (TYPE 2)

[CAN]

Case6

Check steering angle sensor circuit. Refer to [LAN-59, "Steering Angle Sensor Circuit Check"](#) .

SELECT SYSTEM screen		CAN DIAG SUPPORT MNTR							
		Initial diagnosis	Transmit diagnosis	Receive diagnosis					
				ECM	METER /M&A	BCM/SEC	STRG	VDC/TCS /ABS	IPDM E/R
ENGINE	—	NG	UNKWN	—	UNKWN	UNKWN	—	UNKWN	UNKWN
BCM	No indication	NG	UNKWN	UNKWN	UNKWN	—	—	—	UNKWN
ABS	—	NG	UNKWN	UNKWN	UNKWN	—	UNKWN	—	—
IPDM E/R	No indication	—	UNKWN	UNKWN	—	UNKWN	—	—	—

PKIA7920E

//// : Malfunctioning part

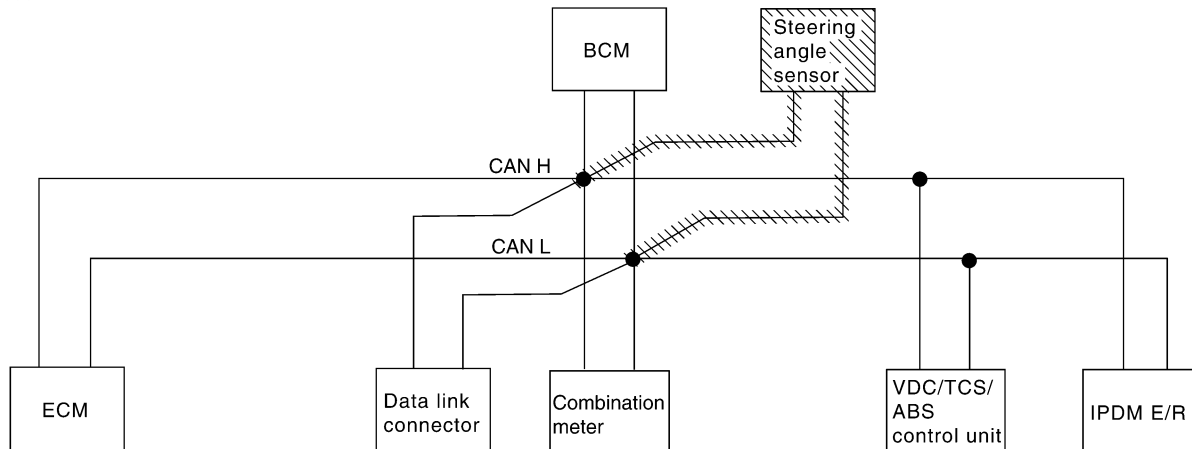

SKIA7106E

CAN SYSTEM (TYPE 2)

[CAN]

Case7

Check VDC/TCS/ABS control unit circuit. Refer to [LAN-59, "VDC/TCS/ABS Control Unit Circuit Check"](#) .

SELECT SYSTEM screen		CAN DIAG SUPPORT MNTR							
		Initial diagnosis	Transmit diagnosis	Receive diagnosis					
				ECM	METER /M&A	BCM/SEC	STRG	VDC/TCS /ABS	IPDM E/R
ENGINE	—	NG	UNKWN	—	UNKWN	UNKWN	—	UNKWN	UNKWN
BCM	No indication	NG	UNKWN	UNKWN	UNKWN	—	—	—	UNKWN
ABS	—	NG	UNKWN	UNKWN	UNKWN	—	UNKWN	—	—
IPDM E/R	No indication	—	UNKWN	UNKWN	—	UNKWN	—	—	—

PKIA7921E

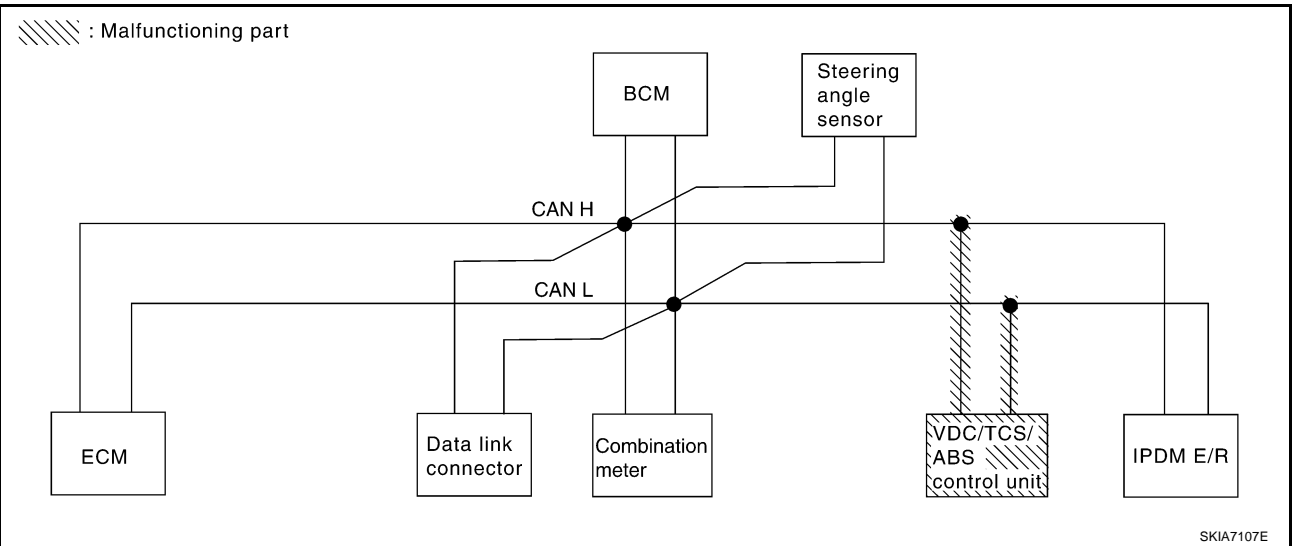

A
B
C
D
E
F
G
H
I
J
LAN
L
M

CAN SYSTEM (TYPE 2)

[CAN]

Case8

Check IPDM E/R circuit. Refer to [LAN-60, "IPDM E/R Circuit Check"](#) .

SELECT SYSTEM screen		CAN DIAG SUPPORT MNTR							
		Initial diagnosis	Transmit diagnosis	Receive diagnosis					
				ECM	METER /M&A	BCM/SEC	STRG	VDC/TCS /ABS	IPDM E/R
ENGINE	—	NG	UNKWN	—	UNKWN	UNKWN	—	UNKWN	UNKWN ✓
BCM	No indication	NG	UNKWN	UNKWN	UNKWN	—	—	—	UNKWN ✓
ABS	—	NG	UNKWN	UNKWN	UNKWN	—	UNKWN	—	—
IPDM E/R	No indication ✓	—	UNKWN	UNKWN	—	UNKWN	—	—	—

PKIA7922E

//// : Malfunctioning part

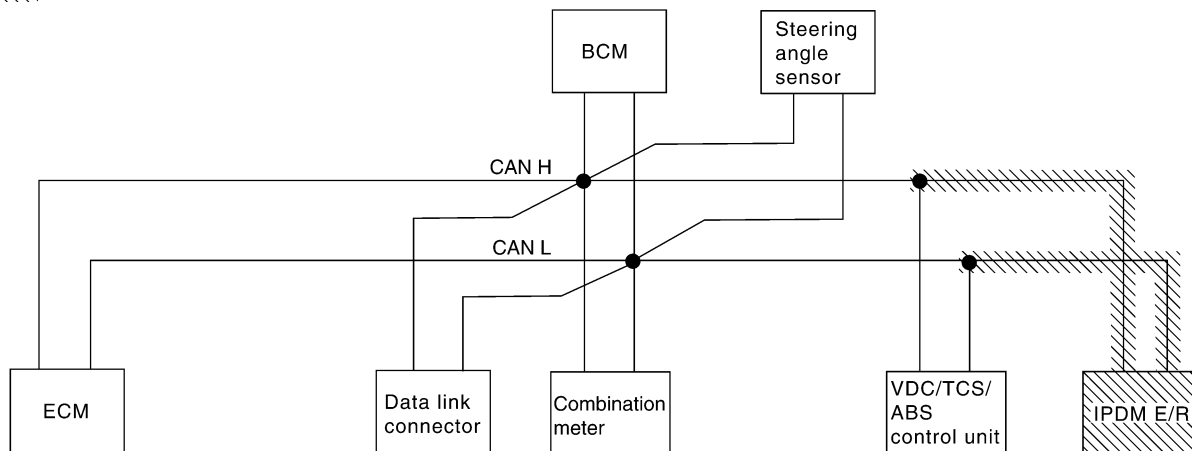

SKIA7108E

CAN SYSTEM (TYPE 2)

[CAN]

Case9

Check CAN communication circuit. Refer to [LAN-61, "CAN Communication Circuit Check"](#)LAN-61, "CAN Communication Circuit Check" .

SELECT SYSTEM screen		CAN DIAG SUPPORT MNTR							
		Initial diagnosis	Transmit diagnosis	Receive diagnosis					
				ECM	METER /M&A	BCM/SEC	STRG	VDC/TCS /ABS	IPDM E/R
ENGINE	—	NG	UNKW N ✓	—	UNKW N ✓	UNKW N ✓	—	UNKW N ✓	UNKW N ✓
BCM	No indicat ion ✓	NG	UNKW N	UNKW N	UNKW N	—	—	—	UNKW N
ABS	—	NG S ✓	UNKW N ✓	UNKW N ✓	UNKW N ✓	—	UNKW N ✓	—	—
IPDM E/R	No indicat ion ✓	—	UNKW N	UNKW N	—	UNKW N	—	—	—

PKIA7923E

Case10

Check IPDM E/R ignition relay circuit continuously sticks "OFF". Refer to [LAN-63, "IPDM E/R Ignition Relay Circuit Check"](#) .

SELECT SYSTEM screen		CAN DIAG SUPPORT MNTR							
		Initial diagnosis	Transmit diagnosis	Receive diagnosis					
				ECM	METER /M&A	BCM/SEC	STRG	VDC/TCS /ABS	IPDM E/R
ENGINE	—	NG	UNKW N	—	UNKW N	UNKW N	—	UNKW N	UNKW N
BCM	No indicat ion ✓	NG	UNKW N	UNKW N	UNKW N	—	—	—	UNKW N
ABS	—	NG	UNKW N	UNKW N ✓	UNKW N	—	UNKW N	—	—
IPDM E/R	No indicat ion ✓	—	UNKW N	UNKW N	—	UNKW N	—	—	—

PKIA7924E

LAN

Case11

Check IPDM E/R ignition relay circuit continuously sticks "ON". Refer to [LAN-63, "IPDM E/R Ignition Relay Circuit Check"](#) .

SELECT SYSTEM screen		CAN DIAG SUPPORT MNTR							
		Initial diagnosis	Transmit diagnosis	Receive diagnosis					
				ECM	METER /M&A	BCM/SEC	STRG	VDC/TCS /ABS	IPDM E/R
ENGINE	—	NG	UNKWN	—	UNKWN ✓	UNKWN	—	UNKWN ✓	UNKWN
BCM	No indication	NG	UNKWN	UNKWN	UNKWN ✓	—	—	—	UNKWN
ABS	—	NG	UNKWN	UNKWN	UNKWN	—	UNKWN	—	—
IPDM E/R	No indication	—	UNKWN	UNKWN	—	UNKWN	—	—	—

PKIA7925E

Circuit Check Between Data Link Connector and VDC/TCS/ABS Control Unit

AKS00AAK

1. CHECK CONNECTOR

1. Turn ignition switch OFF.
2. Disconnect the negative battery terminal.
3. Check following terminals and connectors for damage, bend and loose connection (connector side and harness side).
 - Harness connector M15
 - Harness connector E108

OK or NG

- OK >> GO TO 2.
- NG >> Repair terminal or connector.

2. CHECK HARNESS FOR OPEN CIRCUIT

1. Disconnect harness connector M15.
2. Check continuity between data link connector M8 terminals 6 (L), 14 (R) and harness connector M15 terminals 9G (L), 8G (R).

6 (L) - 9G (L) : Continuity should exist.
14 (R) - 8G (R) : Continuity should exist.

OK or NG

- OK >> GO TO 3.
- NG >> Repair harness.

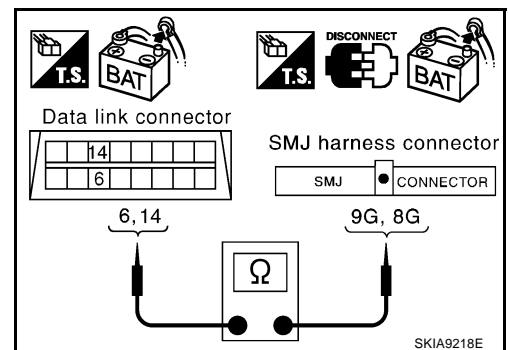

3. CHECK HARNESS FOR OPEN CIRCUIT

1. Disconnect VDC/TCS/ABS control unit connector.
2. Check continuity between harness connector E108 terminals 9G (L), 8G (R) and VDC/TCS/ABS control unit harness connector E118 terminals 61 (L), 63 (R).

9G (L) - 61 (L) : Continuity should exist.

8G (R) - 63 (R) : Continuity should exist.

OK or NG

- OK >> Connect all the connectors and diagnose again. Refer to [LAN-44, "Work Flow"](#).
- NG >> Repair harness.

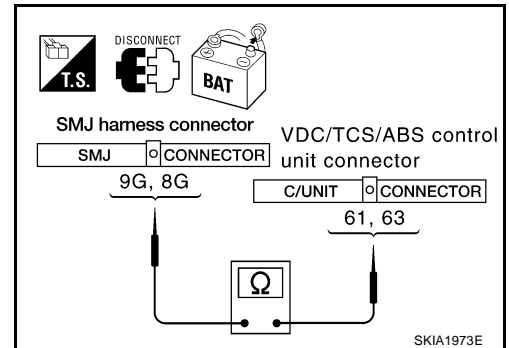

AKS00AAL

ECM Circuit Check

1. CHECK CONNECTOR

1. Turn ignition switch OFF.
2. Disconnect the negative battery terminal.
3. Check following terminals and connector for damage, bend and loose connection (control module side and harness side).
 - ECM connector
 - Harness connector F102
 - Harness connector M72

OK or NG

- OK >> GO TO 2.
- NG >> Repair terminal or connector.

2. CHECK HARNESS FOR OPEN CIRCUIT

1. Disconnect ECM connector.
2. Check resistance between ECM harness connector F108 terminals 94 (L) and 86 (R).

94 (L) - 86 (R) : Approx. 108 - 132Ω

OK or NG

- OK >> Replace ECM.
- NG >> Repair harness between data link connector and ECM.

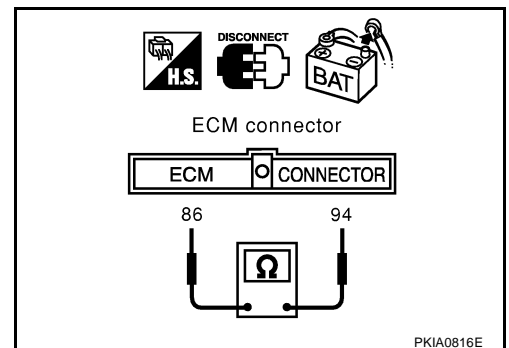

AKS00AAM

Data Link Connector Circuit Check

1. CHECK CONNECTOR

1. Turn ignition switch OFF.
2. Disconnect the negative battery terminal.
3. Check terminals and connector of data link connector for damage, bend and loose connection (connector side and harness side).

OK or NG

- OK >> GO TO 2.
- NG >> Repair terminal or connector.

2. CHECK HARNESS FOR OPEN CIRCUIT

Check resistance between data link connector M8 terminals 6 (L) and 14 (R).

6 (L) - 14 (R) : Approx. 54 - 66Ω

OK or NG

- OK >> Diagnose again. Refer to [LAN-44, "Work Flow"](#) .
 NG >> Repair harness between data link connector and combination meter.

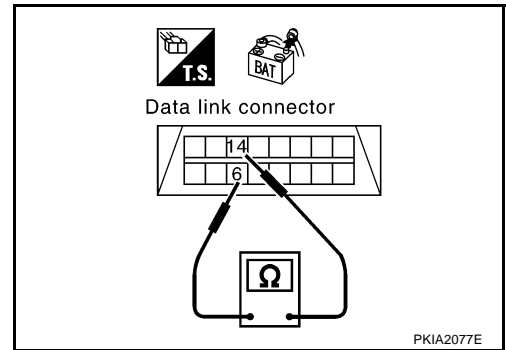

AKS00AAN

Combination Meter Circuit Check

1. CHECK CONNECTOR

1. Turn ignition switch OFF.
2. Disconnect the negative battery terminal.
3. Check terminals and connector of combination meter for damage, bend and loose connection (meter side and harness side).

OK or NG

- OK >> GO TO 2.
 NG >> Repair terminal or connector.

2. CHECK HARNESS FOR OPEN CIRCUIT

1. Disconnect combination meter connector.
2. Check resistance between combination meter harness connector M20 terminals 28 (L) and 27 (R).

28 (L) - 27 (R) : Approx. 54 - 66Ω

OK or NG

- OK >> Replace combination meter.
 NG >> Repair harness between data link connector and combination meter.

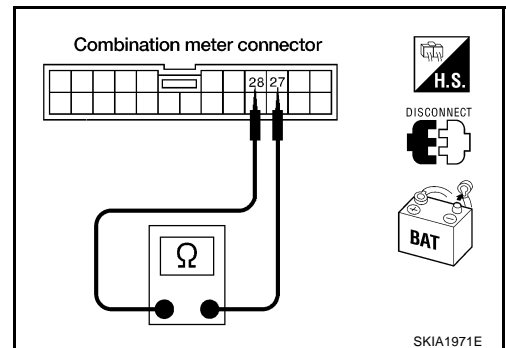

AKS00AAO

BCM Circuit Check

1. CHECK CONNECTOR

1. Turn ignition switch OFF.
2. Disconnect the negative battery terminal.
3. Check terminals and connector of BCM for damage, bend and loose connection (control module side and harness side).

OK or NG

- OK >> GO TO 2.
 NG >> Repair terminal or connector.

2. CHECK HARNESS FOR OPEN CIRCUIT

1. Disconnect BCM connector.
2. Check resistance between BCM harness connector M1 terminals 39 (L) and 40 (R).

39 (L) - 40 (R) : Approx. 54 - 66Ω

OK or NG

- OK >> Replace BCM. Refer to [BCS-15, "Removal and Installation of BCM"](#).
- NG >> Repair harness between data link connector and BCM.

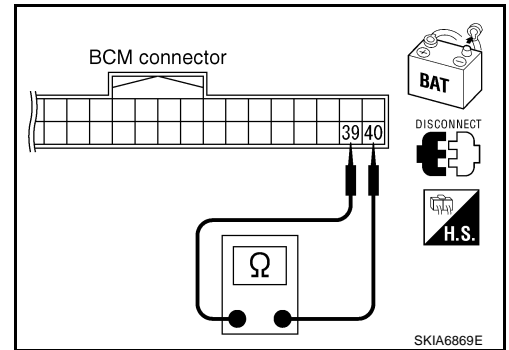

AKS00AAP

Steering Angle Sensor Circuit Check

1. CHECK CONNECTOR

1. Turn ignition switch OFF.
2. Disconnect the negative battery terminal.
3. Check terminals and connector of steering angle sensor for damage, bend and loose connection (sensor side and harness side).

OK or NG

- OK >> GO TO 2.
- NG >> Repair terminal or connector.

2. CHECK HARNESS FOR OPEN CIRCUIT

1. Disconnect steering angle sensor connector.
2. Check resistance between steering angle sensor harness connector M22 terminals 4 (L) and 5 (R).

4 (L) - 5 (R) : Approx. 54 - 66Ω

OK or NG

- OK >> Replace steering angle sensor.
- NG >> Repair harness between data link connector and steering angle sensor.

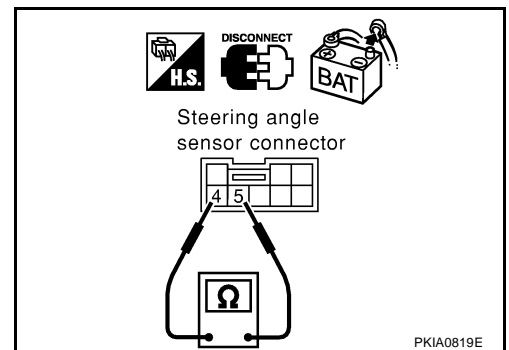

AKS00AAQ

VDC/TCS/ABS Control Unit Circuit Check

1. CHECK CONNECTOR

1. Turn ignition switch OFF.
2. Disconnect the negative battery terminal.
3. Check terminals and connector of VDC/TCS/ABS control unit for damage, bend and loose connection (control unit side and harness side).

OK or NG

- OK >> GO TO 2.
- NG >> Repair terminal or connector.

2. CHECK HARNESS FOR OPEN CIRCUIT

1. Disconnect VDC/TCS/ABS control unit connector.
2. Check resistance between VDC/TCS/ABS control unit harness connector E118 terminals 61 (L) and 63 (R).

61 (L) - 63 (R) : Approx. 54 - 66Ω

OK or NG

- OK >> Replace VDC/TCS/ABS control unit.
 NG >> Repair harness between harness connector E108 and VDC/TCS/ABS control unit.

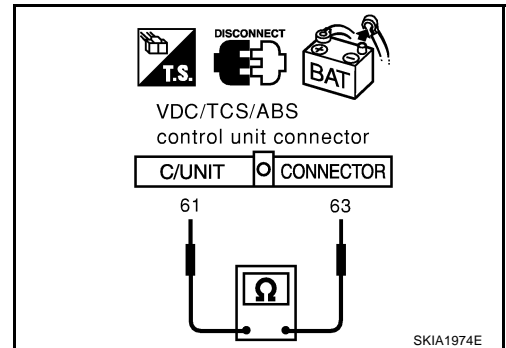

AKS00AAR

IPDM E/R Circuit Check

1. CHECK CONNECTOR

1. Turn ignition switch OFF.
2. Disconnect the negative battery terminal.
3. Check terminals and connector of IPDM E/R for damage, bend and loose connection (control module side and harness side).

OK or NG

- OK >> GO TO 2.
 NG >> Repair terminal or connector.

2. CHECK HARNESS FOR OPEN CIRCUIT

1. Disconnect IPDM E/R connector.
2. Check resistance between IPDM E/R harness connector E9 terminals 48 (L) and 49 (R).

48 (L) - 49 (R) : Approx. 108 - 132Ω

OK or NG

- OK >> Replace IPDM E/R.
 NG >> Repair harness between harness connector E108 and IPDM E/R.

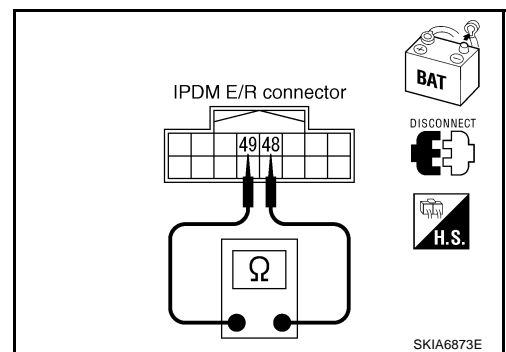

CAN Communication Circuit Check

1. CHECK CONNECTOR

1. Turn ignition switch OFF.
2. Disconnect the negative battery terminal.
3. Check following terminals and connectors for damage, bend and loose connection (control module side, control unit side, meter side, sensor side and harness side).
 - ECM
 - Combination meter
 - BCM
 - Steering angle sensor
 - VDC/TCS/ABS control unit
 - IPDM E/R
 - Between ECM and IPDM E/R

OK or NG

- OK >> GO TO 2.
 NG >> Repair terminal or connector.

2. CHECK HARNESS FOR SHORT CIRCUIT

1. Disconnect following connectors.
 - ECM connector
 - Harness connector F102
2. Check continuity between ECM harness connector F108 terminals 94 (L) and 86 (R).

94 (L) - 86 (R) : Continuity should not exist.

OK or NG

- OK >> GO TO 3.
 NG >> Repair harness between ECM and harness connector F102.

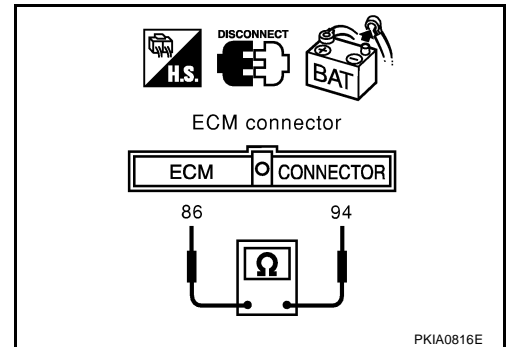

3. CHECK HARNESS FOR SHORT CIRCUIT

Check continuity between ECM harness connector F108 terminals 94 (L), 86 (R) and ground.

94 (L) - Ground : Continuity should not exist.

86 (R) - Ground : Continuity should not exist.

OK or NG

- OK >> GO TO 4.
 NG >> Repair harness between ECM and harness connector F102.

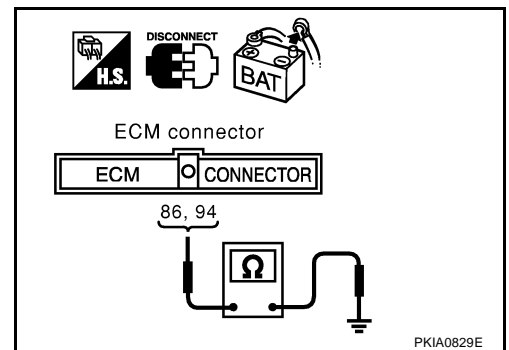

4. CHECK HARNESS FOR SHORT CIRCUIT

1. Disconnect following connectors.
 - Combination meter connector
 - BCM connector
 - Steering angle sensor connector
 - Harness connector M15
2. Check continuity between data link connector M8 terminals 6 (L) and 14 (R).

6 (L) - 14 (R) : Continuity should not exist.

OK or NG

OK >> GO TO 5.

NG >> Check the following harnesses. If any harness is damaged, repair the harness.

- Harness between harness connector M72 and harness connector M15
- Harness between harness connector M72 and combination meter
- Harness between harness connector M72 and data link connector
- Harness between harness connector M72 and BCM
- Harness between harness connector M72 and steering angle sensor

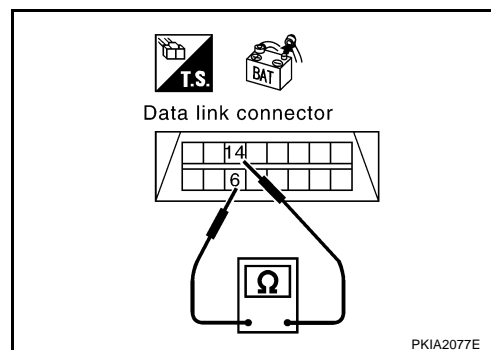

5. CHECK HARNESS FOR SHORT CIRCUIT

Check continuity between data link connector M8 terminals 6 (L), 14 (R) and ground.

6 (L) - Ground : Continuity should not exist.

14 (R) - Ground : Continuity should not exist.

OK or NG

OK >> GO TO 6.

NG >> Check the following harnesses. If any harness is damaged, repair the harness.

- Harness between harness connector M72 and harness connector M15
- Harness between harness connector M72 and combination meter
- Harness between harness connector M72 and data link connector
- Harness between harness connector M72 and BCM
- Harness between harness connector M72 and steering angle sensor

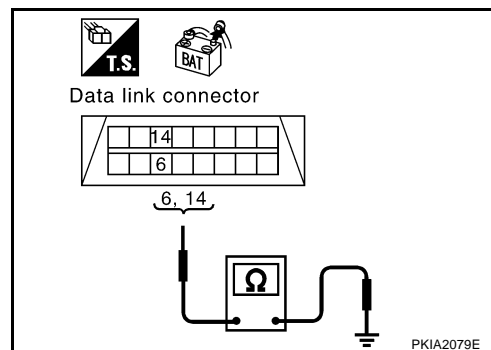

6. CHECK HARNESS FOR SHORT CIRCUIT

1. Disconnect VDC/TCS/ABS control unit connector and IPDM E/R connector.
2. Check continuity between IPDM E/R harness connector E9 terminals 48 (L) and 49 (R).

48 (L) - 49 (R) : Continuity should not exist.

OK or NG

- OK >> GO TO 7.
 NG >> Check the following harnesses. If any harness is damaged, repair the harness.
- Harness between harness connector E108 and VDC/TCS/ABS control unit
 - Harness between harness connector E108 and IPDM E/R

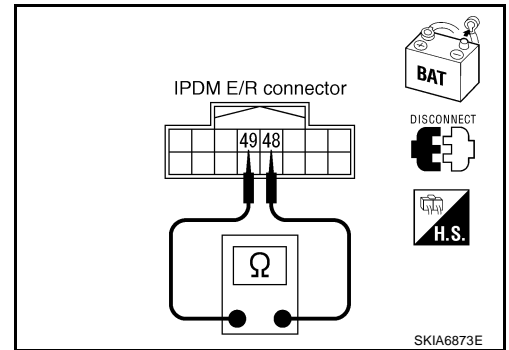

7. CHECK HARNESS FOR SHORT CIRCUIT

Check continuity between IPDM E/R harness connector E9 terminals 48 (L), 49 (R) and ground.

48 (L) - Ground : Continuity should not exist.

49 (R) - Ground : Continuity should not exist.

OK or NG

- OK >> GO TO 8.
 NG >> Check the following harnesses. If any harness is damaged, repair the harness.
- Harness between harness connector E108 and VDC/TCS/ABS control unit
 - Harness between harness connector E108 and IPDM E/R

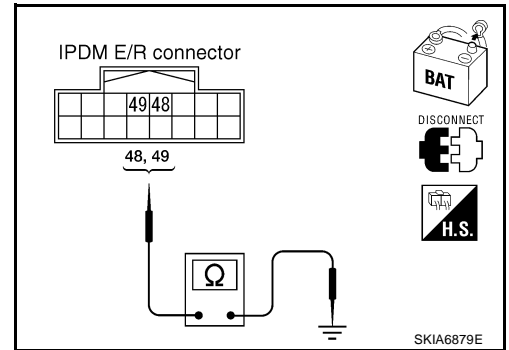

8. ECM/IPDM E/R INTERNAL CIRCUIT INSPECTION

Check components inspection. Refer to [LAN-63, "ECM/IPDM E/R INTERNAL CIRCUIT INSPECTION"](#).

OK or NG

- OK >> Reconnect all the connectors and diagnose again. Refer to [LAN-44, "Work Flow"](#).
 NG >> Replace ECM and/or IPDM E/R.

IPDM E/R Ignition Relay Circuit Check

AKS00AAT

Check the following. If no malfunction is found, replace the IPDM E/R.

- IPDM E/R power supply circuit. Refer to [PG-26, "IPDM E/R Power/Ground Circuit Inspection"](#).
- Ignition power supply circuit. Refer to [PG-10, "IGNITION POWER SUPPLY - IGNITION SW. IN "ON" AND/OR "START" "](#).

Component Inspection

AKS00AAU

ECM/IPDM E/R INTERNAL CIRCUIT INSPECTION

- Remove ECM and IPDM E/R from vehicle.
- Check resistance between ECM terminals 94 and 86.
- Check resistance between IPDM E/R terminals 48 and 49.

Unit	Terminal	Resistance value (Ω) (Approx.)
ECM	94 - 86	108 - 132
IPDM E/R	48 - 49	

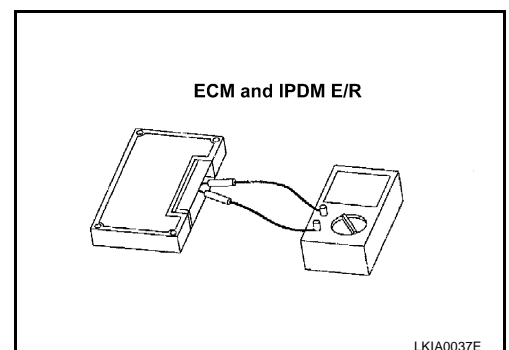

CAN SYSTEM (TYPE 3)

System Description

AKS00AU3

CAN (Controller Area Network) is a serial communication line for real time application. It is an on-vehicle multiplex communication line with high data communication speed and excellent error detection ability. Many electronic control units are equipped onto a vehicle, and each control unit shares information and links with other control units during operation (not independent). In CAN communication, control units are connected with 2 communication lines (CAN H line, CAN L line) allowing a high rate of information transmission with less wiring. Each control unit transmits/receives data but selectively reads required data only.

Component Parts and Harness Connector Location

AKS00AU4

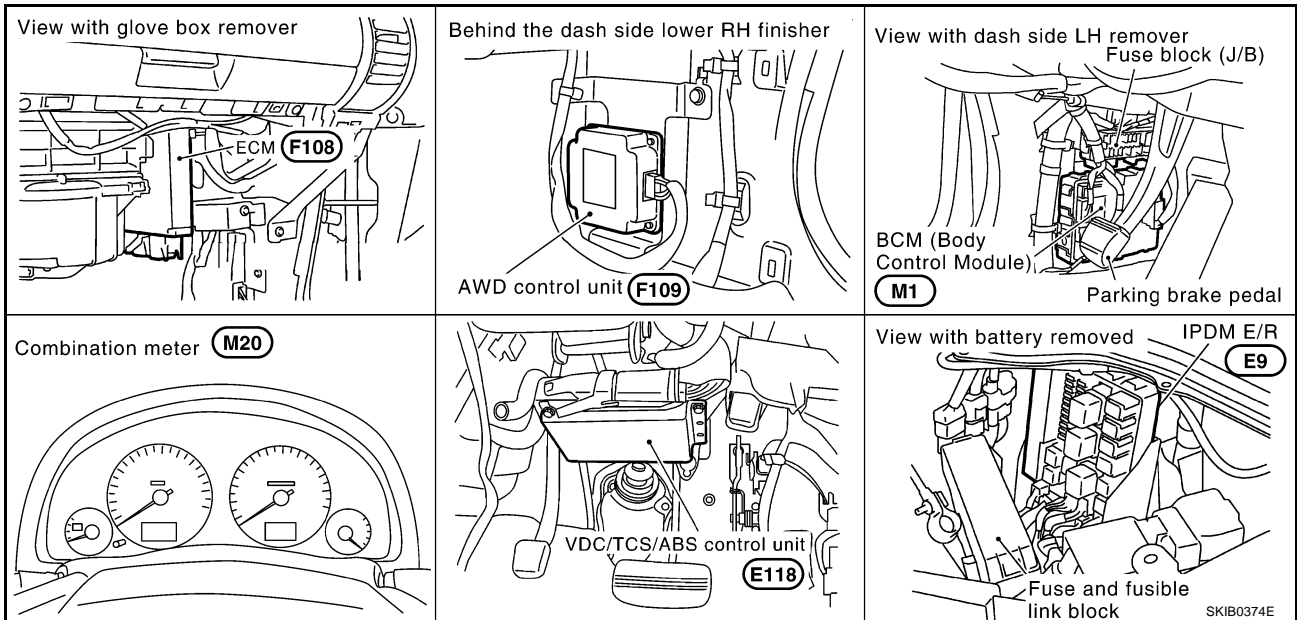

CAN SYSTEM (TYPE 3)

[CAN]

Schematic

AKS00AU5

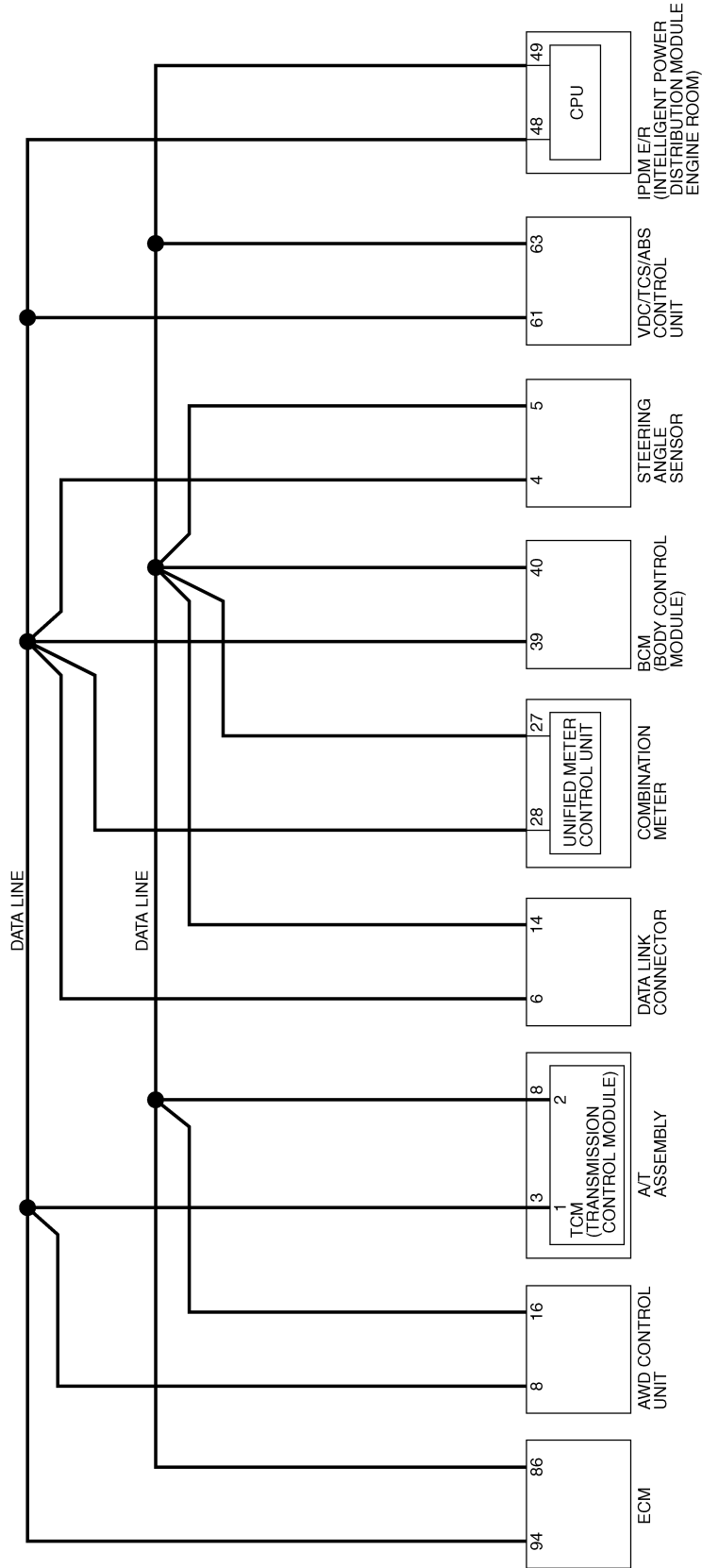

A
B
C
D
E
F
G
H
I
J
LAN
L
M

TKWM1421E

CAN SYSTEM (TYPE 3)

[CAN]

AKS00AU6

Wiring Diagram - CAN -

LAN-CAN-07

▬ : DATA LINE

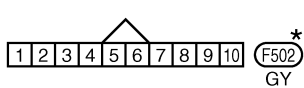
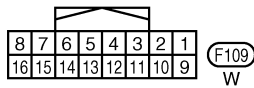
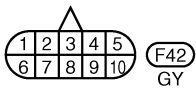
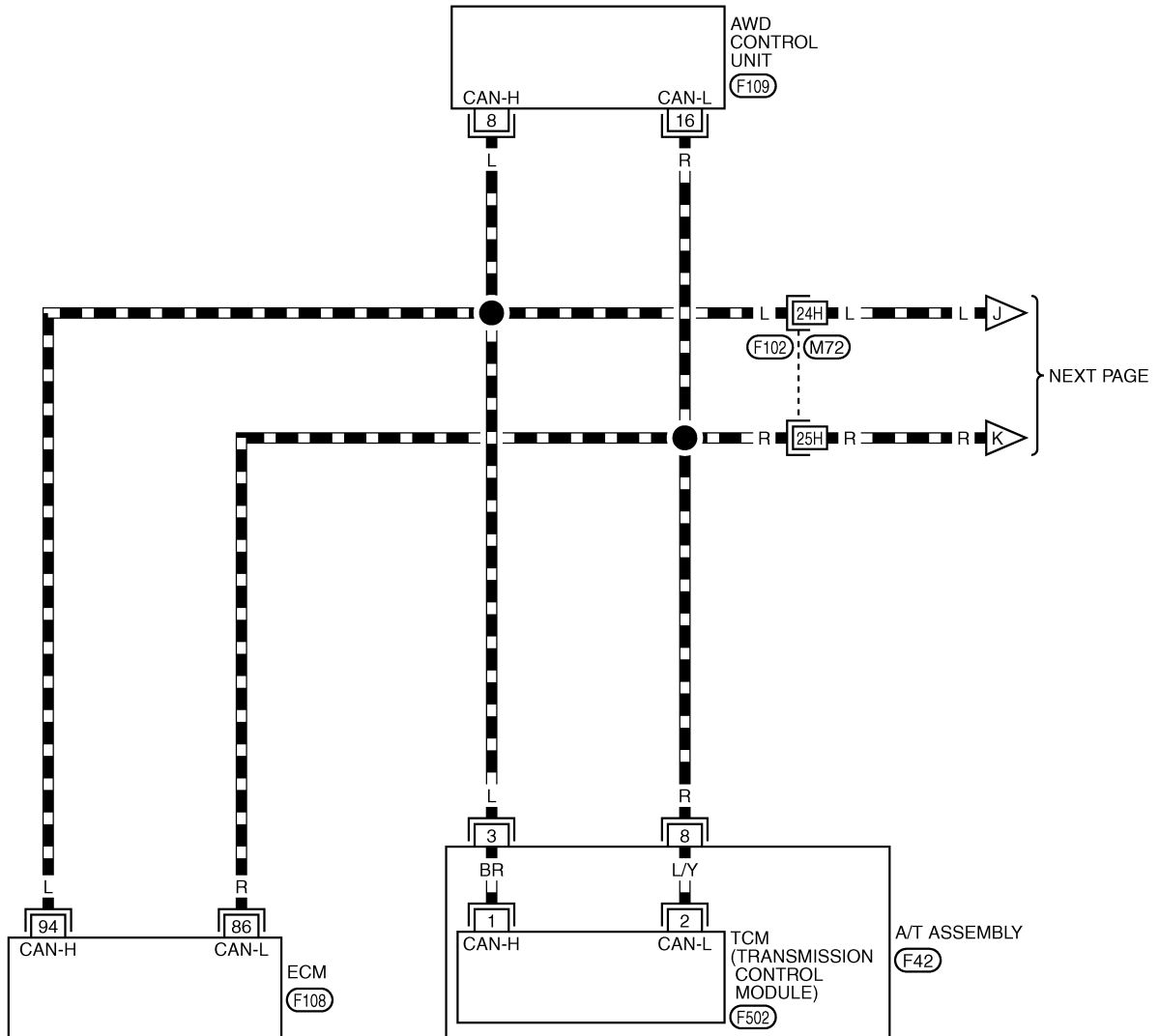

REFER TO THE FOLLOWING.

F102 -SUPER MULTIPLE JUNCTION (SMJ)

F108 -ELECTRICAL UNITS

*: THIS CONNECTOR IS NOT SHOWN IN "HARNESS LAYOUT", PG SECTION.

TKWM1422E

CAN SYSTEM (TYPE 3)

[CAN]

LAN-CAN-08

▬ : DATA LINE

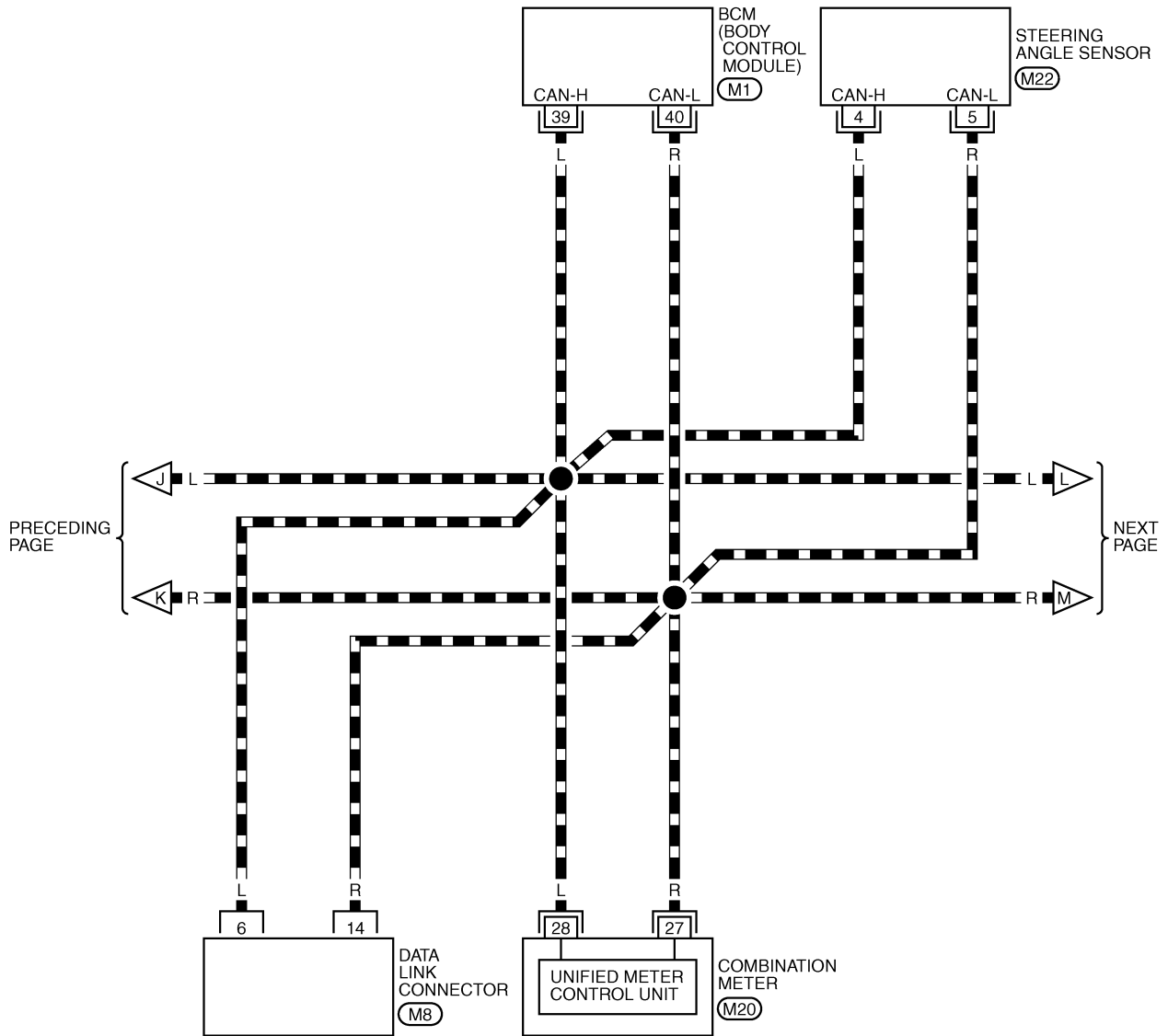

16	15	14	13	12	11	10	9
8	7	6	5	4	3	2	1

(M8)
W

25	26	27	28	29	30	31	32	33	34	35		
36	37	38	39	40	41	42	43	44	45	46	47	48

(M20)
W

3	2	1		
8	7	6	5	4

(M22)
W

REFER TO THE FOLLOWING.
(M1) -ELECTRICAL UNITS

TKWT2215E

▬ : DATA LINE

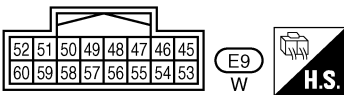
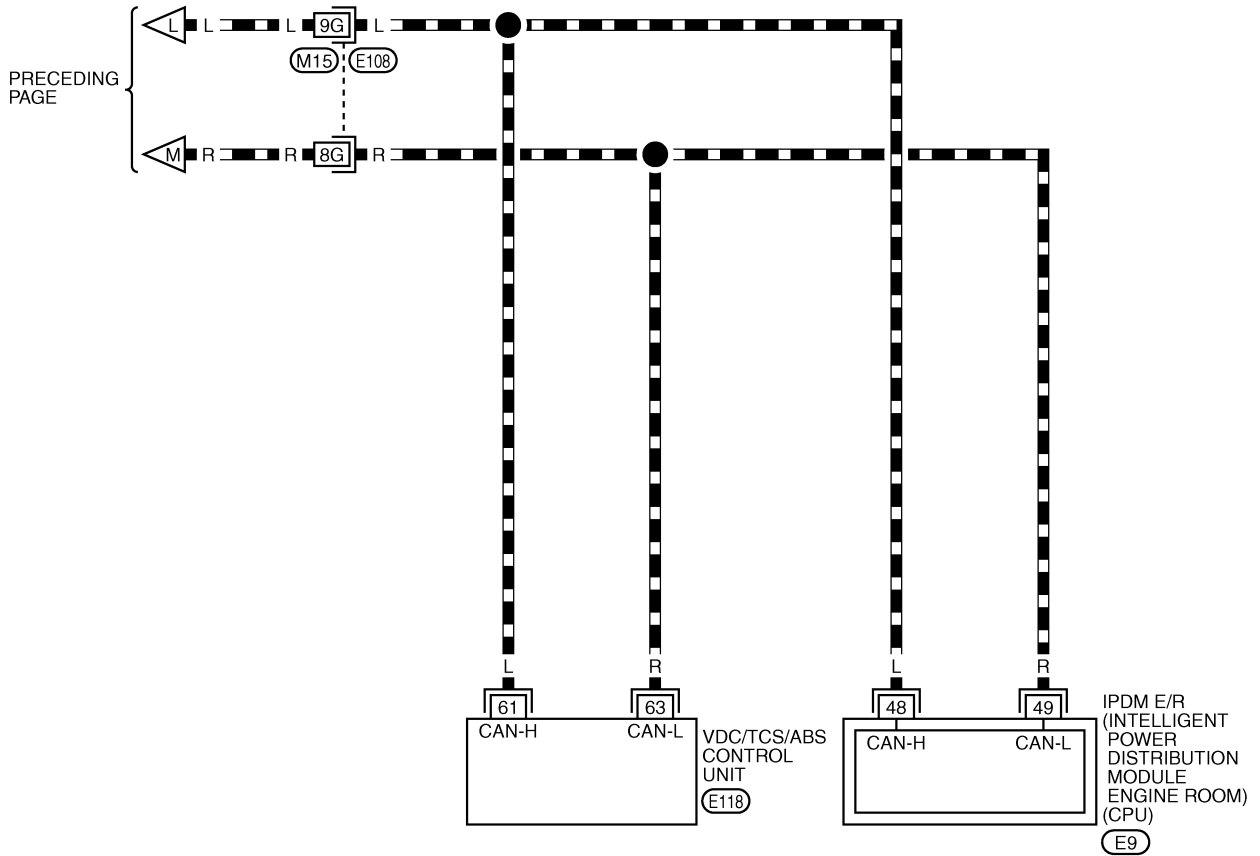

REFER TO THE FOLLOWING.

E108 -SUPER MULTIPLE JUNCTION (SMJ)

E118 -ELECTRICAL UNITS

TKWT2216E

CAN SYSTEM (TYPE 3)

[CAN]

AKS00AU7

Work Flow

- When there are no indications of "BCM" or "IPDM E/R" on "SELECT SYSTEM" display of CONSULT-II, print the "SELECT SYSTEM".

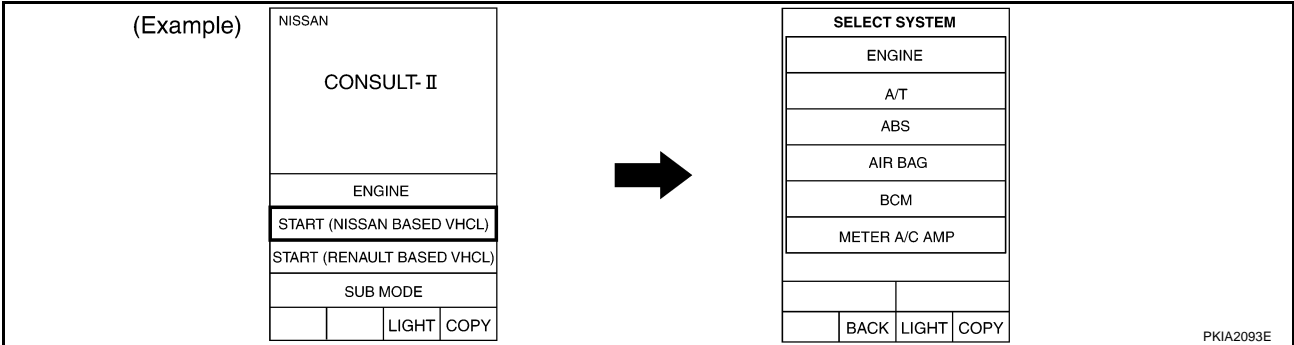

- Print all the data of "SELF-DIAG RESULTS" for "ENGINE", "ALL MODE AWD/4WD", "A/T", "BCM", "ABS" and "IPDM E/R" displayed on CONSULT-II.

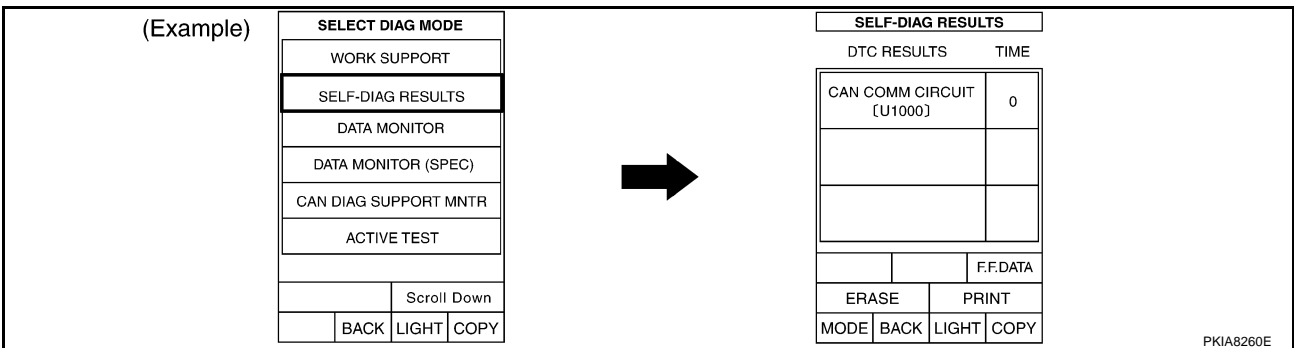

- Print all the data of "CAN DIAG SUPPORT MNTR" for "ENGINE", "ALL MODE AWD/4WD", "A/T", "BCM", "ABS" and "IPDM E/R" displayed on CONSULT-II.

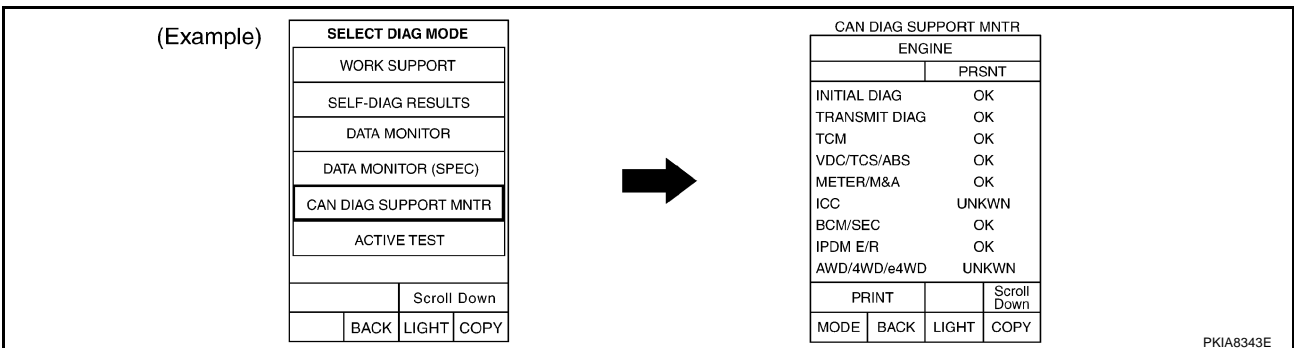

- Attach the printed sheet of "SELECT SYSTEM", "SELF-DIAG RESULTS" and "CAN DIAG SUPPORT MNTR" onto the check sheet. Refer to [LAN-70, "CHECK SHEET"](#) .
- Based on the indications of "SELECT SYSTEM" and the results of "CAN DIAG SUPPORT MNTR", put marks "v" onto the items with "No indication", "NG", or "UNKWVN" in the check sheet table. Refer to [LAN-70, "CHECK SHEET"](#) .

NOTE:

- If "NG" is displayed on "INITIAL DIAG (Initial diagnosis)" as "CAN DIAG SUPPORT MNTR" for the diagnosed control unit, replace the control unit.
- The "CAN DIAG SUPPORT MNTR" items, which are not in check sheet table, are not related to diagnostic procedure on service manual. So it is not necessary to check the status of the "CAN DIAG SUPPORT MNTR" items not in check sheet table.

- According to the check sheet results (example), start inspection. Refer to [LAN-72, "CHECK SHEET RESULTS \(EXAMPLE\)"](#) .

CAN SYSTEM (TYPE 3)

[CAN]

CHECK SHEET

NOTE:

If "NG" is displayed on "INITIAL DIAG (Initial diagnosis)" as "CAN DIAG SUPPORT MNTR" for the diagnosed control unit, replace the control unit.

Check sheet table		CAN DIAG SUPPORT MNTR									
SELECT SYSTEM screen		Initial diagnosis	Transmit diagnosis	Receive diagnosis							
				ECM	AWD/4WD /e4WD	TCM	METER /M&A	BCM /SEC	STRG	VDC/TCS /ABS	IPDM E/R
ENGINE	-	NG	UNKWN	-	UNKWN	UNKWN	UNKWN	UNKWN	-	UNKWN	UNKWN
ALL MODE AWD/4WD	-	NG	UNKWN	UNKWN	-	-	UNKWN	-	-	UNKWN	-
A/T	-	NG	UNKWN	UNKWN	UNKWN	-	UNKWN	-	-	UNKWN	-
BCM	No indication	NG	UNKWN	UNKWN	-	-	UNKWN	-	-	-	UNKWN
ABS	-	NG	UNKWN	UNKWN	UNKWN	UNKWN	UNKWN	-	UNKWN	-	-
IPDM E/R	No indication	-	UNKWN	UNKWN	-	-	-	UNKWN	-	-	-

Symptoms :

Attach copy of
SELECT SYSTEM

Attach copy of
SELECT SYSTEM

PKIA8869E

CAN SYSTEM (TYPE 3)

[CAN]

A
B
C
D
E
F
G
H
I
J
LAN
L
M

Attach copy of
ENGINE
SELF-DIAG RESULTS

Attach copy of
ALL MODE AWD/4WD
SELF-DIAG RESULTS

Attach copy of
A/T
SELF-DIAG RESULTS

Attach copy of
BCM
SELF-DIAG RESULTS

Attach copy of
ABS
SELF-DIAG RESULTS

Attach copy of
IPDM E/R
SELF-DIAG RESULTS

Attach copy of
ENGINE
CAN DIAG SUPPORT
MNTR

Attach copy of
ALL MODE AWD/4WD
CAN DIAG SUPPORT
MNTR

Attach copy of
A/T
CAN DIAG SUPPORT
MNTR

Attach copy of
BCM
CAN DIAG SUPPORT
MNTR

Attach copy of
ABS
CAN DIAG SUPPORT
MNTR

Attach copy of
IPDM E/R
CAN DIAG SUPPORT
MNTR

PKIA8870E

CHECK SHEET RESULTS (EXAMPLE)

NOTE:

If "NG" is displayed on "INITIAL DIAG (Initial diagnosis)" as "CAN DIAG SUPPORT MNTR" for the diagnosed control unit, replace the control unit.

Case1

Check harness between TCM and data link connector. Refer to [LAN-84, "Circuit Check Between TCM and Data Link Connector"](#).

SELECT SYSTEM screen		CAN DIAG SUPPORT MNTR										
		Initial diagnosis	Transmit diagnosis	Receive diagnosis								
				ECM	AWD/4WD /e4WD	TCM	METER /M&A	BCM /SEC	STRG	VDC/TCS /ABS	IPDM E/R	
ENGINE	—	NG	UNKWN	—	UNKWN	UNKWN	UNKWN ✓	UNKWN ✓	—	UNKWN ✓	UNKWN ✓	
ALL MODE AWD/4WD	—	NG	UNKWN	UNKWN	—	—	UNKWN ✓	—	—	UNKWN ✓	—	
A/T	—	NG	UNKWN	UNKWN	UNKWN	—	UNKWN ✓	—	—	UNKWN ✓	—	
BCM	No indication	NG	UNKWN	UNKWN ✓	—	—	UNKWN	—	—	—	UNKWN	
ABS	—	NG	UNKWN	UNKWN ✓	UNKWN ✓	UNKWN ✓	UNKWN	—	UNKWN	—	—	
IPDM E/R	No indication	—	UNKWN	UNKWN ✓	—	—	—	UNKWN	—	—	—	

PKIA8871E

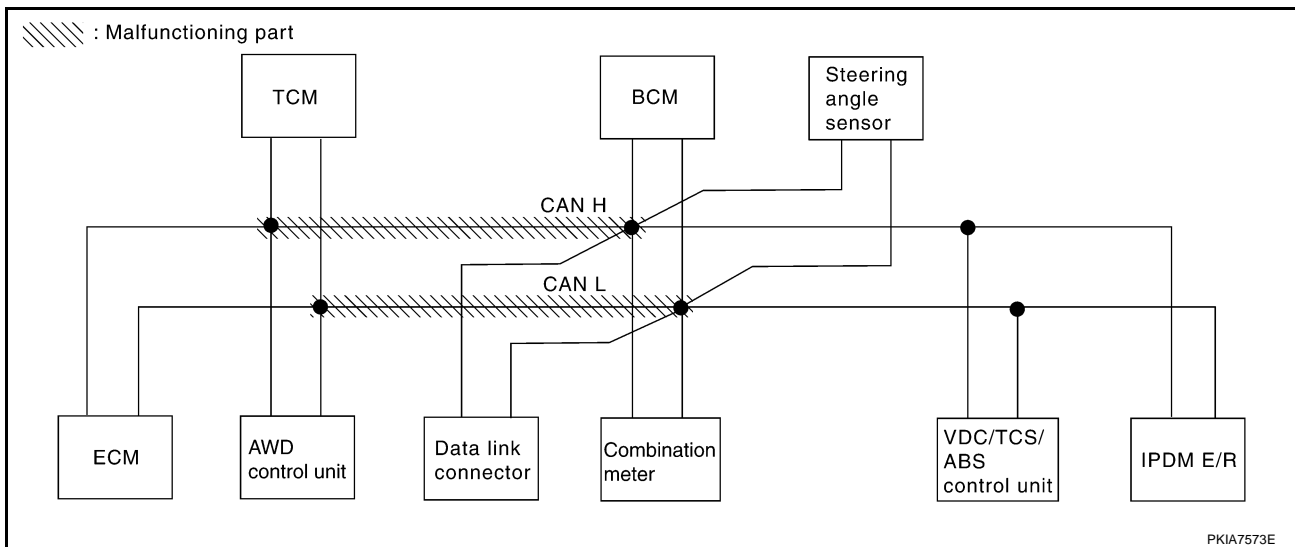

PKIA7573E

CAN SYSTEM (TYPE 3)

[CAN]

Case2

Check harness between data link connector and VDC/TCS/ABS control unit. Refer to [LAN-85, "Circuit Check Between Data Link Connector and VDC/TCS/ABS Control Unit"](#) .

SELECT SYSTEM screen		CAN DIAG SUPPORT MNTR									
		Initial diagnosis	Transmit diagnosis	Receive diagnosis							
				ECM	AWD/4WD /e4WD	TCM	METER /M&A	BCM /SEC	STRG	VDC/TCS /ABS	IPDM E/R
ENGINE	—	NG	UNKWN	—	UNKWN	UNKWN	UNKWN	UNKWN	—	UNKWN	UNKWN
ALL MODE AWD/4WD	—	NG	UNKWN	UNKWN	—	—	UNKWN	—	—	UNKWN	—
A/T	—	NG	UNKWN	UNKWN	UNKWN	—	UNKWN	—	—	UNKWN	—
BCM	No indication	NG	UNKWN	UNKWN	—	—	UNKWN	—	—	—	UNKWN
ABS	—	NG	UNKWN	UNKWN	UNKWN	UNKWN	UNKWN	—	UNKWN	—	—
IPDM E/R	No indication	—	UNKWN	UNKWN	—	—	—	UNKWN	—	—	—

PKIA6872E

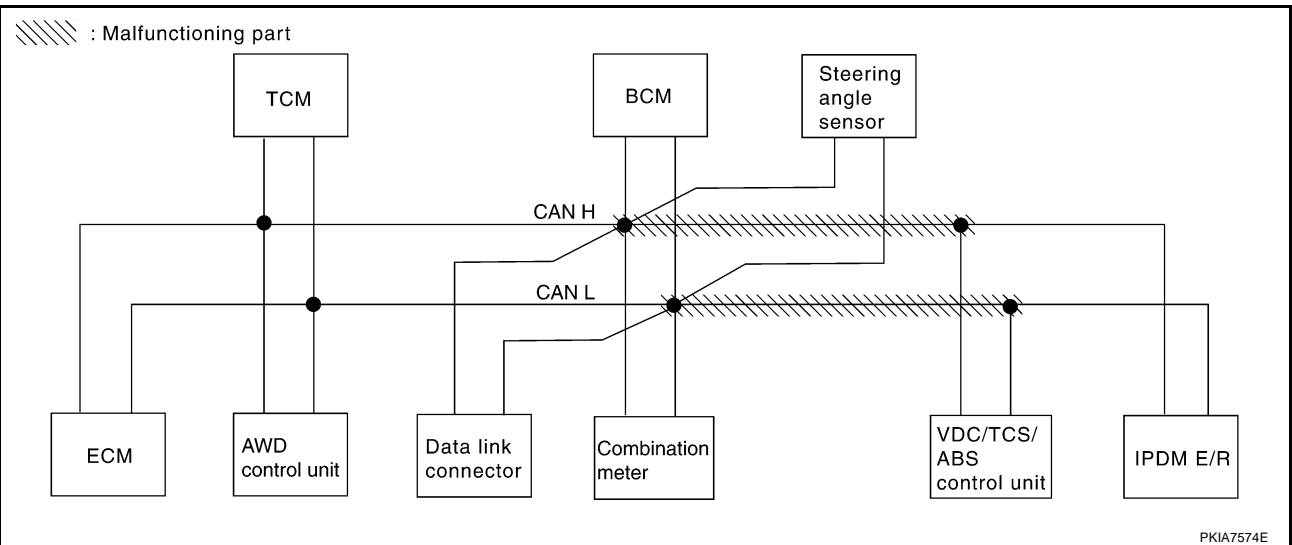

CAN SYSTEM (TYPE 3)

[CAN]

Case3

Check ECM circuit. Refer to [LAN-86, "ECM Circuit Check"](#) .

SELECT SYSTEM screen		CAN DIAG SUPPORT MNTR										
		Initial diagnosis	Transmit diagnosis	Receive diagnosis								
				ECM	AWD/4WD /e4WD	TCM	METER /M&A	BCM /SEC	STRG	VDC/TCS /ABS	IPDM E/R	
ENGINE	—	NG	UNKW N	—	UNKW N	UNKW N	UNKW N	UNKW N	—	UNKW N	UNKW N	
ALL MODE AWD/4WD	—	NG	UNKW N	UNKW N	—	—	UNKW N	—	—	UNKW N	—	
A/T	—	NG	UNKW N	UNKW N	UNKW N	—	UNKW N	—	—	UNKW N	—	
BCM	No indication	NG	UNKW N	UNKW N	—	—	UNKW N	—	—	—	UNKW N	
ABS	—	NG	UNKW N	UNKW N	UNKW N	UNKW N	UNKW N	—	UNKW N	—	—	
IPDM E/R	No indication	—	UNKW N	UNKW N	—	—	—	UNKW N	—	—	—	

PKIA8873E

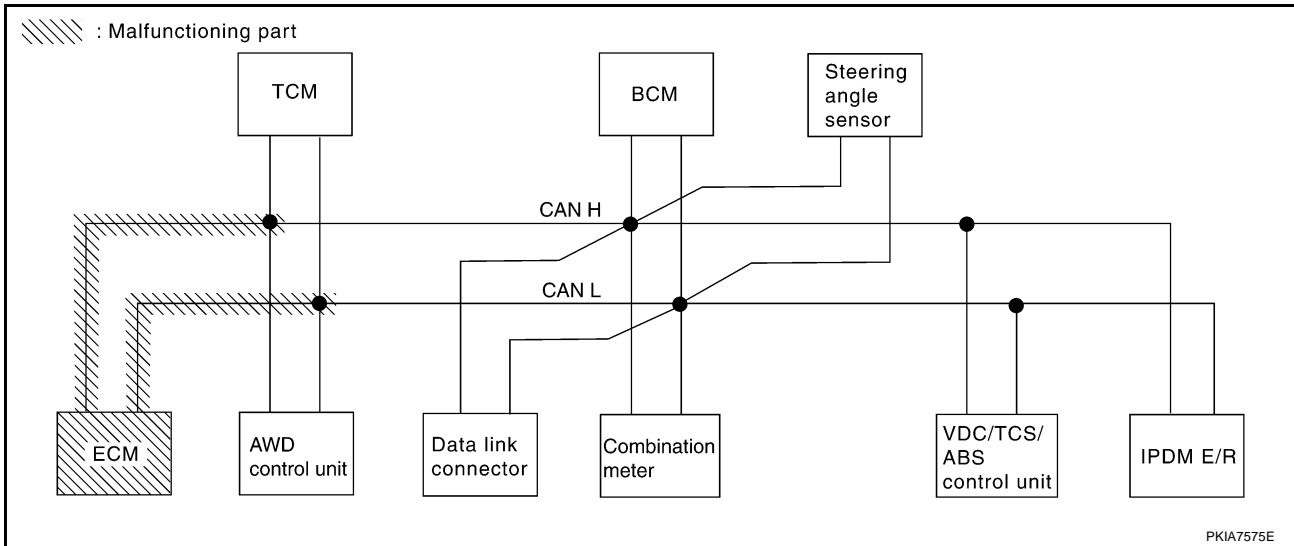

CAN SYSTEM (TYPE 3)

[CAN]

Case4

Check AWD control unit circuit. Refer to [LAN-86, "AWD Control Unit Circuit Check"](#) .

SELECT SYSTEM screen		CAN DIAG SUPPORT MNTR									
		Initial diagnosis	Transmit diagnosis	Receive diagnosis							
				ECM	AWD/4WD /e4WD	TCM	METER /M&A	BCM /SEC	STRG	VDC/TCS /ABS	IPDM E/R
ENGINE	—	NG	UNKWN	—	UNKWN	UNKWN	UNKWN	UNKWN	—	UNKWN	UNKWN
ALL MODE AWD/4WD	—	NG	UNKWN	UNKWN	—	—	UNKWN	—	—	UNKWN	—
A/T	—	NG	UNKWN	UNKWN	UNKWN	—	UNKWN	—	—	UNKWN	—
BCM	No indication	NG	UNKWN	UNKWN	—	—	UNKWN	—	—	—	UNKWN
ABS	—	NG	UNKWN	UNKWN	UNKWN	UNKWN	UNKWN	—	UNKWN	—	—
IPDM E/R	No indication	—	UNKWN	UNKWN	—	—	—	UNKWN	—	—	—

PKIA8874E

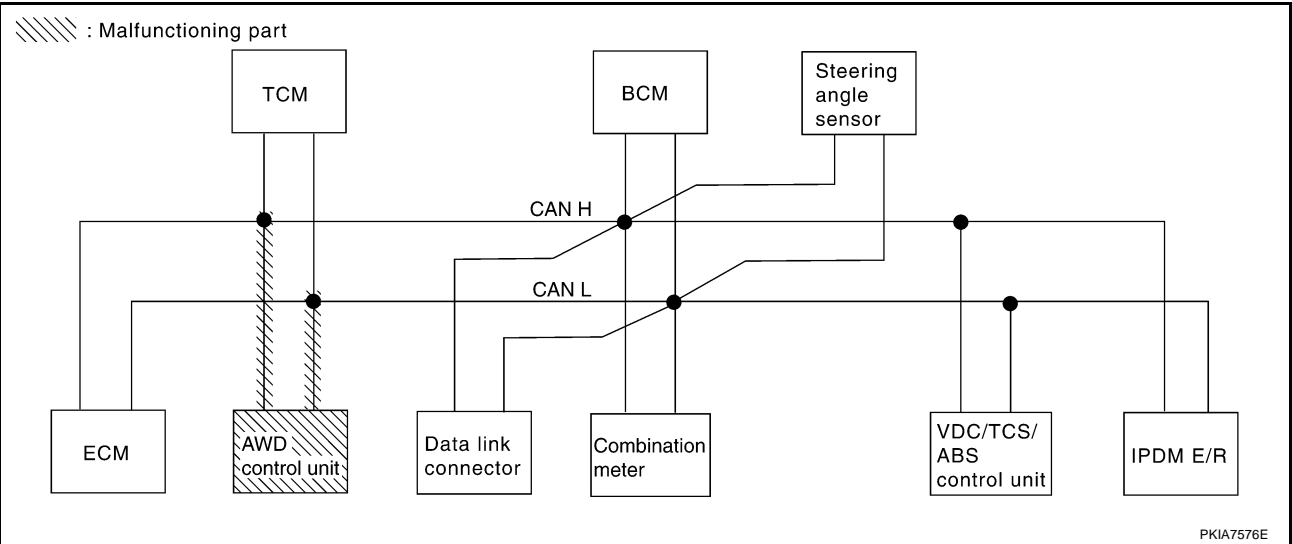

A
B
C
D
E
F
G
H
I
J
LAN
L
M

CAN SYSTEM (TYPE 3)

[CAN]

Case5

Check TCM circuit. Refer to [LAN-87, "TCM Circuit Check"](#) .

SELECT SYSTEM screen		CAN DIAG SUPPORT MNTR										
		Initial diagnosis	Transmit diagnosis	Receive diagnosis								
				ECM	AWD/4WD /e4WD	TCM	METER /M&A	BCM /SEC	STRG	VDC/TCS /ABS	IPDM E/R	
ENGINE	—	NG	UNKWN	—	UNKWN	UNKWN	UNKWN	UNKWN	—	UNKWN	UNKWN	
ALL MODE AWD/4WD	—	NG	UNKWN	UNKWN	—	—	UNKWN	—	—	UNKWN	—	
A/T	—	NG	UNKWN	UNKWN	UNKWN	—	UNKWN	—	—	UNKWN	—	
BCM	No indication	NG	UNKWN	UNKWN	—	—	UNKWN	—	—	—	UNKWN	
ABS	—	NG	UNKWN	UNKWN	UNKWN	UNKWN	UNKWN	—	UNKWN	—	—	
IPDM E/R	No indication	—	UNKWN	UNKWN	—	—	—	UNKWN	—	—	—	

PKIA8875E

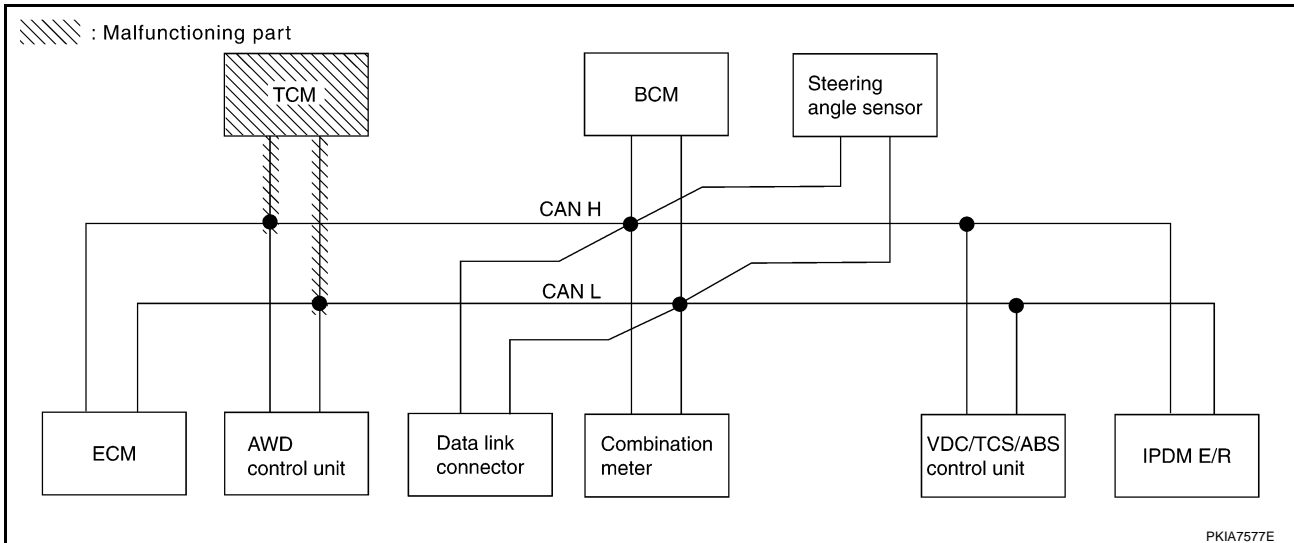

CAN SYSTEM (TYPE 3)

[CAN]

Case6

Check data link connector circuit. Refer to [LAN-87, "Data Link Connector Circuit Check"](#) .

SELECT SYSTEM screen		CAN DIAG SUPPORT MNTR										
		Initial diagnosis	Transmit diagnosis	Receive diagnosis								
				ECM	AWD/4WD /e4WD	TCM	METER /M&A	BCM /SEC	STRG	VDC/TCS /ABS	IPDM E/R	
ENGINE	—	NG	UNKWN	—	UNKWN	UNKWN	UNKWN	UNKWN	—	UNKWN	UNKWN	
ALL MODE AWD/4WD	—	NG	UNKWN	UNKWN	—	—	UNKWN	—	—	UNKWN	—	
A/T	—	NG	UNKWN	UNKWN	UNKWN	—	UNKWN	—	—	UNKWN	—	
BCM	No indication ✓	NG	UNKWN	UNKWN	—	—	UNKWN	—	—	—	UNKWN	
ABS	—	NG	UNKWN	UNKWN	UNKWN	UNKWN	UNKWN	—	UNKWN	—	—	
IPDM E/R	No indication ✓	—	UNKWN	UNKWN	—	—	—	UNKWN	—	—	—	

PKIA8876E

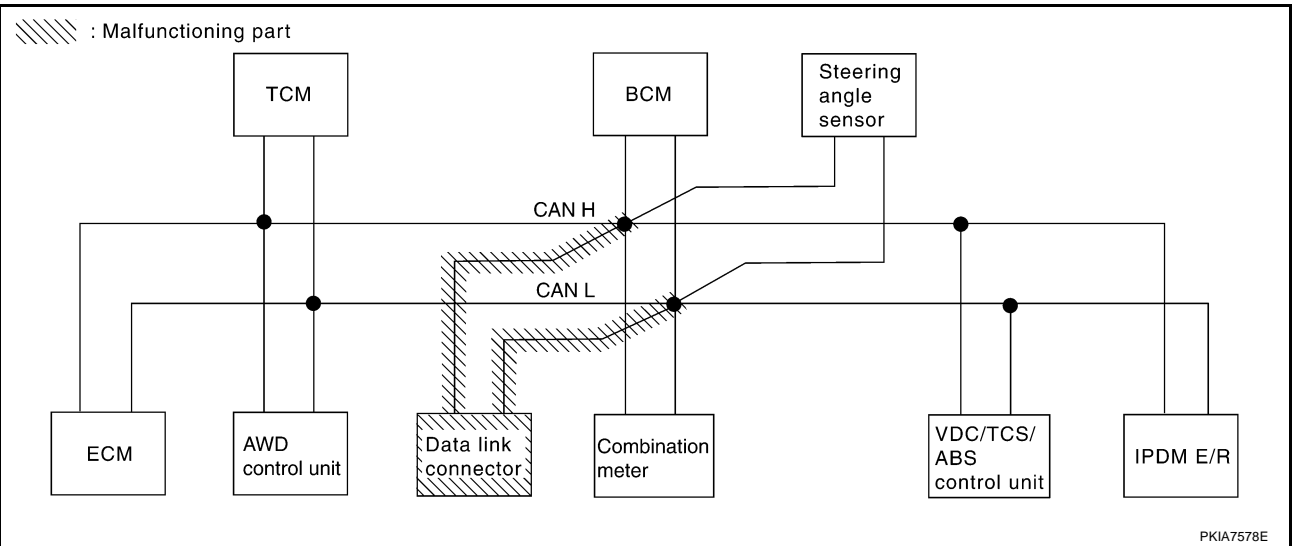

A
B
C
D
E
F
G
H
I
J
LAN
L
M

CAN SYSTEM (TYPE 3)

[CAN]

Case7

Check combination meter circuit. Refer to [LAN-88, "Combination Meter Circuit Check"](#) .

SELECT SYSTEM screen		CAN DIAG SUPPORT MNTR										
		Initial diagnosis	Transmit diagnosis	Receive diagnosis								
				ECM	AWD/4WD /e4WD	TCM	METER /M&A	BCM /SEC	STRG	VDC/TCS /ABS	IPDM E/R	
ENGINE	—	NG	UNKWN	—	UNKWN	UNKWN	UNKWN	UNKWN	—	UNKWN	UNKWN	
ALL MODE AWD/4WD	—	NG	UNKWN	UNKWN	—	—	UNKWN	—	—	UNKWN	—	
A/T	—	NG	UNKWN	UNKWN	UNKWN	—	UNKWN	—	—	UNKWN	—	
BCM	No indication	NG	UNKWN	UNKWN	—	—	UNKWN	—	—	—	UNKWN	
ABS	—	NG	UNKWN	UNKWN	UNKWN	UNKWN	UNKWN	—	UNKWN	—	—	
IPDM E/R	No indication	—	UNKWN	UNKWN	—	—	—	UNKWN	—	—	—	

PKIA8877E

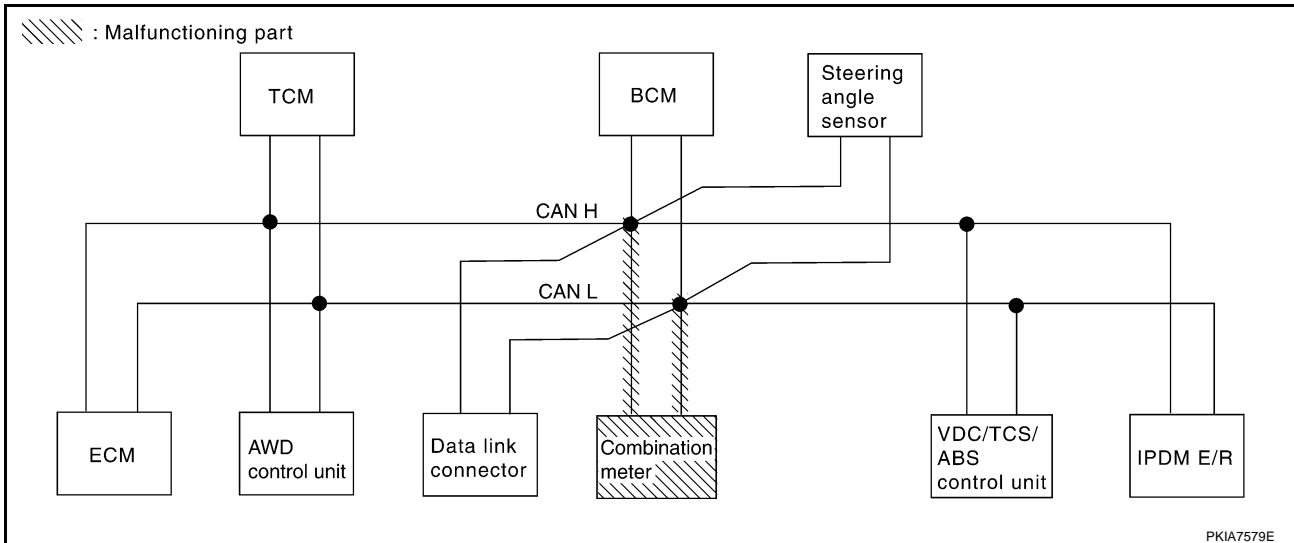

CAN SYSTEM (TYPE 3)

[CAN]

Case8

Check BCM circuit. Refer to [LAN-88. "BCM Circuit Check"](#) .

SELECT SYSTEM screen		CAN DIAG SUPPORT MNTR										
		Initial diagnosis	Transmit diagnosis	Receive diagnosis								
				ECM	AWD/4WD /e4WD	TCM	METER /M&A	BCM /SEC	STRG	VDC/TCS /ABS	IPDM E/R	
ENGINE	—	NG	UNKWN	—	UNKWN	UNKWN	UNKWN	UNKWN	—	UNKWN	UNKWN	
ALL MODE AWD/4WD	—	NG	UNKWN	UNKWN	—	—	UNKWN	—	—	UNKWN	—	
A/T	—	NG	UNKWN	UNKWN	UNKWN	—	UNKWN	—	—	UNKWN	—	
BCM	No indication	NG	UNKWN	UNKWN	—	—	UNKWN	—	—	—	UNKWN	
ABS	—	NG	UNKWN	UNKWN	UNKWN	UNKWN	UNKWN	—	UNKWN	—	—	
IPDM E/R	No indication	—	UNKWN	UNKWN	—	—	—	UNKWN	—	—	—	

PKIA8878E

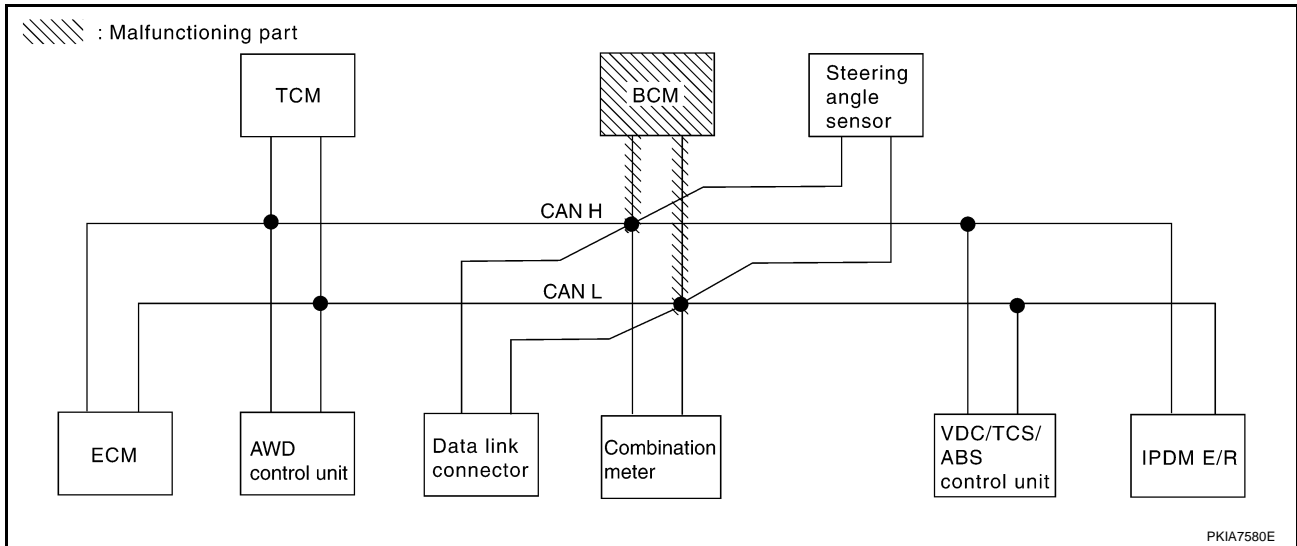

A
B
C
D
E
F
G
H
I
J
L
M

LAN

CAN SYSTEM (TYPE 3)

[CAN]

Case9

Check steering angle sensor circuit. Refer to [LAN-89, "Steering Angle Sensor Circuit Check"](#) .

SELECT SYSTEM screen		CAN DIAG SUPPORT MNTR										
		Initial diagnosis	Transmit diagnosis	Receive diagnosis								
				ECM	AWD/4WD /e4WD	TCM	METER /M&A	BCM /SEC	STRG	VDC/TCS /ABS	IPDM E/R	
ENGINE	—	NG	UNKWN	—	UNKWN	UNKWN	UNKWN	UNKWN	—	UNKWN	UNKWN	
ALL MODE AWD/4WD	—	NG	UNKWN	UNKWN	—	—	UNKWN	—	—	UNKWN	—	
A/T	—	NG	UNKWN	UNKWN	UNKWN	—	UNKWN	—	—	UNKWN	—	
BCM	No indication	NG	UNKWN	UNKWN	—	—	UNKWN	—	—	—	UNKWN	
ABS	—	NG	UNKWN	UNKWN	UNKWN	UNKWN	UNKWN	—	UNKWN	—	—	
IPDM E/R	No indication	—	UNKWN	UNKWN	—	—	—	UNKWN	—	—	—	

PKIA8879E

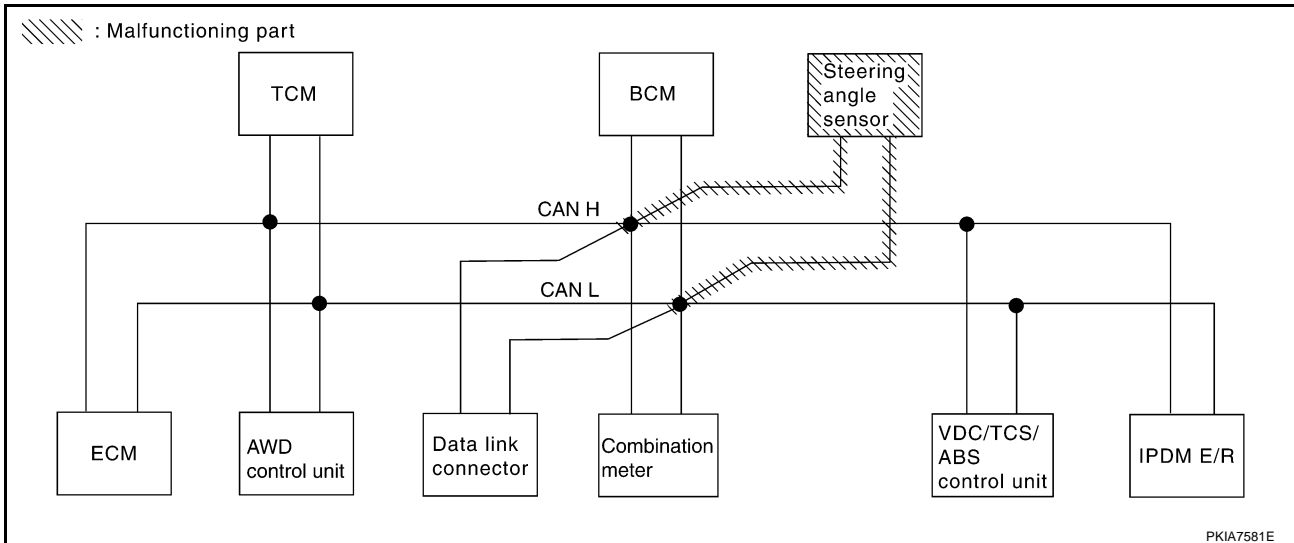

CAN SYSTEM (TYPE 3)

[CAN]

Case10

Check VDC/TCS/ABS control unit circuit. Refer to [LAN-89, "VDC/TCS/ABS Control Unit Circuit Check"](#) .

SELECT SYSTEM screen		CAN DIAG SUPPORT MNTR									
		Initial diagnosis	Transmit diagnosis	Receive diagnosis							
				ECM	AWD/4WD /e4WD	TCM	METER /M&A	BCM /SEC	STRG	VDC/TCS /ABS	IPDM E/R
ENGINE	—	NG	UNKWN	—	UNKWN	UNKWN	UNKWN	UNKWN	—	UNKWN	UNKWN
ALL MODE AWD/4WD	—	NG	UNKWN	UNKWN	—	—	UNKWN	—	—	UNKWN	—
A/T	—	NG	UNKWN	UNKWN	UNKWN	—	UNKWN	—	—	UNKWN	—
BCM	No indication	NG	UNKWN	UNKWN	—	—	UNKWN	—	—	—	UNKWN
ABS	—	NG	UNKWN	UNKWN	UNKWN	UNKWN	UNKWN	—	UNKWN	—	—
IPDM E/R	No indication	—	UNKWN	UNKWN	—	—	—	UNKWN	—	—	—

PKIA8880E

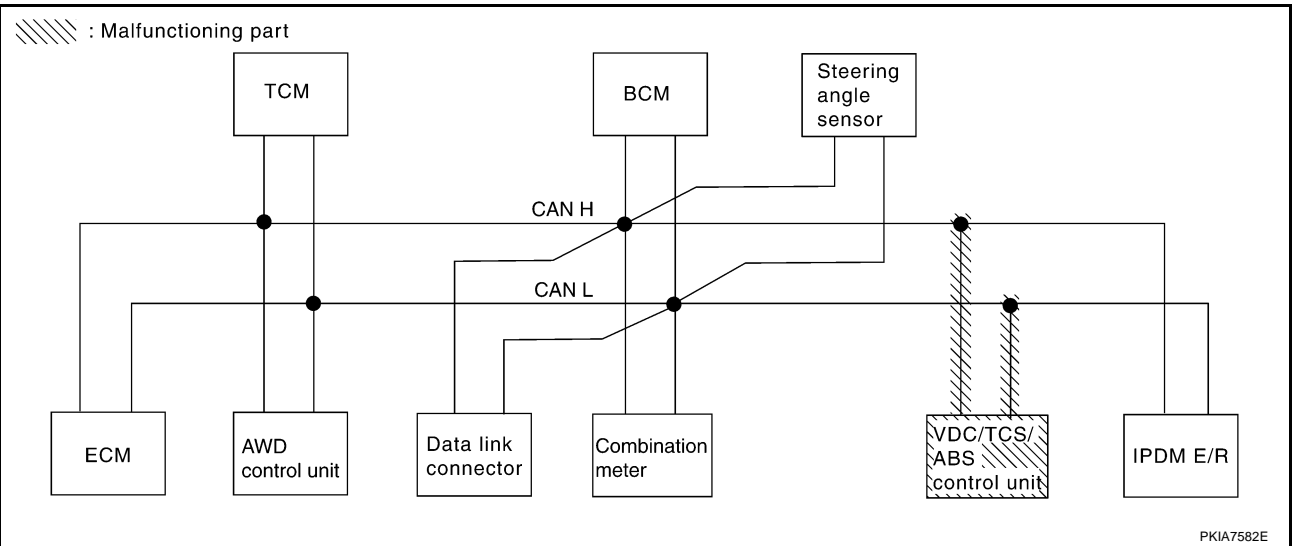

A
B
C
D
E
F
G
H
I
J
LAN
L
M

CAN SYSTEM (TYPE 3)

[CAN]

Case11

Check IPDM E/R circuit. Refer to [LAN-90, "IPDM E/R Circuit Check"](#) .

SELECT SYSTEM screen		CAN DIAG SUPPORT MNTR										
		Initial diagnosis	Transmit diagnosis	Receive diagnosis								
				ECM	AWD/4WD /e4WD	TCM	METER /M&A	BCM /SEC	STRG	VDC/TCS /ABS	IPDM E/R	
ENGINE	—	NG	UNKWN	—	UNKWN	UNKWN	UNKWN	UNKWN	—	UNKWN	UNKWN ✓	
ALL MODE AWD/4WD	—	NG	UNKWN	UNKWN	—	—	UNKWN	—	—	UNKWN	—	
A/T	—	NG	UNKWN	UNKWN	UNKWN	—	UNKWN	—	—	UNKWN	—	
BCM	No indication	NG	UNKWN	UNKWN	—	—	UNKWN	—	—	—	UNKWN ✓	
ABS	—	NG	UNKWN	UNKWN	UNKWN	UNKWN	UNKWN	—	UNKWN	—	—	
IPDM E/R	No indication ✓	—	UNKWN	UNKWN	—	—	—	UNKWN	—	—	—	

PKIA8881E

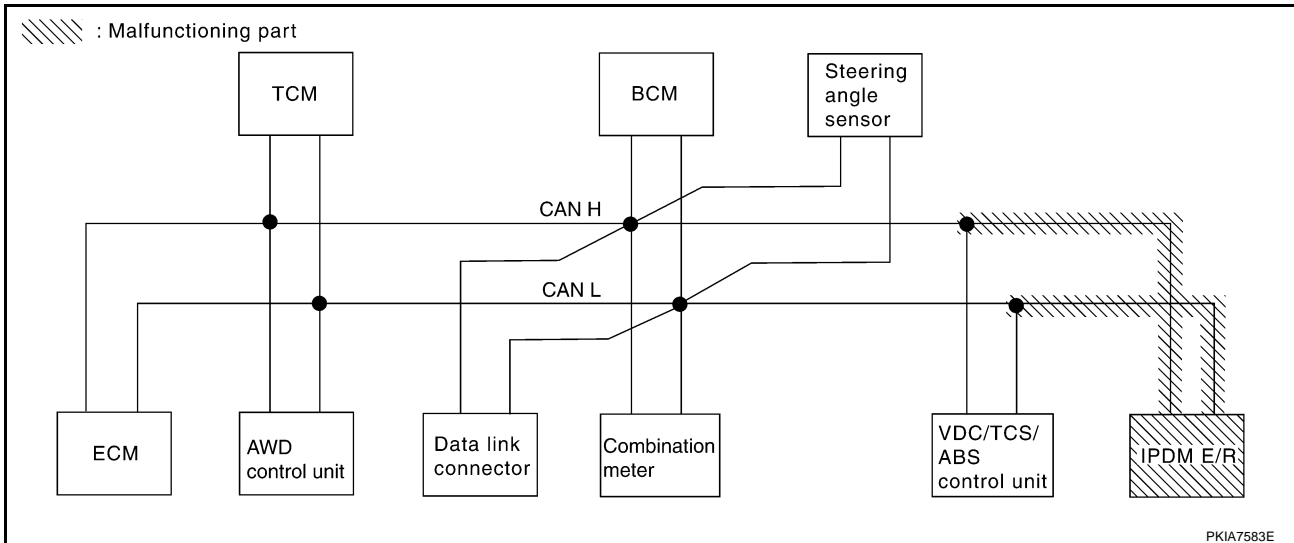

CAN SYSTEM (TYPE 3)

[CAN]

Case12

Check CAN communication circuit. Refer to [LAN-90, "CAN Communication Circuit Check"](#) .

SELECT SYSTEM screen		CAN DIAG SUPPORT MNTR										
		Initial diagnosis	Transmit diagnosis	Receive diagnosis								
				ECM	AWD/4WD /e4WD	TCM	METER /M&A	BCM /SEC	STRG	VDC/TCS /ABS	IPDM E/R	
ENGINE	—	NG	UNKW N	—	UNKW N	UNKW N	UNKW N	UNKW N	UNKW N	—	UNKW N	UNKW N
ALL MODE AWD/4WD	—	NG	UNKW N	UNKW N	—	—	UNKW N	—	—	—	UNKW N	—
A/T	—	NG	UNKW N	UNKW N	UNKW N	—	UNKW N	—	—	—	UNKW N	—
BCM	No indication	NG	UNKW N	UNKW N	—	—	UNKW N	—	—	—	—	UNKW N
ABS	—	NG	UNKW N	UNKW N	UNKW N	UNKW N	UNKW N	UNKW N	—	UNKW N	—	—
IPDM E/R	No indication	—	UNKW N	UNKW N	—	—	—	—	UNKW N	—	—	—

PKIA8882E

Case13

Check IPDM E/R ignition relay circuit continuously sticks "OFF". Refer to [LAN-93, "IPDM E/R Ignition Relay Circuit Check"](#) .

SELECT SYSTEM screen		CAN DIAG SUPPORT MNTR										
		Initial diagnosis	Transmit diagnosis	Receive diagnosis								
				ECM	AWD/4WD /e4WD	TCM	METER /M&A	BCM /SEC	STRG	VDC/TCS /ABS	IPDM E/R	
ENGINE	—	NG	UNKW N	—	UNKW N	UNKW N	UNKW N	UNKW N	UNKW N	—	UNKW N	UNKW N
ALL MODE AWD/4WD	—	NG	UNKW N	UNKW N	—	—	UNKW N	—	—	—	UNKW N	—
A/T	—	NG	UNKW N	UNKW N	UNKW N	—	UNKW N	—	—	—	UNKW N	—
BCM	No indication	NG	UNKW N	UNKW N	—	—	UNKW N	—	—	—	—	UNKW N
ABS	—	NG	UNKW N	UNKW N	UNKW N	UNKW N	UNKW N	UNKW N	—	UNKW N	—	—
IPDM E/R	No indication	—	UNKW N	UNKW N	—	—	—	—	UNKW N	—	—	—

PKIA8883E

A
B
C
D
E
F
G
H
I
J
L
M

LAN

Case14

Check IPDM E/R ignition relay circuit continuously sticks "ON". Refer to [LAN-93, "IPDM E/R Ignition Relay Circuit Check"](#) .

SELECT SYSTEM screen		CAN DIAG SUPPORT MNTR										
		Initial diagnosis	Transmit diagnosis	Receive diagnosis								
				ECM	AWD/4WD /e4WD	TCM	METER /M&A	BCM /SEC	STRG	VDC/TCS /ABS	IPDM E/R	
ENGINE	-	NG	UNKWN	-	✓	✓	✓	UNKWN	-	✓	UNKWN	
ALL MODE AWD/4WD	-	NG	UNKWN	UNKWN	-	-	UNKWN	-	-	UNKWN	-	
A/T	-	NG	UNKWN	UNKWN	UNKWN	-	UNKWN	-	-	UNKWN	-	
BCM	No indication	NG	UNKWN	UNKWN	-	-	✓	-	-	-	UNKWN	
ABS	-	NG	UNKWN	UNKWN	UNKWN	UNKWN	UNKWN	-	UNKWN	-	-	
IPDM E/R	No indication	-	UNKWN	UNKWN	-	-	-	UNKWN	-	-	-	

PKIA8884E

Circuit Check Between TCM and Data Link Connector

AKS00AUB

1. CHECK CONNECTOR

1. Turn ignition switch OFF.
2. Disconnect the negative battery terminal.
3. Check following terminals and connectors for damage, bend and loose connection (connector side and harness side).
 - Harness connector F102
 - Harness connector M72

OK or NG

- OK >> GO TO 2.
 NG >> Repair terminal or connector.

2. CHECK HARNESS FOR OPEN CIRCUIT

1. Disconnect A/T assembly connector and harness connector F102.
2. Check continuity between A/T assembly harness connector F42 terminals 3 (L), 8 (R) and harness connector F102 terminals 24H (L), 25H (R).

3 (L) - 24H (L) : Continuity should exist.
8 (R) - 25H (R) : Continuity should exist.

OK or NG

- OK >> GO TO 3.
 NG >> Repair harness.

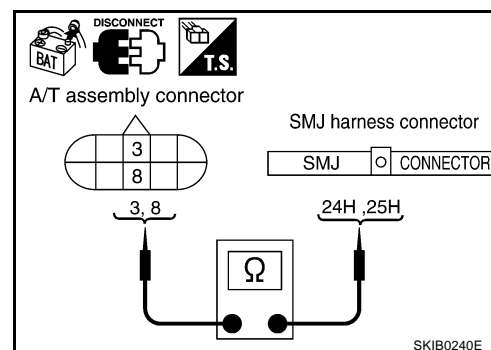

3. CHECK HARNESS FOR OPEN CIRCUIT

Check continuity between harness connector M72 terminals 24H (L), 25H (R) and data link connector M8 terminals 6 (L), 14 (R).

- 24H (L) - 6 (L) : Continuity should exist.**
- 25H (R) - 14 (R) : Continuity should exist.**

OK or NG

- OK >> Connect all the connectors and diagnose again. Refer to [LAN-69. "Work Flow"](#).
- NG >> Repair harness.

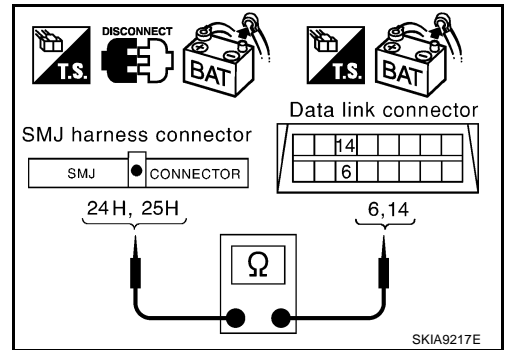

Circuit Check Between Data Link Connector and VDC/TCS/ABS Control Unit

AKS00AU9

1. CHECK CONNECTOR

1. Turn ignition switch OFF.
2. Disconnect the negative battery terminal.
3. Check following terminals and connectors for damage, bend and loose connection (connector side and harness side).
 - Harness connector M15
 - Harness connector E108

OK or NG

- OK >> GO TO 2.
- NG >> Repair terminal or connector.

2. CHECK HARNESS FOR OPEN CIRCUIT

1. Disconnect harness connector M15.
2. Check continuity between data link connector M8 terminals 6 (L), 14 (R) and harness connector M15 terminals 9G (L), 8G (R).

- 6 (L) - 9G (L) : Continuity should exist.**
- 14 (R) - 8G (R) : Continuity should exist.**

OK or NG

- OK >> GO TO 3.
- NG >> Repair harness.

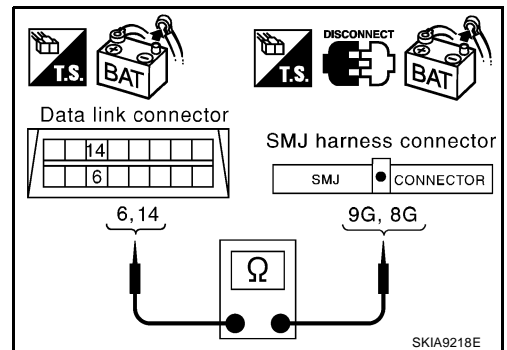

3. CHECK HARNESS FOR OPEN CIRCUIT

1. Disconnect VDC/TCS/ABS control unit connector.
2. Check continuity between harness connector E108 terminals 9G (L), 8G (R) and VDC/TCS/ABS control unit harness connector E118 terminals 61 (L), 63 (R).

- 9G (L) - 61 (L) : Continuity should exist.**
- 8G (R) - 63 (R) : Continuity should exist.**

OK or NG

- OK >> Connect all the connectors and diagnose again. Refer to [LAN-69. "Work Flow"](#).
- NG >> Repair harness.

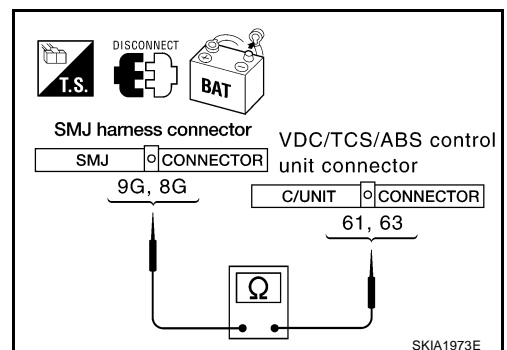

ECM Circuit Check**1. CHECK CONNECTOR**

1. Turn ignition switch OFF.
2. Disconnect the negative battery terminal.
3. Check terminals and connector of ECM for damage, bend and loose connection (control module side and harness side).

OK or NG

- OK >> GO TO 2.
 NG >> Repair terminal or connector.

2. CHECK HARNESS FOR OPEN CIRCUIT

1. Disconnect ECM connector.
2. Check resistance between ECM harness connector F108 terminals 94 (L) and 86 (R).

94 (L) - 86 (R) : Approx. 108 - 132Ω

OK or NG

- OK >> Replace ECM.
 NG >> Repair harness between harness connector F102 and ECM.

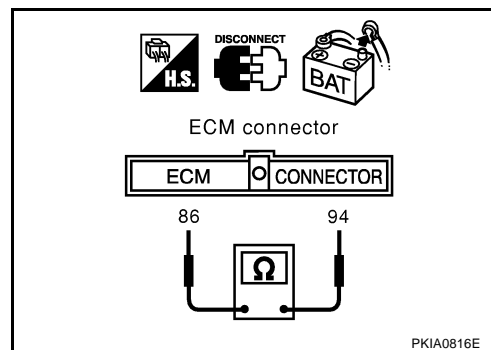
**AWD Control Unit Circuit Check****1. CHECK CONNECTOR**

1. Turn ignition switch OFF.
2. Disconnect the negative battery terminal.
3. Check terminals and connector of AWD control unit for damage, bend and loose connection (control unit side and harness side).

OK or NG

- OK >> GO TO 2.
 NG >> Repair terminal or connector.

2. CHECK HARNESS FOR OPEN CIRCUIT

1. Disconnect AWD control unit connector.
2. Check resistance between AWD control unit harness connector F109 terminals 8 (L) and 16 (R).

8 (L) - 16 (R) : Approx. 54 - 66Ω

OK or NG

- OK >> Replace AWD control unit.
 NG >> Repair harness between harness connector F102 and AWD control unit.

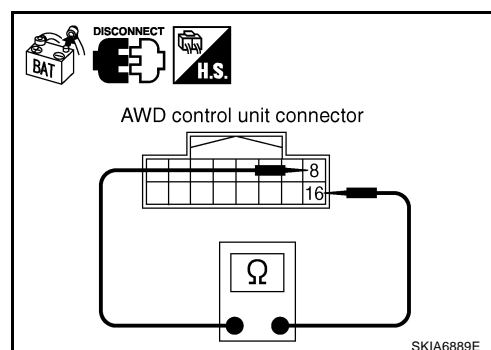

TCM Circuit Check**1. CHECK CONNECTOR**

1. Turn ignition switch OFF.
2. Disconnect the negative battery terminal.
3. Check terminals and connector of A/T assembly for damage, bend and loose connection (control module side and harness side).

OK or NG

- OK >> GO TO 2.
 NG >> Repair terminal or connector.

2. CHECK HARNESS FOR OPEN CIRCUIT

1. Disconnect A/T assembly connector.
2. Check resistance between A/T assembly harness connector F42 terminals 3 (L) and 8 (R).

3 (L) - 8 (R) : Approx. 54 - 66Ω

OK or NG

- OK >> Replace control valve with TCM.
 NG >> Repair harness between harness connector F102 and A/T assembly.

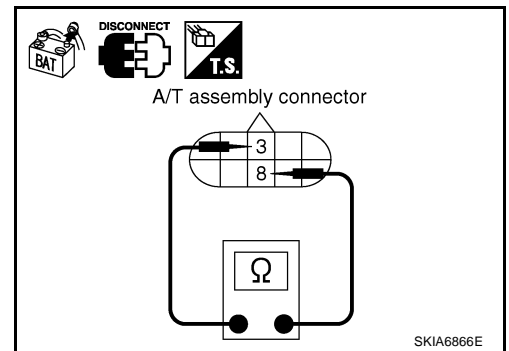

AKS00AUC

Data Link Connector Circuit Check**1. CHECK CONNECTOR**

1. Turn ignition switch OFF.
2. Disconnect the negative battery terminal.
3. Check terminals and connector of data link connector for damage, bend and loose connection (connector side and harness side).

OK or NG

- OK >> GO TO 2.
 NG >> Repair terminal or connector.

2. CHECK HARNESS FOR OPEN CIRCUIT

Check resistance between data link connector M8 terminals 6 (L) and 14 (R).

6 (L) - 14 (R) : Approx. 54 - 66Ω

OK or NG

- OK >> Diagnose again. Refer to [LAN-69, "Work Flow"](#) .
 NG >> Repair harness between data link connector and combination meter.

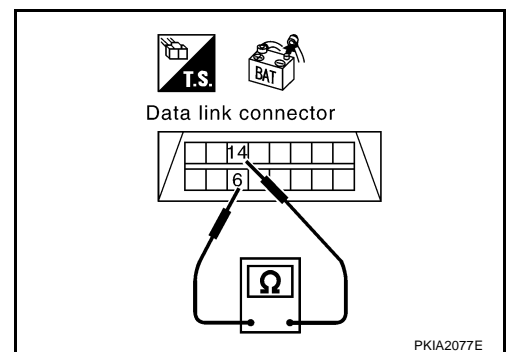

PKIA2077E

Combination Meter Circuit Check**1. CHECK CONNECTOR**

1. Turn ignition switch OFF.
2. Disconnect the negative battery terminal.
3. Check terminals and connector of combination meter for damage, bend and loose connection (meter side and harness side).

OK or NG

- OK >> GO TO 2.
 NG >> Repair terminal or connector.

2. CHECK HARNESS FOR OPEN CIRCUIT

1. Disconnect combination meter connector.
2. Check resistance between combination meter harness connector M20 terminals 28 (L) and 27 (R).

28 (L) - 27 (R) : Approx. 54 - 66Ω

OK or NG

- OK >> Replace combination meter.
 NG >> Repair harness between data link connector and combination meter.

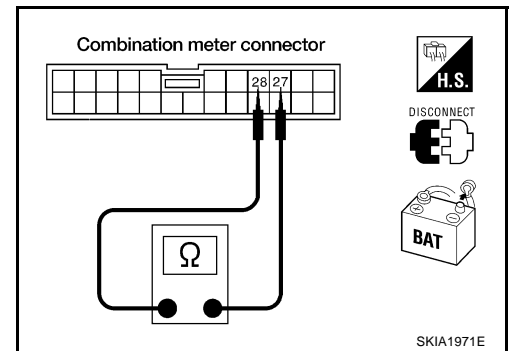
**BCM Circuit Check****1. CHECK CONNECTOR**

1. Turn ignition switch OFF.
2. Disconnect the negative battery terminal.
3. Check terminals and connector of BCM for damage, bend and loose connection (control module side and harness side).

OK or NG

- OK >> GO TO 2.
 NG >> Repair terminal or connector.

2. CHECK HARNESS FOR OPEN CIRCUIT

1. Disconnect BCM connector.
2. Check resistance between BCM harness connector M1 terminals 39 (L) and 40 (R).

39 (L) - 40 (R) : Approx. 54 - 66Ω

OK or NG

- OK >> Replace BCM. Refer to [BCS-15, "Removal and Installation of BCM"](#) .
 NG >> Repair harness between data link connector and BCM.

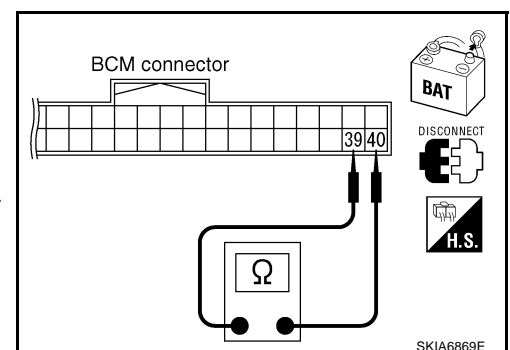

Steering Angle Sensor Circuit Check**1. CHECK CONNECTOR**

1. Turn ignition switch OFF.
2. Disconnect the negative battery terminal.
3. Check terminals and connector of steering angle sensor for damage, bend and loose connection (sensor side and harness side).

OK or NG

- OK >> GO TO 2.
 NG >> Repair terminal or connector.

2. CHECK HARNESS FOR OPEN CIRCUIT

1. Disconnect steering angle sensor connector.
2. Check resistance between steering angle sensor harness connector M22 terminals 4 (L) and 5 (R).

4 (L) - 5 (R) : Approx. 54 - 66Ω

OK or NG

- OK >> Replace steering angle sensor.
 NG >> Repair harness between data link connector and steering angle sensor.

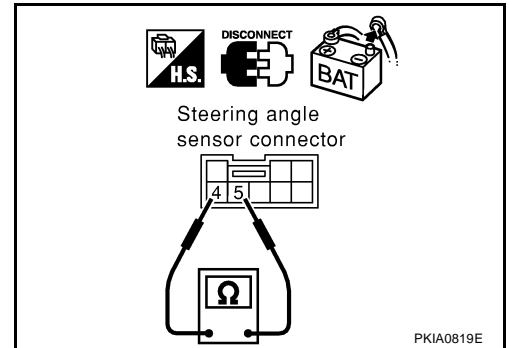

AKS00AUG

VDC/TCS/ABS Control Unit Circuit Check**1. CHECK CONNECTOR**

1. Turn ignition switch OFF.
2. Disconnect the negative battery terminal.
3. Check terminals and connector of VDC/TCS/ABS control unit for damage, bend and loose connection (control unit side and harness side).

OK or NG

- OK >> GO TO 2.
 NG >> Repair terminal or connector.

2. CHECK HARNESS FOR OPEN CIRCUIT

1. Disconnect VDC/TCS/ABS control unit connector.
2. Check resistance between VDC/TCS/ABS control unit harness connector E118 terminals 61 (L) and 63 (R).

61 (L) - 63 (R) : Approx. 54 - 66Ω

OK or NG

- OK >> Replace VDC/TCS/ABS control unit.
 NG >> Repair harness between harness connector E108 and VDC/TCS/ABS control unit.

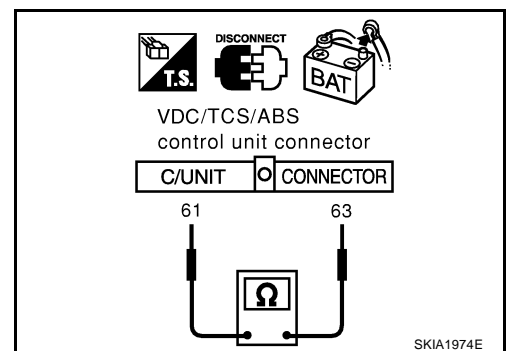

IPDM E/R Circuit Check**1. CHECK CONNECTOR**

1. Turn ignition switch OFF.
2. Disconnect the negative battery terminal.
3. Check terminals and connector of IPDM E/R for damage, bend and loose connection (control module side and harness side).

OK or NG

- OK >> GO TO 2.
 NG >> Repair terminal or connector.

2. CHECK HARNESS FOR OPEN CIRCUIT

1. Disconnect IPDM E/R connector.
2. Check resistance between IPDM E/R harness connector E9 terminals 48 (L) and 49 (R).

48 (L) - 49 (R) : Approx. 108 - 132Ω

OK or NG

- OK >> Replace IPDM E/R.
 NG >> Repair harness between harness connector E108 and IPDM E/R.

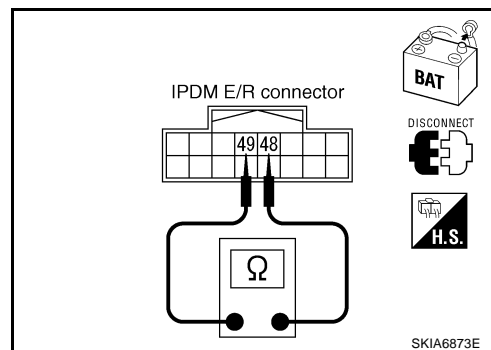
**CAN Communication Circuit Check****1. CHECK CONNECTOR**

1. Turn ignition switch OFF.
2. Disconnect the negative battery terminal.
3. Check following terminals and connectors for damage, bend and loose connection (control module side, control unit side, meter side, sensor side and harness side).
 - ECM
 - AWD control unit
 - A/T assembly
 - Combination meter
 - BCM
 - Steering angle sensor
 - VDC/TCS/ABS control unit
 - IPDM E/R
 - Between ECM and IPDM E/R

OK or NG

- OK >> GO TO 2.
 NG >> Repair terminal or connector.

2. CHECK HARNESS FOR SHORT CIRCUIT

1. Disconnect following connectors.
 - ECM connector
 - A/T assembly connector
 - AWD control unit
 - Harness connector F102
2. Check continuity between ECM harness connector F108 terminals 94 (L) and 86 (R).

94 (L) - 86 (R) : Continuity should not exist.

OK or NG

OK >> GO TO 3.

NG >> Check the following harnesses. If any harness is damaged, repair the harness.

- Harness between ECM and harness connector F102
- Harness between A/T assembly and harness connector F102
- Harness between AWD control unit and harness connector F102

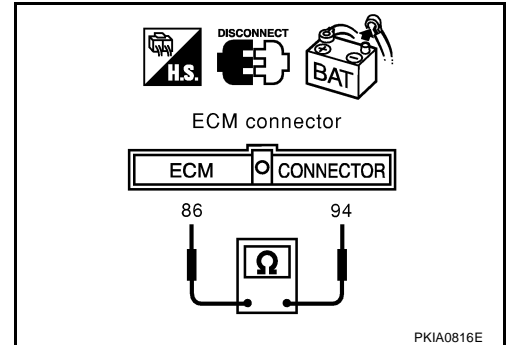

3. CHECK HARNESS FOR SHORT CIRCUIT

Check continuity between ECM harness connector F108 terminals 94 (L), 86 (R) and ground.

94 (L) - Ground : Continuity should not exist.

86 (R) - Ground : Continuity should not exist.

OK or NG

OK >> GO TO 4.

NG >> Check the following harnesses. If any harness is damaged, repair the harness.

- Harness between ECM and harness connector F102
- Harness between A/T assembly and harness connector F102
- Harness between AWD control unit and harness connector F102

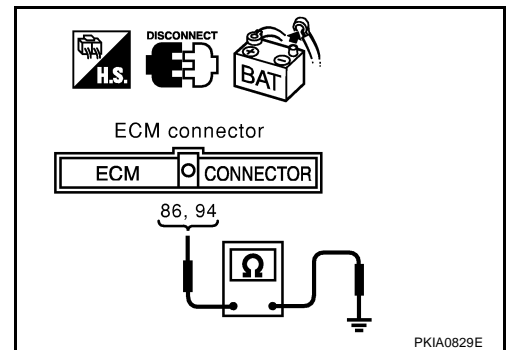

4. CHECK HARNESS FOR SHORT CIRCUIT

1. Disconnect following connectors.
 - Combination meter connector
 - BCM connector
 - Steering angle sensor connector
 - Harness connector M15
2. Check continuity between data link connector M8 terminals 6 (L) and 14 (R).

6 (L) - 14 (R) : Continuity should not exist.

OK or NG

OK >> GO TO 5.

NG >> Check the following harnesses. If any harness is damaged, repair the harness.

- Harness between harness connector M72 and harness connector M15
- Harness between harness connector M72 and combination meter
- Harness between harness connector M72 and data link connector
- Harness between harness connector M72 and BCM
- Harness between harness connector M72 and steering angle sensor

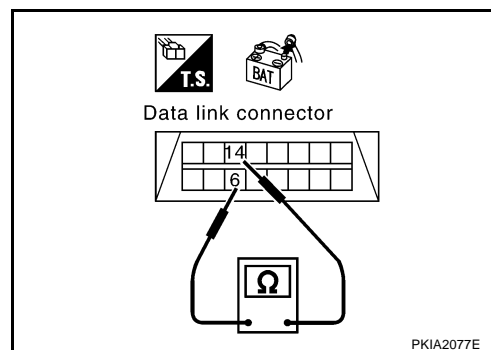

5. CHECK HARNESS FOR SHORT CIRCUIT

Check continuity between data link connector M8 terminals 6 (L), 14 (R) and ground.

6 (L) - Ground : Continuity should not exist.

14 (R) - Ground : Continuity should not exist.

OK or NG

OK >> GO TO 6.

NG >> Check the following harnesses. If any harness is damaged, repair the harness.

- Harness between harness connector M72 and harness connector M15
- Harness between harness connector M72 and combination meter
- Harness between harness connector M72 and data link connector
- Harness between harness connector M72 and BCM
- Harness between harness connector M72 and steering angle sensor

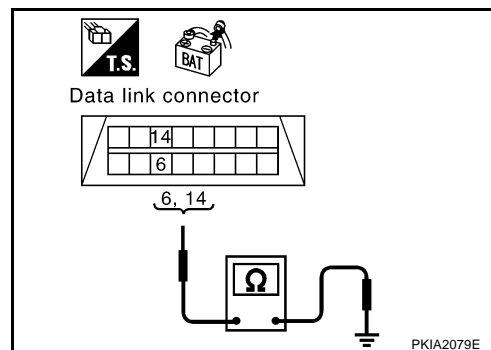

6. CHECK HARNESS FOR SHORT CIRCUIT

1. Disconnect VDC/TCS/ABS control unit connector and IPDM E/R connector.
2. Check continuity between IPDM E/R harness connector E9 terminals 48 (L) and 49 (R).

48 (L) - 49 (R) : Continuity should not exist.

OK or NG

- OK >> GO TO 7.
 NG >> Check the following harnesses. If any harness is damaged, repair the harness.
- Harness between harness connector E108 and VDC/TCS/ABS control unit
 - Harness between harness connector E108 and IPDM E/R

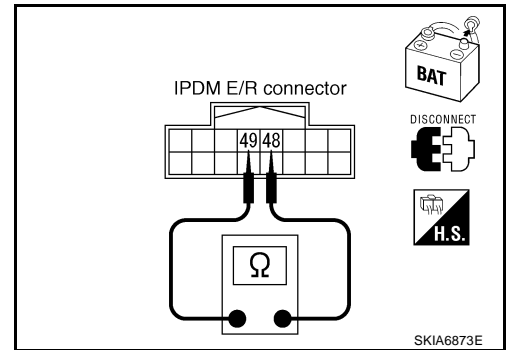

7. CHECK HARNESS FOR SHORT CIRCUIT

Check continuity between IPDM E/R harness connector E9 terminals 48 (L), 49 (R) and ground.

48 (L) - Ground : Continuity should not exist.

49 (R) - Ground : Continuity should not exist.

OK or NG

- OK >> GO TO 8.
 NG >> Check the following harnesses. If any harness is damaged, repair the harness.
- Harness between harness connector E108 and VDC/TCS/ABS control unit
 - Harness between harness connector E108 and IPDM E/R

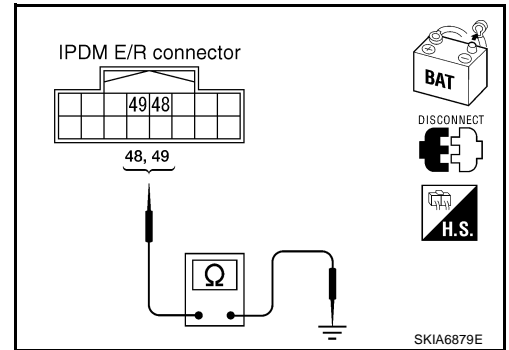

8. ECM/IPDM E/R INTERNAL CIRCUIT INSPECTION

Check components inspection. Refer to [LAN-93, "ECM/IPDM E/R INTERNAL CIRCUIT INSPECTION"](#).

OK or NG

- OK >> Connect all the connectors and diagnose again. Refer to [LAN-69, "Work Flow"](#).
 NG >> Replace ECM and/or IPDM E/R.

IPDM E/R Ignition Relay Circuit Check

AKS00AUJ

Check the following. If no malfunction is found, replace the IPDM E/R.

- IPDM E/R power supply circuit. Refer to [PG-26, "IPDM E/R Power/Ground Circuit Inspection"](#).
- Ignition power supply circuit. Refer to [PG-10, "IGNITION POWER SUPPLY - IGNITION SW. IN "ON" AND/OR "START" "](#).

Component Inspection

AKS00AUK

ECM/IPDM E/R INTERNAL CIRCUIT INSPECTION

- Remove ECM and IPDM E/R from vehicle.
- Check resistance between ECM terminals 94 and 86.
- Check resistance between IPDM E/R terminals 48 and 49.

Unit	Terminal	Resistance value (Ω) (Approx.)
ECM	94 - 86	108 - 132
IPDM E/R	48 - 49	

