

CONTENTS

FUNCTION DIAGNOSIS	2	ON-VEHICLE REPAIR	14	A
DESCRIPTION	2	RADIATOR	14	
Engine Cooling System	2	Exploded View	14	G
Engine Cooling System Schematic	2	Removal and Installation	14	
SYMPTOM DIAGNOSIS	3	Inspection	16	
OVERHEATING CAUSE ANALYSIS	3	COOLING FAN	17	H
Troubleshooting Chart	3	Exploded View	17	
PRECAUTION	5	Removal and Installation	17	
PRECAUTIONS	5	Inspection	17	I
Precaution for Supplemental Restraint System (SRS) "AIR BAG" and "SEAT BELT PRE-TEN- SIONER"	5	Disassembly and Assembly	17	
Liquid Gasket	5	Inspection	18	J
PREPARATION	7	WATER PUMP	19	
PREPARATION	7	Exploded View	19	K
Special Service Tools	7	Removal and Installation	19	
Commercial Service Tools	7	Inspection	21	
ON-VEHICLE MAINTENANCE	8	WATER INLET AND THERMOSTAT ASSEM- BLY	22	L
ENGINE COOLANT	8	Exploded View	22	
Inspection	8	Removal and Installation	22	
Draining	8	Inspection	23	M
Refilling	9	WATER OUTLET AND WATER PIPING	24	
Flushing	10	Exploded View	24	N
RADIATOR	12	Removal and Installation	24	
RADIATOR CAP	12	Inspection	25	
RADIATOR CAP : Inspection	12	SERVICE DATA AND SPECIFICATIONS (SDS)	26	O
RADIATOR	12	SERVICE DATA AND SPECIFICATIONS (SDS)	26	P
RADIATOR : Inspection	12	Periodical Maintenance Specification	26	
		Radiator	26	
		Thermostat	26	

DESCRIPTION

< FUNCTION DIAGNOSIS >

FUNCTION DIAGNOSIS

DESCRIPTION

Engine Cooling System

INFOID:000000000956331

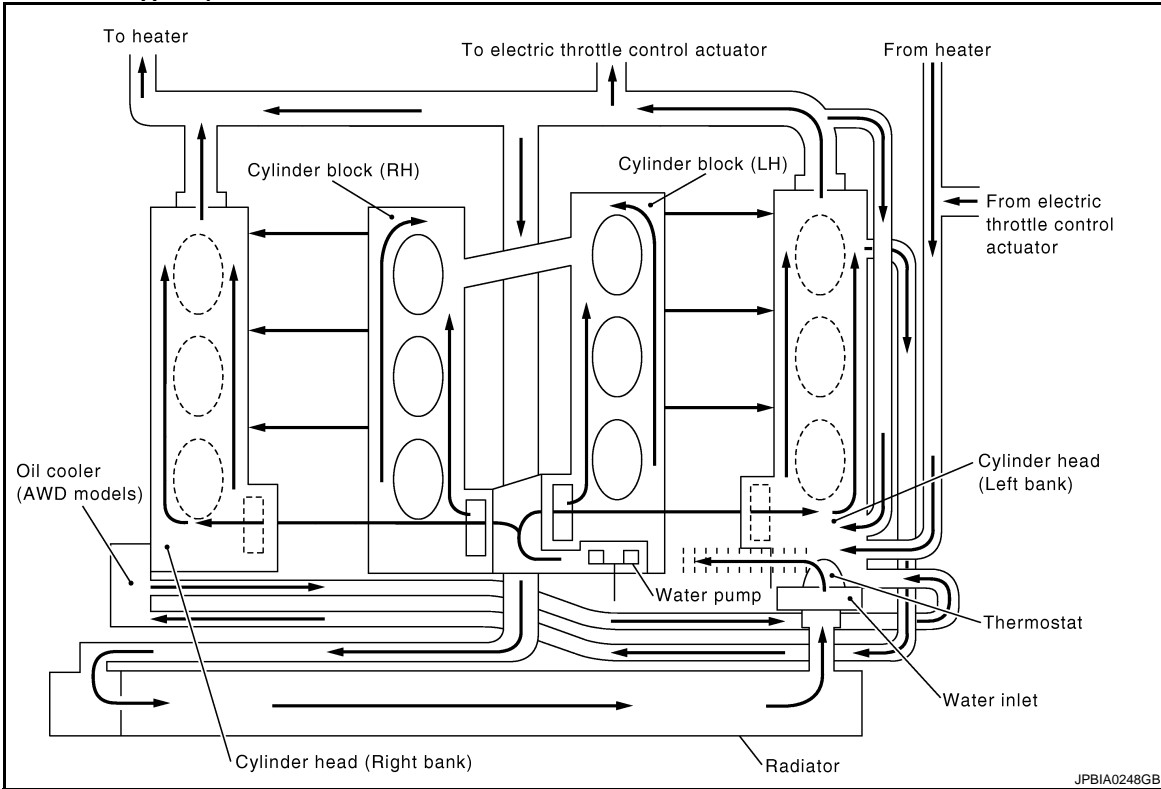

JPBIA0248GB

Engine Cooling System Schematic

INFOID:000000000956332

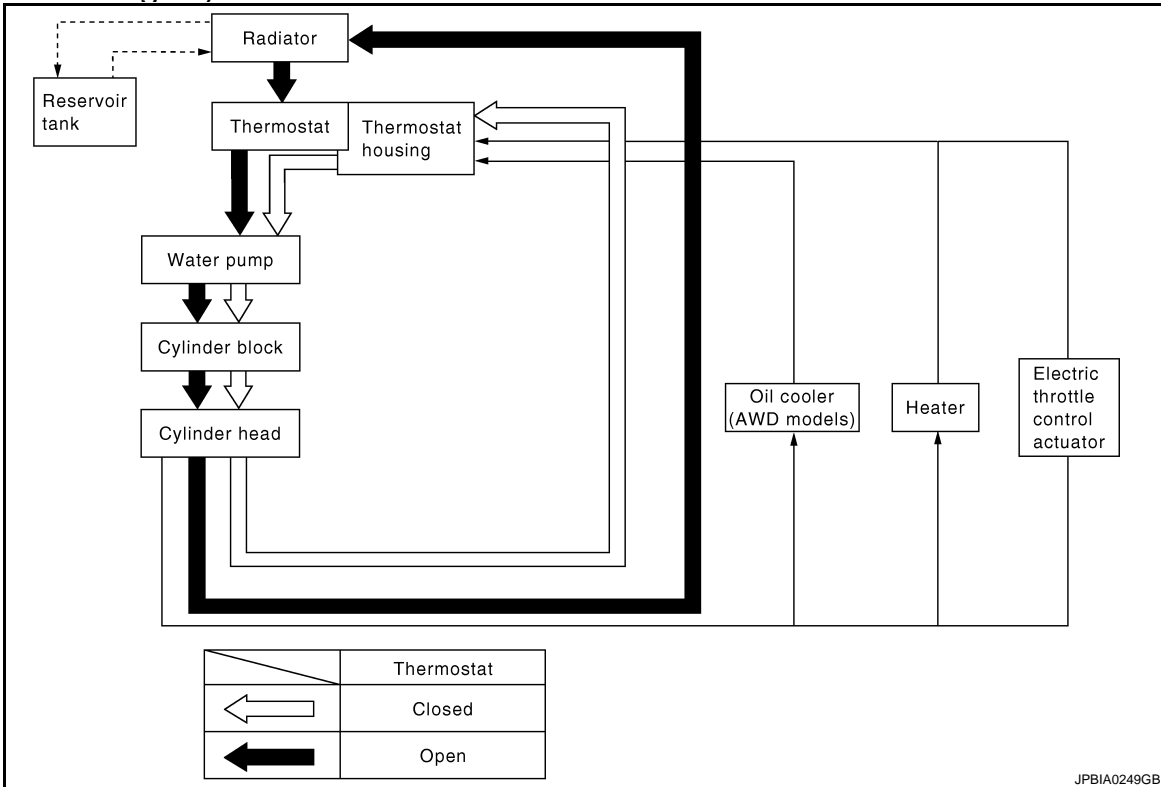

JPBIA0249GB

OVERHEATING CAUSE ANALYSIS

< SYMPTOM DIAGNOSIS >

SYMPTOM DIAGNOSIS

OVERHEATING CAUSE ANALYSIS

Troubleshooting Chart

INFOID:000000000956333

A

CO

		Symptom	Check items		
Cooling system parts malfunction	Poor heat transfer	Water pump malfunction	Worn or loose drive belt	—	
		Thermostat stuck closed	—		
		Damaged fins	Dust contamination or paper clogging		
			Physical damage		
		Clogged radiator cooling tube	Excess foreign material (rust, dirt, sand, etc.)		
	Reduced air flow	Cooling fan does not operate	Fan assembly	—	
		High resistance to fan rotation			
		Damaged fan blades			
		Damaged radiator shroud	—	—	
		Improper engine coolant mixture ratio	—	—	
		Poor engine coolant quality	—	Engine coolant density	—
	Insufficient engine coolant	Engine coolant leaks	Cooling hose	Loose clamp	
				Cracked hose	
			Water pump	Poor sealing	
			Radiator cap	Loose	
Poor sealing					
Radiator		O-ring for damage, deterioration or improper fitting			
		Cracked radiator tank			
		Cracked radiator core			
	Reservoir tank	Cracked reservoir tank			
Overflowing reservoir tank	Exhaust gas leaks into cooling system	Cylinder head deterioration			
		Cylinder head gasket deterioration			

C

D

E

F

G

H

I

J

K

L

M

N

O

P

OVERHEATING CAUSE ANALYSIS

< SYMPTOM DIAGNOSIS >

		Symptom		Check items	
Except cooling system parts malfunction	—	Overload on engine	Abusive driving	High engine rpm under no load	—
				Driving in low gear for extended time	
				Driving at extremely high speed	
			Powertrain system malfunction		
			Installed improper size wheels and tires		
			Dragging brakes		
	Blocked or restricted air flow	Blocked or restricted air flow	Blocked bumper	—	—
			Blocked radiator grille	Installed car brassiere	
				Mud contamination or paper clogging	
			Blocked radiator	—	
Blocked condenser			Blocked air flow		
Installed large fog lamp					

PRECAUTIONS

< PRECAUTION >

PRECAUTION

PRECAUTIONS

Precaution for Supplemental Restraint System (SRS) "AIR BAG" and "SEAT BELT PRE-TENSIONER"

INFOID:000000000956334

The Supplemental Restraint System such as "AIR BAG" and "SEAT BELT PRE-TENSIONER", used along with a front seat belt, helps to reduce the risk or severity of injury to the driver and front passenger for certain types of collision. This system includes seat belt switch inputs and dual stage front air bag modules. The SRS system uses the seat belt switches to determine the front air bag deployment, and may only deploy one front air bag, depending on the severity of a collision and whether the front occupants are belted or unbelted. Information necessary to service the system safely is included in the SRS and SB section of this Service Manual.

WARNING:

- To avoid rendering the SRS inoperative, which could increase the risk of personal injury or death in the event of a collision which would result in air bag inflation, all maintenance must be performed by an authorized NISSAN/INFINITI dealer.
- Improper maintenance, including incorrect removal and installation of the SRS, can lead to personal injury caused by unintentional activation of the system. For removal of Spiral Cable and Air Bag Module, see the SRS section.
- Do not use electrical test equipment on any circuit related to the SRS unless instructed to in this Service Manual. SRS wiring harnesses can be identified by yellow and/or orange harnesses or harness connectors.

Liquid Gasket

INFOID:000000000956335

REMOVAL OF LIQUID GASKET SEALING

- After removing mounting nuts and bolts, separate the mating surface using the seal cutter [SST: KV10111100 (J37228)] (A) and remove old liquid gasket sealing.

CAUTION:

Be careful not to damage the mating surfaces.

- Tap (B) the seal cutter [SST: KV10111100 (J37228)] to insert it, and then slide (C) it by tapping on the side as shown in the figure.
- In areas where seal cutter [SST: KV10111100 (J38228)] is difficult to use, use a plastic hammer to lightly tap the parts, to remove it.

CAUTION:

If for some unavoidable reason tool such as a screwdriver is used, be careful not to damage the mating surfaces.

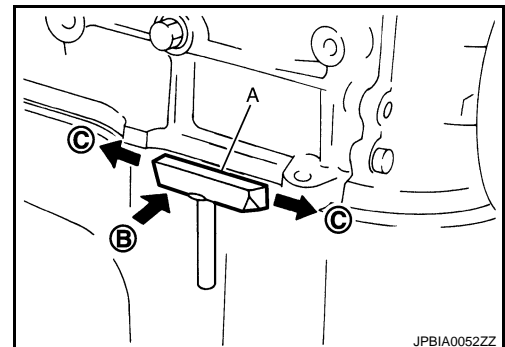

LIQUID GASKET APPLICATION PROCEDURE

1. Using a scraper (A), remove old liquid gasket adhering to the liquid gasket application surface and the mating surface.
 - Remove liquid gasket completely from the groove of the liquid gasket application surface, mounting bolts, and bolt holes.
2. Wipe the liquid gasket application surface and the mating surface with white gasoline (lighting and heating use) to remove adhering moisture, grease and foreign materials.

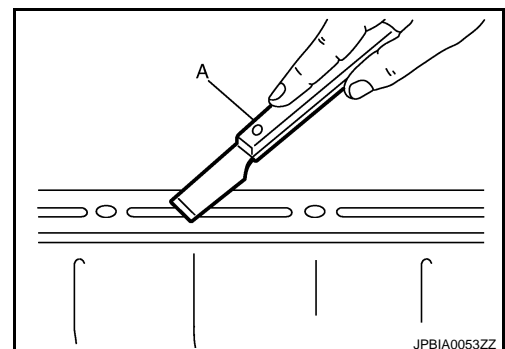

PRECAUTIONS

< PRECAUTION >

3. Attach liquid gasket tube to the tube presser [SST: WS39930000 (—)].
Use Genuine RTV Silicone Sealant or equivalent. Refer to GI-15, "Recommended Chemical Products and Sealants".
4. Apply liquid gasket without breaks to the specified location with the specified dimensions.
 - If there is a groove for the liquid gasket application, apply liquid gasket to the groove.

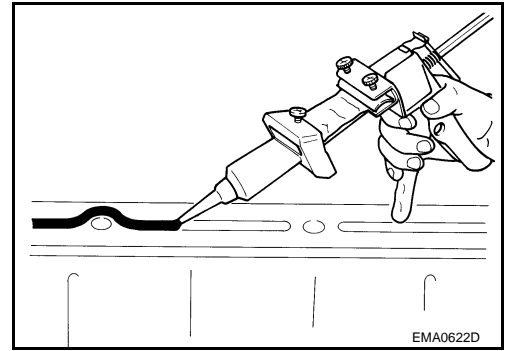

- As for the bolt holes (B), normally apply liquid gasket inside the holes. Occasionally, it should be applied outside the holes. Make sure to read the text of service manual.

A : Groove

⇐ : Inner side

- Within five minutes of liquid gasket application, install the mating component.
- If liquid gasket protrudes, wipe it off immediately.
- Do not retighten after mounting bolts and nuts the installation.
- After 30 minutes or more have passed from the installation, fill engine oil and engine coolant.

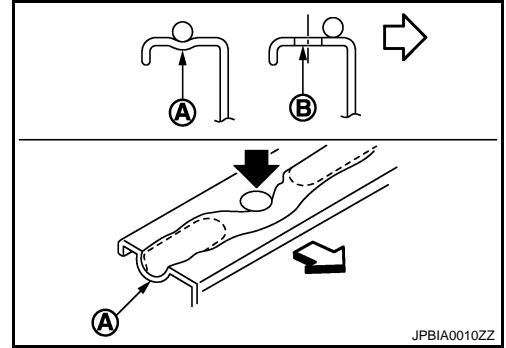

CAUTION:

If there are specific instructions in this manual, observe them.

PREPARATION

< PREPARATION >

PREPARATION

PREPARATION

Special Service Tools

INFOID:000000000956336

A

CO

The actual shapes of Kent-Moore tools may differ from those of special service tools illustrated here.

Tool number (Kent-Moore No.) Tool name	Description
WS39930000 (—) Tube presser	Pressing the tube of liquid gasket

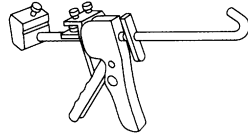

S-NT052

C

D

E

Commercial Service Tools

INFOID:000000000956337

Tool name	Description
Power tool	Loosening nuts and bolts
Radiator cap tester	Checking radiator and radiator cap
Radiator cap tester adapter	Adapting radiator cap tester to radiator cap and water outlet (front) filler neck a: 28 (1.10) dia. b: 31.4 (1.236) dia. c: 41.3 (1.626) dia. Unit: mm (in)

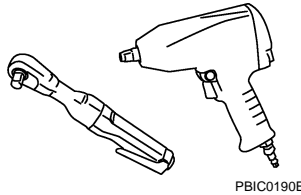

PBIC0190E

F

G

H

I

J

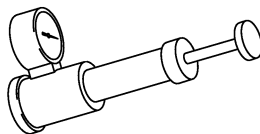

PBIC1982E

K

L

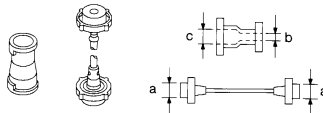

S-NT564

M

N

O

P

ENGINE COOLANT

< ON-VEHICLE MAINTENANCE >

ON-VEHICLE MAINTENANCE

ENGINE COOLANT

Inspection

INFOID:000000000956338

LEVEL

- Check if the reservoir tank engine coolant level is within the “MIN” to “MAX” when the engine is cool.

A : MAX

B : MIN

- Adjust the engine coolant level as necessary.
- Check that the reservoir tank cap is tightened.

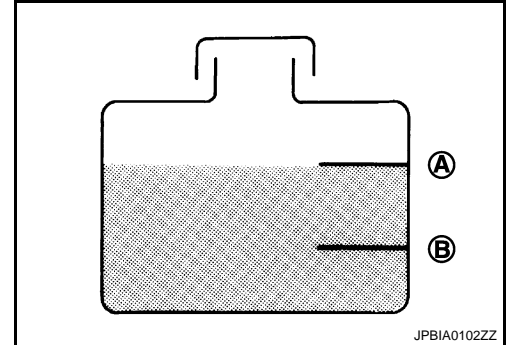

LEAKAGE

- To check for leaks, apply pressure to the cooling system with the radiator cap tester and radiator cap tester adapter (commercial service tool) (A).

Testing pressure : Refer to [CO-26, "Radiator"](#).

WARNING:

Do not remove radiator cap when engine is hot. Serious burns could occur from high-pressure engine coolant escaping from radiator.

CAUTION:

Higher test pressure than specified may cause radiator damage.

NOTE:

In a case that engine coolant decreases, replenish radiator with engine coolant.

- If anything is found, repair or replace damaged parts.

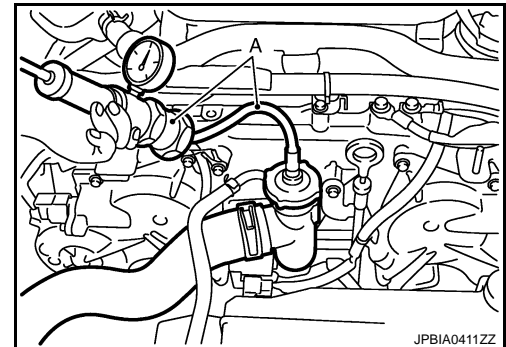

Draining

INFOID:000000000956339

WARNING:

- To avoid being scalded, do not change engine coolant when the engine is hot.
 - Wrap a thick cloth around radiator cap and carefully remove radiator cap. First, turn radiator cap a quarter of a turn to release built-up pressure. Then turn radiator cap all the way.
1. Open radiator drain plug (2) at the bottom of radiator, and then remove radiator cap.

1 : Engine under cover

A : Radiator drain plug hole

← : Vehicle front

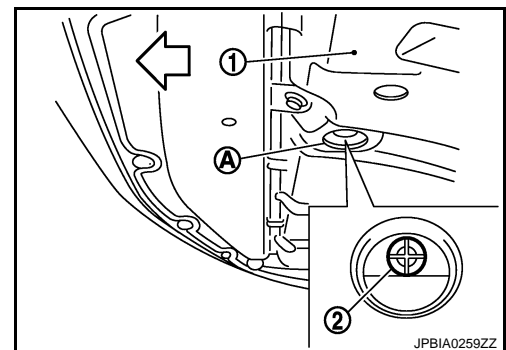

When draining all of engine coolant in the system, open water drain plugs on cylinder block. Refer to [EM-88, "Setting"](#).

2. Remove reservoir tank as necessary, and drain engine coolant and clean reservoir tank before installing.

ENGINE COOLANT

< ON-VEHICLE MAINTENANCE >

3. Check drained engine coolant for contaminants such as rust, corrosion or discoloration. If contaminated, flush the engine cooling system. Refer to [CO-10, "Flushing"](#).

Refilling

INFOID:000000000956340

1. Remove air cleaner case (LH). Refer to [EM-25, "Exploded View"](#).
2. Install reservoir tank if removed, and radiator drain plug.

CAUTION:

Be sure to clean drain plug and install with new O-ring.

Tightening torque : Refer to [CO-14, "Exploded View"](#).

If water drain plugs on cylinder block are removed, close and tighten them. Refer to [EM-114, "Exploded View"](#).

3. Make sure that each hose clamp has been firmly tightened.
4. Remove air relief plug (2) on radiator left side.

- 1 : Reservoir tank
3 : Engine cover
⇐ : Vehicle front

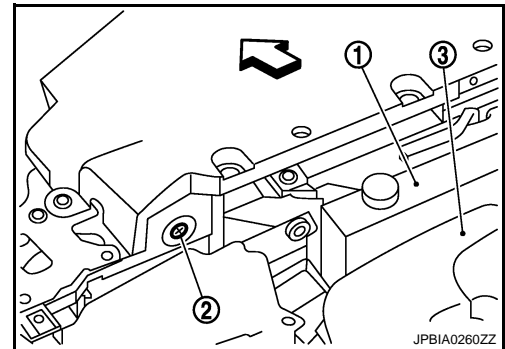

5. Remove air relief plug (1) on heater hose.

- 2 : Heater hose
⇐ : Vehicle front

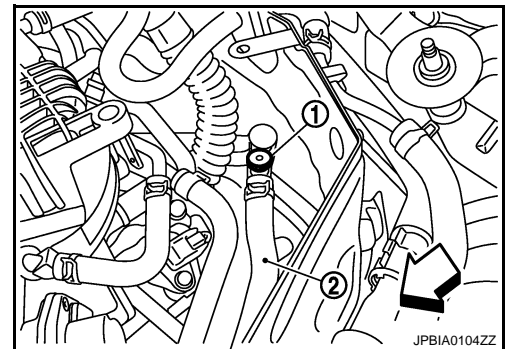

6. Fill radiator, and reservoir tank if removed, to specified level.
 - **Pour engine coolant through engine coolant filler neck slowly of less than 2 l (2-1/8 US qt, 1-3/4 Imp qt) a minute to allow air in system to escape.**
 - **Use Genuine NISSAN Long Life Antifreeze/Coolant or equivalent mixed with water (distilled or demineralized). Refer to [MA-10, "Fluids and Lubricants"](#).**

Engine coolant capacity : Refer to [CO-26, "Periodical Maintenance Specification"](#)
(With reservoir tank at "MAX" level)

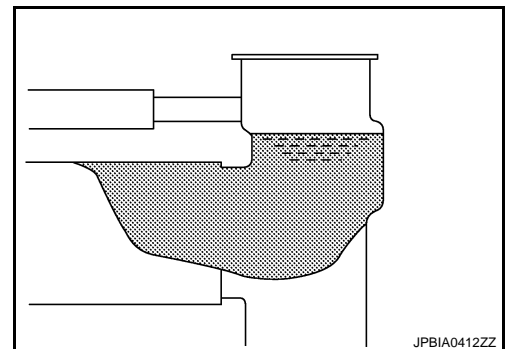

Reservoir tank engine coolant capacity : Refer to [CO-26, "Periodical Maintenance Specification"](#)
(At "MAX" level)

ENGINE COOLANT

< ON-VEHICLE MAINTENANCE >

A : MAX

B : MIN

- When engine coolant overflows air relief hole on radiator, install air relief plug with new O-ring.

Tightening torque : Refer to [CO-14, "Exploded View"](#).

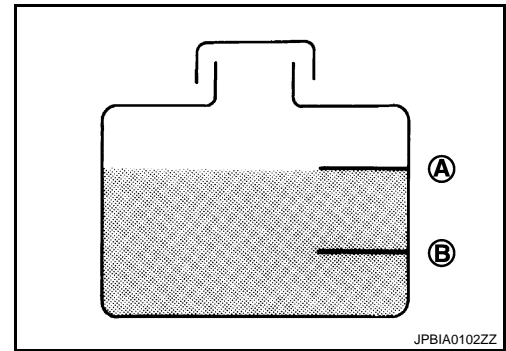

- Repeat step 6.
- When engine coolant overflows air relief hole on heater hose, install air relief plug with new O-ring. Then refill radiator with engine coolant.

 : 1.2 N·m (0.12 kg-m, 11 in-lb)

- Install air cleaner case (LH). Refer to [EM-25, "Exploded View"](#).
 - Install radiator cap.
 - Warm up engine until opening thermostat. Standard for warming-up time is approximately 10 minutes at 3,000 rpm.
 - Make sure thermostat opening condition by touching radiator hose (lower) to see a flow of warm water.
- CAUTION:**
Watch water temperature gauge so as not to overheat engine.
- Stop the engine and cool down to less than approximately 50°C (122°F).
 - Cool down using fan to reduce the time.
 - If necessary, refill radiator up to filler neck with engine coolant.
 - Refill reservoir tank to "MAX" level line with engine coolant.
 - Repeat steps 11 through 14 two or more times with radiator cap installed until engine coolant level no longer drops.
 - Check cooling system for leaks with engine running.
 - Warm up the engine, and check for sound of engine coolant flow while running engine from idle up to 3,000 rpm with heater temperature controller set at several position between "COOL" and "WARM".
 - Sound may be noticeable at heater unit.
 - Repeat step 17 three times.
 - If sound is heard, bleed air from cooling system by repeating step 6, and steps from 11 to 18 until engine coolant level no longer drops.
 - Check that the reservoir tank cap is tightened.

Flushing

INFOID:000000000956341

- Install reservoir tank if removed, and radiator drain plug.
CAUTION:
Be sure to clean drain plug and install with new O-ring.

Tightening torque : Refer to [CO-14, "Exploded View"](#).

If water drain plugs on cylinder block are removed, close and tighten them. Refer to [EM-88, "Setting"](#).

ENGINE COOLANT

< ON-VEHICLE MAINTENANCE >

2. Remove air relief plug (1) on heater hose.

2 : Heater hose
⇐ : Vehicle front

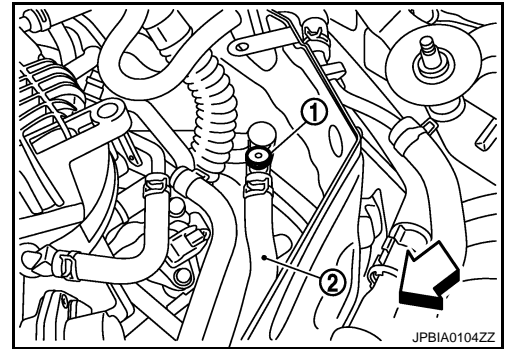

3. Remove air relief plug (2) on radiator.

1 : Reservoir tank
3 : Engine cover
⇐ : Vehicle front

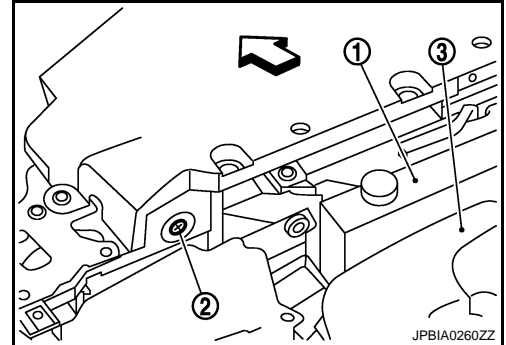

4. Fill radiator with water until water spills from the air relief holes, then close air relief plugs. Fill radiator and reservoir tank with water and reinstall radiator cap.

Tightening torque : Refer to [CO-14, "Exploded View"](#).

5. Run the engine and warm it up to normal operating temperature.
6. Rev the engine two or three times under no-load.
7. Stop the engine and wait until it cools down.
8. Drain water from the system. Refer to [CO-8, "Draining"](#).
9. Repeat steps 1 through 8 until clear water begins to drain from radiator.
10. Check that the reservoir tank cap is tightened.

RADIATOR

< ON-VEHICLE MAINTENANCE >

RADIATOR

RADIATOR CAP

RADIATOR CAP : Inspection

INFOID:000000000956342

- Check valve seat of radiator cap.
- Check if valve seat is swollen to the extent that the edge of the plunger cannot be seen when watching it vertically from the top.
- Check if valve seat has no soil and damage.

- A : Valve seat
- B : Metal plunger

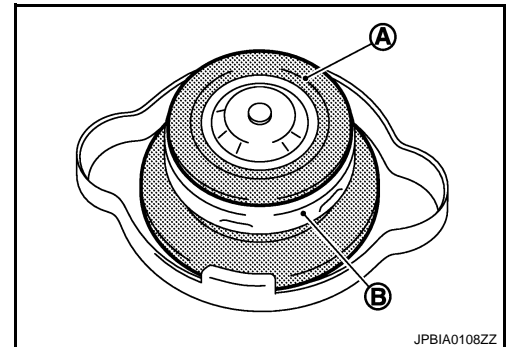

- Pull negative-pressure valve to open it, and make sure that it close completely when released.
- Make sure that there is no dirt or damage on the valve seat of radiator cap negative-pressure valve.
- Make sure that there are no unusualness in the opening and closing conditions of negative-pressure valve.

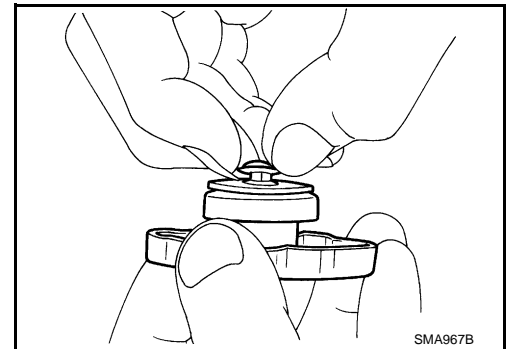

- Check radiator cap relief pressure.

Standard and limit : Refer to [CO-26, "Radiator"](#).

- When connecting radiator cap to the radiator cap tester and the radiator cap tester adapter (commercial service tool) (A), apply engine coolant to the cap seal surface.

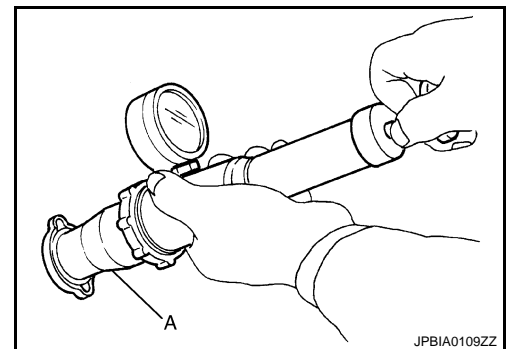

- Replace radiator cap if there is an unusualness related to the above three.

CAUTION:

When installing radiator cap, thoroughly wipe out the water outlet (front) filler neck to remove any waxy residue or foreign material.

RADIATOR

RADIATOR : Inspection

INFOID:000000000956343

Check radiator for mud or clogging. If necessary, clean radiator as follows:

- Be careful not to bend or damage radiator fins.
 - When radiator is cleaned without removal, remove all surrounding parts such as radiator cooling fan assembly and horns. Then tape harness and connectors to prevent water from entering.
1. Apply water by hose to the back side of the radiator core vertically downward.
 2. Apply water again to all radiator core surfaces once per minute.
 3. Stop washing if any stains no longer flow out from radiator.
 4. Blow air into the back side of radiator core vertically downward.

RADIATOR

< ON-VEHICLE MAINTENANCE >

- Use compressed air lower than 490 kPa (5 kg/cm², 71 psi) and keep distance more than 30 cm (11.8 in).
5. Blow air again into all the radiator core surfaces once per minute until no water sprays out.

A

CO

C

D

E

F

G

H

I

J

K

L

M

N

O

P

RADIATOR

< ON-VEHICLE REPAIR >

ON-VEHICLE REPAIR

RADIATOR

Exploded View

INFOID:000000000956344

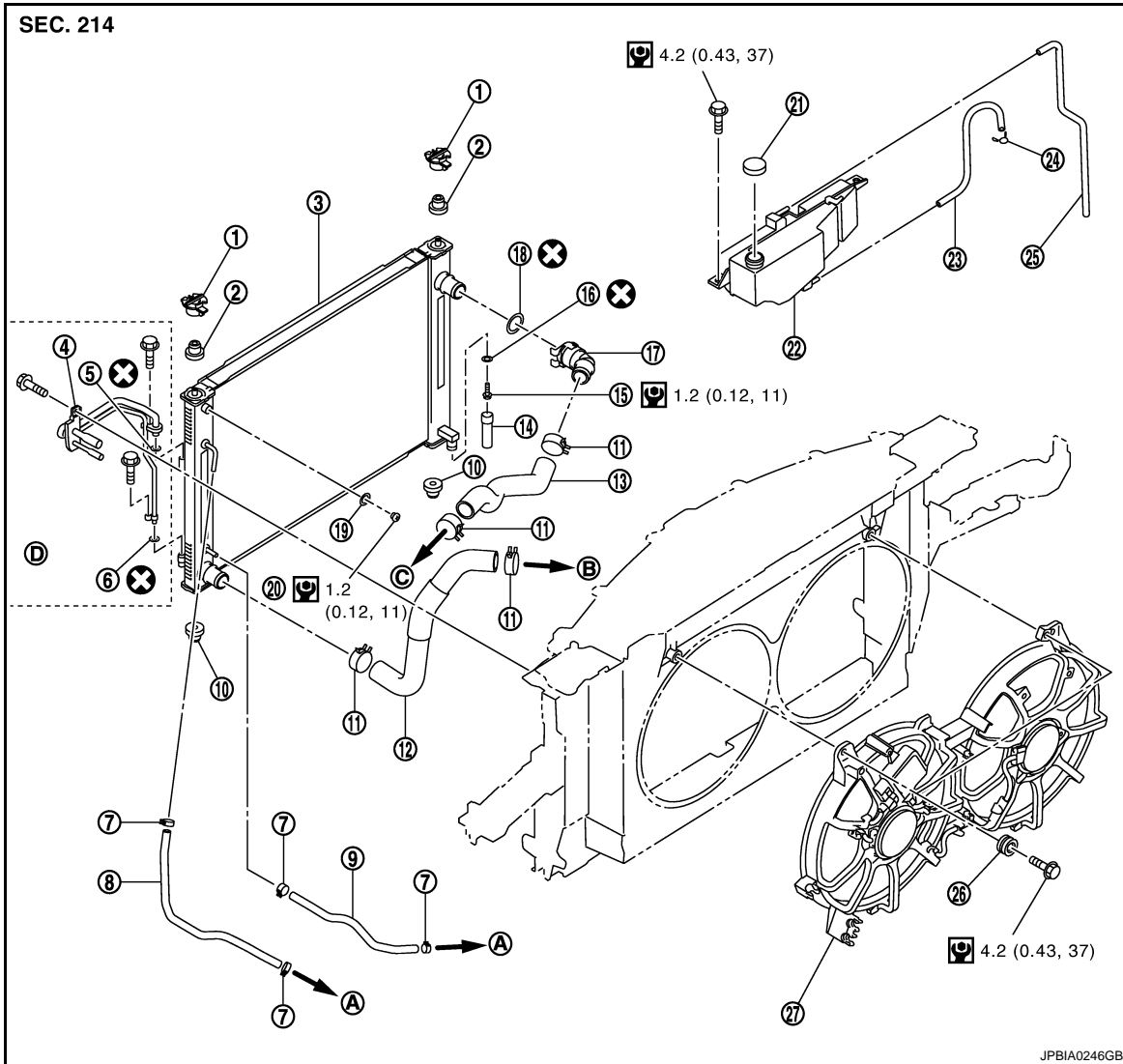

JPBIA0246GB

- | | | |
|-----------------------------------|---------------------------------------|---------------------------------------|
| 1. Upper mount bracket | 2. Mounting rubber (upper) | 3. Radiator & condenser assembly |
| 4. Condenser pipe assembly | 5. O-ring | 6. O-ring |
| 7. Clamp | 8. A/T fluid cooler hose (A/T models) | 9. A/T fluid cooler hose (A/T models) |
| 10. Mounting rubber (lower) | 11. Clamp | 12. Radiator hose (lower) |
| 13. Radiator hose (Upper) | 14. Water drain hose | 15. Drain plug |
| 16. O-ring | 17. Radiator water inlet pipe | 18. O-ring |
| 19. O-ring | 20. Air relief plug | 21. Reservoir tank cap |
| 22. Reservoir tank | 23. Reservoir tank hose | 24. Clamp |
| 25. Reservoir tank hose | 26. Grommet | 27. Radiator cooling fan assembly |
| A. To transmission | B. To water inlet | C. To water outlet |
| D. Refer to HA-54 | | |

Refer to [GI-4, "Components"](#) for symbol marks in the figure.

Removal and Installation

INFOID:000000000956345

RADIATOR

< ON-VEHICLE REPAIR >

REMOVAL

WARNING:

Do not remove radiator cap when engine is hot. Serious burns could occur from high-pressure engine coolant escaping from radiator. Wrap a thick cloth around the cap. Slowly turn it a quarter of a turn to release built-up pressure. Carefully remove radiator cap by turning it all the way.

1. Remove the following parts:
 - Engine under cover with power tool.
 - Engine cover: Refer to [EM-27, "Exploded View"](#).
 - Air cleaner case (RH and LH): Refer to [EM-25, "Exploded View"](#).
 - Reservoir tank: Refer to [CO-14, "Exploded View"](#).
 - Radiator core support ornament, radiator core support center and horn: Refer to [EXT-16, "Removal and Installation"](#).
 - Hood lock: Refer to [DLK-190, "HOOD ASSEMBLY : Exploded View"](#).
2. Remove condenser pipe assembly. Refer to [HA-54, "Removal and Installation"](#).
3. Drain engine coolant from radiator. Refer to [CO-8, "Draining"](#).

CAUTION:

- Perform this step when the engine is cold.
- Do not spill engine coolant on drive belts.

4. Disconnect A/T fluid cooler hoses from radiator. (A/T models)
 - Install blind plug to avoid leakage of A/T fluid.
5. Remove radiator hoses (upper and lower) and reservoir tank hose.

CAUTION:

Be careful not to allow engine coolant to contact drive belts.

6. Remove cooling fan assembly. Refer to [CO-17, "Exploded View"](#).

CAUTION:

Do not damage or scratch radiator & condenser assembly core when removing.

7. Rotate two radiator upper mount brackets 90 degrees in direction as shown in the figure, and remove them.

- 1 : Radiator upper mount bracket
A : Turn 90° counterclockwise

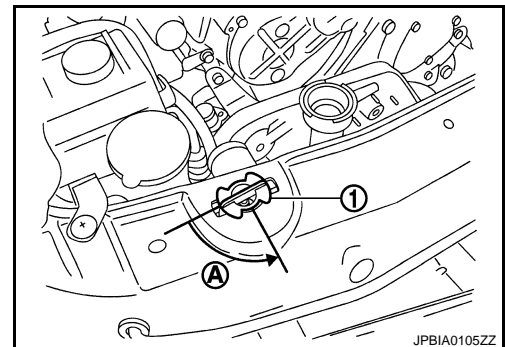

8. Remove radiator & condenser assembly as follows:

CAUTION:

Be careful not to damage radiator & condenser assembly core.

- a. Lift up and pull the radiator & condenser assembly (1) forward, and then remove the mounting rubber (lower) (3) from the radiator core support (2).

- ← : Vehicle front

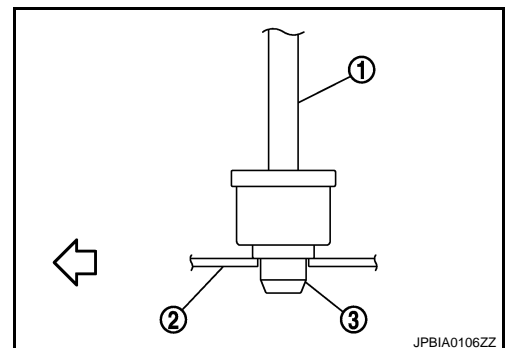

RADIATOR

< ON-VEHICLE REPAIR >

- b. Remove radiator & condenser assembly (1) from front of radiator core support (2).

⇐ : Vehicle front

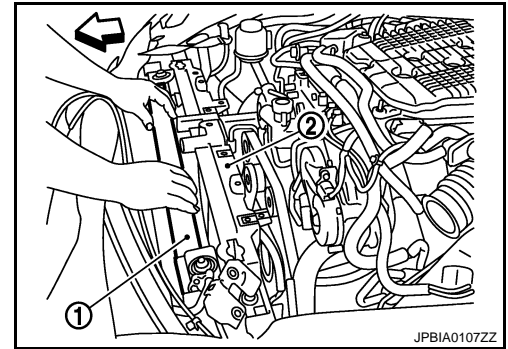

INSTALLATION

Installation is the reverse order of removal.

Inspection

INFOID:000000000956346

INSPECTION AFTER INSTALLATION

- Check that the reservoir tank cap is tightened.
- Check for leaks of engine coolant using the radiator cap tester adapter [SST: EG17650301 (J33984-A)] and the radiator cap tester (commercial service tool). Refer to [CO-8, "Inspection"](#).
- Start and warm up the engine. Visually make sure that there is no leaks of engine coolant and A/T fluid (A/T models).

COOLING FAN

< ON-VEHICLE REPAIR >

COOLING FAN

Exploded View

INFOID:000000000956347

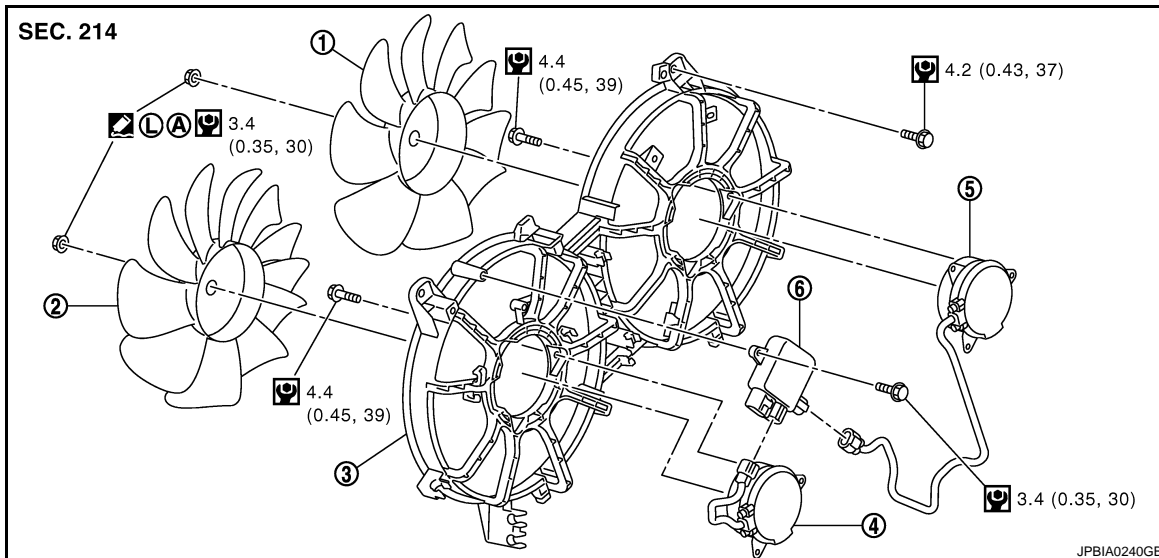

- | | | |
|---------------------|---------------------|-------------------------------|
| 1. Cooling fan (RH) | 2. Cooling fan (LH) | 3. Fan shroud |
| 4. Fan motor (LH) | 5. Fan motor (RH) | 6. Cooling fan control module |

A. Apply on fan motor shaft

: Apply Genuine High Strength Locking Sealant or equivalent.

Refer to [GI-4, "Components"](#) for symbol marks in the figure.

Removal and Installation

INFOID:000000000956348

REMOVAL

1. Remove reservoir tank. Refer to [CO-14, "Exploded View"](#).
2. Remove air cleaner case (LH). Refer to [EM-25, "Exploded View"](#).
3. Disconnect harness connector from cooling fan control module, and move harness to aside.
4. Remove engine under cover with power tool.
5. Remove cooling fan assembly from under the vehicle.

CAUTION:
Be careful not to damage or scratch on radiator core.

INSTALLATION

Note the following, and install in the reverse order of removal.

CAUTION:
Only use genuine parts for cooling fan mounting bolt and observe the specified torque (to prevent radiator from being damaged).

Inspection

INFOID:000000000956349

INSPECTION AFTER REMOVAL

Make sure that fan motors operate normally.

NOTE:

Cooling fans are controlled by cooling fan control module. For details, refer to [EC-23, "Component Parts Location"](#).

Disassembly and Assembly

INFOID:000000000956350

DISASSEMBLY

COOLING FAN

< ON-VEHICLE REPAIR >

1. Disconnect harness from cooling fan control module.
2. Remove cooling fan control module from cooling fan assembly.
CAUTION:
Handle carefully to avoid dropping and shocks.
3. Remove cooling fan mounting nuts, and then remove the cooling fan (RH and LH).
4. Remove fan motors (RH and LH).

ASSEMBLY

Note the following, and assemble in the reverse order of disassembly.

CAUTION:

RH and LH cooling fans are different. Be careful not to misassemble them.

- Install each fan in the following position.

Right side : 9 fans

Left side : 11 fans

- Secure the harness tightly to the fan shroud to prevent the fan rotation area from being loose.

Inspection

INFOID:000000000956351

INSPECTION AFTER DISASSEMBLY

Cooling Fan

Inspect cooling fan for crack or unusual bend.

- If anything is found, replace cooling fan.

WATER PUMP

< ON-VEHICLE REPAIR >

WATER PUMP

Exploded View

INFOID:000000000956352

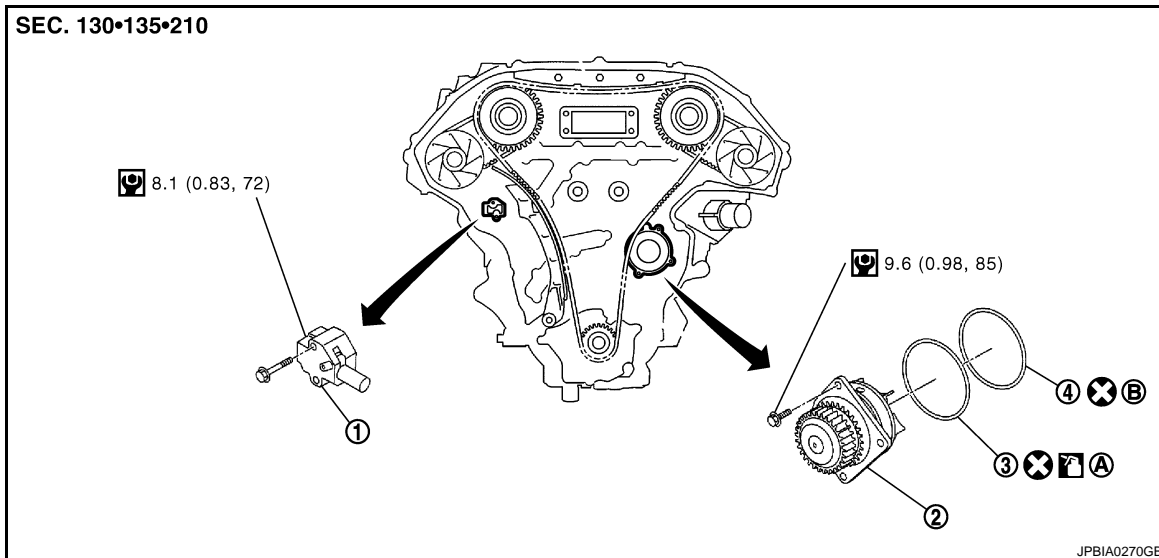

1. Timing chain tensioner (primary)
 2. Water pump
 3. O-ring
 4. O-ring
- A. Identify with yellow paint mark B. Identify with light blue paint mark
Apply engine coolant

Refer to [GI-4, "Components"](#) for symbol marks in the figure.

Removal and Installation

INFOID:000000000956353

CAUTION:

- When removing water pump assembly, be careful not to get engine coolant on drive belts.
- Water pump cannot be disassembled and should be replaced as a unit.
- After installing water pump, connect hose and clamp securely, then check for leaks using the radiator cap tester (commercial service tool) and the radiator cap tester adapter [SST: EG17650301 (J33984-A)].

REMOVAL

1. Remove engine cover. Refer to [EM-27, "Exploded View"](#).
2. Release the fuel pressure. Refer to [EC-543, "Inspection"](#).
3. Disconnect the battery cable from the negative terminal.
4. Remove air duct and air cleaner case assembly (RH and LH). Refer to [EM-25, "Exploded View"](#).
5. Remove reservoir tank. Refer to [CO-14, "Exploded View"](#).
6. Separate engine harness removing their brackets from front timing chain case.
7. Remove engine undercover with power tool.
8. Drain engine oil. Refer to [LU-9, "Draining"](#).
- CAUTION:**
 - Perform this step when the engine is cold.
 - Do not spill engine oil on drive belts.
9. Drain engine coolant from radiator. Refer to [CO-8, "Draining"](#).
- CAUTION:**
 - Perform this step when the engine is cold.
 - Do not spill engine coolant on drive belts.
10. Remove cooling fan assembly. Refer to [CO-17, "Exploded View"](#).
11. Remove radiator hose (upper and lower). Refer to [CO-14, "Exploded View"](#).
12. Remove front timing chain case. Refer to [EM-48, "Exploded View"](#).

WATER PUMP

< ON-VEHICLE REPAIR >

13. Remove timing chain tensioner (primary) as follows:

- a. Remove lower mounting bolt (1).
- b. Loosen upper mounting bolt (2) slowly, and then turn chain tensioner (primary) (3) on the upper mounting bolt so that plunger (4) is fully expanded.

NOTE:

Even if plunger is fully expanded, it is not dropped from the body of timing chain tensioner (primary).

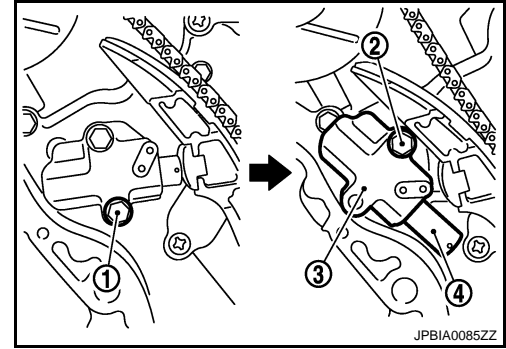

- c. Remove upper mounting bolt, and then remove timing chain tensioner (primary).

14. Remove water pump as follows:

- a. Remove three water pump mounting bolts. Secure a gap between water pump gear and timing chain, by turning crankshaft counterclockwise until timing chain looseness on water pump sprocket becomes maximum.

- b. Screw M8 bolts (A) [pitch: 1.25 mm (0.049 in) length: approx. 50 mm (1.97 in)] into water pumps upper and lower mounting bolt holes until they reach timing chain case. Then, alternately tighten each bolt for a half turn, and pull out water pump (1).

CAUTION:

- Pull straight out while preventing vane from contacting socket in installation area.
- Remove water pump without causing sprocket to contact timing chain.

- c. Remove M8 bolts and O-rings from water pump.

CAUTION:

Do not disassemble water pump.

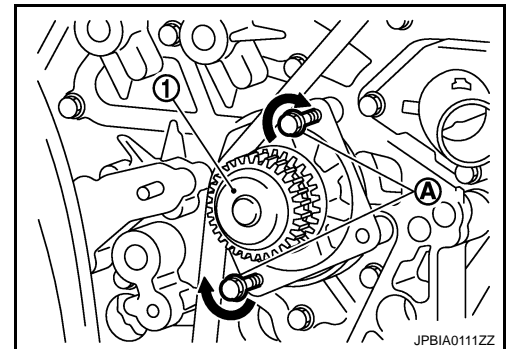

INSTALLATION

1. Install new O-rings to water pump.

- Apply engine oil to O-ring (1) and engine coolant to O-ring (3) as shown in the figure.

2 : Water pump

- Locate O-ring with yellow paint mark (A) to front side.
- Locate O-ring with light blue paint mark (B) to rear side.

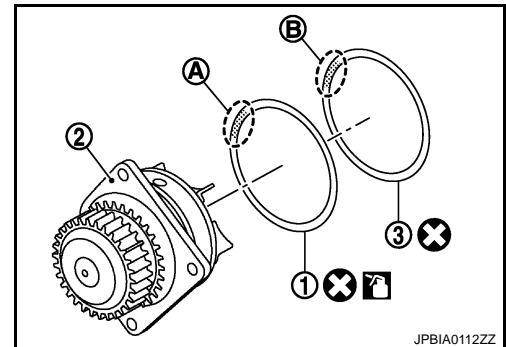

2. Install water pump.

CAUTION:

Do not allow cylinder block to nip O-rings when installing water pump.

- Make sure timing chain and water pump sprocket are engaged.
- Insert water pump by tightening mounting bolts alternately and evenly.

3. Install timing chain tensioner (primary) as follows:

- a. Turn crankshaft clockwise so that timing chain on the timing chain tensioner (primary) side is loose.

WATER PUMP

< ON-VEHICLE REPAIR >

- b. Pull plunger stopper tab (A) up (or turn lever downward) so as to remove plunger stopper tab from the ratchet of plunger (D).

NOTE:

Plunger stopper tab and lever (C) are synchronized.

- c. Push plunger into the inside of tensioner body.
d. Hold plunger in the fully compressed position by engaging plunger stopper tab with the tip of ratchet.
e. To secure lever, insert stopper pin (E) through hole of lever into tensioner body hole (B).
- The lever parts and the tab are synchronized. Therefore, the plunger will be secured under this condition.

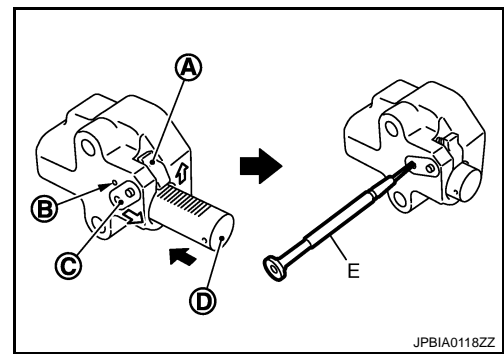

NOTE:

Figure shows the example of 1.2 mm (0.047 in) diameter thin screwdriver being used as the stopper pin.

- f. Install timing chain tensioner (primary).
- Remove dust and foreign material completely from backside of timing chain tensioner (primary) and from installation area of rear timing chain case.
- g. Remove stopper pin.
h. Make sure again that timing chain and water pump sprocket are engaged.
4. Install in the reverse order of removal for remaining parts.
- **After starting engine, let idle for three minutes, then rev engine up to 3,000 rpm under no load to purge air from the high-pressure chamber of chain tensioner. Engine may produce a rattling noise. This indicates that air still remains in the chamber and is not a matter of concern.**

Inspection

INFOID:000000000956354

INSPECTION AFTER REMOVAL

- Check for badly rusted or corroded water pump body assembly.
- Check for rough operation due to excessive end play.
- If anything is found, replace water pump.

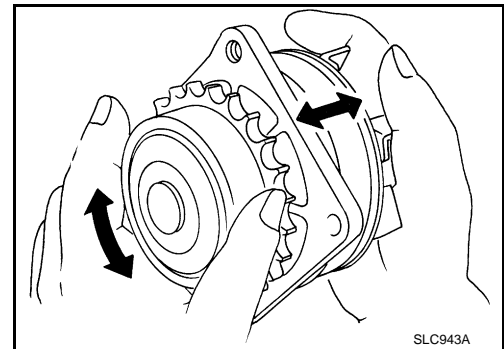

INSPECTION AFTER INSTALLATION

- Check that the reservoir tank cap is tightened.
- Check for leaks of engine coolant using the radiator cap tester adapter [SST: EG17650301 (J33984-A)] and the radiator cap tester (commercial service tool). Refer to [CO-8, "Inspection"](#).
- Start and warm up the engine. Visually make sure that there is no leaks of engine coolant.

WATER INLET AND THERMOSTAT ASSEMBLY

< ON-VEHICLE REPAIR >

WATER INLET AND THERMOSTAT ASSEMBLY

Exploded View

INFOID:000000000956355

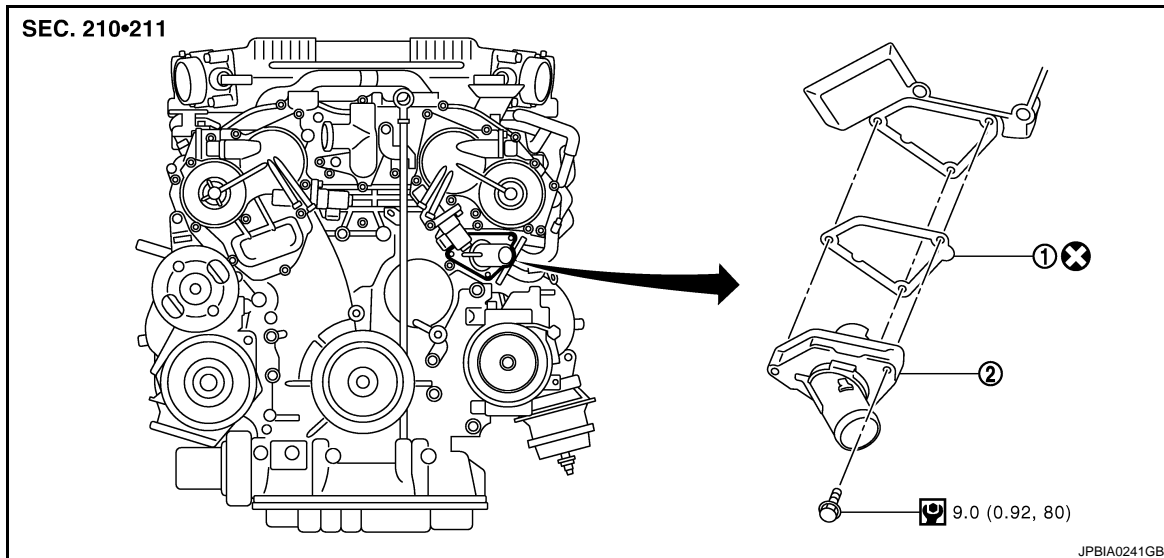

1. Gasket
2. Water inlet and thermostat assembly

Refer to [GI-4, "Components"](#) for symbol marks in the figure.

Removal and Installation

INFOID:000000000956356

REMOVAL

1. Remove engine cover. Refer to [EM-27, "Exploded View"](#).
2. Remove air duct and air cleaner case assembly (LH). Refer to [EM-25, "Exploded View"](#).
3. Remove reservoir tank. Refer to [CO-14, "Exploded View"](#).
4. Remove oil cooler water pipe mounting bolt, and move aside water pipe. (AWD models) Refer to [LU-14, "AWD : Exploded View"](#).
5. Remove engine undercover with power tool.
6. Drain engine coolant from radiator drain plug at the bottom of radiator. Refer to [CO-8, "Draining"](#).
7. Disconnect radiator hose (lower).
8. Disconnect intake valve timing control valve harness connector (LH), and remove intake valve timing control solenoid.
9. Remove water inlet and thermostat assembly (1).

CAUTION:

Do not disassemble water inlet and thermostat assembly. Replace them as a unit, if necessary.

A : Do not loosen these screw,

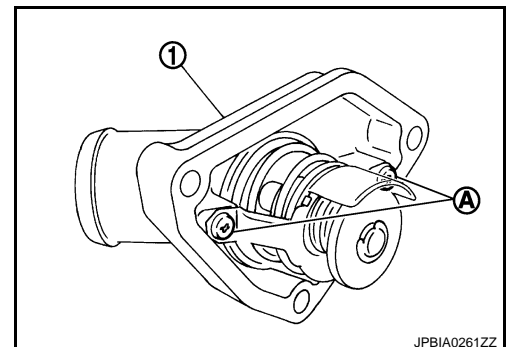

INSTALLATION

Note the following, and install in the reverse order of removal.

- Be careful not to spill engine coolant over engine room. Use rag to absorb engine coolant.

WATER INLET AND THERMOSTAT ASSEMBLY

< ON-VEHICLE REPAIR >

Inspection

INFOID:000000000956357

INSPECTION AFTER REMOVAL

1. Check valve seating condition at ordinary room temperatures. It should seat tightly.
2. Check valve operation.

Thermostat (Standard) : Refer to [CO-26, "Thermostat"](#).

- If the malfunctioning condition, when valve seating at ordinary room temperature, or measured values are out of the standard, replace water inlet and thermostat assembly.

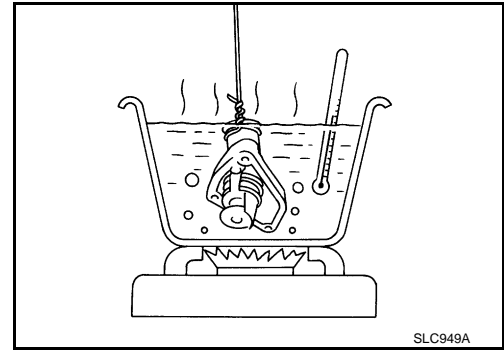

INSPECTION AFTER INSTALLATION

- Check that the reservoir tank cap is tightened.
- Check for leaks of engine coolant using the radiator cap tester adapter [SST: EG17650301 (J33984-A)] and the radiator cap tester (commercial service tool). Refer to [CO-8, "Inspection"](#).
- Start and warm up the engine. Visually make sure that there is no leaks of engine coolant.

WATER OUTLET AND WATER PIPING

< ON-VEHICLE REPAIR >

WATER OUTLET AND WATER PIPING

Exploded View

INFOID:000000000956358

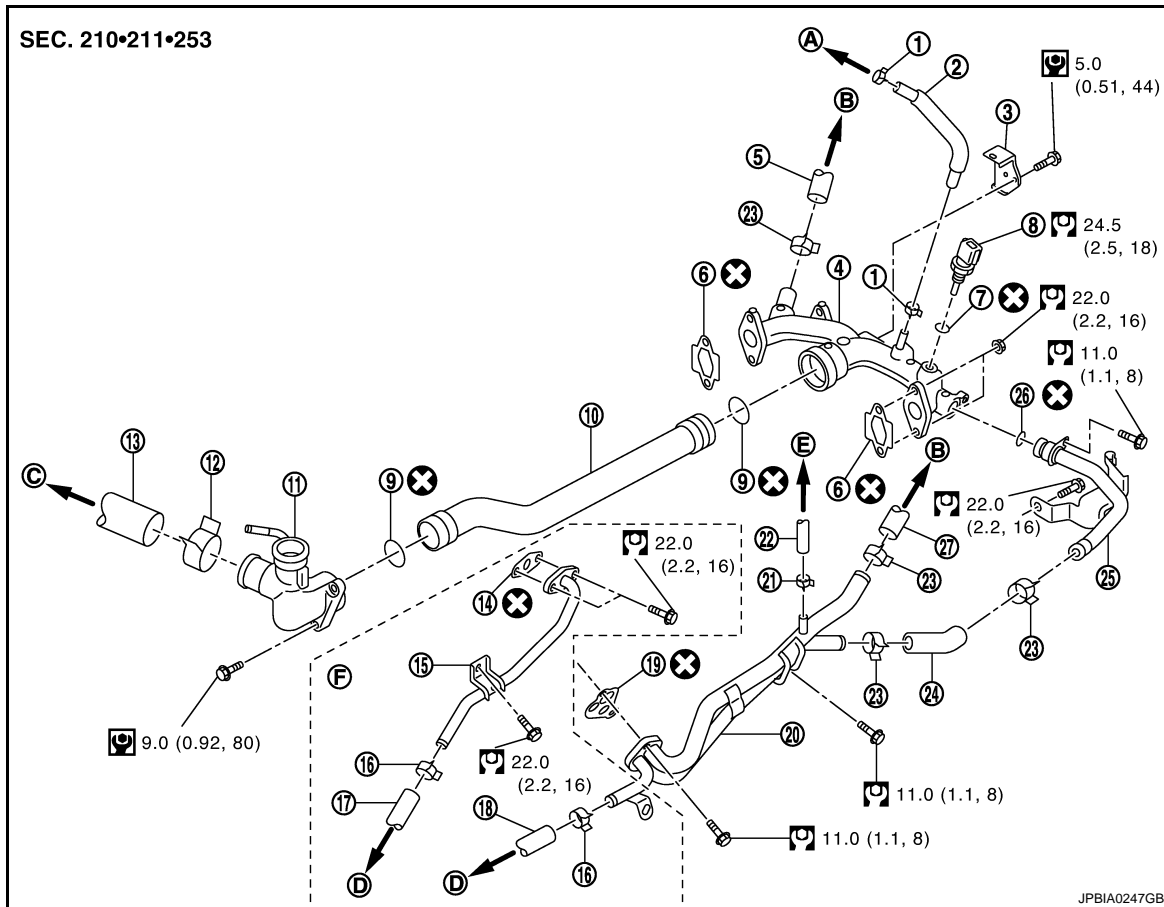

- | | | |
|---------------------------|--|--------------------|
| 1. Clamp | 2. Water hose | 3. Harness bracket |
| 4. Water outlet (rear) | 5. Heater hose | 6. Gasket |
| 7. Washer | 8. Engine coolant temperature sensor | 9. O-ring |
| 10. Water outlet pipe | 11. Water outlet (front) | 12. Clamp |
| 13. Radiator hose (upper) | 14. Gasket | 15. Water pipe |
| 16. Clamp | 17. Water hose | 18. Water hose |
| 19. Gasket | 20. Heater pipe | 21. Clamp |
| 22. Water hose | 23. Clamp | 24. Heater hose |
| 25. Water bypass pipe | 26. O-ring | 27. Heater hose |
| A. To EVAP piping | B. To heater core | C. To radiator |
| D. To oil cooler | E. To electric throttle control actuator | F. AWD models |

Refer to [GI-4, "Components"](#) for symbol marks in the figure.

Removal and Installation

INFOID:000000000956359

REMOVAL

1. Remove engine cover. Refer to [EM-27, "Exploded View"](#).
2. Remove reservoir tank. Refer to [CO-14, "Exploded View"](#).
3. Remove oil level gauge and guide. Refer to [EM-41, "Exploded View \(2WD\)"](#) or [EM-41, "Exploded View \(AWD\)"](#).
4. Remove air duct and air cleaner case assembly (RH and LH). Refer to [EM-25, "Exploded View"](#).
5. Remove engine undercover with power tool.

WATER OUTLET AND WATER PIPING

< ON-VEHICLE REPAIR >

6. Drain engine coolant from radiator drain plug at the bottom of radiator. Refer to [CO-8, "Draining"](#).
CAUTION:
 - Perform this step when the engine is cold.
 - Do not spill engine coolant on drive belts.
7. Remove radiator hose (upper) and heater hose.
8. Remove the following parts, when remove water outlet (rear).
 - A/T fluid charging pipe (A/T models): Refer to [TM-271, "2WD : Removal and Installation"](#) (2WD models) or [TM-273, "AWD : Removal and Installation"](#) (4WD models).
 - Intake manifold collector: Refer to [EM-27, "Exploded View"](#).
9. Separate engine harness removing their bracket from water outlet (rear).
10. Remove engine coolant temperature sensor as necessary.
CAUTION:
Be careful not to damage engine coolant temperature sensor.
11. Remove heater pipe, water bypass pipe and water outlet pipe.

INSTALLATION

Note the following, and install in the reverse order of removal.

- Securely insert each hose, and install clamp at a position where it does not interfere with the pipe bulge.
- When inserting water outlet pipe and water bypass pipe into water outlet, apply neutral detergent to O-ring.

CAUTION:

Do not allow water outlet (rear) to nip O-rings when installing water outlet pipe and water bypass pipe.

Inspection

INFOID:000000000956360

INSPECTION AFTER INSTALLATION

- Check that the reservoir tank cap is tightened.
- Check for leaks of engine coolant using the radiator cap tester adapter [SST: EG17650301 (J33984-A)] and the radiator cap tester (commercial service tool). Refer to [CO-8, "Inspection"](#).
- Start and warm up the engine. Visually make sure that there is no leaks of engine coolant.

SERVICE DATA AND SPECIFICATIONS (SDS)

< SERVICE DATA AND SPECIFICATIONS (SDS)

SERVICE DATA AND SPECIFICATIONS (SDS)

SERVICE DATA AND SPECIFICATIONS (SDS)

Periodical Maintenance Specification

INFOID:000000000956361

ENGINE COOLANT CAPACITY (APPROXIMATE)

Unit: ℓ (US qt, Imp qt)

Engine coolant capacity [With reservoir tank ("MAX" level)]	9.0 (9-1/2, 7-7/8)
Reservoir tank engine coolant capacity (At "MAX" level)	0.8 (7/8, 3/4)

Radiator

INFOID:000000000956362

Unit: kPa (kg/cm², psi)

Cap relief pressure	Standard	122.3 - 151.7 (1.2 - 1.5, 18 - 22)
	Limit	107 (1.1, 16)
Leakage testing pressure		157 (1.6, 23)

Thermostat

INFOID:000000000956363

Thermostat	Standard
Valve opening temperature	82°C (180°F)
Maximum valve lift	9.0 mm/95°C (0.354 in/203°F)
Valve closing temperature	77°C (171°F)