

SECTION **HA**

HEATER & AIR CONDITIONING SYSTEM

A
B
C
D
E
F
G
H
HA
J
K
L
M
N
O
P

CONTENTS

BASIC INSPECTION	LEAK DETECTION DYE	3	20	
	General Precautions		20	
DIAGNOSIS AND REPAIR WORKFLOW	PREPARATION	3	21	
Work Flow		3		
SYSTEM DESCRIPTION	PREPARATION	4	21	
REFRIGERATION SYSTEM	Special Service Tool	4	21	
System Diagram	Commercial Service Tool	4	24	
System Description	Sealant or/and Lubricant	4	24	
Component Parts Location	PERIODIC MAINTENANCE	5	25	
Component Description	REFRIGERANT	6	25	
SYMPTOM DIAGNOSIS	Collection and Charge	7	25	
REFRIGERATION SYSTEM SYMPTOMS	LUBRICANT	7	29	
Trouble Diagnosis For Unusual Pressure	Description	7	29	
Symptom Table	Adjustment	7	29	
COMPRESSOR SYSTEM SYMPTOMS	Lubricant Adjusting Procedure for Components	10		
Symptom Table	Replacement Except Compressor	10	29	
PRECAUTION	Lubricant Adjusting Procedure for Compressor	11	30	
PRECAUTIONS	Replacement	11	30	
Precaution for Supplemental Restraint System	REFRIGERATION SYSTEM	11	32	
(SRS) "AIR BAG" and "SEAT BELT PRE-TEN-	Inspection	11	32	
SIONER"	Performance Chart	11	32	
Service Procedure Precautions for Models with a	Refrigerant Leakages	11	33	
Pop-up Roll Bar	FLUORESCENT LEAK DETECTOR	11	34	
Precaution Necessary for Steering Wheel Rota-	Inspection	11	34	
tion after Battery Disconnect	ELECTRICAL LEAK DETECTOR	11	35	
Precaution for Battery Service	Inspection	12	35	
Precaution for Procedure without Cowl Top Cover...	REMOVAL AND INSTALLATION	12	38	
Working with HFC-134a (R-134a)	COMPRESSOR	12	38	
General Refrigerant Precaution	Exploded View	13	38	
Refrigerant Connection	COMPRESSOR	13	38	
Service Equipment	COMPRESSOR : Removal and Installation	17	38	
COMPRESSOR	MAGNET CLUTCH	19	39	
General Precautions		19		

MAGNET CLUTCH : Removal and Installation of Compressor Clutch	39	LIQUID TANK	46
Inspection	40	LIQUID TANK : Removal and Installation	46
COOLER PIPE AND HOSE	41	REFRIGERANT PRESSURE SENSOR	46
Exploded View	41	REFRIGERANT PRESSURE SENSOR : Removal and Installation	46
LOW-PRESSURE FLEXIBLE HOSE AND PIPE 2... ..	41	HEATER & COOLING UNIT ASSEMBLY	48
LOW-PRESSURE FLEXIBLE HOSE AND PIPE 2 : Removal and Installation	41	Exploded View	48
HIGH-PRESSURE FLEXIBLE HOSE	42	HEATER & COOLING UNIT ASSEMBLY	50
HIGH-PRESSURE FLEXIBLE HOSE : Removal and Installation	42	HEATER & COOLING UNIT ASSEMBLY : Removal and Installation	50
HIGH-PRESSURE PIPE 1	43	HEATER CORE	51
HIGH-PRESSURE PIPE 1 : Removal and Installation	43	HEATER CORE : Removal and Installation	51
LOW-PRESSURE PIPE 1 AND HIGH-PRESSURE PIPE 2	43	EVAPORATOR	52
LOW-PRESSURE PIPE 1 AND HIGH-PRESSURE PIPE 2 : Removal and Installation	43	EVAPORATOR : Removal and Installation	52
CONDENSER	45	EXPANSION VALVE	52
Exploded View	45	EXPANSION VALVE : Removal and Installation ...	53
CONDENSER	45	SERVICE DATA AND SPECIFICATIONS (SDS)	54
CONDENSER : Removal and Installation	45	SERVICE DATA AND SPECIFICATIONS (SDS)	54
CONDENSER PIPE ASSEMBLY	45	Compressor	54
CONDENSER PIPE ASSEMBLY : Removal and Installation	45	Lubricant	54
		Refrigerant	54
		Engine Idling Speed	54
		Belt Tension	54

DIAGNOSIS AND REPAIR WORKFLOW

< BASIC INSPECTION >

BASIC INSPECTION

DIAGNOSIS AND REPAIR WORKFLOW

Work Flow

INFOID:000000004786061

DETAILED FLOW

1. LISTEN TO CUSTOMER COMPLAINT

Listen to customer complaint. (Get detailed information about the conditions and environment when the symptom occurs.)

>> GO TO 2.

2. VERIFY THE SYMPTOM WITH OPERATIONAL CHECK

Verify the symptom with operational check. Refer to [HAC-7, "Description & Inspection"](#).

>> GO TO 3.

3. GO TO APPROPRIATE TROUBLE DIAGNOSIS

Go to appropriate trouble diagnosis (Refer to [HAC-118, "Diagnosis Chart By Symptom"](#) below).

>> GO TO 4.

4. REPAIR OR REPLACE

Repair or replace the specific parts.

>> GO TO 5.

5. FINAL CHECK

Final check.

Is the inspection result normal?

YES >> INSPECTION END

NO >> GO TO 3.

A
B
C
D
E
F
G
H
HA
J
K
L
M
N
O
P

REFRIGERATION SYSTEM

< SYSTEM DESCRIPTION >

SYSTEM DESCRIPTION

REFRIGERATION SYSTEM

System Diagram

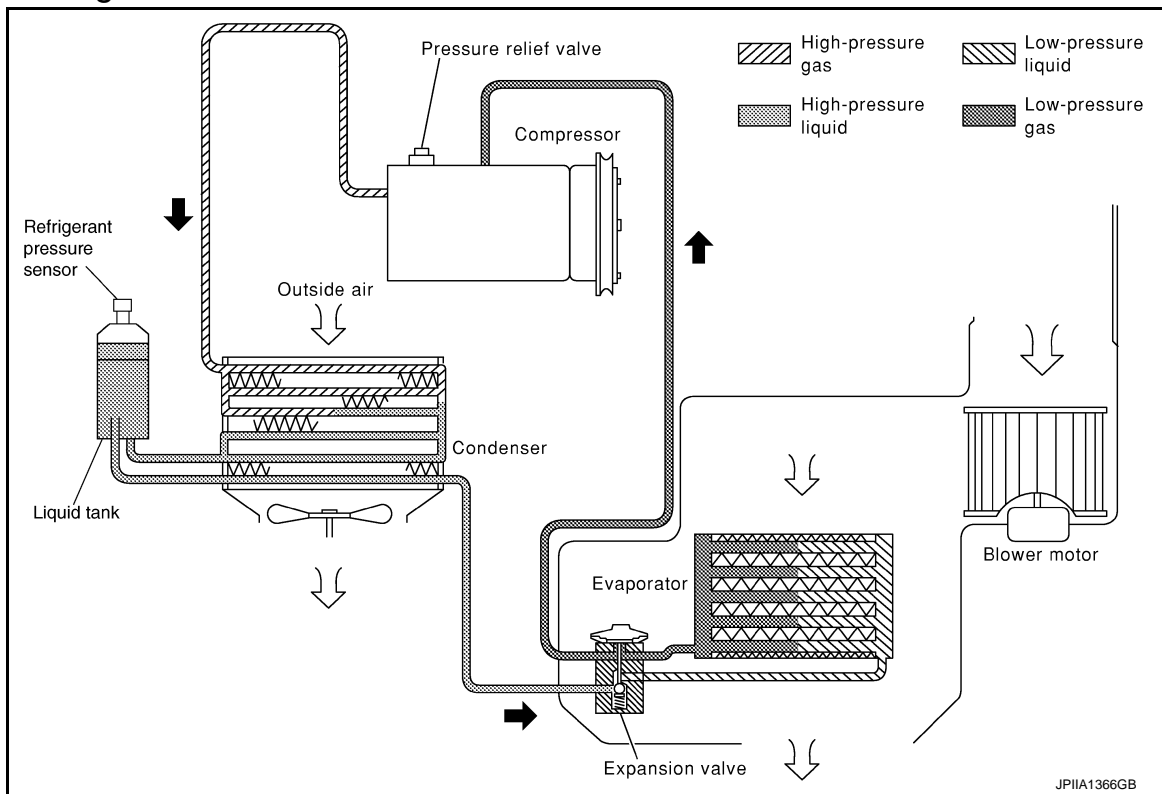

System Description

INFOID:000000004786063

REFRIGERANT CYCLE

Refrigerant Flow

The refrigerant flows from the compressor, through the condenser with liquid tank, through the evaporator, and back to the compressor. The refrigerant evaporation in the evaporator is controlled by an externally equalized expansion valve, located inside the evaporator case.

Freeze Protection

To prevent evaporator from freezing up, the evaporator air temperature is monitored, and the voltage signal to the unified meter and A/C amp. makes the A/C relay go OFF and stop the compressor.

REFRIGERANT SYSTEM PROTECTION

Refrigerant Pressure Sensor

The refrigerant system is protected against excessively high- or low-pressures by the refrigerant pressure sensor, located on the liquid tank. The refrigerant pressure sensor detects the pressure inside the refrigerant line and sends the voltage signal to the ECM if the system pressure rises above, or falls below the specifications. ECM makes the A/C relay go OFF and stops the compressor when pressure on the high-pressure side detected by refrigerant pressure sensor is over approximately 3,119 kPa (31.8 kg/cm², 452 psi), or below approximately 118 kPa (1.2 kg/cm², 17 psi).

Pressure Relief Valve

The refrigerant system is also protected by a pressure relief valve, located in the rear head of the compressor. The release port on the pressure relief valve automatically opens and releases refrigerant into the atmosphere when the pressure of refrigerant in the system increases to an unusual level [more than 3,800 kPa (38.8 kg/cm², 551 psi)].

REFRIGERATION SYSTEM

< SYSTEM DESCRIPTION >

Component Parts Location

INFOID:000000004786064

ENGINE COMPARTMENT

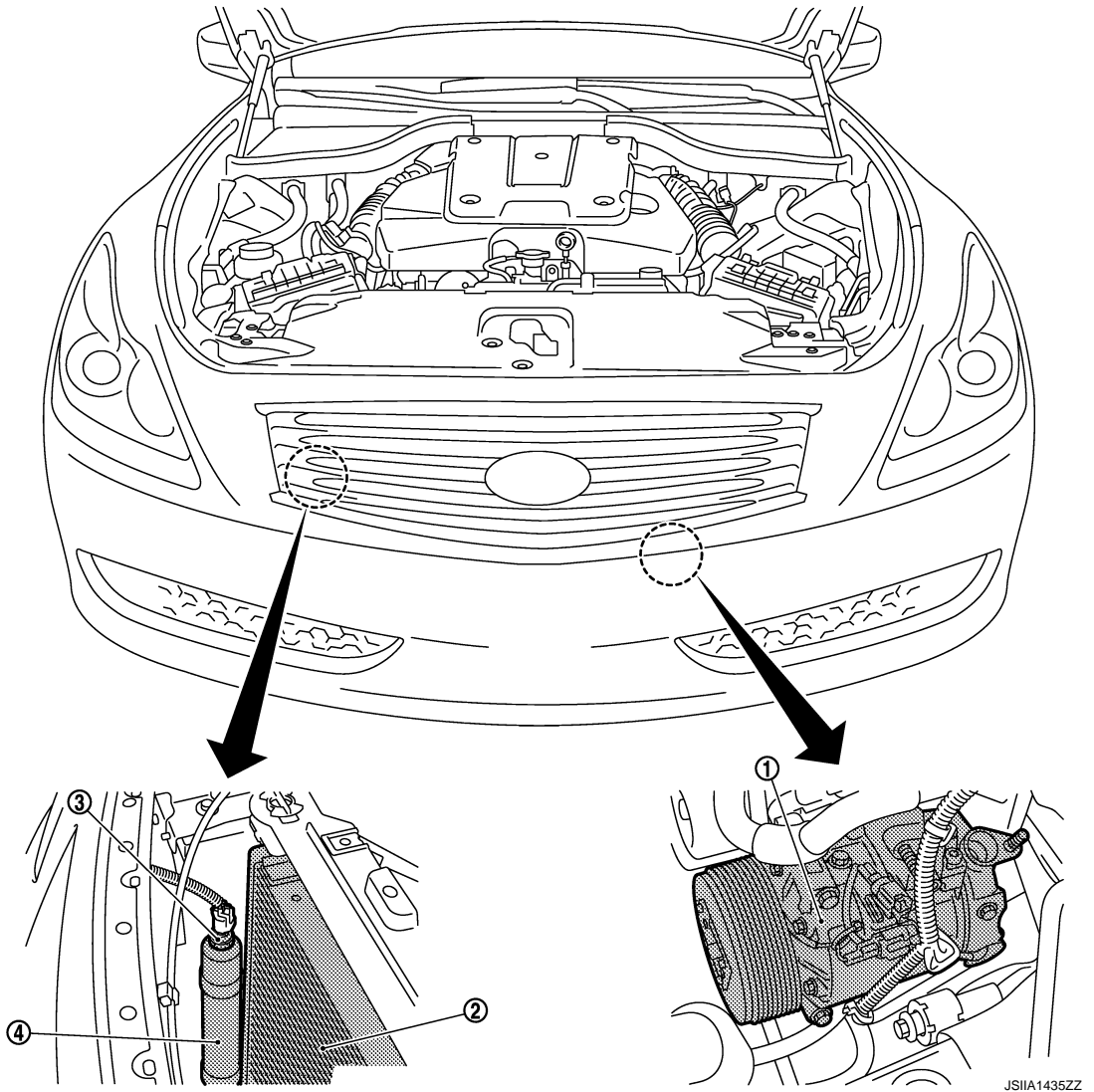

- 1. Compressor
- 4. Liquid tank

- 2. Condenser

- 3. Refrigerant pressure sensor

PASSENGER COMPARTMENT

A
B
C
D
E
F
G
H
HA
J
K
L
M
N
O
P

REFRIGERATION SYSTEM

< SYSTEM DESCRIPTION >

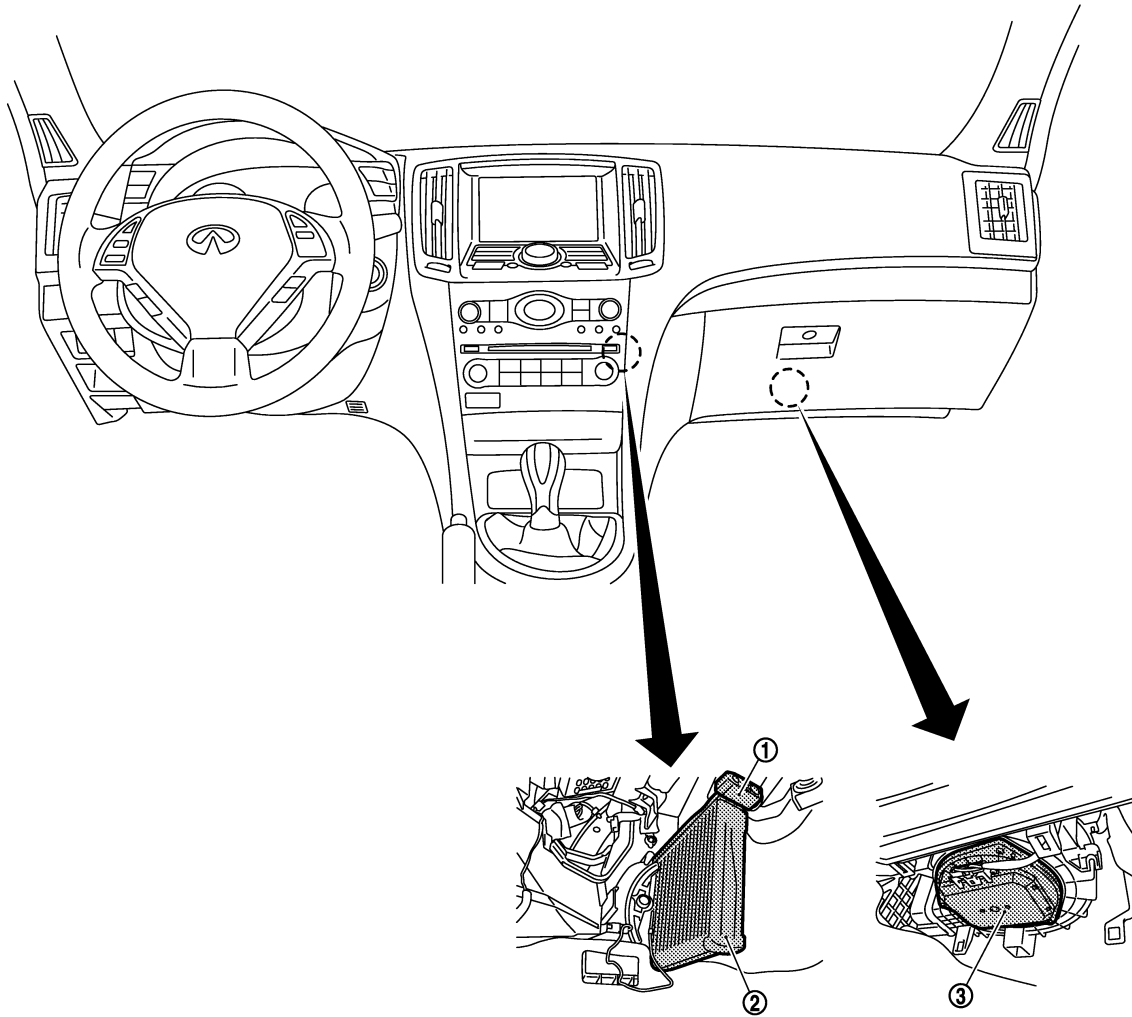

JSIA1436ZZ

1. Expansion valve

2. Evaporator

3. Blower motor

Component Description

INFOID:000000004786065

Component	Description
Compressor	Intakes, compresses, and discharges refrigerant, to circulate refrigerant inside the refrigerant cycle.
Condenser	Cools refrigerant discharged from compressor, and transforms it to liquid refrigerant.
Liquid tank	Eliminates foreign matter in refrigerant, and stores temporarily liquid refrigerant.
Refrigerant pressure sensor	Refer to EC-516, "Description" .
Expansion valve	Transforms high-pressure liquid refrigerant to mist form low-pressure liquid refrigerant by drawing function.
Evaporator	The mist form liquid refrigerant transforms to gas by evaporation by the air conveyed from the blower motor. The air is cooled by the heat by evaporation.
Blower motor	Takes in air in the vehicle or fresh outside air, provides it forcedly to the air conditioner, and conveys it inside the vehicle.

REFRIGERATION SYSTEM SYMPTOMS

< SYMPTOM DIAGNOSIS >

SYMPTOM DIAGNOSIS

REFRIGERATION SYSTEM SYMPTOMS

Trouble Diagnosis For Unusual Pressure

INFOID:000000004786066

Diagnose using a manifold gauge whenever system's high and/or low side pressure(s) is/are unusual. The marker above the gauge scale in the following tables indicates the standard (usual) pressure range. Refer to above table (Ambient air temperature-to-operating pressure table) since the standard (usual) pressure, however, differs from vehicle to vehicle.

Symptom Table

INFOID:000000004786067

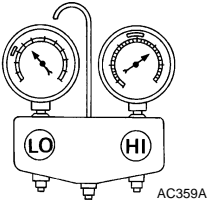
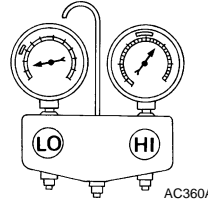
Gauge indication	Refrigerant cycle	Probable cause	Corrective action
<p>Both high- and low-pressure sides are too high.</p>  <p>AC359A</p>	<p>The pressure returns to normal is reduced soon after water is splashed on condenser.</p>	<p>Excessive refrigerant charge in refrigeration cycle.</p>	<p>Reduce refrigerant until specified pressure is obtained.</p>
	<p>Air suction by cooling fan is insufficient.</p>	<p>Insufficient condenser cooling performance. ↓ 1. Condenser fins are clogged. 2. Improper fan rotation of cooling fan.</p>	<ul style="list-style-type: none"> Clean condenser. Check and repair cooling fan if necessary.
	<ul style="list-style-type: none"> Low-pressure pipe is not cold. When compressor is stopped, high-pressure reading quickly drops by approximately 196 kPa (2 kg/cm², 28 psi). It then decreases gradually thereafter. 	<p>Poor heat exchange in condenser (After compressor operation stops, high-pressure decreases too slowly). ↓ Air in refrigeration cycle.</p>	<p>Evacuate repeatedly and re-charge system.</p>
	<p>Engine tends to overheat.</p>	<p>Engine cooling systems malfunction.</p>	<p>Check and repair each engine cooling system.</p>
	<ul style="list-style-type: none"> An area of the low-pressure pipe is colder than areas near the evaporator outlet. Low-pressure pipe is sometimes covered with frost. 	<ul style="list-style-type: none"> Excessive liquid refrigerant on low-pressure side. Excessive refrigerant discharge flow. Expansion valve is open a little compared with the specification. <p>↓ Improper expansion valve adjustment.</p>	<p>Replace expansion valve.</p>
<p>High-pressure side is too high and low-pressure side is too low.</p>  <p>AC360A</p>	<p>Upper side of condenser and high-pressure side are hot, however, liquid tank is not so hot.</p>	<p>High-pressure tube or parts located between compressor and condenser are clogged or crushed.</p>	<ul style="list-style-type: none"> Check and repair or replace malfunctioning parts. Check lubricant for contamination.

REFRIGERATION SYSTEM SYMPTOMS

< SYMPTOM DIAGNOSIS >

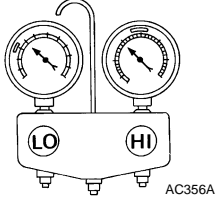
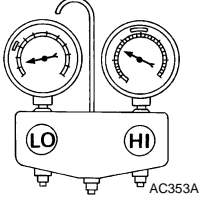
Gauge indication	Refrigerant cycle	Probable cause	Corrective action
High-pressure side is too low and low-pressure side is too high. 	High- and low-pressure sides become equal soon after compressor operation stops.	Compressor pressure operation is improper. ↓ Damaged inside compressor packings.	Replace compressor.
	No temperature difference between high- and low-pressure sides.	Compressor pressure operation is improper. ↓ Damaged inside compressor packings.	Replace compressor.
Both high- and low-pressure sides are too low. 	<ul style="list-style-type: none"> There is a big temperature difference between liquid tank outlet and inlet. Outlet temperature is extremely low. Liquid tank inlet and expansion valve are frosted. 	Liquid tank inside is slightly clogged.	<ul style="list-style-type: none"> Replace liquid tank. Check lubricant for contamination.
	<ul style="list-style-type: none"> Expansion valve inlet temperature is extremely low as compared with areas near liquid tank. Expansion valve inlet is frosted. Temperature difference occurs somewhere in high-pressure side. 	High-pressure pipe located between liquid tank and expansion valve is clogged.	<ul style="list-style-type: none"> Check and repair malfunctioning parts. Check lubricant for contamination.
	Expansion valve and liquid tank are warm or slightly cool when touched.	Low refrigerant charge. ↓ Leaking fittings or components.	Check refrigerant for leakages. Refer to HA-33, "Refrigerant Leakages" .
	There is a big temperature difference between expansion valve inlet and outlet while the valve itself is frosted.	Expansion valve closes a little compared with the specification. ↓ 1. Improper expansion valve adjustment. 2. Malfunctioning expansion valve. 3. Outlet and inlet may be clogged.	<ul style="list-style-type: none"> Remove foreign particles by using compressed air. Replace expansion valve. Check lubricant for contamination.
	An area of the low-pressure pipe is colder than areas near the evaporator outlet.	Low-pressure pipe is clogged or crushed.	<ul style="list-style-type: none"> Check and repair malfunctioning parts. Check lubricant for contamination.
	Air flow volume is not enough or is too low.	Evaporator is frozen.	<ul style="list-style-type: none"> Check intake sensor circuit. Refer to HAC-76, "Diagnosis Procedure". Replace compressor. Repair evaporator fins. Replace evaporator. Check the blower motor circuit. Refer to HAC-59, "Diagnosis Procedure".

REFRIGERATION SYSTEM SYMPTOMS

< SYMPTOM DIAGNOSIS >

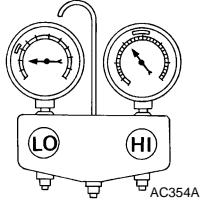
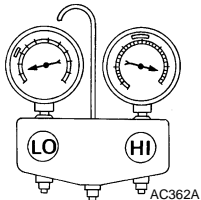
Gauge indication	Refrigerant cycle	Probable cause	Corrective action
<p>Low-pressure side sometimes becomes negative.</p> 	<ul style="list-style-type: none"> • Air conditioning system does not function and does not cyclically cool the compartment air. • The system constantly functions for a period of time after compressor is stopped and restarted. 	<p>Refrigerant does not discharge cyclically.</p> <p>↓</p> <p>Moisture is frozen at expansion valve outlet and inlet.</p> <p>↓</p> <p>Water is mixed with refrigerant.</p>	<ul style="list-style-type: none"> • Drain water from refrigerant or replace refrigerant. • Replace liquid tank.
<p>Low-pressure side becomes negative.</p> 	<p>Liquid tank or front/rear side of expansion valve's pipe is frosted or wet with dew.</p>	<p>High-pressure side is closed and refrigerant does not flow.</p> <p>↓</p> <p>Expansion valve or liquid tank is frosted.</p>	<p>Leave the system at rest until no frost is present. Start it again to check whether or not the malfunction is caused by water or foreign particles.</p> <ul style="list-style-type: none"> • Cooling is initially okay if water is the cause. Then the water freezes causing a blockage. Drain water from refrigerant or replace refrigerant. • Remove expansion valve and remove the particles with dry and compressed air (not shop air) if due to foreign particles. • Replace expansion valve if either of the above methods cannot correct the malfunction. • Replace liquid tank. • Check lubricant for contamination.

A
B
C
D
E
F
G
H
HA
J
K
L
M
N
O
P

COMPRESSOR SYSTEM SYMPTOMS

< SYMPTOM DIAGNOSIS >

COMPRESSOR SYSTEM SYMPTOMS

Symptom Table

INFOID:000000004786068

Follow the next table and perform trouble diagnosis if there is a compressor unit malfunction (internal noise, insufficient cooling).

Symptom	Inspection method	Check list	Result	Action
Noise from compressor unit When A/C is ON. (rattling or rolling sound)	Cookeer system internal pressure	Check with manifold gauge	Both high- and low-pressure sides are high.*2	Recharge with proper amount of refrigerant.
			High/low-pressures hunt.*2	Replace compressor only.
	Check compressor oil condition.	Sample compressor oil and judge.	Refer to the criteria shown in compressor lubricant.	Judgment result 1: Replace compressor only. Judgment result 2: Replace compressor and liquid tank.
Insufficient cooling*1	Compressor body	Check rotation of compressor. If sized or stuck, sample compressor oil and judge.		
	Cooler system internal pressure	Check with a manifold gauge. Sample compressor oil and judge if the difference between high-pressure and low-pressure is small or if they are almost the same.		
Outlet air temperature rises temporarily while driving.*2	—	—	—	Replace compressor only.

*1: First conduct inspection according to trouble diagnosis for each malfunction. Refer to [HAC-119, "Inspection procedure"](#).

*2: Applicable to variable capacity compressor only.

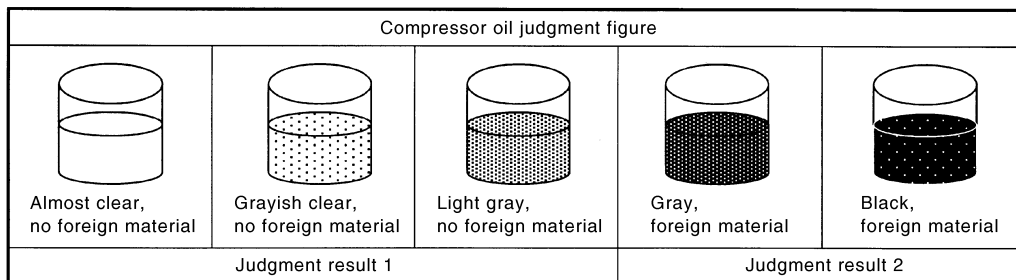

JSIIA0927GB

PRECAUTIONS

< PRECAUTION >

PRECAUTION

PRECAUTIONS

Precaution for Supplemental Restraint System (SRS) "AIR BAG" and "SEAT BELT PRE-TENSIONER"

INFOID:000000005153378

The Supplemental Restraint System such as "AIR BAG" and "SEAT BELT PRE-TENSIONER", used along with a front seat belt, helps to reduce the risk or severity of injury to the driver and front passenger for certain types of collision. This system includes seat belt switch inputs and dual stage front air bag modules. The SRS system uses the seat belt switches to determine the front air bag deployment, and may only deploy one front air bag, depending on the severity of a collision and whether the front occupants are belted or unbelted. Information necessary to service the system safely is included in the "SRS AIR BAG" and "SEAT BELT" of this Service Manual.

WARNING:

- To avoid rendering the SRS inoperative, which could increase the risk of personal injury or death in the event of a collision that would result in air bag inflation, all maintenance must be performed by an authorized NISSAN/INFINITI dealer.
- Improper maintenance, including incorrect removal and installation of the SRS, can lead to personal injury caused by unintentional activation of the system. For removal of Spiral Cable and Air Bag Module, see the "SRS AIR BAG".
- Do not use electrical test equipment on any circuit related to the SRS unless instructed to in this Service Manual. SRS wiring harnesses can be identified by yellow and/or orange harnesses or harness connectors.

PRECAUTIONS WHEN USING POWER TOOLS (AIR OR ELECTRIC) AND HAMMERS

WARNING:

- When working near the Air Bag Diagnosis Sensor Unit or other Air Bag System sensors with the ignition ON or engine running, DO NOT use air or electric power tools or strike near the sensor(s) with a hammer. Heavy vibration could activate the sensor(s) and deploy the air bag(s), possibly causing serious injury.
- When using air or electric power tools or hammers, always switch the ignition OFF, disconnect the battery, and wait at least 3 minutes before performing any service.

Service Procedure Precautions for Models with a Pop-up Roll Bar

INFOID:000000005153379

WARNING:

- Risk of passenger injury or death may increase if the pop-up roll bar does not deploy during a roll over collision. In order to reduce the chance of an incident where the pop-up roll bar is inoperative, all maintenance must be performed by a NISSAN or INFINITI dealer.
- Before removing and installing the pop-up roll bar component parts and harness, always turn the ignition switch OFF, disconnect the battery negative terminal, and wait for 3 minutes or more. (The purpose of this operation is to discharge electricity that is accumulated in the auxiliary power supply circuit in the air bag diagnosis sensor unit.)
- When repairing, removing, and installing a pop-up roll bar, always refer to SRS AIR BAG and SRS AIR BAG CONTROL warnings in the Service Manual.

Precaution Necessary for Steering Wheel Rotation after Battery Disconnect

INFOID:000000005153380

NOTE:

- Before removing and installing any control units, first turn the push-button ignition switch to the LOCK position, then disconnect both battery cables.
- After finishing work, confirm that all control unit connectors are connected properly, then re-connect both battery cables.
- Always use CONSULT-III to perform self-diagnosis as a part of each function inspection after finishing work. If a DTC is detected, perform trouble diagnosis according to self-diagnosis results.

For vehicle with steering lock unit, if the battery is disconnected or discharged, the steering wheel will lock and cannot be turned.

If turning the steering wheel is required with the battery disconnected or discharged, follow the operation procedure below before starting the repair operation.

PRECAUTIONS

< PRECAUTION >

OPERATION PROCEDURE

1. Connect both battery cables.
NOTE:
Supply power using jumper cables if battery is discharged.
2. Turn the push-button ignition switch to ACC position.
(At this time, the steering lock will be released.)
3. Disconnect both battery cables. The steering lock will remain released with both battery cables disconnected and the steering wheel can be turned.
4. Perform the necessary repair operation.
5. When the repair work is completed, re-connect both battery cables. With the brake pedal released, turn the push-button ignition switch from ACC position to ON position, then to LOCK position. (The steering wheel will lock when the push-button ignition switch is turned to LOCK position.)
6. Perform self-diagnosis check of all control units using CONSULT-III.

Precaution for Battery Service

INFOID:000000005153381

Before disconnecting the battery, lower both the driver and passenger windows. This will prevent any interference between the window edge and the vehicle when the door is opened/closed. During normal operation, the window slightly raises and lowers automatically to prevent any window to vehicle interference. The automatic window function will not work with the battery disconnected.

Precaution for Procedure without Cowl Top Cover

INFOID:000000005153382

When performing the procedure after removing cowl top cover, cover the lower end of windshield with urethane, etc.

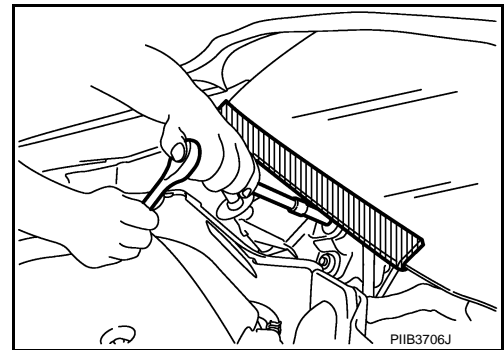

Working with HFC-134a (R-134a)

INFOID:000000004786074

CAUTION:

- CFC-12 (R-12) refrigerant and HFC-134a (R-134a) refrigerant are not compatible. Compressor malfunction is likely to occur if the refrigerants are mixed, refer to “CONTAMINATED REFRIGERANT” below. To determine the purity of HFC-134a (R-134a) in the vehicle and recovery tank, use Refrigerant recovery/recycling recharging equipment and Refrigerant Identifier.
- Use only specified lubricant for the HFC-134a (R-134a) A/C system and HFC-134a (R-134a) components. Compressor malfunction is likely to occur if lubricant other than that specified is used.
- The specified HFC-134a (R-134a) lubricant rapidly absorbs moisture from the atmosphere. The following handling precautions must be observed:
 - Cap (seal) immediately the component to minimize the entry of moisture from the atmosphere when removing refrigerant components from a vehicle.
 - Never remove the caps (unseal) until just before connecting the components when installing refrigerant components to a vehicle. Connect all refrigerant loop components as quickly as possible to minimize the entry of moisture into system.
 - Use only the specified lubricant from a sealed container. Reseal immediately containers of lubricant. Lubricant becomes moisture saturated and should not be used without proper sealing.
 - Never allow lubricant (UV Luminous Oil Type S) to come in contact with styrene foam parts. Damage may result.

CONTAMINATED REFRIGERANT

Take appropriate steps shown below if a refrigerant other than pure HFC-134a (R-134a) is identified in a vehicle:

PRECAUTIONS

< PRECAUTION >

- Explain to the customer that environmental regulations prohibit the release of contaminated refrigerant into the atmosphere.
- Explain that recovery of the contaminated refrigerant could damage service equipment and refrigerant supply.
- Suggest the customer return the vehicle to the location of previous service where the contamination may have occurred.
- In case of repairing, recover the refrigerant using only **dedicated equipment and containers. Never recover contaminated refrigerant into the existing service equipment.** Contact a local refrigerant product retailer for available service if the facility does not have dedicated recovery equipment. This refrigerant must be disposed of in accordance with all federal and local regulations. In addition, replacement of all refrigerant system components on the vehicle is recommended.
- The air conditioner warranty is void if the vehicle is within the warranty period. Please contact Nissan Customer Affairs for further assistance.

General Refrigerant Precaution

INFOID:000000004786075

WARNING:

- **Never breathe A/C refrigerant and lubricant vapor or mist. Exposure may irritate eyes, nose and throat. Remove HFC-134a (R-134a) from the A/C system, using certified service equipment meeting requirements of SAE J-2210 [HFC-134a (R-134a) recycling equipment], or J-2209 [HFC-134a (R-134a) recovery equipment]. Ventilate work area before resuming service if accidental system discharge occurs. Additional health and safety information may be obtained from refrigerant and lubricant manufacturers.**
- **Never release refrigerant into the air. Use approved recovery/recycling recharging equipment to capture the refrigerant each time an air conditioning system is discharged.**
- **Wear always eye and hand protection (goggles and gloves) when working with any refrigerant or air conditioning system.**
- **Never store or heat refrigerant containers above 52°C (126°F).**
- **Never heat a refrigerant container with an open flame; Place the bottom of the container in a warm pail of water if container warming is required.**
- **Never intentionally drop, puncture, or incinerate refrigerant containers.**
- **Keep refrigerant away from open flames: poisonous gas is produced if refrigerant burns.**
- **Refrigerant displaces oxygen, therefore be certain to work in well ventilated areas to prevent suffocation.**
- **Never pressure test or leakage test HFC-134a (R-134a) service equipment and/or vehicle air conditioning systems with compressed air during repair. Some mixtures of air and HFC-134a (R-134a) have been shown to be combustible at elevated pressures. These mixtures, if ignited, may cause injury or property damage. Additional health and safety information may be obtained from refrigerant manufacturers.**

Refrigerant Connection

INFOID:000000004786076

A new type refrigerant connection has been introduced to all refrigerant lines except the following location.

- Expansion valve to evaporator
- Refrigerant pressure sensor to liquid tank

ABOUT ONE-TOUCH JOINT

Description

- One-touch joints are pipe joints which do not require tools during piping connection.
- Unlike conventional connection methods using union nuts and flanges, controlling tightening torque at connection point is not necessary.
- Use a disconnecter when removing a pipe joint.

PRECAUTIONS

< PRECAUTION >

Component Parts

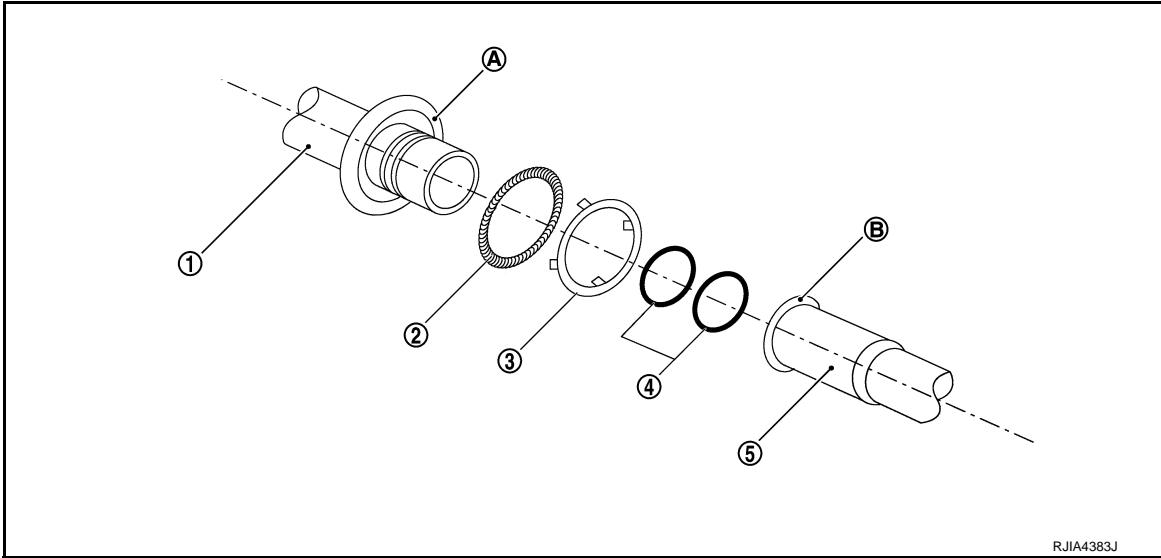

Functions Of Component Parts

1	Pipe (Male-side)	<ul style="list-style-type: none"> Retains O-rings. Retains garter spring in cage (A).
2	Garter spring	Anchors female-side piping.
3	Indicator ring	When connection is made properly, this is ejected from male-side piping. (This part is no longer necessary after connection.)
4	O-ring	Seals connection point. (Not reusable)
5	Pipe (Female-side)	<ul style="list-style-type: none"> Seals connection by compressing O-rings. Anchors piping connection using flare (B) and garter spring.

NOTE:

- Garter spring cannot be removed from cage of male-side piping.
- Indicator ring remains near piping connection point, however, this is not a malfunction. (This is to check piping connection during factory assembly.)

Removal

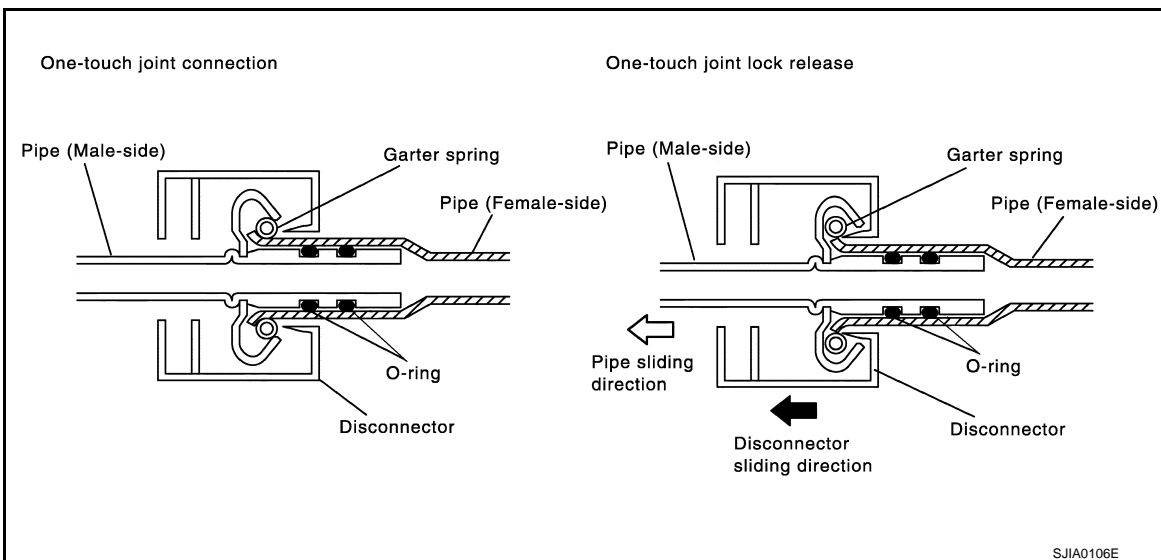

- Clean piping connection point, and set a disconnecter.
- Slide disconnecter in axial direction of piping, and stretch garter spring with tapered point of disconnecter.
- Slide disconnecter farther so that inside diameter of garter spring becomes larger than outside diameter of female-side piping flare. Then male-side piping can be disconnected.

PRECAUTIONS

< PRECAUTION >

Installation

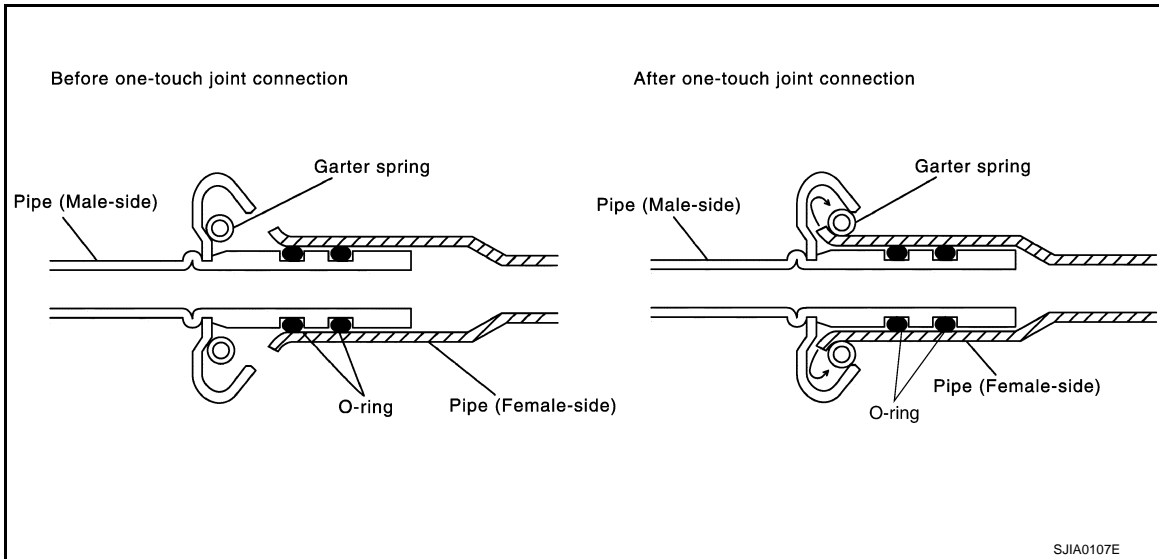

1. Clean piping connection points, and insert male-side piping into female-side piping.
2. Push inserted male-side piping harder so that female-side piping flare stretches garter spring.
3. Garter spring seats on flare if inside diameter of garter spring becomes larger than outside diameter of female-side piping flare. Then, it fits in between male-side piping cage and female-side piping flare to anchor piping connection point.

NOTE:

When garter spring seats on flare, and fits in between male-side piping cage and female-side piping flare, it clicks.

CAUTION:

- Female-side piping connection point is thin and easy to deform. Slowly insert the male-side piping straight in axial direction.
- Insert piping securely until a click is heard.
- After piping connection is completed, pull male-side piping by hand to make sure that connection does not come loose.

O-RING AND REFRIGERANT CONNECTION

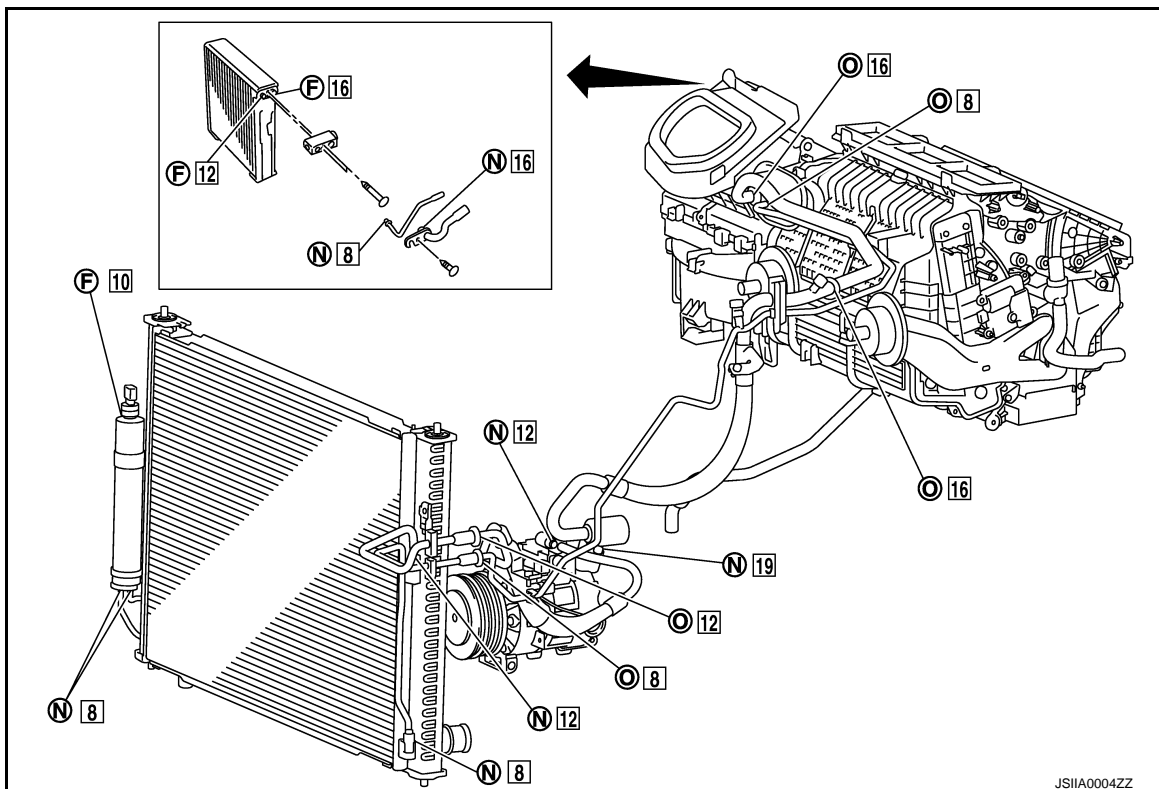

PRECAUTIONS

< PRECAUTION >

F. Former type refrigerant connection N. New type refrigerant connection O. One-touch joint

: O-ring size

CAUTION:

The new and former refrigerant connections use different O-ring configurations. Never confuse O-rings since they are not interchangeable. Refrigerant may leak at the connection if a wrong O-ring is installed.

O-Ring Part Numbers and Specifications

Connection type	Piping connection point		QTY	O-ring size
One-touch joint	Low-pressure pipe 1 to low-pressure pipe 2		2	φ16
	Low-pressure flexible hose to low-pressure pipe 2		2	φ16
	High-pressure pipe 1 to high-pressure pipe 2		2	φ8
	Condenser pipe assembly to high-pressure flexible hose		2	φ12
	Condenser pipe assembly to high-pressure pipe 1		2	φ8
New	Condenser to condenser pipe assembly	Inlet	1	φ12
		Outlet	1	φ8
	Low-pressure pipe 1 to expansion valve		1	φ16
	High-pressure pipe 2 to expansion valve		1	φ8
	Compressor to low-pressure flexible hose		1	φ19
	Compressor to high-pressure flexible hose		1	φ12
	Liquid tank to Condenser	Inlet	1	φ8
Outlet		1		
Former	Refrigerant pressure sensor to liquid tank		1	φ10
	Expansion valve to evaporator	Inlet	1	φ12
		Outlet	1	φ16

WARNING:

Check that all refrigerant is discharged into the recycling equipment and the pressure in the system is less than atmospheric pressure. Then gradually loosen the discharge side hose fitting and remove it.

CAUTION:

Observe the following when replacing or cleaning refrigerant cycle components.

- Store it in the same way at it is when mounted on the car when the compressor is removed. Failure to do so will cause lubricant to enter the low-pressure chamber.
- Use always a torque wrench and a back-up wrench when connecting tubes.
- Plug immediately all openings to prevent entry of dust and moisture after disconnecting tubes.
- Connect the pipes at the final stage of the operation when installing an air conditioner in the vehicle. Never remove the seal caps of pipes and other components until just before required for connection.
- Allow components stored in cool areas to warm to working area temperature before removing seal caps. This prevents condensation from forming inside A/C components.
- Remove thoroughly moisture from the refrigeration system before charging the refrigerant.
- Replace always used O-rings.
- Apply lubricant to circle of the O-rings shown in illustration when connecting tube. Be careful not to apply lubricant to threaded portion.

Name : UV Luminous Oil Type S

- O-ring must be closely attached to the groove portion of tube.
- Be careful not to damage O-ring and tube when replacing the O-ring.
- Connect tube until a click can be heard. Then tighten the nut or bolt by hand. Check that the O-ring is installed to tube correctly.

PRECAUTIONS

< PRECAUTION >

- Perform leakage test and make sure that there is no leakage from connections after connecting line. Disconnect that line and replace the O-ring when the refrigerant leaking point is found. Then tighten connections of seal seat to the specified torque.

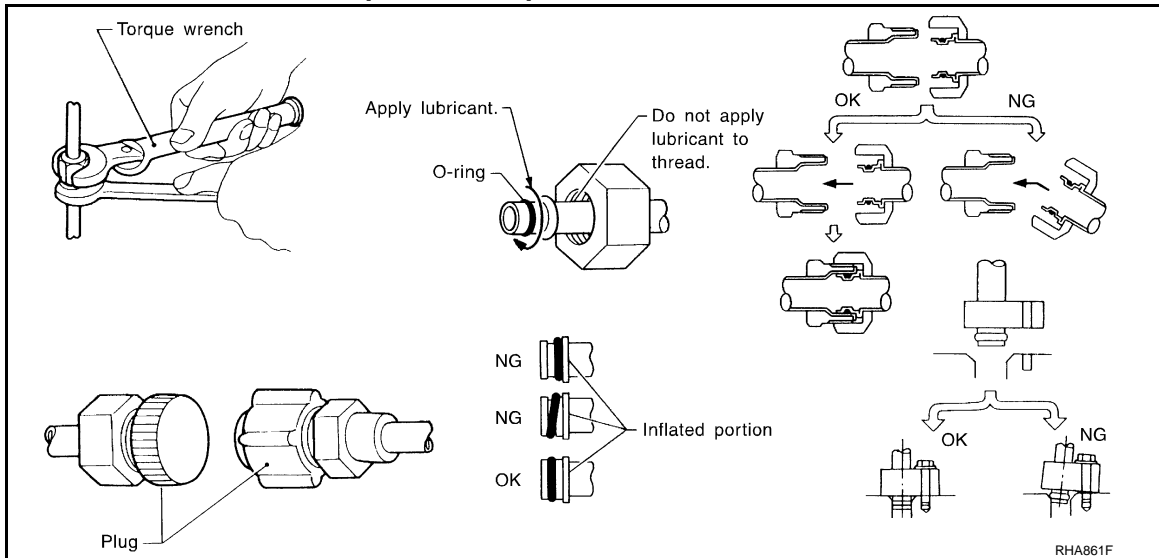

Service Equipment

INFOID:000000004786077

RECOVERY/RECYCLING RECHARGING EQUIPMENT

Be certain to follow the manufacturer's instructions for machine operation and machine maintenance. Never introduce any refrigerant other than that specified into the machine.

ELECTRICAL LEAK DETECTOR

Be certain to follow the manufacturer's instructions for tester operation and tester maintenance.

VACUUM PUMP

The lubricant contained inside the vacuum pump is not compatible with the specified lubricant for HFC-134a (R-134a) A/C systems. The vent side of the vacuum pump is exposed to atmospheric pressure. So the vacuum pump lubricant may migrate out of the pump into the service hose. This is possible when the pump is switched OFF after evacuation (vacuuming) and hose is connected to it. To prevent this migration, use a manual valve placed near the hose-to-pump connection, as per the following.

- Vacuum pumps usually have a manual isolator valve as part of the pump. Close this valve to isolate the service hose from the pump.
- Use a hose equipped with a manual shut-off valve near the pump end for pumps without an isolator. Close the valve to isolate the hose from the pump.
- Disconnect the hose from the pump if the hose has an automatic shut-off valve. As long as the hose is connected, the valve is open and lubricating oil may migrate.

Some one-way valves open when vacuum is applied and close under no vacuum condition. Such valves may restrict the pump's ability to pull a deep vacuum and are not recommended.

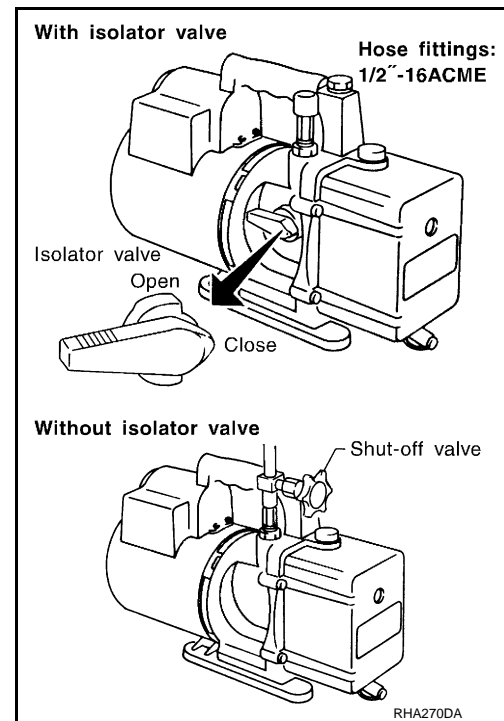

MANIFOLD GAUGE SET

PRECAUTIONS

< PRECAUTION >

Be certain that the gauge face indicates HFC-134a or R-134a. Be sure the gauge set has 1/2"-16 ACME threaded connections for service hoses. Confirm the set has been used only with refrigerant HFC-134a (R-134a) and specified lubricants.

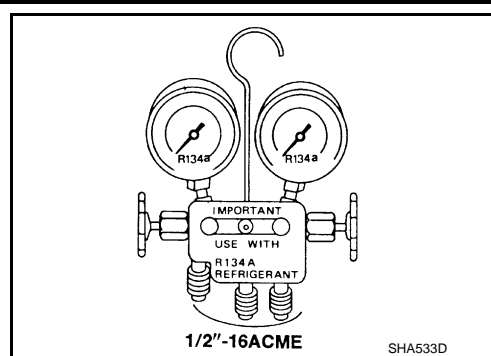

SERVICE HOSES

Be certain that the service hoses display the markings described (colored hose with black stripe). All hoses must equip positive shut-off devices (either manual or automatic) near the end of the hoses opposite to the manifold gauge.

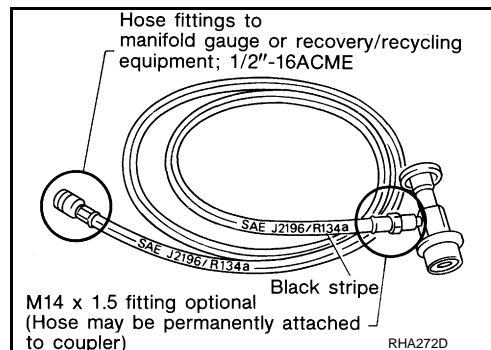

SERVICE COUPLERS

Never attempt to connect HFC-134a (R-134a) service couplers to the CFC-12 (R-12) A/C system. The HFC-134a (R-134a) couplers do not properly connect to the CFC-12 (R-12) system. However, if an improper connection is attempted, discharging and contamination may occur.

Shut-off valve rotation	A/C service valve
Clockwise	Open
Counterclockwise	Close

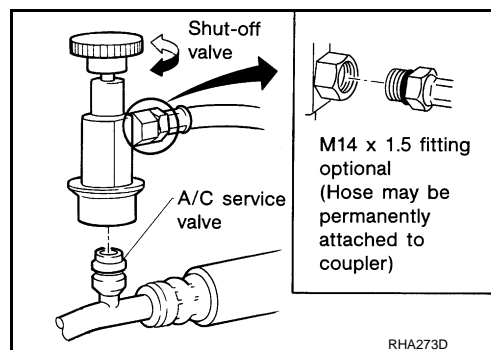

REFRIGERANT WEIGHT SCALE

Verify that no refrigerant other than HFC-134a (R-134a) and specified lubricants have been used with the scale. The hose fitting must be 1/2"-16 ACME if the scale controls refrigerant flow electronically.

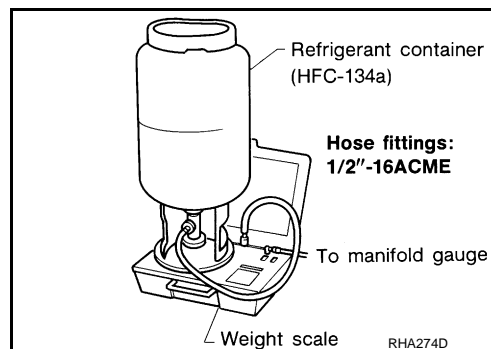

CHARGING CYLINDER

Using a charging cylinder is not recommended. Refrigerant may be vented into air from cylinder's top valve when filling the cylinder with refrigerant. Also, the accuracy of the cylinder is generally less than that of an electronic scale or of quality recycle/recharge equipment.

COMPRESSOR

< PRECAUTION >

COMPRESSOR

General Precautions

INFOID:000000004786078

CAUTION:

- Plug all openings to prevent moisture and foreign matter from entering.
- Store it in the same way as it is when mounted on the car when the compressor is removed.
- Follow "Maintenance of Lubricant Quantity in Compressor" exactly when replacing or repairing compressor. Refer to [HA-29, "Description"](#).
- Keep friction surfaces between clutch and pulley clean. Wipe it off by using a clean waste cloth moistened with thinner if the surface is contaminated with lubricant.
- Turn the compressor shaft by hand more than five turns in both directions after compressor service operation. This distributes equally lubricant inside the compressor. Let the engine idle and operate the compressor for one hour after the compressor is installed.
- Apply voltage to the new one and check for normal operation after replacing the compressor magnet clutch.

A
B
C
D
E
F
G
H
HA
J
K
L
M
N
O
P

HA

LEAK DETECTION DYE

< PRECAUTION >

LEAK DETECTION DYE

General Precautions

INFOID:000000004786079

CAUTION:

- The A/C system contains a fluorescent leak detection dye used for locating refrigerant leakages. An ultraviolet (UV) lamp is required to illuminate the dye when inspecting for leakages.
- Wear always fluorescence enhancing UV safety goggles to protect eyes and enhance the visibility of the fluorescent dye.
- The fluorescent dye leak detector is not a replacement for an electrical leak detector (SST: J-41995). The fluorescent dye leak detector should be used in conjunction with an electrical leak detector (SST: J-41995) to pin-point refrigerant leakages.
- Read and follow all manufacture's operating instructions and precautions prior to performing the work for the purpose of safety and customer's satisfaction.
- A compressor shaft seal should not necessarily be repaired because of dye seepage. The compressor shaft seal should only be repaired after confirming the leakage with an electrical leak detector (SST: J-41995).
- Remove always any remaining dye from the leakage area after repairs are completed to avoid a misdiagnosis during a future service.
- Never allow dye to come into contact with painted body panels or interior components. Clean immediately with the approved dye cleaner if dye is spilled. Fluorescent dye left on a surface for an extended period of time cannot be removed.
- Never spray the fluorescent dye cleaning agent on hot surfaces (engine exhaust manifold, etc.).
- Never use more than one refrigerant dye bottle [1/4 ounce (7.4 cc)] per A/C system.
- Leak detection dyes for HFC-134a (R-134a) and CFC-12 (R-12) A/C systems are different. Never use HFC-134a (R-134a) leak detection dye in CFC-12 (R-12) A/C system, or CFC-12 (R-12) leak detection dye in HFC-134a (R-134a) A/C system, or A/C system damage may result.
- The fluorescent properties of the dye remains for three or more years unless a compressor malfunction occurs.

IDENTIFICATION

NOTE:

Vehicles with factory installed fluorescent dye have a green label.

Vehicles without factory installed fluorescent dye have a blue label.

IDENTIFICATION LABEL FOR VEHICLE

Vehicles with factory installed fluorescent dye have the identification label on the front side of hood.

PREPARATION

< PREPARATION >

PREPARATION

PREPARATION



Special Service Tool

INFOID:000000004786080

The actual shapes of Kent-Moore tools may differ from those of special service tools illustrated here.



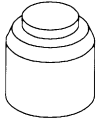
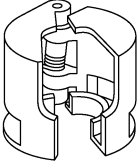

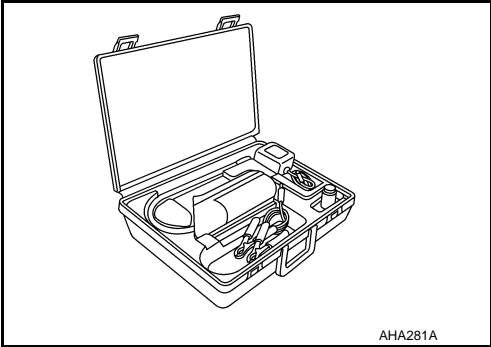
HFC-134a (R-134a) Service Tool and Equipment

- Never mix HFC-134a (R-134a) refrigerant and/or its specified lubricant with CFC-12 (R-12) refrigerant and/or its lubricant.
- Separate and non-interchangeable service equipment must be used for handling each type of refrigerant/lubricant.
- Refrigerant container fittings, service hose fittings and service equipment fittings (equipment which handles refrigerant and/or lubricant) are different between CFC-12 (R-12) and HFC-134a (R-134a). This is to avoid mixed use of the refrigerants/lubricant.
- Never use adapters that convert one size fitting to another: refrigerant/lubricant contamination occurs and compressor malfunction may result.

Tool number (Kent-Moore No.) Tool name		Description
KV99106100 (J-41260) Pulley installer	 S-NT235	Installing pulley
(J-45815) Disconnecter tool set	 RJIA0391J	Disconnect one-touch joint connection
(ACR2005-NI) ACR5 A/C Service Center	 WJIA0293E	Function: Refrigerant recovery, recycling and recharging
(J-41995) Electrical leak detector	 AHA281A	Power supply: DC 12 V (Battery terminal)

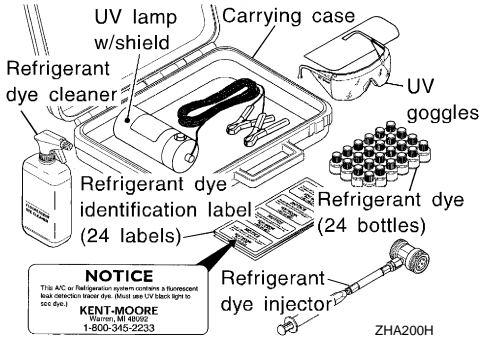
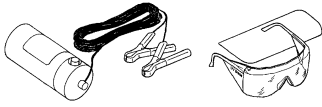
PREPARATION

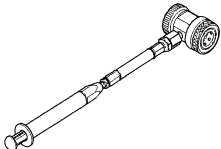
< PREPARATION >

Tool number (Kent-Moore No.) Tool name	Description
<p>(J-43926) Refrigerant dye leak detection kit Kit includes: (J-42220) UV lamp and UV safety goggles (J-41459) HFC-134a (R-134a) dye injector Use with J-41447, 1/4 ounce bottle (J-41447) HFC-134a (R-134a) fluorescent leak detection dye (Box of 24, 1/4 ounce bottles) (J-43872) Refrigerant dye cleaner</p>	 <p style="text-align: center;">Power supply: DC 12 V (Battery terminal)</p>
<p>(J-42220) UV lamp and UV safety goggles</p>	 <p style="text-align: center;">Power supply: DC 12 V (Battery terminal) For checking refrigerant leakage when fluorescent dye is equipped in A/C system Includes: UV lamp and UV safety goggles</p>
<p>(J-41447) HFC-134a (R-134a) fluorescent leak detection dye (Box of 24, 1/4 ounce bottles)</p>	 <p style="text-align: center;">Application: For HFC-134a (R-134a) PAG oil Container: 1/4 ounce (7.4 cc) bottle (Includes self-adhesive dye identification labels for affixing to vehicle after charging system with dye.)</p>
<p>(J-41459) HFC-134a (R-134a) dye injector Use with J-41447, 1/4 ounce bottle</p>	 <p style="text-align: center;">For injecting 1/4 ounce of fluorescent leak detection dye into A/C system</p>
<p>(J-43872) Refrigerant dye cleaner</p>	 <p style="text-align: center;">For cleaning dye spills</p>

PREPARATION

< PREPARATION >

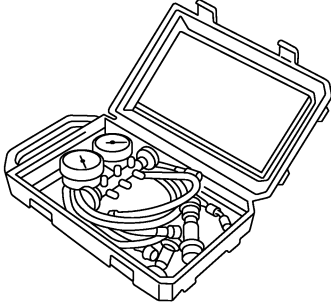
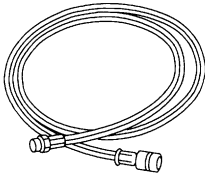
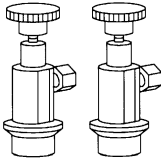
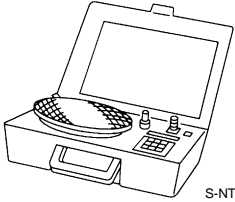
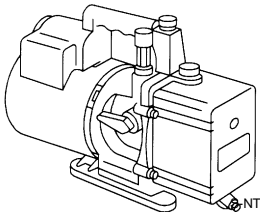
Tool number (Kent-Moore No.) Tool name	Description	A
<p>(J-39183) Manifold gauge set (with hoses and couplers)</p>  <p style="text-align: right; font-size: small;">RJIA0196E</p>	<p>Identification:</p> <ul style="list-style-type: none"> The gauge face indicates HFC-134a (R-134a). <p>Fitting size: Thread size</p> <ul style="list-style-type: none"> 1/2"-16 ACME 	B C D
<p>Service hoses</p> <ul style="list-style-type: none"> High-pressure side hose (J-39501-72) Low-pressure side hose (J-39502-72) Utility hose (J-39476-72)  <p style="text-align: right; font-size: small;">S-NT201</p>	<p>Hose color:</p> <ul style="list-style-type: none"> Low-pressure side hose: Blue with black stripe High-pressure side hose: Red with black stripe Utility hose: Yellow with black stripe or green with black stripe <p>Hose fitting to gauge:</p> <ul style="list-style-type: none"> 1/2"-16 ACME 	E F G
<p>Service couplers</p> <ul style="list-style-type: none"> High-pressure side coupler (J-39500-20) Low-pressure side coupler (J-39500-24)  <p style="text-align: right; font-size: small;">S-NT202</p>	<p>Hose fitting to service hose: M14 x 1.5 fitting is optional or permanently attached.</p>	H HA
<p>(J-39650) Refrigerant weight scale</p>  <p style="text-align: right; font-size: small;">S-NT200</p>	<p>For measuring of refrigerant</p> <p>Fitting size: Thread size</p> <p>1/2"-16 ACME</p>	J K L
<p>(J-39649) Vacuum pump (Including the isolator valve)</p>  <p style="text-align: right; font-size: small;">S-NT203</p>	<p>Capacity:</p> <ul style="list-style-type: none"> Air displacement: 4 CFM Micron rating: 20 microns Oil capacity: 482 g (17 oz.) <p>Fitting size: Thread size</p> <ul style="list-style-type: none"> 1/2"-16 ACME 	M N O P

PREPARATION

< PREPARATION >

Commercial Service Tool

INFOID:000000004786081

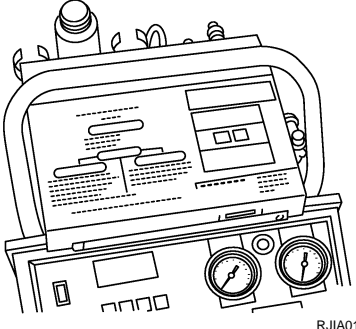
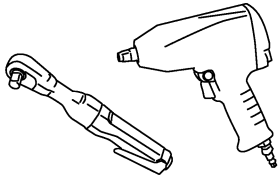

Tool name	Description
<p>Refrigerant identifier equipment</p>  <p style="text-align: right; font-size: small;">RJIA0197E</p>	<p>Checking for refrigerant purity and system contamination</p>
<p>Power tool</p>  <p style="text-align: right; font-size: small;">PBIC0190E</p>	<p>For loosening bolts and nuts</p>

Sealant or/and Lubricant

INFOID:000000004786082

HFC-134a (R-134a) Service Tool and Equipment

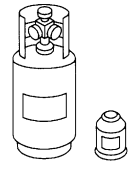
- Never mix HFC-134a (R-134a) refrigerant and/or its specified lubricant with CFC-12 (R-12) refrigerant and/or its lubricant.
- Separate and non-interchangeable service equipment must be used for handling each type of refrigerant/lubricant.
- Refrigerant container fittings, service hose fittings and service equipment fittings (equipment which handles refrigerant and/or lubricant) are different between CFC-12 (R-12) and HFC-134a (R-134a). This is to avoid mixed use of the refrigerants/lubricant.
- Never use adapters that convert one size fitting to another: refrigerant/lubricant contamination occurs and compressor malfunction may result.

Tool name	Description
<p>HFC-134a (R-134a) refrigerant</p>  <p style="text-align: right; font-size: small;">S-NT196</p>	<p>Container color: Light blue Container marking: HFC-134a (R-134a) Fitting size: Thread size</p> <ul style="list-style-type: none"> • Large container 1/2" -16 ACME
<p>UV Luminous Oil Type S (DH-PS)</p>  <p style="text-align: right; font-size: small;">S-NT197</p>	<p>Type: Polyalkylene glycol oil (PAG), type S (DH-PS) Application: HFC-134a (R-134a) swash plate compressors Capacity: 40 mℓ (1.4 US fl oz., 1.4 Imp fl oz.)</p>

REFRIGERANT

< PERIODIC MAINTENANCE >

PERIODIC MAINTENANCE

REFRIGERANT

Collection and Charge

INFOID:000000004786083

SETTING OF SERVICE TOOLS AND EQUIPMENT

Discharging Refrigerant

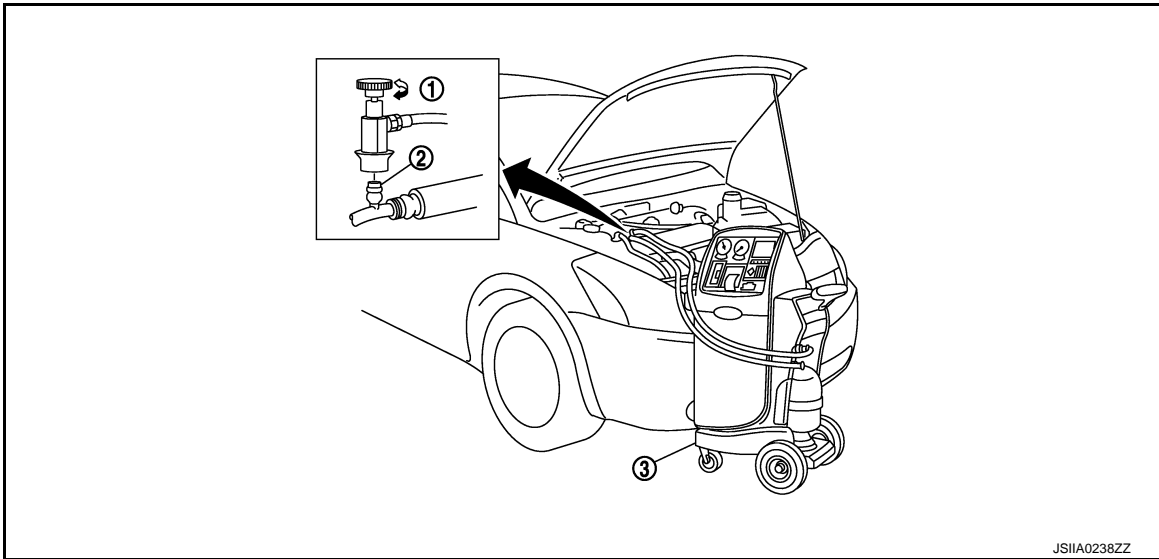

1. Shut-off valve
2. A/C service valve
3. Recovery/recycling recharging equipment

Evacuating System and Charging Refrigerant

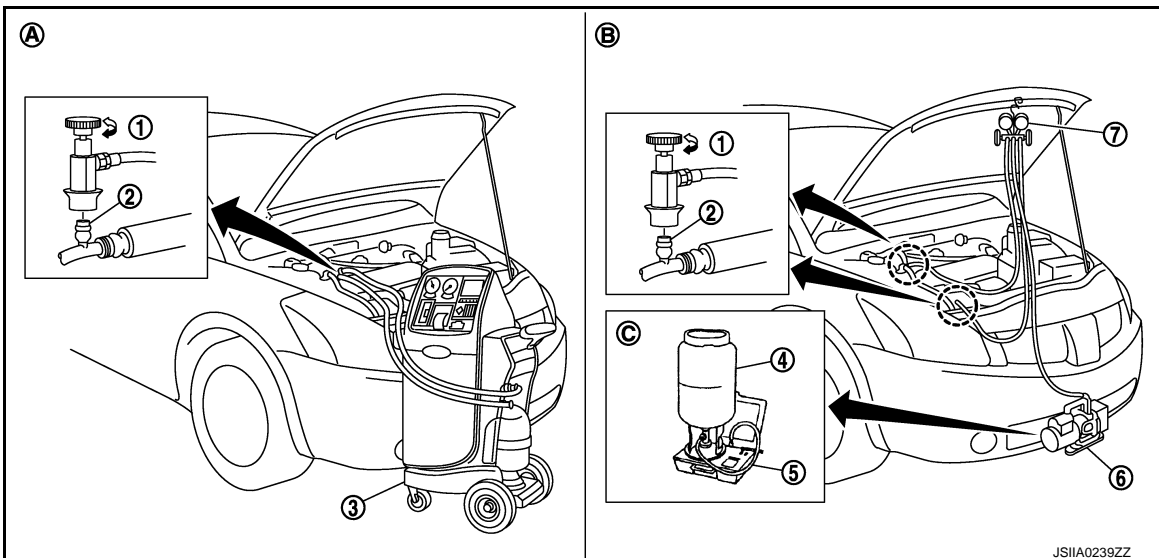

1. Shut-off valve
 2. A/C service valve
 3. Recovery/recycling recharging equipment
 4. Refrigerant container (HFC-134a)
 5. Weight scale (J-39650)
 6. Vacuum pump (J-39649)
 7. Manifold gauge set (J-39183)
- A. Preferred (best) method B. Alternative method C. For charging

Procedure

A
B
C
D
E
F
G
H
HA
J
K
L
M
N
O
P

REFRIGERANT

< PERIODIC MAINTENANCE >

WARNING:

Never breathe A/C refrigerant and lubricant vapor or mist. Exposure may irritate eyes, nose and throat. Remove HFC-134a (R-134a) from A/C system using certified service equipment meeting requirements of SAE J-2210 [HFC-134a (R-134a) recycling equipment] or J-2209 [HFC-134a (R-134a) recovery equipment]. Ventilate work area before resuming service if accidental system discharge occurs. Additional health and safety information may be obtained from refrigerant and lubricant manufacturers.

1. CHECK A/C SYSTEM

1. Check that A/C system operates normally. Refer to [HAC-7, "Description & Inspection"](#).
2. Check if there is a large amount of leakage of refrigerant or lubricant.

CAUTION:

Never perform the lubricant return operation if a large amount of leakage of lubricant is detected.

Is the inspection result normal?

YES >> GO TO 2.

NO-1 >> Check for refrigerant leakage. Refer to [HA-34, "Inspection"](#).

NO-2 >> If using electrical leak detector (SST: J-41995). Refer to [HA-35, "Inspection"](#).

2. LUBRICANT RETURN OPERATION

1. Start the engine and run it as follows.
 - Engine speed: Idle – 1,200 rpm
 - A/C switch: ON
 - Fan speed: Maximum position
 - Set temperature: Full hot
 - Intake position: Recirculation (REC)
2. Perform lubricant return operation for approximately 10 minutes.
3. Stop the engine.

>> GO TO 3.

3. CHECK RECOVERY/RECYCLING RECHARGING EQUIPMENT

1. Operate recovery/recycling recharging equipment.

CAUTION:

- Follow the instructions of the manufacturer for the handling or maintenance of the equipment.
- Never fill the equipment with undesignated refrigerant.

2. Check the gauge pressure of recovery/recycling recharging equipment.

Is there pressure?

YES >> GO TO 4.

NO >> GO TO 5.

4. DISCHARGE REFRIGERANT INSIDE PIPES

Discharge the refrigerant from the high-pressure hose and low-pressure hose of recovery/recycling recharging equipment.

>> GO TO 5.

5. CONNECT RECOVERY/RECYCLING RECHARGING EQUIPMENT

1. Remove the service valve caps from the vehicle.
2. Connect recovery/recycling recharging equipment to the service valves.

>> GO TO 6.

6. DISCHARGE REFRIGERANT FROM THE VEHICLE

Operate recovery/recycling recharging equipment to discharge the refrigerant from the vehicle.

>> GO TO 7.

7. REMOVE ANY REMAINING REFRIGERANT

REFRIGERANT

< PERIODIC MAINTENANCE >

Evacuate air for approximately 10 minutes or more to remove any remaining refrigerant integrated to the compressor oil, etc.

>> GO TO 8.

8. REPLACE OR REPAIR REFRIGERANT SYSTEM PARTS

1. Replace or repair the malfunctioning part.

CAUTION:

- Always use a new O-ring for the parts that the cooler system was removed.
- Apply compressor oil to the O-rings of piping when installing the piping. However, never apply it to the threads.

2. Adjust the compressor oil amount according to the replaced parts. Refer to [HA-29, "Description"](#).

>> GO TO 9.

9. EVACUATE AIR FROM THE REFRIGERANT SYSTEM

Evacuate air from the refrigerant system for approximately 25 minutes or more.

CAUTION:

Evacuate air for at least approximately 15 minutes or more if the parts are replaced.

>> GO TO 10.

10. CHECK AIRTIGHTNESS OF REFRIGERANT SYSTEM

Check the airtightness of the refrigerant system for approximately 25 minutes or more.

CAUTION:

Check the airtightness for at least approximately 15 minutes or more if the parts are replaced.

Does the pressure decrease?

YES >> GO TO 11.

NO >> GO TO 8.

11. CHECK REFRIGERANT LEAKAGE

1. Connect refrigerant recovery/recycling recharging equipment or manifold gauge set (SST: J-39183).

2. Charge the refrigerant of approximately 200 g (7.05 oz) to the refrigerant system.

3. Check for refrigerant leakage. Refer to [HA-34, "Inspection"](#).

NOTE:

When using electrical leak detector (SST: J-41995). Refer to [HA-35, "Inspection"](#).

Is the inspection result normal?

YES >> GO TO 12.

NO >> Repair or replace parts according to the inspection results.

12. CHARGE REFRIGERANT

1. Connect recovery/recycling recharging equipment or manifold gauge set (SST: J-39183).

2. Evacuate air again.

3. Charge the specified amount of refrigerant to the refrigerant system.

>> GO TO 13.

13. CHECK REFRIGERANT LEAKAGE

Check for refrigerant leakage again. Refer to [HA-34, "Inspection"](#).

NOTE:

When using electrical leak detector (SST: J-41995). Refer to [HA-35, "Inspection"](#).

Is the inspection result normal?

YES >> GO TO 14.

NO >> GO TO 6.

14. CHECK OPERATION

Check the A/C system for normal operation. Refer to [HA-32, "Inspection"](#).

A

B

C

D

E

F

G

H

HA

J

K

L

M

N

O

P

REFRIGERANT

< PERIODIC MAINTENANCE >

Is the inspection result normal?

YES >> GO TO 15.

NO >> Repair or replace parts according to the inspection results.

15.CHECK RECOVERY/RECYCLING RECHARGING EQUIPMENT

1. Disconnect recovery/recycling recharging equipment or manifold gauge set (SST: J-39183).
2. Discharge the refrigerant from the high-pressure hose and low-pressure hose of the recovery/recycling recharging equipment.
3. Install the service valve caps.

>> INSPECTION END

LUBRICANT

< PERIODIC MAINTENANCE >

LUBRICANT

Description

INFOID:000000004786084

MAINTENANCE OF LUBRICANT QUANTITY

The lubricant in the compressor circulates through the system with the refrigerant. Add lubricant to compressor when replacing any component or after a large refrigerant leakage occurred. It is important to maintain the specified amount.

The following malfunctions may result if lubricant quantity is not maintained normally:

- Lack of lubricant: May lead to a seized compressor.
- Excessive lubricant: Inadequate cooling (thermal exchange interference)

LUBRICANT

Name : **UV Luminous Oil Type S**

Adjustment

INFOID:000000004786085

LUBRICANT RETURN OPERATION

Adjust the lubricant quantity according to the test group shown below.

1. CHECK A/C SYSTEM

1. Check that A/C system operates normally. Refer to [HAC-7, "Description & Inspection"](#).
2. Check if there is a large amount of leakage of refrigerant or lubricant.

CAUTION:

Never perform the lubricant return operation if a large amount of leakage of lubricant is detected.

Is the inspection result normal?

YES >> GO TO 2.

NO-1 >> Check for refrigerant leakage. Refer to [HA-34, "Inspection"](#).

NO-2 >> If using electrical leak detector (SST: J-41995). Refer to [HA-35, "Inspection"](#).

2. PERFORM LUBRICANT RETURN OPERATION

1. Start the engine, and run it as following.
 - Engine speed: Idle – 1,200 rpm
 - A/C switch: ON
 - Fan speed: Maximum position
 - Set temperature: Full hot
 - Intake position: Recirculation (REC)
2. Perform lubricant return operation for approximately 10 minutes.
3. Stop the engine.

>> GO TO 3.

3. REPAIR OR REPLACE MALFUNCTIONING PART

1. Repair or replace the malfunctioning part.
2. Perform the lubricant adjustment depending on the replaced part.

Except compressor >> Refer to [HA-29, "Lubricant Adjusting Procedure for Components Replacement Except Compressor"](#).

Compressor >> Refer to [HA-30, "Lubricant Adjusting Procedure for Compressor Replacement"](#).

Lubricant Adjusting Procedure for Components Replacement Except Compressor

INFOID:000000004786086

Add the correct amount of lubricant to the system after replacing any of the following major components.
Amount of lubricant to be added:

A
B
C
D
E
F
G
H
HA
J
K
L
M
N
O
P

LUBRICANT

< PERIODIC MAINTENANCE >

Replaced part	Lubricant to be added to system	Remarks
	Amount of lubricant m ℓ (US fl oz., Imp fl oz.)	
Evaporator	75 (2.5, 2.6)	—
Condenser	35 (1.2, 1.2)	—
Liquid tank	10 (0.3, 0.4)	—
In case of refrigerant leakage	30 (1.0, 1.1)	Large leakage
	—	Small leakage *1

*1: No addition of lubricant is needed if the refrigerant leakage is small.

Lubricant Adjusting Procedure for Compressor Replacement

INFOID:000000004786087

1. Check recovery/recycling recharging equipment gauges before connecting recovery/recycling recharging equipment to vehicle. No refrigerant pressure should be displayed. Recover refrigerant from equipment lines if NG.
2. Connect recovery/recycling recharging equipment to vehicle. Confirm refrigerant purity in supply tank using recovery/recycling recharging equipment and refrigerant identifier. Refer to [HA-12, "Working with HFC-134a \(R-134a\)"](#) if NG.
3. Confirm refrigerant purity in vehicle A/C system using recovery/recycling recharging equipment and refrigerant identifier. If NG, refer to [HA-12, "Working with HFC-134a \(R-134a\)"](#).
4. Discharge refrigerant into the recovery/recycling recharging equipment. Measure lubricant discharged into the recovery/recycling recharging equipment.
5. Drain the lubricant from the old (removed) compressor into a graduated container and recover the amount of lubricant drained.
6. Drain the lubricant from the new compressor into a separate. Then clean container.
7. Measure an amount of new lubricant installed equal to amount drained from old compressor. Add this lubricant to new compressor through the suction port opening.
8. Measure an amount of new lubricant equal to the amount recovered during discharging. Add this lubricant to new compressor through the suction port opening.
9. Add another 5 m ℓ (0.2 US fl oz., 0.2 Imp fl oz.) of lubricant at this time if the liquid tank also needs to be replaced.

LUBRICANT

< PERIODIC MAINTENANCE >

Do not add this 5 mℓ (0.2 US fl oz., 0.2 Imp fl oz.) of lubricant when replacing the compressor only.

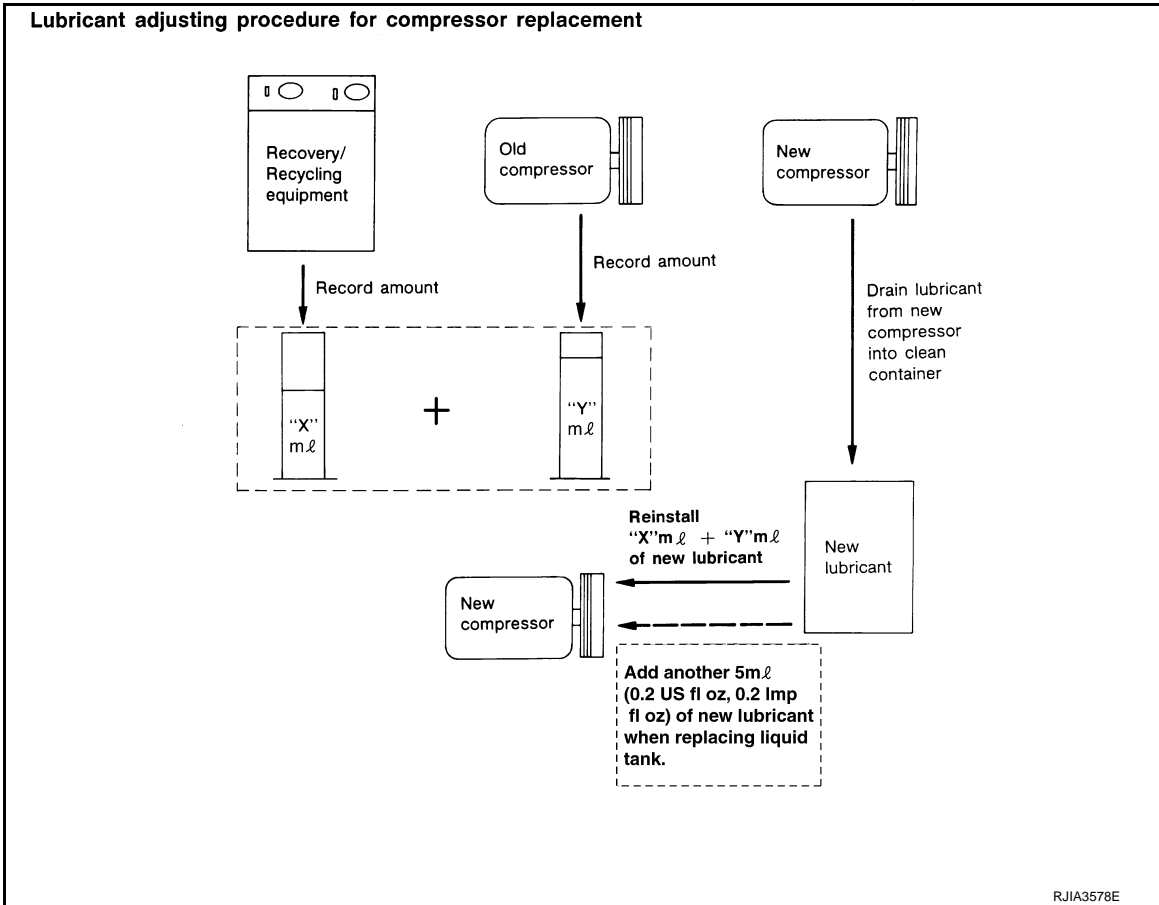

A
B
C
D
E
F
G
H
HA
J
K
L
M
N
O
P

REFRIGERATION SYSTEM

< PERIODIC MAINTENANCE >

REFRIGERATION SYSTEM

Inspection

INFOID:000000004786088

1. CHECK THE BLOWER MOTOR OPERATION

Check the blower motor operation. Refer to [HAC-59, "Component Function Check"](#).

Is the inspection result normal?

YES >> GO TO 2.

NO >> Repair or replace the parts according to the inspection results.

2. CHECK COMPRESSOR OPERATION

Check compressor operation. Refer to [HAC-63, "Component Function Check"](#).

Is the inspection result normal?

YES >> GO TO 3.

NO >> Repair or replace the parts according to the inspection results.

3. CHECK REFRIGERANT CYCLE PRESSURE

Connect recovery/recycling/recharging equipment to the vehicle and perform the diagnosis with the gauge pressure. Refer to [HA-7, "Trouble Diagnosis For Unusual Pressure"](#).

Is the inspection result normal?

YES >> Perform the performance test. Refer to [HA-32, "Performance Chart"](#).



NO >> Repair or replace the parts according to the inspection results.

Performance Chart

INFOID:000000004786089

TEST CONDITION

Testing must be performed as per the following:

Vehicle condition	Indoors or in the shade (in a well-ventilated place)
Doors	Closed
Door windows	Open
Hood	Open
Set temperature	Full cold
Mode switch	 (Ventilation) set
Intake switch	 (Recirculation) set
Fan speed	Maximum speed set
Engine speed	Idle speed

Operate the air conditioning system for 10 minutes before taking measurements.

TEST READING

Recirculating-to-discharge Air Temperature Table

Inside air (Recirculating air) at blower assembly inlet		Discharge air temperature at center ventilator °C (°F)
Relative humidity %	Air temperature °C (°F)	
50 – 60	20 (68)	6.3 – 7.9 (43 – 46)
	25 (77)	10.6 – 12.8 (51 – 55)
	30 (86)	14.8 – 17.6 (59 – 64)
	35 (95)	19.0 – 22.3 (66 – 72)
60 – 70	20 (68)	7.9 – 9.4 (46 – 49)
	25 (77)	12.8 – 14.9 (55 – 59)
	30 (86)	17.6 – 20.3 (64 – 69)
	35 (95)	22.3 – 25.7 (72 – 78)

REFRIGERATION SYSTEM

< PERIODIC MAINTENANCE >

Ambient Air Temperature-to-operating Pressure Table

Ambient air		High-pressure (Discharge side) kPa (kg/cm ² , psi)	Low-pressure (Suction side) kPa (kg/cm ² , psi)
Relative humidity %	Air temperature °C (°F)		
50 – 70	20 (68)	768 – 940 (7.8 – 9.6, 111.4 – 136.3)	180 – 220 (1.8 – 2.2, 26.1 – 31.9)
	25 (77)	925 – 1,131 (9.4 – 11.5, 134.1 – 164.0)	218 – 267 (2.2 – 2.7, 31.6 – 38.7)
	30 (86)	1,082 – 1,322 (11.0 – 13.5, 156.9 – 191.7)	258 – 314 (2.6 – 3.2, 37.4 – 45.5)
	35 (95)	1,238 – 1,513 (12.6 – 15.4, 179.5 – 219.4)	296 – 362 (3.0 – 3.7, 42.9 – 52.5)
	40 (104)	1,395 – 1,704 (14.2 – 17.4, 202.3 – 247.1)	335 – 408 (3.4 – 4.2, 48.6 – 59.2)

Refrigerant Leakages

INFOID:000000004786090

Perform a visual inspection of all refrigeration parts, fittings, hoses and components for signs of A/C lubricant leakage, damage and corrosion. A/C lubricant leakage may indicate an area of refrigerant leakage. Allow extra inspection time in these areas when using either an electrical leak detector or fluorescent dye leak detector [refrigerant dye leak detection kit (SST: J-43926)].

Confirm the leakage with an electrical leak detector if dye is observed. It is possible a prior leakage was repaired and not properly cleaned.

Do not stop when one leakage is found but continue checking for additional leakages at all system components and connections when searching for leakages.

Move the probe along the suspected leakage area at 1 to 2 inches per second and no further than 1/4 inch from the component when searching for refrigerant leakages using an electrical leak detector.

CAUTION:

Moving the electrical leak detector probe slower and closer to the suspected leakage area improves the chances of finding a leakage.

A
B
C
D
E
F
G
H
HA
J
K
L
M
N
O
P

FLUORESCENT LEAK DETECTOR

< PERIODIC MAINTENANCE >

FLUORESCENT LEAK DETECTOR

Inspection

INFOID:000000004786091

CHECKING SYSTEM FOR LEAKAGES USING THE FLUORESCENT LEAK DETECTOR

1. Check A/C system for leakages using the UV lamp and safety goggles (SST: J-42220) in a low sunlight area (area without windows preferable). Illuminate all components, fittings and lines. The dye appears as a bright green/yellow area at the point of leakage. Fluorescent dye observed at the evaporator drain opening indicates an evaporator core assembly (tubes, core or expansion valve) leakage.
2. Use an adjustable mirror or wipe the area with a clean shop rag or cloth, with the UV lamp for dye residue if the suspected area is difficult to see.
3. Remove any residual dye using dye cleaner (SST: J-43872) to prevent future misdiagnosis after the leakage is repaired.
4. Perform a system performance check and verify the leakage repair with an approved electrical leak detector.

NOTE:

Other gases in the work area or substances on the A/C components, for example, anti-freeze, windshield washer fluid, solvents and lubricants, may falsely trigger the leak detector. Make sure the surfaces to be checked are clean.

Clean with a dry cloth or blow off with shop air.

Do not allow the sensor tip of the detector to contact with any substance. This may also cause false readings and may damage the detector.

DYE INJECTION

(This procedure is only necessary when recharging the system or when the compressor has seized and was replaced.)

1. Check A/C system static (at rest) pressure. Pressure must be at least 345 kPa (3.52 kg/cm², 50 psi).
2. Pour one bottle [1/4 ounce (7.4 cc)] of the A/C refrigerant dye into the injector tool (SST: J-41459).
3. Connect the injector tool to the A/C low-pressure side service valve.
4. Start the engine. Then A/C switch ON.
5. Inject one bottle [1/4 ounce (7.4 cc)] of fluorescent dye through the low-pressure service valve using dye injector tool (SST: J-41459) (refer to the manufacture's operating instructions) when the A/C operating (compressor running).
6. Disconnect the injector tool from the service valve with the engine still running.

CAUTION:

Be careful when replacing the A/C system or a component, pour the dye directly into the open system connection and proceed with the service procedures.

7. Operate the A/C system for a minimum of 20 minutes to mix the dye with the system oil. Depending on the leakage size, operating conditions and location of the leakage, it may take from minutes to days for the dye to penetrate a leakage and become visible.
8. Attach a blue label if necessary.

ELECTRICAL LEAK DETECTOR

< PERIODIC MAINTENANCE >

ELECTRICAL LEAK DETECTOR

Inspection

INFOID:000000004786092

PRECAUTIONS FOR HANDLING LEAK DETECTOR

Use an electrical leak detector (SST: J-41995) or equivalent when performing a refrigerant leakage check. Ensure that the instrument is calibrated and set properly per the operating instructions.

The leak detector is a delicate device. Read the operating instructions and perform any specified maintenance for using the leak detector properly.

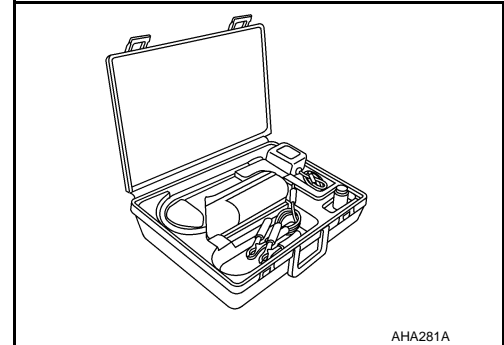

1. Position probe approximately 3 mm (0.12 in) away from point to be checked.

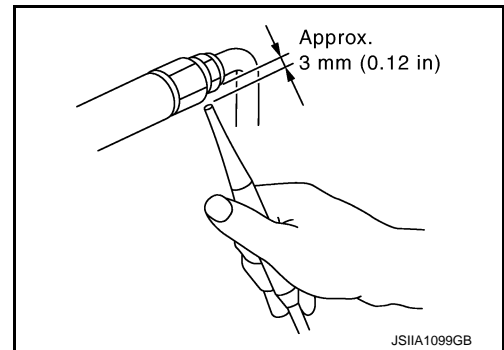

2. Circle each fitting completely with probe when testing.

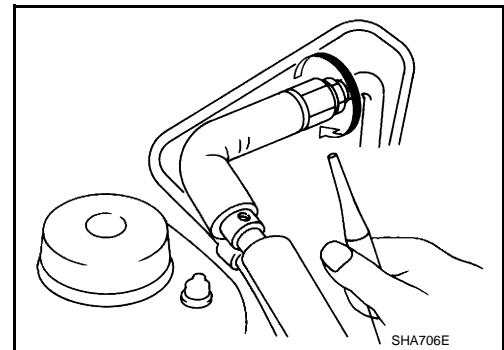

3. Move probe along component approximately 25 to 50 mm (1 to 2 in)/sec.

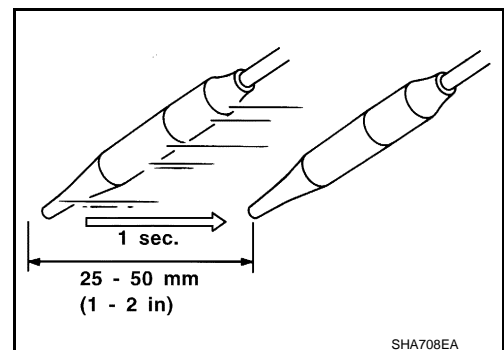

CHECKING PROCEDURE

Check that there is no refrigerant vapor, shop chemicals, or cigarette smoke in the vicinity of the vehicle to prevent inaccurate or false readings. Perform the leakage test in calm area (low air/wind movement) so that the leaking refrigerant is not dispersed.

1. Stop the engine.

A
B
C
D
E
F
G
H
HA
J
K
L
M
N
O
P

ELECTRICAL LEAK DETECTOR

< PERIODIC MAINTENANCE >

2. Connect a suitable A/C manifold gauge set (SST: J-39183) to the A/C service valves.
3. Check if the A/C refrigerant pressure is at least 345 kPa (3.45 bar, 3.52 kg/cm², 50 psi) above 16°C (61°F). Recover/evacuate and recharge the system with the specified amount of refrigerant if less than specification.

NOTE:

Leakages may not be detected since the system may not reach 345 kPa (3.45 bar, 3.52 kg/cm², 50 psi) at temperatures below 16°C (61°F).

4. Perform the leakage test in the numerical as shown in the figure. [high-pressure side (compressor discharge “a” to evaporator inlet “j”) to low-pressure side (evaporator drain hose “k” to shaft seal “p”)]
Clean the component to be checked and move the leakage detected probe completely around the connection/component.

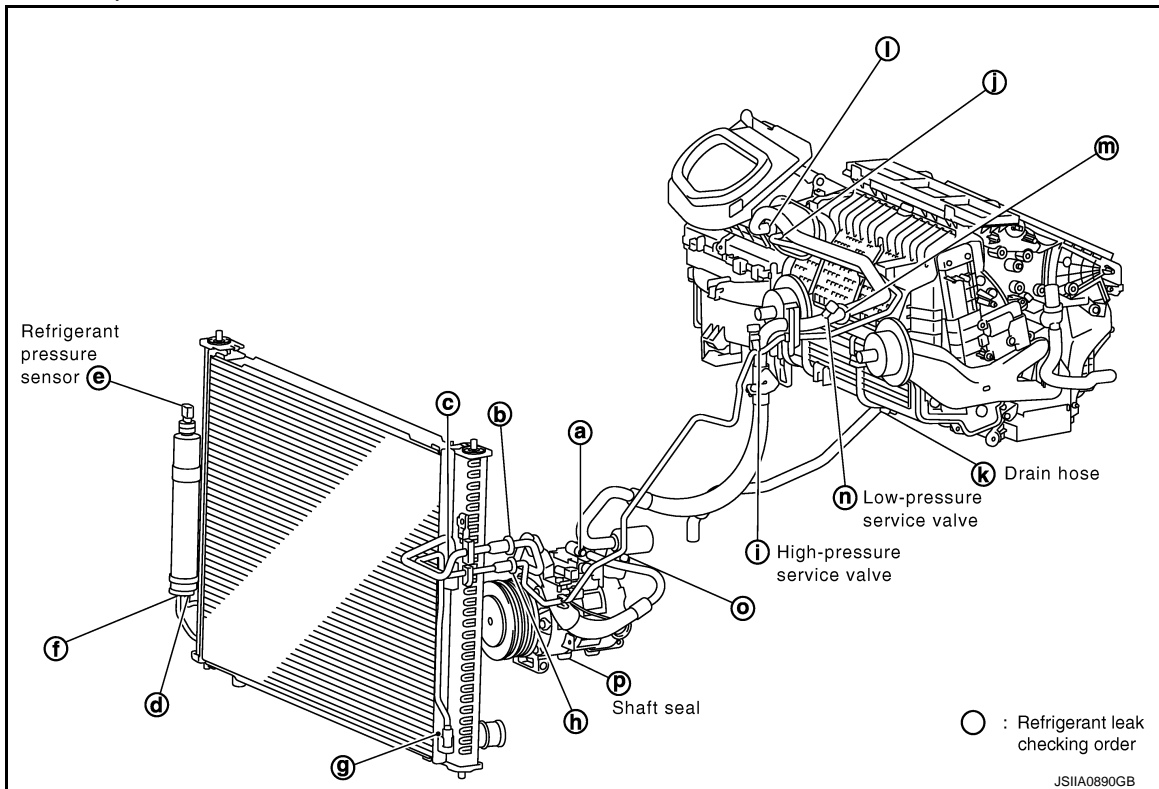

NOTE:

Check the following carefully.

Service valves

- Check all around the service valves. Ensure service valve caps are secured on the service valves (to prevent leakages).
- Wipe any residue from valves to prevent any false readings by leak detector after removing manifold gauge set (SST: J-39183) from service valves.

Cooling unit (Evaporator)

- Turn blower fan on “High” for at least 15 seconds to dissipate any refrigerant trace in the cooling unit with engine OFF.
 - Wait a minimum of 10 minutes accumulation time (refer to the manufacturer’s recommended procedure for actual wait time) before inserting the leak detector probe into the drain hose.
 - Keep the probe inserted for at least 10 seconds. Use caution not to contaminate the probe tip with water or dirt that may be in the drain hose.
5. Verify at least once by blowing compressed air into area of suspected leakage, then repeat check as outlined above if a leak detector detects a leakage.
 6. If a leakage is found, but continue checking for additional leakages at all system components. When leakages are not found, go to next step.
 7. Start the engine.
 8. Set the A/C control as per the following:
 - a. A/C switch: ON
 - b. Air flow: VENT

ELECTRICAL LEAK DETECTOR

< PERIODIC MAINTENANCE >

- c. Intake door position: REC
- d. Temperature setting: Full cold
- e. Fan speed: Maximum speed set
9. Run engine at 1,500 rpm for at least 2 minutes.
10. Stop the engine and perform leakage check again, steps 4 – 6. Refrigerant leakages should be checked immediately after stopping the engine. Begin with the leak detector at the compressor. The pressure on the high-pressure side drops gradually after refrigerant circulation stops and pressure on the low-pressure side rises gradually, as shown in the graph. Some leakages are more easily detected when pressure is high.

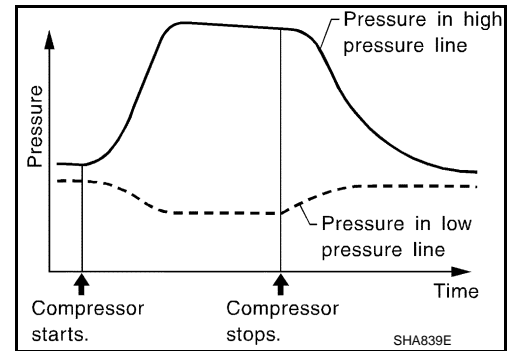

11. Check recovery/recycling recharging equipment gauges before connecting recovery/recycling recharging equipment to vehicle. No refrigerant pressure should be displayed. Recover refrigerant from equipment lines if pressure is displayed, and then refrigerant purity.
12. Confirm refrigerant purity in supply tank using recovery/recycling recharging equipment and refrigerant identifier.
13. Confirm refrigerant purity in vehicle A/C system using recovery/recycling recharging equipment and refrigerant identifier.
14. Discharge A/C system using approved refrigerant recovery equipment. Repair the leaking fitting or component if necessary.
15. Evacuate and recharge A/C system and perform the leakage test to confirm no refrigerant leakages.
16. Perform A/C performance test to ensure system works normally.

COMPRESSOR

< REMOVAL AND INSTALLATION >

REMOVAL AND INSTALLATION

COMPRESSOR

Exploded View

INFOID:000000004786093

REMOVAL

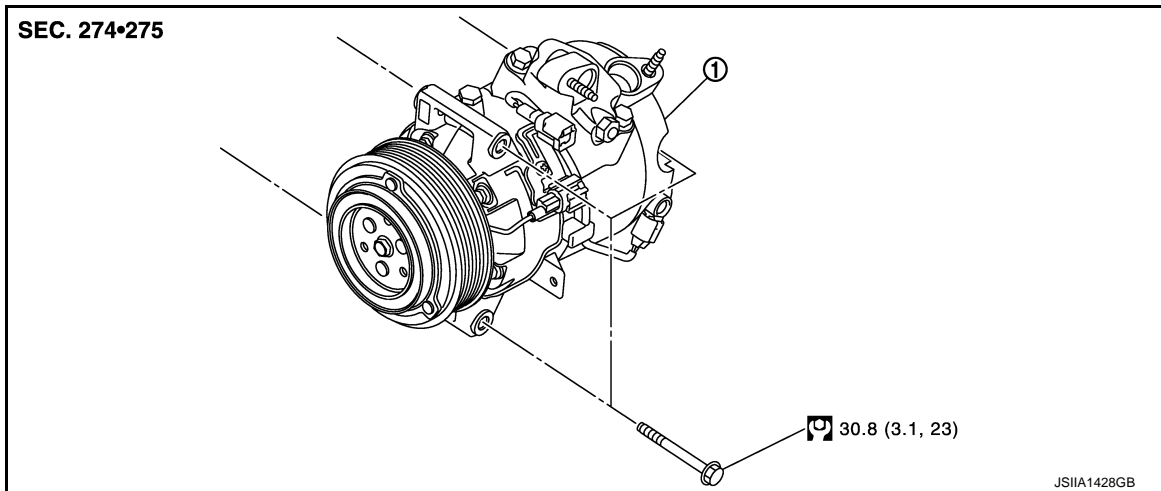

1. Compressor

Refer to [GI-4, "Components"](#) for symbols in the figure.

DISASSEMBLY

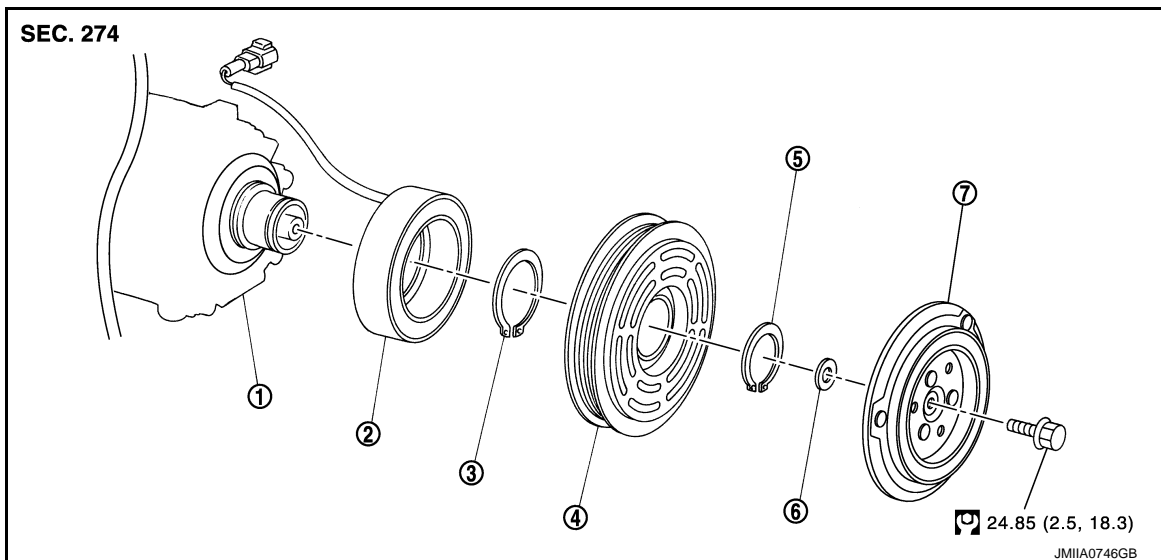

1. Compressor unit

2. Field coil

3. Snap ring

4. Pulley assembly

5. Snap ring

6. Shim

7. Clutch disc

Refer to [GI-4, "Components"](#) for symbols in the figure.

COMPRESSOR

COMPRESSOR : Removal and Installation

INFOID:000000004786094

REMOVAL

COMPRESSOR

< REMOVAL AND INSTALLATION >

1. Use a refrigerant collecting equipment (for HFC-134a) to discharge the refrigerant.
2. Remove air cleaner case (LH) and air duct (LH). Refer to [EM-27, "Exploded View"](#).
3. Remove engine undercover, using power tools.
4. Drain engine coolant from radiator. Refer to [CO-7, "Draining"](#).
5. Remove cooling fan assembly. Refer to [CO-15, "Exploded View"](#).
6. Remove drive belt. Refer to [EM-13, "Exploded View"](#).
7. Remove radiator hose (lower). Refer to [CO-12, "Exploded View"](#).
8. Remove mounting nuts from low-pressure flexible hose and high-pressure flexible hose. Refer to [HA-41, "Exploded View"](#).
9. Disconnect low-pressure flexible hose and high-pressure flexible hose from compressor.
CAUTION:
Cap or wrap the joint of the A/C piping and compressor with suitable material such as vinyl tape to avoid the entry of air.
10. Disconnect ECV connector (A).
11. Disconnect magnet clutch connector (B).

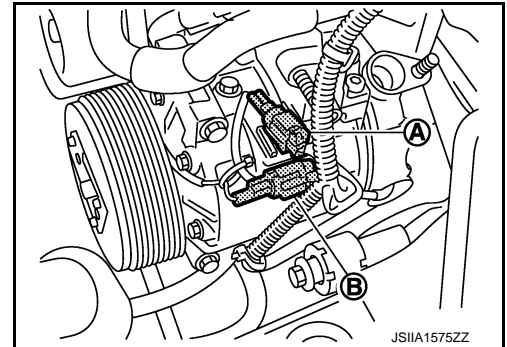

12. Remove mounting bolts from compressor, using power tools.
13. Remove the compressor from top of the vehicle.

INSTALLATION

Installation is basically the reverse order of removal.

CAUTION:

- Replace O-rings with new ones. Then apply compressor oil to them when installing.
- Check for leakages when recharging refrigerant.
- Check tension of the drive belt after installing compressor. Refer to [EM-13, "Checking"](#).

MAGNET CLUTCH

MAGNET CLUTCH : Removal and Installation of Compressor Clutch

INFOID:000000006139978

REMOVAL

Overhaul

1. Fix clutch disc.
2. Remove center bolt, and then remove clutch disc.
3. Remove snap ring using external snap ring pliers.
4. Position center pulley puller on the end of the drive shaft, and remove pulley assembly using any commercially available pulley puller.
To prevent pulley groove from being deformed, puller claws should be positioned into the edge of the pulley assembly.
5. Disconnect field coil harness connector from compressor unit.
6. Remove snap ring using external snap ring pliers, and then remove field coil.

INSTALLATION

1. Install field coil (1).

COMPRESSOR

< REMOVAL AND INSTALLATION >

Be sure to align the coil's pin (2) with the hole in the compressor's front head.

2. Connect field coil harness connector to compressor unit.

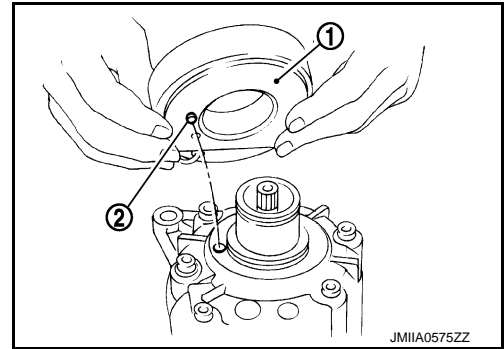

3. Install pulley assembly (1) using pulley installer (SST:KV99106200) (A) and a hand press, and then install snap ring (2) using snap ring pliers.

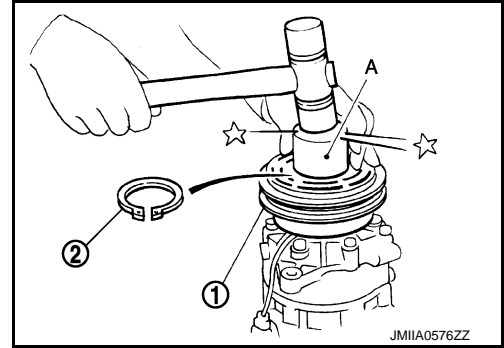

4. Install clutch disc on drive shaft, together with original shim(s). Press clutch disc down by hand.

5. Tighten center bolt to the specified torque while fixing clutch disc not to rotate.
After tightening the bolt, check that the pulley rotates smoothly.

Break-in Operation

When replacing compressor clutch assembly, always perform the break-in operation, by engaging and disengaging the clutch approximately 30-times. Break-in operation increases the level of transmitted torque.

Inspection

INFOID:000000004786095

CHECK DISC TO PULLEY CLEARANCE

Check the clearance (B) between pulley assembly (1) and clutch disc (2) along the entire periphery with a feeler gauge (A).

Standard : Refer to [HA-54, "Compressor"](#).

Replace compressor if specified clearance is not obtained.

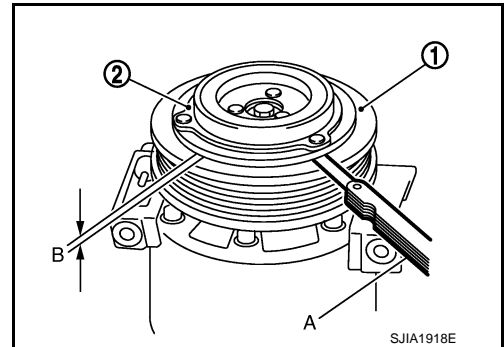

COOLER PIPE AND HOSE

< REMOVAL AND INSTALLATION >

COOLER PIPE AND HOSE

Exploded View

INFOID:000000004786096

Refer to [HA-13, "Refrigerant Connection"](#).

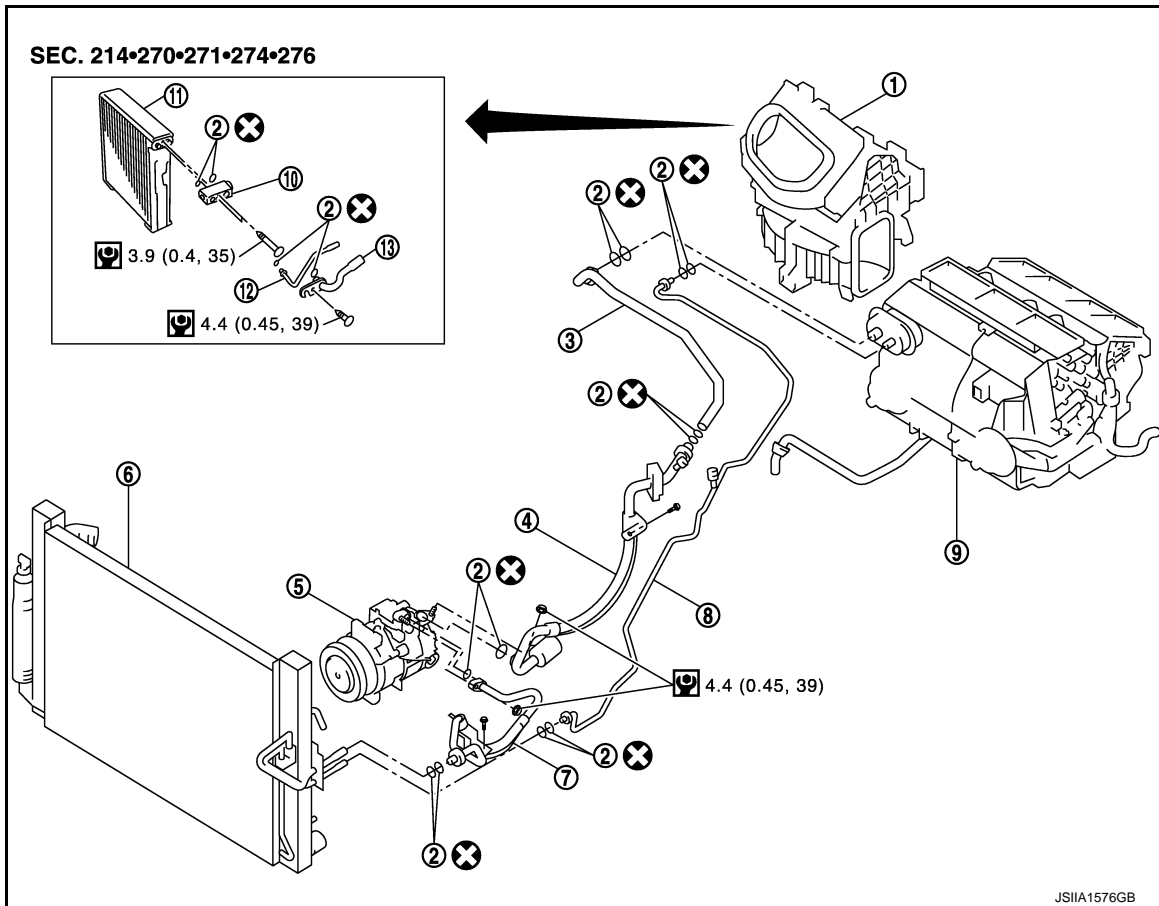

- | | | |
|--------------------------------|-------------------------|-----------------------------------|
| 1. Blower unit | 2. O-ring | 3. Low-pressure pipe 2 |
| 4. Low-pressure flexible hose | 5. Compressor | 6. Radiator & condenser assembly |
| 7. High-pressure flexible hose | 8. High-pressure pipe 1 | 9. Heater & cooling unit assembly |
| 10. Expansion valve | 11. Evaporator | 12. High-pressure pipe 2 |
| 13. Low-pressure pipe 1 | | |

Refer to [GI-4, "Components"](#) for symbols in the figure.

LOW-PRESSURE FLEXIBLE HOSE AND PIPE 2

LOW-PRESSURE FLEXIBLE HOSE AND PIPE 2 : Removal and Installation

INFOID:000000004786097

REMOVAL

1. Use a refrigerant collecting equipment (for HFC-134a) to discharge the refrigerant.
2. Remove engine cover. Refer to [EM-25, "Exploded View"](#).
3. Remove air cleaner case (LH) and air duct (LH). Refer to [EM-27, "Exploded View"](#).
4. Remove cowl top cover. Refer to [EXT-21, "Exploded View"](#).
5. Remove mounting bolt from low-pressure flexible hose bracket.
6. Disconnect one-touch joint between low-pressure pipe 1 and low-pressure pipe 2 with disconnecter (SST: J-45815).

CAUTION:

COOLER PIPE AND HOSE

< REMOVAL AND INSTALLATION >

Cap or wrap the joint of the A/C piping with suitable material such as vinyl tape to avoid the entry of air.

7. Disconnect one-touch joint between low-pressure pipe 2 (1) and low-pressure flexible hose (2) with disconnecter (A) (SST: J-45815).

CAUTION:

Cap or wrap the joint of the A/C piping with suitable material such as vinyl tape to avoid the entry of air.

8. Remove low-pressure pipe 2 clip (B).
9. Remove low-pressure pipe 2.

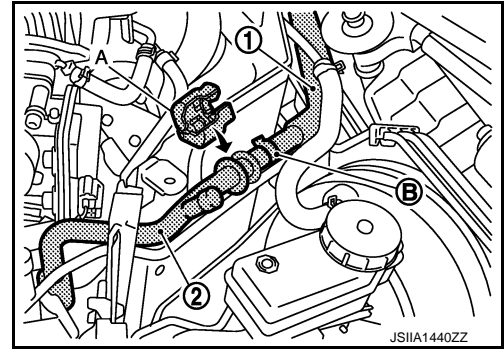

10. Remove mounting nut from low-pressure flexible hose.

CAUTION:

Cap or wrap the joint of the A/C piping and compressor with suitable material such as vinyl tape to avoid the entry of air.

11. Remove low-pressure flexible hose.

INSTALLATION

Installation is basically the reverse order of removal.

CAUTION:

- Replace O-rings with new ones. Then apply compressor oil to them when installing.
- Female-side piping connection is thin and easy to deform. Slowly insert the male-side piping straight in axial direction.
- Insert piping securely until a click is heard.
- After piping connection is completed, pull male-side piping by hand to check that connection does not come loose.
- Check for leakages when recharging refrigerant.

HIGH-PRESSURE FLEXIBLE HOSE

HIGH-PRESSURE FLEXIBLE HOSE : Removal and Installation

INFOID:000000004786098

REMOVAL

1. Use a refrigerant collecting equipment (for HFC-134a) to discharge the refrigerant.
2. Remove engine cover. Refer to [EM-25. "Exploded View"](#).
3. Remove air cleaner case (LH) and air duct (LH). Refer to [EM-27. "Exploded View"](#).
4. Remove mounting bolt from high-pressure flexible hose bracket.
5. Disconnect one-touch joint between high-pressure flexible hose and condenser pipe assembly with disconnecter (SST: J-45815).

CAUTION:

Cap or wrap the joint of the A/C piping with suitable material such as vinyl tape to avoid the entry of air.

6. Remove mounting nut from high-pressure flexible hose, and then remove high-pressure flexible hose.

CAUTION:

Cap or wrap the joint of the A/C piping and compressor with suitable material such as vinyl tape to avoid the entry of air.

INSTALLATION

Installation is basically the reverse order of removal.

CAUTION:

- Replace O-rings with new ones. Then apply compressor oil to them when installing.
- Female-side piping connection is thin and easy to deform. Slowly insert the male-side piping straight in axial direction.
- Insert piping securely until a click is heard.
- After piping connection is completed, pull male-side piping by hand to check that connection does not come loose.

COOLER PIPE AND HOSE

< REMOVAL AND INSTALLATION >

- Check for leakages when recharging refrigerant.

HIGH-PRESSURE PIPE 1

HIGH-PRESSURE PIPE 1 : Removal and Installation

INFOID:000000004786099

REMOVAL

1. Remove low-pressure flexible hose and pipe 2. Refer to [HA-41, "Exploded View"](#).
2. Remove mounting bolt from high-pressure flexible hose bracket.
3. Remove high-pressure pipe 1 (1) from vehicle clips (A).

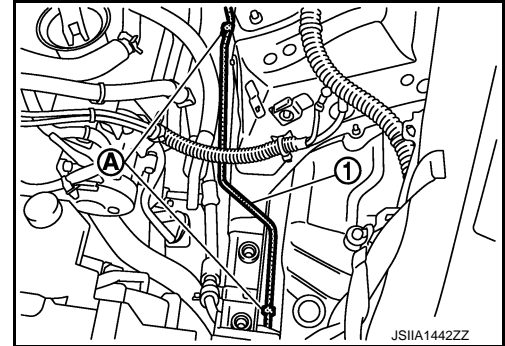

4. Disconnect one-touch joint between high-pressure pipe 1 and high-pressure pipe 2 with disconnecter (SST: J-45815).
CAUTION:
Cap or wrap the joint of the A/C piping with suitable material such as vinyl tape to avoid the entry of air.
5. Disconnect one-touch joint between high-pressure pipe 1 and condenser pipe assembly with disconnecter (SST: J-45815).
CAUTION:
Cap or wrap the joint of the A/C piping with suitable material such as vinyl tape to avoid the entry of air.
6. Remove vacuum hose. Refer to [BR-36, "Exploded View"](#).
7. Remove high-pressure pipe 1.

INSTALLATION

Installation is basically the reverse order of removal.

CAUTION:

- Replace O-rings with new ones. Then apply compressor oil to them when installing.
- Female-side piping connection is thin and easy to deform. Slowly insert the male-side piping straight in axial direction.
- Insert piping securely until a click is heard.
- After piping connection is completed, pull male-side piping by hand to check that connection does not come loose.
- Check for leakages when recharging refrigerant.

LOW-PRESSURE PIPE 1 AND HIGH-PRESSURE PIPE 2

LOW-PRESSURE PIPE 1 AND HIGH-PRESSURE PIPE 2 : Removal and Installation

INFOID:000000004786100

REMOVAL

1. Set the temperature at 18.0°C (60°F).
CAUTION:
The angle may be out, when installing the air mix door motor to the air mix door, unless the above procedure is performed.
2. Disconnect the battery cable from the negative terminal.
3. Use a refrigerant collecting equipment (for HFC-134a) to discharge the refrigerant.
4. Remove cowl top cover. Refer to [EXT-21, "Exploded View"](#).

COOLER PIPE AND HOSE

< REMOVAL AND INSTALLATION >

5. Disconnect one-touch joint between low-pressure pipe 1 and low-pressure pipe 2 with disconnecter (SST: J-45815).
CAUTION:
Cap or wrap the joint of the A/C piping with suitable material such as vinyl tape to avoid the entry of air.
6. Disconnect one-touch joints between high-pressure pipe 1 and high-pressure pipe 2 with disconnecter (SST: J-45815).
CAUTION:
Cap or wrap the joint of the A/C piping with suitable material such as vinyl tape to avoid the entry of air.
7. Remove foot grille (right). Refer to [VTL-10, "Exploded View"](#).
8. Remove blower unit. Refer to [VTL-16, "Exploded View"](#).
9. Remove air mix door motor (passenger side). Refer to [HAC-138, "Exploded View"](#).
10. Remove mode door motor. Refer to [HAC-138, "Exploded View"](#).
11. Remove main link (right) and max. cool door link (right). Refer to [HAC-138, "Exploded View"](#).
12. Remove mounting screws (A), and then remove evaporator cover (1).

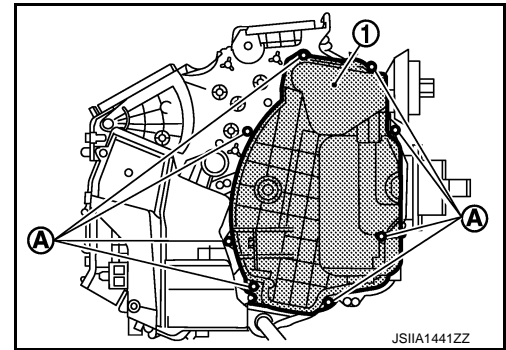

13. Remove mounting bolt, and then remove low-pressure pipe 1 and high-pressure pipe 2.
CAUTION:
Cap or wrap the joint of the A/C piping and expansion valve with suitable material such as vinyl tape to avoid the entry of air.

INSTALLATION

Installation is basically the reverse order of removal.

CAUTION:

- Replace O-rings with new ones. Then apply compressor oil to them when installing.
- Female-side piping connection is thin and easy to deform. Slowly insert the male-side piping straight in axial direction.
- Insert piping securely until a click is heard.
- After piping connection is completed, pull male-side piping by hand to check that connection does not come loose.
- Check for leakages when recharging refrigerant.

CONDENSER

< REMOVAL AND INSTALLATION >

CONDENSER

Exploded View

INFOID:000000004786101

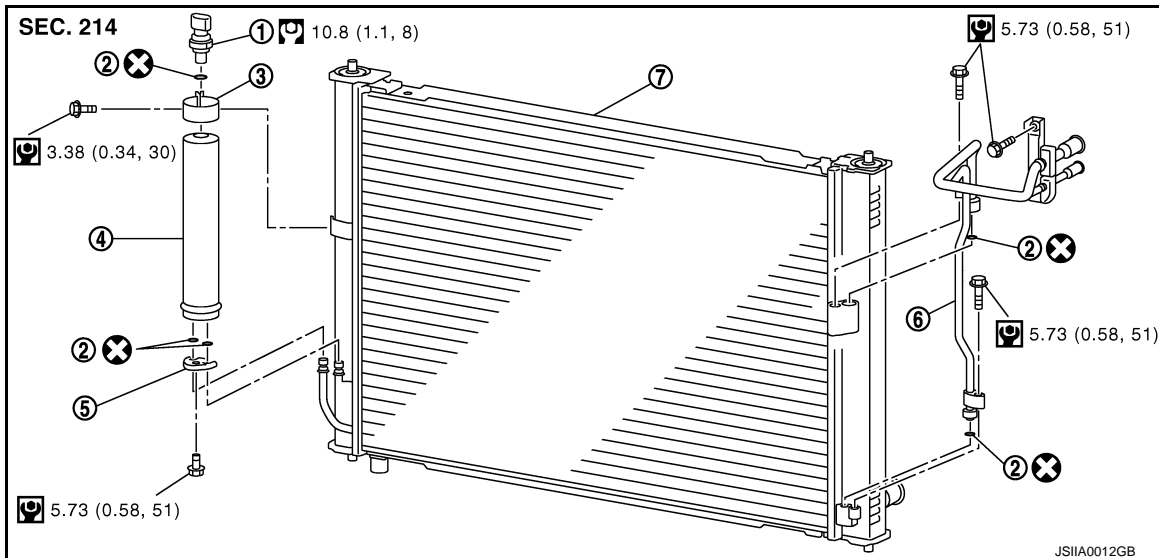

- | | | |
|----------------------------------|------------|----------------------------|
| 1. Refrigerant pressure sensor | 2. O-ring | 3. Liquid tank bracket |
| 4. Liquid tank | 5. Bracket | 6. Condenser pipe assembly |
| 7. Radiator & condenser assembly | | |

Refer to [GI-4, "Components"](#) for symbols in the figure.

CONDENSER

CONDENSER : Removal and Installation

INFOID:000000004786102

REMOVAL

1. Use a refrigerant collecting equipment (for HFC-134a) to discharge the refrigerant.
2. Remove radiator & condenser assembly. Refer to [HA-45, "Exploded View"](#).

CAUTION:

Be careful not to damage core surface of radiator & condenser assembly.

INSTALLATION

Installation is basically the reverse order of removal.

CAUTION:

- Replace O-rings with new ones. Then apply compressor oil to them when installing.
- Female-side piping connection is thin and easy to deform. Slowly insert the male-side piping straight in axial direction.
- Insert piping securely until a click is heard.
- After piping connection is completed, pull male-side piping by hand to check that connection does not come loose.
- Check for leakages when recharging refrigerant.

CONDENSER PIPE ASSEMBLY

CONDENSER PIPE ASSEMBLY : Removal and Installation

INFOID:000000004786103

REMOVAL

1. Use a refrigerant collecting equipment (for HFC-134a) to discharge the refrigerant.
2. Remove bumper fascia assembly. [EXT-12, "Exploded View"](#).
3. Remove air cleaner case (LH) and air duct (LH). Refer to [EM-27, "Exploded View"](#).

CONDENSER

< REMOVAL AND INSTALLATION >

4. Disconnect one-touch joint between high-pressure flexible hose and condenser pipe assembly with disconnecter (SST: J-45815).
CAUTION:
Cap or wrap the joint of the A/C piping with suitable material such as vinyl tape to avoid the entry of air.
5. Disconnect one-touch joints between high-pressure pipe 1 and condenser pipe assembly with disconnecter (SST: J-45815).
CAUTION:
Cap or wrap the joint of the A/C piping with suitable material such as vinyl tape to avoid the entry of air.
6. Remove mounting bolts from condenser pipe assembly.
7. Remove mounting bolt from condenser pipe assembly.
8. Remove condenser pipe assembly.

INSTALLATION

Installation is basically the reverse order of removal.

CAUTION:

- Replace O-rings with new ones. Then apply compressor oil to them when installing.
- Female-side piping connection is thin and easy to deform. Slowly insert the male-side piping straight in axial direction.
- Insert piping securely until a click is heard.
- After piping connection is completed, pull male-side piping by hand to check that connection does not come loose.
- Check for leakages when recharging refrigerant.

LIQUID TANK

LIQUID TANK : Removal and Installation

INFOID:000000004786104

REMOVAL

1. Use a refrigerant collecting equipment (for HFC-134a) to discharge the refrigerant.
2. Remove front grille. Refer to [EXT-19, "Exploded View"](#).
3. Clean liquid tank and its surrounding area. Then remove dust and rust from liquid tank.

CAUTION:

Be sure to clean carefully.

4. Remove mounting bolts from liquid tank.
5. Remove liquid tank.

INSTALLATION

Install liquid tank, and then install liquid tank bracket on condenser.

CAUTION:

- Check that liquid tank bracket is securely installed at protrusion of condenser. (Check that liquid tank bracket does not move to a position below center of liquid tank.)
- Replace O-rings of the A/C piping with new ones. Then apply compressor oil to them when installing.
- Check for leakages when recharging refrigerant.

REFRIGERANT PRESSURE SENSOR

REFRIGERANT PRESSURE SENSOR : Removal and Installation

INFOID:000000004786105

REMOVAL

1. Remove liquid tank. Refer to [HA-45, "Exploded View"](#).

CONDENSER

< REMOVAL AND INSTALLATION >

2. Fix the liquid tank (1) with a vise (A). Remove the refrigerant pressure sensor (2) with a wrench (B).

CAUTION:

Be careful not to damage liquid tank.

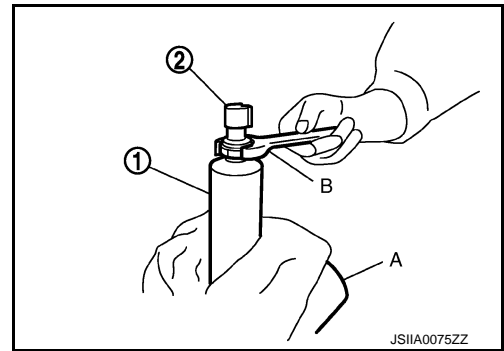

INSTALLATION

Installation is basically the reverse order of removal.

CAUTION:

- Replace O-ring with new one. Then apply compressor oil to them when installing.
- Check for leakages when recharging refrigerant.

A
B
C
D
E
F
G
H
HA
J
K
L
M
N
O
P

HEATER & COOLING UNIT ASSEMBLY

< REMOVAL AND INSTALLATION >

HEATER & COOLING UNIT ASSEMBLY

Exploded View

INFOID:000000004786106

REMOVAL

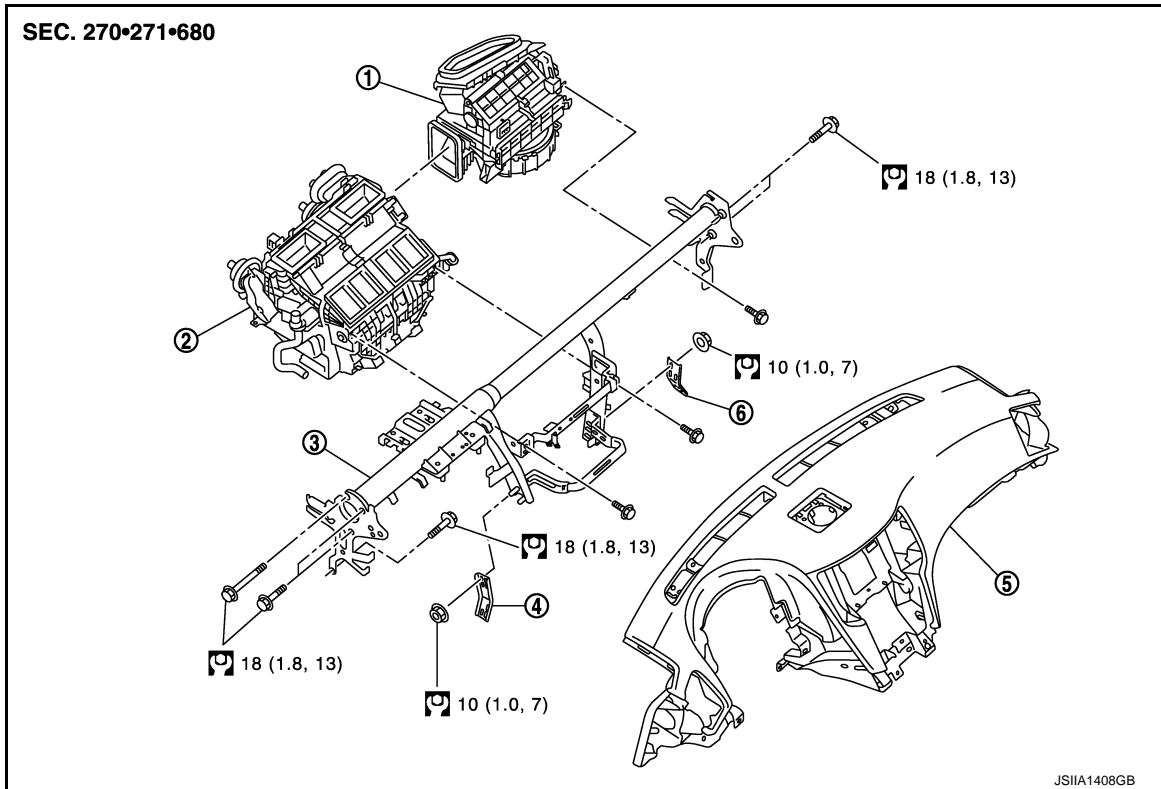

- | | | |
|---------------------------|-----------------------------------|----------------------------|
| 1. Blower unit | 2. Heater & cooling unit assembly | 3. Steering member |
| 4. Instrument stay (left) | 5. Instrument panel assembly | 6. Instrument stay (right) |

Refer to [GI-4, "Components"](#) for symbols in the figure.

DISASSEMBLY

HEATER & COOLING UNIT ASSEMBLY

< REMOVAL AND INSTALLATION >

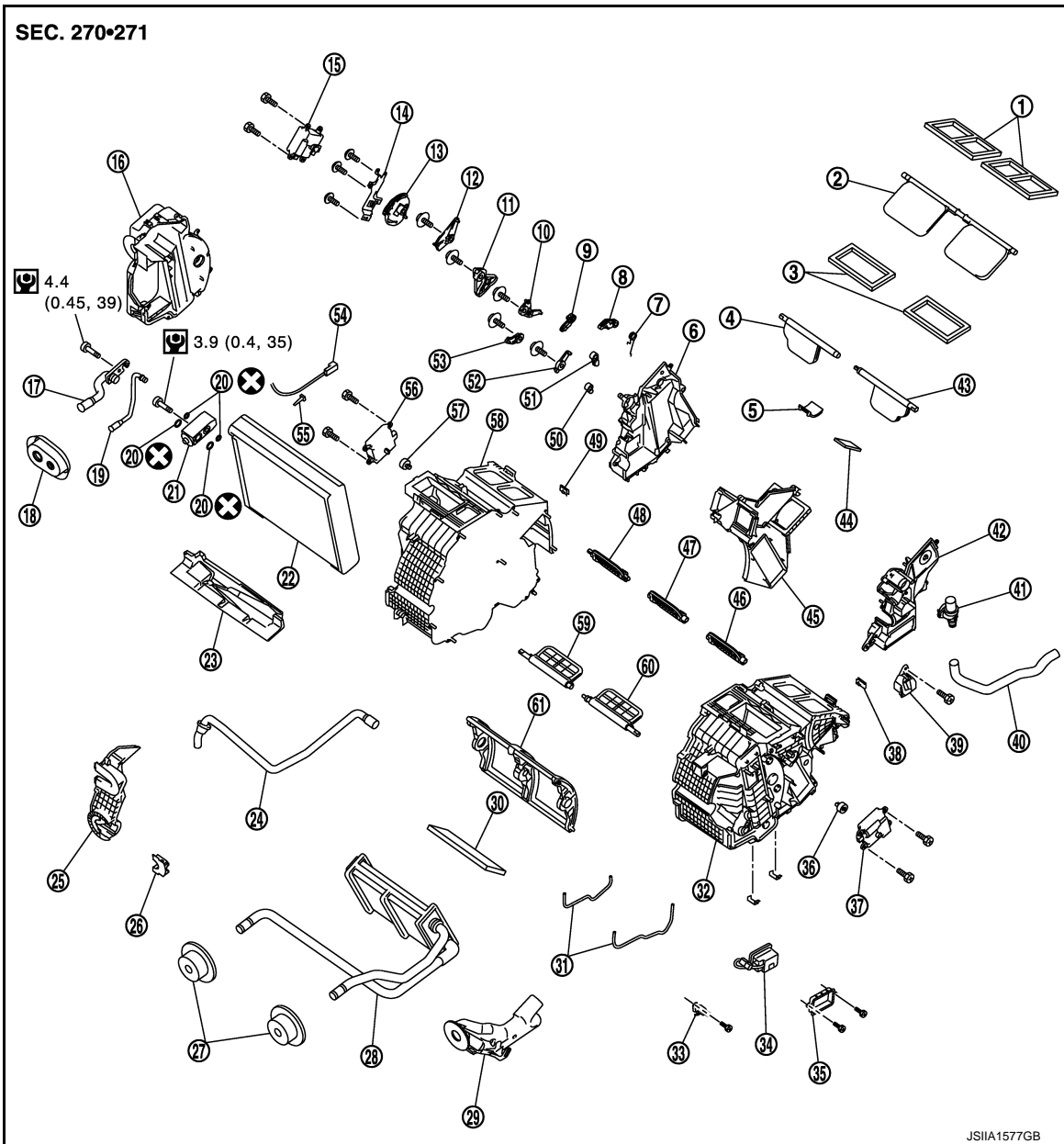

- | | | |
|--------------------------------------|---------------------------------------|------------------------------|
| 1. Ventilator seal | 2. Ventilator door | 3. Defroster seal |
| 4. Defroster door (right) | 5. Packing | 6. Foot duct (right) |
| 7. Ventilator door spring | 8. Ventilator door lever | 9. Foot door lever |
| 10. Foot door link | 11. Main link sub | 12. Ventilator door link |
| 13. Main link | 14. Mode door motor bracket | 15. Mode door motor |
| 16. Evaporator cover | 17. Low-pressure pipe 1 | 18. Cooler pipe grommet |
| 19. High-pressure pipe 2 | 20. O-ring | 21. Expansion valve |
| 22. Evaporator | 23. Insulator | 24. Drain hose |
| 25. Evaporator cover adapter | 26. Heater pipe bracket | 27. Heater pipe grommet |
| 28. Heater core | 29. Heater pipe cover | 30. Packing |
| 31. Case packing | 32. Heater & cooling unit case (left) | 33. Ionizer harness bracket* |
| 34. Ionizer* | 35. Ionizer bracket* | 36. Air mix door adapter |
| 37. Air mix door motor (driver side) | 38. J-nut | 39. Front heater duct |
| 40. Aspirator hose | 41. Aspirator | 42. Foot duct (left) |
| 43. Defroster door (left) | 44. Packing | 45. Center case |
| 46. Foot door (left) | 47. Rear ventilator door | 48. Foot door (right) |

A
B
C
D
E
F
G
H
HA
J
K
L

M
N
O
P

HEATER & COOLING UNIT ASSEMBLY

< REMOVAL AND INSTALLATION >

- | | | |
|--|---|---------------------------|
| 49. J-nut | 50. Max. cool door lever | 51. Defroster door lever |
| 52. Defroster door link | 53. Max. cool door link | 54. Intake sensor |
| 55. Intake sensor bracket | 56. Air mix door motor (passenger side) | 57. Air mix door adapter |
| 58. Heater & cooling unit case (right) | 59. Max. cool door (right) | 60. Max. cool door (left) |
| 61. Air mix door (Slide door) | | |

*: With ACCS

Refer to [GI-4, "Components"](#) for symbols in the figure.

HEATER & COOLING UNIT ASSEMBLY

HEATER & COOLING UNIT ASSEMBLY : Removal and Installation

INFOID:000000004786107

REMOVAL

1. Use a refrigerant collecting equipment (for HFC-134a) to discharge the refrigerant.
2. Drain engine coolant from cooling system. Refer to [CO-7, "Draining"](#).
3. Remove cowl top cover. Refer to [EXT-21, "Exploded View"](#).
4. Disconnect one-touch joint between low-pressure pipe 1 and low-pressure pipe 2 with disconnecter (SST: J-45815).
CAUTION:
Cap or wrap the joint of the A/C piping with suitable material such as vinyl tape to avoid the entry of air.
5. Disconnect one-touch joint between high-pressure pipe 1 and high-pressure pipe 2 with disconnecter (SST: J-45815).
CAUTION:
Cap or wrap the joint of the A/C piping with suitable material such as vinyl tape to avoid the entry of air.
6. Remove clamp (A), and then disconnect heater hoses (1).

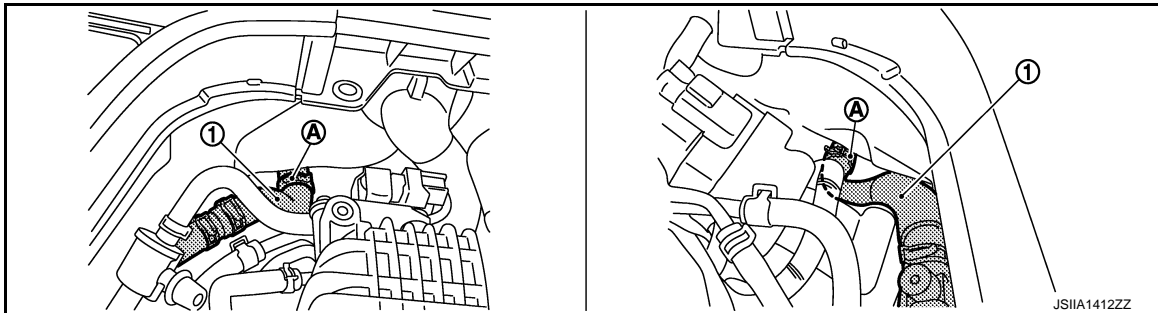

7. Remove instrument panel assembly. Refer to [IP-12, "Exploded View"](#).
8. Remove blower unit. Refer to [VTL-16, "Exploded View"](#).
9. Remove clips of vehicle harness from steering member.
10. Remove instrument stay.
11. Disconnect drain hose from heater & cooling unit assembly.
12. Remove mounting bolts (A) from heater & cooling unit assembly (1).

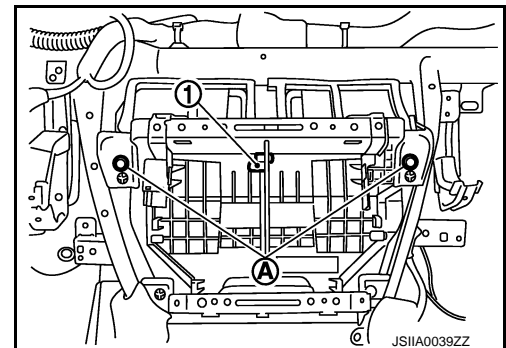

HEATER & COOLING UNIT ASSEMBLY

< REMOVAL AND INSTALLATION >

13. Remove front defroster nozzle, side defroster nozzles and ventilator duct. Refer to [VTL-10. "Exploded View"](#).
14. Remove steering column mounting bolts (A) and nuts (B). Refer to [ST-15. "WITHOUT ELECTRIC MOTOR : Exploded View"](#) (WITHOUT ELECTRIC MOTOR) or [ST-18. "WITH ELECTRIC MOTOR : Exploded View"](#) (WITH ELECTRIC MOTOR).

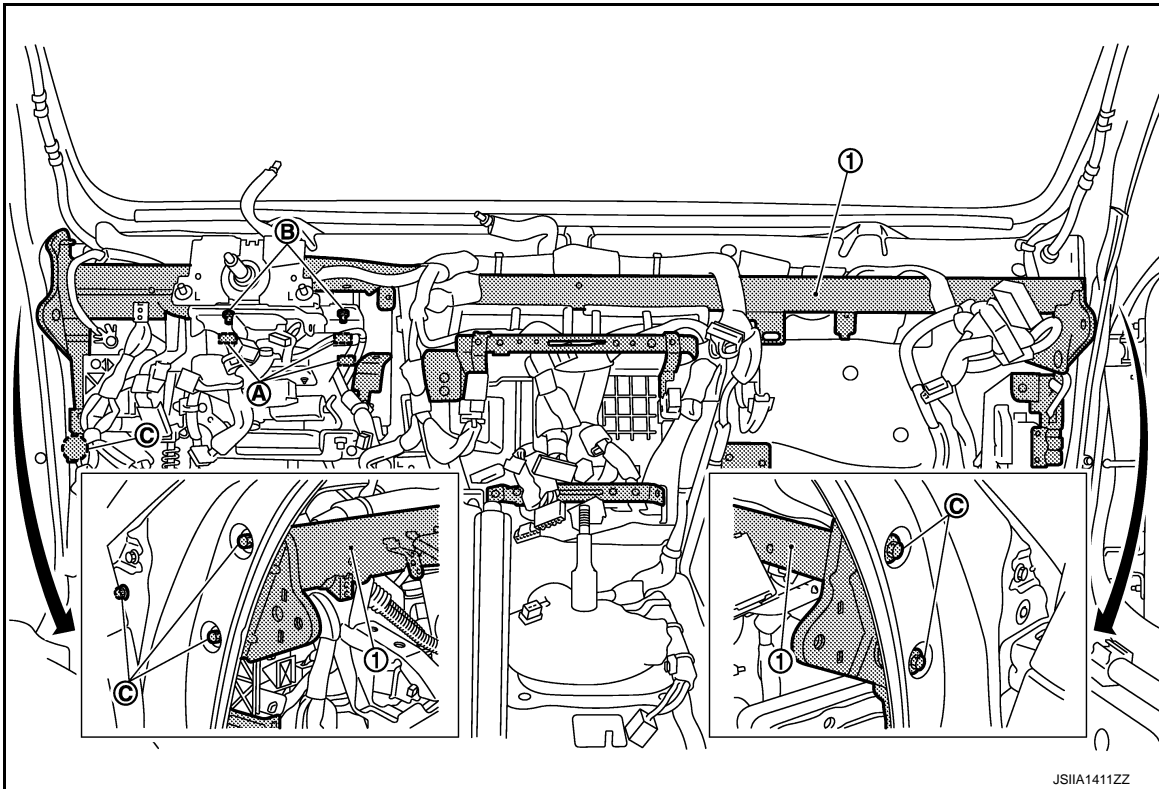

15. Remove steering member mounting bolts (C).
16. Remove steering member (1).
17. Remove heater & cooling unit assembly.

INSTALLATION

Installation is basically the reverse order of removal.

CAUTION:

- Replace O-rings with new ones. Then apply compressor oil to them when installing.
- Female-side piping connection is thin and easy to deform. Slowly insert the male-side piping straight in axial direction.
- Insert piping securely until a clicks is heard.
- After piping connection is completed, pull male-side piping by hand to make sure that connection does not come loose.
- Check for leakages when recharging refrigerant.

NOTE:

- Refer to [CO-8. "Refilling"](#) when filling radiator with engine coolant.
- Recharge the refrigerant.

HEATER CORE

HEATER CORE : Removal and Installation

INFOID:000000004786108

REMOVAL

1. Remove foot duct. Refer to [VTL-10. "Exploded View"](#).

HEATER & COOLING UNIT ASSEMBLY

< REMOVAL AND INSTALLATION >

- Slide heater core (1) to driver side (as shown in the figure).

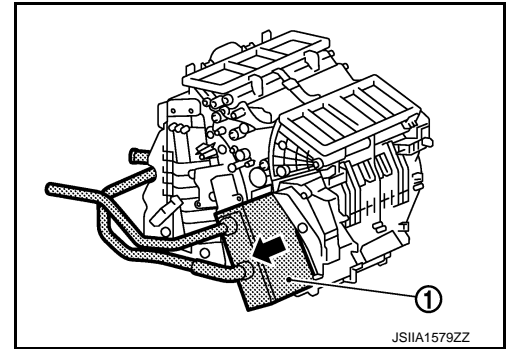

INSTALLATION

Installation is basically the reverse order of removal.

NOTE:

Refer to [CO-8, "Refilling"](#) when filling radiator with engine coolant.

EVAPORATOR

EVAPORATOR : Removal and Installation

INFOID:000000004786109

REMOVAL

- Remove low-pressure pipe 1 and high-pressure pipe 2. Refer to [HA-41, "Exploded View"](#).

CAUTION:

Cap or wrap the joint of the A/C piping and expansion valve with suitable material such as vinyl tape to avoid the entry of air.

- Slide evaporator (1) from heater & cooling unit assembly.
- Remove intake sensor (2) from evaporator, and then remove evaporator.

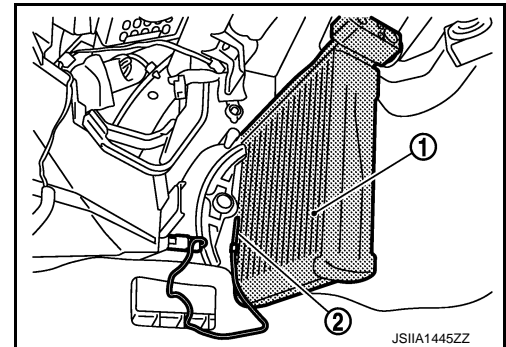

- Remove mounting bolts, and then remove expansion valve from evaporator.

CAUTION:

Cap or wrap the joint of evaporator and expansion valve with suitable material such as vinyl tape to avoid the entry of air.

INSTALLATION

Installation is basically the reverse order of removal.

CAUTION:

- Replace O-rings with new ones. Then apply compressor oil to them when installing.
- Female-side piping connection is thin and easy to deform. Slowly insert the male-side piping straight in axial direction.
- Insert piping securely until a click is heard.
- After piping connection is completed, pull male-side piping by hand to check that connection does not come loose.
- O-rings differ from low-pressure flexible hose (high-pressure pipe 1) and low-pressure pipe 1 (high-pressure pipe 2).
- Mark the mounting position of intake sensor bracket prior to removal so that the reinstalled sensor can be located in the same position.
- Check for leakages when recharging refrigerant.

EXPANSION VALVE

HEATER & COOLING UNIT ASSEMBLY

< REMOVAL AND INSTALLATION >

EXPANSION VALVE : Removal and Installation

INFOID:000000004786110

REMOVAL

1. Remove low-pressure pipe 1 and high-pressure pipe 2. Refer to [HA-41. "Exploded View"](#).
2. Remove mounting bolts, and then remove expansion valve from evaporator.

CAUTION:

Cap or wrap the joint of evaporator and expansion valve with suitable material such as vinyl tape to avoid the entry of air.

INSTALLATION

Installation is basically the reverse order of removal.

CAUTION:

- Replace O-rings with new ones. Then apply compressor oil to them when installing.
- O-rings are different from low-pressure pipe 1 (high-pressure pipe 1) and low-pressure pipe 2 (high-pressure pipe 2).
- Check for leakages when recharging refrigerant.

A

B

C

D

E

F

G

H

HA

J

K

L

M

N

O

P

SERVICE DATA AND SPECIFICATIONS (SDS)

< SERVICE DATA AND SPECIFICATIONS (SDS)

SERVICE DATA AND SPECIFICATIONS (SDS)

SERVICE DATA AND SPECIFICATIONS (SDS)

Compressor

INFOID:000000004786111

Model	CALSONIC KANSEI make CSE-617	
Type	Variable displacement swash plate	
Displacement cm ³ (cu in)/rev	Maximum	170 (10.4)
Number of cylinders	6	
Cylinder bore × stroke (Maximum) mm (in.)	34.8 (1.37) × 29.8 (1.17)	
Direction of rotation	Clockwise (viewed from clutch)	
Drive belt	Poly V	
Disc to pulley clearance mm (in.)	Standard	0.3 – 0.6 (0.012 – 0.024)

Lubricant

INFOID:000000004786112

Name	NISSAN A/C System Oil Type S (DH-PS)	
Capacity mℓ (US fl oz., Imp fl oz.)	Total in system	150 (5.07, 5.3)
	Compressor (service part) charging amount	150 (5.07, 5.3)

Refrigerant

INFOID:000000004786113

Type	HFC-134a (R-134a)	
Capacity kg (lb)	0.55 (1.21)	

Engine Idling Speed

INFOID:000000004786114

Refer to [EC-612. "Idle Speed"](#).

Belt Tension

INFOID:000000004786115

Refer to [EM-138. "Drive Belt"](#).