

A
B
C

DLK

SECTION DOOR & LOCK

CONTENTS

<p>BASIC INSPECTION 7</p> <p>DIAGNOSIS AND REPAIR WORK FLOW 7</p> <p style="padding-left: 20px;">Work Flow7</p> <p>INSPECTION AND ADJUSTMENT10</p> <p>ADDITIONAL SERVICE WHEN REPLACING CONTROL UNIT 10</p> <p style="padding-left: 20px;">ADDITIONAL SERVICE WHEN REPLACING CONTROL UNIT : Description 10</p> <p style="padding-left: 20px;">ADDITIONAL SERVICE WHEN REPLACING CONTROL UNIT : Special Repair Requirement 10</p> <p>SYSTEM DESCRIPTION11</p> <p>POWER DOOR LOCK SYSTEM11</p> <p style="padding-left: 20px;">System Diagram 11</p> <p style="padding-left: 20px;">System Description 11</p> <p style="padding-left: 20px;">Component Parts Location 13</p> <p style="padding-left: 20px;">Component Description 14</p> <p>INTELLIGENT KEY SYSTEM15</p> <p>INTELLIGENT KEY SYSTEM15</p> <p style="padding-left: 20px;">INTELLIGENT KEY SYSTEM : System Diagram.... 15</p> <p style="padding-left: 20px;">INTELLIGENT KEY SYSTEM : System Description 15</p> <p style="padding-left: 20px;">INTELLIGENT KEY SYSTEM :</p> <p style="padding-left: 40px;">Component Parts Location 16</p> <p style="padding-left: 20px;">INTELLIGENT KEY SYSTEM :</p> <p style="padding-left: 40px;">Component Description 18</p> <p>DOOR LOCK FUNCTION 18</p> <p style="padding-left: 20px;">DOOR LOCK FUNCTION : System Diagram 19</p> <p style="padding-left: 20px;">DOOR LOCK FUNCTION : System Description 19</p> <p style="padding-left: 20px;">DOOR LOCK FUNCTION :</p> <p style="padding-left: 40px;">Component Parts Location21</p> <p style="padding-left: 20px;">DOOR LOCK FUNCTION :</p> <p style="padding-left: 40px;">Component Description23</p> <p>TRUNK OPEN FUNCTION23</p> <p style="padding-left: 20px;">TRUNK OPEN FUNCTION : System Diagram23</p>	<p style="text-align: right;">D E F G H I J</p> <p style="padding-left: 20px;">TRUNK OPEN FUNCTION : System Description....24</p> <p style="padding-left: 20px;">TRUNK OPEN FUNCTION :</p> <p style="padding-left: 40px;">Component Parts Location25</p> <p style="padding-left: 20px;">TRUNK OPEN FUNCTION :</p> <p style="padding-left: 40px;">Component Description27</p> <p>REMOTE KEYLESS ENTRY FUNCTION27</p> <p style="padding-left: 20px;">REMOTE KEYLESS ENTRY FUNCTION : System Diagram27</p> <p style="padding-left: 20px;">REMOTE KEYLESS ENTRY FUNCTION : System Description28</p> <p style="padding-left: 20px;">REMOTE KEYLESS ENTRY FUNCTION :</p> <p style="padding-left: 40px;">Component Parts Location30</p> <p style="padding-left: 20px;">REMOTE KEYLESS ENTRY FUNCTION :</p> <p style="padding-left: 40px;">Component Description32</p> <p>KEY REMINDER FUNCTION32</p> <p style="padding-left: 20px;">KEY REMINDER FUNCTION : System Diagram33</p> <p style="padding-left: 20px;">KEY REMINDER FUNCTION : System Description33</p> <p style="padding-left: 20px;">KEY REMINDER FUNCTION :</p> <p style="padding-left: 40px;">Component Parts Location34</p> <p>WARNING FUNCTION35</p> <p style="padding-left: 20px;">WARNING FUNCTION : System Description36</p> <p style="padding-left: 20px;">WARNING FUNCTION :</p> <p style="padding-left: 40px;">Component Parts Location40</p> <p>TRUNK OPEN FUNCTION43</p> <p style="padding-left: 20px;">System Diagram43</p> <p style="padding-left: 20px;">System Description43</p> <p style="padding-left: 20px;">Component Parts Location44</p> <p style="padding-left: 20px;">Component Description44</p> <p>TRUNK LID AUTO CLOSURE SYSTEM45</p> <p style="padding-left: 20px;">System Diagram45</p> <p style="padding-left: 20px;">System Description45</p> <p style="padding-left: 20px;">Component Parts Location47</p> <p style="padding-left: 20px;">Component Description47</p> <p>INTEGRATED HOMELINK TRANSMITTER48</p> <p style="padding-left: 20px;">Component Description48</p>
---------------------------------------------------------------------------------------------------------------------------------------------------------------------------------------------------------------------------------------------------------------------------------------------------------------------------------------------------------------------------------------------------------------------------------------------------------------------------------------------------------------------------------------------------------------------------------------------------------------------------------------------------------------------------------------------------------------------------------------------------------------------------------------------------------------------------------------------------------------------------------------------------------------------------------------------------------------------------------------------------------------------------------------------------------------------------------------------------------------------------------------------------------------------------------------------------------------------------------------------------------------------------------------------------------------------------------------------------------------------------------------------------------------------------------------------------------------------------------------------------------------------------------------------------------------------------------------------------------------------------------------------------------------------------------------------------------------------------------------------------------------------------------------------------------------------------------------------------------------------------------------------------------------------------------------------------------------------------------------------	-------------------------------------------------------------------------------------------------------------------------------------------------------------------------------------------------------------------------------------------------------------------------------------------------------------------------------------------------------------------------------------------------------------------------------------------------------------------------------------------------------------------------------------------------------------------------------------------------------------------------------------------------------------------------------------------------------------------------------------------------------------------------------------------------------------------------------------------------------------------------------------------------------------------------------------------------------------------------------------------------------------------------------------------------------------------------------------------------------------------------------------------------------------------------------------------------------------------------------------------------------------------------------------------------------------------------------------------------------------------------------------------------------------------------------------------------------------------------------------------------------------------------------------------------------------------------------------------------------------------------------------------------------------------------------------------------------------------------------------------------------------------------------------------------------------------------------------------------------------------------------------------------------------------------------------------------------------------------------------------------------------------------------------------------------------------------------------------------------------------------------------------------------------------------------------------------------------------------------------------------------------------------------------------

DLK

DIAGNOSIS SYSTEM (BCM)	49	DRIVER SIDE	72
COMMON ITEM	49	DRIVER SIDE : Description	72
COMMON ITEM : CONSULT-III Function (BCM - COMMON ITEM)	49	DRIVER SIDE : Component Function Check	72
DOOR LOCK	50	DRIVER SIDE : Diagnosis Procedure	72
DOOR LOCK : CONSULT-III Function (BCM - DOOR LOCK)	50	PASSENGER SIDE	72
INTELLIGENT KEY	51	PASSENGER SIDE : Description	72
INTELLIGENT KEY : CONSULT-III Function (BCM - INTELLIGENT KEY)	52	PASSENGER SIDE : Component Function Check	72
TRUNK	55	PASSENGER SIDE : Diagnosis Procedure	72
TRUNK : CONSULT-III Function (BCM - TRUNK)..	55	DOOR LOCK ACTUATOR	74
DIAGNOSIS SYSTEM (RETRACTABLE HARD TOP CONTROL UNIT)	56	DRIVER SIDE	74
CONSULT-III Function	56	DRIVER SIDE : Description	74
DTC/CIRCUIT DIAGNOSIS	61	DRIVER SIDE : Component Function Check	74
B2621 INSIDE ANTENNA	61	DRIVER SIDE : Diagnosis Procedure	74
Description	61	PASSENGER SIDE	74
DTC Logic	61	PASSENGER SIDE : Description	75
Diagnosis Procedure	61	PASSENGER SIDE : Component Function Check	75
B2622 INSIDE ANTENNA	63	PASSENGER SIDE : Diagnosis Procedure	75
Description	63	FUEL LID LOCK ACTUATOR	76
DTC Logic	63	Description	76
Diagnosis Procedure	63	Component Function Check	76
B2623 INSIDE ANTENNA	65	Diagnosis Procedure	76
Description	65	TRUNK LID OPEN SIGNAL CIRCUIT	77
DTC Logic	65	Description	77
Diagnosis Procedure	65	Component Function Check	77
POWER SUPPLY AND GROUND CIRCUIT	67	Diagnosis Procedure	77
BCM (BODY CONTROL MODULE)	67	TRUNK LID OPENER ACTUATOR	79
BCM (BODY CONTROL MODULE) : Diagnosis Procedure	67	Description	79
TRUNK CLOSURE CONTROL UNIT	67	Component Function Check	79
TRUNK CLOSURE CONTROL UNIT : Diagnosis Procedure	67	Diagnosis Procedure	79
RETRACTABLE HARD TOP CONTROL UNIT	68	TRUNK ROOM LAMP SWITCH	81
RETRACTABLE HARD TOP CONTROL UNIT : Diagnosis Procedure	68	Description	81
TRUNK CLOSURE SUB-CONTROL UNIT	69	Component Function Check	81
TRUNK CLOSURE SUB-CONTROL UNIT : Diag- nosis Procedure	69	Diagnosis Procedure	81
DOOR SWITCH	70	Component Inspection	82
Description	70	TRUNK ROOM LAMP SWITCH CIRCUIT	84
Component Function Check	70	Description	84
Diagnosis Procedure	70	Component Function Check	84
Component Inspection	71	Diagnosis Procedure	84
DOOR LOCK AND UNLOCK SWITCH	72	DOOR KEY CYLINDER SWITCH	86
DRIVER SIDE	72	Description	86
DRIVER SIDE : Description	72	Component Function Check	86
DRIVER SIDE : Component Function Check	72	Diagnosis Procedure	86
DRIVER SIDE : Diagnosis Procedure	72	Component Inspection	87
PASSENGER SIDE	72	REMOTE KEYLESS ENTRY RECEIVER	88
PASSENGER SIDE : Description	72	Description	88
PASSENGER SIDE : Component Function Check	72	Component Function Check	88
PASSENGER SIDE : Diagnosis Procedure	72	Diagnosis Procedure	88
DOOR LOCK ACTUATOR	74	TRUNK LID OPENER SWITCH	91
DRIVER SIDE	74		
DRIVER SIDE : Description	74		
DRIVER SIDE : Component Function Check	74		
DRIVER SIDE : Diagnosis Procedure	74		
PASSENGER SIDE	74		
PASSENGER SIDE : Description	75		
PASSENGER SIDE : Component Function Check	75		
PASSENGER SIDE : Diagnosis Procedure	75		
FUEL LID LOCK ACTUATOR	76		
Description	76		
Component Function Check	76		
Diagnosis Procedure	76		
TRUNK LID OPEN SIGNAL CIRCUIT	77		
Description	77		
Component Function Check	77		
Diagnosis Procedure	77		
TRUNK LID OPENER ACTUATOR	79		
Description	79		
Component Function Check	79		
Diagnosis Procedure	79		
TRUNK ROOM LAMP SWITCH	81		
Description	81		
Component Function Check	81		
Diagnosis Procedure	81		
Component Inspection	82		
TRUNK ROOM LAMP SWITCH CIRCUIT	84		
Description	84		
Component Function Check	84		
Diagnosis Procedure	84		
DOOR KEY CYLINDER SWITCH	86		
Description	86		
Component Function Check	86		
Diagnosis Procedure	86		
Component Inspection	87		
REMOTE KEYLESS ENTRY RECEIVER	88		
Description	88		
Component Function Check	88		
Diagnosis Procedure	88		
TRUNK LID OPENER SWITCH	91		

Description	91	Component Inspection	112	
Component Function Check	91	COMBINATION METER DISPLAY FUNCTION	113	A
Diagnosis Procedure	91	Description	113	B
Component Inspection	92	Component Function Check	113	
TRUNK LID OPENER REQUEST SWITCH	93	Diagnosis Procedure	113	
Description	93	BUZZER (COMBINATION METER)	114	C
Component Function Check	93	Description	114	
Diagnosis Procedure	93	Component Function Check	114	D
Component Inspection	94	Diagnosis Procedure	114	
TRUNK LID OPENER CANCEL SWITCH	95	KEY WARNING LAMP	115	E
Description	95	Description	115	
Component Function Check	95	Component Function Check	115	
Diagnosis Procedure	95	Diagnosis Procedure	115	
Component Inspection	96	HAZARD FUNCTION	116	F
STRIKER SWITCH	97	Description	116	
Description	97	Component Function Check	116	G
Component Function Check	97	Diagnosis Procedure	116	
Diagnosis Procedure	97	INTEGRATED HOMELINK TRANSMITTER ..	117	H
Component Inspection	98	Description	117	
DOOR REQUEST SWITCH	99	Component Function Check	117	
Description	99	Diagnosis Procedure	117	
Component Function Check	99	POWER DOOR LOCK SYSTEM	119	I
Diagnosis Procedure	99	Wiring Diagram - POWER DOOR LOCK SYSTEM		
Component Inspection	100	-	119	
UNLOCK SENSOR	101	INTELLIGENT KEY SYSTEM	128	J
Description	101	Wiring Diagram - INTELLIGENT KEY SYSTEM -	128	
Component Function Check	101	TRUNK LID OPENER	142	
Diagnosis Procedure	101	Wiring Diagram - TRUNK LID OPENER -	142	DLK
Component Inspection	102	INTEGRATED HOMELINK TRANSMITTER SYSTEM	148	L
OUTSIDE KEY ANTENNA	103	Wiring Diagram - INTEGRATED HOMELINK TRANSMITTER SYSTEM -	148	
Description	103	ECU DIAGNOSIS INFORMATION	150	M
Component Function Check	103	BCM (BODY CONTROL MODULE)	150	
Diagnosis Procedure	103	Reference Value	150	N
INTELLIGENT KEY WARNING BUZZER	106	Wiring Diagram - BCM -	173	
Description	106	Fail-safe	178	
Component Function Check	106	DTC Inspection Priority Chart	180	O
Diagnosis Procedure	106	DTC Index	181	
Component Inspection	107	TRUNK CLOSURE CONTROL UNIT	184	P
INTELLIGENT KEY	108	Reference Value	184	
Description	108	Wiring Diagram - TRUNK LID AUTO CLOSURE SYSTEM -	185	
Component Function Check	108	Fail-safe	190	
Diagnosis Procedure	108	RETRACTABLE HARD TOP CONTROL UNIT ..	192	
KEY SLOT	109	Reference Value	192	
Description	109	Wiring Diagram	202	
Component Function Check	109			
Diagnosis Procedure	109			
Component Inspection	110			
KEY SLOT INDICATOR	111			
Description	111			
Component Function Check	111			
Diagnosis Procedure	111			

Fail-safe	220	TRUNK LID OPENER REQUEST SWITCH	238
DTC Inspection Priority Chart	223	TRUNK LID OPENER REQUEST SWITCH : De-	
DTC Index	226	scription	238
TRUNK CLOSURE SUB-CONTROL UNIT	229	TRUNK LID OPENER REQUEST SWITCH : Di-	
Reference Value	229	agnosis Procedure	238
SYMPTOM DIAGNOSIS	230	TRUNK LID AUTO CLOSURE SYSTEM	
DOOR DOES NOT LOCK/UNLOCK WITH		DOES NOT OPERATE	240
DOOR LOCK AND UNLOCK SWITCH	230	OPEN/CLOSURE FUNCTION	240
ALL DOOR	230	OPEN/CLOSURE FUNCTION : Description	240
ALL DOOR : Description	230	OPEN/CLOSURE FUNCTION : Diagnosis Proce-	
ALL DOOR : Diagnosis Procedure	230	dure	240
DRIVER SIDE	230	CLOSURE FUNCTION	240
DRIVER SIDE : Description	230	CLOSURE FUNCTION : Description	240
DRIVER SIDE : Diagnosis Procedure	230	CLOSURE FUNCTION : Diagnosis Procedure	240
PASSENGER SIDE	231	OPEN FUNCTION	240
PASSENGER SIDE : Description	231	OPEN FUNCTION : Description	240
PASSENGER SIDE : Diagnosis Procedure	231	OPEN FUNCTION : Diagnosis Procedure	241
DOOR DOES NOT LOCK/UNLOCK WITH		SELECTIVE UNLOCK FUNCTION DOES	
DOOR KEY CYLINDER OPERATION	232	NOT OPERATE	242
Diagnosis Procedure	232	Diagnosis Procedure	242
DOOR DOES NOT LOCK/UNLOCK WITH		VEHICLE SPEED SENSING AUTO LOCK	
DOOR REQUEST SWITCH	233	OPERATION DOES NOT OPERATE	243
ALL DOOR	233	Diagnosis Procedure	243
ALL DOOR : Description	233	IGN OFF INTERLOCK DOOR UNLOCK	
ALL DOOR : Diagnosis Procedure	233	FUNCTION DOES NOT OPERATE	244
DRIVER SIDE	233	Diagnosis Procedure	244
DRIVER SIDE : Description	233	P RANGE INTERLOCK DOOR LOCK/UN-	
DRIVER SIDE : Diagnosis Procedure	233	LOCK FUNCTION DOES NOT OPERATE	245
PASSENGER SIDE	234	Diagnosis Procedure	245
PASSENGER SIDE : Description	234	AUTO DOOR LOCK OPERATION DOES NOT	
PASSENGER SIDE : Diagnosis Procedure	234	OPERATE	246
DOOR DOES NOT LOCK/UNLOCK WITH IN-		Diagnosis Procedure	246
TELLIGENT KEY	235	FUEL LID LOCK ACTUATOR DOES NOT OP-	
Diagnosis Procedure	235	ERATE	247
ALL DOORS DO NOT UNLOCK WHEN		Diagnosis Procedure	247
ROOF IS OPEN BY DOOR REQUEST		HAZARD AND HORN REMINDER DOES	
SWITCH OPERATION	236	NOT OPERATE	248
Diagnosis Procedure	236	Diagnosis Procedure	248
TRUNK LID DOES NOT OPEN	237	HAZARD AND BUZZER REMINDER DOES	
TRUNK LID OPENER SWITCH	237	NOT OPERATE	249
TRUNK LID OPENER SWITCH : Description	237	Diagnosis Procedure	249
TRUNK LID OPENER SWITCH : Diagnosis Pro-		KEY REMINDER FUNCTION DOES NOT OP-	
cedure	237	ERATE	251
INTELLIGENT KEY	237	INTELLIGENT KEY SYSTEM	251
INTELLIGENT KEY : Description	237	INTELLIGENT KEY SYSTEM : Description	251
INTELLIGENT KEY : Diagnosis Procedure	238	INTELLIGENT KEY SYSTEM : Diagnosis Proce-	
		dure	251

POWER DOOR LOCK SYSTEM	251	PREPARATION	273	A
POWER DOOR LOCK SYSTEM : Description	251	PREPARATION	273	
POWER DOOR LOCK SYSTEM : Diagnosis Pro-		Special Service Tools	273	B
cedure	252	Commercial Service Tools	273	
KEY WARNING DOES NOT OPERATE	253	REMOVAL AND INSTALLATION	274	C
Diagnosis Procedure	253	HOOD	274	
OFF POSITION WARNING DOES NOT OP-		HOOD ASSEMBLY	274	D
ERATE	254	HOOD ASSEMBLY : Exploded View	274	
Diagnosis Procedure	254	HOOD ASSEMBLY : Removal and Installation	274	E
P POSITION WARNING DOES NOT OPER-		HOOD ASSEMBLY : Adjustment	275	
ATE	255	HOOD ASSEMBLY : Disposal	276	F
Diagnosis Procedure	255	HOOD LOCK CONTROL	277	
ACC WARNING DOES NOT OPERATE	257	HOOD LOCK CONTROL : Exploded View	277	G
Diagnosis Procedure	257	HOOD LOCK CONTROL : Removal and Installa-		
TAKE AWAY WARNING DOES NOT OPER-		tion	277	H
ATE	258	HOOD LOCK CONTROL : Inspection	279	
Diagnosis Procedure	258	RADIATOR CORE SUPPORT	280	I
INTELLIGENT KEY LOW BATTERY WARN-		Exploded View	280	
ING DOES NOT OPERATE	260	Removal and Installation	280	J
Diagnosis Procedure	260	FRONT FENDER	283	
DOOR LOCK OPERATION WARNING DOES		Exploded View	283	
NOT OPERATE	261	Removal and Installation	283	
Diagnosis Procedure	261	DOOR	284	
KEY ID WARNING DOES NOT OPERATE	262	DOOR ASSEMBLY	284	
Diagnosis Procedure	262	DOOR ASSEMBLY : Exploded View	284	
KEY WARNING LAMP DOES NOT ILLUMI-		DOOR ASSEMBLY : Removal and Installation	284	
NATE	263	DOOR ASSEMBLY : Adjustment	284	DLK
Diagnosis Procedure	263	DOOR STRIKER	286	
INTEGRATED HOMELINK TRANSMITTER		DOOR STRIKER : Exploded View	286	
DOES NOT OPERATE	264	DOOR STRIKER : Removal and Installation	286	L
Diagnosis Procedure	264	DOOR HINGE	286	
SQUEAK AND RATTLE TROUBLE DIAG-		DOOR HINGE : Exploded View	287	
NOSES	265	DOOR HINGE : Removal and Installation	287	M
Work Flow	265	DOOR CHECK LINK	287	
Inspection Procedure	267	DOOR CHECK LINK : Exploded View	288	
Diagnostic Worksheet	269	DOOR CHECK LINK : Removal and Installation ..	288	N
PRECAUTION	271	TRUNK LID	289	
PRECAUTIONS	271	TRUNK LID ASSEMBLY	289	
Precaution for Supplemental Restraint System		TRUNK LID ASSEMBLY : Exploded View	289	
(SRS) "AIR BAG" and "SEAT BELT PRE-TEN-		TRUNK LID ASSEMBLY : Removal and Installa-		
SIONER"	271	tion	289	O
Service Procedure Precautions for Models with a		TRUNK LID ASSEMBLY : Adjustment	291	
Pop-up Roll Bar	271	TRUNK LID STRIKER	293	P
Precaution Necessary for Steering Wheel Rota-		TRUNK LID STRIKER : Exploded View	294	
tion after Battery Disconnect	271	TRUNK LID STRIKER : Removal and Installation.	294	
Precaution for Procedure without Cowl Top Cover.	272	TRUNK LID HINGE	295	
Precaution for Battery Service	272	TRUNK LID HINGE : Exploded View	295	
Work	272			

TRUNK LID HINGE : Removal and Installation	295	INSIDE KEY ANTENNA	313
TRUNK LID HINGE : Adjustment	297	INSTRUMENT CENTER	313
TRUNK LID STAY	298	INSTRUMENT CENTER : Exploded View	313
TRUNK LID STAY : Exploded View	299	INSTRUMENT CENTER : Removal and Installa- tion	313
TRUNK LID STAY : Removal and Installation	299	CONSOLE	313
TRUNK LID STAY : Disposal	300	CONSOLE : Exploded View	313
TRUNK LID WEATHERSTRIP	300	CONSOLE : Removal and Installation	313
TRUNK LID WEATHERSTRIP : Exploded View ..	300	TRUNK ROOM	313
TRUNK LID WEATHERSTRIP : Removal and In- stallation	301	TRUNK ROOM : Exploded View	313
DOOR LOCK	302	TRUNK ROOM : Removal and Installation	314
DOOR LOCK	302	OUTSIDE KEY ANTENNA	315
DOOR LOCK : Exploded View	302	Exploded View	315
DOOR LOCK : Removal and Installation	302	Removal and Installation	315
INSIDE HANDLE	304	INTELLIGENT KEY WARNING BUZZER	316
INSIDE HANDLE : Exploded View	305	Exploded View	316
INSIDE HANDLE : Removal and Installation	305	Removal and Installation	316
OUTSIDE HANDLE	305	TRUNK LID OPENER REQUEST SWITCH	317
OUTSIDE HANDLE : Exploded View	306	Exploded View	317
OUTSIDE HANDLE : Removal and Installation	306	Removal and Installation	317
TRUNK LID LOCK	309	TRUNK LID OPENER SWITCH	318
TRUNK LID LOCK	309	Exploded View	318
TRUNK LID LOCK : Exploded View	309	Removal and Installation	318
TRUNK LID LOCK : Removal and Installation	309	TRUNK LID OPENER CANCEL SWITCH	319
FUEL FILLER LID OPENER	310	Exploded View	319
Exploded View	310	Removal and Installation	319
Removal and Installation	310	REMOTE KEYLESS ENTRY RECEIVER	320
DOOR SWITCH	312	Exploded View	320
Exploded View	312	Removal and Installation	320
Removal and Installation	312	INTELLIGENT KEY BATTERY	321
		Removal and Installation	321

DIAGNOSIS AND REPAIR WORK FLOW

< BASIC INSPECTION >

BASIC INSPECTION

DIAGNOSIS AND REPAIR WORK FLOW

Work Flow

INFOID:000000005624126

OVERALL SEQUENCE

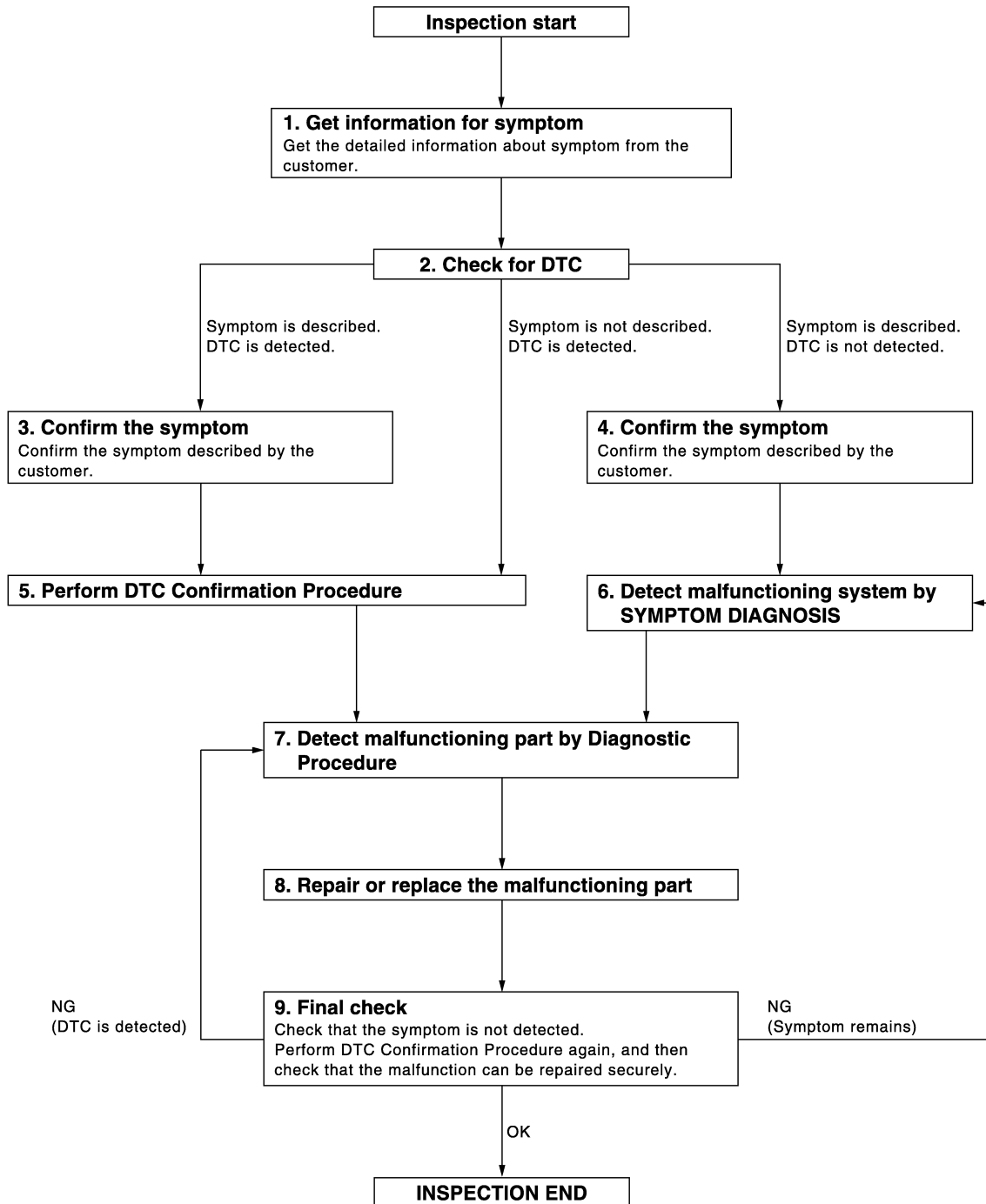

A
B
C
D
E
F
G
H
I
J
L
M
N
O
P

DLK

DETAILED FLOW

JMKIA3620GB

DIAGNOSIS AND REPAIR WORK FLOW

< BASIC INSPECTION >

1. GET INFORMATION FOR SYMPTOM

1. Get detailed information from the customer about the symptom (the condition and the environment when the incident/malfunction occurred).
2. Check operation condition of the function that is malfunctioning.

>> GO TO 2.

2. CHECK FOR DTC

1. Check DTC for BCM and convertible roof.
2. Perform the following procedure if DTC is displayed.
 - Record DTC and freeze frame data (print them out with CONSULT-III).
 - Erase DTC.
 - Study the relationship between the cause detected by DTC and the symptom described by the customer.
3. Check related service bulletins for information.

Are any symptoms described or any DTC detected?

Symptom is described, DTC is displayed>>GO TO 3.

Symptom is described, DTC is not displayed>>GO TO 4.

Symptom is not described, DTC is displayed>>GO TO 5.

3. CONFIRM THE SYMPTOM

Confirm the symptom described by the customer.

Connect CONSULT-III to the vehicle in the "DATA MONITOR" mode and check real time diagnosis results. Verify relation between the symptom and the condition when the symptom is detected.

>> GO TO 5.

4. CONFIRM THE SYMPTOM

Confirm the symptom described by the customer.

Connect CONSULT-III to the vehicle in the "DATA MONITOR" mode and check real time diagnosis results. Verify relation between the symptom and the condition when the symptom is detected.

>> GO TO 6.

5. PERFORM DTC CONFIRMATION PROCEDURE

Perform DTC Confirmation Procedure for the displayed DTC, and then check that DTC is detected again. At this time, always connect CONSULT-III to the vehicle, and check diagnostic results in real time.

If two or more DTCs are detected, refer to [BCS-73, "DTC Inspection Priority Chart"](#) (BCM), [RF-57, "DTC Inspection Priority Chart"](#) (convertible roof) determine trouble diagnosis order.

NOTE:

Perform Component Function Check if DTC Confirmation Procedure is not included in Service Manual. This simplified check procedure is an effective alternative though DTC cannot be detected during this check. If the result of Component Function Check is NG, it is the same as the detection of DTC by DTC Confirmation Procedure.

Is DTC detected?

YES >> GO TO 7.

NO >> Refer to [GI-37, "Intermittent Incident"](#).

6. DETECT MALFUNCTIONING SYSTEM BY SYMPTOM DIAGNOSIS

Detect malfunctioning system according to SYMPTOM DIAGNOSIS based on the confirmed symptom in step 4, and determine the trouble diagnosis order based on possible causes and symptoms.

>> GO TO 7.

7. DETECT MALFUNCTIONING PART BY DIAGNOSTIC PROCEDURE

Inspect according to Diagnostic Procedure of the system.

NOTE:

DIAGNOSIS AND REPAIR WORK FLOW

< BASIC INSPECTION >

The Diagnostic Procedure described based on open circuit inspection. A short circuit inspection is also required for the circuit check in the Diagnostic Procedure.

Is malfunctioning part detected?

YES >> GO TO 8.

NO >> Check voltage of related BCM and retractable hard top control unit terminals using CONSULT-III.

8.REPAIR OR REPLACE THE MALFUNCTIONING PART

1. Repair or replace the malfunctioning part.
2. Reconnect parts or connectors disconnected during Diagnostic Procedure again after repair and replacement.
3. Check for DTC. If DTC is displayed, erase it.

>> GO TO 9.

9.FINAL CHECK

When DTC was detected in step 2, perform DTC Confirmation Procedure or Component Function Check again, and then check that the malfunction has been repaired securely.

When symptom was described by the customer, refer to confirmed symptom in step 3 or 4, and check that the symptom is not detected.

Does the symptom reappear?

YES (DTC is detected)>>GO TO 7.

YES (Symptom remains)>>GO TO 6.

NO >> INSPECTION END

A
B
C
D
E
F
G
H
I
J
L
M
N
O
P

DLK

INSPECTION AND ADJUSTMENT

< BASIC INSPECTION >

INSPECTION AND ADJUSTMENT

ADDITIONAL SERVICE WHEN REPLACING CONTROL UNIT

ADDITIONAL SERVICE WHEN REPLACING CONTROL UNIT : Description

INFOID:000000005624127

Perform the system initialization when replacing BCM, replacing Intelligent Key or registering an additional Intelligent Key.

ADDITIONAL SERVICE WHEN REPLACING CONTROL UNIT : Special Repair Requirement

INFOID:000000005624128

Refer to CONSULT-III Operation Manual NATS-IVIS/NVIS.

POWER DOOR LOCK SYSTEM

< SYSTEM DESCRIPTION >

SYSTEM DESCRIPTION

POWER DOOR LOCK SYSTEM

System Diagram

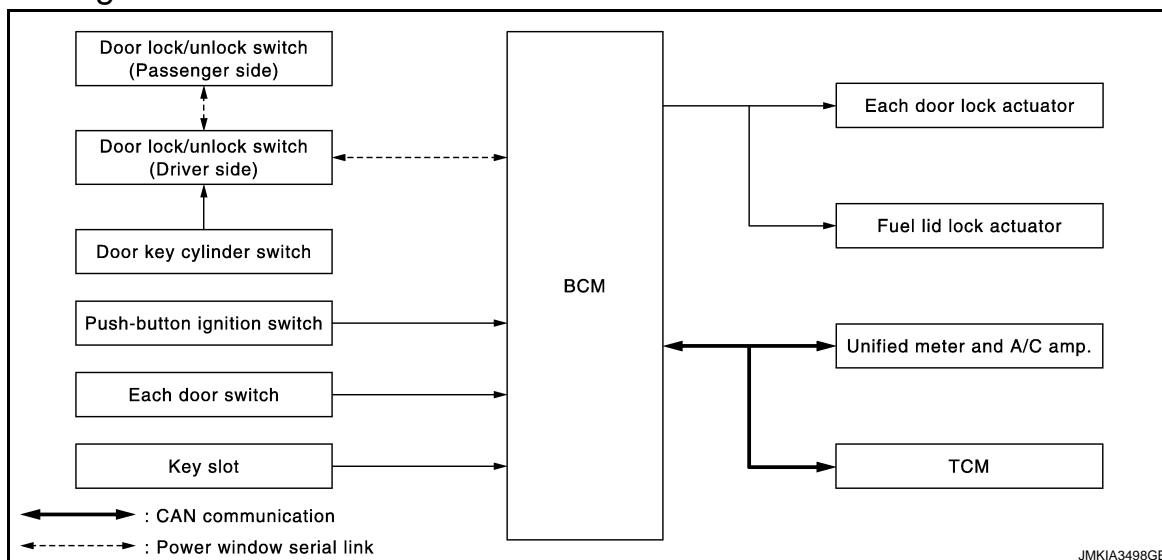

System Description

INFOID:0000000005624130

DOOR LOCK FUNCTION

Door Lock and Unlock Switch

- The door lock and unlock switch (driver side) is build into power window main switch.
- The door lock and unlock switch (passenger side) is build into power window sub-switch.
- Interlocked with the locking operation of door lock and unlock switch, door lock actuators of all doors and fuel lid lock actuator are locked.
- Interlocked with the unlocking operation of door lock and unlock switch, door lock actuators of all doors and fuel lid lock actuator are unlocked.

Door Key Cylinder Switch

- With the door key inserted in the door key cylinder on driver side, turning it to “LOCK”, locks door lock actuator of all doors and fuel lid lock actuator.
- With the door key inserted in the door key cylinder on driver side, turning it to “UNLOCK” once unlocks the driver side door, turning it to “UNLOCK” again within 60 seconds after the first unlock operation unlocks all of the other doors actuator and fuel lid lock actuator. - (SELECTIVE UNLOCK OPERATION)

Selective unlock operation mode can be changed using “DOOR LOCK-UNLOCK SET” mode in “WORK SUPPORT”. Refer to [DLK-50, "DOOR LOCK : CONSULT-III Function \(BCM - DOOR LOCK\)"](#).

KEY REMINDER FUNCTION

When door lock and unlock switch are operated while Intelligent Key is inserted into key slot and any door is open, door locks once but immediately unlocks. This operation prevents Intelligent Key from being left in the vehicle.

DOOR KEY CYLINDER SWITCH POWER WINDOW FUNCTION

Driver side key cylinder LOCK/UNLOCK operation can activate driver side and passenger side power window UP/DOWN operation. Refer to [PWC-7, "System Description"](#).

AUTOMATIC DOOR LOCK/UNLOCK FUNCTION (LOCK OPERATION)

The interlock door lock function is the function that locks all doors linked with the vehicle speed or shift position. It has 2 types as per the following items.

Vehicle Speed Sensing Auto Door Lock*¹

All doors are locked when the vehicle speed reaches 24 km/h (15 MPH) or more.

POWER DOOR LOCK SYSTEM

< SYSTEM DESCRIPTION >

BCM outputs the lock signal to all door lock actuators when it detects that the ignition switch is turned ON, all doors are closed and the vehicle speed received from the combination meter via CAN communication becomes 15 MPH (24 km/h) or more.

P Range Interlock Door Lock*²

All doors are locked when shifting the selector lever from the P position to any position other than P. BCM outputs the lock signal to all door lock actuators when it detects that the ignition switch is in the ON position and the shift signal received from the TCM via CAN communication is shifted from the P position to any position other than P.

Setting change of Automatic Door Lock/Unlock Function

The lock operation setting of the automatic door lock/unlock function can be changed.

NOTE:

P range interlock door lock can be selected for M/T models, but automatic door lock/unlock function does not operate.

With CONSULT-III

The ON/OFF switching of the automatic door lock function and the type selection of the automatic door lock/unlock function can be performed at the WORK SUPPORT setting of CONSULT-III.

Without CONSULT- III

The automatic door lock function ON/OFF can be switched by performing the following operation.

1. Close all doors (door switch OFF)
2. Turn ignition switch ON
3. Press and hold the door lock and unlock switch for 5 seconds or more in the lock direction within 20 seconds after turning the ignition switch ON.
4. The switching is complete when the hazard lamp blinks.

OFF → ON : 2 blinks

ON → OFF : 1 blink

*1: This function is set to ON before delivery.

*2: This function does not operate on M/T models.

AUTOMATIC DOOR LOCK/UNLOCK FUNCTION (UNLOCK OPERATION)

The automatic door lock/unlock function is the function that unlocks all doors linked with the key position or shift position. It has 2 types as per the following items.

IGN OFF Interlock Door Unlock*¹

All doors are unlocked when the power supply position is changed from ON to OFF. BCM outputs the unlock signal to all door lock actuators when it detects that the power supply position is changed from ignition switch ON to OFF.

P Range Interlock Door Unlock*²

All doors are unlocked when shifting the selector lever from any position other than the P to P position. BCM outputs the unlock signal to all door lock actuators when it detects that the ignition switch is in the ON position and the shift signal received from TCM via CAN communication is shifted from any position other than the P to P position.

Setting change of Automatic Door Lock/Unlock Function

The unlock operation setting of the automatic door lock/unlock function can be changed.

NOTE:

P range interlock door lock can be selected for M/T models, but automatic door lock/unlock function does not operate.

With CONSULT- III

The ON/OFF switching of the automatic door lock/unlock function and the type selection of the automatic door lock/unlock function can be performed at the WORK SUPPORT setting of CONSULT-III.

Without CONSULT- III

The automatic door lock/unlock function ON/OFF can be switched by performing the following operation.

1. Close all doors below (door switch OFF)
2. Turn ignition switch ON

POWER DOOR LOCK SYSTEM

< SYSTEM DESCRIPTION >

3. Press and hold the door lock and unlock switch for 5 seconds or more in the unlock direction within 20 seconds after turning the ignition switch ON.
4. The switching is complete when the hazard lamp blinks.

OFF → ON : 2 blinks
 ON → OFF : 1 blink

- *1: This function is set to ON before delivery.
 *2: This function does not operate on M/T models.

INTERIOR ROOM LAMP CONTROL FUNCTION

Interior room lamp is controlled according to door lock/unlock state, refer to [INL-5. "System Description"](#).

Component Parts Location

INFOID:000000005624131

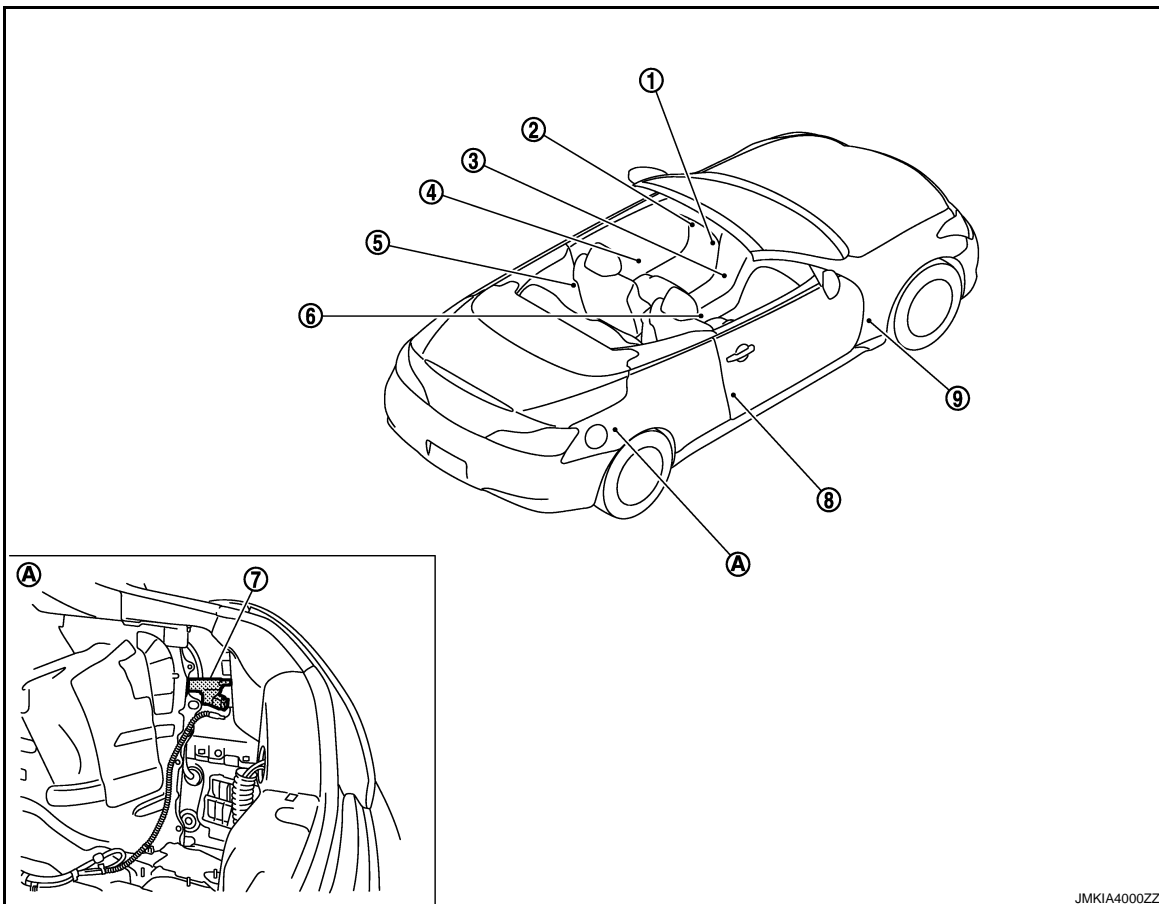

- | | | |
|------------------------------------------------------------------|---------------------------------------|-----------------------------------------------------------------------------------------------------------------|
| 1. Push-button ignition switch (push switch) M50 | 2. Key slot M22 | 3. Unified meter and A/C amp. M67
Refer to MWI-10, "METER SYSTEM : Component Parts Location" |
| 4. Power window main switch (door lock and unlock switch) D8, D9 | 5. Driver side door lock assembly D15 | 6. A/T assembly (TCM)* F51
Refer to TM-107, "Component Parts Location" |
| 7. Fuel lid lock actuator B40 | 8. Passenger side door switch B216 | 9. BCM M118, M119, M122, M123
Refer to BCS-5, "Component Parts Location" |

A. View with trunk side finisher removed

*:With A/T models

A
B
C
D
E
F
G
H
I
J
L
M
N
O
P

DLK

POWER DOOR LOCK SYSTEM

< SYSTEM DESCRIPTION >

Component Description

INFOID:000000005624132

Item	Function
BCM	Controls the door lock function
Door lock and unlock switch	Inputs lock or unlock signal to BCM
Door lock actuator	Inputs lock/unlock signal from BCM and locks/unlocks each door
Door key cylinder switch	Built-in driver side door lock assembly <ul style="list-style-type: none">• Inputs lock or unlock signal to power window main switch• Power window main switch transmits door lock/unlock signal to BCM
Door switch	Inputs door open/close condition to BCM
Key slot	Inputs key insert/remove signal to BCM
Unified meter and A/C amp.	Transmits vehicle speed signal to CAN communication line
TCM	Transmits shift position signal to BCM via CAN communication line
Fuel lid lock actuator	Inputs lock/unlock signal from BCM and lock/unlocks fuel filler lid
Push-button ignition switch	Inputs push-button ignition switch ON/OFF condition to BCM

INTELLIGENT KEY SYSTEM

< SYSTEM DESCRIPTION >

INTELLIGENT KEY SYSTEM

INTELLIGENT KEY SYSTEM

INTELLIGENT KEY SYSTEM : System Diagram

INFOID:0000000005624133

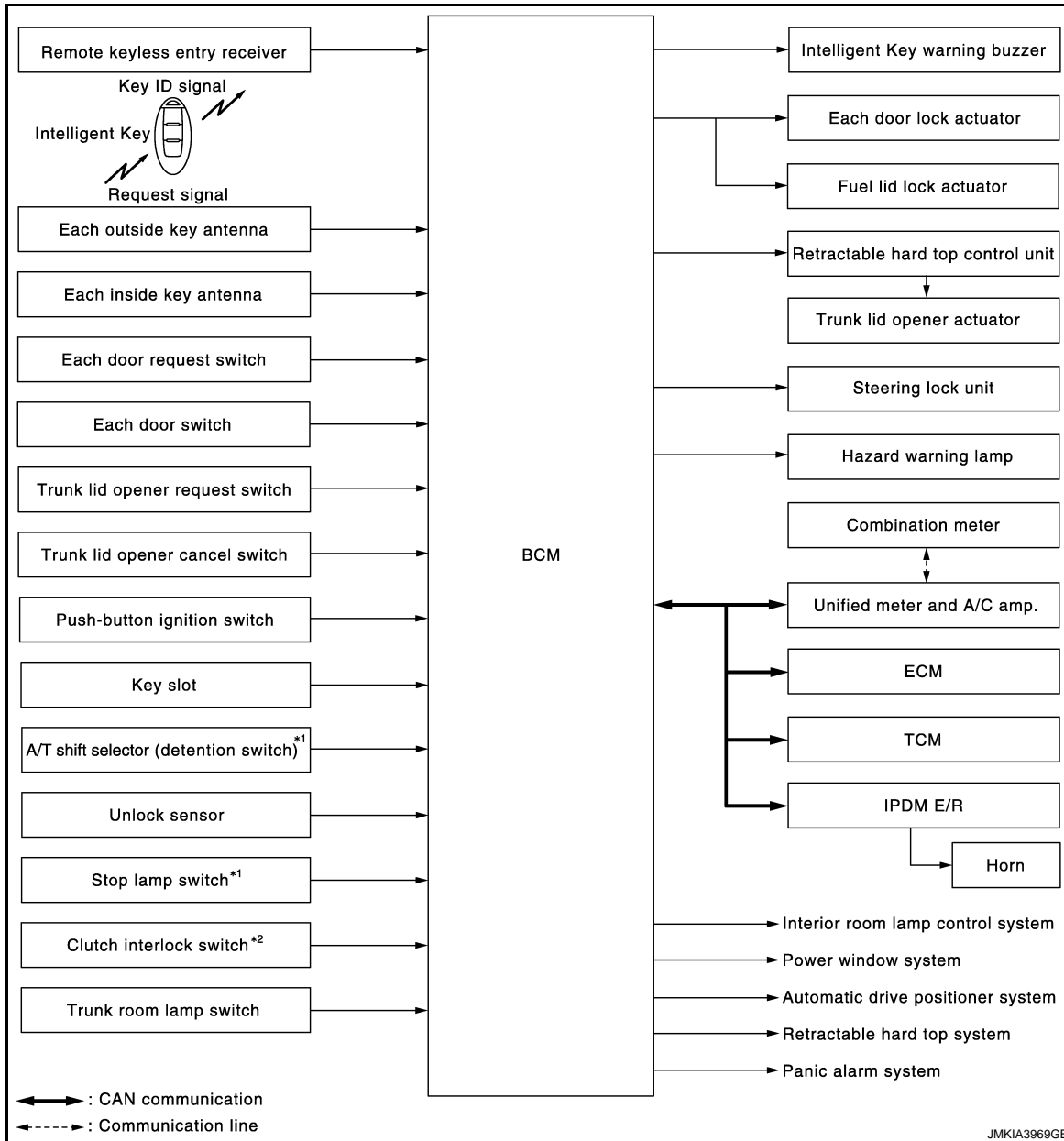

*1: With A/T models

*2: With M/T models

INTELLIGENT KEY SYSTEM : System Description

INFOID:0000000005624134

- The Intelligent Key system is a system that makes it possible to lock and unlock the door locks (door lock/unlock function) by carrying the Intelligent Key, which operates based on the results of electronic ID verification using two-way communication between the Intelligent Key and the vehicle (BCM).

CAUTION:

The driver should always carry the Intelligent Key

- The settings for each function can be changed with CONSULT-III.
- If an Intelligent Key is lost, a new Intelligent Key can be registered. A maximum of 4 Intelligent Keys can be registered.
- It is possible to perform a diagnosis on the system and register an Intelligent Key with CONSULT-III.

A
B
C
D
E
F
G
H
I
J
K
L
M
N
O
P

DLK

INTELLIGENT KEY SYSTEM

< SYSTEM DESCRIPTION >

Function	Description	Refer
Door lock	Lock/unlock can be performed by pressing the door request switch	DLK-19
Remote keyless entry	Lock/unlock can be performed by pressing the remote controller button of the Intelligent Key	DLK-28
Trunk open	The trunk lid can be opened by carrying the Intelligent Key and pressing the trunk lid opener request switch	DLK-24
Key reminder	The key reminder buzzer sounds a warning if the door is locked with the key left inside the vehicle	DLK-33
Warning	If an action that does not meet the operating condition of the Intelligent Key system is taken, the buzzer sounds to inform the driver	DLK-36
Engine start	The engine can be turned on while carrying the Intelligent Key	SEC-9
Panic alarm	When Intelligent Key panic alarm button is pressed, horn sounds and headlamp blinks	SEC-19
Interior room lamp control	Interior room lamp is controlled according to door lock/unlock state	INL-5
Power window	Power window can be operated by Intelligent Key button operation	PWC-7
Automatic drive positioner	Automatic drive positioner system can be operated by door unlock operation	ADP-34
Retractable hard top	Retractable hard top system can be operated by door request switch operation	RF-16

INTELLIGENT KEY SYSTEM : Component Parts Location

INFOID:000000005624135

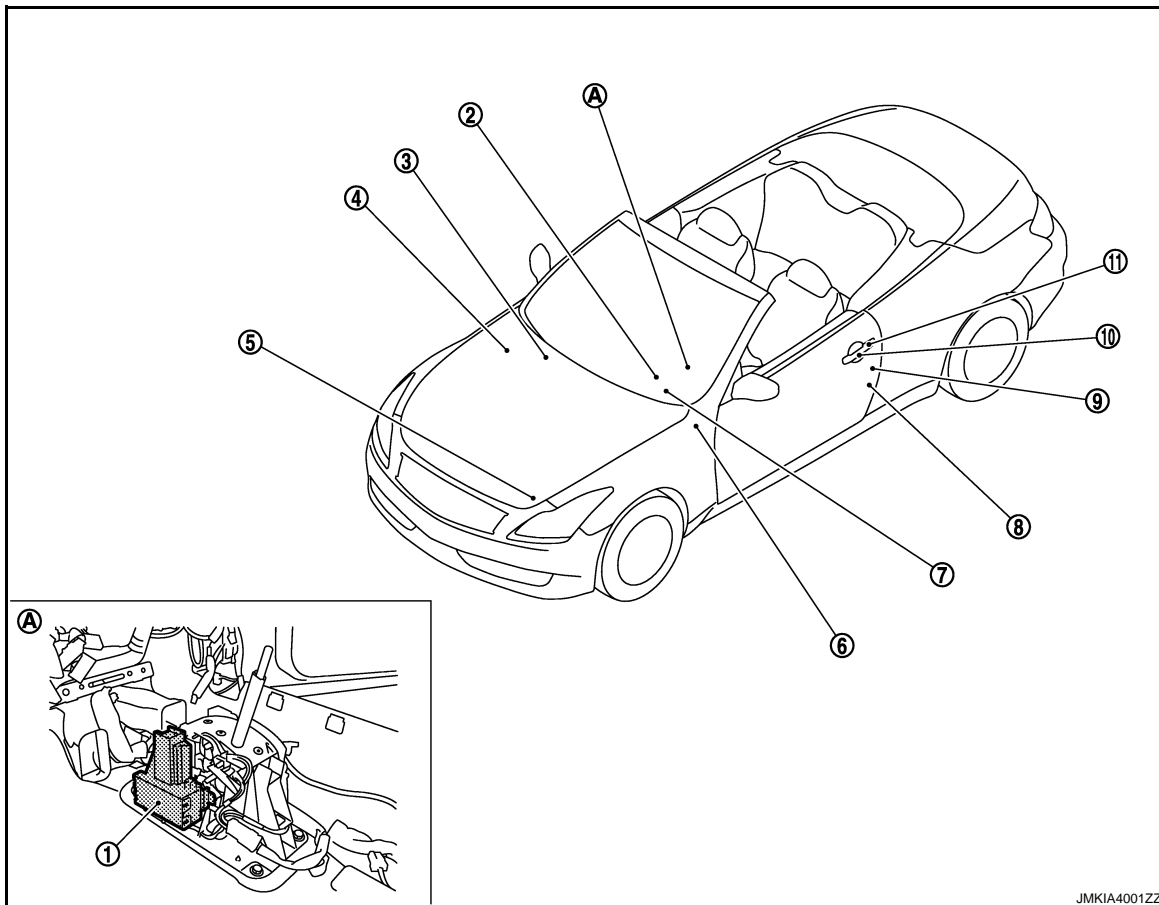

JMKIA4001ZZ

INTELLIGENT KEY SYSTEM

< SYSTEM DESCRIPTION >

- | | | | |
|------------------------------------------------------------------------------------------------------------------|--------------------------------------------------|---------------------------------------------------------------------------------------------------------|---|
| 1. A/T shift selector (detention switch)*
M137
Refer to SEC-12, "Component Parts Location" | 2. Push-button ignition switch (push switch) M50 | 3. BCM M118, M119, M120, M121, M122, M123
Refer to BCS-5, "Component Parts Location" | A |
| 4. IPDM E/R E5, E6
Refer to PCS-4, "Component Parts Location" | 5. Intelligent Key warning buzzer E57 | 6. Key slot M22 | B |
| 7. Combination meter M53 | 8. Driver side door switch B16 | 9. Driver side door lock assembly D15 | C |
| 10. Outside handle LH (outside key antenna) D14 | 11. Outside handle LH (request switch) D13 | | D |
| A. View with center console assembly removed | | | E |

*: With A/T models

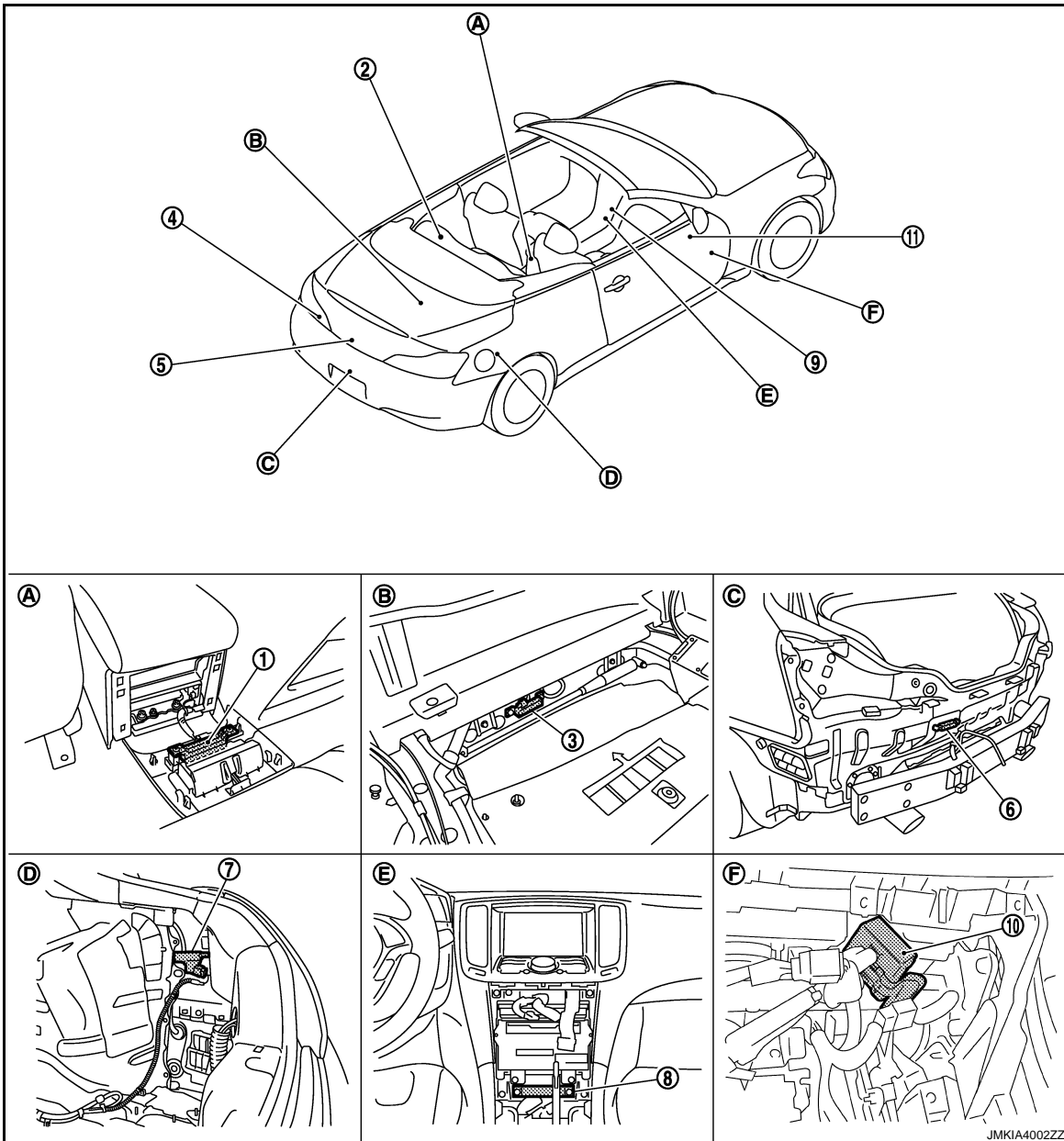

DLK

INTELLIGENT KEY SYSTEM

< SYSTEM DESCRIPTION >

- | | | |
|-------------------------------------------------------------------|------------------------------------------------------------------------------------------------------------------|----------------------------------------------------------------------------------------------------------------------|
| 1. Inside key antenna (console) M146 | 2. Retractable hard top control unit B82, B83, B84
Refer to RF-11. "Component Parts Location" | 3. Inside key antenna (trunk room) B49 |
| 4. Rear combination lamp LH (trunk lid opener request switch) B60 | 5. Trunk lid lock assembly
• Trunk lid opener actuator: B305
• Trunk room lamp switch: B306 | 6. Outside key antenna (rear bumper) B63 |
| 7. Fuel lid lock actuator B40 | 8. Inside key antenna (instrument center) M131 | 9. Unified meter and A/C amp. M66, M67
Refer to MWI-10. "METER SYSTEM : Component Parts Location" |
| 10. Remote keyless entry receiver M104 | 11. Trunk lid opener cancel switch M105 | |
| A. View with console rear finisher removed | B. View with trunk front finisher removed | C. View with rear bumper removed |
| D. View with trunk side finisher RH removed | E. View with cluster lid C removed | F. View with instrument lower panel RH removed |

INTELLIGENT KEY SYSTEM : Component Description

INFOID:000000005624136

Item	Function
BCM	Controls the Intelligent Key system
IPDM E/R	Sounds horn and blinks head lamp via CAN communication between BCM
Door lock actuator	Inputs lock/unlock signal from BCM and locks/unlocks each door
Fuel lid lock actuator	Inputs lock/unlock signal from BCM and lock/unlocks fuel filler lid
Door switch	Inputs door open/close condition to BCM
Remote keyless entry receiver	Receives lock/unlock signal from the Intelligent Key, and then transmits to BCM
Door request switch	Inputs lock/unlock operation to BCM
Key slot	Inputs key insert/remove signal to BCM
Intelligent Key	Transmits button operation to remote keyless entry receiver
Outside key antenna	Detects if Intelligent Key is outside the vehicle
Inside key antenna	Detects if Intelligent Key is inside the vehicle
Unlock sensor	Detects door lock condition of driver door
A/T shift selector (detention switch)*	Detects the P range position of A/T selector lever
Unified meter and A/C amp.	Transmits vehicle seep signal to CAN communication line
Combination meter	Display, buzzer (combination meter) and KEY warning lamp are installed to combination meter
Trunk lid opener actuator	Opens the trunk after receiving the open signal from retractable hard top control unit or BCM
Trunk lid opener request switch	Inputs lock/unlock operation to BCM
Trunk lid opener cancel switch	Cancels the trunk open operation
Trunk room lamp switch	Inputs trunk lid open/close condition to BCM
Intelligent Key warning buzzer	Warns the user of the lock/unlock condition and inappropriate operations with the buzzer sound
Hazard warning lamp	Warns the user of the door and trunk lid open/close condition and inappropriate operations with the lamps blink
TCM*	Transmits shift position signal to BCM via CAN communication line
Push-button ignition switch	Inputs push-button ignition switch ON/OFF condition to BCM
Retractable hard top control unit	Controls the retractable hard top system

*: With A/T models

DOOR LOCK FUNCTION

INTELLIGENT KEY SYSTEM

< SYSTEM DESCRIPTION >

DOOR LOCK FUNCTION : System Diagram

INFOID:000000005624137

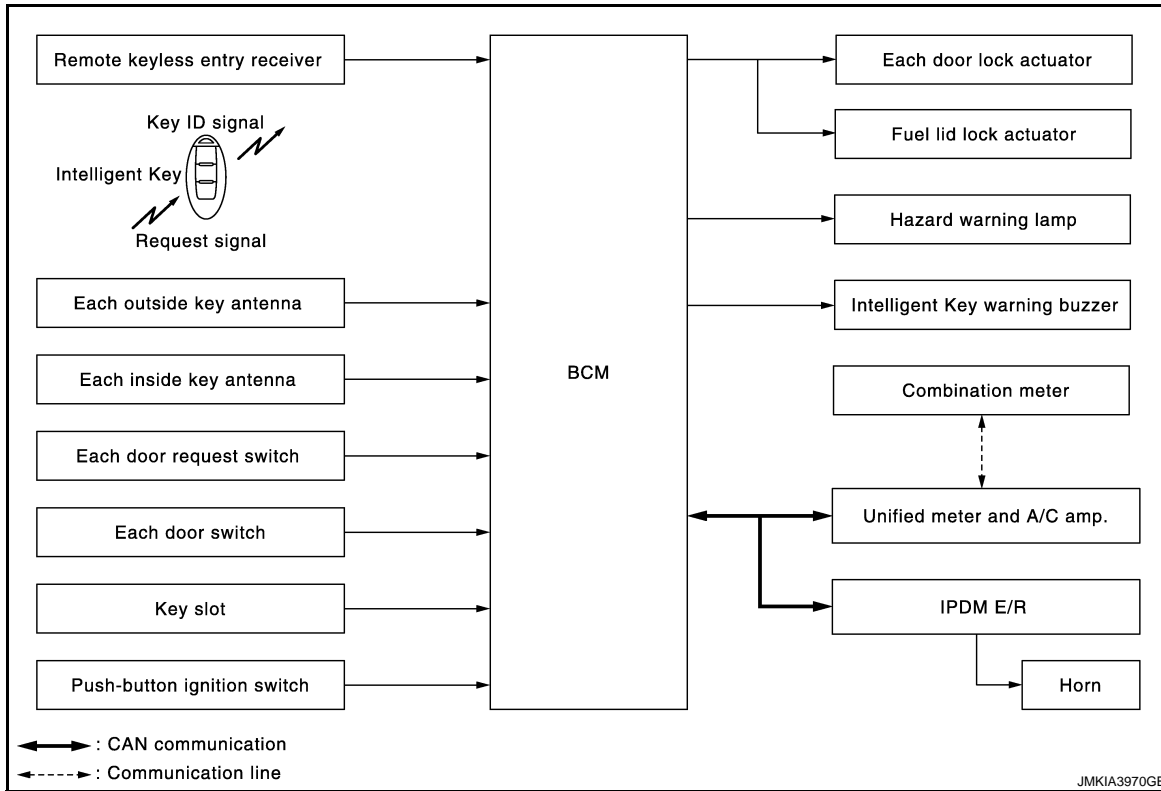

DOOR LOCK FUNCTION : System Description

INFOID:000000005624138

Only when pressing the door request switch, it is possible to lock and unlock the door by carrying the Intelligent Key.

OPERATION DESCRIPTION

- When the BCM detects that each door request switch is pressed, it starts the outside key antenna and inside key antenna corresponding to the pressed door request switch and transmits the request signal to the Intelligent Key. Then check that the Intelligent Key is near the door.
- If the Intelligent Key is within the outside key antenna detection area, it receives the request signal and transmits the key ID signal to the BCM via remote keyless entry receiver.
- BCM receives the key ID signal and compares it with the registered key ID.
- BCM lock/unlock each door and fuel lid and sounds Intelligent Key buzzer warning (lock: 2 times, unlock: 1 time) at the same time as a reminder.

NOTE:

All doors unlock when retractable hardtop opening operation is performed by door request switch operation. But hazard and buzzer reminder function does not operate.

For retractable hard top system, refer to [RF-37, "TRUNK LID CONTROL FUNCTION : System Description"](#).

OPERATION CONDITION

If the following conditions are satisfied, door lock/unlock operation is performed if the door request switch is operated.

Each door request switch operation	Operation condition
Lock	<ul style="list-style-type: none"> • All doors are closed • P position warning is not activated • Panic alarm is not activated • Intelligent Key is outside the vehicle • Intelligent Key is within outside key antenna detection area
Unlock	<ul style="list-style-type: none"> • Panic alarm is not activated • Intelligent Key is outside the vehicle • Intelligent Key is within outside key antenna detection area *

A
B
C
D
E
F
G
H
I
J
L
M
N
O
P

DLK

INTELLIGENT KEY SYSTEM

< SYSTEM DESCRIPTION >

*: Even with a registered Intelligent Key remaining inside the vehicle, door locks can be unlocked from outside of the vehicle with a spare Intelligent Key as long as key IDs are different.

OUTSIDE KEY ANTENNA DETECTION AREA

The outside key antenna detection area of door lock/unlock function is in the range of approximately 80 cm (31.50 in) surrounding the driver and passenger door handles (1). However, this operating range depends on the ambient conditions.

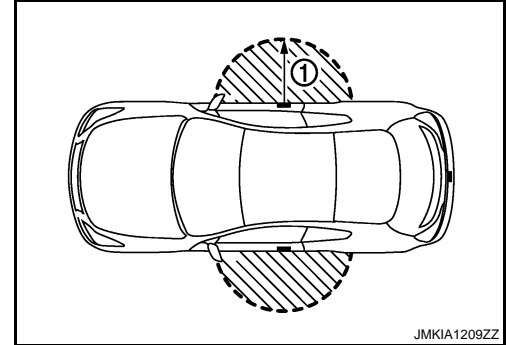

SELECTIVE UNLOCK FUNCTION

Lock Operation

When an LOCK signal is sent from door request switch (driver side or passenger side), all doors and fuel lid are locked.

Unlock Operation

- When an UNLOCK signal from driver side door request switch is transmitted, driver side door and fuel lid unlocks. When another UNLOCK signal is transmitted within 60 seconds, passenger side door unlocks.
- When an UNLOCK signal from passenger side door request switch is transmitted, passenger side door unlock. When another UNLOCK signal is transmitted within 60 seconds, driver side door and fuel lid unlocks.

Selective unlock operation mode can be changed using “DOOR LOCK-UNLOCK SET” mode in “WORK SUPPORT”. Refer to [DLK-50, "DOOR LOCK : CONSULT-III Function \(BCM - DOOR LOCK\)"](#).

HAZARD AND BUZZER REMINDER FUNCTION

During lock, unlock, operation by each door request switch, the hazard warning lamps and Intelligent Key warning buzzer blinks or honk as a reminder.

When doors are locked, unlocked by each door request switch, BCM honks Intelligent Key warning buzzer as a reminder and blinks.

Operating Function of Hazard and Buzzer Reminder

Operation	Hazard warning lamp blinks	Intelligent Key warning buzzer honk
Unlock	Once	Once
Lock	Twice	Twice

Hazard and buzzer reminder does not operate in the following conditions.

- Ignition switch position is ON
- Door is open (only lock operation)

How to Change Hazard and Buzzer Reminder Mode

Refer to [DLK-52, "INTELLIGENT KEY : CONSULT-III Function \(BCM - INTELLIGENT KEY\)"](#).

AUTO DOOR LOCK FUNCTION

After door is unlocked by door request switch operation and if 60 seconds or more passes without performing the following operation, all doors and fuel filler lid are automatically locked. However, operation check function does not activate.

Operating condition	<ul style="list-style-type: none"> • Door switch is ON (door is open) • Door is locked • Push switch is pressed • Intelligent Key is inserted in key slot
---------------------	-----------------------------------------------------------------------------------------------------------------------------------------------------------------------------------------------------

Auto door lock mode can be changed by the “AUTO LOCK SET” mode in “WORK SUPPORT”. Refer to [DLK-52, "INTELLIGENT KEY : CONSULT-III Function \(BCM - INTELLIGENT KEY\)"](#).

LIST OF OPERATION RELATED PARTS

Parts marked with × are the parts related to operation.

INTELLIGENT KEY SYSTEM

< SYSTEM DESCRIPTION >

Door lock function	Intelligent Key	Key slot	Remote keyless entry receiver	Door switch	Door request switch	Door lock actuator and fuel lid lock actuator	Inside key antenna	Outside key antenna	Intelligent Key warning buzzer	CAN communication system	BCM	Hazard warning lamp	Push-button ignition switch	Combination meter
Door lock/unlock function	×	×	×	×	×	×	×	×			×			
Hazard and buzzer reminder function									×	×	×	×		×
Selective unlock function	×				×	×	×	×			×			
Auto door lock function	×	×		×	×	×					×		×	

DOOR LOCK FUNCTION : Component Parts Location

INFOID:000000005624139

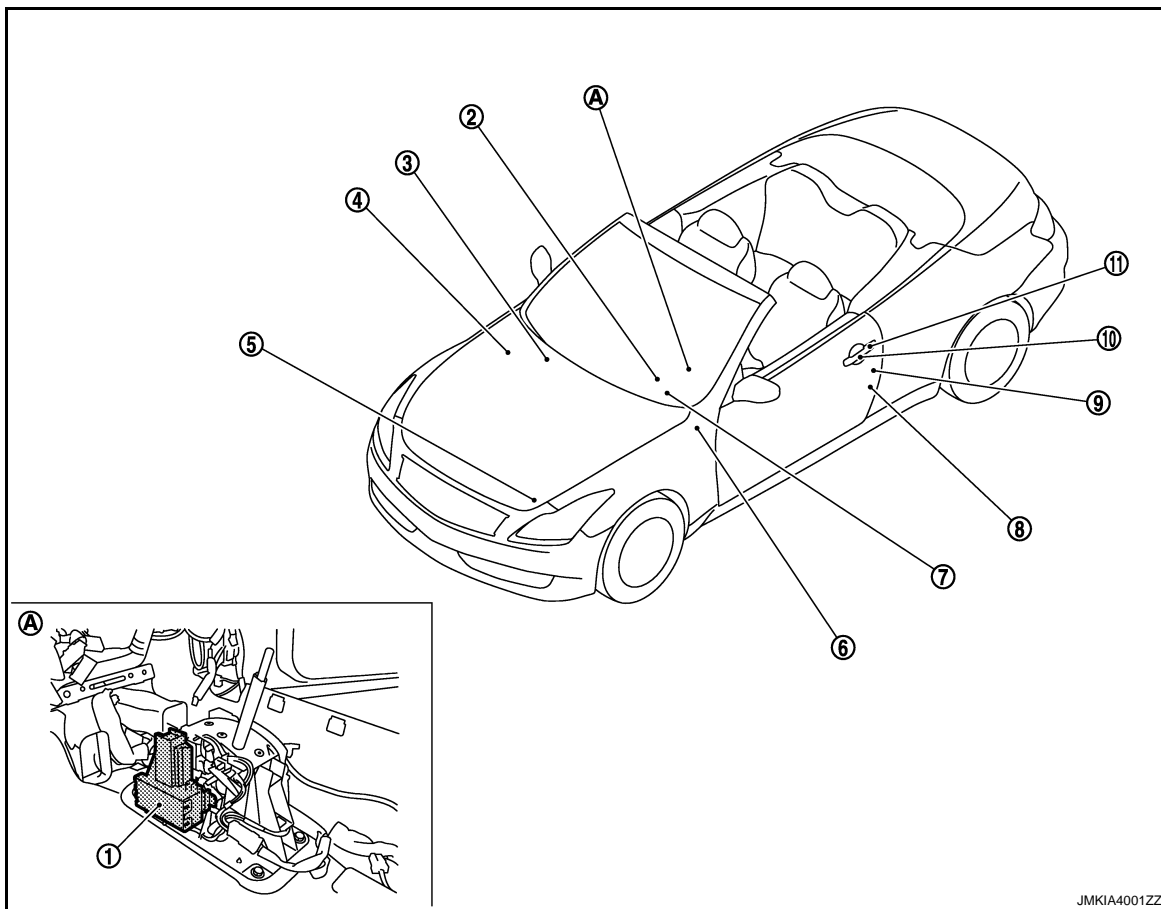

- A/T shift selector (detention switch)* M137
Refer to [SEC-12. "Component Parts Location"](#)
- Push-button ignition switch (push switch) M50
- BCM M118, M119, M120, M121, M122, M123
Refer to [BCS-5. "Component Parts Location"](#)
- IPDM E/R E5, E6
Refer to [PCS-4. "Component Parts Location"](#)
- Intelligent Key warning buzzer E57
- Key slot M22
- Combination meter M53
- Driver side door switch B16
- Driver side door lock assembly D15

A
B
C
D
E
F
G
H
I
J
K
L
M
N
O
P

DLK

INTELLIGENT KEY SYSTEM

< SYSTEM DESCRIPTION >

10. Outside handle LH (outside key antenna) D14 11. Outside handle LH (request switch) D13
- A. View with center console assembly removed

*: With A/T models

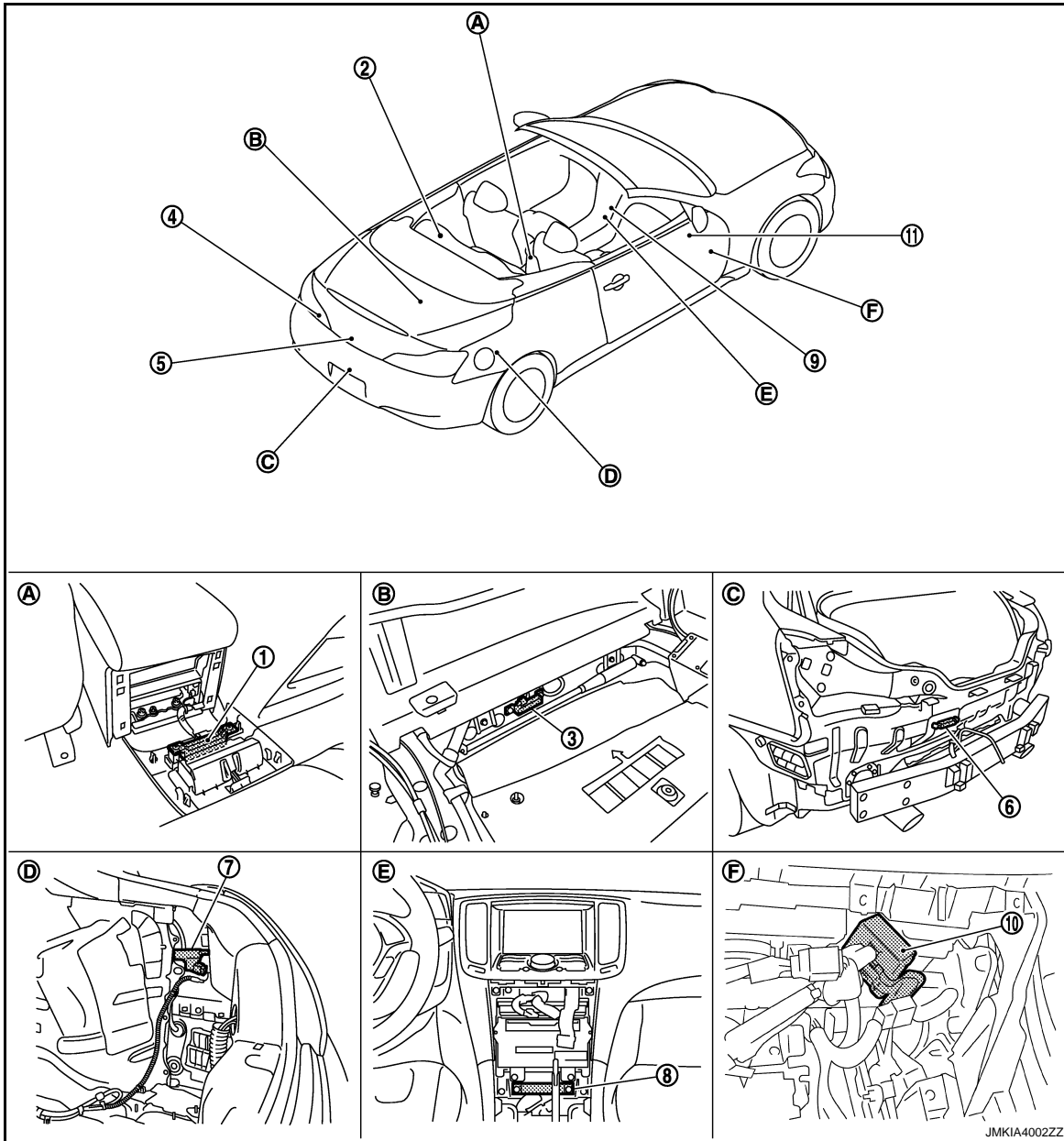

1. Inside key antenna (console) M146 2. Retractable hard top control unit B82, B83, B84
Refer to [RF-11, "Component Parts Location"](#)
3. Inside key antenna (trunk room) B49
4. Rear combination lamp LH (trunk lid opener request switch) B60 5. Trunk lid lock assembly
• Trunk lid opener actuator: B305
• Trunk room lamp switch: B306
6. Outside key antenna (rear bumper) B63
7. Fuel lid lock actuator B40 8. Inside key antenna (instrument center) M131
9. Unified meter and A/C amp. M66, M67
Refer to [MWI-10, "METER SYSTEM : Component Parts Location"](#)
10. Remote keyless entry receiver M104 11. Trunk lid opener cancel switch M105

INTELLIGENT KEY SYSTEM

< SYSTEM DESCRIPTION >

- | | | |
|---------------------------------------------|-------------------------------------------|------------------------------------------------|
| A. View with console rear finisher removed | B. View with trunk front finisher removed | C. View with rear bumper removed |
| D. View with trunk side finisher RH removed | E. View with cluster lid C removed | F. View with instrument lower panel RH removed |

DOOR LOCK FUNCTION : Component Description

INFOID:000000005624140

Item	Function
BCM	Controls the door lock function
IPDM E/R	Sounds horn via CAN communication between BCM
Door lock actuator	Inputs lock/unlock signal from BCM and locks/unlocks each door
Door switch	Inputs door open/close condition to BCM
Remote keyless entry receiver	Receives lock/unlock signal from the Intelligent Key, and then transmits to BCM
Door request switch	Inputs lock/unlock operation to BCM
Intelligent Key	Transmits button operation to remote keyless entry receiver
Outside key antenna	Detects if Intelligent Key is outside the vehicle
Inside key antenna	Detects if Intelligent Key is inside the vehicle
Fuel lid lock actuator	Inputs lock/unlock signal from BCM and lock/unlocks fuel filler lid
Combination meter	Hazard warning lamp is installed to combination meter
Unified meter and A/C amp.	Transmits hazard warning lamp signal to BCM via CAN communication line
Push-button ignition switch	Inputs push-button ignition switch ON/OFF condition to BCM
Key slot	Inputs key insert/remove signal to BCM
Intelligent Key warning buzzer	Warns the user of the lock/unlock condition and inappropriate operations with the buzzer sound
Hazard warning lamp	Warns the user of the door lock/unlock condition and in appropriate operations with the lamps blink

TRUNK OPEN FUNCTION

TRUNK OPEN FUNCTION : System Diagram

INFOID:000000005624141

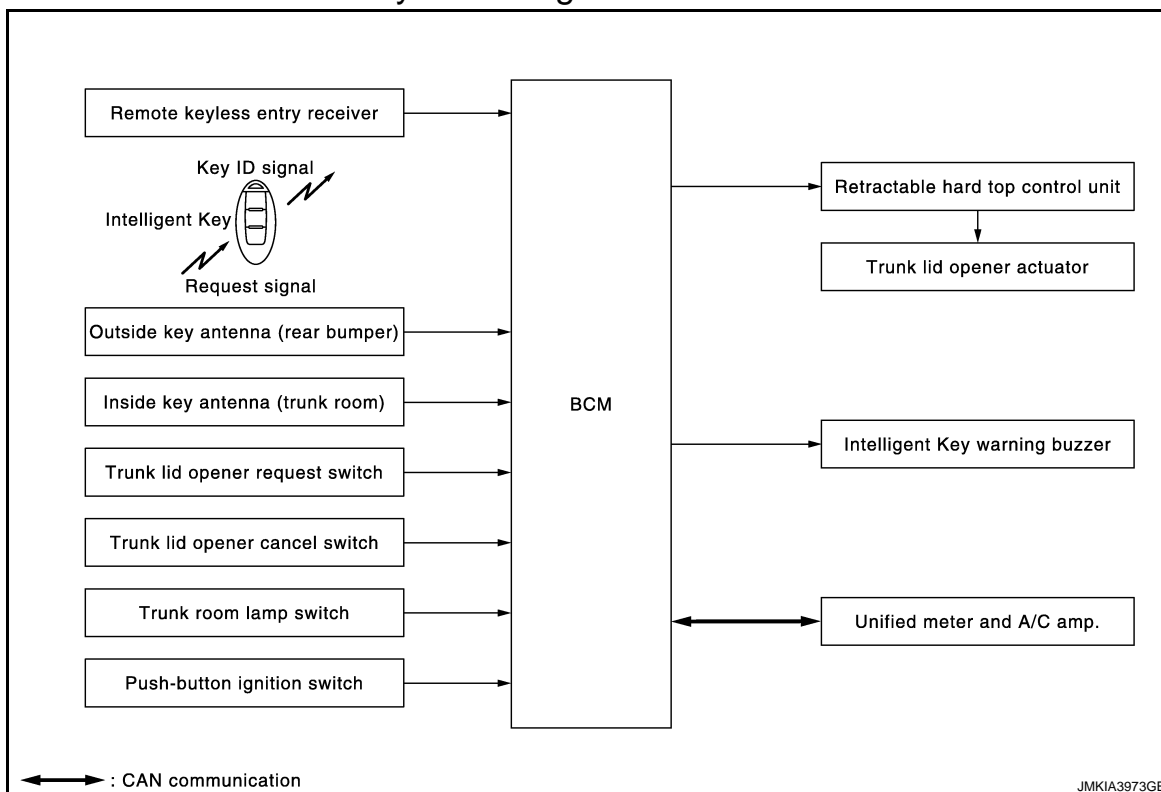

A
B
C
D
E
F
G
H
I
J
L
M
N
O
P

DLK

INTELLIGENT KEY SYSTEM

< SYSTEM DESCRIPTION >

TRUNK OPEN FUNCTION : System Description

INFOID:000000005624142

TRUNK LID OPENER

- When the BCM detects that trunk lid opener request switch is pressed, it activates the outside key antenna (rear bumper) and inside key antenna and transmits the request signal to the Intelligent Key. And then, checks that the Intelligent Key is near the trunk lid.
- If the Intelligent Key is within the outside key antenna detection area, it receives the request signal and transmits the key ID signal to the BCM via remote keyless entry receiver.
- BCM receives the key ID signal and compares it with the registered key ID.
- BCM transmits trunk lid open request signal to retractable hard top control unit and sounds Intelligent Key warning buzzer 4 times at the same time (buzzer remainder).
- Retractable hard top control unit transmits trunk lid open request signal to trunk lid opener actuator trunk lid is open.
- When trunk lid is open, trunk lid auto closure system performs waiting operation for next trunk lid close operation.

For trunk lid auto closure system, refer to [DLK-45. "System Description"](#).

Buzzer reminder does not operate if ignition switch ON position.

How to change buzzer reminder mode

With CONSULT-III

Refer to [DLK-52. "INTELLIGENT KEY : CONSULT-III Function \(BCM - INTELLIGENT KEY\)"](#).

OPERATION CONDITION

If the following conditions are not satisfied, trunk open operation is not performed even if the trunk lid opener request switch is operated.

Trunk lid opener request switch operation	Operation condition
Trunk open	<ul style="list-style-type: none"> • Vehicle speed is less than 5 km/h (3 MPH) • Intelligent Key is within outside key antenna (rear bumper) detection area • Trunk lid opener cancel switch is ON • Trunk lid is closed • Panic alarm is not activated • Retractable hard top is not operated

OUTSIDE KEY ANTENNA DETECTION AREA

The outside key antenna detection area of trunk open function is in the range of approximately 80 cm (31.50 in) surrounding rear bumper center (1). However, this operating range depends on the ambient conditions.

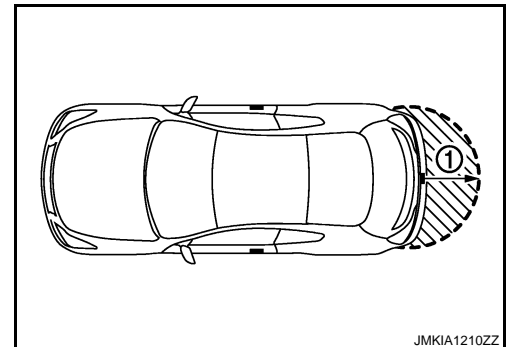

LIST OF OPERATION RELATED PARTS

Parts marked with × are the parts related to operation.

INTELLIGENT KEY SYSTEM

< SYSTEM DESCRIPTION >

	Intelligent Key	Remote keyless entry receiver	Trunk room lamp switch	Trunk lid opener request switch	Trunk lid opener actuator	Inside key antenna (trunk)	Outside key antenna (rear bumper)	Intelligent Key warning buzzer	CAN communication system	BCM	Retractable hard top control unit	Trunk lid opener cancel switch	Push-button ignition switch
Trunk open function	x	x	x	x	x	x	x		x	x	x	x	
Buzzer reminder function								x	x	x			x

TRUNK OPEN FUNCTION : Component Parts Location

INFOID:0000000005624143

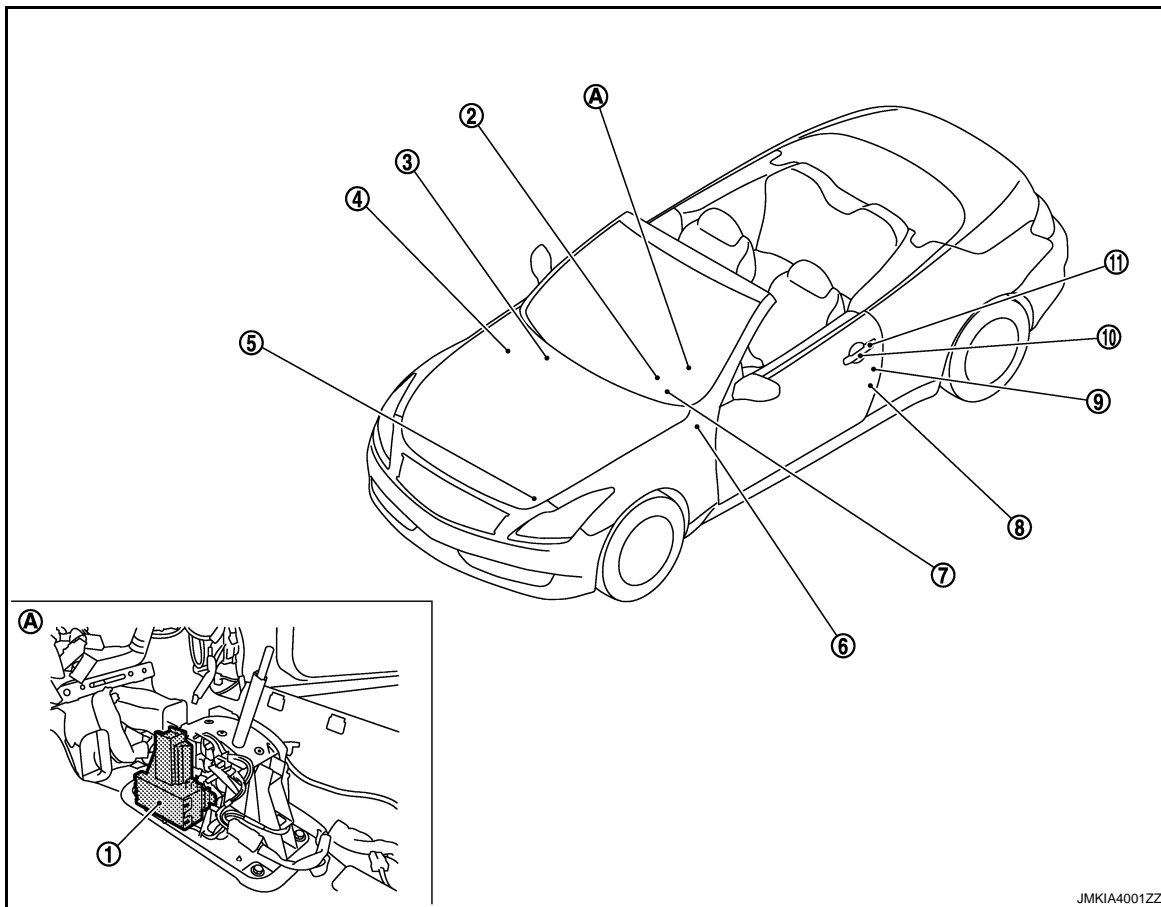

- | | | |
|---------------------------------------------------------------------------------------------------------------|--------------------------------------------------|---------------------------------------------------------------------------------------------------------|
| 1. A/T shift selector (detention switch)* M137
Refer to SEC-12, "Component Parts Location" | 2. Push-button ignition switch (push switch) M50 | 3. BCM M118, M119, M120, M121, M122, M123
Refer to BCS-5, "Component Parts Location" |
| 4. IPDM E/R E5, E6
Refer to PCS-4, "Component Parts Location" | 5. Intelligent Key warning buzzer E57 | 6. Key slot M22 |
| 7. Combination meter M53 | 8. Driver side door switch B16 | 9. Driver side door lock assembly D15 |

INTELLIGENT KEY SYSTEM

< SYSTEM DESCRIPTION >

10. Outside handle LH (outside key antenna) D14
 11. Outside handle LH (request switch) D13
- A. View with center console assembly removed

*: With A/T models

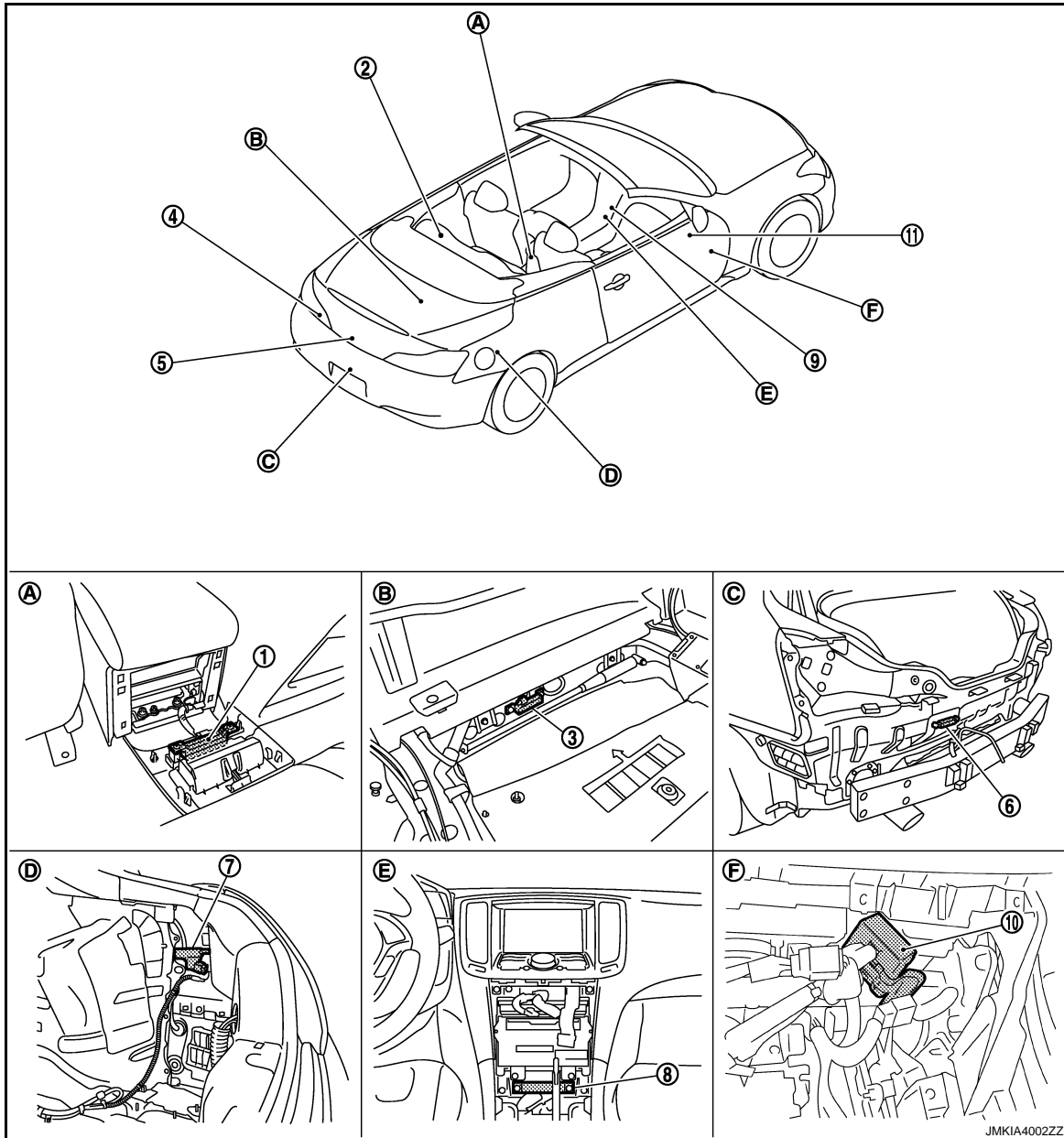

1. Inside key antenna (console) M146
 2. Retractable hard top control unit B82, B83, B84
 Refer to [RF-11, "Component Parts Location"](#)
 3. Inside key antenna (trunk room) B49
 4. Rear combination lamp LH (trunk lid opener request switch) B60
 5. Trunk lid lock assembly
 • Trunk lid opener actuator: B305
 • Trunk room lamp switch: B306
 6. Outside key antenna (rear bumper) B63
 7. Fuel lid lock actuator B40
 8. Inside key antenna (instrument center) M131
 9. Unified meter and A/C amp. M66, M67
 Refer to [MWI-10, "METER SYSTEM : Component Parts Location"](#)
 10. Remote keyless entry receiver M104
 11. Trunk lid opener cancel switch M105

INTELLIGENT KEY SYSTEM

< SYSTEM DESCRIPTION >

- | | | |
|---------------------------------------------|-------------------------------------------|------------------------------------------------|
| A. View with console rear finisher removed | B. View with trunk front finisher removed | C. View with rear bumper removed |
| D. View with trunk side finisher RH removed | E. View with cluster lid C removed | F. View with instrument lower panel RH removed |

TRUNK OPEN FUNCTION : Component Description

INFOID:000000005624144

Item	Function
BCM	Controls the trunk open function
Trunk lid opener actuator	Opens the trunk lid after receiving the open signal from retractable hard top control unit or BCM
Unified meter and A/C amp.	Transmits vehicle sleep signal to CAN communication line
Remote keyless entry receiver	Receives lock/unlock signal from the Intelligent Key, and then transmits to BCM
Trunk lid opener request switch	Inputs lock/unlock operation to BCM
Intelligent Key	Transmits button operation to remote keyless entry receiver
Outside key antenna (rear bumper)	Detects if Intelligent Key is outside the vehicle
Inside key antenna (trunk room)	Detects if Intelligent Key is inside the vehicle
Trunk room lamp switch	Inputs trunk lid open/close condition to BCM
Trunk lid opener cancel switch	Cancels the trunk open operation
Intelligent Key warning buzzer	Warns the user of the open condition and inappropriate operations with the buzzer sound
Push-button ignition switch	Inputs push-button ignition switch ON/OFF condition to BCM
Retractable hard top control unit	Controls the retractable hard top system

REMOTE KEYLESS ENTRY FUNCTION

REMOTE KEYLESS ENTRY FUNCTION : System Diagram

INFOID:000000005624145

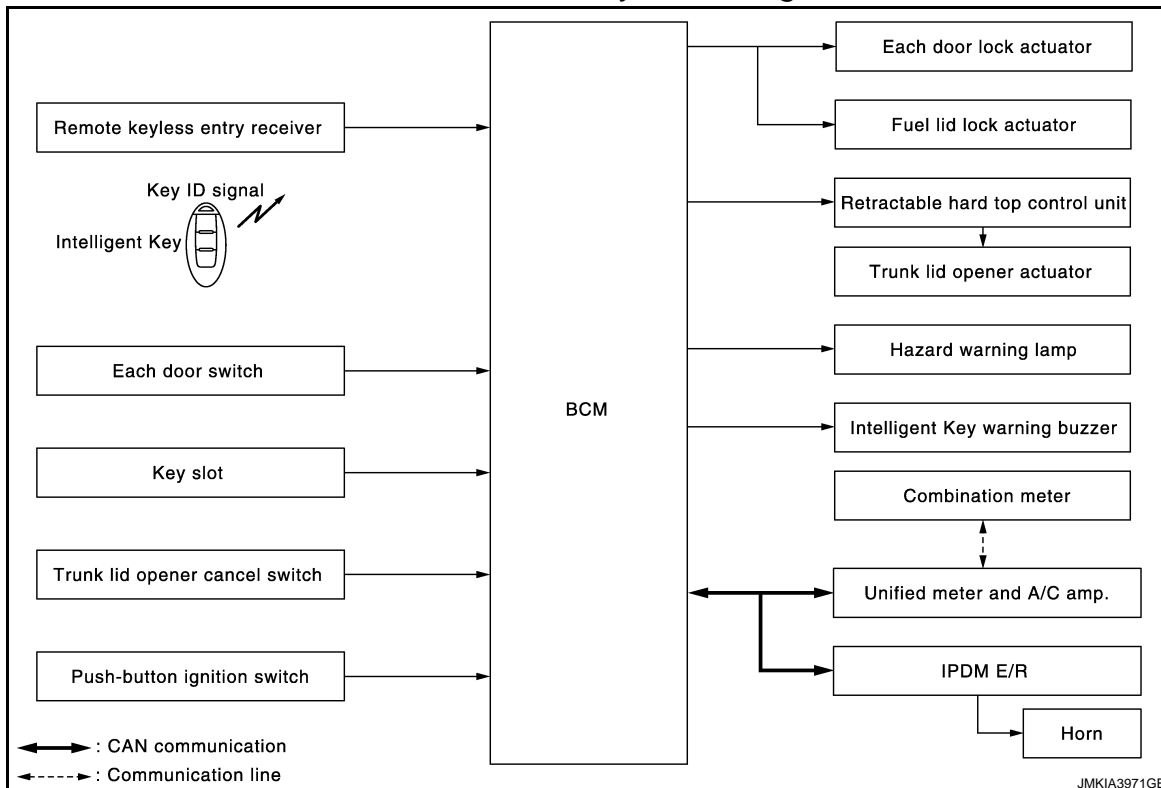

A
B
C
D
E
F
G
H
I
J

DLK

INTELLIGENT KEY SYSTEM

< SYSTEM DESCRIPTION >

REMOTE KEYLESS ENTRY FUNCTION : System Description

INFOID:000000005624146

The Intelligent Key has the same functions as the remote control entry system. Therefore, it can be used in the same manner as the remote controller by operating the door lock/unlock button.

OPERATION

Remote keyless entry system controls operation of the following items.

- Door lock/unlock
- Selective unlock
- Trunk lid open
- Hazard and horn reminder
- Auto door lock

OPERATION AREA

To check that the Intelligent Key works normally, use within 1 m (3 ft) range of each doors, however the operable range may differ according to surroundings.

DOOR LOCK/UNLOCK FUNCTION

- When door lock/unlock button of the Intelligent Key is pressed, lock signal or unlock signal transmitted from Intelligent Key to BCM via remote keyless entry receiver.
- When BCM receives the door lock/unlock signal, it operates all door lock actuators and fuel lid lock actuator the hazard lamp (lock: 2 times, unlock: 1 time) and horn chirp signal to IPDM E/R at the same time as a reminder.
- IPDM E/R honks horn (lock: 2 times) as a reminder

OPERATION CONDITION

Remote controller operation	Operation condition
Lock	<ul style="list-style-type: none">• More than 3 seconds are passed since Intelligent Key removed from key slot• Panic alarm is not activated• P position warning is not activated
Unlock	<ul style="list-style-type: none">• More than 3 seconds are passed since Intelligent Key removed from key slot• Panic alarm is not activated

SELECTIVE UNLOCK FUNCTION

- When an LOCK signal is transmitted from Intelligent Key, all doors and fuel lid are locked.
- When an UNLOCK signal is transmitted from Intelligent Key once, driver side door and fuel lid are unlocked.
- Then, if an UNLOCK signal is transmitted from Intelligent Key again within 60 seconds, all other doors are unlocked.

Selective unlock operation mode can be changed using "DOOR LOCK-UNLOCK SET" mode in "WORK SUPPORT". Refer to [DLK-50, "DOOR LOCK : CONSULT-III Function \(BCM - DOOR LOCK\)"](#).

TRUNK OPEN FUNCTION

- When trunk button of the Intelligent Key is pressed, the trunk lid open signal is transmitted from the Intelligent Key to the BCM via remote keyless entry receiver.
- BCM transmits trunk lid open request signal to retractable hard top control unit.
- Retractable hard top control unit transmits trunk lid open request signal to trunk lid opener actuator. Trunk lid is open.
- When trunk lid is open, trunk lid auto closure system performs waiting operation for next trunk lid close operation.

For trunk lid auto closure system, refer to [DLK-45, "System Description"](#).

OPERATION CONDITION

Remote controller operation	Operation condition
Trunk open	<ul style="list-style-type: none">• Vehicle speed is less than 5 km/h (3 MPH)• Press and hold the trunk open button for 0.5 second or more*• More than 3 seconds are passed since Intelligent Key removed from key slot• Panic alarm is not activated• Ignition switch is except the ON position• Trunk lid opener cancel switch is ON• Retractable hard top is not operated

INTELLIGENT KEY SYSTEM

< SYSTEM DESCRIPTION >

*: Pattern of trunk open button can be selected using CONSULT-III. Refer to [DLK-52. "INTELLIGENT KEY : CONSULT-III Function \(BCM - INTELLIGENT KEY\)".](#)

HAZARD AND HORN REMINDER FUNCTION

When doors are locked or unlocked by Intelligent Key, BCM blinks hazard warning lamps as a reminder and transmits horn chirp signal to IPDM E/R. IPDM E/R sounds horn as a reminder.

The hazard and horn reminder has a horn chirp mode (C mode) and a non-horn chirp mode (S mode).

Operating Function of Hazard and Horn Reminder

Intelligent Key operation	C mode			S mode		
	Lock	Unlock	Trunk open	Lock	Unlock	Trunk open
Hazard warning lamp blinks	Twice	Once	—	Twice	—	—
Horn sound	Once	—	—	—	—	—

Hazard and horn reminder does not operate in the following condition.

- Ignition switch position is ON
- Door is open (only lock operation)

How to change hazard and horn reminder mode

With CONSULT-III

Refer to [DLK-52. "INTELLIGENT KEY : CONSULT-III Function \(BCM - INTELLIGENT KEY\)".](#)

Without CONSULT-III

When LOCK and UNLOCK signals are sent from the Intelligent Key for more than 2 seconds at the same time, the hazard and horn reminder mode is changed and hazard warning lamp blinks and horn sounds as per the following items:

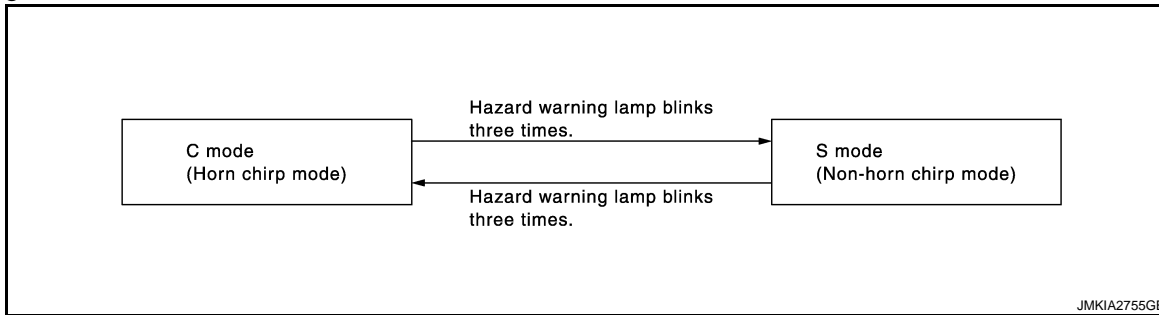

AUTO DOOR LOCK FUNCTION

After door is unlocked by Intelligent Key button operation and if 60 seconds or more passes without performing the following operation, all doors and fuel filler lid are automatically locked. However, operation check function does not activate.

Operating condition	<ul style="list-style-type: none"> • Door switch is ON (door is open) • Door is locked • Push switch is pressed • Intelligent Key is inserted in key slot
---------------------	-----------------------------------------------------------------------------------------------------------------------------------------------------------------------------------------------------

Auto door lock mode can be changed by the "AUTO LOCK SET" mode in "WORK SUPPORT". Refer to [DLK-52. "INTELLIGENT KEY : CONSULT-III Function \(BCM - INTELLIGENT KEY\)".](#)

LIST OF OPERATION RELATED PARTS

Parts marked with × are the parts related to operation.

INTELLIGENT KEY SYSTEM

< SYSTEM DESCRIPTION >

Remote keyless entry functions	Intelligent Key	Key slot	Push-button ignition switch	Door switch	Door lock actuator and fuel lid lock actuator	Intelligent Key warning buzzer	CAN communication system	BCM	Combination meter	Unified meter and A/C amp.	Hazard warning lamp	Horn	IPDM E/R	Retractable hard top control unit	Trunk lid opener actuator	Trunk lid opener cancel switch
Door lock/unlock function	x	x			x		x	x								
Trunk open function	x	x	x				x	x		x				x	x	x
Hazard and horn reminder function	x		x	x		x	x	x	x	x	x	x	x			
Selective unlock function	x			x	x		x	x								
Auto door lock function	x	x	x	x			x	x								

REMOTE KEYLESS ENTRY FUNCTION : Component Parts Location

INFOID:000000005624147

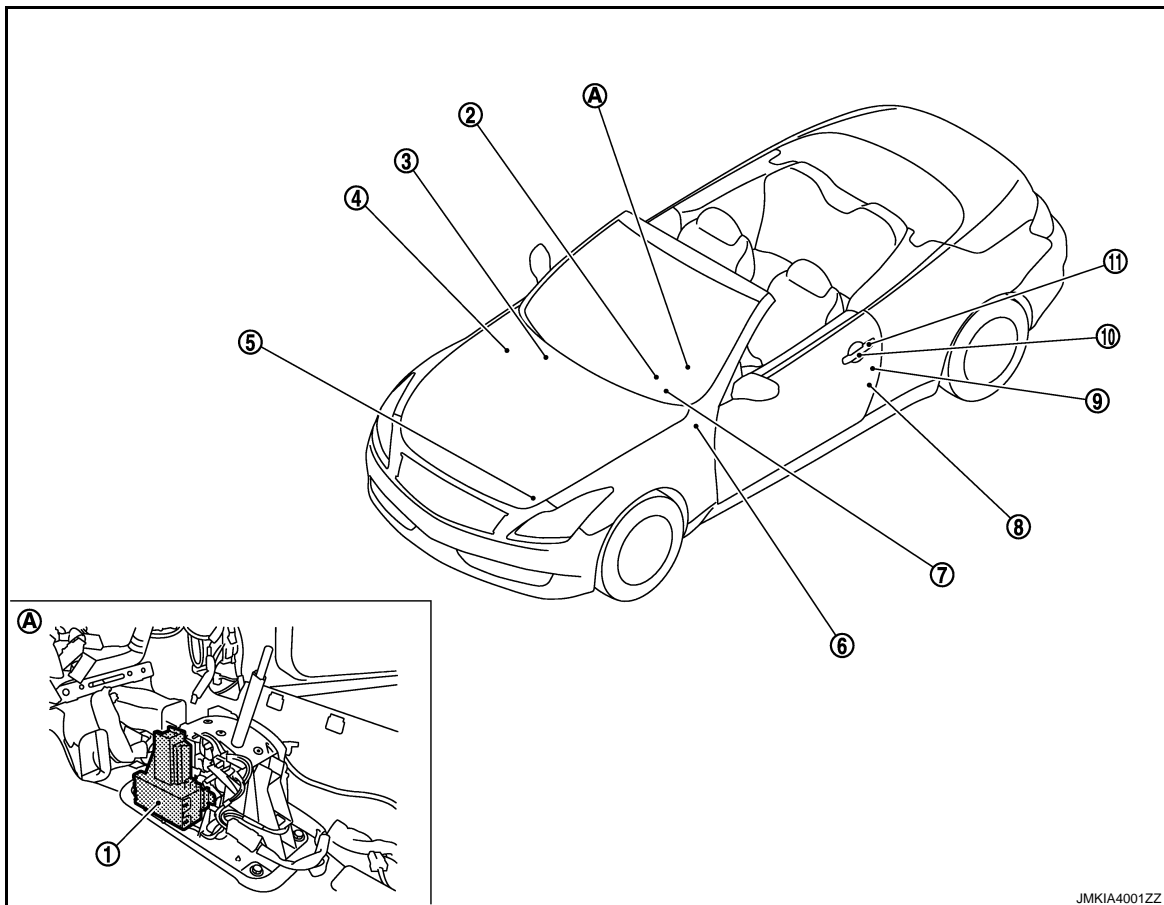

JMKIA4001ZZ

INTELLIGENT KEY SYSTEM

< SYSTEM DESCRIPTION >

- | | | | |
|------------------------------------------------------------------------------------------------------------------|--------------------------------------------------|---------------------------------------------------------------------------------------------------------|---|
| 1. A/T shift selector (detention switch)*
M137
Refer to SEC-12, "Component Parts Location" | 2. Push-button ignition switch (push switch) M50 | 3. BCM M118, M119, M120, M121, M122, M123
Refer to BCS-5, "Component Parts Location" | A |
| 4. IPDM E/R E5, E6
Refer to PCS-4, "Component Parts Location" | 5. Intelligent Key warning buzzer E57 | 6. Key slot M22 | B |
| 7. Combination meter M53 | 8. Driver side door switch B16 | 9. Driver side door lock assembly D15 | C |
| 10. Outside handle LH (outside key antenna) D14 | 11. Outside handle LH (request switch) D13 | | D |
| A. View with center console assembly removed | | | E |

*: With A/T models

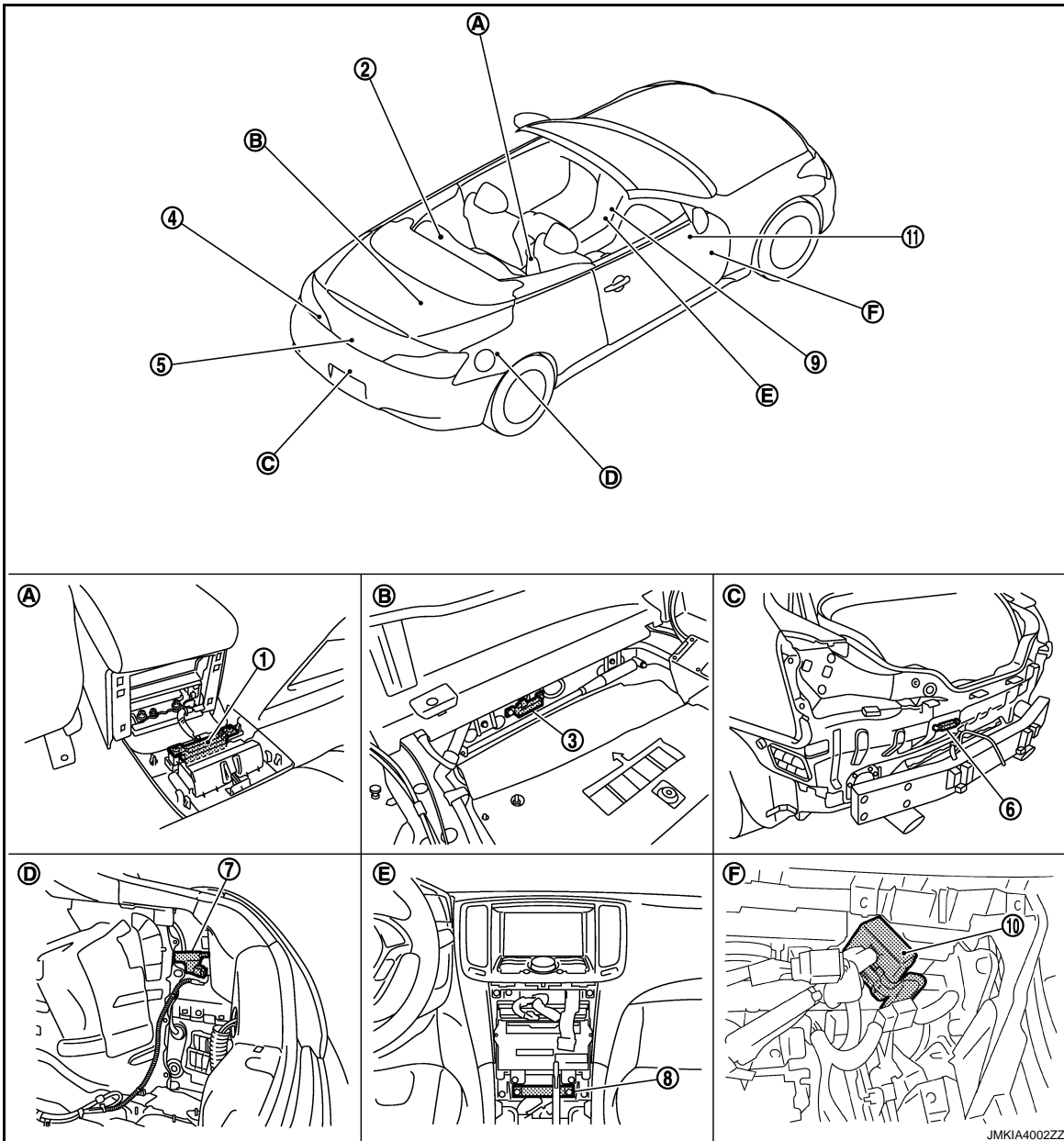

DLK

INTELLIGENT KEY SYSTEM

< SYSTEM DESCRIPTION >

- | | | |
|-------------------------------------------------------------------|--------------------------------------------------------------------------------------------------------------------------------------------------------|----------------------------------------------------------------------------------------------------------------------|
| 1. Inside key antenna (console) M146 | 2. Retractable hard top control unit B82, B83, B84
Refer to RF-11. "Component Parts Location" | 3. Inside key antenna (trunk room) B49 |
| 4. Rear combination lamp LH (trunk lid opener request switch) B60 | 5. Trunk lid lock assembly <ul style="list-style-type: none"> • Trunk lid opener actuator: B305 • Trunk room lamp switch: B306 | 6. Outside key antenna (rear bumper) B63 |
| 7. Fuel lid lock actuator B40 | 8. Inside key antenna (instrument center) M131 | 9. Unified meter and A/C amp. M66, M67
Refer to MWI-10. "METER SYSTEM : Component Parts Location" |
| 10. Remote keyless entry receiver M104 | 11. Trunk lid opener cancel switch M105 | |
| A. View with console rear finisher removed | B. View with trunk front finisher removed | C. View with rear bumper removed |
| D. View with trunk side finisher RH removed | E. View with cluster lid C removed | F. View with instrument lower panel RH removed |

REMOTE KEYLESS ENTRY FUNCTION : Component Description

INFOID:000000005624148

Item	Function
BCM	Controls the door lock function and trunk open function
IPDM E/R	Sounds horn via CAN communication between BCM
Door lock actuator	Inputs lock/unlock signal from BCM and locks/unlocks each door
Door switch	Inputs door open/close condition to BCM
Key slot	Inputs key insert/remove signal to BCM
Remote keyless entry receiver	Receives lock/unlock signal from the Intelligent Key, and then transmits to BCM
Combination meter	Hazard warning lamp is installed to combination meter
Unified meter and A/C amp.	Transmits vehicle sleep signal to CAN communication line
Intelligent Key	Transmits button operation to remote keyless entry receiver
Trunk lid opener actuator	Opens the trunk lid after receiving the open signal from retractable hard top control unit or BCM
Trunk lid opener cancel switch	Cancels the trunk open operation
Fuel lid lock actuator	Inputs lock/unlock signal from BCM and lock/unlocks fuel filler lid
Push-button ignition switch	Input push-button ignition switch ON/OFF condition to BCM
Intelligent Key warning buzzer	Warns the user of the lock/unlock condition and inappropriate operations with the buzzer sound
Hazard warning lamp	Warns the user of the door lock/unlock condition and in appropriate operations with the lamps blink
Retractable hard top control unit	Controls the retractable hard top system

KEY REMINDER FUNCTION

INTELLIGENT KEY SYSTEM

< SYSTEM DESCRIPTION >

KEY REMINDER FUNCTION : System Diagram

INFOID:0000000005624149

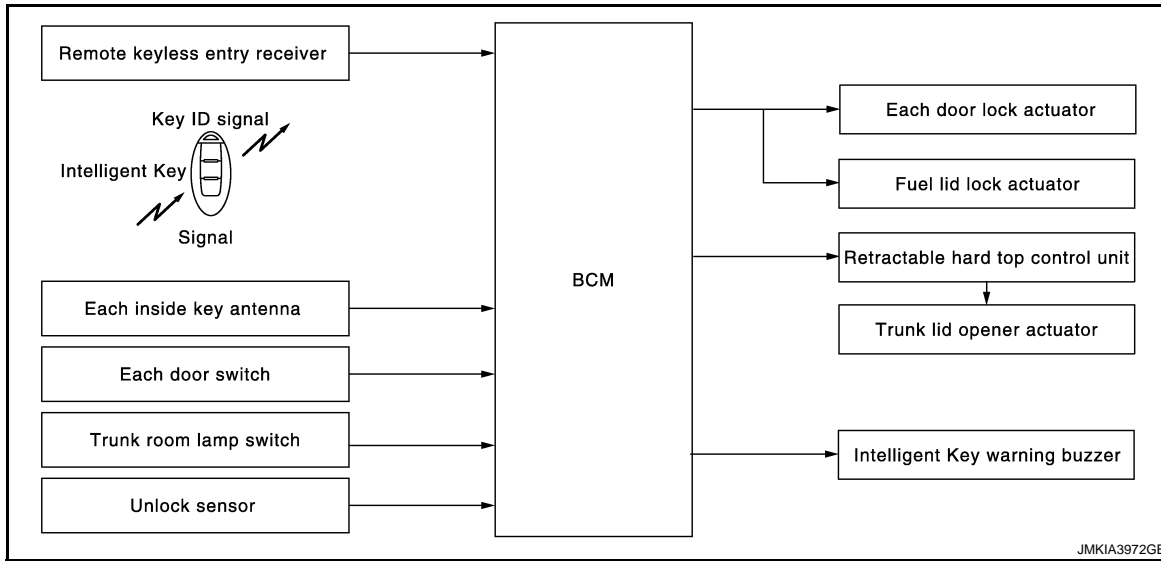

KEY REMINDER FUNCTION : System Description

INFOID:0000000005624150

Key reminder is the function that prevents the key from being left in the vehicle. Key reminder has the following 3 functions.

Key remainder function	Operation condition	Operation
Driver door is closed*	Right after driver side door is closed under the following conditions <ul style="list-style-type: none"> • Door lock operation is performed • Driver side door is open • Driver side door is in unlock state 	All doors unlock
Door is open or closed	Right after all doors are closed under the following conditions <ul style="list-style-type: none"> • Intelligent Key is inside the vehicle • Any door is open • All doors are locked by door lock and unlock switch or door lock knob 	<ul style="list-style-type: none"> • All doors unlock • Honk Intelligent Key warning buzzer
Trunk is closed	Right after trunk is closed under the following conditions <ul style="list-style-type: none"> • Intelligent Key is inside trunk room • All doors are closed • All doors are locked 	<ul style="list-style-type: none"> • Trunk lid open • Honk Intelligent Key warning buzzer

*:If the door closing impact shocks the door lock knob, or contacts against baggage with the door lock knob might activate the door locks accidentally but unlock operation is perform in these cases.

CAUTION:

- The above function operates when the Intelligent Key is inside the vehicle. However, there may be times when the Intelligent Key cannot be detected, and this function does not operate when the Intelligent Key is on the instrument panel, rear parcel shelf, or in the glove box. Also, this system sometimes does not operate if the Intelligent Key is in the door pocket for the open door.

INTELLIGENT KEY SYSTEM

< SYSTEM DESCRIPTION >

KEY REMINDER FUNCTION : Component Parts Location

INFOID:000000005624151

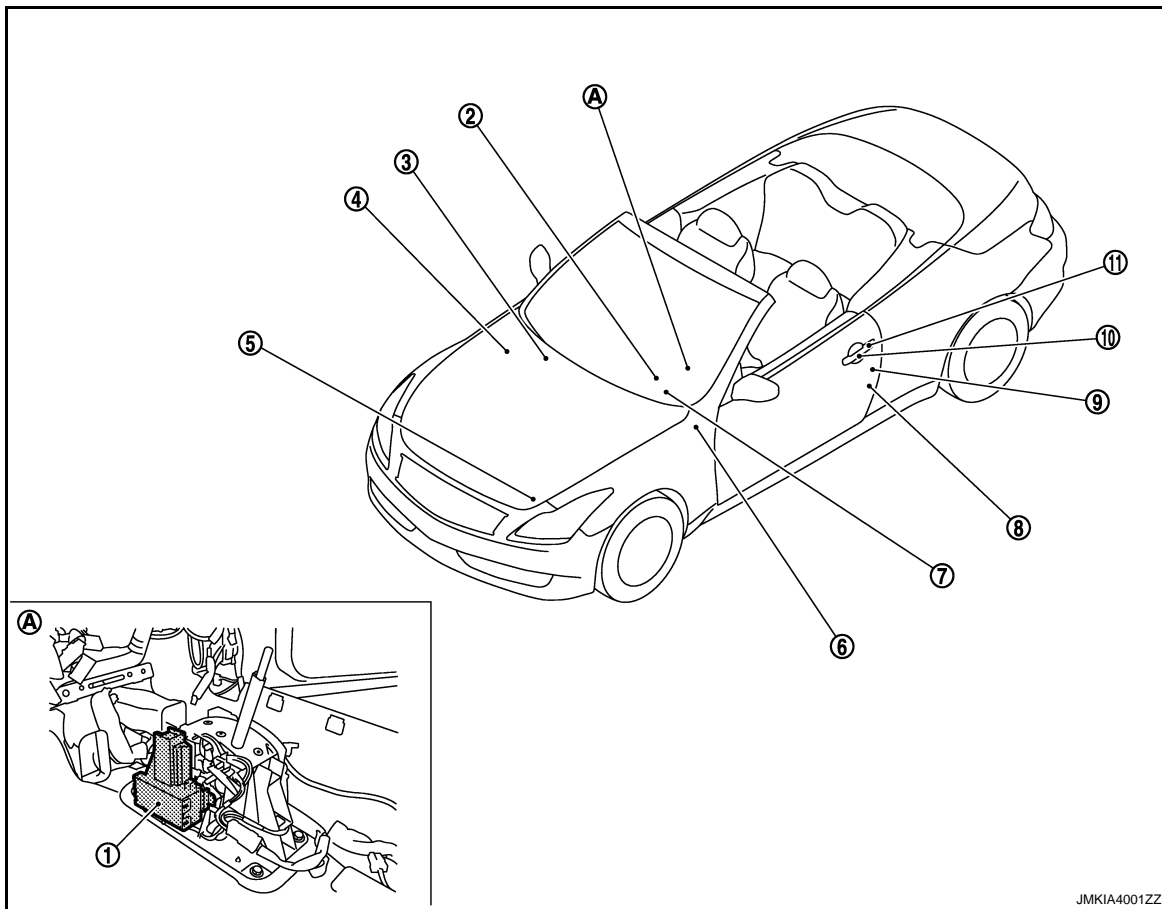

JMKIA4001ZZ

- | | | |
|---------------------------------------------------------------------------------------------------------------|--------------------------------------------------|---------------------------------------------------------------------------------------------------------|
| 1. A/T shift selector (detention switch)* M137
Refer to SEC-12. "Component Parts Location" | 2. Push-button ignition switch (push switch) M50 | 3. BCM M118, M119, M120, M121, M122, M123
Refer to BCS-5. "Component Parts Location" |
| 4. IPDM E/R E5, E6
Refer to PCS-4. "Component Parts Location" | 5. Intelligent Key warning buzzer E57 | 6. Key slot M22 |
| 7. Combination meter M53 | 8. Driver side door switch B16 | 9. Driver side door lock assembly D15 |
| 10. Outside handle LH (outside key antenna) D14 | 11. Outside handle LH (request switch) D13 | |
| A. View with center console assembly removed | | |

*: With A/T models

INTELLIGENT KEY SYSTEM

< SYSTEM DESCRIPTION >

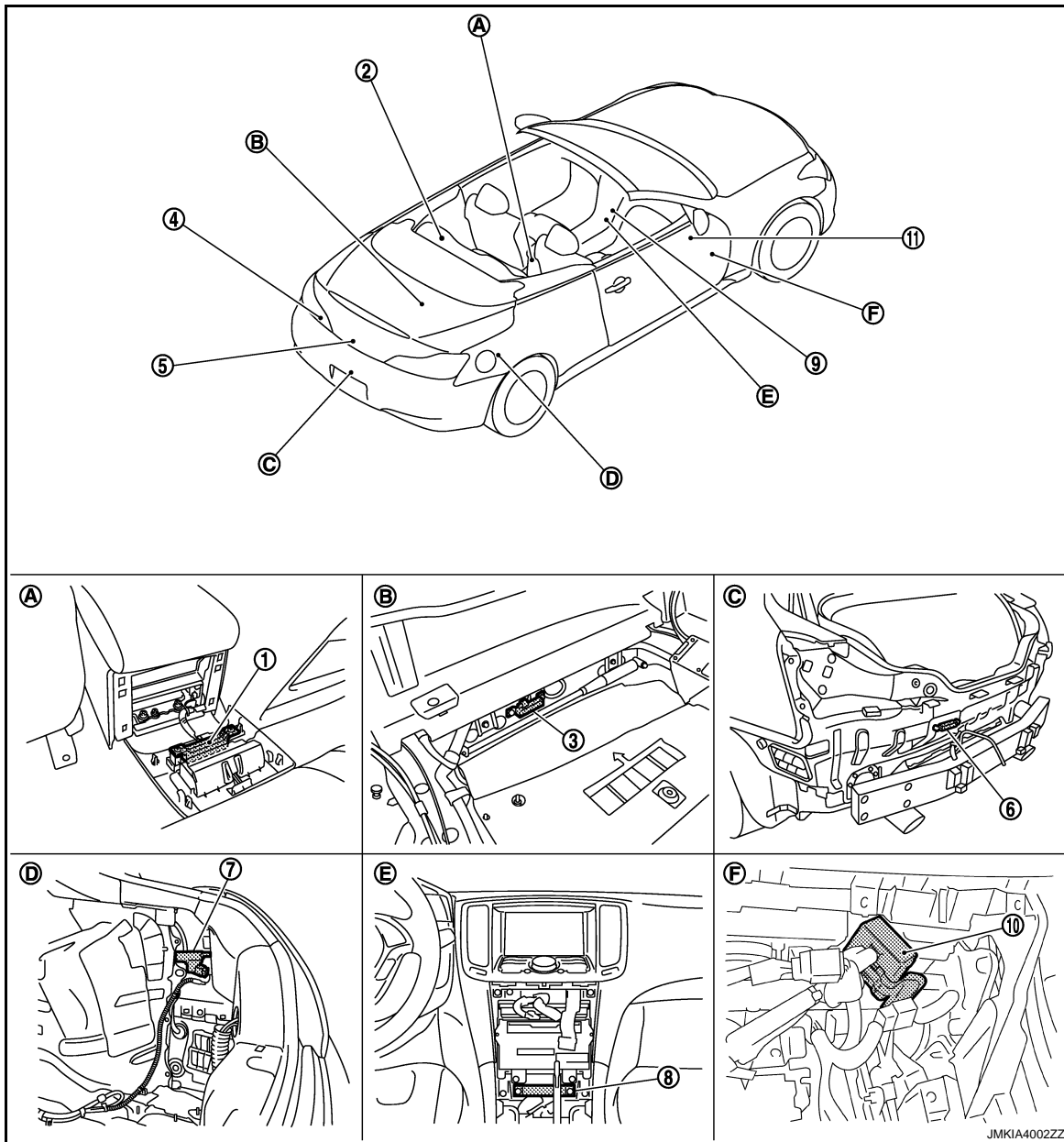

- | | | |
|-------------------------------------------------------------------|------------------------------------------------------------------------------------------------------------------|----------------------------------------------------------------------------------------------------------------------|
| 1. Inside key antenna (console) M146 | 2. Retractable hard top control unit B82, B83, B84
Refer to RF-11, "Component Parts Location" | 3. Inside key antenna (trunk room) B49 |
| 4. Rear combination lamp LH (trunk lid opener request switch) B60 | 5. Trunk lid lock assembly
• Trunk lid opener actuator: B305
• Trunk room lamp switch: B306 | 6. Outside key antenna (rear bumper) B63 |
| 7. Fuel lid lock actuator B40 | 8. Inside key antenna (instrument center) M131 | 9. Unified meter and A/C amp. M66, M67
Refer to MWI-10, "METER SYSTEM : Component Parts Location" |
| 10. Remote keyless entry receiver M104 | 11. Trunk lid opener cancel switch M105 | |
| A. View with console rear finisher removed | B. View with trunk front finisher removed | C. View with rear bumper removed |
| D. View with trunk side finisher RH removed | E. View with cluster lid C removed | F. View with instrument lower panel RH removed |

WARNING FUNCTION

A
B
C
D
E
F
G
H
I
J
K
L
M
N
O
P

DLK

JMKIA400ZZ

INTELLIGENT KEY SYSTEM

< SYSTEM DESCRIPTION >

WARNING FUNCTION : System Description

INFOID:000000005624152

OPERATION DESCRIPTION

The warning function are as per the following items and are given to the user as warning information and warnings using combinations of Intelligent Key warning buzzer, combination meter buzzer, KEY warning lamp, key slot indicator and information display in combination meter.

- Intelligent Key system malfunction
- OFF position warning
- P position warning
- ACC warning
- Take away warning
- Door lock operation warning
- Key warning
- Intelligent Key insert information
- Engine start information
- Steering lock information
- Intelligent Key low battery warning
- Key ID warning

OPERATION CONDITION

Once the following condition from below is established, alert or warning is executed.

Warning/Information functions		Operation procedure
Intelligent Key system malfunction		When a malfunction is detected on BCM, "KEY" warning lamp illuminates
OFF position warning	For internal	<ul style="list-style-type: none"> • Ignition switch: ACC position • Door switch (driver side): ON (Door is open)
	For external*	OFF position warning (For internal) is in active mode, driver side door is closed NOTE: OFF position (For external) active only when each of the sequence occurs as below: P position warning → ACC warning → OFF position warning (For internal) → OFF position warning (For internal)
P position warning*	For internal	<ul style="list-style-type: none"> • Shift position: Except P position • Engine is running to stopped (Ignition switch is ON to OFF)
	For external	Warning is activated when driver door is closed from the open position while the P position warning (for inside vehicle) is ON
ACC warning*		<ul style="list-style-type: none"> • When P position warning is in active mode, shift position changes P position • Ignition switch: ACC position
Take away warning	Door is open to close	<ul style="list-style-type: none"> • Ignition switch: Except LOCK position • Door switch: ON to OFF (Door is open to close) • Intelligent Key cannot be detected inside the vehicle
	Door is open	<ul style="list-style-type: none"> • Door switch: ON (Door is open) • Key ID verification every 5 seconds when registered Intelligent Key cannot be detected inside the vehicle
	Push-button ignition switch operation	<ul style="list-style-type: none"> • Ignition switch: Except LOCK position • Press push-button ignition switch • Intelligent Key cannot be detected inside the vehicle
	Intelligent Key is removed from key slot	<ul style="list-style-type: none"> • When Intelligent Key is removed from key slot, Intelligent Key cannot be detected inside the vehicle
Door lock operation warning		When door lock operation is requested while door lock operating condition of door request switch not satisfied
Key warning		<ul style="list-style-type: none"> • Ignition switch is OFF position • Driver side door switch: ON (Driver side door is open) • Intelligent Key is inserted in key slot
Intelligent Key insert information		<ul style="list-style-type: none"> • Door switch: ON to OFF (Door is open to close) • Intelligent Key is out of key slot • Intelligent Key cannot be detected inside the vehicle

INTELLIGENT KEY SYSTEM

< SYSTEM DESCRIPTION >



Warning/Information functions		Operation procedure
Engine start information	Ignition switch is ON position	<ul style="list-style-type: none"> Ignition switch: ON position Shift position: P position* Engine is stopped
	Ignition switch is except ON position	<ul style="list-style-type: none"> Ignition switch: Except ON position Shift position: P position* Intelligent Key is inserted in key slot or Intelligent Key can be detected inside the vehicle
Steering lock information		When steering lock cannot be released after ignition switch is turned ON
Intelligent Key low battery warning		When Intelligent Key is low battery, BCM is detected after ignition switch is turned ON
Key ID warning		When registered intelligent Key cannot be detected inside the vehicle after ignition switch is turned ON

*: M/T models do not apply.

WARNING METHOD



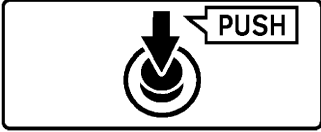

The following table shows the alarm or warning methods with chime.

Information display (combination meter), "KEY" indicator or key slot indicator when the warning conditions are met.

Warning/Information functions		"KEY" warning lamp	Information display (combination meter)	Key slot indicator	Warning chime	
					Combination meter buzzer	Intelligent Key warning buzzer
Intelligent Key system malfunction		Illuminate	—	—	—	—
OFF position warning	For internal	—	—	—	Activate	—
	For external*	—	—	—	—	Activate
P position warning*	For internal	—	 <small>JMKIA0037GB</small>	—	Activate	—
	For external	—		—	—	Active
ACC warning*		—	 <small>JMKIA0047GB</small>	—	—	—
Take away warning	Door is open to close	—	 <small>JMKIA0036GB</small>	Blink	Activate	Activate
	Door is open	—		Blink	—	—
	Push button-ignition switch operation	—		Blink	Activate	—
	Intelligent Key is removed from key slot	—		Blink	—	—
Door lock operation warning	Request switch operation	—	—	—	—	Activate

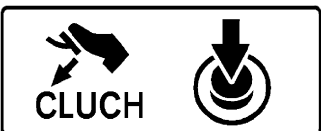

INTELLIGENT KEY SYSTEM

< SYSTEM DESCRIPTION >

Warning/Information functions		"KEY" warning lamp	Information display (combination meter)	Key slot indicator	Warning chime	
					Combination meter buzzer	Intelligent Key warning buzzer
Key ID warning		—	 <small>JMKIA0036GB</small>	—	—	—
Key warning		—	 <small>JMKIA0035GB</small>	Blink	Activate	—
Intelligent Key insert information		—	 <small>JMKIA0034GB</small>	Illuminate	—	—
Engine start information	Automatic transmission models	—	 <small>JMKIA0032GB</small>	—	—	—
	Manual transmission models	—	 <small>JMKIA0049GB</small>	—	—	—

INTELLIGENT KEY SYSTEM

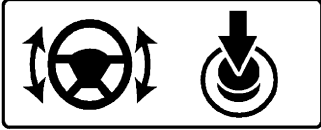
< SYSTEM DESCRIPTION >

Warning/Information functions	"KEY" warning lamp	Information display (combination meter)	Key slot indicator	Warning chime	
				Combination meter buzzer	Intelligent Key warning buzzer
Steering lock information	—	 <small>JMKIA0033GB</small>	—	—	—
Intelligent Key low battery warning	—	 <small>JMKIA3049ZZ</small>	—	—	—

*: M/T models do not apply.

LIST OF OPERATION RELATED PARTS

Parts marked with × are the parts related to operation.

Warning function		Intelligent Key	Key slot	Ignition switch	Door switch	Door request switch	Inside key antenna	Outside key antenna	Intelligent Key warning buzzer	Combination meter warning buzzer	CAN communication system	BCM	Combination meter display	Key slot indicator	Detention switch	"KEY" warning lamp
Intelligent Key system malfunction											×	×				×
OFF position warning	For internal				×					×	×	×				
	For external				×				×			×				
P position warning				×						×	×	×	×		×	
ACC warning				×						×	×	×	×		×	
Take away warning	Door is open or close	×			×		×		×	×	×	×	×	×		
	Door is open	×			×		×				×	×	×	×		
	Push-button ignition switch operation	×		×			×		×	×	×	×	×	×		
	Intelligent Key is removed from key slot	×	×				×				×	×	×	×		
Door lock operation warning		×	×		×	×	×	×	×			×				
Key ID warning			×	×			×				×	×	×			
Key warning		×	×		×				×	×	×	×	×	×		
Intelligent Key insert information		×	×	×	×		×				×	×	×	×		

INTELLIGENT KEY SYSTEM

< SYSTEM DESCRIPTION >

Warning function		Intelligent Key	Key slot	Ignition switch	Door switch	Door request switch	Inside key antenna	Outside key antenna	Intelligent Key warning buzzer	Combination meter warning buzzer	CAN communication system	BCM	Combination meter display	Key slot indicator	Detention switch	"KEY" warning lamp
Engine start information	Ignition switch is ON position	×	×	×			×				×	×	×		×	
	Ignition switch is except ON position	×	×	×			×				×	×	×			
Steering lock information				×							×	×	×			
Intelligent Key low battery warning		×					×				×	×	×			

WARNING FUNCTION : Component Parts Location

INFOID:000000005624153

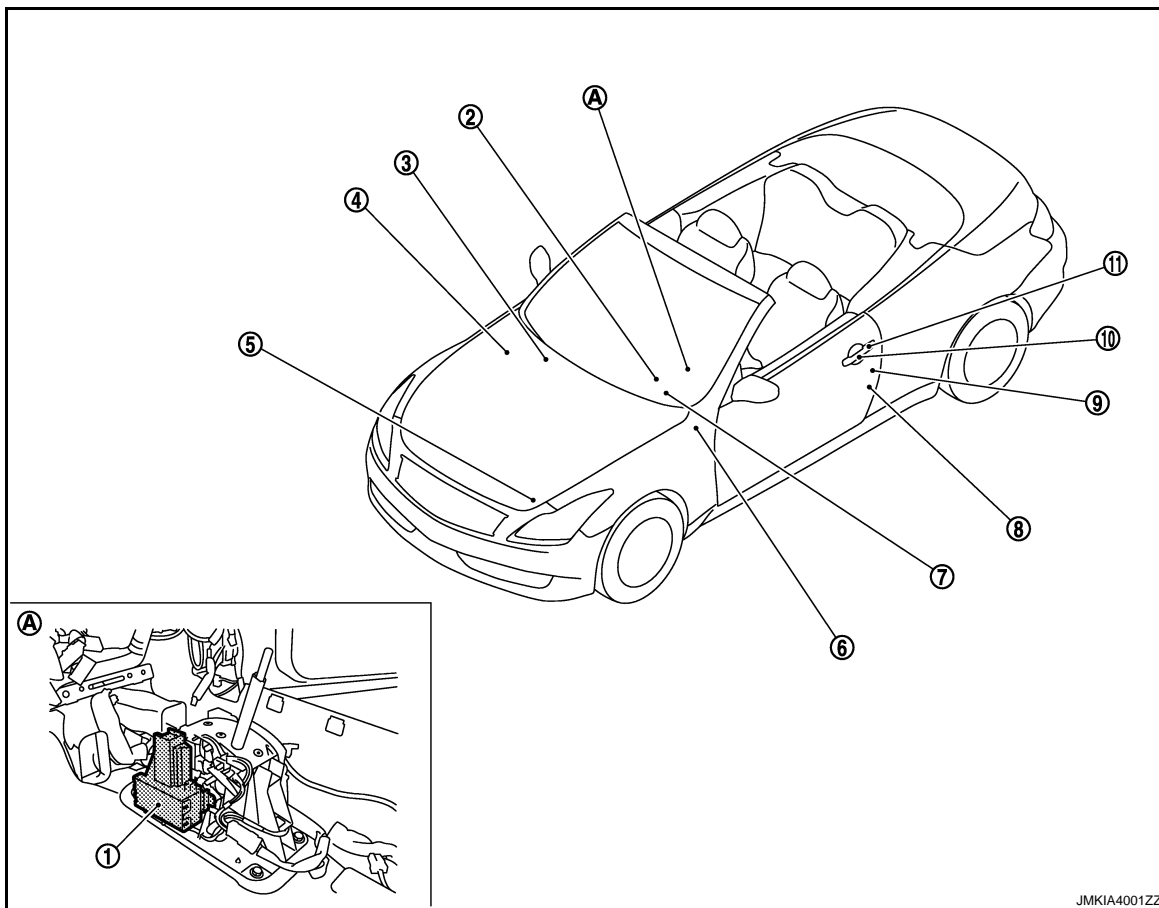

JMKIA4001ZZ

1. A/T shift selector (detention switch)* M137
Refer to [SEC-12. "Component Parts Location"](#)
2. Push-button ignition switch (push switch) M50
3. BCM M118, M119, M120, M121, M122, M123
Refer to [BCS-5. "Component Parts Location"](#)
4. IPDM E/R E5, E6
Refer to [PCS-4. "Component Parts Location"](#)
5. Intelligent Key warning buzzer E57
6. Key slot M22

INTELLIGENT KEY SYSTEM

< SYSTEM DESCRIPTION >

- | | | |
|-------------------------------------------------|--------------------------------------------|---------------------------------------|
| 7. Combination meter M53 | 8. Driver side door switch B16 | 9. Driver side door lock assembly D15 |
| 10. Outside handle LH (outside key antenna) D14 | 11. Outside handle LH (request switch) D13 | |
| A. View with center console assembly removed | | |

*: With A/T models

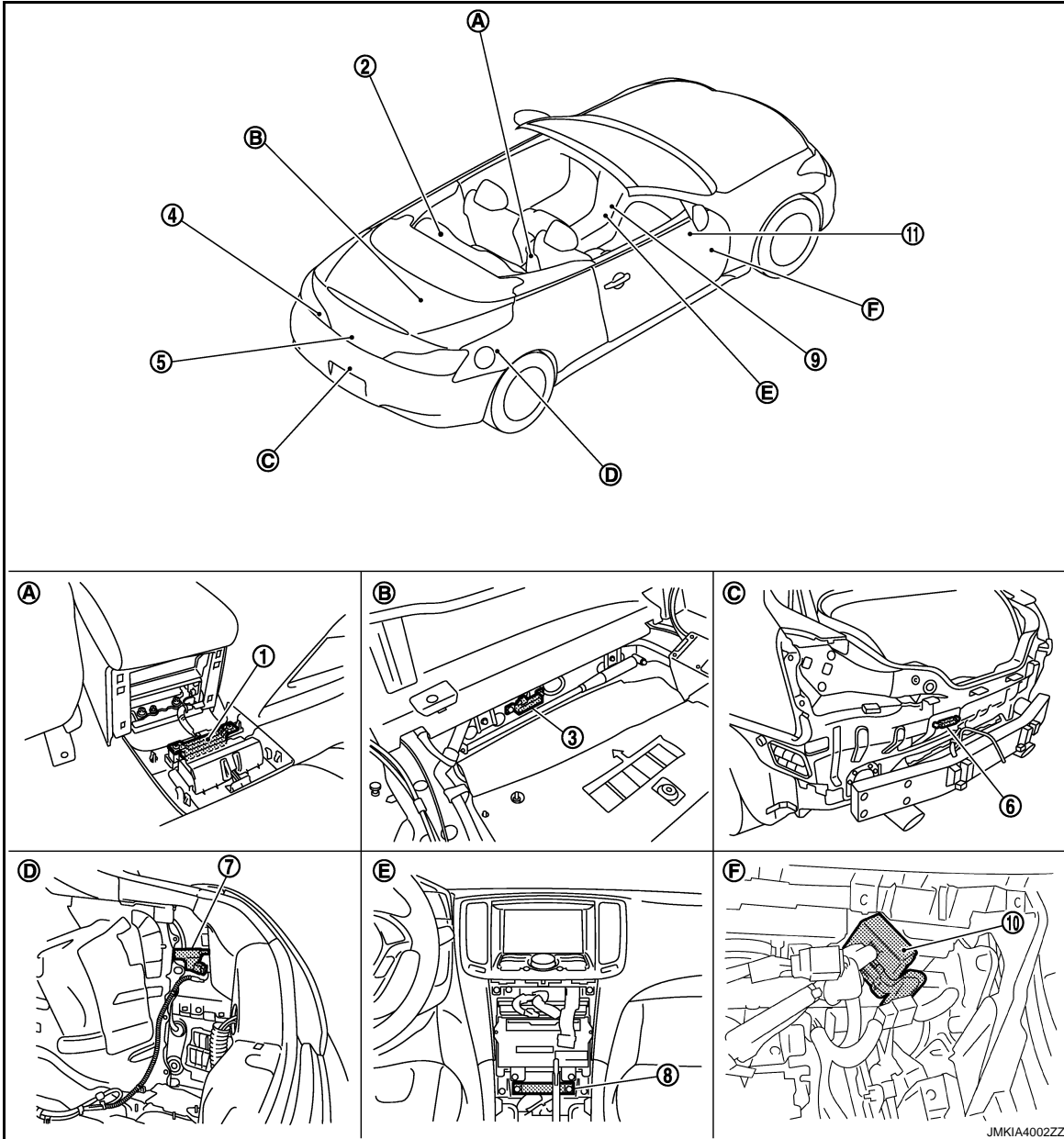

- | | | |
|-------------------------------------------------------------------|------------------------------------------------------------------------------------------------------------------|----------------------------------------------------------------------------------------------------------------------|
| 1. Inside key antenna (console) M146 | 2. Retractable hard top control unit B82, B83, B84
Refer to RF-11, "Component Parts Location" | 3. Inside key antenna (trunk room) B49 |
| 4. Rear combination lamp LH (trunk lid opener request switch) B60 | 5. Trunk lid lock assembly
• Trunk lid opener actuator: B305
• Trunk room lamp switch: B306 | 6. Outside key antenna (rear bumper) B63 |
| 7. Fuel lid lock actuator B40 | 8. Inside key antenna (instrument center) M131 | 9. Unified meter and A/C amp. M66, M67
Refer to MWI-10, "METER SYSTEM : Component Parts Location" |
| 10. Remote keyless entry receiver M104 | 11. Trunk lid opener cancel switch M105 | |

A
B
C
D
E
F
G
H
I
J
K
L
M
N
O
P

DLK

INTELLIGENT KEY SYSTEM

< SYSTEM DESCRIPTION >

- | | | |
|---------------------------------------------|-------------------------------------------|------------------------------------------------|
| A. View with console rear finisher removed | B. View with trunk front finisher removed | C. View with rear bumper removed |
| D. View with trunk side finisher RH removed | E. View with cluster lid C removed | F. View with instrument lower panel RH removed |

TRUNK OPEN FUNCTION

< SYSTEM DESCRIPTION >

TRUNK OPEN FUNCTION

System Diagram

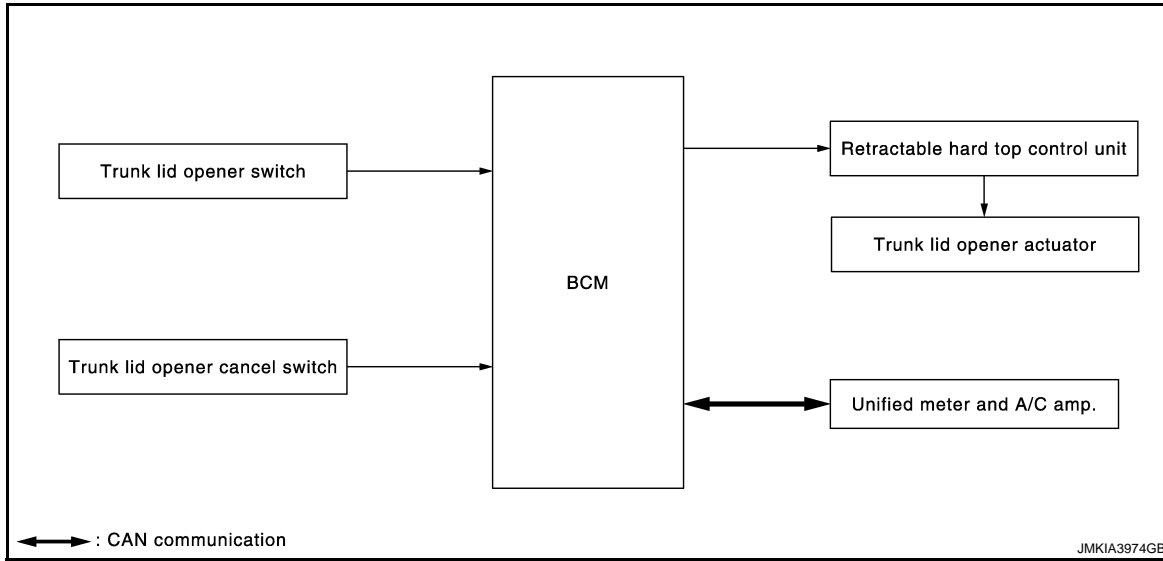

System Description

INFOID:0000000005624155

- When trunk lid opener switch turns ON, BCM transmits trunk lid open request signal to retractable hard top control unit.
- Retractable hard top control unit transmits trunk lid open request signal to trunk lid opener actuator. Trunk lid is open.
- When trunk lid is open, trunk lid auto closure system performs waiting operation for next trunk lid close operation.
For trunk lid auto closure system, refer to [DLK-45, "System Description"](#).

OPERATION CONDITION

If the following conditions are satisfied, trunk open operation is performed.

Trunk lid opener switch operation	Operation condition
Trunk lid open	<ul style="list-style-type: none"> • Trunk lid opener cancel switch is ON • Vehicle speed is less than 5 km/h (3 MPH) • Vehicle security system is in the disarmed or pre-armed phase • Retractable hard top is not operated

A
B
C
D
E
F
G
H
I
J
L
M
N
O
P

DLK

TRUNK OPEN FUNCTION

< SYSTEM DESCRIPTION >

Component Parts Location

INFOID:000000005624156

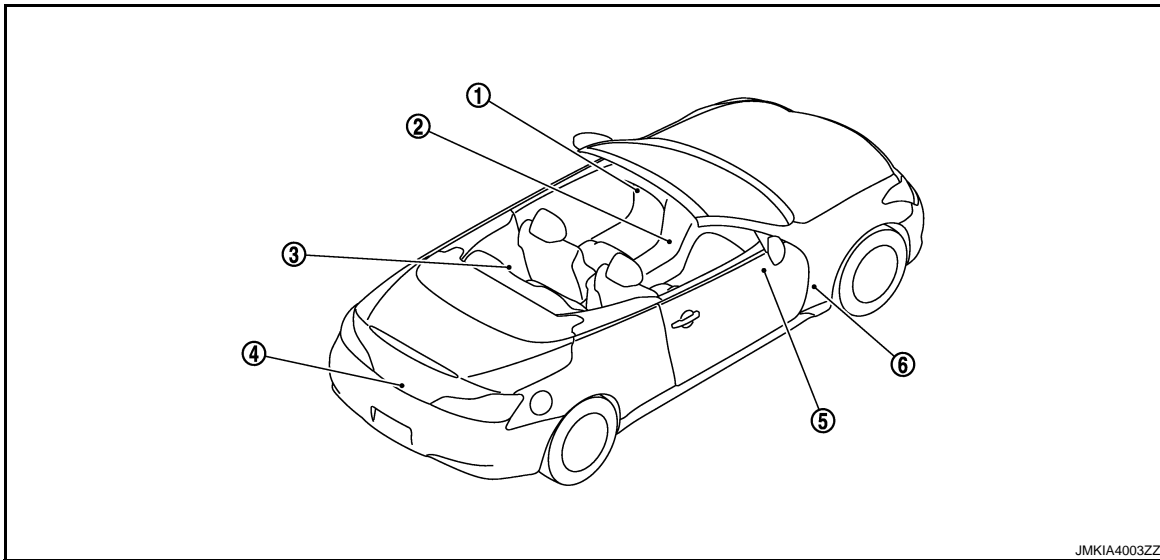

JMKIA4003ZZ

- | | | |
|-------------------------------------------------------------|-----------------------------------------------------------------------------------------------------------------|------------------------------------------------------------------------------------------------------------------|
| 1. Trunk lid opener switch M20 | 2. Unified meter and A/C amp. M67
Refer to MWI-10, "METER SYSTEM : Component Parts Location" | 3. Retractable hard top control unit B82, B83, B84
Refer to RF-11, "Component Parts Location" |
| 4. Trunk lid lock assembly (trunk lid opener actuator B305) | 5. Trunk lid opener cancel switch M105 | 6. BCM M118, M119, M120, M121, M122, M123
Refer to BCS-5, "Component Parts Location" |

Component Description

INFOID:000000005624157

Item	Function
BCM	Controls trunk lid open operation
Trunk lid opener switch	Transmits trunk lid open operation to BCM
Trunk lid opener actuator	Opens the trunk lid after receiving the open signal from retractable hard top control unit or BCM
Trunk lid opener cancel switch	Cancels the trunk lid open operation
Unified meter and A/C amp.	Transmits vehicle speed signal to CAN communication line
Retractable hard top control unit	Controls the retractable hard top control system

TRUNK LID AUTO CLOSURE SYSTEM

< SYSTEM DESCRIPTION >

TRUNK LID AUTO CLOSURE SYSTEM

System Diagram

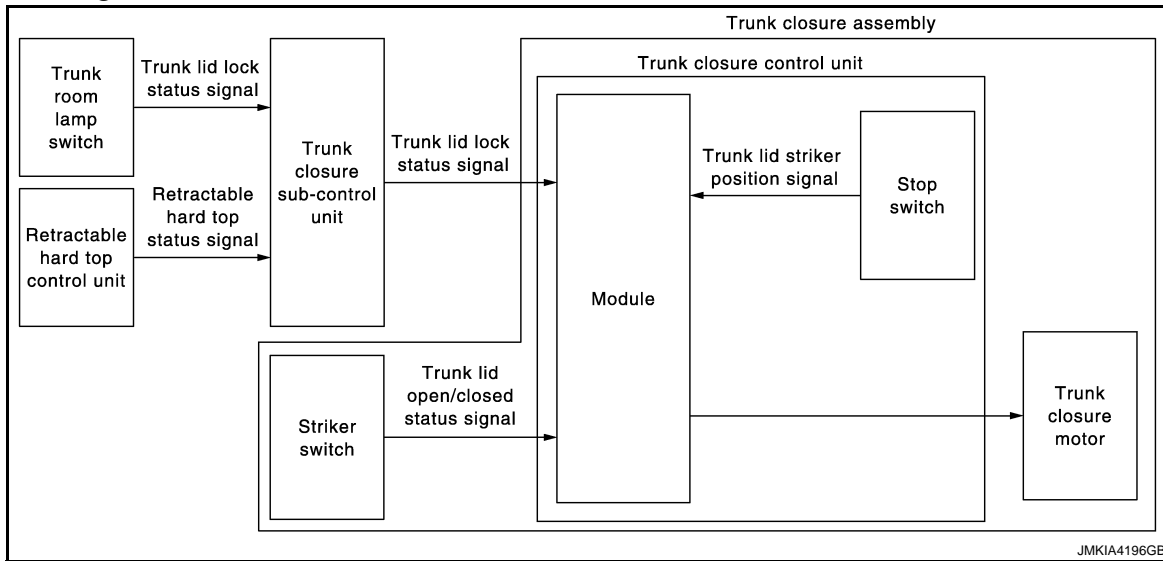

System Description

- Trunk lid auto closure system consists of trunk room lamp switch, striker switch, trunk closure motor, trunk closure sub-control unit, and trunk closure control unit that integrates stop switch.
- Trunk lid auto closure system is a system that fully closes trunk lid automatically when it is closed partly.
- Trunk lid striker is in the bottom position while trunk lid is in fully closed state. When trunk lid is open for next closure operation, waiting operation is performed so that trunk lid striker returns to the top position.

NOTE:

When battery terminal is re-connected, trunk closure motor is not operated regardless of trunk lid state (trunk room lamp switch and striker switch) and trunk lid striker position (stop switch).

TRUNK LID CLOSE OPERATION

From fully Open to Fully Closed Operation

The trunk lid closure system operates as per the following.

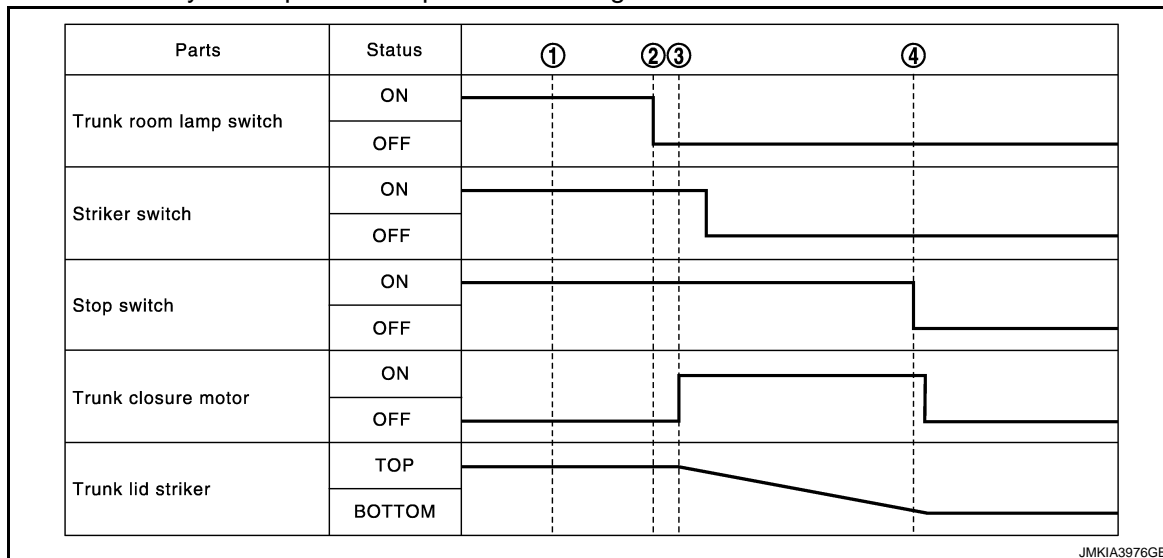

1. While trunk lid is open, trunk room lamp switch, striker switch, and stop switch are ON.
2. When closing trunk lid partly, trunk lid lock assembly and trunk lid striker are engaged and trunk room lamp switch turns OFF.
3. Module in trunk closure control unit, when it detects that trunk room lamp switch turns OFF, activates trunk closure motor and trunk lid striker starts to move downward.

TRUNK LID AUTO CLOSURE SYSTEM

< SYSTEM DESCRIPTION >

When trunk lid striker lowers, striker switch turns OFF from ON.

- When trunk lid striker reaches the bottom position and stop switch turns OFF, trunk closure motor stops and trunk lid close operation is complete.

NOTE:

- Operation of trunk closure motor is continued and trunk lid striker returns to the TOP position, if engagement of trunk lid lock assembly and trunk lid striker is released (trunk room lamp switch, striker switch: OFF→ON) when trunk lid striker reaches the bottom position (stop switch: ON→OFF).
- Operation of trunk closure motor is stopped if the bottom position of trunk lid striker is detected (stop switch: ON→OFF) and trunk room lamp switch or striker switch is OFF when trunk lid open and close operation (trunk room lamp switch: ON→OFF→ON→OFF) is performed again immediately after closing trunk lid from open state and trunk closure motor is operated.

WAITING OPERATION (TRUNK LID OPEN OPERATION)

From fully Closed to Fully Open Operation

The trunk lid closure system operates as per the following.

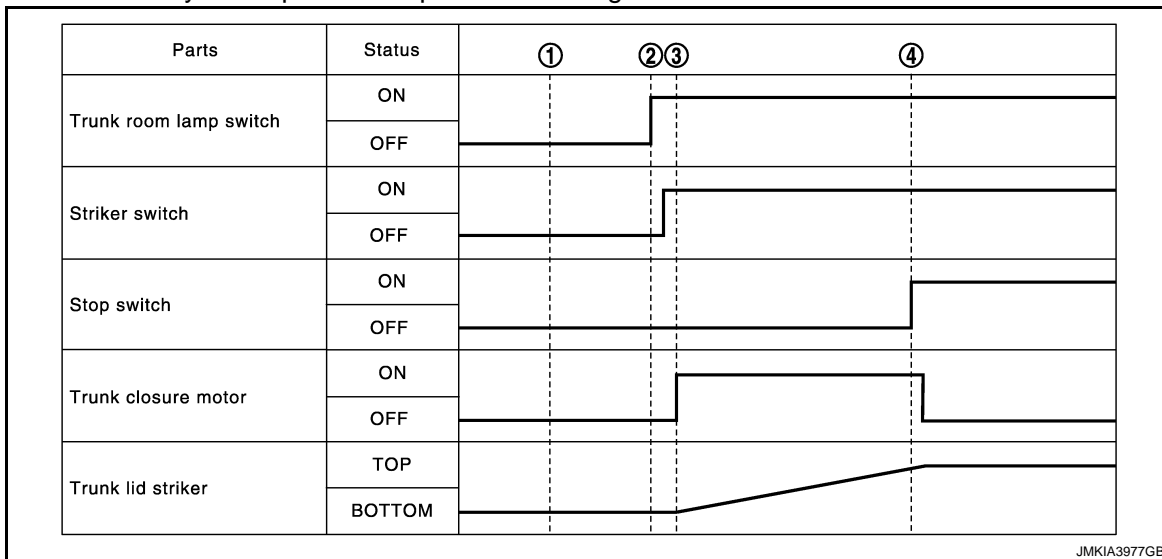

- While trunk lid is closed, trunk room lamp switch, striker switch, and stop switch are OFF.
- When performing trunk lid open operation, engagement of trunk lid lock assembly and trunk lid striker is released and trunk room lamp switch turns ON. When trunk lid is open, striker switch turns ON.
- Module in trunk closure control unit, when it detects that trunk room lamp switch and striker switch turns ON, activates trunk closure motor and trunk lid striker starts to move upward.
- When trunk lid striker reaches to the top position and stop switch turns ON, trunk closure motor stops and waiting operation (trunk lid open operation) is complete.

NOTE:

- Operation of trunk closure motor is continued and trunk lid striker is moved to the bottom position, if engagement of trunk lid lock assembly and trunk lid striker is detected (trunk room lamp switch: OFF) when trunk lid striker reaches the top position (stop switch: OFF→ON).
- Operation of trunk closure motor is stopped if the top position of trunk lid striker is detected (stop switch: OFF→ON) and trunk room lamp switch is ON when trunk lid open and close operation (trunk room lamp switch: OFF→ON→OFF→ON) is performed again immediately after opening trunk lid from closed state.
- When striker switch OFF is detected while trunk lid striker moves upward, trunk closure motor stops. After that, when striker switch ON is detected, trunk closure motor restarts and performs ordinary upward operation. If striker switch ON is not detected and trunk room lamp switch OFF is detected, trunk closure motor performs ordinary downward operation.

OPERATION CONDITION

Trunk lid auto closure system operates when all of the following conditions are satisfied.

TRUNK LID AUTO CLOSURE SYSTEM

< SYSTEM DESCRIPTION >

Trunk lid auto closure system	Operation condition
Trunk lid close operation	<ul style="list-style-type: none"> • Trunk room lamp switch turns OFF • Stop switch turns ON • Retractable hard top operation is complete
Waiting operation (Trunk lid open operation)	<ul style="list-style-type: none"> • Trunk room lamp switch turns ON • Striker switch turns ON • Stop switch turns OFF

FAIL-SAFE

The fail-safe function is adopted for the trunk closure control unit. Refer to [DLK-190. "Fail-safe"](#).

Component Parts Location

INFOID:000000005624160

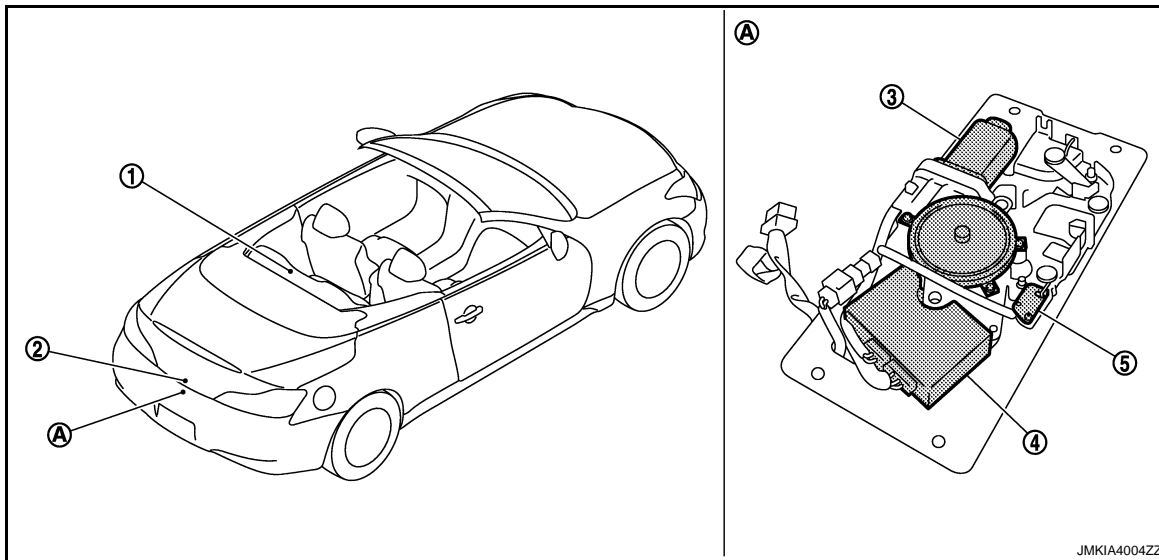

1. • Trunk closure sub-control unit B85
• Retractable hard top control unit B82, B83, B84
Refer to [RF-11. "Component Parts Location"](#)
 2. Trunk lid lock assembly (trunk room lamp switch B306)
 3. Trunk closure motor
 4. Trunk closure control unit (integrates stop switch) B363, B364
 5. Striker switch B362
- A. View with trunk rear finisher removed (trunk closure assembly)

Component Description

INFOID:000000005624161

Item	Function
Trunk closure control unit	It controls trunk lid auto closure system
Trunk closure motor	It is integrated in trunk closure assembly and moves trunk lid striker upward or downward
Striker switch	It is integrated in trunk closure assembly and detects open/close state of trunk lid
Stop switch	It is integrated in trunk closure control unit and detects the top and bottom position of trunk lid striker
Trunk room lamp switch	It detects engagement of trunk lid lock assembly and trunk lid striker
Trunk closure sub-control unit	It controls trunk operation during retractable hard top operation
Retractable hard top control unit	Controls the retractable hard top system

INTEGRATED HOMELINK TRANSMITTER

< SYSTEM DESCRIPTION >

INTEGRATED HOMELINK TRANSMITTER

Component Description

INFOID:000000005624162

Item	Function
Integrated homelink transmitter	A maximum of 3 radio signals can be stored and transmitted to operate the garage door, etc.

DIAGNOSIS SYSTEM (BCM)

< SYSTEM DESCRIPTION >

DIAGNOSIS SYSTEM (BCM)

COMMON ITEM

COMMON ITEM : CONSULT-III Function (BCM - COMMON ITEM)

INFOID:000000005897689

APPLICATION ITEM

CONSULT-III performs the following functions via CAN communication with BCM.

Diagnosis mode	Function Description
Work Support	Changes the setting for each system function.
Self Diagnostic Result	Displays the diagnosis results judged by BCM.
CAN Diag Support Monitor	Monitors the reception status of CAN communication viewed from BCM. Refer to CONSULT-III operation manual.
Data Monitor	The BCM input/output signals are displayed.
Active Test	The signals used to activate each device are forcibly supplied from BCM.
Ecu Identification	The BCM part number is displayed.
Configuration	This function is not used even though it is displayed.

SYSTEM APPLICATION

BCM can perform the following functions for each system.

NOTE:

It can perform the diagnosis modes except the following for all sub system selection items.

×: Applicable item

System	Sub system selection item	Diagnosis mode		
		Work Support	Data Monitor	Active Test
Door lock	DOOR LOCK	×	×	×
Rear window defogger	REAR DEFOGGER		×	×
Warning chime	BUZZER		×	×
Interior room lamp timer	INT LAMP	×	×	×
—	MULTI REMOTE ENT*1			
Exterior lamp	HEAD LAMP	×	×	×
Wiper and washer	WIPER	×*2	×	×
Turn signal and hazard warning lamps	FLASHER	×	×	×
—	AIR CONDITONER*1			
• Intelligent Key system • Engine start system	INTELLIGENT KEY	×	×	×
Combination switch	COMB SW		×	
Body control system	BCM	×		
IVIS - NATS	IMMU		×	×
Interior room lamp battery saver	BATTERY SAVER	×	×	×
Trunk lid open	TRUNK		×	×
Vehicle security system	THEFT ALM	×	×	×
RAP system	RETAINED PWR		×	
Signal buffer system	SIGNAL BUFFER		×	×
TPMS	TPMS (AIR PRESSURE MONITOR)	×	×	×

NOTE:

- *1: This item is displayed, but is not used.
- *2: At models with rain sensor this mode is displayed, but is not used.

FREEZE FRAME DATA (FFD)

DIAGNOSIS SYSTEM (BCM)

< SYSTEM DESCRIPTION >

The BCM records the following vehicle condition at the time a particular DTC is detected, and displays on CONSULT-III.

CONSULT screen item	Indication/Unit	Description	
Vehicle Speed	km/h	Vehicle speed of the moment a particular DTC is detected	
Odo/Trip Meter	km	Total mileage (Odometer value) of the moment a particular DTC is detected	
Vehicle Condition	SLEEP>LOCK	Power position status of the moment a particular DTC is detected	While turning BCM status from low power consumption mode to normal mode (Power supply position is "LOCK".)
	SLEEP>OFF		While turning BCM status from low power consumption mode to normal mode (Power supply position is "OFF".)
	LOCK>ACC		While turning power supply position from "LOCK" to "ACC"
	ACC>ON		While turning power supply position from "ACC" to "IGN"
	RUN>ACC		While turning power supply position from "RUN" to "ACC" (Vehicle is stopping and selector lever is except P position.)
	CRANK>RUN		While turning power supply position from "CRANKING" to "RUN" (From cranking up the engine to run it)
	RUN>URGENT		While turning power supply position from "RUN" to "ACC" (Emergency stop operation)
	ACC>OFF		While turning power supply position from "ACC" to "OFF"
	OFF>LOCK		While turning power supply position from "OFF" to "LOCK"
	OFF>ACC		While turning power supply position from "OFF" to "ACC"
	ON>CRANK		While turning power supply position from "IGN" to "CRANKING"
	OFF>SLEEP		While turning BCM status from normal mode (Power supply position is "OFF".) to low power consumption mode
	LOCK>SLEEP		While turning BCM status from normal mode (Power supply position is "LOCK".) to low power consumption mode
	LOCK		Power supply position is "LOCK" (Ignition switch OFF with steering is locked.)
	OFF		Power supply position is "OFF" (Ignition switch OFF with steering is unlocked.)
	ACC		Power supply position is "ACC" (Ignition switch ACC)
	ON		Power supply position is "IGN" (Ignition switch ON with engine stopped)
	ENGINE RUN		Power supply position is "RUN" (Ignition switch ON with engine running)
	CRANKING		Power supply position is "CRANKING" (At engine cranking)
IGN Counter	0 - 39	The number of times that ignition switch is turned ON after DTC is detected <ul style="list-style-type: none"> • The number is 0 when a malfunction is detected now. • The number increases like 1 → 2 → 3...38 → 39 after returning to the normal condition whenever ignition switch OFF → ON. • The number is fixed to 39 until the self-diagnosis results are erased if it is over 39. 	

DOOR LOCK

DOOR LOCK : CONSULT-III Function (BCM - DOOR LOCK)

INFOID:000000005624164

BCM CONSULT-III FUNCTION

CONSULT-III performs the following functions via CAN communication with BCM.

Diagnosis mode	Function Description
WORK SUPPORT	Changes the setting for each system function
DATA MONITOR	The BCM input/output signals are displayed
ACTIVE TEST	The signals used to activate each device are forcibly supplied from BCM

DIAGNOSIS SYSTEM (BCM)

< SYSTEM DESCRIPTION >

WORK SUPPORT

Monitor item	Description
DOOR LOCK-UNLOCK SET	Selective unlock function mode can be changed to operate (ON) or not operate (OFF) with this mode
AUTOMATIC DOOR LOCK SELECT	Automatic door lock function mode can be selected from the following in this mode <ul style="list-style-type: none"> VH SPD: All doors are locked when vehicle speed more than 24km/h (15MPH) P RANGE*: All doors are locked when shifting the selector lever from P position to other than the P position
AUTOMATIC DOOR UNLOCK SELECT	Automatic door unlock function mode can be selected from the following in the mode <ul style="list-style-type: none"> MODE 1: All doors are unlocked when the power supply position is changed from ON to OFF MODE 2*: All doors are unlocked when shifting the selector lever from any position other than the P to P position MODE 3: Driver side door is unlocked when the power supply position is changed from ON to OFF MODE 4*: Driver side door is unlocked when shifting the selector lever from any position other than the P to P position
AUTOMATIC LOCK/UNLOCK SET	Automatic door lock/unlock function mode can be selected from the following in this mode <ul style="list-style-type: none"> Off: non-operational Unlock Only: door unlock operation only Lock Only: door lock operation only Lock/Unlock: lock/unlock operation

*: P range interlock door lock can be selected for M/T models, but automatic door lock/unlock function does not operate.

DATA MONITOR

Monitor Item	Contents
REQ SW-DR	Indicated [ON/OFF] condition of door request switch (driver side)
REQ SW-AS	Indicated [ON/OFF] condition of door request switch (passenger side)
REQ SW-BD/TR	Indicated [ON/OFF] condition of trunk lid opener request switch
DOOR SW-DR	Indicated [ON/OFF] condition of front door switch (driver side)
DOOR SW-AS	Indicated [ON/OFF] condition of front door switch (passenger side)
DOOR SW-RR	NOTE: This item is displayed, but cannot be monitored
DOOR SW-RL	NOTE: This item is displayed, but cannot be monitored
DOOR SW-BK	NOTE: This item is displayed, but cannot be monitored
CDL LOCK SW	Indicated [ON/OFF] condition of lock signal from door lock unlock switch
CDL UNLOCK SW	Indicated [ON/OFF] condition of unlock signal from door lock unlock switch
KEY CYL LK-SW	Indicated [ON/OFF] condition of lock signal from door key cylinder
KEY CYL UN-SW	Indicated [ON/OFF] condition of unlock signal from door key cylinder

ACTIVE TEST

Test item	Description
DOOR LOCK	This test is able to check door lock/unlock operation <ul style="list-style-type: none"> The all door lock actuators are locked when "ALL LCK" on CONSULT-III screen is touched The all door lock actuators are unlocked when "ALL UNLK" on CONSULT-III screen is touched The door lock actuator (driver side) is unlocked when "DR UNLK" on CONSULT-III screen is touched The door lock actuator (passenger side) is unlocked when "AS UNLK" on CONSULT- III screen is touched "OTR ULK" item is displayed, but cannot be monitored

INTELLIGENT KEY

DIAGNOSIS SYSTEM (BCM)

< SYSTEM DESCRIPTION >

INTELLIGENT KEY : CONSULT-III Function (BCM - INTELLIGENT KEY)

INFOID:000000005624165

WORK SUPPORT

Monitor item	Description
CONFIRM KEY FOB ID	It can be checked whether Intelligent Key ID code is registered or not in this mode
AUTO LOCK SET	Auto door lock time can be changed in this mode <ul style="list-style-type: none"> • MODE 1: 1 minute • MODE 2: 5 minutes • MODE 3: 30 seconds • MODE 4: 2 minutes
LOCK/UNLOCK BY I-KEY	Door lock/unlock function by door request switch (driver side and passenger side) mode can be changed to operate (ON) or not operate (OFF) in this mode
ENGINE START BY I-KEY	Engine start function mode can be changed to operate (ON) or not operate (OFF) with this mode
TRUNK/GLASS HATCH OPEN	Buzzer reminder function mode by trunk lid opener request switch can be changed to operate (ON) or not operate (OFF) with this mode
PANIC ALARM SET	Panic alarm button pressing time on Intelligent Key remote control button can be selected from the following with this mode <ul style="list-style-type: none"> • MODE 1: 0.5 sec • MODE 2: Non-operation • MODE 3: 1.5 sec
PW DOWN SET	Unlock button pressing time on Intelligent Key button can be selected from the following with this mode <ul style="list-style-type: none"> • MODE 1: 3 sec • MODE 2: Non-operation • MODE 3: 5 sec
TRUNK OPEN DELAY	Trunk button pressing on Intelligent Key button can be selected as per the following in this mode <ul style="list-style-type: none"> • MODE 1: Press and hold • MODE 2: Press twice • MODE 3: Press and hold, or press twice
LO- BATT OF KEY FOB WARN	Intelligent Key low battery warning mode can be changed to operate (ON) or not operate (OFF) with this mode
ANTI KEY LOCK IN FUNCTI	Key reminder function mode can be changed to operate (ON) or not operate (OFF) with this mode
HAZARD ANSWER BACK	Hazard reminder function mode can be selected from the following with this mode <ul style="list-style-type: none"> • LOCK ONLY: Door lock operation only • UNLOCK ONLY: Door unlock operation only • LOCK/UNLOCK: Lock/unlock operation • OFF: Non-operation
ANS BACK I-KEY LOCK	Buzzer reminder function (lock operation) mode by door request switch (driver side and passenger side) can be selected from the following with this mode <ul style="list-style-type: none"> • Horn chirp: Sound horn • Buzzer: Sound Intelligent Key warning buzzer • OFF: Non-operation
ANS BACK I-KEY UNLOCK	Buzzer reminder function (unlock operation) mode by door request switch can be changed to operate (ON) or not operate (OFF) with this mode
SHORT CRANKING OUTPUT	Starter motor can operate during the times below <ul style="list-style-type: none"> • 70 msec • 100 msec • 200 msec
INSIDE ANT DIAGNOSIS	This function allows inside key antenna self-diagnosis
HORN WITH KEYLESS LOCK	Horn reminder function mode by Intelligent Key button can be changed to operate (ON) or not operate (OFF) with this mode

SELF-DIAG RESULT

Refer to [BCS-74, "DTC Index"](#).

DIAGNOSIS SYSTEM (BCM)

< SYSTEM DESCRIPTION >

DATA MONITOR

Monitor Item	Condition
REQ SW -DR	Indicates [ON/OFF] condition of door request switch (driver side)
REQ SW -AS	Indicates [ON/OFF] condition of door request switch (passenger side)
REQ SW -BD/TR	Indicates [ON/OFF] condition of trunk lid opener request switch
PUSH SW	Indicates [ON/OFF] condition of push-button ignition switch
IGN RLY2 -F/B	Indicates [ON/OFF] condition of ignition relay 2
ACC RLY-FB	NOTE: This item is displayed, but cannot be monitored
CLUTCH SW*1	Indicates [ON/OFF] condition of clutch switch
BRAKE SW 1	Indicates [ON/OFF]*3 condition of brake switch power supply
BRAKE SW 2	Indicates [ON/OFF] condition of brake switch
DETE/CANCL SW*2	Indicates [ON/OFF] condition of P position
SFT PN/N SW*2	Indicates [ON/OFF] condition of P or N position
S/L -LOCK	Indicates [ON/OFF] condition of steering lock unit (LOCK)
S/L -UNLOCK	Indicates [ON/OFF] condition of steering lock unit (UNLOCK)
S/L RELAY -F/B	Indicates [ON/OFF] condition of steering lock relay
UNLK SEN -DR	Indicates [ON/OFF] condition of driver door UNLOCK status
PUSH SW -IPDM	Indicates [ON/OFF] condition of push-button ignition switch
IGN RLY1 -F/B	Indicates [ON/OFF] condition of ignition relay 1
DETE SW -IPDM*2	Indicates [ON/OFF] condition of P position
SFT PN -IPDM*2	Indicates [ON/OFF] condition of P or N position
SFT P -MET*2	Indicates [ON/OFF] condition of P position
SFT N -MET*2	Indicates [ON/OFF] condition of N position
ENGINE STATE	Indicates [STOP/STALL/CRANK/RUN] condition of engine states
S/L LOCK-IPDM	Indicates [ON/OFF] condition of steering lock unit (LOCK)
S/L UNLK-IPDM	Indicates [ON/OFF] condition of steering lock unit (UNLOCK)
S/L RELAY-REQ	Indicates [ON/OFF] condition of steering lock relay
VEH SPEED 1	Display the vehicle speed signal received from combination meter by numerical value [Km/h]
VEH SPEED 2	Display the vehicle speed signal received from ABS or VDC or TCM by numerical value [Km/h]
DOOR STAT-DR	Indicates [LOCK/READY/UNLOCK] condition of driver side door status
DOOR STAT-AS	Indicates [LOCK/READY/UNLOCK] condition of passenger side door status
ID OK FLAG	Indicates [SET/RESET] condition of key ID
PRMT ENG STRT	Indicates [SET/RESET] condition of engine start possibility
PRMT RKE STRT	NOTE: This item is displayed, but cannot be monitored
KEY SW -SLOT	Indicates [ON/OFF] condition of key slot
TRNK/HAT MNTR	Indicates [ON/OFF] condition of trunk lid
RKE-LOCK	Indicates [ON/OFF] condition of LOCK signal from Intelligent Key
RKE-UNLOCK	Indicates [ON/OFF] condition of UNLOCK signal from Intelligent Key
RKE-TR/BD	Indicates [ON/OFF] condition of TRUNK LID OPEN signal from Intelligent Key
RKE-PANIC	Indicates [ON/OFF] condition of PANIC button of Intelligent Key
RKE-P/W OPEN	Indicates [ON/OFF] condition of P/W DOWN signal from Intelligent Key
RKE-MODE CHG	Indicates [ON/OFF] condition of MODE CHANGE signal from Intelligent Key

A
B
C
D
E
F
G
H
I
J
DLK
L
M
N
O
P

DIAGNOSIS SYSTEM (BCM)

< SYSTEM DESCRIPTION >

Monitor Item	Condition
RKE OPE COUN1	When remote keyless entry receiver receives the signal transmitted while operating on Intelligent Key, the numerical value start changing
RKE OPE COUN2	NOTE: This item is displayed, but cannot be monitored
REVERSE SW*1	Indicates [ON/OFF] condition of R position

*1: It is displayed but does not operate on A/T models.

*2: It is displayed but does not operate on M/T models.

*3: OFF is displayed when brake pedal is depressed while brake switch power supply is OFF.

ACTIVE TEST

Test item	Description
BATTERY SAVER	This test is able to check interior room lamp operation The interior room lamp is activated after "On" on CONSULT-III screen is touched
PW REMOTO DOWN SET	This test is able to check power window down operation The power window down is activated after "On" on CONSULT-III screen is touched
OUTSIDE BUZZER	This test is able to check Intelligent Key warning buzzer operation The Intelligent Key warning buzzer is activated after "On" on CONSULT-III screen is touched
INSIDE BUZZER	This test is able to check warning chime in combination meter operation <ul style="list-style-type: none"> • Take away warning chime sounds when "Take out" on CONSULT-III screen is touched • Key warning chime sounds when "Key" on CONSULT-III screen is touched • OFF position warning chime sounds when "Knob" on CONSULT-III screen is touched
INDICATOR	This test is able to check warning lamp operation <ul style="list-style-type: none"> • "KEY" Warning lamp illuminates when "KEY ON" on CONSULT-III screen is touched • "KEY" Warning lamp blinks when "KEY IND" on CONSULT-III screen is touched
INT LAMP	This test is able to check interior room lamp operation The interior room lamp is activated after "On" on CONSULT-III screen is touched
LCD	This test is able to check meter display information <ul style="list-style-type: none"> • Engine start information displays when "BP N" on CONSULT-III screen is touched • Engine start information displays when "BP I" on CONSULT-III screen is touched • Key ID warning displays when "ID NG" on CONSULT-III screen is touched • Steering lock information displays when "ROTAT" on CONSULT-III screen is touched • P position warning displays when "SFT P" on CONSULT-III screen is touched • Intelligent Key insert information displays when "INSRT" on CONSULT-III screen is touched • Intelligent Key low battery warning displays when "BATT" on CONSULT-III screen is touched • Take away through window warning displays when "NO KY" on CONSULT-III screen is touched • Take away warning display when "OUTKEY" on CONSULT-III screen is touched • OFF position warning display when "LK WN" on CONSULT-III screen is touched
TRUNK/GLASS HATCH	This test is able to check trunk lid opener actuator open operation This actuator opens when "Open" on CONSULT-III screen is touched
FLASHER	This test is able to check security hazard lamp operation The hazard lamps are activated after "LH/RH/Off" on CONSULT-III screen is touched
HORN	This test is able to check horn operation The horn is activated after "On" on CONSULT-III screen is touched
P RANGE	This test is able to check control device power supply Control device power is supplied when "On" on CONSULT-III screen is touched
ENGINE SW ILLUMI	This test is able to check push-ignition switch illumination operation Push-ignition switch illumination illuminates when "On" on CONSULT-III screen is touched
LOCK INDICATOR	This test is able to check LOCK indicator in push-ignition switch operation LOCK indicator in push-ignition switch illuminates when "On" on CONSULT-III screen is touched

DIAGNOSIS SYSTEM (BCM)

< SYSTEM DESCRIPTION >

Test item	Description
ACC INDICATOR	This test is able to check ACC indicator in push-ignition switch operation ACC indicator in push-ignition switch illuminates when "On" on CONSULT-III screen is touched
IGNITION ON IND	This test is able to check on indicator in push-ignition switch operation ON indicator in push-ignition switch illuminates when "On" on CONSULT-III screen is touched
KEY SLOT ILLUMI	This test is able to check key slot illumination operation Key slot illumination blinks when "On" on CONSULT-III screen is touched
TRUNK/BACK DOOR	This test is able to check trunk lid opener actuator open operation This actuator opens when "Open" on CONSULT-III screen is touched

TRUNK

TRUNK : CONSULT-III Function (BCM - TRUNK)

INFOID:000000005624166

BCM CONSULT-III FUNCTION

CONSULT-III performs the following functions via CAN communication with BCM.

Diagnosis mode	Function Description
DATA MONITOR	The BCM input/output signals are displayed

DATA MONITOR

Monitor Item	Contents
PUSH SW	Indicates [ON/OFF] condition of push switch
UNLK SEN -DR	Indicates [ON/OFF] condition of unlock sensor
VEH SPEED 1	Indicates [Km/h] condition of vehicle speed signal from combination meter
KEY CYL SW-TR	NOTE: This item is displayed, but cannot be monitored
TR CANCEL SW	Indicates [ON/OFF] condition of trunk lid opener cancel switch
TR/BD OPEN SW	Indicates [ON/OFF] condition of trunk lid opener switch
TRNK/HAT MNTR	Indicates [ON/OFF] condition of trunk room lamp switch
RKE-TR/BD	Indicates [ON/OFF] condition of trunk lid open signal from Intelligent Key remote controller button

ACTIVE TEST

Test item	Description
TRUNK/GLASS HATCH	This test is able to check trunk lid opener actuator open operation This actuator opens when "OPEN" on CONSULT-III screen is touched

DIAGNOSIS SYSTEM (RETRACTABLE HARD TOP CONTROL UNIT)

< SYSTEM DESCRIPTION >

DIAGNOSIS SYSTEM (RETRACTABLE HARD TOP CONTROL UNIT)

CONSULT-III Function

INFOID:000000005897690

APPLICATION ITEM

CONSULT-III performs the following functions via CAN communication with retractable hard top control unit.

Diagnosis mode	Function Description
Ecu Identification	The retractable hard top control unit part number is displayed.
Self Diagnostic Result	Displays the diagnosis results judged by retractable hard top control unit.
Freeze Frame Data	The retractable hard top control unit records the vehicle condition at the time a particular DTC is detected, and displays.
Data Monitor	The retractable hard top control unit input/output signals are displayed.
Active Test	The signals used to activate each device are forcibly supplied from retractable hard top control unit.
Work Support	Changes the setting for each system function.
CAN Diag Support Monitor	Monitors the reception status of CAN communication viewed from retractable hard top control unit. Refer to CONSULT-III operation manual.

WORK SUPPORT

CONSULT-III display		Description
Item	Indication	
TRUNK OPENER	ON	Perform trunk opener actuator OPEN operation
FLIPPER DOOR Always perform this operation after completely understanding about retractable hard top operation. Refer to RF-16. "RETRACTABLE HARD TOP SYSTEM : System Description" . CAUTION: This operation may result in serious damage to components. Never operate the flipper door if the roof and trunk lid are in the closed position. Doing so may cause the roof to open inside the trunk. Check the roof and trunk lid position before proceeding.	UP	Flipper door (LH/RH) performs UP operation
	DOWN	Flipper door (LH/RH) performs DOWN operation
ROOF LATCH	OPEN	Roof latch performs UNLOCK operation
	CLOSE	Roof latch performs LOCK operation
TEACH ROOF STATUS	START	Roof position is learned
RESET ROOF STATUS	START	Roof position memory is erased
PARCEL SHELF(DRAW) Always perform this operation after completely understanding about retractable hard top operation. Refer to RF-16. "RETRACTABLE HARD TOP SYSTEM : System Description" . CAUTION: This operation may result in serious damage to components. Never operate the parcel shelf if the roof, the trunk lid and the flipper door are in the closed position. Doing so may cause the roof to open inside the trunk. Check the roof, trunk lid and flipper door position before proceeding.	UP	Parcel shelf performs UP operation
	DOWN	Parcel shelf performs DOWN operation

DIAGNOSIS SYSTEM (RETRACTABLE HARD TOP CONTROL UNIT)

< SYSTEM DESCRIPTION >

CONSULT-III display		Description
Item	Indication	
PARCEL SHELF(ROTA) Always perform this operation after completely understanding about retractable hard top operation. Refer to RF-16, "RETRACTABLE HARD TOP SYSTEM : System Description" . CAUTION: This operation may result in serious damage to components. Never operate the parcel shelf if the roof, the trunk lid and the flipper door are in the closed position. Doing so may cause the roof to open inside the trunk. Check the roof, trunk lid and flipper door position before proceeding.	VERT	Parcel shelf performs VERTICAL operation
	HORI	Parcel shelf performs HORIZONTAL operation

SELF-DIAG RESULT

Refer to [DLK-226, "DTC Index"](#).

Freeze Frame Data

The retractable hard top control unit records the following vehicle condition at the time a particular DTC is detected, and displays on CONSULT-III.

CONSULT-III display		Description
Item	Indication	
ROOF SW(OPEN)	ON/OFF	OPEN input state of roof open/close switch is displayed
ROOF SW(CLOSE)	ON/OFF	CLOSE input state of roof open/close switch is displayed
TONNEAU SW	ON/OFF	State of tonneau board switch is displayed
LATCH LIMIT SW	ON/OFF	Input state of roof latch limit switch is displayed
LATCH LOCK SEN	ON/OFF	Input state of roof latch lock sensor is displayed
TRUNK STATUS SEN	ON/OFF	Input state of trunk status sensor is displayed
TR LINK SEN A(LH)	ON/OFF	Input state of trunk link sensor (RH) is displayed
TR LINK SEN A(RH)	ON/OFF	Input state of trunk link sensor (LH) is displayed
FLPD LIMIT SW(DWN)	ON/OFF	Input state of flipper door limit switch (DOWN) is displayed
FLPD LIMIT SW(UP)	ON/OFF	Input state of flipper door limit switch (UP) is displayed
ROOF STATE	OK/NG	Condition of retractable hard top system state is displayed
HYDRAULIC STATE	OK/NG	Condition of hydraulic system state is displayed
LATCH STATE	OK/NG	Condition of roof latch state is displayed
FLPD STATE	OK/NG	Condition of flipper door (LH/RH) state is displayed
PUMP OUT(LH)	ON/OFF	Left rotation output state to hydraulic motor is displayed
PUMP OUT(RH)	ON/OFF	Right rotation output state to hydraulic motor is displayed
SWITCH VALVE 1 OUT	ON/OFF	Output state to switching valve 1 is displayed
SWITCH VALVE 2 OUT	ON/OFF	Output state to switching valve 2 is displayed
TR LINK SEN B(LH)	ON/OFF	Input state of trunk link sensor (RH) is displayed
TR LINK SEN B(RH)	ON/OFF	Input state of trunk link sensor (LH) is displayed
PS STATE(TOP)	ON/OFF	Parcel shelf (DRAW) position (TOP) is displayed
PS STATE(BOTTOM)	ON/OFF	Parcel shelf (DRAW) position (BOTTOM) is displayed
LATCH OUT(ULK)	ON/OFF	OPEN output state to roof latch motor is displayed
LATCH OUT(LCK)	ON/OFF	CLOSE output state to roof latch motor is displayed
R WIN LH OUT(UP)	ON/OFF	CLOSE output state to rear power window motor (LH) is displayed
R WIN LH OUT(DWN)	ON/OFF	OPEN output state to rear power window motor (LH) is displayed
R WIN RH OUT(UP)	ON/OFF	CLOSE output state to rear power window motor (RH) is displayed

DIAGNOSIS SYSTEM (RETRACTABLE HARD TOP CONTROL UNIT)

< SYSTEM DESCRIPTION >

CONSULT-III display		Description
Item	Indication	
R WIN RH OUT(DWN)	ON/OFF	OPEN output state to rear power window motor (RH) is displayed
REAR DEF ON SIG	ON/OFF	Input state of rear window defogger ON signal from BCM is displayed
PS OUT(UP)	ON/OFF	UP output state to parcel shelf motor (DRAW) is displayed
PS OUT(DOWN)	ON/OFF	DOWN output state to parcel shelf motor (DRAW) is displayed
PS OUT(HORI)	ON/OFF	HORIZONTAL output state to parcel shelf motor (ROTATE) is displayed
PS OUT(VERT)	ON/OFF	VERTICAL output state to parcel shelf motor (ROTATE) is displayed
TRUNK OPEN OUT	ON/OFF	OPEN output state to trunk opener actuator is displayed
FLPD OUT(UP)	ON/OFF	UP output state to flipper door motor (LH/RH) is displayed
FLPD OUT(DWN)	ON/OFF	DOWN output state to flipper door motor (LH/RH) is displayed
DTC OCCURRENCE COUNTER	—	The number of times that ignition switch is turned ON after DTC is detected

DATA MONITOR

CONSULT-III display		Description
Item	Indication/Unit	
LATCH OUT(ULK)	ON/OFF/NG	OPEN output state to roof latch motor is displayed
LATCH OUT(LCK)	ON/OFF/NG	CLOSE output state to roof latch motor is displayed
LATCH VALUE	0-255	Pulse number from roof latch status sensor is displayed
LATCH LIMIT SW	LOCK/UNLK	Input state of roof latch limit switch is displayed
LATCH STATE	NG/CLOSE/ MID/OPEN	State of roof latch is displayed
PS VALUE(DRAW)	0-65535	Pulse number from parcel shelf status sensor (DRAW) is displayed
PS VALUE(ROTA)	0-65535	Pulse number from parcel shelf status sensor (ROTATE) is displayed
PS OUT(UP)	ON/OFF/NG	UP output state to parcel shelf motor (DRAW) is displayed
PS OUT(DOWN)	ON/OFF/NG	DOWN output state to parcel shelf motor (DRAW) is displayed
PS OUT(VERT)	ON/OFF/NG	VERTICAL output state to parcel shelf motor (ROTATE) is displayed
PS OUT(HORI)	ON/OFF/NG	HORIZONTAL output state to parcel shelf motor (ROTATE) is displayed
PS STATE(DRAW)	NG/1-6	DRAW state of parcel shelf is displayed
PS STATE(ROTA)	NG/1-4	ROTATE state of parcel shelf is displayed
ROOF VALUE	0-1023	Pulse number from roof status sensor is displayed
PUMP OUT(RH)	ON/OFF/NG	Right rotation output state to hydraulic motor is displayed
PUMP OUT(LH)	ON/OFF/NG	Left rotation output state to hydraulic motor is displayed
SWITCH VLV 1 OUT	ON/OFF/NG	Output state to switching valve 1 is displayed
SWITCH VLV 2 OUT	ON/OFF/NG	Output state to switching valve 2 is displayed
ROOF STATE	NG/1-42	State of retractable hard top system is displayed
HYDRAULIC STATE	NG/1-22	State of hydraulic system is displayed
ROOF SW(OPEN)	ON/OFF	OPEN input state of roof open/close switch is displayed
ROOF SW(CLOSE)	ON/OFF	CLOSE input state of roof open/close switch is displayed
ROOF LINK STATE	NG/1-8	State of roof link is displayed
TRUNK LINK SEN(RH)	ON/OFF/NG	Input state of trunk link sensor (RH) is displayed
TRUNK LINK SEN(LH)	ON/OFF/NG	Input state of trunk link sensor (LH) is displayed
TR ROOM LAMP SW	ON/OFF	Input state from trunk room lamp switch is displayed
TRUNK STATUS SEN	ON/OFF/NG	Input state of trunk status sensor is displayed
TRUNK OPEN OUT	ON/OFF/NG	OPEN output state to trunk opener actuator is displayed
FLPD LIMIT SW(DWN)	ON/OFF	Input state of flipper door limit switch (DOWN) is displayed

DIAGNOSIS SYSTEM (RETRACTABLE HARD TOP CONTROL UNIT)

< SYSTEM DESCRIPTION >

CONSULT-III display		Description	
Item	Indication/Unit		
FLPD LIMIT SW(UP)	ON/OFF	Input state of flipper door limit switch (UP) is displayed	A
FLPD OUT(UP)	ON/OFF/NG	UP output state to flipper door motor (LH/RH) is displayed	B
FLPD OUT(DWN)	ON/OFF/NG	DOWN output state to flipper door motor (LH/RH) is displayed	
FLPD STATE	NG/1, 2, 4	State of flipper door (LH/RH) is displayed	
R WIN LH OUT(UP)	ON/OFF/NG	CLOSE output state to rear power window motor (LH) is displayed	C
R WIN LH OUT(DWN)	ON/OFF/NG	OPEN output state to rear power window motor (LH) is displayed	
R WIN RH OUT(UP)	ON/OFF/NG	CLOSE output state to rear power window motor (RH) is displayed	D
R WIN RH OUT(DWN)	ON/OFF/NG	OPEN output state to rear power window motor (RH) is displayed	
REAR DEF ON SIG	ON/OFF	Input state of rear window defogger ON signal from BCM is displayed	
REAR DEF OUT	ON/OFF/NG	Output state to rear window defogger is displayed	E
R WIN CURENT(LH)	0-25.5	Current value to rear power window motor (LH) is displayed	
R WIN CURENT(RH)	0-25.5	Current value to rear power window motor (RH) is displayed	F
RR WIN STATE(LH)	UP/MID/DOWN	State of rear power window motor (LH) is displayed	
RR WIN STATE(RH)	UP/MID/DOWN	State of rear power window motor (RH) is displayed	
RAP SIGNAL	ON/OFF	Input state of RAP signal from BCM is displayed	G
TR MODE SIGNAL	ON/OFF	Output state of trunk mode signal to trunk closure sub-control unit is displayed	
ROOF STATE(AUDIO)	ON/OFF/NG	Output state of roof status signal to audio unit is displayed	H
ROOF BUZZER OUT	ON/OFF/NG	Out put state to roof warning buzzer is displayed	
LOCAL COMM 1	NG/SLEEP/NG	State of serial link 1 is displayed	I
LOCAL COMM 2	NG/SLEEP/NG	State of serial link 2 is displayed	
ROOF MODE	NG/STOP/ CLOSE/OK	Inhibition mode of retractable hard top system is displayed	
POP-UP BAR DPLOY	OK/NG	It is displayed whether or not pop-up bar is deployed	J
POP-UP BAR DIAG	OK/NG	It is displayed whether or not pop-up bar is malfunctioning	
SWITCH VLV COND	OK/NG	Diagnosis result of switching valve is displayed	DLK
PWR SOURCE COND	OK/NG	Diagnosis result of battery power supply is displayed	
CPU COND	OK/NG	Diagnosis result of CPU is displayed	
ROOF COND	OK/NG	Diagnosis result of roof position is displayed	L
SENSOR COND	OK/NG	Diagnosis result of sensor (hall sensor) is displayed	
IGN ON SIG(BCM)	OK/NG	Receiving state of ignition ON signal from BCM is displayed	
VHCL STOP-METER	OK/NG	Receiving state of vehicle speed (0 km/h) from combination meter is displayed	M
CIRCUIT COND	OK/NG	Diagnosis result of circuit is displayed	
ROOF TIMEOUT	OK/NG	Time out state of roof operation is displayed	N
CAN COMM	OK/NG	Diagnosis result of CAN communication is displayed	
THERMO PROTECT 1	OK/NG	Non-operation state of thermo protection (stage1) is displayed	
PRMIT ENG ST (BCM)	OK/NG	Input state of engine cranking signal from BCM is displayed	O
SHIFT R SIG	OK/NG	Input state of shift position (R position) is displayed	
THERMO PROTECT 2	OK/NG	Non-operation state of thermo protection (stage 2) is displayed	P
TONNEAU SW	OK/NG	State of tonneau board switch is displayed	
BRK LAMP SW(BCM)	OK/NG	Receiving state of brake lamp switch signal from BCM is displayed	
THERMO VALUE	0-65535	Count value of thermo protection is displayed	
PWR SOURCE VALUE	0-20	Voltage value of power supply is displayed	
ROOF INITIAL(OPEN)	OK/NG	Learning state of roof position (OPEN) is displayed	
ROOF INITIAL(CLOSE)	OK/NG	Learning state of roof position (CLOSE) is displayed	

DIAGNOSIS SYSTEM (RETRACTABLE HARD TOP CONTROL UNIT)

< SYSTEM DESCRIPTION >

CONSULT-III display		Description
Item	Indication/Unit	
PSHELF INITIAL(ROTA)	OK/NG	Learning state of parcel shelf position (ROTATE) is displayed
PSHELF INITIAL(DRAW)	OK/NG	Learning position of parcel shelf position (DRAW) is displayed

ACTIVE TEST

CONSULT-III display		Description
Item	Indication	
ROOF SYSTEM	OPEN	Retractable hard top system performs open operation
	CLOSE	Retractable hard top system performs close operation
ROOF STATE OUTPUT(AUDIO)	ON	Full open position signal of roof is transmitted to audio unit
FRONT POWER WINDOW (LH/RH)	DOWN	Front power window (LH/RH) performs open operation
REAR POWER WINDOW(LH)	UP	Rear power window (LH) performs close operation
	DOWN	Rear power window (LH) performs open operation
REAR POWER WINDOW(RH)	UP	Rear power window (RH) performs close operation
	DOWN	Rear power window (RH) performs open operation

B2621 INSIDE ANTENNA

< DTC/CIRCUIT DIAGNOSIS >

DTC/CIRCUIT DIAGNOSIS

B2621 INSIDE ANTENNA

Description

INFOID:0000000005624168

- Detects whether Intelligent Key is inside the vehicle
- Installed in the instrument center

DTC Logic

INFOID:0000000005624169

DTC DETECTION LOGIC

DTC	CONSULT-III display description	DTC detecting condition	Possible cause
B2621	INSIDE ANTENNA	An excessive high or low voltage from inside antenna (instrument center) is sent to BCM	<ul style="list-style-type: none"> • Inside key antenna (instrument center) • Between BCM ~ Inside key antenna (instrument center)

DTC CONFIRMATION PROCEDURE

1. PERFORM DTC CONFIRMATION PROCEDURE

1. Perform inside key antenna ("INSIDE ANT DIAGNOSIS") on "Work Support" of "INTELLIGENT KEY".
2. Perform "INTELLIGENT KEY" Self Diagnostic Result.

Is inside key antenna DTC detected?

- YES >> Refer to [DLK-61. "Diagnosis Procedure"](#).
 NO >> Inside key antenna (instrument center) is OK.

Diagnosis Procedure

INFOID:0000000005624170

1. CHECK INSIDE KEY ANTENNA INPUT SIGNAL 1

1. Turn ignition switch OFF.
2. Check signal between BCM harness connector and ground using oscilloscope.

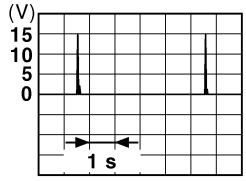
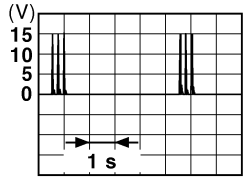
(+)		(-)	Condition	Signal (Reference value)
BCM				
Connector	Terminal			
Instrument center	M122	78, 79	Ground	When Intelligent Key is in the passenger compartment 
				When Intelligent Key is not in the passenger compartment 

Is the inspection result normal?

- YES >> GO TO 4.
 NO >> GO TO 2.

A
B
C
D
E
F
G
H
I
J
L
M
N
O
P

DLK

B2621 INSIDE ANTENNA

< DTC/CIRCUIT DIAGNOSIS >

2. CHECK INSIDE KEY ANTENNA CIRCUIT

1. Disconnect BCM connector and inside key antenna (instrument center) connector.
2. Check continuity between BCM harness connector and inside key antenna (instrument center) harness connector.

BCM		Inside key antenna (instrument center)		Continuity
Connector	Terminal	Connector	Terminal	
M122	78	M131	2	Existed
	79		1	

3. Check continuity between BCM harness connector and ground.

BCM		Ground	Continuity
Connector	Terminal		
M122	78		Not existed
	79		

Is the inspection result normal?

YES >> GO TO 3.

NO >> Repair or replace harness.

3. CHECK INSIDE KEY ANTENNA INPUT SIGNAL 2

1. Replace inside key antenna (instrument center). (New antenna or other antenna)
2. Connect BCM connector and inside key antenna (instrument center) connector.
3. Check signal between BCM harness connector and ground using oscilloscope.

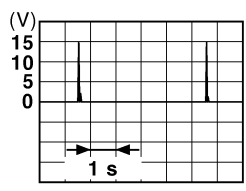
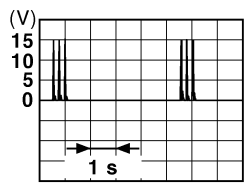
(+)			(-)	Condition	Signal (Reference value)
BCM		Terminal			
Connector					
Instrument center	M122	78, 79	Ground	When Intelligent Key is in the passenger compartment	
				When Intelligent Key is not in the passenger compartment	

Is the inspection result normal?

YES >> Replace inside key antenna (instrument center). Refer to [DLK-313, "INSTRUMENT CENTER : Removal and Installation"](#).

NO >> Replace BCM. Refer to [BCS-79, "Removal and Installation"](#).

4. CHECK INTERMITTENT INCIDENT

Refer to [GI-37, "Intermittent Incident"](#).

>> INSPECTION END

B2622 INSIDE ANTENNA

< DTC/CIRCUIT DIAGNOSIS >

B2622 INSIDE ANTENNA

Description

INFOID:000000005624171

- Detects whether Intelligent Key is inside the vehicle
- Installed in the console

DTC Logic

INFOID:000000005624172

DTC DETECTION LOGIC

DTC	CONSULT-III display description	DTC detecting condition	Possible cause
B2622	INSIDE ANTENNA	An excessive high or low voltage from inside antenna (console) is sent to BCM	<ul style="list-style-type: none"> • Inside key antenna (console) • Between BCM ~ Inside key antenna (console)

DTC CONFIRMATION PROCEDURE

1. PERFORM DTC CONFIRMATION PROCEDURE

1. Perform inside key antenna ("INSIDE ANT DIAGNOSIS") on "Work Support" of "INTELLIGENT KEY".
2. Perform "INTELLIGENT KEY" Self Diagnostic Result.

Is inside key antenna DTC detected?

- YES >> Refer to [DLK-63, "Diagnosis Procedure"](#).
 NO >> Inside key antenna (console) is OK.

Diagnosis Procedure

INFOID:000000005624173

1. CHECK INSIDE KEY ANTENNA INPUT SIGNAL 1

1. Turn ignition switch OFF.
2. Check signal between BCM harness connector and ground using oscilloscope.

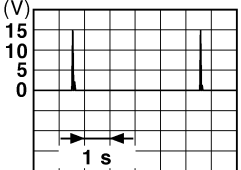
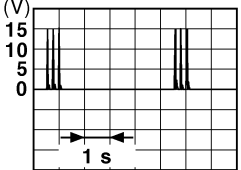
(+)		(-)	Condition	Signal (Reference value)
BCM				
Connector	Terminal			
Console	M122	72, 73	Ground	When Intelligent Key is in the passenger compartment  JMkia0062GB
				When Intelligent Key is not in the passenger compartment  JMkia0063GB

Is the inspection result normal?

- YES >> GO TO 4.
 NO >> GO TO 2.

2. CHECK INSIDE KEY ANTENNA CIRCUIT

1. Disconnect BCM connector and inside key antenna (console) connector.
2. Check continuity between BCM harness connector and inside key antenna (console) harness connector.

A
B
C
D
E
F
G
H
I
J
L
M
N
O
P

DLK

B2622 INSIDE ANTENNA

< DTC/CIRCUIT DIAGNOSIS >

BCM		Inside key antenna (console)		Continuity
Connector	Terminal	Connector	Terminal	
M122	72	M146	2	Existed
	73		1	

3. Check continuity between BCM harness connector and ground.

BCM		Ground	Continuity
Connector	Terminal		
M122	72		Not existed
	73		

Is the inspection result normal?

YES >> GO TO 3.

NO >> Repair or replace harness.

3. CHECK INSIDE KEY ANTENNA INPUT SIGNAL 2

1. Replace inside key antenna (console). (New antenna or other antenna)
2. Connect BCM connector and inside key antenna (console) connector.
3. Check signal between BCM harness connector and ground using oscilloscope.

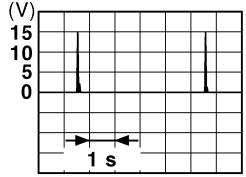
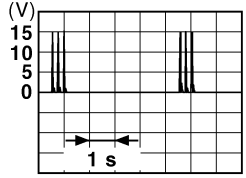
(+)			(-)	Condition	Signal (Reference value)
BCM		Terminal			
Connector					
Console	M122	72, 73	Ground	When Intelligent Key is in the passenger compartment	
				When Intelligent Key is not in the passenger compartment	

Is the inspection result normal?

YES >> Replace inside key antenna (console). Refer to [DLK-313, "CONSOLE : Removal and Installation"](#).

NO >> Replace BCM. Refer to [BCS-79, "Removal and Installation"](#).

4. CHECK INTERMITTENT INCIDENT

Refer to [GI-37, "Intermittent Incident"](#).

>> INSPECTION END

B2623 INSIDE ANTENNA

< DTC/CIRCUIT DIAGNOSIS >

B2623 INSIDE ANTENNA

Description

INFOID:000000005624174

- Detects whether Intelligent Key is inside the vehicle
- Installed in the trunk room

DTC Logic

INFOID:000000005624175

DTC DETECTION LOGIC

DTC	CONSULT-III display description	DTC detecting condition	Possible cause
B2623	INSIDE ANTENNA	An excessive high or low voltage from inside antenna (trunk room) is sent to BCM	<ul style="list-style-type: none"> • Inside key antenna (trunk room) • Between BCM – Inside key antenna (trunk room)

DTC CONFIRMATION PROCEDURE

1. PERFORM DTC CONFIRMATION PROCEDURE

1. Perform inside key antenna (“INSIDE ANT DIAGNOSIS”) on “Work Support” of “INTELLIGENT KEY”.
2. Perform “INTELLIGENT KEY” Self Diagnostic Result.

Is inside key antenna DTC detected?

- YES >> Refer to [DLK-65, "Diagnosis Procedure"](#).
 NO >> Inside key antenna (trunk room) is OK.

Diagnosis Procedure

INFOID:000000005624176

1. CHECK INSIDE KEY ANTENNA INPUT SIGNAL 1

1. Turn ignition switch OFF.
2. Check signal between BCM harness connector and ground using oscilloscope.

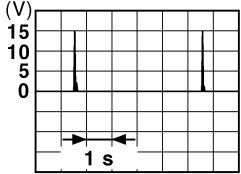
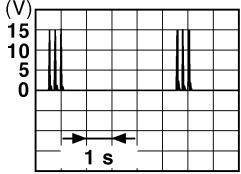
(+)		(-)	Condition	Signal (Reference value)
BCM				
Connector	Terminal			
Trunk room	M121	34, 35	Ground	When Intelligent Key is in the passenger compartment 
				When Intelligent Key is not in the passenger compartment 

Is the inspection result normal?

- YES >> GO TO 4.
 NO >> GO TO 2.

2. CHECK INSIDE KEY ANTENNA CIRCUIT

1. Disconnect BCM connector and inside key antenna (trunk room) connector.

A
B
C
D
E
F
G
H
I
J
L
M
N
O
P

DLK

B2623 INSIDE ANTENNA

< DTC/CIRCUIT DIAGNOSIS >

- Check continuity between BCM harness connector and inside key antenna (trunk room) harness connector.

BCM		Inside key antenna (trunk room)		Continuity
Connector	Terminal	Connector	Terminal	
M121	34	B49	2	Existed
	35		1	

- Check continuity between BCM harness connector and ground.

BCM		Ground	Continuity
Connector	Terminal		
M121	34		Not existed
	35		

Is the inspection result normal?

YES >> GO TO 3.

NO >> Repair or replace harness.

3. CHECK INSIDE KEY ANTENNA INPUT SIGNAL 2

- Replace inside key antenna (trunk room). (New antenna or other antenna)
- Connect BCM and inside key antenna (trunk room) connector.
- Check signal between BCM harness connector and ground using oscilloscope.

(+) BCM			(-)	Condition	Signal (Reference value)
Connector	Terminal				
Trunk room	M121	34, 35	Ground	When Intelligent Key is in the passenger compartment	
				When Intelligent Key is not in the passenger compartment	

Is the inspection result normal?

YES >> Replace inside key antenna (trunk room). Refer to [DLK-314, "TRUNK ROOM : Removal and Installation"](#).

NO >> Replace BCM. Refer to [BCS-79, "Removal and Installation"](#).

4. CHECK INTERMITTENT INCIDENT

Refer to [GI-37, "Intermittent Incident"](#).

>> INSPECTION END

POWER SUPPLY AND GROUND CIRCUIT

< DTC/CIRCUIT DIAGNOSIS >

POWER SUPPLY AND GROUND CIRCUIT

BCM (BODY CONTROL MODULE)

BCM (BODY CONTROL MODULE) : Diagnosis Procedure

INFOID:000000005624177

1. CHECK FUSE AND FUSIBLE LINK

Check that the following fuse and fusible link are not blown.

Signal name	Fuse and fusible link No.
Battery power supply	I
	10

Is the fuse fusing?

YES >> Replace the blown fuse or fusible link after repairing the affected circuit if a fuse or fusible link is blown.

NO >> GO TO 2.

2. CHECK POWER SUPPLY CIRCUIT

1. Turn ignition switch OFF.
2. Disconnect BCM connectors.
3. Check voltage between BCM harness connector and ground.

Terminals		Voltage (Approx.)
(+)	(-)	
BCM		Ground Battery voltage
Connector	Terminal	
M118	1	
M119	11	

Is the measurement value normal?

YES >> GO TO 3.

NO >> Repair harness or connector.

3. CHECK GROUND CIRCUIT

Check continuity between BCM harness connector and ground.

BCM		Ground	Continuity
Connector	Terminal		
M119	13		Existed

Does continuity exist?

YES >> INSPECTION END

NO >> Repair harness or connector.

TRUNK CLOSURE CONTROL UNIT

TRUNK CLOSURE CONTROL UNIT : Diagnosis Procedure

INFOID:000000005624178

1. CHECK FUSIBLE LINK

Check that the following fusible link is not fusing.

Signal name	Fusible link No.
Battery power supply	O (30 A)

Is the inspection result normal?

YES >> GO TO 2.

A
B
C
D
E
F
G
H
I
J
DLK
L
M
N
O
P

POWER SUPPLY AND GROUND CIRCUIT

< DTC/CIRCUIT DIAGNOSIS >

NO >> Replace the blown fusible link after repairing the affected circuit if a fusible link is blown.

2.CHECK POWER SUPPLY CIRCUIT

1. Turn ignition switch OFF.
2. Disconnect trunk closure control unit connector.
3. Check voltage between trunk closure control unit harness connector and ground.

(+)		(-)	Voltage (Approx.)
Trunk closure control unit			
Connector	Terminal	Ground	Battery voltage
B363	2		

Is the inspection result normal?

YES >> GO TO 3.

NO >> Repair or replace harness.

3.CHECK GROUND CIRCUIT

Check continuity between trunk closure control unit harness connector and ground.

Trunk closure control unit		Ground	Continuity
Connector	Terminal		Existed
B363	4		

Is the inspection result normal?

YES >> INSPECTION END

NO >> Repair or replace harness.

RETRACTABLE HARD TOP CONTROL UNIT

RETRACTABLE HARD TOP CONTROL UNIT : Diagnosis Procedure

INFOID:000000005624179

1.CHECK FUSE AND FUSIBLE LINK

Check that the following fuse and fusible link are not blown.

Signal name	Fuse and fusible link No.
Battery power supply	O

Is the fuse fusing?

YES >> Replace the blown fuse or fusible link after repairing the affected circuit if a fuse or fusible link is blown.

NO >> GO TO 2.

2.CHECK POWER SUPPLY CIRCUIT

1. Turn ignition switch OFF.
2. Disconnect retractable hard top control unit connectors.
3. Check voltage between retractable hard top control unit harness connector and ground.

Terminals			Voltage (Approx.)
(+)		(-)	
Retractable hard top control unit			Ground
Connector	Terminal		
B84	57		
	58		
	59		
			Battery voltage

Is the measurement value normal?

YES >> GO TO 3.

POWER SUPPLY AND GROUND CIRCUIT

< DTC/CIRCUIT DIAGNOSIS >

NO >> Repair harness or connector.

3.CHECK GROUND CIRCUIT

Check continuity between retractable hard top control unit harness connector and ground.

Retractable hard top control unit		Ground	Continuity
Connector	Terminal		
B84	60		Existed
	61		

Does continuity exist?

YES >> INSPECTION END

NO >> Repair harness or connector.

TRUNK CLOSURE SUB-CONTROL UNIT

TRUNK CLOSURE SUB-CONTROL UNIT : Diagnosis Procedure

INFOID:000000005624180

1.CHECK FUSIBLE LINK

Check that the following fuse and fusible link are not blown.

Signal name	Fuse and fusible link No.
Power source (BAT)	O

Is the fuse fusing?

YES >> Replace the blown fuse or fusible link after repairing the affected circuit if a fuse or fusible link is blown.

NO >> GO TO 2.

2.CHECK POWER SUPPLY CIRCUIT

1. Turn ignition switch OFF.
2. Disconnect trunk closure sub-control unit connectors.
3. Check voltage between trunk closure sub-control unit harness connector and ground.

Terminals		Ground	Voltage (Approx.)
(+)	(-)		
Trunk closure sub-control unit			Battery voltage
Connector	Terminal		
B85	1		

Is the measurement value normal?

YES >> GO TO 3.

NO >> Repair harness or connector.

3.CHECK GROUND CIRCUIT

Check continuity between trunk closure sub-control unit harness connector and ground.

Trunk closure sub-control unit		Ground	Continuity
Connector	Terminal		
B85	4		Existed

Does continuity exist?

YES >> INSPECTION END

NO >> Repair harness or connector.

DOOR SWITCH

< DTC/CIRCUIT DIAGNOSIS >

DOOR SWITCH

Description

INFOID:000000005624181

Detects door open/close condition.

Component Function Check

INFOID:000000005624182

1.CHECK FUNCTION

Check ("DOOR SW-DR" or "DOOR SW-AS") in BCM "Data Monitor" mode using CONSULT-III.

Monitor item	Condition		Status
DOOR SW-DR	Driver side door	Open	ON
		Closed	OFF
DOOR SW-AS	Passenger side door	Open	ON
		Closed	OFF

Is the inspection result normal?

- YES >> Door switch is OK.
 NO >> Refer to [DLK-70, "Diagnosis Procedure"](#).

Diagnosis Procedure

INFOID:000000005624183

1.CHECK DOOR SWITCH INPUT SIGNAL

- Turn ignition switch OFF.
- Disconnect malfunctioning door switch connector.
- Check signal between malfunctioning door switch harness connector and ground using oscilloscope.

(+)		Terminal	(-)	Signal (Reference value)
Door switch				
Connector				
Driver side	B16	2	Ground	
Passenger side	B216			

Is the inspection result normal?

- YES >> GO TO 3.
 NO >> GO TO 2.

2.CHECK DOOR SWITCH CIRCUIT

- Disconnect BCM connector.
- Check continuity between door switch harness connector and BCM harness connector.

DOOR SWITCH

< DTC/CIRCUIT DIAGNOSIS >

Door switch		BCM		Continuity
Connector	Terminal	Connector	Terminal	
Driver side	B16	M123	150	Existed
Passenger side	B216		124	

3. Check continuity between door switch harness connector and ground.

Door switch		Ground	Continuity
Connector	Terminal		
Driver side	B16	2	Not existed
Passenger side	B216		

Is the inspection result normal?

YES >> Replace BCM. Refer to [BCS-79. "Removal and Installation"](#).

NO >> Repair or replace harness.

3.CHECK DOOR SWITCH GROUND CIRCUIT

Check continuity between door switch harness connector and ground.

Door switch		Ground	Continuity
Connector	Terminal		
Driver side	B16	3	Existed
Passenger side	B216		

Is the inspection result normal?

YES >> GO TO 4.

NO >> Repair or replace harness.

4.CHECK DOOR SWITCH

Refer to [DLK-71. "Component Inspection"](#).

Is the inspection result normal?

YES >> GO TO 5.

NO >> Replace malfunctioning door switch. Refer to [DLK-312. "Removal and Installation"](#).

5.CHECK INTERMITTENT INCIDENT

Refer to [GI-37. "Intermittent Incident"](#).

>> INSPECTION END

Component Inspection

INFOID:000000005624184

1.CHECK DOOR SWITCH

1. Turn ignition switch OFF.
2. Disconnect malfunctioning door switch connector.
3. Check continuity between door switch terminals.

Terminal		Condition	Continuity
Door switch			
2	3	Door switch	Not existed
		Released	Existed

Is the inspection result normal?

YES >> INSPECTION END

NO >> Replace malfunction door switch. Refer to [DLK-312. "Removal and Installation"](#).

DOOR LOCK AND UNLOCK SWITCH

< DTC/CIRCUIT DIAGNOSIS >

DOOR LOCK AND UNLOCK SWITCH DRIVER SIDE

DRIVER SIDE : Description

INFOID:000000005624185

Transmits door lock/unlock operation to BCM.

DRIVER SIDE : Component Function Check

INFOID:000000005624186

1.CHECK FUNCTION

Check ("CDL LOCK SW ", "CDL UNLOCK SW") in BCM "Data Monitor" mode using CONSULT-III.

Monitor item	Condition	Status
CDL LOCK SW	Lock	ON
	Unlock	OFF
CDL UNLOCK SW	Lock	OFF
	Unlock	ON

Is the inspection result normal?

YES >> Door lock and unlock switch is OK.

NO >> Refer to [DLK-72, "DRIVER SIDE : Diagnosis Procedure"](#).

DRIVER SIDE : Diagnosis Procedure

INFOID:000000005624187

1.CHECK POWER WINDOW SWITCH

1. Turn ignition switch ON.
2. Check power window operation.

Does power window (driver side) operate?

YES >> Replace power window main switch. Refer to [PWC-141, "Removal and Installation"](#).

NO >> Refer to [PWC-128, "Diagnosis Procedure"](#).

PASSENGER SIDE

PASSENGER SIDE : Description

INFOID:000000005624188

Transmits door lock/unlock operation to BCM.

PASSENGER SIDE : Component Function Check

INFOID:000000005624189

1.CHECK FUNCTION

Check ("CDL LOCK SW ", "CDL UNLOCK SW") in BCM "Data Monitor" mode using CONSULT-III.

Monitor item	Condition	Status
CDL LOCK SW	Lock	ON
	Unlock	OFF
CDL UNLOCK SW	Lock	OFF
	Unlock	ON

Is the inspection result normal?

YES >> Door lock and unlock switch is OK.

NO >> Refer to [DLK-72, "PASSENGER SIDE : Diagnosis Procedure"](#).

PASSENGER SIDE : Diagnosis Procedure

INFOID:000000005624190

1.CHECK POWER WINDOW SWITCH

1. Turn ignition switch ON.
2. Check passenger side power window operation.

DOOR LOCK AND UNLOCK SWITCH

< DTC/CIRCUIT DIAGNOSIS >

Does power window (passenger side) operate?

YES >> Replace power window sub-switch. Refer to [PWC-141, "Removal and Installation"](#).

NO >> Refer to [PWC-129, "Diagnosis Procedure"](#).

A

B

C

D

E

F

G

H

I

J

DLK

L

M

N

O

P

DOOR LOCK ACTUATOR

< DTC/CIRCUIT DIAGNOSIS >

DOOR LOCK ACTUATOR DRIVER SIDE

DRIVER SIDE : Description

INFOID:000000005624191

Locks/unlocks the door with the signal from BCM.

DRIVER SIDE : Component Function Check

INFOID:000000005624192

1. CHECK FUNCTION

1. Use CONSULT-III to perform BCM "Active Test" ("DOOR LOCK").
2. Touch "ALL LCK" or "ALL UNLK" to check that it works normally.

Is the inspection result normal?

YES >> Door lock actuator is OK.

NO >> Refer to [DLK-74, "DRIVER SIDE : Diagnosis Procedure"](#).

DRIVER SIDE : Diagnosis Procedure

INFOID:000000005624193

1. CHECK DOOR LOCK ACTUATOR INPUT SIGNAL

1. Turn ignition switch OFF.
2. Disconnect driver side door lock assembly connector.
3. Check voltage between driver side door lock assembly harness connector and ground.

(+)		(-)	Condition	Voltage (V) (Approx.)	
Connector	Terminal				
D15	1	Ground	Door lock and unlock switch	Lock	0 → Battery voltage → 0
	2		Unlock	0 → Battery voltage → 0	

Is the inspection result normal?

YES >> Replace driver side door lock assembly. Refer to [DLK-302, "DOOR LOCK : Removal and Installation"](#).

NO >> GO TO 2.

2. CHECK DOOR LOCK ACTUATOR CIRCUIT

1. Disconnect BCM connector, passenger side door lock assembly connector and fuel lid lock actuator connector.
2. Check continuity between BCM harness connector and driver side door lock assembly harness connector.

BCM		Driver side door lock assembly		Continuity
Connector	Terminal	Connector	Terminal	
M119	8	D15	1	Existed
	9		2	

3. Check continuity between BCM harness connector and ground.

BCM		Ground	Continuity
Connector	Terminal		
M119	8		Not existed
	9		

Is the inspection result normal?

YES >> Replace BCM. Refer to [BCS-79, "Removal and Installation"](#).

NO >> Repair or replace harness.

PASSENGER SIDE

DOOR LOCK ACTUATOR

< DTC/CIRCUIT DIAGNOSIS >

PASSENGER SIDE : Description

INFOID:000000005624194

Locks/unlocks the door with the signal from BCM.

PASSENGER SIDE : Component Function Check

INFOID:000000005624195

1.CHECK FUNCTION

1. Use CONSULT-III to perform BCM Active Test ("DOOR LOCK").
2. Touch "ALL LCK" or "ALL UNLK" to check that it works normally.

Is the inspection result normal?

- YES >> Door lock actuator is OK.
 NO >> Refer to [DLK-75. "PASSENGER SIDE : Diagnosis Procedure"](#).

PASSENGER SIDE : Diagnosis Procedure

INFOID:000000005624196

1.CHECK DOOR LOCK ACTUATOR INPUT SIGNAL

1. Turn ignition switch OFF.
2. Disconnect passenger side door lock assembly connector.
3. Check voltage between passenger side door lock assembly harness connector and ground.

(+) Passenger side door lock assembly		(-)	Condition	Voltage (V) (Approx.)
Connector	Terminal			
D45	1	Ground	Door lock and unlock switch	Unlock
	2		Lock	0 → Battery voltage → 0

Is the inspection result normal?

- YES >> Replace passenger side door lock assembly. Refer to [DLK-302. "DOOR LOCK : Removal and Installation"](#).
 NO >> GO TO 2.

2.CHECK DOOR LOCK ACTUATOR CIRCUIT

1. Disconnect BCM connector, driver side door lock assembly connector and fuel lid lock actuator connector.
2. Check continuity between BCM harness connector and passenger side door lock assembly harness connector.

BCM		Passenger side door lock assembly		Continuity
Connector	Terminal	Connector	Terminal	
M119	5	D45	1	Existed
	8		2	

3. Check continuity between BCM harness connector and ground.

BCM		Ground	Continuity
Connector	Terminal		
M119	5		Not existed
	8		

Is the inspection result normal?

- YES >> Replace BCM. Refer to [BCS-79. "Removal and Installation"](#).
 NO >> Repair or replace harness.

A
B
C
D
E
F
G
H
I
J
L
M
N
O
P

DLK

FUEL LID LOCK ACTUATOR

< DTC/CIRCUIT DIAGNOSIS >

FUEL LID LOCK ACTUATOR

Description

INFOID:000000005624197

Locks/unlocks the fuel filler lid with the signal from BCM.

Component Function Check

INFOID:000000005624198

1.CHECK FUNCTION

1. Use CONSULT-III to perform BCM "Active Test" ("DOOR LOCK").
2. Touch "ALL LOCK" or "ALL UNLOCK" to check that it works normally.

Is the inspection result normal?

- YES >> Fuel lid lock actuator is OK.
NO >> Refer to [DLK-76, "Diagnosis Procedure"](#).

Diagnosis Procedure

INFOID:000000005624199

1.CHECK FUEL LID LOCK ACTUATOR INPUT SIGNAL

1. Turn ignition switch OFF.
2. Disconnect fuel lid lock actuator connector.
3. Check voltage between fuel lid lock actuator harness connector and ground.

(+)		(-)	Condition	Voltage (V) (Approx.)
Connector	Terminal			
B40	1	Ground	Door lock and unlock switch	Unlock 0 → Battery voltage → 0
	2		Lock 0 → Battery voltage → 0	

Is the inspection result normal?

- YES >> Replace fuel lid lock actuator. Refer to [DLK-310, "Removal and Installation"](#).
NO >> GO TO 2.

2.CHECK FUEL LID LOCK ACTUATOR CIRCUIT

1. Disconnect BCM connector and all door lock assembly connector.
2. Check continuity between BCM harness connector and fuel lid lock actuator harness connector.

BCM		Fuel lid lock actuator		Continuity
Connector	Terminal	Connector	Terminal	
M119	8	B40	2	Existed
	9		1	

3. Check continuity between BCM harness connector and ground.

BCM		Ground	Continuity
Connector	Terminal		
M119	8		Not existed
	9		

Is the inspection result normal?

- YES >> Replace BCM. Refer to [BCS-79, "Removal and Installation"](#).
NO >> Repair or replace harness.

TRUNK LID OPEN SIGNAL CIRCUIT

< DTC/CIRCUIT DIAGNOSIS >

TRUNK LID OPEN SIGNAL CIRCUIT

Description

INFOID:0000000005624200

Transmits trunk lid open signal to retractable hard top control unit from BCM.

Component Function Check

INFOID:0000000005624201

1.CHECK TRUNK LID OPENER CANCEL SWITCH

Check trunk lid opener cancel switch position.

Does trunk lid opener cancel switch turn OFF (CANCEL)?

- YES >> Turn on trunk lid opener cancel switch.
- NO >> GO TO 2.

2.CHECK RETRACTABLE HARD TOP SYSTEM

Check that retractable hard top system operates normally.

Refer to [RF-16. "RETRACTABLE HARD TOP SYSTEM : System Description"](#).

Is the inspection result normal?

- YES >> GO TO 3.
- NO >> Refer to [RF-84. "Work Flow"](#).

3.CHECK FUNCTION

1. Use CONSULT-III to perform BCM "Active Test" ("TRUNK/GLASS HATCH").
2. Touch "OPEN" to check that it works normally.

Is the inspection result normal?

- YES >> Trunk lid open signal circuit is OK.
- NO >> Refer to [DLK-77. "Diagnosis Procedure"](#).

Diagnosis Procedure

INFOID:0000000005624202

1.CHECK TRUNK LID OPEN SIGNAL 1

1. Use CONSULT-III to perform BCM "Active Test" ("TRUNK/GLASS HATCH").
2. Touch "OPEN" to check voltage between retractable hard top control unit harness connector and ground.

(+)		(-)	CONSULT-III Active Test condition		Voltage (V) (Approx.)
Retractable hard top control unit Connector	Terminal				
B83	51	Ground	TRUNK/GLASS HATCH	OPEN	0 → Battery voltage → 0

Is the inspection result normal?

- YES >> INSPECTION END
- NO >> GO TO 2.

2.CHECK TRUNK LID OPEN SIGNAL 2

1. Turn ignition switch OFF.
2. Disconnect retractable hard top control unit harness connector.
3. Turn ignition switch ON.
4. Use CONSULT-III to perform BCM "Active Test" ("TRUNK/GLASS HATCH").
5. Touch "OPEN" to check voltage between retractable hard top control unit harness connector and ground.

(+)		(-)	CONSULT-III Active Test condition		Voltage (V) (Approx.)
Retractable hard top control unit Connector	Terminal				
B82	27	Ground	TRUNK/GLASS HATCH	OPEN	0 → Battery voltage → 0

Is the inspection result normal?

- YES >> Replace retractable hard top control unit. Refer to [RF-303. "Removal and Installation"](#).

A
B
C
D
E
F
G
H
I
J
L
M
N
O
P

DLK

TRUNK LID OPEN SIGNAL CIRCUIT

< DTC/CIRCUIT DIAGNOSIS >

NO >> GO TO 3.

3. CHECK TRUNK LID OPEN SIGNAL CIRCUIT

1. Disconnect BCM connector.
2. Check continuity between BCM harness connector and retractable hard top control unit harness connector.

BCM		Retractable hard top control unit		Continuity
Connector	Terminal	Connector	Terminal	
M120	23	B82	27	Existed

3. Check continuity between BCM harness connector and ground.

BCM		Ground	Continuity
Connector	Terminal		
M120	23		Not existed

Is the inspection result normal?

- YES >> Replace BCM. Refer to [BCS-79. "Removal and Installation"](#).
NO >> Repair or replace harness.

TRUNK LID OPENER ACTUATOR

< DTC/CIRCUIT DIAGNOSIS >

TRUNK LID OPENER ACTUATOR

Description

INFOID:0000000005624203

Performs trunk lid open with signal from retractable hard top control unit or BCM.

Component Function Check

INFOID:0000000005624204

1. CHECK FUNCTION

1. Use CONSULT-III to perform convertible roof "Work Support" ("TRUNK OPENER").
2. Touch "ON" to check that it works normally.

Is the inspection result normal?

- YES >> Trunk lid opener actuator is OK.
NO >> Refer to [DLK-79. "Diagnosis Procedure"](#).

Diagnosis Procedure

INFOID:0000000005624205

1. CHECK TRUNK LID OPENER ACTUATOR INPUT SIGNAL

1. Turn ignition switch OFF.
2. Disconnect trunk lid opener actuator connector.
3. Turn ignition switch ON.
4. Use CONSULT-III to perform convertible roof "Work Support" ("TRUNK OPENER").
5. Touch "ON" to check voltage between trunk lid opener actuator harness connector and ground.

(+)		(-)	CONSULT-III Work Support condition		Voltage (V) (Approx.)
Connector	Terminal				
B305	2	Ground	TRUNK OPENER	ON	0 → Battery voltage → 0

Is the inspection result normal?

- YES >> GO TO 3.
NO >> GO TO 2.

2. CHECK TRUNK LID OPENER ACTUATOR CIRCUIT

1. Disconnect retractable hard top control unit connector.
2. Check continuity between retractable hard top control unit harness connector and trunk lid opener actuator harness connector.

Retractable hard top control unit		Trunk lid opener actuator		Continuity
Connector	Terminal	Connector	Terminal	
B83	51	B305	2	Existed

3. Check continuity between retractable hard top control unit harness connector and ground.

Retractable hard top control unit		Ground	Continuity
Connector	Terminal		
B83	51		Not existed

Is the inspection result normal?

- YES >> Replace retractable hard top control unit. Refer to [RF-303. "Removal and Installation"](#).
NO >> Repair or replace harness.

3. CHECK TRUNK LID OPENER ACTUATOR GROUND CIRCUIT

1. Turn ignition switch OFF.
2. Disconnect retractable hard top control unit connector and trunk room lamp switch connector.
3. Check continuity between retractable hard top control unit harness connector and trunk lid opener actuator harness connector.

A
B
C
D
E
F
G
H
I
J
L
M
N
O
P

DLK

TRUNK LID OPENER ACTUATOR

< DTC/CIRCUIT DIAGNOSIS >

Retractable hard top control unit		Trunk lid opener actuator		Continuity
Connector	Terminal	Connector	Terminal	
B83	52	B305	1	Existed

4. Check continuity between retractable hard top control unit harness connector and ground.

Retractable hard top control unit		Ground	Continuity
Connector	Terminal		
B83	52		Not existed

Is the inspection result normal?

YES >> GO TO 4.

NO >> Repair or replace harness.

4. CHECK TRUNK LID OPENER ACTUATOR GROUND

1. Connect retractable hard top control unit connector.
2. Check continuity between retractable hard top control unit harness connector and ground.

Retractable hard top control unit		Ground	Continuity
Connector	Terminal		
B83	52		Existed

Does continuity exist?

YES >> Replace trunk lid opener actuator (trunk lid lock assembly). Refer to [DLK-309. "TRUNK LID LOCK : Removal and Installation"](#).

NO >> Replace retractable hard top control unit. Refer to [RF-303. "Removal and Installation"](#).

TRUNK ROOM LAMP SWITCH

< DTC/CIRCUIT DIAGNOSIS >

TRUNK ROOM LAMP SWITCH

Description

INFOID:000000005624206

It detects engagement of trunk lid lock assembly and trunk lid striker.

Component Function Check

INFOID:000000005624207

1.CHECK FUNCTION

Check ("TRNK/HAT MNTR") in BCM "Data Monitor" mode using CONSULT-III.

Monitor item	Condition	Status
TRNK/HAT MNTR	Open	ON
	Closed	OFF

Is the inspection result normal?

- YES >> Trunk room lamp switch is OK.
 NO >> Refer to [DLK-81, "Diagnosis Procedure"](#).

Diagnosis Procedure

INFOID:000000005624208

1.CHECK TRUNK ROOM LAMP SWITCH INPUT SIGNAL

- Turn ignition switch OFF.
- Disconnect trunk room lamp switch connector.
- Check signal between trunk room lamp switch harness connector and ground using oscilloscope.

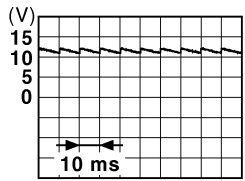
(+)		(-)	Signal (Reference value)
Connector	Terminal		
B306	2	Ground	 <p>JPMA0011GB</p>

Is the inspection result normal?

- YES >> GO TO 3.
 NO >> GO TO 2.

2.CHECK TRUNK ROOM LAMP SWITCH CIRCUIT

- Disconnect BCM connector trunk closure sub-control unit connector and retractable hard top control unit connector.
- Check continuity between BCM harness connector and trunk room lamp switch harness connector.

BCM		Trunk room lamp switch		Continuity
Connector	Terminal	Connector	Terminal	
M121	50	B306	2	Existed

- Check continuity between BCM harness connector and ground.

BCM		Ground	Continuity
Connector	Terminal		
M121	50		Not existed

Is the inspection result normal?

A
B
C
D
E
F
G
H
I
J
K
L
M
N
O
P

DLK

TRUNK ROOM LAMP SWITCH

< DTC/CIRCUIT DIAGNOSIS >

YES >> Replace BCM. Refer to [BCS-79, "Removal and Installation"](#).

NO >> Repair harness or connector.

3.CHECK TRUNK ROOM LAMP SWITCH GROUND CIRCUIT

1. Disconnect trunk lid opener actuator connector.
2. Check continuity between retractable hard top control unit harness connector and trunk room lamp switch harness connector.

Retractable hard top control unit		Trunk room lamp switch		Continuity
Connector	Terminal	Connector	Terminal	
B83	52	B306	1	Existed

3. Check continuity between retractable hard top control unit harness connector and ground.

Retractable hard top control unit		Ground	Continuity
Connector	Terminal		
B83	52		Not existed

Is the inspection result normal?

YES >> GO TO 4.

NO >> Repair or replace harness.

4.CHECK RETRACTABLE HARD TOP CONTROL UNIT POWER SUPPLY AND GROUND CIRCUIT

Refer to [DLK-68, "RETRACTABLE HARD TOP CONTROL UNIT : Diagnosis Procedure"](#).

Is the inspection result normal?

YES >> GO TO 5.

NO >> Repair or replace the malfunctioning parts.

5.CHECK TRUNK ROOM LAMP SWITCH GROUND

1. Connect retractable hard top control unit connector.
2. Check continuity between retractable hard top control unit harness connector and ground.

Retractable hard top control unit		Ground	Continuity
Connector	Terminal		
B83	52		Existed

Is the inspection result normal?

YES >> GO TO 6.

NO >> Replace retractable hard top control unit. Refer to [RF-303, "Removal and Installation"](#).

6.CHECK TRUNK ROOM LAMP SWITCH

Refer to [DLK-82, "Component Inspection"](#).

Is the inspection result normal?

YES >> GO TO 7.

NO >> Replace trunk room lamp switch (trunk lid lock assembly). Refer to [DLK-309, "TRUNK LID LOCK : Removal and Installation"](#).

7.CHECK INTERMITTENT INCIDENT

Refer to [GI-37, "Intermittent Incident"](#).

>> INSPECTION END

Component Inspection

INFOID:000000005624209

1.CHECK TRUNK ROOM LAMP SWITCH

1. Turn ignition switch OFF.
2. Disconnect trunk room lamp switch connector.
3. Check continuity between trunk room lamp switch terminals.

TRUNK ROOM LAMP SWITCH

< DTC/CIRCUIT DIAGNOSIS >

Trunk room lamp switch		Condition		Continuity
Terminal				
1	2	Trunk lid lock assembly	Unlocked	Existed
			Locked	Not existed

Is the inspection result normal?

YES >> INSPECTION END

NO >> Replace trunk room lamp switch (trunk lid lock assembly). Refer to [DLK-309, "TRUNK LID LOCK : Removal and Installation"](#).

A
B
C
D
E
F
G
H
I
J
L
M
N
O
P

DLK

TRUNK ROOM LAMP SWITCH CIRCUIT

< DTC/CIRCUIT DIAGNOSIS >

TRUNK ROOM LAMP SWITCH CIRCUIT

Description

INFOID:000000005624210

Transmits trunk room lamp switch signal to trunk closure control unit through trunk closure sub-control unit.

Component Function Check

INFOID:000000005624211

1.CHECK FUNCTION

1. Turn ignition switch OFF.
2. Check that trunk lid auto closure system operates normally when trunk lid is closed.

Is the inspection result normal?

- YES >> Trunk room lamp switch circuit is OK.
NO >> Refer to [DLK-84, "Diagnosis Procedure"](#).

Diagnosis Procedure

INFOID:000000005624212

1.CHECK TRUNK ROOM LAMP SWITCH SIGNAL 1

1. Turn ignition switch OFF.
2. Disconnect trunk closure control unit connector.
3. Check voltage between trunk closure control unit harness connector and ground.

(+)		(-)	Condition	Voltage (V) (Approx.)
Connector	Terminal			
B363	1	Ground	Trunk lid lock assembly and trunk lid striker are engaged	Battery voltage
			Trunk open operation activates when retractable hard top is operated	Battery voltage → 0
			Trunk lid lock assembly and trunk lid striker are not engaged	0

Is the inspection result normal?

- YES >> Trunk room lamp switch circuit is OK.
NO >> GO TO 2.

2.CHECK TRUNK ROOM LAMP SWITCH SIGNAL CIRCUIT

1. Disconnect trunk closure sub-control unit connector.
2. Check continuity between trunk closure sub-control unit harness connector and trunk closure control unit harness connector.

Trunk closure sub-control unit		Trunk closure control unit		Continuity
Connector	Terminal	Connector	Terminal	
B85	3	B363	1	Existed

3. Check continuity between trunk closure sub-control unit harness connector and ground.

Trunk closure sub-control unit		Ground	Continuity
Connector	Terminal		
B85	3		Not existed

Is the inspection result normal?

- YES >> GO TO 3.
NO >> Repair or replace harness.

3.CHECK TRUNK ROOM LAMP SWITCH INPUT SIGNAL 2

Check signal between trunk closure sub-control unit harness connector and ground using oscilloscope.

TRUNK ROOM LAMP SWITCH CIRCUIT

< DTC/CIRCUIT DIAGNOSIS >

(+)		(-)	Signal (Reference value)
Trunk closure sub-control unit			
Connector	Terminal		
B85	2	Ground	

Is the inspection result normal?

- YES >> GO TO 4.
- NO >> Repair or replace harness.

4.CHECK TRUNK CLOSURE SUB-CONTROL UNIT POWER SUPPLY AND GROUND CIRCUIT

Refer to [DLK-69, "TRUNK CLOSURE SUB-CONTROL UNIT : Diagnosis Procedure"](#).

Is the inspection result normal?

- YES >> GO TO 5.
- NO >> Replace trunk closure sub-control unit.

5.CHECK INTERMITTENT INCIDENT

Refer to [GI-37, "Intermittent Incident"](#).

>> INSPECTION END

A
B
C
D
E
F
G
H
I
J
L
M
N
O
P

DLK

DOOR KEY CYLINDER SWITCH

< DTC/CIRCUIT DIAGNOSIS >

DOOR KEY CYLINDER SWITCH

Description

INFOID:000000005624213

Power window main switch detects condition of the door key cylinder switch and transmits to BCM as the LOCK or UNLOCK signals.

Component Function Check

INFOID:000000005624214

1. CHECK DOOR KEY CYLINDER SWITCH INPUT SIGNAL

Check ("KEY CYL LK-SW", "KEY CYL UN-SW") in BCM "Data Monitor" mode using CONSULT-III.

Monitor item	Condition		Status
KEY CYL LK-SW	Driver side door key cylinder	Lock	ON
		Neutral / Unlock	OFF
KEY CYL UN-SW		Unlock	ON
		Neutral / Lock	OFF

Is the inspection result normal?

- YES >> Door key cylinder switch is OK.
 NO >> Refer to [DLK-86, "Diagnosis Procedure"](#).

Diagnosis Procedure

INFOID:000000005624215

1. CHECK DOOR KEY CYLINDER SWITCH INPUT SIGNAL

- Turn ignition switch OFF.
- Disconnect driver side door lock assembly connector.
- Check voltage between driver side door lock assembly harness connector and ground.

(+)		(-)	Voltage (V) (Approx.)
Driver side door lock assembly			
Connector	Terminal	Ground	5
D15	5		
	6		

Is the inspection result normal?

- YES >> GO TO 3.
 NO >> GO TO 2.

2. CHECK DOOR KEY CYLINDER SWITCH SIGNAL CIRCUIT

- Disconnect power window main switch connector.
- Check continuity between power window main switch harness connector and driver side door lock assembly harness connector.

Power window main switch		Driver side door lock assembly		Continuity
Connector	Terminal	Connector	Terminal	
D8	4	D15	6	Existed
	6		5	

- Check continuity between power window main switch harness connector and ground.

Power window main switch		Ground	Continuity
Connector	Terminal		Not existed
D8	4		
	6		

DOOR KEY CYLINDER SWITCH

< DTC/CIRCUIT DIAGNOSIS >

Is the inspection result normal?

- YES >> Replace power window main switch. Refer to [PWC-141, "Removal and Installation"](#).
 NO >> Repair or replace harness.

3.CHECK DOOR KEY CYLINDER SWITCH GROUND CIRCUIT

Check continuity between driver side door lock assembly harness connector and ground.

Driver side door lock assembly		Ground	Continuity
Connector	Terminal		
D15	4		Existed

Is the inspection result normal?

- YES >> GO TO 4.
 NO >> Repair or replace harness.

4.CHECK DOOR KEY CYLINDER SWITCH

Refer to [DLK-87, "Component Inspection"](#).

Is the inspection result normal?

- YES >> GO TO 5.
 NO >> Replace door key cylinder switch (driver side door lock assembly). Refer to [DLK-302, "DOOR LOCK : Removal and Installation"](#).

5.CHECK INTERMITTENT INCIDENT

Refer to [GI-37, "Intermittent Incident"](#).

>> INSPECTION END

Component Inspection

INFOID:000000005624216

COMPONENT INSPECTION

1.CHECK DOOR KEY CYLINDER SWITCH

1. Turn ignition switch OFF.
2. Disconnect driver side door lock assembly terminal.
3. Check continuity between driver side door lock assembly terminals.

Driver side door lock assembly		Condition	Continuity
Terminal			
5	4	Driver side door key cylinder	Unlock Existed
		Neutral / Lock Not existed	
6		Lock Existed	
		Neutral / Unlock Not existed	

Is the inspection result normal?

- YES >> INSPECTION END
 NO >> Replace door key cylinder switch (driver side door lock assembly). Refer to [DLK-302, "DOOR LOCK : Removal and Installation"](#).

REMOTE KEYLESS ENTRY RECEIVER

< DTC/CIRCUIT DIAGNOSIS >

REMOTE KEYLESS ENTRY RECEIVER

Description

INFOID:000000005624217

Receives Intelligent Key operation and transmits to BCM.

Component Function Check

INFOID:000000005624218

1.CHECK FUNCTION

Check ("RKE OPE COUN1") in BCM "Data Monitor" mode using CONSULT-III.

Monitor item	Condition
RKE OPE COUN1	Checks whether value changes when operating Intelligent Key

Is the inspection result normal?

- YES >> Remote keyless entry receiver is OK.
 NO >> Refer to [DLK-88, "Diagnosis Procedure"](#).

Diagnosis Procedure

INFOID:000000005624219

1.CHECK REMOTE KEYLESS ENTRY RECEIVER OUTPUT SIGNAL

- Turn ignition switch OFF.
- Check signal between remote keyless entry receiver harness connector and ground using oscilloscope.

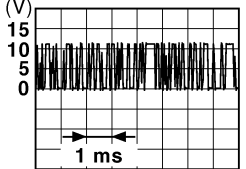
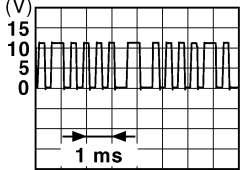
(+)		(-)	Condition	Signal (Reference value)
Connector	Terminal			
M104	2	Ground	During waiting	 <p style="text-align: right;">JMkia0064GB</p>
			When operating either button on the Intelligent Key	 <p style="text-align: right;">JMkia0065GB</p>

Is the inspection result normal?

- YES >> GO TO 2.
 NO >> GO TO 3.

2.CHECK REMOTE KEYLESS ENTRY RECEIVER CIRCUIT 1

- Disconnect BCM connector and remote keyless entry receiver connector
- Check continuity between BCM harness connector and remote keyless entry receiver harness connector.

BCM		Remote keyless entry receiver		Continuity
Connector	Terminal	Connector	Terminal	
M122	83	M104	2	Existed

- Check continuity between BCM harness connector and ground.

REMOTE KEYLESS ENTRY RECEIVER

< DTC/CIRCUIT DIAGNOSIS >

BCM		Ground	Continuity
Connector	Terminal		
M122	83		Not existed

Is the inspection result normal?

- YES >> Replace BCM. Refer to [BCS-79, "Removal and Installation"](#).
 NO >> Repair or replace harness.

3.CHECK REMOTE KEYLESS ENTRY RECEIVER POWER SUPPLY

1. Disconnect remote keyless entry receiver connector.
2. Check voltage between remote keyless entry receiver harness connector and ground.

(+)		(-)	Voltage (V) (Approx.)
Remote keyless entry receiver			
Connector	Terminal		
M104	4	Ground	12

Is the inspection result normal?

- YES >> GO TO 5.
 NO >> GO TO 4.

4.CHECK REMOTE KEYLESS ENTRY RECEIVER CIRCUIT 2

1. Disconnect BCM connector.
2. Check continuity between BCM harness connector and remote keyless entry receiver harness connector.

BCM		Remote keyless entry receiver		Continuity
Connector	Terminal	Connector	Terminal	
M122	103	M104	4	Existed

3. Check continuity between BCM harness connector and ground.

BCM		Ground	Continuity
Connector	Terminal		
M122	103		Not existed

Is the inspection result normal?

- YES >> Replace BCM. Refer to [BCS-79, "Removal and Installation"](#).
 NO >> Repair or replace harness.

5.CHECK REMOTE KEYLESS ENTRY RECEIVER CIRCUIT 3

1. Disconnect BCM connector.
2. Check continuity between BCM harness connector and remote keyless entry receiver harness connector.

BCM		Remote keyless entry receiver		Continuity
Connector	Terminal	Connector	Terminal	
M123	137	M104	1	Existed

3. Check continuity between BCM harness connector and ground.

BCM		Ground	Continuity
Connector	Terminal		
M123	137		Existed

Is the inspection result normal?

- YES >> GO TO 6.
 NO >> Repair or replace harness.

6.CHECK REMOTE KEYLESS ENTRY RECEIVER GROUND CIRCUIT

A
B
C
D
E
F
G
H
I
J
L
M
N
O
P

DLK

REMOTE KEYLESS ENTRY RECEIVER

< DTC/CIRCUIT DIAGNOSIS >

1. Connect BCM connector.
2. Check continuity between BCM harness connector and ground.

BCM		Ground	Continuity
Connector	Terminal		
M123	137		Existed

Is the inspection result normal?

- YES >> Replace remote keyless entry receiver. Refer to [DLK-320. "Removal and Installation"](#).
- NO >> Replace BCM. Refer to [BCS-79. "Removal and Installation"](#).

TRUNK LID OPENER SWITCH

< DTC/CIRCUIT DIAGNOSIS >

TRUNK LID OPENER SWITCH

Description

INFOID:000000005624220

Transmits trunk lid open signal to BCM.

Component Function Check

INFOID:000000005624221

1.CHECK TRUNK LID OPENER CANCEL SWITCH

Check trunk lid opener cancel switch position.

Does trunk lid opener cancel switch turn ON (CANCEL)?

- YES >> Turn off trunk lid opener cancel switch.
- NO >> GO TO 2.

2.CHECK FUNCTION

Check ("TR/BD OPEN SW") in BCM "Data Monitor" mode using CONSULT-III.

Monitor item	Condition	Status
TR/BD OPEN SW	Trunk lid opener switch Pressed	ON
	Released	OFF

Is the inspection result normal?

- YES >> Trunk lid opener switch is OK.
- NO >> Refer to [DLK-91, "Diagnosis Procedure"](#).

Diagnosis Procedure

INFOID:000000005624222

1.CHECK TRUNK LID OPENER SWITCH INPUT SIGNAL

1. Turn ignition switch OFF.
2. Disconnect trunk lid opener switch connector.
3. Check signal between trunk lid opener switch harness connector and ground using oscilloscope.

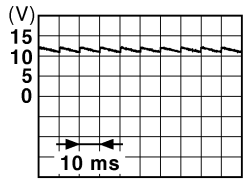
(+)		(-)	Signal (Reference value)
Connector	Terminal		
M20	1	Ground	 <p style="text-align: right;">JPMA0011GB</p>

Is the inspection result normal?

- YES >> GO TO 3.
- NO >> GO TO 2.

2.CHECK TRUNK LID OPENER SWITCH CIRCUIT

1. Disconnect BCM connector.
2. Check continuity between BCM harness connector and trunk lid opener switch harness connector.

BCM		Trunk lid opener switch		Continuity
Connector	Terminal	Connector	Terminal	
M121	67	M20	1	Existed

3. Check continuity between BCM harness connector and ground.

TRUNK LID OPENER SWITCH

< DTC/CIRCUIT DIAGNOSIS >

BCM		Ground	Continuity
Connector	Terminal		
M121	67		Not existed

Is the inspection result normal?

YES >> Replace BCM. Refer to [BCS-79, "Removal and Installation"](#).

NO >> Repair harness or connector.

3.CHECK TRUNK LID OPENER SWITCH GROUND CIRCUIT

Check continuity between trunk lid opener switch harness connector and ground.

Trunk lid opener switch		Ground	Continuity
Connector	Terminal		
M20	2		Existed

Is the inspection result normal?

YES >> GO TO 4.

NO >> Repair or replace harness.

4.CHECK TRUNK LID OPENER SWITCH

Refer to [DLK-92, "Component Inspection"](#).

Is the inspection result normal?

YES >> GO TO 5.

NO >> Replace trunk lid opener switch. Refer to [DLK-318, "Removal and Installation"](#).

5.CHECK INTERMITTENT INCIDENT

Refer to [GI-37, "Intermittent Incident"](#).

>> INSPECTION END

Component Inspection

INFOID:000000005624223

1.CHECK TRUNK LID OPENER SWITCH

1. Turn ignition switch OFF.
2. Disconnect trunk lid opener switch connector.
3. Check continuity between trunk lid opener switch terminals.

Trunk lid opener switch		Condition	Continuity	
Terminal				
1	2	Trunk lid opener switch	Pressed	Existed
			Released	Not existed

Is the inspection result normal?

YES >> INSPECTION END

NO >> Replace trunk lid opener switch. Refer to [DLK-318, "Removal and Installation"](#).

TRUNK LID OPENER REQUEST SWITCH

< DTC/CIRCUIT DIAGNOSIS >

TRUNK LID OPENER REQUEST SWITCH

Description

INFOID:0000000005624224

Performs trunk lid open request when it is pressed.

Component Function Check

INFOID:0000000005624225

1.CHECK TRUNK LID OPENER CANCEL SWITCH

Check trunk lid opener cancel switch position.

Does trunk lid opener cancel switch turn ON (CANCEL)?

- YES >> Turn off trunk lid opener cancel switch.
- NO >> GO TO 2.

2.CHECK FUNCTION

Check ("REQSW-BD/TR") in BCM "Data Monitor" mode using CONSULT-III.

Monitor item	Condition	Status
REQSW-BD/TR	Trunk lid opener request switch Pressed	ON
	Released	OFF

Is the inspection result normal?

- YES >> Trunk lid opener request switch is OK.
- NO >> Refer to [DLK-93, "Diagnosis Procedure"](#).

Diagnosis Procedure

INFOID:0000000005624226

1.CHECK TRUNK LID OPENER REQUEST SWITCH INPUT SIGNAL

1. Turn ignition switch OFF.
2. Disconnect rear combination lamp LH connector.
3. Check signal between rear combination lamp LH harness connector and ground using oscilloscope.

(+)		(-)	Signal (Reference value)
Connector	Terminal		
B60	5	Ground	

Is the inspection result normal?

- YES >> GO TO 3.
- NO >> GO TO 2.

2.CHECK TRUNK LID OPENER REQUEST SWITCH CIRCUIT

1. Disconnect BCM connector.
2. Check continuity between BCM harness connector and rear combination lamp LH harness connector.

BCM		Rear combination lamp LH		Continuity
Connector	Terminal	Connector	Terminal	
M121	61	B60	5	Existed

3. Check continuity between BCM harness connector and ground.

TRUNK LID OPENER REQUEST SWITCH

< DTC/CIRCUIT DIAGNOSIS >

BCM		Ground	Continuity
Connector	Terminal		
M121	61		Not existed

Is the inspection result normal?

- YES >> Replace BCM. Refer to [BCS-79, "Removal and Installation"](#).
 NO >> Repair harness or connector.

3.CHECK TRUNK LID OPENER REQUEST SWITCH GROUND CIRCUIT

Check continuity between rear combination lamp LH harness connector and ground.

Rear combination lamp LH		Ground	Continuity
Connector	Terminal		
B60	3		Existed

Is the inspection result normal?

- YES >> GO TO 4.
 NO >> Repair or replace harness.

4.CHECK TRUNK LID OPENER REQUEST SWITCH

Refer to [DLK-94, "Component Inspection"](#).

Is the inspection result normal?

- YES >> GO TO 5.
 NO >> Replace trunk lid opener request switch. Refer to [DLK-317, "Removal and Installation"](#).

5.CHECK INTERMITTENT INCIDENT

Refer to [GI-37, "Intermittent Incident"](#).

>> INSPECTION END

Component Inspection

INFOID:000000005624227

1.CHECK TRUNK LID OPENER REQUEST SWITCH

1. Turn ignition switch OFF.
2. Disconnect rear combination lamp LH connector.
3. Check continuity between rear combination lamp LH terminals.

Rear combination lamp LH		Condition	Continuity
Terminal			
3	5	Trunk lid opener request switch	Existed
			Not existed

Is the inspection result normal?

- YES >> INSPECTION END
 NO >> Replace trunk lid opener request switch. Refer to [DLK-317, "Removal and Installation"](#).

TRUNK LID OPENER CANCEL SWITCH

< DTC/CIRCUIT DIAGNOSIS >

TRUNK LID OPENER CANCEL SWITCH

Description

INFOID:000000005624228

Cancels trunk lid open operation.

Component Function Check

INFOID:000000005624229

1.CHECK FUNCTION

Check ("TR CANCEL SW") in BCM "Data Monitor" mode using CONSULT-III.

Monitor item	Condition	Status
TR CANCEL SW	Trunk lid opener cancel switch ON	ON
	Trunk lid opener cancel switch OFF (Cancel)	OFF

Is the inspection result normal?

- YES >> Trunk lid opener cancel switch is OK.
 NO >> Refer to [DLK-95, "Diagnosis Procedure"](#).

Diagnosis Procedure

INFOID:000000005624230

1.CHECK TRUNK LID OPENER CANCEL SWITCH INPUT SIGNAL

- Turn ignition switch OFF.
- Disconnect trunk lid opener cancel switch connector.
- Check signal between trunk lid opener cancel switch harness connector and ground using oscilloscope.

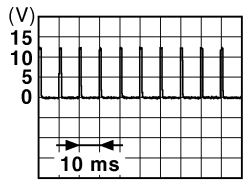
(+)		(-)	Signal (Reference value)
Connector	Terminal		
M105	1	Ground	 <p>JPMA0012GB</p>

Is the inspection result normal?

- YES >> GO TO 3.
 NO >> GO TO 2.

2.CHECK TRUNK LID OPENER CANCEL SWITCH CIRCUIT

- Disconnect BCM connector.
- Check continuity between BCM harness connector and trunk lid opener cancel switch harness connector.

BCM		Trunk lid opener cancel switch		Continuity
Connector	Terminal	Connector	Terminal	
M123	129	M105	1	Existed

- Check continuity between BCM harness connector and ground.

BCM		Ground	Continuity
Connector	Terminal		
M123	129		Not existed

Is the inspection result normal?

- YES >> Replace BCM. Refer to [BCS-79, "Removal and Installation"](#).

A
B
C
D
E
F
G
H
I
J
K
L
M
N
O
P

DLK

TRUNK LID OPENER CANCEL SWITCH

< DTC/CIRCUIT DIAGNOSIS >

NO >> Repair harness or connector.

3.CHECK TRUNK LID OPENER CANCEL SWITCH GROUND CIRCUIT

Check continuity between trunk lid opener cancel switch harness connector and ground.

Trunk lid opener cancel switch		Ground	Continuity
Connector	Terminal		
M105	2		Existed

Is the inspection result normal?

YES >> GO TO 4.

NO >> Repair or replace harness.

4.CHECK TRUNK LID OPENER CANCEL SWITCH

Refer to [DLK-96, "Component Inspection"](#).

Is the inspection result normal?

YES >> GO TO 5.

NO >> Replace trunk lid opener cancel switch. Refer to [DLK-319, "Removal and Installation"](#).

5.CHECK INTERMITTENT INCIDENT

Refer to [GI-37, "Intermittent Incident"](#).

>> INSPECTION END

Component Inspection

INFOID:000000005624231

1.CHECK TRUNK LID OPENER CANCEL SWITCH

1. Turn ignition switch OFF.
2. Disconnect trunk lid opener cancel switch connector.
3. Check continuity between trunk lid opener cancel switch terminals.

Trunk lid opener cancel switch		Condition	Continuity
Terminal			
1	2	Trunk lid opener cancel switch ON	Existed
		Trunk lid opener cancel switch OFF (Cancel)	Not existed

Is the inspection result normal?

YES >> INSPECTION END

NO >> Replace trunk lid opener cancel switch. Refer to [DLK-319, "Removal and Installation"](#).

STRIKER SWITCH

< DTC/CIRCUIT DIAGNOSIS >

STRIKER SWITCH

Description

INFOID:0000000005624232

It is integrated in trunk closure assembly and detects open/close state of trunk lid.

Component Function Check

INFOID:0000000005624233

1.CHECK FUNCTION

1. Turn ignition switch OFF.
2. Check that waiting operation of trunk lid auto closure system operates normally when trunk lid is open.

Is the inspection result normal?

- YES >> Striker switch is OK.
NO >> Refer to [DLK-97. "Diagnosis Procedure"](#).

Diagnosis Procedure

INFOID:0000000005624234

1.CHECK STRIKER SWITCH INPUT SIGNAL

1. Turn ignition switch OFF.
2. Disconnect striker switch connector.
3. Check voltage between striker switch harness connector and ground.

(+)		(-)	Voltage (V) (Approx.)
Striker switch			
Connector	Terminal	Ground	Battery voltage
B362	2		

Is the inspection result normal?

- YES >> GO TO 3.
NO >> GO TO 2.

2.CHECK STRIKER SWITCH CIRCUIT

1. Disconnect trunk closure control unit connector.
2. Check continuity between trunk closure control unit harness connector and striker switch harness connector.

DLK

Trunk closure control unit		Striker switch		Continuity
Connector	Terminal	Connector	Terminal	
B363	3	B362	2	Existed

3. Check continuity between trunk closure control unit harness connector and ground.

Trunk closure control unit		Ground	Continuity
Connector	Terminal		
B363	3		Not existed

Is the inspection result normal?

- YES >> Replace trunk closure control unit. Refer to [DLK-294. "TRUNK LID STRIKER : Removal and Installation"](#).

- NO >> Repair or replace harness.

3.CHECK STRIKER SWITCH GROUND CIRCUIT

Check continuity between striker switch harness connector and ground.

Striker switch		Ground	Continuity
Connector	Terminal		
B362	1		Existed

STRIKER SWITCH

< DTC/CIRCUIT DIAGNOSIS >

Is the inspection result normal?

- YES >> GO TO 4.
NO >> Repair or replace harness.

4.CHECK STRIKER SWITCH

Refer to [DLK-98. "Component Inspection"](#).

Is the inspection result normal?

- YES >> GO TO 5.
NO >> Replace striker switch (trunk closure assembly). Refer to [DLK-294. "TRUNK LID STRIKER : Removal and Installation"](#).

5.CHECK INTERMITTENT INCIDENT

Refer to [GI-37. "Intermittent Incident"](#).

>> INSPECTION END

Component Inspection

INFOID:000000005624235

1.CHECK STRIKER SWITCH

1. Turn ignition switch OFF.
2. Disconnect striker switch connector.
3. Check continuity between striker switch terminals.

Striker switch		Condition		Continuity
Terminal				
1	2	Striker switch	Pressed	Existed
			Released	Not existed

Is the inspection result normal?

- YES >> INSPECTION END
NO >> Replace striker switch (trunk closure assembly). Refer to [DLK-294. "TRUNK LID STRIKER : Removal and Installation"](#).

DOOR REQUEST SWITCH

< DTC/CIRCUIT DIAGNOSIS >

DOOR REQUEST SWITCH

Description

INFOID:000000005624236

Transmits lock/unlock operation to BCM.

Component Function Check

INFOID:000000005624237

1.CHECK FUNCTION

Check ("REQ SW -DR" or "REQ SW -AS") in BCM "Data Monitor" mode using CONSULT-III.

Monitor item	Condition		Status
REQ SW -DR	Driver side door request switch	Pressed	ON
		Released	OFF
REQ SW -AS	Passenger side door request switch	Pressed	ON
		Released	OFF

Is the inspection result normal?

- YES >> Door request switch is OK.
 NO >> Refer to [DLK-99. "Diagnosis Procedure"](#).

Diagnosis Procedure

INFOID:000000005624238

1.CHECK DOOR REQUEST SWITCH INPUT SIGNAL

- Turn ignition switch OFF.
- Disconnect malfunctioning outside handle connector.
- Check signal between malfunctioning outside handle harness connector and ground using oscilloscope.

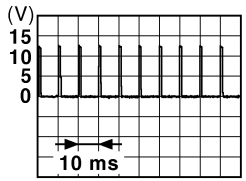
(+)		Terminal	(-)	Signal (Reference value)
Outside handle				
Connector				
LH	D13	1	Ground	 <p>JPMIA0016GB</p>
RH	D43			

Is the inspection result normal?

- YES >> GO TO 3.
 NO >> GO TO 2.

2.CHECK DOOR REQUEST SWITCH CIRCUIT

- Disconnect BCM connector.
- Check continuity between malfunctioning outside handle harness connector and BCM harness connector.

A
B
C
D
E
F
G
H
I
J
L
M
N
O
P

DLK

DOOR REQUEST SWITCH

< DTC/CIRCUIT DIAGNOSIS >

Outside handle		BCM		Continuity
Connector	Terminal	Connector	Terminal	
LH	D13	M122	101	Existed
RH	D43		100	

3. Check continuity between malfunctioning outside handle harness connector and ground.

Outside handle		Ground	Continuity
Connector	Terminal		
LH	D13	1	Not existed
RH	D43		

Is the inspection result normal?

YES >> Replace BCM. Refer to [BCS-79, "Removal and Installation"](#).

NO >> Repair or replace harness.

3.CHECK DOOR REQUEST SWITCH GROUND CIRCUIT

Check continuity between malfunctioning outside handle harness connector and ground.

Outside handle		Ground	Continuity
Connector	Terminal		
LH	D13	2	Existed
RH	D43		

Is the inspection result normal?

YES >> GO TO 4.

NO >> Repair or replace harness.

4.CHECK DOOR REQUEST SWITCH

Refer to [DLK-100, "Component Inspection"](#).

Is the inspection result normal?

YES >> GO TO 5.

NO >> Replace malfunctioning outside handle. Refer to [DLK-306, "OUTSIDE HANDLE : Removal and Installation"](#).

5.CHECK INTERMITTENT INCIDENT

Refer to [GI-37, "Intermittent Incident"](#).

>> INSPECTION END

Component Inspection

INFOID:000000005624239

1.CHECK DOOR REQUEST SWITCH

1. Turn ignition switch OFF.
2. Disconnect malfunctioning outside handle connector.
3. Check continuity between malfunctioning outside handle terminals.

Terminal		Condition	Continuity	
Outside handle				
1	2	Door request switch	Pressed	Existed
			Released	Not existed

Is the inspection result normal?

YES >> INSPECTION END

NO >> Replace malfunctioning outside handle. Refer to [DLK-306, "OUTSIDE HANDLE : Removal and Installation"](#).

UNLOCK SENSOR

< DTC/CIRCUIT DIAGNOSIS >

UNLOCK SENSOR

Description

INFOID:0000000005624240

Detects door lock condition of driver side door.

Component Function Check

INFOID:0000000005624241

1. CHECK FUNCTION

Check ("UNLK SEN -DR") in BCM "Data Monitor" mode using CONSULT-III.

Monitor item	Condition		Status
UNLK SEN -DR	Driver side door	Lock	OFF
		Unlock	ON

Is the inspection result normal?

- YES >> Unlock sensor is OK.
 NO >> Refer to [DLK-101, "Diagnosis Procedure"](#).

Diagnosis Procedure

INFOID:0000000005624242

1. CHECK UNLOCK SENSOR INPUT SIGNAL

- Turn ignition switch OFF.
- Disconnect driver side door lock assembly connector.
- Check signal between driver side door lock assembly harness connector and ground using oscilloscope.

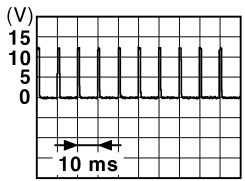
(+)		(-)	Signal (Reference value)
Connector	Terminal		
D15	3	Ground	 <p>JPMA0012GB</p>

Is the inspection result normal?

- YES >> GO TO 3.
 NO >> GO TO 2.

2. CHECK UNLOCK SENSOR CIRCUIT

- Disconnect BCM connector.
- Check continuity between BCM harness connector and driver side door lock assembly harness connector.

BCM		Driver side door lock assembly		Continuity
Connector	Terminal	Connector	Terminal	
M123	119	D15	3	Existed

- Check continuity between BCM harness connector and ground.

BCM		Ground	Continuity
Connector	Terminal		
M123	119		Not existed

Is the inspection result normal?

- YES >> Replace BCM. Refer to [BCS-79, "Removal and Installation"](#).

A
B
C
D
E
F
G
H
I
J
K
L
M
N
O
P

DLK

UNLOCK SENSOR

< DTC/CIRCUIT DIAGNOSIS >

NO >> Repair or replace harness.

3.CHECK UNLOCK SENSOR GROUND CIRCUIT

Check continuity between driver side door lock assembly harness connector and ground.

Driver side door lock assembly		Ground	Continuity
Connector	Terminal		
D15	4		Existed

Is the inspection result normal?

YES >> GO TO 4.

NO >> Repair or replace harness.

4.CHECK UNLOCK SENSOR

Refer to [DLK-102, "Component Inspection"](#).

Is the inspection result normal?

YES >> GO TO 5.

NO >> Replace driver side door lock assembly. Refer to [DLK-302, "DOOR LOCK : Removal and Installation"](#).

5.CHECK INTERMITTENT INCIDENT

Refer to [GI-37, "Intermittent Incident"](#).

>> INSPECTION END

Component Inspection

INFOID:000000005624243

1.CHECK UNLOCK SENSOR

1. Turn ignition switch OFF.
2. Disconnect driver side door lock assembly connector.
3. Check continuity between driver side door lock assembly terminals.

Driver side door lock assembly		Condition	Continuity
Terminal			
3	4	Driver side door	Unlock Existed
			Lock Not existed

Is the inspection result normal?

YES >> INSPECTION END

NO >> Replace driver side door lock assembly. Refer to [DLK-302, "DOOR LOCK : Removal and Installation"](#).

OUTSIDE KEY ANTENNA

< DTC/CIRCUIT DIAGNOSIS >

OUTSIDE KEY ANTENNA

Description

INFOID:000000005624244

- Detects whether Intelligent Key is outside the vehicle.
- Integrated in outside handle (driver side, passenger side) and installed in rear bumper.

Component Function Check

INFOID:000000005624245

1. CHECK OUT SIDE KEY ANTENNA FUNCTION

Check that intelligent key is in each outside key antenna detection range.

Does door lock/unlock when each request switch is pressed?

- YES >> Outside key antenna is OK.
 NO >> Refer to [DLK-103. "Diagnosis Procedure"](#).

Diagnosis Procedure

INFOID:000000005624246

1. CHECK OUTSIDE KEY ANTENNA INPUT SIGNAL 1

1. Turn ignition switch OFF.
2. Check signal between BCM harness connector and ground using oscilloscope.

(+)		(-)	Condition	Signal (Reference value)
BCM				
Connector	Terminal			
LH	M122	76, 77	Ground Door request switch is pressed	
RH		74, 75		
Rear bumper	M121	38, 39		

Is the inspection result normal?

- YES >> Replace BCM. Refer to [BCS-79. "Removal and Installation"](#)
 NO >> GO TO 2.

2. CHECK OUTSIDE KEY ANTENNA CIRCUIT

1. Disconnect BCM connector and malfunctioning outside key antenna connector.
2. Check continuity between malfunctioning outside handle or outside key antenna harness connector and BCM harness connector.

A
B
C
D
E
F
G
H
I
J
L
M
N
O
P

DLK

OUTSIDE KEY ANTENNA

< DTC/CIRCUIT DIAGNOSIS >

Outside handle/outside key antenna			BCM		Continuity
Connector		Terminal	Connector	Terminal	
LH	D14	1	M122	77	Existed
		2		76	
RH	D44	1		75	
		2		74	
Rear bumper	B63	1	M121	39	
		2		38	

3. Check continuity between malfunctioning outside handle or outside key antenna harness connector and ground.

Outside handle/outside key antenna			Ground	Continuity
Connector		Terminal		
LH	D14	1	Ground	Not existed
		2		
RH	D44	1		
		2		
Rear bumper	B63	1		
		2		

Is the inspection result normal?

- YES >> GO TO 3.
NO >> Repair or replace harness.

3. CHECK OUTSIDE KEY ANTENNA INPUT SIGNAL 2

1. Replace malfunctioning outside key antenna. (New antenna or other antenna)
2. Connect BCM connector and malfunctioning outside key antenna (New antenna or other antenna) connector.
3. Check signal between BCM harness connector and ground using oscilloscope.

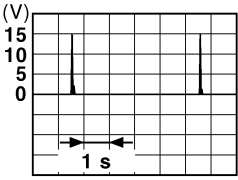
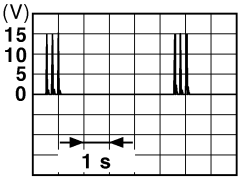
(+)			(-)	Condition	Signal (Reference value)
BCM					
Connector		Terminal			
LH	M122	76, 77	Ground	When Intelligent Key is in the antenna detection area	
RH		74, 75			
Rear bumper	M121	38, 39		When Intelligent Key is not in the antenna detection area	

Is the inspection result normal?

- YES-1 >> Replace malfunctioning outside handle. Refer to [DLK-306. "OUTSIDE HANDLE : Removal and Installation"](#).
YES-2 >> Replace outside key antenna (rear bumper). Refer to [DLK-315. "Removal and Installation"](#).

OUTSIDE KEY ANTENNA

< DTC/CIRCUIT DIAGNOSIS >

NO >> Replace BCM. Refer to [BCS-79. "Removal and Installation"](#).

A

B

C

D

E

F

G

H

I

J

DLK

L

M

N

O

P

INTELLIGENT KEY WARNING BUZZER

< DTC/CIRCUIT DIAGNOSIS >

INTELLIGENT KEY WARNING BUZZER

Description

INFOID:000000005624247

Answers back and warns for an inappropriate operation.

Component Function Check

INFOID:000000005624248

1.CHECK FUNCTION

1. Use CONSULT-III to perform BCM "Active Test" ("OUTSIDE BUZZER").
2. Touch "ON" to check that it works normally.

Is the inspection result normal?

- YES >> Intelligent Key warning buzzer is OK.
NO >> Refer to [DLK-106, "Diagnosis Procedure"](#).

Diagnosis Procedure

INFOID:000000005624249

1.CHECK FUSE

1. Turn ignition switch OFF.
2. Check 10 A fuse, [No.6, located in fuse block (J/B)].

Is the inspection result normal?

- YES >> GO TO 2.
NO >> Replace the blown fuse after repairing the affected circuit if a fuse is blown.

2.CHECK INTELLIGENT KEY WARNING BUZZER POWER SUPPLY CIRCUIT

1. Disconnect Intelligent Key warning buzzer connector.
2. Check voltage between Intelligent Key warning buzzer harness connector and ground.

(+)		(-)	Voltage (V) (Approx.)
Connector	Terminal		
E57	1	Ground	Battery voltage

Is the inspection result normal?

- YES >> GO TO 3.
NO >> Repair or replace harness.

3.CHECK INTELLIGENT KEY WARNING BUZZER CIRCUIT

1. Disconnect BCM connector.
2. Check continuity between BCM harness connector and Intelligent Key warning buzzer harness connector.

BCM		Intelligent Key warning buzzer		Continuity
Connector	Terminal	Connector	Terminal	
M121	64	E57	3	Existed

3. Check continuity between BCM harness connector and ground.

BCM		Ground	Continuity
Connector	Terminal		
M121	64		Not existed

Is the inspection result normal?

- YES >> GO TO 4.
NO >> Repair or replace harness.

4.CHECK INTELLIGENT KEY WARNING BUZZER

Refer to [DLK-107, "Component Inspection"](#).

INTELLIGENT KEY WARNING BUZZER

< DTC/CIRCUIT DIAGNOSIS >

Is the inspection result normal?

- YES >> Replace BCM. Refer to [BCS-79, "Removal and Installation"](#).
NO >> Replace Intelligent Key warning buzzer. Refer to [DLK-316, "Removal and Installation"](#).

Component Inspection

INFOID:0000000005624250

1. CHECK INTELLIGENT KEY WARNING BUZZER

1. Turn ignition switch OFF.
2. Disconnect Intelligent Key warning buzzer connector.
3. Connect battery power supply directly to Intelligent Key warning buzzer terminals and check the operation.

Intelligent Key warning buzzer		Operation
Terminal		
(+)	(-)	
1	3	Buzzer sounds

Is the inspection result normal?

- YES >> INSPECTION END
NO >> Replace Intelligent Key warning buzzer. Refer to [DLK-316, "Removal and Installation"](#).

A
B
C
D
E
F
G
H
I
J
L
M
N
O
P

DLK

INTELLIGENT KEY

< DTC/CIRCUIT DIAGNOSIS >

INTELLIGENT KEY

Description

INFOID:000000005624251

The following functions are available when having and carrying electronic ID.

- Door lock/unlock
- Engine start

Remote control entry function and panic alarm function are available when operating on button.

Component Function Check

INFOID:000000005624252

1. CHECK FUNCTION

Check ("RKE OPE COUN1") in BCM "Data Monitor" mode using CONSULT-III.

Monitor item	Condition
RKE OPE COUN1	Check that the numerical value is changing while operating on the Intelligent Key

Is the inspection result normal?

- YES >> Intelligent Key is OK.
NO >> Refer to [DLK-108, "Diagnosis Procedure"](#).

Diagnosis Procedure

INFOID:000000005624253

1. CHECK INTELLIGENT KEY BATTERY

Check by connecting a resistance (approximately 300Ω) so that the current value becomes about 10 mA. Refer to [DLK-321, "Removal and Installation"](#).

Standard : Approx. 2.5 - 3.0V

Is the measurement value within the specification?

- YES >> Replace Intelligent Key.
NO >> Replace Intelligent Key battery.

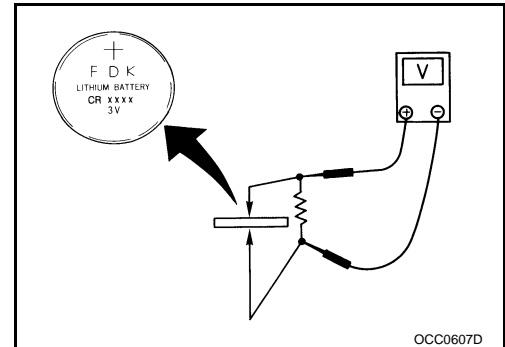

KEY SLOT

< DTC/CIRCUIT DIAGNOSIS >

KEY SLOT

Description

INFOID:0000000005624254

- Detects whether Intelligent Key is inserted.
- Immobilizer antenna amp checks Intelligent Key transponder.

Component Function Check

INFOID:0000000005624255

1.CHECK FUNCTION

Check ("KEY SW -SLOT") in BCM "Data Monitor" mode using CONSULT-III.

Monitor item	Condition		Status
KEY SW-SLOT	Intelligent Key	Inserted in key slot	ON
		Removed from key slot	OFF

Is the inspection result normal?

YES >> Key slot is OK.

NO >> Refer to [DLK-109, "Diagnosis Procedure"](#).

Diagnosis Procedure

INFOID:0000000005624256

1.CHECK FUSE

1. Turn ignition switch OFF.
2. Check 10 A fuse, [No.9, located in fuse block (J/B)].

Is the inspection result normal?

YES >> GO TO 2.

NO >> Replace the blown fuse after repairing the affected circuit if a fuse is blown.

2.CHECK KEY SLOT POWER SUPPLY CIRCUIT

1. Disconnect key slot connector.
2. Check voltage between key slot harness connector and ground.

(+)		(-)	Voltage (V) (Approx.)
Key slot			
Connector	Terminal	Ground	Battery voltage
M22	1		

Is the inspection result normal?

YES >> GO TO 3.

NO >> Repair or replace harness.

3.CHECK KEY SLOT CIRCUIT

1. Disconnect BCM connector.
2. Check continuity between BCM harness connector and key slot harness connector.

BCM		Key slot		Continuity
Connector	Terminal	Connector	Terminal	
M123	121	M22	11	Existed

3. Check continuity between BCM harness connector and ground.

BCM		Ground	Continuity
Connector	Terminal		
M123	121		Not existed

Is the inspection result normal?

YES >> GO TO 4.

A
B
C
D
E
F
G
H
I
J
L
M
N
O
P

DLK

KEY SLOT

< DTC/CIRCUIT DIAGNOSIS >

NO >> Repair or replace harness.

4.CHECK KEY SLOT

Refer to [DLK-110, "Component Inspection"](#).

Is the inspection result normal?

YES >> Replace BCM. Refer to [BCS-79, "Removal and Installation"](#).

NO >> Replace key slot. Refer to [SEC-211, "Removal and Installation"](#).

Component Inspection

INFOID:000000005624257

1.CHECK KEY SLOT

1. Turn ignition switch OFF.
2. Disconnect key slot connector.
3. Check continuity between key slot terminals.

Key slot		Condition		Continuity
Terminal				
1	11	Intelligent Key	Inserted in key slot	Existed
			Removed in key slot	Not existed

Is the inspection result normal?

YES >> INSPECTION END

NO >> Replace key slot. Refer to [SEC-211, "Removal and Installation"](#).

KEY SLOT INDICATOR

< DTC/CIRCUIT DIAGNOSIS >

KEY SLOT INDICATOR

Description

INFOID:0000000005624258

Blinks when Intelligent Key insertion is required.

Component Function Check

INFOID:0000000005624259

1.CHECK FUNCTION

1. Use CONSULT-III to perform BCM "Active Test" ("KEY SLOT ILLUMI").
2. Touch "ON" to check that it works normally.

Is the inspection result normal?

- YES >> Key slot is OK.
NO >> Refer to [DLK-111, "Diagnosis Procedure"](#).

Diagnosis Procedure

INFOID:0000000005624260

1.CHECK FUSE

1. Turn ignition switch OFF.
2. Check 10 A fuse, [No. 6, located in fuse block (J/B)].

Is the inspection result normal?

- YES >> GO TO 2.
NO >> Replace the blown fuse after repairing the affected circuit if a fuse is blown.

2.CHECK KEY SLOT POWER SUPPLY CIRCUIT

1. Disconnect key slot connector.
2. Check voltage between key slot harness connector and ground.

(+)		(-)	Voltage (V) (Approx.)
Key slot			
Connector	Terminal	Ground	Battery voltage
M22	5		

Is the inspection result normal?

- YES >> GO TO 3.
NO >> Repair or replace harness.

3.CHECK KEY SLOT CIRCUIT

1. Disconnect BCM connector.
2. Check continuity between BCM harness connector and key slot harness connector.

BCM		Key slot		Continuity
Connector	Terminal	Connector	Terminal	
M122	92	M22	6	Existed

3. Check continuity between BCM harness connector and ground.

BCM		Ground	Continuity
Connector	Terminal		
M122	92		Not existed

Is the inspection result normal?

- YES >> GO TO 4.
NO >> Repair or replace harness.

4.CHECK KEY SLOT

Refer to [DLK-112, "Component Inspection"](#).

A
B
C
D
E
F
G
H
I
J
L
M
N
O
P

DLK

KEY SLOT INDICATOR

< DTC/CIRCUIT DIAGNOSIS >

Is the inspection result normal?

- YES >> Replace BCM. Refer to [BCS-79, "Removal and Installation"](#).
NO >> Replace key slot. Refer to [SEC-211, "Removal and Installation"](#).

Component Inspection

INFOID:000000005624261

1. CHECK KEY SLOT INDICATOR

1. Turn ignition switch OFF.
2. Disconnect key slot connector.
3. Connect battery power supply directly to key slot terminals and check the operation.

Terminal		Operation
Key slot		
(+)	(-)	Key slot illuminates
5	6	

Is the inspection result normal?

- YES >> INSPECTION END
NO >> Replace key slot. Refer to [SEC-211, "Removal and Installation"](#).

COMBINATION METER DISPLAY FUNCTION

< DTC/CIRCUIT DIAGNOSIS >

COMBINATION METER DISPLAY FUNCTION

Description

INFOID:0000000005624262

Displays each operation method guide and warning for system malfunction.

Component Function Check

INFOID:0000000005624263

1.CHECK FUNCTION

1. Use CONSULT-III to perform BCM "Active Test" ("LCD").
2. Check each warning display on meter display.

Is the inspection result normal?

- YES >> Combination meter display function is OK.
NO >> Refer to [DLK-113, "Diagnosis Procedure"](#).

Diagnosis Procedure

INFOID:0000000005624264

1.CHECK COMBINATION METER

Refer to [MWI-4, "Work flow"](#).

Is the inspection result normal?

- YES >> GO TO 2.
NO >> Repair or replace the malfunctioning parts.

2.CHECK INTERMITTENT INCIDENT

Refer to [GI-37, "Intermittent Incident"](#).

>> INSPECTION END

A
B
C
D
E
F
G
H
I
J
L
M
N
O
P

DLK

BUZZER (COMBINATION METER)

< DTC/CIRCUIT DIAGNOSIS >

BUZZER (COMBINATION METER)

Description

INFOID:000000005624265

Performs operation method guide and warning with buzzer.

Component Function Check

INFOID:000000005624266

1.CHECK FUNCTION

1. Use CONSULT-III to perform BCM "Active Test" ("INSIDE BUZZER").
2. Touch "TAKE OUT", "KNOB" or "KEY" to check that it works normally.

Is the inspection result normal?

- Yes >> Warning buzzer into combination meter is OK.
- No >> Refer to [DLK-114, "Diagnosis Procedure"](#).

Diagnosis Procedure

INFOID:000000005624267

1.CHECK METER BUZZER CIRCUIT

Refer to [WCS-22, "Component Function Check"](#).

Is the inspection result normal?

- Yes >> GO TO 2.
- No >> Repair or replace the malfunctioning parts.

2.CHECK INTERMITTENT INCIDENT

Refer to [GI-37, "Intermittent Incident"](#).

>> INSPECTION END

KEY WARNING LAMP

< DTC/CIRCUIT DIAGNOSIS >

KEY WARNING LAMP

Description

INFOID:0000000005624268

Performs operation method guide and warning together with buzzer.

Component Function Check

INFOID:0000000005624269

1.CHECK FUNCTION

1. Use CONSULT-III to perform BCM "Active Test" ("INDICATOR").
2. Touch "KEY IND" or "KEY ON" to check that it works normally.

Is the inspection result normal?

- YES >> Key warning lamp is OK.
NO >> Refer to [DLK-115, "Diagnosis Procedure"](#).

Diagnosis Procedure

INFOID:0000000005624270

1.CHECK KEY WARNING LAMP

Refer to [MWI-4, "Work flow"](#).

Is the inspection result normal?

- YES >> GO TO 2.
NO >> Repair or replace the malfunctioning parts.

2.CHECK INTERMITTENT INCIDENT

Refer to [GI-37, "Intermittent Incident"](#).

>> INSPECTION END

A
B
C
D
E
F
G
H
I
J
L
M
N
O
P

DLK

HAZARD FUNCTION

< DTC/CIRCUIT DIAGNOSIS >

HAZARD FUNCTION

Description

INFOID:000000005624271

Performs answer-back for each operation with number of blinks.

Component Function Check

INFOID:000000005624272

1.CHECK FUNCTION

1. Use CONSULT-III to perform BCM "Active Test" ("FLASHER").
2. Touch "LH" or "RH" to check that it works normally.

Is the inspection result normal?

- YES >> Hazard warning lamp circuit is OK.
NO >> Refer to [DLK-116, "Diagnosis Procedure"](#).

Diagnosis Procedure

INFOID:000000005624273

1.CHECK HAZARD SWITCH CIRCUIT

Refer to [EXL-99, "Symptom Table"](#).

Is the inspection result normal?

- YES >> GO TO 2.
NO >> Repair or replace the malfunctioning parts.

2.CHECK INTERMITTENT INCIDENT

Refer to [GI-37, "Intermittent Incident"](#).

>> INSPECTION END

INTEGRATED HOMELINK TRANSMITTER

< DTC/CIRCUIT DIAGNOSIS >

INTEGRATED HOMELINK TRANSMITTER

Description

INFOID:000000005624274

- Integrated homelink transmitter can store and transmit a maximum of 3 radio signals.
- Allows operation of garage doors, gates, home and office lighting, entry door locks and security system, etc.
- Integrated homelink transmitter power supply uses vehicle battery, which enables it to maintain every program in case battery is discharged or removed.

Component Function Check

INFOID:000000005624275

1.CHECK FUNCTION

Check that system receiver (garage door opener, etc.) operates with original hand-held transmitter.

Is the inspection result normal?

- YES >> GO TO 2.
 NO >> Receiver or hand-held transmitter is malfunctioning.

2.CHECK ILLUMINATE

1. Turn ignition switch OFF.
2. Does red light of transmitter illuminate when any transmitter button is pressed?

Is the inspection result normal?

- YES >> GO TO 3.
 NO >> Refer to [DLK-117. "Diagnosis Procedure"](#).

3.CHECK TRANSMITTER

Check transmitter using Tool*.

*:For details, refer to Technical Service Bulletin.

Is the inspection result normal?

- YES >> Receiver or hand-held transmitter malfunction, not vehicle related.
 NO >> Replace auto anti-dazzling inside mirror (integrated homelink transmitter). Refer to [MIR-18. "Removal and Installation"](#).

Diagnosis Procedure

INFOID:000000005624276

1.CHECK POWER SUPPLY

1. Turn ignition switch OFF.
2. Disconnect auto anti-dazzling inside mirror (integrated homelink transmitter) connector.
3. Check voltage between auto anti-dazzling inside mirror (integrated homelink transmitter) harness connector and ground.

(+)		(-)	Condition	Voltage (V) (Approx.)
Connector	Terminal			
R3	10	Ground	Ignition switch position	OFF
			ON	Battery voltage

Is the inspection result normal?

- YES >> GO TO 2.
 NO-1 >> Check 10A fuse [No. 6 located in the fuse block (J/B)].
 NO-2 >> Harness for open or short between fuse and auto anti-dazzling inside mirror (integrated homelink transmitter).

2.CHECK GROUND CIRCUIT

Check continuity between auto anti-dazzling inside mirror (integrated homelink transmitter) harness connector and ground.

A
B
C
D
E
F
G
H
I
J
DLK

INTEGRATED HOMELINK TRANSMITTER

< DTC/CIRCUIT DIAGNOSIS >

Auto anti-dazzling inside mirror (Integrated homelink transmitter)		Ground	Continuity
Connector	Terminal		Existed
R3	8		

Is the inspection result normal?

YES >> GO TO 3.

NO >> Repair or replace harness.

3.CHECK INTERMITTENT INCIDENT

Refer to [GI-37, "Intermittent Incident"](#).

>> INSPECTION END

POWER DOOR LOCK SYSTEM

< DTC/CIRCUIT DIAGNOSIS >

POWER DOOR LOCK SYSTEM

Wiring Diagram - POWER DOOR LOCK SYSTEM -

INFOID:000000005624277

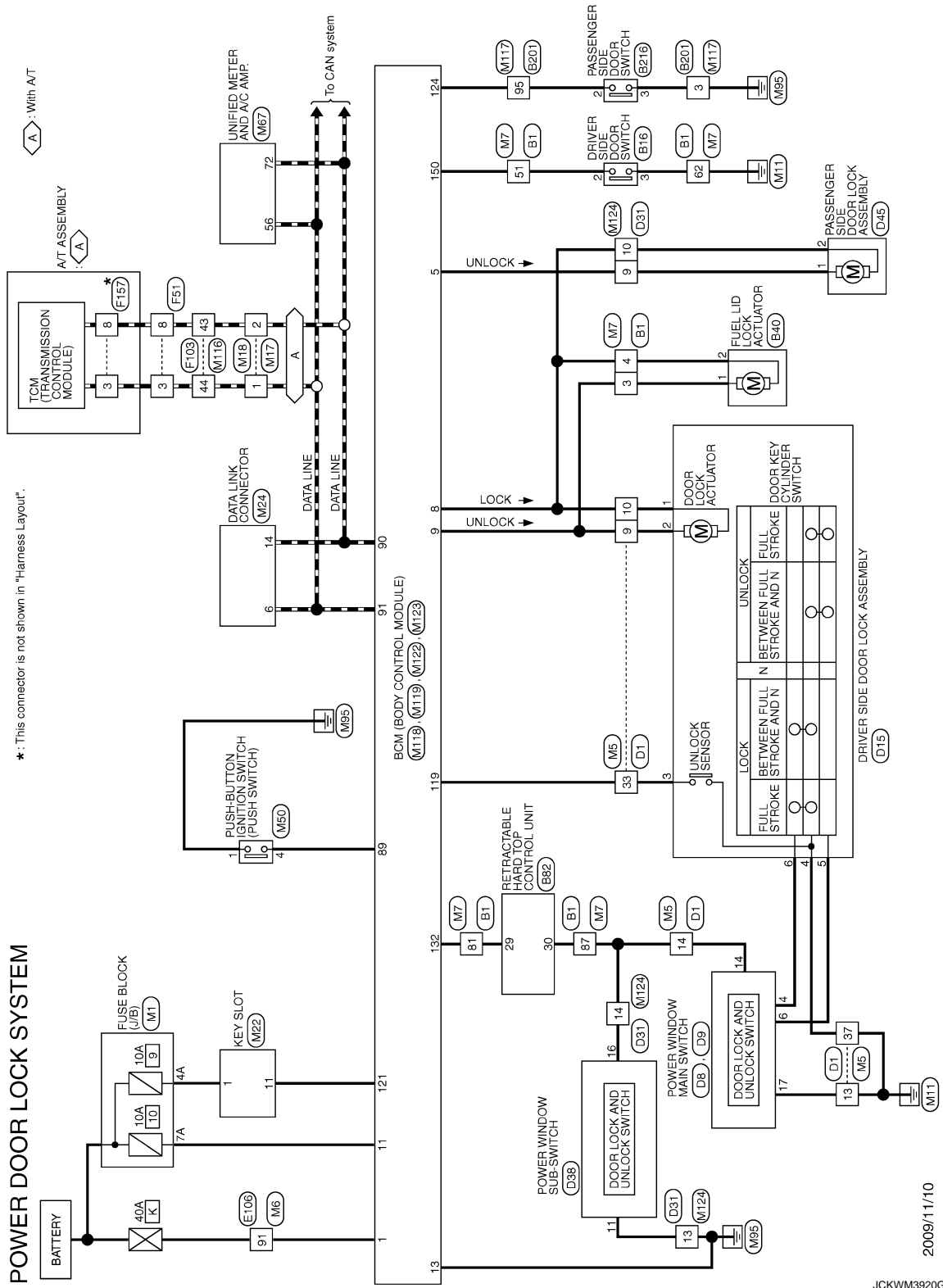

2009/11/10

JCKWM3920GI

A
B
C
D
E
F
G
H
I
J
K
L
M
N
O
P

DLK

POWER DOOR LOCK SYSTEM

< DTC/CIRCUIT DIAGNOSIS >

POWER DOOR LOCK SYSTEM

Connector No.	B1
Connector Name	WIRE TO WIRE
Connector Type	TH00FW-C516-TM44



Terminal No.	Color of Wire	Signal Name [Specification]
1	W	-
2	L	-
3	R	-
4	V	-
5	W	-
6	B	-
8	G	-
10	BR	-
12	SHIELD	-
13	Y	-
14	L	-
15	R	-
16	W	-
17	BR	-
20	G	-
21	SB	-
22	GR	-
23	W	-
24	SB	-
25	BR	-
26	LG	-
27	Y	-
28	R	-
29	V	-
31	SHIELD	-
32	G	-
33	R	-
34	BG	-
35	GR	-
36	BR	-
37	P	- [With climate controlled seat]
37	Y	- [Without climate controlled seat]
38	V	- [With climate controlled seat]
38	GR	- [Without climate controlled seat]
40	SHIELD	-
41	L	-
42	P	-
43	SHIELD	-

Connector No.	B16
Connector Name	DRIVER SIDE DOOR SWITCH
Connector Type	A03FW

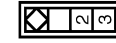

Terminal No.	Color of Wire	Signal Name [Specification]
2	SB	-
3	B	-

Connector No.	B40
Connector Name	FUEL LID LOCK ACTUATOR
Connector Type	M04FW-LC

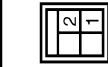

Terminal No.	Color of Wire	Signal Name [Specification]
1	R	-
2	V	-

Connector No.	B82
Connector Name	RETRACTABLE HARD TOP CONTROL UNIT
Connector Type	TH00FW-NH

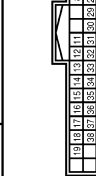

Terminal No.	Color of Wire	Signal Name [Specification]
1	G	ROOF OPEN / CLOSE SWITCH (OPEN)
2	BR	ROOF OPEN / CLOSE SWITCH (CLOSE)

3	B	FLIPPER DOOR LIMIT SWITCH GND
4	L	TONNEAU BOARD SWITCH
5	SB	TRUNK ROOM LAMP SWITCH
6	L	ROOF LATCH LIMIT SWITCH
7	W	FLIPPER DOOR LIMIT SWITCH (UP)
8	G	FLIPPER DOOR LIMIT SWITCH (DOWN)
11	W	RETAINED ACC POWER
12	Y	REVERSE SIGNAL
13	BG	PARCEL SHELF STATUS SENSOR POWER SUPPLY
14	P	TRUNK LINK SENSOR SIGNAL (LH)
15	SB	TRUNK LINK SENSOR SIGNAL (RH)
16	GR	ROOF LATCH STATUS SENSOR SIGNAL
17	G	ROOF LATCH LOCK SENSOR SIGNAL
18	LG	TRUNK STATUS SENSOR SIGNAL
22	V	ROOF STATUS SENSOR POWER SUPPLY
23	B	ROOF STATUS SENSOR GND
24	GR	PARCEL SHELF STATUS SENSOR SIGNAL (DRAW)
25	R	PARCEL SHELF STATUS SENSOR SIGNAL (ROTATION)
26	P	ROOF STATUS SENSOR SIGNAL
27	Y	TRUNK LID OPEN REQUEST SIGNAL
28	BG	FLIPPER DOOR RELAY GND
29	V	LOCAL COMMUNICATION (BGM)
30	GR	LOCAL COMMUNICATION (POWER WINDOW)
31	L	CAN-H
32	P	CAN-L
33	V	ROOF STATUS SIGNAL (AUDIO)
34	R	ROOF STATUS SIGNAL (TRUNK)
35	B	ROOF WARNING BUZZER
36	Y	HYDRAULIC MOTOR RELAY GND (RH)
37	W	HYDRAULIC MOTOR RELAY GND (LH)
38	BR	HYDRAULIC MOTOR RELAY POWER SUPPLY

POWER DOOR LOCK SYSTEM

< DTC/CIRCUIT DIAGNOSIS >

POWER DOOR LOCK SYSTEM

Connector No.	B201
Connector Name	WIRE TO WIRE
Connector Type	TH80PW-CS16-TM4

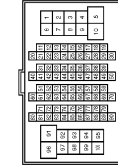

Terminal No.	Color of Wire	Signal Name [Specification]
1	W	
3	B	
5	W	
6	R	
7	B	
7	O	[With climate controlled seat]
8	BG	
9	GR	
10	LG	
40	GR	
41	LG	
42	BG	
43	R	
44	SHIELD	
45	G	
47	G	
48	Y	
49	SHIELD	
50	P	
51	SB	
52	LG	
53	L	
54	G	
55	GR	
56	LG	
57	G	
58	R	
67	L	
68	P	
80	G	
81	R	
82	W	
83	B	
84	SHIELD	
85	O	
86	BR	
87	Y	
88	SHIELD	

89	SB	
90	V	
91	GR	
92	P	[With BOSE system]
92	Y	[Without BOSE system]
93	L	
94	SB	
95	V	
96	P	
97	L	[With BOSE system]
97	LG	[Without BOSE system]
98	Y/B	
99	Y	

Connector No.	B216
Connector Name	PASSENGER SIDE DOOR SWITCH
Connector Type	A03PW

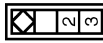

Terminal No.	Color of Wire	Signal Name [Specification]
2	V	
3	B	

Connector No.	D1
Connector Name	WIRE TO WIRE
Connector Type	TH40PW-CS15

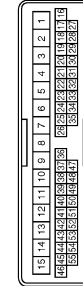

Terminal No.	Color of Wire	Signal Name [Specification]
4	BR	
5	P	[With A/T]
5	B	[With M/T]
6	SR	
7	R	

Connector No.	D8
Connector Name	POWER WINDOW MAIN SWITCH
Connector Type	NS38PW-CS

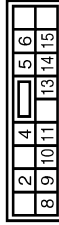

Terminal No.	Color of Wire	Signal Name [Specification]
2	G	
4	V	
5	BR	
6	W	
8	L	
9	W	
10	SB	
11	BR	
13	R	
14	V	
15	O	

Connector No.	D9
Connector Name	POWER WINDOW MAIN SWITCH
Connector Type	NS303PW-CS



Terminal No.	Color of Wire	Signal Name [Specification]
17	B	
19	Y	

8	G	
9	P	
10	LG	
11	W	
12	L	
13	B	
14	V	
15	Y	
16	Y/B	
17	Y	
20	V	
21	R	
22	P	
23	O	
24	Y	
25	SB	
26	GR	
27	GR	
28	LG	
28	G	
30	Y	
31	W	
32	BR	
33	L	
34	R	
35	V	
37	B	
38	O	
39	GR	
40	G	
41	Y	
42	LG	
43	BR	
44	V	
45	P	
46	W	
47	V	
48	P	
49	W	
50	SB	
51	R	
52	L	

A
B
C
D
E
F
G
H
I
J
K
L
M
N
O
P

DLK

JCKWM3922G1

POWER DOOR LOCK SYSTEM

< DTC/CIRCUIT DIAGNOSIS >

POWER DOOR LOCK SYSTEM

Connector No.	D15
Connector Name	DRIVER SIDE DOOR LOCK ASSEMBLY
Connector Type	ED0FCY-RS



Terminal No.	Color of Wire	Signal Name [Specification]
1	LG	-
2	P	-
3	L	-
4	B	-
5	W	-
6	Y	-

Connector No.	D31
Connector Name	WIRE TO WIRE
Connector Type	TH00FW-CS15

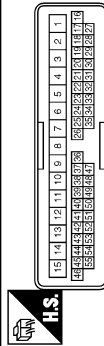

Terminal No.	Color of Wire	Signal Name [Specification]
6	BR	-
7	R	-
8	G	-
9	P	-
10	LG	-
11	W	-
12	L	-
13	B	-
14	Y	-
15	W	-
34	Y	-
35	Y/B	-
38	O	-
39	GR	-
40	G	-
41	Y	-

42	LG	-
43	BR	-
44	V	-
45	P	-
46	W	-
47	V	-
48	P	-
49	W	-
50	SB	-
51	R	-
52	L	-
53	O	-
54	GR	-
55	G	-

Connector No.	D38
Connector Name	POWER WINDOW SUB-SWITCH
Connector Type	NS10FW-CS

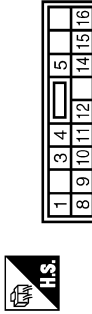

Terminal No.	Color of Wire	Signal Name [Specification]
3	G	-
4	O	-
8	L	-
9	V	-
10	W	-
11	B	-
12	R	-
14	BR	-
15	SB	-
16	Y	-

Connector No.	D45
Connector Name	PASSENGER SIDE DOOR LOCK ASSEMBLY
Connector Type	ED0FCY-RS



Terminal No.	Color of Wire	Signal Name [Specification]
1	P	-
2	LG	-

Connector No.	E106
Connector Name	WIRE TO WIRE
Connector Type	TH00FW-CS16-TM4

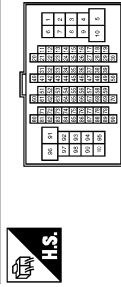

Terminal No.	Color of Wire	Signal Name [Specification]
1	GR	-
3	BG	-
4	B/W	-
5	G	-
8	BG	-
7	LG	-
10	W	-
11	V	-
12	R	-
13	L	-
14	GR	-
15	P	-
16	W	-
17	V	-
18	BG	-
19	GR	-
20	LG	-
30	R	-
31	L	-

32	BG	-
33	P	-
34	V	-
35	BR	-
36	W	-
37	Y	-
38	R	-
39	B	-
40	G	-
41	W	-
42	LG	-
43	SB	-
44	GR	-
45	BG	-
46	LG	-
47	V	-
48	P	-
49	L	-
59	B	-
66	LG	-
67	SB	-
68	R	-
69	W	-
70	G	-
80	W	-
81	P	-
82	G	-
83	V	-
84	L	-
85	BG	-
86	LG	-
87	Y	-
88	GR	-
89	W	-
90	W	-
91	G	-
92	B	-
93	GR	-
94	L	-
95	Y	-
97	BR	-
98	SHIELD	-
99	L	-
100	P	-

JCKWMM3923G1

POWER DOOR LOCK SYSTEM

< DTC/CIRCUIT DIAGNOSIS >

POWER DOOR LOCK SYSTEM

Connector No.	F51
Connector Name	A/T ASSEMBLY
Connector Type	RK10FG-DCY

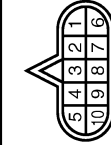

Terminal No.	Color of Wire	Signal Name [Specification]
1	Y	-
2	R	-
3	L	-
4	V	-
5	B	-
6	Y	-
7	R	-
8	P	-
9	GR	-
10	B	-

Connector No.	F103
Connector Name	WIRE TO WIRE
Connector Type	TK36FW-NS10

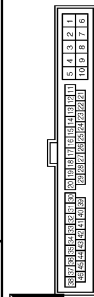

Terminal No.	Color of Wire	Signal Name [Specification]
2	G	-
3	W	-
4	R	-
5	B	-
9	Y	-
10	GR	-
19	O	-
20	Y	-
28	B	-
29	LG	-
30	R	-
31	R	-

41	O	-
42	BR	-
43	P	-
44	L	-
45	Y	-
46	V	-

Connector No.	F157
Connector Name	TCM (TRANSMISSION CONTROL MODULE)
Connector Type	SPT0FG

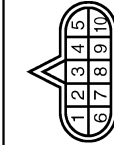

Terminal No.	Color of Wire	Signal Name [Specification]
1	W	VIGN
2	B	BATT
3	R	CAN-H
4	O	K-LINE
5	G	GND
6	GR	VIGN
7	L	REV LAMP RLY
8	BR	CAN-L
9	Y	STARTER RLY
10	W/B	GND

Connector No.	M1
Connector Name	FUSE BLOCK (J/B)
Connector Type	NS06FW-M2



Terminal No.	Color of Wire	Signal Name [Specification]
1A	V	-
2A	G	-
3A	L	-
4A	P	-

5A	BR	-
6A	Y	-
7A	GR	-
8A	L	-

Connector No.	M5
Connector Name	WIRE TO WIRE
Connector Type	TH04MW-CS15

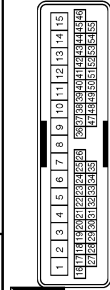

Terminal No.	Color of Wire	Signal Name [Specification]
4	R	-
5	B	-
6	BG	-
7	W	-
8	B	-
9	G	-
10	V	-
11	W	-
12	L	-
13	B	-
14	GR	-
15	Y	-
16	Y/B	-
17	Y	-
20	BG	-
21	W	-
22	P	-
23	BG	-
24	V	-
25	BR	-
26	R	-
27	P	-
28	LG	-
29	SB	-
30	G	-
31	V	-
32	BR	-
33	GR	-
34	G	-
35	L	-
37	B	-
38	G	- [With automatic drive positioner]

38	L	- [Without automatic drive positioner]
39	BR	- [With automatic drive positioner]
39	L	- [Without automatic drive positioner]
40	Y	-
41	BR	- [With automatic drive positioner]
41	G	- [Without automatic drive positioner]
42	R	-
43	G	-
44	Y	-
45	GR	-
46	BR	-
47	V	-
48	LG	-
49	P	-
50	SB	-
51	GR	-
52	L	-

A
B
C
D
E
F
G
H
I
J
K
L
M
N
O
P

DLK

POWER DOOR LOCK SYSTEM

< DTC/CIRCUIT DIAGNOSIS >

POWER DOOR LOCK SYSTEM

Connector No.	M6
Connector Name	WIRE TO WIRE
Connector Type	TH80MW-CS16-TM4



Terminal No.	Color of Wire	Signal Name [Specification]
1	BG	-
2	R	-
3	R	-
4	G	-
5	G	-
6	BR	-
7	BR	-
8	Y	-
9	W	-
10	W	-
11	GR	-
12	R	-
13	L	-
14	G	-
15	P	-
16	W	-
17	BR	-
18	V	-
19	BG	-
20	L	-
30	R	-
31	L	-
32	Y	-
33	GR	-
34	P	-
35	BR	-
36	BR	-
37	Y	-
38	LG	-
39	SB	-
40	G	-
41	W	-
42	LG	-
43	P	-
44	W	-
45	BG	-
46	G	-
47	G	-
48	R	-
49	BG	-
50	LG	-
51	P	-
52	Y	-
53	LG	-
54	G	-
55	BG	-
56	LG	-
57	P	-
58	GR	-
59	R	-
60	BG	-
61	G	-
62	B	-
63	L	-
64	BR	-
65	P	-

49	L	-
59	B	-
66	Y	-
67	G	-
68	R	-
69	W	-
70	G	-
80	SB	-
81	R	-
82	V	-
83	W	-
84	L	-
85	BG	-
86	G	-
87	V	-
88	B	-
89	SB	-
90	G	-
91	W	-
92	B	-
93	G	-
94	L	-
95	BR	-
97	P	-
98	SHIELD	-
99	V	-
100	SB	-

Connector No.	M7
Connector Name	WIRE TO WIRE
Connector Type	TH80MW-CS16-TM4

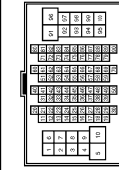

Terminal No.	Color of Wire	Signal Name [Specification]
1	BG	-
2	LG	-
3	G	-
4	V	-
5	L	-
6	B	-
9	L	-
10	BR	-
12	SHIELD	-

66	Y	-
67	P	-
68	L	-
69	P	-
70	L	-
80	G	-
81	LG	-
82	Y	-
83	BR	-
84	V	-
85	L	-
86	Y	-
87	GR	-
91	R	-
93	G	-
94	P	-
95	GR	-
96	Y	-
97	SB	-
99	Y	-
100	Y/B	-

Connector No.	M17
Connector Name	WIRE TO WIRE
Connector Type	TK02FW



Terminal No.	Color of Wire	Signal Name [Specification]
1	L	-
2	P	-

13	V	-
14	BR	-
15	GR	-
16	LG	-
17	L	-
20	BR	-
21	G	-
22	R	-
23	SB	-
24	B	-
25	W	-
26	L	-
27	V	-
28	P	-
29	V	-
31	SHIELD	-
32	G	-
33	R	-
34	BG	-
35	GR	-
36	BR	-
37	P	-
37	L	-
38	V	-
38	GR	-
40	SHIELD	-
41	L	-
42	P	-
43	SHIELD	-
44	Y	-
45	BR	-
46	SB	-
47	SB	-
48	LG	-
48	LG	-
49	SB	-
50	SB	-
50	LG	-
51	R	-
52	V	-
53	P	-
54	BR	-
55	Y	-
55	BG	-
56	L	-
57	V	-
60	LG	-
61	BG	-
62	B	-
63	V	-
64	SR	-
65	BR	-

POWER DOOR LOCK SYSTEM

< DTC/CIRCUIT DIAGNOSIS >

POWER DOOR LOCK SYSTEM

Connector No.	M1B
Connector Name	WIRE TO WIRE
Connector Type	TK22NW



Terminal No.	Color of Wire	Signal Name [Specification]
1	L	
2	P	

Connector No.	M22
Connector Name	KEY SLOT
Connector Type	TH12FW-NH

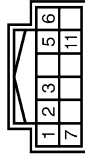

Terminal No.	Color of Wire	Signal Name [Specification]
1	V	BAT
2	GR	CLOCK
3	W	DATA
5	Y	ILL BAT
6	LG	ILL
7	B	GND
11	SB	KEY SWITCH SIGNAL

Connector No.	M24
Connector Name	DATA LINK CONNECTOR
Connector Type	BD1DFW

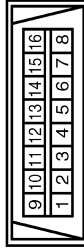

Terminal No.	Color of Wire	Signal Name [Specification]
3	LG	
4	B	
5	BR	
6	L	
7	V	
8	G	
11	SB	
14	P	
16	R	

Connector No.	M60
Connector Name	PUSH-BUTTON IGNITION SWITCH
Connector Type	TK08FR



Terminal No.	Color of Wire	Signal Name [Specification]
1	B	
2	W	
3	Y	
4	BR	
5	LG	
6	BG	
7	V	
8	P	

Connector No.	M67
Connector Name	UNIFIED METER AND A/C AMP.
Connector Type	TH52FW-NH

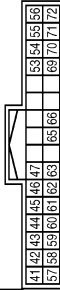

Terminal No.	Color of Wire	Signal Name [Specification]
41	BR	ACC POWER SUPPLY
42	BR	FUEL LEVEL SENSOR SIGNAL
43	R	INTAKE SENSOR SIGNAL
44	LG	IN-VEHICLE SENSOR SIGNAL
45	V	AMBIENT SENSOR SIGNAL
46	BG	SUNLOAD SENSOR SIGNAL
47	G	GAS SENSOR SIGNAL
53	W	IGNITION POWER SUPPLY
54	BG	BATTERY POWER SUPPLY
55	B	GROUND
56	L	GAN-H
57	LG	BRAKE FLUID LEVEL SWITCH SIGNAL
58	Y	FUEL LEVEL SENSOR SIGNAL
59	GR	INTAKE SENSOR GROUND
60	L	IN-VEHICLE SENSOR GROUND
61	R	AMBIENT SENSOR GROUND
62	SB	SUNLOAD SENSOR GROUND
63	L	ION CONTROL MODE OUTPUT SIGNAL
65	BG	ECV SIGNAL
68	L	A/C/LAN SIGNAL
70	R	EACH DOOR MOTOR POWER SUPPLY
71	GR	GROUND
72	P	GAN-L

Connector No.	M116
Connector Name	WIRE TO WIRE
Connector Type	TK38MW-NS10



Terminal No.	Color of Wire	Signal Name [Specification]
2	W	
3	BG	
4	R	
5	B	
9	R	
10	R	
19	BG	
20	Y	
28	GR	
29	LG	
30	LG	
31	W	
41	BG	
42	G	
43	P	
44	L	
45	G	
46	Y	

A
B
C
D
E
F
G
H
I
J
K
L
M
N
O
P

DLK

POWER DOOR LOCK SYSTEM

< DTC/CIRCUIT DIAGNOSIS >

POWER DOOR LOCK SYSTEM

Connector No.	M117
Wire to Wire	
Connector Name	THB0MW-CS (P-TM4)
Connector Type	

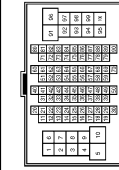

Terminal No.	Color of Wire	Signal Name [Specification]
1	Y	
3	B	
5	SB	
6	R	
7	G	
8	SB	
9	GR	
10	LG	
40	Y	
41	G	
42	LG	
43	R	
44	SHIELD	
45	G	
46	L	
48	SHIELD	
50	V	
51	SB	
52	BG	
53	L	
54	G	
55	Y	
56	LG	
57	SB	
58	LG	
67	SB	
68	LG	
80	W	
81	B	
82	R	
83	G	
84	SHIELD	
85	G	
86	L	
87	P	
88	SHIELD	
88	Y	

90	W	
91	GR	
92	P	
93	W	
94	BG	
95	BG	
96	P	
97	L	
98	Y/B	
99	Y	

Connector No.	M118
Connector Name	BCM (BODY CONTROL MODULE)
Connector Type	M03FB-LC



Terminal No.	Color of Wire	Signal Name [Specification]
1	W	BAT (F/L)
2	Y	POWER WINDOW POWER SUPPLY (BAT)
3	BG	POWER WINDOW POWER SUPPLY (RAP)

Connector No.	M119
Connector Name	BCM (BODY CONTROL MODULE)
Connector Type	NS10FW-CS



Terminal No.	Color of Wire	Signal Name [Specification]
4	LG	INTERIOR ROOM LAMP POWER SUPPLY
5	P	PASSENGER DOOR UNLOCK OUTPUT
7	SB	STEP LAMP
8	V	ALL DOOR FUEL LID LOCK OUTPUT
9	G	DRIVER DOOR FUEL LID UNLOCK OUTPUT
11	GR	BAT (FALSE)
13	B	GNL

14	W	PUSH-BUTTON IGNITION SW ILL GND
15	BG	ACC IND
17	BR	TURN SIGNAL RH (FRONT)
18	BG	TURN SIGNAL LH (FRONT)
19	V	ROOM LAMP-TIMER CONTROL

Connector No.	M122
Connector Name	BCM (BODY CONTROL MODULE)
Connector Type	TH40FB-NH



Terminal No.	Color of Wire	Signal Name [Specification]
72	R	ROOM ANT 2
73	G	ROOM ANT 2+
74	SB	PASSENGER DOOR ANT-
75	BR	PASSENGER DOOR ANT+
76	V	DRIVER DOOR ANT-
77	LG	DRIVER DOOR ANT+
78	Y	ROOM ANT 1
79	BR	ROOM ANT 1+
80	GR	NATS ANTRNNA AMP.
81	W	NATS ANTRNNA AMP.
82	R	IGN RELAY (F/B) CONT
83	Y	KEYLESS ENTRY RECEIVER COMM
87	Y	COMBI SW INPUT 5
88	BG	COMBI SW INPUT 3
89	BR	PUSH SW
90	P	CAN-L
91	L	CAN-H
92	LG	KEY SLOT ILL
93	V	ON IND
95	BG	ACC RELAY CONT
96	GR	A/T SHIFT SELECTOR POWER SUPPLY
97	L	S/L CONDITION 1
98	SB	S/L CONDITION 2
99	R	SHIFT P [With A/T]
99	R	ASD/CC CLUTCH SW [With M/T]
100	Y	PASSENGER DOOR REQUEST SW
101	P	DRIVER DOOR REQUEST SW
102	BG	BLOWER FAN MOTOR RELAY CONT
103	LG	KEYLESS ENTRY RECEIVER POWER SUPPLY
106	W	S/L UNIT POWER SUPPLY
107	LG	COMBI SW INPUT 1

108	R	COMBI SW INPUT 4
109	W	COMBI SW INPUT 2
110	G	HAZARD SW
111	Y	S/L UNIT COMM

Connector No.	M123
Connector Name	BCM (BODY CONTROL MODULE)
Connector Type	TH40FG-NH



Terminal No.	Color of Wire	Signal Name [Specification]
112	BR	RAIN SENSOR SERIAL LINK
113	G	OPTICAL SENSOR
114	R	CLUTCH INTERLOCK SW
116	SB	STOP LAMP SW 1
118	BR	STOP LAMP SW 2
119	GR	DR DOOR UNLOCK SENSOR
121	SB	KEY SLOT SW
123	W	IGN F/B
124	BG	PASSENGER DOOR SW
129	BG	TRUNK LID OPENER CANCEL SW
132	LG	P/W SW & RHT C/U COMM
133	Y	PUSH-BUTTON IGNITION SW ILL POWER
134	LG	LOCK IND
137	BG	RECEIVER / SENSOR GND
138	Y	RECEIVER / SENSOR POWER SUPPLY
139	L	TIRE PRESSURE RECEIVER COMM
140	GR	SHIFT N/P
141	R	SECURITY INDICATOR LAMP
142	BR	COMBI SW OUTPUT 5
143	V	COMBI SW OUTPUT 1
144	G	COMBI SW OUTPUT 2
145	L	COMBI SW OUTPUT 3
146	SB	COMBI SW OUTPUT 4
149	W	TIRE PRESSURE WARN CHECK SW
150	R	DRIVER DOOR SW
151	G	REAR WINDOW DEFOGGER RELAY CONT

POWER DOOR LOCK SYSTEM

< DTC/CIRCUIT DIAGNOSIS >

A
B
C
D
E
F
G
H
I
J
DLK
L
M
N
O
P

POWER DOOR LOCK SYSTEM

Connector No.	M124
Connector Name	WIRE TO WIRE
Connector Type	THRMW-CS 5

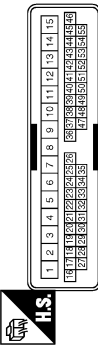

Terminal No.	Color of Wire	Signal Name [Specification]
6	BG	-
7	R	-
8	G	-
9	P	-
10	V	-
11	SB	- [With BOSE system]
11	GR	- [Without BOSE system]
12	BR	-
13	B	-
14	G	-
15	W	-
34	Y	-
35	Y/B	-
36	W	-
39	EG	-
40	SB	-
41	BR	- [With automatic drive positioner]
42	R	- [Without automatic drive positioner]
43	L	-
44	Y	-
45	R	-
46	W	-
47	SB	-
48	BR	-
49	Y	-
50	P	-
51	LG	-
52	EG	-
53	Y	-
54	L	-
55	L	-

JCKWM3928Gf

INTELLIGENT KEY SYSTEM

< DTC/CIRCUIT DIAGNOSIS >

INTELLIGENT KEY SYSTEM

Wiring Diagram - INTELLIGENT KEY SYSTEM -

INFOID:000000005624278

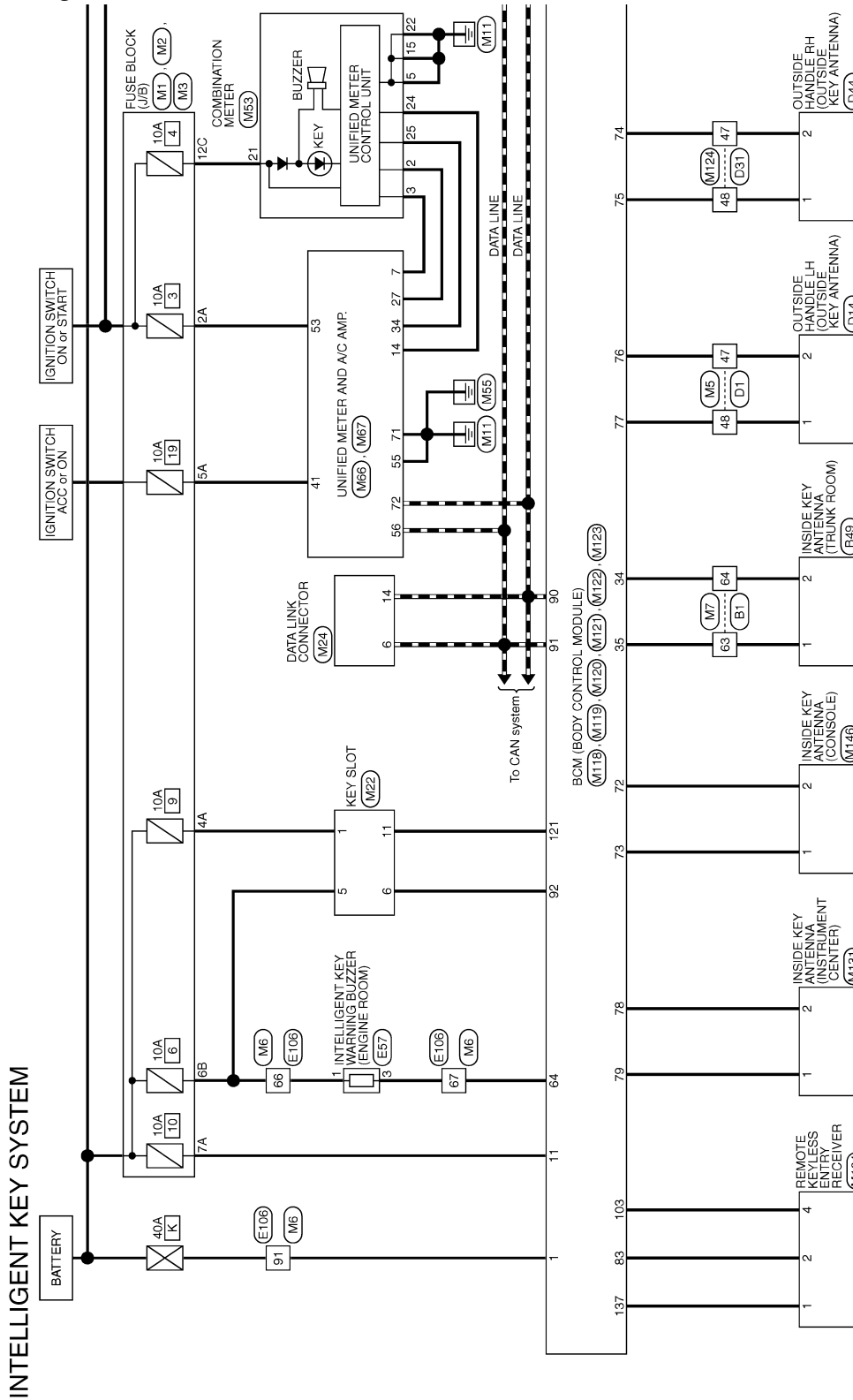

INTELLIGENT KEY SYSTEM

< DTC/CIRCUIT DIAGNOSIS >

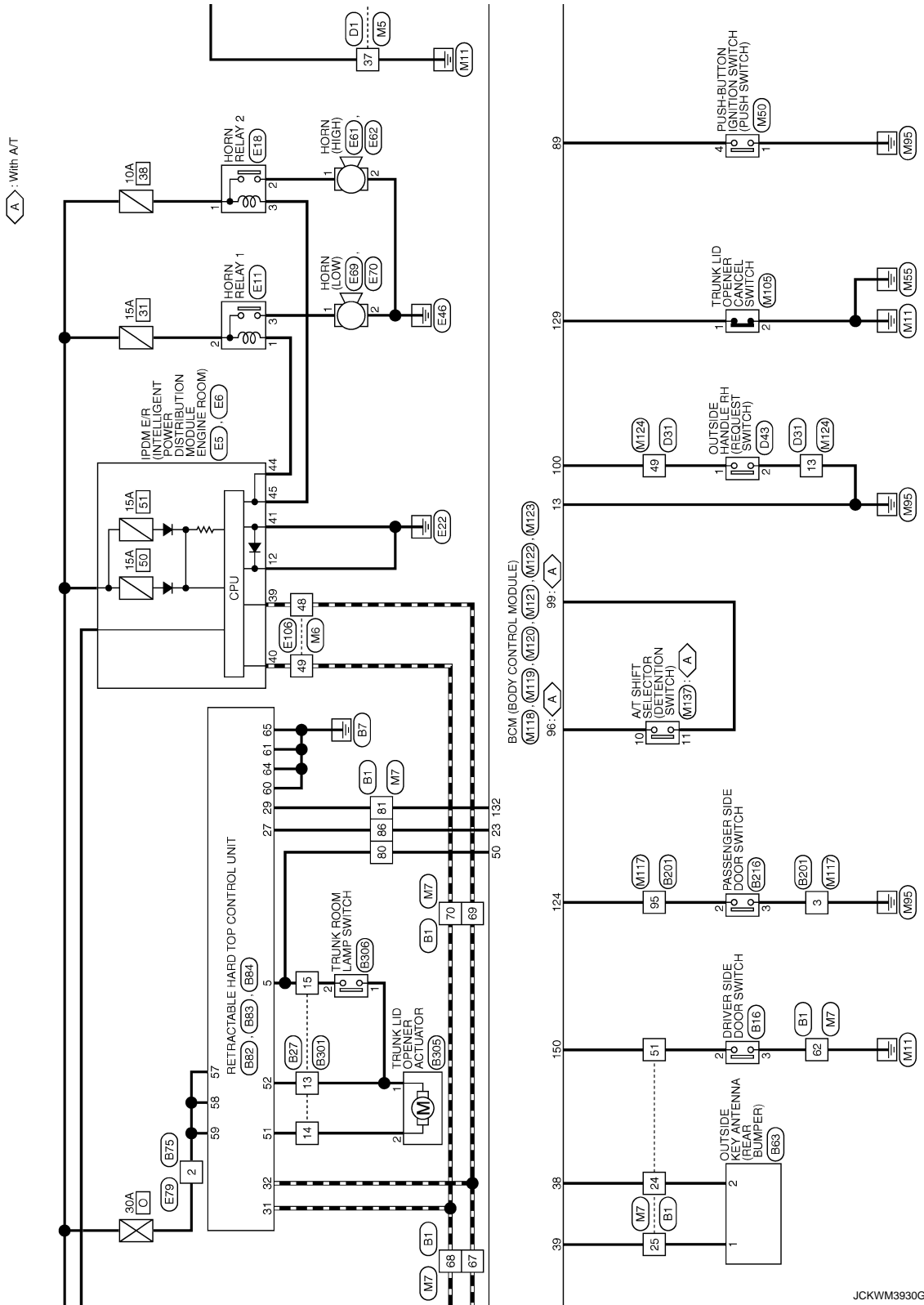

A
B
C
D
E
F
G
H
I
J
K
L
M
N
O
P

DLK

INTELLIGENT KEY SYSTEM

< DTC/CIRCUIT DIAGNOSIS >

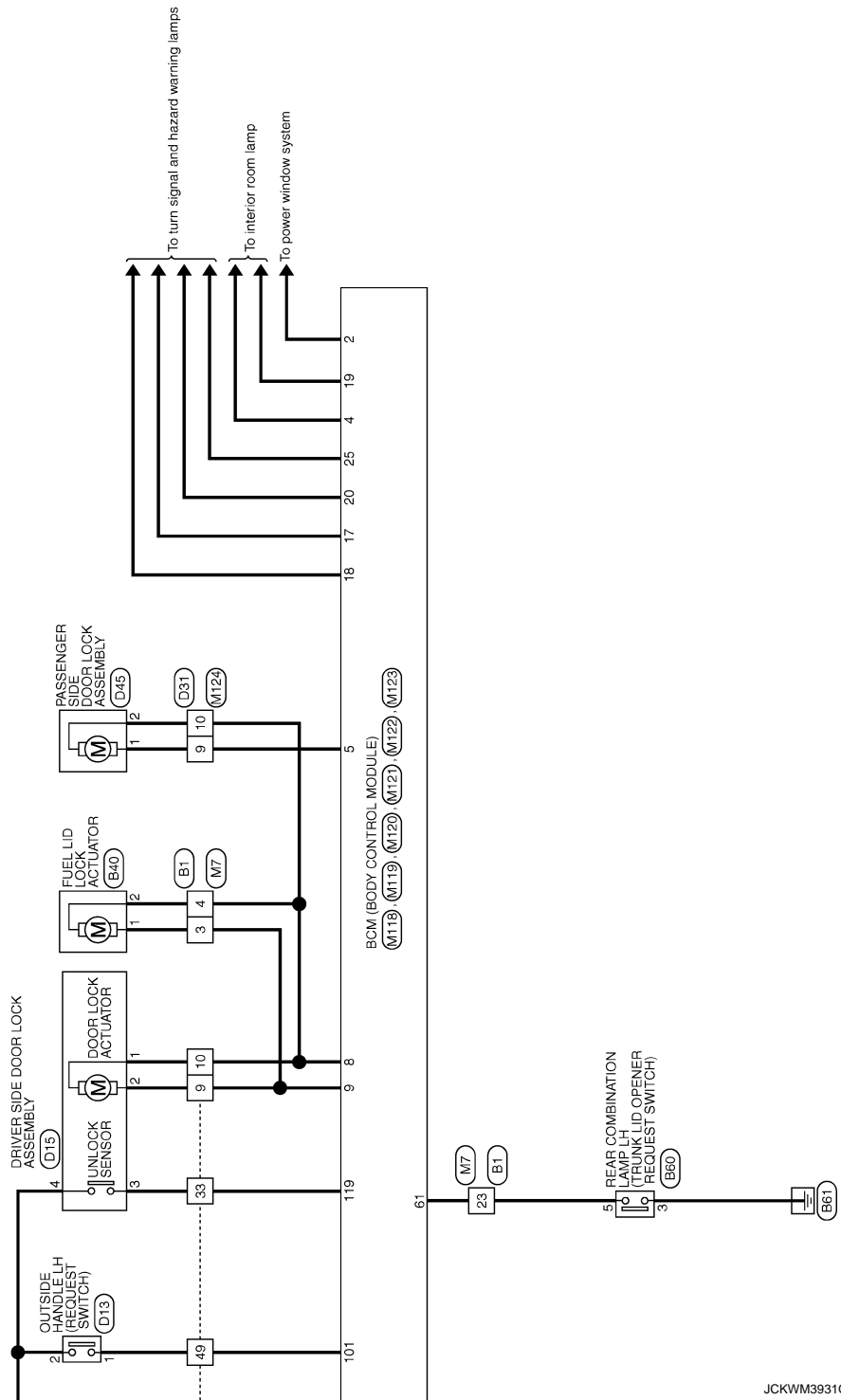

JCKWM3931G1

INTELLIGENT KEY SYSTEM

< DTC/CIRCUIT DIAGNOSIS >

INTELLIGENT KEY SYSTEM

Connector No.	B1
Connector Name	WIRE TO WIRE
Connector Type	TH80PW-CS16-TM4

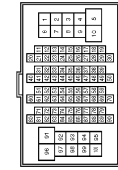

Terminal No.	Color of Wire	Signal Name [Specification]
1	W	
2	L	
3	R	
4	V	
5	W	
6	B	
7	G	
8	G	
9	G	
10	BR	
11	SHIELD	
12	Y	
13	Y	
14	L	
15	R	
16	W	
17	BR	
20	G	
21	SB	
22	GR	
23	W	
24	SB	
25	BR	
26	LG	
27	Y	
28	R	
29	V	
31	SHIELD	
32	G	
33	R	
34	BG	
35	GR	
36	BR	
37	P	- [With climate controlled seat]
37	Y	- [Without climate controlled seat]
38	V	- [With climate controlled seat]
38	GR	- [Without climate controlled seat]
40	SHIELD	
41	L	
42	P	
43	SHIELD	

44	SB	-
45	V	-
46	W	-
47	SB	-
48	LG	-
49	LG	- [With BOSE system]
49	Y	- [Without BOSE system]
50	SB	- [With BOSE system]
50	LG	- [Without BOSE system]
51	SB	-
52	G	-
53	LG	-
54	BR	-
55	Y	-
56	W	-
57	V	-
60	R	-
61	BG	-
62	B	-
63	L	-
64	P	-
65	B	-
66	SB	-
67	P	-
68	L	-
69	P	-
70	L	-
80	G	-
81	V	-
82	R	-
83	BR	-
84	G	-
85	L	-
86	Y	-
87	GR	-
91	R	-
93	BG	-
94	P	-
95	GR	-
96	GR	-
97	SR	-
99	Y	-
100	Y/B	-

Connector No.	B18
Connector Name	DRIVER SIDE DOOR SWITCH
Connector Type	A33PW



Terminal No.	Color of Wire	Signal Name [Specification]
2	SB	
3	B	

Connector No.	B27
Connector Name	WIRE TO WIRE
Connector Type	MS16MW-CS

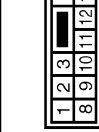

Terminal No.	Color of Wire	Signal Name [Specification]
1	BG	
2	P	
3	G	
4	W	
5	R	
6	P	
7	GR	
10	LG	
11	B	
12	B	
13	V	
14	SB	
15	L	
16	V	

Connector No.	B40
Connector Name	FUEL LID LOCK ACTUATOR
Connector Type	MS4FW-LC



Terminal No.	Color of Wire	Signal Name [Specification]
1	R	
2	V	

Connector No.	B49
Connector Name	INSIDE KEY ANTENNA (TRUNK ROOM)
Connector Type	FR02FGY



Terminal No.	Color of Wire	Signal Name [Specification]
1	L	
2	P	

JCKWM3932G1

A
B
C
D
E
F
G
H
I
J
DLK
L
M
N
O
P

INTELLIGENT KEY SYSTEM

< DTC/CIRCUIT DIAGNOSIS >

INTELLIGENT KEY SYSTEM

Connector No.	B60
Connector Name	REAR COMBINATION LAMP LH
Connector Type	NS08MW-CS



1	6
2	3
3	4
4	5

Terminal No.	Color of Wire	Signal Name [Specification]
1	G	-
2	R	-
3	B	-
4	LG	-
5	W	-
6	BG	-

Connector No.	B63
Connector Name	OUTSIDE KEY ANTENNA (REAR BUMPER)
Connector Type	RK02FGY



Terminal No.	Color of Wire	Signal Name [Specification]
1	BR	-
2	SB	-

Connector No.	B75
Connector Name	WIRE TO WIRE
Connector Type	M02MW-LC



1	2
---	---

Terminal No.	Color of Wire	Signal Name [Specification]
1	L	-
2	Y	-

Connector No.	B82
Connector Name	RETRACTABLE HARD TOP CONTROL UNIT
Connector Type	TH40PW-NH



1	2	3	4	5	6	7	8	9	10	11	12	13	14	15	16	17	18	19	20	21	22	23	24	25	26	27	28	29	30	31	32	33	34	35	36	37
---	---	---	---	---	---	---	---	---	----	----	----	----	----	----	----	----	----	----	----	----	----	----	----	----	----	----	----	----	----	----	----	----	----	----	----	----

Terminal No.	Color of Wire	Signal Name [Specification]
1	G	ROOF OPEN / CLOSE SWITCH (OPEN)
2	BR	ROOF OPEN / CLOSE SWITCH (CLOSE)
3	B	FLIPPER DOOR LIMIT SWITCH GND
4	L	TORNEAU BOARD SWITCH
5	SB	TRUNK ROOM LAMP SWITCH
6	L	ROOF LATCH LIMIT SWITCH (UP)
7	W	FLIPPER DOOR LIMIT SWITCH (DOWN)
8	G	FLIPPER DOOR LIMIT SWITCH (UP)
11	W	RETAINED ACC POWER
12	Y	REVERSE SIGNAL
13	BG	PARCEL SHELF STATUS SENSOR POWER SUPPLY
14	P	TRUNK LINK SENSOR SIGNAL (LH)
15	SB	TRUNK LINK SENSOR SIGNAL (RH)
16	GR	ROOF LATCH STATUS SENSOR SIGNAL
17	G	ROOF LATCH LOCK SENSOR SIGNAL
18	LG	TRUNK STATUS SENSOR SIGNAL
22	V	ROOF STATUS SENSOR POWER SUPPLY
23	B	ROOF STATUS SENSOR GND
24	GR	PARCEL SHELF STATUS SENSOR SIGNAL (DOWN)
25	R	PARCEL SHELF STATUS SENSOR SIGNAL (ROTATION)
26	P	ROOF STATUS SENSOR SIGNAL
27	Y	TRUNK LID OPEN REQUEST SIGNAL
28	BG	FLIPPER DOOR RELAY GND
29	V	LOCAL COMMUNICATION (BCM)
30	GR	LOCAL COMMUNICATION (POWER WINDOW)
31	L	CAN-H
32	P	CAN-L
33	V	ROOF STATUS SIGNAL (AUDIO)
34	R	ROOF STATUS SIGNAL (TRUNK)
35	B	ROOF WARNING BUZZER
36	Y	HYDRAULIC MOTOR RELAY GND (RH)
37	W	HYDRAULIC MOTOR RELAY GND (LH)

38	BR	HYDRAULIC MOTOR RELAY POWER SUPPLY
----	----	------------------------------------

Connector No.	B83
Connector Name	RETRACTABLE HARD TOP CONTROL UNIT
Connector Type	NS10F8H-CS



47	46	45	44	43	42	41
56	55	54	53	52	51	50
49	48	47	46	45	44	43
50	49	48	47	46	45	44

Terminal No.	Color of Wire	Signal Name [Specification]
41	SB	PARCEL SHELF MOTOR RELAY GND (UP)
42	W	PARCEL SHELF MOTOR RELAY GND (DOWN)
43	BR	HYDRAULIC PUMP POWER SUPPLY RELAY
44	R	MOTOR PARCEL SHELF (HORIZONTAL)
45	BR	MOTOR PARCEL SHELF (VERTICAL)
46	G	FLIPPER DOOR RELAY POWER SUPPLY (UP)
47	L	FLIPPER DOOR RELAY POWER SUPPLY (DOWN)
48	R	ROOF LATCH MOTOR (OPEN)
49	Y	ROOF LATCH MOTOR (CLOSE)
51	SB	TRUNK OPENER ACTUATOR
52	V	TRUNK OPENER ACTUATOR GND
53	BG	REAR POWER WINDOW MOTOR LH (UP)
54	LG	REAR POWER WINDOW MOTOR LH (DOWN)
55	GR	REAR POWER WINDOW MOTOR RH (UP)
56	P	REAR POWER WINDOW MOTOR RH (DOWN)

Connector No.	B84
Connector Name	RETRACTABLE HARD TOP CONTROL UNIT
Connector Type	NS10F8H-CS



63	62	61	60	59	58	57
72	71	70	69	68	67	66
63	62	61	60	59	58	57
72	71	70	69	68	67	66

Terminal No.	Color of Wire	Signal Name [Specification]
57	Y	BAT
58	Y	BAT
59	Y	BAT
60	B	GND

61	B	GND
62	GR	BAT (POWER WINDOW)
63	Y	BAT (POWER WINDOW)
64	B	GND (POWER WINDOW)
65	B	GND (POWER WINDOW)
66	P	SWITCHING VALVE 1
67	SB	SWITCHING VALVE 2
68	L	SWITCHING VALVE GND
69	G	REAR WINDOW DEF IN 1
70	P	REAR WINDOW DEF IN 2
71	BR	REAR WINDOW DEF OUT 1
72	W	REAR WINDOW DEF OUT 2

INTELLIGENT KEY SYSTEM

< DTC/CIRCUIT DIAGNOSIS >

INTELLIGENT KEY SYSTEM

Connector No.	B201
Connector Name	WIRE TO WIRE
Connector Type	TH80PW-CS16-TM4



Terminal No.	Color of Wire	Signal Name [Specification]
1	W	
2	W	
3	B	
4	W	
5	W	
6	R	
7	B	
7	G	
8	BG	
9	GR	
10	LG	
41	LG	
42	BG	
43	R	
44	SHIELD	
45	G	
47	G	
48	Y	
49	SHIELD	
50	P	
51	SB	
52	LG	
53	L	
54	G	
55	GR	
56	LG	
57	G	
58	R	
67	L	
68	P	
80	G	
81	R	
82	W	
83	B	
84	SHIELD	
85	O	
86	BR	
87	Y	
88	SHIELD	

89	SB	-
90	V	-
91	GR	-
92	P	- [With BOSE system]
92	Y	- [Without BOSE system]
93	L	-
94	SB	-
95	V	-
96	P	-
97	L	- [With BOSE system]
97	LG	- [Without BOSE system]
98	Y/B	-
99	Y	-

Connector No.	B216
Connector Name	PASSENGER SIDE DOOR SWITCH
Connector Type	A03FW

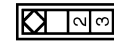

Terminal No.	Color of Wire	Signal Name [Specification]
2	V	
3	B	

Connector No.	B301
Connector Name	WIRE TO WIRE
Connector Type	NS16FF-CS



Terminal No.	Color of Wire	Signal Name [Specification]
1	R	
2	GR	
3	G	
4	W	
5	Y	

6	P	-
7	P	-
10	LG	-
11	B	-
12	B	-
13	V	-
14	BR	-
15	L	-
16	Y	-

Connector No.	B305
Connector Name	TRUNK LID OPENER ACTUATOR
Connector Type	M02FE-LC



Terminal No.	Color of Wire	Signal Name [Specification]
1	V	
2	BR	

Connector No.	B306
Connector Name	TRUNK ROOM LAMP SWITCH
Connector Type	A02FW



Terminal No.	Color of Wire	Signal Name [Specification]
1	V	SIG-
2	L	SIG+

A
B
C
D
E
F
G
H
I
J
K
L
M
N
O
P

DLK

INTELLIGENT KEY SYSTEM

< DTC/CIRCUIT DIAGNOSIS >

INTELLIGENT KEY SYSTEM

Connector No.	D1
Connector Name	WIRE TO WIRE
Connector Type	TH40FW-CS15

1	2	3	4	5	6	7	8	9	10	11	12	13	14	15	16	17	18	19	20	21	22	23	24	25	26	27	28	29	30	31	32	33	34	35	36	37	38	39	40	41	42	43	44	45	46	47	48	49	50	51	52	53	54	55	56	57	58	59	60	61	62	63	64	65	66	67	68	69	70	71	72	73	74	75	76	77	78	79	80	81	82	83	84	85	86	87	88	89	90	91	92	93	94	95	96	97	98	99	100
---	---	---	---	---	---	---	---	---	----	----	----	----	----	----	----	----	----	----	----	----	----	----	----	----	----	----	----	----	----	----	----	----	----	----	----	----	----	----	----	----	----	----	----	----	----	----	----	----	----	----	----	----	----	----	----	----	----	----	----	----	----	----	----	----	----	----	----	----	----	----	----	----	----	----	----	----	----	----	----	----	----	----	----	----	----	----	----	----	----	----	----	----	----	----	----	----	----	----	-----

Terminal No.	Color of Wire	Signal Name [Specification]
4	BR	-
5	P	- [With A/T]
6	B	- [With M/T]
7	SB	-
8	R	-
9	G	-
10	P	-
11	LG	-
12	L	-
13	B	-
14	V	-
15	Y	-
16	Y/B	-
17	Y	-
20	V	-
21	R	-
22	P	-
23	O	-
24	Y	-
25	SB	-
26	GR	-
27	GR	-
28	LG	-
29	G	-
30	Y	-
31	W	-
32	BR	-
33	L	-
34	R	-
35	V	-
37	B	-
38	O	-
39	GR	-
40	G	-
41	Y	-
42	LG	-
43	BR	-

44	V	-
45	P	-
46	W	-
47	V	-
48	P	-
49	W	-
50	SB	-
51	R	-
52	L	-

Connector No.	D13
Connector Name	OUTSIDE HANDLE LH (REQUEST SWITCH)
Connector Type	RK02FL

Terminal No.	Color of Wire	Signal Name [Specification]
1	W	-
2	B	-

Terminal No.	Color of Wire	Signal Name [Specification]
1	W	-
2	B	-

Connector No.	D14
Connector Name	OUTSIDE HANDLE LH (OUTSIDE KEY ANTENNA)
Connector Type	RK02MGY

Terminal No.	Color of Wire	Signal Name [Specification]
1	P	-
2	V	-

Connector No.	D15
Connector Name	DRIVER SIDE DOOR LOCK ASSEMBLY
Connector Type	E08FCY-RS

1	2	3	4	5	6	7	8	9	10	11	12	13	14	15	16	17	18	19	20	21	22	23	24	25	26	27	28	29	30	31	32	33	34	35	36	37	38	39	40	41	42	43	44	45	46	47	48	49	50	51	52	53	54	55	56	57	58	59	60	61	62	63	64	65	66	67	68	69	70	71	72	73	74	75	76	77	78	79	80	81	82	83	84	85	86	87	88	89	90	91	92	93	94	95	96	97	98	99	100
---	---	---	---	---	---	---	---	---	----	----	----	----	----	----	----	----	----	----	----	----	----	----	----	----	----	----	----	----	----	----	----	----	----	----	----	----	----	----	----	----	----	----	----	----	----	----	----	----	----	----	----	----	----	----	----	----	----	----	----	----	----	----	----	----	----	----	----	----	----	----	----	----	----	----	----	----	----	----	----	----	----	----	----	----	----	----	----	----	----	----	----	----	----	----	----	----	----	----	-----

Terminal No.	Color of Wire	Signal Name [Specification]
1	LG	-
2	P	-
3	L	-
4	B	-
5	W	-
6	V	-

Connector No.	D31
Connector Name	WIRE TO WIRE
Connector Type	TH40FW-CS15

1	2	3	4	5	6	7	8	9	10	11	12	13	14	15	16	17	18	19	20	21	22	23	24	25	26	27	28	29	30	31	32	33	34	35	36	37	38	39	40	41	42	43	44	45	46	47	48	49	50	51	52	53	54	55	56	57	58	59	60	61	62	63	64	65	66	67	68	69	70	71	72	73	74	75	76	77	78	79	80	81	82	83	84	85	86	87	88	89	90	91	92	93	94	95	96	97	98	99	100
---	---	---	---	---	---	---	---	---	----	----	----	----	----	----	----	----	----	----	----	----	----	----	----	----	----	----	----	----	----	----	----	----	----	----	----	----	----	----	----	----	----	----	----	----	----	----	----	----	----	----	----	----	----	----	----	----	----	----	----	----	----	----	----	----	----	----	----	----	----	----	----	----	----	----	----	----	----	----	----	----	----	----	----	----	----	----	----	----	----	----	----	----	----	----	----	----	----	----	-----

Terminal No.	Color of Wire	Signal Name [Specification]
6	BR	-
7	R	-
8	G	-
9	P	-
10	LG	-
11	W	-
12	L	-
13	B	-
14	Y	-
15	W	-
34	Y	-
35	Y/B	-
38	O	-
39	GR	-
40	G	-
41	Y	-

42	LG	-
43	BR	-
44	V	-
45	P	-
46	W	-
47	V	-
48	P	-
49	W	-
50	SB	-
51	R	-
52	L	-
53	O	-
54	GR	-
55	G	-

Connector No.	D43
Connector Name	OUTSIDE HANDLE RH (REQUEST SWITCH)
Connector Type	RK02FL

Terminal No.	Color of Wire	Signal Name [Specification]
1	W	-
2	B	-

Terminal No.	Color of Wire	Signal Name [Specification]
1	W	-
2	B	-

Connector No.	D44
Connector Name	OUTSIDE HANDLE RH (OUTSIDE KEY ANTENNA)
Connector Type	RK02MGY

Terminal No.	Color of Wire	Signal Name [Specification]
1	P	-
2	V	-

INTELLIGENT KEY SYSTEM

< DTC/CIRCUIT DIAGNOSIS >

INTELLIGENT KEY SYSTEM

Connector No.	D45
Connector Name	PASSENGER SIDE DOOR LOCK ASSEMBLY
Connector Type	ED0FCY-RS



Terminal No.	Color of Wire	Signal Name [Specification]
1	P	-
2	LG	-

Connector No.	E5
Connector Name	INTELLIGENT POWER DISTRIBUTION MODULE ENGINE ROOM
Connector Type	TH20FW-CS12-MM-1V

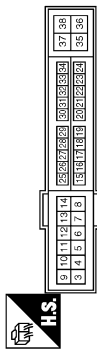

Terminal No.	Color of Wire	Signal Name [Specification]
4	V	-
5	L	-
7	R	-
11	BR	-
12	B/W	-
13	Y	-
16	LG	-
19	W	-
25	G	-
26	R	-
27	BG	-
28	L	-
30	GR	-
32	V	-
33	P	-
36	G	-

Connector No.	E6
Connector Name	INTELLIGENT POWER DISTRIBUTION MODULE ENGINE ROOM
Connector Type	TH00FTV-MH



Terminal No.	Color of Wire	Signal Name [Specification]
39	P	-
40	L	-
41	B/W	-
42	Y	-
43	SB	-
44	LG	-
45	G	-
46	W	-

Connector No.	E11
Connector Name	HORN RELAY 1
Connector Type	Z4331 7900A



Terminal No.	Color of Wire	Signal Name [Specification]
1	LG	-
2	SB	-
3	Y	-

Connector No.	E18
Connector Name	HORN RELAY 2
Connector Type	M03FTV-R-LC



Terminal No.	Color of Wire	Signal Name [Specification]
1	P	-
2	Y	-
3	G	-

Connector No.	E37
Connector Name	INTELLIGENT KEY WARNING BUZZER (ENGINE ROOM)
Connector Type	RK03FBR



Terminal No.	Color of Wire	Signal Name [Specification]
1	LG	-
3	SB	-

Connector No.	E61
Connector Name	HORN (HIGH)
Connector Type	P01FB-A

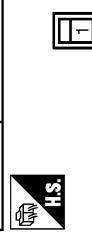

Terminal No.	Color of Wire	Signal Name [Specification]
1	Y	-

Connector No.	E62
Connector Name	HORN (HIGH)
Connector Type	P01FB-A



Terminal No.	Color of Wire	Signal Name [Specification]
2	B	-

Connector No.	E69
Connector Name	HORN (LOW)
Connector Type	P01FB-A

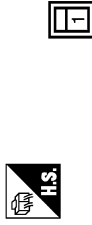

Terminal No.	Color of Wire	Signal Name [Specification]
1	Y	-

Connector No.	E70
Connector Name	HORN (LOW)
Connector Type	P01FB-A



Terminal No.	Color of Wire	Signal Name [Specification]
2	B	-

A
B
C
D
E
F
G
H
I
J
DLK
L
M
N
O
P

INTELLIGENT KEY SYSTEM

< DTC/CIRCUIT DIAGNOSIS >

INTELLIGENT KEY SYSTEM

Connector No.	E79
Connector Name	WIRE TO WIRE
Connector Type	M02FW-LC



Terminal No.	Color of Wire	Signal Name [Specification]
1	Y	-
2	LG	-

Connector No.	E106
Connector Name	WIRE TO WIRE
Connector Type	TH06FW-CS16-TM4

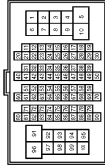

Terminal No.	Color of Wire	Signal Name [Specification]
1	GR	-
3	BG	-
4	B/W	-
5	G	-
8	BG	-
7	LG	-
8	G	-
10	W	-
11	V	-
12	R	-
13	L	-
14	GR	-
15	P	-
16	W	-
17	V	-
18	BG	-
19	GR	-
20	LG	-
30	R	-
31	L	-

32	BG	-
33	P	-
34	V	-
35	BR	-
36	W	-
37	Y	-
38	R	-
39	B	-
40	G	-
41	W	-
42	LG	-
43	SB	-
44	GR	-
45	BG	-
46	LG	-
47	V	-
48	P	-
49	L	-
50	B	-
66	LG	-
67	SB	-
68	R	-
69	W	-
70	G	-
80	W	-
81	P	-
82	G	-
83	V	-
84	L	-
85	BG	-
86	LG	-
87	Y	-
88	GR	-
89	W	-
90	W	-
91	G	-
92	B	-
93	GR	-
94	L	-
95	Y	-
97	BR	-
98	SHIELD	-
99	L	-
100	P	-

Connector No.	M1
Connector Name	FUSE BLOCK (J/B)
Connector Type	NS08FW-M2



Terminal No.	Color of Wire	Signal Name [Specification]
1A	V	-
2A	G	-
3A	L	-
4A	P	-
5A	BR	-
6A	Y	-
7A	GR	-
8A	L	-

Connector No.	M2
Connector Name	FUSE BLOCK (J/B)
Connector Type	NS10FW-CS



Terminal No.	Color of Wire	Signal Name [Specification]
1B	R	-
3B	P	-
4B	G	-
5B	BG	-
6B	Y	-
7B	P	-
8B	R	-
9B	SB	-

Connector No.	M3
Connector Name	FUSE BLOCK (J/B)
Connector Type	NS12FW-CS



Terminal No.	Color of Wire	Signal Name [Specification]
6C	R	-
7C	B	-
8C	W	-
9C	BG	-
10C	L	-
11C	LG	-
12C	R	-

INTELLIGENT KEY SYSTEM

< DTC/CIRCUIT DIAGNOSIS >

INTELLIGENT KEY SYSTEM

Connector No.	M5
Connector Name	WIRE TO WIRE
Connector Type	TH80MW-CS15

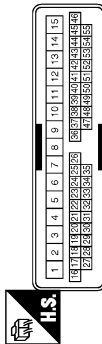

Terminal No.	Color of Wire	Signal Name [Specification]
4	R	
5	B	
6	BG	
7	W	
8	B	
9	G	
10	V	
11	W	
12	L	
13	B	
14	GR	
15	Y	
16	Y/B	
17	Y	
20	BG	
21	W	
22	P	
23	BG	
24	V	
25	BR	
26	R	
27	P	
28	LG	
29	SB	
30	G	
31	V	
32	BR	
33	GR	
34	G	
35	L	
37	B	
38	L	
39	BR	
40	Y	
41	BR	
41	G	

42	R	
43	G	
44	Y	
45	GR	
46	BR	
47	V	
48	LG	
49	P	
50	SB	
51	GR	
52	L	

Connector No.	M6
Connector Name	WIRE TO WIRE
Connector Type	TH80MW-CS16-TM4

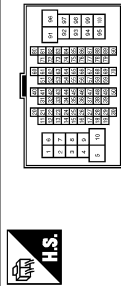

Terminal No.	Color of Wire	Signal Name [Specification]
1	BG	
3	R	
4	G	
5	G	
6	BR	
7	BR	
8	Y	
10	W	
11	GR	
12	R	
13	L	
14	G	
15	P	
16	W	
17	BR	
18	V	
19	BG	
20	L	
30	R	
31	L	
32	Y	
33	GR	
34	P	
35	BR	
36	BR	

37	Y	
38	LG	
39	SB	
40	G	
41	W	
42	LG	
43	P	
44	GR	
44	R	
45	BG	
46	G	
47	P	
48	P	
49	L	
59	B	
66	Y	
67	G	
68	R	
68	W	
70	G	
80	SB	
81	R	
82	V	
83	W	
84	L	
85	BG	
86	G	
87	V	
88	B	
89	SB	
90	G	
91	W	
92	B	
93	G	
94	L	
95	BR	
97	P	
98	SHIELD	
99	V	
100	SB	

A
B
C
D
E
F
G
H
I
J
DLK
L
M
N
O
P

INTELLIGENT KEY SYSTEM

< DTC/CIRCUIT DIAGNOSIS >

INTELLIGENT KEY SYSTEM

Connector No.	M7
Connector Name	WIRE TO WIRE
Connector Type	TH80MW-CS16-TIM4



Terminal No.	Color of Wire	Signal Name [Specification]
1	BG	-
2	LG	-
3	G	-
4	V	-
5	L	-
6	B	-
8	L	-
10	BR	-
12	SHIELD	-
13	V	-
14	BR	-
15	GR	-
16	LG	-
17	L	-
20	BR	-
21	G	-
22	R	-
23	SB	-
24	B	-
25	W	-
26	Y	-
27	V	-
28	P	-
29	V	-
31	SHIELD	-
32	G	-
33	R	-
34	BG	-
35	GR	-
36	BR	-
37	P	- [With climate controlled seat]
37	L	- [Without climate controlled seat]
38	V	- [With climate controlled seat]
38	GR	- [Without climate controlled seat]
40	SHIELD	-
41	L	-
42	P	-
43	SHIELD	-

44	Y	-
45	BR	-
46	SB	-
47	SB	-
48	LG	-
49	LG	- [With BOSE system]
49	SB	- [Without BOSE system]
50	SB	- [With BOSE system]
50	LG	- [Without BOSE system]
51	R	-
52	V	-
53	P	-
54	BR	-
55	Y	- [With A/T]
55	BG	- [Without A/T]
56	L	-
57	V	-
60	LG	-
61	BG	-
62	B	-
63	V	-
64	SB	-
65	BR	-
66	Y	-
67	P	-
68	L	-
69	P	-
70	L	-
80	G	-
81	LG	-
82	Y	-
83	BR	-
84	V	-
85	L	-
86	Y	-
87	GR	-
91	R	-
93	G	-
94	P	-
95	GR	-
96	Y	-
97	SB	-
99	Y	-
100	Y/B	-

Connector No.	M22
Connector Name	KEY SLOT
Connector Type	TH12FW-1H1

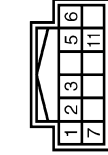

Terminal No.	Color of Wire	Signal Name [Specification]
1	V	BAT
2	GR	CLOCK
3	W	DATA
5	Y	ILL.BAT
6	LG	ILL
7	B	GND
11	SB	KEY SWITCH SIGNAL

Connector No.	M24
Connector Name	DATA LINK CONNECTOR
Connector Type	BD16FW

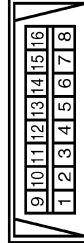

Terminal No.	Color of Wire	Signal Name [Specification]
3	LG	-
4	B	-
5	BR	-
6	L	-
7	V	-
8	G	-
11	SB	-
14	P	-
16	R	-

Connector No.	M60
Connector Name	PUSH-BUTTON (IGNITION SWITCH)
Connector Type	TK08FBR



Terminal No.	Color of Wire	Signal Name [Specification]
1	B	-
2	W	-
3	Y	-
4	BR	-
5	LG	-
6	BG	-
7	V	-
8	P	-

INTELLIGENT KEY SYSTEM

< DTC/CIRCUIT DIAGNOSIS >

INTELLIGENT KEY SYSTEM

Connector No.	IM53
Connector Name	COMBINATION METER
Connector Type	SAB40FW



1	2	3	4	5	6	7	8	9	10	11	12	13	14	15	16	17	18	19	20
21	22	23	24	25	26	27	28	29	30	31	32	33	34	35	36	37	38	39	40

Terminal No.	Color of Wire	Signal Name [Specification]
1	V	BATTERY POWER SUPPLY
2	LG	COMMUNICATION SIGNAL (METER->AMP.)
3	GR	COMMUNICATION SIGNAL (AMP->METER)
5	B	GROUND
6	W	ALTERNATOR SIGNAL
7	LG	AIR BAG SIGNAL
10	R	SECURITY SIGNAL
13	B	GROUND
16	B	METER CONTROL SWITCH GROUND
18	GR	ILL GND
19	B	ILL GND
20	R	ILL
21	R	IGNITION SIGNAL
22	B	GROUND
24	SB	COMMUNICATION SIGNAL (LCD->AMP.)
25	B	COMMUNICATION SIGNAL (AMP->LCD)
26	R	VEHICLE SPEED SIGNAL (8-PULSE)
27	V	PARKING BRAKE SWITCH SIGNAL
28	SB	BRAKE FLUID LEVEL SWITCH SIGNAL
29	L	SEAT BELT BUCKLE SW SIGNAL (DRIVER SIDE)
30	G	SEAT BELT BUCKLE SWITCH SIGNAL (PASSENGER SIDE)
31	L	WASHER LEVEL SWITCH SIGNAL
33	R	ILLUMINATION CONTROL SIGNAL
36	LG	SELECT SWITCH SIGNAL
37	SB	ENTER SWITCH SIGNAL
38	L	TRIP A/B RESET SWITCH SIGNAL
39	P	ILLUMINATION CONTROL SWITCH (-)
40	BG	ILLUMINATION CONTROL SWITCH (+)

Connector No.	IM66
Connector Name	UNIFIED METER AND A.C AMP.
Connector Type	TH43FPH-HH



1	2	3	4	5	6	7	8	9	10	11	12	13	14	15	16	17	18	19	20
21	22	23	24	25	26	27	28	29	30	31	32	33	34	35	36	37	38	39	40

Terminal No.	Color of Wire	Signal Name [Specification]
4	G	STOP LAMP SWITCH
5	L	MANUAL MODE SHIFT UP SIGNAL
6	BG	PADDLE SHIFTER LIP SIGNAL
7	GR	COMMUNICATION SIGNAL (AMP->METER)
8	L	VEHICLE SPEED (2-PUL SE)
9	SB	SEAT BELT BUCKLE SWITCH SIGNAL (DRIVER SIDE)
10	W	MANUAL MODE SIGNAL
11	G	NON-MANUAL MODE SIGNAL
14	SB	COMMUNICATION SIGNAL (LCD->AMP.)
20	G	ION ON / OFF SIGNAL
25	V	MANUAL MODE SHIFT DOWN SIGNAL
26	G	PADDLE SHIFTER DOWN SIGNAL
27	LG	COMMUNICATION SIGNAL (METER->AMP.)
28	R	VEHICLE SPEED (8-PULSE)
30	V	PARKING BRAKE SWITCH SIGNAL
34	B	COMMUNICATION SIGNAL (AMP->LCD)
38	P	BLOWER MOTOR CONTROL SIGNAL

Connector No.	IM67
Connector Name	UNIFIED METER AND A.C AMP.
Connector Type	TH43FPH-HH



41	42	43	44	45	46	47	48	49	50	51	52	53	54	55	56	57	58	59	60	61	62	63	64	65	66	67	68	69	70	71	72
----	----	----	----	----	----	----	----	----	----	----	----	----	----	----	----	----	----	----	----	----	----	----	----	----	----	----	----	----	----	----	----

Terminal No.	Color of Wire	Signal Name [Specification]
41	BR	ACC POWER SUPPLY
42	BR	FUEL LEVEL SENSOR SIGNAL
43	R	INTAKE SENSOR SIGNAL
44	LG	IN-VEHICLE SENSOR SIGNAL
45	V	AMBIENT SENSOR SIGNAL

46	BG	SUNLOAD SENSOR SIGNAL
47	G	GAS SENSOR SIGNAL
52	W	IGNITION POWER SUPPLY
54	BG	BATTERY POWER SUPPLY
55	B	GROUND
56	L	CAN-H
57	LG	BRAKE FLUID LEVEL SWITCH SIGNAL
58	Y	FUEL LEVEL SENSOR SIGNAL
59	GR	INTAKE SENSOR SIGNAL
60	L	IN-VEHICLE SENSOR GROUND
61	R	AMBIENT SENSOR GROUND
62	SB	SUNLOAD SENSOR GROUND
63	L	ION CONTROL MODE OUTPUT SIGNAL
65	BG	ECV SIGNAL
69	L	A/C LAMP SIGNAL
70	R	EACH DOOR MOTOR POWER SUPPLY
71	GR	GROUND
72	P	CAN-L

Connector No.	MI04
Connector Name	REMOTE KEYLESS ENTRY RECEIVER
Connector Type	JAB04FB



1	2	3	4
---	---	---	---

Terminal No.	Color of Wire	Signal Name [Specification]
1	BG	GND
2	Y	SIGNAL OUTPUT
4	LG	BATTERY

Connector No.	MI05
Connector Name	TRUNK LID OPENER CANCEL SWITCH
Connector Type	SJ02FW



1	2
---	---

A
B
C
D
E
F
G
H
I
J
DLK
L
M
N
O
P

INTELLIGENT KEY SYSTEM

< DTC/CIRCUIT DIAGNOSIS >

INTELLIGENT KEY SYSTEM

Connector No.	M117
Connector Name	WIRE TO WIRE
Connector Type	TH80MW-CS (E-TM4)



Terminal No.	Color of Wire	Signal Name [Specification]
1	Y	
3	B	
5	SB	
6	R	
7	G	
8	SB	
9	GR	
10	LG	
40	Y	
41	G	
42	LG	
43	R	
44	SHIELD	
45	G	
47	P	
48	L	
49	SHIELD	
50	V	
51	SB	
52	BG	
53	L	
54	G	
55	Y	
56	LG	
57	SB	
58	LG	
67	SB	
80	W	
81	B	
82	R	
83	G	
84	SHIELD	
85	G	
86	L	
87	P	
88	SHIELD	
88	Y	

90	W	
91	GR	
92	P	
93	W	
94	BG	
95	BG	
96	P	
97	L	
98	Y/B	
99	Y	

Connector No.	M118
Connector Name	BCM (BODY CONTROL MODULE)
Connector Type	M03FB-LG



Terminal No.	Color of Wire	Signal Name [Specification]
1	W	BAT (F/L)
2	Y	POWER WINDOW POWER SUPPLY (BAT)
3	BG	POWER WINDOW POWER SUPPLY (RAP)

Connector No.	M119
Connector Name	BCM (BODY CONTROL MODULE)
Connector Type	NS12FW-CS



Terminal No.	Color of Wire	Signal Name [Specification]
4	LG	INTERIOR ROOM LAMP POWER SUPPLY
5	P	PASSENGER DOOR UNLOCK OUTPUT
7	SB	STEP LAMP
8	V	ALL DOOR FUEL LID LOCK OUTPUT
9	G	DRIVER DOOR FUEL LID UNLOCK OUTPUT
11	GR	BAT (FUSE)
13	B	GND

14	W	PUSH-BUTTON IGNITION SW ILL GND
15	BG	ACC IND
17	BR	TURN SIGNAL RH (FRONT)
18	BG	TURN SIGNAL LH (FRONT)
19	V	ROOM LAMP-TIMER CONTROL

Connector No.	M120
Connector Name	BCM (BODY CONTROL MODULE)
Connector Type	NS12FW-CS



Terminal No.	Color of Wire	Signal Name [Specification]
20	V	TURN SIGNAL RH (REAR)
22	Y	TRUNK LID OPEN OUTPUT
23	Y	TURN SIGNAL LH (REAR)
30	P	TRUNK ROOM LAMP

Connector No.	M121
Connector Name	BCM (BODY CONTROL MODULE)
Connector Type	TH40FGY-NH

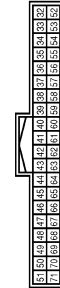

Terminal No.	Color of Wire	Signal Name [Specification]
34	SB	TRUNK ROOM ANT-
35	V	TRUNK ROOM ANT+
38	B	REAR BUMPER ANT-
39	B	REAR BUMPER ANT+
47	Y	IGN RELAY (PDM E/R) CONT
50	G	TRUNK ROOM LAMP SW
52	BR	STARTER RELAY CONT
61	SB	TRUNK LID OPENER REQUEST SW
64	G	I-KEY WARN BUZZER (ENG ROOM)
67	GR	TRUNK LID OPENER SW

Connector No.	M122
Connector Name	BCM (BODY CONTROL MODULE)
Connector Type	TH40FB-NH



Terminal No.	Color of Wire	Signal Name [Specification]
72	R	ROOM ANT Z-
73	G	ROOM ANT Z+
74	SB	PASSENGER DOOR ANT-
75	BR	PASSENGER DOOR ANT+
76	V	DRIVER DOOR ANT-
77	LG	DRIVER DOOR ANT+
78	V	ROOM ANT 1-
79	BR	ROOM ANT 1+
80	GR	MAT'S ANTRINNA AMP
81	W	MAT'S ANTRINNA AMP
82	R	IGN RELAY (F/B) CONT
83	Y	KEYLESS ENTRY RECEIVER COMM
87	Y	COMBI SW INPUT 5
88	BG	COMBI SW INPUT 3
89	BR	PUSH SW
90	P	CAN-L
91	L	CAN-H
92	LG	KEY SLOT ILL
93	V	ON IND
95	BG	ACC RELAY CONT
96	GR	A-T SHIFT SELECTOR POWER SUPPLY
97	L	A-T SHIFT SELECTOR POWER SUPPLY
98	SB	S/L CONDITION 2
98	SB	S/L CONDITION 1
99	R	SHIFT P (W/R) 2-1
100	R	ASCD/CC CLUTCH SW (Min.M.T)
100	Y	PASSENGER DOOR REQUEST SW
101	P	DRIVER DOOR REQUEST SW
102	BG	BLOWER FAN MOTOR RELAY CONT
103	LG	KEYLESS ENTRY RECEIVER POWER SUPPLY
106	W	S/L UNIT POWER SUPPLY
107	LG	S/L UNIT POWER SUPPLY
108	R	COMBI SW INPUT 1
108	R	COMBI SW INPUT 4
109	W	COMBI SW INPUT 2
110	G	HAZARD SW
111	Y	S/L UNIT COMM

INTELLIGENT KEY SYSTEM

< DTC/CIRCUIT DIAGNOSIS >

INTELLIGENT KEY SYSTEM

Connector No.	M123
Connector Name	BCM (BODY CONTROL MODULE)
Connector Type	TH40FG-NH

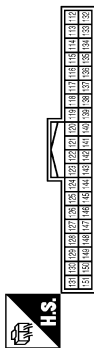

Terminal No.	Color of Wire	Signal Name [Specification]
112	BR	RAIN SENSOR SERIAL LINK
113	G	OPTICAL SENSOR
114	R	CLUTCH INTERLOCK SW
116	SB	STOP LAMP SW 1
118	BR	STOP LAMP SW 2
119	GR	DR DOOR UNLOCK SENSOR
121	SB	KEY SLOT SW
123	W	IGN P/B
124	EG	PASSENGER DOOR SW
129	EG	TRUNK LID OPENER CANCEL SW
132	LG	P/W SW & RHT C/U COMM
133	Y	PUSH-BUTTON IGNITION SW ILL POWER
134	LG	LOCK IND
137	BG	RECEIVER / SENSOR GND
138	Y	RECEIVER / SENSOR POWER SUPPLY
139	L	TIRE PRESSURE RECEIVER COMM
140	GR	SHIFT N/P
141	R	SECURITY INDICATOR LAMP
142	BR	COMBI SW OUTPUT 5
143	V	COMBI SW OUTPUT 1
144	G	COMBI SW OUTPUT 2
145	L	COMBI SW OUTPUT 3
146	SB	COMBI SW OUTPUT 4
149	W	TIRE PRESSURE WARN CHECK SW
150	R	DRIVER DOOR SW
151	G	REAR WINDOW DEFROGGER RELAY COINT

Connector No.	M124
Connector Name	WIRE TO WIRE
Connector Type	TH40MP-CS15

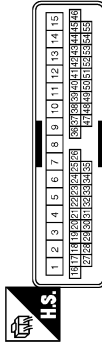

Terminal No.	Color of Wire	Signal Name [Specification]
6	BG	
7	R	
8	G	
9	P	
10	V	
11	SB	-- [With BOSE system]
11	GR	-- [Without BOSE system]
12	BR	
13	B	
14	G	
15	W	
34	Y	
35	Y/B	
38	W	
39	BG	
40	SB	
41	BR	-- [With automatic drive positioner]
41	G	-- [Without automatic drive positioner]
42	R	
43	L	
44	Y	
45	R	
46	W	
47	SB	
48	BR	
49	Y	
50	P	
51	LG	
52	BG	
53	Y	
54	L	
55	L	

Connector No.	M131
Connector Name	INSIDE KEY ANTENNA (INSTRUMENT CENTER)
Connector Type	RK02FGY



Terminal No.	Color of Wire	Signal Name [Specification]
1	BR	
2	Y	

Connector No.	M137
Connector Name	A-T SHIFT SELECTOR
Connector Type	TH12FW-NH

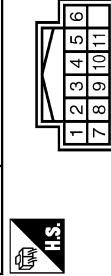

Terminal No.	Color of Wire	Signal Name [Specification]
1	W	
2	V	
3	L	
4	BR	
5	G	
7	Y	
8	SB	
9	B	
10	GR	
11	R	

Connector No.	M146
Connector Name	INSIDE KEY ANTENNA (CONSOLE)
Connector Type	RK02FGY



Terminal No.	Color of Wire	Signal Name [Specification]
1	G	
2	R	

A
B
C
D
E
F
G
H
I
J
DLK
L
M
N
O
P

TRUNK LID OPENER

< DTC/CIRCUIT DIAGNOSIS >

TRUNK LID OPENER

Wiring Diagram - TRUNK LID OPENER -

INFOID:000000005624279

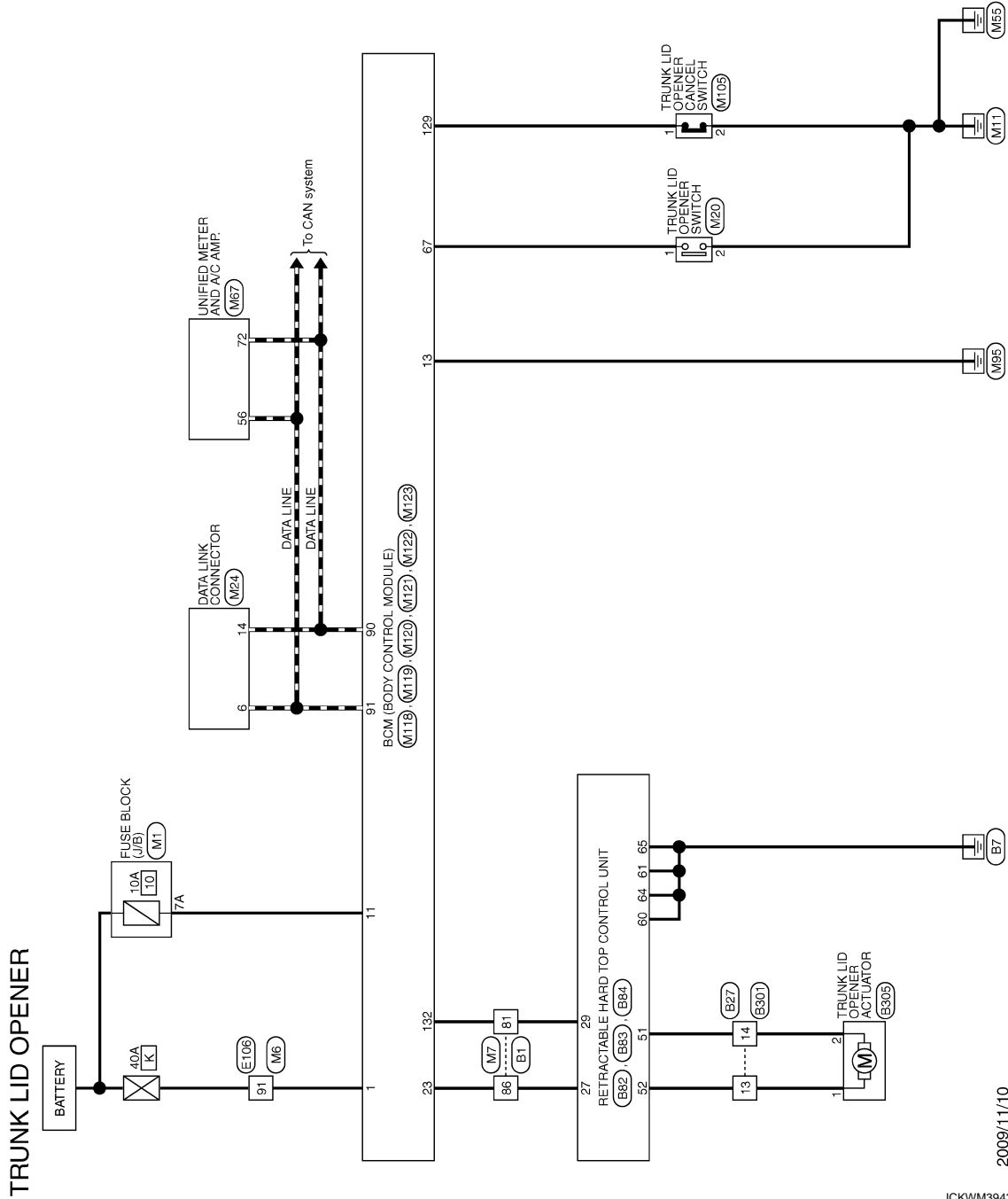

2009/11/10

JCKWM3943GI

TRUNK LID OPENER

< DTC/CIRCUIT DIAGNOSIS >

TRUNK LID OPENER

Connector No.	B1
Connector Name	WIRE TO WIRE
Connector Type	TH80PW-CS16-TM4

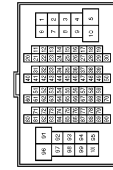

Terminal No.	Color of Wire	Signal Name [Specification]
1	W	
2	L	
3	R	
4	V	
5	W	
6	B	
7	G	
8	G	
9	G	
10	BR	
12	SHIELD	
13	Y	
14	L	
15	R	
16	W	
17	BR	
20	G	
21	SB	
22	GR	
23	W	
24	SB	
25	BR	
26	LG	
27	Y	
28	R	
29	V	
31	SHIELD	
32	G	
33	R	
34	BG	
35	GR	
36	BR	
37	P	- [With climate controlled seat]
37	Y	- [Without climate controlled seat]
38	V	- [With climate controlled seat]
38	GR	- [Without climate controlled seat]
40	SHIELD	
41	L	
42	P	
43	SHIELD	

Connector No.	B27
Connector Name	WIRE TO WIRE
Connector Type	HS16MWF-CS

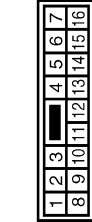

Terminal No.	Color of Wire	Signal Name [Specification]
1	BG	
2	P	
3	G	
4	W	
5	R	
6	R	
7	GR	
10	LG	
11	B	
12	B	
13	V	
14	SB	
15	L	
16	V	

Connector No.	B82
Connector Name	RETRACTABLE HARD TOP CONTROL UNIT
Connector Type	TH80PW-NH



Terminal No.	Color of Wire	Signal Name [Specification]
1	G	ROOF OPEN / CLOSE SWITCH (OPEN)
2	BR	ROOF OPEN / CLOSE SWITCH (CLOSE)
3	B	FLIPPER DOOR LIMIT SWITCH (GND)
4	L	TORQUE BOARD SWITCH
5	SB	TRUNK ROOM LAMP SWITCH
6	L	ROOF LATCH LIMIT SWITCH
7	W	FLIPPER DOOR LIMIT SWITCH (UP)
8	G	FLIPPER DOOR LIMIT SWITCH (DOWN)

11	W	RETAINED ACC POWER
12	Y	REVERSE SIGNAL
13	BG	PARCEL SHELF STATUS SENSOR POWER SUPPLY
14	P	TRUNK LINK SENSOR SIGNAL (LH)
15	SB	TRUNK LINK SENSOR SIGNAL (RH)
16	GR	ROOF LATCH STATUS SENSOR SIGNAL
17	G	ROOF LATCH LOCK SENSOR SIGNAL
18	LG	TRUNK STATUS SENSOR SIGNAL
22	V	ROOF STATUS SENSOR POWER SUPPLY
23	B	ROOF STATUS SENSOR GND
24	GR	PARCEL SHELF STATUS SENSOR SIGNAL (DRAW)
25	R	PARCEL SHELF STATUS SENSOR SIGNAL (ROTATION)
26	P	ROOF STATUS SENSOR SIGNAL
27	Y	TRUNK LID OPEN REQUEST SIGNAL
28	BG	FLIPPER DOOR RELAY GND
29	V	LOCAL COMMUNICATION (ECM)
30	GR	LOCAL COMMUNICATION (POWER WINDOW)
31	L	CAN-H
32	P	CAN-L
33	V	ROOF STATUS SIGNAL (AUDIO)
34	R	ROOF STATUS SIGNAL (TRUNK)
35	B	ROOF WARNING BUZZER
36	Y	HYDRAULIC MOTOR RELAY GND (RH)
37	W	HYDRAULIC MOTOR RELAY GND (LH)
38	BR	HYDRAULIC MOTOR RELAY POWER SUPPLY

A
B
C
D
E
F
G
H
I
J
K
L
M
N
O
P

DLK

TRUNK LID OPENER

< DTC/CIRCUIT DIAGNOSIS >

TRUNK LID OPENER

Connector No.	B83
Connector Name	RETRACTABLE HARD TOP CONTROL UNIT
Connector Type	NS16FW-CS



47	46	45	44	43	42	41
56	55	54	53	52	51	50
49	48	47	46	45	44	43
42	41	40	39	38	37	36

Terminal No.	Color of Wire	Signal Name [Specification]
41	SB	PARCEL SHELF MOTOR RELAY GND (UP)
42	W	PARCEL SHELF MOTOR RELAY GND (DOWN)
43	BR	HYDRAULIC PUMP POWER SUPPLY RELAY
44	R	MOTOR PARCEL SHELF (HORIZONTAL)
45	BR	MOTOR PARCEL SHELF (VERTICAL)
46	G	FLIPPER DOOR RELAY POWER SUPPLY (UP)
47	L	FLIPPER DOOR RELAY POWER SUPPLY (DOWN)
48	R	ROOF LATCH MOTOR (OPEN)
49	Y	ROOF LATCH MOTOR (CLOSE)
51	SB	TRUNK OPENER ACTUATOR
52	V	TRUNK OPENER ACTUATOR GND
53	BG	REAR POWER WINDOW MOTOR LH (UP)
54	LG	REAR POWER WINDOW MOTOR LH (DOWN)
55	GR	REAR POWER WINDOW MOTOR RH (UP)
56	P	REAR POWER WINDOW MOTOR RH (DOWN)

Connector No.	B84
Connector Name	RETRACTABLE HARD TOP CONTROL UNIT
Connector Type	NS16FW-CS



63	62	61	60	59	58	57
72	71	70	69	68	67	66
63	62	61	60	59	58	57
72	71	70	69	68	67	66

Terminal No.	Color of Wire	Signal Name [Specification]
57	Y	BAT
58	Y	BAT
59	Y	BAT
60	B	BAT
61	B	GND
62	GR	BAT (POWER WINDOW)
63	Y	BAT (POWER WINDOW)

64	B	GND (POWER WINDOW)
65	B	GND (POWER WINDOW)
66	P	SWITCHING VALVE 1
67	SB	SWITCHING VALVE 2
68	L	SWITCHING VALVE GND
69	G	REAR WINDOW DEF IN 1
70	P	REAR WINDOW DEF IN 1
71	BR	REAR WINDOW DEF OUT 1
72	W	REAR WINDOW DEF OUT 2

Connector No.	B301
Connector Name	WIRE TO WIRE
Connector Type	NS16FW-CS



7	6	5	4	3	2	1
16	15	14	13	12	11	10
7	6	5	4	3	2	1
16	15	14	13	12	11	10

Terminal No.	Color of Wire	Signal Name [Specification]
1	R	
2	GR	
3	G	
4	W	
5	Y	
6	P	
7	P	
10	LG	
11	B	
12	B	
13	V	
14	BR	
15	L	
16	Y	

Connector No.	B305
Connector Name	TRUNK LID OPENER ACTUATOR
Connector Type	M02FE-LC



1	2
---	---

Terminal No.	Color of Wire	Signal Name [Specification]
1	V	V-
2	BR	V-

Connector No.	E106
Connector Name	WIRE TO WIRE
Connector Type	TR60FW-CS16-TM4



1	2	3	4	5	6
7	8	9	10	11	12
13	14	15	16	17	18
19	20	21	22	23	24
25	26	27	28	29	30
31	32	33	34	35	36

Terminal No.	Color of Wire	Signal Name [Specification]
1	GR	
3	BG	
4	B/W	
5	G	
8	BG	
7	LG	
8	G	
10	W	
11	V	
12	R	
13	L	
14	GR	
15	P	
16	W	
17	V	
18	BG	
19	GR	
20	LG	
30	R	
31	L	

32	BG	
33	P	
34	V	
35	BR	
36	W	
37	Y	
38	R	
39	B	
40	G	
41	W	
42	LG	
43	SB	
44	GR	
45	BG	
46	LG	
47	V	
48	P	
49	L	
59	B	
68	LG	
67	SB	
68	R	
69	W	
70	G	
80	W	
81	P	
82	G	
83	V	
84	L	
85	BG	
86	LG	
87	Y	
88	GR	
89	W	
90	W	
91	G	
92	B	
93	GR	
94	L	
95	Y	
97	BR	
98	SHIELD	
99	L	
100	P	

TRUNK LID OPENER

< DTC/CIRCUIT DIAGNOSIS >

TRUNK LID OPENER

Connector No.	M1
Connector Name	FUSE BLOCK (J/B)
Connector Type	NS88FW-M2



Terminal No.	Color of Wire	Signal Name [Specification]
1A	V	-
2A	G	-
3A	L	-
4A	P	-
5A	BR	- [With A/T]
6A	Y	- [With M/T]
7A	GR	-
8A	L	-

Connector No.	M6
Connector Name	WIRE TO WIRE
Connector Type	TH80MW-CS16-TM4

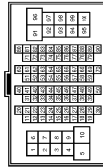

Terminal No.	Color of Wire	Signal Name [Specification]
1	EG	-
2	G	-
3	R	-
4	G	-
5	G	-
6	BR	-
7	BR	-
8	Y	-
9	W	-
10	W	-
11	GR	-
12	R	-
13	L	-
14	G	-
15	P	-
16	W	-

17	BR	-
18	V	-
19	EG	-
20	L	-
30	R	-
31	L	-
32	Y	-
33	GR	-
34	P	-
35	BR	-
36	BR	-
37	Y	-
38	LG	-
39	SB	-
40	G	-
41	W	-
42	LG	-
43	P	-
44	GR	- [With A/T]
45	Y	- [With M/T]
46	G	-
47	P	-
48	P	-
49	L	-
59	B	-
66	Y	-
67	G	-
68	R	-
69	W	-
70	G	-
72	R	-
80	SB	-
81	R	-
82	V	-
83	W	-
84	L	-
85	EG	-
86	G	-
87	V	-
88	B	-
89	SB	-
90	G	-
91	W	-
92	B	-
93	G	-
94	L	-
95	BR	-
97	P	-
98	SHIELD	-
99	V	-
100	SB	-

Connector No.	M7
Connector Name	WIRE TO WIRE
Connector Type	TH80MW-CS16-TM4

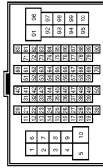

Terminal No.	Color of Wire	Signal Name [Specification]
1	BG	-
2	LG	-
3	G	-
4	V	-
5	L	-
6	B	-
8	L	-
9	L	-
10	BR	-
12	SHIELD	-
13	V	-
14	BR	-
15	GR	-
16	LG	-
17	L	-
20	BR	-
21	G	-
22	R	-
23	SB	-
24	B	-
25	W	-
26	Y	-
27	V	-
28	P	-
29	V	-
31	SHIELD	-
32	G	-
33	R	-
34	BG	-
35	GR	-
36	BR	-
37	P	- [With climate controlled seat]
37	L	- [Without climate controlled seat]
38	V	- [With climate controlled seat]
38	GR	- [Without climate controlled seat]
40	SHIELD	-
41	L	-
42	P	-
43	SHIELD	-

44	Y	-
45	BR	-
46	SB	-
47	SB	-
48	LG	-
49	SB	- [With BOSE system]
49	SB	- [Without BOSE system]
50	SB	- [With BOSE system]
50	LG	- [Without BOSE system]
51	R	-
52	V	-
53	P	-
54	BR	-
55	Y	- [With A/T]
55	BG	- [With M/T]
56	L	-
57	V	-
60	LG	-
61	BG	-
62	B	-
63	V	-
64	SB	-
65	BR	-
66	Y	-
67	P	-
68	L	-
69	P	-
70	L	-
80	G	-
81	LG	-
82	Y	-
83	BR	-
84	V	-
85	L	-
86	Y	-
87	GR	-
81	R	-
83	G	-
94	P	-
95	GR	-
96	Y	-
97	SB	-
99	Y	-
100	Y/B	-

A
B
C
D
E
F
G
H
I
J
K
L
M
N
O
P

DLK

JCKW3946G1

TRUNK LID OPENER

< DTC/CIRCUIT DIAGNOSIS >

TRUNK LID OPENER

Connector No.	M20
Connector Name	TRUNK LID OPENER SWITCH
Connector Type	TK04FW



Terminal No.	Color of Wire	Signal Name [Specification]
1	GR	-
2	BR	-
3	LG	-
4	R	-

Connector No.	M24
Connector Name	DATA LINK CONNECTOR
Connector Type	BD16FW

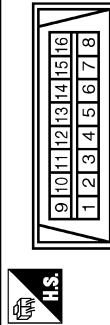

Terminal No.	Color of Wire	Signal Name [Specification]
3	LG	-
4	B	-
5	BR	-
6	L	-
7	V	-
8	G	-
11	SB	-
14	P	-
16	R	-

Connector No.	M67
Connector Name	UNIFIED METER AND A.C AMP.
Connector Type	TH32FW-NH

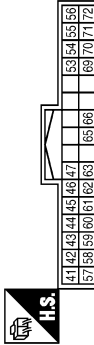

Terminal No.	Color of Wire	Signal Name [Specification]
41	BR	ACC POWER SUPPLY
42	BR	FUEL LEVEL SENSOR SIGNAL
43	R	INTAKE SENSOR SIGNAL
44	LG	IN-VEHICLE SENSOR SIGNAL
45	V	AMBIENT SENSOR SIGNAL
46	BG	SUNLOAD SENSOR SIGNAL
47	G	GAS SENSOR SIGNAL
53	W	IGNITION POWER SUPPLY
54	BG	BATTERY POWER SUPPLY
55	B	GROUND
56	L	CAN-H
57	LG	BRAKE FLUID LEVEL SWITCH SIGNAL
58	Y	FUEL LEVEL SENSOR SIGNAL GROUND
59	GR	INTAKE SENSOR GROUND
60	L	IN-VEHICLE SENSOR GROUND
61	R	AMBIENT SENSOR GROUND
62	SB	SUNLOAD SENSOR GROUND
63	L	ION CONTROL MODE OUTPUT SIGNAL
65	BG	ECV SIGNAL
69	L	A.C LAN SIGNAL
70	R	EACH DOOR MOTOR POWER SUPPLY
71	GR	GROUND
72	P	CAN-L

Connector No.	M105
Connector Name	TRUNK LID OPENER CANCEL SWITCH
Connector Type	IS02FW



Terminal No.	Color of Wire	Signal Name [Specification]
1	BG	-
2	B	-

Connector No.	M118
Connector Name	BCM (BODY CONTROL MODULE)
Connector Type	M03FB-LC



Terminal No.	Color of Wire	Signal Name [Specification]
1	W	BAT (E/L)
2	Y	POWER WINDOW POWER SUPPLY (BAT)
3	BG	POWER WINDOW POWER SUPPLY (RAD)

Connector No.	M119
Connector Name	BCM (BODY CONTROL MODULE)
Connector Type	NS16FW-CS



Terminal No.	Color of Wire	Signal Name [Specification]
4	LG	INTERIOR ROOM LAMP POWER SUPPLY
5	P	PASSENGER DOOR UNLOCK OUTPUT
7	SB	STEP LAMP
8	V	ALL DOOR FUEL LID LOCK OUTPUT
9	G	DRIVER DOOR FUEL LID UNLOCK OUTPUT
11	GR	BAT (FUSE)
13	B	GND
14	W	PUSH-BUTTON IGNITION SW ILL GND
15	BG	ACC IND
17	BR	TURN SIGNAL RH (FRONT)
18	BG	TURN SIGNAL LH (FRONT)
19	V	ROOM LAMP TIMER CONTROL

Connector No.	M120
Connector Name	BCM (BODY CONTROL MODULE)
Connector Type	NS12FW-CS



Terminal No.	Color of Wire	Signal Name [Specification]
20	V	TURN SIGNAL RH (REAR)
23	Y	TRUNK LID OPEN OUTPUT
25	Y	TURN SIGNAL LH (REAR)
30	P	TRUNK ROOM LAMP

Connector No.	M121
Connector Name	BCM (BODY CONTROL MODULE)
Connector Type	TH40FY-NH

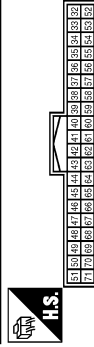

Terminal No.	Color of Wire	Signal Name [Specification]
34	SB	TRUNK ROOM ANT-
35	V	TRUNK ROOM ANT+
38	B	REAR BUMPER ANT-
39	W	REAR BUMPER ANT+
47	Y	IGN RELAY UPDM E/RU CONT
50	G	TRUNK ROOM LAMP SW
52	BR	STARTER RELAY CONT
61	SB	TRUNK LID OPENER REQUEST SW
64	G	I-KEY WARN BUZZER (ENG ROOM)
67	GR	TRUNK LID OPENER SW

TRUNK LID OPENER

< DTC/CIRCUIT DIAGNOSIS >

A
B
C
D
E
F
G
H
I
J
K
L
M
N
O
P

TRUNK LID OPENER

Connector No.	M122
Connector Name	BCM (BODY CONTROL MODULE)
Connector Type	TH4CFB-NH



Terminal No.	Color of Wire	Signal Name [Specification]
72	R	ROOM ANT 2-
73	G	ROOM ANT 2+
74	SB	PASSENGER DOOR ANT-
75	BR	PASSENGER DOOR ANT+
76	V	DRIVER DOOR ANT-
77	LG	DRIVER DOOR ANT+
78	Y	ROOM ANT 1-
79	BR	ROOM ANT 1+
80	GR	NATS ANTRRNA AMP
81	W	NATS ANTRRNA AMP
82	R	IGN RELAY (F/B) CONT
83	Y	KEYLESS ENTRY RECEIVER COMM
87	Y	COMBI SW INPUT 5
88	BG	COMBI SW INPUT 3
89	BR	PUSH SW
90	P	CAN-L
91	L	CAN-H
92	LG	KEY SLOT ILL
93	V	ON IND
95	BG	ACC RELAY CONT
96	GR	A/T SHFT SELECTOR POWER SUPPLY
97	L	S/L CONDITION 1
98	SB	S/L CONDITION 2
99	R	SHFT P (M/G A/T)
99	R	ASCD/ICC CLUTCH SW [With M/T]
100	Y	PASSENGER DOOR REQUEST SW
101	P	DRIVER DOOR REQUEST SW
102	BG	BLOWER FAN MOTOR RELAY CONT
103	LG	KEYLESS ENTRY RECEIVER POWER SUPPLY
106	W	S/L UNIT POWER SUPPLY
107	LG	COMBI SW INPUT 1
108	R	COMBI SW INPUT 4
109	W	COMBI SW INPUT 2
110	G	HAZARD SW
111	Y	S/L UNIT COMM

Connector No.	M123
Connector Name	BCM (BODY CONTROL MODULE)
Connector Type	TH4CFG-NH



Terminal No.	Color of Wire	Signal Name [Specification]
112	BR	RAIN SENSOR SERIAL LINK
113	G	OPTICAL SENSOR
114	R	CLUTCH INTERLOCK SW
116	SB	STOP LAMP SW 1
118	BR	STOP LAMP SW 2
119	GR	DR DOOR UNLOCK SENSOR
121	SB	KEY SLOT SW
122	W	IGN F/B
124	BG	PASSENGER DOOR SW
129	BG	TRUNK LID OPENER CANCEL SW
132	LG	P/W SW & RHT C/L COMM
133	Y	PUSH-BUTTON IGNITION SW ILL POWER
134	LG	LOCK IND
137	BG	RECEIVER / SENSOR GND
138	Y	RECEIVER / SENSOR POWER SUPPLY
139	L	TIRE PRESSURE RECEIVER COMM
140	GR	SHIFT N/P
141	R	SECURITY INDICATOR LAMP
142	BR	COMBI SW OUTPUT 5
143	V	COMBI SW OUTPUT 1
144	G	COMBI SW OUTPUT 2
146	L	COMBI SW OUTPUT 3
146	SB	COMBI SW OUTPUT 4
149	W	TIRE PRESSURE WARN CHECK SW
150	R	DRIVER DOOR SW
151	G	REAR WINDOW DEFROGGER RELAY CONT

DLK

INTEGRATED HOMELINK TRANSMITTER SYSTEM

< DTC/CIRCUIT DIAGNOSIS >

INTEGRATED HOMELINK TRANSMITTER SYSTEM

Wiring Diagram - INTEGRATED HOMELINK TRANSMITTER SYSTEM -

INFOID:000000005624280

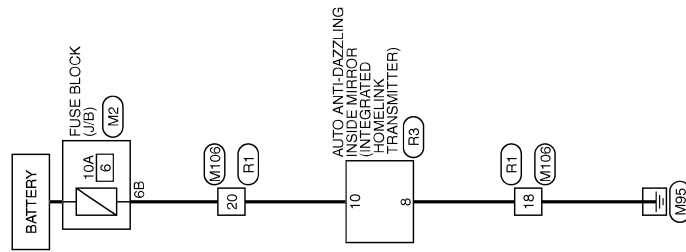

INTEGRATED HOMELINK TRANSMITTER

2009/11/10

JCKWM3949Gf

INTEGRATED HOMELINK TRANSMITTER SYSTEM

< DTC/CIRCUIT DIAGNOSIS >

INTEGRATED HOMELINK TRANSMITTER

Connector No.	M2
Connector Name	FUSE BLOCK (J/B)
Connector Type	MS10PW-CS



4B	8B	2B	1B
10B	9B	6B	7B
6B	5B	8B	5B

Terminal No.	Color of Wire	Signal Name [Specification]
1B	R	-
3B	P	-
4B	G	-
5B	EG	-
6B	Y	-
7B	P	-
8B	R	-
9B	SB	-

Connector No.	M106
Connector Name	WIRE TO WIRE
Connector Type	NH10MW-CS10



1	2	3	4	5	6
7	8	9	10	11	12
13	14	15	16	17	18
19	20				

Terminal No.	Color of Wire	Signal Name [Specification]
1	B	-
2	BR	-
3	Y	-
4	G	-
5	SHIELD	-
6	R	-
7	B	-
8	L	-
9	R	-
10	SB	-
11	V	-
12	LG	-
18	B	-
18	P	-

20	Y	-
----	---	---

Connector No.	R1
Connector Name	WIRE TO WIRE
Connector Type	NH10PW-CS10



6	5	4	3	2	1
20	19	18	17	16	15
14	13	12	11	10	9
8	7				

Terminal No.	Color of Wire	Signal Name [Specification]
1	B	-
2	BR	-
3	Y	-
4	W	-
5	SHIELD	-
6	O	-
7	B	-
8	L	-
9	Y	-
10	B	-
11	V	-
12	R	-
18	B	-
19	BR	-
20	G	-

Connector No.	R3
Connector Name	AUTO ANTI-DAZZLING INSIDE MIRROR
Connector Type	TH10PE-NH



10	8	6
----	---	---

Terminal No.	Color of Wire	Signal Name [Specification]
6	BR	IGN
8	B	GND
10	G	BAT

JCKWM3950G1

A
B
C
D
E
F
G
H
I
J
DLK
L
M
N
O
P

BCM (BODY CONTROL MODULE)

< ECU DIAGNOSIS INFORMATION >

ECU DIAGNOSIS INFORMATION

BCM (BODY CONTROL MODULE)

Reference Value

INFOID:000000005897684

VALUES ON THE DIAGNOSIS TOOL

CONSULT-III MONITOR ITEM

Monitor Item	Condition	Value/Status
FR WIPER HI	Other than front wiper switch HI	Off
	Front wiper switch HI	On
FR WIPER LOW	Other than front wiper switch LO	Off
	Front wiper switch LO	On
FR WASHER SW	Front washer switch OFF	Off
	Front washer switch ON	On
FR WIPER INT	Other than front wiper switch INT/AUTO	Off
	Front wiper switch INT/AUTO	On
FR WIPER STOP	Front wiper is not in STOP position	Off
	Front wiper is in STOP position	On
INT VOLUME	Wiper volume dial is in a dial position 1 - 7	Wiper volume dial position
TURN SIGNAL R	Other than turn signal switch RH	Off
	Turn signal switch RH	On
TURN SIGNAL L	Other than turn signal switch LH	Off
	Turn signal switch LH	On
TAIL LAMP SW	Other than lighting switch 1ST and 2ND	Off
	Lighting switch 1ST or 2ND	On
HI BEAM SW	Other than lighting switch HI	Off
	Lighting switch HI	On
HEAD LAMP SW 1	Other than lighting switch 2ND	Off
	Lighting switch 2ND	On
HEAD LAMP SW 2	Other than lighting switch 2ND	Off
	Lighting switch 2ND	On
PASSING SW	Other than lighting switch PASS	Off
	Lighting switch PASS	On
AUTO LIGHT SW	Other than lighting switch AUTO	Off
	Lighting switch AUTO	On
FR FOG SW	Front fog lamp switch OFF	Off
	Front fog lamp switch ON	On
RR FOG SW	NOTE: The item is indicated, but not monitored.	Off
DOOR SW-DR	Driver door closed	Off
	Driver door opened	On
DOOR SW-AS	Passenger door closed	Off
	Passenger door opened	On
DOOR SW-RR	NOTE: The item is indicated, but not monitored.	Off

BCM (BODY CONTROL MODULE)

< ECU DIAGNOSIS INFORMATION >

Monitor Item	Condition	Value/Status	
DOOR SW-RL	NOTE: The item is indicated, but not monitored.	Off	A
DOOR SW-BK	NOTE: The item is indicated, but not monitored.	Off	B
CDL LOCK SW	Other than power door lock switch LOCK	Off	C
	Power door lock switch LOCK	On	
CDL UNLOCK SW	Other than power door lock switch UNLOCK	Off	D
	Power door lock switch UNLOCK	On	
KEY CYL LK-SW	Other than driver door key cylinder LOCK position	Off	E
	Driver door key cylinder LOCK position	On	
KEY CYL UN-SW	Other than driver door key cylinder UNLOCK position	Off	F
	Driver door key cylinder UNLOCK position	On	
KEY CYL SW-TR	NOTE: The item is indicated, but not monitored.	Off	G
HAZARD SW	Hazard switch is OFF	Off	H
	Hazard switch is ON	On	
REAR DEF SW	NOTE: The item is indicated, but not monitored.	Off	I
H/L WASH SW	NOTE: The item is indicated, but not monitored.	Off	J
TR CANCEL SW	Trunk lid opener cancel switch OFF	Off	K
	Trunk lid opener cancel switch ON	On	
TR/BD OPEN SW	Trunk lid opener switch OFF	Off	L
	While the trunk lid opener switch is turned ON	On	
TRNK/HAT MNTR	Trunk lid closed	Off	M
	Trunk lid opened	On	
RKE-LOCK	LOCK button of the Intelligent Key is not pressed	Off	N
	LOCK button of the Intelligent Key is pressed	On	
RKE-UNLOCK	UNLOCK button of the Intelligent Key is not pressed	Off	O
	UNLOCK button of the Intelligent Key is pressed	On	
RKE-TR/BD	TRUNK OPEN button of the Intelligent Key is not pressed	Off	P
	TRUNK OPEN button of the Intelligent Key is pressed	On	
RKE-PANIC	PANIC button of the Intelligent Key is not pressed	Off	P
	PANIC button of the Intelligent Key is pressed	On	
RKE-P/W OPEN	UNLOCK button of the Intelligent Key is not pressed	Off	P
	UNLOCK button of the Intelligent Key is pressed and held	On	
RKE-MODE CHG	LOCK/UNLOCK button of the Intelligent Key is not pressed and held simultaneously	Off	P
	LOCK/UNLOCK button of the Intelligent Key is pressed and held simultaneously	On	
OPTICAL SENSOR	Bright outside of the vehicle	Close to 5 V	P
	Dark outside of the vehicle	Close to 0 V	
REQ SW -DR	Driver door request switch is not pressed	Off	P
	Driver door request switch is pressed	On	
REQ SW -AS	Passenger door request switch is not pressed	Off	P
	Passenger door request switch is pressed	On	
REQ SW -RR	NOTE: The item is indicated, but not monitored.	Off	P

DLK

BCM (BODY CONTROL MODULE)

< ECU DIAGNOSIS INFORMATION >

Monitor Item	Condition	Value/Status
REQ SW -RL	NOTE: The item is indicated, but not monitored.	Off
REQ SW -BD/TR	Trunk lid opener request switch is not pressed	Off
	Trunk lid opener request switch is pressed	On
PUSH SW	Push-button ignition switch (push switch) is not pressed	Off
	Push-button ignition switch (push switch) is pressed	On
IGN RLY2 -F/B	Ignition switch in OFF or ACC position	Off
	Ignition switch in ON position	On
ACC RLY -F/B	NOTE: The item is indicated, but not monitored.	Off
CLUCH SW	The clutch pedal is not depressed	Off
	The clutch pedal is depressed	On
BRAKE SW 1	The brake pedal is depressed when No. 7 fuse is blown	Off
	The brake pedal is not depressed when No. 7 fuse is blown, or No. 7 fuse is normal	On
BRAKE SW 2	The brake pedal is not depressed	Off
	The brake pedal is depressed	On
DETE/CANCL SW	<ul style="list-style-type: none"> • Selector lever in P position (Except M/T models) • The clutch pedal is depressed (M/T models) 	Off
	<ul style="list-style-type: none"> • Selector lever in any position other than P (Except M/T models) • The clutch pedal is not depressed (M/T models) 	On
SFT PN/N SW	Selector lever in any position other than P and N	Off
	Selector lever in P or N position	On
S/L -LOCK	Steering is unlocked	Off
	Steering is locked	On
S/L -UNLOCK	Steering is locked	Off
	Steering is unlocked	On
S/L RELAY-F/B	Ignition switch in OFF or ACC position	Off
	Ignition switch in ON position	On
UNLK SEN -DR	Driver door is unlocked	Off
	Driver door is locked	On
PUSH SW -IPDM	Push-button ignition switch (push-switch) is not pressed	Off
	Push-button ignition switch (push-switch) is pressed	On
IGN RLY1 -F/B	Ignition switch in OFF or ACC position	Off
	Ignition switch in ON position	On
DETE SW -IPDM	Selector lever in any position other than P	Off
	Selector lever in P position	On
SFT PN -IPDM	<ul style="list-style-type: none"> • Selector lever in any position other than P and N (Except M/T models) • The clutch pedal is not depressed (M/T models) 	Off
	<ul style="list-style-type: none"> • Selector lever in P or N position • The clutch pedal is depressed 	On
SFT P -MET	Selector lever in any position other than P	Off
	Selector lever in P position	On
SFT N -MET	Selector lever in any position other than N	Off
	Selector lever in N position	On

BCM (BODY CONTROL MODULE)

< ECU DIAGNOSIS INFORMATION >

Monitor Item	Condition	Value/Status	
ENGINE STATE	Engine stopped	Stop	A
	While the engine stalls	Stall	
	At engine cranking	Crank	B
	Engine running	Run	
S/L LOCK-IPDM	Steering is unlocked	Off	
	Steering is locked	On	C
S/L UNLK-IPDM	Steering is locked	Off	
	Steering is unlocked	On	D
S/L RELAY-REQ	Steering lock system is not the LOCK condition and the changing condition from LOCK to UNLOCK	Off	
	Steering lock system are not the LOCK condition or the changing condition from LOCK to UNLOCK	On	E
VEH SPEED 1	While driving	Equivalent to speedometer reading	F
VEH SPEED 2	While driving	Equivalent to speedometer reading	
DOOR STAT-DR	Driver door is locked	LOCK	G
	Wait with selective UNLOCK operation (60 seconds)	READY	
	Driver door is unlocked	UNLOCK	
DOOR STAT-AS	Passenger door is locked	LOCK	H
	Wait with selective UNLOCK operation (60 seconds)	READY	
	Passenger door is unlocked	UNLOCK	I
ID OK FLAG	Steering is locked	Reset	
	Steering is unlocked	Set	
PRMT ENG STRT	The engine start is prohibited	Reset	J
	The engine start is permitted	Set	
PRMT RKE STRT	NOTE: The item is indicated, but not monitored.	Reset	DLK
KEY SW -SLOT	The Intelligent Key is not inserted into key slot	Off	
	The Intelligent Key is inserted into key slot	On	L
RKE OPE COUN1	During the operation of the Intelligent Key	Operation frequency of the Intelligent Key	
RKE OPE COUN2	NOTE: The item is indicated, but not monitored.	—	M
CONFIRM ID ALL	The key ID that the key slot receives is not recognized by any key ID registered to BCM.	Yet	
	The key ID that the key slot receives is recognized by any key ID registered to BCM.	Done	N
CONFIRM ID4	The key ID that the key slot receives is not recognized by the fourth key ID registered to BCM.	Yet	O
	The key ID that the key slot receives is recognized by the fourth key ID registered to BCM.	Done	
CONFIRM ID3	The key ID that the key slot receives is not recognized by the third key ID registered to BCM.	Yet	P
	The key ID that the key slot receives is recognized by the third key ID registered to BCM.	Done	

BCM (BODY CONTROL MODULE)

< ECU DIAGNOSIS INFORMATION >

Monitor Item	Condition	Value/Status
CONFIRM ID2	The key ID that the key slot receives is not recognized by the second key ID registered to BCM.	Yet
	The key ID that the key slot receives is recognized by the second key ID registered to BCM.	Done
CONFIRM ID1	The key ID that the key slot receives is not recognized by the first key ID registered to BCM.	Yet
	The key ID that the key slot receives is recognized by the first key ID registered to BCM.	Done
TP 4	The ID of fourth Intelligent Key is not registered to BCM	Yet
	The ID of fourth Intelligent Key is registered to BCM	Done
TP 3	The ID of third Intelligent Key is not registered to BCM	Yet
	The ID of third Intelligent Key is registered to BCM	Done
TP 2	The ID of second Intelligent Key is not registered to BCM	Yet
	The ID of second Intelligent Key is registered to BCM	Done
TP 1	The ID of first Intelligent Key is not registered to BCM	Yet
	The ID of first Intelligent Key is registered to BCM	Done
AIR PRESS FL	Ignition switch ON (Only when the signal from the transmitter is received)	Air pressure of front LH tire
AIR PRESS FR	Ignition switch ON (Only when the signal from the transmitter is received)	Air pressure of front RH tire
AIR PRESS RR	Ignition switch ON (Only when the signal from the transmitter is received)	Air pressure of rear RH tire
AIR PRESS RL	Ignition switch ON (Only when the signal from the transmitter is received)	Air pressure of rear LH tire
ID REGST FL1	ID of front LH tire transmitter is registered	Done
	ID of front LH tire transmitter is not registered	Yet
ID REGST FR1	ID of front RH tire transmitter is registered	Done
	ID of front RH tire transmitter is not registered	Yet
ID REGST RR1	ID of rear RH tire transmitter is registered	Done
	ID of rear RH tire transmitter is not registered	Yet
ID REGST RL1	ID of rear LH tire transmitter is registered	Done
	ID of rear LH tire transmitter is not registered	Yet
WARNING LAMP	Tire pressure indicator OFF	Off
	Tire pressure indicator ON	On
BUZZER	Tire pressure warning alarm is not sounding	Off
	Tire pressure warning alarm is sounding	On

BCM (BODY CONTROL MODULE)

< ECU DIAGNOSIS INFORMATION >

TERMINAL LAYOUT

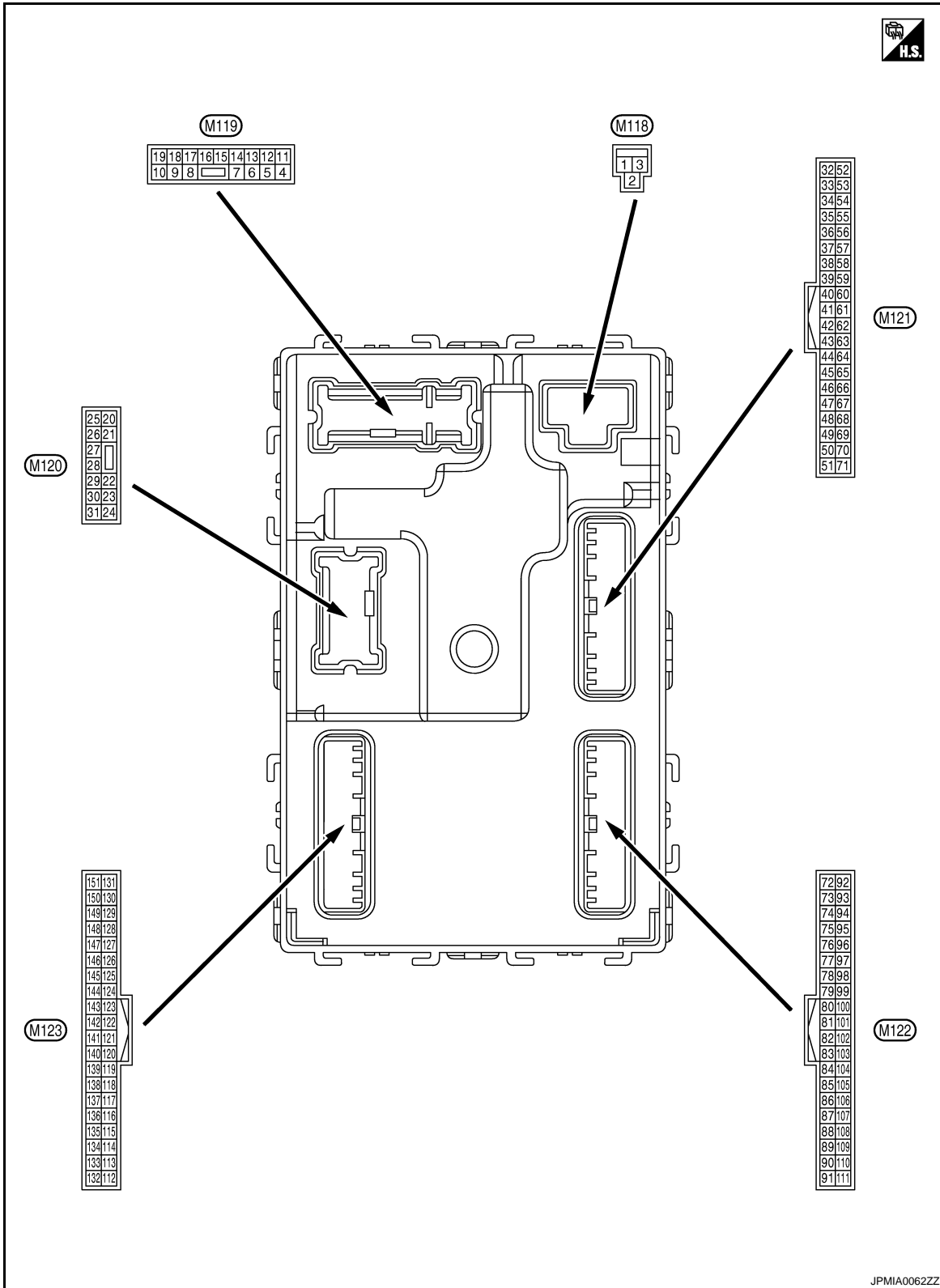

PHYSICAL VALUES

A
B
C
D
E
F
G
H
I
J
K
L
M
N
O
P

DLK

BCM (BODY CONTROL MODULE)

< ECU DIAGNOSIS INFORMATION >

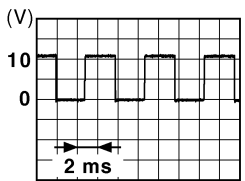
Terminal No. (Wire color)		Description		Condition		Value (Approx.)
		Signal name	Input/ Output			
+	-					
1 (W)	Ground	Battery power supply	Input	Ignition switch OFF		Battery voltage
2 (Y)	Ground	P/W power supply (BAT)	Output	Ignition switch OFF		12 V
3 (BG)	Ground	P/W power supply (RAP)	Output	Ignition switch ON		12 V
4 (LG)	Ground	Interior room lamp power supply	Output	Interior room lamp battery saver is activated. (Cuts the interior room lamp power supply)		0 V
				Interior room lamp battery saver is not activated. (Outputs the interior room lamp power supply)		12 V
5 (P)	Ground	Passenger door UN- LOCK	Output	Passenger door	UNLOCK (Actuator is activated)	12 V
					Other than UNLOCK (Actuator is not activated)	0 V
7 (SB)	Ground	Step lamp	Output	Step lamp	ON	0 V
					OFF	12 V
8 (V)	Ground	All doors, fuel lid LOCK	Output	All doors, fuel lid	LOCK (Actuator is activated)	12 V
					Other than LOCK (Actuator is not activated)	0 V
9 (G)	Ground	Driver door, fuel lid UNLOCK	Output	Driver door, fuel lid	UNLOCK (Actuator is activated)	12 V
					Other than UNLOCK (Actuator is not activated)	0 V
11 (GR)	Ground	Battery power supply	Input	Ignition switch OFF		Battery voltage
13 (B)	Ground	Ground	—	Ignition switch ON		0 V
14 (W)	Ground	Push-button ignition switch illumination ground	Output	Tail lamp	OFF	0 V
					ON	<p style="text-align: center;">NOTE: When the illumination brightening/dimming level is in the neutral position.</p>  <p style="text-align: right; font-size: small;">JSNIA0010GB</p>
15 (BG)	Ground	ACC indicator lamp	Output	Ignition switch	OFF (LOCK indicator is not illuminated)	Battery voltage
					ACC	0 V

BCM (BODY CONTROL MODULE)

< ECU DIAGNOSIS INFORMATION >

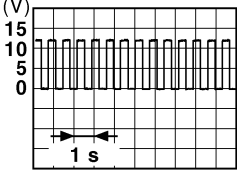
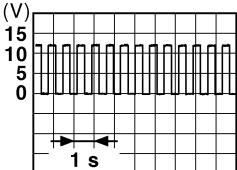
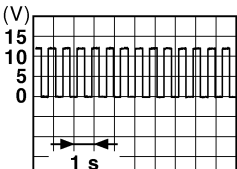
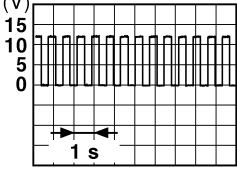
Terminal No. (Wire color)		Description		Condition	Value (Approx.)	
		Signal name	Input/ Output			
+	-					
17 (BR)	Ground	Turn signal RH (Front)	Output	Ignition switch ON	Turn signal switch OFF	0 V
					Turn signal switch RH	 <small>PKID0926E</small>
18 (BG)	Ground	Turn signal LH (Front)	Output	Ignition switch ON	Turn signal switch OFF	0 V
					Turn signal switch LH	 <small>PKID0926E</small>
19 (V)	Ground	Room lamp timer control	Output	Interior room lamp	OFF	12 V
					ON	0 V
20 (V)	Ground	Turn signal RH (Rear)	Output	Ignition switch ON	Turn signal switch OFF	0 V
					Turn signal switch RH	 <small>PKID0926E</small>
23 (Y)	Ground	Trunk lid open	Output	Trunk lid	OPEN (Trunk lid opener actuator is activated)	12 V
					Other than OPEN (Trunk lid opener actuator is not activated)	0 V
25 (Y)	Ground	Turn signal LH (Rear)	Output	Ignition switch ON	Turn signal switch OFF	0 V
					Turn signal switch LH	 <small>PKID0926E</small>
30 (P)	Ground	Trunk room lamp	Output	Trunk room lamp	ON	0 V
					OFF	12 V

A
B
C
D
E
F
G
H
I
J
L
M
N
O
P

DLK

BCM (BODY CONTROL MODULE)

< ECU DIAGNOSIS INFORMATION >

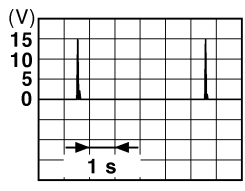
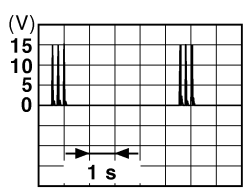
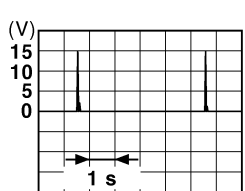
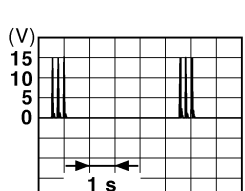
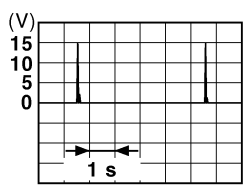
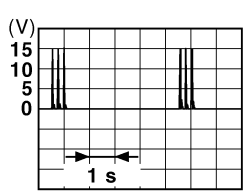
Terminal No. (Wire color)		Description		Condition	Value (Approx.)
		Signal name	Input/ Output		
+	-				
34 (SB)	Ground	Trunk room antenna (-)	Output	Ignition switch OFF	When Intelligent Key is in the passenger compart- ment  <small>JMKIA0062GB</small>
				When Intelligent Key is not in the passenger compart- ment  <small>JMKIA0063GB</small>	
35 (V)	Ground	Trunk room antenna (+)	Output	Ignition switch OFF	When Intelligent Key is in the passenger compart- ment  <small>JMKIA0062GB</small>
				When Intelligent Key is not in the passenger compart- ment  <small>JMKIA0063GB</small>	
38 (B)	Ground	Rear bumper anten- na (-)	Output	When the trunk lid opener re- quest switch is operated with ignition switch OFF	When Intelligent Key is in the antenna detection area  <small>JMKIA0062GB</small>
				When Intelligent Key is not in the antenna detection area  <small>JMKIA0063GB</small>	

BCM (BODY CONTROL MODULE)

< ECU DIAGNOSIS INFORMATION >

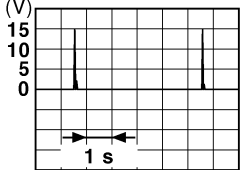
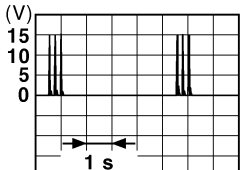
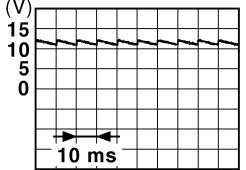
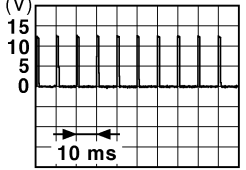
Terminal No. (Wire color)		Description		Condition	Value (Approx.)
		Signal name	Input/ Output		
+	-				
39 (W)	Ground	Rear bumper antenna (+)	Output	When Intelligent Key is in the antenna detection area	 <small>JMKIA0062GB</small>
				When the trunk lid opener request switch is operated with ignition switch OFF	 <small>JMKIA0063GB</small>
47 (Y)	Ground	Ignition relay (IPDM E/R) control	Output	Ignition switch OFF or ACC	12 V
				ON	0 V
50 (G)	Ground	Trunk room lamp switch	Input	Trunk room lamp switch OFF (Trunk lid is closed)	 <small>JPMIA0011GB</small>
				ON (Trunk lid is opened)	0 V
52 (BR)	Ground	Starter relay control	Output	Ignition switch ON (A/T models)	12 V
				When selector lever is in P or N position	0 V
				Ignition switch ON (M/T models)	Battery voltage
				When the clutch pedal is depressed	0 V
61 (SB)	Ground	Trunk lid opener request switch	Input	Trunk lid opener request switch ON (Pressed)	0 V
				OFF (Not pressed)	 <small>JPMIA0016GB</small>
64 (G)	Ground	Intelligent Key warning buzzer (Engine room)	Output	Intelligent Key warning buzzer (Engine room) Sounding	0 V
				Not sounding	12 V

A
B
C
D
E
F
G
H
I
J
L
M
N
O
P

DLK

BCM (BODY CONTROL MODULE)

< ECU DIAGNOSIS INFORMATION >

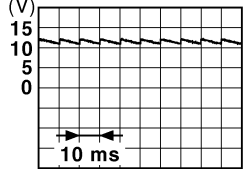
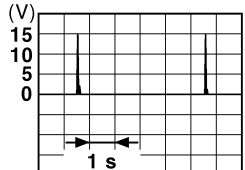
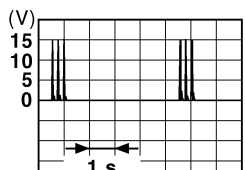
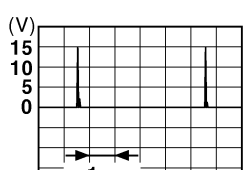
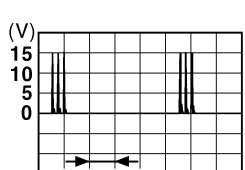
Terminal No. (Wire color)		Description		Condition		Value (Approx.)
+	-	Signal name	Input/ Output			
67 (GR)	Ground	Trunk lid opener switch	Input	Trunk lid open- er switch	Pressed	0 V
					Not pressed	 <p style="text-align: right; font-size: small;">JPMIA0011GB</p>
72 (R)	Ground	Room antenna 2 (-) (Center console)	Output	Ignition switch OFF	When Intelligent Key is in the passenger compart- ment	 <p style="text-align: right; font-size: small;">JMKIA0062GB</p>
					When Intelligent Key is not in the passenger compart- ment	 <p style="text-align: right; font-size: small;">JMKIA0063GB</p>
73 (G)	Ground	Room antenna 2 (+) (Center console)	Output	Ignition switch OFF	When Intelligent Key is in the passenger compart- ment	 <p style="text-align: right; font-size: small;">JMKIA0062GB</p>
					When Intelligent Key is not in the passenger compart- ment	 <p style="text-align: right; font-size: small;">JMKIA0063GB</p>

BCM (BODY CONTROL MODULE)

< ECU DIAGNOSIS INFORMATION >

Terminal No. (Wire color)		Description		Condition	Value (Approx.)
+	-	Signal name	Input/ Output		
74 (SB)	Ground	Passenger door antenna (-)	Output	When Intelligent Key is in the antenna detection area	<p style="text-align: right; font-size: small;">JMKIA0062GB</p>
				When the passenger door request switch is operated with ignition switch OFF	<p style="text-align: right; font-size: small;">JMKIA0063GB</p>
75 (BR)	Ground	Passenger door antenna (+)	Output	When Intelligent Key is in the antenna detection area	<p style="text-align: right; font-size: small;">JMKIA0062GB</p>
				When the passenger door request switch is operated with ignition switch OFF	<p style="text-align: right; font-size: small;">JMKIA0063GB</p>
76 (V)	Ground	Driver door antenna (-)	Output	When Intelligent Key is in the antenna detection area	<p style="text-align: right; font-size: small;">JMKIA0062GB</p>
				When the driver door request switch is operated with ignition switch OFF	<p style="text-align: right; font-size: small;">JMKIA0063GB</p>

A
B
C
D
E
F
G
H
I
J
L
M
N
O
P

DLK

BCM (BODY CONTROL MODULE)

< ECU DIAGNOSIS INFORMATION >

Terminal No. (Wire color)		Description		Condition	Value (Approx.)
+	-	Signal name	Input/ Output		
77 (LG)	Ground	Driver door antenna (+)	Output	When Intelligent Key is in the antenna detection area	<p style="text-align: right; font-size: small;">JMKIA0062GB</p>
				When the driver door request switch is operated with ignition switch OFF	<p style="text-align: right; font-size: small;">JMKIA0063GB</p>
78 (Y)	Ground	Room antenna 1 (-) (Instrument panel)	Output	When Intelligent Key is in the passenger compart- ment	<p style="text-align: right; font-size: small;">JMKIA0062GB</p>
				When Intelligent Key is not in the passenger compart- ment	<p style="text-align: right; font-size: small;">JMKIA0063GB</p>
79 (BR)	Ground	Room antenna 1 (+) (Instrument panel)	Output	When Intelligent Key is in the passenger compart- ment	<p style="text-align: right; font-size: small;">JMKIA0062GB</p>
				When Intelligent Key is not in the passenger compart- ment	<p style="text-align: right; font-size: small;">JMKIA0063GB</p>

BCM (BODY CONTROL MODULE)

< ECU DIAGNOSIS INFORMATION >

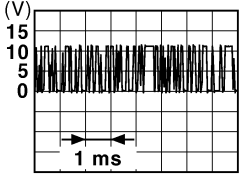
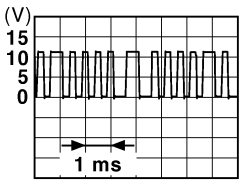
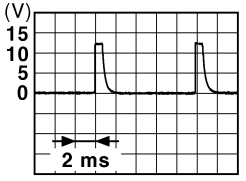
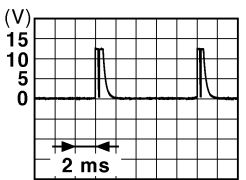
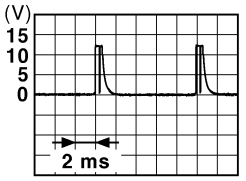
Terminal No. (Wire color)		Description		Condition		Value (Approx.)
+	-	Signal name	Input/ Output			
80 (GR)	Ground	NATS antenna amp.	Input/ Output	During waiting	Ignition switch is pressed while inserting the Intelligent Key into the key slot.	Just after pressing ignition switch. Pointer of tester should move.
81 (W)	Ground	NATS antenna amp.	Input/ Output	During waiting	Ignition switch is pressed while inserting the Intelligent Key into the key slot.	Just after pressing ignition switch. Pointer of tester should move.
82 (R)	Ground	Ignition relay [Fuse block (J/B)] control	Output	Ignition switch	OFF or ACC	0 V
					ON	12 V
83 (Y)	Ground	Remote keyless entry receiver communication	Input/ Output	During waiting		 <p style="text-align: right; font-size: small;">JMKIA0064GB</p>
				When operating either button on the Intelligent Key		 <p style="text-align: right; font-size: small;">JMKIA0065GB</p>
87 (Y)	Ground	Combination switch INPUT 5	Input	Combination switch	All switches OFF (Wiper volume dial 4)	 <p style="text-align: right; font-size: small;">JPMIA0041GB</p> <p style="text-align: center;">1.4 V</p>
					Front fog lamp switch ON (Wiper volume dial 4)	 <p style="text-align: right; font-size: small;">JPMIA0037GB</p> <p style="text-align: center;">1.3 V</p>
					Any of the conditions below with all switches OFF <ul style="list-style-type: none"> • Wiper volume dial 1 • Wiper volume dial 2 • Wiper volume dial 6 • Wiper volume dial 7 	 <p style="text-align: right; font-size: small;">JPMIA0040GB</p> <p style="text-align: center;">1.3 V</p>

A
B
C
D
E
F
G
H
I
J
L
M
N
O
P

DLK

BCM (BODY CONTROL MODULE)

< ECU DIAGNOSIS INFORMATION >

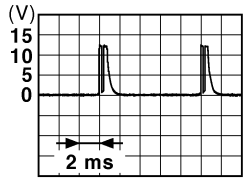
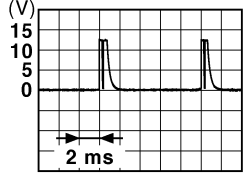
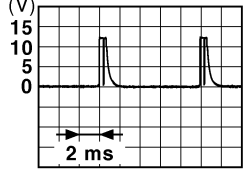
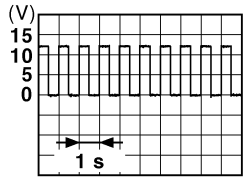
Terminal No. (Wire color)		Description		Condition	Value (Approx.)	
		Signal name	Input/ Output			
+	-					
88 (BG)	Ground	Combination switch INPUT 3	Input	Combination switch	All switches OFF (Wiper volume dial 4)	 <small>JPMIA0041GB</small> 1.4 V
					Lighting switch HI (Wiper volume dial 4)	 <small>JPMIA0036GB</small> 1.3 V
					Lighting switch 2ND (Wiper volume dial 4)	 <small>JPMIA0037GB</small> 1.3 V
					Any of the conditions below with all switches OFF <ul style="list-style-type: none"> • Wiper volume dial 1 • Wiper volume dial 2 • Wiper volume dial 3 	 <small>JPMIA0040GB</small> 1.3 V
89 (BR)	Ground	Push-button ignition switch (Push switch)	Input	Push-button ignition switch (push switch)	Pressed	0 V
					Not pressed	Battery voltage
90 (P)	Ground	CAN-L	Input/ Output	—	—	
91 (L)	Ground	CAN-H	Input/ Output	—	—	
92 (LG)	Ground	Key slot illumination	Output	Key slot illumina- tion	OFF	0 V
					Blinking	 <small>JPMIA0015GB</small> 6.5 V
					ON	12 V

BCM (BODY CONTROL MODULE)

< ECU DIAGNOSIS INFORMATION >

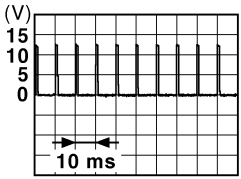
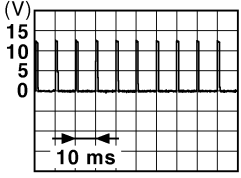

Terminal No. (Wire color)		Description		Condition		Value (Approx.)
		Signal name	Input/ Output			
+	-					
93 (V)	Ground	ON indicator lamp	Output	Ignition switch	OFF (LOCK indicator is not illuminated)	Battery voltage
					ON	0 V
95 (BG)	Ground	ACC relay control	Output	Ignition switch	OFF	0 V
					ACC or ON	12 V
96 (GR)	Ground	A/T shift selector (Detention switch) power supply	Output	—		12 V
97 (L)	Ground	Steering lock condition No. 1	Input	Steering lock	LOCK status	0 V
					UNLOCK status	12 V
98 (SB)	Ground	Steering lock condition No. 2	Input	Steering lock	LOCK status	12 V
					UNLOCK status	0 V
99 (R)	Ground	Selector lever P position switch	Input	Selector lever	P position	0 V
					Any position other than P	12 V
		ASCD clutch switch (M/T models without ICC)		ASCD clutch switch	OFF (Clutch pedal is depressed)	0 V
					ON (Clutch pedal is not depressed)	12 V
		ICC clutch switch (M/T models with ICC)		ICC clutch switch	OFF (Clutch pedal is depressed)	0 V
					ON (Clutch pedal is not depressed)	12 V
100 (Y)	Ground	Passenger door request switch	Input	Passenger door request switch	ON (Pressed)	0 V
					OFF (Not pressed)	 1.0 V
101 (P)	Ground	Driver door request switch	Input	Driver door request switch	ON (Pressed)	0 V
					OFF (Not pressed)	 1.0 V
102 (BG)	Ground	Blower fan motor relay control	Output	Ignition switch	OFF or ACC	0 V
					ON	12 V
103 (LG)	Ground	Remote keyless entry receiver power supply	Output	Ignition switch OFF		12 V
106 (W)	Ground	Steering lock unit power supply	Output	Ignition switch	OFF or ACC	12 V
					ON	0 V

A
B
C
D
E
F
G
H
I
J
L
M
N
O
P

DLK

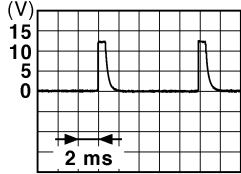
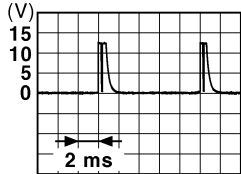

BCM (BODY CONTROL MODULE)

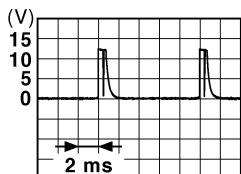
< ECU DIAGNOSIS INFORMATION >

Terminal No. (Wire color)		Description		Condition	Value (Approx.)	
+	-	Signal name	Input/ Output			
107 (LG)	Ground	Combination switch INPUT 1	Input	Combination switch (Wiper volume dial 4)	All switches OFF	 <p style="text-align: right; margin-right: 20px;">JPMIA0041GB</p> <p style="text-align: center;">1.4 V</p>
					Turn signal switch LH	 <p style="text-align: right; margin-right: 20px;">JPMIA0037GB</p> <p style="text-align: center;">1.3 V</p>
					Turn signal switch RH	 <p style="text-align: right; margin-right: 20px;">JPMIA0036GB</p> <p style="text-align: center;">1.3 V</p>
					Front wiper switch LO	 <p style="text-align: right; margin-right: 20px;">JPMIA0038GB</p> <p style="text-align: center;">1.3 V</p>
					Front washer switch ON	 <p style="text-align: right; margin-right: 20px;">JPMIA0039GB</p> <p style="text-align: center;">1.3 V</p>

BCM (BODY CONTROL MODULE)

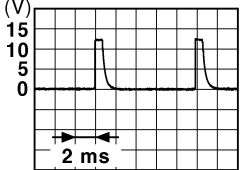
< ECU DIAGNOSIS INFORMATION >

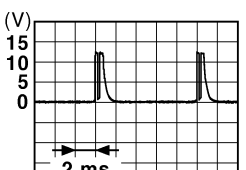
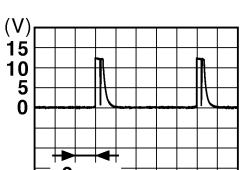
Terminal No. (Wire color)		Description		Condition	Value (Approx.)	
		Signal name	Input/ Output			
+	-					
108 (R)	Ground	Combination switch INPUT 4	Input	Combination switch	All switches OFF (Wiper volume dial 4)	 <p style="text-align: right;">1.4 V</p>
					Lighting switch AUTO (Wiper volume dial 4)	 <p style="text-align: right;">1.3 V</p>
					Lighting switch 1ST (Wiper volume dial 4)	 <p style="text-align: right;">1.3 V</p>
					Any of the conditions below with all switches OFF <ul style="list-style-type: none"> • Wiper volume dial 1 • Wiper volume dial 5 • Wiper volume dial 6 	 <p style="text-align: right;">1.3 V</p>

A
B
C
D
E
F
G
H
I
J
L
M
N
O
P

DLK

BCM (BODY CONTROL MODULE)

< ECU DIAGNOSIS INFORMATION >

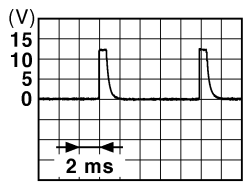
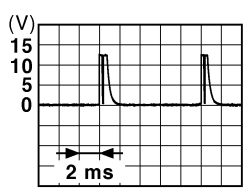
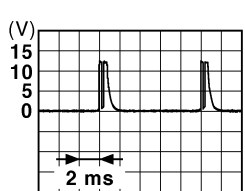
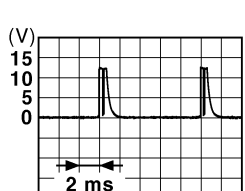
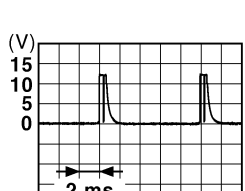
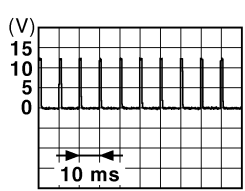
Terminal No. (Wire color)		Description		Condition	Value (Approx.)	
+	-	Signal name	Input/ Output			
109 (W)	Ground	Combination switch INPUT 2	Input	Combination switch (Wiper volume dial 4)	All switches OFF	 <small>JPMIA0041GB</small> 1.4 V
					Lighting switch PASS	 <small>JPMIA0037GB</small> 1.3 V
					Lighting switch 2ND	 <small>JPMIA0036GB</small> 1.3 V
					Front wiper switch INT/ AUTO	 <small>JPMIA0038GB</small> 1.3 V
					Front wiper switch HI	 <small>JPMIA0040GB</small> 1.3 V
					ON	0 V
110 (G)	Ground	Hazard switch	Input	Hazard switch	OFF	 <small>JPMIA0012GB</small> 1.1 V

BCM (BODY CONTROL MODULE)

< ECU DIAGNOSIS INFORMATION >

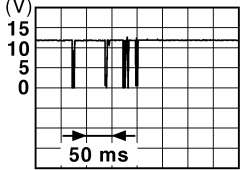
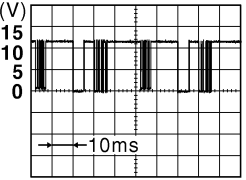
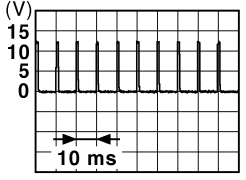
Terminal No. (Wire color)		Description		Condition	Value (Approx.)	
		Signal name	Input/ Output			
+	-					
111 (Y)	Ground	Steering lock unit communication	Input/ Output	Steering lock	LOCK status	12 V
					LOCK or UNLOCK	 <p style="text-align: right; font-size: small;">JMKIA0066GB</p>
					For 15 seconds after UNLOCK	12 V
				15 seconds or later after UNLOCK	0 V	
112 (BR)	Ground	Rain sensor serial link	Input/ Output	Ignition switch ON	 <p style="text-align: right; font-size: small;">JPMIA0156GB</p>	
113 (G)	Ground	Optical sensor	Input	Ignition switch ON	When bright outside of the vehicle	Close to 5 V
				When dark outside of the vehicle	Close to 0 V	
114 (R)	Ground	Clutch interlock switch	Input	Clutch interlock switch	OFF (Clutch pedal is not depressed)	0 V
					ON (Clutch pedal is depressed)	Battery voltage
116 (SB)	Ground	Stop lamp switch 1	Input	—	Battery voltage	
118 (BR)	Ground	Stop lamp switch 2 (Without ICC)	Input	Stop lamp switch	OFF (Brake pedal is not depressed)	0 V
					ON (Brake pedal is depressed)	Battery voltage
		Stop lamp switch 2 (With ICC)		Stop lamp switch OFF (Brake pedal is not depressed) and ICC brake hold relay OFF	0 V	
				Stop lamp switch ON (Brake pedal is depressed) or ICC brake hold relay ON	Battery voltage	
119 (GR)	Ground	Driver side door lock assembly (Unlock sensor)	Input	Driver door	LOCK status (Unlock sensor switch OFF)	 <p style="text-align: right; font-size: small;">JPMIA0012GB</p>
					UNLOCK status (Unlock switch sensor ON)	0 V

A
B
C
D
E
F
G
H
I
J
K
L
M
N
O
P

DLK

BCM (BODY CONTROL MODULE)

< ECU DIAGNOSIS INFORMATION >

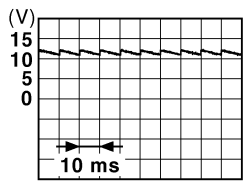
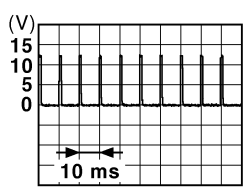
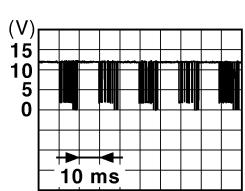
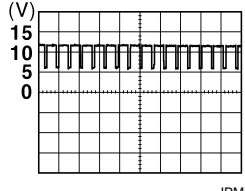
Terminal No. (Wire color)		Description		Condition	Value (Approx.)	
		Signal name	Input/ Output			
+	-					
121 (SB)	Ground	Key slot switch	Input	When the Intelligent Key is inserted into key slot	12 V	
				When the Intelligent Key is not inserted into key slot	0 V	
123 (W)	Ground	IGN feedback	Input	Ignition switch	OFF or ACC	0 V
					ON	Battery voltage
124 (BG)	Ground	Passenger door switch	Input	Passenger door switch	OFF (Door close)	 11.8 V
					ON (Door open)	0 V
129 (BG)	Ground	Trunk lid opener cancel switch	Input	Trunk lid opener cancel switch	CANCEL	 1.1 V
					ON	0 V
132 (LG)	Ground	Power window switch and R.H.T. control unit communication	Input/ Output	Ignition switch ON	 10.2 V	
				Ignition switch OFF or ACC	12 V	
133 (Y)	Ground	Push-button ignition switch illumination	Output	Push-button ignition switch illumination	ON (Tail lamps OFF)	9.5 V
					ON (Tail lamps ON)	<p style="text-align: center;">NOTE: The pulse width of this wave is varied by the illumination brightening/dimming level.</p> 
					OFF	0 V
134 (LG)	Ground	LOCK indicator lamp	Output	LOCK indicator lamp	OFF	Battery voltage
					ON	0 V
137 (BG)	Ground	Receiver and sensor ground	Input	Ignition switch ON	0 V	

BCM (BODY CONTROL MODULE)

< ECU DIAGNOSIS INFORMATION >

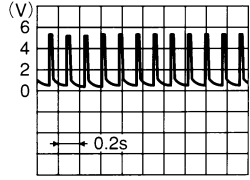
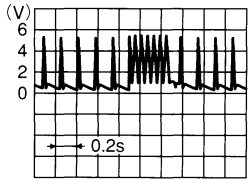
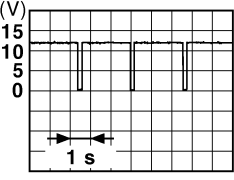
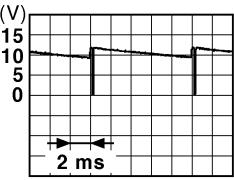
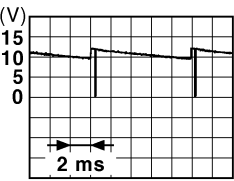
Terminal No. (Wire color)		Description		Condition		Value (Approx.)
		Signal name	Input/ Output			
+	-					
138 (Y)	Ground	Receiver and sensor power supply	Output	Ignition switch	OFF	0 V
					ACC or ON	5.0 V
139 (L)	Ground	Tire pressure receiver communication	Input/ Output	Ignition switch ON	Standby state	 OCC3881D
					When receiving the signal from the transmitter	 OCC3880D
140 (GR)	Ground	Selector lever P/N position (A/T models)	Input	Selector lever	P or N position	12 V
					Except P and N positions	0 V
141 (R)	Ground	Security indicator lamp	Output	Security indicator lamp	ON	0 V
					Blinking	 JPMA0014GB
					OFF	12 V
142 (BR)	Ground	Combination switch OUTPUT 5	Output	Combination switch (Wiper volume dial 4)	All switches OFF	0 V
					Lighting switch 1ST	 JPMA0031GB
					Lighting switch HI	
					Lighting switch 2ND	
					Turn signal switch RH	
Turn signal switch RH	10.7 V					
143 (V)	Ground	Combination switch OUTPUT 1	Output	Combination switch	All switches OFF (Wiper volume dial 4)	0 V
					Front wiper switch HI (Wiper volume dial 4)	 JPMA0032GB
					Any of the conditions below with all switches OFF <ul style="list-style-type: none"> • Wiper volume dial 1 • Wiper volume dial 2 • Wiper volume dial 3 • Wiper volume dial 6 • Wiper volume dial 7 	
Any of the conditions below with all switches OFF <ul style="list-style-type: none"> • Wiper volume dial 1 • Wiper volume dial 2 • Wiper volume dial 3 • Wiper volume dial 6 • Wiper volume dial 7 	10.7 V					

A
B
C
D
E
F
G
H
I
J
K
L
M
N
O
P

DLK

BCM (BODY CONTROL MODULE)

< ECU DIAGNOSIS INFORMATION >

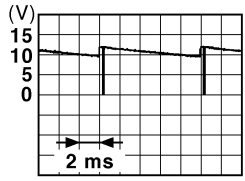
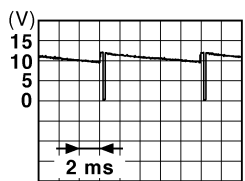
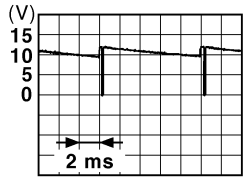
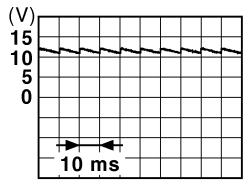
Terminal No. (Wire color)		Description		Condition	Value (Approx.)		
+	-	Signal name	Input/ Output				
144 (G)	Ground	Combination switch OUTPUT 2	Output	Combination switch	All switches OFF (Wiper volume dial 4)	0 V	
					Front washer switch ON (Wiper volume dial 4)	 <p style="text-align: right; font-size: small;">JPMAI0033GB</p>	
					Any of the conditions below with all switches OFF		10.7 V
							<ul style="list-style-type: none"> • Wiper volume dial 1 • Wiper volume dial 5 • Wiper volume dial 6
145 (L)	Ground	Combination switch OUTPUT 3	Output	Combination switch (Wiper volume dial 4)	All switches OFF	0 V	
					Front wiper switch INT/ AUTO	 <p style="text-align: right; font-size: small;">JPMAI0034GB</p>	
					Front wiper switch LO		10.7 V
					Lighting switch AUTO		
146 (SB)	Ground	Combination switch OUTPUT 4	Output	Combination switch (Wiper volume dial 4)	All switches OFF	0 V	
					Front fog lamp switch ON	 <p style="text-align: right; font-size: small;">JPMAI0035GB</p>	
					Lighting switch 2ND		10.7 V
					Lighting switch PASS		
					Turn signal switch LH		
149 (W)	Ground	Tire pressure warning check switch	Input	—	12 V		
150 (R)	Ground	Driver door switch	Input	Driver door switch	OFF (Door close)	 <p style="text-align: right; font-size: small;">JPMAI0011GB</p>	
					ON (Door open)	0 V	
151 (G)	Ground	Rear window defog- ger relay control	Output	Rear window defogger	Active	0 V	
					Not activated	Battery voltage	

BCM (BODY CONTROL MODULE)

< ECU DIAGNOSIS INFORMATION >

Wiring Diagram - BCM -

INFOID:000000005897685

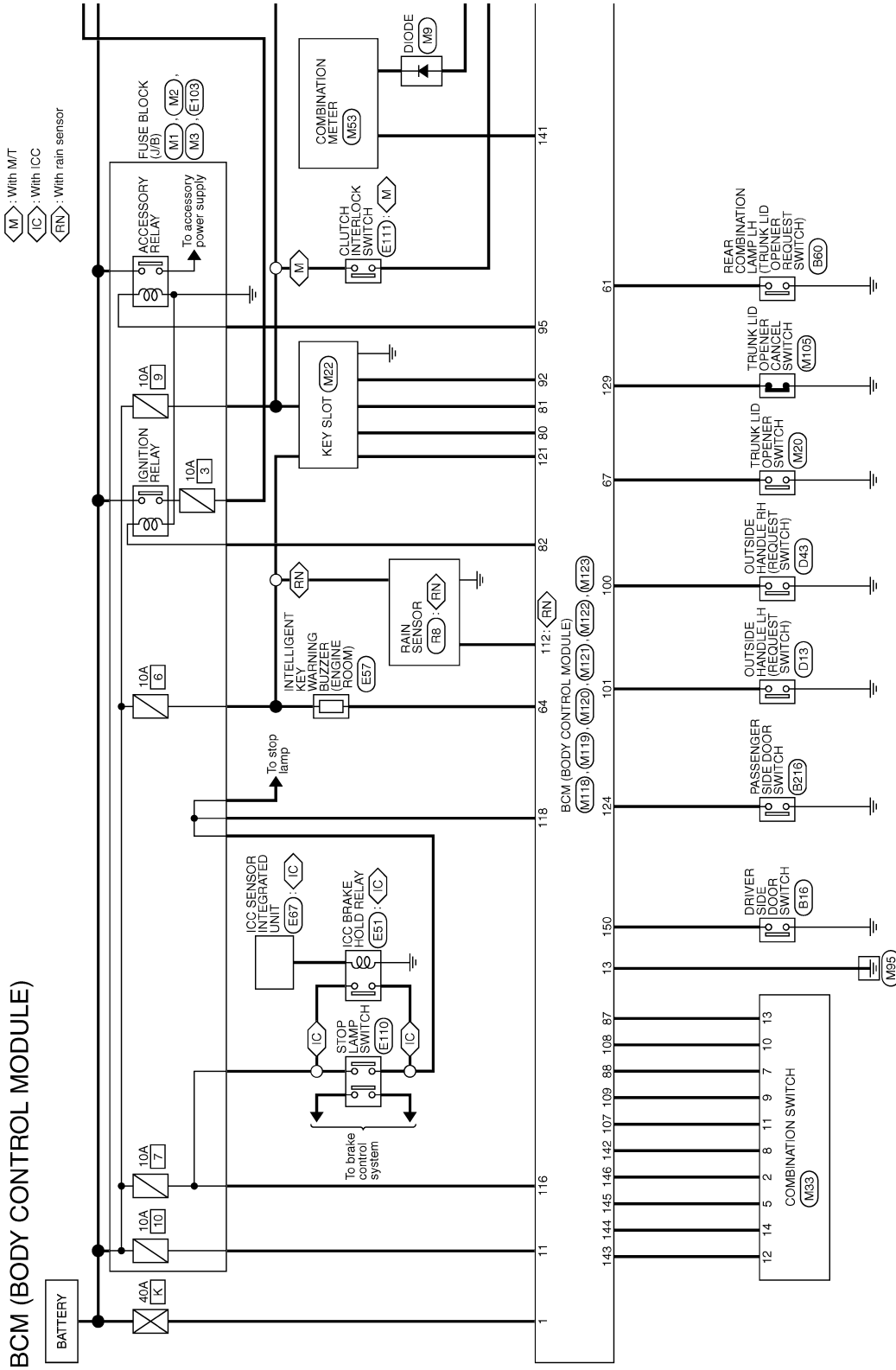

2009/11/10

JCMWM6284G

A
B
C
D
E
F
G
H
I
J
K
L
M
N
O
P

DLK

BCM (BODY CONTROL MODULE)

< ECU DIAGNOSIS INFORMATION >

A : With A/T
M : With M/T

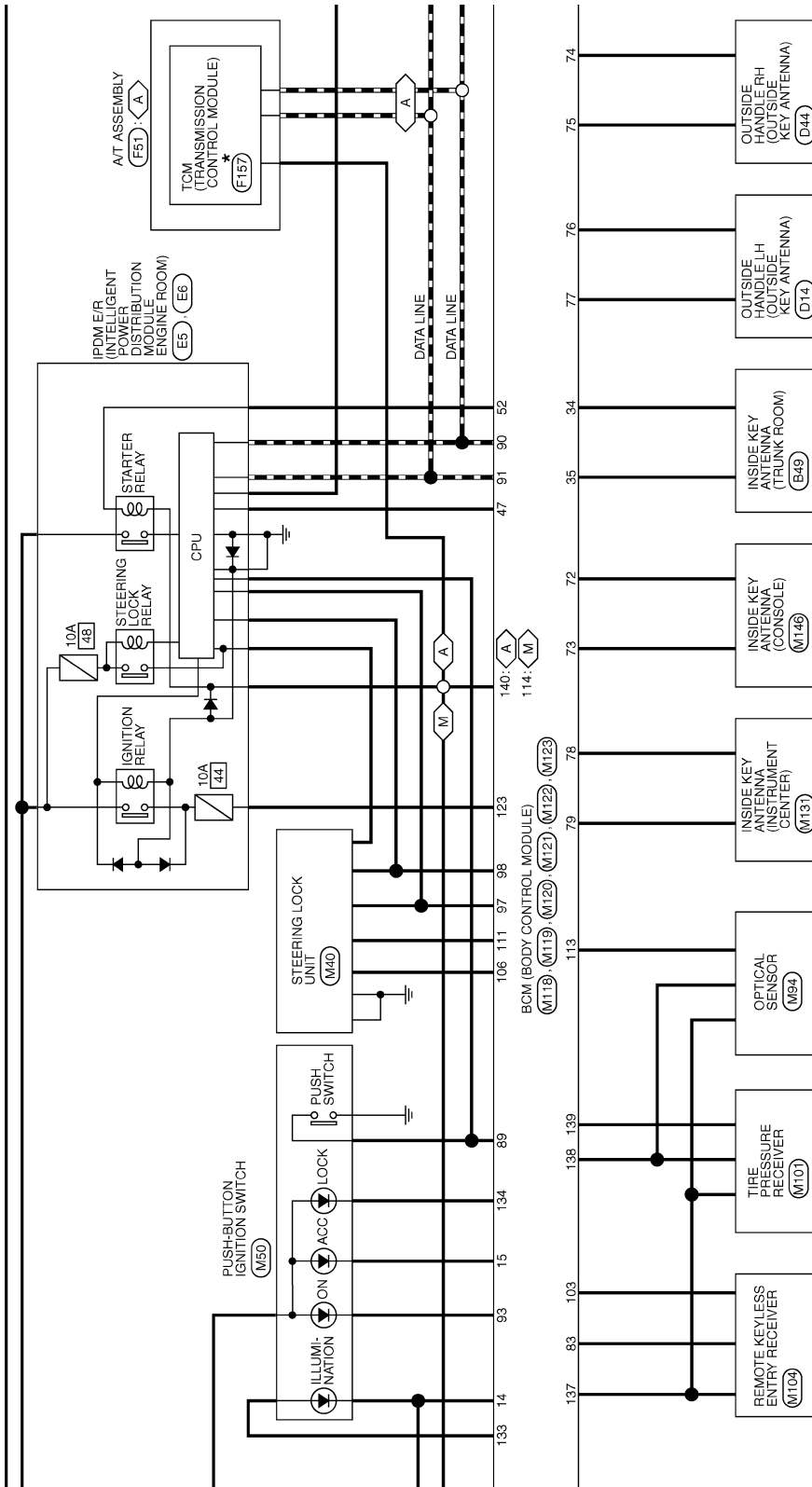

*: This connector is not shown in "Harness Layout".

JCMWM6285G

BCM (BODY CONTROL MODULE)

< ECU DIAGNOSIS INFORMATION >

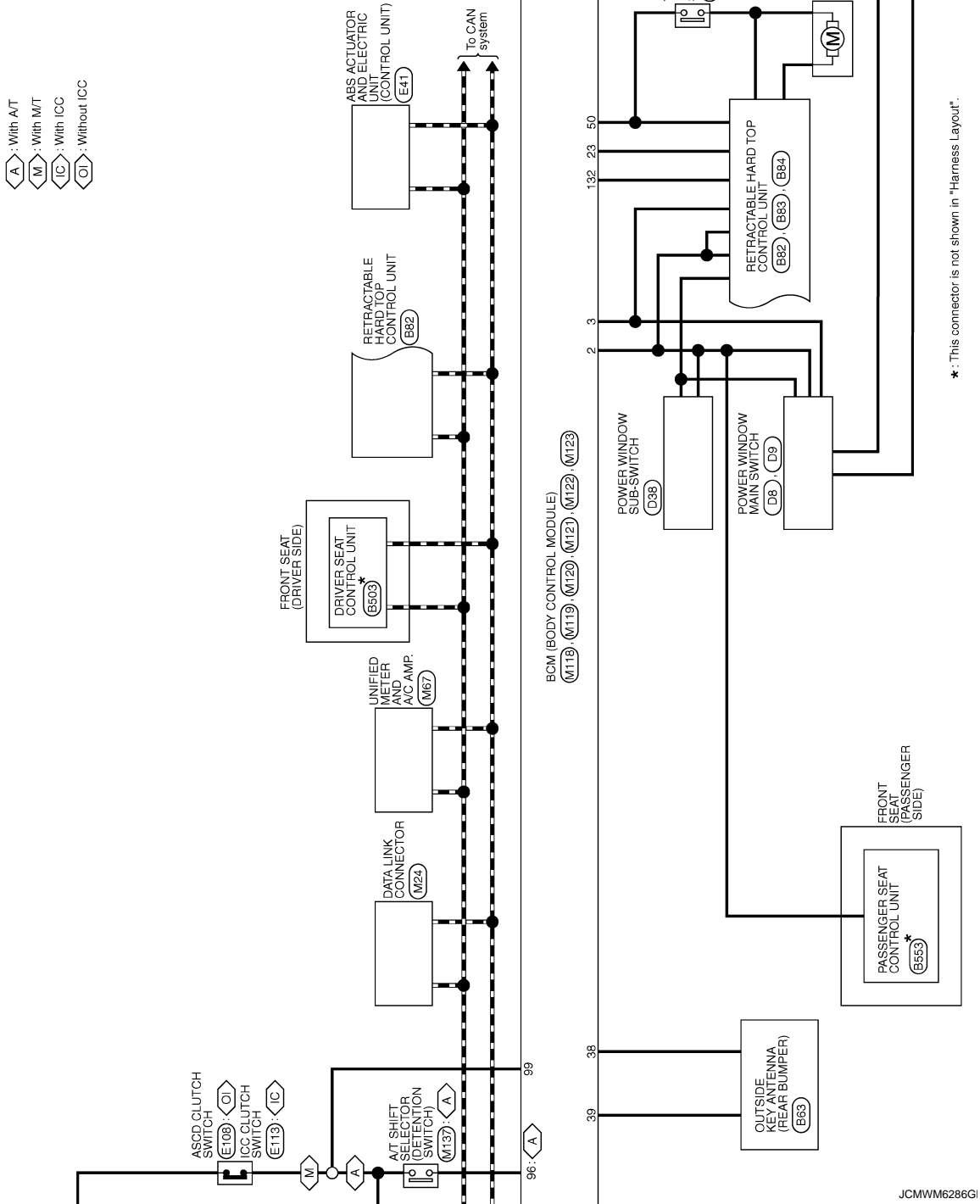

A
B
C
D
E
F
G
H
I
J
DLK
L
M
N
O
P

BCM (BODY CONTROL MODULE)

< ECU DIAGNOSIS INFORMATION >

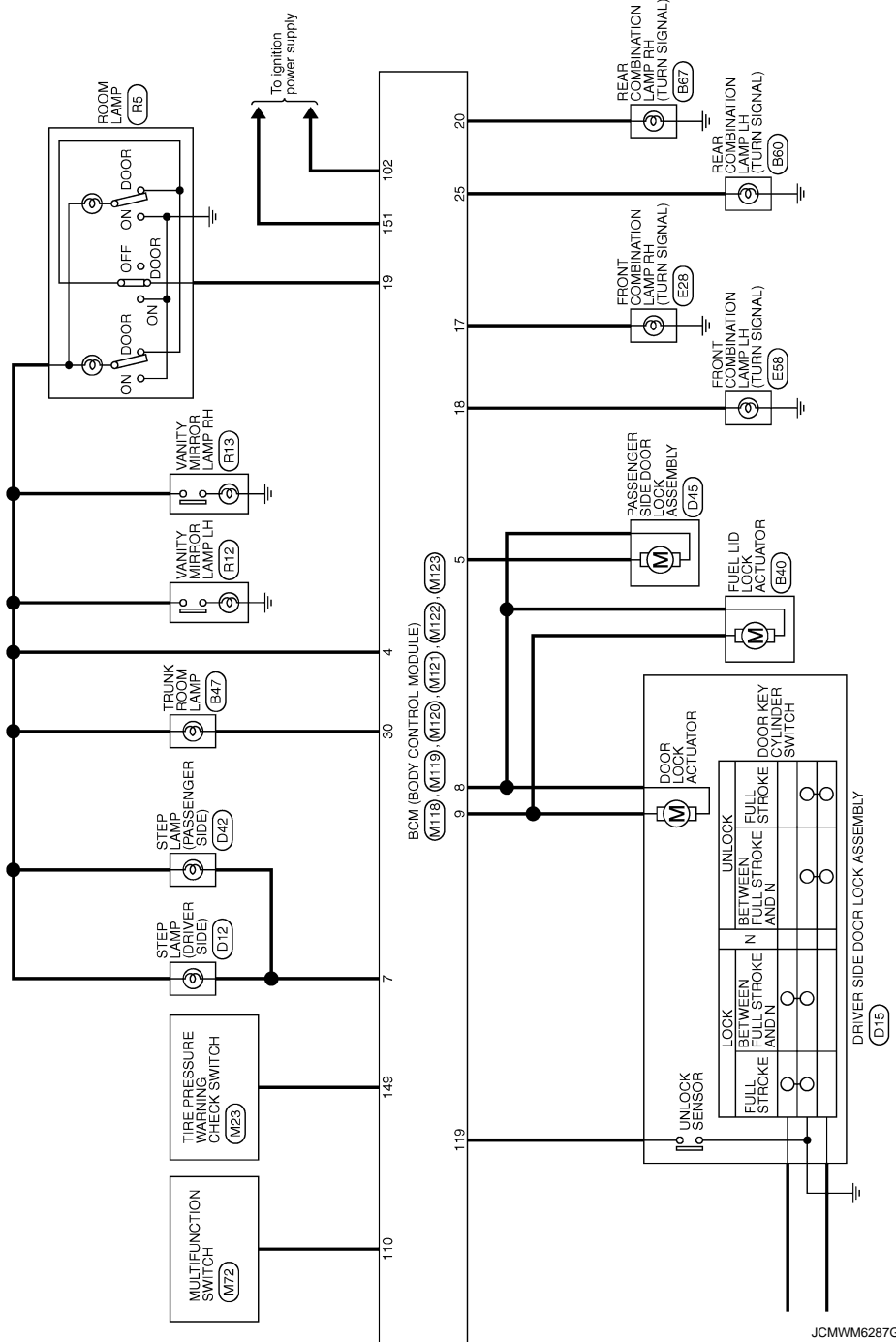

JCMWM6287G

BCM (BODY CONTROL MODULE)

< ECU DIAGNOSIS INFORMATION >

BCM (BODY CONTROL MODULE)

Connector No.	M33
Connector Name	COMBINATION SWITCH
Connector Type	TH16FW-NH

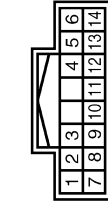

Terminal No.	Color of Wire	Signal Name [Specification]
1	P	FR WASHER (-)
2	SB	OUTPUT 4
5	L	OUTPUT 3
6	B	GND
7	EG	INPUT 3
8	BR	OUTPUT 5
9	W	INPUT 2
10	R	INPUT 4
11	LG	INPUT 1
12	V	OUTPUT 1
13	Y	INPUT 5
14	G	OUTPUT 2

Connector No.	M18
Connector Name	BCM (BODY CONTROL MODULE)
Connector Type	M03FB-LG



Terminal No.	Color of Wire	Signal Name [Specification]
1	W	BAT (E/L)
2	Y	POWER WINDOW POWER SUPPLY (BAT)
3	EG	POWER WINDOW POWER SUPPLY (RAP)

Connector No.	M119
Connector Name	BCM (BODY CONTROL MODULE)
Connector Type	NS16FF-CS

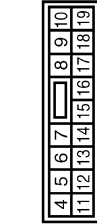

Terminal No.	Color of Wire	Signal Name [Specification]
4	LG	INTERIOR ROOM LAMP POWER SUPPLY
5	P	PASSENGER DOOR UNLOCK OUTPUT
7	SB	STEP LAMP
8	V	ALL DOOR FUEL LID LOCK OUTPUT
9	G	DRIVER DOOR FUEL LID UNLOCK OUTPUT
11	GR	BAT (FUSE)
13	B	GND
14	W	PUSH BUTTON IGNITION SW ILL GND
15	EG	ACC IND
17	BR	TURN SIGNAL RH (FRONT)
18	EG	TURN SIGNAL LH (FRONT)
19	V	ROOM LAMP TIMER CONTROL

Connector No.	M120
Connector Name	BCM (BODY CONTROL MODULE)
Connector Type	NS12FW-CS

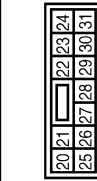

Terminal No.	Color of Wire	Signal Name [Specification]
20	V	TURN SIGNAL RH (REAR)
23	Y	TRUNK LID OPEN OUTPUT
25	Y	TURN SIGNAL LH (REAR)
30	P	TRUNK ROOM LAMP

Connector No.	M121
Connector Name	BCM (BODY CONTROL MODULE)
Connector Type	TH40FG1-NH

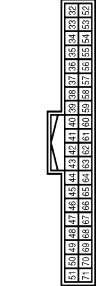

Terminal No.	Color of Wire	Signal Name [Specification]
34	SB	TRUNK ROOM ANT-
35	V	TRUNK ROOM ANT+
38	B	REAR BUMPER ANT-
39	W	REAR BUMPER ANT+
47	Y	IGN RELAY (BDM E/P) CONT
50	G	TRUNK ROOM LAMP SW
52	BR	STARTER RELAY CONT
61	SB	TRUNK LID OPENER REQUEST SW
64	G	F-KEY WARN BUZZER (ENG ROOM)
67	GR	TRUNK LID OPENER SW

Connector No.	M122
Connector Name	BCM (BODY CONTROL MODULE)
Connector Type	TH40FB-NH

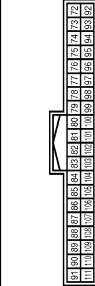

Terminal No.	Color of Wire	Signal Name [Specification]
72	R	ROOM ANT 2-
73	G	ROOM ANT 2+
74	SB	PASSENGER DOOR ANT-
75	BR	PASSENGER DOOR ANT+
76	V	DRIVER DOOR ANT-
77	LG	DRIVER DOOR ANT+
78	Y	ROOM ANT 1-
79	BR	ROOM ANT 1+
80	GR	NATS ANTENNA AMP
81	W	NATS ANTENNA AMP
82	R	IGN RELAY (E/B) CONT
83	Y	KEYLESS ENTRY RECEIVER COMM

87	Y	COMBI SW INPUT 5
88	EG	COMBI SW INPUT 3
89	BR	FUSE SW
90	P	CAN-L
91	L	CAN-H
92	LG	KEY SLOT ILL
93	V	ON IND
95	EG	ACC RELAY CONT
96	GR	A/T SHIFT SELECTOR POWER SUPPLY
97	L	S/L CONDITION 1
98	SB	S/L CONDITION 2
99	R	SHIFT P (With A/T)
99	R	ASCD/ICC CLUTCH SW (With M/T)
100	Y	PASSENGER DOOR REQUEST SW
101	P	DRIVER DOOR REQUEST SW
102	EG	BLOWER FAN MOTOR RELAY CONT
103	LG	KEYLESS ENTRY RECEIVER POWER SUPPLY
106	W	S/L UNIT POWER SUPPLY
107	LG	S/L UNIT POWER SUPPLY 1
108	R	COMBI SW INPUT 4
109	W	COMBI SW INPUT 2
110	G	HAZARD SW
111	Y	S/L UNIT COMM

A
B
C
D
E
F
G
H
I
J
K
L
M
N
O
P

DLK

BCM (BODY CONTROL MODULE)

< ECU DIAGNOSIS INFORMATION >

BCM (BODY CONTROL MODULE)	
Connector No.	M123
Connector Name	BCM (BODY CONTROL MODULE)
Connector Type	TH40FG-1N1

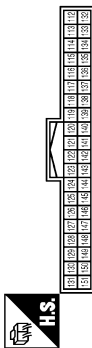

Terminal No.	Color of Wire	Signal Name [Specification]
112	BR	RAIN SENSOR SERIAL LINK
113	G	OPTICAL SENSOR
114	R	CLUTCH INTERLOCK SW
116	SB	STOP LAMP SW 1
118	BR	STOP LAMP SW 2
119	GR	DR DOOR UNLOCK SENSOR
121	SB	KEY SLOT SW
123	W	IGN P/B
124	BG	PASSENGER DOOR SW
129	BG	TRUNK LID OPENER CANCEL SW
132	LG	P/W SW & RHT C/U COMM
133	Y	PUSH-BUTTON IGNITION SW ILL POWER
134	LG	LOCK IND
137	BG	RECEIVER / SENSOR GND
138	Y	RECEIVER / SENSOR POWER SUPPLY
139	L	TIRE PRESSURE RECEIVER COMM
140	GR	SHIFT N/P
141	R	SECURITY INDICATOR LAMP
142	BR	COMBI SW OUTPUT 5
143	V	COMBI SW OUTPUT 1
144	G	COMBI SW OUTPUT 2
145	L	COMBI SW OUTPUT 3
146	SB	COMBI SW OUTPUT 4
148	W	TIRE PRESSURE WARN CHECK SW
150	R	DRIVER DOOR SW
151	G	REAR WINDOW DEFROGGER RELAY CONT

JCMWM6289G

Fail-safe

INFOID:000000005897686

FAIL-SAFE CONTROL BY DTC

BCM performs fail-safe control when any DTC are detected.

BCM (BODY CONTROL MODULE)

< ECU DIAGNOSIS INFORMATION >

Display contents of CONSULT	Fail-safe	Cancellation	A
B2013: ID DISCORD BCM-S/L	Inhibit engine cranking	Erase DTC	A
B2014: CHAIN OF S/L-BCM	Inhibit engine cranking	Erase DTC	B
B2190: NATS ANTENNA AMP	Inhibit engine cranking	Erase DTC	B
B2191: DIFFERENCE OF KEY	Inhibit engine cranking	Erase DTC	C
B2192: ID DISCORD BCM-ECM	Inhibit engine cranking	Erase DTC	C
B2193: CHAIN OF BCM-ECM	Inhibit engine cranking	Erase DTC	D
B2195: ANTI-SCANNING	Inhibit engine cranking	Ignition switch ON → OFF	D
B2557: VEHICLE SPEED	Inhibit steering lock	When normal vehicle speed signals are received from ABS actuator and electric unit (control unit) for 500 ms	E
B2560: STARTER CONT RELAY	Inhibit engine cranking	500 ms after the following CAN signal communication status becomes consistent <ul style="list-style-type: none"> • Starter control relay signal • Starter relay status signal 	E
B2601: SHIFT POSITION	Inhibit steering lock	500 ms after the following signal reception status becomes consistent <ul style="list-style-type: none"> • Selector lever P position switch signal • P range signal (CAN) 	F
B2602: SHIFT POSITION	Inhibit steering lock	5 seconds after the following BCM recognition conditions are fulfilled <ul style="list-style-type: none"> • Ignition switch is in the ON position • Selector lever P position switch signal: Except P position (12 V) • Vehicle speed: 4 km/h (2.5 MPH) or more 	G
B2603: SHIFT POSI STATUS	Inhibit steering lock	500 ms after the following BCM recognition conditions are fulfilled <ul style="list-style-type: none"> • Ignition switch is in the ON position • Selector lever P position switch signal: Except P position (12 V) • Selector lever P/N position signal: Except P and N positions (0 V) 	H
B2604: PNP/CLUTCH SW	Inhibit steering lock	500 ms after any of the following BCM recognition conditions are fulfilled <ul style="list-style-type: none"> • Status 1 <ul style="list-style-type: none"> - Ignition switch is in the ON position - Selector lever P/N position signal: P and N position (12 V) - P range signal or N range signal (CAN): ON • Status 2 <ul style="list-style-type: none"> - Ignition switch is in the ON position - Selector lever P/N position signal: Except P and N positions (0 V) - P range signal and N range signal (CAN): OFF 	I J DLK
B2605: PNP/CLUTCH SW	Inhibit steering lock	500 ms after any of the following BCM recognition conditions are fulfilled <ul style="list-style-type: none"> • Status 1 <ul style="list-style-type: none"> - Ignition switch is in the ON position - Selector lever P/N position signal: Except P and N positions (0 V) - Interlock/PNP switch signal (CAN): OFF • Status 2 <ul style="list-style-type: none"> - Ignition switch is in the ON position - Selector lever P/N position signal: P or N position (12 V) - PNP switch signal (CAN): ON 	L M N
B2606: S/L RELAY	Inhibit engine cranking	500 ms after the following CAN signal communication status becomes consistent <ul style="list-style-type: none"> • Steering lock relay signal (Request signal) • Steering lock relay signal (Condition signal) 	O P
B2607: S/L RELAY	Inhibit engine cranking	500 ms after the following CAN signal communication status has become consistent <ul style="list-style-type: none"> • Steering lock relay signal (Request signal) • Steering lock relay signal (Condition signal) 	

BCM (BODY CONTROL MODULE)

< ECU DIAGNOSIS INFORMATION >

Display contents of CONSULT	Fail-safe	Cancellation
B2608: STARTER RELAY	Inhibit engine cranking	500 ms after the following signal communication status becomes consistent <ul style="list-style-type: none"> Starter motor relay control signal Starter relay status signal (CAN)
B2609: S/L STATUS	<ul style="list-style-type: none"> Inhibit engine cranking Inhibit steering lock 	When the following steering lock conditions agree <ul style="list-style-type: none"> BCM steering lock control status Steering lock condition No. 1 signal status Steering lock condition No. 2 signal status
B260A: IGNITION RELAY	Inhibit engine cranking	500 ms after the following conditions are fulfilled <ul style="list-style-type: none"> IGN relay (IPDM E/R) control signal: OFF (12 V) Ignition ON signal (CAN to IPDM E/R): OFF (Request signal) Ignition ON signal (CAN from IPDM E/R): OFF (Condition signal)
B260F: ENG STATE SIG LOST	Maintains the power supply position attained at the time of DTC detection	When any of the following conditions are fulfilled <ul style="list-style-type: none"> Power position changes to ACC Receives engine status signal (CAN)
B2612: S/L STATUS	<ul style="list-style-type: none"> Inhibit engine cranking Inhibit steering lock 	When any of the following conditions are fulfilled <ul style="list-style-type: none"> Steering lock unit status signal (CAN) is received normally The BCM steering lock control status matches the steering lock status recognized by the steering lock unit status signal (CAN from IPDM E/R)
B2617: BCM	Inhibit engine cranking	1 second after the starter motor relay control inside BCM becomes normal
B2618: BCM	Inhibit engine cranking	1 second after the ignition relay (IPDM E/R) control inside BCM becomes normal
B2619: BCM	Inhibit engine cranking	1 second after the steering lock unit power supply output control inside BCM becomes normal
B261E: VEHICLE TYPE	Inhibit engine cranking	BCM initialization
B26E8: CLUTCH SW	Inhibit engine cranking	When any of the following BCM recognition conditions are fulfilled <ul style="list-style-type: none"> Status 1 <ul style="list-style-type: none"> Clutch switch signal (CAN from ECM): ON Clutch interlock switch signal: OFF (0 V) Status 2 <ul style="list-style-type: none"> Clutch switch signal (CAN from ECM): OFF Clutch interlock switch signal: ON (Battery voltage)
B26E9: S/L STATUS	<ul style="list-style-type: none"> Inhibit engine cranking Inhibit steering lock 	When BCM transmits the LOCK request signal to steering lock unit, and receives LOCK response signal from steering lock unit, the following conditions are fulfilled <ul style="list-style-type: none"> Steering condition No. 1 signal: LOCK (0 V) Steering condition No. 2 signal: LOCK (12 V)

DTC Inspection Priority Chart

INFOID:000000005897687

If some DTCs are displayed at the same time, perform inspections one by one based on the following priority chart.

Priority	DTC
1	B2562: LOW VOLTAGE
2	<ul style="list-style-type: none"> U1000: CAN COMM U1010: CONTROL UNIT (CAN)
3	<ul style="list-style-type: none"> B2190: NATS ANTENNA AMP B2191: DIFFERENCE OF KEY B2192: ID DISCORD BCM-ECM B2193: CHAIN OF BCM-ECM B2195: ANTI-SCANNING

BCM (BODY CONTROL MODULE)

< ECU DIAGNOSIS INFORMATION >

Priority	DTC	
4	• B2013: ID DISCORD BCM-S/L	A
	• B2014: CHAIN OF S/L-BCM	
	• B2553: IGNITION RELAY	B
	• B2555: STOP LAMP	
	• B2556: PUSH-BTN IGN SW	
	• B2557: VEHICLE SPEED	
	• B2560: STARTER CONT RELAY	
	• B2601: SHIFT POSITION	C
	• B2602: SHIFT POSITION	
	• B2603: SHIFT POSI STATUS	
	• B2604: PNP/CLUTCH SW	
	• B2605: PNP/CLUTCH SW	D
	• B2606: S/L RELAY	
	• B2607: S/L RELAY	
	• B2608: STARTER RELAY	
	• B2609: S/L STATUS	E
	• B260A: IGNITION RELAY	
	• B260B: STEERING LOCK UNIT	
	• B260C: STEERING LOCK UNIT	F
	• B260D: STEERING LOCK UNIT	
	• B260F: ENG STATE SIG LOST	
	• B2612: S/L STATUS	
	• B2614: BCM	G
	• B2615: BCM	
	• B2616: BCM	
	• B2617: BCMC	
	• B2618: BCM	H
	• B2619: BCM	
	• B261A: PUSH-BTN IGN SW	
	• B261E: VEHICLE TYPE	
• B26E8: CLUTCH SW	I	
• B26E9: S/L STATUS		
• B26EA: KEY REGISTRATION		
• C1729: VHCL SPEED SIG ERR	J	
• U0415: VEHICLE SPEED		
5	• C1704: LOW PRESSURE FL	
	• C1705: LOW PRESSURE FR	
	• C1706: LOW PRESSURE RR	
	• C1707: LOW PRESSURE RL	
	• C1708: [NO DATA] FL	
	• C1709: [NO DATA] FR	
	• C1710: [NO DATA] RR	
	• C1711: [NO DATA] RL	
	• C1716: [PRESSDATA ERR] FL	
	• C1717: [PRESSDATA ERR] FR	
	• C1718: [PRESSDATA ERR] RR	
	• C1719: [PRESSDATA ERR] RL	
	• C1734: CONTROL UNIT	
6	• B2621: INSIDE ANTENNA	
	• B2622: INSIDE ANTENNA	
	• B2623: INSIDE ANTENNA	

DTC Index

INFOID:000000005897688

NOTE:

The details of time display are as follows.

- CRNT: A malfunction is detected now.
- PAST: A malfunction was detected in the past.

IGN counter is displayed on Freeze Frame Data. For details of Freeze Frame Data, refer to [DLK-49. "COMMON ITEM : CONSULT-III Function \(BCM - COMMON ITEM\)".](#)

BCM (BODY CONTROL MODULE)

< ECU DIAGNOSIS INFORMATION >

CONSULT display	Fail-safe	Freeze Frame Data •Vehicle Speed •Odo/Trip Meter •Vehicle condition	Intelligent Key warning lamp ON	Tire pressure monitor warning lamp ON	Refer- ence page
No DTC is detected. further testing may be required.	—	—	—	—	—
U1000: CAN COMM	—	—	—	—	BCS-34
U1010: CONTROL UNIT (CAN)	—	—	—	—	BCS-35
U0415: VEHICLE SPEED	—	—	—	—	BCS-36
B2013: ID DISCORD BCM-S/L	×	×	—	—	SEC-46
B2014: CHAIN OF S/L-BCM	×	×	—	—	SEC-47
B2190: NATS ANTENNA AMP	×	—	—	—	SEC-38
B2191: DIFFERENCE OF KEY	×	—	—	—	SEC-41
B2192: ID DISCORD BCM-ECM	×	—	—	—	SEC-42
B2193: CHAIN OF BCM-ECM	×	—	—	—	SEC-44
B2195: ANTI-SCANNING	×	—	—	—	SEC-45
B2553: IGNITION RELAY	—	×	—	—	PCS-48
B2555: STOP LAMP	—	×	—	—	SEC-50
B2556: PUSH-BTN IGN SW	—	×	×	—	SEC-52
B2557: VEHICLE SPEED	×	×	×	—	SEC-54
B2560: STARTER CONT RELAY	×	×	×	—	SEC-55
B2562: LOW VOLTAGE	—	×	—	—	BCS-37
B2601: SHIFT POSITION	×	×	×	—	SEC-56
B2602: SHIFT POSITION	×	×	×	—	SEC-59
B2603: SHIFT POSI STATUS	×	×	×	—	SEC-61
B2604: PNP/CLUTCH SW	×	×	×	—	SEC-64
B2605: PNP/CLUTCH SW	×	×	×	—	SEC-66
B2606: S/L RELAY	×	×	×	—	SEC-68
B2607: S/L RELAY	×	×	×	—	SEC-69
B2608: STARTER RELAY	×	×	×	—	SEC-71
B2609: S/L STATUS	×	×	×	—	SEC-73
B260A: IGNITION RELAY	×	×	×	—	PCS-50
B260B: STEERING LOCK UNIT	—	×	×	—	SEC-77
B260C: STEERING LOCK UNIT	—	×	×	—	SEC-78
B260D: STEERING LOCK UNIT	—	×	×	—	SEC-79
B260F: ENG STATE SIG LOST	×	×	×	—	SEC-80
B2612: S/L STATUS	×	×	×	—	SEC-85
B2614: BCM	—	×	×	—	PCS-52
B2615: BCM	—	×	×	—	PCS-55
B2616: BCM	—	×	×	—	PCS-58
B2617: BCM	×	×	×	—	SEC-89
B2618: BCM	×	×	×	—	PCS-61
B2619: BCM	×	×	×	—	SEC-91
B261A: PUSH-BTN IGN SW	—	×	×	—	PCS-62
B261E: VEHICLE TYPE	×	×	× (Turn ON for 15 seconds)	—	SEC-92

BCM (BODY CONTROL MODULE)

< ECU DIAGNOSIS INFORMATION >

CONSULT display	Fail-safe	Freeze Frame Data •Vehicle Speed •Odo/Trip Meter •Vehicle condition	Intelligent Key warning lamp ON	Tire pressure monitor warning lamp ON	Refer- ence page
B2621: INSIDE ANTENNA	—	×	—	—	DLK-61
B2622: INSIDE ANTENNA	—	×	—	—	DLK-63
B2623: INSIDE ANTENNA	—	×	—	—	DLK-65
B26E8: CLUTCH SW	×	×	×	—	SEC-81
B26E9: S/L STATUS	×	×	× (Turn ON for 15 seconds)	—	SEC-83
B26EA: KEY REGISTRATION	—	×	× (Turn ON for 15 seconds)	—	SEC-84
C1704: LOW PRESSURE FL	—	—	—	×	WT-26
C1705: LOW PRESSURE FR	—	—	—	×	
C1706: LOW PRESSURE RR	—	—	—	×	
C1707: LOW PRESSURE RL	—	—	—	×	
C1708: [NO DATA] FL	—	—	—	×	WT-28
C1709: [NO DATA] FR	—	—	—	×	
C1710: [NO DATA] RR	—	—	—	×	
C1711: [NO DATA] RL	—	—	—	×	
C1716: [PRESSDATA ERR] FL	—	—	—	×	WT-31
C1717: [PRESSDATA ERR] FR	—	—	—	×	
C1718: [PRESSDATA ERR] RR	—	—	—	×	
C1719: [PRESSDATA ERR] RL	—	—	—	×	
C1729: VHCL SPEED SIG ERR	—	—	—	×	WT-33
C1734: CONTROL UNIT	—	—	—	×	WT-35

A
B
C
D
E
F
G
H
I
J

L
M
N
O
P

DLK

TRUNK CLOSURE CONTROL UNIT

< ECU DIAGNOSIS INFORMATION >

TRUNK CLOSURE CONTROL UNIT

Reference Value

INFOID:000000005624286

TERMINAL LAYOUT

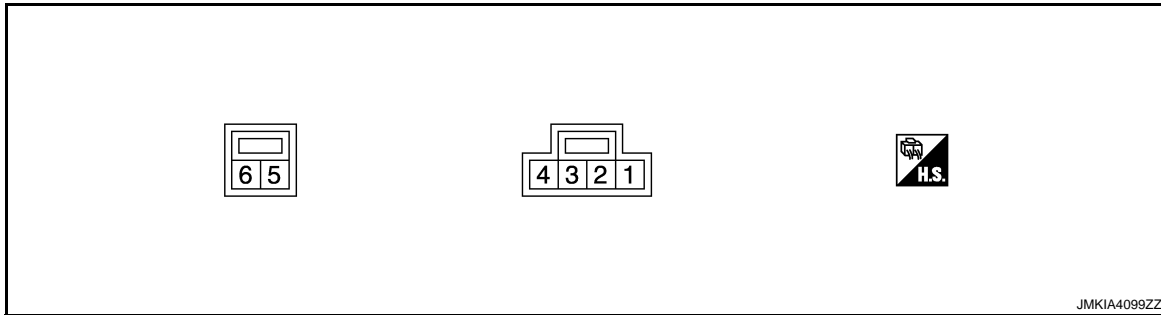

PHYSICAL VALUES

Terminal No. (wire color)		Description		Condition	Voltage (V) (Approx.)
+	-	Signal name	Input/ Output		
1 (P)	Ground	Room lamp switch input signal	Input	Trunk lid lock assembly and trunk lid striker are engaged	0
				Trunk open operation activates when retractable hard top is operated	Battery voltage → 0
				Trunk lid lock assembly and trunk lid striker are not engaged	Battery voltage
2 (Y)	Ground	Battery power supply	Input	-	Battery voltage
3 (GR)	Ground	Striker switch input signal	Input	Trunk lid is open	0
				Trunk lid is closed	Battery voltage
4 (B)	Ground	Ground	-	-	0
5 (B)	Ground	Trunk closure motor ground	-	-	0
6 (BR)	Ground	Trunk closure motor output signal	Output	Trunk lid auto closure is operated	Battery voltage
				Trunk lid auto closure is not operated	0

TRUNK CLOSURE CONTROL UNIT

< ECU DIAGNOSIS INFORMATION >

Wiring Diagram - TRUNK LID AUTO CLOSURE SYSTEM -

INFOID:000000005624287

TRUNK LID AUTO CLOSURE SYSTEM

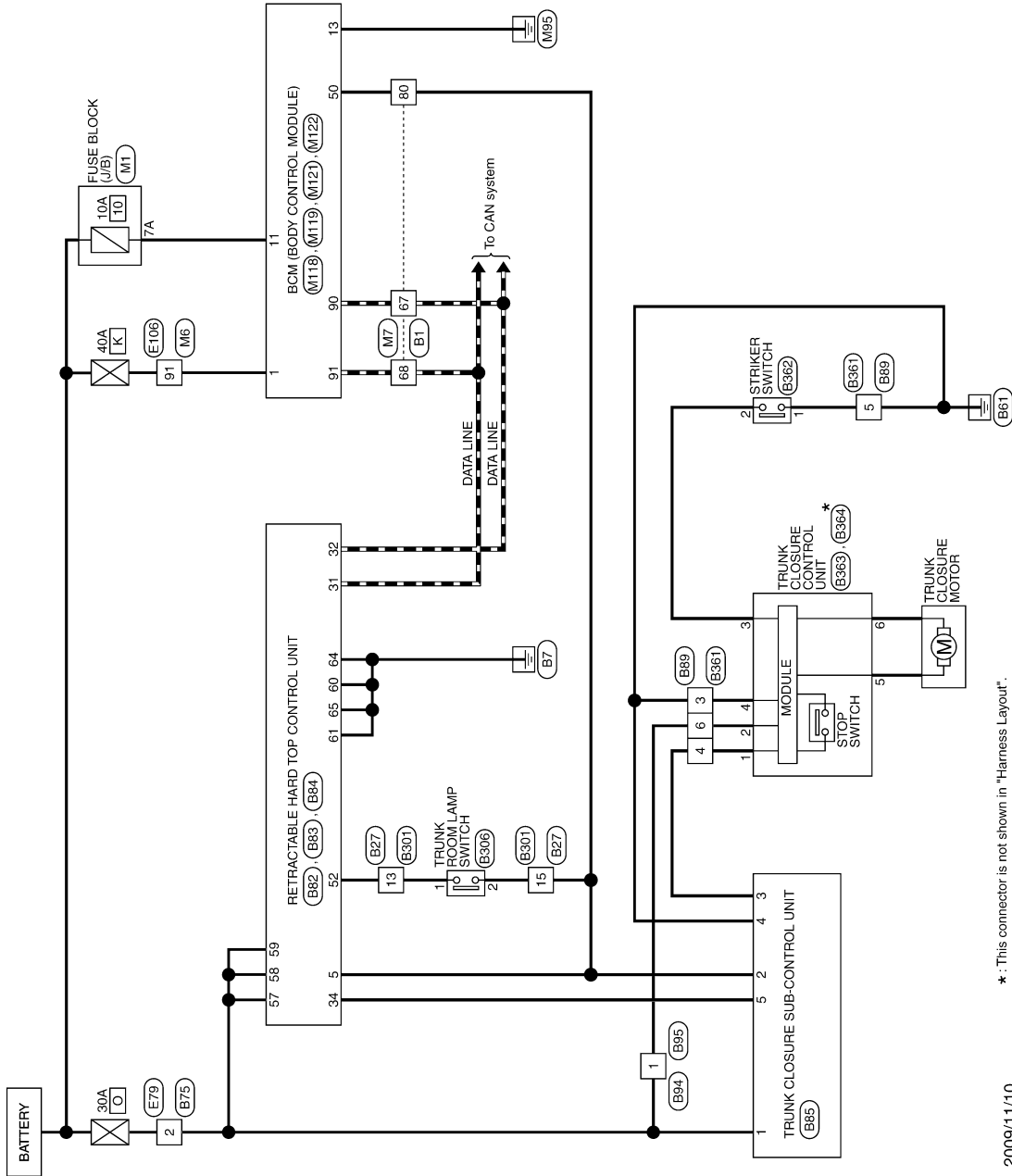

*: This connector is not shown in "Harness Layout".

2009/11/10

JCKWM4072GI

A
B
C
D
E
F
G
H
I
J
K
L
M
N
O
P

DLK

TRUNK CLOSURE CONTROL UNIT

< ECU DIAGNOSIS INFORMATION >

TRUNK LID AUTO CLOSURE SYSTEM

Connector No.	B1
Connector Name	WIRE TO WIRE
Connector Type	TH80VW-CS16-TM4



Terminal No.	Color of Wire	Signal Name [Specification]
1	W	-
2	L	-
3	R	-
4	V	-
5	W	-
6	B	-
8	G	-
10	BR	-
12	SHIELD	-
13	Y	-
14	L	-
15	R	-
16	W	-
17	BR	-
20	G	-
21	SB	-
22	GR	-
23	W	-
24	SB	-
25	BR	-
26	LG	-
27	Y	-
28	R	-
29	V	-
31	SHIELD	-
32	G	-
33	R	-
34	BG	-
35	GR	-
36	BR	-
37	P	- [With climate controlled seat]
37	Y	- [Without climate controlled seat]
38	V	- [With climate controlled seat]
38	GR	- [Without climate controlled seat]
40	SHIELD	-
41	L	-
42	P	-
43	SHIELD	-

Connector No.	B27
Connector Name	WIRE TO WIRE
Connector Type	MS1BMW-CS

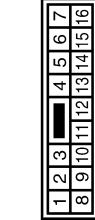

Terminal No.	Color of Wire	Signal Name [Specification]
1	BG	-
2	P	-
3	G	-
4	W	-
5	R	-
6	P	-
7	GR	-
10	LG	-
11	B	-
12	B	-
13	V	-
14	SB	-
15	L	-
16	V	-

Connector No.	B75
Connector Name	WIRE TO WIRE
Connector Type	M02MM-LC



Terminal No.	Color of Wire	Signal Name [Specification]
1	L	-
2	Y	-

Connector No.	B82
Connector Name	RETRACTABLE HARD TOP CONTROL UNIT
Connector Type	TH40VW-NH

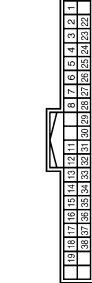

Terminal No.	Color of Wire	Signal Name [Specification]
1	G	ROOF OPEN / CLOSE SWITCH (OPEN)
2	BR	ROOF OPEN / CLOSE SWITCH (CLOSE)
3	B	FLIPPER DOOR LIMIT SWITCH (GND)
4	L	TONNEAU BOARD SWITCH
5	SR	TRUNK ROOM LAMP SWITCH
6	L	ROOF LATCH LIMIT SWITCH
7	W	FLIPPER DOOR LIMIT SWITCH (UP)
8	G	FLIPPER DOOR LIMIT SWITCH (DOWN)
11	W	RETAINED ACC POWER
12	Y	REVERSE SIGNAL
13	BG	PARCEL SHELF STATUS SENSOR POWER SUPPLY
14	P	TRUNK LINK SENSOR SIGNAL (LH)
15	SB	TRUNK LINK SENSOR SIGNAL (RH)
16	GR	ROOF LATCH STATUS SENSOR SIGNAL
17	G	ROOF LATCH LOCK SENSOR SIGNAL
18	LG	TRUNK STATUS SENSOR SIGNAL
22	V	ROOF STATUS SENSOR POWER SUPPLY
23	B	ROOF STATUS SENSOR GND
24	GR	PARCEL SHELF STATUS SENSOR SIGNAL (DRAW)
25	R	PARCEL SHELF STATUS SENSOR SIGNAL (ROTATION)
26	P	ROOF STATUS SENSOR SIGNAL
27	Y	TRUNK LID OPEN REQUEST SIGNAL
28	BG	FLIPPER DOOR RELAY GND
29	V	LOCAL COMMUNICATION (BSM)
30	GR	LOCAL COMMUNICATION (POWER WINDOW)
31	L	CAN-H
32	P	CAN-L
33	V	ROOF STATUS SIGNAL (AUDIO)
34	R	ROOF STATUS SIGNAL (TRUNK)
35	B	ROOF WARNING BUZZER
36	Y	HYDRAULIC MOTOR RELAY GND (RH)
37	W	HYDRAULIC MOTOR RELAY GND (LH)
38	BR	HYDRAULIC MOTOR RELAY POWER SUPPLY

44	SB	-
45	V	-
46	W	-
47	SB	-
48	LG	-
49	LG	- [With BOSE system]
49	Y	- [Without BOSE system]
50	SB	-
50	LG	- [With BOSE system]
50	LG	- [Without BOSE system]
51	SB	-
52	G	-
53	LG	-
54	BR	-
55	Y	-
56	W	-
57	V	-
60	R	-
61	BG	-
62	B	-
63	L	-
64	P	-
65	B	-
66	SB	-
67	P	-
68	L	-
69	P	-
70	L	-
80	G	-
81	V	-
82	R	-
83	BR	-
84	G	-
85	L	-
86	Y	-
87	GR	-
91	P	-
93	BG	-
94	P	-
95	GR	-
96	GR	-
97	SB	-
99	Y	-
100	Y/B	-

JCKWM4073GI

TRUNK CLOSURE CONTROL UNIT

< ECU DIAGNOSIS INFORMATION >

TRUNK LID AUTO CLOSURE SYSTEM

Connector No.	B83
Connector Name	RETRACTABLE HARD TOP CONTROL UNIT
Connector Type	NS16FR-CS

47	46	45	44	43	42	41
56	55	54	53	52	51	50
49	48	47	46	45	44	43
42	41	40	39	38	37	36
35	34	33	32	31	30	29
28	27	26	25	24	23	22
21	20	19	18	17	16	15
14	13	12	11	10	9	8



Terminal No.	Color of Wire	Signal Name [Specification]
41	SB	PARCEL SHELF MOTOR RELAY GND (UP)
42	W	PARCEL SHELF MOTOR RELAY GND (DOWN)
43	BR	HYDRAULIC PUMP POWER SUPPLY (RELAY)
44	R	MOTOR PARCEL SHELF (HORIZONTAL)
45	BR	MOTOR PARCEL SHELF (VERTICAL)
46	G	FLIPPER DOOR RELAY POWER SUPPLY (UP)
47	L	FLIPPER DOOR RELAY POWER SUPPLY (DOWN)
48	R	ROOF LATCH MOTOR (OPEN)
49	Y	ROOF LATCH MOTOR (CLOSE)
51	SB	TRUNK OPENER ACTUATOR
52	V	TRUNK OPENER ACTUATOR GND
53	BG	REAR POWER WINDOW MOTOR LH (UP)
54	LG	REAR POWER WINDOW MOTOR LH (DOWN)
55	GR	REAR POWER WINDOW MOTOR RH (UP)
56	P	REAR POWER WINDOW MOTOR RH (DOWN)

Connector No.	B84
Connector Name	RETRACTABLE HARD TOP CONTROL UNIT
Connector Type	NS16FW-CS

63	62	61	60	59	58	57
72	71	70	69	68	67	66
65	64	63	62	61	60	59
58	57	56	55	54	53	52
51	50	49	48	47	46	45
44	43	42	41	40	39	38
37	36	35	34	33	32	31
30	29	28	27	26	25	24
23	22	21	20	19	18	17
16	15	14	13	12	11	10
9	8	7	6	5	4	3
2	1					



Terminal No.	Color of Wire	Signal Name [Specification]
57	Y	BAT
58	Y	BAT
59	Y	BAT
60	B	GND
61	B	GND
62	GR	BAT (POWER WINDOW)
63	Y	BAT (POWER WINDOW)

64	B	GND (POWER WINDOW)
65	B	GND (POWER WINDOW)
66	P	SWITCHING VALVE 1
67	SB	SWITCHING VALVE 2
68	L	SWITCHING VALVE GND
69	G	REAR WINDOW DEF IN 1
70	P	REAR WINDOW DEF IN 2
71	BR	REAR WINDOW DEF OUT 1
72	W	REAR WINDOW DEF OUT 2

Connector No.	B85
Connector Name	TRUNK CLOSURE SUB-CONTROL UNIT
Connector Type	NS08FW-CS

3	1	5	2
---	---	---	---



Terminal No.	Color of Wire	Signal Name [Specification]
1	Y	BAT
2	SB	TRUNK ROOM LAMP SWITCH
3	P	CLOSURE CONTROL SIGNAL
4	B	GND
5	R	TRUNK MODE SIGNAL

Connector No.	B89
Connector Name	WIRE TO WIRE
Connector Type	NS08MH-CS

1	2	3	4	5	6
---	---	---	---	---	---



Terminal No.	Color of Wire	Signal Name [Specification]
3	B	-
4	P	-
5	B	-
6	Y	-

Connector No.	B94
Connector Name	WIRE TO WIRE
Connector Type	MD1MH-LC



Terminal No.	1	Y	Signal Name [Specification]	-
--------------	---	---	-----------------------------	---

Connector No.	B95
Connector Name	WIRE TO WIRE
Connector Type	MD1FW-LC



Terminal No.	1	Y	Signal Name [Specification]	-
--------------	---	---	-----------------------------	---

Connector No.	B301
Connector Name	WIRE TO WIRE
Connector Type	NS16FW-CS



Terminal No.	Color of Wire	Signal Name [Specification]
1	R	-
2	GR	-
3	G	-
4	W	-

5	Y	-
6	P	-
7	P	-
10	LG	-
11	B	-
12	B	-
13	V	-
14	BR	-
15	L	-
16	Y	-

Connector No.	B308
Connector Name	TRUNK ROOM LAMP SWITCH
Connector Type	A02FW



1	2
---	---

Terminal No.	Color of Wire	Signal Name [Specification]
1	V	SIG-
2	L	SIG+

Connector No.	B361
Connector Name	WIRE TO WIRE
Connector Type	NS08FW-CS



2	1	6	5	4	3
---	---	---	---	---	---

Terminal No.	Color of Wire	Signal Name [Specification]
3	B	-
4	P	-
5	B	-
6	Y	-

JCKWM4074G1

A B C D E F G H I J K L M N O P

DLK

TRUNK CLOSURE CONTROL UNIT

< ECU DIAGNOSIS INFORMATION >

TRUNK LID AUTO CLOSURE SYSTEM

Connector No.	E382
Connector Name	STRIKER SWITCH
Connector Type	RV02FGY



Terminal No.	Color of Wire	Signal Name [Specification]
1	B	SIG-
2	GR	SIG+

Connector No.	E383
Connector Name	TRUNK CLOSURE CONTROL UNIT
Connector Type	NS04FW-CS

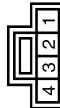

Terminal No.	Color of Wire	Signal Name [Specification]
1	P	TRUNK ROOM LAMP SW SIG
2	Y	POWER
3	GR	STRIKER SW SIG
4	B	GND

Connector No.	E384
Connector Name	TRUNK CLOSURE CONTROL UNIT
Connector Type	NS02FW-CS



Terminal No.	Color of Wire	Signal Name [Specification]

5	B	CLOSURE MOTOR GND
6	BR	CLOSURE MOTOR POWER

Connector No.	E179
Connector Name	WIRE TO WIRE
Connector Type	IM02FW-LC



Terminal No.	Color of Wire	Signal Name [Specification]
1	Y	--
2	LG	--

Connector No.	E108
Connector Name	WIRE TO WIRE
Connector Type	TH08PW-CS16-TM4

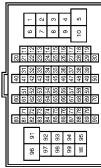

Terminal No.	Color of Wire	Signal Name [Specification]
1	GR	--
3	BG	--
4	B/W	--
5	G	--
6	BG	--
7	LG	--
8	G	--
10	W	--
11	V	--
12	R	--
13	L	--
14	GR	--
15	P	--
16	W	--
17	V	--
18	BG	--

Connector No.	M1
Connector Name	FUSE BLOCK (J/B)
Connector Type	NS06FW-M2



Terminal No.	Color of Wire	Signal Name [Specification]
1A	V	--
2A	G	--
3A	L	--
4A	P	--
5A	BR	--
6A	Y	--
7A	GR	--
8A	L	--

19	GR	--
20	LG	--
30	R	--
31	L	--
32	BG	--
33	P	--
34	V	--
35	BR	--
36	W	--
37	Y	--
38	R	--
39	B	--
40	G	--
41	W	--
42	LG	--
43	SB	--
44	GR	--
45	BG	--
46	LG	--
47	V	--
48	P	--
49	L	--
59	B	--
66	LG	--
67	SB	--
68	R	--
69	W	--
70	G	--
80	W	--
81	P	--
82	G	--
83	V	--
84	L	--
85	BG	--
86	LG	--
87	Y	--
88	GR	--
89	W	--
90	W	--
91	G	--
92	B	--
93	GR	--
94	L	--
95	Y	--
97	BR	--
98	SHIELD	--
99	L	--
100	P	--

TRUNK CLOSURE CONTROL UNIT

< ECU DIAGNOSIS INFORMATION >

TRUNK LID AUTO CLOSURE SYSTEM

Connector No.	M6
Connector Name	WIRE TO WIRE
Connector Type	TH80MW-CS (F-TM4)

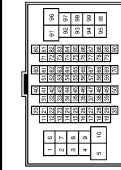

Terminal No.	Color of Wire	Signal Name [Specification]
1	BG	-
3	R	-
4	G	-
5	G	-
6	BR	-
7	BR	-
8	Y	-
10	W	-
11	GR	-
12	R	-
13	L	-
14	G	-
15	P	-
16	W	-
17	BR	-
18	V	-
19	BG	-
20	L	-
30	R	-
31	L	-
32	Y	-
33	GR	-
34	P	-
35	BR	-
36	BR	-
37	Y	-
38	LG	-
39	SB	-
40	G	-
41	W	-
42	LG	-
43	P	-
44	GR	- [With A/T] - [With M/T]
45	BG	-
46	G	-
47	P	-
48	P	-

49	L	-
59	B	-
66	Y	-
67	G	-
68	R	-
69	W	-
70	G	-
80	SB	-
81	R	-
82	V	-
83	W	-
84	L	-
85	BG	-
86	G	-
87	V	-
88	B	-
89	SB	-
90	G	-
91	W	-
92	B	-
93	G	-
94	L	-
95	BR	-
97	P	-
98	SHIELD	-
99	V	-
100	SB	-

Connector No.	M7
Connector Name	WIRE TO WIRE
Connector Type	TH80MW-CS (F-TM4)

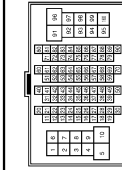

Terminal No.	Color of Wire	Signal Name [Specification]
1	BG	-
2	LG	-
3	G	-
4	V	-
5	L	-
6	B	-
9	L	-
10	BR	-
12	SHIELD	-

13	V	-
14	BR	-
15	GR	-
16	LG	-
17	L	-
20	BR	-
21	G	-
22	R	-
23	SB	-
24	B	-
25	W	-
26	Y	-
27	V	-
28	P	-
29	V	-
31	SHIELD	-
32	G	-
33	R	-
34	BG	-
35	GR	-
36	GR	-
37	P	-
37	L	- [With climate controlled seat] - [Without climate controlled seat]
38	V	-
38	GR	- [Without climate controlled seat]
40	SHIELD	-
41	L	-
42	P	-
43	SHIELD	-
44	Y	-
45	BR	-
46	SB	-
47	SB	-
48	LG	-
49	LG	-
49	SB	- [With BOSE system] - [Without BOSE system]
50	SB	- [With BOSE system] - [Without BOSE system]
50	LG	-
51	R	-
52	V	-
53	P	-
54	BR	-
55	Y	-
55	BG	- [With A/T] - [With M/T]
56	L	-
57	V	-
60	LG	-
61	BG	-
62	B	-
63	V	-
64	SB	-
65	BR	-

66	Y	-
67	P	-
68	L	-
69	P	-
70	L	-
80	G	-
81	LG	-
82	Y	-
83	BR	-
84	V	-
85	L	-
86	Y	-
87	GR	-
91	R	-
93	G	-
94	P	-
95	GR	-
96	Y	-
97	SB	-
99	Y	-
100	Y/B	-

Connector No.	MT18
Connector Name	BCM (BODY CONTROL MODULE)
Connector Type	M03FB-LC



Terminal No.	Color of Wire	Signal Name [Specification]
1	W	BAT (F/L)
2	Y	POWER WINDOW POWER SUPPLY (BAT)
3	BG	POWER WINDOW POWER SUPPLY (RAP)

A
B
C
D
E
F
G
H
I
J
DLK
L
M
N
O
P

TRUNK CLOSURE CONTROL UNIT

< ECU DIAGNOSIS INFORMATION >

TRUNK LID AUTO CLOSURE SYSTEM

Connector No.	M119
Connector Name	BCM (BODY CONTROL MODULE)
Connector Type	MS16FW-CS



4	5	6	7	8	9	10		
11	12	13	14	15	16	17	18	19

Terminal No.	Color of Wire	Signal Name [Specification]
4	LG	INTERIOR ROOM LAMP POWER SUPPLY
5	P	PASSENGER DOOR UNLOCK OUTPUT
7	SB	STEP LAMP
8	V	ALL DOOR FUEL LID LOCK OUTPUT
9	G	DRIVER DOOR FUEL LID UNLOCK OUTPUT
11	GR	BAT.(FUSE)
13	B	GND
14	W	PUSH-BUTTON IGNITION SW ILL GND
15	EG	ACC IND
17	BR	TURN SIGNAL RH (FRONT)
18	BG	TURN SIGNAL LH (FRONT)
19	V	ROOM LAMP TIMER CONTROL

Connector No.	M121
Connector Name	BCM (BODY CONTROL MODULE)
Connector Type	TH40FGY-NH



31	32	33	34	35	36	37	38	39	40	41	42	43	44	45	46	47	48	49	50	51	52	53	54	55	56	57	58	59	60	61	62	63	64	65	66	67	68	69	70	71	72	73	74	75	76	77	78	79	80	81	82	83	84	85	86	87	88	89	90	91	92	93	94	95	96	97	98	99	100	101	102	103	104	105	106	107	108	109	110	111
----	----	----	----	----	----	----	----	----	----	----	----	----	----	----	----	----	----	----	----	----	----	----	----	----	----	----	----	----	----	----	----	----	----	----	----	----	----	----	----	----	----	----	----	----	----	----	----	----	----	----	----	----	----	----	----	----	----	----	----	----	----	----	----	----	----	----	----	----	-----	-----	-----	-----	-----	-----	-----	-----	-----	-----	-----	-----

Terminal No.	Color of Wire	Signal Name [Specification]
34	SB	TRUNK ROOM ANT-
35	V	TRUNK ROOM ANT+
38	B	REAR BUMPER ANT-
39	W	REAR BUMPER ANT+
47	Y	IGN RELAY (PDM E/R) CONT
50	G	TRUNK ROOM LAMP SW
52	BR	STARTER RELAY CONT
61	SB	TRUNK LID OPENER REQUEST SW
64	G	I-KEY WARM BUZZER (ENG ROOM)
67	GR	TRUNK LID OPENER SW

Connector No.	M122
Connector Name	BCM (BODY CONTROL MODULE)
Connector Type	TH40FB-NH



11	12	13	14	15	16	17	18	19	20	21	22	23	24	25	26	27	28	29	30	31	32	33	34	35	36	37	38	39	40	41	42	43	44	45	46	47	48	49	50	51	52	53	54	55	56	57	58	59	60	61	62	63	64	65	66	67	68	69	70	71	72	73	74	75	76	77	78	79	80	81	82	83	84	85	86	87	88	89	90	91	92	93	94	95	96	97	98	99	100	101	102	103	104	105	106	107	108	109	110	111
----	----	----	----	----	----	----	----	----	----	----	----	----	----	----	----	----	----	----	----	----	----	----	----	----	----	----	----	----	----	----	----	----	----	----	----	----	----	----	----	----	----	----	----	----	----	----	----	----	----	----	----	----	----	----	----	----	----	----	----	----	----	----	----	----	----	----	----	----	----	----	----	----	----	----	----	----	----	----	----	----	----	----	----	----	----	----	----	----	-----	-----	-----	-----	-----	-----	-----	-----	-----	-----	-----	-----

Terminal No.	Color of Wire	Signal Name [Specification]
72	R	ROOM ANT 2-
73	G	ROOM ANT 2+
74	SB	PASSENGER DOOR ANT-
75	BR	PASSENGER DOOR ANT+
76	V	DRIVER DOOR ANT-
77	LG	DRIVER DOOR ANT+
78	Y	ROOM ANT 1-
79	BR	ROOM ANT 1+
80	GR	MATS ANTRINNA AMP
81	W	MATS ANTRINNA AMP
82	R	IGN RELAY (F/B) CONT
83	Y	KEYLESS ENTRY RECEIVER COMM
87	Y	COMBI SW INPUT 5
88	BG	PUSH SW
89	BR	CAN-L
90	P	CAN-L
91	L	CAN-H
92	LG	KEY SLOT ILL
93	V	ON IND
95	BG	ACC RELAY CONT
96	GR	A/T SHIFT SELECTOR POWER SUPPLY
97	L	S/L CONDITION 1
98	SB	S/L CONDITION 2
99	R	SHIFT P [Mtr.A.]
100	Y	ASCD/ICC CLUTCH SW [Mtr.M/T]
101	P	PASSENGER DOOR REQUEST SW
102	P	DRIVER DOOR REQUEST SW
103	LG	BLOWER FAN MOTOR RELAY CONT
104	W	KEYLESS ENTRY RECEIVER POWER SUPPLY
106	W	S/L UNIT POWER SUPPLY
107	LG	COMBI SW INPUT 1
108	R	COMBI SW INPUT 4
109	W	COMBI SW INPUT 2
110	G	HAZARD SW
111	Y	S/L UNIT COMM

Fail-safe

FAIL-SAFE CONTROL

Fail-safe function is adopted to trunk lid auto closure system as per the following table.

JCKWM4077G1

INFOID:000000005624288

TRUNK CLOSURE CONTROL UNIT

< ECU DIAGNOSIS INFORMATION >

Malfunction	Malfunctioning condition	
When trunk lid striker moves downward	<ul style="list-style-type: none"> • Operation of trunk closure motor is stopped if the top position of trunk lid striker is not detected (stop switch: OFF→ON) when 6 seconds are passed after trunk lid is open from closed state and trunk closure motor is operated • When trunk lid is closed in above fail-safe state (trunk room lamp switch: ON→OFF), trunk closure motor is operated and trunk lid striker moves downward • When trunk lid striker reaches to the bottom position (stop switch: ON→OFF), operation of trunk closure motor is stopped and trunk lid striker downward operation is complete 	A B
When trunk lid striker moves upward	<ul style="list-style-type: none"> • Operation of trunk closure motor is stopped if the bottom position of trunk lid striker is not detected (stop switch: ON→OFF) when 6 seconds are passed after trunk lid is closed from open state and trunk closure motor is operated • When trunk lid is open in above fail-safe state (trunk room lamp switch: OFF→ON), trunk closure motor is operated and trunk lid striker moves upward • When trunk lid striker reaches to the top position (stop switch: OFF→ON), operation of trunk closure motor is stopped and trunk lid striker upward operation is complete 	C D
		E
		F
		G
		H
		I
		J
		DLK
		L
		M
		N
		O
		P

RETRACTABLE HARD TOP CONTROL UNIT

< ECU DIAGNOSIS INFORMATION >

RETRACTABLE HARD TOP CONTROL UNIT

Reference Value

INFOID:000000005897691

VALUES ON THE DIAGNOSIS TOOL

CONSULT-III MONITOR ITEM

Monitor Item	Condition	Status/Value	
LATCH LOCK SEN	State of roof latch	Lock	ON
		Other than above	OFF
		Roof latch lock sensor circuit is short	NG
LATCH STATE SEN	State of roof latch motor	Operate	ON ↔ OFF
		Stop	ON or OFF
		Roof latch lock sensor circuit is short	NG
LATCH OUT(ULK)	Operation of roof latch motor	Unlock is in operation	ON
		Other than above	OFF
		Roof latch motor (UNLOCK) circuit is short	NG
LATCH OUT(LCK)	Operation of roof latch motor	Lock is in operation	ON
		Other than above	OFF
		Roof latch motor (LOCK) circuit is short	NG
LATCH VALUE	State of roof latch	Lock	0
		Halfway position	1-77
		Unlock	78 or more
LATCH LIMIT SW	State of roof latch	Roof is fully close and roof latch is in LOCK	CLOSE
		Other than above	OPEN
LATCH STATE	State of roof latch	Initialization is not complete	NG
		LOCK	CLOSE
		Halfway position	MID
		UNLOCK	OPEN
PS VALUE(DRAW)	State of parcel shelf	Top	Retractable hard top fully open state: 2246 Retractable hard top fully closed state: 2220
		Bottom	1000
PS VALUE(ROTA)	State of parcel shelf	Vertical	3190
		Horizontal	Retractable hard top fully open state: 1340 Retractable hard top fully closed state: 1000
PS OUT(UP)	Operation of parcel shelf	Up operation is in operation	ON
		Other than above	OFF
		Parcel shelf (UP) circuit is short	NG
PS OUT(DOWN)	Operation of parcel shelf	DOWN operation is in operation	ON
		Other than above	OFF
		Parcel shelf (DOWN) circuit is short	NG
PS OUT(VERT)	Operation of parcel shelf	Vertical operation is in operation	ON
		Other than above	OFF
		Parcel shelf (VERTICAL) circuit is short	NG

RETRACTABLE HARD TOP CONTROL UNIT

< ECU DIAGNOSIS INFORMATION >

Monitor Item	Condition		Status/Value
PS OUT(HORI)	Operation of parcel shelf	Horizontal operation is in operation	ON
		Other than above	OFF
		Parcel shelf (HORIZONTAL) circuit is short	NG
PS STATE(DRAW)	State of parcel shelf	For the details, refer to RF-33. "PARCEL SHELF FUNCTION : System Description"	1-6
		State of parcel shelf status sensor (DRAW) is not recognized	NG
PS STATE(ROTA)	State of parcel shelf	For the details, refer to RF-33. "PARCEL SHELF FUNCTION : System Description"	1-4
		State of parcel shelf status sensor (ROTATE) is not recognized	NG
ROOF VALUE	Roof status sensor signal		0-1023
PUMP OUT(RH)	Operation of hydraulic pump motor	Turning clockwise	ON
		Other than above	OFF
		Hydraulic pump motor (RH) circuit is short	NG
PUMP OUT(LH)	Operation of hydraulic pump motor	Turning counterclockwise	ON
		Other than above	OFF
		Hydraulic pump motor (LH) circuit is short	NG
SWITCH VLV 1 OUT	Operation of switching valve 1	Operate	ON
		Stop	OFF
		Switching valve 1 circuit is short	NG
SWITCH VLV 2 OUT	Operation of switching valve 2	Operate	ON
		Stop	OFF
		Switching valve 2 circuit is short	NG
ROOF STATE	State of roof	For the details, refer to RF-16. "RETRACTABLE HARD TOP SYSTEM : System Description"	1-42
		State of roof is not recognized	NG
HYDRAULIC STATE	State of hydraulic system	For the details, refer to RF-27. "HYDRAULIC SYSTEM CONTROL FUNCTION : System Description"	1-22
		State of hydraulic system is not recognized	NG
ROOF SW(OPEN)	State of roof open/close switch	OPEN operation is in operation	ON
		Other than above	OFF
ROOF SW(CLOSE)	State of roof open/close switch	CLOSE operation is in operation	ON
		Other than above	OFF
ROOF LINK STATE	State of roof link	For the details, refer to RF-27. "HYDRAULIC SYSTEM CONTROL FUNCTION : System Description"	1-8
		State of roof is not recognized	NG
TRUNK LINK SEN(RH)	State of trunk link lock (RH)	LOCK	ON
		Other than above	OFF
		Trunk link lock (RH) circuit is short or open	NG
TRUNK LINK SEN(LH)	State of trunk link lock (LH)	LOCK	ON
		Other than above	OFF
		Trunk link lock (LH) circuit is short or open	NG
TR ROOM LAMP SW	State of trunk lid (trunk room lamp switch)	Open	ON
		Other than above	OFF

A

B

C

D

E

F

G

H

I

J

DLK

L

M

N

O

P

RETRACTABLE HARD TOP CONTROL UNIT

< ECU DIAGNOSIS INFORMATION >

Monitor Item	Condition		Status/Value
TRUNK STATUS SEN	State of trunk lid	Fully OPEN	ON
		Other than above	OFF
		Trunk status sensor circuit is short or open	NG
TRUNK OPEN OUT	Operation of trunk lid opener actuator	OPEN operation is in operation	ON
		Other than above	OFF
		Trunk lid opener actuator circuit is short	NG
FLPD LIMIT SW(DWN)	State of flipper door	Both of flipper door (LH/RH) are in DOWN position	ON
		Other than above	OFF
FLPD LIMIT SW(UP)	State of flipper door	Both of flipper door (LH/RH) are in UP position	ON
		Other than above	OFF
FLPD OUT(UP)	Operation of flipper door	UP operation is in operation	ON
		Other than above	OFF
		Flipper door motor (UP) circuit is short	NG
FLPD OUT(DWN)	Operation of flipper door	DOWN operation is in operation	ON
		Other than above	OFF
		Flipper door motor (DOWN) circuit is short	NG
FLPD STATE	State of flipper door	For the details, refer to RF-35. "FLIPPER DOOR FUNCTION : System Description"	1, 2, 4
		State of flipper door is not recognized	NG
R WIN LH OUT(UP)	Operation of rear power window (LH)	UP operation is in operation	ON
		Other than above	OFF
		Rear power window LH (UP) circuit is short	NG
R WIN LH OUT(DWN)	Operation of rear power window (LH)	DOWN operation is in operation	ON
		Other than above	OFF
		Rear power window LH (DOWN) circuit is short	NG
R WIN RH OUT(UP)	Operation of rear power window (RH)	UP operation is in operation	ON
		Other than above	OFF
		Rear power window RH (UP) circuit is short	NG
R WIN RH OUT(DWN)	Operation of rear power window (RH)	DOWN operation is in operation	ON
		Other than above	OFF
		Rear power window RH (DOWN) circuit is short	NG
REAR DEF ON SIG	State of rear window defogger switch	While operating	ON
		Stop	OFF
REAR DEF OUT	State of rear window defogger system	Operate	ON
		Stop	OFF
		Rear window defogger circuit is short	NG
R WIN CURENT(LH)	Current value to rear power window motor (LH)		0-25.5 (A)
R WIN CURENT(RH)	Current value to rear power window motor (RH)		0-25.5 (A)
RR WIN STATE(LH)	State of rear power window (LH)	Upper	UP
		Halfway	MID
		Lower end	DOWN

RETRACTABLE HARD TOP CONTROL UNIT

< ECU DIAGNOSIS INFORMATION >

Monitor Item	Condition	Status/Value		
RR WIN STATE(RH)	State of rear power window (RH)	Upper	UP	A
		Halfway	MID	
		Lower end	DOWN	B
RAP SIGNAL	State of RAP	Operate	ON	
		Stop	OFF	
TR MODE SIGNAL	State of trunk mode signal	Output	ON	C
		Stop	OFF	
ROOF STATE(AUDIO)	State of roof	State of fully open	ON	D
		Other than above	OFF	
		Roof state signal (audio) circuit is short	NG	
ROOF BUZZER OUT	State of roof warning buzzer	Operate	ON	E
		Stop	OFF	
		Roof warning buzzer circuit is short	NG	F
LOCAL COMM 1	State of local communication 1	Normal	OK	
		It is in sleep mode	SLEEP	
		Communication error	NG	G
LOCAL COMM 2	State of local communication 2	Normal	OK	
		It is in sleep mode	SLEEP	
		Communication error	NG	H
ROOF MODE	Roof operation mode	Normal	OK	
		Only close operation is possible	CLOSE	I
		Operation is stop	STOP	
		Operation is inhibited	NG	
POP-UP BAR DPLOY	State of pop-up bar	Normal	OK	J
		State of deployment	NG	
POP-UP BAR DIAG	Self-diagnosis result of pop-up bar	Normal	OK	DLK
		Malfunctioning is detected	NG	
SWITCH VLV COND	Diagnosis result of retractable hard top control unit	Diagnosis result of retractable hard top control unit	OK	L
		Switching valve (1/2) system is malfunctioning	NG	
PWR SOURCE COND	Power supply voltage state of retractable hard top control unit	Normal	OK	M
		Malfunction	NG	
CPU COND	Diagnosis result of retractable hard top control unit	CPU is normal	OK	N
		CPU is not normal	NG	
ROOF COND	Diagnosis result of retractable hard top control unit	Roof position is normal	OK	O
		Roof position is not normal	NG	
SENSOR COND	Diagnosis result of retractable hard top control unit	Hole sensor system is normal	OK	
		Hole sensor system is not normal	NG	P
IGN ON SIG(BCM)	Power position signal (via CAN from BCM)	ON	OK	
		Other than above	NG	
VHCL STOP-METER	Vehicle speed signal (via CAN from meter and A/C amp.)	0km/h	OK	
		Other than above	NG	

RETRACTABLE HARD TOP CONTROL UNIT

< ECU DIAGNOSIS INFORMATION >

Monitor Item	Condition	Status/Value
CIRCUIT COND	Diagnosis result of retractable hard top control unit	Circuit system is normal
		Circuit system is not normal
ROOF TIMEOUT	State of roof operation	Normal
		Malfunction
CAN COMM	CAN communication status	Normal
		Malfunction
THERMO PROTECT 1	Thermo protection (Stage1)	In non-operation
		In operation
SHIFT R SIG	Shift position	Other than R position
		R position
PRMIT ENG ST(BCM)	Permit engine start signal	Signal is not received
		Signal is in receiving
THERMO PROTECT-2	Thermo protection (Stage2)	In non-operation
		In operation
TONNEAU SW	Tonneau board	Set
		Other than above
BRK LAMP SW(BCM)	Brake lamp switch signal (via CAN from BCM)	Brake is depressed
		Brake is released
THERMO VALUE	Conversion value of thermo protection	0-65535
PWR SOURCE VALUE	Power supply voltage value of retractable hard top control unit	0-20 (V)
ROOF INITIAL(OPEN)	State of performing roof position initialization	Registration of full open position is complete
		Registration of full open position is not complete
ROOF INITIAL(CLOSE)	State of performing roof position initialization	Registration of full closed position is complete
		Registration of full closed position is not complete
PSHELF INITIAL(ROTA)	State of performing parcel shelf position initialization	Registration of rotation position is complete
		Registration of rotation position is not complete
PSHELF INITIAL(DRAW)	State of performing parcel shelf position initialization	Registration of draw position is complete
		Registration of draw position is not complete

TERMINAL LAYOUT

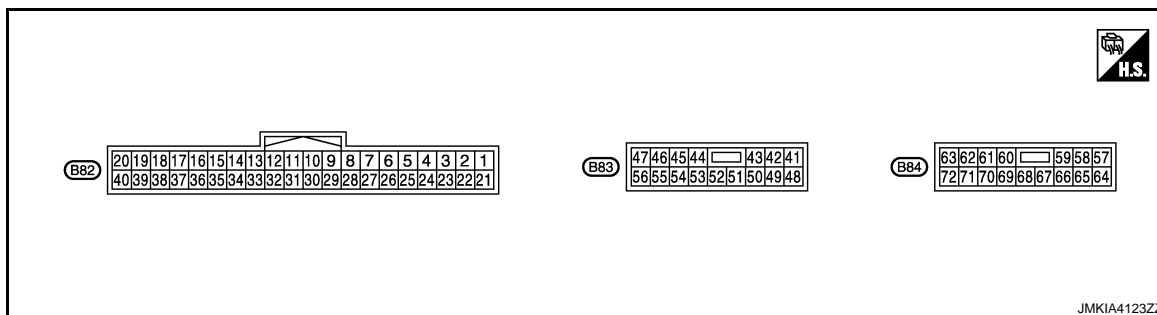

PHYSICAL VALUES

RETRACTABLE HARD TOP CONTROL UNIT

< ECU DIAGNOSIS INFORMATION >

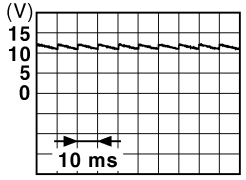
Terminal No. (Wire color)		Description		Condition			Value (Approx.)
+	-	Signal name	Input/ Output				
1 (G)	Ground	Roof open/close switch (OPEN)	Input	Ignition switch ON	Roof open/close switch (OPEN)	Pressed	0 V
						Released	Battery voltage
2 (BR)	Ground	Roof open/close switch (CLOSE)	Input	Ignition switch ON	Roof open/close switch (CLOSE)	Pressed	0 V
						Released	Battery voltage
3 (B)	Ground	Flipper door limit switch ground	—	Ignition switch ON	—		0 V
4 (L)	Ground	Tonneau board switch	Input	Ignition switch ON	Tonneau board	Hooked	Battery voltage
						Released	0 V
5 (SB)	Ground	Trunk room lamp switch	Input	Ignition switch ON	Trunk lid	Locked	 <small>JPMIA0011GB</small>
						Other than above	0 V
6 (L)	Ground	Roof latch limit switch	Input	Ignition switch ON	Roof	Close	0 V
						Other than above	Battery voltage
7 (W)	Ground	Flipper door limit switch (UP)	Input	Ignition switch ON	Flipper door LH and RH	Top	0 V
						Other than above	Battery voltage
8 (G)	Ground	Flipper door limit switch (DOWN)	Input	Ignition switch ON	Flipper door LH and RH	Bottom	0 V
						Other than above	Battery voltage
11 (W)	Ground	RAP signal	Input	Ignition switch ON	RAP function	Active	Battery voltage
						Inactive	0 V
12 (Y)	Ground	Back up lamp signal	Input	Ignition switch ON	Shift position	R position	Battery voltage
						Other than above	0 V
13 (BG)	Ground	Sensor power supply	Output	Ignition switch OFF	—		5 V
14 (P)	Ground	Trunk link sensor (LH)	Input	Ignition switch ON	Trunk link lock (LH)	LOCK	0.3 V
						Other than above	1.5 V
15 (SB)	Ground	Trunk link sensor (RH)	Input	Ignition switch ON	Trunk link lock (RH)	LOCK	0.3 V
						Other than above	1.5 V

A
B
C
D
E
F
G
H
I
J
K
L
M
N
O
P

DLK

RETRACTABLE HARD TOP CONTROL UNIT

< ECU DIAGNOSIS INFORMATION >

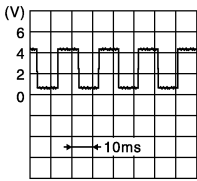
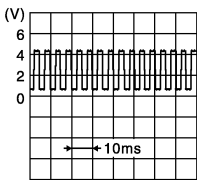
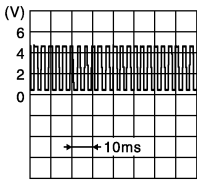
Terminal No. (Wire color)		Description		Condition			Value (Approx.)
+	-	Signal name	Input/ Output				
16 (GR)	Ground	Roof latch status sensor	Input	Ignition switch ON	Roof latch	Operate	 <small>JMKIA4021GB</small>
						Stop	0.5 or 4.5 V
17 (G)	Ground	Roof latch lock sensor	Input	Ignition switch ON	Roof latch	LOCK	1.0 V
						Other than above	3.8 V
18 (LG)	Ground	Trunk status sensor	Input	Ignition switch ON	Trunk lid (front)	Fully open	1.0 V
						Other than above	3.8 V
22 (V)	Ground	Roof status sensor power supply	Output	Ignition switch ON	—		5 V
23 (B)	Ground	Roof status sensor ground	—	Ignition switch ON	—		0 V
24 (GR)	Ground	Parcel shelf status sensor (DRAW)	Input	Ignition switch ON	Parcel shelf motor (DRAW)	Active	 <small>JMKIA4022GB</small>
						Inactive	0.5 V or 5 V
25 (R)	Ground	Parcel shelf status sensor (ROTATION)	Input	Ignition switch ON	Parcel shelf motor (ROTATE)	Active	 <small>JMKIA4023GB</small>
						Inactive	0.5 V or 5 V
26 (P)	Ground	Roof status sensor signal	Input	Ignition switch ON	Roof	Fully close → Fully open	0.5 V → 5 V
27 (Y)	Ground	Trunk lid open request signal (BCM)	Output	—	Trunk opener	Operate	0 V → Battery voltage → 0 V
						Other than above	0 V
28 (BG)	Ground	Flipper door motor ground	—	Ignition switch ON	—		0 V

RETRACTABLE HARD TOP CONTROL UNIT

< ECU DIAGNOSIS INFORMATION >

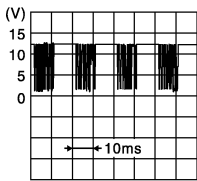
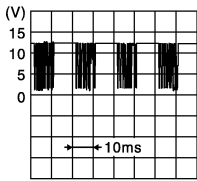
Terminal No. (Wire color)		Description		Condition		Value (Approx.)	
+	-	Signal name	Input/ Output				
29 (V)	Ground	Local communication (BCM)	Input/ Output	Ignition switch ON	—	 <p style="text-align: right; font-size: small;">JMKIA4024GB</p>	
30 (GR)	Ground	Local communication (POWER WINDOW)	Input/ Output	Ignition switch ON	—	 <p style="text-align: right; font-size: small;">JMKIA4024GB</p>	
31 (L)	Ground	CAN-H	Input/ Output	—	—	—	
32 (P)	Ground	CAN-L	Input/ Output	—	—	—	
33 (V)	Ground	Roof status signal (AUDIO)	Output	Ignition switch ON	Retractable hard top	Fully open	Battery voltage
						Other than above	0 V
34 (R)	Ground	Roof status signal (TRUNK)	Input	Ignition switch ON	Trunk	Fully close	Battery voltage
						Other than above	0 V
35 (B)	Ground	Roof warning buzzer	Output	Ignition switch ON	Roof warning buzzer	Sounds	0 V
						Not sounds	Battery voltage
36 (Y)	Ground	Hydraulic pump relay (RH)	—	Ignition switch ON	Hydraulic pump motor (RH)	Active	0 V
						Inactive	Battery voltage
37 (W)	Ground	Hydraulic pump relay (LH)	—	Ignition switch ON	Hydraulic pump motor (LH)	Active	0 V
						Inactive	Battery voltage
38 (BR)	Ground	Hydraulic pump relay ground	—	Ignition switch ON	—	0 V	
41 (SB)	Ground	Parcel shelf motor (UP)	Output	Ignition switch ON	Parcel shelf motor (DRAW-UP)	Active	Battery voltage
						Inactive	0 V
42 (W)	Ground	Parcel shelf motor (DOWN)	Output	Ignition switch ON	Parcel shelf motor (DRAW-DOWN)	Active	Battery voltage
						Inactive	0 V
43 (BR)	Ground	Hydraulic pump power supply relay	Output	Ignition switch ON	Retractable hard top system	Active	Battery voltage
						Inactive	0 V
44 (R)	Ground	Parcel shelf motor (HORIZONTAL)	Output	Ignition switch ON	Parcel shelf motor (ROTATION-HORI- ZONTAL)	Active	Battery voltage
						Inactive	0 V
45 (BR)	Ground	Parcel shelf motor (VERTICAL)	Output	Ignition switch ON	Parcel shelf motor (ROTATION-VER- TICAL)	Active	Battery voltage
						Inactive	0 V

A
B
C
D
E
F
G
H
I
J
K
L
M
N
O
P

DLK

RETRACTABLE HARD TOP CONTROL UNIT

< ECU DIAGNOSIS INFORMATION >

Terminal No. (Wire color)		Description		Condition			Value (Approx.)
+	-	Signal name	Input/ Output				
46 (G)	Ground	Flipper door motor (UP)	Output	Ignition switch ON	Flipper door motor (UP)	Active	Battery voltage
						Inactive	0 V
47 (L)	Ground	Flipper door motor (DOWN)	Output	Ignition switch ON	Flipper door motor (DOWN)	Active	Battery voltage
						Inactive	0 V
48 (R)	Ground	Roof latch motor (OPEN)	Output	Ignition switch ON	Roof latch motor (OPEN)	Active	Battery voltage
						Inactive	0 V
49 (Y)	Ground	Roof latch motor (CLOSE)	Output	Ignition switch ON	Roof latch motor (CLOSE)	Active	Battery voltage
						Inactive	0 V
51 (SB)	Ground	Trunk lid opener ac- tuator	Output	—	Trunk lid opener	Operate	0 V → Battery voltage → 0 V
						Stop	0 V
52 (V)	Ground	Trunk lid opener ac- tuator ground	—	Ignition switch ON	—		0 V
53 (BG)	Ground	Rear power window motor LH (UP)	Output	Ignition switch ON	Rear power window motor LH (UP)	Active	Battery voltage
						Inactive	0 V
54 (LG)	Ground	Rear power window motor LH (DOWN)	Output	Ignition switch ON	Rear power window motor LH (DOWN)	Active	Battery voltage
						Inactive	0 V
55 (GR)	Ground	Rear power window motor RH (UP)	Output	Ignition switch ON	Rear power window motor RH (UP)	Active	Battery voltage
						Inactive	0 V
56 (P)	Ground	Rear power window motor RH (DOWN)	Output	Ignition switch ON	Rear power window motor RH (DOWN)	Active	Battery voltage
						Inactive	0 V
57 (Y)	Ground	Power source (ROOF)	Input	—	—		Battery voltage
58 (Y)	Ground	Power source (ROOF)	Input	—	—		Battery voltage
59 (Y)	Ground	Power source (ROOF)	Input	—	—		Battery voltage
60 (B)	Ground	Ground (ROOF)	—	Ignition switch ON	—		0 V
61 (B)	Ground	Ground (ROOF)	—	Ignition switch ON	—		0 V
62 (GR)	Ground	Power source (POWER WINDOW)	Input	—	—		Battery voltage
63 (Y)	Ground	Power source (POWER WINDOW)	Input	—	—		Battery voltage
64 (B)	Ground	Ground (POWER WINDOW)	—	Ignition switch ON	—		0 V
65 (B)	Ground	Ground (POWER WINDOW)	—	Ignition switch ON	—		0 V

RETRACTABLE HARD TOP CONTROL UNIT

< ECU DIAGNOSIS INFORMATION >

Terminal No. (Wire color)		Description		Condition			Value (Approx.)
+	-	Signal name	Input/ Output				
66 (P)	Ground	Switching valve 1	Output	Ignition switch ON	Switching valve 1	Active	Battery voltage
						Inactive	0 V
67 (SB)	Ground	Switching valve 2	Output	Ignition switch ON	Switching valve 2	Active	Battery voltage
						Inactive	0 V
68 (L)	Ground	Switching valve ground	—	Ignition switch ON	—		0 V
69 (G)	Ground	Power source (REAR WINDOW DEFOGGER)	Input	—	—		Battery voltage
70 (P)	Ground	Power source (REAR WINDOW DEFOGGER)	Input	—	—		Battery voltage
71 (BR)	Ground	Rear window defog- ger power supply	Output	Ignition switch ON	Rear defogger switch ON and roof is fully closed		Battery voltage
72 (W)	Ground	Rear window defog- ger power supply	Output	Ignition switch ON	Rear defogger switch ON and roof is fully closed		Battery voltage

A
B
C
D
E
F
G
H
I
J
L
M
N
O
P

DLK

RETRACTABLE HARD TOP CONTROL UNIT

< ECU DIAGNOSIS INFORMATION >

Wiring Diagram

INFOID:000000005897695

RETRACTABLE HARD TOP SYSTEM

*: This connector is not shown in "Harness Layout".

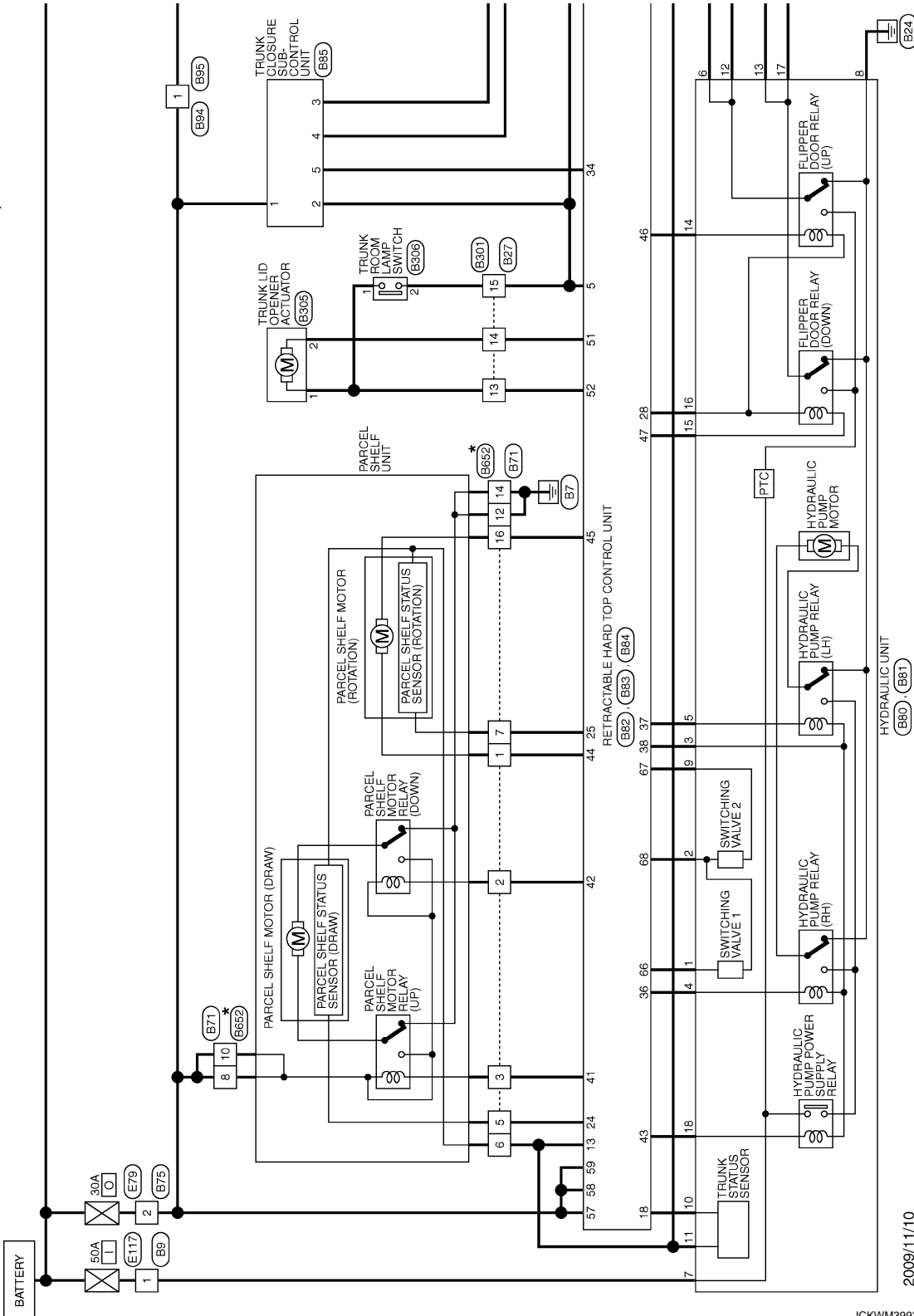

2009/11/10

JCKWM3992GI

RETRACTABLE HARD TOP CONTROL UNIT

< ECU DIAGNOSIS INFORMATION >

*: This connector is not shown in "Harness Layout".

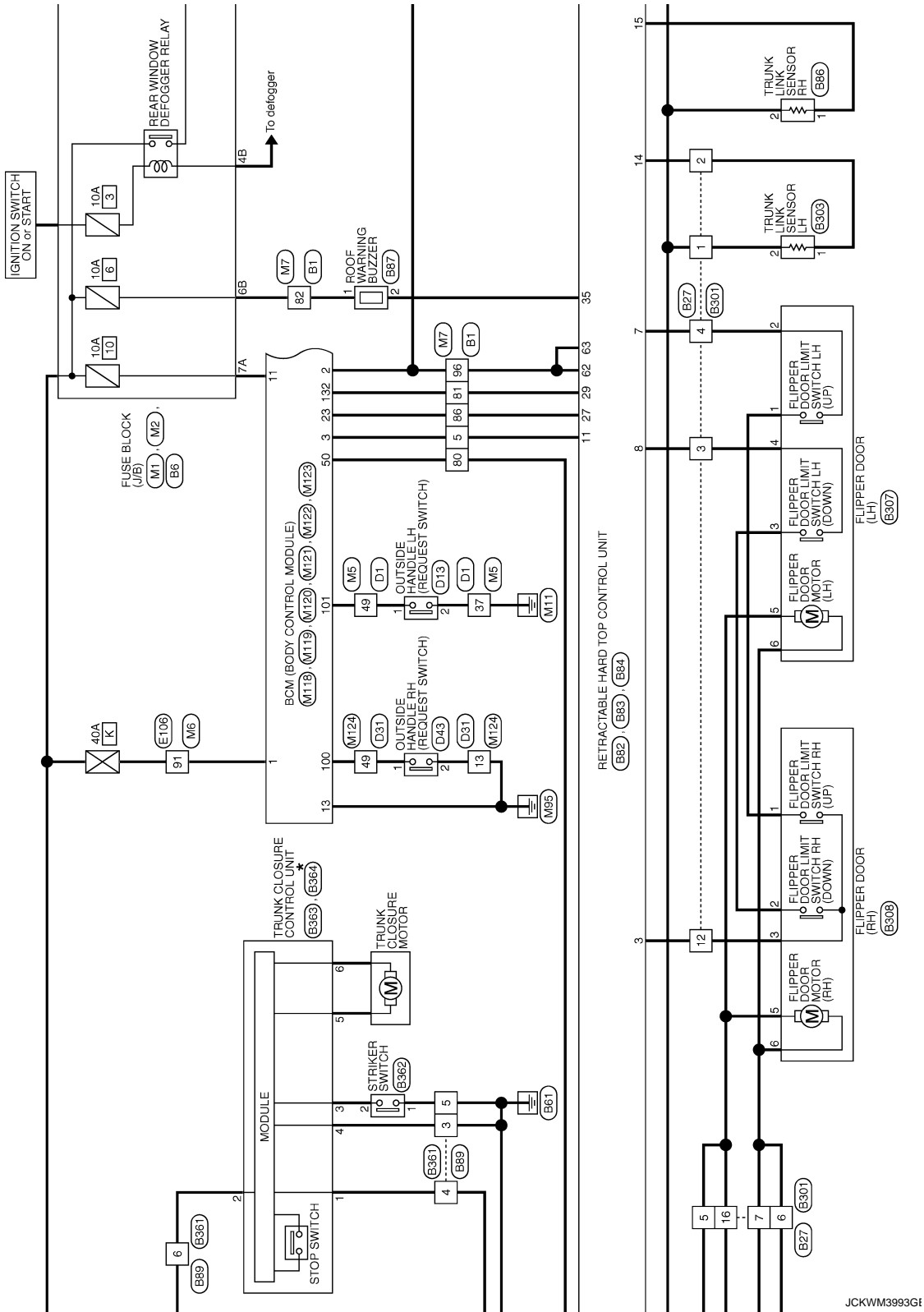

JCKWM3993GI

A
B
C
D
E
F
G
H
I
J
K
L
M
N
O
P

DLK

RETRACTABLE HARD TOP CONTROL UNIT

< ECU DIAGNOSIS INFORMATION >

A : With A/T
M : With M/T

*: This connector is not shown in "Harness Layout".

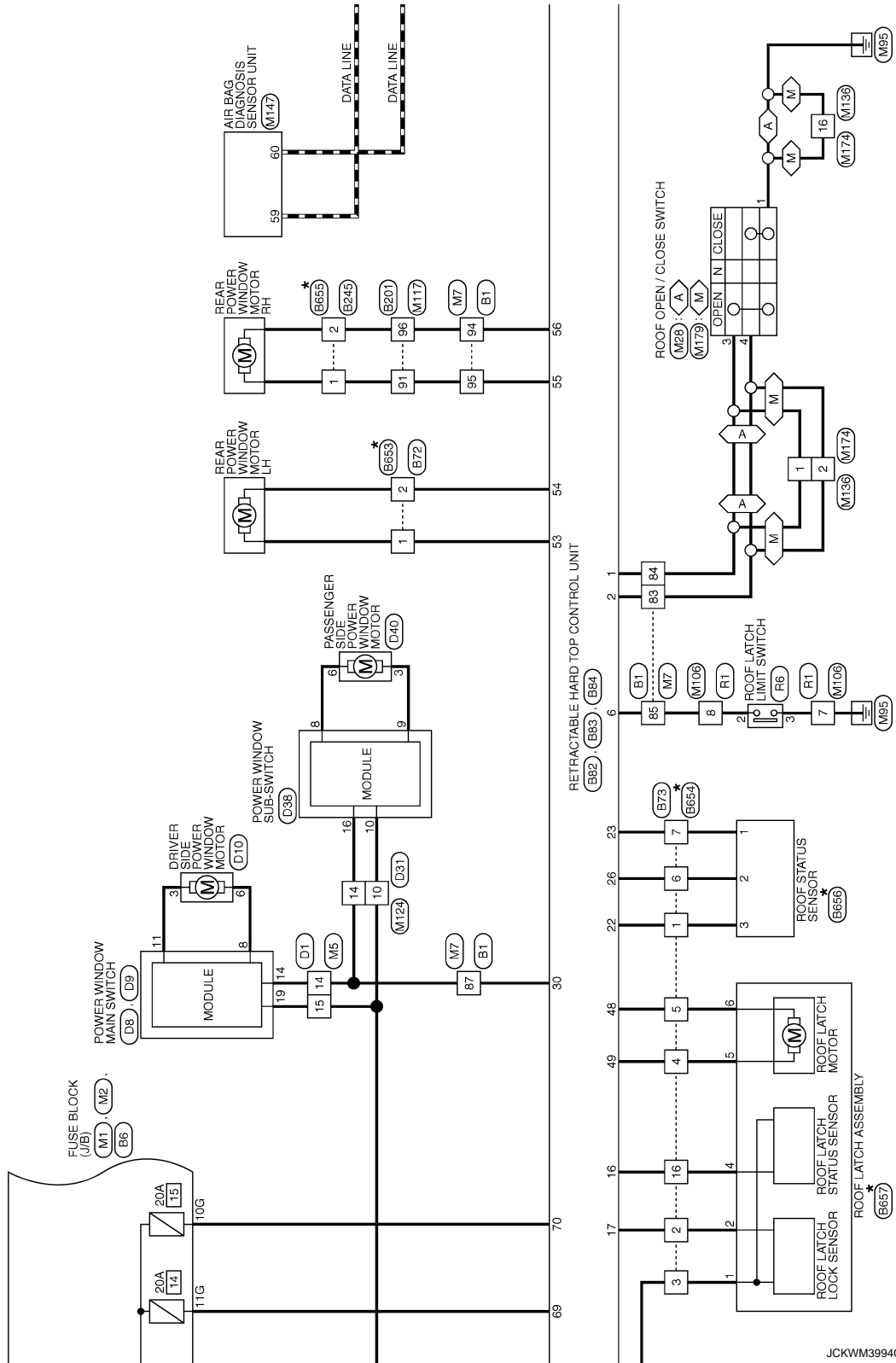

JCKWM3994Gf

RETRACTABLE HARD TOP CONTROL UNIT

< ECU DIAGNOSIS INFORMATION >

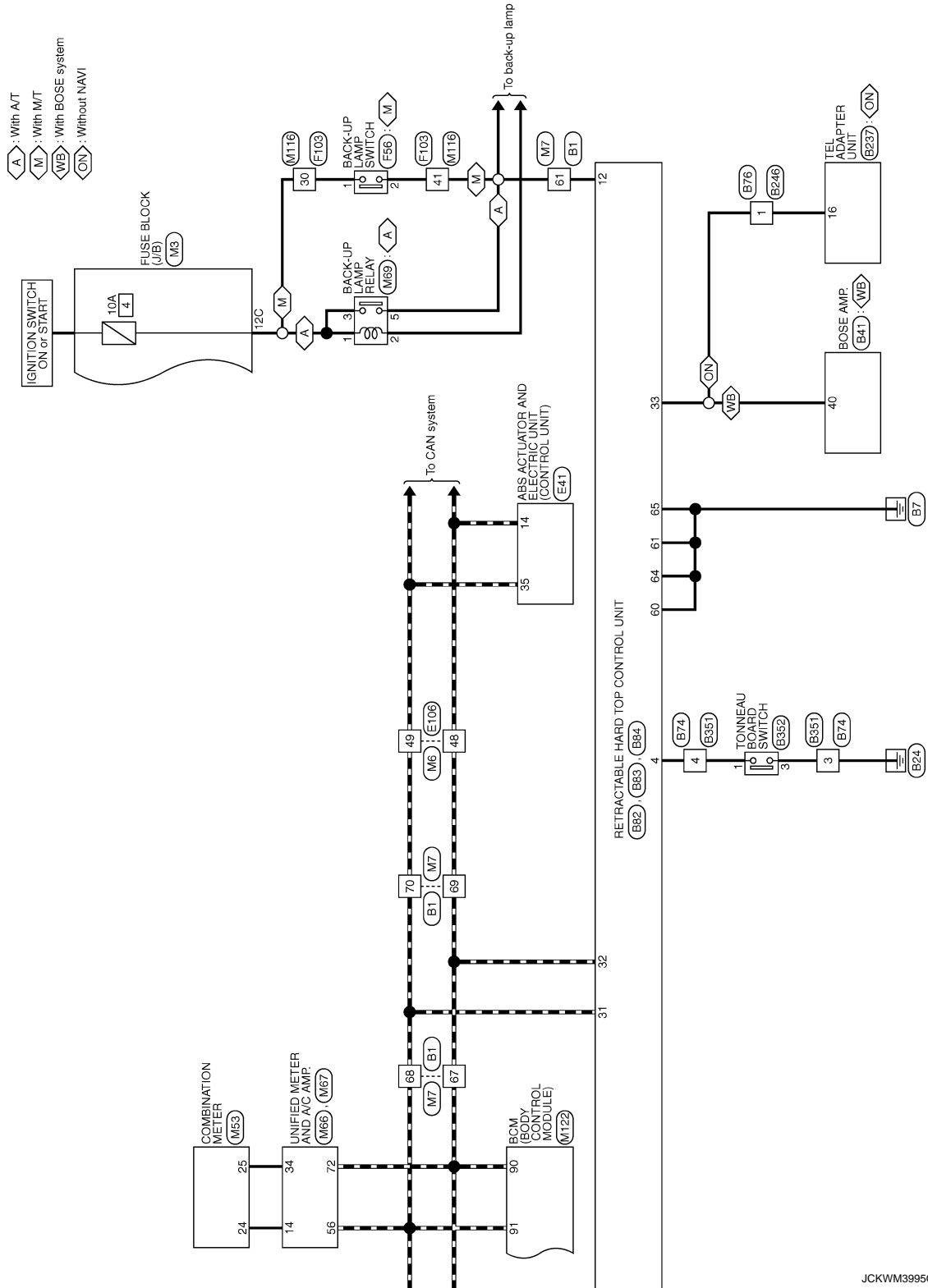

JCKWM3995G1

A
B
C
D
E
F
G
H
I
J
DLK
L
M
N
O
P

RETRACTABLE HARD TOP CONTROL UNIT

< ECU DIAGNOSIS INFORMATION >

RETRACTABLE HARD TOP SYSTEM

Connector No.	B1
Connector Name	WIRE TO WIRE
Connector Type	THBDFW-CS16-TM44



Terminal No.	Color of Wire	Signal Name [Specification]
1	W	-
2	L	-
3	R	-
4	V	-
5	W	-
6	B	-
8	G	-
10	BR	-
12	SHIELD	-
13	Y	-
14	L	-
15	R	-
16	W	-
17	BR	-
20	G	-
21	SB	-
22	GR	-
23	W	-
24	SB	-
25	BR	-
26	LG	-
27	Y	-
28	R	-
29	Y	-
31	SHIELD	-
32	G	-
33	R	-
34	BG	-
35	GR	-
36	BR	-
37	P	- [With climate controlled seat] - [Without climate controlled seat]
38	Y	- [With climate controlled seat] - [Without climate controlled seat]
39	GR	- [With climate controlled seat] - [Without climate controlled seat]
40	SHIELD	-
41	L	-
42	P	-
43	SHIELD	-

44	SB	-
45	V	-
46	W	-
47	SB	-
48	LG	-
49	LG	- [With BOSE system] - [Without BOSE system]
50	SB	- [With BOSE system] - [Without BOSE system]
51	SB	-
52	G	-
53	LG	-
54	BR	-
55	Y	-
56	W	-
57	V	-
60	R	-
61	BG	-
62	B	-
63	L	-
64	P	-
65	B	-
66	SB	-
67	P	-
68	L	-
69	P	-
70	L	-
80	G	-
81	V	-
82	R	-
83	BR	-
84	G	-
85	L	-
86	Y	-
87	GR	-
91	R	-
93	BG	-
94	L	-
95	GR	-
96	GR	-
97	SB	-
99	Y	-
100	Y/B	-

Connector No.	B6
Connector Name	FUSE BLOCK (U/B)
Connector Type	NS1ZFBR-CS

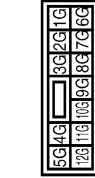

Terminal No.	Color of Wire	Signal Name [Specification]
4G	R	-
5G	LG	-
6G	G	-
10G	P	-
11G	G	-
12G	Y	-

Connector No.	B9
Connector Name	WIRE TO WIRE
Connector Type	MOBFW-LC



Terminal No.	Color of Wire	Signal Name [Specification]
1	Y	-
3	GR	-
4	LG	-
5	BR	-
6	BG	-

Connector No.	B27
Connector Name	WIRE TO WIRE
Connector Type	NS16MW-CS



Terminal No.	Color of Wire	Signal Name [Specification]
1	BG	-
2	P	-
3	G	-
4	W	-
5	R	-
6	P	-
7	GR	-
10	LG	-
11	B	-
12	B	-
13	V	-
14	SB	-
15	L	-
16	V	-

JCKWMM3996G1

RETRACTABLE HARD TOP CONTROL UNIT

< ECU DIAGNOSIS INFORMATION >

RETRACTABLE HARD TOP SYSTEM

Connector No.	B41
Connector Name	BOSE AMP.
Connector Type	TH40PV-NH

Terminal No.	10	11	12	13	14	15	16	17	18	19	20
Color of Wire											
Signal Name [Specification]											

Terminal No.	9	10	11	12	14	15	16	18	20	30	31	32	33	34	35	40
Color of Wire	L	G	G	SB	LG	LG	W	W	P	R	Y	V	SHIELD	SB	SB	V
Signal Name [Specification]	SOUND SIGNAL LH (-)	SOUND SIGNAL RH (-)	MICROPHONE SIGNAL (-)	VOICE GUIDANCE SIGNAL (-)	AV COMM (L)	AV COMM (L)	ACC	SOUND SIGNAL LH (+)	SOUND SIGNAL RH (+)	MICROPHONE SIGNAL (+)	VOICE GUIDANCE SIGNAL (+)	SHIELD	AV COMM (H)	AV COMM (H)	ROOF STATUS SIGNAL (AUDIO)	

Connector No.	B71
Connector Name	WIRE TO WIRE
Connector Type	NS10FBR-CS

Terminal No.	7	6	5	4	3	2	1
Color of Wire							
Signal Name [Specification]							

Terminal No.	1	2	3	5	6	7	8
Color of Wire	R	W	SB	SB	EG	R	Y
Signal Name [Specification]							

Terminal No.	10	12	14	16
Color of Wire	LG	P	W	BR
Signal Name [Specification]				

Connector No.	B72
Connector Name	WIRE TO WIRE
Connector Type	NS02MW-CS

Terminal No.	1	2
Color of Wire		
Signal Name [Specification]		

Terminal No.	1	2
Color of Wire	EG	LG
Signal Name [Specification]		

Connector No.	B73
Connector Name	WIRE TO WIRE
Connector Type	NS16FSY-CS

Terminal No.	7	6	5	4	3	2	1
Color of Wire							
Signal Name [Specification]							

Terminal No.	1	2	3	4	5	6	7	8	9	10	11	12	13	14	15	16
Color of Wire	V	G	EG	Y	R	P	B	B	B	W	W	GR				
Signal Name [Specification]																

Connector No.	B74
Connector Name	WIRE TO WIRE
Connector Type	TH40MW-NH

Terminal No.	1	2	3	4
Color of Wire				
Signal Name [Specification]				

Terminal No.	3	4
Color of Wire	B	L
Signal Name [Specification]		

Connector No.	B75
Connector Name	WIRE TO WIRE
Connector Type	IM02MW-LC

Terminal No.	1	2
Color of Wire		
Signal Name [Specification]		

Terminal No.	1	2
Color of Wire	L	Y
Signal Name [Specification]		

Connector No.	B76
Connector Name	WIRE TO WIRE
Connector Type	TH16MW-NH

Terminal No.	1	2	3	4	5	6	7	8
Color of Wire								
Signal Name [Specification]								

Terminal No.	1	4
Color of Wire	V	LG
Signal Name [Specification]		

Terminal No.	5	6	7	8	10	11	12	13	14	15	16
Color of Wire	SR	SHIELD	B	W	B	W	W	R	SHIELD	G	Y
Signal Name [Specification]											

Connector No.	B80
Connector Name	HYDRAULIC UNIT
Connector Type	NS10FW-CS



Terminal No.	17	18	5	4	3	2	1
Color of Wire							
Signal Name [Specification]							

Terminal No.	1	2	3	4	5	6	9	10	11	12
Color of Wire	P	L	BR	Y	W	R	SR	LG	EG	V
Signal Name [Specification]										

A
B
C
D
E
F
G
H
I
J
K
L
M
N
O
P

DLK

RETRACTABLE HARD TOP CONTROL UNIT

< ECU DIAGNOSIS INFORMATION >

RETRACTABLE HARD TOP SYSTEM

Connector No.	B81
Connector Name	HYDRAULIC UNIT
Connector Type	LOTFE-MC



Terminal No.	Color of Wire	Signal Name [Specification]
7	Y	-
8	B	-

Connector No.	B82
Connector Name	RETRACTABLE HARD TOP CONTROL UNIT
Connector Type	TH04FV-NH

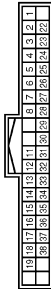

Terminal No.	Color of Wire	Signal Name [Specification]
1	G	ROOF OPEN / CLOSE SWITCH (OPEN)
2	BR	ROOF OPEN / CLOSE SWITCH (CLOSE)
3	B	FLIPPER DOOR LIMIT SWITCH (CLOSE)
4	L	TONNEAU BOARD SWITCH
5	SB	TRUNK ROOM LAMP SWITCH
6	L	ROOF LATCH LIMIT SWITCH
7	W	FLIPPER DOOR LIMIT SWITCH (UP)
8	G	FLIPPER DOOR LIMIT SWITCH (DOWN)
11	W	RETAINED ACC POWER
12	Y	REVERSE SIGNAL
13	BG	PARCEL SHELF STATUS SENSOR POWER SUPPLY
14	P	TRUNK LINK SENSOR SIGNAL (LH)
15	SB	TRUNK LINK SENSOR SIGNAL (RH)
16	GR	ROOF LATCH STATUS SENSOR SIGNAL
17	G	ROOF LATCH LOCK SIGNAL
18	LG	TRUNK STATUS SENSOR SIGNAL
22	V	ROOF STATUS SENSOR POWER SUPPLY
23	B	ROOF STATUS SENSOR GND
24	GR	PARCEL SHELF STATUS SENSOR SIGNAL (DRAW)
25	R	PARCEL SHELF STATUS SENSOR SIGNAL (ROTATION)

26	P	ROOF STATUS SENSOR SIGNAL
27	Y	TRUNK LID OPEN REQUEST SIGNAL
28	BG	FLIPPER DOOR RELAY GND
29	V	LOCAL COMMUNICATION (GMA)
30	GR	LOCAL COMMUNICATION (POWER WINDOW)
31	L	CAN-H
32	P	CAN-L
33	V	ROOF STATUS SIGNAL (AUDIO)
34	R	ROOF STATUS SIGNAL (TRUNK)
35	B	ROOF WARNING BUZZER
36	Y	HYDRAULIC MOTOR RELAY GND (RH)
37	W	HYDRAULIC MOTOR RELAY GND (LH)
38	BR	HYDRAULIC MOTOR RELAY POWER SUPPLY

Connector No.	B83
Connector Name	RETRACTABLE HARD TOP CONTROL UNIT
Connector Type	NSI06FR-CS



Terminal No.	Color of Wire	Signal Name [Specification]
41	SB	PARCEL SHELF MOTOR RELAY GND (UP)
42	W	PARCEL SHELF MOTOR RELAY GND (DOWN)
43	BR	HYDRAULIC PUMP POWER SUPPLY RELAY
44	R	MOTOR PARCEL SHELF (HORIZONTAL)
45	BR	MOTOR PARCEL SHELF (VERTICAL)
46	G	FLIPPER DOOR RELAY POWER SUPPLY (UP)
47	L	FLIPPER DOOR RELAY POWER SUPPLY (DOWN)
48	R	ROOF LATCH MOTOR (OPEN)
49	Y	ROOF LATCH MOTOR (CLOSE)
51	SB	TRUNK OPENER ACTUATOR
52	V	TRUNK OPENER ACTUATOR GND
53	BG	REAR POWER WINDOW MOTOR LH (UP)
54	LG	REAR POWER WINDOW MOTOR RH (UP)
55	GR	REAR POWER WINDOW MOTOR LH (DOWN)
56	P	REAR POWER WINDOW MOTOR RH (DOWN)

Connector No.	B84
Connector Name	RETRACTABLE HARD TOP CONTROL UNIT
Connector Type	NSI06FW-CS

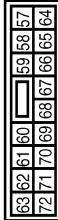

Terminal No.	Color of Wire	Signal Name [Specification]
57	Y	BAT
58	Y	BAT
59	Y	BAT
60	B	BAT
61	B	GND
62	GR	BAT (POWER WINDOW)
63	Y	BAT (POWER WINDOW)
64	B	GND (POWER WINDOW)
65	B	GND (POWER WINDOW)
66	P	SWITCHING VALVE 1
67	SB	SWITCHING VALVE 2
68	L	SWITCHING VALVE GND
69	G	REAR WINDOW DEF IN 1
70	P	REAR WINDOW DEF IN 2
71	BR	REAR WINDOW DEF OUT 1
72	W	REAR WINDOW DEF OUT 2

Connector No.	B85
Connector Name	TRUNK CLOSURE SUB-CONTROL UNIT
Connector Type	NSI06FW-CS



Terminal No.	Color of Wire	Signal Name [Specification]
1	Y	BAT
2	SB	TRUNK ROOM LAMP SWITCH
3	P	CLOSURE CONTROL SIGNAL
4	B	GND
5	R	TRUNK MODE SIGNAL

Connector No.	B86
Connector Name	TRUNK LINK SENSOR RH
Connector Type	TH04FV-NH



Terminal No.	Color of Wire	Signal Name [Specification]
1	SB	-
2	BG	-

Connector No.	B87
Connector Name	ROOF WARNING BUZZER
Connector Type	FK02FER



Terminal No.	Color of Wire	Signal Name [Specification]
1	R	-
2	B	-

RETRACTABLE HARD TOP CONTROL UNIT

< ECU DIAGNOSIS INFORMATION >

RETRACTABLE HARD TOP SYSTEM

Connector No.	B89
Connector Name	WIRE TO WIRE
Connector Type	NS28MW-CS



1	2
3	4
5	6

Terminal No.	Color of Wire	Signal Name [Specification]
3	B	-
4	P	-
5	B	-
6	Y	-

Connector No.	B84
Connector Name	WIRE TO WIRE
Connector Type	MD1MW-LC



1

Terminal No.	Color of Wire	Signal Name [Specification]
1	Y	-

Connector No.	B85
Connector Name	WIRE TO WIRE
Connector Type	MD1FW-LC



1

Terminal No.	Color of Wire	Signal Name [Specification]
1	Y	-

Connector No.	B201
Connector Name	WIRE TO WIRE
Connector Type	TH8GFW-CS16-TM4



1	2	3	4	5	6	7	8	9	10	11	12	13	14	15	16	17	18	19	20	21	22	23	24	25	26	27	28	29	30	31	32
---	---	---	---	---	---	---	---	---	----	----	----	----	----	----	----	----	----	----	----	----	----	----	----	----	----	----	----	----	----	----	----

Terminal No.	Color of Wire	Signal Name [Specification]
1	W	-
3	B	-
5	W	-
6	R	-
7	B	-
7	G	- [With climate controller seat]
7	G	- [Without climate controller seat]
8	BG	-
9	GR	-
10	LG	-
40	GR	-
41	LG	-
42	BG	-
43	R	-
44	SHIELD	-
45	G	-
47	G	-
48	Y	-
49	SHIELD	-
50	P	-
51	SR	-
52	LG	-
53	L	-
54	G	-
55	GR	-
56	LG	-
57	G	-
58	R	-
67	L	-
68	P	-
80	G	-
81	R	-
82	W	-
83	B	-
84	SHIELD	-
85	O	-
86	BR	-
87	Y	-
88	SHIELD	-

89	SB	-
91	V	-
91	GR	-
92	P	- [With BOSE system]
92	Y	- [Without BOSE system]
93	L	-
94	SB	-
95	V	-
96	P	-
97	L	- [With BOSE system]
97	LG	- [Without BOSE system]
98	Y/B	-
99	Y	-

Connector No.	B237
Connector Name	TEL ADAPTER UNIT
Connector Type	TH22FW-NH



2	4	6	8	10	12	14	16	18	20	22	24	26	28	30	32
1	3	5	7	9	11	13	15	17	19	21	23	25	27	29	31

Terminal No.	Color of Wire	Signal Name [Specification]
1	GR	BATTERY
2	LG	ACC
3	BG	IGNITION
4	B	GND
5	SHIELD	SHIELD
7	R	MICROPHONE SIGNAL
8	SHIELD	MICROPHONE GND
9	Y	TEL VOICE SIGNAL (+)
10	G	TEL VOICE SIGNAL (-)
14	B	GND
16	P	ROOF STATUS SIGNAL (AUDIO)
21	B	CONTROL SIGNAL
23	B	CONTROL SIGNAL
27	B	CONTROL SIGNAL
28	P	VEHICLE SPEED (8-PULSE)
29	G	MICROPHONE VCC

Connector No.	B245
Connector Name	WIRE TO WIRE
Connector Type	NS22MW-CS



1	2
---	---

Terminal No.	Color of Wire	Signal Name [Specification]
1	GR	-
2	P	-

Connector No.	B246
Connector Name	WIRE TO WIRE
Connector Type	TH16FW-NH



8	7	6	5	4	3	2	1
16	15	14	13	12	11	10	9

Terminal No.	Color of Wire	Signal Name [Specification]
1	P	-
4	P	-
5	L	-
6	SHIELD	-
7	B	-
8	W	-
10	B	-
11	G	-
12	W	-
13	R	-
14	SHIELD	-
15	G	-
16	Y	-

A
B
C
D
E
F
G
H
I
J
K
L
M
N
O
P



DLK

RETRACTABLE HARD TOP CONTROL UNIT

< ECU DIAGNOSIS INFORMATION >

RETRACTABLE HARD TOP SYSTEM

Connector No.	B301
Connector Name	WIRE TO WIRE
Connector Type	NS16FW-CS



Terminal No.	Color of Wire	Signal Name [Specification]
1	R	-
2	GR	-
3	G	-
4	W	-
5	Y	-
6	P	-
7	P	-
10	LG	-
11	B	-
12	B	-
13	V	-
14	BR	-
15	L	-
16	Y	-

Connector No.	B303
Connector Name	TRUNK LINK SENSOR LH
Connector Type	THM4FW-NH



Terminal No.	Color of Wire	Signal Name [Specification]
1	GR	-
2	R	-

Connector No.	B305
Connector Name	TRUNK LID OPENER ACTUATOR
Connector Type	M02FB-LC

Terminal No.	Color of Wire	Signal Name [Specification]
1	V	V-
2	BR	V+

Connector No.	B308
Connector Name	TRUNK ROOM LAMP SWITCH
Connector Type	A02FW



Terminal No.	Color of Wire	Signal Name [Specification]
1	V	SIG-
2	L	SIG+

Connector No.	B307
Connector Name	FLIPPER DOOR (LH)
Connector Type	NS06FB-CS



Terminal No.	Color of Wire	Signal Name [Specification]
1	V	SWITCH FD UP
2	W	SWITCH FD UP 1



3	Y	SWITCH FD DOWN
4	G	SWITCH FD DOWN 1
5	BR	MOTOR FD UP
6	L	MOTOR FD DOWN

Connector No.	B308
Connector Name	FLIPPER DOOR (RH)
Connector Type	NS06FW-CS



Terminal No.	Color of Wire	Signal Name [Specification]
1	V	SWITCH FD UP 1
2	Y	SWITCH FD DOWN 1
3	B	SWITCH FD GND COMBINED
4	BR	MOTOR FD UP
5	L	MOTOR FD DOWN

Connector No.	B351
Connector Name	WIRE TO WIRE
Connector Type	THM4FW-NH



Terminal No.	Color of Wire	Signal Name [Specification]
3	B	-
4	P	-
5	B	-
6	Y	-

Connector No.	B342
Connector Name	TONNEAU BOARD SWITCH
Connector Type	AG0FW

Terminal No.	Color of Wire	Signal Name [Specification]
1	G	-
3	B	-

Connector No.	B361
Connector Name	WIRE TO WIRE
Connector Type	NS06FW-CS

Terminal No.	Color of Wire	Signal Name [Specification]
3	B	-
4	P	-
5	B	-
6	Y	-

RETRACTABLE HARD TOP CONTROL UNIT

< ECU DIAGNOSIS INFORMATION >

RETRACTABLE HARD TOP SYSTEM

Connector No.	E362
Connector Name	STRIKER SWITCH
Connector Type	RV02FGY



Terminal No.	Color of Wire	Signal Name [Specification]
1	B	SIG-
2	GR	SIG+

Connector No.	E363
Connector Name	TRUNK CLOSURE CONTROL UNIT
Connector Type	NS04FW-CS



Terminal No.	Color of Wire	Signal Name [Specification]
1	P	TRUNK ROOM LAMP SW SIG
2	Y	POWER
3	GR	STRIKER SW SIG
4	B	GND

Connector No.	E364
Connector Name	TRUNK CLOSURE CONTROL UNIT
Connector Type	NS02FW-CS



Terminal No.	Color of Wire	Signal Name [Specification]
1	-	-

5	B	CLOSURE MOTOR GND
6	BR	CLOSURE MOTOR POWER

Connector No.	E322
Connector Name	WIRE TO WIRE
Connector Type	NS16MBR-CS



Terminal No.	Color of Wire	Signal Name [Specification]
1	-	-
2	-	-
3	-	-
4	-	-
5	-	-
6	-	-
7	-	-
8	-	-
9	-	-
10	-	-
11	-	-
12	-	-
13	-	-
14	-	-
15	-	-
16	-	-

Connector No.	E653
Connector Name	WIRE TO WIRE
Connector Type	NS02FW-CS



Terminal No.	Color of Wire	Signal Name [Specification]
1	-	-
2	-	-

Connector No.	E654
Connector Name	WIRE TO WIRE
Connector Type	NS16MGY-CS

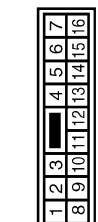

Terminal No.	Color of Wire	Signal Name [Specification]
1	-	-
2	-	-
3	-	-
4	-	-
5	-	-
6	-	-
7	-	-
8	-	-
9	-	-
10	-	-
11	-	-
12	-	-
13	-	-
14	-	-
15	-	-
16	-	-

Connector No.	E655
Connector Name	WIRE TO WIRE
Connector Type	NS02FW-CS



Terminal No.	Color of Wire	Signal Name [Specification]
1	-	-
2	-	-

Connector No.	E656
Connector Name	ROOF STATUS SENSOR
Connector Type	1-962700-1

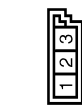

Terminal No.	Color of Wire	Signal Name [Specification]
1	-	-
2	-	-
3	-	-

Connector No.	E657
Connector Name	ROOF LATCH ASSEMBLY
Connector Type	NS06FW-CS



Terminal No.	Color of Wire	Signal Name [Specification]
1	-	-
2	-	-
3	-	-
4	-	-
5	-	-
6	-	-

JCKWM4001G1

A
B
C
D
E
F
G
H
I
J
K
L
M
N
O
P

DLK

RETRACTABLE HARD TOP CONTROL UNIT

< ECU DIAGNOSIS INFORMATION >

RETRACTABLE HARD TOP SYSTEM

Connector No.	D1
Connector Name	WIRE TO WIRE
Connector Type	TH40FW-CS15

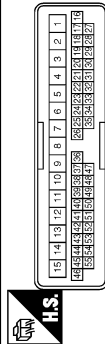

Terminal No.	Color of Wire	Signal Name [Specification]
4	BR	-
5	P	- [With A/T]
6	SB	- [With M/T]
7	R	-
8	G	-
9	P	-
10	LG	-
11	W	-
12	L	-
13	B	-
14	V	-
15	Y	-
16	Y/B	-
17	Y	-
20	V	-
21	R	-
22	P	-
23	O	-
24	Y	-
25	SB	-
26	GR	-
27	GR	-
28	LG	-
29	G	-
30	Y	-
31	W	-
32	BR	-
33	L	-
34	R	-
35	V	-
37	B	-
38	O	-
39	GR	-
40	G	-
41	Y	-
42	LG	-
43	BR	-

44	V	-
45	P	-
46	W	-
47	V	-
48	P	-
49	W	-
50	SB	-
51	R	-
52	L	-

Connector No.	D8
Connector Name	POWER WINDOW MAIN SWITCH
Connector Type	NS16FW-CS

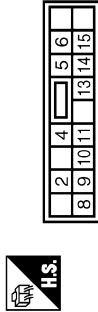

Terminal No.	Color of Wire	Signal Name [Specification]
2	G	-
4	V	-
5	BR	-
6	W	-
8	L	-
9	W	-
10	SB	-
11	BR	-
13	R	-
14	V	-
15	O	-

Connector No.	D9
Connector Name	POWER WINDOW MAIN SWITCH
Connector Type	NS50FW-CS

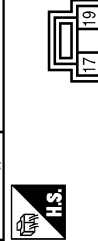

Terminal No.	Color of Wire	Signal Name [Specification]
17	W	-
19	B	-

17	B	-
19	Y	-

Connector No.	D10
Connector Name	DRIVER SIDE POWER WINDOW MOTOR
Connector Type	PH60FGY-Z



Terminal No.	Color of Wire	Signal Name [Specification]
1	G	-
2	R	-
3	BR	-
4	O	-
5	W	-
6	L	-

Connector No.	D13
Connector Name	OUTSIDE HANDLE LH (REQUEST SWITCH)
Connector Type	RK02FL



Terminal No.	Color of Wire	Signal Name [Specification]
1	W	-
2	B	-

Connector No.	D31
Connector Name	WIRE TO WIRE
Connector Type	TH40FW-CS15

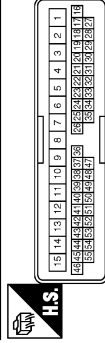

Terminal No.	Color of Wire	Signal Name [Specification]
6	BR	-
7	R	-
8	G	-
9	P	-
10	LG	-
11	W	-
12	L	-
13	B	-
14	Y	-
15	W	-
34	Y	-
35	Y/B	-
38	O	-
39	GR	-
40	G	-
41	Y	-
42	LG	-
43	BR	-
44	V	-
45	P	-
46	W	-
47	V	-
48	P	-
49	W	-
50	SB	-
51	R	-
52	L	-
53	O	-
54	GR	-
55	G	-

RETRACTABLE HARD TOP CONTROL UNIT

< ECU DIAGNOSIS INFORMATION >

RETRACTABLE HARD TOP SYSTEM

Connector No.	D38
Connector Name	POWER WINDOW SUB-SWITCH
Connector Type	NS16FW-CS

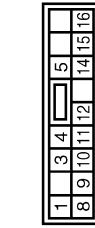

Terminal No.	Color of Wire	Signal Name [Specification]
3	G	
4	O	
8	L	
9	V	
10	W	
11	B	
12	R	
14	BR	
15	SB	
16	Y	

Connector No.	D40
Connector Name	PASSENGER SIDE POWER WINDOW MOTOR
Connector Type	FHB0BFGY-Z



Terminal No.	Color of Wire	Signal Name [Specification]
1	G	
2	R	
3	V	
4	O	
5	SB	
6	L	

Connector No.	D43
Connector Name	OUTSIDE HANDLE RH (REQUEST SWITCH)
Connector Type	RK02FL



Terminal No.	Color of Wire	Signal Name [Specification]
1	W	
2	B	

Connector No.	E41
Connector Name	AIRB ACTUATOR AND ELECTRIC LIMIT (CONTROL UNIT)
Connector Type	BAA42FB-AH24-LH

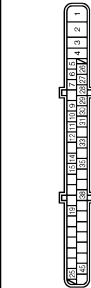

Terminal No.	Color of Wire	Signal Name [Specification]
1	B	GND
2	L	URMR
3	R	URVR
4	B	GND
5	Y	DS FL
6	BG	DP RL
7	BR	DP RR
8	B	DP FR
9	W	DS FR
10	V	DIAG-K
11	P	CAN-L
12	L	CAN-R
13	L	BUS-L
14	P	DP FL
15	Y	DP RL
16	W	DS RL
17	G	UZ
18	P	DS RR
19	GR	BLS
20	LG	VDG OFF SWITCH
31	R	CAN-H
35	L	BUS-H
45	B	BUS-H

Connector No.	E19
Connector Name	WIRE TO WIRE
Connector Type	MO2FFV-LC



Terminal No.	Color of Wire	Signal Name [Specification]
1	Y	
2	LG	

Connector No.	E106
Connector Name	WIRE TO WIRE
Connector Type	TH60FW-CS16-TM4

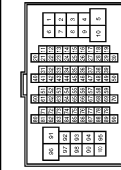

Terminal No.	Color of Wire	Signal Name [Specification]
1	GR	
3	BG	
4	B/W	
5	G	
6	BG	
7	LG	
8	G	
10	W	
11	V	
12	R	
13	L	
14	GR	
15	P	
16	W	
17	V	
18	BG	
19	GR	
20	LG	
30	R	
31	L	

32	BG	
33	P	
34	V	
35	BR	
36	W	
37	Y	
38	R	
39	B	
40	G	
41	W	
42	LG	
43	SB	
44	GR	
45	BG	
46	LG	
47	V	
48	P	
49	L	
59	B	
68	LG	
67	SB	
68	R	
69	W	
70	G	
80	W	
81	P	
82	G	
83	V	
84	L	
85	BG	
86	LG	
87	Y	
88	GR	
89	W	
90	W	
91	G	
92	B	
93	GR	
94	L	
95	Y	
97	BR	
98	SHIELD	
99	L	
100	P	

A
B
C
D
E
F
G
H
I
J
K
L
M
N
O
P

DLK

RETRACTABLE HARD TOP CONTROL UNIT

< ECU DIAGNOSIS INFORMATION >

RETRACTABLE HARD TOP SYSTEM

Connector No.	E117
Connector Name	WIRE TO WIRE
Connector Type	M08MWF-LC

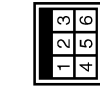

Terminal No.	Color of Wire	Signal Name [Specification]
1	Y	-
3	GR	-
4	P	-
5	BR	-
6	BG	-

Connector No.	F56
Connector Name	BACK-UP LAMP SWITCH
Connector Type	RK02FB



Terminal No.	Color of Wire	Signal Name [Specification]
1	R	-
2	O	-

Connector No.	F103
Connector Name	WIRE TO WIRE
Connector Type	TK36FW-NS10



Terminal No.	Color of Wire	Signal Name [Specification]
2	G	-
3	W	-
4	R	-
5	B	-
9	Y	-
10	GR	-
19	O	-
20	Y	-
28	B	-
29	LG	-
30	R	-
31	R	-
41	O	-
42	BR	-
43	P	-
44	L	-
45	Y	-
46	V	-

Connector No.	M1
Connector Name	FUSE BLOCK (J/B)
Connector Type	NS06FW-M2



Terminal No.	Color of Wire	Signal Name [Specification]
1A	V	-
2A	G	-
3A	L	-
4A	P	-
5A	BR	-
6A	Y	-
7A	GR	-
8A	L	-

Connector No.	M2
Connector Name	FUSE BLOCK (J/B)
Connector Type	NS10FW-CS



Terminal No.	Color of Wire	Signal Name [Specification]
1B	R	-
3B	P	-
4B	G	-
5B	BG	-
8B	Y	-
9B	P	-
9B	R	-
9B	SB	-

Connector No.	M3
Connector Name	FUSE BLOCK (J/B)
Connector Type	NS12FW-CS

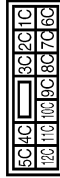

Terminal No.	Color of Wire	Signal Name [Specification]
9C	R	-
7C	B	-
8C	W	-
9C	BG	-
10C	L	-
11C	LG	-
12C	R	-

RETRACTABLE HARD TOP CONTROL UNIT

< ECU DIAGNOSIS INFORMATION >

RETRACTABLE HARD TOP SYSTEM

Connector No.	M5
Connector Name	WIRE TO WIRE
Connector Type	TH80MM-CS15

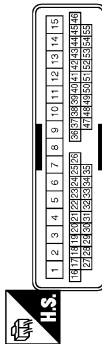

Terminal No.	Color of Wire	Signal Name [Specification]
4	R	-
5	B	-
6	BG	-
7	W	-
8	B	-
9	G	-
10	V	-
11	W	-
12	L	-
13	B	-
14	GR	-
15	Y	-
16	Y/B	-
17	Y	-
20	BG	-
21	W	-
22	P	-
23	BG	-
24	V	-
25	BR	-
26	R	-
27	P	-
28	LG	-
29	SB	-
30	G	-
31	V	-
32	BR	-
33	GR	-
34	G	-
35	L	-
37	B	-
38	L	- [With automatic drive positioner]
39	BR	- [Without automatic drive positioner]
39	BR	- [With automatic drive positioner]
40	L	- [Without automatic drive positioner]
40	Y	- [With automatic drive positioner]
41	BR	- [Without automatic drive positioner]
41	G	- [With automatic drive positioner]

42	R	-
43	G	-
44	Y	-
45	GR	-
46	BR	-
47	V	-
48	LG	-
49	P	-
50	SB	-
51	GR	-
52	L	-

Connector No.	M6
Connector Name	WIRE TO WIRE
Connector Type	TH80MM-CS16-TM4



Terminal No.	Color of Wire	Signal Name [Specification]
1	BG	-
3	R	-
4	G	-
5	G	-
6	BR	-
7	BR	-
8	Y	-
10	W	-
11	GR	-
12	R	-
13	L	-
14	G	-
15	P	-
16	W	-
17	BR	-
18	V	-
19	BG	-
20	L	-
30	R	-
31	L	-
32	Y	-
33	GR	-
34	P	-
35	BR	-
36	BR	-

37	Y	-
38	LG	-
38	SB	-
40	G	-
41	W	-
42	LG	-
43	P	-
44	GR	- [With A/T]
44	R	- [With M/T]
45	BG	-
46	G	-
47	P	-
48	P	-
49	L	-
59	B	-
66	Y	-
67	G	-
68	R	-
68	W	-
70	G	-
80	SB	-
81	R	-
82	V	-
83	W	-
84	L	-
85	BG	-
86	G	-
87	V	-
88	B	-
89	SB	-
90	G	-
91	W	-
92	B	-
93	G	-
94	L	-
95	BR	-
97	P	-
98	SHIELD	-
99	V	-
100	SB	-

A
B
C
D
E
F
G
H
I
J
K
L
M
N
O
P

DLK

RETRACTABLE HARD TOP CONTROL UNIT

< ECU DIAGNOSIS INFORMATION >

RETRACTABLE HARD TOP SYSTEM

Connector No.	M7
Connector Name	WIRE TO WIRE
Connector Type	TH80MW-CS16-TIM4



Terminal No.	Color of Wire	Signal Name [Specification]
1	BG	-
2	LG	-
3	G	-
4	V	-
5	L	-
6	B	-
8	L	-
10	BR	-
12	SHIELD	-
13	V	-
14	BR	-
15	GR	-
16	LG	-
17	L	-
20	BR	-
21	G	-
22	R	-
23	SB	-
24	B	-
25	W	-
26	Y	-
27	V	-
28	P	-
29	V	-
31	SHIELD	-
32	G	-
33	R	-
34	BG	-
35	GR	-
36	BR	-
37	P	- [With climate controlled seat]
37	L	- [Without climate controlled seat]
38	V	- [With climate controlled seat]
38	GR	- [Without climate controlled seat]
40	SHIELD	-
41	L	-
42	P	-
43	SHIELD	-

Connector No.	M28
Connector Name	ROOF OPEN / CLOSE SWITCH
Connector Type	TKG8FW-IV

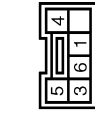

Terminal No.	Color of Wire	Signal Name [Specification]
1	B	-
3	V	-
4	BR	-
5	R	-
6	GR	-

Connector No.	M53
Connector Name	COMBINATION METER
Connector Type	SAB40FW



Terminal No.	Color of Wire	Signal Name [Specification]
1	V	BATTERY POWER SUPPLY
2	LG	COMMUNICATION SIGNAL (METER->AMP)
3	GR	COMMUNICATION SIGNAL (AMP->METER)
5	B	GROUND
6	W	AIR BAG SIGNAL
7	LG	SECURITY SIGNAL
10	R	GROUND
15	B	METER CONTROL SWITCH GROUND
16	GR	ILL.GND
18	B	ILL.GND
19	B	ILL.GND
20	R	ILL.
21	R	IGNITION SIGNAL
22	B	GROUND
24	SB	COMMUNICATION SIGNAL (LCD->AMP)
25	B	COMMUNICATION SIGNAL (AMP->LCD)
26	R	VEHICLE SPEED SIGNAL (8-PULSE)

27	V	PARKING BRAKE SWITCH SIGNAL
28	SB	BRAKE FLUID LEVEL SWITCH SIGNAL
29	L	SEAT BELT BUCKLE SW SIGNAL (DRIVER SIDE)
30	G	SEAT BELT BUCKLE SWITCH SIGNAL (PASSENGER SIDE)
31	L	WASHER LEVEL SWITCH SIGNAL
32	R	ILLUMINATION CONTROL SIGNAL
36	LG	SELECT SWITCH SIGNAL
37	SB	ENTER SWITCH SIGNAL
38	L	TRIP A/B RESET SWITCH SIGNAL
39	P	ILLUMINATION CONTROL SWITCH (-)
40	BG	ILLUMINATION CONTROL SWITCH (+)

Connector No.	M86
Connector Name	UNIFIED METER AND A/C AMP.
Connector Type	TH40FW-NH

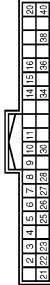

Terminal No.	Color of Wire	Signal Name [Specification]
4	G	STOP LAMP SWITCH
5	L	MANUAL MODE SHIFT UP SIGNAL
6	BG	PADDLE SHIFTER UP SIGNAL
7	GR	COMMUNICATION SIGNAL (AMP->METER)
8	L	VEHICLE SPEED (2-PULSE)
9	SB	SEAT BELT BUCKLE SWITCH SIGNAL (DRIVER SIDE)
10	W	MANUAL MODE SIGNAL
11	G	NON-MANUAL MODE SIGNAL
14	SB	COMMUNICATION SIGNAL (LCD->AMP)
20	G	IGN ON / OFF SIGNAL
25	V	MANUAL MODE SHIFT DOWN SIGNAL
26	G	PADDLE SHIFTER DOWN SIGNAL
27	LG	COMMUNICATION SIGNAL (METER->AMP)
28	R	VEHICLE SPEED (8-PULSE)
30	V	PARKING BRAKE SWITCH SIGNAL
34	B	COMMUNICATION SIGNAL (AMP->LCD)
38	P	BLOWER MOTOR CONTROL SIGNAL

RETRACTABLE HARD TOP CONTROL UNIT

< ECU DIAGNOSIS INFORMATION >

RETRACTABLE HARD TOP SYSTEM

Connector No.	M87
Connector Name	UNIFIED METER AND A/C AMP.
Connector Type	TH22FN-NH



41	42	43	44	45	46	47	48	49	50	51	52	53	54	55	56
57	58	59	60	61	62	63	64	65	66	67	68	69	70	71	72

Terminal No.	Color of Wire	Signal Name [Specification]
41	BR	ACC POWER SUPPLY
42	BR	FUEL LEVEL SENSOR SIGNAL
43	R	INTAKE SENSOR SIGNAL
44	LG	IN-VEHICLE SENSOR SIGNAL
45	V	AMBIENT SENSOR SIGNAL
46	BG	SUNLOAD SENSOR SIGNAL
47	G	GAS SENSOR SIGNAL
53	W	IGNITION POWER SUPPLY
54	BG	BATTERY POWER SUPPLY
55	B	GROUND
56	L	CAN-H
57	LG	BRAKE FLUID LEVEL SWITCH SIGNAL
58	Y	FUEL LEVEL SENSOR SIGNAL GROUND
59	GR	INTAKE SENSOR GROUND
60	L	IN-VEHICLE SENSOR GROUND
61	R	AMBIENT SENSOR GROUND
62	SB	SUNLOAD SENSOR GROUND
63	L	ION CONTROL MODE OUTPUT SIGNAL
65	BG	ECV SIGNAL
68	L	A/C LAN SIGNAL
70	R	EACH DOOR MOTOR POWER SUPPLY
71	GR	GROUND
72	P	CAN-L

Connector No.	M89
Connector Name	BACK-UP LAMP RELAY
Connector Type	MS02FL-M2-LG



Terminal No.	Color of Wire	Signal Name [Specification]
1	R	
2	W	
3	LG	
5	BG	

Connector No.	M106
Connector Name	WIRE TO WIRE
Connector Type	NH10MW-CS10

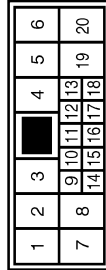

Terminal No.	Color of Wire	Signal Name [Specification]
1	B	
2	BR	
3	Y	
4	G	
5	SHIELD	
6	R	
7	B	
8	L	
9	R	
10	SB	
11	V	
12	LG	
18	B	
19	P	
20	Y	

Connector No.	M116
Connector Name	WIRE TO WIRE
Connector Type	TK38MW-NS10



Terminal No.	Color of Wire	Signal Name [Specification]
2	W	
3	BG	
4	R	
5	B	
9	R	
10	R	
19	BG	
20	Y	
28	GR	
29	LG	
30	LG	
31	W	
41	BG	
42	G	
43	P	
44	L	
45	G	
46	Y	

Connector No.	M117
Connector Name	WIRE TO WIRE
Connector Type	TH80MW-CS16-TM4

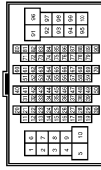

Terminal No.	Color of Wire	Signal Name [Specification]
1	Y	
3	B	
5	SB	
6	R	
7	G	
8	SB	
9	GR	
10	LG	
40	Y	
41	G	
42	LG	
43	R	
44	SHIELD	
45	G	
47	P	
48	L	

Terminal No.	Color of Wire	Signal Name [Specification]
49	SHIELD	
50	V	
51	SB	
52	BG	
53	L	
54	G	
55	Y	
56	LG	
57	SB	
58	LG	
67	SB	
68	LG	
80	W	
81	B	
82	R	
83	G	
84	SHIELD	
85	G	
86	L	
87	P	
88	SHIELD	
89	Y	
90	W	
91	GR	
92	P	
93	W	
94	BG	
95	BG	
96	P	
97	L	
98	Y/B	
99	Y	

Connector No.	M118
Connector Name	BCM (BODY CONTROL MODULE)
Connector Type	MS03FB-LG



Terminal No.	Color of Wire	Signal Name [Specification]
1	W	BAT (F/L)
2	Y	POWER WINDOW POWER SUPPLY (BAT)
3	BG	POWER WINDOW POWER SUPPLY (RAP)

A
B
C
D
E
F
G
H
I
J
DLK
L
M
N
O
P

RETRACTABLE HARD TOP CONTROL UNIT

< ECU DIAGNOSIS INFORMATION >

RETRACTABLE HARD TOP SYSTEM

Connector No.	M119
Connector Name	BCM (BODY CONTROL MODULE)
Connector Type	NS16FW-CS

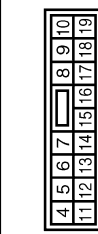

Terminal No.	Color of Wire	Signal Name [Specification]
4	LG	INTERIOR ROOM LAMP POWER SUPPLY
5	P	PASSENGER DOOR UNLOCK OUTPUT
7	SB	STEP LAMP
8	V	ALL DOOR FUEL LID LOCK OUTPUT
9	G	DRIVER DOOR FUEL LID UNLOCK OUTPUT
11	GR	BATT (FUSE)
13	B	GND
14	W	PUSH-BUTTON IGNITION SW (L) GND
15	EG	ACC IND
17	BR	TURN SIGNAL RH (FRONT)
18	EG	TURN SIGNAL LH (FRONT)
19	V	ROOM LAMP TIMER CONTROL

Connector No.	M120
Connector Name	BCM (BODY CONTROL MODULE)
Connector Type	NS12FW-CS

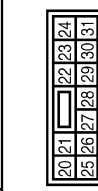

Terminal No.	Color of Wire	Signal Name [Specification]
20	V	TURN SIGNAL RH (REAR)
23	Y	TRUNK LID OPEN OUTPUT
25	Y	TURN SIGNAL LH (REAR)
30	P	TRUNK ROOM LAMP

Connector No.	M121
Connector Name	BCM (BODY CONTROL MODULE)
Connector Type	TH40FG-NH

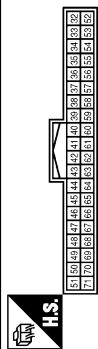

Terminal No.	Color of Wire	Signal Name [Specification]
34	SB	TRUNK ROOM ANT-
35	V	TRUNK ROOM ANT+
38	B	REAR BUMPER ANT-
39	W	REAR BUMPER ANT+
47	Y	IGN RELAY (R) (M/L/R) CONT
50	G	TRUNK ROOM LAMP SW
52	BR	STARTER RELAY CONT
61	SB	TRUNK LID OPENER REQUEST SW
64	G	P-KEY WARM BUZZER (ENG ROOM)
67	GR	TRUNK LID OPENER SW

Connector No.	M122
Connector Name	BCM (BODY CONTROL MODULE)
Connector Type	TH40FE-NH

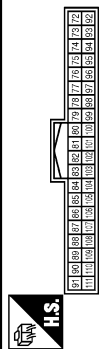

Terminal No.	Color of Wire	Signal Name [Specification]
72	R	ROOM ANT 2-
73	G	ROOM ANT 2+
74	SB	PASSENGER DOOR ANT-
75	BR	PASSENGER DOOR ANT+
76	V	DRIVER DOOR ANT-
77	LG	DRIVER DOOR ANT+
78	Y	ROOM ANT 1-
79	BR	ROOM ANT 1+
80	GR	NATS ANTENNA AMP
81	W	NATS ANTENNA AMP
82	R	IGN RELAY (F/B) CONT
83	Y	KEYLESS ENTRY RECEIVER COMM

87	Y	COMBI SW INPUT 5
88	BG	COMBI SW INPUT 3
89	BR	PUSH SW
90	P	IGN L
91	L	IGN H
92	LG	KEY SLOT ILL
93	V	ON IND
95	BG	ACC RELAY CONT
96	GR	A/T SHIFT SELECTOR POWER SUPPLY
97	L	S/L CONDITION 1
98	SB	S/L CONDITION 2
99	R	SHIFT P [With A/T]
99	R	ASCD/ICC CLUTCH SW [With M/T]
100	Y	PASSENGER DOOR REQUEST SW
101	P	DRIVER DOOR REQUEST SW
102	BG	BLOWER FAN MOTOR RELAY CONT
103	LG	KEYLESS ENTRY RECEIVER POWER SUPPLY
106	W	S/L UNIT POWER SUPPLY
107	LG	COMBI SW INPUT 1
108	R	COMBI SW INPUT 4
109	W	COMBI SW INPUT 2
110	G	HAZARD SW
111	Y	S/L UNIT COMM

Connector No.	M123
Connector Name	BCM (BODY CONTROL MODULE)
Connector Type	TH40FG-NH

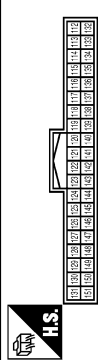

Terminal No.	Color of Wire	Signal Name [Specification]
112	BR	RAIN SENSOR SERIAL LINK
113	G	OPTICAL SENSOR
114	R	CLUTCH INTERLOCK SW
116	SB	STOP LAMP SW 1
118	BR	STOP LAMP SW 2
119	GR	DR DOOR UNLOCK SENSOR
121	SB	KEY SLOT SW
123	W	IGN F/B
124	BG	PASSENGER DOOR SW
129	BG	TRUNK LID OPENER CANCEL SW
132	LG	P/W SW & RHT G/U COMM
133	Y	PUSH-BUTTON IGNITION SW ILL POWER
134	LG	LOCK IND

137	BG	RECEIVER / SENSOR GND
138	Y	RECEIVER / SENSOR POWER SUPPLY
139	L	TIRE PRESSURE RECEIVER COMM
140	GR	SHIFT N/P
141	R	SECURITY INDICATOR LAMP
142	BR	COMBI SW OUTPUT 5
143	V	COMBI SW OUTPUT 1
144	G	COMBI SW OUTPUT 2
145	L	COMBI SW OUTPUT 3
146	SB	COMBI SW OUTPUT 4
149	W	TIRE PRESSURE WARN CHECK SW
150	R	DRIVER DOOR SW
151	G	REAR WINDOW DEFOGGER RELAY CONT

RETRACTABLE HARD TOP CONTROL UNIT

< ECU DIAGNOSIS INFORMATION >

RETRACTABLE HARD TOP SYSTEM

Connector No.	M124
Connector Name	WIRE TO WIRE
Connector Type	TH40MW-CS-5

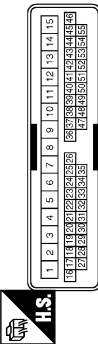

Terminal No.	Color of Wire	Signal Name [Specification]
6	BG	-
7	R	-
8	G	-
9	P	-
10	V	-
11	SB	- [With BOSE system]
11	GR	- [Without BOSE system]
12	BR	-
13	B	-
14	G	-
15	W	-
34	Y	-
35	Y/B	-
36	W	-
38	BG	-
40	SB	-
41	BR	- [With automatic drive positioner]
41	G	- [Without automatic drive positioner]
42	R	-
43	L	-
44	Y	-
46	R	-
46	W	-
47	SB	-
48	BR	-
48	Y	-
50	P	-
51	LG	-
52	BG	-
53	Y	-
54	L	-
55	L	-

Connector No.	M136
Connector Name	WIRE TO WIRE
Connector Type	TH24FP-NH

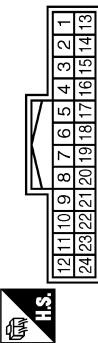

Terminal No.	Color of Wire	Signal Name [Specification]
1	V	-
2	BR	-
3	R	-
4	GR	-
5	W	-
6	W	-
7	R	-
8	GR	-
9	SB	-
10	R	-
11	L	-
12	GR	-
16	B	-
21	GR	-
22	W	-
23	GR	-
24	W	-

Connector No.	M147
Connector Name	AIR BAG DIAGNOSIS SENSOR UNIT
Connector Type	NH28FY-EX

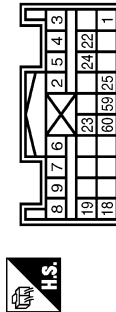

Terminal No.	Color of Wire	Signal Name [Specification]
1	LG	IGN
2	B	GND
3	Y	DR1 (-)
4	Y	DR1 (-)DR2 (-)
5	Y	DR2 (-)

6	Y	ASI (+)
7	Y	ASI (-)
8	Y	ASZ (+)
8	Y	ASZ (-)
18	SB	ECZS (+)
19	V	ECZS (-)
22	SHIELD	GND
23	LG	AIRBAG W/L
24	G	SEAT BELT
25	R	CUTOFF TELLTALE
59	L	CAN-H
60	P	CAN-L

Connector No.	M174
Connector Name	WIRE TO WIRE
Connector Type	TH24MW-NH



Terminal No.	Color of Wire	Signal Name [Specification]
1	V	-
2	BR	-
3	R	-
4	GR	-
5	W	-
6	LG	-
7	R	-
8	B	-
9	SB	-
10	O	-
11	L	-
12	G	-
16	B	-
21	GR	-
22	W	-
23	B	-
24	Y	-

Connector No.	M179
Connector Name	ROOF OPEN / CLOSE SWITCH
Connector Type	TK06FW-IV



Terminal No.	Color of Wire	Signal Name [Specification]
1	B	-
3	V	-
4	BR	-
5	R	-
6	GR	-

Connector No.	RI
Connector Name	WIRE TO WIRE
Connector Type	NH10FW-GS10

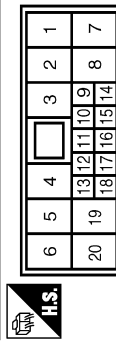

Terminal No.	Color of Wire	Signal Name [Specification]
1	B	-
2	BR	-
3	Y	-
4	W	-
5	SHIELD	-
6	O	-
7	B	-
8	L	-
9	Y	-
10	B	-
11	V	-
12	R	-
18	B	-
19	BR	-
20	G	-

A
B
C
D
E
F
G
H
I
J
K
L
M
N
O
P

DLK

RETRACTABLE HARD TOP CONTROL UNIT

< ECU DIAGNOSIS INFORMATION >

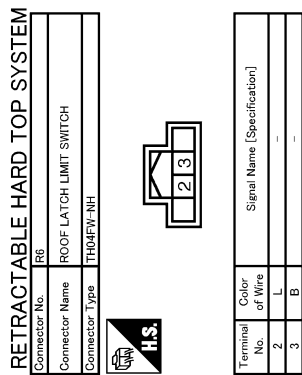

Fail-safe

FAIL-SAFE CONTROL BY DTC

Retractable hard top control unit performs fail-safe control when any DTC are detected.

JCKWM4010G1

INFOID:000000005897692

RETRACTABLE HARD TOP CONTROL UNIT

< ECU DIAGNOSIS INFORMATION >

Display contents of CONSULT-III		Fail-safe	Cancellation
U1000	CAN COMM CIRCUIT	Inhibit retractable hard top operation.	Communication is normal
U1010	CONTROL UNIT (CAN)	Inhibit retractable hard top operation.	Communication is normal
U0140	LOCAL COMM-1	Inhibit retractable hard top operation.	Communication is normal
U0215	LOCAL COMM-1	Inhibit retractable hard top operation.	Communication is normal
B1701	ROOF CONTROL UNIT	Inhibit retractable hard top operation.	Replace retractable hard top control unit.
B1702	ROOF CONTROL UNIT	Inhibit retractable hard top operation.	Replace retractable hard top control unit.
B1709	ROOF SWITCH(OPEN)	Inhibit retractable hard top operation.	Detects roof open/close switch (OPEN) is OFF
B170A	ROOF SWITCH(CLOSE)	Inhibit retractable hard top operation.	Detects roof open/close switch (CLOSE) is OFF
B170B	ROOF SWITCH	Inhibit retractable hard top operation.	Detects roof open/close switch (OPEN/CLOSE) is OFF
B170C	TRUNK LINK SENSOR(LH)	Inhibit retractable hard top operation.	Detects normal value
B170D	TRUNK LINK SENSOR(RH)	Inhibit retractable hard top operation.	Detects normal value
B170F	SENSOR POWER SUPPLY	Inhibit retractable hard top operation.	Detects normal value
B1710	LATCH STATUS SENSOR	Inhibit retractable hard top operation.	Detects normal value
B1711	LATCH LOCK SENSOR	Inhibit retractable hard top operation.	Detects normal value
B1712	TRUNK STATUS SENSOR	Inhibit retractable hard top operation.	Detects normal value
B1715	ROOF STATUS SEN PWR	Inhibit retractable hard top operation.	Detects normal value
B1716	PS STATUS SEN(DRAW)	Inhibit retractable hard top operation.	Detects normal value
B1718	PS STATUS SEN(ROTA)	Inhibit retractable hard top operation.	Detects normal value
B1719	ROOF STATUS SEN	Inhibit retractable hard top operation.	Detects normal value
B171A	HYDRAULIC PMP(LH)	Inhibit retractable hard top operation.	Detects normal value
B171B	HYDRAULIC PMP(RH)	Inhibit retractable hard top operation.	Detects normal value
B171C	SWITCHING VALVE 1	Inhibit retractable hard top operation.	Detects normal value
B171D	SWITCHING VALVE 2	Inhibit retractable hard top operation.	Detects normal value
B171E	ROOF CONTROL UNIT	Inhibit retractable hard top operation.	Detects normal value
B171F	ROOF CONTROL UNIT	Inhibit retractable hard top operation.	Detects normal value
B1720	ROOF CONTROL UNIT	Inhibit retractable hard top operation.	Detects normal value
B1721	ROOF CONTROL UNIT	Inhibit retractable hard top operation.	Detects normal value
B1722	ROOF CONTROL UNIT	Inhibit retractable hard top operation.	Detects normal value
B1723	ROOF CONTROL UNIT	Inhibit retractable hard top operation.	Detects normal value
B1724	ROOF CONTROL UNIT	Inhibit retractable hard top operation.	Detects normal value
B1725	ROOF CONTROL UNIT	Inhibit retractable hard top operation.	Detects normal value
B1726	ROOF CONTROL UNIT	Inhibit retractable hard top operation.	Detects normal value
B1728	ROOF CONTROL UNIT	Inhibit retractable hard top operation.	Detects normal value
B1729	ROOF CONTROL UNIT	Inhibit retractable hard top operation.	Detects normal value
B172A	ROOF CONTROL UNIT	Inhibit retractable hard top operation.	Detects normal value
B172B	ROOF STATE SIG(AUDIO)	Inhibit retractable hard top operation.	Detects normal value
B172C	ROOF STATE SIG(TRUNK)	Inhibit retractable hard top operation.	Detects normal value
B172D	ROOF WARNING BUZZER	Inhibit retractable hard top operation.	Detects normal value
B172E	ROOF CONTROL UNIT	Inhibit retractable hard top operation.	Detects normal value

A

B

C

D

E

F

G

H

I

J

DLK

L

M

N

O

P

RETRACTABLE HARD TOP CONTROL UNIT

< ECU DIAGNOSIS INFORMATION >

Display contents of CONSULT-III		Fail-safe	Cancellation
B172F	REAR PWR WINDOW(LH)	Inhibit retractable hard top operation.	Detects normal value
B1730	REAR PWR WINDOW(RH)	Inhibit retractable hard top operation.	Detects normal value
B1731	HYDRAULIC STATE 1	Inhibit retractable hard top operation.	Turn ignition switch OFF
B1732	HYDRAULIC STATE 2	Inhibit retractable hard top operation.	Turn ignition switch OFF
B1733	HYDRAULIC STATE 3	Inhibit retractable hard top operation.	Turn ignition switch OFF
B1734	HYDRAULIC STATE 4	Inhibit retractable hard top operation.	Turn ignition switch OFF
B1735	HYDRAULIC STATE 5	Inhibit retractable hard top operation.	Turn ignition switch OFF
B1736	HYDRAULIC STATE 6	Inhibit retractable hard top operation.	Turn ignition switch OFF
B1737	HYDRAULIC STATE 7	Inhibit retractable hard top operation.	Turn ignition switch OFF
B1738	HYDRAULIC STATE 8	Inhibit retractable hard top operation.	Turn ignition switch OFF
B1739	HYDRAULIC STATE 9	Inhibit retractable hard top operation.	Turn ignition switch OFF
B173A	HYDRAULIC STATE 10	Inhibit retractable hard top operation.	Turn ignition switch OFF
B173B	HYDRAULIC STATE 11	Inhibit retractable hard top operation.	Turn ignition switch OFF
B173C	HYDRAULIC STATE 12	Inhibit retractable hard top operation.	Turn ignition switch OFF
B173D	HYDRAULIC STATE 13	Inhibit retractable hard top operation.	Turn ignition switch OFF
B173E	HYDRAULIC STATE 14	Inhibit retractable hard top operation.	Turn ignition switch OFF
B173F	HYDRAULIC STATE 15	Inhibit retractable hard top operation.	Turn ignition switch OFF
B1740	HYDRAULIC STATE 16	Inhibit retractable hard top operation.	Turn ignition switch OFF
B1741	HYDRAULIC STATE 17	Inhibit retractable hard top operation.	Turn ignition switch OFF
B1742	HYDRAULIC STATE 18	Inhibit retractable hard top operation.	Turn ignition switch OFF
B1743	HYDRAULIC STATE 19	Inhibit retractable hard top operation.	Turn ignition switch OFF
B1744	HYDRAULIC STATE 20	Inhibit retractable hard top operation.	Turn ignition switch OFF
B1745	HYDRAULIC STATE 21	Inhibit retractable hard top operation.	Turn ignition switch OFF
B1746	HYDRAULIC STATE 22	Inhibit retractable hard top operation.	Turn ignition switch OFF
B1747	P SHELF (DRAW) STATE 1	Inhibit retractable hard top operation.	Turn ignition switch OFF
B1748	P SHELF (DRAW) STATE 2	Inhibit retractable hard top operation.	Turn ignition switch OFF
B1749	P SHELF (DRAW) STATE 3	Inhibit retractable hard top operation.	Turn ignition switch OFF
B174A	P SHELF (DRAW) STATE 4	Inhibit retractable hard top operation.	Turn ignition switch OFF
B174B	P SHELF (DRAW) STATE 5	Inhibit retractable hard top operation.	Turn ignition switch OFF
B174C	P SHELF (DRAW) STATE 6	Inhibit retractable hard top operation.	Turn ignition switch OFF
B174D	P SHELF (ROT) STATE 1	Inhibit retractable hard top operation.	Turn ignition switch OFF
B174E	P SHELF (ROT) STATE 2	Inhibit retractable hard top operation.	Turn ignition switch OFF
B174F	P SHELF (ROT) STATE 3	Inhibit retractable hard top operation.	Turn ignition switch OFF
B1750	P SHELF (ROT) STATE 4	Inhibit retractable hard top operation.	Turn ignition switch OFF
B1751	ROOF LATCH STATE 1	Inhibit retractable hard top operation.	Turn ignition switch OFF
B1752	ROOF LATCH STATE 2	Inhibit retractable hard top operation.	Turn ignition switch OFF
B1753	ROOF LATCH STATE 3	Inhibit retractable hard top operation.	Turn ignition switch OFF
B1754	FLIPPER DOOR STATE 1	Inhibit retractable hard top operation.	Turn ignition switch OFF
B1755	FLIPPER DOOR STATE 2	Inhibit retractable hard top operation.	Turn ignition switch OFF

RETRACTABLE HARD TOP CONTROL UNIT

< ECU DIAGNOSIS INFORMATION >

Display contents of CONSULT-III		Fail-safe	Cancellation
B1756	FLIPPER DOOR STATE 3	Inhibit retractable hard top operation.	Turn ignition switch OFF
B1757	FLIPPER DOOR STATE 4	Inhibit retractable hard top operation.	Turn ignition switch OFF
B1758	THERMO PROTECTION	Inhibit retractable hard top operation.	It is not in thermo protection area (Refer to RF-16. "RETRACTABLE HARD TOP SYSTEM : System Description")
B175C	PWR SOURCE(ROOF)	Inhibit retractable hard top operation.	Power source is 11.4 (V) or more for 0.5 second
B175D	PWR SOURCE(ROOF)	Inhibit retractable hard top operation.	Power source is 14.5 (V) or more for 4 seconds
B175E	PWR SOURCE(WINDOW)	Inhibit retractable hard top operation and rear power window operation.	Power source (power window) is 9.5 (V) or less
B175F	PWR SOURCE(WINDOW)	Inhibit retractable hard top operation and rear power window operation.	Power source (power window) is 15.5 (V) or more
B1760	ROOF CONTROL UNIT	Inhibit rear window defogger operation.	Detects normal value
B1761	ROOF CONTROL UNIT	Inhibit retractable hard top operation.	Detects normal value
B1762	ROOF STATE	Inhibit retractable hard top operation.	Detects normal value
B1763	HYDRAULIC STATE	Inhibit retractable hard top operation.	Detects normal value
B1764	ROOF LATCH STATE	Inhibit retractable hard top operation.	Detects normal value
B1765	FLIPPER DOOR STATE	Inhibit retractable hard top operation.	Detects normal value

DTC Inspection Priority Chart

INFOID:000000005897693

If some DTCs are displayed at the same time, perform inspections one by one based on the following priority chart.

Priority	Display contents of CONSULT-III	
1	U1000	CAN COMM CIRCUIT
	U1010	CONTROL UNIT (CAN)
2	B175C	PWR SOURCE(ROOF)
	B175D	PWR SOURCE(ROOF)
	B175E	PWR SOURCE(WINDOW)
	B175F	PWR SOURCE(WINDOW)

DLK

RETRACTABLE HARD TOP CONTROL UNIT

< ECU DIAGNOSIS INFORMATION >

Priority	Display contents of CONSULT-III	
3	B1701	ROOF CONTROL UNIT
	B1702	ROOF CONTROL UNIT
	B171E	ROOF CONTROL UNIT
	B171F	ROOF CONTROL UNIT
	B1720	ROOF CONTROL UNIT
	B1721	ROOF CONTROL UNIT
	B1722	ROOF CONTROL UNIT
	B1723	ROOF CONTROL UNIT
	B1724	ROOF CONTROL UNIT
	B1725	ROOF CONTROL UNIT
	B1726	ROOF CONTROL UNIT
	B1728	ROOF CONTROL UNIT
	B1729	ROOF CONTROL UNIT
	B172A	ROOF CONTROL UNIT
	B172E	ROOF CONTROL UNIT
	B1760	ROOF CONTROL UNIT
	B1761	ROOF CONTROL UNIT
4	B170F	SENSOR POWER SUPPLY
5	U0140	LOCAL COMM-1
	U0215	LOCAL COMM-1
	B1709	ROOF SWITCH(OPEN)
	B170A	ROOF SWITCH(CLOSE)
	B170B	ROOF SWITCH
	B1758	THERMO PROTECTION
	B171A	HYDRAULIC PMP(LH)
	B171B	HYDRAULIC PMP(RH)
	B171C	SWITCHING VALVE 1
	B171D	SWITCHING VALVE 2
	B172F	REAR PWR WINDOW(LH)
	B1730	REAR PWR WINDOW(RH)
	B1715	ROOF STATE SEN PWR
	B170C	TRUNK LINK SENSOR(LH)
	B170D	TRUNK LINK SENSOR(RH)
	B1710	LATCH STATUS SENSOR
	B1711	LATCH LOCK SENSOR
	B1712	TRUNK STATUS SENSOR
	B1716	PS STATUS SEN(ROTA)
B1718	PS STATUS SEN(DRAW)	
B1719	ROOF STATUS SEN	
6	B172D	ROOF WARNING BUZZER

RETRACTABLE HARD TOP CONTROL UNIT

< ECU DIAGNOSIS INFORMATION >

Priority	Display contents of CONSULT-III		
7	B1731	HYDRAULIC STATE 1	A
	B1732	HYDRAULIC STATE 2	
	B1733	HYDRAULIC STATE 3	B
	B1734	HYDRAULIC STATE 4	
	B1735	HYDRAULIC STATE 5	
	B1736	HYDRAULIC STATE 6	C
	B1737	HYDRAULIC STATE 7	
	B1738	HYDRAULIC STATE 8	D
	B1739	HYDRAULIC STATE 9	
	B173A	HYDRAULIC STATE 10	
	B173B	HYDRAULIC STATE 11	E
	B173C	HYDRAULIC STATE 12	
	B173D	HYDRAULIC STATE 13	
	B173E	HYDRAULIC STATE 14	F
	B173F	HYDRAULIC STATE 15	
	B1740	HYDRAULIC STATE 16	G
	B1741	HYDRAULIC STATE 17	
	B1742	HYDRAULIC STATE 18	
	B1743	HYDRAULIC STATE 19	H
	B1744	HYDRAULIC STATE 20	
	B1745	HYDRAULIC STATE 21	I
	B1746	HYDRAULIC STATE 22	
	B1747	P SHELF (DRAW) STATE 1	J
	B1748	P SHELF (DRAW) STATE 2	
	B1749	P SHELF (DRAW) STATE 3	
	B174A	P SHELF (DRAW) STATE 4	DLK
	B174B	P SHELF (DRAW) STATE 5	
	B174C	P SHELF (DRAW) STATE 6	
	B174D	P SHELF (ROT) STATE 1	L
	B174E	P SHELF (ROT) STATE 2	
	B174F	P SHELF (ROT) STATE 3	M
	B1750	P SHELF (ROT) STATE 4	
B1751	ROOF LATCH STATE 1		
B1752	ROOF LATCH STATE 2	N	
B1753	ROOF LATCH STATE 3		
B1754	FLIPPER DOOR STATE 1		
B1755	FLIPPER DOOR STATE 2	O	
B1756	FLIPPER DOOR STATE 3		
B1757	FLIPPER DOOR STATE 4	P	
8	B1707	ROOF OPEN STATE	
	B1708	ROOF CLOSE STATE	
9	B1764	ROOF LATCH STATE	
	B1765	FLIPPER DOOR STATE	
10	B1762	ROOF STATE	

RETRACTABLE HARD TOP CONTROL UNIT

< ECU DIAGNOSIS INFORMATION >

Priority	Display contents of CONSULT-III	
11	B1763	HYDRAULIC STATE
12	B172B	ROOF STATE SIG(AUDIO)
	B172C	ROOF STATE SIG(TRUNK)

DTC Index

INFOID:000000005897694

NOTE:

For details of Freeze Frame Data, refer to [DLK-56, "CONSULT-III Function"](#).

Display contents of CONSULT-III		Fail-safe	Freeze Frame Data	Reference page
No DTC is detected. Further testing may be required.		—	—	—
U1000	CAN COMM CIRCUIT	×	×	RF-90
U1010	CONTROL UNIT (CAN)	×	×	RF-91
U0140	LOCAL COMM-1	×	×	RF-92
U0215	LOCAL COMM-2	×	×	RF-93
B1701	ROOF CONTROL UNIT	×	×	RF-95
B1702	ROOF CONTROL UNIT	×	×	RF-96
B1707	ROOF OPEN STATE	—	×	RF-97
B1708	ROOF CLOSE STATE	—	×	RF-99
B1709	ROOF SWITCH(OPEN)	×	×	RF-101
B170A	ROOF SWITCH(CLOSE)	×	×	RF-103
B170B	ROOF SWITCH	×	×	RF-105
B170C	TRUNK LINK SENSOR(LH)	×	×	RF-107
B170D	TRUNK LINK SENSOR(RH)	×	×	RF-109
B170F	SENSOR POWER SUPPLY	×	×	RF-111
B1710	LATCH STATUS SENSOR	×	×	RF-114
B1711	LATCH LOCK SENSOR	×	×	RF-116
B1712	TRUNK STATUS SENSOR	×	×	RF-118
B1715	ROOF STATUS SEN PWR	×	×	RF-120
B1716	PS STATUS SEN(DRAW)	×	×	RF-122
B1718	PS STATUS SEN(ROTA)	×	×	RF-124
B1719	ROOF STATUS SEN	×	×	RF-126
B171A	HYDRAULIC PMP(LH)	×	×	RF-128
B171B	HYDRAULIC PMP(RH)	×	×	RF-130
B171C	SWITCHING VALVE 1	×	×	RF-132
B171D	SWITCHING VALVE 2	×	×	RF-134
B171E	ROOF CONTROL UNIT	×	×	RF-136
B171F	ROOF CONTROL UNIT	×	×	RF-137
B1720	ROOF CONTROL UNIT	×	×	RF-138
B1721	ROOF CONTROL UNIT	×	×	RF-139
B1722	ROOF CONTROL UNIT	×	×	RF-140
B1723	ROOF CONTROL UNIT	×	×	RF-141
B1724	ROOF CONTROL UNIT	×	×	RF-142
B1725	ROOF CONTROL UNIT	×	×	RF-143
B1726	ROOF CONTROL UNIT	×	×	RF-144

RETRACTABLE HARD TOP CONTROL UNIT

< ECU DIAGNOSIS INFORMATION >

Display contents of CONSULT-III		Fail-safe	Freeze Frame Data	Reference page
B1728	ROOF CONTROL UNIT	×	×	RF-145
B1729	ROOF CONTROL UNIT	×	×	RF-146
B172A	ROOF CONTROL UNIT	×	×	RF-147
B172B	ROOF STATE SIG(AUDIO)	×	×	RF-148
B172C	ROOF STATE SIG(TRUNK)	×	×	RF-150
B172D	ROOF WARNING BUZZER	×	×	RF-152
B172E	ROOF CONTROL UNIT	×	×	RF-154
B172F	REAR PWR WINDOW(LH)	×	×	RF-155
B1730	REAR PWR WINDOW(RH)	×	×	RF-157
B1731	HYDRAULIC STATE 1	×	×	RF-159
B1732	HYDRAULIC STATE 2	×	×	RF-161
B1733	HYDRAULIC STATE 3	×	×	RF-163
B1734	HYDRAULIC STATE 4	×	×	RF-165
B1735	HYDRAULIC STATE 5	×	×	RF-167
B1736	HYDRAULIC STATE 6	×	×	RF-169
B1737	HYDRAULIC STATE 7	×	×	RF-170
B1738	HYDRAULIC STATE 8	×	×	RF-171
B1739	HYDRAULIC STATE 9	×	×	RF-172
B173A	HYDRAULIC STATE 10	×	×	RF-173
B173B	HYDRAULIC STATE 11	×	×	RF-174
B173C	HYDRAULIC STATE 12	×	×	RF-175
B173D	HYDRAULIC STATE 13	×	×	RF-176
B173E	HYDRAULIC STATE 14	×	×	RF-177
B173F	HYDRAULIC STATE 15	×	×	RF-178
B1740	HYDRAULIC STATE 16	×	×	RF-179
B1741	HYDRAULIC STATE 17	×	×	RF-182
B1742	HYDRAULIC STATE 18	×	×	RF-183
B1743	HYDRAULIC STATE 19	×	×	RF-185
B1744	HYDRAULIC STATE 20	×	×	RF-187
B1745	HYDRAULIC STATE 21	×	×	RF-189
B1746	HYDRAULIC STATE 22	×	×	RF-191
B1747	P SHELF (DRAW) STATE 1	×	×	RF-193
B1748	P SHELF (DRAW) STATE 2	×	×	RF-194
B1749	P SHELF (DRAW) STATE 3	×	×	RF-195
B174A	P SHELF (DRAW) STATE 4	×	×	RF-196
B174B	P SHELF (DRAW) STATE 5	×	×	RF-197
B174C	P SHELF (DRAW) STATE 6	×	×	RF-198
B174D	P SHELF (ROT) STATE 1	×	×	RF-199
B174E	P SHELF (ROT) STATE 2	×	×	RF-200
B174F	P SHELF (ROT) STATE 3	×	×	RF-201
B1750	P SHELF (ROT) STATE 4	×	×	RF-202
B1751	ROOF LATCH STATE 1	×	×	RF-203
B1752	ROOF LATCH STATE 2	×	×	RF-204
B1753	ROOF LATCH STATE 3	×	×	RF-205

A

B

C

D

E

F

G

H

I

J

DLK

L

M

N

O

P

RETRACTABLE HARD TOP CONTROL UNIT

< ECU DIAGNOSIS INFORMATION >

Display contents of CONSULT-III		Fail-safe	Freeze Frame Data	Reference page
B1754	FLIPPER DOOR STATE 1	×	×	RF-206
B1755	FLIPPER DOOR STATE 2	×	×	RF-207
B1756	FLIPPER DOOR STATE 3	×	×	RF-208
B1757	FLIPPER DOOR STATE 4	×	×	RF-209
B1758	THERMO PROTECTION	×	×	RF-210
B175C	PWR SOURCE(ROOF)	×	×	RF-211
B175D	PWR SOURCE(ROOF)	×	×	RF-212
B175E	PWR SOURCE(WINDOW)	×	×	RF-213
B175F	PWR SOURCE(WINDOW)	×	×	RF-215
B1760	ROOF CONTROL UNIT	×	×	RF-217
B1761	ROOF CONTROL UNIT	×	×	RF-218
B1762	ROOF STATE	×	×	RF-219
B1763	HYDRAULIC STATE	×	×	RF-222
B1764	ROOF LATCH STATE	×	×	RF-224
B1765	FLIPPER DOOR STATE	×	×	RF-225

TRUNK CLOSURE SUB-CONTROL UNIT

< ECU DIAGNOSIS INFORMATION >

TRUNK CLOSURE SUB-CONTROL UNIT

Reference Value

INFOID:000000005897696

TERMINAL LAYOUT

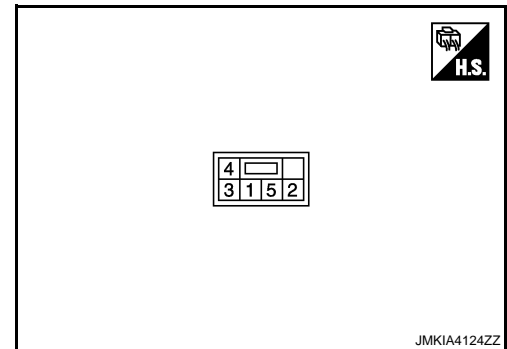

PHYSICAL VALUES

Terminal No. (Wire color)		Description		Condition		Value (Approx.)
+	-	Signal name	Input/ Output			
1 (Y)	Ground	Power source (BAT)	Input	Ignition switch OFF	—	Battery voltage
2 (SB)	Ground	Trunk room lamp switch	Input	Ignition switch OFF	Trunk lid	Battery voltage
						Close
3 (P)	Ground	Closure control sig- nal	Output	Ignition switch OFF	Trunk lid is closed	Battery voltage
					Trunk open operation is performed by retractable hard top operation	Battery voltage→0 V
					Trunk is open by trunk opener sys- tem operation	0 V
4 (B)	Ground	Ground	—	Ignition switch ON	—	0 V
5 (R)	Ground	Trunk mode signal	Input	Ignition switch OFF	Retractable hard top	Battery voltage
						Fully open/ful- ly closed
						0 V

A
B
C
D
E
F
G
H
I
J
K
L
M
N
O
P

DLK

DOOR DOES NOT LOCK/UNLOCK WITH DOOR LOCK AND UNLOCK SWITCH

< SYMPTOM DIAGNOSIS >

SYMPTOM DIAGNOSIS

DOOR DOES NOT LOCK/UNLOCK WITH DOOR LOCK AND UNLOCK SWITCH

ALL DOOR

ALL DOOR : Description

INFOID:000000005624296

All doors do not lock/unlock using door lock and unlock switch.

ALL DOOR : Diagnosis Procedure

INFOID:000000005624297

1. CHECK POWER SUPPLY AND GROUND CIRCUIT

Check power supply and ground circuit.

Refer to [DLK-67. "BCM \(BODY CONTROL MODULE\) : Diagnosis Procedure"](#).

Is the inspection result normal?

YES >> GO TO 2.

NO >> Repair or replace the malfunctioning parts.

2. CHECK DOOR LOCK AND UNLOCK SWITCH

Check door lock and unlock switch.

• Driver side: Refer to [DLK-72. "DRIVER SIDE : Component Function Check"](#).

• Passenger side: Refer to [DLK-72. "PASSENGER SIDE : Component Function Check"](#).

Is the inspection result normal?

YES >> GO TO 3.

NO >> Repair or replace the malfunctioning parts.

3. CHECK DOOR LOCK ACTUATOR

Check door lock actuator (driver side).

Refer to [DLK-74. "DRIVER SIDE : Component Function Check"](#).

Is the inspection result normal?

YES >> GO TO 4.

NO >> Repair or replace the malfunctioning parts.

4. CONFIRM THE OPERATION

Confirm the operation again.

Is the result normal?

YES >> Check intermittent incident. Refer to [GI-37. "Intermittent Incident"](#).

NO >> GO TO 1.

DRIVER SIDE

DRIVER SIDE : Description

INFOID:000000005624298

Driver side door does not lock/unlock using door lock and unlock switch.

DRIVER SIDE : Diagnosis Procedure

INFOID:000000005624299

1. CHECK DOOR LOCK ACTUATOR

Check door lock actuator (driver side).

Refer to [DLK-74. "DRIVER SIDE : Component Function Check"](#).

Is the inspection result normal?

YES >> GO TO 2.

NO >> Repair or replace the malfunctioning parts.

2. CONFIRM THE OPERATION

Confirm the operation again.

DOOR DOES NOT LOCK/UNLOCK WITH DOOR LOCK AND UNLOCK SWITCH

< SYMPTOM DIAGNOSIS >

Is the result normal?

YES >> Check intermittent incident. Refer to [GI-37, "Intermittent Incident"](#).

NO >> GO TO 1.

PASSENGER SIDE

PASSENGER SIDE : Description

INFOID:000000005624300

Passenger side door does not lock/unlock using door lock and unlock switch.

PASSENGER SIDE : Diagnosis Procedure

INFOID:000000005624301

1.CHECK DOOR LOCK ACTUATOR

Check door lock actuator (passenger side).

Refer to [DLK-75, "PASSENGER SIDE : Component Function Check"](#).

Is the inspection result normal?

YES >> GO TO 2.

NO >> Repair or replace the malfunctioning parts.

2.CONFIRM THE OPERATION

Confirm the operation again.

Is the result normal?

YES >> Check intermittent incident. Refer to [GI-37, "Intermittent Incident"](#).

NO >> GO TO 1.

A
B
C
D
E
F
G
H
I
J
L
M
N
O
P

DLK

DOOR DOES NOT LOCK/UNLOCK WITH DOOR KEY CYLINDER OPERATION

< SYMPTOM DIAGNOSIS >

DOOR DOES NOT LOCK/UNLOCK WITH DOOR KEY CYLINDER OPERATION

Diagnosis Procedure

INFOID:000000005624302

1. CHECK POWER DOOR LOCK OPERATION

Check power door lock operation.

Does door lock/unlock with door lock and unlock switch?

YES >> GO TO 2.

NO >> Refer to [DLK-230, "ALL DOOR : Diagnosis Procedure"](#).

2. CHECK DOOR KEY CYLINDER SWITCH

Check door key cylinder switch.

Refer to [DLK-86, "Component Function Check"](#).

Is the inspection result normal?

YES >> GO TO 3.

NO >> Repair or replace the malfunctioning parts.

3. CONFIRM THE OPERATION

Confirm the operation again.

Is the result normal?

YES >> Check intermittent incident. Refer to [GI-37, "Intermittent Incident"](#).

NO >> GO TO 1.

DOOR DOES NOT LOCK/UNLOCK WITH DOOR REQUEST SWITCH

< SYMPTOM DIAGNOSIS >

DOOR DOES NOT LOCK/UNLOCK WITH DOOR REQUEST SWITCH ALL DOOR

ALL DOOR : Description

INFOID:0000000005624303

All doors do not lock/unlock using all door request switches.

ALL DOOR : Diagnosis Procedure

INFOID:0000000005624304

1.CHECK REMOTE KEYLESS ENTRY FUNCTION

Check remote keyless entry function.

Does door lock/unlock with Intelligent Key button?

YES >> GO TO 2.

NO >> Refer to [DLK-28. "REMOTE KEYLESS ENTRY FUNCTION : System Description"](#).

2.CHECK "LOCK/UNLOCK BY I-KEY" SETTING IN "WORK SUPPORT"

Check "LOCK/UNLOCK BY I-KEY" in "WORK SUPPORT".

Refer to [DLK-52. "INTELLIGENT KEY : CONSULT-III Function \(BCM - INTELLIGENT KEY\)"](#).

Is the inspection result normal?

YES >> GO TO 3.

NO >> Set "LOCK/UNLOCK BY I-KEY" in "WORK SUPPORT".

3.CHECK DOOR SWITCH

Check door switch.

Refer to [DLK-70. "Component Function Check"](#).

Is the inspection result normal?

YES >> GO TO 4.

NO >> Repair or replace the malfunctioning parts.

4.CONFIRM THE OPERATION

Confirm the operation again.

Is the result normal?

YES >> Check intermittent incident. Refer to [GI-37. "Intermittent Incident"](#).

NO >> GO TO 1.

DRIVER SIDE

DRIVER SIDE : Description

INFOID:0000000005624305

All doors do not lock/unlock using driver side door request switch.

DRIVER SIDE : Diagnosis Procedure

INFOID:0000000005624306

1.CHECK DRIVER SIDE DOOR REQUEST SWITCH

Check driver side door request switch.

Refer to [DLK-99. "Component Function Check"](#).

Is the inspection result normal?

YES >> GO TO 2.

NO >> Repair or replace the malfunctioning parts.

2.CHECK OUTSIDE KEY ANTENNA LH

Check outside key antenna LH.

Refer to [DLK-103. "Component Function Check"](#).

Is the inspection result normal?

YES >> GO TO 3.

NO >> Repair or replace the malfunctioning parts.

3.CONFIRM THE OPERATION

A

B

C

D

E

F

G

H

I

J

DLK

L

M

N

O

P

DOOR DOES NOT LOCK/UNLOCK WITH DOOR REQUEST SWITCH

< SYMPTOM DIAGNOSIS >

Confirm the operation again.

Is the result normal?

YES >> Check Intermittent Incident. Refer to [GI-37, "Intermittent Incident"](#).

NO >> GO TO 1.

PASSENGER SIDE

PASSENGER SIDE : Description

INFOID:000000005624307

All doors do not lock/unlock using passenger side door request switch.

PASSENGER SIDE : Diagnosis Procedure

INFOID:000000005624308

1.CHECK PASSENGER SIDE DOOR REQUEST SWITCH

Check passenger side door request switch.

Refer to [DLK-99, "Component Function Check"](#).

Is the inspection result normal?

YES >> GO TO 2.

NO >> Repair or replace the malfunctioning parts.

2.CHECK OUTSIDE KEY ANTENNA RH

Check outside key antenna RH.

Refer to [DLK-103, "Component Function Check"](#).

Is the inspection result normal?

YES >> GO TO 3.

NO >> Repair or replace the malfunctioning parts.

3.CONFIRM THE OPERATION

Confirm the operation again.

Is the result normal?

YES >> Check Intermittent Incident. Refer to [GI-37, "Intermittent Incident"](#).

NO >> GO TO 1.

DOOR DOES NOT LOCK/UNLOCK WITH INTELLIGENT KEY

< SYMPTOM DIAGNOSIS >

DOOR DOES NOT LOCK/UNLOCK WITH INTELLIGENT KEY

Diagnosis Procedure

INFOID:000000005624309

1.CHECK POWER DOOR LOCK OPERATION

Check power door lock operation.

Does door lock/unlock with door lock and unlock switch?

YES >> GO TO 2.

NO >> Refer to [DLK-230, "ALL DOOR : Diagnosis Procedure"](#).

2.CHECK REMOTE KEYLESS ENTRY RECEIVER

Check remote keyless entry receiver.

Refer to [DLK-88, "Component Function Check"](#).

Is the inspection result normal?

YES >> GO TO 3.

NO >> Repair or replace the malfunctioning parts.

3.CHECK INTELLIGENT KEY

Check Intelligent Key.

Refer to [DLK-108, "Component Function Check"](#).

Is the inspection result normal?

YES >> GO TO 4.

NO >> Repair or replace the malfunctioning parts.

4.CHECK KEY SLOT

Check key slot.

Refer to [DLK-109, "Component Function Check"](#).

Is the inspection result normal?

YES >> GO TO 5.

NO >> Repair or replace the malfunctioning parts.

5.CHECK DOOR SWITCH

Check door switch.

Refer to [DLK-70, "Component Function Check"](#).

Is the inspection result normal?

YES >> GO TO 6.

NO >> Repair or replace the malfunctioning parts.

6.CONFIRM THE OPERATION

Confirm the operation again.

Is the result normal?

YES >> Check intermittent incident. Refer to [GI-37, "Intermittent Incident"](#).

NO >> GO TO 1.

A
B
C
D
E
F
G
H
I
J
L
M
N
O
P

DLK

ALL DOORS DO NOT UNLOCK WHEN ROOF IS OPEN BY DOOR REQUEST SWITCH OPERATION

< SYMPTOM DIAGNOSIS >

ALL DOORS DO NOT UNLOCK WHEN ROOF IS OPEN BY DOOR REQUEST SWITCH OPERATION

Diagnosis Procedure

INFOID:000000005624310

1. CHECK POWER DOOR LOCK OPERATION

Check power door lock operation.

Does door lock/unlock with door request switch?

YES >> GO TO 2.

NO >> Refer to [DLK-233, "ALL DOOR : Diagnosis Procedure"](#).

2. REPLACE BCM

- Replace BCM. Refer to [BCS-79, "Removal and Installation"](#).
- Confirm the operation after replacement.

Is the result normal?

YES >> INSPECTION END

NO >> Check intermittent incident. Refer to [GI-37, "Intermittent Incident"](#).

TRUNK LID DOES NOT OPEN

< SYMPTOM DIAGNOSIS >

TRUNK LID DOES NOT OPEN

TRUNK LID OPENER SWITCH

A

TRUNK LID OPENER SWITCH : Description

INFOID:000000005624311

Trunk lid does not open by trunk lid opener switch operation.

B

TRUNK LID OPENER SWITCH : Diagnosis Procedure

INFOID:000000005624312

C

1.CHECK TRUNK LID OPENER SWITCH

Check trunk lid opener switch.

Refer to [DLK-91, "Component Function Check"](#).

Is the inspection result normal?

D

YES >> GO TO 2.

NO >> Repair or replace the malfunctioning parts.

E

2.CHECK TRUNK LID OPENER CANCEL SWITCH

Check trunk lid opener cancel switch.

Refer to [DLK-95, "Component Function Check"](#).

Is the inspection result normal?

YES >> GO TO 3.

NO >> Repair or replace the malfunctioning parts.

F

G

3.CHECK TRUNK LID OPEN SIGNAL CIRCUIT

Check trunk lid open signal circuit.

Refer to [DLK-77, "Component Function Check"](#).

Is the inspection result normal?

YES >> GO TO 4.

NO >> Repair or replace the malfunctioning parts.

H

I

4.CHECK TRUNK LID OPENER ACTUATOR

Check trunk lid opener actuator.

Refer to [DLK-79, "Component Function Check"](#).

Is the inspection result normal?

YES >> GO TO 5.

NO >> Repair or replace the malfunctioning parts.

J

DLK

5.CHECK VEHICLE SPEED SIGNAL

Check unified meter and A/C amp.

Refer to [MWI-102, "DTC Index"](#).

Is the inspection result normal?

YES >> GO TO 6.

NO >> Repair or replace the malfunctioning parts.

L

M

6.CONFIRM THE OPERATION

Confirm the operation again.

Is the result normal?

YES >> Check intermittent incident. Refer to [GI-37, "Intermittent Incident"](#).

NO >> GO TO 1.

N

O

INTELLIGENT KEY

P

INTELLIGENT KEY : Description

INFOID:000000005624313

Trunk lid does not open by Intelligent Key remote operation.

TRUNK LID DOES NOT OPEN

< SYMPTOM DIAGNOSIS >

INTELLIGENT KEY : Diagnosis Procedure

INFOID:000000005624314

1.CHECK TRUNK LID OPEN FUNCTION

Check trunk lid open function with trunk lid opener switch.

Does trunk lid open with trunk lid opener switch?

YES >> GO TO 2.

NO >> Refer to [DLK-237, "TRUNK LID OPENER SWITCH : Diagnosis Procedure"](#).

2.CHECK "TRUNK OPEN DELAY" SETTING IN "WORK SUPPORT"

Check "TRUNK OPEN DELAY" setting in "WORK SUPPORT".

Refer to [DLK-52, "INTELLIGENT KEY : CONSULT-III Function \(BCM - INTELLIGENT KEY\)"](#).

Is the inspection result normal?

YES >> GO TO 3.

NO >> Set "TRUNK OPEN DELAY" setting in "WORK SUPPORT".

3.CHECK POWER POSITION

Check if ignition switch position is changing or not.

Does ignition switch position change?

YES >> GO TO 4.

NO >> Check DTC for BCM. Refer to [BCS-74, "DTC Index"](#).

4.CHECK INTELLIGENT KEY

Check Intelligent Key.

Refer to [DLK-108, "Component Function Check"](#).

Is the inspection result normal?

YES >> GO TO 5.

NO >> Repair or replace the malfunctioning parts.

5.CONFIRM THE OPERATION

Confirm the operation again.

Is the result normal?

YES >> Check intermittent incident. Refer to [GI-37, "Intermittent Incident"](#).

NO >> GO TO 1.

TRUNK LID OPENER REQUEST SWITCH

TRUNK LID OPENER REQUEST SWITCH : Description

INFOID:0000000005624315

Trunk lid does not open by trunk lid opener request switch operation.

TRUNK LID OPENER REQUEST SWITCH : Diagnosis Procedure

INFOID:0000000005624316

1.CHECK TRUNK LID OPEN FUNCTION

Check trunk lid open function with Intelligent Key.

Does trunk lid open with Intelligent Key?

YES >> GO TO 2.

NO >> Refer to [DLK-238, "INTELLIGENT KEY : Diagnosis Procedure"](#).

2.CHECK TRUNK LID OPENER REQUEST SWITCH

Check trunk lid opener request switch.

Refer to [DLK-93, "Component Function Check"](#).

Is the inspection result normal?

YES >> GO TO 3.

NO >> Repair or replace the malfunctioning parts.

3.CHECK OUTSIDE KEY ANTENNA (REAR BUMPER)

Check outside key antenna (rear bumper).

TRUNK LID DOES NOT OPEN

< SYMPTOM DIAGNOSIS >

Refer to [DLK-103, "Component Function Check"](#).

Is the inspection result normal?

YES >> GO TO 4.

NO >> Repair or replace the malfunctioning parts.

4.CHECK TRUNK ROOM LAMP SWITCH

Check trunk room lamp switch.

Refer to [DLK-81, "Component Function Check"](#).

Is the inspection result normal?

YES >> GO TO 5.

NO >> Repair or replace the malfunctioning parts.

5.CONFIRM THE OPERATION

Confirm the operation again.

Is the result normal?

YES >> Check intermittent incident. Refer to [GI-37, "Intermittent Incident"](#).

NO >> GO TO 1.

A

B

C

D

E

F

G

H

I

J

DLK

L

M

N

O

P

TRUNK LID AUTO CLOSURE SYSTEM DOES NOT OPERATE

< SYMPTOM DIAGNOSIS >

TRUNK LID AUTO CLOSURE SYSTEM DOES NOT OPERATE OPEN/CLOSURE FUNCTION

OPEN/CLOSURE FUNCTION : Description

INFOID:000000005624317

Trunk lid auto closure system does not operate when trunk lid opening and closing operations are performed.

OPEN/CLOSURE FUNCTION : Diagnosis Procedure

INFOID:000000005624318

1.CHECK TRUNK CLOSURE CONTROL UNIT POWER SUPPLY AND GROUND CIRCUIT

Check trunk closure control unit power supply and ground circuit.

Refer to [DLK-67, "TRUNK CLOSURE CONTROL UNIT : Diagnosis Procedure"](#).

Is the inspection result normal?

YES >> GO TO 2.

NO >> Repair or replace the malfunctioning parts.

2.CHECK TRUNK ROOM LAMP SWITCH

Check trunk room lamp switch.

Refer to [DLK-81, "Component Function Check"](#).

Is the inspection result normal?

YES >> GO TO 3.

NO >> Repair or replace the malfunctioning parts.

3.CHECK TRUNK ROOM LAMP SWITCH CIRCUIT

Check trunk room lamp switch circuit.

Refer to [DLK-84, "Component Function Check"](#).

Is the inspection result normal?

YES >> GO TO 4.

NO >> Repair or replace the malfunctioning parts.

4.REPLACE TRUNK CLOSURE CONTROL UNIT

- Replace trunk closure control unit.Refer to [DLK-294, "TRUNK LID STRIKER : Removal and Installation"](#).
- Confirm the operation after replacement.

Is the result normal?

YES >> INSPECTION END

NO >> Check intermittent incident. Refer to [GI-37, "Intermittent Incident"](#).

CLOSURE FUNCTION

CLOSURE FUNCTION : Description

INFOID:000000005624319

Trunk lid auto closure system does not operate when trunk lid closing operation is performed.

CLOSURE FUNCTION : Diagnosis Procedure

INFOID:000000005624320

1.REPLACE TRUNK CLOSURE CONTROL UNIT

- Replace trunk closure control unit.Refer to [DLK-294, "TRUNK LID STRIKER : Removal and Installation"](#).
- Confirm the operation after replacement.

Is the result normal?

YES >> INSPECTION END

NO >> Check intermittent incident. Refer to [GI-37, "Intermittent Incident"](#).

OPEN FUNCTION

OPEN FUNCTION : Description

INFOID:000000005624321

Trunk lid auto closure system does not operate when trunk lid opening operation is performed.

TRUNK LID AUTO CLOSURE SYSTEM DOES NOT OPERATE

< SYMPTOM DIAGNOSIS >

OPEN FUNCTION : Diagnosis Procedure

INFOID:000000005624322

1.CHECK STRIKER SWITCH

Check striker switch.

Refer to [DLK-97, "Component Function Check"](#).

Is the inspection result normal?

YES >> GO TO 2.

NO >> Repair or replace the malfunctioning parts.

2.REPLACE TRUNK CLOSURE CONTROL UNIT

- Replace trunk closure control unit.Refer to [DLK-294, "TRUNK LID STRIKER : Removal and Installation"](#).
- Confirm the operation after replacement.

Is the result normal?

YES >> INSPECTION END

NO >> Check intermittent incident. Refer to [GI-37, "Intermittent Incident"](#).

A
B
C
D
E
F
G
H
I
J
L
M
N
O
P

DLK

SELECTIVE UNLOCK FUNCTION DOES NOT OPERATE

< SYMPTOM DIAGNOSIS >

SELECTIVE UNLOCK FUNCTION DOES NOT OPERATE

Diagnosis Procedure

INFOID:000000005624323

1. CHECK "DOOR LOCK-UNLOCK SET" SETTING IN "WORK SUPPORT"

Check "DOOR LOCK-UNLOCK SET" setting in "WORK SUPPORT".

Refer to [DLK-50, "DOOR LOCK : CONSULT-III Function \(BCM - DOOR LOCK\)"](#).

Is the inspection result normal?

YES >> GO TO 2.

NO >> Set "DOOR LOCK-UNLOCK SET" in "WORK SUPPORT".

2. CONFIRM THE OPERATION

Confirm the operation again.

Is the result normal?

YES >> Check intermittent incident. Refer to [GI-37, "Intermittent Incident"](#).

NO >> GO TO 1.

VEHICLE SPEED SENSING AUTO LOCK OPERATION DOES NOT OPERATE

< SYMPTOM DIAGNOSIS >

VEHICLE SPEED SENSING AUTO LOCK OPERATION DOES NOT OPERATE

Diagnosis Procedure

INFOID:000000005624324

1. CHECK POWER DOOR LOCK OPERATION

Check power door lock operation.

Does door lock/unlock with door lock and unlock switch?

YES >> GO TO 2.

NO >> Refer to [DLK-230, "ALL DOOR : Diagnosis Procedure"](#).

2. CHECK "AUTOMATIC LOCK/UNLOCK SELECT" SETTING IN "WORK SUPPORT"

Check "AUTOMATIC LOCK/UNLOCK SELECT" in "WORK SUPPORT".

Refer to [DLK-50, "DOOR LOCK : CONSULT-III Function \(BCM - DOOR LOCK\)"](#).

Is the inspection result normal?

YES >> GO TO 3.

NO >> Set "AUTOMATIC LOCK/UNLOCK SELECT" in "WORK SUPPORT".

3. CHECK "AUTOMATIC DOOR LOCK SELECT" SETTING IN "WORK SUPPORT"

Check "AUTOMATIC DOOR LOCK SELECT" in "WORK SUPPORT".

Refer to [DLK-50, "DOOR LOCK : CONSULT-III Function \(BCM - DOOR LOCK\)"](#).

Is the inspection result normal?

YES >> GO TO 4.

NO >> Set "AUTOMATIC DOOR LOCK SELECT" in "WORK SUPPORT".

4. CHECK VEHICLE SPEED SIGNAL

Check unified meter A/C amp.

Refer to [MWI-102, "DTC Index"](#).

Is the inspection result normal?

YES >> GO TO 5.

NO >> Repair or replace the malfunctioning parts.

5. CONFIRM THE OPERATION

Confirm the operation again.

Is the result normal?

YES >> Check intermittent incident. Refer to [GI-37, "Intermittent Incident"](#).

NO >> GO TO 1.

A
B
C
D
E
F
G
H
I
J
L
M
N
O
P

DLK

IGN OFF INTERLOCK DOOR UNLOCK FUNCTION DOES NOT OPERATE

< SYMPTOM DIAGNOSIS >

IGN OFF INTERLOCK DOOR UNLOCK FUNCTION DOES NOT OPERATE

Diagnosis Procedure

INFOID:000000005624325

1. CHECK POWER DOOR LOCK OPERATION

Check power door lock operation.

Does door lock/unlock with door lock and unlock switch?

YES >> GO TO 2.

NO >> Refer to [DLK-230, "ALL DOOR : Diagnosis Procedure"](#).

2. CHECK "AUTOMATIC LOCK/UNLOCK SELECT" SETTING IN "WORK SUPPORT"

Check "AUTOMATIC LOCK/UNLOCK SELECT" in "WORK SUPPORT".

Refer to [DLK-50, "DOOR LOCK : CONSULT-III Function \(BCM - DOOR LOCK\)"](#).

Is the inspection result normal?

YES >> GO TO 3.

NO >> Set "AUTOMATIC LOCK/UNLOCK SELECT" in "WORK SUPPORT".

3. CHECK "AUTOMATIC DOOR UNLOCK SELECT" SETTING IN "WORK SUPPORT"

Check "AUTOMATIC DOOR UNLOCK SELECT" in "WORK SUPPORT".

Refer to [DLK-50, "DOOR LOCK : CONSULT-III Function \(BCM - DOOR LOCK\)"](#).

Is the inspection result normal?

YES >> GO TO 4.

NO >> Set "AUTOMATIC DOOR UNLOCK SELECT" in "WORK SUPPORT".

4. CHECK BCM

Check BCM for DTC.

Refer to [BCS-74, "DTC Index"](#).

Is the inspection result normal?

YES >> GO TO 5.

NO >> Repair or replace the malfunctioning parts.

5. CONFIRM THE OPERATION

Confirm the operation again.

Is the result normal?

YES >> Check intermittent incident. Refer to [GI-37, "Intermittent Incident"](#).

NO >> GO TO 1.

P RANGE INTERLOCK DOOR LOCK/UNLOCK FUNCTION DOES NOT OPERATE

< SYMPTOM DIAGNOSIS >

P RANGE INTERLOCK DOOR LOCK/UNLOCK FUNCTION DOES NOT OPERATE

Diagnosis Procedure

INFOID:000000005624326

1. CHECK POWER DOOR LOCK OPERATION

Check power door lock operation.

Does door lock/unlock with door lock and unlock switch?

YES >> GO TO 2.

NO >> Refer to [DLK-230, "ALL DOOR : Diagnosis Procedure"](#).

2. CHECK "AUTOMATIC LOCK/UNLOCK SELECT" SETTING IN "WORK SUPPORT"

Check "AUTOMATIC LOCK/UNLOCK SELECT" in "WORK SUPPORT".

Refer to [DLK-50, "DOOR LOCK : CONSULT-III Function \(BCM - DOOR LOCK\)"](#).

Is the inspection result normal?

YES >> GO TO 3.

NO >> Set "AUTOMATIC LOCK/UNLOCK SELECT" in "WORK SUPPORT".

3. CHECK "AUTOMATIC DOOR LOCK SELECT" SETTING IN "WORK SUPPORT"

Check "AUTOMATIC DOOR LOCK SELECT" in "WORK SUPPORT".

Refer to [DLK-50, "DOOR LOCK : CONSULT-III Function \(BCM - DOOR LOCK\)"](#).

Is the inspection result normal?

YES >> GO TO 4.

NO >> Set "AUTOMATIC DOOR LOCK SELECT" in "WORK SUPPORT".

4. CHECK "AUTOMATIC DOOR UNLOCK SELECT" SETTING IN "WORK SUPPORT"

Check "AUTOMATIC DOOR UNLOCK SELECT" in "WORK SUPPORT".

Refer to [DLK-50, "DOOR LOCK : CONSULT-III Function \(BCM - DOOR LOCK\)"](#).

Is the inspection result normal?

YES >> GO TO 5.

NO >> Set "AUTOMATIC DOOR UNLOCK SELECT" in "WORK SUPPORT".

5. CHECK TCM

Check TCM for DTC.

Refer to [TM-253, "DTC Index"](#).

Is the inspection result normal?

YES >> GO TO 6.

NO >> Repair or replace the malfunctioning parts.

6. CONFIRM THE OPERATION

Confirm the operation again.

Is the result normal?

YES >> Check intermittent incident. Refer to [GI-37, "Intermittent Incident"](#).

NO >> GO TO 1.

A
B
C
D
E
F
G
H
I
J
L
M
N
O
P

DLK

AUTO DOOR LOCK OPERATION DOES NOT OPERATE

< SYMPTOM DIAGNOSIS >

AUTO DOOR LOCK OPERATION DOES NOT OPERATE

Diagnosis Procedure

INFOID:000000005624327

1. CHECK "AUTO LOCK SET" SETTING IN "WORK SUPPORT"

Check "AUTO LOCK SET" setting in "WORK SUPPORT".

Refer to [DLK-52, "INTELLIGENT KEY : CONSULT-III Function \(BCM - INTELLIGENT KEY\)"](#).

Is the inspection result normal?

YES >> GO TO 2.

NO >> Set "AUTO LOCK SET" setting in "WORK SUPPORT".

2. CONFIRM THE OPERATION

Confirm the operation again.

Is the result normal?

YES >> Check intermittent incident. Refer to [GI-37, "Intermittent Incident"](#).

NO >> GO TO 1.

FUEL LID LOCK ACTUATOR DOES NOT OPERATE

< SYMPTOM DIAGNOSIS >

FUEL LID LOCK ACTUATOR DOES NOT OPERATE

Diagnosis Procedure

INFOID:000000005624328

1. CHECK FUEL LID LOCK ACTUATOR

Check fuel lid lock actuator.

Refer to [DLK-76, "Component Function Check"](#).

Is the inspection result normal?

YES >> GO TO 2.

NO >> Repair or replace the malfunctioning parts.

2. CONFIRM THE OPERATION

Confirm the operation again.

Is the result normal?

YES >> Check intermittent incident. Refer to [GI-37, "Intermittent Incident"](#).

NO >> GO TO 1.

A
B
C
D
E
F
G
H
I
J
L
M
N
O
P

DLK

HAZARD AND HORN REMINDER DOES NOT OPERATE

< SYMPTOM DIAGNOSIS >

HAZARD AND HORN REMINDER DOES NOT OPERATE

Diagnosis Procedure

INFOID:000000005624329

1. CHECK "HAZARD ANSWER BACK" SETTING IN "WORK SUPPORT"

Check "HAZARD ANSWER BACK" setting in "WORK SUPPORT".

Refer to [DLK-52, "INTELLIGENT KEY : CONSULT-III Function \(BCM - INTELLIGENT KEY\)"](#).

Is the inspection result normal?

YES >> GO TO 2.

NO >> Set "HAZARD ANSWER BACK" setting in "WORK SUPPORT".

2. CHECK "HORN WITH KEYLESS LOCK" SETTING IN "WORK SUPPORT"

Check "HORN WITH KEYLESS LOCK" setting in "WORK SUPPORT".

Refer to [DLK-52, "INTELLIGENT KEY : CONSULT-III Function \(BCM - INTELLIGENT KEY\)"](#).

Is the inspection result normal?

YES >> GO TO 3.

NO >> Set "HORN WITH KEYLESS LOCK" setting in "WORK SUPPORT".

3. CHECK POWER POSITION

Check if ignition switch position is changing or not.

Does ignition switch position change?

YES >> GO TO 4.

NO >> Check BCM for DTC. Refer to [BCS-74, "DTC Index"](#).

4. CHECK DOOR SWITCH

Check door switch.

Refer to [DLK-70, "Component Function Check"](#).

Is the inspection result normal?

YES >> GO TO 5.

NO >> Repair or replace the malfunctioning parts.

5. CHECK HAZARD FUNCTION

Check hazard function.

Refer to [DLK-116, "Component Function Check"](#).

Is the inspection result normal?

YES >> GO TO 6.

NO >> Repair or replace the malfunctioning parts.

6. CHECK HORN FUNCTION

Check horn function.

Refer to [SEC-117, "Component Function Check"](#).

Is the inspection result normal?

YES >> GO TO 7.

NO >> Repair or replace the malfunctioning parts.

7. CONFIRM THE OPERATION

Confirm the operation again.

Is the result normal?

YES >> Check intermittent incident. Refer to [GI-37, "Intermittent Incident"](#).

NO >> GO TO 1.

HAZARD AND BUZZER REMINDER DOES NOT OPERATE

< SYMPTOM DIAGNOSIS >

HAZARD AND BUZZER REMINDER DOES NOT OPERATE

Diagnosis Procedure

INFOID:000000005624330

1. CHECK "HAZARD ANSWER BACK" SETTING IN "WORK SUPPORT"

Check "HAZARD ANSWER BACK" setting in "WORK SUPPORT".

Refer to [DLK-52, "INTELLIGENT KEY : CONSULT-III Function \(BCM - INTELLIGENT KEY\)"](#).

Is the inspection result normal?

YES >> GO TO 2.

NO >> Set "HAZARD ANSWER BACK" in "WORK SUPPORT".

2. CHECK "ANS BACK I-KEY LOCK" SETTING IN "WORK SUPPORT"

Check "ANS BACK I-KEY LOCK" setting in "WORK SUPPORT".

Refer to [DLK-52, "INTELLIGENT KEY : CONSULT-III Function \(BCM - INTELLIGENT KEY\)"](#).

Is the inspection result normal?

YES >> GO TO 3.

NO >> Set "ANS BACK I-KEY LOCK" in "WORK SUPPORT".

3. CHECK "ANS BACK I-KEY UNLOCK" SETTING IN "WORK SUPPORT"

Check "ANS BACK I-KEY UNLOCK" setting in "WORK SUPPORT".

Refer to [DLK-52, "INTELLIGENT KEY : CONSULT-III Function \(BCM - INTELLIGENT KEY\)"](#).

Is the inspection result normal?

YES >> GO TO 4.

NO >> Set "ANS BACK I-KEY UNLOCK" in "WORK SUPPORT".

4. CHECK POWER POSITION

Check if ignition switch position is changing or not.

Does ignition switch position change?

YES >> GO TO 5.

NO >> Check BCM for DTC. Refer to [BCS-74, "DTC Index"](#).

5. CHECK DOOR SWITCH

Check door switch.

Refer to [DLK-70, "Component Function Check"](#).

Is the inspection result normal?

YES >> GO TO 6.

NO >> Repair or replace the malfunctioning parts.

6. CHECK HAZARD FUNCTION

Check hazard function.

Refer to [DLK-116, "Component Function Check"](#).

Is the inspection result normal?

YES >> GO TO 7.

NO >> Repair or replace the malfunctioning parts.

7. CHECK INTELLIGENT KEY WARNING BUZZER

Check Intelligent Key warning buzzer.

Refer to [DLK-106, "Component Function Check"](#).

Is the inspection result normal?

YES >> GO TO 8.

NO >> Repair or replace the malfunctioning parts.

8. CONFIRM THE OPERATION

Confirm the operation again.

Is the result normal?

YES >> Check intermittent incident. Refer to [GI-37, "Intermittent Incident"](#).

A

B

C

D

E

F

G

H

I

J

DLK

L

M

N

O

P

HAZARD AND BUZZER REMINDER DOES NOT OPERATE

< SYMPTOM DIAGNOSIS >

NO >> GO TO 1.

KEY REMINDER FUNCTION DOES NOT OPERATE

< SYMPTOM DIAGNOSIS >

KEY REMINDER FUNCTION DOES NOT OPERATE INTELLIGENT KEY SYSTEM

INTELLIGENT KEY SYSTEM : Description

INFOID:000000005624331

Key reminder function is not operated by intelligent Key system.

INTELLIGENT KEY SYSTEM : Diagnosis Procedure

INFOID:000000005624332

1.CHECK "ANTI KEY LOCK IN FUNCTI" SETTING IN "WORK SUPPORT"

Check "ANTI KEY LOCK IN FUNCTI" setting in "WORK SUPPORT".

Refer to [DLK-52, "INTELLIGENT KEY : CONSULT-III Function \(BCM - INTELLIGENT KEY\)"](#).

Is the inspection result normal?

YES >> GO TO 2.

NO >> Set "ANTI KEY LOCK IN FUNCTI" setting in "WORK SUPPORT".

2.CHECK DOOR SWITCH

Check door switch.

Refer to [DLK-70, "Component Function Check"](#).

Is the inspection result normal?

YES >> GO TO 3.

NO >> Repair or replace the malfunctioning parts.

3.CHECK TRUNK ROOM LAMP SWITCH

Check trunk room lamp switch.

Refer to [DLK-81, "Component Function Check"](#).

Is the inspection result normal?

YES >> GO TO 4.

NO >> Repair or replace the malfunctioning parts.

4.CHECK INSIDE KEY ANTENNA

Check inside key antenna.

• Instrument center: Refer to [DLK-61, "DTC Logic"](#).

• Console: Refer to [DLK-63, "DTC Logic"](#).

• Trunk room: Refer to [DLK-65, "DTC Logic"](#).

Is the inspection result normal?

YES >> GO TO 5.

NO >> Repair or replace the malfunctioning parts.

5.CHECK UNLOCK SENSOR

Check unlock sensor.

Refer to [DLK-101, "Component Function Check"](#).

Is the inspection result normal?

YES >> GO TO 6.

NO >> Repair or replace the malfunctioning parts.

6.CONFIRM THE OPERATION

Confirm the operation again.

Is the result normal?

YES >> Check intermittent incident. Refer to [GI-37, "Intermittent Incident"](#).

NO >> GO TO 1.

POWER DOOR LOCK SYSTEM

POWER DOOR LOCK SYSTEM : Description

INFOID:000000005624333

Key reminder function is not operated by power door lock system.

A

B

C

D

E

F

G

H

I

J

DLK

L

M

N

O

P

KEY REMINDER FUNCTION DOES NOT OPERATE

< SYMPTOM DIAGNOSIS >

POWER DOOR LOCK SYSTEM : Diagnosis Procedure

INFOID:000000005624334

1.CHECK KEY SLOT

Check key slot.

Refer to [DLK-109, "Component Function Check"](#).

Is the inspection result normal?

YES >> GO TO 2.

NO >> Repair or replace the malfunctioning parts.

2.CHECK DOOR SWITCH

Check door switch.

Refer to [DLK-70, "Component Function Check"](#).

Is the inspection result normal?

YES >> GO TO 3.

NO >> Repair or replace the malfunctioning parts.

3.CONFIRM THE OPERATION

Confirm the operation again.

Is the result normal?

YES >> Check intermittent incident. Refer to [GI-37, "Intermittent Incident"](#).

NO >> GO TO 1.

KEY WARNING DOES NOT OPERATE

< SYMPTOM DIAGNOSIS >

KEY WARNING DOES NOT OPERATE

Diagnosis Procedure

INFOID:000000005624335

1.CHECK DRIVER SIDE DOOR SWITCH

Check driver side door switch.

Refer to [DLK-70, "Component Function Check"](#).

Is the inspection result normal?

YES >> GO TO 2.

NO >> Repair or replace the malfunctioning parts.

2.CHECK KEY SLOT

Check key slot.

Refer to [DLK-109, "Component Function Check"](#).

Is the inspection result normal?

YES >> GO TO 3.

NO >> Repair or replace the malfunctioning parts.

3.CHECK BUZZER (COMBINATION METER)

Check buzzer (combination meter).

Refer to [DLK-114, "Component Function Check"](#).

Is the inspection result normal?

YES >> GO TO 4.

NO >> Repair or replace the malfunctioning parts.

4.CHECK COMBINATION METER DISPLAY

Check combination meter display.

Refer to [DLK-113, "Component Function Check"](#).

Is the inspection result normal?

YES >> GO TO 5.

NO >> Repair or replace the malfunctioning parts.

5.CHECK KEY SLOT INDICATOR

Check key slot indicator.

Refer to [DLK-111, "Component Function Check"](#).

Is the inspection result normal?

YES >> GO TO 6.

NO >> Repair or replace the malfunctioning parts.

6.CONFIRM THE OPERATION

Confirm the operation again.

Is the result normal?

YES >> Check intermittent incident. Refer to [GI-37, "Intermittent Incident"](#).

NO >> GO TO 1.

A
B
C
D
E
F
G
H
I
J
L
M
N
O
P

DLK

OFF POSITION WARNING DOES NOT OPERATE

< SYMPTOM DIAGNOSIS >

OFF POSITION WARNING DOES NOT OPERATE

Diagnosis Procedure

INFOID:000000005624336

1. CHECK POWER POSITION

Check if ignition switch position is changing or not.

Does ignition switch position change?

YES >> GO TO 2.

NO >> Check BCM for DTC. Refer to [BCS-74, "DTC Index"](#).

2. CHECK DRIVER SIDE DOOR SWITCH

Check driver side door switch.

Refer to [DLK-70, "Component Function Check"](#).

Is the inspection result normal?

YES >> GO TO 3.

NO >> Repair or replace the malfunctioning parts.

3. CHECK BUZZER (COMBINATION METER)

Check buzzer (combination meter).

Refer to [DLK-114, "Component Function Check"](#).

Is the inspection result normal?

YES >> GO TO 4.

NO >> Repair or replace the malfunctioning parts.

4. CHECK INTELLIGENT KEY WARNING BUZZER

Check Intelligent Key warning buzzer.

Refer to [DLK-106, "Component Function Check"](#).

Is the inspection result normal?

YES >> GO TO 5.

NO >> Repair or replace the malfunctioning parts.

5. CONFIRM THE OPERATION

Confirm the operation again.

Is the result normal?

YES >> Check intermittent incident. Refer to [GI-37, "Intermittent Incident"](#).

NO >> GO TO 1.

P POSITION WARNING DOES NOT OPERATE

< SYMPTOM DIAGNOSIS >

P POSITION WARNING DOES NOT OPERATE

Diagnosis Procedure

INFOID:000000005624337

1.CHECK POWER POSITION

Check if ignition switch position is changing or not.

Does ignition switch position change?

YES >> GO TO 2.

NO >> Check BCM for DTC. Refer to [BCS-74, "DTC Index"](#).

2.CHECK DETENTION SWITCH

Check BCM for DTC.

Refer to [BCS-74, "DTC Index"](#).

Is the inspection result normal?

YES >> GO TO 3.

NO >> Repair or replace the malfunctioning parts.

3.CHECK DRIVER SIDE DOOR SWITCH

Check driver side door switch.

Refer to [DLK-70, "Component Function Check"](#).

Is the inspection result normal?

YES >> GO TO 4.

NO >> Repair or replace the malfunctioning parts.

4.CHECK INSIDE KEY ANTENNA

Check inside key antenna.

• Instrument center: Refer to [DLK-61, "DTC Logic"](#).

• Console: Refer to [DLK-63, "DTC Logic"](#).

• Trunk room: Refer to [DLK-65, "DTC Logic"](#).

Is the inspection result normal?

YES >> GO TO 5.

NO >> Repair or replace the malfunctioning parts.

5.CHECK BUZZER (COMBINATION METER)

Check buzzer (combination meter).

Refer to [DLK-114, "Component Function Check"](#).

Is the inspection result normal?

YES >> GO TO 6.

NO >> Repair or replace the malfunctioning parts.

6.CHECK COMBINATION METER DISPLAY

Check combination meter display.

Refer to [DLK-113, "Component Function Check"](#).

Is the inspection result normal?

YES >> GO TO 7.

NO >> Repair or replace the malfunctioning parts.

7.CHECK INTELLIGENT KEY WARNING BUZZER

Check Intelligent Key warning buzzer.

Refer to [DLK-106, "Component Function Check"](#).

Is the inspection result normal?

YES >> GO TO 8.

NO >> Repair or replace the malfunctioning parts.

8.CONFIRM THE OPERATION

Confirm the operation again.

A

B

C

D

E

F

G

H

I

J

DLK

L

M

N

O

P

P POSITION WARNING DOES NOT OPERATE

< SYMPTOM DIAGNOSIS >

Is the result normal?

YES >> Check intermittent incident. Refer to [GI-37, "Intermittent Incident"](#).

NO >> GO TO 1.

ACC WARNING DOES NOT OPERATE

< SYMPTOM DIAGNOSIS >

ACC WARNING DOES NOT OPERATE

Diagnosis Procedure

INFOID:000000005624338

1.CHECK POWER POSITION

Check if ignition switch position is changing or not.

Does ignition switch position change?

YES >> GO TO 2.

NO >> Check BCM for DTC. Refer to [BCS-74, "DTC Index"](#).

2.CHECK BUZZER (COMBINATION METER)

Check buzzer (combination meter).

Refer to [DLK-114, "Component Function Check"](#).

Is the inspection result normal?

YES >> GO TO 3.

NO >> Repair or replace the malfunctioning parts.

3.CHECK COMBINATION METER DISPLAY FUNCTION

Check combination meter display function.

Refer to [DLK-113, "Component Function Check"](#).

Is the inspection result normal?

YES >> GO TO 4.

NO >> Repair or replace the malfunctioning parts.

4.CONFIRM THE OPERATION

Confirm the operation again.

Is the result normal?

YES >> Check intermittent incident. Refer to [GI-37, "Intermittent Incident"](#).

NO >> GO TO 1.

A
B
C
D
E
F
G
H
I
J
L
M
N
O
P

DLK

TAKE AWAY WARNING DOES NOT OPERATE

< SYMPTOM DIAGNOSIS >

TAKE AWAY WARNING DOES NOT OPERATE

Diagnosis Procedure

INFOID:000000005624339

1.CHECK POWER POSITION

Check if ignition switch position is changing or not.

Does ignition switch position change?

YES >> GO TO 2.

NO >> Check BCM for DTC. Refer to [BCS-74, "DTC Index"](#).

2.CHECK DOOR SWITCH

Check door switch.

Refer to [DLK-70, "Component Function Check"](#).

Is the inspection result normal?

YES >> GO TO 3.

NO >> Repair or replace the malfunctioning parts.

3.CHECK KEY SLOT

Check key slot.

Refer to [DLK-109, "Component Function Check"](#).

Is the inspection result normal?

YES >> GO TO 4.

NO >> Repair or replace the malfunctioning parts.

4.CHECK INSIDE KEY ANTENNA

Check inside key antenna.

- Instrument center: Refer to [DLK-61, "DTC Logic"](#).
- Console: Refer to [DLK-63, "DTC Logic"](#).
- Trunk room: Refer to [DLK-65, "DTC Logic"](#).

Is the inspection result normal?

YES >> GO TO 5.

NO >> Repair or replace the malfunctioning parts.

5.CHECK BUZZER (COMBINATION METER)

Check buzzer (combination meter).

Refer to [DLK-114, "Component Function Check"](#).

Is the inspection result normal?

YES >> GO TO 6.

NO >> Repair or replace the malfunctioning parts.

6.CHECK COMBINATION METER DISPLAY FUNCTION

Check combination meter display function.

Refer to [DLK-113, "Component Function Check"](#).

Is the inspection result normal?

YES >> GO TO 7.

NO >> Repair or replace the malfunctioning parts.

7.CHECK INTELLIGENT KEY WARNING BUZZER

Check Intelligent Key warning buzzer.

Refer to [DLK-106, "Component Function Check"](#).

Is the inspection result normal?

YES >> GO TO 8.

NO >> Repair or replace the malfunctioning parts.

8.CHECK KEY SLOT INDICATOR

Check key slot indicator.

Refer to [DLK-111, "Component Function Check"](#).

TAKE AWAY WARNING DOES NOT OPERATE

< SYMPTOM DIAGNOSIS >

Is the inspection result normal?

YES >> GO TO 9.

NO >> Repair or replace the malfunctioning parts.

9.CONFIRM THE OPERATION

Confirm the operation again.

Is the result normal?

YES >> Check intermittent incident. Refer to [GI-37. "Intermittent Incident"](#).

NO >> GO TO 1.

A

B

C

D

E

F

G

H

I

J

DLK

L

M

N

O

P

INTELLIGENT KEY LOW BATTERY WARNING DOES NOT OPERATE

< SYMPTOM DIAGNOSIS >

INTELLIGENT KEY LOW BATTERY WARNING DOES NOT OPERATE

Diagnosis Procedure

INFOID:000000005624340

1. CHECK "LO- BATT OF KEY FOB WARN" SETTING IN "WORK SUPPORT"

Check "LO- BATT OF KEY FOB WARN" setting in "WORK SUPPORT".

Refer to [DLK-52, "INTELLIGENT KEY : CONSULT-III Function \(BCM - INTELLIGENT KEY\)"](#).

Is the inspection result normal?

YES >> GO TO 2.

NO >> Set "LO- BATT OF KEY FOB WARN" setting in "WORK SUPPORT".

2. CHECK INTELLIGENT KEY

Check Intelligent Key.

Refer to [DLK-108, "Component Function Check"](#).

Is the inspection result normal?

YES >> GO TO 3.

NO >> Repair or replace the malfunctioning parts.

3. CHECK INSIDE KEY ANTENNA

Check inside key antenna.

• Instrument center: Refer to [DLK-61, "DTC Logic"](#).

• Console: Refer to [DLK-63, "DTC Logic"](#).

• Trunk room: Refer to [DLK-65, "DTC Logic"](#).

Is the inspection result normal?

YES >> GO TO 4.

NO >> Repair or replace the malfunctioning parts.

4. CHECK COMBINATION METER DISPLAY FUNCTION

Check combination meter display function.

Refer to [DLK-113, "Component Function Check"](#).

Is the inspection result normal?

YES >> GO TO 5.

NO >> Repair or replace the malfunctioning parts.

5. CONFIRM THE OPERATION

Confirm the operation again.

Is the result normal?

YES >> Check intermittent incident. Refer to [GI-37, "Intermittent Incident"](#).

NO >> GO TO 1.

DOOR LOCK OPERATION WARNING DOES NOT OPERATE

< SYMPTOM DIAGNOSIS >

DOOR LOCK OPERATION WARNING DOES NOT OPERATE

Diagnosis Procedure

INFOID:000000005624341

1.CHECK DOOR LOCK FUNCTION

Check door lock function.

Does door lock/unlock using door request switch?

YES >> GO TO 2.

NO >> Refer to [DLK-233, "ALL DOOR : Diagnosis Procedure"](#).

2.CHECK INTELLIGENT KEY WARNING BUZZER

Check Intelligent Key warning buzzer.

Refer to [DLK-106, "Component Function Check"](#).

Is the inspection result normal?

YES >> GO TO 3.

NO >> Repair or replace the malfunctioning parts.

3.CONFIRM THE OPERATION

Confirm the operation again.

Is the result normal?

YES >> Check intermittent incident. Refer to [GI-37, "Intermittent Incident"](#).

NO >> GO TO 1.

A
B
C
D
E
F
G
H
I
J
L
M
N
O
P

DLK

KEY ID WARNING DOES NOT OPERATE

< SYMPTOM DIAGNOSIS >

KEY ID WARNING DOES NOT OPERATE

Diagnosis Procedure

INFOID:000000005624342

1.CHECK INTELLIGENT KEY

Check Intelligent Key.

Refer to [DLK-108, "Component Function Check"](#).

Is the inspection result normal?

YES >> GO TO 2.

NO >> Repair or replace the malfunctioning parts.

2.CHECK COMBINATION METER DISPLAY FUNCTION

Check combination meter display function.

Refer to [DLK-113, "Component Function Check"](#).

Is the inspection result normal?

YES >> GO TO 3.

NO >> Repair or replace the malfunctioning parts.

3.CONFIRM THE OPERATION

Confirm the operation again.

Is the result normal?

YES >> Check intermittent incident. Refer to [GI-37, "Intermittent Incident"](#).

NO >> GO TO 1.

KEY WARNING LAMP DOES NOT ILLUMINATE

< SYMPTOM DIAGNOSIS >

KEY WARNING LAMP DOES NOT ILLUMINATE

Diagnosis Procedure

INFOID:000000005624343

1.CHECK KEY WARNING LAMP

Check key warning lamp.

Refer to [DLK-115, "Component Function Check"](#).

Is the inspection result normal?

YES >> GO TO 2.

NO >> Repair or replace the malfunctioning parts.

2.CONFIRM THE OPERATION

Confirm the operation again.

Is the result normal?

YES >> Check intermittent incident. Refer to [GI-37, "Intermittent Incident"](#).

NO >> GO TO 1.

A
B
C
D
E
F
G
H
I
J
L
M
N
O
P

DLK

INTEGRATED HOMELINK TRANSMITTER DOES NOT OPERATE

< SYMPTOM DIAGNOSIS >

INTEGRATED HOMELINK TRANSMITTER DOES NOT OPERATE

Diagnosis Procedure

INFOID:000000005624344

1. CHECK INTEGRATED HOMELINK TRANSMITTER

Check integrated homelink transmitter.

Refer to [DLK-117, "Component Function Check"](#).

Is the inspection result normal?

YES >> GO TO 2.

NO >> Repair or replace the malfunctioning parts.

2. CONFIRM THE OPERATION

Confirm the operation again.

Is the result normal?

YES >> Check intermittent incident. Refer to [GI-37, "Intermittent Incident"](#).

NO >> GO TO 1.

SQUEAK AND RATTLE TROUBLE DIAGNOSES

< SYMPTOM DIAGNOSIS >

SQUEAK AND RATTLE TROUBLE DIAGNOSES

Work Flow

INFOID:000000005624345

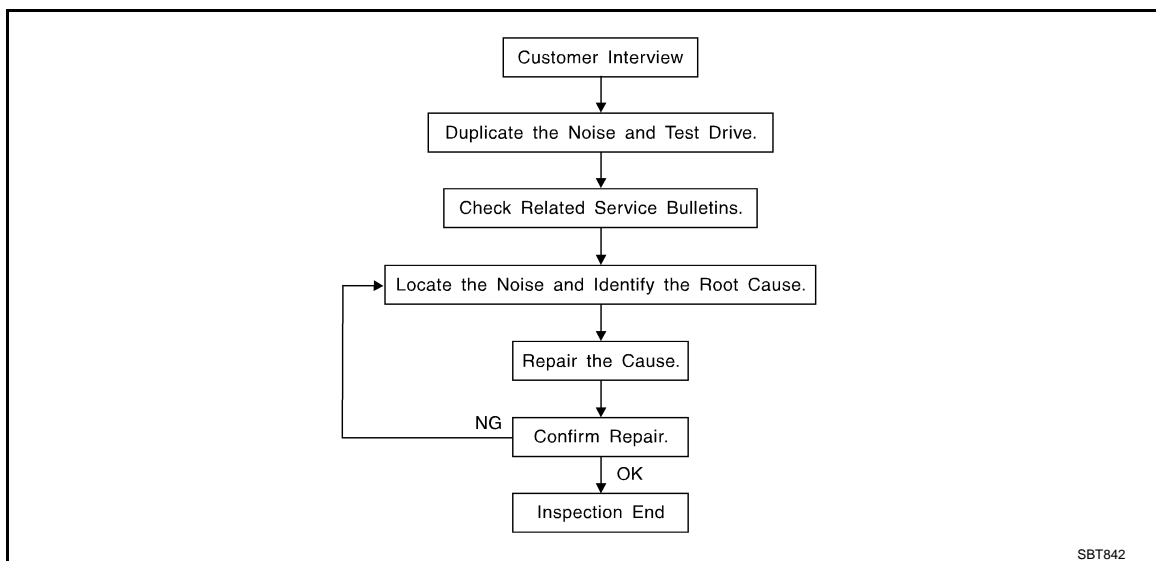

CUSTOMER INTERVIEW

Interview the customer if possible, to determine the conditions that exist when the noise occurs. Use the Diagnostic Worksheet during the interview to document the facts and conditions when the noise occurs and any of customer's comments; refer to [DLK-269, "Diagnostic Worksheet"](#). This information is necessary to duplicate the conditions that exist when the noise occurs.

- The customer may not be able to provide a detailed description or the location of the noise. Attempt to obtain all the facts and conditions that exist when the noise occurs (or does not occur).
- If there is more than one noise in the vehicle, perform a diagnosis and repair the noise that the customer is concerned about. This can be accomplished by performing a cruise test on the vehicle with the customer.
- After identifying the type of noise, isolate the noise in terms of its characteristics. The noise characteristics are provided so the customer, service adviser and technician are all speaking the same language when defining the noise.
- Squeak – (Like tennis shoes on a clean floor)
Squeak characteristics include the light contact/fast movement/brought on by road conditions/hard surfaces = higher pitch noise/softer surfaces = lower pitch noises/edge to surface = chirping
- Creak – (Like walking on an old wooden floor)
Creak characteristics include firm contact/slow movement/twisting with a rotational movement/pitch dependent on materials/often brought on by activity.
- Rattle – (Like shaking a baby rattle)
Rattle characteristics include the fast repeated contact/vibration or similar movement/loose parts/missing clip or fastener/incorrect clearance.
- Knock – (Like a knock on a door)
Knock characteristics include hollow sounding/sometimes repeating/often brought on by driver action.
- Tick – (Like a clock second hand)
Tick characteristics include gentle contacting of light materials/loose components/can be caused by driver action or road conditions.
- Thump – (Heavy, muffled knock noise)
Thump characteristics include softer knock/dead sound often brought on by activity.
- Buzz – (Like a bumblebee)
Buzz characteristics include high frequency rattle/firm contact.
- Often the degree of acceptable noise level will vary depending up on the person. A noise that a technician may judge as acceptable may be very irritating to the customer.
- Weather conditions, especially humidity and temperature, may have a great effect on noise level.

DUPLICATE THE NOISE AND TEST DRIVE

If possible, drive the vehicle with the customer until the noise is duplicated. Note any additional information on the Diagnostic Worksheet regarding the conditions or location of the noise. This information can be used to duplicate the same conditions when the repair is reconfirmed.

SQUEAK AND RATTLE TROUBLE DIAGNOSES

< SYMPTOM DIAGNOSIS >

If the noise can be duplicated easily during the test drive, to help identify the source of the noise, try to duplicate the noise with the vehicle stopped by doing one or all of the following:

- 1) Close a door.
 - 2) Tap or push/pull around the area where the noise appears to be coming from.
 - 3) Rev the engine.
 - 4) Use a floor jack to recreate vehicle "twist".
 - 5) At idle, apply engine load (electrical load, half-clutch on M/T models, drive position on A/T models).
 - 6) Raise the vehicle on a hoist and hit a tire with a rubber hammer.
- Drive the vehicle and attempt to duplicate the conditions the customer states exist when the noise occurs.
 - If it is difficult to duplicate the noise, drive the vehicle slowly on an undulating or rough road to stress the vehicle body.

CHECK RELATED SERVICE BULLETINS

After verifying the customer concern or symptom, check ASIST for Technical Service Bulletins (TSBs) related to that concern or symptom.

If a TSB relates to the symptom, follow the procedure to repair the noise.

LOCATE THE NOISE AND IDENTIFY THE ROOT CAUSE

1. Narrow down the noise to a general area. To help pinpoint the source of the noise, use a listening tool (Chassis ear: J-39570, Engine ear and mechanics stethoscope).
2. Narrow down the noise to a more specific area and identify the cause of the noise by:
 - Removing the components in the area that is are suspected to be the cause of the noise.
Do not use too much force when removing clips and fasteners, otherwise clips and fastener can be broken or lost during the repair, resulting in the creation of new noise.
 - Tapping or pushing/pulling the component that is are suspected to be the cause of the noise.
Do not tap or push/pull the component with excessive force, otherwise the noise will be eliminated only temporarily.
 - Feeling for a vibration by hand by touching the component(s) that is are suspected to be the cause of the noise.
 - Placing a piece of paper between components that are suspected to be the cause of the noise.
 - Looking for loose components and contact marks.
Refer to [DLK-267. "Inspection Procedure"](#).

REPAIR THE CAUSE

- If the cause is a loose component, tighten the component securely.
- If the cause is insufficient clearance between components:
 - Separate components by repositioning or loosening and retightening the component, if possible.
 - Insulate components with a suitable insulator such as urethane pads, foam blocks, felt cloth tape or urethane tape. A Nissan Squeak and Rattle Kit (J-43980) is available through the authorized Nissan Parts Department.

CAUTION:

Never use excessive force as many components are constructed of plastic and may be damaged.

NOTE:

Always check with the Parts Department for the latest parts information.

The following materials are contained in the Nissan Squeak and Rattle Kit (J-43980). Each item can be ordered separately as needed.

URETHANE PADS [1.5 mm (0.059 in) thick]

Insulates connectors, harness, etc.

76268-9E005: 100 × 135 mm (3.94 × 5.31 in)/76884-71L01: 60 × 85 mm (2.36 × 3.35 in)/76884-71L02: 15 × 25 mm (0.59 × 0.98 in)

INSULATOR (Foam blocks)

Insulates components from contact. Can be used to fill space behind a panel.

73982-9E000: 45 mm (1.77 in) thick, 50 × 50 mm (1.97 × 1.97 in)/73982-

50Y00: 10 mm (0.39 in) thick, 50 × 50 mm (1.97 × 1.97 in)

INSULATOR (Light foam block)

80845-71L00: 30 mm (1.18 in) thick, 30 × 50 mm (1.18 × 1.97 in)

FELT CLOTHTAPE

Used to insulate where movement does not occur. Ideal for instrument panel applications.

68370-4B000: 15 × 25 mm (0.59 × 0.98 in) pad/68239-13E00: 5 mm (0.20 in) wide tape roll

The following materials, not found in the kit, can also be used to repair squeaks and rattles.

UHMW (TEFLON) TAPE

SQUEAK AND RATTLE TROUBLE DIAGNOSES

< SYMPTOM DIAGNOSIS >

Insulates where slight movement is present. Ideal for instrument panel applications.

SILICONE GREASE

Used in place of UHMW tape that is be visible or does not fit. Will only last a few months.

SILICONE SPRAY

Used when grease cannot be applied.

DUCT TAPE

Used to eliminate movement.

CONFIRM THE REPAIR

Confirm that the cause of a noise is repaired by test driving the vehicle. Operate the vehicle under the same conditions as when the noise originally occurred. Refer to the notes on the Diagnostic Worksheet.

Inspection Procedure

INFOID:000000005624346

Refer to Table of Contents for specific component removal and installation information.

INSTRUMENT PANEL

Most incidents are caused by contact and movement between:

1. The cluster lid A and instrument panel
2. Acrylic lens and combination meter housing
3. Instrument panel to front pillar garnish
4. Instrument panel to windshield
5. Instrument panel mounting pins
6. Wiring harnesses behind the combination meter
7. A/C defroster duct and duct joint

These incidents can usually be located by tapping or moving the components to duplicate the noise or by pressing on the components while driving to stop the noise. Most of these incidents can be repaired by applying felt cloth tape or silicon spray (in hard to reach areas). Urethane pads can be used to insulate wiring harness.

CAUTION:

Never use silicone spray to isolate a squeak or rattle. If the area is saturated with silicone, the recheck of repair becomes impossible.

CENTER CONSOLE

Components to pay attention to include:

1. Shifter assembly cover to finisher
2. A/C control unit and cluster lid C
3. Wiring harnesses behind audio and A/C control unit

The instrument panel repair and isolation procedures also apply to the center console.

DOORS

Pay attention to the following:

1. Finisher and inner panel making a slapping noise
2. Inside handle escutcheon to door finisher
3. Wiring harnesses tapping
4. Door striker out of alignment causing a popping noise on starts and stops

Tapping or moving the components or pressing on them while driving to duplicate the conditions can isolate many of these incidents. The areas can usually be insulated with felt cloth tape or insulator foam blocks from the Nissan Squeak and Rattle Kit (J-43980) to repair the noise.

TRUNK

Trunk noises are often caused by a loose jack or loose items put into the trunk by the customer.

In addition look for the following:

1. Trunk lid dumpers out of adjustment
2. Trunk lid striker out of adjustment
3. The trunk lid torsion bars knocking together
4. A loose license plate or bracket

A

B

C

D

E

F

G

H

I

J

DLK

L

M

N

O

P

SQUEAK AND RATTLE TROUBLE DIAGNOSES

< SYMPTOM DIAGNOSIS >

Most of these incidents can be repaired by adjusting, securing or insulating the item(s) or component(s) causing the noise.

SUNROOF/HEADLINING

Noises in the sunroof/headlining area can often be traced to one of the following:

1. Sunroof lid, rail, linkage or seals making a rattle or light knocking noise
2. Sunvisor shaft shaking in the holder
3. Front or rear windshield touching headlining and squeaking

Again, pressing on the components to stop the noise while duplicating the conditions can isolate most of these incidents. Repairs usually consist of insulating with felt cloth tape.

SEATS

When isolating seat noise it's important to note the position the seats in and the load placed on the seat when the noise occurs. These conditions should be duplicated when verifying and isolating the cause of the noise.

Cause of seat noise include:

1. Headrest rods and holder
2. A squeak between the seat pad cushion and frame
3. The rear seatback lock and bracket

These noises can be isolated by moving or pressing on the suspected components while duplicating the conditions under which the noise occurs. Most of these incidents can be repaired by repositioning the component or applying urethane tape to the contact area.

UNDERHOOD

Some interior noise may be caused by components under the hood or on the engine wall. The noise is then transmitted into the passenger compartment.

Causes of transmitted underhood noise include:

1. Any component mounted to the engine wall
2. Components that pass through the engine wall
3. Engine wall mounts and connectors
4. Loose radiator mounting pins
5. Hood bumpers out of adjustment
6. Hood striker out of adjustment

These noises can be difficult to isolate since they cannot be reached from the interior of the vehicle. The best method is to secure, move or insulate one component at a time and test drive the vehicle. Also, engine RPM or load can be changed to isolate the noise. Repairs can usually be made by moving, adjusting, securing, or insulating the component causing the noise.

SQUEAK AND RATTLE TROUBLE DIAGNOSES

< SYMPTOM DIAGNOSIS >

Diagnostic Worksheet

INFOID:000000005624347



SQUEAK & RATTLE DIAGNOSTIC WORKSHEET

Dear Infiniti Customer:

We are concerned about your satisfaction with your Infiniti vehicle. Repairing a squeak or rattle sometimes can be very difficult. To help us fix your Infiniti right the first time, please take a moment to note the area of the vehicle where the squeak or rattle occurs and under what conditions. You may be asked to take a test drive with a service consultant or technician to ensure we confirm the noise you are hearing.

I. WHERE DOES THE NOISE COME FROM? (circle the area of the vehicle)

The illustrations are for reference only, and may not reflect the actual configuration of your vehicle.

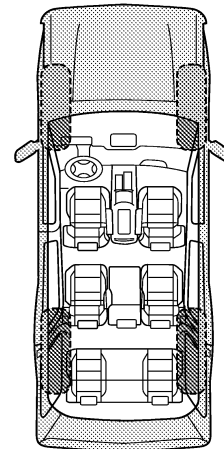
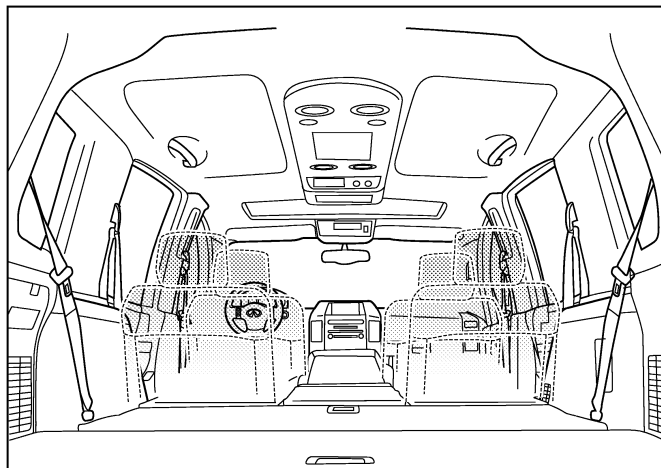
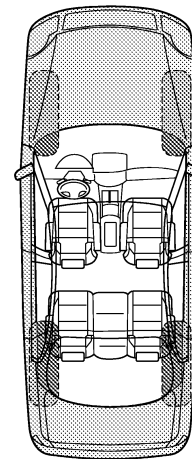
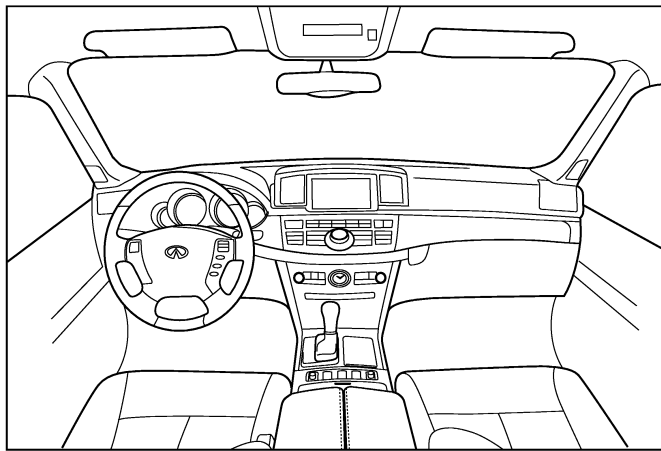

Continue to page 2 of the worksheet and briefly describe the location of the noise or rattle. In addition, please indicate the conditions which are present when the noise occurs.

PIIB8741E

A
B
C
D
E
F
G
H
I
J
DLK
L
M
N
O
P

SQUEAK AND RATTLE TROUBLE DIAGNOSES

< SYMPTOM DIAGNOSIS >

SQUEAK & RATTLE DIAGNOSTIC WORKSHEET - page 2

Briefly describe the location where the noise occurs:

II. WHEN DOES IT OCCUR? (please check the boxes that apply)

- | | |
|-------------------------------------------------------|--------------------------------------------------------|
| <input type="checkbox"/> anytime | <input type="checkbox"/> after sitting out in the rain |
| <input type="checkbox"/> 1st time in the morning | <input type="checkbox"/> when it is raining or wet |
| <input type="checkbox"/> only when it is cold outside | <input type="checkbox"/> dry or dusty conditions |
| <input type="checkbox"/> only when it is hot outside | <input type="checkbox"/> other: |

III. WHEN DRIVING:

- through driveways
- over rough roads
- over speed bumps
- only about ____ mph
- on acceleration
- coming to a stop
- on turns: left, right or either (circle)
- with passengers or cargo
- other: _____
- after driving ____ miles or ____ minutes

IV. WHAT TYPE OF NOISE

- squeak (like tennis shoes on a clean floor)
- creak (like walking on an old wooden floor)
- rattle (like shaking a baby rattle)
- knock (like a knock at the door)
- tick (like a clock second hand)
- thump (heavy, muffled knock noise)
- buzz (like a bumble bee)

TO BE COMPLETED BY DEALERSHIP PERSONNEL

Test Drive Notes:

	YES	NO	Initials of person performing
Vehicle test driven with customer	<input type="checkbox"/>	<input type="checkbox"/>	_____
- Noise verified on test drive	<input type="checkbox"/>	<input type="checkbox"/>	_____
- Noise source located and repaired	<input type="checkbox"/>	<input type="checkbox"/>	_____
- Follow up test drive performed to confirm repair	<input type="checkbox"/>	<input type="checkbox"/>	_____

VIN: _____ Customer Name: _____
W.O.# _____ Date: _____

This form must be attached to Work Order

PIIB8742E

PRECAUTIONS

< PRECAUTION >

PRECAUTION

PRECAUTIONS

Precaution for Supplemental Restraint System (SRS) "AIR BAG" and "SEAT BELT PRE-TENSIONER"

INFOID:000000005624348

The Supplemental Restraint System such as "AIR BAG" and "SEAT BELT PRE-TENSIONER", used along with a front seat belt, helps to reduce the risk or severity of injury to the driver and front passenger for certain types of collision. This system includes seat belt switch inputs and dual stage front air bag modules. The SRS system uses the seat belt switches to determine the front air bag deployment, and may only deploy one front air bag, depending on the severity of a collision and whether the front occupants are belted or unbelted. Information necessary to service the system safely is included in the "SRS AIR BAG" and "SEAT BELT" of this Service Manual.

WARNING:

- To avoid rendering the SRS inoperative, which could increase the risk of personal injury or death in the event of a collision which would result in air bag inflation, all maintenance must be performed by an authorized NISSAN/INFINITI dealer.
- Improper maintenance, including incorrect removal and installation of the SRS, can lead to personal injury caused by unintentional activation of the system. For removal of Spiral Cable and Air Bag Module, see the "SRS AIR BAG".
- Do not use electrical test equipment on any circuit related to the SRS unless instructed to in this Service Manual. SRS wiring harnesses can be identified by yellow and/or orange harnesses or harness connectors.

PRECAUTIONS WHEN USING POWER TOOLS (AIR OR ELECTRIC) AND HAMMERS

WARNING:

- When working near the Air Bag Diagnosis Sensor Unit or other Air Bag System sensors with the ignition ON or engine running, DO NOT use air or electric power tools or strike near the sensor(s) with a hammer. Heavy vibration could activate the sensor(s) and deploy the air bag(s), possibly causing serious injury.
- When using air or electric power tools or hammers, always switch the ignition OFF, disconnect the battery, and wait at least 3 minutes before performing any service.

Service Procedure Precautions for Models with a Pop-up Roll Bar

INFOID:000000005624349

WARNING:

- Risk of passenger injury or death may increase if the pop-up roll bar does not deploy during a roll over collision. In order to reduce the chance of an incident where the pop-up roll bar is inoperative, all maintenance must be performed by a NISSAN or INFINITI dealer.
- Before removing and installing the pop-up roll bar component parts and harness, always turn the ignition switch OFF, disconnect the battery negative terminal, and wait for 3 minutes or more. (The purpose of this operation is to discharge electricity that is accumulated in the auxiliary power supply circuit in the air bag diagnosis sensor unit.)
- When repairing, removing, and installing a pop-up roll bar, always refer to SRS AIR BAG and SRS AIR BAG CONTROL warnings in the Service Manual.

Precaution Necessary for Steering Wheel Rotation after Battery Disconnect

INFOID:000000005624350

NOTE:

- Before removing and installing any control units, first turn the push-button ignition switch to the LOCK position, then disconnect both battery cables.
- After finishing work, confirm that all control unit connectors are connected properly, then re-connect both battery cables.
- Always use CONSULT-III to perform self-diagnosis as a part of each function inspection after finishing work. If a DTC is detected, perform trouble diagnosis according to self-diagnosis results.

For vehicle with steering lock unit, if the battery is disconnected or discharged, the steering wheel will lock and cannot be turned.

If turning the steering wheel is required with the battery disconnected or discharged, follow the operation procedure below before starting the repair operation.

A

B

C

D

E

F

G

H

I

J

DLK

L

M

N

O

P

PRECAUTIONS

< PRECAUTION >

OPERATION PROCEDURE

1. Connect both battery cables.
NOTE:
Supply power using jumper cables if battery is discharged.
2. Turn the push-button ignition switch to ACC position.
(At this time, the steering lock will be released.)
3. Disconnect both battery cables. The steering lock will remain released with both battery cables disconnected and the steering wheel can be turned.
4. Perform the necessary repair operation.
5. When the repair work is completed, re-connect both battery cables. With the brake pedal released, turn the push-button ignition switch from ACC position to ON position, then to LOCK position. (The steering wheel will lock when the push-button ignition switch is turned to LOCK position.)
6. Perform self-diagnosis check of all control units using CONSULT-III.

Precaution for Procedure without Cowl Top Cover

INFOID:000000005624351

When performing the procedure after removing cowl top cover, cover the lower end of windshield with urethane, etc.

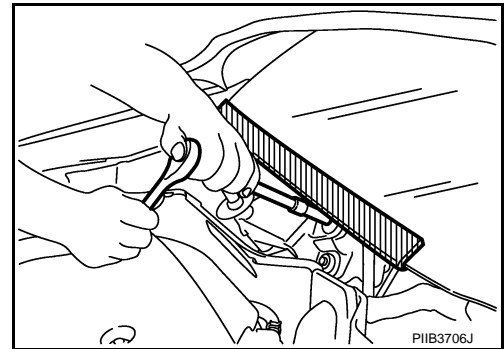

Precaution for Battery Service

INFOID:000000005624352

Before disconnecting the battery, lower both the driver and passenger windows. This will prevent any interference between the window edge and the vehicle when the door is opened/closed. During normal operation, the window slightly raises and lowers automatically to prevent any window to vehicle interference. The automatic window function will not work with the battery disconnected.

Work

INFOID:000000005624353

- After removing and installing the opening/closing parts, be sure to carry out fitting adjustments to check their operational.
- Check the lubrication level, damage, and wear of each part. If necessary, grease or replace it.

PREPARATION

< PREPARATION >

PREPARATION

PREPARATION

Special Service Tools

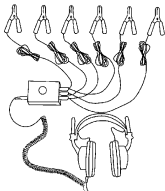
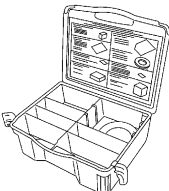

INFOID:000000005624354

The actual shapes of Kent-Moore tools may differ from those of special service tools illustrated here.

Tool number (Kent-Moore No.) Tool name	Description
<p>(J-39570) Chassis ear</p>  <p style="text-align: right;">SIA0993E</p>	<p>Locates the noise</p>
<p>(J-43980) NISSAN Squeak and Rattle Kit</p>  <p style="text-align: right;">SIA0994E</p>	<p>Repairs the cause of noise</p>

Commercial Service Tools

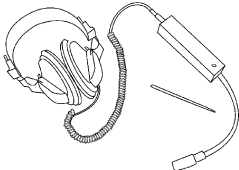
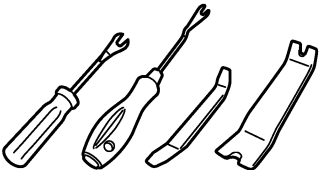
INFOID:000000005624355

Tool name	Description
<p>Engine ear</p>  <p style="text-align: right;">SIA0995E</p>	<p>Locates the noise</p>
<p>Remover tool</p>  <p style="text-align: right;">JMKIA3050ZZ</p>	<p>Removes clips, pawls and metal clips</p>
<p>Power tool</p>  <p style="text-align: right;">PIIB1407E</p>	

HOOD

< REMOVAL AND INSTALLATION >

REMOVAL AND INSTALLATION

HOOD

HOOD ASSEMBLY

HOOD ASSEMBLY : Exploded View

INFOID:000000005624356

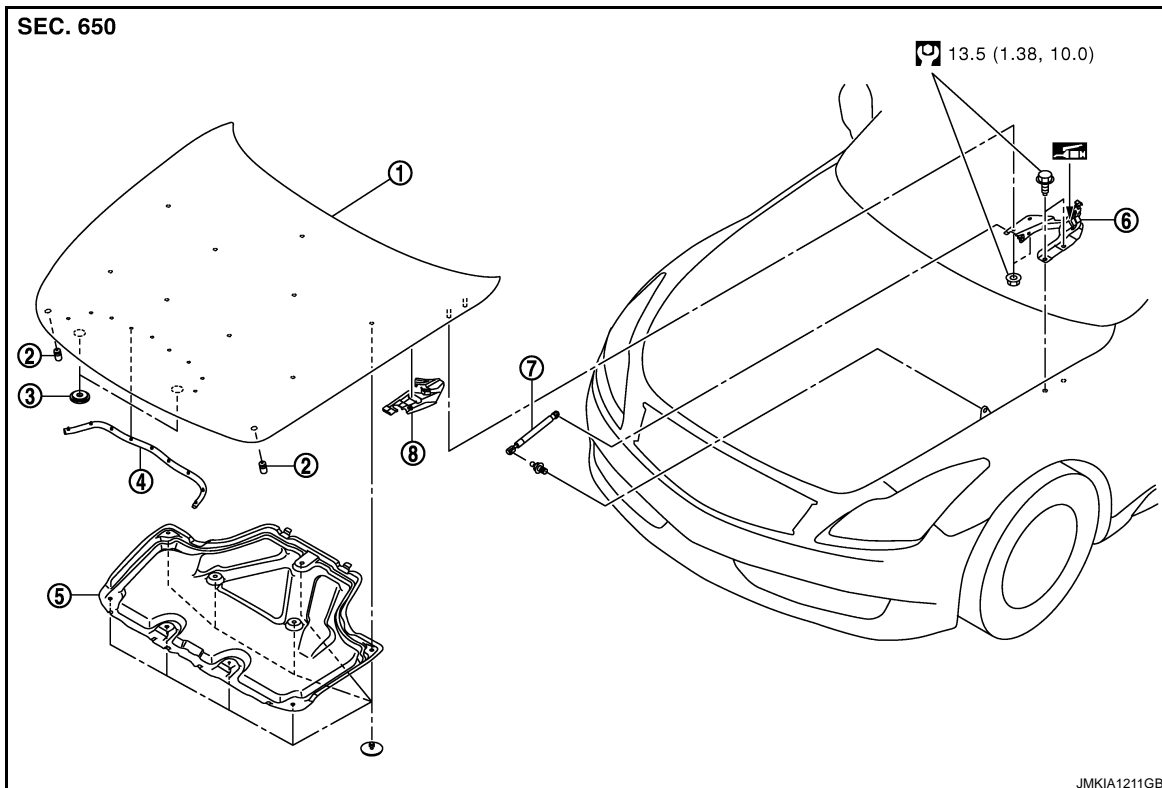

- | | | |
|-----------------------|-----------------------|---------------|
| 1. Hood assembly | 2. Hood bumper rubber | 3. Seal |
| 4. Radiator core seal | 5. Hood insulator | 6. Hood hinge |
| 7. Hood stay | 8. Hood hinge cover | |

Refer to [GI-4, "Components"](#) for symbols in the figure.

HOOD ASSEMBLY : Removal and Installation

INFOID:000000005624357

CAUTION:

Operate with two workers, because of its heavy weight.

REMOVAL

1. Support the hood lock assembly with a proper material to prevent it from falling.

WARNING:

Body injury may occur if no supporting rod is holding the hood open when removing the hood stay.

2. Remove the hood hinge cover (LH/RH).
3. Remove the washer nozzle and washer tube. Refer to [WW-99, "Removal and Installation"](#).
4. Remove the stud balls on the hood stays at the hood side.
5. Remove the hinge mounting nuts on the hood to remove the hood assembly.

INSTALLATION

Install in the reverse order of removal.

CAUTION:

HOOD

< REMOVAL AND INSTALLATION >

- Before installing hood hinge, apply anticorrosive agent onto the mounting surface of the vehicle body.
- After installing, perform hood fitting adjustment. Refer to [DLK-275, "HOOD ASSEMBLY : Adjustment"](#).
- After installing, perform front washer nozzle and tube inspection and adjustment. Refer to [WW-99, "Inspection and Adjustment"](#).

HOOD ASSEMBLY : Adjustment

INFOID:000000005624358

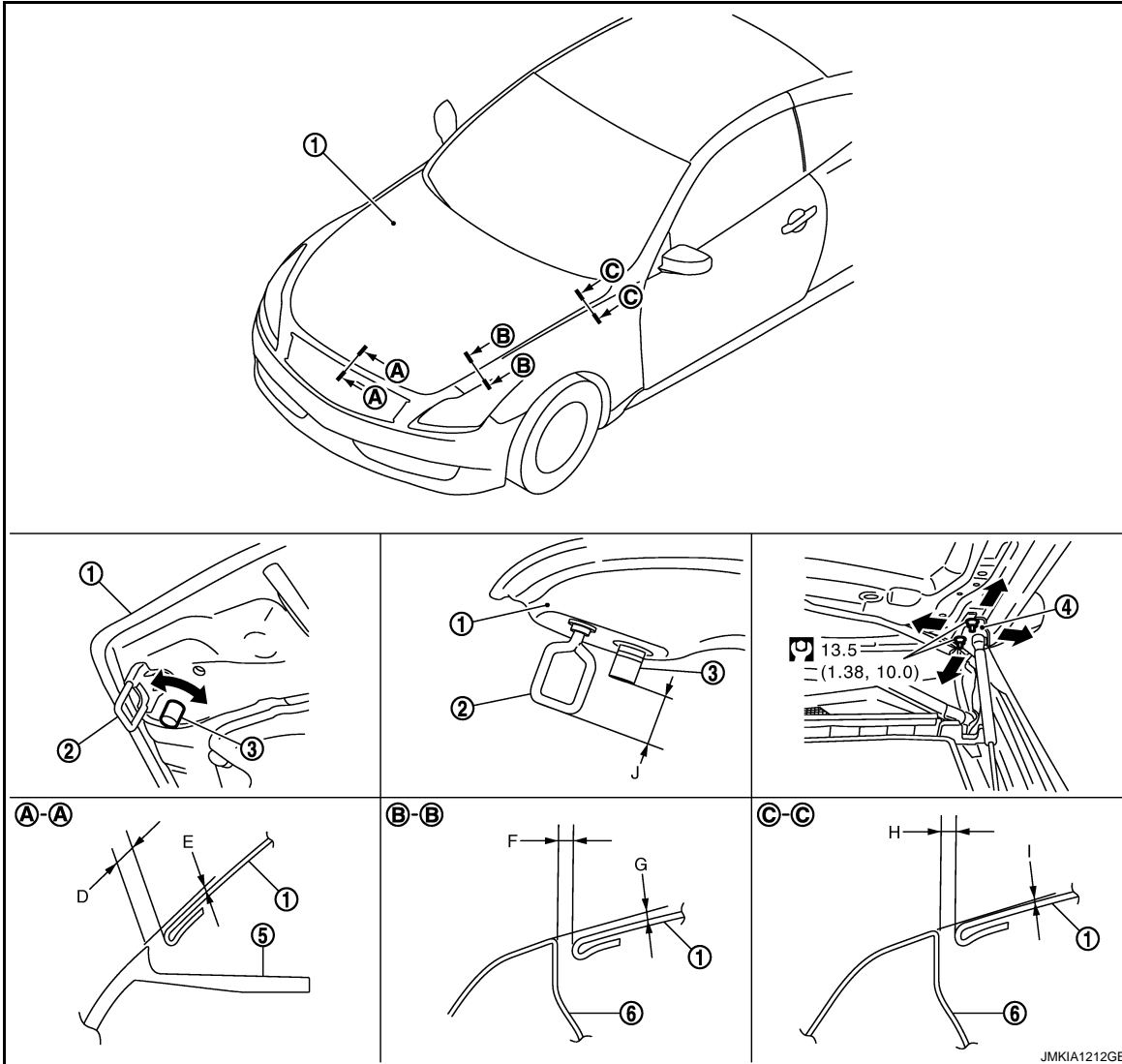

1. Hood assembly

2. Striker

3. Hood bumper rubber

4. Hood hinge

5. Front bumper

6. Front fender

Refer to [GI-4, "Components"](#) for symbols in the figure.

Portion			Standard	Right/left Clearance (MAX)
Hood – Front bumper	A – A	D	2.0 – 5.0 mm (0.079 – 0.197 in)	—
		E	-1.0 – 2.0 mm (-0.039 – 0.079 in)	—

HOOD

< REMOVAL AND INSTALLATION >

Portion			Standard	Right/left Clearance (MAX)
Hood – Front fender	B – B	F	Clearance 2.5 – 4.5 mm (0.098 – 0.177 in)	2.0 mm (0.079 in)
		G	Surface height –1.0 – 2.0 mm (–0.039 – 0.079 in)	—
	C – C	H	Clearance 2.5 – 4.5 mm (0.098 – 0.177 in)	2.0 mm (0.079 in)
		I	Surface height –1.0 – 1.0 mm (–0.039 – 0.039 in)	—
Striker – Hood bumper rubber	—	J	Height difference 32.5 – 33.5 mm (1.280 – 1.319 in)	—

1. Check the clearance and the surface height between the hood and each part visually and by touching. (Fitting standard dimension in the table below should be satisfied.)
2. In case out of specification, adjust them according to the procedures shown below.
3. Remove the striker and adjust the surface height of hood, front bumper and front fender according to the fitting standard dimension, by rotating hood bumper rubbers.
4. Adjust the height difference of striker, hood bumper rubber according to the fitting standard dimension.
5. Loosen the hood hinge mounting nuts on the hood.
6. Adjust the clearance of hood, front bumper and front fender according to the fitting standard dimension, for the hood.
7. Check that the hood lock primary latch is securely engaged with the striker by dropping hood from approximately 200 mm (7.874 in) height or pressing lightly on the hood.

CAUTION:

Never drop hood from a height of 300 mm (11.811 in) or more.

8. Install as static closing face of hood is 94 – 490 N·m (9.6 – 50.0 kg·m).

NOTE:

- Exercise vertical force on right side and left side of hood lock.
- Do not press simultaneously both sides.

9. After adjustment tighten hood hinge mounting nuts to the specified torque.

HOOD ASSEMBLY : Disposal

INFOID:000000005624359

DISPOSAL OF HOOD STAY

1. Fix hood stay (1) using a vise (C).
2. Using hacksaw (A) slowly make 2 holes in the hood stay, in numerical order as shown in the figure.

CAUTION:

- When cutting a hole on hood stay, always cover a hacksaw using a shop cloth (B) to avoid scattering metal fragments or oil.
- Wear eye protection (safety glasses).
- Wear gloves.

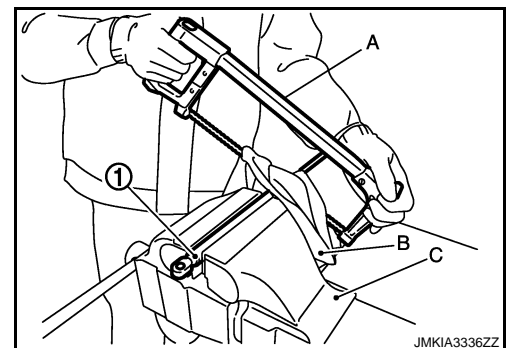

JMKIA3336ZZ

HOOD

< REMOVAL AND INSTALLATION >

- A: 20 mm (0.787 in)
- B: Cut at the groove.

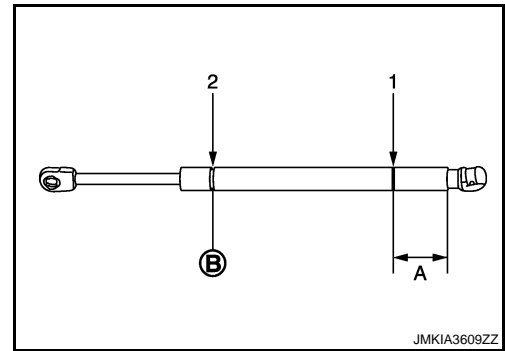

HOOD LOCK CONTROL

HOOD LOCK CONTROL : Exploded View

INFOID:0000000005624360

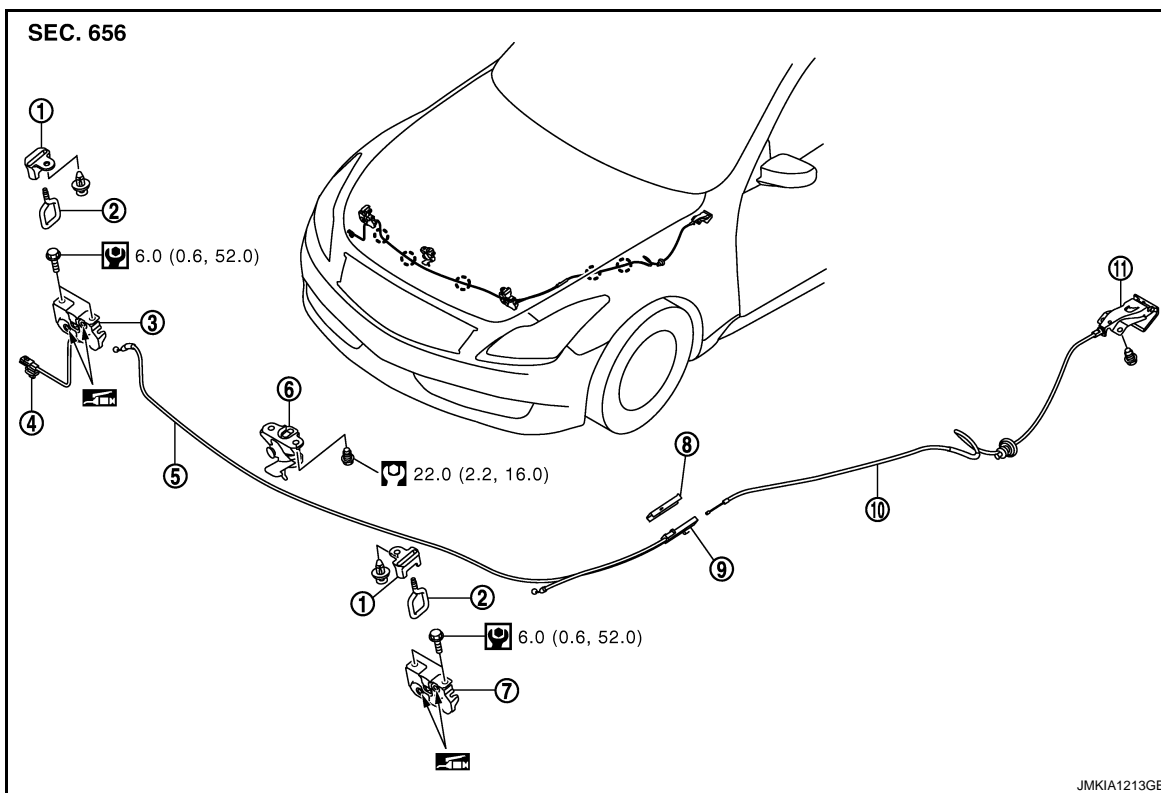

- | | | |
|---------------------------------------|--------------------------------------------|--------------------------------------|
| 1. Hood lock cover | 2. Striker | 3. Hood lock (RH) |
| 4. Hood lock switch harness connector | 5. Hood lock control cable (Front) | 6. Secondary latch |
| 7. Hood lock (LH) | 8. Hood lock control cable protector cover | 9. Hood lock control cable protector |
| 10. Hood lock control cable (Rear) | 11. Hood lock opener | |

 : Clip

Refer to [GI-4, "Components"](#) for symbols in the figure.

HOOD LOCK CONTROL : Removal and Installation

INFOID:0000000005624361

REMOVAL

1. Remove the washer tank. Refer to [WW-96, "Removal and Installation"](#).
2. Remove the radiator core support ornament.

HOOD

< REMOVAL AND INSTALLATION >

- Remove the radiator core support ornament mounting bolts and clips.

NOTE:

To remove the mounting bolts on both sides of radiator core support ornament, first remove the mounting bolts of front bumper (shown by arrows in the figure) and pull up the bumper edge slightly to get working clearance.

CAUTION:

Never apply excessive force while pulling front bumper to prevent front bumper and front fender from being damaged.

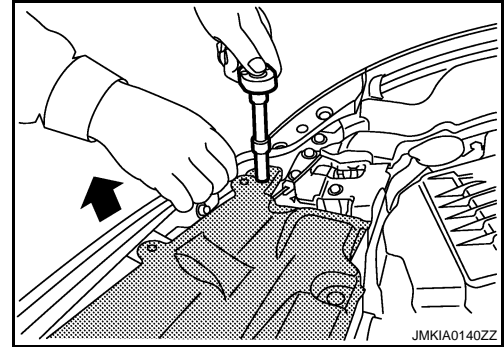

- Hold both sides of radiator core support ornament, pull it upwards and slide it rearwards of the vehicle.
- Disconnect the harness clips and hood lock control cable clips on radiator core support.

 : Clip

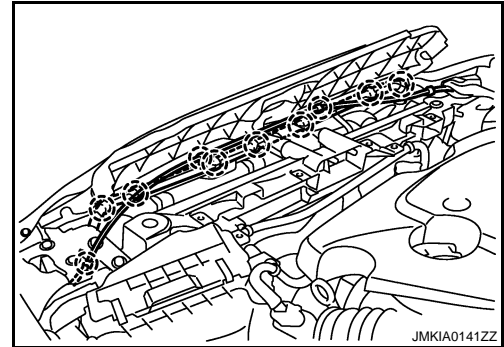

3. Remove the fender protector (LH). Refer to [DLK-283, "Removal and Installation"](#).
4. Disconnect hood lock switch (RH side) harness connector.
5. Remove the hood lock bracket mounting bolts, and remove the hood lock bracket assembly. Refer to [DLK-280, "Exploded View"](#).
6. Remove the hood lock mounting bolts, and disassemble the hood lock from the hood lock bracket.
7. Disconnect the hood lock control cable from the hood lock and clip it to the hood ledge.

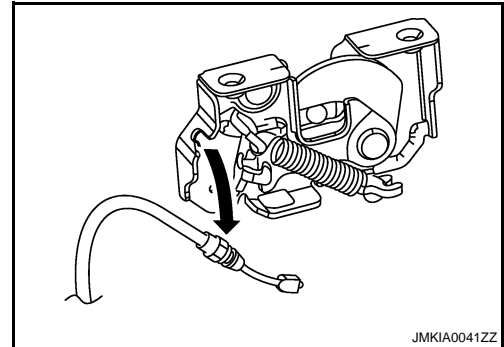

8. Remove the hood lock control cable protector (1) from the headlamp assembly (2).

 : Pawl

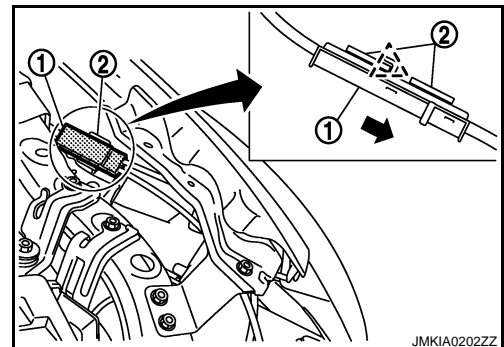

9. Remove the hood lock control cable cover from hood lock control cable protector.

HOOD

< REMOVAL AND INSTALLATION >

10. Disconnect the hood lock control cable from hood lock control cable protector.

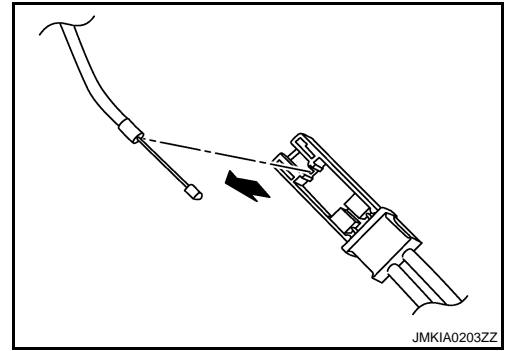

11. Remove the mounting screws and then remove the hood lock opener.
12. Remove the grommet on the dashboard, and pull the hood lock control cable toward the passenger compartment.

CAUTION:

While pulling, never damage (peel off) the outside of the hood lock control cable.

INSTALLATION

Install in the reverse order of removal.

CAUTION:

- Never bend the cable too much, keeping the radius 100 mm (3.937 in) or more.
- Check that the hood lock control cable is properly engaged with the hood lock.
- After installing, perform hood fitting adjustment. Refer to [DLK-275, "HOOD ASSEMBLY : Adjustment"](#).
- After installing, perform the hood lock control inspection. Refer to [DLK-279, "HOOD LOCK CONTROL : Inspection"](#).

HOOD LOCK CONTROL : Inspection

INFOID:000000005624362

NOTE:

If the hood lock cable is bent or deformed, replace it.

1. Check that the secondary latch is properly engaged with the hood lock stay by hood weight.
2. While operating the hood opener, carefully check that the front end of the hood is raised by approximately 20 mm (0.787 in). Also check that the hood opener returns to the original position.
3. Check that the hood opener operating is 49 N (5.0 kg) or below.
4. Install so that static closing face of hood is 94 – 490 N·m (9.6 – 50.0 kg·m).

NOTE:

- Exercise vertical force on right side and left side of hood lock.
 - Do not press simultaneously both sides.
5. Check the hood lock lubrication condition. If necessary, apply body grease to the hood lock.

A
B
C
D
E
F
G
H
I
J
DLK
L
M
N
O
P

RADIATOR CORE SUPPORT

< REMOVAL AND INSTALLATION >

RADIATOR CORE SUPPORT

Exploded View

INFOID:000000005624363

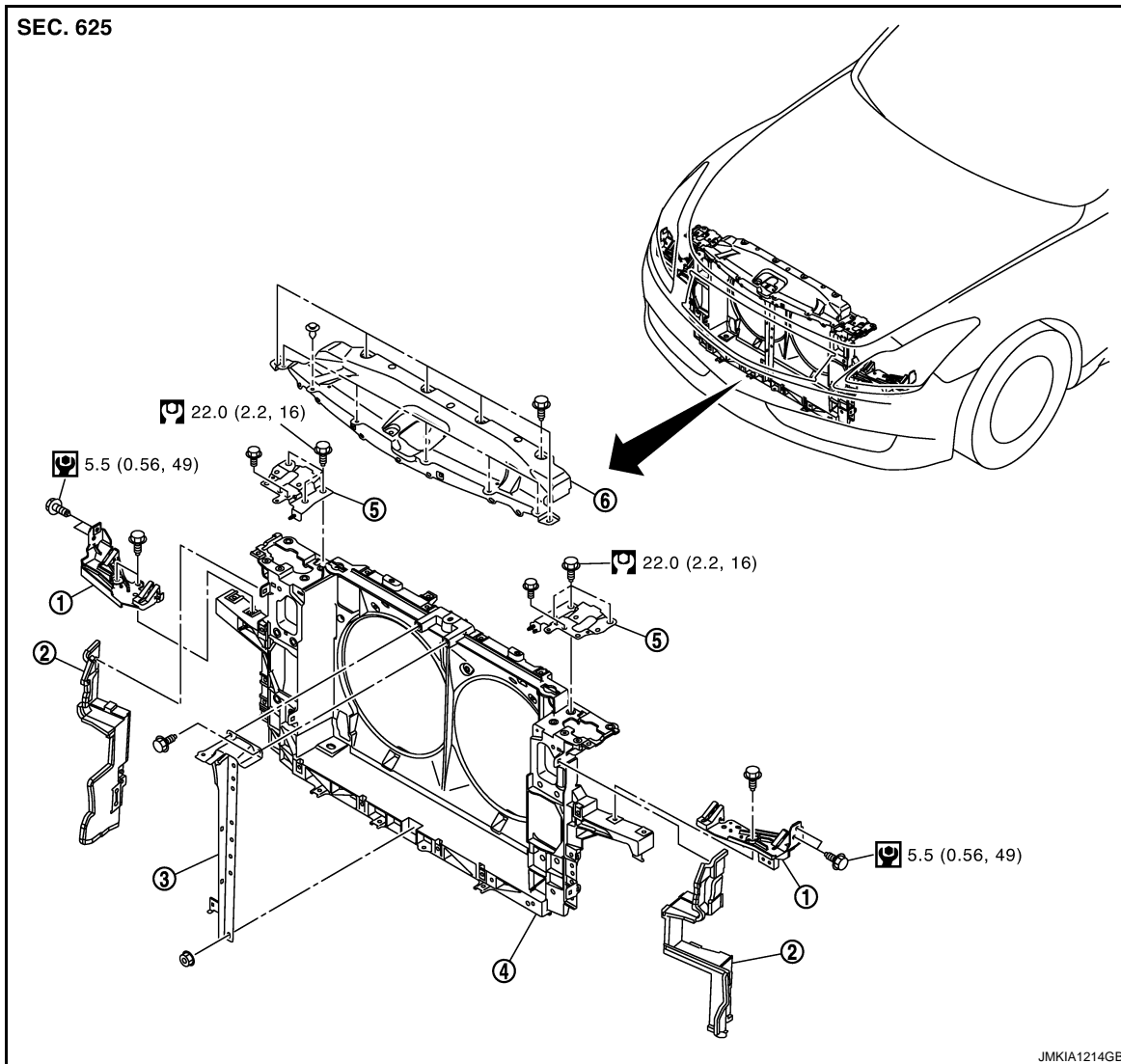

- | | | |
|-----------------------------------|----------------------|-----------------------------------|
| 1. Headlamp bracket | 2. Air guide | 3. Hood lock stay |
| 4. Radiator core support assembly | 5. Hood lock bracket | 6. Radiator core support ornament |

Refer to [GI-4, "Components"](#) for symbols in the figure.

Removal and Installation

INFOID:000000005624364

REMOVAL

1. Remove the front bumper fascia and front bumper reinforcement. Refer to [EXT-13, "Removal and Installation"](#).
2. Remove the radiator reservoir tank. Refer to [CO-12, "Exploded View"](#).
3. Remove horn (High/Low). Refer to [HRN-6, "Removal and Installation"](#).
4. Remove the radiator core support ornament.
 - Remove the radiator core support ornament mounting bolts and clips.

NOTE:

RADIATOR CORE SUPPORT

< REMOVAL AND INSTALLATION >

In the case that only radiator core support ornament is removed (front bumper is not removed), remove them according to the procedures shown below.

- To remove the mounting bolts on both sides of radiator core support ornament, first remove the mounting bolts of front bumper (shown by arrows in the figure) and pull up the bumper edge slightly to get working clearance.

CAUTION:

Never apply excessive force while pulling front bumper to prevent front bumper and front fender from being damaged.

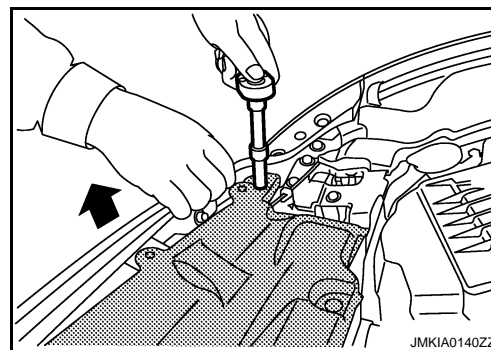

- Hold both sides of radiator core support ornament, pull it upwards and slide it rearwards of the vehicle.
- Disconnect the harness clips and hood lock control cable clips on radiator core support.

○ : Clip

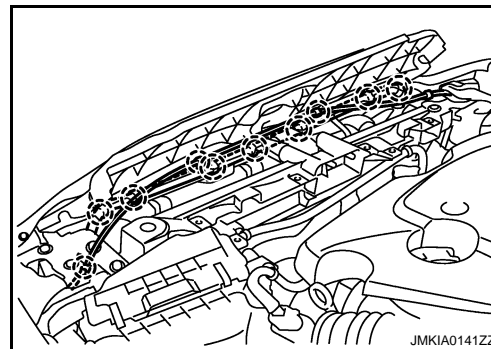

5. Remove the front combination lamp. Refer to [EXL-113. "Removal and Installation"](#).
6. Remove the hood lock bracket assembly.
7. Remove the washer inlet and washer tank. Refer to [WW-96. "Removal and Installation"](#).
8. Remove the ambient sensor. Refer to [HAC-130. "Removal and Installation"](#).
9. Remove the power steering fluid cooler. Refer to [ST-43. "Exploded View"](#).
10. Remove the air guide mounting clips and then remove air guide.
11. Disconnect the harness connector from refrigerant pressure sensor. Refer to [HAC-135. "Removal and Installation"](#).
12. Disconnect harness clamp from radiator core support.
13. Remove the hood lock stay.
14. Remove the engine lower cover. Refer to [EXT-29. "Removal and Installation"](#).
15. Drain engine coolant from radiator. Refer to [CO-7. "Draining"](#).
16. Remove the radiator upper hose and lower hose on radiator & condenser assembly sides.
17. Remove the A/T fluid cooler hose on radiator & condenser assembly sides. Refer to [CO-12. "Exploded View"](#).
18. Disconnect condenser pipe assembly at one touch joint. Refer to [HA-44. "CONDENSER PIPE ASSEMBLY : Removal and Installation"](#).
19. Remove the radiator core support assembly mounting bolts, and pull out radiator core support assembly toward the front of the vehicle.
20. Disconnect the cooling fan and crush zone sensor harness connector and clamp.
21. Remove the radiator core support assembly.
22. Remove the following parts after removing the radiator core support assembly.
 - Headlamp bracket.
 - Cooling fan. Refer to [CO-16. "Removal and Installation"](#).
 - Radiator & condenser assembly. Refer to [CO-13. "Removal and Installation"](#).
 - Crush zone sensor. Refer to [SR-25. "Removal and Installation"](#).

INSTALLATION

Install in the reverse order of removal.

CAUTION:

RADIATOR CORE SUPPORT

< REMOVAL AND INSTALLATION >

After installation, refill the following.

- Power steering fluid. Refer to [ST-9, "Inspection"](#).
- A/T fluid. Refer to [TM-262, "Changing"](#).
- Engine coolant. Refer to [CO-8, "Refilling"](#).

FRONT FENDER

< REMOVAL AND INSTALLATION >

FRONT FENDER

Exploded View

INFOID:000000005624365

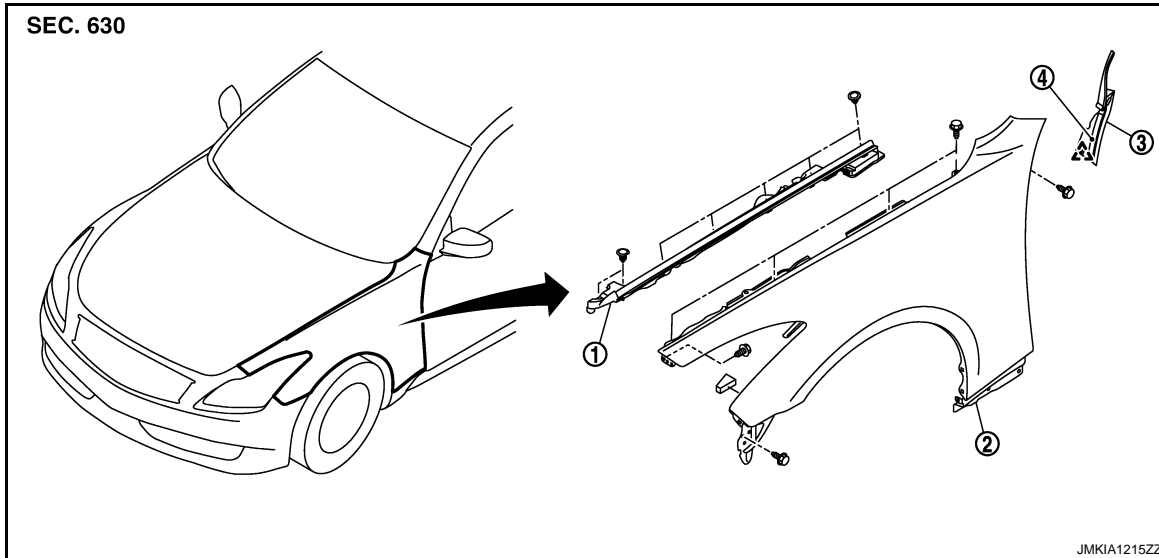

1. Hood seal assembly (side)
2. Front fender
3. Baffle assembly
4. Double-faced adhesive tape [t : 0.8 mm (0.031 in)]

Removal and Installation

INFOID:000000005624366

REMOVAL

1. Remove the front bumper fascia. Refer to [EXT-13, "Removal and Installation"](#).
2. Remove the hood seal assembly (side) and baffle assembly.
3. Remove the front combination lamp. Refer to [EXL-113, "Removal and Installation"](#).
4. Remove the fender protector. Refer to [EXT-24, "FENDER PROTECTOR : Removal and Installation"](#).
5. Remove the sill cover. Refer to [EXT-27, "Removal and Installation"](#).
6. Remove the mounting bolts and remove the front fender.

CAUTION:

While removing use a shop cloth to protect body from damaging.

INSTALLATION

Install in the reverse order of removal.

CAUTION:

- After installing, apply touch-up paint (the body color) onto the head of the front fender mounting bolts.
- After installing, check front fender adjustment. Refer to [DLK-275, "HOOD ASSEMBLY : Adjustment"](#) and [DLK-284, "DOOR ASSEMBLY : Adjustment"](#).

DOOR

< REMOVAL AND INSTALLATION >

DOOR

DOOR ASSEMBLY

DOOR ASSEMBLY : Exploded View

INFOID:000000005624367

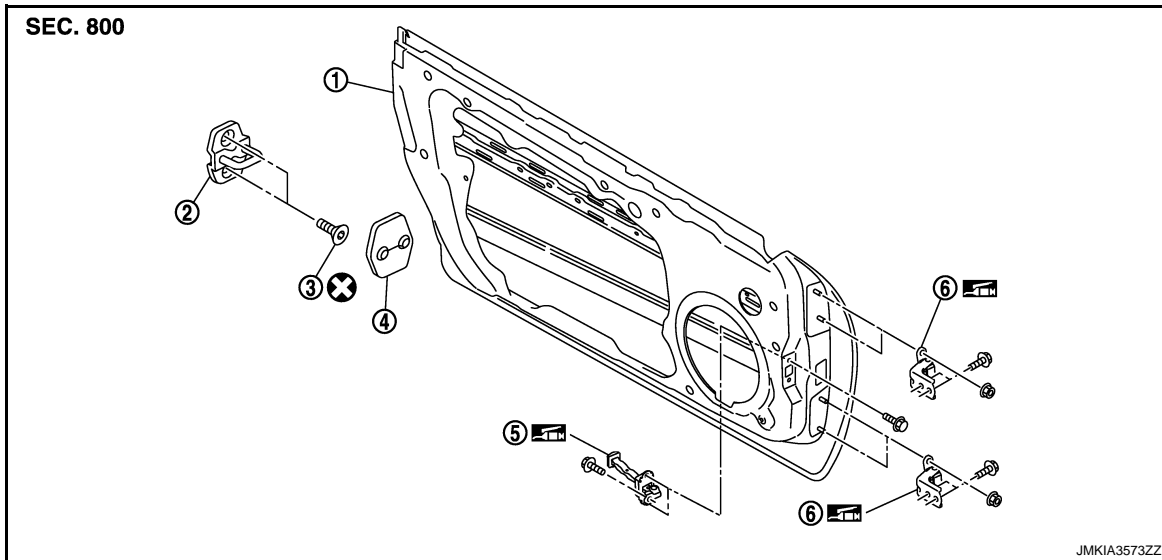

- | | | |
|-----------------------|-----------------|------------------------------|
| 1. Door panel | 2. Door striker | 3. TORX bolt |
| 4. Door striker cover | 5. Check link | 6. Door hinge (upper, lower) |

Refer to [GI-4. "Components"](#) for symbols in the figure.

DOOR ASSEMBLY : Removal and Installation

INFOID:000000005624368

REMOVAL

WARNING:

- Before servicing, turn ignition switch OFF, disconnect battery negative terminal and wait 3 minutes or more.
- Never use the air tools or electric tools for servicing.

CAUTION:

- When removing and installing the door assembly, support the door with a jack and cloth to protect the door and body.
- When removing and installing door assembly, perform the fitting adjustment. Refer to [DLK-284, "DOOR ASSEMBLY : Adjustment"](#).
- After installing, apply touch-up paint (the body color) onto the head of the hinge mounting nuts.
- Check the hinge rotating part for poor lubrication. If necessary, apply body grease.
- Operate with two workers, because of its heavy weight.
- Check door open/close operation after installation.

1. Remove the mounting bolts of the check link on the vehicle.
2. Pull the lever and disconnect the door harness connector while removing tabs of door harness connector.
3. Remove the door side hinge mounting nuts, then remove the door assembly.

INSTALLATION

Install in the reverse order of removal.

DOOR ASSEMBLY : Adjustment

INFOID:000000005624369

CLEARANCE, SURFACE HEIGHT AND SURFACE MISMATCH ADJUSTMENT

DOOR

< REMOVAL AND INSTALLATION >

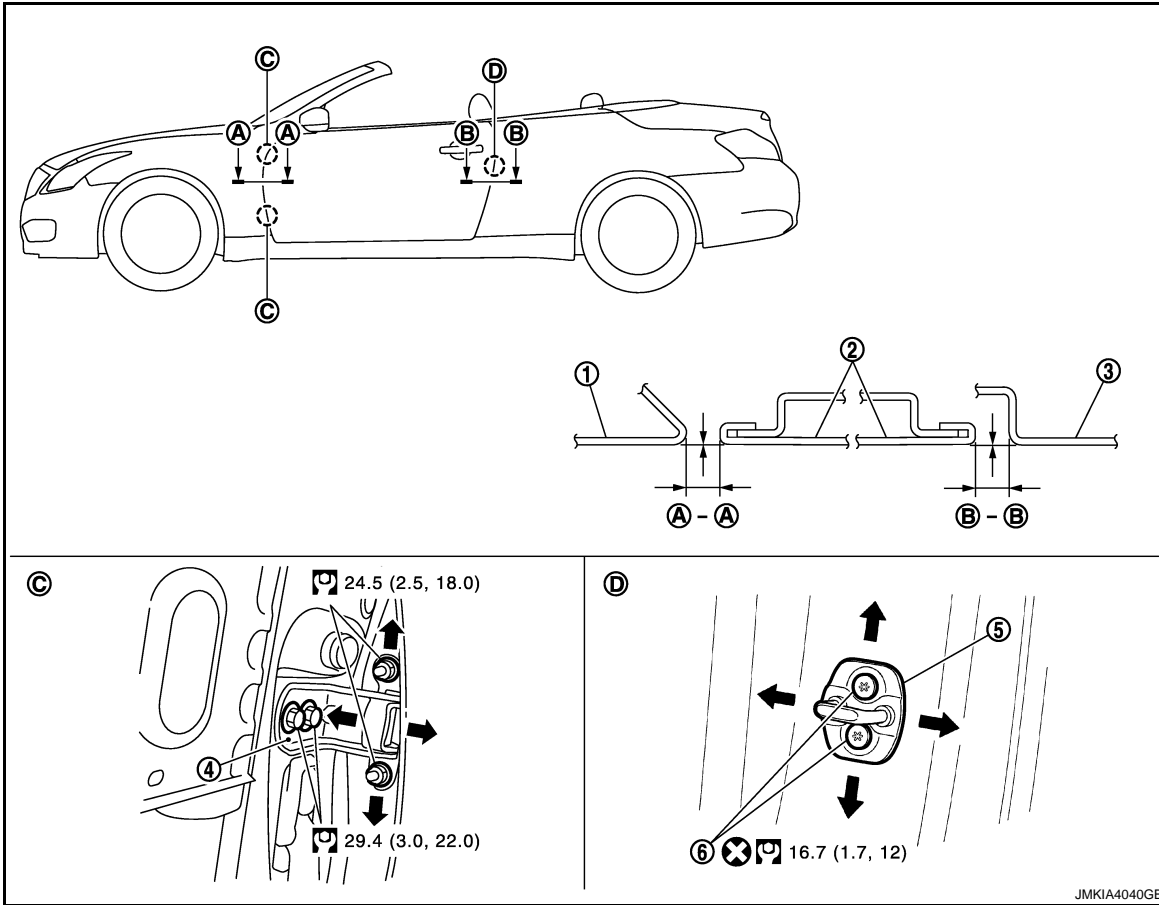

- 1. Front fender
- 2. Door panel
- 3. Rear fender
- 4. Door hinge
- 5. Door striker
- 6. TORX bolt

Refer to [GI-4, "Components"](#) for symbols in the figure.

1. Check the clearance and surface height and surface mismatch between the door and each part visually and by touching. (Fitting standard dimension in the table below should be satisfied.)

Portion		Clearance	Surface height
Front fender – Door	A – A	2.5 – 4.5 mm (0.098 – 0.177 in)	-1.0 – 1.0 mm (-0.039 – 0.039 in)
Door – Rear fender	B – B	2.5 – 4.5 mm (0.098 – 0.177 in)	-1.0 – 1.0 mm (-0.039 – 0.039 in)

2. In case out of specification, adjust them according to the procedures shown below.
3. Remove the front fender. Refer to [DLK-283, "Removal and Installation"](#).
4. Loosen the hinge mounting nuts on door side.
5. Adjust the surface height and surface mismatch of the door according to the fitting standard dimension.
6. Temporarily tighten the hinge mounting nuts on door side.
7. Loosen the hinge mounting bolts on body side.
8. Raise the door at rear end to adjust clearance of the front according to the fitting standard dimension.
9. After adjustment tighten bolts and nuts to the specified torque.
10. Install the front fender. Refer to [DLK-283, "Removal and Installation"](#).

STRIKER ADJUSTMENT

DOOR

< REMOVAL AND INSTALLATION >

Adjust the striker so that it becomes parallel with the lock insertion direction.

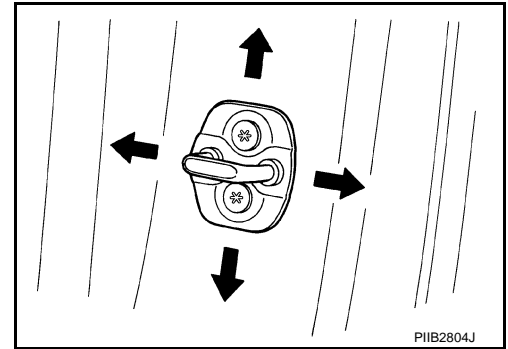

DOOR STRIKER

DOOR STRIKER : Exploded View

INFOID:000000005624370

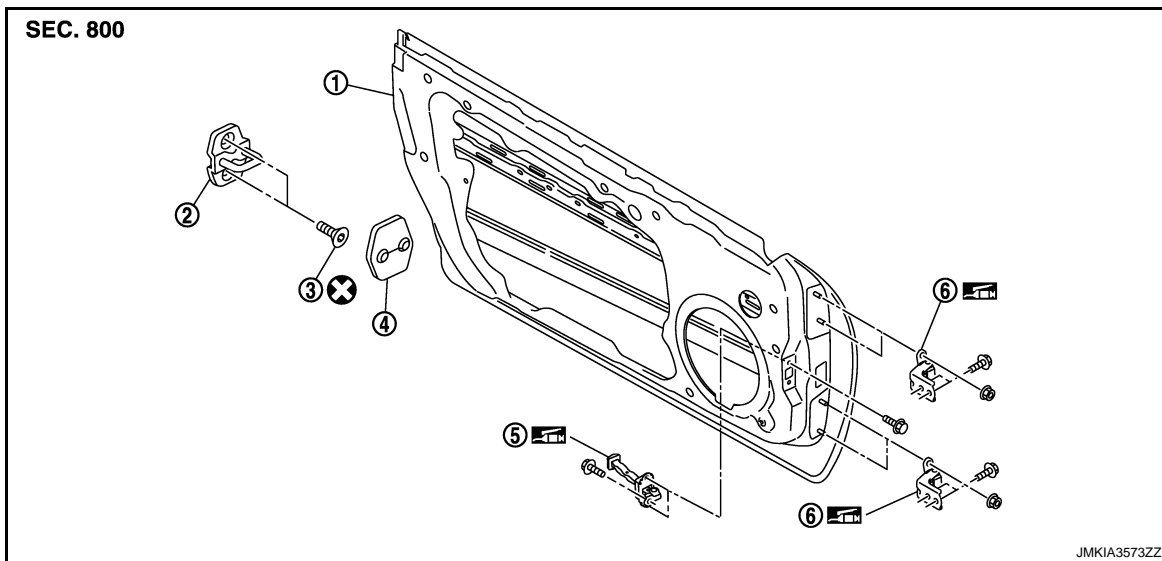

- | | | |
|-----------------------|-----------------|------------------------------|
| 1. Door panel | 2. Door striker | 3. TORX bolt |
| 4. Door striker cover | 5. Check link | 6. Door hinge (upper, lower) |

Refer to [GI-4, "Components"](#) for symbols in the figure.

DOOR STRIKER : Removal and Installation

INFOID:000000005624371

REMOVAL

1. Remove the door striker cover.
2. Remove the TORX bolts, and then remove the door striker.

INSTALLATION

Install in the reverse order of removal.

CAUTION:

- Check the door open/close operation after installation.
- When removing and installing the door striker, be sure to perform the fitting adjustment. Refer to [DLK-284, "DOOR ASSEMBLY : Adjustment"](#).

DOOR HINGE

DOOR

< REMOVAL AND INSTALLATION >

DOOR HINGE : Exploded View

INFOID:000000005624372

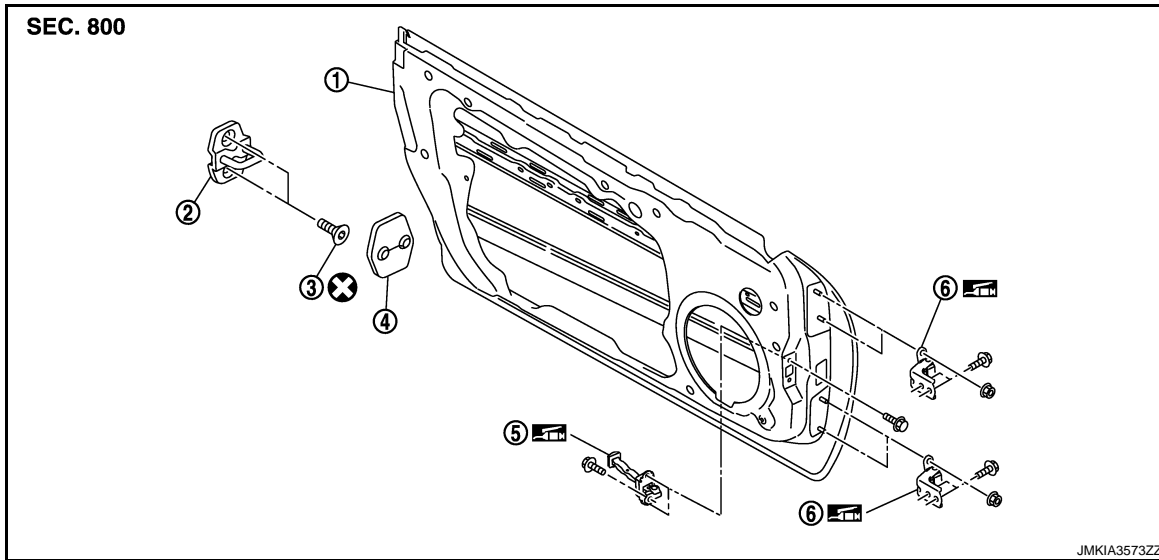

- | | | |
|-----------------------|-----------------|------------------------------|
| 1. Door panel | 2. Door striker | 3. TORX bolt |
| 4. Door striker cover | 5. Check link | 6. Door hinge (upper, lower) |

Refer to [GI-4, "Components"](#) for symbols in the figure.

DOOR HINGE : Removal and Installation

INFOID:000000005624373

REMOVAL

WARNING:

- Before servicing, turn ignition switch OFF, disconnect battery negative terminal and wait 3 minutes or more.
- Never use the air tools or electric tools for servicing.

1. Remove the door assembly. Refer to [DLK-284, "DOOR ASSEMBLY : Removal and Installation"](#).
2. Remove the door hinge mounting bolts, and then remove the door hinge.

INSTALLATION

Install in the reverse order of removal.

CAUTION:

- When removing and installing the door assembly, perform the fitting adjustment. Refer to [DLK-284, "DOOR ASSEMBLY : Adjustment"](#).
- After installation, apply touch-up paint (the body color) onto the head of the door hinge mounting nuts.
- Check the door hinge rotating part for poor lubrication. If necessary, apply body grease.
- Check the door open/close operation after installation.

DOOR CHECK LINK

DOOR

< REMOVAL AND INSTALLATION >

DOOR CHECK LINK : Exploded View

INFOID:000000005624374

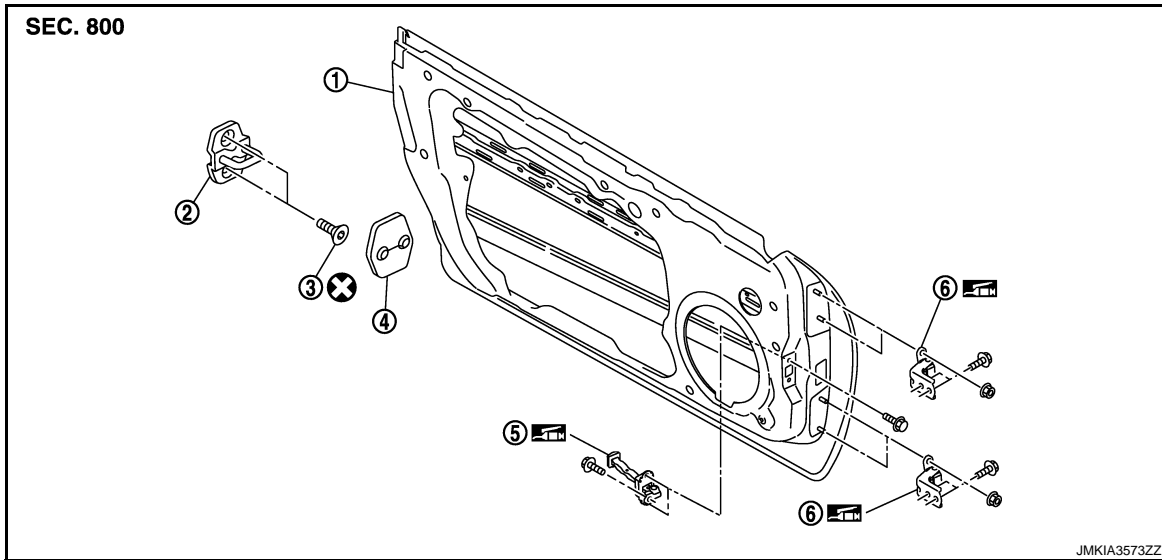

- | | | |
|-----------------------|-----------------|------------------------------|
| 1. Door panel | 2. Door striker | 3. TORX bolt |
| 4. Door striker cover | 5. Check link | 6. Door hinge (upper, lower) |

Refer to [GI-4. "Components"](#) for symbols in the figure.

DOOR CHECK LINK : Removal and Installation

INFOID:000000005624375

REMOVAL

WARNING:

- Before servicing, turn ignition switch OFF, disconnect battery negative terminal and wait 3 minutes or more.
- Never use the air tools or electric tools for servicing.

1. Remove the door finisher. Refer to [INT-12. "Removal and Installation"](#).
2. Remove the door speaker.
3. Remove the mounting bolt of the door check link on the vehicle.
4. Remove the door check link mounting bolts on the door side.
5. Remove the door check link.

INSTALLATION

Install in the reverse order of removal.

CAUTION:

Check the door open/close operation after installation.

TRUNK LID

< REMOVAL AND INSTALLATION >

TRUNK LID

TRUNK LID ASSEMBLY

TRUNK LID ASSEMBLY : Exploded View

INFOID:000000005624376

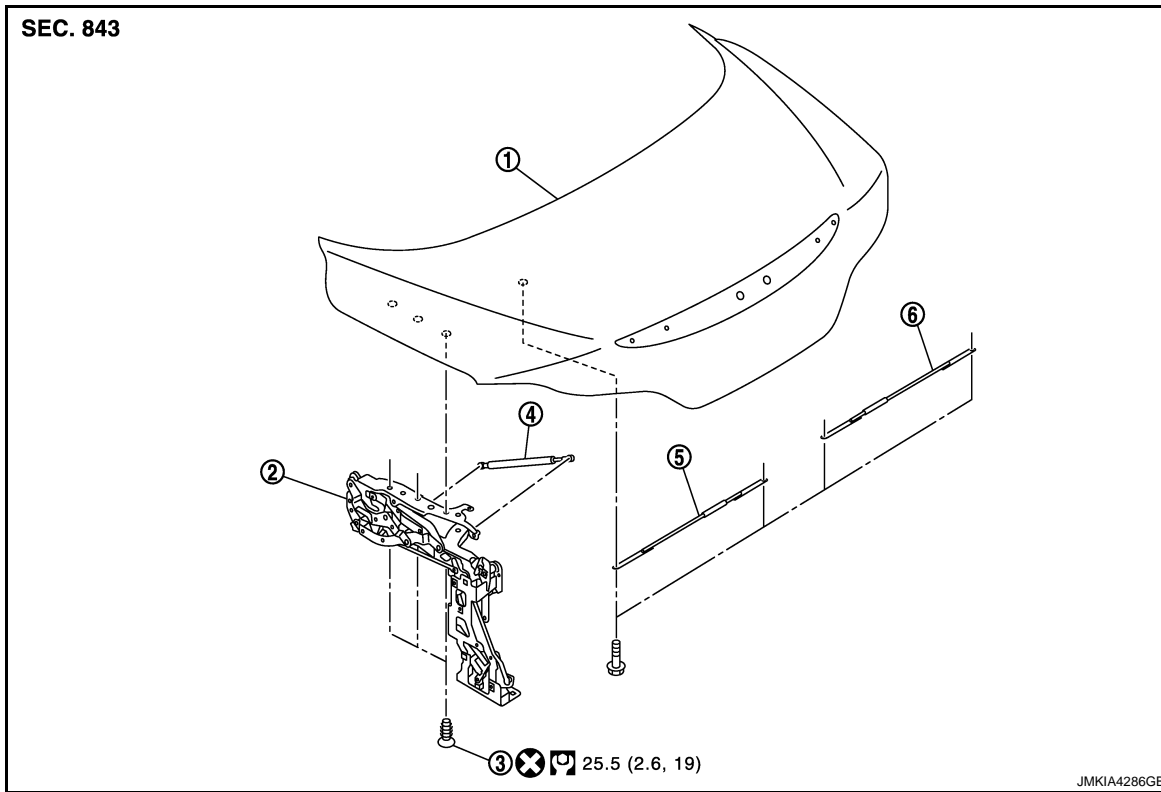

1. Trunk lid assembly

2. Trunk lid hinge assembly

3. TORX bolt

4. Trunk lid stay

5. Adjustment rod (LH)

6. Adjustment rod (RH)

Refer to [GI-4, "Components"](#) for the symbols in the figure.

TRUNK LID ASSEMBLY : Removal and Installation

INFOID:000000005624377

REMOVAL

1. Open trunk lid from coupe state by roof open operation and stop the operation when trunk lid is open to rear of the vehicle.

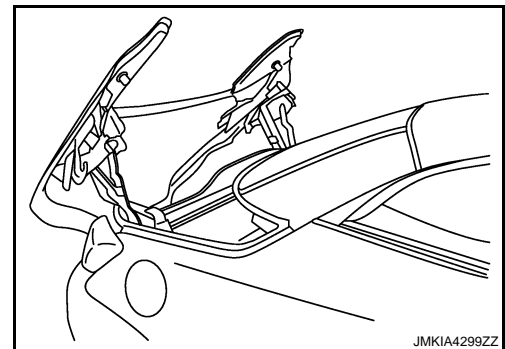

A
B
C
D
E
F
G
H
I
J
DLK
L
M
N
O
P

TRUNK LID

< REMOVAL AND INSTALLATION >

2. Unlock trunk lid hinge lock (1) and lift trunk lid in upward direction.

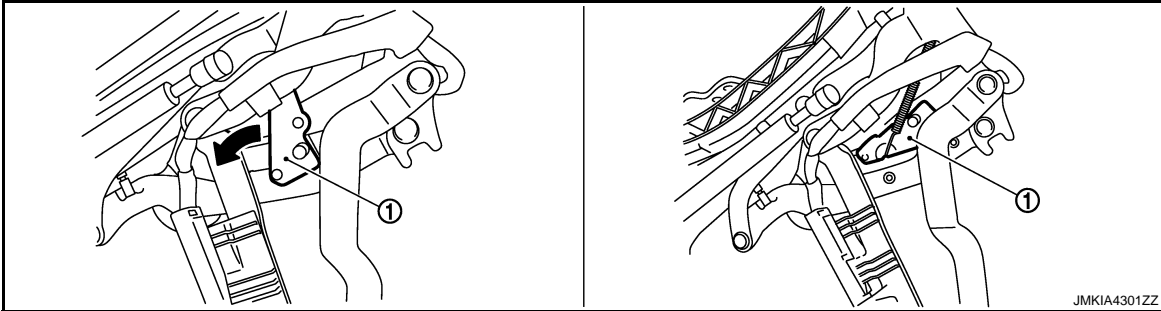

3. Place a supporting block against the trunk lid lock.

WARNING:

Body injury may occur if no supporting rod is holding the trunk lid open when removing the stay.

CAUTION:

While removing use a shop cloth or tape to protect from damaging.

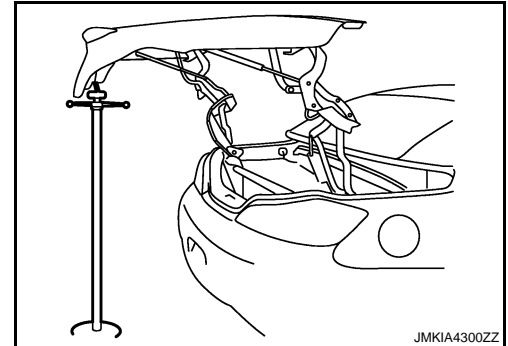

4. Remove trunk lid finisher. Refer to [JNT-26, "Removal and Installation"](#).
5. Disconnect harness connector and harness clamp.
6. Remove mounting bolts, and then remove trunk lid assembly.
7. Remove shim. (trunk lid side)

INSTALLATION

Install in the reverse order of removal.

CAUTION:

- After installing, check operation.
- After installing, perform fitting adjustment. Refer to [DLK-291, "TRUNK LID ASSEMBLY : Adjustment"](#).

TRUNK LID

< REMOVAL AND INSTALLATION >

TRUNK LID ASSEMBLY : Adjustment

INFOID:000000005624378

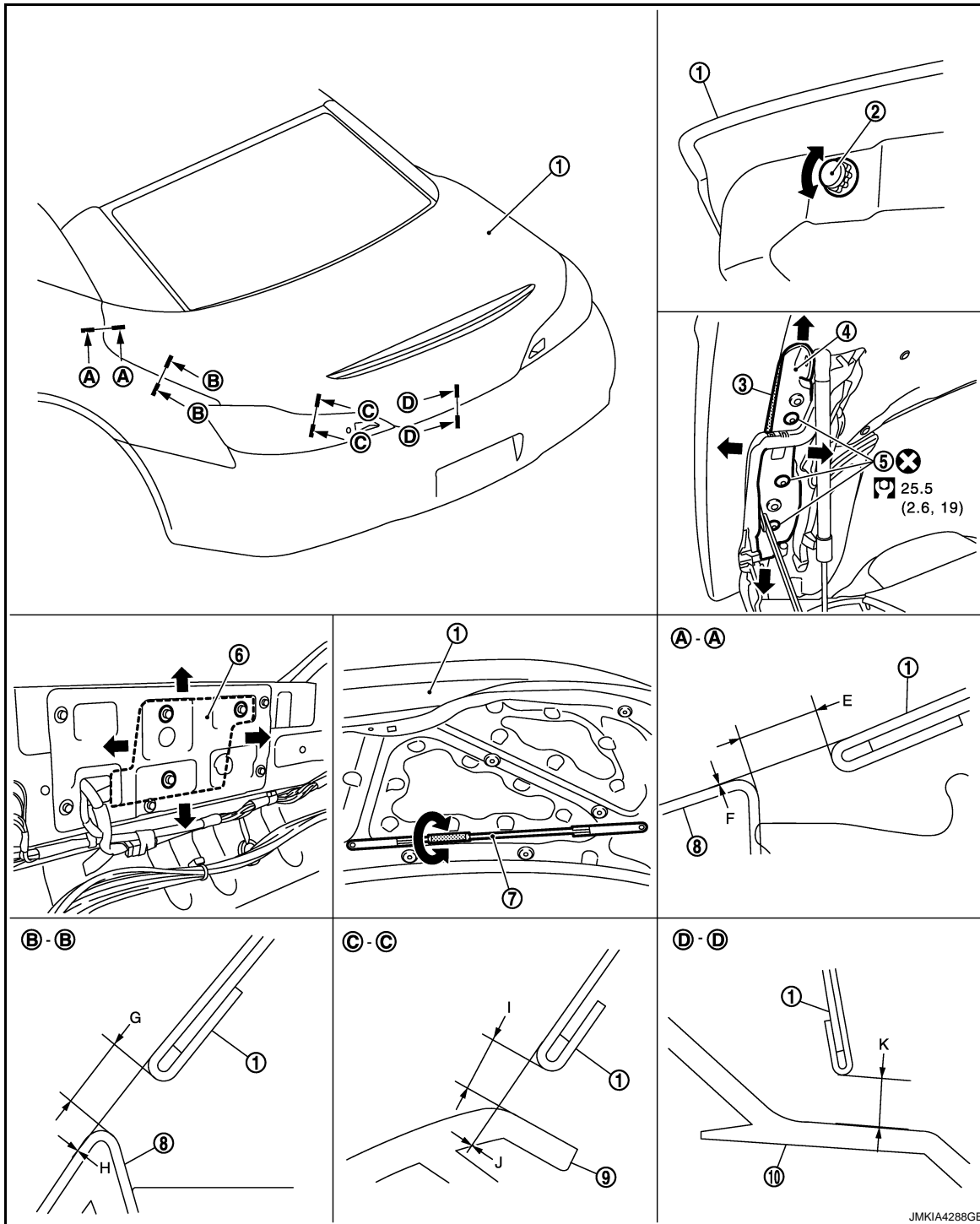

- | | | |
|-----------------------------|------------------|---------------------------|
| 1. Trunk lid assembly | 2. Bumper rubber | 3. Shim |
| 4. Trunk lid hinge assembly | 5. TORX bolt | 6. Trunk closure assembly |
| 7. Adjustment rod | 8. Rear fender | 9. Rear combination lamp |
| 10. Rear bumper | | |

Refer to [GI-4. "Components"](#) for symbols in the figure.

Check the clearance and the evenness between the trunk lid and each part visually and by touching. (Fitting standard dimension in the table below should be satisfied.)

A
B
C
D
E
F
G
H
I
J
K
L
M
N
O
P

DLK

JMKIA4288GB

TRUNK LID

< REMOVAL AND INSTALLATION >

Portion			Standard	Right/left Clearance (MAX)
Trunk lid – Rear fender	A – A	E	Clearance 3.0 – 7.0 mm (0.118 – 0.276 in)	1.6 mm (0.063 in)
		F	Surface height –2.0 – 2.0 mm (–0.079 – 0.079 in)	—
Trunk lid – Rear fender	B – B	G	Clearance 3.0 – 7.0 mm (0.118 – 0.276 in)	1.6 mm (0.063 in)
		H	Surface height –2.0 – 2.0 mm (–0.079 – 0.079 in)	—
Trunk lid – Rear combination lamp	C – C	I	Clearance 2.2 – 6.2 mm (0.087 – 0.244 in)	—
		J	Surface height – 2.0 – 2.0 mm (– 0.079 – 0.079 in)	—
Trunk lid – Rear bumper	D – D	K	Clearance 4.0 – 8.0 mm (0.157 – 0.315 in)	—

ADJUSTMENT OPERATION CONDITIONS

- All necessary parts are installed to trunk lid assembly.
- Trunk lid weather-strip is installed.
- Retractable hard roof assembly is set.

ADJUST REAR END HEIGHT OF TRUNK LID ASSEMBLY

1. Remove trunk rear plate. Refer to [INT-24. "Removal and Installation"](#).
2. Loosen trunk closure assembly mounting bolts.
3. Adjust striker to come to center of trunk lid lock and tighten bolts.
4. Adjust bumper rubber.

ADJUST TRUNK LID ASSEMBLY LONGITUDINALLY AND Laterally

1. Loosen trunk lid assembly mounting bolts. Adjust by centering so that difference of parting between left and right is eliminated. Tighten bolts.

NOTE:

If the adjustment is difficult, remove trunk lid once and perform adjustment using trunk hinge pin. Refer to [DLK-297. "TRUNK LID HINGE : Adjustment"](#).

CAUTION:

- Perform adjustment only when trunk hinge pin is replaced or removed and installed.
 - Trunk lid cannot be installed if longitudinal pin pitch is changed.
2. Adjust side wedge.
 - Open trunk lid from coupe state by roof open operation and stop the operation when trunk lid is open to rear of the vehicle.

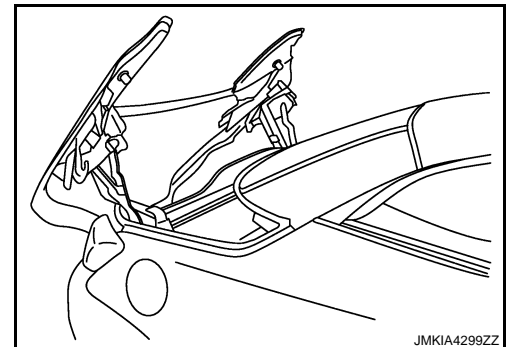

TRUNK LID

< REMOVAL AND INSTALLATION >

- Loosen mounting bolt of side wedge (1) and hold at the position of clip hole upper end.

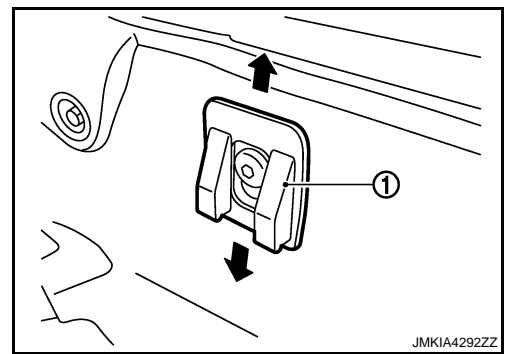

- Close trunk gently.
- Open trunk lid from coupe state by roof open operation and stop the operation when trunk lid is open to rear of the vehicle.

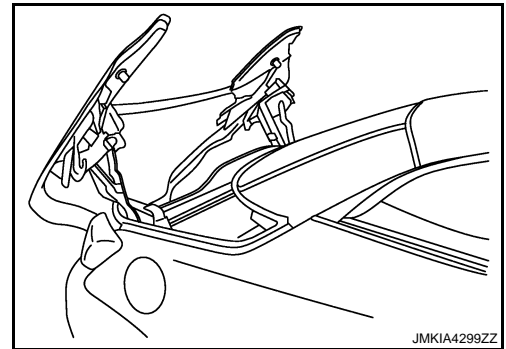

- Tighten mounting bolt while side wedge is in hold state.

3. Adjust adjustment rod.

- Loosen adjustment rod mounting bolts. Refer to [DLK-289, "TRUNK LID ASSEMBLY : Exploded View"](#).
- Loosen lock nut. Rotate turn buckle so that installation looseness is absorbed.
- Tighten lock nut while turnbuckle is in fixed state.
- Tighten adjustment rod mounting bolts.

ADJUST HEIGHT OF TRUNK LID ASSEMBLY

Loosen trunk lid assembly mounting bolts. Adjust height by increasing or decreasing shim thickness. Tighten mounting bolts.

CAUTION:

- Check the trunk lid open/close operation after installation.
- After installation, apply touch-up paint (the body color) onto the head of the trunk lid mounting bolts.

TRUNK LID STRIKER

A
B
C
D
E
F
G
H
I
J
DLK
L
M
N
O
P

TRUNK LID

< REMOVAL AND INSTALLATION >

TRUNK LID STRIKER : Exploded View

INFOID:000000005624379

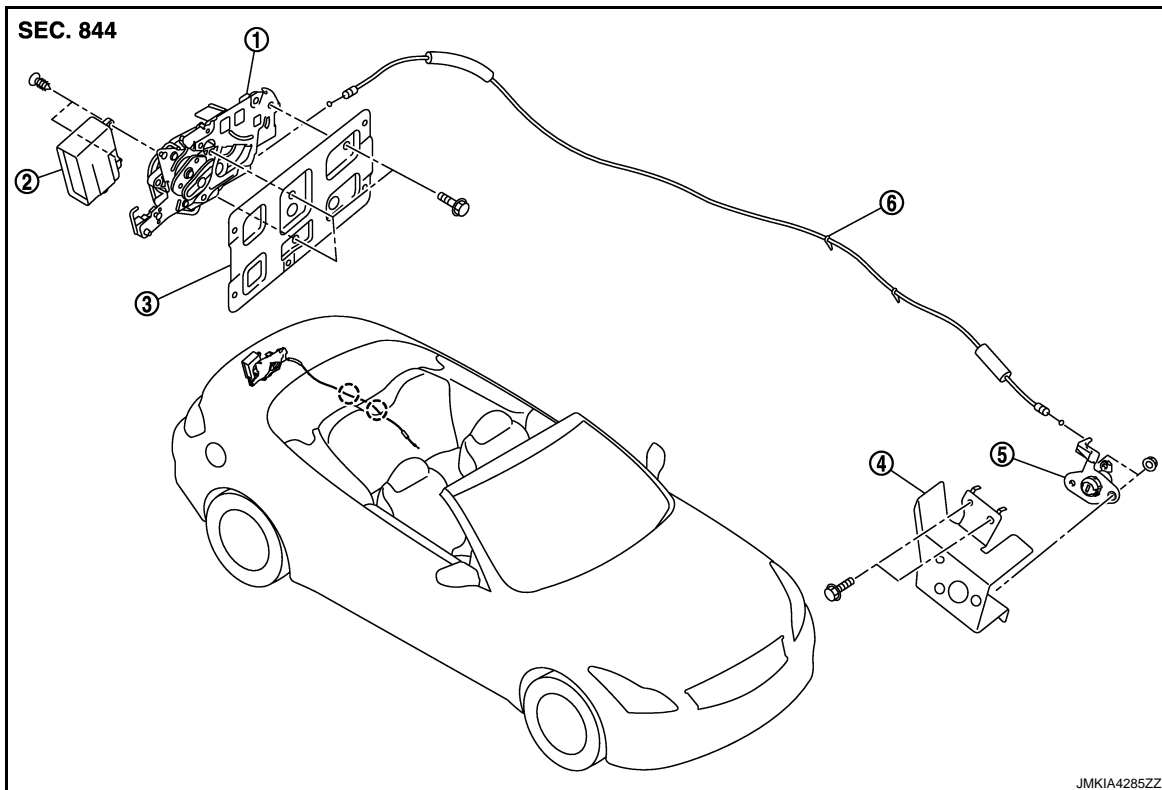

- | | | |
|-----------------------------------|-------------------------------|--------------------------|
| 1. Trunk closure assembly | 2. Trunk closure control unit | 3. Trunk closure bracket |
| 4. Emergency key cylinder bracket | 5. Emergency key cylinder | 6. Emergency cable |

() : Clip

Refer to [GI-4, "Components"](#) for the symbols in the figure.

TRUNK LID STRIKER : Removal and Installation

INFOID:000000005624380

TRUNK LID STRIKER

REMOVAL

1. Fully open trunk lid.
2. Remove trunk rear plate. Refer to [INT-24, "Removal and Installation"](#).
3. Remove BOSE amp (BOSE audio with navigation). Refer to [AV-418, "Removal and Installation"](#).
4. Remove mounting bolts of trunk closure bracket.
5. Remove emergency cable from trunk closure assembly.
6. Disconnect harness connector from trunk closure assembly.
7. Disconnect harness connector from trunk closure control unit.
8. Remove mounting bolts. Remove trunk closure assembly.
9. Remove mounting screws. Remove trunk closure control unit.

CAUTION:

- Be careful that harness is not pinched when installing.
- Check the trunk lid open/close operation after installation.
- After installing, perform fitting adjustment. Refer to [DLK-291, "TRUNK LID ASSEMBLY : Adjustment"](#).

EMERGENCY CABLE

REMOVAL

TRUNK LID

< REMOVAL AND INSTALLATION >

1. Remove pop-up roll bar. Refer to [SR-21, "Removal and Installation"](#).
2. Remove mounting bolts of emergency key cylinder bracket.
3. Remove emergency key cylinder bracket.
4. Remove mounting nuts. Remove emergency key cylinder.
5. Remove emergency cable from emergency key cylinder.
6. Remove trunk closure assembly.
7. Remove trunk floor trim (LH). Refer to [INT-24, "Removal and Installation"](#).
8. Disconnect each mounting clip of emergency cable.
9. Remove emergency cable.

INSTALLATION

Install in the reverse order of removal.

CAUTION:

- Check the trunk lid open/close operation after installation.
- After installing, perform fitting adjustment. Refer to [DLK-291, "TRUNK LID ASSEMBLY : Adjustment"](#).

TRUNK LID HINGE

TRUNK LID HINGE : Exploded View

INFOID:000000005624381

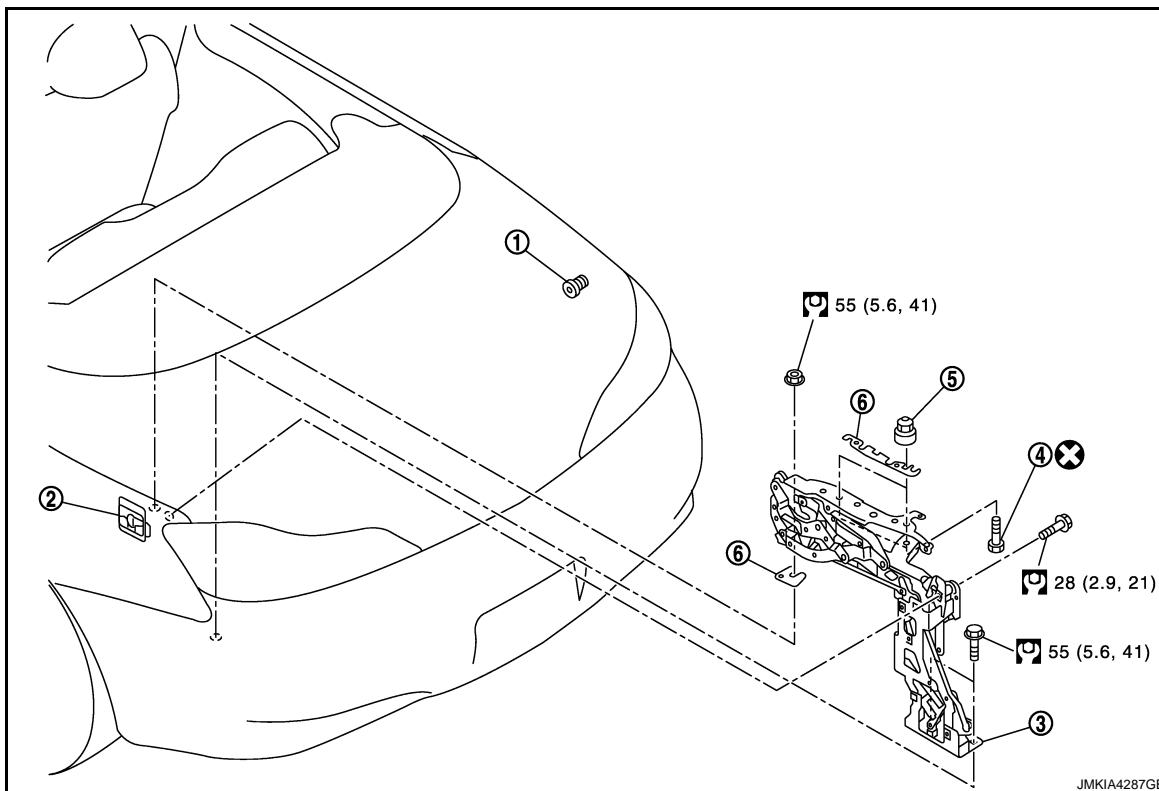

- | | | |
|-------------------|--------------------|-----------------------------|
| 1. Adjustment nut | 2. Side wedge | 3. Trunk lid hinge assembly |
| 4. TORX bolt | 5. Trunk hinge pin | 6. Shim |

Refer to [GI-4, "Components"](#) for the symbols in the figure.

TRUNK LID HINGE : Removal and Installation

INFOID:000000005624382

REMOVAL

1. Remove trunk lid assembly. Refer to [DLK-289, "TRUNK LID ASSEMBLY : Removal and Installation"](#).
2. Remove shim (trunk lid side).
3. Disconnect harness connectors and clips from trunk lid hinge.

A
B
C
D
E
F
G
H
I
J
L
M
N
O
P

DLK

TRUNK LID

< REMOVAL AND INSTALLATION >

4. Remove trunk lid stay. Refer to [DLK-299, "TRUNK LID STAY : Removal and Installation"](#).
5. Remove following part. Refer to [INT-24, "Removal and Installation"](#).
 - Trunk floor spacer center
 - Trunk floor carpet
 - Trunk rear plate
 - Trunk room trim cap (LH/RH)
 - Jack lid assembly
 - Trunk floor trim (LH/RH)
 - Rear wheel finisher
 - Trunk center box (with spare tire)
 - Spare tire (with spare tire)
6. Remove hydraulic unit assembly mounting bolts. Refer to [RF-299, "Removal and Installation"](#).
7. Remove trunk lid drive cylinder (LH/RH). Refer to [RF-299, "Removal and Installation"](#).
8. Remove mounting bolts and nut. Remove trunk lid hinge.
9. Remove shim (body side).

INSTALLATION

Install in the reverse order of removal.

CAUTION:

- **Check the trunk lid open/close operation after installation.**
- **When removing and installing the trunk lid hinge assembly, perform the fitting adjustment. Refer to [DLK-297, "TRUNK LID HINGE : Adjustment"](#).**
- **After installation, apply touch-up paint (the body color) onto the head of the hinge mounting nuts.**

TRUNK LID

< REMOVAL AND INSTALLATION >

TRUNK LID HINGE : Adjustment

INFOID:000000005624383

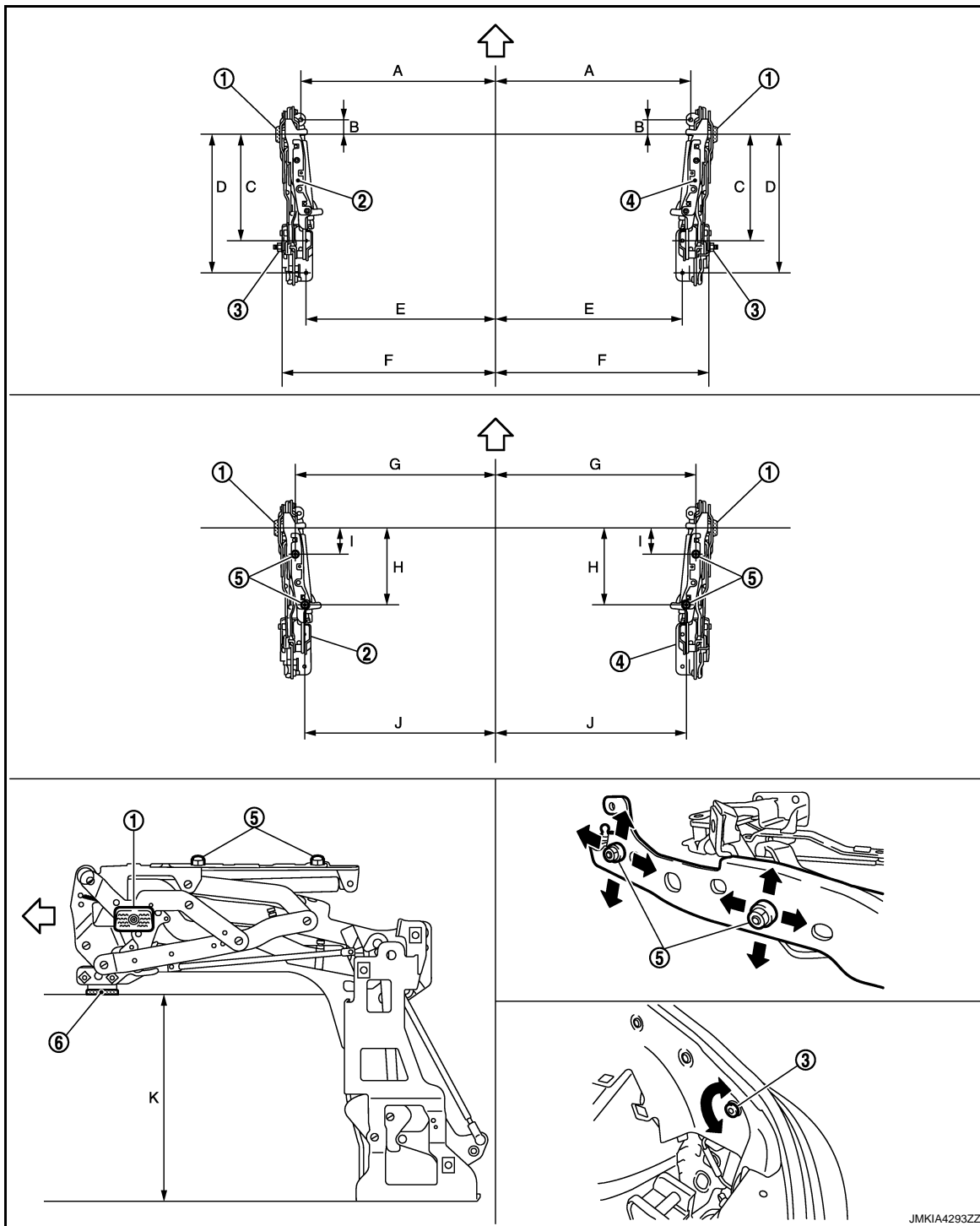

- | | | |
|----------------------------------|----------------------------------|-------------------|
| 1. Side wedge (hinge side) | 2. Trunk lid hinge assembly (LH) | 3. Adjustment nut |
| 4. Trunk lid hinge assembly (RH) | 5. Trunk hinge pin | 6. Shim |

↔ : Vehicle front

Perform trunk lid hinge adjustment when trunk lid hinge is replaced or removed and installed. Adjust the values to the standards indicated in the following table.

A
B
C
D
E
F
G
H
I
J
K
L
M
N
O
P

DLK

JMKIA4293ZZ

TRUNK LID

< REMOVAL AND INSTALLATION >

Portion	Standard
A	669.0 mm (26.339 in)
B	53.0 mm (2.087 in)
C	377.0 mm (14.842 in)
D	492.0 mm (19.370 in)
E	645.0 mm (25.394 in)
F	733.0 – 734.0 mm (28.858 – 28.898 in)
G	685.0 mm (26.968 in)
H	273.0 mm (10.748 in)
I	92.0 mm (3.622 in)
J	649.0 mm (25.551 in)
K	320.8 mm (12.630 in)

1. Remove trunk lid assembly. Refer to [DLK-289, "TRUNK LID ASSEMBLY : Removal and Installation"](#).
2. Remove trunk lid hinge assembly. Refer to [DLK-295, "TRUNK LID HINGE : Removal and Installation"](#).
3. Set shim (body side).
4. Set trunk lid hinge to the vehicle. Temporarily tighten mounting bolt and nut.
5. Adjust dimension by adjusting shim and adjustment nut.
6. Tighten mounting bolt and nut of trunk lid hinge to the specified torque.
7. Adjust trunk hinge pin.
CAUTION:
 - Perform adjustment only when trunk hinge pin is replaced or removed and installed.
 - Trunk lid cannot be installed if longitudinal pin pitch is changed.
8. Install trunk lid. Refer to [DLK-289, "TRUNK LID ASSEMBLY : Removal and Installation"](#).
9. Perform trunk lid fitting adjustment. Refer to [DLK-291, "TRUNK LID ASSEMBLY : Adjustment"](#).
10. Adjust bumper rubber.
11. Adjust side wedge. Refer to [DLK-291, "TRUNK LID ASSEMBLY : Adjustment"](#).

CAUTION:

- Check the trunk lid open/close operation after installation.

TRUNK LID STAY

TRUNK LID

< REMOVAL AND INSTALLATION >

TRUNK LID STAY : Exploded View

INFOID:000000005624384

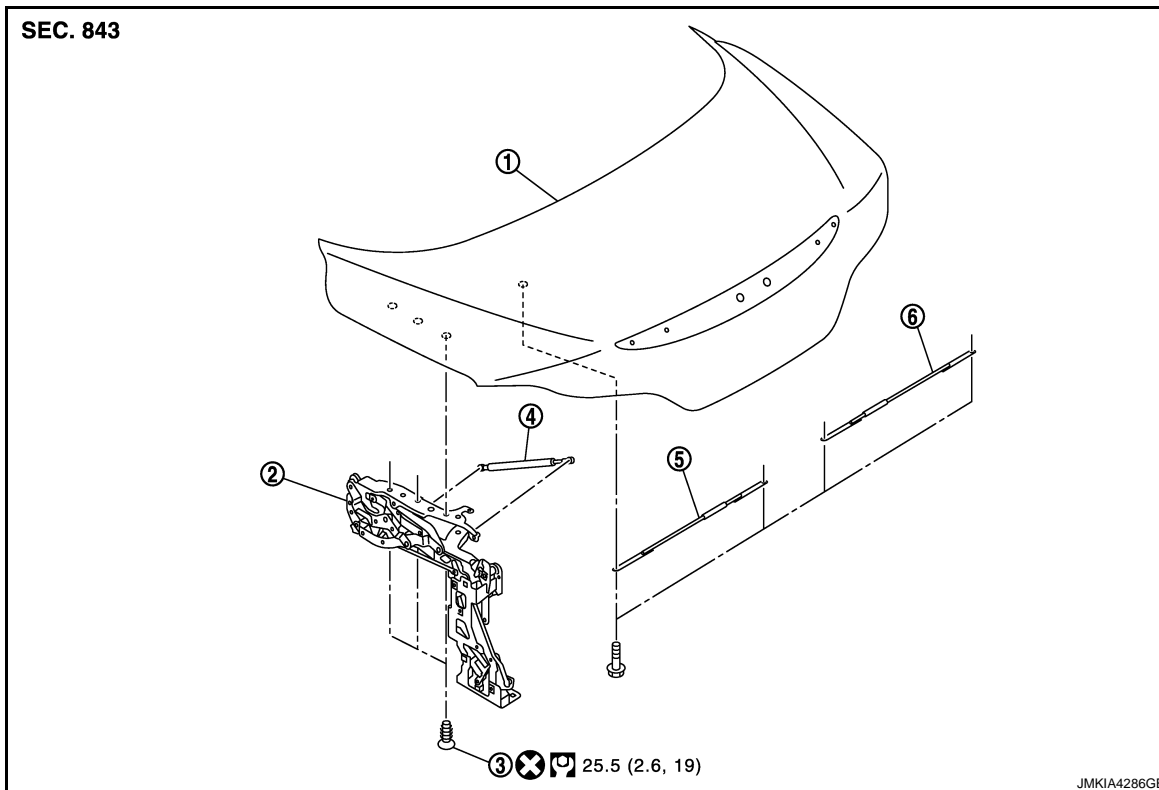

- | | | |
|-----------------------|-----------------------------|--------------------|
| 1. Trunk lid assembly | 2. Trunk lid hinge assembly | 3. TORX bolt |
| 4. Trunk lid stay | 5. Adjust rod (LH) | 6. Adjust rod (RH) |

Refer to [GI-4. "Components"](#) for the symbols in the figure.

TRUNK LID STAY : Removal and Installation

INFOID:000000005624385

WARNING:

Body injury may occur if no supporting rod is holding the trunk lid open when removing the trunk lid stay.

REMOVAL

1. Fully open trunk lid.
2. Insert flat-bladed screwdriver into the gap and remove the trunk lid stay.

INSTALLATION

Install in the reverse order of removal.

CAUTION:

Check the trunk lid open/close operation after installation.

A
B
C
D
E
F
G
H
I
J
DLK
L
M
N
O
P

TRUNK LID

< REMOVAL AND INSTALLATION >

TRUNK LID STAY : Disposal

INFOID:000000005624386

1. Fix trunk lid stay (1) using a vise (C).
2. Using hacksaw (A) slowly make 2 holes in the trunk lid stay, in numerical order as shown in the figure.

CAUTION:

- When cutting a hole on trunk lid stay, always cover a hacksaw using a shop cloth (B) to avoid scattering metal fragments or oil.
- Wear eye protection (safety glasses).
- Wear gloves.

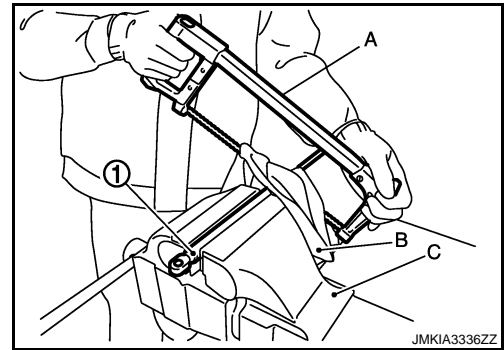

A: 20 mm (0.787 in)

B: Cut at the groove.

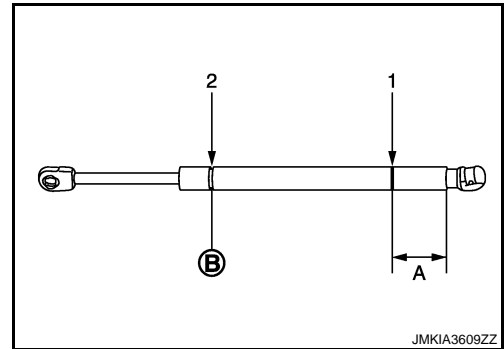

TRUNK LID WEATHERSTRIP

TRUNK LID WEATHERSTRIP : Exploded View

INFOID:000000005624387

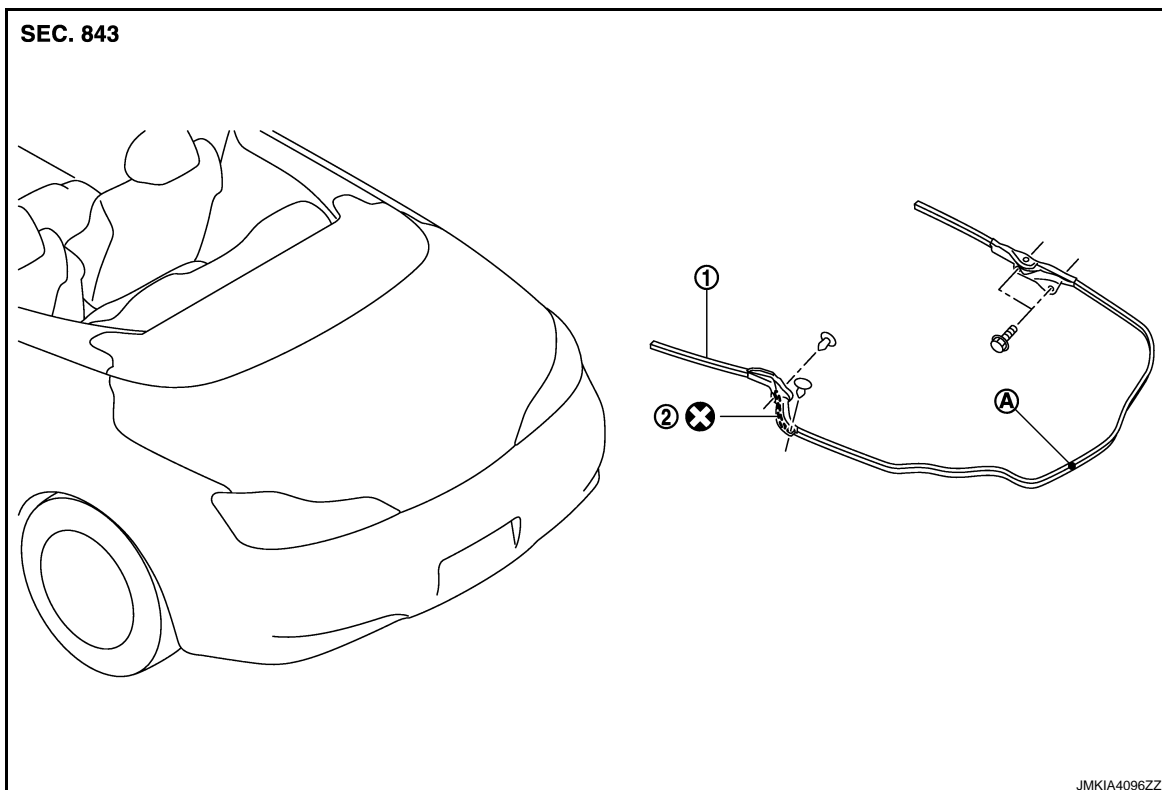

TRUNK LID

< REMOVAL AND INSTALLATION >

1. Trunk lid weather-strip
2. Double-faced adhesive tape [t : 0.8 mm (0.031 in)]

A : Center mark

Refer to [G1-4, "Components"](#) for the symbols in the figure.

TRUNK LID WEATHERSTRIP : Removal and Installation

INFOID:000000005624388

REMOVAL

1. Roof is fully open.
2. Fully open trunk lid.
3. Remove mounting bolts from trunk lid weather-strip.
4. Remove mounting clips from trunk lid weather-strip.
5. Pull up and remove engagement with body from trunk lid weather-strip joint.

CAUTION:

After removal, never pull strongly on the weather-strip.

INSTALLATION

1. Align the weather-strip seem (lower) with center of the striker and weather-strip onto the vehicle.
2. After installation, pull the weather-strip gently to ensure that there is no loose section.

NOTE:

Check that the weather-strip fits tightly at each corner and trunk rear plate.

A
B
C
D
E
F
G
H
I
J
L
M
N
O
P

DLK

DOOR LOCK

< REMOVAL AND INSTALLATION >

DOOR LOCK

DOOR LOCK

DOOR LOCK : Exploded View

INFOID:000000005624389

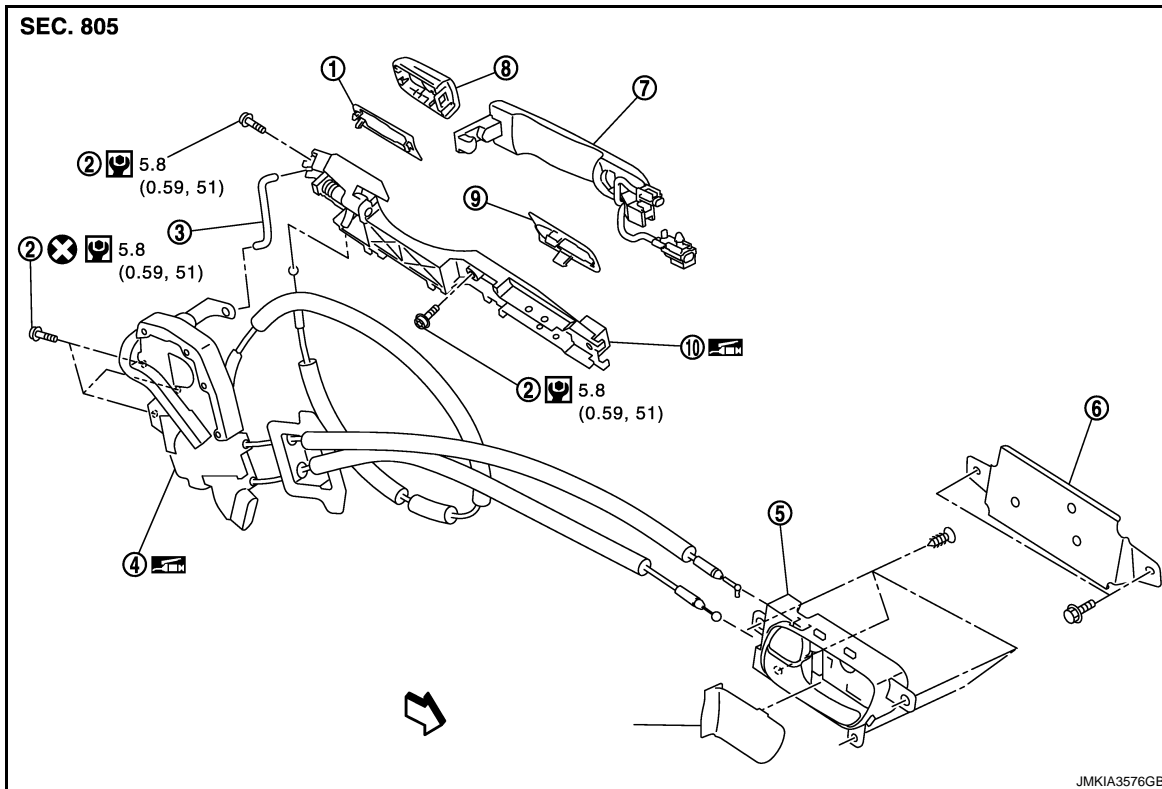

- | | | |
|-----------------------|-------------------------------------------------------------------------------------------|-------------------------------|
| 1. Rear gasket | 2. TORX bolt | 3. Key rod (Driver side only) |
| 4. Door lock assembly | 5. Inside handle | 6. Inside handle bracket |
| 7. Outside handle | 8. Door key cylinder assembly (Driver side)
Outside handle escutcheon (Passenger side) | 9. Front gasket |
| | 10. Outside handle bracket | |

↔ : Vehicle front

Refer to [GI-4. "Components"](#) for symbols in the figure.

DOOR LOCK : Removal and Installation

INFOID:000000005624390

REMOVAL

WARNING:

Before servicing, turn ignition switch OFF, disconnect battery negative terminal and wait 3 minutes or more.

• **Never use the air tools or electric tools for servicing.**

1. Remove the door finisher. Refer to [INT-12. "Removal and Installation"](#).
2. Remove the door glass and door module assembly.
 - Door glass: Refer to [GW-22. "Removal and Installation"](#).
 - Door module: Refer to [GW-27. "Removal and Installation"](#).
3. Remove the door side grommet, and loosen the door key cylinder assembly (driver side) and outside handle escutcheon (passenger side) TORX bolt from grommet hole.

CAUTION:

DOOR LOCK

< REMOVAL AND INSTALLATION >

Never forcibly remove the TORX bolt.

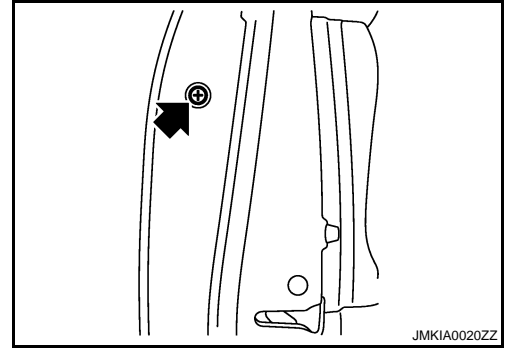

4. Disconnect the door antenna and door request switch connector and remove the harness clamp.
5. Reach in to separate the key rod connection (on the handle).
6. While pulling the outside handle, remove the door key cylinder assembly.

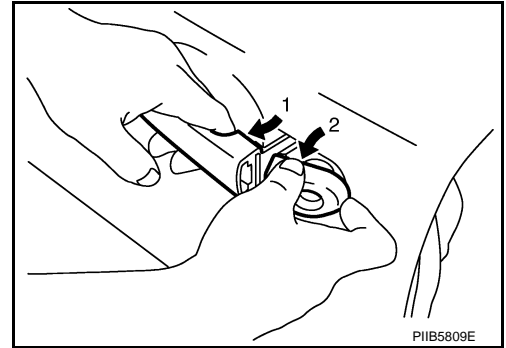

7. Slide toward rear of vehicle, and pull forward to remove the outside handle.

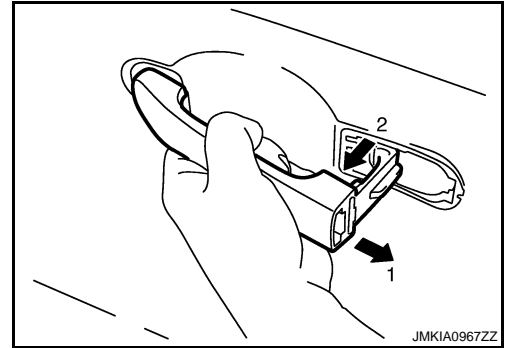

8. Remove the front gasket and rear gasket.

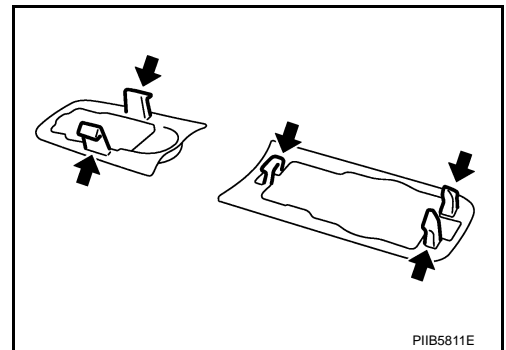

9. Remove the TORX bolts, and remove the door lock assembly.

A
B
C
D
E
F
G
H
I
J
DLK
L
M
N
O
P

DOOR LOCK

< REMOVAL AND INSTALLATION >

10. Remove the TORX bolt of the outside handle bracket.

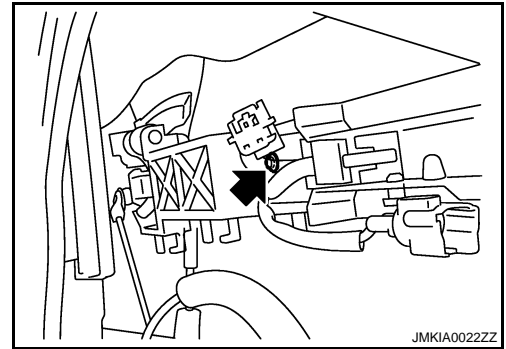

11. While pulling the outside handle bracket, slide toward rear of vehicle to remove the outside handle bracket.

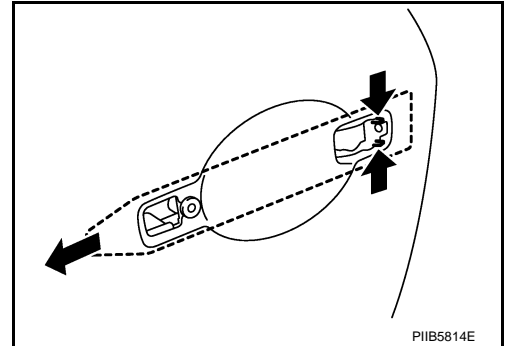

12. Disconnect the door lock actuator connector and remove the door lock assembly.

13. Reach in to separate the outside handle cable connection.

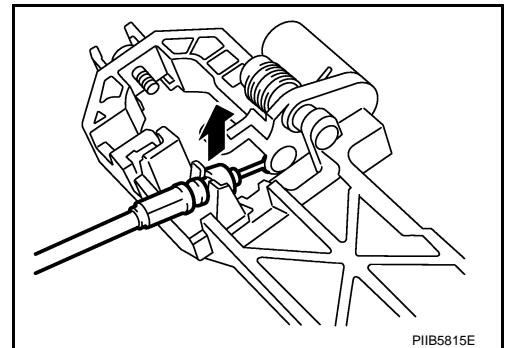

INSTALLATION

Install in the reverse order of removal.

CAUTION:

To install each rod, rotate the rod holder until a click is felt.

INSIDE HANDLE

DOOR LOCK

< REMOVAL AND INSTALLATION >

INSIDE HANDLE : Exploded View

INFOID:000000005624391

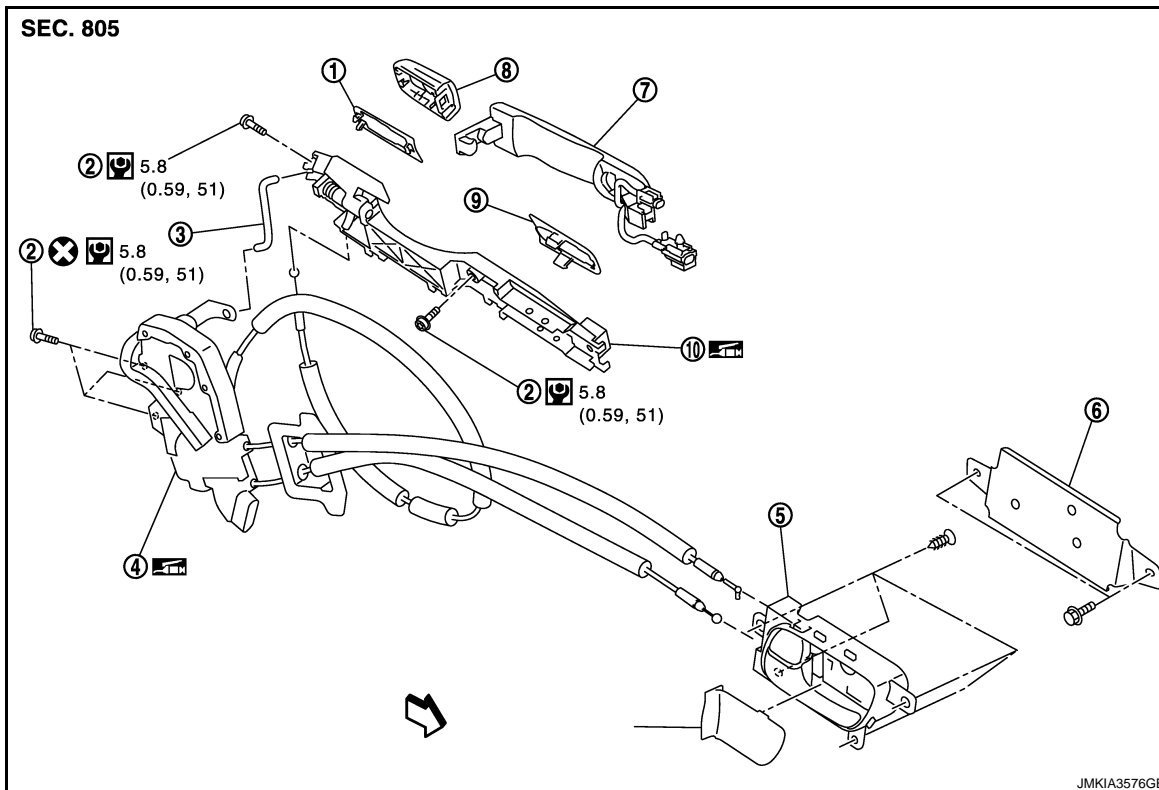

- | | | |
|----------------------------|-------------------------------------------------------------------------------------------|-------------------------------|
| 1. Rear gasket | 2. TORX bolt | 3. Key rod (Driver side only) |
| 4. Door lock assembly | 5. Inside handle | 6. Inside handle bracket |
| 7. Outside handle | 8. Door key cylinder assembly (Driver side)
Outside handle escutcheon (Passenger side) | 9. Front gasket |
| 10. Outside handle bracket | | |

← : Vehicle front

Refer to [GI-4, "Components"](#) for symbols in the figure.

INSIDE HANDLE : Removal and Installation

INFOID:000000005624392

REMOVAL

WARNING:

Before servicing, turn ignition switch OFF, disconnect battery negative terminal and wait 3 minutes or more.

• **Never use the air tools or electric tools for servicing.**

1. Remove the door finisher. Refer to [INT-12, "Removal and Installation"](#).
2. Remove the inside handle mounting bolts.
3. Disconnect the inside handle cable, and then remove the inside handle.

INSTALLATION

Install in the reverse order of removal.

CAUTION:

- **Check the door lock/unlock operation after installation.**
- **Check the door open/close operation after installation.**

OUTSIDE HANDLE

A
B
C
D
E
F
G
H
I
J
K
L
M
N
O
P

DLK

DOOR LOCK

< REMOVAL AND INSTALLATION >

OUTSIDE HANDLE : Exploded View

INFOID:000000005624393

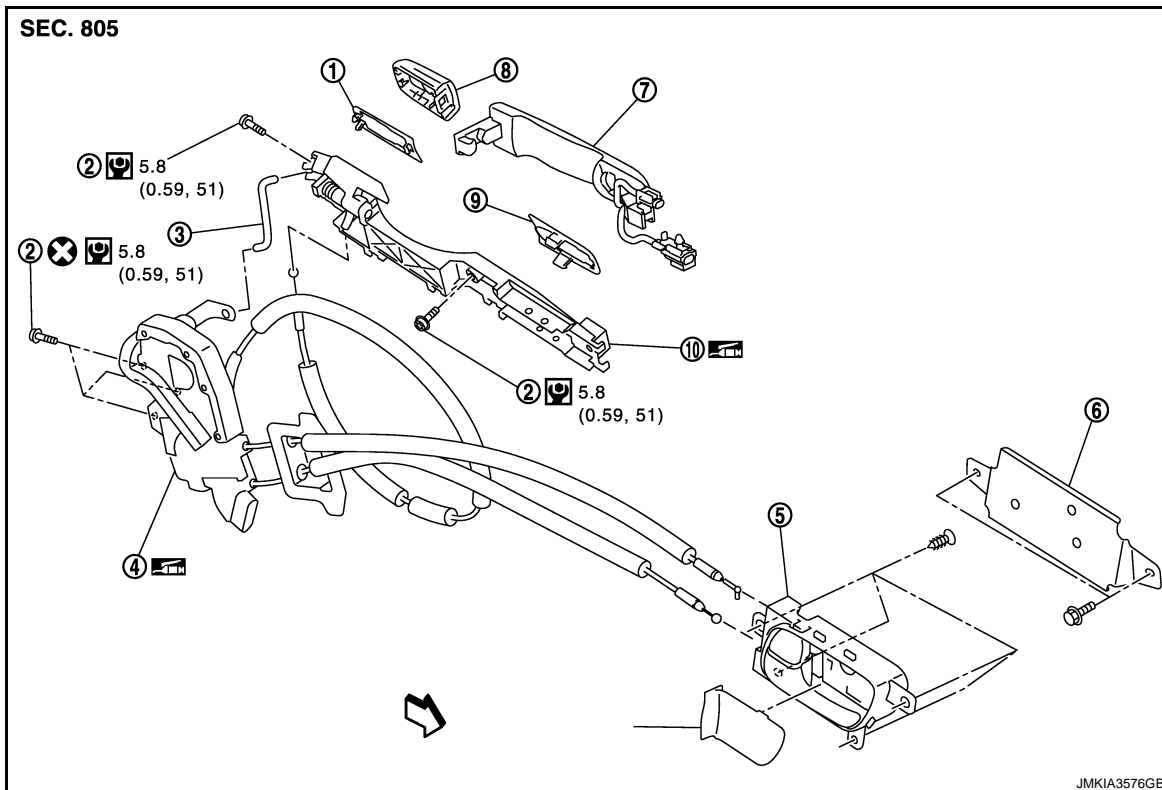

- | | | |
|----------------------------|---------------------------------------------|-------------------------------|
| 1. Rear gasket | 2. TORX bolt | 3. Key rod (Driver side only) |
| 4. Door lock assembly | 5. Inside handle | 6. Inside handle bracket |
| 7. Outside handle | 8. Door key cylinder assembly (Driver side) | 9. Front gasket |
| | Outside handle escutcheon (Passenger side) | |
| 10. Outside handle bracket | | |

↔ : Vehicle front

Refer to [GI-4, "Components"](#) for symbols in the figure.

OUTSIDE HANDLE : Removal and Installation

INFOID:000000005624394

REMOVAL

WARNING:

Before servicing, turn ignition switch OFF, disconnect battery negative terminal and wait 3 minutes or more.

• **Never use the air tools or electric tools for servicing.**

1. Remove the door finisher. Refer to [INT-12, "Removal and Installation"](#).
2. Remove the door glass and door module assembly.
 - Door glass: Refer to [GW-22, "Removal and Installation"](#).
 - Door module: Refer to [GW-27, "Removal and Installation"](#).
3. Remove the door side grommet, and loosen door key cylinder assembly (driver side) and outside handle escutcheon (passenger side) TORX bolt from grommet hole.

CAUTION:

DOOR LOCK

< REMOVAL AND INSTALLATION >

Never forcibly remove the TORX bolt.

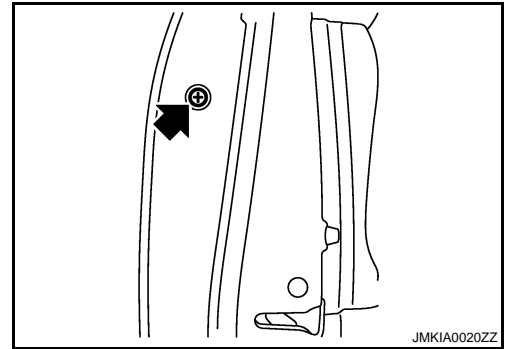

4. Disconnect the door antenna and door request switch connector and remove the harness clamp.
5. Reach in to separate the key rod connection (on the handle).
6. While pulling the outside handle, remove the door key cylinder assembly.

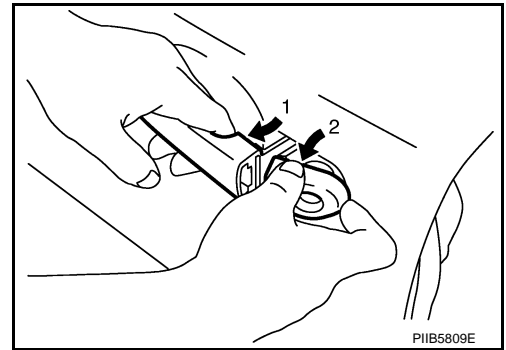

7. Slide toward rear of vehicle, and pull forward to remove the outside handle.

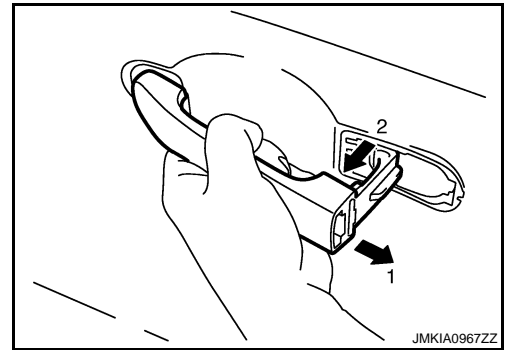

8. Remove the front gasket and rear gasket.

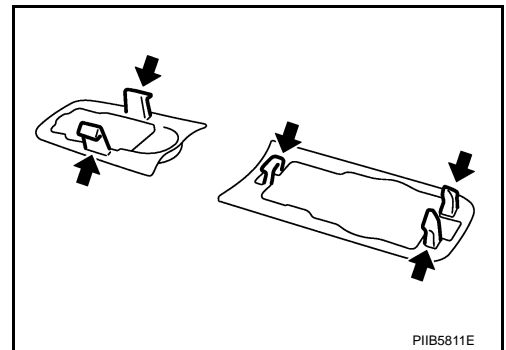

A
B
C
D
E
F
G
H
I
J
DLK
L
M
N
O
P

DOOR LOCK

< REMOVAL AND INSTALLATION >

9. Remove the TORX bolt of the outside handle bracket.

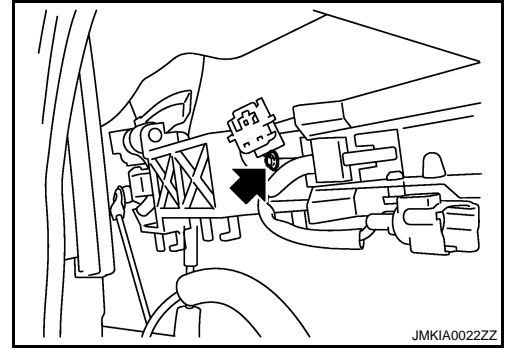

10. While pulling the outside handle bracket, slide toward rear of vehicle to remove the outside handle bracket.

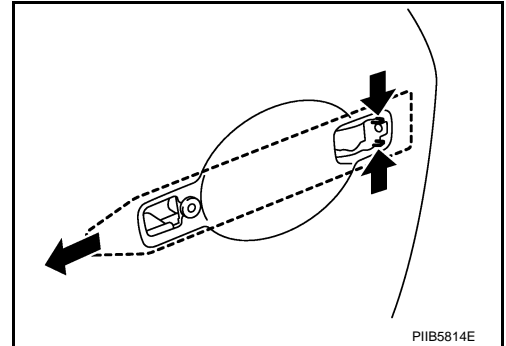

11. Reach in to separate the outside handle cable connection.

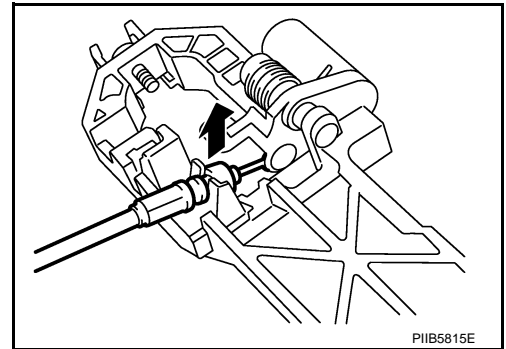

INSTALLATION

Install in the reverse order of removal.

CAUTION:

To install each rod, rotate the rod holder until a click is felt.

TRUNK LID LOCK

< REMOVAL AND INSTALLATION >

TRUNK LID LOCK

TRUNK LID LOCK

TRUNK LID LOCK : Exploded View

INFOID:000000005624395

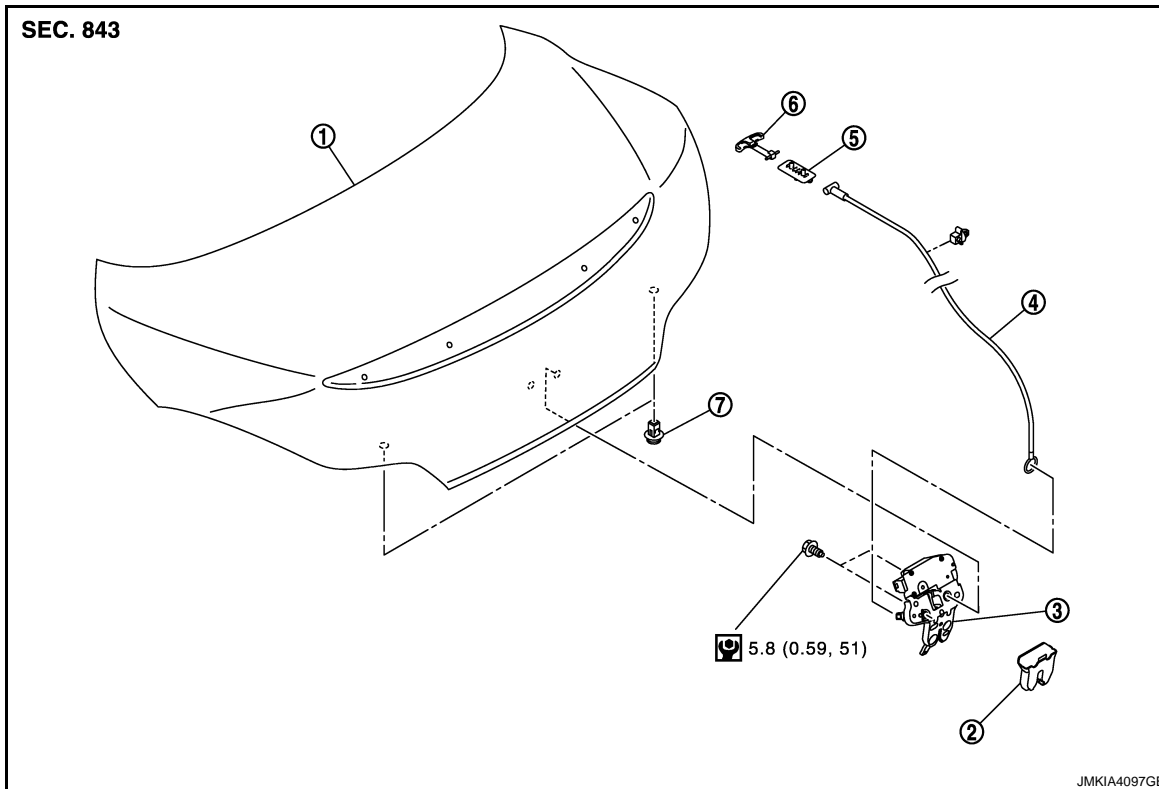

- | | | |
|---------------------------|--------------------------------------------|-------------------------------------|
| 1. Trunk lid assembly | 2. Trunk lid lock cover | 3. Trunk lid lock assembly |
| 4. Trunk lid opener cable | 5. Trunk lid emergency opener lever holder | 6. Trunk lid emergency opener lever |
| 7. Bumper rubber | | |

Refer to [GI-4. "Components"](#) for the symbols in the figure.

TRUNK LID LOCK : Removal and Installation

INFOID:000000005624396

REMOVAL

1. Remove trunk lid finisher. Refer to [INT-26. "Removal and Installation"](#).
2. Remove trunk lid emergency opener lever.
3. Disconnect trunk lid opener cable.
4. Disconnect connector from trunk lid lock assembly.
5. Remove mounting bolts, and remove trunk lid lock assembly.

INSTALLATION

Install in the reverse order of removal.

NOTE:

- After installing, perform trunk lid fitting adjustment. Refer to [DLK-291. "TRUNK LID ASSEMBLY : Adjustment"](#).
- After installing, check the operation.

A
B
C
D
E
F
G
H
I
J

DLK

L
M
N
O
P

FUEL FILLER LID OPENER

< REMOVAL AND INSTALLATION >

FUEL FILLER LID OPENER

Exploded View

INFOID:000000005624397

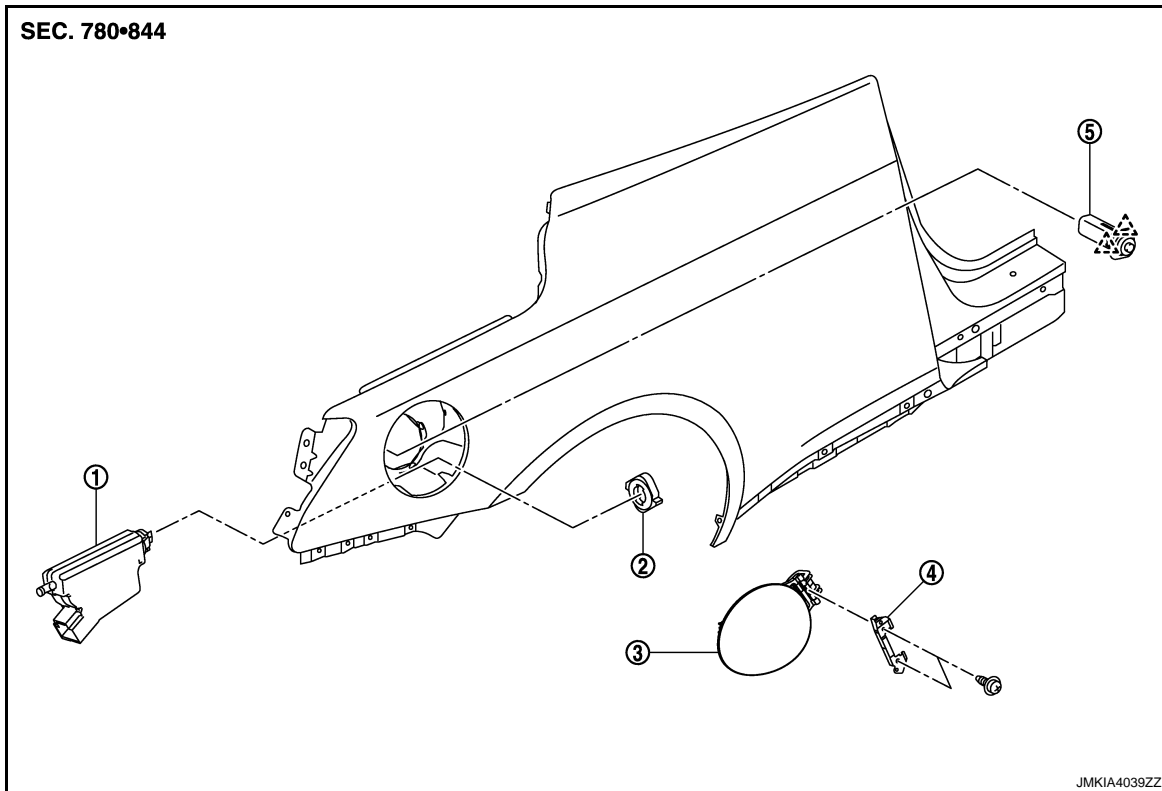

- | | | |
|------------------------------------|--------------------------|-----------------------------|
| 1. Fuel filler lid opener actuator | 2. Lock nut | 3. Fuel filler lid assembly |
| 4. Cover | 5. Lock and rod assembly | |

 : Pawl

Removal and Installation

INFOID:000000005624398

REMOVAL

1. Remove rear bumper. Refer to [EXT-17. "Removal and Installation"](#).
2. Remove drafter (RH).
3. Rotate lock nut counterclockwise, and then remove lock nut.
4. Push fuel filler lid opener actuator behind the vehicle, while pushing the pawl.
5. Remove fuel filler lid actuator through the access hole used to remove the drafter. Disconnect harness connector.
6. Pull and remove lock and rod assembly forward, while pushing the pawls through the access hole used to remove the drafter.
7. Remove mounting screws, and then remove fuel filler lid.

INSTALLATION

Install in the reverse order of removal.

UNLOCK PROCEDURES

NOTE:

When fuel filler lid opener actuator is a defective operation, pull the rod to open fuel filler lid.

FUEL FILLER LID OPENER

< REMOVAL AND INSTALLATION >

1. Remove rear trunk finisher (RH) mounting clips (A).

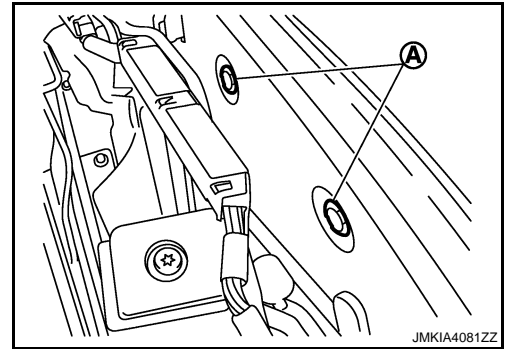

2. Pull up rear trunk finisher (RH).

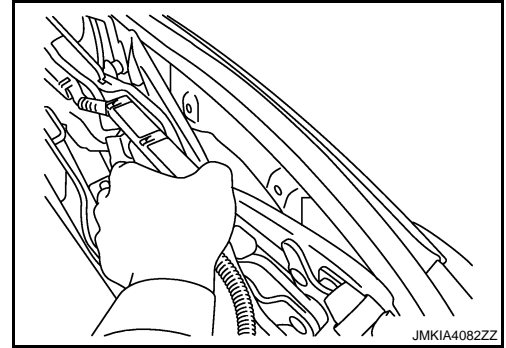

3. Unlock fuel filler lid actuator (1) lock by pressing it toward rear of the vehicle using a flat-bladed screwdriver (A) [383 mm (15.079 in) length] through the slit as shown in the figure.

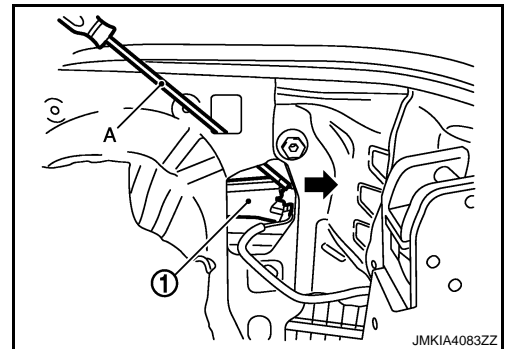

A
B
C
D
E
F
G
H
I
J
DLK
L
M
N
O
P

DOOR SWITCH

< REMOVAL AND INSTALLATION >

DOOR SWITCH

Exploded View

INFOID:000000005624399

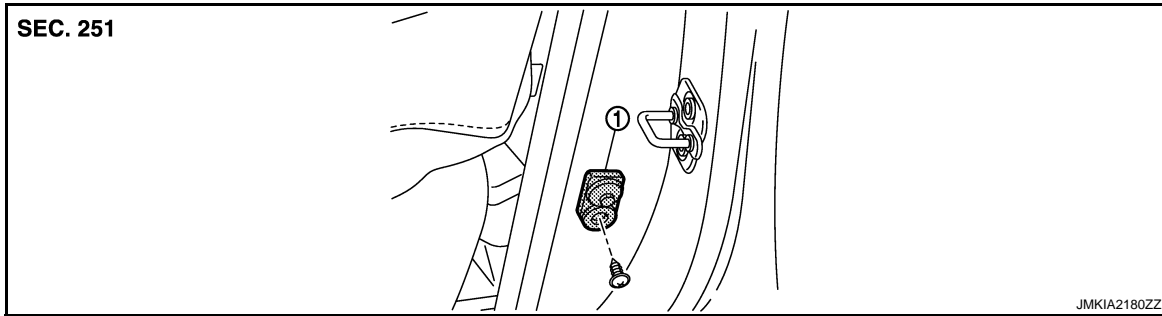

1. Door switch

Removal and Installation

INFOID:000000005624400

REMOVAL

1. Remove the door switch mounting bolt (A), and then remove door switch (1).

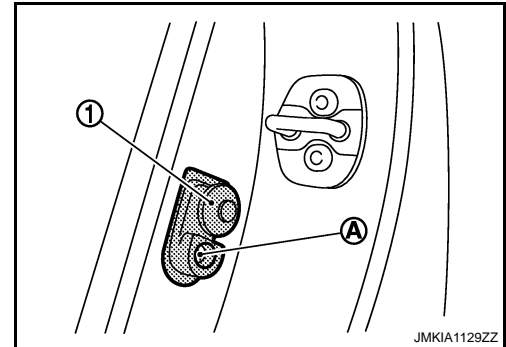

INSTALLATION

Install in the reverse order of removal.

INSIDE KEY ANTENNA

< REMOVAL AND INSTALLATION >

INSIDE KEY ANTENNA INSTRUMENT CENTER

INSTRUMENT CENTER : Exploded View

INFOID:000000005624401

Refer to [IP-12, "A/T MODELS : Exploded View"](#).

INSTRUMENT CENTER : Removal and Installation

INFOID:000000005624402

REMOVAL

1. Remove the console finisher. Refer to [IP-13, "A/T MODELS : Removal and Installation"](#).
2. Remove the key slot mounting screw (A), and then remove inside key antenna (instrument center) (1).

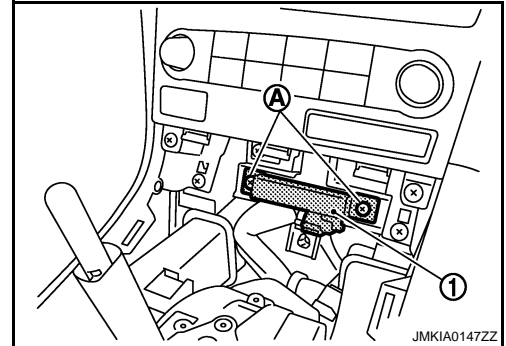

INSTALLATION

Install in the reverse order of removal.

CONSOLE

CONSOLE : Exploded View

INFOID:000000005624403

Refer to [IP-33, "A/T MODELS : Exploded View"](#).

CONSOLE : Removal and Installation

INFOID:000000005624404

REMOVAL

1. Remove the console ashtray.
2. Remove the console rear finisher (2). Refer to [IP-34, "A/T MODELS : Removal and Installation"](#).
3. Remove the inside key antenna mounting screw (A), and then remove inside key antenna (console) (1) from console rear finisher.

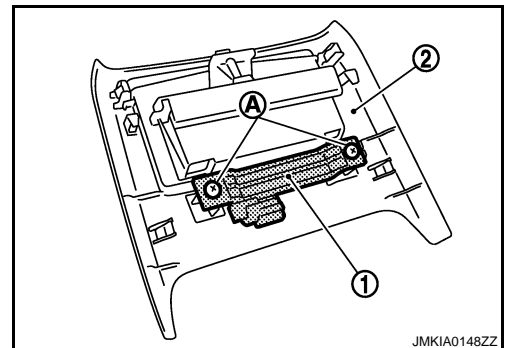

INSTALLATION

Install in the reverse order of removal.

TRUNK ROOM

TRUNK ROOM : Exploded View

INFOID:000000005624405

Refer to [INT-23, "Exploded View"](#).

A
B
C
D
E
F
G
H
I
J
DLK
L
M
N
O
P

INSIDE KEY ANTENNA

< REMOVAL AND INSTALLATION >

TRUNK ROOM : Removal and Installation

INFOID:000000005624406

REMOVAL

1. Remove trunk floor carpet and trunk front finisher. Refer to [INT-24. "Removal and Installation"](#).
2. Remove the inside key antenna (trunk room) mounting clips (A), and then remove inside key antenna (trunk room) (1).

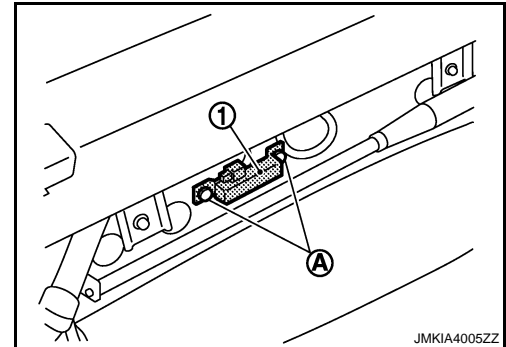

INSTALLATION

Install in the reverse order of removal.

OUTSIDE KEY ANTENNA

< REMOVAL AND INSTALLATION >

OUTSIDE KEY ANTENNA

Exploded View

INFOID:0000000005624407

Refer to [EXT-16. "Exploded View"](#).

Removal and Installation

INFOID:0000000005624408

REMOVAL

1. Remove the rear bumper. Refer to [EXT-17. "Removal and Installation"](#).
2. Remove the outside key antenna (rear bumper) mounting nuts (A), and then remove outside key antenna (rear bumper) (1).

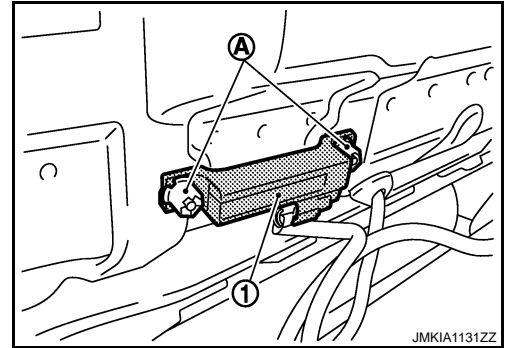

INSTALLATION

Install in the reverse order of removal.

A
B
C
D
E
F
G
H
I
J
L
M
N
O
P

DLK

INTELLIGENT KEY WARNING BUZZER

< REMOVAL AND INSTALLATION >

INTELLIGENT KEY WARNING BUZZER

Exploded View

INFOID:000000005624409

Refer to [DLK-283. "Exploded View"](#).

Removal and Installation

INFOID:000000005624410

REMOVAL

1. Remove the hood seal assembly (side). Refer to [DLK-283. "Removal and Installation"](#).
2. Remove the Intelligent Key warning buzzer mounting bolt (A), and then remove the Intelligent Key warning buzzer (1).

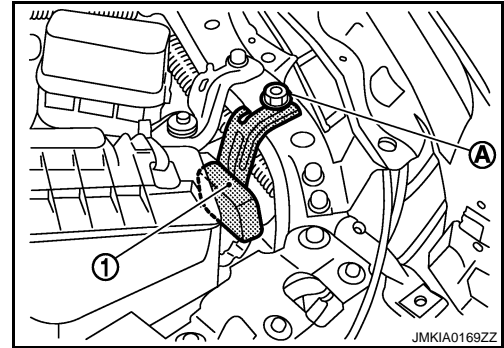

INSTALLATION

Install in the reverse order of removal.

TRUNK LID OPENER REQUEST SWITCH

< REMOVAL AND INSTALLATION >

TRUNK LID OPENER REQUEST SWITCH

Exploded View

INFOID:0000000005624411

Refer to [EXL-121, "Exploded View"](#).

Removal and Installation

INFOID:0000000005624412

REMOVAL

1. Remove the rear combination lamp LH (1). Refer to [EXL-121, "Removal and Installation"](#).
2. Remove the trunk lid opener request switch connector (B).

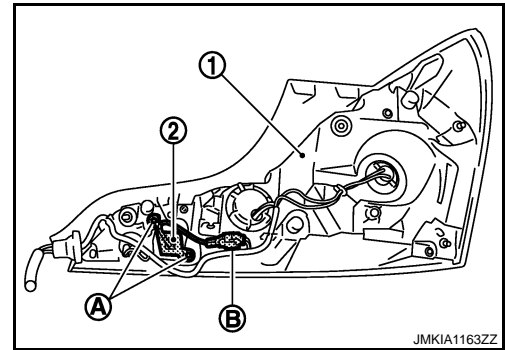

3. Remove the trunk lid opener request switch mounting screw (A), and then remove trunk lid opener request switch (2) from rear combination lamp LH.

INSTALLATION

Install in the reverse order of removal.

A
B
C
D
E
F
G
H
I
J
L
M
N
O
P

DLK

TRUNK LID OPENER SWITCH

< REMOVAL AND INSTALLATION >

TRUNK LID OPENER SWITCH

Exploded View

INFOID:000000005624413

Refer to [IP-12, "A/T MODELS : Exploded View"](#).

Removal and Installation

INFOID:000000005624414

REMOVAL

1. Remove the instrument driver lower panel. Refer to [IP-34, "A/T MODELS : Removal and Installation"](#).
2. Remove the trunk lid opener switch (1) from instrument driver lower panel, and then remove pawl (A). Press trunk lid opener switch front side to disengage from instrument driver lower panel.

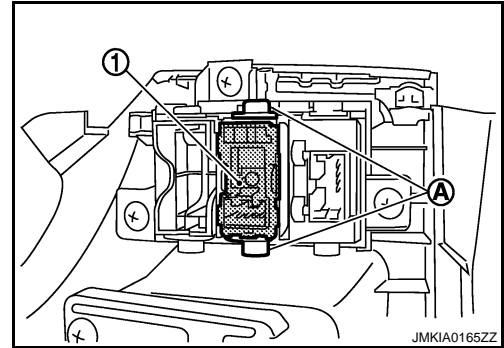

INSTALLATION

Install in the reverse order of removal.

TRUNK LID OPENER CANCEL SWITCH

< REMOVAL AND INSTALLATION >

TRUNK LID OPENER CANCEL SWITCH

Exploded View

INFOID:0000000005624415

Refer to [IP-12, "A/T MODELS : Exploded View"](#).

Removal and Installation

INFOID:0000000005624416

REMOVAL

1. Remove the instrument assist lower panel. Refer to [IP-13, "A/T MODELS : Removal and Installation"](#).
2. Remove the trunk lid opener cancel switch (1) from instrument assist lower panel, and then remove pawl (A). Press trunk lid opener cancel switch back side to disengage from instrument assist lower panel.

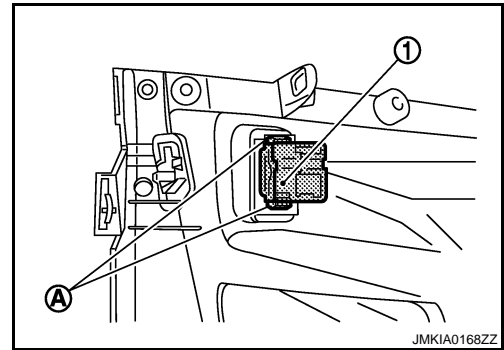

INSTALLATION

Install in the reverse order of removal.

A
B
C
D
E
F
G
H
I
J
L
M
N
O
P

DLK

REMOTE KEYLESS ENTRY RECEIVER

< REMOVAL AND INSTALLATION >

REMOTE KEYLESS ENTRY RECEIVER

Exploded View

INFOID:000000005624417

Refer to [IP-12, "A/T MODELS : Exploded View"](#).

Removal and Installation

INFOID:000000005624418

REMOVAL

1. Remove the instrument assist lower panel. Refer to [IP-13, "A/T MODELS : Removal and Installation"](#).
2. Remove the remote keyless entry receiver mounting bolt (A), and then remove remote keyless entry receiver (1).

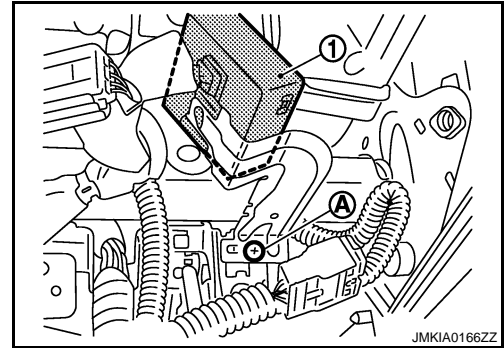

INSTALLATION

Install in the reverse order of removal.

INTELLIGENT KEY BATTERY

< REMOVAL AND INSTALLATION >

INTELLIGENT KEY BATTERY

Removal and Installation

INFOID:000000005624419

1. Release the lock knob at the back of the Intelligent Key and remove the mechanical key.

2. Insert a flat-blade screwdriver (A) wrapped with a cloth into the slit of the corner and twist it to separate the upper part from the lower part.

CAUTION:

- Do not touch the circuit board or battery terminal.
- The key fob is water-resistant. However, if it does get wet, immediately wipe it dry.

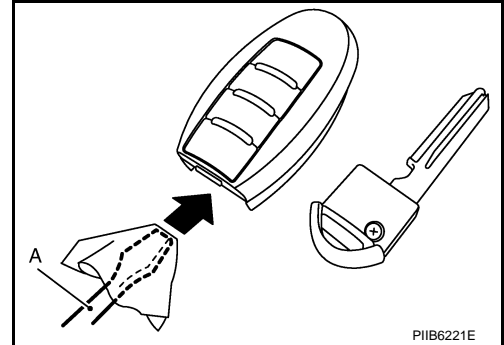

3. Replace the battery with new one.

Battery replacement

:Coin-type lithium battery (CR2032)

4. Align the tips of the upper and lower parts, and then push them together until it is securely closed.

CAUTION:

- When replacing battery, keep dirt, grease, and other foreign materials off the electrode contact area.
- After replacing the battery, check that all Intelligent Key functions work normally.

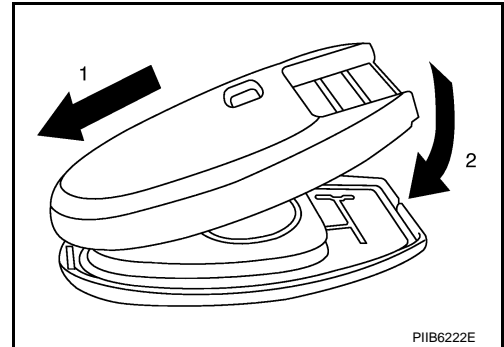

A
B
C
D
E
F
G
H
I
J
DLK
L
M
N
O
P