

SECTION **BRM**
BODY REPAIR

A
B
C
D
E
F
G
H
I
J
K
L
M
N
O
P

CONTENTS

| | | | |
|--|----|---|----|
| VEHICLE INFORMATION | 2 | REPLACEMENT OPERATIONS | 22 |
| BODY EXTERIOR PAINT COLOR | 2 | Description | 22 |
| Body Exterior Paint Color | 2 | Radiator Core Support | 26 |
| PRECAUTION | 3 | Hoodledge | 26 |
| REPAIRING HIGH STRENGTH STEEL | 3 | Front Side Member | 29 |
| High Strength Steel (HSS) | 3 | Front Side Member (Partial Replacement) | 32 |
| Handling of Ultra High Strength Steel Plate Parts..... | 5 | Front Pillar | 33 |
| PREPARATION | 6 | Outer Step Sill | 36 |
| REPAIRING MATERIAL | 6 | Outer Sill | 37 |
| Foam Repair | 6 | Rear Fender | 40 |
| BODY COMPONENT PARTS | 8 | Lock Pillar Reinforcement | 42 |
| Underbody Component Parts | 8 | Rear Panel | 44 |
| Body Component Parts | 10 | Rear Floor Rear | 44 |
| REMOVAL AND INSTALLATION | 12 | Rear Side Member Extension (LH) | 46 |
| CORROSION PROTECTION | 12 | Rear Side Member Extension (RH) | 46 |
| Description | 12 | SERVICE DATA AND SPECIFICATIONS | |
| Anti-corrosive Wax | 12 | (SDS) | 48 |
| Undercoating | 14 | BODY ALIGNMENT | 48 |
| Body Sealing | 15 | Body Center Marks | 48 |
| BODY CONSTRUCTION | 19 | Description | 49 |
| Body Construction | 19 | Engine Compartment | 49 |
| Rear Fender Hemming Process | 20 | Underbody | 51 |
| | | Passenger Compartment | 54 |
| | | Rear Body | 56 |
| | | LOCATION OF PLASTIC PARTS | 58 |
| | | Precautions for Plastics | 58 |
| | | Location of Plastic Parts | 58 |

BRM

BODY EXTERIOR PAINT COLOR

< VEHICLE INFORMATION >

VEHICLE INFORMATION

BODY EXTERIOR PAINT COLOR

Body Exterior Paint Color

INFOID:000000006934741

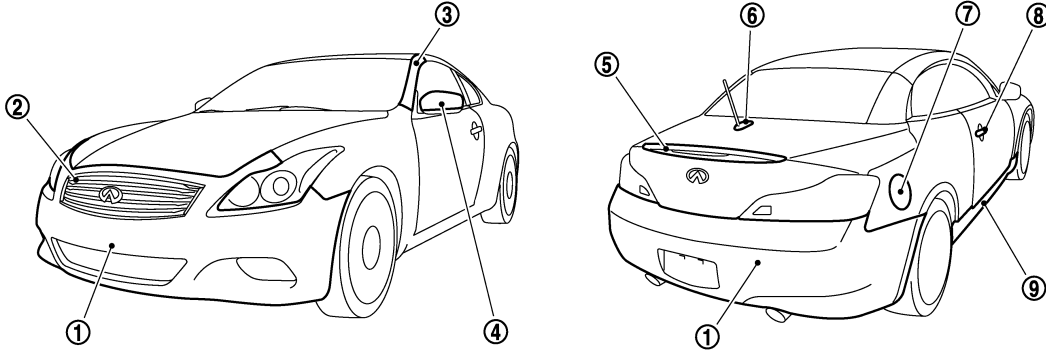

JSKIA1257ZZ

| Component | | Color code | BA54 | BGAC | BK23 | BKAD | BKH3 | BQAA | BRAF | BRAW | |
|-----------|-------------------------|----------------------------|------------|-------|--------|------|-------|-------|------------|------|------|
| | | Description | Red | Black | Silver | Gray | Black | White | Light Blue | Blue | |
| | | Paint type ^{Note} | CS | P | M | M | 2S | 3P | M | PM | |
| | | Hard clear coat | × | × | - | - | × | - | - | × | |
| 1 | Bumper fascia | Body color | BA54 | BGAC | BK23 | BKAD | BKH3 | BQAA | BRAF | BRAW | |
| 2 | Front grille | Chromium plate | Cr | Cr | Cr | Cr | Cr | Cr | Cr | Cr | |
| 3 | Front pillar finisher | Body color | BA54 | BGAC | BK23 | BKAD | BKH3 | BQAA | BRAF | BRAW | |
| 4 | Door outside mirror | Cover | Body color | BA54 | BGAC | BK23 | BKAD | BKH3 | BQAA | BRAF | BRAW |
| 5 | Trunk lid finisher | Chromium plate | Cr | Cr | Cr | Cr | Cr | Cr | Cr | Cr | |
| 6 | Satellite radio antenna | Body color | BA54 | BGAC | BK23 | BKAD | BKH3 | BQAA | BRAF | BRAW | |
| 7 | Fuel filler lid | Body color | BA54 | BGAC | BK23 | BKAD | BKH3 | BQAA | BRAF | BRAW | |
| 8 | Door outside handle | Body color | BA54 | BGAC | BK23 | BKAD | BKH3 | BQAA | BRAF | BRAW | |
| 9 | Center mudguard | Body color | BA54 | BGAC | BK23 | BKAD | BKH3 | BQAA | BRAF | BRAW | |

NOTE:

- 2S: Solid + Clear
- 3S: 3-Coat solid
- CS: Color clear solid
- M: Metallic
- P: 2-Coat pearl
- 3P: 3-Coat pearl
- FPM: Iron oxide pearl
- RPM: Multi flex color
- TM: Micro titanium metallic
- PM: Pearl metallic

REPAIRING HIGH STRENGTH STEEL

< PRECAUTION >

PRECAUTION

REPAIRING HIGH STRENGTH STEEL

High Strength Steel (HSS)

INFOID:000000006934742

High strength steel is used for body panels in order to reduce vehicle weight. Accordingly, precautions in repairing automotive bodies made of high strength steel are described below:

| Tensile strength | Major applicable parts |
|------------------|---|
| 370 - 780 MPa | <ul style="list-style-type: none"> • Front strut housing • Upper front hoodledge • Hoodledge reinforcement • Upper rear hoodledge • Lower dash crossmember assembly • Lower dash • Front roof assembly • Upper front pillar reinforcement • Trans control reinforcement (Center front floor component part) • 2nd and 3rd crossmember (Front floor component part) • Inner sill • Rear seat crossmember reinforcement assembly • Rear floor seat belt anchor reinforcement • Rear seat crossmember • Outer sill reinforcement • Lower front pillar reinforcement assembly • Outer lock pillar reinforcement • Inner lock pillar • Outer rear wheelhouse extension • Seat back support • Inner rear wheelhouse reinforcement • Front side member assembly • Front side member closing plate assembly • Front side member outrigger assembly • Rear side member assembly • Other reinforcements |
| 980 - 1350 MPa | <ul style="list-style-type: none"> • Front side member stiffener (Front floor component part) • Front side member rear extension (Front floor component part) |

Read the following precautions when repairing HSS:

1. Additional points to consider
 - The repair of reinforcements (such as side members) by heating is not recommended, because it may weaken the component. When heating is unavoidable, never heat HSS parts above 550°C (1,022°F). Verify heating temperature with a thermometer. (Crayon-type and other similar type thermometer are appropriate.)

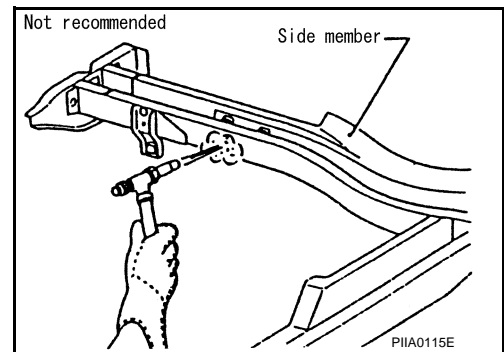

REPAIRING HIGH STRENGTH STEEL

< PRECAUTION >

- When straightening body panels, use caution in pulling any HSS panel. Because HSS is very strong, pulling may cause deformation in adjacent sections of the body. In this case, increase the number of measuring points, and carefully pull the HSS panel.

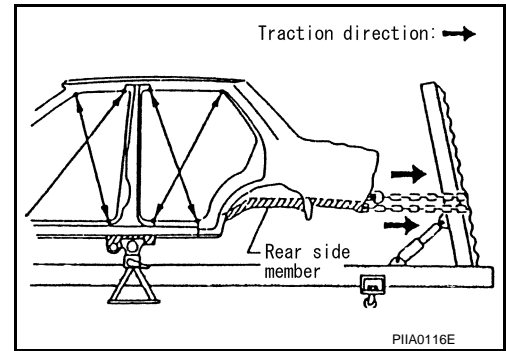

- When cutting HSS panels, avoid gas (torch) cutting if possible. Instead, use a saw to avoid weakening surrounding areas due to heat. If gas (torch) cutting is unavoidable, allow a minimum margin of 50 mm (1.97in).

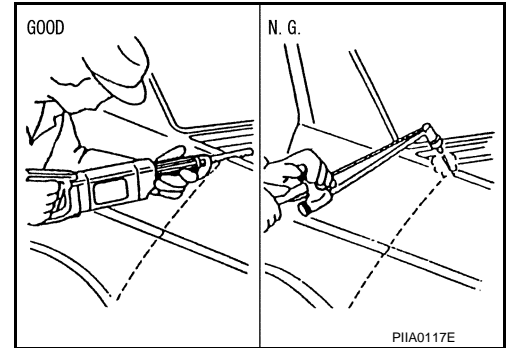

- When welding HSS panels, use spot welding whenever possible in order to minimize weakening surrounding areas due to heat. If spot welding is impossible, use MIG. welding. Do not use gas (torch) for welding because it is inferior in welding strength.

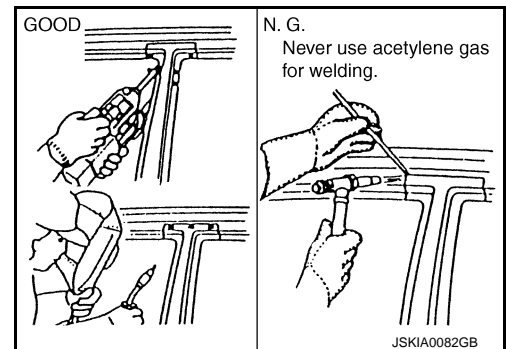

- Spot welding on HSS panels is harder than that of an ordinary steel panel. Therefore, when cutting spot welds on a HSS panel, use a low speed high torque drill (1,000 to 1,200 rpm) to increase drill bit durability and facilitate the operation.

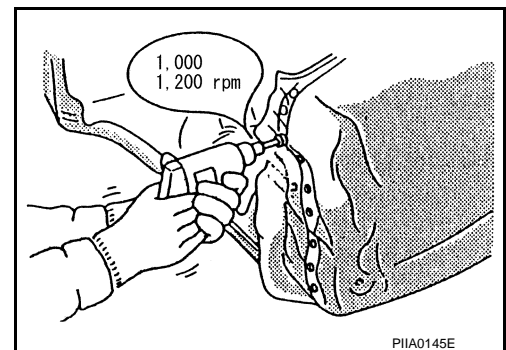

REPAIRING HIGH STRENGTH STEEL

< PRECAUTION >

2. Precautions in spot welding HSS

This work should be performed under standard working conditions. Always note the following when spot welding HSS:

- The electrode tip diameter must be sized properly according to the metal thickness.

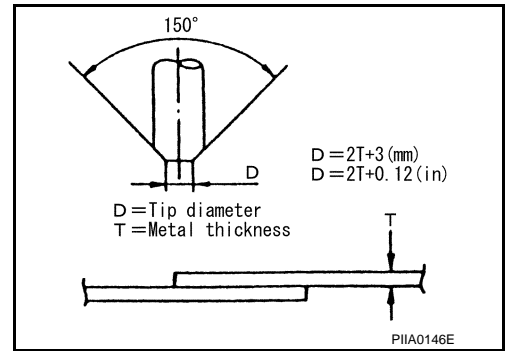

- The panel surfaces must fit flush to each other, leaving no gaps.

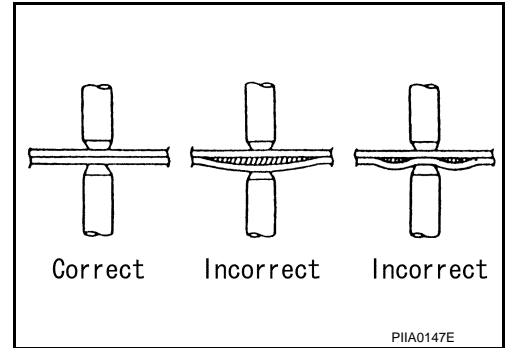

- Follow the specifications for the proper welding pitch.

Unit: mm (in)

| Thickness (T) | Minimum pitch (L) |
|---------------|-------------------|
| 0.6 (0.024) | 10 (0.39) or more |
| 0.8 (0.031) | 12 (0.47) or more |
| 1.0 (0.039) | 18 (0.71) or more |
| 1.2 (0.047) | 20 (0.79) or more |
| 1.6 (0.063) | 27 (1.06) or more |
| 1.8 (0.071) | 31 (1.22) or more |

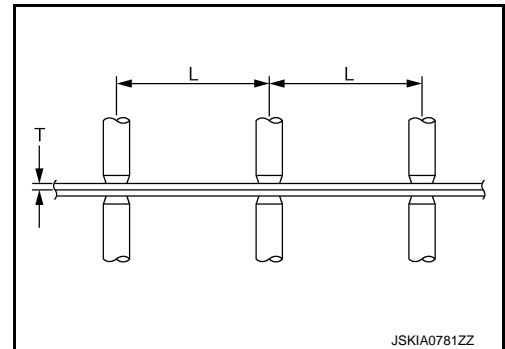

Handling of Ultra High Strength Steel Plate Parts

INFOID:0000000006934743

PROHIBITION OF CUT AND CONNECTION

Never cut and Joint the stiffener front side member (front floor inside frame parts) because its material is high strength steel plate (ultra high strength steel plate).

The front floor assembly must be replaced if this part is damaged.

A
B
C
D
E
F
G
H
I
J
L
M
N
O
P

BRM

REPAIRING MATERIAL

< PREPARATION >

PREPARATION

REPAIRING MATERIAL

Foam Repair

INFOID:000000006934744

During factory body assembly, foam insulators are installed in certain body panels and locations around the vehicle. Use the following procedure(s) to replace any factory-installed foam insulators.

URETHANE FOAM APPLICATIONS

Use commercially available Urethane foam for sealant (foam material) repair of material used on vehicle.

<Urethane foam for foaming agent>

3M™ Automix™ Flexible Foam 08463 or equivalent

Read instructions on product for fill procedures.

Example of foaming agent filling operation procedure

1. Fill procedures after installation of service part.
 - a. Eliminate foam material remaining on vehicle side.
 - b. Clean area after eliminating form insulator and foam material.
 - c. Install service part.
 - d. Insert nozzle into hole near fill area and fill foam material or fill enough to close gap with the service part.

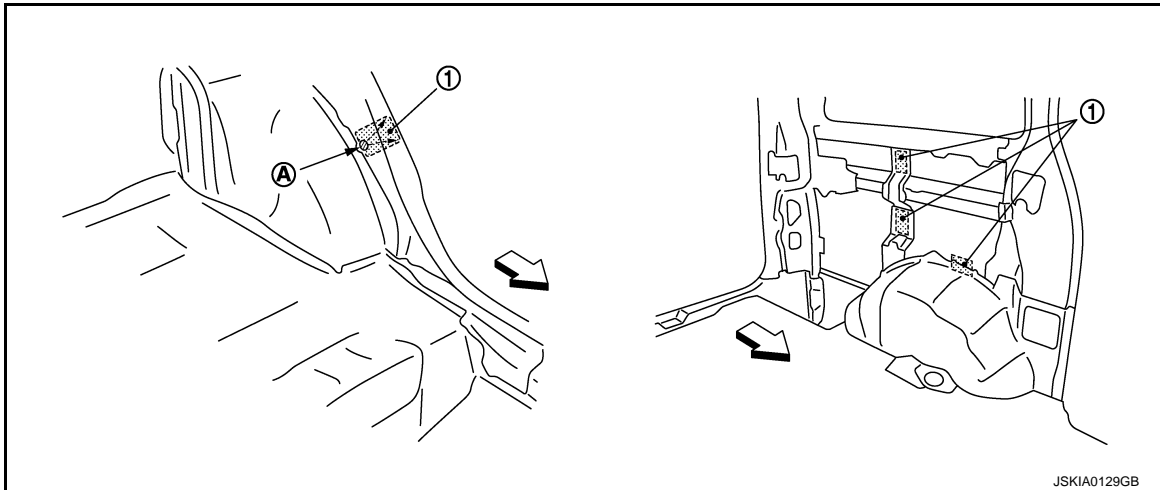

1. Urethane foam
 - A. Nozzle insert hole
- ↙: Vehicle front

2. Fill procedures before installation of service part.
 - a. Eliminate foam material remaining on vehicle side.
 - b. Clean area after eliminating foam insulator and foam material.
 - c. Fill foam material on wheelhouse outer side.

REPAIRING MATERIAL

< PREPARATION >

- 1. Urethane foam
- A. Fill while avoiding flange area

←: Vehicle front

NOTE:

Fill enough to close gap with service part while avoiding flange area.

- d. Install service part.

NOTE:

Refer to label for information on working times.

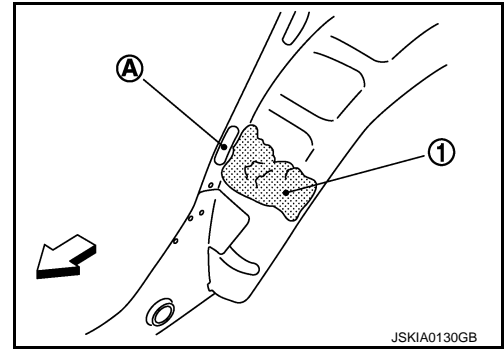

A
B
C
D
E
F
G
H
I
J
L
M
N
O
P

BRM

BODY COMPONENT PARTS

< PREPARATION >

BODY COMPONENT PARTS

Underbody Component Parts

INFOID:000000006934745

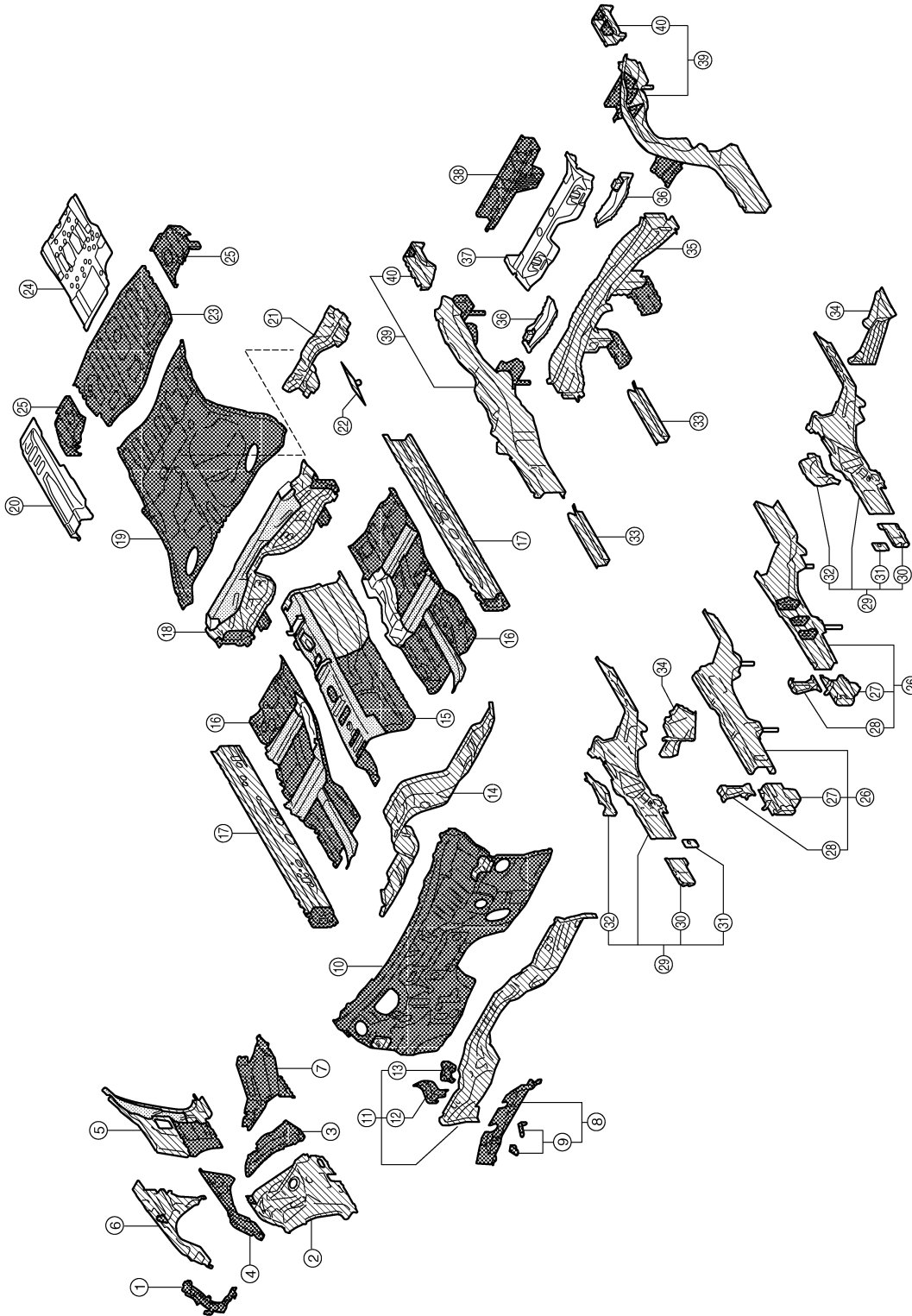



JSKIA1230ZZ

- | | | |
|---|-----------------------------------|--------------------------------------|
| 1. Radiator core support assembly (RH & LH) | 2. Front strut housing (RH & LH) | 3. Lower rear hoodledge (RH & LH) |
| 4. Upper front hoodledge (RH & LH) | 5. Upper rear hoodledge (RH & LH) | 6. Hoodledge reinforcement (RH & LH) |

BODY COMPONENT PARTS

< PREPARATION >

- | | | | |
|---|--|---|---|
| 7. Upper side cowl top (RH & LH) | 8. Upper front cowl top assembly | 9. Cowl top bracket | |
| 10. Upper dash | 11. Lower dash crossmember assembly | 12. Lower outer battery support bracket | A |
| 13. Lower battery support bracket | 14. Lower dash | 15. Center front floor | |
| 16. Front floor (RH & LH) | 17. Inner sill (RH & LH) | 18. Rear seat crossmember reinforcement assembly | B |
| 19. Rear floor front | 20. Rear floor reinforcement assembly | 21. Rear floor seat belt anchor reinforcement | |
| 22. Nut plate (RH & LH) | 23. Rear floor rear | 24. Spare wheel clamp reinforcement | C |
| 25. Rear floor side (RH & LH) | 26. Front side member assembly (RH & LH) | 27. Front side member front extension (RH & LH) | |
| 28. Front side member connector assembly (RH & LH) | 29. Front side member closing plate assembly (RH & LH) | 30. Front side member front closing plate (RH & LH) | D |
| 31. Front side rear closing reinforcement (RH & LH) | 32. Front side member center closing plate (RH & LH) | 33. Front side member rear extension (RH & LH) | |
| 34. Front side member outrigger assembly (RH & LH) | 35. Rear seat crossmember | 36. Rear seat crossmember (RH & LH) | E |
| 37. 2nd rear crossmember | 38. Rear crossmember center assembly | 39. Rear side member assembly (RH & LH) | F |
| 40. Rear side member extension (RH & LH) | | | |

-  Both sided anti-corrosive precoated steel sections
-  High strength steel (HSS) sections
-  Both sided anti-corrosive steel and HSS sections

NOTE:

For the parts without a number described in the figure, it is supplied only with the assembly part that the part is included with.

A
B
C
D
E
F
G
H
I
J
L
M
N
O
P

BRM

BODY COMPONENT PARTS

< PREPARATION >

Body Component Parts

INFOID:000000006934746

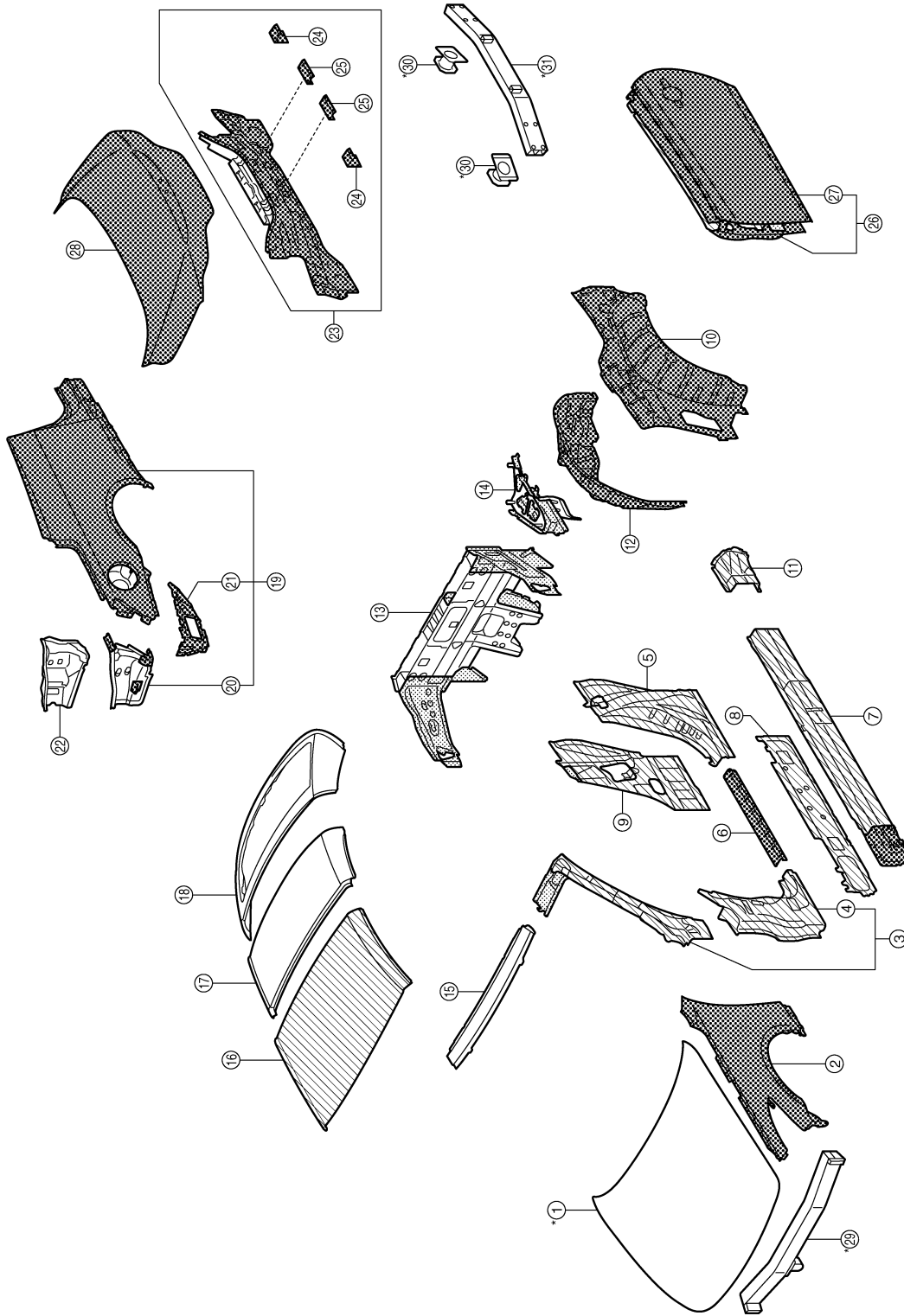

JSKIA1231ZZ

- | | | |
|---------------------------------|--|---|
| 1. Hood | 2. Front fender (RH & LH) | 3. Upper front pillar reinforcement (RH & LH) |
| 4. Front pillar brace (RH & LH) | 5. Outer lock pillar reinforcement (RH & LH) | 6. Outer step sill (RH & LH) |

BODY COMPONENT PARTS

< PREPARATION >

- | | | | |
|--|--|---------------------------------------|---|
| 7. Outer sill reinforcement (RH & LH) | 8. Lower front pillar reinforcement assembly (RH & LH) | 9. Inner lock pillar (RH & LH) | A |
| 10. Outer rear wheelhouse (RH & LH) | 11. Outer rear wheelhouse extension (RH & LH) | 12. Inner rear wheelhouse (RH & LH) | B |
| 13. Seat back support | 14. Inner rear wheelhouse reinforcement (RH & LH) | 15. Roof assembly | B |
| 16. Front roof assembly | 17. Center roof assembly | 18. Rear roof assembly | C |
| 19. Rear fender assembly (RH & LH) | 20. Rear combination lamp base (RH & LH) | 21. Rear fender extension (RH & LH) | C |
| 22. Rear lamp bracket reinforcement assembly (RH & LH) | 23. Rear panel assembly | 24. Rear bumper fascia center bracket | D |
| 25. Rear bumper fascia bracket | 26. Door assembly (RH & LH) | 27. Outer door panel (RH & LH) | D |
| 28. Trunk lid | 29. Inner center front bumper reinforcement | 30. Rear bumper stay (RH & LH) | E |
| 31. Inner center rear bumper reinforcement assembly | | | E |

 Both sided anti-corrosive pre-coated steel sections

 High strength steel (HSS) sections

 Both sided anti-corrosive steel and HSS sections

*: Aluminum portion

NOTE:

For the parts without a number described in the figure, it is supplied only with the assembly part that the part is included with.

A
B
C
D
E
F
G
H
I
J
L
M
N
O
P

BRM

CORROSION PROTECTION

< REMOVAL AND INSTALLATION >

REMOVAL AND INSTALLATION

CORROSION PROTECTION

Description

INFOID:000000006934747

To provide improved corrosion prevention, the following anti-corrosive measures have been implemented in NISSAN production plants. When repairing or replacing body panels, it is necessary to use the same anti-corrosive measures.

ANTI-CORROSIVE PRECOATED STEEL (GALVANNEALED STEEL)

To improve repairability and corrosion resistance, a new type of anti-corrosive precoated steel sheet has been adopted replacing conventional zinc-coated steel sheet.

Galvannealed steel is electroplated and heated to form Zinc-iron alloy, which provides excellent and long term corrosion resistance with cationic electrodeposition primer.

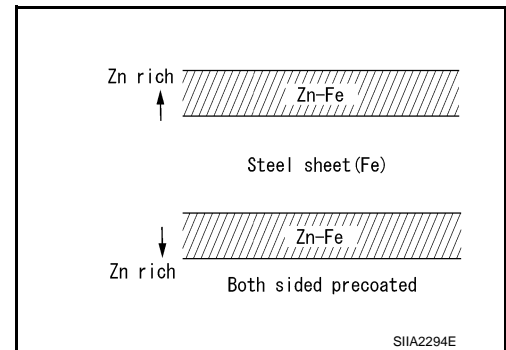

Nissan Genuine Service Parts are fabricated from galvannealed steel. Therefore, it is recommended that GENUINE NISSAN PARTS or equivalent be used for panel replacement to maintain the anti-corrosive performance built into the vehicle at the factory.

PHOSPHATE COATING TREATMENT AND CATIONIC ELECTRODEPOSITION PRIMER

A phosphate coating treatment and a cationic electrodeposition primer, which provide excellent corrosion protection, are employed on all body components.

CAUTION:

Confine paint removal during welding operations to an absolute minimum.

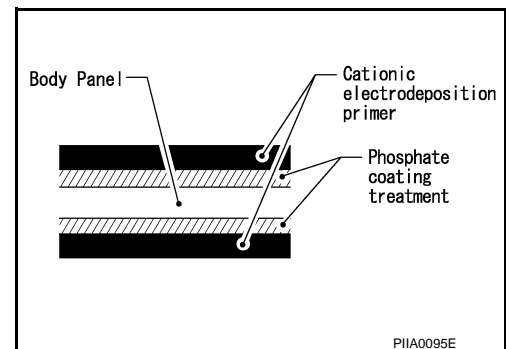

Nissan Genuine Service Parts are also treated in the same manner. Therefore, it is recommended that GENUINE NISSAN PARTS or an equivalent be used for panel replacement to maintain anti-corrosive performance built into the vehicle at the factory.

Anti-corrosive Wax

INFOID:000000006934748

To improve corrosion resistance, anti-corrosive wax is applied inside the body sill and inside other closed sections. Accordingly, when replacing these parts, be sure to apply anti-corrosive wax to the appropriate areas of the new parts. Select an excellent anti-corrosive wax which will penetrate after application and has a long shelf life.

DOOR

CORROSION PROTECTION

< REMOVAL AND INSTALLATION >

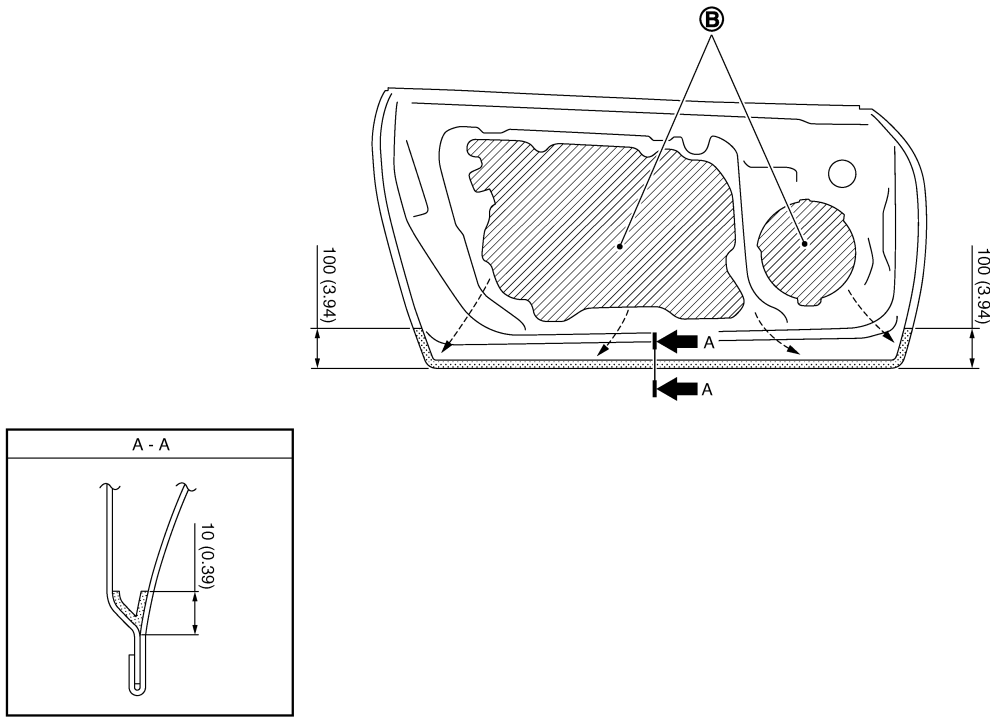

JSKIA1135GB

B. Nozzle insert hole

Unit: mm (in)

: Anti-corrosive wax coated portions

REAR FENDER

A
B
C
D
E
F
G
H
I
J
L
M
N
O
P

BRM

CORROSION PROTECTION

< REMOVAL AND INSTALLATION >

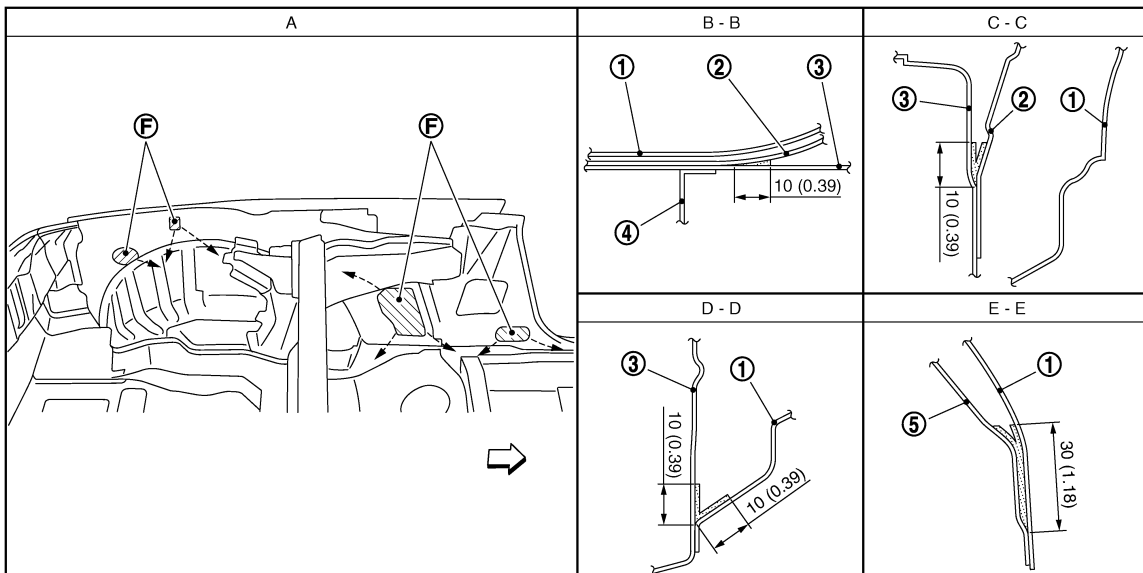
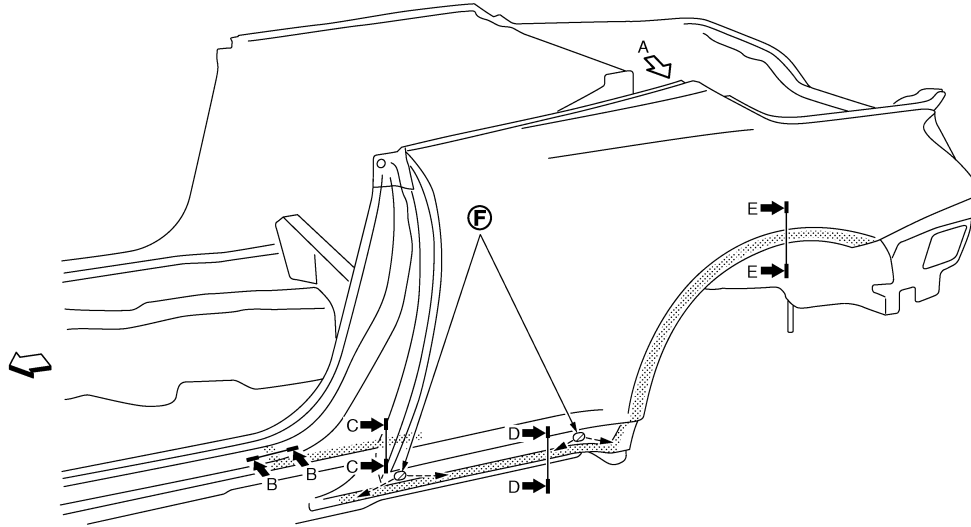

JSKIA1136GB

- | | | |
|-----------------------|------------------------------|-----------------------------|
| 1. Rear fender | 2. Lock pillar reinforcement | 3. Outer sill reinforcement |
| 4. Outer sill brace | 5. Outer rear wheelhouse | |
| F. Nozzle insert hole | | |

Unit: mm (in)

↔: Vehicle front

▨: Anti-corrosive wax coated portions

Undercoating

INFOID:000000006934749

The underside of the floor and wheelhouse are undercoated to prevent rust, vibration, noise and stone chipping. Therefore, when such a panel is replaced or repaired, apply undercoating to that part. Use an undercoating which is rust resistant, soundproof, vibration-proof, shock-resistant, adhesive, and durable.

PRECAUTIONS IN UNDERCOATING

1. Never apply undercoating to any place unless specified (such as the areas above the muffler and three-way catalyst that are subjected to heat).
2. Never undercoat the exhaust pipe or other parts that become hot.



CORROSION PROTECTION

< REMOVAL AND INSTALLATION >

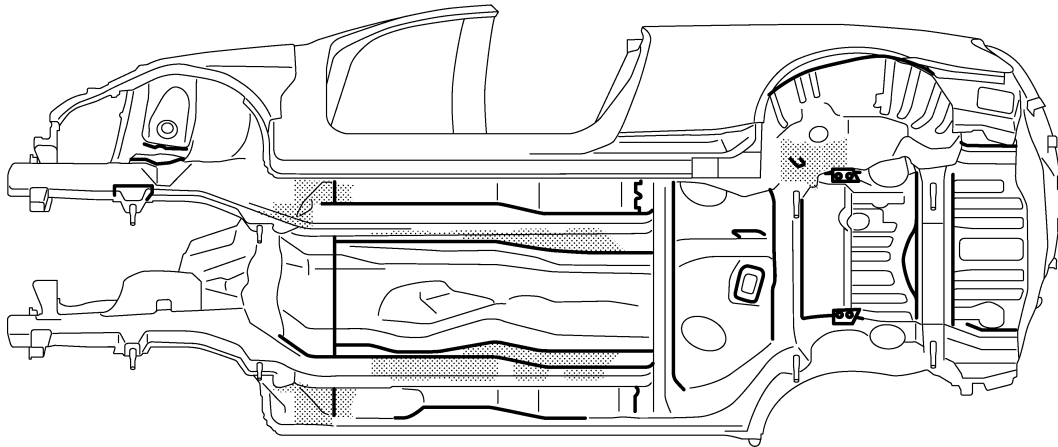
3. Never undercoat rotating parts.
4. Apply bitumen wax after applying undercoating.
5. After putting seal on the vehicle, put undercoating on it.



JSKIA1137ZZ

-  Undercoated areas
-  Sealed portions

Body Sealing

INFOID:000000006934750

The following figure shows the areas that are sealed at the factory. Sealant that is applied to these areas should be smooth and free from cuts or gaps. Care should be taken not to apply an excess amount of sealant and not to allow other unaffected parts to come into contact with the sealant.

A
B
C
D
E
F
G
H
I
J
L
M
N
O
P

BRM

CORROSION PROTECTION

< REMOVAL AND INSTALLATION >

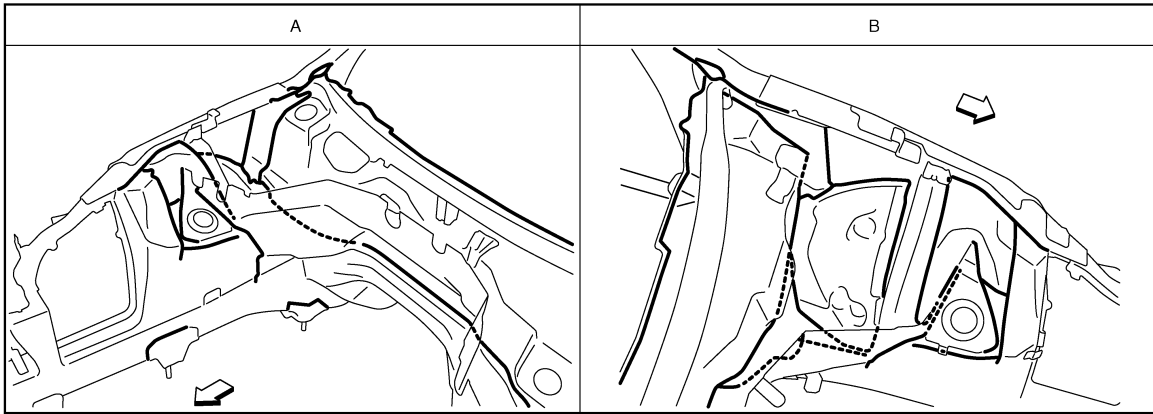
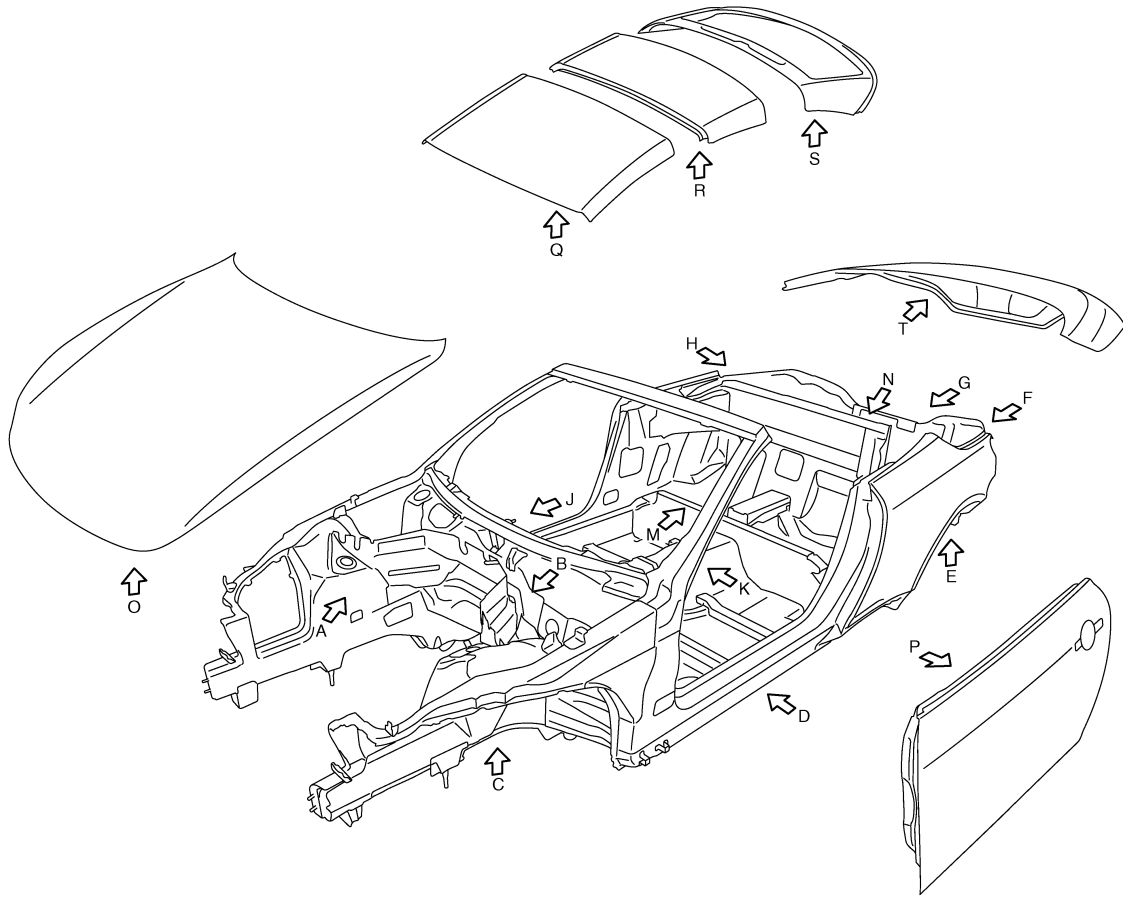

JSKIA1138ZZ

←: Vehicle front
—: Sealed portions

CORROSION PROTECTION

< REMOVAL AND INSTALLATION >

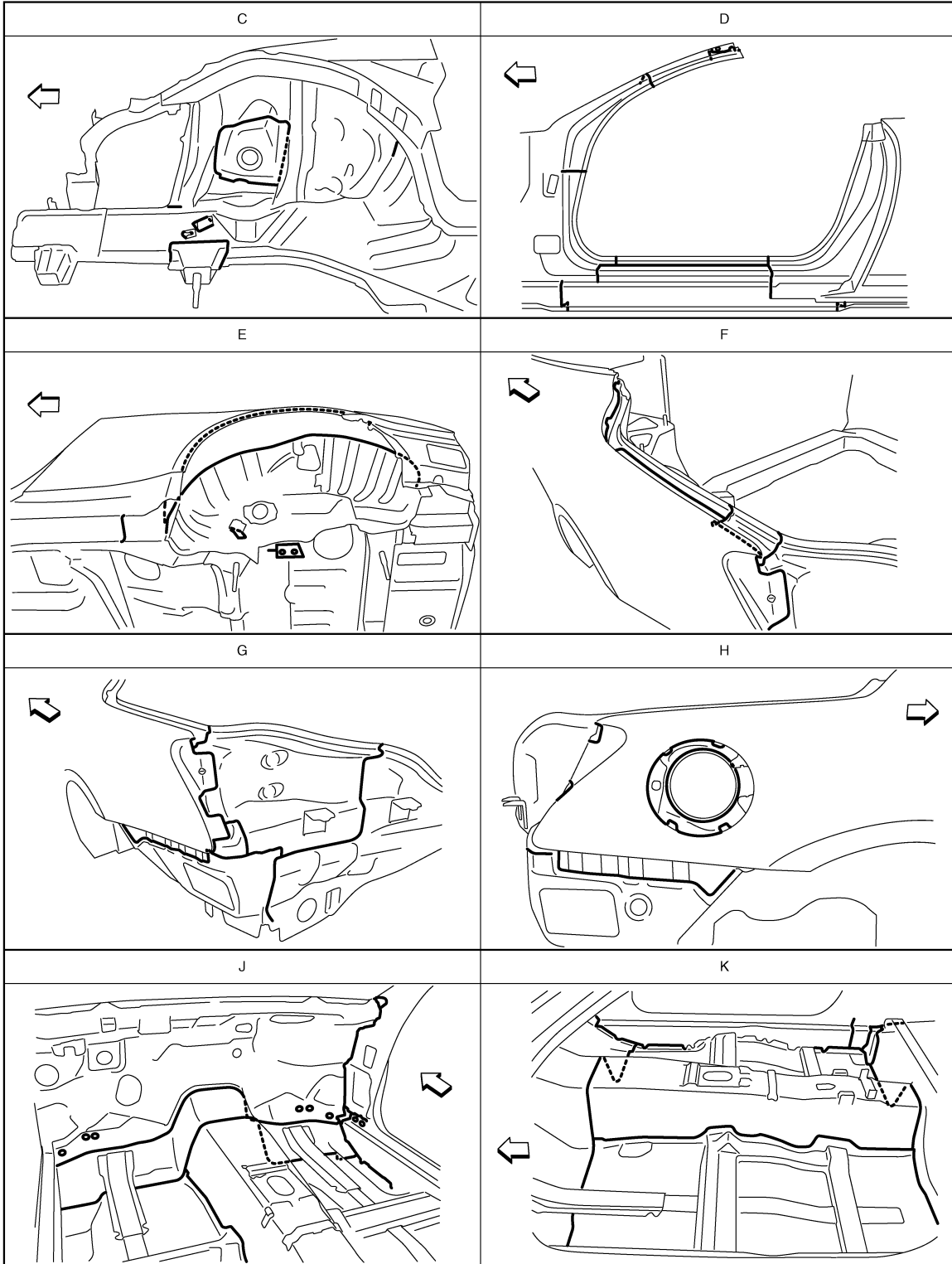

A
B
C
D
E
F
G
H
I
J
K
L
M
N
O
P

BRM

JSKIA1139ZZ

↔: Vehicle front
 —: Sealed portions

CORROSION PROTECTION

< REMOVAL AND INSTALLATION >

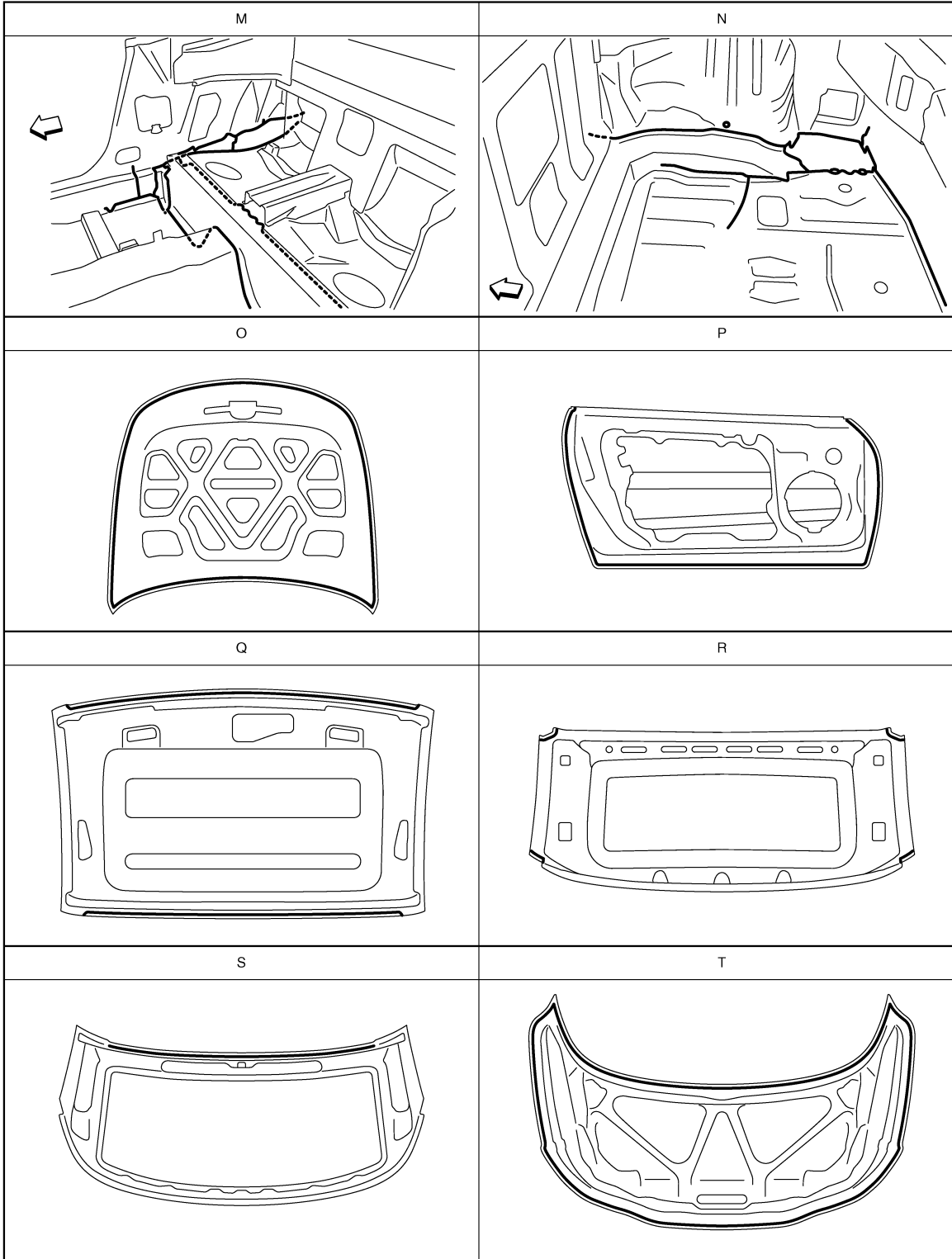

JSKIA1140ZZ

↔: Vehicle front
—: Sealed portions

BODY CONSTRUCTION

< REMOVAL AND INSTALLATION >

BODY CONSTRUCTION

Body Construction

INFOID:000000006934751

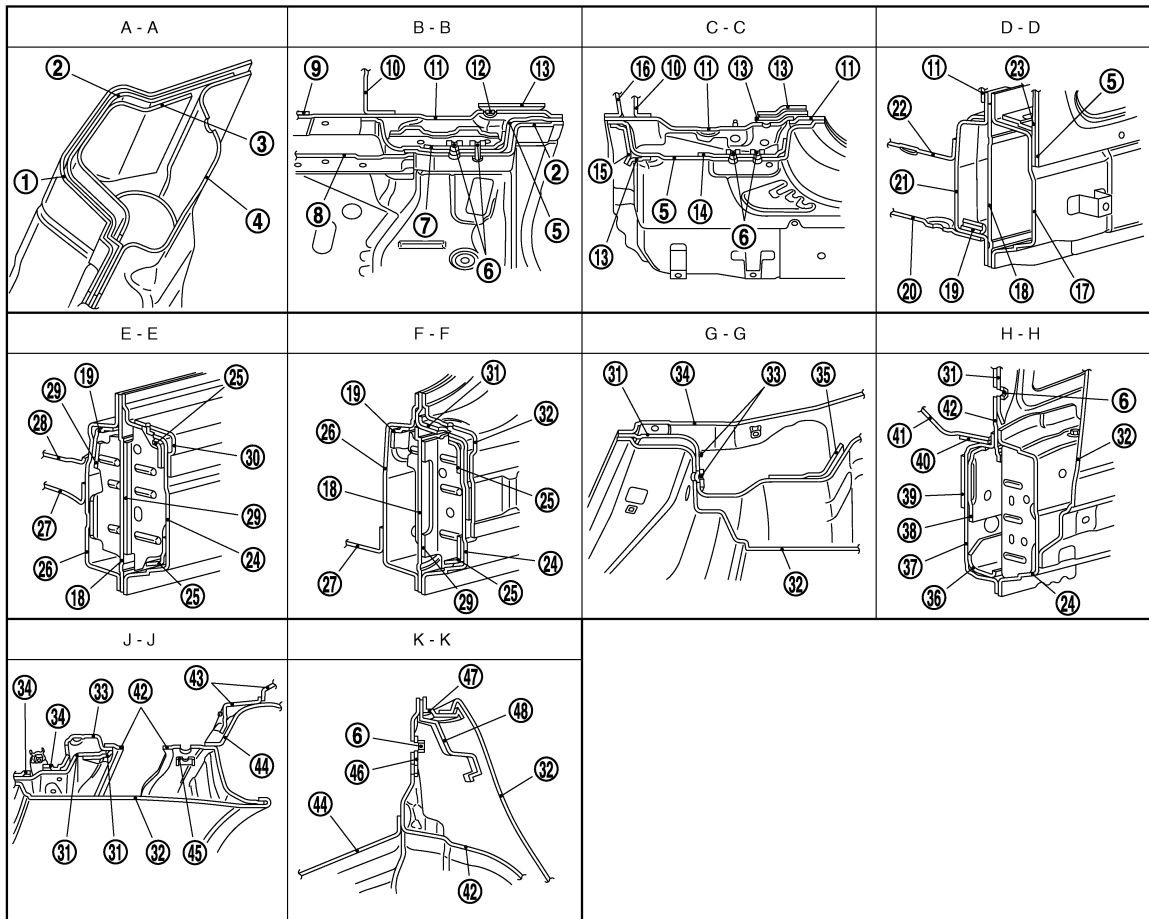
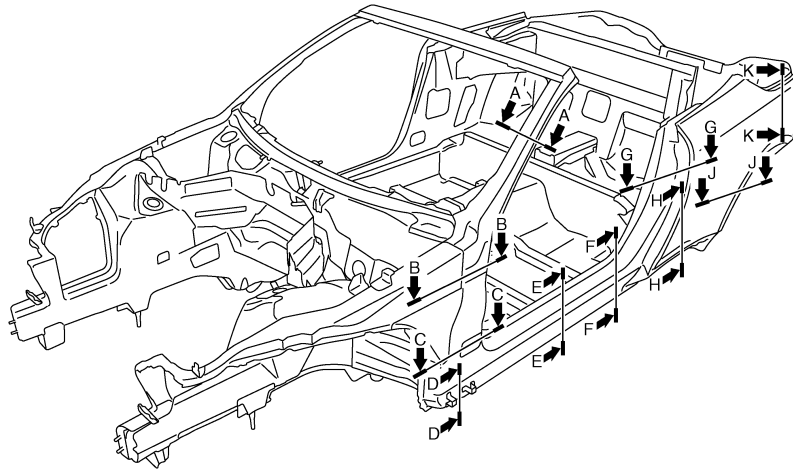

1. Upper outer front pillar
4. Upper inner front pillar
7. Upper hinge plate

2. Outer front pillar
5. Front pillar hinge brace
8. Hoodledge reinforcement

3. Outer front pillar reinforcement
6. Weld nut
9. Upper hoodledge

JSKIA1134ZZ

A
B
C
D
E
F
G
H
I
J
K
L
M
N
O
P

BRM

BODY CONSTRUCTION

< REMOVAL AND INSTALLATION >

- | | | |
|---|---|--|
| 10. Upper dash | 11. Upper rear hoodledge | 12. Weld bolt |
| 13. Rear hoodledge reinforcement | 14. Lower hinge plate | 15. Hoodledge reinforcement gusset |
| 16. Lower dash crossmember | 17. Outer front sill brace | 18. Lower front pillar reinforcement |
| 19. Inner sill reinforcement | 20. Front side member outrigger | 21. Inner front sill reinforcement |
| 22. Lower dash | 23. Lower front pillar gusset | 24. Outer sill reinforcement |
| 25. Center sill reinforcement | 26. Inner sill | 27. Front floor |
| 28. 2nd crossmember | 29. Outer sill brace | 30. Outer sill step |
| 31. Lock pillar reinforcement | 32. Rear fender | 33. Striker plate |
| 34. Inner lock pillar | 35. Upper inner lock pillar reinforcement | 36. Rear tie down hook bracket |
| 37. Rear tie down hook bracket | 38. Rear side member front reinforcement | 39. Rear seat crossmember |
| 40. Rear seat crossmember reinforcement | 41. Rear floor front | 42. Outer rear wheelhouse |
| 43. Inner rear wheelhouse reinforcement | 44. Inner rear wheelhouse | 45. Lower rear window regulator bracket |
| 46. Nut plate | 47. Upper rear fender extension | 48. Center outer body side reinforcement |

Rear Fender Hemming Process

INFOID:000000006934752

1. A wheel arch is to be installed and hemmed over the left and right outer wheel houses.
2. In order to hem the wheel arch, it is necessary to repair any damaged or defaced parts around outer wheel house.

CAUTION:

Ensure that the area that is to be glued around the outer wheelhouse is undamaged or defaced.

PROCEDURE OF THE HEMMING PROCESS

- Peel off old bonding material on the surface of the outer wheelhouse and clean thoroughly.
- Peel off a primer coat in the specified area where new adhesive is to be applied on rear fender (the replacing part).
- Apply new adhesive to both specified areas of the outer wheelhouse and rear fender.

<Adhesive> **3M™ Automix™ Panel Bonding Adhesive 08115 or equivalent**

- Attach rear fender to the body of the car, and weld the required part except the hemming part.

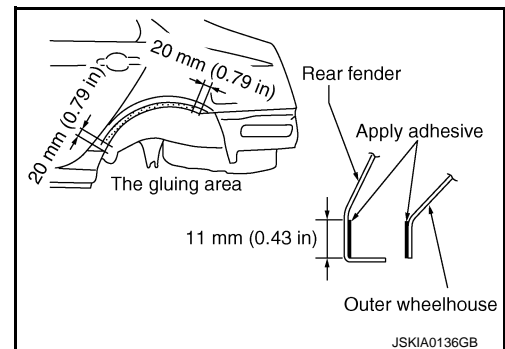

- Bend the welded part starting from the center of the wheel arch gradually with a hammer and a dolly. (Also hem the end of the flange.)
- Hemming with a hammer is conducted to an approximate angle of 80 degrees.

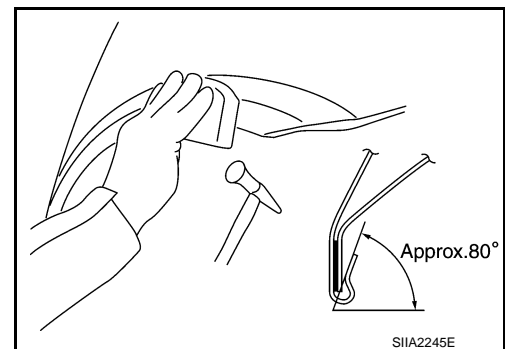

BODY CONSTRUCTION

< REMOVAL AND INSTALLATION >

- Starting from the center, hem the wheel arch gradually, using slight back and forth motion with a hemming tool.

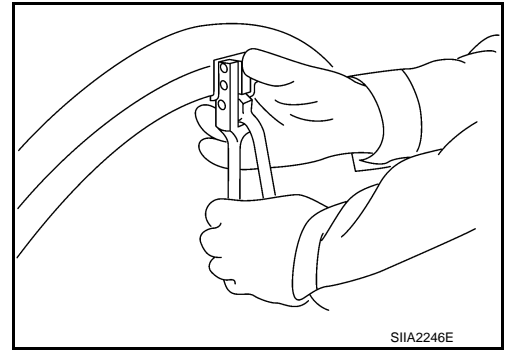

- Seal up the area around the hemmed end of the flange.

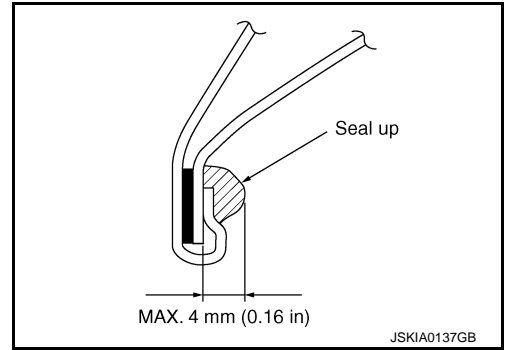

A
B
C
D
E
F
G
H
I
J
L
M
N
O
P

BRM

REPLACEMENT OPERATIONS

< REMOVAL AND INSTALLATION >





REPLACEMENT OPERATIONS

Description

INFOID:000000006934753

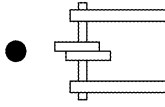
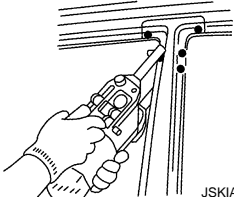
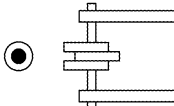
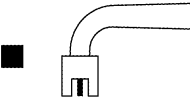
- This section is prepared for technicians who have attained a high level of skill and experience in repairing collision-damaged vehicles and also use modern service tools and equipment. Persons unfamiliar with body repair techniques should not attempt to repair collision-damaged vehicles by using this section.
- Technicians are also encouraged to read Body Repair Manual (Fundamentals) in order to ensure that the original functions and quality of the vehicle can be maintained. The Body Repair Manual (Fundamentals) contains additional information, including cautions and warning, that are not including in this manual. Technicians should refer to both manuals to ensure proper repairs.
- Please note that these information are prepared for worldwide usage, and as such, certain procedures might not apply in some regions or countries.

The symbols used in this section for welding operations are shown below.

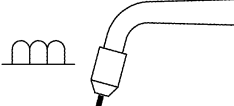
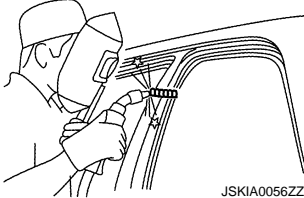
| Symbol marks | Description | |
|--|----------------------------|---|
|  <p data-bbox="402 844 490 861">JSKIA0049ZZ</p> | 2-spot welds |  <p data-bbox="1291 970 1377 987">JSKIA0053ZZ</p> |
|  <p data-bbox="402 1096 490 1113">JSKIA0050ZZ</p> | 3-spot welds | |
|  <p data-bbox="402 1474 490 1491">JSKIA0051ZZ</p> | MIG plug weld |  <p data-bbox="1291 1348 1377 1365">JSKIA0054ZZ</p> <p data-bbox="1010 1381 1318 1407">For 3 panels plug weld method</p> <div style="display: flex; flex-direction: column; align-items: center;"> <div data-bbox="1144 1438 1307 1480"> <p data-bbox="1144 1449 1177 1470">■ A</p>  </div> <div data-bbox="1144 1533 1307 1575"> <p data-bbox="1144 1543 1177 1564">■ B</p>  </div> </div> <p data-bbox="1291 1600 1377 1617">JSKIA0055ZZ</p> |
|  <p data-bbox="402 1852 490 1869">JSKIA0052ZZ</p> | MIG seam weld / Point weld |  <p data-bbox="1291 1852 1377 1869">JSKIA0056ZZ</p> |

REPLACEMENT OPERATIONS

< REMOVAL AND INSTALLATION >

- Front pillar butt joint can be determined anywhere within shaded area as shown in the figure. The best location for the butt joint is at position A due to the construction of the vehicle. Refer to the front pillar section.

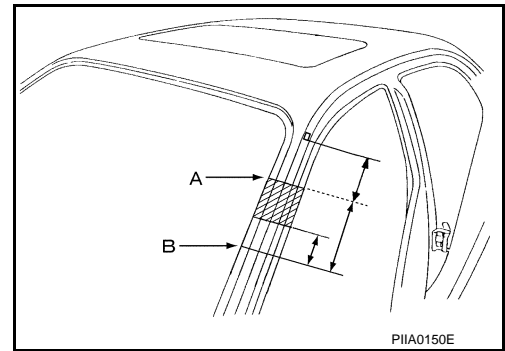

- Determine cutting position and record distance from the locating indent. Use this distance when cutting the service part. Cut outer front pillar over 60 mm (2.36 in) above inner front pillar cut position.

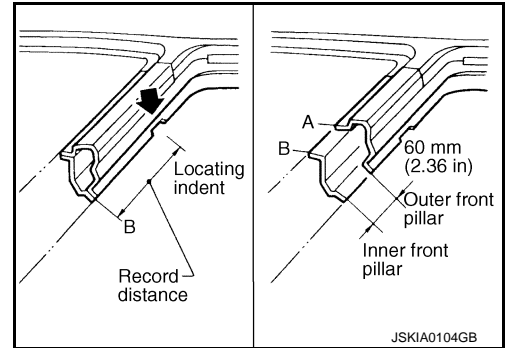

- Prepare a cutting jig to make outer pillar easier to cut. Also, this will permit service part to be accurately cut at joint position.

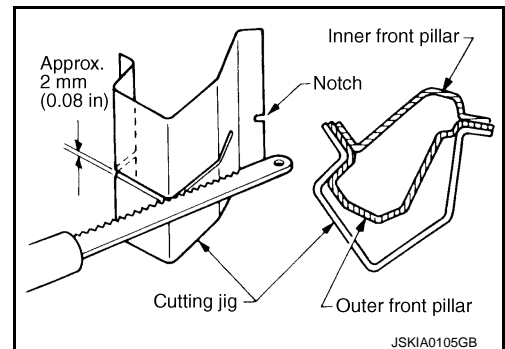

- An example of cutting operation using a cutting jig is as follows.

1. Mark cutting lines.
A: Cut position of outer pillar
B: Cut position of inner pillar
2. Align cutting line with notch on jig. Clamp jig to pillar.
3. Cut outer pillar along groove of jig (at position A).
4. Remove jig and cut remaining portions.
5. Cut inner pillar at position B in same manner.

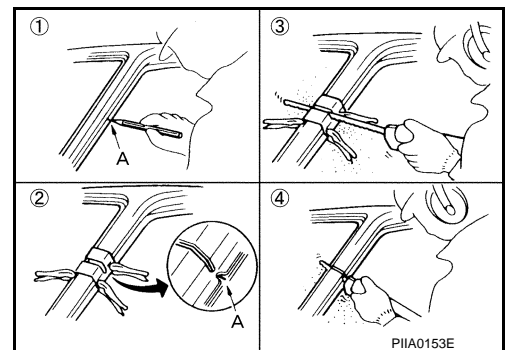

REAR FENDER HEMMING PROCESS

1. A wheel arch is to be installed and hemmed over left and right outer wheel house.
2. In order to hem the wheel arch, it is necessary to repair any damaged or defaced parts around outer wheel house.

CAUTION:

Ensure that the area that is to be glued around outer wheelhouse is undamaged or defaced.

Procedure of the hemming process

A
B
C
D
E
F
G
H
I
J
L
M
N
O
P

BRM

REPLACEMENT OPERATIONS

< REMOVAL AND INSTALLATION >

- Peel off old bonding material on the surface of outer wheelhouse and clean thoroughly.
- Peel off a primer coat in the specified area where new adhesive is to be applied on rear fender (the replacing part).
- Apply new adhesive to both specified areas of outer wheelhouse and rear fender.

**<Adhesive> 3M automix panel bond 8115,
or any equivalents**

- Attach rear fender to the body of the car, and weld the required part except the hemming part.

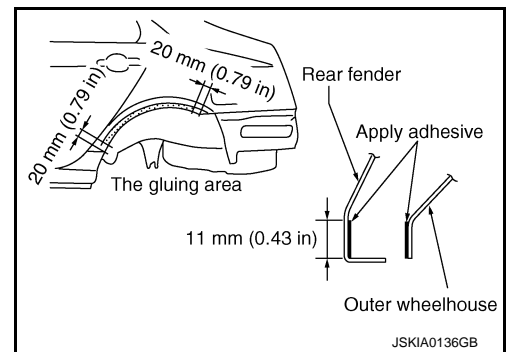

- Bend the welded part starting from the center of the wheel arch gradually with a hammer and a dolly. (Also hem the end of the flange.)
- Hemming with a hammer is conducted to an approximate angle of 80 degrees.

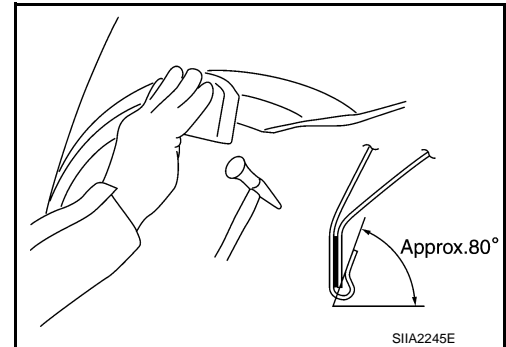

- Starting from the center, hem the wheel arch gradually, using slight back and forth motion with a hemming tool.

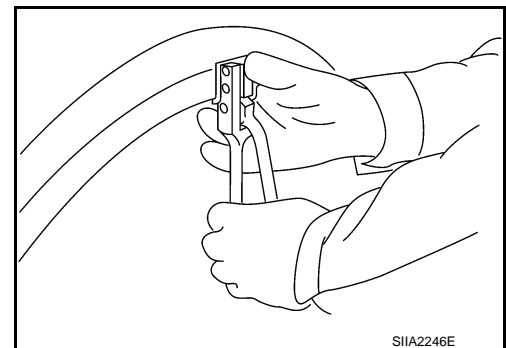

- Seal up the area around the hemmed end of the flange.

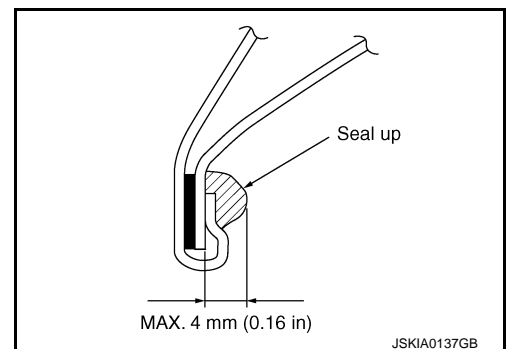

FOAM REPAIR

During factory body assembly, foam insulators are installed in certain body panels and locations around the vehicle. Use the following procedure (s) to replace any factory-installed foam insulators.

Urethane foam applications

Use commercially available spray foam for sealant (foam material) repair of material used on vehicle. Read instructions on product for fill procedures.

1. Fill procedures after installation of service part.
 - Remove foam material remaining on vehicle side.
 - Clean area in which foam was removed.
 - Install service part.

REPLACEMENT OPERATIONS

< REMOVAL AND INSTALLATION >

- Insert nozzle into hole near fill area and fill foam material or fill in enough to close gap with the service part.

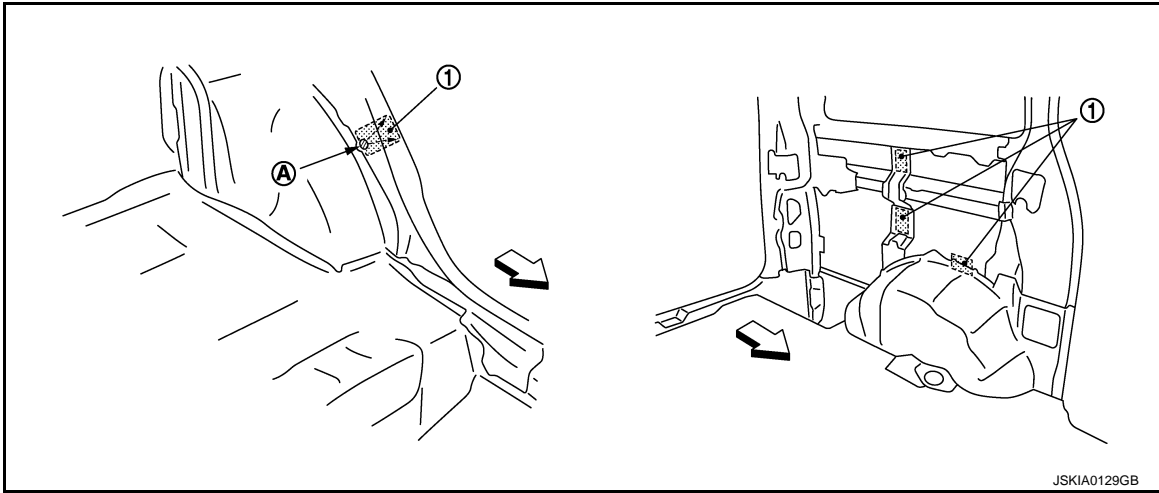

- 1. Urethane foam
- A. Nozzle insert hole
- ⇐ : Vehicle front

- 2. Fill procedures before installation of service part.
 - Remove foam material remaining on vehicle side.
 - Clean area in which foam was removed.
 - Fill foam material on wheelhouse outer side.

- 1. Urethane foam
- A. Fill while avoiding flange area
- ⇐ : Vehicle front

NOTE:

Fill in enough to close gap with service part while avoiding flange area.

- Install service part.

NOTE:

Refer to label for information on working times.

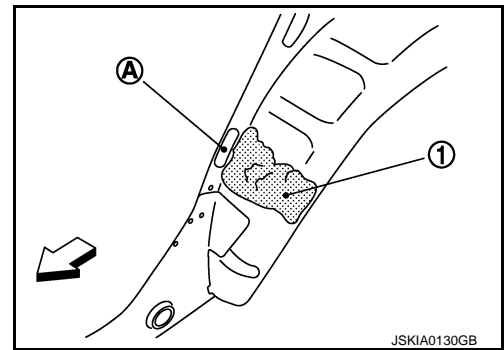

A
B
C
D
E
F
G
H
I
J
BRM
L
M
N
O
P

REPLACEMENT OPERATIONS

< REMOVAL AND INSTALLATION >

Radiator Core Support

INFOID:000000006934754

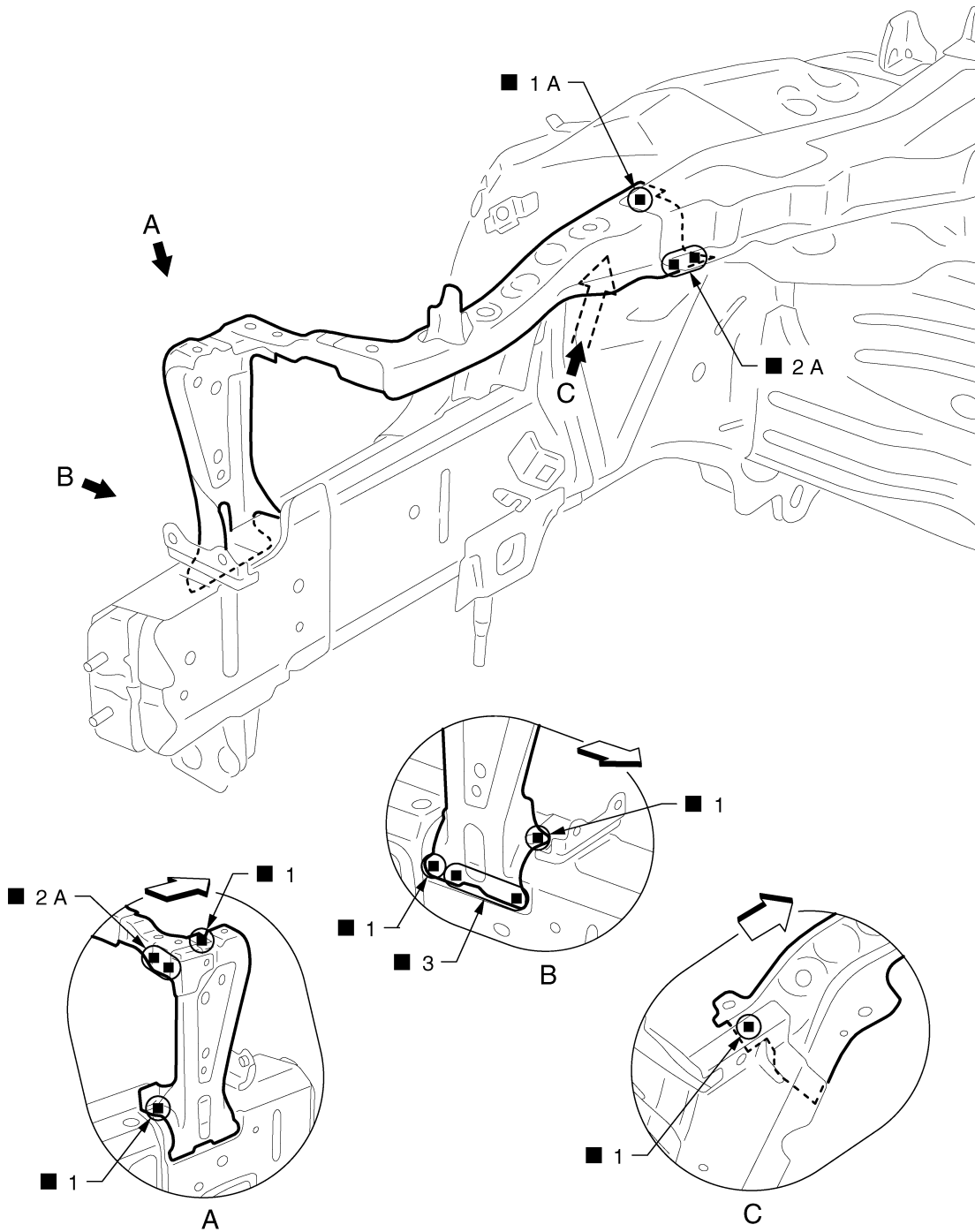

JSKIA0373GB

←: Vehicle front

Replacement parts

- Radiator core support assembly (LH)
- Front side member connector assembly (LH)

Hoodledge

INFOID:000000006934755

Work after radiator core support is removed.
Remove the front side member center closing plate (reusable).

REPLACEMENT OPERATIONS

< REMOVAL AND INSTALLATION >

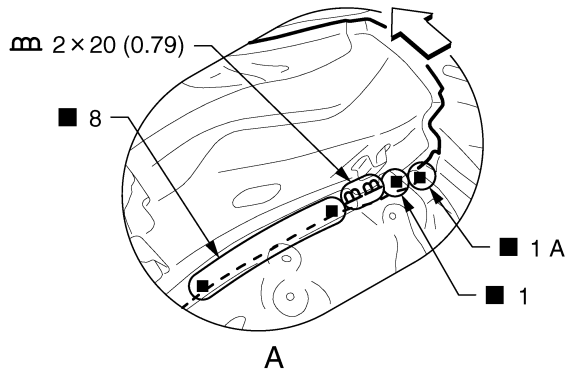
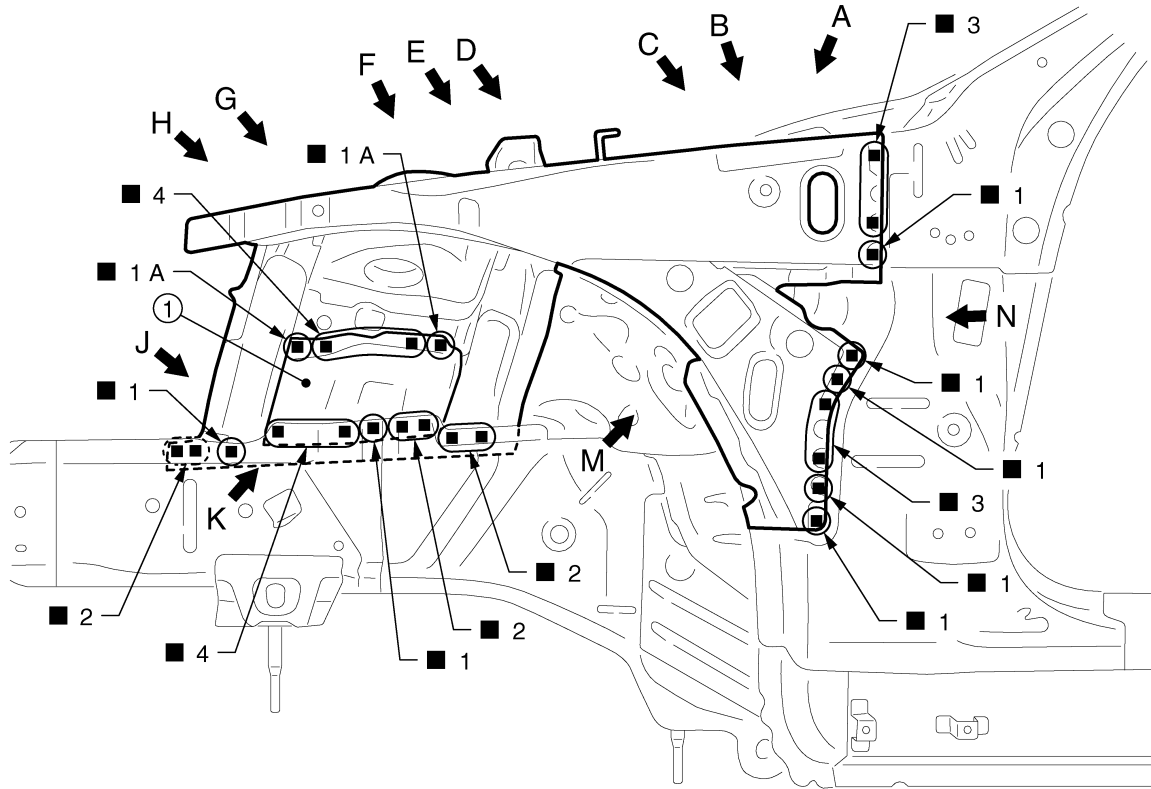

JSKIA1109GB

1. Front side member center closing plate

Unit: mm (in)

← Vehicle front

○: Weld the parts onto the back of the component part.

Replacement parts

- Upper front hoodedge (LH)
- Hoodedge reinforcement (LH)
- Front strut housing (LH)

REPLACEMENT OPERATIONS

< REMOVAL AND INSTALLATION >

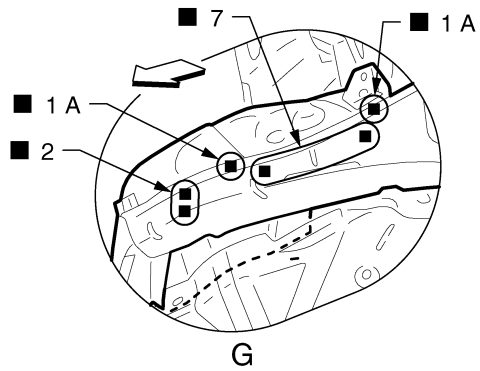
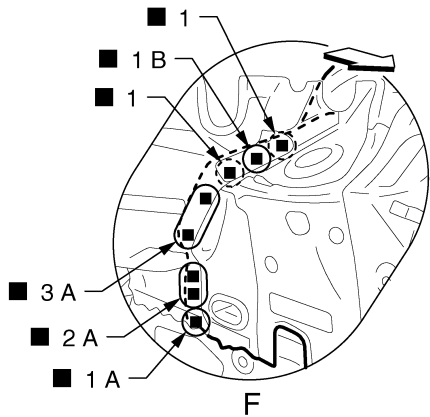
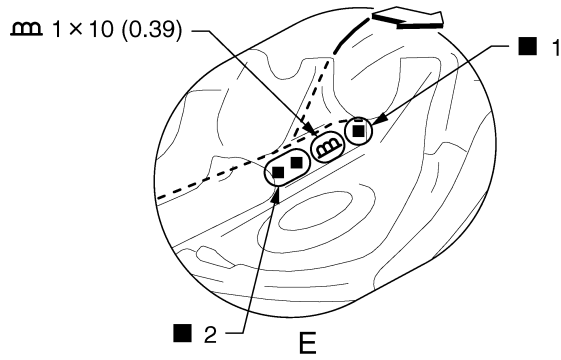
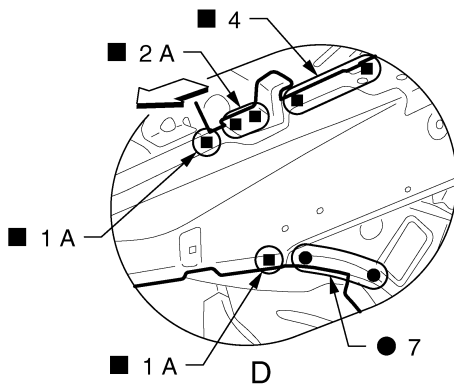
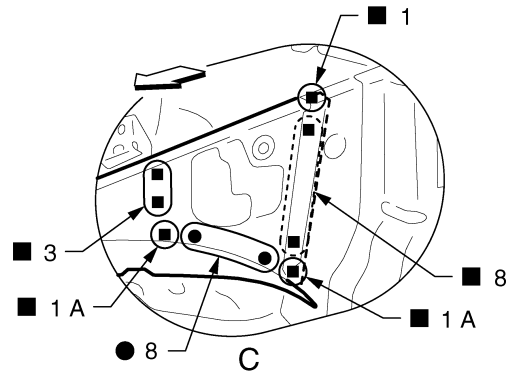
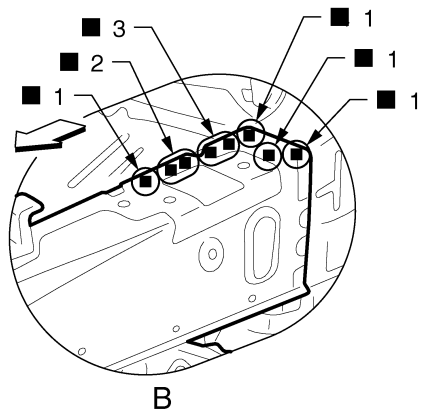

JSKIA1110GB

Unit: mm (in)

↔: Vehicle front

○: Weld the parts onto the back of the component part.

View C and G: Before installing hoodledge reinforcement

REPLACEMENT OPERATIONS

< REMOVAL AND INSTALLATION >

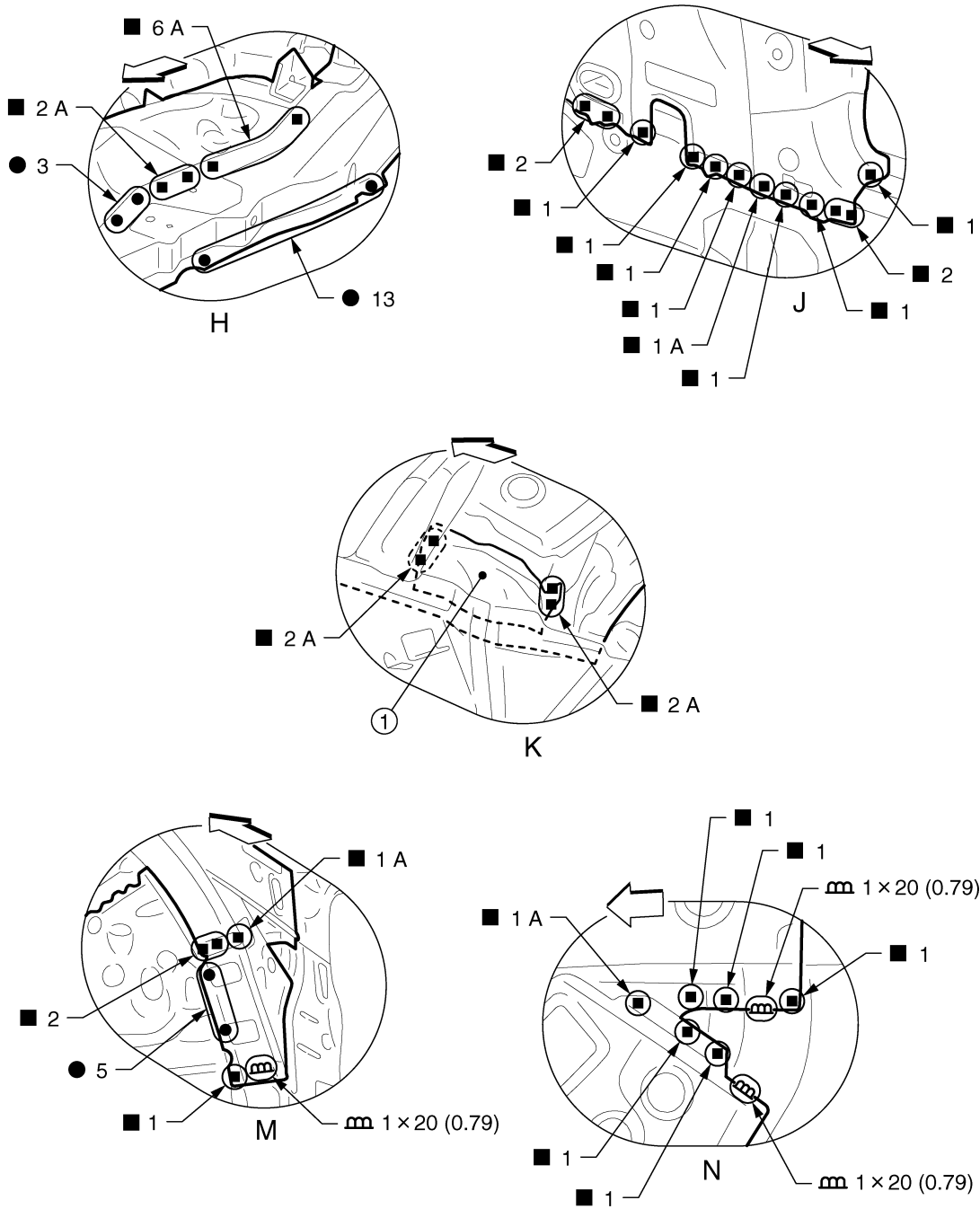

- 1. Front side member center closing plate

Unit: mm (in)

← Vehicle front

○: Weld the parts onto the back of the component part.

Front Side Member

INFOID:000000006934756

Work after radiator core support and hoodledge are removed.
 Remove the front side member center closing plate (reusable) from the service part "front side member closing plate assembly" for easier installation of hoodledge.

A
B
C
D
E
F
G
H
I
J
K
L
M
N
O
P

BRM

REPLACEMENT OPERATIONS

< REMOVAL AND INSTALLATION >

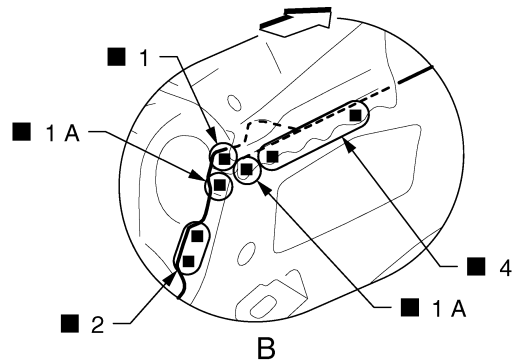
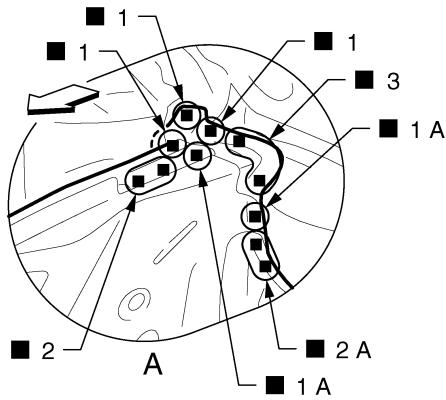
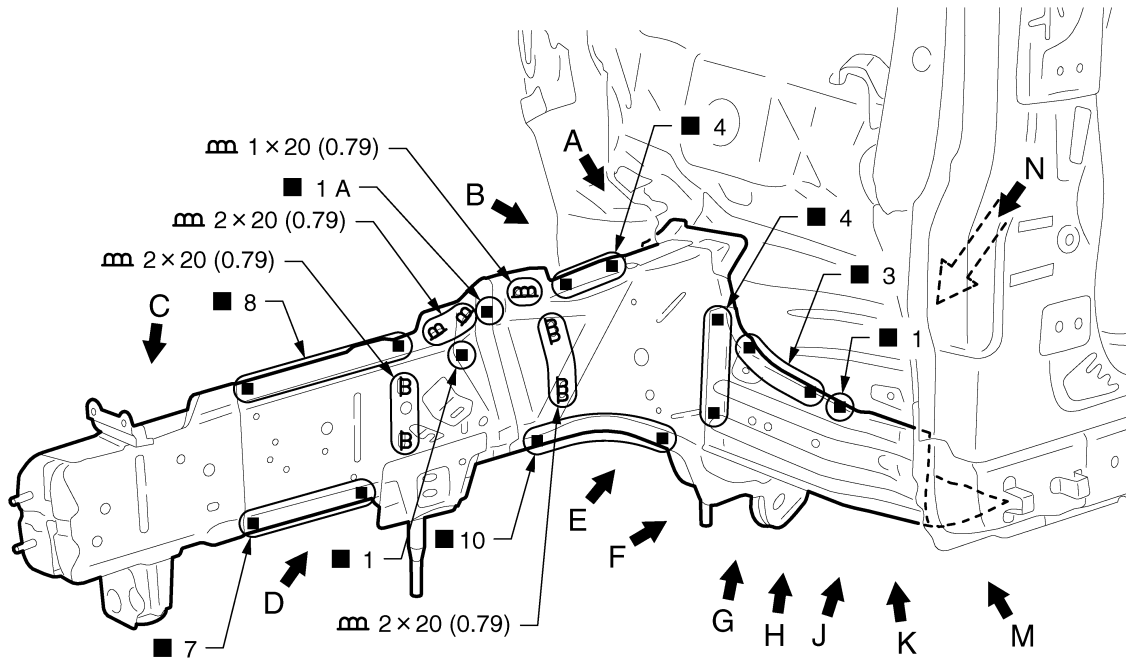

JSKIA1112GB

Unit: mm (in)

↔: Vehicle front

Replacement parts

- Front side member assembly (LH)
- Front side member closing plate assembly (LH)
- Front side member outrigger assembly (LH)

REPLACEMENT OPERATIONS

< REMOVAL AND INSTALLATION >

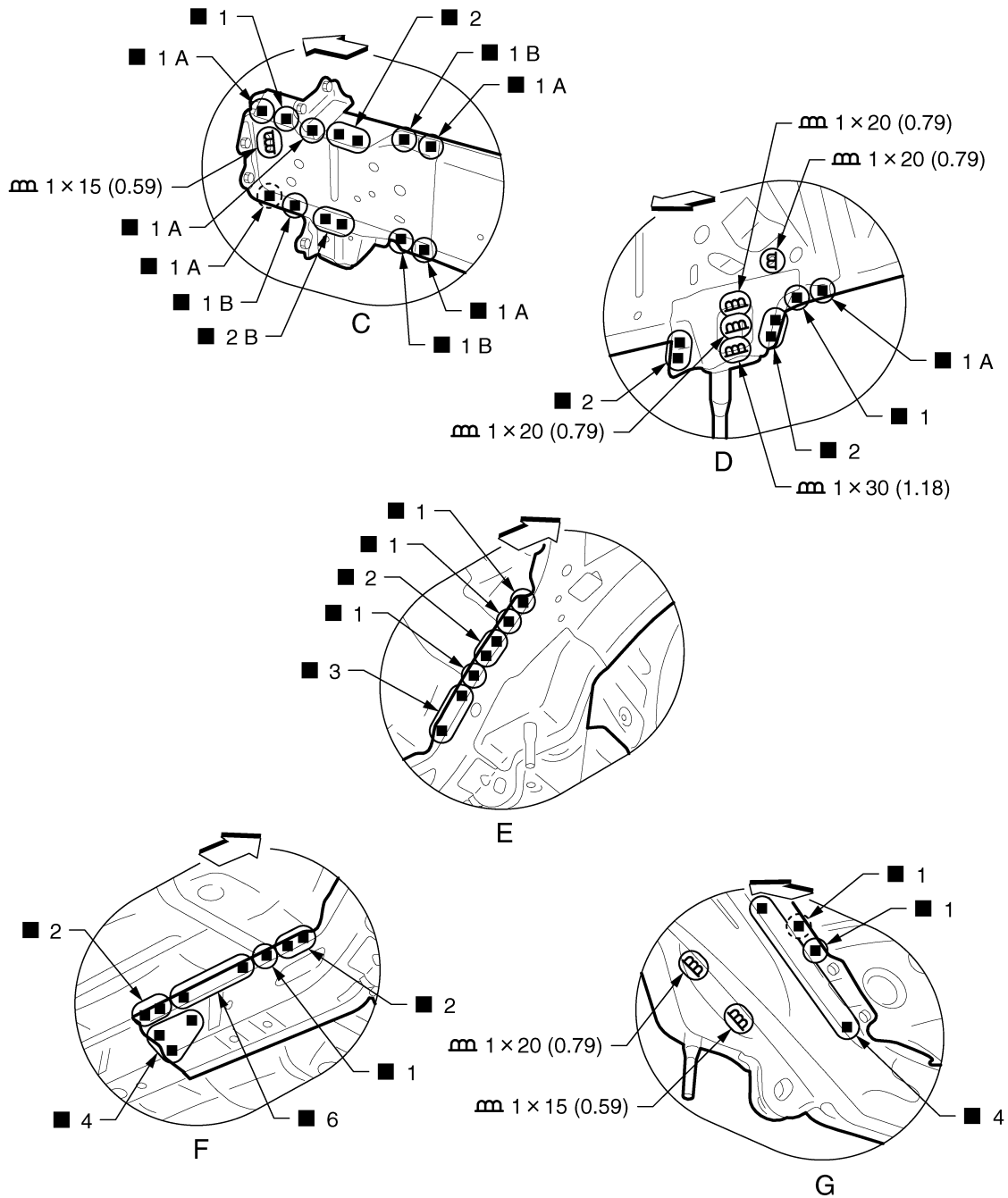

JSKIA1113GB

Unit: mm (in)

↔: Vehicle front

⊕: Weld the parts onto the back of the component part.

View G: Before installing front side member outrigger assembly

A
B
C
D
E
F
G
H
I
J
L
M
N
O
P

BRM

REPLACEMENT OPERATIONS

< REMOVAL AND INSTALLATION >

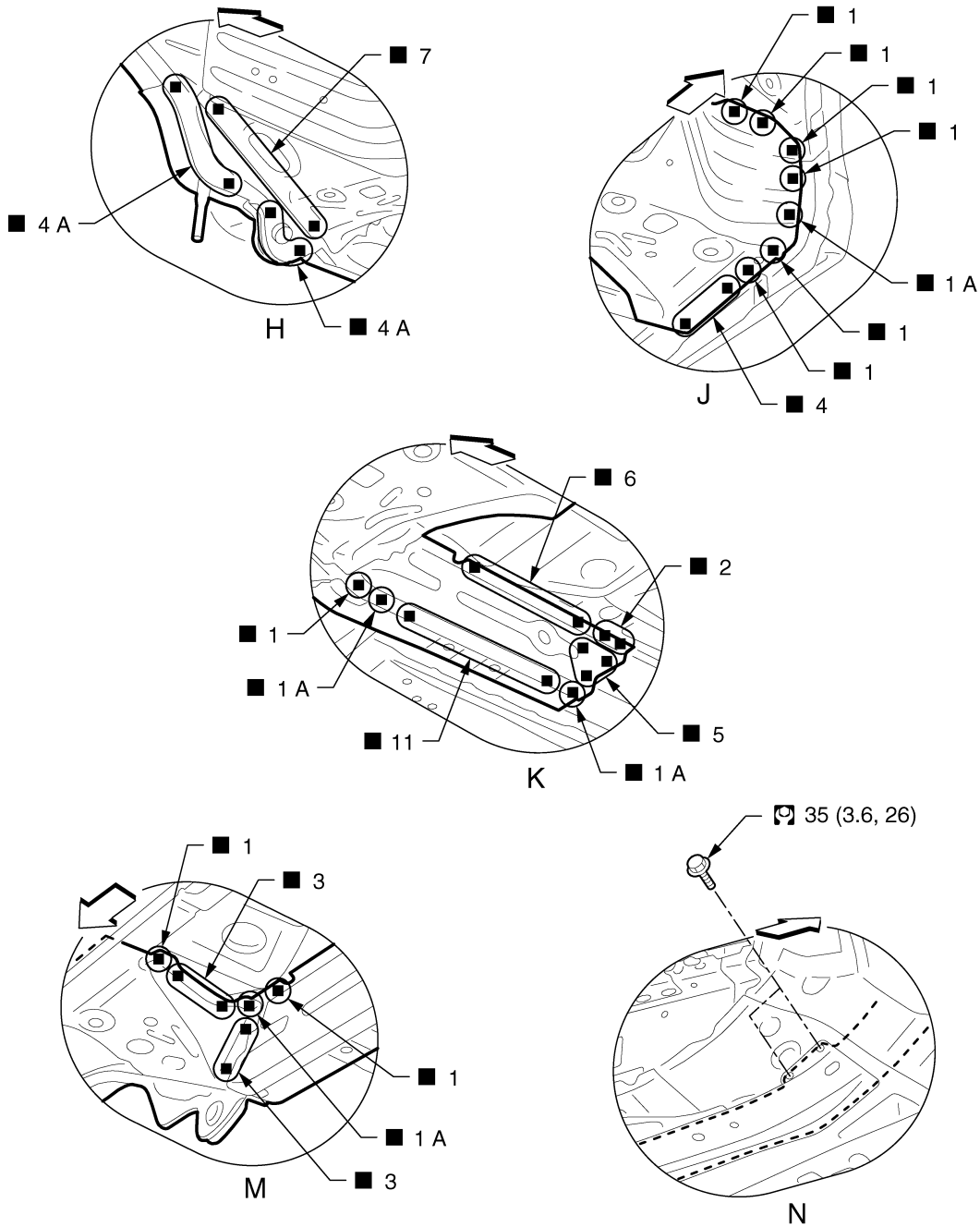

JSKIA1114GB

↔: Vehicle front

Refer to [GI-4, "Components"](#) for symbols in the figure.

Front Side Member (Partial Replacement)

INFOID:000000006934757

Work after radiator core support is removed.

REPLACEMENT OPERATIONS

< REMOVAL AND INSTALLATION >

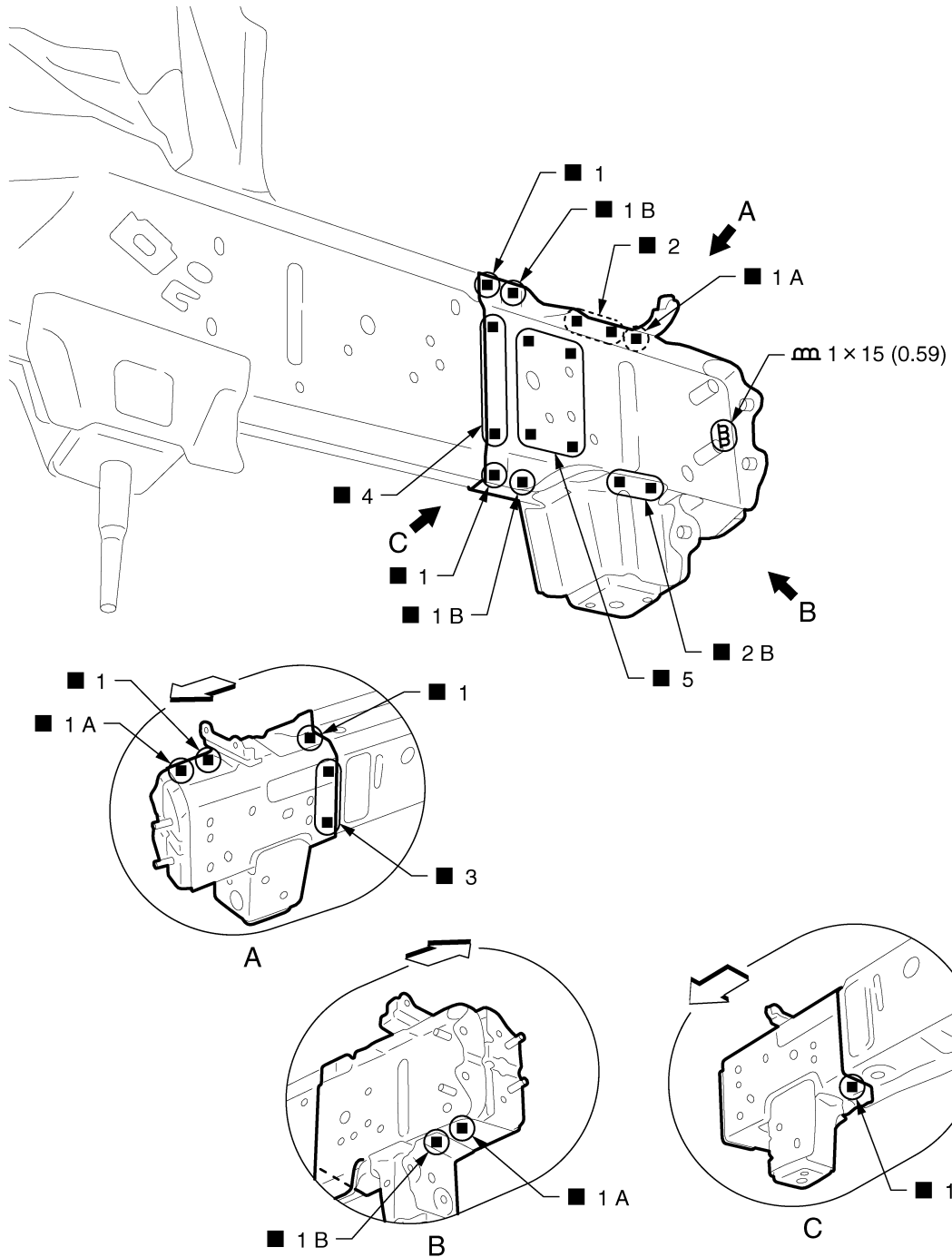

JSKIA1115GB

Unit: mm (in)

↔: Vehicle front

⊕: Weld the parts onto the back of the component part.

Replacement parts

- Front side member front extension (RH)
- Front side member front closing plate (RH)
- Front side rear closing reinforcement (RH)

Front Pillar

INFOID:000000006934758

Work after hoodledge reinforcement and outer step sill are removed.

A
B
C
D
E
F
G
H
I
J
BRM
L
M
N
O
P

REPLACEMENT OPERATIONS

< REMOVAL AND INSTALLATION >

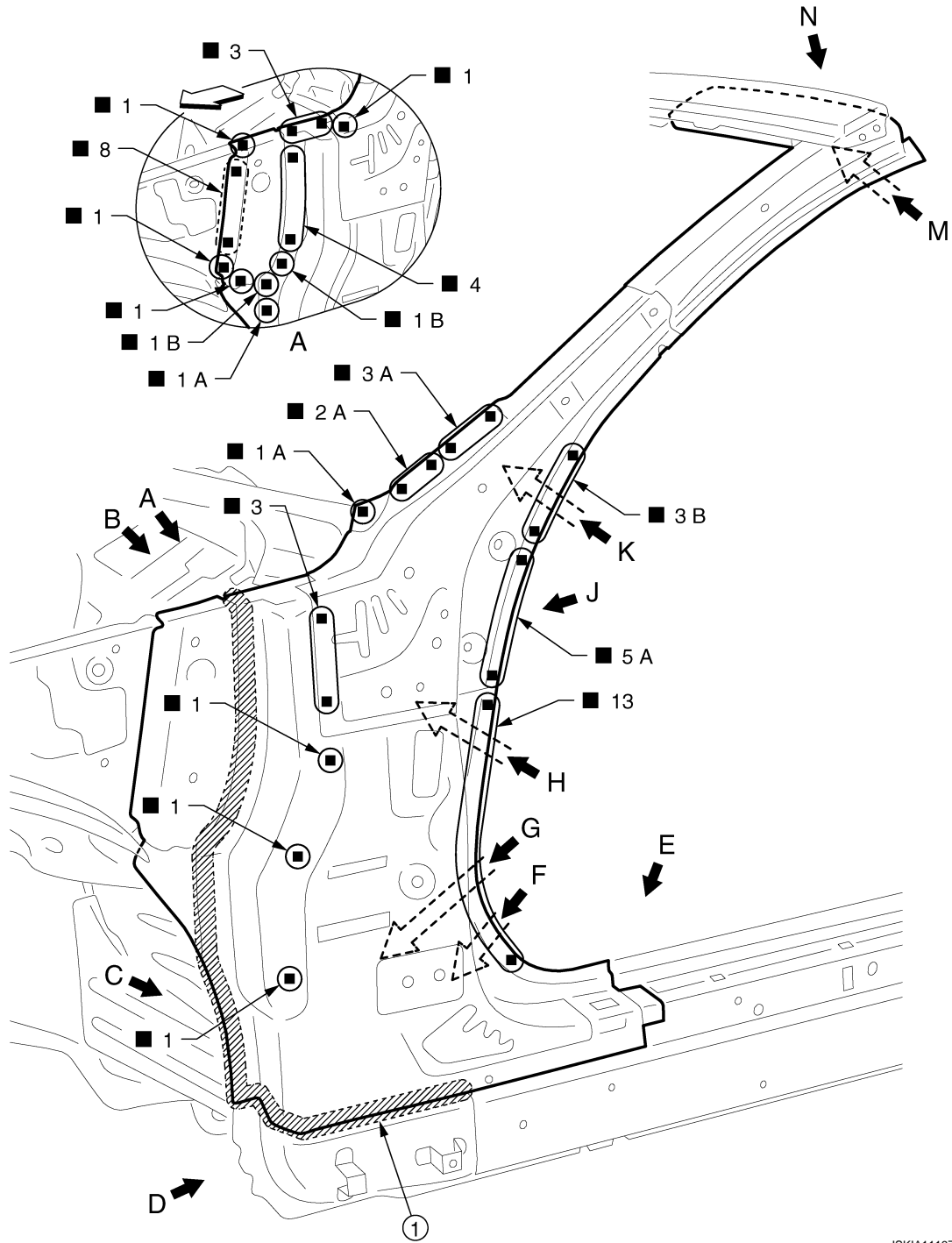

JSKIA116ZZ

1. Body sealing

↔: Vehicle front

○: Weld the parts onto the back of the component part.

Replacement parts

- Upper front pillar reinforcement (LH)
- Upper rear hoodledge (LH)

REPLACEMENT OPERATIONS

< REMOVAL AND INSTALLATION >

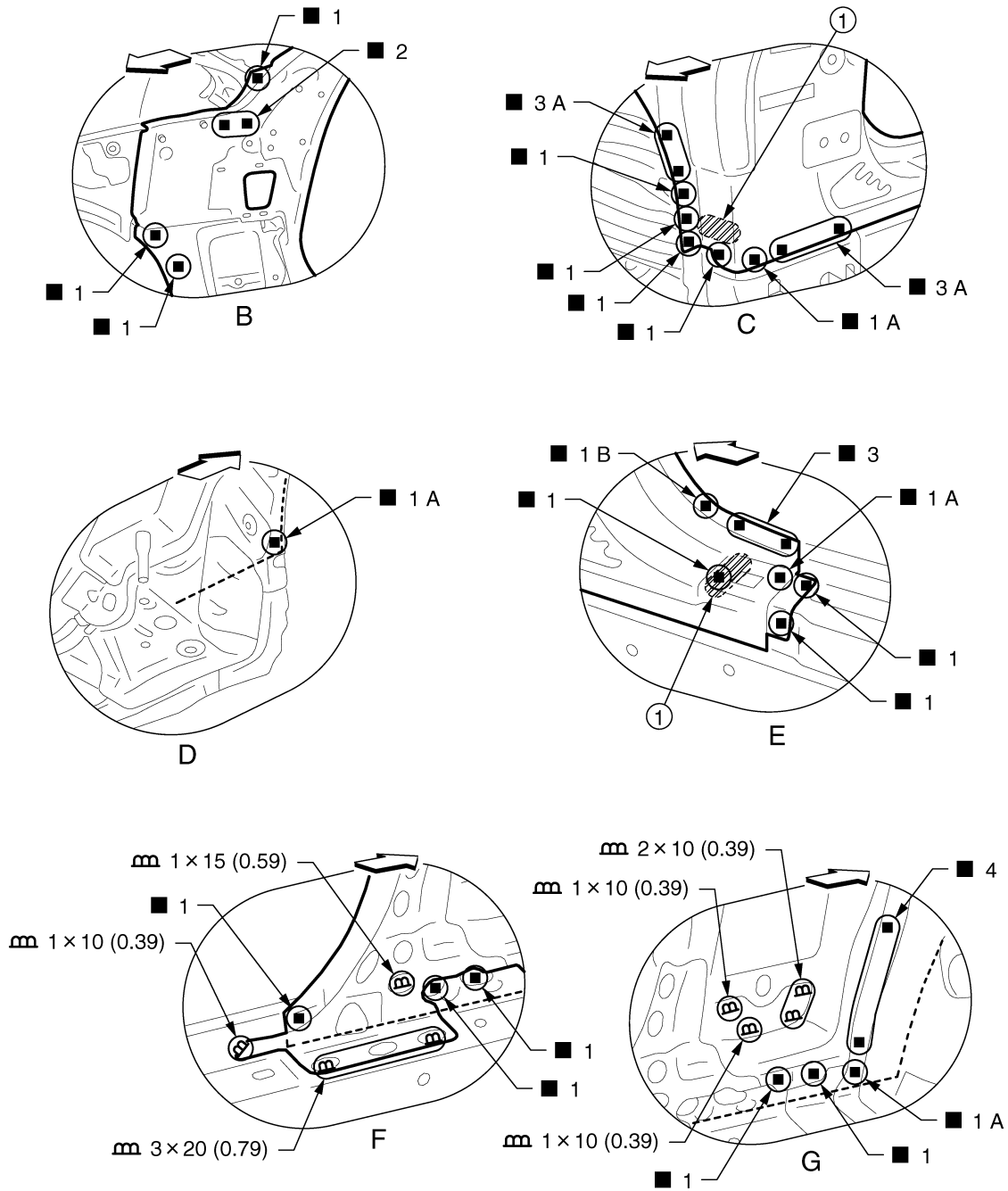

JSKIA1117GB

1. Urethane foam

Unit: mm (in)

↔: Vehicle front

View B: Before installing upper front pillar reinforcement

A
B
C
D
E
F
G
H
I
J
K
L
M
N
O
P

BRM

REPLACEMENT OPERATIONS

< REMOVAL AND INSTALLATION >

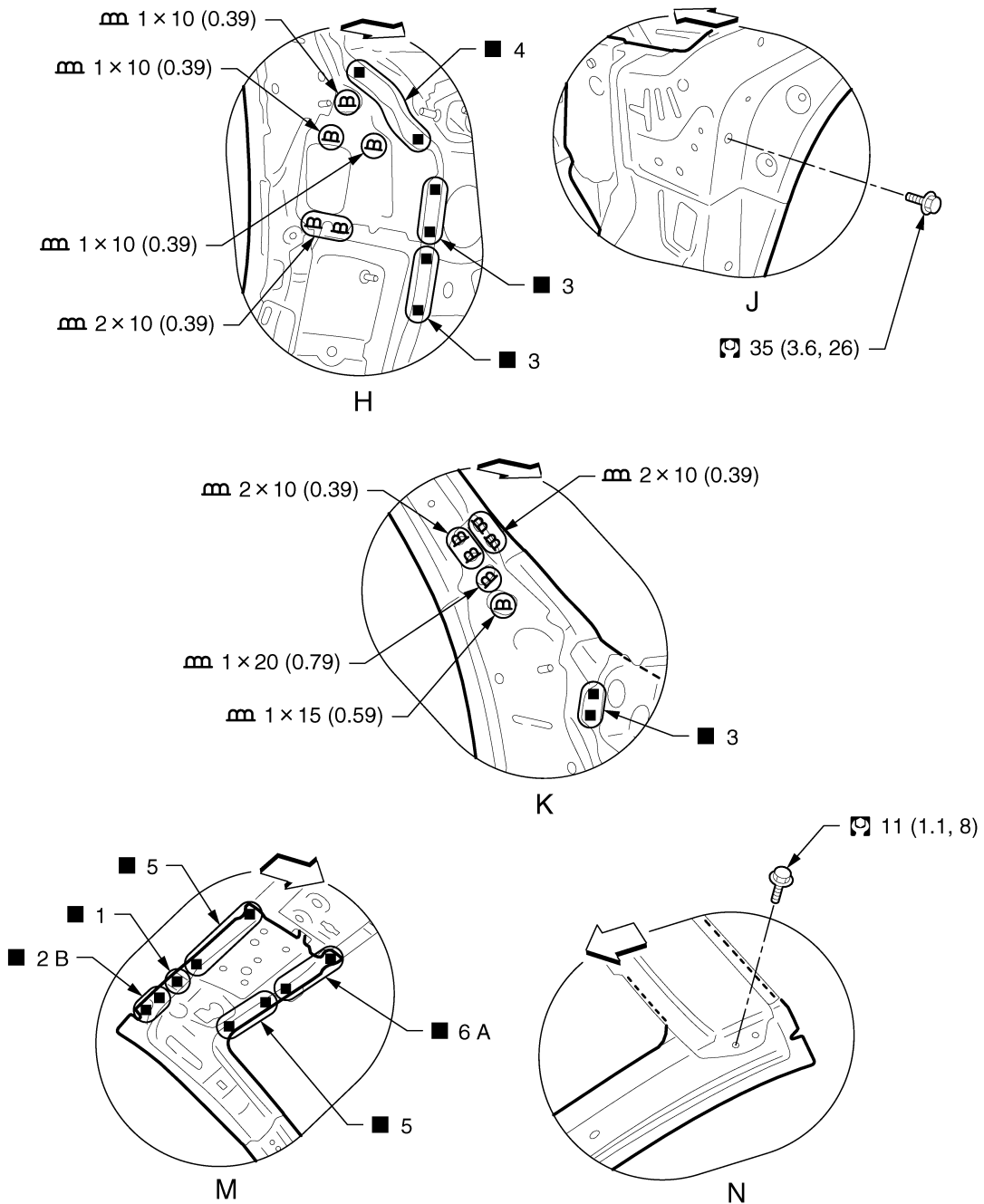

JSKIA1118GB

Unit: mm (in)

↔: Vehicle front

Refer to [GI-4, "Components"](#) for symbols in the figure.

Outer Step Sill

INFOID:000000006934759

Remove the welding point "b" for easier replacement.

REPLACEMENT OPERATIONS

< REMOVAL AND INSTALLATION >

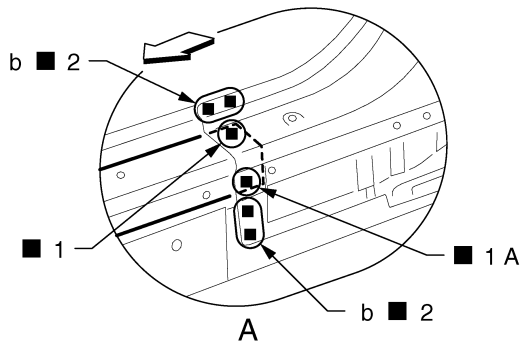
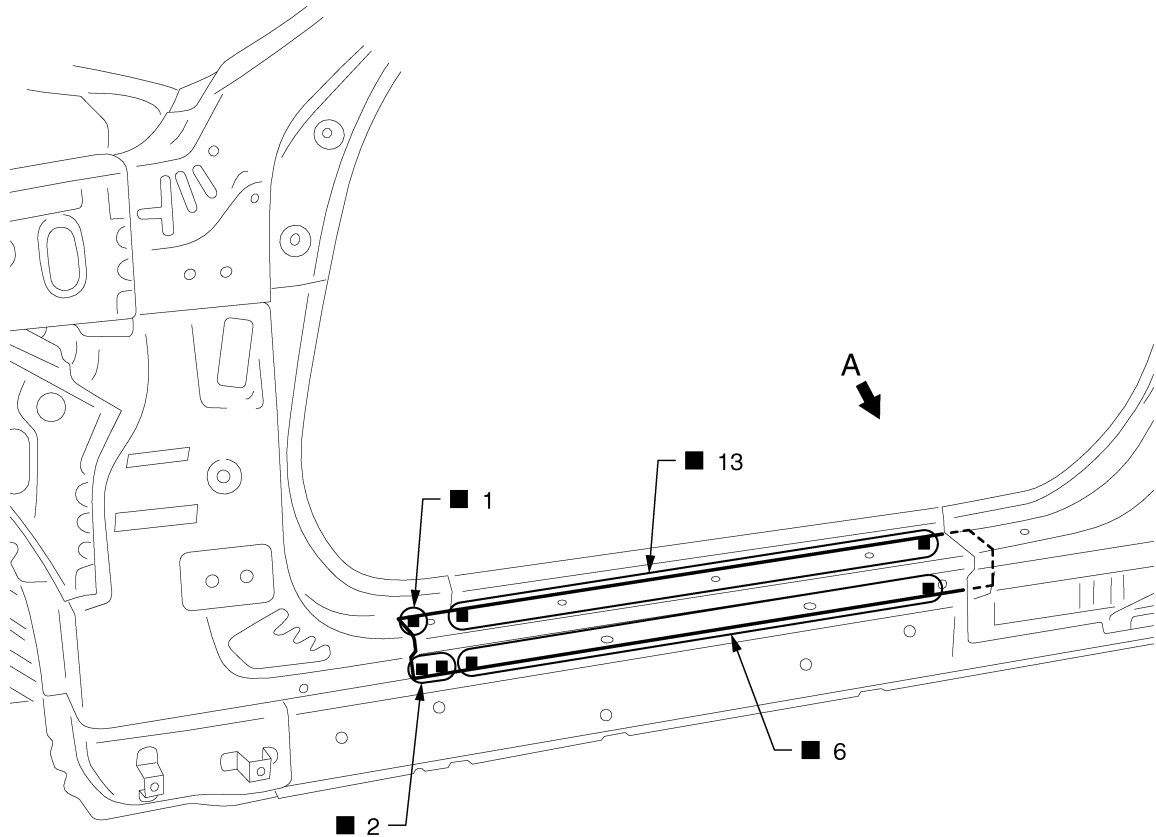

- ←: Vehicle front
- Replacement parts
- Outer step sill (LH)

Outer Sill

INFOID:000000006934760

Work after hoodledge reinforcement, outer step sill, outer lock pillar reinforcement and rear fender are removed.

Remove the front pillar brace (reusable).

A
B
C
D
E
F
G
H
I
J
L
M
N
O
P

BRM

REPLACEMENT OPERATIONS

< REMOVAL AND INSTALLATION >

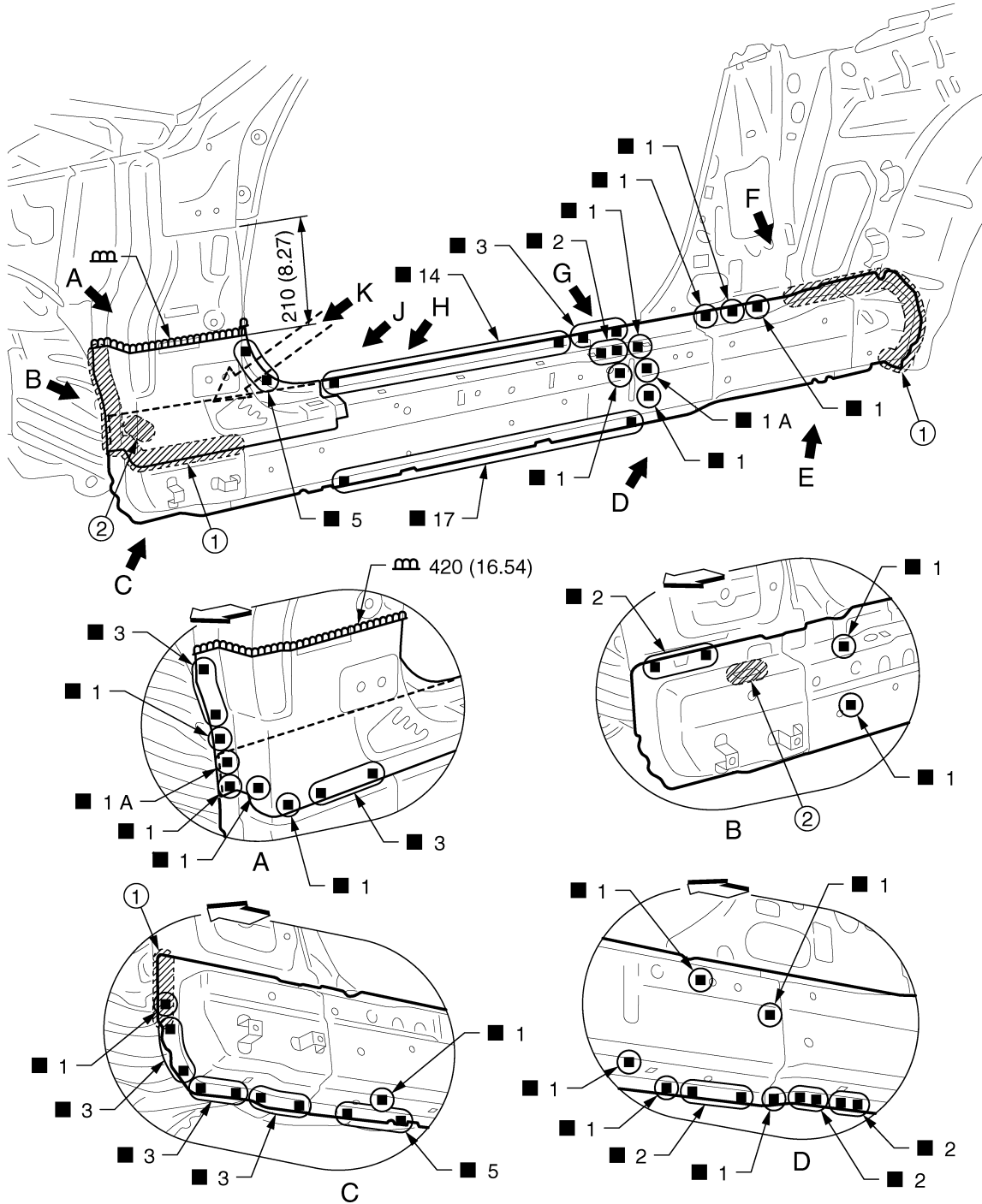

JSKIA1120GB

1. Body sealing
Unit: mm (in)

2. Urethane foam (Cover the hole with urethane foam completely.)

↔: Vehicle front

Replacement parts

● Outer sill reinforcement (LH)

● Outer rear wheelhouse extension (LH)

View B and C: Before installing front pillar brace

REPLACEMENT OPERATIONS

< REMOVAL AND INSTALLATION >

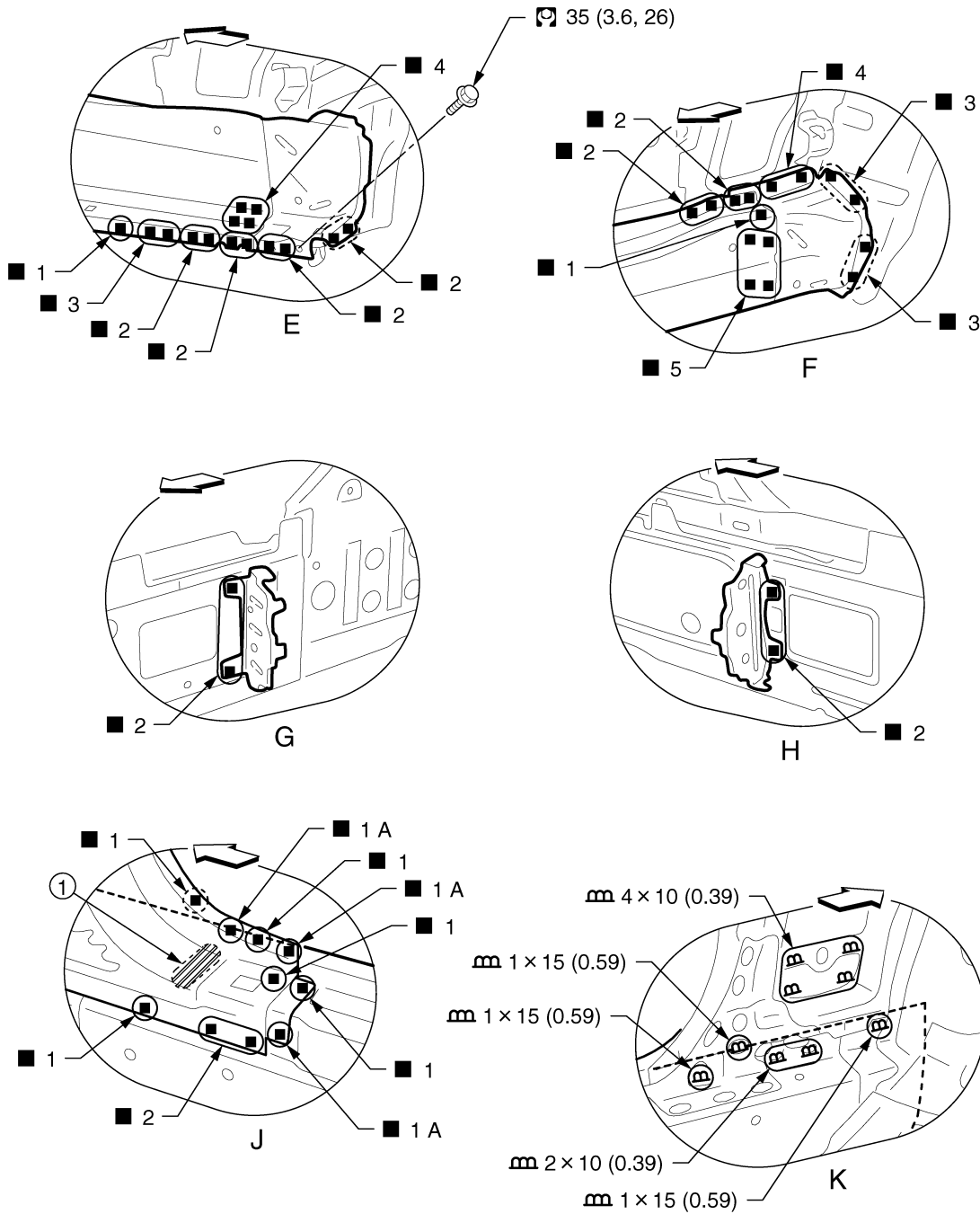

JSKIA1121GB

1. Urethane foam

Unit: mm (in)

◀: Vehicle front

⊕: Weld the parts onto the back of the component part.

Refer to [GI-4, "Components"](#) for symbols in the figure.

View G and H: Before installing front pillar brace and outer sill reinforcement

A
B
C
D
E
F
G
H
I
J
K
L
M
N
O
P

BRM

REPLACEMENT OPERATIONS

< REMOVAL AND INSTALLATION >

Rear Fender

INFOID:00000006934761

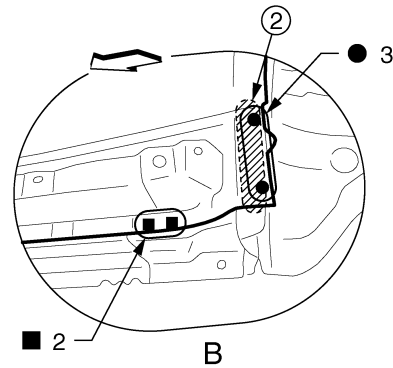
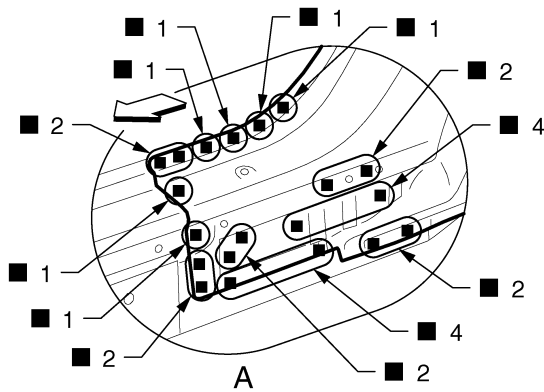
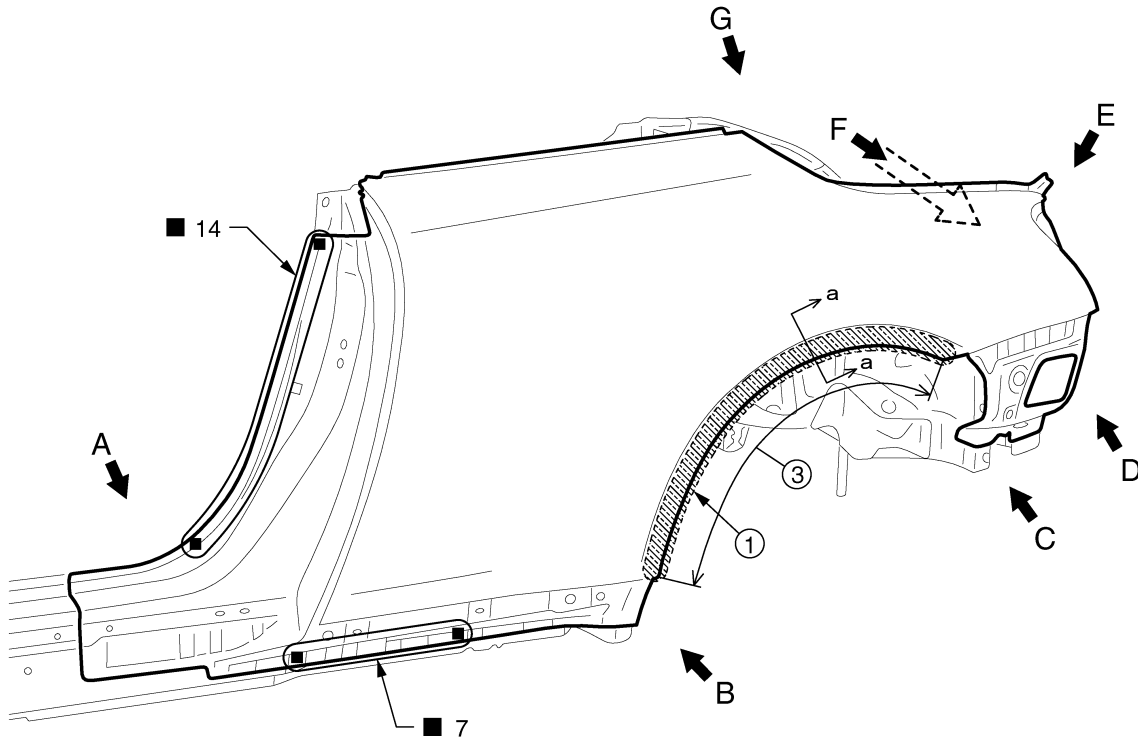

JSKIA1122ZZ

- 1. Adhesive
 - 2. Body sealing
 - 3. Hemming portion
- ◀: Vehicle front
- Replacement parts
- Rear fender assembly (LH)

REPLACEMENT OPERATIONS

< REMOVAL AND INSTALLATION >

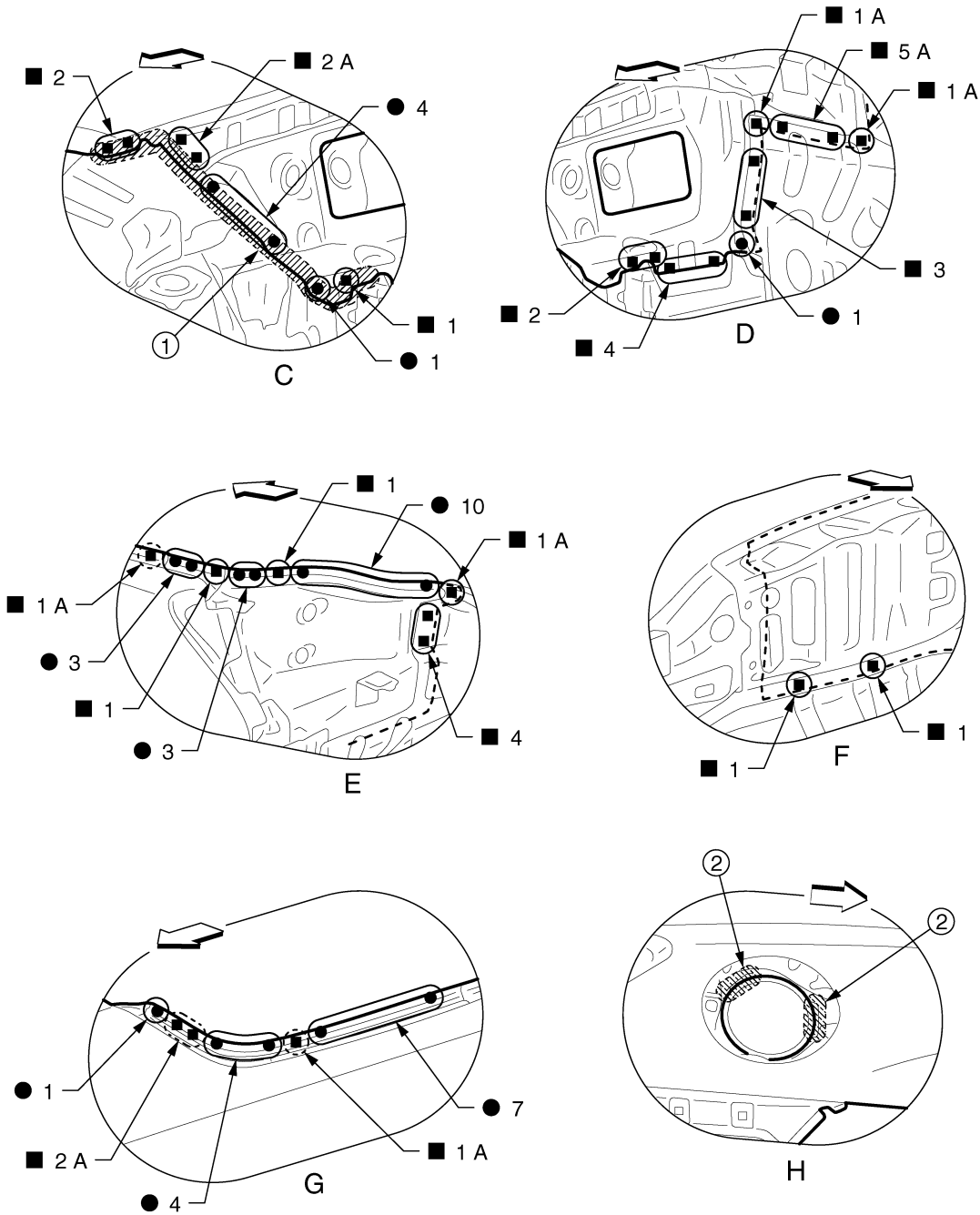

JSKIA1123ZZ

- 1. Body sealing
- 2. Adhesive
- ←: Vehicle front
- : Weld the parts onto the back of the component part.

View H: Right side rear fender

POINT

A
B
C
D
E
F
G
H
I
J
K
L
M
N
O
P

BRM

REPLACEMENT OPERATIONS

< REMOVAL AND INSTALLATION >

- Perform the hemming to the flange of wheelarch after applying the adhesive.
- Apply the sealing to the flange end.
- Refer to [BRM-20. "Rear Fender Hemming Process"](#).

1. **Outer rear wheelhouse**
2. **Rear fender**
3. **Adhesive**
4. **Sealant**

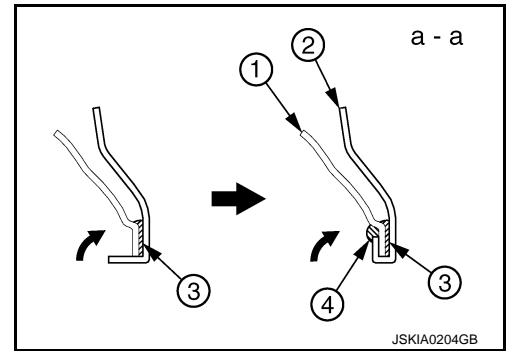

Lock Pillar Reinforcement

Work after rear fender is removed.

INFOID:000000006934762

REPLACEMENT OPERATIONS

< REMOVAL AND INSTALLATION >

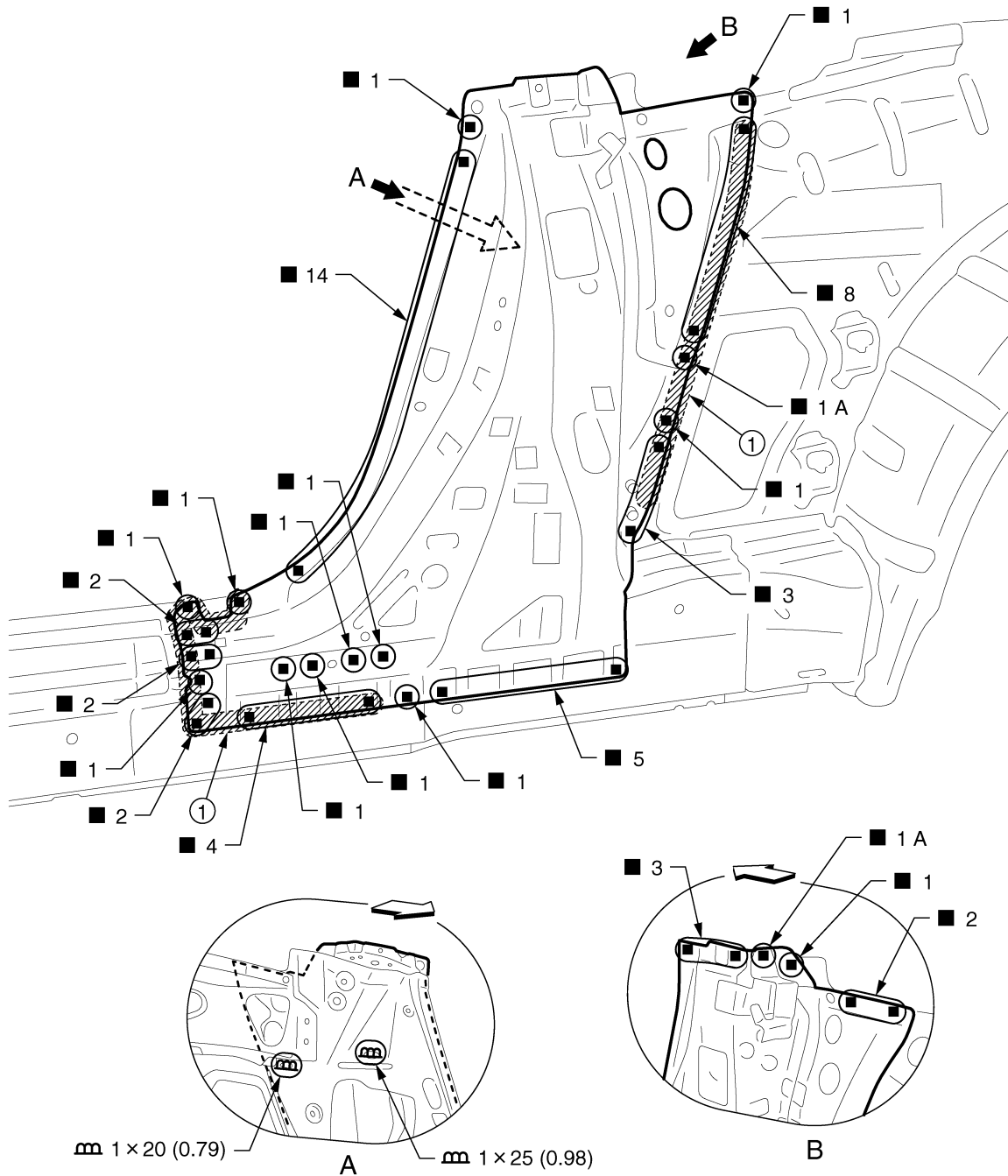

1. Body sealing

Unit: mm (in)

⇐: Vehicle front

Replacement parts

- Outer lock pillar reinforcement (LH)

JSKIA1124GB

A
B
C
D
E
F
G
H
I
J
L
M
N
O
P

BRM

REPLACEMENT OPERATIONS

< REMOVAL AND INSTALLATION >

Rear Panel

INFOID:000000006934763

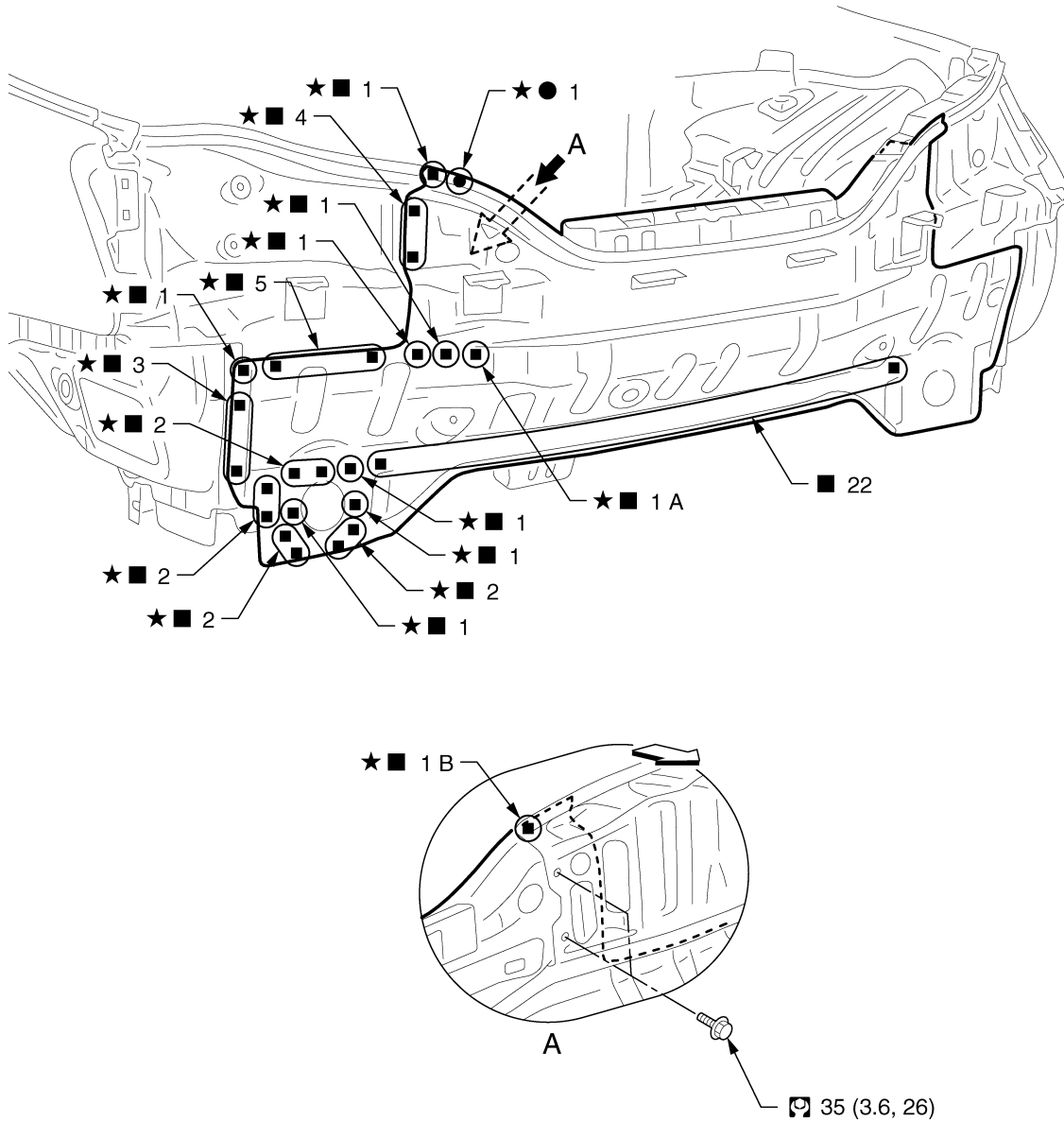

JSKIA1125GB

↔: Vehicle front

★: An equivalent welding portion with the same dimensions is on the opposite side.

Refer to [GI-4, "Components"](#) for symbols in the figure.

Replacement parts

- Rear panel assembly

Rear Floor Rear

INFOID:000000006934764

Work after rear panel is removed.

REPLACEMENT OPERATIONS

< REMOVAL AND INSTALLATION >

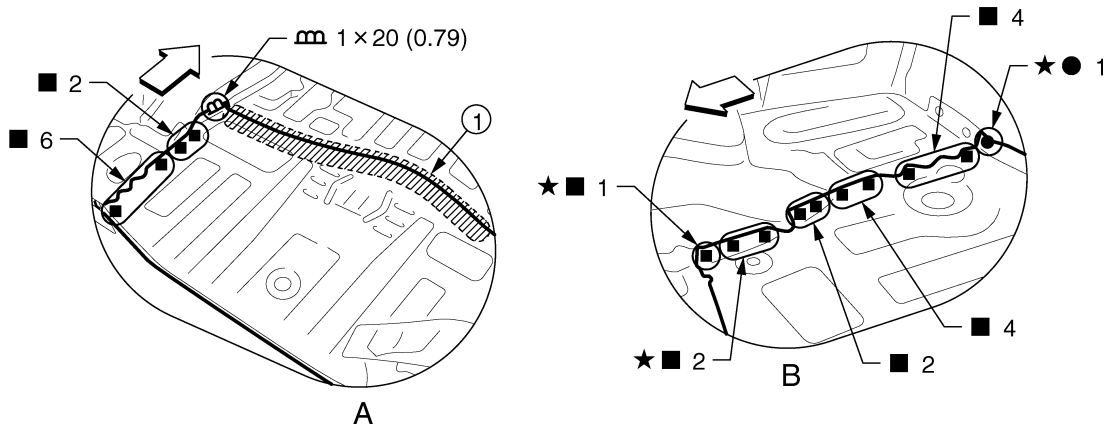
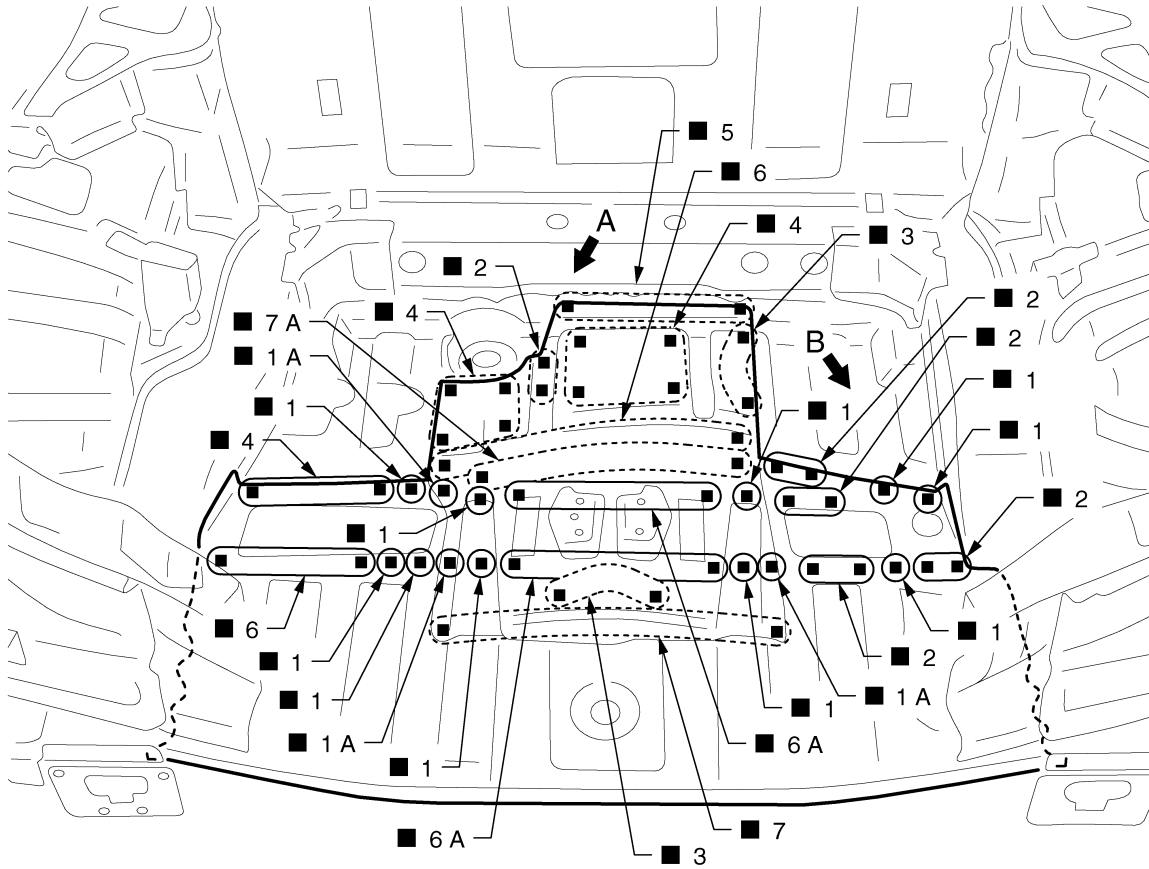

JSKIA1126GB

1. Body sealing

Unit: mm (in)

⇐: Vehicle front

★: An equivalent welding portion with the same dimensions is on the opposite side.

○: Weld the parts onto the back of the component part.

Replacement parts

● Rear floor rear

● Spare wheel clamp reinforcement

View A: Before installing spare wheel clamp reinforcement

A
B
C
D
E
F
G
H
I
J
K
L
M
N
O
P

BRM

REPLACEMENT OPERATIONS

< REMOVAL AND INSTALLATION >

Rear Side Member Extension (LH)

INFOID:000000006934765

Work after rear panel and rear floor side (LH) are removed.

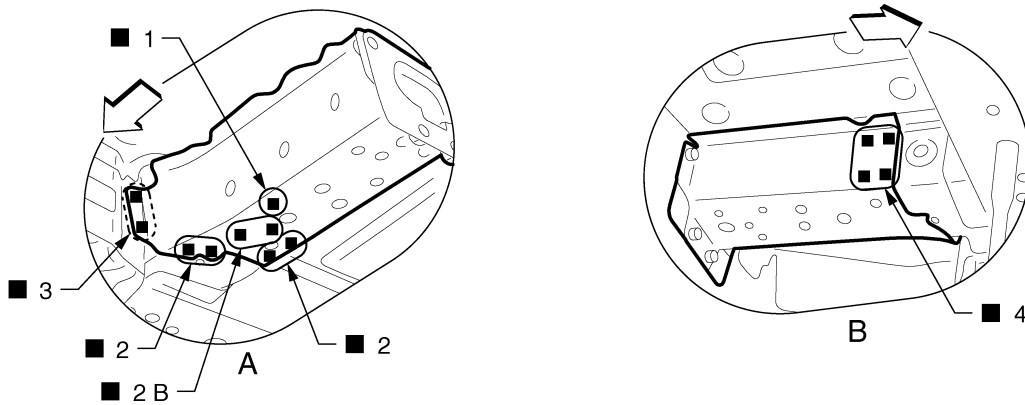
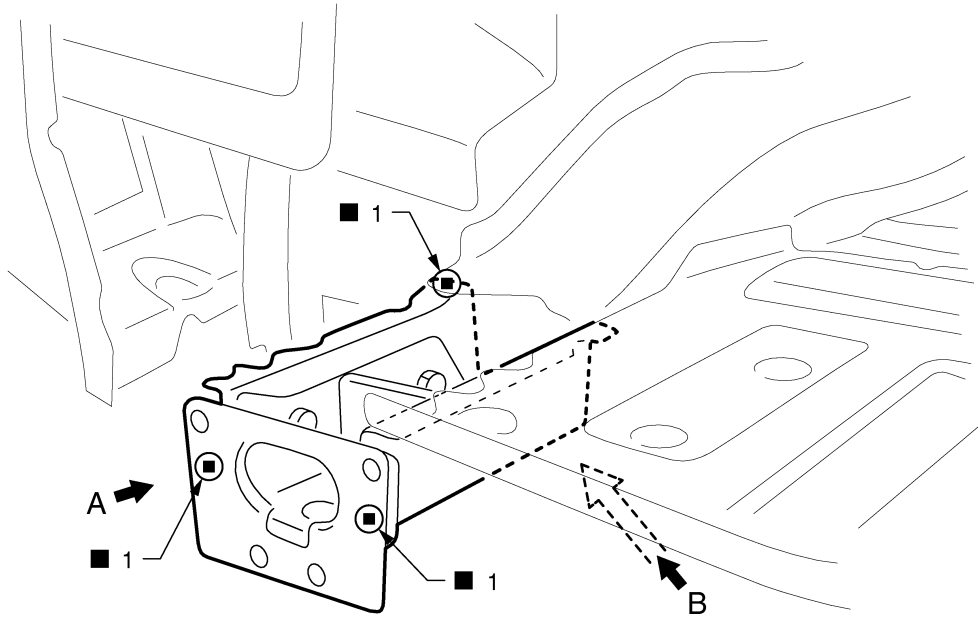

JSKIA1127ZZ

←: Vehicle front

(○): Weld the parts onto the back of the component part.

Replacement parts

- Rear side member extension (LH)

Rear Side Member Extension (RH)

INFOID:000000006934766

Work after rear panel is removed.

REPLACEMENT OPERATIONS

< REMOVAL AND INSTALLATION >

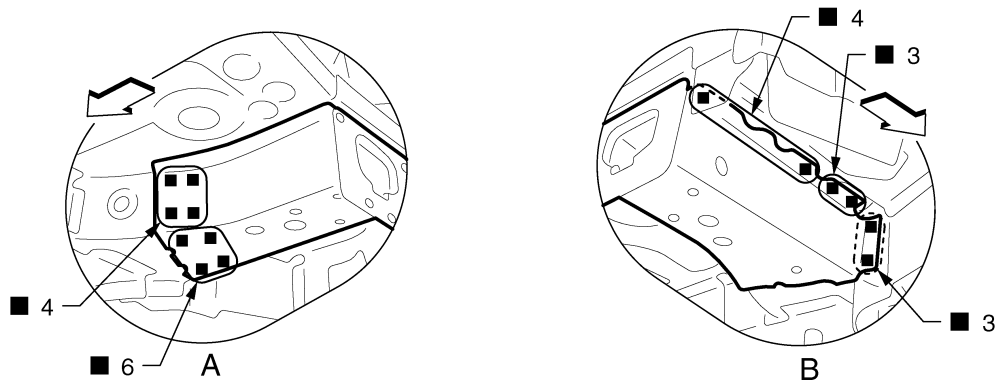
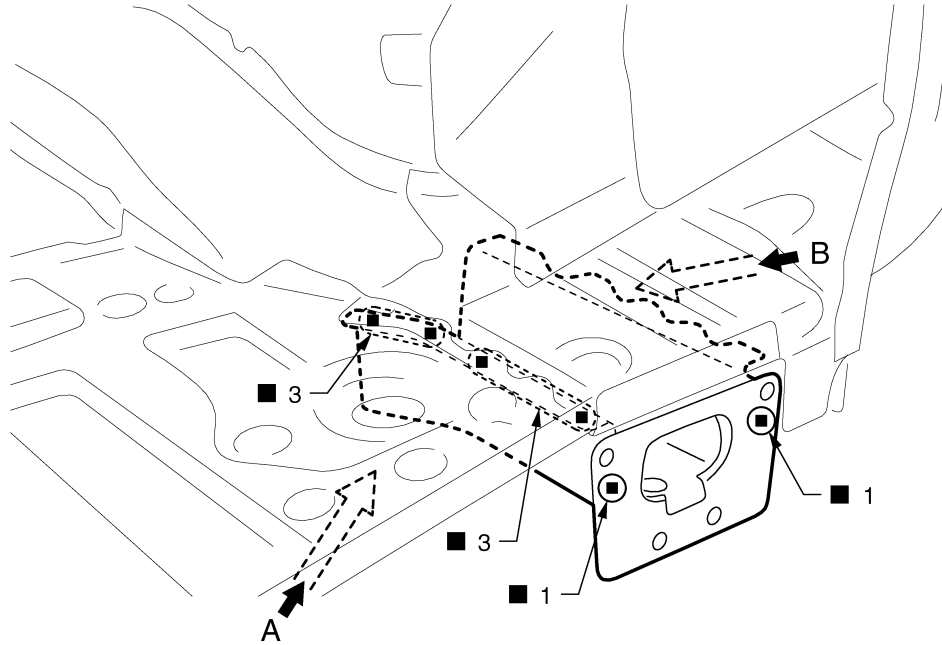

⇐: Vehicle front

○: Weld the parts onto the back of the component part.

Replacement parts

- Rear side member extension (RH)

JSKIA1128ZZ

A
B
C
D
E
F
G
H
I
J
K
L
M
N
O
P

BRM

BODY ALIGNMENT

< SERVICE DATA AND SPECIFICATIONS (SDS)

SERVICE DATA AND SPECIFICATIONS (SDS)

BODY ALIGNMENT

Body Center Marks

INFOID:000000006934767

A mark is placed on each part of the body to indicate the vehicle center. When repairing the vehicle frame (members, pillars, etc.) damaged by an accident which it enables more accurate and effective repair by using these marks together with body alignment specifications.

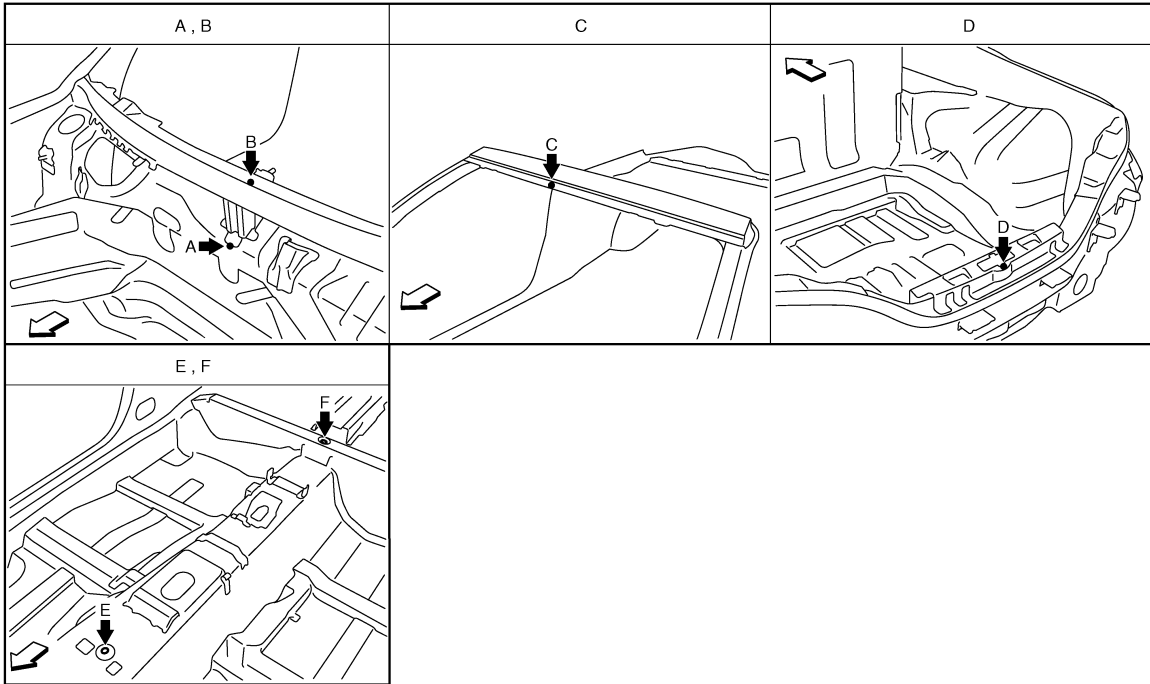
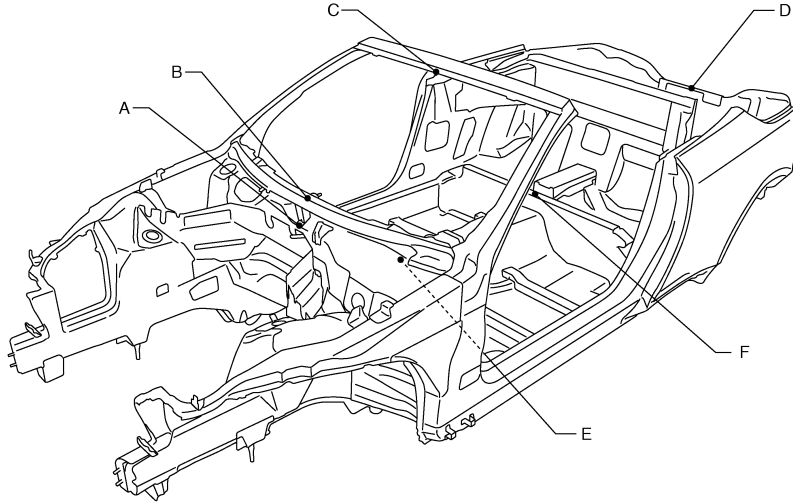

JSKIA1097ZZ

↶: Vehicle front

Unit: mm (in)

| Points | Portion | Marks |
|--------|------------|------------|
| A, B | Upper dash | Embossment |
| C | Roof | Embossment |
| D | Rear panel | Indent |

BODY ALIGNMENT

< SERVICE DATA AND SPECIFICATIONS (SDS)

| Points | Portion | Marks |
|--------|-------------------------------------|-----------------------|
| E | Trans control reinforcement | Hole $\phi 14$ (0.55) |
| F | Rear seat crossmember reinforcement | Hole $\phi 5$ (0.20) |

Description

INFOID:000000006934768

- All dimensions indicated in the figures are actual.
- When using a tracking gauge, adjust both pointers to equal length. Then check the pointers and gauge itself to make sure there is no free play.
- When a measuring tape is used, check to be sure there is no elongation, twisting or bending.
- Measurements should be taken at the center of the mounting holes.
- An asterisk (*) following the value at the measuring point indicates that the measuring point on the other side is symmetrically the same value.
- The coordinates of the measurement points are the distances measured from the standard line of "X", "Y" and "Z".
- "Z": Imaginary base line [200 mm (7.87 in) below datum line ("0Z" at design plan)]

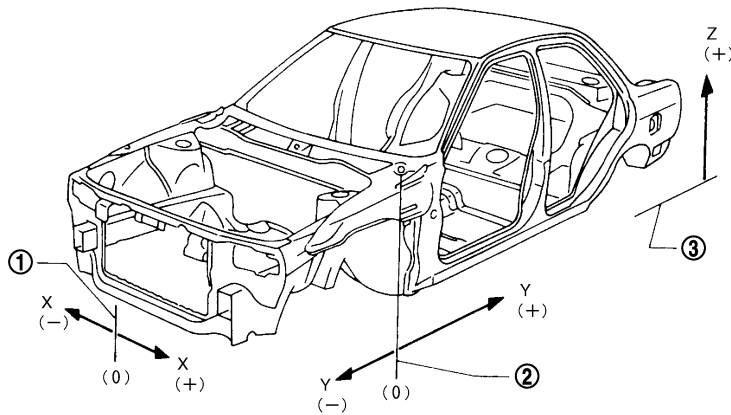

JSKIA0073GB

1. Vehicle center

2. Front axle center

3. Imaginary base line

Engine Compartment

INFOID:000000006934769

MEASUREMENT

Dimensions marked with "*" indicate symmetrically identical dimensions on both the right and left hand of the vehicle.

A
B
C
D
E
F
G
H
I
J
L
M
N
O
P

BRM

BODY ALIGNMENT

< SERVICE DATA AND SPECIFICATIONS (SDS)

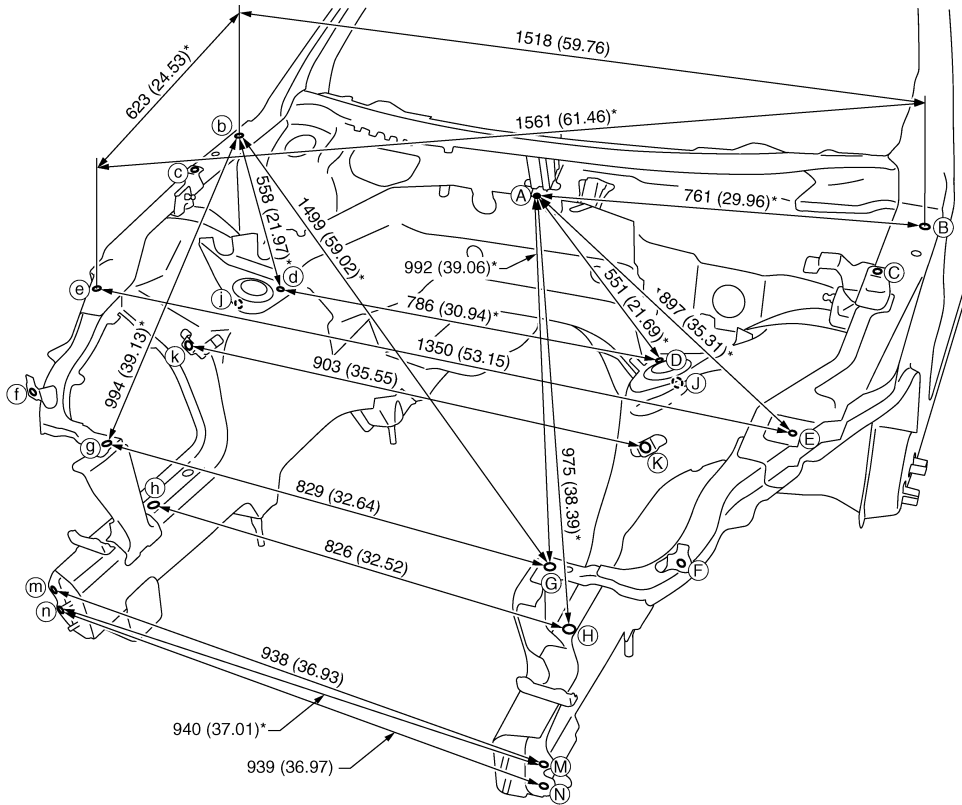

JSKIA1098GB

Unit: mm (in)

«The others»

Unit: mm (in)

| Point | Dimension | Memo | Point | Dimension | Memo | Point | Dimension | Memo | Point | Dimension | Memo |
|-------|---------------|------|-------|---------------|------|-------|---------------|------|-------|--------------|------|
| A - C | 744 (29.29)* | | B - d | 1227 (48.31)* | | E - g | 1135 (44.68)* | | J - j | 903 (35.55)* | |
| A - F | 1057 (41.61)* | | C - c | 1427 (56.18)* | | F - f | 1199 (47.20)* | | | | |
| B - C | 227 (8.94)* | | D - k | 875 (34.45)* | | F - G | 192 (7.56)* | | | | |
| B - c | 1490 (58.66)* | | E - G | 412 (16.22)* | | F - g | 1015 (39.96)* | | | | |

MEASUREMENT POINTS

BODY ALIGNMENT

< SERVICE DATA AND SPECIFICATIONS (SDS)

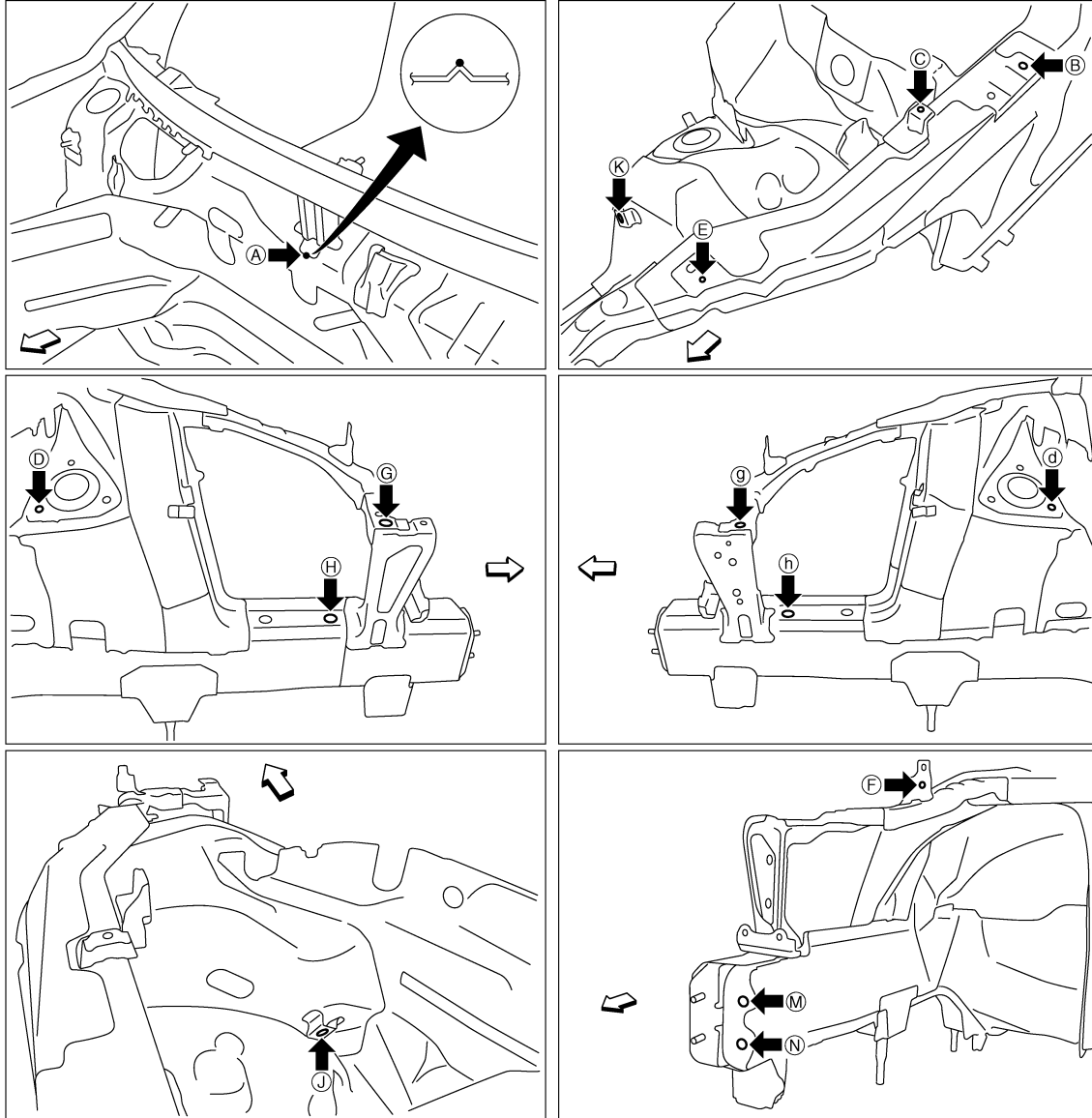

JSKIA1099ZZ

←: Vehicle front

Unit: mm (in)

| Point | Material | Point | Material |
|------------|--|------------|--|
| A | Upper dash positioning mark of center positioning mark | G, g | Radiator core stay installing hole center $\phi 15$ (0.59) |
| B, b | Hood hinge installing hole center $\phi 9$ (0.35) | H, h | Front side member hole center $\phi 20$ (0.79) |
| C, c, F, f | Front fender installing hole center $\phi 7$ (0.28) | J, j, K, k | Nut holder hole center $\phi 16$ (0.63) |
| D, d | Front strut installing hole center $\phi 11$ (0.43) | M, m, N, n | Front bumper reinforcement installing hole center $\phi 11$ (0.43) |
| E, e | Hoodledge reinforcement hole center $\phi 6$ (0.24) | | |

Underbody

INFOID:0000000006934770

MEASUREMENT

Dimensions marked with "*" indicate symmetrically identical dimensions on both the right and left hand of the vehicle.

A
B
C
D
E
F
G
H
I
J
K
L
M
N
O
P

BRM

BODY ALIGNMENT

< SERVICE DATA AND SPECIFICATIONS (SDS)

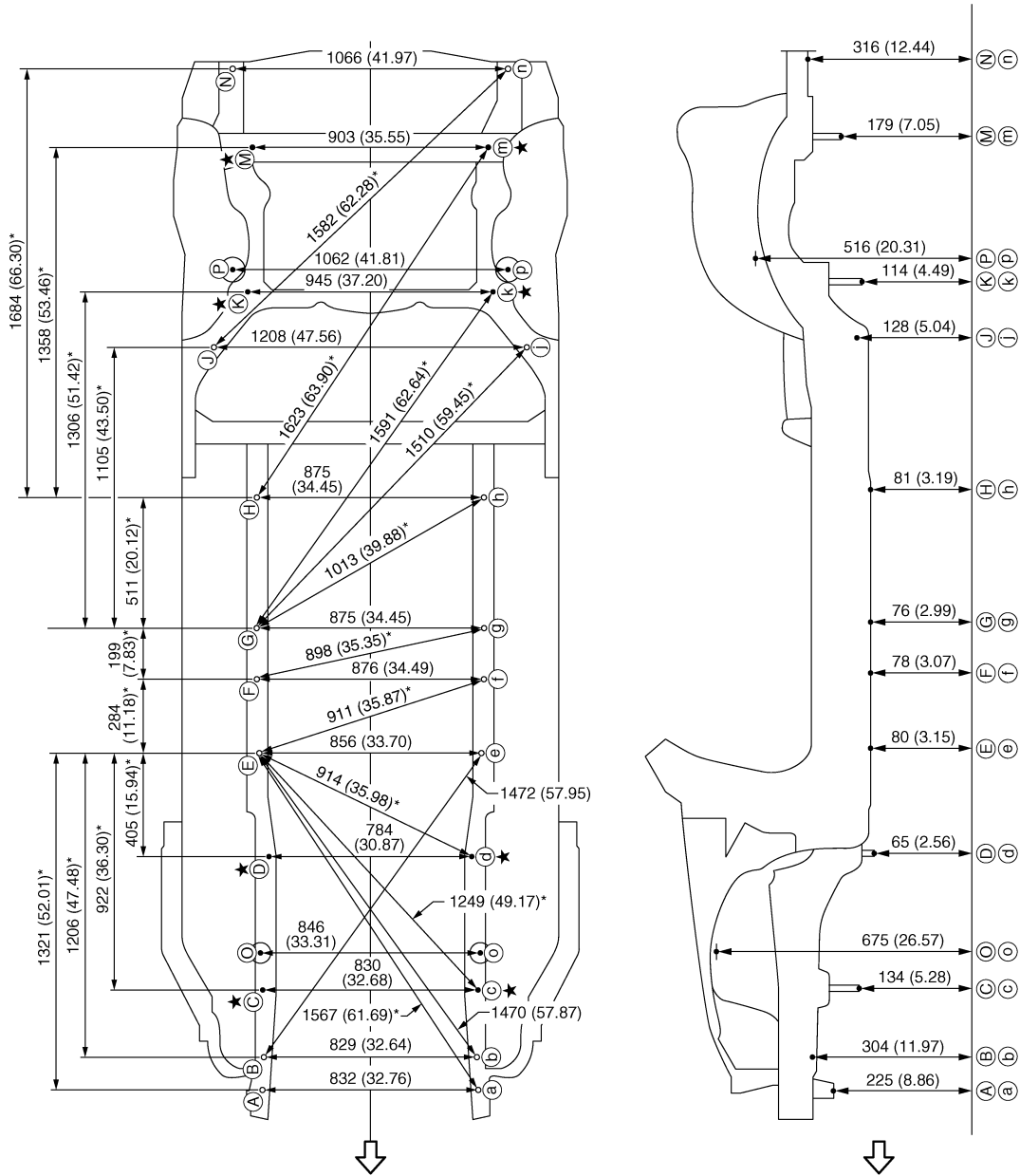

JSKIA1100GB

Unit: mm (in)

↳: Vehicle front

★: Bolt head

MEASUREMENT POINTS

BODY ALIGNMENT

< SERVICE DATA AND SPECIFICATIONS (SDS)

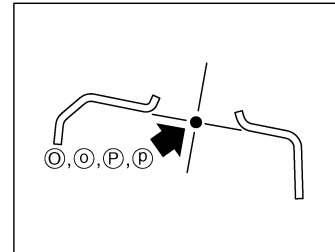
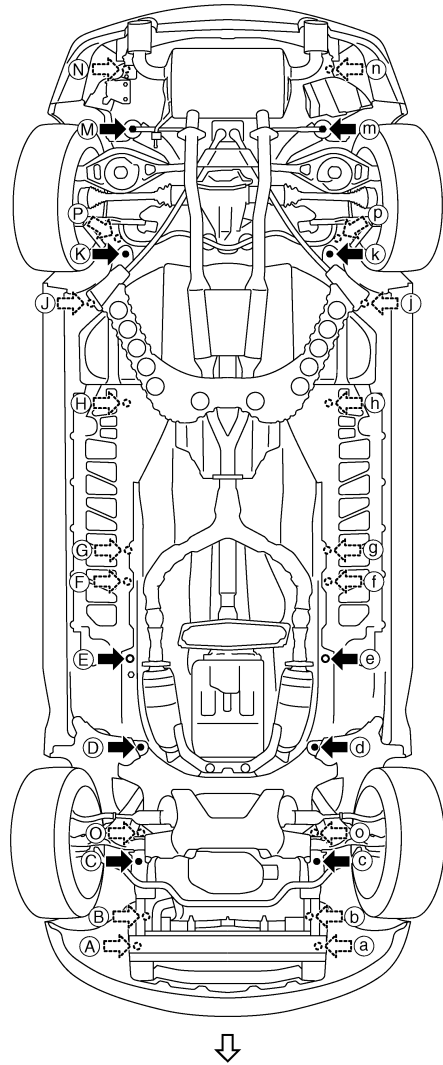

A
B
C
D
E
F
G
H
I
J
L
M
N
O
P

BRM

JSKIA1101GB

←: Vehicle front

BODY ALIGNMENT

< SERVICE DATA AND SPECIFICATIONS (SDS)

Unit: mm (in)

| Points | Coordinates | | | Remarks | Points | Coordinates | | | Remarks |
|--------|---------------------|---------------------|-------------------|---------------------------|--------|---------------------|---------------------|-------------------|--------------------|
| | X | Y | Z | | | X | Y | Z | |
| A, a | ±416.0 (±16.378) | -496.0 (-19.528) | 224.5 (8.839) | Hole φ13 (0.51) | H, h | ±437.5 (±17.224) | 1810.0 (71.260) | 81.2 (3.197) | Hole φ16 (0.63) |
| B | 416.2 (16.386) | -368.0 (-14.488) | 303.5 (11.949) | Hole φ16 (0.63) | J, j | ±604.0 (±23.779) | 2390.5 (94.114) | 128.3 (5.051) | Hole φ13 (0.51) |
| b | -413.0 (-16.260) | -368.0 (-14.488) | 303.5 (11.949) | Hole φ16 (0.63) | K, k | ±472.6 (±18.606) | 2603.8 (102.512) | 114.0 (4.488) | Bolt head |
| C, c | ±415.0 (±16.339) | -104.0 (-4.094) | 133.5 (5.256) | Bolt head | M, m | ±451.5 (±17.776) | 3163.9 (124.563) | 179.1 (7.051) | Bolt head |
| D, d | ±392.0 (±15.433) | 414.0 (16.299) | 64.5 (2.539) | Bolt head | N, n | ±533.0 (±20.984) | 3475.0 (136.811) | 316.4 (12.457) | Hole φ16 (0.63) |
| E, e | ±428.0 (±16.850) | 816.6 (32.150) | 80.0 (3.150) | Hole 16×18 (0.63×0.71) | O, o | ±423.0 (±16.654) | 38.0 (1.496) | 674.5 (26.555) | Hole φ50.1 (1.972) |
| F, f | ±438.0 (±17.244) | 1100.0 (43.307) | 78.0 (3.071) | Hole φ16 (0.63) | P, p | ±531.2 (±20.913) | 2692.7 (106.012) | 515.6 (20.299) | Hole φ63.5 (2.500) |
| G, g | ±437.5 (±17.224) | 1299.0 (51.142) | 76.0 (2.992) | Hole φ16 (0.63) | | | | | |

Passenger Compartment

INFOID:000000006934771

MEASUREMENT

Dimensions marked with "*" indicate symmetrically identical dimensions on both the right and left hand of the vehicle.

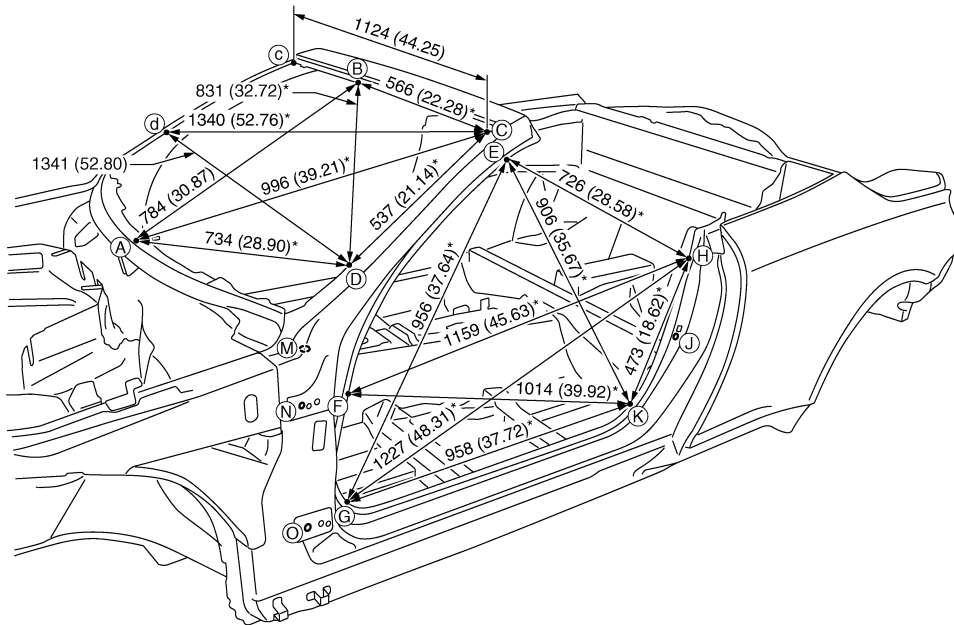

JSKIA1102GB

Unit: mm (in)

BODY ALIGNMENT

< SERVICE DATA AND SPECIFICATIONS (SDS)

«The others»

Unit: mm (in)

| Point | Dimension | Memo | Point | Dimension | Memo | Point | Dimension | Memo | Point | Dimension | Memo |
|-------|---------------|------|-------|---------------|------|-------|---------------|------|-------|---------------|------|
| E - e | 1227 (48.31) | | G - g | 1440 (56.69) | | M - F | 772 (30.39)* | | N - K | 1174 (46.22)* | |
| E - g | 1637 (64.45)* | | G - h | 1896 (74.65)* | | M - G | 736 (28.98)* | | O - o | 1599 (62.95) | |
| E - h | 1519 (59.80)* | | G - k | 1734 (68.27)* | | M - H | 1300 (51.18)* | | O - H | 1372 (54.02)* | |
| E - k | 1613 (63.50)* | | H - h | 1451 (57.13) | | M - K | 1106 (43.54)* | | O - J | 1283 (50.51)* | |
| F - f | 1447 (56.97) | | H - k | 1526 (60.08)* | | N - n | 1576 (62.05) | | O - K | 1126 (44.33)* | |
| F - h | 1856 (73.07)* | | K - k | 1451 (57.13) | | N - H | 1309 (51.54)* | | | | |
| F - k | 1769 (69.65)* | | M - E | 1015 (39.96)* | | N - J | 1277 (50.28)* | | | | |

MEASUREMENT POINTS

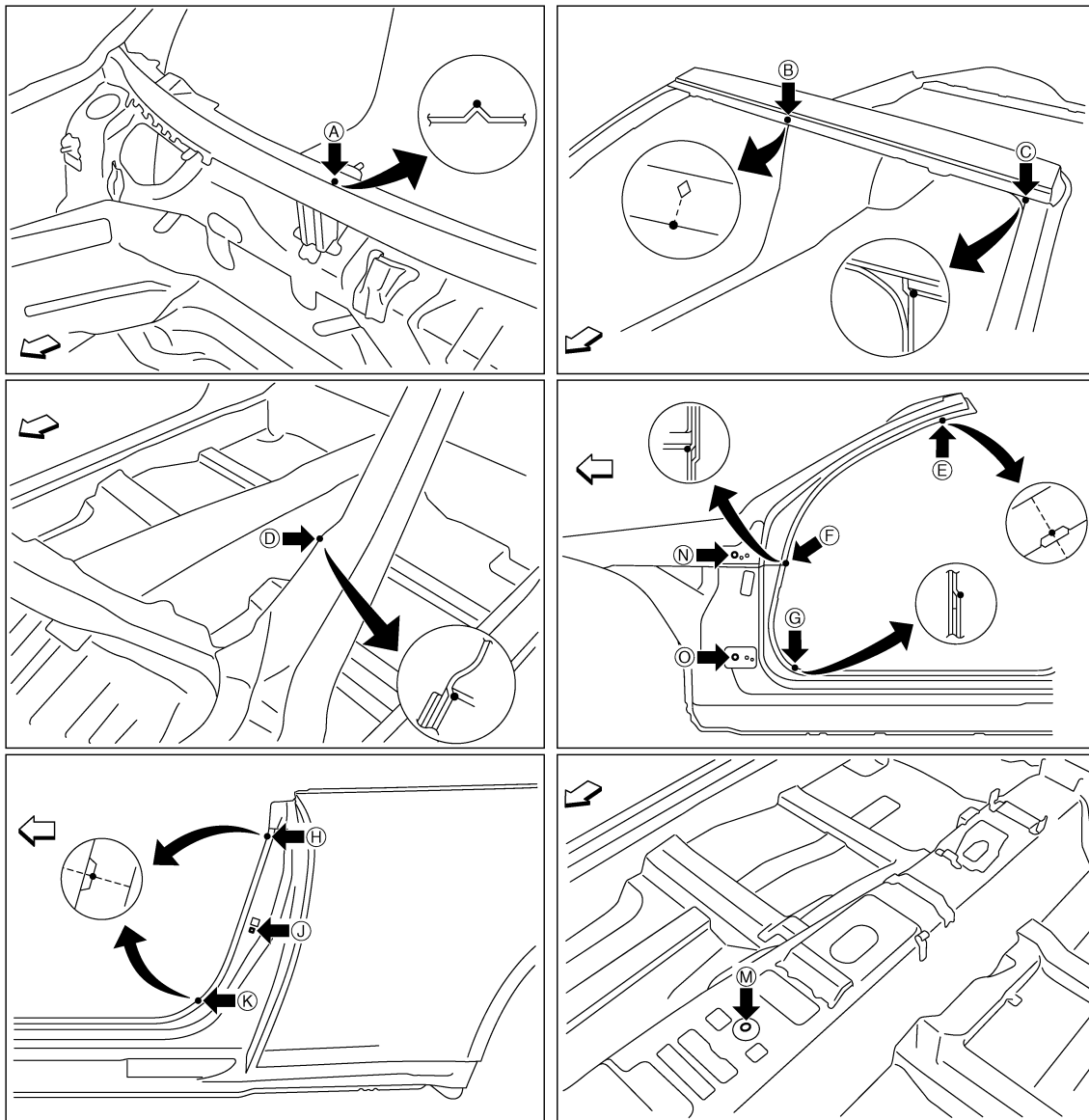

↶ Vehicle front

JSKIA1103ZZ

A
B
C
D
E
F
G
H
I
J
K
L
M
N
O
P

BRM

BODY ALIGNMENT

< SERVICE DATA AND SPECIFICATIONS (SDS)

Unit: mm (in)

| Point | Material | Point | Material |
|------------|--|------------|---|
| A | Upper dash positioning mark of center positioning mark | G, g | Rear upper hoodledge joggle |
| B | Roof flange end of center positioning mark | H, h, K, k | Rear fender indent |
| C, c, D, d | Front pillar joggle | J, j | Door switch installing hole center $\phi 7$ (0.28) |
| E, e | Front pillar indent | M, m | Trans control reinforcement hole center of center positioning mark $\phi 14$ (0.55) |
| F, f | Front pillar hinge brace joggle | N, n, O, o | Door hinge installing hole center $\phi 12$ (0.47) |

Rear Body

INFOID:000000006934772

MEASUREMENT

Dimensions marked with "*" indicate symmetrically identical dimensions on both the right and left hand of the vehicle.

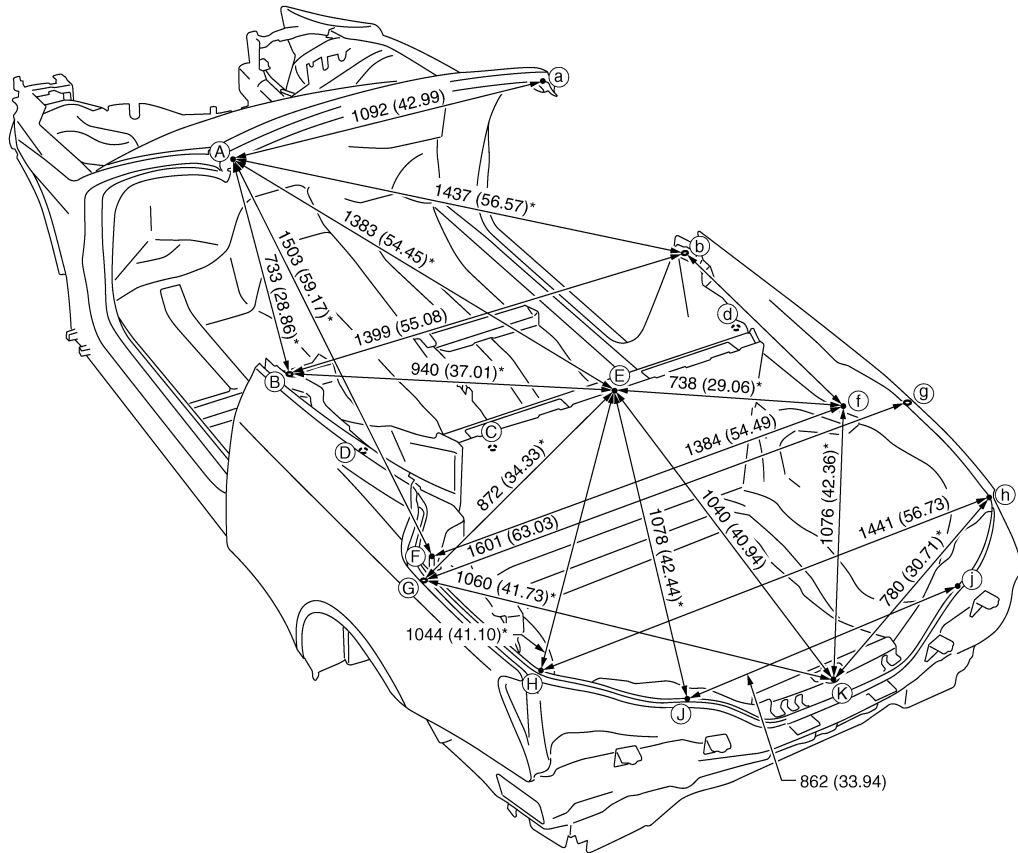

JSKIA1104GB

Unit: mm (in)

«The others»

Unit: mm (in)

| Point | Dimension | Memo | Point | Dimension | Memo | Point | Dimension | Memo | Point | Dimension | Memo |
|-------|---------------|------|-------|---------------|------|-------|---------------|------|-------|---------------|------|
| A - C | 1180 (46.46)* | | B - d | 1392 (54.80)* | | C - F | 1104 (43.46)* | | G - J | 748 (29.45)* | |
| A - D | 1110 (43.70)* | | B - F | 813 (32.01)* | | D - d | 1266 (49.84) | | G - j | 1393 (54.84)* | |
| A - d | 1617 (63.66)* | | B - f | 1612 (63.46)* | | D - f | 1388 (54.65)* | | H - j | 1175 (46.26)* | |
| B - C | 836 (32.91)* | | C - D | 820 (32.28)* | | G - H | 427 (16.81)* | | J - K | 445 (17.52)* | |
| B - D | 409 (16.10)* | | C - E | 805 (31.69)* | | G - h | 1578 (62.13)* | | | | |

MEASUREMENT POINTS

BODY ALIGNMENT

< SERVICE DATA AND SPECIFICATIONS (SDS)

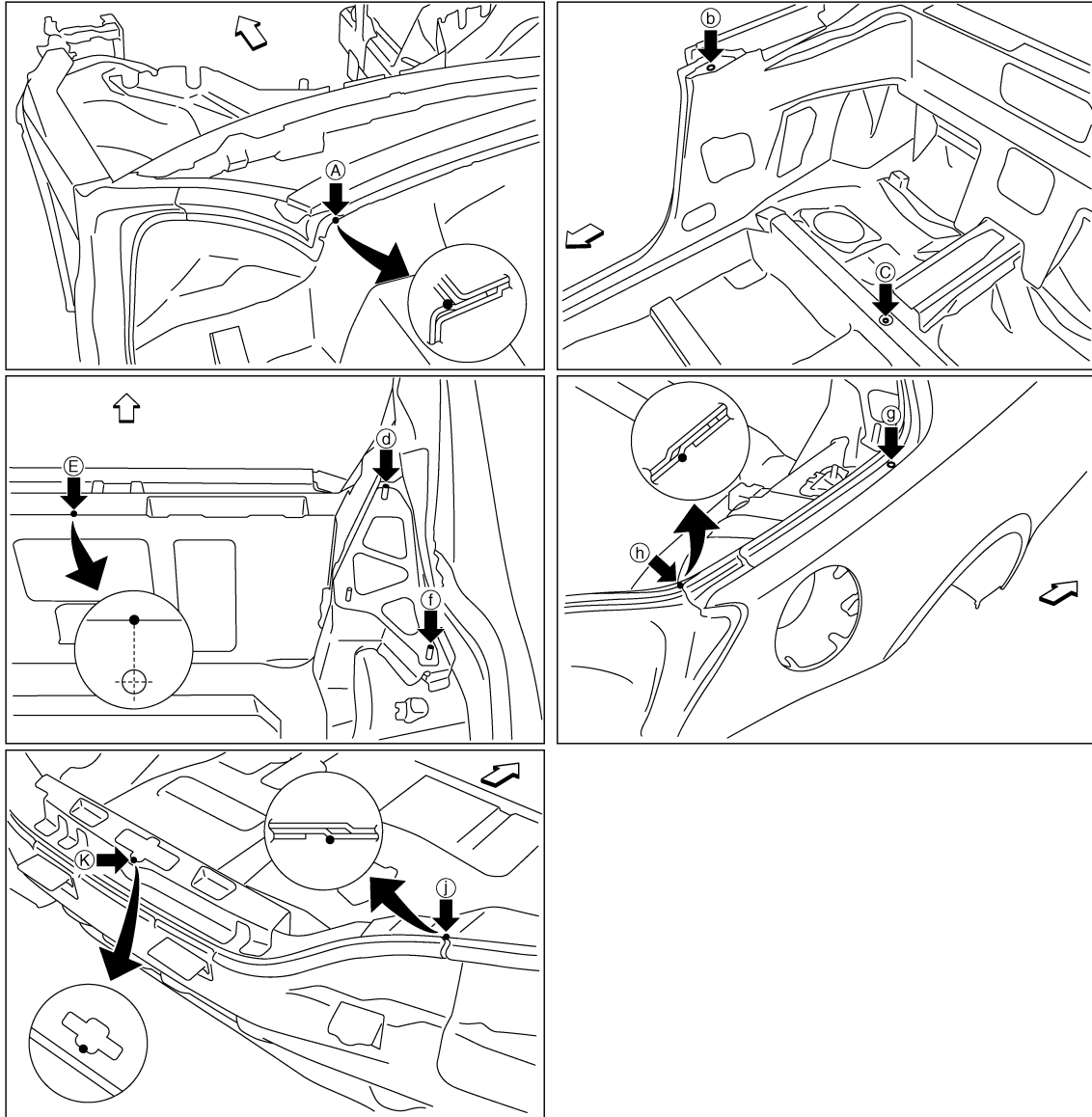

JSKIA1105ZZ

←: Vehicle front

Unit: mm (in)

| Point | Material | Point | Material |
|------------|--|------------|---|
| A, a | Upper front pillar joggle | E | Rear seatback support flange end of center positioning mark |
| B, b | Lock pillar seat belt anchor hole center $\phi 10$ (0.39) | G, g | Rear fender hole center $\phi 8$ (0.31) |
| C | Rear seat crossmember reinforcement hole center of center positioning mark $\phi 5$ (0.20) | H, h, J, j | Rear combination lamp base joggle |
| D, d, F, f | Fixing main bearing bolt head | K | Upper rear panel flange end of center positioning mark |

A
B
C
D
E
F
G
H
I
J
L
M
N
O
P

BRM

LOCATION OF PLASTIC PARTS

< SERVICE DATA AND SPECIFICATIONS (SDS)

LOCATION OF PLASTIC PARTS

Precautions for Plastics

INFOID:000000006934773

| Abbreviation | Material name | Heatresisting temperature °C (°F) | Resistance to gasoline and solvents | Other cautions |
|--------------|---|-----------------------------------|--|---------------------------------------|
| PE | Polyethylene | 60 (140) | Gasoline and most solvents are harmless if applied for a very short time (wipe out quickly). | Flammable |
| ABS | Acrylonitrile Butadiene Styrene | 80 (176) | Avoid gasoline and solvents. | — |
| EPM/EPDM | Ethylene Propylene (Diene) copolymer | 80 (176) | Gasoline and most solvents are harmless if applied for a very short time (wipe out quickly). | Flammable |
| PS | Polystyrene | 80 (176) | Avoid solvents. | Flammable |
| PVC | Poly Vinyl Chloride | 80 (176) | Gasoline and most solvents are harmless if applied for a very short time (wipe out quickly). | Poisonous gas is emitted when burned. |
| TPO | Thermoplastic Olefine | 80 (176) | ↑ | Flammable |
| AAS | Acrylonitrile Acrylic Styrene | 85 (185) | Avoid gasoline and solvents. | — |
| PMMA | Poly Methyl Methacrylate | 85 (185) | ↑ | — |
| EVAC | Ethylene Vinyl Acetate | 90 (194) | ↑ | — |
| PP | Polypropylene | 90 (194) | Gasoline and most solvents are harmless if applied for a very short time (wipe out quickly). | Flammable, avoid battery acid. |
| PUR | Polyurethane | 90 (194) | Avoid gasoline and solvents. | — |
| UP | Unsaturated Polyester | 90 (194) | ↑ | Flammable |
| ASA | Acrylonitrile Styrene Acrylate | 100 (212) | ↑ | Flammable |
| PPE | Poly Phenylene Ether | 110 (230) | ↑ | — |
| TPU | Thermoplastic Urethane | 110 (230) | ↑ | — |
| PBT+PC | Poly Butylene Terephthalate + Polycarbonate | 120 (248) | ↑ | Flammable |
| PC | Polycarbonate | 120 (248) | ↑ | — |
| POM | Poly Oxymethylene | 120 (248) | ↑ | Avoid battery acid. |
| PA | Polyamide | 140 (284) | ↑ | Avoid immersing in water. |
| PBT | Poly Butylene Terephthalate | 140 (284) | ↑ | — |
| PAR | Polyarylate | 180 (356) | ↑ | — |
| PET | Polyethylene terephthalate | 180 (356) | ↑ | — |
| PEI | Polyetherimide | 200 (392) | ↑ | — |

CAUTION:

- When repairing and painting a portion of the body adjacent to plastic parts, consider their characteristics (influence of heat and solvent) and remove them if necessary or take suitable measures to protect them.
- Plastic parts should be repaired and painted using methods suiting the materials' characteristics.

Location of Plastic Parts

INFOID:000000006934774

LOCATION OF PLASTIC PARTS

LOCATION OF PLASTIC PARTS

< SERVICE DATA AND SPECIFICATIONS (SDS)

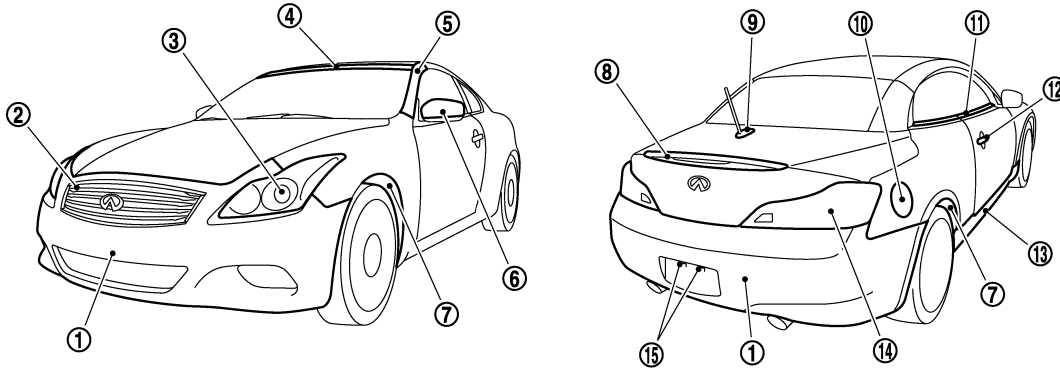

JSKIA1258ZZ

| Component | | Material | Component | | Material | |
|-----------|------------------------|----------|-----------|-------------------------------|----------------------|--------------------|
| 1 | Bumper fascia | PP + EPM | 8 | High mount stop lamp cover | ABS | |
| 2 | Front grille | ABS | 9 | Satellite radio antenna cover | PC + ASA | |
| 3 | Front combination lamp | Lens | 10 | Fuel filler lid | PA + PPE | |
| | | Housing | PP | 11 | Door outside molding | PVC + Stainless |
| 4 | Windshield molding | TPO | 12 | Door outside handle | PC + PET | |
| 5 | Front pillar finisher | PC + PET | 13 | Center mudguard | PP | |
| 6 | Door outside mirror | Cover | 14 | Rear combination lamp | Lens | PMMA |
| | | Housing | | | ASA | Housing |
| | | Base | | PA + Glass fiber | 15 | License plate lamp |
| Front | PP | Housing | PC | | | |
| 7 | Fender protector | Front | | | | |
| | | Rear | PET | | | |

A
B
C
D
E
F
G
H
I
J
K
L
M
N
O
P

BRM

LOCATION OF PLASTIC PARTS

< SERVICE DATA AND SPECIFICATIONS (SDS)

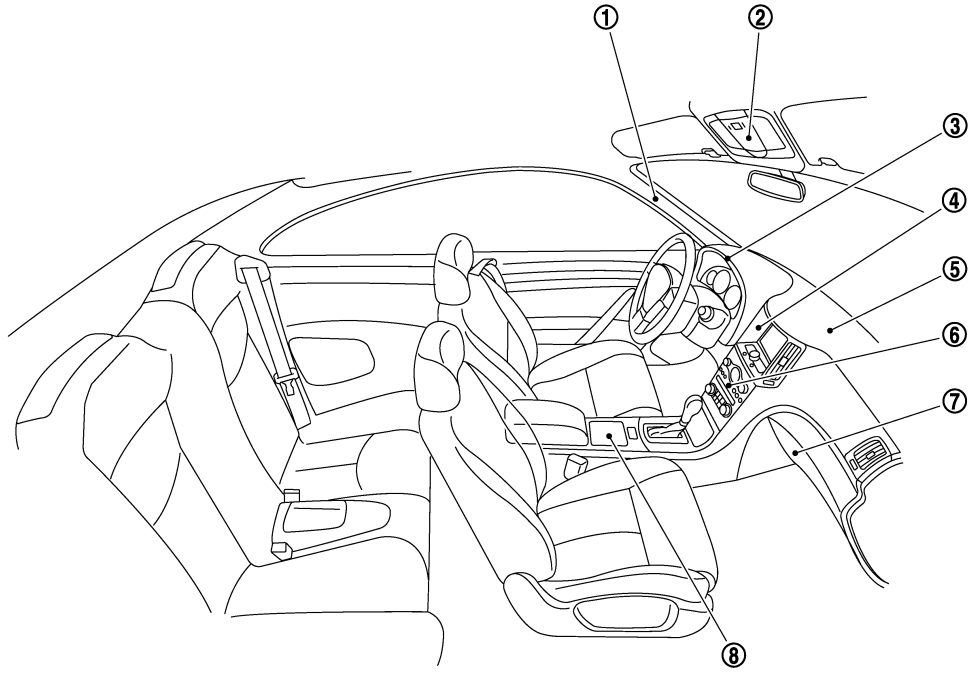

JSKIA1259ZZ

| Component | | Material | Component | | Material | | |
|-----------|-----------------------|----------|-----------|----------------|-------------------|---------------|-----|
| 1 | Front pillar finisher | PP | 6 | Cluster lid C | Standard finisher | PC + ABS | |
| 2 | Map lamp | Lens | | | PC | Wood finisher | ABS |
| | | Housing | PP | 7 | Glove box | Core | ABS |
| 3 | Cluster lid A | Upper | ABS | | | Pad | PUR |
| | | Lower | PP | | | Skin | PVC |
| 4 | Cluster lid D | ABS | 8 | Center console | ABS + PVC | | |
| 5 | Instrument panel | Core | PP | | | | |
| | | Pad | PUR | | | | |
| | | Skin | TPU | | | | |