

SECTION **RF**  
ROOF

A  
B  
C  
D  
E  
F  
G  
H  
I  
J  
RF  
L  
M  
N  
O  
P

**CONTENTS**

<b>PRECAUTION</b> .....	8	ROOF LATCH FUNCTION : System Description.....	35
<b>PRECAUTIONS</b> .....	8	<b>PARCEL SHELF FUNCTION</b> .....	36
Precaution for Supplemental Restraint System (SRS) "AIR BAG" and "SEAT BELT PRE-TENSIONER" .....	8	PARCEL SHELF FUNCTION : System Diagram .....	36
Service Procedure Precautions for Models with a Pop-up Roll Bar .....	8	PARCEL SHELF FUNCTION : System Description .....	37
Precaution for Battery Service .....	8	<b>FLIPPER DOOR FUNCTION</b> .....	39
Precaution for Hydraulic System .....	8	FLIPPER DOOR FUNCTION : System Diagram .....	39
Precaution for Pop Up Engine Hood .....	9	FLIPPER DOOR FUNCTION : System Description .....	39
Service Notice .....	9	<b>TRUNK LID CONTROL FUNCTION</b> .....	40
Precaution for Work .....	9	TRUNK LID CONTROL FUNCTION : System Diagram .....	41
Precautions for Retractable Hard Top Service .....	10	TRUNK LID CONTROL FUNCTION : System Description .....	41
<b>PREPARATION</b> .....	14	<b>WARNING FUNCTION</b> .....	41
<b>PREPARATION</b> .....	14	WARNING FUNCTION : System Diagram .....	42
Commercial Service Tool .....	14	WARNING FUNCTION : System Description .....	42
<b>SYSTEM DESCRIPTION</b> .....	15	<b>DIAGNOSIS SYSTEM (RETRACTABLE HARD TOP CONTROL UNIT)</b> .....	45
<b>COMPONENT PARTS</b> .....	15	CONSULT-III Function .....	45
Component Parts Location .....	15	<b>ECU DIAGNOSIS INFORMATION</b> .....	50
Component Description .....	17	<b>RETRACTABLE HARD TOP CONTROL UNIT</b> .....	50
<b>SYSTEM</b> .....	19	Reference Value .....	50
<b>RETRACTABLE HARD TOP SYSTEM</b> .....	19	Fail-safe .....	59
RETRACTABLE HARD TOP SYSTEM : System Diagram .....	19	DTC Inspection Priority Chart .....	61
RETRACTABLE HARD TOP SYSTEM : System Description .....	20	DTC Index .....	64
RETRACTABLE HARD TOP SYSTEM : Fail-safe.....	27	<b>WIRING DIAGRAM</b> .....	67
<b>HYDRAULIC SYSTEM CONTROL FUNCTION</b> .....	30	<b>RETRACTABLE HARD TOP SYSTEM</b> .....	67
HYDRAULIC SYSTEM CONTROL FUNCTION : System Diagram .....	31	Wiring Diagram .....	67
HYDRAULIC SYSTEM CONTROL FUNCTION : System Description .....	31	<b>BASIC INSPECTION</b> .....	86
<b>ROOF LATCH FUNCTION</b> .....	34	<b>DIAGNOSIS AND REPAIR WORK FLOW</b> .....	86
ROOF LATCH FUNCTION : System Diagram .....	35		

Work Flow .....	86	Component Inspection .....	104
<b>ADDITIONAL SERVICE WHEN REMOVING BATTERY NEGATIVE TERMINAL .....</b>	<b>88</b>	<b>B170A ROOF OPEN/CLOSE SWITCH (CLOSE) .....</b>	<b>105</b>
Description .....	88	DTC Logic .....	105
Work Procedure .....	88	Diagnosis Procedure .....	105
<b>ADDITIONAL SERVICE WHEN REPLACING CONTROL UNIT .....</b>	<b>89</b>	Component Inspection .....	106
Description .....	89	<b>B170B ROOF OPEN/CLOSE SWITCH .....</b>	<b>107</b>
Work Procedure .....	89	DTC Logic .....	107
<b>INITIALIZATION OF ROOF SYSTEM .....</b>	<b>90</b>	Diagnosis Procedure .....	107
Description .....	90	Component Inspection .....	108
Work Procedure .....	90	<b>B170C TRUNK LINK SENSOR (LH) .....</b>	<b>109</b>
<b>DTC/CIRCUIT DIAGNOSIS .....</b>	<b>92</b>	DTC Logic .....	109
<b>U1000 CAN COMM CIRCUIT .....</b>	<b>92</b>	Diagnosis Procedure .....	109
Description .....	92	<b>B170D TRUNK LINK SENSOR (RH) .....</b>	<b>111</b>
DTC Logic .....	92	DTC Logic .....	111
Diagnosis Procedure .....	92	Diagnosis Procedure .....	111
<b>U1010 CONTROL UNIT (CAN) .....</b>	<b>93</b>	<b>B170F SENSOR POWER SUPPLY .....</b>	<b>113</b>
DTC Logic .....	93	DTC Logic .....	113
Diagnosis Procedure .....	93	Diagnosis Procedure .....	113
<b>U0140 LOCAL COMMUNICATION-1 .....</b>	<b>94</b>	<b>B1710 ROOF LATCH STATUS SENSOR .....</b>	<b>116</b>
Description .....	94	DTC Logic .....	116
DTC Logic .....	94	Diagnosis Procedure .....	116
Diagnosis Procedure .....	94	<b>B1711 ROOF LATCH LOCK SENSOR .....</b>	<b>118</b>
<b>U0215 LOCAL COMMUNICATION-2 .....</b>	<b>95</b>	DTC Logic .....	118
Description .....	95	Diagnosis Procedure .....	118
DTC Logic .....	95	<b>B1712 TRUNK STATUS SENSOR .....</b>	<b>120</b>
Diagnosis Procedure .....	95	DTC Logic .....	120
<b>B1701 RETRACTABLE HARD TOP CONTROL UNIT .....</b>	<b>97</b>	Diagnosis Procedure .....	120
DTC Logic .....	97	<b>B1715 ROOF STATUS SENSOR POWER SUPPLY .....</b>	<b>122</b>
Diagnosis Procedure .....	97	DTC Logic .....	122
<b>B1702 RETRACTABLE HARD TOP CONTROL UNIT .....</b>	<b>98</b>	Diagnosis Procedure .....	122
DTC Logic .....	98	<b>B1716 PARCEL SHELF STATUS SENSOR (DRAW) .....</b>	<b>124</b>
Diagnosis Procedure .....	98	DTC Logic .....	124
<b>B1707 ROOF OPEN STATE .....</b>	<b>99</b>	Diagnosis Procedure .....	124
Description .....	99	<b>B1718 PARCEL SHELF STATUS SENSOR (ROTATE) .....</b>	<b>126</b>
DTC Logic .....	99	DTC Logic .....	126
Diagnosis Procedure .....	99	Diagnosis Procedure .....	126
<b>B1708 ROOF CLOSE STATE .....</b>	<b>101</b>	<b>B1719 ROOF STATUS SENSOR .....</b>	<b>128</b>
Description .....	101	DTC Logic .....	128
DTC Logic .....	101	Diagnosis Procedure .....	128
Diagnosis Procedure .....	101	<b>B171A HYDRAULIC PUMP (LH) .....</b>	<b>130</b>
<b>B1709 ROOF OPEN/CLOSE SWITCH (OPEN) .....</b>	<b>103</b>	DTC Logic .....	130
DTC Logic .....	103	Diagnosis Procedure .....	130
Diagnosis Procedure .....	103	<b>B171B HYDRAULIC PUMP (RH) .....</b>	<b>132</b>
		DTC Logic .....	132

Diagnosis Procedure .....	132	<b>B1729 RETRACTABLE HARD TOP CONTROL UNIT .....</b>	<b>148</b>	A
<b>B171C SWITCHING VALVE 1 .....</b>	<b>134</b>	DTC Logic .....	148	
DTC Logic .....	134	Diagnosis Procedure .....	148	
Diagnosis Procedure .....	134	<b>B172A RETRACTABLE HARD TOP CONTROL UNIT .....</b>	<b>149</b>	B
<b>B171D SWITCHING VALVE 2 .....</b>	<b>136</b>	DTC Logic .....	149	
DTC Logic .....	136	Diagnosis Procedure .....	149	C
Diagnosis Procedure .....	136	<b>B172B ROOF STATUS SIGNAL (AUDIO) .....</b>	<b>150</b>	D
<b>B171E RETRACTABLE HARD TOP CONTROL UNIT .....</b>	<b>138</b>	Description .....	150	
DTC Logic .....	138	DTC Logic .....	150	
Diagnosis Procedure .....	138	Diagnosis Procedure .....	150	
<b>B171F RETRACTABLE HARD TOP CONTROL UNIT .....</b>	<b>139</b>	<b>B172D ROOF WARNING BUZZER .....</b>	<b>152</b>	E
DTC Logic .....	139	DTC Logic .....	152	
Diagnosis Procedure .....	139	Diagnosis Procedure .....	152	
<b>B1720 RETRACTABLE HARD TOP CONTROL UNIT .....</b>	<b>140</b>	<b>B172E RETRACTABLE HARD TOP CONTROL UNIT .....</b>	<b>154</b>	F
DTC Logic .....	140	DTC Logic .....	154	
Diagnosis Procedure .....	140	Diagnosis Procedure .....	154	G
<b>B1721 RETRACTABLE HARD TOP CONTROL UNIT .....</b>	<b>141</b>	<b>B172F REAR POWER WINDOW (LH) .....</b>	<b>155</b>	H
DTC Logic .....	141	DTC Logic .....	155	
Diagnosis Procedure .....	141	Diagnosis Procedure .....	155	
<b>B1722 RETRACTABLE HARD TOP CONTROL UNIT .....</b>	<b>142</b>	<b>B1730 REAR POWER WINDOW (RH) .....</b>	<b>157</b>	I
DTC Logic .....	142	DTC Logic .....	157	
Diagnosis Procedure .....	142	Diagnosis Procedure .....	157	
<b>B1723 RETRACTABLE HARD TOP CONTROL UNIT .....</b>	<b>143</b>	<b>B1731 HYDRAULIC STATE 1 .....</b>	<b>159</b>	J
DTC Logic .....	143	Description .....	159	
Diagnosis Procedure .....	143	DTC Logic .....	159	
<b>B1724 RETRACTABLE HARD TOP CONTROL UNIT .....</b>	<b>144</b>	Diagnosis Procedure .....	159	RF
DTC Logic .....	144	<b>B1732 HYDRAULIC STATE 2 .....</b>	<b>161</b>	
Diagnosis Procedure .....	144	Description .....	161	
<b>B1725 RETRACTABLE HARD TOP CONTROL UNIT .....</b>	<b>145</b>	DTC Logic .....	161	L
DTC Logic .....	145	Diagnosis Procedure .....	161	
Diagnosis Procedure .....	145	<b>B1733 HYDRAULIC STATE 3 .....</b>	<b>163</b>	M
<b>B1726 RETRACTABLE HARD TOP CONTROL UNIT .....</b>	<b>146</b>	Description .....	163	
DTC Logic .....	146	DTC Logic .....	163	
Diagnosis Procedure .....	146	Diagnosis Procedure .....	163	N
<b>B1728 RETRACTABLE HARD TOP CONTROL UNIT .....</b>	<b>147</b>	<b>B1734 HYDRAULIC STATE 4 .....</b>	<b>165</b>	
DTC Logic .....	147	Description .....	165	
Diagnosis Procedure .....	147	DTC Logic .....	165	O
<b>B1729 RETRACTABLE HARD TOP CONTROL UNIT .....</b>	<b>148</b>	Diagnosis Procedure .....	165	
DTC Logic .....	148	<b>B1735 HYDRAULIC STATE 5 .....</b>	<b>167</b>	P
Diagnosis Procedure .....	148	Description .....	167	
<b>B172A RETRACTABLE HARD TOP CONTROL UNIT .....</b>	<b>149</b>	DTC Logic .....	167	
DTC Logic .....	149	Diagnosis Procedure .....	167	
Diagnosis Procedure .....	149	<b>B1736 HYDRAULIC STATE 6 .....</b>	<b>169</b>	
<b>B172B ROOF STATUS SIGNAL (AUDIO) .....</b>	<b>150</b>	Description .....	169	
Description .....	150	DTC Logic .....	169	
DTC Logic .....	150	Diagnosis Procedure .....	169	
Diagnosis Procedure .....	150			
<b>B172D ROOF WARNING BUZZER .....</b>	<b>152</b>			
DTC Logic .....	152			
Diagnosis Procedure .....	152			
<b>B172E RETRACTABLE HARD TOP CONTROL UNIT .....</b>	<b>154</b>			
DTC Logic .....	154			
Diagnosis Procedure .....	154			
<b>B172F REAR POWER WINDOW (LH) .....</b>	<b>155</b>			
DTC Logic .....	155			
Diagnosis Procedure .....	155			
<b>B1730 REAR POWER WINDOW (RH) .....</b>	<b>157</b>			
DTC Logic .....	157			
Diagnosis Procedure .....	157			
<b>B1731 HYDRAULIC STATE 1 .....</b>	<b>159</b>			
Description .....	159			
DTC Logic .....	159			
Diagnosis Procedure .....	159			
<b>B1732 HYDRAULIC STATE 2 .....</b>	<b>161</b>			
Description .....	161			
DTC Logic .....	161			
Diagnosis Procedure .....	161			
<b>B1733 HYDRAULIC STATE 3 .....</b>	<b>163</b>			
Description .....	163			
DTC Logic .....	163			
Diagnosis Procedure .....	163			
<b>B1734 HYDRAULIC STATE 4 .....</b>	<b>165</b>			
Description .....	165			
DTC Logic .....	165			
Diagnosis Procedure .....	165			
<b>B1735 HYDRAULIC STATE 5 .....</b>	<b>167</b>			
Description .....	167			
DTC Logic .....	167			
Diagnosis Procedure .....	167			
<b>B1736 HYDRAULIC STATE 6 .....</b>	<b>169</b>			
Description .....	169			
DTC Logic .....	169			
Diagnosis Procedure .....	169			

<b>B1737 HYDRAULIC STATE 7</b> .....	<b>170</b>	DTC Logic .....	185
Description .....	170	Diagnosis Procedure .....	185
DTC Logic .....	170		
Diagnosis Procedure .....	170		
<b>B1738 HYDRAULIC STATE 8</b> .....	<b>171</b>	<b>B1744 HYDRAULIC STATE 20</b> .....	<b>187</b>
Description .....	171	Description .....	187
DTC Logic .....	171	DTC Logic .....	187
Diagnosis Procedure .....	171	Diagnosis Procedure .....	187
<b>B1739 HYDRAULIC STATE 9</b> .....	<b>172</b>	<b>B1745 HYDRAULIC STATE 21</b> .....	<b>189</b>
Description .....	172	Description .....	189
DTC Logic .....	172	DTC Logic .....	189
Diagnosis Procedure .....	172	Diagnosis Procedure .....	189
<b>B173A HYDRAULIC STATE 10</b> .....	<b>173</b>	<b>B1746 HYDRAULIC STATE 22</b> .....	<b>191</b>
Description .....	173	Description .....	191
DTC Logic .....	173	DTC Logic .....	191
Diagnosis Procedure .....	173	Diagnosis Procedure .....	191
<b>B173B HYDRAULIC STATE 11</b> .....	<b>174</b>	<b>B1747 PARCEL SHELF (DRAW)-STATE 1</b> ...	<b>193</b>
Description .....	174	Description .....	193
DTC Logic .....	174	DTC Logic .....	193
Diagnosis Procedure .....	174	Diagnosis Procedure .....	193
<b>B173C HYDRAULIC STATE 12</b> .....	<b>175</b>	<b>B1748 PARCEL SHELF (DRAW)-STATE 2</b> ...	<b>194</b>
Description .....	175	Description .....	194
DTC Logic .....	175	DTC Logic .....	194
Diagnosis Procedure .....	175	Diagnosis Procedure .....	194
<b>B173D HYDRAULIC STATE 13</b> .....	<b>176</b>	<b>B1749 PARCEL SHELF (DRAW)-STATE 3</b> ...	<b>195</b>
Description .....	176	Description .....	195
DTC Logic .....	176	DTC Logic .....	195
Diagnosis Procedure .....	176	Diagnosis Procedure .....	195
<b>B173E HYDRAULIC STATE 14</b> .....	<b>177</b>	<b>B174A PARCEL SHELF (DRAW)-STATE 4</b> ...	<b>196</b>
Description .....	177	Description .....	196
DTC Logic .....	177	DTC Logic .....	196
Diagnosis Procedure .....	177	Diagnosis Procedure .....	196
<b>B173F HYDRAULIC STATE 15</b> .....	<b>178</b>	<b>B174B PARCEL SHELF (DRAW)-STATE 5</b> ...	<b>197</b>
Description .....	178	Description .....	197
DTC Logic .....	178	DTC Logic .....	197
Diagnosis Procedure .....	178	Diagnosis Procedure .....	197
<b>B1740 HYDRAULIC STATE 16</b> .....	<b>179</b>	<b>B174C PARCEL SHELF (DRAW)-STATE 6</b> ...	<b>198</b>
Description .....	179	Description .....	198
DTC Logic .....	179	DTC Logic .....	198
Diagnosis Procedure .....	179	Diagnosis Procedure .....	198
<b>B1741 HYDRAULIC STATE 17</b> .....	<b>182</b>	<b>B174D PARCEL SHELF (ROTATE)-STATE 1.</b>	<b>199</b>
Description .....	182	Description .....	199
DTC Logic .....	182	DTC Logic .....	199
Diagnosis Procedure .....	182	Diagnosis Procedure .....	199
<b>B1742 HYDRAULIC STATE 18</b> .....	<b>183</b>	<b>B174E PARCEL SHELF (ROTATE)-STATE 2.</b>	<b>200</b>
Description .....	183	Description .....	200
DTC Logic .....	183	DTC Logic .....	200
Diagnosis Procedure .....	183	Diagnosis Procedure .....	200
<b>B1743 HYDRAULIC STATE 19</b> .....	<b>185</b>	<b>B174F PARCEL SHELF (ROTATE)-STATE 3.</b>	<b>201</b>
Description .....	185	Description .....	201
		DTC Logic .....	201
		Diagnosis Procedure .....	201

<b>B1750 PARCEL SHELF (ROTATE)-STATE 4</b> .....	<b>202</b>	<b>B175F POWER SOURCE (POWER WIN- DOW)</b> .....	<b>215</b>	A
Description .....	202	Description .....	215	
DTC Logic .....	202	DTC Logic .....	215	B
Diagnosis Procedure .....	202	Diagnosis Procedure .....	215	
<b>B1751 ROOF LATCH STATE 1</b> .....	<b>203</b>	<b>B1760 RETRACTABLE HARD TOP CON- TROL UNIT</b> .....	<b>217</b>	C
Description .....	203	DTC Logic .....	217	
DTC Logic .....	203	Diagnosis Procedure .....	217	D
Diagnosis Procedure .....	203	<b>B1761 RETRACTABLE HARD TOP CON- TROL UNIT</b> .....	<b>218</b>	
<b>B1752 ROOF LATCH STATE 2</b> .....	<b>204</b>	DTC Logic .....	218	E
Description .....	204	Diagnosis Procedure .....	218	
DTC Logic .....	204	<b>B1762 ROOF STATE</b> .....	<b>219</b>	F
Diagnosis Procedure .....	204	Description .....	219	
<b>B1753 ROOF LATCH STATE 3</b> .....	<b>205</b>	DTC Logic .....	219	G
Description .....	205	Diagnosis Procedure .....	219	
DTC Logic .....	205	<b>B1763 HYDRAULIC STATE</b> .....	<b>222</b>	H
Diagnosis Procedure .....	205	Description .....	222	
<b>B1754 FLIPPER DOOR STATE 1</b> .....	<b>206</b>	DTC Logic .....	222	I
Description .....	206	Diagnosis Procedure .....	222	
DTC Logic .....	206	<b>B1764 ROOF LATCH STATE</b> .....	<b>224</b>	J
Diagnosis Procedure .....	206	Description .....	224	
<b>B1755 FLIPPER DOOR STATE 2</b> .....	<b>207</b>	DTC Logic .....	224	
Description .....	207	Diagnosis Procedure .....	224	
DTC Logic .....	207	<b>B1765 FLIPPER DOOR STATE</b> .....	<b>225</b>	
Diagnosis Procedure .....	207	Description .....	225	
<b>B1756 FLIPPER DOOR STATE 3</b> .....	<b>208</b>	DTC Logic .....	225	
Description .....	208	Diagnosis Procedure .....	225	
DTC Logic .....	208	<b>POWER SUPPLY AND GROUND CIRCUIT</b> ..	<b>226</b>	RF
Diagnosis Procedure .....	208	Diagnosis Procedure .....	226	
<b>B1757 FLIPPER DOOR STATE 4</b> .....	<b>209</b>	<b>ROOF OPEN/CLOSE SWITCH</b> .....	<b>227</b>	L
Description .....	209	Component Function Check .....	227	
DTC Logic .....	209	Diagnosis Procedure .....	227	
Diagnosis Procedure .....	209	<b>TONNEAU BOARD SWITCH</b> .....	<b>229</b>	M
<b>B1758 THERMO PROTECTION</b> .....	<b>210</b>	Component Function Check .....	229	
Description .....	210	Diagnosis Procedure .....	229	
DTC Logic .....	210	<b>FLIPPER DOOR LIMIT SWITCH</b> .....	<b>231</b>	N
Diagnosis Procedure .....	210	Diagnosis Procedure .....	231	
<b>B175C POWER SOURCE (ROOF)</b> .....	<b>211</b>	<b>BACK-UP LAMP CIRCUIT</b> .....	<b>233</b>	O
Description .....	211	Description .....	233	
DTC Logic .....	211	Component Function Check .....	233	
Diagnosis Procedure .....	211	Diagnosis Procedure .....	233	P
<b>B175D POWER SOURCE (ROOF)</b> .....	<b>212</b>	<b>FLIPPER DOOR MOTOR</b> .....	<b>235</b>	
Description .....	212	Diagnosis Procedure .....	235	
DTC Logic .....	212	<b>ROOF LATCH MOTOR</b> .....	<b>237</b>	
Diagnosis Procedure .....	212	Diagnosis Procedure .....	237	
<b>B175E POWER SOURCE (POWER WIN- DOW)</b> .....	<b>213</b>	<b>PARCEL SHELF MOTOR (DRAW)</b> .....	<b>238</b>	
Description .....	213			
DTC Logic .....	213			
Diagnosis Procedure .....	213			

Diagnosis Procedure .....	238	Exploded View .....	277
<b>PARCEL SHELF MOTOR (ROTATION) .....</b>	<b>240</b>	Removal and Installation .....	277
Diagnosis Procedure .....	240	Adjustment .....	279
<b>ROOF WARNING BUZZER .....</b>	<b>241</b>	<b>REAR ROOF PANEL .....</b>	<b>281</b>
Diagnosis Procedure .....	241	Exploded View .....	281
<b>HYDRAULIC PUMP MOTOR POWER SUP- PLY RELAY .....</b>	<b>242</b>	Removal and Installation .....	281
Diagnosis Procedure .....	242	Adjustment .....	283
<b>SYMPTOM DIAGNOSIS .....</b>	<b>243</b>	<b>ROOF SEALING .....</b>	<b>285</b>
<b>RETRACTABLE HARD TOP DOES NOT OP- ERATE USING DOOR REQUEST SWITCH ..</b>	<b>243</b>	Exploded View .....	285
Diagnosis Procedure .....	243	Removal and Installation .....	286
<b>ROOF WARNING BUZZER DOES NOT SOUND .....</b>	<b>244</b>	<b>ROOF LINK ASSEMBLY .....</b>	<b>287</b>
Diagnosis Procedure .....	244	Exploded View .....	287
<b>SQUEAK AND RATTLE TROUBLE DIAG- NOSES .....</b>	<b>245</b>	Removal and Installation .....	288
Work Flow .....	245	<b>REAR PARCEL SHELF FINISHER .....</b>	<b>290</b>
Inspection Procedure .....	247	<b>REAR PARCEL SHELF UNIT .....</b>	<b>290</b>
Diagnostic Worksheet .....	249	REAR PARCEL SHELF UNIT : Exploded View ...	290
<b>PERIODIC MAINTENANCE .....</b>	<b>251</b>	REAR PARCEL SHELF UNIT : Removal and In- stallation .....	290
<b>WATER LEAKAGE TROUBLE DIAGNOSIS .</b>	<b>251</b>	<b>PARCEL SHELF MOTOR (ROTATE) .....</b>	<b>291</b>
Repairing Method for Water Leakage Around Re- tractable Hard Top .....	251	PARCEL SHELF MOTOR (ROTATE) : Exploded View .....	292
Water Leakage Test .....	255	PARCEL SHELF MOTOR (ROTATE) : Removal and Installation .....	292
<b>REMOVAL AND INSTALLATION .....</b>	<b>257</b>	<b>PARCEL SHELF MOTOR (DRAW) .....</b>	<b>293</b>
<b>FRONT LATCH ASSEMBLY .....</b>	<b>257</b>	PARCEL SHELF MOTOR (DRAW) : Exploded View .....	293
Exploded View .....	257	PARCEL SHELF MOTOR (DRAW) : Removal and Installation .....	293
Removal and Installation .....	257	<b>FLIPPER DOOR .....</b>	<b>295</b>
<b>HEADLINING .....</b>	<b>259</b>	Exploded View .....	295
Exploded View .....	259	Removal and Installation .....	295
Removal and Installation .....	260	Adjustment .....	296
<b>ROOF LOCK ASSEMBLY .....</b>	<b>269</b>	<b>ROOF SUPPORT BUMPER .....</b>	<b>297</b>
<b>ROOF LOCK ASSEMBLY .....</b>	<b>269</b>	Exploded View .....	297
ROOF LOCK ASSEMBLY : Exploded View .....	269	Removal and Installation .....	297
ROOF LOCK ASSEMBLY : Removal and Installa- tion .....	269	<b>HYDRAULIC SYSTEM .....</b>	<b>299</b>
<b>ROOF LATCH MOTOR .....</b>	<b>270</b>	Exploded View .....	299
ROOF LATCH MOTOR : Exploded View .....	271	Removal and Installation .....	299
ROOF LATCH MOTOR : Removal and Installation .....	271	<b>HYDRAULIC CYLINDER .....</b>	<b>303</b>
<b>FRONT ROOF PANEL .....</b>	<b>272</b>	Exploded View .....	303
Exploded View .....	272	Removal and Installation .....	304
Removal and Installation .....	272	<b>RETRACTABLE HARD TOP CONTROL UNIT .....</b>	<b>309</b>
Adjustment .....	274	Removal and Installation .....	309
<b>CENTER ROOF PANEL .....</b>	<b>277</b>	<b>UNIT REMOVAL AND INSTALLATION ...</b>	<b>310</b>
		<b>RETRACTABLE HARD ROOF ASSEMBLY ..</b>	<b>310</b>
		Exploded View .....	310
		Removal and Installation .....	311

A

B

C

D

E

F

G

H

I

J

**RF**

L

M

N

O

P

# PRECAUTIONS

< PRECAUTION >

## PRECAUTION

### PRECAUTIONS

#### Precaution for Supplemental Restraint System (SRS) "AIR BAG" and "SEAT BELT PRE-TENSIONER"

INFOID:000000006468630

The Supplemental Restraint System such as "AIR BAG" and "SEAT BELT PRE-TENSIONER", used along with a front seat belt, helps to reduce the risk or severity of injury to the driver and front passenger for certain types of collision. This system includes seat belt switch inputs and dual stage front air bag modules. The SRS system uses the seat belt switches to determine the front air bag deployment, and may only deploy one front air bag, depending on the severity of a collision and whether the front occupants are belted or unbelted. Information necessary to service the system safely is included in the "SRS AIR BAG" and "SEAT BELT" of this Service Manual.

#### **WARNING:**

Always observe the following items for preventing accidental activation.

- To avoid rendering the SRS inoperative, which could increase the risk of personal injury or death in the event of a collision that would result in air bag inflation, all maintenance must be performed by an authorized NISSAN/INFINITI dealer.
- Improper maintenance, including incorrect removal and installation of the SRS, can lead to personal injury caused by unintentional activation of the system. For removal of Spiral Cable and Air Bag Module, see "SRS AIR BAG".
- Never use electrical test equipment on any circuit related to the SRS unless instructed to in this Service Manual. SRS wiring harnesses can be identified by yellow and/or orange harnesses or harness connectors.

#### PRECAUTIONS WHEN USING POWER TOOLS (AIR OR ELECTRIC) AND HAMMERS

#### **WARNING:**

Always observe the following items for preventing accidental activation.

- When working near the Air Bag Diagnosis Sensor Unit or other Air Bag System sensors with the ignition ON or engine running, never use air or electric power tools or strike near the sensor(s) with a hammer. Heavy vibration could activate the sensor(s) and deploy the air bag(s), possibly causing serious injury.
- When using air or electric power tools or hammers, always switch the ignition OFF, disconnect the battery, and wait at least 3 minutes before performing any service.

#### Service Procedure Precautions for Models with a Pop-up Roll Bar

INFOID:000000006468631

#### **WARNING:**

Always observe the following items for preventing accidental activation.

- Risk of passenger injury or death may increase if the pop-up roll bar does not deploy during a roll over collision. In order to reduce the chance of an incident where the pop-up roll bar is inoperative, all maintenance must be performed by a NISSAN or INFINITI dealer.
- Before removing and installing the pop-up roll bar component parts and harness, always turn the ignition switch OFF, disconnect the battery negative terminal, and wait for 3 minutes or more. (The purpose of this operation is to discharge electricity that is accumulated in the auxiliary power supply circuit in the air bag diagnosis sensor unit.)
- When repairing, removing, and installing a pop-up roll bar, always refer to SRS AIR BAG and SRS AIR BAG CONTROL warnings in the Service Manual.

#### Precaution for Battery Service

INFOID:000000006468632

Before disconnecting the battery, lower both the driver and passenger windows. This will prevent any interference between the window edge and the vehicle when the door is opened/closed. During normal operation, the window slightly raises and lowers automatically to prevent any window to vehicle interference. The automatic window function will not work with the battery disconnected.

#### Precaution for Hydraulic System

INFOID:000000006468633

#### **CAUTION:**

- Never bend or twist hydraulic hoses sharply, or strongly pull them.



# PRECAUTIONS

## < PRECAUTION >

- Serviceable parts for hydraulic circuit are not various. Before disassembly refer to [RF-299](#), "[Exploded View](#)".

### WARNING:

- The retractable hard top may fall suddenly. Avoid working on the vehicle with hydraulic circuit under pressure. Always depressurize the system before starting. To depressurize the system, disconnect both battery cables starting by negative terminal.
- Never allow hydraulic fluid to come in contact with skin, eyes, fabrics, or.
- After touching hydraulic fluid, never touch or rub your eyes until you have thoroughly washed your hands.
  - If hydraulic fluid contacts cloths, change them immediately.
  - If hydraulic fluid contacts skin, wash skin with soap and water.
  - If hydraulic fluid contacts eyes, immediately flush with water for 15 minutes and seek medical attention.

## Precaution for Pop Up Engine Hood

INFOID:000000006468634

### WARNING:

Always observe the following items for preventing accidental activation.

- Before removal or installation of the pop-up engine hood and harness, always turn OFF the key switch, disconnect the battery negative terminal, and wait for 3 minutes or more. (To discharge the accumulated electricity in the pop-up engine hood control unit auxiliary power supply circuit)
- Never use pneumatic or electric tools, etc., to remove or install components of the pop-up engine hood.
- Never repair the harness for the pop-up engine hood with a solder. Also, always avoid contact or interference between the harness and other parts.
- Never use an electric tester like a circuit tester, etc., when inspecting the pop-up engine hood circuit or other individual parts. (To prevent activation due to the low voltage of the tester)
- Never allow foreign materials like a screwdriver, etc., to enter the pop-up engine hood harness connector. (To prevent activation due to static electricity)
- The yellow harness connector is used with the pop-up engine hood for identification purposes compared to other harnesses.

## Service Notice

INFOID:000000006468635

- When removing or installing various parts, place a cloth or padding onto the vehicle body to prevent scratches.
- Handle trim, molding, instruments, grille, etc. carefully during removing or installing. Be careful not to oil or damage them.
- Apply sealing compound where necessary when installing parts.
- When applying sealing compound, be careful that the sealing compound does not protrude from parts.
- When replacing any metal parts (for example body outer panel, members, etc.), be sure to take rust prevention measures.

## Precaution for Work

INFOID:000000006468636

- When removing or disassembling each component, be careful not to damage or deform it. If a component may be subject to interference, be sure to protect it with a shop cloth.
- When removing (disengaging) components with a screwdriver or similar tool, be sure to wrap the component with a shop cloth or vinyl tape to protect it.
- Protect the removed parts with a shop cloth and keep them.
- Replace a deformed or damaged clip.
- If a part is specified as a non-reusable part, always replace it with new one.
- Be sure to tighten bolts and nuts securely to the specified torque.
- After re-installation is completed, be sure to check that each part works normally.
- Follow the steps below to clean components.
  - Water soluble foul: Dip a soft cloth into lukewarm water, and wring the water out of the cloth to wipe the fouled area.  
Then rub with a soft and dry cloth.
  - Oily foul: Dip a soft cloth into lukewarm water with mild detergent (concentration: within 2 to 3%), and wipe the fouled area.  
Then dip a cloth into fresh water, and wring the water out of the cloth to wipe the detergent off. Then rub with a soft and dry cloth.

# PRECAUTIONS

## < PRECAUTION >

- Do not use organic solvent such as thinner, benzene, alcohol, and gasoline.
- For genuine leather seats, use a genuine leather seat cleaner.

### Precautions for Retractable Hard Top Service

INFOID:000000006871589

#### CAUTION:

Operate each part using **CONSULT** after understanding how roof normally operates. Otherwise, each part may interfere and may be damage.

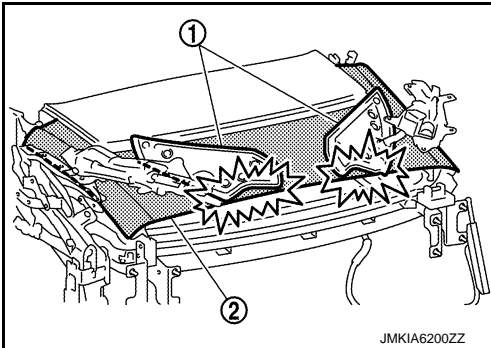
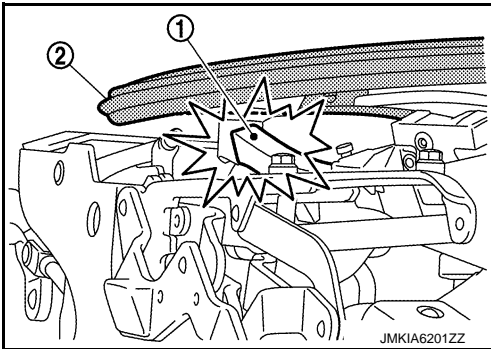
CONSULT command			NO	Special check items	Condition	Action to take	
Item	Button	Operation				Preparation	CON-SULT
Roof/ Trunk/ Parcel shelf	Trunk CLOSE	Trunk closes	1	Check the roof and flap do not interfere.	When trunk is closed while roof is close and flap is expanded forward, flap interferes with roof.	Before closing trunk, always operate and retract flap.	FLIP- PER DOOR → Down
			2	Check that roof and flap do not interfere.	When trunk is closed while flap (1) is retracted, flap interferes with retracted roof (2). 	Before opening roof, always operate flap and expand it forward.	FLIP- PER DOOR → UP
			3	Check that retracted roof is locked.	When trunk is closed while roof is not locked, base of flap (1) may interfere with roof (2). 	Before closing trunk, always lock roof.	ROOF LATCH → Close
Trunk OPEN	Trunk opens (Lock is not released).	4	Check that rear lock is released.	When trunk is operated while rear lock is locked, trunk does open and deforms.	Before opening trunk, always unlock trunk lock.	TRUNK OPEN- ER → ON	
Roof OPEN	Roof opens (Roof lock is not released).	5	Check that roof lock is released.	When roof is operated while roof lock is locked, roof does not open and deforms.	Before opening roof, always unlock roof lock.	ROOF LATCH → Open	

# PRECAUTIONS

## < PRECAUTION >

Roof/ Trunk/ Parcel shelf	Roof OPEN	Roof opens (Roof lock is not re- leased).	6	Check that trunk is open.	When roof is operated while trunk is not open, roof interferes with trunk.	Open trunk.	Trunk open (Refer to above item.)
			7	Check that flap is expanded forward. (The vehicle is in convertible status.)	When flap is operated after roof is retracted, flap interferes with roof.	Operated flap and expand it forward.	FLIPPER DOOR → Down
			8	Check that parcel board is moved downward.	When roof is operated while parcel board is not moved downward, roof interferes with parcel board.	Move parcel board downward.	PS up down: Down
			9	Check that parcel board is set to the stand straight position.	If parcel board (1) is not set to the stand straight position, roof (2) interferes with parcel board.	Rotate parcel board and set it to the stand straight position.	PS rotation: Vertical
			10	Check that parcel board and rear end of roof 2 do not interfere.	When roof is operated from closed status, check that the portion shown in the figure does not interfere and that parcel board (1) is not pressed backward.	Set parcel board in the stand straight position at bottom dead center.	PS up down: Down → PS rotation: Vertical
			11	Check that front end of roof 1 and upper end of parcel board do not interfere.	When roof is operated from closed status, check that the portion shown in the figure does not interfere and that parcel board (1) is not pressed backward.	Set parcel board in the stand straight position at bottom dead center.	PS up down: Down → PS rotation: Vertical

A  
B  
C  
D  
E  
F  
G  
H  
I  
J  
L  
M  
N  
O  
P

RF

# PRECAUTIONS

## < PRECAUTION >

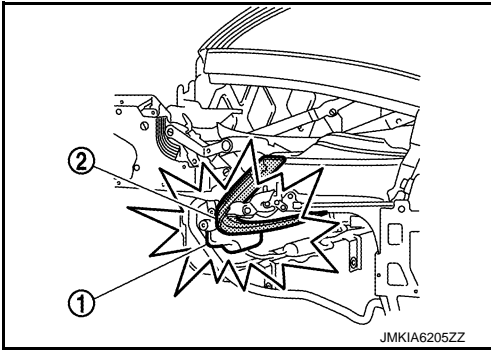
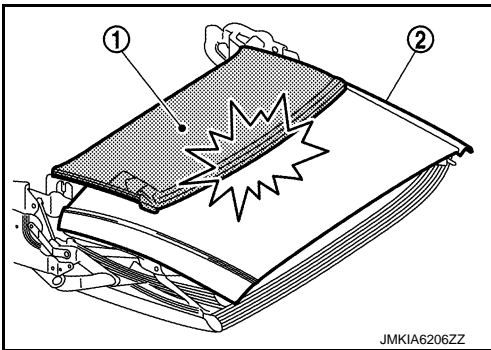
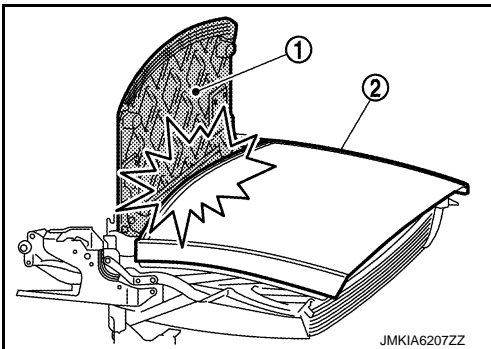
Roof/ Trunk/ Parcel shelf	Roof OPEN	Roof opens (Roof lock is not re- leased).	12	Check that lower end of roof 3 and parcel unit do not interfere.	When roof passes parcel board in No.11 and roof is continuously operated, lower end of parcel (1) and roof (2) interfere.  JMKIA6205ZZ	Check that roof pass- es in No.11, and then gradually move par- cel board for approxi- mately 100 mm in up- ward direc- tion. Operate rear roof to the retract- ed position.	PS up down: UP
	Roof CLOSE	Roof closes (Roof lock is not re- leased).	13	Check that roof lock is released.	When roof is operated while roof lock is locked, roof does not close and deforms.	Before closing roof, al- ways un- lock roof lock.	ROOF LATCH → Open
			14	Check that trunk is open.	When roof is operated while trunk is not open, roof interferes with trunk.	Open trunk.	Trunk open (Refer to above item.)
			15	Check that par- cel board is set to the stand straight position.	If parcel board (1) is not set to the stand straight po- sition, roof (2) interferes with parcel board.  JMKIA6206ZZ	Rotate par- cel board and set it to the stand straight po- sition.	PS rota- tion: Ver- tical
			16	Check that par- cel board is moved down- ward. Check that parcel board is not excessively moved down- ward.	If parcel board (1) is not moved downward, front end of roof (2) interferes with parcel board. If parcel board is moved downward excessively, rear end of roof interferes with parcel board.  JMKIA6207ZZ	Move par- cel board downward to approxi- mately 300 mm from upper dead center.	PS up down: Down

# PRECAUTIONS

## < PRECAUTION >

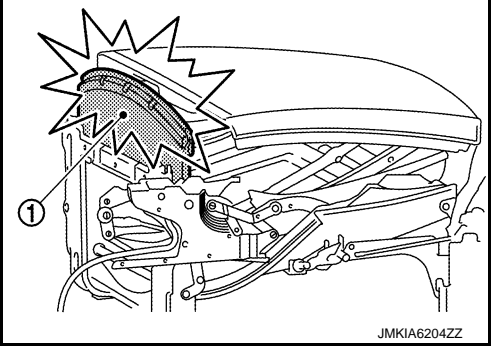
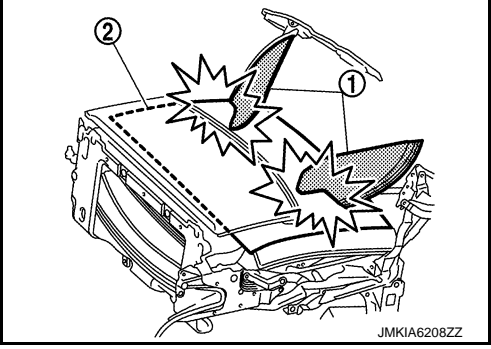
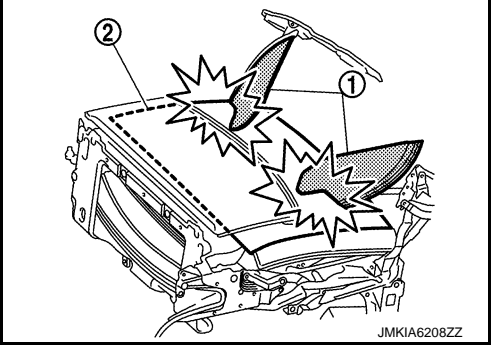
Roof/ Trunk/ Parcel shelf	Roof CLOSE	Roof closes (Roof lock is not re- leased).	17	Check that front end of roof 1 and upper end of parcel board do not interfere.	When rear end of rear roof moves further rearward of parcel unit lower in No.11 and roof is continuously operated, front end of roof interferes with upper end of parcel board (1). 	Move parcel board downward to bottom dead center.	PS up down: Down
	PS up down and ro- tation	Parcel board moves upward, down- ward, or rotates.	18	Check that roof and parcel do not interfere.	Interference between flap (1) and roof panel (2) oc- curs depending on the position of roof. 	When operat- ing parcel, always operate it while checking the position of roof. Op- erate roof in advance when inter- ference may occur.	Roof OPEN or CLOSE
FLIP- PER DOOR	UP, Down	Flap ro- tates.	19	Check that roof and flap do not interfere.	Interference between flap (1) and roof panel (2) oc- curs depending on the position of roof. 	When operat- ing flap, always op- erate it while checking the position of roof. Op- erate roof in advance when inter- ference may occur.	Roof OPEN or CLOSE

A  
B  
C  
D  
E  
F  
G  
H  
I  
J  
RF  
L  
M  
N  
O  
P

# PREPARATION

< PREPARATION >

## PREPARATION

### PREPARATION

#### Commercial Service Tool

INFOID:000000006468637

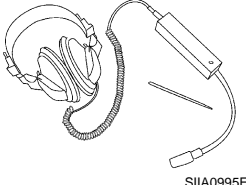
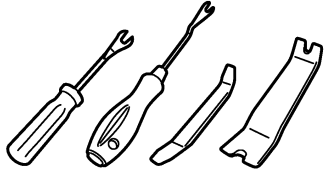
Tool name	Description
<p data-bbox="159 520 267 546">Engine ear</p>  <p data-bbox="771 630 836 646">SIA0995E</p>	<p data-bbox="1006 520 1185 546">Locates the noise</p>
<p data-bbox="159 772 292 798">Remover tool</p>  <p data-bbox="771 882 868 898">JMKIA3050ZZ</p>	<p data-bbox="1006 772 1421 798">Removes the clips, pawls and metal clips</p>

# COMPONENT PARTS

< SYSTEM DESCRIPTION >

## SYSTEM DESCRIPTION

### COMPONENT PARTS

#### Component Parts Location

INFOID:000000006468638

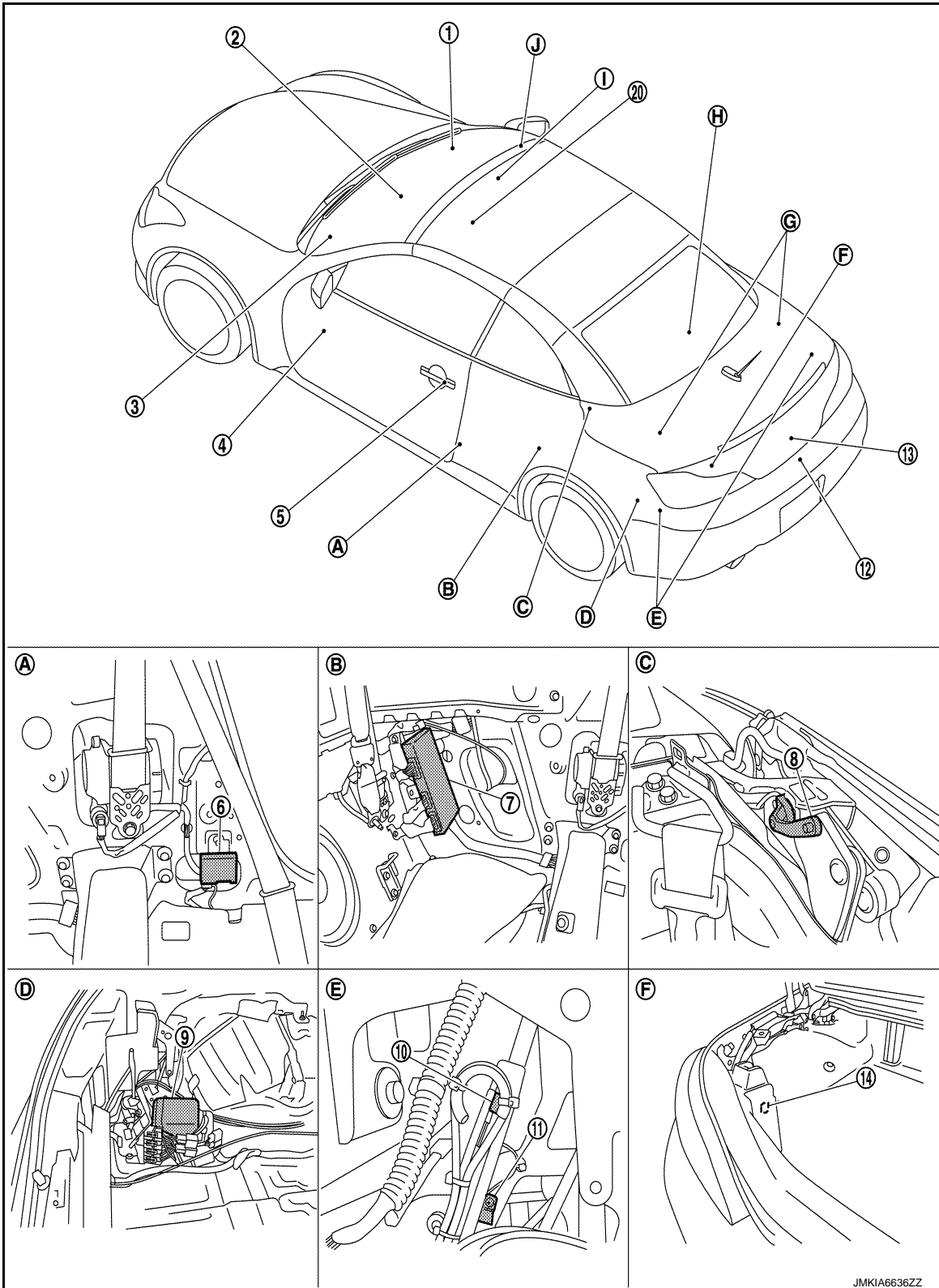

A  
B  
C  
D  
E  
F  
G  
H  
I  
J  
RF  
L  
M  
N  
O  
P

# COMPONENT PARTS

< SYSTEM DESCRIPTION >

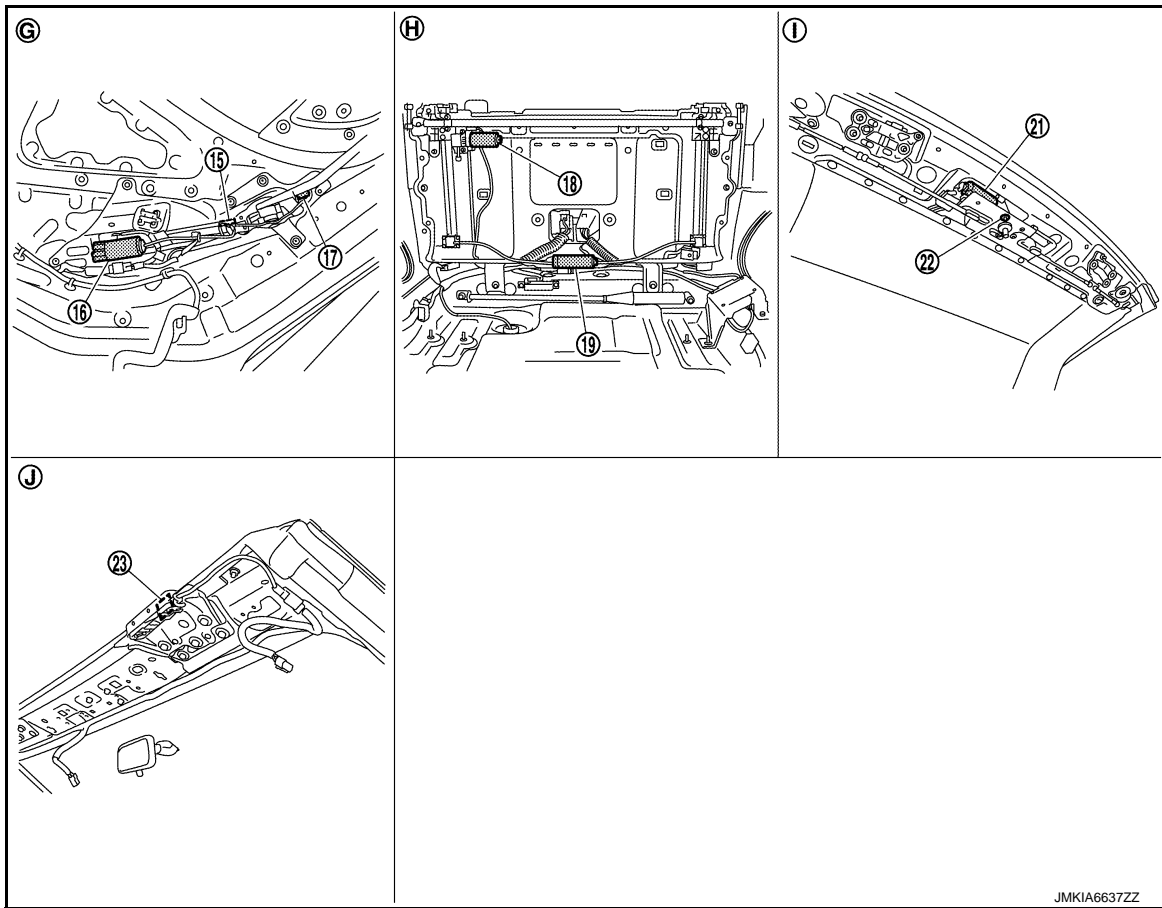

- |  |   |  |
|--|---|--|
| 1. BCM<br>Refer to <a href="#">BCS-6</a>                             | 2. Unified meter and A/C amp.<br>Refer to <a href="#">HAC-44</a>                | 3. Combination meter<br>Refer to <a href="#">MWI-11</a>                            |
| 4. Power window main switch<br>Refer to <a href="#">PWC-9</a> .      | 5. • Outside handle LH (Request switch)<br>• Outside handle RH (Request switch) | 6. Roof warning buzzer   |
| 7. Retractable hard top control unit                                 | 8. Roof status sensor   | 9. Hydraulic unit  |
| 10. Trunk status sensor  | 11. • Trunk link sensor LH<br>• Trunk link sensor RH                            | 12. Trunk closure control unit<br>Refer to <a href="#">DLK-47</a>                  |
| 13. Trunk room lamp switch   | 14. Tonneau board switch  | 15. • Flipper door limit switch LH (DOWN)<br>• Flipper door limit switch RH (DOWN) |
| 16. • Flipper door motor LH<br>• Flipper door motor RH               | 17. • Flipper door limit switch LH (UP)<br>• Flipper door limit switch RH (UP)  | 18. Parcel shelf motor (rotation)<br>[Parcel shelf status sensor (rotation)]       |
| 19. Parcel shelf motor (draw)<br>[Parcel shelf status sensor (draw)] | 20. Roof open/close switch  | 21. Roof latch motor (roof latch status sensor)                                    |
| 22. Roof latch lock sensor   | 23. Roof latch limit switch   |  |
| A. Behind rear side finisher LH                                      | B. Behind rear side finisher LH   | C. Behind rear side finisher RH  |
| D. Behind rear wheel finisher LH                                     | E. Behind rear wheel finisher LH  | F. Trunk room trim cap LH  |
| G. Behind trunk lid finisher inner                                   | H. Behind trunk lower finisher front  | I. Behind front roof garnish   |
| J. Behind roof front finisher  |   |  |



# COMPONENT PARTS

< SYSTEM DESCRIPTION >

## Component Description

INFOID:000000006468639

	Component	Reference page
Control unit	Retractable hard top control unit	Retractable hard top control unit is a main unit that controls retractable hard top system. It is installed to rear side finisher back of left side rear seat.
	Unified meter and A/C amp.	Refer to <a href="#">HAC-44, "Diagnosis Description"</a> .
	Combination meter	Refer to <a href="#">MWI-6, "METER SYSTEM : System Description"</a> .
Input	Roof open/close switch	Retractable hard top can be opened and closed by roof open/close switch operation. Retractable hard top operates only while roof open/close switch is being operated.
	Flipper door limit switch LH/RH (UP/DOWN)	Flipper door (LH/RH) is installed on trunk lid back side. Each flipper door integrates flipper door motor and flipper door limit switch. Up and down operations are performed by flipper door motor. Up and down positions of flipper door are detected by flipper door limit switch.
	Parcel shelf status sensor (ROTATION/DRAW)	Parcel shelf is installed in trunk room and integrates parcel shelf motor (rotation) and parcel shelf motor (draw). During sequential operations of retractable hard top system, parcel shelf motor (rotation) rotates parcel shelf board, parcel shelf motor (draw) draws parcel shelf board.
	Roof status sensor	Roof status sensor is installed to roof link assembly LH. This sensor is a potentiometer that converts the roof position to a voltage signal and transmits it to retractable hard top control unit. Retractable hard top control unit recognizes the roof position using this signal.
	Trunk status sensor	Trunk status sensor is in trunk drive cylinder LH. This sensor is a hall sensor that generates a magnetic field. This changes sensor output voltage. Retractable hard top control unit detects trunk (front side) fully open position by this voltage change.
	Roof latch limit switch	Roof latch limit switch is installed to roof front finisher RH. it detects engaging state of roof lock assembly hook and front lock striker and transmits ON signal to retractable hard top control unit.
	Roof latch status sensor	Roof latch status sensor is in roof latch motor and detects roof lock state by movement of linkage from roof latch motor.
	Roof latch lock sensor	Roof latch lock sensor detects roof lock state by movement of linkage from roof latch motor.
	Tonneau board switch	Tonneau board switch detects tonneau board condition for the precondition.
	Trunk link sensor (LH/RH)	Trunk link sensor is installed to trunk arm. This sensor detects the magnet that is installed to the opponent arm and transmits trunk lid (front side) lock state signal to retractable hard top control unit.
	Trunk room lamp switch	Refer to <a href="#">DLK-82, "Description"</a> .
	Striker switch	Refer to <a href="#">DLK-98, "Description"</a> .
	Stop switch	Refer to <a href="#">DLK-80, "Description"</a> .

A  
B  
C  
D  
E  
F  
G  
H  
I  
J  
RF  
L  
M  
N  
O  
P

## COMPONENT PARTS

### < SYSTEM DESCRIPTION >

		Component	Reference page
Output	Electrical	Flipper door motor (LH/RH)	Flipper door (LH/RH) is installed on trunk lid back side. Each flipper door integrates flipper door motor and flipper door limit switch. Up and down operations are performed by flipper door motor. Up and down positions of flipper door are detected by flipper door limit switch.
		Parcel shelf motor (ROTATION/DRAW)	Parcel shelf is installed in trunk room and integrates parcel shelf motor (rotation) and parcel shelf motor (draw). During sequential operations of retractable hard top system, parcel shelf motor (rotation) rotates parcel shelf board, parcel shelf motor (draw) draws parcel shelf board.
		Switching valve (1/2)	Hydraulic pump relay hydraulic pump motor and switching valve are in hydraulic unit. Retractable hard top control unit switches hydraulic pump rotation direction by hydraulic pump relay, hydraulic circuit by switching valve 1/2 ON or OFF, and extends or retracts each cylinder.
		Hydraulic pump motor	Hydraulic pump motor drives hydraulic pump and controls the rotation direction using hydraulic pump motor relay.
		Roof warning buzzer	Roof warning buzzer is installed to lower end of left center pillar, and indicates retractable hard top is in operation.
		Trunk opener actuator	Refer to <a href="#">DLK-44, "Component Description"</a> .
		Trunk closure motor	Refer to <a href="#">DLK-47, "Component Description"</a> .
		Roof latch motor	Roof latch assembly on the roof front end operates roof latch and roof link lock on the rod end, by roof latch motor operation through roof latch rod. When retractable hard top is fully closed, roof latch is engaged with roof latch striker on the front screen upper side and, when fully open, is engaged with roof support bumper ( <a href="#">RF-297, "Exploded View"</a> ) in trunk room.
	Hydraulic	Hydraulic pump	Hydraulic pump relay hydraulic pump motor and switching valve are in hydraulic unit. Retractable hard top control unit switches hydraulic pump rotation direction by hydraulic pump relay, hydraulic circuit by switching valve 1/2 ON or OFF, and extends or retracts each cylinder.
		Roof drive cylinder (LH/RH)	Refer to <a href="#">RF-31, "HYDRAULIC SYSTEM CONTROL FUNCTION : System Description"</a> .
		Roof lock cylinder (LH/RH)	Refer to <a href="#">RF-31, "HYDRAULIC SYSTEM CONTROL FUNCTION : System Description"</a> .
		Trunk drive cylinder	Refer to <a href="#">RF-31, "HYDRAULIC SYSTEM CONTROL FUNCTION : System Description"</a> .

# SYSTEM

< SYSTEM DESCRIPTION >

## SYSTEM

### RETRACTABLE HARD TOP SYSTEM

### RETRACTABLE HARD TOP SYSTEM : System Diagram

INFOID:000000006468640

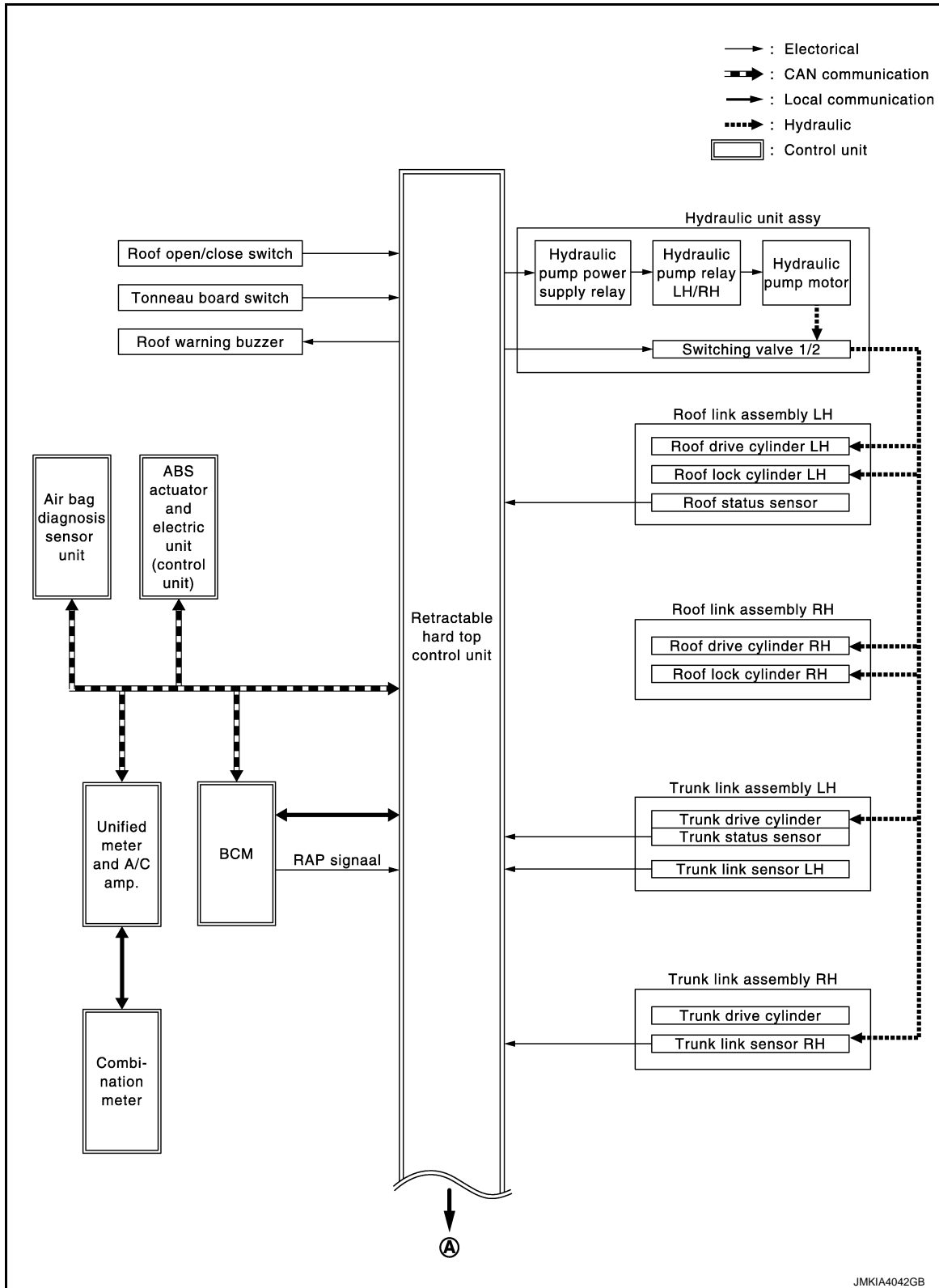

A  
B  
C  
D  
E  
F  
G  
H  
I  
J  
RF  
L  
M  
N  
O  
P

# SYSTEM

## < SYSTEM DESCRIPTION >

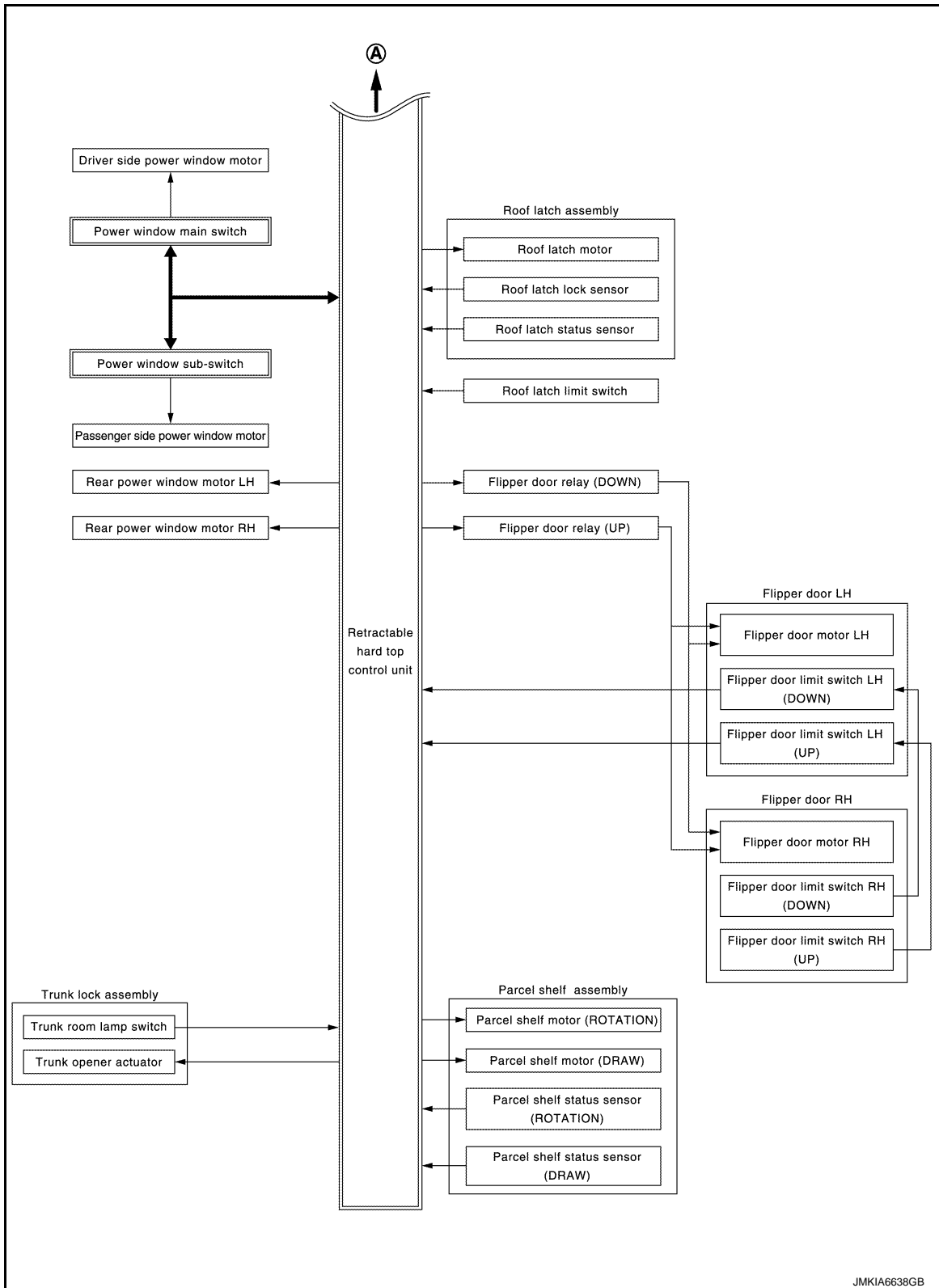

## RETRACTABLE HARD TOP SYSTEM : System Description

INFOID:000000006468641

### DESCRIPTION

Retractable hard top system is a system that opens or closes roof using hydraulic pressure generated by each electric system part and oil pump when operating roof open/close switch. Retractable hard top control unit relates to the following functions.

# SYSTEM

## < SYSTEM DESCRIPTION >

	Functions	Reference page
Retractable hard top system control	Hydraulic system control function	<a href="#">RF-31</a>
	Roof latch function	<a href="#">RF-35</a>
	Parcel shelf function	<a href="#">RF-37</a>
	Flipper door function	<a href="#">RF-39</a>
	Trunk lid control function (roof operation)	<a href="#">RF-41</a>
	Warning function	<a href="#">RF-42</a>
Trunk lid system control	Trunk lid open function	<a href="#">DLK-43</a>
	Trunk lid auto closure system	<a href="#">DLK-45</a>
Power window control		<a href="#">PWC-7</a>
Rear window defogger control		<a href="#">DEF-4</a>
Automatic air conditioning system		<a href="#">HAC-18</a>
Audio system		<a href="#">AV-280</a>

### PRECONDITIONS FOR RETRACTABLE HARD TOP

Retractable hard top system opens or closes the roof when roof open/close switch is operated to OPEN or CLOSE, or door request switch (LH/RH) is pressed and held, while all of the following conditions are satisfied. (Operation by door request switch allows opening only.)

Item		Condition	
For user	Power position	ON (not in START) *	
	Vehicle speed	5 km/h or less	
	Tonneau board	Hooked	
	Shift position	Not in R position.	
	Trunk lid	Closed	
For system	Self diagnostic result	DTC is not detected.	
	Thermo protection	Open operation	Thermo protection (STAGE 1) is not active.
		Close operation	Thermo protection (STAGE 2) is not active.
	Initialize	Roof latch and parcel shelf state are initialized.	
Pop-up roll bar	Air bag diagnosis sensor unit does not detect DTC relating to pop-up roll bar.		

\*: Except for operating with Intelligent Key (door request switch LH/RH).

### OPERATION WITH DOOR REQUEST SWITCH

In addition to roof open/close switch, door request switch (LH/RH) can perform an open operation. When BCM detects that door request switch is operated, BCM requests an open operation of retractable hard top to retractable hard top control unit via local communication. After this, the operation is the same as that of an open operation by roof open/close switch.

### POWER WINDOW INTERLOCK OPERATION

If power window is not fully open during when open and close operations of retractable hard top are performed, retractable hard top control unit opens front power window and rear power window. Front power window is operated via local communication between power window main switch/sub-switch.

#### NOTE:

For power window system operation by power window main/sub-switch, refer to [PWC-7. "System Description"](#).

### SYSTEM PROTECT FUNCTION

Retractable hard top control unit restricts or inhibits the operation due to safety and system protection reasons, when detecting an operation and activation that are not normal.

# SYSTEM

## < SYSTEM DESCRIPTION >

Functions	Description
Thermo protect function	When open and close operations of retractable hard top are performed for 3 to 4 times continuously, retractable hard top system restricts the operation judging that hydraulic pump temperature increased.
Pop-up bar malfunction roof protect	<ul style="list-style-type: none"> <li>When pop-up bar system (air bag diagnosis sensor unit: <a href="#">SRC-9, "System Description"</a>) detects deployment, retractable hard top control unit inhibits all of the retractable hard top system functions.</li> <li>When pop-up bar system (air bag diagnosis sensor unit: <a href="#">SRC-9, "System Description"</a>) detects a malfunction, retractable hard top control unit inhibits the retractable hard top system open operation.</li> </ul>

### Thermo Protect Function

Retractable hard top system calculates hydraulic pump temperature according to system operating time, prevents hydraulic system temperature from increasing excessively, and protects the system.

Retractable hard top control unit controls of the following items.

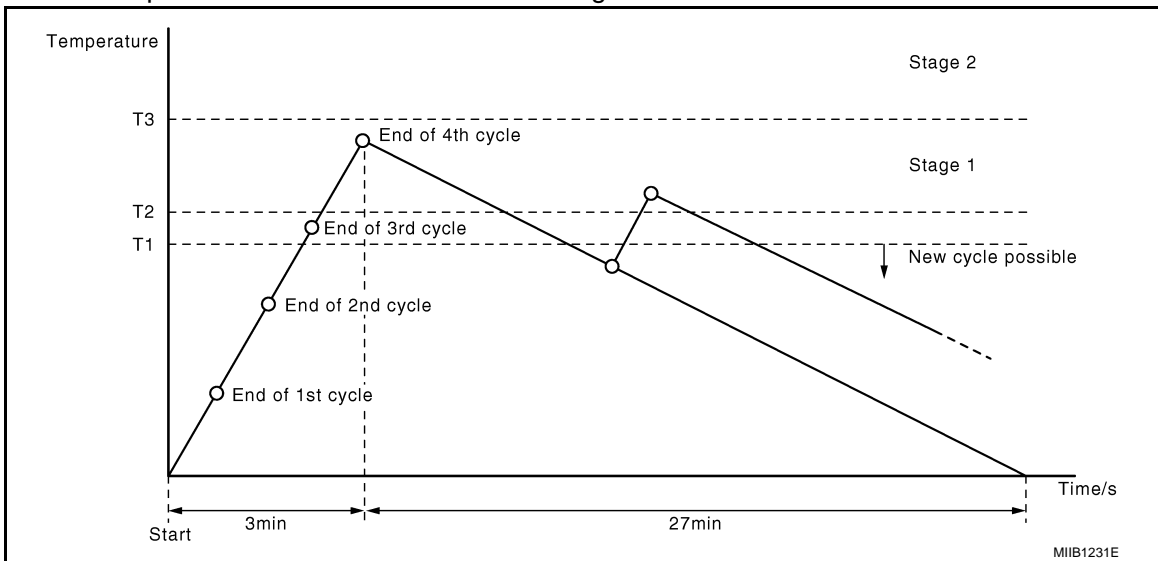

Stage	Operation
Stage 1	Between T2 and T3 New retractable hard top cycle is not possible.
Stage 2	Above T3 All retractable hard top operation is not possible.
	Bellow T1 (cooling down from T3) After cooling down, all operations are possible.

### SEQUENCE OF RETRACTABLE HARD TOP SYSTEM

There are 42 states in retractable hard top, regardless of open and close operations. Retractable hard top system performs open and close operations using a combination of these 42 states.

#### NOTE:

For changing order of roof state, refer to ORDER OF ROOF STATE CHANGING.

Parts state (CONSULT-III display) according to each roof state of retractable hard top system is shown in the following table.

#### NOTE:

For the operation details of hydraulic system, roof latch, parcel shelf, and flipper door, refer to the following table.

Function	Reference page
Hydraulic system control function	<a href="#">RF-31, "HYDRAULIC SYSTEM CONTROL FUNCTION : System Description"</a>
Roof latch function	<a href="#">RF-35, "ROOF LATCH FUNCTION : System Description"</a>

# SYSTEM

## < SYSTEM DESCRIPTION >

Function	Reference page
Parcel shelf function	<a href="#">RF-37, "PARCEL SHELF FUNCTION : System Description"</a>
Flipper door function	<a href="#">RF-39, "FLIPPER DOOR FUNCTION : System Description"</a>

### Open Operation

When roof open/close switch is operated to OPEN, retractable hard top system checks that operation conditions are satisfied and performs an open operation. Parts state (CONSULT-III display) is shown in the following table.

—: It is not related to the operation

—	Parts state								
	Present state					Target state			
	Roof latch limit switch	Hydraulic state	Parcel shelf state (draw)	Parcel shelf (rotation)	Flipper door state	Hydraulic state	Parcel shelf state (draw)	Parcel shelf (rotation)	Flipper door state
CONSULT-III data monitor item									
ROOF STATE	LATCH LIMIT SW	HYDRAULIC STATE	PS STATE (DRAW)	PS STATE (ROTA)	FLPD STATE	HYDRAULIC STATE	PS STATE (DRAW)	PS STATE (ROTA)	FLPD STATE
Status on CONSULT-III									
1	LOCK	1	2	1	—	6	6	1	1
2	LOCK	1	—	1	—	6	6	1	1
3	LOCK	2	—	1	—	6	6	1	1
4	LOCK	3	—	1	—	6	6	1	1
5	LOCK	4	—	1	—	6	6	1	1
6	—	5	—	1	—	6	6	1	1
7	—	6	6	1	1	8	6	1	1
8	—	6	5	1	1	6	6	1	1
9	—	6	—	—	—	6	6	1	1
10	—	7	6	—	—	8	6	4	4
11	UNLOCK	8	6	4	4	9	6	4	4
12	UNLOCK	8	6	3	—	8	6	4	4
13	UNLOCK	8	—	—	—	8	6	4	4
14	UNLOCK	9	6	4	4	10	6	4	4
15	UNLOCK	9	—	4	4	9	6	4	4
16	UNLOCK	10	6	4	4	11	6	4	4
17	UNLOCK	10	—	4	4	11	6	4	4
18	UNLOCK	11	5	4	4	12	4	4	4
19	UNLOCK	11	—	4	4	12	4	4	4
20	UNLOCK	12	4	4	4	13	4	4	4
21	UNLOCK	12	5	4	4	12	4	4	4
22	UNLOCK	12	—	4	4	12	4	4	4
23	UNLOCK	13	4	4	4	14	1	4	4
24	UNLOCK	13	5	4	4	13	4	4	4
25	UNLOCK	13	6	4	4	13	4	4	4
26	UNLOCK	13	—	4	4	14	1	4	4
27	UNLOCK	14	1	4	4	15	1	4	4
28	UNLOCK	14	2	4	4	15	1	4	4

A  
B  
C  
D  
E  
F  
G  
H  
I  
J  
L  
M  
N  
O  
P

RF

# SYSTEM

## < SYSTEM DESCRIPTION >

Parts state									
Present state					Target state				
Roof latch limit switch	Hydraulic state	Parcel shelf state (draw)	Parcel shelf (rotation)	Flipper door state	Hydraulic state	Parcel shelf state (draw)	Parcel shelf (rotation)	Flipper door state	
CONSULT-III data monitor item									
ROOF STATE	LATCH LIMIT SW	HYDRAU-LIC STATE	PS STATE (DRAW)	PS STATE (ROTA)	FLPD STATE	HYDRAU-LIC STATE	PS STATE (DRAW)	PS STATE (ROTA)	FLPD STATE
Status on CONSULT-III									
29	UNLOCK	14	3	4	4	15	1	4	4
30	UNLOCK	14	—	4	4	14	1	4	4
31	UNLOCK	15	1	4	4	17	1	4	4
32	UNLOCK	15	—	4	4	17	1	4	4
33	UNLOCK	16	—	—	4	17	1	4	4
34	UNLOCK	17	1	2	4	22	1	2	4
35	UNLOCK	17	1	4	4	17	1	2	4
36	UNLOCK	17	—	4	4	17	1	4	4
37	UNLOCK	17	1	—	4	17	1	2	4
38	UNLOCK	18	1	2	4	22	1	2	4
39	UNLOCK	19	1	2	4	22	1	2	4
40	UNLOCK	20	1	2	4	22	1	2	4
41	UNLOCK	21	1	2	4	22	1	2	4
42	UNLOCK	22	1	2	4	22	1	2	4

### Close Operation

When roof open/close switch is operated to CLOSE, retractable hard top system checks that operation conditions are satisfied and performs a close operation, as shown in the following table. Parts state (CONSULT-III display) is shown in the following table.

—: It is not related to the operation

Parts state									
Present state					Target state				
Roof latch limit switch	Hydraulic state	Parcel shelf state (draw)	Parcel shelf (rotation)	Flipper door state	Hydraulic state	Parcel shelf state (draw)	Parcel shelf (rotation)	Flipper door state	
CONSULT-III data monitor item									
ROOF STATE	LATCH LIMIT SW	HYDRAU-LIC STATE	PS STATE (DRAW)	PS STATE (ROTA)	FLPD STATE	HYDRAU-LIC STATE	PS STATE (DRAW)	PS STATE (ROTA)	FLPD STATE
Status on CONSULT-III									
42	UNLOCK	22	1	2	4	17	1	2	4
41	UNLOCK	21	1	2	4	17	1	2	4
40	UNLOCK	20	1	2	4	17	1	2	4
39	UNLOCK	19	1	2	4	17	1	2	4
38	UNLOCK	18	1	2	4	17	1	4	4
37	UNLOCK	17	1	—	4	17	1	4	4
36	UNLOCK	17	—	4	4	17	1	4	4
35	UNLOCK	17	1	4	4	15	1	4	4
34	UNLOCK	17	1	2	4	17	1	4	4
33	UNLOCK	16	—	—	4	15	1	4	4



# SYSTEM

## < SYSTEM DESCRIPTION >

	Parts state								
	Present state					Target state			
	Roof latch limit switch	Hydraulic state	Parcel shelf state (draw)	Parcel shelf (rotation)	Flipper door state	Hydraulic state	Parcel shelf state (draw)	Parcel shelf (rotation)	Flipper door state
CONSULT-III data monitor item									
ROOF STATE	LATCH LIMIT SW	HYDRAULIC STATE	PS STATE (DRAW)	PS STATE (ROTA)	FLPD STATE	HYDRAULIC STATE	PS STATE (DRAW)	PS STATE (ROTA)	FLPD STATE
Status on CONSULT-III									
32	UNLOCK	15	—	4	4	14	4	4	4
31	UNLOCK	15	1	4	4	14	4	4	4
30	UNLOCK	14	—	4	4	13	4	4	4
29	UNLOCK	14	3	4	4	13	4	4	4
28	UNLOCK	14	2	4	4	13	4	4	4
27	UNLOCK	14	1	4	4	13	4	4	4
26	UNLOCK	13	—	4	4	12	5	4	4
25	UNLOCK	13	6	4	4	12	5	4	4
24	UNLOCK	13	5	4	4	12	5	4	4
23	UNLOCK	13	4	4	4	12	5	4	4
22	UNLOCK	12	—	4	4	12	5	4	4
21	UNLOCK	12	5	4	4	11	5	4	4
20	UNLOCK	12	4	4	4	12	5	4	4
19	UNLOCK	11	—	4	4	10	6	4	4
18	UNLOCK	11	5	4	4	10	6	4	4
17	UNLOCK	10	—	4	4	9	6	4	4
16	UNLOCK	10	6	4	4	9	6	4	4
15	UNLOCK	9	—	4	4	8	6	4	4
14	UNLOCK	9	6	4	4	8	6	4	4
13	UNLOCK	8	—	—	—	6	6	4	4
12	UNLOCK	8	6	3	—	6	6	4	4
11	UNLOCK	8	6	4	4	6	6	4	4
10	—	7	6	—	—	6	6	1	1
9	—	6	—	—	—	6	6	1	1
8	—	6	5	1	1	1	6	1	1
7	—	6	6	1	1	1	6	1	1
6	—	5	—	1	—	1	2	1	1
5	LOCK	4	—	1	—	1	2	1	1
4	LOCK	3	—	1	—	1	2	1	1
3	LOCK	2	—	1	—	1	2	1	1
2	LOCK	1	—	1	—	1	2	1	1
1	LOCK	1	2	1	—	1	2	1	1

A  
B  
C  
D  
E  
F  
G  
H  
I  
J  
RF  
L  
M  
N  
O  
P

### ORDER OF ROOF STATE CHANGING

Roof state change in normal operation is performed according to the patterns as shown in the following table.

# SYSTEM

## < SYSTEM DESCRIPTION >

### Open Operation

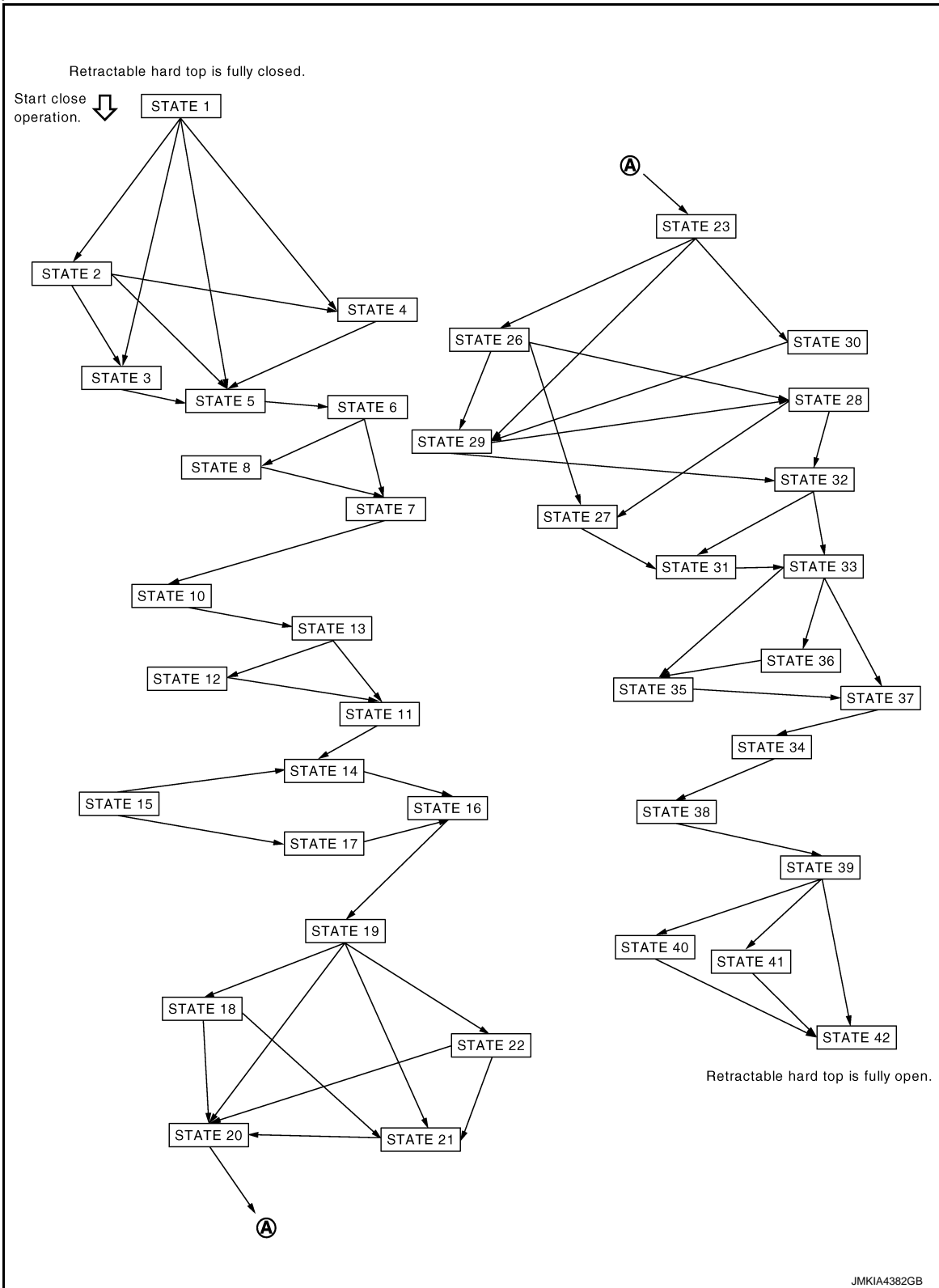

# SYSTEM

## < SYSTEM DESCRIPTION >

### Close Operation

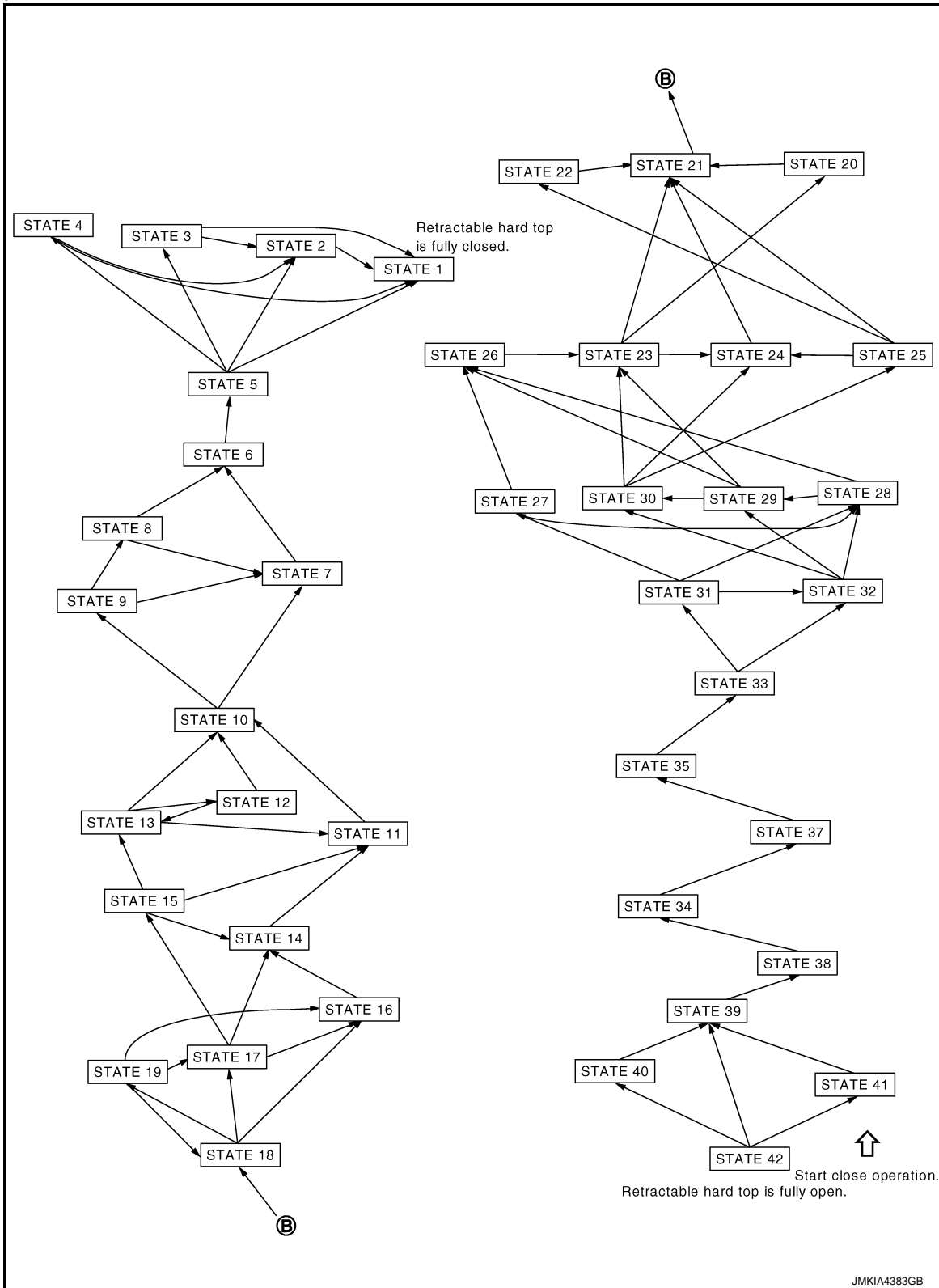

## RETRACTABLE HARD TOP SYSTEM : Fail-safe

INFOID:000000006894487

### FAIL-SAFE CONTROL BY DTC

Retractable hard top control unit performs fail-safe control when any DTC are detected.

A  
B  
C  
D  
E  
F  
G  
H  
I  
J  
RF  
L  
M  
N  
O  
P

# SYSTEM

## < SYSTEM DESCRIPTION >

Display contents of CONSULT-III		Fail-safe	Cancellation
U1000	CAN COMM CIRCUIT	Inhibit retractable hard top operation.	Communication is normal
U1010	CONTROL UNIT (CAN)	Inhibit retractable hard top operation.	Communication is normal
U0140	LOCAL COMM-1	Inhibit retractable hard top operation.	Communication is normal
U0215	LOCAL COMM-1	Inhibit retractable hard top operation.	Communication is normal
B1701	ROOF CONTROL UNIT	Inhibit retractable hard top operation.	Replace retractable hard top control unit.
B1702	ROOF CONTROL UNIT	Inhibit retractable hard top operation.	Replace retractable hard top control unit.
B1709	ROOF SWITCH(OPEN)	Inhibit retractable hard top operation.	Detects roof open/close switch (OPEN) is OFF
B170A	ROOF SWITCH(CLOSE)	Inhibit retractable hard top operation.	Detects roof open/close switch (CLOSE) is OFF
B170B	ROOF SWITCH	Inhibit retractable hard top operation.	Detects roof open/close switch (OPEN/CLOSE) is OFF
B170C	TRUNK LINK SENSOR(LH)	Inhibit retractable hard top operation.	Detects normal value
B170D	TRUNK LINK SENSOR(RH)	Inhibit retractable hard top operation.	Detects normal value
B170F	SENSOR POWER SUPPLY	Inhibit retractable hard top operation.	Detects normal value
B1710	LATCH STATUS SENSOR	Inhibit retractable hard top operation.	Detects normal value
B1711	LATCH LOCK SENSOR	Inhibit retractable hard top operation.	Detects normal value
B1712	TRUNK STATUS SENSOR	Inhibit retractable hard top operation.	Detects normal value
B1715	ROOF STATUS SEN PWR	Inhibit retractable hard top operation.	Detects normal value
B1716	PS STATUS SEN(DRAW)	Inhibit retractable hard top operation.	Detects normal value
B1718	PS STATUS SEN(ROTA)	Inhibit retractable hard top operation.	Detects normal value
B1719	ROOF STATUS SEN	Inhibit retractable hard top operation.	Detects normal value
B171A	HYDRAULIC PMP(LH)	Inhibit retractable hard top operation.	Detects normal value
B171B	HYDRAULIC PMP(RH)	Inhibit retractable hard top operation.	Detects normal value
B171C	SWITCHING VALVE 1	Inhibit retractable hard top operation.	Detects normal value
B171D	SWITCHING VALVE 2	Inhibit retractable hard top operation.	Detects normal value
B171E	ROOF CONTROL UNIT	Inhibit retractable hard top operation.	Detects normal value
B171F	ROOF CONTROL UNIT	Inhibit retractable hard top operation.	Detects normal value
B1720	ROOF CONTROL UNIT	Inhibit retractable hard top operation.	Detects normal value
B1721	ROOF CONTROL UNIT	Inhibit retractable hard top operation.	Detects normal value
B1722	ROOF CONTROL UNIT	Inhibit retractable hard top operation.	Detects normal value
B1723	ROOF CONTROL UNIT	Inhibit retractable hard top operation.	Detects normal value
B1724	ROOF CONTROL UNIT	Inhibit retractable hard top operation.	Detects normal value
B1725	ROOF CONTROL UNIT	Inhibit retractable hard top operation.	Detects normal value
B1726	ROOF CONTROL UNIT	Inhibit retractable hard top operation.	Detects normal value
B1728	ROOF CONTROL UNIT	Inhibit retractable hard top operation.	Detects normal value
B1729	ROOF CONTROL UNIT	Inhibit retractable hard top operation.	Detects normal value
B172A	ROOF CONTROL UNIT	Inhibit retractable hard top operation.	Detects normal value
B172B	ROOF STATE SIG(AUDIO)	Inhibit retractable hard top operation.	Detects normal value
B172D	ROOF WARNING BUZZER	Inhibit retractable hard top operation.	Detects normal value
B172E	ROOF CONTROL UNIT	Inhibit retractable hard top operation.	Detects normal value
B172F	REAR PWR WINDOW(LH)	Inhibit retractable hard top operation.	Detects normal value

# SYSTEM

## < SYSTEM DESCRIPTION >

Display contents of CONSULT-III		Fail-safe	Cancellation	
B1730	REAR PWR WIN-DOW(RH)	Inhibit retractable hard top operation.	Detects normal value	A
B1731	HYDRAULIC STATE 1	Inhibit retractable hard top operation.	Turn ignition switch OFF	B
B1732	HYDRAULIC STATE 2	Inhibit retractable hard top operation.	Turn ignition switch OFF	
B1733	HYDRAULIC STATE 3	Inhibit retractable hard top operation.	Turn ignition switch OFF	C
B1734	HYDRAULIC STATE 4	Inhibit retractable hard top operation.	Turn ignition switch OFF	
B1735	HYDRAULIC STATE 5	Inhibit retractable hard top operation.	Turn ignition switch OFF	
B1736	HYDRAULIC STATE 6	Inhibit retractable hard top operation.	Turn ignition switch OFF	D
B1737	HYDRAULIC STATE 7	Inhibit retractable hard top operation.	Turn ignition switch OFF	
B1738	HYDRAULIC STATE 8	Inhibit retractable hard top operation.	Turn ignition switch OFF	
B1739	HYDRAULIC STATE 9	Inhibit retractable hard top operation.	Turn ignition switch OFF	E
B173A	HYDRAULIC STATE 10	Inhibit retractable hard top operation.	Turn ignition switch OFF	
B173B	HYDRAULIC STATE 11	Inhibit retractable hard top operation.	Turn ignition switch OFF	F
B173C	HYDRAULIC STATE 12	Inhibit retractable hard top operation.	Turn ignition switch OFF	
B173D	HYDRAULIC STATE 13	Inhibit retractable hard top operation.	Turn ignition switch OFF	
B173E	HYDRAULIC STATE 14	Inhibit retractable hard top operation.	Turn ignition switch OFF	G
B173F	HYDRAULIC STATE 15	Inhibit retractable hard top operation.	Turn ignition switch OFF	
B1740	HYDRAULIC STATE 16	Inhibit retractable hard top operation.	Turn ignition switch OFF	H
B1741	HYDRAULIC STATE 17	Inhibit retractable hard top operation.	Turn ignition switch OFF	
B1742	HYDRAULIC STATE 18	Inhibit retractable hard top operation.	Turn ignition switch OFF	
B1743	HYDRAULIC STATE 19	Inhibit retractable hard top operation.	Turn ignition switch OFF	I
B1744	HYDRAULIC STATE 20	Inhibit retractable hard top operation.	Turn ignition switch OFF	
B1745	HYDRAULIC STATE 21	Inhibit retractable hard top operation.	Turn ignition switch OFF	J
B1746	HYDRAULIC STATE 22	Inhibit retractable hard top operation.	Turn ignition switch OFF	
B1747	P SHELF (DRAW) STATE 1	Inhibit retractable hard top operation.	Turn ignition switch OFF	RF
B1748	P SHELF (DRAW) STATE 2	Inhibit retractable hard top operation.	Turn ignition switch OFF	
B1749	P SHELF (DRAW) STATE 3	Inhibit retractable hard top operation.	Turn ignition switch OFF	L
B174A	P SHELF (DRAW) STATE 4	Inhibit retractable hard top operation.	Turn ignition switch OFF	
B174B	P SHELF (DRAW) STATE 5	Inhibit retractable hard top operation.	Turn ignition switch OFF	M
B174C	P SHELF (DRAW) STATE 6	Inhibit retractable hard top operation.	Turn ignition switch OFF	N
B174D	P SHELF (ROT) STATE 1	Inhibit retractable hard top operation.	Turn ignition switch OFF	
B174E	P SHELF (ROT) STATE 2	Inhibit retractable hard top operation.	Turn ignition switch OFF	O
B174F	P SHELF (ROT) STATE 3	Inhibit retractable hard top operation.	Turn ignition switch OFF	
B1750	P SHELF (ROT) STATE 4	Inhibit retractable hard top operation.	Turn ignition switch OFF	
B1751	ROOF LATCH STATE 1	Inhibit retractable hard top operation.	Turn ignition switch OFF	P
B1752	ROOF LATCH STATE 2	Inhibit retractable hard top operation.	Turn ignition switch OFF	
B1753	ROOF LATCH STATE 3	Inhibit retractable hard top operation.	Turn ignition switch OFF	
B1754	FLIPPER DOOR STATE 1	Inhibit retractable hard top operation.	Turn ignition switch OFF	
B1755	FLIPPER DOOR STATE 2	Inhibit retractable hard top operation.	Turn ignition switch OFF	
B1756	FLIPPER DOOR STATE 3	Inhibit retractable hard top operation.	Turn ignition switch OFF	

# SYSTEM

## < SYSTEM DESCRIPTION >

Display contents of CONSULT-III		Fail-safe	Cancellation
B1757	FLIPPER DOOR STATE 4	Inhibit retractable hard top operation.	Turn ignition switch OFF
B1758	THERMO PROTECTION	Inhibit retractable hard top operation.	It is not in thermo protection area (Refer to <a href="#">RF-20. "RETRACTABLE HARD TOP SYSTEM : System Description"</a> )
B175C	PWR SOURCE(ROOF)	Inhibit retractable hard top operation.	Power source is 11.4 (V) or more for 0.5 second
B175D	PWR SOURCE(ROOF)	Inhibit retractable hard top operation.	Power source is 14.5 (V) or more for 4 seconds
B175E	PWR SOURCE(WINDOW)	Inhibit retractable hard top operation and rear power window operation.	Power source (power window) is 9.5 (V) or less
B175F	PWR SOURCE(WINDOW)	Inhibit retractable hard top operation and rear power window operation.	Power source (power window) is 15.5 (V) or more
B1760	ROOF CONTROL UNIT	Inhibit rear window defogger operation.	Detects normal value
B1761	ROOF CONTROL UNIT	Inhibit retractable hard top operation.	Detects normal value
B1762	ROOF STATE	Inhibit retractable hard top operation.	Detects normal value
B1763	HYDRAULIC STATE	Inhibit retractable hard top operation.	Detects normal value
B1764	ROOF LATCH STATE	Inhibit retractable hard top operation.	Detects normal value
B1765	FLIPPER DOOR STATE	Inhibit retractable hard top operation.	Detects normal value

## HYDRAULIC SYSTEM CONTROL FUNCTION

# SYSTEM

< SYSTEM DESCRIPTION >

## HYDRAULIC SYSTEM CONTROL FUNCTION : System Diagram

INFOID:000000006468643

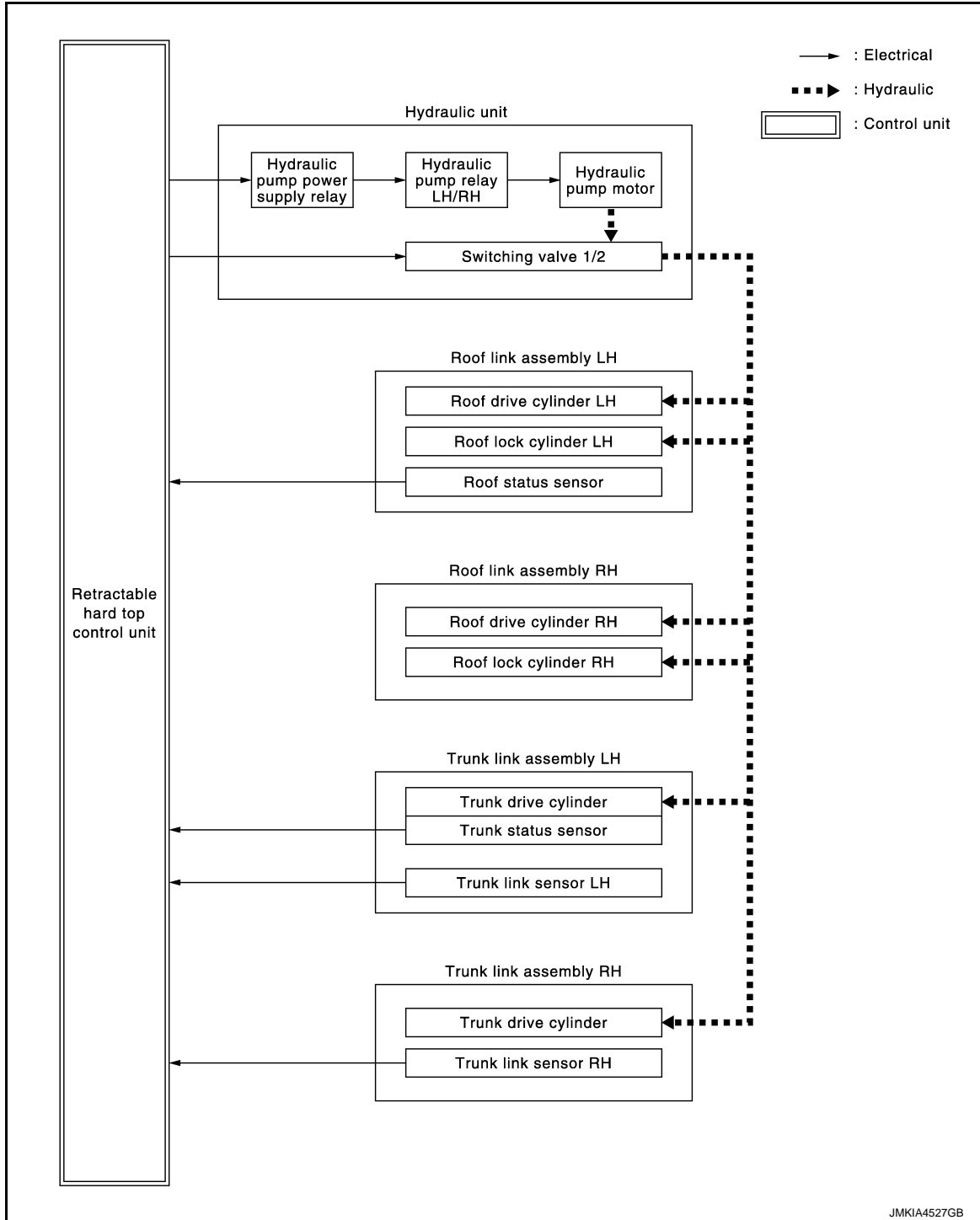

A  
B  
C  
D  
E  
F  
G  
H  
I  
J  
RF  
L  
M  
N  
O  
P

## HYDRAULIC SYSTEM CONTROL FUNCTION : System Description

INFOID:000000006468644

### SYSTEM DESCRIPTION

Retractable hard top control unit controls hydraulic system using hydraulic motor and switching valve 1/2, extends or retracts each hydraulic cylinder, and operates retractable hard top. Functions of each hydraulic cylinder are as shown in the following table.

Cylinder	Description
Roof drive cylinder	Roof open (Cylinder: Extend) operation and close (Cylinder: Retract) operation

# SYSTEM

## < SYSTEM DESCRIPTION >

Cylinder	Description
Roof lock cylinder	Roof link lock (Cylinder: Retract) operation and unlock (Cylinder: Extend) operation
Trunk drive cylinder	<ul style="list-style-type: none"> <li>• Trunk lid (front side) open (Cylinder: Extend) operation and close (Cylinder: Retract) operation</li> <li>• Trunk link lock (Cylinder: Retract) operation and unlock (Cylinder: Extend) operation</li> </ul>

### Electrical Parts In Hydraulic System

Retractable hard top control unit switches hydraulic pump rotation direction, hydraulic circuit by switching valve 1/2 ON or OFF, and extends or retracts each cylinder. Operation according to each parts state is as shown in the following table.

**NOTE:**

For the details of operation, refer to SEQUENCE OF HYDRAULIC SYSTEM.

#### In Open Procedure

—	Output parts			
	Hydraulic pump motor (LH)	Hydraulic pump motor (RH)	Switching valve 1	Switching valve 2
Condition	CONSULT-III data monitor item			
	PUMP OUT (LH)	PUMP OUT (RH)	SWITCH VLV1 OUT	SWITCH VLV2 OUT
	Status on CONSULT-III			
Trunk lid: OPEN (Roof: CLOSE)	ON	OFF	ON	OFF
Roof: OPEN (Trunk lid: OPEN)	OFF	ON	ON	OFF
Trunk lid: CLOSE (Roof: OPEN)	OFF	ON	OFF	OFF

#### In Close Procedure

—	Output parts			
	Hydraulic pump motor (LH)	Hydraulic pump motor (RH)	Switching valve 1	Switching valve 2
Condition	CONSULT-III data monitor item			
	PUMP OUT (LH)	PUMP OUT (RH)	SWITCH VLV1 OUT	SWITCH VLV2 OUT
	Status on CONSULT-III			
Trunk lid: OPEN (Roof: OPEN)	OFF	ON	ON	OFF
Roof: CLOSE (Trunk lid: OPEN)	ON	OFF	ON	OFF
Roof: CLOSE (Roof: CLOSE)	ON	OFF	OFF	OFF

### SEQUENCE OF HYDRAULIC SYSTEM

There are 22 states in hydraulic system. Hydraulic system is controlled using combination of these 22 states and, at the same time, open and close operations of retractable hard top system are performed interlocking with other retractable hard top system components. (For interlock with other components, refer to [RF-20, "RETRACTABLE HARD TOP SYSTEM : System Description"](#))

Parts state (CONSULT-III display) according to sequential hydraulic system operations is as shown in the following table.

#### Open Operation



# SYSTEM

## < SYSTEM DESCRIPTION >

—	Parts state											
	Input parts						Output parts					
	Roof link status	Trunk link sensor LH	Trunk link sensor RH	Trunk room lamp switch	Trunk status sensor	Roof latch status sensor	Hydraulic pump motor (LH)	Hydraulic pump motor (RH)	Switching valve 1	Switching valve 2	Trunk opener actuator	Roof latch motor
CONSULT-III data monitor item												
HY-DRAULIC STATE	ROOF LINK STATE	TRUNK LINK SEN(LH)	TRUNK LINK SEN(RH)	TR ROOM LAMP SW	TRUNK STATUS SEN	ROOF LATCH STATE	PUMP OUT (LH)	PUMP OUT (RH)	SWITC HVLV1 OUT	SWITC HVLV2 OUT	TRUNK OPEN OUT	ROOF LATCH STATE (Target state)
Status on CONSULT-III												
1	1	ON	ON	ON	OFF	CLOSE	ON	OFF	ON	OFF	OFF	CLOSE
2	1	OFF	ON	ON	OFF	CLOSE	ON	OFF	ON	OFF	OFF	CLOSE
3	1	ON	OFF	ON	OFF	CLOSE	ON	OFF	ON	OFF	OFF	CLOSE
4	1	OFF	OFF	ON	OFF	CLOSE	ON	OFF	ON	OFF	ON	CLOSE
5	1	OFF	OFF	OFF	OFF	—	ON	OFF	ON	OFF	ON	CLOSE
6	1	OFF	OFF	OFF	ON	CLOSE	OFF	OFF	ON	OFF	OFF	OPEN
7	1	OFF	OFF	OFF	ON	MID	OFF	OFF	ON	OFF	OFF	OPEN
8	1	OFF	OFF	OFF	ON	OPEN	OFF	ON	ON	OFF	OFF	OPEN
9	2	OFF	OFF	OFF	ON	OPEN	OFF	ON	ON	OFF	OFF	OPEN
10	3	OFF	OFF	OFF	ON	OPEN	OFF	ON	ON	OFF	OFF	OPEN
11	4	OFF	OFF	OFF	ON	OPEN	OFF	ON	ON	OFF	OFF	OPEN
12	5	OFF	OFF	OFF	ON	OPEN	OFF	ON	ON	OFF	OFF	OPEN
13	6	OFF	OFF	OFF	ON	OPEN	OFF	ON	ON	OFF	OFF	OPEN
14	7	OFF	OFF	OFF	ON	OPEN	OFF	ON	ON	OFF	OFF	OPEN
15	8	OFF	OFF	OFF	ON	OPEN	OFF	ON	ON	OFF	OFF	CLOSE
16	8	OFF	OFF	OFF	ON	MID	OFF	ON	ON	OFF	OFF	CLOSE
17	8	OFF	OFF	OFF	ON	CLOSE	OFF	ON	OFF	OFF	OFF	CLOSE
18	8	OFF	OFF	OFF	OFF	CLOSE	OFF	ON	OFF	OFF	OFF	CLOSE
19	8	OFF	OFF	ON	OFF	CLOSE	OFF	ON	OFF	OFF	OFF	CLOSE
20	8	OFF	ON	ON	OFF	CLOSE	OFF	ON	OFF	OFF	OFF	CLOSE
21	8	ON	OFF	ON	OFF	CLOSE	OFF	ON	OFF	OFF	OFF	CLOSE
22	8	ON	ON	ON	OFF	CLOSE	OFF	OFF	OFF	OFF	OFF	CLOSE

Close Operation

A  
B  
C  
D  
E  
F  
G  
H  
I  
J  
L  
M  
N  
O  
P

RF

# SYSTEM

## < SYSTEM DESCRIPTION >

—	Parts state											
	Input parts						Output parts					
	Roof link status	Trunk link sensor LH	Trunk link sensor RH	Trunk room lamp switch	Trunk status sensor	Roof latch status sensor	Hydraulic pump motor (LH)	Hydraulic pump motor (RH)	Switching valve 1	Switching valve 2	Trunk opener actuator	Roof latch motor

### CONSULT-III data monitor item

HY-DRAULIC STATE	ROOF LINK STATE	TRUNK LINK SEN(LH)	TRUNK LINK SEN(RH)	TR ROOM LAMP SW	TRUNK STATUS SEN	ROOF LATCH STATE	PUMP OUT (LH)	PUMP OUT (RH)	SWITCH HVLV1 OUT	SWITCH HVLV2 OUT	TRUNK OPEN OUT	ROOF LATCH STATE (Target state)
------------------	-----------------	--------------------	--------------------	-----------------	------------------	------------------	---------------	---------------	------------------	------------------	----------------	---------------------------------

### Status on CONSULT-III

22	8	ON	ON	ON	OFF	CLOSE	OFF	ON	ON	OFF	OFF	CLOSE
21	8	ON	OFF	ON	OFF	CLOSE	OFF	ON	ON	OFF	OFF	CLOSE
20	8	OFF	ON	ON	OFF	CLOSE	OFF	ON	ON	OFF	OFF	CLOSE
19	8	OFF	OFF	ON	OFF	CLOSE	OFF	ON	ON	OFF	ON	CLOSE
18	8	OFF	OFF	OFF	OFF	CLOSE	OFF	ON	ON	OFF	ON	CLOSE
17	8	OFF	OFF	OFF	ON	CLOSE	OFF	OFF	ON	OFF	OFF	OPEN
16	8	OFF	OFF	OFF	ON	MID	OFF	OFF	ON	OFF	OFF	OPEN
15	8	OFF	OFF	OFF	ON	OPEN	ON	OFF	ON	OFF	OFF	OPEN
14	7	OFF	OFF	OFF	ON	OPEN	ON	OFF	ON	OFF	OFF	OPEN
13	6	OFF	OFF	OFF	ON	OPEN	ON	OFF	ON	OFF	OFF	OPEN
12	5	OFF	OFF	OFF	ON	OPEN	ON	OFF	ON	OFF	OFF	OPEN
11	4	OFF	OFF	OFF	ON	OPEN	ON	OFF	ON	OFF	OFF	OPEN
10	3	OFF	OFF	OFF	ON	OPEN	ON	OFF	ON	OFF	OFF	OPEN
9	2	OFF	OFF	OFF	ON	OPEN	ON	OFF	ON	ON	OFF	OPEN
8	1	OFF	OFF	OFF	ON	OPEN	ON	OFF	ON	ON	OFF	CLOSE
7	1	OFF	OFF	OFF	ON	MID	ON	OFF	ON	ON	OFF	CLOSE
6	1	OFF	OFF	OFF	ON	CLOSE	ON	OFF	OFF	OFF	OFF	CLOSE
5	1	OFF	OFF	OFF	OFF	—	ON	OFF	OFF	OFF	OFF	CLOSE
4	1	OFF	OFF	ON	OFF	CLOSE	ON	OFF	OFF	OFF	OFF	CLOSE
3	1	ON	OFF	ON	OFF	CLOSE	ON	OFF	OFF	OFF	OFF	CLOSE
2	1	OFF	ON	ON	OFF	CLOSE	ON	OFF	OFF	OFF	OFF	CLOSE
1	1	ON	ON	ON	OFF	CLOSE	OFF	OFF	OFF	OFF	OFF	CLOSE

## ROOF LATCH FUNCTION

# SYSTEM

< SYSTEM DESCRIPTION >

## ROOF LATCH FUNCTION : System Diagram

INFOID:000000006468645

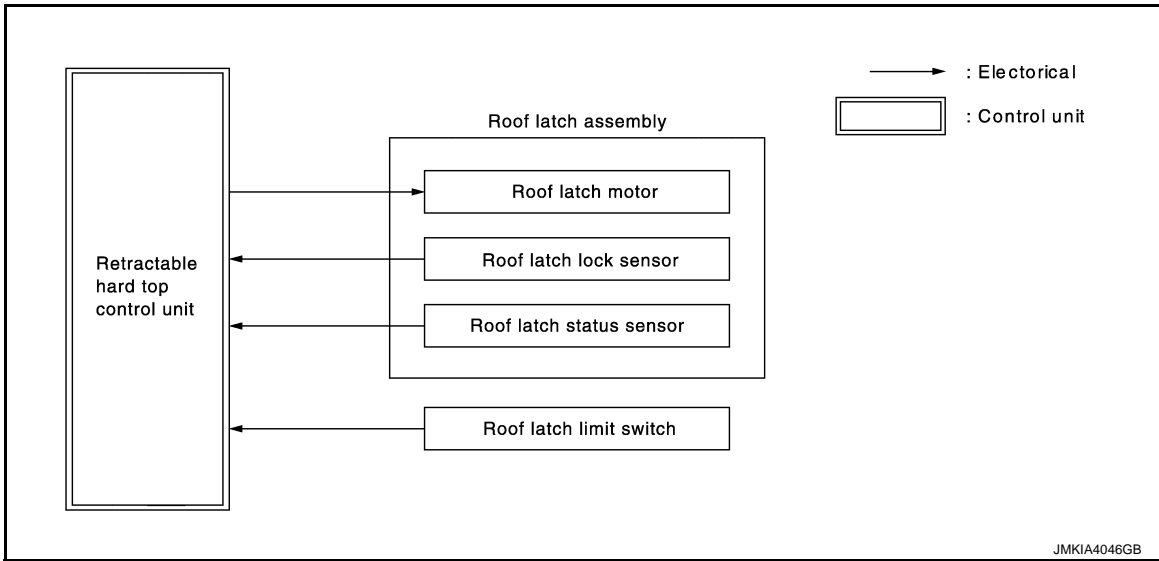

## ROOF LATCH FUNCTION : System Description

INFOID:000000006468646

### SYSTEM DESCRIPTION

Roof latch assembly on the roof front end operates roof latch and roof link lock on the rod end, by roof latch motor operation through roof latch rod. When retractable hard top is fully closed, roof latch is engaged with roof latch striker on the front screen upper side and roof link assembly, when fully open, is engaged with roof support bumper (RF-297, "Exploded View") and roof link assembly.

Retractable hard top control unit recognizes roof latch state by roof latch status sensor (in roof latch motor), roof latch lock sensor (in roof latch assembly), and roof latch limit switch (in front latch assembly, refer to RF-257, "Exploded View").

### Roof Latch Structure

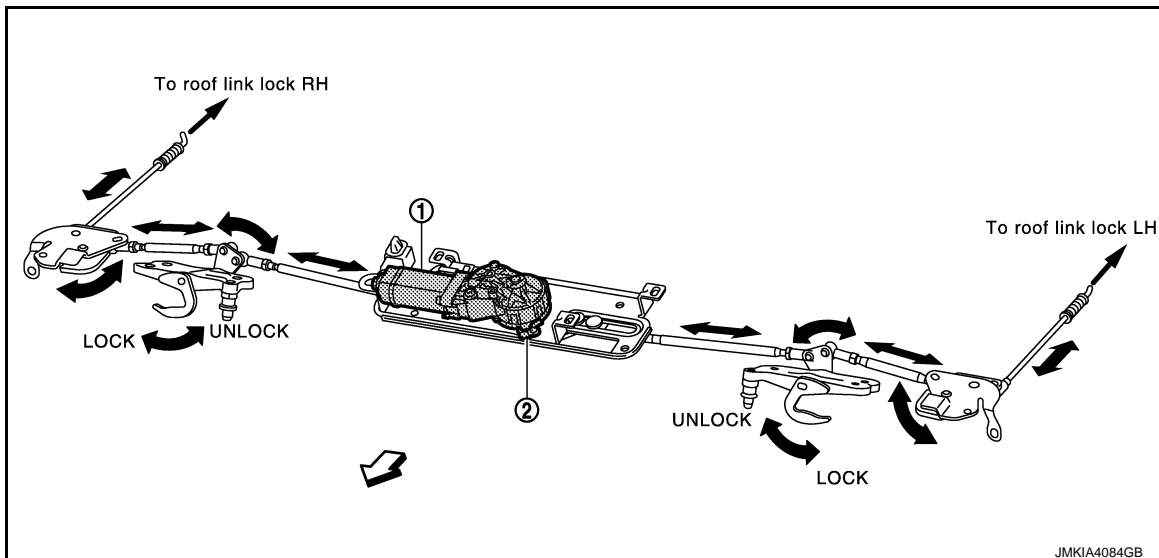

1. Roof latch motor (with integrated roof latch status sensor)

2. Roof latch lock sensor

### SEQUENCE OF ROOF LATCH STATE

There are 3 states in roof latch. Open and close operations of retractable hard top system are performed interlocking with other retractable hard top system components. (For interlocking with other components, refer to RF-20, "RETRACTABLE HARD TOP SYSTEM : System Description".)

# SYSTEM

## < SYSTEM DESCRIPTION >

Parts state (CONSULT-III display) according to sequential roof latch operations is as shown in the following table.

### Lock Operation

Parts state					
Input parts			Output parts		
Roof latch status sensor	Roof latch lock sensor	Roof latch limit switch	Roof latch motor (UNLOCK)	Roof latch motor (LOCK)	
CONSULT-III data monitor item					
LATCH STATE	LATCH VALUE	LATCH LOCK SEN	LATCH LIMIT SW	LATCH OUT(ULK)	LATCH OUT(LCK)
Status on CONSULT-III					
OPEN	78 or more	OFF	OPEN	OFF	ON
MID	77-1	OFF	OPEN	OFF	ON
CLOSE	0	ON	CLOSE*1/OPEN*2	OFF	OFF

\*1: when retractable hard top is fully closed

\*2: when retractable hard top is fully open

### Unlock Operation

Parts state					
Input parts			Output parts		
Roof latch status sensor	Roof latch status sensor	Roof latch limit switch	Roof latch motor (UNLOCK)	Roof latch motor (LOCK)	
CONSULT-III data monitor item					
LATCH STATE	LATCH VALUE	LATCH STATE SEN	LATCH LIMIT SWITCH	LATCH OUT(ULK)	LATCH OUT(LCK)
Status on CONSULT-III					
CLOSE	0	ON	CLOSE*1/OPEN*2	ON	OFF
MID	77-1	OFF	OPEN	ON	OFF
OPEN	78 or more	OFF	OPEN	OFF	OFF

\*1: when retractable hard top is fully closed

\*2: when retractable hard top is fully open

## PARCEL SHELF FUNCTION

### PARCEL SHELF FUNCTION : System Diagram

INFOID:000000006468647

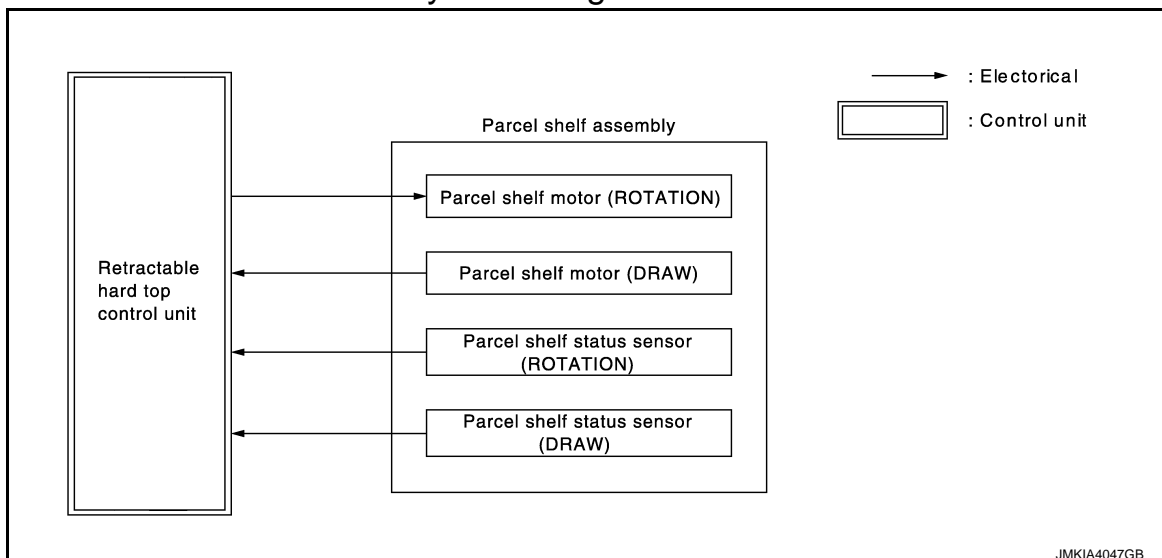

JMKIA4047GB

# SYSTEM

< SYSTEM DESCRIPTION >

## PARCEL SHELF FUNCTION : System Description

INFOID:000000006468648

### SYSTEM DESCRIPTION

Parcel shelf is installed in trunk room and integrates parcel shelf motor (rotation) and parcel shelf motor (draw). During sequential operations of retractable hard top system, parcel shelf motor (rotation) rotates parcel shelf board, parcel shelf motor (draw) draws parcel shelf board, and open and close operations of retractable hard top system are performed interlocking with other retractable hard top system components than parcel self.

Retractable hard top control unit recognizes the rotation position of parcel shelf by parcel shelf status sensor (rotation) in parcel shelf motor (rotation), up and down positions of parcel shelf by parcel shelf status sensor (draw) in parcel shelf motor (draw).

### Parcel Shelf Structure/Rotation

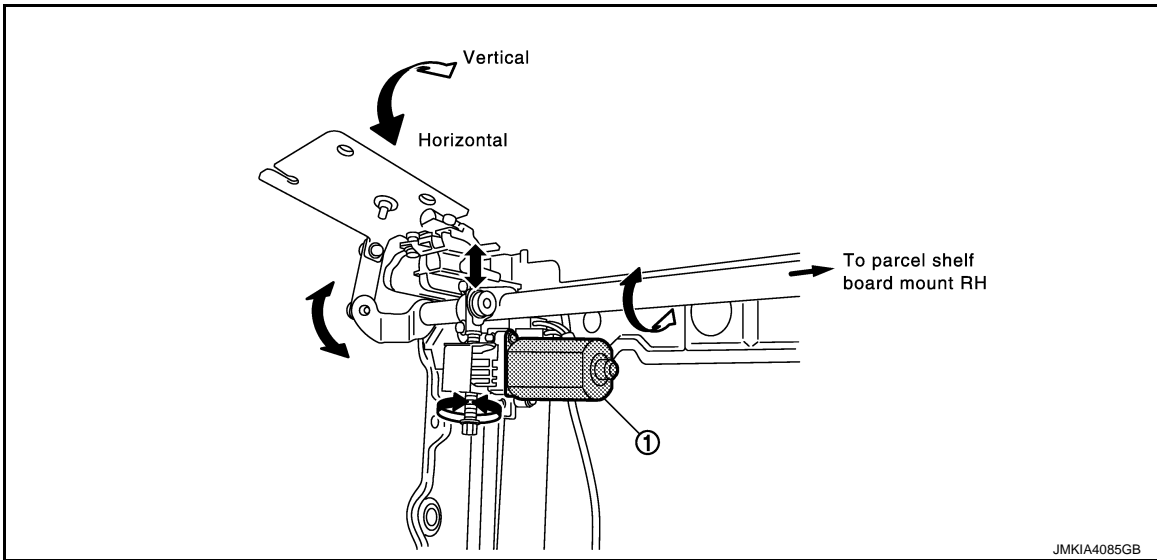

View with parcel shelf board and parcel shelf motor (rotation) cover removed.

1. Parcel shelf motor (rotation)  
[with integrated parcel shelf status sensor (rotation)]

### Parcel Shelf Structure/Draw

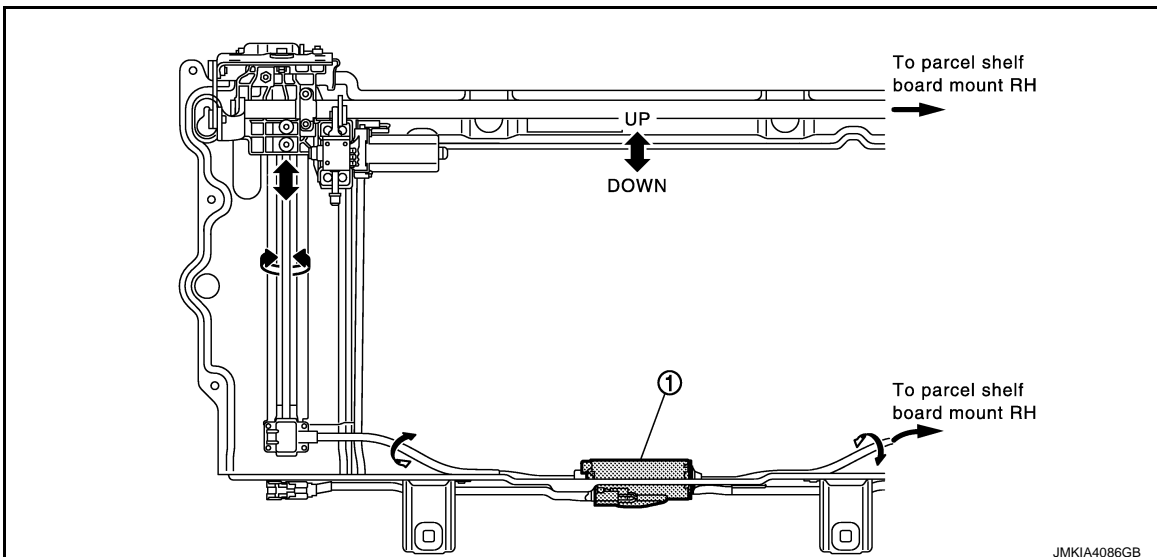

View with parcel shelf board and parcel shelf motor (rotation) cover removed.

1. Parcel shelf motor (draw)  
[with integrated parcel shelf status sensor (draw)]

A  
B  
C  
D  
E  
F  
G  
H  
I  
J  
L  
M  
N  
O  
P

RF

# SYSTEM

## < SYSTEM DESCRIPTION >

### SEQUENCE OF PARCEL SHELF

There are 4 rotation operation states and 6 draw operation states in parcel shelf. Open and close operations of retractable hard tops are performed interlocking with other retractable hard top system components. (For interlocking with other components, refer to [RF-20, "RETRACTABLE HARD TOP SYSTEM : System Description"](#).) Parts state (CONSULT-III display) according to sequential parcel shelf operations is as shown in the following table.

#### Rotation Operation/Vertical

—	Parts state	
	Output parts	
	Parcel shelf motor (rotation)	
CONSULT-III data monitor item		
PS STATE(ROTA)	PS OUT(HORI)	PS OUT(VERT)
Status on CONSULT-III		
1	OFF	ON
2	OFF	ON
3	OFF	ON
4	OFF	OFF

#### Rotation Operation/Horizontal

—	Parts state	
	Output parts	
	Parcel shelf motor (rotation)	
CONSULT-III data monitor item		
PS STATE(ROTA)	PS OUT(HORI)	PS OUT(VERT)
Status on CONSULT-III		
4	ON	OFF
3	ON	OFF
2	ON	OFF
1	OFF	OFF

#### Draw Operation/Down

—	Parts state	
	Output parts	
	Parcel shelf motor (draw)	
CONSULT-III data monitor item		
PS STATE(DRAW)	PS OUT(UP)	PS OUT(DOWN)
Status on CONSULT-III		
1	OFF	ON
2	OFF	ON
3	OFF	ON
4	OFF	ON
5	OFF	ON
6	OFF	OFF

#### Draw Operation/Up

# SYSTEM

## < SYSTEM DESCRIPTION >

—	Parts state	
	Output parts	
	Parcel shelf motor (draw)	
CONSULT-III data monitor item		
PS STATE(DRAW)	PS OUT(UP)	PS OUT(DOWN)
Status on CONSULT-III		
6	ON	OFF
5	ON	OFF
4	ON	OFF
3	ON	OFF
2	ON	OFF
1	OFF	OFF

## FLIPPER DOOR FUNCTION

### FLIPPER DOOR FUNCTION : System Diagram

INFOID:0000000006468649

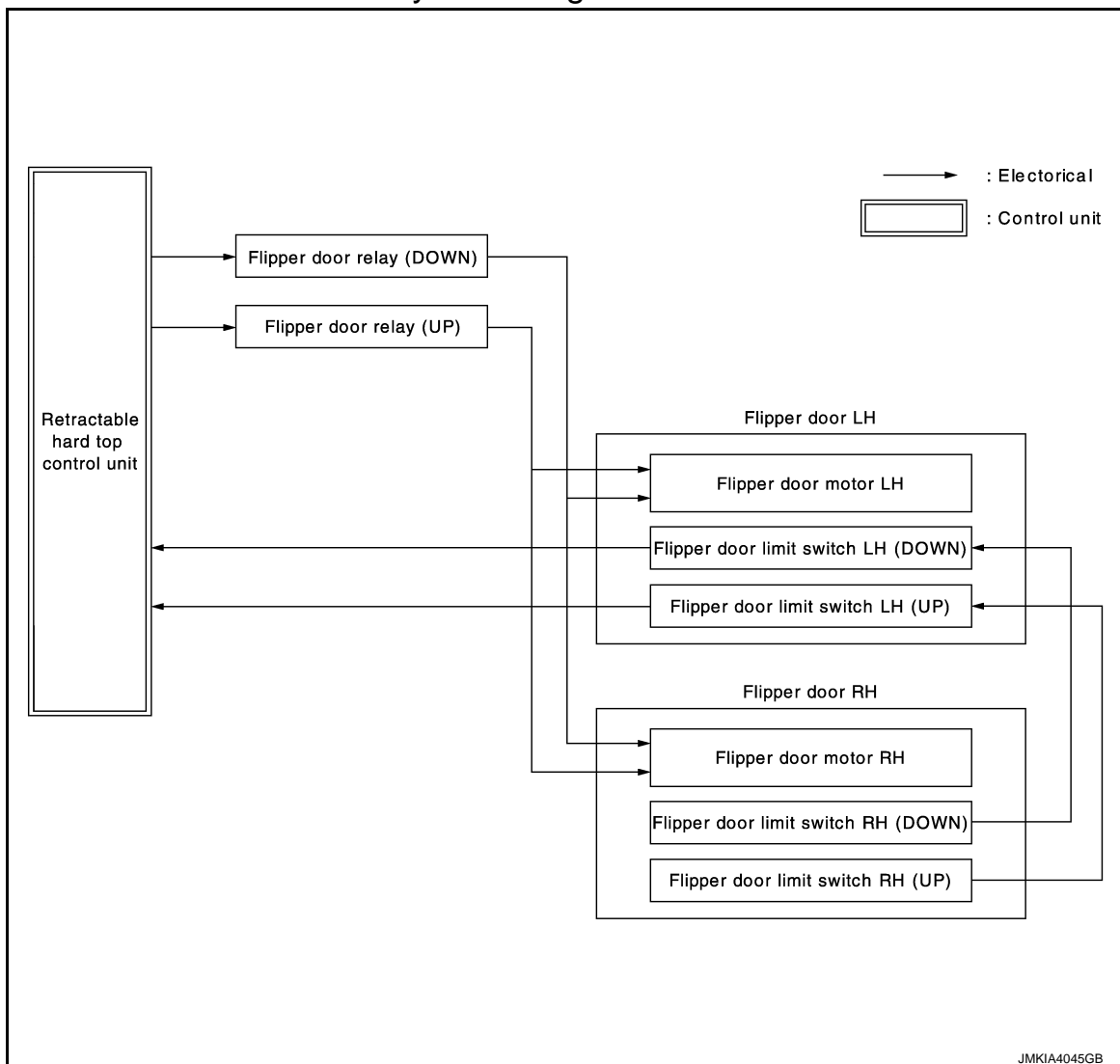

JMKIA4045GB

### FLIPPER DOOR FUNCTION : System Description

INFOID:0000000006468650

## SYSTEM DESCRIPTION

# SYSTEM

## < SYSTEM DESCRIPTION >

Flipper door (LH/RH) is installed on trunk lid back side. Each flipper door integrates flipper door motor and flipper door limit switch. Up and down operations are performed by flipper door motor. Up and down positions of flipper door are detected by flipper door limit switch.

Retractable hard top control unit performs open and close operations of retractable hard top system interlocking with flipper door and other retractable hard top components.

### SEQUENCE OF FLIPPER DOOR

There are 3 states in flipper door. Open and close operations of retractable hard top system are performed interlocking with other retractable hard top components. (For interlocking with other components, refer to [RF-20, "RETRACTABLE HARD TOP SYSTEM : System Description".](#))

Parts state (CONSULT-III display) according to sequential flipper door operations is as shown in the following table.

#### Up Operation

—	Parts state			
	Input parts		Output parts	
	Flipper door limit switch (up)	Flipper door limit switch (down)	Flipper door motor	
CONSULT-III data monitor item				
FLPD STATE	FLPD LIMIT SW(UP)	FLPD LIMIT SW(DOWN)	FLPD OUT(UP)	FLPD OUT(DOWN)
Status on CONSULT-III				
1	OFF	ON	ON	OFF
2	OFF	OFF	ON	OFF
4	ON	OFF	OFF	OFF

**NOTE:**

FLPD STATE 3 is not available.

#### Down Operation

—	Parts state			
	Input parts		Output parts	
	Flipper door limit switch (up)	Flipper door limit switch (down)	Flipper door motor	
CONSULT-III data monitor item				
FLPD STATE	FLPD LIMIT SW(UP)	FLPD LIMIT SW(DOWN)	FLPD OUT(UP)	FLPD OUT(DOWN)
Status on CONSULT-III				
4	ON	OFF	OFF	ON
2	OFF	OFF	OFF	ON
1	OFF	ON	OFF	OFF

**NOTE:**

FLPD STATE 3 is not available.

## TRUNK LID CONTROL FUNCTION



# SYSTEM

< SYSTEM DESCRIPTION >

## TRUNK LID CONTROL FUNCTION : System Diagram

INFOID:000000006468651

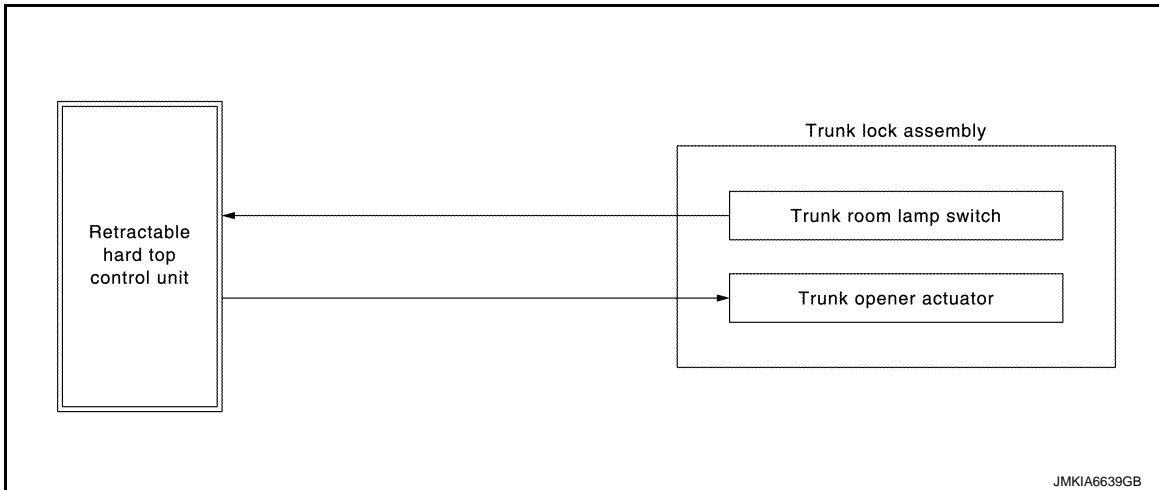

## TRUNK LID CONTROL FUNCTION : System Description

INFOID:000000006468652

### SYSTEM DESCRIPTION

Retractable hard top control unit performs trunk lid opener operation and trunk lid closure operation, when open and close operations of retractable hard top are performed.

#### NOTE:

For trunk lid opener operation other than retractable hard top system operation, refer to [DLK-43. "System Description"](#). For trunk lid auto closure other than retractable hard top system operation, refer to [DLK-45. "System Description"](#).

### TRUNK LID OPERATION FOR RETRACTABLE HARD TOP SYSTEM

Trunk opener operation and trunk closure operation during retractable hard top system operation are as shown in the following.

#### Trunk Lid Opener Operation

Trunk lid opener operation does not need trunk lid opener switch input, when retractable hard top system operation is performed. Retractable hard top control unit performs trunk lid open operation. Other operations are the same as trunk lid open function ([DLK-43. "System Description"](#)) of door lock system.

### WARNING FUNCTION

# SYSTEM

< SYSTEM DESCRIPTION >

## WARNING FUNCTION : System Diagram

INFOID:000000006468653

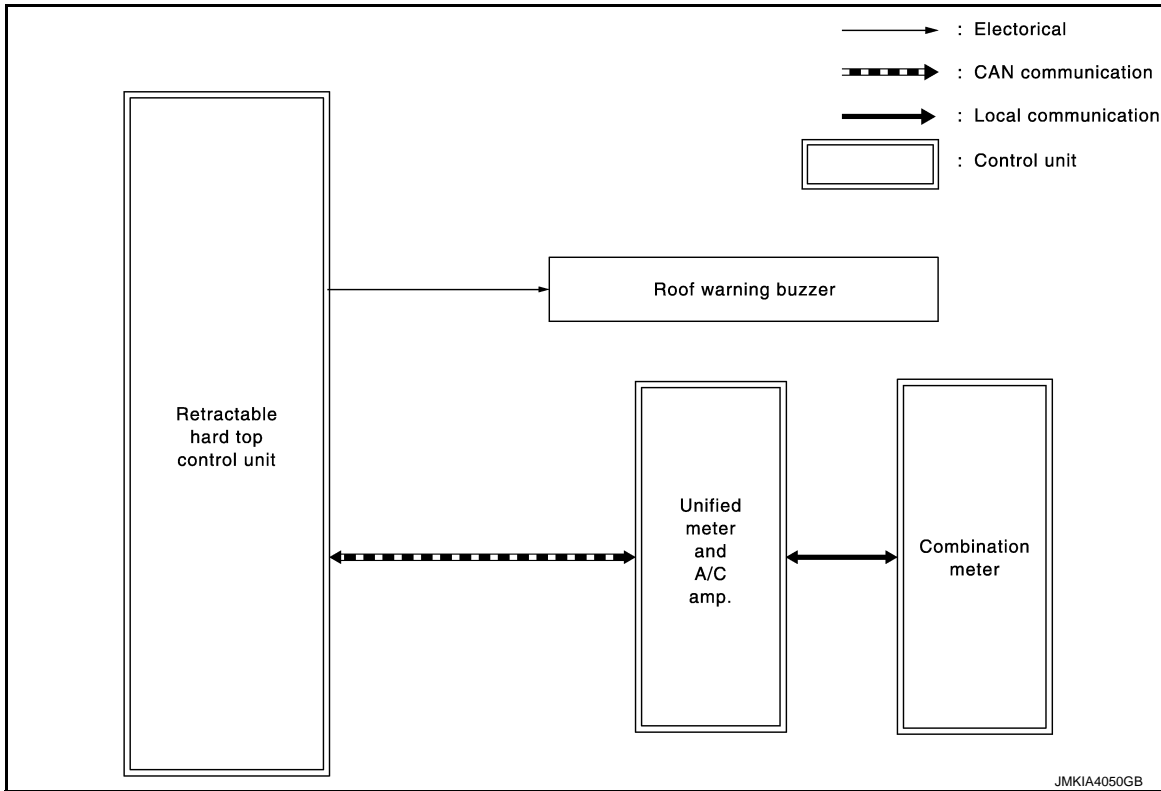

## WARNING FUNCTION : System Description

INFOID:000000006468654

### SYSTEM DESCRIPTION

Retractable hard top control unit indicates retractable hard top system state using roof warning buzzer and LCD.

### LCD INDICATION

LCD in combination meter displays the following items.

#### NOTE:

- LCD does not display the following items if initialization (roof state, roof latch state, or parcel shelf state) is not complete.  
Perform initialization when the following screen is not displayed. Refer to [RF-88. "Description"](#).
- LCD does not display the following screen if battery voltage is low when roof open/close switch is operated. When roof open/ close switch is released, "Roof in operation" is displayed. (roof warning buzzer does not sound)

# SYSTEM

## < SYSTEM DESCRIPTION >

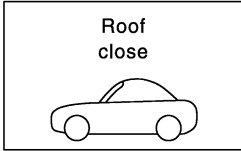
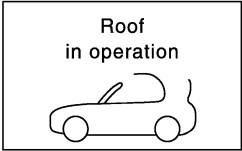
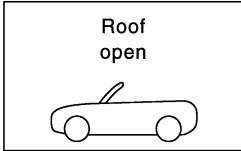
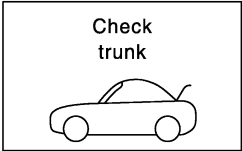
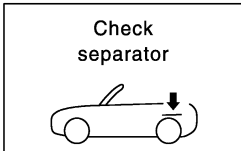
Item	Display on LCD	Item	Display on LCD
Roof close : It is displayed when retractable hard top system is fully closed	 <p style="text-align: center;">JMKIA4118ZZ</p>	Roof in operation : It is displayed when retractable hard top system is in operation	 <p style="text-align: center;">JMKIA4119ZZ</p>
Roof open : It is displayed when retractable hard top system is fully open	 <p style="text-align: center;">JMKIA4120ZZ</p>	Check trunk : Retractable hard top can not operate when trunk lid is open	 <p style="text-align: center;">JMKIA4121ZZ</p>
Check separator : Retractable hard top can not operate when tonneau board is not set	 <p style="text-align: center;">JMKIA4122ZZ</p>		

### WARNING BUZZER FUNCTION

Roof warning buzzer sounds due to the following conditions.

#### NOTE:

Warning buzzer operation in initialize procedure, Refer to [RF-88, "Description"](#).

Operation/condition	Buzzer sounds	Cause	Action
Normal <ul style="list-style-type: none"> <li>Open and close operations by roof open /close switch, or an open operation by door request switch is performed</li> <li>Operation is complete (fully closed or fully open)</li> </ul>	Pi-	—	
Retractable hard top stops during operation	Pi, Pi	Foreign materials are trapped in moving parts	Check moving part for trapped foreign materials, deformation, and looseness Check operation and DTC, after erasing self diagnosis result
Release roof open/close switch		Roof state is not in end position (not in fully close or fully open position)	Operate retractable hard top to end position.
Retractable hard top does not operate		Shift position is R	Shift the shift position to P or N
		Trunk lid is not closed	Close trunk lid
		Tonneau board is not set	Set tonneau board
		Thermo protection (stage 2) is in operation	Wait for 20 minutes or more without performing operation
Engine stops		Retractable hard top is not fully closed or fully open	Fully close or fully open retractable hard top

## SYSTEM

### < SYSTEM DESCRIPTION >

Operation/condition	Buzzer sounds	Cause	Action
The vehicle is driven	Pi-----...	Retractable hard top is not fully closed or fully open	Fully close or fully open retractable hard top
Ignition switch is OFF	Buzzer sounds 2 times in 5 second intervals from 1 minute after reconnecting battery for 15 minutes	Roof state is not in end position (not in fully close or fully open position)	Operate retractable hard top to end position.
Ignition is OFF after battery is re-connected		Initialization is not complete	Perform initialization

# DIAGNOSIS SYSTEM (RETRACTABLE HARD TOP CONTROL UNIT)

< SYSTEM DESCRIPTION >

## DIAGNOSIS SYSTEM (RETRACTABLE HARD TOP CONTROL UNIT)

### CONSULT-III Function

INFOID:000000006468655

#### APPLICATION ITEM

CONSULT-III performs the following functions via CAN communication with retractable hard top control unit.

Diagnosis mode	Function Description
Ecu Identification	The retractable hard top control unit part number is displayed.
Self Diagnostic Result	Displays the diagnosis results judged by retractable hard top control unit.
Freeze Frame Data	The retractable hard top control unit records the vehicle condition at the time a particular DTC is detected, and displays.
Data Monitor	The retractable hard top control unit input/output signals are displayed.
Active Test	The signals used to activate each device are forcibly supplied from retractable hard top control unit.
Work Support	Changes the setting for each system function.
CAN Diag Support Monitor	Monitors the reception status of CAN communication viewed from retractable hard top control unit. Refer to CONSULT-III operation manual.

#### WORK SUPPORT

CONSULT-III display		Description
Item	Indication	
TRUNK OPENER	ON	Perform trunk opener actuator OPEN operation
FLIPPER DOOR Always perform this operation after completely understanding about retractable hard top operation. Refer to <a href="#">RF-39, "FLIPPER DOOR FUNCTION : System Description"</a> . <b>CAUTION:</b> <b>This operation may interfere with and damage parts. Always check the precautions. Refer to <a href="#">RF-10, "Precautions for Retractable Hard Top Service"</a>.</b>	UP	Flipper door (LH/RH) performs UP operation
	DOWN	Flipper door (LH/RH) performs DOWN operation
ROOF LATCH	OPEN	Roof latch performs UNLOCK operation
	CLOSE	Roof latch performs LOCK operation
ROOF STATE LEARNING	START	Roof position is learned
ROOF STATE RESET	START	Roof position memory is erased
ROOF/TRUNK/PARCEL SHELF Always perform this operation after completely understanding about retractable hard top operation. Refer to <a href="#">RF-37, "PARCEL SHELF FUNCTION : System Description"</a> . <b>CAUTION:</b> <b>This operation may interfere with and damage parts. Always check the precautions. Refer to <a href="#">RF-10, "Precautions for Retractable Hard Top Service"</a>.</b> • Before opening trunk lid, release trunk opener lock-up. • Before operating roof, release roof opener lock-up.	PS (DRAW)	UP DOWN
	PS (ROTA)	VERT HORI
	ROOF	OPEN CLOSE
	TRUNK	OPEN CLOSE

#### SELF-DIAG RESULT

Refer to [RF-64, "DTC Index"](#).

Freeze Frame Data

# DIAGNOSIS SYSTEM (RETRACTABLE HARD TOP CONTROL UNIT)

## < SYSTEM DESCRIPTION >

The retractable hard top control unit records the following vehicle condition at the time a particular DTC is detected, and displays on CONSULT-III.

CONSULT-III display		Description
Item	Indication	
ROOF SW(OPEN)	ON/OFF	OPEN input state of roof open/close switch is displayed
ROOF SW(CLOSE)	ON/OFF	CLOSE input state of roof open/close switch is displayed
TONNEAU SW	ON/OFF	State of tonneau board switch is displayed
LATCH LIMIT SW	ON/OFF	Input state of roof latch limit switch is displayed
LATCH LOCK SEN	ON/OFF	Input state of roof latch lock sensor is displayed
TRUNK STATUS SEN	ON/OFF	Input state of trunk status sensor is displayed
TR LINK SEN A(LH)	ON/OFF	Input state of trunk link sensor (RH) is displayed
TR LINK SEN A(RH)	ON/OFF	Input state of trunk link sensor (LH) is displayed
FLPD LIMIT SW(DWN)	ON/OFF	Input state of flipper door limit switch (DOWN) is displayed
FLPD LIMIT SW(UP)	ON/OFF	Input state of flipper door limit switch (UP) is displayed
ROOF STATE	OK/NG	Condition of retractable hard top system state is displayed
HYDRAULIC STATE	OK/NG	Condition of hydraulic system state is displayed
LATCH STATE	OK/NG	Condition of roof latch state is displayed
FLPD STATE	OK/NG	Condition of flipper door (LH/RH) state is displayed
PUMP OUT(LH)	ON/OFF	Left rotation output state to hydraulic motor is displayed
PUMP OUT(RH)	ON/OFF	Right rotation output state to hydraulic motor is displayed
SWITCH VALVE 1 OUT	ON/OFF	Output state to switching valve 1 is displayed
SWITCH VALVE 2 OUT	ON/OFF	Output state to switching valve 2 is displayed
TR LINK SEN B(LH)	ON/OFF	Input state of trunk link sensor (RH) is displayed
TR LINK SEN B(RH)	ON/OFF	Input state of trunk link sensor (LH) is displayed
PS STATE(TOP)	ON/OFF	Parcel shelf (DRAW) position (TOP) is displayed
PS STATE(BOTTOM)	ON/OFF	Parcel shelf (DRAW) position (BOTTOM) is displayed
LATCH OUT(ULK)	ON/OFF	OPEN output state to roof latch motor is displayed
LATCH OUT(LCK)	ON/OFF	CLOSE output state to roof latch motor is displayed
R WIN LH OUT(UP)	ON/OFF	CLOSE output state to rear power window motor (LH) is displayed
R WIN LH OUT(DWN)	ON/OFF	OPEN output state to rear power window motor (LH) is displayed
R WIN RH OUT(UP)	ON/OFF	CLOSE output state to rear power window motor (RH) is displayed
R WIN RH OUT(DWN)	ON/OFF	OPEN output state to rear power window motor (RH) is displayed
REAR DEF ON SIG	ON/OFF	Input state of rear window defogger ON signal from BCM is displayed
PS OUT(UP)	ON/OFF	UP output state to parcel shelf motor (DRAW) is displayed
PS OUT(DOWN)	ON/OFF	DOWN output state to parcel shelf motor (DRAW) is displayed
PS OUT(HORI)	ON/OFF	HORIZONTAL output state to parcel shelf motor (ROTATE) is displayed
PS OUT(VERT)	ON/OFF	VERTICAL output state to parcel shelf motor (ROTATE) is displayed
TRUNK OPEN OUT	ON/OFF	OPEN output state to trunk opener actuator is displayed
FLPD OUT(UP)	ON/OFF	UP output state to flipper door motor (LH/RH) is displayed
FLPD OUT(DWN)	ON/OFF	DOWN output state to flipper door motor (LH/RH) is displayed
DTC OCCURRENCE COUNTER	—	The number of times that ignition switch is turned ON after DTC is detected

## DATA MONITOR

# DIAGNOSIS SYSTEM (RETRACTABLE HARD TOP CONTROL UNIT)

## < SYSTEM DESCRIPTION >

CONSULT-III display		Description	
Item	Indication/Unit		
LATCH OUT(ULK)	ON/OFF/NG	OPEN output state to roof latch motor is displayed	A
LATCH OUT(LCK)	ON/OFF/NG	CLOSE output state to roof latch motor is displayed	B
LATCH VALUE	0-255	Pulse number from roof latch status sensor is displayed	
LATCH LIMIT SW	LOCK/UNLK	Input state of roof latch limit switch is displayed	C
LATCH STATE	NG/CLOSE/ MID/OPEN	State of roof latch is displayed	
PS VALUE(DRAW)	0-65535	Pulse number from parcel shelf status sensor (DRAW) is displayed	D
PS VALUE(ROTA)	0-65535	Pulse number from parcel shelf status sensor (ROTATE) is displayed	
PS OUT(UP)	ON/OFF/NG	UP output state to parcel shelf motor (DRAW) is displayed	E
PS OUT(DOWN)	ON/OFF/NG	DOWN output state to parcel shelf motor (DRAW) is displayed	
PS OUT(VERT)	ON/OFF/NG	VERTICAL output state to parcel shelf motor (ROTATE) is displayed	F
PS OUT(HORI)	ON/OFF/NG	HORIZONTAL output state to parcel shelf motor (ROTATE) is displayed	
PS STATE(DRAW)	NG/1-6	DRAW state of parcel shelf is displayed	G
PS STATE(ROTA)	NG/1-4	ROTATE state of parcel shelf is displayed	
ROOF VALUE	0-1023	Pulse number from roof status sensor is displayed	H
PUMP OUT(RH)	ON/OFF/NG	Right rotation output state to hydraulic motor is displayed	
PUMP OUT(LH)	ON/OFF/NG	Left rotation output state to hydraulic motor is displayed	I
SWITCH VLV 1 OUT	ON/OFF/NG	Output state to switching valve 1 is displayed	
SWITCH VLV 2 OUT	ON/OFF/NG	Output state to switching valve 2 is displayed	J
ROOF STATE	NG/1-42	State of retractable hard top system is displayed	
HYDRAULIC STATE	NG/1-22	State of hydraulic system is displayed	
ROOF SW(OPEN)	ON/OFF	OPEN input state of roof open/close switch is displayed	
ROOF SW(CLOSE)	ON/OFF	CLOSE input state of roof open/close switch is displayed	
ROOF LINK STATE	NG/1-8	State of roof link is displayed	
TRUNK LINK SEN(RH)	ON/OFF/NG	Input state of trunk link sensor (RH) is displayed	RF
TRUNK LINK SEN(LH)	ON/OFF/NG	Input state of trunk link sensor (LH) is displayed	
TR ROOM LAMP SW	ON/OFF	Input state from trunk room lamp switch is displayed	
TRUNK STATUS SEN	ON/OFF/NG	Input state of trunk status sensor is displayed	L
TRUNK OPEN OUT	ON/OFF/NG	OPEN output state to trunk opener actuator is displayed	
FLPD LIMIT SW(DWN)	ON/OFF	Input state of flipper door limit switch (DOWN) is displayed	M
FLPD LIMIT SW(UP)	ON/OFF	Input state of flipper door limit switch (UP) is displayed	
FLPD OUT(UP)	ON/OFF/NG	UP output state to flipper door motor (LH/RH) is displayed	N
FLPD OUT(DWN)	ON/OFF/NG	DOWN output state to flipper door motor (LH/RH) is displayed	
FLPD STATE	NG/1, 2, 4	State of flipper door (LH/RH) is displayed	
R WIN LH OUT(UP)	ON/OFF/NG	CLOSE output state to rear power window motor (LH) is displayed	O
R WIN LH OUT(DWN)	ON/OFF/NG	OPEN output state to rear power window motor (LH) is displayed	
R WIN RH OUT(UP)	ON/OFF/NG	CLOSE output state to rear power window motor (RH) is displayed	P
R WIN RH OUT(DWN)	ON/OFF/NG	OPEN output state to rear power window motor (RH) is displayed	
REAR DEF ON SIG	ON/OFF	Input state of rear window defogger ON signal from BCM is displayed	
REAR DEF OUT	ON/OFF/NG	Output state to rear window defogger is displayed	
R WIN CURENT(LH)	0-25.5	Current value to rear power window motor (LH) is displayed	
R WIN CURENT(RH)	0-25.5	Current value to rear power window motor (RH) is displayed	
RR WIN STATE(LH)	UP/MID/DOWN	State of rear power window motor (LH) is displayed	

# DIAGNOSIS SYSTEM (RETRACTABLE HARD TOP CONTROL UNIT)

## < SYSTEM DESCRIPTION >

CONSULT-III display		Description
Item	Indication/Unit	
RR WIN STATE(RH)	UP/MID/DOWN	State of rear power window motor (RH) is displayed
RAP SIGNAL	ON/OFF	Input state of RAP signal from BCM is displayed
TR MODE SIGNAL	ON/OFF	Output state of trunk mode signal to trunk closure control unit is displayed
ROOF STATE(AUDIO)	ON/OFF/NG	Output state of roof status signal to audio unit is displayed
ROOF BUZZER OUT	ON/OFF/NG	Output state to roof warning buzzer is displayed
LOCAL COMM 1	NG/SLEEP/NG	State of serial link 1 is displayed
LOCAL COMM 2	NG/SLEEP/NG	State of serial link 2 is displayed
ROOF MODE	NG/STOP/ CLOSE/OK	Inhibition mode of retractable hard top system is displayed
POP-UP BAR DPLOY	OK/NG	It is displayed whether or not pop-up bar is deployed
POP-UP BAR DIAG	OK/NG	It is displayed whether or not pop-up bar is malfunctioning
SWITCH VLV COND	OK/NG	Diagnosis result of switching valve is displayed
PWR SOURCE COND	OK/NG	Diagnosis result of battery power supply is displayed
CPU COND	OK/NG	Diagnosis result of CPU is displayed
ROOF COND	OK/NG	Diagnosis result of roof position is displayed
SENSOR COND	OK/NG	Diagnosis result of sensor (hall sensor) is displayed
IGN ON SIG(BCM)	OK/NG	Receiving state of ignition ON signal from BCM is displayed
VHCL STOP-METER	OK/NG	Receiving state of vehicle speed (0 km/h) from combination meter is displayed
CIRCUIT COND	OK/NG	Diagnosis result of circuit is displayed
ROOF TIMEOUT	OK/NG	Time out state of roof operation is displayed
CAN COMM	OK/NG	Diagnosis result of CAN communication is displayed
THERMO PROTECT 1	OK/NG	Non-operation state of thermo protection (stage1) is displayed
PRMIT ENG ST (BCM)	OK/NG	Input state of engine cranking signal from BCM is displayed
SHIFT R SIG	OK/NG	Input state of shift position (R position) is displayed
THERMO PROTECT 2	OK/NG	Non-operation state of thermo protection (stage 2) is displayed
TONNEAU SW	OK/NG	State of tonneau board switch is displayed
BRK LAMP SW(BCM)	OK/NG	Receiving state of brake lamp switch signal from BCM is displayed
THERMO VALUE	0-65535	Count value of thermo protection is displayed
PWR SOURCE VALUE	0-20	Voltage value of power supply is displayed
ROOF INITIAL(OPEN)	OK/NG	Learning state of roof position (OPEN) is displayed
ROOF INITIAL(CLOSE)	OK/NG	Learning state of roof position (CLOSE) is displayed
PSHELF INITIAL(ROTA)	OK/NG	Learning state of parcel shelf position (ROTATE) is displayed
PSHELF INITIAL(DRAW)	OK/NG	Learning position of parcel shelf position (DRAW) is displayed

## ACTIVE TEST

CONSULT-III display		Description
Item	Indication	
ROOF SYSTEM	OPEN	Retractable hard top system performs open operation
	CLOSE	Retractable hard top system performs close operation
ROOF STATE OUTPUT(AUDIO)	ON	Full open position signal of roof is transmitted to audio unit
FRONT POWER WINDOW (LH/RH)	DOWN	Front power window (LH/RH) performs open operation
REAR POWER WINDOW(LH)	UP	Rear power window (LH) performs close operation
	DOWN	Rear power window (LH) performs open operation



# DIAGNOSIS SYSTEM (RETRACTABLE HARD TOP CONTROL UNIT)

## < SYSTEM DESCRIPTION >

CONSULT-III display		Description
Item	Indication	
REAR POWER WINDOW(RH)	UP	Rear power window (RH) performs close operation
	DOWN	Rear power window (RH) performs open operation

A

B

C

D

E

F

G

H

I

J

**RF**

L

M

N

O

P

# RETRACTABLE HARD TOP CONTROL UNIT

< ECU DIAGNOSIS INFORMATION >

## ECU DIAGNOSIS INFORMATION

### RETRACTABLE HARD TOP CONTROL UNIT

Reference Value

INFOID:000000006468656

#### VALUES ON THE DIAGNOSIS TOOL

CONSULT-III MONITOR ITEM

Monitor Item	Condition	Status/Value	
LATCH LOCK SEN	State of roof latch	Lock	ON
		Other than above	OFF
		Roof latch lock sensor circuit is short	NG
LATCH STATE SEN	State of roof latch motor	Operate	ON ⇔ OFF
		Stop	ON or OFF
		Roof latch lock sensor circuit is short	NG
LATCH OUT(ULK)	Operation of roof latch motor	Unlock is in operation	ON
		Other than above	OFF
		Roof latch motor (UNLOCK) circuit is short	NG
LATCH OUT(LCK)	Operation of roof latch motor	Lock is in operation	ON
		Other than above	OFF
		Roof latch motor (LOCK) circuit is short	NG
LATCH VALUE	State of roof latch	Lock	0
		Halfway position	1-77
		Unlock	78 or more
LATCH LIMIT SW	State of roof latch	Roof is fully close and roof latch is in LOCK	CLOSE
		Other than above	OPEN
LATCH STATE	State of roof latch	Initialization is not complete	NG
		LOCK	CLOSE
		Halfway position	MID
		UNLOCK	OPEN
PS VALUE(DRAW)	State of parcel shelf	Top	Retractable hard top fully open state: 2246 Retractable hard top fully closed state: 2220
		Bottom	1000
PS VALUE(ROTA)	State of parcel shelf	Vertical	3190
		Horizontal	Retractable hard top fully open state: 1340 Retractable hard top fully closed state: 1000
PS OUT(UP)	Operation of parcel shelf	Up operation is in operation	ON
		Other than above	OFF
		Parcel shelf (UP) circuit is short	NG
PS OUT(DOWN)	Operation of parcel shelf	DOWN operation is in operation	ON
		Other than above	OFF
		Parcel shelf (DOWN) circuit is short	NG
PS OUT(VERT)	Operation of parcel shelf	Vertical operation is in operation	ON
		Other than above	OFF
		Parcel shelf (VERTICAL) circuit is short	NG

# RETRACTABLE HARD TOP CONTROL UNIT

## < ECU DIAGNOSIS INFORMATION >

Monitor Item	Condition	Status/Value		
PS OUT(HORI)	Operation of parcel shelf	Horizontal operation is in operation	ON	A
		Other than above	OFF	
		Parcel shelf (HORIZONTAL) circuit is short	NG	B
PS STATE(DRAW)	State of parcel shelf	For the details, refer to <a href="#">RF-37, "PARCEL SHELF FUNCTION : System Description"</a>	1-6	
		State of parcel shelf status sensor (DRAW) is not recognized	NG	C
PS STATE(ROTA)	State of parcel shelf	For the details, refer to <a href="#">RF-37, "PARCEL SHELF FUNCTION : System Description"</a>	1-4	D
		State of parcel shelf status sensor (ROTATE) is not recognized	NG	
ROOF VALUE	Roof status sensor signal		0-1023	E
PUMP OUT(RH)	Operation of hydraulic pump motor	Turning clockwise	ON	
		Other than above	OFF	
		Hydraulic pump motor (RH) circuit is short	NG	F
PUMP OUT(LH)	Operation of hydraulic pump motor	Turning counterclockwise	ON	
		Other than above	OFF	G
		Hydraulic pump motor (LH) circuit is short	NG	
SWITCH VLV 1 OUT	Operation of switching valve 1	Operate	ON	
		Stop	OFF	H
		Switching valve 1 circuit is short	NG	
SWITCH VLV 2 OUT	Operation of switching valve 2	Operate	ON	
		Stop	OFF	I
		Switching valve 2 circuit is short	NG	
ROOF STATE	State of roof	For the details, refer to <a href="#">RF-20, "RETRACTABLE HARD TOP SYSTEM : System Description"</a>	1-42	J
		State of roof is not recognized	NG	RF
HYDRAULIC STATE	State of hydraulic system	For the details, refer to <a href="#">RF-31, "HYDRAULIC SYSTEM CONTROL FUNCTION : System Description"</a>	1-22	
		State of hydraulic system is not recognized	NG	L
ROOF SW(OPEN)	State of roof open/close switch	OPEN operation is in operation	ON	
		Other than above	OFF	M
ROOF SW(CLOSE)	State of roof open/close switch	CLOSE operation is in operation	ON	
		Other than above	OFF	N
ROOF LINK STATE	State of roof link	For the details, refer to <a href="#">RF-31, "HYDRAULIC SYSTEM CONTROL FUNCTION : System Description"</a>	1-8	
		State of roof is not recognized	NG	O
TRUNK LINK SEN(RH)	State of trunk link lock (RH)	LOCK	ON	
		Other than above	OFF	
		Trunk link lock (RH) circuit is short or open	NG	P
TRUNK LINK SEN(LH)	State of trunk link lock (LH)	LOCK	ON	
		Other than above	OFF	
		Trunk link lock (LH) circuit is short or open	NG	
TR ROOM LAMP SW	State of trunk lid (trunk room lamp switch)	Open	ON	
		Other than above	OFF	

# RETRACTABLE HARD TOP CONTROL UNIT

## < ECU DIAGNOSIS INFORMATION >

Monitor Item	Condition		Status/Value
TRUNK STATUS SEN	State of trunk lid	Fully OPEN	ON
		Other than above	OFF
		Trunk status sensor circuit is short or open	NG
TRUNK OPEN OUT	Operation of trunk lid opener actuator	OPEN operation is in operation	ON
		Other than above	OFF
		Trunk lid opener actuator circuit is short	NG
FLPD LIMIT SW(DWN)	State of flipper door	Both of flipper door (LH/RH) are in DOWN position	ON
		Other than above	OFF
FLPD LIMIT SW(UP)	State of flipper door	Both of flipper door (LH/RH) are in UP position	ON
		Other than above	OFF
FLPD OUT(UP)	Operation of flipper door	UP operation is in operation	ON
		Other than above	OFF
		Flipper door motor (UP) circuit is short	NG
FLPD OUT(DWN)	Operation of flipper door	DOWN operation is in operation	ON
		Other than above	OFF
		Flipper door motor (DOWN) circuit is short	NG
FLPD STATE	State of flipper door	For the details, refer to <a href="#">RF-39, "FLIPPER DOOR FUNCTION : System Description"</a>	1, 2, 4
		State of flipper door is not recognized	NG
R WIN LH OUT(UP)	Operation of rear power window (LH)	UP operation is in operation	ON
		Other than above	OFF
		Rear power window LH (UP) circuit is short	NG
R WIN LH OUT(DWN)	Operation of rear power window (LH)	DOWN operation is in operation	ON
		Other than above	OFF
		Rear power window LH (DOWN) circuit is short	NG
R WIN RH OUT(UP)	Operation of rear power window (RH)	UP operation is in operation	ON
		Other than above	OFF
		Rear power window RH (UP) circuit is short	NG
R WIN RH OUT(DWN)	Operation of rear power window (RH)	DOWN operation is in operation	ON
		Other than above	OFF
		Rear power window RH (DOWN) circuit is short	NG
REAR DEF ON SIG	State of rear window defogger switch	While operating	ON
		Stop	OFF
REAR DEF OUT	State of rear window defogger system	Operate	ON
		Stop	OFF
		Rear window defogger circuit is short	NG
R WIN CURENT(LH)	Current value to rear power window motor (LH)	0-25.5 (A)	
R WIN CURENT(RH)	Current value to rear power window motor (RH)	0-25.5 (A)	
RR WIN STATE(LH)	State of rear power window (LH)	Upper	UP
		Halfway	MID
		Lower end	DOWN

# RETRACTABLE HARD TOP CONTROL UNIT

## < ECU DIAGNOSIS INFORMATION >

Monitor Item	Condition	Status/Value		
RR WIN STATE(RH)	State of rear power window (RH)	Upper	UP	A
		Halfway	MID	
		Lower end	DOWN	B
RAP SIGNAL	State of RAP	Operate	ON	
		Stop	OFF	
TR MODE SIGNAL	State of trunk mode signal	Output	ON	C
		Stop	OFF	
ROOF STATE(AUDIO)	State of roof	State of fully open	ON	D
		Other than above	OFF	
		Roof state signal (audio) circuit is short	NG	
ROOF BUZZER OUT	State of roof warning buzzer	Operate	ON	E
		Stop	OFF	
		Roof warning buzzer circuit is short	NG	F
LOCAL COMM 1	State of local communication 1	Normal	OK	
		It is in sleep mode	SLEEP	
		Communication error	NG	G
LOCAL COMM 2	State of local communication 2	Normal	OK	
		It is in sleep mode	SLEEP	
		Communication error	NG	H
ROOF MODE	Roof operation mode	Normal	OK	
		Only close operation is possible	CLOSE	I
		Operation is stop	STOP	
		Operation is inhibited	NG	
POP-UP BAR DPLOY	State of pop-up bar	Normal	OK	J
		State of deployment	NG	
POP-UP BAR DIAG	Self-diagnosis result of pop-up bar	Normal	OK	RF
		Malfunctioning is detected	NG	
SWITCH VLV COND	Diagnosis result of retractable hard top control unit	Diagnosis result of retractable hard top control unit	OK	L
		Switching valve (1/2) system is malfunctioning	NG	
PWR SOURCE COND	Power supply voltage state of retractable hard top control unit	Normal	OK	M
		Malfunction	NG	
CPU COND	Diagnosis result of retractable hard top control unit	CPU is normal	OK	N
		CPU is not normal	NG	
ROOF COND	Diagnosis result of retractable hard top control unit	Roof position is normal	OK	O
		Roof position is not normal	NG	
SENSOR COND	Diagnosis result of retractable hard top control unit	Hole sensor system is normal	OK	
		Hole sensor system is not normal	NG	P
IGN ON SIG(BCM)	Power position signal (via CAN from BCM)	ON	OK	
		Other than above	NG	
VHCL STOP-METER	Vehicle speed signal (via CAN from meter and A/C amp.)	0km/h	OK	
		Other than above	NG	

# RETRACTABLE HARD TOP CONTROL UNIT

## < ECU DIAGNOSIS INFORMATION >

Monitor Item	Condition	Status/Value
CIRCUIT COND	Diagnosis result of retractable hard top control unit	Circuit system is normal
		Circuit system is not normal
ROOF TIMEOUT	State of roof operation	Normal
		Malfunction
CAN COMM	CAN communication status	Normal
		Malfunction
THERMO PROTECT 1	Thermo protection (Stage1)	In non-operation
		In operation
SHIFT R SIG	Shift position	Other than R position
		R position
PRMIT ENG ST(BCM)	Permit engine start signal	Signal is not received
		Signal is in receiving
THERMO PROTECT-2	Thermo protection (Stage2)	In non-operation
		In operation
TONNEAU SW	Tonneau board	Set
		Other than above
BRK LAMP SW(BCM)	Brake lamp switch signal (via CAN from BCM)	Brake is depressed
		Brake is released
THERMO VALUE	Conversion value of thermo protection	0-65535
PWR SOURCE VALUE	Power supply voltage value of retractable hard top control unit	0-20 (V)
ROOF INITIAL(OPEN)	State of performing roof position initialization	Registration of full open position is complete
		Registration of full open position is not complete
ROOF INITIAL(CLOSE)	State of performing roof position initialization	Registration of full closed position is complete
		Registration of full closed position is not complete
PSHELF INITIAL(ROTA)	State of performing parcel shelf position initialization	Registration of rotation position is complete
		Registration of rotation position is not complete
PSHELF INITIAL(DRAW)	State of performing parcel shelf position initialization	Registration of draw position is complete
		Registration of draw position is not complete

## TERMINAL LAYOUT

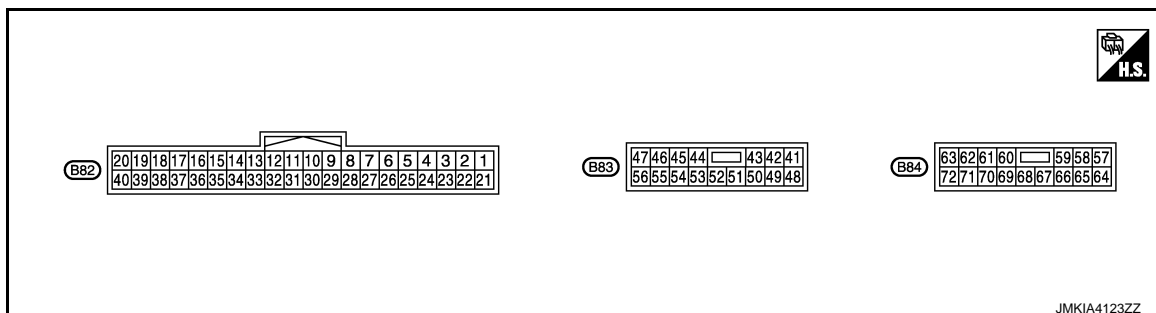

## PHYSICAL VALUES

# RETRACTABLE HARD TOP CONTROL UNIT

## < ECU DIAGNOSIS INFORMATION >

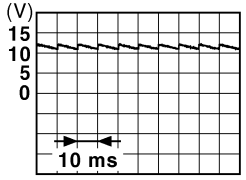
Terminal No. (Wire color)		Description		Condition			Value (Approx.)
+	-	Signal name	Input/ Output				
1 (G)	Ground	Roof open/close switch (OPEN)	Input	Ignition switch ON	Roof open/close switch (OPEN)	Pressed	0 V
						Released	Battery voltage
2 (BR)	Ground	Roof open/close switch (CLOSE)	Input	Ignition switch ON	Roof open/close switch (CLOSE)	Pressed	0 V
						Released	Battery voltage
3 (B)	Ground	Flipper door limit switch ground	—	Ignition switch ON	—		0 V
4 (L)	Ground	Tonneau board switch	Input	Ignition switch ON	Tonneau board	Hooked	Battery voltage
						Released	0 V
5 (SB)	Ground	Trunk room lamp switch	Input	Ignition switch ON	Trunk lid	Locked	
						Other than above	0 V
6 (L)	Ground	Roof latch limit switch	Input	Ignition switch ON	Roof	Close	0 V
						Other than above	Battery voltage
7 (W)	Ground	Flipper door limit switch (UP)	Input	Ignition switch ON	Flipper door LH and RH	Top	0 V
						Other than above	Battery voltage
8 (G)	Ground	Flipper door limit switch (DOWN)	Input	Ignition switch ON	Flipper door LH and RH	Bottom	0 V
						Other than above	Battery voltage
11 (W)	Ground	RAP signal	Input	Ignition switch ON	RAP function	Active	Battery voltage
						Inactive	0 V
12 (Y)	Ground	Back up lamp signal	Input	Ignition switch ON	Shift position	R position	Battery voltage
						Other than above	0 V
13 (BG)	Ground	Sensor power supply	Output	Ignition switch OFF	—		5 V
14 (P)	Ground	Trunk link sensor (LH)	Input	Ignition switch ON	Trunk link lock (LH)	LOCK	0.3 V
						Other than above	1.5 V
15 (SB)	Ground	Trunk link sensor (RH)	Input	Ignition switch ON	Trunk link lock (RH)	LOCK	0.3 V
						Other than above	1.5 V

A  
B  
C  
D  
E  
F  
G  
H  
I  
J  
RF  
L  
M  
N  
O  
P

# RETRACTABLE HARD TOP CONTROL UNIT

## < ECU DIAGNOSIS INFORMATION >

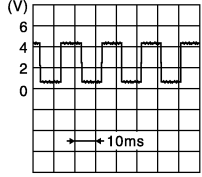
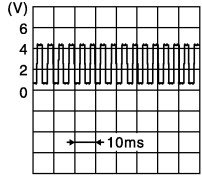
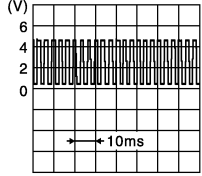
Terminal No. (Wire color)		Description		Condition			Value (Approx.)
+	-	Signal name	Input/ Output				
16 (GR)	Ground	Roof latch status sensor	Input	Ignition switch ON	Roof latch	Operate	 <small>JMKIA4021GB</small>
						Stop	0.5 or 4.5 V
17 (G)	Ground	Roof latch lock sensor	Input	Ignition switch ON	Roof latch	LOCK	1.0 V
						Other than above	3.8 V
18 (LG)	Ground	Trunk status sensor	Input	Ignition switch ON	Trunk lid (front)	Fully open	1.0 V
						Other than above	3.8 V
22 (V)	Ground	Roof status sensor power supply	Output	Ignition switch ON	—		5 V
23 (B)	Ground	Roof status sensor ground	—	Ignition switch ON	—		0 V
24 (GR)	Ground	Parcel shelf status sensor (DRAW)	Input	Ignition switch ON	Parcel shelf motor (DRAW)	Active	 <small>JMKIA4022GB</small>
						Inactive	0.5 V or 5 V
25 (R)	Ground	Parcel shelf status sensor (ROTATION)	Input	Ignition switch ON	Parcel shelf motor (ROTATE)	Active	 <small>JMKIA4023GB</small>
						Inactive	0.5 V or 5 V
26 (P)	Ground	Roof status sensor signal	Input	Ignition switch ON	Roof	Fully close→Fully open	0.5 V→5 V
27 (Y)	Ground	Trunk lid open request signal (BCM)	Output	—	Trunk opener	Operate	0 V →Battery voltage →0 V
						Other than above	0 V
28 (BG)	Ground	Flipper door motor ground	—	Ignition switch ON	—		0 V



# RETRACTABLE HARD TOP CONTROL UNIT

## < ECU DIAGNOSIS INFORMATION >

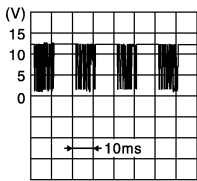
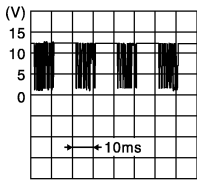
Terminal No. (Wire color)		Description		Condition		Value (Approx.)	
+	-	Signal name	Input/ Output				
29 (V)	Ground	Local communication (BCM)	Input/ Output	Ignition switch ON	—	 <small>JMKIA4024GB</small>	
30 (GR)	Ground	Local communication (POWER WINDOW)	Input/ Output	Ignition switch ON	—	 <small>JMKIA4024GB</small>	
31 (L)	Ground	CAN-H	Input/ Output	—	—	—	
32 (P)	Ground	CAN-L	Input/ Output	—	—	—	
33 (V)	Ground	Roof status signal (AUDIO)	Output	Ignition switch ON	Retractable hard top	Fully open	Battery voltage
						Other than above	0 V
35 (B)	Ground	Roof warning buzzer	Output	Ignition switch ON	Roof warning buzzer	Sounds	0 V
						Not sounds	Battery voltage
36 (Y)	Ground	Hydraulic pump relay (RH)	—	Ignition switch ON	Hydraulic pump motor (RH)	Active	0 V
						Inactive	Battery voltage
37 (W)	Ground	Hydraulic pump relay (LH)	—	Ignition switch ON	Hydraulic pump motor (LH)	Active	0 V
						Inactive	Battery voltage
38 (BR)	Ground	Hydraulic pump relay ground	—	Ignition switch ON	—	0 V	
41 (SB)	Ground	Parcel shelf motor (UP)	Output	Ignition switch ON	Parcel shelf motor (DRAW-UP)	Active	Battery voltage
						Inactive	0 V
42 (W)	Ground	Parcel shelf motor (DOWN)	Output	Ignition switch ON	Parcel shelf motor (DRAW-DOWN)	Active	Battery voltage
						Inactive	0 V
43 (BR)	Ground	Hydraulic pump power supply relay	Output	Ignition switch ON	Retractable hard top system	Active	Battery voltage
						Inactive	0 V
44 (R)	Ground	Parcel shelf motor (HORIZONTAL)	Output	Ignition switch ON	Parcel shelf motor (ROTATION-HORI- ZONTAL)	Active	Battery voltage
						Inactive	0 V
45 (BR)	Ground	Parcel shelf motor (VERTICAL)	Output	Ignition switch ON	Parcel shelf motor (ROTATION-VER- TICAL)	Active	Battery voltage
						Inactive	0 V
46 (G)	Ground	Flipper door motor (UP)	Output	Ignition switch ON	Flipper door motor (UP)	Active	Battery voltage
						Inactive	0 V

A  
B  
C  
D  
E  
F  
G  
H  
I  
J  
K  
L  
M  
N  
O  
P

RF

## RETRACTABLE HARD TOP CONTROL UNIT

### < ECU DIAGNOSIS INFORMATION >

Terminal No. (Wire color)		Description		Condition			Value (Approx.)
+	-	Signal name	Input/ Output				
47 (L)	Ground	Flipper door motor (DOWN)	Output	Ignition switch ON	Flipper door motor (DOWN)	Active	Battery voltage
						Inactive	0 V
48 (R)	Ground	Roof latch motor (OPEN)	Output	Ignition switch ON	Roof latch motor (OPEN)	Active	Battery voltage
						Inactive	0 V
49 (Y)	Ground	Roof latch motor (CLOSE)	Output	Ignition switch ON	Roof latch motor (CLOSE)	Active	Battery voltage
						Inactive	0 V
51 (SB)	Ground	Trunk lid opener ac- tuator	Output	—	Trunk lid opener	Operate	0 V → Battery voltage → 0 V
						Stop	0 V
52 (V)	Ground	Trunk lid opener ac- tuator ground	—	Ignition switch ON	—		0 V
53 (BG)	Ground	Rear power window motor LH (UP)	Output	Ignition switch ON	Rear power window motor LH (UP)	Active	Battery voltage
						Inactive	0 V
54 (LG)	Ground	Rear power window motor LH (DOWN)	Output	Ignition switch ON	Rear power window motor LH (DOWN)	Active	Battery voltage
						Inactive	0 V
55 (GR)	Ground	Rear power window motor RH (UP)	Output	Ignition switch ON	Rear power window motor RH (UP)	Active	Battery voltage
						Inactive	0 V
56 (P)	Ground	Rear power window motor RH (DOWN)	Output	Ignition switch ON	Rear power window motor RH (DOWN)	Active	Battery voltage
						Inactive	0 V
57 (Y)	Ground	Power source (ROOF)	Input	—	—		Battery voltage
58 (Y)	Ground	Power source (ROOF)	Input	—	—		Battery voltage
59 (Y)	Ground	Power source (ROOF)	Input	—	—		Battery voltage
60 (B)	Ground	Ground (ROOF)	—	Ignition switch ON	—		0 V
61 (B)	Ground	Ground (ROOF)	—	Ignition switch ON	—		0 V
62 (GR)	Ground	Power source (POWER WINDOW)	Input	—	—		Battery voltage
63 (Y)	Ground	Power source (POWER WINDOW)	Input	—	—		Battery voltage
64 (B)	Ground	Ground (POWER WINDOW)	—	Ignition switch ON	—		0 V
65 (B)	Ground	Ground (POWER WINDOW)	—	Ignition switch ON	—		0 V
66 (P)	Ground	Switching valve 1	Output	Ignition switch ON	Switching valve 1	Active	Battery voltage
						Inactive	0 V

# RETRACTABLE HARD TOP CONTROL UNIT

## < ECU DIAGNOSIS INFORMATION >

Terminal No. (Wire color)		Description		Condition			Value (Approx.)
+	-	Signal name	Input/ Output				
67 (SB)	Ground	Switching valve 2	Output	Ignition switch ON	Switching valve 2	Active	Battery voltage
						Inactive	0 V
68 (L)	Ground	Switching valve ground	—	Ignition switch ON	—		0 V
69 (G)	Ground	Power source (REAR WINDOW DEFOGGER)	Input	—	—		Battery voltage
70 (P)	Ground	Power source (REAR WINDOW DEFOGGER)	Input	—	—		Battery voltage
71 (BR)	Ground	Rear window defog- ger power supply	Output	Ignition switch ON	Rear defogger switch ON and roof is fully closed		Battery voltage
72 (W)	Ground	Rear window defog- ger power supply	Output	Ignition switch ON	Rear defogger switch ON and roof is fully closed		Battery voltage

### Fail-safe

INFOID:000000006468657

### FAIL-SAFE CONTROL BY DTC

Retractable hard top control unit performs fail-safe control when any DTC are detected.

Display contents of CONSULT-III		Fail-safe	Cancellation
U1000	CAN COMM CIRCUIT	Inhibit retractable hard top operation.	Communication is normal
U1010	CONTROL UNIT (CAN)	Inhibit retractable hard top operation.	Communication is normal
U0140	LOCAL COMM-1	Inhibit retractable hard top operation.	Communication is normal
U0215	LOCAL COMM-1	Inhibit retractable hard top operation.	Communication is normal
B1701	ROOF CONTROL UNIT	Inhibit retractable hard top operation.	Replace retractable hard top control unit.
B1702	ROOF CONTROL UNIT	Inhibit retractable hard top operation.	Replace retractable hard top control unit.
B1709	ROOF SWITCH(OPEN)	Inhibit retractable hard top operation.	Detects roof open/close switch (OPEN) is OFF
B170A	ROOF SWITCH(CLOSE)	Inhibit retractable hard top operation.	Detects roof open/close switch (CLOSE) is OFF
B170B	ROOF SWITCH	Inhibit retractable hard top operation.	Detects roof open/close switch (OPEN/CLOSE) is OFF
B170C	TRUNK LINK SEN- SOR(LH)	Inhibit retractable hard top operation.	Detects normal value
B170D	TRUNK LINK SEN- SOR(RH)	Inhibit retractable hard top operation.	Detects normal value
B170F	SENSOR POWER SUP- PLY	Inhibit retractable hard top operation.	Detects normal value
B1710	LATCH STATUS SENSOR	Inhibit retractable hard top operation.	Detects normal value
B1711	LATCH LOCK SENSOR	Inhibit retractable hard top operation.	Detects normal value
B1712	TRUNK STATUS SENSOR	Inhibit retractable hard top operation.	Detects normal value
B1715	ROOF STATUS SEN PWR	Inhibit retractable hard top operation.	Detects normal value
B1716	PS STATUS SEN(DRAW)	Inhibit retractable hard top operation.	Detects normal value
B1718	PS STATUS SEN(ROTA)	Inhibit retractable hard top operation.	Detects normal value
B1719	ROOF STATUS SEN	Inhibit retractable hard top operation.	Detects normal value

# RETRACTABLE HARD TOP CONTROL UNIT

## < ECU DIAGNOSIS INFORMATION >

Display contents of CONSULT-III		Fail-safe	Cancellation
B171A	HYDRAULIC PMP(LH)	Inhibit retractable hard top operation.	Detects normal value
B171B	HYDRAULIC PMP(RH)	Inhibit retractable hard top operation.	Detects normal value
B171C	SWITCHING VALVE 1	Inhibit retractable hard top operation.	Detects normal value
B171D	SWITCHING VALVE 2	Inhibit retractable hard top operation.	Detects normal value
B171E	ROOF CONTROL UNIT	Inhibit retractable hard top operation.	Detects normal value
B171F	ROOF CONTROL UNIT	Inhibit retractable hard top operation.	Detects normal value
B1720	ROOF CONTROL UNIT	Inhibit retractable hard top operation.	Detects normal value
B1721	ROOF CONTROL UNIT	Inhibit retractable hard top operation.	Detects normal value
B1722	ROOF CONTROL UNIT	Inhibit retractable hard top operation.	Detects normal value
B1723	ROOF CONTROL UNIT	Inhibit retractable hard top operation.	Detects normal value
B1724	ROOF CONTROL UNIT	Inhibit retractable hard top operation.	Detects normal value
B1725	ROOF CONTROL UNIT	Inhibit retractable hard top operation.	Detects normal value
B1726	ROOF CONTROL UNIT	Inhibit retractable hard top operation.	Detects normal value
B1728	ROOF CONTROL UNIT	Inhibit retractable hard top operation.	Detects normal value
B1729	ROOF CONTROL UNIT	Inhibit retractable hard top operation.	Detects normal value
B172A	ROOF CONTROL UNIT	Inhibit retractable hard top operation.	Detects normal value
B172B	ROOF STATE SIG(AUDIO)	Inhibit retractable hard top operation.	Detects normal value
B172D	ROOF WARNING BUZZ-ER	Inhibit retractable hard top operation.	Detects normal value
B172E	ROOF CONTROL UNIT	Inhibit retractable hard top operation.	Detects normal value
B172F	REAR PWR WINDOW(LH)	Inhibit retractable hard top operation.	Detects normal value
B1730	REAR PWR WIN-DOW(RH)	Inhibit retractable hard top operation.	Detects normal value
B1731	HYDRAULIC STATE 1	Inhibit retractable hard top operation.	Turn ignition switch OFF
B1732	HYDRAULIC STATE 2	Inhibit retractable hard top operation.	Turn ignition switch OFF
B1733	HYDRAULIC STATE 3	Inhibit retractable hard top operation.	Turn ignition switch OFF
B1734	HYDRAULIC STATE 4	Inhibit retractable hard top operation.	Turn ignition switch OFF
B1735	HYDRAULIC STATE 5	Inhibit retractable hard top operation.	Turn ignition switch OFF
B1736	HYDRAULIC STATE 6	Inhibit retractable hard top operation.	Turn ignition switch OFF
B1737	HYDRAULIC STATE 7	Inhibit retractable hard top operation.	Turn ignition switch OFF
B1738	HYDRAULIC STATE 8	Inhibit retractable hard top operation.	Turn ignition switch OFF
B1739	HYDRAULIC STATE 9	Inhibit retractable hard top operation.	Turn ignition switch OFF
B173A	HYDRAULIC STATE 10	Inhibit retractable hard top operation.	Turn ignition switch OFF
B173B	HYDRAULIC STATE 11	Inhibit retractable hard top operation.	Turn ignition switch OFF
B173C	HYDRAULIC STATE 12	Inhibit retractable hard top operation.	Turn ignition switch OFF
B173D	HYDRAULIC STATE 13	Inhibit retractable hard top operation.	Turn ignition switch OFF
B173E	HYDRAULIC STATE 14	Inhibit retractable hard top operation.	Turn ignition switch OFF
B173F	HYDRAULIC STATE 15	Inhibit retractable hard top operation.	Turn ignition switch OFF
B1740	HYDRAULIC STATE 16	Inhibit retractable hard top operation.	Turn ignition switch OFF
B1741	HYDRAULIC STATE 17	Inhibit retractable hard top operation.	Turn ignition switch OFF
B1742	HYDRAULIC STATE 18	Inhibit retractable hard top operation.	Turn ignition switch OFF
B1743	HYDRAULIC STATE 19	Inhibit retractable hard top operation.	Turn ignition switch OFF
B1744	HYDRAULIC STATE 20	Inhibit retractable hard top operation.	Turn ignition switch OFF
B1745	HYDRAULIC STATE 21	Inhibit retractable hard top operation.	Turn ignition switch OFF

# RETRACTABLE HARD TOP CONTROL UNIT

## < ECU DIAGNOSIS INFORMATION >

Display contents of CONSULT-III		Fail-safe	Cancellation	
B1746	HYDRAULIC STATE 22	Inhibit retractable hard top operation.	Turn ignition switch OFF	A
B1747	P SHELF (DRAW) STATE 1	Inhibit retractable hard top operation.	Turn ignition switch OFF	B
B1748	P SHELF (DRAW) STATE 2	Inhibit retractable hard top operation.	Turn ignition switch OFF	C
B1749	P SHELF (DRAW) STATE 3	Inhibit retractable hard top operation.	Turn ignition switch OFF	D
B174A	P SHELF (DRAW) STATE 4	Inhibit retractable hard top operation.	Turn ignition switch OFF	E
B174B	P SHELF (DRAW) STATE 5	Inhibit retractable hard top operation.	Turn ignition switch OFF	F
B174C	P SHELF (DRAW) STATE 6	Inhibit retractable hard top operation.	Turn ignition switch OFF	G
B174D	P SHELF (ROT) STATE 1	Inhibit retractable hard top operation.	Turn ignition switch OFF	H
B174E	P SHELF (ROT) STATE 2	Inhibit retractable hard top operation.	Turn ignition switch OFF	I
B174F	P SHELF (ROT) STATE 3	Inhibit retractable hard top operation.	Turn ignition switch OFF	J
B1750	P SHELF (ROT) STATE 4	Inhibit retractable hard top operation.	Turn ignition switch OFF	
B1751	ROOF LATCH STATE 1	Inhibit retractable hard top operation.	Turn ignition switch OFF	
B1752	ROOF LATCH STATE 2	Inhibit retractable hard top operation.	Turn ignition switch OFF	
B1753	ROOF LATCH STATE 3	Inhibit retractable hard top operation.	Turn ignition switch OFF	
B1754	FLIPPER DOOR STATE 1	Inhibit retractable hard top operation.	Turn ignition switch OFF	
B1755	FLIPPER DOOR STATE 2	Inhibit retractable hard top operation.	Turn ignition switch OFF	
B1756	FLIPPER DOOR STATE 3	Inhibit retractable hard top operation.	Turn ignition switch OFF	
B1757	FLIPPER DOOR STATE 4	Inhibit retractable hard top operation.	Turn ignition switch OFF	
B1758	THERMO PROTECTION	Inhibit retractable hard top operation.	It is not in thermo protection area (Refer to <a href="#">RF-20</a> , "RETRACTABLE HARD TOP SYSTEM : System Description")	RF
B175C	PWR SOURCE(ROOF)	Inhibit retractable hard top operation.	Power source is 11.4 (V) or more for 0.5 second	
B175D	PWR SOURCE(ROOF)	Inhibit retractable hard top operation.	Power source is 14.5 (V) or more for 4 seconds	
B175E	PWR SOURCE(WINDOW)	Inhibit retractable hard top operation and rear power window operation.	Power source (power window) is 9.5 (V) or less	L
B175F	PWR SOURCE(WINDOW)	Inhibit retractable hard top operation and rear power window operation.	Power source (power window) is 15.5 (V) or more	M
B1760	ROOF CONTROL UNIT	Inhibit rear window defogger operation.	Detects normal value	N
B1761	ROOF CONTROL UNIT	Inhibit retractable hard top operation.	Detects normal value	O
B1762	ROOF STATE	Inhibit retractable hard top operation.	Detects normal value	P
B1763	HYDRAULIC STATE	Inhibit retractable hard top operation.	Detects normal value	
B1764	ROOF LATCH STATE	Inhibit retractable hard top operation.	Detects normal value	
B1765	FLIPPER DOOR STATE	Inhibit retractable hard top operation.	Detects normal value	

## DTC Inspection Priority Chart

INFOID:000000006468658

If some DTCs are displayed at the same time, perform inspections one by one based on the following priority chart.

Priority	Display contents of CONSULT-III	
1	U1000	CAN COMM CIRCUIT
	U1010	CONTROL UNIT (CAN)

# RETRACTABLE HARD TOP CONTROL UNIT

< ECU DIAGNOSIS INFORMATION >

Priority	Display contents of CONSULT-III	
2	B175C	PWR SOURCE(ROOF)
	B175D	PWR SOURCE(ROOF)
	B175E	PWR SOURCE(WINDOW)
	B175F	PWR SOURCE(WINDOW)
3	B1701	ROOF CONTROL UNIT
	B1702	ROOF CONTROL UNIT
	B171E	ROOF CONTROL UNIT
	B171F	ROOF CONTROL UNIT
	B1720	ROOF CONTROL UNIT
	B1721	ROOF CONTROL UNIT
	B1722	ROOF CONTROL UNIT
	B1723	ROOF CONTROL UNIT
	B1724	ROOF CONTROL UNIT
	B1725	ROOF CONTROL UNIT
	B1726	ROOF CONTROL UNIT
	B1728	ROOF CONTROL UNIT
	B1729	ROOF CONTROL UNIT
	B172A	ROOF CONTROL UNIT
	B172E	ROOF CONTROL UNIT
	B1760	ROOF CONTROL UNIT
B1761	ROOF CONTROL UNIT	
4	B170F	SENSOR POWER SUPPLY
5	U0140	LOCAL COMM-1
	U0215	LOCAL COMM-1
	B1709	ROOF SWITCH(OPEN)
	B170A	ROOF SWITCH(CLOSE)
	B170B	ROOF SWITCH
	B1758	THERMO PROTECTION
	B171A	HYDRAULIC PMP(LH)
	B171B	HYDRAULIC PMP(RH)
	B171C	SWITCHING VALVE 1
	B171D	SWITCHING VALVE 2
	B172F	REAR PWR WINDOW(LH)
	B1730	REAR PWR WINDOW(RH)
	B1715	ROOF STATE SEN PWR
	B170C	TRUNK LINK SENSOR(LH)
	B170D	TRUNK LINK SENSOR(RH)
	B1710	LATCH STATUS SENSOR
	B1711	LATCH LOCK SENSOR
	B1712	TRUNK STATUS SENSOR
	B1716	PS STATUS SEN(ROTA)
B1718	PS STATUS SEN(DRAW)	
B1719	ROOF STATUS SEN	
6	B172D	ROOF WARNING BUZZER

# RETRACTABLE HARD TOP CONTROL UNIT

< ECU DIAGNOSIS INFORMATION >

Priority	Display contents of CONSULT-III		
	B1731	HYDRAULIC STATE 1	A
	B1732	HYDRAULIC STATE 2	
	B1733	HYDRAULIC STATE 3	B
	B1734	HYDRAULIC STATE 4	
	B1735	HYDRAULIC STATE 5	
	B1736	HYDRAULIC STATE 6	C
	B1737	HYDRAULIC STATE 7	
	B1738	HYDRAULIC STATE 8	D
	B1739	HYDRAULIC STATE 9	
	B173A	HYDRAULIC STATE 10	
	B173B	HYDRAULIC STATE 11	E
	B173C	HYDRAULIC STATE 12	
	B173D	HYDRAULIC STATE 13	
	B173E	HYDRAULIC STATE 14	F
	B173F	HYDRAULIC STATE 15	
	B1740	HYDRAULIC STATE 16	G
	B1741	HYDRAULIC STATE 17	
	B1742	HYDRAULIC STATE 18	
	B1743	HYDRAULIC STATE 19	H
	B1744	HYDRAULIC STATE 20	
	B1745	HYDRAULIC STATE 21	I
	B1746	HYDRAULIC STATE 22	
	B1747	P SHELF (DRAW) STATE 1	J
	B1748	P SHELF (DRAW) STATE 2	
	B1749	P SHELF (DRAW) STATE 3	
	B174A	P SHELF (DRAW) STATE 4	RF
	B174B	P SHELF (DRAW) STATE 5	
	B174C	P SHELF (DRAW) STATE 6	
	B174D	P SHELF (ROT) STATE 1	L
	B174E	P SHELF (ROT) STATE 2	
	B174F	P SHELF (ROT) STATE 3	
	B1750	P SHELF (ROT) STATE 4	M
	B1751	ROOF LATCH STATE 1	
	B1752	ROOF LATCH STATE 2	
	B1753	ROOF LATCH STATE 3	N
	B1754	FLIPPER DOOR STATE 1	
	B1755	FLIPPER DOOR STATE 2	
	B1756	FLIPPER DOOR STATE 3	O
	B1757	FLIPPER DOOR STATE 4	
	B1757	FLIPPER DOOR STATE 4	P
	B1707	ROOF OPEN STATE	
	B1708	ROOF CLOSE STATE	
	B1764	ROOF LATCH STATE	
	B1765	FLIPPER DOOR STATE	
	B1762	ROOF STATE	

# RETRACTABLE HARD TOP CONTROL UNIT

## < ECU DIAGNOSIS INFORMATION >

Priority	Display contents of CONSULT-III	
11	B1763	HYDRAULIC STATE
12	B172B	ROOF STATE SIG(AUDIO)

### DTC Index

INFOID:000000006468659

**NOTE:**

For details of Freeze Frame Data, refer to [RF-45, "CONSULT-III Function"](#).

Display contents of CONSULT-III		Fail-safe	Freeze Frame Data	Reference page
No DTC is detected. Further testing may be required.		—	—	—
U1000	CAN COMM CIRCUIT	×	×	<a href="#">RF-92</a>
U1010	CONTROL UNIT (CAN)	×	×	<a href="#">RF-93</a>
U0140	LOCAL COMM-1	×	×	<a href="#">RF-94</a>
U0215	LOCAL COMM-2	×	×	<a href="#">RF-95</a>
B1701	ROOF CONTROL UNIT	×	×	<a href="#">RF-97</a>
B1702	ROOF CONTROL UNIT	×	×	<a href="#">RF-98</a>
B1707	ROOF OPEN STATE	—	×	<a href="#">RF-99</a>
B1708	ROOF CLOSE STATE	—	×	<a href="#">RF-101</a>
B1709	ROOF SWITCH(OPEN)	×	×	<a href="#">RF-103</a>
B170A	ROOF SWITCH(CLOSE)	×	×	<a href="#">RF-105</a>
B170B	ROOF SWITCH	×	×	<a href="#">RF-107</a>
B170C	TRUNK LINK SENSOR(LH)	×	×	<a href="#">RF-109</a>
B170D	TRUNK LINK SENSOR(RH)	×	×	<a href="#">RF-111</a>
B170F	SENSOR POWER SUPPLY	×	×	<a href="#">RF-113</a>
B1710	LATCH STATUS SENSOR	×	×	<a href="#">RF-116</a>
B1711	LATCH LOCK SENSOR	×	×	<a href="#">RF-118</a>
B1712	TRUNK STATUS SENSOR	×	×	<a href="#">RF-120</a>
B1715	ROOF STATUS SEN PWR	×	×	<a href="#">RF-122</a>
B1716	PS STATUS SEN(DRAW)	×	×	<a href="#">RF-124</a>
B1718	PS STATUS SEN(ROTA)	×	×	<a href="#">RF-126</a>
B1719	ROOF STATUS SEN	×	×	<a href="#">RF-128</a>
B171A	HYDRAULIC PMP(LH)	×	×	<a href="#">RF-130</a>
B171B	HYDRAULIC PMP(RH)	×	×	<a href="#">RF-132</a>
B171C	SWITCHING VALVE 1	×	×	<a href="#">RF-134</a>
B171D	SWITCHING VALVE 2	×	×	<a href="#">RF-136</a>
B171E	ROOF CONTROL UNIT	×	×	<a href="#">RF-138</a>
B171F	ROOF CONTROL UNIT	×	×	<a href="#">RF-139</a>
B1720	ROOF CONTROL UNIT	×	×	<a href="#">RF-140</a>
B1721	ROOF CONTROL UNIT	×	×	<a href="#">RF-141</a>
B1722	ROOF CONTROL UNIT	×	×	<a href="#">RF-142</a>
B1723	ROOF CONTROL UNIT	×	×	<a href="#">RF-143</a>
B1724	ROOF CONTROL UNIT	×	×	<a href="#">RF-144</a>
B1725	ROOF CONTROL UNIT	×	×	<a href="#">RF-145</a>
B1726	ROOF CONTROL UNIT	×	×	<a href="#">RF-146</a>
B1728	ROOF CONTROL UNIT	×	×	<a href="#">RF-147</a>



# RETRACTABLE HARD TOP CONTROL UNIT

< ECU DIAGNOSIS INFORMATION >

Display contents of CONSULT-III		Fail-safe	Freeze Frame Data	Reference page
B1729	ROOF CONTROL UNIT	×	×	<a href="#">RF-148</a>
B172A	ROOF CONTROL UNIT	×	×	<a href="#">RF-149</a>
B172B	ROOF STATE SIG(AUDIO)	×	×	<a href="#">RF-150</a>
B172D	ROOF WARNING BUZZER	×	×	<a href="#">RF-152</a>
B172E	ROOF CONTROL UNIT	×	×	<a href="#">RF-154</a>
B172F	REAR PWR WINDOW(LH)	×	×	<a href="#">RF-155</a>
B1730	REAR PWR WINDOW(RH)	×	×	<a href="#">RF-157</a>
B1731	HYDRAULIC STATE 1	×	×	<a href="#">RF-159</a>
B1732	HYDRAULIC STATE 2	×	×	<a href="#">RF-161</a>
B1733	HYDRAULIC STATE 3	×	×	<a href="#">RF-163</a>
B1734	HYDRAULIC STATE 4	×	×	<a href="#">RF-165</a>
B1735	HYDRAULIC STATE 5	×	×	<a href="#">RF-167</a>
B1736	HYDRAULIC STATE 6	×	×	<a href="#">RF-169</a>
B1737	HYDRAULIC STATE 7	×	×	<a href="#">RF-170</a>
B1738	HYDRAULIC STATE 8	×	×	<a href="#">RF-171</a>
B1739	HYDRAULIC STATE 9	×	×	<a href="#">RF-172</a>
B173A	HYDRAULIC STATE 10	×	×	<a href="#">RF-173</a>
B173B	HYDRAULIC STATE 11	×	×	<a href="#">RF-174</a>
B173C	HYDRAULIC STATE 12	×	×	<a href="#">RF-175</a>
B173D	HYDRAULIC STATE 13	×	×	<a href="#">RF-176</a>
B173E	HYDRAULIC STATE 14	×	×	<a href="#">RF-177</a>
B173F	HYDRAULIC STATE 15	×	×	<a href="#">RF-178</a>
B1740	HYDRAULIC STATE 16	×	×	<a href="#">RF-179</a>
B1741	HYDRAULIC STATE 17	×	×	<a href="#">RF-182</a>
B1742	HYDRAULIC STATE 18	×	×	<a href="#">RF-183</a>
B1743	HYDRAULIC STATE 19	×	×	<a href="#">RF-185</a>
B1744	HYDRAULIC STATE 20	×	×	<a href="#">RF-187</a>
B1745	HYDRAULIC STATE 21	×	×	<a href="#">RF-189</a>
B1746	HYDRAULIC STATE 22	×	×	<a href="#">RF-191</a>
B1747	P SHELF (DRAW) STATE 1	×	×	<a href="#">RF-193</a>
B1748	P SHELF (DRAW) STATE 2	×	×	<a href="#">RF-194</a>
B1749	P SHELF (DRAW) STATE 3	×	×	<a href="#">RF-195</a>
B174A	P SHELF (DRAW) STATE 4	×	×	<a href="#">RF-196</a>
B174B	P SHELF (DRAW) STATE 5	×	×	<a href="#">RF-197</a>
B174C	P SHELF (DRAW) STATE 6	×	×	<a href="#">RF-198</a>
B174D	P SHELF (ROT) STATE 1	×	×	<a href="#">RF-199</a>
B174E	P SHELF (ROT) STATE 2	×	×	<a href="#">RF-200</a>
B174F	P SHELF (ROT) STATE 3	×	×	<a href="#">RF-201</a>
B1750	P SHELF (ROT) STATE 4	×	×	<a href="#">RF-202</a>
B1751	ROOF LATCH STATE 1	×	×	<a href="#">RF-203</a>
B1752	ROOF LATCH STATE 2	×	×	<a href="#">RF-204</a>
B1753	ROOF LATCH STATE 3	×	×	<a href="#">RF-205</a>
B1754	FLIPPER DOOR STATE 1	×	×	<a href="#">RF-206</a>
B1755	FLIPPER DOOR STATE 2	×	×	<a href="#">RF-207</a>

A  
B  
C  
D  
E  
F  
G  
H  
I  
J  
L  
M  
N  
O  
P

RF

# RETRACTABLE HARD TOP CONTROL UNIT

## < ECU DIAGNOSIS INFORMATION >

Display contents of CONSULT-III		Fail-safe	Freeze Frame Data	Reference page
B1756	FLIPPER DOOR STATE 3	×	×	<a href="#">RF-208</a>
B1757	FLIPPER DOOR STATE 4	×	×	<a href="#">RF-209</a>
B1758	THERMO PROTECTION	×	×	<a href="#">RF-210</a>
B175C	PWR SOURCE(ROOF)	×	×	<a href="#">RF-211</a>
B175D	PWR SOURCE(ROOF)	×	×	<a href="#">RF-212</a>
B175E	PWR SOURCE(WINDOW)	×	×	<a href="#">RF-213</a>
B175F	PWR SOURCE(WINDOW)	×	×	<a href="#">RF-215</a>
B1760	ROOF CONTROL UNIT	×	×	<a href="#">RF-217</a>
B1761	ROOF CONTROL UNIT	×	×	<a href="#">RF-218</a>
B1762	ROOF STATE	×	×	<a href="#">RF-219</a>
B1763	HYDRAULIC STATE	×	×	<a href="#">RF-222</a>
B1764	ROOF LATCH STATE	×	×	<a href="#">RF-224</a>
B1765	FLIPPER DOOR STATE	×	×	<a href="#">RF-225</a>

# RETRACTABLE HARD TOP SYSTEM

< WIRING DIAGRAM >

## WIRING DIAGRAM

### RETRACTABLE HARD TOP SYSTEM

#### Wiring Diagram

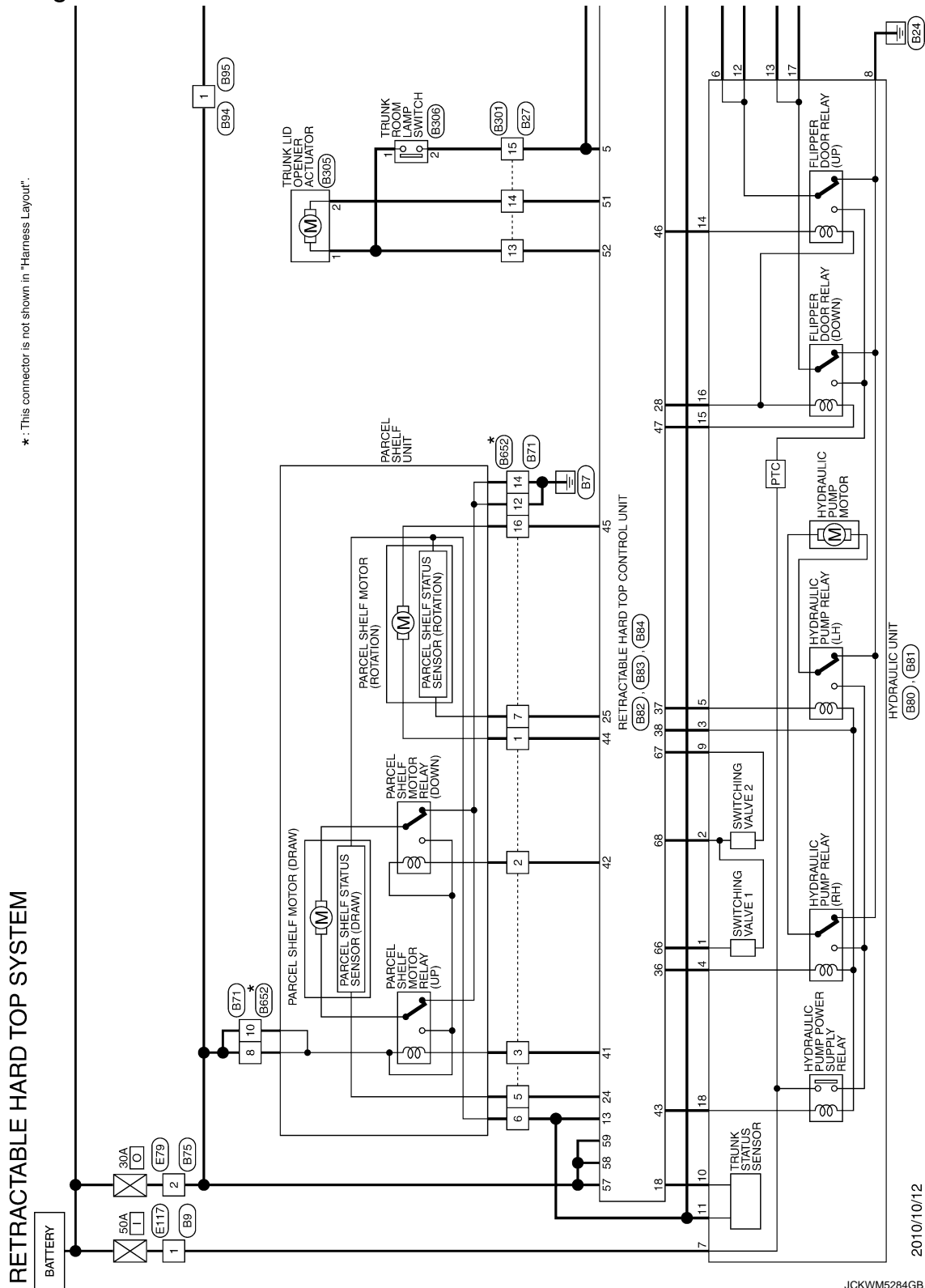

A  
B  
C  
D  
E  
F  
G  
H  
I  
J  
K  
L  
M  
N  
O  
P

RF

# RETRACTABLE HARD TOP SYSTEM

< WIRING DIAGRAM >

\*: This connector is not shown in "Harness Layout".

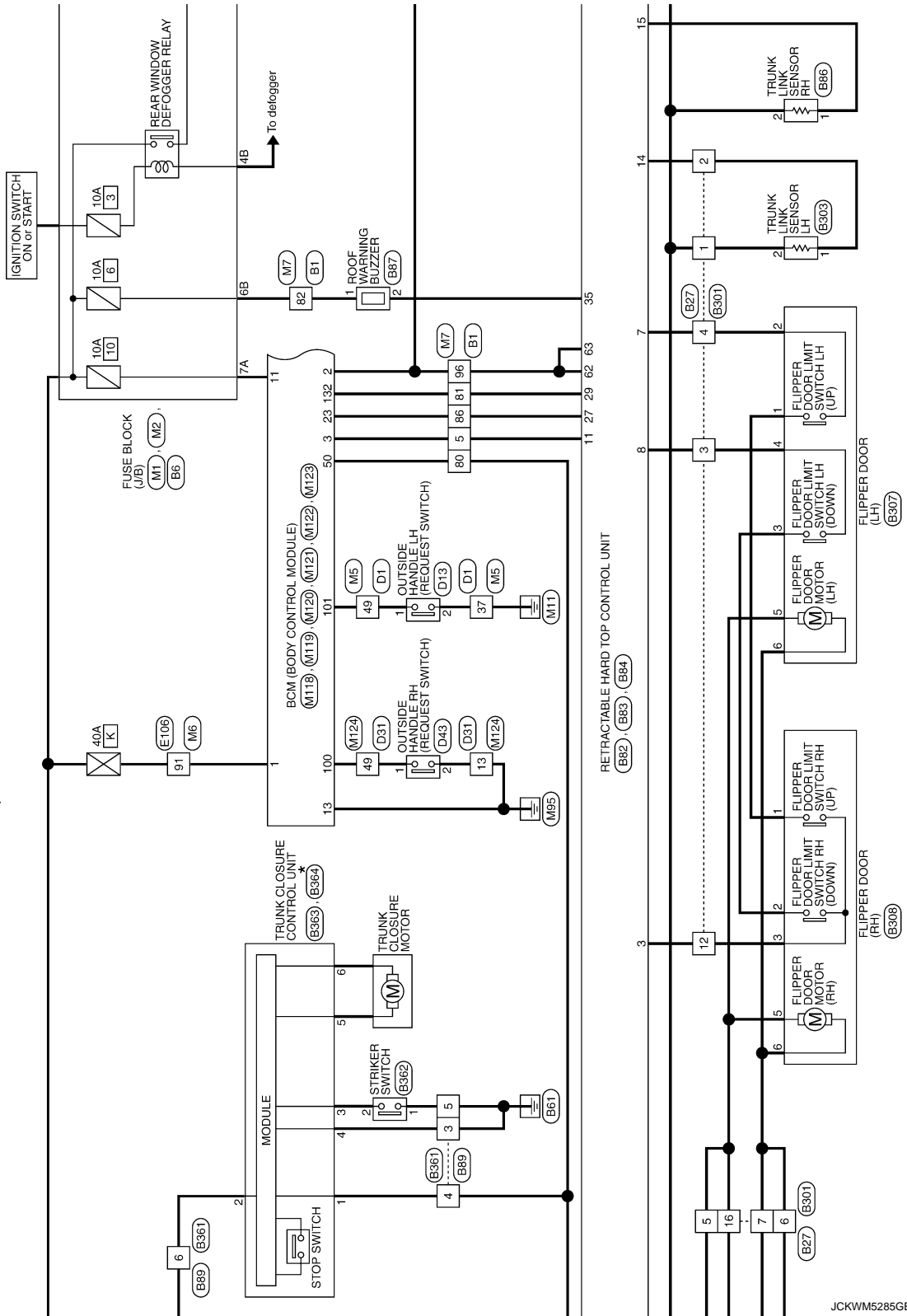

JCKWM5285GB



# RETRACTABLE HARD TOP SYSTEM

< WIRING DIAGRAM >

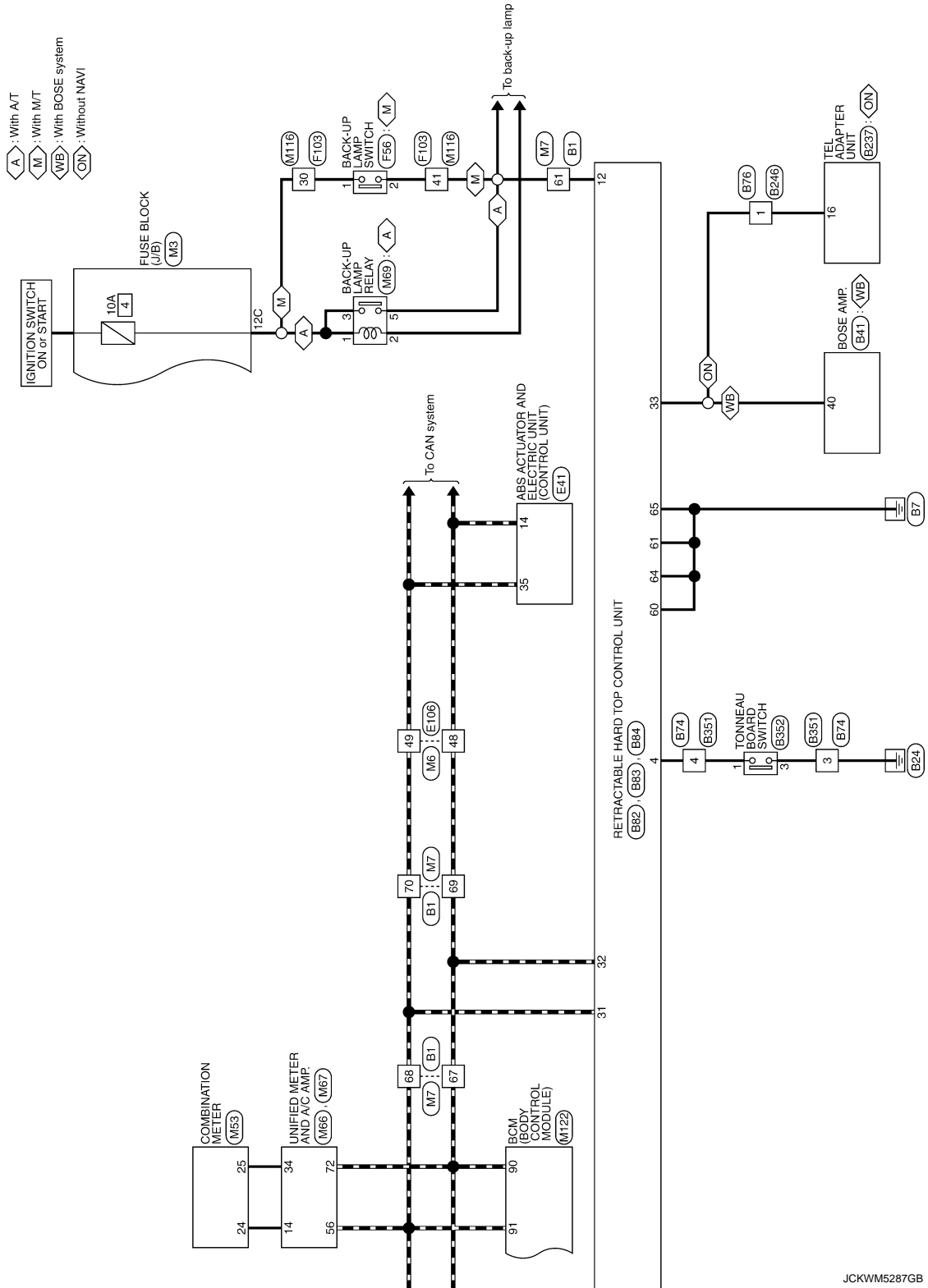

JCKWM5287GB

# RETRACTABLE HARD TOP SYSTEM

< WIRING DIAGRAM >

## RETRACTABLE HARD TOP SYSTEM

Connector No.	B1
Connector Name	WIRE TO WIRE
Connector Type	TH80FW-CS16-TM4

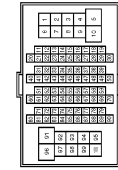

Terminal No.	Color of Wire	Signal Name [Specification]
1	W	
2	L	
3	R	
4	V	
5	W	
6	B	
7	G	
8	BR	
9	LG	
10	BR	
11	SHIELD	
12	SHIELD	
13	Y	
14	L	
15	R	
16	W	
17	BR	
20	G	
21	SB	
22	GR	
23	W	
24	SB	
25	BR	
26	LG	
27	Y	
28	R	
29	V	
31	SHIELD	
32	G	
33	R	
34	BG	
35	GR	
36	BR	
37	P	- [With climate controlled seat]
37	Y	- [Without climate controlled seat]
38	V	- [With climate controlled seat]
38	GR	- [Without climate controlled seat]
40	SHIELD	
41	L	
42	P	
43	SHIELD	

44	SB	-
45	V	-
46	W	-
47	SB	-
48	LG	-
49	LG	- [With BOSE system]
49	Y	- [Without BOSE system]
50	SB	- [With BOSE system]
50	LG	- [Without BOSE system]
51	SB	-
52	G	-
53	LG	-
54	BR	-
55	Y	-
56	W	-
57	V	-
58	R	-
60	R	-
61	BG	-
62	B	-
63	L	-
64	P	-
65	B	-
66	SB	-
67	P	-
68	L	-
69	P	-
70	L	-
80	G	-
81	V	-
82	R	-
83	BR	-
84	G	-
85	L	-
86	Y	-
87	GR	-
88	R	-
89	BG	-
94	P	-
95	GR	-
96	GR	-
97	SB	-
99	Y	-
100	Y/B	-

Connector No.	B6
Connector Name	FUSE BLOCK (U/B)
Connector Type	MS12FBR-CS



Terminal No.	Color of Wire	Signal Name [Specification]
5G	LG	
6G	P	
10G	G	
11G	G	
12G	Y	

Connector No.	B9
Connector Name	WIRE TO WIRE
Connector Type	MO8FW-LC



Terminal No.	Color of Wire	Signal Name [Specification]
1	Y	
3	GR	
4	LG	
5	BR	
6	BG	

Connector No.	B27
Connector Name	WIRE TO WIRE
Connector Type	MS16MP-CS



Terminal No.	Color of Wire	Signal Name [Specification]
1	BG	
2	P	
3	G	
4	W	
5	R	
6	P	
7	GR	
10	LG	
11	B	
12	B	
13	V	
14	SS	
15	L	
16	V	

JCKWM5288GB

A  
B  
C  
D  
E  
F  
G  
H  
I  
J  
RF  
L  
M  
N  
O  
P

# RETRACTABLE HARD TOP SYSTEM

< WIRING DIAGRAM >

## RETRACTABLE HARD TOP SYSTEM

Connector No.	B41
Connector Name	BOSE AMP.
Connector Type	TH407V-NH

Terminal No.	1	2	3	4	5	6	7	8	9	10	11	12	13	14	15	16	17	18	19	20
Color of Wire																				
Signal Name [Specification]																				

Terminal No.	9	10	11	12	14	15	16	18	28	30	31	32	33	34	35	40
Color of Wire	L	G	G	SB	LG	LG	W	P	P	R	Y	V	SHIELD	SB	SB	V
Signal Name [Specification]	SOUND SIGNAL LH (-)	SOUND SIGNAL RH (-)	MICROPHONE SIGNAL (-)	VOICE GUIDANCE SIGNAL (-)	AV COMM (L)	AV COMM (L)	ACC	SOUND SIGNAL LH (+)	SOUND SIGNAL RH (+)	MICROPHONE SIGNAL (+)	VOICE GUIDANCE SIGNAL (+)	SHIELD	AV COMM (H)	AV COMM (H)	ROOF STATUS SIGNAL (AUDIO)	

Connector No.	B71
Connector Name	WIRE TO WIRE
Connector Type	NS10FBR-CS

Terminal No.	1	2	3	4	5	6	7	8	9	10	11	12	13	14	15	16
Color of Wire																
Signal Name [Specification]																

Terminal No.	1	2	3	5	6	7	8
Color of Wire	R	W	SB	GR	EG	R	Y
Signal Name [Specification]							

Terminal No.	10	12	14	16
Color of Wire	LG	P	W	BR
Signal Name [Specification]				

Connector No.	B72
Connector Name	WIRE TO WIRE
Connector Type	NS02MW-CS

Terminal No.	1	2
Color of Wire		
Signal Name [Specification]		

Terminal No.	1	2
Color of Wire	EG	LG
Signal Name [Specification]		

Connector No.	B73
Connector Name	WIRE TO WIRE
Connector Type	NS10FCY-CS

Terminal No.	1	2	3	4	5	6	7	8	9	10	11	12	13	14	15	16
Color of Wire																
Signal Name [Specification]																

Terminal No.	1	2	3	4	5	6	7	8	9	10	11	12	13	14	15	16
Color of Wire	V	G	EG	Y	R	P	B	B	B	B	BR	W	W	GR		
Signal Name [Specification]																

Connector No.	B74
Connector Name	WIRE TO WIRE
Connector Type	TH407V-NH

Terminal No.	1	2	3	4
Color of Wire				
Signal Name [Specification]				

Terminal No.	3	4
Color of Wire	B	L
Signal Name [Specification]		

Connector No.	B75
Connector Name	WIRE TO WIRE
Connector Type	MG2MP-LC

Terminal No.	1	2
Color of Wire		
Signal Name [Specification]		

Terminal No.	1	2
Color of Wire	L	Y
Signal Name [Specification]		

Connector No.	B76
Connector Name	WIRE TO WIRE
Connector Type	TH10MW-NH

Terminal No.	1	2	3	4	5	6	7	8	9	10	11	12	13	14	15	16
Color of Wire																
Signal Name [Specification]																

Terminal No.	1	4
Color of Wire	V	LG
Signal Name [Specification]		

Terminal No.	5	6	7	8	10	11	12	13	14	15	16
Color of Wire	SB	SHIELD	B	W	SHIELD	B	W	R	SHIELD	G	Y
Signal Name [Specification]											

Connector No.	B80
Connector Name	HYDRAULIC UNIT
Connector Type	NS10FW-CS



Terminal No.	17	18	15	14	13	6	11	10	9	12
Color of Wire										
Signal Name [Specification]										

Terminal No.	1	2	3	4	5	6	9	10	11	12	13	14	15	16	17	18
Color of Wire	P	L	BR	Y	W	R	SB	LG	LG	BG	V	GR	L	BG	P	BR
Signal Name [Specification]																



# RETRACTABLE HARD TOP SYSTEM

< WIRING DIAGRAM >

## RETRACTABLE HARD TOP SYSTEM

Connector No.	B81
Connector Name	HYDRAULIC UNIT
Connector Type	LOPE-MC



Terminal No.	Color of Wire	Signal Name [Specification]
7	Y	-
8	B	-

Connector No.	B82
Connector Name	RETRACTABLE HARD TOP CONTROL UNIT
Connector Type	TH0FV-NH



Terminal No.	Color of Wire	Signal Name [Specification]
1	G	ROOF OPEN / CLOSE SWITCH (OPEN)
2	BR	ROOF OPEN / CLOSE SWITCH (CLOSE)
3	B	FLIPPER DOOR LIMIT SWITCH (GRD)
4	L	TORNEAU BOARD SWITCH
5	SB	TRUNK ROOM LAMP SWITCH
6	L	ROOF LATCH LIMIT SWITCH
7	W	FLIPPER DOOR LIMIT SWITCH (UP)
8	G	FLIPPER DOOR LIMIT SWITCH (DOWN)
11	W	RETAINED ACC POWER
12	Y	REVERSE SIGNAL
13	BG	PARCEL SHELF STATUS SENSOR POWER SUPPLY
14	P	TRUNK LINK SENSOR SIGNAL (LH)
15	SB	TRUNK LINK SENSOR SIGNAL (RH)
16	GR	ROOF LATCH STATUS SENSOR SIGNAL
17	G	ROOF LATCH LOCK SENSOR SIGNAL
18	LG	TRUNK STATUS SENSOR SIGNAL
22	V	ROOF STATUS SENSOR POWER SUPPLY
23	B	ROOF STATUS SENSOR GND
24	GR	PARCEL SHELF STATUS SENSOR SIGNAL (DRAW)
25	R	PARCEL SHELF STATUS SENSOR SIGNAL (ROTATION)

26	P	ROOF STATUS SENSOR SIGNAL
27	Y	TRUNK LID OPEN REQUEST SIGNAL
28	BG	FLIPPER DOOR RELAY GND
29	GR	LOCAL COMMUNICATION (EGM)
30	GR	LOCAL COMMUNICATION (POWER WINDOW)
31	L	CAN-H
32	P	CAN-L
33	V	ROOF STATUS SIGNAL (AUDIO)
35	B	ROOF WARNING BUZZER
36	Y	HYDRAULIC MOTOR RELAY GND (RH)
37	W	HYDRAULIC MOTOR RELAY GND (LH)
38	BR	HYDRAULIC MOTOR RELAY POWER SUPPLY

Connector No.	B83
Connector Name	RETRACTABLE HARD TOP CONTROL UNIT
Connector Type	NSI0FBR-CS



Terminal No.	Color of Wire	Signal Name [Specification]
41	SB	PARCEL SHELF MOTOR RELAY GND (UP)
42	W	PARCEL SHELF MOTOR RELAY GND (DOWN)
43	BR	HYDRAULIC PUMP POWER SUPPLY RELAY
44	R	MOTOR PARCEL SHELF (HORIZONTAL)
45	BR	MOTOR PARCEL SHELF (VERTICAL)
46	G	FLIPPER DOOR RELAY POWER SUPPLY (UP)
47	L	FLIPPER DOOR RELAY POWER SUPPLY (DOWN)
48	R	ROOF LATCH MOTOR (OPEN)
48	Y	ROOF LATCH MOTOR (CLOSE)
51	SB	TRUNK OPENER ACTUATOR
52	V	TRUNK OPENER ACTUATOR GND
53	BG	REAR POWER WINDOW MOTOR LH (UP)
54	LG	REAR POWER WINDOW MOTOR LH (DOWN)
55	GR	REAR POWER WINDOW MOTOR RH (UP)
56	P	REAR POWER WINDOW MOTOR RH (DOWN)

Connector No.	B84
Connector Name	RETRACTABLE HARD TOP CONTROL UNIT
Connector Type	NSI0FVH-CS



Terminal No.	Color of Wire	Signal Name [Specification]
57	Y	BAT
58	Y	BAT
59	Y	BAT
60	B	GND
61	B	GND
62	GR	BAT (POWER WINDOW)
63	Y	BAT (POWER WINDOW)
64	B	GND (POWER WINDOW)
65	B	GND (POWER WINDOW)
66	P	SWITCHING VALVE 1
67	SB	SWITCHING VALVE 2
68	L	SWITCHING VALVE GND
69	G	REAR WINDOW DEF IN 2
70	P	REAR WINDOW DEF IN 1
71	BR	REAR WINDOW DEF OUT 1
72	W	REAR WINDOW DEF OUT 2

Connector No.	B86
Connector Name	TRUNK LINK SENSOR RH
Connector Type	TH04FV-NH



Terminal No.	Color of Wire	Signal Name [Specification]
1	SB	-
2	BG	-

Connector No.	B87
Connector Name	ROOF WARNING BUZZER
Connector Type	RK02FER



Terminal No.	Color of Wire	Signal Name [Specification]
1	R	-
2	B	-

Connector No.	B89
Connector Name	WIRE TO WIRE
Connector Type	NSI0BMW-CS



Terminal No.	Color of Wire	Signal Name [Specification]
3	B	-
4	SB	-
5	B	-
6	Y	-

JCKWM5290GB

A B C D E F G H I J L M N O P RF

# RETRACTABLE HARD TOP SYSTEM

< WIRING DIAGRAM >

## RETRACTABLE HARD TOP SYSTEM

Connector No.	B894
Connector Name	WIRE TO WIRE
Connector Type	MD1MW-LC



Terminal No.	Color of Wire	Signal Name [Specification]
1	Y	-

Connector No.	B895
Connector Name	WIRE TO WIRE
Connector Type	MD1FW-LC



Terminal No.	Color of Wire	Signal Name [Specification]
1	Y	-

Connector No.	B201
Connector Name	WIRE TO WIRE
Connector Type	TH80PW-CS16-TM4

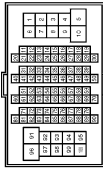

Terminal No.	Color of Wire	Signal Name [Specification]
1	W	-
3	B	-
5	W	-
6	R	-

7	B	- [With climate controlled seat]
7	G	- [Without climate controlled seat]
8	BG	-
9	GR	-
10	LG	-
40	GR	-
41	LG	-
42	BG	-
43	R	-
44	SHIELD	-
45	G	-
47	G	-
48	Y	-
49	SHIELD	-
50	P	-
51	SB	-
52	LG	-
53	L	-
54	G	-
55	GR	-
56	LG	-
57	G	-
58	R	-
67	L	-
68	P	-
80	G	-
81	R	-
82	W	-
83	B	-
84	SHIELD	-
85	O	-
86	BR	-
87	Y	-
88	SHIELD	-
89	SB	-
90	V	-
91	GR	-
92	P	- [With BOSE system]
92	Y	- [Without BOSE system]
93	L	-
94	SB	-
95	V	-
96	P	-
97	L	- [With BOSE system]
97	LG	- [Without BOSE system]
98	Y/B	-
99	Y	-

Connector No.	B237
Connector Name	TEL ADAPTER UNIT
Connector Type	TH2FW-NH



Terminal No.	Color of Wire	Signal Name [Specification]
1	GR	BATTERY
2	LG	ACC
3	BG	IGNITION
4	B	IGNITION
5	SHIELD	IGNITION
6	L	ACC
7	B	IGNITION
8	Y	MICROPHONE SIGNAL
9	SHIELD	MICROPHONE SIGNAL
10	G	MICROPHONE GND
14	B	TEL VOICE SIGNAL (+)
14	G	TEL VOICE SIGNAL (-)
16	P	GND
21	B	ROOF STATUS SIGNAL (AUDIO)
23	B	CONTROL SIGNAL
27	B	CONTROL SIGNAL
28	P	VEHICLE SPEED (8-PULSE)
29	G	MICROPHONE VCC

Connector No.	B245
Connector Name	WIRE TO WIRE
Connector Type	NS02MW-CS



Terminal No.	Color of Wire	Signal Name [Specification]
1	GR	-
2	P	-

Connector No.	B246
Connector Name	WIRE TO WIRE
Connector Type	TH16FW-NH



Terminal No.	Color of Wire	Signal Name [Specification]
1	P	-
4	P	-
5	L	-
6	SHIELD	-
7	B	-
8	W	-
10	SHIELD	-
11	B	-
12	W	-
13	R	-
14	SHIELD	-
15	G	-
16	Y	-

JCKWM5291GB

# RETRACTABLE HARD TOP SYSTEM

< WIRING DIAGRAM >

## RETRACTABLE HARD TOP SYSTEM

Connector No.	B301
Connector Name	WIRE TO WIRE
Connector Type	NS16FW-CS

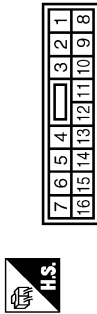

Terminal No.	Color of Wire	Signal Name [Specification]
1	R	-
2	GR	-
3	G	-
4	W	-
5	Y	-
6	P	-
7	LG	-
8	B	-
9	B	-
10	B	-
11	B	-
12	B	-
13	V	-
14	BR	-
15	L	-
16	Y	-

Connector No.	B303
Connector Name	TRUNK LINK SENSOR LH
Connector Type	THM6FW-RH



Terminal No.	Color of Wire	Signal Name [Specification]
1	GR	-
2	R	-

Connector No.	B305
Connector Name	TRUNK LID OPENER ACTUATOR
Connector Type	M02FB-LC



Terminal No.	Color of Wire	Signal Name [Specification]
1	V	V-
2	BR	V+

Connector No.	B306
Connector Name	TRUNK ROOM LAMP SWITCH
Connector Type	A02FW



Terminal No.	Color of Wire	Signal Name [Specification]
1	V	SIG-
2	L	SIG+

Connector No.	B307
Connector Name	FLIPPER DOOR (LH)
Connector Type	NS06FB-CS

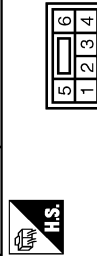

Terminal No.	Color of Wire	Signal Name [Specification]
1	V	SWITCH FD UP
2	W	SWITCH FD UP I

3	Y	SWITCH FD DOWN
4	G	SWITCH FD DOWN I
5	BR	MOTOR FD UP
6	L	MOTOR FD DOWN

Connector No.	B308
Connector Name	FLIPPER DOOR (RH)
Connector Type	NS06FW-CS

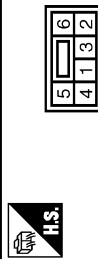

Terminal No.	Color of Wire	Signal Name [Specification]
1	V	SWITCH FD UP I
2	Y	SWITCH FD DOWN I
3	B	SWITCH FD GND COMBINED
5	BR	MOTOR FD UP
6	L	MOTOR FD DOWN

Connector No.	B351
Connector Name	WIRE TO WIRE
Connector Type	THM6FW-RH



Terminal No.	Color of Wire	Signal Name [Specification]
3	B	-
4	P	-
5	B	-
6	Y	-

Connector No.	B352
Connector Name	TONNEAU BOARD SWITCH
Connector Type	A03FW



Terminal No.	Color of Wire	Signal Name [Specification]
1	G	-
3	B	-

Connector No.	B361
Connector Name	WIRE TO WIRE
Connector Type	NS06FW-CS

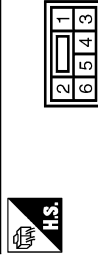

Terminal No.	Color of Wire	Signal Name [Specification]
3	B	-
4	P	-
5	B	-
6	Y	-

A  
B  
C  
D  
E  
F  
G  
H  
I  
J  
RF  
L  
M  
N  
O  
P

# RETRACTABLE HARD TOP SYSTEM

< WIRING DIAGRAM >

## RETRACTABLE HARD TOP SYSTEM

Connector No.	B362
Connector Name	STRIKER SWITCH
Connector Type	RV02FGY



Terminal No.	Color of Wire	Signal Name [Specification]
1	B	SIG-
2	GR	SIG+

Connector No.	B363
Connector Name	TRUNK CLOSURE CONTROL UNIT
Connector Type	NS04FW-CS



Terminal No.	Color of Wire	Signal Name [Specification]
1	P	TRUNK ROOM LAMP SW SIG
2	Y	POWER
3	GR	STRIKER SW SIG
4	B	GND

Connector No.	B364
Connector Name	TRUNK CLOSURE CONTROL UNIT
Connector Type	NS02FW-CS

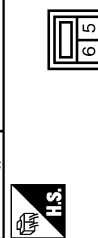

Terminal No.	Color of Wire	Signal Name [Specification]
1		
2		

5	B	CLOSURE MOTOR GND
6	BR	CLOSURE MOTOR POWER

Connector No.	B322
Connector Name	WIRE TO WIRE
Connector Type	NS12MBR-CS

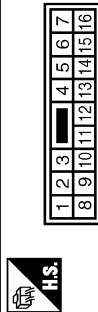

Terminal No.	Color of Wire	Signal Name [Specification]
1	--	--
2	--	--
3	--	--
5	--	--
6	--	--
7	--	--
8	--	--
10	--	--
12	--	--
14	--	--
16	--	--

Connector No.	B653
Connector Name	WIRE TO WIRE
Connector Type	NS02FW-CS



Terminal No.	Color of Wire	Signal Name [Specification]
1	--	--
2	--	--

Connector No.	B654
Connector Name	WIRE TO WIRE
Connector Type	NS16MGY-CS

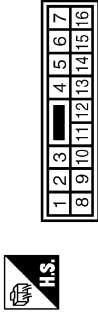

Terminal No.	Color of Wire	Signal Name [Specification]
1	--	--
2	--	--
3	--	--
4	--	--
5	--	--
6	--	--
7	--	--
12	--	--
13	--	--
14	--	--
15	--	--
16	--	--

Connector No.	B655
Connector Name	WIRE TO WIRE
Connector Type	NS02FW-CS



Terminal No.	Color of Wire	Signal Name [Specification]
1	--	--
2	--	--

Connector No.	B656
Connector Name	ROOF STATUS SENSOR
Connector Type	1-985700-1



Terminal No.	Color of Wire	Signal Name [Specification]
1	--	--
2	--	--
3	--	--

Connector No.	B657
Connector Name	ROOF LATCH ASSEMBLY
Connector Type	NS03FW-CS

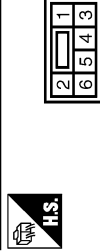

Terminal No.	Color of Wire	Signal Name [Specification]
1	--	--
2	--	--
4	--	--
5	--	--
6	--	--

JCKWM5293GB

# RETRACTABLE HARD TOP SYSTEM

< WIRING DIAGRAM >

## RETRACTABLE HARD TOP SYSTEM

Connector No.	D1
Connector Name	WIRE TO WIRE
Connector Type	TH40PW-CS15

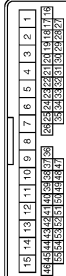
Terminal No.	Color of Wire	Signal Name [Specification]
4	BR	-
5	P	- [A/T models with automatic drive positioner]
6	SB	- [Except for A/T models with automatic drive positioner]
7	R	-
8	G	-
9	P	-
10	LG	-
11	W	-
12	L	-
13	B	-
14	V	-
15	Y	-
16	Y/B	-
17	Y	-
20	Y	-
21	R	-
22	P	-
23	O	-
24	Y	-
25	SB	-
26	GR	-
27	GR	-
28	LG	-
29	G	-
30	Y	-
31	W	-
32	BR	-
33	L	-
34	R	-
35	V	-
37	B	-
38	O	-
39	GR	-
40	G	-
41	Y	-
42	LG	-
43	BR	-

44	V	-
45	P	-
46	W	-
47	V	-
48	P	-
49	W	-
50	SB	-
51	R	-
52	L	-

Connector No.	D8
Connector Name	POWER WINDOW MAIN SWITCH
Connector Type	NS16FW-CS



Terminal No.	Color of Wire	Signal Name [Specification]
2	G	-
4	V	-
5	BR	-
6	W	-
8	L	-
9	W	-
10	SB	-
11	BR	-
13	R	-
14	V	-
15	BG	-

Connector No.	D9
Connector Name	POWER WINDOW MAIN SWITCH
Connector Type	NS03PW-CS



Terminal No.	Color of Wire	Signal Name [Specification]
17	B	-
19	Y	-

Connector No.	D10
Connector Name	DRIVER SIDE POWER WINDOW MOTOR
Connector Type	FHB06FY-Z



Terminal No.	Color of Wire	Signal Name [Specification]
1	G	-
2	R	-
3	BR	-
4	BG	-
5	W	-
6	L	-

Connector No.	D13
Connector Name	OUTSIDE HANDLE LH (REQUEST SWITCH)
Connector Type	RK02FL



Terminal No.	Color of Wire	Signal Name [Specification]
38	O	-
39	GR	-
40	G	-
41	Y	-
42	LG	-
43	BR	-
44	V	-
45	P	-
46	W	-
47	V	-
48	P	-
49	W	-
50	SB	-
51	R	-
52	L	-
53	O	-
54	GR	-
55	G	-

Terminal No.	Color of Wire	Signal Name [Specification]
1	W	-
2	B	-

Connector No.	D31
Connector Name	WIRE TO WIRE
Connector Type	TH40PW-CS15

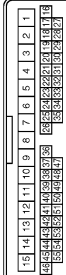
Terminal No.	Color of Wire	Signal Name [Specification]
6	BR	-
7	R	-
8	G	-
9	P	-
10	LG	-
11	W	-
12	L	-
13	B	-
14	Y	-
15	W	-
34	Y	-
35	Y/B	-
38	O	-
39	GR	-
40	G	-
41	Y	-
42	LG	-
43	BR	-
44	V	-
45	P	-
46	W	-
47	V	-
48	P	-
49	W	-
50	SB	-
51	R	-
52	L	-
53	O	-
54	GR	-
55	G	-

JCKWM5294GB

A  
B  
C  
D  
E  
F  
G  
H  
I  
J  
K  
L  
M  
N  
O  
P

RF

# RETRACTABLE HARD TOP SYSTEM

< WIRING DIAGRAM >

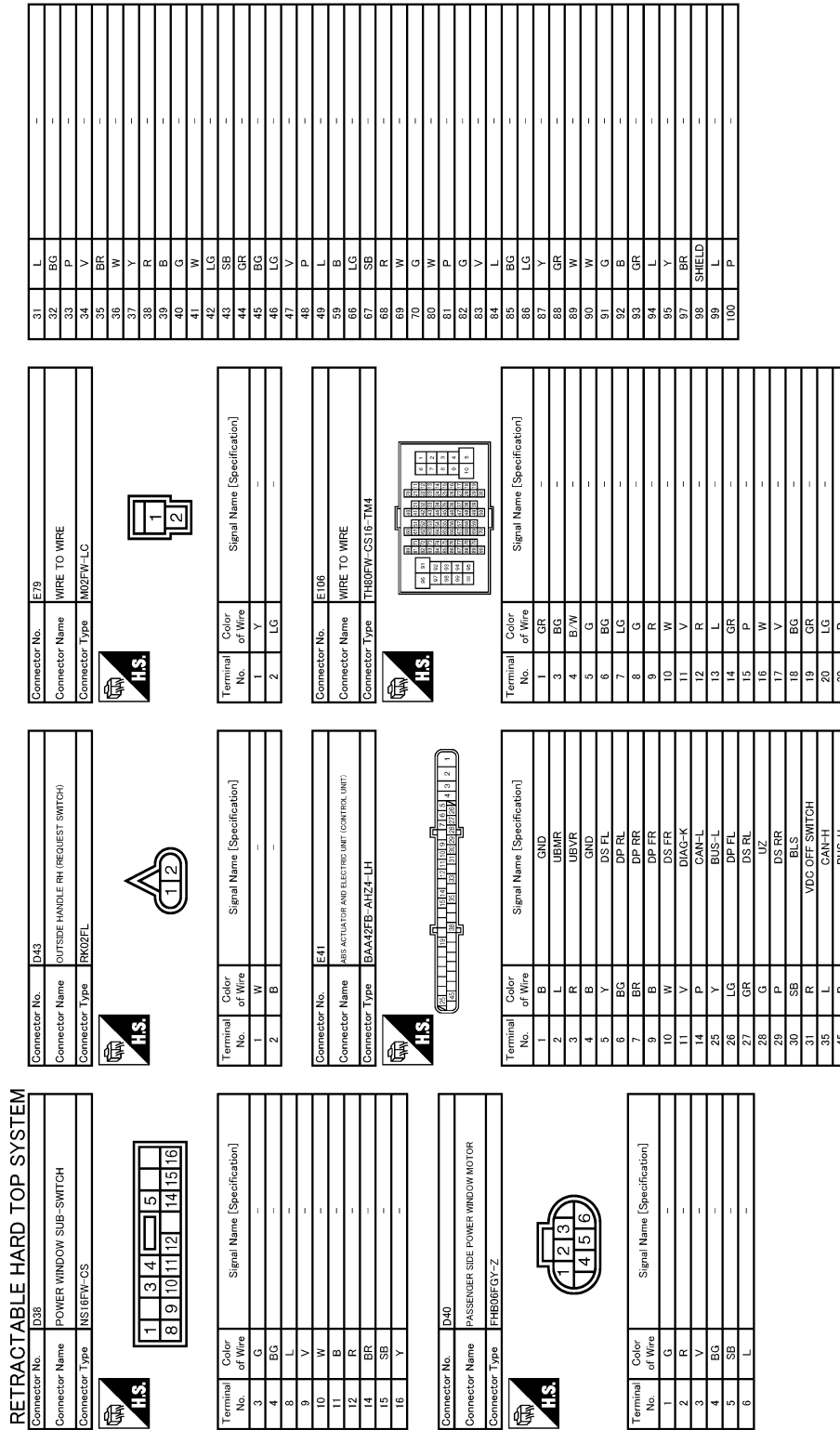

31	L	-
32	BG	-
33	P	-
34	V	-
35	BR	-
36	W	-
37	Y	-
38	R	-
39	B	-
40	G	-
41	W	-
42	LG	-
43	SB	-
44	GR	-
45	BG	-
46	LG	-
47	V	-
48	P	-
49	L	-
50	B	-
66	LG	-
67	SB	-
68	R	-
69	W	-
70	G	-
80	W	-
81	P	-
82	G	-
83	V	-
84	L	-
85	BG	-
86	LG	-
87	Y	-
88	GR	-
89	W	-
90	W	-
91	G	-
92	S	-
93	GR	-
94	L	-
95	Y	-
97	BR	-
98	SHIELD	-
99	L	-
100	P	-

JCKWM5295GB

# RETRACTABLE HARD TOP SYSTEM

< WIRING DIAGRAM >

## RETRACTABLE HARD TOP SYSTEM

Connector No.	E117
Connector Name	WIRE TO WIRE
Connector Type	M08MW-LC

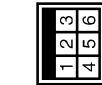

Terminal No.	Color of Wire	Signal Name [Specification]
1	Y	
3	GR	
4	P	
5	BR	
6	EG	

Connector No.	F56
Connector Name	BACK-UP LAMP SWITCH
Connector Type	RK02FB



Terminal No.	Color of Wire	Signal Name [Specification]
1	R	
2	O	

Connector No.	F103
Connector Name	WIRE TO WIRE
Connector Type	TK36FW-NS10



Terminal No.	Color of Wire	Signal Name [Specification]
2	G	
3	W	
4	R	
5	B	
9	Y	
10	GR	
19	O	
20	Y	
28	B	
29	LG	
30	R	
31	R	
41	O	
42	BR	
43	P	
44	L	
45	Y	
46	V	

Connector No.	M1
Connector Name	FUSE BLOCK (J/B)
Connector Type	NS06FW-M2



Terminal No.	Color of Wire	Signal Name [Specification]
1A	V	
2A	G	
3A	L	
4A	P	
5A	BR	
6A	Y	
7A	GR	
8A	L	

Connector No.	M2
Connector Name	FUSE BLOCK (J/B)
Connector Type	NS12FW-CS



Terminal No.	Color of Wire	Signal Name [Specification]
1B	R	
3B	P	
4B	G	
5B	BG	
6B	Y	
7B	P	
8B	R	
9B	SB	

Connector No.	M3
Connector Name	FUSE BLOCK (J/B)
Connector Type	NS12FW-CS

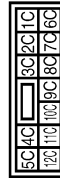

Terminal No.	Color of Wire	Signal Name [Specification]
8C	R	
7C	B	
8C	W	
9C	BG	
10C	L	
11C	LG	
12C	R	

JCKWM5296GB

A  
B  
C  
D  
E  
F  
G  
H  
I  
J  
RF  
L  
M  
N  
O  
P

# RETRACTABLE HARD TOP SYSTEM

< WIRING DIAGRAM >

## RETRACTABLE HARD TOP SYSTEM

Connector No.	M5
Connector Name	WIRE TO WIRE
Connector Type	TH80MW-CS15

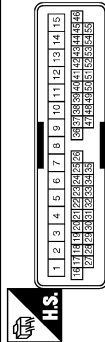

Terminal No.	Color of Wire	Signal Name [Specification]
4	R	-
5	B	-
6	BG	-
7	W	-
8	B	-
9	G	-
10	V	-
11	W	-
12	L	-
13	B	-
14	GR	-
15	Y	-
16	Y/B	-
17	Y	-
20	BG	-
21	W	-
22	P	-
23	BG	-
24	V	-
25	BR	-
26	R	-
27	P	-
28	LG	-
29	SB	-
30	G	-
31	V	-
32	BR	-
33	GR	-
34	G	-
35	L	-
37	B	-
38	G	- [With automatic drive positioner]
38	L	- [Without automatic drive positioner]
39	BR	- [With automatic drive positioner]
39	L	- [Without automatic drive positioner]
40	Y	-
41	BR	- [With automatic drive positioner]
41	G	- [Without automatic drive positioner]

42	R	-
43	G	-
44	Y	-
45	GR	-
46	BR	-
47	V	-
48	LG	-
49	P	-
50	SB	-
51	GR	-
52	L	-

Connector No.	M6
Connector Name	WIRE TO WIRE
Connector Type	TH80MW-CS16-TM4

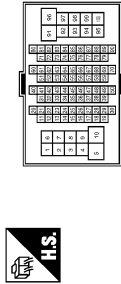

Terminal No.	Color of Wire	Signal Name [Specification]
1	BG	-
3	R	-
4	G	-
5	G	-
6	BR	-
7	BR	-
8	Y	-
9	R	-
10	W	-
11	GR	-
12	R	-
13	L	-
14	G	-
15	P	-
16	W	-
17	BR	-
18	V	-
19	BG	-
20	L	-
30	R	-
31	L	-
32	Y	-
33	GR	-
34	P	-
35	BR	-

36	BR	-
37	Y	-
38	LG	-
39	SB	-
40	G	-
41	W	-
42	LG	-
43	P	-
44	GR	- [With A/T]
44	R	- [With M/T]
45	BG	-
46	G	-
47	P	-
48	L	-
49	B	-
59	Y	-
66	Y	-
67	G	-
68	R	-
69	W	-
70	G	-
80	SB	-
81	R	-
82	V	-
83	W	-
84	L	-
85	BG	-
86	G	-
87	V	-
88	B	-
89	SB	-
90	G	-
91	W	-
92	B	-
93	G	-
94	L	-
95	BR	-
96	P	-
97	SHIELD	-
99	V	-
100	SB	-

JCKWM5297GB



# RETRACTABLE HARD TOP SYSTEM

< WIRING DIAGRAM >

## RETRACTABLE HARD TOP SYSTEM

Connector No.	M7
Connector Name	WIRE TO WIRE
Connector Type	TH80MW-CS(E)-TM4

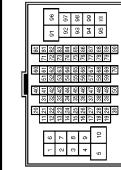

Terminal No.	Color of Wire	Signal Name [Specification]
1	BG	-
2	LG	-
3	G	-
4	Y	-
5	L	-
6	B	-
7	L	-
8	L	-
9	BR	-
10	BR	-
12	SHIELD	-
13	Y	-
14	BR	-
15	GR	-
16	LG	-
17	L	-
20	BR	-
21	G	-
22	R	-
23	SB	-
24	B	-
25	W	-
26	Y	-
27	V	-
28	P	-
29	V	-
31	SHIELD	-
32	G	-
33	R	-
34	BG	-
35	GR	-
36	BR	-
37	P	- [With climate controlled seat]
38	V	- [Without climate controlled seat]
39	GR	- [With climate controlled seat]
40	SHIELD	- [Without climate controlled seat]
41	L	-
42	P	-
43	SHIELD	-

44	Y	-
45	BR	-
46	SB	-
47	SB	-
48	LG	-
49	LG	- [With BOSE system]
49	SB	- [Without BOSE system]
50	SB	- [With BOSE system]
50	LG	- [Without BOSE system]
51	R	-
52	V	-
53	P	-
54	BR	-
55	Y	- [With A/T]
55	BG	- [With M/T]
56	L	-
57	V	-
58	R	-
60	LG	-
61	BG	-
62	B	-
63	V	-
64	SB	-
65	BR	-
66	Y	-
67	P	-
68	L	-
69	P	-
70	L	-
80	G	-
81	LG	-
82	Y	-
83	BR	-
84	V	-
85	L	-
86	Y	-
87	GR	-
91	R	-
93	G	-
94	P	-
95	GR	-
96	Y	-
97	SB	-
99	Y	-
100	Y/B	-

Connector No.	M28
Connector Name	ROOF OPEN / CLOSE SWITCH
Connector Type	TK88FW-1V

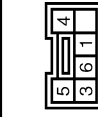

Terminal No.	Color of Wire	Signal Name [Specification]
1	B	-
3	V	-
4	BR	-
5	R	-
6	GR	-

Connector No.	M53
Connector Name	COMBINATION METER
Connector Type	SAB40FW



Terminal No.	Color of Wire	Signal Name [Specification]
1	V	BATTERY POWER SUPPLY
2	LG	COMMUNICATION SIGNAL (METER->AMP)
3	GR	COMMUNICATION SIGNAL (AMP->METER)
5	B	GROUND
6	W	ALTERNATOR SIGNAL
7	LG	AIR BAG SIGNAL
10	R	SECURITY SIGNAL
15	B	GROUND
16	B	METER CONTROL SWITCH GROUND
18	GR	ILL.GND
19	B	ILL.GND
20	R	ILL
21	R	IGNITION SIGNAL
22	B	GROUND
24	SB	COMMUNICATION SIGNAL (LCD->AMP)
25	B	COMMUNICATION SIGNAL (AMP->LCD)
26	R	VEHICLE SPEED SIGNAL (0-PULSE)

27	V	PARKING BRAKE SWITCH SIGNAL
28	SB	BRAKE FLUID LEVEL SWITCH SIGNAL
29	L	SEAT BELT BUCKLE SW SIGNAL (DRIVER SIDE)
30	G	SEAT BELT BUCKLE SWITCH SIGNAL (PASSENGER SIDE)
31	L	WASHER LEVEL SWITCH SIGNAL
33	R	ILLUMINATION CONTROL SIGNAL
36	LG	SELECT SWITCH SIGNAL
37	SB	ENTER SWITCH SIGNAL
38	L	TRIP A/B RESET SWITCH SIGNAL
39	P	ILLUMINATION CONTROL SWITCH (-)
40	BG	ILLUMINATION CONTROL SWITCH (+)

Connector No.	M86
Connector Name	UNIFIED METER AND A/C AMP.
Connector Type	TH40FW-NH



Terminal No.	Color of Wire	Signal Name [Specification]
4	G	STOP LAMP SWITCH
5	L	MANUAL MODE SHIFT UP SIGNAL
6	BG	PADDLE SHIFTER UP SIGNAL
7	GR	COMMUNICATION SIGNAL (AMP->METER)
8	L	VEHICLE SPEED (2-PULSE)
9	SB	SEAT BELT BUCKLE SWITCH SIGNAL (DRIVER SIDE)
10	W	MANUAL MODE SIGNAL
11	G	NON-MANUAL MODE SIGNAL
14	SB	COMMUNICATION SIGNAL (LCD->AMP)
20	G	IGN ON / OFF SIGNAL
25	V	MANUAL MODE SHIFT DOWN SIGNAL
26	G	PADDLE SHIFTER DOWN SIGNAL
27	LG	COMMUNICATION SIGNAL (METER->AMP)
28	R	VEHICLE SPEED (0-PULSE)
30	V	PARKING BRAKE SWITCH SIGNAL
34	B	COMMUNICATION SIGNAL (AMP->LCD)
38	P	BLOWER MOTOR CONTROL SIGNAL

A  
B  
C  
D  
E  
F  
G  
H  
I  
J  
K  
L  
M  
N  
O  
P

RF

# RETRACTABLE HARD TOP SYSTEM

< WIRING DIAGRAM >

## RETRACTABLE HARD TOP SYSTEM

Connector No.	M67
Connector Name	UNIFIED METER AND A/C AMP.
Connector Type	TH227V-NH

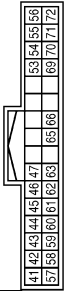

Terminal No.	Color of Wire	Signal Name [Specification]
41	BR	ACC POWER SUPPLY
42	BR	FUEL LEVEL SENSOR SIGNAL
43	R	INTAKE SENSOR SIGNAL
44	LG	IN-VEHICLE SENSOR SIGNAL
45	V	AMBIENT SENSOR SIGNAL
46	EG	SUNLOAD SENSOR SIGNAL
47	G	EXHAUST GAS TEMPERATURE SENSOR SIGNAL
53	W	IGNITION POWER SUPPLY
54	EG	BATTERY POWER SUPPLY
55	B	GROUND
56	L	CAN-H
57	LG	BRAKE FLUID LEVEL SWITCH SIGNAL
58	Y	FUEL LEVEL SENSOR SIGNAL GROUND
59	GR	INTAKE SENSOR GROUND
60	L	IN-VEHICLE SENSOR GROUND
61	R	AMBIENT SENSOR GROUND
62	SB	SUNLOAD SENSOR GROUND
63	L	ION CONTROL MODE OUTPUT SIGNAL
65	EG	ECV SIGNAL
68	L	A/C LAN SIGNAL
70	R	EACH DOOR MOTOR POWER SUPPLY
71	GR	GROUND
72	P	CAN-L

Connector No.	M69
Connector Name	BACK-UP LAMP RELAY
Connector Type	MS02FL-M2-LC



Terminal No.	Color of Wire	Signal Name [Specification]
1	R	
2	W	
3	LG	
5	EG	

Connector No.	M106
Connector Name	WIRE TO WIRE
Connector Type	NH10MW-CS10

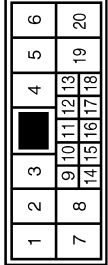

Terminal No.	Color of Wire	Signal Name [Specification]
1	B	
2	BR	
3	Y	
4	G	
5	SHIELD	
6	R	
7	B	
8	L	
9	R	
10	SB	
11	V	
12	LG	
18	B	
19	P	
20	Y	

Connector No.	M116
Connector Name	WIRE TO WIRE
Connector Type	TK3BMW-NS10



Terminal No.	Color of Wire	Signal Name [Specification]
2	W	
3	EG	
4	R	
5	B	
9	R	
10	R	
19	BG	
20	Y	
28	GR	
29	LG	
30	LG	
31	W	
41	BG	
42	G	
43	P	
44	L	
45	G	
46	Y	

Connector No.	M117
Connector Name	WIRE TO WIRE
Connector Type	TH50MW-CS16-TM4

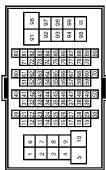

Terminal No.	Color of Wire	Signal Name [Specification]
1	Y	
3	B	
5	SB	
6	R	
7	G	
8	SB	
9	GR	
10	LG	
40	Y	
41	G	
42	LG	
43	R	
44	SHIELD	
45	G	
47	P	
48	L	

Terminal No.	Color of Wire	Signal Name [Specification]
49	SHIELD	
50	V	
51	SB	
52	BG	
53	L	
54	G	
55	Y	
56	LG	
57	SB	
58	LG	
67	SB	
68	LG	
80	W	
81	B	
82	R	
83	G	
84	SHIELD	
85	G	
86	L	
87	P	
88	SHIELD	
89	Y	
90	W	
91	GR	
92	P	
93	W	
94	BG	
95	BG	
96	P	
97	L	
98	Y/B	
99	Y	

Connector No.	M118
Connector Name	BCM (BODY CONTROL MODULE)
Connector Type	MS03FB-LC



Terminal No.	Color of Wire	Signal Name [Specification]
1	W	BAT (F/L)
2	Y	POWER WINDOW POWER SUPPLY (BAT)
3	BG	POWER WINDOW POWER SUPPLY (R4P)

# RETRACTABLE HARD TOP SYSTEM

< WIRING DIAGRAM >

## RETRACTABLE HARD TOP SYSTEM

Connector No.	M119
Connector Name	BCM (BODY CONTROL MODULE)
Connector Type	NS16FW-CS



4	5	6	7	8	9	10		
11	12	13	14	15	16	17	18	19

Terminal No.	Color of Wire	Signal Name [Specification]
4	LG	INTERIOR ROOM LAMP POWER SUPPLY
5	P	PASSENGER DOOR UNLOCK OUTPUT
7	SB	STEP LAMP
8	V	ALL DOOR FUEL LID LOCK OUTPUT
9	G	DRIVER DOOR FUEL LID UNLOCK OUTPUT
11	GR	BAT.(FUSE)
13	B	GND
14	W	PUSH-BUTTON IGNITION SW ILL GND
15	BG	ACC IND
17	BR	TURN SIGNAL RH (FRONT)
18	BG	TURN SIGNAL LH (FRONT)
19	V	ROOM LAMP TIMER CONTROL

Connector No.	M120
Connector Name	BCM (BODY CONTROL MODULE)
Connector Type	NS12FW-CS



20	21	22	23	24		
25	26	27	28	29	30	31

Terminal No.	Color of Wire	Signal Name [Specification]
20	V	TURN SIGNAL RH (REAR)
23	Y	TRUNK LID OPEN OUTPUT
25	Y	TURN SIGNAL LH (REAR)
30	P	TRUNK ROOM LAMP

Connector No.	M121
Connector Name	BCM (BODY CONTROL MODULE)
Connector Type	TH40FGY-NH



31	32	33	34	35	36	37	38	39	40	41	42	43	44	45	46	47	48	49	50	51	52
----	----	----	----	----	----	----	----	----	----	----	----	----	----	----	----	----	----	----	----	----	----

Terminal No.	Color of Wire	Signal Name [Specification]
34	SB	TRUNK ROOM ANT-
35	V	TRUNK ROOM ANT+
38	B	REAR BUMPER ANT-
39	W	REAR BUMPER ANT+
47	Y	IGN RELAY (PDM) LE (RY) CONT
50	G	TRUNK ROOM LAMP SW
52	BR	STARTER RELAY CONT
60	BR	PUSH SW
61	SB	TRUNK LID OPENER REQUEST SW
64	G	F-KEY WARM BUZZER (ENG ROOM)
67	GR	TRUNK LID OPENER SW

Connector No.	M122
Connector Name	BCM (BODY CONTROL MODULE)
Connector Type	TH40FB-NH



61	62	63	64	65	66	67	68	69	70	71	72	73	74	75	76	77	78	79	80	81	82
----	----	----	----	----	----	----	----	----	----	----	----	----	----	----	----	----	----	----	----	----	----

Terminal No.	Color of Wire	Signal Name [Specification]
72	R	ROOM ANT 2-
73	G	ROOM ANT 2+
74	SB	PASSENGER DOOR ANT-
75	BR	PASSENGER DOOR ANT+
76	V	DRIVER DOOR ANT-
77	LG	DRIVER DOOR ANT+
78	Y	ROOM ANT 1-
79	BR	ROOM ANT 1+
80	GR	NATS ANTENNA AMP
81	W	NATS ANTENNA AMP
82	R	IGN RELAY (F/B) CONT

83	Y	KEYLESS ENTRY RECEIVER COMM
87	Y	COMBI SW INPUT 5
88	BG	COMBI SW INPUT 3
89	BR	PUSH SW
90	P	CAN-H
91	L	CAN-L
92	LG	KEY SLOT ILL
93	V	ON IND
95	BG	ACC RELAY CONT
96	GR	A/T SHIFT SELECTOR POWER SUPPLY
97	L	S/L CONDITION 1
98	SB	S/L CONDITION 2
99	R	ASCD CLUTCH SW [With M/T]
99	R	SHIFT P [With A/T]
100	Y	PASSENGER DOOR REQUEST SW
101	P	DRIVER DOOR REQUEST SW
102	BG	BLOWER FAN MOTOR RELAY CONT
103	LG	KEYLESS ENTRY RECEIVER POWER SUPPLY
106	W	S/L UNIT POWER SUPPLY
107	LG	COMBI SW INPUT 1
108	R	COMBI SW INPUT 4
109	W	COMBI SW INPUT 2
110	G	HAZARD SW
111	Y	S/L UNIT COMM

Connector No.	M123
Connector Name	BCM (BODY CONTROL MODULE)
Connector Type	TH40FG-NH



121	122	123	124	125	126	127	128	129	130	131	132	133	134	135	136	137	138	139	140	141	142	143	144	145	146	147	148	149	150	151
-----	-----	-----	-----	-----	-----	-----	-----	-----	-----	-----	-----	-----	-----	-----	-----	-----	-----	-----	-----	-----	-----	-----	-----	-----	-----	-----	-----	-----	-----	-----

Terminal No.	Color of Wire	Signal Name [Specification]
112	BR	RAIN SENSOR SERIAL LINK
113	G	OPTICAL SENSOR
114	R	CLUTCH INTERLOCK SW
116	SB	STOP LAMP SW 1
118	BR	STOP LAMP SW 2
119	GR	DR DOOR UNLOCK SENSOR
121	SB	KEY SLOT SW
123	W	IGN F/B
124	BG	PASSENGER DOOR SW
129	BG	TRUNK LID OPENER CANCEL SW
132	LG	P/W SW & PHT C/U COMM
133	Y	PUSH-BUTTON IGNITION SW ILL POWER

134	LG	LOCK IND
137	BG	RECEIVER / SENSOR GND
138	Y	RECEIVER / SENSOR POWER SUPPLY
139	L	TIRE PRESSURE RECEIVER COMM
140	GR	SHIFT N/P
141	R	SECURITY INDICATOR LAMP
142	BR	COMBI SW OUTPUT 5
143	V	COMBI SW OUTPUT 1
144	G	COMBI SW OUTPUT 2
145	L	COMBI SW OUTPUT 3
146	SB	COMBI SW OUTPUT 4
150	R	DRIVER DOOR SW
151	G	REAR WINDOW DEFOGGER RELAY CONT

A  
B  
C  
D  
E  
F  
G  
H  
I  
J  
K  
L  
M  
N  
O  
P

RF

# RETRACTABLE HARD TOP SYSTEM

< WIRING DIAGRAM >

## RETRACTABLE HARD TOP SYSTEM

Connector No.	M124
Connector Name	WIRE TO WIRE
Connector Type	TH40MW-CS15

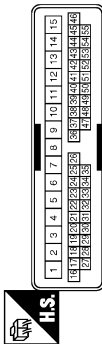

Terminal No.	Color of Wire	Signal Name [Specification]
6	BG	-
7	R	-
8	G	-
9	P	-
10	V	-
11	SB	- [With BOSE system]
12	BR	- [Without BOSE system]
13	B	-
14	G	-
15	W	-
34	Y	-
35	Y/B	-
38	W	-
39	BG	-
40	SB	-
41	BR	- [With automatic drive positioner]
41	G	- [Without automatic drive positioner]
42	R	-
43	L	-
44	Y	-
45	R	-
46	W	-
47	SB	-
48	BR	-
49	Y	-
50	P	-
51	LG	-
52	BG	-
53	Y	-
54	L	-
55	L	-

Connector No.	M136
Connector Name	WIRE TO WIRE
Connector Type	TH24FY-NH

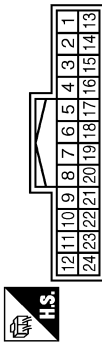

Terminal No.	Color of Wire	Signal Name [Specification]
1	V	-
2	BR	-
3	R	-
4	GR	-
5	W	-
6	W	-
7	R	-
8	GR	-
9	SB	-
10	R	-
11	L	-
12	GR	-
16	B	-
21	GR	-
22	W	-
23	GR	-
24	W	-

Connector No.	M147
Connector Name	AIR BAG DIAGNOSIS SENSOR UNIT
Connector Type	NH28FY-EX

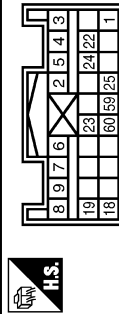

Terminal No.	Color of Wire	Signal Name [Specification]
1	LG	IGN
2	B	GND
3	Y	DR1 (-)
4	Y	DR1 (-)DR2 (-)
5	Y	DR2 (-)

6	Y	ASI (+)
7	Y	ASI (-)
8	Y	ASZ (+)
9	Y	ASZ (-)
18	SB	ECZS (+)
19	V	ECZS (-)
22	SHIELD	GND
23	LG	AIRBAG W/L
24	G	SEAT BELT
25	L	CUTOFF TELLTALE
59	L	CAN-H
60	P	CAN-L

Connector No.	M174
Connector Name	WIRE TO WIRE
Connector Type	TH24MW-NH



Terminal No.	Color of Wire	Signal Name [Specification]
1	V	-
2	BR	-
3	R	-
4	GR	-
5	W	-
6	LG	-
7	R	-
8	P	-
9	SB	-
10	O	-
11	L	-
12	G	-
16	B	-
21	GR	-
22	W	-
23	B	-
24	Y	-

Connector No.	M179
Connector Name	ROOF OPEN / CLOSE SWITCH
Connector Type	TK08FW-IV



Terminal No.	Color of Wire	Signal Name [Specification]
1	B	-
3	V	-
4	BR	-
5	R	-
6	GR	-

Connector No.	RI
Connector Name	WIRE TO WIRE
Connector Type	NH10FW-CS10

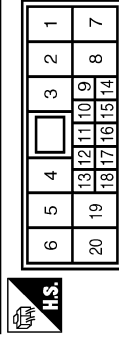

Terminal No.	Color of Wire	Signal Name [Specification]
1	B	-
2	BR	-
3	Y	-
4	W	-
5	SHIELD	-
6	O	-
7	B	-
8	L	-
9	Y	-
10	B	-
11	V	-
12	R	-
18	B	-
19	BR	-
20	G	-

# RETRACTABLE HARD TOP SYSTEM

< WIRING DIAGRAM >

A  
B  
C  
D  
E  
F  
G  
H  
I  
J  
RF  
L  
M  
N  
O  
P

## RETRACTABLE HARD TOP SYSTEM

Connector No.	R6
Connector Name	ROOF LATCH LIMIT SWITCH
Connector Type	TH04FV-NH



Terminal No.	Color of Wire	Signal Name [Specification]
2	L	-
3	B	-

JCKWM5302GB

# DIAGNOSIS AND REPAIR WORK FLOW

< BASIC INSPECTION >

## BASIC INSPECTION

### DIAGNOSIS AND REPAIR WORK FLOW

Work Flow

INFOID:000000006468662

#### OVERALL SEQUENCE

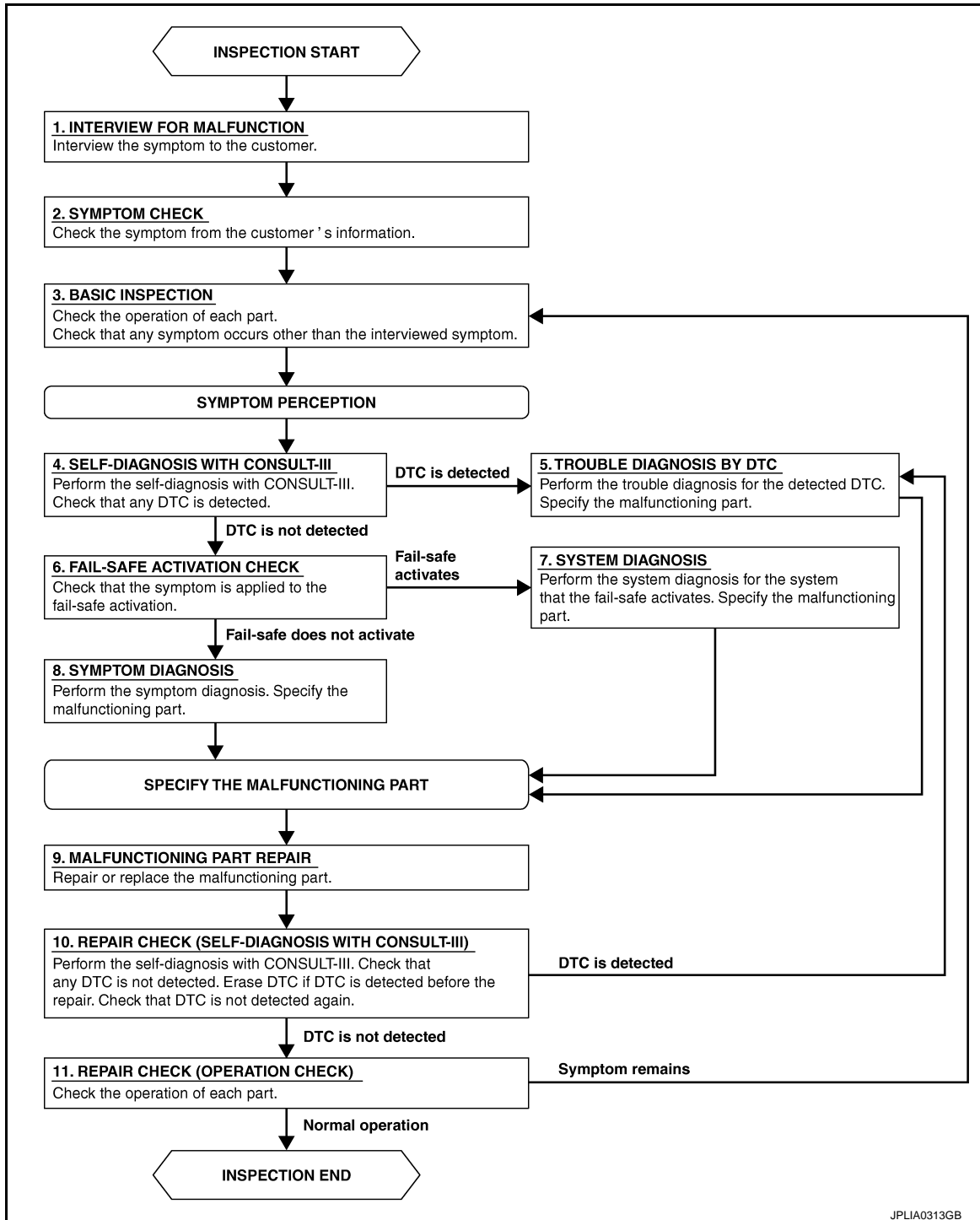

JPLIA0313GB

#### DETAILED FLOW

##### 1. INTERVIEW FOR MALFUNCTION

Interview the symptom to the customer.

# DIAGNOSIS AND REPAIR WORK FLOW

< BASIC INSPECTION >

---

>> GO TO 2.

## 2. SYMPTOM CHECK

---

Check the symptom from the customer's information.

>> GO TO 3.

## 3. BASIC INSPECTION

---

Check the operation of each part. Check that any symptom occurs other than the interviewed symptom.

>> GO TO 4.

## 4. SELF-DIAGNOSIS WITH CONSULT-III

---

Perform the self-diagnosis with CONSULT-III. Check that any DTC is detected.

Is any DTC detected?

YES >> GO TO 5.

NO >> GO TO 6.

## 5. TROUBLE DIAGNOSIS BY DTC

---

Perform the trouble diagnosis for the detected DTC. Specify the malfunctioning part.

>> GO TO 9.

## 6. FAIL-SAFE ACTIVATION CHECK

---

Check that the symptom is applied to the fail-safe activation.

Does the fail-safe activate?

YES >> GO TO 7.

NO >> GO TO 8.

## 7. SYSTEM DIAGNOSIS

---

Perform the system diagnosis for the system that the fail-safe activates. Specify the malfunctioning part.

>> GO TO 9.

## 8. SYMPTOM DIAGNOSIS

---

Perform the symptom diagnosis. Specify the malfunctioning part.

>> GO TO 9.

## 9. MALFUNCTION PART REPAIR

---

Repair or replace the malfunctioning part.

>> GO TO 10.

## 10. REPAIR CHECK (SELF-DIAGNOSIS WITH CONSULT-III)

---

Perform the self-diagnosis with CONSULT-III. Check that any DTC is not detected. Erase DTC if DTC is detected before the repair. Check that DTC is not detected again.

Is any DTC detected?

YES >> GO TO 5.

NO >> GO TO 11.

## 11. REPAIR CHECK (OPERATION CHECK)

---

Check the operation of each part.

Does it operate normally?

YES >> INSPECTION END

NO >> GO TO 3.

A

B

C

D

E

F

G

H

I

J

RF

L

M

N

O

P

# ADDITIONAL SERVICE WHEN REMOVING BATTERY NEGATIVE TERMINAL

< BASIC INSPECTION >

## ADDITIONAL SERVICE WHEN REMOVING BATTERY NEGATIVE TERMINAL

### Description

INFOID:000000006468663

There are 2 kinds of operations in initialization of retractable hard top system.

- Without CONSULT-III: Position information of parcel shelf and roof latch is memorized.
- With CONSULT-III: Roof position information is memorized.

It is necessary to perform initialization, because normal position information of each part is lost when the operation show in the following table are performed.

Operation	Operation procedure	Refer to
Battery terminal is disconnected	1. Without CONSULT-III	<a href="#">RF-88</a>
	2. For front power window system	
Retractable hard top control unit is replaced	1. Without CONSULT-III	<a href="#">RF-89</a>
	2. For front power window system	
	3. With CONSULT-III	
Roof components are replaced or removed and installed (Roof link, Roof panel No.1-3, Roof latch)	With CONSULT-III	<a href="#">RF-90</a>
Parcel shelf components are replaced or removed and installed	Without CONSULT-III	<a href="#">RF-90</a>
Roof latch components are replaced or removed and installed	Without CONSULT-III	<a href="#">RF-90</a>
Open and close operations of retractable hard top are repeated without fully closing and fully opening	Without CONSULT-III	<a href="#">RF-90</a>
15 minutes or more are passed without fully closing or fully opening retractable hard top	Without CONSULT-III	<a href="#">RF-90</a>

### NOTE:

The following state occurs if initialization is not complete.

- LCD on combination meter does not display retractable hard top system state.
- Audio system functions (Sound equalizer automatic switching function, hands-free phone system and voice recognition) do not operate.
- Fun speed control at roof open function of automatic air conditioner system does not operate.

### Work Procedure

INFOID:000000006468664

#### 1.PERFORM INITIALIZATION WITHOUT CONSULT-III

Perform initialization without CONSULT-III. Refer to [RF-90, "Work Procedure"](#).

>> GO TO 2.

#### 2.PERFORM INITIALIZATION FOR FRONT POWER WINDOW

Perform initialization for front power window. Refer to [PWC-5, "ADDITIONAL SERVICE WHEN REMOVING BATTERY NEGATIVE TERMINAL : Special Repair Requirement"](#).

>> GO TO 3.

#### 3.CHECK RETRACTABLE HARD TOP OPERATION

Check retractable hard top operation.

Does it operate normally?

- YES >> WORK END  
NO >> GO TO 1.



# ADDITIONAL SERVICE WHEN REPLACING CONTROL UNIT

< BASIC INSPECTION >

## ADDITIONAL SERVICE WHEN REPLACING CONTROL UNIT

### Description

INFOID:000000006468665

There are 2 kinds of operations in initialization of retractable hard top system.

- Without CONSULT-III: Position information of parcel shelf and roof latch is memorized.
- With CONSULT-III: Roof position information is memorized.

It is necessary to perform initialization, because normal position information of each part is lost when the operation show in the following table are performed.

Operation	Operation procedure	Refer to
Battery terminal is disconnected	1. Without CONSULT-III	<a href="#">RF-88</a>
	2. For front power window system	
Retractable hard top control unit is replaced	1. Without CONSULT-III	<a href="#">RF-89</a>
	2. For front power window system	
	3. With CONSULT-III	
Roof components are replaced or removed and installed (Roof link, Roof panel No.1-3, Roof latch)	With CONSULT-III	<a href="#">RF-90</a>
Parcel shelf components are replaced or removed and installed	Without CONSULT-III	<a href="#">RF-90</a>
Roof latch components are replaced or removed and installed	Without CONSULT-III	<a href="#">RF-90</a>
Open and close operations of retractable hard top are repeated without fully closing and fully opening	Without CONSULT-III	<a href="#">RF-90</a>
15 minutes or more are passed without fully closing or fully opening retractable hard top	Without CONSULT-III	<a href="#">RF-90</a>

### NOTE:

The following state occurs if initialization is not complete.

- LCD on combination meter does not display retractable hard top system state.
- Audio system functions (Sound equalizer automatic switching function, hands-free phone system and voice recognition) do not operate.
- Fun speed control at roof open function of automatic air conditioner system does not operate.

### Work Procedure

INFOID:000000006468666

#### 1.PERFORM INITIALIZATION WITHOUT CONSULT-III

Perform initialization without CONSULT-III. Refer to [RF-90, "Work Procedure"](#).

>> GO TO 2.

#### 2.PERFORM INITIALIZATION FOR FRONT POWER WINDOW

Perform initialization for front power window. Refer to [PWC-5, "ADDITIONAL SERVICE WHEN REMOVING BATTERY NEGATIVE TERMINAL : Special Repair Requirement"](#).

>> GO TO 3.

#### 3.PERFORM INITIALIZATION WITH CONSULT-III

Perform initialization with CONSULT-III. Refer to [RF-90, "Work Procedure"](#).

>> GO TO 4.

#### 4.CHECK RETRACTABLE HARD TOP OPERATION

Check retractable hard top operation.

Is the inspection result normal ?

- YES >> WORK END
- NO >> GO TO 1.

# INITIALIZATION OF ROOF SYSTEM

< BASIC INSPECTION >

## INITIALIZATION OF ROOF SYSTEM

### Description

INFOID:000000006468667

There are 2 kinds of operations in initialization of retractable hard top system.

- Without CONSULT-III: Position information of parcel shelf and roof latch is memorized.
- With CONSULT-III: Roof position information is memorized.

It is necessary to perform initialization, because normal position information of each part is lost when the operation show in the following table are performed.

Operation	Operation procedure	Refer to
Battery terminal is disconnected	1. Without CONSULT-III	<a href="#">RF-88</a>
	2. For front power window system	
Retractable hard top control unit is replaced	1. Without CONSULT-III	<a href="#">RF-89</a>
	2. For front power window system	
	3. With CONSULT-III	
Roof components are replaced or removed and installed (Roof link, Roof panel No.1-3, Roof latch)	With CONSULT-III	<a href="#">RF-90</a>
Parcel shelf components are replaced or removed and installed	Without CONSULT-III	<a href="#">RF-90</a>
Roof latch components are replaced or removed and installed	Without CONSULT-III	<a href="#">RF-90</a>
Open and close operations of retractable hard top are repeated without fully closing and fully opening	Without CONSULT-III	<a href="#">RF-90</a>
15 minutes or more are passed without fully closing or fully opening retractable hard top	Without CONSULT-III	<a href="#">RF-90</a>

### NOTE:

The following state occurs if initialization is not complete.

- LCD on combination meter does not display retractable hard top system state.
- Audio system functions (Sound equalizer automatic switching function, hands-free phone system and voice recognition) do not operate.
- Fun speed control at roof open function of automatic air conditioner system does not operate.

### Work Procedure

INFOID:000000006468668

#### 1. INSPECTION START

Will CONSULT-III be used?

Will CONSULT-III be used?

YES >> GO TO 2.

NO >> GO TO 7.

#### 2. STEP 1

**Ⓟ With CONSULT-III**

1. Start engine.
2. Fully close retractable hard top.

>> GO TO 3.

#### 3. STEP 2

Check the operation.

What was the operation performed?

Replace or remove and install roof components.>>GO TO 4.

Replace retractable hard top control unit.>>GO TO 5.

#### 4. STEP 3

Perform "ROOF STATE RESET" in "Work Support" mode of "RETRACTABLE HARD TOP" using CONSULT-III and erase the current memorized position. Refer to [RF-45, "CONSULT-III Function"](#).

# INITIALIZATION OF ROOF SYSTEM

< BASIC INSPECTION >

---

>> GO TO 5.

## 5. STEP 4

---

Perform "ROOF STATE LEARNING" in "Work Support" mode of "RETRACTABLE HARD TOP" using CONSULT-III and memorize the new roof position. Refer to [RF-45. "CONSULT-III Function"](#). Fully close the roof and repeat this operation (STEP 4), if roof warning buzzer sounds twice or does not sound during the initialization.

### NOTE:

Retractable hard top operation during this procedure is as per the following items.

1. Roof warning buzzer sounds once at the same time retractable hard top open operation is performed by roof open/close switch (OPEN) operation, after touching "Start" on CONSULT-III screen.
2. Roof warning buzzer sounds once when the roof is fully open.
3. Roof warning buzzer sounds once at the same time retractable hard top close operation is performed by roof open/close switch (CLOSE) operation.
4. Roof warning buzzer sounds once when the roof is fully closed.

>> GO TO 6.

## 6. STEP 5

---

Check that retractable hard top operates normally by operating from fully closed to fully open positions and from fully open to fully closed positions.

>> WORK END

## 7. STEP 1

---

### Without CONSULT-III

1. Start engine.
2. Press and hold OPEN or CLOSE of roof open/close switch and check that parcel shelf and roof latch\* stop after operating.  
\*: Depending on the operation ([RF-88. "Description"](#)), roof latch may not operate.

Does roof warning buzzer sounds once at the same time parcel shelf stops?

YES >> GO TO 9.

NO >> GO TO 8.

## 8. STEP 2

---

Repeat operation of step 1 until roof warning buzzer sounds once at the same time parcel shelf stops.

>> GO TO 9.

## 9. STEP 3

---

Check that retractable hard top operates normally by operating from fully closed to fully open positions and from fully open to fully closed positions.

>> WORK END

A  
B  
C  
D  
E  
F  
G  
H  
I  
J  
RF  
L  
M  
N  
O  
P

# U1000 CAN COMM CIRCUIT

< DTC/CIRCUIT DIAGNOSIS >

## DTC/CIRCUIT DIAGNOSIS

### U1000 CAN COMM CIRCUIT

#### Description

INFOID:000000006468669

CAN (Controller Area Network) is a serial communication line for real time applications. It is an on-vehicle multiplex communication line with high data communication speed and excellent error detection ability. Modern vehicle is equipped with many electronic control unit, and each control unit shares information and links with other control units during operation (not independent). In CAN communication, control units are connected with 2 communication lines (CAN H-line, CAN L-line) allowing a high rate of information transmission with less wiring. Each control unit transmits/receives data but selectively reads required data only.

#### DTC Logic

INFOID:000000006468670

#### DTC DETECTION LOGIC

##### NOTE:

If two or more DTCs are detected, refer to [RF-61, "DTC Inspection Priority Chart"](#), and determine trouble diagnosis order.

DTC No.	Trouble diagnosis name	DTC detection condition	Possible cause
U1000	CAN COMM CIRCUIT	When retractable hard top control unit cannot communicate CAN communication signal continuously for 2 seconds or more.	CAN communication system

#### Diagnosis Procedure

INFOID:000000006468671

#### 1. PERFORM SELF DIAGNOSTIC

1. Turn ignition switch ON and wait for 2 seconds or more.
2. Check "Self Diagnostic Results" mode of "RETRACTABLE HARD TOP" using CONSULT-III.

##### Is the DTC displayed?

- YES >> Refer to [LAN-14, "Trouble Diagnosis Flow Chart"](#).  
NO >> Refer to [GI-43, "Intermittent Incident"](#).

# U1010 CONTROL UNIT (CAN)

< DTC/CIRCUIT DIAGNOSIS >

## U1010 CONTROL UNIT (CAN)

DTC Logic

INFOID:000000006468672

DTC DETECTION LOGIC

DTC No.	Trouble doagnosis name	DTC detection condition	Possible cause
U1010	CONTROL UNIT (CAN)	Retractable hard top control unit detected internal CAN communication circuit malfunction.	Retractable hard top control unit

Diagnosis Procedure

INFOID:000000006468673

### 1. REPLACE BCM

When DTC "U1010" is detected, replace retractable hard top control unit.

>> Replace retractable hard top control unit. Refer to [RF-309, "Removal and Installation"](#).

A  
B  
C  
D  
E  
F  
G  
H  
I  
J  
L  
M  
N  
O  
P

RF

# U0140 LOCAL COMMUNICATION-1

< DTC/CIRCUIT DIAGNOSIS >

## U0140 LOCAL COMMUNICATION-1

### Description

INFOID:000000006468674

Retractable hard top control unit performs local communication with BCM, power window main switch and power window sub-switch using communication line.

### DTC Logic

INFOID:000000006468675

### DTC DETECTION LOGIC

#### NOTE:

If two or more DTCs are detected, refer to [RF-61, "DTC Inspection Priority Chart"](#), and determine trouble diagnosis order.

DTC No.	Trouble diagnosis name	DTC detecting condition	Possible cause
U0140	LOCAL COMM-1	The communication between retractable hard top control unit and BCM is interrupted for a period of time.	<ul style="list-style-type: none"><li>• Communication line</li><li>• BCM</li></ul>

### DTC CONFIRMATION PROCEDURE

#### 1. PERFORM DTC CONFIRMATION PROCEDURE

1. Start engine.
2. Operate retractable hard top to fully open and fully close.
3. Check "Self Diagnostic Results" mode of "RETRACTABLE HARD TOP" using CONSULT-III.

#### Is the DTC detected?

- YES >> Perform diagnosis procedure. Refer to [RF-94, "Diagnosis Procedure"](#).  
NO >> INSPECTION END

### Diagnosis Procedure

INFOID:000000006468676

#### 1. CHECK COMMUNICATION LINE

1. Turn ignition switch OFF.
2. Disconnect retractable hard top control unit and BCM connector.
3. Check continuity between retractable hard top control unit harness connector and BCM harness connector.

Retractable hard top control unit		BCM		Continuity
Connector	Terminal	Connector	Terminal	
B82	29	M123	132	Existed

4. Check continuity between retractable hard top control unit harness connector and ground.

Retractable hard top control unit		Ground	Continuity
Connector	Terminal		
B82	29		Not existed

#### Is the inspection result normal?

- YES >> Replace BCM. Refer to [BCS-81, "Removal and Installation"](#).  
NO >> Repair or replace harness.

# U0215 LOCAL COMMUNICATION-2

< DTC/CIRCUIT DIAGNOSIS >

## U0215 LOCAL COMMUNICATION-2

### Description

INFOID:000000006468677

Retractable hard top control unit performs local communication with BCM, power window main switch and power window sub-switch using communication line.

### DTC Logic

INFOID:000000006468678

### DTC DETECTION LOGIC

#### NOTE:

If two or more DTCs are detected, refer to [RF-61. "DTC Inspection Priority Chart"](#), and determine trouble diagnosis order.

DTC No.	Trouble diagnosis name	DTC detecting condition	Possible cause
U0215	LOCAL COMM-2	The communication between retractable hard top control unit, power window main switch and power window sub-switch is interrupted for a period of time.	<ul style="list-style-type: none"> <li>• Communication line</li> <li>• Power window main switch</li> <li>• Power window sub-switch</li> </ul>

### DTC CONFIRMATION PROCEDURE

#### 1. RERFORM DTC CONFIRMATION PROCEDURE

1. Start engine.
2. Operate retractable hard top to fully open and fully close.
3. Check "Self Diagnostic Results" mode of "RETRACTABLE HARD TOP" using CONSULT-III.

Is the DTC detected?

- YES >> Perform diagnosis procedure. Refer to [RF-95. "Diagnosis Procedure"](#).  
 NO >> INSPECTION END

### Diagnosis Procedure

INFOID:000000006468679

#### 1. CHECK POWER WINDOW MAIN SWITCH

Check power window main switch. Refer to [PWC-14. "POWER WINDOW MAIN SWITCH : Diagnosis Procedure"](#).

Is the inspection result normal?

- YES >> GO TO 2.  
 NO >> Repair or replace malfunctioning part.

#### 2. CHECK POWER WINDOW SUB-SWITCH

Check power window sub-switch. Refer to [PWC-15. "POWER WINDOW SUB-SWITCH : Diagnosis Procedure"](#).

Is the inspection result normal?

- YES >> GO TO 3.  
 NO >> Repair or replace malfunctioning part.

#### 3. CHECK COMMUNICATION LINE-1

1. Turn ignition switch OFF.
2. Disconnect retractable hard top control unit, power window main switch connector and power window sub-switch connector.
3. Check continuity between retractable hard top control unit harness connector and power window main switch harness connector.

Retractable hard top control unit		Power window main switch		Continuity
Connector	Terminal	Connector	Terminal	
B82	30	D8	7	Existed

4. Check continuity between retractable hard top control unit harness connector and ground.

## U0215 LOCAL COMMUNICATION-2

### < DTC/CIRCUIT DIAGNOSIS >

Retractable hard top control unit		Ground	Continuity
Connector	Terminal		
B82	30		Not existed

Is the inspection result normal?

YES >> GO TO 4.

NO >> Repair or replace harness.

#### 4. CHECK COMMUNICATION LINE-2

1. Check continuity between retractable hard top control unit harness connector and power window sub-switch harness connector.

Retractable hard top control unit		Power window sub-switch		Continuity
Connector	Terminal	Connector	Terminal	
B82	30	D38	15	Existed

2. Check continuity between retractable hard top control unit harness connector and ground.

Retractable hard top control unit		Ground	Continuity
Connector	Terminal		
B82	30		Not existed

Is the inspection result normal?

YES >> Check intermittent incident. Refer to [GI-43, "Intermittent Incident"](#).

NO >> Repair or replace harness.



# B1701 RETRACTABLE HARD TOP CONTROL UNIT

< DTC/CIRCUIT DIAGNOSIS >

## B1701 RETRACTABLE HARD TOP CONTROL UNIT

### DTC Logic

INFOID:000000006468680

### DTC DETECTION LOGIC

#### NOTE:

If two or more DTCs are detected, refer to [RF-61, "DTC Inspection Priority Chart"](#), and determine trouble diagnosis order.

DTC No.	Trouble diagnosis name	DTC detecting condition	Possible cause
B1701	ROOF CONTROL UNIT	Retractable hard top control unit detects internal malfunction.	Retractable hard top control unit

### DTC CONFIRMATION PROCEDURE

#### 1. PERFORM DTC CONFIRMATION PROCEDURE

1. Turn ignition switch ON.
2. Check "Self-Diagnostic Result" of "RETRACTABLE HARD TOP" using CONSULT-III.

#### Is DTC detected?

- YES >> Refer to [RF-97, "Diagnosis Procedure"](#).  
NO >> INSPECTION END

### Diagnosis Procedure

INFOID:000000006468681

#### 1. CHECK SELF DIAGNOSTIC RESULT

1. Turn ignition switch OFF.
2. Replace retractable hard top control unit. Refer to [RF-309, "Removal and Installation"](#).
3. Perform DTC Confirmation Procedure. Refer to [RF-97, "DTC Logic"](#).

>> INSPECTION END

A  
B  
C  
D  
E  
F  
G  
H  
I  
J  
L  
M  
N  
O  
P

RF

# B1702 RETRACTABLE HARD TOP CONTROL UNIT

< DTC/CIRCUIT DIAGNOSIS >

## B1702 RETRACTABLE HARD TOP CONTROL UNIT

### DTC Logic

INFOID:000000006468682

### DTC DETECTION LOGIC

**NOTE:**

If two or more DTCs are detected, refer to [RF-61, "DTC Inspection Priority Chart"](#), and determine trouble diagnosis order.

DTC No.	Trouble diagnosis name	DTC detecting condition	Possible cause
B1702	ROOF CONTROL UNIT	Retractable hard top control unit detects internal malfunction.	Retractable hard top control unit

### DTC CONFIRMATION PROCEDURE

#### 1. PERFORM DTC CONFIRMATION PROCEDURE

1. Turn ignition switch ON.
2. Check "Self-Diagnostic Result" of "RETRACTABLE HARD TOP" using CONSULT-III.

#### Is DTC detected?

- YES >> Refer to [RF-98, "Diagnosis Procedure"](#).
- NO >> INSPECTION END

### Diagnosis Procedure

INFOID:000000006468683

#### 1. CHECK SELF DIAGNOSTIC RESULT

1. Turn ignition switch OFF.
2. Replace retractable hard top control unit. Refer to [RF-309, "Removal and Installation"](#).
3. Perform DTC Confirmation Procedure. Refer to [RF-98, "DTC Logic"](#).

>> INSPECTION END

# B1707 ROOF OPEN STATE

< DTC/CIRCUIT DIAGNOSIS >

## B1707 ROOF OPEN STATE

### Description

INFOID:000000006468684

Roof status sensor is installed to roof link assembly LH. This sensor is a potentiometer that converts the roof position to a voltage signal and transmits it to retractable hard top control unit. Retractable hard top control unit recognizes the roof position using this signal.

### DTC Logic

INFOID:000000006468685

### DTC DETECTION LOGIC

#### NOTE:

If two or more DTCs are detected, refer to [RF-61, "DTC Inspection Priority Chart"](#), and determine trouble diagnosis order.

DTC No.	Trouble diagnosis name		DTC detecting condition	Possible causes
B1707	ROOF OPEN STATE	[LOST]	Retractable hard top control unit does not learn roof fully open position	<ul style="list-style-type: none"><li>• Harness or connectors (The sensor circuit is open or shorted.)</li><li>• Retractable hard top</li><li>• Retractable hard top control unit</li><li>• Roof status sensor</li><li>• Initialization is not complete</li></ul>

### DTC CONFIRMATION PROCEDURE

#### 1. PERFORM INITIALIZE

Refer to [RF-90, "Description"](#).

>> GO TO 2.

#### 2. PERFORM DTC CONFIRMATION PROCEDURE

1. Start engine.
2. Operate retractable hard top to fully open and fully close.
3. Check DTC.

#### Is DTC detected?

- YES >> Go to [RF-99, "Diagnosis Procedure"](#).  
NO >> INSPECTION END

### Diagnosis Procedure

INFOID:000000006468686

#### 1. CHECK ROOF STATUS SENSOR POWER SUPPLY CIRCUIT

1. Turn ignition switch OFF.
2. Disconnect roof status sensor harness connector.
3. Turn ignition switch ON.
4. Check the voltage between roof status sensor harness connector and ground.

(+)		(-)	Voltage (V) (Approx.)
Roof status sensor			
Connector	Terminal		
B656	3	Ground	5

#### Is the inspection result normal?

- YES >> GO TO 2.  
NO >> Repair or replace harness.

#### 2. CHECK ROOF STATUS SENSOR GROUND CIRCUIT FOR OPEN AND SHORT

1. Turn ignition switch OFF.

# B1707 ROOF OPEN STATE

## < DTC/CIRCUIT DIAGNOSIS >

2. Disconnect retractable hard top control unit harness connector.
3. Check the continuity between roof status sensor harness connector and retractable hard top control unit harness connector.

Roof status sensor		Retractable hard top control unit		Continuity
Connector	Terminal	Connector	Terminal	
B656	1	B82	23	Existed

4. Check harness for short to ground and short to power.

### Is the inspection result normal?

YES >> GO TO 3.

NO >> Repair or replace harness.

## 3.CHECK ROOF STATUS SENSOR INPUT SIGNAL CIRCUIT FOR OPEN AND SHORT

1. Check the continuity between roof status sensor harness connector and retractable hard top control unit harness connector.

Roof status sensor		Retractable hard top control unit		Continuity
Connector	Terminal	Connector	Terminal	
B656	2	B82	26	Existed

2. Check harness for short to ground and short to power.

### Is the inspection result normal?

YES >> GO TO 4.

NO >> Repair or replace harness.

## 4.REPLACE ROOF STATUS SENSOR

Replace roof status sensor. Refer to [RF-15, "Component Parts Location"](#).

### Is the inspection result normal?

YES >> INSPECTION END

NO >> GO TO 5.

## 5.CHECK RETRACTABLE HARD TOP

Check retractable hard top mechanism deformation, looseness, rattle, interference with other parts, and pinched foreign materials. Refer to [RF-287, "Exploded View"](#).

### Is the inspection result normal?

YES >> GO TO 6.

NO >> Repair or replace malfunctioning part.

## 6.REPLACE RETRACTABLE HARD TOP CONTROL UNIT

Replace retractable hard top control unit. Refer to [RF-309, "Removal and Installation"](#).

### Is the inspection result normal?

YES >> INSPECTION END

NO >> GO TO 7.

## 7.CHECK INTERMITTENT INCIDENT

Refer to [GI-43, "Intermittent Incident"](#).

>> INSPECTION END

# B1708 ROOF CLOSE STATE

< DTC/CIRCUIT DIAGNOSIS >

## B1708 ROOF CLOSE STATE

### Description

INFOID:000000006468687

Roof status sensor is installed to roof link assembly LH. This sensor is a potentiometer that converts the roof position to a voltage signal and transmits it to retractable hard top control unit. Retractable hard top control unit recognizes the roof position using this signal.

### DTC Logic

INFOID:000000006468688

### DTC DETECTION LOGIC

#### NOTE:

If two or more DTCs are detected, refer to [RF-61, "DTC Inspection Priority Chart"](#), and determine trouble diagnosis order.

DTC No.	Trouble diagnosis name		DTC detecting condition	Possible causes
B1708	ROOF CLOSE STATE	[LOST]	Retractable hard top control unit does not learn roof fully closed position	<ul style="list-style-type: none"> <li>• Harness or connectors (The sensor circuit is open or shorted.)</li> <li>• Retractable hard top</li> <li>• Retractable hard top control unit</li> <li>• Roof status sensor</li> <li>• Initialization is not complete</li> </ul>

### DTC CONFIRMATION PROCEDURE

#### 1. PERFORM INITIALIZE

Refer to [RF-90, "Description"](#).

>> GO TO 2.

#### 2. PERFORM DTC CONFIRMATION PROCEDURE

1. Start engine.
2. Operate retractable hard top to fully open and fully close.
3. Check DTC.

#### Is DTC detected?

- YES >> Go to [RF-101, "Diagnosis Procedure"](#).  
 NO >> INSPECTION END

### Diagnosis Procedure

INFOID:000000006468689

#### 1. CHECK ROOF STATUS SENSOR POWER SUPPLY CIRCUIT

1. Turn ignition switch OFF.
2. Disconnect roof status sensor harness connector.
3. Turn ignition switch ON.
4. Check the voltage between roof status sensor harness connector and ground.

(+)		(-)	Voltage (V) (Approx.)
Roof status sensor			
Connector	Terminal		
B656	3	Ground	5

#### Is the inspection result normal?

- YES >> GO TO 2.  
 NO >> Repair or replace harness.

#### 2. CHECK ROOF STATUS SENSOR GROUND CIRCUIT FOR OPEN AND SHORT

1. Turn ignition switch OFF.

# B1708 ROOF CLOSE STATE

## < DTC/CIRCUIT DIAGNOSIS >

2. Disconnect retractable hard top control unit harness connector.
3. Check the continuity between roof status sensor harness connector and retractable hard top control unit harness connector.

Roof status sensor		Retractable hard top control unit		Continuity
Connector	Terminal	Connector	Terminal	
B656	1	B82	23	Existed

4. Check harness for short to ground and short to power.

Is the inspection result normal?

YES >> GO TO 3.

NO >> Repair or replace harness.

## 3.CHECK ROOF STATUS SENSOR INPUT SIGNAL CIRCUIT FOR OPEN AND SHORT

1. Check the continuity between roof status sensor harness connector and retractable hard top control unit harness connector.

Roof status sensor		Retractable hard top control unit		Continuity
Connector	Terminal	Connector	Terminal	
B656	2	B82	26	Existed

2. Check harness for short to ground and short to power.

Is the inspection result normal?

YES >> GO TO 4.

NO >> Repair or replace harness.

## 4.REPLACE ROOF STATUS SENSOR

Replace roof status sensor. Refer to [RF-15, "Component Parts Location"](#).

Is the inspection result normal?

YES >> INSPECTION END

NO >> GO TO 5.

## 5.CHECK RETRACTABLE HARD TOP

Check retractable hard top mechanism deformation, looseness, rattle, interference with other parts, and pinched foreign materials. Refer to [RF-287, "Exploded View"](#).

Is the inspection result normal?

YES >> GO TO 6.

NO >> Repair or replace malfunctioning part.

## 6.REPLACE RETRACTABLE HARD TOP CONTROL UNIT

Replace retractable hard top control unit. Refer to [RF-309, "Removal and Installation"](#).

Is the inspection result normal?

YES >> INSPECTION END

NO >> GO TO 7.

## 7.CHECK INTERMITTENT INCIDENT

Refer to [GI-43, "Intermittent Incident"](#).

>> INSPECTION END

# B1709 ROOF OPEN/CLOSE SWITCH (OPEN)

< DTC/CIRCUIT DIAGNOSIS >

## B1709 ROOF OPEN/CLOSE SWITCH (OPEN)

### DTC Logic

INFOID:000000006468690

### DTC DETECTION LOGIC

**NOTE:**

If two or more DTCs are detected, refer to [RF-61, "DTC Inspection Priority Chart"](#), and determine trouble diagnosis order.

DTC No.	Trouble diagnosis name		DTC detecting condition	Possible cause
B1709	ROOF SWITCH-OPEN	[TIMEOUT]	Retractable hard top control unit detects roof open/close switch (open) operation for 60 seconds	<ul style="list-style-type: none"> <li>• Harness or connectors (The roof open/close switch circuit is shorted.)</li> <li>• Retractable hard top control unit</li> <li>• Roof open/close switch</li> </ul>

### DTC CONFIRMATION PROCEDURE

#### 1.CHECK ROOF OPEN/CLOSE SWITCH SIGNAL

1. Start engine.
2. Operate retractable hard top to fully open and fully close.
3. Check DTC.

Is DTC detected?

- YES >> Go to [RF-103, "Diagnosis Procedure"](#).  
 NO >> INSPECTION END

### Diagnosis Procedure

INFOID:000000006468691

#### 1.CHECK ROOF OPEN/CLOSE SWITCH POWER SUPPLY CIRCUIT-I

1. Turn ignition switch OFF.
2. Disconnect roof open/close switch harness connector.
3. Turn ignition switch ON.
4. Check the voltage between roof open/close switch harness connector and ground.

(+)		Roof open/close switch	(-)	Voltage (V) (Approx.)
Connector	Terminal			
M28 (A/T models)	3		Ground	Battery voltage
M179 (M/T models)				

Is the inspection result normal?

- YES >> GO TO 3.  
 NO >> GO TO 2.

#### 2.CHECK ROOF OPEN/CLOSE SWITCH POWER SUPPLY CIRCUIT-II

1. Turn ignition switch OFF.
2. Disconnect retractable hard top control unit harness connector.
3. Check the continuity between retractable hard top control unit harness connector and roof open/close switch harness connector.

Retractable hard top control unit		Roof open/close switch		Continuity
Connector	Terminal	Connector	Terminal	
B82	1	M28 (A/T models)	3	Existed
		M179 (M/T models)		

4. Check harness for short to ground.

Is the inspection result normal?

A  
B  
C  
D  
E  
F  
G  
H  
I  
J  
L  
M  
N  
O  
P



## B1709 ROOF OPEN/CLOSE SWITCH (OPEN)

### < DTC/CIRCUIT DIAGNOSIS >

---

- YES >> GO TO 3.  
NO >> Repair or replace harness.

### 3.CHECK ROOF OPEN/CLOSE SWITCH

---

Check roof open/close switch. Refer to [RF-104. "Component Inspection"](#).

Is the inspection result normal?

- YES >> GO TO 4.  
NO >> Replace roof open/close switch. Refer to [RF-15. "Component Parts Location"](#).

### 4.REPLACE RETRACTABLE HARD TOP CONTROL UNIT

---

Replace retractable hard top control unit. Refer to [RF-309. "Removal and Installation"](#)

Is the inspection result normal?

- YES >> INSPECTION END  
NO >> GO TO 5.

### 5.CHECK INTERMITTENT INCIDENT

---

Refer to [GI-43. "Intermittent Incident"](#).

>> INSPECTION END

## Component Inspection

INFOID:000000006468692

### 1.CHECK ROOF OPEN/CLOSE SWITCH

---

1. Turn ignition switch OFF.
2. Disconnect roof open/close switch harness connector.
3. Check the continuity between roof open/close switch terminals under the following conditions.

Terminal	Condition	Continuity
1 and 3	Open pressed	Existed
	Except above	Not existed
1 and 4	Close pressed	Existed
	Except above	Not existed

Is the inspection result normal?

- YES >> INSPECTION END  
NO >> Replace roof open/close switch. Refer to [RF-15. "Component Parts Location"](#).



# B170A ROOF OPEN/CLOSE SWITCH (CLOSE)

< DTC/CIRCUIT DIAGNOSIS >

## B170A ROOF OPEN/CLOSE SWITCH (CLOSE)

### DTC Logic

INFOID:000000006468693

### DTC DETECTION LOGIC

**NOTE:**

If two or more DTCs are detected, refer to [RF-61, "DTC Inspection Priority Chart"](#), and determine trouble diagnosis order.

DTC No.	Trouble diagnosis name		DTC detecting condition	Possible cause
B170A	ROOF SWITCH-CLOSE	[TIMEOUT]	Retractable hard top control unit detects roof open/close switch (close) operation for 60 seconds	<ul style="list-style-type: none"> <li>Harness or connectors (The roof open/close switch circuit is shorted.)</li> <li>Retractable hard top control unit</li> <li>Roof open/close switch</li> </ul>

### DTC CONFIRMATION PROCEDURE

#### 1.CHECK ROOF OPEN/CLOSE SWITCH SIGNAL

1. Start engine.
2. Operate retractable hard top to fully open and fully close.
3. Check DTC.

Is DTC detected?

- YES >> Go to [RF-105, "Diagnosis Procedure"](#).  
 NO >> INSPECTION END

### Diagnosis Procedure

INFOID:000000006468694

#### 1.CHECK ROOF OPEN/CLOSE SWITCH POWER SUPPLY CIRCUIT-I

1. Turn ignition switch OFF.
2. Disconnect roof open/close switch harness connector.
3. Turn ignition switch ON.
4. Check the voltage between roof open/close switch harness connector and ground.

(+)		(-)	Voltage (V) (Approx.)
Roof open/close switch			
Connector	Terminal		
M28 (A/T models)	4	Ground	Battery voltage
M179 (M/T models)			

Is the inspection result normal?

- YES >> GO TO 3.  
 NO >> GO TO 2.

#### 2.CHECK ROOF OPEN/CLOSE SWITCH POWER SUPPLY CIRCUIT-II

1. Turn ignition switch OFF.
2. Disconnect retractable hard top control unit harness connector.
3. Check the continuity between retractable hard top control unit harness connector and roof open/close switch harness connector.

Retractable hard top control unit		Roof open/close switch		Continuity
Connector	Terminal	Connector	Terminal	
B82	2	M28 (A/T models)	4	Existed
		M179 (M/T models)		

4. Check harness for short to ground.

Is the inspection result normal?

A  
B  
C  
D  
E  
F  
G  
H  
I  
J  
L  
M  
N  
O  
P

RF

## B170A ROOF OPEN/CLOSE SWITCH (CLOSE)

### < DTC/CIRCUIT DIAGNOSIS >

---

- YES >> GO TO 3.  
NO >> Repair or replace harness.

### 3.CHECK ROOF OPEN/CLOSE SWITCH

---

Check roof open/close switch. Refer to [RF-106. "Component Inspection"](#).

Is the inspection result normal?

- YES >> GO TO 4.  
NO >> Replace roof open/close switch. Refer to [RF-15. "Component Parts Location"](#).

### 4.REPLACE RETRACTABLE HARD TOP CONTROL UNIT

---

Replace retractable hard top control unit. Refer to [RF-309. "Removal and Installation"](#).

Is the inspection result normal?

- YES >> INSPECTION END  
NO >> GO TO 5.

### 5.CHECK INTERMITTENT INCIDENT

---

Refer to [GI-43. "Intermittent Incident"](#).

>> INSPECTION END

## Component Inspection

INFOID:000000006468695

### 1.CHECK ROOF OPEN/CLOSE SWITCH

---

1. Turn ignition switch OFF.
2. Disconnect roof open/close switch harness connector.
3. Check the continuity between roof open/close switch terminals under the following conditions.

Terminal	Condition	Continuity
1 and 3	Open pressed	Existed
	Except above	Not existed
1 and 4	Close pressed	Existed
	Except above	Not existed

Is the inspection result normal?

- YES >> INSPECTION END  
NO >> Replace roof open/close switch. Refer to [RF-15. "Component Parts Location"](#).

# B170B ROOF OPEN/CLOSE SWITCH

< DTC/CIRCUIT DIAGNOSIS >

## B170B ROOF OPEN/CLOSE SWITCH

### DTC Logic

INFOID:000000006468696

### DTC DETECTION LOGIC

**NOTE:**

If two or more DTCs are detected, refer to [RF-61, "DTC Inspection Priority Chart"](#), and determine trouble diagnosis order.

DTC No.	Trouble diagnosis name		DTC detecting condition	Possible cause
B170B	ROOF SWITCH	[INCORRECT]	Retractable hard top control unit detects roof open/close switch open operation and close operation at the same time	<ul style="list-style-type: none"> <li>• Harness or connectors (The roof open/close switch circuit is shorted.)</li> <li>• Retractable hard top control unit</li> <li>• Roof open/close switch</li> </ul>

### DTC CONFIRMATION PROCEDURE

#### 1.CHECK ROOF OPEN/CLOSE SWITCH SIGNAL

1. Start engine.
2. Operate retractable hard top to fully open and fully close.
3. Check DTC.

Is DTC detected?

- YES >> Go to [RF-107, "Diagnosis Procedure"](#).  
 NO >> INSPECTION END

### Diagnosis Procedure

INFOID:000000006468697

#### 1.CHECK ROOF OPEN/CLOSE SWITCH POWER SUPPLY CIRCUIT-I

1. Turn ignition switch OFF.
2. Disconnect roof open/close switch harness connector.
3. Turn ignition switch ON.
4. Check the voltage between roof open/close switch harness connector and ground.

(+)		(-)	Voltage (V) (Approx.)
Roof open/close switch			
Connector	Terminal	Ground	Battery voltage
M28 (A/T models)	3		
M179 (M/T models)			
M28 (A/T models)	4		
M179 (M/T models)			

Is the inspection result normal?

- YES >> GO TO 3.  
 NO >> GO TO 2.

#### 2.CHECK ROOF OPEN/CLOSE SWITCH POWER SUPPLY CIRCUIT-II

1. Turn ignition switch OFF.
2. Disconnect retractable hard top control unit harness connector.
3. Check the continuity between retractable hard top control unit harness connector and roof open/close switch harness connector.

# B170B ROOF OPEN/CLOSE SWITCH

## < DTC/CIRCUIT DIAGNOSIS >

Retractable hard top control unit		Roof open/close switch		Continuity
Connector	Terminal	Connector	Terminal	
B82	1	M28 (A/T models)	3	Existed
		M179 (M/T models)		
	2	M28 (A/T models)	4	
		M179 (M/T models)		

4. Check harness for short to ground.

Is the inspection result normal?

YES >> GO TO 3.

NO >> Repair or replace harness.

### 3.CHECK ROOF OPEN/CLOSE SWITCH

Check roof open/close switch. Refer to [RF-108. "Component Inspection"](#).

Is the inspection result normal?

YES >> GO TO 4.

NO >> Replace roof open/close switch. Refer to [RF-15. "Component Parts Location"](#).

### 4.REPLACE RETRACTABLE HARD TOP CONTROL UNIT

Replace retractable hard top control unit. Refer to [RF-309. "Removal and Installation"](#).

Is the inspection result normal?

YES >> INSPECTION END

NO >> GO TO 5.

### 5.CHECK INTERMITTENT INCIDENT

Refer to [GI-43. "Intermittent Incident"](#).

>> INSPECTION END

## Component Inspection

INFOID:000000006468698

### 1.CHECK ROOF OPEN/CLOSE SWITCH

1. Turn ignition switch OFF.
2. Disconnect roof open/close switch harness connector.
3. Check the continuity between roof open/close switch terminals under the following conditions.

Terminal	Condition	Continuity
1 and 3	Open pressed	Existed
	Except above	Not existed
1 and 4	Close pressed	Existed
	Except above	Not existed

Is the inspection result normal?

YES >> INSPECTION END

NO >> Replace roof open/close switch. Refer to [RF-15. "Component Parts Location"](#).

# B170C TRUNK LINK SENSOR (LH)

< DTC/CIRCUIT DIAGNOSIS >

## B170C TRUNK LINK SENSOR (LH)

### DTC Logic

INFOID:000000006468699

### DTC DETECTION LOGIC

**NOTE:**

If two or more DTCs are detected, refer to [RF-61, "DTC Inspection Priority Chart"](#), and determine trouble diagnosis order.

DTC No.	Trouble diagnosis name		DTC detecting condition	Possible cause
B170C	TRUNK LINK SENSOR-LH	[PWR-SHORT]	Trunk link sensor (LH) circuit is open, short to ground or short to power.	<ul style="list-style-type: none"> <li>• Harness or connectors (The sensor circuit is open or shorted.)</li> <li>• Retractable hard top control unit</li> <li>• Trunk link (LH)</li> <li>• Trunk link sensor (LH)</li> </ul>
		[GND-SHORT/ OPEN]		

### DTC CONFIRMATION PROCEDURE

#### 1. PERFORM DTC CONFIRMATION PROCEDURE

1. Start engine.
2. Operate retractable hard top to fully open and fully close.
3. Check DTC.

Is DTC detected?

- YES >> Go to [RF-109, "Diagnosis Procedure"](#).  
 NO >> INSPECTION END

### Diagnosis Procedure

INFOID:000000006468700

#### 1. CHECK TRUNK LINK SENSOR (LH) POWER SUPPLY CIRCUIT-I

1. Turn ignition switch OFF.
2. Disconnect trunk link sensor (LH) harness connector.
3. Turn ignition switch ON.
4. Check the voltage between trunk link sensor (LH) harness connector and ground.

(+)		(-)	Voltage (V) (Approx.)
Trunk link sensor (LH)			
Connector	Terminal	Ground	5
B303	2		

Is the inspection result normal?

- YES >> GO TO 2.  
 NO >> Repair or replace harness.

#### 2. CHECK TRUNK LINK SENSOR (LH) GROUND CIRCUIT FOR OPEN AND SHORT

1. Turn ignition switch OFF.
2. Disconnect retractable hard top control unit harness connector.
3. Check the continuity between trunk link sensor (LH) sensor harness connector and retractable hard top control unit harness connector.

Trunk link sensor (LH)		Retractable hard top control unit		Continuity
Connector	Terminal	Connector	Terminal	
B303	1	B82	14	Existed

4. Check harness for short to ground and short to power.

Is the inspection result normal?

- YES >> GO TO 3.  
 NO >> Repair or replace harness.

## B170C TRUNK LINK SENSOR (LH)

< DTC/CIRCUIT DIAGNOSIS >

---

### 3.REPLACE TRUNK LINK SENSOR (LH)

---

Replace trunk link sensor (LH) sensor. Refer to [RF-15, "Component Parts Location"](#).

Is the inspection result normal?

YES >> INSPECTION END

NO >> GO TO 4.

### 4.CHECK RETRACTABLE HARD TOP

---

Check retractable hard top mechanism deformation, looseness, rattle, interference with other parts, and pinched foreign materials. Refer to [RF-287, "Exploded View"](#).

Is the inspection result normal?

YES >> GO TO 5.

NO >> Repair or replace malfunctioning part.

### 5.REPLACE RETRACTABLE HARD TOP CONTROL UNIT

---

Replace retractable hard top control unit. Refer to [RF-309, "Removal and Installation"](#).

Is the inspection result normal?

YES >> INSPECTION END

NO >> GO TO 6.

### 6.CHECK INTERMITTENT INCIDENT

---

Refer to [GI-43, "Intermittent Incident"](#).

>> INSPECTION END

# B170D TRUNK LINK SENSOR (RH)

< DTC/CIRCUIT DIAGNOSIS >

## B170D TRUNK LINK SENSOR (RH)

### DTC Logic

INFOID:000000006468701

### DTC DETECTION LOGIC

**NOTE:**

If two or more DTCs are detected, refer to [RF-61, "DTC Inspection Priority Chart"](#), and determine trouble diagnosis order.

DTC No.	Trouble diagnosis name		DTC detecting condition	Possible cause
B170D	TRUNK LINK SENSOR-RH	[PWR-SHORT]	Trunk link sensor (RH) circuit is open, short to ground or short to power.	<ul style="list-style-type: none"> <li>• Harness or connectors (The sensor circuit is open or shorted.)</li> <li>• Retractable hard top control unit</li> <li>• Trunk link (RH)</li> <li>• Trunk link sensor (RH)</li> </ul>
		[GND-SHORT/ OPEN]		

### DTC CONFIRMATION PROCEDURE

#### 1. PERFORM DTC CONFIRMATION PROCEDURE

1. Start engine.
2. Operate retractable hard top to fully open and fully close.
3. Check DTC.

Is DTC detected?

- YES >> Go to [RF-111, "Diagnosis Procedure"](#).  
 NO >> INSPECTION END

### Diagnosis Procedure

INFOID:000000006468702

#### 1. CHECK TRUNK LINK SENSOR (RH) POWER SUPPLY CIRCUIT-I

1. Turn ignition switch OFF.
2. Disconnect trunk link sensor (RH) harness connector.
3. Turn ignition switch ON.
4. Check the voltage between trunk link sensor (RH) harness connector and ground.

(+)		(-)	Voltage (V) (Approx.)
Trunk link sensor (RH)			
Connector	Terminal	Ground	5
B86	2		

Is the inspection result normal?

- YES >> GO TO 2.  
 NO >> Repair or replace harness.

#### 2. CHECK TRUNK LINK SENSOR (RH) GROUND CIRCUIT FOR OPEN AND SHORT

1. Turn ignition switch OFF.
2. Disconnect retractable hard top control unit harness connector.
3. Check the continuity between trunk link sensor (RH) sensor harness connector and retractable hard top control unit harness connector.

Trunk link sensor (RH)		Retractable hard top control unit		Continuity
Connector	Terminal	Connector	Terminal	
B86	1	B82	15	Existed

4. Check harness for short to ground and short to power.

Is the inspection result normal?

- YES >> GO TO 3.  
 NO >> Repair or replace harness.

## B170D TRUNK LINK SENSOR (RH)

< DTC/CIRCUIT DIAGNOSIS >

---

### 3.CHECK TRUNK LINK SENSOR (RH)

---

Replace trunk link sensor (RH) sensor. Refer to [RF-15. "Component Parts Location"](#).

Is the inspection result normal?

YES >> INSPECTION END

NO >> GO TO 4.

### 4.CHECK RETRACTABLE HARD TOP

---

Check retractable hard top mechanism deformation, looseness, rattle, interference with other parts, and pinched foreign materials. Refer to [RF-287. "Exploded View"](#).

Is the inspection result normal?

YES >> GO TO 5.

NO >> Repair or replace malfunctioning part.

### 5.REPLACE RETRACTABLE HARD TOP CONTROL UNIT

---

Replace retractable hard top control unit. Refer to [RF-309. "Removal and Installation"](#).

Is the inspection result normal?

YES >> INSPECTION END

NO >> GO TO 6.

### 6.CHECK INTERMITTENT INCIDENT

---

Refer to [GI-43. "Intermittent Incident"](#).

>> INSPECTION END



# B170F SENSOR POWER SUPPLY

< DTC/CIRCUIT DIAGNOSIS >

## B170F SENSOR POWER SUPPLY

### DTC Logic

INFOID:000000006468703

### DTC DETECTION LOGIC

**NOTE:**

If two or more DTCs are detected, refer to [RF-61, "DTC Inspection Priority Chart"](#), and determine trouble diagnosis order.

DTC No.	Trouble diagnosis name		DTC detecting condition	Possible cause
B170F	SENSOR POWER SUPPLY	[GND-SHORT]	Sensor power supply circuit is short to ground	<ul style="list-style-type: none"> <li>• Harness or connectors [Parcel shelf motor (draw) circuit is shorted.] [Parcel shelf motor (rotation) circuit is shorted.] (Trunk status sensor circuit is shorted.) [Trunk link sensor (LH) circuit is shorted.] [Trunk link sensor (RH) circuit is shorted.] (Roof latch lock sensor circuit is shorted.) (Roof latch status sensor circuit is shorted.)</li> <li>• Hydraulic unit</li> <li>• Parcel shelf unit</li> <li>• Trunk link sensor (LH)</li> <li>• Trunk link sensor (RH)</li> <li>• Roof latch assembly</li> <li>• Retractable hard top control unit</li> </ul>

### DTC CONFIRMATION PROCEDURE

#### 1. PERFORM DTC CONFIRMATION PROCEDURE

1. Start engine.
2. Operate retractable hard top fully open and fully close.
3. Check DTC.

Is DTC detected?

- YES >> Go to [RF-109, "Diagnosis Procedure"](#).  
 NO >> INSPECTION END

### Diagnosis Procedure

INFOID:000000006468704

#### 1. CHECK ROOF LATCH LOCK SENSOR POWER SUPPLY CIRCUIT-I

1. Turn ignition switch OFF.
2. Disconnect roof latch assembly (roof latch lock sensor) harness connector.
3. Turn ignition switch ON.
4. Check the voltage between roof latch assembly (roof latch lock sensor) harness connector and ground.

(+)		(-)	Voltage (V) (Approx.)
Roof latch assembly (roof latch lock sensor)	Terminal		
Connector	Terminal	Ground	5
B657	1		

Is the inspection result normal?

- YES >> GO TO 9.  
 NO >> GO TO 2.

# B170F SENSOR POWER SUPPLY

< DTC/CIRCUIT DIAGNOSIS >

## 2. CHECK ROOF LATCH LOCK SENSOR POWER SUPPLY CIRCUIT-II

1. Turn ignition switch OFF.
2. Disconnect retractable hard top control unit harness connector.
3. Check the continuity between roof latch assembly (roof latch lock sensor) harness connector and retractable hard top control unit harness connector.

Roof latch assembly (roof latch lock sensor)		Retractable hard top control unit		Continuity
Connector	Terminal	Connector	Terminal	
B657	1	B82	13	Existed

Is the inspection result normal?

- YES >> GO TO 3.  
 NO >> Repair or replace harness.

## 3. CHECK SENSOR POWER SUPPLY CIRCUIT

1. Disconnect following parts harness connector.
  - Hydraulic unit
  - Parcel shelf unit
  - Roof latch assembly
  - Trunk link sensor (LH)
  - Trunk link sensor (RH)
2. Check harness for short to ground (Check the continuity between following parts harness connector and ground, or retractable hard top control unit harness connector and ground).

Parts			Ground	Continuity
Name	Connector	Terminal		
Hydraulic unit (trunk status sensor)	B80	11	Ground	Not existed
Parcel shelf unit [parcel shelf motor (draw) and parcel shelf motor (rotation)]	B71	6		
Roof latch assembly (roof latch lock sensor and roof latch status sensor)	B657	1		
Trunk link sensor (LH)	B303	2		
Trunk link sensor (RH)	B86	2		

Retractable hard top control unit		Ground	Continuity
Connector	Terminal		
B82	13	Ground	Not existed

Is the inspection result normal?

- YES >> GO TO 4.  
 NO >> Repair or replace harness.

## 4. CHECK PARCEL SHELF UNIT

1. Reconnect retractable hard top control unit harness connector and parcel shelf unit harness connector.
2. Turn ignition switch ON.
3. Check DTC.

Is DTC B170F displayed?

- YES >> Replace parcel shelf unit. Refer to [RF-290, "REAR PARCEL SHELF UNIT : Removal and Installation"](#).  
 NO >> GO TO 5.

## 5. CHECK ROOF LATCH ASSEMBLY

1. Turn ignition switch OFF.
2. Reconnect roof latch assembly harness connector.
3. Turn ignition switch ON.
4. Check DTC.

# B170F SENSOR POWER SUPPLY

## < DTC/CIRCUIT DIAGNOSIS >

### Is DTC B170F displayed?

YES >> Replace roof latch assembly. Refer to [RF-269, "ROOF LOCK ASSEMBLY : Removal and Installation"](#).

NO >> GO TO 6.

### **6.CHECK TRUNK LINK SENSOR (LH)**

1. Turn ignition switch OFF.
2. Reconnect trunk link sensor (LH) harness connector.
3. Turn ignition switch ON.
4. Check DTC.

### Is DTC B170F displayed?

YES >> Replace trunk link sensor (LH). Refer to [RF-15, "Component Parts Location"](#).

NO >> GO TO 7.

### **7.CHECK TRUNK LINK SENSOR (RH)**

1. Turn ignition switch OFF.
2. Reconnect trunk link sensor (RH) harness connector.
3. Turn ignition switch ON.
4. Check DTC.

### Is DTC B170F displayed?

YES >> Replace trunk link sensor (RH). Refer to [RF-15, "Component Parts Location"](#).

NO >> GO TO 8.

### **8.CHECK HYDRAULIC UNIT**

1. Turn ignition switch OFF.
2. Reconnect hydraulic unit harness connector.
3. Turn ignition switch ON.
4. Check DTC.

### Is DTC B170F displayed?

YES >> Replace hydraulic unit. Refer to [RF-299, "Removal and Installation"](#).

NO >> GO TO 9.

### **9.REPLACE RETRACTABLE HARD TOP CONTROL UNIT**

Replace retractable hard top control unit. Refer to [RF-309, "Removal and Installation"](#).

### Is the inspection result normal?

YES >> INSPECTION END

NO >> GO TO 10.

### **10.CHECK INTERMITTENT INCIDENT**

Refer to [GI-43, "Intermittent Incident"](#).

>> INSPECTION END

A  
B  
C  
D  
E  
F  
G  
H  
I  
J  
RF  
L  
M  
N  
O  
P

# B1710 ROOF LATCH STATUS SENSOR

< DTC/CIRCUIT DIAGNOSIS >

## B1710 ROOF LATCH STATUS SENSOR

### DTC Logic

INFOID:000000006468705

### DTC DETECTION LOGIC

#### NOTE:

If two or more DTCs are detected, refer to [RF-61, "DTC Inspection Priority Chart"](#), and determine trouble diagnosis order.

DTC No.	Trouble diagnosis name		DTC detecting condition	Possible cause
B1710	LATCH STATUS SENSOR	[PWR-SHORT]	Roof latch status sensor circuit is open, short to ground or short to power.	<ul style="list-style-type: none"> <li>• Harness or connectors (The sensor circuit is open or shorted.)</li> <li>• Retractable hard top</li> <li>• Retractable hard top control unit</li> <li>• Roof latch status sensor</li> </ul>
		[GND-SHORT/ OPEN]		

### DTC CONFIRMATION PROCEDURE

#### 1. PERFORM DTC CONFIRMATION PROCEDURE

1. Start engine.
2. Operate retractable hard top to fully open and fully close.
3. Check DTC.

#### Is DTC detected?

- YES >> Go to [RF-109, "Diagnosis Procedure"](#).  
 NO >> INSPECTION END

### Diagnosis Procedure

INFOID:000000006468706

#### 1. CHECK ROOF LATCH STATUS SENSOR POWER SUPPLY CIRCUIT

1. Turn ignition switch OFF.
2. Disconnect roof latch assembly (roof latch status sensor) harness connector.
3. Turn ignition switch ON.
4. Check the voltage between roof latch assembly (roof latch status sensor) harness connector and ground.

(+)		(-)	Voltage (V) (Approx.)
Roof latch assembly (roof latch status sensor)			
Connector	Terminal		
B657	1	Ground	5

#### Is the inspection result normal?

- YES >> GO TO 2.  
 NO >> Repair or replace harness.

#### 2. CHECK ROOF LATCH STATUS SENSOR GROUND CIRCUIT FOR OPEN AND SHORT

1. Turn ignition switch OFF.
2. Disconnect retractable hard top control unit harness connector.
3. Check the continuity between roof latch assembly (roof latch status sensor) harness connector and retractable hard top control unit harness connector.

Roof latch assembly (roof latch status sensor)		Retractable hard top control unit		Continuity
Connector	Terminal	Connector	Terminal	
B657	4	B82	16	Existed

4. Check harness for short to ground and short to power.

#### Is the inspection result normal?

- YES >> GO TO 3.

## B1710 ROOF LATCH STATUS SENSOR

### < DTC/CIRCUIT DIAGNOSIS >

---

NO >> Repair or replace harness.

### 3.REPLACE ROOF LATCH ASSEMBLY

---

Replace roof latch assembly. Refer to [RF-269, "ROOF LOCK ASSEMBLY : Removal and Installation"](#).

Is the inspection result normal?

YES >> INSPECTION END

NO >> GO TO 4.

### 4.CHECK RETRACTABLE HARD TOP

---

Check retractable hard top mechanism deformation, looseness, rattle, interference with other parts, and pinched foreign materials. Refer to [RF-287, "Exploded View"](#).

Is the inspection result normal?

YES >> GO TO 5.

NO >> Repair or replace malfunctioning part.

### 5.REPLACE RETRACTABLE HARD TOP CONTROL UNIT

---

Replace retractable hard top control unit. Refer to [RF-309, "Removal and Installation"](#).

Is the inspection result normal?

YES >> INSPECTION END

NO >> GO TO 6.

### 6.CHECK INTERMITTENT INCIDENT

---

Refer to [GI-43, "Intermittent Incident"](#).

>> INSPECTION END

A  
B  
C  
D  
E  
F  
G  
H  
I  
J  
L  
M  
N  
O  
P

RF

# B1711 ROOF LATCH LOCK SENSOR

< DTC/CIRCUIT DIAGNOSIS >

## B1711 ROOF LATCH LOCK SENSOR

### DTC Logic

INFOID:000000006468707

### DTC DETECTION LOGIC

**NOTE:**

If two or more DTCs are detected, refer to [RF-61, "DTC Inspection Priority Chart"](#), and determine trouble diagnosis order.

DTC No.	Trouble diagnosis name		DTC detecting condition	Possible cause
B1711	LATCH LOCK SENSOR	[PWR-SHORT]	Roof latch lock sensor circuit is open, short to ground or short to power.	<ul style="list-style-type: none"> <li>• Harness or connectors (The sensor circuit is open or shorted.)</li> <li>• Retractable hard top</li> <li>• Retractable hard top control unit</li> <li>• Roof latch lock sensor</li> </ul>
		[GND-SHORT/ OPEN]		

### DTC CONFIRMATION PROCEDURE

#### 1. PERFORM DTC CONFIRMATION PROCEDURE

1. Start engine.
2. Operate retractable hard top fully open and fully close.
3. Check DTC.

Is DTC detected?

- YES >> Go to [RF-109, "Diagnosis Procedure"](#).  
 NO >> INSPECTION END

### Diagnosis Procedure

INFOID:000000006468708

#### 1. CHECK ROOF LATCH LOCK SENSOR POWER SUPPLY CIRCUIT

1. Turn ignition switch OFF.
2. Disconnect roof latch assembly (roof latch lock sensor) harness connector.
3. Turn ignition switch ON.
4. Check the voltage between roof latch assembly (roof latch lock sensor) harness connector and ground.

(+)		(-)	Voltage (V) (Approx.)
Roof latch assembly (roof latch lock sensor)			
Connector	Terminal		
B657	1	Ground	5

Is the inspection result normal?

- YES >> GO TO 2.  
 NO >> Repair or replace harness.

#### 2. CHECK ROOF LATCH LOCK SENSOR GROUND CIRCUIT FOR OPEN AND SHORT

1. Turn ignition switch OFF.
2. Disconnect retractable hard top control unit harness connector.
3. Check the continuity between roof latch assembly (roof latch lock sensor) harness connector and retractable hard top control unit harness connector.

Roof latch assembly (roof latch lock sensor)		Retractable hard top control unit		Continuity
Connector	Terminal	Connector	Terminal	
B657	2	B82	17	Existed

4. Check harness for short to ground and short to power.

Is the inspection result normal?

- YES >> GO TO 3.

## B1711 ROOF LATCH LOCK SENSOR

### < DTC/CIRCUIT DIAGNOSIS >

---

NO >> Repair or replace harness.

#### 3.REPLACE ROOF LATCH ASSEMBLY

---

Replace roof latch assembly. Refer to [RF-269, "ROOF LOCK ASSEMBLY : Removal and Installation"](#).

Is the inspection result normal?

YES >> INSPECTION END

NO >> GO TO 4.

#### 4.CHECK RETRACTABLE HARD TOP

---

Check retractable hard top mechanism deformation, looseness, rattle, interference with other parts, and pinched foreign materials. Refer to [RF-287, "Exploded View"](#).

Is the inspection result normal?

YES >> GO TO 5.

NO >> Repair or replace malfunctioning part.

#### 5.REPLACE RETRACTABLE HARD TOP CONTROL UNIT

---

Replace retractable hard top control unit. Refer to [RF-309, "Removal and Installation"](#),

Is the inspection result normal?

YES >> INSPECTION END

NO >> GO TO 6.

#### 6.CHECK INTERMITTENT INCIDENT

---

Refer to [GI-43, "Intermittent Incident"](#).

>> INSPECTION END

A  
B  
C  
D  
E  
F  
G  
H  
I  
J  
L  
M  
N  
O  
P

RF

# B1712 TRUNK STATUS SENSOR

< DTC/CIRCUIT DIAGNOSIS >

## B1712 TRUNK STATUS SENSOR

### DTC Logic

INFOID:000000006468709

### DTC DETECTION LOGIC

**NOTE:**

If two or more DTCs are detected, refer to [RF-61, "DTC Inspection Priority Chart"](#), and determine trouble diagnosis order.

DTC No.	Trouble diagnosis name		DTC detecting condition	Possible causes
B1712	TRUNK STA-TUS SENSOR	[PWR-SHORT]	Trunk status sensor circuit is open, short to ground or short to power.	<ul style="list-style-type: none"> <li>• Harness or connectors (The sensor circuit is open or shorted.)</li> <li>• Hydraulic unit</li> <li>• Retractable hard top control unit</li> </ul>
		[GND-SHORT/ OPEN]		

### DTC CONFIRMATION PROCEDURE

#### 1. PERFORM DTC CONFIRMATION PROCEDURE

1. Start engine.
2. Operate retractable hard top to fully open and fully close.
3. Check DTC.

Is DTC detected?

- YES >> Go to [RF-109, "Diagnosis Procedure"](#).  
 NO >> INSPECTION END

### Diagnosis Procedure

INFOID:000000006468710

#### 1. CHECK TRUNK STATUS SENSOR POWER SUPPLY CIRCUIT

1. Turn ignition switch OFF.
2. Disconnect hydraulic unit (trunk status sensor) harness connector.
3. Turn ignition switch ON.
4. Check the voltage between hydraulic unit (trunk status sensor) harness connector and ground.

(+)		(-)	Voltage (V) (Approx.)
Hydraulic unit (trunk status sensor)			
Connector	Terminal		
B80	11	Ground	5

Is the inspection result normal?

- YES >> GO TO 2.  
 NO >> Repair or replace harness.

#### 2. CHECK TRUNK STATUS SENSOR GROUND CIRCUIT FOR OPEN AND SHORT

1. Turn ignition switch OFF.
2. Disconnect retractable hard top control unit harness connector.
3. Check the continuity between hydraulic unit (trunk status sensor) harness connector and retractable hard top control unit harness connector.

Hydraulic unit (trunk status sensor)		Retractable hard top control unit		Continuity
Connector	Terminal	Connector	Terminal	
B80	10	B82	18	Existed

4. Check harness for short to ground and short to power.

Is the inspection result normal?

- YES >> GO TO 3.  
 NO >> Repair or replace harness.



## B1712 TRUNK STATUS SENSOR

< DTC/CIRCUIT DIAGNOSIS >

---

### 3.REPLACE HYDRAULIC UNIT

---

Replace hydraulic unit. Refer to [RF-299, "Removal and Installation"](#).

Is the inspection result normal?

YES >> INSPECTION END

NO >> GO TO 4.

### 4.REPLACE RETRACTABLE HARD TOP CONTROL UNIT

---

Replace retractable hard top control unit. Refer to [RF-309, "Removal and Installation"](#).

Is the inspection result normal?

YES >> INSPECTION END

NO >> GO TO 5.

### 5.CHECK INTERMITTENT INCIDENT

---

Refer to [GI-43, "Intermittent Incident"](#).

>> INSPECTION END

A  
B  
C  
D  
E  
F  
G  
H  
I  
J  
L  
M  
N  
O  
P

RF

# B1715 ROOF STATUS SENSOR POWER SUPPLY

< DTC/CIRCUIT DIAGNOSIS >

## B1715 ROOF STATUS SENSOR POWER SUPPLY

### DTC Logic

INFOID:000000006468711

### DTC DETECTION LOGIC

**NOTE:**

If two or more DTCs are detected, refer to [RF-61, "DTC Inspection Priority Chart"](#), and determine trouble diagnosis order.

DTC No.	Trouble diagnosis name		DTC detecting condition	Possible causes
B1715	ROOF STAUS SEN PWR	[GND- SHORT]	Roof status sensor power supply circuit is short to ground.	<ul style="list-style-type: none"> <li>• Harness or connectors (The sensor circuit is shorted.)</li> <li>• Retractable hard top</li> <li>• Retractable hard top control unit</li> <li>• Roof status sensor</li> </ul>

### DTC CONFIRMATION PROCEDURE

#### 1. PERFORM DTC CONFIRMATION PROCEDURE

1. Start engine.
2. Operate retractable hard top to fully open and fully close.
3. Check DTC.

Is DTC detected?

- YES >> Go to [RF-122, "Diagnosis Procedure"](#).  
 NO >> INSPECTION END

### Diagnosis Procedure

INFOID:000000006468712

#### 1. CHECK ROOF STATUS SENSOR POWER SUPPLY CIRCUIT

1. Turn ignition switch OFF.
2. Disconnect roof status sensor harness connector.
3. Turn ignition switch ON.
4. Check the voltage between roof status sensor harness connector and ground.

(+)		(-)	Voltage (V) (Approx.)
Roof status sensor			
Connector	Terminal		
B656	3	Ground	5

Is the inspection result normal?

- YES >> GO TO 2.  
 NO >> Repair or replace harness.

#### 2. CHECK ROOF STATUS SENSOR GROUND CIRCUIT FOR OPEN AND SHORT

1. Turn ignition switch OFF.
2. Disconnect retractable hard top control unit harness connector.
3. Check the continuity between roof status sensor harness connector and retractable hard top control unit harness connector.

Roof status sensor		Retractable hard top control unit		Continuity
Connector	Terminal	Connector	Terminal	
B656	1	B82	23	Existed

4. Check harness for short to ground and short to power.

Is the inspection result normal?

- YES >> GO TO 3.

## B1715 ROOF STATUS SENSOR POWER SUPPLY

### < DTC/CIRCUIT DIAGNOSIS >

---

NO >> Repair or replace harness.

### 3.REPLACE ROOF STATUS SENSOR

---

Replace roof status sensor. Refer to [RF-15, "Component Parts Location"](#).

Is the inspection result normal?

YES >> INSPECTION END

NO >> GO TO 4.

### 4.CHECK RETRACTABLE HARD TOP

---

Check retractable hard top mechanism deformation, looseness, rattle, interference with other parts, and pinched foreign materials. Refer to [RF-287, "Exploded View"](#).

Is the inspection result normal?

YES >> GO TO 5.

NO >> Repair or replace malfunctioning part.

### 5.REPLACE RETRACTABLE HARD TOP CONTROL UNIT

---

Replace retractable hard top control unit. Refer to [RF-309, "Removal and Installation"](#).

Is the inspection result normal?

YES >> INSPECTION END

NO >> GO TO 6.

### 6.CHECK INTERMITTENT INCIDENT

---

Refer to [GI-43, "Intermittent Incident"](#).

>> INSPECTION END

A  
B  
C  
D  
E  
F  
G  
H  
I  
J  
RF  
L  
M  
N  
O  
P

# B1716 PARCEL SHELF STATUS SENSOR (DRAW)

< DTC/CIRCUIT DIAGNOSIS >

## B1716 PARCEL SHELF STATUS SENSOR (DRAW)

### DTC Logic

INFOID:000000006468713

### DTC DETECTION LOGIC

#### NOTE:

If two or more DTCs are detected, refer to [RF-61, "DTC Inspection Priority Chart"](#), and determine trouble diagnosis order.

DTC No.	Trouble diagnosis name		DTC detecting condition	Possible causes
B1718	PS STAUS SEN (DRAW)	[PWR-SHORT]	Parcel shelf status sensor (draw) circuit is open, short to ground or short to power.	<ul style="list-style-type: none"> <li>Harness or connectors (The sensor circuit is open or shorted.)</li> <li>Parcel shelf unit</li> <li>Retractable hard top control unit</li> </ul>
		[GND-SHORT/OPEN]		

### DTC CONFIRMATION PROCEDURE

#### 1. PERFORM DTC CONFIRMATION PROCEDURE

1. Start engine.
2. Operate retractable hard top to fully open and fully close.
3. Check DTC.

#### Is DTC detected?

- YES >> Go to [RF-124, "Diagnosis Procedure"](#).  
 NO >> INSPECTION END

### Diagnosis Procedure

INFOID:000000006468714

#### 1. CHECK PARCEL SHELF STATUS SENSOR (DRAW) POWER SUPPLY CIRCUIT

1. Turn ignition switch OFF.
2. Disconnect parcel shelf unit [parcel shelf status sensor (draw)] harness connector.
3. Turn ignition switch ON.
4. Check the voltage between parcel shelf unit [parcel shelf status sensor (draw)] harness connector and ground.

(+)		(-)	Voltage (V) (Approx.)
Parcel shelf unit [parcel shelf status sensor (draw)]			
Connector	Terminal	Ground	5
B71	6		

#### Is the inspection result normal?

- YES >> GO TO 2.  
 NO >> Repair or replace harness.

#### 2. CHECK PARCEL SHELF STATUS SENSOR (DRAW) GROUND CIRCUIT FOR OPEN AND SHORT

1. Turn ignition switch OFF.
2. Disconnect retractable hard top control unit harness connector.
3. Check the continuity between parcel shelf unit [parcel shelf status sensor (draw)] harness connector and retractable hard top control unit harness connector.

Parcel shelf unit [parcel shelf status sensor (draw)]		Retractable hard top control unit		Continuity
Connector	Terminal	Connector	Terminal	
B71	5	B82	24	Existed

4. Check harness for short to ground and short to power.

#### Is the inspection result normal?

- YES >> GO TO 3.

## B1716 PARCEL SHELF STATUS SENSOR (DRAW)

< DTC/CIRCUIT DIAGNOSIS >

---

NO >> Repair or replace harness.

### 3.CHECK PARCEL SHELF UNIT

---

Replace parcel shelf unit. Refer to [RF-290, "REAR PARCEL SHELF UNIT : Removal and Installation"](#).

Is the inspection result normal?

YES >> INSPECTION END

NO >> GO TO 4.

### 4.CHECK RETRACTABLE HARD TOP

---

Check retractable hard top mechanism deformation, looseness, rattle, interference with other parts, and pinched foreign materials. Refer to [RF-287, "Exploded View"](#).

Is the inspection result normal?

YES >> GO TO 5.

NO >> Repair or replace malfunctioning part.

### 5.REPLACE RETRACTABLE HARD TOP CONTROL UNIT

---

Replace retractable hard top control unit. Refer to [RF-309, "Removal and Installation"](#).

Is the inspection result normal?

YES >> INSPECTION END

NO >> GO TO 6.

### 6.CHECK INTERMITTENT INCIDENT

---

Refer to [GI-43, "Intermittent Incident"](#).

>> INSPECTION END

A  
B  
C  
D  
E  
F  
G  
H  
I  
J  
L  
M  
N  
O  
P

RF

# B1718 PARCEL SHELF STATUS SENSOR (ROTATE)

< DTC/CIRCUIT DIAGNOSIS >

## B1718 PARCEL SHELF STATUS SENSOR (ROTATE)

### DTC Logic

INFOID:000000006468715

### DTC DETECTION LOGIC

#### NOTE:

If two or more DTCs are detected, refer to [RF-61, "DTC Inspection Priority Chart"](#), and determine trouble diagnosis order.

DTC No.	Trouble diagnosis name		DTC detecting condition	Possible causes
B1716	PS STATUS SEN(RO-TA)	[PWR-SHORT]	Parcel shelf status sensor (rotation) circuit is open, short to ground or short to power.	<ul style="list-style-type: none"> <li>• Harness or connectors (The sensor circuit is open or shorted.)</li> <li>• Parcel shelf motor (rotation)</li> <li>• Retractable hard top control unit</li> </ul>
		[GND-SHORT/OPEN]		

### DTC CONFIRMATION PROCEDURE

#### 1. PERFORM DTC CONFIRMATION PROCEDURE

1. Start engine.
2. Operate retractable hard top to fully open and fully close.
3. Check DTC.

#### Is DTC detected?

- YES >> Go to [RF-126, "Diagnosis Procedure"](#).  
 NO >> INSPECTION END

### Diagnosis Procedure

INFOID:000000006468716

#### 1. CHECK PARCEL SHELF STATUS SENSOR (ROTATION) POWER SUPPLY CIRCUIT

1. Turn ignition switch OFF.
2. Disconnect parcel shelf unit [parcel shelf status sensor (rotation)] harness connector.
3. Turn ignition switch ON.
4. Check the voltage between parcel shelf unit [parcel shelf status sensor (rotation)] harness connector and ground.

(+)		(-)	Voltage (V) (Approx.)
Parcel shelf unit [parcel shelf status sensor (rotation)]			
Connector	Terminal		
B71	6	Ground	5

#### Is the inspection result normal?

- YES >> GO TO 2.  
 NO >> Repair or replace harness.

#### 2. CHECK PARCEL SHELF STATUS SENSOR (ROTATION) GROUND CIRCUIT FOR OPEN AND SHORT

1. Turn ignition switch OFF.
2. Disconnect retractable hard top control unit harness connector.
3. Check the continuity between parcel shelf unit [parcel shelf status sensor (rotation)] harness connector and retractable hard top control unit harness connector.

Parcel shelf unit [parcel shelf status sensor (rotation)]		Retractable hard top control unit		Continuity
Connector	Terminal	Connector	Terminal	
B71	7	B82	25	Existed

4. Check harness for short to ground and short to power.

#### Is the inspection result normal?

## B1718 PARCEL SHELF STATUS SENSOR (ROTATE)

< DTC/CIRCUIT DIAGNOSIS >

---

- YES >> GO TO 3.
- NO >> Repair or replace harness.

### 3.REPLACE PARCEL SHELF UNIT

---

Replace parcel shelf unit. Refer to [RF-290. "REAR PARCEL SHELF UNIT : Removal and Installation"](#).

Is the inspection result normal?

- YES >> INSPECTION END
- NO >> GO TO 4.

### 4.CHECK RETRACTABLE HARD TOP

---

Check retractable hard top mechanism deformation, looseness, rattle, interference with other parts, and pinched foreign materials. Refer to [RF-287. "Exploded View"](#).

Is the inspection result normal?

- YES >> GO TO 5.
- NO >> Repair or replace malfunctioning part.

### 5.REPLACE RETRACTABLE HARD TOP CONTROL UNIT

---

Replace retractable hard top control unit. Refer to [RF-309. "Removal and Installation"](#).

Is the inspection result normal?

- YES >> INSPECTION END
- NO >> GO TO 6.

### 6.CHECK INTERMITTENT INCIDENT

---

Refer to [GI-43. "Intermittent Incident"](#).

>> INSPECTION END

A  
B  
C  
D  
E  
F  
G  
H  
I  
J  
RF  
L  
M  
N  
O  
P

# B1719 ROOF STATUS SENSOR

< DTC/CIRCUIT DIAGNOSIS >

## B1719 ROOF STATUS SENSOR

### DTC Logic

INFOID:000000006468717

### DTC DETECTION LOGIC

#### NOTE:

If two or more DTCs are detected, refer to [RF-61, "DTC Inspection Priority Chart"](#), and determine trouble diagnosis order.

DTC No.	Trouble diagnosis name		DTC detecting condition	Possible causes
B1719	ROOF STATUS SEN	[GND-SHORT] [PWR-SHORT/OPEN]	Roof status sensor signal circuit is open, short to ground or short to power.	<ul style="list-style-type: none"><li>• Harness or connectors (The sensor circuit is open or shorted.)</li><li>• Retractable hard top control unit</li><li>• Roof status sensor</li></ul>

### DTC CONFIRMATION PROCEDURE

#### 1. PERFORM DTC CONFIRMATION PROCEDURE

1. Start engine
2. Operate retractable hard top to fully open and fully close.
3. Check DTC.

#### Is DTC detected?

- YES >> Go to [RF-128, "Diagnosis Procedure"](#).  
NO >> INSPECTION END

### Diagnosis Procedure

INFOID:000000006468718

#### 1. CHECK ROOF STATUS SENSOR GROUND CIRCUIT FOR OPEN AND SHORT

1. Turn ignition switch OFF.
2. Disconnect roof status sensor harness connector and retractable hard top control unit harness connector.
3. Check the continuity between roof status sensor harness connector and retractable hard top control unit harness connector.

Roof status sensor		Retractable hard top control unit		Continuity
Connector	Terminal	Connector	Terminal	
B656	1	B82	23	Existed

4. Check harness for short to ground and short to power.

#### Is the inspection result normal?

- YES >> GO TO 2.  
NO >> Repair or replace harness.

#### 2. CHECK ROOF STATUS SENSOR INPUT SIGNAL CIRCUIT FOR OPEN AND SHORT

1. Check the continuity between roof status sensor harness connector and retractable hard top control unit harness connector.

Roof status sensor		Retractable hard top control unit		Continuity
Connector	Terminal	Connector	Terminal	
B656	2	B82	26	Existed

2. Check harness for short to ground and short to power.

#### Is the inspection result normal?

- YES >> GO TO 3.  
NO >> Repair or replace harness.

#### 3. REPLACE ROOF STATUS SENSOR



## B1719 ROOF STATUS SENSOR

### < DTC/CIRCUIT DIAGNOSIS >

---

Replace roof status sensor. Refer to [RF-15. "Component Parts Location"](#).

Is the inspection result normal?

- YES >> INSPECTION END
- NO >> GO TO 4.

### 4.CHECK RETRACTABLE HARD TOP

---

Check retractable hard top mechanism deformation, looseness, rattle, interference with other parts, and pinched foreign materials. Refer to [RF-287. "Exploded View"](#).

Is the inspection result normal?

- YES >> GO TO 5.
- NO >> Repair or replace malfunctioning part.

### 5.REPLACE RETRACTABLE HARD TOP CONTROL UNIT

---

Replace retractable hard top control unit. Refer to [RF-309. "Removal and Installation"](#).

Is the inspection result normal?

- YES >> INSPECTION END
- NO >> GO TO 6.

### 6.CHECK INTERMITTENT INCIDENT

---

Refer to [GI-43. "Intermittent Incident"](#).

>> INSPECTION END

A  
B  
C  
D  
E  
F  
G  
H  
I  
J  
RF  
L  
M  
N  
O  
P

# B171A HYDRAULIC PUMP (LH)

< DTC/CIRCUIT DIAGNOSIS >

## B171A HYDRAULIC PUMP (LH)

### DTC Logic

INFOID:000000006468719

#### DTC DETECTION LOGIC

##### NOTE:

If two or more DTCs are detected, refer to [RF-61, "DTC Inspection Priority Chart"](#), and determine trouble diagnosis order.

DTC No.	Trouble diagnosis name		DTC detecting condition	Possible causes
B171A	HYDRAULIC PMP(LH)	[GND-SHORT]	Hydraulic pump relay (LH) circuit is open, short to ground or short to power.	<ul style="list-style-type: none"> <li>• Harness or connectors (The hydraulic pump relay (LH) circuit is open or shorted.)</li> <li>• Hydraulic unit</li> <li>• Retractable hard top control unit</li> </ul>
		[PWR-SHORT]		
		[OPEN]		

#### DTC CONFIRMATION PROCEDURE

##### 1. PERFORM DTC CONFIRMATION PROCEDURE

1. Start engine.
2. Operate retractable hard top to fully open and fully close.
3. Check DTC.

Is DTC detected?

- YES >> Go to [RF-130, "Diagnosis Procedure"](#).  
 NO >> INSPECTION END

#### Diagnosis Procedure

INFOID:000000006468720

##### 1. CHECK HYDRAULIC PUMP RELAY (LH) POWER SUPPLY CIRCUIT

1. Turn ignition switch OFF.
2. Disconnect hydraulic unit [hydraulic pump relay (LH)] harness connector.
3. Turn ignition switch ON.
4. Check the voltage between hydraulic unit [hydraulic pump relay (LH)] harness connector and ground.

(+)		(-)	Voltage (V) (Approx)
Hydraulic unit [hydraulic pump relay (LH)]			
Connector	Terminal		
B80	5	Ground	Battery voltage

Is the inspection result normal?

- YES >> GO TO 2.  
 NO >> Repair or replace harness.

##### 2. CHECK HYDRAULIC PUMP RELAY (LH) GROUND CIRCUIT FOR OPEN AND SHORT

1. Turn ignition switch OFF.
2. Disconnect retractable hard top control unit harness connector.
3. Check the continuity between hydraulic unit [hydraulic pump relay (LH)] harness connector and retractable hard top control unit harness connector.

Hydraulic unit [hydraulic pump relay (LH)]		Retractable hard top control unit		Continuity
Connector	Terminal	Connector	Terminal	
B80	3	B82	38	Existed

4. Check harness for short to ground and short to power.

Is the inspection result normal?

- YES >> GO TO 3.

## B171A HYDRAULIC PUMP (LH)

### < DTC/CIRCUIT DIAGNOSIS >

---

NO >> Repair or replace harness.

### 3.REPLACE HYDRAULIC UNIT

---

Replace hydraulic unit. Refer to [RF-299, "Removal and Installation"](#).

Is the inspection result normal?

YES >> INSPECTION END

NO >> GO TO 4.

### 4.REPLACE RETRACTABLE HARD TOP CONTROL UNIT

---

Replace retractable hard top control unit. Refer to [RF-309, "Removal and Installation"](#).

Is the inspection result normal?

YES >> INSPECTION END

NO >> GO TO 5.

### 5.CHECK INTERMITTENT INCIDENT

---

Refer to [GI-43, "Intermittent Incident"](#).

>> INSPECTION END

A  
B  
C  
D  
E  
F  
G  
H  
I  
J  
RF  
L  
M  
N  
O  
P

# B171B HYDRAULIC PUMP (RH)

< DTC/CIRCUIT DIAGNOSIS >

## B171B HYDRAULIC PUMP (RH)

### DTC Logic

INFOID:000000006468721

#### DTC DETECTION LOGIC

##### NOTE:

If two or more DTCs are detected, refer to [RF-61, "DTC Inspection Priority Chart"](#), and determine trouble diagnosis order.

DTC No.	Trouble diagnosis name		DTC detecting condition	Possible causes
B171B	HYDRAULIC PMP (RH)	[GND-SHORT]	Hydraulic pump relay (RH) circuit is open, short to ground or short to power.	<ul style="list-style-type: none"> <li>• Harness or connectors (The hydraulic pump relay (RH) circuit is open or shorted.)</li> <li>• Hydraulic unit</li> <li>• Retractable hard top control unit</li> </ul>
		[PWR-SHORT]		
		[OPEN]		

#### DTC CONFIRMATION PROCEDURE

##### 1. PERFORM DTC CONFIRMATION PROCEDURE

1. Start engine.
2. Operate retractable hard top to fully open and fully close.
3. Check DTC.

##### Is DTC detected?

- YES >> Go to [RF-132, "Diagnosis Procedure"](#).  
 NO >> INSPECTION END

#### Diagnosis Procedure

INFOID:000000006468722

##### 1. CHECK HYDRAULIC PUMP RELAY (RH) POWER SUPPLY CIRCUIT

1. Turn ignition switch OFF.
2. Disconnect hydraulic unit [hydraulic pump relay (RH)] harness connector.
3. Turn ignition switch ON.
4. Check the voltage between hydraulic unit [hydraulic pump relay (RH)] harness connector and ground.

(+)		(-)	Voltage (V) (Approx.)
Hydraulic unit [hydraulic pump relay (RH)]	Connector		
	Terminal	Ground	Battery voltage
B80	4		

##### Is the inspection result normal?

- YES >> GO TO 2.  
 NO >> Repair or replace harness.

##### 2. CHECK HYDRAULIC PUMP RELAY (RH) GROUND CIRCUIT FOR OPEN AND SHORT

1. Turn ignition switch OFF.
2. Disconnect retractable hard top control unit harness connector.
3. Check the continuity between hydraulic unit [hydraulic pump relay (RH)] harness connector and retractable hard top control unit harness connector.

Hydraulic unit [hydraulic pump relay (RH)]		Retractable hard top control unit		Continuity
Connector	Terminal	Connector	Terminal	
B80	3	B82	38	Existed

4. Check harness for short to ground and short to power.

##### Is the inspection result normal?

- YES >> GO TO 3.

## B171B HYDRAULIC PUMP (RH)

### < DTC/CIRCUIT DIAGNOSIS >

---

NO >> Repair or replace harness.

### 3.REPLACE HYDRAULIC UNIT

---

Replace hydraulic unit. Refer to [RF-299, "Removal and Installation"](#).

Is the inspection result normal?

YES >> INSPECTION END

NO >> GO TO 4.

### 4.REPLACE RETRACTABLE HARD TOP CONTROL UNIT

---

Replace retractable hard top control unit. Refer to [RF-309, "Removal and Installation"](#).

Is the inspection result normal?

YES >> INSPECTION END

NO >> GO TO 5.

### 5.CHECK INTERMITTENT INCIDENT

---

Refer to [GI-43, "Intermittent Incident"](#).

>> INSPECTION END

A

B

C

D

E

F

G

H

I

J

RF

L

M

N

O

P

# B171C SWITCHING VALVE 1

< DTC/CIRCUIT DIAGNOSIS >

## B171C SWITCHING VALVE 1

### DTC Logic

INFOID:000000006468723

### DTC DETECTION LOGIC

**NOTE:**

If two or more DTCs are detected, refer to [RF-61, "DTC Inspection Priority Chart"](#), and determine trouble diagnosis order.

DTC No.	Trouble diagnosis name		DTC detecting condition	Possible causes
B171C	SWITCHING VALVE 1	[GND-SHORT]	Switching valve 1 circuit is open, short to ground or short to power.	<ul style="list-style-type: none"> <li>• Harness or connectors (The switching valve 1 circuit is open or shorted.)</li> <li>• Hydraulic unit</li> <li>• Retractable hard top control unit</li> </ul>
		[PWR-SHORT]		
		[OPEN]		

### DTC CONFIRMATION PROCEDURE

#### 1. PERFORM DTC CONFIRMATION PROCEDURE

1. Start engine.
2. Operate retractable hard top to fully open and fully close.
3. Check DTC.

Is DTC detected?

- YES >> Go to [RF-134, "Diagnosis Procedure"](#).  
 NO >> INSPECTION END

### Diagnosis Procedure

INFOID:000000006468724

#### 1. CHECK SWITCHING VALVE 1 POWER SUPPLY CIRCUIT

1. Turn ignition switch OFF.
2. Disconnect hydraulic unit (switching valve 1) harness connector.
3. Turn ignition switch ON.
4. Check the voltage between hydraulic unit (switching valve 1) harness connector and ground.

(+)		(-)	Voltage (V) (Approx.)
Hydraulic unit (switching valve 1)			
Connector	Terminal		
B80	1	Ground	Battery voltage

Is the inspection result normal?

- YES >> GO TO 2.  
 NO >> Repair or replace harness.

#### 2. CHECK SWITCHING VALVE 1 GROUND CIRCUIT FOR OPEN AND SHORT

1. Turn ignition switch OFF.
2. Disconnect retractable hard top control unit harness connector.
3. Check the continuity between hydraulic unit (switching valve 1) harness connector and retractable hard top control unit harness connector.

Hydraulic unit (switching valve 1)		Retractable hard top control unit		Continuity
Connector	Terminal	Connector	Terminal	
B80	2	B84	68	Existed

4. Check harness for short to ground and short to power.

Is the inspection result normal?

- YES >> GO TO 3.  
 NO >> Repair or replace harness.

# B171C SWITCHING VALVE 1

< DTC/CIRCUIT DIAGNOSIS >

---

## 3.REPLACE HYDRAULIC UNIT

---

Replace hydraulic unit. Refer to [RF-299, "Removal and Installation"](#).

Is the inspection result normal?

YES >> INSPECTION END

NO >> GO TO 4.

## 4.REPLACE RETRACTABLE HARD TOP CONTROL UNIT

---

Replace retractable hard top control unit. Refer to [RF-309, "Removal and Installation"](#).

Is the inspection result normal?

YES >> INSPECTION END

NO >> GO TO 5.

## 5.CHECK INTERMITTENT INCIDENT

---

Refer to [GI-43, "Intermittent Incident"](#).

>> INSPECTION END

A  
B  
C  
D  
E  
F  
G  
H  
I  
J  
L  
M  
N  
O  
P

RF

# B171D SWITCHING VALVE 2

< DTC/CIRCUIT DIAGNOSIS >

## B171D SWITCHING VALVE 2

### DTC Logic

INFOID:000000006468725

### DTC DETECTION LOGIC

**NOTE:**

If two or more DTCs are detected, refer to [RF-61, "DTC Inspection Priority Chart"](#), and determine trouble diagnosis order.

DTC No.	Trouble diagnosis name		DTC detecting condition	Possible causes
B171D	SWITCHING VALVE 2	[GND-SHORT]	Switching valve 2 circuit is open, short to ground or short to power.	<ul style="list-style-type: none"> <li>• Harness or connectors (The switching valve 2 circuit is open or shorted.)</li> <li>• Hydraulic unit</li> <li>• Retractable hard top control unit</li> </ul>
		[PWR-SHORT]		
		[OPEN]		

### DTC CONFIRMATION PROCEDURE

#### 1. PERFORM DTC CONFIRMATION PROCEDURE

1. Start engine.
2. Operate retractable hard top to fully open and fully close.
3. Check DTC.

Is DTC detected?

- YES >> Go to [RF-134, "Diagnosis Procedure"](#).  
 NO >> INSPECTION END

### Diagnosis Procedure

INFOID:000000006468726

#### 1. CHECK SWITCHING VALVE 2 POWER SUPPLY CIRCUIT

1. Turn ignition switch OFF.
2. Disconnect hydraulic unit (switching valve 2) harness connector.
3. Turn ignition switch ON.
4. Check the voltage between hydraulic unit (switching valve 2) harness connector and ground.

(+)		(-)	Voltage (V) (Approx.)
Hydraulic unit (switching valve 2)			
Connector	Terminal		
B80	9	Ground	Battery voltage

Is the inspection result normal?

- YES >> GO TO 2.  
 NO >> Repair or replace harness.

#### 2. CHECK SWITCHING VALVE 2 GROUND CIRCUIT FOR OPEN AND SHORT

1. Turn ignition switch OFF.
2. Disconnect retractable hard top control unit harness connector.
3. Check the continuity between hydraulic unit (switching valve 2) harness connector and retractable hard top control unit harness connector.

Hydraulic unit (switching valve 2)		Retractable hard top control unit		Continuity
Connector	Terminal	Connector	Terminal	
B80	9	B84	67	Existed

4. Check harness for short to ground and short to power.

Is the inspection result normal?

- YES >> GO TO 3.  
 NO >> Repair or replace harness.



## B171D SWITCHING VALVE 2

< DTC/CIRCUIT DIAGNOSIS >

---

### 3.REPLACE HYDRAULIC UNIT

---

Replace hydraulic unit. Refer to [RF-299, "Removal and Installation"](#).

Is the inspection result normal?

YES >> INSPECTION END

NO >> GO TO 4.

### 4.REPLACE RETRACTABLE HARD TOP CONTROL UNIT

---

Replace retractable hard top control unit. Refer to [RF-309, "Removal and Installation"](#).

Is the inspection result normal?

YES >> INSPECTION END

NO >> GO TO 5.

### 5.CHECK INTERMITTENT INCIDENT

---

Refer to [GI-43, "Intermittent Incident"](#).

>> INSPECTION END

A  
B  
C  
D  
E  
F  
G  
H  
I  
J  
RF  
L  
M  
N  
O  
P

# B171E RETRACTABLE HARD TOP CONTROL UNIT

< DTC/CIRCUIT DIAGNOSIS >

## B171E RETRACTABLE HARD TOP CONTROL UNIT

### DTC Logic

INFOID:000000006468727

### DTC DETECTION LOGIC

#### NOTE:

If two or more DTCs are detected, refer to [RF-61, "DTC Inspection Priority Chart"](#), and determine trouble diagnosis order.

DTC No.	Trouble diagnosis name	DTC detecting condition	Possible cause
B171E	ROOF CONTROL UNIT	<ul style="list-style-type: none"><li>Retractable hard top control unit detects output to parcel shelf motor (draw)-UP without output request.</li><li>Retractable hard top control unit requests output to parcel shelf motor (draw)-UP but cannot detect output.</li></ul>	Retractable hard top control unit

### DTC CONFIRMATION PROCEDURE

#### 1.PERFORM DTC CONFIRMATION PROCEDURE

1. Start engine.
2. Operate retractable hard top to fully open and fully close.
3. Check "Self-Diagnostic Result" of "RETRACTABLE HARD TOP" using CONSULT-III.

#### Is DTC detected?

- YES >> Refer to [RF-138, "Diagnosis Procedure"](#).  
NO >> INSPECTION END

### Diagnosis Procedure

INFOID:000000006468728

#### 1.CHECK SELF DIAGNOSTIC RESULT

1. Turn ignition switch OFF.
2. Replace retractable hard top control unit. Refer to [RF-309, "Removal and Installation"](#).
3. Perform DTC Confirmation Procedure. Refer to [RF-138, "DTC Logic"](#).

>> INSPECTION END

# B171F RETRACTABLE HARD TOP CONTROL UNIT

< DTC/CIRCUIT DIAGNOSIS >

## B171F RETRACTABLE HARD TOP CONTROL UNIT

### DTC Logic

INFOID:000000006468729

### DTC DETECTION LOGIC

#### NOTE:

If two or more DTCs are detected, refer to [RF-61, "DTC Inspection Priority Chart"](#), and determine trouble diagnosis order.

DTC No.	Trouble diagnosis name	DTC detecting condition	Possible cause
B171F	ROOF CONTROL UNIT	<ul style="list-style-type: none"><li>Retractable hard top control unit detects output to parcel shelf motor (draw)-DOWN without output request.</li><li>Retractable hard top control unit requests output to parcel shelf motor (draw)-DOWN but cannot detect output.</li></ul>	Retractable hard top control unit

### DTC CONFIRMATION PROCEDURE

#### 1. PERFORM DTC CONFIRMATION PROCEDURE

1. Start engine.
2. Operate retractable hard top to fully open and fully close.
3. Check "Self-Diagnostic Result" of "RETRACTABLE HARD TOP" using CONSULT-III.

#### Is DTC detected?

- YES >> Refer to [RF-139, "Diagnosis Procedure"](#).  
NO >> INSPECTION END

### Diagnosis Procedure

INFOID:000000006468730

#### 1. CHECK SELF DIAGNOSTIC RESULT

1. Turn ignition switch OFF.
2. Replace retractable hard top control unit. Refer to [RF-309, "Removal and Installation"](#).
3. Perform DTC Confirmation Procedure. Refer to [RF-139, "DTC Logic"](#).

>> INSPECTION END

# B1720 RETRACTABLE HARD TOP CONTROL UNIT

< DTC/CIRCUIT DIAGNOSIS >

## B1720 RETRACTABLE HARD TOP CONTROL UNIT

### DTC Logic

INFOID:000000006468731

### DTC DETECTION LOGIC

#### NOTE:

If two or more DTCs are detected, refer to [RF-61, "DTC Inspection Priority Chart"](#), and determine trouble diagnosis order.

DTC No.	Trouble diagnosis name	DTC detecting condition	Possible cause
B1720	ROOF CONTROL UNIT	<ul style="list-style-type: none"><li>Retractable hard top control unit detects output to parcel shelf motor (rotation)-HORIZONTAL without output request.</li><li>Retractable hard top control unit requests output to parcel shelf motor (rotation)-HORIZONTAL but cannot detect output.</li></ul>	Retractable hard top control unit

### DTC CONFIRMATION PROCEDURE

#### 1. PERFORM DTC CONFIRMATION PROCEDURE

1. Start engine.
2. Operate retractable hard top to fully open and fully close.
3. Check "Self-Diagnostic Result" of "RETRACTABLE HARD TOP" using CONSULT-III.

#### Is DTC detected?

- YES >> Refer to [RF-140, "Diagnosis Procedure"](#).  
NO >> INSPECTION END

### Diagnosis Procedure

INFOID:000000006468732

#### 1. CHECK SELF DIAGNOSTIC RESULT

1. Turn ignition switch OFF.
2. Replace retractable hard top control unit. Refer to [RF-309, "Removal and Installation"](#).
3. Perform DTC Confirmation Procedure. Refer to [RF-140, "DTC Logic"](#).

>> INSPECTION END

# B1721 RETRACTABLE HARD TOP CONTROL UNIT

< DTC/CIRCUIT DIAGNOSIS >

## B1721 RETRACTABLE HARD TOP CONTROL UNIT

### DTC Logic

INFOID:000000006468733

### DTC DETECTION LOGIC

#### NOTE:

If two or more DTCs are detected, refer to [RF-61, "DTC Inspection Priority Chart"](#), and determine trouble diagnosis order.

DTC No.	Trouble diagnosis name	DTC detecting condition	Possible cause
B1721	ROOF CONTROL UNIT	<ul style="list-style-type: none"><li>Retractable hard top control unit detects output to parcel shelf motor (rotation)-VERTICAL without output request.</li><li>Retractable hard top control unit requests output to parcel shelf motor (rotation)-VERTICAL but cannot detect output.</li></ul>	Retractable hard top control unit

### DTC CONFIRMATION PROCEDURE

#### 1.PERFORM DTC CONFIRMATION PROCEDURE

1. Start engine.
2. Operate retractable hard top to fully open and fully close.
3. Check "Self-Diagnostic Result" of "RETRACTABLE HARD TOP" using CONSULT-III.

#### Is DTC detected?

- YES >> Refer to [RF-141, "Diagnosis Procedure"](#).  
NO >> INSPECTION END

### Diagnosis Procedure

INFOID:000000006468734

#### 1.CHECK SELF DIAGNOSTIC RESULT

1. Turn ignition switch OFF.
2. Replace retractable hard top control unit. Refer to [RF-309, "Removal and Installation"](#).
3. Perform DTC Confirmation Procedure. Refer to [RF-141, "DTC Logic"](#).

>> INSPECTION END

# B1722 RETRACTABLE HARD TOP CONTROL UNIT

< DTC/CIRCUIT DIAGNOSIS >

## B1722 RETRACTABLE HARD TOP CONTROL UNIT

### DTC Logic

INFOID:000000006468735

### DTC DETECTION LOGIC

#### NOTE:

If two or more DTCs are detected, refer to [RF-61, "DTC Inspection Priority Chart"](#), and determine trouble diagnosis order.

DTC No.	Trouble diagnosis name	DTC detecting condition	Possible cause
B1722	ROOF CONTROL UNIT	<ul style="list-style-type: none"><li>Retractable hard top control unit detects output to flipper door motor (LH/RH)-UP without output request.</li><li>Retractable hard top control unit requests output to parcel shelf motor flipper door motor (LH/RH)-UP but cannot detect output.</li></ul>	Retractable hard top control unit

### DTC CONFIRMATION PROCEDURE

#### 1. PERFORM DTC CONFIRMATION PROCEDURE

1. Start engine.
2. Operate retractable hard top to fully open and fully close.
3. Check "Self-Diagnostic Result" of "RETRACTABLE HARD TOP" using CONSULT-III.

#### Is DTC detected?

- YES >> Refer to [RF-142, "Diagnosis Procedure"](#).  
NO >> INSPECTION END

### Diagnosis Procedure

INFOID:000000006468736

#### 1. CHECK SELF DIAGNOSTIC RESULT

1. Turn ignition switch OFF.
2. Replace retractable hard top control unit. Refer to [RF-309, "Removal and Installation"](#).
3. Perform DTC Confirmation Procedure. Refer to [RF-142, "DTC Logic"](#).

>> INSPECTION END

# B1723 RETRACTABLE HARD TOP CONTROL UNIT

< DTC/CIRCUIT DIAGNOSIS >

## B1723 RETRACTABLE HARD TOP CONTROL UNIT

### DTC Logic

INFOID:000000006468737

### DTC DETECTION LOGIC

#### NOTE:

If two or more DTCs are detected, refer to [RF-61, "DTC Inspection Priority Chart"](#), and determine trouble diagnosis order.

DTC No.	Trouble diagnosis name	DTC detecting condition	Possible cause
B1723	ROOF CONTROL UNIT	<ul style="list-style-type: none"><li>Retractable hard top control unit detects output to flipper door motor (LH/RH)-DOWN without output request.</li><li>Retractable hard top control unit requests output to parcel shelf motor flipper door motor (LH/RH)-DOWN but cannot detect output.</li></ul>	Retractable hard top control unit

### DTC CONFIRMATION PROCEDURE

#### 1. PERFORM DTC CONFIRMATION PROCEDURE

1. Start engine.
2. Operate retractable hard top to fully open and fully close.
3. Check "Self-Diagnostic Result" of "RETRACTABLE HARD TOP" using CONSULT-III.

#### Is DTC detected?

- YES >> Refer to [RF-143, "Diagnosis Procedure"](#).  
NO >> INSPECTION END

### Diagnosis Procedure

INFOID:000000006468738

#### 1. CHECK SELF DIAGNOSTIC RESULT

1. Turn ignition switch OFF.
2. Replace retractable hard top control unit. Refer to [RF-309, "Removal and Installation"](#).
3. Perform DTC Confirmation Procedure. Refer to [RF-143, "DTC Logic"](#).

>> INSPECTION END

# B1724 RETRACTABLE HARD TOP CONTROL UNIT

< DTC/CIRCUIT DIAGNOSIS >

## B1724 RETRACTABLE HARD TOP CONTROL UNIT

### DTC Logic

INFOID:000000006468739

### DTC DETECTION LOGIC

#### NOTE:

If two or more DTCs are detected, refer to [RF-61, "DTC Inspection Priority Chart"](#), and determine trouble diagnosis order.

DTC No.	Trouble diagnosis name	DTC detecting condition	Possible cause
B1724	ROOF CONTROL UNIT	Retractable hard top control unit requests output to roof latch motor-UNLOCK but cannot detect output.	Retractable hard top control unit

### DTC CONFIRMATION PROCEDURE

#### 1. PERFORM DTC CONFIRMATION PROCEDURE

1. Start engine.
2. Operate retractable hard top to fully open and fully close.
3. Check "Self-Diagnostic Result" of "RETRACTABLE HARD TOP" using CONSULT-III.

#### Is DTC detected?

- YES >> Refer to [RF-144, "Diagnosis Procedure"](#).  
NO >> INSPECTION END

### Diagnosis Procedure

INFOID:000000006468740

#### 1. CHECK SELF DIAGNOSTIC RESULT

1. Turn ignition switch OFF.
2. Replace retractable hard top control unit. Refer to [RF-309, "Removal and Installation"](#).
3. Perform DTC Confirmation Procedure. Refer to [RF-144, "DTC Logic"](#).

>> INSPECTION END



# B1725 RETRACTABLE HARD TOP CONTROL UNIT

< DTC/CIRCUIT DIAGNOSIS >

## B1725 RETRACTABLE HARD TOP CONTROL UNIT

### DTC Logic

INFOID:000000006468741

### DTC DETECTION LOGIC

#### NOTE:

If two or more DTCs are detected, refer to [RF-61, "DTC Inspection Priority Chart"](#), and determine trouble diagnosis order.

DTC No.	Trouble diagnosis name	DTC detecting condition	Possible cause
B1725	ROOF CONTROL UNIT	Retractable hard top control unit requests output to roof latch motor-LOCK but cannot detect output.	Retractable hard top control unit

### DTC CONFIRMATION PROCEDURE

#### 1. PERFORM DTC CONFIRMATION PROCEDURE

1. Start engine.
2. Operate retractable hard top to fully open and fully close.
3. Check "Self-Diagnostic Result" of "RETRACTABLE HARD TOP" using CONSULT-III.

#### Is DTC detected?

- YES >> Refer to [RF-145, "Diagnosis Procedure"](#).  
NO >> INSPECTION END

### Diagnosis Procedure

INFOID:000000006468742

#### 1. CHECK SELF DIAGNOSTIC RESULT

1. Turn ignition switch OFF.
2. Replace retractable hard top control unit. Refer to [RF-309, "Removal and Installation"](#).
3. Perform DTC Confirmation Procedure. Refer to [RF-145, "DTC Logic"](#).

>> INSPECTION END

A  
B  
C  
D  
E  
F  
G  
H  
I  
J  
L  
M  
N  
O  
P

RF

# B1726 RETRACTABLE HARD TOP CONTROL UNIT

< DTC/CIRCUIT DIAGNOSIS >

## B1726 RETRACTABLE HARD TOP CONTROL UNIT

### DTC Logic

INFOID:000000006468743

### DTC DETECTION LOGIC

#### NOTE:

If two or more DTCs are detected, refer to [RF-61, "DTC Inspection Priority Chart"](#), and determine trouble diagnosis order.

DTC No.	Trouble diagnosis name	DTC detecting condition	Possible cause
B1726	ROOF CONTROL UNIT	<ul style="list-style-type: none"><li>Retractable hard top control unit detects output to trunk lid opener actuator without output request.</li><li>Retractable hard top control unit requests output to trunk lid opener actuator but cannot detect output.</li></ul>	Retractable hard top control unit

### DTC CONFIRMATION PROCEDURE

#### 1. PERFORM DTC CONFIRMATION PROCEDURE

1. Start engine.
2. Operate retractable hard top to fully open and fully close.
3. Check "Self-Diagnostic Result" of "RETRACTABLE HARD TOP" using CONSULT-III.

#### Is DTC detected?

- YES >> Refer to [RF-146, "Diagnosis Procedure"](#).  
NO >> INSPECTION END

### Diagnosis Procedure

INFOID:000000006468744

#### 1. CHECK SELF DIAGNOSTIC RESULT

1. Turn ignition switch OFF.
2. Replace retractable hard top control unit. Refer to [RF-309, "Removal and Installation"](#).
3. Perform DTC Confirmation Procedure. Refer to [RF-146, "DTC Logic"](#).

>> INSPECTION END

# B1728 RETRACTABLE HARD TOP CONTROL UNIT

< DTC/CIRCUIT DIAGNOSIS >

## B1728 RETRACTABLE HARD TOP CONTROL UNIT

### DTC Logic

INFOID:000000006468745

### DTC DETECTION LOGIC

#### NOTE:

If two or more DTCs are detected, refer to [RF-61, "DTC Inspection Priority Chart"](#), and determine trouble diagnosis order.

DTC	Trouble diagnosis name	DTC detecting condition	Possible cause
B1728	ROOF CONTROL UNIT	<ul style="list-style-type: none"><li>Retractable hard top control unit detects output to rear power window motor (LH)-UP without output request.</li><li>Retractable hard top control unit requests output to rear power window motor (LH)-UP but cannot detect output.</li></ul>	Retractable hard top control unit

### DTC CONFIRMATION PROCEDURE

#### 1. PERFORM DTC CONFIRMATION PROCEDURE

1. Start engine.
2. Operate retractable hard top to fully open and fully close.
3. Check "Self-Diagnostic Result" of "RETRACTABLE HARD TOP" using CONSULT-III.

#### Is DTC detected?

- YES >> Refer to [RF-147, "Diagnosis Procedure"](#).  
NO >> INSPECTION END

### Diagnosis Procedure

INFOID:000000006468746

#### 1. CHECK SELF DIAGNOSTIC RESULT

1. Turn ignition switch OFF.
2. Replace retractable hard top control unit. Refer to [RF-309, "Removal and Installation"](#).
3. Perform DTC Confirmation Procedure. Refer to [RF-147, "DTC Logic"](#).

>> INSPECTION END

A  
B  
C  
D  
E  
F  
G  
H  
I  
J  
RF  
L  
M  
N  
O  
P

# B1729 RETRACTABLE HARD TOP CONTROL UNIT

< DTC/CIRCUIT DIAGNOSIS >

## B1729 RETRACTABLE HARD TOP CONTROL UNIT

### DTC Logic

INFOID:000000006468747

#### DTC DETECTION LOGIC

**NOTE:**

If two or more DTCs are detected, refer to [RF-61, "DTC Inspection Priority Chart"](#), and determine trouble diagnosis order.

DTC No.	Trouble diagnosis name	DTC detecting condition	Possible cause
B1729	ROOF CONTROL UNIT	<ul style="list-style-type: none"><li>Retractable hard top control unit detects output to rear power window motor (LH)-DOWN without output request.</li><li>Retractable hard top control unit requests output to rear power window motor (LH)-DOWN but cannot detect output.</li></ul>	Retractable hard top control unit

#### DTC CONFIRMATION PROCEDURE

### 1. PERFORM DTC CONFIRMATION PROCEDURE

1. Start engine.
2. Operate retractable hard top to fully open and fully close.
3. Check "Self-Diagnostic Result" of "RETRACTABLE HARD TOP" using CONSULT-III.

Is DTC detected?

YES >> Refer to [RF-148, "Diagnosis Procedure"](#).

NO >> INSPECTION END

### Diagnosis Procedure

INFOID:000000006468748

### 1. CHECK SELF DIAGNOSTIC RESULT

1. Turn ignition switch OFF.
2. Replace retractable hard top control unit. Refer to [RF-309, "Removal and Installation"](#).
3. Perform DTC Confirmation Procedure. Refer to [RF-148, "DTC Logic"](#).

>> INSPECTION END

# B172A RETRACTABLE HARD TOP CONTROL UNIT

< DTC/CIRCUIT DIAGNOSIS >

## B172A RETRACTABLE HARD TOP CONTROL UNIT

### DTC Logic

INFOID:000000006468749

### DTC DETECTION LOGIC

#### NOTE:

If two or more DTCs are detected, refer to [RF-61, "DTC Inspection Priority Chart"](#), and determine trouble diagnosis order.

DTC No.	Trouble diagnosis name	DTC detecting condition	Possible cause
B172A	ROOF CONTROL UNIT	<ul style="list-style-type: none"><li>Retractable hard top control unit detects output to rear power window motor (RH)-UP without output request.</li><li>Retractable hard top control unit requests output to rear power window motor (RH)-UP but cannot detect output.</li></ul>	Retractable hard top control unit

### DTC CONFIRMATION PROCEDURE

#### 1. PERFORM DTC CONFIRMATION PROCEDURE

1. Start engine.
2. Operate retractable hard top to fully open and fully close.
3. Check "Self-Diagnostic Result" of "RETRACTABLE HARD TOP" using CONSULT-III.

#### Is DTC detected?

- YES >> Refer to [RF-149, "Diagnosis Procedure"](#).  
NO >> INSPECTION END

### Diagnosis Procedure

INFOID:000000006468750

#### 1. CHECK SELF DIAGNOSTIC RESULT

1. Turn ignition switch OFF.
2. Replace retractable hard top control unit. Refer to [RF-309, "Removal and Installation"](#).
3. Perform DTC Confirmation Procedure. Refer to [RF-149, "DTC Logic"](#).

>> INSPECTION END

A  
B  
C  
D  
E  
F  
G  
H  
I  
J  
RF  
L  
M  
N  
O  
P

# B172B ROOF STATUS SIGNAL (AUDIO)

< DTC/CIRCUIT DIAGNOSIS >

## B172B ROOF STATUS SIGNAL (AUDIO)

### Description

INFOID:000000006468751

Retractable hard top control unit transmits retractable hard top open and close states to audio volume control unit. Audio volume control unit automatically switches equalizer according to retractable hard top open or close state that is received.

### DTC Logic

INFOID:000000006468752

### DTC DETECTION LOGIC

#### NOTE:

If two or more DTCs are detected, refer to [RF-61, "DTC Inspection Priority Chart"](#), and determine trouble diagnosis order.

DTC No.	Trouble diagnosis name		DTC detecting condition	Possible cause
B172B	ROOF STATE SIG (AUDIO)	[PWR-SHORT]	BOSE AMP. (with NAVI) or tel adapter unit (without NAVI) circuit is short to power.	<ul style="list-style-type: none"><li>• Harness or connectors (The BOSE AMP. circuit is shorted) (The tel adapter unit circuit is shorted)</li><li>• BOSE AMP. (with NAVI)</li><li>• Tel adapter unit (without NAVI)</li><li>• Retractable hard top control unit</li></ul>

### DTC CONFIRMATION PROCEDURE

#### 1. PERFORM DTC CONFIRMATION PROCEDURE

1. Start engine.
2. Operate retractable hard top to fully open and fully close.
3. Check DTC.

#### Is DTC detected?

- YES >> Go to [RF-134, "Diagnosis Procedure"](#).  
NO >> INSPECTION END

### Diagnosis Procedure

INFOID:000000006468753

#### 1. CHECK ROOF POSITION SIGNAL CIRCUIT

1. Turn ignition switch OFF.
2. Disconnect retractable hard top control unit harness connector and BOSE AMP. (with NAVI) or tel adapter unit (without NAVI) harness connector.
3. Check voltage between retractable hard top control unit harness connector and ground.

(+)		(-)	Voltage (V) (Approx.)
Retractable hard top control unit			
Connector	Terminal		
B82	33	Ground	0

#### Is the inspection result normal?

- YES-1 >> BOSE AMP. (with NAVI): GO TO 2.  
YES-2 >> Tel adapter unit (without): GO TO 3.  
NO >> Repair or replace harness or connectors.

#### 2. CHECK BOSE AMP.

Check BOSE AMP. Refer to [AV-388, "BOSE AMP. : Diagnosis Procedure"](#).

#### Is the inspection result normal?

- YES >> GO TO 4.  
NO >> Replace BOSE AMP.

#### 3. CHECK TEL ADAPTER UNIT

## B172B ROOF STATUS SIGNAL (AUDIO)

< DTC/CIRCUIT DIAGNOSIS >

---

Check tel adapter unit. Refer to [AV-222, "TEL ADAPTER UNIT : Diagnosis Procedure"](#).

Is the inspection result normal?

YES >> GO TO 4.

NO >> Replace BOSE AMP.

### 4.REPLACE RETRACTABLE HARD TOP CONTROL UNIT

---

Replace retractable hard top control unit. Refer to [RF-309, "Removal and Installation"](#).

Is the inspection result normal?

YES >> INSPECTION END

NO >> GO TO 5.

### 5.CHECK INTERMITTENT INCIDENT

---

Refer to [GI-43, "Intermittent Incident"](#).

>> INSPECTION END

A  
B  
C  
D  
E  
F  
G  
H  
I  
J  
RF  
L  
M  
N  
O  
P

# B172D ROOF WARNING BUZZER

< DTC/CIRCUIT DIAGNOSIS >

## B172D ROOF WARNING BUZZER

### DTC Logic

INFOID:000000006468757

### DTC DETECTION LOGIC

#### NOTE:

If two or more DTCs are detected, refer to [RF-61, "DTC Inspection Priority Chart"](#), and determine trouble diagnosis order.

DTC No.	Trouble diagnosis name		DTC detecting condition	Possible causes
B172D	ROOF WARNING BUZZER	[PWR-SHORT]	Roof warning buzzer circuit is short to power.	<ul style="list-style-type: none"><li>• Harness or connectors (The roof warning buzzer circuit is shorted)</li><li>• Retractable hard top control unit</li><li>• Roof warning buzzer</li></ul>

### DTC CONFIRMATION PROCEDURE

#### 1. PERFORM DTC CONFIRMATION PROCEDURE

1. Start engine.
2. Operate retractable hard top to fully open and fully close.
3. Check DTC.

#### Is DTC detected?

YES >> Go to [RF-134, "Diagnosis Procedure"](#).

NO >> INSPECTION END

### Diagnosis Procedure

INFOID:000000006468758

#### 1. CHECK ROOF WARNING BUZZER CIRCUIT-I

1. Turn ignition switch OFF.
2. Disconnect retractable hard top control unit harness connector and fuse block (J/B) harness connector.
3. Check voltage between retractable hard top control unit harness connector and ground.

Retractable hard top control unit		(-)	Voltage (V) (Approx.)
(+)			
Connector	Terminal		
B82	35	Ground	0

#### Is the inspection result normal?

YES >> GO TO 3.

NO >> GO TO 2.

#### 2. CHECK ROOF WARNING BUZZER CIRCUIT-II

1. Disconnect roof warning buzzer harness connector.
2. Check voltage between fuse block (J/B) harness connector and ground.

Fuse block (J/B)		(-)	Voltage (V) (Approx.)
(+)			
Connector	Terminal		
M2	6B	Ground	0

3. Check voltage between retractable hard top control unit harness connector and ground.



# B172D ROOF WARNING BUZZER

## < DTC/CIRCUIT DIAGNOSIS >

Retractable hard top control unit		(-)	Voltage (V) (Approx.)
(+) Connector			
Terminal			
B82	35	Ground	0

Is the inspection result normal?

YES >> Replace warning buzzer. Refer to [INT-15, "Removal and Installation"](#).

NO >> Repair or replace harness or connector.

### 3.CHECK FUSE BLOCK (J/B)

Check fuse block (J/B). Refer to [PG-125, "Fuse, Connector and Terminal Arrangement"](#).

Is the inspection result normal?

YES >> GO TO 4.

NO >> Replace fuse block (J/B).

### 4.REPLACE RETRACTABLE HARD TOP CONTROL UNIT

Replace retractable hard top control unit. Refer to [RF-309, "Removal and Installation"](#).

Is the inspection result normal?

YES >> INSPECTION END

NO >> GO TO 5.

### 5.CHECK INTERMITTENT INCIDENT

Refer to [GI-43, "Intermittent Incident"](#).

>> INSPECTION END

A  
B  
C  
D  
E  
F  
G  
H  
I  
J  
L  
M  
N  
O  
P

RF

# B172E RETRACTABLE HARD TOP CONTROL UNIT

< DTC/CIRCUIT DIAGNOSIS >

## B172E RETRACTABLE HARD TOP CONTROL UNIT

### DTC Logic

INFOID:000000006468759

### DTC DETECTION LOGIC

#### NOTE:

If two or more DTCs are detected, refer to [RF-61, "DTC Inspection Priority Chart"](#), and determine trouble diagnosis order.

DTC	Trouble diagnosis name	DTC detecting condition	Possible cause
B172E	ROOF CONTROL UNIT	<ul style="list-style-type: none"><li>Retractable hard top control unit detects output to rear power window motor (RH)-DOWN without output request.</li><li>Retractable hard top control unit requests output to rear power window motor (RH)-DOWN but cannot detect output.</li></ul>	Retractable hard top control unit

### DTC CONFIRMATION PROCEDURE

#### 1. PERFORM DTC CONFIRMATION PROCEDURE

1. Turn ignition switch ON.
2. Operate retractable hard top to fully open and fully close.
3. Check DTC.

Is DTC detected?

YES >> Refer to [RF-154, "Diagnosis Procedure"](#).

NO >> INSPECTION END

### Diagnosis Procedure

INFOID:000000006468760

#### 1. CHECK SELF DIAGNOSTIC RESULT

1. Turn ignition switch OFF.
2. Replace retractable hard top control unit. Refer to [RF-309, "Removal and Installation"](#).
3. Perform DTC Confirmation Procedure. Refer to [RF-97, "DTC Logic"](#).

>> INSPECTION END

# B172F REAR POWER WINDOW (LH)

< DTC/CIRCUIT DIAGNOSIS >

## B172F REAR POWER WINDOW (LH)

### DTC Logic

INFOID:000000006468761

### DTC DETECTION LOGIC

**NOTE:**

If two or more DTCs are detected, refer to [RF-61, "DTC Inspection Priority Chart"](#), and determine trouble diagnosis order.

DTC No.	Trouble diagnosis name		DTC detecting condition	Possible causes
B172F	REAR PWR WINDOW(LH)	[OPEN]	Rear power window motor (LH) circuit is open.	<ul style="list-style-type: none"> <li>• Harness or connectors (The rear power window motor (LH) circuit is open or shorted.)</li> <li>• Rear power window motor (LH)</li> <li>• Retractable hard top control unit</li> </ul>
		[TIME-OUT]	An improper current is sent to the retractable hard top control unit through rear power window motor (LH).	

### DTC CONFIRMATION PROCEDURE

#### 1. PERFORM DTC CONFIRMATION PROCEDURE-I

1. Turn ignition switch ON.
2. Operate rear power window (LH) to fully open and fully close.
3. Check DTC.

Is DTC detected?

- YES >> GO TO 2.
- NO >> INSPECTION END

#### 2. PERFORM DTC CONFIRMATION PROCEDURE-II

1. Turn ignition switch OFF and wait at least 2 minutes.
2. Operate rear power window (LH) to fully open and fully close.
3. Check DTC.

Is DTC detected?

- YES >> Go to [RF-155, "Diagnosis Procedure"](#).
- NO >> INSPECTION END

### Diagnosis Procedure

INFOID:000000006468762

#### 1. CHECK RETRACTABLE HARD TOP CONTROL UNIT OUTPUT SIGNAL

1. Turn ignition switch OFF.
2. Disconnect rear power window motor (LH) harness connector.
3. Turn ignition switch ON.
4. Check voltage between rear power window motor (LH) harness connector and ground.

(+)		(-)	Condition	Voltage (V) (Approx.)	
Connector	Terminal				
B72	1	Ground	Power window main switch (rear LH)	UP	Battery voltage
				DOWN	0
	2		UP	0	
			DOWN	Battery voltage	

Is the inspection result normal?

- YES >> GO TO 2.
- NO >> Repair or replace harness.

#### 2. CHECK REAR POWER WINDOW MOTOR (LH) CIRCUIT FOR OPEN AND SHORT

Check rear power window motor (LH). Refer to [PWC-19, "REAR LH : Component Function Check"](#).

## B172F REAR POWER WINDOW (LH)

< DTC/CIRCUIT DIAGNOSIS >

---

Is the inspection result normal?

YES >> GO TO 3.

NO >> Replace rear power window motor (LH). Refer to [PWC-9, "Component Parts Location"](#).

### 3.REPLACE RETRACTABLE HARD TOP CONTROL UNIT

---

Replace retractable hard top control unit. Refer to [RF-309, "Removal and Installation"](#).

Is the inspection result normal?

YES >> INSPECTION END

NO >> GO TO 4.

### 4.CHECK INTERMITTENT INCIDENT

---

Refer to [GI-43, "Intermittent Incident"](#).

>> INSPECTION END

# B1730 REAR POWER WINDOW (RH)

< DTC/CIRCUIT DIAGNOSIS >

## B1730 REAR POWER WINDOW (RH)

### DTC Logic

INFOID:000000006468763

### DTC DETECTION LOGIC

**NOTE:**

If two or more DTCs are detected, refer to [RF-61, "DTC Inspection Priority Chart"](#), and determine trouble diagnosis order.

DTC No.	Trouble diagnosis name		DTC detecting condition	Possible causes
B1730	REAR PWR WINDOW(RH)	[OPEN]	Rear power window motor (RH) circuit is open.	<ul style="list-style-type: none"> <li>• Harness or connectors (The rear power window motor (RH) circuit is open or shorted.)</li> <li>• Rear power window motor (RH)</li> <li>• Retractable hard top control unit</li> </ul>
		[TIME-OUT]	An improper current is sent to the retractable hard top control unit through rear power window motor (RH).	

### DTC CONFIRMATION PROCEDURE

#### 1. PERFORM DTC CONFIRMATION PROCEDURE-I

1. Turn ignition switch ON.
2. Operate rear power window (RH) to fully open and fully close.
3. Check DTC.

Is DTC detected?

- YES >> GO TO 2.
- NO >> INSPECTION END

#### 2. PERFORM DTC CONFIRMATION PROCEDURE-II

1. Turn ignition switch OFF and wait at least 2 minutes.
2. Operate rear power window (RH) to fully open and fully close.
3. Check DTC.

Is DTC detected?

- YES >> Go to [RF-155, "Diagnosis Procedure"](#).
- NO >> INSPECTION END

### Diagnosis Procedure

INFOID:000000006468764

#### 1. CHECK RETRACTABLE HARD TOP CONTROL UNIT OUTPUT SIGNAL

1. Turn ignition switch OFF.
2. Disconnect rear power window motor (RH) harness connector.
3. Turn ignition switch ON.
4. Check voltage between rear power window motor (RH) harness connector and ground.

(+)		(-)	Condition	Voltage (V) (Approx.)	
Connector	Terminal				
B245	1	Ground	Power window main switch (rear RH)	UP	Battery voltage
				DOWN	0
	2			UP	0
				DOWN	Battery voltage

Is the inspection result normal?

- YES >> GO TO 2.
- NO >> Repair or replace harness.

#### 2. CHECK REAR POWER WINDOW MOTOR (RH) CIRCUIT FOR OPEN AND SHORT

Check rear power window motor (RH). Refer to [PWC-21, "REAR RH : Component Function Check"](#).

## B1730 REAR POWER WINDOW (RH)

< DTC/CIRCUIT DIAGNOSIS >

---

Is the inspection result normal?

YES >> GO TO 3.

NO >> Replace rear power window motor (RH). Refer to [PWC-9, "Component Parts Location"](#).

### 3.REPLACE RETRACTABLE HARD TOP CONTROL UNIT

---

Replace retractable hard top control unit. Refer to [RF-309, "Removal and Installation"](#).

Is the inspection result normal?

YES >> INSPECTION END

NO >> GO TO 4.

### 4.CHECK INTERMITTENT INCIDENT

---

Refer to [GI-43, "Intermittent Incident"](#).

>> INSPECTION END

# B1731 HYDRAULIC STATE 1

< DTC/CIRCUIT DIAGNOSIS >

## B1731 HYDRAULIC STATE 1

### Description

INFOID:000000006468765

There are 22 states in hydraulic system. Hydraulic system is controlled using combination of these 22 states and, at the same time, open and close operations of retractable hard top system are performed interlocking with other retractable hard top system components. For the detail, refer to [RF-31, "HYDRAULIC SYSTEM CONTROL FUNCTION : System Description"](#).

### DTC Logic

INFOID:000000006468766

#### DTC DETECTION LOGIC

##### NOTE:

If two or more DTCs are detected, refer to [RF-61, "DTC Inspection Priority Chart"](#), and determine trouble diagnosis order.

DTC No.	Trouble diagnosis name		DTC detecting condition	Possible cause
B1731	HYDRAULIC STATE 1	[TIMEOUT]	Retractable hard top control unit does not detect changing from hydraulic state 1 for the specified period of time, during an open and close operation <ul style="list-style-type: none"> <li>Open operation: Hydraulic state 2, 3 or 4 is not detected for 2 seconds</li> </ul>	<ul style="list-style-type: none"> <li>Hydraulic system</li> <li>Trunk lid</li> <li>Trunk room lamp switch</li> <li>Hydraulic unit</li> </ul>

#### DTC CONFIRMATION PROCEDURE

##### 1. PERFORM DTC CONFIRMATION PROCEDURE

- Start engine.
- Operate retractable hard top to fully open and fully close.
- Check "Self-Diagnostic Result" of "RETRACTABLE HARD TOP" using CONSULT-III.

##### Is DTC detected?

- YES >> Go to [RF-159, "Diagnosis Procedure"](#).  
NO >> INSPECTION END

### Diagnosis Procedure

INFOID:000000006468767

##### 1. CHECK RETRACTABLE HARD TOP SYSTEM COMPONENT PARTS

Check retractable hard top component parts as bellow deformation, looseness, rattle, interference with other parts, and pinched foreign materials.

- Hydraulic system: Refer to [RF-299, "Exploded View"](#).
- Trunk lid: Refer to [DLK-269, "TRUNK LID ASSEMBLY : Exploded View"](#).

##### Is the inspection result normal?

- YES >> GO TO 2.  
NO >> Repair or replace malfunctioning part.

##### 2. CHECK TRUNK ROOM LAMP SWITCH

Check trunk room lamp switch. Refer to [DLK-82, "Component Function Check"](#).

##### Is the inspection result normal?

- YES >> GO TO 3.  
NO >> Repair or replace malfunctioning part.

##### 3. CHECK TRUNK ROOM LAMP SWITCH SIGNAL

Check "TR ROOM LAMP SW" in "DATA MONITOR" mode of "RETRACTABLE HARD TOP" using CONSULT-III.

Monitor item	Condition	Status
TR ROOM LAMP SW	Open	ON
	Closed	OFF

# B1731 HYDRAULIC STATE 1

< DTC/CIRCUIT DIAGNOSIS >

Is the inspection result normal?

YES >> GO TO 5.

NO >> GO TO 4.

## 4. CHECK TRUNK ROOM LAMP SWITCH CIRCUIT

1. Disconnect trunk room lamp switch connector, BCM connector, trunk closure control unit connector and retractable hard top control unit connector.
2. Check continuity between retractable hard top control unit harness connector and trunk room lamp switch harness connector.

Retractable hard top control unit		Trunk room lamp switch		Continuity
Connector	Terminal	Connector	Terminal	
B82	5	B306	2	Existed

3. Check continuity between BCM harness connector and ground.

Retractable hard top control unit		Ground	Continuity
Connector	Terminal		
B82	5		Not existed

Is the inspection result normal?

YES >> Check trunk lid auto closure system. Refer to [DLK-220, "OPEN/CLOSURE FUNCTION : Diagnosis Procedure"](#).

NO >> Repair harness or connector.

## 5. CHECK HYDRAULIC PUMP POWER SUPPLY RELAY

Check hydraulic pump power supply relay. Refer to [RF-242, "Diagnosis Procedure"](#).

Is the inspection result normal?

YES >> Check intermittent incident. Refer to [GI-43, "Intermittent Incident"](#).

NO >> Replace hydraulic unit. Refer to [RF-299, "Removal and Installation"](#).



# B1732 HYDRAULIC STATE 2

< DTC/CIRCUIT DIAGNOSIS >

## B1732 HYDRAULIC STATE 2

### Description

INFOID:000000006468768

There are 22 states in hydraulic system. Hydraulic system is controlled using combination of these 22 states and, at the same time, open and close operations of retractable hard top system are performed interlocking with other retractable hard top system components. For the detail, refer to [RF-31, "HYDRAULIC SYSTEM CONTROL FUNCTION : System Description"](#).

### DTC Logic

INFOID:000000006468769

#### DTC DETECTION LOGIC

##### NOTE:

If two or more DTCs are detected, refer to [RF-61, "DTC Inspection Priority Chart"](#), and determine trouble diagnosis order.

DTC No.	Trouble diagnosis name		DTC detecting condition	Possible cause
B1732	HYDRAULIC STATE2	[TIMEOUT]	Retractable hard top control unit does not detect changing from hydraulic state 2 for the specified period of time, during an open and close operation • Open operation: Hydraulic state 4 is not detected for 2 seconds • Close operation: Hydraulic state 1 is not detected for 2 seconds	<ul style="list-style-type: none"><li>Hydraulic system</li><li>Trunk lid</li><li>Trunk room lamp switch</li><li>Hydraulic unit</li></ul>

#### DTC CONFIRMATION PROCEDURE

##### 1. PERFORM DTC CONFIRMATION PROCEDURE

- Start engine.
- Operate retractable hard top to fully open and fully close.
- Check "Self-Diagnostic Result" of "RETRACTABLE HARD TOP" using CONSULT-III.

##### Is DTC detected?

- YES >> Go to [RF-161, "Diagnosis Procedure"](#).  
NO >> INSPECTION END

### Diagnosis Procedure

INFOID:000000006468770

##### 1. CHECK RETRACTABLE HARD TOP SYSTEM COMPONENT PARTS

Check retractable hard top component parts as bellow deformation, looseness, rattle, interference with other parts, and pinched foreign materials.

- Hydraulic system: Refer to [RF-299, "Exploded View"](#).
- Trunk lid: Refer to [DLK-269, "TRUNK LID ASSEMBLY : Exploded View"](#).

##### Is the inspection result normal?

- YES >> GO TO 2.  
NO >> Repair or replace malfunctioning part.

##### 2. CHECK TRUNK ROOM LAMP SWITCH

Check trunk room lamp switch. Refer to [DLK-82, "Component Function Check"](#).

##### Is the inspection result normal?

- YES >> GO TO 3.  
NO >> Repair or replace malfunctioning part.

##### 3. CHECK TRUNK ROOM LAMP SWITCH SIGNAL

Check "TR ROOM LAMP SW" in "DATA MONITOR" mode of "RETRACTABLE HARD TOP" using CONSULT-III.

## B1732 HYDRAULIC STATE 2

### < DTC/CIRCUIT DIAGNOSIS >

Monitor item	Condition	Status
TR ROOM LAMP SW	Trunk lid	Open
		Closed
		ON
		OFF

Is the inspection result normal?

YES >> GO TO 5.

NO >> GO TO 4.

#### 4.CHECK TRUNK ROOM LAMP SWITCH CIRCUIT

1. Disconnect trunk room lamp switch connector, BCM connector, trunk closure control unit connector and retractable hard top control unit connector.
2. Check continuity between retractable hard top control unit harness connector and trunk room lamp switch harness connector.

Retractable hard top control unit		Trunk room lamp switch		Continuity
Connector	Terminal	Connector	Terminal	
B82	5	B306	2	Existed

3. Check continuity between BCM harness connector and ground.

Retractable hard top control unit		Ground	Continuity
Connector	Terminal		
B82	5		Not existed

Is the inspection result normal?

YES >> Check trunk lid auto closure system. Refer to [DLK-220. "OPEN/CLOSURE FUNCTION : Diagnosis Procedure"](#).

NO >> Repair harness or connector.

#### 5.CHECK HYDRAULIC PUMP POWER SUPPLY RELAY

Check hydraulic pump power supply relay. Refer to [RF-242. "Diagnosis Procedure"](#).

Is the inspection result normal?

YES >> Check intermittent incident. Refer to [GI-43. "Intermittent Incident"](#).

NO >> Replace hydraulic unit. Refer to [RF-299. "Removal and Installation"](#).

# B1733 HYDRAULIC STATE 3

< DTC/CIRCUIT DIAGNOSIS >

## B1733 HYDRAULIC STATE 3

### Description

INFOID:000000006468771

There are 22 states in hydraulic system. Hydraulic system is controlled using combination of these 22 states and, at the same time, open and close operations of retractable hard top system are performed interlocking with other retractable hard top system components. For the detail, refer to [RF-31, "HYDRAULIC SYSTEM CONTROL FUNCTION : System Description"](#).

### DTC Logic

INFOID:000000006468772

#### DTC DETECTION LOGIC

##### NOTE:

If two or more DTCs are detected, refer to [RF-61, "DTC Inspection Priority Chart"](#), and determine trouble diagnosis order.

DTC No.	Trouble diagnosis name		DTC detecting condition	Possible cause
B1733	HYDRAULIC STATE 3	[TIMEOUT]	Retractable hard top control unit does not detect changing from hydraulic state 3 for the specified period of time, during an open and close operation • Open operation: Hydraulic state 4 is not detected for 2 seconds • Close operation: Hydraulic state 1 is not detected for 2 seconds	<ul style="list-style-type: none"><li>Hydraulic system</li><li>Trunk lid</li><li>Trunk room lamp switch</li><li>Hydraulic unit</li></ul>

#### DTC CONFIRMATION PROCEDURE

##### 1. PERFORM DTC CONFIRMATION PROCEDURE

- Start engine.
- Operate retractable hard top to fully open and fully close.
- Check "Self-Diagnostic Result" of "RETRACTABLE HARD TOP" using CONSULT-III.

##### Is DTC detected?

- YES >> Go to [RF-163, "Diagnosis Procedure"](#).  
NO >> INSPECTION END

### Diagnosis Procedure

INFOID:000000006468773

##### 1. CHECK RETRACTABLE HARD TOP SYSTEM COMPONENT PARTS

Check retractable hard top component parts as bellow deformation, looseness, rattle, interference with other parts, and pinched foreign materials.

- Hydraulic system: Refer to [RF-299, "Exploded View"](#).
- Trunk lid: Refer to [DLK-269, "TRUNK LID ASSEMBLY : Exploded View"](#).

##### Is the inspection result normal?

- YES >> GO TO 2.  
NO >> Repair or replace malfunctioning part.

##### 2. CHECK TRUNK ROOM LAMP SWITCH

Check trunk room lamp switch. Refer to [DLK-82, "Component Function Check"](#).

##### Is the inspection result normal?

- YES >> GO TO 3.  
NO >> Repair or replace malfunctioning part.

##### 3. CHECK TRUNK ROOM LAMP SWITCH SIGNAL

Check "TR ROOM LAMP SW" in "DATA MONITOR" mode of "RETRACTABLE HARD TOP" using CONSULT-III.

# B1733 HYDRAULIC STATE 3

## < DTC/CIRCUIT DIAGNOSIS >

Monitor item	Condition	Status
TR ROOM LAMP SW	Trunk lid	Open
		Closed
		ON
		OFF

Is the inspection result normal?

YES >> GO TO 5.

NO >> GO TO 4.

### 4.CHECK TRUNK ROOM LAMP SWITCH CIRCUIT

1. Disconnect trunk room lamp switch connector, BCM connector, trunk closure control unit connector and retractable hard top control unit connector.
2. Check continuity between retractable hard top control unit harness connector and trunk room lamp switch harness connector.

Retractable hard top control unit		Trunk room lamp switch		Continuity
Connector	Terminal	Connector	Terminal	
B82	5	B306	2	Existed

3. Check continuity between BCM harness connector and ground.

Retractable hard top control unit		Ground	Continuity
Connector	Terminal		
B82	5		Not existed

Is the inspection result normal?

YES >> Check trunk lid auto closure system. Refer to [DLK-220. "OPEN/CLOSURE FUNCTION : Diagnosis Procedure"](#).

NO >> Repair harness or connector.

### 5.CHECK HYDRAULIC PUMP POWER SUPPLY RELAY

Check hydraulic pump power supply relay. Refer to [RF-242. "Diagnosis Procedure"](#).

Is the inspection result normal?

YES >> Check intermittent incident. Refer to [GI-43. "Intermittent Incident"](#).

NO >> Replace hydraulic unit. Refer to [RF-299. "Removal and Installation"](#).

# B1734 HYDRAULIC STATE 4

< DTC/CIRCUIT DIAGNOSIS >

## B1734 HYDRAULIC STATE 4

### Description

INFOID:000000006468774

There are 22 states in hydraulic system. Hydraulic system is controlled using combination of these 22 states and, at the same time, open and close operations of retractable hard top system are performed interlocking with other retractable hard top system components. For the detail, refer to [RF-31, "HYDRAULIC SYSTEM CONTROL FUNCTION : System Description"](#).

### DTC Logic

INFOID:000000006468775

#### DTC DETECTION LOGIC

##### NOTE:

If two or more DTCs are detected, refer to [RF-61, "DTC Inspection Priority Chart"](#), and determine trouble diagnosis order.

DTC No.	Trouble diagnosis name		DTC detecting condition	Possible cause
B1734	HYDRAULIC STATE 4	[TIMEOUT]	Retractable hard top control unit does not detect changing from hydraulic state 4 for the specified period of time, during an open and close operation <ul style="list-style-type: none"><li>Open operation: Hydraulic state 5 is not detected for 0.6 second</li><li>Close operation: Hydraulic state 1, 2 or 3 is not detected for 2 seconds</li></ul>	<ul style="list-style-type: none"><li>Hydraulic system</li><li>Trunk lid</li><li>Trunk room lamp switch</li><li>Hydraulic unit</li></ul>

#### DTC CONFIRMATION PROCEDURE

##### 1. PERFORM DTC CONFIRMATION PROCEDURE

1. Start engine.
2. Operate retractable hard top to fully open and fully close.
3. Check "Self-Diagnostic Result" of "RETRACTABLE HARD TOP" using CONSULT-III.

##### Is DTC detected?

- YES >> Go to [RF-165, "Diagnosis Procedure"](#).  
NO >> INSPECTION END

### Diagnosis Procedure

INFOID:000000006468776

##### 1. CHECK RETRACTABLE HARD TOP SYSTEM COMPONENT PARTS

Check retractable hard top component parts as bellow deformation, looseness, rattle, interference with other parts, and pinched foreign materials.

- Hydraulic system: Refer to [RF-299, "Exploded View"](#).
- Trunk lid: Refer to [DLK-269, "TRUNK LID ASSEMBLY : Exploded View"](#).

##### Is the inspection result normal?

- YES >> GO TO 2.  
NO >> Repair or replace malfunctioning part.

##### 2. CHECK TRUNK ROOM LAMP SWITCH

Check trunk room lamp switch. Refer to [DLK-82, "Component Function Check"](#).

##### Is the inspection result normal?

- YES >> GO TO 3.  
NO >> Repair or replace malfunctioning part.

##### 3. CHECK TRUNK ROOM LAMP SWITCH SIGNAL

Check "TR ROOM LAMP SW" in "DATA MONITOR" mode of "RETRACTABLE HARD TOP" using CONSULT-III.

# B1734 HYDRAULIC STATE 4

## < DTC/CIRCUIT DIAGNOSIS >

Monitor item	Condition	Status
TR ROOM LAMP SW	Trunk lid	Open
		Closed
		ON
		OFF

Is the inspection result normal?

YES >> GO TO 5.

NO >> GO TO 4.

### 4.CHECK TRUNK ROOM LAMP SWITCH CIRCUIT

1. Disconnect trunk room lamp switch connector, BCM connector, trunk closure control unit connector and retractable hard top control unit connector.
2. Check continuity between retractable hard top control unit harness connector and trunk room lamp switch harness connector.

Retractable hard top control unit		Trunk room lamp switch		Continuity
Connector	Terminal	Connector	Terminal	
B82	5	B306	2	Existed

3. Check continuity between BCM harness connector and ground.

Retractable hard top control unit		Ground	Continuity
Connector	Terminal		
B82	5		Not existed

Is the inspection result normal?

YES >> Check trunk lid auto closure system. Refer to [DLK-220. "OPEN/CLOSURE FUNCTION : Diagnosis Procedure"](#).

NO >> Repair harness or connector.

### 5.CHECK HYDRAULIC PUMP POWER SUPPLY RELAY

Check hydraulic pump power supply relay. Refer to [RF-242. "Diagnosis Procedure"](#).

Is the inspection result normal?

YES >> Check intermittent incident. Refer to [GI-43. "Intermittent Incident"](#).

NO >> Replace hydraulic unit. Refer to [RF-299. "Removal and Installation"](#).

# B1735 HYDRAULIC STATE 5

< DTC/CIRCUIT DIAGNOSIS >

## B1735 HYDRAULIC STATE 5

### Description

INFOID:000000006468777

There are 22 states in hydraulic system. Hydraulic system is controlled using combination of these 22 states and, at the same time, open and close operations of retractable hard top system are performed interlocking with other retractable hard top system components. For the detail, refer to [RF-31, "HYDRAULIC SYSTEM CONTROL FUNCTION : System Description"](#).

### DTC Logic

INFOID:000000006468778

### DTC DETECTION LOGIC

#### NOTE:

If two or more DTCs are detected, refer to [RF-61, "DTC Inspection Priority Chart"](#), and determine trouble diagnosis order.

DTC No.	Trouble diagnosis name		DTC detecting condition	Possible cause
B1735	HYDRAULIC STATE 5	[TIMEOUT]	Retractable hard top control unit does not detect changing from hydraulic state 5 for the specified period of time, during an open and close operation <ul style="list-style-type: none"><li>Open operation: Hydraulic state 6 is not detected for 7 seconds</li><li>Close operation: Hydraulic state 4 is not detected for 7 seconds</li></ul>	<ul style="list-style-type: none"><li>Hydraulic system</li><li>Trunk lid</li><li>Trunk room lamp switch</li><li>Hydraulic unit</li></ul>

### DTC CONFIRMATION PROCEDURE

#### 1. PERFORM DTC CONFIRMATION PROCEDURE

1. Start engine.
2. Operate retractable hard top to fully open and fully close.
3. Check "Self-Diagnostic Result" of "RETRACTABLE HARD TOP" using CONSULT-III.

#### Is DTC detected?

- YES >> Go to [RF-167, "Diagnosis Procedure"](#).  
NO >> INSPECTION END

### Diagnosis Procedure

INFOID:000000006468779

#### 1. CHECK RETRACTABLE HARD TOP SYSTEM COMPONENT PARTS

Check retractable hard top component parts as bellow deformation, looseness, rattle, interference with other parts, and pinched foreign materials.

- Hydraulic system: Refer to [RF-299, "Exploded View"](#).
- Trunk lid: Refer to [DLK-269, "TRUNK LID ASSEMBLY : Exploded View"](#).

#### Is the inspection result normal?

- YES >> GO TO 2.  
NO >> Repair or replace malfunctioning part.

#### 2. CHECK TRUNK ROOM LAMP SWITCH

Check trunk room lamp switch. Refer to [DLK-82, "Component Function Check"](#).

#### Is the inspection result normal?

- YES >> GO TO 3.  
NO >> Repair or replace malfunctioning part.

#### 3. CHECK TRUNK ROOM LAMP SWITCH SIGNAL

Check "TR ROOM LAMP SW" in "DATA MONITOR" mode of "RETRACTABLE HARD TOP" using CONSULT-III.

## B1735 HYDRAULIC STATE 5

### < DTC/CIRCUIT DIAGNOSIS >

Monitor item	Condition	Status
TR ROOM LAMP SW	Trunk lid	Open
		Closed
		ON
		OFF

Is the inspection result normal?

YES >> GO TO 5.

NO >> GO TO 4.

#### 4. CHECK TRUNK ROOM LAMP SWITCH CIRCUIT

1. Disconnect trunk room lamp switch connector, BCM connector, trunk closure control unit connector and retractable hard top control unit connector.
2. Check continuity between retractable hard top control unit harness connector and trunk room lamp switch harness connector.

Retractable hard top control unit		Trunk room lamp switch		Continuity
Connector	Terminal	Connector	Terminal	
B82	5	B306	2	Existed

3. Check continuity between BCM harness connector and ground.

Retractable hard top control unit		Ground	Continuity
Connector	Terminal		
B82	5		Not existed

Is the inspection result normal?

YES >> Check trunk lid auto closure system. Refer to [DLK-220. "OPEN/CLOSURE FUNCTION : Diagnosis Procedure"](#).

NO >> Repair harness or connector.

#### 5. CHECK HYDRAULIC PUMP POWER SUPPLY RELAY

Check hydraulic pump power supply relay. Refer to [RF-242. "Diagnosis Procedure"](#).

Is the inspection result normal?

YES >> Check intermittent incident. Refer to [GI-43. "Intermittent Incident"](#).

NO >> Replace hydraulic unit. Refer to [RF-299. "Removal and Installation"](#).



# B1736 HYDRAULIC STATE 6

< DTC/CIRCUIT DIAGNOSIS >

## B1736 HYDRAULIC STATE 6

### Description

INFOID:000000006468780

There are 22 states in hydraulic system. Hydraulic system is controlled using combination of these 22 states and, at the same time, open and close operations of retractable hard top system are performed interlocking with other retractable hard top system components. For the detail, refer to [RF-31, "HYDRAULIC SYSTEM CONTROL FUNCTION : System Description"](#).

### DTC Logic

INFOID:000000006468781

#### DTC DETECTION LOGIC

##### NOTE:

If two or more DTCs are detected, refer to [RF-61, "DTC Inspection Priority Chart"](#), and determine trouble diagnosis order.

DTC No.	Trouble diagnosis name		DTC detecting condition	Possible cause
B1736	HYDRAULIC STATE 6	[TIMEOUT]	Retractable hard top control unit does not detect changing from hydraulic state 6 for the specified period of time, during a close operation <ul style="list-style-type: none"><li>Close operation: Hydraulic state 4 is not detected for 3 seconds</li></ul>	<ul style="list-style-type: none"><li>Hydraulic system</li><li>Hydraulic unit</li><li>Roof</li><li>Roof latch</li><li>Roof latch motor</li></ul>

#### DTC CONFIRMATION PROCEDURE

##### 1. PERFORM DTC CONFIRMATION PROCEDURE

1. Start engine.
2. Operate retractable hard top to fully open and fully close.
3. Check "Self-Diagnostic Result" of "RETRACTABLE HARD TOP" using CONSULT-III.

##### Is DTC detected?

- YES >> Go to [RF-169, "Diagnosis Procedure"](#).  
NO >> INSPECTION END

### Diagnosis Procedure

INFOID:000000006468782

##### 1. CHECK RETRACTABLE HARD TOP SYSTEM COMPONENT PARTS

Check retractable hard top component parts as bellow deformation, looseness, rattle, interference with other parts, and pinched foreign materials.

- Hydraulic system: Refer to [RF-299, "Exploded View"](#).
- Roof: Refer to [RF-287, "Exploded View"](#).
- Roof latch: Refer to [RF-269, "ROOF LOCK ASSEMBLY : Exploded View"](#).

##### Is the inspection result normal?

- YES >> GO TO 2.  
NO >> Repair or replace malfunctioning part.

##### 2. CHECK HYDRAULIC PUMP POWER SUPPLY RELAY

Check hydraulic pump power supply relay. Refer to [RF-242, "Diagnosis Procedure"](#).

##### Is the inspection result normal?

- YES >> GO TO 3.  
NO >> Repair or replace malfunctioning part.

##### 3. CHECK ROOF LATCH MOTOR

Check roof latch motor. Refer to [RF-237, "Diagnosis Procedure"](#).

##### Is the inspection result normal?

- YES >> Check intermittent incident. Refer to [GI-43, "Intermittent Incident"](#).  
NO >> Repair or replace malfunctioning part.

# B1737 HYDRAULIC STATE 7

< DTC/CIRCUIT DIAGNOSIS >

## B1737 HYDRAULIC STATE 7

### Description

INFOID:000000006468783

There are 22 states in hydraulic system. Hydraulic system is controlled using combination of these 22 states and, at the same time, open and close operations of retractable hard top system are performed interlocking with other retractable hard top system components. For the detail, refer to [RF-31, "HYDRAULIC SYSTEM CONTROL FUNCTION : System Description"](#).

### DTC Logic

INFOID:000000006468784

### DTC DETECTION LOGIC

#### NOTE:

If two or more DTCs are detected, refer to [RF-61, "DTC Inspection Priority Chart"](#), and determine trouble diagnosis order.

DTC No.	Trouble diagnosis name		DTC detecting condition	Possible cause
B1737	HYDRAULIC STATE 7	[TIMEOUT]	Retractable hard top control unit does not detect changing from hydraulic state 7 for the specified period of time, during an open and close operation <ul style="list-style-type: none"><li>Open operation: Hydraulic state 8 is not detected for 5 seconds</li><li>Close operation: Hydraulic state 6 is not detected for 5 seconds</li></ul>	<ul style="list-style-type: none"><li>Hydraulic system</li><li>Hydraulic unit</li><li>Roof</li><li>Roof latch</li><li>Roof latch motor</li></ul>

### DTC CONFIRMATION PROCEDURE

#### 1. PERFORM DTC CONFIRMATION PROCEDURE

1. Start engine.
2. Operate retractable hard top to fully open and fully close.
3. Check "Self-Diagnostic Result" of "RETRACTABLE HARD TOP" using CONSULT-III.

#### Is DTC detected?

- YES >> Go to [RF-170, "Diagnosis Procedure"](#).  
NO >> INSPECTION END

### Diagnosis Procedure

INFOID:000000006468785

#### 1. CHECK RETRACTABLE HARD TOP SYSTEM COMPONENT PARTS

Check retractable hard top component parts as bellow deformation, looseness, rattle, interference with other parts, and pinched foreign materials.

- Hydraulic system: Refer to [RF-299, "Exploded View"](#).
- Roof: Refer to [RF-287, "Exploded View"](#).
- Roof latch: Refer to [RF-269, "ROOF LOCK ASSEMBLY : Exploded View"](#).

#### Is the inspection result normal?

- YES >> GO TO 2.  
NO >> Repair or replace malfunctioning part.

#### 2. CHECK HYDRAULIC PUMP POWER SUPPLY RELAY

Check hydraulic pump power supply relay. Refer to [RF-242, "Diagnosis Procedure"](#).

#### Is the inspection result normal?

- YES >> GO TO 3.  
NO >> Repair or replace malfunctioning part.

#### 3. CHECK ROOF LATCH MOTOR

Check roof latch motor. Refer to [RF-237, "Diagnosis Procedure"](#).

#### Is the inspection result normal?

- YES >> Check intermittent incident. Refer to [GI-43, "Intermittent Incident"](#).  
NO >> Repair or replace malfunctioning part.

# B1738 HYDRAULIC STATE 8

< DTC/CIRCUIT DIAGNOSIS >

## B1738 HYDRAULIC STATE 8

### Description

INFOID:000000006468786

There are 22 states in hydraulic system. Hydraulic system is controlled using combination of these 22 states and, at the same time, open and close operations of retractable hard top system are performed interlocking with other retractable hard top system components. For the detail, refer to [RF-31, "HYDRAULIC SYSTEM CONTROL FUNCTION : System Description"](#).

### DTC Logic

INFOID:000000006468787

#### DTC DETECTION LOGIC

##### NOTE:

If two or more DTCs are detected, refer to [RF-61, "DTC Inspection Priority Chart"](#), and determine trouble diagnosis order.

DTC No.	Trouble diagnosis name		DTC detecting condition	Possible cause
B1738	HYDRAULIC STATE 8	[TIMEOUT]	Retractable hard top control unit does not detect changing from hydraulic state 8 for the specified period of time, during an open and close operation <ul style="list-style-type: none"><li>Open operation: Hydraulic state 9 is not detected for 2 seconds</li></ul>	<ul style="list-style-type: none"><li>Hydraulic system</li><li>Hydraulic unit</li><li>Roof</li><li>Roof latch</li><li>Roof latch motor</li></ul>

#### DTC CONFIRMATION PROCEDURE

##### 1. PERFORM DTC CONFIRMATION PROCEDURE

- Start engine.
- Operate retractable hard top to fully open and fully close.
- Check "Self-Diagnostic Result" of "RETRACTABLE HARD TOP" using CONSULT-III.

##### Is DTC detected?

- YES >> Go to [RF-171, "Diagnosis Procedure"](#).  
NO >> INSPECTION END

### Diagnosis Procedure

INFOID:000000006468788

##### 1. CHECK RETRACTABLE HARD TOP SYSTEM COMPONENT PARTS

Check retractable hard top component parts as bellow deformation, looseness, rattle, interference with other parts, and pinched foreign materials.

- Hydraulic system: Refer to [RF-299, "Exploded View"](#).
- Roof: Refer to [RF-287, "Exploded View"](#).
- Roof latch: Refer to [RF-269, "ROOF LOCK ASSEMBLY : Exploded View"](#).

##### Is the inspection result normal?

- YES >> GO TO 2.  
NO >> Repair or replace malfunctioning part.

##### 2. CHECK ROOF LATCH MOTOR

Check roof latch motor. Refer to [RF-237, "Diagnosis Procedure"](#).

##### Is the inspection result normal?

- YES >> GO TO 3.  
NO >> Repair or replace malfunctioning part.

##### 3. CHECK HYDRAULIC PUMP POWER SUPPLY RELAY

Check hydraulic pump power supply relay. Refer to [RF-242, "Diagnosis Procedure"](#).

##### Is the inspection result normal?

- YES >> Check intermittent incident. Refer to [GI-43, "Intermittent Incident"](#).  
NO >> Replace hydraulic unit. Refer to [RF-299, "Removal and Installation"](#).

# B1739 HYDRAULIC STATE 9

< DTC/CIRCUIT DIAGNOSIS >

## B1739 HYDRAULIC STATE 9

### Description

INFOID:000000006468789

There are 22 states in hydraulic system. Hydraulic system is controlled using combination of these 22 states and, at the same time, open and close operations of retractable hard top system are performed interlocking with other retractable hard top system components. For the detail, refer to [RF-31, "HYDRAULIC SYSTEM CONTROL FUNCTION : System Description"](#).

### DTC Logic

INFOID:000000006468790

### DTC DETECTION LOGIC

#### NOTE:

If two or more DTCs are detected, refer to [RF-61, "DTC Inspection Priority Chart"](#), and determine trouble diagnosis order.

DTC No.	Trouble diagnosis name		DTC detecting condition	Possible cause
B1739	HYDRAULIC STATE 9	[TIMEOUT]	Retractable hard top control unit does not detect changing from hydraulic state 9 for the specified period of time, during an open and close operation <ul style="list-style-type: none"><li>Open operation: Hydraulic state 10 is not detected for 4 seconds</li><li>Close operation: Hydraulic state 8 is not detected for 3 seconds</li></ul>	<ul style="list-style-type: none"><li>Hydraulic system</li><li>Roof</li><li>Hydraulic unit</li></ul>

### DTC CONFIRMATION PROCEDURE

#### 1. PERFORM DTC CONFIRMATION PROCEDURE

1. Start engine.
2. Operate retractable hard top to fully open and fully close.
3. Check "Self-Diagnostic Result" of "RETRACTABLE HARD TOP" using CONSULT-III.

#### Is DTC detected?

- YES >> Go to [RF-172, "Diagnosis Procedure"](#).  
NO >> INSPECTION END

### Diagnosis Procedure

INFOID:000000006468791

#### 1. CHECK RETRACTABLE HARD TOP SYSTEM COMPONENT PARTS

Check retractable hard top component parts as bellow deformation, looseness, rattle, interference with other parts, and pinched foreign materials.

- Hydraulic system: Refer to [RF-299, "Exploded View"](#).
- Roof: Refer to [RF-287, "Exploded View"](#).

#### Is the inspection result normal?

- YES >> GO TO 2.  
NO >> Repair or replace malfunctioning part.

#### 2. CHECK HYDRAULIC PUMP POWER SUPPLY RELAY

Check hydraulic pump power supply relay. Refer to [RF-242, "Diagnosis Procedure"](#).

#### Is the inspection result normal?

- YES >> Check intermittent incident. Refer to [GI-43, "Intermittent Incident"](#).  
NO >> Replace hydraulic unit. Refer to [RF-299, "Removal and Installation"](#).

# B173A HYDRAULIC STATE 10

< DTC/CIRCUIT DIAGNOSIS >

## B173A HYDRAULIC STATE 10

### Description

INFOID:000000006468792

There are 22 states in hydraulic system. Hydraulic system is controlled using combination of these 22 states and, at the same time, open and close operations of retractable hard top system are performed interlocking with other retractable hard top system components. For the detail, refer to [RF-31, "HYDRAULIC SYSTEM CONTROL FUNCTION : System Description"](#).

### DTC Logic

INFOID:000000006468793

#### DTC DETECTION LOGIC

##### NOTE:

If two or more DTCs are detected, refer to [RF-61, "DTC Inspection Priority Chart"](#), and determine trouble diagnosis order.

DTC No.	Trouble diagnosis name		DTC detecting condition	Possible cause
B173A	HYDRAULIC STATE 10	[TIMEOUT]	Retractable hard top control unit does not detect changing from hydraulic state 10 for the specified period of time, during an open and close operation <ul style="list-style-type: none"><li>Open operation: Hydraulic state 11 is not detected for 4.5 seconds</li><li>Close operation: Hydraulic state 9 is not detected for 5 seconds</li></ul>	<ul style="list-style-type: none"><li>Hydraulic system</li><li>Roof</li><li>Hydraulic unit</li></ul>

#### DTC CONFIRMATION PROCEDURE

##### 1. PERFORM DTC CONFIRMATION PROCEDURE

1. Start engine.
2. Operate retractable hard top to fully open and fully close.
3. Check "Self-Diagnostic Result" of "RETRACTABLE HARD TOP" using CONSULT-III.

##### Is DTC detected?

- YES >> Go to [RF-173, "Diagnosis Procedure"](#).  
NO >> INSPECTION END

### Diagnosis Procedure

INFOID:000000006468794

##### 1. CHECK RETRACTABLE HARD TOP SYSTEM COMPONENT PARTS

Check retractable hard top component parts as bellow deformation, looseness, rattle, interference with other parts, and pinched foreign materials.

- Hydraulic system: Refer to [RF-299, "Exploded View"](#).
- Roof: Refer to [RF-287, "Exploded View"](#).

##### Is the inspection result normal?

- YES >> GO TO 2.  
NO >> Repair or replace malfunctioning part.

##### 2. CHECK HYDRAULIC PUMP POWER SUPPLY RELAY

Check hydraulic pump power supply relay. Refer to [RF-242, "Diagnosis Procedure"](#).

##### Is the inspection result normal?

- YES >> Check intermittent incident. Refer to [GI-43, "Intermittent Incident"](#).  
NO >> Replace hydraulic unit. Refer to [RF-299, "Removal and Installation"](#).

# B173B HYDRAULIC STATE 11

< DTC/CIRCUIT DIAGNOSIS >

## B173B HYDRAULIC STATE 11

### Description

INFOID:000000006468795

There are 22 states in hydraulic system. Hydraulic system is controlled using combination of these 22 states and, at the same time, open and close operations of retractable hard top system are performed interlocking with other retractable hard top system components. For the detail, refer to [RF-31, "HYDRAULIC SYSTEM CONTROL FUNCTION : System Description"](#).

### DTC Logic

INFOID:000000006468796

#### DTC DETECTION LOGIC

##### NOTE:

If two or more DTCs are detected, refer to [RF-61, "DTC Inspection Priority Chart"](#), and determine trouble diagnosis order.

DTC No.	Trouble diagnosis name		DTC detecting condition	Possible cause
B173B	HYDRAULIC STATE 11	[TIMEOUT]	Retractable hard top control unit does not detect changing from hydraulic state 11 for the specified period of time, during an open and close operation <ul style="list-style-type: none"><li>Open operation: Hydraulic state 12 is not detected for 4 seconds</li><li>Close operation: Hydraulic state 10 is not detected for 7 seconds</li></ul>	<ul style="list-style-type: none"><li>Hydraulic system</li><li>Roof</li><li>Hydraulic unit</li></ul>

#### DTC CONFIRMATION PROCEDURE

##### 1. PERFORM DTC CONFIRMATION PROCEDURE

1. Start engine.
2. Operate retractable hard top to fully open and fully close.
3. Check "Self-Diagnostic Result" of "RETRACTABLE HARD TOP" using CONSULT-III.

##### Is DTC detected?

- YES >> Go to [RF-174, "Diagnosis Procedure"](#).  
NO >> INSPECTION END

### Diagnosis Procedure

INFOID:000000006468797

##### 1. CHECK RETRACTABLE HARD TOP SYSTEM COMPONENT PARTS

Check retractable hard top component parts as bellow deformation, looseness, rattle, interference with other parts, and pinched foreign materials.

- Hydraulic system: Refer to [RF-299, "Exploded View"](#).
- Roof: Refer to [RF-287, "Exploded View"](#).

##### Is the inspection result normal?

- YES >> GO TO 2.  
NO >> Repair or replace malfunctioning part.

##### 2. CHECK HYDRAULIC PUMP POWER SUPPLY RELAY

Check hydraulic pump power supply relay. Refer to [RF-242, "Diagnosis Procedure"](#).

##### Is the inspection result normal?

- YES >> Check intermittent incident. Refer to [GI-43, "Intermittent Incident"](#).  
NO >> Replace hydraulic unit. Refer to [RF-299, "Removal and Installation"](#).

# B173C HYDRAULIC STATE 12

< DTC/CIRCUIT DIAGNOSIS >

## B173C HYDRAULIC STATE 12

### Description

INFOID:000000006468798

There are 22 states in hydraulic system. Hydraulic system is controlled using combination of these 22 states and, at the same time, open and close operations of retractable hard top system are performed interlocking with other retractable hard top system components. For the detail, refer to [RF-31, "HYDRAULIC SYSTEM CONTROL FUNCTION : System Description"](#).

### DTC Logic

INFOID:000000006468799

### DTC DETECTION LOGIC

#### NOTE:

If two or more DTCs are detected, refer to [RF-61, "DTC Inspection Priority Chart"](#), and determine trouble diagnosis order.

DTC No.	Trouble diagnosis name		DTC detecting condition	Possible cause
B173C	HYDRAULIC STATE 12	[TIMEOUT]	Retractable hard top control unit does not detect changing from hydraulic state 12 for the specified period of time, during an open and close operation <ul style="list-style-type: none"> <li>Open operation: Hydraulic state 13 is not detected for 2 seconds</li> <li>Close operation: Hydraulic state 11 is not detected for 2.5 seconds</li> </ul>	<ul style="list-style-type: none"> <li>Hydraulic system</li> <li>Roof</li> <li>Hydraulic unit</li> </ul>

### DTC CONFIRMATION PROCEDURE

#### 1. PERFORM DTC CONFIRMATION PROCEDURE

1. Start engine.
2. Operate retractable hard top to fully open and fully close.
3. Check "Self-Diagnostic Result" of "RETRACTABLE HARD TOP" using CONSULT-III.

#### Is DTC detected?

- YES >> Go to [RF-175, "Diagnosis Procedure"](#).  
 NO >> INSPECTION END

### Diagnosis Procedure

INFOID:000000006468800

#### 1. CHECK RETRACTABLE HARD TOP SYSTEM COMPONENT PARTS

Check retractable hard top component parts as bellow deformation, looseness, rattle, interference with other parts, and pinched foreign materials.

- Hydraulic system: Refer to [RF-299, "Exploded View"](#).
- Roof: Refer to [RF-287, "Exploded View"](#).

#### Is the inspection result normal?

- YES >> GO TO 2.  
 NO >> Repair or replace malfunctioning part.

#### 2. CHECK HYDRAULIC PUMP POWER SUPPLY RELAY

Check hydraulic pump power supply relay. Refer to [RF-242, "Diagnosis Procedure"](#).

#### Is the inspection result normal?

- YES >> Check intermittent incident. Refer to [GI-43, "Intermittent Incident"](#).  
 NO >> Replace hydraulic unit. Refer to [RF-299, "Removal and Installation"](#).



# B173D HYDRAULIC STATE 13

< DTC/CIRCUIT DIAGNOSIS >

## B173D HYDRAULIC STATE 13

### Description

INFOID:000000006468801

There are 22 states in hydraulic system. Hydraulic system is controlled using combination of these 22 states and, at the same time, open and close operations of retractable hard top system are performed interlocking with other retractable hard top system components. For the detail, refer to [RF-31, "HYDRAULIC SYSTEM CONTROL FUNCTION : System Description"](#).

### DTC Logic

INFOID:000000006468802

### DTC DETECTION LOGIC

#### NOTE:

If two or more DTCs are detected, refer to [RF-61, "DTC Inspection Priority Chart"](#), and determine trouble diagnosis order.

DTC No.	Trouble diagnosis name		DTC detecting condition	Possible cause
B173D	HYDRAULIC STATE 13	[TIMEOUT]	Retractable hard top control unit does not detect changing from hydraulic state 13 for the specified period of time, during an open and close operation • Open operation: Hydraulic state 14 is not detected for 3 seconds • Close operation: Hydraulic state 12 is not detected for 2.5 seconds	<ul style="list-style-type: none"><li>Hydraulic system</li><li>Roof</li><li>Hydraulic unit</li></ul>

### DTC CONFIRMATION PROCEDURE

#### 1. PERFORM DTC CONFIRMATION PROCEDURE

- Start engine.
- Operate retractable hard top to fully open and fully close.
- Check "Self-Diagnostic Result" of "RETRACTABLE HARD TOP" using CONSULT-III.

#### Is DTC detected?

- YES >> Go to [RF-176, "Diagnosis Procedure"](#).  
NO >> INSPECTION END

### Diagnosis Procedure

INFOID:000000006468803

#### 1. CHECK RETRACTABLE HARD TOP SYSTEM COMPONENT PARTS

Check retractable hard top component parts as bellow deformation, looseness, rattle, interference with other parts, and pinched foreign materials.

- Hydraulic system: Refer to [RF-299, "Exploded View"](#).
- Roof: Refer to [RF-287, "Exploded View"](#).

#### Is the inspection result normal?

- YES >> GO TO 2.  
NO >> Repair or replace malfunctioning part.

#### 2. CHECK HYDRAULIC PUMP POWER SUPPLY RELAY

Check hydraulic pump power supply relay. Refer to [RF-242, "Diagnosis Procedure"](#).

#### Is the inspection result normal?

- YES >> Check intermittent incident. Refer to [GI-43, "Intermittent Incident"](#).  
NO >> Replace hydraulic unit. Refer to [RF-299, "Removal and Installation"](#).



# B173E HYDRAULIC STATE 14

< DTC/CIRCUIT DIAGNOSIS >

## B173E HYDRAULIC STATE 14

### Description

INFOID:000000006468804

There are 22 states in hydraulic system. Hydraulic system is controlled using combination of these 22 states and, at the same time, open and close operations of retractable hard top system are performed interlocking with other retractable hard top system components. For the detail, refer to [RF-31, "HYDRAULIC SYSTEM CONTROL FUNCTION : System Description"](#).

### DTC Logic

INFOID:000000006468805

#### DTC DETECTION LOGIC

##### NOTE:

If two or more DTCs are detected, refer to [RF-61, "DTC Inspection Priority Chart"](#), and determine trouble diagnosis order.

DTC No.	Trouble diagnosis name		DTC detecting condition	Possible cause
B173E	HYDRAULIC STATE 14	[TIMEOUT]	Retractable hard top control unit does not detect changing from hydraulic state 14 for the specified period of time, during an open and close operation • Open operation: Hydraulic state 15 is not detected for 3.5 seconds • Close operation: Hydraulic state 13 is not detected for 2.5 seconds	<ul style="list-style-type: none"><li>Hydraulic system</li><li>Roof</li><li>Hydraulic unit</li></ul>

#### DTC CONFIRMATION PROCEDURE

##### 1. PERFORM DTC CONFIRMATION PROCEDURE

- Start engine.
- Operate retractable hard top to fully open and fully close.
- Check "Self-Diagnostic Result" of "RETRACTABLE HARD TOP" using CONSULT-III.

##### Is DTC detected?

- YES >> Go to [RF-177, "Diagnosis Procedure"](#).  
NO >> INSPECTION END

### Diagnosis Procedure

INFOID:000000006468806

##### 1. CHECK RETRACTABLE HARD TOP SYSTEM COMPONENT PARTS

Check retractable hard top component parts as bellow deformation, looseness, rattle, interference with other parts, and pinched foreign materials.

- Hydraulic system: Refer to [RF-299, "Exploded View"](#).
- Roof: Refer to [RF-287, "Exploded View"](#).

##### Is the inspection result normal?

- YES >> GO TO 2.  
NO >> Repair or replace malfunctioning part.

##### 2. CHECK HYDRAULIC PUMP POWER SUPPLY RELAY

Check hydraulic pump power supply relay. Refer to [RF-242, "Diagnosis Procedure"](#).

##### Is the inspection result normal?

- YES >> Check intermittent incident. Refer to [GI-43, "Intermittent Incident"](#).  
NO >> Replace hydraulic unit. Refer to [RF-299, "Removal and Installation"](#).

# B173F HYDRAULIC STATE 15

< DTC/CIRCUIT DIAGNOSIS >

## B173F HYDRAULIC STATE 15

### Description

INFOID:000000006468807

There are 22 states in hydraulic system. Hydraulic system is controlled using combination of these 22 states and, at the same time, open and close operations of retractable hard top system are performed interlocking with other retractable hard top system components. For the detail, refer to [RF-31, "HYDRAULIC SYSTEM CONTROL FUNCTION : System Description"](#).

### DTC Logic

INFOID:000000006468808

#### DTC DETECTION LOGIC

##### NOTE:

If two or more DTCs are detected, refer to [RF-61, "DTC Inspection Priority Chart"](#), and determine trouble diagnosis order.

DTC No.	Trouble diagnosis name		DTC detecting condition	Possible cause
B173F	HYDRAULIC STATE 15	[TIMEOUT]	Retractable hard top control unit does not detect changing from hydraulic state 15 for the specified period of time, during an open and close operation <ul style="list-style-type: none"><li>Open operation: Hydraulic state 16 is not detected for 3.5 seconds</li><li>Close operation: Hydraulic state 14 is not detected for 2.5 seconds</li></ul>	<ul style="list-style-type: none"><li>Hydraulic system</li><li>Hydraulic unit</li><li>Roof</li><li>Roof latch</li><li>Roof latch motor</li></ul>

#### DTC CONFIRMATION PROCEDURE

##### 1. PERFORM DTC CONFIRMATION PROCEDURE

1. Start engine.
2. Operate retractable hard top to fully open and fully close.
3. Check "Self-Diagnostic Result" of "RETRACTABLE HARD TOP" using CONSULT-III.

##### Is DTC detected?

- YES >> Go to [RF-178, "Diagnosis Procedure"](#).  
NO >> INSPECTION END

### Diagnosis Procedure

INFOID:000000006468809

##### 1. CHECK RETRACTABLE HARD TOP SYSTEM COMPONENT PARTS

Check retractable hard top component parts as bellow deformation, looseness, rattle, interference with other parts, and pinched foreign materials.

- Hydraulic system: Refer to [RF-299, "Exploded View"](#).
- Roof: Refer to [RF-287, "Exploded View"](#).
- Roof latch: Refer to [RF-269, "ROOF LOCK ASSEMBLY : Exploded View"](#).

##### Is the inspection result normal?

- YES >> GO TO 2.  
NO >> Repair or replace malfunctioning part.

##### 2. CHECK HYDRAULIC PUMP POWER SUPPLY RELAY

Check hydraulic pump power supply relay. Refer to [RF-242, "Diagnosis Procedure"](#).

##### Is the inspection result normal?

- YES >> GO TO 3.  
NO >> Repair or replace malfunctioning part.

##### 3. CHECK ROOF LATCH MOTOR

Check roof latch motor. Refer to [RF-237, "Diagnosis Procedure"](#).

##### Is the inspection result normal?

- YES >> Check intermittent incident. Refer to [GI-43, "Intermittent Incident"](#).  
NO >> Repair or replace malfunctioning part.

# B1740 HYDRAULIC STATE 16

< DTC/CIRCUIT DIAGNOSIS >

## B1740 HYDRAULIC STATE 16

### Description

INFOID:000000006468810

There are 22 states in hydraulic system. Hydraulic system is controlled using combination of these 22 states and, at the same time, open and close operations of retractable hard top system are performed interlocking with other retractable hard top system components. For the detail, refer to [RF-31, "HYDRAULIC SYSTEM CONTROL FUNCTION : System Description"](#).

### DTC Logic

INFOID:000000006468811

#### DTC DETECTION LOGIC

##### NOTE:

If two or more DTCs are detected, refer to [RF-61, "DTC Inspection Priority Chart"](#), and determine trouble diagnosis order.

DTC No.	Trouble diagnosis name		DTC detecting condition	Possible cause
B1740	HYDRAULIC STATE 16	[TIMEOUT]	Retractable hard top control unit does not detect changing from hydraulic state 16 for the specified period of time, during an open and close operation <ul style="list-style-type: none"><li>Open operation: Hydraulic state 17 is not detected for 5 seconds</li></ul>	<ul style="list-style-type: none"><li>Hydraulic system</li><li>Hydraulic unit</li><li>Trunk</li><li>Trunk room lamp switch</li><li>Parcel shelf motor</li><li>Flipper door motor</li><li>Flipper door limit switch</li><li>Roof latch</li><li>Roof latch motor</li></ul>

#### DTC CONFIRMATION PROCEDURE

##### 1. PERFORM DTC CONFIRMATION PROCEDURE

1. Start engine.
2. Operate retractable hard top to fully open and fully close.
3. Check "Self-Diagnostic Result" of "RETRACTABLE HARD TOP" using CONSULT-III.

##### Is DTC detected?

- YES >> Go to [RF-179, "Diagnosis Procedure"](#).  
NO >> INSPECTION END

#### Diagnosis Procedure

INFOID:000000006468812

##### 1. CHECK RETRACTABLE HARD TOP SYSTEM COMPONENT PARTS

Check retractable hard top component parts as bellow deformation, looseness, rattle, interference with other parts, and pinched foreign materials.

- Hydraulic system: Refer to [RF-299, "Exploded View"](#).
- Trunk lid: Refer to [DLK-269, "TRUNK LID ASSEMBLY : Exploded View"](#).
- Parcel shelf: Refer to [RF-290, "REAR PARCEL SHELF UNIT : Exploded View"](#).
- Flipper door: Refer to [RF-295, "Exploded View"](#).
- Roof: Refer to [RF-287, "Exploded View"](#).
- Roof latch assy: Refer to [RF-269, "ROOF LOCK ASSEMBLY : Exploded View"](#).

##### Is the inspection result normal?

- YES >> GO TO 2.  
NO >> Repair or replace malfunctioning part.

##### 2. CHECK TRUNK ROOM LAMP SWITCH

Check trunk room lamp switch. Refer to [DLK-82, "Component Function Check"](#).

##### Is the inspection result normal?

- YES >> GO TO 3.  
NO >> Repair or replace malfunctioning part.

##### 3. CHECK TRUNK ROOM LAMP SWITCH SIGNAL

## B1740 HYDRAULIC STATE 16

### < DTC/CIRCUIT DIAGNOSIS >

Check "TR ROOM LAMP SW" in "DATA MONITOR" mode of "RETRACTABLE HARD TOP" using CONSULT-III.

Monitor item	Condition	Status
TR ROOM LAMP SW	Trunk lid	Open
		Closed
		ON
		OFF

Is the inspection result normal?

YES >> GO TO 5.

NO >> GO TO 4.

#### 4. CHECK TRUNK ROOM LAMP SWITCH CIRCUIT

1. Disconnect trunk room lamp switch connector, BCM connector trunk closure control unit connector and retractable hard top control unit connector.
2. Check continuity between retractable hard top control unit harness connector and trunk room lamp switch harness connector.

Retractable hard top control unit		Trunk room lamp switch		Continuity
Connector	Terminal	Connector	Terminal	
B82	5	B306	2	Existed

3. Check continuity between BCM harness connector and ground.

Retractable hard top control unit		Ground	Continuity
Connector	Terminal		
B82	5		Not existed

Is the inspection result normal?

YES >> Check trunk lid auto closure system. Refer to [DLK-220, "OPEN/CLOSURE FUNCTION : Diagnosis Procedure"](#).

NO >> Repair harness or connector.

#### 5. CHECK HYDRAULIC PUMP POWER SUPPLY RELAY

Check hydraulic pump power supply relay. Refer to [RF-242, "Diagnosis Procedure"](#).

Is the inspection result normal?

YES >> GO TO 6.

NO >> Replace hydraulic unit. Refer to [RF-299, "Removal and Installation"](#).

#### 6. CHECK PARCEL SHELF MOTOR

Check parcel shelf motor. Refer to [RF-238, "Diagnosis Procedure"](#) (DRAW) and [RF-240, "Diagnosis Procedure"](#) (ROTATION).

Is the inspection result normal?

YES >> GO TO 7.

NO >> Replace parcel shelf. Refer to [RF-290, "REAR PARCEL SHELF UNIT : Removal and Installation"](#).

#### 7. CHECK FLIPPER DOOR MOTOR

Check flipper door motor. Refer to [RF-235, "Diagnosis Procedure"](#).

Is the inspection result normal?

YES >> GO TO 8.

NO >> Replace flipper door. Refer to [RF-295, "Removal and Installation"](#).

#### 8. CHECK FLIPPER DOOR LIMIT SWITCH

Check flipper door limit switch. Refer to [RF-235, "Diagnosis Procedure"](#).

Is the inspection result normal?

YES >> GO TO 9.

NO >> Replace flipper door. Refer to [RF-295, "Removal and Installation"](#).

#### 9. CHECK ROOF LATCH MOTOR

## B1740 HYDRAULIC STATE 16

### < DTC/CIRCUIT DIAGNOSIS >

---

Check roof latch motor. Refer to [RF-237. "Diagnosis Procedure"](#).

Is the inspection result normal?

YES >> Check intermittent incident. Refer to [GI-43. "Intermittent Incident"](#).

NO >> Replace roof latch motor. Refer to [RF-269. "ROOF LOCK ASSEMBLY : Removal and Installation"](#).

A

B

C

D

E

F

G

H

I

J

RF

L

M

N

O

P

# B1741 HYDRAULIC STATE 17

< DTC/CIRCUIT DIAGNOSIS >

## B1741 HYDRAULIC STATE 17

### Description

INFOID:000000006468813

There are 22 states in hydraulic system. Hydraulic system is controlled using combination of these 22 states and, at the same time, open and close operations of retractable hard top system are performed interlocking with other retractable hard top system components. For the detail, refer to [RF-31, "HYDRAULIC SYSTEM CONTROL FUNCTION : System Description"](#).

### DTC Logic

INFOID:000000006468814

#### DTC DETECTION LOGIC

##### NOTE:

If two or more DTCs are detected, refer to [RF-61, "DTC Inspection Priority Chart"](#), and determine trouble diagnosis order.

DTC No.	Trouble diagnosis name		DTC detecting condition	Possible cause
B1741	HYDRAULIC STATE 17	[TIMEOUT]	Retractable hard top control unit does not detect changing from hydraulic state 17 for the specified period of time, during an open and close operation • Open operation: Hydraulic state 18 is not detected for 3 seconds	<ul style="list-style-type: none"><li>Hydraulic system</li><li>Hydraulic unit</li><li>Roof</li><li>Roof latch</li><li>Roof latch motor</li></ul>

#### DTC CONFIRMATION PROCEDURE

##### 1. PERFORM DTC CONFIRMATION PROCEDURE

- Start engine.
- Operate retractable hard top to fully open and fully close.
- Check "Self-Diagnostic Result" of "RETRACTABLE HARD TOP" using CONSULT-III.

##### Is DTC detected?

- YES >> Go to [RF-182, "Diagnosis Procedure"](#).  
NO >> INSPECTION END

### Diagnosis Procedure

INFOID:000000006468815

##### 1. CHECK RETRACTABLE HARD TOP SYSTEM COMPONENT PARTS

Check retractable hard top component parts as bellow deformation, looseness, rattle, interference with other parts, and pinched foreign materials.

- Hydraulic system: Refer to [RF-299, "Exploded View"](#).
- Roof: Refer to [RF-287, "Exploded View"](#).
- Roof latch: Refer to [RF-269, "ROOF LOCK ASSEMBLY : Exploded View"](#).

##### Is the inspection result normal?

- YES >> GO TO 2.  
NO >> Repair or replace malfunctioning part.

##### 2. CHECK HYDRAULIC PUMP POWER SUPPLY RELAY

Check hydraulic pump power supply relay. Refer to [RF-242, "Diagnosis Procedure"](#).

##### Is the inspection result normal?

- YES >> GO TO 3.  
NO >> Repair or replace malfunctioning part.

##### 3. CHECK ROOF LATCH MOTOR

Check roof latch motor. Refer to [RF-237, "Diagnosis Procedure"](#).

##### Is the inspection result normal?

- YES >> Check intermittent incident. Refer to [GI-43, "Intermittent Incident"](#).  
NO >> Repair or replace malfunctioning part.

# B1742 HYDRAULIC STATE 18

< DTC/CIRCUIT DIAGNOSIS >

## B1742 HYDRAULIC STATE 18

### Description

INFOID:000000006468816

There are 22 states in hydraulic system. Hydraulic system is controlled using combination of these 22 states and, at the same time, open and close operations of retractable hard top system are performed interlocking with other retractable hard top system components. For the detail, refer to [RF-31, "HYDRAULIC SYSTEM CONTROL FUNCTION : System Description"](#).

### DTC Logic

INFOID:000000006468817

#### DTC DETECTION LOGIC

##### NOTE:

If two or more DTCs are detected, refer to [RF-61, "DTC Inspection Priority Chart"](#), and determine trouble diagnosis order.

DTC No.	Trouble diagnosis name		DTC detecting condition	Possible cause
B1742	HYDRAULIC STATE 18	[TIMEOUT]	Retractable hard top control unit does not detect changing from hydraulic state 18 for the specified period of time, during an open and close operation <ul style="list-style-type: none"><li>Open operation: Hydraulic state 19 is not detected for 7 seconds</li><li>Close operation: Hydraulic state 17 is not detected for 7 seconds</li></ul>	<ul style="list-style-type: none"><li>Hydraulic system</li><li>Trunk lid</li><li>Trunk room lamp switch</li><li>Hydraulic unit</li></ul>

#### DTC CONFIRMATION PROCEDURE

##### 1. PERFORM DTC CONFIRMATION PROCEDURE

1. Start engine.
2. Operate retractable hard top to fully open and fully close.
3. Check "Self-Diagnostic Result" of "RETRACTABLE HARD TOP" using CONSULT-III.

##### Is DTC detected?

- YES >> Go to [RF-183, "Diagnosis Procedure"](#).  
NO >> INSPECTION END

### Diagnosis Procedure

INFOID:000000006468818

##### 1. CHECK RETRACTABLE HARD TOP SYSTEM COMPONENT PARTS

Check retractable hard top component parts as bellow deformation, looseness, rattle, interference with other parts, and pinched foreign materials.

- Hydraulic system: Refer to [RF-299, "Exploded View"](#).
- Trunk lid: Refer to [DLK-269, "TRUNK LID ASSEMBLY : Exploded View"](#).

##### Is the inspection result normal?

- YES >> GO TO 2.  
NO >> Repair or replace malfunctioning part.

##### 2. CHECK TRUNK ROOM LAMP SWITCH

Check trunk room lamp switch. Refer to [DLK-82, "Component Function Check"](#).

##### Is the inspection result normal?

- YES >> GO TO 3.  
NO >> Repair or replace malfunctioning part.

##### 3. CHECK TRUNK ROOM LAMP SWITCH SIGNAL

Check "TR ROOM LAMP SW" in "DATA MONITOR" mode of "RETRACTABLE HARD TOP" using CONSULT-III.

# B1742 HYDRAULIC STATE 18

## < DTC/CIRCUIT DIAGNOSIS >

Monitor item	Condition	Status
TR ROOM LAMP SW	Trunk lid	Open
		Closed
		ON
		OFF

Is the inspection result normal?

YES >> GO TO 5.

NO >> GO TO 4.

### 4.CHECK TRUNK ROOM LAMP SWITCH CIRCUIT

1. Disconnect trunk room lamp switch connector, BCM connector trunk closure control unit connector and retractable hard top control unit connector.
2. Check continuity between retractable hard top control unit harness connector and trunk room lamp switch harness connector.

Retractable hard top control unit		Trunk room lamp switch		Continuity
Connector	Terminal	Connector	Terminal	
B82	5	B306	2	Existed

3. Check continuity between BCM harness connector and ground.

Retractable hard top control unit		Ground	Continuity
Connector	Terminal		
B82	5		Not existed

Is the inspection result normal?

YES >> Check trunk lid auto closure system. Refer to [DLK-220. "OPEN/CLOSURE FUNCTION : Diagnosis Procedure"](#).

NO >> Repair harness or connector.

### 5.CHECK HYDRAULIC PUMP POWER SUPPLY RELAY

Check hydraulic pump power supply relay. Refer to [RF-242. "Diagnosis Procedure"](#).

Is the inspection result normal?

YES >> Check intermittent incident. Refer to [GI-43. "Intermittent Incident"](#).

NO >> Replace hydraulic unit. Refer to [RF-299. "Removal and Installation"](#).



# B1743 HYDRAULIC STATE 19

< DTC/CIRCUIT DIAGNOSIS >

## B1743 HYDRAULIC STATE 19

### Description

INFOID:000000006468819

There are 22 states in hydraulic system. Hydraulic system is controlled using combination of these 22 states and, at the same time, open and close operations of retractable hard top system are performed interlocking with other retractable hard top system components. For the detail, refer to [RF-31, "HYDRAULIC SYSTEM CONTROL FUNCTION : System Description"](#).

### DTC Logic

INFOID:000000006468820

### DTC DETECTION LOGIC

#### NOTE:

If two or more DTCs are detected, refer to [RF-61, "DTC Inspection Priority Chart"](#), and determine trouble diagnosis order.

DTC No.	Trouble diagnosis name		DTC detecting condition	Possible cause
B1743	HYDRAULIC STATE 19	[TIMEOUT]	Retractable hard top control unit does not detect changing from hydraulic state 19 for the specified period of time, during an open and close operation • Open operation: Hydraulic state 20 is not detected for 2 seconds • Close operation: Hydraulic state 18 is not detected for 0.6 second	<ul style="list-style-type: none"><li>Hydraulic system</li><li>Trunk lid</li><li>Trunk room lamp switch</li><li>Hydraulic unit</li></ul>

### DTC CONFIRMATION PROCEDURE

#### 1. PERFORM DTC CONFIRMATION PROCEDURE

- Start engine.
- Operate retractable hard top to fully open and fully close.
- Check "Self-Diagnostic Result" of "RETRACTABLE HARD TOP" using CONSULT-III.

#### Is DTC detected?

- YES >> Go to [RF-185, "Diagnosis Procedure"](#).  
NO >> INSPECTION END

### Diagnosis Procedure

INFOID:000000006468821

#### 1. CHECK RETRACTABLE HARD TOP SYSTEM COMPONENT PARTS

Check retractable hard top component parts as bellow deformation, looseness, rattle, interference with other parts, and pinched foreign materials.

- Hydraulic system: Refer to [RF-299, "Exploded View"](#).
- Trunk lid: Refer to [DLK-269, "TRUNK LID ASSEMBLY : Exploded View"](#).

#### Is the inspection result normal?

- YES >> GO TO 2.  
NO >> Repair or replace malfunctioning part.

#### 2. CHECK TRUNK ROOM LAMP SWITCH

Check trunk room lamp switch. Refer to [DLK-82, "Component Function Check"](#).

#### Is the inspection result normal?

- YES >> GO TO 3.  
NO >> Repair or replace malfunctioning part.

#### 3. CHECK TRUNK ROOM LAMP SWITCH SIGNAL

Check "TR ROOM LAMP SW" in "DATA MONITOR" mode of "RETRACTABLE HARD TOP" using CONSULT-III.

# B1743 HYDRAULIC STATE 19

## < DTC/CIRCUIT DIAGNOSIS >

Monitor item	Condition	Status
TR ROOM LAMP SW	Trunk lid	Open
		Closed
		ON
		OFF

Is the inspection result normal?

YES >> GO TO 5.

NO >> GO TO 4.

### 4.CHECK TRUNK ROOM LAMP SWITCH CIRCUIT

1. Disconnect trunk room lamp switch connector, BCM connector, trunk closure control unit connector and retractable hard top control unit connector.
2. Check continuity between retractable hard top control unit harness connector and trunk room lamp switch harness connector.

Retractable hard top control unit		Trunk room lamp switch		Continuity
Connector	Terminal	Connector	Terminal	
B82	5	B306	2	Existed

3. Check continuity between BCM harness connector and ground.

Retractable hard top control unit		Ground	Continuity
Connector	Terminal		
B82	5		Not existed

Is the inspection result normal?

YES >> Check trunk lid auto closure system. Refer to [DLK-220. "OPEN/CLOSURE FUNCTION : Diagnosis Procedure"](#).

NO >> Repair harness or connector.

### 5.CHECK HYDRAULIC PUMP POWER SUPPLY RELAY

Check hydraulic pump power supply relay. Refer to [RF-242. "Diagnosis Procedure"](#).

Is the inspection result normal?

YES >> Check intermittent incident. Refer to [GI-43. "Intermittent Incident"](#).

NO >> Replace hydraulic unit. Refer to [RF-299. "Removal and Installation"](#).

# B1744 HYDRAULIC STATE 20

< DTC/CIRCUIT DIAGNOSIS >

## B1744 HYDRAULIC STATE 20

### Description

INFOID:000000006468822

There are 22 states in hydraulic system. Hydraulic system is controlled using combination of these 22 states and, at the same time, open and close operations of retractable hard top system are performed interlocking with other retractable hard top system components. For the detail, refer to [RF-31, "HYDRAULIC SYSTEM CONTROL FUNCTION : System Description"](#).

### DTC Logic

INFOID:000000006468823

#### DTC DETECTION LOGIC

##### NOTE:

If two or more DTCs are detected, refer to [RF-61, "DTC Inspection Priority Chart"](#), and determine trouble diagnosis order.

DTC No.	Trouble diagnosis name		DTC detecting condition	Possible cause
B1744	HYDRAULIC STATE 20	[TIMEOUT]	Retractable hard top control unit does not detect changing from hydraulic state 20 for the specified period of time, during an open and close operation <ul style="list-style-type: none"><li>Open operation: Hydraulic state 21 is not detected for 2 seconds</li><li>Close operation: Hydraulic state 19 is not detected for 2 seconds</li></ul>	<ul style="list-style-type: none"><li>Hydraulic system</li><li>Trunk lid</li><li>Trunk room lamp switch</li><li>Hydraulic unit</li></ul>

#### DTC CONFIRMATION PROCEDURE

##### 1. PERFORM DTC CONFIRMATION PROCEDURE

1. Start engine.
2. Operate retractable hard top to fully open and fully close.
3. Check "Self-Diagnostic Result" of "RETRACTABLE HARD TOP" using CONSULT-III.

##### Is DTC detected?

- YES >> Go to [RF-187, "Diagnosis Procedure"](#).  
NO >> INSPECTION END

### Diagnosis Procedure

INFOID:000000006468824

##### 1. CHECK RETRACTABLE HARD TOP SYSTEM COMPONENT PARTS

Check retractable hard top component parts as bellow deformation, looseness, rattle, interference with other parts, and pinched foreign materials.

- Hydraulic system: Refer to [RF-299, "Exploded View"](#).
- Trunk lid: Refer to [DLK-269, "TRUNK LID ASSEMBLY : Exploded View"](#).

##### Is the inspection result normal?

- YES >> GO TO 2.  
NO >> Repair or replace malfunctioning part.

##### 2. CHECK TRUNK ROOM LAMP SWITCH

Check trunk room lamp switch. Refer to [DLK-82, "Component Function Check"](#).

##### Is the inspection result normal?

- YES >> GO TO 3.  
NO >> Repair or replace malfunctioning part.

##### 3. CHECK TRUNK ROOM LAMP SWITCH SIGNAL

Check "TR ROOM LAMP SW" in "DATA MONITOR" mode of "RETRACTABLE HARD TOP" using CONSULT-III.

# B1744 HYDRAULIC STATE 20

## < DTC/CIRCUIT DIAGNOSIS >

Monitor item	Condition	Status
TR ROOM LAMP SW	Trunk lid	Open
		Closed
		ON
		OFF

Is the inspection result normal?

YES >> GO TO 5.

NO >> GO TO 4.

### 4.CHECK TRUNK ROOM LAMP SWITCH CIRCUIT

1. Disconnect trunk room lamp switch connector, BCM connector, trunk closure control unit connector and retractable hard top control unit connector.
2. Check continuity between retractable hard top control unit harness connector and trunk room lamp switch harness connector.

Retractable hard top control unit		Trunk room lamp switch		Continuity
Connector	Terminal	Connector	Terminal	
B82	5	B306	2	Existed

3. Check continuity between BCM harness connector and ground.

Retractable hard top control unit		Ground	Continuity
Connector	Terminal		
B82	5		Not existed

Is the inspection result normal?

YES >> Check trunk lid auto closure system. Refer to [DLK-220. "OPEN/CLOSURE FUNCTION : Diagnosis Procedure"](#).

NO >> Repair harness or connector.

### 5.CHECK HYDRAULIC PUMP POWER SUPPLY RELAY

Check hydraulic pump power supply relay. Refer to [RF-242. "Diagnosis Procedure"](#).

Is the inspection result normal?

YES >> Check intermittent incident. Refer to [GI-43. "Intermittent Incident"](#).

NO >> Replace hydraulic unit. Refer to [RF-299. "Removal and Installation"](#).

# B1745 HYDRAULIC STATE 21

< DTC/CIRCUIT DIAGNOSIS >

## B1745 HYDRAULIC STATE 21

### Description

INFOID:000000006468825

There are 22 states in hydraulic system. Hydraulic system is controlled using combination of these 22 states and, at the same time, open and close operations of retractable hard top system are performed interlocking with other retractable hard top system components. For the detail, refer to [RF-31, "HYDRAULIC SYSTEM CONTROL FUNCTION : System Description"](#).

### DTC Logic

INFOID:000000006468826

#### DTC DETECTION LOGIC

##### NOTE:

If two or more DTCs are detected, refer to [RF-61, "DTC Inspection Priority Chart"](#), and determine trouble diagnosis order.

DTC No.	Trouble diagnosis name		DTC detecting condition	Possible cause
B1745	HYDRAULIC STATE 21	[TIMEOUT]	Retractable hard top control unit does not detect changing from hydraulic state 21 for the specified period of time, during an open and close operation <ul style="list-style-type: none"><li>Open operation: Hydraulic state 22 is not detected for 2 seconds</li><li>Close operation: Hydraulic state 20 is not detected for 2 seconds</li></ul>	<ul style="list-style-type: none"><li>Hydraulic system</li><li>Trunk lid</li><li>Trunk room lamp switch</li><li>Hydraulic unit</li></ul>

#### DTC CONFIRMATION PROCEDURE

##### 1. PERFORM DTC CONFIRMATION PROCEDURE

1. Start engine.
2. Operate retractable hard top to fully open and fully close.
3. Check "Self-Diagnostic Result" of "RETRACTABLE HARD TOP" using CONSULT-III.

##### Is DTC detected?

- YES >> Go to [RF-189, "Diagnosis Procedure"](#).  
NO >> INSPECTION END

### Diagnosis Procedure

INFOID:000000006468827

##### 1. CHECK RETRACTABLE HARD TOP SYSTEM COMPONENT PARTS

Check retractable hard top component parts as bellow deformation, looseness, rattle, interference with other parts, and pinched foreign materials.

- Hydraulic system: Refer to [RF-299, "Exploded View"](#).
- Trunk lid: Refer to [DLK-269, "TRUNK LID ASSEMBLY : Exploded View"](#).

##### Is the inspection result normal?

- YES >> GO TO 2.  
NO >> Repair or replace malfunctioning part.

##### 2. CHECK TRUNK ROOM LAMP SWITCH

Check trunk room lamp switch. Refer to [DLK-82, "Component Function Check"](#).

##### Is the inspection result normal?

- YES >> GO TO 3.  
NO >> Repair or replace malfunctioning part.

##### 3. CHECK TRUNK ROOM LAMP SWITCH SIGNAL

Check "TR ROOM LAMP SW" in "DATA MONITOR" mode of "RETRACTABLE HARD TOP" using CONSULT-III.

# B1745 HYDRAULIC STATE 21

## < DTC/CIRCUIT DIAGNOSIS >

Monitor item	Condition	Status
TR ROOM LAMP SW	Trunk lid	Open
		Closed
		ON
		OFF

Is the inspection result normal?

YES >> GO TO 5.

NO >> GO TO 4.

### 4.CHECK TRUNK ROOM LAMP SWITCH CIRCUIT

1. Disconnect trunk room lamp switch connector, BCM connector, trunk closure control unit connector and retractable hard top control unit connector.
2. Check continuity between retractable hard top control unit harness connector and trunk room lamp switch harness connector.

Retractable hard top control unit		Trunk room lamp switch		Continuity
Connector	Terminal	Connector	Terminal	
B82	5	B306	2	Existed

3. Check continuity between BCM harness connector and ground.

Retractable hard top control unit		Ground	Continuity
Connector	Terminal		
B82	5		Not existed

Is the inspection result normal?

YES >> Check trunk lid auto closure system. Refer to [DLK-220. "OPEN/CLOSURE FUNCTION : Diagnosis Procedure"](#).

NO >> Repair harness or connector.

### 5.CHECK HYDRAULIC PUMP POWER SUPPLY RELAY

Check hydraulic pump power supply relay. Refer to [RF-242. "Diagnosis Procedure"](#).

Is the inspection result normal?

YES >> Check intermittent incident. Refer to [GI-43. "Intermittent Incident"](#).

NO >> Replace hydraulic unit. Refer to [RF-299. "Removal and Installation"](#).

# B1746 HYDRAULIC STATE 22

< DTC/CIRCUIT DIAGNOSIS >

## B1746 HYDRAULIC STATE 22

### Description

INFOID:000000006468828

There are 22 states in hydraulic system. Hydraulic system is controlled using combination of these 22 states and, at the same time, open and close operations of retractable hard top system are performed interlocking with other retractable hard top system components. For the detail, refer to [RF-31, "HYDRAULIC SYSTEM CONTROL FUNCTION : System Description"](#).

### DTC Logic

INFOID:000000006468829

#### DTC DETECTION LOGIC

##### NOTE:

If two or more DTCs are detected, refer to [RF-61, "DTC Inspection Priority Chart"](#), and determine trouble diagnosis order.

DTC No.	Trouble diagnosis name		DTC detecting condition	Possible cause
B1746	HYDRAULIC STATE 22	[TIMEOUT]	Retractable hard top control unit does not detect changing from hydraulic state 22 for the specified period of time, during an open and close operation • Close operation: Hydraulic state 21 is not detected for 2 seconds	<ul style="list-style-type: none"><li>Hydraulic system</li><li>Trunk lid</li><li>Trunk room lamp switch</li><li>Hydraulic unit</li></ul>

#### DTC CONFIRMATION PROCEDURE

##### 1. PERFORM DTC CONFIRMATION PROCEDURE

- Start engine.
- Operate retractable hard top to fully open and fully close.
- Check "Self-Diagnostic Result" of "RETRACTABLE HARD TOP" using CONSULT-III.

##### Is DTC detected?

- YES >> Go to [RF-191, "Diagnosis Procedure"](#).  
NO >> INSPECTION END

### Diagnosis Procedure

INFOID:000000006468830

##### 1. CHECK RETRACTABLE HARD TOP SYSTEM COMPONENT PARTS

Check retractable hard top component parts as bellow deformation, looseness, rattle, interference with other parts, and pinched foreign materials.

- Hydraulic system: Refer to [RF-299, "Exploded View"](#).
- Trunk lid: Refer to [DLK-269, "TRUNK LID ASSEMBLY : Exploded View"](#).

##### Is the inspection result normal?

- YES >> GO TO 2.  
NO >> Repair or replace malfunctioning part.

##### 2. CHECK TRUNK ROOM LAMP SWITCH

Check trunk room lamp switch. Refer to [DLK-82, "Component Function Check"](#).

##### Is the inspection result normal?

- YES >> GO TO 3.  
NO >> Repair or replace malfunctioning part.

##### 3. CHECK TRUNK ROOM LAMP SWITCH SIGNAL

Check "TR ROOM LAMP SW" in "DATA MONITOR" mode of "RETRACTABLE HARD TOP" using CONSULT-III.

Monitor item	Condition	Status
TR ROOM LAMP SW	Open	ON
	Closed	OFF

## B1746 HYDRAULIC STATE 22

### < DTC/CIRCUIT DIAGNOSIS >

---

#### Is the inspection result normal?

YES >> GO TO 5.

NO >> GO TO 4.

#### 4. CHECK TRUNK ROOM LAMP SWITCH CIRCUIT

---

1. Disconnect trunk room lamp switch connector, BCM connector, trunk closure control unit connector and retractable hard top control unit connector.
2. Check continuity between retractable hard top control unit harness connector and trunk room lamp switch harness connector.

Retractable hard top control unit		Trunk room lamp switch		Continuity
Connector	Terminal	Connector	Terminal	
B82	5	B306	2	Existed

3. Check continuity between BCM harness connector and ground.

Retractable hard top control unit		Ground	Continuity
Connector	Terminal		
B82	5		Not existed

#### Is the inspection result normal?

YES >> Check trunk lid auto closure system. Refer to [DLK-220, "OPEN/CLOSURE FUNCTION : Diagnosis Procedure"](#).

NO >> Repair harness or connector.

#### 5. CHECK HYDRAULIC PUMP POWER SUPPLY RELAY

---

Check hydraulic pump power supply relay. Refer to [RF-242, "Diagnosis Procedure"](#).

#### Is the inspection result normal?

YES >> Check intermittent incident. Refer to [GI-43, "Intermittent Incident"](#).

NO >> Replace hydraulic unit. Refer to [RF-299, "Removal and Installation"](#).



# B1747 PARCEL SHELF (DRAW)-STATE 1

< DTC/CIRCUIT DIAGNOSIS >

## B1747 PARCEL SHELF (DRAW)-STATE 1

### Description

INFOID:000000006468831

There are 4 rotation operation states and 6 draw operation states in parcel shelf. Open and close operations of retractable hard tops are performed interlocking with other retractable hard top system components. For the detail, refer to [RF-37, "PARCEL SHELF FUNCTION : System Description"](#).

### DTC Logic

INFOID:000000006468832

#### DTC DETECTION LOGIC

##### NOTE:

If two or more DTCs are detected, refer to [RF-61, "DTC Inspection Priority Chart"](#), and determine trouble diagnosis order.

DTC No.	Trouble diagnosis name		DTC detecting condition	Possible cause
B1747	P SHELF (DRAW) STATE 1	[TIMEOUT]	Retractable hard top control unit does not detect changing from parcel shelf (draw) state 1 for the specified period of time, during an open and close operation • DOWN operation: Parcel shelf (draw) state 1 is not detected for 2 seconds	<ul style="list-style-type: none"><li>Parcel shelf</li><li>Parcel shelf motor (draw)</li></ul>

#### DTC CONFIRMATION PROCEDURE

##### 1.PERFORM INITIALIZE

Perform initialization without CONSULT-III. Refer to [RF-90, "Description"](#).

>> GO TO 2.

##### 2.PERFORM DTC CONFIRMATION PROCEDURE

1. Start engine.
2. Operate retractable hard top to fully open then fully close.
3. Check "Self-Diagnostic Result" of "RETRACTABLE HARD TOP" using CONSULT-III.

##### Is DTC detected?

- YES >> Go to [RF-193, "Diagnosis Procedure"](#).  
NO >> INSPECTION END

#### Diagnosis Procedure

INFOID:000000006468833

##### 1.CHECK RETRACTABLE HARD TOP SYSTEM COMPONENT PARTS

Check retractable hard top component parts as bellow deformation, looseness, rattle, interference with other parts, and pinched foreign materials.

- Parcel shelf: Refer to [RF-290, "REAR PARCEL SHELF UNIT : Exploded View"](#).

##### Is the inspection result normal?

- YES >> GO TO 2.  
NO >> Repair or replace malfunctioning part.

##### 2.CHECK PARCEL SHELF MOTOR

Check parcel shelf motor (draw). Refer to [RF-238, "Diagnosis Procedure"](#).

##### Is the inspection result normal?

- YES >> Check intermittent incident. Refer to [GI-43, "Intermittent Incident"](#).  
NO >> Repair or replace malfunctioning part.

# B1748 PARCEL SHELF (DRAW)-STATE 2

< DTC/CIRCUIT DIAGNOSIS >

## B1748 PARCEL SHELF (DRAW)-STATE 2

### Description

INFOID:000000006468834

There are 4 rotation operation states and 6 draw operation states in parcel shelf. Open and close operations of retractable hard tops are performed interlocking with other retractable hard top system components. For the detail, refer to [RF-37, "PARCEL SHELF FUNCTION : System Description"](#).

### DTC Logic

INFOID:000000006468835

#### DTC DETECTION LOGIC

##### NOTE:

If two or more DTCs are detected, refer to [RF-61, "DTC Inspection Priority Chart"](#), and determine trouble diagnosis order.

DTC No.	Trouble diagnosis name		DTC detecting condition	Possible cause
B1748	P SHELF (DRAW) STATE 2	[TIMEOUT]	Retractable hard top control unit does not detect changing from parcel shelf (draw) state 2 for the specified period of time, during an open and close operation • Down operation: Parcel shelf (draw) state 3 is not detected for 4 seconds • Up operation: Parcel shelf (draw) state 1 is not detected for 4 seconds	<ul style="list-style-type: none"><li>Parcel shelf</li><li>Parcel shelf motor (draw)</li></ul>

#### DTC CONFIRMATION PROCEDURE

##### 1.PERFORM INITIALIZE

Perform initialization without CONSULT-III. Refer to [RF-90, "Description"](#).

>> GO TO 2.

##### 2.PERFORM DTC CONFIRMATION PROCEDURE

1. Start engine.
2. Operate retractable hard top to fully open then fully close.
3. Check "Self-Diagnostic Result" of "RETRACTABLE HARD TOP" using CONSULT-III.

Is DTC detected?

- YES >> Go to [RF-194, "Diagnosis Procedure"](#).  
NO >> INSPECTION END

### Diagnosis Procedure

INFOID:000000006468836

##### 1.CHECK RETRACTABLE HARD TOP SYSTEM COMPONENT PARTS

Check retractable hard top component parts as bellow deformation, looseness, rattle, interference with other parts, and pinched foreign materials.

- Parcel shelf: Refer to [RF-290, "REAR PARCEL SHELF UNIT : Exploded View"](#).

Is the inspection result normal?

- YES >> GO TO 2.  
NO >> Repair or replace malfunctioning part.

##### 2.CHECK PARCEL SHELF MOTOR

Check parcel shelf motor (draw). Refer to [RF-238, "Diagnosis Procedure"](#).

Is the inspection result normal?

- YES >> Check intermittent incident. Refer to [GI-43, "Intermittent Incident"](#).  
NO >> Repair or replace malfunctioning part.

# B1749 PARCEL SHELF (DRAW)-STATE 3

< DTC/CIRCUIT DIAGNOSIS >

## B1749 PARCEL SHELF (DRAW)-STATE 3

### Description

INFOID:000000006468837

There are 4 rotation operation states and 6 draw operation states in parcel shelf. Open and close operations of retractable hard tops are performed interlocking with other retractable hard top system components. For the detail, refer to [RF-37, "PARCEL SHELF FUNCTION : System Description"](#).

### DTC Logic

INFOID:000000006468838

#### DTC DETECTION LOGIC

##### NOTE:

If two or more DTCs are detected, refer to [RF-61, "DTC Inspection Priority Chart"](#), and determine trouble diagnosis order.

DTC No.	Trouble diagnosis name		DTC detecting condition	Possible cause
B1749	P SHELF (DRAW) STATE 3	[TIMEOUT]	Retractable hard top control unit does not detect changing from parcel shelf (draw) state 3 for the specified period of time, during an open and close operation • Down operation: Parcel shelf (draw) state 4 is not detected for 4 seconds • Up operation: Parcel shelf (draw) state 2 is not detected for 4 seconds	<ul style="list-style-type: none"><li>Parcel shelf</li><li>Parcel shelf motor (draw)</li></ul>

#### DTC CONFIRMATION PROCEDURE

##### 1.PERFORM INITIALIZE

Perform initialization without CONSULT-III. Refer to [RF-90, "Description"](#).

>> GO TO 2.

##### 2.PERFORM DTC CONFIRMATION PROCEDURE

- Start engine.
- Operate retractable hard top to fully open then fully close.
- Check "Self-Diagnostic Result" of "RETRACTABLE HARD TOP" using CONSULT-III.

Is DTC detected?

- YES >> Go to [RF-195, "Diagnosis Procedure"](#).  
NO >> INSPECTION END

#### Diagnosis Procedure

INFOID:000000006468839

##### 1.CHECK RETRACTABLE HARD TOP SYSTEM COMPONENT PARTS

Check retractable hard top component parts as bellow deformation, looseness, rattle, interference with other parts, and pinched foreign materials.

- Parcel shelf: Refer to [RF-290, "REAR PARCEL SHELF UNIT : Exploded View"](#).

Is the inspection result normal?

- YES >> GO TO 2.  
NO >> Repair or replace malfunctioning part.

##### 2.CHECK PARCEL SHELF MOTOR

Check parcel shelf motor (draw). Refer to [RF-238, "Diagnosis Procedure"](#).

Is the inspection result normal?

- YES >> Check intermittent incident. Refer to [GI-43, "Intermittent Incident"](#).  
NO >> Repair or replace malfunctioning part.

# B174A PARCEL SHELF (DRAW)-STATE 4

< DTC/CIRCUIT DIAGNOSIS >

## B174A PARCEL SHELF (DRAW)-STATE 4

### Description

INFOID:000000006468840

There are 4 rotation operation states and 6 draw operation states in parcel shelf. Open and close operations of retractable hard tops are performed interlocking with other retractable hard top system components. For the detail, refer to [RF-37, "PARCEL SHELF FUNCTION : System Description"](#).

### DTC Logic

INFOID:000000006468841

#### DTC DETECTION LOGIC

##### NOTE:

If two or more DTCs are detected, refer to [RF-61, "DTC Inspection Priority Chart"](#), and determine trouble diagnosis order.

DTC No.	Trouble diagnosis name		DTC detecting condition	Possible cause
B174A	P SHELF (DRAW) STATE 4	[TIMEOUT]	Retractable hard top control unit does not detect changing from parcel shelf (draw) state 4 for the specified period of time, during an open and close operation • Down operation: Parcel shelf (draw) state 5 is not detected for 4 seconds • Up operation: Parcel shelf (draw) state 3 is not detected for 4 seconds	<ul style="list-style-type: none"><li>Parcel shelf</li><li>Parcel shelf motor (draw)</li></ul>

#### DTC CONFIRMATION PROCEDURE

##### 1.PERFORM INITIALIZE

Perform initialization without CONSULT-III. Refer to [RF-90, "Description"](#).

>> GO TO 2.

##### 2.PERFORM DTC CONFIRMATION PROCEDURE

1. Start engine.
2. Operate retractable hard top to fully open then fully close.
3. Check "Self-Diagnostic Result" of "RETRACTABLE HARD TOP" using CONSULT-III.

##### Is DTC detected?

- YES >> Go to [RF-196, "Diagnosis Procedure"](#).  
NO >> INSPECTION END

### Diagnosis Procedure

INFOID:000000006468842

##### 1.CHECK RETRACTABLE HARD TOP SYSTEM COMPONENT PARTS

Check retractable hard top component parts as bellow deformation, looseness, rattle, interference with other parts, and pinched foreign materials.

- Parcel shelf: Refer to [RF-290, "REAR PARCEL SHELF UNIT : Exploded View"](#).

##### Is the inspection result normal?

- YES >> GO TO 2.  
NO >> Repair or replace malfunctioning part.

##### 2.CHECK PARCEL SHELF MOTOR

Check parcel shelf motor (draw). Refer to [RF-238, "Diagnosis Procedure"](#).

##### Is the inspection result normal?

- YES >> Check intermittent incident. Refer to [GI-43, "Intermittent Incident"](#).  
NO >> Repair or replace malfunctioning part.

# B174B PARCEL SHELF (DRAW)-STATE 5

< DTC/CIRCUIT DIAGNOSIS >

## B174B PARCEL SHELF (DRAW)-STATE 5

### Description

INFOID:000000006468843

There are 4 rotation operation states and 6 draw operation states in parcel shelf. Open and close operations of retractable hard tops are performed interlocking with other retractable hard top system components. For the detail, refer to [RF-37, "PARCEL SHELF FUNCTION : System Description"](#).

### DTC Logic

INFOID:000000006468844

#### DTC DETECTION LOGIC

##### NOTE:

If two or more DTCs are detected, refer to [RF-61, "DTC Inspection Priority Chart"](#), and determine trouble diagnosis order.

DTC No.	Trouble diagnosis name		DTC detecting condition	Possible cause
B174B	P SHELF (DRAW) STATE 5	[TIMEOUT]	Retractable hard top control unit does not detect changing from parcel shelf (draw) state 5 for the specified period of time, during an open and close operation • Down operation: Parcel shelf (draw) state 5 is not detected for 4 seconds • Up operation: Parcel shelf (draw) state 4 is not detected for 6.5 seconds	<ul style="list-style-type: none"><li>Parcel shelf</li><li>Parcel shelf motor (draw)</li></ul>

#### DTC CONFIRMATION PROCEDURE

##### 1.PERFORM INITIALIZE

Perform initialization without CONSULT-III. Refer to [RF-90, "Description"](#).

>> GO TO 2.

##### 2.PERFORM DTC CONFIRMATION PROCEDURE

- Start engine.
- Operate retractable hard top to fully open then fully close.
- Check "Self-Diagnostic Result" of "RETRACTABLE HARD TOP" using CONSULT-III.

##### Is DTC detected?

- YES >> Go to [RF-202, "Diagnosis Procedure"](#).  
NO >> INSPECTION END

### Diagnosis Procedure

INFOID:000000006468845

##### 1.CHECK RETRACTABLE HARD TOP SYSTEM COMPONENT PARTS

Check retractable hard top component parts as bellow deformation, looseness, rattle, interference with other parts, and pinched foreign materials.

- Parcel shelf: Refer to [RF-290, "REAR PARCEL SHELF UNIT : Exploded View"](#).

##### Is the inspection result normal?

- YES >> GO TO 2.  
NO >> Repair or replace malfunctioning part.

##### 2.CHECK PARCEL SHELF MOTOR

Check parcel shelf motor (draw). Refer to [RF-238, "Diagnosis Procedure"](#).

##### Is the inspection result normal?

- YES >> Check intermittent incident. Refer to [GI-43, "Intermittent Incident"](#).  
NO >> Repair or replace malfunctioning part.

# B174C PARCEL SHELF (DRAW)-STATE 6

< DTC/CIRCUIT DIAGNOSIS >

## B174C PARCEL SHELF (DRAW)-STATE 6

### Description

INFOID:000000006468846

There are 4 rotation operation states and 6 draw operation states in parcel shelf. Open and close operations of retractable hard tops are performed interlocking with other retractable hard top system components. For the detail, refer to [RF-37, "PARCEL SHELF FUNCTION : System Description"](#).

### DTC Logic

INFOID:000000006468847

#### DTC DETECTION LOGIC

##### NOTE:

If two or more DTCs are detected, refer to [RF-61, "DTC Inspection Priority Chart"](#), and determine trouble diagnosis order.

DTC No.	Trouble diagnosis name		DTC detecting condition	Possible cause
B174C	P SHELF (DRAW) STATE 6	[TIMEOUT]	Retractable hard top control unit does not detect changing from parcel shelf (draw) state 6 for the specified period of time, during an open and close operation <ul style="list-style-type: none"><li>Up operation: Parcel shelf (draw) state 5 is not detected for 1 seconds</li></ul>	<ul style="list-style-type: none"><li>Parcel shelf</li><li>Parcel shelf motor (draw)</li></ul>

#### DTC CONFIRMATION PROCEDURE

##### 1.PERFORM INITIALIZE

Perform initialization without CONSULT-III. Refer to [RF-90, "Description"](#).

>> GO TO 2.

##### 2.PERFORM DTC CONFIRMATION PROCEDURE

1. Start engine.
2. Operate retractable hard top to fully open then fully close.
3. Check "Self-Diagnostic Result" of "RETRACTABLE HARD TOP" using CONSULT-III.

##### Is DTC detected?

- YES >> Go to [RF-198, "Diagnosis Procedure"](#).  
NO >> INSPECTION END

### Diagnosis Procedure

INFOID:000000006468848

##### 1.CHECK RETRACTABLE HARD TOP SYSTEM COMPONENT PARTS

Check retractable hard top component parts as bellow deformation, looseness, rattle, interference with other parts, and pinched foreign materials.

- Parcel shelf: Refer to [RF-290, "REAR PARCEL SHELF UNIT : Exploded View"](#).

##### Is the inspection result normal?

- YES >> GO TO 2.  
NO >> Repair or replace malfunctioning part.

##### 2.CHECK PARCEL SHELF MOTOR

Check parcel shelf motor (draw). Refer to [RF-238, "Diagnosis Procedure"](#).

##### Is the inspection result normal?

- YES >> Check intermittent incident. Refer to [GI-43, "Intermittent Incident"](#).  
NO >> Repair or replace malfunctioning part.

# B174D PARCEL SHELF (ROTATE)-STATE 1

< DTC/CIRCUIT DIAGNOSIS >

## B174D PARCEL SHELF (ROTATE)-STATE 1

### Description

INFOID:000000006468849

There are 4 rotation operation states and 6 draw operation states in parcel shelf. Open and close operations of retractable hard tops are performed interlocking with other retractable hard top system components. For the detail, refer to [RF-37, "PARCEL SHELF FUNCTION : System Description"](#).

### DTC Logic

INFOID:000000006468850

#### DTC DETECTION LOGIC

##### NOTE:

If two or more DTCs are detected, refer to [RF-61, "DTC Inspection Priority Chart"](#), and determine trouble diagnosis order.

DTC No.	Trouble diagnosis name		DTC detecting condition	Possible cause
B174D	P SHELF (ROT) STATE 1	[TIMEOUT]	Retractable hard top control unit does not detect changing from parcel shelf (rotation) state 1 for the specified period of time, during an open and close operation • Vertical operation: Parcel shelf (rotation) state 2 is not detected for 0.5 second	<ul style="list-style-type: none"><li>Parcel shelf</li><li>Parcel shelf motor (rotation)</li></ul>

#### DTC CONFIRMATION PROCEDURE

##### 1.PERFORM INITIALIZE

Perform initialization without CONSULT-III. Refer to [RF-90, "Description"](#).

>> GO TO 2.

##### 2.PERFORM DTC CONFIRMATION PROCEDURE

1. Start engine.
2. Operate retractable hard top to fully open then fully close.
3. Check "Self-Diagnostic Result" of "RETRACTABLE HARD TOP" using CONSULT-III.

##### Is DTC detected?

- YES >> Go to [RF-199, "Diagnosis Procedure"](#).  
NO >> INSPECTION END

#### Diagnosis Procedure

INFOID:000000006468851

##### 1.CHECK RETRACTABLE HARD TOP SYSTEM COMPONENT PARTS

Check retractable hard top component parts as bellow deformation, looseness, rattle, interference with other parts, and pinched foreign materials.

- Parcel shelf: Refer to [RF-290, "REAR PARCEL SHELF UNIT : Exploded View"](#).

##### Is the inspection result normal?

- YES >> GO TO 2.  
NO >> Repair or replace malfunctioning part.

##### 2.CHECK PARCEL SHELF MOTOR

Check parcel shelf motor (rotation). Refer to [RF-240, "Diagnosis Procedure"](#).

##### Is the inspection result normal?

- YES >> Check intermittent incident. Refer to [GI-43, "Intermittent Incident"](#).  
NO >> Repair or replace malfunctioning part.

# B174E PARCEL SHELF (ROTATE)-STATE 2

< DTC/CIRCUIT DIAGNOSIS >

## B174E PARCEL SHELF (ROTATE)-STATE 2

### Description

INFOID:000000006468852

There are 4 rotation operation states and 6 draw operation states in parcel shelf. Open and close operations of retractable hard tops are performed interlocking with other retractable hard top system components. For the detail, refer to [RF-37, "PARCEL SHELF FUNCTION : System Description"](#).

### DTC Logic

INFOID:000000006468853

#### DTC DETECTION LOGIC

##### NOTE:

If two or more DTCs are detected, refer to [RF-61, "DTC Inspection Priority Chart"](#), and determine trouble diagnosis order.

DTC No.	Trouble diagnosis name		DTC detecting condition	Possible cause
B174E	P SHELF (ROT) STATE 2	[TIMEOUT]	Retractable hard top control unit does not detect changing from parcel shelf (rotation) state 2 for the specified period of time, during an open and close operation <ul style="list-style-type: none"><li>Vertical operation: Parcel shelf (rotation) state 3 is not detected for 0.5 second</li><li>Horizontal operation: Parcel shelf (rotation) state 1 is not detected for 0.5 second</li></ul>	<ul style="list-style-type: none"><li>Parcel shelf</li><li>Parcel shelf motor (rotation)</li></ul>

#### DTC CONFIRMATION PROCEDURE

##### 1.PERFORM INITIALIZE

Perform initialization without CONSULT-III. Refer to [RF-90, "Description"](#).

>> GO TO 2.

##### 2.PERFORM DTC CONFIRMATION PROCEDURE

1. Start engine.
2. Operate retractable hard top to fully open then fully close.
3. Check "Self-Diagnostic Result" of "RETRACTABLE HARD TOP" using CONSULT-III.

Is DTC detected?

- YES >> Go to [RF-200, "Diagnosis Procedure"](#).  
NO >> INSPECTION END

### Diagnosis Procedure

INFOID:000000006468854

##### 1.CHECK RETRACTABLE HARD TOP SYSTEM COMPONENT PARTS

Check retractable hard top component parts as bellow deformation, looseness, rattle, interference with other parts, and pinched foreign materials.

- Parcel shelf: Refer to [RF-290, "REAR PARCEL SHELF UNIT : Exploded View"](#).

Is the inspection result normal?

- YES >> GO TO 2.  
NO >> Repair or replace malfunctioning part.

##### 2.CHECK PARCEL SHELF MOTOR

Check parcel shelf motor (rotation). Refer to [RF-240, "Diagnosis Procedure"](#).

Is the inspection result normal?

- YES >> Check intermittent incident. Refer to [GI-43, "Intermittent Incident"](#).  
NO >> Repair or replace malfunctioning part.



# B174F PARCEL SHELF (ROTATE)-STATE 3

< DTC/CIRCUIT DIAGNOSIS >

## B174F PARCEL SHELF (ROTATE)-STATE 3

### Description

INFOID:000000006468855

There are 4 rotation operation states and 6 draw operation states in parcel shelf. Open and close operations of retractable hard tops are performed interlocking with other retractable hard top system components. For the detail, refer to [RF-37, "PARCEL SHELF FUNCTION : System Description"](#).

### DTC Logic

INFOID:000000006468856

#### DTC DETECTION LOGIC

##### NOTE:

If two or more DTCs are detected, refer to [RF-61, "DTC Inspection Priority Chart"](#), and determine trouble diagnosis order.

DTC No.	Trouble diagnosis name		DTC detecting condition	Possible cause
B174F	P SHELF (ROT) STATE 3	[TIMEOUT]	Retractable hard top control unit does not detect changing from parcel shelf (rotation) state 3 for the specified period of time, during an open and close operation <ul style="list-style-type: none"><li>Vertical operation: Parcel shelf (rotation) state 4 is not detected for 2 seconds</li><li>Horizontal operation: Parcel shelf (rotation) state 2 is not detected for 2 seconds</li></ul>	<ul style="list-style-type: none"><li>Parcel shelf</li><li>Parcel shelf motor (rotation)</li></ul>

#### DTC CONFIRMATION PROCEDURE

##### 1.PERFORM INITIALIZE

Perform initialization without CONSULT-III. Refer to [RF-90, "Description"](#).

>> GO TO 2.

##### 2.PERFORM DTC CONFIRMATION PROCEDURE

1. Start engine.
2. Operate retractable hard top to fully open then fully close.
3. Check "Self-Diagnostic Result" of "RETRACTABLE HARD TOP" using CONSULT-III.

Is DTC detected?

- YES >> Go to [RF-201, "Diagnosis Procedure"](#).  
NO >> INSPECTION END

### Diagnosis Procedure

INFOID:000000006468857

##### 1.CHECK RETRACTABLE HARD TOP SYSTEM COMPONENT PARTS

Check retractable hard top component parts as bellow deformation, looseness, rattle, interference with other parts, and pinched foreign materials.

- Parcel shelf: Refer to [RF-290, "REAR PARCEL SHELF UNIT : Exploded View"](#).

Is the inspection result normal?

- YES >> GO TO 2.  
NO >> Repair or replace malfunctioning part.

##### 2.CHECK PARCEL SHELF MOTOR

Check parcel shelf motor (rotation). Refer to [RF-240, "Diagnosis Procedure"](#).

Is the inspection result normal?

- YES >> Check intermittent incident. Refer to [GI-43, "Intermittent Incident"](#).  
NO >> Repair or replace malfunctioning part.

# B1750 PARCEL SHELF (ROTATE)-STATE 4

< DTC/CIRCUIT DIAGNOSIS >

## B1750 PARCEL SHELF (ROTATE)-STATE 4

### Description

INFOID:000000006468858

There are 4 rotation operation states and 6 draw operation states in parcel shelf. Open and close operations of retractable hard tops are performed interlocking with other retractable hard top system components. For the detail, refer to [RF-37, "PARCEL SHELF FUNCTION : System Description"](#).

### DTC Logic

INFOID:000000006468859

#### DTC DETECTION LOGIC

##### NOTE:

If two or more DTCs are detected, refer to [RF-61, "DTC Inspection Priority Chart"](#), and determine trouble diagnosis order.

DTC No.	Trouble diagnosis name		DTC detecting condition	Possible cause
B1750	P SHELF (ROT) STATE 4	[TIMEOUT]	Retractable hard top control unit does not detect changing from parcel shelf (rotation) state 4 for the specified period of time, during an open and close operation <ul style="list-style-type: none"><li>Horizontal operation: Parcel shelf (rotation) state 3 is not detected for 0.5 second</li></ul>	<ul style="list-style-type: none"><li>Parcel shelf</li><li>Parcel shelf motor (rotation)</li></ul>

#### DTC CONFIRMATION PROCEDURE

##### 1.PERFORM INITIALIZE

Perform initialization without CONSULT-III. Refer to [RF-90, "Description"](#).

>> GO TO 2.

##### 2.PERFORM DTC CONFIRMATION PROCEDURE

1. Start engine.
2. Operate retractable hard top to fully open then fully close.
3. Check "Self-Diagnostic Result" of "RETRACTABLE HARD TOP" using CONSULT-III.

##### Is DTC detected?

- YES >> Go to [RF-202, "Diagnosis Procedure"](#).  
NO >> INSPECTION END

#### Diagnosis Procedure

INFOID:000000006468860

##### 1.CHECK RETRACTABLE HARD TOP SYSTEM COMPONENT PARTS

Check retractable hard top component parts as bellow deformation, looseness, rattle, interference with other parts, and pinched foreign materials.

- Parcel shelf: Refer to [RF-290, "REAR PARCEL SHELF UNIT : Exploded View"](#).

##### Is the inspection result normal?

- YES >> GO TO 2.  
NO >> Repair or replace malfunctioning part.

##### 2.CHECK PARCEL SHELF MOTOR

Check parcel shelf motor (rotation). Refer to [RF-240, "Diagnosis Procedure"](#).

##### Is the inspection result normal?

- YES >> Check intermittent incident. Refer to [GI-43, "Intermittent Incident"](#).  
NO >> Repair or replace malfunctioning part.

# B1751 ROOF LATCH STATE 1

< DTC/CIRCUIT DIAGNOSIS >

## B1751 ROOF LATCH STATE 1

### Description

INFOID:000000006468861

There are 3 states in roof latch. Open and close operations of retractable hard top system are performed interlocking with other retractable hard top system components. For the detail, refer to [RF-35, "ROOF LATCH FUNCTION : System Description"](#).

### DTC Logic

INFOID:000000006468862

#### DTC DETECTION LOGIC

##### NOTE:

If two or more DTCs are detected, refer to [RF-61, "DTC Inspection Priority Chart"](#), and determine trouble diagnosis order.

DTC No.	Trouble diagnosis name		DTC detecting condition	Possible cause
B1751	ROOF LATCH STATE 1	[TIMEOUT]	Retractable hard top control unit does not detect changing from roof latch state 1 for the specified period of time, during an open and close operation • Unlock operation: roof latch state 2 is not detected for 0.5 second	<ul style="list-style-type: none"><li>• Roof latch</li><li>• Roof latch motor</li><li>• Roof</li></ul>

#### DTC CONFIRMATION PROCEDURE

##### 1. PERFORM DTC CONFIRMATION PROCEDURE

1. Start engine.
2. Operate retractable hard top to fully open and fully close.
3. Check "Self-Diagnosis Result" of "RETRACTABLE HARD TOP" using CONSULT-III.

##### Is DTC detected?

- YES >> Go to [RF-203, "Diagnosis Procedure"](#).  
NO >> INSPECTION END

### Diagnosis Procedure

INFOID:000000006468863

##### 1. CHECK RETRACTABLE HARD TOP SYSTEM COMPONENT PARTS

Check retractable hard top component parts as bellow deformation, looseness, rattle, interference with other parts, and pinched foreign materials.

- Roof: Refer to [RF-287, "Exploded View"](#).
- Roof latch: Refer to [RF-269, "ROOF LOCK ASSEMBLY : Exploded View"](#).

##### Is the inspection result normal?

- YES >> GO TO 2.  
NO >> Repair or replace malfunctioning part.

##### 2. CHECK ROOF LATCH MOTOR

Check roof latch motor. Refer to [RF-237, "Diagnosis Procedure"](#).

##### Is the inspection result normal?

- YES >> Check intermittent incident. Refer to [GI-43, "Intermittent Incident"](#).  
NO >> Repair or replace malfunctioning part.

# B1752 ROOF LATCH STATE 2

< DTC/CIRCUIT DIAGNOSIS >

## B1752 ROOF LATCH STATE 2

### Description

INFOID:000000006468864

There are 3 states in roof latch. Open and close operations of retractable hard top system are performed interlocking with other retractable hard top system components. For the detail, refer to [RF-35, "ROOF LATCH FUNCTION : System Description"](#).

### DTC Logic

INFOID:000000006468865

### DTC DETECTION LOGIC

#### NOTE:

If two or more DTCs are detected, refer to [RF-61, "DTC Inspection Priority Chart"](#), and determine trouble diagnosis order.

DTC No.	Trouble diagnosis name		DTC detecting condition	Possible cause
B1752	ROOF LATCH STATE 2	[TIMEOUT]	Retractable hard top control unit does not detect changing from roof latch state 2 for the specified period of time, during an open and close operation • Unlock operation: roof latch state 3 is not detected for 2 seconds • Lock operation: roof latch state 1 is not detected for 2 seconds	<ul style="list-style-type: none"><li>• Roof latch</li><li>• Roof latch motor</li><li>• Roof</li></ul>

### DTC CONFIRMATION PROCEDURE

#### 1. PERFORM DTC CONFIRMATION PROCEDURE

1. Start engine.
2. Operate retractable hard top to fully open and fully close.
3. Check "Self-Diagnosis Result" of "RETRACTABLE HARD TOP" using CONSULT-III.

#### Is DTC detected?

- YES >> Go to [RF-204, "Diagnosis Procedure"](#).  
NO >> INSPECTION END

### Diagnosis Procedure

INFOID:000000006468866

#### 1. CHECK RETRACTABLE HARD TOP SYSTEM COMPONENT PARTS

Check retractable hard top component parts as bellow deformation, looseness, rattle, interference with other parts, and pinched foreign materials.

- Roof: Refer to [RF-287, "Exploded View"](#).
- Roof latch: Refer to [RF-269, "ROOF LOCK ASSEMBLY : Exploded View"](#).

#### Is the inspection result normal?

- YES >> GO TO 2.  
NO >> Repair or replace malfunctioning part.

#### 2. CHECK ROOF LATCH MOTOR

Check roof latch motor. Refer to [RF-237, "Diagnosis Procedure"](#).

#### Is the inspection result normal?

- YES >> Check intermittent incident. Refer to [GI-43, "Intermittent Incident"](#).  
NO >> Repair or replace malfunctioning part.

# B1753 ROOF LATCH STATE 3

< DTC/CIRCUIT DIAGNOSIS >

## B1753 ROOF LATCH STATE 3

### Description

INFOID:000000006468867

There are 3 states in roof latch. Open and close operations of retractable hard top system are performed interlocking with other retractable hard top system components. For the detail, refer to [RF-35, "ROOF LATCH FUNCTION : System Description"](#).

### DTC Logic

INFOID:000000006468868

#### DTC DETECTION LOGIC

##### NOTE:

If two or more DTCs are detected, refer to [RF-61, "DTC Inspection Priority Chart"](#), and determine trouble diagnosis order.

DTC No.	Trouble diagnosis name		DTC detecting condition	Possible cause
B1753	ROOF LATCH STATE 3	[TIMEOUT]	Retractable hard top control unit does not detect changing from roof latch state 3 for the specified period of time, during an open and close operation • Lock operation: roof latch state 2 is not detected for 0.5 second	<ul style="list-style-type: none"><li>• Roof latch</li><li>• Roof latch motor</li><li>• Roof</li></ul>

#### DTC CONFIRMATION PROCEDURE

##### 1. PERFORM DTC CONFIRMATION PROCEDURE

1. Start engine.
2. Operate retractable hard top to fully open and fully close.
3. Check "Self-Diagnosis Result" of "RETRACTABLE HARD TOP" using CONSULT-III.

##### Is DTC detected?

- YES >> Go to [RF-205, "Diagnosis Procedure"](#).  
NO >> INSPECTION END

### Diagnosis Procedure

INFOID:000000006468869

##### 1. CHECK RETRACTABLE HARD TOP SYSTEM COMPONENT PARTS

Check retractable hard top component parts as bellow deformation, looseness, rattle, interference with other parts, and pinched foreign materials.

- Roof: Refer to [RF-287, "Exploded View"](#).
- Roof latch: Refer to [RF-269, "ROOF LOCK ASSEMBLY : Exploded View"](#).

##### Is the inspection result normal?

- YES >> GO TO 2.  
NO >> Repair or replace malfunctioning part.

##### 2. CHECK ROOF LATCH MOTOR

Check roof latch motor. Refer to [RF-237, "Diagnosis Procedure"](#).

##### Is the inspection result normal?

- YES >> Check intermittent incident. Refer to [GI-43, "Intermittent Incident"](#).  
NO >> Repair or replace malfunctioning part.

# B1754 FLIPPER DOOR STATE 1

< DTC/CIRCUIT DIAGNOSIS >

## B1754 FLIPPER DOOR STATE 1

### Description

INFOID:000000006468870

There are 4 states in flipper door. Open and close operations of retractable hard top system are performed interlocking with other retractable hard top components. For the detail, refer to [RF-39, "FLIPPER DOOR FUNCTION : System Description"](#).

### DTC Logic

INFOID:000000006468871

### DTC DETECTION LOGIC

#### NOTE:

If two or more DTCs are detected, refer to [RF-61, "DTC Inspection Priority Chart"](#), and determine trouble diagnosis order.

DTC No.	Trouble diagnosis name		DTC detecting condition	Possible cause
B1754	FLIPPER DOOR STATE 1	[TIMEOUT]	Retractable hard top control unit does not detect changing from flipper door state 3 for the specified period of time, during an open and close operation • Up operation: flipper door state 2 is not detected for 0.5 second	<ul style="list-style-type: none"><li>• Flipper door</li><li>• Flipper door limit switch</li><li>• Flipper door motor</li></ul>

### DTC CONFIRMATION PROCEDURE

#### 1. PERFORM DTC CONFIRMATION PROCEDURE

1. Start engine.
2. Operate retractable hard top to fully open and fully close.
3. Check "Self-Diagnostic Result" of "RETRACTABLE HARD TOP" using CONSULT-III.

#### Is DTC detected?

- YES >> Go to [RF-206, "Diagnosis Procedure"](#).  
NO >> INSPECTION END

### Diagnosis Procedure

INFOID:000000006468872

#### 1. CHECK RETRACTABLE HARD TOP SYSTEM COMPONENT PARTS

Check retractable hard top component parts as bellow deformation, looseness, rattle, interference with other parts, and pinched foreign materials.

- Flipper door: Refer to [RF-295, "Exploded View"](#).

#### Is the inspection result normal?

- YES >> GO TO 2.  
NO >> Repair or replace malfunctioning part.

#### 2. CHECK FLIPPER DOOR LIMIT SWITCH

Check flipper door limit switch. Refer to [RF-231, "Diagnosis Procedure"](#).

#### Is the inspection result normal?

- YES >> GO TO 3.  
NO >> Repair or replace malfunctioning part.

#### 3. CHECK FLIPPER DOOR MOTOR

Check flipper door motor. Refer to [RF-235, "Diagnosis Procedure"](#).

#### Is the inspection result normal?

- YES >> Check intermittent incident. Refer to [GI-43, "Intermittent Incident"](#).  
NO >> Repair or replace malfunctioning part.

# B1755 FLIPPER DOOR STATE 2

< DTC/CIRCUIT DIAGNOSIS >

## B1755 FLIPPER DOOR STATE 2

### Description

INFOID:000000006468873

There are 4 states in flipper door. Open and close operations of retractable hard top system are performed interlocking with other retractable hard top components. For the detail, refer to [RF-39, "FLIPPER DOOR FUNCTION : System Description"](#).

### DTC Logic

INFOID:000000006468874

#### DTC DETECTION LOGIC

##### NOTE:

If two or more DTCs are detected, refer to [RF-61, "DTC Inspection Priority Chart"](#), and determine trouble diagnosis order.

DTC No.	Trouble diagnosis name		DTC detecting condition	Possible cause
B1755	FLIPPER DOOR STATE 2	[TIMEOUT]	Retractable hard top control unit does not detect changing from flipper door state 2 for the specified period of time, during an open and close operation <ul style="list-style-type: none"><li>Up operation: flipper door state 4 is not detected for 5 seconds</li><li>Down operation: flipper door state 1 is not detected for 5 seconds</li></ul>	<ul style="list-style-type: none"><li>Flipper door</li><li>Flipper door limit switch</li><li>Flipper door motor</li></ul>

#### DTC CONFIRMATION PROCEDURE

##### 1. PERFORM DTC CONFIRMATION PROCEDURE

1. Start engine.
2. Operate retractable hard top to fully open and fully close.
3. Check "Self-Diagnostic Result" of "RETRACTABLE HARD TOP" using CONSULT-III.

##### Is DTC detected?

- YES >> Go to [RF-207, "Diagnosis Procedure"](#).  
NO >> INSPECTION END

### Diagnosis Procedure

INFOID:000000006468875

RF

##### 1. CHECK RETRACTABLE HARD TOP SYSTEM COMPONENT PARTS

Check retractable hard top component parts as bellow deformation, looseness, rattle, interference with other parts, and pinched foreign materials.

- Flipper door: Refer to [RF-295, "Exploded View"](#).

##### Is the inspection result normal?

- YES >> GO TO 2.  
NO >> Repair or replace malfunctioning part.

##### 2. CHECK FLIPPER DOOR LIMIT SWITCH

Check flipper door limit switch. Refer to [RF-231, "Diagnosis Procedure"](#).

##### Is the inspection result normal?

- YES >> GO TO 3.  
NO >> Repair or replace malfunctioning part.

##### 3. CHECK FLIPPER DOOR MOTOR

Check flipper door motor. Refer to [RF-235, "Diagnosis Procedure"](#).

##### Is the inspection result normal?

- YES >> Check intermittent incident. Refer to [GI-43, "Intermittent Incident"](#).  
NO >> Repair or replace malfunctioning part.

# B1756 FLIPPER DOOR STATE 3

< DTC/CIRCUIT DIAGNOSIS >

## B1756 FLIPPER DOOR STATE 3

### Description

INFOID:000000006468876

There are 4 states in flipper door. Open and close operations of retractable hard top system are performed interlocking with other retractable hard top components. For the detail, refer to [RF-39, "FLIPPER DOOR FUNCTION : System Description"](#).

### DTC Logic

INFOID:000000006468877

### DTC DETECTION LOGIC

#### NOTE:

If two or more DTCs are detected, refer to [RF-61, "DTC Inspection Priority Chart"](#), and determine trouble diagnosis order.

DTC No.	Trouble diagnosis name		DTC detecting condition	Possible cause
B1756	FLIPPER DOOR STATE 3	[TIMEOUT]	Retractable hard top control unit does not detect changing from flipper door state 2 for the specified period of time, during an open and close operation <ul style="list-style-type: none"><li>Up operation: Flipper door state 4 is not detected for 5 seconds</li><li>Down operation: Flipper door state 1 is not detected for 5 seconds</li></ul>	<ul style="list-style-type: none"><li>Flipper door</li><li>Flipper door limit switch</li><li>Flipper door motor</li></ul>

### DTC CONFIRMATION PROCEDURE

#### 1. PERFORM DTC CONFIRMATION PROCEDURE

1. Start engine.
2. Operate retractable hard top to fully open and fully close.
3. Check "Self-Diagnostic Result" of "RETRACTABLE HARD TOP" using CONSULT-III.

#### Is DTC detected?

- YES >> Go to [RF-208, "Diagnosis Procedure"](#).  
NO >> INSPECTION END

### Diagnosis Procedure

INFOID:000000006468878

#### 1. CHECK RETRACTABLE HARD TOP SYSTEM COMPONENT PARTS

Check retractable hard top component parts as bellow deformation, looseness, rattle, interference with other parts, and pinched foreign materials.

- Flipper door: Refer to [RF-295, "Exploded View"](#).

#### Is the inspection result normal?

- YES >> GO TO 2.  
NO >> Repair or replace malfunctioning part.

#### 2. CHECK FLIPPER DOOR LIMIT SWITCH

Check flipper door limit switch. Refer to [RF-231, "Diagnosis Procedure"](#).

#### Is the inspection result normal?

- YES >> GO TO 3.  
NO >> Repair or replace malfunctioning part.

#### 3. CHECK FLIPPER DOOR MOTOR

Check flipper door motor. Refer to [RF-235, "Diagnosis Procedure"](#).

#### Is the inspection result normal?

- YES >> Check intermittent incident. Refer to [GI-43, "Intermittent Incident"](#).  
NO >> Repair or replace malfunctioning part.



# B1757 FLIPPER DOOR STATE 4

< DTC/CIRCUIT DIAGNOSIS >

## B1757 FLIPPER DOOR STATE 4

### Description

INFOID:000000006468879

There are 4 states in flipper door. Open and close operations of retractable hard top system are performed interlocking with other retractable hard top components. For the detail, refer to [RF-39. "FLIPPER DOOR FUNCTION : System Description"](#).

### DTC Logic

INFOID:000000006468880

#### DTC DETECTION LOGIC

##### NOTE:

If two or more DTCs are detected, refer to [RF-61. "DTC Inspection Priority Chart"](#), and determine trouble diagnosis order.

DTC No.	Trouble diagnosis name		DTC detecting condition	Possible cause
B1757	FLIPPER DOOR STATE 4	[TIMEOUT]	Retractable hard top control unit does not detect changing from flipper door state 4 for the specified period of time, during an open and close operation • Down operation: Flipper door state 3 is not detected for 1 second	<ul style="list-style-type: none"><li>• Flipper door</li><li>• Flipper door limit switch</li><li>• Flipper door motor</li></ul>

#### DTC CONFIRMATION PROCEDURE

##### 1. PERFORM DTC CONFIRMATION PROCEDURE

1. Start engine.
2. Operate retractable hard top to fully open and fully close.
3. Check "Self-Diagnostic Result" of "RETRACTABLE HARD TOP" using CONSULT-III.

##### Is DTC detected?

- YES >> Go to [RF-209. "Diagnosis Procedure"](#).  
NO >> INSPECTION END

### Diagnosis Procedure

INFOID:000000006468881

##### 1. CHECK RETRACTABLE HARD TOP SYSTEM COMPONENT PARTS

Check retractable hard top component parts as bellow deformation, looseness, rattle, interference with other parts, and pinched foreign materials.

- Flipper door: Refer to [RF-295. "Exploded View"](#).

##### Is the inspection result normal?

- YES >> GO TO 2.  
NO >> Repair or replace malfunctioning part.

##### 2. CHECK FLIPPER DOOR LIMIT SWITCH

Check flipper door limit switch. Refer to [RF-231. "Diagnosis Procedure"](#).

##### Is the inspection result normal?

- YES >> GO TO 3.  
NO >> Repair or replace malfunctioning part.

##### 3. CHECK FLIPPER DOOR MOTOR

Check flipper door motor. Refer to [RF-235. "Diagnosis Procedure"](#).

##### Is the inspection result normal?

- YES >> Check intermittent incident. Refer to [GI-43. "Intermittent Incident"](#).  
NO >> Repair or replace malfunctioning part.

# B1758 THERMO PROTECTION

< DTC/CIRCUIT DIAGNOSIS >

## B1758 THERMO PROTECTION

### Description

INFOID:000000006468882

Retractable hard top control unit calculates hydraulic pump temperature according to system operating time, prevents hydraulic system temperature from increasing excessively, and protects the system.

### DTC Logic

INFOID:000000006468883

### DTC DETECTION LOGIC

#### NOTE:

If two or more DTCs are detected, refer to [RF-61, "DTC Inspection Priority Chart"](#), and determine trouble diagnosis order.

DTC No.	Trouble diagnosis name		DTC detecting condition	Possible cause
B1758	THERMO PROTECTION	[ACTIVE]	Thermo protection is active. (Thermo protection: Refer to <a href="#">RF-20, "RETRACTABLE HARD TOP SYSTEM : System Description"</a> )	Retractable hard top system is operated continuously

### DTC CONFIRMATION PROCEDURE

#### 1. COOL DOWN HYDRAULIC SYSTEM

Wait 20 minutes without operation.

>> GO TO 2.

#### 2. PERFORM DTC CONFIRMATION PROCEDURE

1. Turn ignition switch ON.
2. Check "Self-Diagnostic Result" of "RETRACTABLE HARD TOP" using CONSULT-III.

Is DTC detected?

- YES >> Go to [RF-210, "Diagnosis Procedure"](#).  
NO >> INSPECTION END

### Diagnosis Procedure

INFOID:000000006468884

#### 1. PERFORM DTC CONFIRMATION PROCEDURE

Perform DTC Confirmation Procedure. Refer to [RF-97, "DTC Logic"](#).

Is the DTC displayed again?

- YES >> Replace retractable hard top control unit. Refer to [RF-206, "Diagnosis Procedure"](#).  
NO >> INSPECTION END

# B175C POWER SOURCE (ROOF)

< DTC/CIRCUIT DIAGNOSIS >

## B175C POWER SOURCE (ROOF)

### Description

INFOID:000000006468885

Power supply (roof) voltage for retractable hard top control unit is monitored. Retractable hard top system operation is inhibited when voltage outside the specified value is detected.

### DTC Logic

INFOID:000000006468886

### DTC DETECTION LOGIC

#### NOTE:

If two or more DTCs are detected, refer to [RF-61. "DTC Inspection Priority Chart"](#), and determine trouble diagnosis order.

DTC No.	Trouble diagnosis name		DTC detecting condition	Possible causes
B175C	PWR SOURCE(ROOF)	[LOW VOLTAGE]	It is the detected that the battery voltage is 10.6 V or less input to retractable hard top control unit power source (roof) terminal.	<ul style="list-style-type: none"><li>• Power source circuit</li><li>• Battery condition</li><li>• Charging system</li></ul>

### DTC CONFIRMATION PROCEDURE

#### 1. PERFORM DTC CONFIRMATION PROCEDURE

1. Start engine.
2. Operate retractable hard top to fully open and close.
3. Check "Self-Diagnostic Result" of "RETRACTABLE HARD TOP" using CONSULT-III.

Is DTC detected?

- YES >> Go to [RF-210. "Diagnosis Procedure"](#).  
NO >> INSPECTION END

### Diagnosis Procedure

INFOID:000000006468887

#### 1. CHECK CHARGING SYSTEM

Check charging system. Refer to [CHG-3. "Work Flow"](#).

Is the inspection result normal?

- YES >> GO TO 2.  
NO >> Repair or replace malfunction parts.

#### 2. CHECK POWER SUPPLY AND GROUND CIRCUIT

Check power supply and ground circuit for retractable hard top control unit. Refer to [RF-226. "Diagnosis Procedure"](#).

Is the inspection result normal?

- YES >> Check intermittent incident. Refer to [GI-43. "Intermittent Incident"](#).  
NO >> Repair or replace malfunction parts.

# B175D POWER SOURCE (ROOF)

< DTC/CIRCUIT DIAGNOSIS >

## B175D POWER SOURCE (ROOF)

### Description

INFOID:000000006468888

Power supply (roof) voltage for retractable hard top control unit is monitored. Retractable hard top system operation is inhibited when voltage outside the specified value is detected.

### DTC Logic

INFOID:000000006468889

### DTC DETECTION LOGIC

#### NOTE:

If two or more DTCs are detected, refer to [RF-61, "DTC Inspection Priority Chart"](#), and determine trouble diagnosis order.

DTC No.	Trouble diagnosis name		DTC detecting condition	Possible causes
B175D	PWR SOURCE(ROOF)	[HIGH VOLTAGE]	It is the detected that the battery voltage is 15.0 V or more input to retractable hard top control unit power source (roof) terminal.	<ul style="list-style-type: none"><li>• Power source circuit</li><li>• Battery condition</li><li>• Charging system</li></ul>

### DTC CONFIRMATION PROCEDURE

#### 1. PERFORM DTC CONFIRMATION PROCEDURE

1. Start engine.
2. Operate retractable hard top to fully open and fully close.
3. Check "Self-Diagnostic Result" of "RETRACTABLE HARD TOP" using CONSULT-III.

#### Is DTC detected?

- YES >> Go to [RF-210, "Diagnosis Procedure"](#).  
NO >> INSPECTION END

### Diagnosis Procedure

INFOID:000000006468890

#### 1. CHECK CHARGING SYSTEM

Check charging system. Refer to [CHG-3, "Work Flow"](#).

#### Is the inspection result normal?

- YES >> GO TO 2.  
NO >> Repair or replace malfunction parts.

#### 2. CHECK POWER SUPPLY AND GROUND CIRCUIT

Check power supply and ground circuit for retractable hard top control unit. Refer to [RF-226, "Diagnosis Procedure"](#).

#### Is the inspection result normal?

- YES >> Check intermittent incident. Refer to [GI-43, "Intermittent Incident"](#).  
NO >> Repair or replace malfunction parts.

# B175E POWER SOURCE (POWER WINDOW)

< DTC/CIRCUIT DIAGNOSIS >

## B175E POWER SOURCE (POWER WINDOW)

### Description

INFOID:000000006468891

Retractable hard top control unit watches power supply condition of power supply (power window) terminal.

### DTC Logic

INFOID:000000006468892

### DTC DETECTION LOGIC

#### NOTE:

If two or more DTCs are detected, refer to [RF-61, "DTC Inspection Priority Chart"](#), and determine trouble diagnosis order.

DTC No.	Trouble diagnosis name		DTC detecting condition	Possible causes
B175E	PWR SOURCE(WINDOW)	[LOW VOLTAGE]	It is the detected that the battery voltage is 9.0 V or less input to retractable hard top control unit power source (power window) terminal.	<ul style="list-style-type: none"><li>Power source circuit (for power window)</li><li>Battery condition</li><li>Charging system</li><li>BCM power supply and ground</li></ul>

### DTC CONFIRMATION PROCEDURE

#### 1.PERFORM DTC CONFIRMATION PROCEDURE

1. Start engine.
2. Operate retractable hard top to fully open and fully close.
3. Check "Self-Diagnostic Result" of "RETRACTABLE HARD TOP" using CONSULT-III.

#### Is DTC detected?

- YES >> Go to [RF-210, "Diagnosis Procedure"](#).  
NO >> INSPECTION END

### Diagnosis Procedure

INFOID:000000006468893

#### 1.CHECK CHARGING SYSTEM

Check charging system. Refer to [CHG-3, "Work Flow"](#).

#### Is the inspection result normal?

- YES >> GO TO 2.  
NO >> Repair or replace malfunctioning part.

#### 2.CHECK POWER WINDOW MAIN SWITCH AND POWER WINDOW SUB-SWITCH POWER SUPPLY AND GROUND CIRCUIT

Check power window main switch and power window sub-switch power supply and ground circuit. Refer to [PWC-14, "POWER WINDOW MAIN SWITCH : Diagnosis Procedure"](#).

#### Is the inspection result normal?

- YES >> GO TO 3.  
NO >> Repair or replace malfunctioning part.

#### 3.CHECK BCM POWER SUPPLY AND GROUND CIRCUIT

Check BCM power supply and ground circuit. Refer to [BCS-39, "Diagnosis Procedure"](#).

#### Is the inspection result normal?

- YES >> GO TO 4.  
NO >> Repair or replace malfunctioning part.

#### 4.CHECK POWER SUPPLY CIRCUIT

1. Turn ignition switch OFF.
2. Disconnect retractable hard top control unit connector.
3. Turn ignition switch ON.
4. Check voltage between retractable hard top control unit harness connector and ground.

## B175E POWER SOURCE (POWER WINDOW)

### < DTC/CIRCUIT DIAGNOSIS >

(+)		(-)	Voltage (V) (Approx.)
Retractable hard top control unit			
Connector	Terminal	Ground	Battery voltage
B84	62		
	63		

Is the inspection result normal?

YES >> Replace retractable hard top control unit. Refer to [RF-309, "Removal and Installation"](#).

NO >> GO TO 5.

### 5. CHECK CONTINUITY POWER WINDOW POWER SUPPLY CIRCUIT

1. Turn ignition switch OFF.
2. Disconnect BCM connector.
3. Check continuity between BCM harness connector and retractable hard top control unit harness connector.

BCM		Retractable hard top control unit		Continuity
Connector	Terminal	Connector	Terminal	
M118	2	B84	62	Existed
			63	

4. Also check harness for short to ground.

Is the inspection result normal?

YES >> Replace BCM. Refer to [BCS-81, "Removal and Installation"](#).

NO >> Repair or replace harness.

# B175F POWER SOURCE (POWER WINDOW)

< DTC/CIRCUIT DIAGNOSIS >

## B175F POWER SOURCE (POWER WINDOW)

### Description

INFOID:000000006468894

Retractable hard top control unit watches power supply condition of power supply (power window) terminal.

### DTC Logic

INFOID:000000006468895

### DTC DETECTION LOGIC

#### NOTE:

If two or more DTCs are detected, refer to [RF-61, "DTC Inspection Priority Chart"](#), and determine trouble diagnosis order.

DTC No.	Trouble diagnosis name		DTC detecting condition	Possible causes
B175F	PWR SOURCE(WINDOW)	[HIGH VOLTAGE]	It is the detect that the battery voltage is 16.0 V or more input to retractable hard top control unit power source (power window) terminal.	<ul style="list-style-type: none"><li>• Power source circuit (for power window)</li><li>• Battery condition</li><li>• Charging system</li><li>• BCM power supply and ground</li></ul>

### DTC CONFIRMATION PROCEDURE

#### 1. PERFORM DTC CONFIRMATION PROCEDURE

1. Start engine.
2. Operate retractable hard top fully open and fully close.
3. Check "Self-Diagnostic Result" of "RETRACTABLE HARD TOP" using CONSULT-III.

#### Is DTC detected?

- YES >> Go to [RF-215, "Diagnosis Procedure"](#).  
NO >> INSPECTION END

### Diagnosis Procedure

INFOID:000000006468896

#### 1. CHECK CHARGING SYSTEM

Check charging system. Refer to [CHG-3, "Work Flow"](#).

#### Is the inspection result normal?

- YES >> GO TO 2.  
NO >> Repair or replace malfunctioning part.

#### 2. CHECK POWER WINDOW MAIN SWITCH AND POWER WINDOW SUB-SWITCH POWER SUPPLY AND GROUND CIRCUIT

Check power window main switch and power window sub-switch power supply and ground circuit. Refer to [PWC-14, "POWER WINDOW MAIN SWITCH : Diagnosis Procedure"](#).

#### Is the inspection result normal?

- YES >> GO TO 3.  
NO >> Repair or replace malfunctioning part.

#### 3. CHECK BCM POWER SUPPLY AND GROUND CIRCUIT

Check BCM power supply and ground circuit. Refer to [BCS-39, "Diagnosis Procedure"](#).

#### Is the inspection result normal?

- YES >> GO TO 4.  
NO >> Repair or replace malfunctioning part.

#### 4. CHECK POWER SUPPLY CIRCUIT

1. Turn ignition switch OFF.
2. Disconnect retractable hard top control unit connector.
3. Turn ignition switch ON.
4. Check voltage between retractable hard top control unit harness connector and ground.

## B175F POWER SOURCE (POWER WINDOW)

### < DTC/CIRCUIT DIAGNOSIS >

(+)		(-)	Voltage (V) (Approx.)
Retractable hard top control unit			
Connector	Terminal		
B84	62	Ground	Battery voltage
	63		

Is the inspection result normal?

YES >> Replace retractable hard top control unit. Refer to [RF-309, "Removal and Installation"](#).

NO >> GO TO 5.

### 5. CHECK CONTINUITY POWER WINDOW POWER SUPPLY CIRCUIT

1. Turn ignition switch OFF.
2. Disconnect BCM connector.
3. Check continuity between BCM harness connector and retractable hard top control unit harness connector.

BCM		Retractable hard top control unit		Continuity
Connector	Terminal	Connector	Terminal	
M118	2	B84	62	Existed
			63	

4. Also check harness for short to ground.

Is the inspection result normal?

YES >> Replace BCM. Refer to [BCS-81, "Removal and Installation"](#).

NO >> Repair or replace harness.



# B1760 RETRACTABLE HARD TOP CONTROL UNIT

< DTC/CIRCUIT DIAGNOSIS >

## B1760 RETRACTABLE HARD TOP CONTROL UNIT

### DTC Logic

INFOID:000000006468897

### DTC DETECTION LOGIC

#### NOTE:

If two or more DTCs are detected, refer to [RF-61, "DTC Inspection Priority Chart"](#), and determine trouble diagnosis order.

DTC	Trouble diagnosis name	DTC detecting condition	Possible cause
B1760	ROOF CONTROL UNIT	<ul style="list-style-type: none"><li>Retractable hard top control unit detects output to rear window defogger without output request.</li><li>Retractable hard top control unit requests output to rear window defogger but cannot detect output.</li></ul>	Retractable hard top control unit

### DTC CONFIRMATION PROCEDURE

#### 1. PERFORM DTC CONFIRMATION PROCEDURE

- Turn ignition switch ON.
- Turn rear window defogger ON.
- Check "Self-Diagnostic Result" of "RETRACTABLE HARD TOP" using CONSULT-III.

#### Is DTC detected?

- YES >> Refer to [RF-217, "Diagnosis Procedure"](#).  
NO >> INSPECTION END

### Diagnosis Procedure

INFOID:000000006468898

#### 1. CHECK SELF DIAGNOSTIC RESULT

- Turn ignition switch OFF.
- Replace retractable hard top control unit. Refer to [RF-309, "Removal and Installation"](#).
- Perform DTC Confirmation Procedure. Refer to [RF-138, "DTC Logic"](#).

>> INSPECTION END

# B1761 RETRACTABLE HARD TOP CONTROL UNIT

< DTC/CIRCUIT DIAGNOSIS >

## B1761 RETRACTABLE HARD TOP CONTROL UNIT

### DTC Logic

INFOID:000000006468899

#### DTC DETECTION LOGIC

**NOTE:**

If two or more DTCs are detected, refer to [RF-61, "DTC Inspection Priority Chart"](#), and determine trouble diagnosis order.

DTC	Trouble diagnosis name	DTC detecting condition	Possible cause
B1761	ROOF CONTROL UNIT	<ul style="list-style-type: none"><li>Retractable hard top control unit detects output to hydraulic pump power supply relay without output request.</li><li>Retractable hard top control unit requests output to hydraulic pump power supply relay but cannot detect output.</li></ul>	Retractable hard top control unit

#### DTC CONFIRMATION PROCEDURE

##### 1. PERFORM DTC CONFIRMATION PROCEDURE

1. Start engine.
2. Operate retractable hard top to fully open and fully close.
3. Check "Self-Diagnostic Result" of "RETRACTABLE HARD TOP" using CONSULT-III.

Is DTC detected?

- YES >> Refer to [RF-218, "Diagnosis Procedure"](#).  
NO >> INSPECTION END

#### Diagnosis Procedure

INFOID:000000006468900

##### 1. CHECK SELF DIAGNOSTIC RESULT

1. Turn ignition switch OFF.
2. Replace retractable hard top control unit. Refer to [RF-309, "Removal and Installation"](#).
3. Perform DTC Confirmation Procedure. Refer to [RF-97, "DTC Logic"](#).

>> INSPECTION END

# B1762 ROOF STATE

< DTC/CIRCUIT DIAGNOSIS >

## B1762 ROOF STATE

### Description

INFOID:000000006468901

There are 42 states in retractable hard top, regardless of open and close operations. Retractable hard top system performs open and close operations using combination of these 42 states.

### DTC Logic

INFOID:000000006468902

### DTC DETECTION LOGIC

#### NOTE:

If two or more DTCs are detected, refer to [RF-61, "DTC Inspection Priority Chart"](#), and determine trouble diagnosis order.

DTC No.	Trouble diagnosis name		DTC detecting condition	Possible cause
B1762	ROOF STATE	[INCORRECT]	Retractable hard top control unit does not recognize roof condition.	<ul style="list-style-type: none"><li>• Roof</li><li>• Roof latch</li><li>• Hydraulic unit</li><li>• Parcel shelf</li><li>• Flipper door LH/RH</li></ul>

### DTC CONFIRMATION PROCEDURE

#### 1. PERFORM DTC CONFIRMATION PROCEDURE

1. Start engine.
2. Operate retractable hard top to fully open and fully close.
3. Check "Self-diagnostic Result" of "RETRACTABLE HARD TOP" using CONSULT-III.

#### Is DTC detected?

- YES >> Go to [RF-222, "Diagnosis Procedure"](#).  
NO >> INSPECTION END

### Diagnosis Procedure

INFOID:000000006468903

#### 1. CHECK RETRACTABLE HARD TOP SYSTEM COMPONENT PARTS

Check retractable hard top component parts as bellow deformation, looseness, rattle, interference with other parts, and pinched foreign materials.

- Hydraulic system: Refer to [RF-299, "Exploded View"](#).
- Trunk lid: Refer to [DLK-269, "TRUNK LID ASSEMBLY : Exploded View"](#).

#### Is the inspection result normal?

- YES >> GO TO 2.  
NO >> Repair or replace malfunctioning part.

#### 2. PERFORM INITIALIZATION

1. Perform initialization without CONSULT-III (refer to [RF-90, "Work Procedure"](#)).
2. Perform DTC Confirmation Procedure. Refer to [RF-219, "DTC Logic"](#).

#### Is the inspection result normal?

- YES >> INSPECTION END  
NO >> GO TO 3.

#### 3. CHECK TRUNK ROOM LAMP SWITCH

Check trunk room lamp switch. Refer to [DLK-82, "Component Function Check"](#).

#### Is the inspection result normal?

- YES >> GO TO 4.  
NO >> Repair or replace malfunctioning part.

#### 4. CHECK TRUNK ROOM LAMP SWITCH SIGNAL

Check "TR ROOM LAMP SW" in "DATA MONITOR" mode of "RETRACTABLE HARD TOP" using CONSULT-III.

# B1762 ROOF STATE

## < DTC/CIRCUIT DIAGNOSIS >

Monitor item	Condition		Status
TR ROOM LAMP SW	Trunk lid	Open	ON
		Closed	OFF

Is the inspection result normal?

YES >> GO TO 6.

NO >> GO TO 5.

### 5. CHECK TRUNK ROOM LAMP SWITCH CIRCUIT

- Turn ignition switch OFF.
- Disconnect trunk room lamp switch connector, BCM connector, trunk closure control unit connector and retractable hard top control unit connector.
- Check continuity between retractable hard top control unit harness connector and trunk room lamp switch harness connector.

Retractable hard top control unit		Trunk room lamp switch		Continuity
Connector	Terminal	Connector	Terminal	
B82	5	B306	2	Existed

- Check continuity between BCM harness connector and ground.

Retractable hard top control unit		Ground	Continuity
Connector	Terminal		
B82	5		Not existed

Is the inspection result normal?

YES >> Check trunk lid auto closure system. Refer to [DLK-220. "OPEN/CLOSURE FUNCTION : Diagnosis Procedure"](#).

NO >> Repair harness or connector.

### 6. CHECK ROOF LATCH LIMIT SWITCH SIGNAL

- Connect retractable hard top control unit connector.
- Check "LATCH LIMIT SW" in "Data Monitor" mode of "RETRACTABLE HARD TOP" using CONSULT-III.

Monitor item	Condition		Status
LATCH LIMIT SW	ROOF LATCH	Roof is fully closed and roof latch is locked	CLOSE
		Other than above	OPEN

Is the inspection result normal?

YES >> GO TO 9.

NO >> GO TO 7.

### 7. CHECK ROOF LATCH LIMIT SWITCH CIRCUIT

- Disconnect roof latch limit switch connector and retractable hard top control unit connector.
- Check continuity between retractable hard top control unit harness connector and roof latch limit switch harness connector.

Retractable hard top control unit		Roof latch limit switch		Continuity
Connector	Terminal	Connector	Terminal	
B82	6	R6	2	Existed

- Check continuity between retractable hard top control harness connector and ground.

Retractable hard top control unit		Ground	Continuity
Connector	Terminal		
B82	6		Not existed

# B1762 ROOF STATE

## < DTC/CIRCUIT DIAGNOSIS >

Is the inspection result normal?

YES >> GO TO 8.

NO >> Repair harness or connector.

### 8.CHECK ROOF LATCH LIMIT SWITCH CIRCUIT

Check continuity between retractable hard top control harness connector and ground.

Roof latch limit switch		Ground	Continuity
Connector	Terminal		Existed
R6	3		

Is the inspection result normal?

YES >> Replace retractable hard top control unit. Refer to [RF-309, "Removal and Installation"](#).

NO >> Repair harness or connector.

### 9.CHECK HYDRAULIC PUMP POWER SUPPLY RELAY

Check hydraulic pump power supply relay. Refer to [RF-242, "Diagnosis Procedure"](#).

Is the inspection result normal?

YES >> Check intermittent incident. Refer to [GI-43, "Intermittent Incident"](#).

NO >> Replace hydraulic unit. Refer to [RF-299, "Removal and Installation"](#).

A  
B  
C  
D  
E  
F  
G  
H  
I  
J  
L  
M  
N  
O  
P

RF

# B1763 HYDRAULIC STATE

< DTC/CIRCUIT DIAGNOSIS >

## B1763 HYDRAULIC STATE

### Description

INFOID:000000006468904

There are 22 states in hydraulic system. Hydraulic system is controlled using combination of these 22 states and, at the same time, open and close operations of retractable hard top system are performed interlocking with other retractable hard top system components. For the detail, refer to [RF-31, "HYDRAULIC SYSTEM CONTROL FUNCTION : System Description"](#).

### DTC Logic

INFOID:000000006468905

#### DTC DETECTION LOGIC

##### NOTE:

If two or more DTCs are detected, refer to [RF-61, "DTC Inspection Priority Chart"](#), and determine trouble diagnosis order.

DTC No.	Trouble diagnosis name		DTC detecting condition	Possible cause
B1763	HYDRAULIC STATE	[INCORRECT]	Retractable hard top control unit does not recognize hydraulic system condition.	<ul style="list-style-type: none"><li>• Trunk link sensor LH/RH</li><li>• Trunk status sensor</li><li>• Trunk room lamp switch</li><li>• Roof latch condition</li></ul>

#### DTC CONFIRMATION PROCEDURE

##### 1. PERFORM DTC CONFIRMATION PROCEDURE

1. Start engine.
2. Operate retractable hard top to fully open and fully close.
3. Check "Self-diagnostic Result" of "RETRACTABLE HARD TOP" using CONSULT-III.

##### Is DTC detected?

- YES >> Go to [RF-222, "Diagnosis Procedure"](#).  
NO >> INSPECTION END

### Diagnosis Procedure

INFOID:000000006468906

##### 1. CHECK RETRACTABLE HARD TOP SYSTEM COMPONENT PARTS

Check retractable hard top component parts as bellow deformation, looseness, rattle, interference with other parts, and pinched foreign materials.

- Hydraulic system: Refer to [RF-299, "Exploded View"](#).
- Trunk lid: Refer to [DLK-269, "TRUNK LID ASSEMBLY : Exploded View"](#).

##### Is the inspection result normal?

- YES >> GO TO 2.  
NO >> Repair or replace malfunctioning part.

##### 2. PERFORM INITIALIZATION

1. Perform "RESET ROOF STATE" in "WORK SUPPORT" mode of "RETRACTABLE HARD TOP" using CONSULT-III (refer to [RF-45, "CONSULT-III Function"](#)).
2. Perform initialization with CONSULT-III (refer to [RF-90, "Work Procedure"](#)).
3. Perform DTC Confirmation Procedure. Refer to [RF-219, "DTC Logic"](#).

##### Is the inspection result normal?

- YES >> INSPECTION END  
NO >> GO TO 3.

##### 3. CHECK TRUNK LID OPENER ACTUATOR

Check trunk lid opener actuator. Refer to [DLK-220, "OPEN/CLOSURE FUNCTION : Diagnosis Procedure"](#).

##### Is the inspection result normal?

- YES >> GO TO 4.  
NO >> Repair or replace malfunctioning part.

# B1763 HYDRAULIC STATE

< DTC/CIRCUIT DIAGNOSIS >

## 4.CHECK TRUNK ROOM LAMP SWITCH

Check trunk room lamp switch. Refer to [DLK-82. "Component Function Check"](#).

Is the inspection result normal?

YES >> GO TO 5.

NO >> Repair or replace malfunctioning part.

## 5.CHECK TRUNK ROOM LAMP SWITCH SIGNAL

Check "TR ROOM LAMP SW" in "DATA MONITOR" mode of "RETRACTABLE HARD TOP" using CONSULT-III.

Monitor item	Condition		Status
TR ROOM LAMP SW	Trunk lid	Open	ON
		Closed	OFF

Is the inspection result normal?

YES >> GO TO 7.

NO >> GO TO 6.

## 6.CHECK TRUNK ROOM LAMP SWITCH CIRCUIT

1. Disconnect trunk room lamp switch connector, BCM connector trunk closure control unit connector and retractable hard top control unit connector.
2. Check continuity between retractable hard top control unit harness connector and trunk room lamp switch harness connector.

Retractable hard top control unit		Trunk room lamp switch		Continuity
Connector	Terminal	Connector	Terminal	
B82	5	B306	2	Existed

3. Check continuity between BCM harness connector and ground.

Retractable hard top control unit		Ground	Continuity
Connector	Terminal		
B82	5		Not existed

Is the inspection result normal?

YES >> Check trunk lid auto closure system. Refer to [DLK-220. "OPEN/CLOSURE FUNCTION : Diagnosis Procedure"](#).

NO >> Repair harness or connector.

## 7.CHECK HYDRAULIC PUMP POWER SUPPLY RELAY

Check hydraulic pump power supply relay. Refer to [RF-242. "Diagnosis Procedure"](#).

Is the inspection result normal?

YES >> Check intermittent incident. Refer to [GI-43. "Intermittent Incident"](#).

NO >> Replace hydraulic unit. Refer to [RF-299. "Removal and Installation"](#).

# B1764 ROOF LATCH STATE

< DTC/CIRCUIT DIAGNOSIS >

## B1764 ROOF LATCH STATE

### Description

INFOID:000000006468907

There are 3 states in roof latch. Open and close operations of retractable hard top system are performed interlocking with other retractable hard top system components. For the detail, refer to [RF-35, "ROOF LATCH FUNCTION : System Description"](#).

### DTC Logic

INFOID:000000006468908

#### DTC DETECTION LOGIC

##### NOTE:

If two or more DTCs are detected, refer to [RF-61, "DTC Inspection Priority Chart"](#), and determine trouble diagnosis order.

DTC No.	Trouble diagnosis name		DTC detecting condition	Possible cause
B1764	ROOF LATCH STATE	[INCORRECT]	Retractable hard top control unit does not recognize roof latch condition.	<ul style="list-style-type: none"><li>• Roof latch motor</li><li>• Roof latch limit switch</li><li>• Roof latch lock sensor</li></ul>

#### DTC CONFIRMATION PROCEDURE

##### 1. PERFORM DTC CONFIRMATION PROCEDURE

1. Start engine.
2. Operate retractable hard top to fully open and fully close.
3. Check "Self-Diagnosis Result" of "RETRACTABLE HARD TOP" using CONSULT-III.

##### Is DTC detected?

- YES >> Go to [RF-224, "Diagnosis Procedure"](#).  
NO >> INSPECTION END

### Diagnosis Procedure

INFOID:000000006468909

##### 1. CHECK RETRACTABLE HARD TOP SYSTEM COMPONENT PARTS

Check retractable hard top component parts as bellow deformation, looseness, rattle, interference with other parts, and pinched foreign materials.

- Roof: Refer to [RF-287, "Exploded View"](#).
- Roof latch: Refer to [RF-269, "ROOF LOCK ASSEMBLY : Exploded View"](#).

##### Is the inspection result normal?

- YES >> GO TO 2.  
NO >> Repair or replace malfunctioning part.

##### 2. PERFORM INITIALIZATION

1. Perform initialization with roof open/close switch (refer to [RF-90, "Work Procedure"](#)).
2. Perform DTC Confirmation Procedure. Refer to [RF-219, "DTC Logic"](#).

##### Is the inspection result normal?

- YES >> INSPECTION END  
NO >> Replace retractable hard top control unit. Refer to [RF-15, "Component Parts Location"](#).



# B1765 FLIPPER DOOR STATE

< DTC/CIRCUIT DIAGNOSIS >

## B1765 FLIPPER DOOR STATE

### Description

INFOID:000000006468910

There are 4 states in flipper door. Open and close operations of retractable hard top system are performed interlocking with other retractable hard top components. For the detail, refer to [RF-39. "FLIPPER DOOR FUNCTION : System Description"](#).

### DTC Logic

INFOID:000000006468911

#### DTC DETECTION LOGIC

##### NOTE:

If two or more DTCs are detected, refer to [RF-61. "DTC Inspection Priority Chart"](#), and determine trouble diagnosis order.

DTC No.	Trouble diagnosis name		DTC detecting condition	Possible cause
B1765	FLIPPER DOOR STATE	[INCORRECT]	Retractable hard top control unit does not recognize flipper door condition.	<ul style="list-style-type: none"><li>Flipper door limit switch LH/RH (UP/DOWN)</li><li>Flipper door motor LH/RH (UP/DOWN)</li></ul>

#### DTC CONFIRMATION PROCEDURE

##### 1.PERFORM DTC CONFIRMATION PROCEDURE

1. Start engine.
2. Operate retractable hard top to fully open and fully close.
3. Check DTC.

##### Is DTC detected?

- YES >> Go to [RF-225. "Diagnosis Procedure"](#).  
NO >> INSPECTION END

### Diagnosis Procedure

INFOID:000000006468912

##### 1.CHECK RETRACTABLE HARD TOP SYSTEM COMPONENT PARTS

Check retractable hard top component parts as bellow deformation, looseness, rattle, interference with other parts, and pinched foreign materials.

- Flipper door: Refer to [RF-295. "Exploded View"](#).

##### Is the inspection result normal?

- YES >> GO TO 2.  
NO >> Repair or replace malfunctioning part.

##### 2.CHECK FLIPPER DOOR LIMIT SWITCH

Check flipper door limit switch. Refer to [RF-231. "Diagnosis Procedure"](#).

##### Is the inspection result normal?

- YES >> Check intermittent incident. Refer to [GI-43. "Intermittent Incident"](#).  
NO >> Repair or replace malfunctioning part.

# POWER SUPPLY AND GROUND CIRCUIT

< DTC/CIRCUIT DIAGNOSIS >

## POWER SUPPLY AND GROUND CIRCUIT

### Diagnosis Procedure

INFOID:000000006468913

#### 1.CHECK FUSE AND FUSIBLE LINK

Check that the following fuse and fusible link are not blown.

Signal name	Fuse and fusible link No.
Battery power supply	O

#### Is the fuse fusing?

YES >> Replace the blown fuse or fusible link after repairing the affected circuit if a fuse or fusible link is blown.

NO >> GO TO 2.

#### 2.CHECK POWER SUPPLY CIRCUIT-I

1. Turn ignition switch OFF.
2. Disconnect retractable hard top control unit connectors.
3. Check voltage between retractable hard top control unit harness connector and ground.

(+)		(-)	Voltage (Approx.)
Retractable hard top control unit		Ground	Battery voltage
Connector	Terminal		
B84	57		
	58		
	59		

#### Is the measurement value normal?

YES >> GO TO 3.

NO >> Repair harness or connector.

#### 3.CHECK POWER SUPPLY CIRCUIT-II

1. Turn ignition switch ON.
2. Check voltage between retractable hard top control unit harness connector and ground.

(+)		(-)	Voltage (Approx.)
Retractable hard top control unit		Ground	Battery voltage
Connector	Terminal		
B82	11		

#### Is the measurement value normal?

YES >> GO TO 4.

NO >> Repair harness or connector.

#### 4.CHECK GROUND CIRCUIT

Check continuity between retractable hard top control unit harness connector and ground.

Retractable hard top control unit		Ground	Continuity
Connector	Terminal		Existed
B84	60		
	61		

#### Does continuity exist?

YES >> INSPECTION END

NO >> Repair harness or connector.

# ROOF OPEN/CLOSE SWITCH

< DTC/CIRCUIT DIAGNOSIS >

## ROOF OPEN/CLOSE SWITCH

### Component Function Check

INFOID:000000006468915

#### 1.CHECK FUNCTION

Check "ROOF SW(OPEN)" or "ROOF SW(CLOSE)" in "Data Monitor" mode of "RETRACTABLE HARD TOP" using CONSULT-III.

Monitor item	Condition		Status
ROOF SW(OPEN)	Roof open/close switch	Open	ON
		Closed	OFF
ROOF SW(CLOSE)	Roof open/close switch	Open	OFF
		Closed	ON

Is the inspection result normal?

- YES >> Roof open/close switch is normal.  
 NO >> Refer to [RF-227. "Diagnosis Procedure"](#).

### Diagnosis Procedure

INFOID:000000006468916

#### 1.CHECK ROOF OPEN/CLOSE SWITCH POWER SUPPLY

- Turn ignition switch OFF.
- Disconnect roof open/close switch connector.
- Turn ignition switch ON.
- Check the voltage between roof open/close switch harness connector and ground.

(+)		(-)	Voltage (V) (Approx.)
Roof open/close switch			
Connector	Terminal	Ground	Battery voltage
M28 (A/T models)	3		
M179 (M/T models)			
M28 (A/T models)	4		
M179 (M/T models)			

Is the inspection result normal?

- YES >> GO TO 3.  
 NO >> GO TO 2.

#### 2.CHECK ROOF OPEN/CLOSE SWITCH POWER SUPPLY CIRCUIT

- Turn ignition switch OFF.
- Disconnect retractable hard top control unit connector.
- Check the continuity between retractable hard top control unit harness connector and roof open/close switch harness connector.

Retractable hard top control unit		Roof open/close switch		Continuity
Connector	Terminal	Connector	Terminal	
B82	1	M28 (A/T models)	3	Existed
		M179 (M/T models)		
	2	M28 (A/T models)	4	
		M179 (M/T models)		

- Check harness for short to ground.

Is the inspection result normal?

- YES >> GO TO 5.  
 NO >> Repair or replace harness.

# ROOF OPEN/CLOSE SWITCH

< DTC/CIRCUIT DIAGNOSIS >

## 3. CHECK ROOF OPEN/CLOSE SWITCH GROUND CIRCUIT

1. Turn ignition switch OFF.
2. Disconnect retractable hard top control unit connector.
3. Check the continuity between roof open/close switch harness connector and ground.

Roof open/close switch		Ground	Continuity
Connector	Terminal		
M28 (A/T models)	1		Existed
M179 (M/T models)			

4. Check harness for short to ground.

Is the inspection result normal?

- YES >> GO TO 4.  
NO >> Repair or replace harness.

## 4. CHECK ROOF OPEN/CLOSE SWITCH

Refer to [RF-108, "Component Inspection"](#).

Is the inspection result normal?

- YES >> GO TO 5.  
NO >> Replace roof open/close switch. Refer to [RF-15, "Component Parts Location"](#).

## 5. REPLACE RETRACTABLE HARD TOP CONTROL UNIT

1. Replace retractable hard top control unit. Refer to [RF-15, "Component Parts Location"](#).
2. Refer to [RF-89, "Work Procedure"](#).

Is the inspection result normal?

- YES >> INSPECTION END  
NO >> GO TO 6.

## 6. CHECK INTERMITTENT INCIDENT

Refer to [GI-43, "Intermittent Incident"](#).

>> INSPECTION END

# TONNEAU BOARD SWITCH

< DTC/CIRCUIT DIAGNOSIS >

## TONNEAU BOARD SWITCH

### Component Function Check

INFOID:000000006468917

#### 1.CHECK FUNCTION

Check "TONNEAU SW" in "Data Monitor" mode of "RETRACTABLE HARD TOP" using CONSULT-III.

Monitor item	Condition	Status
TONNEAU SW	Tonneau board	Set Other than above
		OK NG

Is the inspection result normal?

YES >> INSPECTION END

NO >> Refer to [RF-238, "Diagnosis Procedure"](#).

#### Diagnosis Procedure

INFOID:000000006468918

#### 1.CHECK TONNEAU BOARD SWITCH POWER SUPPLY

1. Turn ignition switch OFF.
2. Disconnect tonneau board switch connector.
3. Turn ignition switch ON.
4. Check the voltage between tonneau board switch harness connector and ground.

(+)		(-)	Voltage (V) (Approx.)
Connector	Terminal		
B352	1	Ground	Battery voltage

Is the inspection result normal?

YES >> GO TO 2.

NO >> Repair or replace harness.

#### 2.CHECK TONNEAU BOARD SWITCH GROUND CIRCUIT

1. Turn ignition switch OFF.
2. Check the continuity between tonneau board switch harness connector and ground.

Tonneau board switch		Ground	Continuity
Connector	Terminal		
B352	3		Existed

3. Check harness for short to power.

Is the inspection result normal?

YES >> GO TO 3.

NO >> Repair or replace harness.

#### 3.REPLACE TONNEAU BOARD SWITCH

Replace tonneau board switch.

Is the inspection result normal?

YES >> INSPECTION END

NO >> GO TO 4.

#### 4.REPLACE RETRACTABLE HARD TOP CONTROL UNIT

1. Replace retractable hard top control unit. Refer to [RF-15, "Component Parts Location"](#).
2. Refer to [RF-89, "Work Procedure"](#).

Is the inspection result normal?

YES >> INSPECTION END

NO >> GO TO 5.

## TONNEAU BOARD SWITCH

< DTC/CIRCUIT DIAGNOSIS >

---

**5.**CHECK INTERMITTENT INCIDENT

---

Refer to [GI-43. "Intermittent Incident"](#).

>> INSPECTION END

# FLIPPER DOOR LIMIT SWITCH

< DTC/CIRCUIT DIAGNOSIS >

## FLIPPER DOOR LIMIT SWITCH

### Diagnosis Procedure

INFOID:000000006468919

#### 1. CHECK FUNCTION

1. Turn ignition switch ON.
2. Check the voltage between retractable hard top control unit terminals and ground under the following conditions.

(+)		(-)	Condition	Voltage (V) (Approx.)	
Retractable hard top control unit					
Connector	Terminal				
B82	7	Ground	Flipper door (LH & RH))	Top	0
				Other than above	Battery voltage
	8			Bottom	0
				Other than above	Battery voltage

Is the inspection result normal?

YES >> INSPECTION END

NO >> GO TO 2.

#### 2. CHECK FLIPPER DOOR LIMIT SWITCH POWER SUPPLY CIRCUIT-I

1. Turn ignition switch OFF.
2. Disconnect flipper door (LH) harness connector.
3. Turn ignition switch ON.
4. Check the voltage between flipper door (LH) harness connector and ground.

(+)		(-)	Voltage (V) (Approx.)
Flipper door (LH)			
Connector	Terminal		
B307	2	Ground	Battery voltage
	4		

Is the inspection result normal?

YES >> GO TO 3.

NO >> Repair or replace harness.

#### 3. CHECK FLIPPER DOOR LIMIT SWITCH POWER SUPPLY CIRCUIT-II

1. Turn ignition switch OFF.
2. Reconnect flipper door (LH) harness connector.
3. Disconnect flipper door (RH) harness connector.
4. Turn ignition switch ON.
5. Check the voltage between flipper door (RH) harness connector and ground under the following conditions.

(+)		(-)	Condition	Voltage (V) (Approx.)	
Flipper door (RH)					
Connector	Terminal				
B308	1	Ground	Flipper door (LH)	Top	Battery voltage
				Other than above	0
	2			Bottom	Battery voltage
				Other than above	0

Is the inspection result normal?

YES >> GO TO 5.

# FLIPPER DOOR LIMIT SWITCH

## < DTC/CIRCUIT DIAGNOSIS >

NO >> GO TO 4.

### 4. CHECK FLIPPER DOOR LIMIT SWITCH POWER SUPPLY CIRCUIT-III

1. Turn ignition switch OFF.
2. Disconnect flipper door (LH) harness connector.
3. Check the continuity between flipper door (LH) harness connector and flipper door (RH) harness connector.

Flipper door (LH)		Flipper door (RH)		Continuity
Connector	Terminal	Connector	Terminal	
B307	1	B308	1	Existed
	3		2	

4. Check harness for short to ground and short to power.

#### Is the inspection result normal?

YES >> Replace flipper door (LH). Refer to [RF-15. "Component Parts Location"](#).

NO >> Repair or replace harness.

### 5. CHECK FLIPPER DOOR LIMIT SWITCH GROUND CIRCUIT

1. Turn ignition switch OFF.
2. Disconnect flipper door (RH) harness connector.
3. Disconnect retractable hard top control unit harness connector.
4. Check the continuity between flipper door (RH) harness connector and retractable hard top control unit harness connector.

Flipper door (RH)		Retractable hard top control unit		Continuity
Connector	Terminal	Connector	Terminal	
B308	3	B82	3	Existed

5. Check harness for short to short to power.

#### Is the inspection result normal?

YES >> GO TO 6.

NO >> Repair or replace harness.

### 6. REPLACE FLIPPER DOOR (RH)

Replace flipper door (RH). Refer to [RF-15. "Component Parts Location"](#).

#### Is the inspection result normal?

YES >> INSPECTION END

NO >> GO TO 7.

### 7. REPLACE RETRACTABLE HARD TOP CONTROL UNIT

1. Replace retractable hard top control unit. Refer to [RF-15. "Component Parts Location"](#).
2. Refer to [RF-89. "Work Procedure"](#).

#### Is the inspection result normal?

YES >> INSPECTION END

NO >> GO TO 8.

### 8. CHECK INTERMITTENT INCIDENT

Refer to [GI-43. "Intermittent Incident"](#).

>> INSPECTION END



# BACK-UP LAMP CIRCUIT

< DTC/CIRCUIT DIAGNOSIS >

## BACK-UP LAMP CIRCUIT

### Description

INFOID:000000006468920

Retractable hard top control unit receives shift position R signal from back up lamp for the preconditions.

### Component Function Check

INFOID:000000006468921

#### 1.CHECK FUNCTION

Check "SHIFT R SIG" in "Data Monitor" mode of "RETRACTABLE HARD TOP" using CONSULT-III.

Monitor item	Condition	Status
SHIFT R SIG	Shift position	Other than R position
		R position
		OK
		NG

Is the inspection result normal?

YES >> INSPECTION END

NO >> Go to [RF-238, "Diagnosis Procedure"](#).

### Diagnosis Procedure

INFOID:000000006468922

#### 1.CHECK BACK-UP LAMP RELAY OR BACK-UP LAMP SWITCH POWER SUPPLY

1. Turn ignition switch OFF.
2. Disconnect back-up lamp relay (A/T models) or back-up lamp switch (M/T models) harness connector.
3. Check the voltage between back-up lamp relay (A/T models) or back-up lamp switch (M/T models) harness connector and ground.

(+)		(-)	Voltage (V) (Approx.)
Back-up lamp relay			
Connector	Terminal		
M69	3	Ground	Battery voltage

(+)		(-)	Voltage (V) (Approx.)
Back-up lamp switch			
Connector	Terminal		
F56	1	Ground	Battery voltage

Is the inspection result normal?

YES >> GO TO 2.

NO-1 >> Check 10 A fuse [No. 4 located in the fuse block (J/B)].

NO-2 >> Check harness for open or short between back-up lamp relay (A/T models) or back-up lamp switch (M/T models) and fuse.

#### 2.CHECK BACK-UP LAMP RELAY OR BACK-UP LAMP SWITCH GROUND CIRCUIT

1. Disconnect retractable hard top control unit connector.
2. Check the continuity between retractable hard top control unit harness connector and back-up lamp relay (A/T models) or back-up lamp switch (M/T models) harness connector.

Retractable hard top control unit		Back-up lamp relay		Continuity
Connector	Terminal	Connector	Terminal	
B82	12	M69	5	Existed

Retractable hard top control unit		Back-up lamp switch		Continuity
Connector	Terminal	Connector	Terminal	
B82	12	F56	2	Existed

## BACK-UP LAMP CIRCUIT

< DTC/CIRCUIT DIAGNOSIS >

---

3. Check harness for short to ground or short to power.

Is the inspection result normal?

YES >> GO TO 3.

NO >> Repair or replace harness.

### 3.CHECK BACK-UP LAMP RELAY OR BACK-UP LAMP SWITCH

---

Check back-up lamp relay (A/T models) (refer to [TM-103, "Diagnosis Flow"](#)) or back-up lamp switch (M/T models) (refer to [TM-8, "Component Inspection"](#))

Is the inspection result normal?

YES >> GO TO 4.

NO >> Repair or replace malfunctioning part.

### 4.REPLACE RETRACTABLE HARD TOP CONTROL UNIT

---

1. Replace retractable hard top control unit. Refer to [RF-15, "Component Parts Location"](#).

2. Refer to [RF-89, "Work Procedure"](#).

Is the inspection result normal?

YES >> INSPECTION END

NO >> GO TO 5.

### 5.CHECK INTERMITTENT INCIDENT

---

Refer to [GI-43, "Intermittent Incident"](#).

>> INSPECTION END

# FLIPPER DOOR MOTOR

< DTC/CIRCUIT DIAGNOSIS >

## FLIPPER DOOR MOTOR

### Diagnosis Procedure

INFOID:000000006468923

#### 1. CHECK FLIPPER DOOR MOTOR CIRCUIT-1

1. Turn ignition switch OFF.
2. Disconnect retractable hard top control unit connector and hydraulic unit connector.
3. Check the continuity between retractable hard top control unit harness connector and hydraulic unit harness connector.

Retractable hard top control unit		Hydraulic unit		Continuity
Connector	Terminal	Connector	Terminal	
B82	28	B80	16	Existed
B83	46		14	
	47		15	

4. Check harness for short to ground.

Is the inspection result normal?

YES >> GO TO 2.

NO >> Repair or replace harness.

#### 2. CHECK FLIPPER DOOR MOTOR CIRCUIT-2

1. Disconnect flipper door (LH/RH) connector.
2. Check the continuity between hydraulic unit harness connector and flipper door (LH/RH) connector.

Hydraulic unit		Flipper door		Continuity
Connector	Terminal	Connector	Terminal	
B27	6	LH: B307 RH: B308	5	Existed
	12		6	
	13			
	17			

3. Check harness for short to ground.

Is the inspection result normal?

YES >> GO TO 3.

NO >> Repair or replace harness.

#### 3. CHECK FLIPPER DOOR POWER SUPPLY

1. Connect retractable hard top control unit connector and hydraulic unit connector.
2. Turn ignition switch ON.
3. Perform "FLIPPER DOOR" in "WORK SUPPORT" mode of "RETRACTABLE HARD TOP" using CONSULT-III (refer to [RF-45, "CONSULT-III Function"](#)).
4. Check the voltage between flipper door harness connector and ground under the conditions.

(+)		(-)	Work Support item	Voltage (V) (Approx.)	
Flipper door					
Connector	Terminal				
LH: B307 RH: B308	5	Ground	FLIPPER DOOR	UP	Battery voltage
			DOWN	0	
	6		UP	0	
			DOWN	Battery voltage	

**CAUTION:**

# FLIPPER DOOR MOTOR

## < DTC/CIRCUIT DIAGNOSIS >

**This operation may result in serious damage to components. Never operate the flipper door if the roof and trunk lid are in the closed position. Doing so may cause the roof to open inside the trunk. Check the roof and trunk lid position before proceeding.**

### Is the inspection result normal?

- YES >> Replace flipper door (malfunctioning part). Refer to [RF-295, "Removal and Installation"](#).  
NO >> GO TO 4.

## 4. CHECK RETRACTABLE HARD TOP CONTROL UNIT OUTPUT

1. Turn ignition switch OFF.
2. Connect flipper door (LH/RH) connector.
3. Turn ignition switch ON.
4. Check "FLPD OUT(UP)" and "FLPD OUT(DWN)" in "Data Monitor" mode of "RETRACTABLE HARD TOP" using CONSULT-III.

Monitor item	Condition	Status
FLPD OUT (UP)	Up operation	ON
	Down operation	OFF
FLPD OUT (DWN)	Down operation	ON
	Up operation	OFF

### Is the inspection result normal?

- YES >> Replace hydraulic unit. Refer to [RF-299, "Removal and Installation"](#).  
NO >> Replace retractable hard top control unit. Refer to [RF-309, "Removal and Installation"](#).

# ROOF LATCH MOTOR

< DTC/CIRCUIT DIAGNOSIS >

## ROOF LATCH MOTOR

### Diagnosis Procedure

INFOID:000000006468924

#### 1. CHECK ROOF LATCH MOTOR POWER SUPPLY

1. Turn ignition switch ON.
2. Perform "ROOF LATCH" in "WORK SUPPORT" mode of "RETRACTABLE HARD TOP" using CONSULT-III (refer to [RF-45, "CONSULT-III Function"](#)).
3. Check the voltage between roof latch assembly harness connector and ground under the following conditions.

(+)		(-)	Work Support item	Voltage (V) (Approx.)	
Roof latch assembly					
Connector	Terminal				
B657	5	Ground	ROOF LATCH	0	
	6			OPEN	Battery voltage
	5			CLOSE	Battery voltage
	6				0

Is the inspection result normal?

YES >> GO TO 2.

NO >> Replace retractable hard top control unit. Refer to [RF-309, "Removal and Installation"](#).

#### 2. CHECK ROOF LATCH MOTOR CIRCUIT

1. Turn ignition switch OFF.
2. Disconnect retractable hard top control unit connector and roof latch assembly connector.
3. Check the continuity between retractable hard top control unit harness connector and roof latch assembly harness connector.

Retractable hard top control unit		Roof latch assembly		Continuity
Connector	Terminal	Connector	Terminal	
B82	48	B657	6	Existed
	49		5	

4. Check harness for short to ground.

Is the inspection result normal?

YES >> Replace roof latch motor. Refer to [RF-269, "ROOF LOCK ASSEMBLY : Removal and Installation"](#).

NO >> Repair or replace harness.

# PARCEL SHELF MOTOR (DRAW)

< DTC/CIRCUIT DIAGNOSIS >

## PARCEL SHELF MOTOR (DRAW)

### Diagnosis Procedure

INFOID:000000006468925

#### 1. CHECK PARCEL SHELF MOTOR (DRAW) CIRCUIT

1. Turn ignition switch OFF.
2. Disconnect retractable hard top control unit connector and parcel shelf unit connector.
3. Check the continuity between retractable hard top control unit harness connector and parcel shelf unit harness connector.

Retractable hard top control unit		Parcel shelf unit		Continuity
Connector	Terminal	Connector	Terminal	
B83	41	B71	3	Existed
	42		2	

4. Check harness for short to ground.

Is the inspection result normal?

YES >> GO TO 2.

NO >> Repair or replace harness.

#### 2. CHECK PARCEL SHELF MOTOR (DRAW) GROUND CIRCUIT

1. Check the continuity between parcel shelf unit harness connector and ground.

Parcel shelf unit		Ground	Continuity
Connector	Terminal		
B71	12		Existed
	14		

2. Check harness for short to ground.

Is the inspection result normal?

YES >> GO TO 3.

NO >> Repair or replace harness.

#### 3. CHECK PARCEL SHELF MOTOR (DRAW) POWER SUPPLY

1. Turn ignition switch OFF.
2. Connect retractable hard top control unit connector.
3. Turn ignition switch ON.
4. Perform "ROOF/TRUNK/PARCEL SHELF" in "WORK SUPPORT" mode of "RETRACTABLE HARD TOP" using CONSULT-III (refer to [RF-45, "CONSULT-III Function"](#)).
5. Check the voltage between parcel shelf unit harness connector and ground.

(+)		(-)	Work Support item	Voltage (V) (Approx.)
Connector	Terminal			
B71	2	Ground	UP	0
			DOWN	Battery voltage
	3		UP	Battery voltage
			DOWN	0

**CAUTION:**

This operation may interfere with and damage parts. Always check the precautions. Refer to [RF-10, "Precautions for Retractable Hard Top Service"](#).

- Before opening trunk lid, release trunk opener lock-up.
- Before operating roof, release roof opener lock-up.

Is the inspection result normal?

## PARCEL SHELF MOTOR (DRAW)

### < DTC/CIRCUIT DIAGNOSIS >

- YES >> Replace parcel shelf unit. Refer to [RF-290. "REAR PARCEL SHELF UNIT : Removal and Installation"](#).
- NO >> Replace retractable hard top control unit. Refer to [RF-309. "Removal and Installation"](#).

A  
B  
C  
D  
E  
F  
G  
H  
I  
J  
RF  
L  
M  
N  
O  
P

# PARCEL SHELF MOTOR (ROTATION)

< DTC/CIRCUIT DIAGNOSIS >

## PARCEL SHELF MOTOR (ROTATION)

### Diagnosis Procedure

INFOID:000000006468926

#### 1. CHECK PARCEL SHELF MOTOR (ROTATION) CIRCUIT

1. Turn ignition switch OFF.
2. Disconnect retractable hard top control unit connector and parcel shelf unit connector.
3. Check the continuity between retractable hard top control unit harness connector and parcel shelf unit harness connector.

Retractable hard top control unit		Parcel shelf unit		Continuity
Connector	Terminal	Connector	Terminal	
B83	44	B71	1	Existed
	45		16	

4. Check harness for short to ground.

Is the inspection result normal?

YES >> GO TO 2.

NO >> Repair or replace harness.

#### 2. CHECK PARCEL SHELF MOTOR (ROTATION) POWER SUPPLY

1. Turn ignition switch OFF.
2. Connect retractable hard top control unit connector.
3. Turn ignition switch ON.
4. Perform "ROOF/TRUNK/PARCEL SHELF" in "WORK SUPPORT" mode of "RETRACTABLE HARD TOP" using CONSULT-III (refer to [RF-45. "CONSULT-III Function"](#)).
5. Check the voltage between parcel shelf unit harness connector and ground under.

(+) Parcel shelf unit		(-)	Work Support item	Voltage (V) (Approx.)
Connector	Terminal			
B71	1	Ground	PS (ROTA)	0
	16			Battery voltage
	1			Battery voltage
	16			0

**CAUTION:**

This operation may interfere with and damage parts. Always check the precautions. Refer to [RF-10. "Precautions for Retractable Hard Top Service"](#).

- Before opening trunk lid, release trunk opener lock-up.
- Before operating roof, release roof opener lock-up.

Is the inspection result normal?

YES >> Replace parcel shelf unit. Refer to [RF-290. "REAR PARCEL SHELF UNIT : Removal and Installation"](#).

NO >> Replace retractable hard top control unit. Refer to [RF-309. "Removal and Installation"](#).



# ROOF WARNING BUZZER

< DTC/CIRCUIT DIAGNOSIS >

## ROOF WARNING BUZZER

### Diagnosis Procedure

INFOID:000000006468927

#### 1. CHECK ROOF WARNING BUZZER POWER SUPPLY

1. Turn ignition switch OFF.
2. Disconnect roof warning buzzer connector.
3. Check voltage between roof warning buzzer harness connector and ground.

Roof warning buzzer		(-)	Voltage (V) (Approx.)
(+)			
Connector	Terminal		
B87	1	Ground	Battery voltage

Is the inspection result normal?

- YES >> GO TO 2.  
 NO-1 >> Check 10 A fuse [No. 6 located in the fuse block (J/B)].  
 NO-2 >> Check harness for open or short between roof warning buzzer and fuse.

#### 2. CHECK ROOF WARNING BUZZER CIRCUIT

1. Disconnect retractable hard top control unit connector.
2. Check continuity between retractable hard top control unit harness connector and roof warning buzzer harness connector.

Retractable hard top control unit		Roof warning buzzer		Continuity
Connector	Terminal	Connector	Terminal	
B82	35	B87	2	Existed

3. Check continuity between retractable hard top control unit harness connector and ground.

Retractable hard top control unit		Ground	Continuity
Connector	Terminal		
B82	35		Not existed

Is the inspection result normal?

- YES >> GO TO 3.  
 NO >> Repair or replace harness.

#### 3. CHECK ROOF WARNING BUZZER SIGNAL

1. Connect retractable hard top control unit connector and roof warning buzzer connector.
2. Check voltage between retractable hard top control unit harness connector and ground.

Retractable hard top control unit		(-)	Condition	Voltage (V) (Approx.)
(+)				
Connector	Terminal			
B82	35	Ground	Roof warning buzzer (Operate retractable hard top with roof open/close switch)	0
			Sounds Other than above	Battery voltage

Is the inspection result normal?

- YES >> Check intermittent incident. Refer to [GI-43. "Intermittent Incident"](#).  
 NO >> Replace roof warning buzzer. Refer to [RF-15. "Component Parts Location"](#).

# HYDRAULIC PUMP MOTOR POWER SUPPLY RELAY

< DTC/CIRCUIT DIAGNOSIS >

## HYDRAULIC PUMP MOTOR POWER SUPPLY RELAY

### Diagnosis Procedure

INFOID:000000006468928

#### 1. CHECK FUSIBLE LINK

Check 50 A fusible link [letter M, located in the fuse, fusible link and relay box].

Is the fusible link blown?

- YES >> Replace the blown fusible link after repairing the affected circuit if a fusible link is blown.  
 NO >> GO TO 2.

#### 2. CHECK HYDRAULIC UNIT POWER SUPPLY

1. Turn ignition switch OFF.
2. Disconnect hydraulic unit connector.
3. Check the voltage between hydraulic unit harness connector and ground.

(+)		(-)	Voltage (V) (Approx.)
Hydraulic unit			
Connector	Terminal	Ground	Battery voltage
B81	7		

Is the inspection result normal?

- YES >> GO TO 3.  
 NO >> Repair or replace harness.

#### 3. CHECK HYDRAULIC UNIT GROUND CIRCUIT

1. Disconnect retractable hard top control unit connector.
2. Check the continuity between retractable hard top control unit harness connector and hydraulic unit harness connector.

Retractable hard top control unit		Hydraulic unit		Continuity
Connector	Terminal	Connector	Terminal	
B82	38	B80	3	Existed

Is the inspection result normal?

- YES >> GO TO 4.  
 NO >> Repair or replace harness.

#### 4. CHECK RETRACTABLE HARD TOP CONTROL UNIT OUTPUT

1. Connect retractable hard top control unit connector and hydraulic unit connector.
2. Check the voltage between hydraulic unit harness connector and ground.

(+)		(-)	Condition	Voltage (V) (Approx.)
Hydraulic unit				
Connector	Terminal	Ground	Retractable hard top	Operate Stop
B80	18			

Is the inspection result normal?

- YES >> Replace hydraulic unit. Refer to [RF-299, "Removal and Installation"](#)  
 NO >> Replace retractable hard top control unit. Refer to [RF-309, "Removal and Installation"](#)

# RETRACTABLE HARD TOP DOES NOT OPERATE USING DOOR REQUEST SWITCH

< SYMPTOM DIAGNOSIS >

## SYMPTOM DIAGNOSIS

RETRACTABLE HARD TOP DOES NOT OPERATE USING DOOR REQUEST SWITCH

Diagnosis Procedure

INFOID:000000006468929

### 1. CHECK DOOR LOCK FUNCTION

Check door lock function (with door request switch LH/RH).

Does door lock/unlock with with door request switch (LH/RH)?

YES >> GO TO 2.

NO >> Refer to [DLK-213. "ALL DOOR : Diagnosis Procedure"](#).

### 2. CONFIRM THE OPERATION

Confirm the operation again.

Is the result normal?

YES >> Check intermittent incident. Refer to [GI-43. "Intermittent Incident"](#).

NO >> Replace retractable hard top control unit. Refer to [RF-309. "Removal and Installation"](#).

A  
B  
C  
D  
E  
F  
G  
H  
I  
J  
RF  
L  
M  
N  
O  
P

RF

# ROOF WARNING BUZZER DOES NOT SOUND

< SYMPTOM DIAGNOSIS >

---

## ROOF WARNING BUZZER DOES NOT SOUND

### Diagnosis Procedure

INFOID:000000006468930

#### 1.CHECK ROOF WARNING BUZZER

---

Check roof warning buzzer.

Refer to [RF-241, "Diagnosis Procedure"](#).

Is the inspection result normal?

YES >> GO TO 2.

NO >> Repair or replace the malfunctioning parts.

#### 2.CONFIRM THE OPERATION

---

Confirm the operation again.

Is the result normal?

YES >> Check intermittent incident. Refer to [GI-43, "Intermittent Incident"](#).

NO >> Replace retractable hard top control unit. Refer to [RF-309, "Removal and Installation"](#).

# SQUEAK AND RATTLE TROUBLE DIAGNOSES

< SYMPTOM DIAGNOSIS >

## SQUEAK AND RATTLE TROUBLE DIAGNOSES

### Work Flow

INFOID:000000006468931

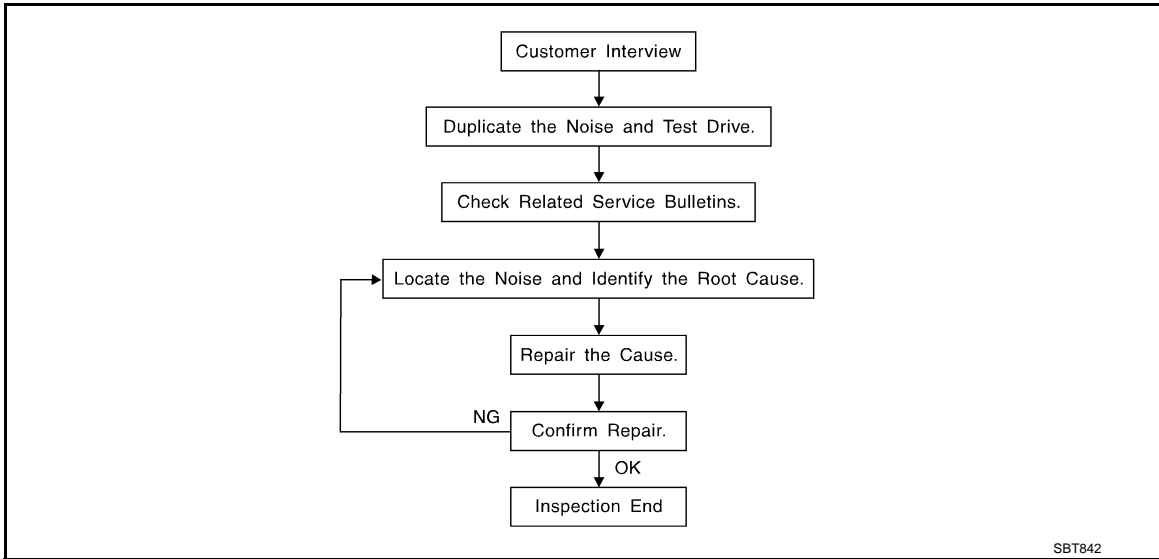

### CUSTOMER INTERVIEW

Interview the customer if possible, to determine the conditions that exist when the noise occurs. Use the Diagnostic Worksheet during the interview to document the facts and conditions when the noise occurs and any of the customer's comments; refer to [RF-249, "Diagnostic Worksheet"](#). This information is necessary to duplicate the conditions that exist when the noise occurs.

- The customer may not be able to provide a detailed description or the location of the noise. Attempt to obtain all the facts and conditions that exist when the noise occurs (or does not occur).
- If there is more than one noise in the vehicle, be sure to diagnose and repair the noise that the customer is concerned about. This can be accomplished by a test drive with the customer.
- After identifying the type of noise, isolate the noise in terms of its characteristics. The noise characteristics are provided so the customer, service adviser and technician are all speaking the same language when defining the noise.
- Squeak – (Like tennis shoes on a clean floor)  
Squeak characteristics include the light contact/fast movement/brought on by road conditions/hard surfaces = higher pitch noise/softer surfaces = lower pitch noises/edge to surface = chirping
- Creak – (Like walking on an old wooden floor)  
Creak characteristics include firm contact/slow movement/twisting with a rotational movement/pitch dependent on materials/often brought on by activity.
- Rattle – (Like shaking a baby rattle)  
Rattle characteristics include the fast repeated contact/vibration or similar movement/loose parts/missing clip or fastener/incorrect clearance.
- Knock – (Like a knock on a door)  
Knock characteristics include hollow sounding/sometimes repeating/often brought on by driver action.
- Tick – (Like a clock second hand)  
Tick characteristics include gentle contacting of light materials/loose components/can be caused by driver action or road conditions.
- Thump – (Heavy, muffled knock noise)  
Thump characteristics include softer knock/dead sound often brought on by activity.
- Buzz – (Like a bumble bee)  
Buzz characteristics include high frequency rattle/firm contact.
- Often the degree of acceptable noise level will vary depending upon the person. A noise that a technician may judge as acceptable may be very irritating to the customer.
- Weather conditions, especially humidity and temperature, may have a great effect on noise level.

### DUPLICATE THE NOISE AND TEST DRIVE

If possible, drive the vehicle with the customer until the noise is duplicated. Note any additional information on the Diagnostic Worksheet regarding the conditions or location of the noise. This information can be used to duplicate the same conditions when the repair is reconfirmed.

# SQUEAK AND RATTLE TROUBLE DIAGNOSES

## < SYMPTOM DIAGNOSIS >

If the noise can be duplicated easily during the test drive, to help identify the source of the noise, try to duplicate the noise with the vehicle stopped by doing one or all of the following:

- 1) Close a door.
  - 2) Tap or push/pull around the area where the noise appears to be coming from.
  - 3) Rev the engine.
  - 4) Use a floor jack to recreate vehicle "twist".
  - 5) At idle, apply engine load (electrical load, half-clutch on M/T model, drive position on A/T model).
  - 6) Raise the vehicle on a hoist and hit a tire with a rubber hammer.
- Drive the vehicle and attempt to duplicate the conditions the customer states exist when the noise occurs.
  - If it is difficult to duplicate the noise, drive the vehicle slowly on an undulating or rough road to stress the vehicle body.

## LOCATE THE NOISE AND IDENTIFY THE ROOT CAUSE

1. Narrow down the noise to a general area. To help pinpoint the source of the noise, use a listening tool (Engine Ear or mechanics stethoscope).
2. Narrow down the noise to a more specific area and identify the cause of the noise by:
  - Removing the components in the area that is are suspected to be the cause of the noise.  
Do not use too much force when removing clips and fasteners, otherwise clips and fastener can be broken or lost during the repair, resulting in the creation of new noise.
  - Tapping or pushing/pulling the component that is are suspected to be the cause of the noise.  
Do not tap or push/pull the component with excessive force, otherwise the noise will be eliminated only temporarily.
  - Feeling for a vibration by hand by touching the component(s) that is are suspected to be the cause of the noise.
  - Placing a piece of paper between components that is are suspected to be the cause of the noise.
  - Looking for loose components and contact marks.  
Refer to [RF-247. "Inspection Procedure"](#).

## REPAIR THE CAUSE

- If the cause is a loose component, tighten the component securely.
- If the cause is insufficient clearance between components:
  - Separate components by repositioning or loosening and retightening the component, if possible.
  - Insulate components with a suitable insulator such as urethane pads, foam blocks, felt cloth tape or urethane tape. These insulators are available through the authorized Nissan Parts Department.

### **CAUTION:**

**Never use excessive force as many components are constructed of plastic and may be damaged.**

### **NOTE:**

- URETHANE PADS  
Insulates connectors, harness, etc.
- INSULATOR (Foam blocks)  
Insulates components from contact. Can be used to fill space behind a panel.
- INSULATOR (Light foam block)
- FELT CLOTHTAPE  
Used to insulate where movement does not occur. Ideal for instrument panel applications.  
The following materials, not available through NISSAN Parts Department, can also be used to repair squeaks and rattles.
- UHMW(TEFLON) TAPE  
Insulates where slight movement is present. Ideal for instrument panel applications.
- SILICONE GREASE  
Used in place of UHMW tape that is be visible or does not fit.  
Note: Will only last a few months.
- SILICONE SPRAY  
Used when grease cannot be applied.
- DUCT TAPE  
Used to eliminate movement.

## CONFIRM THE REPAIR

Confirm that the cause of a noise is repaired by test driving the vehicle. Operate the vehicle under the same conditions as when the noise originally occurred. Refer to the notes on the Diagnostic Worksheet.

# SQUEAK AND RATTLE TROUBLE DIAGNOSES

## < SYMPTOM DIAGNOSIS >

### Inspection Procedure

INFOID:000000006468932

Refer to Table of Contents for specific component removal and installation information.

#### INSTRUMENT PANEL

Most incidents are caused by contact and movement between:

1. Cluster lid A and instrument panel
2. Acrylic lens and combination meter housing
3. Instrument panel to front pillar garnish
4. Instrument panel to windshield
5. Instrument panel mounting pins
6. Wiring harnesses behind the combination meter
7. A/C defroster duct and duct joint

These incidents can usually be located by tapping or moving the components to duplicate the noise or by pressing on the components while driving to stop the noise. Most of these incidents can be repaired by applying felt cloth tape or silicon spray (in hard to reach areas). Urethane pads can be used to insulate wiring harness.

#### **CAUTION:**

**Never use silicone spray to isolate a squeak or rattle. If the area is saturated with silicone, the recheck of repair becomes impossible.**

#### CENTER CONSOLE

Components to pay attention to include:

1. Shifter assembly cover to finisher
2. A/C control unit and cluster lid C
3. Wiring harnesses behind audio and A/C control unit

The instrument panel repair and isolation procedures also apply to the center console.

#### DOORS

Pay attention to the following:

1. Finisher and inner panel making a slapping noise
2. Inside handle escutcheon to door finisher
3. Wiring harnesses tapping
4. Door striker out of alignment causing a popping noise on starts and stops

Tapping or moving the components or pressing on them while driving to duplicate the conditions can isolate many of these incidents. The areas can usually be insulated with felt cloth tape or insulator foam blocks to repair the noise.

#### TRUNK

Trunk noises are often caused by a loose jack or loose items put into the trunk by the customer.

In addition look for the following:

1. Trunk lid dumpers out of adjustment
2. Trunk lid striker out of adjustment
3. Trunk lid torsion bars knocking together
4. A loose license plate or bracket

Most of these incidents can be repaired by adjusting, securing or insulating the item(s) or component(s) causing the noise.

#### SUNROOF/HEADLINING

Noises in the sunroof/headlining area can often be traced to one of the following:

1. Sunroof lid, rail, linkage or seals making a rattle or light knocking noise
2. Sunvisor shaft shaking in the holder
3. Front or rear windshield touching headlining and squeaking

Again, pressing on the components to stop the noise while duplicating the conditions can isolate most of these incidents. Repairs usually consist of insulating with felt cloth tape.

A  
B  
C  
D  
E  
F  
G  
H  
I  
J  
L  
M  
N  
O  
P

RF

# SQUEAK AND RATTLE TROUBLE DIAGNOSES

## < SYMPTOM DIAGNOSIS >

---

### SEATS

When isolating seat noise it is important to note the position the seat is in and the load placed on the seat when the noise occurs. These conditions should be duplicated when verifying and isolating the cause of the noise.

Cause of seat noise include:

1. Headrest rods and holder
2. A squeak between the seat pad cushion and frame
3. Rear seatback lock and bracket

These noises can be isolated by moving or pressing on the suspected components while duplicating the conditions under which the noise occurs. Most of these incidents can be repaired by repositioning the component or applying urethane tape to the contact area.

### UNDERHOOD

Some interior noise may be caused by components under the hood or on the engine wall. The noise is then transmitted into the passenger compartment.

Causes of transmitted underhood noise include:

1. Any component mounted to the engine wall
2. Components that pass through the engine wall
3. Engine wall mounts and connectors
4. Loose radiator mounting pins
5. Hood bumpers out of adjustment
6. Hood striker out of adjustment

These noises can be difficult to isolate since they cannot be reached from the interior of the vehicle. The best method is to secure, move or insulate one component at a time and test drive the vehicle. Also, engine RPM or load can be changed to isolate the noise. Repairs can usually be made by moving, adjusting, securing, or insulating the component causing the noise.



# SQUEAK AND RATTLE TROUBLE DIAGNOSES

< SYMPTOM DIAGNOSIS >

## Diagnostic Worksheet

INFOID:000000006468933



### SQUEAK & RATTLE DIAGNOSTIC WORKSHEET

Dear Infiniti Customer:

We are concerned about your satisfaction with your Infiniti vehicle. Repairing a squeak or rattle sometimes can be very difficult. To help us fix your Infiniti right the first time, please take a moment to note the area of the vehicle where the squeak or rattle occurs and under what conditions. You may be asked to take a test drive with a service consultant or technician to ensure we confirm the noise you are hearing.

#### I. WHERE DOES THE NOISE COME FROM? (circle the area of the vehicle)

The illustrations are for reference only, and may not reflect the actual configuration of your vehicle.

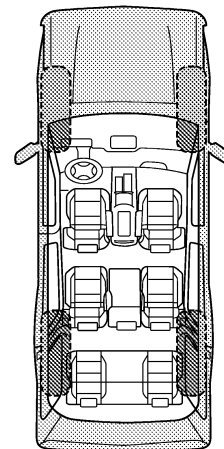
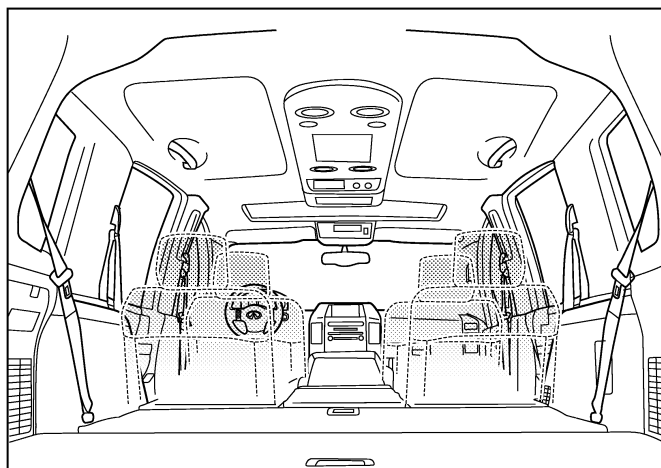
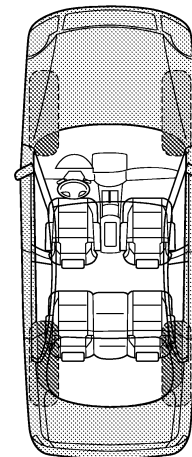
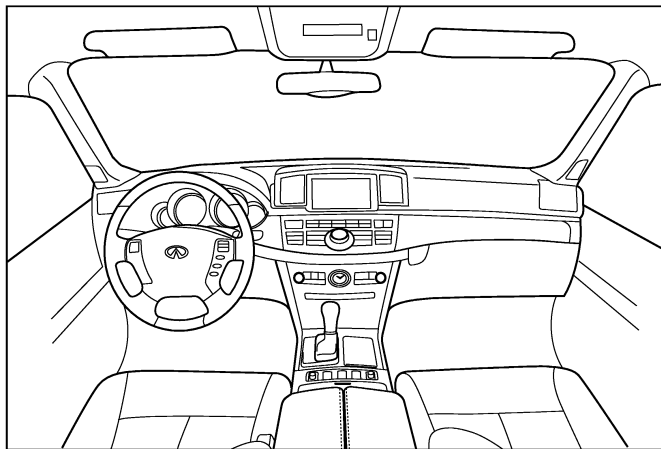

Continue to page 2 of the worksheet and briefly describe the location of the noise or rattle. In addition, please indicate the conditions which are present when the noise occurs.

PIIB8741E

A  
B  
C  
D  
E  
F  
G  
H  
I  
J  
RF  
L  
M  
N  
O  
P

# SQUEAK AND RATTLE TROUBLE DIAGNOSES

< SYMPTOM DIAGNOSIS >

## SQUEAK & RATTLE DIAGNOSTIC WORKSHEET - page 2

Briefly describe the location where the noise occurs:

---

---

### II. WHEN DOES IT OCCUR? (please check the boxes that apply)

- |   |  |
|---|--|
| <input type="checkbox"/> anytime                      | <input type="checkbox"/> after sitting out in the rain |
| <input type="checkbox"/> 1st time in the morning      | <input type="checkbox"/> when it is raining or wet     |
| <input type="checkbox"/> only when it is cold outside | <input type="checkbox"/> dry or dusty conditions       |
| <input type="checkbox"/> only when it is hot outside  | <input type="checkbox"/> other:                        |

### III. WHEN DRIVING:

- through driveways
- over rough roads
- over speed bumps
- only about \_\_\_\_ mph
- on acceleration
- coming to a stop
- on turns: left, right or either (circle)
- with passengers or cargo
- other: \_\_\_\_\_
- after driving \_\_\_\_ miles or \_\_\_\_ minutes

### IV. WHAT TYPE OF NOISE

- squeak (like tennis shoes on a clean floor)
- creak (like walking on an old wooden floor)
- rattle (like shaking a baby rattle)
- knock (like a knock at the door)
- tick (like a clock second hand)
- thump (heavy, muffled knock noise)
- buzz (like a bumble bee)

## TO BE COMPLETED BY DEALERSHIP PERSONNEL

### Test Drive Notes:

---

---

---

	YES	NO	Initials of person performing
Vehicle test driven with customer	<input type="checkbox"/>	<input type="checkbox"/>	_____
- Noise verified on test drive	<input type="checkbox"/>	<input type="checkbox"/>	_____
- Noise source located and repaired	<input type="checkbox"/>	<input type="checkbox"/>	_____
- Follow up test drive performed to confirm repair	<input type="checkbox"/>	<input type="checkbox"/>	_____

VIN: \_\_\_\_\_ Customer Name: \_\_\_\_\_  
W.O.# \_\_\_\_\_ Date: \_\_\_\_\_

This form must be attached to Work Order

PIIB8742E

# WATER LEAKAGE TROUBLE DIAGNOSIS

< PERIODIC MAINTENANCE >

## PERIODIC MAINTENANCE

### WATER LEAKAGE TROUBLE DIAGNOSIS

#### Repairing Method for Water Leakage Around Retractable Hard Top

INFOID:000000006468934

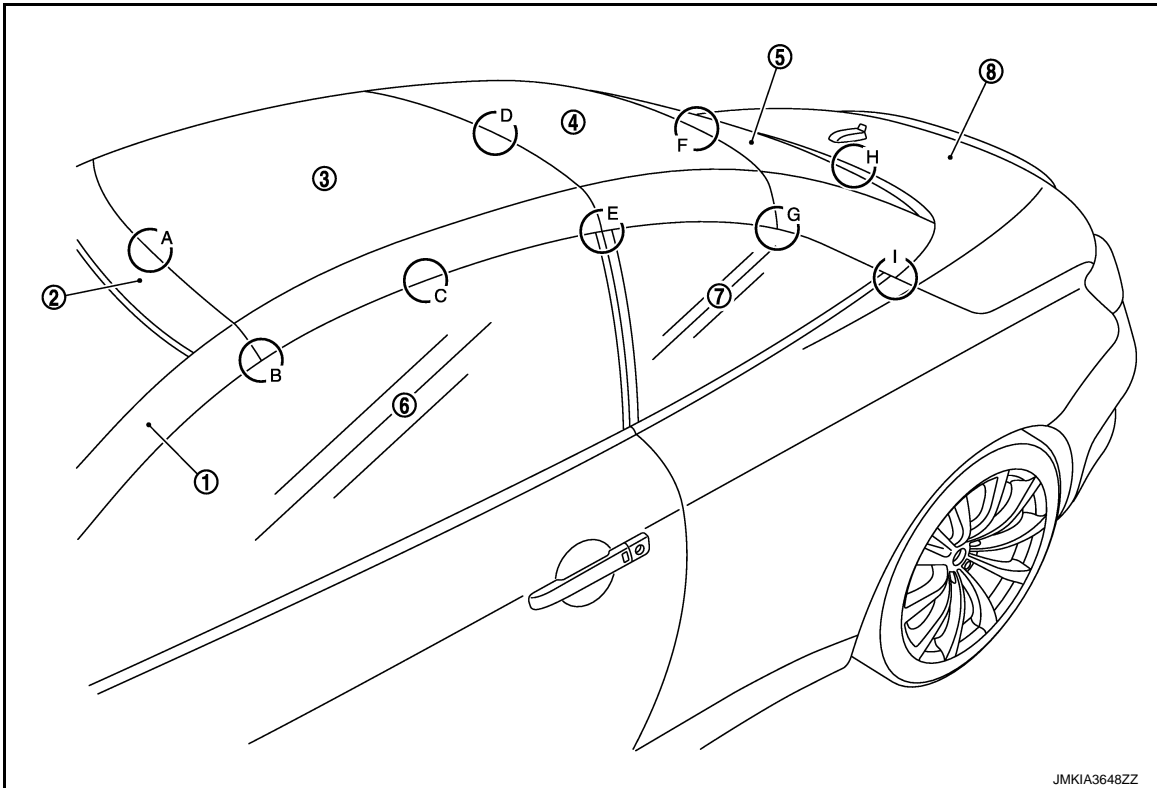

- |                               |                             |                              |
|-------------------------------|-----------------------------|------------------------------|
| 1. Front pillar               | 2. Front roof               | 3. Front roof panel assembly |
| 4. Center roof panel assembly | 5. Rear roof panel assembly | 6. Front door glass          |
| 7. Quarter window glass       | 8. Trunk lid assembly       |                              |

#### WATER LEAKAGE FROM A

The cause of water leakage may be from poor contact between the front roof and the body side weather-strip.  
Cause: There may be incorrect adjustment between the front roof and the body side weather-strip.

##### Repair Procedure 1

Check that front roof and the front roof panel are flush and adjust if necessary.

Refer to [RF-274, "Adjustment"](#).

Check and adjust the gap between the front roof and the front roof panel if necessary.

Refer to [RF-274, "Adjustment"](#).

#### WATER LEAKAGE FROM B

The cause of water leakage may be from poor contact between the front pillar upper portion and body side weather-strip.

# WATER LEAKAGE TROUBLE DIAGNOSIS

## < PERIODIC MAINTENANCE >

Cause: Double-sided tape (2) and EPT seal (3) on body side weather-strip (1) backside does not securely contact front pillar upper portion (4).

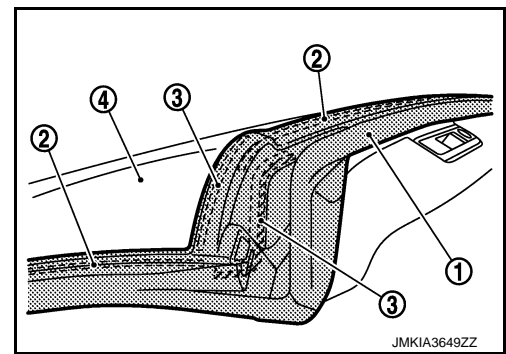

### Repair procedure 2

- Fill the clearance with butyl if clearance is detected between front roof panel and weather-strip. Replace the part if water leakage is still detected.
- Replace body side weather-strip with new one and check that double-sided tape and EPT seal securely contacts front pillar upper portion and front roof.

The cause of water leakage may be from inefficiency of water evacuation.

Cause: The body side weather-strip (1) drain hole (A) is plugged.

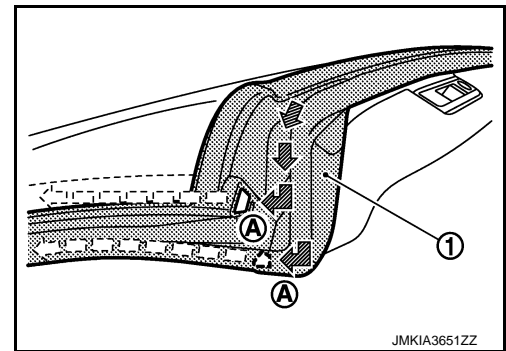

### Repair Procedure 3

Cleanse the drain holes of body side weather-strip.

Unplug the drain hole (A) on both sides of front body side weather-strip.

## WATER LEAKAGE FROM C

The cause of water leakage may be from poor contact between the door glass (1) and front roof panel weather-strip (2) in vertical direction.

Cause: The power window cannot apply enough vertical pressure to the front roof panel weather-strip via the door glass.

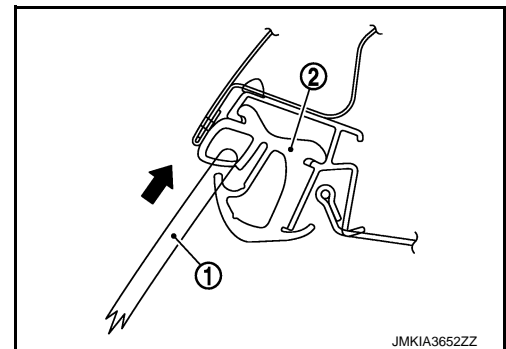

The cause of water leakage may be from poor contact between the door glass (1) and front roof panel weather-strip in (2) lateral direction.

Cause: The power window cannot apply enough lateral pressure to the front roof panel weather-strip via the door glass.

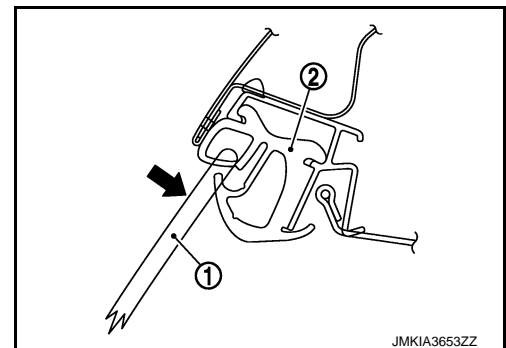

### Repair Procedure 4

Adjust the door glass and quarter window glass. Refer to [GW-18. "Inspection and Adjustment"](#).

# WATER LEAKAGE TROUBLE DIAGNOSIS

## < PERIODIC MAINTENANCE >

### WATER LEAKAGE FROM D

The cause of water leakage may be from poor contact between front roof panel and center roof panel.  
Cause: There may be incorrect adjustment between front roof panel and center roof panel.

#### Repair Procedure 5

Check and adjust the flatness deviation between the front roof panel and the center roof panel if necessary.

Refer to [RF-279, "Adjustment"](#).

Check and adjust the gap between the front roof panel and the center roof panel if necessary.

Refer to [RF-279, "Adjustment"](#).

The cause of water leakage may be from poor contact or gap between the front roof panel and center roof panel weather-strip top.

Cause: Double-sided tape (2), EPT seal (3) and butyl (5) on center roof panel weather-strip (1) backside does not securely contact center roof panel (4).

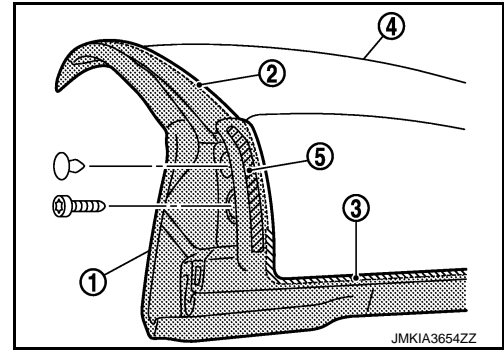

#### Repair Procedure 6

- Fill the clearance with butyl if clearance is detected between center roof panel and weather-strip. Replace the part if water leakage is still detected.
- Replace center roof panel weather-strip with new one and check that double-sided tape and EPT seal securely contacts center roof panel.

The cause of water leakage may be from inefficiency of water evacuation.

Cause: The center roof panel weather-strip front (1) drains holes (A) are plugged.

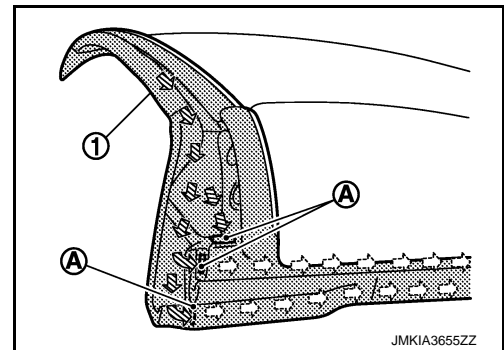

#### Repair Procedure 7

Cleanse the drain holes of center roof panel weather-strip front.

Unplug the drain holes (A) (A) on both sides of center roof panel weather-strip front.

### WATER LEAKAGE FROM E

The cause of water leakage may be between the top edges of door glass and quarter window glasses.

Cause: The flatness between door glass and quarter window glasses is incorrect.

#### Repair Procedure 8

Check the flatness between the door glass and quarter window glass using a thin plastic card. The resistance must be same at each point.

- If the flatness is incorrect.
  - Adjust the door glass and quarter window glass. Refer to [GW-18, "Inspection and Adjustment"](#).

### WATER LEAKAGE FROM F

The cause of water leakage may be from poor contact between the center roof panel and the rear roof panel.

Cause: There may be incorrect adjustment between the center roof panel and the rear roof panel.

#### Repair Procedure 9

Check that center roof panel and the rear roof panel are flush and adjust if necessary.

Refer to [RF-283, "Adjustment"](#).

# WATER LEAKAGE TROUBLE DIAGNOSIS

## < PERIODIC MAINTENANCE >

### WATER LEAKAGE FROM G

The cause of water leakage may be from poor contact or gap between the center roof panel weather-strip and rear roof panel.

Cause: Double-sided tape (2) and EPT seal (3) on center roof panel weather-strip (1) back side does not securely contact center roof panel (4).

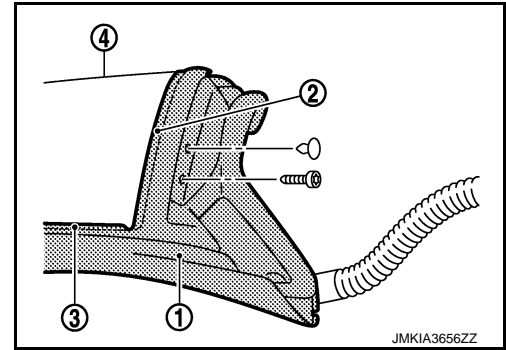

#### Repair Procedure 10

- Fill the clearance with butyl if clearance is detected between rear roof panel and weather-strip. Replace the part if water leakage is still detected.
- Replace center roof panel weather-strip with new one and check that double-sided tape and EPT seal securely contacts center roof panel.

The cause of water leakage may be from inefficiency of water evacuation.

Cause: Center roof panel weather-strip (1) drain holes (A) are plugged.

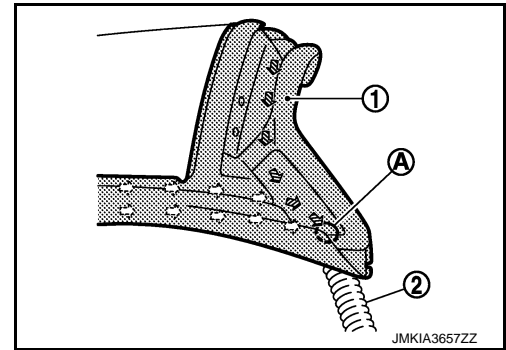

#### Repair Procedure 11

Cleanse the drain holes of center roof panel weather-strip.

Unplug the drain holes (A) on both sides of center roof panel weather-strip rear.

- Check the connection between the center roof panel weather-strip and drain tube.

#### Repair Procedure 12

Align the connection claw position of drain tube (1) and insert.

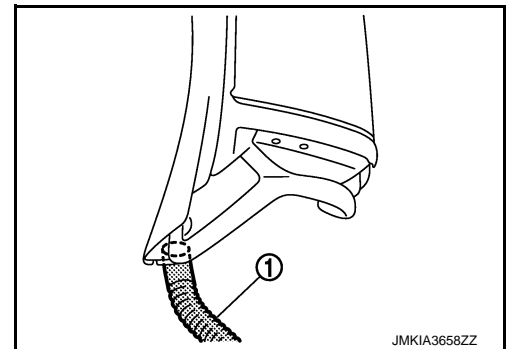

# WATER LEAKAGE TROUBLE DIAGNOSIS

## < PERIODIC MAINTENANCE >

The cause of water leakage may be from poor contact between the quarter window glass (1) and center roof panel weather-strip (2) in vertical direction.

Cause: The power window cannot apply enough vertical pressure to the center roof panel weather-strip via the quarter window glass.

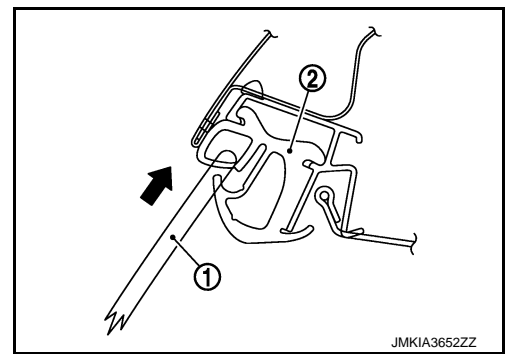

The cause of water leakage may be from poor contact between the quarter window glass (1) and center roof panel weather-strip in (2) lateral direction.

Cause: The power window cannot apply enough lateral pressure to the center roof panel weather-strip via the quarter window glass.

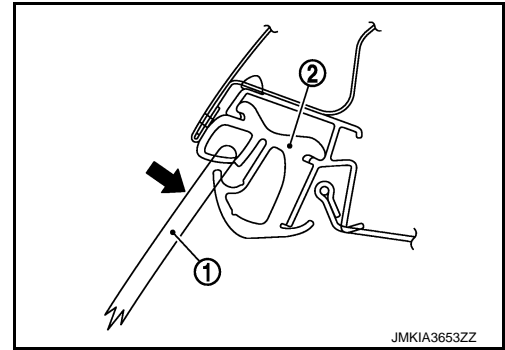

### Repair Procedure 13

Adjust the door glass quarter window glass. Refer to [GW-18, "Inspection and Adjustment"](#).

## WATER LEAKAGE FROM H

If water leakage occurs from front area of trunk lid to trunk room inside, the cause of water leakage may be from poor contact between the rear roof panel and the trunk lid panel.

Cause: There may be incorrect adjustment between the rear roof panel and the trunk lid panel.

### Repair Procedure 14

Check and adjust the contact deviation between the rear roof panel and the trunk lid panel if necessary. Refer to [RF-283, "Adjustment"](#).

## WATER LEAKAGE FROM I

The cause of water leakage may be from inefficiency of water evacuation.

Cause: The body side weather-strip (1) drains holes (A) are plugged.

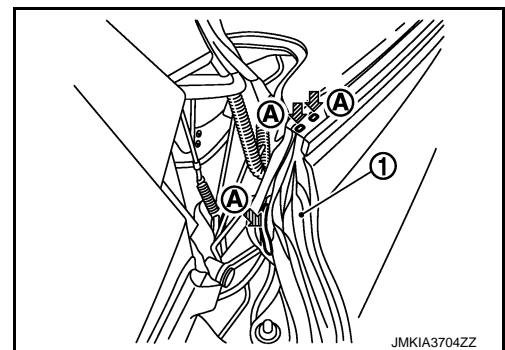

### Repair Procedure 15

Cleanse the drain holes of the body side weather-strip.  
Unplug the drain holes (A) on both sides of the body side weather-strip.

## Water Leakage Test

INFOID:000000006468935

- Visually check for water leakage after repairing.
- If complaint or claim for water leakage come from owner although hose test goes well, shower test is needed.

### NOTE:

It is considered normal if level of water flow on center pillar upper end is kept at a level that water flows along with passenger room side glass.

A  
B  
C  
D  
E  
F  
G  
H  
I  
J  
L  
M  
N  
O  
P

RF

# WATER LEAKAGE TROUBLE DIAGNOSIS

## < PERIODIC MAINTENANCE >

### HOW TO CHECK BY HOSE

1. 2 workers are required. One worker checks inside the vehicle, and the other one washes with water.
2. Use 13 mm (0.51 in) diameter hose (A). Adjust water pressure by following method.

Hold the hose horizontally, and release water at 1000 mm (39.37 in) height from ground. Adjust the distance, between the ground point just below the hose and the water dropping point, to reach 700 mm (27.56 in). (See the figure.)

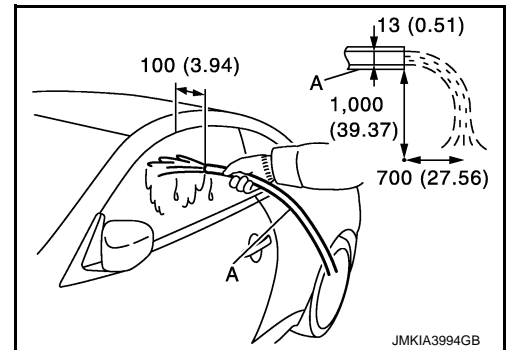

3. Keeping the distance between the hose and the testing area by 100 mm (3.94 in), apply water along the area 3 times. During applying water, move the hose by 100 mm (3.94 in)/sec speed.
4. Visually check for water leakage.

### HOW TO CHECK BY SHOWER

1. Adjust water flow as the same as hose test.
2. Shower by hose with shower head (A) keeping distance about 700 mm (27.56 in) far from vehicle.
3. Keep showering 30min against each weather-strip which might cause water leakage.

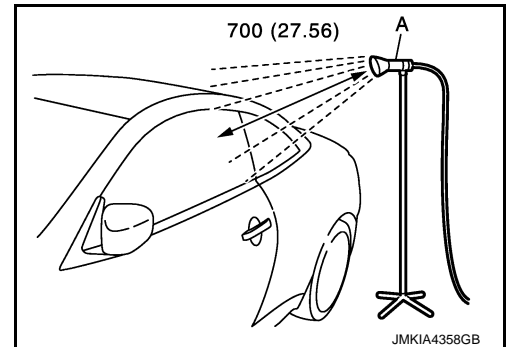

4. Visually check for water leakage.



# FRONT LATCH ASSEMBLY

< REMOVAL AND INSTALLATION >

## REMOVAL AND INSTALLATION

### FRONT LATCH ASSEMBLY

Exploded View

INFOID:000000006468936

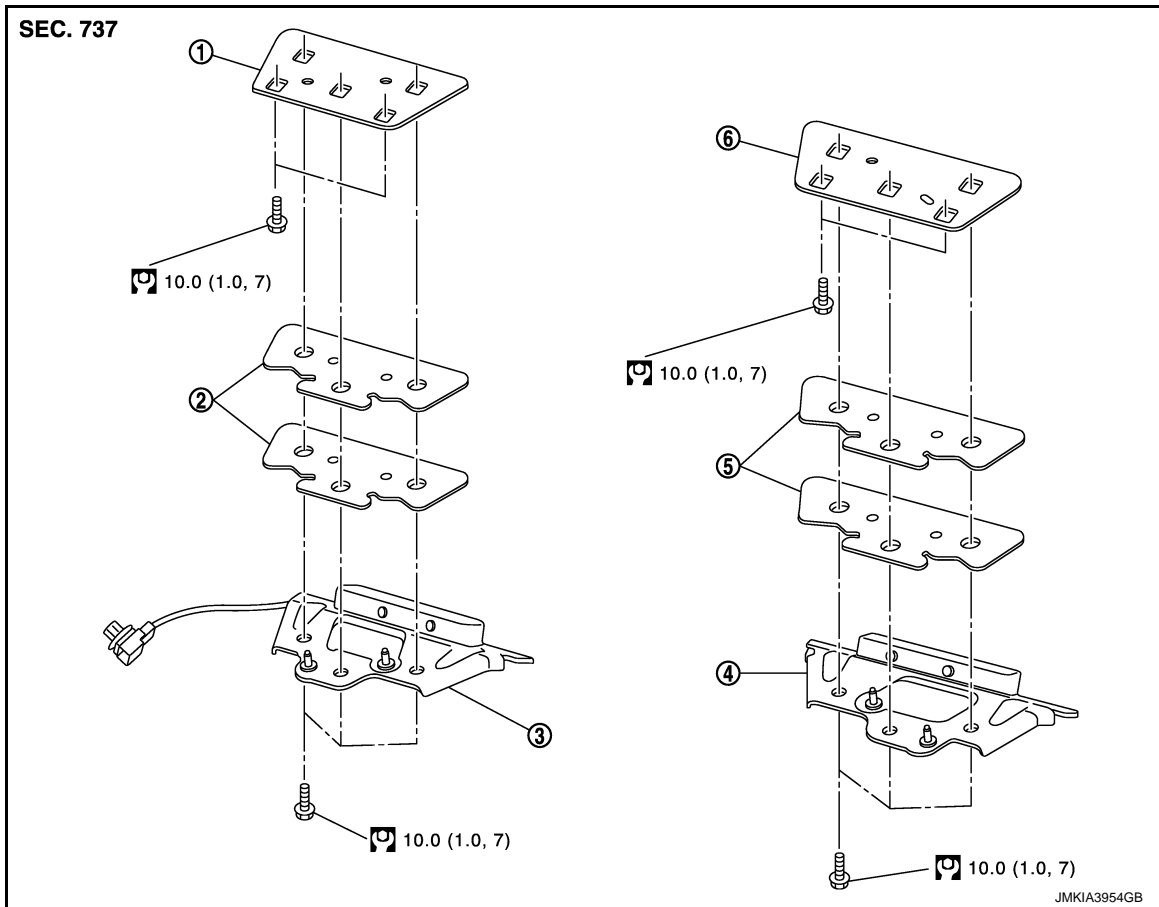

- |                            |            |                            |
|----------------------------|------------|----------------------------|
| 1. Latch plate RH          | 2. Shim RH | 3. Front latch assembly RH |
| 4. Front latch assembly LH | 5. Shim LH | 6. Latch plate LH          |

Refer to [GI-4, "Components"](#) for symbols in the figure.

### Removal and Installation

INFOID:000000006468937

#### REMOVAL

1. Remove roof front finisher. Refer to [RF-260, "Removal and Installation"](#).
2. Disconnect roof latch limit switch harness connector.
3. Remove mounting bolts, and then remove front latch assembly.

**CAUTION:**

- Never loosen mounting bolts (A).
- Never remove latch plate (LH/RH) (1).

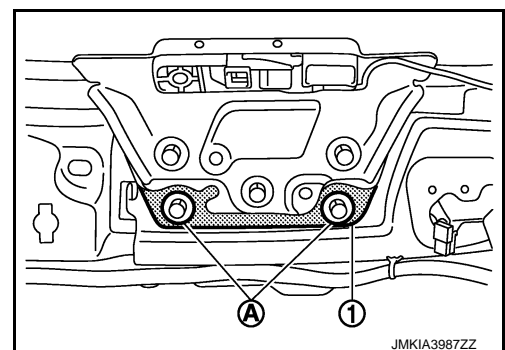

JMKIA3987ZZ

## FRONT LATCH ASSEMBLY

< REMOVAL AND INSTALLATION >

---

### INSTALLATION

Install in the reverse order of removal.

**NOTE:**

- Perform initialization according to the work after installing front latch assembly. Refer to [RF-88, "Description"](#).
- Adjust door glass and quarter window glass. Refer to [GW-18, "Inspection and Adjustment"](#).
- Perform water leakage test. Refer to [RF-255, "Water Leakage Test"](#).

# HEADLINING

< REMOVAL AND INSTALLATION >

## HEADLINING

Exploded View

INFOID:000000006468938

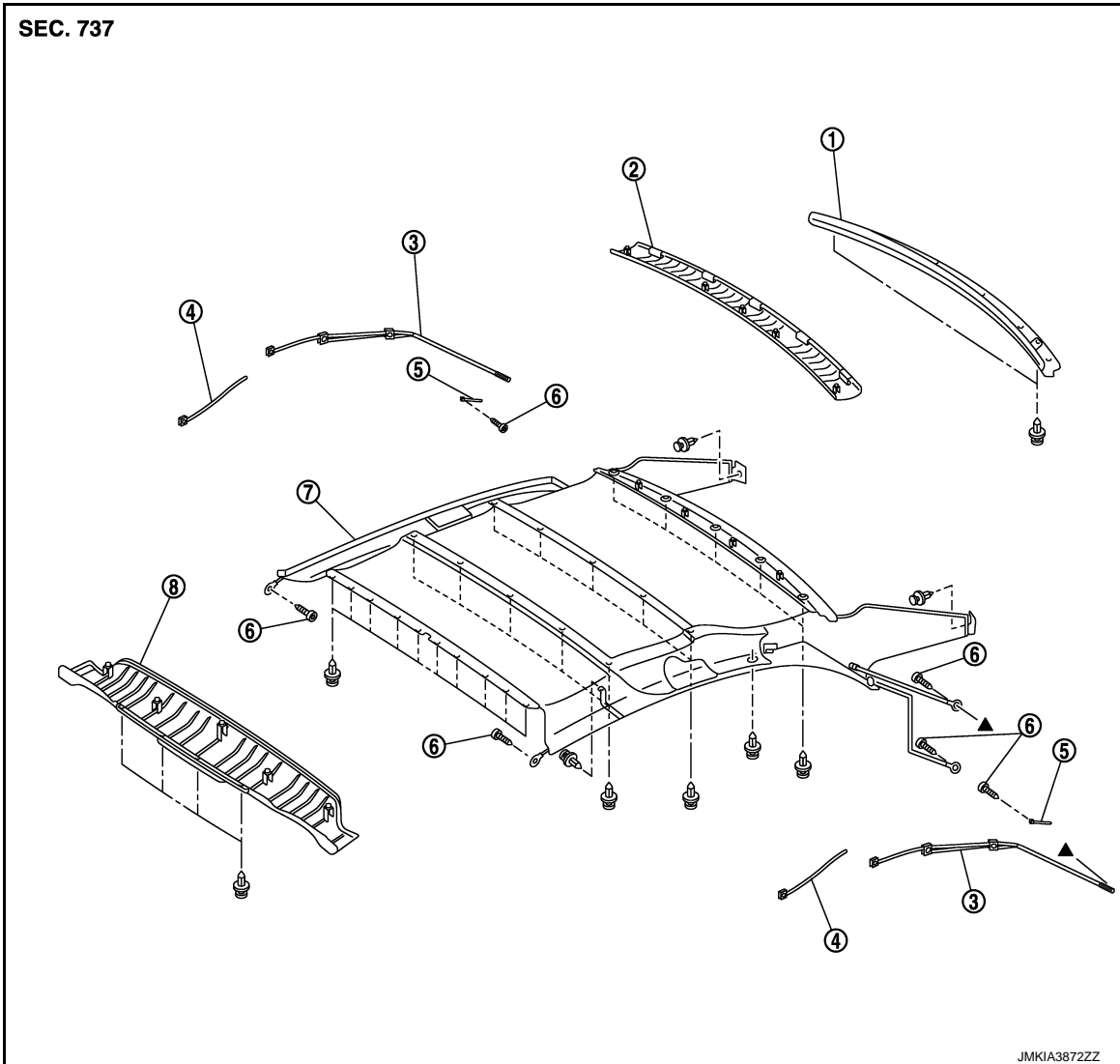

- |                            |                            |                     |
|----------------------------|----------------------------|---------------------|
| 1. Rear roof lower garnish | 2. Rear roof upper garnish | 3. Main tether cord |
| 4. Tension cord            | 5. Guide                   | 6. TORX screw       |
| 7. Headlining              | 8. Front roof garnish      |                     |

CORD

A  
B  
C  
D  
E  
F  
G  
H  
I  
J  
RF  
L  
M  
N  
O  
P

# HEADLINING

## < REMOVAL AND INSTALLATION >

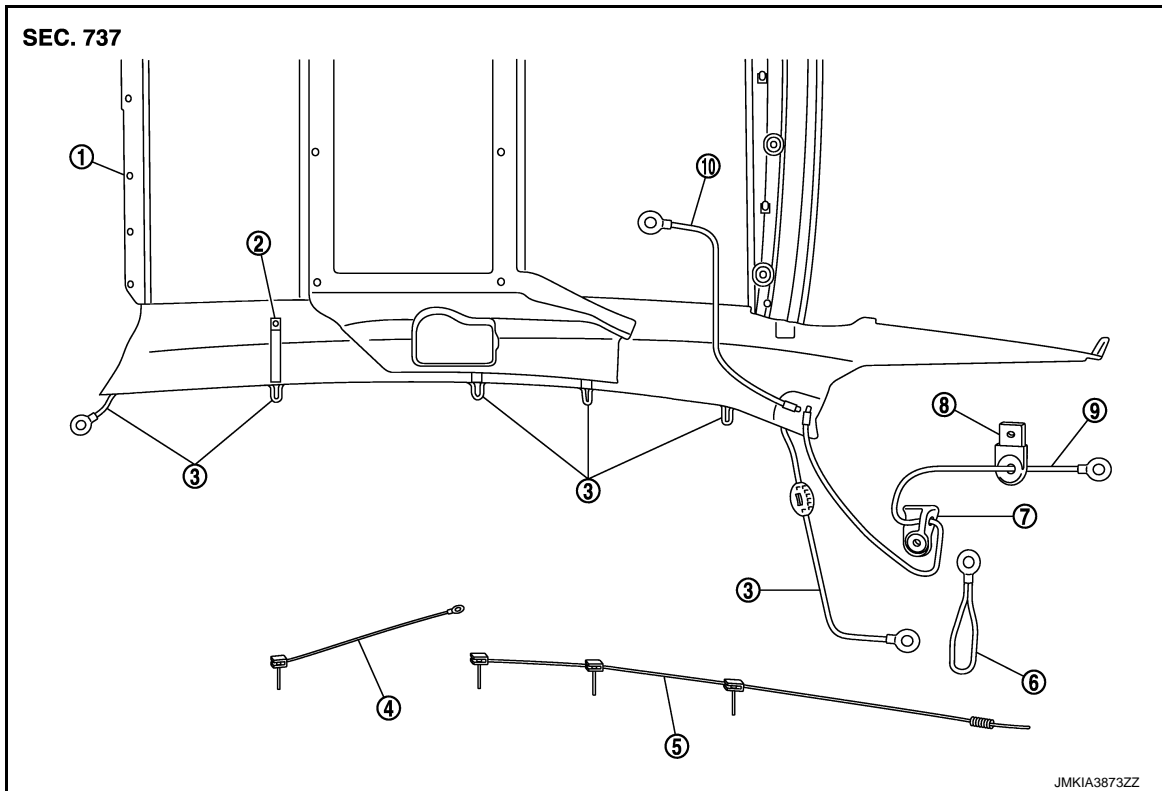

- |                 |                     |                |
|-----------------|---------------------|----------------|
| 1. Headlining   | 2. Rubber strap     | 3. Main cord   |
| 4. Tension cord | 5. Main tether cord | 6. Guide       |
| 7. Deflector A  | 8. Deflector B      | 9. C-post cord |
| 10. Rubber cord |                     |                |

## Removal and Installation

INFOID:000000006468939

### REMOVAL

#### **CAUTION:**

**Protect the rear fender with a fender protector.**

#### **NOTE:**

- Operate roof manually if it does not operate electrically. Refer to [RF-312, "Manual Operation"](#).
- All graphics are on the LH roof link side.

1. Stop roof as shown in the figure (during open operation).

#### **CAUTION:**

**Be careful of the roof and rear parcel shelf unit positions when operating, because roof may drop little by little and may interfere with rear parcel shelf unit when roof is in the middle position for a long period of time.**

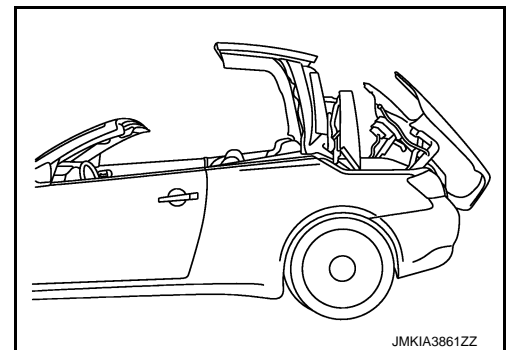

# HEADLINING

## < REMOVAL AND INSTALLATION >

2. Remove clips and metal clips, and then remove front roof garnish (1).

 : Metal clip

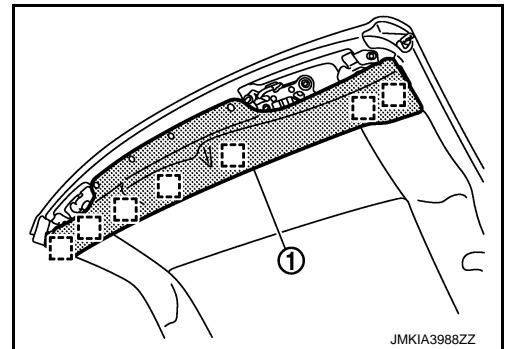

3. Remove headlining and main cord mounting TORX screw (LH/RH) (A) from front roof panel front side.

 : Vehicle front

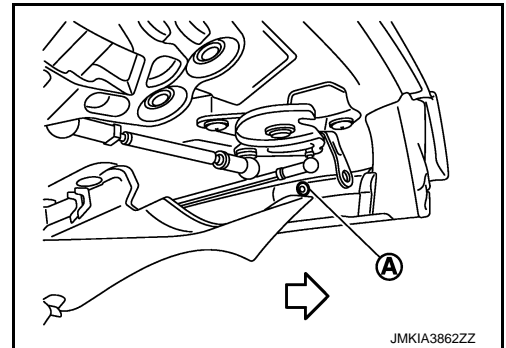

4. Remove front side clips of front roof panel.
5. Remove clip (LH/RH) (A), and then rubber strap (1) from front roof panel.

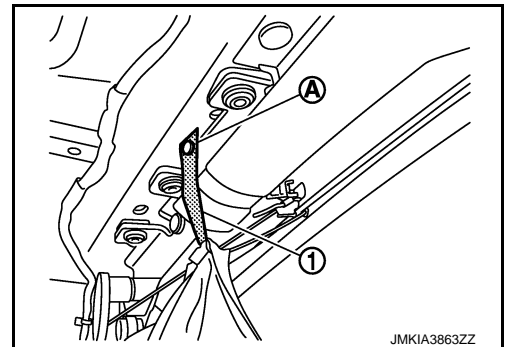

6. Remove rear side clips of front roof panel.
7. Remove TORX screw (A), and then tension cord (1) and rubber cord (2) through clearance between front roof panel and center roof panel.

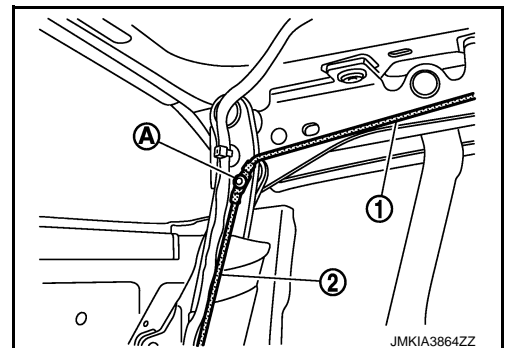

8. Remove tension cord from front roof panel support rail.
9. Remove front side clips and intermediate clips of center roof panel.
10. Remove main tether cord stopper from center roof panel support rail. (3spot)
11. Remove deflector B mounting TORX screws.

# HEADLINING

## < REMOVAL AND INSTALLATION >

12. Remove retainer from center roof panel.

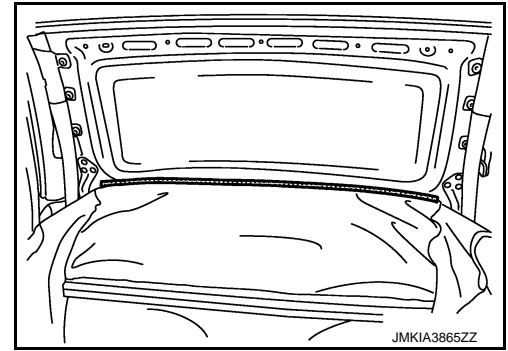

13. Remove rear side clips of center roof panel.

14. Remove metal clips, and then remove headlining from center roof panel.

 : Metal clip

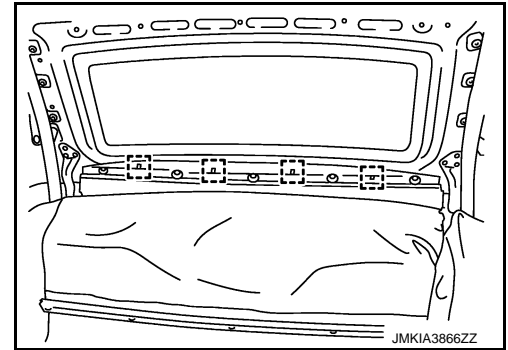

15. Remove clips and metal clips, and then remove rear roof lower garnish.

 : Metal clip

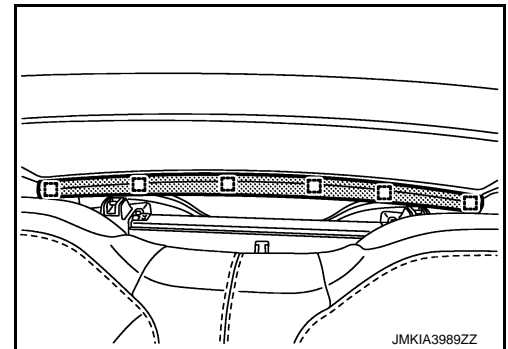

16. Remove clip (LH/RH) (A), and then remove headlining from rear roof panel.

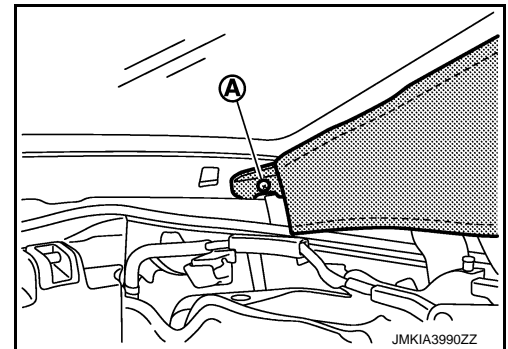

17. Remove main cord (1), main tether cord (2), and C-post cord (3) mounting TORX screws (A) from roof link.

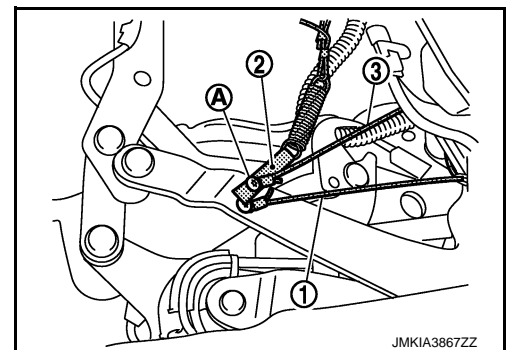

# HEADLINING

## < REMOVAL AND INSTALLATION >

18. Stop roof as shown in the figure (roof is closed and trunk is open).

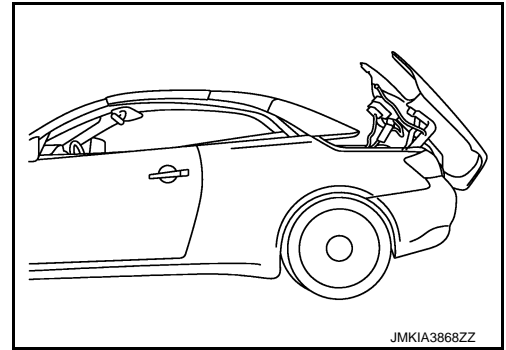

19. Remove deflector A (1) and guide (2) mounting TORX screws (A) from roof link.

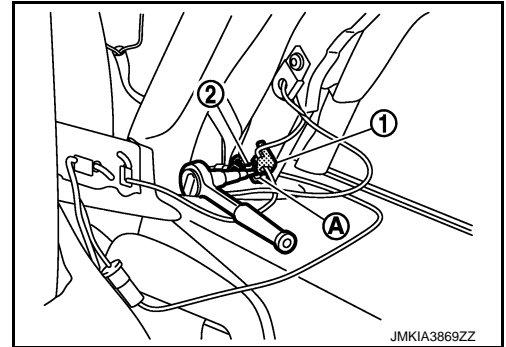

20. Remove the headlining from vehicle.

21. Remove metal clips, and then remove rear roof upper garnish (1).

 : Metal clip

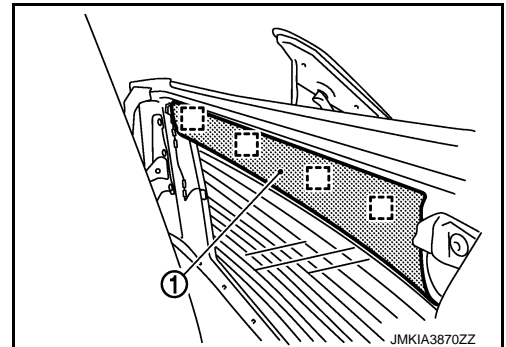

## INSTALLATION

### CAUTION:

Use TORX screws that is larger by a size when re-installing headlining.

### NOTE:

All graphics are on the LH roof link side.

1. Stop roof as shown in the figure (in the middle of open operation).

### CAUTION:

Be careful of the roof and rear parcel shelf unit positions when operating, because roof may drop little by little and may interfere with rear parcel shelf unit when roof is in the middle position for a long period of time.

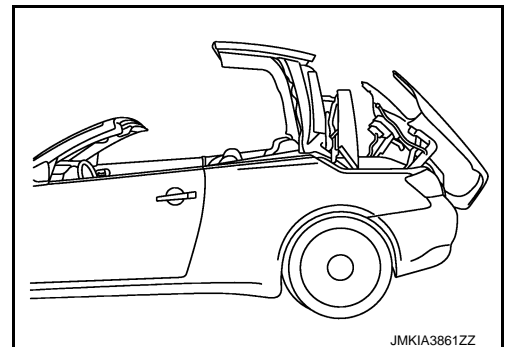

2. Install rear roof upper garnish.

# HEADLINING

## < REMOVAL AND INSTALLATION >

3. Install headlining metal clips and clips to center roof panel rear side.

 : Metal clip

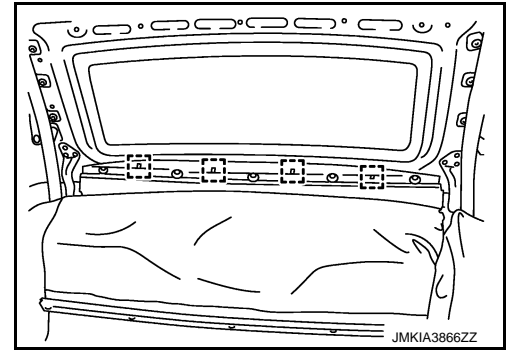

4. Install headlining retainer to center roof panel.

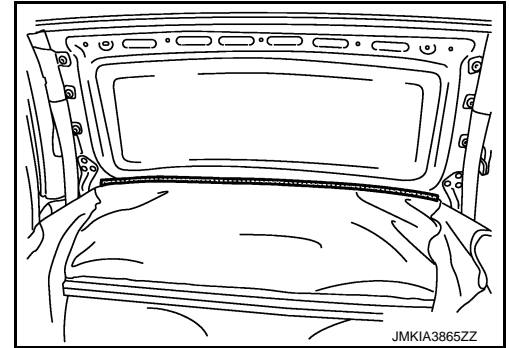

5. Install intermediate clips (A) to center roof panel.  
Fix back side of flap portion (1) of headlining cloth using clips
6. Install front side clips (B) to center roof panel.

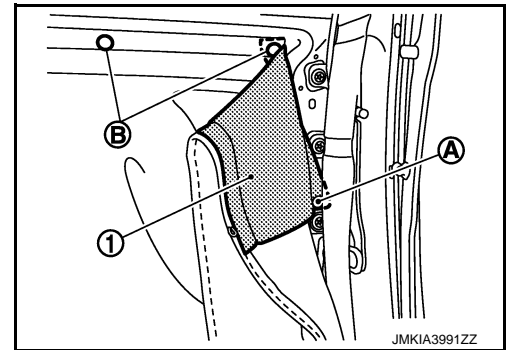

7. Install front side and rear side clips to front roof panel.
8. Install rubber strap (1) using clip (LH/RH) (A).

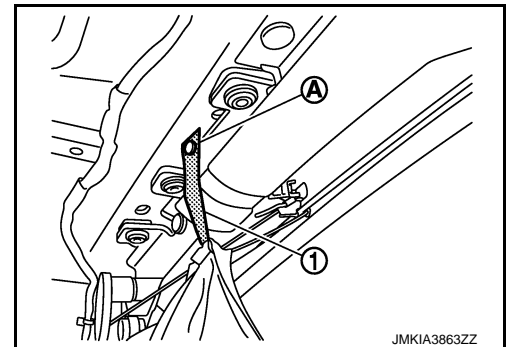



# HEADLINING

## < REMOVAL AND INSTALLATION >

9. Install headlining and main cord mounting TORX screw (LH/RH) (A) to front roof panel front side.

← : Vehicle front

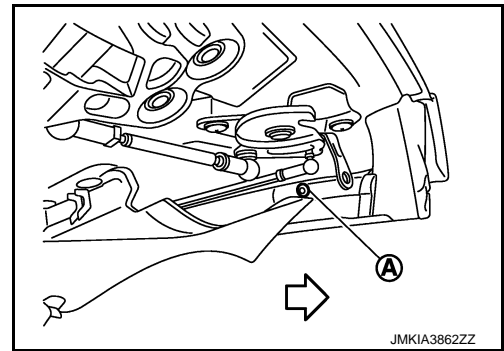

10. As shown in the figure, pass tension code (1) through front roof panel support rail (2) and main code (4) of headlining (3), and then hook tension code crimping portion (5) to stopper groove. Hook stopper (6) claws to roof panel support rail and engage stopper to front roof panel support rail.

← : Vehicle front

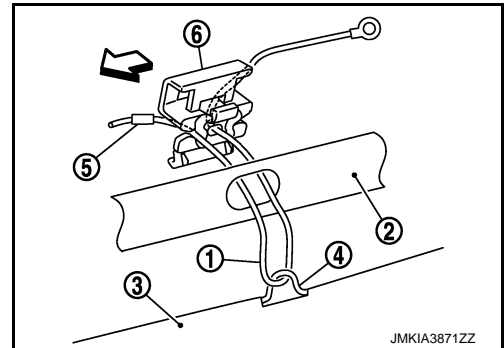

11. Pass rubber code (1) through clearance between roof link and center roof panel (2), and then pass it through trim sleeve (3).
12. Install tension code (4) and rubber code (1) together using TORX screws.

### CAUTION:

Be careful not to allow rubber code (1) to pass upper side of rear side trim (5).

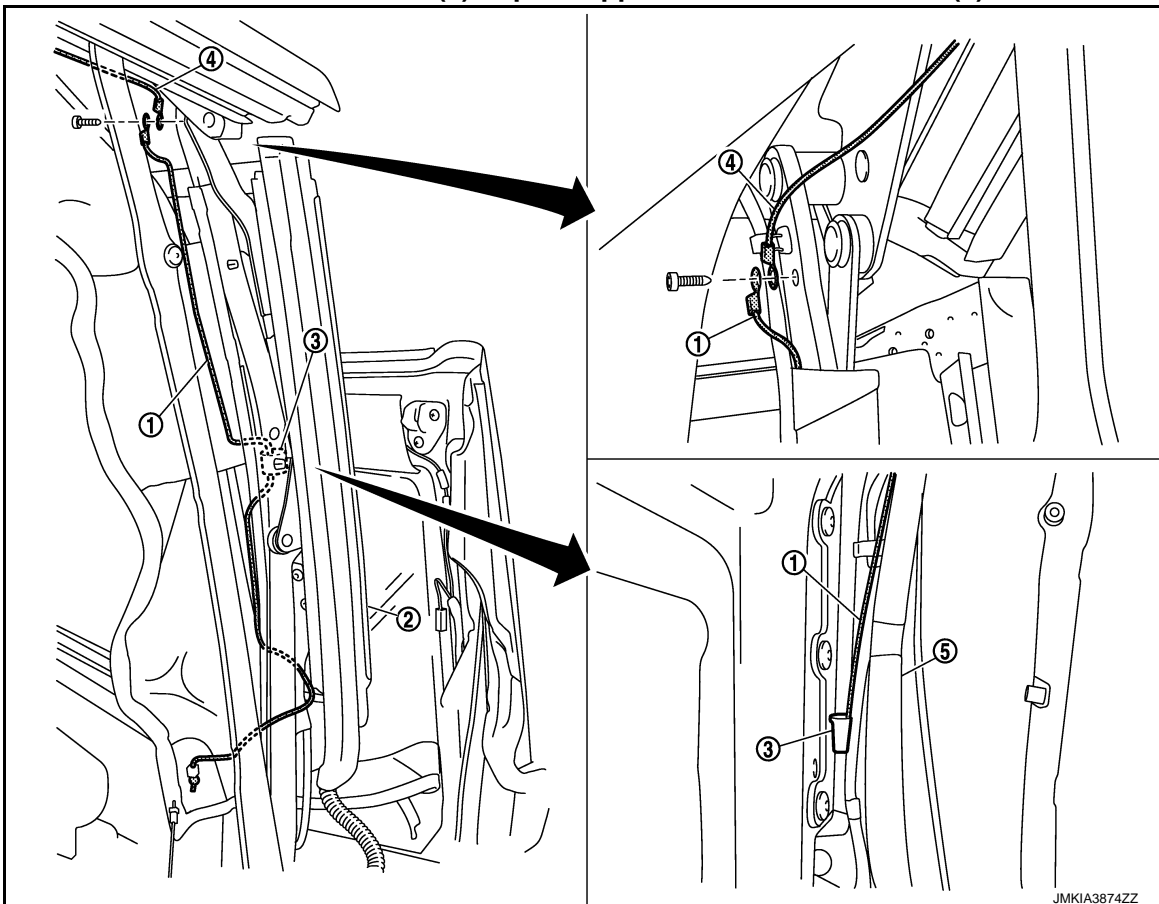

← : Vehicle front

A  
B  
C  
D  
E  
F  
G  
H  
I  
J  
RF  
L  
M  
N  
O  
P

# HEADLINING

## < REMOVAL AND INSTALLATION >

13. As shown in the figure, pass main tether code (1) through center roof panel support rail (2) and main code (4) of headlining (3), and then hook tension code crimping portion (5) to stopper groove. Hook stopper (6) claws to roof panel support rail and engage stopper to center roof panel support rail. (3 spot)

← : Vehicle front

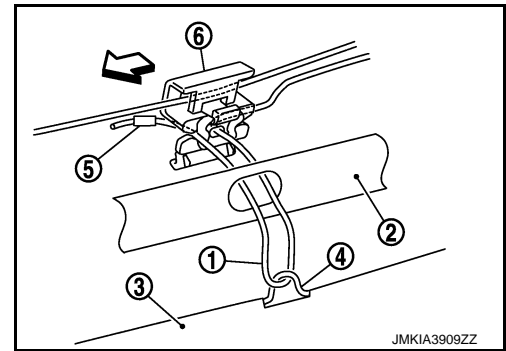

14. Pull strongly main tether code.

15. As shown in the figure, set main code (1), pass it through guide (2), and fix to rear and lower side of roof link using TORX screws (A).

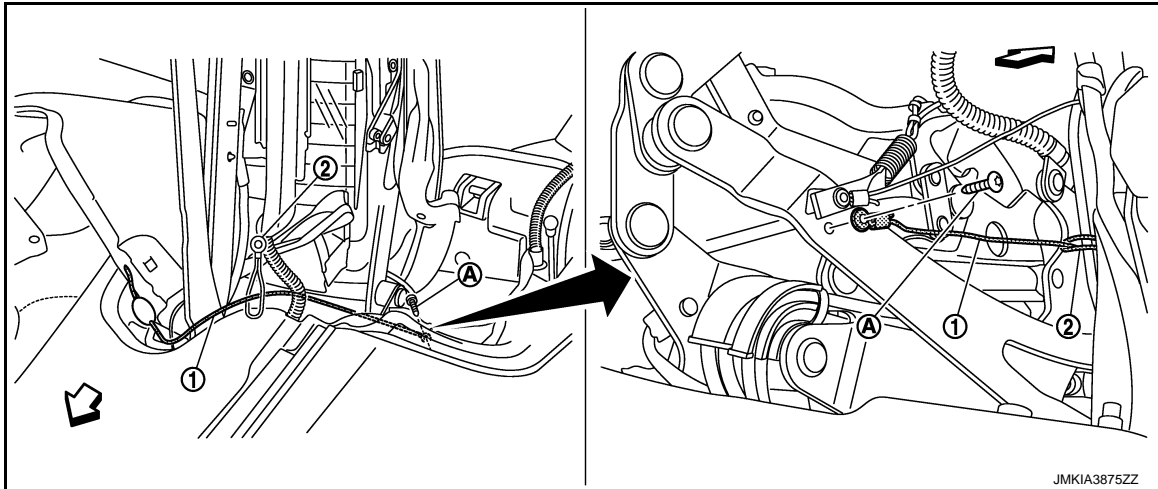

← : Vehicle front

16. As shown in the figure, set C-post code (2) and install deflector B (7) to roof link using TORX screws.

**CAUTION:**

**Pass C-post cord (2) to deflector B (1) from inner side to outer side and fix to roof link assembly (3).**

# HEADLINING

## < REMOVAL AND INSTALLATION >

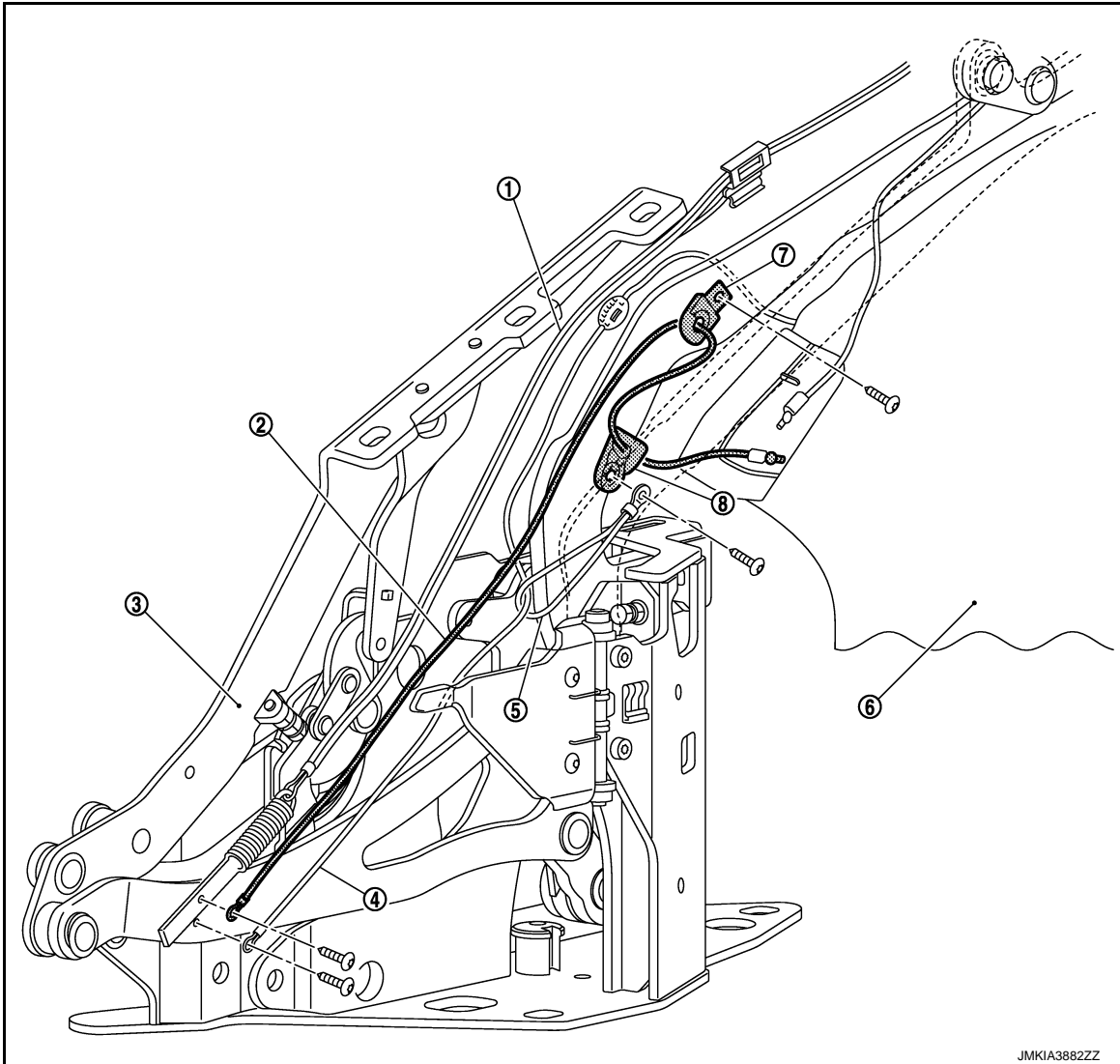

- |                     |                |                          |
|---------------------|----------------|--------------------------|
| 1. Main tether cord | 2. C-post cord | 3. Roof link assembly LH |
| 4. Main cord        | 5. Guide       | 6. Headlining            |
| 7. Deflector B      | 8. Deflector A |                          |

17. Hang main tether code and C-post code to trunk side.
18. Stop roof as shown in the figure (roof is closed and trunk is open).

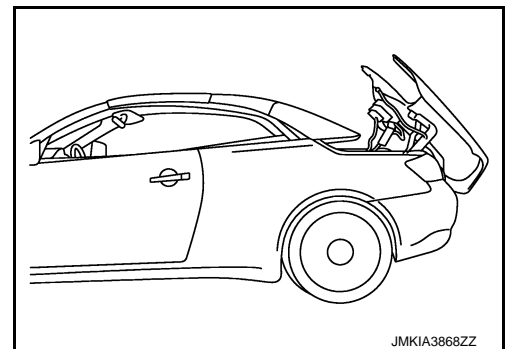

A  
B  
C  
D  
E  
F  
G  
H  
I  
J  
RF  
L  
M  
N  
O  
P

## HEADLINING

### < REMOVAL AND INSTALLATION >

19. From passenger room side, fix guide (2) and deflector A (1) together using TORX screws (A).

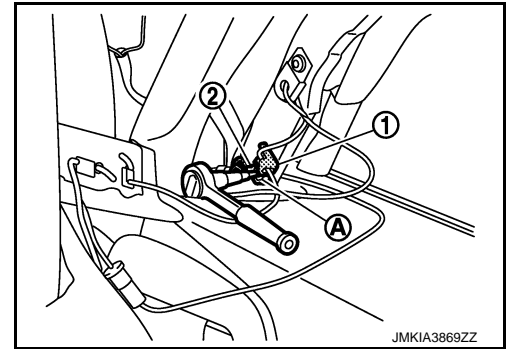

20. Install rear end of headlining to rear roof panel using clip (LH/RH) (A).

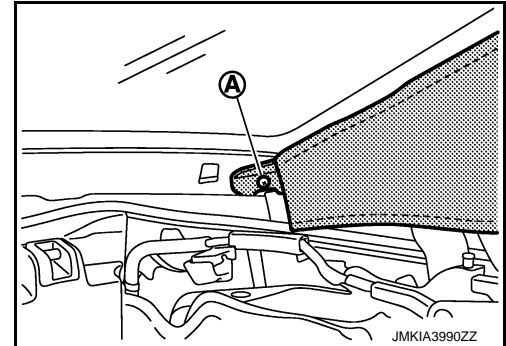

21. Install rear roof lower garnish.  
22. Stop roof as shown in the figure (in the middle of roof open operation).

**CAUTION:**

**Be careful of the roof and rear parcel shelf unit positions when operating, because roof may drop little by little and may interfere with rear parcel shelf unit when roof is in the middle position for a long period of time.**

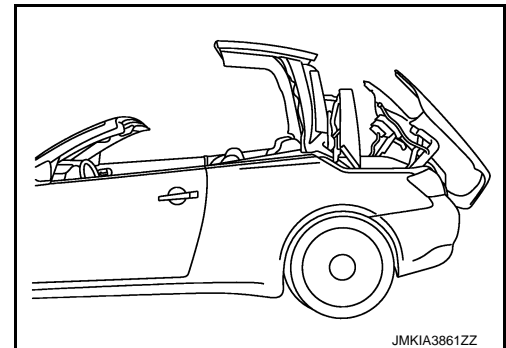

23. Pull main tether code and C-post code and fix to roof link together using TORX screws.  
24. Install front roof garnish.  
25. Fully close roof.

# ROOF LOCK ASSEMBLY

< REMOVAL AND INSTALLATION >

## ROOF LOCK ASSEMBLY

## ROOF LOCK ASSEMBLY

## ROOF LOCK ASSEMBLY : Exploded View

INFOID:000000006468940

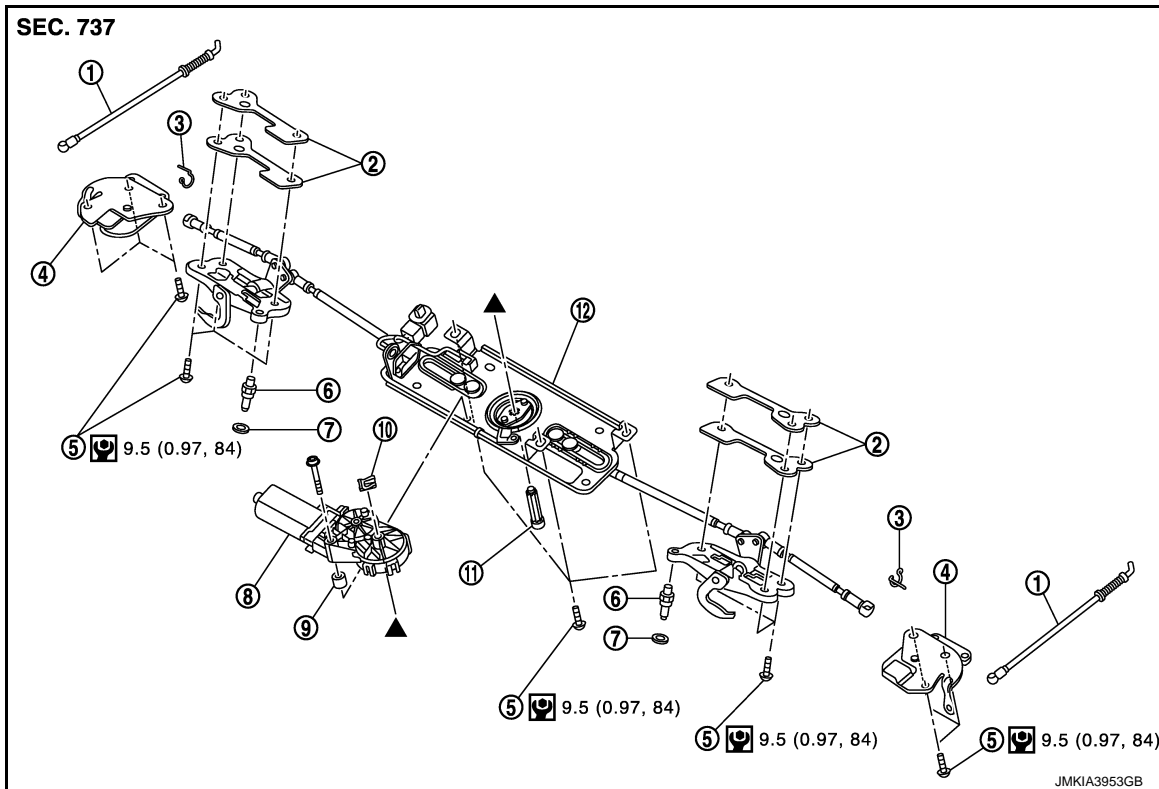

- |                     |                            |                        |
|---------------------|----------------------------|------------------------|
| 1. Rod              | 2. Shim                    | 3. Snap pin            |
| 4. Plate            | 5. TORX bolt               | 6. Centering pin       |
| 7. O-ring           | 8. Roof latch motor        | 9. Spacer              |
| 10. Retaining plate | 11. Roof latch motor shaft | 12. Roof lock assembly |

Refer to [GI-4, "Components"](#) for symbols in the figure.

## ROOF LOCK ASSEMBLY : Removal and Installation

INFOID:000000006468941

### REMOVAL

#### CAUTION:

Protect the rear fender with a fender protector.

#### NOTE:

Operate roof manually if it does not operate electrically. Refer to [RF-312, "Manual Operation"](#).

1. Stop roof as shown in the figure (during open operation).

#### CAUTION:

Be careful of the roof and rear parcel shelf unit positions when operating, because roof may drop little by little and may interfere with rear parcel shelf unit when roof is in the middle position for a long period of time.

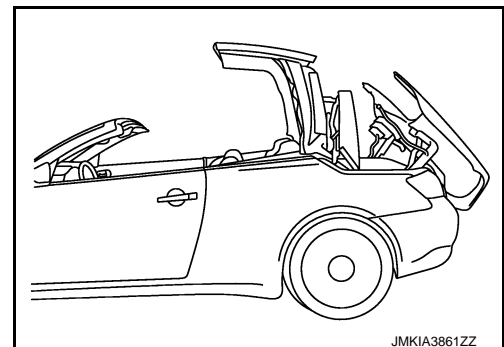

2. Remove front roof garnish. Refer to [RF-260, "Removal and Installation"](#).

# ROOF LOCK ASSEMBLY

## < REMOVAL AND INSTALLATION >

3. Remove headlining and main cord mounting TORX screw (LH/RH) (A) from front roof panel front side.

← :Vehicle front

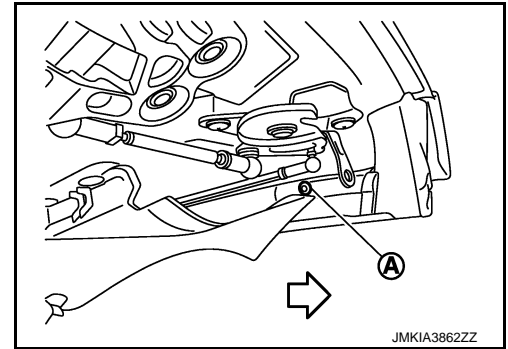

4. Pull ball joint side downward and remove rod.
5. Remove snap pin (1), and then remove roof lock assembly load from plate.

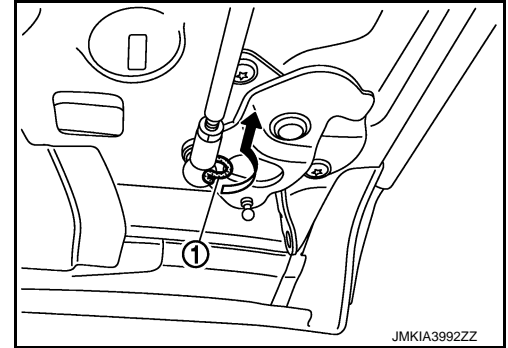

6. Remove mounting bolts, and then remove plate.
7. Remove mounting bolts, and then remove roof lock assembly and shims.

## INSTALLATION

Install in the reverse order of removal.

### NOTE:

- Perform initialization according to the work after installing roof lock assembly. Refer to [RF-88. "Description"](#).
- Adjust door glass and quarter window glass. Refer to [GW-18. "Inspection and Adjustment"](#).
- Perform water leakage test. Refer to [RF-255. "Water Leakage Test"](#).

## ROOF LATCH MOTOR

# ROOF LOCK ASSEMBLY

< REMOVAL AND INSTALLATION >

## ROOF LATCH MOTOR : Exploded View

INFOID:000000006468942

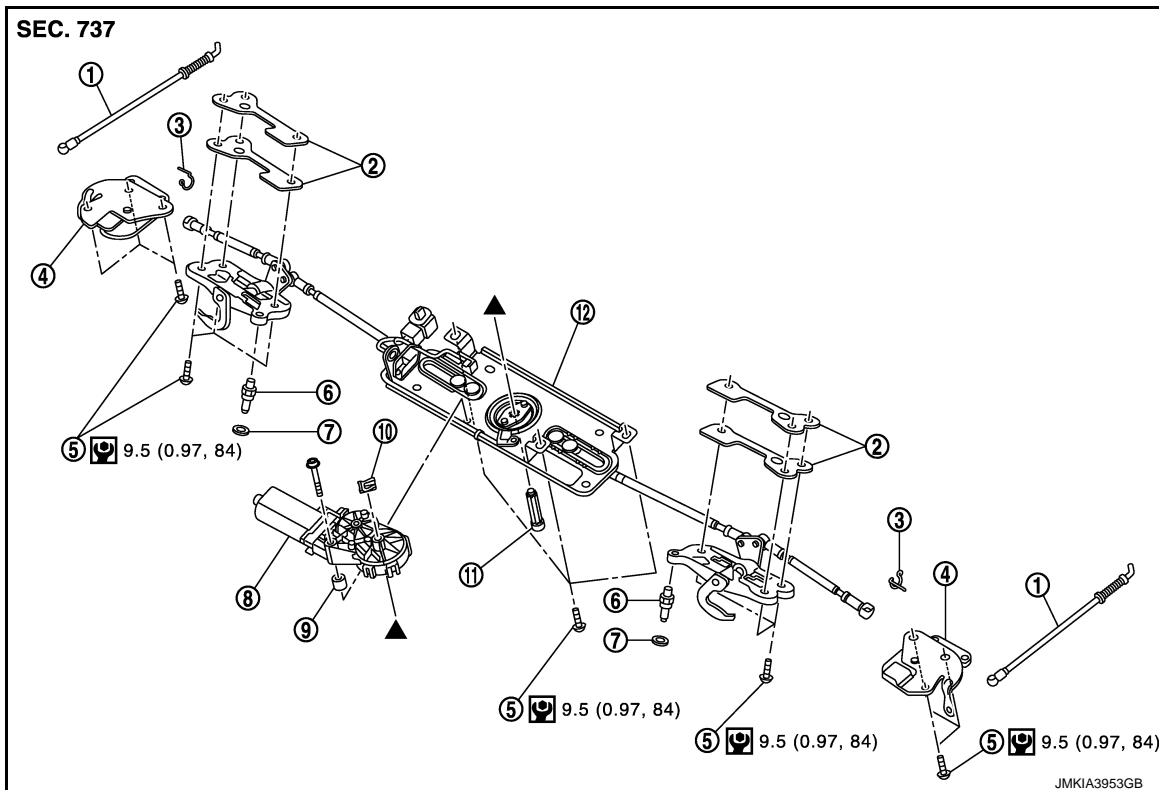

- |                     |                            |                        |
|---------------------|----------------------------|------------------------|
| 1. Rod              | 2. Shim                    | 3. Snap pin            |
| 4. Plate            | 5. TORX bolt               | 6. Centering pin       |
| 7. O-ring           | 8. Roof latch motor        | 9. Spacer              |
| 10. Retaining plate | 11. Roof latch motor shaft | 12. Roof lock assembly |

Refer to [GI-4. "Components"](#) for symbols in the figure.

## ROOF LATCH MOTOR : Removal and Installation

INFOID:000000006468943

### REMOVAL

#### CAUTION:

Protect the rear fender with a fender protector.

#### NOTE:

Operate roof manually if it does not operate electrically. Refer to [RF-312. "Manual Operation"](#).

1. Remove roof lock assembly. Refer to [RF-269. "ROOF LOCK ASSEMBLY : Removal and Installation"](#).
2. Remove retaining plate, and then remove roof latch motor shaft.
3. Disconnect roof latch motor harness connector.
4. Remove mounting bolt, and then remove roof latch motor.

### INSTALLATION

Install in the reverse order of removal.

#### NOTE:

- Perform initialization according to the work after installing roof latch motor. Refer to [RF-88. "Description"](#).
- Adjust door glass and quarter window glass. Refer to [GW-18. "Inspection and Adjustment"](#).
- Perform water leakage test. Refer to [RF-255. "Water Leakage Test"](#).

# FRONT ROOF PANEL

< REMOVAL AND INSTALLATION >

## FRONT ROOF PANEL

Exploded View

INFOID:000000006468944

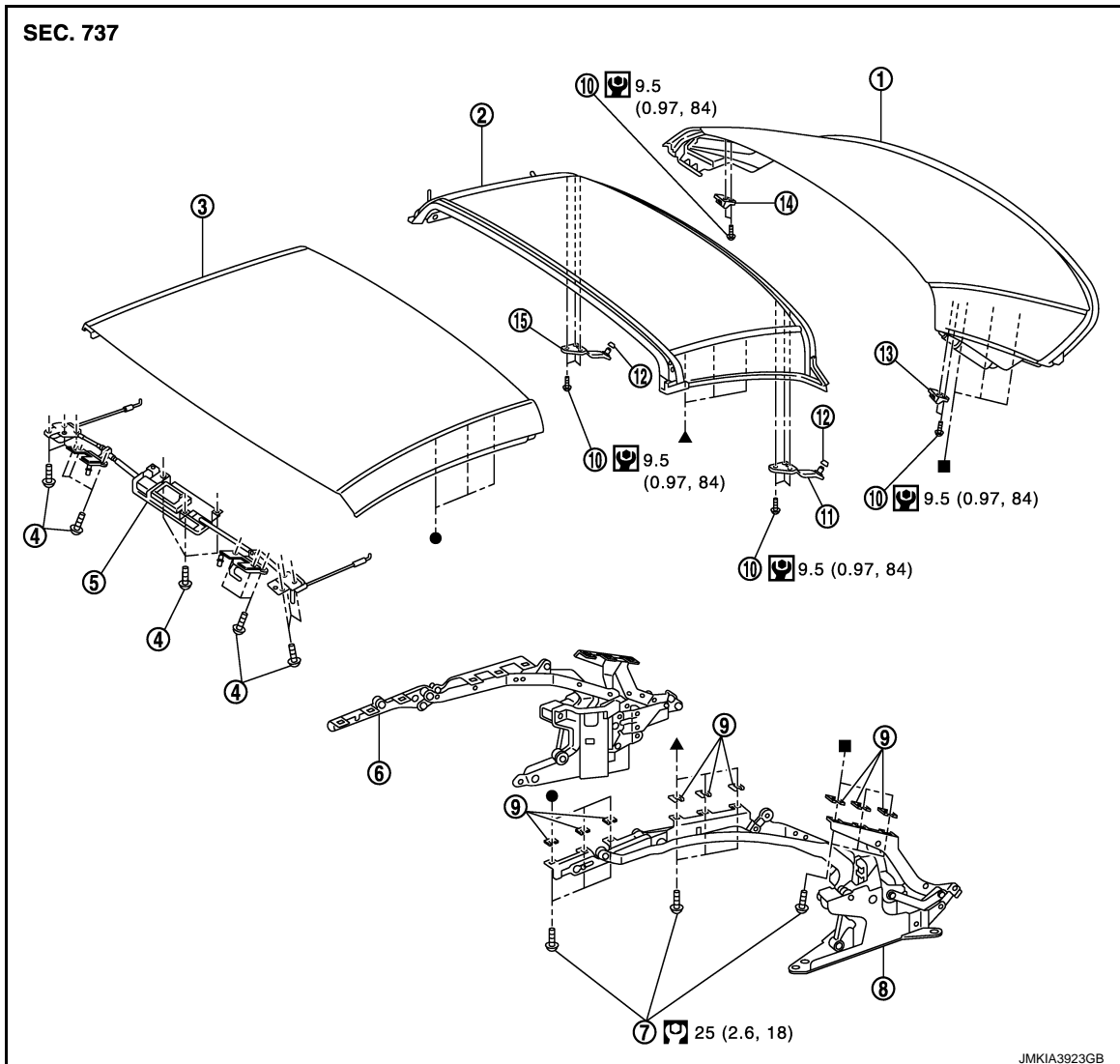

- |                                   |                                   |                              |
|-----------------------------------|-----------------------------------|------------------------------|
| 1. Rear roof panel                | 2. Center roof panel              | 3. Front roof panel          |
| 4. TORX bolt                      | 5. Roof lock assembly             | 6. Roof link assembly RH     |
| 7. TORX bolt                      | 8. Roof link assembly LH          | 9. Shim                      |
| 10. TORX bolt                     | 11. Center roof panel pin LH      | 12. O-ring                   |
| 13. Center roof panel retainer LH | 14. Center roof panel retainer RH | 15. Center roof panel pin RH |

Refer to [GI-4. "Components"](#) for symbols in the figure.

## Removal and Installation

INFOID:000000006468945

### REMOVAL

#### **CAUTION:**

**Protect the rear fender with a fender protector.**

#### **NOTE:**

Operate roof manually if it does not operate electrically. Refer to [RF-312. "Manual Operation"](#).

1. Remove headlining. Refer to [RF-260. "Removal and Installation"](#).
2. Remove trunk room trim. Refer to [INT-24. "Removal and Installation"](#).



# FRONT ROOF PANEL

## < REMOVAL AND INSTALLATION >

- Put small piece to the tonneau board switch, connect harness connector to vehicle.

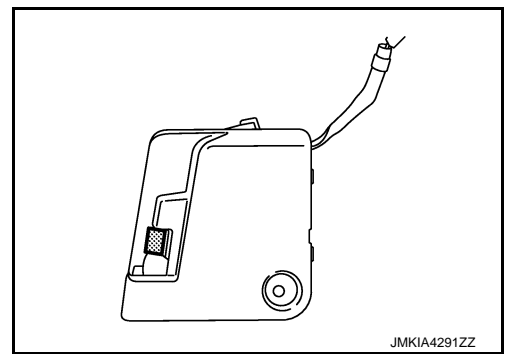

- Stop roof as shown in the figure (during open operation).

**CAUTION:**

Be careful of the roof and rear parcel shelf unit positions when operating, because roof may drop little by little and may interfere with rear parcel shelf unit when roof is in the middle position for a long period of time.

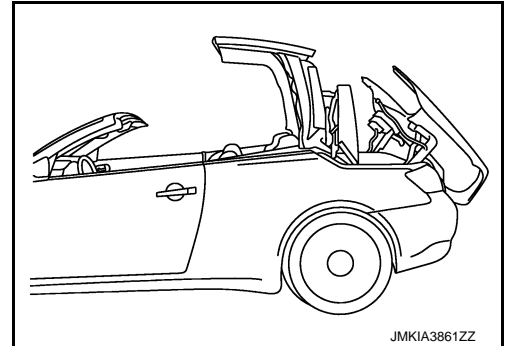

- Remove roof lock assembly. Refer to [RF-269, "ROOF LOCK ASSEMBLY : Removal and Installation"](#).
- Remove harness clamp.
- Remove front side trim. Refer to [RF-287, "Exploded View"](#).
- Put matching mark on front roof panel.
- Loosen front roof panel mounting TORX bolts, record shim quantity, and remove shims.
- Remove front roof panel mounting TORX bolts and remove front roof panel

## INSTALLATION

- Temporarily fix front roof panel to roof link.
- Insert shims between front roof panel and roof link according to recorded shim quantity.
- Align matching mark and tighten TORX bolts.
- Install front side trim. Refer to [RF-287, "Exploded View"](#).
- Install harness clamp.
- Install roof lock assembly. Refer to [RF-269, "ROOF LOCK ASSEMBLY : Removal and Installation"](#).
- Open hydraulic unit valve (1) slowly while supporting roof. Using a hexagon wrench (A).

 **Opening torque: Max 2.0 N·m ( 0.2 kg-m, 18 in-lb )**

**CAUTION:**

Check that valve opening torque is always with in the specified value for preventing oil leakage.

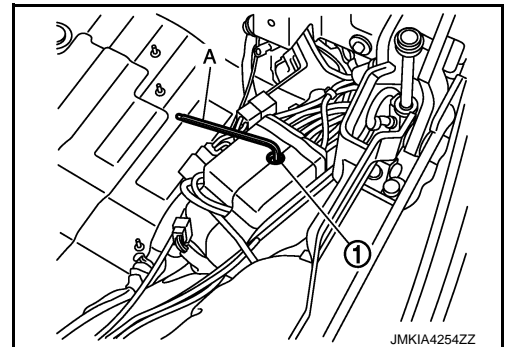

- Open and close roof manually and check that interference is not detected.

**CAUTION:**

- This operation requires two people.
- Keep hands away from the moving parts.

- Close hydraulic unit valve.

# FRONT ROOF PANEL

< REMOVAL AND INSTALLATION >

 Closing torque: 1.8 – 2.2 N·m ( 0.18 – 0.22 kg·m, 16 – 19 in·lb )

## CAUTION:

Check that valve closing torque is always within the specified value for preventing oil leakage.

10. Install trunk room trim. Refer to [INT-24, "Removal and Installation"](#).
11. Perform front roof panel adjustment. Refer to [RF-274, "Adjustment"](#).
12. Install headlining. Refer to [RF-260, "Removal and Installation"](#).

## Adjustment

INFOID:000000006468946

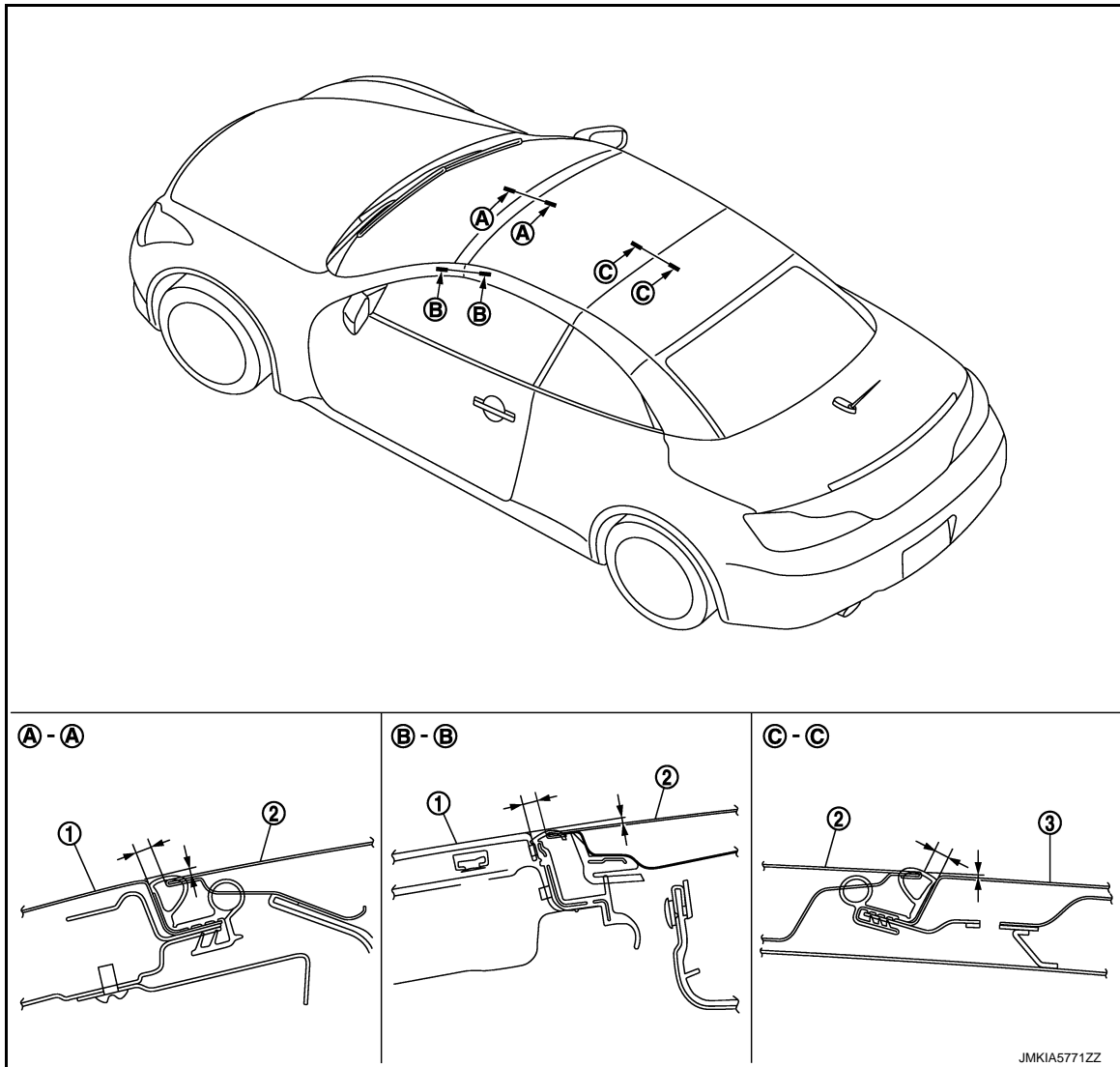

1. Roof panel

2. Front roof panel

3. Center roof panel

Check the clearance and the surface height between front roof panel and each part by visually and touching. If the clearance and the surface height are out of specification, adjust them according to the procedures shown below.

## CAUTION:

Fully close roof. Check that front and rear lock is locked.

# FRONT ROOF PANEL

## < REMOVAL AND INSTALLATION >

Portion		Clearance	Surface height (Front side is to be higher than rear side)
Roof panel – Front roof panel (center)	A – A	4.9 – 7.9 mm (0.193 – 0.311 in)	0.5 – 2.5 mm (0.020 – 0.098 in)
Roof panel – Front roof panel (side)	B – B	4.9 – 7.9 mm (0.193 – 0.311 in)	0.0 – 1.5 mm (0.000 – 0.059 in)
Front roof panel – Center roof panel	C – C	4.9 – 7.9 mm (0.193 – 0.311 in)	0.0 – 2.0 mm (0.000 – 0.079 in)

1. Remove headlining. Refer to [RF-260, "Removal and Installation"](#).
2. Stop roof as shown in the figure (during open operation).

**CAUTION:**

Be careful of the roof and rear parcel shelf unit positions when operating, because roof may drop little by little and may interfere with rear parcel shelf unit when roof is in the middle position for a long period of time.

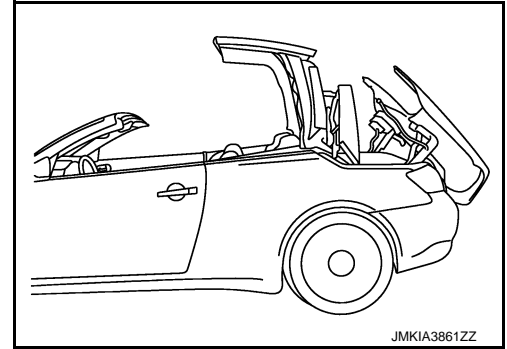

3. Loosen front roof panel mounting TORX bolt.
4. Adjust front roof panel.
  - If surface height difference is out of the specified value, and then adjust using shims.
  - If clearance is out of the specified value, and slide front roof panel to front or rear direction.
5. Tighten each TORX bolt to the specified torque. Refer to [RF-272, "Exploded View"](#).
6. If shim adjustment is not completed normally, rotate the adjusting bolt of roof link assembly and adjust front roof panel inclination.

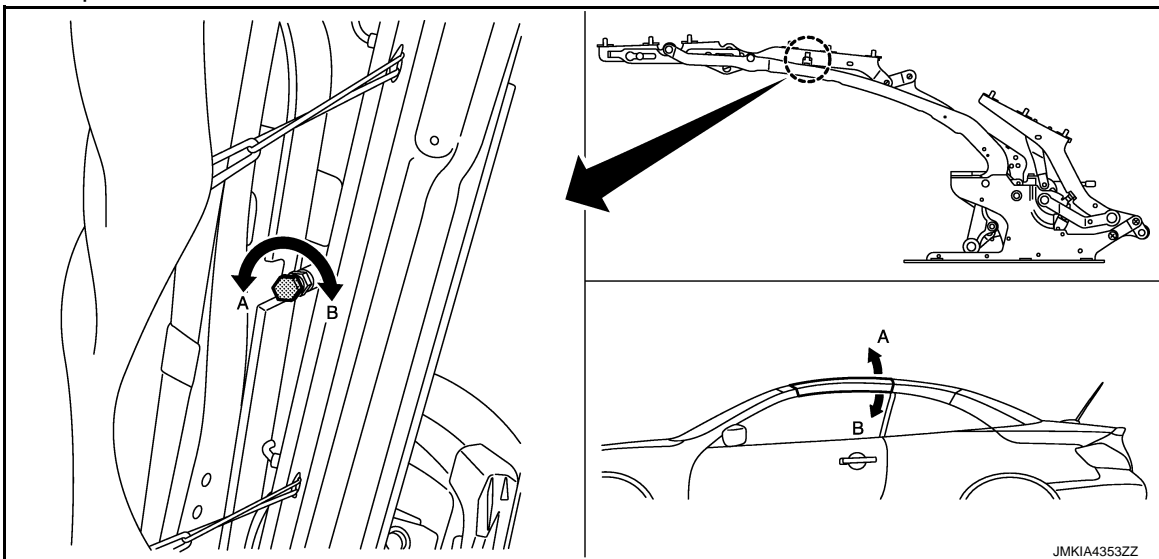

**CAUTION:**

A  
B  
C  
D  
E  
F  
G  
H  
I  
J  
L  
M  
N  
O  
P

RF

## FRONT ROOF PANEL

### < REMOVAL AND INSTALLATION >

Adjust the adjusting bolt so that no clearance (A) and looseness are left between slider (1) and pin (2) when roof is fully closed.

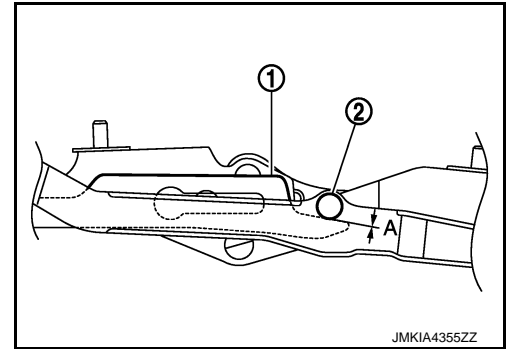

7. If C – C is out of the specified value, adjust center roof panel. Refer to [RF-279. "Adjustment"](#).
8. Open and close roof. Check that lock and unlock operation is normal several times.
9. Perform initialization according to the work after adjusting front roof panel. Refer to [RF-88. "Description"](#).
10. Adjust door glass and quarter window glass. Refer to [GW-18. "Inspection and Adjustment"](#).
11. Perform water leakage test. Refer to [RF-255. "Water Leakage Test"](#).
12. Install headlining. Refer to [RF-260. "Removal and Installation"](#).

# CENTER ROOF PANEL

< REMOVAL AND INSTALLATION >

## CENTER ROOF PANEL

Exploded View

INFOID:000000006468947

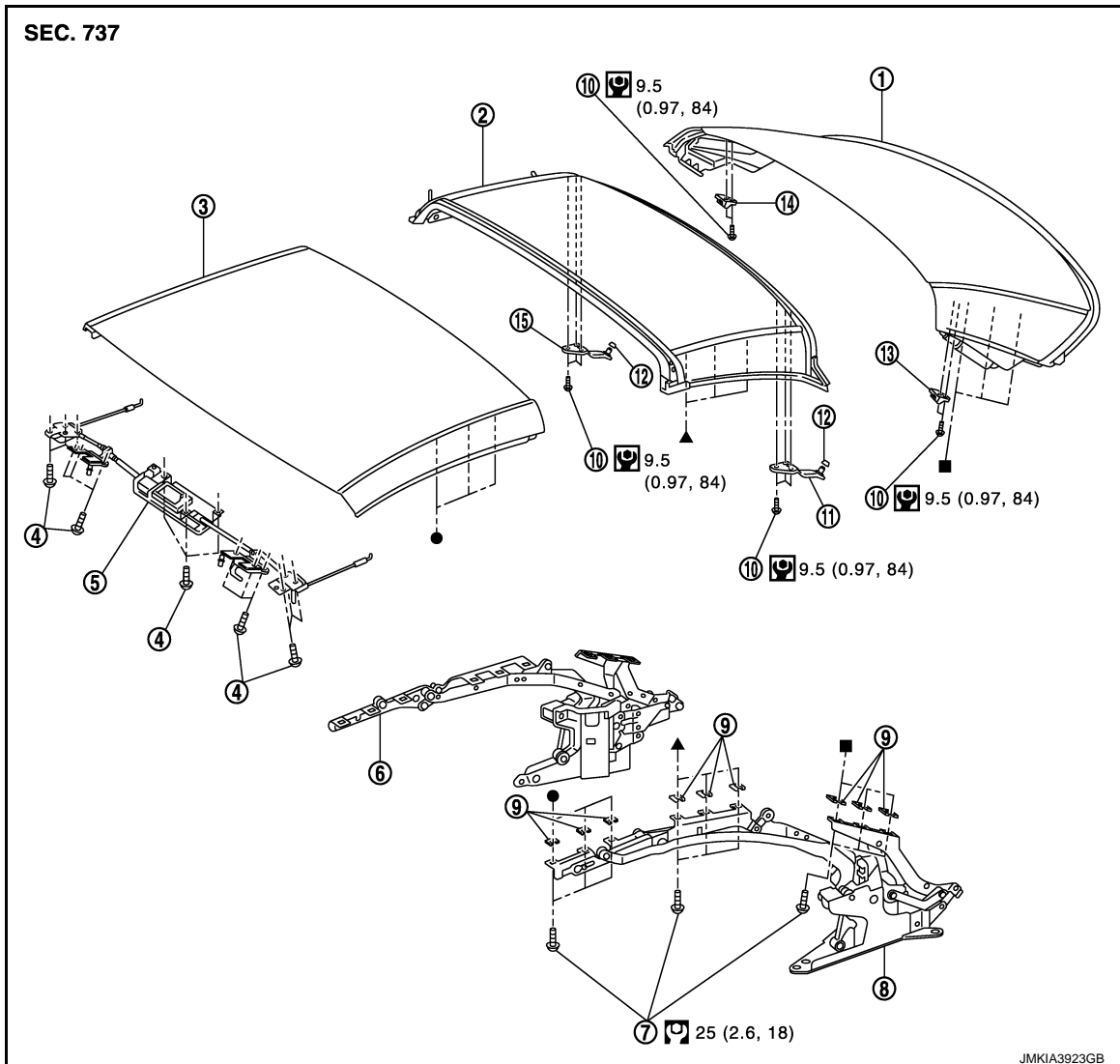

- |                                   |                                   |                              |
|-----------------------------------|-----------------------------------|------------------------------|
| 1. Rear roof panel                | 2. Center roof panel              | 3. Front roof panel          |
| 4. TORX bolt                      | 5. Roof lock assembly             | 6. Roof link assembly RH     |
| 7. TORX bolt                      | 8. Roof link assembly LH          | 9. Shim                      |
| 10. TORX bolt                     | 11. Center roof panel pin LH      | 12. O-ring                   |
| 13. Center roof panel retainer LH | 14. Center roof panel retainer RH | 15. Center roof panel pin RH |

Refer to [GI-4, "Components"](#) for symbols in the figure.

### Removal and Installation

INFOID:000000006468948

#### REMOVAL

#### **CAUTION:**

**Protect the rear fender with a fender protector.**

#### **NOTE:**

Operate roof manually if it does not operate electrically. Refer to [RF-312, "Manual Operation"](#).

1. Remove headlining. Refer to [RF-260, "Removal and Installation"](#).
2. Remove trunk room trim. Refer to [INT-24, "Removal and Installation"](#).

# CENTER ROOF PANEL

## < REMOVAL AND INSTALLATION >

- Put small piece to the tonneau board switch, connect harness connector to vehicle.

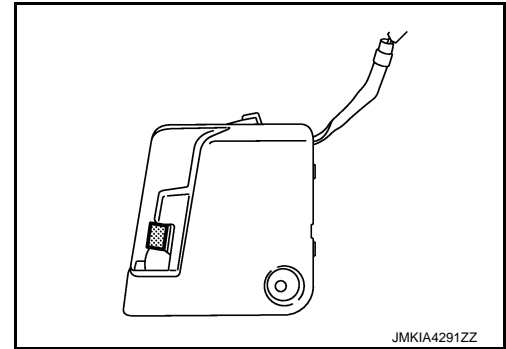

- Stop roof as shown in the figure (during open operation).

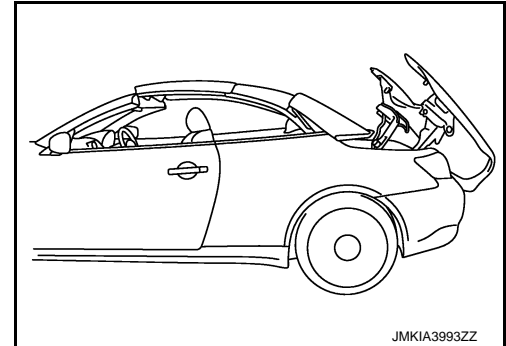

- Remove rear side trim. Refer to [RF-287, "Exploded View"](#).
- Put matching mark on center roof panel.
- Loosen center roof panel mounting TORX bolts, record shim quantity, and remove shims.
- Remove center roof panel mounting TORX bolts and remove center roof panel.

## INSTALLATION

- Temporarily fix center roof panel to roof link.
- Insert shims between center roof panel and roof link according to recorded shim quantity.
- Align matching mark and tighten TORX bolts.
- Install rear side trim. Refer to [RF-287, "Exploded View"](#).
- Open hydraulic unit valve (1) slowly while supporting roof. Using a hexagon wrench (A).

 **Opening torque: Max 2.0 N-m ( 0.2 kg-m, 18 in-lb )**

### CAUTION:

**Check that valve opening torque is always with in the specified value for preventing oil leakage.**

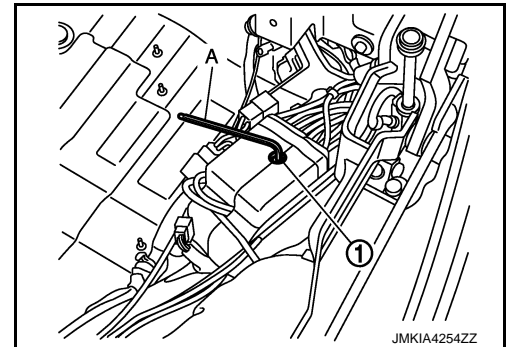

- Open and close roof manually and check that interference is not detected.

### CAUTION:

- This operation requires two people.**
- Keep hands away from the moving parts.**

- Close hydraulic unit valve.

 **Closing torque: 1.8 – 2.2 N-m ( 0.18 – 0.22 kg-m, 16 – 19 in-lb )**

### CAUTION:

**Check that valve closing torque is always with in the specified value for preventing oil leakage.**

- Install trunk room trim. Refer to [INT-24, "Removal and Installation"](#).
- Perform center roof panel adjustment. Refer to [RF-279, "Adjustment"](#).

# CENTER ROOF PANEL

< REMOVAL AND INSTALLATION >

10. Install headlining. Refer to [RF-260, "Removal and Installation"](#).

## Adjustment

INFOID:000000006468949

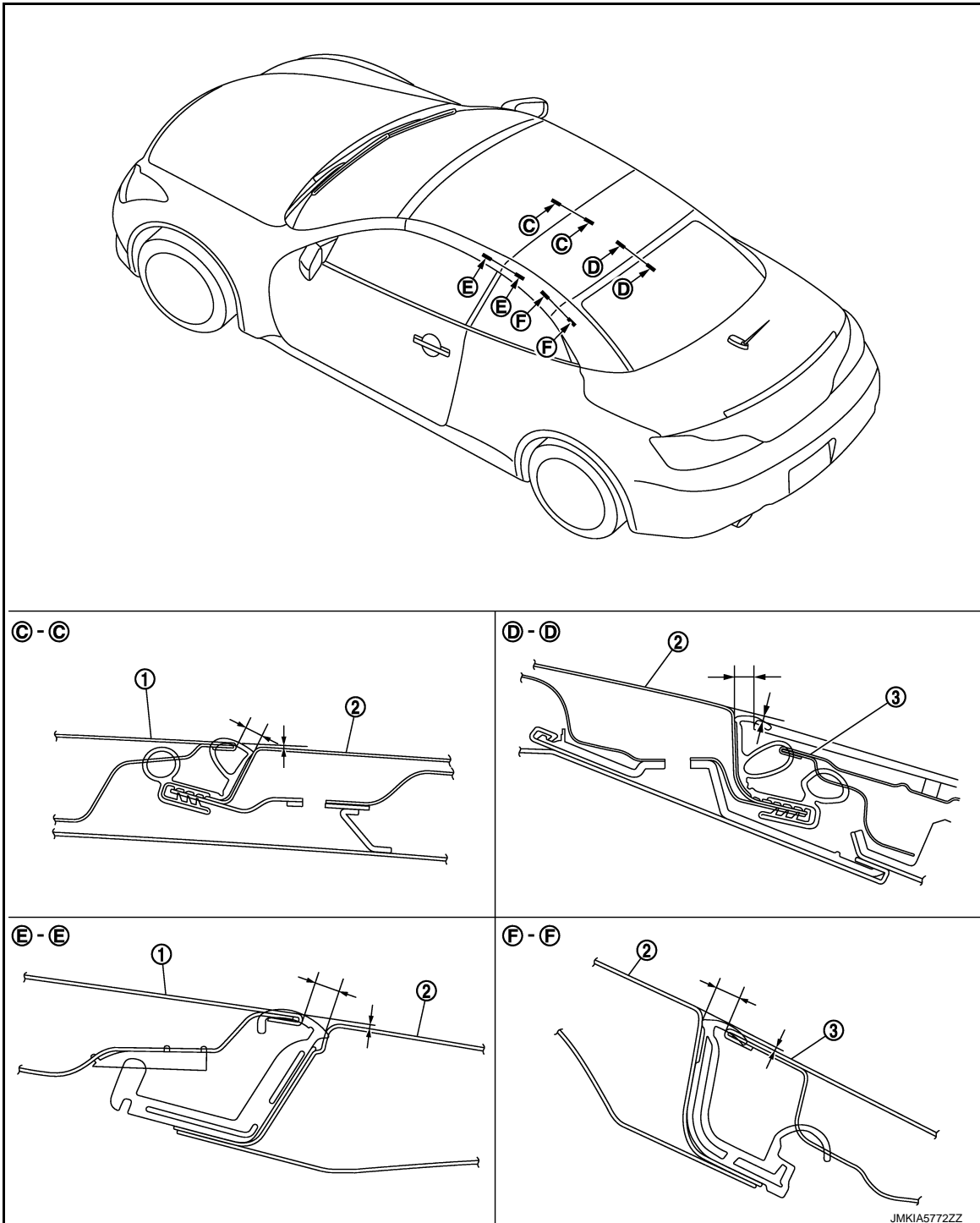

1. Front roof panel

2. Center roof panel

3. Rear roof panel

Check the clearance and the surface height between center roof panel and each part by visually and touching. If the clearance and the surface height are out of specification, adjust them according to the procedures shown below.

### CAUTION:

**Fully close roof. Check that front and rear lock is locked.**

A  
B  
C  
D  
E  
F  
G  
H  
I  
J  
RF  
L  
M  
N  
O  
P

## CENTER ROOF PANEL

### < REMOVAL AND INSTALLATION >

Portion		Clearance	Surface height (Front side is to be higher than rear side)
Front roof panel – Center roof panel	C – C	4.9 – 7.9 mm (0.193 – 0.311 in)	0.0 – 2.0 mm (0.000 – 0.079 in)
Center roof panel – Rear roof panel	D – D	4.9 – 7.9 mm (0.193 – 0.311 in)	0.4 – 3.4 mm (0.016 – 0.134 in)
Front roof panel – Center roof panel	E – E	4.9 – 7.9 mm (0.193 – 0.311 in)	0.0 – 1.5 mm (0.000 – 0.059 in)
Center roof panel – Rear roof panel	F – F	4.9 – 7.9 mm (0.193 – 0.311 in)	0.0 – 1.5 mm (0.000 – 0.059 in)

1. Remove headlining. Refer to [RF-260. "Removal and Installation"](#).
2. Stop roof as shown in the figure (during open operation).

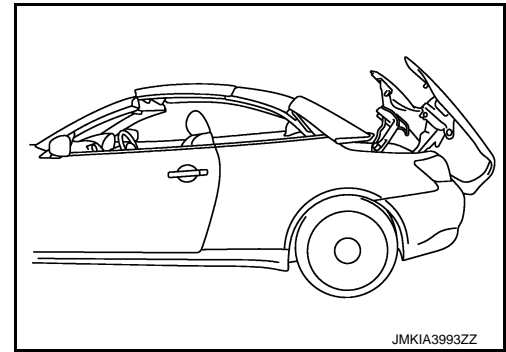

3. Loosen center roof panel mounting TORX bolt.
4. Adjust center roof panel.
  - If surface height difference is out of the specified value, and then adjust using shims.
  - If clearance is out of the specified value, and slide center roof panel to front or rear direction.
5. Tighten each TORX bolt to the specified torque. Refer to [RF-277. "Exploded View"](#).
6. If D – D is out of the specified value, adjust rear roof panel. Refer to [RF-283. "Adjustment"](#).
7. Open and close roof. Check that lock and unlock operation is normal several times.
8. Perform initialization according to the work after adjusting center roof panel. Refer to [RF-88. "Description"](#).
9. Adjust door glass and quarter window glass. Refer to [GW-18. "Inspection and Adjustment"](#).
10. Perform water leakage test. Refer to [RF-255. "Water Leakage Test"](#).
11. Install headlining. Refer to [RF-260. "Removal and Installation"](#).



# REAR ROOF PANEL

< REMOVAL AND INSTALLATION >

## REAR ROOF PANEL

Exploded View

INFOID:000000006468950

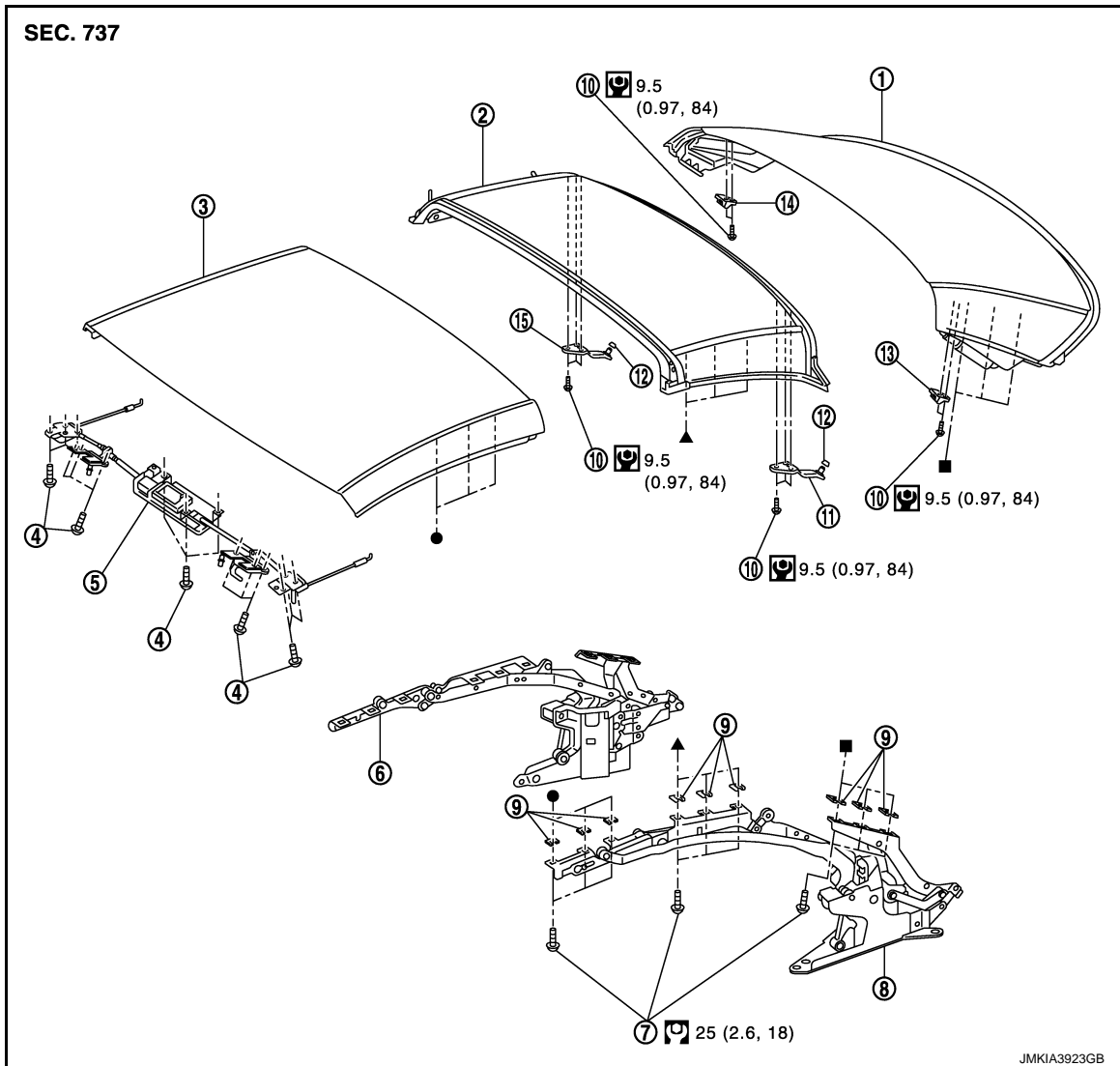

- |                                   |                                   |                              |
|-----------------------------------|-----------------------------------|------------------------------|
| 1. Rear roof panel                | 2. Center roof panel              | 3. Front roof panel          |
| 4. TORX bolt                      | 5. Roof lock assembly             | 6. Roof link assembly RH     |
| 7. TORX bolt                      | 8. Roof link assembly LH          | 9. Shim                      |
| 10. TORX bolt                     | 11. Center roof panel pin LH      | 12. O-ring                   |
| 13. Center roof panel retainer LH | 14. Center roof panel retainer RH | 15. Center roof panel pin RH |

Refer to [GI-4, "Components"](#) for symbols in the figure.

## Removal and Installation

INFOID:000000006468951

### REMOVAL

#### **CAUTION:**

**Protect the rear fender with a fender protector.**

#### **NOTE:**

Operate roof manually if it does not operate electrically. Refer to [RF-312, "Manual Operation"](#).

1. Remove headlining. Refer to [RF-260, "Removal and Installation"](#).
2. Remove trunk room trim. Refer to [INT-24, "Removal and Installation"](#).

## REAR ROOF PANEL

### < REMOVAL AND INSTALLATION >

- Put small piece to the tonneau board switch, connect harness connector to vehicle.

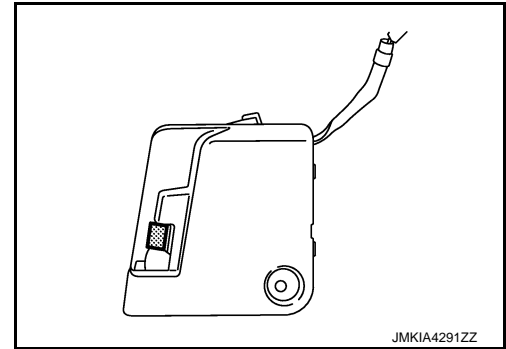

- Stop roof as shown in the figure (during open operation).

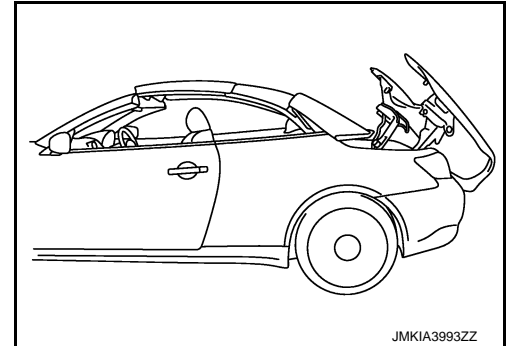

- Remove harness clamp.
- Put matching mark on rear roof panel.
- Loosen rear roof panel mounting TORX bolts, record shim quantity, and remove shims.
- Remove rear roof panel mounting TORX bolts and remove rear roof panel.

### INSTALLATION

- Temporarily fix rear roof panel to roof link.
- Insert shims between rear roof panel and roof link according to recorded them quantity.
- Align matching mark and tighten TORX bolts.
- Install harness clamp.
- Open hydraulic unit valve (1) slowly while supporting roof. Using a hexagon wrench (A).

 **Opening torque: Max 2.0 N·m (0.2 kg·m, 18 in·lb)**

#### **CAUTION:**

**Check that valve opening torque is always with in the specified value for preventing oil leakage.**

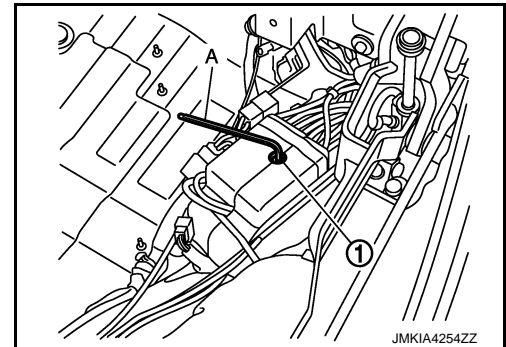

- Open and close roof manually and check that interference is not detected.

#### **CAUTION:**

- This operation requires two people.**
- Keep hands away from the moving parts.**

- Close hydraulic unit valve.

 **Closing torque: 1.8 – 2.2 N·m (0.18 – 0.22 kg·m, 16 – 19 in·lb)**

#### **CAUTION:**

**Check that valve closing torque is always with in the specified value for preventing oil leakage.**

- Install trunk room trim. Refer to [INT-24, "Removal and Installation"](#).
- Perform front roof panel adjustment. Refer to [RF-283, "Adjustment"](#).

# REAR ROOF PANEL

< REMOVAL AND INSTALLATION >

10. Install headlining. Refer to [RF-260, "Removal and Installation"](#).

## Adjustment

INFOID:000000006468952

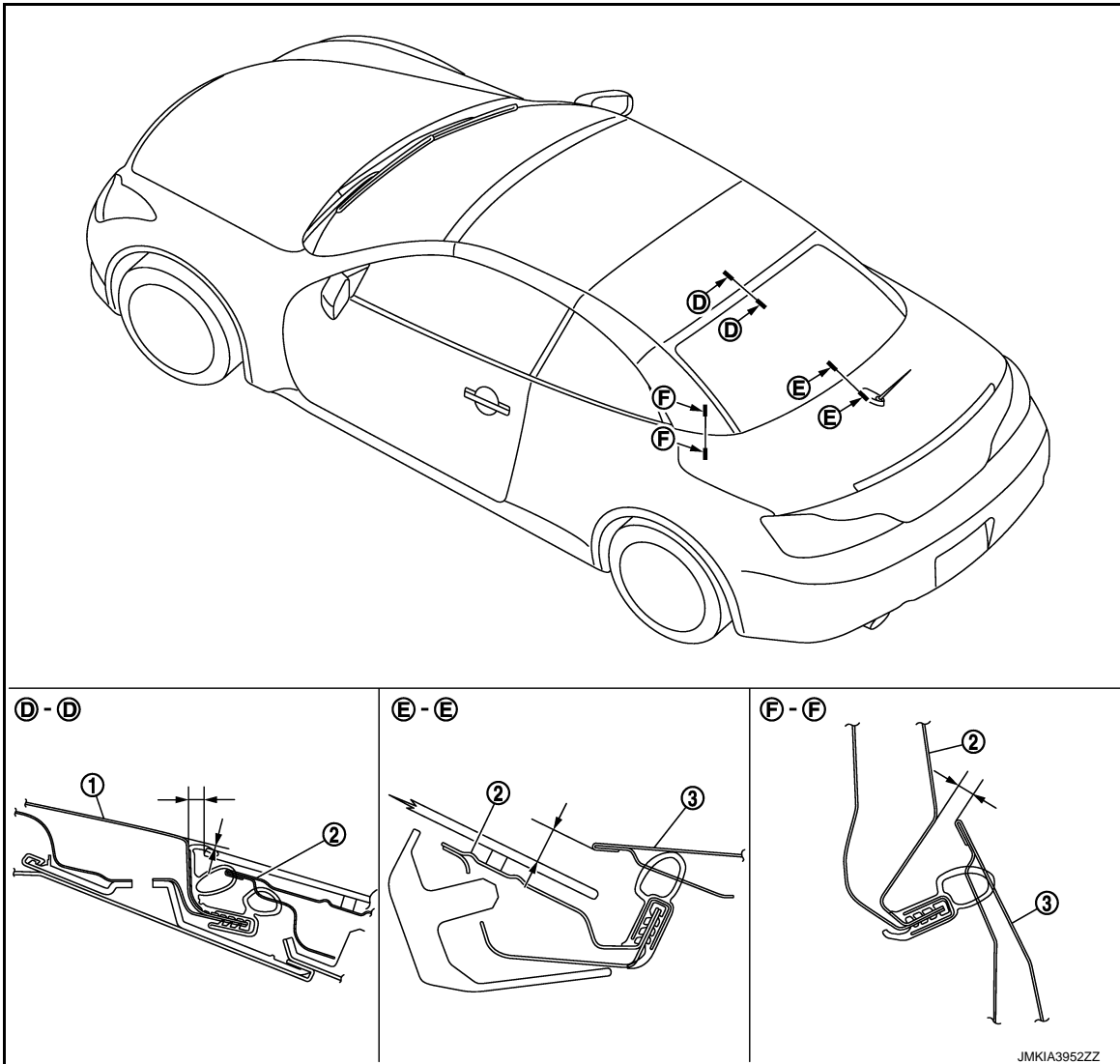

1. Center roof panel

2. Rear roof panel

3. Trunk lid

Check the clearance and the surface height between rear roof panel and each part by visually and touching. If the clearance and the surface height are out of specification, adjust them according to the procedures shown below.

### CAUTION:

**Fully close roof. Check that front and rear lock is locked.**

Portion		Clearance	Surface height
Center roof panel – Rear roof panel	D – D	4.9 – 7.9 mm (0.193 – 0.311 in)	0.4 – 3.4 mm (0.016 – 0.134 in)
Rear roof panel – Trunk lid	E – E	—	7.7 – 15.7 mm (0.303 – 0.618 in)
Rear roof panel – Trunk lid	F – F	6.8 – 10.8 mm (0.268 – 0.425 in)	—

1. Remove headlining. Refer to [RF-260, "Removal and Installation"](#).

## REAR ROOF PANEL

### < REMOVAL AND INSTALLATION >

2. Stop roof as shown in the figure (during open operation).

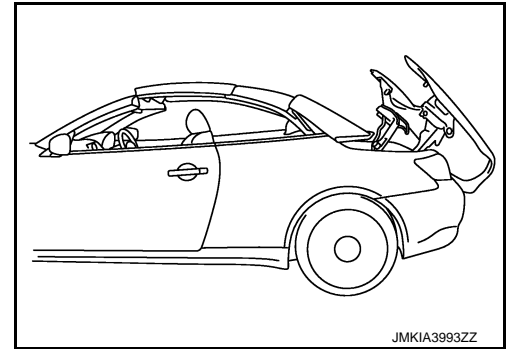

3. Loosen rear roof panel mounting TORX bolt.
4. Adjust rear roof panel.
  - If surface height difference is out of the specified value, and then adjust using shims.
  - If clearance is out of the specified value, and slide rear roof panel to front or rear direction.
5. Tighten each TORX bolt to the specified torque. Refer to [RF-281, "Exploded View"](#).
6. If shim adjustment is not completed normally, rotate the adjusting bolt of roof link assembly and adjust rear roof panel height.

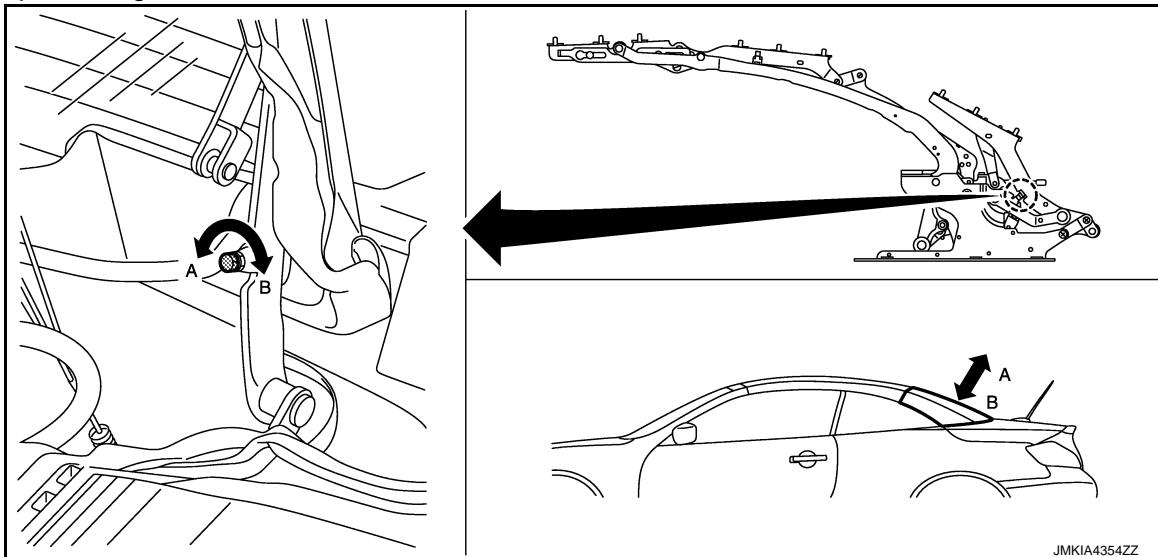

7. Open and close roof. Check that lock and unlock operation is normal several times.
8. Perform initialization according to the work after adjusting rear roof panel. Refer to [RF-88, "Description"](#).
9. Adjust door glass and quarter window glass. Refer to [GW-18, "Inspection and Adjustment"](#).
10. Perform water leakage test. Refer to [RF-255, "Water Leakage Test"](#).
11. Install headlining. Refer to [RF-260, "Removal and Installation"](#).

# ROOF SEALING

< REMOVAL AND INSTALLATION >

## ROOF SEALING

Exploded View

INFOID:000000006468953

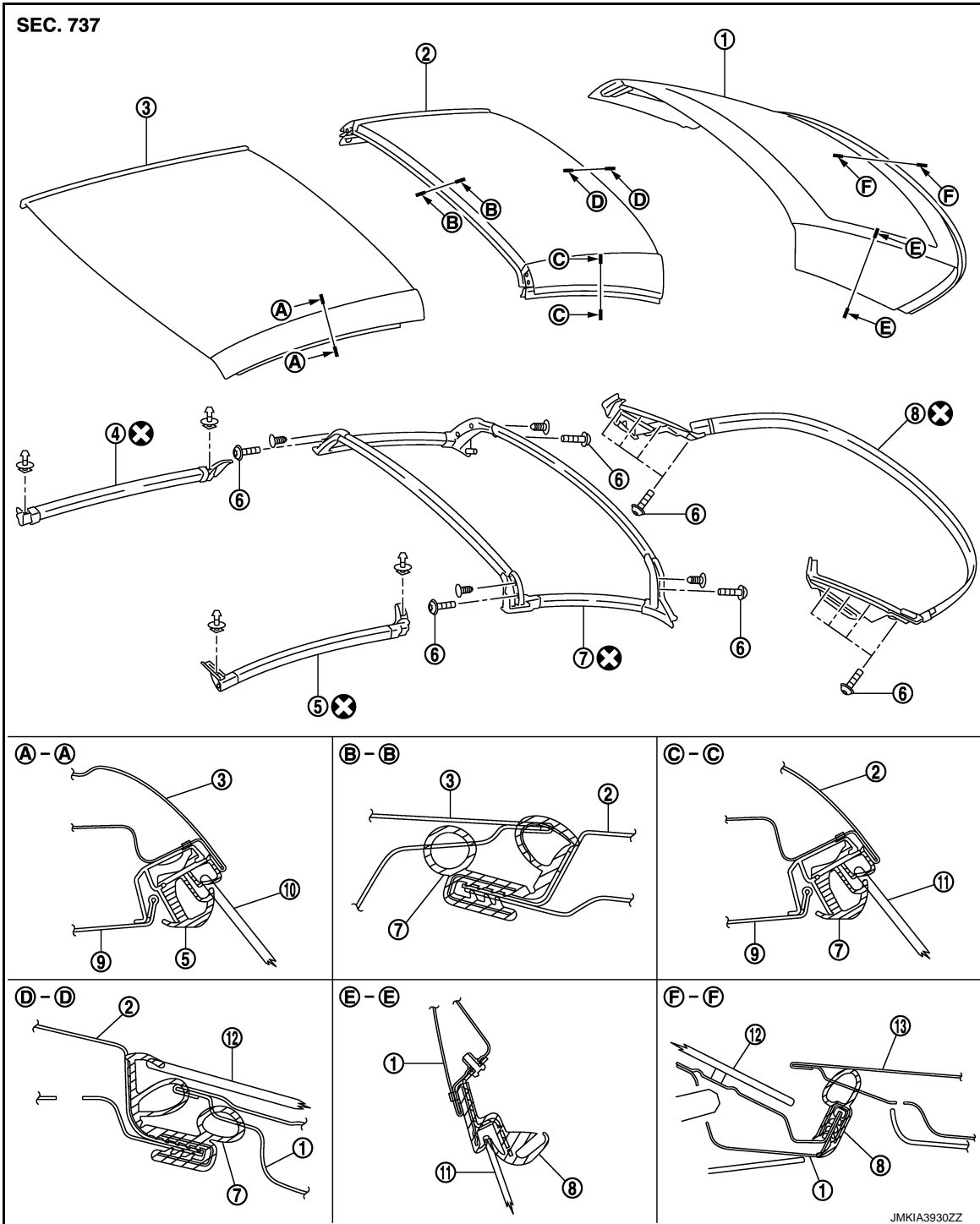

- |                                |                                |                       |
|--------------------------------|--------------------------------|-----------------------|
| 1. Rear roof panel             | 2. Center roof panel           | 3. Front roof panel   |
| 4. Front roof weather-strip RH | 5. Front roof weather-strip LH | 6. TORX bolt          |
| 7. Center roof weather-strip   | 8. Rear roof weather-strip     | 9. Headlining         |
| 10. Door glass                 | 11. Quarter window glass       | 12. Rear window glass |
| 13. Trunk lid                  |                                |                       |

Refer to [GI-4, "Components"](#) for symbols in the figure.

A  
B  
C  
D  
E  
F  
G  
H  
I  
J  
RF  
L  
M  
N  
O  
P

# ROOF SEALING

## < REMOVAL AND INSTALLATION >

### Removal and Installation

INFOID:000000006468954

#### REMOVAL

**CAUTION:**

Protect the rear fender with a fender protector.

**NOTE:**

Operate roof manually if it does not operate electrically. Refer to [RF-312, "Manual Operation"](#).

1. Stop roof as shown in the figure (during open operation).

**CAUTION:**

Be careful of the roof and rear parcel shelf unit positions when operating, because roof may drop little by little and may interfere with rear parcel shelf unit when roof is in the middle position for a long period of time.

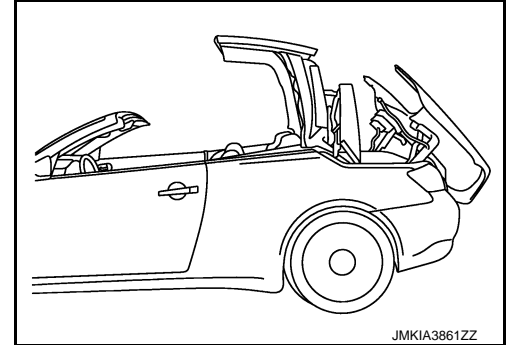

2. Remove clips, and then front roof weather-strip.
3. Remove TORX bolts and clips, and then center roof weather-strip.
4. Remove TORX bolts, and then rear roof weather-strip.

#### INSTALLATION

Install in the reverse order of removal.

**NOTE:**

- Perform initialization according to the work after installing roof sealing. Refer to [RF-88, "Description"](#).
- Adjust door glass and quarter window glass. Refer to [GW-18, "Inspection and Adjustment"](#).
- Perform water leakage test. Refer to [RF-255, "Water Leakage Test"](#).

# ROOF LINK ASSEMBLY

< REMOVAL AND INSTALLATION >

## ROOF LINK ASSEMBLY

Exploded View

INFOID:000000006468955

SEC. 737

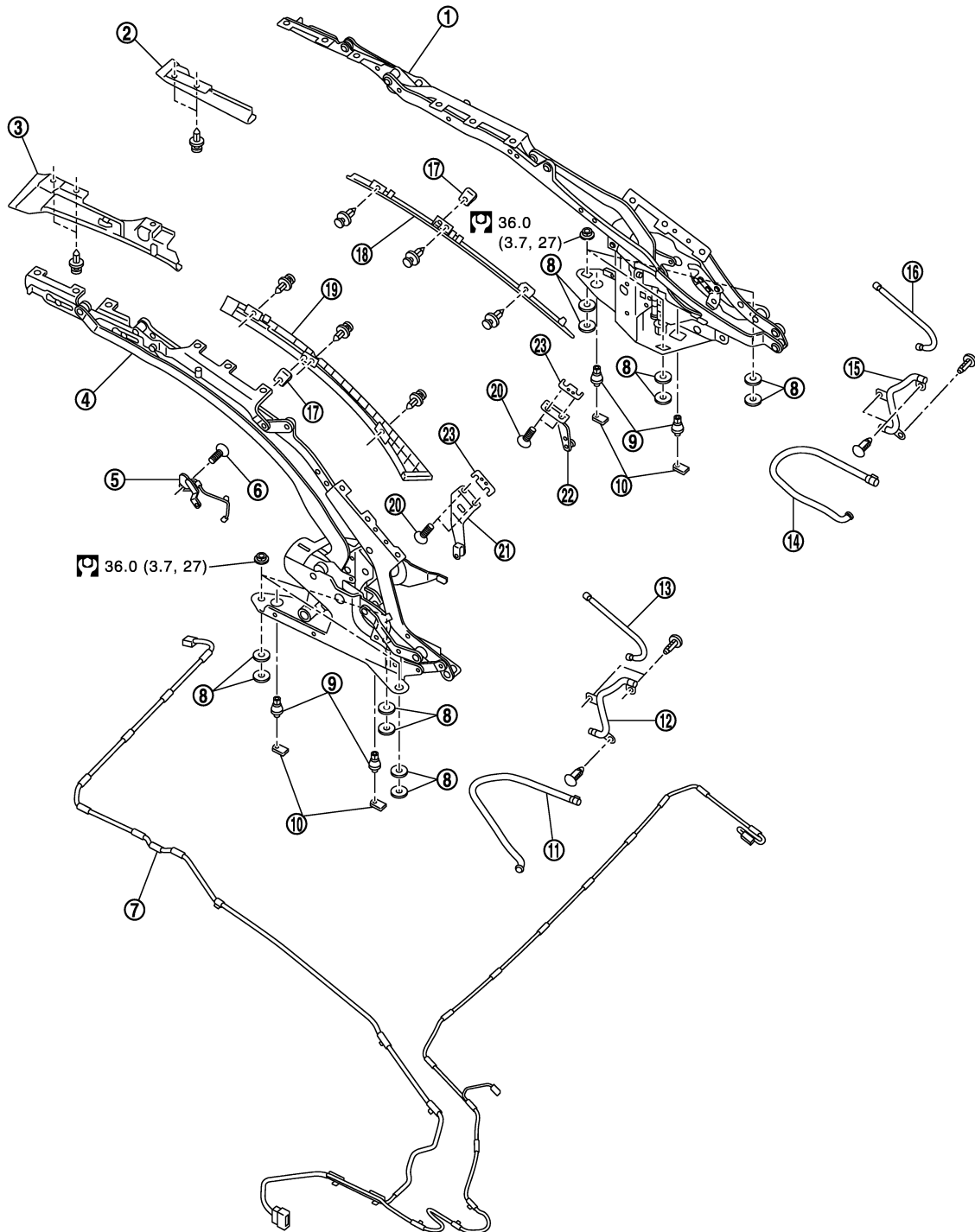

A  
B  
C  
D  
E  
F  
G  
H  
I  
J  
RF  
L  
M  
N  
O  
P

- |                          |                       |                       |
|--------------------------|-----------------------|-----------------------|
| 1. Roof link assembly RH | 2. Front side trim RH | 3. Front side trim LH |
| 4. Roof link assembly LH | 5. Roof status sensor | 6. TORX bolt          |
| 7. Roof harness          | 8. Shim               | 9. Centering bolt     |

JMKIA3967GB

# ROOF LINK ASSEMBLY

## < REMOVAL AND INSTALLATION >

- |                         |                         |                          |
|-------------------------|-------------------------|--------------------------|
| 10. Centering plate     | 11. Drain tube lower LH | 12. Drain tube center LH |
| 13. Drain tube upper LH | 14. Drain tube lower RH | 15. Drain tube center RH |
| 16. Drain tube upper RH | 17. Trim sleeve         | 18. Rear side trim RH    |
| 19. Rear side trim LH   | 20. TORX bolt           | 21. Bolt receiver LH     |
| 22. Bolt receiver RH    | 23. Shim                |                          |

Refer to [GI-4, "Components"](#) for symbols in the figure.

## Removal and Installation

INFOID:000000006468956

### REMOVAL

#### CAUTION:

- Protect the rear fender with a fender protector.
- This work requires two people.
- Keep hands away from the moving parts.

#### NOTE:

Operate roof manually if it does not operate electrically. Refer to [RF-312, "Manual Operation"](#).

1. Remove rear seat cushion and seatback. Refer to [SE-256, "Removal and Installation"](#).
2. Remove rear side finisher. Refer to [INT-15, "Removal and Installation"](#).
3. Remove headlining. Refer to [RF-260, "Removal and Installation"](#).
4. Remove trunk room trim. Refer to [INT-24, "Removal and Installation"](#).
5. Remove front roof panel. Refer to [RF-272, "Removal and Installation"](#).
6. Remove center roof panel. Refer to [RF-277, "Removal and Installation"](#).
7. Remove rear roof panel. Refer to [RF-281, "Removal and Installation"](#).
8. Open hydraulic unit valve (1). Using a hexagon wrench (A).

 **Opening torque: Max 2.0 N·m (0.2 kg·m, 18 in·lb)**

#### CAUTION:

Check that valve opening torque is always within the specified value for preventing oil leakage.

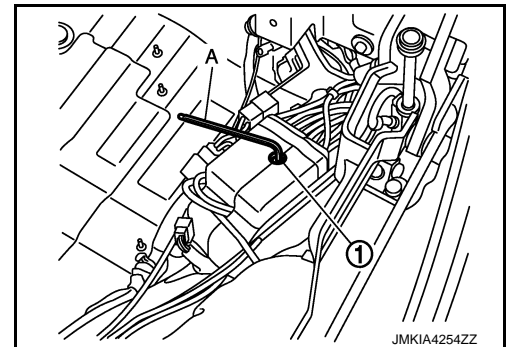

9. Remove roof drive cylinder and roof lock cylinder from roof link assembly. Refer to [RF-299, "Removal and Installation"](#).
10. From passenger room side, disconnect harness connector. (LH side only)

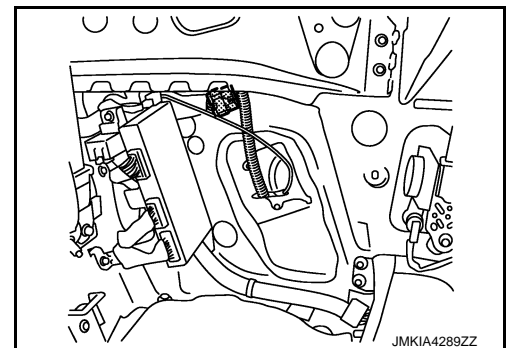

11. Remove mounting nuts, and then remove roof link assembly.

#### CAUTION:

- Never loosen centering bolts.
- Never change shims.

### INSTALLATION

1. Install roof link assembly.

#### CAUTION:



## ROOF LINK ASSEMBLY

### < REMOVAL AND INSTALLATION >

Insert lower end drain tube (1) to the hole of sealing screen (2) through the vehicle.

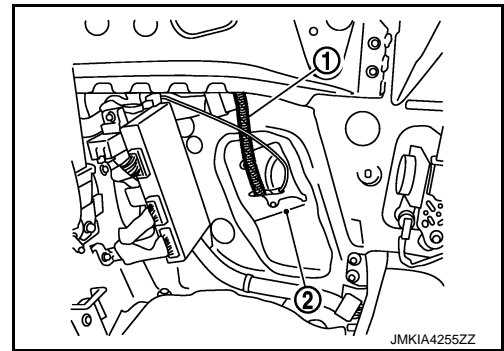

2. From passenger room side connect harness connector. (LH side only)
3. Install roof drive cylinder and roof lock cylinder for roof link assembly. Refer to [RF-299, "Removal and Installation"](#).
4. Close hydraulic unit valve. Using a hexagon wrench.

 **Closing torque: 1.8 – 2.2 N-m ( 0.18 – 0.22 kg-m, 16 – 19 in-lb )**

#### **CAUTION:**

**Check that valve closing torque is always with in the specified value for preventing oil leakage.**

5. Install rear roof panel. Refer to [RF-281, "Removal and Installation"](#).
6. Install center roof panel. Refer to [RF-277, "Removal and Installation"](#).
7. Install front roof panel. Refer to [RF-272, "Removal and Installation"](#).
8. Perform front roof panel adjustment. Refer to [RF-274, "Adjustment"](#).
9. Perform center roof panel adjustment. Refer to [RF-279, "Adjustment"](#).
10. Perform rear roof panel adjustment. Refer to [RF-283, "Adjustment"](#).
11. Install trunk room trim. Refer to [INT-24, "Removal and Installation"](#).
12. Install headlining. Refer to [RF-260, "Removal and Installation"](#).
13. Install rear side finisher. Refer to [INT-15, "Removal and Installation"](#).
14. Install rear seat cushion and seatback. Refer to [SE-256, "Removal and Installation"](#).

A  
B  
C  
D  
E  
F  
G  
H  
I  
J  
L  
M  
N  
O  
P

RF

# REAR PARCEL SHELF FINISHER

< REMOVAL AND INSTALLATION >

## REAR PARCEL SHELF FINISHER

### REAR PARCEL SHELF UNIT

#### REAR PARCEL SHELF UNIT : Exploded View

INFOID:000000006468957

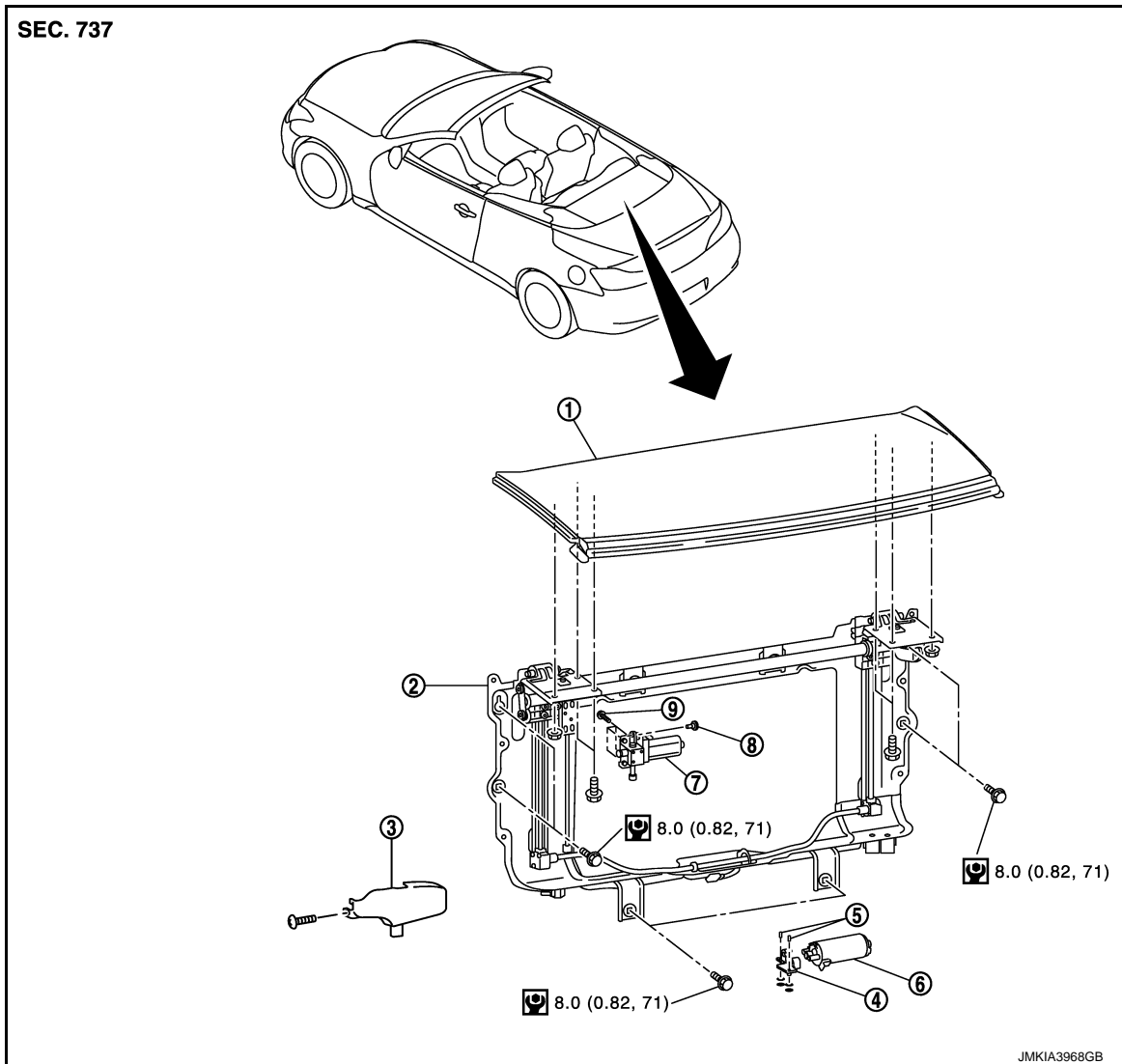

- |                                      |                           |                                      |
|--------------------------------------|---------------------------|--------------------------------------|
| 1. Rear parcel shelf finisher board  | 2. Rear parcel shelf unit | 3. Parcel shelf motor (rotate) cover |
| 4. Parcel shelf motor (draw) bracket | 5. Pin                    | 6. Parcel shelf motor (draw)         |
| 7. Parcel shelf motor (rotate)       | 8. Special bolt           | 9. TORX bolt                         |

Refer to [GI-4, "Components"](#) for symbols in the figure.

#### REAR PARCEL SHELF UNIT : Removal and Installation

INFOID:000000006468958

##### REMOVAL

##### **CAUTION:**

**Protect the rear fender with a fender protector.**

##### **NOTE:**

Operate roof manually if it does not operate electrically. Refer to [RF-312, "Manual Operation"](#).

## REAR PARCEL SHELF FINISHER

### < REMOVAL AND INSTALLATION >

1. Stop roof as shown in the figure (during open operation).

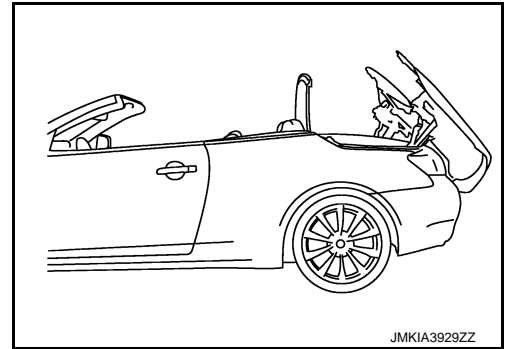

2. Remove mounting bolts and nuts, and then remove rear parcel shelf finisher board.
3. Open trunk while roof is fully close.
4. Remove trunk trim. Refer to [INT-24. "Removal and Installation"](#).
5. Put matching mark on rear parcel shelf unit.
6. Disconnect rear parcel shelf unit harness connector.
7. Remove mounting bolts, and then remove rear parcel shelf unit.

### INSTALLATION

Install in the reverse order of removal.

#### **NOTE:**

Perform initialization according to the work after installing rear parcel shelf unit. Refer to [.RF-88. "Description"](#)

### PARCEL SHELF MOTOR (ROTATE)

A  
B  
C  
D  
E  
F  
G  
H  
I  
J  
RF  
L  
M  
N  
O  
P

# REAR PARCEL SHELF FINISHER

< REMOVAL AND INSTALLATION >

## PARCEL SHELF MOTOR (ROTATE) : Exploded View

INFOID:000000006468959

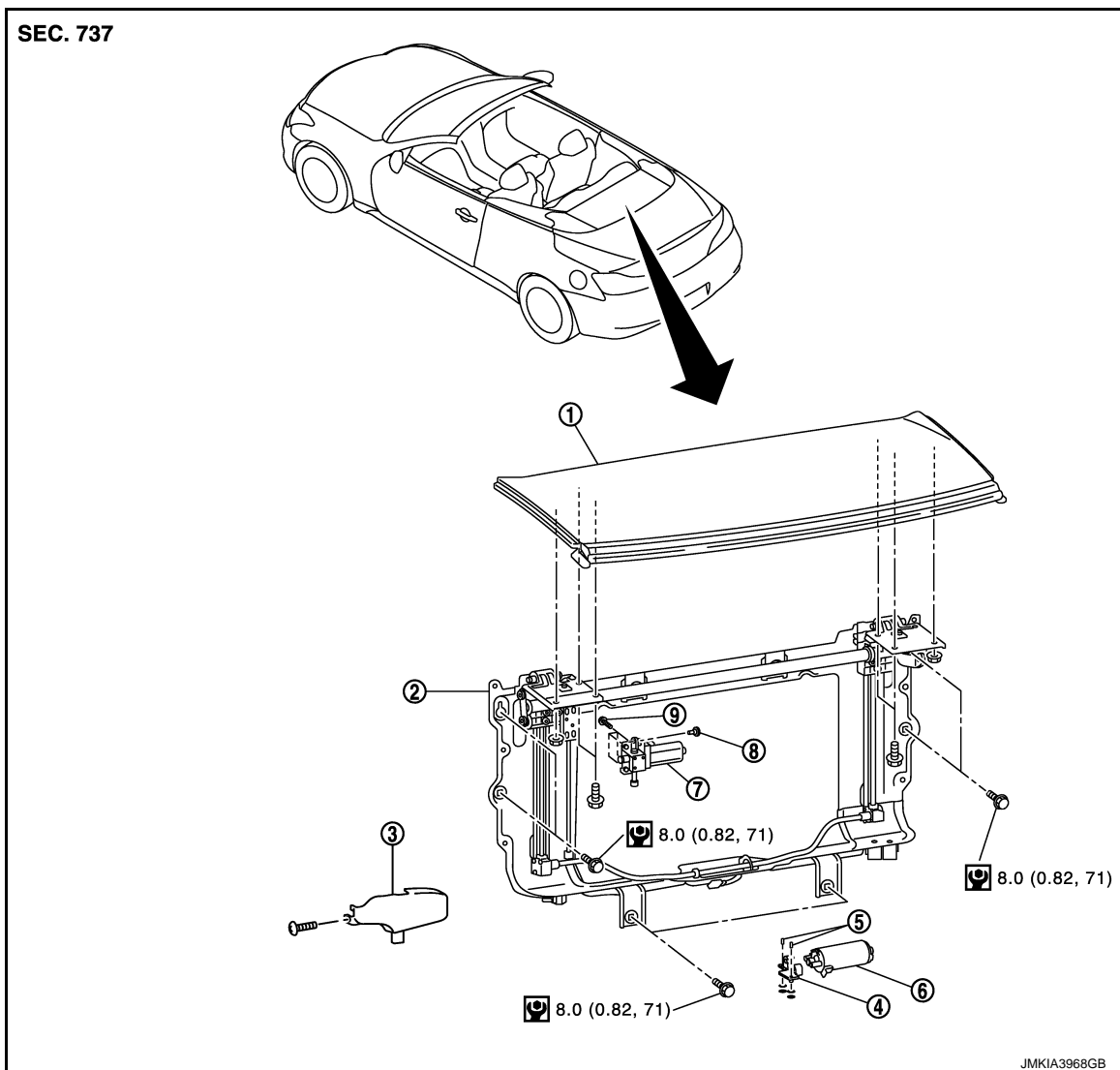

- |                                      |                           |                                      |
|--------------------------------------|---------------------------|--------------------------------------|
| 1. Rear parcel shelf finisher board  | 2. Rear parcel shelf unit | 3. Parcel shelf motor (rotate) cover |
| 4. Parcel shelf motor (draw) bracket | 5. Pin                    | 6. Parcel shelf motor (draw)         |
| 7. Parcel shelf motor (rotate)       | 8. Special bolt           | 9. TORX bolt                         |

Refer to [GI-4, "Components"](#) for symbols in the figure.

## PARCEL SHELF MOTOR (ROTATE) : Removal and Installation

INFOID:000000006468960

### REMOVAL

#### **CAUTION:**

**Protect the rear fender with a fender protector.**

#### **NOTE:**

Operate roof manually if it does not operate electrically. Refer to [RF-312, "Manual Operation"](#).

1. Remove rear parcel shelf unit. Refer to [RF-290, "REAR PARCEL SHELF UNIT : Removal and Installation"](#).
2. Disconnect parcel shelf motor (rotate) harness connector.
3. Remove special bolt and TORX bolts, and then remove parcel shelf motor (rotate).

### INSTALLATION

Install in the reverse order of removal.

#### **NOTE:**



## REAR PARCEL SHELF FINISHER

### < REMOVAL AND INSTALLATION >

---

3. Remove wire from parcel shelf motor (draw).
4. Remove pin and washer, and parcel shelf motor (draw) bracket.

### INSTALLATION

Install in the reverse order of removal.

**NOTE:**

Perform initialization according to the work after installing parcel shelf motor (draw). Refer to [RF-88, "Description"](#).

# FLIPPER DOOR

< REMOVAL AND INSTALLATION >

## FLIPPER DOOR

Exploded View

INFOID:000000006468963

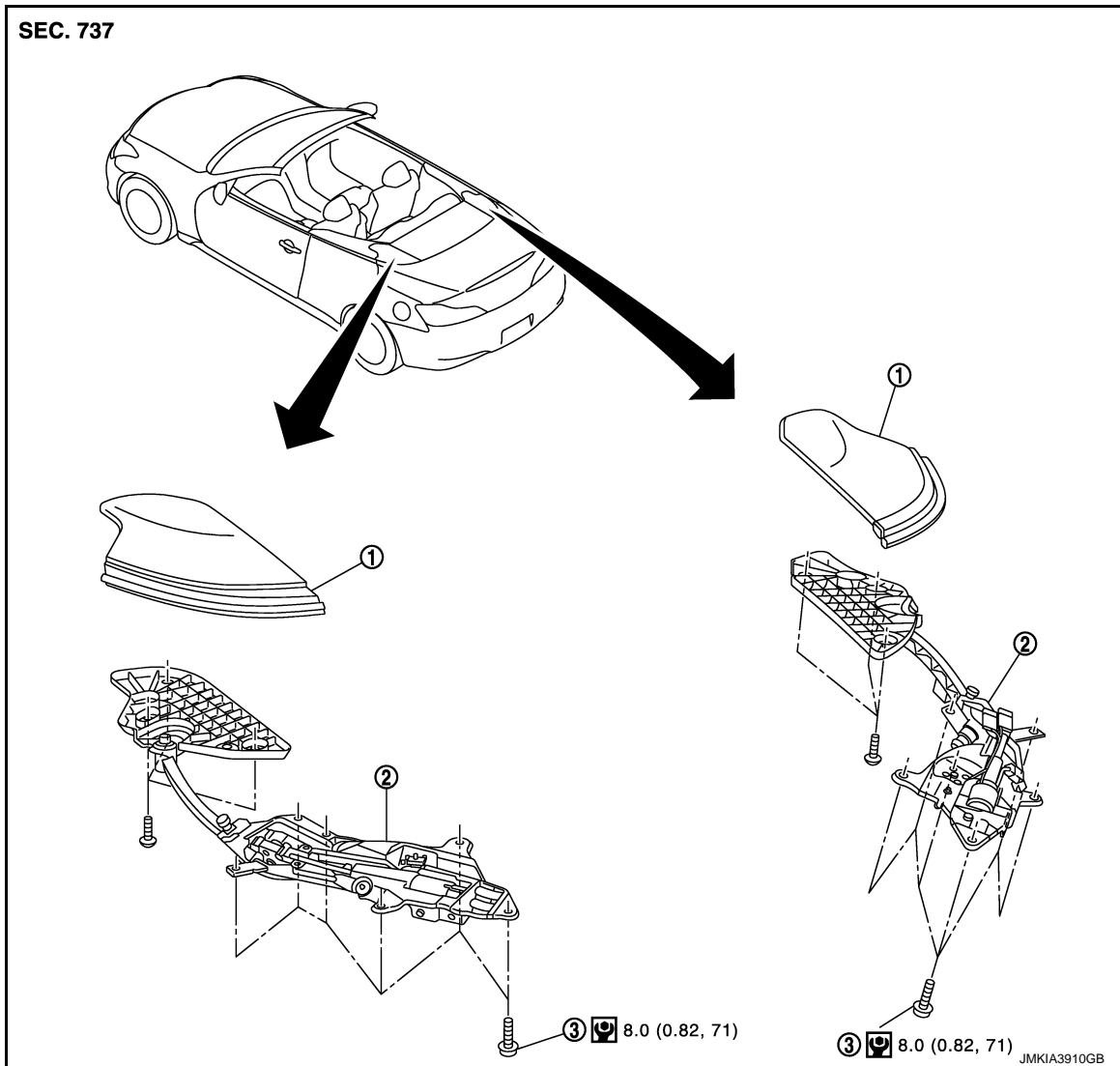

1. Flipper door board

2. Flipper door unit

3. TORX bolt

Refer to [GI-4, "Components"](#) for symbols in the figure.

## Removal and Installation

INFOID:000000006468964

### REMOVAL

#### **CAUTION:**

**Protect the rear fender with a fender protector.**

1. Open trunk while roof is fully open.
2. Remove trunk lid trim. Refer to [INT-24, "Removal and Installation"](#).
3. Remove mounting screws, and then remove flipper door board.
4. Remove trunk hinge harness clamp.

## FLIPPER DOOR

### < REMOVAL AND INSTALLATION >

5. Disconnect flipper door harness connector (A).

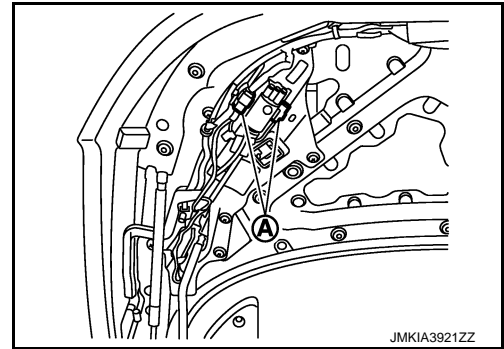

6. Remove TORX bolt, and then remove flipper door unit.

### INSTALLATION

Install in the reverse order of removal.

### Adjustment

INFOID:000000006468965

1. Check offset volume of flipper door board (outside).
2. Remove flipper door board (outside).
3. Loosen flipper door unit adjustment nuts (A), slide flipper door board (inside) (1) back, forth, right, left or tilting for the equivalent offset volume of flipper door board (outside).

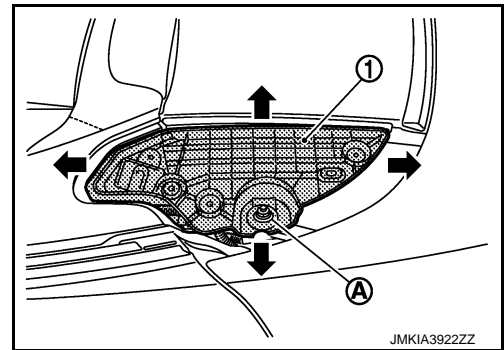

4. Install flipper door board (outside).



# ROOF SUPPORT BUMPER

< REMOVAL AND INSTALLATION >

## ROOF SUPPORT BUMPER

Exploded View

INFOID:000000006468966

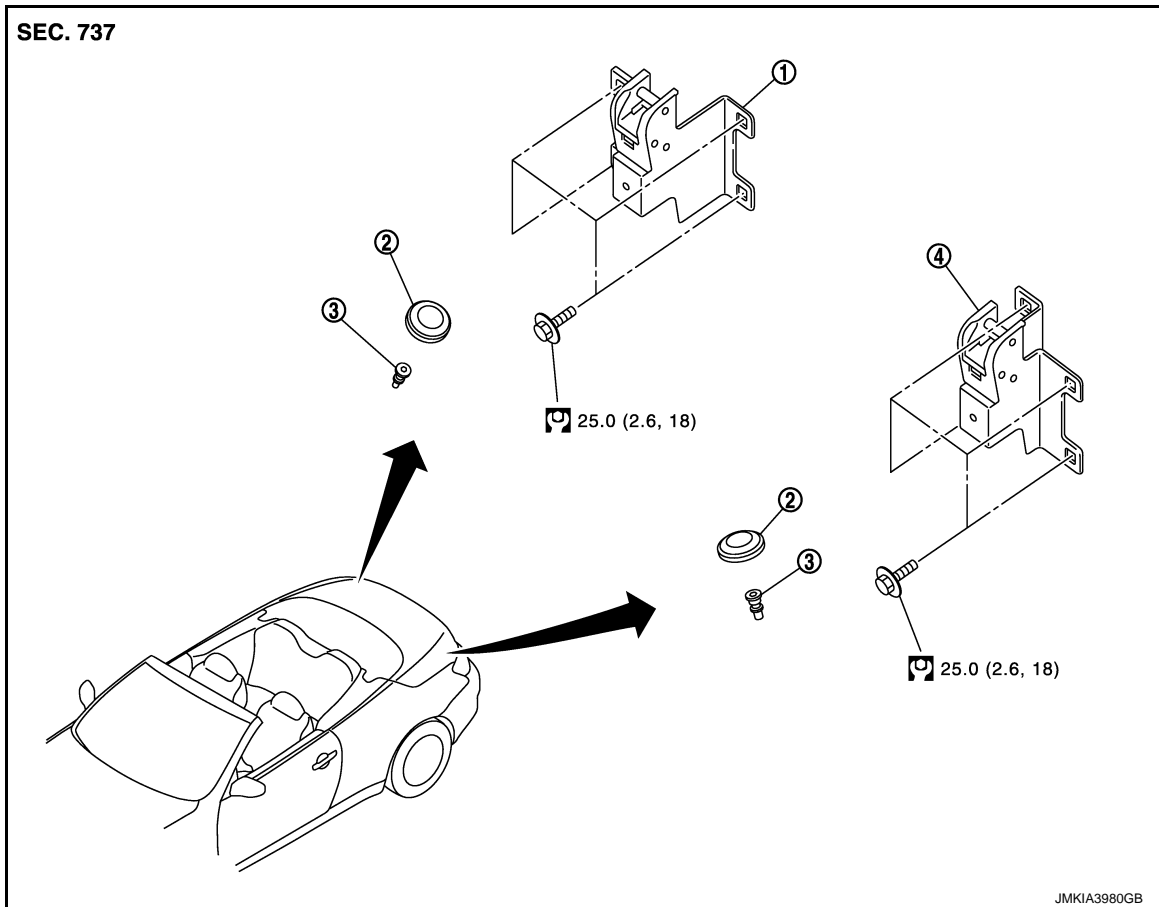

1. Roof support bumper RH
2. Bumper rubber
3. Special bolt
4. Roof support bumper LH

Refer to [GI-4, "Components"](#) for symbols in the figure.

## Removal and Installation

INFOID:000000006468967

### REMOVAL

#### **CAUTION:**

**Protect the rear fender with a fender protector.**

#### **NOTE:**

Operate roof manually if it does not operate electrically. Refer to [RF-312, "Manual Operation"](#).

1. Remove trunk room trim. Refer to [INT-24, "Removal and Installation"](#).
2. Put matching mark on roof support bumper.
3. Remove mounting bolts, and then roof support bumper.
4. Remove bumper rubber.
5. Remove special bolts.

#### **NOTE:**

## ROOF SUPPORT BUMPER

### < REMOVAL AND INSTALLATION >

- Measure the dimension (A) as shown in the figure, before removing special bolt (2).
- Check that no clearance is left between bumper rubber (1) and glass (3) while roof is open.

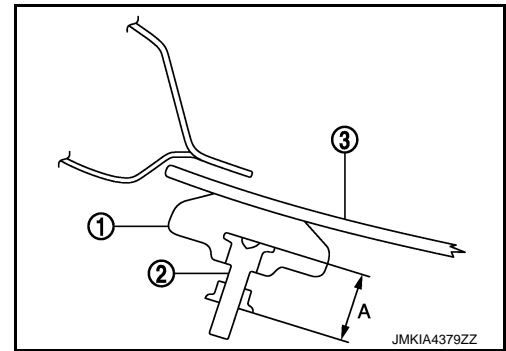

### INSTALLATION

1. Install special bolts.

**CAUTION:**

**When installing bolts, adjust the dimension to a value that is measured before removal.**

2. Install bumper rubber.
3. Install roof support bumper.

**CAUTION:**

- Check that slider (1) and pin (2) never contact each other while roof is open, after the installation.

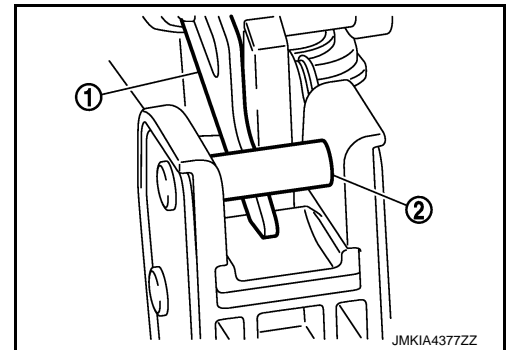

- Check that no clearance is left between plastic parts (3) and roof support bumper.

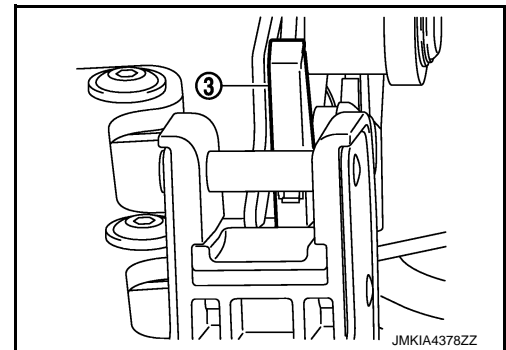

- Check that no clearance is left between bumper rubber and glass while roof is open.
- Drive the vehicle while roof is open and check that low level noise is not detected.

# HYDRAULIC SYSTEM

< REMOVAL AND INSTALLATION >

## HYDRAULIC SYSTEM

Exploded View

INFOID:000000006468968

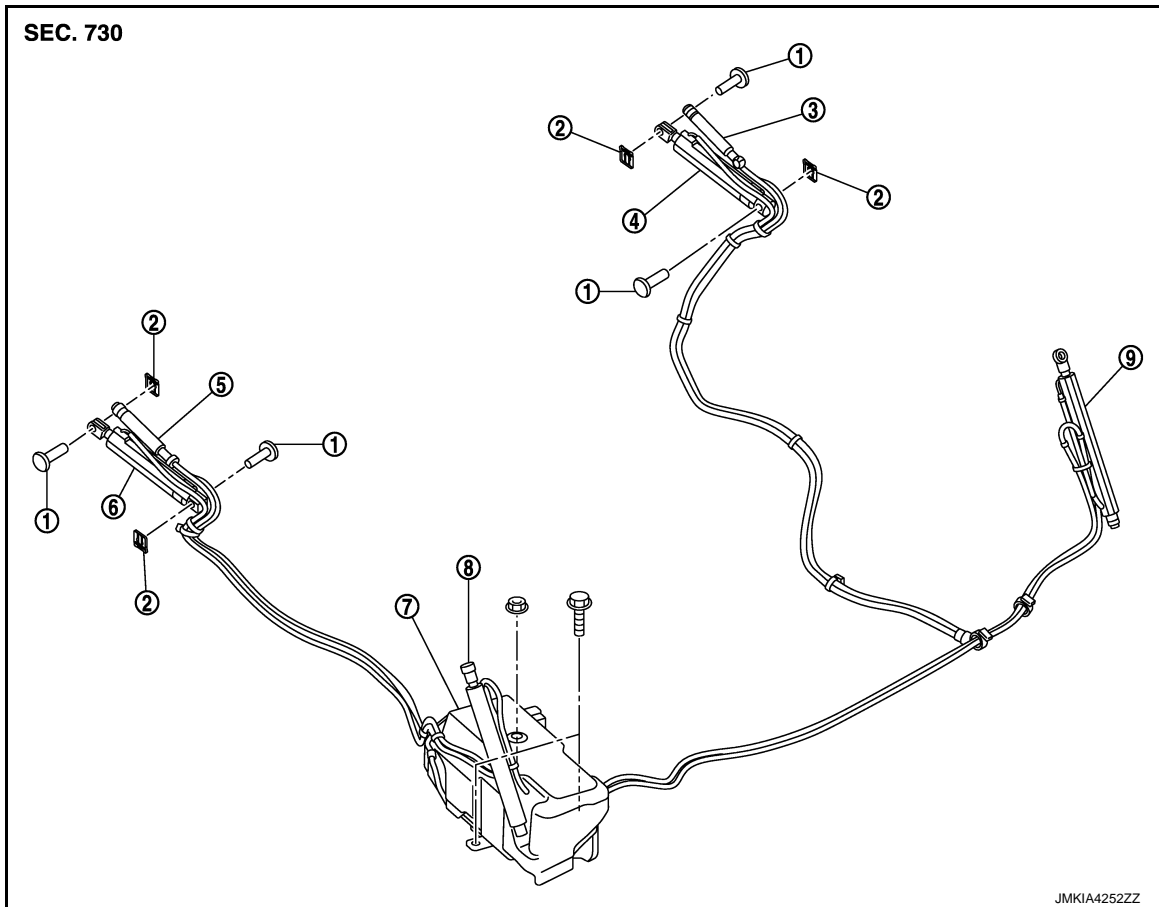

- |                            |                                |                                |
|----------------------------|--------------------------------|--------------------------------|
| 1. Pin                     | 2. Retaining plate             | 3. Roof lock cylinder RH       |
| 4. Roof drive cylinder RH  | 5. Roof lock cylinder LH       | 6. Roof drive cylinder LH      |
| 7. Hydraulic unit assembly | 8. Trunk lid drive cylinder LH | 9. Trunk lid drive cylinder RH |

### Removal and Installation

INFOID:000000006468969

#### REMOVAL

##### **CAUTION:**

- Protect the rear fender with a fender protector.
- Never bend or twist hydraulic hoses sharply, or strongly pull them.
- After installation, hydraulic hoses must not move towards self-locking bands.
- Never let the ends of self-locking bands touch hydraulic hoses.

##### **NOTE:**

Operate roof manually if it does not operate electrically. Refer to [RF-312, "Manual Operation"](#).

1. Remove trunk room trim. Refer to [INT-24, "Removal and Installation"](#).

# HYDRAULIC SYSTEM

## < REMOVAL AND INSTALLATION >

- Put small piece to the tonneau board switch, connect harness connector to vehicle.

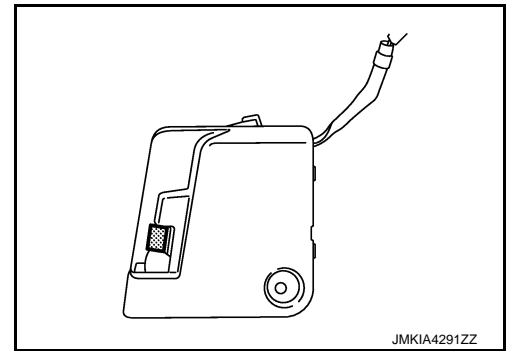

- Stop roof as shown in the figure (during open operation).

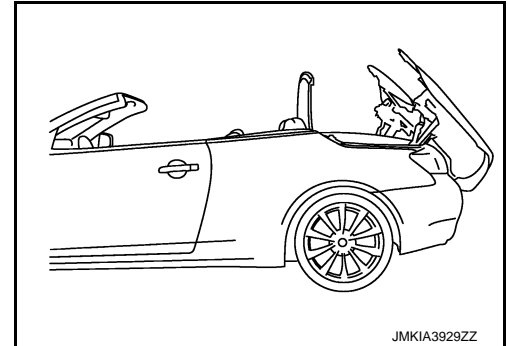

- Remove rear seat cushion and seatback. Refer to [SE-256. "Removal and Installation"](#).
- Remove rear side finisher. Refer to [INT-15. "Removal and Installation"](#).
- Remove metal clip (2) from roof lock cylinder (1) front side.

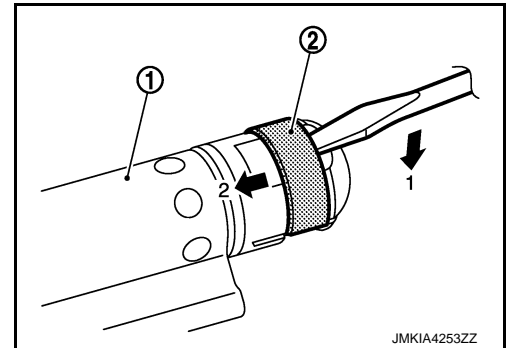

- Stop roof as shown in the figure (roof is closed and trunk is open).

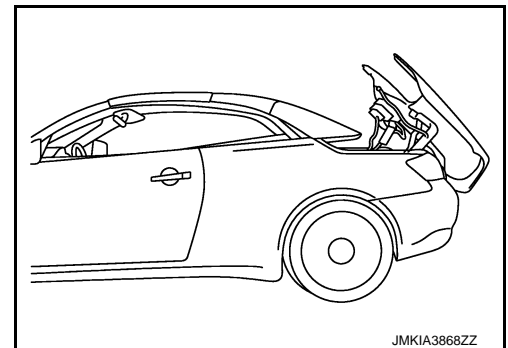

# HYDRAULIC SYSTEM

## < REMOVAL AND INSTALLATION >

8. Open hydraulic unit valve (1). Using a hexagon wrench (A).

 **Opening torque: Max 2.0 N-m (0.2 kg-m, 18 in-lb)**

**CAUTION:**  
Check that valve opening torque is always within the specified value for preventing oil leakage.

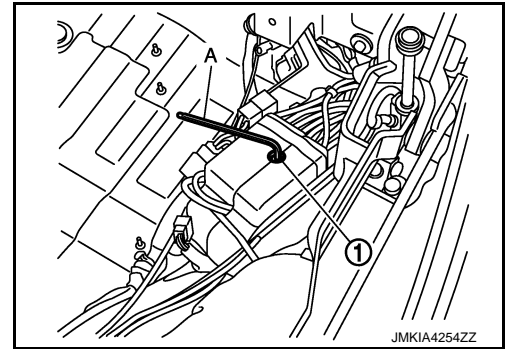

9. Remove metal clip (2) from roof lock cylinder (1) rear side.

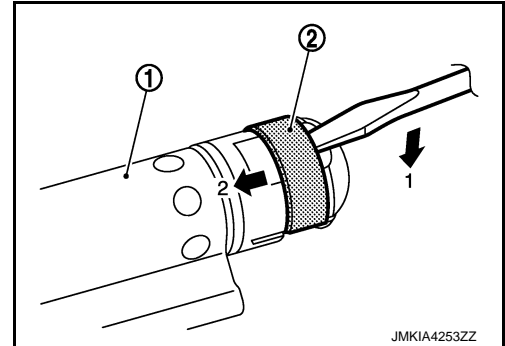

10. Remove retaining plate, and then remove pin from roof drive cylinder front side and rear side.

11. Remove roof drive cylinder and roof lock cylinder from roof link assembly.

12. Remove metal clip (2) from trunk lid drive cylinder (1), front side and rear side.

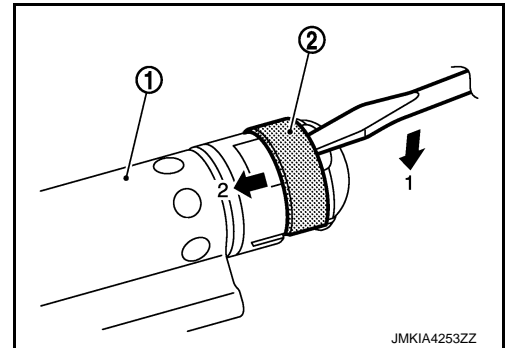

13. Remove hose clamp.

14. Disconnect hydraulic unit harness connectors.

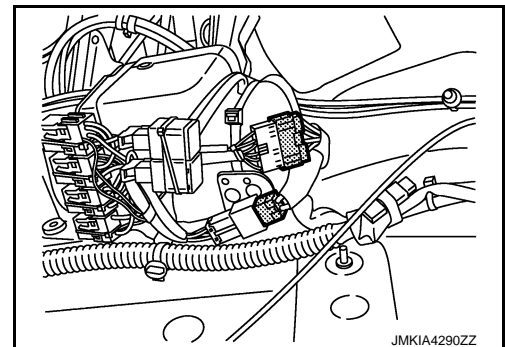

15. Remove mounting bolts and nut, and then remove hydraulic unit assembly.

## INSTALLATION

Install in the reverse order of removal.

### **CAUTION:**

- Never bend or twist hydraulic hoses sharply, or strongly pull them.
- After installation, hydraulic hoses must not move towards self-locking bands.

A  
B  
C  
D  
E  
F  
G  
H  
I  
J  
RF  
L  
M  
N  
O  
P

## HYDRAULIC SYSTEM

< REMOVAL AND INSTALLATION >

---

- **Never let the ends of self-locking bands touch hydraulic hoses.**

# HYDRAULIC CYLINDER

< REMOVAL AND INSTALLATION >

## HYDRAULIC CYLINDER

Exploded View

INFOID:000000006468970

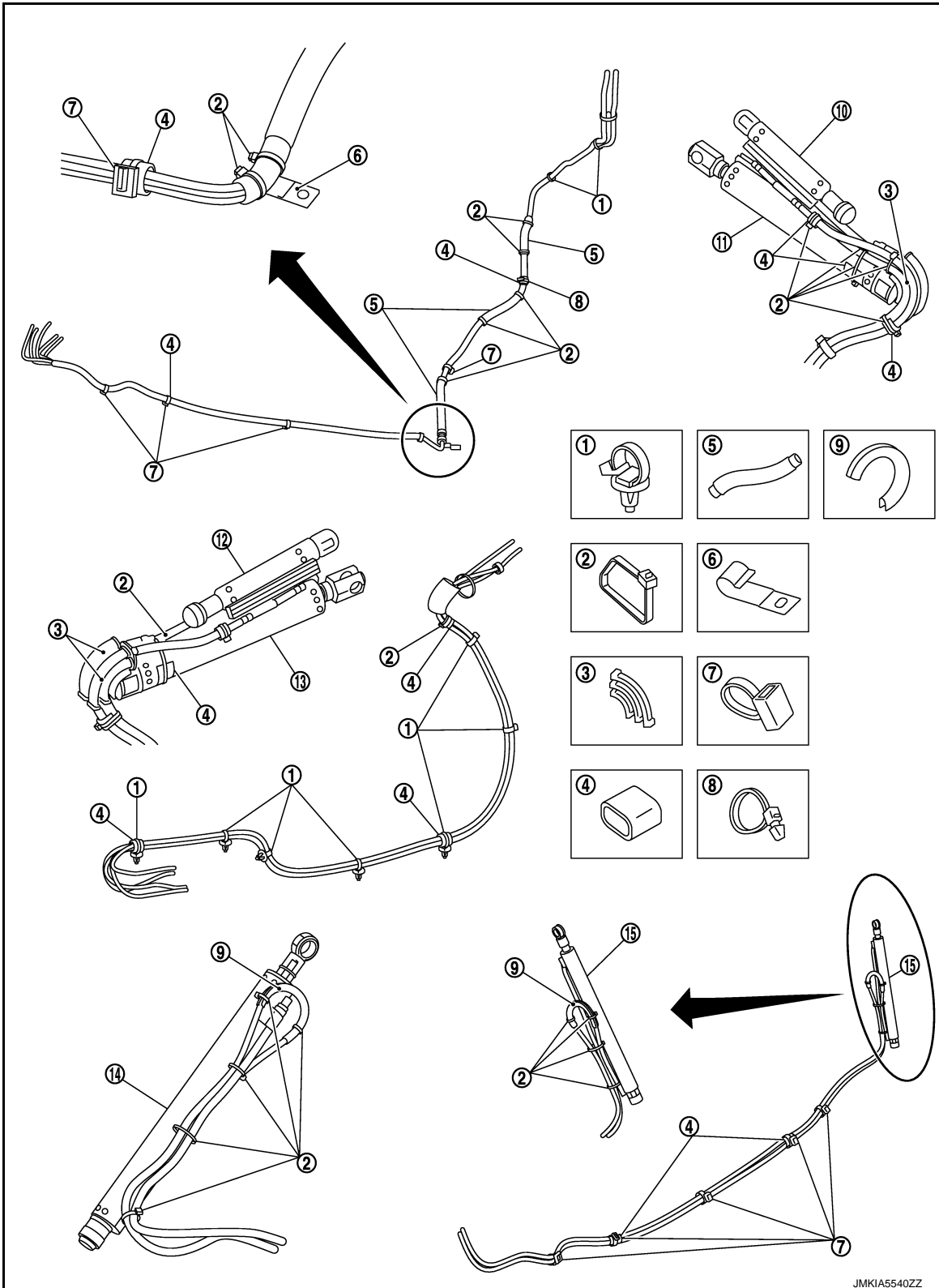

- |                          |                               |                               |
|--------------------------|-------------------------------|-------------------------------|
| 1. Strap tie             | 2. Cable tie                  | 3. Radius holder (double way) |
| 4. Felt                  | 5. Corrugated hose            | 6. Steel clip                 |
| 7. Strap tie (with clip) | 8. Strap tie (with arrowhead) | 9. Radius holder (single way) |

A  
B  
C  
D  
E  
F  
G  
H  
I  
J  
RF  
L  
M  
N  
O  
P

# HYDRAULIC CYLINDER

## < REMOVAL AND INSTALLATION >

- 10. Roof lock cylinder (RH)
- 13. Roof drive cylinder (LH)

- 11. Roof drive cylinder (RH)
- 14. Trunk lid drive cylinder (LH)

- 12. Roof lock cylinder (LH)
- 15. Trunk lid drive cylinder (RH)

## Removal and Installation

INFOID:000000006468971

### HYDRAULIC CYLINDER ASSEMBLY

#### Removal

#### CAUTION:

- Protect the rear fender with a fender protector.
- Never bend or twist hydraulic hoses sharply, or strongly pull them.
- After installation, hydraulic hoses must not move towards self-locking bands.
- Never let the ends of self-locking bands touch hydraulic hoses.
- Remove rear parcel board and set bracket to the straight up position for preventing interference from rear parcel board roof.

1. Remove trunk room trim. Refer to [INT-24, "Removal and Installation"](#).
2. Remove rear cushion and seatback. Refer to [SE-256, "Removal and Installation"](#).
3. Remove rear side finisher. Refer to [INT-15, "Removal and Installation"](#).
4. Open relief valve of oil pump.
5. Set trunk lid to the backdrop status.
  - Open trunk lid manually.
  - Release trunk lid lock (1), (2) toward vehicle rear.

#### CAUTION:

Never move roof manually faster than with automatic operation to prevent hydraulic system from a damage.

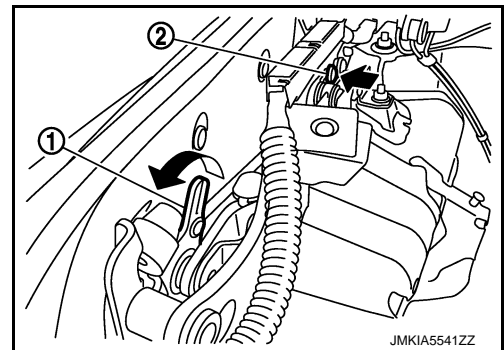

- Lift trunk lid to the backdrop status.
- Support trunk lid (1) using a stand (2) as shown in the figure.

#### CAUTION:

- Always hold trunk lid, because trunk lid moves according to change in hydraulic pressure after removing cylinders.
- Two workers are required for manual operation.

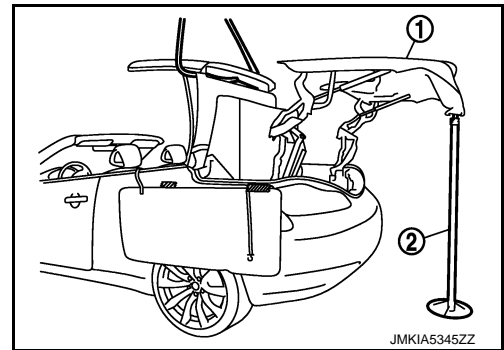

6. Manually set retractable hard top (1) to the straight up position and hold using a lashing belt (2) as shown in the figure. Release front lock on "Work Support" using CONSULT-III.

#### CAUTION:

Always hold retractable hard top using lashing belt, because retractable hard top moves according to change in hydraulic pressure after removing cylinders.

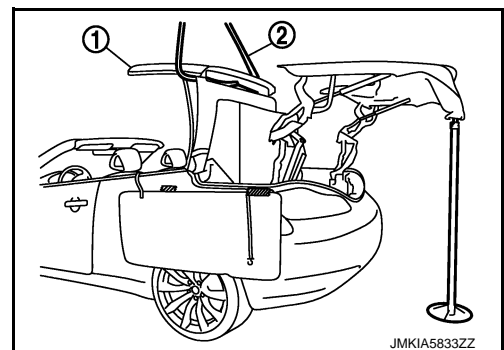



# HYDRAULIC CYLINDER

## < REMOVAL AND INSTALLATION >

7. Remove roof lock cylinder upper portion from roof link assembly (5).
  - Remove clip (3) of roof lock cylinder.
  - Remove roof lock cylinder (1).
8. Remove roof drive cylinder upper portion from roof link assembly (5).
  - Remove retaining plate (4) of roof drive cylinder.
  - Remove roof drive cylinder (2).

↶ : Vehicle front

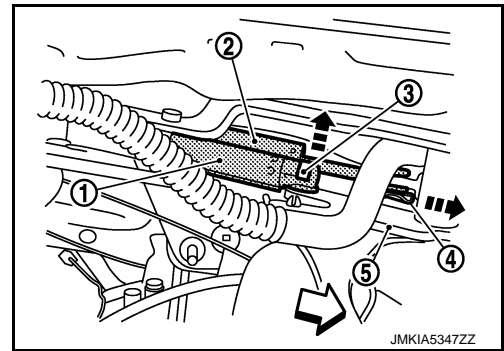

9. Remove roof lock cylinder lower portion from roof link assembly.
  - Remove clip (2) of roof lock cylinder.
  - Remove roof lock cylinder (1).
10. Remove roof drive cylinder lower portion from roof link assembly.
  - Remove retaining plate (4) of roof drive cylinder.
  - Remove roof drive cylinder (3).

↶ : Vehicle front

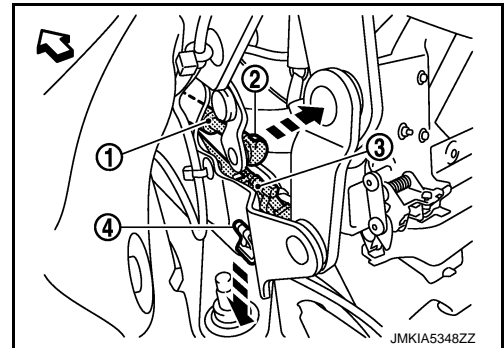

11. Cut clip (1) of roof drive cylinder lower portion using nippers (2) as shown in the figure.

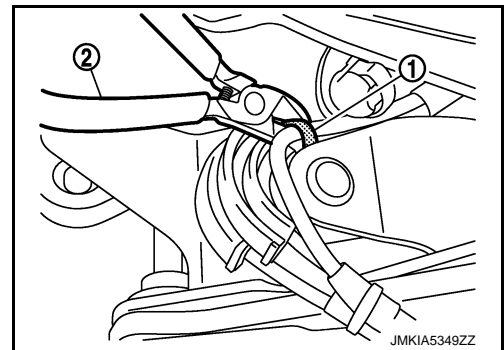

12. Take out roof lock cylinder (1) and roof drive cylinder (2) together in the direction as shown by the arrow in the figure.

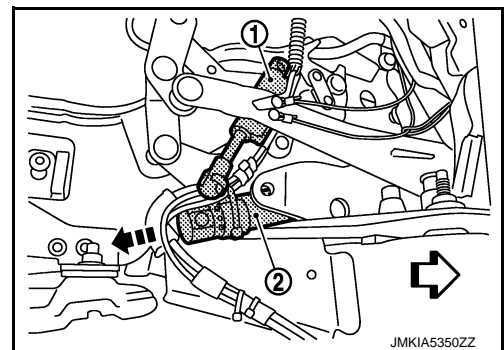

13. Remove trunk lid drive cylinder (1) from trunk link (2).
  - Remove hydraulic pump assembly.
  - Remove clip of trunk lid cylinder. Remove trunk lid cylinder.

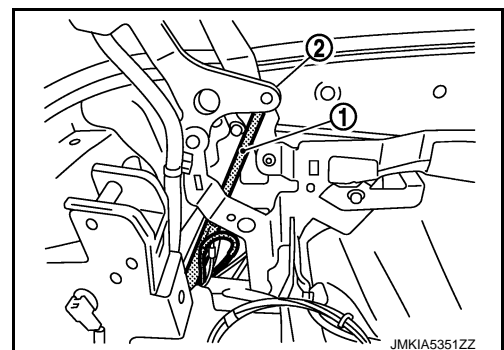

A  
B  
C  
D  
E  
F  
G  
H  
I  
J  
RF  
L  
M  
N  
O  
P

# HYDRAULIC CYLINDER

## < REMOVAL AND INSTALLATION >

### 14. Remove hydraulic hose from hydraulic cylinder.

- Record the installation position of hydraulic cylinder and hydraulic hose.
- Put a paint mark showing the clip band position of hydraulic hose.
- Cut clip band using nippers.
- Remove hydraulic hose.

#### **CAUTION:**

**Never damage hydraulic hose.**

## HYDRAULIC HOSE ASSEMBLY

### Removal

1. Remove the hydraulic hose retaining clip (1) using a flat-bladed screwdriver as show in the figure.

#### **CAUTION:**

- Disengage the clip slowly and carefully.
- Place shop paper under the cylinder to catch any hydraulic fluid that may spill.

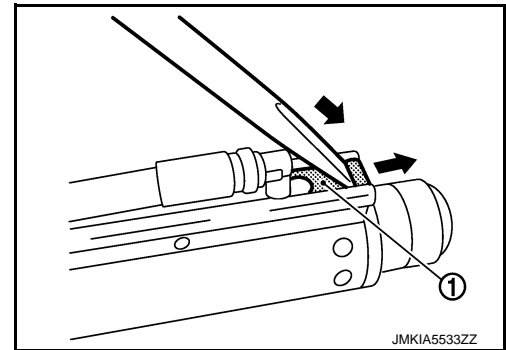

2. Remove the hydraulic hose (1) from cylinder (2).

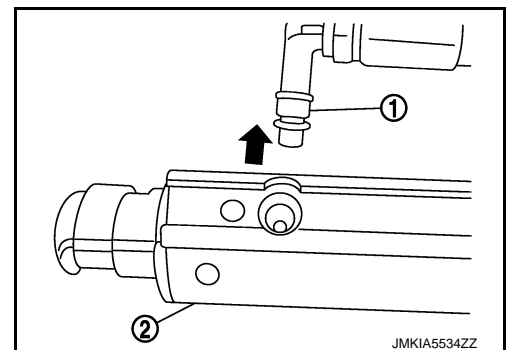

## INSTALLATION

Install in the reverse order of removal.

#### **CAUTION:**

- Prepare the service cylinder for fitting. Remove retaining clips and remove blind plugs.
- Check the connection bore profile if the O-rings are removed from the blind plugs.
- Remove O-ring, if not removed, using a pin that is not sharp.
- Normally, O-ring is attached to blind plugs.
- Check connections including O-ring for damage and cleanliness.

1. Slide retaining clip (1) of new hydraulic cylinder (2) toward outside as shown in the figure, remove blind plugs (4), and remove O-ring (3).

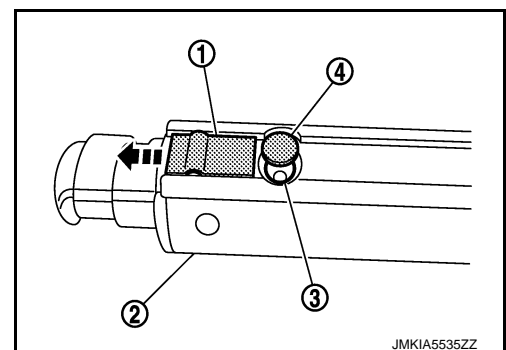

# HYDRAULIC CYLINDER

## < REMOVAL AND INSTALLATION >

2. Apply hydraulic oil to O-ring (1), and install it to hydraulic hose body.

**CAUTION:**

**Never damage O-ring.**

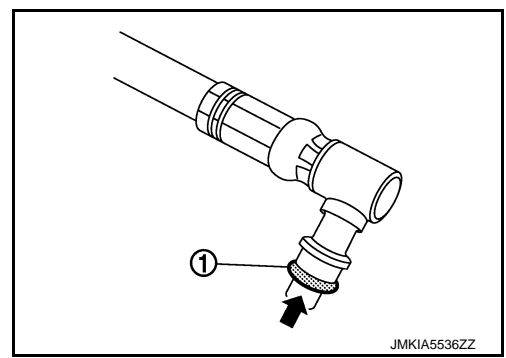

3. Install the hydraulic hose (1) to the cylinder (2).

**CAUTION:**

- **Never damage O-ring.**
- **Install hydraulic hose slowly and carefully.**

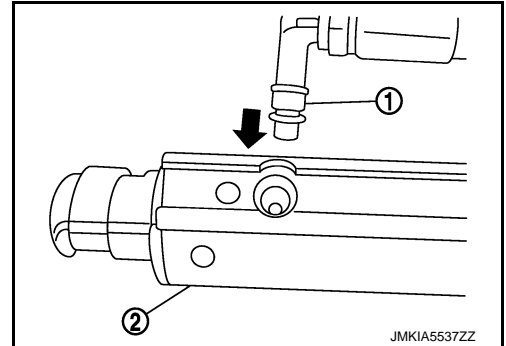

4. Slide the hydraulic hose retaining clip (1) using a flat-bladed screwdriver to the position (2) as show in the figure.

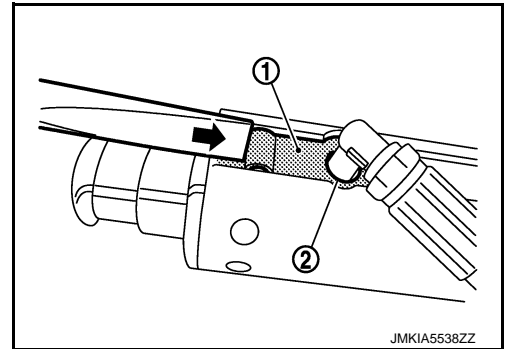

5. Install hydraulic hose to the paint mark position and fix using the specified clip band.

6. Install the hydraulic cylinder to the roof mechanism.

7. Work Support.

- Open relief valve of oil pump.
- Select roof open and close function on "Work Support" using CONSULT-III.
- Operate oil pump toward roof open for 5 seconds, and then toward roof close for 5 seconds.
- Close relief valve of oil pump.

**CAUTION:**

- **Full open and fully close the roof 3 times and check for leakage from hydraulic cylinder.**
- **Always install component parts like clips and hoses to the original installed positions.**
- **Check oil level before and after each cycle. A lower level due to oil leakage may cause hydraulic pump's damage.**

8. Install all of the removed component parts.

## REFILLING

Fill and bleed of hydraulic system

Checking oil level

1. Close the roof completely.
2. Remove the trunk room trim. Refer to [INT-24, "Removal and Installation"](#).
3. Lift the hydraulic unit pump carefully from the hydraulic unit assembly position.
4. Remove the foam cover.

A  
B  
C  
D  
E  
F  
G  
H  
I  
J  
RF  
L  
M  
N  
O  
P

## HYDRAULIC CYLINDER

### < REMOVAL AND INSTALLATION >

5. Put the hydraulic unit pump in the horizontal position and check that the oil level is between "MIN" and "MAX" (A).

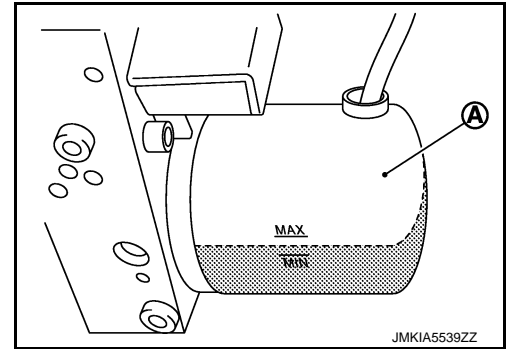

#### Filling oil

1. Remove the filling plug.
2. Fill with hydraulic oil to the max mark on the reservoir using a suitable and clean funnel.
3. Tighten filling plug to the specified torque. Torque: 2.0 N·m (0.2 kg·m, 18 in·lb)

#### NOTE:

- Approximately 250ml of 560ml of oil is drained from the system during removal and installation procedure.
- Be sure to refill oil to the specified level.

#### CAUTION:

- **Never overtighten torque.**
- **Fully open and fully close the roof 3 times. Check for leakage and check oil level.**
- **Filler plug must be tightened to the specified torque for preventing oil leakage.**

# RETRACTABLE HARD TOP CONTROL UNIT

< REMOVAL AND INSTALLATION >

## RETRACTABLE HARD TOP CONTROL UNIT

### Removal and Installation

INFOID:000000006468972

#### REMOVAL

1. Remove rear side finisher LH. Refer to [INT-15. "Removal and Installation"](#).
2. Remove bolts (A).
3. Remove retractable hard top control unit (1) and disconnect the connector.

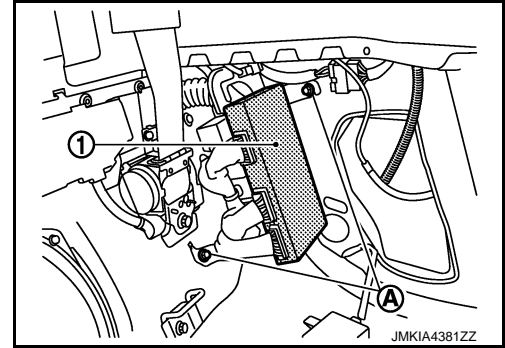

#### INSTALLATION

Install in the reverse order of removal.

**NOTE:**

After installing the retractable hard top control unit, perform additional service when replacing control unit. Refer to [RF-88. "Work Procedure"](#).

A  
B  
C  
D  
E  
F  
G  
H  
I  
J  
RF  
L  
M  
N  
O  
P

# RETRACTABLE HARD ROOF ASSEMBLY

< UNIT REMOVAL AND INSTALLATION >

## UNIT REMOVAL AND INSTALLATION

### RETRACTABLE HARD ROOF ASSEMBLY

Exploded View

INFOID:000000006468973

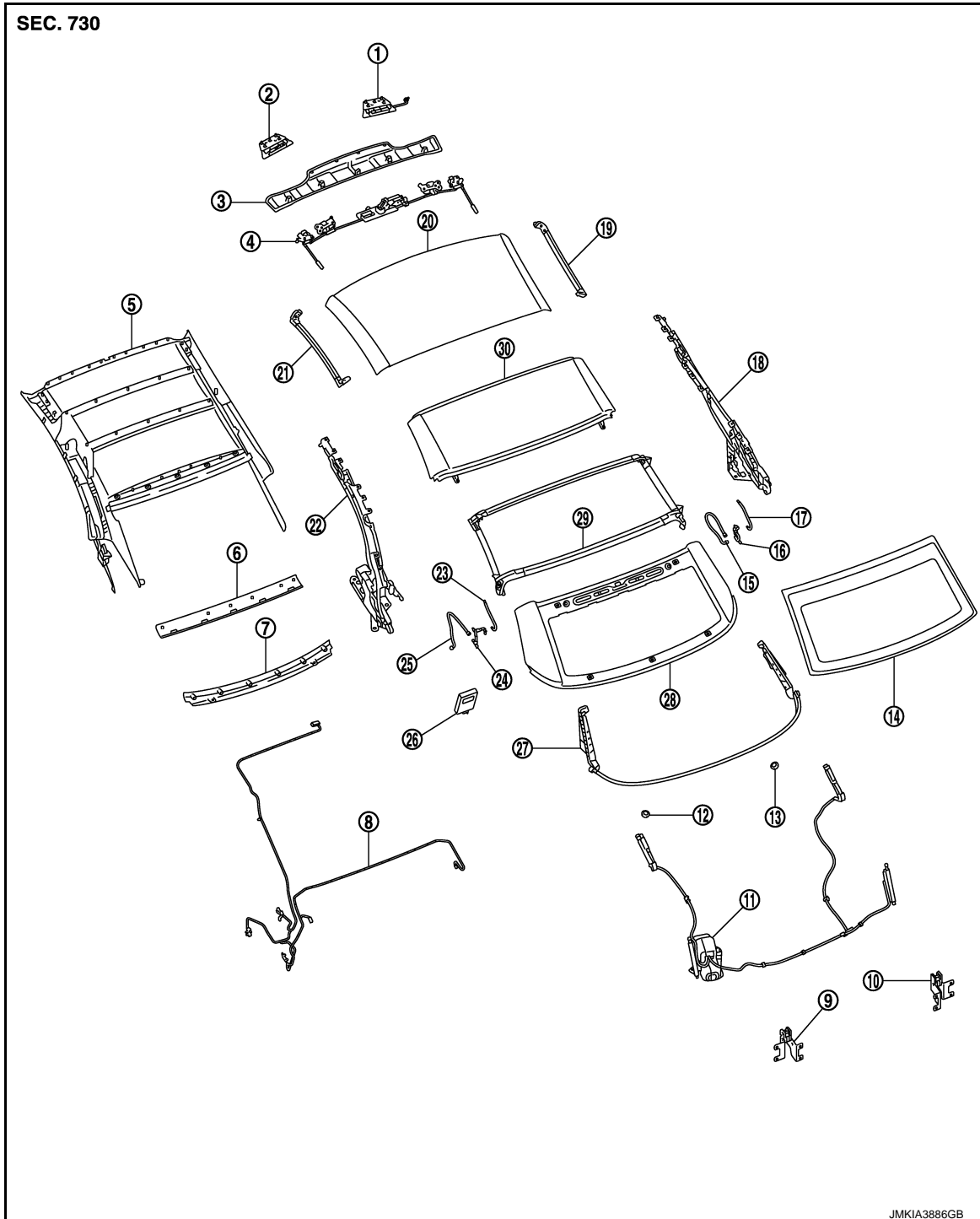

- |                            |                             |                            |
|----------------------------|-----------------------------|----------------------------|
| 1. Front latch assembly RH | 2. Front latch assembly LH  | 3. Front roof garnish      |
| 4. Roof lock assembly      | 5. Headlining               | 6. Rear roof upper garnish |
| 7. Rear roof lower garnish | 8. Roof harness             | 9. Roof support bumper LH  |
| 10. Roof support bumper RH | 11. Hydraulic unit assembly | 12. Bumper rubber LH       |
| 13. Bumper rubber RH       | 14. Rear glass              | 15. Drain tube upper RH    |

# RETRACTABLE HARD ROOF ASSEMBLY

## < UNIT REMOVAL AND INSTALLATION >

- |                                 |                               |                                 |
|---------------------------------|-------------------------------|---------------------------------|
| 16. Drain tube center RH        | 17. Drain tube lower RH       | 18. Roof link assembly RH       |
| 19. Front roof weather-strip RH | 20. Front roof panel          | 21. Front roof weather-strip LH |
| 22. Roof link assembly LH       | 23. Drain tube lower LH       | 24. Drain tube center LH        |
| 25. Drain tube upper LH         | 26. Control unit              | 27. Rear roof weather-strip     |
| 28. Rear roof panel             | 29. Center roof weather-strip | 30. Center roof panel           |

## Removal and Installation

INFOID:000000006468974

### REMOVAL

#### CAUTION:

- Protect the rear fender with a fender protector.
- Take all precaution to avoid any interference between the retractable hard top and the body.
- Never bend or twist hydraulic hoses sharply, or strongly pull them.
- After installation, hydraulic hoses must not move towards self- locking bands.
- Never let the ends of self-locking bands touch hydraulic hoses.

#### NOTE:

Operate roof manually if it does not operate electrically. Refer to [RF-312. "Manual Operation"](#).

1. Roof is fully open.
2. Remove rear seat cushion and seatback. Refer to [SE-256. "Removal and Installation"](#).
3. Remove rear side finisher. Refer to [INT-15. "Removal and Installation"](#).
4. Remove trunk lid trim. Refer to [INT-24. "Removal and Installation"](#).
5. Remove rear parcel shelf finisher board. Refer to [RF-290. "REAR PARCEL SHELF UNIT : Removal and Installation"](#).
6. Roof is fully close.
7. Remove trunk lid assembly. Refer to [DLK-269. "TRUNK LID ASSEMBLY : Removal and Installation"](#).
8. Remove trunk room trim. Refer to [INT-24. "Removal and Installation"](#).
9. Perform unlock operation of roof lock assembly in WORK SUPPORT of CONSULT-III. [RF-45. "CONSULT-III Function"](#)
10. Remove hydraulic unit, hose clamp and trunk drive cylinder. Refer to [RF-299. "Removal and Installation"](#).
11. From passenger roof side, disconnect harness connector. (LH side only)

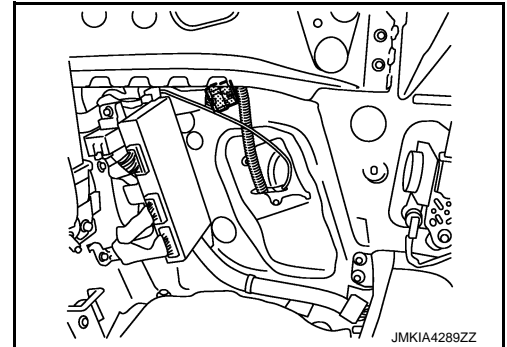

12. Disconnect hydraulic unit harness connector.

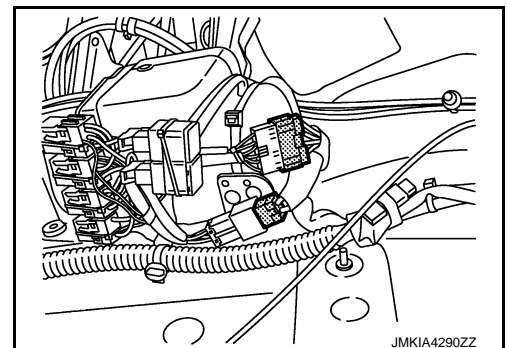

13. Remove roof link assembly mounting nuts. Refer to [RF-288. "Removal and Installation"](#)
14. Lift roof assembly and hydraulic unit assembly simultaneously, and then remove them from the vehicle in the rear direction.

# RETRACTABLE HARD ROOF ASSEMBLY

## < UNIT REMOVAL AND INSTALLATION >

### CAUTION:

This operation requires five people.

### INSTALLATION

Install in the reverse order of removal.

### CAUTION:

- Never bend or twist hydraulic hoses sharply, or strongly pull them.
- After installation, hydraulic hoses must not move towards self-locking bands.
- Never let the ends of self-locking bands touch hydraulic hoses.
- Insert lower end of drain tube (1) to the hole of sealing screen (2) through the vehicle body.

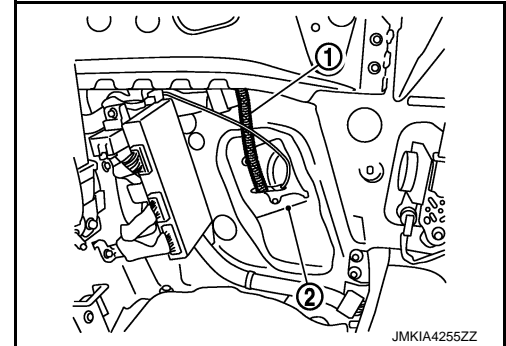

### NOTE:

- Perform initialization according to the work after installing retractable hard roof assembly. Refer to [RF-88, "Description"](#).
- Adjust door glass and quarter window glass. Refer to [GW-18, "Inspection and Adjustment"](#).
- Perform water leakage test. Refer to [RF-255, "Water Leakage Test"](#).

## Manual Operation

INFOID:000000006468975

### CAUTION:

- Protect the rear fender with a fender protector.
- Take all precaution to avoid any interference between the retractable hard top and the body.

### CLOSE STATE TO OPEN STATE

1. Remove metal clip from front roof garnish rear end. Insert a hexagon wrench through clearance between headlining. Rotate roof latch motor shaft using the hexagon wrench and then unlock roof lock assembly.

### CAUTION:

Be careful not to deform front roof garnish.

2. Remove rear parcel shelf finisher board from trunk room side. Refer to [RF-290, "REAR PARCEL SHELF UNIT : Removal and Installation"](#).
3. Remove TORX bolt from rear parcel shelf unit linkage. Check that rear parcel shelf board mounting bracket moves freely while not interfering with other components.
4. Remove trunk room trim, and then open hydraulic unit valve.



**Opening torque: Max 2.0 N-m ( 0.2 kg-m, 18 in-lb )**

### CAUTION:

Check that valve opening torque is always with in the specified value for preventing oil leakage.

5. Remove trunk lid assembly. Refer to [DLK-269, "TRUNK LID ASSEMBLY : Removal and Installation"](#).
6. Pry roof link and unlock roof lock.
7. Open roof by manually.

### CAUTION:

- This operation requires two people.
- Keep hands away from the moving parts.

### OPEN STATE TO CLOSE STATE

1. Remove seat cushion and seatback. Refer to [SE-256, "Removal and Installation"](#).
2. Remove rear side finisher. Refer to [INT-15, "Removal and Installation"](#).



# RETRACTABLE HARD ROOF ASSEMBLY

## < UNIT REMOVAL AND INSTALLATION >

3. Remove TORX bolt from rear parcel shelf unit linkage. Check that rear parcel shelf board mounting bracket moves freely while not interfering with other components. A
4. Remove rear parcel shelf finisher board. Refer to [RF-290, "REAR PARCEL SHELF UNIT : Removal and Installation"](#).
5. Remove trunk lid assembly. Refer to [DLK-269, "TRUNK LID ASSEMBLY : Removal and Installation"](#). B
6. Remove trunk lid drive cylinder upper side pin. Refer to [RF-299, "Removal and Installation"](#).
7. Lift up trunk hinge.
8. Remove front roof garnish. Rotate roof latch motor shaft using the hexagon wrench and then unlock roof lock assembly. C
9. Remove roof drive cylinder front side pin. Refer to [RF-299, "Removal and Installation"](#).  
**CAUTION:**  
**Wait until tension on roof drive cylinder after roof operation is released.** D
10. Close roof by manually.  
**CAUTION:**
  - This operation requires two people.
  - Keep hands away from the moving parts. E
11. Remove trunk room trim, and then open hydraulic unit valve. F

 **Opening torque: Max 2.0 N·m ( 0.2 kg·m, 18 in·lb )** G

**CAUTION:**  
Check that valve opening torque is always with in the specified value for preventing oil leakage. H

A  
B  
C  
D  
E  
F  
G  
H  
I  
J  
L  
M  
N  
O  
P

RF