

A
EM
C
D
E
F
G
H
I
J
K
L
M
N
O
P

SECTION **EM**

ENGINE MECHANICAL

CONTENTS

SYMPTOM DIAGNOSIS	SPARK PLUG	3	16
NOISE, VIBRATION AND HARSHNESS (NVH) TROUBLESHOOTING	Exploded View	3	16
NVH Troubleshooting - Engine Noise	Removal and Installation	3	16
Use the Chart Below to Help You Find the Cause of the Symptom	Inspection	3	17
PRECAUTION	CAMSHAFT VALVE CLEARANCE	5	18
PRECAUTIONS	Inspection and Adjustment	5	18
Precaution for Procedure without Cowl Top Cover.....	COMPRESSION PRESSURE	5	23
Precaution for Supplemental Restraint System (SRS) "AIR BAG" and "SEAT BELT PRE-TENSIONER"	Inspection	5	23
Service Procedure Precautions for Models with a Pop-up Roll Bar	REMOVAL AND INSTALLATION	5	25
Precaution for Battery Service	ENGINE COVER	6	25
Precautions Necessary for Steering Wheel Rotation After Battery Disconnection	Exploded View	6	25
Precautions For Engine Service	Removal and Installation	6	25
Parts Requiring Angle Tightening	DRIVE BELT AUTO TENSIONER AND IDLER PULLEY	7	26
Liquid Gasket	Exploded View	7	26
Definitions of Bank Names	Removal and Installation	8	26
PREPARATION	AIR CLEANER AND AIR DUCT	9	27
PREPARATION	Exploded View	9	27
Special Service Tools	Removal and Installation	9	27
Commercial Service Tools	Inspection	10	28
PERIODIC MAINTENANCE	INTAKE MANIFOLD COLLECTOR	13	29
DRIVE BELT	Exploded View	13	29
Exploded View	Removal and Installation	13	29
Checking	INTAKE MANIFOLD	13	32
Tension Adjustment	Exploded View	13	32
Removal and Installation	Removal and Installation	13	32
Inspection	Inspection	14	33
AIR CLEANER FILTER	EXHAUST MANIFOLD	15	34
Removal and Installation	Exploded View	15	34
	Removal and Installation	15	34
	Inspection	15	36
	FUEL INJECTOR AND FUEL TUBE	15	37
	Exploded View	15	37

Removal and Installation	37	Inspection	78
Inspection	42		
OIL PAN (LOWER)	43	REAR TIMING CHAIN CASE	79
Exploded View	43	Exploded View	79
Removal and Installation	43	Disassembly and Assembly	80
Inspection	45		
IGNITION COIL, SPARK PLUG AND ROCK- ER COVER	46	CAMSHAFT	84
Exploded View	46	Exploded View	84
Removal and Installation	46	Disassembly and Assembly	85
		Inspection	94
TIMING CHAIN	49	CYLINDER HEAD	101
Exploded View	49	Exploded View	101
Removal and Installation	50	Disassembly and Assembly	102
Inspection	64	Inspection	107
OIL SEAL	66	CYLINDER BLOCK	111
FRONT OIL SEAL	66	Exploded View	111
FRONT OIL SEAL : Removal and Installation	66	Disassembly and Assembly	112
REAR OIL SEAL	66	Inspection	121
REAR OIL SEAL : Removal and Installation	66	HOW TO SELECT PISTON AND BEARING ..	132
UNIT REMOVAL AND INSTALLATION	68	Description	132
ENGINE ASSEMBLY	68	Piston	132
Exploded View	68	Connecting Rod Bearing	133
Removal and Installation	68	Main Bearing	136
Inspection	71	SERVICE DATA AND SPECIFICATIONS (SDS)	138
UNIT DISASSEMBLY AND ASSEMBLY ...	73	SERVICE DATA AND SPECIFICATIONS (SDS)	138
ENGINE STAND SETTING	73	General Specification	138
Setting	73	Drive Belt	138
ENGINE UNIT	75	Spark Plug	138
Disassembly	75	Intake Manifold	139
Assembly	75	Exhaust Manifold	139
OIL PAN (UPPER) AND OIL STRAINER	76	Camshaft	139
Exploded View	76	Cylinder Head	141
Disassembly and Assembly	76	Cylinder Block	143
		Main Bearing	147
		Connecting Rod Bearing	148

NOISE, VIBRATION AND HARSHNESS (NVH) TROUBLESHOOTING

< SYMPTOM DIAGNOSIS >

SYMPTOM DIAGNOSIS

NOISE, VIBRATION AND HARSHNESS (NVH) TROUBLESHOOTING

NVH Troubleshooting - Engine Valve Noise

INFOID:000000008154403

A

EM

C

D

E

F

G

H

I

J

K

L

M

N

O

P

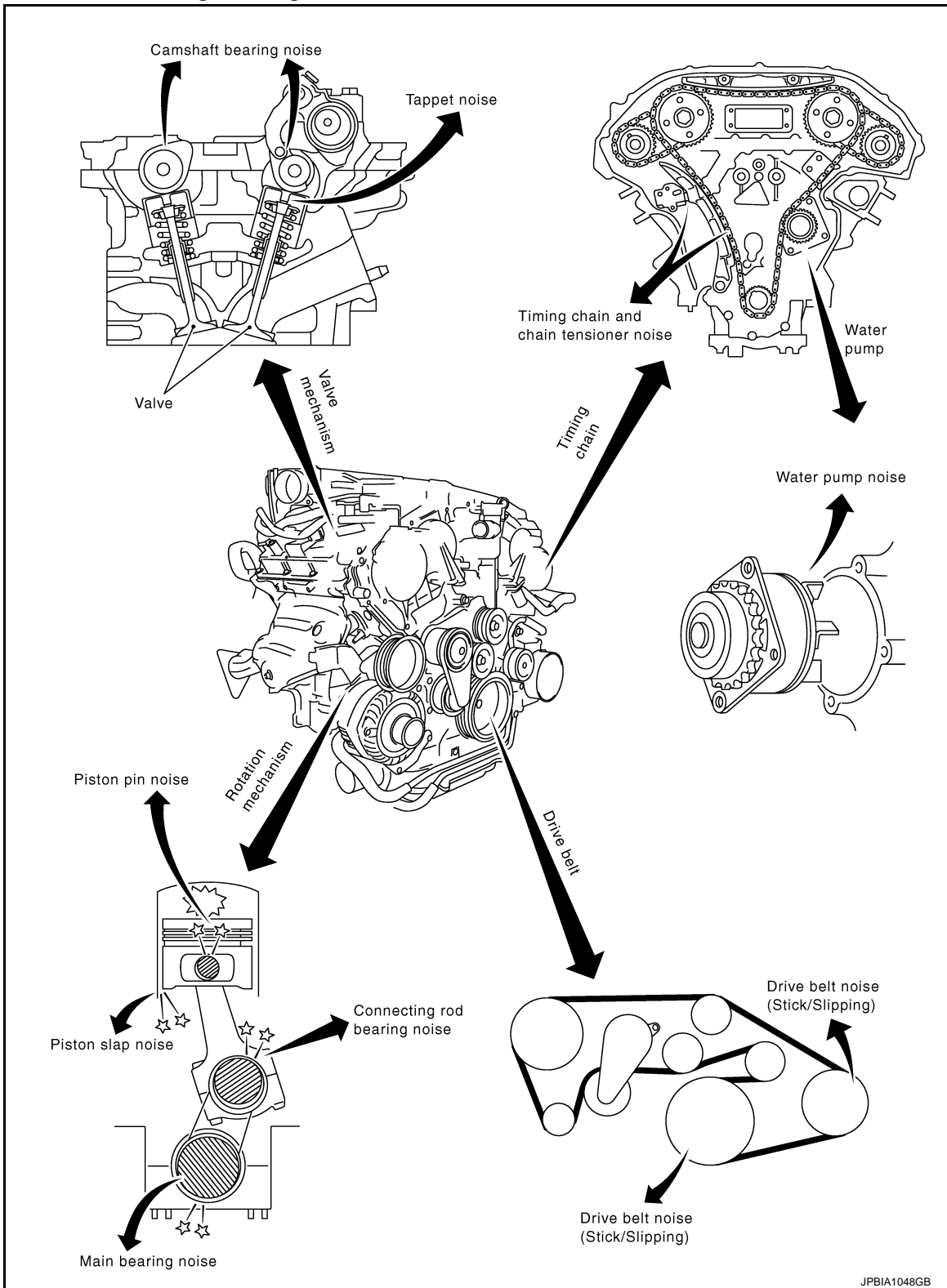

Use the Chart Below to Help You Find the Cause of the Symptom

INFOID:000000008154404

1. Locate the area where noise occurs.

NOISE, VIBRATION AND HARSHNESS (NVH) TROUBLESHOOTING

< SYMPTOM DIAGNOSIS >

2. Confirm the type of noise.
3. Specify the operating condition of the engine.
4. Check specified noise source.

If necessary, repair or replace these parts.

Location of noise	Type of noise	Operating condition of engine						Source of noise	Check item	Reference page
		Before warm-up	After warm-up	When starting	When idling	When racing	While driving			
Top of engine Rocker cover Cylinder head	Ticking or clicking	C	A	—	A	B	—	Tappet noise	Valve clearance	EM-18
	Rattle	C	A	—	A	B	C	Camshaft bearing noise	Camshaft runout Camshaft journal oil clearance	EM-139
Crankshaft pulley Cylinder block (Side of engine) Oil pan	Slap or knock	—	A	—	B	B	—	Piston pin noise	Piston to piston pin oil clearance Connecting rod bushing oil clearance	EM-143
	Slap or rap	A	—	—	B	B	A	Piston slap noise	Piston to cylinder bore clearance Piston ring side clearance Piston ring end gap Connecting rod bend and torsion	EM-143
	Knock	A	B	C	B	B	B	Connecting rod bearing noise	Connecting rod bushing oil clearance Connecting rod bearing oil clearance	EM-143 EM-148
	Knock	A	B	—	A	B	C	Main bearing noise	Main bearing oil clearance Crankshaft runout	EM-147 EM-143
Front of engine Timing chain case	Tapping or ticking	A	A	—	B	B	B	Timing chain and timing chain tensioner noise	Timing chain cracks and wear Timing chain tensioner operation	EM-64 EM-50
Front of engine	Squeaking or fizzing	A	B	—	B	—	C	Drive belt (Sticking or slipping)	Drive belt deflection	EM-13
	Creaking	A	B	A	B	A	B	Drive belt (Slipping)	Idler pulley bearing operation	
	Squall Creak	A	B	—	B	A	B	Water pump noise	Water pump operation	CO-19 , "Exploded View"

A: Closely related B: Related C: Sometimes related —: Not related

PRECAUTIONS

< PRECAUTION >

PRECAUTION

PRECAUTIONS

Precaution for Procedure without Cowl Top Cover

INFOID:000000008154405

When performing the procedure after removing cowl top cover, cover the lower end of windshield with urethane, etc to prevent damage to windshield.

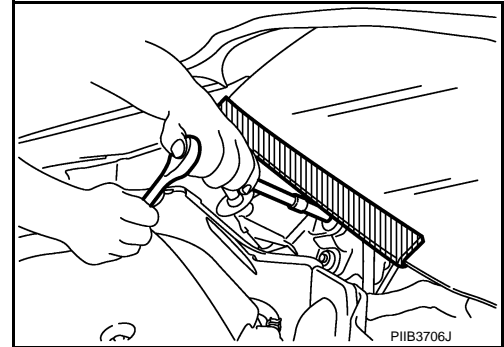

Precaution for Supplemental Restraint System (SRS) "AIR BAG" and "SEAT BELT PRE-TENSIONER"

INFOID:000000008154406

The Supplemental Restraint System such as "AIR BAG" and "SEAT BELT PRE-TENSIONER", used along with a front seat belt, helps to reduce the risk or severity of injury to the driver and front passenger for certain types of collision. This system includes seat belt switch inputs and dual stage front air bag modules. The SRS system uses the seat belt switches to determine the front air bag deployment, and may only deploy one front air bag, depending on the severity of a collision and whether the front occupants are belted or unbelted. Information necessary to service the system safely is included in the "SRS AIR BAG" and "SEAT BELT" of this Service Manual.

WARNING:

Always observe the following items for preventing accidental activation.

- To avoid rendering the SRS inoperative, which could increase the risk of personal injury or death in the event of a collision that would result in air bag inflation, all maintenance must be performed by an authorized NISSAN/INFINITI dealer.
- Improper maintenance, including incorrect removal and installation of the SRS, can lead to personal injury caused by unintentional activation of the system. For removal of Spiral Cable and Air Bag Module, see "SRS AIR BAG".
- Never use electrical test equipment on any circuit related to the SRS unless instructed to in this Service Manual. SRS wiring harnesses can be identified by yellow and/or orange harnesses or harness connectors.

PRECAUTIONS WHEN USING POWER TOOLS (AIR OR ELECTRIC) AND HAMMERS

WARNING:

Always observe the following items for preventing accidental activation.

- When working near the Air Bag Diagnosis Sensor Unit or other Air Bag System sensors with the ignition ON or engine running, never use air or electric power tools or strike near the sensor(s) with a hammer. Heavy vibration could activate the sensor(s) and deploy the air bag(s), possibly causing serious injury.
- When using air or electric power tools or hammers, always switch the ignition OFF, disconnect the battery, and wait at least 3 minutes before performing any service.

Service Procedure Precautions for Models with a Pop-up Roll Bar

INFOID:000000008154407

WARNING:

Always observe the following items for preventing accidental activation.

- Risk of passenger injury or death may increase if the pop-up roll bar does not deploy during a roll over collision. In order to reduce the chance of an incident where the pop-up roll bar is inoperative, all maintenance must be performed by a NISSAN or INFINITI dealer.
- Before removing and installing the pop-up roll bar component parts and harness, always turn the ignition switch OFF, disconnect the battery negative terminal, and wait for 3 minutes or more. (The

PRECAUTIONS

< PRECAUTION >

purpose of this operation is to discharge electricity that is accumulated in the auxiliary power supply circuit in the air bag diagnosis sensor unit.)

- **When repairing, removing, and installing a pop-up roll bar, always refer to SRS AIR BAG and SRS AIR BAG CONTROL warnings in the Service Manual.**

Precaution for Battery Service

INFOID:000000008154408

Before disconnecting the battery, lower both the driver and passenger windows. This will prevent any interference between the window edge and the vehicle when the door is opened/closed. During normal operation, the window slightly raises and lowers automatically to prevent any window to vehicle interference. The automatic window function will not work with the battery disconnected.

Precautions Necessary for Steering Wheel Rotation After Battery Disconnection

INFOID:000000008154409

CAUTION:

Comply with the following cautions to prevent any error and malfunction.

- **Before removing and installing any control units, first turn the ignition switch to the LOCK position, then disconnect both battery cables.**
- **After finishing work, confirm that all control unit connectors are connected properly, then re-connect both battery cables.**
- **Always use CONSULT to perform self-diagnosis as a part of each function inspection after finishing work. If a DTC is detected, perform trouble diagnosis according to self-diagnosis results.**

For vehicle with steering lock unit, if the battery is disconnected or discharged, the steering wheel will lock and cannot be turned.

If turning the steering wheel is required with the battery disconnected or discharged, follow the operation procedure below before starting the repair operation.

OPERATION PROCEDURE

1. Connect both battery cables.

NOTE:

Supply power using jumper cables if battery is discharged.

2. Turn the ignition switch to ACC position.
(At this time, the steering lock will be released.)
3. Disconnect both battery cables. The steering lock will remain released with both battery cables disconnected and the steering wheel can be turned.
4. Perform the necessary repair operation.
5. When the repair work is completed, re-connect both battery cables. With the brake pedal released, turn the ignition switch from ACC position to ON position, then to LOCK position. (The steering wheel will lock when the ignition switch is turned to LOCK position.)
6. Perform self-diagnosis check of all control units using CONSULT.

Precautions For Engine Service

INFOID:000000008154410

DISCONNECTING FUEL PIPING

- Before starting work, check no fire or spark producing items are in the work area.
- Release fuel pressure before disconnecting and disassembly.
- After disconnecting pipes, plug openings to stop fuel leakage.

DRAINING ENGINE COOLANT

Drain engine coolant and engine oil when the engine is cooled.

INSPECTION, REPAIR AND REPLACEMENT

Before repairing or replacing, thoroughly inspect parts. Inspect new replacement parts in the same way, and replace if necessary.

REMOVAL AND DISASSEMBLY

- When instructed to use SST, use specified tools. Always be careful to work safely, avoid forceful or uninstructed operations.

PRECAUTIONS

< PRECAUTION >

- Exercise maximum care to avoid damage to mating or sliding surfaces.
- Dowel pins are used for several parts alignment. When replacing and reassembling parts with dowel pins, check that dowel pins are installed in the original position.
- Must cover openings of engine system with a tape or equivalent, to seal out foreign materials.
- Mark and arrange disassembly parts in an organized way for easy troubleshooting and reassembly.
- When loosening nuts and bolts, as a basic rule, start with the one furthest outside, then the one diagonally opposite, and so on. If the order of loosening is specified, do exactly as specified. Power tools may be used in the step.

A

EM

C

ASSEMBLY AND INSTALLATION

- Use torque wrench to tighten bolts or nuts to specification.
- When tightening nuts and bolts, as a basic rule, equally tighten in several different steps starting with the ones in center, then ones on inside and outside diagonally in this order. If the order of tightening is specified, do exactly as specified.
- Replace with new gasket, packing, oil seal or O-ring.
- Thoroughly wash, clean, and air-blow each part. Carefully check engine oil or engine coolant passages for any restriction and blockage.
- Avoid damaging sliding or mating surfaces. Completely remove foreign materials such as cloth lint or dust. Before assembly, oil sliding surfaces well.
- After disassembling , or exposing any internal engine parts, change engine oil and replace oil filter with a new one.
- Release air within route when refilling after draining engine coolant.
- After repairing, start the engine and increase engine speed to check engine coolant, fuel, engine oil, and exhaust gases for leakage.

D

E

F

G

H

Parts Requiring Angle Tightening

INFOID:000000008154411

- Use the angle wrench [SST: KV10112100 (BT8653-A)] for the final tightening of the following engine parts:
 - Cylinder head bolts
 - Lower cylinder block bolts
 - Connecting rod cap bolts
- Do not use a torque value for final tightening.
- The torque value for these parts are for a preliminary step.
- Ensure thread and seat surfaces are clean and coated with engine oil.

I

J

Liquid Gasket

INFOID:000000008154412

REMOVAL OF LIQUID GASKET SEALING

- After removing mounting nuts and bolts, separate the mating surface using the seal cutter [SST: KV10111100 (J-37228)] (A) and remove old liquid gasket sealing.

L

M

N

O

P

CAUTION:

Be careful not to damage the mating surfaces.

- Tap the seal cutter [SST: KV10111100 (J-37228)] to insert it (B), and then slide it (C) by tapping on the side as shown in the figure.
- In areas where the seal cutter [SST: KV10111100 (J-37228)] is difficult to use, lightly tap the parts using a plastic hammer to remove it.

CAUTION:

If for some unavoidable reason a tool such as a screwdriver is used, be careful not to damage the mating surfaces.

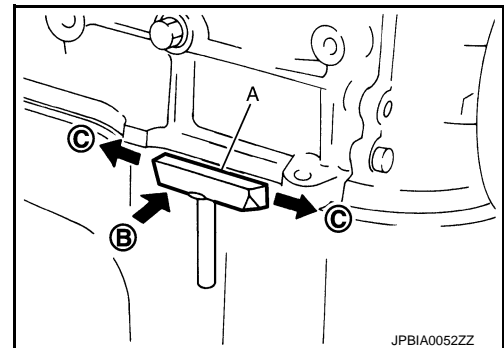

LIQUID GASKET APPLICATION PROCEDURE

PRECAUTIONS

< PRECAUTION >

- Using a scraper (A), remove old liquid gasket adhering to the liquid gasket application surface and the mating surface.
 - Remove liquid gasket completely from the groove of the liquid gasket application surface, mounting bolts and bolt holes.
- Wipe the liquid gasket application surface and the mating surface with white gasoline (lighting and heating use) to remove adhering moisture, grease and foreign materials.

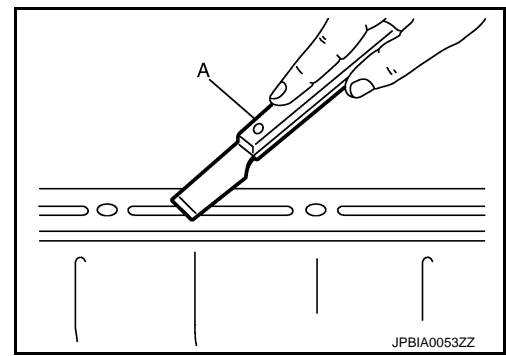

- Attach liquid gasket tube to the tube presser (commercial service tool).
Use Genuine RTV Silicone Sealant or equivalent. Refer to GI-22, "Recommended Chemical Products and Sealants".
- Apply liquid gasket without gaps to the specified location according to the specified dimensions.
 - If there is a groove for liquid gasket application, apply liquid gasket to the groove.

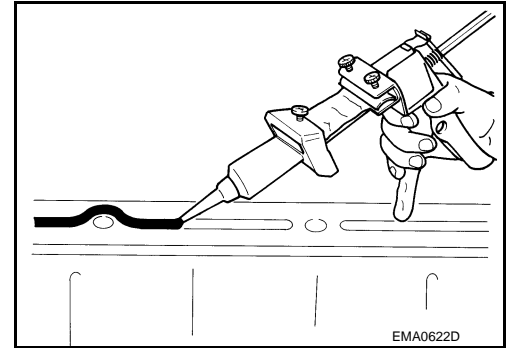

- As for bolt holes (B), normally apply liquid gasket inside the holes. Occasionally, it should be applied outside the holes. Check to read the text of this manual.

A : Groove

↔ : Inside

- Within five minutes of liquid gasket application, install the mating component.
- If liquid gasket protrudes, wipe it off immediately.
- Do not retighten mounting bolts or nuts after the installation.
- After 30 minutes or more have passed from the installation, fill engine oil and engine coolant.

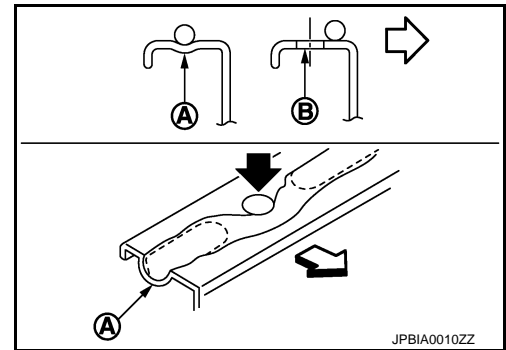

CAUTION:

If there are specific instructions in this manual, observe them.

Definitions of Bank Names

INFOID:000000008154413

- In this manual, each bank name is defined as follows:

A : Bank 1 (The conventional right bank)

B : Bank 2 (The conventional left bank)

↔ : Engine front

- For cylinder numbers and bank layout, refer to the illustration.

Bank 1 : The bank side including cylinder No. 1 (odd-numbered cylinder side)

Bank 2 : The other bank side of the above (even-numbered cylinder side)

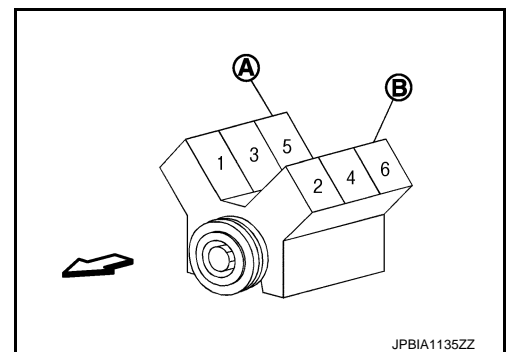

PREPARATION

< PREPARATION >

PREPARATION

PREPARATION



Special Service Tools

INFOID:000000008154414

A

EM

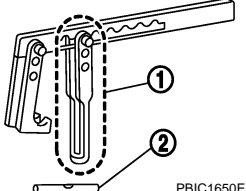
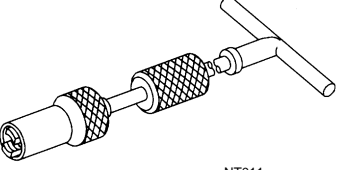
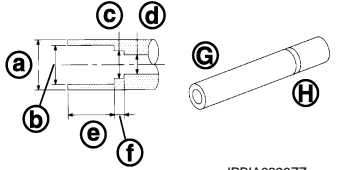
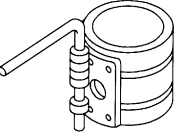
The actual shapes of Kent-Moore tools may differ from those of special service tools illustrated here.

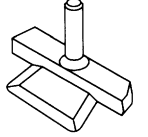
Tool number (Kent-Moore No.) Tool name	Description
KV10116200 (J-26336-A) Valve spring compressor 1. KV10115900 (J-26336-20) Attachment 2. KV10109220 (—) Adapter	 Disassembling valve mechanism Part (1) is a component of KV10116200 (J-26336-A), but Part (2) is not so.
KV10107902 (J-38959) Valve oil seal puller	 Replacing valve oil seal
KV10115600 (J-38958) Valve oil seal drift	 Installing valve oil seal Use side A (G). a: 20 (0.79) dia. d: 8 (0.31) dia. b: 13 (0.51) dia. e: 10.7 (0.421) c: 10.3 (0.406) dia. f: 5 (0.20) H: side B Unit: mm (in)
EM03470000 (J-8037) Piston ring compressor	 Installing piston assembly into cylinder bore
ST16610001 (J-23907) Pilot bushing puller	 Removing pilot converter
KV10111100 (J-37228) Seal cutter	 Removing oil pan (lower and upper), front and rear timing chain case, etc.

C

D

E

F

G

H

I

J

K

L

M

N

O

P

PREPARATION

< PREPARATION >

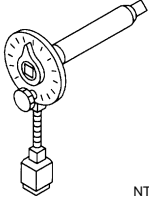
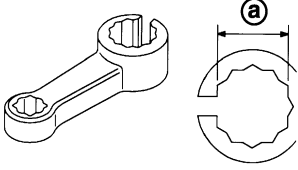
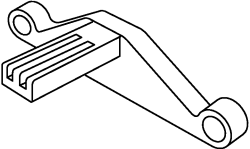
Tool number (Kent-Moore No.) Tool name	Description
KV10112100 (BT8653-A) Angle wrench  NT014	Tightening bolts for connecting rod bearing cap, cylinder head, etc. at an angle
KV10114400 (J-38365) Heated oxygen sensor wrench  JPBIA0397ZZ	Loosening or tightening air fuel ratio sensor 1 a: 22 mm (0.87 in)
KV10118600 (J-48641) Ring gear stopper  JPBIA0409ZZ	Removing and installing crankshaft pulley

Commercial Service Tools

INFOID:000000008154415

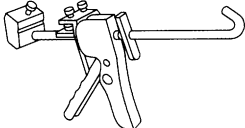
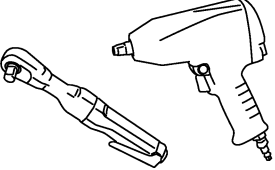
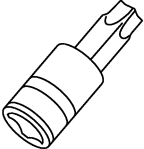
(Kent-Moore No.) Tool name	Description
(—) Tube presser  NT052	Pressing the tube of liquid gasket
(—) Power tool  PBIC0190E	Loosening nuts and bolts
(—) TORX socket  PBIC1113E	Removing and installing flywheel Size: T55

PREPARATION

< PREPARATION >

(Kent-Moore No.) Tool name	Description	
(—) Manual lift table caddy	Removing and installing engine	A EM C
(J-24239-01) Cylinder head bolt wrench	Loosening and tightening cylinder head bolt, and used with the angle wrench [SST: KV10112100 (BT8653-A)] a: 13 (0.51) dia. b: 12 (0.47) c: 10 (0.39) Unit: mm (in)	D E F
(—) 1. Compression gauge 2. Adapter	Checking compression pressure	G H
(—) Spark plug wrench	Removing and installing spark plug a: 14 mm (0.55 in)	I J
(—) Valve seat cutter set	Finishing valve seat (EXH) dimensions	K L M
(—) Piston ring expander	Removing and installing piston ring	N O
(—) Valve guide drift	Removing and installing valve guide (EXH) Exhaust: a: 9.5 mm (0.374 in) dia. b: 5.5 mm (0.217 in) dia.	P

PREPARATION

< PREPARATION >

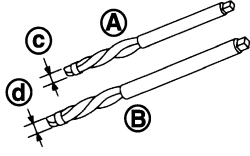
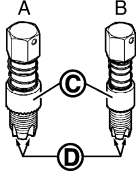
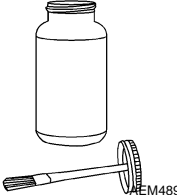
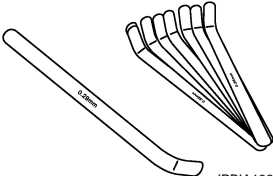
(Kent-Moore No.) Tool name	Description
(—) Valve guide reamer 	A: Reaming valve guide (EXH) inner hole B: Reaming hole for oversize valve guide (EXH) Exhaust: c: 6.0 mm (0.236 in) dia. d: 10.2 mm (0.402 in) dia.
(J-43897-18) (J-43897-12) Oxygen sensor thread cleaner 	Reconditioning the exhaust system threads before installing a new air fuel ratio sensor and heated oxygen sensor (Use with anti-seize lubricant shown below.) A: J-43897-18 [18 mm (0.71 in) dia.] for zirconia heated oxygen sensor and air fuel ratio sensor B: J-43897-12 [12 mm (0.47 in) dia.] for titania heated oxygen sensor C: Mating surface shave cylinder D: Flutes
(—) Anti-seize lubricant (Permatex 133AR or equivalent meeting MIL specification MIL-A-907) 	Lubricating oxygen sensor thread cleaning tool when reconditioning exhaust system threads
(—) Feeler gauge 	Inspection valve clearance (Use a curved-tip gauge)

DRIVE BELT

< PERIODIC MAINTENANCE >

PERIODIC MAINTENANCE

DRIVE BELT

Exploded View

INFOID:000000008154416

A

EM

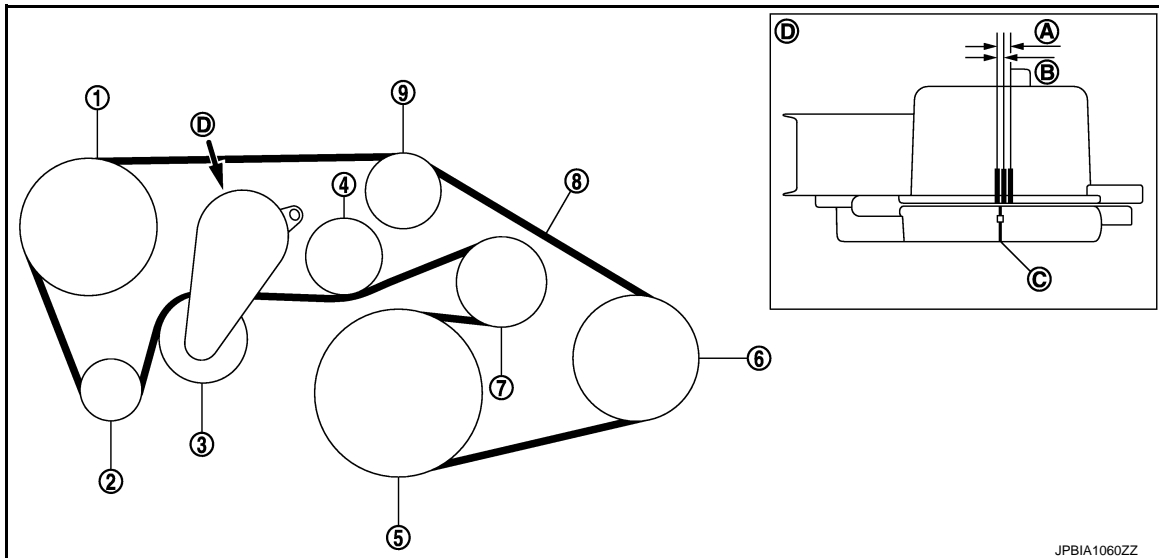

- | | | |
|----------------------------|---|------------------------------|
| 1. Power steering oil pump | 2. Alternator | 3. Drive belt auto-tensioner |
| 4. Idler pulley | 5. Crankshaft pulley | 6. A/C compressor |
| 7. Idler pulley | 8. Drive belt | 9. Idler pulley |
| A. Possible use range | B. Range when new drive belt is installed | C. Indicator |
| D. View D | | |

Checking

INFOID:000000008154417

WARNING:

Be sure to perform this step when engine is stopped.

- Check that the indicator (C) (notch on fixed side) of drive belt auto-tensioner is within the possible use range (A).

NOTE:

- Check the drive belt auto-tensioner indication when the engine is cold.
- When new drive belt is installed, the indicator (notch on fixed side) should be within the range (B) in the figure.
- Visually check the entire drive belt for wear, damage or crack.
- If the indicator (notch on fixed side) is out of the possible use range or belt is damaged, replace drive belt.

Tension Adjustment

INFOID:000000008154418

Refer to [EM-138. "Drive Belt"](#).

Removal and Installation

INFOID:000000008154419

REMOVAL

1. Remove engine undercover with power tool.

DRIVE BELT

< PERIODIC MAINTENANCE >

2. While securely holding the square hole (A) in pulley center of auto tensioner (1) with a spinner handle, move spinner handle in the direction of arrow (loosening direction of drive belt).

CAUTION:

Never place hand in a location where pinching may occur if the holding tool accidentally comes off.

← : Loosening direction of drive belt

3. Under the above condition, insert a metallic bar of approximately 6 mm (0.24 in) in diameter [hexagonal wrench (C) shown as example in the figure] through the holding boss (B) to lock auto-tensioner pulley arm.

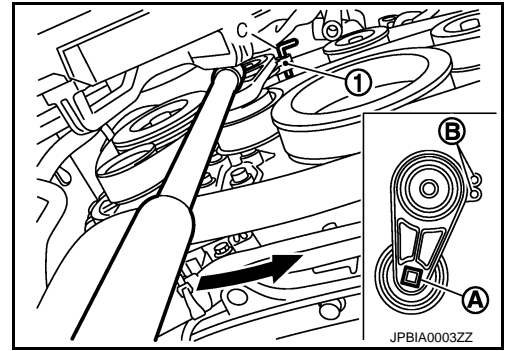

4. Remove drive belt.

INSTALLATION

Note the following, and install in the reverse order of removal.

CAUTION:

- Check drive belt is securely installed around all pulleys.
- Check drive belt is correctly engaged with the pulley groove.
- Check for engine oil and engine coolant are not adhered drive belt and pulley groove.

Inspection

INFOID:000000008154420

INSPECTION AFTER INSTALLATION

- Turn crankshaft pulley clockwise several times to equalize tension between each pulley, and then confirm tension of drive belt at indicator (notch on fixed side) is within the possible use range. Refer to [EM-13, "Exploded View"](#).

AIR CLEANER FILTER

< PERIODIC MAINTENANCE >

AIR CLEANER FILTER

Removal and Installation

INFOID:000000008154421

REMOVAL

1. Unhook clips (A).

- 1 : Holder
- 2 : Air cleaner case

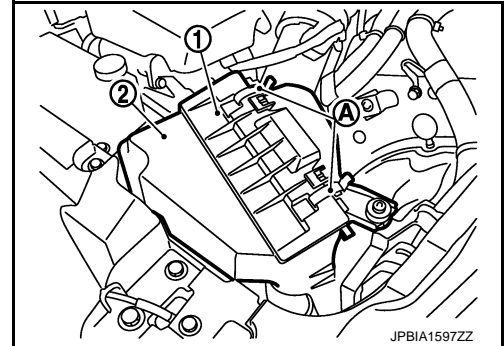

2. Remove holder (3) from air cleaner case (2), and then remove air cleaner filter (1) from holder.

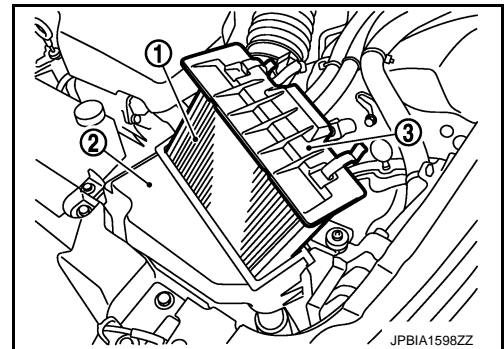

INSTALLATION

Note the following, and install in the reverse order of removal.

- Install the air cleaner filter by aligning the seal with the notch of air cleaner case.

A

EM

C

D

E

F

G

H

I

J

K

L

M

N

O

P

SPARK PLUG

< PERIODIC MAINTENANCE >

SPARK PLUG

Exploded View

INFOID:000000008154422

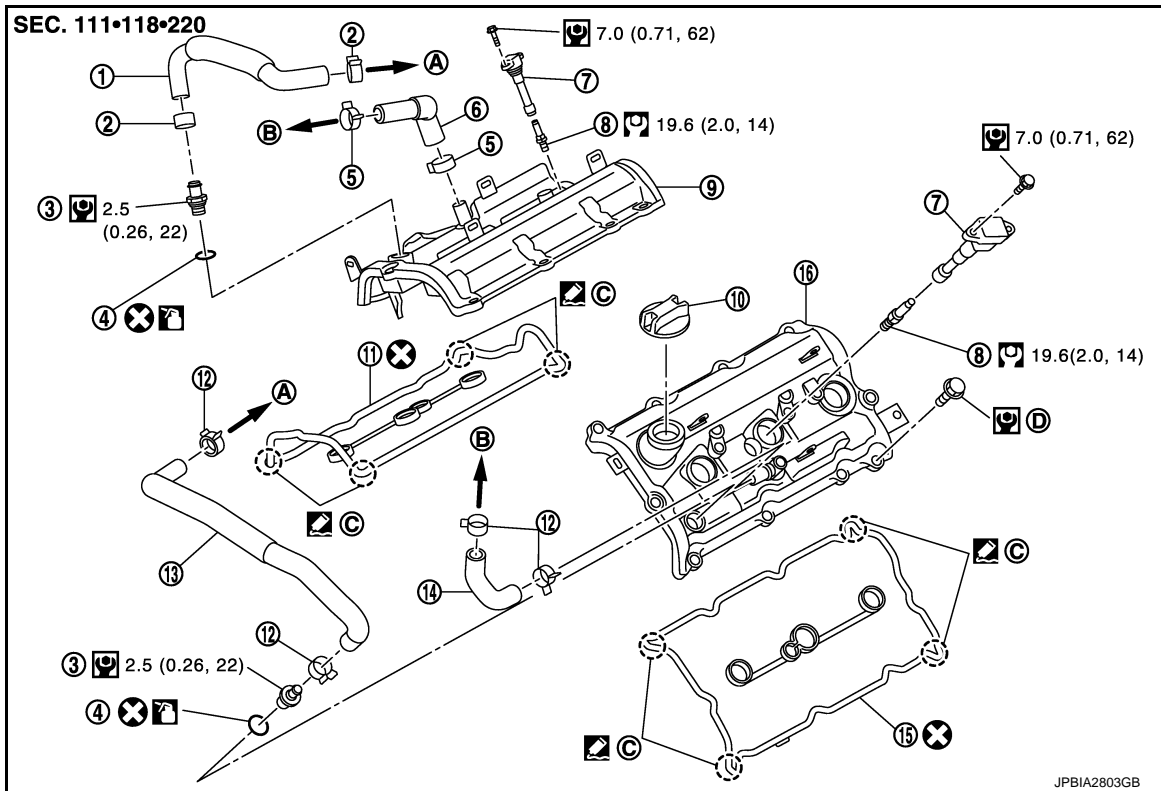

- | | | |
|---|----------------------------------|----------------------------------|
| 1. PCV hose | 2. Clamp | 3. PCV valve |
| 4. O-ring | 5. Clamp | 6. PCV hose |
| 7. Ignition coil | 8. Spark plug | 9. Rocker cover (bank 1) |
| 10. Oil filler cap | 11. Rocker cover gasket (bank 1) | 12. Clamp |
| 13. PCV hose | 14. PCV hose | 15. Rocker cover gasket (bank 2) |
| 16. Rocker cover (bank 2) | | |
| A. To intake manifold collector | B. To air duct | C. VVEL ladder assembly side |
| D. Comply with the installation procedure when tightening. Refer to EM-46 | | |

Refer to [GI-4, "Components"](#) for symbols in the figure.

Removal and Installation

INFOID:000000008154423

REMOVAL

1. Remove engine cover with power tool. Refer to [EM-25, "Exploded View"](#).
2. Remove air cleaner case and air duct (RH and LH). Refer to [EM-27, "Exploded View"](#).
3. Remove electric throttle control actuator. Refer to [EM-29, "Exploded View"](#).
4. Remove ignition coil. Refer to [EM-46, "Removal and Installation"](#).

SPARK PLUG

< PERIODIC MAINTENANCE >

- Remove spark plug with a spark plug wrench (commercial service tool).

a : 14 mm (0.55 in)

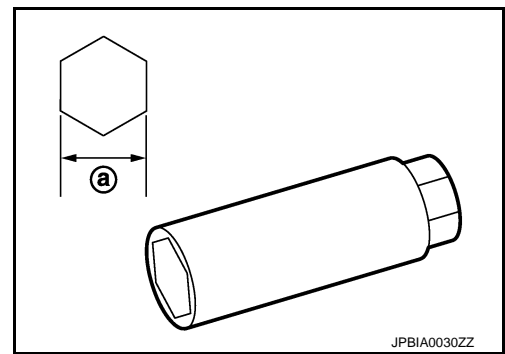

INSTALLATION

Installation is the reverse order of removal.

Inspection

INFOID:000000008154424

INSPECTION AFTER REMOVAL

Use the standard type spark plug for normal condition.

Spark plug (Standard type) : Refer to [EM-138, "Spark Plug"](#).

CAUTION:

- Never drop or shock spark plug.
- Never use a wire brush for cleaning.
- If plug tip is covered with carbon, use spark plug cleaner to clean.

Cleaner air pressure

: Less than 588 kPa (6 kg/cm², 85 psi)

Cleaning time

: Less than 20 seconds

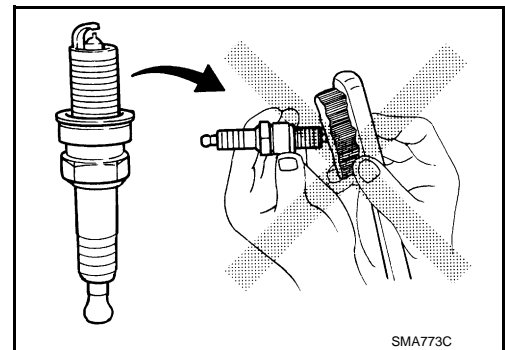

- Spark plug gap adjustment is not required between replacement intervals.
- Measure spark plug gap. When it exceeds the limit, replace spark plug even if it is within the specified replacement mileage. Refer to [EM-138, "Spark Plug"](#).

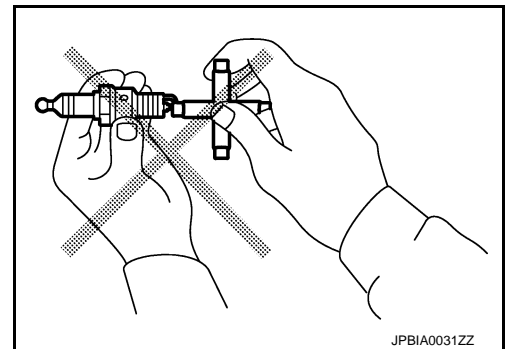

CAMSHAFT VALVE CLEARANCE

< PERIODIC MAINTENANCE >

CAMSHAFT VALVE CLEARANCE

Inspection and Adjustment

INFOID:000000008154425

INSPECTION

Check valve clearance if applicable to the following cases:

Intake side:

- At the removal and installation of VVEL ladder assembly or valve-related parts, or at the occurrence of malfunction (poor starting, idle malfunction, unusual noise) due to aged deterioration in valve clearance.

CAUTION:

Valve clearance check on the intake side is not required after replacing the VVEL ladder assembly and cylinder head assembly with a new one. (Install new VVEL ladder assembly and cylinder head assembly in factory-shipped condition because it is factory-adjusted and inspected.)

NOTE:

VVEL ladder assembly cannot be replaced as a single part, because it is machined together with cylinder head assembly.

Exhaust side:

- At the removal, installation, and replacement of camshaft (EXH) or valve-related parts, or at the occurrence of malfunction (poor starting, idle malfunction, unusual noise) due to aged deterioration in valve clearance.

1. Remove rocker covers (bank 1 and bank 2). Refer to [EM-46. "Removal and Installation"](#).
2. Measure the valve clearance as follows:
 - Use the feeler gauge (commercial service tool) of curved-tip. This allows the feeler gauge to access the clearance between camshaft and valve lifter with ease.

Valve clearance : Refer to [EM-139. "Camshaft"](#).

NOTE:

Be sure to note the following points when measuring valve clearance on the intake side.

- Before measuring, check that the position of drive shaft nose is within the angle shown in the figure.

A : Bank 1

B : Feeler gauge (commercial service tool)

D : View D

c : 45 degrees (drive shaft nose angle)

⇐ : Insertion direction of feeler gauge on the bank 1

⇐ : Insertion direction of feeler gauge on the bank 2

- Refer to the illustration for the insertion direction of the feeler gauge since the direction depends on the bank.

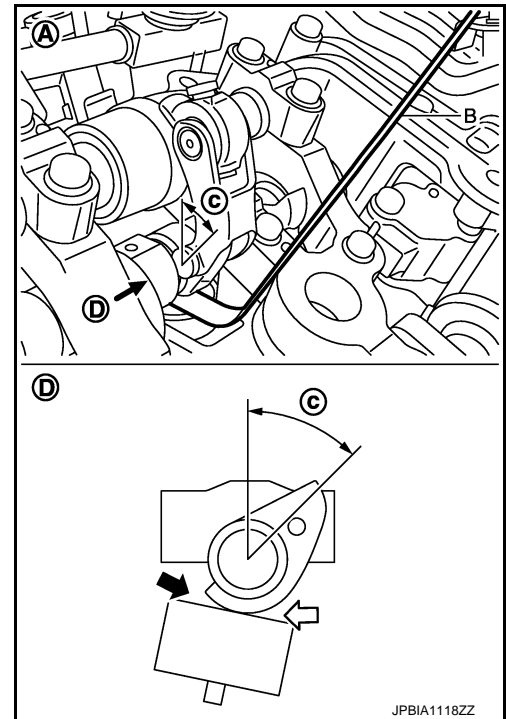

- a. Set No. 1 cylinder at TDC of its compression stroke.

CAMSHAFT VALVE CLEARANCE

< PERIODIC MAINTENANCE >

- Rotate crankshaft pulley clockwise to align timing mark (grooved line without color) with timing indicator.

← : Timing mark (grooved line without color)

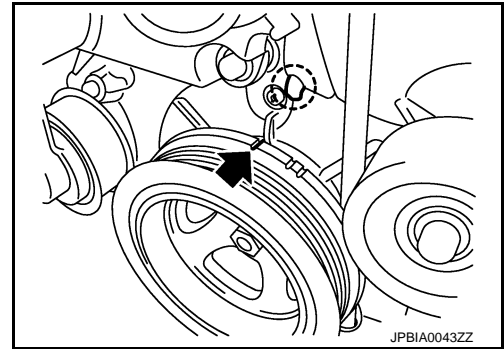

- Check that exhaust cam nose on No. 1 cylinder (engine front side of bank 1) is located as shown in the figure.

1 : Camshaft (EXH) (bank 1)

↔ : Engine front

- If not, turn crankshaft one revolution (360 degrees) and align as shown in the figure.

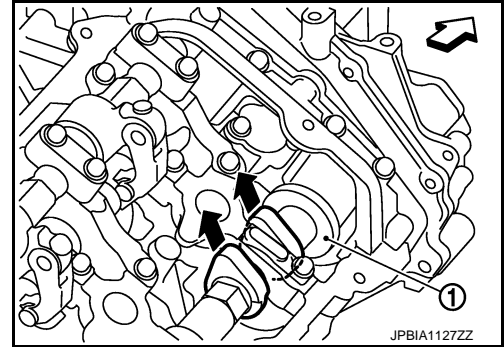

- By referring to the figure, measure the valve clearances at locations marked "x" as shown in the table below (locations indicated in the figure).

↔ : Engine front

- No. 1 cylinder at compression TDC

Measuring position [bank 1 (A)]		No. 1 CYL.	No. 3 CYL.	No. 5 CYL.
No. 1 cylinder at compression TDC	EXH		× (C)	
	INT	× (D)		
Measuring position [bank 2 (B)]		No. 2 CYL.	No. 4 CYL.	No. 6 CYL.
No. 1 cylinder at compression TDC	INT			× (E)
	EXH	× (F)		

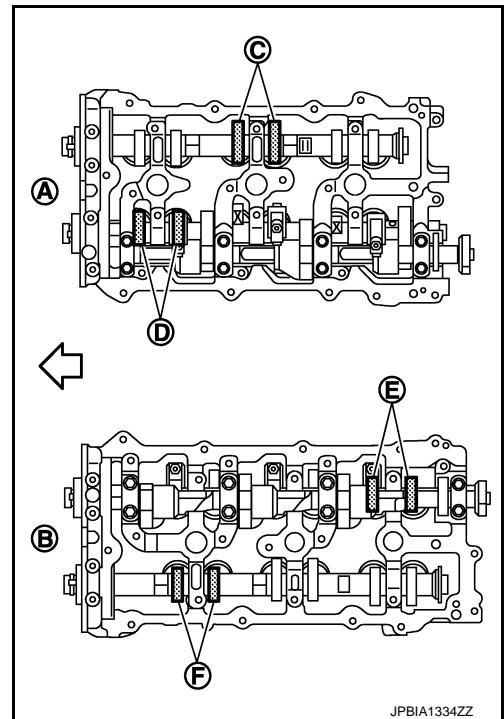

- b. Rotate crankshaft 240 degrees clockwise (when viewed from engine front) to align No. 3 cylinder at TDC its compression stroke.

NOTE:

A
EM
C
D
E
F
G
H
I
J
K
L
M
N
O
P

CAMSHAFT VALVE CLEARANCE

< PERIODIC MAINTENANCE >

Mark a position 240 degrees (b) from a corner of the hexagonal part of crankshaft pulley mounting bolt as shown in the figure. Use the hexagonal part as a guide.

- 1 : Crankshaft pulley
- A : Paint mark

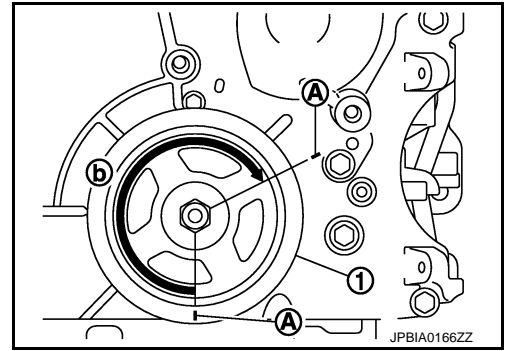

- By referring to the figure, measure the valve clearances at locations marked "x" as shown in the table below (locations indicated in the figure).

⇐ : Engine front

- No. 3 cylinder at compression TDC

Measuring position [bank 1 (A)]		No. 1 CYL.	No. 3 CYL.	No. 5 CYL.
No. 3 cylinder at compression TDC	EXH			× (C)
	INT		× (D)	
Measuring position [bank 2 (B)]		No. 2 CYL.	No. 4 CYL.	No. 6 CYL.
No. 3 cylinder at compression TDC	INT	× (E)		
	EXH		× (F)	

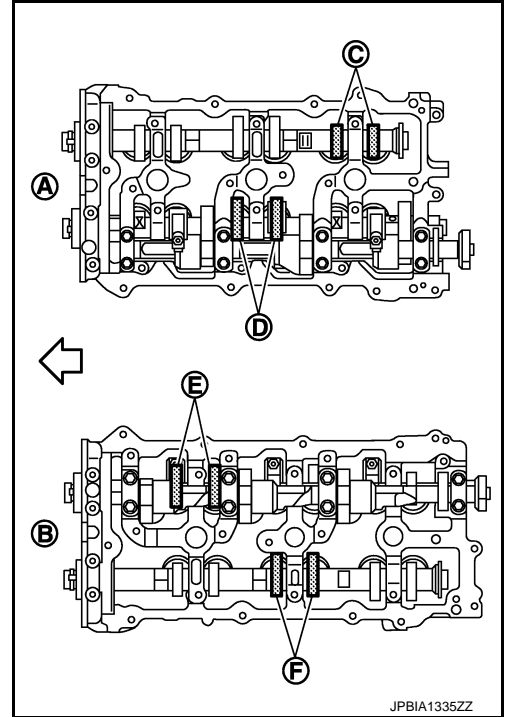

- c. Rotate crankshaft 240 degrees clockwise (when viewed from engine front) to align No. 5 cylinder at TDC of compression stroke.

NOTE:

Mark a position 240 degrees (b) from a corner of the hexagonal part of crankshaft pulley mounting bolt as shown in the figure. Use the hexagonal part as a guide.

- 1 : Crankshaft pulley
- A : Paint mark

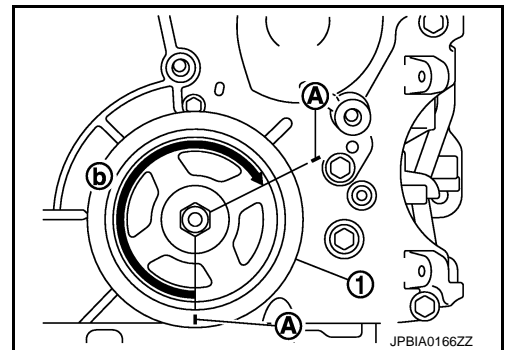

CAMSHAFT VALVE CLEARANCE

< PERIODIC MAINTENANCE >

- By referring to the figure, measure the valve clearances at locations marked "x" as shown in the table below (locations indicated in the figure).

← : Engine front

- No. 5 cylinder at compression TDC

Measuring position [bank 1 (A)]		No. 1 CYL.	No. 3 CYL.	No. 5 CYL.
No. 5 cylinder at compression TDC	EXH	× (C)		
	INT			× (D)
Measuring position [bank 2 (B)]		No. 2 CYL.	No. 4 CYL.	No. 6 CYL.
No. 5 cylinder at compression TDC	INT		× (E)	
	EXH			× (F)

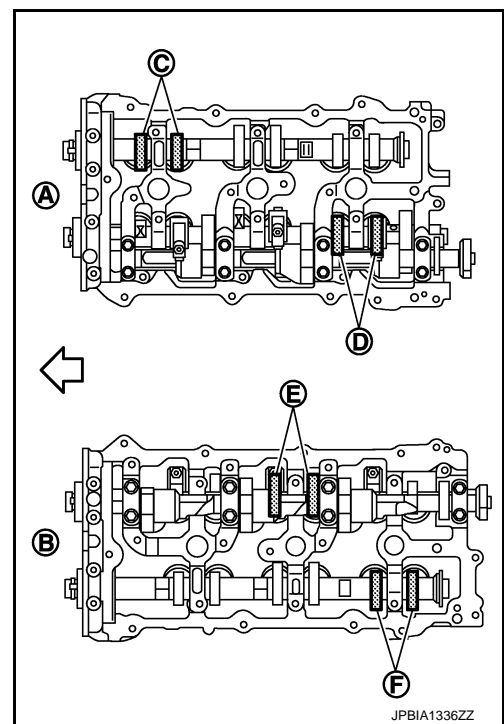

- Perform adjustment or replacement if the measured value is out of the standard.
 - If a valve clearance on the exhaust side is out of specification, adjust the valve clearance.
 - If a valve clearance on the intake side is out of specification, replace VVEL ladder assembly and cylinder head assembly. Refer to [EM-84, "Exploded View"](#) and [EM-101, "Exploded View"](#).

CAUTION:

Never adjust valve clearance on the intake side.

NOTE:

Since the valve lifter (INT) cannot be replaced by the piece, VVEL ladder assembly and cylinder head assembly replacement are required.

CAMSHAFT (EXH) VALVE CLEARANCE ADJUSTMENT

- Perform adjustment depending on selected head thickness of valve lifter (EXH).
- Measure the valve clearance. Refer to "INSPECTION".
 - Remove VVEL ladder assembly and camshaft (EXH). Refer to [EM-85, "Disassembly and Assembly"](#).

CAUTION:

Never loosen adjusting bolts and mounting bolts (black color) of VVEL ladder assembly.

- Remove valve lifter (EXH) at the locations that are out of the standard.
- Measure the center thickness of the removed valve lifters (EXH) with a micrometer (A).

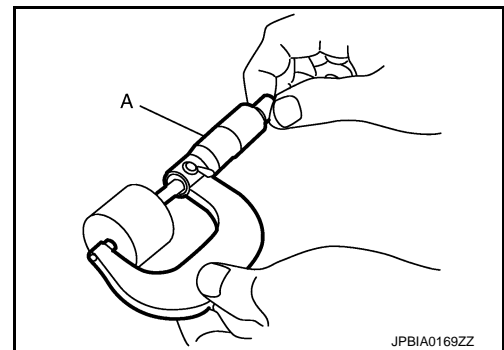

- Use the equation below to calculate valve lifter (EXH) thickness for replacement.

Valve lifter (EXH) thickness calculation: $t = t_1 + (C_1 - C_2)$

t = Valve lifter (EXH) thickness to be replaced

t₁ = Removed valve lifter (EXH) thickness

CAMSHAFT VALVE CLEARANCE

< PERIODIC MAINTENANCE >

C1 = Measured valve clearance

C2 = Standard valve clearance:

Exhaust : 0.33 mm (0.013 in)

- Thickness of new valve lifter (EXH) can be identified by stamp marks on the reverse side (inside the cylinder). Stamp mark 788 indicates 7.88 mm (0.3102 in) in thickness.

A : Stamp

B : Thickness of valve lifter (EXH)

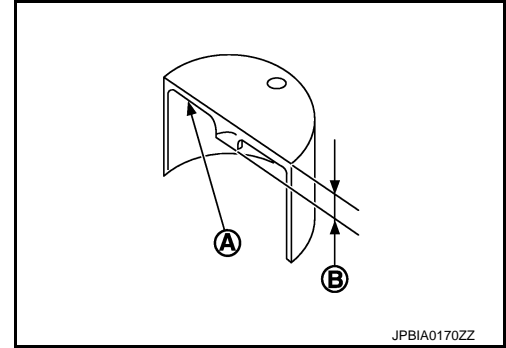

Available thickness of valve lifter (EXH): 27 sizes with range 7.88 to 8.40 mm (0.3102 to 0.3307 in) in steps of 0.02 mm (0.0008 in) (when manufactured at factory). Refer to [EM-139. "Camshaft"](#).

6. Install selected valve lifter (EXH).
7. Install VVEL ladder assembly and camshaft (EXH). Refer to [EM-85. "Disassembly and Assembly"](#).
8. Manually turn crankshaft pulley a few turns.
9. Check that the valve clearances for cold engine are within the specifications by referring to the specified values. Refer to [EM-18. "Inspection and Adjustment"](#).
10. Install all removed parts in the reverse order of removal.
11. Warm up the engine, and check for unusual noise and vibration.

COMPRESSION PRESSURE

< PERIODIC MAINTENANCE >

COMPRESSION PRESSURE

Inspection

INFOID:000000008154426

1. Warm up engine thoroughly. Then, stop it.
2. Release fuel pressure. Refer to [EC-595, "Inspection"](#).
3. Disconnect fuel pump fuse (1) from IPDM E/R (2) to avoid fuel injection during measurement.

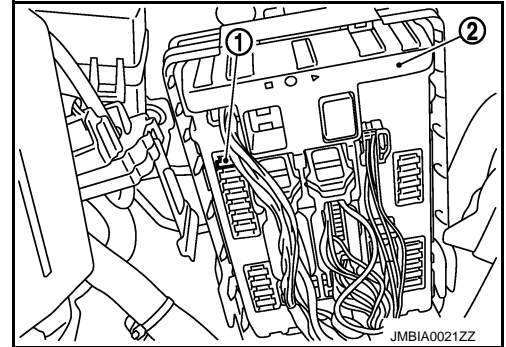

4. Remove engine cover with power tool. Refer to [EM-25, "Exploded View"](#).
5. Remove ignition coil and spark plug from each cylinder. Refer to [EM-46, "Exploded View"](#).
6. Connect engine tachometer (not required in use of CONSULT).
7. Install compression gauge with an adapter (commercial service tool) onto spark plug hole.

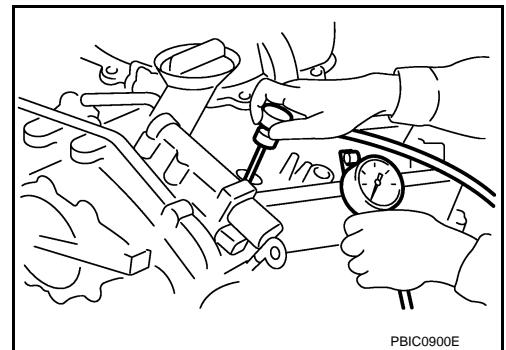

- Use the adapter whose picking up end inserted to spark plug hole is smaller than 20 mm (0.79 in) in diameter. Otherwise, it may be caught by cylinder head during removal.

a : 20 mm (0.79 in)

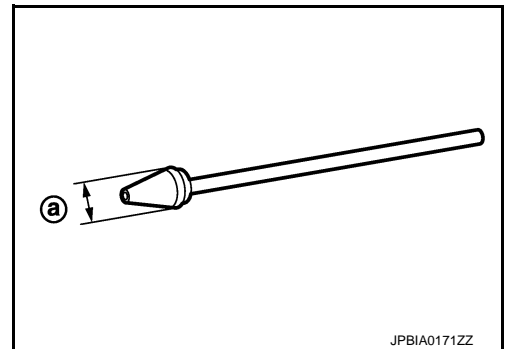

8. With accelerator pedal fully depressed, turn ignition switch to "START" for cranking. When the gauge pointer stabilizes, read the compression pressure and the engine rpm. Perform these steps to check each cylinder.

Compression pressure : Refer to [EM-138, "General Specification"](#).

CAUTION:

- Measure a six-cylinder under the same conditions since a measurement depends on measurement conditions (engine water temperature, etc.).
- Always use a fully charged battery to obtain the specified engine speed.
- If the engine speed is out of the specified range, check battery liquid for proper gravity. Check the engine speed again with normal battery gravity.

COMPRESSION PRESSURE

< PERIODIC MAINTENANCE >

- If compression pressure is below the minimum value, check valve clearances and parts associated with combustion chamber (valve, valve seat, piston, piston ring, cylinder bore, cylinder head, and cylinder head gasket). After checking, measure compression pressure again.
 - If a cylinder has low compression pressure, pour a small amount of engine oil into the spark plug hole of the cylinder to recheck it for compression.
 - If the added engine oil improves the compression, piston rings may be worn out or damaged. Check piston rings and replace if necessary.
 - If the compression pressure remains at low level despite the addition of engine oil, valves may be malfunctioning. Check valves for damage. Replace valve or valve seat accordingly.
 - If two adjacent cylinders have respectively low compression pressure and their compression remains low even after the addition of engine oil, cylinder head gaskets are leaking. In such a case, replace cylinder head gaskets.
9. After inspection is completed, install removed parts.
 10. Start the engine, and check that the engine runs smoothly.
 11. Perform trouble diagnosis. If DTC appears, erase it. Refer to [EC-148, "Description"](#).

ENGINE COVER

< REMOVAL AND INSTALLATION >

REMOVAL AND INSTALLATION

ENGINE COVER

Exploded View

INFOID:000000008154427

1 : Engine cover

Refer to [GI-4, "Components"](#) for symbols in the figure.

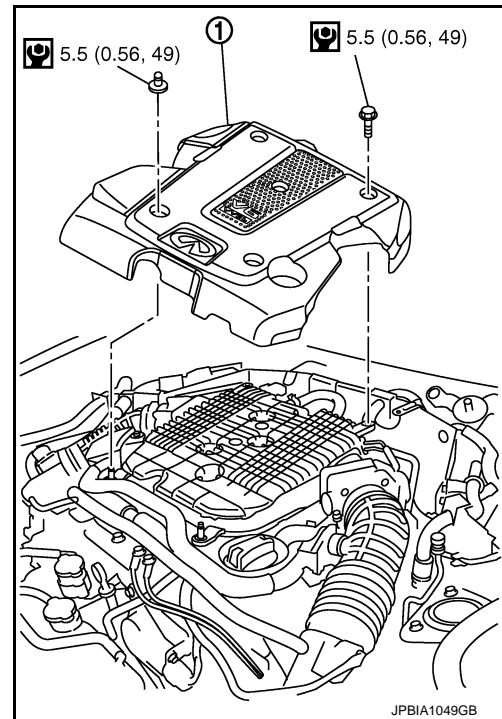

Removal and Installation

INFOID:000000008154428

REMOVAL

Loosen mounting bolts and nuts in the reverse order as shown in the figure, and then remove engine cover.

CAUTION:

Never damage or scratch engine cover when installing or removing.

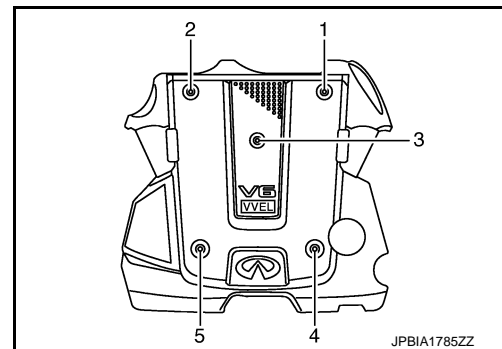

INSTALLATION

Install engine cover, and then tighten mounting bolts and nuts in numerical order as shown in the figure.

CAUTION:

Never damage or scratch engine cover when installing or removing.

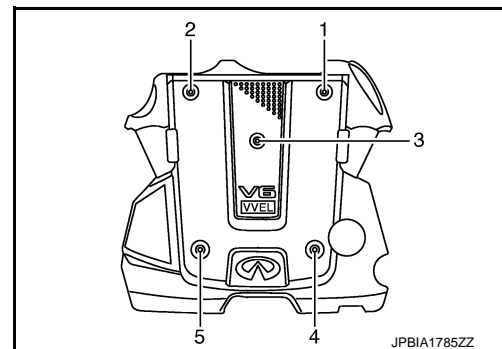

A
EM

C
D
E
F
G
H
I
J

K
L
M
N

O
P

DRIVE BELT AUTO TENSIONER AND IDLER PULLEY

< REMOVAL AND INSTALLATION >

DRIVE BELT AUTO TENSIONER AND IDLER PULLEY

Exploded View

INFOID:000000008154429

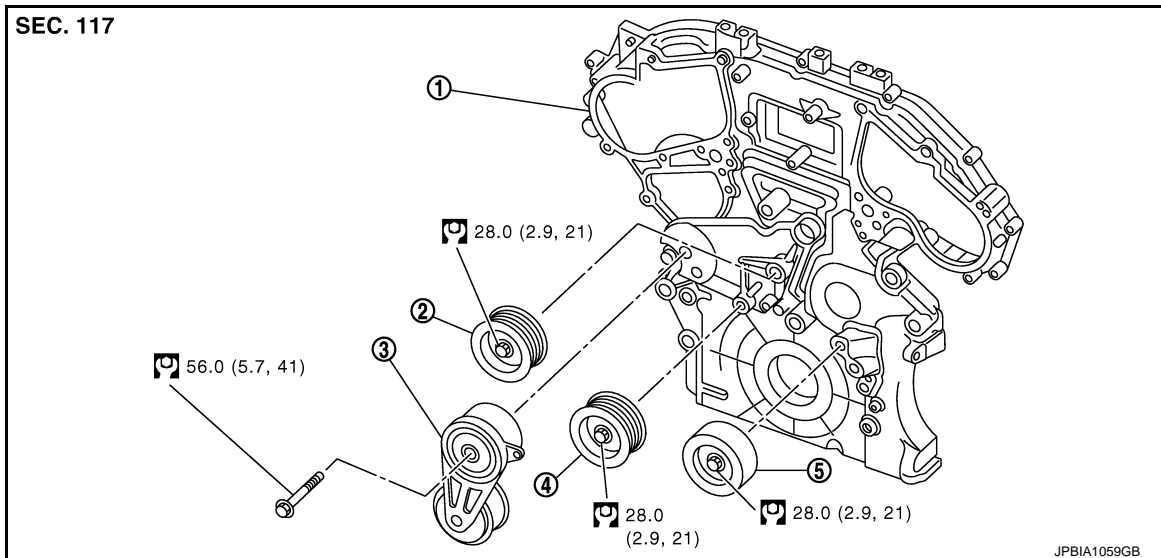

1. Front timing chain case
2. Idler pulley
3. Drive belt auto-tensioner
4. Idler pulley
5. Idler pulley

Refer to [GI-4, "Components"](#) for symbols in the figure.

Removal and Installation

INFOID:000000008154430

REMOVAL

1. Remove drive belt. Refer to [EM-13, "Exploded View"](#).
 - Keep auto-tensioner pulley arm locked after drive belt is removed.
2. Remove auto-tensioner and idler pulley.
 - Keep auto-tensioner pulley arm locked to install or remove auto-tensioner.

INSTALLATION

Install in the reverse order of removal.

CAUTION:

If there is damage greater than peeled paint, replace drive belt auto-tensioner.

AIR CLEANER AND AIR DUCT

< REMOVAL AND INSTALLATION >

AIR CLEANER AND AIR DUCT

Exploded View

INFOID:000000008154431

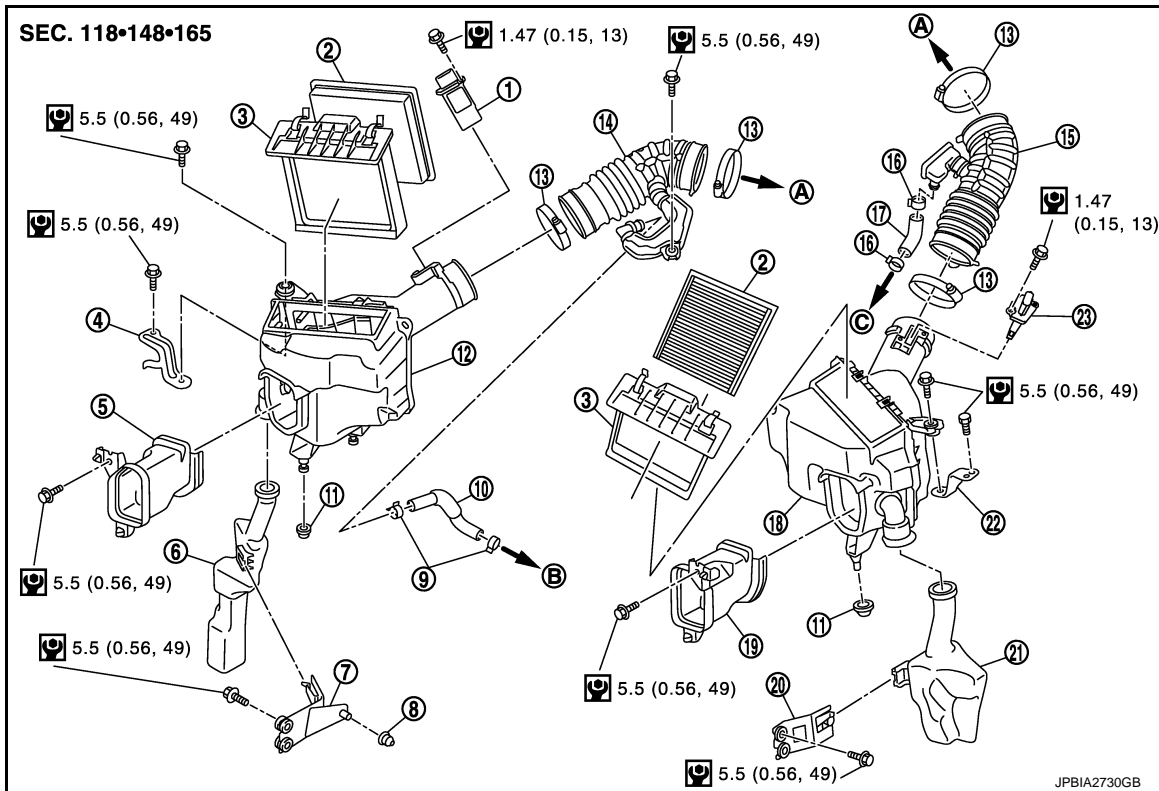

- | | | |
|--|-----------------------------------|-----------------------------|
| 1. Mass air flow sensor (bank 1) | 2. Air cleaner filter | 3. Holder |
| 4. Bracket | 5. Air dust side duct (RH) | 6. Resonator (RH) |
| 7. Bracket | 8. Grommet | 9. Clamp |
| 10. PCV hose | 11. Grommet | 12. Air cleaner case (RH) |
| 13. Clamp | 14. Air duct (RH) | 15. Air duct (LH) |
| 16. Clamp | 17. PCV hose | 18. Air cleaner case (LH) |
| 19. Air dust side duct (LH) | 20. Bracket | 21. Resonator (LH) |
| 22. Bracket | 23. Mass air flow sensor (bank 2) | |
| A. To electric throttle control actuator | B. To rocker cover (bank 1) | C. To rocker cover (bank 2) |

Refer to [GI-4, "Components"](#) for symbols in the figure.

Removal and Installation

INFOID:000000008154432

REMOVAL

NOTE:

Mass air flow sensor is removable under the car-mounted condition.

1. Disconnect mass air flow sensor harness connector.
2. Disconnect PCV hose.
3. Remove air cleaner case and mass air flow sensor assembly and air duct and air hose by disconnecting their joints.
 - Add marks if necessary for easier installation.
4. Remove mass air flow sensor from air cleaner case, if necessary.

CAUTION:

Handle mass air flow sensor according to the following instructions.

- Never shock the mass air flow sensor.
- Never disassemble the mass air flow sensor.

AIR CLEANER AND AIR DUCT

< REMOVAL AND INSTALLATION >

- **Never touch the sensor of the mass air flow sensor.**

INSTALLATION

Note the following, and install in the reverse order of removal.

- Align marks. Attach each joint. Screw clamps firmly.

Inspection

INFOID:000000008154433

INSPECTION AFTER REMOVAL

Inspect air duct and resonator assembly for crack or tear.

- If anything is found, replace air duct and resonator assembly

INTAKE MANIFOLD COLLECTOR

< REMOVAL AND INSTALLATION >

INTAKE MANIFOLD COLLECTOR

Exploded View

INFOID:000000008154434

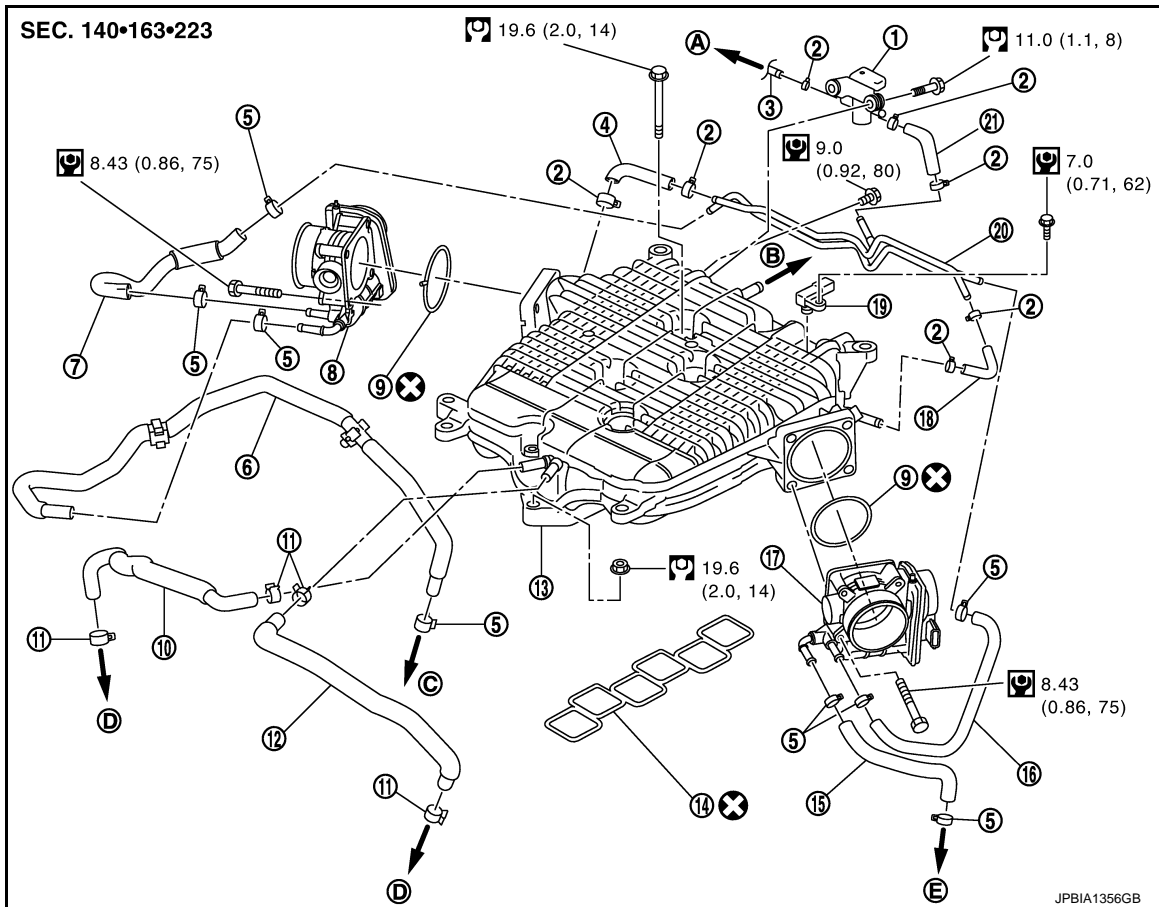

- | | | |
|---|---|---------------------------|
| 1. EVAP canister purge control solenoid valve | 2. Clamp | 3. EVAP hose |
| 4. EVAP hose | 5. Clamp | 6. Water hose |
| 7. Water hose | 8. Electric throttle control actuator (bank 1) | 9. Gasket |
| 10. PCV hose | 11. Clamp | 12. PCV hose |
| 13. Intake manifold collector | 14. Gasket | 15. Water hose |
| 16. Water hose | 17. Electric throttle control actuator (bank 2) | 18. EVAP hose |
| 19. Manifold absolute Pressure (MAP) sensor | 20. EVAP tube assembly | 21. EVAP hose |
| A. To vacuum pipe | B. To brake booster | C. To water outlet (rear) |
| D. To PCV valve | E. To heater pipe | |

Refer to [GI-4, "Components"](#) for symbols in the figure.

Removal and Installation

INFOID:000000008154435

REMOVAL

WARNING:

Never drain engine coolant when the engine is hot to avoid the danger of being scalded.

1. Remove engine cover with power tool. Refer to [EM-25, "Exploded View"](#).
2. Remove air cleaner case and air duct (RH and LH). Refer to [EM-27, "Exploded View"](#).
3. Remove electric throttle control actuator as follows:
 - a. Drain engine coolant. When water hoses are disconnected, attach plug to prevent engine coolant leakage.

INTAKE MANIFOLD COLLECTOR

< REMOVAL AND INSTALLATION >

CAUTION:

- Perform this step when engine is cold.
- Never spill engine coolant on drive belt.

- Disconnect water hoses from electric throttle control actuator. When engine coolant is not drained from radiator, attach plug to water hoses to prevent engine coolant leakage.
- Disconnect harness connector.
- Loosen mounting bolts in reverse order as shown in the figure.

NOTE:

- When removing only intake manifold collector, move electric throttle control actuator without disconnecting the water hose.
- The figure shows the electric throttle control actuator (bank 1) viewed from the air duct side.
- Viewed from the air duct side, the order of loosening mounting bolts of electric throttle control actuator (bank 2) is the same as that of the electric throttle control actuator (bank 1).

CAUTION:

Handle carefully to avoid any shock to electric throttle control actuator.

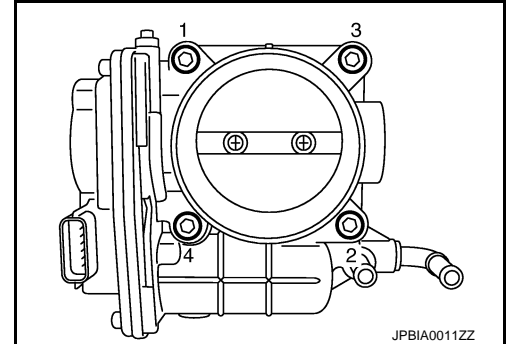

- Disconnect vacuum hose, PCV hose, and EVAP hose from intake manifold collector.
- Remove EVAP canister purge volume control solenoid valve and EVAP tube assembly from intake manifold collector.
- Loosen mounting bolts and nuts with power tool in the reverse order as shown in the figure to remove intake manifold collector.

← : Engine front

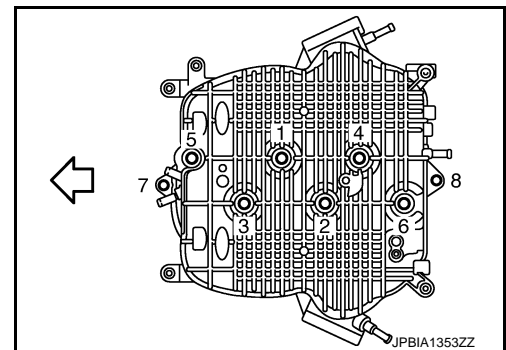

INSTALLATION

Note the following, and install in the reverse order of removal.

INTAKE MANIFOLD COLLECTOR

- If stud bolts were removed, install them and tighten to the torque specified below.

: 10.8 N·m (1.1 kg·m, 8 ft·lb)

- Tighten mounting bolts and nuts in numerical order as shown in the figure.

← : Engine front

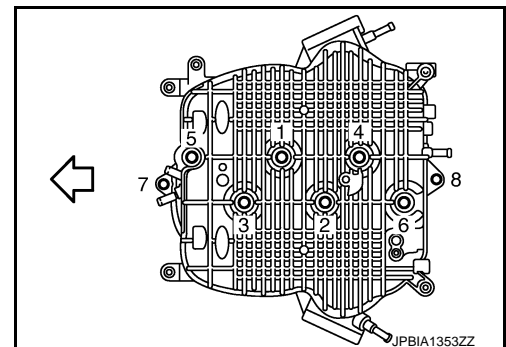

WATER HOSE

- Insert hose by 27 to 32 mm (1.06 to 1.26 in) from connector end.
- Clamp hose at location of 3 to 7 mm (0.12 to 0.28 in) from hose end.

ELECTRIC THROTTLE CONTROL ACTUATOR (BANK 1 AND BANK 2)

INTAKE MANIFOLD COLLECTOR

< REMOVAL AND INSTALLATION >

- Tighten in numerical order as shown in the figure.

NOTE:

- The figure shows the electric throttle control actuator (bank 1) viewed from the air duct side.
- Viewed from the air duct side, the order of tightening mounting bolts of electric throttle control actuator (bank 2) is the same as that of the electric throttle control actuator (bank 1).
- Perform the "Throttle Valve Closed Position Learning" when harness connector of electric throttle control actuator is disconnected. Refer to [EC-19, "THROTTLE VALVE CLOSED POSITION LEARNING : Description"](#).
- Perform the "Idle Air Volume Learning" and "Throttle Valve Closed Position Learning" when electric throttle control actuator is replaced. Refer to [EC-20, "IDLE AIR VOLUME LEARNING : Description"](#) and [EC-19, "THROTTLE VALVE CLOSED POSITION LEARNING : Description"](#).

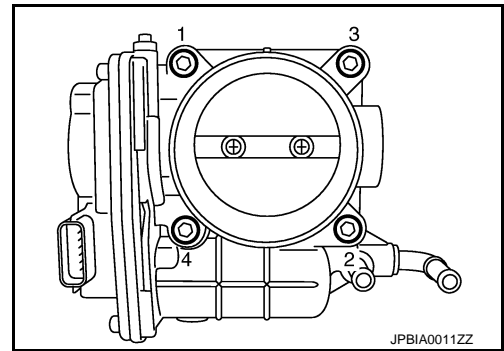

A

EM

C

D

E

F

G

H

I

J

K

L

M

N

O

P

INTAKE MANIFOLD

< REMOVAL AND INSTALLATION >

INTAKE MANIFOLD

Exploded View

INFOID:000000008154436

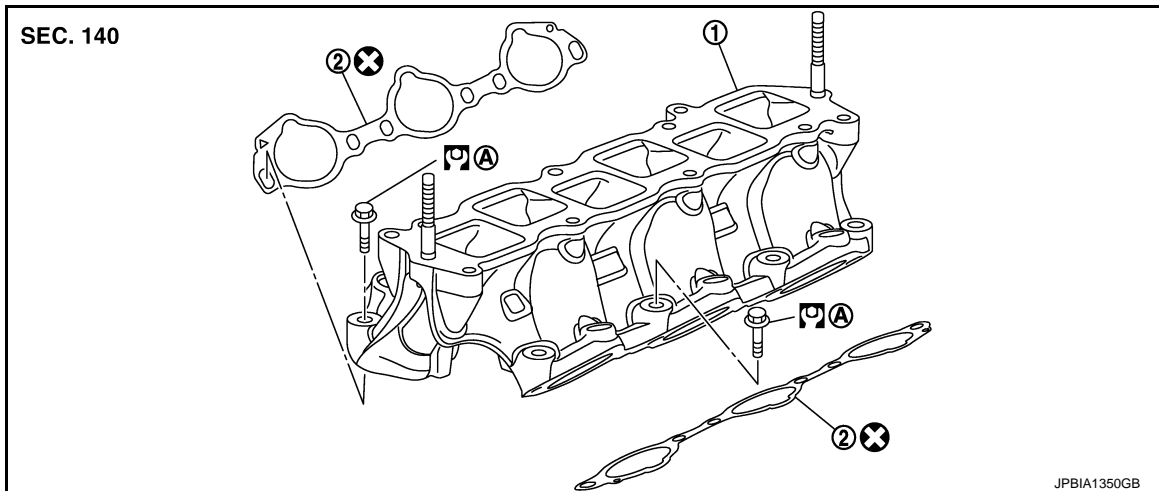

1. Intake manifold
2. Gasket

A. Comply with the installation procedure when tightening. Refer to [EM-32](#)

Refer to [GI-4, "Components"](#) for symbols in the figure.

Removal and Installation

INFOID:000000008154437

REMOVAL

1. Release fuel pressure. Refer to [EC-595, "Inspection"](#).
2. Remove intake manifold collector. Refer to [EM-29, "Exploded View"](#).
3. Remove fuel tube and fuel injector assembly. Refer to [EM-37, "Exploded View"](#).
4. Loosen mounting bolts in reverse order as shown in the figure to remove intake manifold with power tool.

← : Engine front

CAUTION:

- Cover engine openings to avoid entry of foreign materials.
- Put a mark on the intake manifold and the cylinder head with paint before removal because they need to be installed in the specified direction.

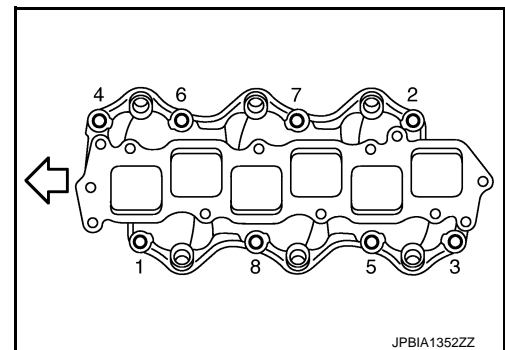

5. Remove gaskets.

INSTALLATION

Note the following, and install in the reverse order of removal.

INTAKE MANIFOLD

- If stud bolts were removed, install them and tighten to the torque specified below.

: 10.8 N·m (1.1 kg-m, 8 ft-lb)

INTAKE MANIFOLD

< REMOVAL AND INSTALLATION >

- Tighten all mounting bolts to the specified torque in two or more steps in numerical order as shown in the figure.

← : Engine front

CAUTION:

- Install intake manifold with the marks (put on the intake manifold and the cylinder head before removal) aligned.

1st step:

: 7.4 N·m (0.75 kg-m, 5 ft-lb)

2nd step and after:

: 25.5 N·m (2.6 kg-m, 19 ft-lb)

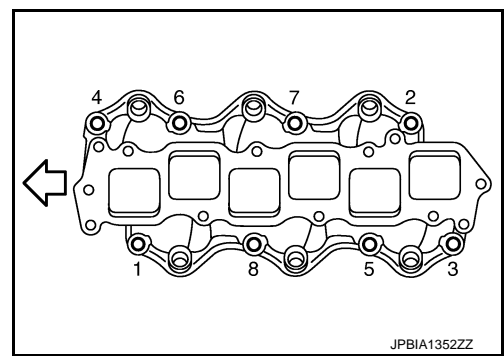

Inspection

INFOID:000000008154438

INSPECTION AFTER REMOVAL

Surface Distortion

- Check the surface distortion of the intake manifold mating surface with a straightedge (A) and a feeler gauge (B).

Limit : Refer to [EM-139, "Intake Manifold"](#).

- If it exceeds the limit, replace intake manifold.

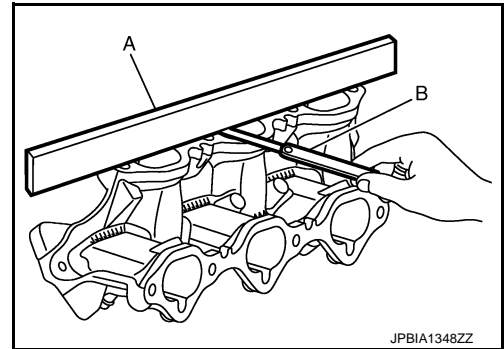

EXHAUST MANIFOLD

< REMOVAL AND INSTALLATION >

EXHAUST MANIFOLD

Exploded View

INFOID:000000008154439

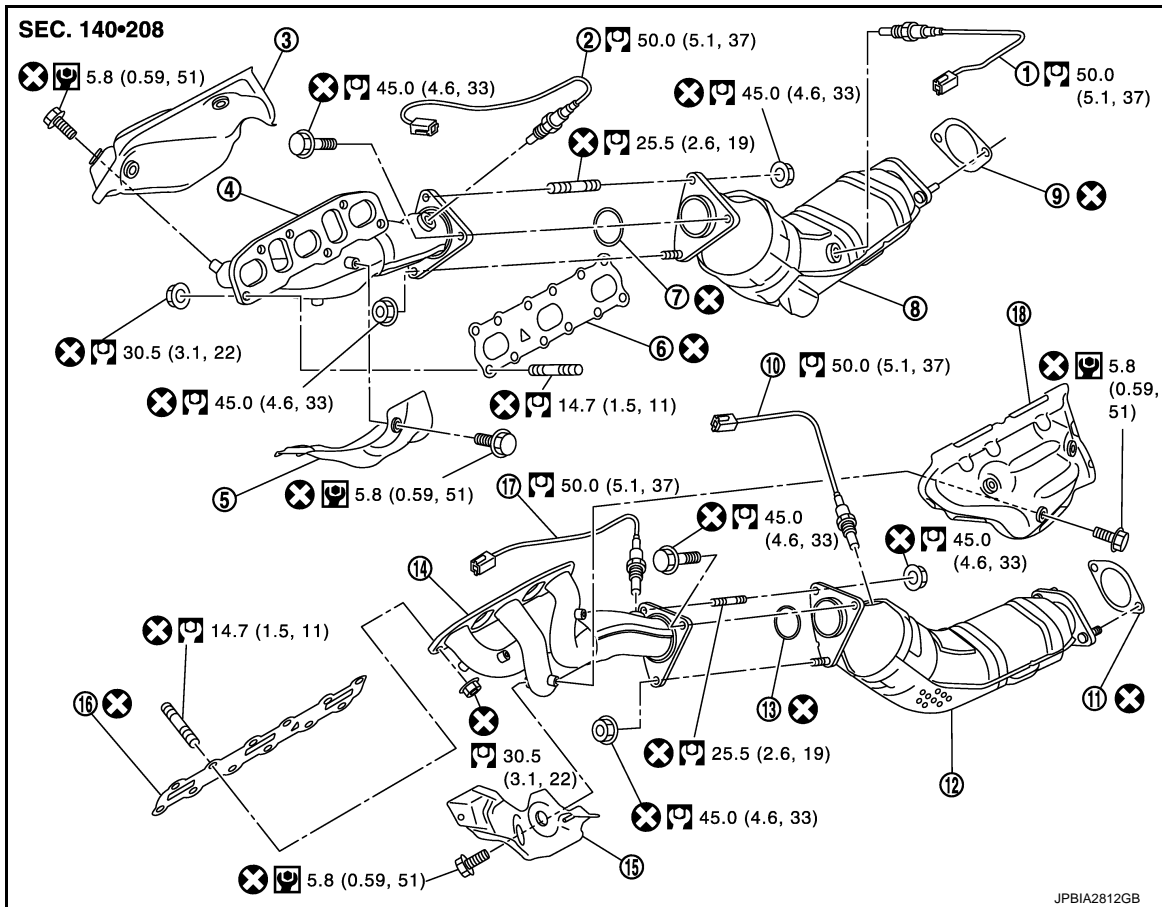

- | | | |
|-------------------------------------|--------------------------------------|------------------------------------|
| 1. Heated oxygen sensor 2 (bank 1) | 2. Air fuel ratio sensor 1 (bank 1) | 3. Exhaust manifold cover (upper) |
| 4. Exhaust manifold (bank 1) | 5. Exhaust manifold cover (lower) | 6. Gasket |
| 7. Ring gasket | 8. Three way catalyst (bank 1) | 9. Gasket |
| 10. Heated oxygen sensor 2 (bank 2) | 11. Gasket | 12. Three way catalyst (bank 2) |
| 13. Ring gasket | 14. Exhaust manifold (bank 2) | 15. Exhaust manifold cover (lower) |
| 16. Gasket | 17. Air fuel ratio sensor 1 (bank 2) | 18. Exhaust manifold cover (upper) |

Refer to [GI-4, "Components"](#) for symbols in the figure.

Removal and Installation

INFOID:000000008154440

REMOVAL

WARNING:

Perform the work when the exhaust and cooling system have completely cooled down.

NOTE:

When removing bank 1 side parts only, steps 1, 4, and 7 are unnecessary.

1. Drain engine coolant. Refer to [CO-7, "Draining"](#).
2. Remove engine cover with power tool. Refer to [EM-25, "Exploded View"](#).
3. Remove air cleaner case and air duct (RH and LH). Refer to [EM-27, "Exploded View"](#).
4. Remove water pipe and water hose. Refer to [CO-24, "Exploded View"](#).
5. Remove engine undercover with power tool.
6. Remove exhaust front tube and three way catalysts (bank 1 and bank 2). Refer to [EX-5, "Exploded View"](#).

EXHAUST MANIFOLD

< REMOVAL AND INSTALLATION >

7. Disconnect steering lower joint at power steering gear assembly side, and release steering lower shaft. Refer to [ST-22, "Exploded View"](#).
8. Disconnect air fuel ratio sensor 1 (bank 1 and bank 2) harness connectors and remove harness clip.
9. Using the heated oxygen sensor wrench [SST: KV10114400 (J-38365)] (C), remove air fuel ratio sensor 1 (bank 1 and bank 2).

- A : Bank 1
- B : Bank 2

CAUTION:

- Be careful not to damage air fuel ratio sensor 1.
- Discard any air fuel ratio sensor 1 that has been dropped onto a hard surface such as a concrete floor. Replace with a new sensor.

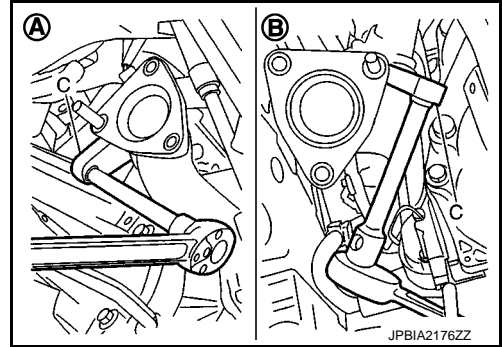

10. Remove exhaust manifold cover (upper) (bank 1 and bank 2).
11. Loosen mounting nuts in the reverse order as shown in the figure to remove exhaust manifold.

- A : Bank 1
- B : Bank 2
- ⇐ : Engine front

NOTE:

Disregard the numerical order No. 7 and 8 in removal.

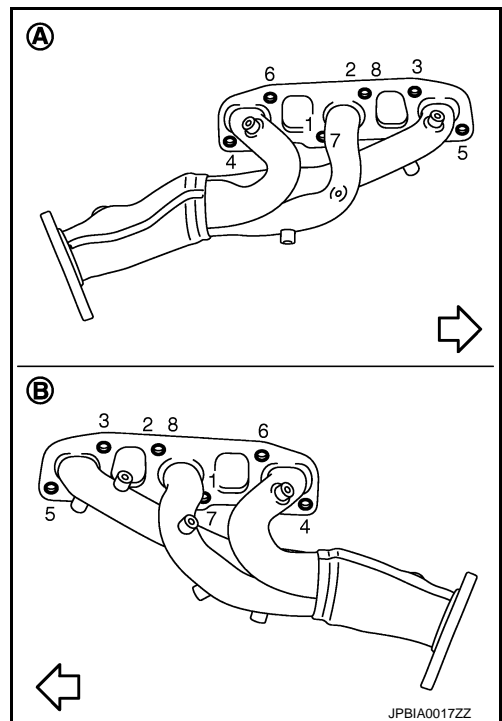

12. Remove gaskets.

CAUTION:

Cover engine openings to avoid entry of foreign materials.

INSTALLATION

Note the following, and install in the reverse order of removal.

EXHAUST MANIFOLD GASKET

- Install exhaust manifold gasket in direction shown in the figure. (Follow the same procedure for both banks.)

- A : Bank 1
- B : Triangle press
- C : Bank 2
- ⇐ : Engine front

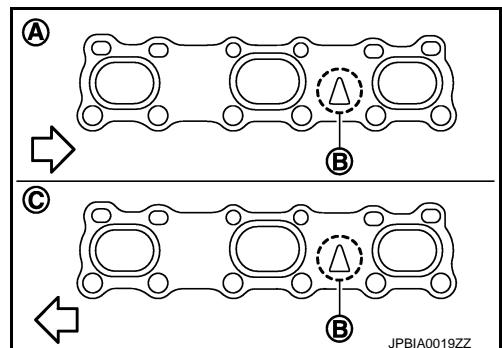

EXHAUST MANIFOLD

< REMOVAL AND INSTALLATION >

EXHAUST MANIFOLD

- If stud bolts were removed, install them and tighten to the torque specified below.

Tightening torque : Refer to [EM-34, "Exploded View"](#).

- Install exhaust manifold and tighten mounting bolts in numerical order as shown in the figure.

A : Bank 1

B : Bank 2

⇐ : Engine front

NOTE:

Tighten nuts the No. 1 and 2 in two steps. The numerical order No. 7 and 8 shows the second step.

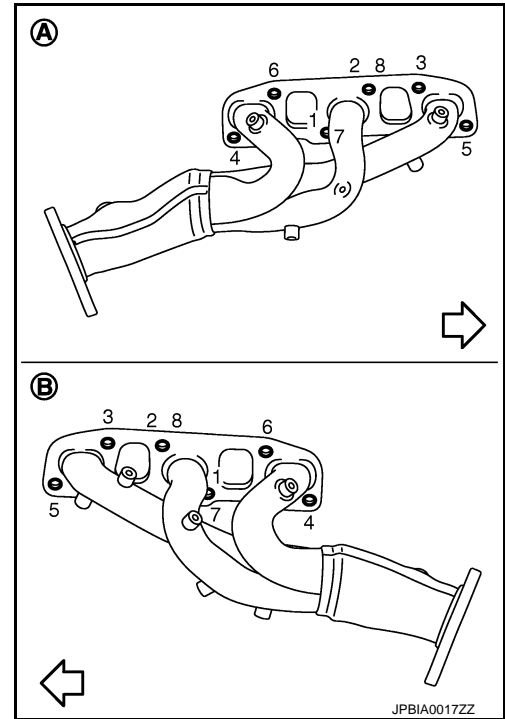

AIR FUEL RATIO SENSOR 1

CAUTION:

- Before installing a new air fuel ratio sensor 1, clean exhaust system threads using heated oxygen sensor thread cleaner tool (commercial service tool: J-43897-18 or J-43897-12) and apply anti-seize lubricant.
- Never apply excessive torque to air fuel ratio sensor 1. Doing so may cause damage to air fuel ratio sensor 1, resulting in the "MIL" illuminating.
- Prevent rust preventives from adhering to the sensor body.

Inspection

INFOID:000000008154441

INSPECTION AFTER REMOVAL

Surface Distortion

- Check the surface distortion of the exhaust manifold mating surface with a straightedge (A) and a feeler gauge (B).

Limit : Refer to [EM-139, "Exhaust Manifold"](#).

- If it exceeds the limit, replace exhaust manifold.

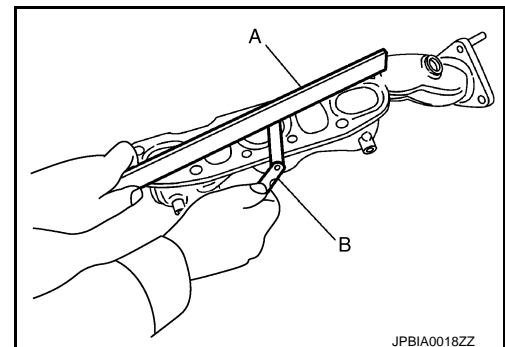

FUEL INJECTOR AND FUEL TUBE

< REMOVAL AND INSTALLATION >

FUEL INJECTOR AND FUEL TUBE

Exploded View

INFOID:000000008154442

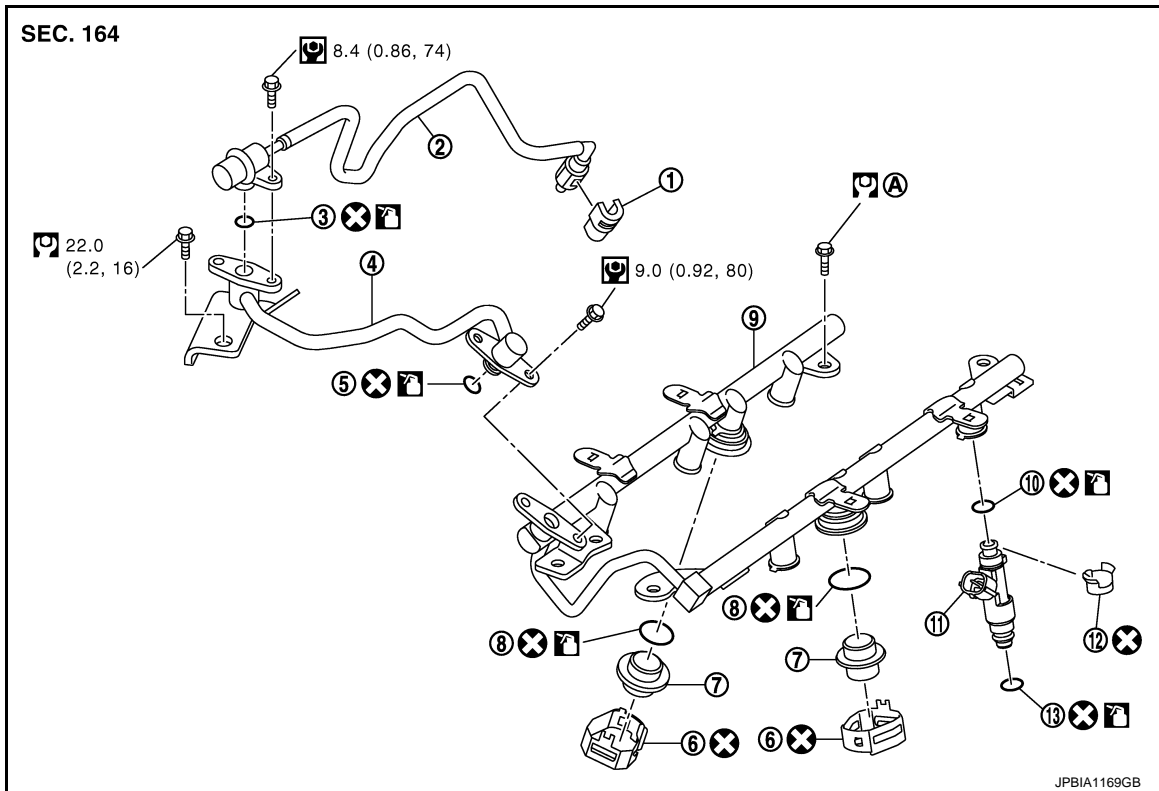

- | | | |
|------------------------|---------------------------------|--------------|
| 1. Quick connector cap | 2. Fuel feed hose (with damper) | 3. O-ring |
| 4. Fuel sub tube | 5. O-ring | 6. Clip |
| 7. Fuel damper | 8. O-ring | 9. Fuel tube |
| 10. O-ring (black) | 11. Fuel injector | 12. Clip |
| 13. O-ring (green) | | |

Tightening must be done following

A. the installation procedure.

Refer to [EM-37](#)

Refer to [GI-4, "Components"](#) for symbols in the figure.

CAUTION:

Never remove or disassemble parts unless instructed as shown in the figure.

Removal and Installation

INFOID:000000008154443

REMOVAL

WARNING:

- Put a "CAUTION: FLAMMABLE" sign in the workshop.
- Be sure to work in a well ventilated area and furnish workshop with a CO₂ fire extinguisher.
- Never smoke while servicing fuel system. Keep open flames and sparks away from the work area.
- Never drain engine coolant when the engine is hot to avoid the danger of being scalded.

1. Release fuel pressure. Refer to [EC-595, "Inspection"](#).
2. Disconnect battery cable from the negative terminal. Refer to [PG-116, "Exploded View"](#).
3. Remove engine cover with power tool. Refer to [EM-25, "Exploded View"](#).
4. Remove air cleaner case and air duct (RH and LH). Refer to [EM-27, "Exploded View"](#).
5. Remove intake manifold collector. Refer to [EM-29, "Exploded View"](#).

FUEL INJECTOR AND FUEL TUBE

< REMOVAL AND INSTALLATION >

6. Remove fuel feed hose (with damper) (1) from fuel sub-tube (2) and remove harness bracket (3).

⇐ : Engine front

NOTE:

There is no fuel return route.

CAUTION:

- While hoses are disconnected, plug them to prevent fuel from draining.
- Never separate damper and hose.

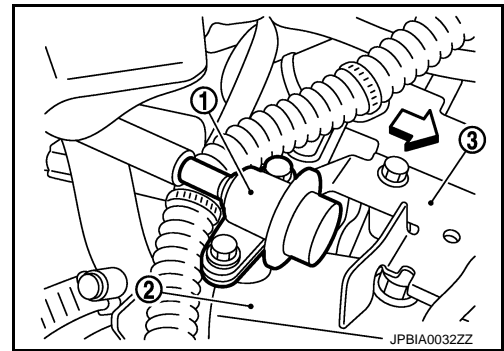

7. When separating fuel feed hose (with damper) and centralized under-floor piping connection, disconnect quick connector as follows:

- a. Remove quick connector cap (2) from quick connector connection on right member side.
- b. Disconnect fuel feed hose (with damper) (1) from bracket hose clamp.

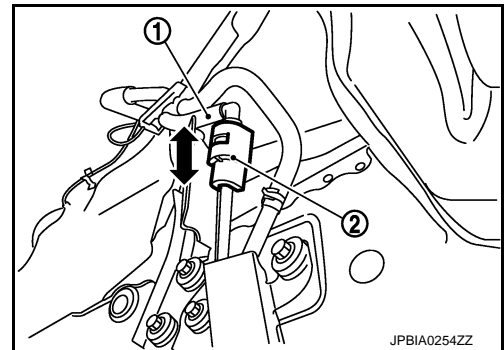

- c. Push in retainer tabs (2).
- d. Draw and pull out quick connector (1) straight from centralized under-floor piping (3).

CAUTION:

- Pull quick connector holding (A) position as shown in the figure.
- Never pull with lateral force applied. O-ring inside quick connector may be damaged.
- Prepare container and cloth beforehand because fuel will leakage out.
- Avoid fire and sparks.
- Keep parts away from heat source. Especially, be careful when welding is performed around them.
- Never expose parts to battery electrolyte or other acids.
- Never bend or twist connection between quick connector and fuel feed hose (with damper) during installation/removal.
- To keep the connecting portion clean and to avoid damage and foreign materials, cover them completely with plastic bags, etc. (A) or a similar item.

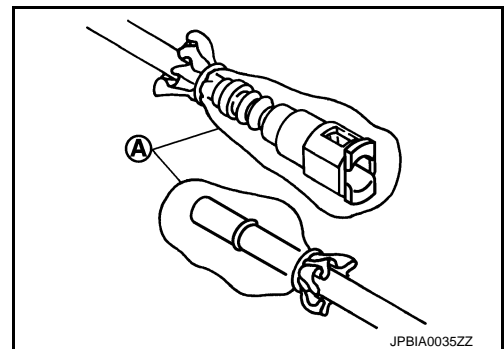
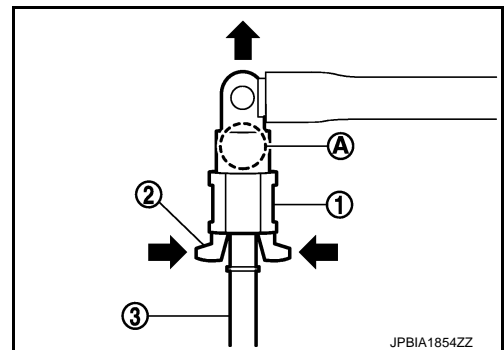

8. Remove fuel sub tube mounting bolt.
9. Disconnect harness connector from fuel injector.

FUEL INJECTOR AND FUEL TUBE

< REMOVAL AND INSTALLATION >

10. Loosen mounting bolts in reverse order as shown in the figure, and remove fuel tube and fuel injector assembly.

← : Engine front

CAUTION:

Never tilt it, or remaining fuel in pipes may flow out from pipes.

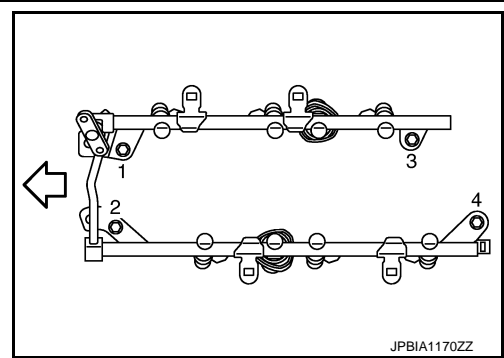

11. Remove fuel injector (2) from fuel tube (4) as follows:

3 : O-ring

A : Installed condition

B : Clip mounting groove

- Open and remove clip (1).
- Remove fuel injector from fuel tube by pulling straight.

CAUTION:

- Be careful with remaining fuel that may go out from fuel tube.
- Be careful not to damage injector nozzles during removal.
- Never bump or drop fuel injector.
- Never disassemble fuel injector.

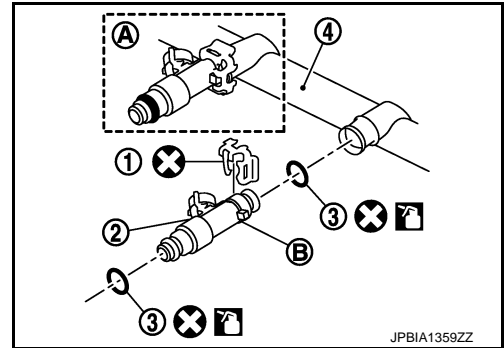

12. Remove fuel sub-tube and fuel damper, if necessary.

INSTALLATION

CAUTION:

Do not reuse O-rings.

1. Install fuel damper (4) as follows:

2 : Cup

5 : Clip

C : Cut-out

- Install new O-ring (1) to fuel tube as shown. When handling new O-ring, pay attention to the following caution items:

CAUTION:

- Do not reuse O-ring.
- Handle O-ring with bare hands. Never wear gloves.
- Lubricate O-ring with new engine oil.
- Never clean O-ring with solvent.
- Check that O-ring and its mating part are free of foreign material.
- When installing O-ring, be careful not to scratch it with tool or fingernails. Also be careful not to twist or stretch O-ring. If O-ring was stretched while it was being attached, never insert it quickly into fuel tube.
- Insert new O-ring straight into fuel tube. Never twist it.

- Install spacer (3) to fuel damper.
- Insert fuel damper straight into fuel tube.

CAUTION:

- Insert straight, checking that the axis is lined up.
- Never pressure-fit with excessive force.

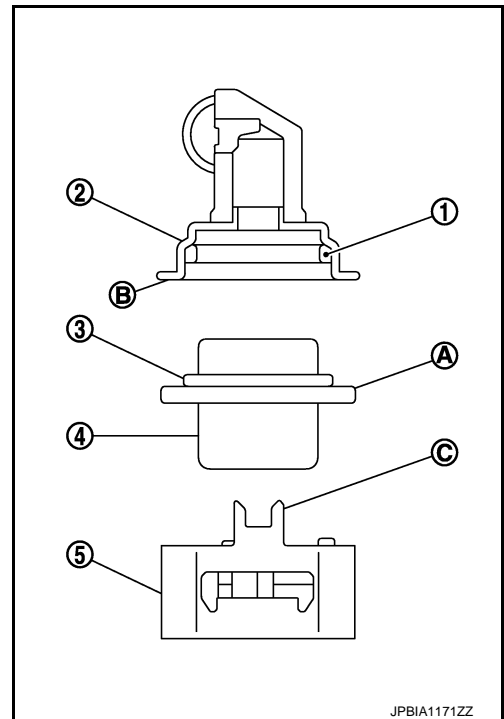

Reference value : 130 N (13.3 kg, 29.2 lb)

FUEL INJECTOR AND FUEL TUBE

< REMOVAL AND INSTALLATION >

- Insert fuel damper until (A) is touching (B) of fuel tube.

- d. Install the cut-out (A) of the clip (2) to the projection (B), which ensures that the fuel tube does not move or rotate.

1 : Fuel tube

- e. Unlock the clip after checking that the rib of the cup and the brim of the fuel damper are mated each other and positioned in the holes (C) of the clip.

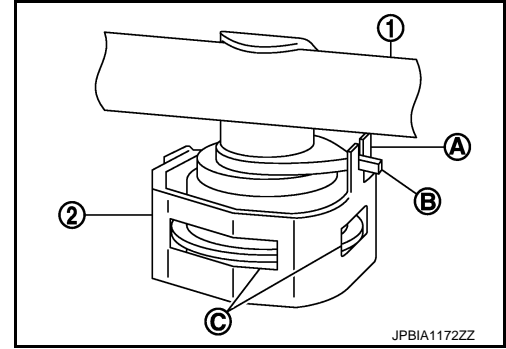

- f. Check that the opening (B) and the slit (C) of the clip are positioned and fixed properly so it does not rotate or pull out.

A : Under view

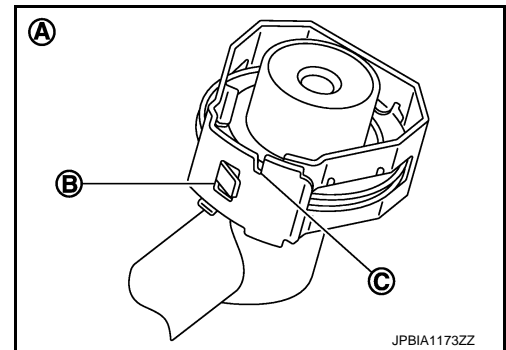

2. Install fuel sub-tube.

- When handling new O-rings, be careful of the following caution items:

CAUTION:

- Do not reuse O-rings.
- Handle O-ring with bare hands. Never wear gloves.
- Lubricate O-ring with new engine oil.
- Never clean O-ring with solvent.
- Check that O-ring and its mating part are free of foreign material.
- When installing O-ring, be careful not to scratch it with tool or fingernails. Also be careful not to twist or stretch O-ring. If O-ring was stretched while it was being attached, never insert it quickly into fuel tube.
- Insert new O-ring straight into fuel tube. Never decenter or twist it.

- Insert fuel sub-tube straight into fuel tube.

- Tighten mounting bolts evenly in turn.

- After tightening mounting bolts, Check that there is no gap between flange and fuel tube.

3. Install new O-rings to fuel injector, paying attention to the following items.

CAUTION:

- Do not reuse O-rings.

- Upper and lower O-ring are different. Be careful not to confuse them.

Fuel tube side : Black

Nozzle side : Green

- Handle O-ring with bare hands. Never wear gloves.
- Lubricate O-ring with new engine oil.
- Never clean O-ring with solvent.
- Check that O-ring and its mating part are free of foreign material.
- When installing O-ring, be careful not to scratch it with tool or fingernails. Also be careful not to twist or stretch O-ring. If O-ring was stretched while it was being attached, never insert it quickly into fuel tube.
- Insert O-ring straight into fuel injector. Never decenter or twist it.

FUEL INJECTOR AND FUEL TUBE

< REMOVAL AND INSTALLATION >

4. Install fuel injector to fuel tube as follows:

- 2 : O-ring (Black)
- 4 : O-ring (Green)

a. Insert clip (3) into clip mounting groove (F) on fuel injector (5).

CAUTION:

- Never reuse clip. Replace it with a new one.
- Be careful to keep clip from interfering with O-ring. If interference occurs, replace O-ring.
- Insert clip so that protrusion (E) of fuel injector matches cut-out (C) of clip.

b. Insert fuel injector into fuel tube (1) with clip attached.

- Insert it while matching it to the axial center.
- Insert fuel injector so that protrusion (A) of fuel tube matches cutout (B) of clip.
- Check that fuel tube flange (G) is securely fixed in flange fixing groove (D) on clip.

c. Check that installation is complete by checking that fuel injector does not rotate or come off.

- Check that protrusions of fuel injectors and fuel tube are aligned with cutouts of clips after installation.

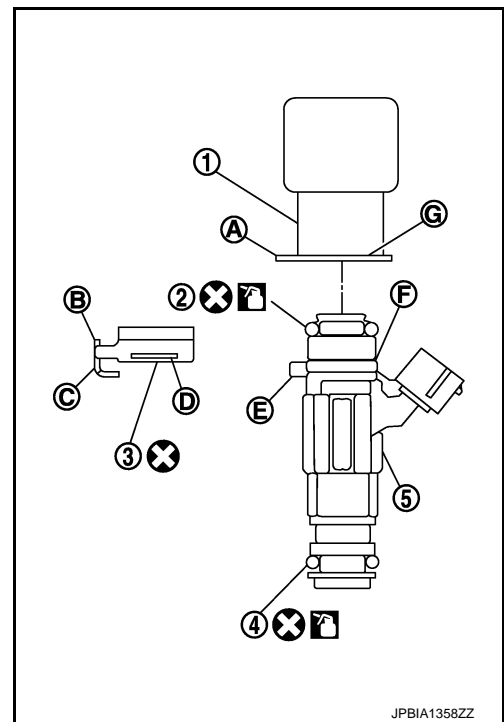

5. Install fuel tube and fuel injector assembly to intake manifold.

CAUTION:

Be careful not to let tip of injector nozzle come in contact with other parts.

- Tighten mounting bolts in two steps in numerical order as shown in the figure.

← : Engine front

1st step: 10.1 N-m (1.0 kg-m, 7 ft-lb)

2nd step: 23.6 N-m (2.4 kg-m, 17 ft-lb)

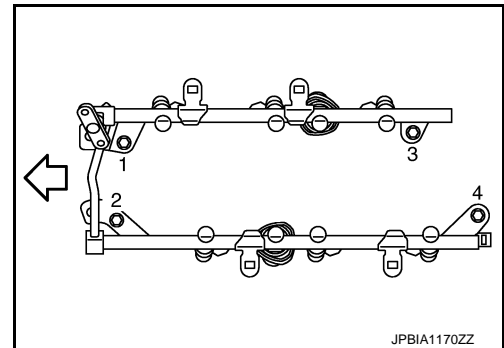

6. Connect injector sub-harness.

7. Install fuel sub tube mounting bolt.

8. Connect fuel feed hose (with damper).

- Handling procedure of O-ring is the same as that of fuel damper and fuel sub-tube.
- Insert fuel damper straight into fuel sub-tube.
- Tighten mounting bolts evenly in turn.
- After tightening mounting bolts, check that there is no gap between flange and fuel sub-tube.

9. Connect quick connector between fuel feed hose (with damper) and centralized under-floor piping connection as follows:

- a. Check that no foreign substances are deposited in and around centralized under-floor piping and quick connector, and that there is no damage to them.
- b. Thinly apply new engine oil around centralized under-floor piping from tip end to spool end.
- c. Align center to insert quick connector straightly into centralized under-floor piping.
 - Insert quick connector to centralized under-floor piping until top spool is completely inside quick connector and 2nd level spool exposes right below quick connector.

CAUTION:

- Hold align center to avoid inclined insertion to prevent damage to O-ring inside quick connector.
- Insert until you hear a “click” sound and actually feel the engagement.
- To avoid misidentification of engagement with a similar sound, be sure to perform the next step.

FUEL INJECTOR AND FUEL TUBE

< REMOVAL AND INSTALLATION >

- d. Pull quick connector by hand holding position (A). Check it is completely engaged (connected) so that it does not come out from centralized under-floor piping (1).

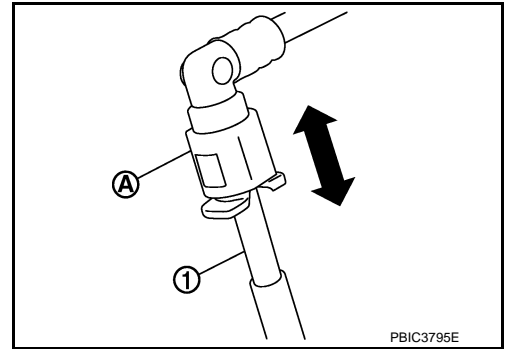

- e. Install quick connector cap (3) to quick connector connection.

- 1 : Centralized under-floor piping
- 2 : Fuel feed hose
- B : Under view

- Install quick connector cap with arrow (A) on surface facing in direction of quick connector (fuel feed hose side).

CAUTION:

If quick connector cap cannot be installed smoothly, quick connector may have not been installed correctly. Check the connection again.

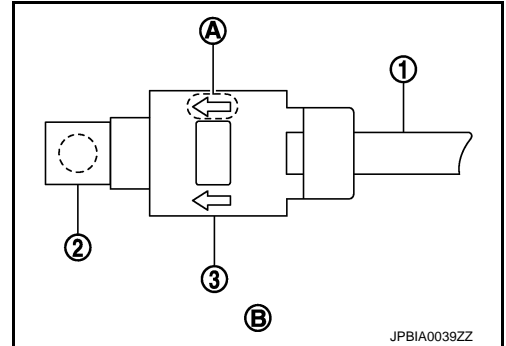

10. Install in the reverse order of removal after this step.

Inspection

INFOID:000000008154444

INSPECTION AFTER INSTALLATION

Check for Fuel Leakage

1. Turn ignition switch "ON" (with the engine stopped). With fuel pressure applied to fuel piping, check that there is no fuel leakage at connection points.

NOTE:

Use mirrors for checking at points out of clear sight.

2. Start the engine. With engine speed increased, check that again that there is no fuel leakage at connection points.

CAUTION:

Never touch the engine immediately after it is stopped because the engine is extremely hot.

OIL PAN (LOWER)

< REMOVAL AND INSTALLATION >

OIL PAN (LOWER)

Exploded View

INFOID:000000008154445

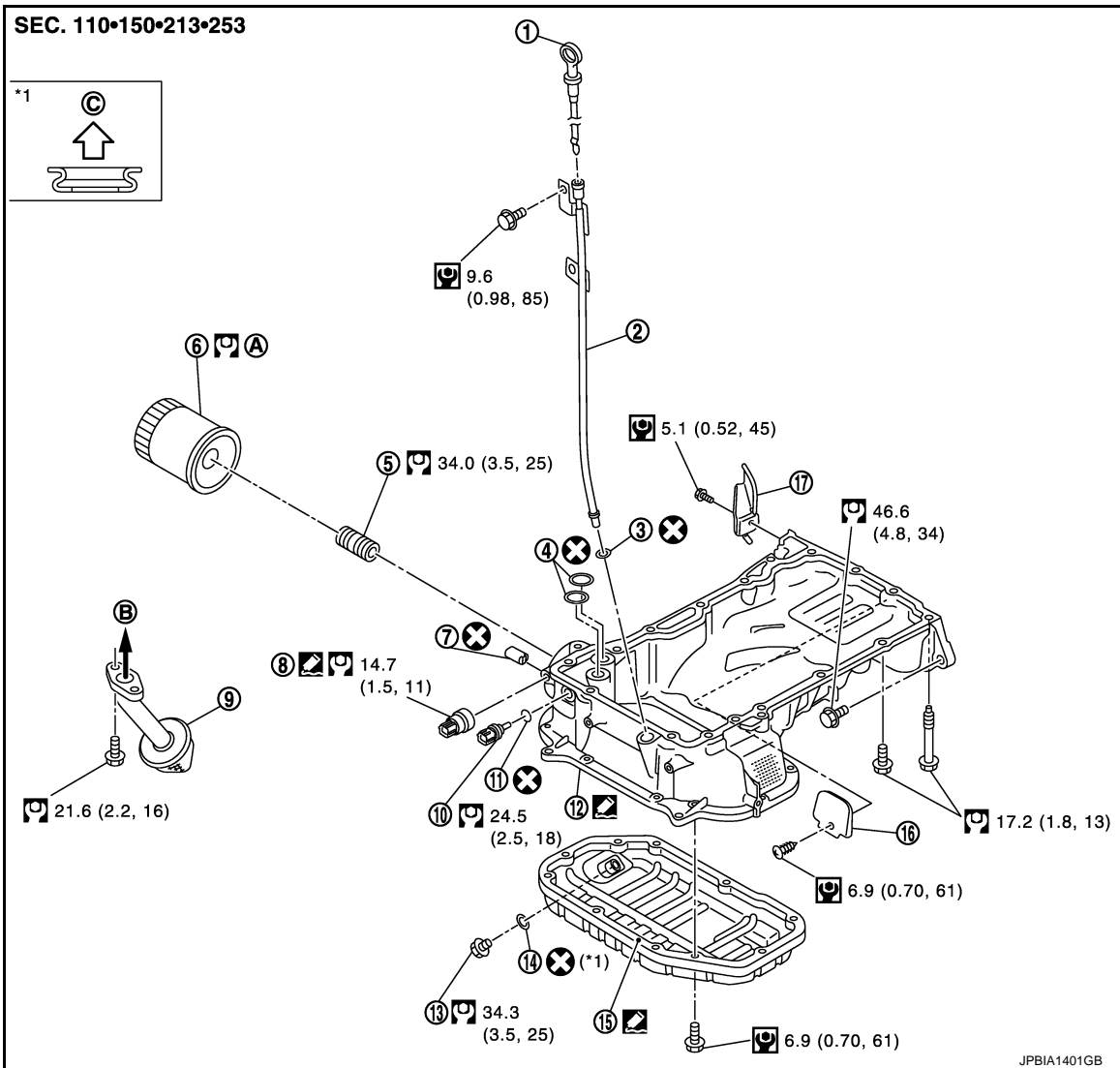

- | | | |
|-----------------------------------|-----------------------------------|---------------------|
| 1. Oil level gauge | 2. Oil level gauge guide | 3. O-ring |
| 4. O-ring | 5. Connector bolt | 6. Oil filter |
| 7. Relief valve | 8. Oil pressure switch | 9. Oil strainer |
| 10. Oil temperature sensor | 11. Washer | 12. Oil pan (upper) |
| 13. Drain plug | 14. Drain plug washer | 15. Oil pan (lower) |
| 16. Rear plate cover | 17. Rear cover plate (M/T models) | |
| A. Refer to LU-10 | B. To oil pump | C. Oil pan side |

Refer to [GI-4. "Components"](#) for symbols in the figure.

Removal and Installation

INFOID:000000008154446

REMOVAL

CAUTION:

Never drain engine oil when the engine is hot to avoid the danger of being scalded.

1. Remove engine undercover with power tool.
2. Remove oil pan (lower) as follows:

OIL PAN (LOWER)

< REMOVAL AND INSTALLATION >

- a. Loosen mounting bolts in reverse order as shown in the figure to remove.

⇐ : Engine front

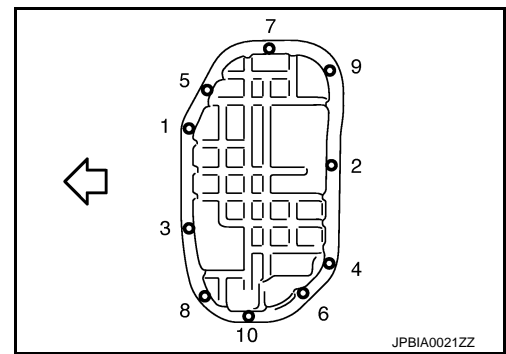

- b. Insert the seal cutter [SST: KV10111100 (J-37228)] (A) between oil pan (upper) and oil pan (lower).

CAUTION:

- Be careful not to damage the mating surfaces.
- Never insert a screwdriver. This damages the mating surfaces.

- c. Slide the seal cutter by tapping on the side of tool with a hammer. Remove oil pan (lower).

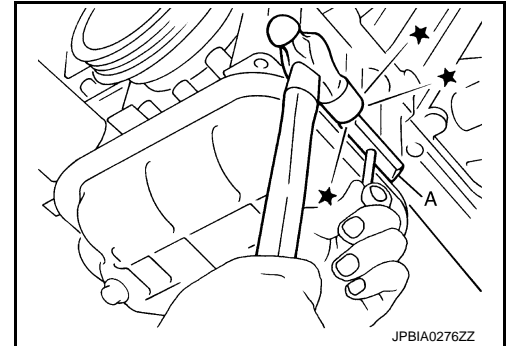

INSTALLATION

CAUTION:

Do not reuse drain plug washer.

1. Install oil pan (lower) as follows:

- a. Use scraper (A) to remove old liquid gasket from mating surfaces.

- Remove old liquid gasket from the bolt holes and thread.

CAUTION:

Never scratch or damage the mating surfaces when cleaning off old liquid gasket.

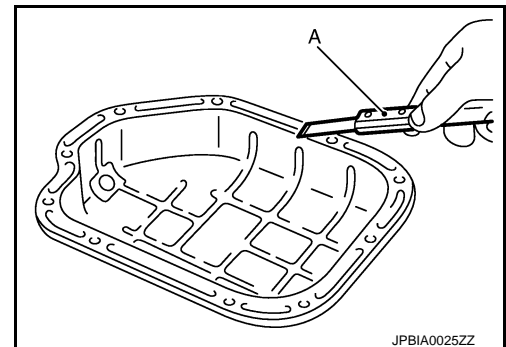

- b. Apply a continuous bead of liquid gasket with the tube presser (commercial service tool) to the oil pan (lower) as shown in the figure.

a : $\phi 4.0 - 5.0$ mm (0.157 - 0.197 in)

⇐ : Engine front

Use Genuine RTV Silicone Sealant or equivalent. Refer to [GI-22, "Recommended Chemical Products and Sealants"](#).

CAUTION:

Attaching should be done within 5 minutes after coating.

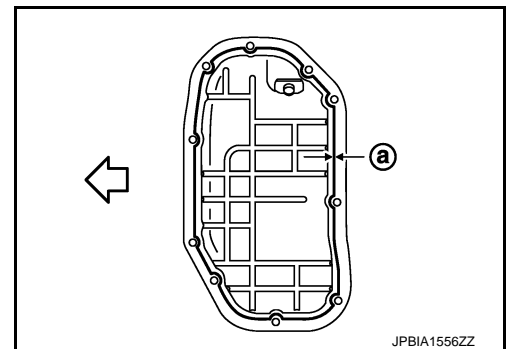

- c. Install oil pan (lower).

OIL PAN (LOWER)

< REMOVAL AND INSTALLATION >

- Tighten mounting bolts in numerical order as shown in the figure.

⇐ : Engine front

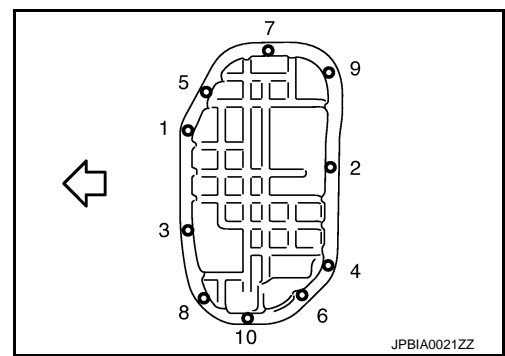

2. Install oil pan drain plug.

CAUTION:

Do not reuse drain plug washer.

- Refer to the figure of the components of on the prior page for installation direction of drain plug washer. Refer to [EM-43, "Exploded View"](#).

3. Install in the reverse order of removal after this step.

NOTE:

Wait at least 30 minutes after oil pan is installed before pouring engine oil.

Inspection

INFOID:000000008154447

INSPECTION AFTER REMOVAL

Clean oil strainer if any object is attached.

INSPECTION AFTER INSTALLATION

1. Check the engine oil level and adjust engine oil. Refer to [LU-7, "Inspection"](#).
2. Start engine, and check there is no leakage of engine oil.
3. Stop engine and wait for 10 minutes.
4. Check the engine oil level again. Refer to [LU-7, "Inspection"](#).

IGNITION COIL, SPARK PLUG AND ROCKER COVER

< REMOVAL AND INSTALLATION >

IGNITION COIL, SPARK PLUG AND ROCKER COVER

Exploded View

INFOID:000000008154448

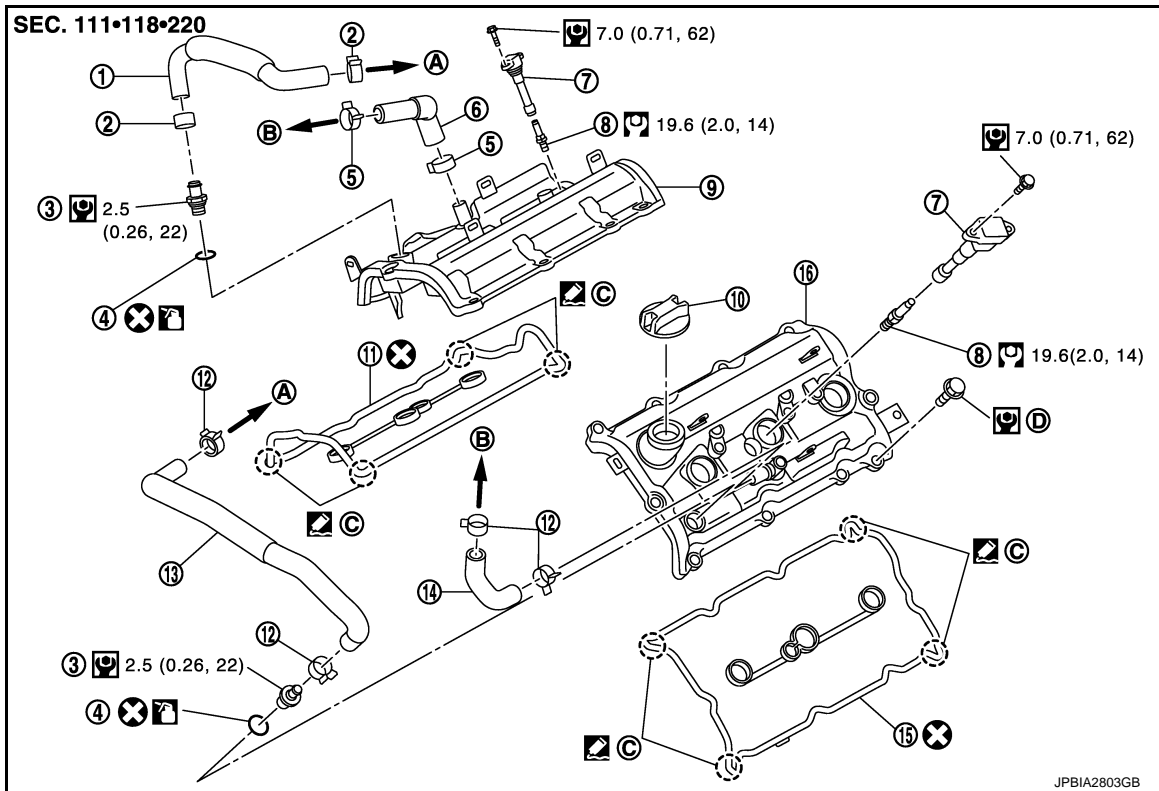

- | | | |
|---|----------------------------------|----------------------------------|
| 1. PCV hose | 2. Clamp | 3. PCV valve |
| 4. O-ring | 5. Clamp | 6. PCV hose |
| 7. Ignition coil | 8. Spark plug | 9. Rocker cover (bank 1) |
| 10. Oil filler cap | 11. Rocker cover gasket (bank 1) | 12. Clamp |
| 13. PCV hose | 14. PCV hose | 15. Rocker cover gasket (bank 2) |
| 16. Rocker cover (bank 2) | | |
| A. To intake manifold collector | B. To air duct | C. VVEL ladder assembly side |
| D. Comply with the installation procedure when tightening. Refer to EM-46 | | |

Refer to [GI-4, "Components"](#) for symbols in the figure.

Removal and Installation

INFOID:000000008154449

REMOVAL

- Remove the following parts:
 - Engine cover: Refer to [EM-25, "Exploded View"](#).
 - Air cleaner case and air duct (RH and LH): Refer to [EM-27, "Exploded View"](#).
 - Intake manifold collector: Refer to [EM-29, "Exploded View"](#).
- Disconnect PCV hose from rocker cover.
- Remove PCV valve and O-ring from rocker cover, if necessary.
- Remove oil filler cap from rocker cover, if necessary.
- Remove ignition coil.
CAUTION:
Never shock ignition coil.
- Remove harness clips on the rocker cover.

IGNITION COIL, SPARK PLUG AND ROCKER COVER

< REMOVAL AND INSTALLATION >

7. Loosen mounting bolts with power tool in reverse order as shown in the figure.

- A : Bank 1
 B : Bank 2
 ⇐ : Engine front

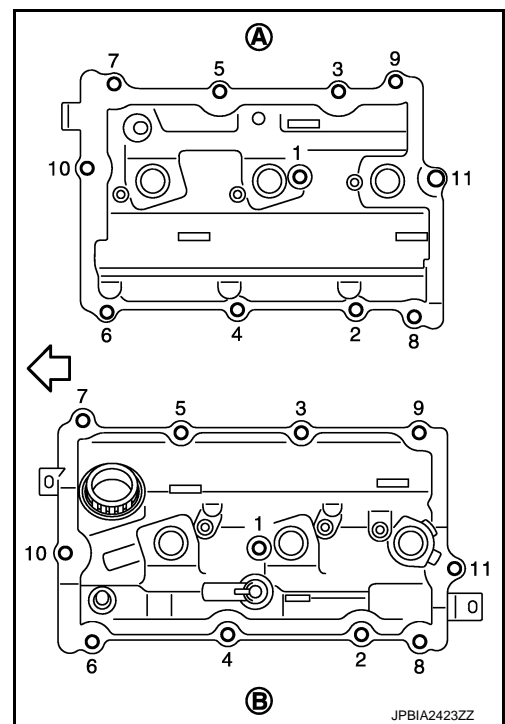

8. Remove rocker cover gasket from rocker cover.
 9. Use scraper to remove all traces of liquid gasket from cylinder head and VVEL ladder assembly.

CAUTION:

Never scratch or damage the mating surface when cleaning off old liquid gasket.

INSTALLATION

CAUTION:

Do not reuse O-rings.

1. Apply liquid gasket to the position shown in the figure with the following procedure:

- 2 : Actuator bracket (rear)
 3 : VVEL actuator sub assembly
 A : Liquid gasket application point
 F : View F
 I : End surface of VVEL ladder assembly
 b : 4 mm (0.16 in)
 c : $\phi 2.5 - 3.5$ mm (0.098 - 0.138 in)
 d : 5 mm (0.20 in)
 g : 10 mm (0.39 in)
 ⇐ : Engine front

- a. Refer to figure (E) to apply liquid gasket to joint part of VVEL ladder assembly (1) and cylinder head.
 b. Refer to figure (H) to apply liquid gasket in 90 degrees to figure. **Use Genuine RTV Silicone Sealant or equivalent. Refer to [GI-22, "Recommended Chemical Products and Sealants"](#).**

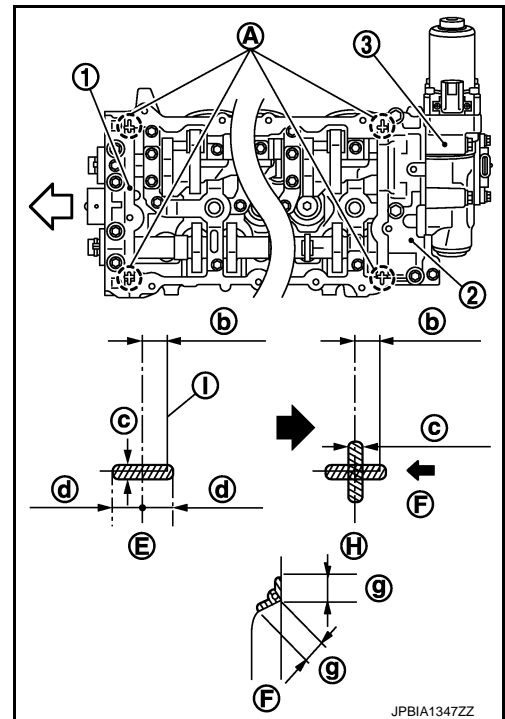

2. Install rocker cover gasket to rocker cover.
 3. Install rocker cover.
 • Check that rocker cover gasket does not drop from the installation groove of rocker cover.

IGNITION COIL, SPARK PLUG AND ROCKER COVER

< REMOVAL AND INSTALLATION >

4. Tighten bolts in two steps separately in numerical order as shown in the figure.

A : Bank 1

B : Bank 2

↔ : Engine front

 **1st step: 2.0 N·m (0.20 kg-m, 18 in-lb)**

 **2nd step: 8.3 N·m (0.85 kg-m, 73 in-lb)**

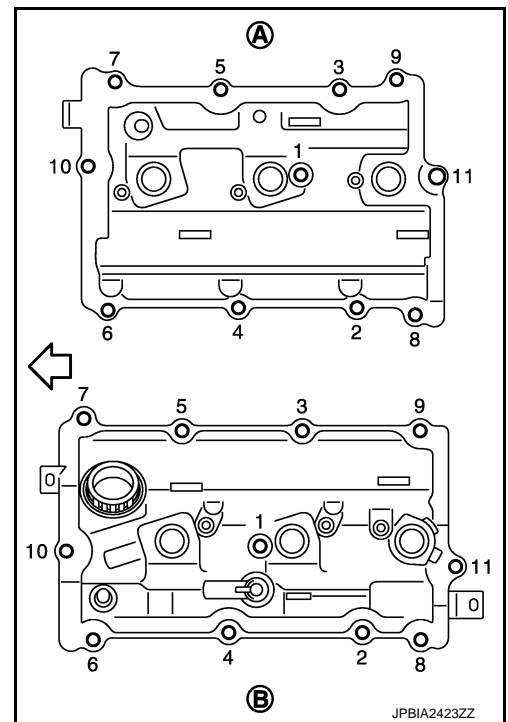

5. Install in the reverse order of removal after this step.

TIMING CHAIN

< REMOVAL AND INSTALLATION >

TIMING CHAIN

Exploded View

INFOID:00000008154450

A

EM

C

D

E

F

G

H

I

J

K

L

M

N

O

P

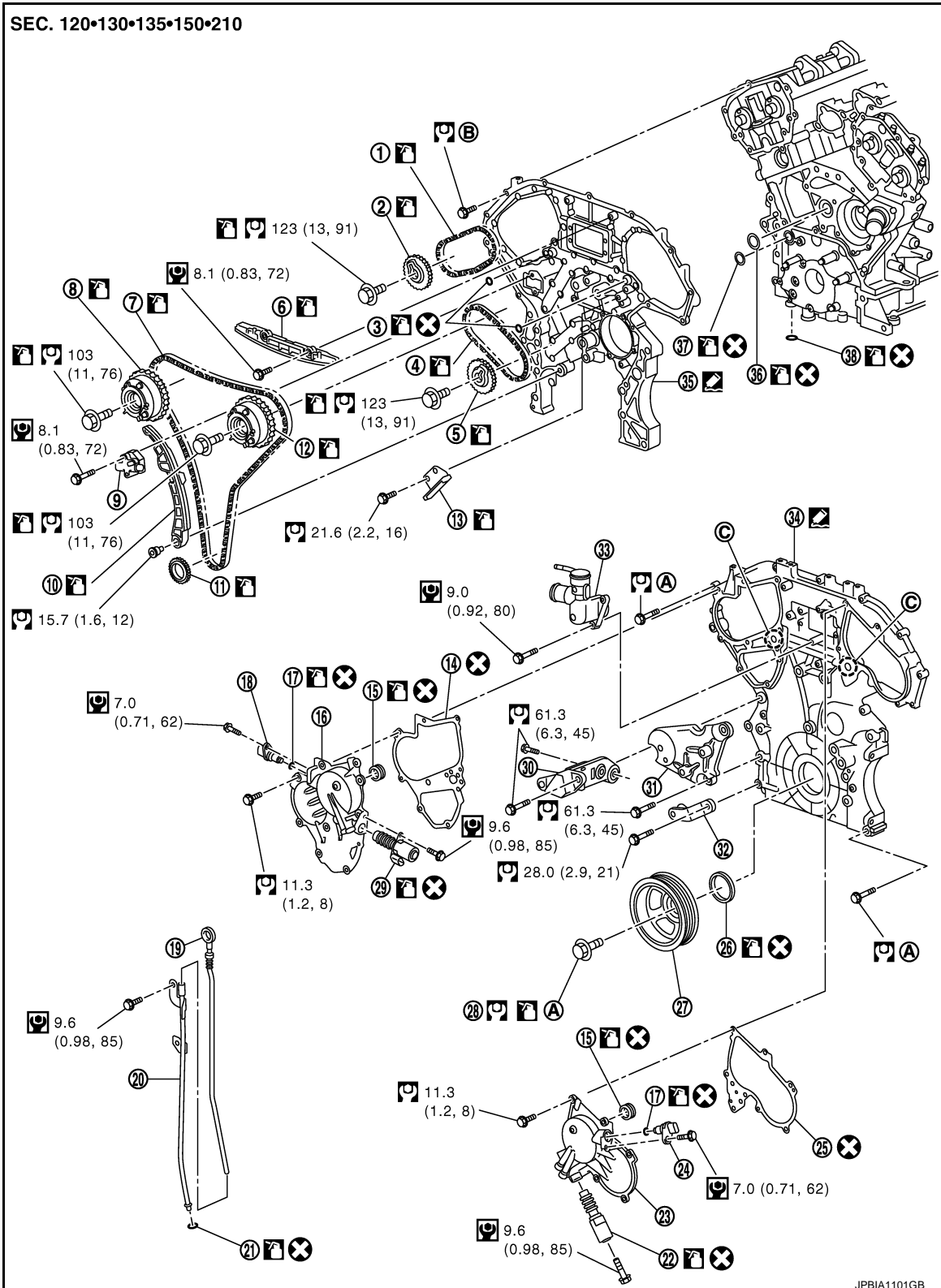

- | | | |
|--------------------------------------|-------------------------------------|-------------------------------------|
| 1. Timing chain (secondary) (bank 1) | 2. Camshaft sprocket (EXH) (bank 1) | 3. O-ring |
| 4. Timing chain (secondary) (bank 2) | 5. Camshaft sprocket (EXH) (bank 2) | 6. Internal chain guide |
| 7. Timing chain (primary) | 8. Camshaft sprocket (INT) (bank 1) | 9. Timing chain tensioner (primary) |

TIMING CHAIN

< REMOVAL AND INSTALLATION >

- | | | |
|---|---|---|
| 10. Slack guide | 11. Crankshaft sprocket | 12. Camshaft sprocket (INT) (bank 2) |
| 13. Tension guide | 14. Intake valve timing control cover gasket (bank 1) | 15. Seal ring |
| 16. Intake valve timing control cover (bank 1) | 17. O-ring | 18. Camshaft position sensor (PHASE) (bank 1) |
| 19. Oil level gauge | 20. Oil level gauge guide | 21. O-ring |
| 22. Intake valve timing control solenoid valve (bank 2) | 23. Intake valve timing control cover (bank 2) | 24. Camshaft position sensor (PHASE) (bank 2) |
| 25. Intake valve timing control cover gasket (bank 2) | 26. Front oil seal | 27. Crankshaft pulley |
| 28. Crankshaft pulley bolt | 29. Intake valve timing control solenoid valve (bank 1) | 30. Power steering oil pump bracket |
| 31. Idler pulley bracket | 32. Alternator bracket | 33. Water outlet (front) |
| 34. Front timing chain case | 35. Rear timing chain case | 36. O-ring |
| 37. O-ring | 38. O-ring | |
- A. Comply with the installation procedure when tightening. Refer to [EM-50](#)
- B. Comply with the installation procedure when tightening. Refer to [EM-80](#)
- C. Oil filter

Refer to [GI-4, "Components"](#) for symbols in the figure.

Removal and Installation

INFOID:000000008154451

REMOVAL

1. Release the fuel pressure. Refer to [EC-595, "Inspection"](#).
2. Disconnect the battery cable from the negative terminal.
3. Remove engine cover with power tool. Refer to [EM-25, "Exploded View"](#).
4. Remove radiator reservoir tank. Refer to [CO-13, "Exploded View"](#).
5. Remove air duct and air cleaner case assembly (RH and LH). Refer to [EM-27, "Exploded View"](#).
6. Remove engine undercover with power tool.
7. Drain engine coolant from radiator. Refer to [CO-7, "Draining"](#).
CAUTION:
 - Perform this step when the engine is cold.
 - Never spill engine coolant on drive belt.
8. Remove radiator hose (upper and lower). Refer to [CO-13, "Exploded View"](#).
9. Drain engine oil. Refer to [LU-8, "Draining"](#).
CAUTION:
Perform this step when the engine is cold.
10. Remove radiator cooling fan assembly. Refer to [CO-13, "Exploded View"](#).
11. Remove drive belt. Refer to [EM-13, "Removal and Installation"](#).
12. Separate engine harnesses by removing their brackets from front timing chain case.
13. Remove intake manifold collector. Refer to [EM-29, "Exploded View"](#).
14. Remove fuel sub tube mounting bolt. Refer to [EM-37, "Exploded View"](#).
15. Remove oil level gauge and oil level gauge guide.
16. Remove A/C compressor from bracket with piping connected, and temporarily secure it aside. Refer to [HA-38, "Exploded View"](#).
17. Remove power steering oil pump from bracket with piping connected, and temporarily secure it aside. Refer to [ST-32, "EXCEPT FOR SPORT MODELS : Exploded View"](#) or [ST-37, "SPORT MODELS : Exploded View"](#).
18. Remove power steering oil pump bracket.
19. Remove idler pulley, drive belt auto-tensioner and bracket. Refer to [EM-26, "Exploded View"](#).
20. Remove alternator and alternator bracket. Refer to [CHG-27, "Exploded View"](#).
21. Remove water pipe. Refer to [CO-24, "Exploded View"](#).

TIMING CHAIN

< REMOVAL AND INSTALLATION >

22. Remove camshaft position sensor (PHASE).

A : Keep free from magnetic materials

CAUTION:

- Handle carefully to avoid dropping and shocks.
- Never disassemble.
- Never allow metal powder to adhere to magnetic part at sensor tip.
- Never place sensors in a location where they are exposed to magnetism.

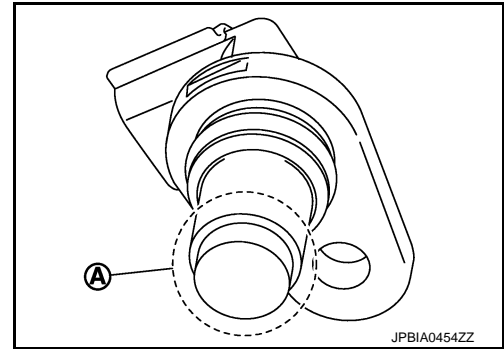

23. Remove intake valve timing control covers and gasket as follows:

- Disconnect intake valve timing control solenoid valve harness connector.
- Loosen mounting bolts in reverse order as shown in the figure.

A : Bank 1
 B : Bank 2
 C : Dowel pin hole

CAUTION:

Shaft is internally jointed with camshaft sprocket (INT) center hole. When removing, keep it horizontal until it is completely disconnected.

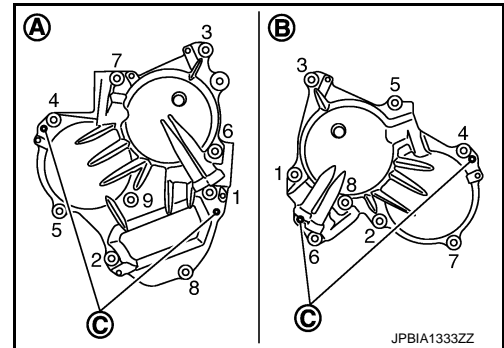

- Shaft is engaged with camshaft sprocket (INT) center hole on inside. Pull straight out so that it does not tilt until the joint is disengaged.
24. Remove intake valve timing control solenoid valve, if necessary.

CAUTION:

Intake valve timing control solenoid valve is nonreusable. Never remove it unless required.

25. Remove rocker covers (bank 1 and bank 2). Refer to [EM-46. "Exploded View"](#).
26. Obtain No. 1 cylinder at TDC of its compression stroke as follows:

- Rotate crankshaft pulley clockwise to align timing mark (grooved line without color) with timing indicator.

← : Timing mark (grooved line without color)

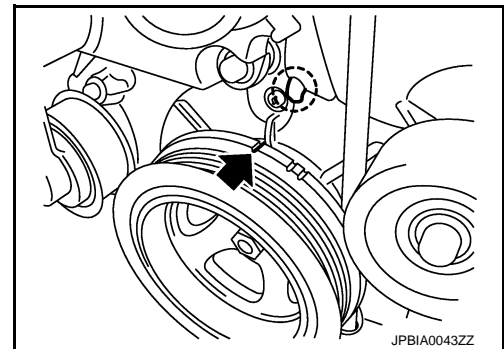

- Check that exhaust cam noses on No. 1 cylinder (engine front side of bank 1) is located as shown in the figure.

1 : Camshaft (EXH) (bank 1)
 ⇐ : Engine front

- If not, turn crankshaft one revolution (360 degrees) and align as shown in the figure.

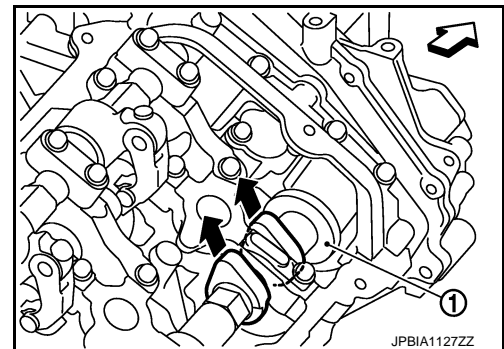

27. Remove crankshaft pulley as follows:

A
 EM
 C
 D
 E
 F
 G
 H
 I
 J
 K
 L
 M
 N
 O
 P

TIMING CHAIN

< REMOVAL AND INSTALLATION >

- a. Remove rear cover plate and set the ring gear stopper [SST: KV10118600 (J-48641)] (A) as shown in the figure.

- 1 : Oil pan (upper)
- 2 : Flywheel (M/T models) or drive plate (A/T models)
- ⇐ : Vehicle front

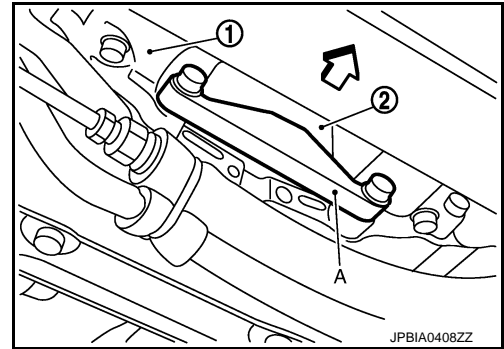

- b. Loosen crankshaft pulley bolt and rotate bolt seating surface at 10 mm (0.39 in) from its original position.

- 1 : Crankshaft pulley

CAUTION:

Never remove crankshaft pulley bolt because it is used as a supporting point for suitable puller.

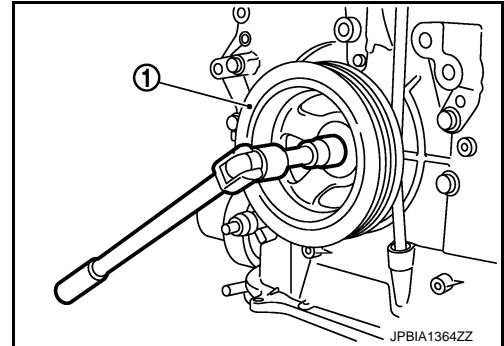

- c. Place suitable puller tab on holes of crankshaft pulley, and pull crankshaft pulley through.

CAUTION:

Never put suitable puller tab on crankshaft pulley periphery, because this damages internal damper.

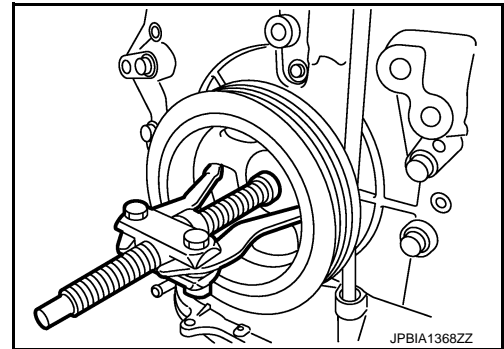

28. Remove oil pan (lower). Refer to [EM-43, "Exploded View"](#).

29. Loosen two mounting bolts in front of oil pan (upper) with power tool in reverse order as shown in the figure.

- ⇐ : Engine front

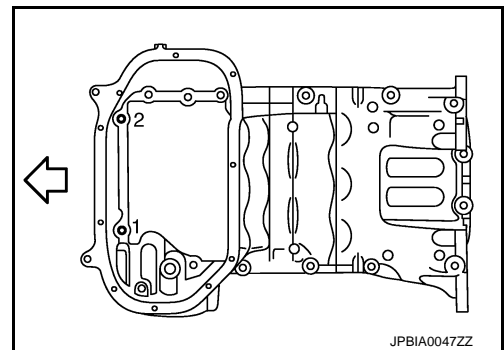

30. Remove front timing chain case as follows:

TIMING CHAIN

< REMOVAL AND INSTALLATION >

a. Loosen mounting bolts in reverse order as shown in the figure.

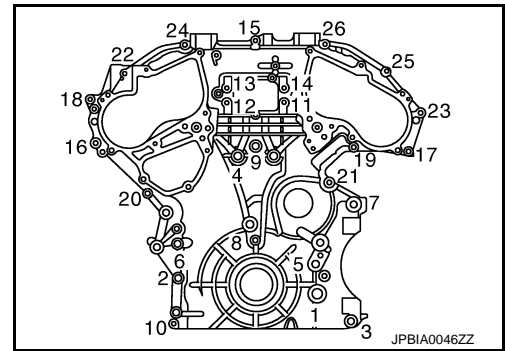

b. Insert a suitable tool (A) into the notch at the top of front timing chain case as shown.

c. Pry off case by moving the suitable tool as shown.

- Use the seal cutter [SST: KV10111100 (J-37228)] to cut liquid gasket for removal.

CAUTION:

- **Never use a screwdriver or a similar item.**
- **After removal, handle front timing chain case carefully so it does not tilt, cant, or warp under a load.**

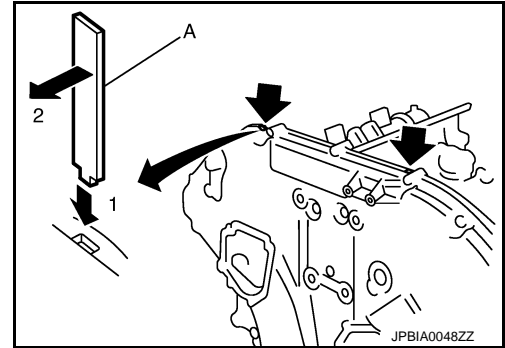

31. Remove front oil seal from front timing chain case using a suitable tool.

- Use a screwdriver for removal.

CAUTION:

Be careful not to damage front timing chain case.

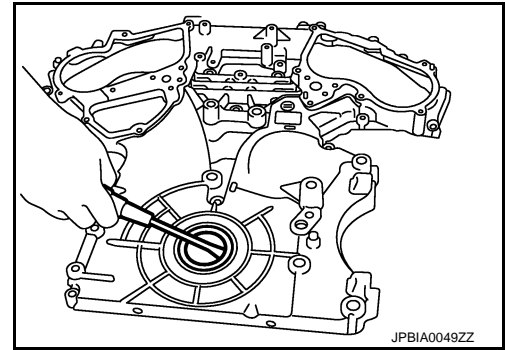

32. Remove O-ring (1) from rear timing chain case.

- A : Bank 1
- B : Bank 2

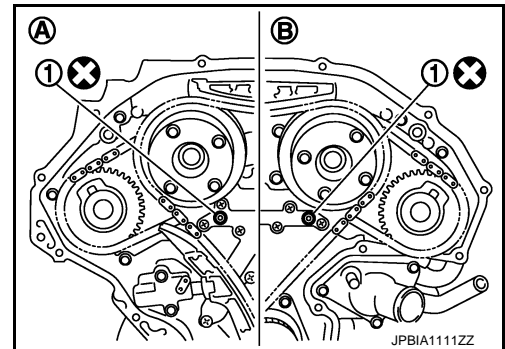

TIMING CHAIN

< REMOVAL AND INSTALLATION >

33. Remove timing chain tensioner (primary) (1) as follows:

- Remove lower mounting bolt (A).
- Loosen upper mounting bolt (B) slowly, and then turn timing chain tensioner (primary) on the upper mounting bolt so that plunger (C) is fully expanded.

NOTE:

Even if plunger is fully expanded, it does not drop from the body of timing chain tensioner (primary).

- Remove upper mounting bolt, and then remove timing chain tensioner (primary).

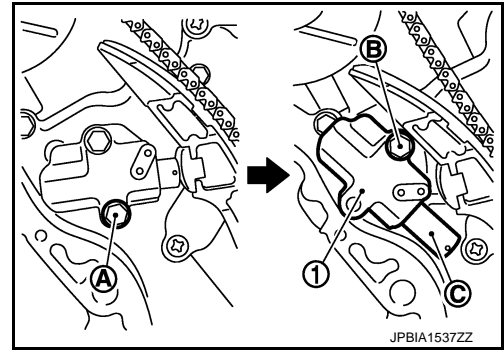

34. Remove internal chain guide (1), slack guide (2) and tension guide (3).

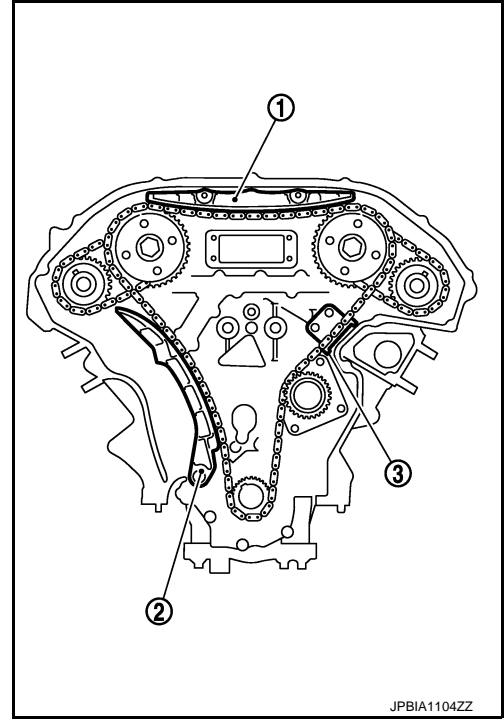

35. Remove timing chain (primary) and crankshaft sprocket.

CAUTION:

After removing timing chain (primary), never turn crankshaft and camshaft separately, or valves strike the piston heads.

36. Remove timing chain (secondary) and camshaft sprockets as follows:

- Attach suitable stopper pin (C) to the timing chain tensioners (secondary) (1), (2).

A : Bank 1

B : Bank 2

NOTE:

- Use approximately 0.5 mm (0.02 in) dia. hard metal pin as a stopper pin.
- For removal of timing chain tensioners (secondary), refer to [EM-84, "Exploded View"](#). (Removing VVEL ladder assembly is required.)

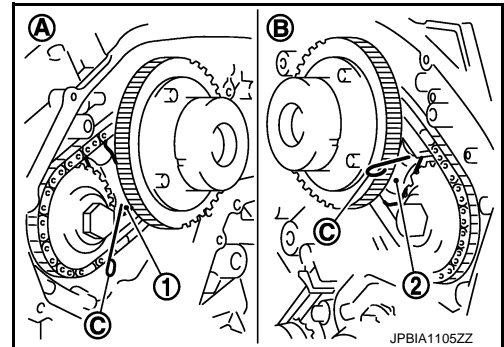

- Remove camshaft sprocket (EXH) mounting bolt.
 - Secure the hexagonal portion of camshaft (EXH) using a wrench to loosen mounting bolt.

CAUTION:

Never loosen the mounting bolt by securing anything other than the camshaft (EXH) hexagonal portion or with tensioning the timing chain.

TIMING CHAIN

< REMOVAL AND INSTALLATION >

- c. Remove camshaft sprocket (INT) mounting bolt.
- Secure the hexagonal portion (located in between journal No. 1 and journal No. 2) of drive shaft (A) using a wrench to loosen mounting bolt.

1 : Camshaft (EXH) (bank 2)

⇐ : Engine front

CAUTION:

- Never loosen the mounting bolt by securing anything other than the drive shaft hexagonal portion or with tensioning the timing chain.
- When holding the hexagonal part of drive shaft on the intake side with a wrench, be careful not to allow the wrench to cause interference with other parts.
- Never disassemble camshaft sprocket (INT). [Never loosen bolts (A) as shown in the figure.]

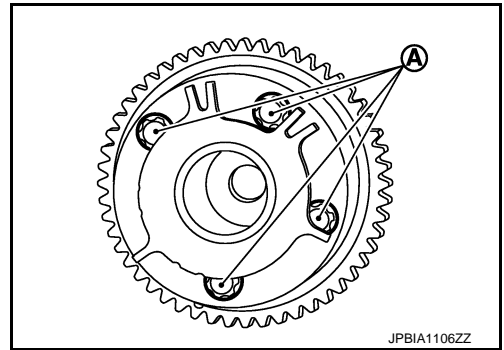
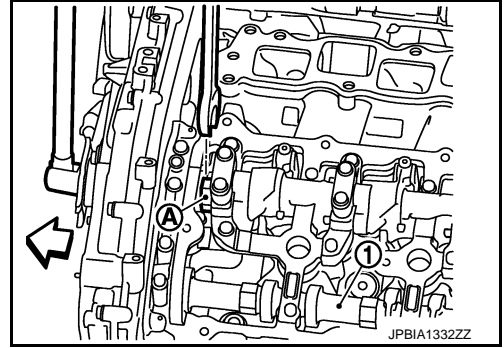

- d. Remove timing chain (secondary) together with camshaft sprockets.
37. Use a scraper to remove all traces of old liquid gasket from front and rear timing chain cases and oil pan (upper), and liquid gasket mating surfaces.

CAUTION:

Be careful not to allow gasket fragments to enter oil pan.

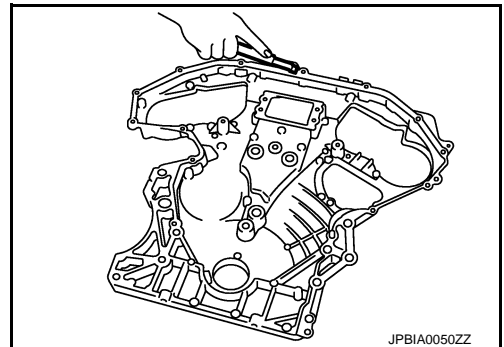

38. Remove old liquid gasket from bolt hole and thread.

A : Remove old liquid gasket that is stuck

B : Bolt hole

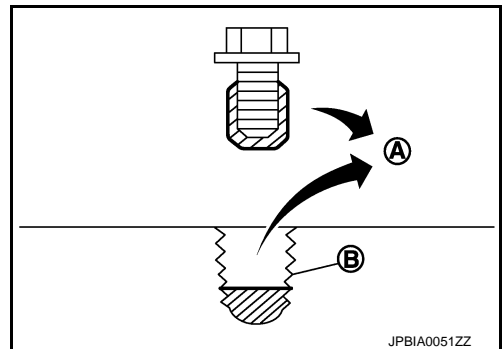

INSTALLATION

CAUTION:

Do not reuse O-rings.

NOTE:

The figure below shows the relationship between the matching mark on each timing chain and that on the corresponding sprocket with the components installed.

A
EM
C
D
E
F
G
H
I
J
K
L
M
N
O
P

TIMING CHAIN

< REMOVAL AND INSTALLATION >

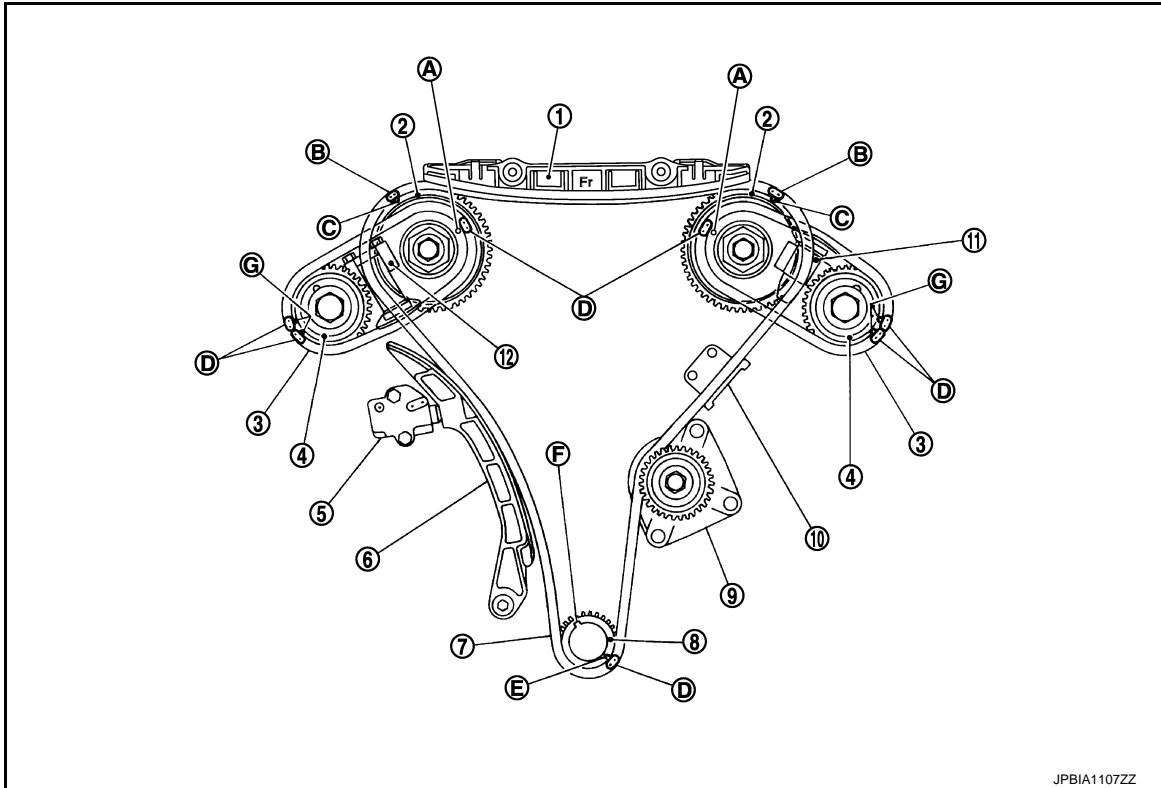

- | | | |
|--|---|---|
| 1. Internal chain guide | 2. Camshaft sprocket (INT) | 3. Timing chain (secondary) |
| 4. Camshaft sprocket (EXH) | 5. Timing chain tensioner (primary) | 6. Slack guide |
| 7. Timing chain (primary) | 8. Crankshaft sprocket | 9. Water pump |
| 10. Tension guide | 11. Timing chain tensioner (secondary) (bank 2) | 12. Timing chain tensioner (secondary) (bank 1) |
| A. Matching mark [punched (back side)] | B. Matching mark (yellow link) | C. Matching mark (punched) |
| D. Matching mark (orange link) | E. Matching mark (notched) | F. Crankshaft key |
| G. Matching mark (punched) | | |

1. Check that dowel pin (A) and crankshaft key (1) are located as shown in the figure. (No. 1 cylinder at compression TDC)

NOTE:

Though camshaft does not stop at the position as shown in the figure, for the placement of cam noses, it is generally accepted that camshaft is placed in the same direction as that of the figure.

Camshaft dowel pin

: At cylinder head upper face side in each bank.

Crankshaft key

: At cylinder head side of bank 1.

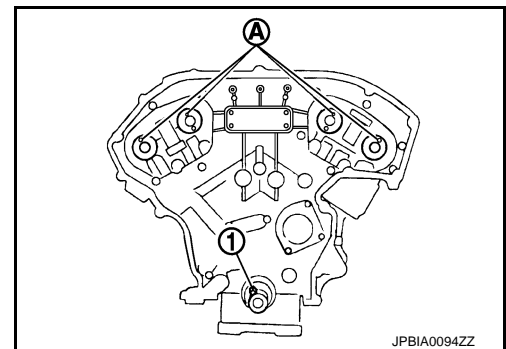

2. Install timing chains (secondary) and camshaft sprockets as follows:

CAUTION:

Matching marks between timing chain and sprockets slip easily. Confirm all matching mark positions repeatedly during the installation process.

TIMING CHAIN

< REMOVAL AND INSTALLATION >

- a. Push plunger of timing chain tensioner (secondary) and keep it pressed in with a stopper pin (A).

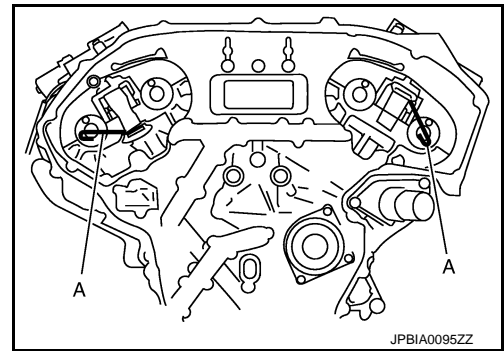

- b. Install timing chains (secondary) and camshaft sprockets.

- A : Camshaft sprocket (INT) back face
- B : Orange link
- C : Dowel groove
- D : Matching mark (oval)
- E : Matching mark (2 oval: on front face)
- F : Matching mark (circle)
- G : Camshaft sprocket (EXH) back face
- H : Matching mark (2 circle: on front face)
- I : Timing chain (secondary)

NOTE:

Figure shows bank 1 (rear view).

- Align the matching marks on timing chain (secondary) (orange link) with the ones on intake and exhaust camshaft sprockets (punched), and install them.

NOTE:

- Matching marks for camshaft sprockets (INT) are on the back side of camshaft sprockets (secondary).
- There are two types of matching marks, the circle and oval types. They should be used for the bank 1 and bank 2, respectively.

Bank 1 : Use circle type

Bank 2 : Use oval type

- Shape (orientation of signal plate) of camshaft sprocket (INT) varies depending on the bank position. See the right figure to install.

- A : Bank 1
- B : Bank 2

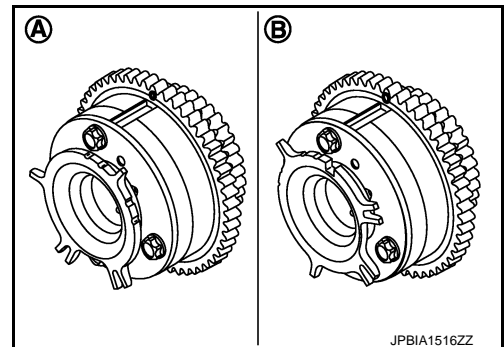
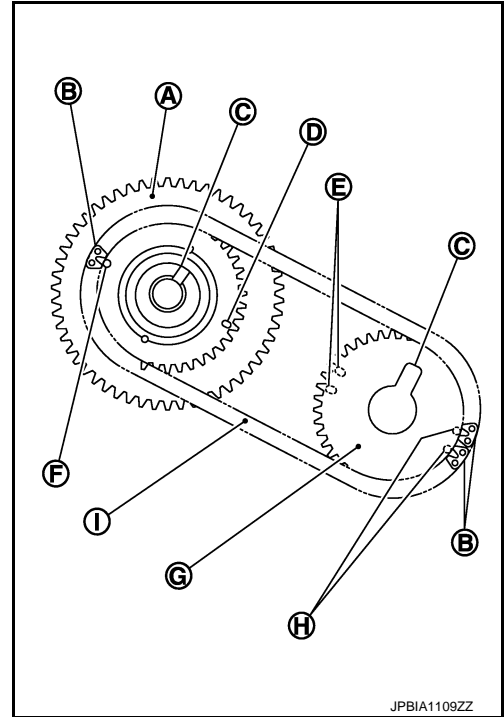

- Align dowel pin camshafts with the pin groove on sprockets, and install them.
- In case that positions of each matching mark and each dowel pin do not fit with matching parts, make fine adjustment to the position holding the hexagonal portion on camshaft (EXH) or drive shaft with wrench or equivalent tool.
- Mounting bolts for camshaft sprockets must be tightened in the next step. Tightening them by hand is sufficient to prevent the dislocation of dowel pins.

TIMING CHAIN

< REMOVAL AND INSTALLATION >

- It may be difficult to visually check the dislocation of matching marks during and after installation. To make the matching easier, make a matching mark on the top of sprocket teeth and its extended line in advance with paint.

- A : Matching mark (painted)
- B : Matching mark (orange link)

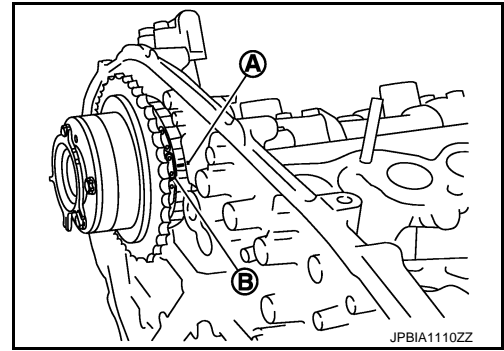

- c. Tighten camshaft sprocket (EXH) mounting bolt.
 - Secure camshaft (EXH) using a wrench at the hexagonal portion to tighten mounting bolt.
- d. After confirming the matching marks are aligned, tighten camshaft sprocket (INT) mounting bolt.
 - Secure the hexagonal portion (located in between journal No. 1 and journal No. 2) of drive shaft (A) using a wrench to tighten mounting bolt.

- 1 : Camshaft (EXH) (bank 2)
- ⇐ : Engine front

CAUTION:

When holding the hexagonal part of drive shaft on the intake side with a wrench, be careful not to allow the wrench to cause interference with other parts.

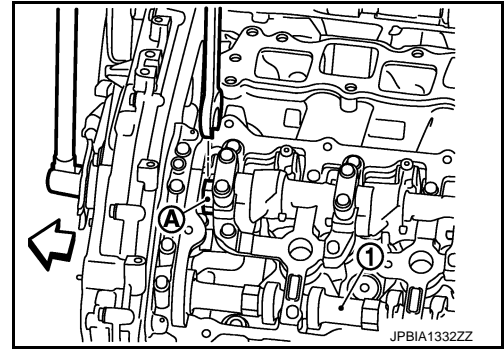

- e. Pull stopper pins (C) out from timing chain tensioners (secondary) (1), (2).

- A : Bank 1
- B : Bank 2

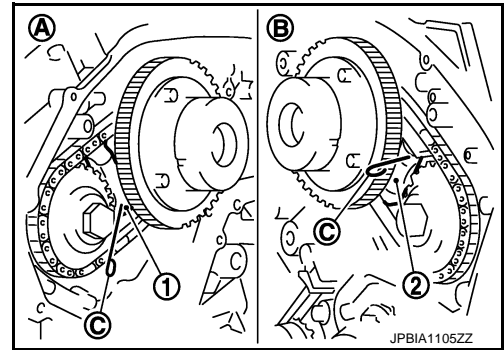

3. Install timing chain (primary) as follows:

- a. Install crankshaft sprocket (1).

- A : Matching mark (front side)
- ⇐ : Engine front

- Check that the matching marks on crankshaft sprocket face the front of the engine.

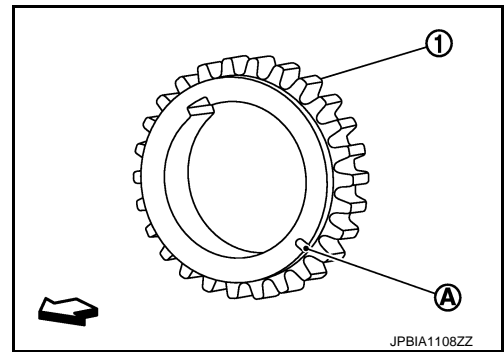

- b. Install timing chain (primary).

TIMING CHAIN

< REMOVAL AND INSTALLATION >

- Install timing chain (primary) so that the matching mark (punched) (B) on camshaft sprocket (INT) (1) is aligned with the yellow link (A) on timing chain, while the matching mark (notched) (C) on crankshaft sprocket (2) is aligned with the orange link (D) one on timing chain, as shown in the figure.

3 : Water pump

- When it is difficult to align matching marks of timing chain (primary) with each sprocket, gradually turn drive shaft using wrench on the hexagonal portion to align it with the matching marks.

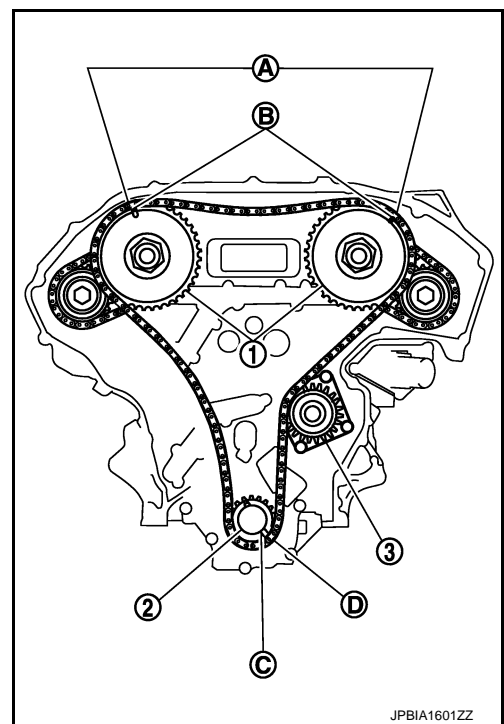

4. Install internal chain guide (1), slack guide (2), and tension guide (3).

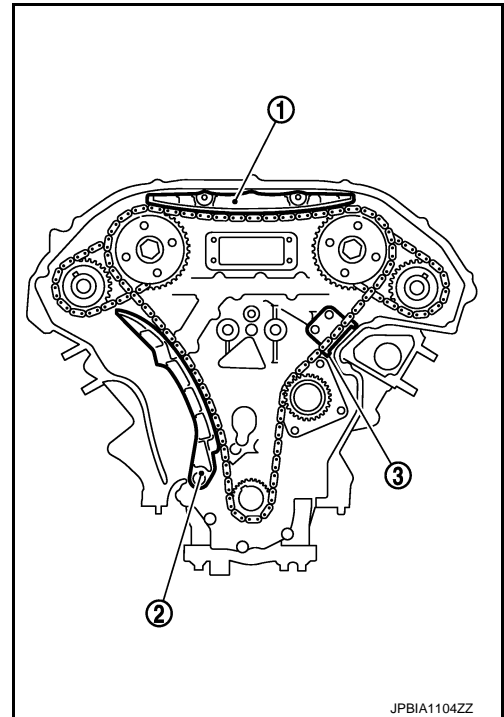

CAUTION:

A
EM
C
D
E
F
G
H
I
J
K
L
M
N
O
P

TIMING CHAIN

< REMOVAL AND INSTALLATION >

Never overtighten slack guide mounting bolt (2). It is normal for a gap (A) to exist under the bolt seats when mounting bolt are tightened to the specification.

- 1 : Slack guide
- 2 : Slack guide mounting bolt
- 3 : Cylinder block

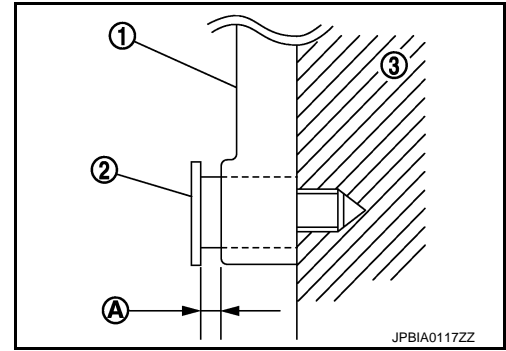

5. Install the timing chain tensioner (primary) with the following procedure:

- a. Pull plunger stopper tab (A) up (or turn lever downward) so as to remove plunger stopper tab from the ratchet of plunger (D).

NOTE:

Plunger stopper tab and lever (C) are synchronized.

- b. Push plunger into the inside of tensioner body.
 c. Hold plunger in the fully compressed position by engaging plunger stopper tab with the tip of ratchet.
 d. To secure lever, insert stopper pin (E) through hole of lever into tensioner body hole (B).
 • The lever parts and the plunger stopper tab are synchronized. Therefore, the plunger is secured under this condition.

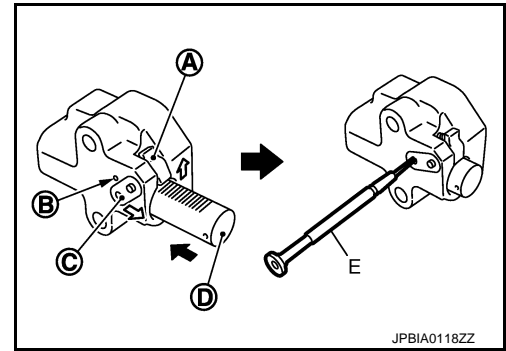

NOTE:

Figure shows the example of 1.2 mm (0.047 in) diameter thin screwdriver being used as the stopper pin.

- e. Install timing chain tensioner (primary) (1).
 • Remove any dirt and foreign materials completely from the back and the mounting surfaces of timing chain tensioner (primary).
 f. Pull out stopper pin (A) after installing, and then release plunger.

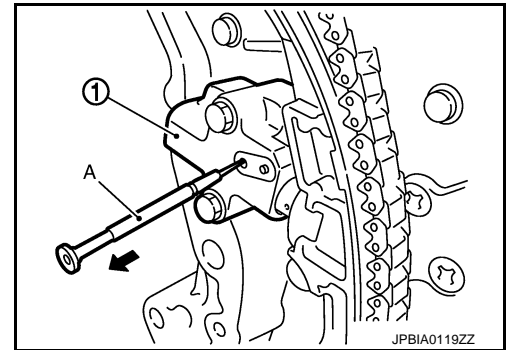

6. Check again that the matching marks on sprockets and timing chain have not slipped out of alignment.

7. Install new O-rings (1) on rear timing chain case.

- A : Bank 1
- B : Bank 2

CAUTION:

Do not reuse O-rings.

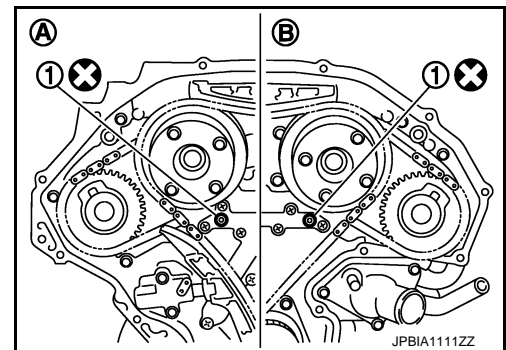

TIMING CHAIN

< REMOVAL AND INSTALLATION >

8. Install new front oil seal on front timing chain case.

⇐ : Engine inside

➡ : Engine outside

- Apply new engine oil to both oil seal lip (A) and dust seal lip (B).
- Install it so that each seal lip is oriented as shown in the figure.

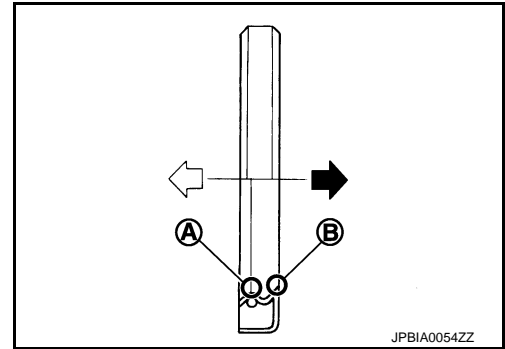

- Using a suitable drift [outer diameter: 60 mm (2.36 in)] (A), press-fit oil seal until it becomes flush with front timing chain case end face.
- Check that the garter spring is in position and seal lip is not inverted.

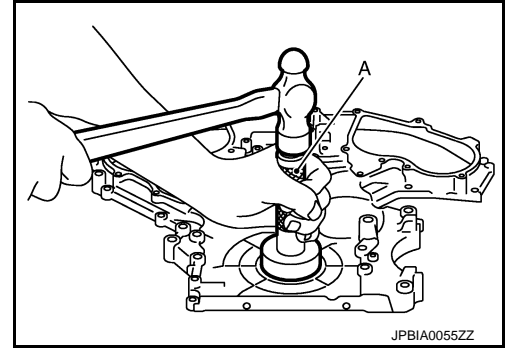

9. Install front timing chain case as follows:

- Check that O-rings stay in place during installation to rear timing chain case.

a. Apply a continuous bead of liquid gasket with the tube presser (commercial service tool) to front timing chain case back side as shown in the figure.

B : Protrusion

c : $\phi 3.4 - 4.4$ mm (0.134 - 0.173 in)

d : $\phi 2.6 - 3.6$ mm (0.102 - 0.142 in)

e : 4.0 - 5.6 mm (0.157 - 0.220 in)

Use Genuine RTV Silicone Sealant or equivalent. Refer to [GI-22, "Recommended Chemical Products and Sealants"](#).

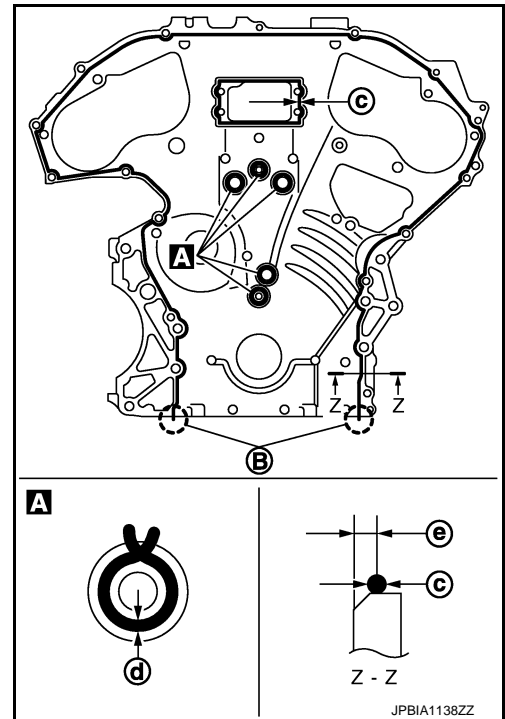

TIMING CHAIN

< REMOVAL AND INSTALLATION >

- b. Apply liquid gasket to top surface of oil pan (upper) as shown in the figure.

A : $\phi 4.0 - 5.0$ mm (0.157 - 0.197 in)

Use **Genuine RTV Silicone Sealant** or equivalent. Refer to [GI-22, "Recommended Chemical Products and Sealants"](#).

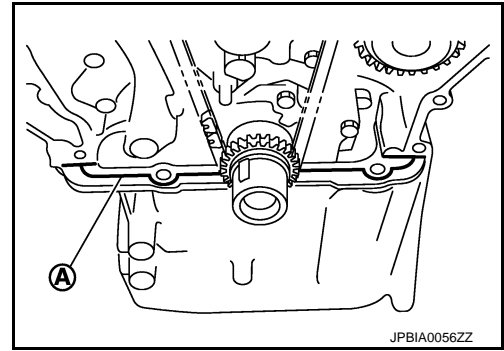

- c. Assemble front timing chain case.

- 1 : Front timing chain case
- 2 : Oil pan (upper)
- 3 : Cylinder block
- ⇐ : Engine front

CAUTION:

- Be careful not to damage front oil seal by interference with front end of crankshaft.
- Attaching should be done within 5 minutes after liquid gasket application.

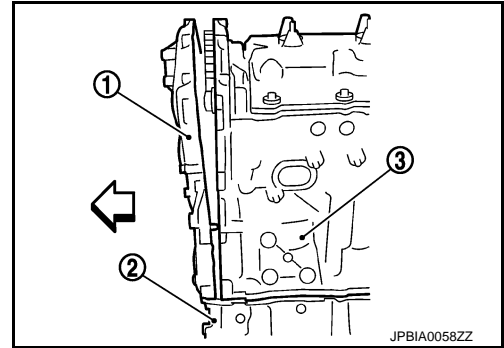

- d. Install front timing chain case fitting its dowel pin hole together with dowel pin on rear timing chain case.

- e. Tighten mounting bolts to the specified torque in numerical order as shown in the figure.

- There are two types of mounting bolts. Refer to the following for locating bolts.

M10 bolts : 1, 2, 3, 4, 5, 6, 7

: 55.0 N·m (5.6 kg-m, 41 ft-lb)

M6 bolts : Except the above

: 12.7 N·m (1.3 kg-m, 9 ft-lb)

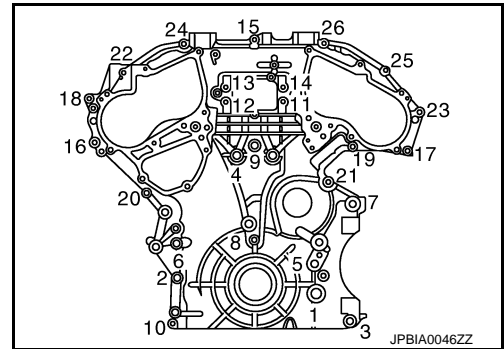

- f. After all bolts are tightened, retighten them to the specified torque in numerical order shown in the figure.

CAUTION:

Be sure to wipe off any excessive liquid gasket leaking on surface mating with oil pan (upper).

- g. Install two mounting bolts in front of oil pan (upper) in numerical order shown in the figure.

⇐ : Engine front

Tightening torque : Refer to [EM-76, "Exploded View"](#).

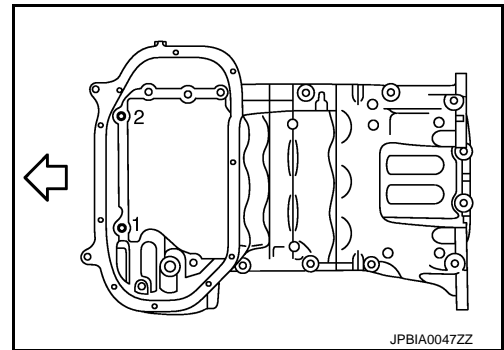

10. Install intake valve timing control covers as follows:

TIMING CHAIN

< REMOVAL AND INSTALLATION >

- a. Install new seal rings (1) in shaft grooves.

A : Bank 2

CAUTION:

When replacing seal ring, replace all rings with new ones.

NOTE:

The figure shows an example of bank 2.

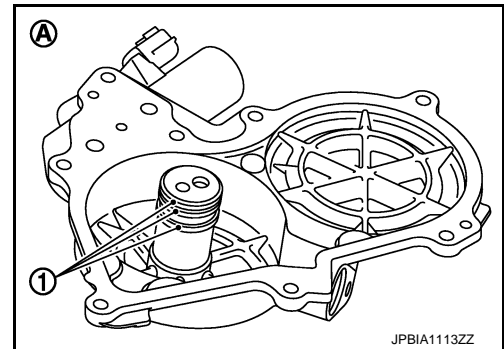

- b. Install intake valve timing control cover with new gasket to front timing chain case.

CAUTION:

- Align the center of both shaft holes of the shaft and the intake side camshaft sprocket, and then insert them.

- Be careful not to drop the seal ring from the shaft groove.

- c. Being careful not to move seal ring from the installation groove, align dowel pins on front timing chain case with dowel pin holes (C) to install intake valve timing control covers.

A : Bank 1

B : Bank 2

- d. Tighten mounting bolts in numerical order as shown in the figure.

- After all bolts are tightened, tighten No. 1 bolt to the specified torque again.

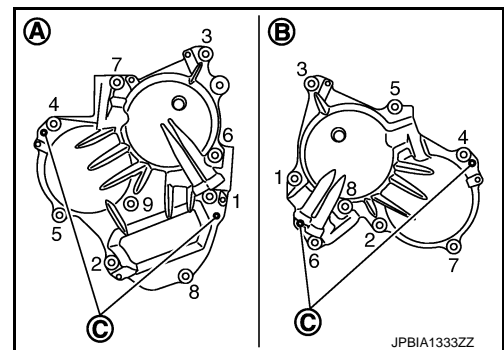

11. Install oil pan (lower). Refer to [EM-43. "Exploded View"](#).

12. Install rocker covers (bank 1 and bank 2). Refer to [EM-46. "Exploded View"](#).

13. Install crankshaft pulley as follows:

- a. Fix crankshaft using the ring gear stopper [SST: KV10118600 (J-48641)].

- b. Install crankshaft pulley, taking care not to damage front oil seal.

- When press-fitting crankshaft pulley with plastic hammer, tap on its center portion (not circumference).

- c. Tighten crankshaft pulley bolt.

: 44.1 N·m (4.5 kg·m, 33 ft·lb)

- d. Tighten the bolt 90 degrees (one mark) (b).

- Place a matching mark (A) on crankshaft pulley (2) aligning with the matching (C) of crankshaft pulley bolt (1).

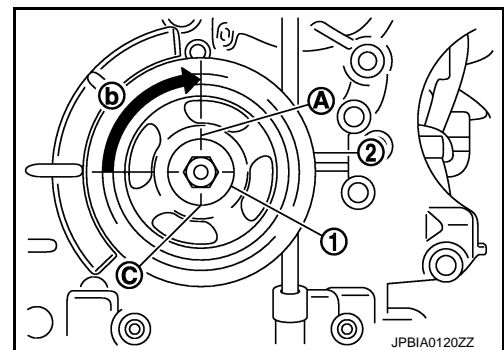

- e. Rotate crankshaft pulley in normal direction (clockwise when viewed from front) to confirm it turns smoothly.

14. Install power steering oil pump bracket and idler pulley bracket as follows:

TIMING CHAIN

< REMOVAL AND INSTALLATION >

a. Tighten mounting bolts in numerical order as shown in the figure. (temporarily)

- 1 : Idler pulley bracket
- 2 : Power steering oil pump bracket
- 3 : Crankshaft pulley
- A : Engine front side
- B : Engine right side
- ⇐ : Engine front

b. Tighten mounting bolts to specified torque in numerical order as shown in the figure.

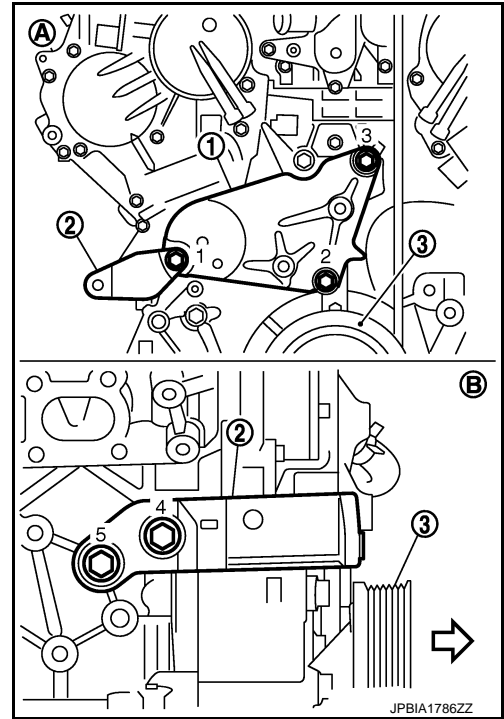

15. For the following operations, perform steps in the reverse order of removal.

Inspection

INFOID:000000008154452

INSPECTION AFTER REMOVAL

Timing Chain

Check for cracks and any excessive wear at link plates and roller links of timing chain. Replace timing chain if necessary.

- A : Crack
- B : Wear

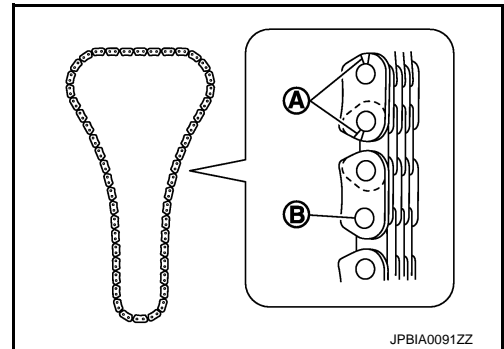

INSPECTION AFTER INSTALLATION

Inspection for Leakage

The following are procedures for checking fluid leakage, lubricant leakage.

- Before starting engine, check oil/fluid levels including engine coolant and engine oil. If any are less than the required quantity, fill them to the specified level. Refer to [MA-10. "Fluids and Lubricants"](#).
- Follow the procedure below to check for fuel leakage.
 - Turn ignition switch to the "ON" position (with engine stopped). With fuel pressure applied to fuel piping, check for fuel leakage at connection points.
 - Start engine. With engine speed increased, check again for fuel leakage at connection points.
- Run engine to check for unusual noise and vibration.

NOTE:

If hydraulic pressure inside chain tensioner drops after removal/installation, slack in guide may generate a pounding noise during and just after the engine start. However, this does not indicate a malfunction. The noise will stop after hydraulic pressure rises.

- Warm up engine thoroughly to check that there is no leakage of fuel, or any oil/fluids including engine oil and engine coolant.
- Bleed air from lines and hoses of applicable lines, such as in cooling system.

TIMING CHAIN

< REMOVAL AND INSTALLATION >

- After cooling down engine, again check oil/fluid levels including engine oil and engine coolant. Refill them to the specified level, if necessary.

A
EM
C
D
E
F
G
H
I
J
K
L
M
N
O
P

Summary of the inspection items:

Items		Before starting engine	Engine running	After engine stopped
Engine coolant		Level	Leakage	Level
Engine oil		Level	Leakage	Level
Transmission / transaxle fluid	AT & CVT Models	Leakage	Level / Leakage	Leakage
	MT Models	Level / Leakage	Leakage	Level / Leakage
Other oils and fluids*		Level	Leakage	Level
Fuel		Leakage	Leakage	Leakage

* Power steering fluid, brake fluid, etc.

OIL SEAL

< REMOVAL AND INSTALLATION >

OIL SEAL

FRONT OIL SEAL

FRONT OIL SEAL : Removal and Installation

INFOID:000000008154453

REMOVAL

1. Remove the following parts:
 - Engine undercover with power tool.
 - Drive belt: Refer to [EM-13, "Exploded View"](#).
 - Crankshaft pulley: Refer to [EM-49, "Exploded View"](#).
2. Remove front oil seal using a suitable tool.

CAUTION:

Be careful not to damage front timing chain case and crankshaft.

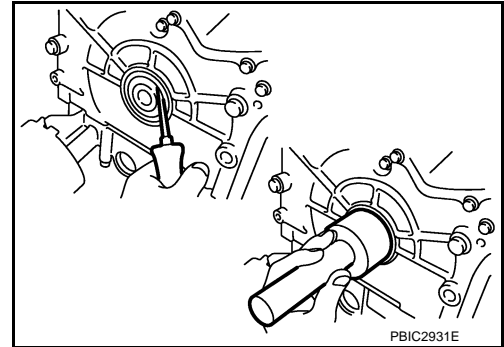

INSTALLATION

1. Apply new engine oil to both oil seal lip and dust seal lip of new front oil seal.
2. Install front oil seal.
 - Install front oil seal so that each seal lip is oriented as shown in the figure.

- A : Oil seal lip
- B : Dust seal lip
- ⇐ : Engine inside
- ⇨ : Engine outside

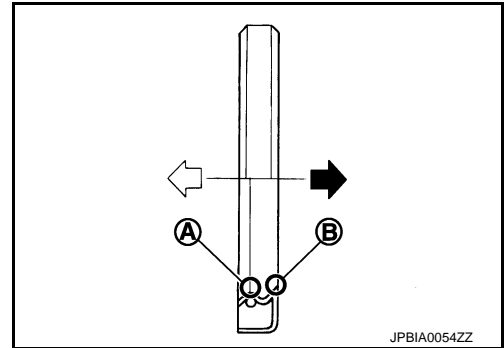

- Using a suitable drift, press-fit until the height of front oil seal is level with the mounting surface.
- Suitable drift: outer diameter 60 mm (2.36 in), inner diameter 50 mm (1.97 in).
- Check that the garter spring is in position and seal lips are not inverted.

CAUTION:

- **Be careful not to damage front timing chain case and crankshaft.**
- **Press-fit straight and avoid causing burrs or tilting oil seal.**

3. Install in the reverse order of removal after this step.

REAR OIL SEAL

REAR OIL SEAL : Removal and Installation

INFOID:000000008154454

REMOVAL

1. Remove transmission assembly. Refer to [TM-32, "Exploded View"](#) (M/T models) or [TM-300, "Exploded View"](#) (A/T models).

OIL SEAL

< REMOVAL AND INSTALLATION >

- Remove drive plate (A/T models) or fly wheel (M/T models). Refer to [EM-111. "Exploded View"](#).
- Remove rear oil seal with a suitable tool.

CAUTION:

Be careful not to damage crankshaft and cylinder block.

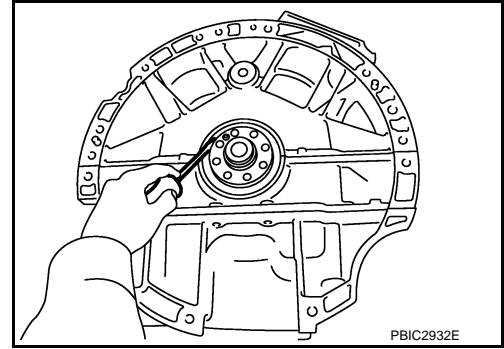

INSTALLATION

- Install rear oil seal.
 - Install rear oil seal so that each seal lip is oriented as shown in the figure.

- A : Oil seal lip
- B : Dust seal lip
- ← : Engine inside
- : Engine outside

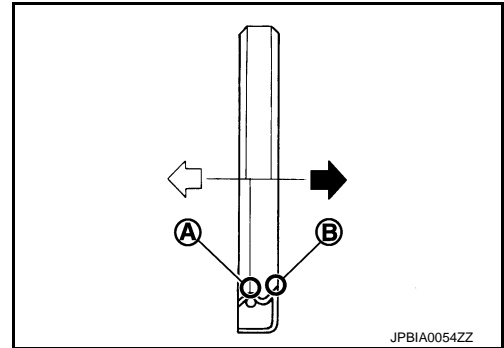

- Press in rear oil seal (1) to the position as shown in the figure.

- B : Cylinder block rear end face
- a : 0 - 0.5 mm (0 - 0.020 in)

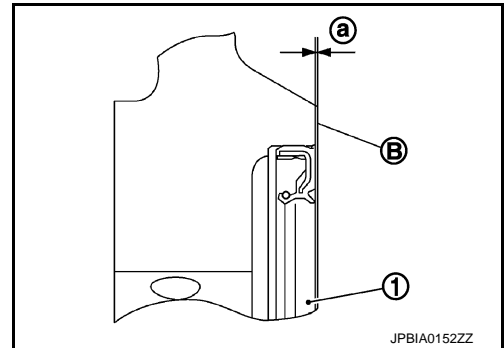

- Using a suitable drift (A), press-fit until the height of rear oil seal is level with the mounting surface.
- Suitable drift: outer diameter 100 mm (3.94 in), inner diameter 85 mm (3.35 in).

CAUTION:

- Be careful not to damage crankshaft and cylinder block.
- Press-fit straight and avoid causing burrs or tilting oil seal.

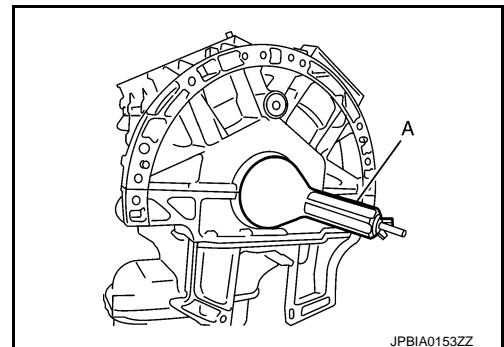

- Install in the reverse order of removal after this step.

ENGINE ASSEMBLY

< UNIT REMOVAL AND INSTALLATION >

UNIT REMOVAL AND INSTALLATION

ENGINE ASSEMBLY

Exploded View

INFOID:000000008154455

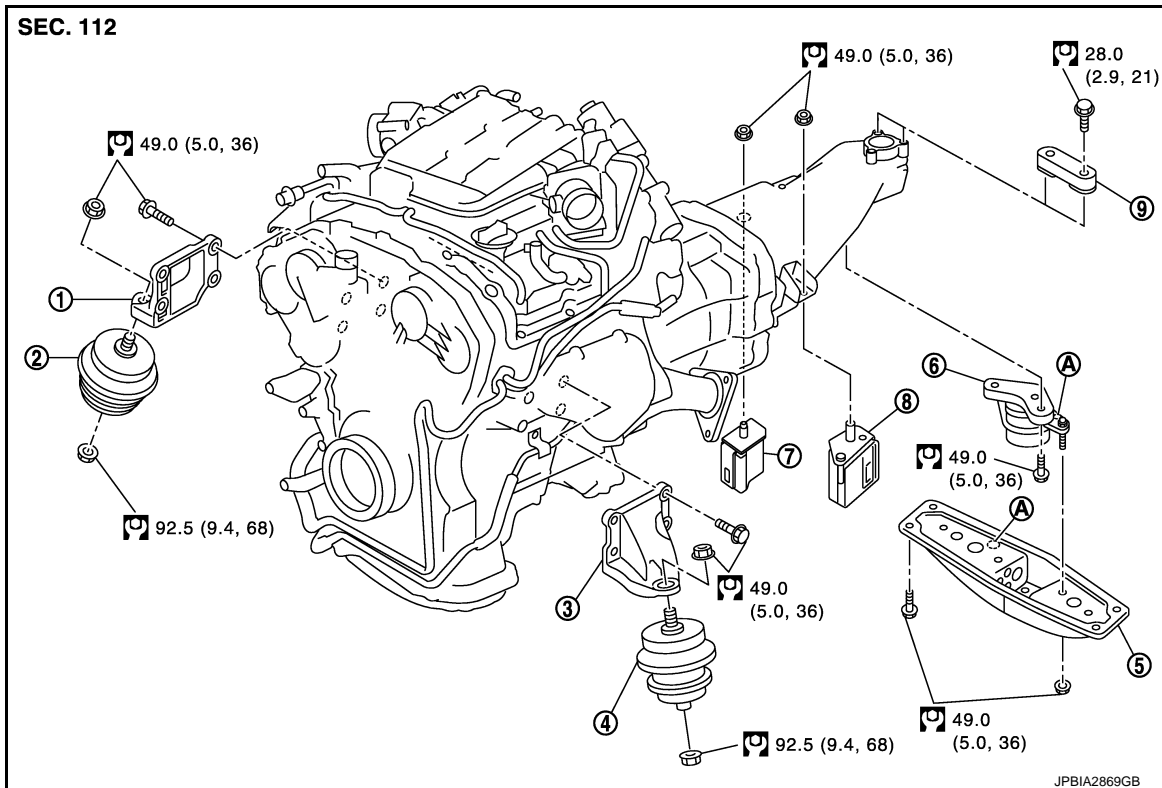

- | | | |
|-------------------------------------|-------------------------------------|-------------------------------------|
| 1. Engine mounting bracket (RH) | 2. Engine mounting insulator (RH) | 3. Engine mounting bracket (LH) |
| 4. Engine mounting insulator (LH) | 5. Rear engine mounting member | 6. Engine mounting insulator (rear) |
| 7. Dynamic damper (RH) (M/T models) | 8. Dynamic damper (LH) (M/T models) | 9. Dynamic damper (A/T models) |
- A. Front mark

Refer to [GI-4, "Components"](#) for symbols in the figure.

Removal and Installation

INFOID:000000008154456

WARNING:

- Situate the vehicle on a flat and solid surface.
- Place chocks at the front and back of rear wheels.
- For engines not equipped with engine slingers, attach proper slingers and bolts described in PARTS CATALOG.

CAUTION:

- Always be careful to work safely, and avoid forceful or uninstructed operations.
- Never start working until exhaust system and engine coolant are cool enough.
- If items or work required are not covered by the engine section, refer to the applicable sections.
- Always use the support point specified for lifting.
- Use either 2-pole lift type or separate type lift as much as possible. If board-on type is used for unavoidable reasons, support at rear axle jacking point with transmission jack or similar tool before starting work, in preparation for the backward shift of the center of gravity.
- For supporting points for lifting and jacking point at rear axle, refer to [GI-34, "Garage Jack and Safety Stand and 2-Pole Lift"](#).

NOTE:

When removing components such as hoses, tubes/lines, etc., cap or plug openings to prevent fluid from spilling.

ENGINE ASSEMBLY

< UNIT REMOVAL AND INSTALLATION >

REMOVAL

Outline

At first, remove the engine and the transmission assembly with front suspension member facing downward. Then separate the engine from transmission.

Preparation

1. Release fuel pressure. Refer to [EC-595, "Inspection"](#).
2. Disconnect both battery cables. Refer to [PG-116, "Exploded View"](#).
3. Drain engine coolant from radiator. Refer to [CO-7, "Draining"](#).
CAUTION:
 - Perform this step when engine is cold.
 - Never spill engine coolant on drive belt.
4. Remove the following parts:
 - Radiator reservoir tank: Refer to [CO-13, "Exploded View"](#).
 - Engine cover: Refer to [EM-25, "Exploded View"](#).
 - Front road wheel and tires (power tool)
 - Engine undercover (power tool)
 - Cowl top cover: Refer to [EXT-23, "Exploded View"](#)
 - Air duct and air cleaner case assembly (RH and LH): Refer to [EM-27, "Exploded View"](#).
 - Cooling fan assembly: Refer to [CO-13, "Exploded View"](#).
5. Discharge refrigerant from A/C circuit. Refer to [HA-25, "Collection and Charge"](#).
6. Remove radiator hoses (upper and lower). Refer to [CO-13, "Exploded View"](#).

Engine Room LH

1. Disconnect heater hose at vehicle side, and fit a plug onto hose end to prevent engine coolant leakage.
2. Disconnect A/C piping from A/C compressor, and temporarily fasten it on vehicle with a rope. Refer to [HA-41, "Exploded View"](#).
3. Disconnect brake booster vacuum hose.
4. Disconnect ground cable.

Engine Room RH

1. Disconnect battery positive cable at vehicle side and temporarily fasten it on engine.
2. Disconnect all clips and connectors of the engine room harness from engine back side.
3. Disconnect fuel feed hose (with damper) and EVAP hose. Refer to [EM-37, "Exploded View"](#).
CAUTION:
Fit plugs onto disconnected hoses to prevent fuel leakage.
4. Remove reservoir tank of power steering oil pump and piping from vehicle, and temporarily secure them on engine. Refer to [ST-43, "Exploded View"](#).
CAUTION:
When temporarily securing, keep the reservoir tank upright to avoid fluid leakage.

Vehicle Inside

Follow the procedure below to disconnect engine room harness connectors at passenger room side, and temporarily secure them on engine.

1. Remove passenger-side kicking plate and dash side finisher. Refer to [INT-15, "Exploded View"](#).
2. Disconnect engine room harness connectors at unit sides TCM, ECM and other locations.
3. Disengage intermediate fixing point. Pull out engine room harnesses to engine room side, and temporarily secure them on engine.
CAUTION:
 - When pulling out harnesses, take care not to damage harnesses and connectors.
 - After temporarily securing, cover connectors with vinyl or similar material to protect against adhesion of foreign materials.

Vehicle Underbody

1. Remove A/T fluid cooler hoses (A/T models) and power steering oil pump oil cooler hoses.
2. Disconnect heated oxygen sensor 2 harness. Refer to [EX-5, "Exploded View"](#).
3. Remove three way catalyst and exhaust front tube. Refer to [EX-5, "Exploded View"](#).

ENGINE ASSEMBLY

< UNIT REMOVAL AND INSTALLATION >

4. Disconnect steering lower joint at power steering gear assembly side, and release steering lower shaft. Refer to [ST-22, "Exploded View"](#).
5. Remove rear propeller shaft. Refer to [DLN-6, "Exploded View"](#) (M/T models) or [DLN-14, "Exploded View"](#) (A/T models).
6. Disengage control rod and remove clutch tube. Refer to [TM-32, "Exploded View"](#) (M/T models).
7. Disengage A/T control rod at A/T shift selector side. Then, temporarily secure it on the transmission assembly, so that it does not sag. Refer to [TM-275, "Exploded View"](#) (A/T models).
8. Remove rear plate cover from oil pan (upper). Then remove bolts fixing drive plate to torque converter. Refer to [EM-43, "Exploded View"](#) (A/T models).
9. Remove transmission joint bolts that pierce at oil pan (upper) lower rear side. Refer to [EM-76, "Exploded View"](#).
10. Remove front stabilizer connecting rod from transverse link. Refer to [FSU-17, "Exploded View"](#).
11. Remove lower ends of left and right steering knuckle from transverse link. Refer to [FAX-6, "Exploded View"](#).
12. Separate steering outer sockets from steering knuckle. Refer to [ST-24, "Exploded View"](#).
13. Remove transverse links mounting bolts at suspension member side. Refer to [FSU-13, "Exploded View"](#).

Removal Work

1. Use a manual lift table caddy (commercial service tool) or equivalently rigid tool such as a transmission jack. Securely support bottom of suspension member and the transmission assembly.

CAUTION:

Use a piece of wood or a similar item as the supporting surface to secure a completely stable condition.

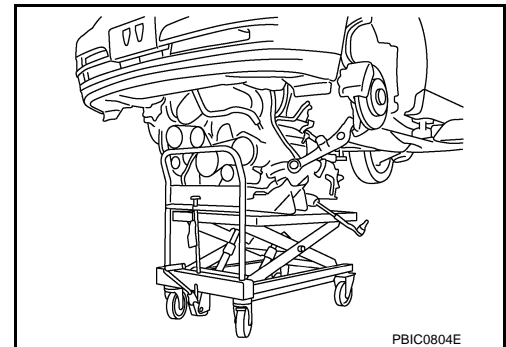

2. Remove rear engine mounting member bolts.
3. Remove front suspension member mounting bolts and nuts. Refer to [FSU-18, "Exploded View"](#).
4. Carefully lower jack, or raise lift, to remove the engine, the transmission assembly and front suspension member. When performing work, observe the following caution items:

CAUTION:

- Confirm there is no interference with the vehicle.
- Check that all connection points have been disconnected.
- Keep in mind that the center of gravity of the vehicle changes. If necessary, use jack(s) to support the vehicle at rear jacking point(s) to prevent it from falling off the lift.

Separation Work

1. Install engine slingers into front of cylinder head (bank 1) and rear of cylinder head (bank 2).

1 : Engine front slinger

2 : Engine rear slinger

A : Bank 1

B : Bank 2

⇐: Engine front

Slinger bolts:

: **28.0 N·m (2.9 kg·m, 21 ft·lb)**

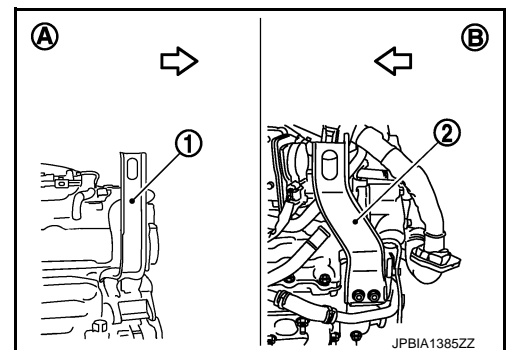

2. Remove power steering oil pump from engine side. Refer to [ST-32, "EXCEPT FOR SPORT MODELS : Exploded View"](#) or [ST-37, "SPORT MODELS : Exploded View"](#).
3. Remove engine mounting insulators (RH and LH) under side nuts with power tool.

ENGINE ASSEMBLY

< UNIT REMOVAL AND INSTALLATION >

4. Lift with hoist and separate the engine and the transmission assembly from front suspension member.
CAUTION:
 - Before and during this lifting, always check that any harnesses are left connected.
 - Never damage engine mounting insulator and avoid oil/grease smearing or spills onto engine mounting insulator.
5. Remove alternator. Refer to [CHG-27, "Exploded View"](#).
6. Remove starter motor. Refer to [STR-16, "Exploded View"](#).
7. Remove crankshaft position sensor. Refer to [EM-111, "Exploded View"](#).
CAUTION:
 - Handle crankshaft position sensor carefully and avoid impacts.
 - Never disassemble.
 - Never place crankshaft position sensor in a location where it is exposed to magnetism.
8. Separate the engine from the transmission assembly. Refer to [TM-32, "Exploded View"](#) (M/T models) or [TM-300, "Exploded View"](#) (A/T models).
9. Remove each engine mounting insulator and each engine mounting bracket from the engine with power tool.

INSTALLATION

Note the following, and install in the reverse order of removal.

- Do not damage engine mounting insulator and do not spill oil on it.
- For a location with a positioning pin, insert it securely into hole of mating part.
- For a part with a specified installation orientation, refer to component figure in [EM-68, "Exploded View"](#).
- When installing engine mounting bracket (RH and LH) on cylinder block, tighten two upper bolts [shown as (B) in the figure] first. Then tighten two lower bolts [shown as (C) in the figure].

A : Example Left

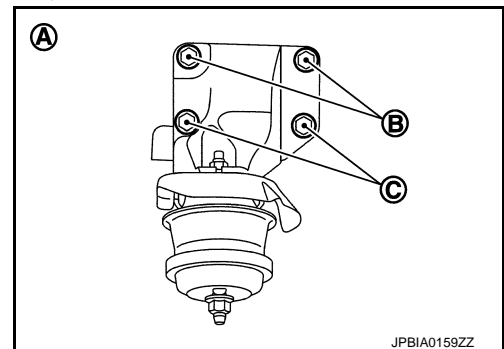

- Check that all engine mounting insulators are seated properly, then tighten mounting nuts.
- Tighten rear engine mounting member bolts in numerical order as shown in the figure.

↔ : Vehicle front

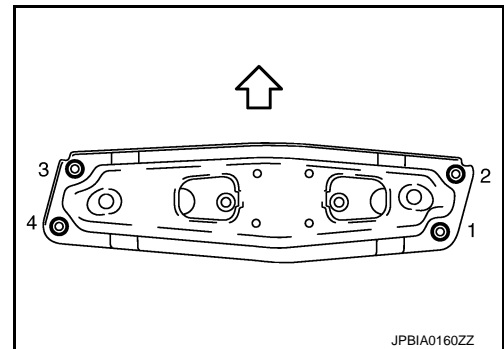

INFOID:000000008154457

Inspection

INSPECTION AFTER INSTALLATION

Inspection for Leakage

The following are procedures for checking fluid leakage, lubricant leakage.

- Before starting engine, check oil/fluid levels including engine coolant and engine oil. If any are less than the required quantity, fill them to the specified level. Refer to [MA-10, "Fluids and Lubricants"](#).
- Follow the procedure below to check for fuel leakage.
 - Turn ignition switch to the "ON" position (with engine stopped). With fuel pressure applied to fuel piping, check for fuel leakage at connection points.
 - Start engine. With engine speed increased, check again for fuel leakage at connection points.

ENGINE ASSEMBLY

< UNIT REMOVAL AND INSTALLATION >

- Run engine to check for unusual noise and vibration.

NOTE:

If hydraulic pressure inside chain tensioner drops after removal/installation, slack in guide may generate a pounding noise during and just after the engine start. However, this does not indicate a malfunction. The noise will stop after hydraulic pressure rises.

- Warm up engine thoroughly to check that there is no leakage of fuel, or any oil/fluids including engine oil and engine coolant.
- Bleed air from lines and hoses of applicable lines, such as in cooling system.
- After cooling down engine, again check oil/fluid levels including engine oil and engine coolant. Refill them to the specified level, if necessary.

Summary of the inspection items:

Items		Before starting engine	Engine running	After engine stopped
Engine coolant		Level	Leakage	Level
Engine oil		Level	Leakage	Level
Transmission / transaxle fluid	AT & CVT Models	Leakage	Level / Leakage	Leakage
	MT Models	Level / Leakage	Leakage	Level / Leakage
Other oils and fluids*		Level	Leakage	Level
Fuel		Leakage	Leakage	Leakage

* Power steering fluid, brake fluid, etc.

ENGINE STAND SETTING

< UNIT DISASSEMBLY AND ASSEMBLY >

UNIT DISASSEMBLY AND ASSEMBLY

ENGINE STAND SETTING

Setting

INFOID:000000008154458

A

EM

NOTE:

Explained here is how to disassemble with engine stand supporting transmission surface. When using a different type of engine stand, note the difference in the steps, etc.

1. Remove the engine assembly from the vehicle. Refer to [EM-68, "Exploded View"](#).
2. Remove the parts that may restrict installation of engine to a widely use engine stand.

NOTE:

The procedure is described assuming that you use a widely use engine stand holding the surface, to which transmission is installed.

- Remove clutch cover and clutch disc. Refer to [CL-21, "Exploded View"](#) (M/T models).
- Remove drive plate (A/T models) or flywheel (M/T models) with power tool. Fix crankshaft with a ring gear stopper [SST: KV10118600 (J-48641)], and remove mounting bolts.
- Loosen mounting bolts in diagonal order.
- Check for deformation or damage of drive plate (A/T models) or flywheel (M/T models).

CAUTION:

- Never disassemble drive plate (A/T models) or flywheel (M/T models).
- Never place drive plate (A/T models) or flywheel (M/T models) with signal plate facing down.
- When handling signal plate, take care not to damage or scratch it.
- Handle signal plate in a manner that prevents it from becoming magnetized.

3. Remove pilot converter (A/T models) using the pilot bushing puller [SST: ST16610001 (J-23907)] (A) if necessary.

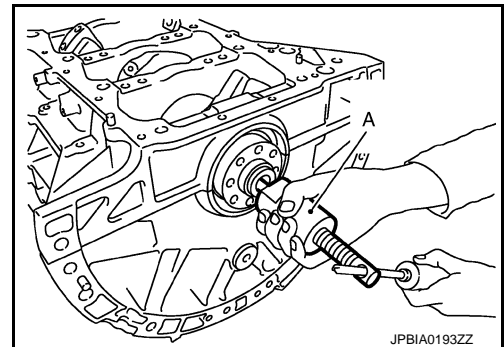

4. Lift the engine with hoist to install it onto the widely use engine stand.

CAUTION:

Use an engine stand that has a load capacity [220 kg (485 lb) or more] large enough for supporting the engine weight.

- If the load capacity of the stand is not adequate, remove the following parts beforehand to reduce the potential risk of overturning the stand.
 - Remove intake manifold collector. Refer to [EM-29, "Exploded View"](#).
 - Remove fuel injector and fuel tube assembly. Refer to [EM-37, "Exploded View"](#).
 - Remove intake manifold. Refer to [EM-32, "Exploded View"](#).
 - Remove ignition coil. Refer to [EM-46, "Exploded View"](#).
 - Remove rocker cover. Refer to [EM-46, "Exploded View"](#).
 - Remove exhaust manifold. Refer to [EM-34, "Exploded View"](#).
 - Other removable brackets.

NOTE:

C

D

E

F

G

H

I

J

K

L

M

N

O

P

ENGINE STAND SETTING

< UNIT DISASSEMBLY AND ASSEMBLY >

The figure shows an example of widely use engine stand (A) that can hold mating surface of transmission with drive plate (A/T models) or flywheel (M/T models) removed.

CAUTION:

Before removing the hanging chains, check the engine stand is stable and there is no risk of overturning.

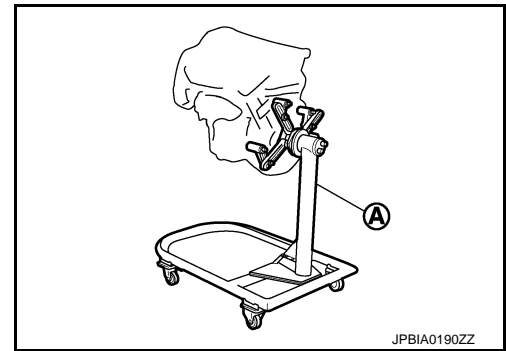

5. Drain engine oil. Refer to [LU-8. "Draining"](#).
6. Drain engine coolant by removing water drain plug (1) from both sides of the cylinder block as shown in the figure.

- 2 : Washer
- 3 : Plug
- 4 : Drain plug
- ⇐ : Engine front

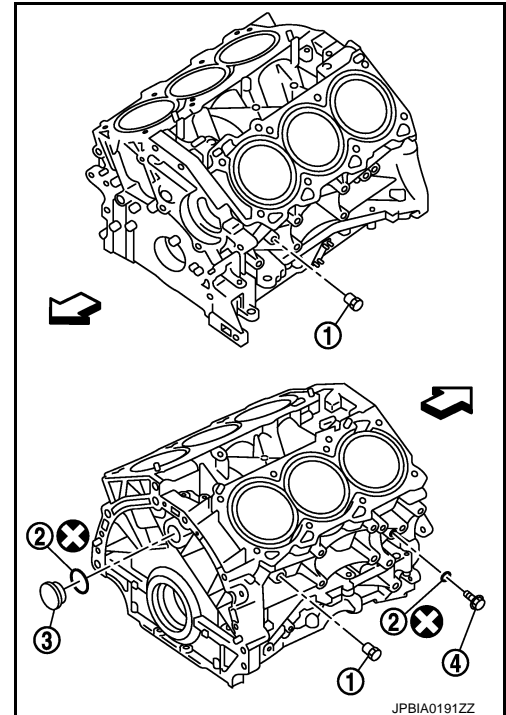

ENGINE UNIT

< UNIT DISASSEMBLY AND ASSEMBLY >

ENGINE UNIT

Disassembly

INFOID:000000008154459

1. Remove intake manifold collector. Refer to [EM-29, "Exploded View"](#).
2. Remove fuel injector and fuel tube. Refer to [EM-37, "Exploded View"](#).
3. Remove intake manifold. Refer to [EM-32, "Exploded View"](#).
4. Remove exhaust manifold. Refer to [EM-34, "Exploded View"](#).
5. Remove oil pan (lower). Refer to [EM-43, "Exploded View"](#).
6. Remove ignition coil, spark plug, and rocker cover. Refer to [EM-46, "Exploded View"](#).
7. Remove timing chain. Refer to [EM-49, "Exploded View"](#).
8. Remove rear timing chain case. Refer to [EM-79, "Exploded View"](#).
9. Remove camshaft (EXH) and VVEL ladder assembly. Refer to [EM-84, "Exploded View"](#).
10. Remove cylinder head. Refer to [EM-101, "Exploded View"](#).

Assembly

INFOID:000000008154460

Assemble in the reverse order of disassembly.

A

EM

C

D

E

F

G

H

I

J

K

L

M

N

O

P

OIL PAN (UPPER) AND OIL STRAINER

< UNIT DISASSEMBLY AND ASSEMBLY >

OIL PAN (UPPER) AND OIL STRAINER

Exploded View

INFOID:000000008154461

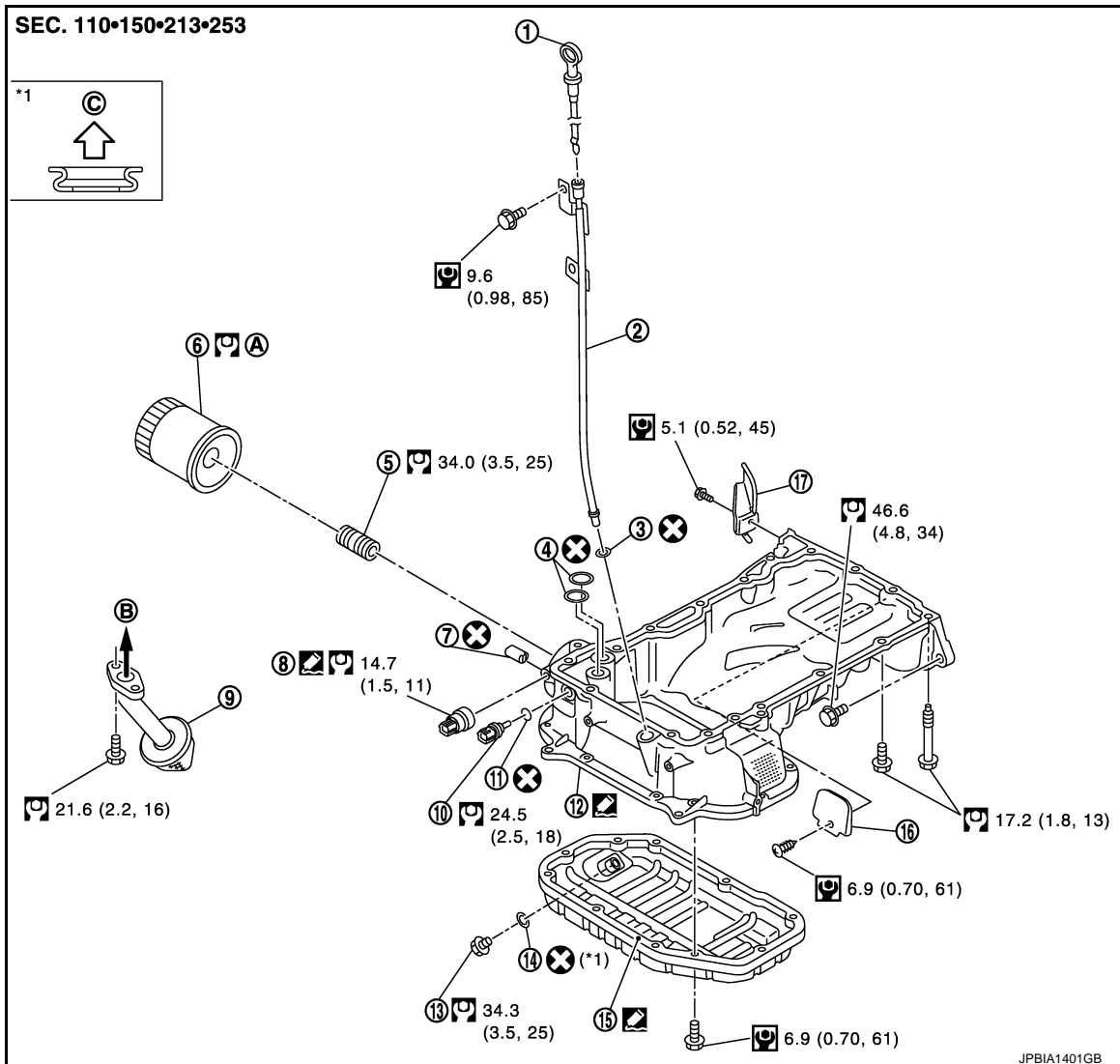

- | | | |
|-----------------------------------|-----------------------------------|---------------------|
| 1. Oil level gauge | 2. Oil level gauge guide | 3. O-ring |
| 4. O-ring | 5. Connector bolt | 6. Oil filter |
| 7. Relief valve | 8. Oil pressure switch | 9. Oil strainer |
| 10. Oil temperature sensor | 11. Washer | 12. Oil pan (upper) |
| 13. Drain plug | 14. Drain plug washer | 15. Oil pan (lower) |
| 16. Rear plate cover | 17. Rear cover plate (M/T models) | |
| A. Refer to LU-10 | B. To oil pump | C. Oil pan side |

Refer to [GI-4, "Components"](#) for symbols in the figure.

Disassembly and Assembly

INFOID:000000008154462

REMOVAL

CAUTION:

Never drain engine oil when the engine is hot to avoid the danger of being scalded.

1. Remove oil level gauge, oil pressure switch and oil temperature sensor.
2. Remove oil pan (lower). Refer to [EM-43, "Exploded View"](#).
3. Remove oil strainer.

OIL PAN (UPPER) AND OIL STRAINER

< UNIT DISASSEMBLY AND ASSEMBLY >

4. Loosen mounting bolts in the reverse order as shown in the figure with power tool to remove.

← : Engine front

- Insert the seal cutter [SST: KV10111100 (J-37228)] between oil pan (upper) and lower cylinder block. Slide seal cutter by tapping on the side of tool with a hammer. Remove oil pan (upper).

CAUTION:

- Be careful not to damage the mating surfaces.
- Never insert a screwdriver, because this damages the mating surfaces.

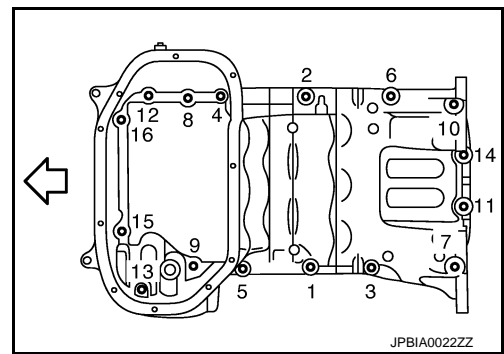

5. Remove O-rings (2) from bottom of lower cylinder block (1) and oil pump (3).

← : Engine front

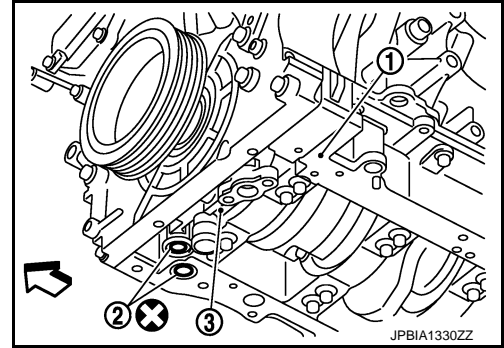

INSTALLATION

CAUTION:

Do not reuse O-rings or washers.

1. Install oil pan (upper) as follows:

- a. Use a scraper (A) to remove old liquid gasket from mating surfaces.

CAUTION:

Never scratch or damage the mating surfaces when cleaning off old liquid gasket.

- Also remove old liquid gasket from mating surface of lower cylinder block.
- Remove old liquid gasket from the bolt holes and threads.

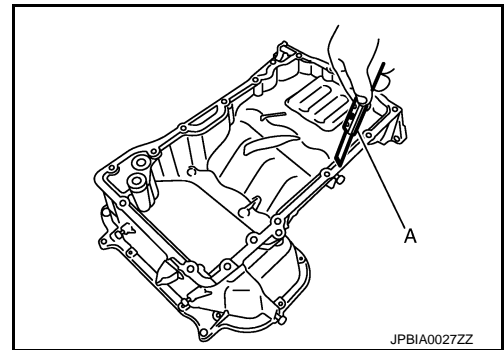

- b. Install new O-rings (2) on the bottom of lower cylinder block (1) and oil pump (3).

← : Engine front

CAUTION:

Do not reuse O-rings.

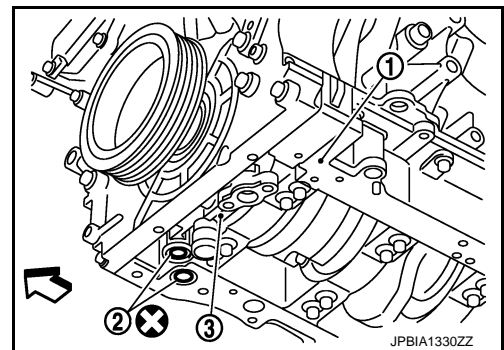

A
EM
C
D
E
F
G
H
I
J
K
L
M
N
O
P

OIL PAN (UPPER) AND OIL STRAINER

< UNIT DISASSEMBLY AND ASSEMBLY >

- c. Apply a continuous bead of liquid gasket with the tube presser (commercial service tool) to the cylinder block mating surface of oil pan (upper) to a limited portion as shown in the figure.

a : $\phi 4.0 - 5.0$ mm (0.157 - 0.197 in)

↶ : Engine front

Use Genuine RTV Silicone Sealant or equivalent. Refer to [GI-22, "Recommended Chemical Products and Sealants"](#).

CAUTION:

- For bolt holes with ▲ marks (7 locations), apply liquid gasket outside the holes.
- Attaching should be done within 5 minutes after coating.

- d. Install oil pan (upper).

CAUTION:

Never misalign both O-rings during installation.

- Tighten mounting bolts in numerical order as shown in the figure.

↶ : Engine front

- There are two types of mounting bolts. Refer to the following for locating bolts.

M8 × 90 mm (3.54 in) : 7, 10, 13

M8 × 25 mm (0.98 in) : Except the above

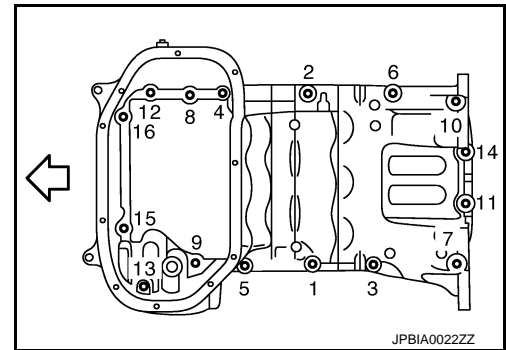
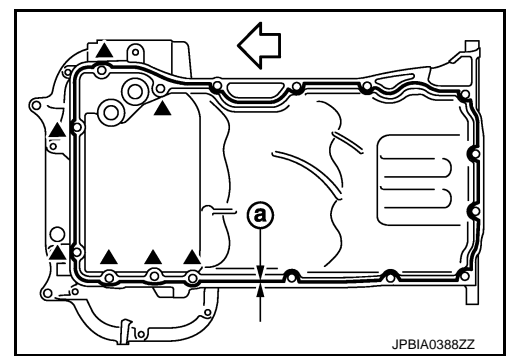

2. Install oil strainer to oil pump.
3. Install oil pan (lower). Refer to [EM-43, "Exploded View"](#).
4. Install oil pan drain plug.
 - Refer to the figure of components on the prior page for installation direction of drain plug washer. Refer to [EM-43, "Exploded View"](#).
5. Install in the reverse order of removal after this step.

NOTE:

Wait at least 30 minutes after oil pan is installed before pouring engine oil.

Inspection

INFOID:000000008154463

INSPECTION AFTER REMOVAL

Clean oil strainer if any object is attached.

INSPECTION AFTER INSTALLATION

1. Check the engine oil level and adjust engine oil. Refer to [LU-7, "Inspection"](#).
2. Start engine, and check there is no leakage of engine oil.
3. Stop engine and wait for 10 minutes.
4. Check the engine oil level again. Refer to [LU-7, "Inspection"](#).

REAR TIMING CHAIN CASE

< UNIT DISASSEMBLY AND ASSEMBLY >

REAR TIMING CHAIN CASE

Exploded View

INFOID:000000008154464

A

EM

C

D

E

F

G

H

I

J

K

L

M

N

O

P

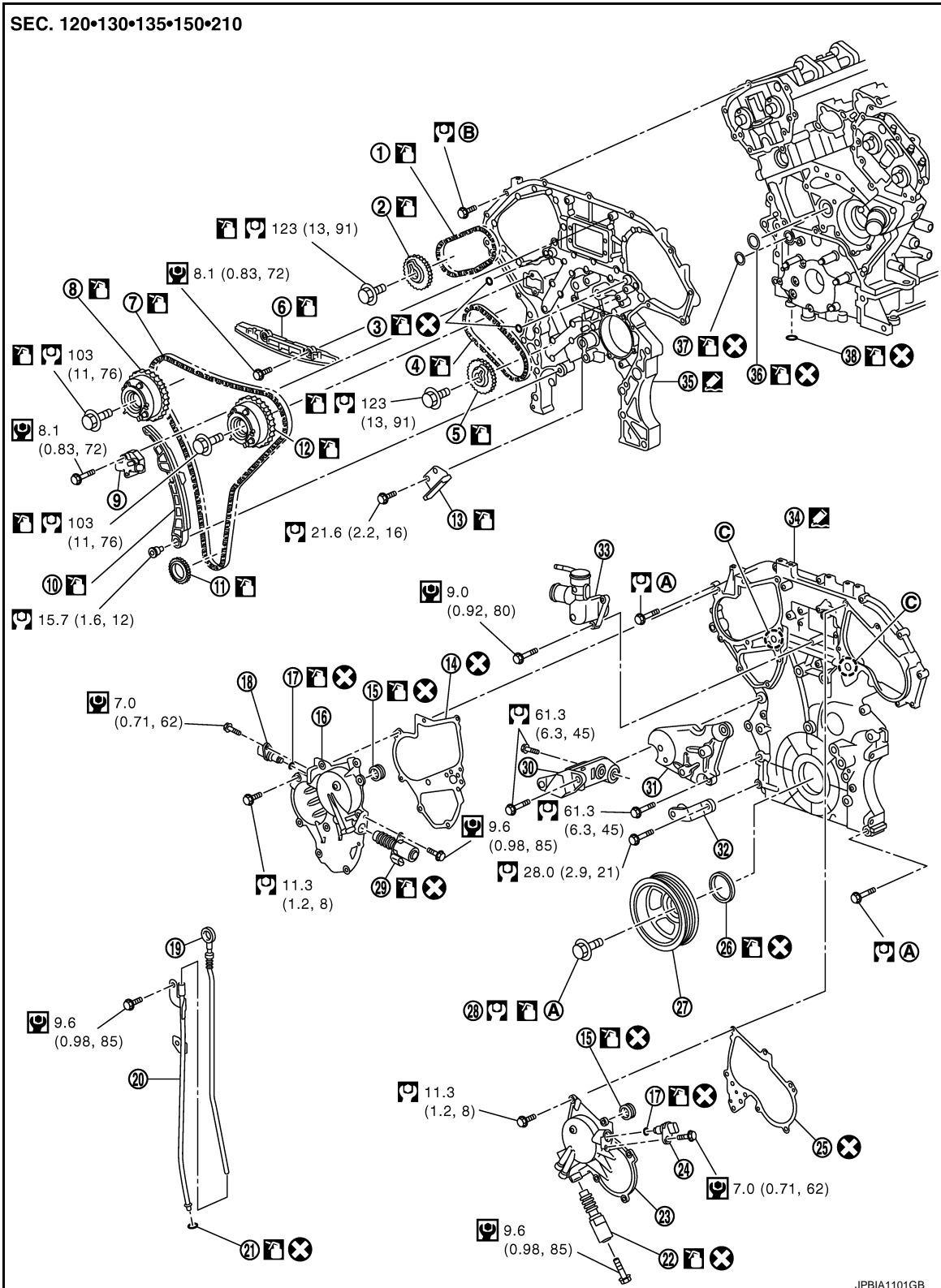

- | | | |
|--------------------------------------|-------------------------------------|-------------------------------------|
| 1. Timing chain (secondary) (bank 1) | 2. Camshaft sprocket (EXH) (bank 1) | 3. O-ring |
| 4. Timing chain (secondary) (bank 2) | 5. Camshaft sprocket (EXH) (bank 2) | 6. Internal chain guide |
| 7. Timing chain (primary) | 8. Camshaft sprocket (INT) (bank 1) | 9. Timing chain tensioner (primary) |

REAR TIMING CHAIN CASE

< UNIT DISASSEMBLY AND ASSEMBLY >

- | | | |
|---|---|---|
| 10. Slack guide | 11. Crankshaft sprocket | 12. Camshaft sprocket (INT) (bank 2) |
| 13. Tension guide | 14. Intake valve timing control cover gasket (bank 1) | 15. Seal ring |
| 16. Intake valve timing control cover (bank 1) | 17. O-ring | 18. Camshaft position sensor (PHASE) (bank 1) |
| 19. Oil level gauge | 20. Oil level gauge guide | 21. O-ring |
| 22. Intake valve timing control solenoid valve (bank 2) | 23. Intake valve timing control cover (bank 2) | 24. Camshaft position sensor (PHASE) (bank 2) |
| 25. Intake valve timing control cover gasket (bank 2) | 26. Front oil seal | 27. Crankshaft pulley |
| 28. Crankshaft pulley bolt | 29. Intake valve timing control solenoid valve (bank 1) | 30. Power steering oil pump bracket |
| 31. Idler pulley bracket | 32. Alternator bracket | 33. Water outlet (front) |
| 34. Front timing chain case | 35. Rear timing chain case | 36. O-ring |
| 37. O-ring | 38. O-ring | |

A. Comply with the installation procedure when tightening. Refer to [EM-50](#)

B. Comply with the installation procedure when tightening. Refer to [EM-80](#)

C. Oil filter

Refer to [GI-4, "Components"](#) for symbols in the figure.

Disassembly and Assembly

INFOID:000000008154465

DISASSEMBLY

- Remove front timing chain case and timing chain. Refer to [EM-50, "Removal and Installation"](#).
- Remove water pump. Refer to [CO-19, "Exploded View"](#).
- Remove oil pan (upper). Refer to [EM-76, "Exploded View"](#).
- Remove rear timing chain case as follows:
 - Loosen mounting bolts in reverse order as shown in the figure.
 - Cut liquid gasket using the seal cutter [SST: KV10111100 (J-37228)] and remove rear timing chain case.

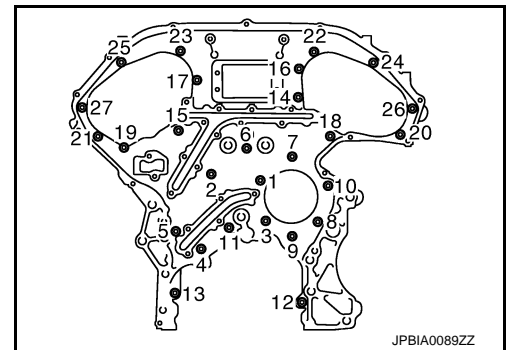

CAUTION:

- Never remove plate metal cover (1) of oil passage.
- After removal, handle rear timing chain case carefully so it does not tilt, cant, or warp under a load.

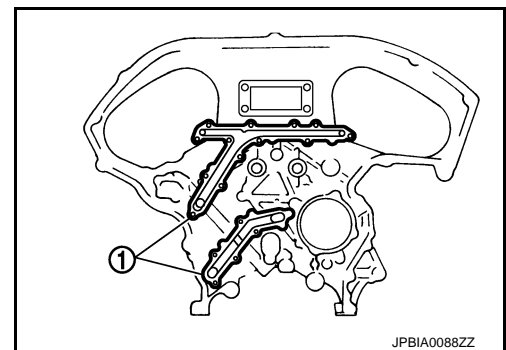

REAR TIMING CHAIN CASE

< UNIT DISASSEMBLY AND ASSEMBLY >

5. Remove O-rings (1) from cylinder block.

⇐ : Engine front

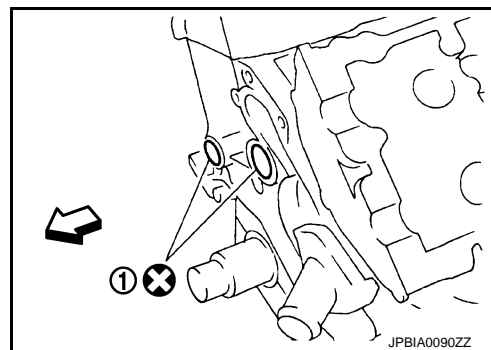

6. Use a scraper to remove all traces of liquid gasket from rear timing chain cases and opposite mating surfaces.
7. Remove old liquid gasket from bolt hole and thread.

A : Remove old liquid gasket that is stuck
B : Bolt hole

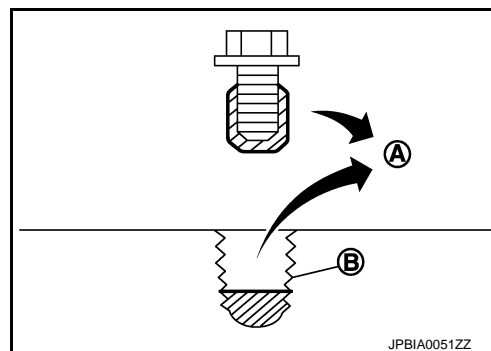

ASSEMBLY

CAUTION:

Do not reuse O-rings.

1. Install rear timing chain case as follows:
a. Install new O-rings (1) onto cylinder block.

⇐ : Engine front

CAUTION:

Do not reuse O-rings.

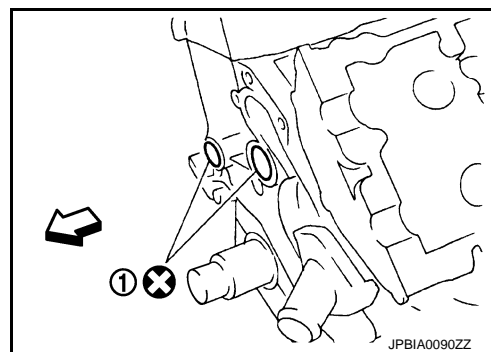

- b. Apply liquid gasket with the tube presser (commercial service tool) to rear timing chain case back side as shown in the figure.
Use Genuine RTV Silicone Sealant or equivalent. Refer to [GI-22, "Recommended Chemical Products and Sealants"](#).

CAUTION:

- For **A** in the figure, completely wipe off liquid gasket extended on a portion touching at engine coolant.
- Apply liquid gasket on installation position of water pump and cylinder head completely.

REAR TIMING CHAIN CASE

< UNIT DISASSEMBLY AND ASSEMBLY >

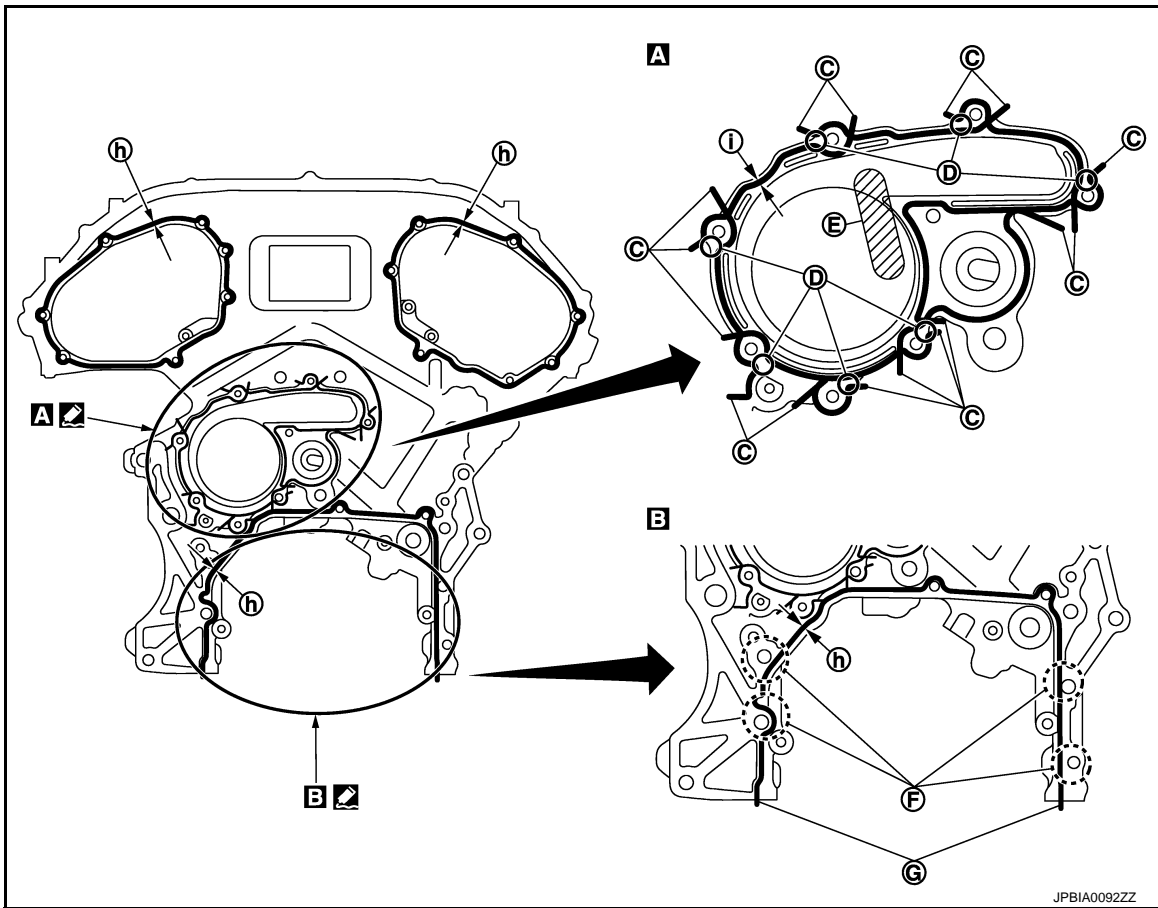

JPBIA0092ZZ

- | | | |
|---|---|---------------------------------|
| C. Protrusion | D. Clearance 1 mm (0.04 in) | E. Do not protrude in this area |
| F. Run along bolt hole inner side | G. Protrusions at beginning and end of gasket | |
| h. $\phi 3.4 - 4.4$ mm (0.134 - 0.173 in) | i. $\phi 2.6 - 2.8$ mm (0.102 - 0.110 in) | |

Refer to [GI-4, "Components"](#) for symbols in the figure.

- c. Align rear timing chain case with dowel pins (bank 1 and bank 2) on cylinder block and install rear timing chain case.
 - Check that O-rings stay in place during installation to cylinder block.
- d. Tighten mounting bolts in numerical order as shown in the figure.
 - There are three types of mounting bolts. Refer to the following for locating bolts.

- | | |
|------------------------|---|
| Bolt length: | Bolt position |
| 20 mm (0.79 in) | : 1, 2, 3, 6, 7, 8, 9, 10 |
| 16 mm (0.63 in) | : Except the above |
| |  : 12.7 N·m (1.3 kg-m, 9 ft-lb) |

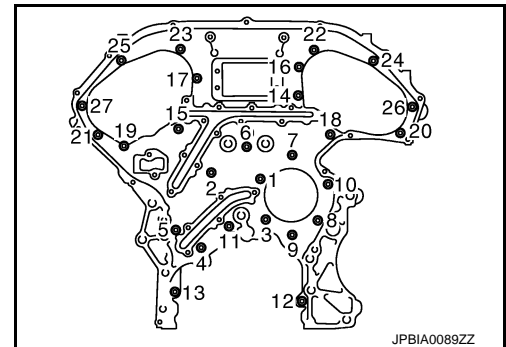

JPBIA0089ZZ

- e. After all bolts are tightened, retighten them to the specified torque in numerical order shown in the figure.
 - If liquid gasket protrudes, wipe it off immediately.

REAR TIMING CHAIN CASE

< UNIT DISASSEMBLY AND ASSEMBLY >

- f. After installing rear timing chain case, check the surface height difference between the following parts on the oil pan (upper) mounting surface.

- 1 : Rear timing chain case
- 2 : Lower cylinder block

Standard

Rear timing chain case to lower cylinder block:

-0.24 to 0.14 mm (-0.0094 to 0.0055 in)

- If not within the standard, repeat the installation procedure.
2. Install water pump with new O-rings. Refer to [CO-19, "Exploded View"](#).

CAUTION:

Do not reuse O-rings.

3. Install timing chains, camshaft sprockets and front timing chain case. Refer to [EM-50, "Removal and Installation"](#).

- After installing front timing chain case, check the surface height difference between the following parts on the oil pan (upper) mounting surface.

- 1 : Front timing chain case
- 2 : Rear timing chain case
- 3 : Lower cylinder block

Standard

Front timing chain case to rear timing chain case:

-0.14 to 0.14 mm (-0.0055 to 0.0055 in)

- If not within the standard, repeat the installation procedure.
4. Install oil pan (upper). Refer to [EM-76, "Exploded View"](#).
5. Install in the reverse order of removal after this step.

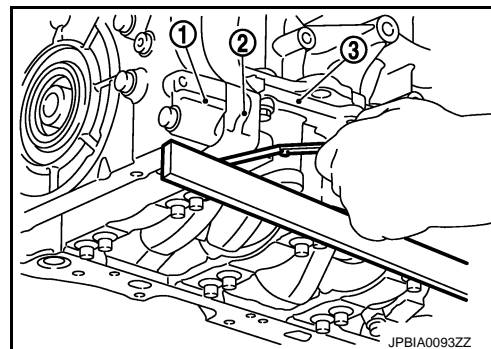
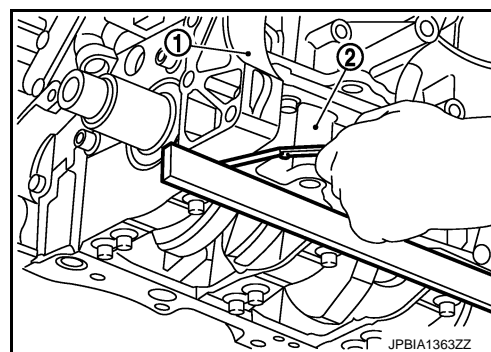

A
EM
C
D
E
F
G
H
I
J
K
L
M
N
O
P

CAMSHAFT

< UNIT DISASSEMBLY AND ASSEMBLY >

CAMSHAFT

Exploded View

INFOID:000000008154466

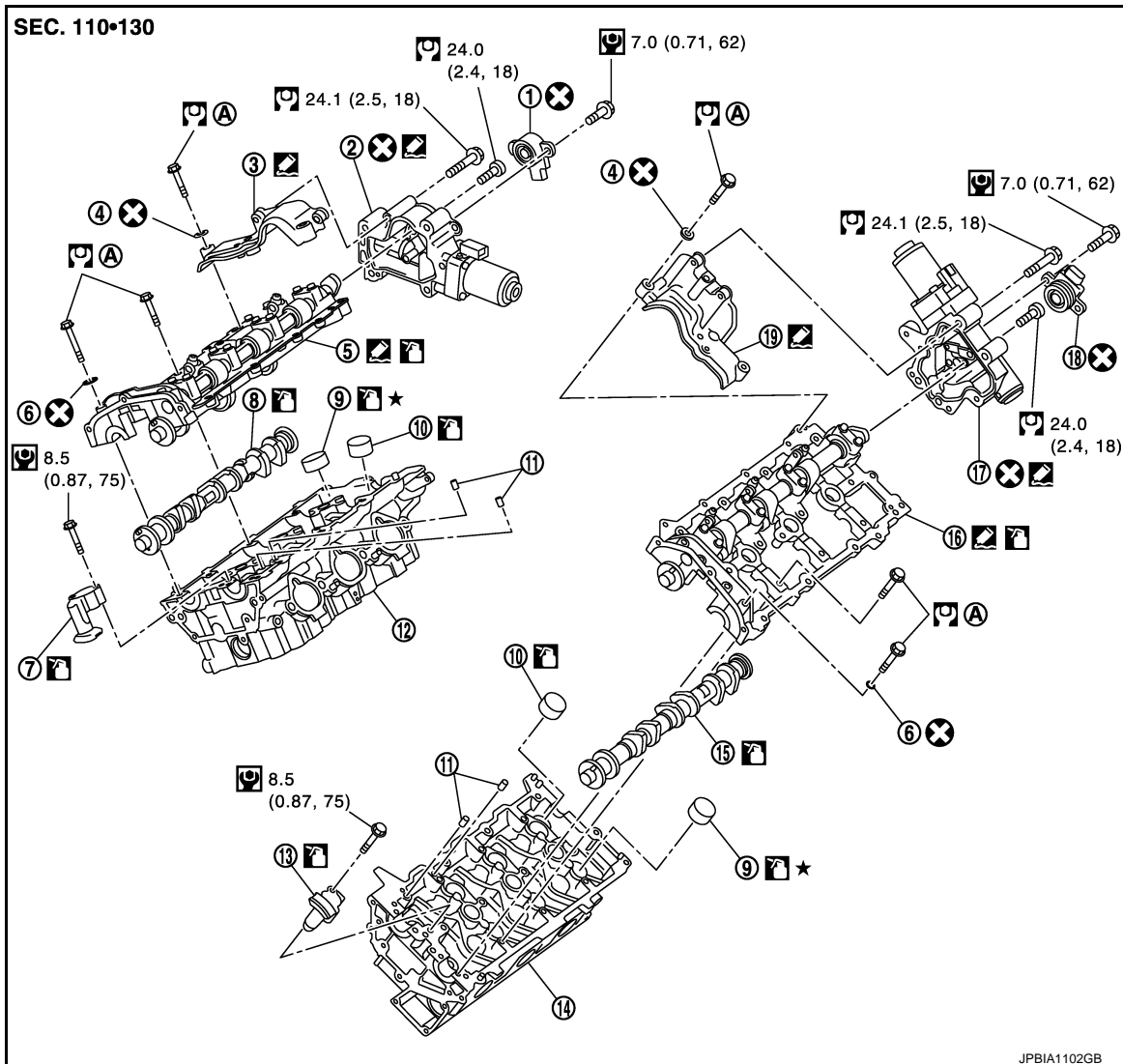

- | | | |
|---|---|---|
| 1. VVEL control shaft position sensor (bank 1) | 2. VVEL actuator sub assembly (bank 1) | 3. Actuator bracket (rear) (bank 1) |
| 4. Washer | 5. VVEL ladder assembly (bank 1) | 6. Washer |
| 7. Timing chain tensioner (secondary) (bank 1) | 8. Camshaft (EXH) (bank 1) | 9. Valve lifter (EXH) |
| 10. Valve lifter (INT) | 11. Oil filter | 12. Cylinder head (bank 1) |
| 13. Timing chain tensioner (secondary) (bank 2) | 14. Cylinder head (bank 2) | 15. Camshaft (EXH) (bank 2) |
| 16. VVEL ladder assembly (bank 2) | 17. VVEL actuator sub assembly (bank 2) | 18. VVEL control shaft position sensor (bank 2) |
| 19. Actuator bracket (rear) (bank 2) | | |
- A. Comply with the installation procedure when tightening. Refer to [EM-85](#)

Refer to [GI-4, "Components"](#) for symbols in the figure.

CAUTION:

A high degree of precision is required for a valve on the intake side. Never remove the valve related-parts unless necessary.

CAMSHAFT

< UNIT DISASSEMBLY AND ASSEMBLY >

NOTE:

- As for replacement of parts on the intake side as shown in the exploded view, replace VVEL ladder assembly and cylinder head assembly.
- VVEL ladder assembly cannot be replaced as a single part, because it is machined together with cylinder head assembly.

VVEL Ladder Assembly and Cylinder Head Assembly Features

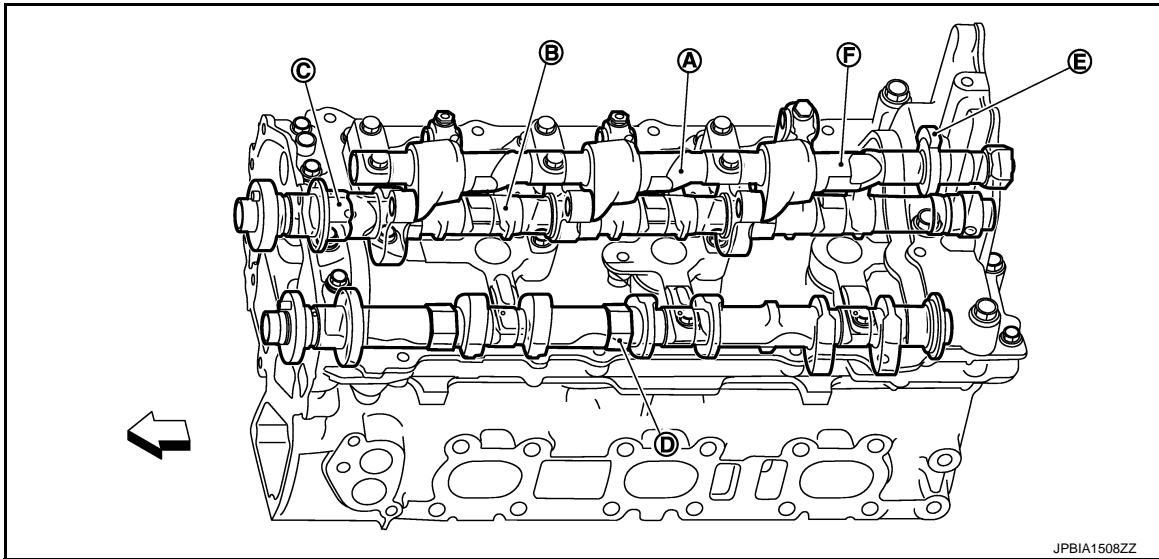

- | | | |
|---|-----------------------------|---|
| A. Control shaft | B. Drive shaft | C. Hexagonal part of drive shaft (for holding) |
| D. Hexagonal part of camshaft (EXH) (for holding) | E. Stopper of control shaft | F. Two flat area of control shaft (for holding) |
- ⇐ : Engine front

NOTE:

The figure shows an example of bank 2.

Disassembly and Assembly

INFOID:000000008154467

DISASSEMBLY

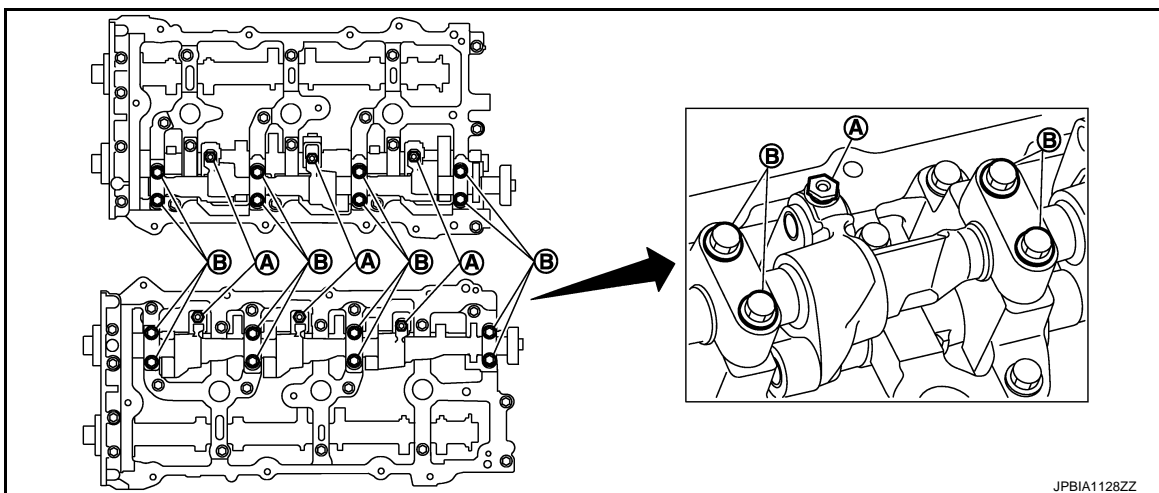

CAUTION:

Never loosen adjusting bolts (A) and mounting bolts (black color) (B) of VVEL ladder assembly. If loosened, the stroke of cam lift becomes out of adjustment. In such case, replacement of VVEL ladder assembly and cylinder head assembly is required.

NOTE:

VVEL ladder assembly cannot be replaced as a single part, because it is machined together with cylinder head assembly.

CAMSHAFT

< UNIT DISASSEMBLY AND ASSEMBLY >

1. Remove rocker covers (bank 1 and bank 2). Refer to [EM-46. "Exploded View"](#).
2. Remove VVEL actuator sub assembly as follows:
CAUTION:
VVEL actuator sub assembly and VVEL control shaft position sensor are nonreusable. Never remove them unless they are required.
 - a. Remove VVEL control shaft position sensor.
 - b. Turn control shaft to the large lift side and fix it in order to prevent the interference of the stopper surface.
 - If control shaft cannot be moved, set crankshaft in position referring to the information below. (To displace cam nose)

Bank 1 : Turn 120 degrees from no. 1 cylinder at TDC

Bank 2 : No. 1 cylinder at TDC

- c. Fix two flat areas (C) of control shaft with a wrench to remove mounting bolts of control shaft.

A : Bank 1
B : Bank 2
⇐ : Engine front

CAUTION:

- During the operation, never allow a wrench to interfere with other parts.
- Fix control shaft to prevent the interference of the stopper surface.

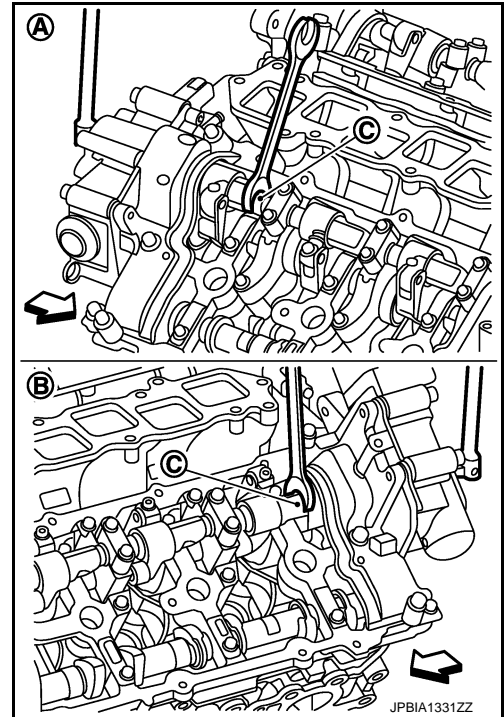

- d. Remove VVEL actuator sub assembly.
 - Loosen mounting bolts in the reverse order as shown in the figure.

A : Bank 2
B : Bank 1

CAUTION:

- When removing, prepare wastes because oil spills.
- When installing, be careful with VVEL actuator sub assembly (bank 2) mounting bolt No. 1 because its length is different.

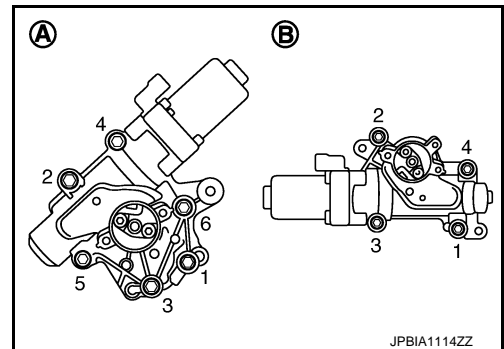

- e. Remove actuator bracket (rear).

CAMSHAFT

< UNIT DISASSEMBLY AND ASSEMBLY >

- Loosen mounting bolts in the reverse order as shown in the figure.

A : Bank 1
 B : Bank 2
 ⇐ : Engine front

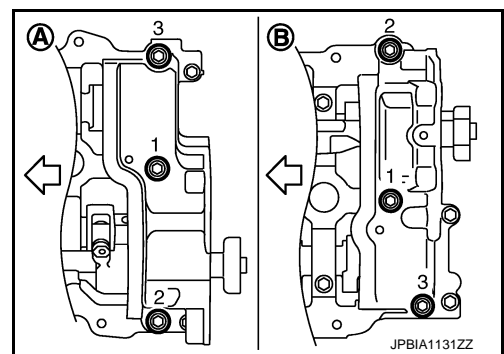

- Remove front timing chain case, camshaft sprockets, and timing chain. Refer to [EM-49, "Exploded View"](#).
- Remove rear timing chain case. Refer to [EM-79, "Exploded View"](#).
- Remove VVEL ladder assembly.
 - Loosen mounting bolts (gold color) in the reverse order as shown in the figure.

A : Bank 1
 B : Bank 2
 ⇐ : Engine front

CAUTION:

- Never loosen adjusting bolts and mounting bolts (black color).
- When removing VVEL ladder assembly, hold the drive shaft from below so as not to drop it.

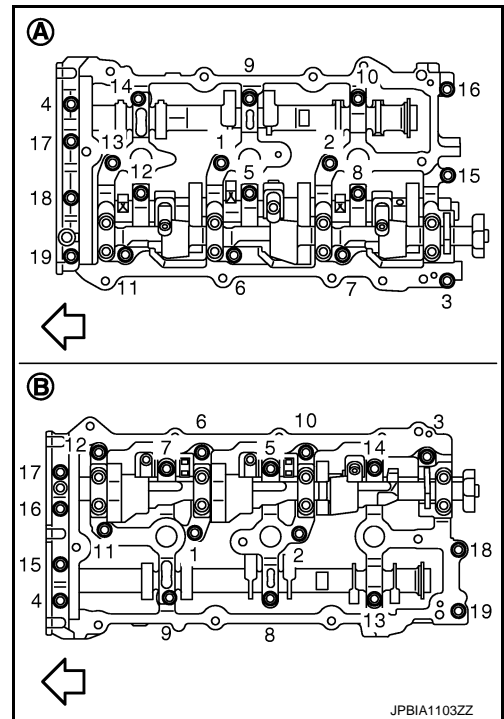

- Remove camshaft (EXH).
- Remove valve lifter.
 - Identify installation positions, and store them without mixing them up.
- Remove timing chain tensioners (secondary) (1) from cylinder head.

A : Bank 1
 B : Bank 2

- Remove timing chain tensioners (secondary) with its stopper pin (C) attached.

NOTE:

Stopper pin should be attached when timing chain (secondary) is removed.

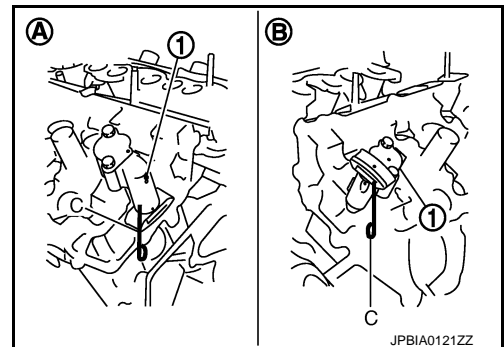

- Remove oil filter from cylinder head, if necessary.

ASSEMBLY

CAUTION:

Do not reuse washers.

CAMSHAFT

< UNIT DISASSEMBLY AND ASSEMBLY >

1. Install timing chain tensioners (secondary) (1) on both sides of cylinder head.

A : Bank 1
B : Bank 2

- Install timing chain tensioner with its stopper pin (C) attached.
- Install timing chain tensioner with sliding part facing downward on cylinder head (bank 1), and with sliding part facing upward on cylinder head (bank 2).

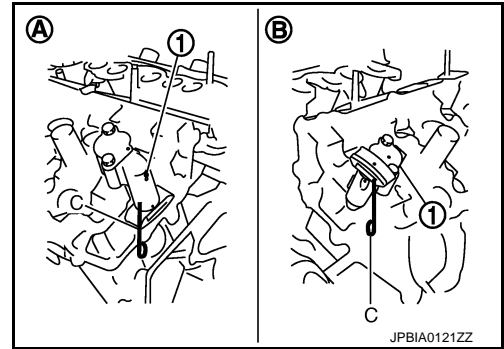

2. Install oil filter (1), if removed.
 - Do not project from the cylinder head (2) surface.

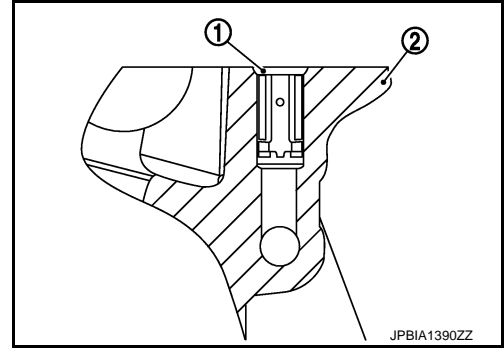

3. Install valve lifter.
 - Install it in the original position.
4. Install camshaft (EXH).
 - Distinction between camshaft (EXH) (bank 1 and bank 2) is performed with the identification mark.

⇐ : Engine front

Bank	Paint marks			Identification mark (F)
	M1 (C)	M2 (D)	M3 (E)	
Bank 1 (A)	No	Blue	Light blue	1 N
Bank 2 (B)	No	Blue	Light blue	1 P

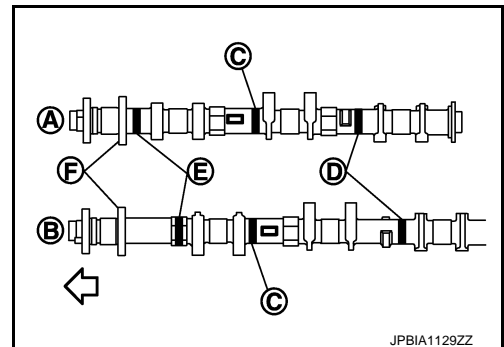

5. Install VVEL ladder assembly as follows:

CAMSHAFT

< UNIT DISASSEMBLY AND ASSEMBLY >

- a. Apply a continuous bead of liquid gasket with tube presser (commercial service tool) to the cylinder head as shown in the figure.

- A : Bank 1
- B : Bank 2
- c : $\phi 3.4 - 4.4$ mm (0.134 - 0.173 in)
- ↶ : Engine front

Use Genuine RTV Silicone Sealant or equivalent. Refer to [GI-22, "Recommended Chemical Products and Sealants"](#).

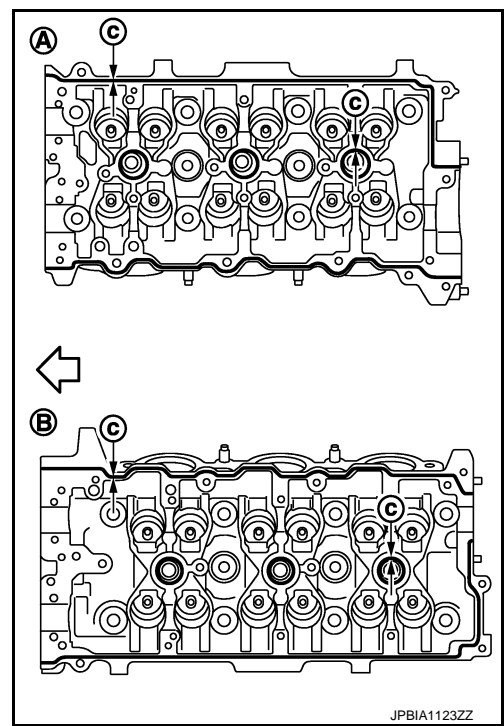

- b. Tighten mounting bolts in the following step, in numerical order as shown in the figure.

- A : Bank 1
- B : Bank 2
- ↶ : Engine front

- i. Tighten bolts in numerical order as shown in the figure.

CAUTION:
Do not reuse washers.

 : 1.96 N·m (0.20 kg-m, 1 ft-lb)

- ii. Tighten bolts in numerical order as shown in the figure.

 : 5.88 N·m (0.60 kg-m, 4 ft-lb)

- iii. Tighten bolts in numerical order as shown in the figure.

 : 10.4 N·m (1.1 kg-m, 8 ft-lb)

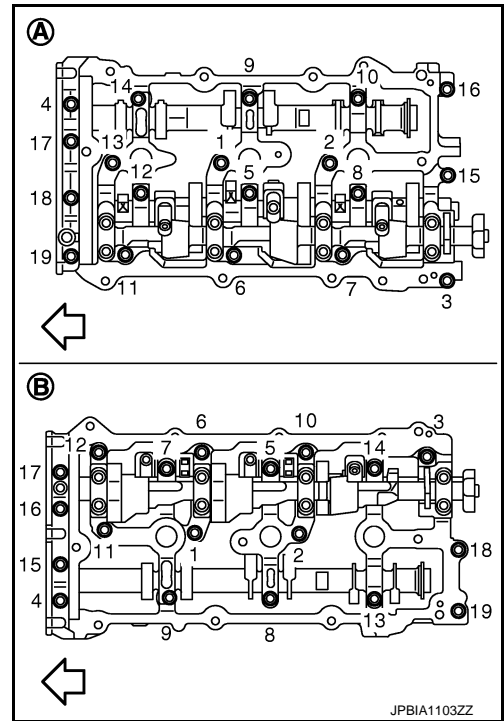

6. Measure difference in levels between front end faces of VVEL ladder assembly and cylinder head.

Standard : -0.14 to 0.14 mm (-0.0055 to 0.0055 in)

- Measure two positions (both intake and exhaust side) for a single bank.
- If the measured value is out of the standard, reinstall VVEL ladder assembly.

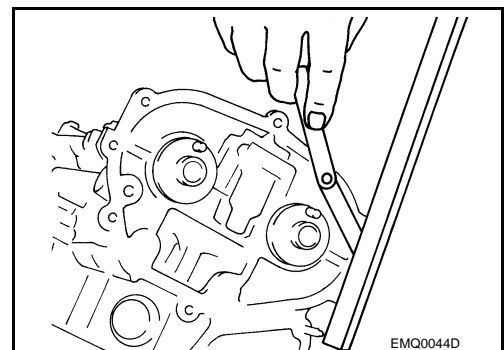

A
EM
C
D
E
F
G
H
I
J
K
L
M
N
O
P

CAMSHAFT

< UNIT DISASSEMBLY AND ASSEMBLY >

7. Install rear timing chain case. Refer to [EM-79, "Exploded View"](#).
8. Install camshaft sprockets and timing chains. Refer to [EM-49, "Exploded View"](#).
9. Install actuator bracket (rear) as follows:

- a. Apply a continuous bead of liquid gasket with tube presser (commercial service tool) to the actuator bracket (rear) as shown in the figure.

A : Bank 1
B : Bank 2
c : $\phi 3.4 - 4.4$ mm (0.134 - 0.173 in)
⇐ : Engine front

Use **Genuine RTV Silicone Sealant** or equivalent. Refer to [GI-22, "Recommended Chemical Products and Sealants"](#).

CAUTION:

Never apply gasket to the oil passage.

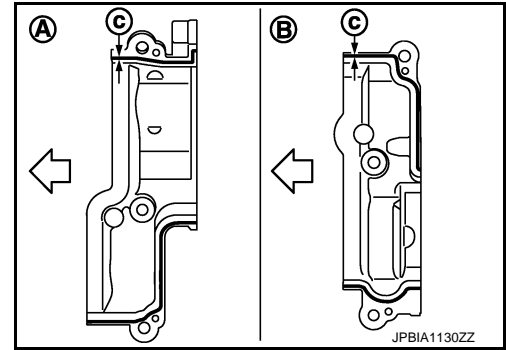

- b. Tighten mounting bolts in the following steps, in numerical order as shown in the figure.

A : Bank 1
B : Bank 2
⇐ : Engine front

- i. Tighten bolts in numerical order as shown in the figure.

CAUTION:

Do not reuse washers.

 : 1.96 N·m (0.20 kg-m, 1 ft-lb)

- ii. Tighten bolts in numerical order as shown in the figure.

 : 5.88 N·m (0.60 kg-m, 4 ft-lb)

- iii. Tighten bolts in numerical order as shown in the figure.

 : 31.4 N·m (3.2 kg-m, 23 ft-lb)

10. Install new VVEL actuator sub assembly as follows:

CAUTION:

Regarding replacement, because VVEL actuator sub assembly and VVEL control shaft position sensor are controlled on a one-on-one basis, replace them as a set.

NOTE:

- VVEL actuator arm (B) is factory-fixed at 5.5 degrees from the small lift with a holding jig (A).
- The holding jig is supplied in the new VVEL actuator sub assembly.

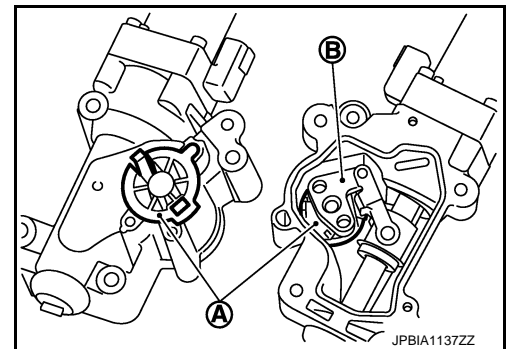
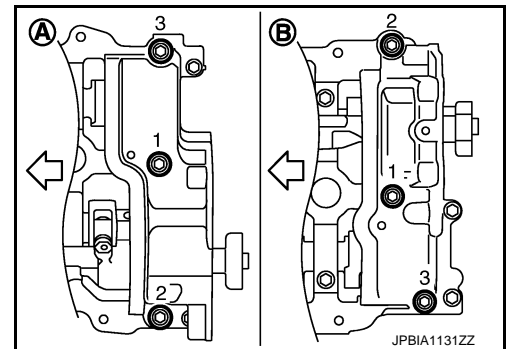

CAUTION:

CAMSHAFT

< UNIT DISASSEMBLY AND ASSEMBLY >

- Never disassemble VVEL actuator sub assembly. [Never loosen actuator motor mounting bolts (A) shown in the figure]
- Never shock VVEL actuator sub assembly.

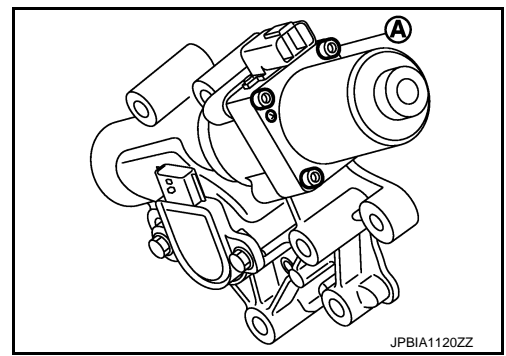

- a. Move control shaft to the position of small lift stopper.
- The position where a part of the stopper of control shaft contacts VVEL ladder bracket.

- 1 : VVEL ladder assembly (bank 2)
- 2 : VVEL ladder assembly (bank 1)
- A : Stopper of control shaft
- ← : Small lift side

CAUTION:
Be careful not to damage the stopper surface.

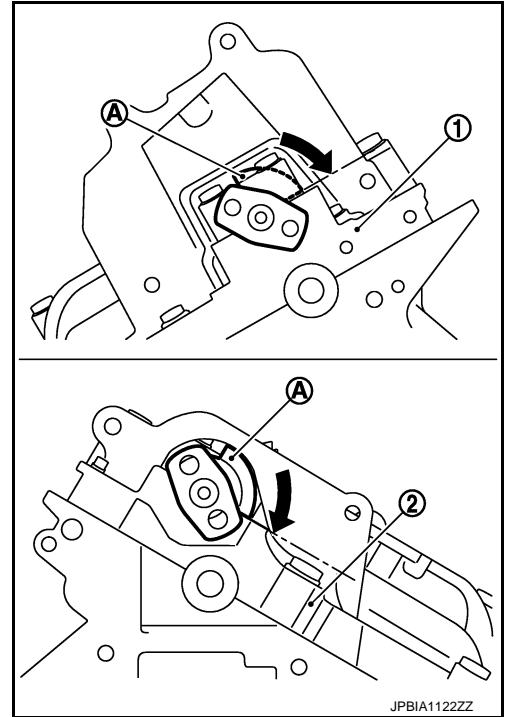

- If control shaft cannot be moved, set crankshaft in position referring to the information below. (To displace cam nose)

- Bank 1 : Turn 120 degrees from No. 1 cylinder at TDC**
- Bank 2 : No. 1 cylinder at TDC**

CAMSHAFT

< UNIT DISASSEMBLY AND ASSEMBLY >

- b. Hold two flat areas of control shaft with a wrench, and rotate the control shaft (5.5 degrees from the stopper) to the large lift side. (This is for aligning the bolt hole of control shaft and the hole of VVEL actuator arm.)

- 1 : VVEL actuator sub assembly (bank 1)
- A : Control shaft
- b : 5.5 degrees
- ← : Large lift side

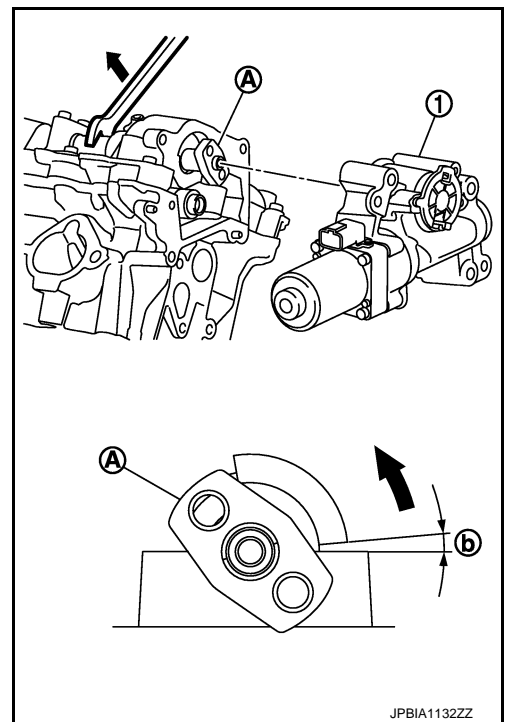

JPBIA1132ZZ

- c. Apply a continuous bead of liquid gasket with tube presser (commercial service tool) to the VVEL actuator sub assembly as shown in the figure.

- 1 : VVEL actuator sub assembly (bank 2)
- 2 : VVEL actuator sub assembly (bank 1)
- a : 4.0 - 5.6 mm (0.157 - 0.220 in)
- b : ϕ 3.4 - 4.4 mm (0.134 - 0.173 in)

Use Genuine RTV Silicone Sealant or equivalent. Refer to [GI-22, "Recommended Chemical Products and Sealants"](#).

CAUTION:
Never apply gasket to the oil passage.

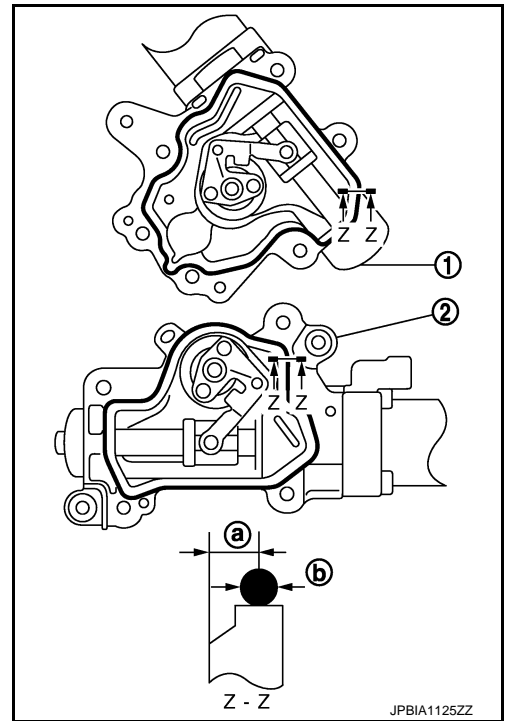

JPBIA1125ZZ

- d. Install new VVEL actuator sub assembly.
- Tighten mounting bolts in the following step, in numerical order as shown in the figure.

- A : Bank 2
- B : Bank 1

CAUTION:
• When installing, be careful with VVEL actuator sub assembly (bank 2) mounting bolt No. 1 because its length is different.

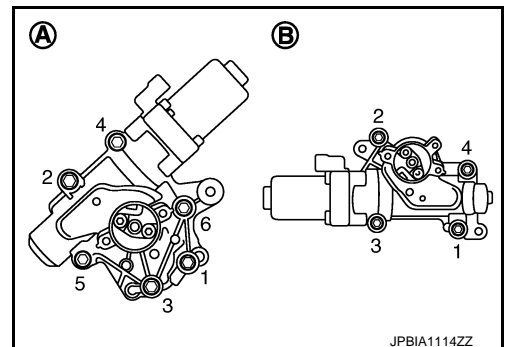

JPBIA1114ZZ

CAMSHAFT

< UNIT DISASSEMBLY AND ASSEMBLY >

- Be sure to check that the VVEL actuator sub assembly is in contact with the cylinder head before tightening the mounting bolts.

- Remove holding jig.
- Check that VVEL actuator arm bolt hole is aligned with control shaft tapped hole. If it is not aligned, turn control shaft for alignment.
- Fix two flat areas (C) of control shaft with a wrench to install mounting bolts of control shaft.

- A : Bank 1
- B : Bank 2
- ⇐ : Engine front

CAUTION:

- During the operation, never allow a wrench to interfere with other parts.
- Fix control shaft to prevent the interference of the stopper surface.

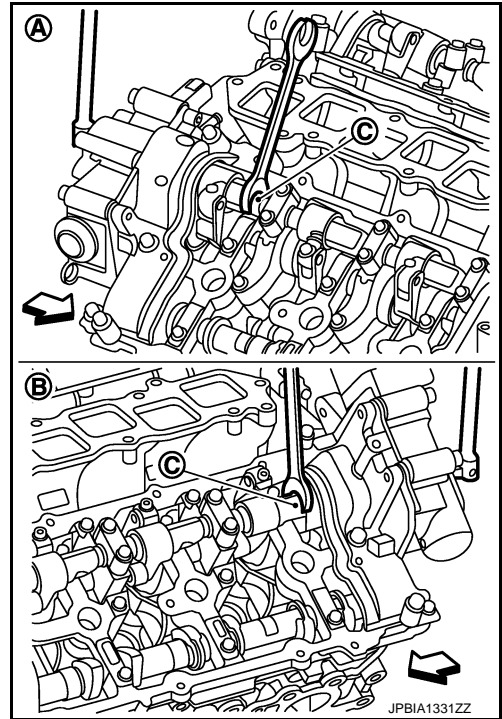

- Install new VVEL control shaft position sensor as follows:

CAUTION:

Regarding replacement, because VVEL actuator sub assembly and VVEL control shaft position sensor are controlled on a one-on-one basis, replace them as a set.

- Apply engine oil to O-ring or contact surface of O-ring.
- Align matching marks (B) of VVEL control shaft position sensor and upper housing.

- C : Bank 2

- Face connector toward matching mark (A).

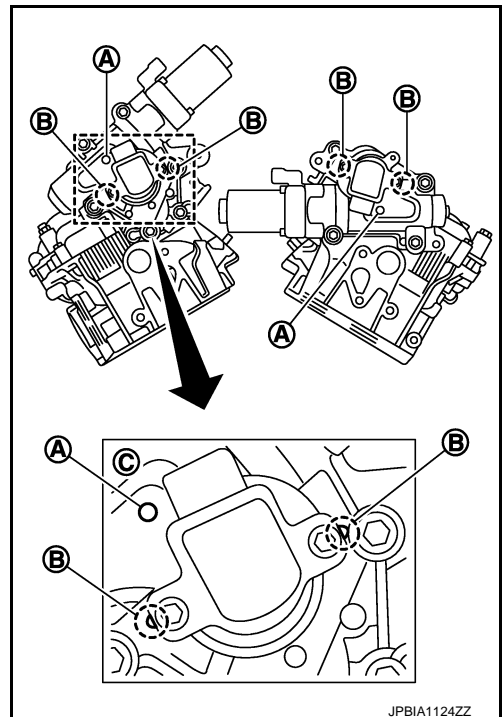

- Temporarily tighten bolt.

CAMSHAFT

< UNIT DISASSEMBLY AND ASSEMBLY >

- d. Adjust VVEL control shaft position sensor after setting the engine assembly in the vehicle. Refer to [EC-22, "VVEL CONTROL SHAFT POSITION SENSOR ADJUSTMENT : Description"](#).
- CAUTION:**
Be sure to adjust VVEL control shaft position sensor.
- e. After adjusting VVEL control shaft position sensor, tighten bolts to the specified torque.
12. Inspect the valve clearance. Refer to [EM-18, "Inspection and Adjustment"](#).
13. Install in the reverse order of removal after this step.

Inspection

INFOID:000000008154468

INSPECTION AFTER REMOVAL (EXHAUST SIDE)

Camshaft (EXH) Runout

- Put V-block on precise flat table, and support No. 2 and 4 journals of camshaft.
- CAUTION:**
Never support No. 1 journal (on the side of camshaft sprocket) because it has a different diameter from the other three locations.
- Set a dial indicator vertically to No. 3 journal.
 - Turn camshaft (EXH) to one direction with hands, and measure the camshaft runout on a dial indicator. (Total indicator reading)

Standard and limit : Refer to [EM-139, "Camshaft"](#).

- If it exceeds the limit, replace camshaft (EXH).

Camshaft (EXH) Cam Height

- Measure the camshaft (EXH) cam height with a micrometer.

Standard : Refer to [EM-139, "Camshaft"](#).

- If wear exceeds the limit, replace camshaft (EXH).

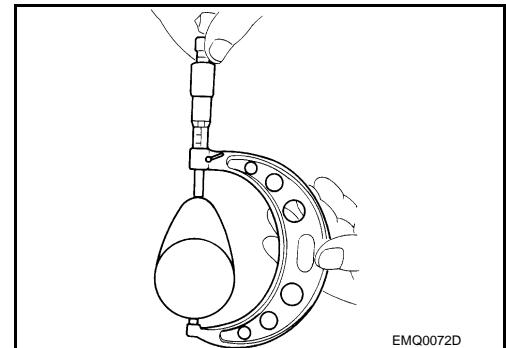
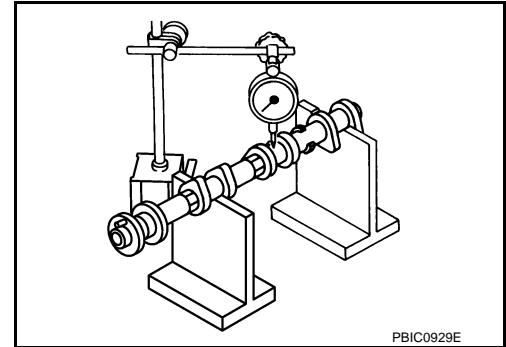

Camshaft (EXH) Journal Oil Clearance

CAMSHAFT (EXH) JOURNAL DIAMETER

- Measure the outer diameter of camshaft (EXH) journal with a micrometer (A).

Standard : Refer to [EM-139, "Camshaft"](#).

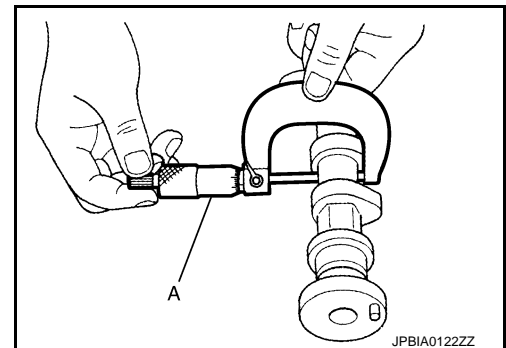

VVEL LADDER ASSEMBLY (EXHAUST SIDE) INNER DIAMETER

- Tighten VVEL ladder assembly bolts to the specified torque. Refer to "INSTALLATION" for the tightening procedure.

CAMSHAFT

< UNIT DISASSEMBLY AND ASSEMBLY >

- Measure inner diameter (A) of VVEL ladder assembly (Exhaust side) with a bore gauge.

Standard : Refer to [EM-139, "Camshaft"](#).

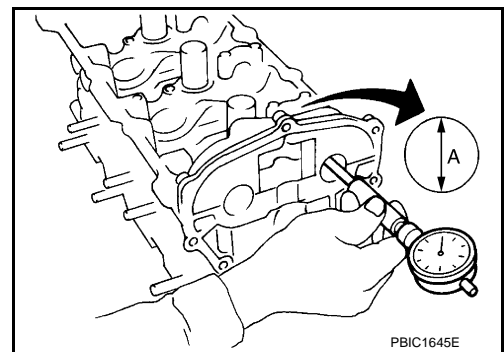

CAMSHAFT (EXH) JOURNAL OIL CLEARANCE

- (Oil clearance) = [VVEL ladder assembly (Exhaust side) inner diameter] – [Camshaft (EXH) journal diameter].

Standard and limit : Refer to [EM-139, "Camshaft"](#).

- If the calculated value exceeds the limit, replace either or both camshaft (EXH) and VVEL ladder assembly and cylinder head assembly.

NOTE:

VVEL ladder assembly cannot be replaced as a single part, because it is machined together with cylinder head assembly.

Camshaft (EXH) End Play

- Install a dial indicator in thrust direction on front end of camshaft. Measure the end play of a dial indicator when camshaft (EXH) is moved forward/backward (in direction of axis).

Standard and limit : Refer to [EM-139, "Camshaft"](#).

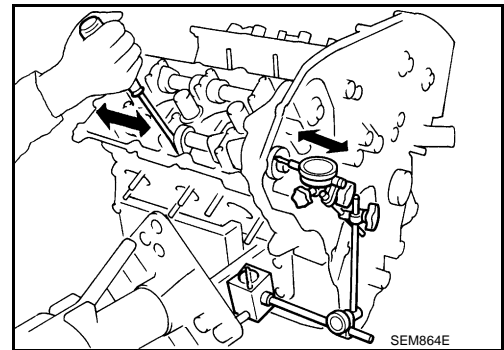

- Measure the following parts if out of the limit.
 - Dimension "A" for camshaft (EXH) No. 1 journal

Standard : 27.500 - 27.548 mm (1.0827 - 1.0846 in)

- Dimension "B" for cylinder head No. 1 journal bearing

Standard : 27.360 - 27.385 mm (1.0772 - 1.0781 in)

- Refer to the standards above, and then replace camshaft (EXH) and/or VVEL ladder assembly and cylinder head assembly.

NOTE:

Cylinder head assembly cannot be replaced as a single part, because it is machined together with VVEL ladder assembly.

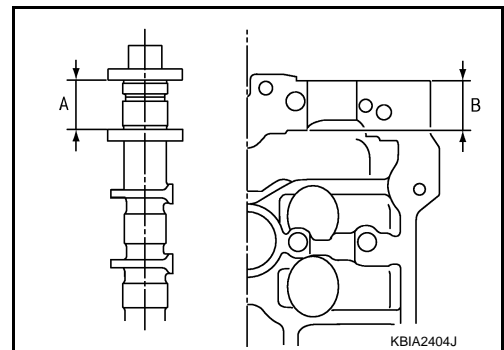

Camshaft Sprocket (EXH) Runout

1. Put V-block on precise flat table, and support No. 2 and 4 journals of camshaft (EXH).

CAUTION:

Never support No. 1 journal (on the side of camshaft sprocket) because it has a different diameter from the other three locations.

CAMSHAFT

< UNIT DISASSEMBLY AND ASSEMBLY >

2. Measure the camshaft sprocket (EXH) runout with a dial indicator. (Total indicator reading)

Limit : Refer to [EM-139, "Camshaft"](#).

3. If it exceeds the limit, replace camshaft sprocket (EXH).

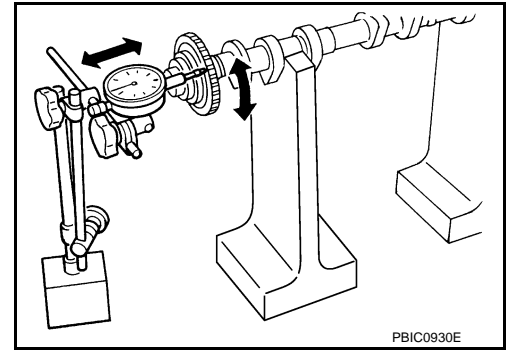

Valve Lifter (EXH)

- Check if surface of valve lifter has any wear or crack.
- If wear or crack is found, replace valve lifter (EXH). Refer to [EM-139, "Camshaft"](#).

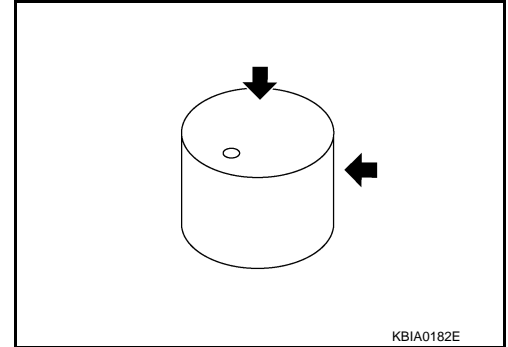

Valve Lifter Clearance (EXH)

VALVE LIFTER OUTER DIAMETER

- Measure the outer diameter at 1/2 height of valve lifter with a micrometer (A) since valve lifter is in barrel shape.

Standard : Refer to [EM-139, "Camshaft"](#).

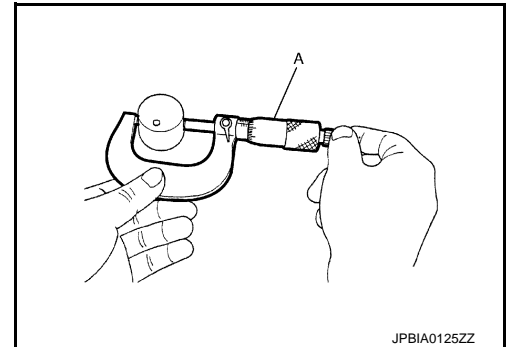

VALVE LIFTER HOLE DIAMETER

- Measure the inner diameter of valve lifter hole of cylinder head with an inside micrometer.

Standard : Refer to [EM-139, "Camshaft"](#).

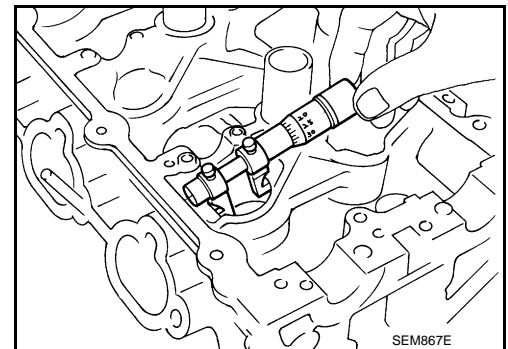

VALVE LIFTER CLEARANCE

- (Valve lifter clearance) = (Valve lifter hole diameter) – (Valve lifter outer diameter)

Standard : Refer to [EM-139, "Camshaft"](#).

- If the calculated value is out of the standard, referring to each standard of valve lifter outer diameter and valve lifter hole diameter, replace either or both valve lifter and VVEL ladder assembly and cylinder head assembly.

CAMSHAFT

< UNIT DISASSEMBLY AND ASSEMBLY >

NOTE:

Cylinder head assembly cannot be replaced as a single part, because it is machined together with VVEL ladder assembly.

INSPECTION AFTER REMOVAL (INTAKE SIDE)

Drive Shaft End Play

- Install a dial indicator in thrust direction on front end of drive shaft. Measure the end play of a dial indicator when drive shaft is moved forward/backward (in direction of axis).

Standard and limit : Refer to [EM-139, "Camshaft"](#).

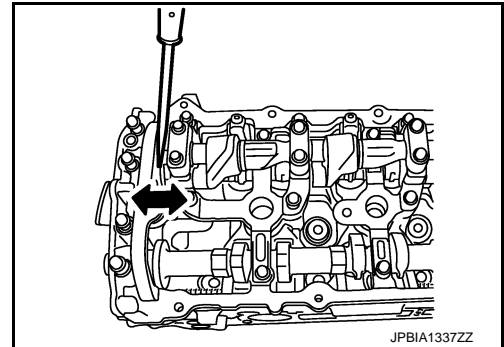

- Measure the following parts if out of the limit.
 - Dimension "A" for drive shaft No. 1 journal

Standard : 27.500 - 27.548 mm (1.0827 - 1.0846 in)

- Dimension "B" for cylinder head No. 1 journal bearing

Standard : 27.360 - 27.385 mm (1.0772 - 1.0781 in)

- If it exceeds the limit, replace VVEL ladder assembly and cylinder head assembly.

NOTE:

Cylinder head assembly cannot be replaced as a single part, because it is machined together with VVEL ladder assembly.

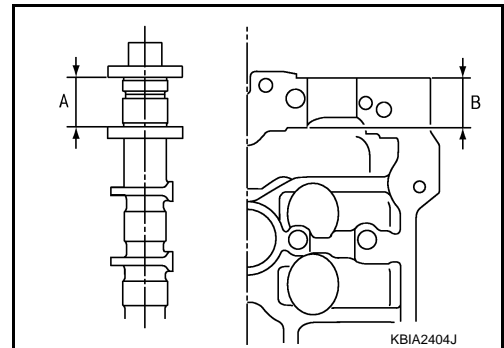

Camshaft Sprocket (INT) Runout

1. Put V-block on precise flat table, and support No. 2 and 4 journals of drive shaft.

CAUTION:

Never support No. 1 journal (on the side of camshaft sprocket) because it has a different diameter from the other three locations.

2. Measure the camshaft sprocket (INT) runout with a dial indicator. (Total indicator reading)

Limit : Refer to [EM-139, "Camshaft"](#).

3. If it exceeds the limit, replace camshaft sprocket (INT).

Valve Lifter (INT)

- Check if surface of valve lifter has any wear or crack.
- If wear or crack is found, replace VVEL ladder assembly and cylinder head assembly. Refer to [EM-139, "Camshaft"](#).

NOTE:

Since the valve lifter (INT) cannot be replaced by the piece, VVEL ladder assembly and cylinder head assembly replacement are required.

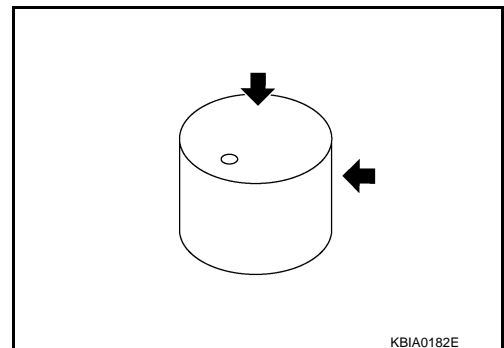

Valve Lifter Clearance (INT)

VALVE LIFTER OUTER DIAMETER

CAMSHAFT

< UNIT DISASSEMBLY AND ASSEMBLY >

- Measure the outer diameter at 1/2 height of valve lifter (INT) with a micrometer (A) since valve lifter is in barrel shape.

Standard : Refer to [EM-139, "Camshaft"](#).

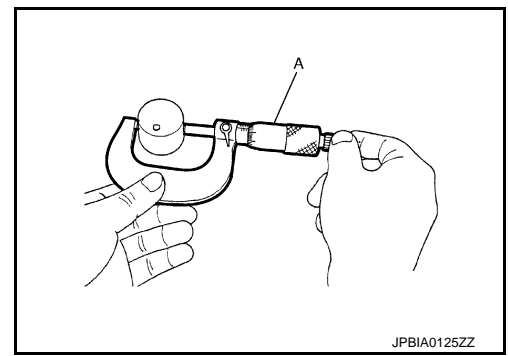

VALVE LIFTER HOLE DIAMETER

- Measure the inner diameter of valve lifter hole of cylinder head with an inside micrometer.

Standard : Refer to [EM-139, "Camshaft"](#).

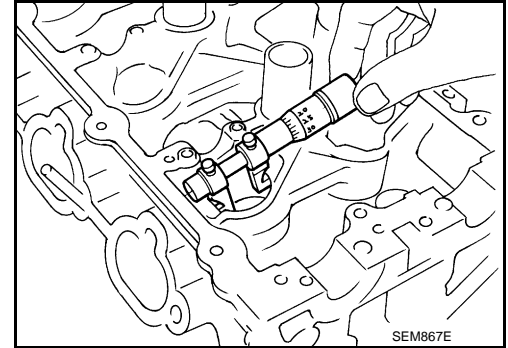

VALVE LIFTER CLEARANCE

- (Valve lifter clearance) = (Valve lifter hole diameter) – (Valve lifter outer diameter)

Standard : Refer to [EM-139, "Camshaft"](#).

- If the calculated value is out of the standard, replace VVEL ladder assembly and cylinder head assembly.

NOTE:

Since the valve lifter (INT) cannot be replaced by the piece, VVEL ladder assembly and cylinder head assembly replacement are required.

VVEL Ladder Assembly

DRIVE SHAFT OPERATIONAL CHECK

- Hold the both ends of the drive shaft (A) and rotate it to check that it rotates smoothly.

CAUTION:

Turn VVEL ladder assembly upside down to prevent the drive shaft from dropping off.

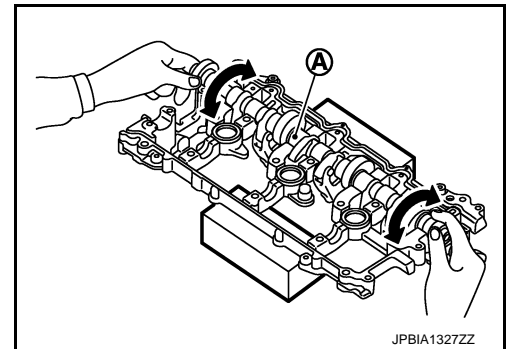

CONTROL SHAFT OPERATIONAL CHECK

CAMSHAFT

< UNIT DISASSEMBLY AND ASSEMBLY >

- Move control shaft (A) to the small stopper and large stopper to check that the control shaft functions smoothly.

CAUTION:

Turn VVEL ladder assembly upside down to prevent the drive shaft from dropping off.

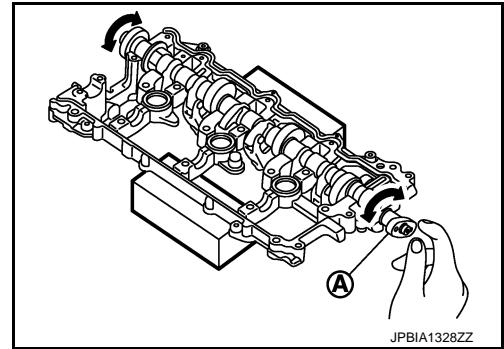

LINK CHECK FOR BACK-LASH (BONDING)

- Check that the link and the shaft of drive shaft and control shaft are not fixed.
- Check this by moving drive shaft and control shaft in the axial and rotation directions.

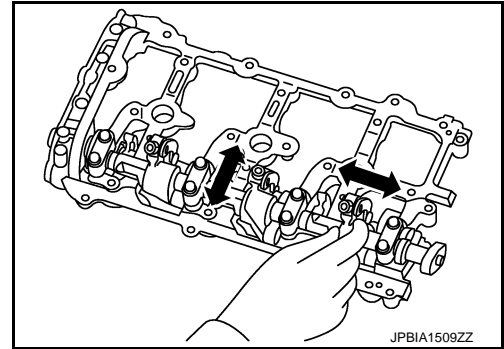

- If there is an unusualness related to the above three, replace VVEL ladder assembly and cylinder head assembly.

NOTE:

VVEL ladder assembly cannot be replaced as a single part, because it is machined together with cylinder head assembly.

INSPECTION AFTER INSTALLATION

Inspection of Camshaft Sprocket (INT) Oil Groove

CAUTION:

- Perform this inspection only when DTC P0011, P0021 is detected in self-diagnostic results of CONSULT and it is directed according to inspection procedure of EC section. Refer to [EC-127, "Diagnosis Description"](#).

- Check when engine is cold to prevent burns from the splashing engine oil.

1. Check engine oil level. Refer to [LU-7, "Inspection"](#).
2. Perform the following procedure to prevent the engine from being unintentionally started while checking.
 - a. Release the fuel pressure. Refer to [EC-595, "Inspection"](#).
 - b. Disconnect ignition coil and injector harness connectors. Refer to [EM-46, "Exploded View"](#).
 - c. Remove intake valve timing control solenoid valve. Refer to [EM-49, "Exploded View"](#).
3. Crank engine, and then check that engine oil comes out from intake valve timing control solenoid valve hole (A). End crank after checking.

1 : Intake valve timing control cover (bank 1)

↔ : Engine front

WARNING:

Be careful not to touch rotating parts (drive belt, idler pulley, and crankshaft pulley, etc.).

CAUTION:

- Prevent splashing by using a shop cloth to prevent the worker from injury from engine oil and to prevent engine oil contamination.

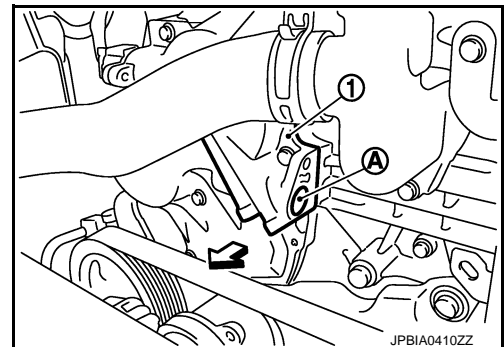

CAMSHAFT

< UNIT DISASSEMBLY AND ASSEMBLY >

- **Prevent splashing by using a shop cloth to prevent engine oil from being splashed to engine and vehicle. Especially, be careful no to apply engine oil to rubber parts of drive belt, engine mounting insulator, etc. Wipe engine oil off immediately if it is splashed.**
5. Perform the following inspection if engine oil does not come out from intake valve timing control solenoid valve oil hole of the cylinder head.
 - Remove oil filter, and then clean it. Refer to [EM-49, "Exploded View"](#).
 - Clean oil groove between oil strainer and intake valve timing control solenoid valve. Refer to [LU-2, "Engine Lubrication System"](#).
 6. Remove components between intake valve timing control solenoid valve and camshaft sprocket (INT), and then check each oil groove for clogging.
 - Clean oil groove if necessary. Refer to [LU-2, "Engine Lubrication System"](#).
 7. After inspection, install removed parts in the reverse order.

Inspection for Leakage

The following are procedures for checking fluid leakage, lubricant leakage.

- Before starting engine, check oil/fluid levels including engine coolant and engine oil. If any are less than the required quantity, fill them to the specified level. Refer to [MA-10, "Fluids and Lubricants"](#).
- Follow the procedure below to check for fuel leakage.
 - Turn ignition switch to the "ON" position (with engine stopped). With fuel pressure applied to fuel piping, check for fuel leakage at connection points.
 - Start engine. With engine speed increased, check again for fuel leakage at connection points.
- Run engine to check for unusual noise and vibration.

NOTE:

If hydraulic pressure inside chain tensioner drops after removal/installation, slack in guide may generate a pounding noise during and just after the engine start. However, this does not indicate a malfunction. The noise will stop after hydraulic pressure rises.

- Warm up engine thoroughly to check that there is no leakage of fuel, or any oil/fluids including engine oil and engine coolant.
- Bleed air from lines and hoses of applicable lines, such as in cooling system.
- After cooling down engine, again check oil/fluid levels including engine oil and engine coolant. Refill them to the specified level, if necessary.

Summary of the inspection items:

Items		Before starting engine	Engine running	After engine stopped
Engine coolant		Level	Leakage	Level
Engine oil		Level	Leakage	Level
Transmission / transaxle fluid	AT & CVT Models	Leakage	Level / Leakage	Leakage
	MT Models	Level / Leakage	Leakage	Level / Leakage
Other oils and fluids*		Level	Leakage	Level
Fuel		Leakage	Leakage	Leakage

* Power steering fluid, brake fluid, etc.

CYLINDER HEAD

< UNIT DISASSEMBLY AND ASSEMBLY >

CYLINDER HEAD

Exploded View

INFOID:000000008154469

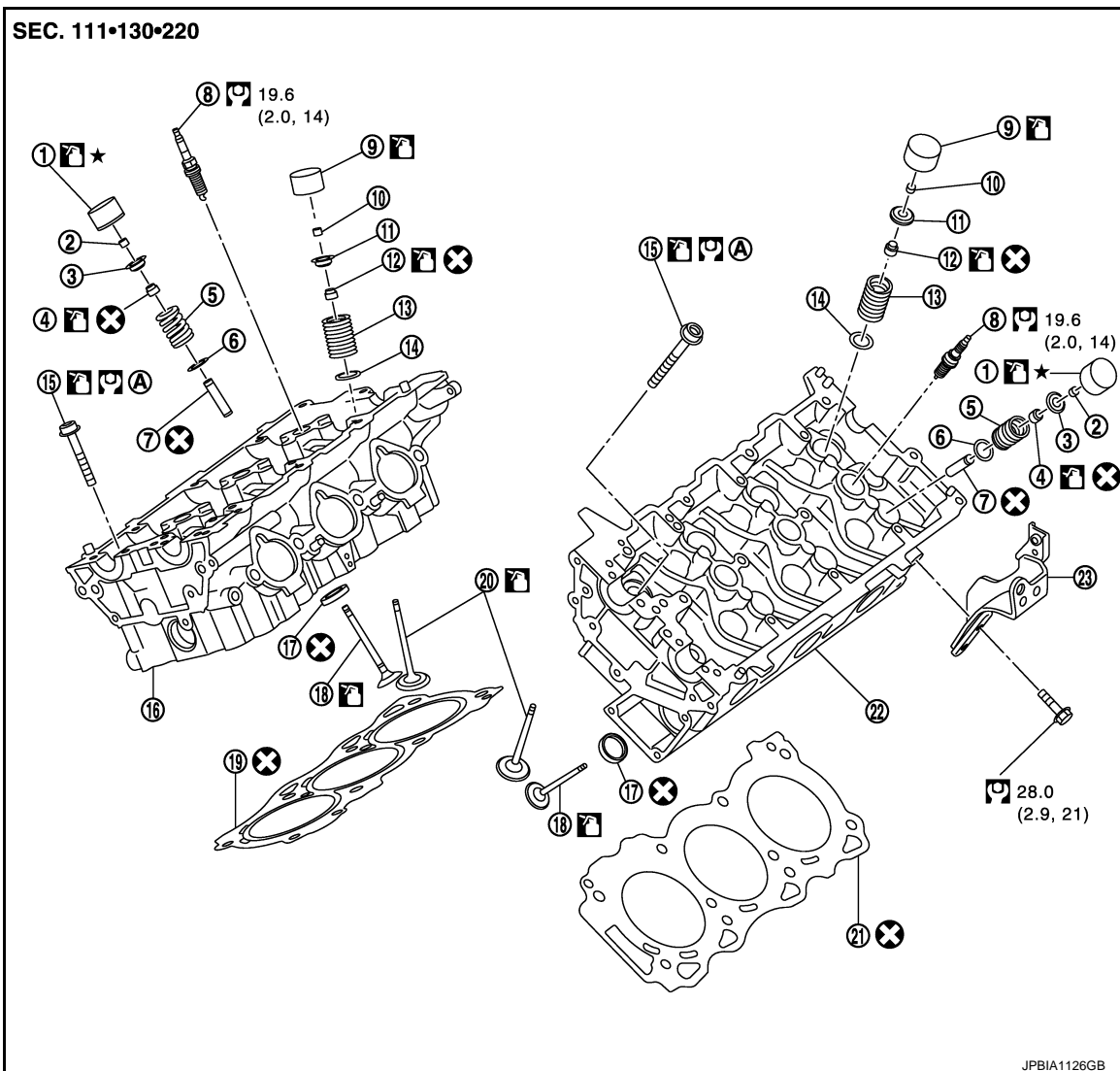

- | | | |
|-----------------------------------|---------------------------------|-----------------------------------|
| 1. Valve lifter (EXH) | 2. Valve collet (EXH) | 3. Valve spring retainer (EXH) |
| 4. Valve oil seal (EXH) | 5. Valve spring (EXH) | 6. Valve spring seat (EXH) |
| 7. Valve guide (EXH) | 8. Spark plug | 9. Valve lifter (INT) |
| 10. Valve collet (INT) | 11. Valve spring retainer (INT) | 12. Valve oil seal (INT) |
| 13. Valve spring (INT) | 14. Valve spring seat (INT) | 15. Cylinder head bolt |
| 16. Cylinder head (bank 1) | 17. Valve seat (EXH) | 18. Valve (EXH) |
| 19. Cylinder head gasket (bank 1) | 20. Valve (INT) | 21. Cylinder head gasket (bank 2) |
| 22. Cylinder head (bank 2) | 23. Engine rear lower slinger | |

Comply with the installation procedure when tightening. Refer to [EM-102](#)

Refer to [GI-4, "Components"](#) for symbols in the figure.

CAUTION:

A high degree of precision is required for a valve on the intake side. Never remove the valve related-parts unless necessary.

NOTE:

CYLINDER HEAD

< UNIT DISASSEMBLY AND ASSEMBLY >

- As for replacement of parts on the intake side as shown in the exploded view, replace VVEL ladder assembly and cylinder head assembly. (Only valve oil seals are replaceable as a single part.)
- VVEL ladder assembly cannot be replaced as a single part, because it is machined together with cylinder head assembly.

Disassembly and Assembly

INFOID:000000008154470

DISASSEMBLY

1. Remove the following parts:
 - Intake manifold collector: Refer to [EM-29. "Exploded View"](#).
 - Rocker cover: Refer to [EM-46. "Exploded View"](#).
 - Fuel tube and fuel injector assembly: Refer to [EM-37. "Exploded View"](#).
 - Intake manifold: Refer to [EM-32. "Exploded View"](#).
 - Exhaust manifold: Refer to [EM-34. "Exploded View"](#).
 - Water inlet and thermostat assembly: Refer to [CO-22. "Exploded View"](#).
 - Water outlet, water pipe and heater pipe: Refer to [CO-24. "Exploded View"](#).
 - Timing chain: Refer to [EM-49. "Exploded View"](#).
 - Rear timing chain case: Refer to [EM-79. "Exploded View"](#).
 - Camshaft (EXH) and VVEL ladder assembly: Refer to [EM-84. "Exploded View"](#).
2. Remove cylinder head.
 - Loosen mounting bolts in reverse order as shown in the figure.

A : Bank 1

B : Bank 2

← : Engine front

- Use the cylinder head bolt wrench [commercial service tool:
— (J-24239-01)] and power tool.

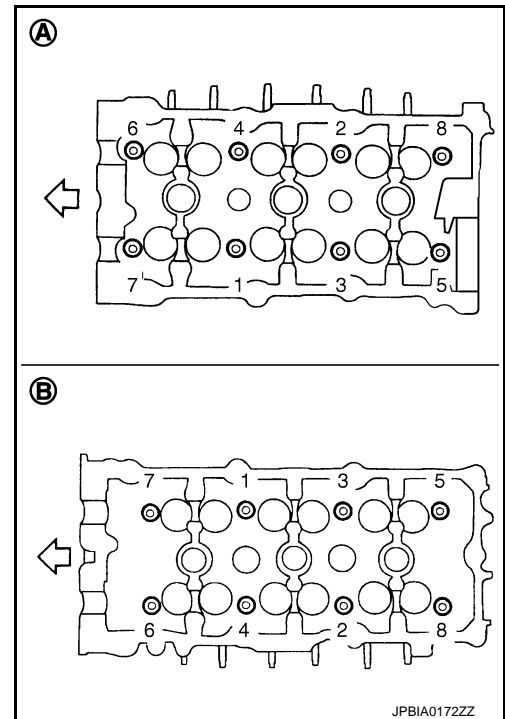

3. Remove cylinder head gaskets.
4. Remove spark plug with spark plug wrench (commercial service tool).
5. Remove valve lifter.
 - Identify installation positions, and store them without mixing them up.
6. Remove valve collet.

CYLINDER HEAD

< UNIT DISASSEMBLY AND ASSEMBLY >

- Compress valve spring with the valve spring compressor [SST: KV10116200 (J-26336-A)] (A), the attachment [SST: KV10115900 (J-26336-20)] (C), and the adapter [SST: KV10109220 (—)] (B). Remove valve collet with a magnet hand.

CAUTION:

When working, take care not to damage valve lifter holes.

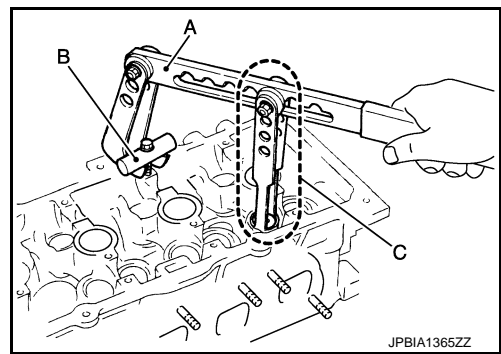

- Remove valve spring retainer, valve spring and valve spring seat.
- Push valve stem to combustion chamber side, and remove valve.
 - Identify installation positions, and store them without mixing them up.
- Remove valve oil seal using the valve oil seal puller [SST: KV10107902 (J-38959)] (A).

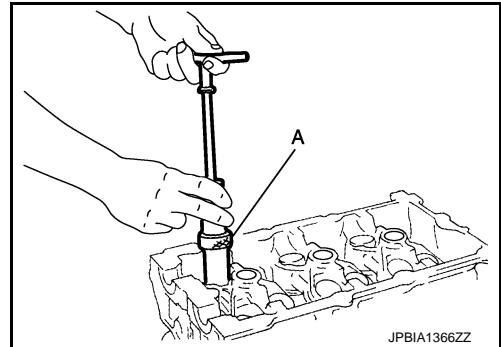

- Remove valve seat (EXH), if valve seat (EXH) must be replaced.
 - Bore out old seat until it collapses. Boring should not continue beyond the bottom face of the seat recess in cylinder head. Set the machine depth stop to ensure this. Refer to [EM-141. "Cylinder Head"](#).

CAUTION:

Prevent to scratch cylinder head by excessive boring.

- Remove valve guide (EXH), if valve guide (EXH) must be replaced.
 - To remove valve guide (EXH), heat cylinder head to 110 to 130°C (230 to 266°F) by soaking in heated oil (A).

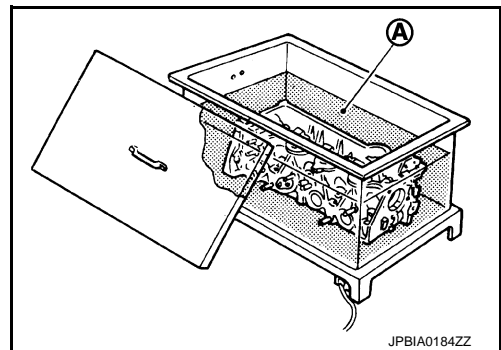

- Drive out valve guide (EXH) with a press [under a 20 kN (2 ton, 2.2 US ton, 2.0 Imp ton) pressure] or a hammer and the valve guide drift (commercial service tool).

WARNING:

Cylinder head contains heat. When working, wear protective equipment to avoid getting burned.

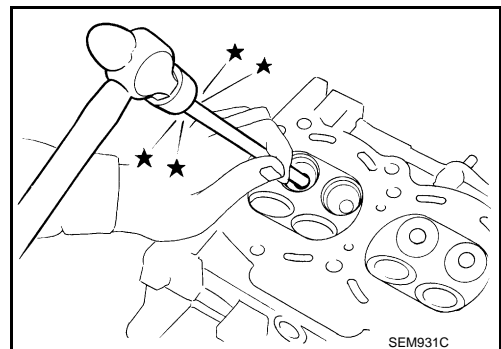

ASSEMBLY

CYLINDER HEAD

< UNIT DISASSEMBLY AND ASSEMBLY >

1. If valve guide (EXH) is removed in step 11 (DISASSEMBLY), install it.
Replace with oversized [0.2 mm (0.008 in)] valve guide (EXH).
 - a. Using the valve guide reamer (commercial service tool) (A), ream cylinder head valve guide (EXH) hole.

Oversize (service) [0.2 mm (0.008 in)]

: Refer to [EM-141, "Cylinder Head"](#).

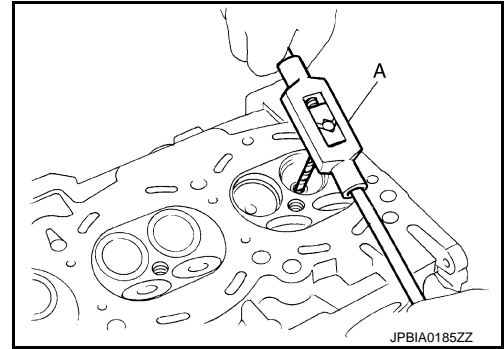

- b. Heat cylinder head to 110 to 130°C (230 to 266°F) by soaking in heated oil (A).

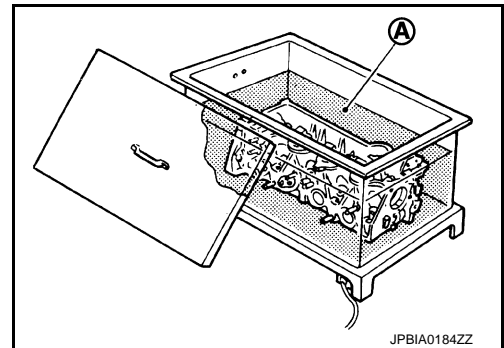

- c. Using the valve guide drift (commercial service tool), press valve guide (EXH) from camshaft side to the dimensions as shown in the figure.

Projection (A)

: Refer to [EM-141, "Cylinder Head"](#).

WARNING:

Cylinder head contains heat. When working, wear protective equipment to avoid getting burned.

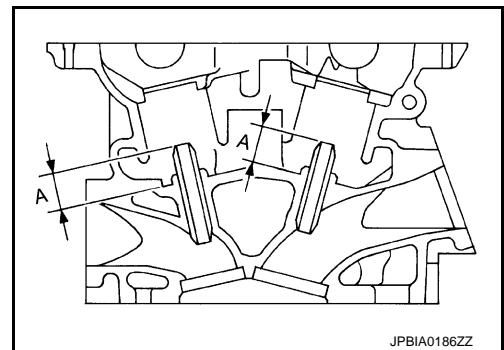

- d. Using the valve guide reamer (commercial service tool) (A), apply reamer finish to valve guide (EXH).

Standard

: Refer to [EM-141, "Cylinder Head"](#).

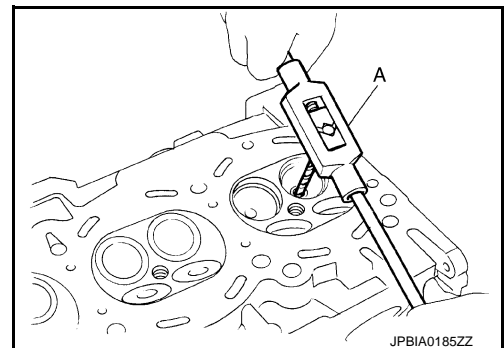

2. If valve seat (EXH) is removed in step 10 (DISASSEMBLY), install it.
Replace with oversize [0.5 mm (0.020 in)] valve seat (EXH).

CYLINDER HEAD

< UNIT DISASSEMBLY AND ASSEMBLY >

- a. Ream cylinder head recess diameter (a) for service valve seat (EXH).

Oversize (service) [0.5 mm (0.020 in)]

: Refer to [EM-141, "Cylinder Head"](#).

- Be sure to ream in circles concentric to valve guide center. This will enable valve to fit correctly.

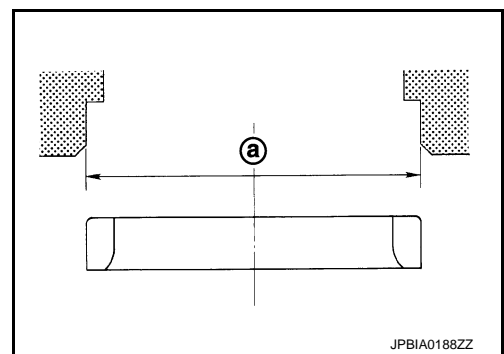

- b. Heat cylinder head to 110 to 130°C (230 to 266°F) by soaking in heated oil (A).

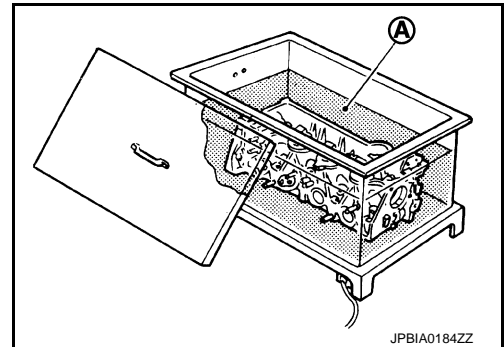

- c. Provide valve seats (EXH) cooled well with dry ice. Force fit valve seat (EXH) into cylinder head.

WARNING:

Cylinder head contains heat. When working, wear protective equipment to avoid getting burned.

CAUTION:

Avoid directly touching cold valve seats.

- d. Using the valve seat cutter set (commercial service tool) or valve seat grinder, finish seat to the specified dimensions. Refer to [EM-141, "Cylinder Head"](#).

CAUTION:

When using the valve seat cutter, firmly grip cutter handle with both hands. Then, press on the contacting surface all around the circumference to cut in a single drive. Improper pressure on cutter or cutting many different times may result in staged valve seat.

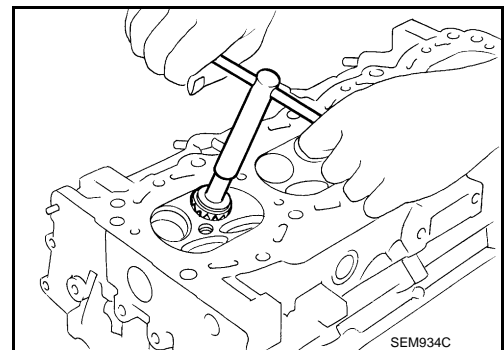

- e. Using compound, grind to adjust valve fitting.
f. Check again for normal contact. Refer to "VALVE SEAT CONTACT".
3. Install new valve oil seals as follows.

- a. Apply new engine oil on new valve oil seal joint and seal lip.
b. Using the valve oil seal drift [SST: KV10115600 (J-38958)] (A), press fit valve seal to height (b) shown in figure.

NOTE:

Dimension: Height measured before valve spring seat installation

Height (b) : 14.3 - 14.9 mm (0.563 - 0.587 in)

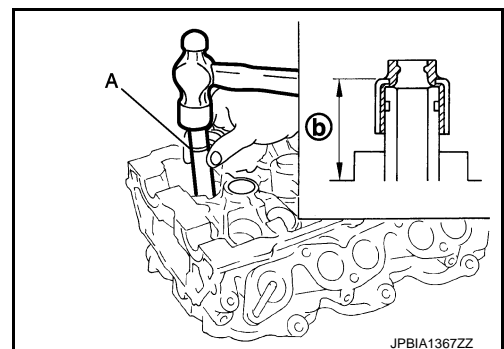

4. Install valve spring seat.

CYLINDER HEAD

< UNIT DISASSEMBLY AND ASSEMBLY >

5. Install valve.

NOTE:

Larger diameter valves are for intake side.

6. Install new cylinder head gaskets.
 7. Turn crankshaft until No. 1 piston is set at TDC.
 • Crankshaft key should line up with the cylinder center line (bank 1) as shown in the figure.

1 : Crankshaft key

↔ : Bank 1 side

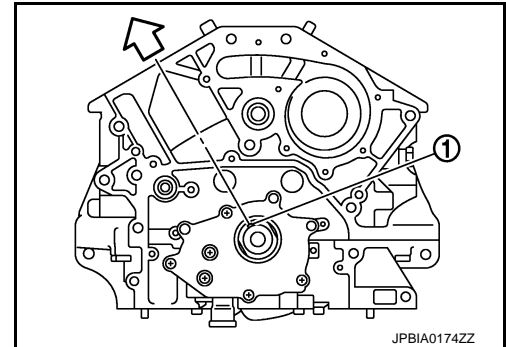

8. Install cylinder head, and tighten cylinder head bolts in numerical order as shown in figure as follows:

A : Bank 1

B : Bank 2

↔ : Engine front

- Use the cylinder head bolt wrench [commercial service tool: — (J-24239-01)] and power tool.

CAUTION:

- If cylinder head bolts are reused, check their outer diameters before installation. Refer to [EM-107, "Inspection"](#).
 • Before installing cylinder head, inspect cylinder head distortion. Refer to [EM-107, "Inspection"](#).

- a. Apply new engine oil to threads and seat surfaces of cylinder head bolts.
 b. Tighten all cylinder head bolts.

: 105 N·m (11 kg·m, 77 ft·lb)

- c. Completely loosen all cylinder head bolts.

: 0 N·m (0 kg·m, 0 ft·lb)

CAUTION:

In step "c", loosen bolts in the reverse order of that indicated in the figure.

- d. Tighten all cylinder head bolts.

: 40.0 N·m (4.1 kg·m, 30 ft·lb)

- e. Turn all cylinder head bolts 95 degrees clockwise (angle tightening).

CAUTION:

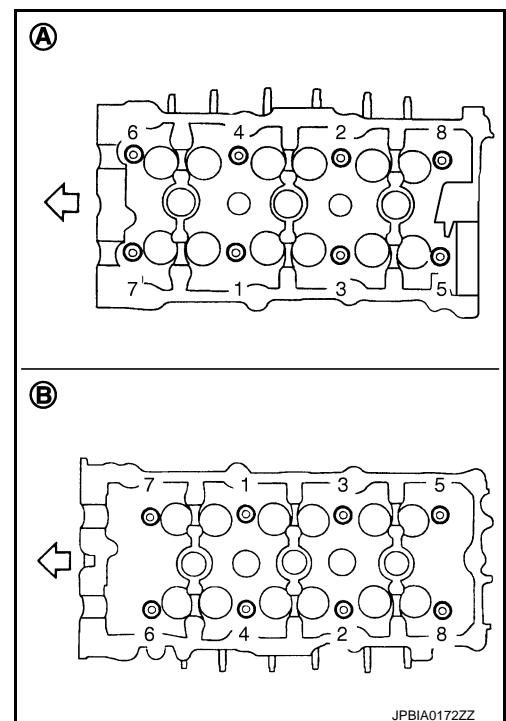

CYLINDER HEAD

< UNIT DISASSEMBLY AND ASSEMBLY >

Check the tightening angle using the angle wrench [SST: KV10112100 (BT8653-A)] (A). Never make judgment by visual inspection.

- Check tightening angle indicated on the angle wrench indicator plate.
- f. Turn all cylinder head bolts 95 degrees clockwise again (angle tightening).

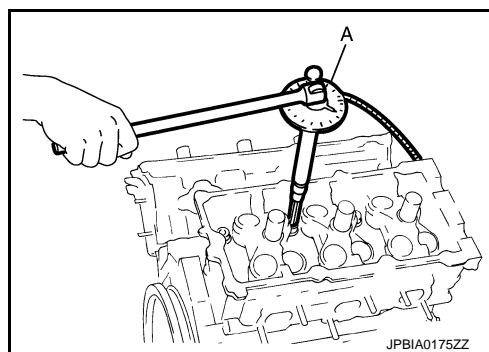

9. After installing cylinder head, measure distance between front end faces of cylinder block and cylinder head (bank 1 and bank 2).

Standard : 14.1 - 14.9 mm (0.555 - 0.587 in)

- If measured value is out of the standard, reinstall cylinder head.

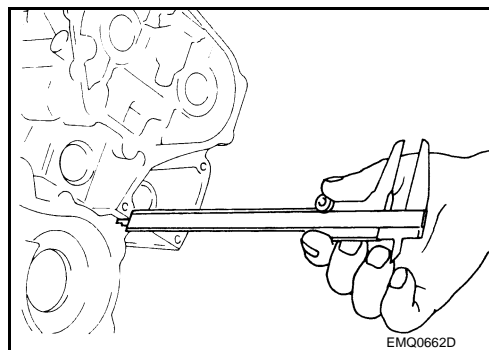

10. Install valve spring (uneven pitch type).

- Install narrow pitch (B) end [paint mark (C)] to cylinder head side (valve spring seat side).

A : Wide pitch

⇐ : Cylinder head side

Paint mark color

Intake : Purple

Exhaust : Yellowish green

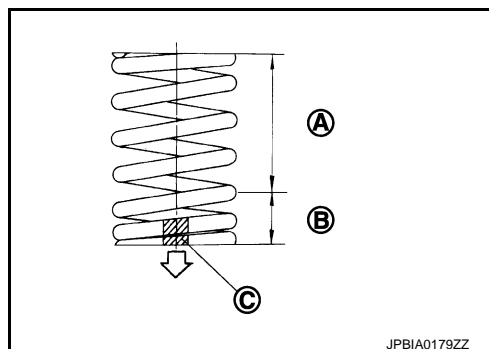

11. Install valve spring retainer.

12. Install valve collet.

- Compress valve spring with the valve spring compressor [SST: KV10116200 (J-26336-A)] (A), the attachment [SST: KV10115900 (J-26336-20)] (C) and the adapter [SST: KV10109220 (—)] (B). Install valve collet with a magnet hand.

CAUTION:

When working, take care not to damage valve lifter holes.

- Tap valve stem edge lightly with plastic hammer after installation to check its installed condition.

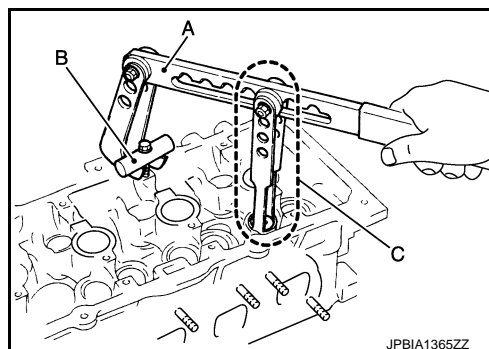

13. Install valve lifter.

- Install it in the original position.

14. Install spark plug with spark plug wrench (commercial service tool).

15. Install in the reverse order of removal after this step.

Inspection

INFOID:000000008154471

INSPECTION AFTER DISASSEMBLY

CYLINDER HEAD

< UNIT DISASSEMBLY AND ASSEMBLY >

Cylinder Head Bolts Outer Diameter

- Cylinder head bolts are tightened by plastic zone tightening method. Whenever the size difference between (B) and (A) exceeds the limit, replace them with new one.

c : 48 mm (1.89 in)

d : 11 mm (0.43 in)

Limit [(B) - (A)] : 0.18 mm (0.0071 in)

- If reduction of outer diameter appears in a position other than (A), use it as (A) point.

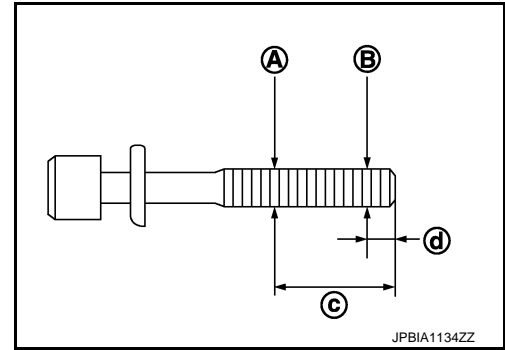

Cylinder Head Distortion

NOTE:

When performing this inspection, cylinder block distortion should be also checked. Refer to [EM-121, "Inspection"](#).

1. Using a scraper, wipe off oil, scale, gasket, sealant and carbon deposits from surface of cylinder head.

CAUTION:

Never allow gasket fragments to enter engine oil or engine coolant passages.

2. At each of several locations on bottom surface of cylinder head, measure the distortion in six directions (A), (B), (C), (D), (E), and (F).

Limit : Refer to [EM-141, "Cylinder Head"](#).

- If it exceeds the limit, replace VVEL ladder assembly and cylinder head assembly.

NOTE:

Cylinder head assembly cannot be replaced as a single part, because it is machined together with VVEL ladder assembly.

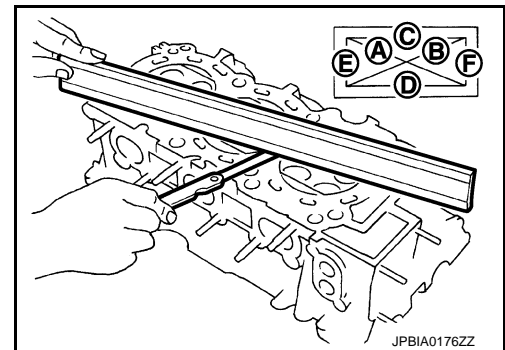

Valve Dimensions

- Check the dimensions of each valve. For the dimensions, refer to [EM-141, "Cylinder Head"](#).
- If dimensions are out of the standard.
 - Replace valve (EXH) and check valve seat contact. Refer to "VALVE SEAT CONTACT". (Exhaust side)
 - Replace VVEL ladder assembly and cylinder head assembly. Refer to [EM-84, "Exploded View"](#). (Intake side)

NOTE:

Since the valve (INT) cannot be replaced by the piece, VVEL ladder assembly and cylinder head assembly replacement are required.

Valve Guide Clearance

Valve Stem Diameter

- Measure the diameter of valve stem with micrometer (A).

Standard : Refer to [EM-141, "Cylinder Head"](#).

Valve Guide Inner Diameter

- Measure the inner diameter of valve guide with bore gauge.

Standard : Refer to [EM-141, "Cylinder Head"](#).

Valve Guide Clearance

- (Valve guide clearance) = (Valve guide inner diameter) – (Valve stem diameter)

Standard : Refer to [EM-141, "Cylinder Head"](#).

- If the calculated value exceeds the limit.
 - Replace valve (EXH) and/or valve guide (EXH). Refer to [EM-101, "Exploded View"](#). (Exhaust side)
 - Replace VVEL ladder assembly and cylinder head assembly. Refer to [EM-84, "Exploded View"](#). (Intake side)

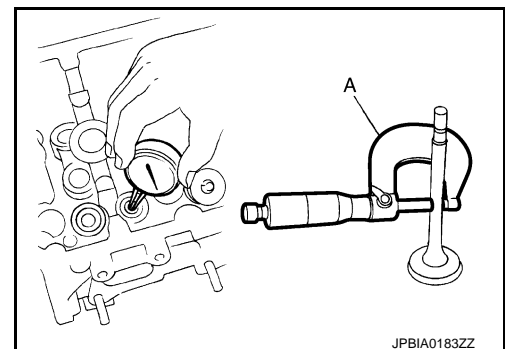

CYLINDER HEAD

< UNIT DISASSEMBLY AND ASSEMBLY >

NOTE:

Since the valve (INT) and valve guide (INT) cannot be replaced by the piece, VVEL ladder assembly and cylinder head assembly replacement are required.

Valve Seat Contact

- After confirming that the dimensions of valve guides and valves are within the specifications, perform this procedure.
- Apply prussian blue (or white lead) onto contacting surface of valve seat to check the condition of the valve contact on the surface.
- Check if the contact area band is continuous all around the circumference.

A : OK
B : NG

- If not, grind to adjust valve fitting and check again. If the contacting surface still has "NG" conditions even after the recheck, replace valve seat (EXH). Refer to [EM-101, "Exploded View"](#). (Exhaust side)
- If not, replace VVEL ladder assembly and cylinder head assembly. Refer to [EM-84, "Exploded View"](#). (Intake side)

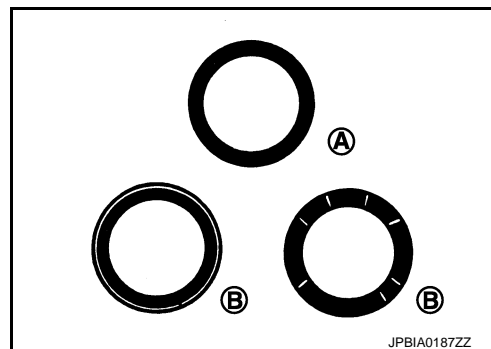

NOTE:

Since the valve seat (INT) cannot be replaced by the piece, VVEL ladder assembly and cylinder head assembly replacement are required.

Valve Spring Squareness

- Set a try square (A) along the side of valve spring and rotate spring. Measure the maximum clearance between the top of spring and try square.

B : Contact

Limit : Refer to [EM-141, "Cylinder Head"](#).

- If it exceeds the limit.
- Replace valve spring (EXH). Refer to [EM-101, "Exploded View"](#). (Exhaust side)
- Replace VVEL ladder assembly and cylinder head assembly. Refer to [EM-84, "Exploded View"](#). (Intake side)

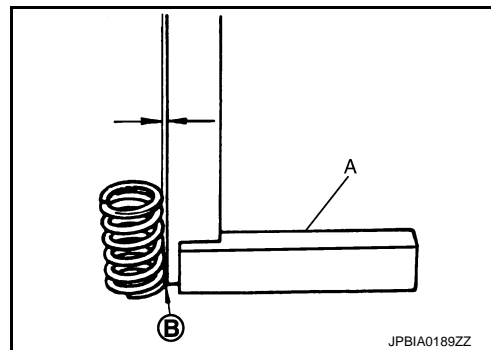

NOTE:

Since the valve spring (INT) cannot be replaced by the piece, VVEL ladder assembly and cylinder head assembly replacement are required.

Valve Spring Dimensions and Valve Spring Pressure Load

- Check the valve spring pressure at specified spring height.

Standard

: Refer to [EM-141, "Cylinder Head"](#).

- If the installation load or load with valve open is out of the standard.
- Replace valve spring (EXH). Refer to [EM-101, "Exploded View"](#). (Exhaust side)
- Replace VVEL ladder assembly and cylinder head assembly. Refer to [EM-84, "Exploded View"](#). (Intake side)

NOTE:

Since the valve spring (INT) cannot be replaced by the piece, VVEL ladder assembly and cylinder head assembly replacement are required.

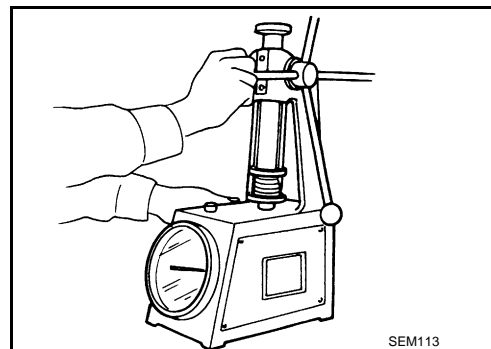

INSPECTION AFTER INSTALLATION

Inspection for Leakage

The following are procedures for checking fluid leakage, lubricant leakage.

CYLINDER HEAD

< UNIT DISASSEMBLY AND ASSEMBLY >

- Before starting engine, check oil/fluid levels including engine coolant and engine oil. If any are less than the required quantity, fill them to the specified level. Refer to [MA-10, "Fluids and Lubricants"](#).
- Follow the procedure below to check for fuel leakage.
 - Turn ignition switch to the "ON" position (with engine stopped). With fuel pressure applied to fuel piping, check for fuel leakage at connection points.
 - Start engine. With engine speed increased, check again for fuel leakage at connection points.
- Run engine to check for unusual noise and vibration.

NOTE:

If hydraulic pressure inside chain tensioner drops after removal/installation, slack in guide may generate a pounding noise during and just after the engine start. However, this does not indicate a malfunction. The noise will stop after hydraulic pressure rises.

- Warm up engine thoroughly to check that there is no leakage of fuel, or any oil/fluids including engine oil and engine coolant.
- Bleed air from lines and hoses of applicable lines, such as in cooling system.
- After cooling down engine, again check oil/fluid levels including engine oil and engine coolant. Refill them to the specified level, if necessary.

Summary of the inspection items:

Items		Before starting engine	Engine running	After engine stopped
Engine coolant		Level	Leakage	Level
Engine oil		Level	Leakage	Level
Transmission / transaxle fluid	AT & CVT Models	Leakage	Level / Leakage	Leakage
	MT Models	Level / Leakage	Leakage	Level / Leakage
Other oils and fluids*		Level	Leakage	Level
Fuel		Leakage	Leakage	Leakage

* Power steering fluid, brake fluid, etc.

CYLINDER BLOCK

< UNIT DISASSEMBLY AND ASSEMBLY >

CYLINDER BLOCK

Exploded View

INFOID:000000008154472

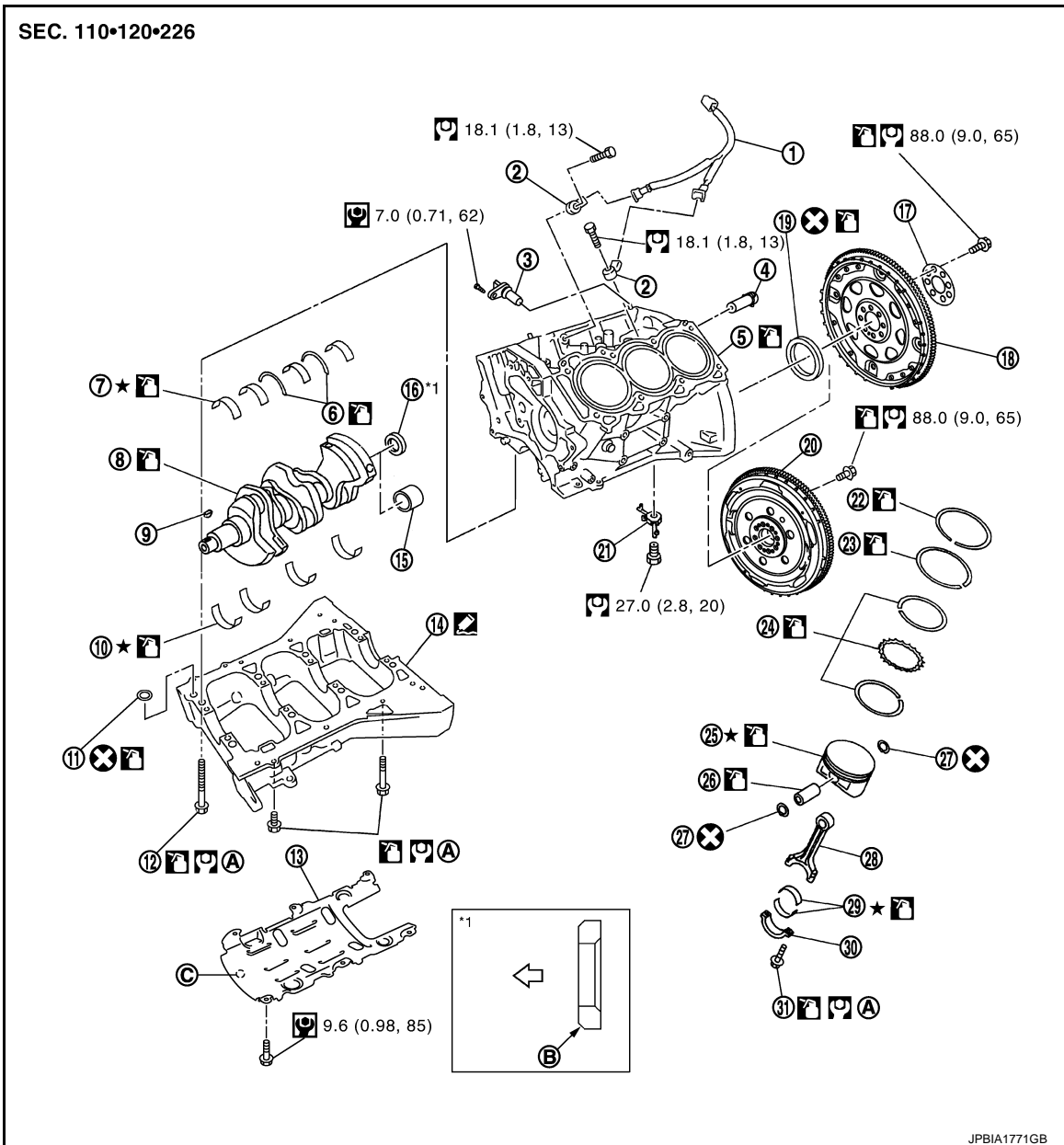

- | | | |
|---------------------------------------|--------------------------------------|--------------------------------|
| 1. Sub harness | 2. Knock sensor | 3. Crankshaft position sensor |
| 4. Cylinder block heater (for Canada) | 5. Cylinder block | 6. Thrust bearing |
| 7. Main bearing (upper) | 8. Crankshaft | 9. Crankshaft key |
| 10. Main bearing (lower) | 11. O-ring | 12. Lower cylinder block bolt |
| 13. Baffle plate | 14. Lower cylinder block | 15. Pilot bush (M/T models) |
| 16. Pilot converter (A/T models) | 17. Reinforcement plate (A/T models) | 18. Drive plate (A/T models) |
| 19. Rear oil seal | 20. Flywheel (M/T models) | 21. Oil jet |
| 22. Top ring | 23. Second ring | 24. Oil ring |
| 25. Piston | 26. Piston pin | 27. Snap ring |
| 28. Connecting rod | 29. Connecting rod bearing | 30. Connecting rod bearing cap |
| 31. Connecting rod bolt | | |

CYLINDER BLOCK

< UNIT DISASSEMBLY AND ASSEMBLY >

- Comply with the installation procedure when tightening. Refer to [EM-112](#)
- A. Chamfered B. Front mark C. Front mark

↩ : Crankshaft side

Refer to [GI-4, "Components"](#) for symbols in the figure.

Disassembly and Assembly

INFOID:000000008154473

DISASSEMBLY

- Remove the following parts:
 - Oil pans (upper and lower): Refer to [EM-43, "Exploded View"](#) and [EM-76, "Exploded View"](#).
 - Front and rear timing chain case: Refer to [EM-49, "Exploded View"](#) and [EM-79, "Exploded View"](#).
 - Cylinder head: Refer to [EM-101, "Exploded View"](#).
- Remove knock sensor.
CAUTION:
Carefully handle sensor avoiding shocks.
- Remove baffle plate from lower cylinder block.
- Remove piston and connecting rod assembly with the following procedure:
 - Before removing piston and connecting rod assembly, check the connecting rod side clearance. Refer to [EM-121, "Inspection"](#).

CAUTION:

Be careful not to drop connecting rod bearing, and to scratch the surface.

- Position crankshaft pin corresponding to connecting rod to be removed onto the bottom dead center.
- Remove connecting rod bearing cap.
- Using a hammer handle or similar tool, push piston and connecting rod assembly out to the cylinder head side.

CAUTION:

Be careful not to damage the cylinder wall and crankshaft pin, resulting from an interference of the connecting rod big end.

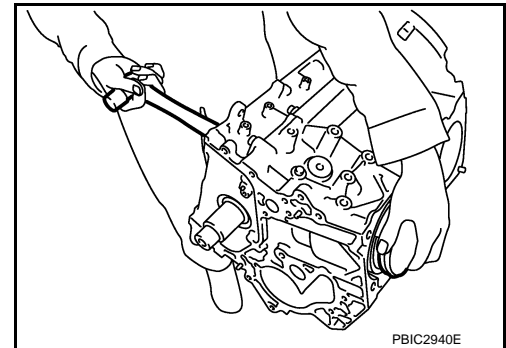

- Remove connecting rod bearings from connecting rod and connecting rod bearing cap.
CAUTION:
 - Be careful not to drop connecting rod bearing, and to scratch the surface.
 - Identify installation positions, and store them without mixing them up.
- Remove piston rings from piston.
 - Before removing piston rings, check the piston ring side clearance. Refer to [EM-121, "Inspection"](#).
 - Use a piston ring expander (commercial service tool) (A).

CAUTION:

- When removing piston rings, be careful not to damage piston.
- Be careful not to damage piston rings by expanding them excessively.

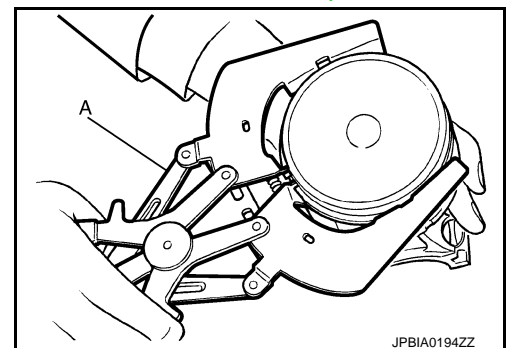

- Remove piston from connecting rod as follows:

CYLINDER BLOCK

< UNIT DISASSEMBLY AND ASSEMBLY >

- a. Using snap ring pliers (A), remove snap rings.

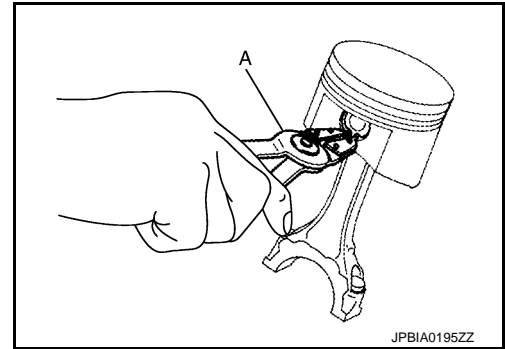

- b. Heat piston to 60 to 70°C (140 to 158°F) with an industrial use dryer (A) or equivalent.

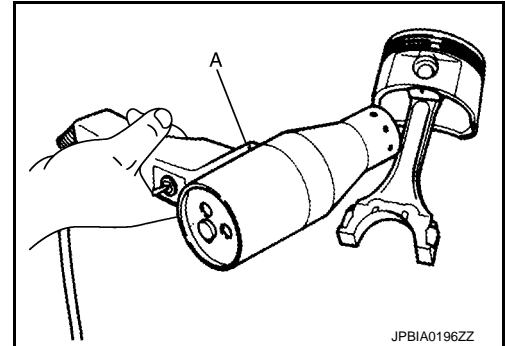

- c. Push out piston pin using a stick that has an outer diameter of approximately 20 mm (0.79 in).

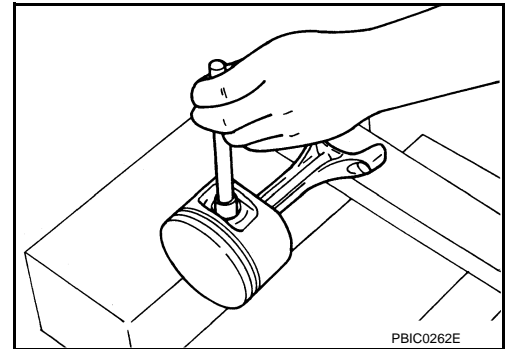

8. Remove lower cylinder block bolts.
- Before loosening lower cylinder block bolts, measure the crankshaft end play. Refer to [EM-121. "Inspection"](#).
 - Loosen lower cylinder block bolts in the reverse order shown in the figure in several different steps.

← : Engine front

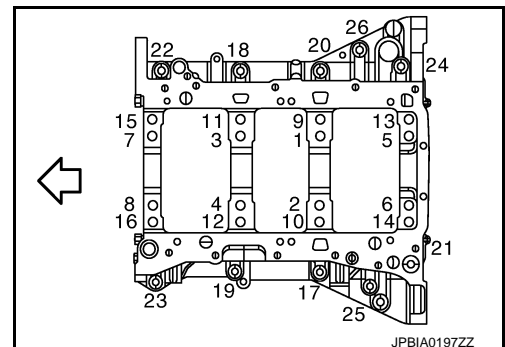

9. Remove lower cylinder block as follows:

A
EM
C
D
E
F
G
H
I
J
K
L
M
N
O
P

CYLINDER BLOCK

< UNIT DISASSEMBLY AND ASSEMBLY >

Screw M8 bolt [pitch: 1.25 mm (0.049 in) length: approximately 50 mm (1.97 in)] into bolt holes (A). Then equally tighten each bolt, and remove lower cylinder block.

⇐ : Engine front

CAUTION:

- Be careful not to damage the mounting surfaces.
- Never tighten bolts excessively.
- Never insert screwdriver, this will damage the mating surface.

10. Remove crankshaft.

11. Pull rear oil seal out from rear end of crankshaft.

12. Remove main bearings and thrust bearings from cylinder block and lower cylinder block.

CAUTION:

- Be careful not to drop main bearing, and to scratch the surface.
- Identify installation positions, and store them without mixing them up.

13. Remove oil jet.

ASSEMBLY

CAUTION:

Do not reuse O-rings or washers.

1. Fully air-blow engine coolant and engine oil passages in cylinder block, cylinder bore and crankcase to remove any foreign material.

CAUTION:

Use goggles to protect your eyes.

2. Install each plug to cylinder block as shown in the figure.

3 : Plug

⇐ : Engine front

- Apply sealant to the thread of water drain plug (1).
Use Genuine RTV Silicone Sealant or equivalent. Refer to [GI-22, "Recommended Chemical Products and Sealants"](#).
- Apply sealant to the thread of plug (4).
Use Genuine High Strength Thread Locking Sealant or equivalent. Refer to [GI-22, "Recommended Chemical Products and Sealants"](#).
- Replace washers (2) with new ones.

CAUTION:

Do not reuse washers.

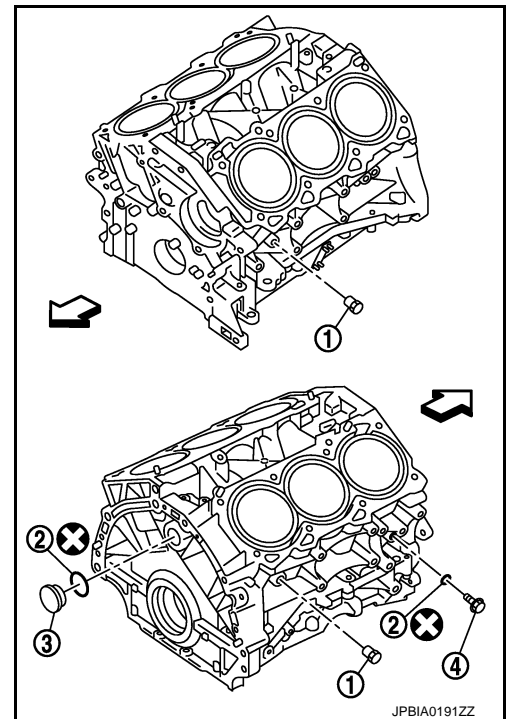
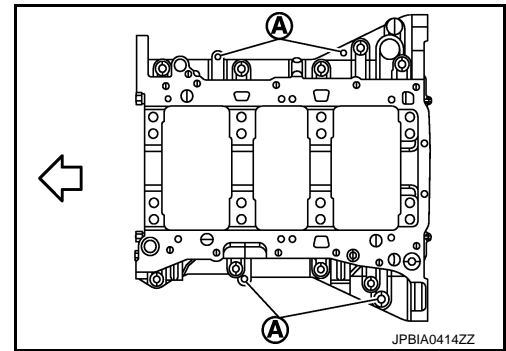

- Tighten each plug as specified below.

Unit: N·m (kg·m, ft·lb)

Part	Washer	Tightening torque
1	No	19.6 (2.0, 14)
3	Yes	78.0 (8.0, 58)
4	Yes	12.3 (1.3, 9)

3. Install oil jet.

CYLINDER BLOCK

< UNIT DISASSEMBLY AND ASSEMBLY >

- Insert oil jet dowel pin (A) into cylinder block dowel pin hole, and tighten mounting bolts.

↶ : Engine front

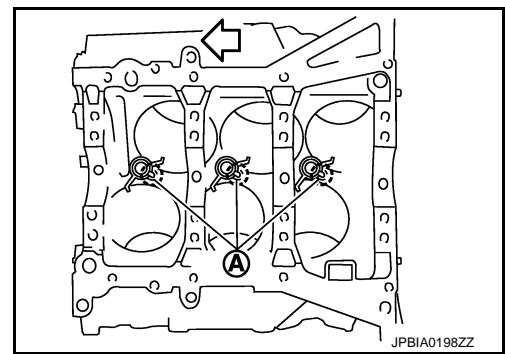

4. Install main bearings and thrust bearings as follows:

CAUTION:

Be careful not to drop main bearing, and to scratch the surface.

- a. Remove dust, dirt, and engine oil on bearing mating surfaces of cylinder block and lower cylinder block.
- b. Install thrust bearings (1) to both sides of the No. 3 journal housing on cylinder block.

- A : No. 1
- B : No. 2
- C : No. 3
- D : No. 4
- F : Thrust bearing installation position
- ↶ : Engine front

- Install thrust bearings with the oil groove (E) facing crankshaft arm (outside).

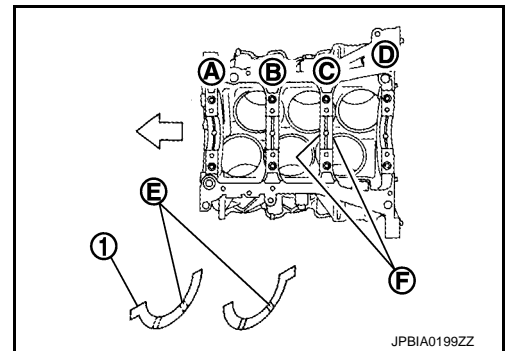

- c. Install main bearings paying attention to the direction.

- A : Cylinder block side
- D : Lower cylinder block side
- ↶ : Engine front

- Main bearing with oil hole (B) and groove (C) goes on cylinder block. The one without them goes on lower cylinder block.
- Before installing main bearings, apply engine oil to the bearing surface (inside). Do not apply engine oil to the back surface, but thoroughly clean it.
- When installing, align main bearing stopper protrusion to cut-out of cylinder block and lower cylinder block.
- Ensure the oil holes on cylinder block and those on the corresponding bearing are aligned.

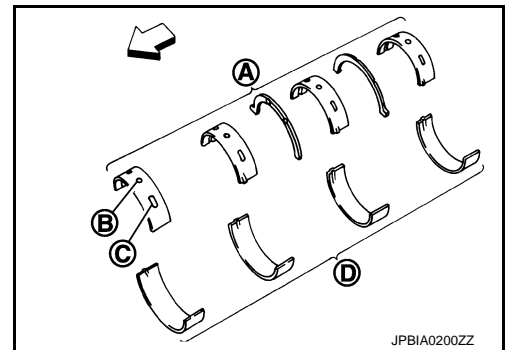

5. Install crankshaft to cylinder block.
 - While turning crankshaft by hand, check that it turns smoothly.
6. Install lower cylinder block.

CAUTION:

Do not reuse O-rings.

NOTE:

Lower cylinder block cannot be replaced as a single part, because it is machined together with cylinder block.

A
EM
C
D
E
F
G
H
I
J
K
L
M
N
O
P

CYLINDER BLOCK

< UNIT DISASSEMBLY AND ASSEMBLY >

- Apply a continuous bead of liquid gasket with the tube presser (commercial service tool) to lower cylinder block as shown in the figure.

B : Apply to end

a : $\phi 4.0 - 5.0$ mm (0.157 - 0.197 in)

Use Genuine RTV Silicone Sealant or equivalent. Refer to [GI-22, "Recommended Chemical Products and Sealants"](#).

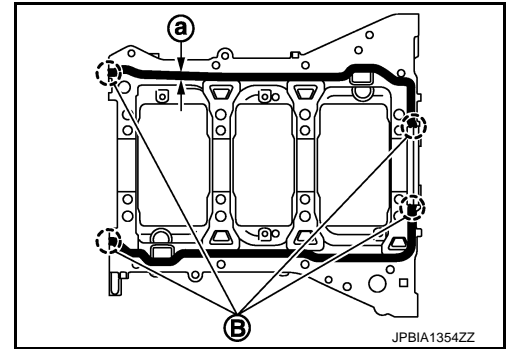

- Inspect the outer diameter of lower cylinder block bolt. Refer to [EM-121, "Inspection"](#).
- Install lower cylinder block bolts in numerical order as shown in the figure as follows:

CAUTION:

Do not reuse O-ring.

- Apply new engine oil to threads and seat surfaces of lower cylinder block bolts.
- Tighten bolts (No. 17 to 26) in numerical order as shown in the figure.

↩ : Engine front

: **25.0 N·m (2.6 kg·m, 18 ft·lb)**

- Repeat step b.

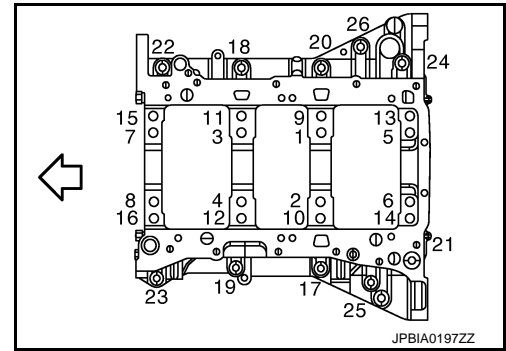

- Tighten bolts (No. 1 to 16) in numerical order as shown in the figure.

↩ : Engine front

NOTE:

Use TORX socket for bolts No. 1 to 16.

: **35.3 N·m (3.6 kg·m, 26 ft·lb)**

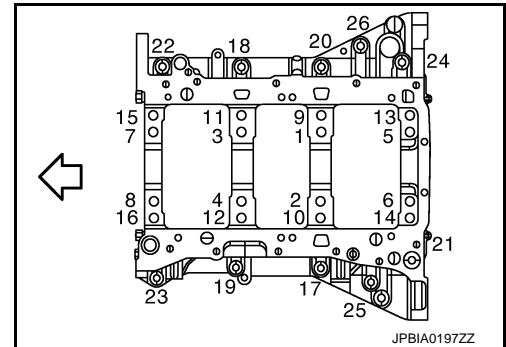

- Turn bolts (No. 1 to 16) 90 degrees clockwise (angle tightening).

CAUTION:

Use the angle wrench [SST: KV10112100 (BT8653-A)] (A) to check tightening angle. Never make judgment by visual inspection.

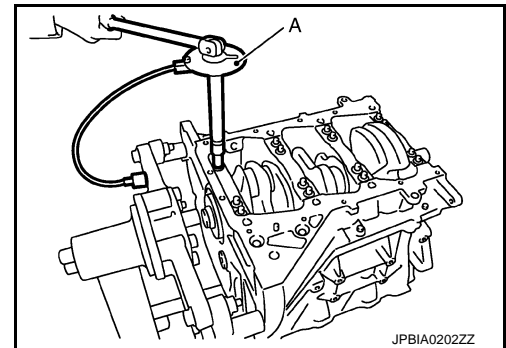

- After installing lower cylinder block bolts, check that crankshaft can be rotated smoothly by hand.
- Check the crankshaft end play. Refer to [EM-121, "Inspection"](#).

- Install piston to connecting rod as follows:

CYLINDER BLOCK

< UNIT DISASSEMBLY AND ASSEMBLY >

- a. Using snap ring pliers, install new snap ring to the groove of piston rear side.
 - Insert it fully into groove to install.
- b. Install piston to connecting rod.
 - Using an industrial use dryer or similar tool, heat piston until piston pin can be pushed in by hand without excess force [approximately 60 to 70°C (140 to 158°F)]. From the front to the rear, insert piston pin into piston and connecting rod.
 - Assemble so that the front mark on the piston head and the cylinder number on connecting rod are positioned as shown in the figure.

- A : Example RH
- B : Piston grade number
- C : Front mark
- D : Pin grade number
- E : Cylinder number
- F : Front mark
- ↶ : Engine front

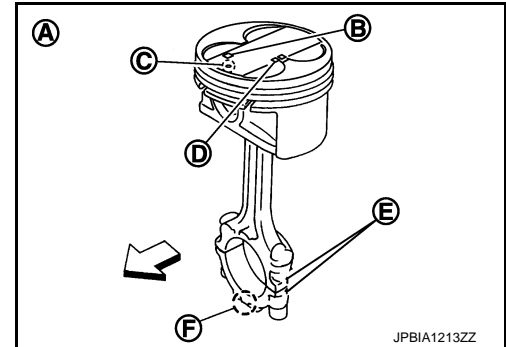

- c. Install new snap ring to the groove of the piston front side.
 - Insert it fully into groove to install.
 - After installing, check that connecting rod moves smoothly.

10. Using a piston ring expander (commercial service tool) (A), install piston rings.

CAUTION:

- When installing piston rings, be careful not to damage piston.
- Be careful not to damage piston rings by expanding them excessively.

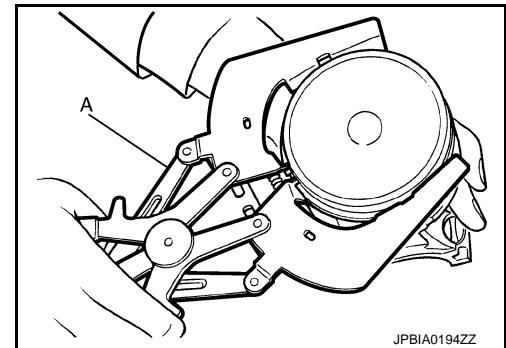

- If there is stamped mark on ring, mount it with marked side up.

Stamped mark:

- Top ring (A) : 1 N**
- Second ring (B) : 2 N**

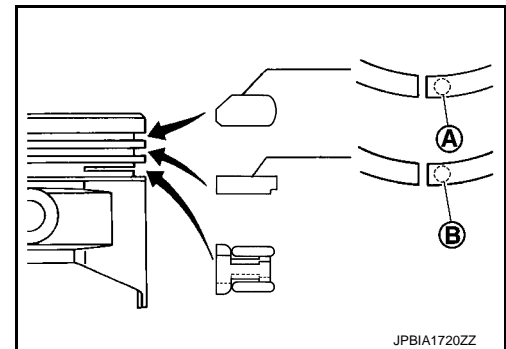

- Position each ring with the gap as shown in the figure referring to the piston front mark (D).

- C : Top ring gap
- E : Oil ring upper or lower rail gap (either of them)
- F : Second ring and oil ring spacer gap
- a : 90 degrees
- b : 45 degrees

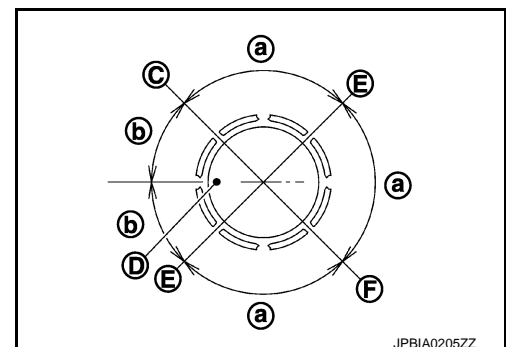

CYLINDER BLOCK

< UNIT DISASSEMBLY AND ASSEMBLY >

- Check the piston ring side clearance. Refer to [EM-121, "Inspection"](#).

11. Install connecting rod bearings to connecting rod and connecting rod bearing cap.

CAUTION:

Be careful not to drop connecting rod bearing, and to scratch the surface.

- Before installing connecting rod bearings, apply engine oil to the bearing surface (inside). Do not apply engine oil to the back surface, but thoroughly clean it.
- When installing, align connecting rod bearing stopper protrusion (B) with cutout (C) of connecting rods and connecting rod bearing caps to install.
- Ensure the oil hole (A) on connecting rod and that on the corresponding bearing are aligned.

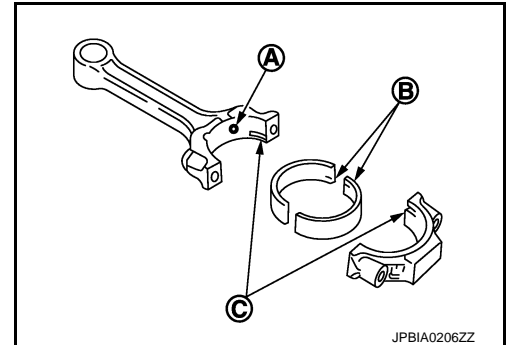

12. Install piston and connecting rod assembly to crankshaft.

- Position crankshaft pin corresponding to connecting rod to be installed onto the bottom dead center.
- Apply engine oil sufficiently to the cylinder bore, piston and crankshaft pin journal.
- Match the cylinder position with the cylinder number on connecting rod to install.
- Be sure that front mark on piston crown is facing the front of the engine.
- Using a piston ring compressor [SST: EM03470000 (J-8037)] (A) or suitable tool, install piston with the front mark on the piston crown facing the front of the engine.

CAUTION:

Be careful not to damage the cylinder wall and crankshaft pin, resulting from an interference of the connecting rod big end.

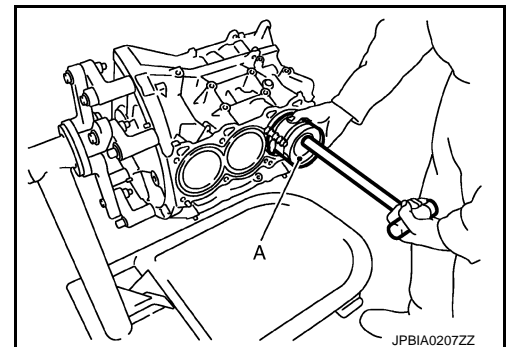

13. Install connecting rod bearing cap.

- Match the stamped cylinder number marks on connecting rod with those on connecting rod bearing cap to install.

- A : Sample codes
- B : Bearing stopper groove
- C : Small-end diameter grade
- D : Big-end diameter grade
- E : Weight grade
- F : Cylinder No.
- G : Management code
- I : Management code

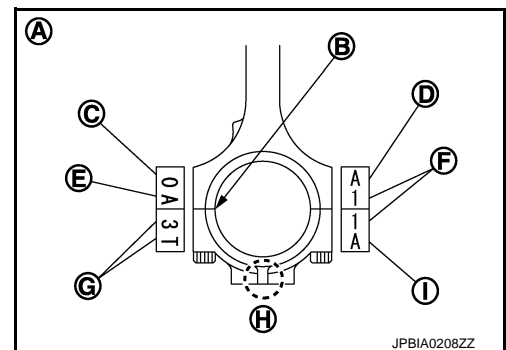

- Be sure that front mark (H) on connecting rod bearing cap is facing the front of the engine.

14. Tighten connecting rod bolt as follows:

- Inspect the outer diameter of connecting rod bolt. Refer to [EM-121, "Inspection"](#).
- Apply engine oil to the threads and seats of connecting rod bolts.
- Tighten connecting rod bolts.

: 28.4 N·m (2.9 kg·m, 21 ft·lb)

- Completely loosen connecting rod bolts.

CYLINDER BLOCK

< UNIT DISASSEMBLY AND ASSEMBLY >

: **0 N·m (0 kg-m, 0 ft-lb)**

e. Tighten connecting rod bolts.

: **24.5 N·m (2.5 kg-m, 18 ft-lb)**

f. Then turn connecting rod bolts 90 degrees clockwise (angle tightening).

CAUTION:

Always use the angle wrench [SST: KV10112100 (BT8653-A)] (A). Never make judgment by visual inspection.

- After tightening connecting rod bolts, check that crankshaft rotates smoothly.
- Check the connecting rod side clearance. Refer to [EM-121, "Inspection"](#).

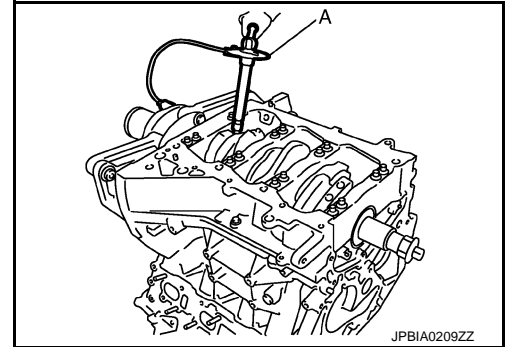

15. Install baffle plate.

16. Install new rear oil seal. Refer to [EM-66, "REAR OIL SEAL : Removal and Installation"](#).

- Apply new engine oil to both oil seal lip and dust seal lip.

17. Install pilot converter (A/T models) or pilot bushing (M/T models).

- With a drift of the following outer diameter, press-fit as far as it will go.

Pilot bushing : Approximately. 17 mm (0.67 in)

Pilot converter : Approximately. 33 mm (1.30 in)

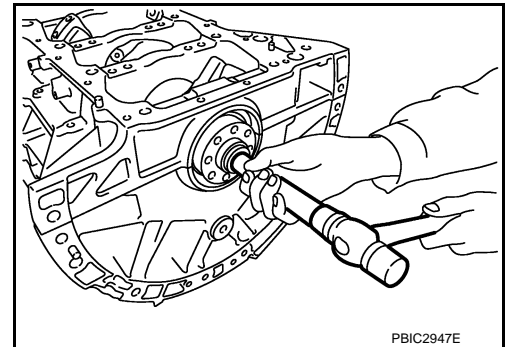

- Press-fit pilot converter with its chamfer facing crankshaft as shown in the figure. (A/T models)

 : Crankshaft side

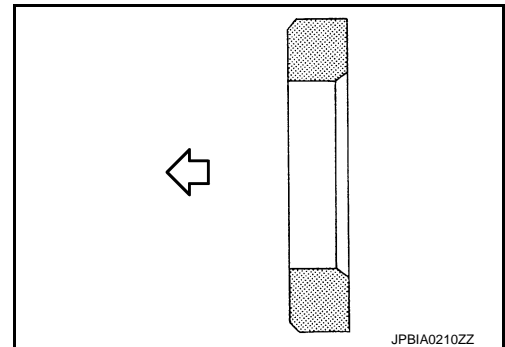

CYLINDER BLOCK

< UNIT DISASSEMBLY AND ASSEMBLY >

- Press-fit pilot bushing (1) as the dimension shown in the figure. (M/T models)

- A** : Crankshaft (rear end surface)
b : 10.20 – 10.85 mm (0.402 – 0.427 in)
[Target: 10.20 mm (0.402 in)]

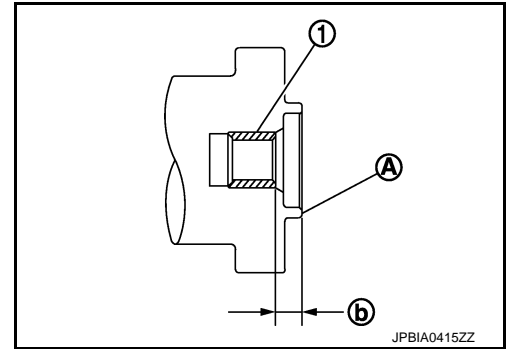

18. Install knock sensors.

- A : Bank 1
B : Bank 2
⇐ : Engine front

- Install knock sensor so that connector faces the rear of the engine.
- After installing knock sensor, connect harness connector, and lay it out to rear of the engine.

CAUTION:

- **Never tighten mounting bolts while holding connector.**
- **If any impact by dropping is applied to knock sensor, replace it with new one.**

NOTE:

- Check that there is no foreign material on the cylinder block mating surface and the back surface of knock sensor.
- Check that knock sensor does not interfere with other parts.

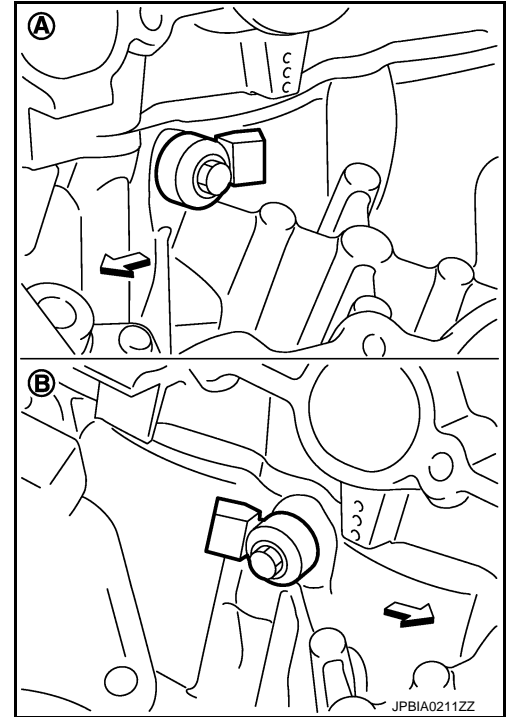

19. Note the following, assemble in the reverse order of disassembly after this step.

Flywheel (M/T models)

- Ensure the dowel pin (1) is installed in the crankshaft.

- 4 : Rear oil seal

- When installing flywheel (3) to crankshaft (2), be sure to correctly align crankshaft side dowel pin and flywheel side dowel pin hole (A).

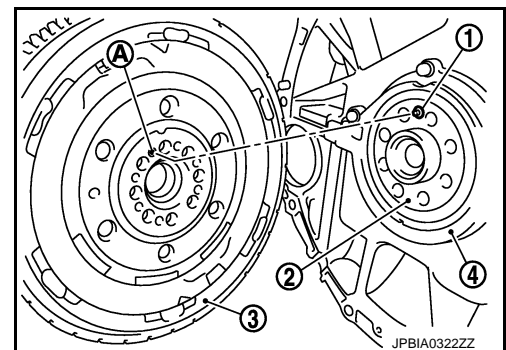

CYLINDER BLOCK

< UNIT DISASSEMBLY AND ASSEMBLY >

- There is a matching mark (B) on the clutch cover side of flywheel (4). Refer it during installation.

- 1 : Dowel pin
- 2 : Rear oil seal
- 3 : Crankshaft
- A : Hole

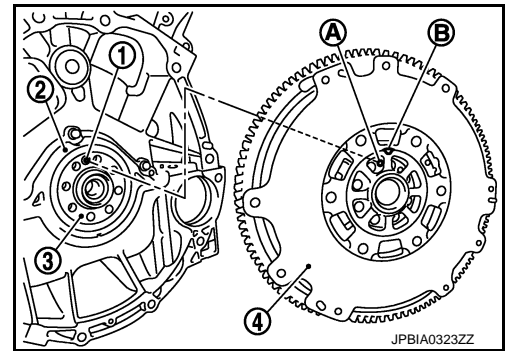

Drive plate (A/T models)

- When installing drive plate to crankshaft, be sure to correctly align crankshaft side dowel pin and drive plate side dowel pin hole.

CAUTION:

If these are not aligned correctly, engine runs roughly and "MIL" illuminates.

- Install drive plate (2) and reinforcement plate (3) as shown in the figure.

- 1 : Ring gear
- 4 : Pilot converter
- 5 : Crankshaft
- A : Rounded
- ⇐ : Engine front

- Holding ring gear with the ring gear stopper [SST: KV10118600 (J-48641)].
- Tighten the mounting bolts crosswise over several times.

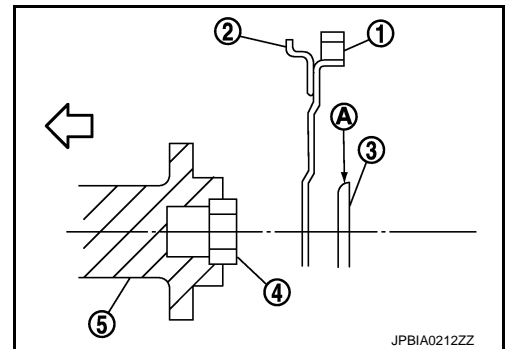

Inspection

INFOID:000000008154474

CRANKSHAFT END PLAY

- Measure the clearance between thrust bearings and crankshaft arm when crankshaft is moved fully forward or backward with a dial indicator.

Standard and limit : Refer to EM-143, "Cylinder Block".

- If the measured value exceeds the limit, replace thrust bearings, and measure again. If it still exceeds the limit, replace crankshaft also.

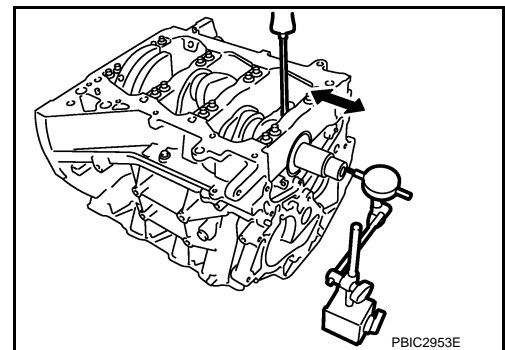

CONNECTING ROD SIDE CLEARANCE

- Measure the side clearance between connecting rod and crankshaft arm with a feeler gauge.

Standard and limit : Refer to EM-143, "Cylinder Block".

- If the measured value exceeds the limit, replace connecting rod, and measure again. If it still exceeds the limit, replace crankshaft also.

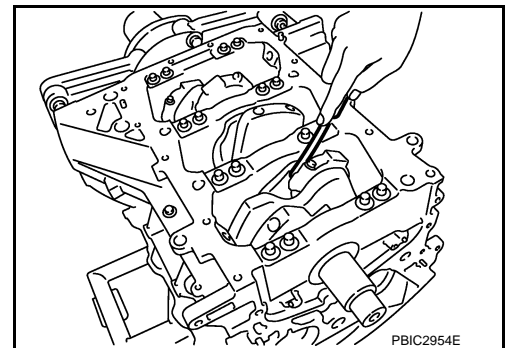

PISTON TO PISTON PIN OIL CLEARANCE

CYLINDER BLOCK

< UNIT DISASSEMBLY AND ASSEMBLY >

Piston Pin Hole Diameter

Measure the inner diameter of piston pin hole with an inside micrometer (A).

Standard : Refer to [EM-143, "Cylinder Block"](#).

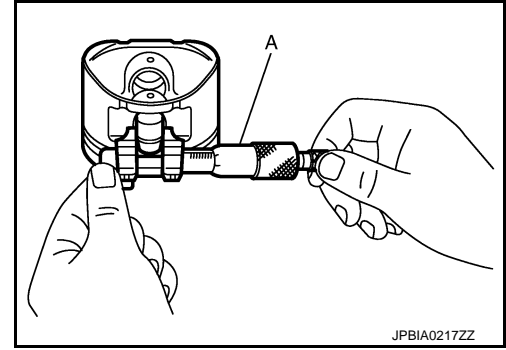

Piston Pin Outer Diameter

Measure the outer diameter of piston pin with a micrometer (A).

Standard : Refer to [EM-143, "Cylinder Block"](#).

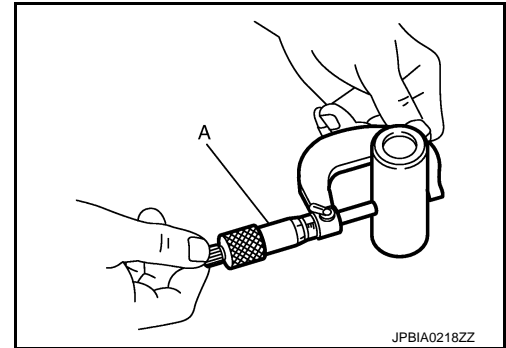

Piston to Piston Pin Oil Clearance

(Piston to piston pin oil clearance) = (Piston pin hole diameter) – (Piston pin outer diameter)

Standard : Refer to [EM-143, "Cylinder Block"](#).

- If the calculated value is out of the standard, replace piston and piston pin assembly.
- When replacing piston and piston pin assembly, refer to [EM-132, "Description"](#).

NOTE:

- Piston is available together with piston pin as assembly.
- Piston pin (piston pin hole) grade is provided only for the parts installed at the plant. For service parts, no piston pin grades can be selected. (Only "0" grade is available.)

PISTON RING SIDE CLEARANCE

- Measure the side clearance of piston ring (1) and piston ring groove with a feeler gauge (C).

A : NG

B : OK

Standard and limit : Refer to [EM-143, "Cylinder Block"](#).

- If the measured value exceeds the limit, replace piston ring, and measure again. If it still exceeds the limit, replace piston also.

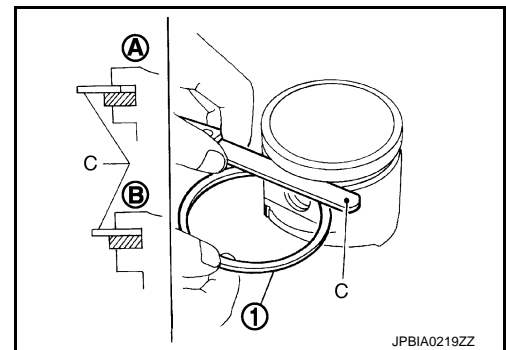

PISTON RING END GAP

- Check that the cylinder bore inner diameter is within the specification. Refer to [EM-112, "Disassembly and Assembly"](#).

CYLINDER BLOCK

< UNIT DISASSEMBLY AND ASSEMBLY >

- Lubricate with new engine oil to piston (1) and piston ring (2), and then insert piston ring until middle of cylinder with piston, and measure the piston ring end gap with a feeler gauge (B).

A : Press-fit
C : Measuring point

Standard and limit : Refer to [EM-143. "Cylinder Block"](#).

- If the measured value exceeds the limit, replace piston ring, and measure again. If it still exceeds the limit, rebore cylinder and use oversize piston and piston rings.

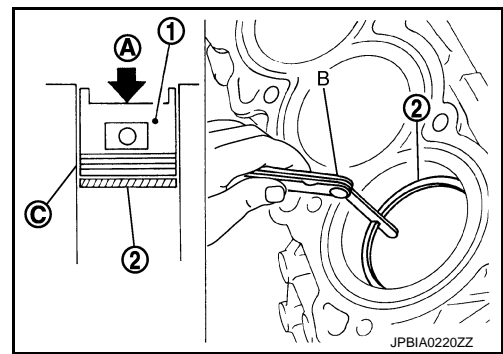

CONNECTING ROD BEND AND TORSION

- Check with a connecting rod aligner.

A : Bend
B : Torsion
C : Feeler gauge

Bend limit
Torsion limit : Refer to [EM-143. "Cylinder Block"](#).

- If it exceeds the limit, replace connecting rod assembly.

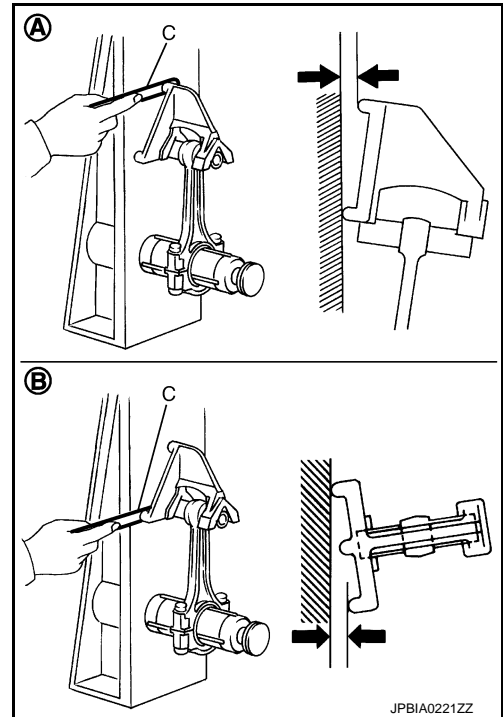

CONNECTING ROD BIG END DIAMETER

- Install connecting rod bearing cap without installing connecting rod bearing, and tighten connecting rod bolts to the specified torque. Refer to [EM-112. "Disassembly and Assembly"](#) for the tightening procedure.

1 : Connecting rod

- Measure the inner diameter of connecting rod big end with an inside micrometer.

Standard : Refer to [EM-143. "Cylinder Block"](#).

- If out of the standard, replace connecting rod assembly.

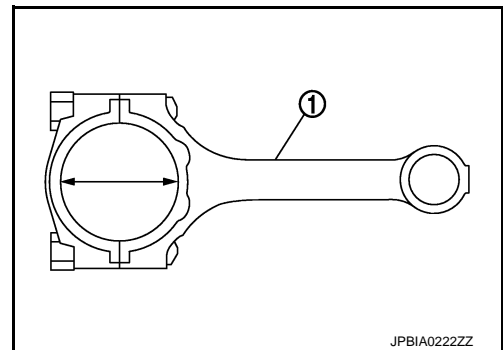

CONNECTING ROD BUSHING OIL CLEARANCE

Connecting Rod Bushing Inner Diameter

CYLINDER BLOCK

< UNIT DISASSEMBLY AND ASSEMBLY >

Measure the inner diameter of connecting rod bushing with an inside micrometer (A).

Standard : Refer to [EM-143, "Cylinder Block"](#).

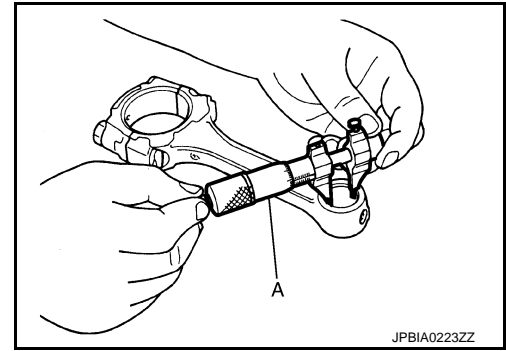

Piston Pin Outer Diameter

Measure the outer diameter of piston pin with a micrometer (A).

Standard : Refer to [EM-143, "Cylinder Block"](#).

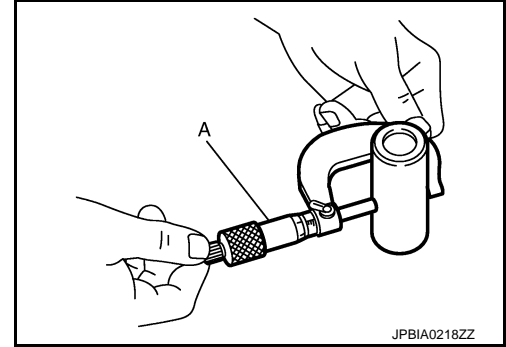

Connecting Rod Bushing Oil Clearance

(Connecting rod bushing oil clearance) = (Connecting rod bushing inner diameter) – (Piston pin outer diameter)

Standard and limit : Refer to [EM-143, "Cylinder Block"](#).

- If the calculated value exceeds the limit, replace connecting rod assembly and/or piston and piston pin assembly.
- If replacing piston and piston pin assembly, refer to [EM-132, "Description"](#).
- If replacing connecting rod assembly, refer to [EM-133, "Connecting Rod Bearing"](#) to select the connecting rod bearing.

- A : Sample codes
- B : Bearing stopper groove
- C : Small-end diameter grade
- D : Big-end diameter grade
- E : Weight grade
- F : Cylinder No.
- G : Management code
- H : Front mark
- I : Management code

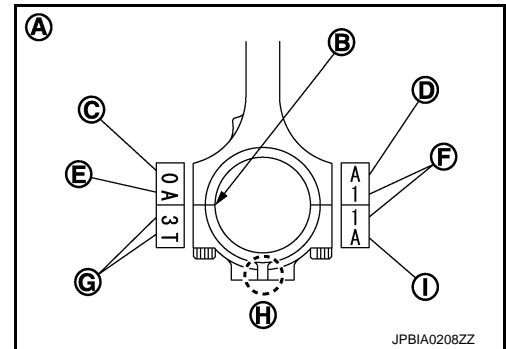

Factory installed parts grading:

CYLINDER BLOCK

< UNIT DISASSEMBLY AND ASSEMBLY >

- Service parts apply only to grade "0".

- A : RH
- B : LH
- C : Piston pin grade number
- D : Piston grade number
- E : Front mark
- F : Identification code

Unit: mm (in)

Grade	0	1
Connecting rod bushing inner diameter *	22.000 - 22.006 (0.8661 - 0.8664)	22.006 - 22.012 (0.8664 - 0.8666)
Piston pin hole diameter	21.993 - 21.999 (0.8659 - 0.8661)	21.999 - 22.005 (0.8661 - 0.8663)
Piston pin outer diameter	21.989 - 21.995 (0.8657 - 0.8659)	21.995 - 22.001 (0.8659 - 0.8662)

*: After installing in connecting rod

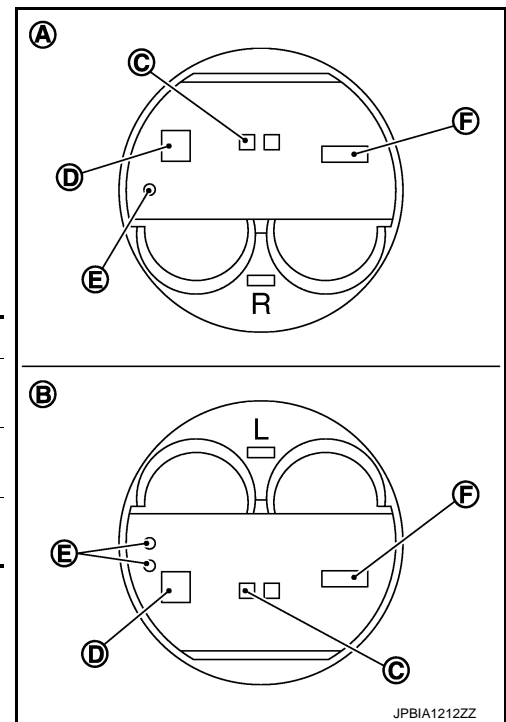

CYLINDER BLOCK DISTORTION

- Using a scraper, remove gasket on the cylinder block surface, and also remove engine oil, scale, carbon, or other contamination.

CAUTION:

Be careful not to allow gasket flakes to enter engine oil or engine coolant passages.

- Measure the distortion on the cylinder block upper face at some different points in six directions (C), (D), (E), (F), (G), and (H) with a straightedge (A) and a feeler gauge (B).

Limit : Refer to [EM-143, "Cylinder Block"](#).

- If it exceeds the limit, replace cylinder block.

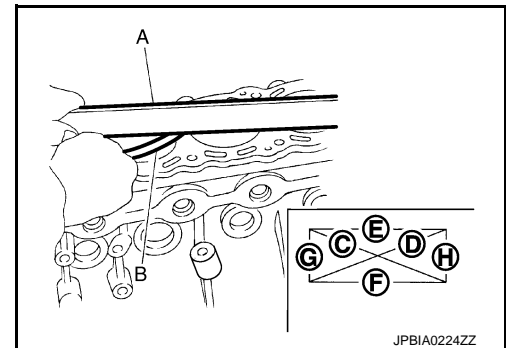

MAIN BEARING HOUSING INNER DIAMETER

- Install lower cylinder block (2) without installing main bearings, and tighten lower cylinder block bolts to the specified torque. Refer to [EM-112, "Disassembly and Assembly"](#) for the tightening procedure.
- Measure the inner diameter of main bearing housing with a bore gauge.

Standard : Refer to [EM-143, "Cylinder Block"](#).

- If out of the standard, replace cylinder block (1) and lower cylinder block as assembly.

NOTE:

Cylinder block cannot be replaced as a single part, because it is machined together with lower cylinder block.

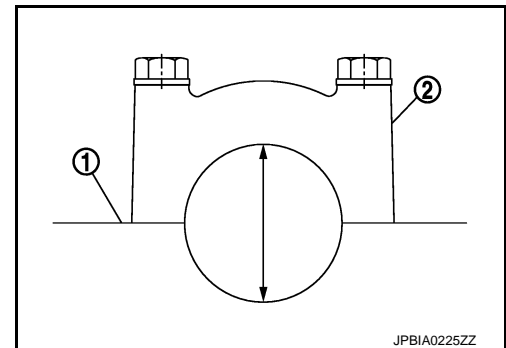

PISTON TO CYLINDER BORE CLEARANCE

Cylinder Bore inner Diameter

CYLINDER BLOCK

< UNIT DISASSEMBLY AND ASSEMBLY >

- Using a bore gauge, measure cylinder bore for wear, out-of-round and taper at six different points on each cylinder. [(A) and (B) directions at (C), (D) and (E)] is in longitudinal direction of engine.

f : 10 mm (0.39 in)
 g : 60 mm (2.36 in)
 h : 125 mm (4.92 in)

Standard and limit : Refer to [EM-143, "Cylinder Block"](#).

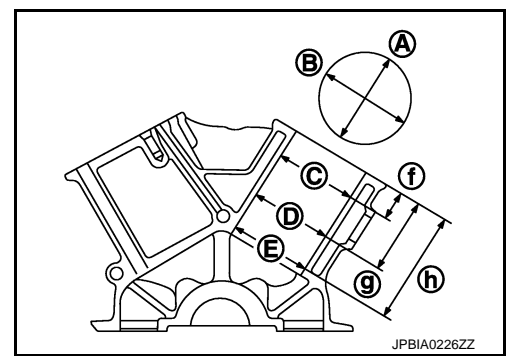

- If the measured value exceeds the limit, or if there are scratches and/or seizure on the cylinder inner wall, hone or rebore the inner wall.
- Oversize piston is provided. When using oversize piston, rebore cylinder so that the clearance of the piston-to-cylinder bore satisfies the standard.

CAUTION:

When using oversize piston, use oversize pistons for all cylinders with oversize piston rings.

Oversize (O/S) : 0.2 mm (0.008 in)

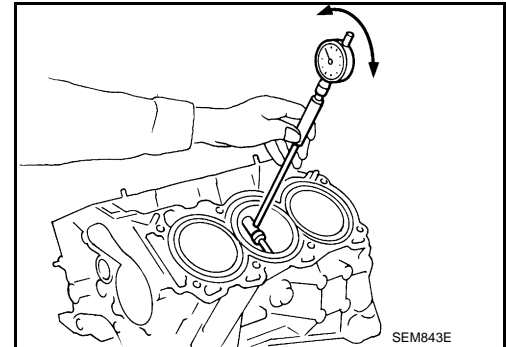

Piston Skirt Diameter

Measure the outer diameter of piston skirt with a micrometer (A).

Measure point
Standard : Refer to [EM-143, "Cylinder Block"](#).

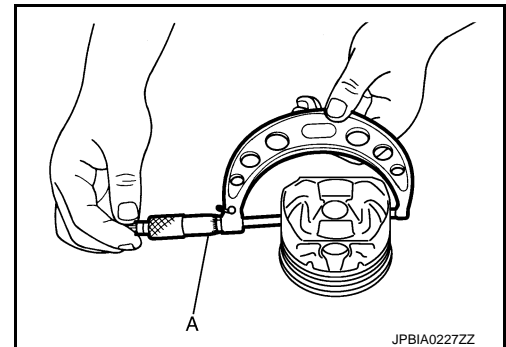

Piston-to-Cylinder Bore Clearance

Calculate by piston skirt diameter and cylinder bore inner diameter [direction (B), position (D)].

A : Direction A
 C : Position C
 E : Position E
 f : 10 mm (0.39 in)
 g : 60 mm (2.36 in)
 h : 125 mm (4.92 in)

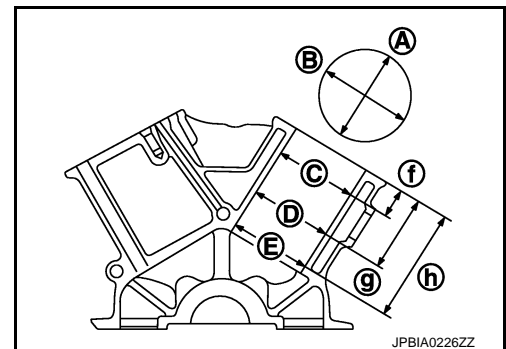

(Clearance) = (Cylinder bore inner diameter) – (Piston skirt diameter).

Standard and limit : Refer to [EM-143, "Cylinder Block"](#).

- If the calculated value exceeds the limit, replace piston and piston pin assembly. Refer to [EM-143, "Cylinder Block"](#).

Reboring Cylinder Bore

- Cylinder bore size is determined by adding piston to cylinder bore clearance to piston skirt diameter.

CYLINDER BLOCK

< UNIT DISASSEMBLY AND ASSEMBLY >

Rebored size calculation: $D = A + B - C$

where,

A: Piston skirt diameter as measured

B: Piston to cylinder bore clearance (standard value)

C: Honing allowance 0.02 mm (0.0008 in)

D: Bored diameter

2. Install lower cylinder block, and tighten to the specified torque. Otherwise, cylinder bores may be distorted in final assembly.

3. Cut cylinder bores.

NOTE:

- When any cylinder needs boring, all other cylinders must also be bored.
- Do not cut too much out of cylinder bore at a time. Cut only 0.05 mm (0.0020 in) or so in diameter at a time.

4. Hone cylinders to obtain the specified piston to cylinder bore clearance.

5. Measure finished cylinder bore for the out-of-round and taper.

NOTE:

Perform measurement after cylinder bore cools down.

CRANKSHAFT MAIN JOURNAL DIAMETER

- Measure the outer diameter of crankshaft main journals with a micrometer.

Standard : Refer to [EM-143, "Cylinder Block"](#).

- If out of the standard, measure the main bearing oil clearance. Then use undersize bearing. Refer to [EM-136, "Main Bearing"](#).

CRANKSHAFT PIN JOURNAL DIAMETER

- Measure the outer diameter of crankshaft pin journal with a micrometer (A).

Standard : Refer to [EM-143, "Cylinder Block"](#).

- If out of the standard, measure the connecting rod bearing oil clearance. Then use undersize bearing. Refer to [EM-133, "Connecting Rod Bearing"](#).

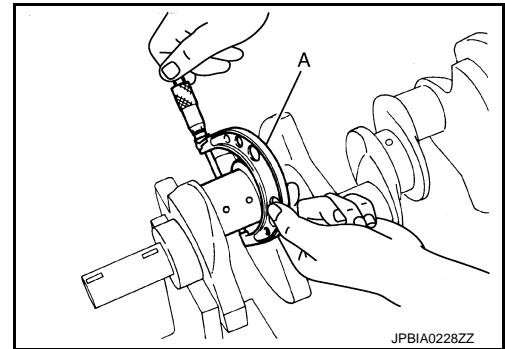

CRANKSHAFT OUT-OF-ROUND AND TAPER

- Measure the dimensions at four different points as shown in the figure on each main journal and pin journal with a micrometer.
- Out-of-round is indicated by the difference in the dimensions between (d) and (c) at (a) and (b).
- Taper is indicated by the difference in the dimensions between.

Limit : Refer to [EM-143, "Cylinder Block"](#).

- If the measured value exceeds the limit, correct or replace crankshaft.
- If corrected, measure the bearing oil clearance of the corrected main journal and/or pin journal. Then select the main bearing and/or connecting rod bearing. Refer to [EM-136, "Main Bearing"](#) and/or [EM-133, "Connecting Rod Bearing"](#).

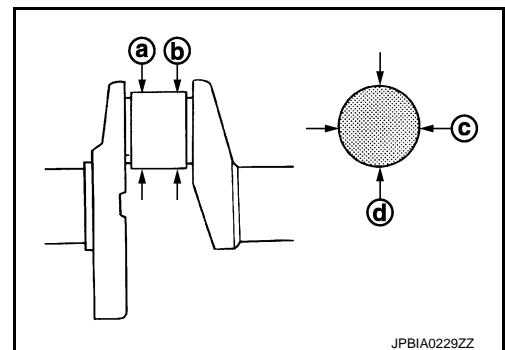

CRANKSHAFT RUNOUT

CYLINDER BLOCK

< UNIT DISASSEMBLY AND ASSEMBLY >

- Place V-block on precise flat table, and support the journals on both ends of crankshaft.
- Place a dial indicator straight up on the No. 3 journal.
- While rotating crankshaft, read the movement of the pointer on a dial indicator. (Total indicator reading)

Standard and limit : Refer to [EM-143, "Cylinder Block"](#).

- If it exceeds the limit, replace crankshaft.

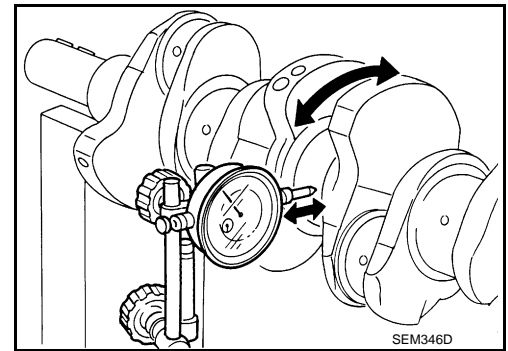

CONNECTING ROD BEARING OIL CLEARANCE

Method by Calculation

- Install connecting rod bearings (1) to connecting rod (2) and connecting rod cap, and tighten connecting rod bolts to the specified torque. Refer to [EM-112, "Disassembly and Assembly"](#) for the tightening procedure.

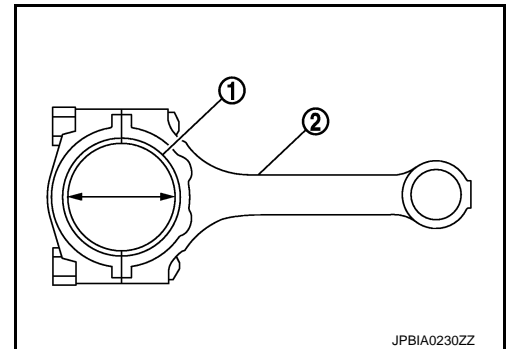

- Measure the inner diameter of connecting rod bearing with an inside micrometer.
(Oil clearance) = (Connecting rod bearing inner diameter) – (Crankshaft pin journal diameter)

Standard and limit : Refer to [EM-148, "Connecting Rod Bearing"](#).

- If the calculated value exceeds the limit, select proper connecting rod bearing according to connecting rod big end diameter and crankshaft pin journal diameter to obtain the specified bearing oil clearance. Refer to [EM-132, "Description"](#).

Method of Using Plastigage

- Remove oil and dust on crankshaft pin journal and the surfaces of each bearing completely.
- Cut a plastigage slightly shorter than the bearing width, and place it in crankshaft axial direction, avoiding oil holes.
- Install connecting rod bearings to connecting rod and connecting rod bearing cap, and tighten connecting rod bolts to the specified torque. Refer to [EM-112, "Disassembly and Assembly"](#) for the tightening procedure.

CAUTION:

Never rotate crankshaft.

- Remove connecting rod bearing cap and bearings, and using the scale on the plastigage bag, measure the plastigage width.

NOTE:

The procedure when the measured value exceeds the limit is the same as that described in the "Method by Calculation".

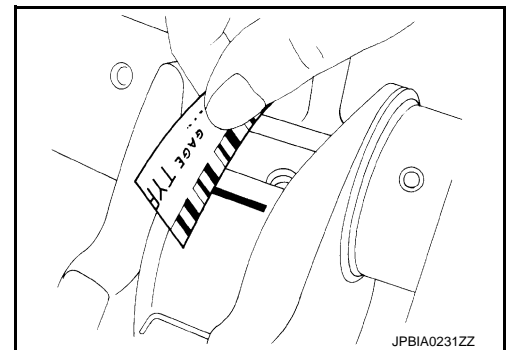

MAIN BEARING OIL CLEARANCE

Method by Calculation

CYLINDER BLOCK

< UNIT DISASSEMBLY AND ASSEMBLY >

- Install main bearings (3) to cylinder block (1) and lower cylinder block (2), and tighten lower cylinder block bolts to the specified torque. Refer to [EM-112. "Disassembly and Assembly"](#) for the tightening procedure.
- Measure the inner diameter of main bearing with a bore gauge.
(Oil clearance) = (Main bearing inner diameter) – (Crankshaft main journal diameter)

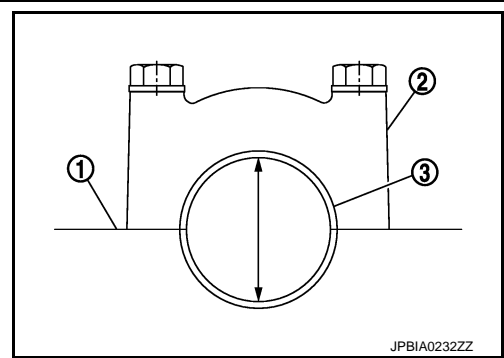

Standard and limit : Refer to [EM-147. "Main Bearing"](#).

- If the calculated value exceeds the limit, select proper main bearing according to main bearing inner diameter and crankshaft main journal diameter to obtain the specified bearing oil clearance. Refer to [EM-132. "Description"](#).

Method of Using Plastigage

- Remove engine oil and dust on crankshaft journal and the surfaces of each bearing completely.
- Cut a plastigage slightly shorter than the bearing width, and place it in crankshaft axial direction, avoiding oil holes.
- Install main bearing to cylinder block and lower cylinder block, and tighten lower cylinder block to the specified torque. Refer to [EM-112. "Disassembly and Assembly"](#) for the tightening procedure.

CAUTION:

Never rotate crankshaft.

- Remove lower cylinder block and bearings, and using the scale on the plastigage bag, measure the plastigage width.

NOTE:

The procedure when the measured value exceeds the limit is the same as that described in the "Method by Calculation".

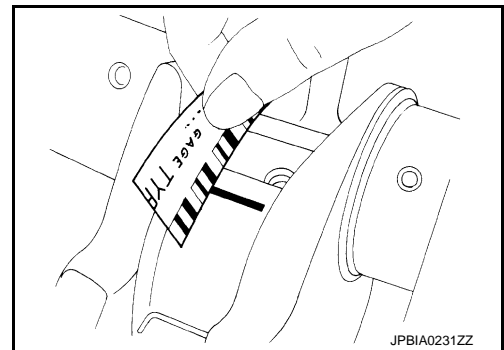

MAIN BEARING CRUSH HEIGHT

- When lower cylinder block is removed after being tightened to the specified torque with main bearings (1) installed, the tip end of bearing must protrude. Refer to [EM-112. "Disassembly and Assembly"](#) for the tightening procedure.

A : Crush height

Standard : There must be crush height.

- If the standard is not met, replace main bearings.

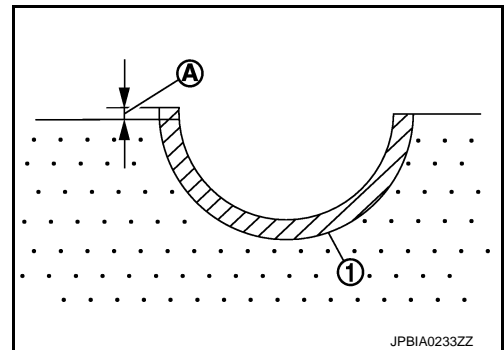

CONNECTING ROD BEARING CRUSH HEIGHT

- When connecting rod bearing cap is removed after being tightened to the specified torque with connecting rod bearings (1) installed, the tip end of bearing must protrude. Refer to [EM-112. "Disassembly and Assembly"](#) for the tightening procedure.

A : Crush height

Standard : There must be crush height.

- If the standard is not met, replace connecting rod bearings.

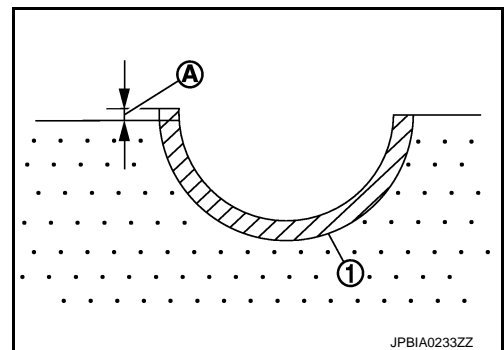

CYLINDER BLOCK

< UNIT DISASSEMBLY AND ASSEMBLY >

LOWER CYLINDER BLOCK BOLT OUTER DIAMETER

- Measure the outer diameters (c), (d) at two positions as shown in the figure.

- a : 20 mm (0.79 in)
- b : 30 mm (1.18 in)
- e : 10 mm (0.39 in)

- If reduction appears in (a) range, regard it (c).

Limit [(d) – (c)] : 0.11 mm (0.0043 in)

- If it exceeds the limit (large difference in dimensions), replace lower cylinder block bolt with new one.

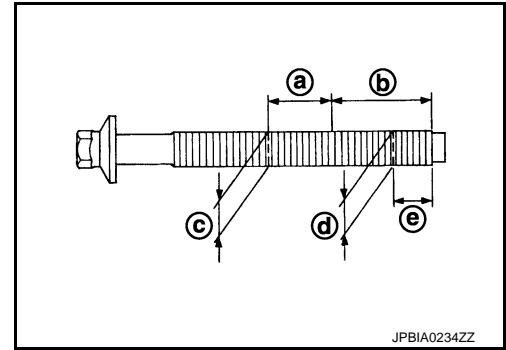

CONNECTING ROD BOLT OUTER DIAMETER

1. Measure the outer diameters [(a), (b) and (c)] at the position shown in the figure.

- a : Value at the end of the smaller diameter of the bolt
- b : Value at the end of the smaller diameter of the bolt [opposite side of (a)]
- c : Value of the smallest diameter of the smaller of the bolt

2. Obtain a mean value (d) of (a) and (b).
3. Subtract (c) from (d).

Limit [(d) – (c)] : 0.09 mm (0.0035 in)

4. If it exceeds the limit (large difference in dimensions), replace the bolt with new one.

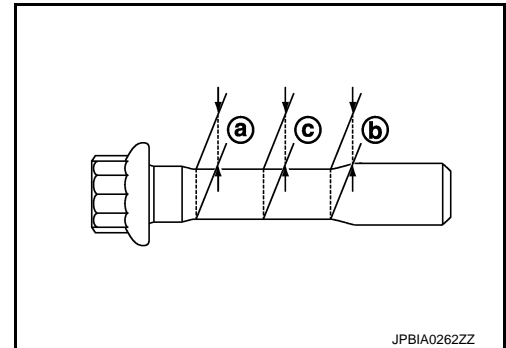

FLYWHEEL DEFLECTION (M/T models)

- Measure the deflection of flywheel contact surface to clutch with a dial indicator (A).
- Measure the deflection at 210 mm (8.27 in) dia.

Standard : 0.45 mm (0.0177 in) or less.

- If measured value is out of the standard, replace flywheel.

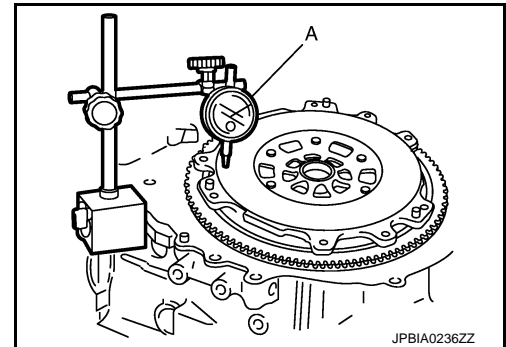

MOVEMENT AMOUNT OF FLYWHEEL (M/T models)

CAUTION:

Never disassemble double mass flywheel.

Movement Amount in Radial (Rotation) Direction

Check the movement amount of radial (rotation) direction with the following procedure:

1. Install a bolt to clutch cover mounting hole, and place a torque wrench on the extended line of the flywheel center line.
 - Tighten bolt at a force of 9.8 N·m (1.00 kg·m, 87 in·lb) to keep it from loosening.

CYLINDER BLOCK

< UNIT DISASSEMBLY AND ASSEMBLY >

- Put a matching mark on circumferences of the two flywheel masses without applying any load (measurement standard points).

- 1 : Clutch cover mounting bolt
- 2 : Flywheel (transaxle side)
- A : Torque wrench
- b : 9.8 N·m (1.00 kg·m, 87 in-lb)

- Apply a force of 9.8 N·m (1.00 kg·m, 87 in-lb) in each direction, and mark the movement amount on the mass on the transaxle side.
- Measure the dimensions of movement amounts (C) and (D) on circumference of the flywheel on the transaxle side.

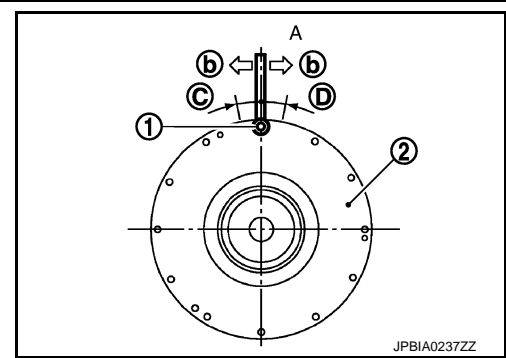

Standard: Less than 29.9 mm (1.177 in)

- If measured value is out of the standard, replace flywheel.

DRIVE PLATE (A/T models)

- Check drive plate and signal plate for deformation or damage.

CAUTION:

- Never disassemble drive plate.
- Never place drive plate with signal plate facing down.
- When handling signal plate, take care not to damage or scratch it.
- Handle signal plate in a manner that prevents it from becoming magnetized.
- If anything is found, replace drive plate.

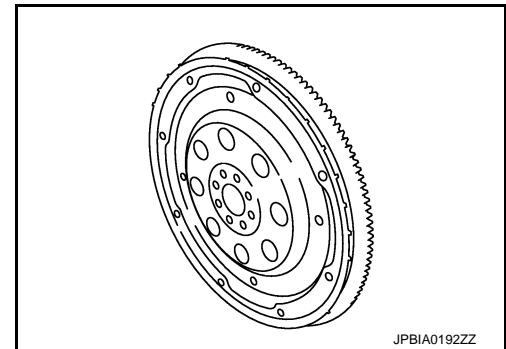

OIL JET

- Check nozzle for deformation and damage.
- Blow compressed air from nozzle, and check for clogs.
- If it is not satisfied, clean or replace oil jet.

OIL JET RELIEF VALVE

- Using a clean plastic stick, press check valve in oil jet relief valve. Check that valve moves smoothly with proper reaction force.
- If it is not satisfied, replace oil jet relief valve.

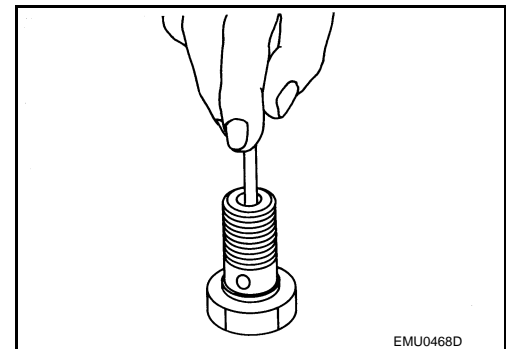

HOW TO SELECT PISTON AND BEARING

< UNIT DISASSEMBLY AND ASSEMBLY >

HOW TO SELECT PISTON AND BEARING

Description

INFOID:000000008154475

Selection points	Selection parts	Selection items	Selection methods
Between cylinder block and crankshaft	Main bearing	Main bearing grade (bearing thickness)	Determined by match of cylinder block bearing housing grade (inner diameter of housing) and crankshaft journal grade (outer diameter of journal)
Between crankshaft and connecting rod	Connecting rod bearing	Connecting rod bearing grade (bearing thickness)	Combining service grades for connecting rod big end diameter and crankshaft pin outer diameter determine connecting rod bearing selection.
Between cylinder block and piston	Piston and piston pin assembly (Piston is available together with piston pin as assembly.)	Piston grade (piston skirt diameter)	Piston grade = cylinder bore grade (inner diameter of bore)
Between piston and connecting rod*	—	—	—

*: For the service parts, the grade for fitting cannot be selected between piston pin and connecting rod. (Only "0" grade is available.) The information at the shipment from the plant is described as a reference.

- The identification grade stamped on each part is the grade for the dimension measured in new condition. This grade cannot apply to reused parts.
- For reused or repaired parts, measure the dimension accurately. Determine the grade by comparing the measurement with the values of each selection table.
- For details of the measurement method of each part, the reuse standards and the selection method of the selective fitting parts, refer to the text.

Piston

INFOID:000000008154476

WHEN NEW CYLINDER BLOCK IS USED

Check the cylinder bore grade ("1", "2" or "3") on rear side of cylinder block, and select piston of the same grade.

- A : Bearing housing grade No. 1
- B : Bearing housing grade No. 2
- C : Bearing housing grade No. 3
- D : Bearing housing grade No. 4
- E : Cylinder bore grade No. 1
- F : Cylinder bore grade No. 2
- G : Cylinder bore grade No. 3
- H : Cylinder bore grade No. 4
- I : Cylinder bore grade No. 5
- J : Cylinder bore grade No. 6
- K : Identification
- ⇐ : Engine front

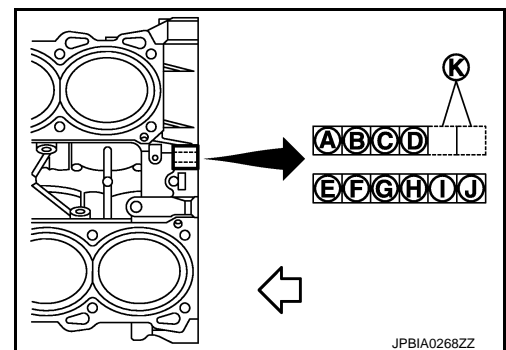

NOTE:

Piston is available with piston pin as a set for the service part. (Only "0" grade piston pin is available.)

WHEN CYLINDER BLOCK IS REUSED

1. Measure the cylinder bore inner diameter. Refer to [EM-121, "Inspection"](#).

HOW TO SELECT PISTON AND BEARING

< UNIT DISASSEMBLY AND ASSEMBLY >

2. Determine the bore grade by comparing the measurement with the values under the cylinder bore inner diameter of the "PISTON SELECTION TABLE".

- A : RH
- B : LH
- C : Piston pin grade number
- D : Piston grade number
- E : Front mark
- F : Identification code

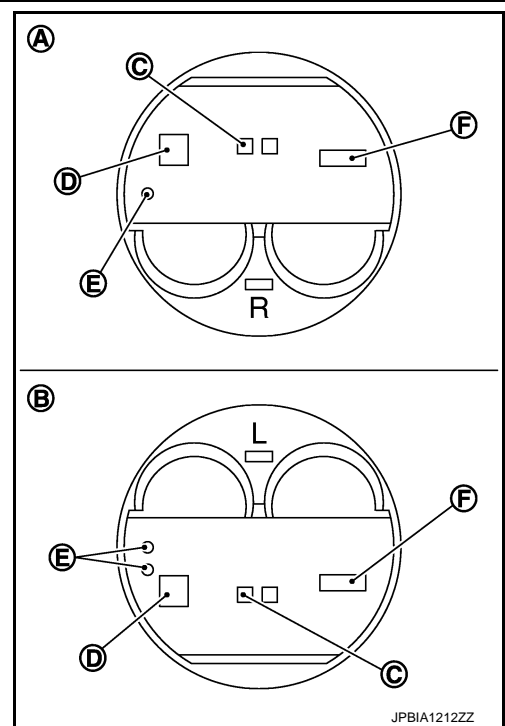

3. Select piston of the same grade.

PISTON SELECTION TABLE

Unit: mm (in)

Grade	1	2	3
Cylinder bore inner diameter	95.500 - 95.510 (3.7598 - 3.7602)	95.510 - 95.520 (3.7602 - 3.7606)	95.520 - 95.530 (3.7606 - 3.7610)
Piston skirt diameter	95.480 - 95.490 (3.7590 - 3.7594)	95.490 - 95.500 (3.7594 - 3.7598)	95.500 - 95.510 (3.7598 - 3.7602)

NOTE:

- Piston is available together with piston pin as assembly.
- Piston pin (piston pin hole) grade is provided only for the parts installed at the plant. For service parts, no piston pin grades can be selected. (Only "0" grade is available.)
- No second grade mark is available on piston.

Connecting Rod Bearing

INFOID:000000008154477

WHEN NEW CONNECTING ROD AND CRANKSHAFT ARE USED

1. Apply connecting rod big end diameter grade stamped (D) on connecting rod side face to the row in the "CONNECTING ROD BEARING SELECTION TABLE".

- A : Sample codes
- B : Bearing stopper groove
- C : Small-end diameter grade
- E : Weight grade
- F : Cylinder No.
- G : Management code
- H : Front mark
- I : Management code

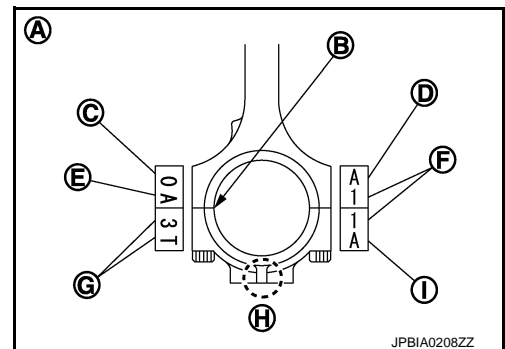

HOW TO SELECT PISTON AND BEARING

< UNIT DISASSEMBLY AND ASSEMBLY >

2. Apply crankshaft pin journal diameter grade stamped on crankshaft front side to the column in the "CONNECTING ROD BEARING SELECTION TABLE"

- A : Journal diameter grade No. 1
- B : Journal diameter grade No. 2
- C : Journal diameter grade No. 3
- D : Journal diameter grade No. 4
- E : Pin diameter grade No. 1
- F : Pin diameter grade No. 2
- G : Pin diameter grade No. 3
- H : Pin diameter grade No. 4
- I : Pin diameter grade No. 5
- J : Pin diameter grade No. 6
- K : Identification

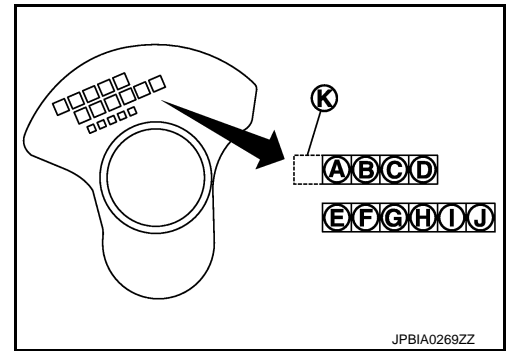

3. Read the symbol at the cross point of selected row and column in the "CONNECTING ROD BEARING SELECTION TABLE".
4. Apply the symbol obtained to the "CONNECTING ROD BEARING GRADE TABLE" to select connecting rod bearing.

WHEN CONNECTING ROD AND CRANKSHAFT ARE REUSED

1. Measure connecting rod big end diameter and crankshaft pin journal diameter. Refer to [EM-121. "Inspection"](#).
2. Correspond the measured dimension in "connecting rod big end diameter" row of "CONNECTING ROD BEARING SELECTION TABLE".
3. Correspond the measured dimension in "crankshaft pin diameter" column of "CONNECTING ROD BEARING SELECTION TABLE".
4. Follow step 3 and later in "WHEN NEW CONNECTING ROD AND CRANKSHAFT ARE USED".

CONNECTING ROD BEARING SELECTION TABLE

HOW TO SELECT PISTON AND BEARING

< UNIT DISASSEMBLY AND ASSEMBLY >

Mark	Axle diameter	Connecting rod big end diameter Unit: mm (in)		Crankshaft pin journal diameter Unit: mm (in)													
		Hole diameter		Mark													
				A	B	C	D	E	F	G	H	J	K	L	M	N	
A	53.974 - 53.973 (2.1250 - 2.1249)	0	0	0	0	0	0	0	0	1	1	1	1	1	1	2	
B	53.973 - 53.972 (2.1249 - 2.1249)	0	0	0	0	0	0	0	1	1	1	1	1	1	1	2	
C	53.972 - 53.971 (2.1249 - 2.1248)	0	0	0	0	0	1	1	1	1	1	1	1	2	2	2	
D	53.971 - 53.970 (2.1248 - 2.1248)	0	0	0	1	1	1	1	1	1	1	1	2	2	2	2	
E	53.970 - 53.969 (2.1248 - 2.1248)	0	0	1	1	1	1	1	1	1	1	2	2	2	2	2	
F	53.969 - 53.968 (2.1248 - 2.1247)	0	1	1	1	1	1	1	1	2	2	2	2	2	2	2	
G	53.968 - 53.967 (2.1247 - 2.1247)	1	1	1	1	1	1	1	2	2	2	2	2	2	2	3	
H	53.967 - 53.966 (2.1247 - 2.1246)	1	1	1	1	1	1	2	2	2	2	2	2	2	3	3	
J	53.966 - 53.965 (2.1246 - 2.1246)	1	1	1	1	2	2	2	2	2	2	2	3	3	3	3	
K	53.965 - 53.964 (2.1246 - 2.1246)	1	1	1	2	2	2	2	2	2	2	3	3	3	3	3	
L	53.964 - 53.963 (2.1246 - 2.1245)	1	1	2	2	2	2	2	2	2	3	3	3	3	3	3	
M	53.963 - 53.962 (2.1245 - 2.1245)	1	2	2	2	2	2	2	2	3	3	3	3	3	3	3	
N	53.962 - 53.961 (2.1245 - 2.1244)	2	2	2	2	2	2	2	3	3	3	3	3	3	3	4	
P	53.961 - 53.960 (2.1244 - 2.1244)	2	2	2	2	2	2	3	3	3	3	3	3	3	4	4	
R	53.960 - 53.959 (2.1244 - 2.1244)	2	2	2	2	3	3	3	3	3	3	3	4	4	4	4	
S	53.959 - 53.958 (2.1244 - 2.1243)	2	2	2	3	3	3	3	3	3	3	4	4	4	4	4	
T	53.958 - 53.957 (2.1243 - 2.1243)	2	2	3	3	3	3	3	3	3	4	4	4	4	4	4	
U	53.957 - 53.956 (2.1243 - 2.1242)	2	3	3	3	3	3	3	3	4	4	4	4	4	4	4	

PBIC5435E

CONNECTING ROD BEARING GRADE TABLE

Connecting rod bearing grade table : Refer to [EM-148, "Connecting Rod Bearing"](#).

UNDERSIZE BEARING USAGE GUIDE

- When the specified connecting rod bearing oil clearance is not obtained with standard size connecting rod bearings, use undersize (US) bearings.
- When using undersize (US) bearing, measure the connecting rod bearing inner diameter with bearing installed, and grind crankshaft pin so that the connecting rod bearing oil clearance satisfies the standard.

CAUTION:

In grinding crankshaft pin to use undersize bearings, keep the fillet R (A) [1.5 - 1.7 mm (0.059 - 0.067 in)].

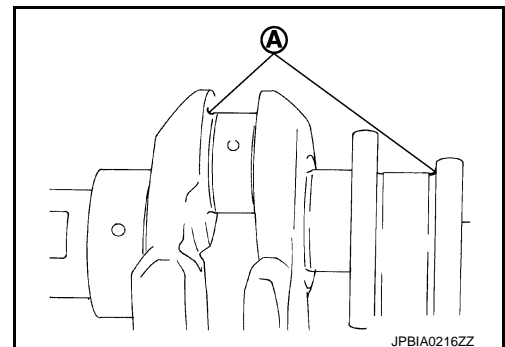

HOW TO SELECT PISTON AND BEARING

< UNIT DISASSEMBLY AND ASSEMBLY >

Bearing undersize table : Refer to [EM-148, "Connecting Rod Bearing"](#).

Main Bearing

INFOID:000000008154478

WHEN NEW CYLINDER BLOCK AND CRANKSHAFT ARE USED

1. "MAIN BEARING SELECTION TABLE" rows correspond to bearing housing grade on rear side of cylinder block.

- A : Bearing housing grade No. 1
- B : Bearing housing grade No. 2
- C : Bearing housing grade No. 3
- D : Bearing housing grade No. 4
- E : Cylinder bore grade No. 1
- F : Cylinder bore grade No. 2
- G : Cylinder bore grade No. 3
- H : Cylinder bore grade No. 4
- I : Cylinder bore grade No. 5
- J : Cylinder bore grade No. 6
- K : Identification code
- ⇐ : Engine front

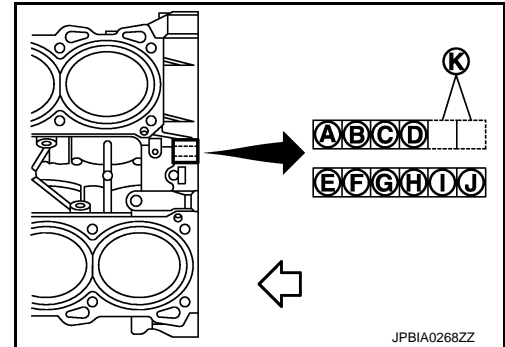

2. "MAIN BEARING SELECTION TABLE" columns correspond to journal diameter grade on front side of crankshaft.

- A : Journal diameter grade No. 1
- B : Journal diameter grade No. 2
- C : Journal diameter grade No. 3
- D : Journal diameter grade No. 4
- E : Pin diameter grade No. 1
- F : Pin diameter grade No. 2
- G : Pin diameter grade No. 3
- H : Pin diameter grade No. 4
- I : Pin diameter grade No. 5
- J : Pin diameter grade No. 6
- K : Identification code

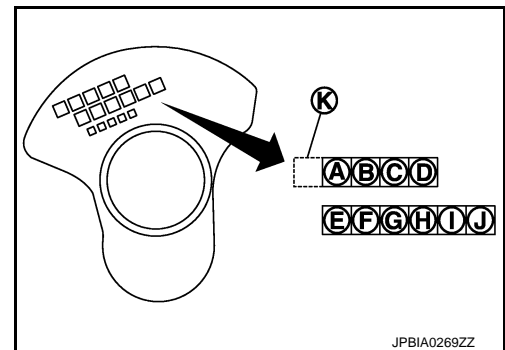

3. Select main bearing grade at the point where selected row and column meet in "MAIN BEARING SELECTION TABLE".
4. Apply sign at crossing in above step 3 to "MAIN BEARING GRADE TABLE".

NOTE:

- "MAIN BEARING GRADE TABLE" applies to all journals.
- Service parts are available as a set of both upper and lower.

WHEN CYLINDER BLOCK AND CRANKSHAFT ARE REUSED

1. Measure cylinder block main bearing housing inner diameter and crankshaft main journal diameter. Refer to [EM-121, "Inspection"](#).
2. Correspond the measured dimension in "Cylinder block main bearing housing inner diameter" row of "MAIN BEARING SELECTION TABLE".
3. Correspond the measured dimension in "Crankshaft main journal diameter" column of "MAIN BEARING SELECTION TABLE".
4. Follow step 3 and later in "When New Cylinder Block and Crankshaft are Used".

HOW TO SELECT PISTON AND BEARING

< UNIT DISASSEMBLY AND ASSEMBLY >

MAIN BEARING SELECTION TABLE

Mark	Axle diameter Unit: mm (in)	Cylinder block main bearing housing inner diameter Unit: mm (in)		Crankshaft main journal diameter Unit: mm (in)	
		Hole diameter	Mark	Hole diameter	Mark
A	64.975 - 64.974 (2.5581 - 2.5580)	69.993 - 69.994 (2.7556 - 2.7557)	A	69.993 - 69.994 (2.7556 - 2.7557)	A
B	64.974 - 64.973 (2.5580 - 2.5580)	69.994 - 69.995 (2.7557 - 2.7557)	B	69.994 - 69.995 (2.7557 - 2.7557)	B
C	64.973 - 64.972 (2.5580 - 2.5579)	69.995 - 69.996 (2.7557 - 2.7557)	C	69.995 - 69.996 (2.7557 - 2.7557)	C
D	64.972 - 64.971 (2.5579 - 2.5579)	69.996 - 69.997 (2.7557 - 2.7558)	D	69.996 - 69.997 (2.7557 - 2.7558)	D
E	64.971 - 64.970 (2.5579 - 2.5578)	69.997 - 69.998 (2.7558 - 2.7558)	E	69.997 - 69.998 (2.7558 - 2.7558)	E
F	64.970 - 64.969 (2.5579 - 2.5578)	69.998 - 69.999 (2.7558 - 2.7559)	F	69.998 - 69.999 (2.7558 - 2.7559)	F
G	64.969 - 64.968 (2.5578 - 2.5578)	69.999 - 70.000 (2.7559 - 2.7559)	G	69.999 - 70.000 (2.7559 - 2.7559)	G
H	64.968 - 64.967 (2.5578 - 2.5578)	70.000 - 70.001 (2.7559 - 2.7560)	H	70.000 - 70.001 (2.7559 - 2.7560)	H
J	64.967 - 64.966 (2.5578 - 2.5577)	70.001 - 70.002 (2.7559 - 2.7560)	J	70.001 - 70.002 (2.7559 - 2.7560)	J
K	64.966 - 64.965 (2.5577 - 2.5577)	70.002 - 70.003 (2.7560 - 2.7560)	K	70.002 - 70.003 (2.7560 - 2.7560)	K
L	64.965 - 64.964 (2.5577 - 2.5576)	70.003 - 70.004 (2.7560 - 2.7561)	L	70.003 - 70.004 (2.7560 - 2.7561)	L
M	64.964 - 64.963 (2.5576 - 2.5576)	70.004 - 70.005 (2.7561 - 2.7561)	M	70.004 - 70.005 (2.7561 - 2.7561)	M
N	64.963 - 64.962 (2.5576 - 2.5576)	70.005 - 70.006 (2.7561 - 2.7561)	N	70.005 - 70.006 (2.7561 - 2.7561)	N
P	64.962 - 64.961 (2.5576 - 2.5575)	70.006 - 70.007 (2.7562 - 2.7562)	P	70.006 - 70.007 (2.7562 - 2.7562)	P
R	64.961 - 64.960 (2.5575 - 2.5575)	70.007 - 70.008 (2.7562 - 2.7562)	R	70.007 - 70.008 (2.7562 - 2.7562)	R
S	64.960 - 64.959 (2.5575 - 2.5574)	70.008 - 70.009 (2.7562 - 2.7563)	S	70.008 - 70.009 (2.7562 - 2.7563)	S
T	64.959 - 64.958 (2.5574 - 2.5574)	70.009 - 70.010 (2.7563 - 2.7563)	T	70.009 - 70.010 (2.7563 - 2.7563)	T
U	64.958 - 64.957 (2.5574 - 2.5574)	70.010 - 70.011 (2.7563 - 2.7563)	U	70.010 - 70.011 (2.7563 - 2.7563)	U
V	64.957 - 64.956 (2.5574 - 2.5573)	70.011 - 70.012 (2.7563 - 2.7564)	V	70.011 - 70.012 (2.7563 - 2.7564)	V
W	64.956 - 64.955 (2.5573 - 2.5573)	70.012 - 70.013 (2.7564 - 2.7564)	W	70.012 - 70.013 (2.7564 - 2.7564)	W
X	64.955 - 64.954 (2.5573 - 2.5572)	70.013 - 70.014 (2.7564 - 2.7565)	X	70.013 - 70.014 (2.7564 - 2.7565)	X
Y	64.954 - 64.953 (2.5572 - 2.5572)	70.014 - 70.015 (2.7565 - 2.7565)	Y	70.014 - 70.015 (2.7565 - 2.7565)	Y
4	64.953 - 64.952 (2.5572 - 2.5572)	70.015 - 70.016 (2.7565 - 2.7565)	4	70.015 - 70.016 (2.7565 - 2.7565)	4
7	64.952 - 64.951 (2.5572 - 2.5571)	70.016 - 70.017 (2.7565 - 2.7566)	7	70.016 - 70.017 (2.7565 - 2.7566)	7

JPBIA0264ZZ

MAIN BEARING GRADE TABLE (ALL JOURNALS)

Main bearing grade table (All journals) : Refer to [EM-147, "Main Bearing"](#).

UNDERSIZE BEARING USAGE GUIDE

- When the specified main bearing oil clearance is not obtained with standard size main bearings, use undersize (US) bearing.
- When using undersize (US) bearing, measure the main bearing inner diameter with bearing installed, and grind main journal so that the main bearing oil clearance satisfies the standard.

CAUTION:

In grinding crankshaft main journal to use undersize bearings, keep the fillet R (A) [1.5 - 1.7 mm (0.059 - 0.067 in)].

Bearing undersize table : Refer to [EM-147, "Main Bearing"](#).

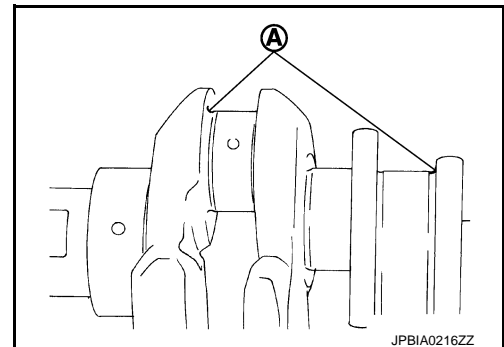

JPBIA0216ZZ

SERVICE DATA AND SPECIFICATIONS (SDS)

< SERVICE DATA AND SPECIFICATIONS (SDS)

SERVICE DATA AND SPECIFICATIONS (SDS)

SERVICE DATA AND SPECIFICATIONS (SDS)

General Specification

INFOID:000000008154479

GENERAL SPECIFICATIONS

Cylinder arrangement		V-6
Displacement cm ³ (cu in)		3,696 (225.53)
Bore and stroke mm (in)		95.5×86.0 (3.760×3.386)
Valve arrangement		DOHC
Firing order		1-2-3-4-5-6
Number of piston rings	Compression	2
	Oil	1
Number of main bearings		4
Compression ratio		11
Compression pressure kPa (kg/cm ² , psi)/200 rpm	Standard	1,667 - 2,354 (17 - 24, 242 - 341)
	Minimum	1,226 (12.5, 178)
	Differential limit between cylinders	98 (1.0, 14)

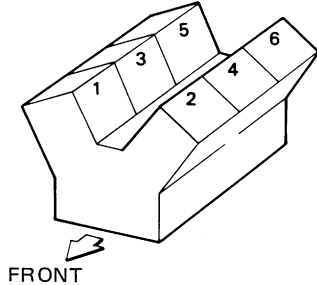
Cylinder number	 <p style="text-align: center;">FRONT</p> <p style="text-align: right;">SEM713A</p>	
	Unit: degree	

Valve timing	Intake valve open (BTDC)	63 - -64
	Intake valve close (ABDC)	-73 - 82
	Exhaust valve open (BBDC)	64
	Exhaust valve close (ATDC)	12

Drive Belt

INFOID:000000008154480

DRIVE BELT

Tension of drive belt	Belt tension is not necessary, as it is automatically adjusted by drive belt auto-tensioner.
-----------------------	--

Spark Plug

INFOID:000000008154481

SPARK PLUG

Unit: mm (in)	
Make	DENSO
Standard type	FXE24HR11

SERVICE DATA AND SPECIFICATIONS (SDS)

< SERVICE DATA AND SPECIFICATIONS (SDS)

Gap (Nominal)	Standard	1.1 (0.043)
	Limit	1.4 (0.055)

Intake Manifold

INFOID:000000008154482

INTAKE MANIFOLD

Unit: mm (in)

Items		Limit
Surface distortion	Intake manifold	0.1 (0.004)

Exhaust Manifold

INFOID:000000008154483

EXHAUST MANIFOLD

Unit: mm (in)

Items		Limit
Surface distortion	Exhaust manifold	0.7 (0.028)

Camshaft

INFOID:000000008154484

CAMSHAFT (EXH)

Unit: mm (in)

Items		Standard	Limit
Camshaft (EXH) journal oil clearance	No. 1	0.045 - 0.086 (0.0018 - 0.0034)	0.150 (0.0059)
	No. 2, 3, 4	0.035 - 0.076 (0.0014 - 0.0030)	
VVEL ladder assembly bracket inner diameter (EXH)	No. 1	26.000 - 26.021 (1.0236 - 1.0244)	—
	No. 2, 3, 4	23.500 - 23.521 (0.9252 - 0.9260)	—
Camshaft (EXH) journal diameter	No. 1	25.935 - 25.955 (1.0211 - 1.0218)	—
	No. 2, 3, 4	23.445 - 23.465 (0.9230 - 0.9238)	—
Camshaft (EXH) end play		0.115 - 0.188 (0.0045 - 0.0074)	0.24 (0.0094)
Camshaft (EXH) cam height "A"	Bank 1	45.015 - 45.205 (1.7722 - 1.7797)	0.2 (0.008)*1
	Bank 2	46.735 - 46.925 (1.8400 - 1.8474)	
Camshaft (EXH) runout [TIR*2]		Less than 0.02 (0.0008)	0.05 (0.0020)
Camshaft sprocket (EXH) runout [TIR*2]		—	0.15 (0.0059)

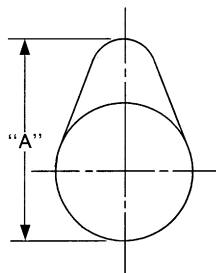

SEM671

*1: Cam wear limit

*2: Total indicator reading

CAMSHAFT (INT)

SERVICE DATA AND SPECIFICATIONS (SDS)

< SERVICE DATA AND SPECIFICATIONS (SDS)

Unit: mm (in)

Items	Standard	Limit
Drive shaft end play	0.115 - 0.188 (0.0045 - 0.0074)	0.24 (0.0094)
Camshaft sprocket (INT) runout [TIR* ¹]	—	0.15 (0.0059)

*¹: Total indicator reading

VALVE LIFTER

Unit: mm (in)

Items	Standard
Valve lifter outer diameter	33.980 - 33.990 (1.3378 - 1.3382)
Valve lifter hole diameter	34.000 - 34.016 (1.3386 - 1.3392)
Valve lifter clearance	0.010 - 0.036 (0.0004 - 0.0014)

VALVE CLEARANCE

Unit: mm (in)

Items	Cold	Hot* (reference data)
Intake	0.26 - 0.34 (0.010 - 0.013)	0.304 - 0.416 (0.012 - 0.016)
Exhaust	0.29 - 0.37 (0.011 - 0.015)	0.308 - 0.432 (0.012 - 0.017)

*: Approximately 80°C (176°F)

AVAILABLE VALVE LIFTER

Unit: mm (in)

Identification (stamped) mark	Thickness
788	7.88 (0.3102)
790	7.90 (0.3110)
792	7.92 (0.3118)
794	7.94 (0.3126)
796	7.96 (0.3134)
798	7.98 (0.3142)
800	8.00 (0.3150)
802	8.02 (0.3157)
804	8.04 (0.3165)
806	8.06 (0.3173)
808	8.08 (0.3181)
810	8.10 (0.3189)
812	8.12 (0.3197)
814	8.14 (0.3205)
816	8.16 (0.3213)
818	8.18 (0.3220)
820	8.20 (0.3228)
822	8.22 (0.3236)
824	8.24 (0.3244)
826	8.26 (0.3252)
828	8.28 (0.3260)
830	8.30 (0.3268)
832	8.32 (0.3276)
834	8.34 (0.3283)
836	8.36 (0.3291)

SERVICE DATA AND SPECIFICATIONS (SDS)

< SERVICE DATA AND SPECIFICATIONS (SDS)

Identification (stamped) mark	Thickness
838	8.38 (0.3299)
840	8.40 (0.3307)

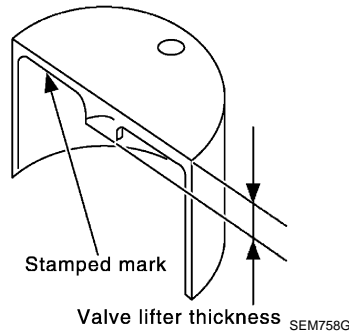

Cylinder Head

INFOID:000000008154485

CYLINDER HEAD

Unit: mm (in)

Items	Standard	Limit
Head surface distortion	Less than 0.03 (0.0012)	0.1 (0.004)
Normal cylinder head height "H"	126.4 (4.98)	—

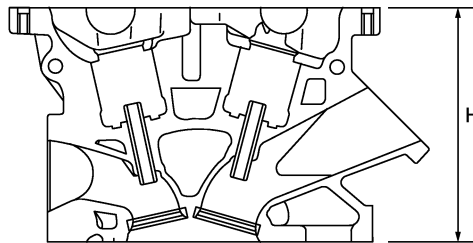

PBIC0924E

VALVE DIMENSIONS

Unit: mm (in)

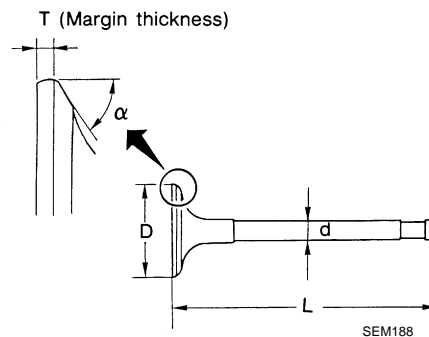

Valve head diameter "D"	Intake	36.6 - 36.9 (1.441 - 1.453)
	Exhaust	30.2 - 30.5 (1.189 - 1.201)
Valve length "L"	Intake	100.11 (3.94)
	Exhaust	94.67 (3.7272)

SERVICE DATA AND SPECIFICATIONS (SDS)

< SERVICE DATA AND SPECIFICATIONS (SDS)

Valve stem diameter "d"	Intake	5.965 - 5.980 (0.2348 - 0.2354)
	Exhaust	5.962 - 5.970 (0.2347 - 0.2350)
Valve seat angle "α"	Intake	45°15' - 45°45'
	Exhaust	
Valve margin "T"	Intake	1.1 (0.043)
	Exhaust	1.3 (0.051)
Valve margin "T" limit		0.5 (0.020)
Valve stem end surface grinding limit		0.2 (0.008)

VALVE GUIDE

Unit: mm (in)

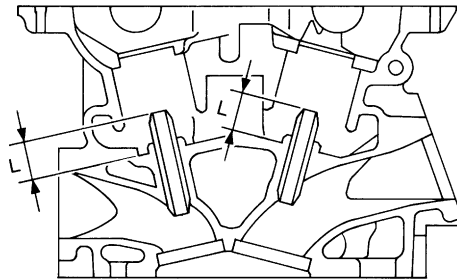

SEM950E

Items		Standard	Oversize (Service) [0.2 (0.008)]*
Valve guide	Outer diameter	10.023 - 10.034 (0.3946 - 0.3950)	10.223 - 10.234 (0.4025 - 0.4029)*
	Inner diameter (Finished size)	6.000 - 6.018 (0.2362 - 0.2369)	
Cylinder head valve guide hole diameter		9.975 - 9.996 (0.3927 - 0.3935)	10.175 - 10.196 (0.4006 - 0.4014)*
Interference fit of valve guide		0.027 - 0.059 (0.0011 - 0.0023)	
Items		Standard	Limit
Valve guide clearance	Intake	0.020 - 0.053 (0.0008 - 0.0021)	0.08 (0.003)
	Exhaust	0.030 - 0.056 (0.0012 - 0.0022)	0.09 (0.004)
Projection length "L"		12.6 - 12.8 (0.496 - 0.504)	

*: Parts settings are for exhaust side only

VALVE SEAT

Unit: mm (in)

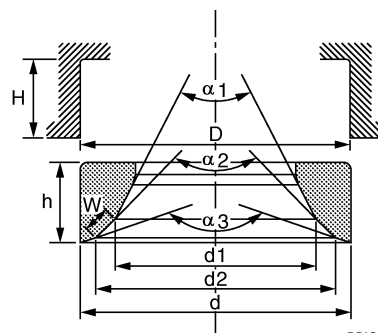

PBIC2745E

Items		Standard	Oversize (Service) [0.5 (0.02)]* ⁴
Cylinder head seat recess diameter "D"	Intake	38.000 - 38.016 (1.4961 - 1.4967)	—
	Exhaust	31.600 - 31.616 (1.2441 - 1.2447)	32.100 - 32.116 (1.2638 - 1.2644)* ⁴

SERVICE DATA AND SPECIFICATIONS (SDS)

< SERVICE DATA AND SPECIFICATIONS (SDS)

Valve seat outer diameter "d"	Intake	38.097 - 38.113 (1.4999 - 1.5005)	—
	Exhaust	31.680 - 31.696 (1.2472 - 1.2479)	32.180 - 32.196 (1.2669 - 1.2676)* ⁴
Valve seat interference fit	Intake	0.081 - 0.113 (0.0032 - 0.0044)	
	Exhaust	0.064 - 0.096 (0.0025 - 0.0038)	
Diameter "d1"* ¹	Intake	34.6 (1.362)	
	Exhaust	27.7 (1.091)	
Diameter "d2"* ²	Intake	35.9 - 36.4 (1.413 - 1.433)	
	Exhaust	29.3 - 29.8 (1.154 - 1.173)	
Angle "α1"	Intake	60°	
	Exhaust	60°	
Angle "α2"	Intake	88°45' - 90°15'	
	Exhaust	88°45' - 90°15'	
Angle "α3"	Intake	120°	
	Exhaust	120°	
Contacting width "W"* ³	Intake	1.0 - 1.4 (0.039 - 0.055)	
	Exhaust	1.2 - 1.6 (0.047 - 0.063)	
Height "h"	Intake	5.9 - 6.0 (0.232 - 0.236)	—
	Exhaust	5.9 - 6.0 (0.232 - 0.236)	4.95 - 5.05 (0.1949 - 0.1988)* ⁴
Depth "H"	6.0 (0.236)		

*1: Diameter made by intersection point of conic angles "α1" and "α2"

*2: Diameter made by intersection point of conic angles "α2" and "α3"

*3: Machining data

*4: Parts settings are for exhaust side only

VALVE SPRING

Items		Standard	
		Intake	Exhaust
Free height		45.66 mm (1.7976 in)	43.85 mm (1.7264 in)
Pressure	Installation	191.1 - 215.5 N (19.5 - 22 kg, 43 - 48 lb) at 40.90 mm (1.6102 in)	166 - 188 N (16.9 - 19.2 kg, 37 - 42 lb) at 37.00 mm (1.4567 in)
	Valve open	830.9 - 936.9 N (84.8 - 95.6 kg, 187 - 211 lb) at 28.07 mm (1.1051 in)	502 - 566 N (51.2 - 57.7 kg, 113 - 127 lb) at 26.80 mm (1.0551 in)
Identification color		Purple	Yellowish green

Items		Limit	
		Intake	Exhaust
Out-of-square		2.0 mm (0.079 in)	1.9 mm (0.075 in)

Cylinder Block

INFOID:000000008154486

CYLINDER BLOCK

SERVICE DATA AND SPECIFICATIONS (SDS)

< SERVICE DATA AND SPECIFICATIONS (SDS)

Unit: mm (in)

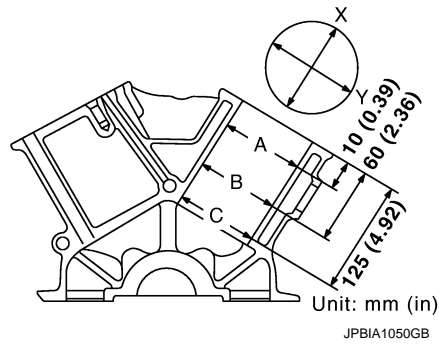

Surface flatness		Standard		Less than 0.03 (0.0012)
		Limit		0.1 (0.004)
Main bearing housing inner diameter		Standard		69.993 - 70.017 (2.7556 - 2.7566)
Cylinder bore	Inner diameter	Standard	Grade No. 1	95.500 - 95.510 (3.7598 - 3.7602)
			Grade No. 2	95.510 - 95.520 (3.7602 - 3.7606)
			Grade No. 3	95.520 - 95.530 (3.7606 - 3.7610)
		Wear limit		0.2 (0.008)
Out-of-round		Limit		0.015 (0.0006)
Taper				0.010 (0.0004)
Main bearing housing inner diameter grade (Without bearing)		Grade No. A		69.993 - 69.994 (2.7556 - 2.7557)
		Grade No. B		69.994 - 69.995 (2.7557 - 2.7557)
		Grade No. C		69.995 - 69.996 (2.7557 - 2.7557)
		Grade No. D		69.996 - 69.997 (2.7557 - 2.7558)
		Grade No. E		69.997 - 69.998 (2.7558 - 2.7558)
		Grade No. F		69.998 - 69.999 (2.7558 - 2.7559)
		Grade No. G		69.999 - 70.000 (2.7559 - 2.7559)
		Grade No. H		70.000 - 70.001 (2.7559 - 2.7559)
		Grade No. J		70.001 - 70.002 (2.7559 - 2.7560)
		Grade No. K		70.002 - 70.003 (2.7560 - 2.7560)
		Grade No. L		70.003 - 70.004 (2.7560 - 2.7561)
		Grade No. M		70.004 - 70.005 (2.7561 - 2.7561)
		Grade No. N		70.005 - 70.006 (2.7561 - 2.7561)
		Grade No. P		70.006 - 70.007 (2.7561 - 2.7562)
		Grade No. R		70.007 - 70.008 (2.7562 - 2.7562)
		Grade No. S		70.008 - 70.009 (2.7562 - 2.7563)
		Grade No. T		70.009 - 70.010 (2.7563 - 2.7563)
Grade No. U		70.010 - 70.011 (2.7563 - 2.7563)		
Grade No. V		70.011 - 70.012 (2.7563 - 2.7564)		
Grade No. W		70.012 - 70.013 (2.7564 - 2.7564)		
Grade No. X		70.013 - 70.014 (2.7564 - 2.7565)		
Grade No. Y		70.014 - 70.015 (2.7565 - 2.7565)		
Grade No. 4		70.015 - 70.016 (2.7565 - 2.7565)		
Grade No. 7		70.016 - 70.017 (2.7565 - 2.7566)		
Difference in inner diameter between cylinders		Standard		Less than 0.03 (0.0012)

AVAILABLE PISTON

SERVICE DATA AND SPECIFICATIONS (SDS)

< SERVICE DATA AND SPECIFICATIONS (SDS)

Unit: mm (in)

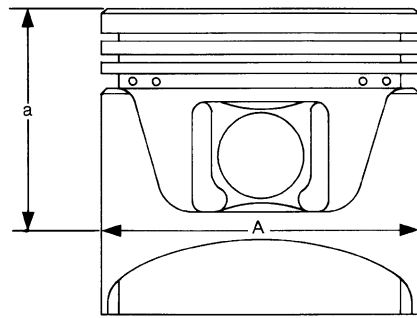

Items		Standard	Oversize (Service) [0.2 (0.008)]
Piston skirt diameter "A"	Grade No. 1	95.480 - 95.490 (3.7590 - 3.7594)	—
	Grade No. 2	95.490 - 95.500 (3.7594 - 3.7598)	—
	Grade No. 3	95.500 - 95.510 (3.7598 - 3.7602)	—
	Service	—	95.680 - 95.710 (3.7669 - 3.7681)
Items		Standard	Limit
"a" dimension		38.8 (1.528)	—
Piston pin hole diameter	Grade No. 0	21.993 - 21.999 (0.8659 - 0.8661)	—
	Grade No. 1	21.999 - 22.005 (0.8661 - 0.8663)	—
Piston to cylinder bore clearance		0.010 - 0.030 (0.0004 - 0.0012)	0.08 (0.0031)

PISTON RING

Unit: mm (in)

Items		Standard	Limit
Side clearance	Top	0.040 - 0.080 (0.0016 - 0.0031)	0.11 (0.0043)
	2nd	0.030 - 0.070 (0.0012 - 0.0028)	0.10 (0.0039)
	Oil ring	0.055 - 0.155 (0.0022 - 0.0061)	0.19 (0.0075)
End gap	Top	0.23 - 0.33 (0.0091 - 0.0130)	0.42 (0.0169)
	2nd	0.23 - 0.33 (0.0091 - 0.0130)	0.57 (0.0224)
	Oil (rail ring)	0.17 - 0.47 (0.0067 - 0.0185)	0.63 (0.0248)

PISTON PIN

Unit: mm (in)

Items		Standard	Limit
Piston pin outer diameter	Grade No. 0	21.989 - 21.995 (0.8657 - 0.8659)	—
	Grade No. 1	21.995 - 22.001 (0.8659 - 0.8662)	—
Piston to piston pin oil clearance		0.002 - 0.006 (0.0001 - 0.0002)	—
Connecting rod bushing oil clearance		0.005 - 0.017 (0.0002 - 0.0007)	0.030 (0.0012)

CONNECTING ROD

Unit: mm (in)

Items		Standard	Limit
Center distance		149.45 - 149.55 (5.88 - 5.89)	—
Bend [per 100 (3.94)]		—	0.15 (0.0059)
Torsion [per 100 (3.94)]		—	0.30 (0.0118)
Connecting rod bushing inner diameter*	Grade No. 0	22.000 - 22.006 (0.8661 - 0.8664)	—
	Grade No. 1	22.006 - 22.012 (0.8664 - 0.8666)	—

SERVICE DATA AND SPECIFICATIONS (SDS)

< SERVICE DATA AND SPECIFICATIONS (SDS)

Connecting rod big end diameter (Without bearing)	Grade No. A	57.000 - 57.001 (2.2441 - 2.2441)	—
	Grade No. B	57.001 - 57.002 (2.2441 - 2.2442)	—
	Grade No. C	57.002 - 57.003 (2.2442 - 2.2442)	—
	Grade No. D	57.003 - 57.004 (2.2442 - 2.2442)	—
	Grade No. E	57.004 - 57.005 (2.2442 - 2.2443)	—
	Grade No. F	57.005 - 57.006 (2.2443 - 2.2443)	—
	Grade No. G	57.006 - 57.007 (2.2443 - 2.2444)	—
	Grade No. H	57.007 - 57.008 (2.2444 - 2.2444)	—
	Grade No. J	57.008 - 57.009 (2.2444 - 2.2444)	—
	Grade No. K	57.009 - 57.010 (2.2444 - 2.2445)	—
	Grade No. L	57.010 - 57.011 (2.2445 - 2.2445)	—
	Grade No. M	57.011 - 57.012 (2.2445 - 2.2446)	—
	Grade No. N	57.012 - 57.013 (2.2446 - 2.2446)	—
	Items	Standard	Limit
Side clearance	0.20 - 0.35 (0.0079 - 0.0138)	0.40 (0.0157)	

*: After installing in connecting rod

CRANKSHAFT

Unit: mm (in)

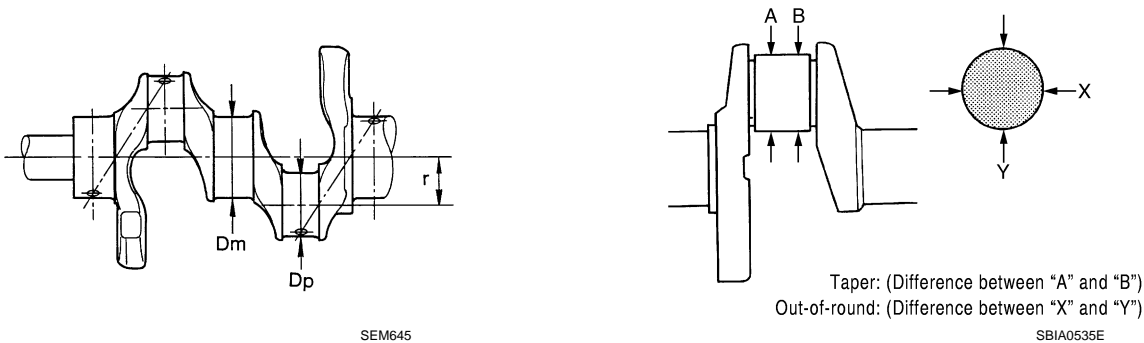

Main journal diameter. "Dm" grade	Standard	Grade No. A	64.975 - 64.974 (2.5581 - 2.5580)
		Grade No. B	64.974 - 64.973 (2.5580 - 2.5580)
		Grade No. C	64.973 - 64.972 (2.5580 - 2.5579)
		Grade No. D	64.972 - 64.971 (2.5579 - 2.5579)
		Grade No. E	64.971 - 64.970 (2.5579 - 2.5579)
		Grade No. F	64.970 - 64.969 (2.5579 - 2.5578)
		Grade No. G	64.969 - 64.968 (2.5578 - 2.5578)
		Grade No. H	64.968 - 64.967 (2.5578 - 2.5578)
		Grade No. J	64.967 - 64.966 (2.5578 - 2.5577)
		Grade No. K	64.966 - 64.965 (2.5577 - 2.5577)
		Grade No. L	64.965 - 64.964 (2.5577 - 2.5576)
		Grade No. M	64.964 - 64.963 (2.5576 - 2.5576)
		Grade No. N	64.963 - 64.962 (2.5576 - 2.5576)
		Grade No. P	64.962 - 64.961 (2.5576 - 2.5575)
		Grade No. R	64.961 - 64.960 (2.5575 - 2.5575)
		Grade No. S	64.960 - 64.959 (2.5575 - 2.5574)
		Grade No. T	64.959 - 64.958 (2.5574 - 2.5574)
		Grade No. U	64.958 - 64.957 (2.5574 - 2.5574)
		Grade No. V	64.957 - 64.956 (2.5574 - 2.5573)
		Grade No. W	64.956 - 64.955 (2.5573 - 2.5573)
Grade No. X	64.955 - 64.954 (2.5573 - 2.5572)		
Grade No. Y	64.954 - 64.953 (2.5572 - 2.5572)		
Grade No. 4	64.953 - 64.952 (2.5572 - 2.5572)		
Grade No. 7	64.952 - 64.951 (2.5572 - 2.5571)		

SERVICE DATA AND SPECIFICATIONS (SDS)

< SERVICE DATA AND SPECIFICATIONS (SDS)

Pin journal diameter. "Dp" grade	Standard	Grade No. A	53.974 - 53.973 (2.1250 - 2.1249)
		Grade No. B	53.973 - 53.972 (2.1249 - 2.1249)
		Grade No. C	53.972 - 53.971 (2.1249 - 2.1248)
		Grade No. D	53.971 - 53.970 (2.1248 - 2.1248)
		Grade No. E	53.970 - 53.969 (2.1248 - 2.1248)
		Grade No. F	53.969 - 53.968 (2.1248 - 2.1247)
		Grade No. G	53.968 - 53.967 (2.1247 - 2.1247)
		Grade No. H	53.967 - 53.966 (2.1247 - 2.1246)
		Grade No. J	53.966 - 53.965 (2.1246 - 2.1246)
		Grade No. K	53.965 - 53.964 (2.1246 - 2.1246)
		Grade No. L	53.964 - 53.963 (2.1246 - 2.1245)
		Grade No. M	53.963 - 53.962 (2.1245 - 2.1245)
		Grade No. N	53.962 - 53.961 (2.1245 - 2.1244)
		Grade No. P	53.961 - 53.960 (2.1244 - 2.1244)
		Grade No. R	53.960 - 53.959 (2.1244 - 2.1244)
		Grade No. S	53.959 - 53.958 (2.1244 - 2.1243)
		Grade No. T	53.958 - 53.957 (2.1243 - 2.1243)
Grade No. U	53.957 - 53.956 (2.1243 - 2.1242)		
Center distance "r"		42.96 - 43.04 (1.6913 - 1.6945)	
Taper (Difference between "A" and "B")	Limit	0.0025 (0.0001)	
Out-of-round (Difference between "X" and "Y")		0.0025 (0.0001)	
Crankshaft runout [TIR*]	Standard	Less than 0.05 (0.0020)	
	Limit	0.10 (0.0039)	
Crankshaft end play	Standard	0.10 - 0.25 (0.0039 - 0.0098)	
	Limit	0.30 (0.0118)	

*: Total indicator reading

Main Bearing

INFOID:000000008154487

MAIN BEARING

Unit: mm (in)

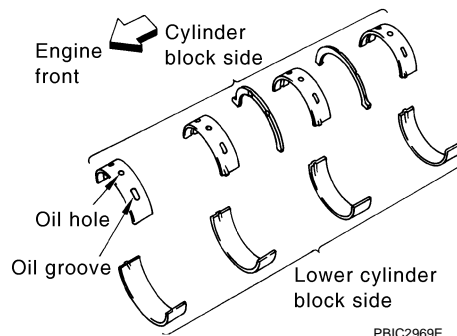

Grade number	Thickness	Width	Identification color	Remarks
--------------	-----------	-------	----------------------	---------

SERVICE DATA AND SPECIFICATIONS (SDS)

< SERVICE DATA AND SPECIFICATIONS (SDS)

Grade	Type	Thickness	Main journal diameter	Identification color (mark)	Remarks
0		2.500 - 2.503 (0.0984 - 0.0985)	19.9 - 20.1 (0.783 - 0.791)	Black	Grade is the same for upper and lower bearings.
1		2.503 - 2.506 (0.0985 - 0.0987)		Brown	
2		2.506 - 2.509 (0.0987 - 0.0988)		Green	
3		2.509 - 2.512 (0.0988 - 0.0989)		Yellow	
4		2.512 - 2.515 (0.0989 - 0.0990)		Blue	
5		2.515 - 2.518 (0.0990 - 0.0991)		Pink	
6		2.518 - 2.521 (0.0991 - 0.0993)		Purple	
7		2.521 - 2.524 (0.0993 - 0.0994)		White	
01	UPR	2.503 - 2.506 (0.0985 - 0.0987)		Brown	Grade and color are different for upper and lower bearings.
	LWR	2.500 - 2.503 (0.0984 - 0.0985)		Black	
12	UPR	2.506 - 2.509 (0.0987 - 0.0988)		Green	
	LWR	2.503 - 2.506 (0.0985 - 0.0987)		Brown	
23	UPR	2.509 - 2.512 (0.0988 - 0.0989)		Yellow	
	LWR	2.506 - 2.509 (0.0987 - 0.0988)		Green	
34	UPR	2.512 - 2.515 (0.0989 - 0.0990)	Blue		
	LWR	2.509 - 2.512 (0.0988 - 0.0989)	Yellow		
45	UPR	2.515 - 2.518 (0.0990 - 0.0991)	Pink		
	LWR	2.512 - 2.515 (0.0989 - 0.0990)	Blue		
56	UPR	2.518 - 2.521 (0.0991 - 0.0993)	Purple		
	LWR	2.515 - 2.518 (0.0990 - 0.0991)	Pink		
67	UPR	2.521 - 2.524 (0.0993 - 0.0994)	White		
	LWR	2.518 - 2.521 (0.0991 - 0.0993)	Purple		

UNDERSIZE

Unit: mm (in)

Items	Thickness	Main journal diameter
0.25 (0.0098)	2.633 - 2.641 (0.1037 - 0.1040)	Grind so that bearing clearance is the specified value.

MAIN BEARING OIL CLEARANCE

Unit: mm (in)

Items	Standard	Limit
Main bearing oil clearance	0.035 - 0.045 (0.0014 - 0.0018)*	0.065 (0.0026)

*: Actual clearance

Connecting Rod Bearing

INFOID:000000008154488

CONNECTING ROD BEARING

Unit: mm (in)

Grade number	Thickness	Identification color (mark)
0	1.497 - 1.500 (0.0589 - 0.0591)	Black
1	1.500 - 1.503 (0.0591 - 0.0592)	Brown
2	1.503 - 1.506 (0.0592 - 0.0593)	Green
3	1.506 - 1.509 (0.0593 - 0.0594)	Yellow
4	1.509 - 1.512 (0.0594 - 0.0595)	Blue

UNDERSIZE

Unit: mm (in)

Items	Thickness	Crank pin journal diameter
0.25 (0.0098)	1.626 - 1.634 (0.0640 - 0.0643)	Grind so that bearing clearance is the specified value.

SERVICE DATA AND SPECIFICATIONS (SDS)

< SERVICE DATA AND SPECIFICATIONS (SDS)

CONNECTING ROD BEARING OIL CLEARANCE

Unit: mm (in)

Items	Standard	Limit
Connecting rod bearing oil clearance	0.040 - 0.053 (0.0016 - 0.0021)*	0.070 (0.0028)

*: Actual clearance

A

EM

C

D

E

F

G

H

I

J

K

L

M

N

O

P