

SECTION **RAX**  
REAR AXLE

A  
B  
C

RAX

CONTENTS

E

<b>SYMPTOM DIAGNOSIS</b> .....	2	<b>REMOVAL AND INSTALLATION</b> .....	7	F
<b>NOISE, VIBRATION AND HARSHNESS (NVH) TROUBLESHOOTING</b> .....	2	<b>REAR WHEEL HUB AND HOUSING</b> .....	7	G
NVH Troubleshooting Chart .....	2	Exploded View .....	7	
<b>PRECAUTION</b> .....	3	Removal and Installation .....	7	
<b>PRECAUTIONS</b> .....	3	Inspection .....	9	H
Precautions for Drive Shaft .....	3	<b>REAR DRIVE SHAFT</b> .....	10	
<b>PREPARATION</b> .....	4	Exploded View .....	10	
<b>PREPARATION</b> .....	4	Removal and Installation .....	10	I
Special Service Tool .....	4	<b>WHEEL SIDE</b> .....	12	
Commercial Service Tool .....	4	WHEEL SIDE : Disassembly and Assembly .....	12	J
<b>PERIODIC MAINTENANCE</b> .....	5	<b>FINAL DRIVE SIDE</b> .....	13	
<b>REAR WHEEL HUB AND HOUSING</b> .....	5	FINAL DRIVE SIDE : Disassembly and Assembly...13		
Inspection .....	5	Inspection .....	15	K
<b>REAR DRIVE SHAFT</b> .....	6	<b>SERVICE DATA AND SPECIFICATIONS (SDS)</b> .....	16	L
Inspection .....	6	<b>SERVICE DATA AND SPECIFICATIONS (SDS)</b> .....	16	
		Wheel Bearing .....	16	M
		Drive Shaft .....	16	

F  
G  
H  
I  
J  
K  
L  
M  
N  
O  
P

# NOISE, VIBRATION AND HARSHNESS (NVH) TROUBLESHOOTING

< SYMPTOM DIAGNOSIS >

## SYMPTOM DIAGNOSIS

### NOISE, VIBRATION AND HARSHNESS (NVH) TROUBLESHOOTING

#### NVH Troubleshooting Chart

INFOID:000000008154172

Use chart below to find the cause of the symptom. If necessary, repair or replace these parts.

Reference			—	<a href="#">RAX-15</a>	—	<a href="#">RAX-7</a>	—	NVH in DLN section.	NVH in DLN section.	NVH in RAX and RSU sections.	Refer to REAR AXLE in this chart.	NVH in WT section.	NVH in WT section.	Refer to DRIVE SHAFT in this chart.	NVH in BR section.	NVH in ST section.	
Possible cause and SUSPECTED PARTS			Excessive joint angle	Joint sliding resistance	Imbalance	Improper installation, looseness	Parts interference	PROPELLER SHAFT	DIFFERENTIAL	REAR AXLE AND REAR SUSPENSION	REAR AXLE	TIRE	ROAD WHEEL	DRIVE SHAFT	BRAKE	STEERING	
Symptom	DRIVE SHAFT	Noise	x	x				x	x	x	x	x	x		x	x	
		Shake	x		x			x		x	x	x	x		x	x	
	REAR AXLE	Noise				x	x	x	x	x		x	x	x	x	x	x
		Shake				x	x	x		x		x	x	x	x	x	x
		Vibration				x	x	x		x		x		x			x
		Shimmy				x	x			x		x	x			x	x
		Judder				x				x		x	x			x	x
Poor quality ride or handling				x	x			x		x	x						

x: Applicable

# PRECAUTIONS

< PRECAUTION >

## PRECAUTION

### PRECAUTIONS

#### Precautions for Drive Shaft

INFOID:000000008154173

- Observe the following precautions when disassembling and assembling drive shaft.
- Never disassemble joint sub-assembly because it is non-overhaul parts.
- Perform work in a location which is as dust-free as possible.
- Clean the parts, before disassembling and assembling.
- Prevent the entry of foreign objects during disassembly of the service location.
- Reassemble disassembled parts carefully in the correct order. If work is interrupted, a clean cover must be placed over parts.
- Use paper waste. Fabric shop cloths must not be used because of the danger of lint adhering to parts.
- Clean disassembled parts (except for rubber parts) with kerosene which shall be removed by blowing with air or wiping with paper waste.

A

B

C

RAX

E

F

G

H

I

J

K

L

M

N

O

P

# PREPARATION

< PREPARATION >

## PREPARATION

### PREPARATION

#### Special Service Tool

INFOID:000000008154174

The actual shapes of Kent-Moore tools may differ from those of special service tools illustrated here.

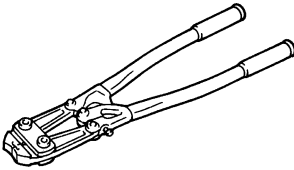
Tool number (Kent-Moore No.) Tool name	Description
KV40107300 ( - ) Boot band crimping tool	Installing boot band
 <p style="text-align: center; font-size: small;">ZZA1229D</p>	

#### Commercial Service Tool

INFOID:000000008154175

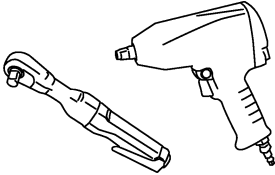
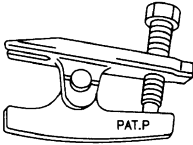
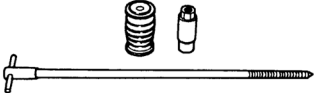
Tool name	Description
Power tool	Loosening bolts and nuts
 <p style="text-align: center; font-size: small;">PBIC0190E</p>	
Ball joint remover	Removing ball joint from axle housing
 <p style="text-align: center; font-size: small;">PAT.P</p> <p style="text-align: center; font-size: x-small;">NT146</p>	
Drive shaft puller	Removing drive shaft joint sub assembly
 <p style="text-align: center; font-size: x-small;">JPDIG0152ZZ</p>	

# REAR WHEEL HUB AND HOUSING

< PERIODIC MAINTENANCE >

## PERIODIC MAINTENANCE

### REAR WHEEL HUB AND HOUSING

#### Inspection

INFOID:000000008154176

#### MOUNTING INSPECTION

Check the mounting conditions (looseness, back lash) of each component and component conditions (wear, damage) are normal.

#### WHEEL BEARING INSPECTION

- Move wheel hub and bearing assembly in the axial direction by hand. Check there is no looseness of wheel bearing.

**Axial end play** : Refer to [RAX-16. "Wheel Bearing"](#).

- Rotate wheel hub and bearing assembly and check that is no unusual noise or other irregular conditions. If there is any of irregular conditions, replace wheel hub and bearing assembly.

A  
B  
C  
RAX  
E  
F  
G  
H  
I  
J  
K  
L  
M  
N  
O  
P

## REAR DRIVE SHAFT

< PERIODIC MAINTENANCE >

---

### REAR DRIVE SHAFT

#### Inspection

INFOID:000000008154177

- Check drive shaft mounting point and joint for looseness and other damage.
- Check boot for cracks and other damage.

**CAUTION:**

**Replace entire drive shaft assembly when noise or vibration occurs from drive shaft.**

# REAR WHEEL HUB AND HOUSING

< REMOVAL AND INSTALLATION >

## REMOVAL AND INSTALLATION

### REAR WHEEL HUB AND HOUSING

Exploded View

INFOID:000000008154178

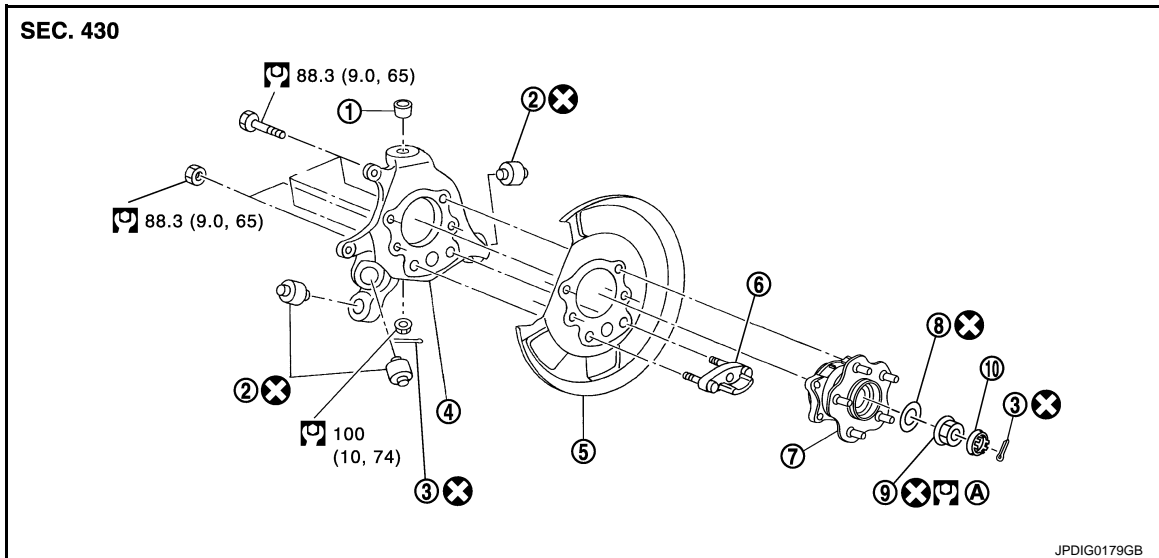

- |                                   |                  |                       |
|-----------------------------------|------------------|-----------------------|
| 1. Ball seat                      | 2. Bushing       | 3. Cotter pin         |
| 4. Axle housing                   | 5. Back plate    | 6. Anchor block       |
| 7. Wheel hub and bearing assembly | 8. Spring washer | 9. Wheel hub lock nut |
| 10. Adjusting cap                 |                  |                       |
- A. Tightening must be done following the installation procedure. Refer to [RAX-7, "Removal and Installation"](#).

Refer to [GI-4, "Components"](#) for symbols in the figure.

### Removal and Installation

INFOID:000000008154179

#### REMOVAL

1. Remove tires with power tool. Refer to [WT-45, "Exploded View"](#).
  2. Remove caliper assembly. Hang caliper assembly in a place where it will not interfere with work. Refer to [BR-54, "BRAKE CALIPER ASSEMBLY \(1 PISTON TYPE\) : Exploded View"](#) (1 piston type) or [BR-58, "BRAKE CALIPER ASSEMBLY \(2 PISTON TYPE\) : Exploded View"](#) (2 piston type).
- CAUTION:**  
**Never depress brake pedal while caliper assembly is removed.**
3. Remove disc rotor. Refer to [BR-55, "BRAKE CALIPER ASSEMBLY \(1 PISTON TYPE\) : Removal and Installation"](#) (1 piston type) or [BR-59, "BRAKE CALIPER ASSEMBLY \(2 PISTON TYPE\) : Removal and Installation"](#) (2 piston type).
  4. Remove cotter pin and adjusting cap, then loosen wheel hub lock nut with a power tool.

## REAR WHEEL HUB AND HOUSING

### < REMOVAL AND INSTALLATION >

- Put matching marks (A) on drive shaft and wheel hub and bearing assembly.

**CAUTION:**

Use paint or similar substance for matching marks. Never scratch the surface.

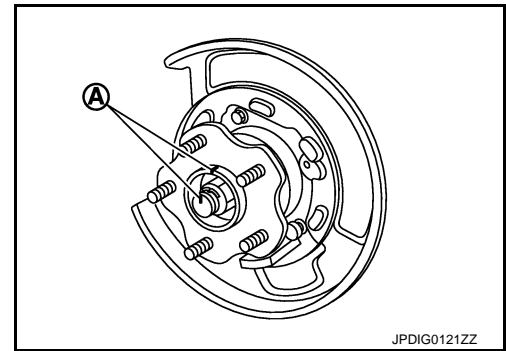

- Patch wheel hub lock nut with a piece of wood. Hammer the wood to disengage wheel hub and bearing assembly from drive shaft.

**CAUTION:**

- Never place drive shaft joint at an extreme angle. Also be careful not to overextend slide joint.
- Never allow drive shaft to hang down without support for counterpart such as joint sub-assembly, and other parts.

**NOTE:**

Use a suitable puller, if wheel hub and bearing assembly and drive shaft cannot be separated even after performing the above procedure.

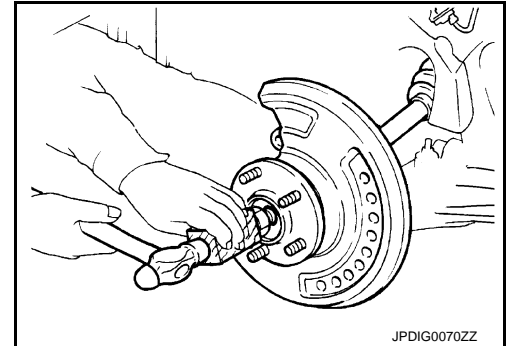

- Remove wheel hub lock nut and spring washer.
- Remove parking brake shoe and parking brake cable. Refer to [PB-9, "Exploded View"](#) and [PB-6, "PEDAL TYPE : Exploded View"](#) (pedal type) or [PB-7, "LEVER TYPE : Exploded View"](#) (lever type).
- Remove stabilizer connecting rod (upper side) with power tool. Refer to [RSU-16, "Exploded View"](#).
- Remove coil spring. Refer to [RSU-8, "Exploded View"](#).
- Set suitable jack under axle housing.
- Remove radius rod. Refer to [RSU-14, "Exploded View"](#).
- Remove shock absorber (lower side) with power tool. Refer to [RSU-10, "Exploded View"](#).
- Remove front lower link (axle housing side). Refer to [RSU-15, "Exploded View"](#).
- Remove rear lower link (axle housing side). Refer to [RSU-8, "Exploded View"](#).
- Separate axle housing from suspension arm, using the ball joint remover (commercial service tool), and then remove axle housing.

**CAUTION:**

- Temporarily tighten nuts to prevent damage to threads and to prevent the ball joint remover from coming off.
- Never place drive shaft joint at an extreme angle. Also be careful not to overextend slide joint.
- Never allow drive shaft to hang down without support for counterpart such as joint sub-assembly, and other parts.

- Remove the wheel hub and bearing assembly.
- Remove anchor block and back plate from axle housing.

### INSTALLATION

Note the following, and install in the reverse order of removal.

- Clean the matching surface of wheel hub lock nut and wheel hub and bearing assembly.

**CAUTION:**

Never apply lubricating oil to these matching surface.



# REAR WHEEL HUB AND HOUSING

## < REMOVAL AND INSTALLATION >

- Clean the matching surface of drive shaft and wheel hub and bearing assembly. And then apply paste [service parts (440037S000)] to surface (A) of joint sub-assembly of drive shaft.

**CAUTION:**

**Apply paste to cover entire flat surface of joint sub-assembly of drive shaft.**

**Amount paste      1.0 – 3.0 g (0.04 – 0.10 oz)**

- When installing drive shaft, change the drive shaft and wheel hub and bearing assembly matching marks put at the removal step by 180 degree.
- Use the following torque range for tightening the wheel hub lock nut.

 : **100 – 105 N·m (10 – 11 kg·m, 74 – 77 ft·lb)**

**CAUTION:**

- **Since the drive shaft is assembled by press-fitting, use the tightening torque range for the wheel hub lock nut.**
- **Be sure to use torque wrench to tighten the wheel hub lock nut. Never use a power tool.**
- **Never reuse wheel hub lock nut.**

**NOTE:**

Wheel hub lock nut tightening torque does not over torque for avoiding axle noise, and does not less than torque for avoiding looseness.

- When installing the spring washer, face the identification paint mark to the wheel hub and bearing assembly side.

**CAUTION:**

**Never reuse spring washer.**

- Align the matching marks that have been made during removal when reusing the disc rotor.
- When installing a cotter pin (1) and adjusting cap (2), securely bend the basal portion to prevent rattles.

**CAUTION:**

**Never reuse cotter pin.**

- Perform the final tightening of each of parts under unladen conditions, which were removed when removing wheel hub assembly and axle housing.
- Never reuse bushing. Refer to [RAX-7. "Exploded View"](#).
- Perform inspection after installation. Refer to [RAX-9. "Inspection"](#).

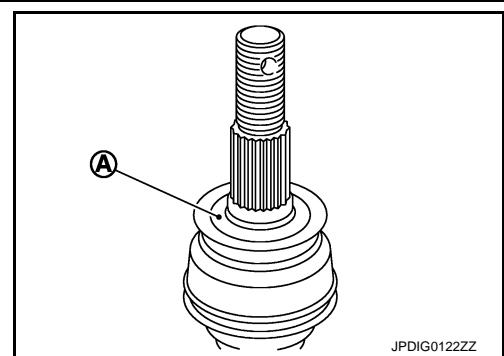

A

B

C

RAX

E

F

G

H

I

J

K

L

M

N

O

P

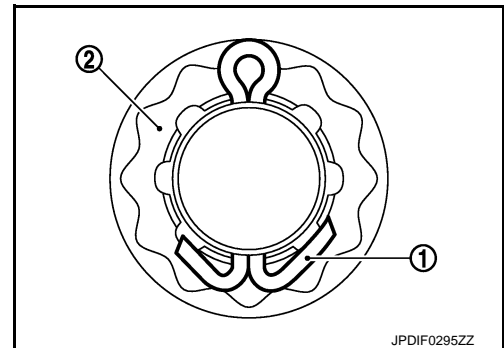

INFOID:000000008154180

## Inspection

### INSPECTION AFTER REMOVAL

#### Wheel Hub and Bearing Assembly

Check the wheel hub and bearing assembly for wear, cracks, and damage. Replace if necessary.

#### Axle Housing

Check the axle housing for wear, cracks, and damage. Replace if necessary.

#### Ball Joint Inspection

Check for boot breakage, axial looseness, and torque of suspension arm ball joint. Refer to [RSU-12. "Inspection"](#).

### INSPECTION AFTER INSTALLATION

1. Adjust parking brake operation (stroke). Refer to [PB-3. "PEDAL TYPE : Inspection and Adjustment"](#) (pedal type) or [PB-3. "LEVER TYPE : Inspection and Adjustment"](#) (lever type).
2. Check wheel alignment. Refer to [RSU-6. "Inspection"](#).
3. Adjust neutral position of steering angle sensor. Refer to [BRC-9. "ADJUSTMENT OF STEERING ANGLE SENSOR NEUTRAL POSITION : Special Repair Requirement"](#).

# REAR DRIVE SHAFT

< REMOVAL AND INSTALLATION >

## REAR DRIVE SHAFT

Exploded View

INFOID:000000008154181

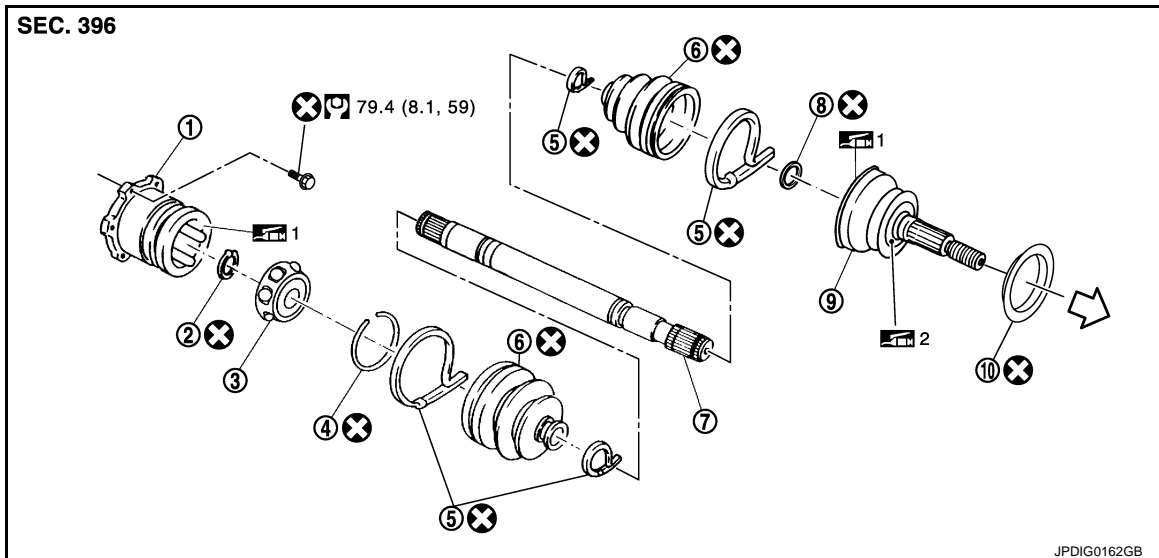

- |                 |                  |   |
|-----------------|------------------|---|
| 1. Housing      | 2. Snap ring     | 3. Ball cage/steel ball/inner race assembly |
| 4. Stopper ring | 5. Boot band     | 6. Boot                                     |
| 7. Shaft        | 8. Circular clip | 9. Joint sub-assembly                       |
| 10. Dust shield |                  |   |

⇐: Wheel side

1: NISSAN genuine grease or an equivalent.

2: Apply paste [service parts (440037S000)].

Refer to [GI-4, "Components"](#) for symbols not described on the above.

## Removal and Installation

INFOID:000000008154182

### REMOVAL

1. Remove tires with power tool. Refer to [WT-45, "Exploded View"](#).
2. Remove cotter pin and adjusting cap, then loosen wheel hub lock nut with power tool. Refer to [RAX-7, "Exploded View"](#).
3. Put matching marks (A) on drive shaft and wheel hub and bearing assembly.  
**CAUTION:**  
**Use paint or similar substance for matching marks. Never scratch the surface.**
4. Remove diag brace. Refer to [RSU-17, "Exploded View"](#).
5. Remove center muffler. Refer to [EX-5, "Exploded View"](#).

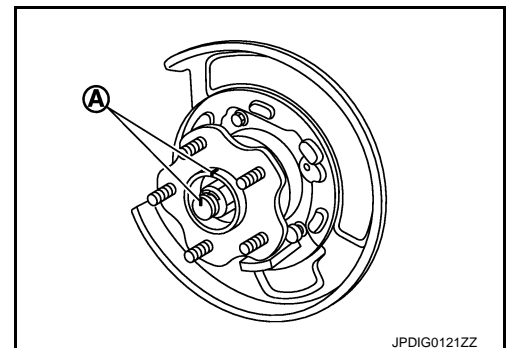

# REAR DRIVE SHAFT

## < REMOVAL AND INSTALLATION >

6. Patch wheel hub lock nut with a piece of wood. Hammer the wood to disengage wheel hub and bearing assembly from drive shaft.

**CAUTION:**

- Never place drive shaft joint at an extreme angle. Also be careful not to overextend slide joint.
- Never allow drive shaft to hang down without support for counterpart such as joint sub-assembly, and other parts.

**NOTE:**

Using a suitable puller if wheel hub and bearing assembly and drive shaft cannot be separated even after performing the above procedure.

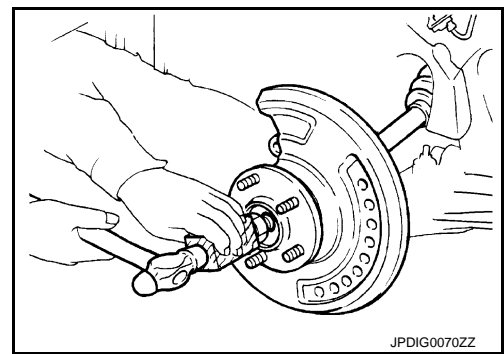

7. Remove wheel hub lock nut and spring washer.
8. Remove mounting bolts between side flange and drive shaft.

## INSTALLATION

Note the following, and install in the reverse order of removal.

- Clean the matching surface of wheel hub lock nut and wheel hub and bearing assembly.

**CAUTION:**

**Never apply lubricating oil to these matching surface.**

- Clean the matching surface of drive shaft and wheel hub and bearing assembly. And then apply paste [service parts (440037S000)] to surface (A) of joint sub-assembly of drive shaft.

**CAUTION:**

**Apply paste to cover entire flat surface of joint sub-assembly of drive shaft.**

**Amount paste      1.0 – 3.0 g (0.04 – 0.10 oz)**

- When installing drive shaft, change the drive shaft and wheel hub and bearing assembly matching marks put at the removal step by 180 degree.
- Use the following torque range for tightening the wheel hub lock nut.

 : 100 – 105 N·m (10 – 11 kg·m, 74 – 77 ft·lb)

**CAUTION:**

- Since the drive shaft is assembled by press-fitting, use the tightening torque range for the wheel hub lock nut.
- Be sure to use torque wrench to tighten the wheel hub lock nut. Never use a power tool.
- Never reuse wheel hub lock nut.

**NOTE:**

Wheel hub lock nut tightening torque does not over torque for avoiding axle noise, and does not less than torque for avoiding looseness.

- When installing the spring washer, face the identification paint mark to the wheel hub and bearing assembly side.

**CAUTION:**

**Never reuse spring washer.**

- Align the matching marks that have been made during removal when reusing the disc rotor.
- When installing a cotter pin (1) and adjusting cap (2), securely bend the basal portion to prevent rattles.

**CAUTION:**

**Never reuse cotter pin.**

- Perform the final tightening of each of parts under unladen conditions, which were removed when removing wheel hub assembly and axle housing.
- Perform inspection after installation. Refer to [RAX-15. "Inspection"](#).

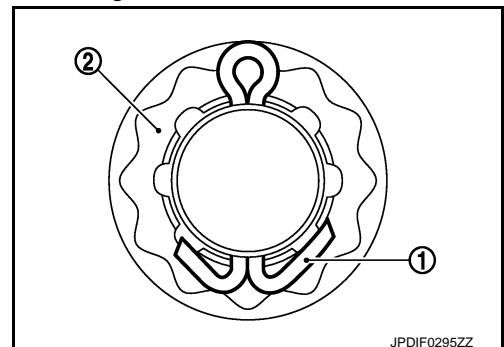
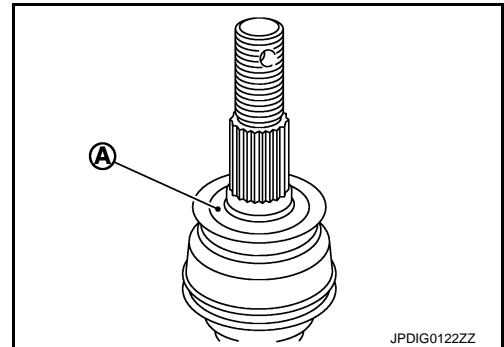

A

B

C

RAX

E

F

G

H

I

J

K

L

M

N

O

P

# REAR DRIVE SHAFT

< REMOVAL AND INSTALLATION >

## WHEEL SIDE

### WHEEL SIDE : Disassembly and Assembly

INFOID:000000008154183

#### DISASSEMBLY

1. Fix shaft with a vise.

**CAUTION:**

**Protect shaft when fixing with a vise using aluminum or copper plates.**

2. Remove dust shield from drive shaft.
3. Remove boot bands, and then remove boot from joint sub-assembly.
4. Screw the drive shaft puller (A) (commercial service tool) 30 mm (1.18 in) or more into the thread of joint sub-assembly, and remove joint sub-assembly from shaft.

**CAUTION:**

- **Align drive shaft puller and drive shaft and remove them by pulling directory.**
- **If joint sub-assembly cannot be removed after five or more unsuccessful attempts, replace shaft and joint sub assembly as a set.**

5. Remove circular clip from shaft.
6. Remove boot from shaft.

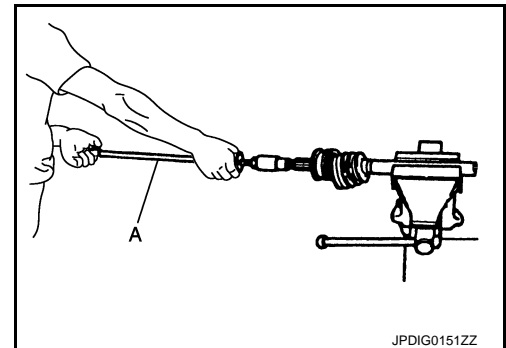

#### ASSEMBLY

1. Clean old grease on joint sub-assembly with paper waste.
2. Fill serration slot joint sub-assembly with NISSAN genuine grease or equivalent until the serration slot and ball groove become full to the brim.

**CAUTION:**

**After applying grease, use a paper waste to wipe off old grease that has oozed out.**

3. Install boot and boot bands to shaft.

**CAUTION:**

- **Wrap serration on shaft with tape to protect the boot from damage.**
- **Never reuse boot and boot band.**

4. Remove the tape wrapped around the serrated on shaft.
5. Position circular clip on groove at the shaft edge.

**CAUTION:**

**Never reuse circular clip.**

6. Align both center axes of the shaft edge and joint sub-assembly. Then assemble shaft with circular clip joint sub-assembly.
7. Install joint sub-assembly to shaft using plastic hammer.

**CAUTION:**

- **Check circular clip is properly positioned on groove of the joint sub-assembly.**
- **Confirm that joint sub-assembly is correctly engaged while rotating drive shaft.**

8. Apply the balance of the specified amount of grease into the boot inside from large diameter side of boot.

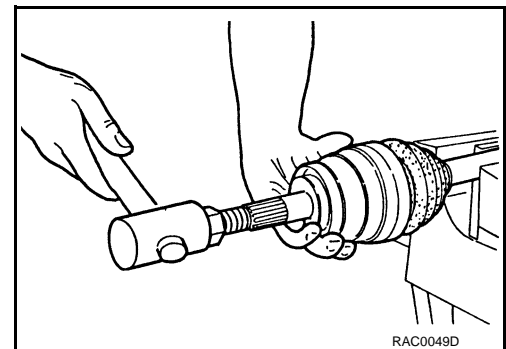

**Grease amount** : Refer to [RAX-16. "Drive Shaft"](#).

# REAR DRIVE SHAFT

## < REMOVAL AND INSTALLATION >

9. Install the boot securely into grooves (indicated by "\*" marks) shown in the figure.

**CAUTION:**

If grease adheres to the boot mounting surface (indicated by "\*" mark) on the shaft or housing, boot may come off. Remove all grease from the surfaces.

10. To prevent the deformation of the boot, adjust the boot installation length (L) to the specified value shown below by inserting the suitable tool into inside of the boot from the large diameter side of boot and discharging the inside air.

**L** : Refer to [RAX-16, "Drive Shaft"](#).

**CAUTION:**

- If the boot installation length is outside the standard, it may cause breakage of the boot.
- Be careful not to touch the inside of the boot with the tip of tool.

11. Secure the ends of the boot with boot bands using the boot band crimping tool (A) [SST: KV40107300 ( - )].

**CAUTION:**

Never reuse boot band.

**NOTE:**

Secure boot band so that dimension (M) meets the specification as shown in the figure.

**M** : 2.0 – 3.0 mm (0.079 – 0.118 in)

12. Secure joint sub-assembly and shaft, and then check that they are in the correct position when rotating boot. Install them with boot band when boot installation positions become incorrect.

**CAUTION:**

Never reuse boot band.

13. Install dust shield to drive shaft.

**CAUTION:**

Never reuse dust shield.

## FINAL DRIVE SIDE

### FINAL DRIVE SIDE : Disassembly and Assembly

INFOID:000000008154184

#### DISASSEMBLY

1. Fix shaft with a vise.

**CAUTION:**

Protect shaft when fixing with a vise using aluminum or copper plates.

2. Remove boot bands, and then remove boot from housing.

3. Put matching marks on housing and shaft.

**CAUTION:**

Use paint or similar substance for matching marks. Never scratch the surface.

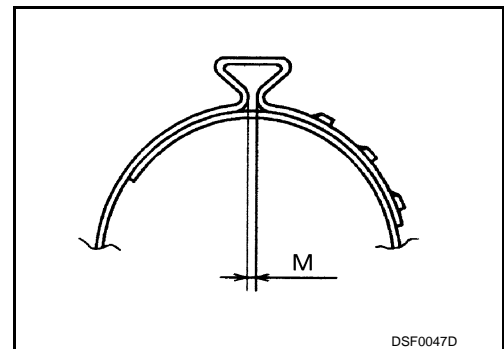
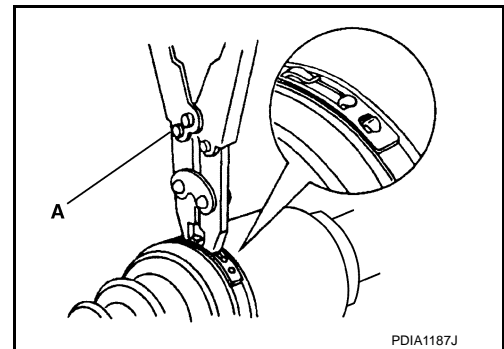
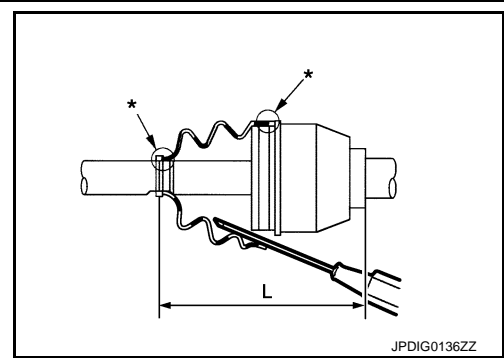

A  
B  
C  
RAX

E  
F  
G  
H  
I

J  
K  
L  
M

N  
O  
P

## REAR DRIVE SHAFT

### < REMOVAL AND INSTALLATION >

4. Remove stopper ring with suitable tool, and pull out housing.
5. Put matching marks on ball cage/steel ball/inner race assembly and shaft.

**CAUTION:**

Use paint or similar substance for matching marks. Never scratch the surface.

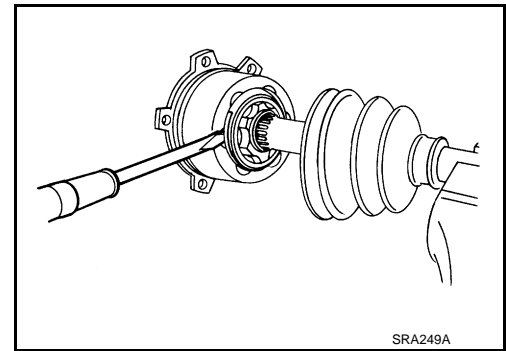

6. Remove snap ring, and then remove ball cage/steel ball/inner race assembly from shaft.
7. Remove boot from shaft.

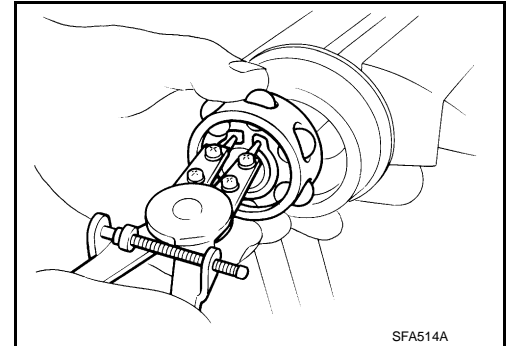

### ASSEMBLY

1. Remove old grease on housing with paper waste.
2. Install boot and boot bands to shaft.  
**CAUTION:**
  - Wrap serration shaft with tape to protect the boot from damage.
  - Never reuse boot and boot bands.
3. Remove the tape wrapped around the serrated on shaft.

4. Install ball cage/steel ball/inner race assembly (1), align it with the matching marks on shaft (2) put during the removal.
5. Secure ball cage/steel ball/inner race assembly onto shaft with snap ring (3).

**CAUTION:**

Never reuse snap ring.

6. Apply the appropriate amount of grease onto housing and sliding surface.

**Grease amount** : Refer to [RAX-16, "Drive Shaft"](#).

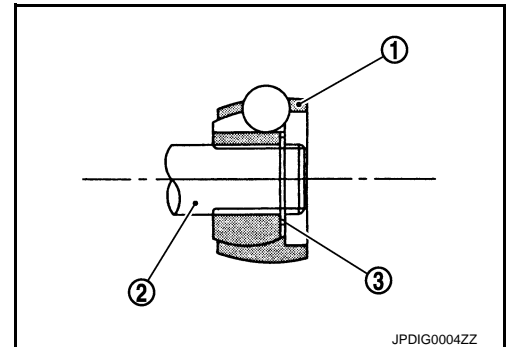

7. Install stopper ring to housing.  
**CAUTION:**  
Never reuse stopper ring.
8. After installed, pull shaft to check engagement between housing and stopper ring.
9. Install boot securely into grooves (indicated by "\*" marks) shown in the figure.

**CAUTION:**

If grease adheres to the boot mounting surfaces (indicated by "\*" marks) on shaft or housing, boot may be removed. Remove all grease from the surfaces.

10. To prevent the deformation of the boot, adjust the boot installation length (L) to the value shown below by inserting the suitable tool into the inside of boot from the large diameter side of boot and discharging inside air.

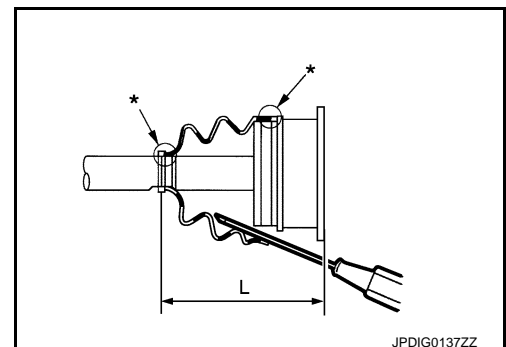

# REAR DRIVE SHAFT

## < REMOVAL AND INSTALLATION >

L : Refer to [RAX-16, "Drive Shaft"](#).

**CAUTION:**

- If the boot installation length is outside the standard, it may cause breakage of the boot.
- Be careful not to touch the inside of the boot with the tip of tool.

11. Install boot bands securely as shown in the figure.

**CAUTION:**

**Never reuse boot bands.**

12. Secure housing and shaft, and then check that they are in the correct position when rotating boot. Install them with boot band when the mounting positions become incorrect.

**CAUTION:**

**Never reuse boot bands.**

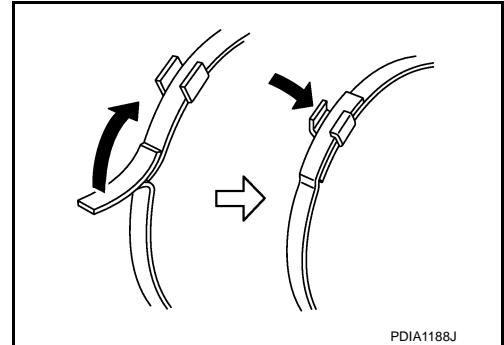

INFOID:000000008154185

## Inspection

### INSPECTION AFTER REMOVAL

- Move joint up/down, left/right, and in the axial direction. Check for any rough movement or significant looseness.
- Check boot for cracks or other damage, and also for grease leakage.
- If a malfunction is found, disassemble drive shaft, and then replace with new one.

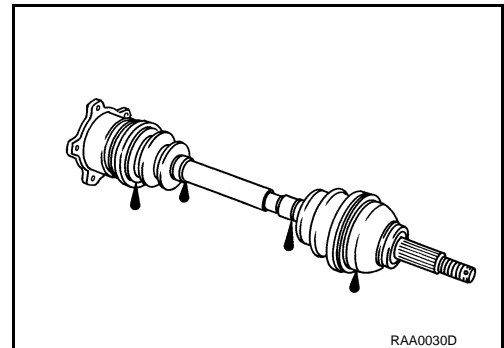

A  
B  
C  
RAX  
E  
F  
G  
H  
I  
J  
K  
L  
M  
N  
O  
P

## SERVICE DATA AND SPECIFICATIONS (SDS)

< SERVICE DATA AND SPECIFICATIONS (SDS)

## SERVICE DATA AND SPECIFICATIONS (SDS)

### SERVICE DATA AND SPECIFICATIONS (SDS)

#### Wheel Bearing

INFOID:000000008154186

Item	Standard
Axial end play	0.05 mm (0.002 in) or less

#### Drive Shaft

INFOID:000000008154187

Item	Standard	
	Wheel side	Final drive side
Joint		
Grease quantity	100 – 120 g (3.53 – 4.23 oz)	105 – 125 g (3.70 – 4.40 oz)
Boots installed length	133.5 mm (5.26 in)	130.2 mm (5.13 in)