

A
CO
C
D
E
F
G
H
I
J
K
L
M
N
O
P

SECTION CO

ENGINE COOLING SYSTEM

CONTENTS

SYSTEM DESCRIPTION	REMOVAL AND INSTALLATION	
DESCRIPTION	RADIATOR	
Engine Cooling System	Exploded View	
Engine Cooling System Schematic	Removal and Installation	
SYMPTOM DIAGNOSIS	Inspection	
OVERHEATING CAUSE ANALYSIS	COOLING FAN	
Troubleshooting Chart	Exploded View	
PRECAUTION	Removal and Installation	
PRECAUTIONS	Disassembly and Assembly	
Precaution for Supplemental Restraint System (SRS) "AIR BAG" and "SEAT BELT PRE-TEN- SIONER"	Inspection	
Precaution for Battery Service	WATER PUMP	
PREPARATION	Exploded View	
PREPARATION	Removal and Installation	
Commercial Service Tools	Inspection	
PERIODIC MAINTENANCE	WATER INLET AND THERMOSTAT ASSEM- BLY	
ENGINE COOLANT	Exploded View	
Inspection	Removal and Installation	
Draining	Inspection	
Refilling	WATER OUTLET AND WATER PIPING	
Flushing	Exploded View	
RADIATOR	Removal and Installation	
RADIATOR CAP	Inspection	
RADIATOR CAP : Inspection	SERVICE DATA AND SPECIFICATIONS (SDS)	
RADIATOR	SERVICE DATA AND SPECIFICATIONS (SDS)	
RADIATOR : Inspection	Periodical Maintenance Specification	
	Radiator	
	Thermostat	

DESCRIPTION

< SYSTEM DESCRIPTION >

SYSTEM DESCRIPTION

DESCRIPTION

Engine Cooling System

INFOID:000000004250561

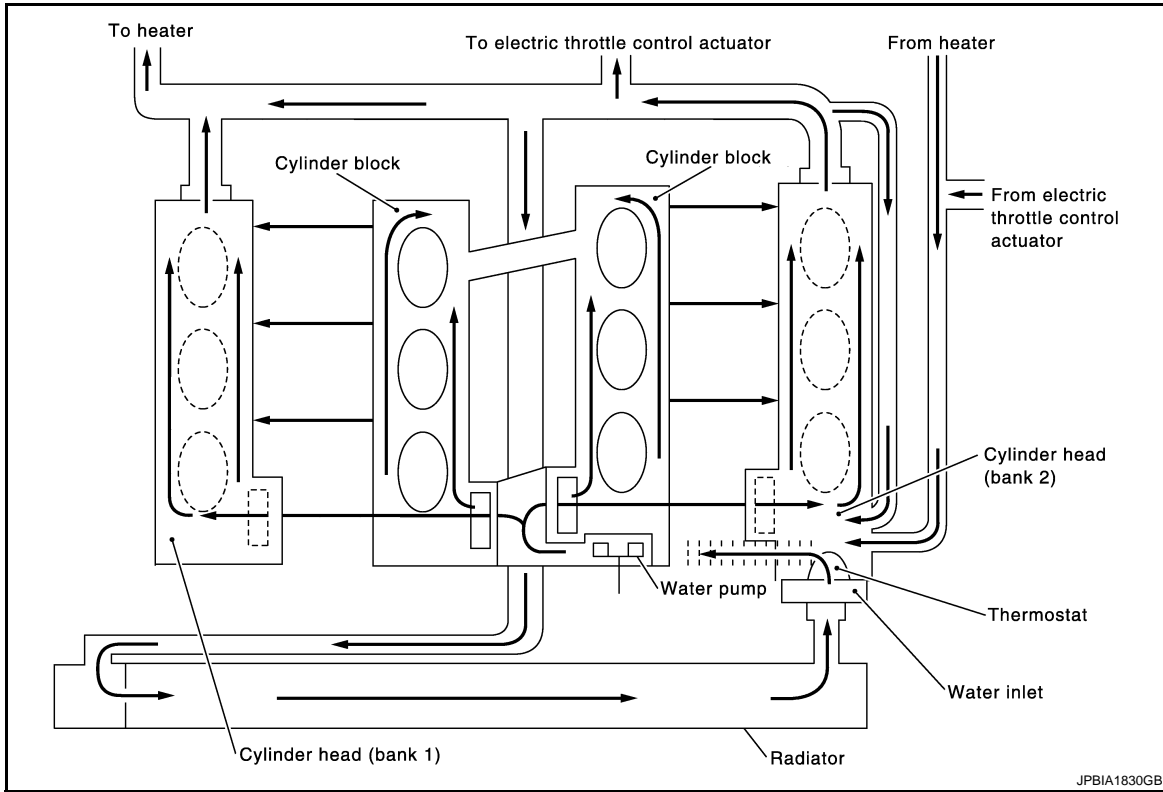

JPBIA1830GB

Engine Cooling System Schematic

INFOID:000000004250562

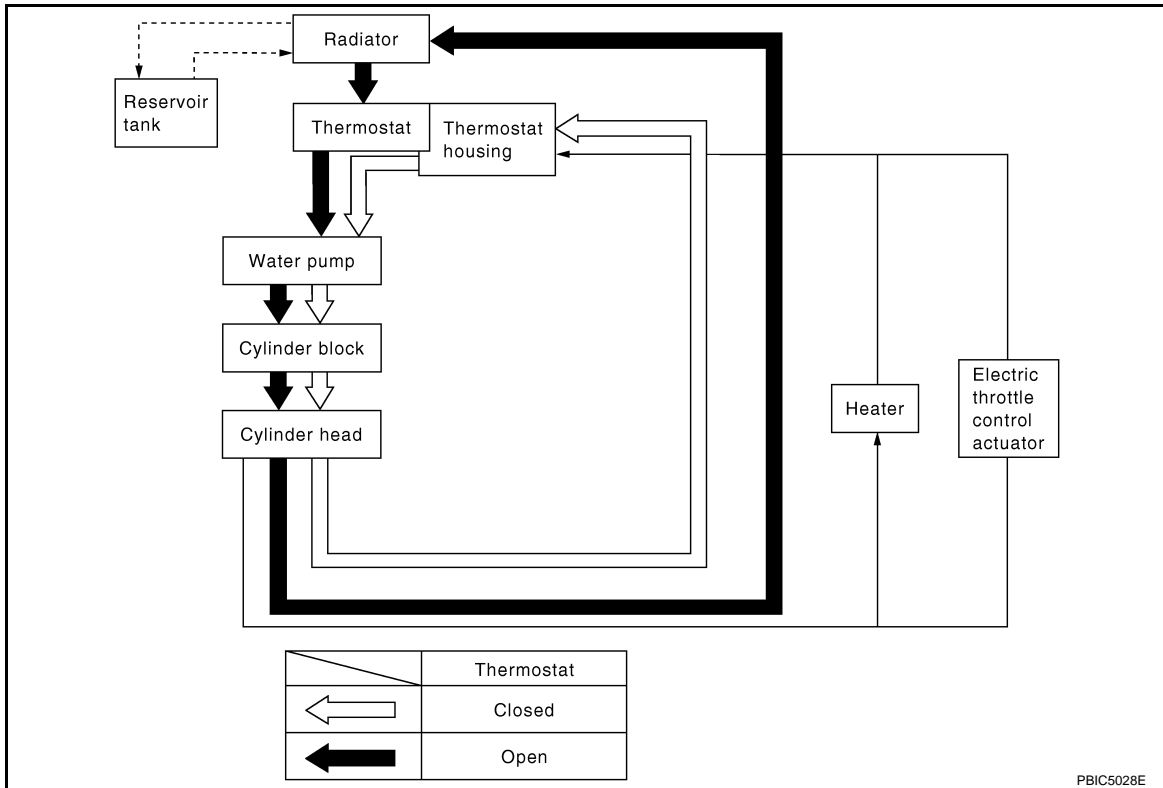

PBIC5028E

OVERHEATING CAUSE ANALYSIS

< SYMPTOM DIAGNOSIS >

SYMPTOM DIAGNOSIS

OVERHEATING CAUSE ANALYSIS

Troubleshooting Chart

INFOID:000000004250563

A

CO

		Symptom	Check items	
Cooling system parts malfunction	Poor heat transfer	Water pump malfunction	Worn or loose drive belt	—
		Thermostat stuck closed	—	
		Damaged fins	Dust contamination or paper clogging	
			Physical damage	
		Clogged radiator cooling tube	Excess foreign material (rust, dirt, sand, etc.)	
	Reduced air flow	Cooling fan does not operate	Fan assembly	—
		High resistance to fan rotation		
		Damaged fan blades		
		Damaged radiator shroud	—	—
		Improper engine coolant mixture ratio	—	—
		Poor engine coolant quality	—	Engine coolant density
	Insufficient engine coolant	Engine coolant leakage	Cooling hose	Loose clamp
				Cracked hose
			Water pump	Poor sealing
			Radiator cap	Loose
Poor sealing				
Radiator			O-ring for damage, deterioration or improper fitting	
		Cracked radiator tank		
		Cracked radiator core		
		Reservoir tank	Cracked reservoir tank	
Overflowing reservoir tank		Exhaust gas leakage into cooling system	Cylinder head deterioration	
	Cylinder head gasket deterioration			

C

D

E

F

G

H

I

J

K

L

M

N

O

P

OVERHEATING CAUSE ANALYSIS

< SYMPTOM DIAGNOSIS >

		Symptom		Check items	
Except cooling system parts malfunction	—	Overload on engine	Abusive driving	High engine rpm under no load	—
				Driving in low gear for extended time	
				Driving at extremely high speed	
			Powertrain system malfunction		
			Installed improper size wheels and tires		
			Dragging brakes		
	Blocked or restricted air flow	Blocked or restricted air flow	Blocked bumper	—	—
			Blocked radiator grille	Installed car brassiere	
				Mud contamination or paper clogging	
			Blocked radiator	—	
Blocked condenser			Blocked air flow		
Installed large fog lamp					

PRECAUTIONS

< PRECAUTION >

PRECAUTION

PRECAUTIONS

Precaution for Supplemental Restraint System (SRS) "AIR BAG" and "SEAT BELT PRE-TENSIONER"

INFOID:000000004685369

The Supplemental Restraint System such as "AIR BAG" and "SEAT BELT PRE-TENSIONER", used along with a front seat belt, helps to reduce the risk or severity of injury to the driver and front passenger for certain types of collision. This system includes seat belt switch inputs and dual stage front air bag modules. The SRS system uses the seat belt switches to determine the front air bag deployment, and may only deploy one front air bag, depending on the severity of a collision and whether the front occupants are belted or unbelted. Information necessary to service the system safely is included in the "SRS AIR BAG" and "SEAT BELT" of this Service Manual.

WARNING:

- To avoid rendering the SRS inoperative, which could increase the risk of personal injury or death in the event of a collision which would result in air bag inflation, all maintenance must be performed by an authorized NISSAN/INFINITI dealer.
- Improper maintenance, including incorrect removal and installation of the SRS, can lead to personal injury caused by unintentional activation of the system. For removal of Spiral Cable and Air Bag Module, see the "SRS AIR BAG".
- Do not use electrical test equipment on any circuit related to the SRS unless instructed to in this Service Manual. SRS wiring harnesses can be identified by yellow and/or orange harnesses or harness connectors.

PRECAUTIONS WHEN USING POWER TOOLS (AIR OR ELECTRIC) AND HAMMERS

WARNING:

- When working near the Air Bag Diagnosis Sensor Unit or other Air Bag System sensors with the ignition ON or engine running, DO NOT use air or electric power tools or strike near the sensor(s) with a hammer. Heavy vibration could activate the sensor(s) and deploy the air bag(s), possibly causing serious injury.
- When using air or electric power tools or hammers, always switch the ignition OFF, disconnect the battery, and wait at least 3 minutes before performing any service.

Precaution for Battery Service

INFOID:000000004704594

Before disconnecting the battery, lower both the driver and passenger windows. This will prevent any interference between the window edge and the vehicle when the door is opened/closed. During normal operation, the window slightly raises and lowers automatically to prevent any window to vehicle interference. The automatic window function will not work with the battery disconnected.

A

CO

C

D

E

F

G

H

I

J

K

L

M

N

O

P

PREPARATION

< PREPARATION >

PREPARATION

PREPARATION

Commercial Service Tools

INFOID:000000004250566

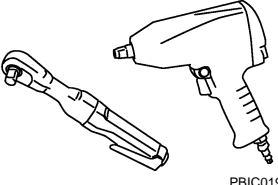
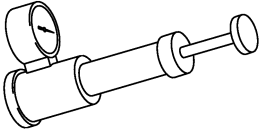
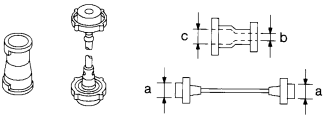
Tool name	Description
<p data-bbox="164 415 272 443">Power tool</p>  <p data-bbox="852 632 922 653">PBIC0190E</p>	<p data-bbox="1013 415 1263 443">Loosening nuts and bolts</p>
<p data-bbox="164 667 354 695">Radiator cap tester</p>  <p data-bbox="852 884 922 905">PBIC1982E</p>	<p data-bbox="1013 667 1360 695">Checking radiator and radiator cap</p>
<p data-bbox="164 919 440 947">Radiator cap tester adapter</p>  <p data-bbox="852 1136 922 1157">S-NT564</p>	<p data-bbox="1013 919 1442 968">Adapting radiator cap tester to radiator cap and water outlet (front) filler neck</p> <p data-bbox="1013 974 1175 1001">a: 28 (1.10) dia.</p> <p data-bbox="1013 1005 1208 1033">b: 31.4 (1.236) dia.</p> <p data-bbox="1013 1037 1208 1064">c: 41.3 (1.626) dia.</p> <p data-bbox="1013 1068 1143 1096">Unit: mm (in)</p>

ENGINE COOLANT

< PERIODIC MAINTENANCE >

PERIODIC MAINTENANCE

ENGINE COOLANT

Inspection

INFOID:000000004250567

A

CO

LEVEL

- Check if the reservoir tank engine coolant level is within the “MIN” to “MAX” when the engine is cool.

A : MAX

B : MIN

- Adjust the engine coolant level if necessary.
- Check that the reservoir tank cap is tightened.

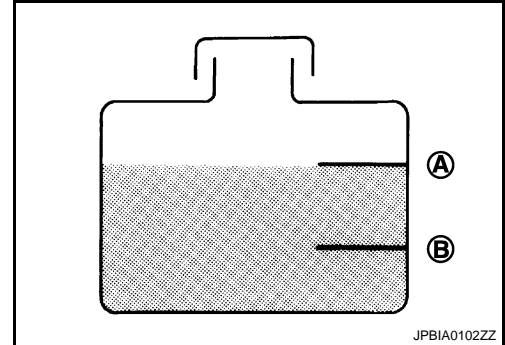

C

D

E

F

LEAKAGE

- To check for leakage, apply pressure to the cooling system with the radiator cap tester and radiator cap tester adapter (commercial service tool) (A).

Testing pressure : Refer to [CO-25, "Radiator"](#).

WARNING:

Never remove radiator cap when engine is hot. Serious burns could occur from high-pressure engine coolant escaping from water inlet (front).

CAUTION:

Higher test pressure than specified may cause radiator damage.

NOTE:

In a case that engine coolant decreases, replenish radiator with engine coolant.

- If anything is found, repair or replace damaged parts.

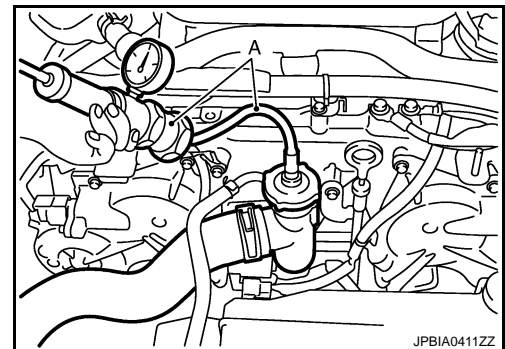

G

H

I

J

Draining

INFOID:000000004250568

WARNING:

- To avoid being scalded, never change engine coolant when the engine is hot.
- Wrap a thick cloth around radiator cap and carefully remove radiator cap. First, turn radiator cap a quarter of a turn to release built-up pressure. Then turn radiator cap all the way.

1. Open radiator drain plug (2) at the bottom of radiator, and then remove radiator cap.

1 : Engine under cover

A : Radiator drain plug hole

↶ : Vehicle front

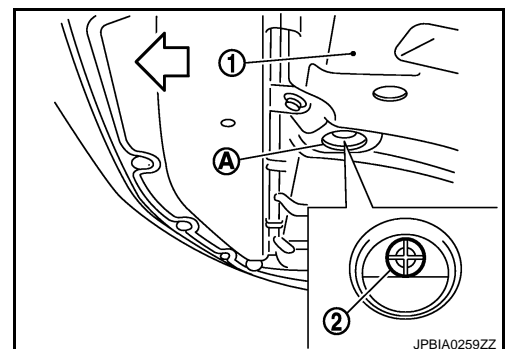

L

M

N

O

P

When draining all of engine coolant in the system, open water drain plugs on cylinder block. Refer to [EM-79, "Setting"](#).

2. Remove reservoir tank if necessary, and drain engine coolant and clean reservoir tank before installing.
3. Check drained engine coolant for contaminants such as rust, corrosion or discoloration.

ENGINE COOLANT

< PERIODIC MAINTENANCE >

If contaminated, flush the engine cooling system. Refer to [CO-9. "Flushing"](#).

Refilling

INFOID:000000004250569

1. Remove air cleaner case (LH). Refer to [EM-27. "Exploded View"](#).
2. Install reservoir tank if removed, and radiator drain plug.

CAUTION:

Be sure to clean drain plug and install with new O-ring.

Tightening torque : Refer to [CO-13. "Exploded View"](#).

If water drain plugs on cylinder block are removed, close and tighten them. Refer to [EM-122. "Disassembly and Assembly"](#).

3. Check that each hose clamp has been firmly tightened.
4. Remove air relief plug (2) on radiator left side.

1 : Reservoir tank

3 : Engine cover

↔ : Vehicle front

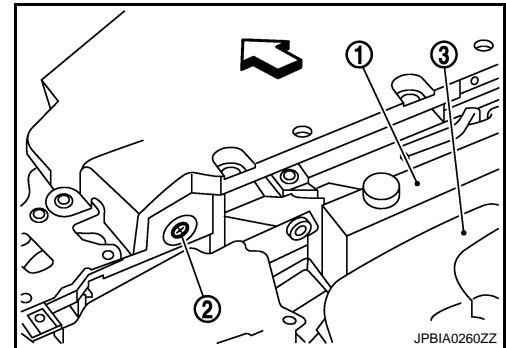

5. Remove air relief plug (1) on heater hose.

2 : Heater hose

↔ : Vehicle front

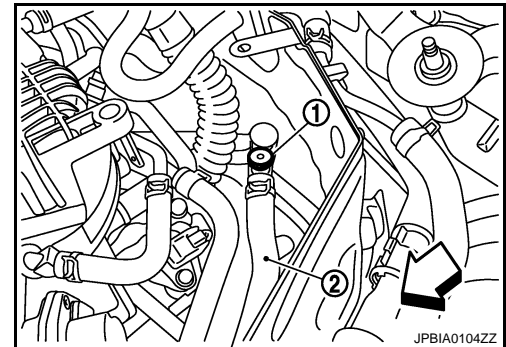

6. Fill radiator, and reservoir tank if removed, to specified level.
 - Pour engine coolant through engine coolant filler neck slowly of less than 2 ℓ (2-1/8 US qt, 1-3/4 Imp qt) a minute to allow air in system to escape.
 - Use Genuine NISSAN Long Life Antifreeze/Coolant or equivalent mixed with water (distilled or demineralized). Refer to [MA-10. "Fluids and Lubricants"](#).

Engine coolant capacity
(With reservoir tank at
"MAX" level)

: Refer to [CO-25.](#)
["Periodical Maintenance](#)
[Specification"](#).

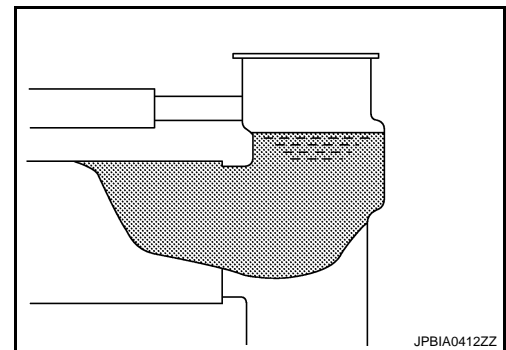

Reservoir tank engine coolant capacity
(At "MAX" level)

:Refer to [CO-25.](#)
["Periodical Maintenance Specification"](#)

ENGINE COOLANT

< PERIODIC MAINTENANCE >

A : MAX

B : MIN

- When engine coolant overflows air relief hole on radiator, install air relief plug with new O-ring.

Tightening torque : Refer to [CO-13, "Exploded View"](#).

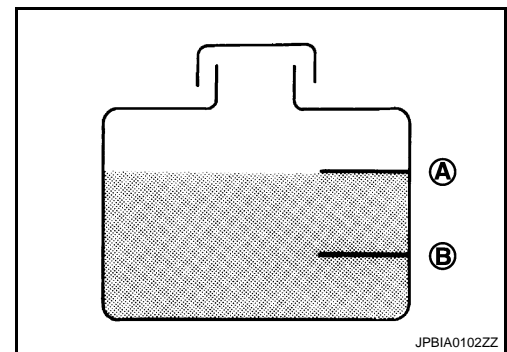

- Repeat step 6.
- When engine coolant overflows air relief hole on heater hose, install air relief plug with new O-ring. Then refill radiator with engine coolant.

 : **1.2 N-m (0.12 kg-m, 11 in-lb)**

- Install air cleaner case (LH). Refer to [EM-27, "Exploded View"](#).
 - Install radiator cap.
 - Warm up engine until opening thermostat. Standard for warming-up time is approximately 10 minutes at 3,000 rpm.
 - Check thermostat opening condition by touching radiator hose (lower) to see a flow of warm water.
- CAUTION:**
Watch water temperature gauge so as not to overheat engine.
- Stop the engine and cool down to less than approximately 50°C (122°F).
 - Cool down using fan to reduce the time.
 - If necessary, refill radiator up to filler neck with engine coolant.
 - Refill reservoir tank to "MAX" level line with engine coolant.
 - Repeat steps 11 through 14 two or more times with radiator cap installed until engine coolant level no longer drops.
 - Check cooling system for leakage with engine running.
 - Warm up the engine, and check for sound of engine coolant flow while running engine from idle up to 3,000 rpm with heater temperature controller set at several position between "COOL" and "WARM".
 - Sound may be noticeable at heater unit.
 - Repeat step 17 three times.
 - If sound is heard, bleed air from cooling system by repeating step 6, and steps from 11 to 18 until engine coolant level no longer drops.
 - Check that the reservoir tank cap is tightened.

Flushing

INFOID:000000004250570

- Install reservoir tank if removed, and radiator drain plug.

CAUTION:

Be sure to clean drain plug and install with new O-ring.

Tightening torque : Refer to [CO-13, "Exploded View"](#).

If water drain plugs on cylinder block are removed, close and tighten them. Refer to [EM-121, "Exploded View"](#).

ENGINE COOLANT

< PERIODIC MAINTENANCE >

2. Remove air relief plug (1) on heater hose (2).

⇐ : Vehicle front

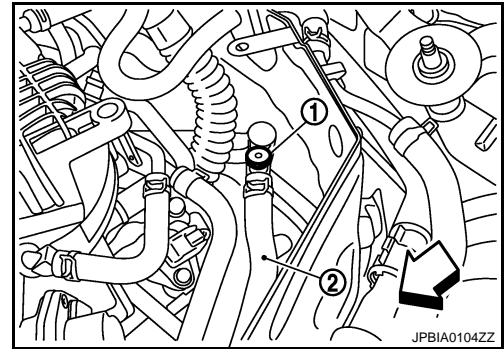

3. Remove air relief plug (2) on radiator.

1 : Reservoir tank
3 : Engine cover
⇐ : Vehicle front

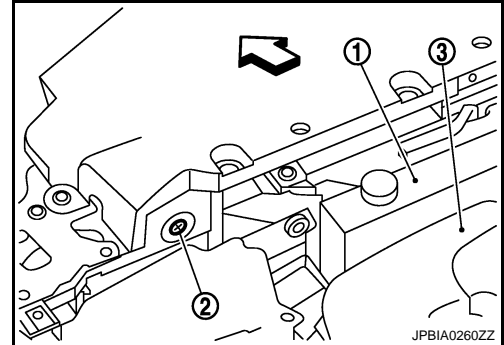

4. Fill radiator with water until water spills from the air relief holes, then close air relief plugs. Fill radiator and reservoir tank with water and reinstall radiator cap.

Tightening torque : Refer to [CO-13. "Exploded View"](#).

5. Run the engine and warm it up to normal operating temperature.
6. Rev the engine two or three times under no-load.
7. Stop the engine and wait until it cools down.
8. Drain water from the system. Refer to [CO-7. "Draining"](#).
9. Repeat steps 1 through 8 until clear water begins to drain from radiator.
10. Check that the reservoir tank cap is tightened.

RADIATOR

< PERIODIC MAINTENANCE >

RADIATOR

RADIATOR CAP

RADIATOR CAP : Inspection

INFOID:000000004250571

- Check valve seat (A) of radiator cap.

B : Metal plunger

- Check if valve seat is swollen to the extent that the edge of the plunger cannot be seen when watching it vertically from the top.
- Check if valve seat has no soil and damage.

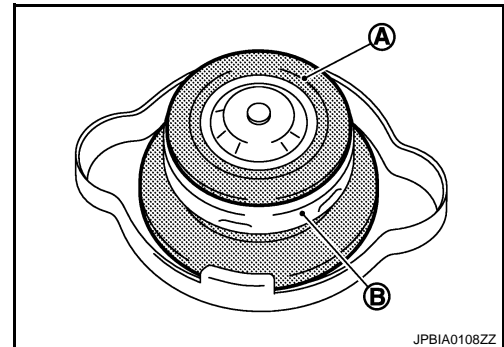

- Pull negative-pressure valve to open it, and check that it close completely when released.
- Check that there is no dirt or damage on the valve seat of radiator cap negative-pressure valve.
- Check that there are no unusualness in the opening and closing conditions of negative-pressure valve.

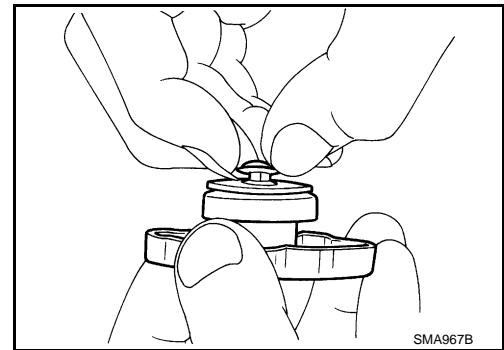

- Check radiator cap relief pressure.

Standard and limit : Refer to [CO-25, "Radiator"](#).

- When connecting radiator cap to the radiator cap tester and the radiator cap tester adapter (commercial service tool) (A), apply engine coolant to the cap seal surface.

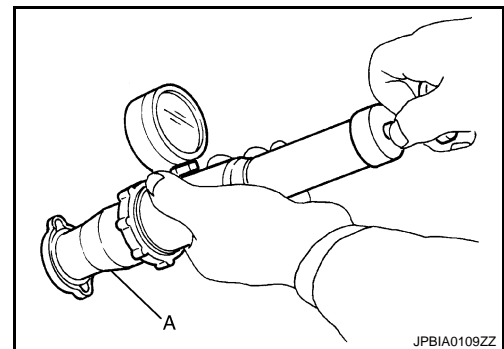

- Replace radiator cap if there is an unusualness related to the above three.

CAUTION:

When installing radiator cap, thoroughly wipe out the water outlet (front) filler neck to remove any waxy residue or foreign material.

RADIATOR

RADIATOR : Inspection

INFOID:000000004250572

Check radiator for mud or clogging. If necessary, clean radiator as follows:

- Be careful not to bend or damage radiator fins.
 - When radiator is cleaned without removal, remove all surrounding parts such as radiator cooling fan assembly and horns. Then tape harness and connectors to prevent water from entering.
1. Apply water by hose to the back side of the radiator core vertically downward.
 2. Apply water again to all radiator core surfaces once per minute.
 3. Stop washing if any stains no longer flow out from radiator.
 4. Blow air into the back side of radiator core vertically downward.

RADIATOR

< PERIODIC MAINTENANCE >

- Use compressed air lower than 490 kPa (5 kg/cm², 71 psi) and keep distance more than 30 cm (11.8 in).
5. Blow air again into all the radiator core surfaces once per minute until no water sprays out.

RADIATOR

< REMOVAL AND INSTALLATION >

REMOVAL AND INSTALLATION

RADIATOR

Exploded View

INFOID:000000004250573

A

CO

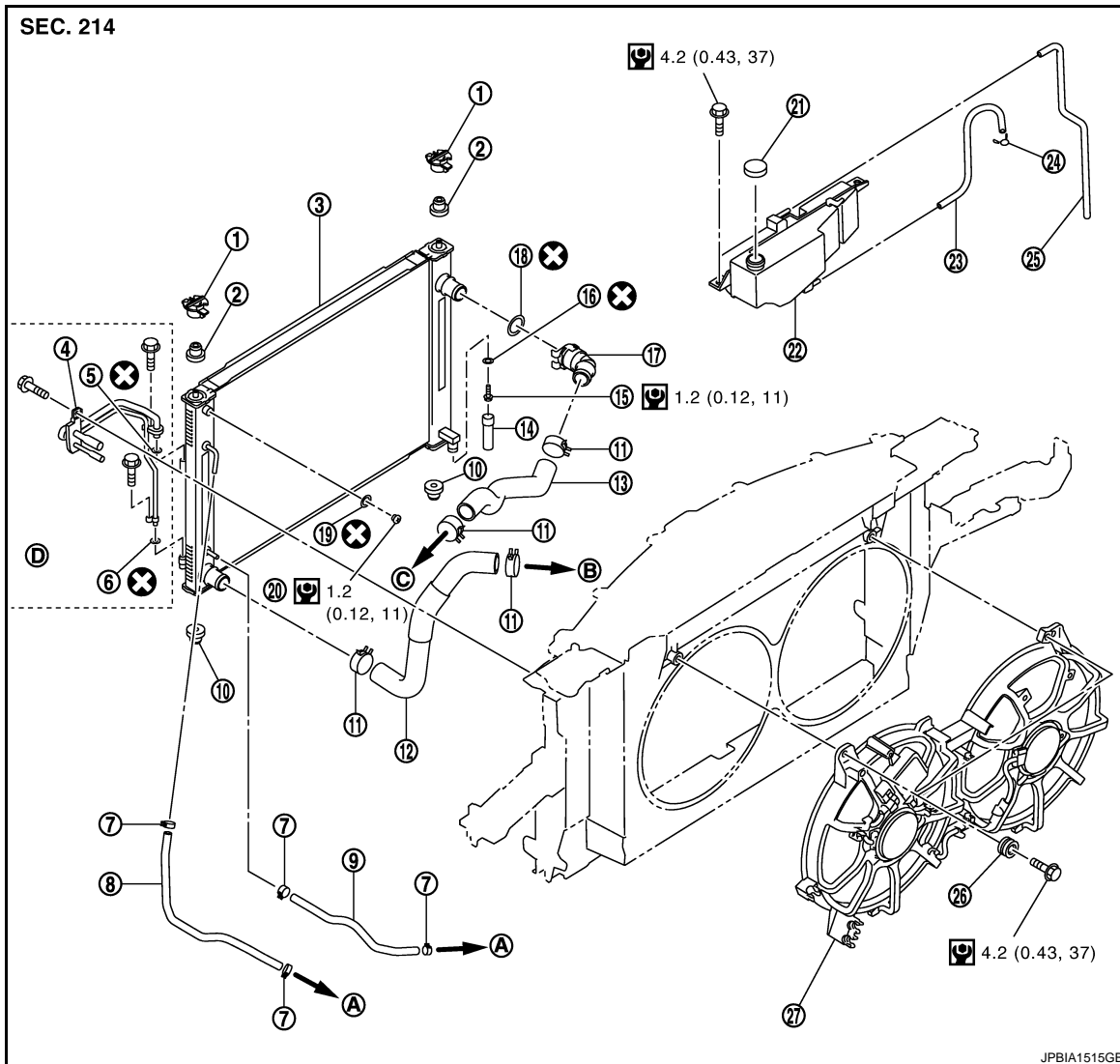

C

D

E

F

G

H

I

J

K

L

M

N

O

P

- | | | |
|-----------------------------|---|---------------------------------------|
| 1. Upper mount bracket | 2. Mounting rubber (upper) | 3. Radiator & condenser assembly |
| 4. Condenser pipe assembly | 5. O-ring | 6. O-ring |
| 7. Clamp | 8. A/T fluid cooler hose (A/T models) | 9. A/T fluid cooler hose (A/T models) |
| 10. Mounting rubber (lower) | 11. Clamp | 12. Radiator hose (lower) |
| 13. Radiator hose (Upper) | 14. Water drain hose | 15. Drain plug |
| 16. O-ring | 17. Radiator water inlet pipe | 18. O-ring |
| 19. O-ring | 20. Air relief plug | 21. Reservoir tank cap |
| 22. Reservoir tank | 23. Reservoir tank hose | 24. Clamp |
| 25. Reservoir tank hose | 26. Grommet | 27. Radiator cooling fan assembly |
| A. To transmission | B. To water inlet and thermostat assembly | C. To water outlet |

D. Refer to [HA-41](#), "Exploded View"

Refer to [GI-4](#), "Components" for symbols in the figure.

RADIATOR

< REMOVAL AND INSTALLATION >

Removal and Installation

INFOID:000000004250574

REMOVAL

WARNING:

Never remove radiator cap when engine is hot. Serious burns could occur from high-pressure engine coolant escaping from water inlet (front). Wrap a thick cloth around the cap. Slowly turn it a quarter of a turn to release built-up pressure. Carefully remove radiator cap by turning it all the way.

1. Remove the following parts:
 - Engine under cover with power tool.
 - Engine cover: Refer to [EM-25, "Exploded View"](#).
 - Air cleaner case (RH and LH): Refer to [EM-27, "Exploded View"](#).
 - Reservoir tank: Refer to [CO-13, "Exploded View"](#).
 - Radiator core support ornament, radiator core support center: Refer to [DLK-212, "Exploded View"](#).
 - Horn: Refer to [HRN-6, "Exploded View"](#).
 - Hood lock: Refer to [DLK-209, "HOOD LOCK CONTROL : Exploded View"](#).
2. Remove condenser pipe assembly. Refer to [HA-47, "Exploded View"](#).
3. Drain engine coolant from radiator. Refer to [CO-7, "Draining"](#).

CAUTION:

- **Perform this step when the engine is cold.**
- **Never spill engine coolant on drive belt.**

4. Disconnect A/T fluid cooler hoses from radiator. (A/T models)
 - Install blind plug to avoid leakage of A/T fluid.
5. Remove radiator hoses (upper and lower) and reservoir tank hose.

CAUTION:

Be careful not to allow engine coolant to contact drive belt.

6. Remove cooling fan assembly. Refer to [CO-16, "Exploded View"](#).

CAUTION:

Never damage or scratch radiator & condenser assembly core when removing.

7. Rotate two radiator upper mount brackets 90 degrees in direction as shown in the figure, and remove them.

1 : Radiator upper mount bracket

A : Turn 90° counterclockwise

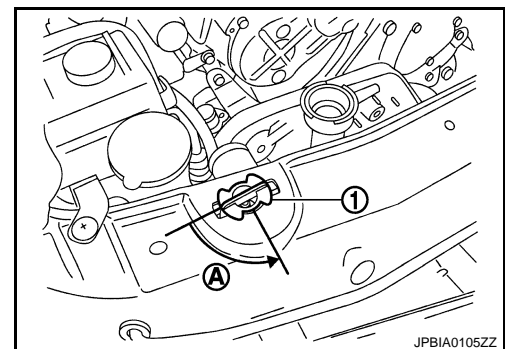

8. Remove radiator & condenser assembly as follows:

CAUTION:

Be careful not to damage radiator & condenser assembly core.

- a. Lift up and pull the radiator & condenser assembly (1) forward, and then remove the mounting rubber (lower) (3) from the radiator core support (2).

⇐ : Vehicle front

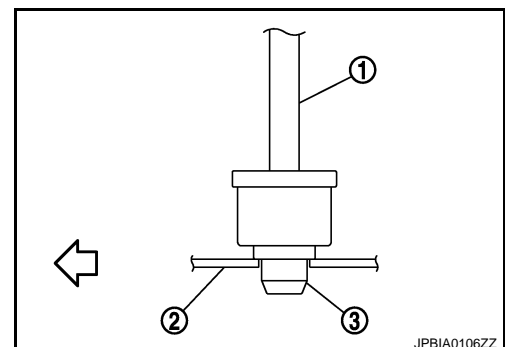

RADIATOR

< REMOVAL AND INSTALLATION >

- b. Remove radiator & condenser assembly (1) from front of radiator core support (2).

← : Vehicle front

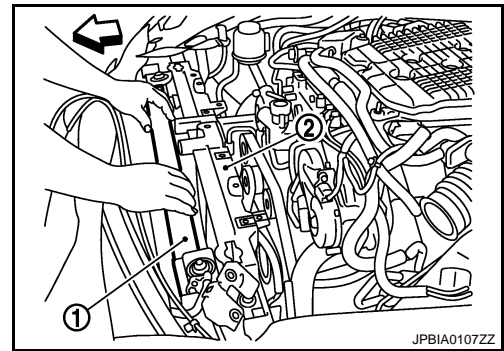

INSTALLATION

Installation is the reverse order of removal.

Inspection

INFOID:000000004250575

INSPECTION AFTER INSTALLATION

- Check that the reservoir tank cap is tightened.
- Check for leakage of engine coolant using the radiator cap tester adapter and the radiator cap tester (commercial service tool). Refer to [CO-7, "Inspection"](#).
- Start and warm up the engine. Visually check that there is no leakage of engine coolant and A/T fluid (A/T models).

A
CO
C
D
E
F
G
H
I
J
K
L
M
N
O
P

COOLING FAN

< REMOVAL AND INSTALLATION >

COOLING FAN

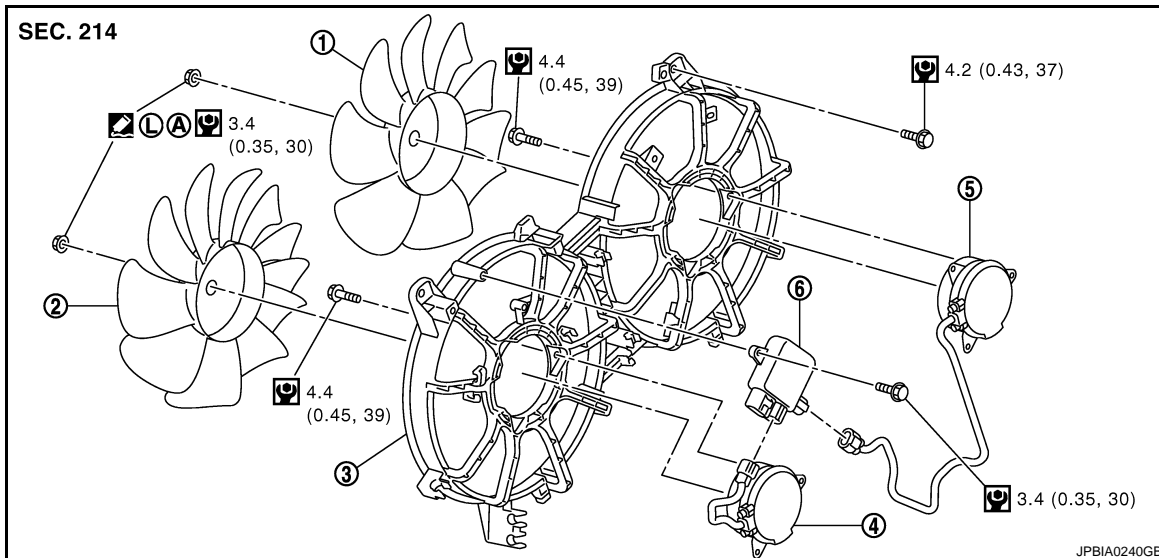

Exploded View

INFOID:000000004250576



- | | | |
|---------------------|---------------------|-------------------------------|
| 1. Cooling fan (RH) | 2. Cooling fan (LH) | 3. Fan shroud |
| 4. Fan motor (LH) | 5. Fan motor (RH) | 6. Cooling fan control module |

A. Apply on fan motor shaft

  : Apply Genuine High Strength thread Locking Sealant or equivalent.

Refer to [GI-4, "Components"](#) for symbols in the figure.

Removal and Installation

INFOID:000000004250577

REMOVAL

1. Remove reservoir tank. Refer to [CO-13, "Exploded View"](#).
2. Remove air cleaner case (LH). Refer to [EM-27, "Exploded View"](#).
3. Disconnect harness connector from cooling fan control module, and move harness to aside.
4. Remove engine under cover with power tool.
5. Remove cooling fan assembly from under the vehicle.

CAUTION:

Be careful not to damage or scratch on radiator core.

INSTALLATION

Note the following, and install in the reverse order of removal.

CAUTION:

Only use genuine parts for cooling fan mounting bolt and observe the specified torque (to prevent core support from being damaged).

Disassembly and Assembly

INFOID:000000004250578

DISASSEMBLY

1. Disconnect harness from cooling fan control module.
2. Remove cooling fan control module from cooling fan assembly.
CAUTION:
Handle carefully to avoid dropping and shocks.
3. Remove cooling fan mounting nuts, and then remove the cooling fan (RH and LH).
4. Remove fan motors (RH and LH).

ASSEMBLY

COOLING FAN

< REMOVAL AND INSTALLATION >

Note the following, and assemble in the reverse order of disassembly.

CAUTION:

RH and LH cooling fans are different. Be careful not to misassemble them.

- Install each fan in the following position.

Right side : 9 blades

Left side : 11 blades

- Secure the harness tightly to the fan shroud to prevent the fan rotation area from being loose.

Inspection

INFOID:000000004250579

INSPECTION AFTER REMOVAL

Check that fan motors operate normally.

NOTE:

Cooling fans are controlled by cooling fan control module. For details, refer to [EC-74. "System Diagram"](#).

INSPECTION AFTER DISASSEMBLY

Cooling Fan

Inspect cooling fan for crack or unusual bend.

- If anything is found, replace cooling fan.

A

CO

C

D

E

F

G

H

I

J

K

L

M

N

O

P

WATER PUMP

< REMOVAL AND INSTALLATION >

WATER PUMP

Exploded View

INFOID:000000004250580

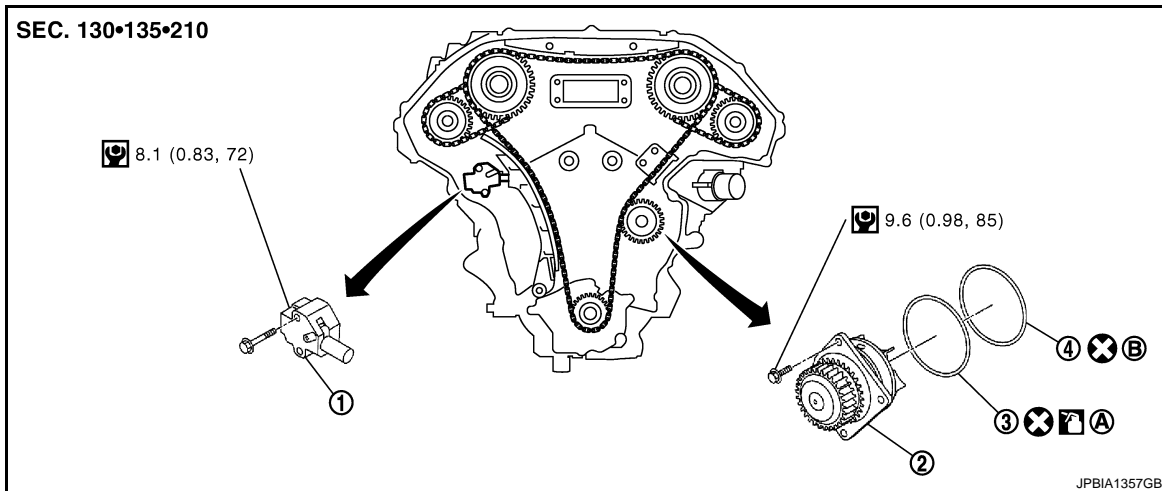

1. Timing chain tensioner (primary) 2. Water pump 3. O-ring
4. O-ring
A. Identify with yellow paint mark B. Identify with light blue paint mark
Apply engine coolant

Refer to [GI-4, "Components"](#) for symbols in the figure.

Removal and Installation

INFOID:000000004250581

CAUTION:

- When removing water pump assembly, be careful not to get engine coolant on drive belt.
- Water pump cannot be disassembled and should be replaced as a unit.
- After installing water pump, connect hose and clamp securely, then check for leakage using the radiator cap tester and the radiator cap tester adapter (commercial service tool).

REMOVAL

1. Remove engine cover. Refer to [EM-25, "Exploded View"](#).
2. Release the fuel pressure. Refer to [EC-614, "Inspection"](#).
3. Disconnect the battery cable from the negative terminal.
4. Remove air duct and air cleaner case assembly (RH and LH). Refer to [EM-27, "Exploded View"](#).
5. Remove reservoir tank. Refer to [CO-13, "Exploded View"](#).
6. Separate engine harness removing their brackets from front timing chain case.
7. Remove engine undercover with power tool.
8. Drain engine oil. Refer to [LU-8, "Draining"](#).
CAUTION:
 - Perform this step when the engine is cold.
 - Never spill engine oil on drive belt.
9. Drain engine coolant from radiator. Refer to [CO-7, "Draining"](#).
CAUTION:
 - Perform this step when the engine is cold.
 - Never spill engine coolant on drive belt.
10. Remove cooling fan assembly. Refer to [CO-16, "Exploded View"](#).
11. Remove radiator hose (upper and lower). Refer to [CO-13, "Exploded View"](#).
12. Remove front timing chain case. Refer to [EM-50, "Exploded View"](#).

WATER PUMP

< REMOVAL AND INSTALLATION >

13. Remove timing chain tensioner (primary) (1) as follows:

- Remove lower mounting bolt (A).
- Loosen upper mounting bolt (B) slowly, and then turn chain tensioner (primary) on the upper mounting bolt so that plunger (C) is fully expanded.

NOTE:

Even if plunger is fully expanded, it is not dropped from the body of timing chain tensioner (primary).

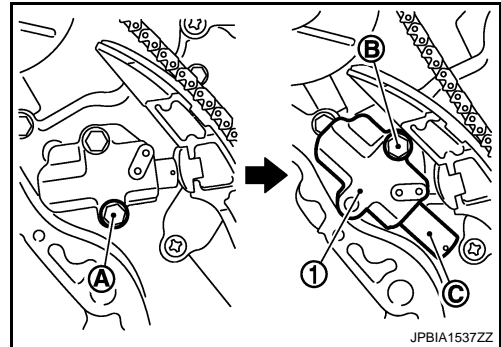

c. Remove upper mounting bolt, and then remove timing chain tensioner (primary).

14. Remove water pump as follows:

a. Remove three water pump mounting bolts. Secure a gap between water pump gear and timing chain, by turning crankshaft counterclockwise until timing chain looseness on water pump sprocket becomes maximum.

- Screw M8 bolts (A) [pitch: 1.25 mm (0.049 in) length: approx. 50 mm (1.97 in)] into water pumps upper and lower mounting bolt holes until they reach timing chain case. Then, alternately tighten each bolt for a half turn, and pull out water pump (1).

CAUTION:

- Pull straight out while preventing vane from contacting socket in installation area.
- Remove water pump without causing sprocket to contact timing chain.

c. Remove M8 bolts and O-rings from water pump.

CAUTION:

Never disassemble water pump.

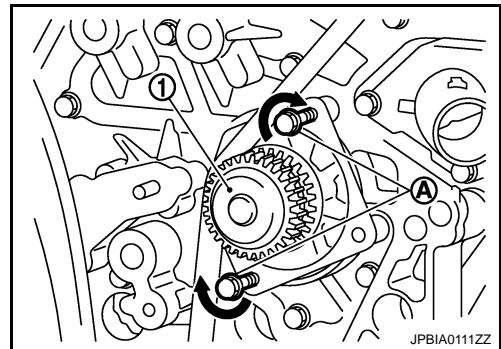

INSTALLATION

1. Install new O-rings to water pump.

- Apply engine oil to O-ring (1) and engine coolant to O-ring (3) as shown in the figure.

2 : Water pump

- Locate O-ring with yellow paint mark (A) to front side.
- Locate O-ring with light blue paint mark (B) to rear side.

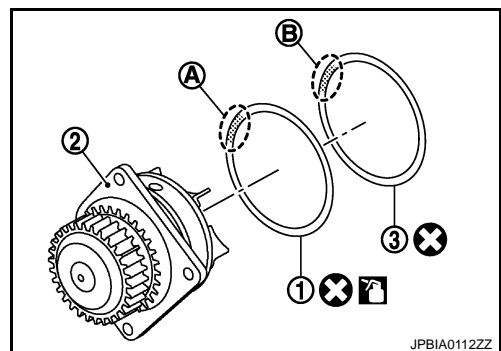

2. Install water pump.

CAUTION:

Never allow cylinder block to nip O-rings when installing water pump.

- Check timing chain and water pump sprocket are engaged.
- Insert water pump by tightening mounting bolts alternately and evenly.

3. Install timing chain tensioner (primary) as follows:

a. Turn crankshaft clockwise so that timing chain on the timing chain tensioner (primary) side is loose.

WATER PUMP

< REMOVAL AND INSTALLATION >

- b. Pull plunger stopper tab (A) up (or turn lever downward) so as to remove plunger stopper tab from the ratchet of plunger (D).

NOTE:

Plunger stopper tab and lever (C) are synchronized.

- c. Push plunger into the inside of tensioner body.
- d. Hold plunger in the fully compressed position by engaging plunger stopper tab with the tip of ratchet.
- e. To secure lever, insert stopper pin (E) through hole of lever into tensioner body hole (B).
- The lever parts and the tab are synchronized. Therefore, the plunger will be secured under this condition.

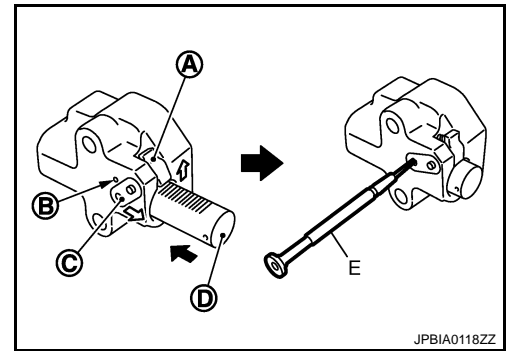

JPBIA0118ZZ

NOTE:

Figure shows the example of 1.2 mm (0.047 in) diameter thin screwdriver being used as the stopper pin.

- f. Install timing chain tensioner (primary).
- Remove dust and foreign material completely from backside of timing chain tensioner (primary) and from installation area of rear timing chain case.
- g. Remove stopper pin.
- h. Check again that timing chain and water pump sprocket are engaged.
4. Install in the reverse order of removal for remaining parts.
- **After starting engine, let idle for three minutes, then rev engine up to 3,000 rpm under no load to purge air from the high-pressure chamber of chain tensioner. Engine may produce a rattling noise. This indicates that air still remains in the chamber and is not a matter of concern.**

Inspection

INFOID:000000004250582

INSPECTION AFTER REMOVAL

- Check for badly rusted or corroded water pump body assembly.
- Check for rough operation due to excessive end play.
- If anything is found, replace water pump.

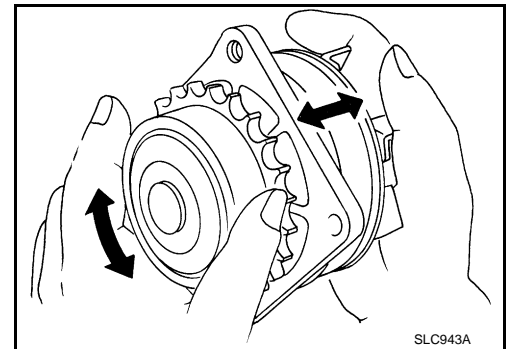

SLC943A

INSPECTION AFTER INSTALLATION

- Check that the reservoir tank cap is tightened.
- Check for leakage of engine coolant using the radiator cap tester adapter and the radiator cap tester (commercial service tool). Refer to [CO-7, "Inspection"](#).
- Start and warm up the engine. Visually check that there is no leakage of engine coolant.

WATER INLET AND THERMOSTAT ASSEMBLY

< REMOVAL AND INSTALLATION >

WATER INLET AND THERMOSTAT ASSEMBLY

Exploded View

INFOID:000000004250583

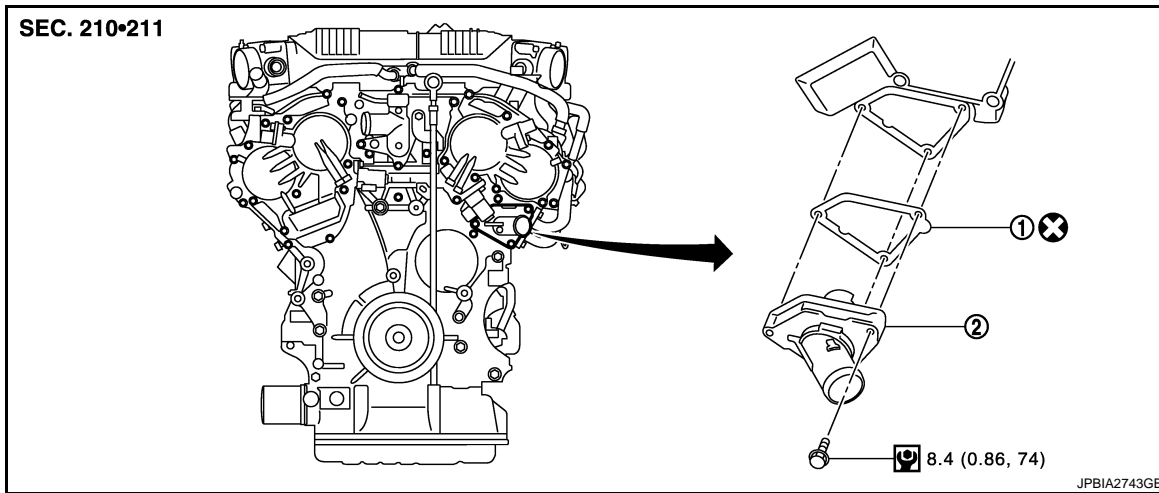

1. Gasket
2. Water inlet and thermostat assembly

Refer to [GI-4, "Components"](#) for symbols in the figure.

Removal and Installation

INFOID:000000004250584

REMOVAL

1. Remove engine cover. Refer to [EM-25, "Exploded View"](#).
2. Remove air duct and air cleaner case assembly (LH). Refer to [EM-27, "Exploded View"](#).
3. Remove reservoir tank. Refer to [CO-13, "Exploded View"](#).
4. Remove engine undercover with power tool.
5. Drain engine coolant from radiator drain plug at the bottom of radiator. Refer to [CO-7, "Draining"](#).

CAUTION:

- Perform this step when the engine is cold.
- Never spill engine coolant on drive belt.

6. Disconnect radiator hose (lower).
7. Disconnect intake valve timing control valve harness connector (LH), and remove intake valve timing control solenoid.
8. Remove water inlet and thermostat assembly (1).

A : Do not loosen these screw.

CAUTION:

Never disassemble water inlet and thermostat assembly. Replace them as a unit, if necessary.

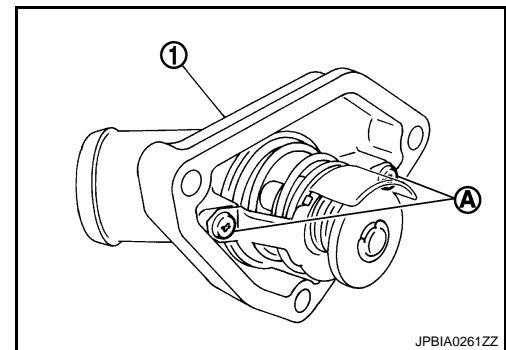

INSTALLATION

Note the following, and install in the reverse order of removal.

- Be careful not to spill engine coolant over engine room. Use rag to absorb engine coolant.

Inspection

INFOID:000000004250585

INSPECTION AFTER REMOVAL

WATER INLET AND THERMOSTAT ASSEMBLY

< REMOVAL AND INSTALLATION >

1. Check valve seating condition at ordinary room temperatures. It should seat tightly.
2. Check valve operation.

Thermostat (Standard) : Refer to [CO-25, "Thermostat"](#).

- If the malfunctioning condition, when valve seating at ordinary room temperature, or measured values are out of the standard, replace water inlet and thermostat assembly.

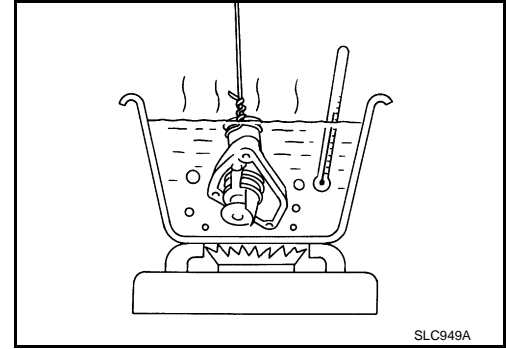

INSPECTION AFTER INSTALLATION

- Check that the reservoir tank cap is tightened.
- Check for leakage of engine coolant using the radiator cap tester adapter and the radiator cap tester (commercial service tool). Refer to [CO-7, "Inspection"](#).
- Start and warm up the engine. Visually check that there is no leakage of engine coolant.

WATER OUTLET AND WATER PIPING

< REMOVAL AND INSTALLATION >

WATER OUTLET AND WATER PIPING

Exploded View

INFOID:000000004496653

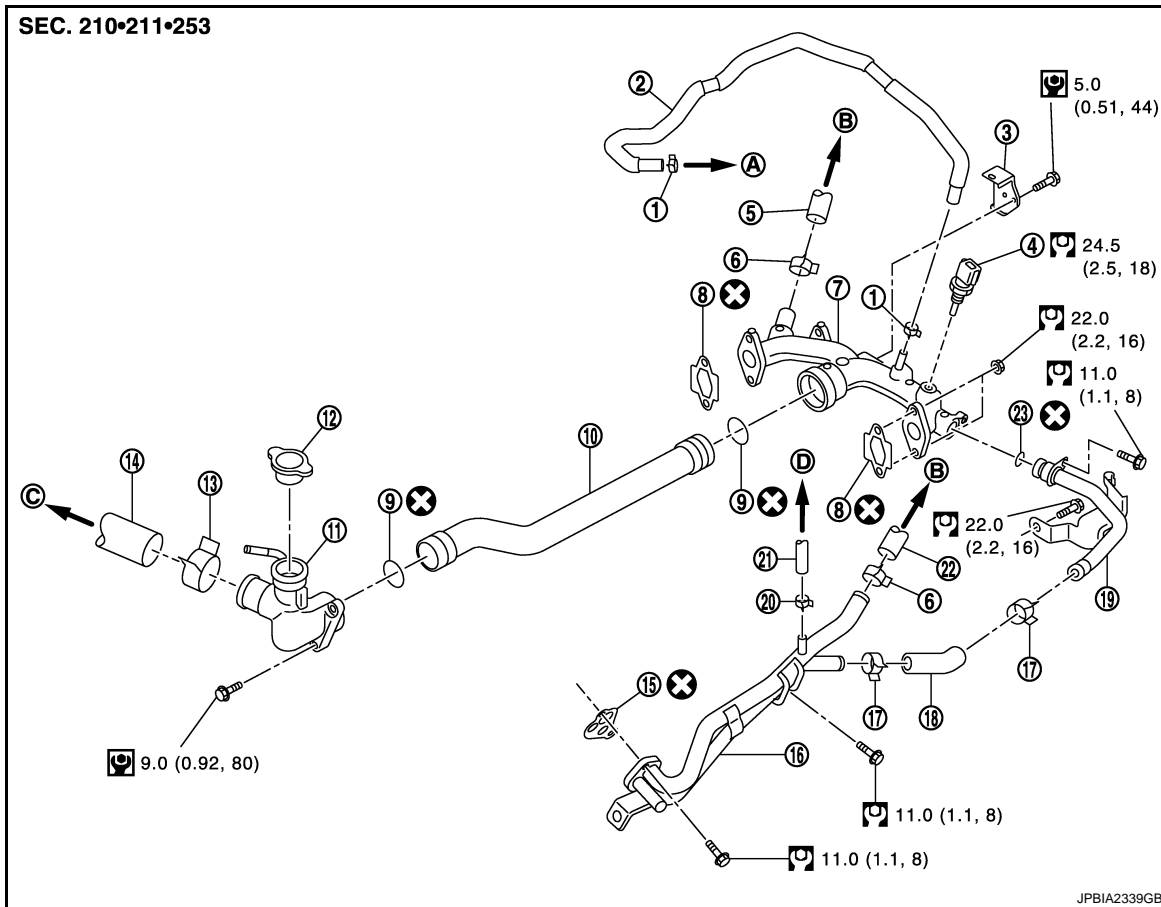

- | | | |
|--|---------------------------|--------------------|
| 1. Clamp | 2. Water hose | 3. Harness bracket |
| 4. Engine coolant temperature sensor | 5. Heater hose | 6. Clamp |
| 7. Water outlet (rear) | 8. Gasket | 9. O-ring |
| 10. Water outlet pipe | 11. Water outlet (front) | 12. Radiator cap |
| 13. Clamp | 14. Radiator hose (upper) | 15. Gasket |
| 16. Heater pipe | 17. Clamp | 18. Water hose |
| 19. Water bypass pipe | 20. Clamp | 21. Water hose |
| 22. Heater hose | 23. O-ring | |
| A. To EVAP piping | B. To heater core | C. To radiator |
| D. To electric throttle control actuator | | |

Refer to [GI-4, "Components"](#) for symbols in the figure.

Removal and Installation

INFOID:000000004250587

REMOVAL

1. Remove engine cover. Refer to [EM-25, "Exploded View"](#).
2. Remove reservoir tank. Refer to [CO-13, "Exploded View"](#).
3. Remove oil level gauge and guide. Refer to [EM-82, "2WD : Exploded View"](#) (2WD models) or [EM-85, "AWD : Exploded View"](#) (AWD models).
4. Remove air duct and air cleaner case assembly (RH and LH). Refer to [EM-27, "Exploded View"](#).
5. Remove engine undercover with power tool.
6. Drain engine coolant from radiator drain plug at the bottom of radiator. Refer to [CO-7, "Draining"](#).

WATER OUTLET AND WATER PIPING

< REMOVAL AND INSTALLATION >

CAUTION:

- Perform this step when the engine is cold.
- Never spill engine coolant on drive belts.

7. Remove radiator hose (upper) and heater hose.
8. Separate engine harness removing their bracket from water outlet (rear).
9. Remove engine coolant temperature sensor if necessary.

CAUTION:

Be careful not to damage engine coolant temperature sensor.

10. Remove heater pipe, water bypass pipe and water outlet pipe.
11. Remove water outlet (rear) if necessary.

NOTE:

Removing engine assembly is required. Refer to [EM-69, "2WD : Exploded View"](#) (2WD models) or [EM-73, "AWD : Exploded View"](#) (AWD models).

INSTALLATION

Note the following, and install in the reverse order of removal.

- Securely insert each hose, and install clamp at a position where it does not interfere with the pipe bulge.
- When inserting water outlet pipe and water bypass pipe into water outlet, apply neutral detergent to O-ring.

CAUTION:

Never allow water outlet (rear) to nip O-rings when installing water outlet pipe and water bypass pipe.

Inspection

INFOID:000000004250588

INSPECTION AFTER INSTALLATION

- Check that the reservoir tank cap is tightened.
- Check for leakage of engine coolant using the radiator cap tester adapter and the radiator cap tester (commercial service tool). Refer to [CO-7, "Inspection"](#).
- Start and warm up the engine. Visually check that there is no leakage of engine coolant.

SERVICE DATA AND SPECIFICATIONS (SDS)

< SERVICE DATA AND SPECIFICATIONS (SDS)

SERVICE DATA AND SPECIFICATIONS (SDS)

SERVICE DATA AND SPECIFICATIONS (SDS)

Periodical Maintenance Specification

INFOID:0000000004250589

ENGINE COOLANT CAPACITY (APPROXIMATE)

Unit: ℓ (US qt, Imp qt)

Engine coolant capacity [With reservoir tank ("MAX" level)]	A/T models	8.5 (9, 7-1/2)
	M/T models	8.6 (9-1/8, 7-5/8)
Reservoir tank engine coolant capacity (At "MAX" level)		0.8 (7/8, 3/4)

Radiator

INFOID:0000000004250590

Unit: kPa (kg/cm², psi)

Cap relief pressure	Standard	122.3 - 151.7 (1.2 - 1.5, 18 - 22)
	Limit	107 (1.1, 16)
Leakage testing pressure		157 (1.6, 23)

Thermostat

INFOID:0000000004250591

Thermostat	Standard
Valve opening temperature	82°C (180°F)
Maximum valve lift	8.6 mm/95°C (0.339 in/203°F)
Valve closing temperature	77°C (171°F)