

SECTION **RSU**  
 REAR SUSPENSION

A  
B  
C  
D

RSU

CONTENTS

<b>SYMPTOM DIAGNOSIS</b> .....	2	<b>SUSPENSION ARM</b> .....	14	F
<b>NOISE, VIBRATION AND HARSHNESS (NVH) TROUBLESHOOTING</b> .....	2	Exploded View .....	14	
NVH Troubleshooting Chart .....	2	Removal and Installation .....	15	
<b>PRECAUTION</b> .....	3	Inspection .....	15	G
<b>PRECAUTIONS</b> .....	3	<b>RADIUS ROD</b> .....	17	
Precautions for Suspension .....	3	Exploded View .....	17	
<b>PREPARATION</b> .....	4	Removal and Installation .....	18	H
<b>PREPARATION</b> .....	4	Inspection .....	18	
Special Service Tool .....	4	<b>FRONT LOWER LINK</b> .....	19	I
Commercial Service Tool .....	4	Exploded View .....	19	
<b>PERIODIC MAINTENANCE</b> .....	5	Removal and Installation .....	20	
<b>REAR SUSPENSION ASSEMBLY</b> .....	5	Inspection .....	20	J
Inspection and Adjustment .....	5	<b>REAR STABILIZER</b> .....	21	
<b>WHEEL ALIGNMENT</b> .....	6	Exploded View .....	21	
Inspection .....	6	Removal and Installation .....	22	K
<b>REMOVAL AND INSTALLATION</b> .....	8	Inspection .....	22	
<b>REAR LOWER LINK &amp; COIL SPRING</b> .....	8	<b>UNIT REMOVAL AND INSTALLATION</b> .....	23	L
Exploded View .....	8	<b>REAR SUSPENSION MEMBER</b> .....	23	
Removal and Installation .....	9	Exploded View .....	23	
Inspection .....	9	Removal and Installation .....	24	M
<b>REAR SHOCK ABSORBER</b> .....	11	Inspection .....	25	
Exploded View .....	11	<b>SERVICE DATA AND SPECIFICATIONS (SDS)</b> .....	26	N
Removal and Installation .....	12	<b>SERVICE DATA AND SPECIFICATIONS (SDS)</b> .....	26	O
Disassembly and Assembly .....	12	Wheel Alignment .....	26	
Inspection .....	12	Ball Joint .....	26	
		Wheelarch Height .....	26	P

# NOISE, VIBRATION AND HARSHNESS (NVH) TROUBLESHOOTING

< SYMPTOM DIAGNOSIS >

## SYMPTOM DIAGNOSIS

### NOISE, VIBRATION AND HARSHNESS (NVH) TROUBLESHOOTING

#### NVH Troubleshooting Chart

INFOID:000000004670316

Use chart below to find the cause of the symptom. If necessary, repair or replace these parts.

Symptom		Possible cause and SUSPECTED PARTS														Reference page		
		Improper installation, looseness	Shock absorber deformation, damage or deflection	Bushing or mounting deterioration	Parts interference	Spring fatigue	Suspension looseness	Incorrect wheel alignment	Stabilizer bar fatigue	PROPELLER SHAFT	DIFFERENTIAL	REAR AXLE AND REAR SUSPENSION	TIRE	ROAD WHEEL	DRIVE SHAFT		BRAKE	STEERING
REAR SUSPENSION	Noise	x	x	x	x	x	x			x	x	x	x	x	x	x	x	RSU-8, RSU-11, RSU-14, RSU-17, RSU-19, RSU-21
	Shake	x	x	x	x		x			x		x	x	x	x			RSU-12
	Vibration	x	x	x	x	x				x		x	x		x			—
	Shimmy	x	x	x	x			x				x	x	x		x	x	—
	Judder	x	x	x								x	x	x		x	x	—
	Poor quality ride or handling	x	x	x	x	x		x	x			x	x	x				RSU-8, RSU-11, RSU-14, RSU-17, RSU-19, RSU-21
																	RSU-6	
																	RSU-22	
																	NVH in DLN section.	
																	NVH in DLN section.	
																	NVH in RAX and RSU sections.	
																	NVH in WT section.	
																	NVH in WT section.	
																	NVH in RAX section.	
																	NVH in BR section.	
																	NVH in ST section.	

x: Applicable

# PRECAUTIONS

< PRECAUTION >

## PRECAUTION

### PRECAUTIONS

#### Precautions for Suspension

INFOID:000000004670317

- When installing rubber bushings, the final tightening must be carried out under unladen conditions with tires on ground. Spilled oil might shorten the life of rubber bushings. Be sure to wipe off any spilled oil.
- Unladen conditions mean that fuel, engine coolant and lubricant are full. Spare tire, jack, hand tools and mats are in designated positions.
- After servicing suspension parts, be sure to check wheel alignment.
- Self-lock nuts are not reusable. Always use new ones when installing. Since new self-lock nuts are pre-oiled, tighten as they are.

A

B

C

D

RSU

F

G

H

I

J

K

L

M

N

O

P

# PREPARATION

< PREPARATION >

## PREPARATION

### PREPARATION

#### Special Service Tool

INFOID:000000004670318

The actual shapes of Kent-Moore tools may differ from those of special service tools illustrated here.

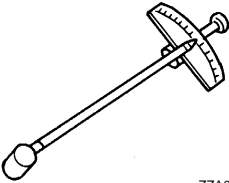
Tool number (Kent-Moore No.) Tool name	Description
ST3127S000 (J-25765-A) Preload gauge  ZZA0806D	Measuring rotating torque of ball joint

#### Commercial Service Tool

INFOID:000000004670319

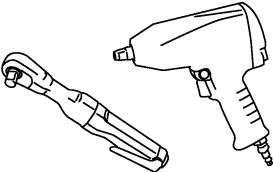
Tool name	Description
Power tool  PBIC0190E	Loosening bolts and nuts

# REAR SUSPENSION ASSEMBLY

< PERIODIC MAINTENANCE >

## PERIODIC MAINTENANCE

### REAR SUSPENSION ASSEMBLY

#### Inspection and Adjustment

INFOID:000000004670320

#### MOUNTING INSPECTION

Make sure the mounting conditions (looseness, backlash) of each component and component conditions (wear, damage) are normal.

#### BALL JOINT AXIAL END PLAY

Measure axial end play by placing and moving up/down with an iron bar or equivalent between suspension arm and axle assembly.

#### Standard

Axial end play : Refer to [RSU-26, "Ball Joint"](#).

#### CAUTION:

Be careful not to damage ball joint boot.

#### SHOCK ABSORBER

Check for oil leakage, damage and replace if malfunction is detected.

A  
B  
C  
D  
F  
G  
H  
I  
J  
K  
L  
M  
N  
O  
P

RSU

# WHEEL ALIGNMENT

< PERIODIC MAINTENANCE >

## WHEEL ALIGNMENT

### Inspection

INFOID:000000004670321

### DESCRIPTION

- Measure wheel alignment under unladen conditions.

#### NOTE:

“Unladen conditions” means that fuel, engine coolant, and lubricant are full. Spare tire, jack, hand tools and mats are in designated positions.

### GENERAL INFORMATION AND RECOMMENDATIONS

- A four-wheel thrust alignment should be performed.
- This type of alignment is recommended for any NISSAN/INFINITI vehicle.
- The four-wheel “thrust” process helps ensure that the vehicle is properly aligned and the steering wheel is centered.
- The alignment rack itself should be capable of accepting any NISSAN/INFINITI vehicle.
- The rack should be checked to ensure that it is level.
- Make sure the machine is properly calibrated.
- Your alignment equipment should be regularly calibrated in order to give correct information.
- Check with the manufacturer of your specific equipment for their recommended Service/Calibration Schedule.

### ALIGNMENT PROCESS

#### IMPORTANT:

Use only the alignment specifications listed in this Service Manual.

- When displaying the alignment settings, many alignment machines use “indicators”: (Green/red, plus or minus, Go/No Go). **Never use these indicators.**
- The alignment specifications programmed into your machine that operate these indicators may not be correct.
- This may result in an ERROR.
- Some newer alignment machines are equipped with an optional “Rolling Compensation” method to “compensate” the sensors (alignment targets or head units). **Never use this “Rolling Compensation” method.**
- Use the “Jacking Compensation Method”. After installing the alignment targets or head units, raise the vehicle and rotate the wheels 1/2 turn both ways.
- See Instructions in the alignment machine you’re using for more information on this.

### PRELIMINARY CHECK

Check the following:

- Tires for improper air pressure and wear.
- Road wheels for runout. Refer to [WT-95, "Inspection"](#).
- Wheel bearing axial end play. Refer to [RAX-5, "Inspection"](#).
- Ball joint axial end play of suspension arm. Refer to [RSU-15, "Inspection"](#).
- Shock absorber operation.
- Each mounting point of axle and suspension for looseness and deformation.
- Each of front lower link, rear lower link, radius rod, rear suspension member, suspension arm and shock absorber for cracks, deformation, and other damage.
- Vehicle height (posture).

### ADJUSTMENT

#### Camber

- If outside the standard value, adjust with adjusting bolt (1) in front lower link (2).

**Standard**

**Camber:** Refer to [RSU-26, "Wheel Alignment"](#).

#### CAUTION:

**After adjusting camber, be sure to check toe-in.**

- If camber is not still within the specification, inspect and replace any damaged or worn suspension parts.

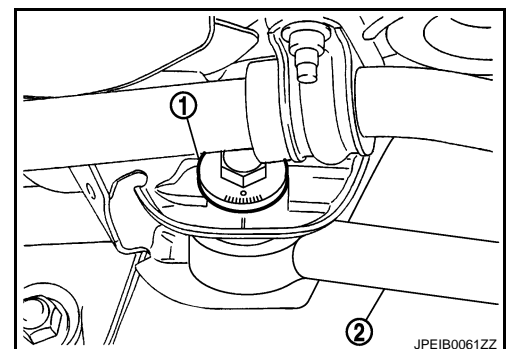

# WHEEL ALIGNMENT

## < PERIODIC MAINTENANCE >

### Toe-In

- If toe-in is not within the specification, adjust with adjusting bolt (1) in rear lower link (2).

#### Standard

Toe-In: Refer to [RSU-26, "Wheel Alignment"](#).

#### CAUTION:

**Be sure to adjust equally on RH and LH side with adjusting bolt.**

- If toe-in is not still within the specification, inspect and replace any damaged or worn suspension parts.

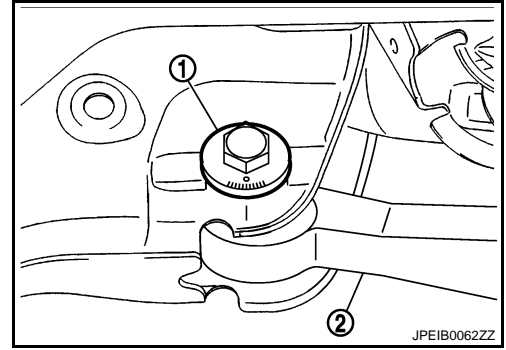

A  
B  
C  
D

RSU

F  
G  
H  
I  
J  
K  
L  
M  
N  
O  
P

# REAR LOWER LINK & COIL SPRING

< REMOVAL AND INSTALLATION >

## REMOVAL AND INSTALLATION

### REAR LOWER LINK & COIL SPRING

Exploded View

INFOID:000000004670322

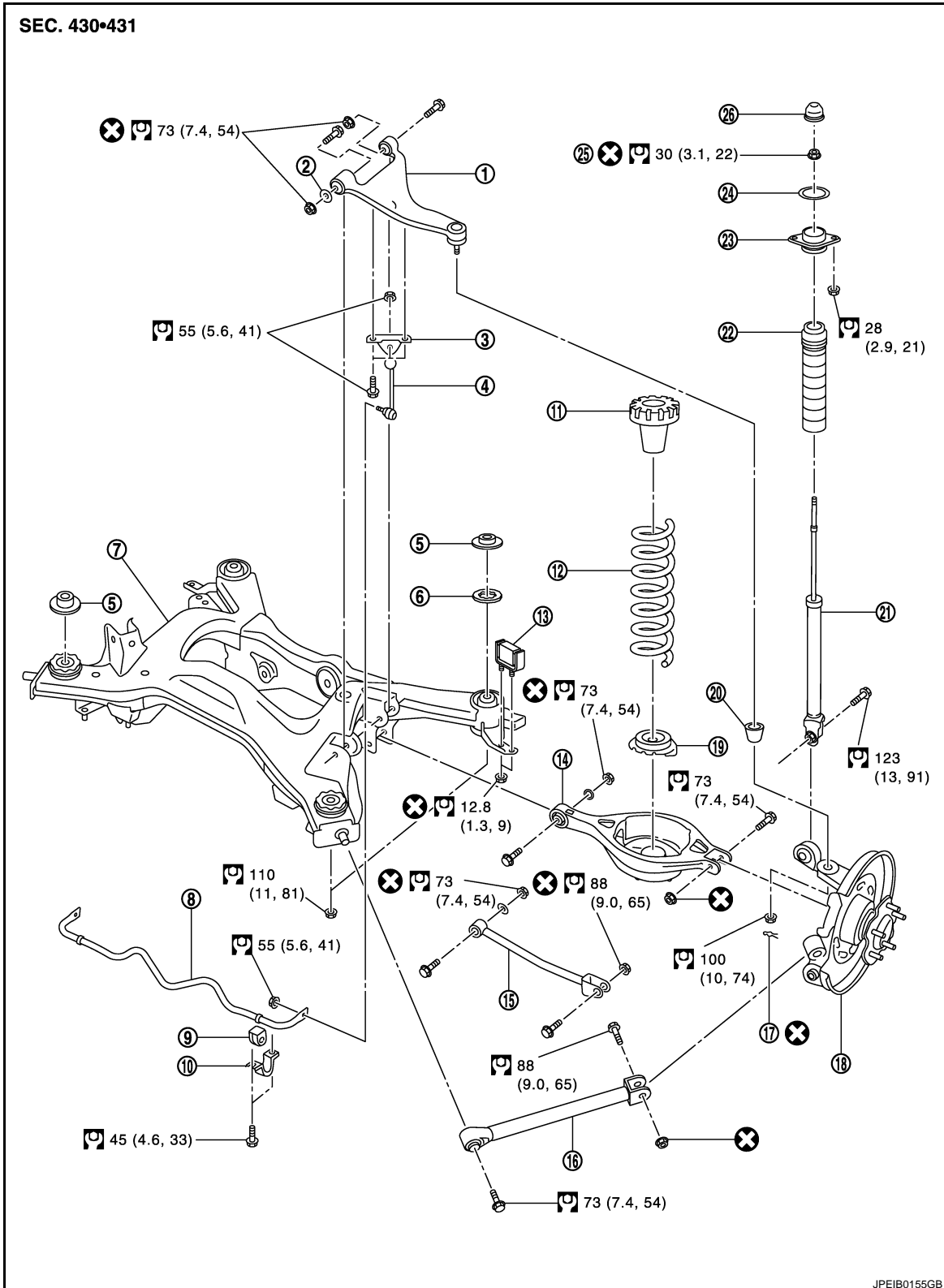



# REAR LOWER LINK & COIL SPRING

## < REMOVAL AND INSTALLATION >

- |                                 |                                     |   |
|---------------------------------|-------------------------------------|---|
| 1. Suspension arm               | 2. Stopper rubber                   | 3. Stabilizer connecting rod mounting bracket |
| 4. Stabilizer connecting rod    | 5. Upper stopper (4WD model)        | 6. Mount stopper                              |
| 7. Suspension member            | 8. Stabilizer bar                   | 9. Stabilizer bushing                         |
| 10. Stabilizer clamp            | 11. Upper seat                      | 12. Coil spring                               |
| 13. Damper assembly (A/T model) | 14. Rear lower link                 | 15. Front lower link                          |
| 16. Radius rod                  | 17. Cotter pin                      | 18. Axle assembly                             |
| 19. Rubber seat                 | 20. Ball seat                       | 21. Shock absorber                            |
| 22. Bound bumper cover          | 23. Shock absorber mounting bracket | 24. Mounting seal                             |
| 25. Piston rod lock nut         | 26. Cap                             |   |

Refer to [GI-4, "Components"](#) for symbols in the figure.

## Removal and Installation

INFOID:000000004670323

RSU

### REMOVAL

1. Remove tires with power tool.
2. Set suitable jack under rear lower link to relieve the coil spring tension.
3. Loosen rear lower link mounting bolts and nuts (rear suspension member side), and then remove rear lower link mounting bolts and nuts (axle housing side) with power tool.
4. Slowly lower jack, then remove upper seat, coil spring and rubber sheet from rear lower link.
5. Remove rear lower link mounting bolts and nuts (rear suspension member side) to remove rear lower link with power tool.

### INSTALLATION

Note the following, and install in the reverse order of removal.

- Make sure that upper seat is attached as shown in the figure.

#### CAUTION:

**Make sure that the projecting parts (A) on upper seat (1) inside is securely fitted on the bracket (2) tabs (B).**

← Body

- Match up rubber seat indentions and rear lower link grooves and attach.

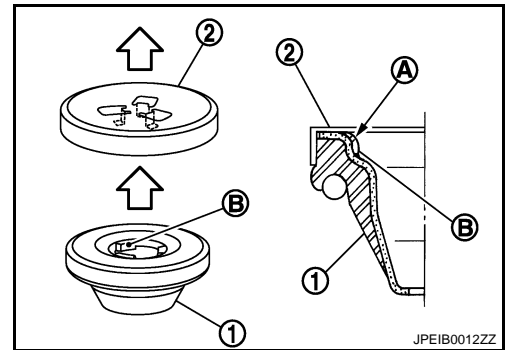

- Install the coil spring by aligning the lower end of the large diameter side to the step (A) between the rubber seat (1) and the rear lower link (2).

#### CAUTION:

**Make sure spring is not up side down. The top and bottom are indicated by paint color.**

- Perform the final tightening of rear suspension member and axle installation position (rubber bushing) under unladen condition with tires on level ground.

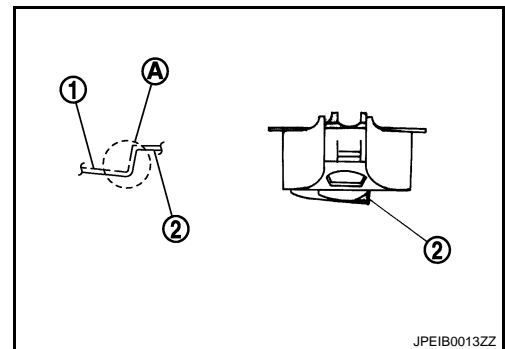

## Inspection

INFOID:000000004670324

### INSPECTION AFTER REMOVAL

Check rear lower link, bushing and coil spring for deformation, crack, and damage. Replace it if necessary.

### INSPECTION AFTER INSTALLATION

## REAR LOWER LINK & COIL SPRING

### < REMOVAL AND INSTALLATION >

---

- Check wheel alignment. Refer to [RSU-6, "Inspection"](#).
- Adjust neutral position of steering angle sensor. Refer to [BRC-8, "ADJUSTMENT OF STEERING ANGLE SENSOR NEUTRAL POSITION : Special Repair Requirement"](#).

# REAR SHOCK ABSORBER

< REMOVAL AND INSTALLATION >

## REAR SHOCK ABSORBER

Exploded View

INFOID:000000004670325

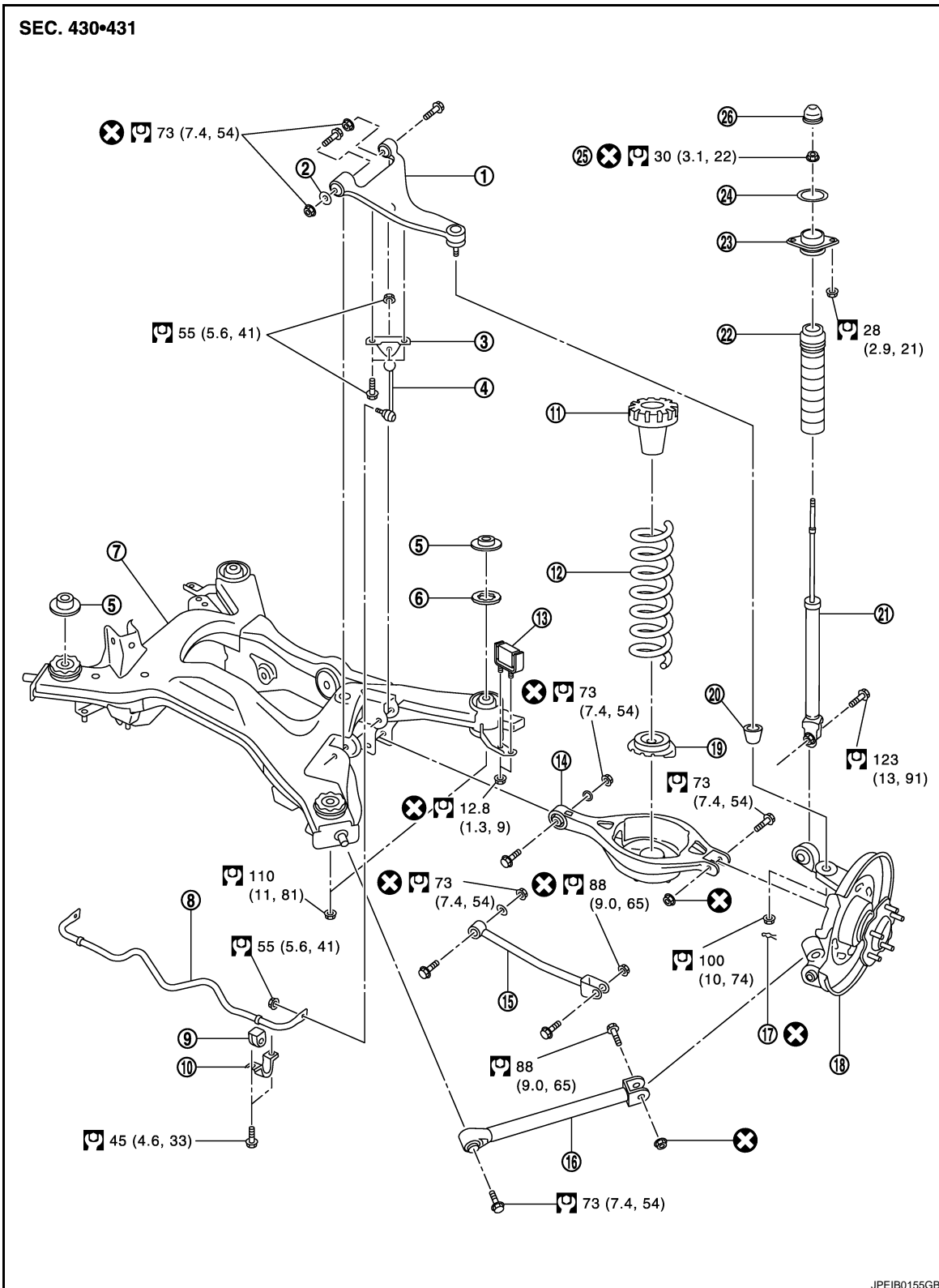

- |                              |                              |   |
|------------------------------|------------------------------|---|
| 1. Suspension arm            | 2. Stopper rubber            | 3. Stabilizer connecting rod mounting bracket |
| 4. Stabilizer connecting rod | 5. Upper stopper (4WD model) | 6. Mount stopper                              |

A  
B  
C  
D  
RSU  
F  
G  
H  
I  
J  
K  
L  
M  
N  
O  
P

# REAR SHOCK ABSORBER

## < REMOVAL AND INSTALLATION >

- |                                 |                                     |                       |
|---------------------------------|-------------------------------------|-----------------------|
| 7. Suspension member            | 8. Stabilizer bar                   | 9. Stabilizer bushing |
| 10. Stabilizer clamp            | 11. Upper seat                      | 12. Coil spring       |
| 13. Damper assembly (A/T model) | 14. Rear lower link                 | 15. Front lower link  |
| 16. Radius rod                  | 17. Cotter pin                      | 18. Axle assembly     |
| 19. Rubber seat                 | 20. Ball seat                       | 21. Shock absorber    |
| 22. Bound bumper cover          | 23. Shock absorber mounting bracket | 24. Mounting seal     |
| 25. Piston rod lock nut         | 26. Cap                             |                       |

Refer to [GI-4. "Components"](#) for symbols in the figure.

## Removal and Installation

INFOID:000000004670326

### REMOVAL

1. Remove tires with power tool.
2. Set suitable jack under axle assembly to relieve the coil spring tension.
3. Remove shock absorber (lower side).
4. Gradually lower the jack to remove it from rear lower link.
5. Remove shock absorber assembly mounting nuts (upper side) (←) with power tool, and then remove shock absorber assembly.

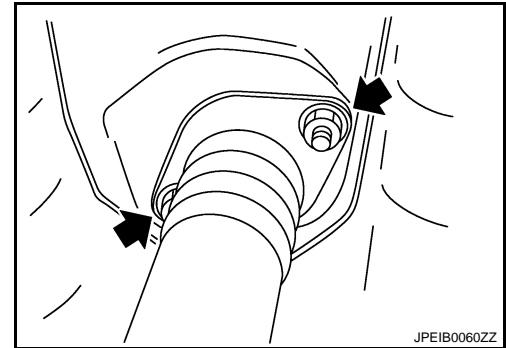

### INSTALLATION

Note the following, and install in the reverse order of removal.

- Perform final tightening of bolts and nuts at the shock absorber lower side (rubber bushing), under unladen conditions with tires on level ground.

## Disassembly and Assembly

INFOID:000000004670327

### DISASSEMBLY

#### **CAUTION:**

**Never damage shock absorber piston rod when removing components from shock absorber.**

1. Remove cap from mounting bracket
2. Wrap a shop cloth around lower side of shock absorber and fix it with a vise.  
**CAUTION:**  
**Never set the cylindrical part of shock absorber with a vise.**
3. Secure the piston rod tip so that piston rod does not turn, and remove piston rod lock nut.
4. Remove mounting seal, mounting bracket and bound bumper cover from shock absorber.

### ASSEMBLY

Install in the reverse order of removal.

## Inspection

INFOID:000000004670328

### INSPECTION AFTER REMOVAL

Check the following items, and replace the part if necessary.

- Check shock absorber assembly for deformation, cracks, damage.
- Check welded and sealed areas for oil leakage.

### INSPECTION AFTER DISASSEMBLY

Bound Bumper and Bushing

## REAR SHOCK ABSORBER

### < REMOVAL AND INSTALLATION >

---

Check bound bumper cover and bushing for cracks and damage. Replace if necessary.

Shock Absorber

Check the following, and replace the part if necessary.

- Shock absorber for deformation, cracks, and other damage.
- Piston rod for damage, uneven wear, and distortion.

### INSPECTION AFTER ASSEMBLY

Make sure piston rod on shock absorber is not damaged when attaching components to shock absorber.

### INSPECTION AFTER INSTALLATION

- Check wheel alignment. Refer to [RSU-6. "Inspection"](#).
- Adjust neutral position of steering angle sensor. Refer to [BRC-8. "ADJUSTMENT OF STEERING ANGLE SENSOR NEUTRAL POSITION : Special Repair Requirement"](#).

A

B

C

D

RSU

F

G

H

I

J

K

L

M

N

O

P

# SUSPENSION ARM

< REMOVAL AND INSTALLATION >

## SUSPENSION ARM

Exploded View

INFOID:000000004670329

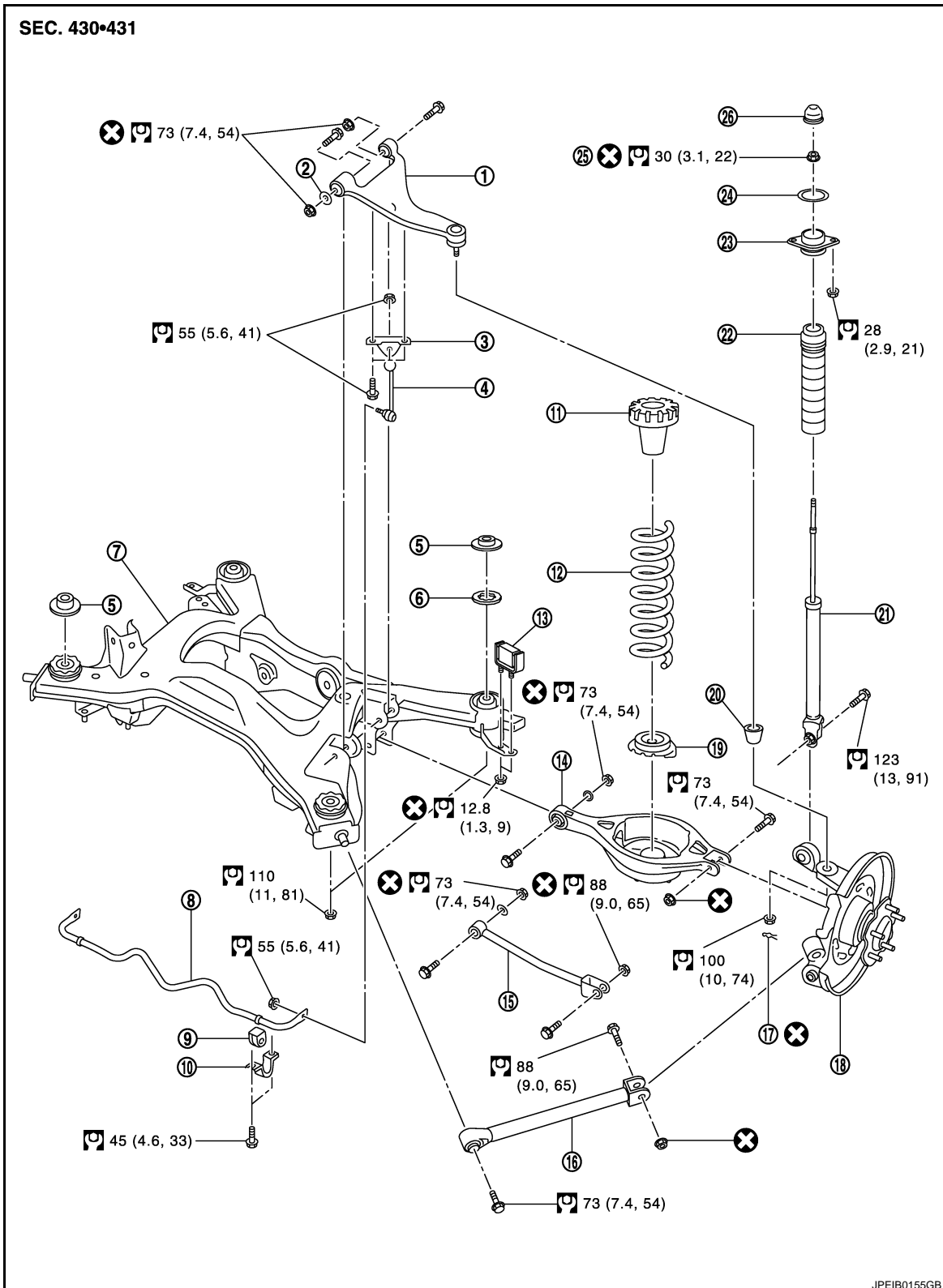

JPEIB0155GB

- |                              |                              |   |
|------------------------------|------------------------------|---|
| 1. Suspension arm            | 2. Stopper rubber            | 3. Stabilizer connecting rod mounting bracket |
| 4. Stabilizer connecting rod | 5. Upper stopper (4WD model) | 6. Mount stopper                              |

# SUSPENSION ARM

## < REMOVAL AND INSTALLATION >

- |                                 |                                     |                       |
|---------------------------------|-------------------------------------|-----------------------|
| 7. Suspension member            | 8. Stabilizer bar                   | 9. Stabilizer bushing |
| 10. Stabilizer clamp            | 11. Upper seat                      | 12. Coil spring       |
| 13. Damper assembly (A/T model) | 14. Rear lower link                 | 15. Front lower link  |
| 16. Radius rod                  | 17. Cotter pin                      | 18. Axle assembly     |
| 19. Rubber seat                 | 20. Ball seat                       | 21. Shock absorber    |
| 22. Bound bumper cover          | 23. Shock absorber mounting bracket | 24. Mounting seal     |
| 25. Piston rod lock nut         | 26. Cap                             |                       |

Refer to [GI-4, "Components"](#) for symbols in the figure.

## Removal and Installation

INFOID:000000004670330

### REMOVAL

1. Remove tire with power tool.
2. Remove caliper assembly. Hang caliper assembly in a place where it will not interfere with work. Refer to [BR-64, "BRAKE CALIPER ASSEMBLY \(FRONT CALIPER 1 PISTON TYPE\) : Exploded View"](#) (front caliper 1 piston type), [BR-68, "BRAKE CALIPER ASSEMBLY \(FRONT CALIPER 2 PISTON TYPE\) : Exploded View"](#) (front caliper 2 piston type), [BR-73, "BRAKE CALIPER ASSEMBLY \(2 PISTON TYPE\) : Exploded View"](#) (2 piston type).
3. Set suitable jack under axle assembly to relieve the coil spring tension.
4. Remove connecting rod mounting bracket from suspension arm with power tool.
5. Remove drive shaft. Refer to [RAX-11, "Exploded View"](#).
6. Remove height sensor. Refer to [EXL-202, "Exploded View"](#).
7. Remove cotter pin of suspension arm ball joint, and loosen nut. Refer to [RSU-14, "Exploded View"](#).
8. Remove suspension mounting bolts and nuts (rear suspension member side).
9. Use the ball joint remover to remove suspension arm from axle assembly. Be careful not to damage ball joint boot.  
**CAUTION:**  
**Tighten temporarily mounting nut to prevent damage to threads and to prevent ball joint remover from coming off.**
10. Remove suspension arm.

### INSTALLATION

Note the following and, install in the reverse order of removal.

- Perform final tightening of rear suspension member installation position (rubber bussing), under unladen conditions with tires on level ground.
- Never reuse cotter pin.

### Inspection

INFOID:000000004670331

#### INSPECTION AFTER REMOVAL

##### Appearance

Check the following items, and replace the part if necessary.

- Check suspension arm and bushing for deformation, cracks or damage.
- Check boot of ball joint for cracks or damage, and also for grease leakage.

##### Ball Joint Inspection

Manually move ball stud at least ten times by hand to check for smooth movement.

##### Swing Torque Inspection

## SUSPENSION ARM

### < REMOVAL AND INSTALLATION >

- Hook spring balance (A) at cotter pin mounting hole. Confirm spring balance measurement value is within specifications when ball stud begins moving.

#### Standard

**Swing torque** : Refer to [RSU-26, "Ball Joint"](#).

- If it is outside the specified range, replace suspension arm assembly.

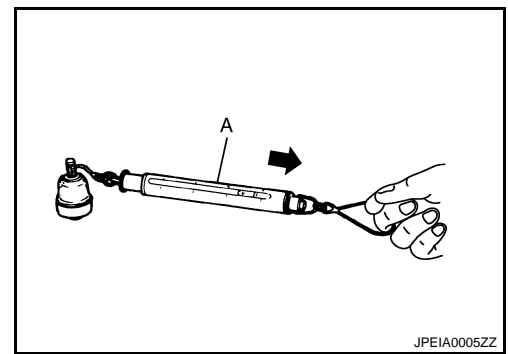

### Rotating Torque Inspection

- Attach the mounting nut to ball stud. Make sure that rotating torque is within the specifications with a preload gauge (A) [SST:ST3127S000 (J-25765-A)].

#### Standard

**Rotating torque** : Refer to [RSU-26, "Ball Joint"](#).

- If it is outside the specified range, replace suspension arm assembly.

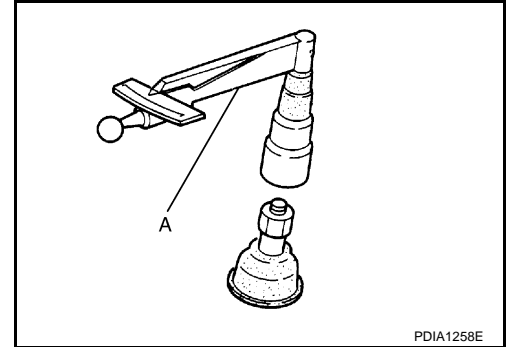

### Axial End Play Inspection

- Move tip of ball stud in axial direction to check for looseness.

#### Standard

**Axial end play** : Refer to [RSU-26, "Ball Joint"](#).

- If it is outside the specified range, replace suspension arm assembly.

### INSPECTION AFTER INSTALLATION

- Check wheel alignment. Refer to [RSU-6, "Inspection"](#).
- Adjust neutral position of steering angle sensor. Refer to [BRC-8, "ADJUSTMENT OF STEERING ANGLE SENSOR NEUTRAL POSITION : Special Repair Requirement"](#).





# RADIUS ROD

## < REMOVAL AND INSTALLATION >

---

- |                                 |                                     |                       |
|---------------------------------|-------------------------------------|-----------------------|
| 7. Suspension member            | 8. Stabilizer bar                   | 9. Stabilizer bushing |
| 10. Stabilizer clamp            | 11. Upper seat                      | 12. Coil spring       |
| 13. Damper assembly (A/T model) | 14. Rear lower link                 | 15. Front lower link  |
| 16. Radius rod                  | 17. Cotter pin                      | 18. Axle assembly     |
| 19. Rubber seat                 | 20. Ball seat                       | 21. Shock absorber    |
| 22. Bound bumper cover          | 23. Shock absorber mounting bracket | 24. Mounting seal     |
| 25. Piston rod lock nut         | 26. Cap                             |                       |

Refer to [GI-4, "Components"](#) for symbols in the figure.

## Removal and Installation

INFOID:000000004670333

### REMOVAL

1. Remove tire with power tool.
2. Set suitable jack under axle assembly.
3. Remove radius rod mounting bolts and nuts (axle housing side).
4. Remove radius rod mounting bolt (rear suspension member side), and then remove radius rod.

### INSTALLATION

Note the following, and install in the reverse order of removal.

- Perform final tightening of rear suspension member and axle installation position (rubber bushing), under unladen conditions with tires on level ground.

### Inspection

INFOID:000000004670334

### INSPECTION AFTER REMOVAL

Check radius rod and bushing for any deformation, cracks, or damage. Replace if necessary.

### INSPECTION AFTER INSTALLATION

- Check wheel alignment. Refer to [RSU-6, "Inspection"](#).
- Adjust neutral position of steering angle sensor. Refer to [BRC-8, "ADJUSTMENT OF STEERING ANGLE SENSOR NEUTRAL POSITION : Special Repair Requirement"](#).

# FRONT LOWER LINK

< REMOVAL AND INSTALLATION >

## FRONT LOWER LINK

Exploded View

INFOID:000000004670335

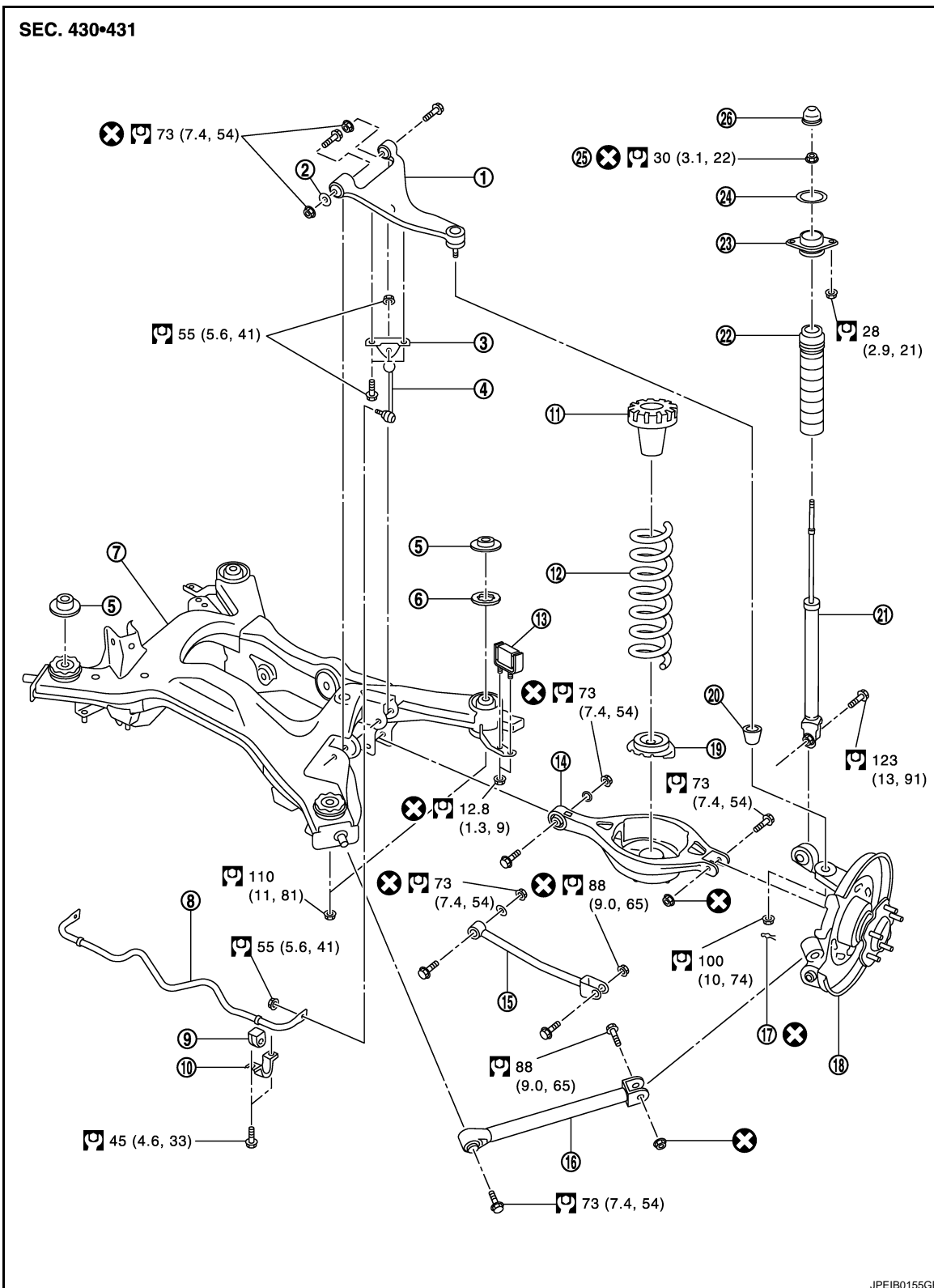

- |                              |                              |   |
|------------------------------|------------------------------|---|
| 1. Suspension arm            | 2. Stopper rubber            | 3. Stabilizer connecting rod mounting bracket |
| 4. Stabilizer connecting rod | 5. Upper stopper (4WD model) | 6. Mount stopper                              |

A  
B  
C  
D  
RSU  
F  
G  
H  
I  
J  
K  
L  
M  
N  
O  
P

# FRONT LOWER LINK

## < REMOVAL AND INSTALLATION >

---

- |                                 |                                     |                       |
|---------------------------------|-------------------------------------|-----------------------|
| 7. Suspension member            | 8. Stabilizer bar                   | 9. Stabilizer bushing |
| 10. Stabilizer clamp            | 11. Upper seat                      | 12. Coil spring       |
| 13. Damper assembly (A/T model) | 14. Rear lower link                 | 15. Front lower link  |
| 16. Radius rod                  | 17. Cotter pin                      | 18. Axle assembly     |
| 19. Rubber seat                 | 20. Ball seat                       | 21. Shock absorber    |
| 22. Bound bumper cover          | 23. Shock absorber mounting bracket | 24. Mounting seal     |
| 25. Piston rod lock nut         | 26. Cap                             |                       |

Refer to [GI-4, "Components"](#) for symbols in the figure.

## Removal and Installation

INFOID:000000004670336

### REMOVAL

1. Remove tire with power tool.
2. Set suitable jack under axle assembly to relieve the coil spring tension.
3. Remove front lower link mounting bolts and nuts (rear suspension member side).
4. Remove front lower link mounting bolts and nuts (axle housing side).
5. Remove front lower link.

### INSTALLATION

Note the following, and install in the reverse order of removal.

- Perform final tightening of rear suspension member and axle installation position (rubber bushing), under unladen conditions with tires on level ground.

### Inspection

INFOID:000000004670337

### INSPECTION AFTER REMOVAL

Check front lower link and bushing for any deformation, cracks, or damage. Replace if necessary.

### INSPECTION AFTER INSTALLATION

- Check wheel alignment. Refer to [RSU-6, "Inspection"](#).
- Adjust neutral position of steering angle sensor. Refer to [BRC-8, "ADJUSTMENT OF STEERING ANGLE SENSOR NEUTRAL POSITION : Special Repair Requirement"](#).

# REAR STABILIZER

< REMOVAL AND INSTALLATION >

## REAR STABILIZER

Exploded View

INFOID:000000004670338

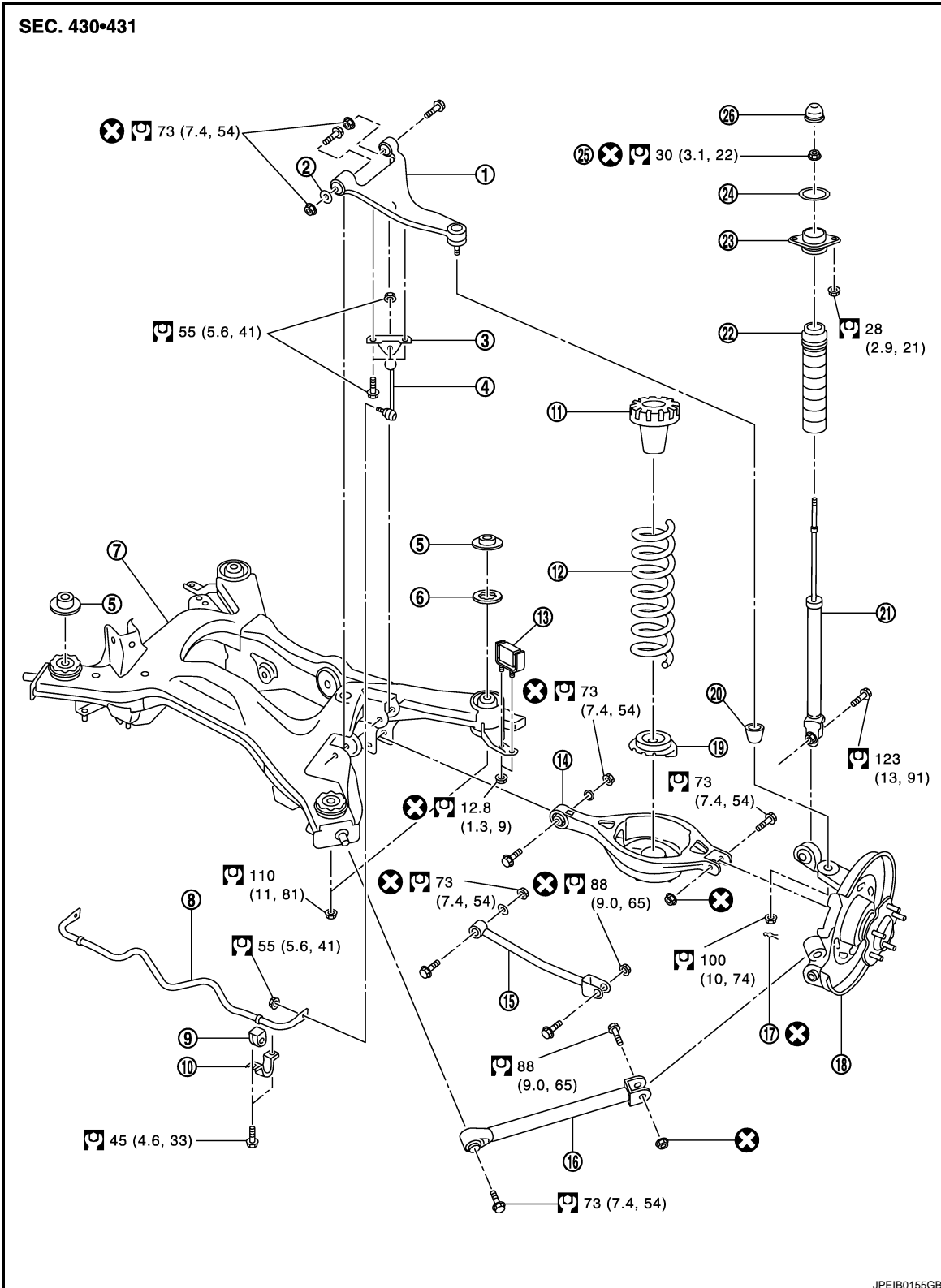

- |                              |                              |   |
|------------------------------|------------------------------|---|
| 1. Suspension arm            | 2. Stopper rubber            | 3. Stabilizer connecting rod mounting bracket |
| 4. Stabilizer connecting rod | 5. Upper stopper (4WD model) | 6. Mount stopper                              |

A  
B  
C  
D  
RSU  
F  
G  
H  
I  
J  
K  
L  
M  
N  
O  
P

# REAR STABILIZER

## < REMOVAL AND INSTALLATION >

---

- |                                 |                                     |                       |
|---------------------------------|-------------------------------------|-----------------------|
| 7. Suspension member            | 8. Stabilizer bar                   | 9. Stabilizer bushing |
| 10. Stabilizer clamp            | 11. Upper seat                      | 12. Coil spring       |
| 13. Damper assembly (A/T model) | 14. Rear lower link                 | 15. Front lower link  |
| 16. Radius rod                  | 17. Cotter pin                      | 18. Axle assembly     |
| 19. Rubber seat                 | 20. Ball seat                       | 21. Shock absorber    |
| 22. Bound bumper cover          | 23. Shock absorber mounting bracket | 24. Mounting seal     |
| 25. Piston rod lock nut         | 26. Cap                             |                       |

Refer to [GI-4. "Components"](#) for symbols in the figure.

## Removal and Installation

INFOID:000000004670339

### REMOVAL

1. Remove mounting bracket of center muffler and remove mounting rubber of main muffler. Refer to [EX-5. "Exploded View"](#).
2. Remove stabilizer connecting rod mounting nuts (lower side), and remove stabilizer connecting rod from stabilizer bar.
3. Remove mounting nuts on stabilizer clamp and remove stabilizer bar.

### INSTALLATION

Note the following, and install in the reverse order of removal.

- Tighten the mounting nut to the specified torque while holding a hexagonal part of stabilizer connecting rod side.

### Inspection

INFOID:000000004670340

### INSPECTION AFTER REMOVAL

Check stabilizer bar, stabilizer connecting rod, stabilizer bushing and stabilizer clamp for deformation, cracks or damage. Replace it if a malfunction is detected.

# REAR SUSPENSION MEMBER

< UNIT REMOVAL AND INSTALLATION >

## UNIT REMOVAL AND INSTALLATION

### REAR SUSPENSION MEMBER

Exploded View

INFOID:000000004670341

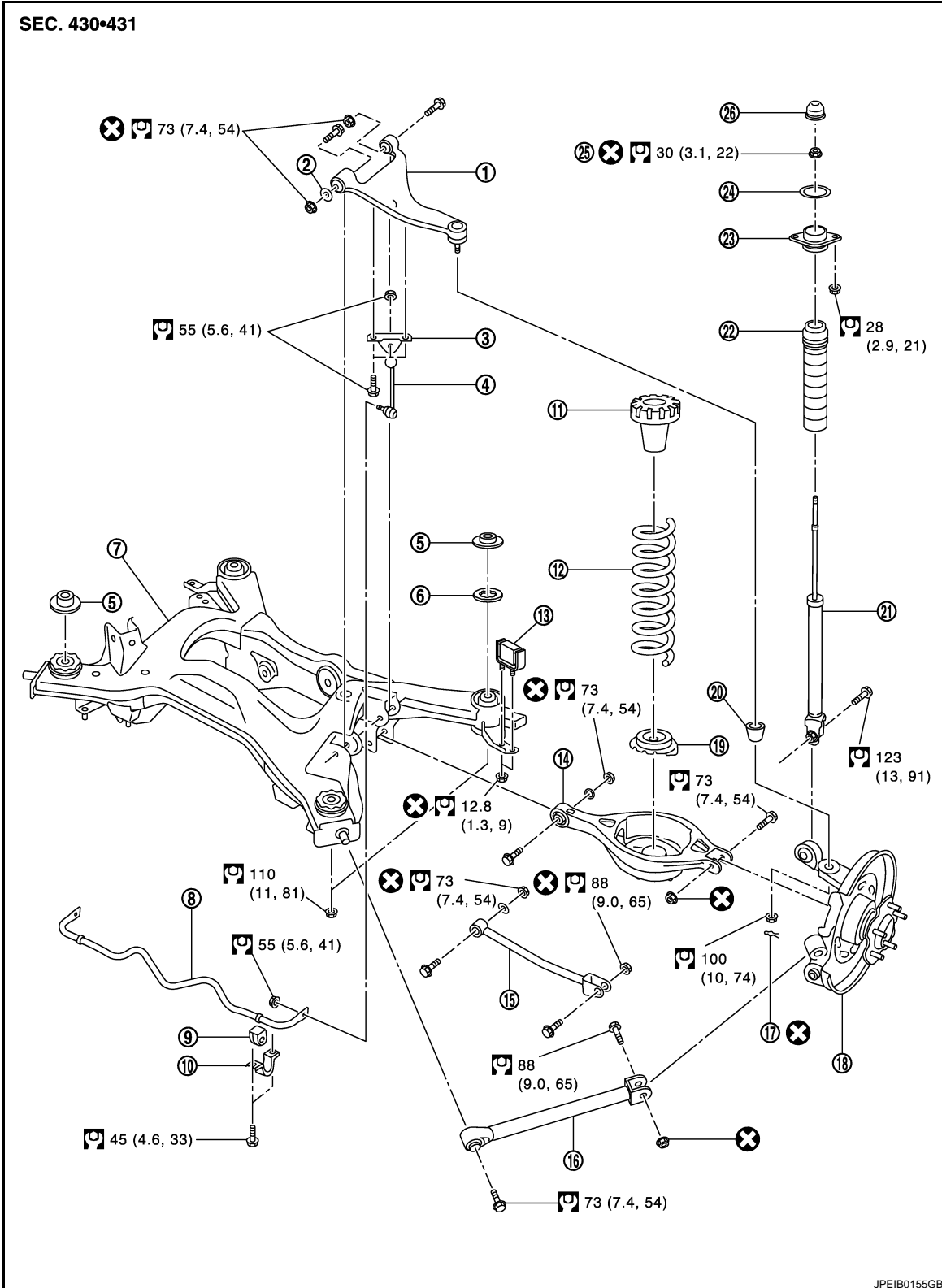

A  
B  
C  
D  
RSU  
F  
G  
H  
I  
J  
K  
L  
M  
N  
O  
P

# REAR SUSPENSION MEMBER

## < UNIT REMOVAL AND INSTALLATION >

- |                                 |                                     |   |
|---------------------------------|-------------------------------------|---|
| 1. Suspension arm               | 2. Stopper rubber                   | 3. Stabilizer connecting rod mounting bracket |
| 4. Stabilizer connecting rod    | 5. Upper stopper (4WD model)        | 6. Mount stopper                              |
| 7. Suspension member            | 8. Stabilizer bar                   | 9. Stabilizer bushing                         |
| 10. Stabilizer clamp            | 11. Upper seat                      | 12. Coil spring                               |
| 13. Damper assembly (A/T model) | 14. Rear lower link                 | 15. Front lower link                          |
| 16. Radius rod                  | 17. Cotter pin                      | 18. Axle assembly                             |
| 19. Rubber seat                 | 20. Ball seat                       | 21. Shock absorber                            |
| 22. Bound bumper cover          | 23. Shock absorber mounting bracket | 24. Mounting seal                             |
| 25. Piston rod lock nut         | 26. Cap                             |   |

Refer to [GI-4, "Components"](#) for symbols in the figure.

## Removal and Installation

INFOID:000000004670342

### REMOVAL

1. Remove tires from vehicle with power tool.
2. Remove caliper assembly. Hang caliper assembly in a place where it will not interfere with work. Refer to [BR-64, "BRAKE CALIPER ASSEMBLY \(FRONT CALIPER 1 PISTON TYPE\) : Exploded View"](#) (front caliper 1 piston type), [BR-68, "BRAKE CALIPER ASSEMBLY \(FRONT CALIPER 2 PISTON TYPE\) : Exploded View"](#) (front caliper 2 piston type), [BR-73, "BRAKE CALIPER ASSEMBLY \(2 PISTON TYPE\) : Exploded View"](#) (2 piston type).

#### **CAUTION:**

**Avoid depressing brake pedal while brake caliper is removed.**

3. Remove disc rotor. Refer to [BR-65, "BRAKE CALIPER ASSEMBLY \(FRONT CALIPER 1 PISTON TYPE\) : Removal and Installation"](#) (front caliper 1 piston type), [BR-69, "BRAKE CALIPER ASSEMBLY \(FRONT CALIPER 2 PISTON TYPE\) : Removal and Installation"](#) (front caliper 2 piston type), [BR-73, "BRAKE CALIPER ASSEMBLY \(2 PISTON TYPE\) : Removal and Installation"](#) (2 piston type).
4. Remove wheel sensor and sensor harness from axle assembly and suspension arm. Refer to [BRC-100, "Exploded View"](#).
5. Remove height sensor harness from rear suspension member. Refer to [EXL-202, "Exploded View"](#).
6. Remove center muffler and main muffler. Refer to [EX-5, "Exploded View"](#).
7. Remove stabilizer bar. Refer to [RSU-21, "Exploded View"](#).
8. Remove drive shaft. Refer to [RAX-11, "Exploded View"](#).
9. Remove propeller shaft. Refer to [DLN-90, "Exploded View"](#) (3S80A), [DLN-97, "Exploded View"](#) (3S80A-R), [DLN-105, "Exploded View"](#) (3S80A-1VL107).
10. Remove harness from rear final drive and rear suspension member.
11. Remove final drive. Refer to [DLN-245, "M/T : Exploded View"](#) [R200V (M/T)], [DLN-247, "A/T : Exploded View"](#) [R200V (A/T)], [DLN-172, "2WD : Exploded View"](#) [R200 (2WD)], [DLN-174, "AWD : Exploded View"](#) [R200 (AWD)].
12. Remove parking brake cable mounting bolt and separate parking brake cable from vehicle and rear suspension member. Refer to [PB-6, "PEDAL TYPE : Exploded View"](#) (pedal type), [PB-7, "LEVER TYPE : Exploded View"](#) (lever type).
13. Remove mounting bolts in lower side of shock absorber.
14. Remove rear lower link and coil spring. Refer to [RSU-8, "Exploded View"](#).
15. Set suitable jack under rear suspension member.
16. Remove mounting nuts rear suspension member.
17. Slowly lower jack, then remove rear suspension member, suspension arm, radius rod, front lower link and axle from vehicle as a unit.
18. Remove mounting bolts and nuts, then remove suspension arm, front lower link, and radius rod from rear suspension member.

### INSTALLATION

Note the following, and install in the reverse order of the removal.



# REAR SUSPENSION MEMBER

## < UNIT REMOVAL AND INSTALLATION >

- Perform the final tightening of each of parts under unladen conditions, which were removed when removing rear suspension assembly.
- Check wheel sensor harness for proper connection. Refer to [BRC-100, "Exploded View"](#).

### **CAUTION:**

**Never reuse cotter pin.**

### Inspection

INFOID:000000004670343

### INSPECTION AFTER REMOVAL

Check front suspension member for deformation, cracks, or any other damage. Replace if necessary.

### INSPECTION AFTER INSTALLATION

- Check wheel alignment. Refer to [RSU-6, "Inspection"](#).
- Adjust neutral position of steering angle sensor. Refer to [BRC-8, "ADJUSTMENT OF STEERING ANGLE SENSOR NEUTRAL POSITION : Special Repair Requirement"](#).
- Adjust parking brake operation (stroke). [PB-3, "PEDAL TYPE : Inspection and Adjustment"](#) (pedal type), [PB-4, "LEVER TYPE : Inspection and Adjustment"](#) (lever type).

A

B

C

D

RSU

F

G

H

I

J

K

L

M

N

O

P

# SERVICE DATA AND SPECIFICATIONS (SDS)

< SERVICE DATA AND SPECIFICATIONS (SDS)

## SERVICE DATA AND SPECIFICATIONS (SDS)

### SERVICE DATA AND SPECIFICATIONS (SDS)

#### Wheel Alignment

INFOID:000000004504373

Item		Standard	
Camber Degree minute (Decimal degree)	Minimum	-1° 45' (-1.75°)	
	Nominal	-1° 15' (-1.25°)	
	Maximum	-0° 45' (-0.75°)	
Total toe-in	Distance	Minimum	0 mm (0 in)
		Nominal	In 2.8 mm (0.110 in)
		Maximum	In 5.6 mm (0.220 in)
	Angle (left wheel or right wheel) Degree minute (Decimal degree)	Minimum	0° 00' (0.00°)
		Nominal	In 0° 07' (0.12°)
		Maximum	In 0° 14' (0.23°)

Measure value under unladen\* conditions.

\*: Fuel, engine coolant and lubricant are full. Spare tire, jack, hand tools and mats are in designated positions.

#### Ball Joint

INFOID:000000004504374

Item	Standard
Swing torque	0.5 – 3.4 N·m (0.06 – 0.34 kg-m, 5 – 30 in-lb)
Measurement on spring balance (cotter pinhole position)	8.1 – 54.8 N (0.83 – 5.6 kg, 1.82 – 12.32 lb)
Rotating torque	0.5 – 3.4 N·m (0.06 – 0.34 kg-m, 5 – 30 in-lb)
Axial end play	0 mm (0 in)

#### Wheelarch Height

INFOID:000000004504375

Applied model	2WD			AWD
	Except for sports models		For sports models	
Wheel size	18 inch	19 inch		18 inch
Front (Hf)	712 mm (28.03 in)	715 mm (28.15 in)	716 mm (28.19 in)	726 mm (28.58 in)
Rear (Hr)	702 mm (27.64 in)	705 mm (27.76 in)	706 mm (27.80 in)	718 mm (28.27 in)

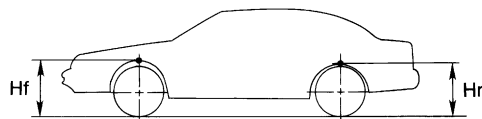

SFA818A

Measure value under unladen\* conditions.

\*: Fuel, engine coolant and lubricant are full. Spare tire, jack, hand tools and mats are in designated positions.