

SECTION **DLN**
DRIVELINE

A
B
C

DLN

CONTENTS

E

TRANSFER: ETX13C		
BASIC INSPECTION	7	
DIAGNOSIS AND REPAIR WORK FLOW	7	
Work Flow	7	
SYSTEM DESCRIPTION	8	
AWD SYSTEM	8	
System Diagram	8	
System Description	9	
Component Parts Location	11	
Component Description	11	
DIAGNOSIS SYSTEM (AWD CONTROL UNIT)	12	
CONSULT-III Function	12	
DTC/CIRCUIT DIAGNOSIS	14	
C1201 AWD CONTROL UNIT	14	
Description	14	
DTC Logic	14	
Diagnosis Procedure	14	
C1203 ABS ACTUATOR AND ELECTRIC UNIT (CONTROL UNIT)	15	
Description	15	
DTC Logic	15	
Diagnosis Procedure	15	
C1204 AWD SOLENOID	16	
Description	16	
DTC Logic	16	
Diagnosis Procedure	16	
Component Inspection	17	
C1205 AWD ACTUATOR RELAY	18	
Description	18	
DTC Logic	18	
Diagnosis Procedure	18	
C1210 ECM	19	
Description	19	
DTC Logic	19	
Diagnosis Procedure	19	
P1804 TRANSFER CONTROL UNIT	20	
Description	20	
DTC Logic	20	
Diagnosis Procedure	20	
P1809 TRANSFER CONTROL UNIT	21	
Description	21	
DTC Logic	21	
Diagnosis Procedure	21	
P1826 TRANSFER FLUID TEMPERATURE	22	
Description	22	
DTC Logic	22	
Diagnosis Procedure	22	
Component Inspection	24	
U1000 CAN COMM CIRCUIT	25	
Description	25	
DTC Logic	25	
Diagnosis Procedure	25	
U1010 CONTROL UNIT (CAN)	26	
Description	26	
DTC Logic	26	
Diagnosis Procedure	26	
POWER SUPPLY AND GROUND CIRCUIT	27	
Description	27	
Diagnosis Procedure	27	
AWD WARNING LAMP	30	
Description	30	
Component Function Check	30	
Diagnosis Procedure	30	
ECU DIAGNOSIS INFORMATION	32	

F

G

H

I

J

K

L

M

N

O

P

AWD CONTROL UNIT	32	Refilling	54
Reference Value	32	REMOVAL AND INSTALLATION	55
Wiring Diagram - AWD SYSTEM -	34	AWD CONTROL UNIT	55
Fail-Safe	39	Exploded View	55
DTC Inspection Priority Chart	40	Removal and Installation	55
DTC Index	40	FRONT OIL SEAL	56
SYMPTOM DIAGNOSIS	42	Exploded View	56
AWD WARNING LAMP DOES NOT TURN ON		Removal and Installation	56
.....	42	REAR OIL SEAL	57
Description	42	Exploded View	57
Diagnosis Procedure	42	Removal and Installation	57
AWD WARNING LAMP DOES NOT TURN OFF	43	UNIT REMOVAL AND INSTALLATION	60
Description	43	TRANSFER ASSEMBLY	60
Diagnosis Procedure	43	Exploded View	60
HEAVY TIGHT-CORNER BRAKING SYMPTOM OCCURS	44	Removal and Installation	60
Description	44	UNIT DISASSEMBLY AND ASSEMBLY ...	62
Diagnosis Procedure	44	FRONT CASE AND REAR CASE	62
VEHICLE DOES NOT ENTER AWD MODE	45	Exploded View	62
Description	45	Disassembly	63
Diagnosis Procedure	45	Assembly	66
AWD WARNING LAMP BLINKS QUICKLY	46	Inspection	70
Description	46	MAIN SHAFT	72
AWD WARNING LAMP BLINKS SLOWLY	47	Exploded View	72
Description	47	Disassembly	73
Diagnosis Procedure	47	Assembly	74
NOISE, VIBRATION AND HARSHNESS (NVH) TROUBLESHOOTING	48	Inspection	75
NVH Troubleshooting Chart	48	FRONT DRIVE SHAFT AND DRIVE CHAIN	77
PRECAUTION	49	Exploded View	77
PRECAUTIONS	49	Disassembly	78
Precaution for Supplemental Restraint System (SRS) "AIR BAG" and "SEAT BELT PRE-TENSIONER"	49	Assembly	78
Precaution Necessary for Steering Wheel Rotation after Battery Disconnect	49	Inspection	79
Precaution for Battery Service	50	SERVICE DATA AND SPECIFICATIONS (SDS)	81
Service Notice or Precautions for Transfer	50	SERVICE DATA AND SPECIFICATIONS (SDS)	81
PREPARATION	51	General Specifications	81
PREPARATION	51	FRONT PROPELLER SHAFT: 2S56A	
Special Service Tools	51	SYMPTOM DIAGNOSIS	82
Commercial Service Tools	52	NOISE, VIBRATION AND HARSHNESS (NVH) TROUBLESHOOTING	82
PERIODIC MAINTENANCE	54	NVH Troubleshooting Chart	82
TRANSFER FLUID	54	PREPARATION	83
Inspection	54	PREPARATION	83
Draining	54	Commercial Service Tools	83
		PERIODIC MAINTENANCE	84

FRONT PROPELLER SHAFT	84	PREPARATION	98	
Inspection	84	Commercial Service Tools	98	A
REMOVAL AND INSTALLATION	85	PERIODIC MAINTENANCE	99	
FRONT PROPELLER SHAFT	85	REAR PROPELLER SHAFT	99	B
Exploded View	85	Inspection	99	
Removal and Installation	85	REMOVAL AND INSTALLATION	100	C
Inspection	86	REAR PROPELLER SHAFT	100	
SERVICE DATA AND SPECIFICATIONS		Exploded View	100	
(SDS)	88	Removal and Installation	100	
SERVICE DATA AND SPECIFICATIONS		Inspection	103	DLN
(SDS)	88	SERVICE DATA AND SPECIFICATIONS		E
General Specifications	88	(SDS)	104	
Propeller Shaft Runout	88	SERVICE DATA AND SPECIFICATIONS		F
Journal Axial Play	88	(SDS)	104	
REAR PROPELLER SHAFT: 3S80A		General Specifications	104	
SYMPTOM DIAGNOSIS	89	Propeller Shaft Runout	104	
NOISE, VIBRATION AND HARSHNESS		Journal Axial Play	104	G
(NVH) TROUBLESHOOTING	89	REAR PROPELLER SHAFT: 3F80A-1VL107		
NVH Troubleshooting Chart	89	SYMPTOM DIAGNOSIS	105	H
PREPARATION	90	NOISE, VIBRATION AND HARSHNESS		
PREPARATION	90	(NVH) TROUBLESHOOTING	105	
Commercial Service Tools	90	NVH Troubleshooting Chart	105	I
PERIODIC MAINTENANCE	91	PREPARATION	106	J
REAR PROPELLER SHAFT	91	PREPARATION	106	
Inspection	91	Commercial Service Tools	106	
REMOVAL AND INSTALLATION	92	PERIODIC MAINTENANCE	107	K
REAR PROPELLER SHAFT	92	REAR PROPELLER SHAFT	107	
Exploded View	92	Inspection	107	L
Removal and Installation	93	REMOVAL AND INSTALLATION	108	
Inspection	94	REAR PROPELLER SHAFT	108	M
SERVICE DATA AND SPECIFICATIONS		Exploded View	108	
(SDS)	96	Removal and Installation	108	
SERVICE DATA AND SPECIFICATIONS		Inspection	111	N
(SDS)	96	SERVICE DATA AND SPECIFICATIONS		O
General Specifications	96	(SDS)	112	
Propeller Shaft Runout	96	SERVICE DATA AND SPECIFICATIONS		P
Journal Axial Play	96	(SDS)	112	
REAR PROPELLER SHAFT: 3S80A-R		General Specifications	112	
SYMPTOM DIAGNOSIS	97	Propeller Shaft Runout	112	
NOISE, VIBRATION AND HARSHNESS		Journal Axial Play	112	
(NVH) TROUBLESHOOTING	97	FRONT FINAL DRIVE: F160A		
NVH Troubleshooting Chart	97	SYSTEM DESCRIPTION	113	
PREPARATION	98	FRONT FINAL DRIVE ASSEMBLY	113	

System Diagram	113	DRIVE PINION	142
SYMPTOM DIAGNOSIS	114	Exploded View	142
NOISE, VIBRATION AND HARSHNESS		Disassembly	143
(NVH) TROUBLESHOOTING	114	Assembly	144
NVH Troubleshooting Chart	114	Adjustment	146
PRECAUTION	115	Inspection After Disassembly	149
PRECAUTIONS	115	SERVICE DATA AND SPECIFICATIONS	
Precaution Necessary for Steering Wheel Rotation after Battery Disconnect	115	(SDS)	150
Service Notice or Precautions for Front Final Drive	115	SERVICE DATA AND SPECIFICATIONS	
PREPARATION	116	(SDS)	150
PREPARATION	116	General Specifications	150
Special Service Tools	116	Drive Gear Runout	150
Commercial Service Tools	118	Differential Side Gear Clearance	150
PERIODIC MAINTENANCE	119	Preload Torque	150
FRONT DIFFERENTIAL GEAR OIL	119	Backlash	150
Inspection	119	Companion Flange Runout	150
Draining	119	REAR FINAL DRIVE: R200	
Refilling	119	SYSTEM DESCRIPTION	151
REMOVAL AND INSTALLATION	120	REAR FINAL DRIVE ASSEMBLY	151
SIDE OIL SEAL	120	System Diagram	151
RIGHT SIDE	120	SYMPTOM DIAGNOSIS	153
RIGHT SIDE : Exploded View	120	NOISE, VIBRATION AND HARSHNESS	
RIGHT SIDE : Removal and Installation	120	(NVH) TROUBLESHOOTING	153
LEFT SIDE	121	NVH Troubleshooting Chart	153
LEFT SIDE : Exploded View	121	PRECAUTION	155
LEFT SIDE : Removal and Installation	121	PRECAUTIONS	155
UNIT REMOVAL AND INSTALLATION ...	123	Service Notice or Precautions for Rear Final Drive	155
FRONT FINAL DRIVE ASSEMBLY	123	PREPARATION	156
Exploded View	123	PREPARATION	156
Removal and Installation	123	Special Service Tools	156
UNIT DISASSEMBLY AND ASSEMBLY ..	125	Commercial Service Tools	159
SIDE SHAFT	125	PERIODIC MAINTENANCE	160
Exploded View	125	REAR DIFFERENTIAL GEAR OIL	160
Disassembly	126	Inspection	160
Assembly	126	Draining	160
Inspection After Disassembly	127	Refilling	160
DIFFERENTIAL ASSEMBLY	128	REMOVAL AND INSTALLATION	161
Exploded View	128	FRONT OIL SEAL	161
Disassembly	129	2WD	161
Assembly	132	2WD : Exploded View	161
Adjustment	136	2WD : Removal and Installation	161
Inspection After Disassembly	140	AWD	165
		AWD : Exploded View	165
		AWD : Removal and Installation	166
		SIDE OIL SEAL	

2WD	171	Preload Torque	223	
2WD : Exploded View	171	Backlash	223	A
2WD : Removal and Installation	171	Drive Pinion Runout (2WD)	223	
AWD	172	Companion Flange Runout (AWD)	223	
AWD : Exploded View	172	REAR FINAL DRIVE: R200V		
AWD : Removal and Installation	173			B
UNIT REMOVAL AND INSTALLATION ...	175	SYSTEM DESCRIPTION	225	
REAR FINAL DRIVE ASSEMBLY	175	REAR FINAL DRIVE ASSEMBLY	225	C
2WD	175	System Diagram	225	
2WD : Exploded View	175	SYMPTOM DIAGNOSIS	226	
2WD : Removal and Installation	175	NOISE, VIBRATION AND HARSHNESS (NVH) TROUBLESHOOTING	226	DLN
AWD	176	NVH Troubleshooting Chart	226	E
AWD : Exploded View	177	PRECAUTION	228	
AWD : Removal and Installation	177	PRECAUTIONS	228	F
UNIT DISASSEMBLY AND ASSEMBLY .	179	Service Notice or Precautions for Rear Final Drive.	228	
DIFFERENTIAL ASSEMBLY	179	PREPARATION	229	G
2WD	179	PREPARATION	229	
2WD : Exploded View	179	Special Service Tools	229	H
2WD : Disassembly	180	Commercial Service Tools	232	
2WD : Assembly	182	PERIODIC MAINTENANCE	233	I
2WD : Adjustment	186	REAR DIFFERENTIAL GEAR OIL	233	
2WD : Inspection After Disassembly	191	Inspection	233	J
AWD	191	Draining	233	
AWD : Exploded View	192	Refilling	233	K
AWD : Disassembly	192	REMOVAL AND INSTALLATION	234	
AWD : Assembly	195	FRONT OIL SEAL	234	
AWD : Adjustment	199	M/T	234	L
AWD : Inspection After Disassembly	204	M/T : Exploded View	234	
DRIVE PINION	205	M/T : Removal and Installation	234	M
2WD	205	A/T	238	
2WD : Exploded View	205	A/T : Exploded View	239	
2WD : Disassembly	206	A/T : Removal and Installation	239	N
2WD : Assembly	207	SIDE OIL SEAL	244	
2WD : Adjustment	209	M/T	244	
2WD : Inspection After Disassembly	212	M/T : Exploded View	244	
AWD	213	M/T : Removal and Installation	244	O
AWD : Exploded View	213	A/T	245	
AWD : Disassembly	214	A/T : Exploded View	246	
AWD : Assembly	216	A/T : Removal and Installation	246	P
AWD : Adjustment	218	UNIT REMOVAL AND INSTALLATION ...	248	
AWD : Inspection After Disassembly	221	REAR FINAL DRIVE ASSEMBLY	248	
SERVICE DATA AND SPECIFICATIONS (SDS)	223	M/T	248	
SERVICE DATA AND SPECIFICATIONS (SDS)	223	M/T : Exploded View	248	
General Specification	223			
Drive Gear Runout	223			
Differential Side Gear Clearance	223			

M/T : Removal and Installation	248	M/T : Exploded View	277
A/T	249	M/T : Disassembly	278
A/T : Exploded View	250	M/T : Assembly	279
A/T : Removal and Installation	250	M/T : Adjustment	281
UNIT DISASSEMBLY AND ASSEMBLY ..	252	M/T : Inspection After Disassembly	285
DIFFERENTIAL ASSEMBLY	252	A/T	285
M/T	252	A/T : Exploded View	286
M/T : Exploded View	252	A/T : Disassembly	286
M/T : Disassembly	253	A/T : Assembly	288
M/T : Assembly	255	A/T : Adjustment	290
M/T : Adjustment	259	A/T : Inspection After Disassembly	293
M/T : Inspection After Disassembly	263	SERVICE DATA AND SPECIFICATIONS	
A/T	264	(SDS)	295
A/T : Exploded View	264	SERVICE DATA AND SPECIFICATIONS	
A/T : Disassembly	265	(SDS)	295
A/T : Assembly	268	General Specification	295
A/T : Adjustment	271	Drive Gear Runout	295
A/T : Inspection After Disassembly	276	Differential Side Gear Clearance	295
DRIVE PINION	277	Preload Torque	295
M/T	277	Backlash	295
		Companion flange Runout (M/T Models)	295
		Drive Pinion Runout (A/T Models)	296

BASIC INSPECTION

DIAGNOSIS AND REPAIR WORK FLOW

Work Flow

INFOID:000000005649578

DETAILED FLOW

1. INTERVIEW FROM THE CUSTOMER

Clarify customer complaints before inspection. First of all, reproduce symptoms, and understand them fully. Ask customer about his/her complaints carefully. Check symptoms by driving vehicle with customer, if necessary.

CAUTION:

Customers are not professional. Never guess easily like “maybe the customer means that...,” or “maybe the customer mentions this symptom”.

>> GO TO 2.

2. CHECK AWD WARNING LAMP

Start the engine and drive at 30 km/h (19 MPH) or more for approximately 1 minute.

Does AWD warning lamp turn ON?

YES >> GO TO 3.

NO >> GO TO 6.

3. PERFORM SELF-DIAGNOSIS

With CONSULT-III

1. Perform self-diagnosis for “ALL MODE AWD/4WD”.
2. Check malfunction detected by self-diagnosis.
3. Erase self-diagnostic results for “ALL MODE AWD/4WD”.

>> GO TO 4.

4. CHECK TERMINALS AND HARNESS CONNECTORS

Check pin terminals for damage or loose connection with harness connector.

>> GO TO 5.

5. CHECK SYMPTOM REPRODUCTION

With CONSULT-III

Perform DTC reproduction procedure for the error system.

Is any error detected?

YES >> GO TO 2.

NO >> GO TO 6.

6. PERFORM SYMPTOM DIAGNOSIS

Perform the symptom diagnosis for each system.

Is any malfunction present?

YES >> GO TO 2.

NO >> GO TO 7.

7. FINAL CHECK

With CONSULT-III

Check input/output signal standard of “ALL MODE AWD/4WD”.

Is the input/output the standard value?

YES >> INSPECTION END

NO >> GO TO 2.

A
B
C
DLN
E
F
G
H
I
J
K
L
M
N
O
P

AWD SYSTEM

< SYSTEM DESCRIPTION >

[TRANSFER: ETX13C]

SYSTEM DESCRIPTION

AWD SYSTEM

System Diagram

INFOID:000000005649579

CONTROL DIAGRAM

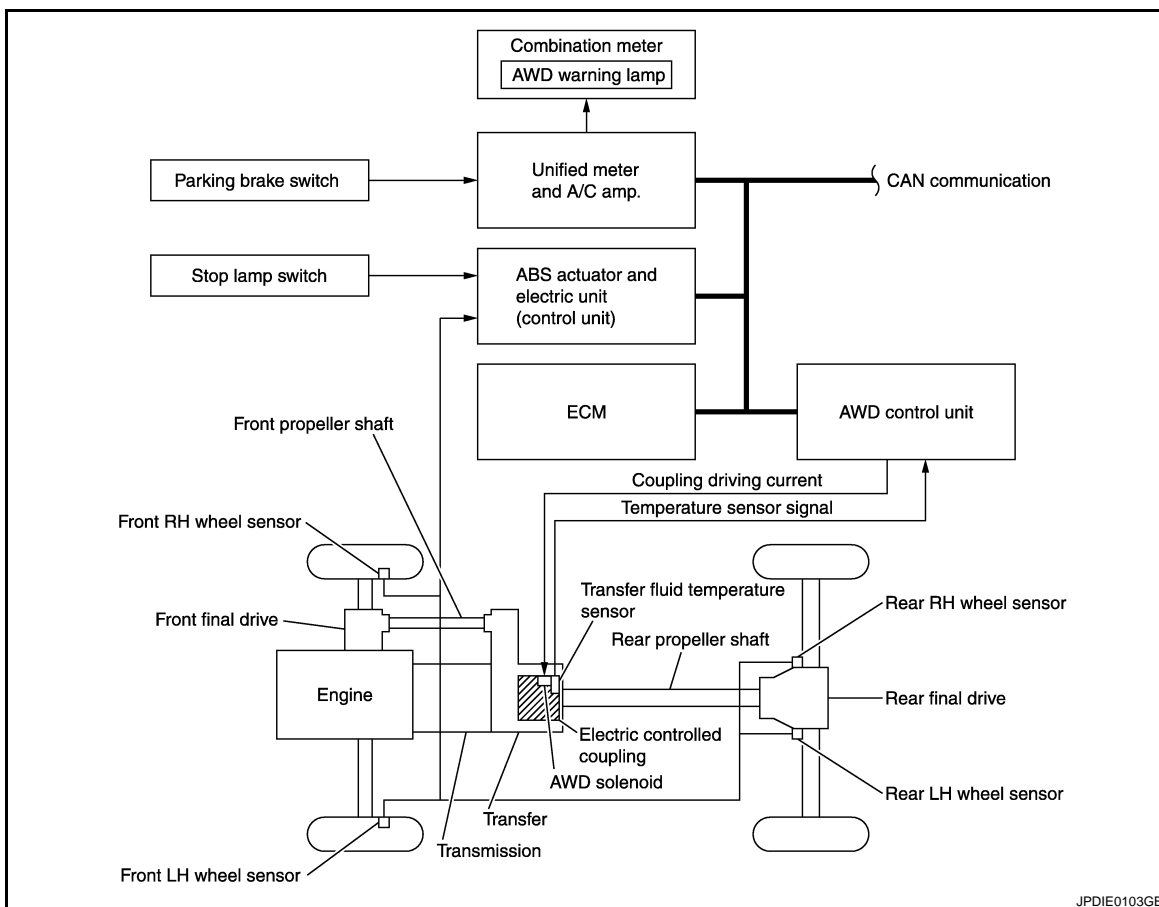

CROSS-SECTIONAL VIEW

AWD SYSTEM

< SYSTEM DESCRIPTION >

[TRANSFER: ETX13C]

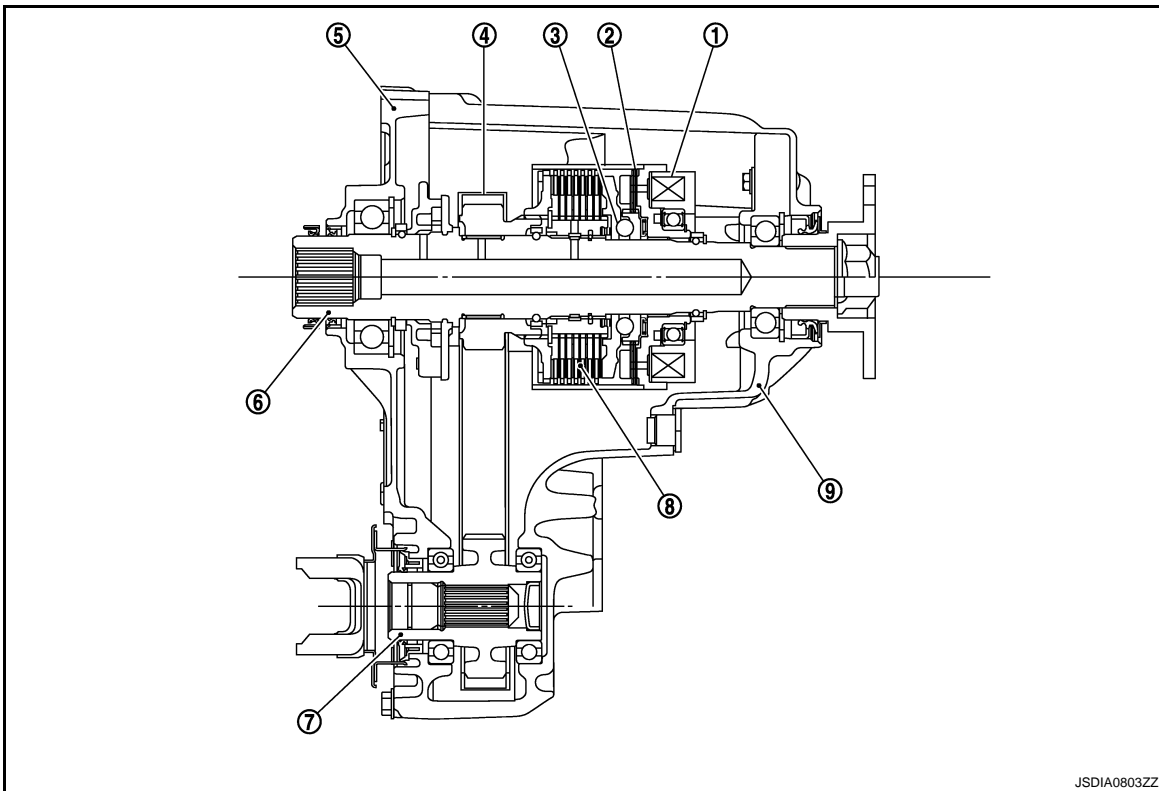

- | | | |
|----------------------|-------------------|---------------|
| 1. Electromagnet | 2. Control clutch | 3. Cam |
| 4. Drive chain | 5. Front case | 6. Main shaft |
| 7. Front drive shaft | 8. Main clutch | 9. Rear case |

System Description

INFOID:000000005649580

DESCRIPTION

- Electronic control allows optimal distribution of torque to front/rear wheels to match road conditions.
- Makes possible stable driving, with no wheel spin, on snowy roads or other slippery surfaces.
- On roads which do not require AWD, it contributes to improved fuel economy by driving in conditions close to rear-wheel drive.
- Sensor inputs determine the vehicle's turning condition, and in response tight cornering/braking are controlled by distributing optimum torque to front wheels.
- It transmits/receives each signal from the following control unit via CAN communication line.

Component parts	Function
ABS actuator and electric unit (control unit)	Transmits the following signals via CAN communication to AWD control unit. <ul style="list-style-type: none"> • Vehicle speed signal • Stop lamp switch signal (brake signal)
ECM	Transmits the following signals via CAN communication to AWD control unit. <ul style="list-style-type: none"> • Accelerator pedal position signal • Engine speed signal
Unified meter and A/C amp.	Transmits conditions of parking brake switch via CAN communication to AWD control unit.

NOTE:

- When driving, if there is a large difference between front and rear wheel speed which continues for a long time, fluid temperature of drive system parts becomes too high and AWD warning lamp blinks quickly. (When AWD warning lamp blinks, vehicle changes to rear-wheel drive conditions.) Also, optional distribution of torque sometimes becomes rigid before lamp blinks quickly, but it is not a malfunction.
- If AWD warning lamp is blinking quickly, stop vehicle and allow it to idle for some time. Blinking will stop and AWD system will be restored.

AWD SYSTEM

[TRANSFER: ETX13C]

< SYSTEM DESCRIPTION >

- When driving, AWD warning lamp may blink slowly if there is a significant difference in diameter of the tires. At this time, vehicle performance is not fully available and cautious driving is required. (Continues until the engine is turned OFF.)
- If the warning lamp blinks slowly during driving but remains OFF after the engine is restarted, the system is normal. If it again blinks slowly after driving for some time, vehicle must be inspected.
- When there is a difference of revolution speed between the front and rear wheel the shift occasionally changes to direct 4-wheel driving conditions automatically. This is not a malfunction.

OPERATION PRINCIPLE

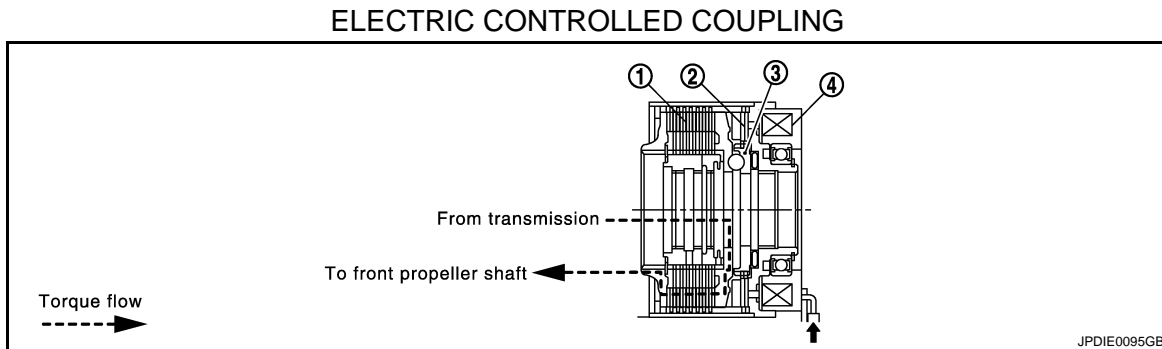

1. Main clutch
2. Control clutch
3. Cam
4. Electromagnet

←: Current commanded from AWD control unit.

1. AWD control unit supplies command current to electric controlled coupling (AWD solenoid).
2. Control clutch is engaged by electromagnet and torque is detected in control clutch.
3. The cam operates in response to control clutch torque and applies pressure to main clutch.
4. Main clutch transmits torque to front wheels according to pressing power.
 - Transmission torque to front wheels is determined according to command current.

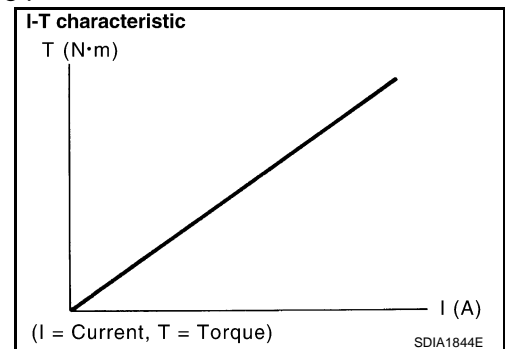

AWD SYSTEM

< SYSTEM DESCRIPTION >

[TRANSFER: ETX13C]

Component Parts Location

INFOID:000000005649581

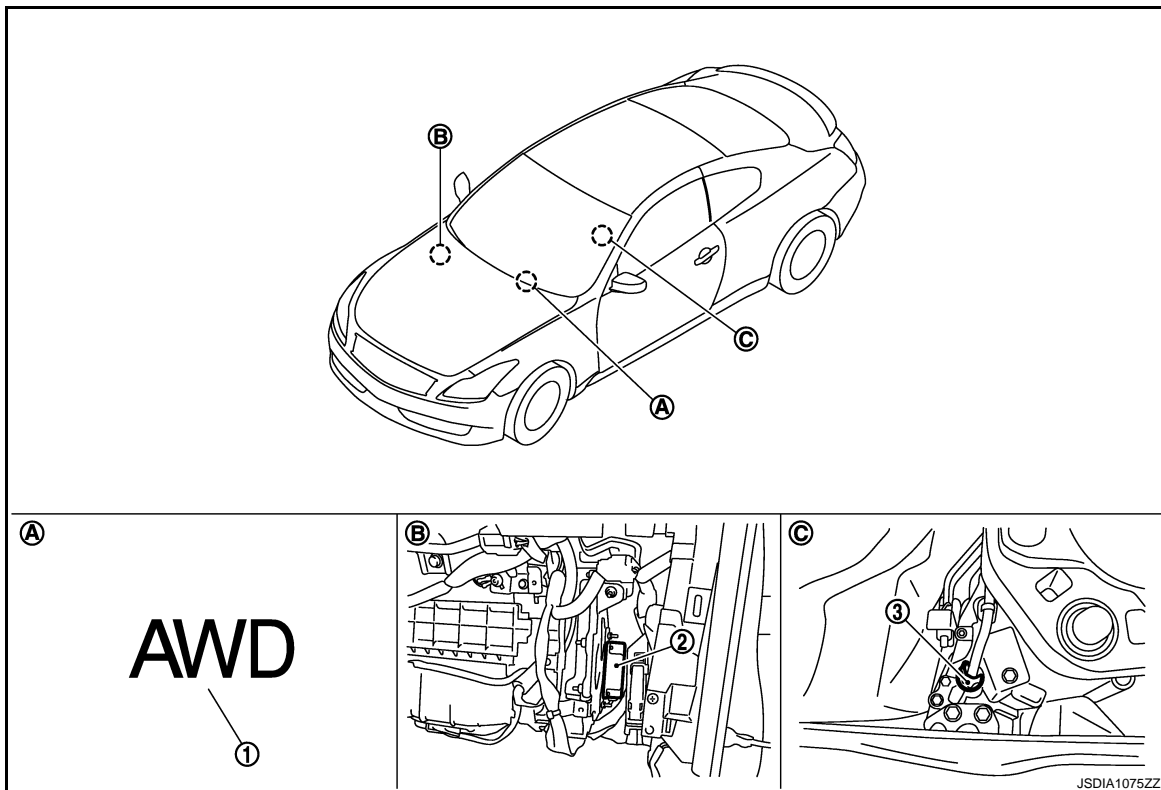

- | | | |
|----------------------|-------------------------------|-----------------------------------|
| 1. AWD warning lamp | 2. AWD control unit | 3. AWD solenoid harness connector |
| A. Combination meter | B. Glove box assembly removed | C. Transfer assembly |

Component Description

INFOID:000000005649582

Component parts	Reference/Function
AWD control unit	DLN-14. "Description"
Wheel sensors	BRC-31. "Description"
AWD solenoid	DLN-16. "Description"
Transfer fluid temperature sensor	DLN-22. "Description"
Electric controlled coupling	Transmits driving force to rear final drive.
AWD warning lamp	DLN-30. "Description"
ABS actuator and electric unit (control unit)	DLN-15. "Description"
ECM	DLN-19. "Description"
Unified meter and A/C amp.	DLN-30. "Description"

DIAGNOSIS SYSTEM (AWD CONTROL UNIT)

< SYSTEM DESCRIPTION >

[TRANSFER: ETX13C]

DIAGNOSIS SYSTEM (AWD CONTROL UNIT)

CONSULT-III Function

INFOID:000000005649583

FUNCTION

CONSULT-III can display each diagnostic item using the diagnostic test modes as follows.

Diagnostic test mode	Function
ECU Identification	AWD control unit part number can be read.
Self Diagnostic Result	Self-diagnostic results can be read and erased quickly.
Data Monitor	Input/Output data in the AWD control unit can be read.
Active Test	Diagnostic Test Mode in which CONSULT-III drives some actuators apart from the AWD control unit and also shifts some parameters in a specified range.

ECU IDENTIFICATION

AWD control unit part number can be read.

SELF DIAGNOSTIC RESULT

Before performing the self-diagnosis, start the engine and drive vehicle at 30 km/h (19 MPH) or more for approximately 1 minute.

Display Item List

Refer to [DLN-40, "DTC Index"](#).

How to Erase Self-Diagnostic Results

Before erasing DTC memory, start the engine and drive at 30 km/h (19 MPH) or more for approximately 1 minute. Check that ABS warning lamp turns OFF.

NOTE:

When AWD warning lamp is ON with system malfunction of DTC "C1203", run the vehicle at 30 km/h (19MPH) or more for a minute and check that ABS warning lamp is turned OFF. Then turn ignition switch OFF, and start the engine again. Otherwise AWD warning lamp may not turn OFF even if it is normal.

DATA MONITOR

Display Item List

Monitor item (Unit)	Remarks
STOP LAMP SW [On/Off]	Stop lamp switch signal status via CAN communication line is displayed.
ENG SPEED SIG [Run/Stop]	Engine status is displayed.
ETS ACTUATOR [On/Off]	Operating condition of AWD actuator relay (integrated in AWD control unit) is displayed.
4WD WARN LAMP [On/Off]	Control status of AWD warning lamp is displayed.
4WD MODE SW [##]	Mode switch is not equipped, but displayed.
4WD MODE MON [AUTO]	Control status of AWD is displayed.
DIS-TIRE MONI [mm]	Improper size tire installed condition is displayed.
P BRAKE SW [On/Off]	Parking brake switch signal status via CAN communication line is displayed.
BATTERY VOLT [V]	Power supply voltage for AWD control unit
THRTL POS SEN [%]	Throttle opening status is displayed.
ETS SOLENOID [A]	Monitored value of current at AWD solenoid
FR RH SENSOR [km/h] or [mph]	Wheel speed calculated by front RH wheel sensor signal is displayed.
FR LH SENSOR [km/h] or [mph]	Wheel speed calculated by front LH wheel sensor signal is displayed.
RR RH SENSOR [km/h] or [mph]	Wheel speed calculated by rear RH wheel sensor signal is displayed.
RR LH SENSOR [km/h] or [mph]	Wheel speed calculated by rear LH wheel sensor signal is displayed.

ACTIVE TEST

Description

DIAGNOSIS SYSTEM (AWD CONTROL UNIT)

< SYSTEM DESCRIPTION >

[TRANSFER: ETX13C]

Use this mode to determine and identify the details of a malfunction based on self-diagnostic results or data monitor. AWD control unit gives drive signal to actuator with receiving command from CONSULT-III to check operation of actuator.

Test Item

Test item	Condition	Description
ETS S/V (Detects AWD solenoid)	<ul style="list-style-type: none"> • Vehicle stopped • Engine running • No DTC detected 	Change command current value to AWD solenoid, and then change driving mode. (Monitor value is normal if it is within approx. $\pm 10\%$ of command value.) <ul style="list-style-type: none"> • Qu: Increase current value in increments of 0.2 A • Qd: Decrease current value in increments of 0.2 A • UP: Increase current value in increments of 0.02 A • DOWN: Decrease current value in increments of 0.02 A

CAUTION:

Never energize continuously for a long time.

A
B
C
DLN
E
F
G
H
I
J
K
L
M
N
O
P

DLN

DTC/CIRCUIT DIAGNOSIS

C1201 AWD CONTROL UNIT

Description

INFOID:000000005649584

- Controls driving force distribution by signals from each sensor from rear wheel driving mode (0:100) to 4-wheel driving mode (50:50).
- Rear wheel driving conditions is available by fail-safe function if malfunction is detected in AWD system.

DTC Logic

INFOID:000000005649585

DTC DETECTION LOGIC

DTC	Display item	Malfunction detected condition	Possible cause
C1201	CONTROLLER FAILURE	Malfunction has occurred inside AWD control unit.	Internal malfunction of AWD control unit

DTC CONFIRMATION PROCEDURE

1. DTC REPRODUCTION PROCEDURE

With CONSULT-III

1. Turn the ignition switch OFF to ON.
2. Perform self-diagnosis for "ALL MODE AWD/4WD".

Is DTC "C1201" detected?

- YES >> Proceed to diagnosis procedure. Refer to [DLN-14, "Diagnosis Procedure"](#).
- NO >> INSPECTION END

Diagnosis Procedure

INFOID:000000005649586

1. PERFORM SELF-DIAGNOSIS

With CONSULT-III

1. Erase self-diagnostic results for "ALL MODE AWD/4WD".
2. Turn the ignition switch OFF, and then wait 10 seconds or more.
3. Perform self-diagnosis for "ALL MODE AWD/4WD".

Is DTC "C1201" detected?

- YES >> Replace AWD control unit. Refer to [DLN-55, "Exploded View"](#).
- NO >> Check AWD control unit pin terminals for damage or loose connection with harness connector. If any items are damaged, repair or replace error-detected parts.

C1203 ABS ACTUATOR AND ELECTRIC UNIT (CONTROL UNIT)

< DTC/CIRCUIT DIAGNOSIS >

[TRANSFER: ETX13C]

C1203 ABS ACTUATOR AND ELECTRIC UNIT (CONTROL UNIT)

Description

INFOID:000000005649587

Transmits the following signals via CAN communication to AWD control unit.

- Vehicle speed signal
- Stop lamp switch signal (brake signal)

DTC Logic

INFOID:000000005649588

DTC DETECTION LOGIC

DTC	Display items	Malfunction detected condition	Possible cause
C1203	ABS SYSTEM	Malfunction related to ABS system has been detected by ABS actuator and electric unit (control unit).	ABS malfunction <ul style="list-style-type: none">• Malfunction of ABS actuator and electric unit (control unit)• Vehicle speed signal error

DTC CONFIRMATION PROCEDURE

1. DTC REPRODUCTION PROCEDURE

With CONSULT-III

1. Start the engine and drive at 30 km/h (19 MPH) or more for approximately 1 minute.
2. Perform self-diagnosis for "ALL MODE AWD/4WD".

Is DTC "C1203" detected?

- YES >> Proceed to diagnosis procedure. Refer to [DLN-15, "Diagnosis Procedure"](#).
NO >> INSPECTION END

Diagnosis Procedure

INFOID:000000005649589

1. PERFORM ABS ACTUATOR AND ELECTRIC UNIT (CONTROL UNIT) SELF-DIAGNOSIS

With CONSULT-III

Perform self-diagnosis for "ABS".

Is any DTC detected?

- YES >> Check the DTC.
NO >> GO TO 2.

2. PERFORM SELF-DIAGNOSIS

With CONSULT-III

1. Erase self-diagnostic results for "ALL MODE AWD/4WD".
2. Start the engine and drive vehicle at 30 km/h (19 MPH) or more for approximately 1 minute.
3. Make sure that ABS warning lamp turns OFF.
4. Perform self-diagnosis for "ALL MODE AWD/4WD".

Is DTC "C1203" detected?

- YES >> Replace AWD control unit. Refer to [DLN-55, "Exploded View"](#).
NO >> Check AWD control unit pin terminals for damage or loose connection with harness connector. If any items are damaged, repair or replace error-detected parts.

C1204 AWD SOLENOID

< DTC/CIRCUIT DIAGNOSIS >

[TRANSFER: ETX13C]

C1204 AWD SOLENOID

Description

INFOID:000000005649590

Controls electric controlled coupling by command current from AWD control unit.

DTC Logic

INFOID:000000005649591

DTC DETECTION LOGIC

DTC	Display items	Malfunction detected condition	Possible cause
C1204	4WD SOLENOID	Malfunction related to AWD solenoid has been detected.	Internal malfunction of electric controlled coupling

DTC CONFIRMATION PROCEDURE

1. DTC REPRODUCTION PROCEDURE

With CONSULT-III

1. Turn the ignition switch OFF to ON.
2. Perform self-diagnosis for "ALL MODE AWD/4WD".

Is DTC "C1204" detected?

- YES >> Proceed to diagnosis procedure. Refer to [DLN-16. "Diagnosis Procedure"](#).
 NO >> INSPECTION END

Diagnosis Procedure

INFOID:000000005649592

1. CHECK AWD SOLENOID POWER SUPPLY

1. Turn the ignition switch OFF.
2. Disconnect AWD control unit harness connector.
3. Check the voltage between AWD control unit harness connector and ground.

AWD control unit		—	Voltage
Connector	Terminal		
F108	9	Ground	Battery voltage

Is the inspection result normal?

- YES >> GO TO 2.
 NO >> Perform the trouble diagnosis for power supply circuit. Refer to [DLN-27. "Diagnosis Procedure"](#).

2. CHECK AWD CONTROL UNIT GROUND

Check the continuity between AWD control unit harness connector and ground.

AWD control unit		—	Continuity
Connector	Terminal		
F108	10	Ground	Existed
	11		

Is the inspection result normal?

- YES >> GO TO 3.
 NO >> Repair or replace error-detected parts.

3. CHECK AWD SOLENOID CIRCUIT

1. Disconnect AWD solenoid harness connector.
2. Check the continuity between AWD control unit harness connector and AWD solenoid harness connector.

C1204 AWD SOLENOID

< DTC/CIRCUIT DIAGNOSIS >

[TRANSFER: ETX13C]

AWD control unit		AWD solenoid		Continuity
Connector	Terminal	Connector	Terminal	
F108	1	F57	1	Existed
	2		2	

3. Check the continuity between AWD control unit harness connector and the ground.

AWD control unit		—	Continuity
Connector	Terminal		
F108	1	Ground	Not existed
	2		

Is the inspection result normal?

YES >> GO TO 4.

NO >> Repair or replace error-detected parts.

4.CHECK AWD SOLENOID

Check the resistance between AWD solenoid harness connector terminals. Refer to [DLN-17, "Component Inspection"](#).

Is the inspection result normal?

YES >> GO TO 5.

NO >> AWD solenoid is malfunctioning. Replace electric controlled coupling. Refer to [DLN-72, "Exploded View"](#).

5.CHECK TERMINALS AND HARNESS CONNECTORS

1. Check AWD control unit pin terminals for damage or loose connection with harness connector.
2. Check AWD solenoid pin terminals for damage or loose connection with harness connector.

Is the inspection result normal?

YES >> Replace AWD control unit. Refer to [DLN-55, "Exploded View"](#).

NO >> Repair or replace error-detected parts.

Component Inspection

INFOID:000000005649593

1.CHECK AWD SOLENOID

1. Turn the ignition switch OFF.
2. Disconnect AWD solenoid harness connector.
3. Check the resistance between AWD solenoid harness connector terminals.

AWD solenoid		Resistance (Approx.)
Terminal		
1	2	2.45 Ω

Is the inspection result normal?

YES >> INSPECTION END

NO >> AWD solenoid is malfunctioning. Replace electric controlled coupling. Refer to [DLN-72, "Exploded View"](#).

C1205 AWD ACTUATOR RELAY

< DTC/CIRCUIT DIAGNOSIS >

[TRANSFER: ETX13C]

C1205 AWD ACTUATOR RELAY

Description

INFOID:000000005649594

AWD solenoid is supplied with voltage by the internal circuit of AWD control unit.

DTC Logic

INFOID:000000005649595

DTC DETECTION LOGIC

DTC	Display item	Malfunction detected condition	Possible cause
C1205	4WD ACTUATOR RLY	Malfunction has been detected from AWD actuator relay integrated with AWD control unit, or malfunction related to AWD solenoid has been detected.	Internal malfunction of AWD control unit

DTC CONFIRMATION PROCEDURE

1. DTC REPRODUCTION PROCEDURE

With CONSULT-III

1. Turn the ignition switch OFF to ON.
2. Perform self-diagnosis for "ALL MODE AWD/4WD".

Is DTC "C1205" detected?

- YES >> Proceed to diagnosis procedure. Refer to [DLN-18, "Diagnosis Procedure"](#).
NO >> INSPECTION END

Diagnosis Procedure

INFOID:000000005649596

1. PERFORM SELF-DIAGNOSIS

With CONSULT-III

1. Erase self-diagnostic results for "ALL MODE AWD/4WD".
2. Turn ignition switch OFF, and wait 10 seconds or more.
3. Perform self-diagnosis for "ALL MODE AWD/4WD".

Is DTC "C1205" detected?

- YES >> Replace AWD control unit. Refer to [DLN-55, "Exploded View"](#).
NO >> Check AWD control unit pin terminals for damage or loose connection with harness connector. If any items are damaged, repair or replace error-detected parts.

C1210 ECM

Description

INFOID:000000005649597

Transmits the following signals via CAN communication to AWD control unit.

- Accelerator pedal position signal
- Engine speed signal

DTC Logic

INFOID:000000005649598

DTC DETECTION LOGIC

DTC	Display item	Malfunction detected condition	Possible cause
C1210	ENGINE SIGNAL 1	Malfunction related to engine signal has been detected.	Malfunction of engine control system

DTC CONFIRMATION PROCEDURE

1. DTC REPRODUCTION PROCEDURE

 With CONSULT-III

1. Start the engine. Drive the vehicle for a while.
2. Perform self-diagnosis for "ALL MODE AWD/4WD".

Is DTC "C1210" detected?

- YES >> Proceed to diagnosis procedure. Refer to [DLN-19, "Diagnosis Procedure"](#).
- NO >> INSPECTION END

Diagnosis Procedure

INFOID:000000005649599

1. PERFORM ECM SELF-DIAGNOSIS

 With CONSULT-III

Perform self-diagnosis for "ENGINE".

Is any DTC detected?

- YES >> Check the DTC.
- NO >> GO TO 2.

2. PERFORM SELF-DIAGNOSIS

 With CONSULT-III

1. Erase self-diagnostic results for "ALL MODE AWD/4WD".
2. Turn the ignition switch OFF.
3. Start the engine. Drive the vehicle for a while.
4. Make sure that malfunction indicator lamp (MIL) turns OFF.
5. Stop the vehicle. Perform self-diagnosis for "ALL MODE AWD/4WD".

Is DTC "C1210" detected?

- YES >> Replace AWD control unit. Refer to [DLN-55, "Exploded View"](#).
- NO >> Check AWD control unit pin terminals for damage or loose connection with harness connector. If any items are damaged, repair or replace error-detected parts.

P1804 TRANSFER CONTROL UNIT

< DTC/CIRCUIT DIAGNOSIS >

[TRANSFER: ETX13C]

P1804 TRANSFER CONTROL UNIT

Description

INFOID:000000005649600

- Controls driving force distribution by signals from each sensor from rear wheel driving mode (0:100) to 4-wheel driving mode (50:50).
- Rear wheel driving conditions is available by fail-safe function if malfunction is detected in AWD system.

DTC Logic

INFOID:000000005649601

DTC DETECTION LOGIC

DTC	Display item	Malfunction detected condition	Possible cause
P1804	CONTROL UNIT 3	Malfunction has occurred inside AWD control unit.	Malfunction is detected in the memory (EEPROM) system of transfer control unit.

DTC CONFIRMATION PROCEDURE

1. DTC REPRODUCTION PROCEDURE

With CONSULT-III

1. Turn the ignition switch ON.
2. Perform self-diagnosis for "ALL MODE AWD/4WD".

Is DTC "P1804" detected?

- YES >> Proceed to diagnosis procedure. Refer to [DLN-20. "Diagnosis Procedure"](#).
NO >> INSPECTION END

Diagnosis Procedure

INFOID:000000005649602

1. REPLACE AWD CONTROL UNIT

CAUTION:

Replace AWD control unit when self-diagnostic results show items other than this DTC simultaneously, too.

- >> Replace AWD control unit. Refer to [DLN-55. "Exploded View"](#).

P1809 TRANSFER CONTROL UNIT

< DTC/CIRCUIT DIAGNOSIS >

[TRANSFER: ETX13C]

P1809 TRANSFER CONTROL UNIT

Description

INFOID:000000005649603

- Controls driving force distribution by signals from each sensor from rear wheel driving mode (0:100) to 4-wheel driving mode (50:50).
- Rear wheel driving conditions is available by fail-safe function if malfunction is detected in AWD system.

DTC Logic

INFOID:000000005649604

DTC DETECTION LOGIC

DTC	Display item	Malfunction detected condition	Possible cause
P1809	CONTROL UNIT 4	Malfunction has occurred inside AWD control unit.	AD converter system of transfer control unit is malfunctioning.

DTC CONFIRMATION PROCEDURE

1. DTC REPRODUCTION PROCEDURE

With CONSULT-III

1. Turn the ignition switch ON.
2. Perform self-diagnosis for "ALL MODE AWD/4WD".

Is DTC "P1809" detected?

- YES >> Proceed to diagnosis procedure. Refer to [DLN-21, "Diagnosis Procedure"](#).
NO >> INSPECTION END

Diagnosis Procedure

INFOID:000000005649605

1. REPLACE AWD CONTROL UNIT

CAUTION:

Replace AWD control unit when self-diagnostic results show items other than this DTC simultaneously, too.

- >> Replace AWD control unit. Refer to [DLN-55, "Exploded View"](#).

P1826 TRANSFER FLUID TEMPERATURE

< DTC/CIRCUIT DIAGNOSIS >

[TRANSFER: ETX13C]

P1826 TRANSFER FLUID TEMPERATURE

Description

INFOID:000000005649606

- Transfer fluid temperature sensor detects the transfer fluid temperature and transmits a signal to AWD control unit.

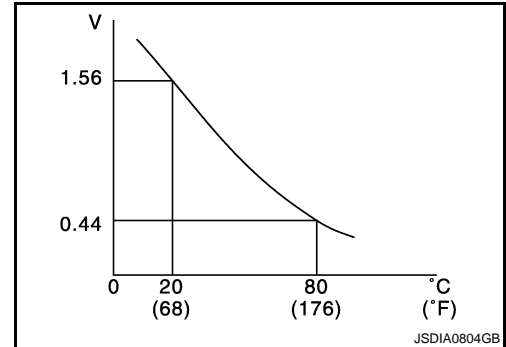

- The electrical resistance of the sensor decreases as temperature increases.

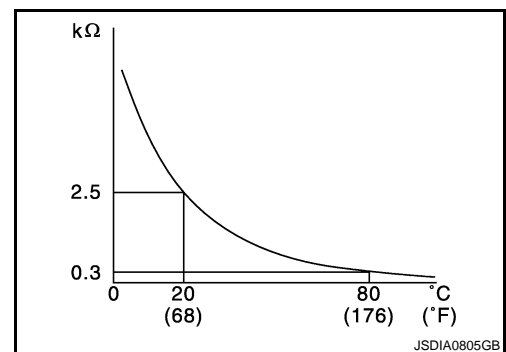

DTC Logic

INFOID:000000005649607

DTC DETECTION LOGIC

DTC	Display item	Malfunction detected condition	Possible cause
P1826	OIL TEMP SEN	Transfer fluid temperature sensor voltage condition is continued 0 V or more than 2.45 V for several seconds.	<ul style="list-style-type: none"> Malfunction of transfer fluid temperature sensor or transfer fluid temperature sensor circuit. Malfunction of AWD control unit.

DTC CONFIRMATION PROCEDURE

1. DTC REPRODUCTION PROCEDURE

With CONSULT-III

- Turn the ignition switch ON.
- Perform self-diagnosis for "ALL MODE AWD/4WD".

Is DTC "P1826" detected?

- YES >> Proceed to diagnosis procedure. Refer to [DLN-22, "Diagnosis Procedure"](#).
- NO >> INSPECTION END

Diagnosis Procedure

INFOID:000000005649608

1. CHECK TRANSFER FLUID TEMPERATURE SENSOR SIGNAL (1)

- Turn the ignition switch OFF.
- Disconnect AWD solenoid harness connector.
- Turn the ignition switch ON.
- Check the voltage between AWD solenoid harness connector terminals.

P1826 TRANSFER FLUID TEMPERATURE

< DTC/CIRCUIT DIAGNOSIS >

[TRANSFER: ETX13C]

AWD solenoid			Voltage (Approx.)
Connector	Terminal		
F57	6	7	2.5 V

Is the inspection result normal?

YES >> GO TO 2.

NO >> GO TO 3.

2.CHECK TRANSFER FLUID TEMPERATURE SENSOR

Check the resistance between transfer fluid temperature sensor harness connector terminals. Refer to [DLN-24. "Component Inspection"](#).

Is the inspection result normal?

YES >> GO TO 6.

NO >> Replace transfer fluid temperature sensor. Refer to [DLN-72. "Exploded View"](#).

3.CHECK TRANSFER FLUID TEMPERATURE SENSOR SIGNAL (2)

Check the voltage between AWD solenoid harness connector and ground.

AWD solenoid		—	Voltage (Approx.)
Connector	Terminal		
F57	6	Ground	2.5 V

Is the inspection result normal?

YES >> GO TO 4.

NO >> GO TO 5.

4.CHECK AWD CONTROL UNIT GROUND

1. Turn the ignition switch OFF.
2. Disconnect AWD control unit harness connector.
3. Check the continuity between AWD control unit harness connector and ground.

AWD control unit		—	Continuity
Connector	Terminal		
F108	10	Ground	Existed
	11		

Is the inspection result normal?

YES >> GO TO 5.

NO >> Repair or replace error-detected parts.

5.CHECK TRANSFER FLUID TEMPERATURE SENSOR CIRCUIT

1. Turn the ignition switch OFF.
2. Disconnect AWD control unit harness connector.
3. Check the continuity between AWD control unit harness connector and AWD solenoid harness connector.

AWD control unit		AWD solenoid		Continuity
Connector	Terminal	Connector	Terminal	
F108	13	F57	6	Existed
	3		7	

4. Check the continuity between AWD control unit harness connector and the ground.

P1826 TRANSFER FLUID TEMPERATURE

< DTC/CIRCUIT DIAGNOSIS >

[TRANSFER: ETX13C]

AWD control unit		—	Continuity
Connector	Terminal		
F108	13	Ground	Not existed
	3		

Is the inspection result normal?

YES >> GO TO 6.

NO >> Repair or replace error-detected parts.

6. CHECK TERMINALS AND HARNESS CONNECTORS

1. Check AWD control unit pin terminals for damage or loose connection with harness connector.
2. Check transfer fluid temperature sensor pin terminals for damage or loose connection with harness connector.

Is the inspection result normal?

YES >> Replace AWD control unit. Refer to [DLN-55, "Exploded View"](#).

NO >> Repair or replace error-detected parts.

Component Inspection

INFOID:000000005649609

1. CHECK TRANSFER FLUID TEMPERATURE SENSOR

1. Turn ignition switch OFF.
2. Disconnect AWD solenoid harness connector.
3. Check resistance between AWD solenoid harness connector terminals.

AWD solenoid	Terminal	Condition	Resistance (Approx.)
6	7	20°C (68°F)	2.5 kΩ
		80°C (176°F)	0.3 kΩ

Is inspection result normal?

YES >> INSPECTION END

NO >> Transfer fluid temperature sensor is malfunctioning. Replace electric controlled coupling. Refer to [DLN-72, "Exploded View"](#).

U1000 CAN COMM CIRCUIT

< DTC/CIRCUIT DIAGNOSIS >

[TRANSFER: ETX13C]

U1000 CAN COMM CIRCUIT

Description

INFOID:000000005649610

CAN (Controller Area Network) is a serial communication line for real time application. It is an on-vehicle multiplex communication line with high data communication speed and excellent error detection ability. Many electronic control units are equipped onto a vehicle, and each control unit shares information and links with other control units during operation (not independent). In CAN communication, control units are connected with 2 communication lines (CAN-H line, CAN-L line) allowing a high rate of information transmission with less wiring. Each control unit communicate data but selectively reads required data only.

DTC Logic

INFOID:000000005649611

DTC DETECTION LOGIC

DTC	Display item	Malfunction detected condition	Possible cause
U1000	CAN COMM CIRCUIT	AWD control unit is not transmitting/receiving CAN communication signal for 2 seconds or more.	<ul style="list-style-type: none">• CAN communication error• Malfunction of AWD control unit

DTC CONFIRMATION PROCEDURE

1. DTC REPRODUCTION PROCEDURE

With CONSULT-III

1. Turn the ignition switch OFF to ON.
2. Perform self-diagnosis for "ALL MODE AWD/4WD".

Is DTC "U1000" detected?

- YES >> Proceed to diagnosis procedure. Refer to [DLN-25, "Diagnosis Procedure"](#).
NO >> INSPECTION END

Diagnosis Procedure

INFOID:000000005649612

1. PERFORM SELF-DIAGNOSIS

With CONSULT-III

Perform self-diagnosis for "ALL MODE AWD/4WD".

Is DTC "U1000" detected?

- YES >> CAN specification chart. Refer to [LAN-18, "Trouble Diagnosis Flow Chart"](#).
NO >> Check AWD control unit pin terminals for damage or loose connection with harness connector. If any items are damaged, repair or replace error-detected parts.

U1010 CONTROL UNIT (CAN)

< DTC/CIRCUIT DIAGNOSIS >

[TRANSFER: ETX13C]

U1010 CONTROL UNIT (CAN)

Description

INFOID:000000005649613

CAN (Controller Area Network) is a serial communication line for real time application. It is an on-vehicle multiplex communication line with high data communication speed and excellent error detection ability. Many electronic control units are equipped onto a vehicle, and each control unit shares information and links with other control units during operation (not independent). In CAN communication, control units are connected with 2 communication lines (CAN-H line, CAN-L line) allowing a high rate of information transmission with less wiring. Each control unit communicate data but selectively reads required data only.

DTC Logic

INFOID:000000005649614

DTC DETECTION LOGIC

DTC	Display item	Malfunction detected condition	Possible cause
U1010	CONTROL UNIT (CAN)	Detecting error during the initial diagnosis of CAN controller of AWD control unit.	Malfunction of AWD control unit

DTC CONFIRMATION PROCEDURE

1. DTC REPRODUCTION PROCEDURE

Ⓔ With CONSULT-III

1. Turn the ignition switch OFF to ON.
2. Perform self-diagnosis for "ALL MODE AWD/4WD".

Is DTC "U1010" detected?

- YES >> Proceed to diagnosis procedure. Refer to [DLN-26, "Diagnosis Procedure"](#).
NO >> INSPECTION END

Diagnosis Procedure

INFOID:000000005649615

1. CHECK AWD CONTROL UNIT

Check AWD control unit harness connector for disconnection and deformation.

Is the inspection result normal?

- YES >> Replace AWD control unit. Refer to [DLN-55, "Exploded View"](#).
NO >> Repair or replace error-detected parts.

POWER SUPPLY AND GROUND CIRCUIT

< DTC/CIRCUIT DIAGNOSIS >

[TRANSFER: ETX13C]

POWER SUPPLY AND GROUND CIRCUIT

Description

INFOID:000000005649616

Supplies power to AWD control unit.

Diagnosis Procedure

INFOID:000000005649617

1.CHECK AWD CONTROL UNIT POWER SUPPLY (1)

1. Turn the ignition switch OFF.
2. Disconnect AWD control unit harness connector.
3. Check the voltage between AWD control unit harness connector and ground.

AWD control unit		—	Voltage (Approx.)
Connector	Terminal		
F108	7	Ground	0 V

4. Turn the ignition switch ON.
CAUTION:
Never start the engine.
5. Check the voltage between AWD control unit harness connector and ground.

AWD control unit		—	Voltage
Connector	Terminal		
F108	7	Ground	Battery voltage

Is the inspection result normal?

- YES >> GO TO 3.
NO >> GO TO 2.

2.CHECK AWD CONTROL UNIT POWER SUPPLY (2)

1. Turn the ignition switch OFF.
2. Check the 10A fuse (#45).
3. Disconnect IPDM E/R harness connector.
4. Check the continuity between AWD control unit harness connector and IPDM E/R harness connector.

AWD control unit		IPDM E/R		Continuity
Connector	Terminal	Connector	Terminal	
F108	7	E5	25	Existed

5. Check the continuity between AWD control unit harness connector and the ground.

AWD control unit		—	Continuity
Connector	Terminal		
F108	7	Ground	Not existed

Is the inspection result normal?

- YES >> Perform the trouble diagnosis for ignition power supply circuit. Refer to [PG-63, "Wiring Diagram - IGNITION POWER SUPPLY -"](#).
- NO >> Repair or replace error-detected parts.

3.CHECK AWD CONTROL UNIT POWER SUPPLY (3)

1. Turn the ignition switch OFF.
2. Check the voltage between AWD control unit harness connector and ground.

POWER SUPPLY AND GROUND CIRCUIT

< DTC/CIRCUIT DIAGNOSIS >

[TRANSFER: ETX13C]

AWD control unit		—	Voltage (Approx.)
Connector	Terminal		
F108	15	Ground	Battery voltage

3. Turn the ignition switch ON.

CAUTION:

Never start the engine.

4. Check the voltage between AWD control unit harness connector and ground.

AWD control unit		—	Voltage
Connector	Terminal		
F108	15	Ground	Battery voltage

Is the inspection result normal?

YES >> GO TO 5.

NO >> GO TO 4.

4. CHECK AWD CONTROL UNIT POWER SUPPLY (4)

1. Turn the ignition switch OFF.
2. Check the 10A fuse (#11).
3. Disconnect fuse block (J/B) harness connector.
4. Check the continuity between AWD control unit harness connector and fuse block (J/B).

AWD control unit		Fuse block (J/B)		Continuity
Connector	Terminal	Connector	Terminal	
F108	15	M1	1A	Existed

5. Check the continuity between AWD control unit harness connector and the ground.

AWD control unit		—	Continuity
Connector	Terminal		
F108	15	Ground	Not existed

Is the inspection result normal?

YES >> Perform the trouble diagnosis for ignition power supply circuit. Refer to [PG-6, "Wiring Diagram - BATTERY POWER SUPPLY -"](#).

NO >> Repair or replace error-detected parts.

5. CHECK AWD SOLENOID POWER SUPPLY (1)

1. Turn the ignition switch OFF.
2. Disconnect AWD solenoid harness connector.
3. Check the voltage between AWD control unit harness connector and ground.

AWD control unit		—	Voltage
Connector	Terminal		
F108	9	Ground	Battery voltage

4. Turn the ignition switch ON.

CAUTION:

Never start the engine.

5. Check the voltage between AWD control unit harness connector and ground.

AWD control unit		—	Voltage
Connector	Terminal		
F108	9	Ground	Battery voltage

POWER SUPPLY AND GROUND CIRCUIT

< DTC/CIRCUIT DIAGNOSIS >

[TRANSFER: ETX13C]

Is the inspection result normal?

- YES >> GO TO 7.
- NO >> GO TO 6.

6. CHECK AWD SOLENOID POWER SUPPLY (2)

1. Turn the ignition switch OFF.
2. Check the 10A fuse (#33).
3. Check the harness for open or short between AWD control unit harness connector No.9 terminal and fuse box.

Is the inspection result normal?

- YES >> Perform the trouble diagnosis for power supply circuit. Refer to [PG-63. "Wiring Diagram - IGNITION POWER SUPPLY -"](#).
- NO >> Repair or replace error-detected parts.

7. CHECK AWD CONTROL UNIT GROUND

1. Turn the ignition switch OFF.
2. Check the continuity between AWD control unit harness connector and ground.

AWD control unit		—	Continuity
Connector	Terminal		
F108	10	Ground	Existed
	11		

Is the inspection result normal?

- YES >> INSPECTION END
- NO >> Repair or replace error-detected parts.

A
B
C
DLN
E
F
G
H
I
J
K
L
M
N
O
P

AWD WARNING LAMP

Description

INFOID:000000005649618

- Turns ON when there is a malfunction in AWD system. AWD warning lamp indicates the vehicle is in fail-safe mode and shifting to rear-wheel drive or 4-wheel drive (front-wheels still have some driving torque).
- Also turns ON when ignition switch is turned ON, for the purpose of lamp check. Turns OFF approximately for 1 second after the engine starts if system is normal.

AWD WARNING LAMP INDICATION

Condition	AWD warning lamp
Lamp check	Turns ON when ignition switch is turned ON. Turns OFF approx. 1 second after the engine start.
AWD system malfunction	ON
Protection function is activated due to heavy load to electric controlled coupling. (AWD system is not malfunctioning and AWD system changes to rear wheel drive.)	Quick blinking: 2 times/second (Blinking in approx. 1 minute and then turning OFF)
Large difference in diameter of front/rear tires	Slow blinking: 1 time/2 seconds (Continuing to blink until turning ignition switch OFF)
Other than above (system normal)	OFF

CAUTION:

- **AWD warning lamp also turns ON due to data reception error, CAN communication error etc.**

Component Function Check

INFOID:000000005649619

1. CHECK AWD WARNING LAMP FUNCTION

1. Turn the ignition switch ON.
2. Check that AWD warning lamp lights up.

Is the inspection result normal?

- YES >> INSPECTION END
 NO >> Proceed to diagnosis procedure. Refer to [DLN-30, "Diagnosis Procedure"](#).

Diagnosis Procedure

INFOID:000000005649620

1. CHECK POWER SUPPLY AND GROUND CIRCUIT

Perform the trouble diagnosis for power supply and ground circuit. Refer to [DLN-27, "Diagnosis Procedure"](#).

Is the inspection result normal?

- YES >> GO TO 2.
 NO >> Repair or replace the error-detected parts.

2. PERFORM SELF-DIAGNOSIS

With CONSULT-III

Perform self-diagnosis for "ALL MODE AWD/4WD".

Is any DTC detected?

- YES >> Check the DTC.
 NO >> GO TO 3.

3. CHECK AWD WARNING LAMP SIGNAL

With CONSULT-III

1. Turn the ignition switch ON.

CAUTION:

Never start the engine.

2. Check "4WD WARN LAMP" of CONSULT-III "DATA MONITOR" for "ALL MODE AWD/4WD".

Does the item on "DATA MONITOR" indicate "On"?

- YES >> GO TO 4.

AWD WARNING LAMP

[TRANSFER: ETX13C]

< DTC/CIRCUIT DIAGNOSIS >

NO >> Replace AWD control unit. Refer to [DLN-55. "Exploded View"](#).

4.CHECK COMBINATION METER POWER SUPPLY CIRCUIT

Perform the trouble diagnosis for combination meter power supply circuit. Refer to [MWI-50. "COMBINATION METER : Diagnosis Procedure"](#).

Is the inspection result normal?

YES >> INSPECTION END

NO >> Repair or replace the error-detected parts.

A
B
C
DLN
E
F
G
H
I
J
K
L
M
N
O
P

AWD CONTROL UNIT

< ECU DIAGNOSIS INFORMATION >

[TRANSFER: ETX13C]

ECU DIAGNOSIS INFORMATION

AWD CONTROL UNIT

Reference Value

INFOID:000000005649621

VALUES ON THE DIAGNOSIS TOOL

Monitor item	Condition	Value/Status
STOP LAMP SW	Brake pedal: Depressed	On
	Brake pedal: Released	Off
ENG SPEED SIG	Engine stopped (Engine speed: Less than 400 rpm)	Stop
	Engine running (Engine speed: 400 rpm or more)	Run
ETS ACTUATOR	Engine stopped (Ignition switch: ON)	Off
	Engine running	On
4WD WARN LAMP	AWD warning lamp: ON	On
	AWD warning lamp: OFF	Off
4WD MODE SW	Always	##
4WD MODE MON	Engine running	AUTO
DIS-TIRE MONI	Vehicle running with normal size tire installed	0 – 4 mm
	Vehicle running with improper size tire installed (Front/rear tire size difference, wear condition)	4 – 8 mm, 8 – mm
P BRAKE SW	Parking brake operated	On
	Parking brake not operated	Off
BATTERY VOLT	Always	Battery voltage
THRTL POS SEN	When depressing accelerator pedal (Value rises gradually in response to throttle position.)	0 – 100%
ETS SOLENOID	Engine running • At idle speed	Approx. 0.000 A
	Engine running • 3,000 rpm or more constant	Approx. 0.000 – 0.500 A*
FR RH SENSOR	Vehicle stopped	0.00 km/h (0.00 mph)
	Vehicle running CAUTION: Check air pressure of tire under standard condition.	Approx. equal to the indication on speedometer (Inside of ±10%)
FR LH SENSOR	Vehicle stopped	0.00 km/h (0.00 mph)
	Vehicle running CAUTION: Check air pressure of tire under standard condition.	Approx. equal to the indication on speedometer (Inside of ±10%)
RR RH SENSOR	Vehicle stopped	0.00 km/h (0.00 mph)
	Vehicle running CAUTION: Check air pressure of tire under standard condition.	Approx. equal to the indication on speedometer (Inside of ±10%)
RR LH SENSOR	Vehicle stopped	0.00 km/h (0.00 mph)
	Vehicle running CAUTION: Check air pressure of tire under standard condition.	Approx. equal to the indication on speedometer (Inside of ±10%)

*: The values are changed by throttle opening and engine speed.

TERMINAL LAYOUT

AWD CONTROL UNIT

< ECU DIAGNOSIS INFORMATION >

[TRANSFER: ETX13C]

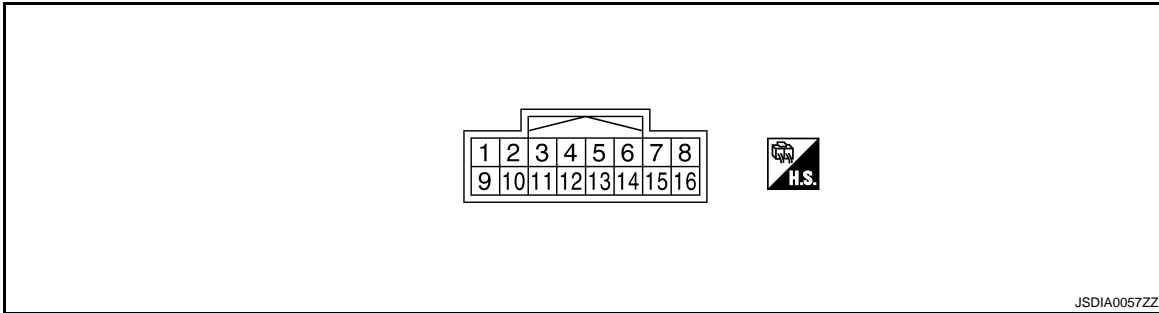

PHYSICAL VALUES

Terminal No. (Wire color)		Description		Condition	Value (Approx.)
+	-	Signal name	Input/ Output		
1 (BR)	Ground	AWD solenoid power supply	Output	Engine speed: At idle	0 V
				Engine speed: 3,000 rpm or more constant	2.5 V*
2 (Y)	Ground	AWD solenoid ground	—	Engine speed: At idle	0 V
				Engine speed: 3,000 rpm or more constant	0 V
3 (W)	Ground	Transfer fluid temperature sensor ground	—	Always	0 V
7 (G)	Ground	Ignition switch	Input	Ignition switch: ON	Battery voltage
				Ignition switch: OFF	0 V
8 (L)	—	CAN-H	Input/ Output	—	—
9 (O)	Ground	Power supply (AWD solenoid)	Input	Always	Battery voltage
10 (B)	Ground	Ground	—	Always	0 V
11 (B)	Ground	Ground	—	Always	0 V
13 (LG)	Ground	Transfer fluid temperature sensor power supply	Output	Transfer temperature: 20C° (68°F)	1.56 V
				Transfer temperature: 80C° (176°F)	0.44 V
15 (Y)	Ground	Power supply (AWD control unit)	Input	Always	Battery voltage
16 (P)	—	CAN-L	Input/ Output	—	—

*: The values are changed by throttle opening and engine speed.

CAUTION:

When using circuit tester to measure voltage for inspection, be sure not to extend forcibly any connector terminals.

AWD CONTROL UNIT

< ECU DIAGNOSIS INFORMATION >

[TRANSFER: ETX13C]

A
B
C
DLN
E
F
G
H
I
J
K
L
M
N
O
P

AWD SYSTEM

Connector No.	E3
Connector Name	WIRE TO WIRE
Connector Type	3AA30MB-RS3-SH28

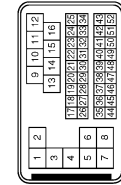

Terminal No.	Color of Wire	Signal Name [Specification]
1	L/Y	
2	SHIELD	
3	L/B	
4	SHIELD	
5	BR	
7	G	
8	W	
9	W	
10	Y	
11	P	
12	SB	
13	BR	
14	G	
15	R	
16	LG	
17	P	
18	Y	
19	BG	
20	B	
21	SB	
22	W	
23	L	
24	G	
25	V	
27	GR	
28	V	
29	P	
30	R	
31	BR	
32	Y	
33	G	
34	BG	
37	SHIELD	
38	L	
39	P	
40	R	
41	W	
42	LG	

43	G	
45	BG	
46	SHIELD	
47	W	
48	BR	
49	G	
50	B	
51	SB	
52	R	

Connector No.	E5
Connector Name	SOLENOID INTELLENT POWER DISTRIBUTION MODULE (ENGINE ROOM)
Connector Type	TH20FW-CS12-M4-TV

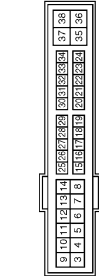

Terminal No.	Color of Wire	Signal Name [Specification]
4	V	
5	L	
7	R	
11	BR	
12	B/W	
13	Y	
16	LG	
18	W	
25	G	
26	R	
27	BG	
30	GR	
32	V	
33	P	
36	G	

Connector No.	E41
Connector Name	ABS ACTUATOR AND ELECTRIC UNIT (CONTROL UNIT)
Connector Type	3AA42FB-AH24-LH

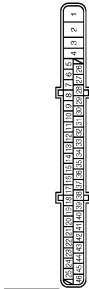

AWD CONTROL UNIT

< ECU DIAGNOSIS INFORMATION >

[TRANSFER: ETX13C]

AWD SYSTEM

Connector No.	E106
Connector Name	WIRE TO WIRE
Connector Type	TH809FH-CS16-TM4

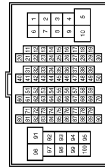

Terminal No.	Color of Wire	Signal Name [Specification]
1	GR	-
3	BG	-
5	G	-
6	BG	-
7	LG	-
10	W	-
11	V	-
12	R	-
13	L	-
14	GR	-
15	P	-
16	W	-
17	V	-
18	BG	-
19	GR	-
20	LG	-
30	R	-
31	L	-
32	BG	-
33	P	-
34	V	-
35	BR	-
36	W	-
37	Y	-
38	R	-
39	B	-
40	G	-
41	W	-
42	LG	-
43	SB	-
44	GR	-
45	BG	-
46	LG	-
47	V	-
48	P	-
49	L	-
59	B	-
66	LG	-

67	SB	-
68	R	-
69	W	-
70	G	-
80	W	-
81	P	-
82	G	-
83	V	-
84	L	-
85	BG	-
86	LG	-
87	Y	-
88	GR	-
89	W	-
91	G	-
93	GR	-
95	Y	-
96	Y	-
97	BR	-
98	SHIELD	-
99	L	-
100	P	-

Connector No.	F1
Connector Name	WIRE TO WIRE
Connector Type	SAA38FE-RSP-SHZ8

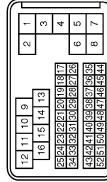

Terminal No.	Color of Wire	Signal Name [Specification]
1	L/Y	-
2	SHIELD	-
3	L/B	-
4	SHIELD	-
5	BR	-
7	G	-
8	W	-
9	W	-
10	G	-
11	R	-
12	P	-
13	L	-
14	LG	-
15	R	-

16	Y	-
17	W	-
18	LG	-
19	P	-
20	O	-
21	BR	-
22	G	-
23	Y	-
24	LG	-
25	V	-
27	GR	-
28	BR	-
29	L	-
30	R	-
31	P	-
32	W	-
33	SB	-
34	O	-
37	SHIELD	-
38	W	-
39	Y	-
40	G	-
41	B	-
42	GR	-
43	R	-
45	O	-
46	SHIELD	-
47	W/L	-
48	LG	-
49	O/L	-
50	L/Y	-
51	W	-
52	L/G	-

Connector No.	F51
Connector Name	A/T ASSEMBLY
Connector Type	RK10FG-DGY

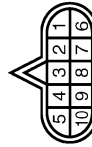

Terminal No.	Color of Wire	Signal Name [Specification]
1	Y	-
2	R	-
3	L	-

4	V	-
5	B	-
6	G	-
7	B	-
8	B	-
9	GR	-
10	B	-

Connector No.	F57
Connector Name	AWD SOLENOID
Connector Type	RK09FB



Terminal No.	Color of Wire	Signal Name [Specification]
1	BR	-
2	Y	-
6	LG	-
7	W	-

JCDWM0898GI

AWD CONTROL UNIT

< ECU DIAGNOSIS INFORMATION >

[TRANSFER: ETX13C]

AWD SYSTEM

Connector No.	F103
Connector Name	WIRE TO WIRE
Connector Type	TK38FW-NS10

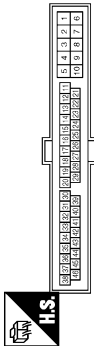

Terminal No.	Color of Wire	Signal Name [Specification]
2	G	
3	W	
4	R	
5	Y	
9	GR	
10	GR	
19	O	
20	Y	
28	B	
29	LG	
30	R	
31	R	
33	B	
34	B	
35	L	
36	P	
37	Y	
38	G	
41	O	
42	BR	
43	P	
44	L	
45	G	
46	V	

Terminal No.	Color of Wire	Signal Name [Specification]
1	BR	AWD SOL (+)
2	Y	AWD SOL (-)
3	W	OIL TEMP (-)
7	G	IGN
8	L	CAN-H
9	O	AWD SOL BAT
10	B	GND
11	B	GND
13	LG	OIL TEMP (+)
15	Y	VB
16	P	CAN-L

Connector No.	F157
Connector Name	TCM (TRANSMISSION CONTROL MODULE)
Connector Type	SPI0FG



Terminal No.	Color of Wire	Signal Name [Specification]
1	W	VIGN
2	B	BATT
3	R	CAN-H
4	O	K-LINE
5	G	GND
6	GR	VIGN
7	L	REV LAMP RLY
8	BR	CAN-L
9	Y	STARTER RLY
10	W/B	GND

Connector No.	F108
Connector Name	AWD CONTROL UNIT
Connector Type	TH18FW-NH

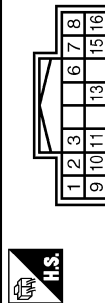

Connector No.	M1
Connector Name	FUSE BLOCK (J/B)
Connector Type	NS06FW-M2



Terminal No.	Color of Wire	Signal Name [Specification]
1A	V	
2A	LG	
3A	L	
4A	SB	
5A	L	
6A	BR	
7A	R	
8A	L	

Connector No.	M6
Connector Name	WIRE TO WIRE
Connector Type	TH80MW-CS16-TM4



Terminal No.	Color of Wire	Signal Name [Specification]
1	EG	
3	R	
5	G	
6	L	
7	W	
10	W	
11	V	
12	R	
13	L	
14	GR	
15	P	
16	W	
17	BR	
18	EG	

19	L	
20	L	
30	R	
31	SB	
32	Y	
33	BG	
34	R	
35	BR	
36	SB	
37	Y	
38	LG	
39	SB	
40	P	
41	W	
42	LG	
43	R	
44	Y	
44	B	-- [With A/T]
44	B	-- [With M/T]
44	BG	
46	G	
47	V	
48	P	
49	L	
59	B	
66	GR	
67	P	
68	L	
69	W	
70	BR	
80	L	
81	R	
82	V	
83	W	
84	L	
85	BG	
86	W	
87	G	
88	B	
89	SB	
91	L	
93	Y	
95	Y	
96	R	
97	P	
98	SHIELD	
99	V	
100	SB	

A
B
C
DLN
E
F
G
H
I
J
K
L
M
N
O
P

AWD CONTROL UNIT

< ECU DIAGNOSIS INFORMATION >

[TRANSFER: ETX13C]

AWD SYSTEM

Connector No.	M24
Connector Name	DATA LINK CONNECTOR
Connector Type	BD18FV-P

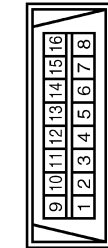

Terminal No.	Color of Wire	Signal Name [Specification]
3	LG	-
4	B	-
5	B	-
6	L	-
7	V	-
8	LG	-
11	SB	-
14	P	-
16	Y	-

Connector No.	M63
Connector Name	COMBINATION METER
Connector Type	SAB40FW

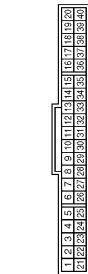

Terminal No.	Color of Wire	Signal Name [Specification]
1	V	BATTERY
2	LG	COMMUNICATION SIGNAL (METER->AMP)
3	GR	COMMUNICATION SIGNAL (AMP->METER)
5	B	GROUND
6	W	ALTERNATOR SIGNAL
7	LG	AIR BAG
10	P	SECURITY
15	B	GROUND
16	W	METER CONTROL SWITCH GROUND
18	GR	ILL GND
19	B	ILL
20	R	ILL
21	GR	IGNITION POWER SUPPLY

Terminal No.	Color of Wire	Signal Name [Specification]
22	B	GROUND
24	BR	COMMUNICATION SIGNAL (LCD->AMP)
25	Y	COMMUNICATION SIGNAL (AMP->LCD)
26	G	VEHICLE SPEED (8-PULSE)
27	EG	PARKING BRAKE SWITCH
28	L	BRAKE FLUID LEVEL SWITCH
29	LG	SEAT BELT BUCKLE SW (DRIVER SIDE)
30	G	SEAT BELT
31	L	WASHER LEVEL SWITCH
33	R	ILLUMINATION CONTROL
36	LG	SELECT SWITCH
37	SB	ENTER SWITCH
38	L	TRIP A/B RESET SWITCH
39	P	ILLUMINATION CONTROL SWITCH (-)
40	EG	ILLUMINATION CONTROL SWITCH (+)

Connector No.	M66
Connector Name	UNIFIED METER AND A/C AMP.
Connector Type	TH40FY-NH

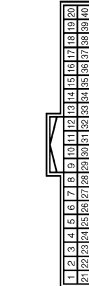

Terminal No.	Color of Wire	Signal Name [Specification]
4	SB	STOP LAMP SWITCH
5	L	SHIFT UP
6	EG	PADDLE UP
7	GR	COMMUNICATION SIGNAL (AMP->METER)
8	L	VEHICLE SPEED (2-PULSE)
9	SB	SEAT BELT BUCKLE SWITCH (DRIVER SIDE)
10	W	MANUAL MODE
11	G	NON-MANUAL MODE
14	BR	COMMUNICATION SIGNAL (LCD->AMP)
20	G	IGN ON / OFF SIGNAL
23	L	AT SNOW SW
25	V	SHIFT DOWN
26	G	PADDLE DOWN
27	LG	COMMUNICATION SIGNAL (METER->AMP)
28	G	VEHICLE SPEED (8-PULSE)
30	EG	PARKING BRAKE SWITCH
34	Y	COMMUNICATION SIGNAL (AMP->LCD)
38	P	BLOWER MOTOR CONTROL SIGNAL

Connector No.	M67
Connector Name	UNIFIED METER AND A/C AMP.
Connector Type	TH43FY-NH



Terminal No.	Color of Wire	Signal Name [Specification]
41	L	AGC POWER SUPPLY
42	BR	FUEL LEVEL SENSOR SIGNAL
43	V	INTAKE SENSOR SIGNAL
44	LG	IN-VEHICLE SENSOR SIGNAL
45	V	AMBIENT SENSOR SIGNAL
46	GR	SUNLOAD SENSOR SIGNAL
47	W	GAS SENSOR SIGNAL
53	G	IGNITION POWER SUPPLY
54	Y	BATTERY POWER SUPPLY
55	B	GROUND
56	L	CAN-H
57	LG	BRAKE FLUID LEVEL SWITCH
58	P	FUEL LEVEL SENSOR GROUND
59	Y	IN-VEHICLE SENSOR GROUND
60	W	IN-VEHICLE SENSOR GROUND
61	R	AMBIENT SENSOR GROUND
62	SB	SUNLOAD SENSOR GROUND
63	L	ION CONTROL MODE OUTPUT SIGNAL
65	EG	ECV SIGNAL
69	P	A/C LAM SIGNAL
70	R	EACH DOOR MOTOR POWER SUPPLY
71	GR	GROUND
72	P	CAN-L

Connector No.	M107
Connector Name	ECM
Connector Type	RH24FY-R28-R-LH-Z

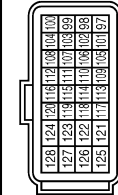

A
B
C
DLN
E
F
G
H
I
J
K
L
M
N
O
P

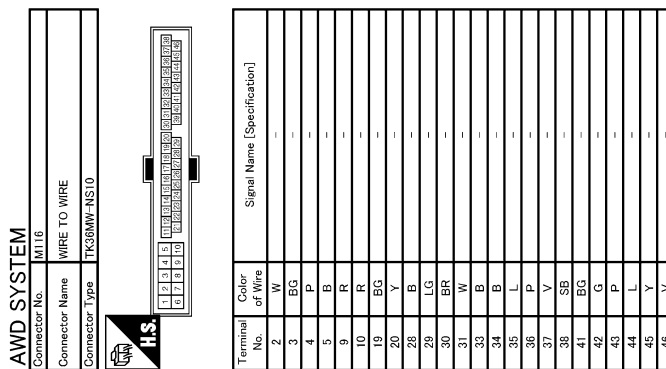

JCDWM0901GI

INFOID:000000005649623

Fail-Safe

AWD system

- If any malfunction occurs in AWD electrical system, and control unit detects the malfunction, AWD warning lamp on combination meter turns ON to indicate system malfunction.
- When AWD warning lamp is ON, vehicle changes to rear-wheel drive or shifts to 4-wheel drive (front-wheels still have some driving torque).

AWD CONTROL UNIT

< ECU DIAGNOSIS INFORMATION >

[TRANSFER: ETX13C]

- AWD system activates its protection function (shuts down AWD system temporarily) if AWD system detects high load continuously or the front wheel tire size differs from the rear tire size. (AWD system is automatically restored if AWD system no longer detects any overload or the tire size difference is eliminated.)

Mode	Warning lamp	DTC	Detected area (Error area)	Error area and root cause
Protection function	Blinking *1	—	AWD control unit	Transfer assembly in protection mode. It is not malfunction. (Internal temperature rise of electric controlled coupling)
	Blinking *2	—	Outer diameters of front and rear wheel tires	Malfunction in each tire or different tire diameter
Fail-safe	ON	C1201	AWD control unit	Internal malfunction of AWD control unit
		C1203	ABS actuator and electric unit (control unit)	<ul style="list-style-type: none"> • Malfunction of ABS actuator and electric unit (control unit) • Vehicle speed signal error
		C1204	AWD solenoid	Internal malfunction of electric controlled coupling
		C1205	AWD control unit	Internal malfunction of AWD control unit
		C1210	ECM	Malfunction of engine control system
		P1804	AWD control unit	Internal malfunction of AWD control unit
		P1809	AWD control unit	Internal malfunction of AWD control unit
		P1826	Transfer fluid temperature sensor	Internal malfunction of electric controlled coupling
		U1000	CAN communication line	<ul style="list-style-type: none"> • CAN communication error • Malfunction of AWD control unit
U1010	AWD control unit	Malfunction of AWD control unit		

*1: Quick blinking: 2 times/second (blinking for approximately 1 minute and then turned OFF)

*2: Slow blinking: 1 time/2 seconds (continuing to blink until ignition switch is turned OFF)

DTC Inspection Priority Chart

INFOID:000000005649624

If some DTCs are displayed at the same time, perform inspections one by one based on the following priority chart.

Priority	Detected items (DTC)
1	<ul style="list-style-type: none"> • U1000 CAN COMM CIRCUIT • U1010 CONTROL UNIT (CAN)
2	<ul style="list-style-type: none"> • C1201 CONTROLLER FAILURE • C1205 4WD ACTUATOR RLY • P1804 CONTROL UNIT 3 • P1809 CONTROL UNIT 4
3	<ul style="list-style-type: none"> • C1204 4WD SOLENOID • P1826 OIL TEMP SEN
4	<ul style="list-style-type: none"> • C1203 ABS SYSTEM • C1210 ENGINE SIGNAL 1

DTC Index

INFOID:000000005649625

DTC	Display Items	Reference
C1201	CONTROLLER FAILURE	DLN-14, "DTC Logic"
C1203	ABS SYSTEM	DLN-15, "DTC Logic"
C1204	4WD SOLENOID	DLN-16, "DTC Logic"
C1205	4WD ACTUATOR RLY	DLN-18, "DTC Logic"
C1210	ENGINE SIGNAL 1	DLN-19, "DTC Logic"
P1804	CONTROL UNIT 3	DLN-20, "DTC Logic"
P1809	CONTROL UNIT 4	DLN-21, "DTC Logic"

AWD CONTROL UNIT

< ECU DIAGNOSIS INFORMATION >

[TRANSFER: ETX13C]

DTC	Display Items	Reference
P1826	OIL TEMP SEN	DLN-22. "DTC Logic"
U1000	CAN COMM CIRCUIT	DLN-25. "DTC Logic"
U1010	CONTROL UNIT (CAN)	DLN-26. "DTC Logic"

A

B

C

DLN

E

F

G

H

I

J

K

L

M

N

O

P

AWD WARNING LAMP DOES NOT TURN ON

< SYMPTOM DIAGNOSIS >

[TRANSFER: ETX13C]

SYMPTOM DIAGNOSIS

AWD WARNING LAMP DOES NOT TURN ON

Description

INFOID:000000005649626

AWD warning lamp does not turn ON when the ignition switch is turned to ON.

Diagnosis Procedure

INFOID:000000005649627

1. CHECK AWD WARNING LAMP

Perform the trouble diagnosis for AWD warning lamp. Refer to [DLN-30. "Diagnosis Procedure"](#).

Is the inspection result normal?

- YES >> Check each harness connector pin terminal for malfunction or disconnection.
- NO >> Repair or replace the error-detected parts.

AWD WARNING LAMP DOES NOT TURN OFF

< SYMPTOM DIAGNOSIS >

[TRANSFER: ETX13C]

AWD WARNING LAMP DOES NOT TURN OFF

Description

INFOID:000000005649628

AWD warning lamp does not turn OFF several seconds after the engine started.

Diagnosis Procedure

INFOID:000000005649629

1.PERFORM SELF-DIAGNOSIS

With CONSULT-III

Perform self-diagnosis for "ALL MODE AWD/4WD".

Is any DTC detected?

YES >> Check the DTC.

NO >> GO TO 2.

2.CHECK AWD WARNING LAMP

Perform the trouble diagnosis of the AWD warning lamp. Refer to [DLN-30, "Diagnosis Procedure"](#).

Is the inspection result normal?

YES >> GO TO 3.

NO >> Repair or replace the error-detected parts.

3.CHECK AWD CONTROL UNIT POWER SUPPLY AND GROUND CIRCUIT

Perform the trouble diagnosis of the power supply and ground circuit. Refer to [DLN-27, "Diagnosis Procedure"](#).

Is the inspection result normal?

YES >> Check each harness connector pin terminal for malfunction or disconnection.

NO >> Repair or replace the error-detected parts.

A
B
C
DLN
E
F
G
H
I
J
K
L
M
N
O
P

HEAVY TIGHT-CORNER BRAKING SYMPTOM OCCURS

< SYMPTOM DIAGNOSIS >

[TRANSFER: ETX13C]

HEAVY TIGHT-CORNER BRAKING SYMPTOM OCCURS

Description

INFOID:000000005649630

Heavy tight-corner braking symptom occurs when the vehicle is driven and the steering wheel is turned fully to either side after the engine is started.

NOTE:

Light tight-corner braking symptom may occur depending on driving conditions. This is not malfunction.

Diagnosis Procedure

INFOID:000000005649631

1. PERFORM ECM SELF-DIAGNOSIS

With CONSULT-III

Perform self-diagnosis for "ENGINE".

Is any DTC detected?

- YES >> Check the DTC.
- NO >> GO TO 2.

2. PERFORM SELF-DIAGNOSIS

With CONSULT-III

Perform self-diagnosis for "ALL MODE AWD/4WD".

Is DTC "U1000" detected?

- YES >> CAN specification chart. Refer to [LAN-18, "Trouble Diagnosis Flow Chart"](#).
- NO >> GO TO 3.

3. CHECK TRANSFER FLUID TEMPERATURE SENSOR

Perform the trouble diagnosis of the transfer fluid temperature sensor. Refer to [DLN-22, "Diagnosis Procedure"](#).

Is the inspection result normal?

- YES >> GO TO 4.
- NO >> Repair or replace the error-detected parts.

4. CHECK AWD SOLENOID

Perform the trouble diagnosis of the AWD solenoid. Refer to [DLN-16, "Diagnosis Procedure"](#).

Is the inspection result normal?

- YES >> GO TO 5.
- NO >> Repair or replace the error-detected parts.

5. CHECK ELECTRIC CONTROLLED COUPLING

1. Turn the ignition switch OFF.
2. Set the transmission to neutral. Release the parking brake.
3. Lift up the vehicle.
4. Rotate the rear propeller shaft.
5. Hold the front propeller shaft lightly.

Does the front propeller shaft rotate?

- YES >> Replace electric controlled coupling for mechanical malfunction (clutch sticking etc.). Refer to [DLN-72, "Exploded View"](#).
- NO >> Check each harness connector pin terminal for disconnection.

VEHICLE DOES NOT ENTER AWD MODE

< SYMPTOM DIAGNOSIS >

[TRANSFER: ETX13C]

VEHICLE DOES NOT ENTER AWD MODE

Description

INFOID:000000005649632

Vehicle does not enter 4-wheel drive mode even though AWD warning lamp turned to OFF.

Diagnosis Procedure

INFOID:000000005649633

1.CHECK AWD WARNING LAMP

Turn the ignition switch ON.

Does AWD warning lamp turn ON?

YES >> GO TO 2.

NO >> Proceed to diagnosis procedure. Refer to [DLN-30, "Diagnosis Procedure"](#).

2.CRUISE TEST

Drive the vehicle for a period of time.

Does any symptom occur?

YES >> Replace electric controlled coupling for mechanical malfunction (mechanical engagement of clutch is not possible). Refer to [DLN-72, "Exploded View"](#).

NO >> Check each harness connector pin terminal for disconnection.

A
B
C
DLN
E
F
G
H
I
J
K
L
M
N
O
P

AWD WARNING LAMP BLINKS QUICKLY

< SYMPTOM DIAGNOSIS >

[TRANSFER: ETX13C]

AWD WARNING LAMP BLINKS QUICKLY

Description

INFOID:000000005649634

While driving, AWD warning lamp blinks 2 times in 1 second and it turns OFF after 1 minute.

- This symptom protects drivetrain parts when a heavy load is applied to the electric controlled coupling and multiple disc clutch temperature increases. Also, optional distribution of torque sometimes becomes rigid before lamp blinks quickly. Both cases are not malfunction.
- When this symptom occurs, stop vehicle and allow it to idle for some times. Blinking will stop and system will be restored.

AWD WARNING LAMP BLINKS SLOWLY

< SYMPTOM DIAGNOSIS >

[TRANSFER: ETX13C]

AWD WARNING LAMP BLINKS SLOWLY

Description

INFOID:000000005649635

AWD warning lamp blinks at approximately 2 seconds intervals while driving.

Diagnosis Procedure

INFOID:000000005649636

1.CHECK TIRE

Check the following.

- Tire pressure
- Wear condition
- Front and rear tire size (There is no difference between front and rear tires.)

Is the inspection result normal?

YES >> GO TO 2.

NO >> Repair or replace error-detected parts. And then, drive the vehicle at speed of 20 km/h (12 MPH) or more for 5 seconds or more. Improper size information is initialized accordingly.

2.CHECK INPUT SIGNAL OF TIRE DIAMETER

 **With CONSULT-III**

1. Start the engine.
2. Drive at 20 km/h (12 MPH) or more for approximately 4 minutes.
3. Check "DIS-TIRE MONI" of CONSULT-III "DATA MONITOR" for "ALL MODE AWD/4WD".

Does the item on "DATA MONITOR" indicate "0 - 4 mm"?

YES >> INSPECTION END

NO >> GO TO 3.

3.TERMINAL INSPECTION

Check AWD control unit harness connector for disconnection.

Is the inspection result normal?

YES >> Replace AWD control unit. Refer to [DLN-55. "Exploded View"](#).

NO >> Repair or replace the error-detected parts.

A
B
C
DLN
E
F
G
H
I
J
K
L
M
N
O
P

NOISE, VIBRATION AND HARSHNESS (NVH) TROUBLESHOOTING

< SYMPTOM DIAGNOSIS >

[TRANSFER: ETX13C]

NOISE, VIBRATION AND HARSHNESS (NVH) TROUBLESHOOTING

NVH Troubleshooting Chart

INFOID:000000005649637

Use the chart below to find the cause of the symptom. The numbers indicate the order of the inspection. If necessary, repair or replace these parts.

Symptom		TRANSFER FLUID (Level low)			LIQUID GASKET (Damaged)		GEAR (Worn or damaged)	BEARING (Worn or damaged)	TRANSFER CASE (Damaged)
		1	2		2	2	3	3	3
SUSPECTED PARTS (Possible cause)		TRANSFER FLUID (Level low)	TRANSFER FLUID (Wrong)	TRANSFER FLUID (Level too high)	LIQUID GASKET (Damaged)	OIL SEAL (Worn or damaged)	GEAR (Worn or damaged)	BEARING (Worn or damaged)	TRANSFER CASE (Damaged)
Reference			DLN-54, "Inspection"		DLN-62, "Exploded View"	DLN-62, "Exploded View"	DLN-75, "Inspection"	DLN-75, "Inspection"	DLN-70, "Inspection"

PRECAUTION

PRECAUTIONS

Precaution for Supplemental Restraint System (SRS) "AIR BAG" and "SEAT BELT PRE-TENSIONER"

INFOID:000000005649638

The Supplemental Restraint System such as "AIR BAG" and "SEAT BELT PRE-TENSIONER", used along with a front seat belt, helps to reduce the risk or severity of injury to the driver and front passenger for certain types of collision. This system includes seat belt switch inputs and dual stage front air bag modules. The SRS system uses the seat belt switches to determine the front air bag deployment, and may only deploy one front air bag, depending on the severity of a collision and whether the front occupants are belted or unbelted. Information necessary to service the system safely is included in the "SRS AIR BAG" and "SEAT BELT" of this Service Manual.

WARNING:

- To avoid rendering the SRS inoperative, which could increase the risk of personal injury or death in the event of a collision which would result in air bag inflation, all maintenance must be performed by an authorized NISSAN/INFINITI dealer.
- Improper maintenance, including incorrect removal and installation of the SRS, can lead to personal injury caused by unintentional activation of the system. For removal of Spiral Cable and Air Bag Module, see the "SRS AIR BAG".
- Do not use electrical test equipment on any circuit related to the SRS unless instructed to in this Service Manual. SRS wiring harnesses can be identified by yellow and/or orange harnesses or harness connectors.

PRECAUTIONS WHEN USING POWER TOOLS (AIR OR ELECTRIC) AND HAMMERS

WARNING:

- When working near the Air Bag Diagnosis Sensor Unit or other Air Bag System sensors with the ignition ON or engine running, DO NOT use air or electric power tools or strike near the sensor(s) with a hammer. Heavy vibration could activate the sensor(s) and deploy the air bag(s), possibly causing serious injury.
- When using air or electric power tools or hammers, always switch the ignition OFF, disconnect the battery, and wait at least 3 minutes before performing any service.

Precaution Necessary for Steering Wheel Rotation after Battery Disconnect

INFOID:000000005649639

NOTE:

- Before removing and installing any control units, first turn the push-button ignition switch to the LOCK position, then disconnect both battery cables.
- After finishing work, confirm that all control unit connectors are connected properly, then re-connect both battery cables.
- Always use CONSULT-III to perform self-diagnosis as a part of each function inspection after finishing work. If a DTC is detected, perform trouble diagnosis according to self-diagnosis results.

For vehicle with steering lock unit, if the battery is disconnected or discharged, the steering wheel will lock and cannot be turned.

If turning the steering wheel is required with the battery disconnected or discharged, follow the operation procedure below before starting the repair operation.

OPERATION PROCEDURE

1. Connect both battery cables.

NOTE:

Supply power using jumper cables if battery is discharged.

2. Turn the push-button ignition switch to ACC position.
(At this time, the steering lock will be released.)
3. Disconnect both battery cables. The steering lock will remain released with both battery cables disconnected and the steering wheel can be turned.
4. Perform the necessary repair operation.

A
B
C
DLN
E
F
G
H
I
J
K
L
M
N
O
P

PRECAUTIONS

< PRECAUTION >

[TRANSFER: ETX13C]

5. When the repair work is completed, re-connect both battery cables. With the brake pedal released, turn the push-button ignition switch from ACC position to ON position, then to LOCK position. (The steering wheel will lock when the push-button ignition switch is turned to LOCK position.)
6. Perform self-diagnosis check of all control units using CONSULT-III.

Precaution for Battery Service

INFOID:000000005649640

Before disconnecting the battery, lower both the driver and passenger windows. This will prevent any interference between the window edge and the vehicle when the door is opened/closed. During normal operation, the window slightly raises and lowers automatically to prevent any window to vehicle interference. The automatic window function will not work with the battery disconnected.

Service Notice or Precautions for Transfer

INFOID:000000005649641

- Never reuse transfer fluid, once it has been drained.
- Check the fluid level or replace the fluid only with the vehicle parked on level ground.
- During removal or installation, keep inside of transfer clear of dust or dirt.
- Replace all tires at the same time. Always use tires of the proper size and the same brand and pattern. Fitting improper size and unusually worn tires applies excessive force to vehicle mechanism and can cause longitudinal vibration.
- Disassembly should be done in a clean work area, it is preferable to work in dustproof area.
- Before proceeding with disassembly, thoroughly clean the transfer. It is important to prevent the internal parts from becoming contaminated by dirt or other foreign matter.
- All parts should be carefully cleaned with a general purpose, non-flammable solvent before inspection or reassembly.
- Check for the correct installation status prior to removal or disassembly. If matching marks are required, be certain they do not interfere with the function of the parts when applied.
- Check appearance of the disassembled parts for damage, deformation, and unusual wear. Replace them with a new ones if necessary.
- Gaskets, seals and O-rings should be replaced any time the transfer is disassembled.
- In principle, tighten bolts or nuts gradually in several steps working diagonally from inside to outside. If tightening sequence is specified, use it.
- Observe the specified torque when assembling.
- Clean and flush the parts sufficiently and blow-dry them.
- Be careful not to damage sliding surfaces and mating surfaces.
- Clean inner parts with lint-free cloth or towels. Do not use cotton work gloves and rags to prevent adhering fibers.

PREPARATION

< PREPARATION >

[TRANSFER: ETX13C]

PREPARATION

PREPARATION

Special Service Tools

INFOID:000000005649642

The actual shapes of Kent-Moore tools may differ from those of special service tools illustrated here.

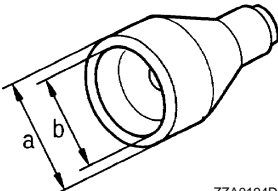
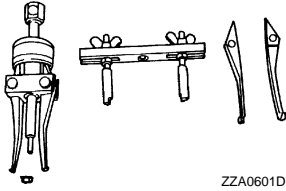
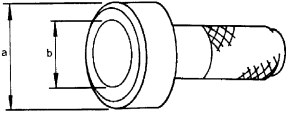
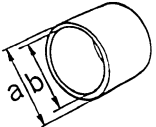
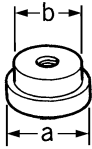
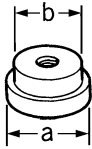
Tool number (Kent-Moore No.) Tool name	Description
ST27862000 (—) Drift a: 62.5 mm (2.461 in) dia. b: 42 mm (1.65 in) dia.	Installing front oil seal
 <p style="text-align: center;">ZZA0194D</p>	
KV381054S0 (J-34286) Puller	Removing rear oil seal
 <p style="text-align: center;">ZZA0601D</p>	
ST30720000 (J-25405) Drift a: 77 mm (3.03 in) dia. b: 55.5 mm (2.185 in) dia.	<ul style="list-style-type: none"> • Installing rear oil seal • Installing main shaft oil seal
 <p style="text-align: center;">ZZA0811D</p>	
KV40104830 (—) Drift a: 70 mm (2.76 in) dia. b: 63.5 mm (2.500 in) dia.	Installing rear oil seal
 <p style="text-align: center;">ZZA1003D</p>	
ST33052000 (—) Drift a: 28 mm (1.10 in) dia. b: 22 mm (0.87 in) dia.	Removing main shaft assembly
 <p style="text-align: center;">ZZA1000D</p>	
ST35321000 (—) Drift a: 49 mm (1.93 in) dia. b: 41 mm (1.61 in) dia.	Installing main shaft assembly
 <p style="text-align: center;">ZZA1000D</p>	

A
B
C
DLN
E
F
G
H
I
J
K
L
M
N
O
P

PREPARATION

< PREPARATION >

[TRANSFER: ETX13C]

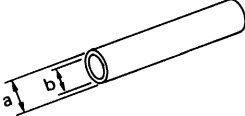
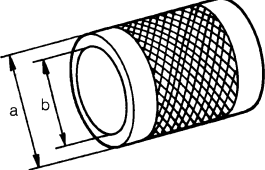
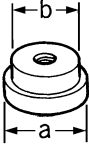
Tool number (Kent-Moore No.) Tool name	Description
<p>ST31214000 (J-25269-B) Drift a: 34 mm (1.34 in) dia. b: 25.5 mm (1.004 in) dia.</p> <div style="text-align: center;">  <p style="margin-top: 5px;">ZZA0534D</p> </div>	<ul style="list-style-type: none"> Removing front drive shaft front bearing Removing front drive shaft rear bearing
<p>ST33200000 (J-26082) Drift a: 60 mm (2.36 in) dia. b: 44.5 mm (1.752 in) dia.</p> <div style="text-align: center;">  <p style="margin-top: 5px;">ZZA1002D</p> </div>	<p>Installing front drive shaft rear bearing</p>
<p>KV38104010 (—) Drift a: 67 mm (2.64 in) dia. b: 49 mm (1.93 in) dia.</p> <div style="text-align: center;">  <p style="margin-top: 5px;">ZZA1000D</p> </div>	<p>Installing front drive shaft front bearing</p>

Commercial Service Tools

INFOID:000000005649643

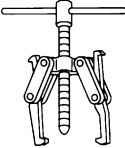
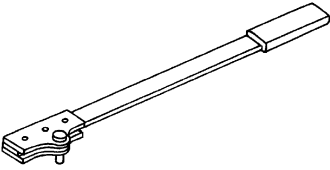
Tool name	Description
<p>Puller</p> <div style="text-align: center;">  <p style="margin-top: 5px;">NT077</p> </div>	<p>Removing companion flange</p>
<p>Flange wrench</p> <div style="text-align: center;">  <p style="margin-top: 5px;">NT771</p> </div>	<p>Removing and installing self-lock nut</p>

PREPARATION

< PREPARATION >

[TRANSFER: ETX13C]

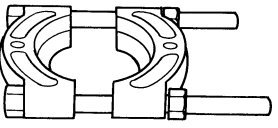
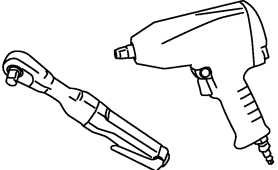
Tool name	Description
<p>Replacer</p>  <p style="text-align: right;">ZZB0823D</p>	<ul style="list-style-type: none"> • Removing front drive shaft front bearing • Removing front drive shaft rear bearing
<p>Power tool</p>  <p style="text-align: right;">PBIC0190E</p>	<p>Loosening bolts and nuts</p>

A
B
C
DLN
E
F
G
H
I
J
K
L
M
N
O
P

PERIODIC MAINTENANCE

TRANSFER FLUID

Inspection

INFOID:000000005649644

FLUID LEAKAGE

Check transfer surrounding area (oil seal, drain plug, and filler plug etc.) for fluid leakage.

FLUID LEVEL

1. Remove filler plug (1) and gasket. Then check that fluid is filled up from mounting hole for the filler plug.

CAUTION:

Never start engine while checking fluid level.

2. Set a new gasket onto filler plug, and install it on transfer and tighten to the specified torque. Refer to [DLN-62, "Exploded View"](#).

CAUTION:

Never reuse gasket.

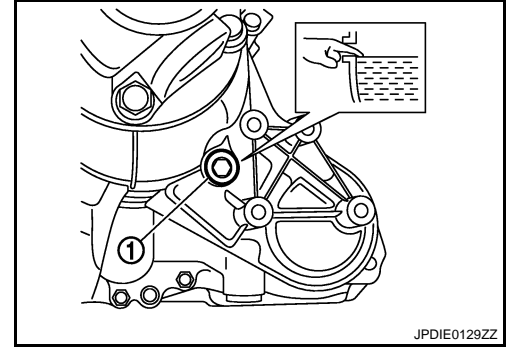

Draining

INFOID:000000005649645

1. Run the vehicle to warm up the transfer unit sufficiently.
2. Stop the engine, and remove the drain plug (1) to drain the transfer fluid.
3. Set a new gasket onto the drain plug, and install it on the transfer and tighten to the specified torque. Refer to [DLN-62, "Exploded View"](#).

CAUTION:

Never reuse gasket.

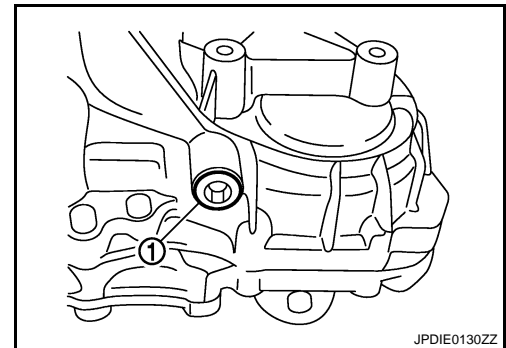

Refilling

INFOID:000000005649646

1. Remove filler plug (1) and gasket. Then fill fluid up to mounting hole for the filler plug.

Fluid and viscosity

: Refer to [MA-10, "Fluids and Lubricants"](#).

Fluid capacity

: Refer to [DLN-81, "General Specifications"](#).

CAUTION:

Carefully fill the fluid. (Fill up for approximately 3 minutes.)

2. Leave the vehicle for 3 minutes, and check the fluid level again.
3. Set a new gasket onto filler plug, and install it on transfer and tighten to the specified torque. Refer to [DLN-62, "Exploded View"](#).

CAUTION:

Never reuse gasket.

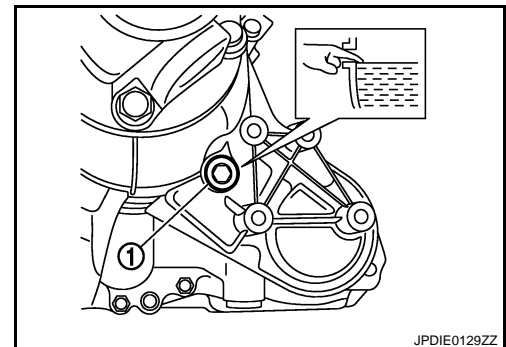

AWD CONTROL UNIT

< REMOVAL AND INSTALLATION >

[TRANSFER: ETX13C]

REMOVAL AND INSTALLATION

AWD CONTROL UNIT

Exploded View

INFOID:000000005649647

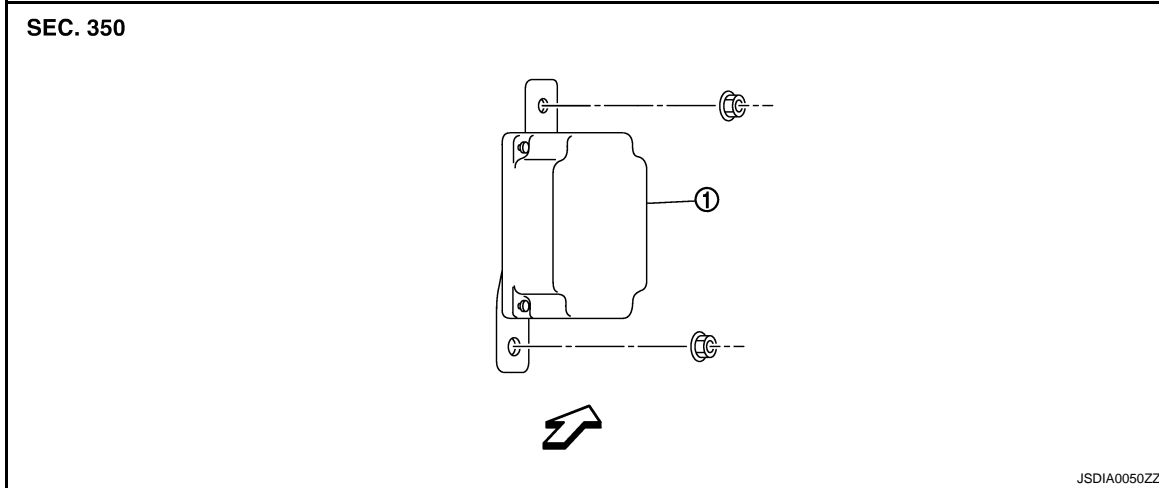

1. AWD control unit

←: Vehicle front

Removal and Installation

INFOID:000000005649648

REMOVAL

1. Remove the glove box assembly. Refer to [IP-12, "A/T MODELS : Exploded View"](#).
2. Disconnect AWD control unit harness connector.
3. Remove AWD control unit (1) mounting nuts.
4. Remove AWD control unit.

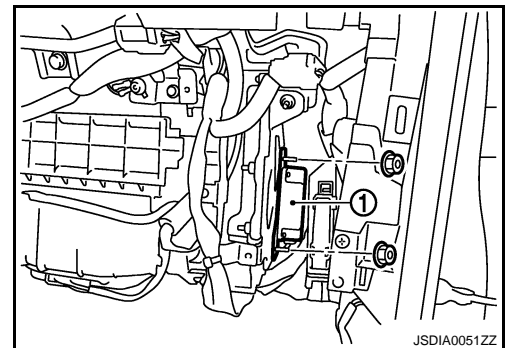

INSTALLATION

Install in the reverse order of removal.

A
B
C
DLN
E
F
G
H
I
J
K
L
M
N
O
P

FRONT OIL SEAL

< REMOVAL AND INSTALLATION >

[TRANSFER: ETX13C]

FRONT OIL SEAL

Exploded View

INFOID:000000005649649

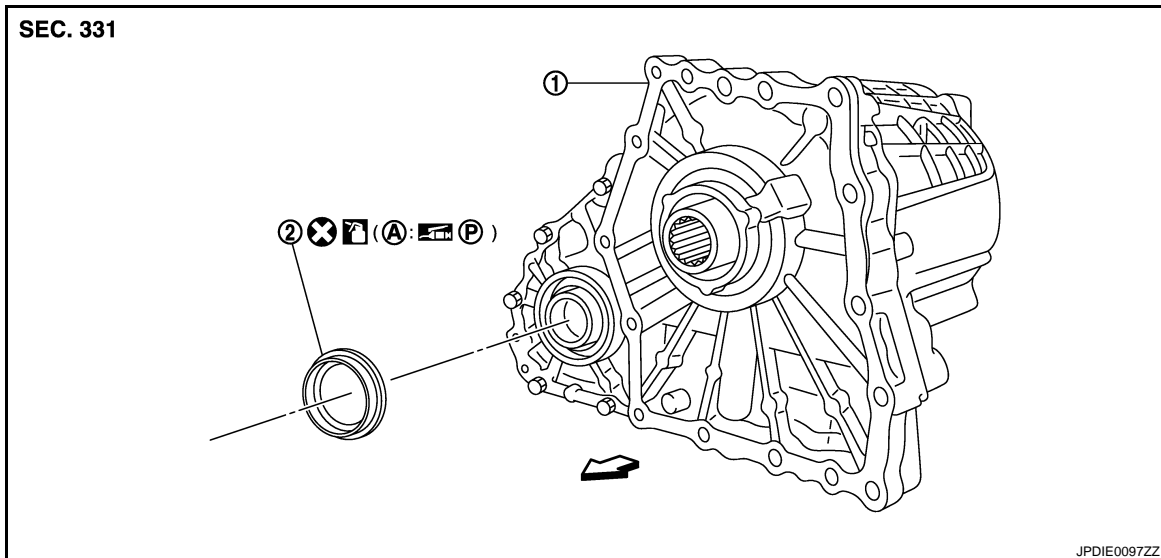

1. Transfer assembly 2. Front oil seal

A. Oil seal lip

↔: Vehicle front

: Apply transfer fluid. Refer to [MA-10, "Fluids and Lubricants"](#).

: Apply petroleum jelly.

Refer to [GI-4, "Components"](#) for symbols not described above.

Removal and Installation

INFOID:000000005649650

REMOVAL

1. Remove the drain plug to drain the transfer fluid. Refer to [DLN-54, "Draining"](#).
2. Remove the front propeller shaft. Refer to [DLN-85, "Exploded View"](#).
3. Remove front oil seal.

CAUTION:

Never damage the front case and front drive shaft.

INSTALLATION

1. Apply transfer fluid to outside of front oil seal, install it with a drift (A) [SST: ST27862000 (—)] until the end face of front case.

CAUTION:

- **Never reuse front oil seal.**
- **Apply petroleum jelly to oil seal lip.**
- **When installing, never incline front oil seal.**

2. Install front propeller shaft. Refer to [DLN-85, "Exploded View"](#).
3. Fill with new transfer fluid, check fluid level and for fluid leakage. Refer to [DLN-54, "Inspection"](#).

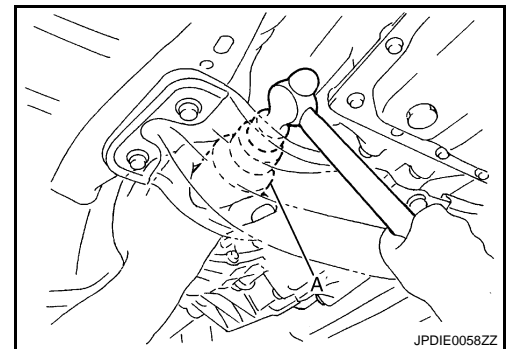

REAR OIL SEAL

< REMOVAL AND INSTALLATION >

[TRANSFER: ETX13C]

REAR OIL SEAL

Exploded View

INFOID:000000005649651

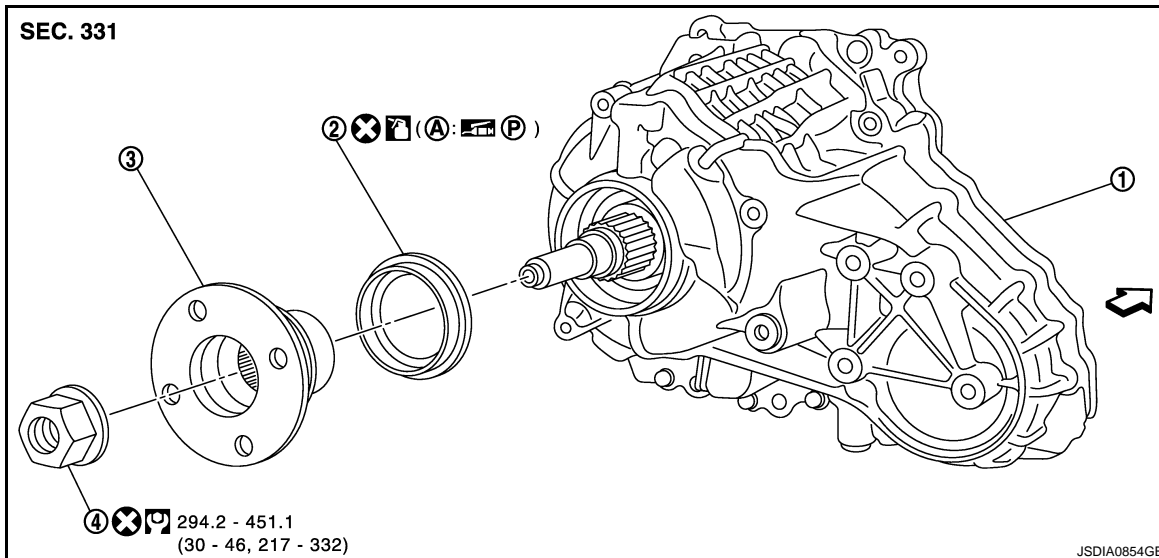

- 1. Transfer assembly
- 2. Rear oil seal
- 3. Companion flange
- 4. Self-lock nut
- A. Oil seal lip

⇐: Vehicle front

: Apply transfer fluid. Refer to [MA-10. "Fluids and Lubricants"](#).

: Apply petroleum jelly.

Refer to [GI-4. "Components"](#) for symbols not described above.

Removal and Installation

INFOID:000000005649652

REMOVAL

1. Remove the rear propeller shaft. Refer to [DLN-108. "Exploded View"](#).
2. Remove self-lock nut of companion flange with a flange wrench (commercial service tool).
3. Put matching mark (A) on the end of the main shaft. The mark should be in line with the mark (B) on the companion flange.

CAUTION:

For matching mark, use paint. Never damage main shaft.

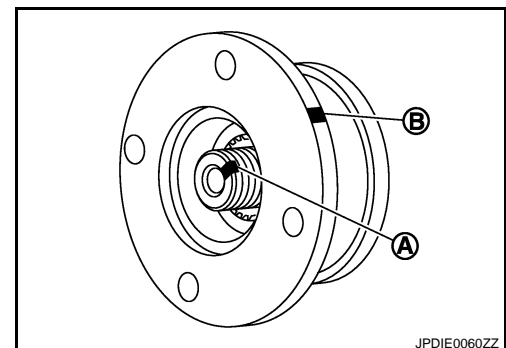

A
B
C
DLN
E
F
G
H
I
J
K
L
M
N
O
P

REAR OIL SEAL

[TRANSFER: ETX13C]

< REMOVAL AND INSTALLATION >

4. Remove the companion flange with a puller (A) (commercial service tool).
CAUTION:
Never damage the companion flange.

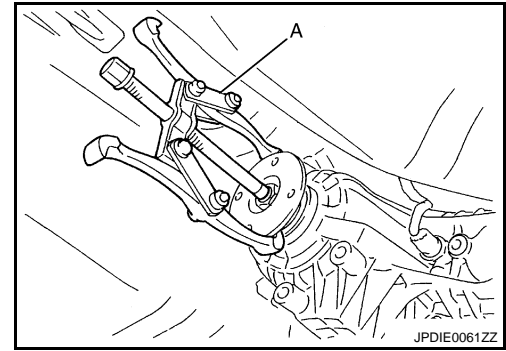

5. Remove the rear oil seal with the puller (A) [SST: KV381054S0 (J-34286)].
CAUTION:
Never damage the rear case.

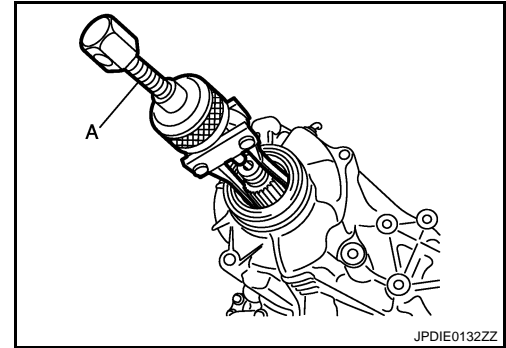

INSTALLATION

1. Apply transfer fluid to rear oil seal, install it with the drifts within the dimension (L) shown as follows.

A : Drift [SST: ST30720000 (J-25405)]

B : Drift [SST: KV40104830 (—)]

L : 6.7 – 7.3 mm (0.264 – 0.287 in)

CAUTION:

- Never reuse rear oil seal.
- Apply petroleum jelly to oil seal lip.
- When installing, never incline rear oil seal.

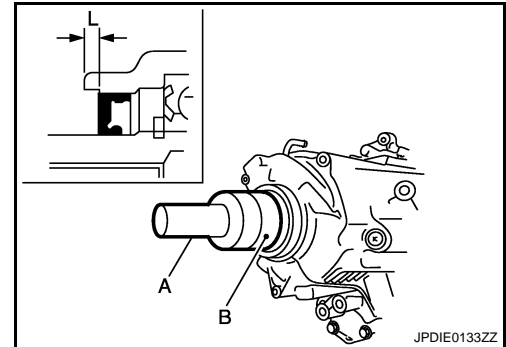

2. Align the matching mark (A) of main shaft with the mark (B) of companion flange, then install the companion flange.

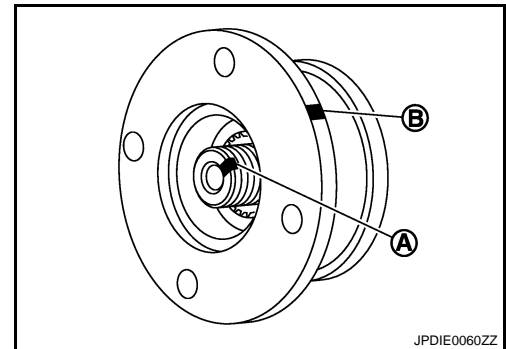

REAR OIL SEAL

< REMOVAL AND INSTALLATION >

[TRANSFER: ETX13C]

- Using a flange wrench (A) (commercial service tool), install the self-lock nut of companion flange and tighten to the specified torque. Refer to [DLN-57. "Exploded View"](#).

CAUTION:

Never reuse self-lock nut.

- Install the rear propeller shaft. Refer to [DLN-108. "Exploded View"](#).
- Check fluid level. Refer to [DLN-54. "Inspection"](#).

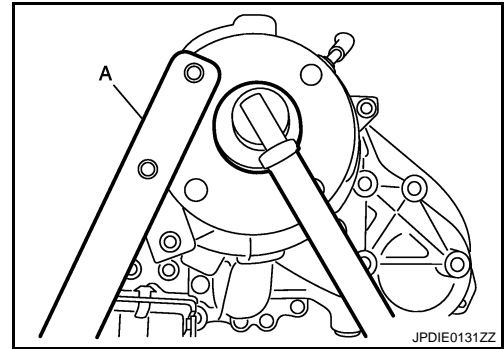

A

B

C

DLN

E

F

G

H

I

J

K

L

M

N

O

P

UNIT REMOVAL AND INSTALLATION

TRANSFER ASSEMBLY

Exploded View

INFOID:000000005649653

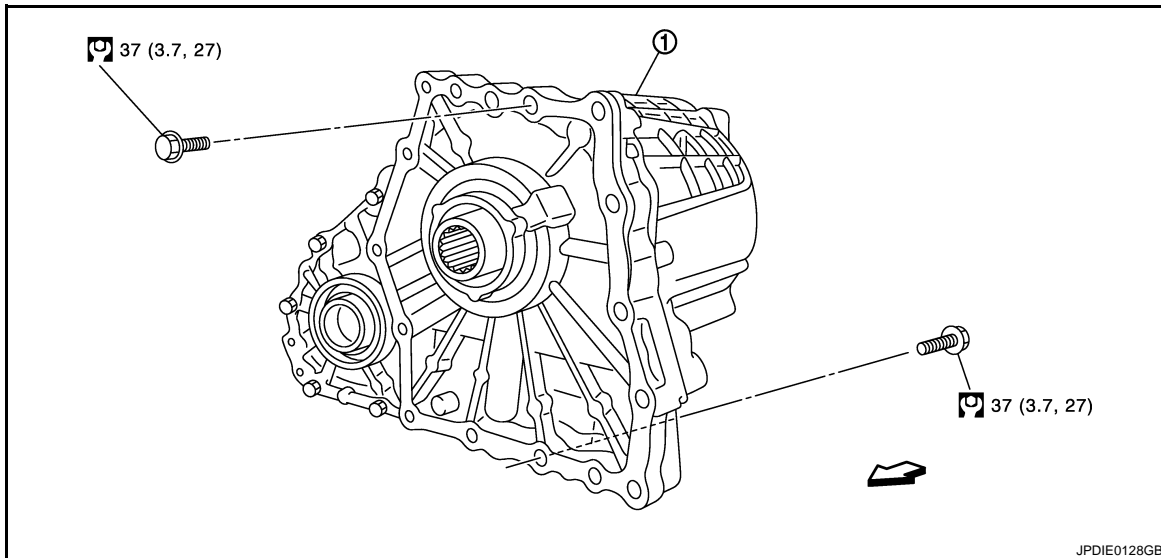

1. Transfer assembly

↔: Vehicle front

Refer to [GI-4, "Components"](#) for symbols in the figure.

Removal and Installation

INFOID:000000005649654

REMOVAL

1. Remove rear propeller shaft. Refer to [DLN-108, "Exploded View"](#).
2. Remove front propeller shaft. Refer to [DLN-85, "Exploded View"](#).
3. Disconnect AWD solenoid harness connector and separate harness from transfer assembly.
4. Remove transfer air breather hose.
5. Remove control rod. Refer to [TM-271, "Exploded View"](#).
6. Support transfer assembly and transmission assembly with a jack.
7. Remove rear engine mounting member and engine mounting insulator with power tool. Refer to [EM-73, "AWD : Exploded View"](#).
8. Lower jack to the position where the top transfer mounting bolts can be removed.
9. Remove transfer mounting bolts and separate transfer from transmission.

CAUTION:

Secure transfer assembly and transmission assembly to a jack.

INSTALLATION

Note the following, and install in the reverse order of removal.

TRANSFER ASSEMBLY

< UNIT REMOVAL AND INSTALLATION >

[TRANSFER: ETX13C]

- When installing the transfer to the transmission, install the mounting bolts following the standard below, tighten bolts to the specified torque.

Bolt No.	A	B	C	D
Quantity	4	3	4	2
Bolt length " L " mm (in)	75 (2.95)	45 (1.77)	40 (1.57)	30 (1.18)

●:Transfer to transmission.

○:Transmission to transfer.

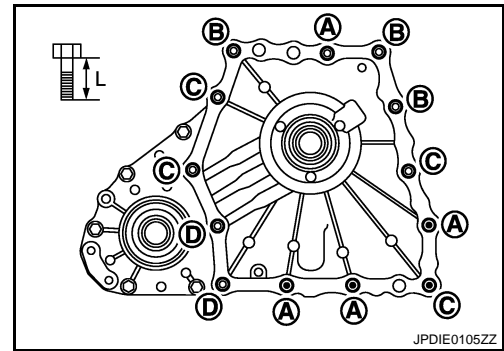

A

B

C

DLN

- When installing transfer air breather hose, make sure there are no pinched or restricted areas on the transfer air breather hose caused by bending or winding.
- Set transfer air breather hose (1) of transmission side with the paint mark (A) facing upward, and insert air breather hose to air breather tube until hose end reaches the tube bend R portion.

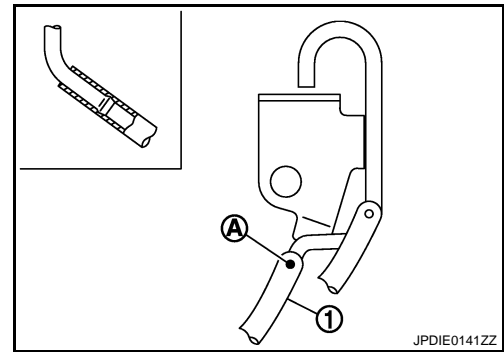

E

F

G

H

- Be sure to insert air breather hose (1) of transfer side to air breather tube (2) until hose end reaches the tube bend R portion.

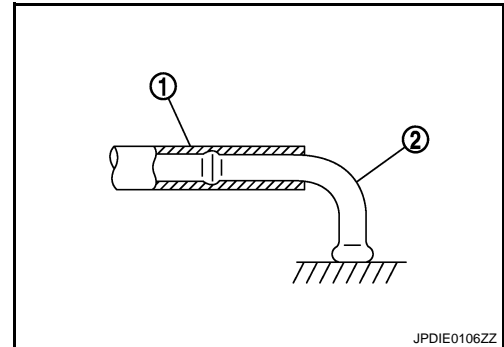

I

J

K

L

- Be sure to fix air breather hose in (A) positions.
- After the installation, check the fluid level, fluid leakage and the A/T positions. Refer to [DLN-54. "Inspection"](#).

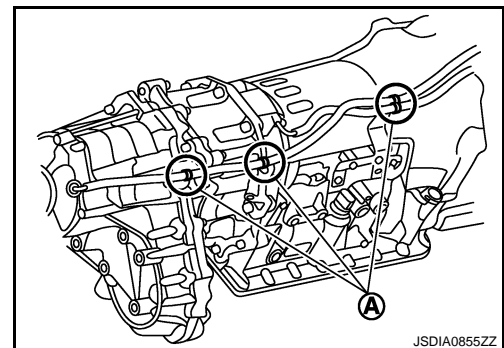

M

N

O

P

FRONT CASE AND REAR CASE

< UNIT DISASSEMBLY AND ASSEMBLY >

[TRANSFER: ETX13C]

UNIT DISASSEMBLY AND ASSEMBLY

FRONT CASE AND REAR CASE

Exploded View

INFOID:000000005649655

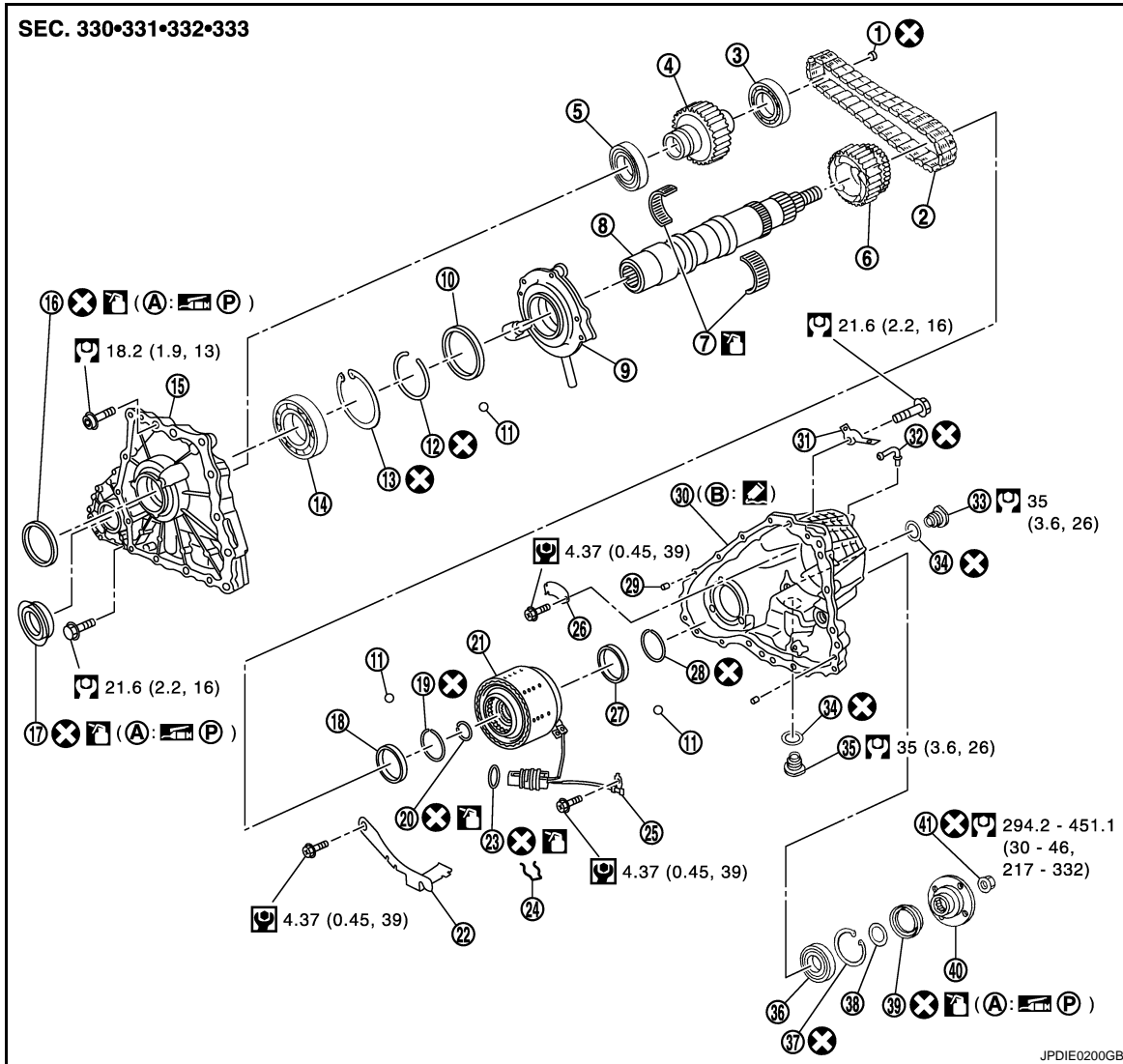

- | | | |
|---------------------------------------|-----------------------------------|------------------------------------|
| 1. Plug | 2. Drive chain | 3. Front drive shaft front bearing |
| 4. Front drive shaft | 5. Front drive shaft rear bearing | 6. Sprocket |
| 7. Needle bearing | 8. Main shaft | 9. Oil pump |
| 10. Spacer | 11. Steel ball | 12. Snap ring |
| 13. Snap ring | 14. Main shaft bearing | 15. Front case |
| 16. Main shaft oil seal | 17. Front oil seal | 18. Spacer |
| 19. Snap ring | 20. Circlip | 21. Electric controlled coupling |
| 22. Oil cover | 23. O-ring | 24. Retainer |
| 25. Transfer fluid temperature sensor | 26. Baffle plate | 27. Spacer |
| 28. Snap ring | 29. Dowel pin | 30. Rear case |
| 31. Harness bracket | 32. Breather tube | 33. Filler plug |
| 34. Gasket | 35. Drain plug | 36. Rear bearing |
| 37. Snap ring | 38. Spacer | 39. Rear oil seal |
| 40. Companion flange | 41. Self-lock nut | |
| A. Oil seal lip | B. Matching surface | |

FRONT CASE AND REAR CASE

< UNIT DISASSEMBLY AND ASSEMBLY >

[TRANSFER: ETX13C]

 Apply Genuine Anaerobic Liquid Gasket or equivalent. Refer to [GI-18. "Recommended Chemical Products and Sealants"](#).

 Apply petroleum jelly.

 Apply transfer fluid. Refer to [MA-10. "Fluids and Lubricants"](#).

Refer to [GI-4. "Components"](#) for symbols not described above.

Disassembly

INFOID:000000005649656

1. Remove drain plug and filler plug.
2. Remove harness brackets.
3. Remove main shaft oil seal from front case.

CAUTION:
Never damage the front case and main shaft.

4. Remove front oil seal from front case.

CAUTION:
Never damage the front case and front drive shaft.

5. Remove self-lock nut.

6. Put a matching mark (A) on the end of main shaft. The mark should be in line with the mark (B) on the companion flange.

CAUTION:
For the matching mark, use paint. Never damage main shaft.

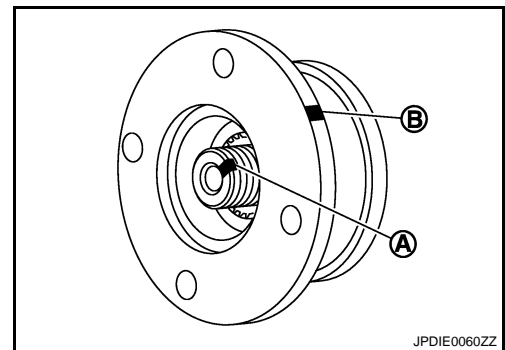

7. Remove companion flange with a puller (A) (commercial service tool).

CAUTION:
Never damage the companion flange.

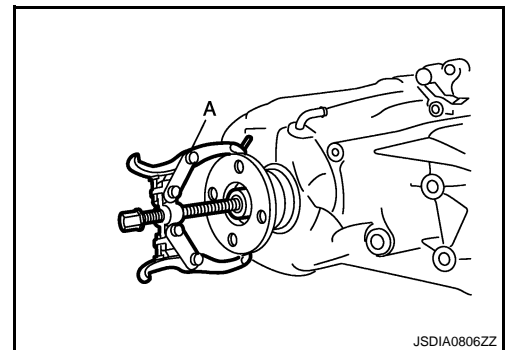

8. Remove rear oil seal from rear case with the puller (A) [SST:KV381054S0 (J-34286)].

CAUTION:
Never damage the rear case.

9. Remove spacer from main shaft.

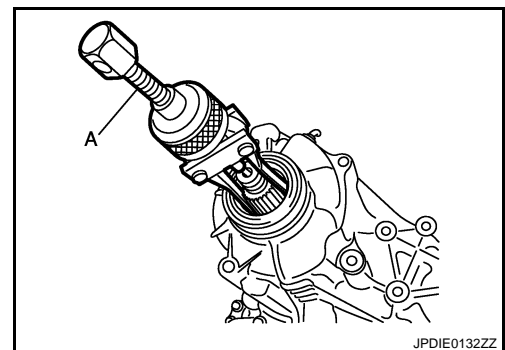

A

B

C

DLN

E

F

G

H

I

J

K

L

M

N

O

P

FRONT CASE AND REAR CASE

< UNIT DISASSEMBLY AND ASSEMBLY >

[TRANSFER: ETX13C]

10. Remove front case and rear case fixing bolts, then remove harness bracket.

Bolts symbol	Quantity
A	14
T (TORX bolt)	1

*: With harness bracket.

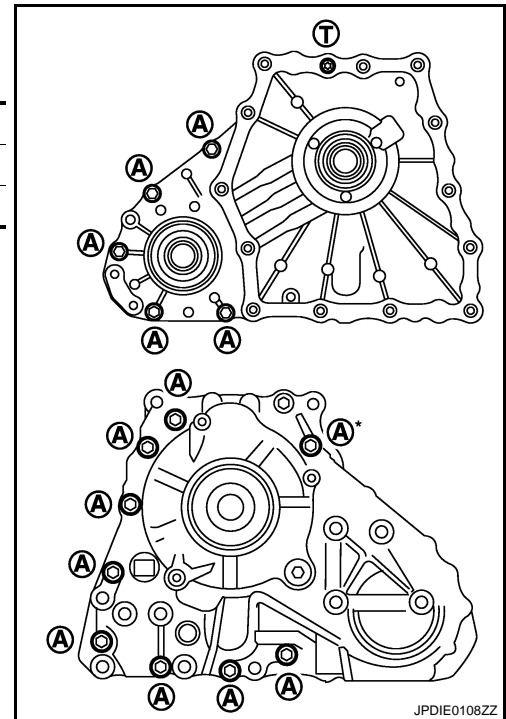

11. Remove front case (1) from rear case by levering it up with a suitable tool.

CAUTION:
Never damage the mating surface.

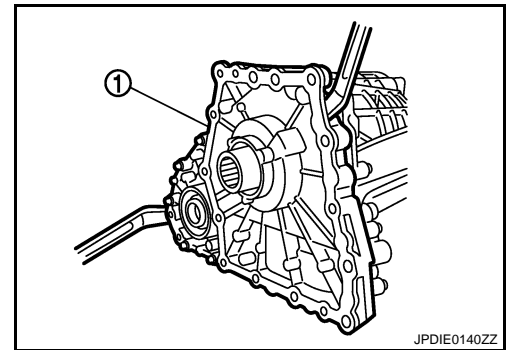

12. Remove snap ring (1) from front case.

13. Remove main shaft bearing from front case.

CAUTION:
Never use tools. Always remove by hand.

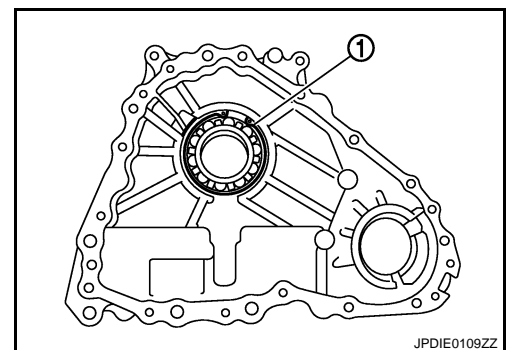

14. Remove snap ring (1) from main shaft.

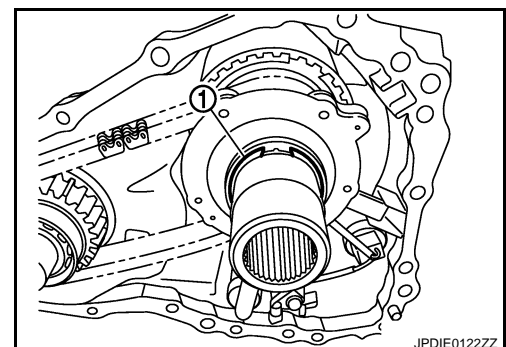

FRONT CASE AND REAR CASE

< UNIT DISASSEMBLY AND ASSEMBLY >

[TRANSFER: ETX13C]

15. Remove spacer (1) and steel ball (2) from main shaft.

CAUTION:

Be careful not to drop the steel ball.

16. Remove oil pump from main shaft.
17. Remove drive chain and front drive shaft.

CAUTION:

Never use tools. Always remove by hand.

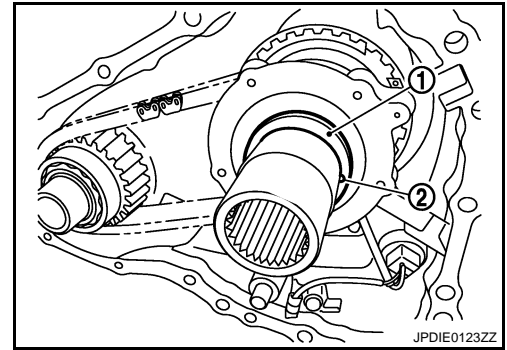

18. Remove transfer fluid temperature sensor bolt from rear case. And then, remove transfer fluid temperature sensor (1).

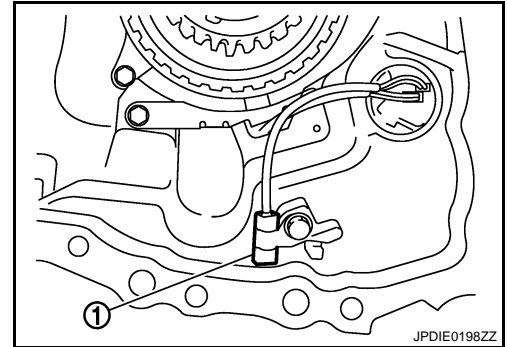

19. Remove oil cover bolts from rear case. And then, remove oil cover (1).
20. Remove retainer from AWD solenoid harness connector.
21. Remove AWD solenoid harness connector from rear case.
22. Remove O-ring from AWD solenoid harness connector.

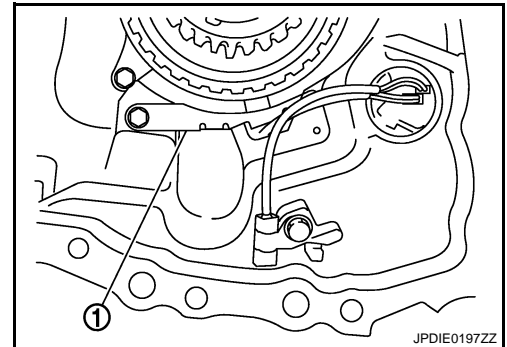

23. Remove main shaft assembly from rear case with the drift (A) [SST: ST33052000 (—)].

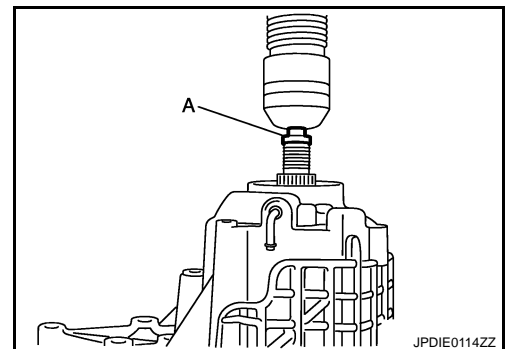

24. Remove snap ring (1) from rear case.
25. Remove rear bearing from rear case.
CAUTION:
Never use tools. Always remove by hand.

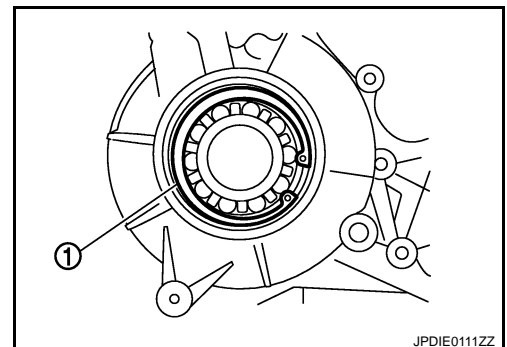

A
B
C
DLN
E
F
G
H
I
J
K
L
M
N
O
P

FRONT CASE AND REAR CASE

< UNIT DISASSEMBLY AND ASSEMBLY >

[TRANSFER: ETX13C]

26. Remove baffle plate (1) from rear case.
27. Remove breather tube from rear case.

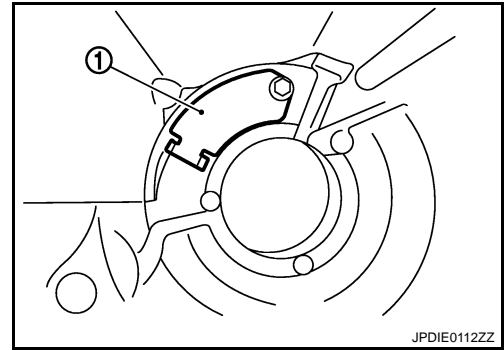

Assembly

INFOID:000000005649657

1. Install breather tube to rear case within the angle (A) shown as follows.

A : 80 – 100°

CAUTION:

Never reuse breather tube.

2. Install baffle plate to rear case.
3. Install rear bearing to rear case.

CAUTION:

Never use tools. Always install by hand.

4. Install snap ring (1) to rear case.

CAUTION:

Never reuse snap ring.

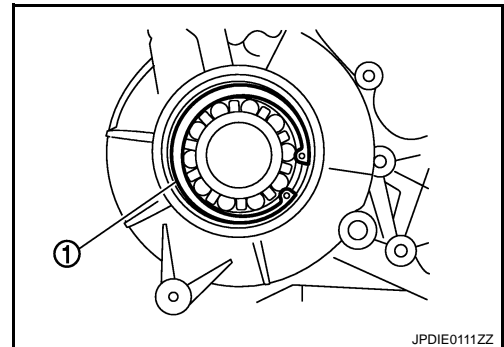
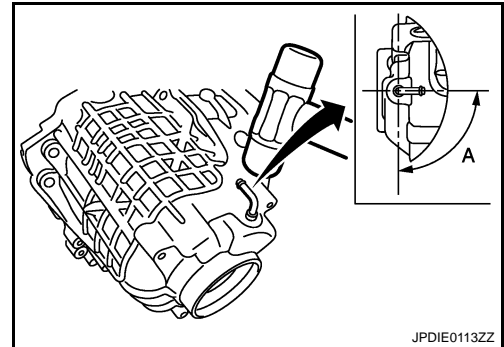

5. Install main shaft assembly to rear case with the drift (A) [SST: ST35321000 (—)].
6. Install O-ring to AWD solenoid harness connector.
CAUTION:
 - **Never reuse O-ring.**
 - **Apply transfer fluid to O-ring.**
7. Install AWD solenoid harness connector into rear case.
8. Install retainer to AWD solenoid harness connector.

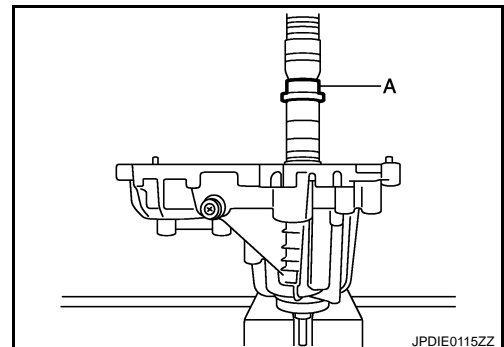

FRONT CASE AND REAR CASE

< UNIT DISASSEMBLY AND ASSEMBLY >

[TRANSFER: ETX13C]

9. Hold electric controlled coupling harness (1) with oil cover hold plate (2), install oil cover (3) to rear case (4).

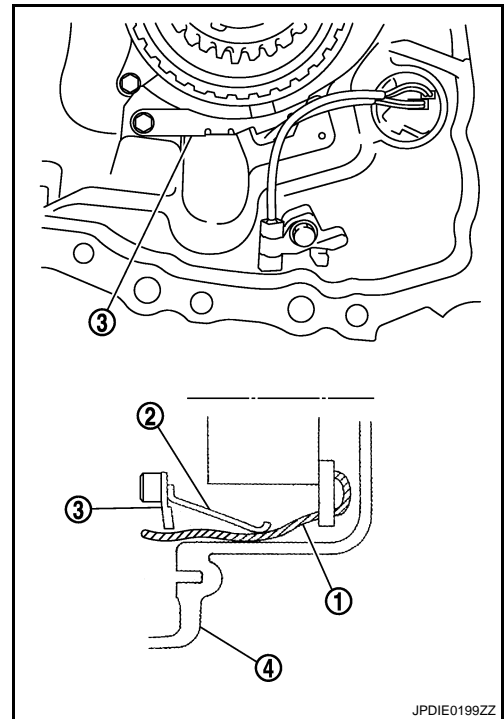

10. Install transfer fluid temperature sensor (1) to rear case.

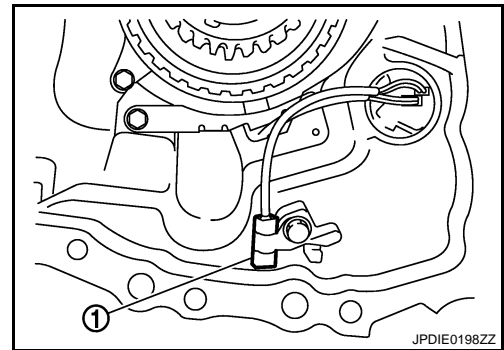

11. Set drive chain to front drive shaft.

CAUTION:

Identification mark (A) of drive chain should be in the side of front bearing (1) of front drive shaft.

12. Install drive chain to main shaft, and then install front drive shaft.

CAUTION:

Never use tools. Always install by hand.

13. Install oil pump to main shaft.

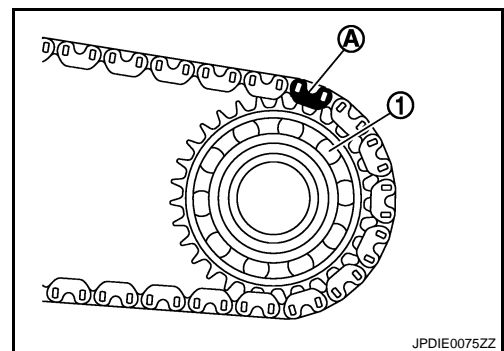

14. Install spacer (1) and steel ball (2) to main shaft.

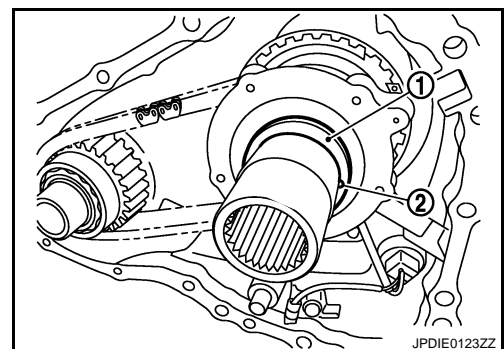

A
B
C
DLN
E
F
G
H
I
J
K
L
M
N
O
P

FRONT CASE AND REAR CASE

< UNIT DISASSEMBLY AND ASSEMBLY >

[TRANSFER: ETX13C]

15. Install snap ring (1) to main shaft.

CAUTION:
Never reuse snap ring.

16. Install main shaft bearing to front case.

CAUTION:
Never use tools. Always install by hand.

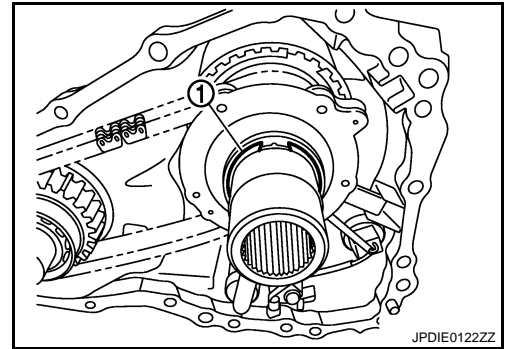

17. Install snap ring (1) to front case.

CAUTION:
Never reuse snap ring.

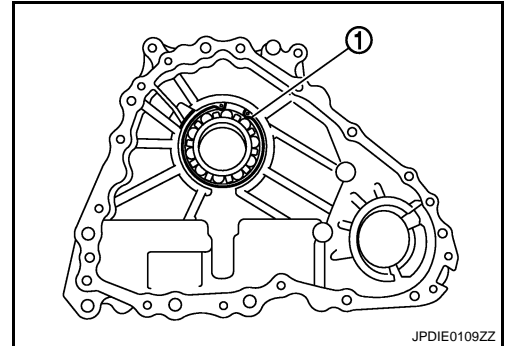

18. Apply liquid gasket (1) to mating surface of rear case. Use Genuine Anaerobic Liquid Gasket or equivalent. Refer to [GI-18. "Recommended Chemical Products and Sealants"](#).

CAUTION:
Remove old sealant adhering to mounting surfaces. Also remove any moisture, oil, or foreign material adhering to application and mounting surfaces.

19. Set front case to rear case.

CAUTION:
Never damage the mating surface transmission side.

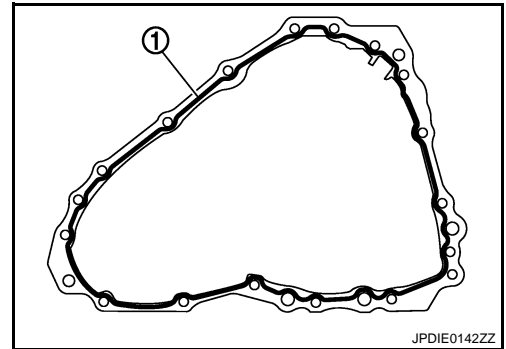

20. Tighten front case and rear case fixing bolts.

Bolts symbol	Quantity
A	14
T (TORX bolt)	1

*: With harness bracket.

21. Install spacer to main shaft.

CAUTION:
Apply transfer fluid to spacer.

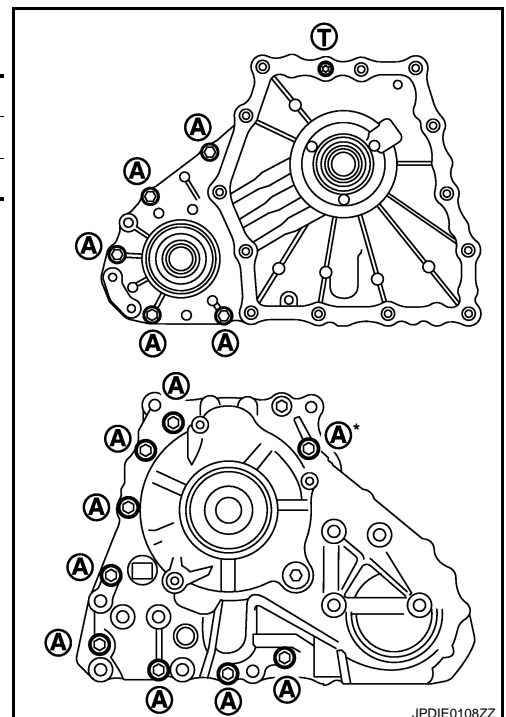

FRONT CASE AND REAR CASE

< UNIT DISASSEMBLY AND ASSEMBLY >

[TRANSFER: ETX13C]

22. Apply transfer fluid to outside of rear oil seal, and install rear oil seal to rear case with the drifts within the dimension (L) shown as follows.

A : Drift [SST: ST30720000 (J-25405)]

B : Drift [SST: KV40104830 (—)]

L : 6.7 – 7.3 mm (0.264 – 0.287 in)

CAUTION:

- Never reuse rear oil seal.
- Apply petroleum jelly to oil seal lip.
- When installing, never incline rear oil seal.

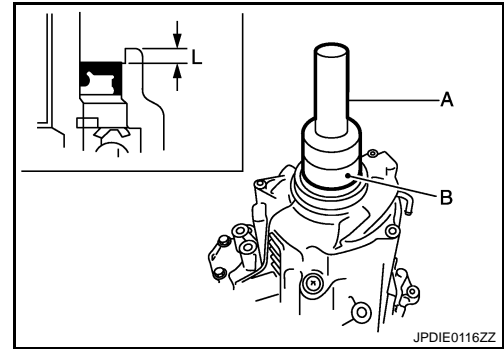

23. Install companion flange while aligning the matching mark (A) of main shaft with the mark (B) of companion flange.

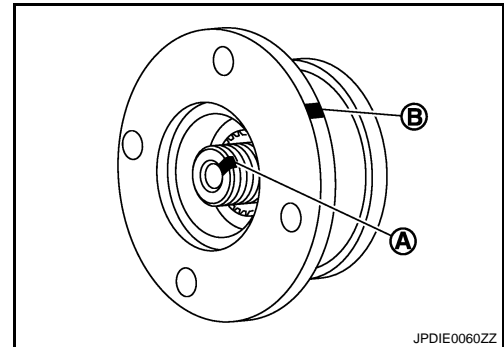

24. Tighten self-lock nut to the specified torque with flange wrench (A) (commercial service tool).

CAUTION:

Never reuse self-lock nut.

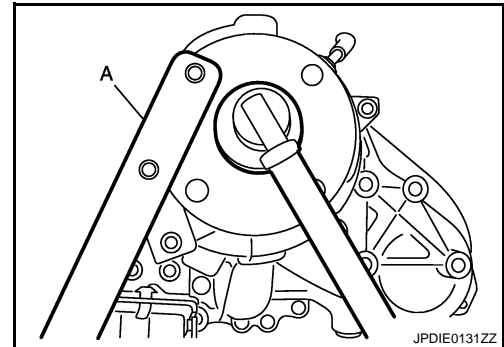

25. Apply transfer fluid to outside of main shaft oil seal, and install main shaft oil seal until it is flush with the end face of front case with the drift (A) [SST: ST30720000 (J-25405)].

CAUTION:

- Never reuse main shaft oil seal.
- Apply petroleum jelly to oil seal lip.
- When installing, never incline main shaft oil seal.

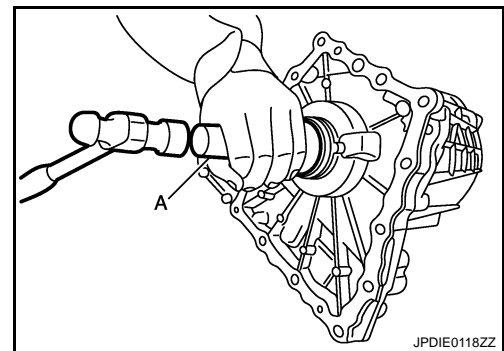

A
B
C
DLN
E
F
G
H
I
J
K
L
M
N
O
P

FRONT CASE AND REAR CASE

< UNIT DISASSEMBLY AND ASSEMBLY >

[TRANSFER: ETX13C]

26. Apply transfer fluid to outside of front oil seal, and install front oil seal until it is flush with the end face of front case with the drift (A) [SST: ST27862000 (—)].

CAUTION:

- Never reuse front oil seal.
- Apply petroleum jelly to oil seal lip.
- When installing, never incline front oil seal.

27. Set gasket to drain plug. Install it to rear case and tighten it to specified torque.

CAUTION:

Never reuse gasket.

28. Set gasket to filler plug. Install it to rear case.

CAUTION:

- Never reuse gasket.
- After oil is filled, tighten filler plug to specified torque.

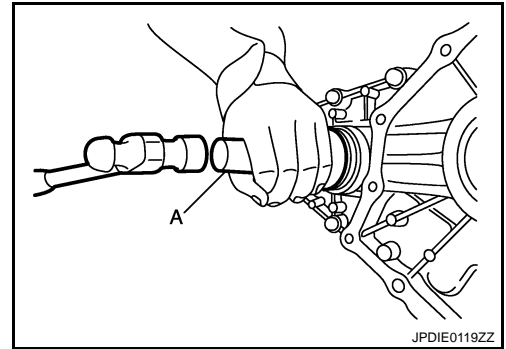

Inspection

INFOID:000000005649658

Check items below. If necessary, replace them with new ones.

CASES

- Contact surfaces of bearing for wear, damage, etc.
- Damage and cracks of case.

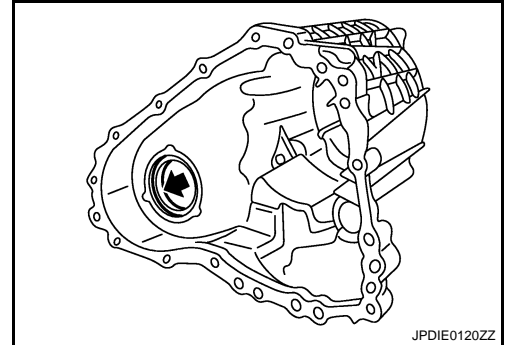

BEARING

Damage and rough rotation of bearing.

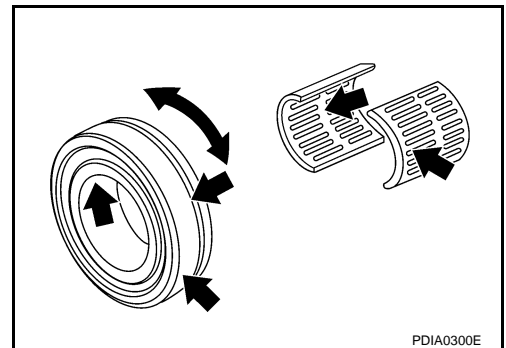

SHAFT

Damage, peeling, dent, uneven wear, bending, etc. of shaft.

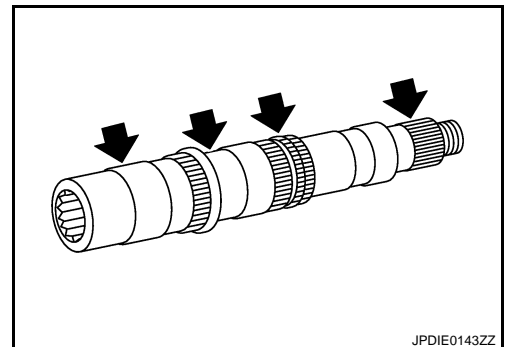

GEARS AND CHAIN

FRONT CASE AND REAR CASE

< UNIT DISASSEMBLY AND ASSEMBLY >

[TRANSFER: ETX13C]

Excessive wear, damage, peeling, etc. of gear and chain.

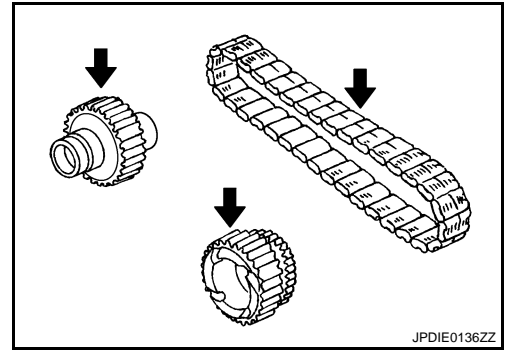

A
B
C

DLN

E
F
G
H
I
J
K
L
M
N
O
P

MAIN SHAFT

< UNIT DISASSEMBLY AND ASSEMBLY >

[TRANSFER: ETX13C]

MAIN SHAFT

Exploded View

INFOID:000000005649659

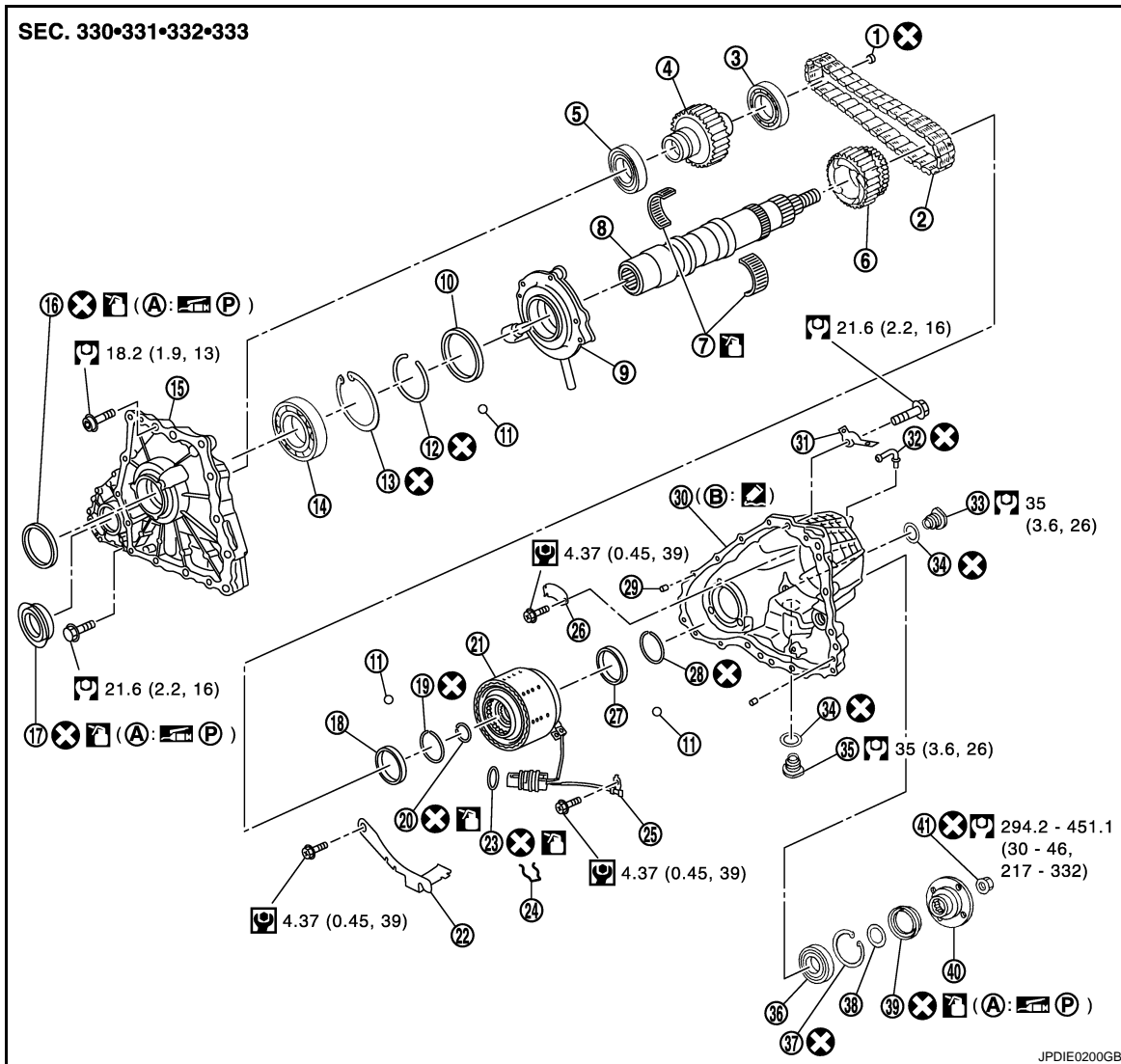

- | | | |
|---------------------------------------|-----------------------------------|------------------------------------|
| 1. Plug | 2. Drive chain | 3. Front drive shaft front bearing |
| 4. Front drive shaft | 5. Front drive shaft rear bearing | 6. Sprocket |
| 7. Needle bearing | 8. Main shaft | 9. Oil pump |
| 10. Spacer | 11. Steel ball | 12. Snap ring |
| 13. Snap ring | 14. Main shaft bearing | 15. Front case |
| 16. Main shaft oil seal | 17. Front oil seal | 18. Spacer |
| 19. Snap ring | 20. Circlip | 21. Electric controlled coupling |
| 22. Oil cover | 23. O-ring | 24. Retainer |
| 25. Transfer fluid temperature sensor | 26. Baffle plate | 27. Spacer |
| 28. Snap ring | 29. Dowel pin | 30. Rear case |
| 31. Harness bracket | 32. Breather tube | 33. Filler plug |
| 34. Gasket | 35. Drain plug | 36. Rear bearing |
| 37. Snap ring | 38. Spacer | 39. Rear oil seal |
| 40. Companion flange | 41. Self-lock nut | |
| A. Oil seal lip | B. Matching surface | |

: Apply Genuine Anaerobic Liquid Gasket or equivalent. Refer to [GI-18, "Recommended Chemical Products and Sealants"](#).

MAIN SHAFT

< UNIT DISASSEMBLY AND ASSEMBLY >

[TRANSFER: ETX13C]

: Apply petroleum jelly.

: Apply transfer fluid. Refer to [MA-10. "Fluids and Lubricants"](#).

Refer to [GI-4. "Components"](#) for symbols not described above.

Disassembly

INFOID:000000005649660

1. Separate front case and rear case, then remove main shaft assembly. Refer to [DLN-63. "Disassembly"](#).
2. Remove snap ring (1) from main shaft.

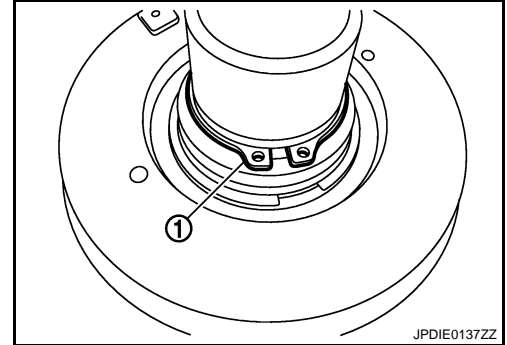

3. Remove spacer (1) and steel ball (2) from main shaft.
CAUTION:
Be careful not to drop the steel ball.

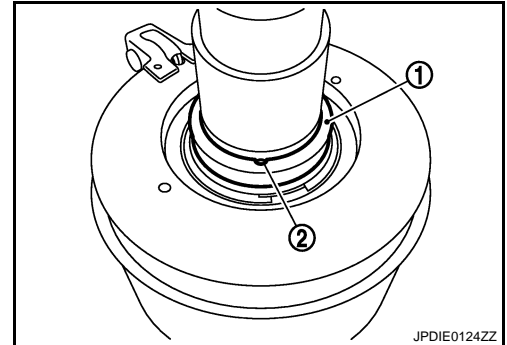

4. Using a press, remove electric controlled coupling from main shaft.

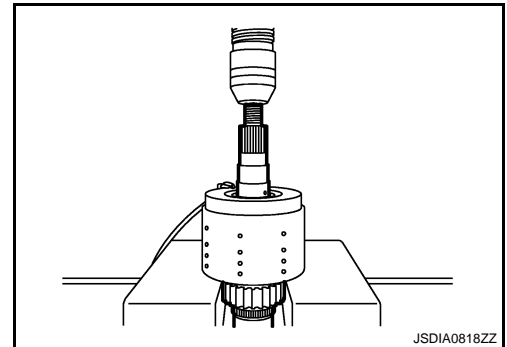

5. Remove circlip (1) from notch (A) of electric controlled coupling.

: Front side

CAUTION:

- Never remove the circlip from the electric controlled coupling rear side.
- Never damage electric control coupling spline, bush, etc.

6. Remove snap ring from main shaft.

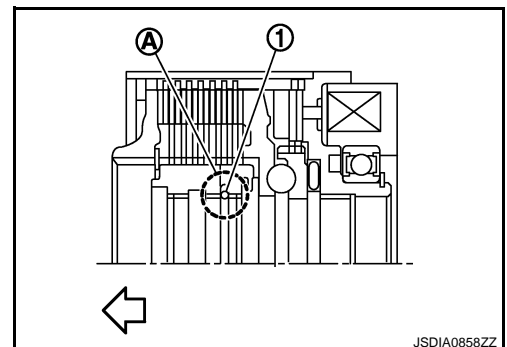

A
B
C
DLN
E
F
G
H
I
J
K
L
M
N
O
P

MAIN SHAFT

< UNIT DISASSEMBLY AND ASSEMBLY >

[TRANSFER: ETX13C]

7. Remove spacer (1) and steel ball (2) from main shaft.
CAUTION:
Be careful not to drop the steel ball.
8. Remove sprocket from main shaft.
9. Remove needle bearing from main shaft.

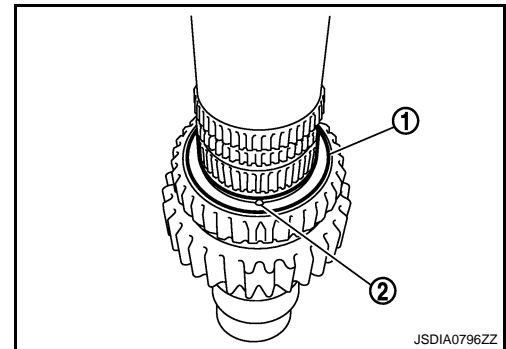

INFOID:000000005649661

Assembly

1. Install needle bearing to main shaft.
CAUTION:
Apply transfer fluid to the periphery of needle bearing.
2. Install sprocket to main shaft.
3. Install spacer (1) and steel ball (2) to main shaft.
CAUTION:
Be careful not to drop the steel ball.
4. Install snap ring to main shaft.
CAUTION:
Never reuse snap ring.

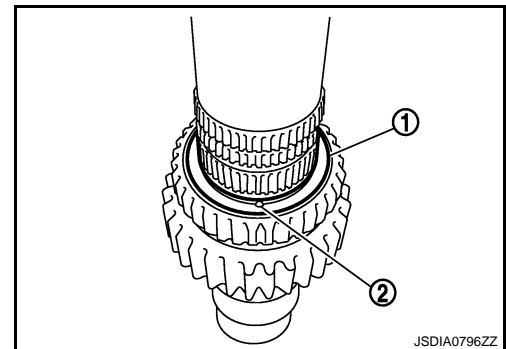

5. Install circlip (1) to notch (A) of the electric controlled coupling.

⇐:Front side

CAUTION:

- Never install the circlip to the notches other than notch (A).
- Never install the circlip from the electric controlled coupling rear side.
- Never reduce the outer diameter of circlip to less than 43.2 mm (1.701 in).
- Never damage electric control coupling spline, bush, etc.
- Never reuse circlip.

6. Install electric controlled coupling to main shaft.
CAUTION:
Securely insert it until locked.

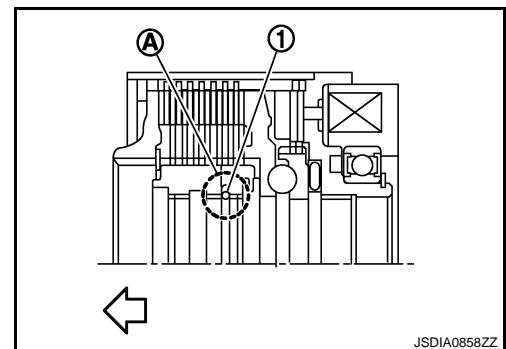

7. Install spacer (1) and steel ball (2) to main shaft.
CAUTION:
Be careful not to drop the steel ball.

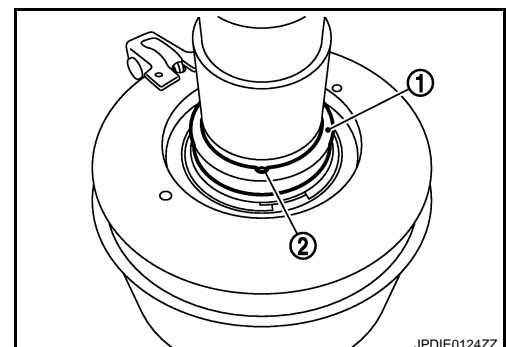

MAIN SHAFT

< UNIT DISASSEMBLY AND ASSEMBLY >

[TRANSFER: ETX13C]

8. Install snap ring (1) to main shaft.
CAUTION:
Never reuse snap ring.
9. Install main shaft assembly to rear case, then install front case and rear case. Refer to [DLN-66, "Assembly"](#).

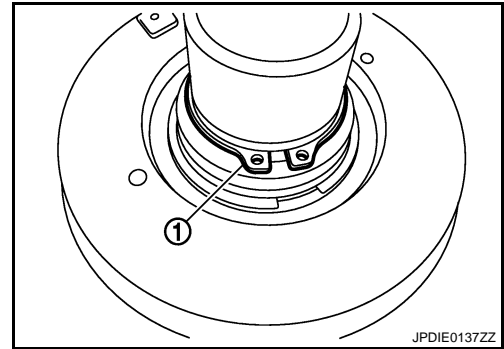

INFOID:000000005649662

Inspection

Check items below. If necessary, replace them with new ones.

CASES

- Contact surfaces of bearing for wear, damage, etc.
- Damage and cracks of case.

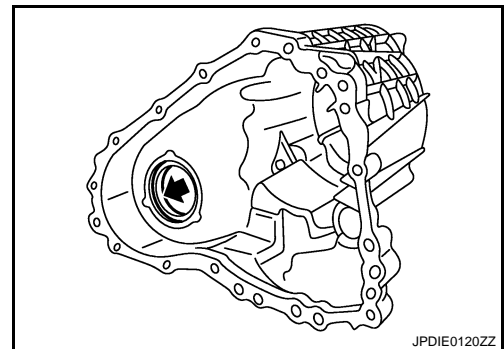

BEARING

Damage and rough rotation of bearing.

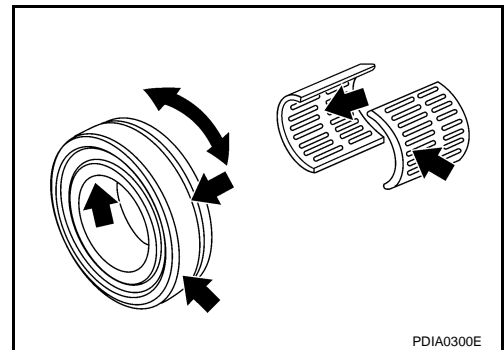

SHAFT

Damage, peeling, dent, uneven wear, bending, etc. of shaft.

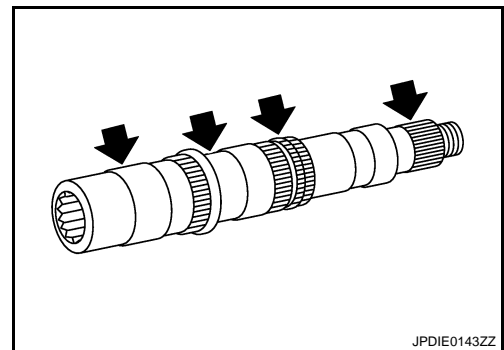

GEARS AND CHAIN

A
B
C
DLN
E
F
G
H
I
J
K
L
M
N
O
P

MAIN SHAFT

< UNIT DISASSEMBLY AND ASSEMBLY >

[TRANSFER: ETX13C]

Excessive wear, damage, peeling, etc. of gear and chain.

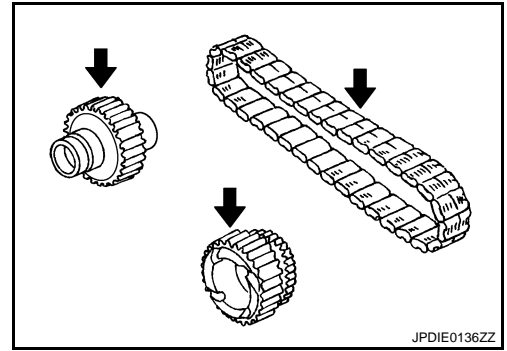

FRONT DRIVE SHAFT AND DRIVE CHAIN

< UNIT DISASSEMBLY AND ASSEMBLY >

[TRANSFER: ETX13C]

FRONT DRIVE SHAFT AND DRIVE CHAIN

Exploded View

INFOID:000000005649663

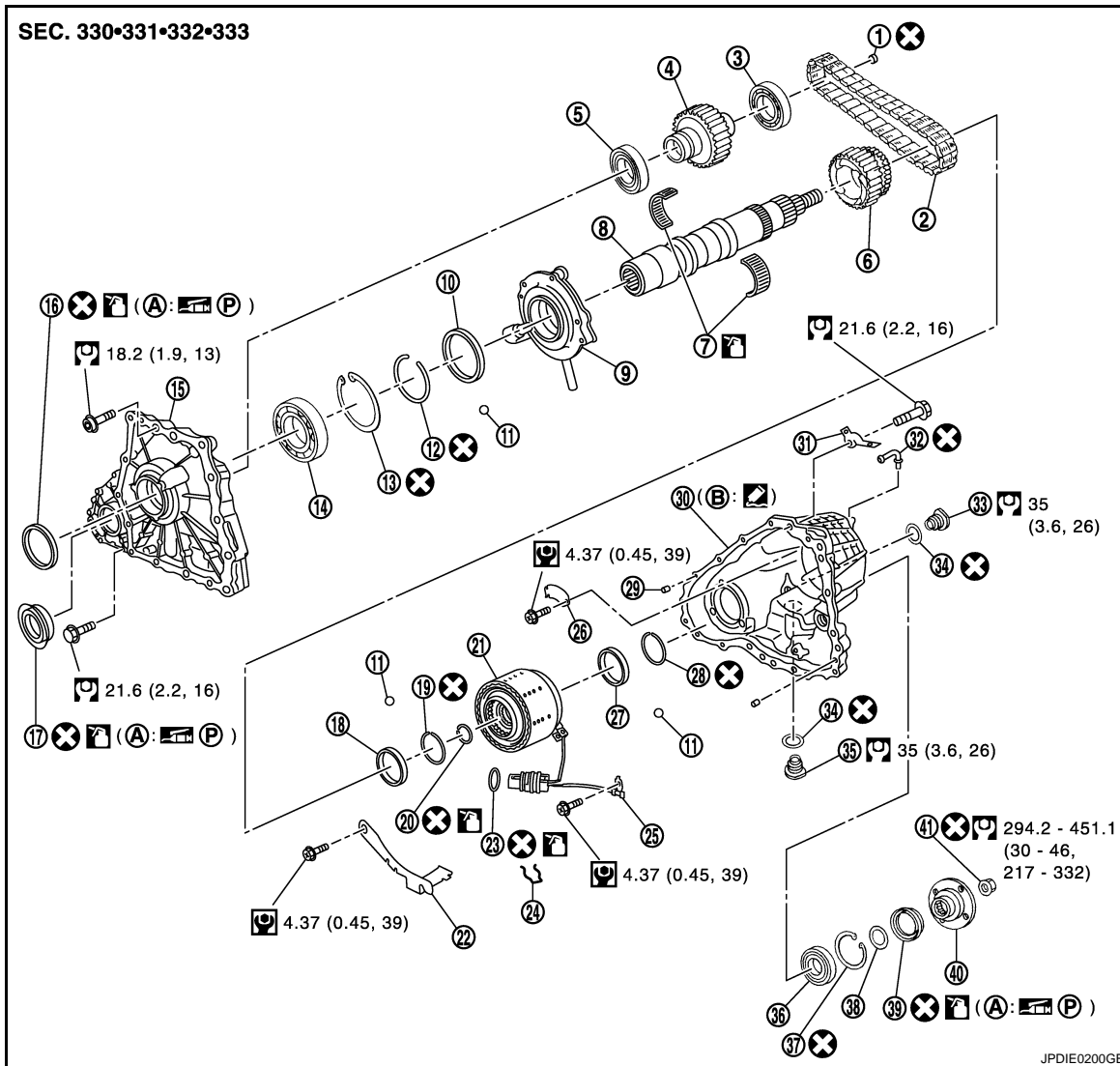

- | | | |
|---------------------------------------|-----------------------------------|------------------------------------|
| 1. Plug | 2. Drive chain | 3. Front drive shaft front bearing |
| 4. Front drive shaft | 5. Front drive shaft rear bearing | 6. Sprocket |
| 7. Needle bearing | 8. Main shaft | 9. Oil pump |
| 10. Spacer | 11. Steel ball | 12. Snap ring |
| 13. Snap ring | 14. Main shaft bearing | 15. Front case |
| 16. Main shaft oil seal | 17. Front oil seal | 18. Spacer |
| 19. Snap ring | 20. Circlip | 21. Electric controlled coupling |
| 22. Oil cover | 23. O-ring | 24. Retainer |
| 25. Transfer fluid temperature sensor | 26. Baffle plate | 27. Spacer |
| 28. Snap ring | 29. Dowel pin | 30. Rear case |
| 31. Harness bracket | 32. Breather tube | 33. Filler plug |
| 34. Gasket | 35. Drain plug | 36. Rear bearing |
| 37. Snap ring | 38. Spacer | 39. Rear oil seal |
| 40. Companion flange | 41. Self-lock nut | |
| A. Oil seal lip | B. Matching surface | |

 Apply Genuine Anaerobic Liquid Gasket or equivalent. Refer to [GI-18, "Recommended Chemical Products and Sealants"](#).

FRONT DRIVE SHAFT AND DRIVE CHAIN

< UNIT DISASSEMBLY AND ASSEMBLY >

[TRANSFER: ETX13C]

: Apply petroleum jelly.

: Apply transfer fluid. Refer to [MA-10. "Fluids and Lubricants"](#).

Refer to [GI-4. "Components"](#) for symbols not described above.

Disassembly

INFOID:000000005649664

1. Separate front case and rear case. Refer to [DLN-63. "Disassembly"](#).
2. Remove drive chain and front drive shaft.

CAUTION:

Never use tools. Always remove by hand.

3. Remove front drive shaft rear bearing with the drift (A) and replacer (B).

A: Drift [SST: ST31214000 (J-25269-B)]

B: replacer (commercial service tool)

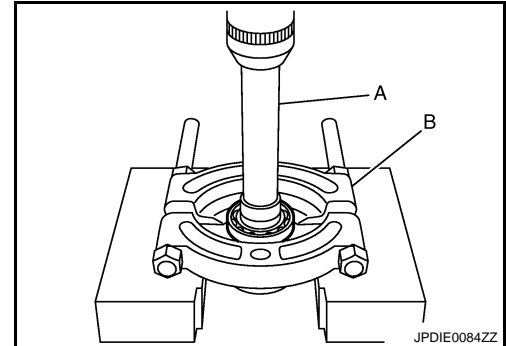

4. Remove front drive shaft front bearing with the drift (A) and replacer (B).

A: Drift [SST: ST31214000 (J-25269-B)]

B: replacer (commercial service tool)

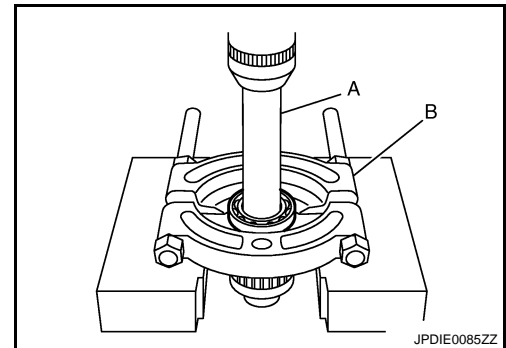

5. Remove plug from front drive shaft.

Assembly

INFOID:000000005649665

1. Install plug to front drive shaft.

CAUTION:

Never reuse plug.

2. Install front drive shaft rear bearing with the drift (A) [SST: ST33200000 (J-26082)].

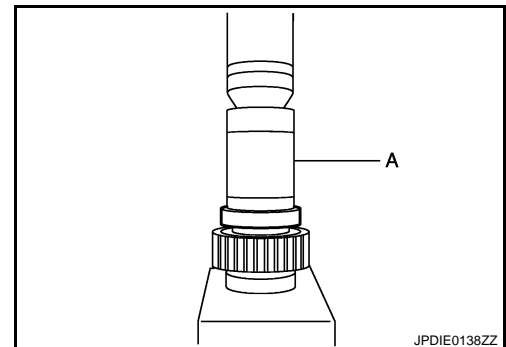

FRONT DRIVE SHAFT AND DRIVE CHAIN

< UNIT DISASSEMBLY AND ASSEMBLY >

[TRANSFER: ETX13C]

3. Install front drive shaft front bearing with the drift (A) [SST: KV38104010 (—)].

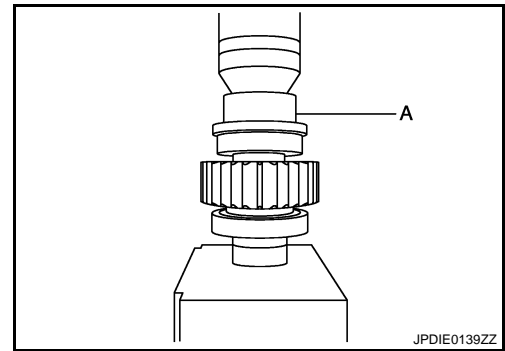

4. Set drive chain to front drive shaft.
CAUTION:
Identification mark (A) of drive chain should be in the side of front bearing (1) of front drive shaft.
5. Install drive chain to main shaft, and then install front drive shaft.
CAUTION:
Never use tools. Always install by hand.
6. Install front case to rear case. Refer to [DLN-66, "Assembly"](#).

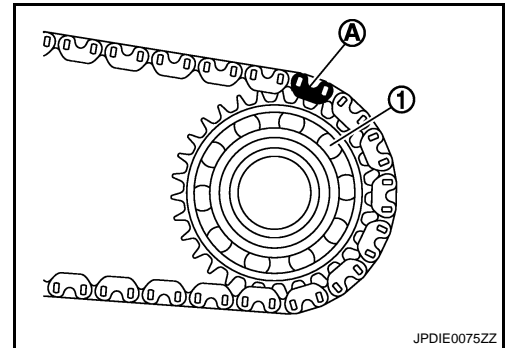

INFOID:000000005649666

Inspection

Check items below. If necessary, replace them with new ones.

CASES

- Contact surfaces of bearing for wear, damage, etc.
- Damage and cracks of case.

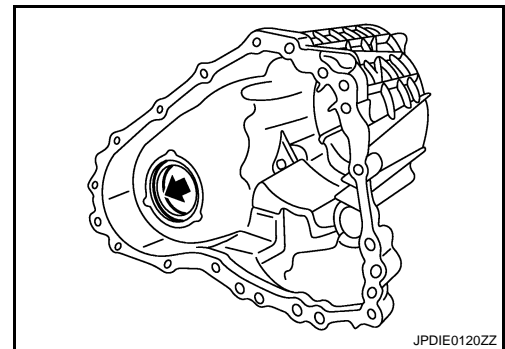

BEARING

Damage and rough rotation of bearing.

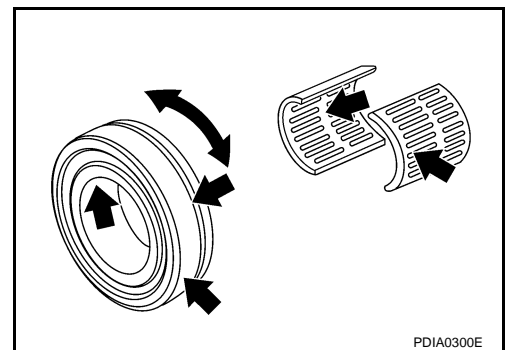

SHAFT

FRONT DRIVE SHAFT AND DRIVE CHAIN

< UNIT DISASSEMBLY AND ASSEMBLY >

[TRANSFER: ETX13C]

Damage, peeling, dent, uneven wear, bending, etc. of shaft.

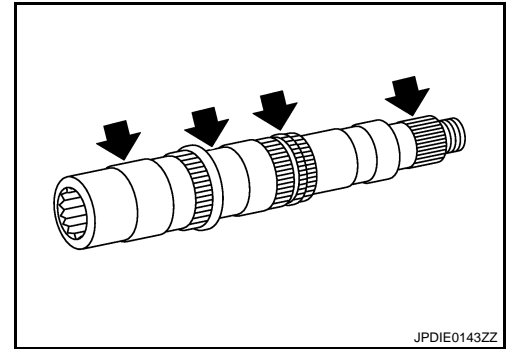

GEARS AND CHAIN

Excessive wear, damage, peeling, etc. of gear and chain.

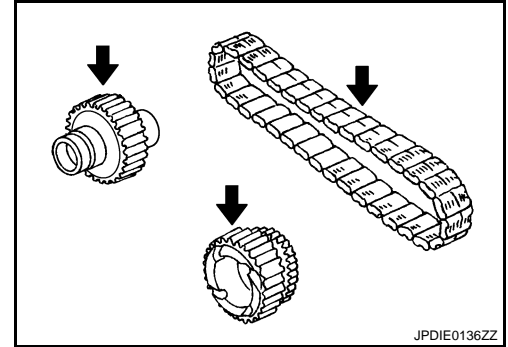

SERVICE DATA AND SPECIFICATIONS (SDS)

< SERVICE DATA AND SPECIFICATIONS (SDS)

[TRANSFER: ETX13C]

SERVICE DATA AND SPECIFICATIONS (SDS)

SERVICE DATA AND SPECIFICATIONS (SDS)

General Specifications

INFOID:000000005649667

Applied model	AWD
	VQ37VHR
	A/T
Transfer model	ETX13C
Fluid capacity (Approx.)	<i>ℓ</i> (US pt, Imp pt) 1.0 (2-1/8, 1-3/4)

A

B

C

DLN

E

F

G

H

I

J

K

L

M

N

O

P

NOISE, VIBRATION AND HARSHNESS (NVH) TROUBLESHOOTING

< SYMPTOM DIAGNOSIS >

[FRONT PROPELLER SHAFT: 2S56A]

SYMPTOM DIAGNOSIS

NOISE, VIBRATION AND HARSHNESS (NVH) TROUBLESHOOTING

NVH Troubleshooting Chart

INFOID:000000005649668

Use the chart below to find the cause of the symptom. If necessary, repair or replace these parts.

Symptom		Possible cause and SUSPECTED PARTS													
		Uneven rotating torque	Center bearing improper installation	Excessive center bearing axial end play	Center bearing mounting (insulator) cracks, damage or deterioration	Excessive joint angle	Rotation imbalance	Excessive runout	DIFFERENTIAL	AXLE AND SUSPENSION	TIRE	ROAD WHEEL	DRIVE SHAFT	BRAKE	STEERING
Reference	Noise	DLN-84, "Inspection"	—	—	—	—	DLN-84, "Inspection"	DLN-84, "Inspection"	NVH in DLN section.	NVH in FAX, RAX, FSU and RSU section.	NVH in WT section.	NVH in WT section.	NVH in FAX and RAX section.	NVH in BR section.	NVH in ST section.
	Shake														
	Vibration	x	x	x	x	x	x	x	x	x	x	x	x	x	x

x: Applicable

PREPARATION

< PREPARATION >

[FRONT PROPELLER SHAFT: 2S56A]

PREPARATION

PREPARATION

Commercial Service Tools

INFOID:000000005649669

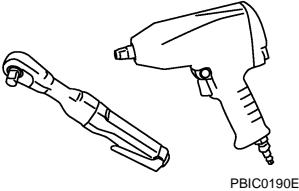
Tool name	Description
<p data-bbox="162 411 276 438">Power tool</p>  <p data-bbox="852 632 922 646">PBIC0190E</p>	<p data-bbox="1015 411 1263 438">Loosening bolts and nuts</p>

A

B

C

DLN

E

F

G

H

I

J

K

L

M

N

O

P

FRONT PROPELLER SHAFT

< PERIODIC MAINTENANCE >

[FRONT PROPELLER SHAFT: 2S56A]

PERIODIC MAINTENANCE

FRONT PROPELLER SHAFT

Inspection

INFOID:000000005649670

NOISE

Check the propeller shaft tube surface for dents or cracks. If damaged, replace propeller shaft assembly.

VIBRATION

If vibration is present at high speed, inspect propeller shaft runout first.

1. With a dial indicator, measure propeller shaft runout at runout measuring points by rotating final drive companion flange with hands.

←: Vehicle front

Limit

Propeller shaft runout : Refer to [DLN-88, "Propeller Shaft Runout"](#).

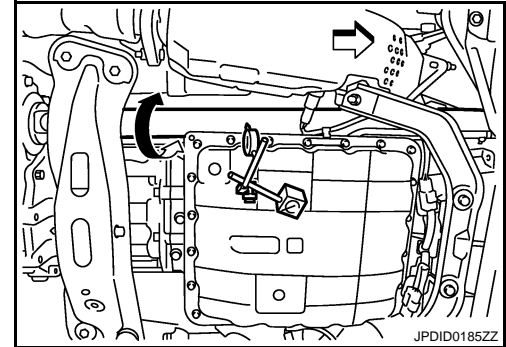

2. If runout still exceeds specifications, separate propeller shaft at final drive companion flange; then rotate companion flange 90, 180, 270 degrees and install propeller shaft.
3. Check runout again. If runout still exceeds specifications, replace propeller shaft assembly.
4. Check the vibration by driving vehicle.

RUNOUT MEASURING POINT

Propeller shaft runout measuring point (Point "△").

Standard

A : 381.5 mm (15.02 in)

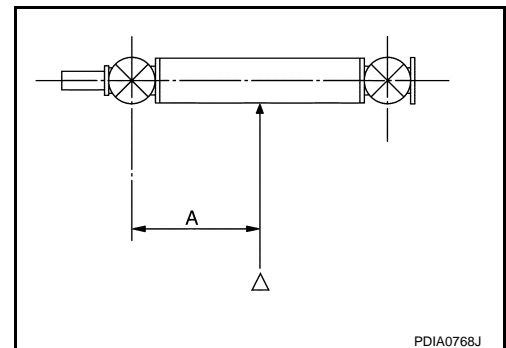

FRONT PROPELLER SHAFT

< REMOVAL AND INSTALLATION >

[FRONT PROPELLER SHAFT: 2S56A]

8. Remove propeller shaft assembly from the front final drive and transfer.

⇐: Vehicle front

CAUTION:

- Never damage the transfer front oil seal.
- Wrap transmission interference area (A) with shop cloth or equivalent to protect propeller shaft from damage.

9. Remove propeller shaft assembly from O-ring.
10. Remove heat bracket.

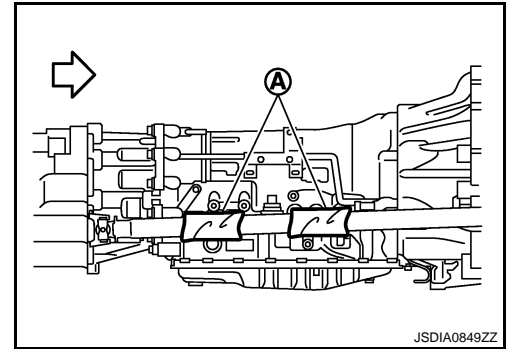

INSTALLATION

Note the following, and install in the reverse order of removal.

- Align matching mark to install propeller shaft assembly to final drive companion flange.
- After assembly, perform a driving test to check propeller shaft vibration. If vibration occurred, separate propeller shaft from final drive. Reinstall companion flange after rotating it by 90, 180, 270 degrees. Then perform driving test and check propeller shaft vibration again at each point.

CAUTION:

- Never damage the transfer front oil seal.
- Wrap power steering piping interference area with shop cloth or equivalent to protect power steering piping from damage.

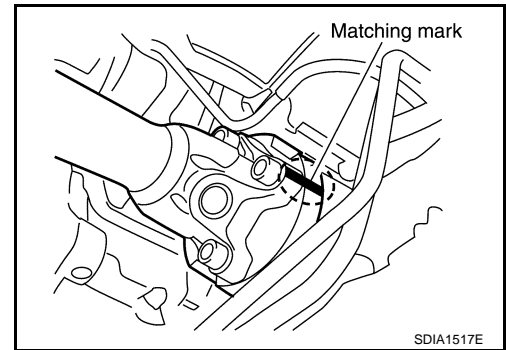

- Wrap transmission interference area (A) with shop cloth or equivalent to protect propeller shaft from damage.

⇐: Vehicle front

- Never reuse O-ring.
- Apply multi-purpose grease onto O-ring.

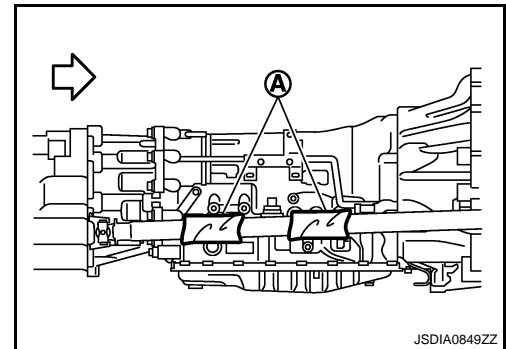

Inspection

INFOID:000000005649673

APPEARANCE

Check propeller shaft for bend and damage. If damage is detected, replace propeller shaft assembly.

PROPELLER SHAFT RUNOUT

Check propeller shaft runout at measuring point with a dial indicator. If runout exceeds specifications, replace propeller shaft assembly. For measuring point, refer to [DLN-84, "Inspection"](#).

Limit

Propeller shaft runout

: Refer to [DLN-88, "Propeller Shaft Runout"](#).

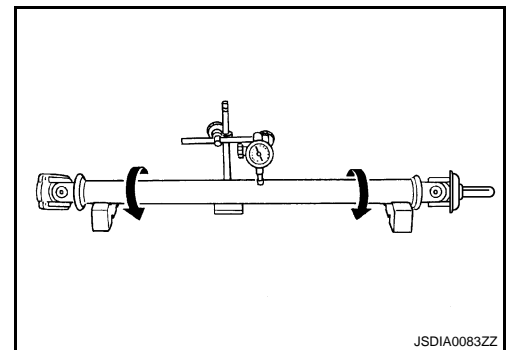

JOURNAL AXIAL PLAY

FRONT PROPELLER SHAFT

< REMOVAL AND INSTALLATION >

[FRONT PROPELLER SHAFT: 2S56A]

As shown in the figure, while fixing yoke on one side, check axial play of joint. If it is outside the standard, replace propeller shaft assembly.

Standard

Journal axial play

: Refer to [DLN-88, "Journal Axial Play"](#).

CAUTION:

Never disassemble joints.

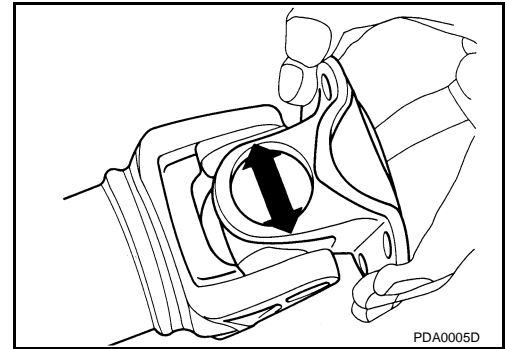

A
B
C

DLN

E
F
G
H
I
J
K
L
M
N
O
P

SERVICE DATA AND SPECIFICATIONS (SDS)

< SERVICE DATA AND SPECIFICATIONS (SDS)

[FRONT PROPELLER SHAFT: 2S56A]

SERVICE DATA AND SPECIFICATIONS (SDS)

SERVICE DATA AND SPECIFICATIONS (SDS)

General Specifications

INFOID:000000005649674

Applied model	AWD
	VQ37VHR
	A/T
Propeller shaft model	2S56A
Number of joints	2
Type of journal bearings (Non-disassembly type)	Shell type
Coupling method with transfer	Sleeve type
Coupling method with front final drive	Flange type
Shaft length (Spider to spider)	763 mm (30.04 in)
Shaft outer diameter	42.7 mm (1.681 in)

Propeller Shaft Runout

INFOID:000000005649675

Unit: mm (in)

Item	Limit
Propeller shaft runout	0.8 (0.031)

Journal Axial Play

INFOID:000000005649676

Unit: mm (in)

Item	Standard
Journal axial play	0 (0)

NOISE, VIBRATION AND HARSHNESS (NVH) TROUBLESHOOTING

< SYMPTOM DIAGNOSIS >

[REAR PROPELLER SHAFT: 3S80A]

SYMPTOM DIAGNOSIS

NOISE, VIBRATION AND HARSHNESS (NVH) TROUBLESHOOTING

NVH Troubleshooting Chart

INFOID:000000005649677

Use the chart below to find the cause of the symptom. If necessary, repair or replace these parts.

Symptom		Possible cause and SUSPECTED PARTS													
		Uneven rotating torque	Center bearing improper installation	Excessive center bearing axial end play	Center bearing mounting (insulator) cracks, damage or deterioration	Excessive joint angle	Rotation imbalance	Excessive runout	DIFFERENTIAL	AXLE AND SUSPENSION	TIRE	ROAD WHEEL	DRIVE SHAFT	BRAKE	STEERING
Noise	Noise	x	x	x	x	x	x	x	x	x	x	x	x	x	x
	Shake		x			x				x	x	x	x	x	
	Vibration	x	x	x	x	x	x	x		x		x			x
Reference		DLN-91, "Inspection"	DLN-94, "Inspection"	—	DLN-94, "Inspection"	—	DLN-94, "Inspection"	DLN-94, "Inspection"	NVH in DLN section.	NVH in FAX, RAX, FSU and RSU section.	NVH in WT section.	NVH in WT section.	NVH in RAX section.	NVH in BR section.	NVH in ST section.

x: Applicable

A
B
C
DLN
E
F
G
H
I
J
K
L
M
N
O
P

PREPARATION

< PREPARATION >

[REAR PROPELLER SHAFT: 3S80A]

PREPARATION

PREPARATION

Commercial Service Tools

INFOID:000000005649678

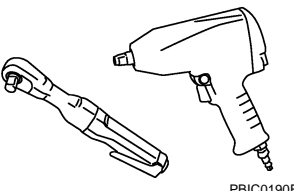
Tool name	Description
Power tool  PBIC0190E	Loosening bolts and nuts

REAR PROPELLER SHAFT

< PERIODIC MAINTENANCE >

[REAR PROPELLER SHAFT: 3S80A]

PERIODIC MAINTENANCE

REAR PROPELLER SHAFT

Inspection

INFOID:000000005649679

NOISE

- Check the propeller shaft tube surface for dents or cracks. If damaged, replace propeller shaft assembly.
- If center bearing is noisy or damaged, replace propeller shaft assembly.

VIBRATION

If vibration is present at high speed, inspect propeller shaft runout first.

1. Measure propeller shaft runout at several points by rotating final drive companion flange with hands.

Limit

Propeller shaft runout : Refer to [DLN-96. "Propeller Shaft Runout"](#).

2. If runout still exceeds specifications, separate propeller shaft at final drive companion flange; then rotate companion flange 90, 180, 270 degrees and install propeller shaft.
3. Check runout again. If runout still exceeds specifications, replace propeller shaft assembly.
4. Check the vibration by driving vehicle.

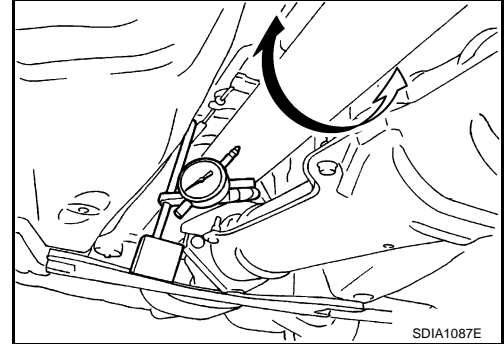

RUNOUT MEASURING POINT

Propeller shaft runout measuring point (Point "△").

←: Vehicle front

Dimension

A: 192 mm (7.56 in)

B: 172 mm (6.77 in)

C: 170 mm (6.69 in)

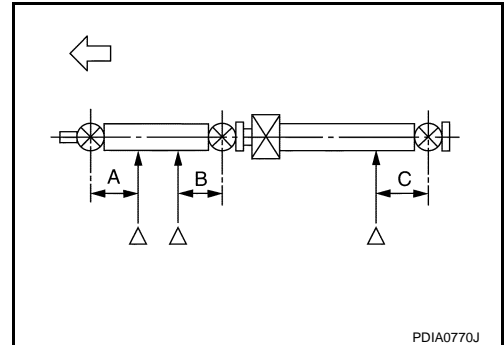

A
B
C
DLN
E
F
G
H
I
J
K
L
M
N
O
P

REAR PROPELLER SHAFT

< REMOVAL AND INSTALLATION >

[REAR PROPELLER SHAFT: 3S80A]

REMOVAL AND INSTALLATION

REAR PROPELLER SHAFT

Exploded View

INFOID:000000005649680

2nd joint connecting type : Flange connection

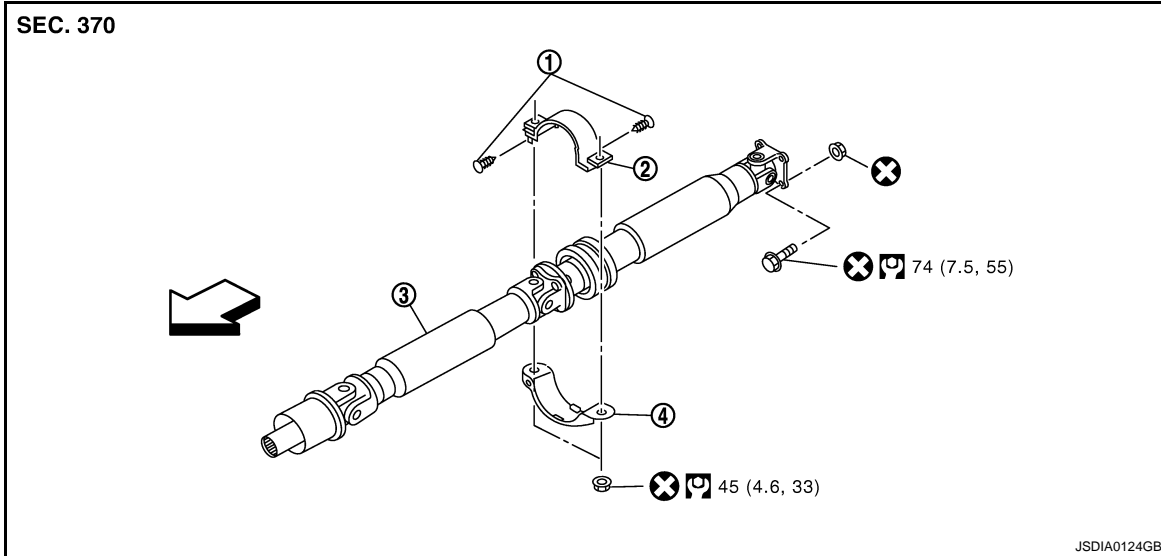

1. Clip
2. Center bearing mounting bracket (upper)
3. Propeller shaft assembly
4. Center bearing mounting bracket (lower)

⇐: Vehicle front

Refer to [GI-4. "Components"](#) for symbols in the figure.

2nd joint connecting type : Stem connection

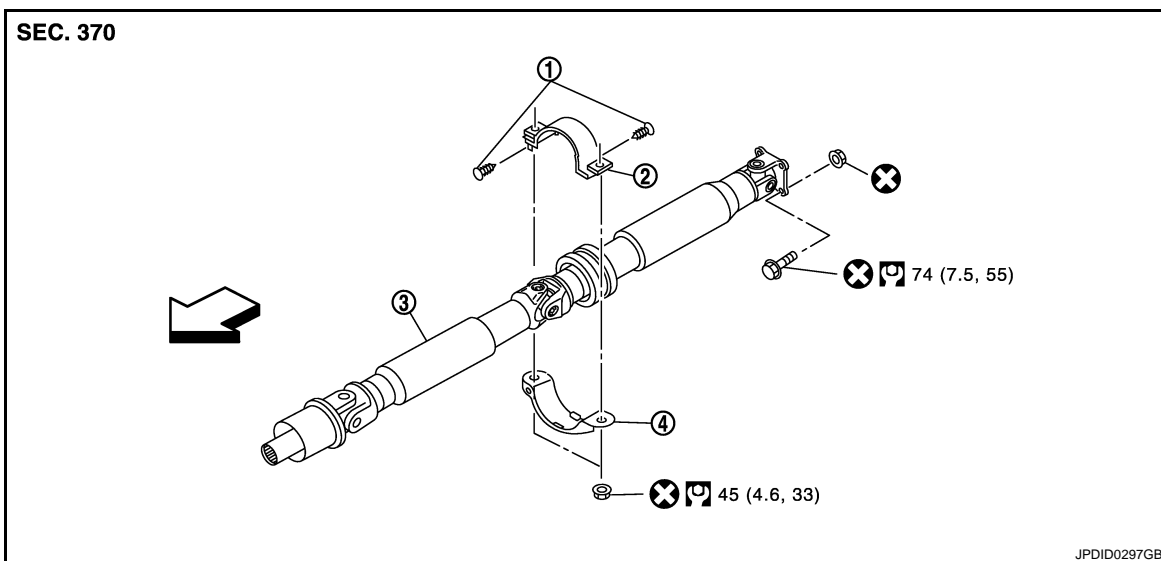

1. Clip
2. Center bearing mounting bracket (upper)
3. Propeller shaft assembly
4. Center bearing mounting bracket (lower)

REAR PROPELLER SHAFT

< REMOVAL AND INSTALLATION >

[REAR PROPELLER SHAFT: 3S80A]

↶: Vehicle front

Refer to [GI-4, "Components"](#) for symbols in the figure.

Removal and Installation

INFOID:000000005649681

REMOVAL

1. Move the M/T shift lever to neutral position and release the parking brake.
2. Remove the floor reinforcement.
3. Remove the center muffler with power tool. Refer to [EX-5, "Exploded View"](#).
4. Remove the heat plate (1).

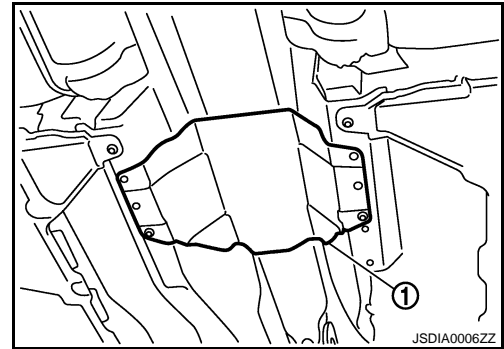

5. Put matching marks on propeller shaft flange yoke with final drive companion flange.

CAUTION:

For matching marks, use paint. Never damage propeller shaft flange yoke and final drive companion flange.

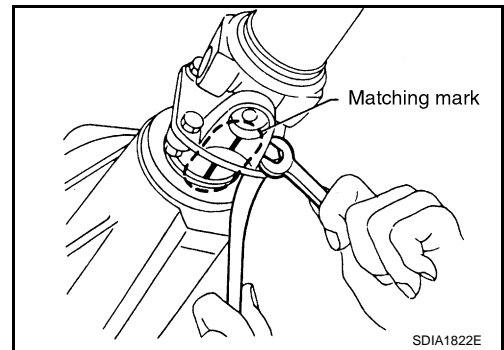

6. Loosen mounting nuts of center bearing mounting brackets.

CAUTION:

Tighten mounting nuts temporarily.

7. Remove propeller shaft assembly fixing bolts and nuts.
8. Remove center bearing mounting bracket fixing nuts.
9. Remove propeller shaft assembly.

CAUTION:

- Never damage the rear oil seal of transmission.
- If constant velocity joint was bent during propeller shaft assembly removal, installation, or transportation, its boot may be damaged. Wrap boot interference area to metal part with shop cloth or rubber to protect boot from breakage.

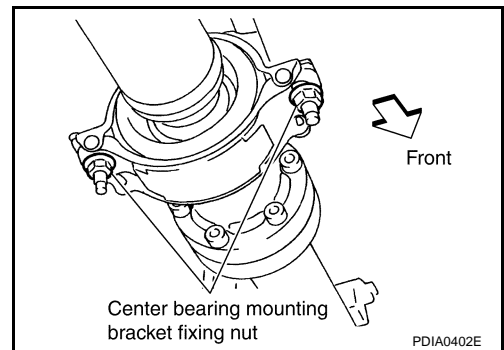

INSTALLATION

Note the following, and install in the reverse order of removal.

A
B
C
DLN
E
F
G
H
I
J
K
L
M
N
O
P

REAR PROPELLER SHAFT

< REMOVAL AND INSTALLATION >

[REAR PROPELLER SHAFT: 3S80A]

- Install center bearing mounting bracket (upper) (1) with its arrow mark (A) facing forward.
- Adjust position of center bearing mounting bracket (upper) (1) and center bearing mounting bracket (lower) (2) sliding back and forth to prevent play in thrust direction of center bearing insulator (3). Install bracket to vehicle.

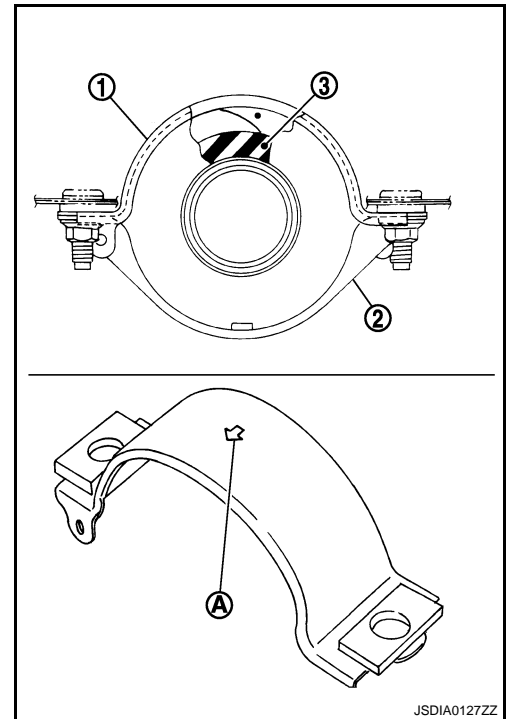

- Align matching marks to install propeller shaft flange yoke with final drive companion flange.
- After assembly, perform a driving test to check propeller shaft vibration. If vibration occurred, separate propeller shaft from final drive. Reinstall companion flange after rotating it by 90, 180, 270 degrees. Then perform driving test and check propeller shaft vibration again at each point.

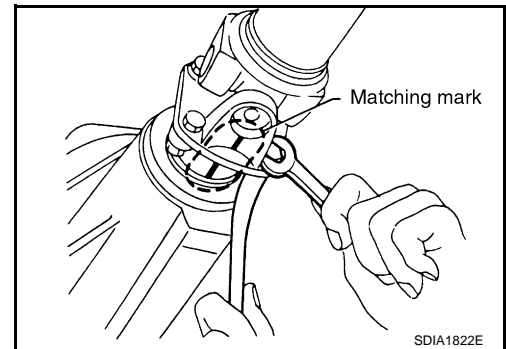

- If propeller shaft or final drive has been replaced, connect them as follows:
 - Install the propeller shaft while aligning its matching mark (A) with the matching mark (B) on the joint as close as possible.

CAUTION:

Never damage the rear oil seal of transmission.

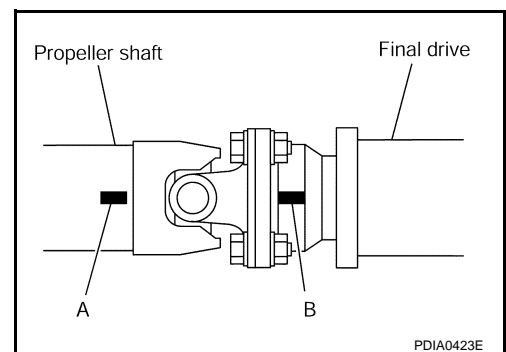

Inspection

APPEARANCE

- Check propeller shaft for bend and damage. If damage is detected, replace propeller shaft assembly.

PROPELLER SHAFT RUNOUT

INFOID:000000005649682

REAR PROPELLER SHAFT

< REMOVAL AND INSTALLATION >

[REAR PROPELLER SHAFT: 3S80A]

- Check propeller shaft runout at measuring points. If runout exceeds specifications, replace propeller shaft assembly. For measuring point, refer to [DLN-91, "Inspection"](#).

Limit

Propeller shaft runout : Refer to [DLN-96, "Propeller Shaft Runout"](#).

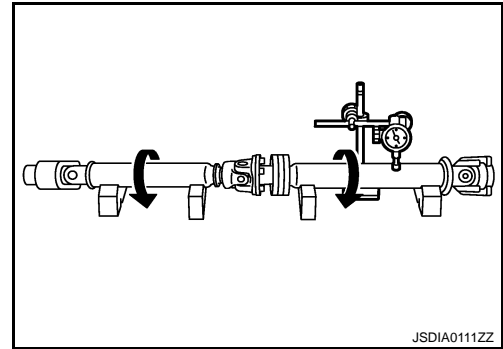

JOURNAL AXIAL PLAY

- As shown in the figure, while fixing yoke on one side, check axial play of joint. If outside the standard, replace propeller shaft assembly.

Standard

Journal axial play : Refer to [DLN-96, "Journal Axial Play"](#).

CAUTION:

Never disassemble joints.

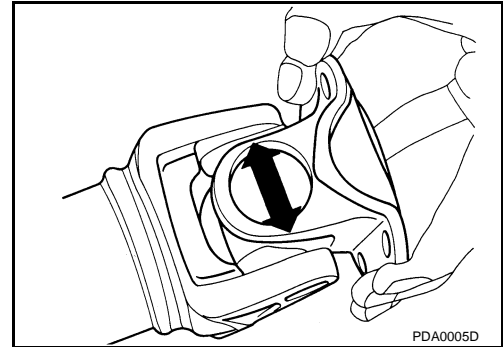

CENTER BEARING

- Check center bearing for noise and damage. If noise or damage is detected, replace propeller shaft assembly.

CAUTION:

Never disassemble center bearing.

A
B
C
DLN
E
F
G
H
I
J
K
L
M
N
O
P

SERVICE DATA AND SPECIFICATIONS (SDS)

< SERVICE DATA AND SPECIFICATIONS (SDS)

[REAR PROPELLER SHAFT: 3S80A]

SERVICE DATA AND SPECIFICATIONS (SDS)

SERVICE DATA AND SPECIFICATIONS (SDS)

General Specifications

INFOID:000000005649683

2nd joint connecting type : Flange connection

Applied model		2WD
		VQ37VHR
		M/T
Propeller shaft model		3S80A
Number of joints		3
Type of journal bearings (Non-disassembly type)	1st joint	Shell type
	2nd joint	Shell type
	3rd joint	Shell type
Coupling method with transmission		Sleeve type
Coupling method with rear final drive		Flange type
Shaft length	1st (Spider to spider)	762 mm (30.00 in)
	2nd (Spider to spider)	759 mm (29.88 in)
Shaft outer diameter	1st	82.6 mm (3.25 in)
	2nd	75.0 mm (2.95 in)

2nd joint connecting type : Stem connection

Applied model		2WD
		VQ37VHR
		M/T
Propeller shaft model		3S80A
Number of joints		3
Type of journal bearings (Non-disassembly type)	1st joint	Shell type
	2nd joint	Shell type
	3rd joint	Shell type
Coupling method with transmission		Sleeve type
Coupling method with rear final drive		Flange type
Shaft length	1st (Spider to spider)	779 mm (30.67 in)
	2nd (Spider to spider)	742 mm (29.21 in)
Shaft outer diameter	1st	82.6 mm (3.25 in)
	2nd	75.0 mm (2.95 in)

Propeller Shaft Runout

INFOID:000000005649684

Unit: mm (in)

Item	Limit
Propeller shaft runout	0.8 (0.031)

Journal Axial Play

INFOID:000000005649685

Unit: mm (in)

Item	Standard
Journal axial play	0 (0)

NOISE, VIBRATION AND HARSHNESS (NVH) TROUBLESHOOTING

< SYMPTOM DIAGNOSIS >

[REAR PROPELLER SHAFT: 3S80A-R]

SYMPTOM DIAGNOSIS

NOISE, VIBRATION AND HARSHNESS (NVH) TROUBLESHOOTING

NVH Troubleshooting Chart

INFOID:000000005649686

Use the chart below to find the cause of the symptom. If necessary, repair or replace these parts.

Symptom	Possible cause and SUSPECTED PARTS														
	Noise	DLN-99, "Inspection"	DLN-103, "Inspection"	—	DLN-103, "Inspection"	—	DLN-103, "Inspection"	DLN-103, "Inspection"	NVH in DLN section.	NVH in FAX, RAX, FSU and RSU section.	NVH in WT section.	NVH in WT section.	NVH in RAX section.	NVH in BR section.	NVH in ST section.
		Uneven rotating torque	Center bearing improper installation	Excessive center bearing axial end play	Center bearing mounting (insulator) cracks, damage or deterioration	Excessive joint angle	Rotation imbalance	Excessive runout	DIFFERENTIAL	AXLE AND SUSPENSION	TIRE	ROAD WHEEL	DRIVE SHAFT	BRAKE	STEERING
		×	×	×	×	×	×	×	×	×	×	×	×	×	×
	Shake		×			×				×	×	×	×	×	×
	Vibration	×	×	×	×	×	×	×		×	×		×		×

×: Applicable

A
B
C
DLN
E
F
G
H
I
J
K
L
M
N
O
P

PREPARATION

< PREPARATION >

[REAR PROPELLER SHAFT: 3S80A-R]

PREPARATION

PREPARATION

Commercial Service Tools

INFOID:000000005649687

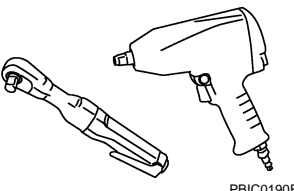
Tool name	Description
Power tool  PBIC0190E	Loosening bolts and nuts

REAR PROPELLER SHAFT

< PERIODIC MAINTENANCE >

[REAR PROPELLER SHAFT: 3S80A-R]

PERIODIC MAINTENANCE

REAR PROPELLER SHAFT

Inspection

INFOID:000000005649688

NOISE

- Check the propeller shaft tube surface for dents or cracks. If damaged, replace propeller shaft assembly.
- If center bearing is noisy or damaged, replace propeller shaft assembly.

VIBRATION

If vibration is present at high speed, inspect propeller shaft runout first.

1. Measure propeller shaft runout at several points by rotating final drive companion flange with hands.

Limit

Propeller shaft runout : Refer to [DLN-104, "Propeller Shaft Runout"](#).

2. If runout still exceeds specifications, separate propeller shaft at final drive companion flange; then rotate companion flange 120, 240 degrees and install propeller shaft.
3. Check runout again. If runout still exceeds specifications, replace propeller shaft assembly.
4. Check the vibration by driving vehicle.

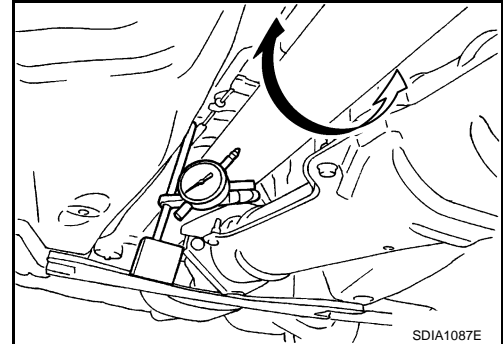

RUNOUT MEASURING POINT

Propeller shaft runout measuring point (Point "△").

←: Vehicle front

Dimension

A: 192 mm (7.56 in)

B: 172 mm (6.77 in)

C: 172 mm (6.77 in)

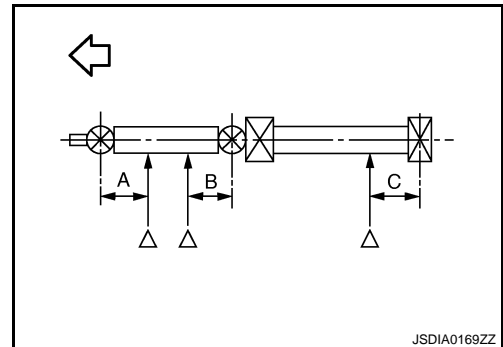

A
B
C
DLN
E
F
G
H
I
J
K
L
M
N
O
P

REAR PROPELLER SHAFT

< REMOVAL AND INSTALLATION >

[REAR PROPELLER SHAFT: 3S80A-R]

REMOVAL AND INSTALLATION

REAR PROPELLER SHAFT

Exploded View

INFOID:000000005649689

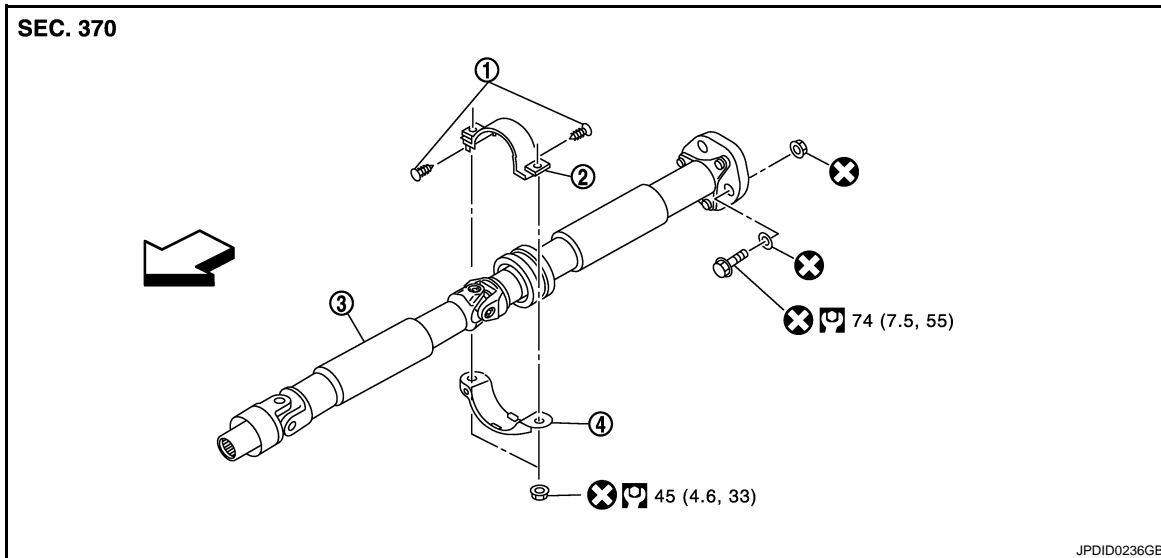

1. Clip
2. Center bearing mounting bracket (upper)
3. Propeller shaft assembly
4. Center bearing mounting bracket (lower)

↔: Vehicle front

Refer to [GI-4, "Components"](#) for symbols in the figure.

Removal and Installation

INFOID:000000005649690

REMOVAL

1. Move the A/T selector lever to N position and release the parking brake.
2. Remove the floor reinforcement.
3. Remove the center muffler with power tool. Refer to [GI-4, "Components"](#).
4. Remove the heat plate (1).

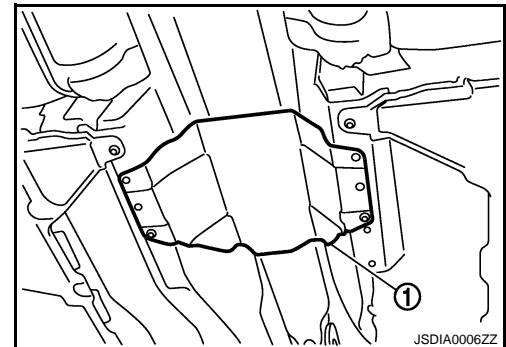

REAR PROPELLER SHAFT

< REMOVAL AND INSTALLATION >

[REAR PROPELLER SHAFT: 3S80A-R]

5. Put matching marks on propeller shaft rubber coupling with final drive companion flange.

CAUTION:

For matching marks, use paint. Never damage propeller shaft rubber coupling and final drive companion flange.

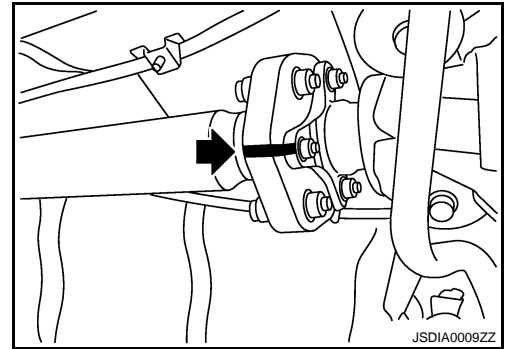

6. Loosen mounting nuts of center bearing mounting brackets.

CAUTION:

Tighten mounting nuts temporarily.

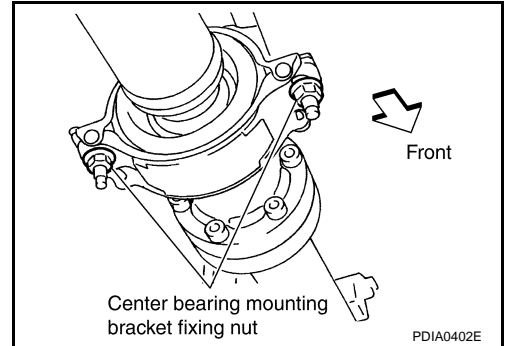

7. Remove propeller shaft assembly fixing bolts and nuts.

CAUTION:

Never remove the rubber coupling from the propeller shaft assembly.

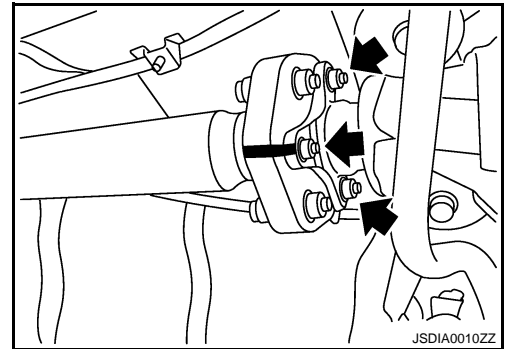

8. Slightly separate the rubber coupling (1) from the final drive companion flange (2).

CAUTION:

Never damage the final drive companion flange and rubber coupling.

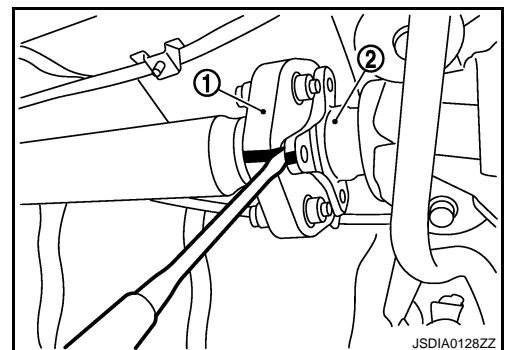

9. Remove center bearing mounting bracket fixing nuts.

CAUTION:

- The angle (A), which the third axis rubber coupling (1) forms with the final drive companion flange (2), must be 5° or less.
- Never damage the grease seal (3).
- Never damage the rubber coupling.

10. Slide the propeller shaft in the vehicle forward direction slightly. Separate the propeller shaft from the final drive companion flange.

CAUTION:

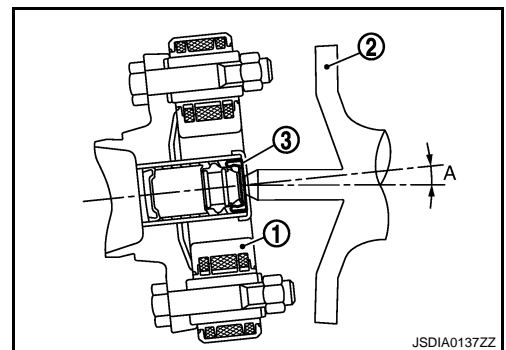

A

B

C

DLN

E

F

G

H

I

J

K

L

M

N

O

P

REAR PROPELLER SHAFT

< REMOVAL AND INSTALLATION >

[REAR PROPELLER SHAFT: 3S80A-R]

- The angle, which the third axis rubber coupling forms with the final drive companion flange, must be 5° or less.
- Never damage the grease seal.
- Never damage the rubber coupling.

11. Remove the propeller shaft assembly from the vehicle.

CAUTION:

Never damage the rear oil seal of transmission.

INSTALLATION

Note the following, and install in the reverse order of removal.

- Install center bearing mounting bracket (upper) (1) with its arrow mark (A) facing forward.
- Adjust position of center bearing mounting bracket (upper) (1) and center bearing mounting bracket (lower) (2) sliding back and forth to prevent play in thrust direction of center bearing insulator (3). Install bracket to vehicle.

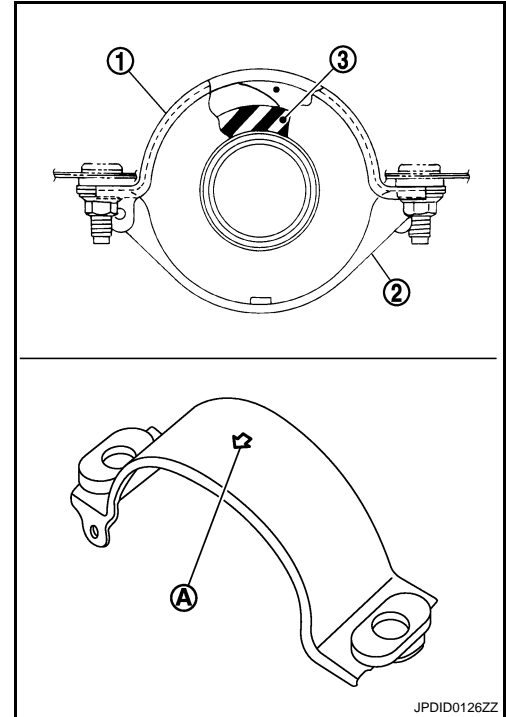

- Align matching marks to install propeller shaft rubber coupling to final drive companion flange.
- After assembly, perform a driving test to check propeller shaft vibration. If vibration occurred, separate propeller shaft from final drive. Reinstall companion flange after rotating it by 120, 240 degrees. Then perform driving test and check propeller shaft vibration again at each point.

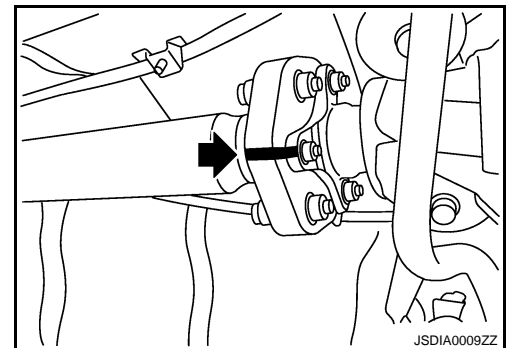

- If propeller shaft or final drive has been replaced, connect them as follows:
 - Install the propeller shaft (1) while aligning its matching mark (A) with the matching mark (B) on the joint as close as possible.

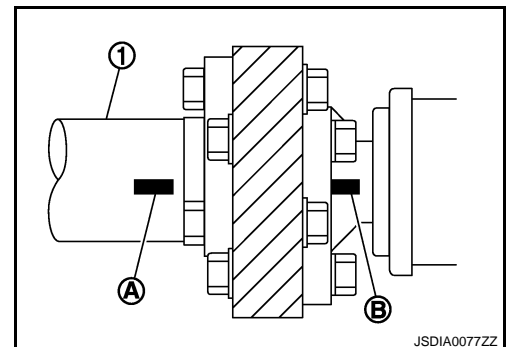

CAUTION:

REAR PROPELLER SHAFT

< REMOVAL AND INSTALLATION >

[REAR PROPELLER SHAFT: 3S80A-R]

- The angle (A), which the third axis rubber coupling (1) forms with the final drive companion flange (2), must be 5° or less.
- Never damage the grease seal (3).
- Never damage the rubber coupling.
- Never damage the rear oil seal of transmission.
- Never damage the rubber coupling, protect it with a shop towel or equivalent.

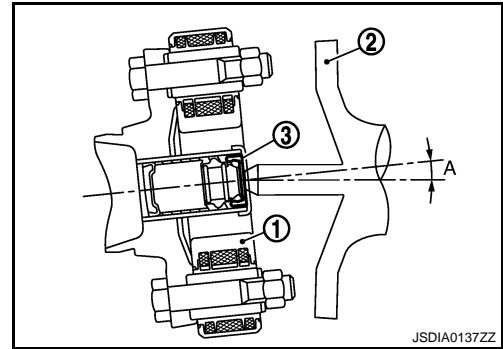

Inspection

APPEARANCE

- Check propeller shaft for bend and damage. If damage is detected, replace propeller shaft assembly.

PROPELLER SHAFT RUNOUT

- Check propeller shaft runout at measuring points. If runout exceeds specifications, replace propeller shaft assembly. For measuring point, refer to [DLN-99, "Inspection"](#)

Limit

Propeller shaft runout : Refer to [DLN-104, "Propeller Shaft Runout"](#).

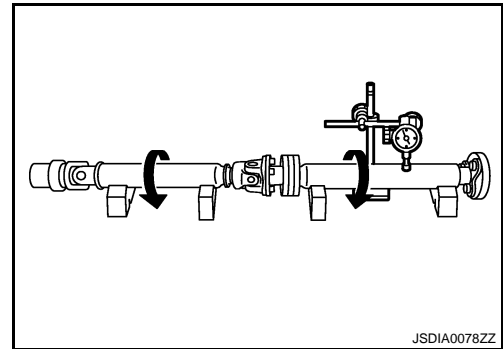

JOURNAL AXIAL PLAY

- As shown in the figure, while fixing yoke on one side, check axial play of joint. If outside the standard, replace propeller shaft assembly.

Standard

Journal axial play : Refer to [DLN-104, "Journal Axial Play"](#).

CAUTION:

Never disassemble joints.

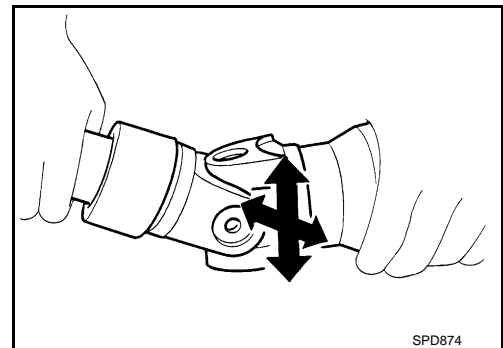

CENTER BEARING

- Check center bearing for noise and damage. If noise or damage is detected, replace propeller shaft assembly.

CAUTION:

Never disassemble center bearing.

SERVICE DATA AND SPECIFICATIONS (SDS)

< SERVICE DATA AND SPECIFICATIONS (SDS)

[REAR PROPELLER SHAFT: 3S80A-R]

SERVICE DATA AND SPECIFICATIONS (SDS)

SERVICE DATA AND SPECIFICATIONS (SDS)

General Specifications

INFOID:0000000005649692

Applied model		2WD
		VQ37VHR
		A/T
Propeller shaft model		3S80A-R
Number of joints		3
Type of journal bearings (Non-disassembly type)	1st joint	Shell type
	2nd joint	Shell type
	3rd joint	Rubber coupling type
Coupling method with transmission		Sleeve type
Coupling method with rear final drive		Rubber coupling type
Shaft length	1st (Spider to spider)	697 mm (27.44 in)
	2nd (Spider to rubber coupling center)	772 mm (30.39 in)
Shaft outer diameter	1st	82.6 mm (3.25 in)
	2nd	75.0 mm (2.95 in)

Propeller Shaft Runout

INFOID:0000000005649693

Unit: mm (in)

Item	Limit
Propeller shaft runout	0.8 (0.031)

Journal Axial Play

INFOID:0000000005649694

Unit: mm (in)

Item	Standard
Journal axial play	0 (0)

NOISE, VIBRATION AND HARSHNESS (NVH) TROUBLESHOOTING

< SYMPTOM DIAGNOSIS >

[REAR PROPELLER SHAFT: 3F80A-1VL107]

SYMPTOM DIAGNOSIS

NOISE, VIBRATION AND HARSHNESS (NVH) TROUBLESHOOTING

NVH Troubleshooting Chart

INFOID:000000005649695

Use the chart below to find the cause of the symptom. If necessary, repair or replace these parts.

Symptom	Possible cause and SUSPECTED PARTS														
	Noise	DLN-107, "Inspection"	DLN-111, "Inspection"	—	DLN-111, "Inspection"	—	DLN-107, "Inspection"	DLN-107, "Inspection"	NVH in DLN section.	NVH in FAX, RAX, FSU and RSU section.	NVH in WT section.	NVH in WT section.	NVH in FAX and RAX section.	NVH in BR section.	NVH in ST section.
		Uneven rotating torque	Center bearing improper installation	Excessive center bearing axial end play	Center bearing mounting (insulator) cracks, damage or deterioration	Excessive joint angle	Rotation imbalance	Excessive runout	DIFFERENTIAL	AXLE AND SUSPENSION	TIRE	ROAD WHEEL	DRIVE SHAFT	BRAKE	STEERING
		×	×	×	×	×	×	×	×	×	×	×	×	×	×
	Shake		×			×				×	×	×	×	×	×
	Vibration	×	×	×	×	×	×	×		×	×		×		×

x: Applicable

A
B
C
DLN
E
F
G
H
I
J
K
L
M
N
O
P

PREPARATION

[REAR PROPELLER SHAFT: 3F80A-1VL107]

< PREPARATION >

PREPARATION

PREPARATION

Commercial Service Tools

INFOID:000000005649696

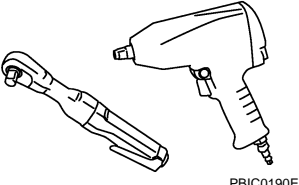
Tool name	Description
<p data-bbox="162 415 272 441">Power tool</p>  <p data-bbox="852 630 922 646">PBIC0190E</p>	<p data-bbox="1015 415 1263 441">Loosening bolts and nuts</p>

REAR PROPELLER SHAFT

< PERIODIC MAINTENANCE >

[REAR PROPELLER SHAFT: 3F80A-1VL107]

PERIODIC MAINTENANCE

REAR PROPELLER SHAFT

Inspection

INFOID:000000005649697

NOISE

- Check the propeller shaft tube surface for dents or cracks. If damaged, replace propeller shaft assembly.
- If center bearing is noisy or damaged, replace propeller shaft assembly.

VIBRATION

If vibration is present at high speed, inspect propeller shaft runout first.

1. With a dial indicator, measure propeller shaft runout at runout measuring points by rotating final drive companion flange with hands.

Limit

Propeller shaft runout : Refer to [DLN-112. "Propeller Shaft Runout"](#).

2. If runout still exceeds specifications, separate propeller shaft at final drive companion flange, then rotate companion flange 60, 120, 180, 240, 300 degrees and install propeller shaft.
3. Check runout again. If runout still exceeds specifications, replace propeller shaft assembly.
4. Check the vibration by driving vehicle.

RUNOUT MEASURING POINT

Propeller shaft runout measuring point (Point "△").

←: Vehicle front

Standard

- A** : 162 mm (6.38 in)
B : 245 mm (9.65 in)
C : 185 mm (7.28 in)

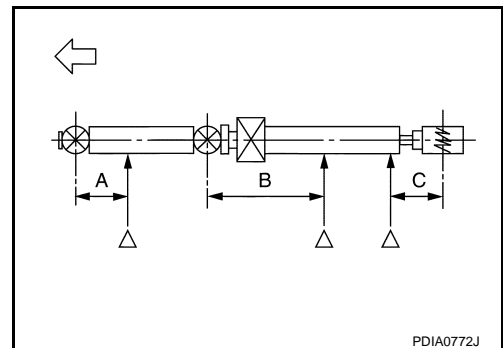
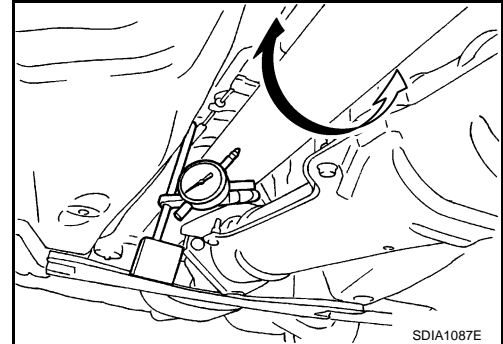

A
B
C
DLN
E
F
G
H
I
J
K
L
M
N
O
P

REAR PROPELLER SHAFT

< REMOVAL AND INSTALLATION >

[REAR PROPELLER SHAFT: 3F80A-1VL107]

REMOVAL AND INSTALLATION

REAR PROPELLER SHAFT

Exploded View

INFOID:000000005649698

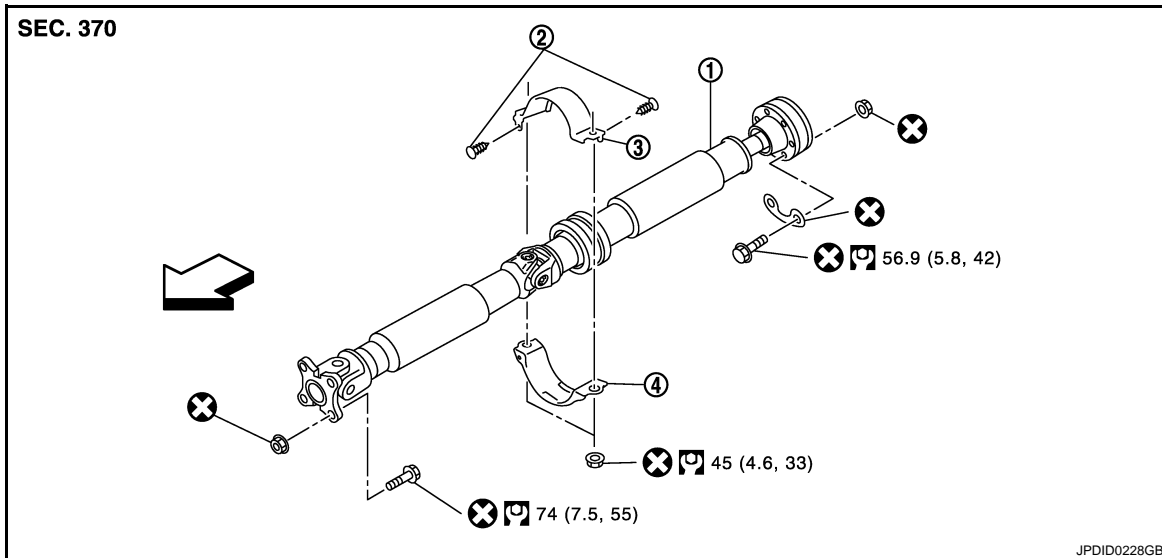

1. Propeller shaft assembly
2. Clip
3. Center bearing mounting bracket (upper)
4. Center bearing mounting bracket (lower)

↔: Vehicle front

Refer to [GI-4, "Components"](#) for symbols in the figure.

Removal and Installation

INFOID:000000005649699

REMOVAL

1. Shift the transmission to the neutral position, and release the parking brake.
2. Remove the center muffler and exhaust front tube with power tool. Refer to [EX-5, "Exploded View"](#).
3. Remove the heat plate (1).

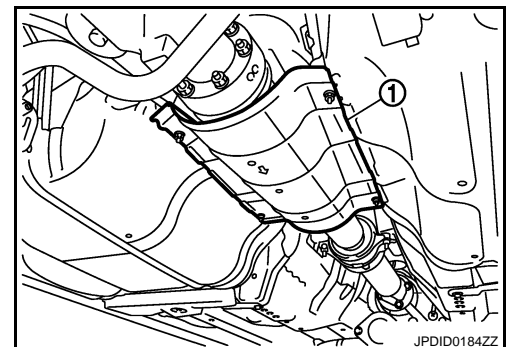

REAR PROPELLER SHAFT

< REMOVAL AND INSTALLATION >

[REAR PROPELLER SHAFT: 3F80A-1VL107]

4. Put matching marks (A) on propeller shaft flange yoke and transfer companion flange.

CAUTION:

For matching marks, use paint. Never damage propeller shaft flange yoke and transfer companion flange.

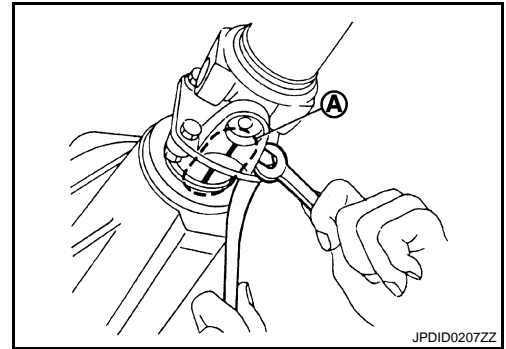

5. Put matching marks (A) on propeller shaft rebro joint and final drive companion flange.

CAUTION:

For matching marks, use paint. Never damage propeller shaft rebro joint and final drive companion flange.

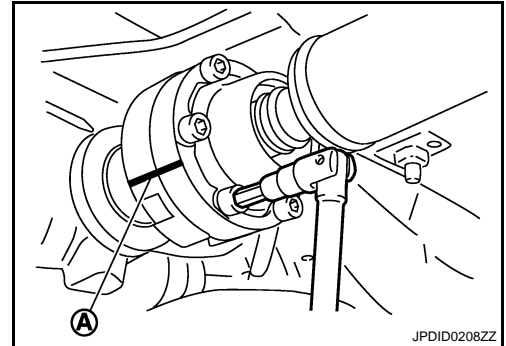

6. Loosen mounting nuts (1) of center bearing mounting brackets (upper/lower).

CAUTION:

Tighten mounting nuts temporarily.

⇐ : Vehicle front

7. Remove propeller shaft assembly fixing bolts and nuts.
8. Remove center bearing mounting bracket fixing nuts.
9. Remove propeller shaft assembly.

CAUTION:

- **Never damage the rear oil seal of transmission.**
- **If constant velocity joint was bent during propeller shaft assembly removal, installation, or transportation, its boot may be damaged. Wrap boot interference area to metal part with shop cloth or equivalent to protect boot from breakage.**

10. Remove clip and center bearing mounting bracket (upper/lower).

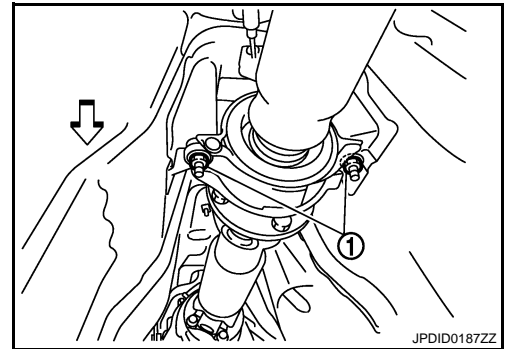

INSTALLATION

Note the following, and install in the reverse order of removal.

A
B
C
DLN
E
F
G
H
I
J
K
L
M
N
O
P

REAR PROPELLER SHAFT

< REMOVAL AND INSTALLATION >

[REAR PROPELLER SHAFT: 3F80A-1VL107]

- Install center bearing mounting bracket (upper) (1) with its arrow mark (A) facing forward.
- Adjust position of center bearing mounting bracket (upper), center bearing mounting bracket (lower) (2) sliding back and forth to prevent play in thrust direction of center bearing insulator (3). Install center bearing mounting bracket (upper/lower) to vehicle.

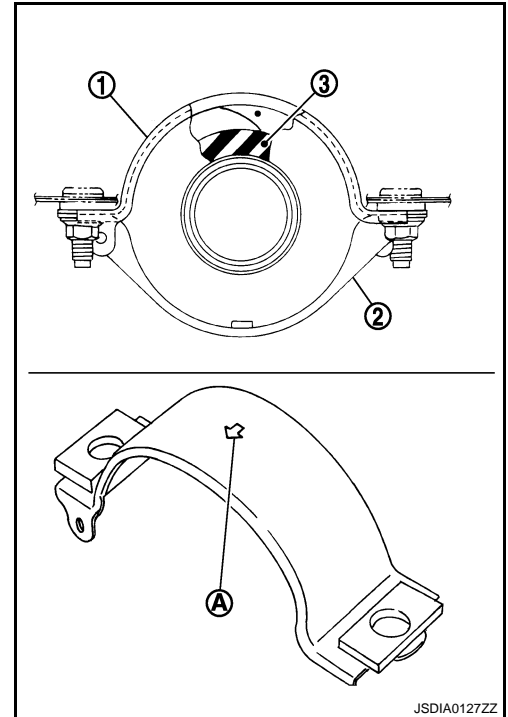

- Align matching marks (A) to install propeller shaft flange yoke and transfer companion flange.

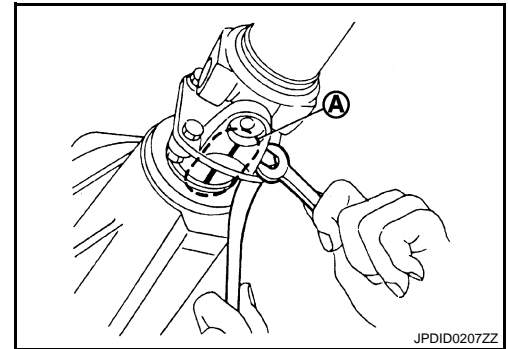

- Align matching marks (A) to install propeller shaft rebro joint and final drive companion flange.

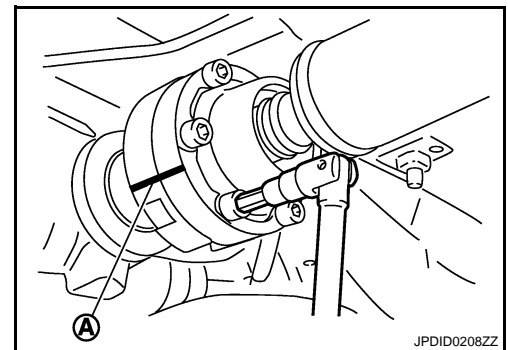

CAUTION:

REAR PROPELLER SHAFT

< REMOVAL AND INSTALLATION >

[REAR PROPELLER SHAFT: 3F80A-1VL107]

Tighten mounting bolt and nut in the order shown in the figure.

- After assembly, perform a driving test to check propeller shaft vibration. If vibration occurred, separate propeller shaft from final drive. Reinstall companion flange after rotating it by 60, 120, 180, 240, 300 degrees. Then perform driving test and check propeller shaft vibration again at each point.

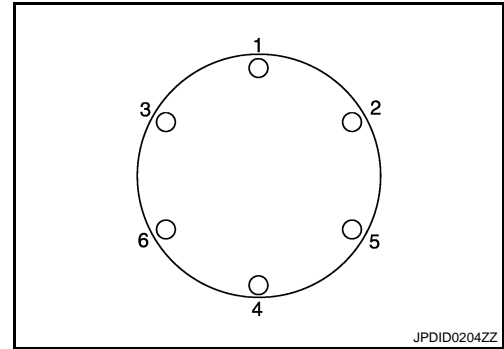

JPDID0204ZZ

- If propeller shaft or final drive has been replaced, connect them as follows:

- Install the propeller shaft while aligning its matching mark (A) with the matching mark (B) on the joint as close as possible.

CAUTION:

- **Avoid damaging the rebro joint boot, protect it with a shop cloth or equivalent.**

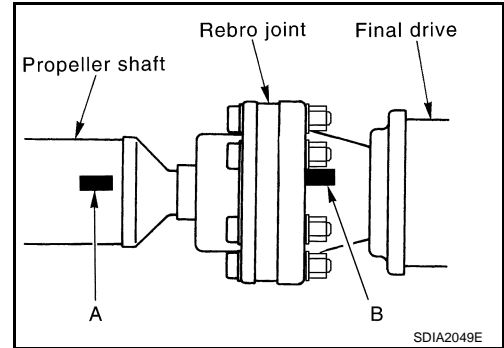

SDIA2049E

Inspection

INFOID:000000005649700

APPEARANCE

Check propeller shaft for bend and damage. If damage is detected, replace propeller shaft assembly.

PROPELLER SHAFT RUNOUT

Check propeller shaft runout at measuring points with a dial indicator. If runout exceeds specifications, replace propeller shaft assembly. For measuring point, refer to [DLN-107, "Inspection"](#).

Limit

Propeller shaft runout : Refer to [DLN-112, "Propeller Shaft Runout"](#).

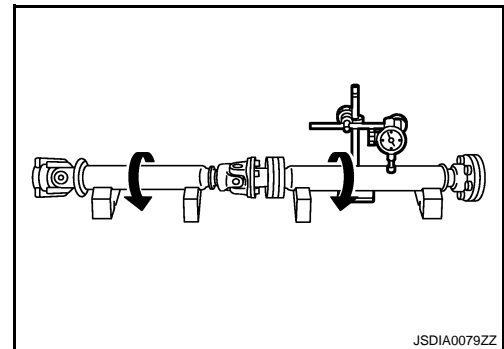

JSDIA0079ZZ

JOURNAL AXIAL PLAY

As shown in the figure, while fixing yoke on one side, check axial play of joint. If it is outside the standard, replace propeller shaft assembly.

Standard

Journal axial play : Refer to [DLN-112, "Journal Axial Play"](#).

CAUTION:

Never disassemble joints.

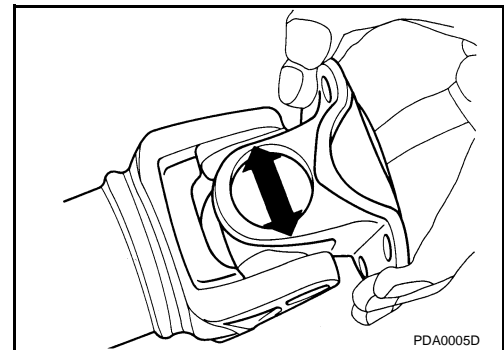

PDA0005D

CENTER BEARING

Check center bearing for noise and damage. If noise or damage is detected, replace propeller shaft assembly.

CAUTION:

Never disassemble center bearing.

A
B
C
DLN
E
F
G
H
I
J
K
L
M
N
O
P

SERVICE DATA AND SPECIFICATIONS (SDS)

< SERVICE DATA AND SPECIFICATIONS (SDS)

[REAR PROPELLER SHAFT: 3F80A-1VL107]

SERVICE DATA AND SPECIFICATIONS (SDS)

SERVICE DATA AND SPECIFICATIONS (SDS)

General Specifications

INFOID:000000005649701

Applied model		AWD
		VQ37VHR
		A/T
Propeller shaft model		3F80A-1VL107
Number of joints		3
Type of journal bearings (Non-disassembly type)	1st joint	Shell type
	2nd joint	Shell type
	3rd joint	Rebro joint type
Coupling method with transfer		Flange type
Coupling method with rear final drive		Rebro joint type
Shaft length	1st (Spider to spider)	435 mm (17.13 in)
	2nd (Spider to rebro joint center)	757 mm (29.80 in)
Shaft outer diameter	1st	82.6 mm (3.252 in)
	2nd	75.0 mm (2.953 in)

Propeller Shaft Runout

INFOID:000000005649702

Unit: mm (in)

Item	Limit
Propeller shaft runout	0.8 (0.031)

Journal Axial Play

INFOID:000000005649703

Unit: mm (in)

Item	Standard
Journal axial play	0 (0)

FRONT FINAL DRIVE ASSEMBLY

< SYSTEM DESCRIPTION >

[FRONT FINAL DRIVE: F160A]

SYSTEM DESCRIPTION

FRONT FINAL DRIVE ASSEMBLY

System Diagram

INFOID:000000005649704

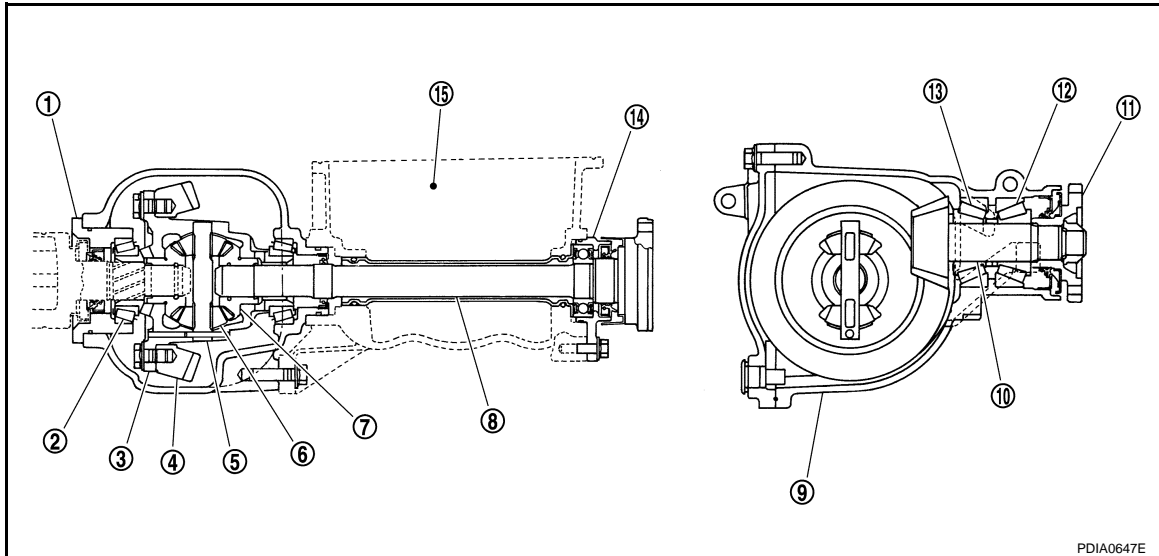

- | | | |
|-------------------------|-----------------------------|--------------------------|
| 1. Side retainer | 2. Side bearing | 3. Differential case |
| 4. Drive gear | 5. Pinion mate shaft | 6. Pinion mate gear |
| 7. Side gear | 8. Side shaft | 9. Gear carrier |
| 10. Drive pinion | 11. Companion flange | 12. Pinion front bearing |
| 13. Pinion rear bearing | 14. Extension tube retainer | 15. Engine assembly |

A
B
C
DLN
E
F
G
H
I
J
K
L
M
N
O
P

PRECAUTION

PRECAUTIONS

Precaution Necessary for Steering Wheel Rotation after Battery Disconnect

INFOID:000000005649706

NOTE:

- Before removing and installing any control units, first turn the push-button ignition switch to the LOCK position, then disconnect both battery cables.
- After finishing work, confirm that all control unit connectors are connected properly, then re-connect both battery cables.
- Always use CONSULT-III to perform self-diagnosis as a part of each function inspection after finishing work. If a DTC is detected, perform trouble diagnosis according to self-diagnosis results.

For vehicle with steering lock unit, if the battery is disconnected or discharged, the steering wheel will lock and cannot be turned.

If turning the steering wheel is required with the battery disconnected or discharged, follow the operation procedure below before starting the repair operation.

OPERATION PROCEDURE

1. Connect both battery cables.

NOTE:

Supply power using jumper cables if battery is discharged.

2. Turn the push-button ignition switch to ACC position. (At this time, the steering lock will be released.)
3. Disconnect both battery cables. The steering lock will remain released with both battery cables disconnected and the steering wheel can be turned.
4. Perform the necessary repair operation.
5. When the repair work is completed, re-connect both battery cables. With the brake pedal released, turn the push-button ignition switch from ACC position to ON position, then to LOCK position. (The steering wheel will lock when the push-button ignition switch is turned to LOCK position.)
6. Perform self-diagnosis check of all control units using CONSULT-III.

Service Notice or Precautions for Front Final Drive

INFOID:000000005649707

- Check for the correct installation status prior to removal or disassembly. If matching marks are required, be certain they never interfere with the function of the parts when applied.
- Overhaul should be done in a clean work area, it is preferable to work in dustproof area.
- Before disassembly, using steam or white gasoline, completely remove sand and mud from the exterior of the unit, preventing them from entering into the unit during disassembly or assembly.
- Check appearance of the disassembled parts for damage, deformation, and unusual wear. Replace them with new ones if necessary.
- Gaskets, seals and O-rings should be replaced any time when the unit is disassembled.
- In principle, tighten bolts or nuts gradually in several steps working diagonally from inside to outside. If tightening sequence is specified, observe it.
- Clean and flush the parts sufficiently and blow-dry them.
- Be careful not to damage sliding surfaces and mating surfaces.
- When applying sealant, remove the old sealant from the mounting surface; then remove any moisture, oil, and foreign materials from the application and mounting surfaces.
- Always use shop paper for cleaning the inside of components.
- Avoid using cotton gloves or shop rags to prevent entering of lint.
- During assembly, observe the specified tightening torque, and apply new gear oil, petroleum jelly, or multi-purpose grease as specified for each vehicle, if necessary.

NOTE:

Front oil seal cannot be replaced on vehicle, because there is not enough room.

A
B
C
DLN
E
F
G
H
I
J
K
L
M
N
O
P

PREPARATION

< PREPARATION >

[FRONT FINAL DRIVE: F160A]

PREPARATION

PREPARATION

Special Service Tools

INFOID:000000005649708

The actual shapes of Kent-Moore tools may differ from those of special service tools illustrated here.

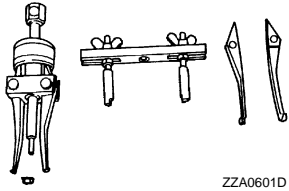
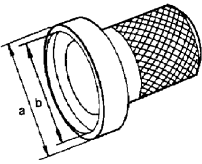
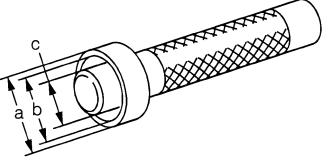
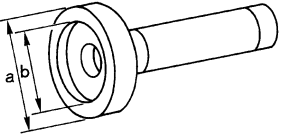
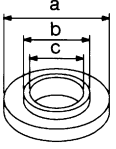
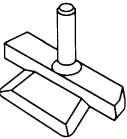
Tool number (Kent-Moore No.) Tool name	Description
KV381054S0 (J-34286) Puller  ZZA0601D	<ul style="list-style-type: none"> • Removing side oil seal (right side) • Removing side bearing outer race
ST33400001 (J-26082) Drift a: 60 mm (2.36 in) dia. b: 47 mm (1.85 in) dia.  ZZA0702D	<ul style="list-style-type: none"> • Installing side oil seal (right side) • Installing front oil seal
KV38102100 (J-25803-01) Drift a: 44 mm (1.73 in) dia. b: 36 mm (1.42 in) dia. c: 24.5 mm (0.965 in) dia.  ZZA1046D	Installing side oil seal (left side)
KV38100200 (—) Drift a: 65 mm (2.56 in) dia. b: 49 mm (1.93 in) dia.  ZZA1143D	Installing side shaft oil seal
ST30032000 (J-26010-01) Drift a: 80 mm (3.15 in) dia. b: 38 mm (1.50 in) dia. c: 31 mm (1.22 in) dia.  S-NT107	<ul style="list-style-type: none"> • Installing side shaft • Installing pinion rear bearing inner race
KV10111100 (J-37228) Seal cutter  S-NT046	Removing carrier cover

PREPARATION

< PREPARATION >

[FRONT FINAL DRIVE: F160A]

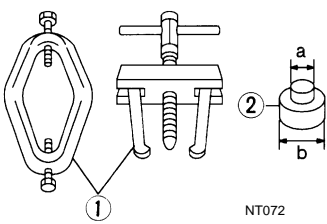
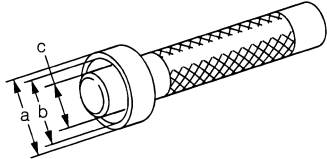
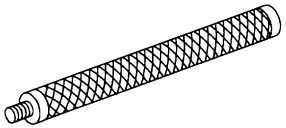
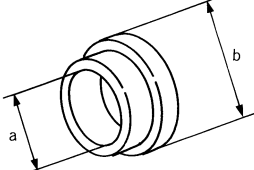
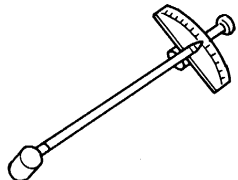
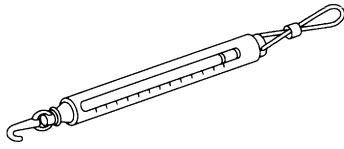
Tool number (Kent-Moore No.) Tool name	Description	
ST3306S001 (J-22888-D) Differential side bearing puller set 1: ST33051001 (J-22888-20) Puller 2: ST33061000 (J-8107-2) Base a: 28.5 mm (1.122 in) dia. b: 38 mm (1.50 in) dia.	 Removing and installing side bearing inner race	A B C DLN
ST33230000 (J-25805-01) Drift a: 51 mm (2.01 in) dia. b: 41 mm (1.61 in) dia. c: 28.5 mm (1.122 in) dia.	 Installing side bearing inner race	E F
ST30611000 (J-25742-1) Drift bar	 Installing side bearing outer race	G H I
KV31103000 (J-38982) Drift a: 49 mm (1.93 in) dia. b: 70 mm (2.76 in) dia.	 Installing side bearing outer race	J K
ST3127S000 (J-25765-A) Preload gauge	 Measuring pinion bearing preload and total preload	L M
(J-8129) Spring gauge	 Measuring turning torque	N O P

PREPARATION

< PREPARATION >

[FRONT FINAL DRIVE: F160A]

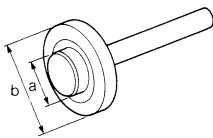
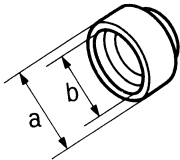
Tool number (Kent-Moore No.) Tool name	Description
ST37820000 (—) Drift a: 39 mm (1.54 in) dia. b: 72 mm (2.83 in) dia.	Installing pinion front and rear bearing outer race
 ZZA0836D	
KV38102510 (—) Drift a: 71 mm (2.80 in) dia. b: 65 mm (2.56 in) dia.	Installing front oil seal
 ZZA0838D	

Commercial Service Tools

INFOID:000000005649709

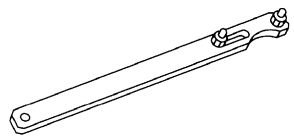
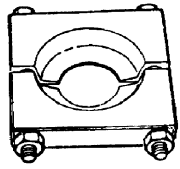
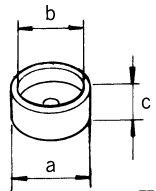
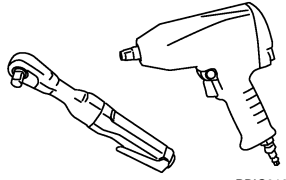
Tool name	Description
Flange wrench	Removing and installing drive pinion lock nut
 NT035	
Replacer	Removing pinion rear bearing inner race
 ZZA0700D	
Spacer a: 60 mm (2.36 in) dia. b: 36 mm (1.42 in) dia. c: 30 mm (1.18 in)	Installing pinion front bearing inner race
 ZZA1133D	
Power tool	Loosening bolts and nuts
 PBIC0190E	

PERIODIC MAINTENANCE

FRONT DIFFERENTIAL GEAR OIL

Inspection

INFOID:000000005649710

OIL LEAKAGE

Make sure that oil is not leaking from final drive assembly or around it.

OIL LEVEL

- Remove filler plug (1) and check oil level from filler plug mounting hole as shown in the figure.

CAUTION:

Never start engine while checking oil level.

- Set a gasket on filler plug (1) and install it on final drive assembly. Refer to [DLN-125, "Exploded View"](#).

CAUTION:

Never reuse gasket.

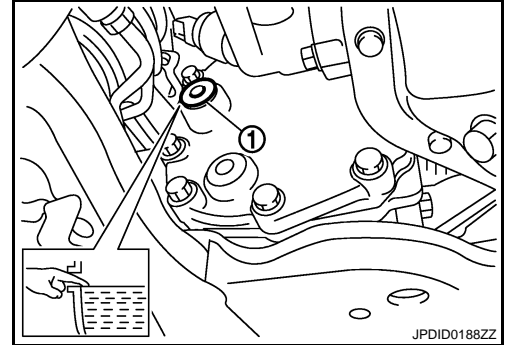

INFOID:000000005649711

Draining

- Stop engine.
- Remove drain plug (1) and drain gear oil.
- Set a gasket on drain plug (1) and install it to final drive assembly and tighten to the specified torque. Refer to [DLN-125, "Exploded View"](#).

CAUTION:

Never reuse gasket.

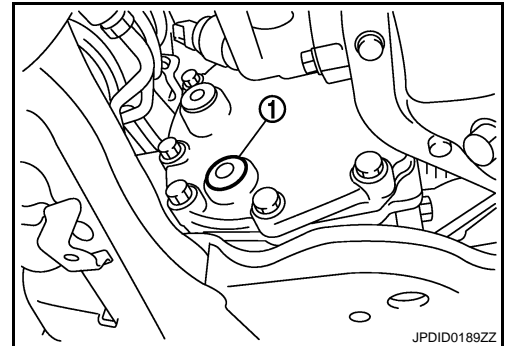

INFOID:000000005649712

Refilling

- Remove filler plug (1). Fill with new gear oil until oil level reaches the specified level near filler plug mounting hole.

Oil grade and Viscosity : Refer to [MA-10, "Fluids and Lubricants"](#).

Oil capacity : Refer to [DLN-150, "General Specifications"](#).

- After refilling oil, check oil level. Set a gasket to filler plug (1), then install it to final drive assembly. Refer to [DLN-125, "Exploded View"](#).

CAUTION:

Never reuse gasket.

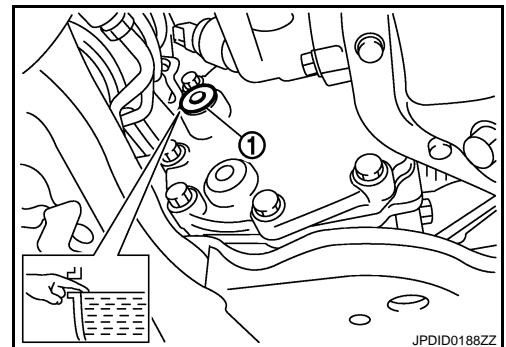

A
B
C
DLN
E
F
G
H
I
J
K
L
M
N
O
P

SIDE OIL SEAL

< REMOVAL AND INSTALLATION >

[FRONT FINAL DRIVE: F160A]

REMOVAL AND INSTALLATION

SIDE OIL SEAL

RIGHT SIDE

RIGHT SIDE : Exploded View

INFOID:000000005649713

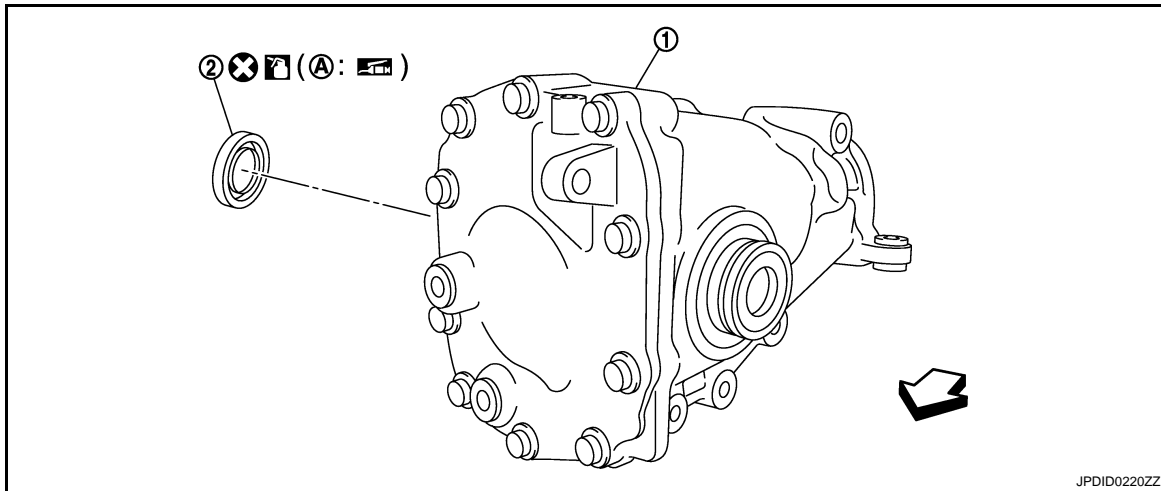

1. Front final drive assembly
2. Side oil seal (right side)

A: Oil seal lip

⇐: Vehicle front

: Apply gear oil.

: Apply multi-purpose grease.

Refer to [GI-4. "Components"](#) for symbols not described above.

RIGHT SIDE : Removal and Installation

INFOID:000000005649714

REMOVAL

1. Remove the front drive shaft. Refer to [FAX-23. "Exploded View"](#).
2. Remove the side oil seal using a puller (A) [SST: KV381054S0 (J-34286)].

CAUTION:

Never damage gear carrier.

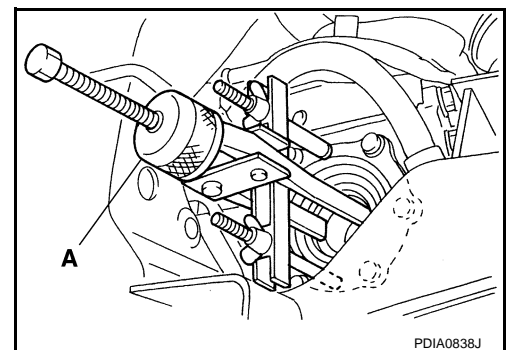

INSTALLATION

1. Apply multi-purpose grease to sealing lips of side oil seal.

SIDE OIL SEAL

< REMOVAL AND INSTALLATION >

[FRONT FINAL DRIVE: F160A]

- Using the drift (A) [SST: ST33400001 (J-26082)], press-fit side oil seal so that its surface comes face-to-face with the end surface of the side retainer.

CAUTION:

- Never reuse oil seal.
- When installing, never incline oil seal.

- Install the front drive shaft. Refer to [FAX-23, "Exploded View"](#).
- When oil leaks while removing, check oil level after the installation. Refer to [DLN-119, "Inspection"](#).

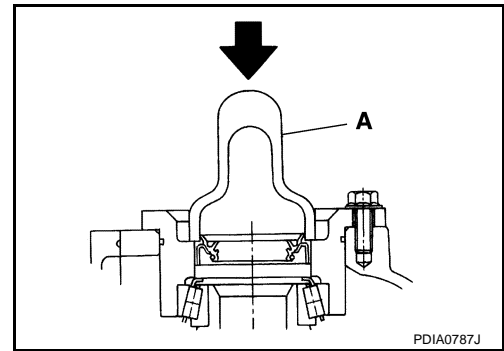

LEFT SIDE

LEFT SIDE : Exploded View

INFOID:000000005649715

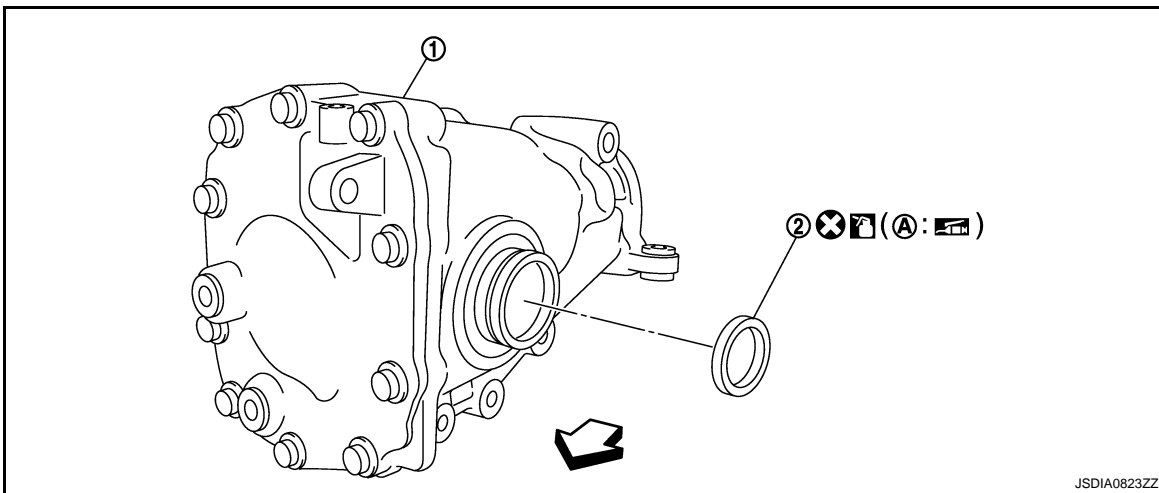

- Front final drive assembly
- Side oil seal (left side)

A: Oil seal lip

↔: Vehicle front

: Apply gear oil.

: Apply multi-purpose grease.

Refer to [GI-4, "Components"](#) for symbols not described above.

LEFT SIDE : Removal and Installation

INFOID:000000005649716

REMOVAL

- Remove the front final drive assembly from vehicle with power tool. Refer to [DLN-123, "Exploded View"](#).
NOTE:
Left side oil seal is attached to engine assembly. Replace it after removing front final drive assembly from vehicle.
- Remove the side oil seal using a suitable tool.
CAUTION:
Never damage gear carrier.

INSTALLATION

- Apply multi-purpose grease to sealing lips of side oil seal.

SIDE OIL SEAL

< REMOVAL AND INSTALLATION >

[FRONT FINAL DRIVE: F160A]

- Using the drift (A) [SST: KV38102100 (J-25803-01)], press-fit side oil seal so that its surface comes face-to-face with the end surface of the gear carrier.

CAUTION:

- Never reuse oil seal.
 - When installing, never incline oil seal.
- Install the front final drive assembly on vehicle. Refer to [DLN-123](#), "Exploded View".
 - When oil leaks while removing, check oil level after the installation. Refer to [DLN-119](#), "Inspection".

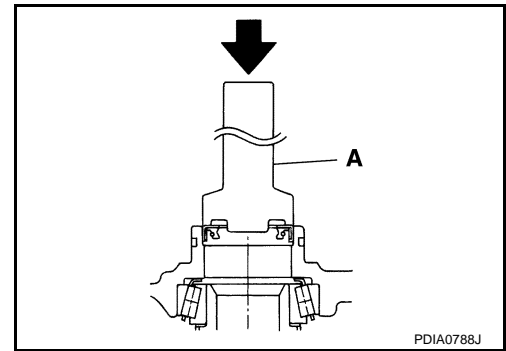

FRONT FINAL DRIVE ASSEMBLY

< UNIT REMOVAL AND INSTALLATION >

[FRONT FINAL DRIVE: F160A]

UNIT REMOVAL AND INSTALLATION

FRONT FINAL DRIVE ASSEMBLY

Exploded View

INFOID:000000005649717

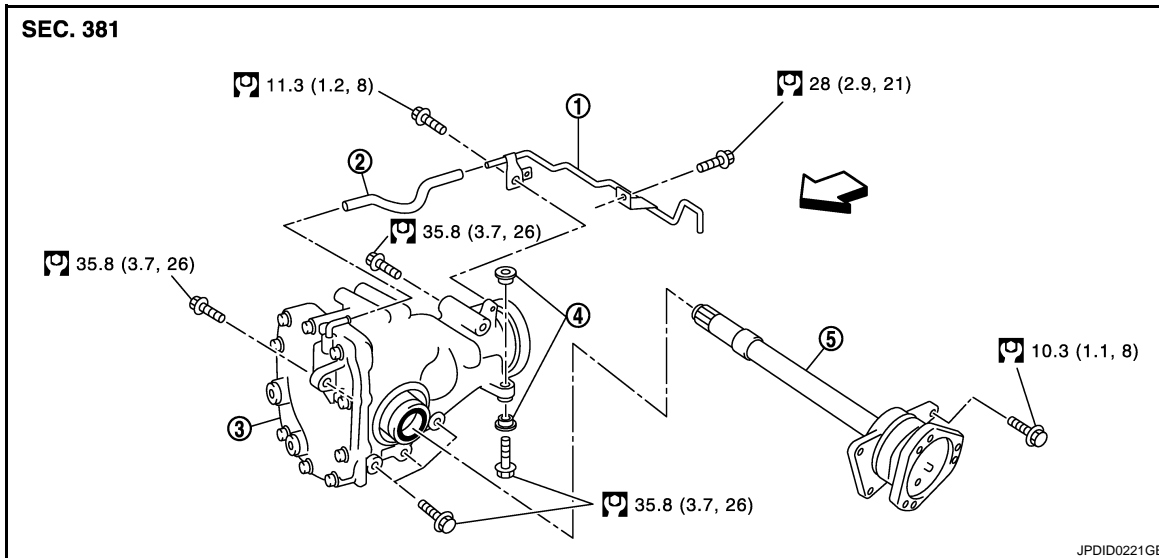

- | | | |
|------------------|------------------|-------------------------------|
| 1. Breather tube | 2. Breather hose | 3. Front final drive assembly |
| 4. Bushing | 5. Side shaft | |

←: Vehicle front

Refer to [GI-4, "Components"](#) for symbols in the figure.

Removal and Installation

INFOID:000000005649718

REMOVAL

1. Remove engine assembly from the vehicle. Refer to [EM-73, "AWD : Exploded View"](#).
2. Separate engine assembly and suspension member.
3. Remove engine mounting bracket (RH) (lower). Refer to [EM-73, "AWD : Exploded View"](#).
4. Remove air breather hose and tube.
5. Remove side shaft.
6. Remove final drive assembly mounting bolts with power tool and separate front final drive assembly from engine.

INSTALLATION

Note the following, install in the reverse order of removal.

- When installing the side shaft, apply multi-purpose grease to contact surface of side shaft and side shaft oil seal.
- Tighten mounting bolts in the order described below when installing front final drive assembly: side of gear carrier (1), upper side of gear carrier (2), part of carrier cover (3), lower part of gear carrier (4).

CAUTION:

Align the mating faces of gear carrier and oil pan for installation.

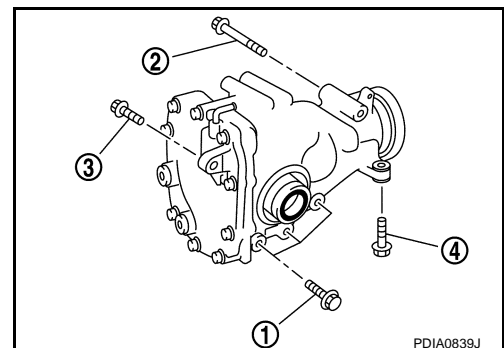

FRONT FINAL DRIVE ASSEMBLY

< UNIT REMOVAL AND INSTALLATION >

[FRONT FINAL DRIVE: F160A]

- Install breather hose (1) and tube (2) as shown in the figure.

CAUTION:

Make sure there are no pinched or restricted areas on the breather hose caused by bending or winding when installing it.

- Make sure the paint mark facing up (←).
- Securely install the hose until it seats the rounded portion of the tube. (←) (front final drive assembly side).
- Securely install the hose until it to paint mark of the tube. (←) (vehicle rear side).
- Face the bend of the breather hose (↔) to the engine.
- When oil leaks while removing final drive assembly, check oil level after the installation. Refer to [DLN-119. "Inspection"](#).

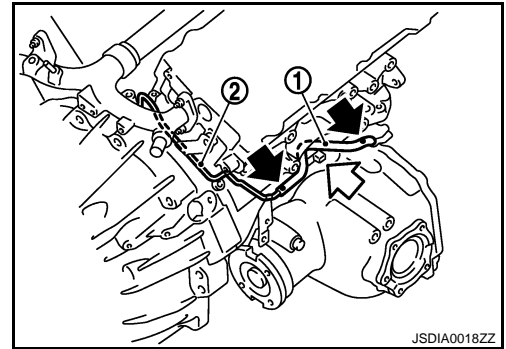

SIDE SHAFT

< UNIT DISASSEMBLY AND ASSEMBLY >

[FRONT FINAL DRIVE: F160A]

UNIT DISASSEMBLY AND ASSEMBLY

SIDE SHAFT

Exploded View

INFOID:000000005649719

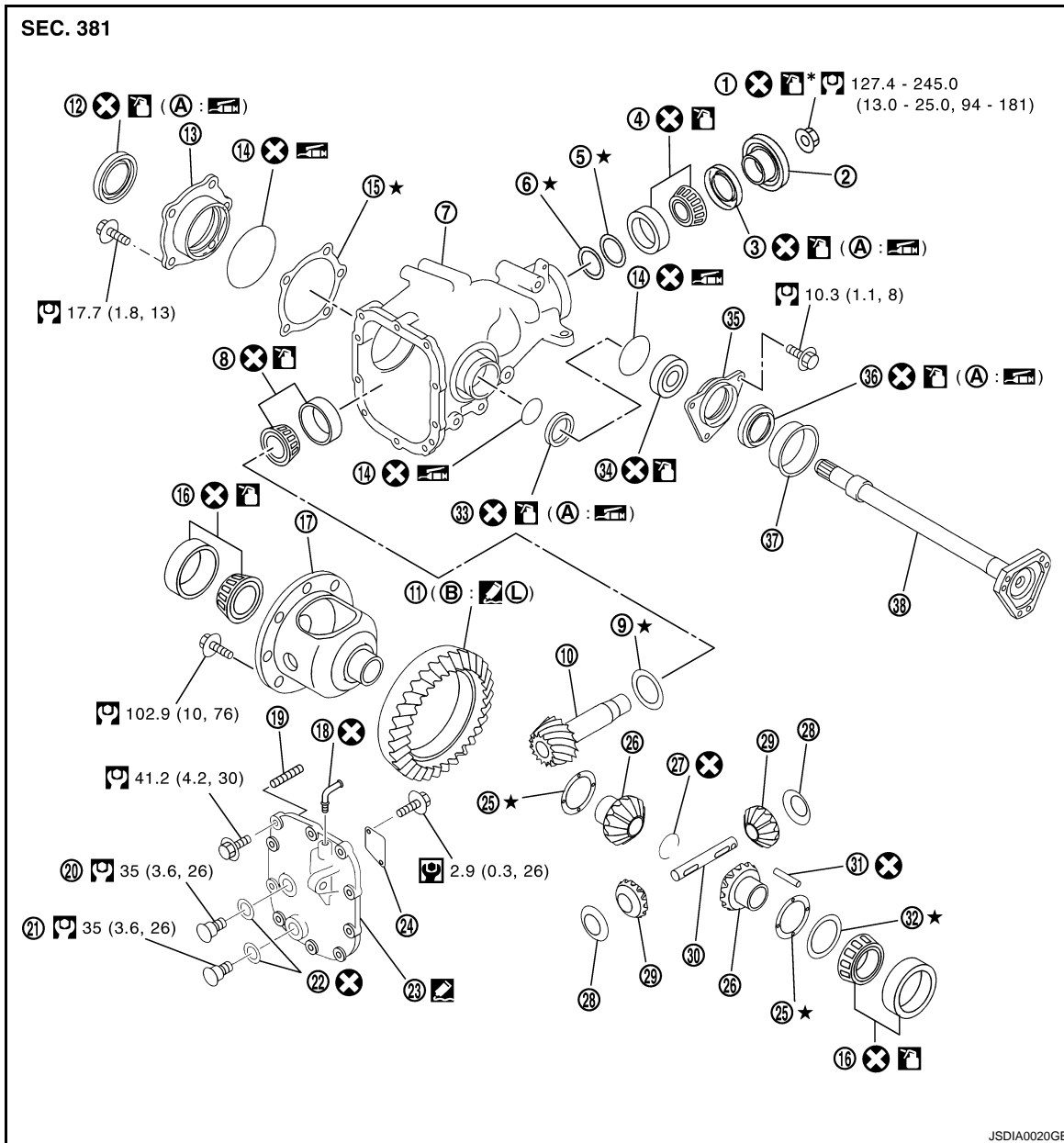

- | | | |
|-------------------------------|--|-----------------------------------|
| 1. Drive pinion lock nut | 2. Companion flange | 3. Front oil seal |
| 4. Pinion front bearing | 5. Drive pinion bearing adjusting washer | 6. Drive pinion adjusting washer |
| 7. Gear carrier | 8. Pinion rear bearing | 9. Pinion height adjusting washer |
| 10. Drive pinion | 11. Drive gear | 12. Side oil seal (right side) |
| 13. Side retainer | 14. O-ring | 15. Side bearing adjusting shim |
| 16. Side bearing | 17. Differential case | 18. Breather connector |
| 19. Dowel pin | 20. Filler plug | 21. Drain plug |
| 22. Gasket | 23. Carrier cover | 24. Gear oil defense |
| 25. Side gear thrust washer | 26. Side gear | 27. Circular clip |
| 28. Pinion mate thrust washer | 29. Pinion mate gear | 30. Pinion mate shaft |

SIDE SHAFT

< UNIT DISASSEMBLY AND ASSEMBLY >

[FRONT FINAL DRIVE: F160A]

- | | | |
|------------------------|-----------------------------------|-------------------------------|
| 31. Lock pin | 32. Side bearing adjusting washer | 33. Side oil seal (left side) |
| 34. Side shaft bearing | 35. Extension tube retainer | 36. Side shaft oil seal |
| 37. Dust seal | 38. Side shaft | |
| A: Oil seal lip | B: Screw hole | |

: Apply gear oil.

*: Apply anti-corrosion oil.

: Apply multi-purpose grease.

: Apply Genuine Silicone RTV or equivalent. Refer to [GI-18, "Recommended Chemical Products and Sealants"](#).

L: Apply Genuine Medium Strength Thread Locking Sealant or equivalent. Refer to [GI-18, "Recommended Chemical Products and Sealants"](#).

Refer to [GI-4, "Components"](#) for symbols not described above.

Disassembly

INFOID:000000005649720

1. Hold extension tube retainer with puller, then press out side shaft using a press.

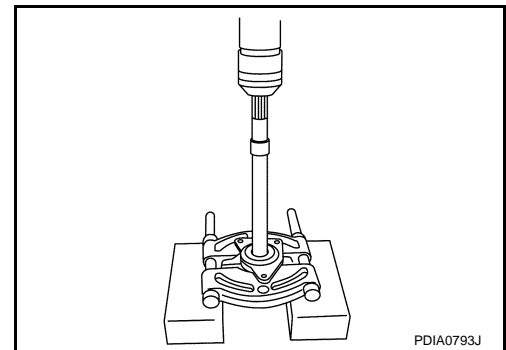

2. Remove side shaft oil seal (1) from extension tube retainer with a suitable tool.

CAUTION:

Never damage extension tube retainer.

3. Remove side shaft bearing from extension tube retainer.
4. Remove O-ring from extension tube retainer.
5. Remove dust seal from side shaft.

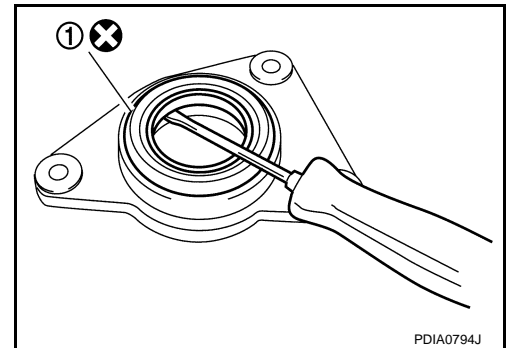

Assembly

INFOID:000000005649721

1. Using the drift (A) [SST: KV38100200 (—)], install side shaft oil seal.

CAUTION:

- Never reuse oil seal.
- When installing, never incline oil seal.
- Apply multi-purpose grease onto oil seal lips, and gear oil onto the circumference of oil seal.

2. Install dust seal.

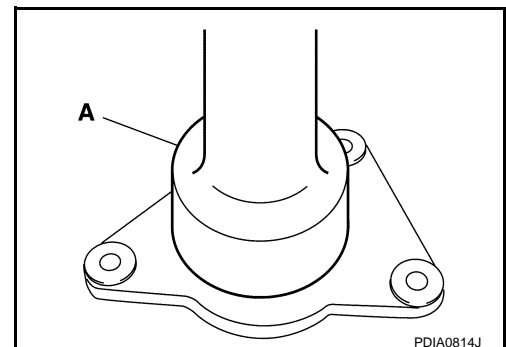

SIDE SHAFT

< UNIT DISASSEMBLY AND ASSEMBLY >

[FRONT FINAL DRIVE: F160A]

- Support side shaft bearing with the drift (A) [SST: ST30032000 (J-26010-01)], then press side shaft (1) into the side shaft bearing using a press.
- Apply multi-purpose grease to O-ring, and install it to extension tube retainer.

CAUTION:

Never reuse O-ring.

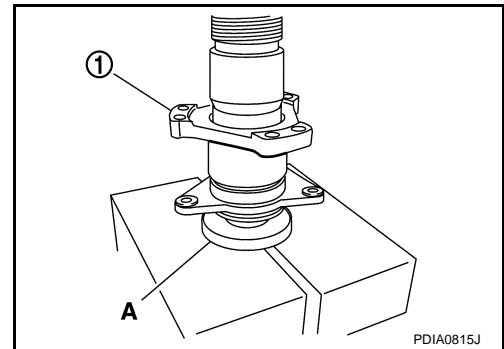

Inspection After Disassembly

INFOID:000000005649722

DRIVE GEAR AND DRIVE PINION

- Clean up the disassembled parts.
- If the gear teeth never mesh or line-up correctly, determine the cause and adjust or replace as necessary.
- If the gears are worn, cracked, damaged, pitted or chipped (by friction) noticeably, replace with new drive gear and drive pinion as a set.

BEARING

- Clean up the disassembled parts.
- If any chipped (by friction), pitted, worn, rusted or scratched marks, or unusual noise from the bearing is observed, replace as a bearing assembly (as a new set).

SIDE GEAR AND PINION MATE GEAR

- Clean up the disassembled parts.
- If any cracks or damage on the surface of the tooth is found, replace.
- If any worn or chipped mark on the contact sides of the thrust washer is found, replace.

SIDE GEAR THRUST WASHER AND PINION MATE THRUST WASHER

- Clean up the disassembled parts.
- If it is chipped (by friction), damaged, or unusually worn, replace.

OIL SEAL

- Whenever disassembled, replace.
- If wear, deterioration of adherence (sealing force lips), or damage is detected on the lips, replace them.

DIFFERENTIAL CASE

- Clean up the disassembled parts.
- If any wear or crack on the contact sides of the differential case is found, replace.

COMPANION FLANGE

- Clean up the disassembled parts.
- If any chipped mark [about 0.1 mm, (0.004 in)] or other damage on the contact sides of the lips of the companion flange is found, replace.

A
B
C

DLN

E
F

G

H

I

J

K

L

M

N

O

P

DIFFERENTIAL ASSEMBLY

< UNIT DISASSEMBLY AND ASSEMBLY >

[FRONT FINAL DRIVE: F160A]

DIFFERENTIAL ASSEMBLY

Exploded View

INFOID:000000005649723

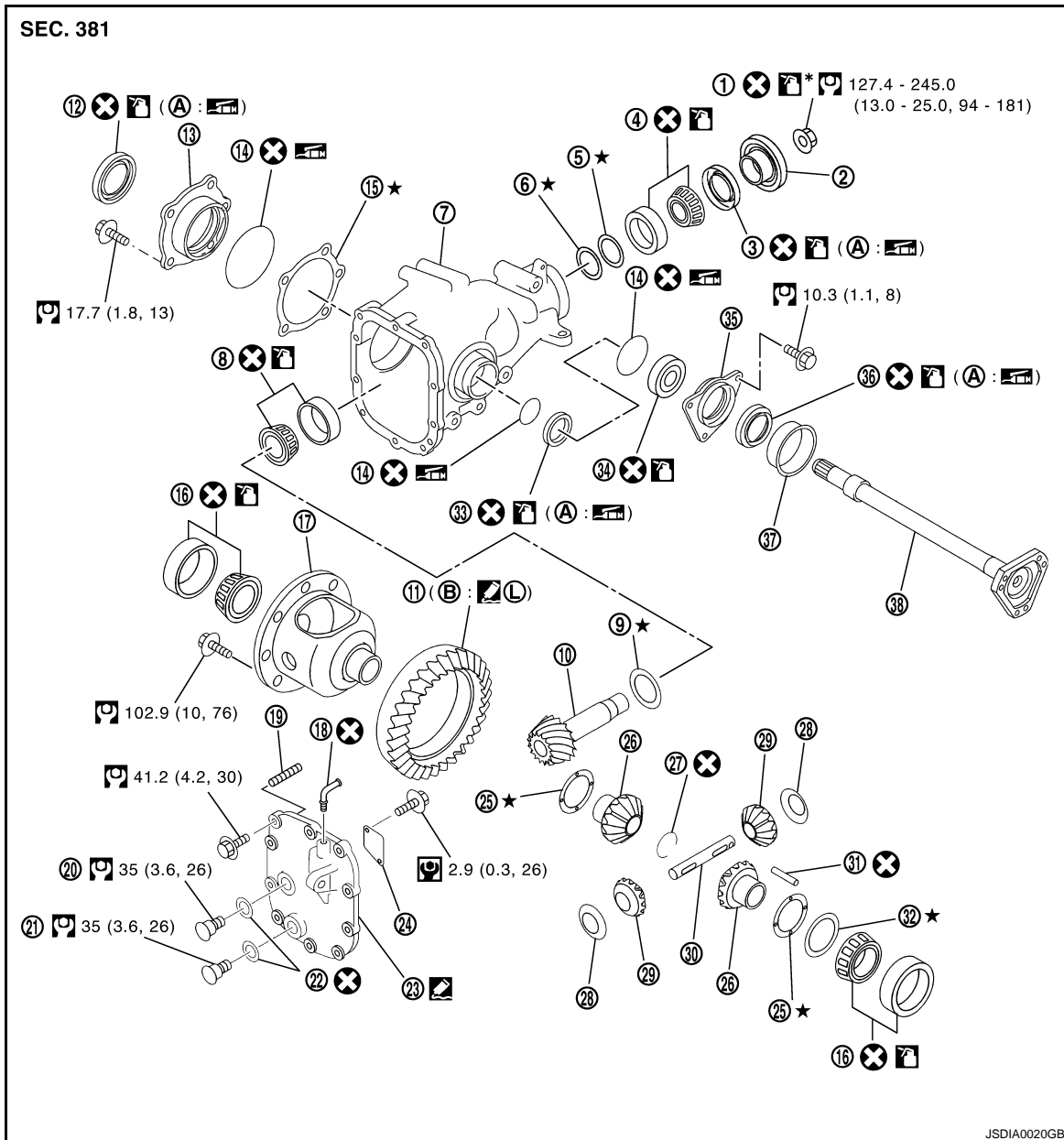

- | | | |
|-------------------------------|--|-----------------------------------|
| 1. Drive pinion lock nut | 2. Companion flange | 3. Front oil seal |
| 4. Pinion front bearing | 5. Drive pinion bearing adjusting washer | 6. Drive pinion adjusting washer |
| 7. Gear carrier | 8. Pinion rear bearing | 9. Pinion height adjusting washer |
| 10. Drive pinion | 11. Drive gear | 12. Side oil seal (right side) |
| 13. Side retainer | 14. O-ring | 15. Side bearing adjusting shim |
| 16. Side bearing | 17. Differential case | 18. Breather connector |
| 19. Dowel pin | 20. Filler plug | 21. Drain plug |
| 22. Gasket | 23. Carrier cover | 24. Gear oil defense |
| 25. Side gear thrust washer | 26. Side gear | 27. Circular clip |
| 28. Pinion mate thrust washer | 29. Pinion mate gear | 30. Pinion mate shaft |
| 31. Lock pin | 32. Side bearing adjusting washer | 33. Side oil seal (left side) |

DIFFERENTIAL ASSEMBLY

< UNIT DISASSEMBLY AND ASSEMBLY >

[FRONT FINAL DRIVE: F160A]

- | | | |
|------------------------|-----------------------------|-------------------------|
| 34. Side shaft bearing | 35. Extension tube retainer | 36. Side shaft oil seal |
| 37. Dust seal | 38. Side shaft | |
| A: Oil seal lip | B: Screw hole | |

: Apply gear oil.

: Apply anti-corrosion oil.

: Apply multi-purpose grease.

: Apply Genuine Silicone RTV or equivalent. Refer to [GI-18, "Recommended Chemical Products and Sealants"](#).

: Apply Genuine Medium Strength Thread Locking Sealant or equivalent. Refer to [GI-18, "Recommended Chemical Products and Sealants"](#).

Refer to [GI-4, "Components"](#) for symbols not described above.

Disassembly

INFOID:000000005649724

1. Drain gear oil, if necessary.
2. Remove carrier cover mounting bolts.
3. Remove carrier cover to insert the seal cutter (A) [SST: KV10111100 (J-37228)] between gear carrier and carrier cover.

CAUTION:

- Never damage the mating surface.
- Never insert flat-bladed screwdriver, this may damage the mating surface.

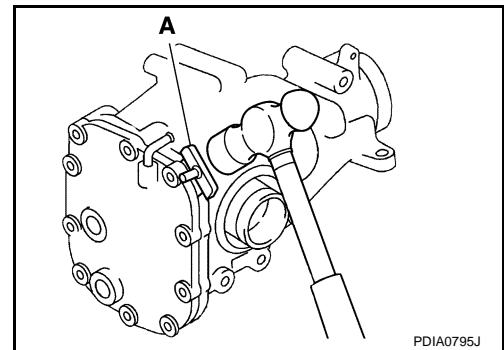

4. Remove side retainer.
5. Remove side bearing adjusting shim.
6. Remove O-ring from side retainer.

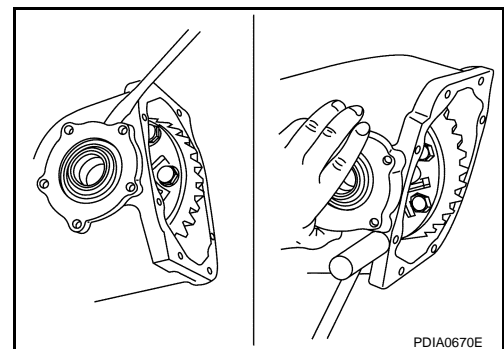

7. Remove differential case assembly from gear carrier.

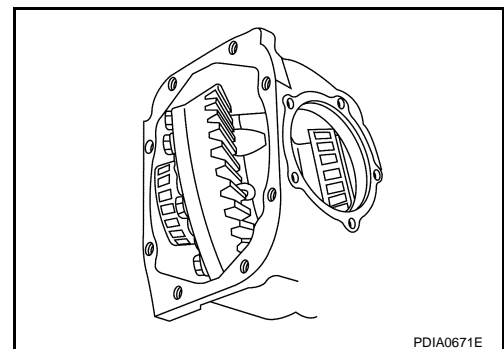

A
B
C
DLN
E
F
G
H
I
J
K
L
M
N
O
P

DIFFERENTIAL ASSEMBLY

< UNIT DISASSEMBLY AND ASSEMBLY >

[FRONT FINAL DRIVE: F160A]

8. Remove side oil seal (right side) from side retainer.

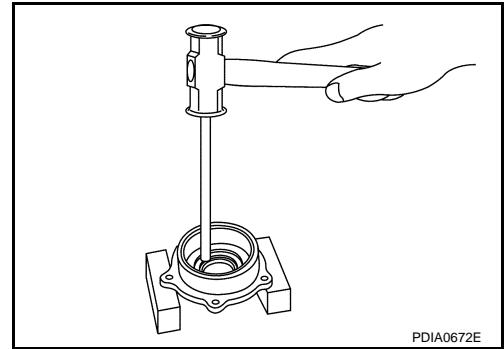

9. Remove side bearing outer race with puller (A) [SST: KV381054S0 (J-34286)].

10. Remove O-ring from gear carrier.

11. Remove side oil seal (left side) from gear carrier.

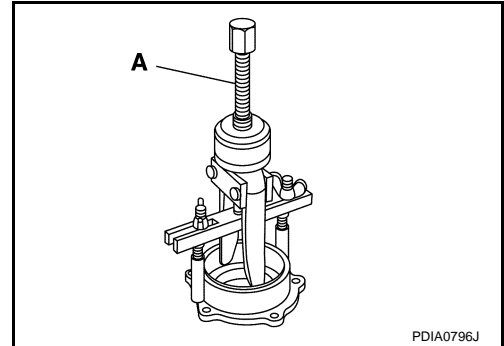

12. Remove side bearing outer race with puller (A) [SST: KV381054S0 (J-34286)].

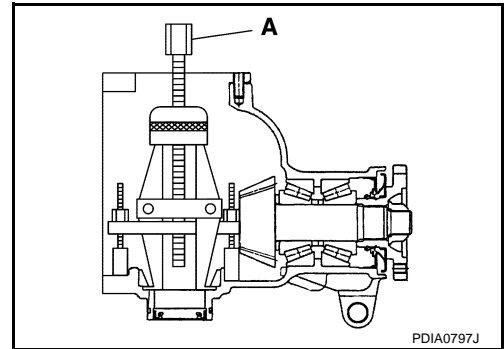

13. Remove side bearing inner race.
To prevent damage to bearing, engage puller jaws in groove (←).

A: Puller [SST: ST33051001 (J-22888-20)]

B: Base [SST: ST33061000 (J-8107-2)]

CAUTION:

- To prevent damage to the side bearing and drive gear, place copper plates between these parts and vise.
- It is not necessary to remove side bearing inner race except if it is replaced.

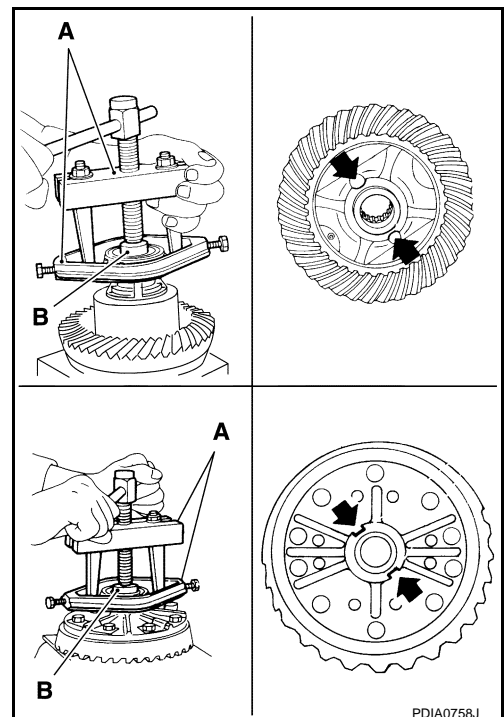

DIFFERENTIAL ASSEMBLY

< UNIT DISASSEMBLY AND ASSEMBLY >

[FRONT FINAL DRIVE: F160A]

14. For proper reinstallation, paint matching marks on one differential case assembly.

CAUTION:

For matching marks, use paint. Never damage differential case and drive gear.

15. Remove drive gear mounting bolts.

16. Tap drive gear off differential case assembly with a soft hammer.

CAUTION:

Tap evenly all around to keep drive gear from bending.

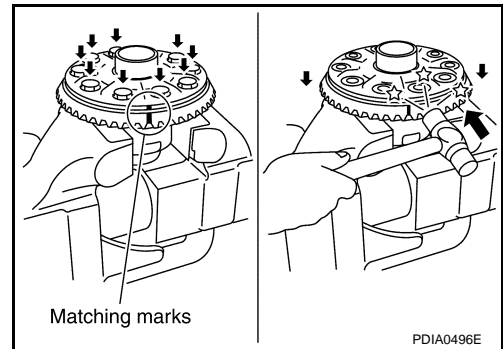

17. Remove lock pin of pinion mate shaft with a punch from drive gear side.

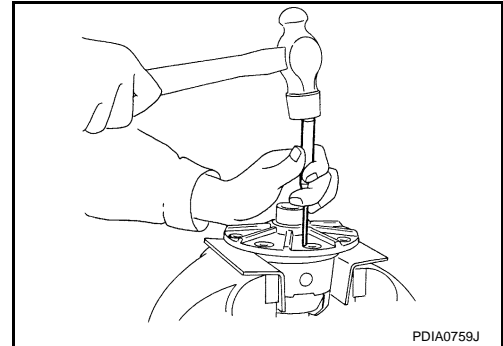

18. Remove pinion mate shaft.

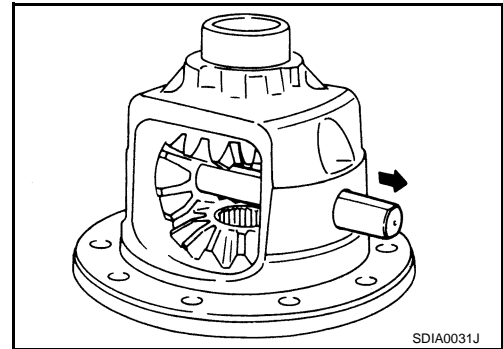

19. Turn pinion mate gear, then remove pinion mate gears, pinion mate thrust washers, side gears and side gear thrust washers from differential case.

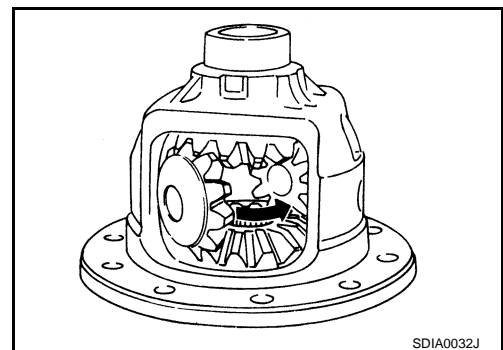

A
B
C
DLN
E
F
G
H
I
J
K
L
M
N
O
P

DIFFERENTIAL ASSEMBLY

< UNIT DISASSEMBLY AND ASSEMBLY >

[FRONT FINAL DRIVE: F160A]

INFOID:00000005649725

Assembly

1. Install side gear thrust washers with the same thickness as the ones installed prior to disassembly or reinstall the old ones on the side gears.

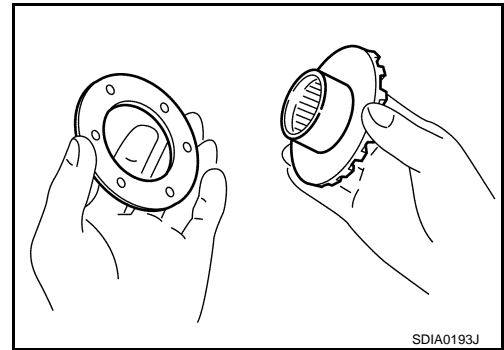

2. Install side gears and thrust washers into differential case.
CAUTION:
 - Never reuse circular clip.
 - Make sure that the circular clip is installed to side gear (side retainer side).
3. Align 2 pinion mate gears in diagonally opposite positions, then rotate and install them into differential case after installing thrust washer to pinion mate gear.

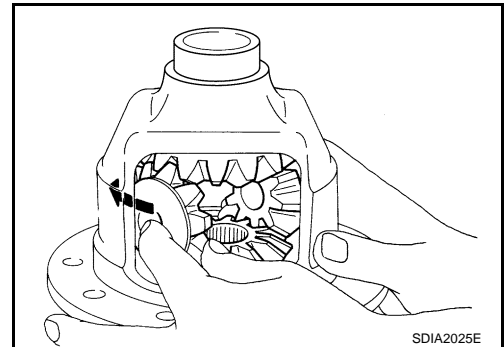

4. Align the lock pin holes on differential case with shaft, and install pinion mate shaft.

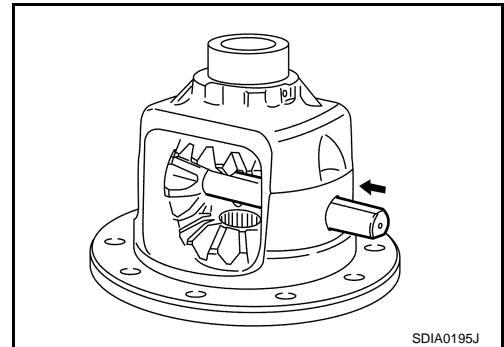

5. Measure side gear end play. If necessary, select the appropriate side gear thrust washers.
 - a. Place differential case straight up so that side gear to be measured comes upward.

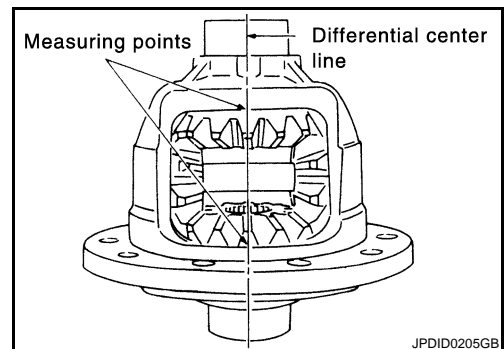

DIFFERENTIAL ASSEMBLY

< UNIT DISASSEMBLY AND ASSEMBLY >

[FRONT FINAL DRIVE: F160A]

- b. Using feeler gauge, measure the clearance between side gear back and differential case at 3 different points, while rotating side gear. Average the 3 readings, and then measure the clearance of the other side as well.

Standard

Side gear back clearance : Refer to [DLN-150, "Differential Side Gear Clearance"](#).

CAUTION:

To prevent side gear from tilting, insert feeler gauges with the same thickness from both sides.

- c. If the back clearance is outside the specification, use a thicker/thinner side gear thrust washer to adjust.

When the back clearance is large: Use a thicker thrust washer.

When the back clearance is small: Use a thinner thrust washer.

CAUTION:

Select a side gear thrust washer for right and left individually.

6. Drive a lock pin into pinion mate shaft, using a punch. Make sure lock pin is flush with differential case.

CAUTION:

Never reuse lock pin.

7. Align the matching mark of drive gear with the mark of differential case, then place drive gear.

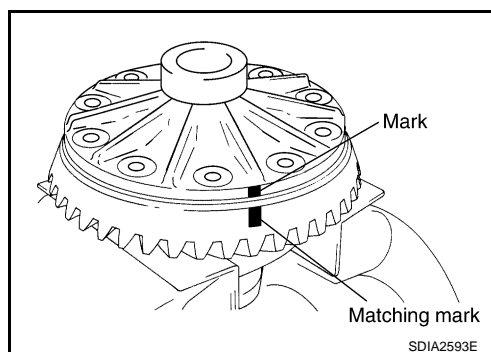
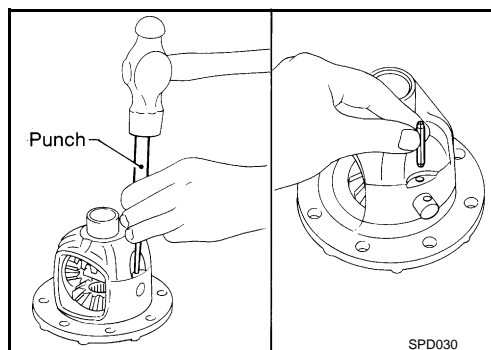
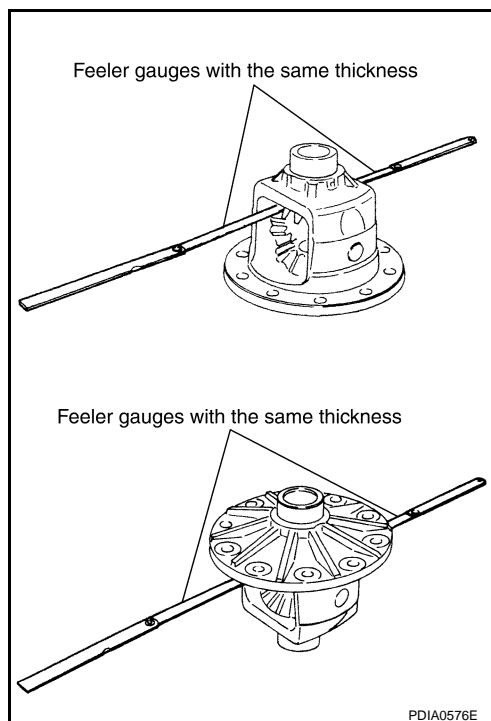

A
B
C
DLN
E
F
G
H
I
J
K
L
M
N
O
P

DIFFERENTIAL ASSEMBLY

< UNIT DISASSEMBLY AND ASSEMBLY >

[FRONT FINAL DRIVE: F160A]

8. Apply thread locking sealant into the thread hole of drive gear. Use Genuine Medium Strength Thread Locking Sealant or equivalent. Refer to [GI-18. "Recommended Chemical Products and Sealants"](#).

CAUTION:

Drive gear back and threaded holes must be cleaned and degreased sufficiently.

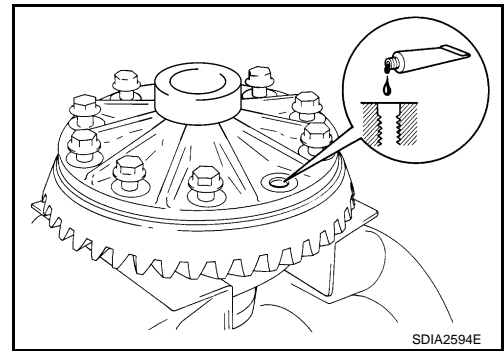

9. Install drive gear on the mounting bolts.

CAUTION:

Tighten bolts in a crisscross fashion.

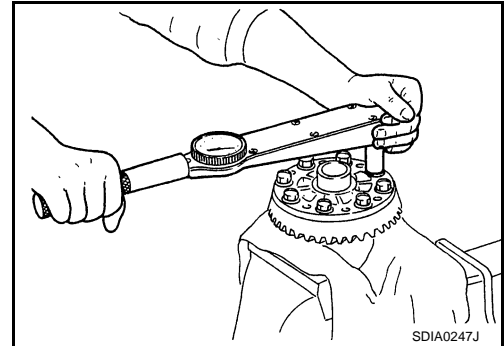

10. Press side bearing inner races to differential case, using the drift and the base.

A: Drift [SST: ST33230000 (J-25805-01)]

B: Base [SST: ST33061000 (J-8107-2)]

CAUTION:

Never reuse side bearing inner race.

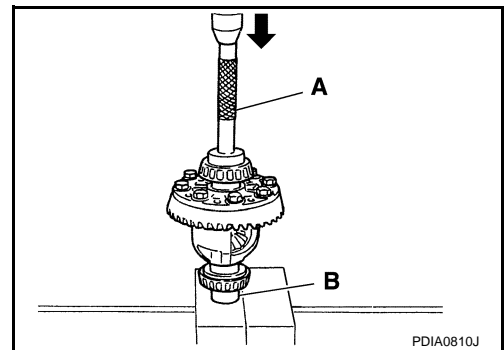

11. Press-fit side bearing outer race into side retainer with the drift and the drift bar.

A: Drift bar [SST: ST30611000 (J-25742-1)]

B: Drift [SST: KV31103000 (J-38982)]

CAUTION:

- At first, using a hammer, tap bearing outer race until it becomes flat to side retainer.
- Never reuse side bearing outer race.

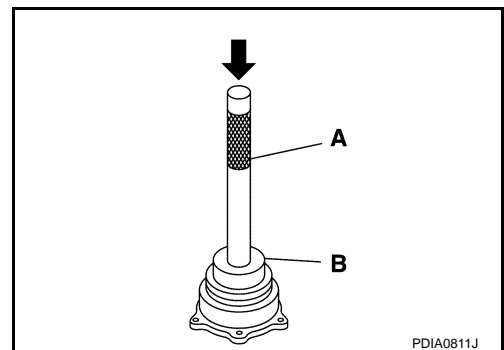

12. Press-fit side bearing outer race into gear carrier with the drift and the drift bar.

A: Drift bar [SST: ST30611000 (J-25742-1)]

B: Drift [SST: KV31103000 (J-38982)]

CAUTION:

- At first, using a hammer, tap bearing outer race until it becomes flat to gear carrier.
- Never reuse side bearing outer race.

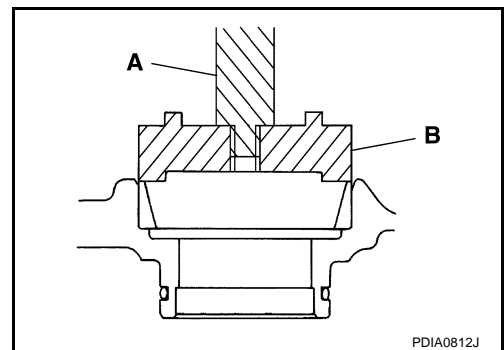

DIFFERENTIAL ASSEMBLY

< UNIT DISASSEMBLY AND ASSEMBLY >

[FRONT FINAL DRIVE: F160A]

13. Place the differential case assembly into gear carrier.
14. Measure side bearing preload. If necessary, select the appropriate side bearing adjusting shim. Refer to [DLN-136. "Adjustment"](#).

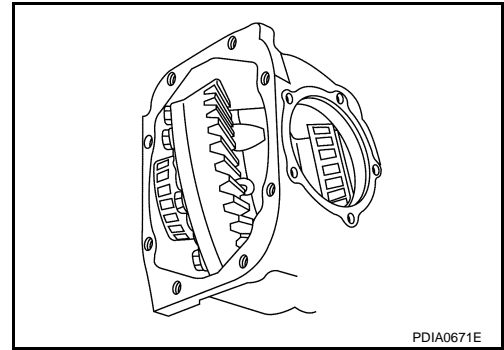

15. Install selected side bearing adjusting shim (1). Refer to [DLN-136. "Adjustment"](#).
16. Apply multi-purpose grease to O-ring (2), and install it to side retainer.
CAUTION:
Never reuse O-ring.
17. Install side retainer assembly to gear carrier.

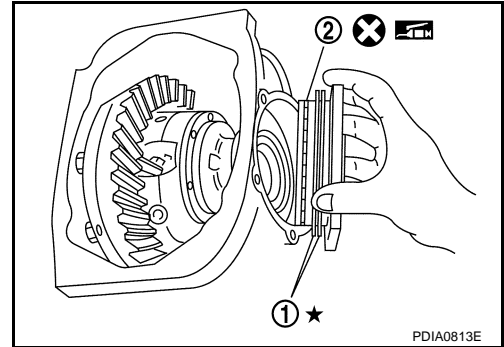

18. Install side retainer mounting bolts.

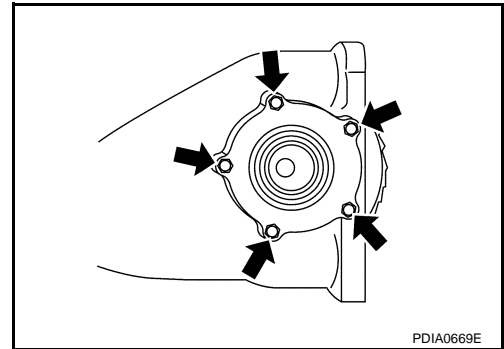

19. Using the drift (A) [SST: ST33400001 (J-26082)], press-fit side oil seal so that its surface comes face-to-face with the end surface of the side retainer.
CAUTION:
 - Never reuse oil seal.
 - When installing, never incline oil seal.
 - Apply multi-purpose grease onto oil seal lips, and gear oil onto the circumference of oil seal.

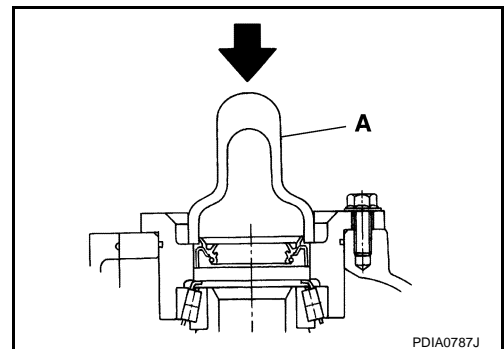

20. Using the drift (A) [SST: KV38102100 (J-25803-01)], press-fit side oil seal so that its surface comes face-to-face with the end surface of gear carrier.
CAUTION:
 - Never reuse oil seal.
 - When installing, never incline oil seal.
 - Apply multi-purpose grease onto oil seal lips, and gear oil onto the circumference of oil seal.

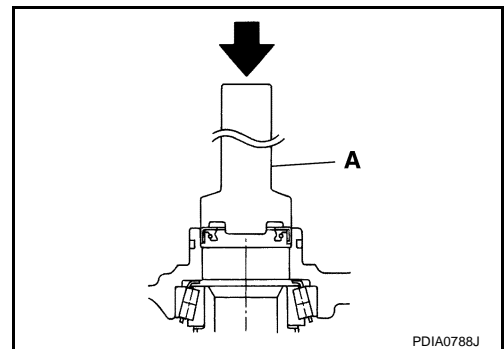

21. Apply multi-purpose grease to O-ring, and install it to gear carrier.
CAUTION:

A
B
C
DLN

E
F
G

H
I
J

K
L
M

N
O
P

DIFFERENTIAL ASSEMBLY

< UNIT DISASSEMBLY AND ASSEMBLY >

[FRONT FINAL DRIVE: F160A]

Never reuse O-ring.

22. Check and adjust drive gear runout, tooth contact, drive gear to drive pinion backlash, and total preload torque. Refer to [DLN-136, "Adjustment"](#).
Recheck above items. Readjust as described above, if necessary.

23. Apply sealant to mating surface of carrier cover.
Use Genuine Silicone RTV or equivalent. Refer to [GI-18, "Recommended Chemical Products and Sealants"](#).

CAUTION:

Remove old sealant adhering to mounting surfaces. Also remove any moisture, oil, or foreign material adhering to application and mounting surfaces.

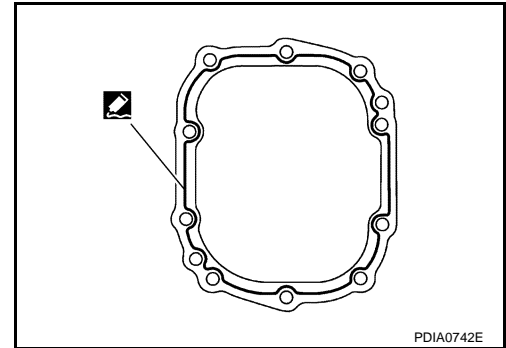

24. Install carrier cover on gear carrier and tighten mounting bolts.

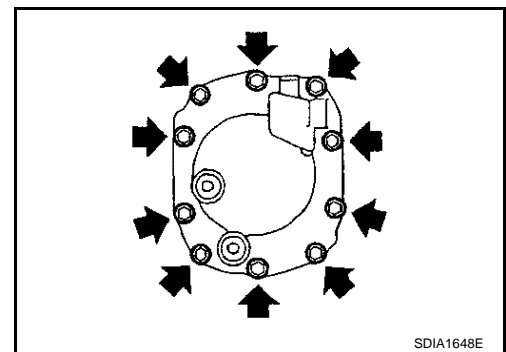

25. Set breather connector angle (A) as shown in the figure.

↔: Vehicle front

A : 0 – 30°

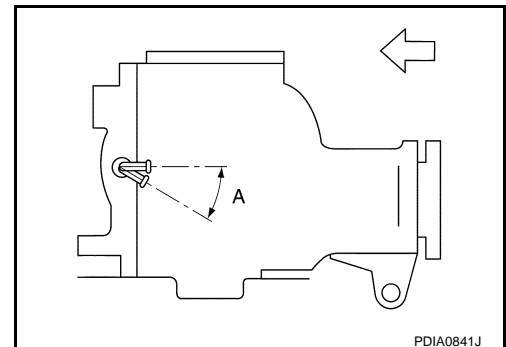

INFOID:000000005649726

Adjustment

TOTAL PRELOAD TORQUE

- Before inspection and adjustment, drain gear oil.
1. Rotate drive pinion back and forth 2 to 3 times to check for unusual noise and rotation malfunction.
 2. Rotate drive pinion at least 20 times to check for smooth operation of the bearing.
 3. Measure total preload with preload gauge (A) [SST: ST3127S000 (J-25765-A)].

Standard

Total preload torque

: Refer to [DLN-150, "Preload Torque"](#).

NOTE:

Total preload torque = Pinion bearing preload torque + Side bearing preload torque

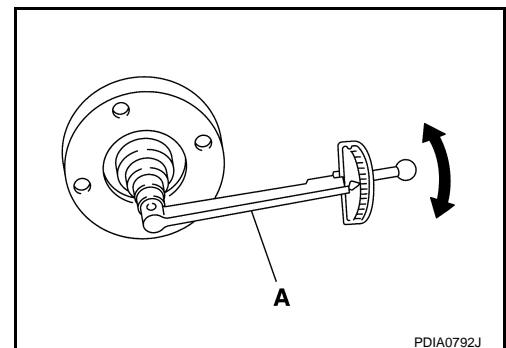

DIFFERENTIAL ASSEMBLY

< UNIT DISASSEMBLY AND ASSEMBLY >

[FRONT FINAL DRIVE: F160A]

- If measured value is out of the specification, disassemble it to check and adjust each part. Adjust the pinion bearing preload and side bearing preload.
Adjust the pinion bearing preload first, then adjust the side bearing preload.

When the preload torque is large

On pinion bearings: Decrease the drive pinion bearing adjusting washer and drive pinion adjusting washer thickness.

On side bearings: Increase the side bearing adjusting shim thickness. For select parts refer to parts information.

When the preload torque is small

On pinion bearings: Increase the drive pinion bearing adjusting washer and drive pinion adjusting washer thickness.

On side bearings: Decrease the side bearing adjusting shim thickness. For select parts refer to parts information.

SIDE BEARING PRELOAD

- Before inspection and adjustment, drain gear oil.
1. Remove carrier cover and side retainer. Refer to [DLN-129, "Disassembly"](#).
 2. Make sure all parts are clean. Also, make sure the bearings are well lubricated with gear oil.
 3. Place the differential case assembly into gear carrier.

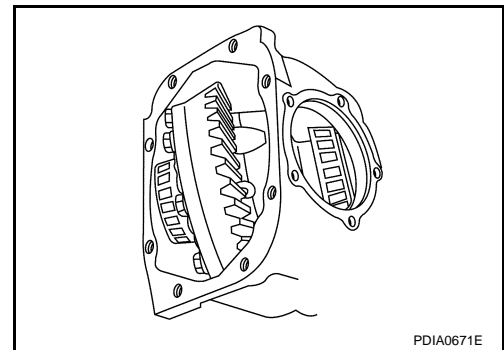

4. Install side bearing adjusting shim before disassembling or shim which thickness is the same as the one before disassembling.
5. Install side retainer assembly to gear carrier.

CAUTION:
Never install O-ring.

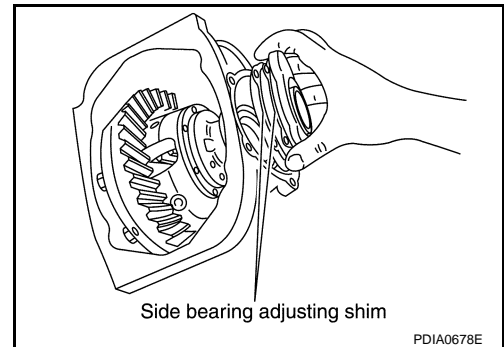

6. Install side retainer mounting bolts to the specified torque.

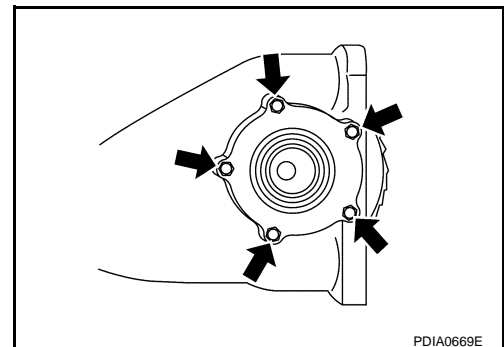

A

B

C

DLN

E

F

G

H

I

J

K

L

M

N

O

P

DIFFERENTIAL ASSEMBLY

< UNIT DISASSEMBLY AND ASSEMBLY >

[FRONT FINAL DRIVE: F160A]

7. Measure the turning torque of the gear carrier at the drive gear mounting bolts with a spring gauge [SST: — (J-8129)].

Specification : 34.2 – 39.2 N (3.5 – 4.0 kg, 7.7 – 8.8 lb) of pulling force at the drive gear bolt

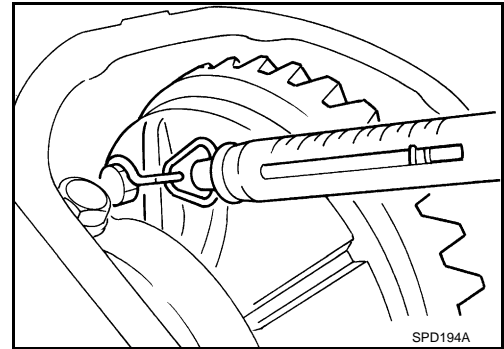

8. If the turning torque is outside the specification, use a thicker/thinner side bearing adjusting shim to adjust.

If the turning torque is less than the specified range:
Decrease the side bearing adjusting shim thickness.

If the turning torque is greater than the specification:
Increase the side bearing adjusting shim thickness.

9. Record the total amount of shim thickness required for the correct carrier side bearing preload.

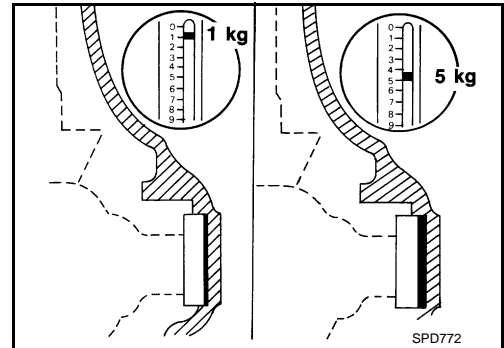

DRIVE GEAR RUNOUT

1. Remove carrier cover. Refer to [DLN-129, "Disassembly"](#).
2. Fit a dial indicator to the drive gear back face.
3. Rotate the drive gear to measure runout.

Limit
Drive gear runout : Refer to [DLN-150, "Drive Gear Runout"](#).

- If the runout is outside of the repair limit, check drive gear assembly condition; foreign material may be caught between drive gear and differential case, or differential case or drive gear may be deformed, etc.

CAUTION:

Replace drive gear and drive pinion gear as a set.

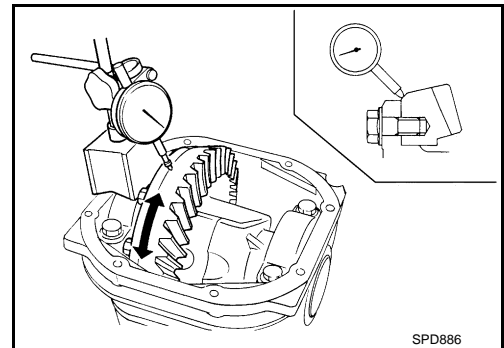

TOOTH CONTACT

Before inspection and adjustment, drain gear oil.

1. Remove carrier cover. Refer to [DLN-129, "Disassembly"](#).
2. Apply red lead to drive gear.

CAUTION:

Apply red lead to both the faces of 3 to 4 gears at 4 locations evenly spaced on drive gear.

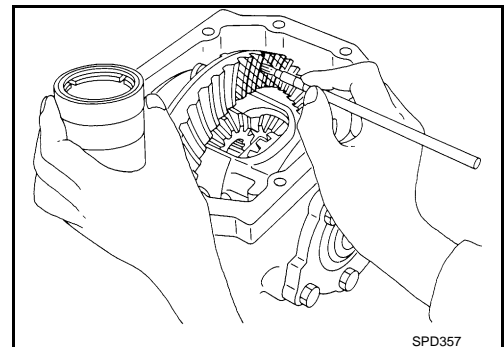

DIFFERENTIAL ASSEMBLY

< UNIT DISASSEMBLY AND ASSEMBLY >

[FRONT FINAL DRIVE: F160A]

3. Rotate drive gear back and forth several times, check drive pinion gear to drive gear tooth contact.

CAUTION:

Check tooth contact on drive side and reverse side.

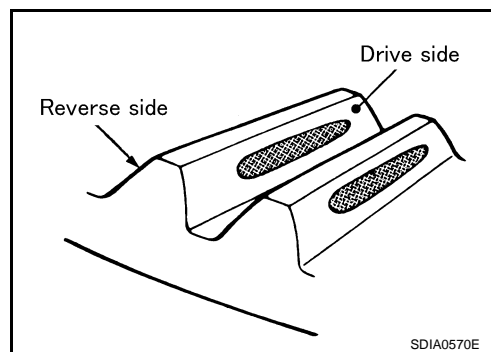

SDIA0570E

Tooth contact pattern				Pinion height adjusting washer selection value [mm (in)]	Adjustment requirement (Yes/No)
Back side		Drive side			
Heel side	Toe side	Toe side	Heel side		
				+0.15 (+0.0059)	Yes
				+0.12 (+0.0047)	
				+0.09 (+0.0035)	
				+0.06 (+0.0024)	No
				+0.03 (+0.0012)	
				0	
				-0.03 (-0.0012)	
				-0.06 (-0.0024)	
				-0.09 (-0.0035)	Yes
				-0.12 (-0.0047)	
				-0.15 (-0.0059)	

PDIA0667E

A
B
C

DLN

E
F
G
H
I
J
K
L
M
N
O
P

DIFFERENTIAL ASSEMBLY

< UNIT DISASSEMBLY AND ASSEMBLY >

[FRONT FINAL DRIVE: F160A]

4. If tooth contact is improperly adjusted, follow the procedure below to adjust the pinion height [dimension (X)].

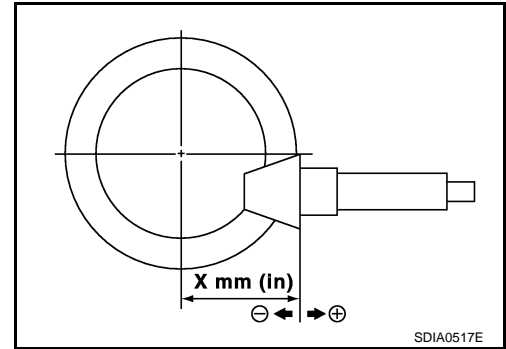

- If the tooth contact is near the face (face contact), or near the heel (heel contact), thicken pinion height adjusting washers to move drive pinion closer to drive gear.

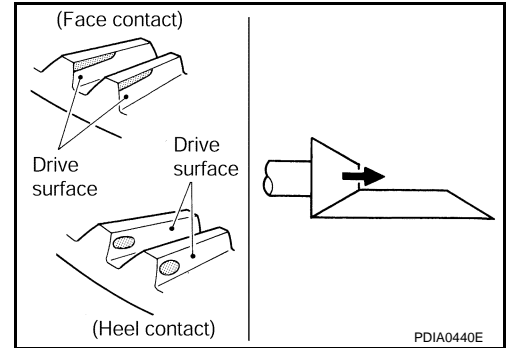

- If the tooth contact is near the flank (flank contact), or near the toe (toe contact), thin pinion height adjusting washers to move drive pinion farther from drive gear.

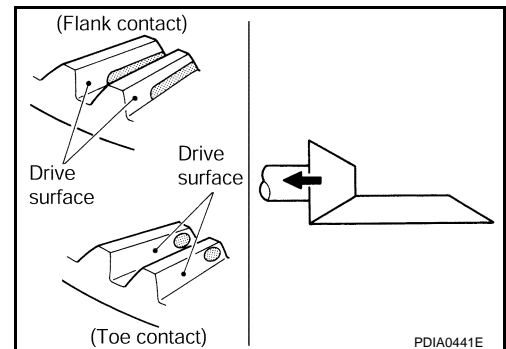

BACKLASH

Before inspection and adjustment, drain gear oil.

1. Remove carrier cover. Refer to [DLN-129, "Disassembly"](#).
2. Fit a dial indicator to the drive gear face to measure the backlash.

Standard Backlash

: Refer to [DLN-150, "Backlash"](#).

- If the backlash is outside of the specified value, change the thickness of side bearing adjusting washer.

When the backlash is large:

Decrease side bearing adjusting washer thickness.

When the backlash is small:

Increase side bearing adjusting washer thickness.

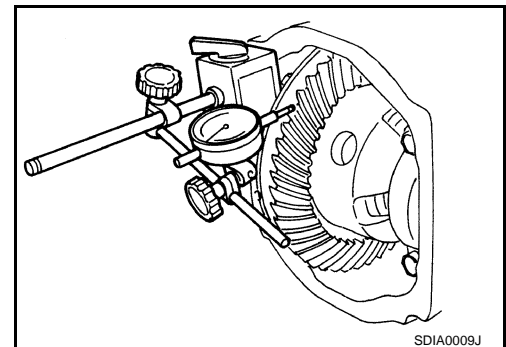

Inspection After Disassembly

INFOID:000000005649727

DRIVE GEAR AND DRIVE PINION

DIFFERENTIAL ASSEMBLY

< UNIT DISASSEMBLY AND ASSEMBLY >

[FRONT FINAL DRIVE: F160A]

- Clean up the disassembled parts.
- If the gear teeth never mesh or line-up correctly, determine the cause and adjust or replace as necessary.
- If the gears are worn, cracked, damaged, pitted or chipped (by friction) noticeably, replace with new drive gear and drive pinion as a set.

A

BEARING

- Clean up the disassembled parts.
- If any chipped (by friction), pitted, worn, rusted or scratched marks, or unusual noise from the bearing is observed, replace as a bearing assembly (as a new set).

B

C

SIDE GEAR AND PINION MATE GEAR

- Clean up the disassembled parts.
- If any cracks or damage on the surface of the tooth is found, replace.
- If any worn or chipped mark on the contact sides of the thrust washer is found, replace.

DLN

SIDE GEAR THRUST WASHER AND PINION MATE THRUST WASHER

- Clean up the disassembled parts.
- If it is chipped (by friction), damaged, or unusually worn, replace.

E

OIL SEAL

- Whenever disassembled, replace.
- If wear, deterioration of adherence (sealing force lips), or damage is detected on the lips, replace them.

F

DIFFERENTIAL CASE

- Clean up the disassembled parts.
- If any wear or crack on the contact sides of the differential case is found, replace.

G

COMPANION FLANGE

- Clean up the disassembled parts.
- If any chipped mark [about 0.1 mm, (0.004 in)] or other damage on the contact sides of the lips of the companion flange is found, replace.

H

I

J

K

L

M

N

O

P

DRIVE PINION

< UNIT DISASSEMBLY AND ASSEMBLY >

[FRONT FINAL DRIVE: F160A]

DRIVE PINION

Exploded View

INFOID:000000005649728

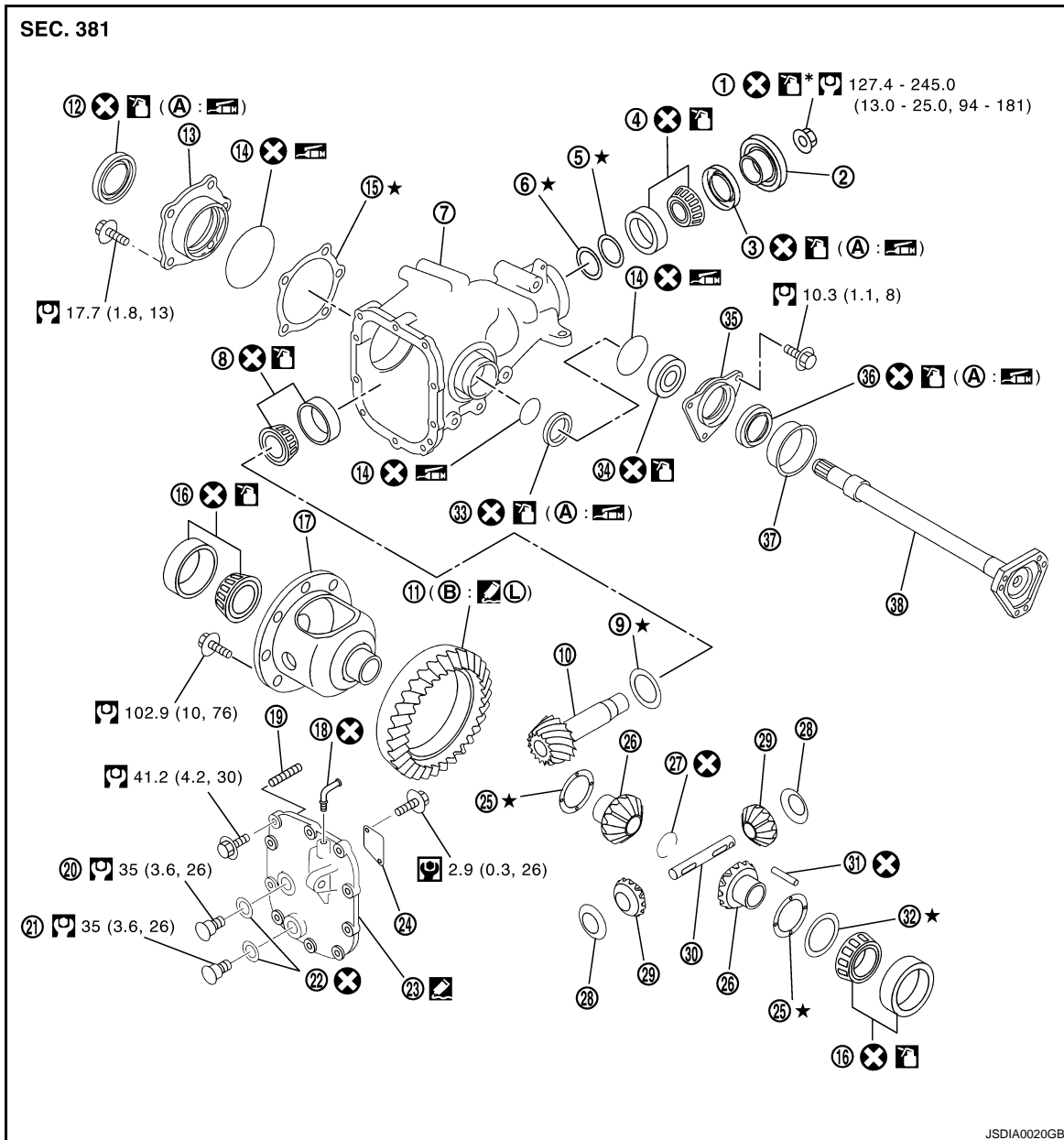

- | | | |
|-------------------------------|--|-----------------------------------|
| 1. Drive pinion lock nut | 2. Companion flange | 3. Front oil seal |
| 4. Pinion front bearing | 5. Drive pinion bearing adjusting washer | 6. Drive pinion adjusting washer |
| 7. Gear carrier | 8. Pinion rear bearing | 9. Pinion height adjusting washer |
| 10. Drive pinion | 11. Drive gear | 12. Side oil seal (right side) |
| 13. Side retainer | 14. O-ring | 15. Side bearing adjusting shim |
| 16. Side bearing | 17. Differential case | 18. Breather connector |
| 19. Dowel pin | 20. Filler plug | 21. Drain plug |
| 22. Gasket | 23. Carrier cover | 24. Gear oil defense |
| 25. Side gear thrust washer | 26. Side gear | 27. Circular clip |
| 28. Pinion mate thrust washer | 29. Pinion mate gear | 30. Pinion mate shaft |
| 31. Lock pin | 32. Side bearing adjusting washer | 33. Side oil seal (left side) |

DRIVE PINION

< UNIT DISASSEMBLY AND ASSEMBLY >

[FRONT FINAL DRIVE: F160A]

- | | | |
|------------------------|-----------------------------|-------------------------|
| 34. Side shaft bearing | 35. Extension tube retainer | 36. Side shaft oil seal |
| 37. Dust seal | 38. Side shaft | |
| A: Oil seal lip | B: Screw hole | |

: Apply gear oil.

: Apply anti-corrosion oil.

: Apply multi-purpose grease.

: Apply Genuine Silicone RTV or equivalent. Refer to [GI-18, "Recommended Chemical Products and Sealants"](#).

: Apply Genuine Medium Strength Thread Locking Sealant or equivalent. Refer to [GI-18, "Recommended Chemical Products and Sealants"](#).

Refer to [GI-4, "Components"](#) for symbols not described above.

Disassembly

INFOID:000000005649729

1. Remove differential case assembly. Refer to [DLN-129, "Disassembly"](#).
2. Remove drive pinion lock nut with a flange wrench.

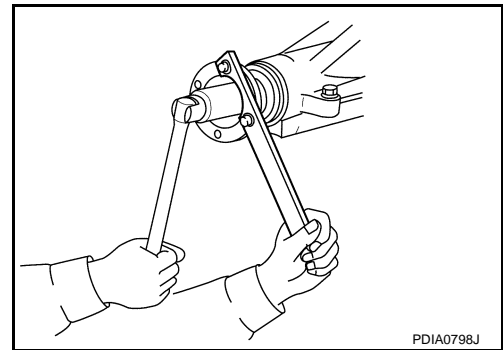

3. Put matching mark (B) on the end of drive pinion. The matching mark should be in line with the matching mark (A) on companion flange (1).

CAUTION:

For matching mark, use paint. Never damage companion flange and drive pinion.

NOTE:

The matching mark (A) on the final drive companion flange (1) indicates the maximum vertical runout position.

When replacing companion flange, matching mark is not necessary.

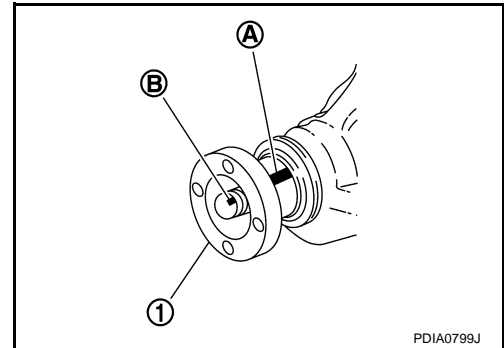

4. Remove companion flange using the suitable puller.

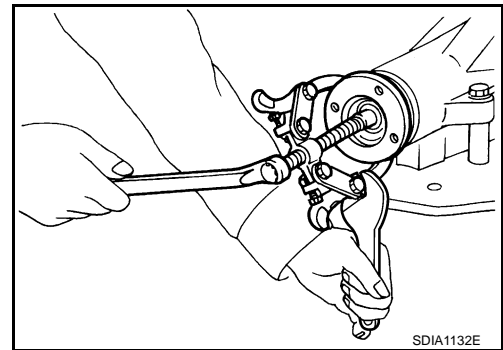

A
B
C
DLN
E
F
G
H
I
J
K
L
M
N
O
P

DRIVE PINION

< UNIT DISASSEMBLY AND ASSEMBLY >

[FRONT FINAL DRIVE: F160A]

5. Press drive pinion assembly out of gear carrier.
CAUTION:
Never drop drive pinion assembly.
6. Remove front oil seal.
7. Remove pinion front bearing inner race.
8. Remove drive pinion bearing adjusting washer and drive pinion adjusting washer.

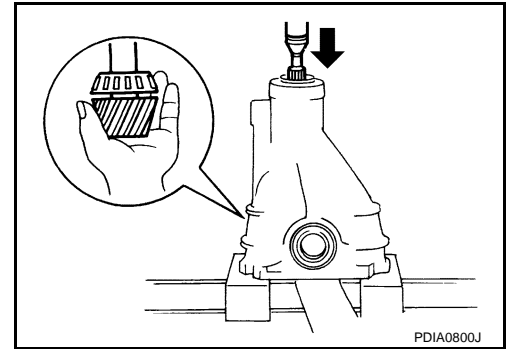

9. Remove pinion rear bearing inner race and pinion height adjusting washer with replacer (A) (commercial service tool).

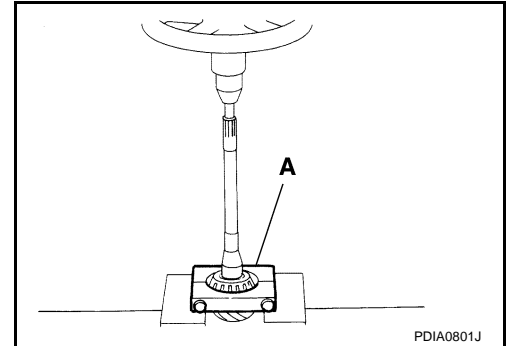

10. Tap pinion front/rear bearing outer races uniformly a brass rod or equivalent to removed.

CAUTION:
Never damage gear carrier.

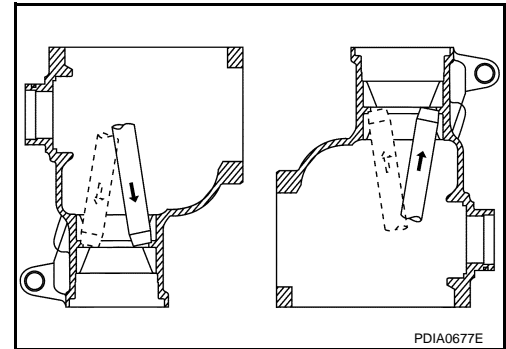

Assembly

INFOID:000000005649730

1. Install pinion front and rear bearing outer races using drift (A) [SST: ST37820000 (—)].

CAUTION:

- At first, using a hammer, tap bearing outer race until it becomes flat to gear carrier.
- Never reuse pinion front and rear bearing outer race.

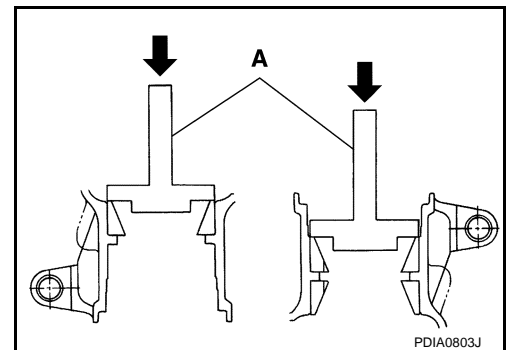

DRIVE PINION

< UNIT DISASSEMBLY AND ASSEMBLY >

[FRONT FINAL DRIVE: F160A]

2. Temporarily install pinion height adjusting washer (1).

When hypoid gear set has been replaced

- Select pinion height adjusting washer. Refer to [DLN-146](#). "[Adjustment](#)".

When hypoid gear set has been reused

- Temporarily install the removed pinion height adjusting washer or same thickness washer to drive pinion.

CAUTION:

- Pay attention to the direction of pinion height adjusting washer. (Assemble as shown in the figure.)
- Never reuse pinion rear bearing inner race.

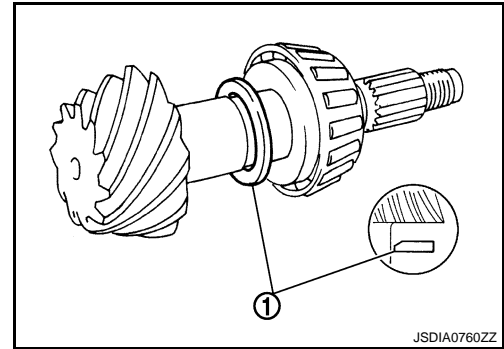

3. Install pinion rear bearing inner race (1) to drive pinion with the drift (A) [SST: ST30032000 (J-26010-01)].

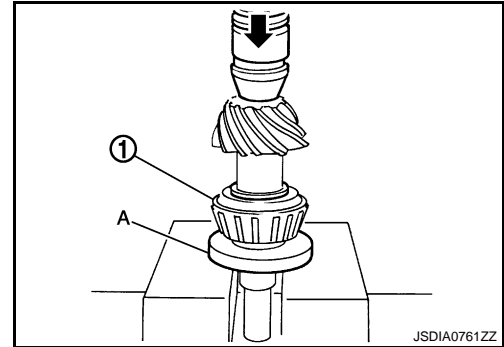

4. Temporarily assemble removed drive pinion adjusting washer and drive pinion bearing adjusting washer or same thickness of them to drive pinion.
5. Apply gear oil to pinion rear bearing, and assemble drive pinion into gear carrier.
6. Apply gear oil to pinion front bearing, and assemble pinion front bearing inner race to drive pinion assembly.

CAUTION:

Never reuse pinion front bearing inner race.

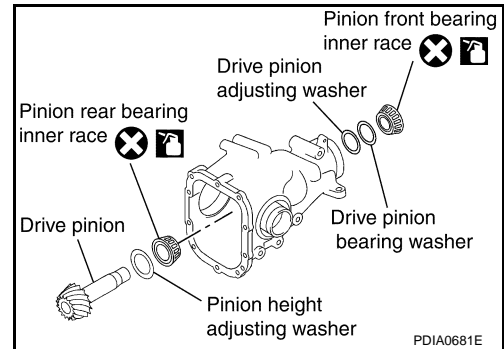

7. Using suitable spacer (A), press the pinion front bearing inner race to drive pinion as far as drive pinion nut can be tightened.
8. Adjust pinion bearing preload. If necessary, select the appropriate drive pinion adjusting washer and drive pinion bearing adjusting washer. Refer to [DLN-146](#). "[Adjustment](#)".

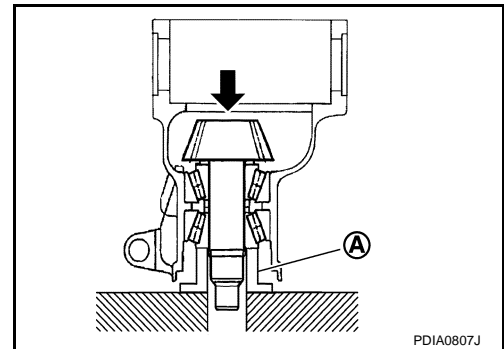

A
B
C
DLN
E
F
G
H
I
J
K
L
M
N
O
P

DRIVE PINION

< UNIT DISASSEMBLY AND ASSEMBLY >

[FRONT FINAL DRIVE: F160A]

9. Using the drifts, install front oil seal as shown in figure.

A: Drift [SST: ST33400001 (J-26082)]

B: Drift [SST: KV38102510 (—)]

CAUTION:

- Never reuse oil seal.
- When installing, never incline oil seal.
- Apply multi-purpose grease onto oil seal lips, and gear oil onto the circumference of oil seal.

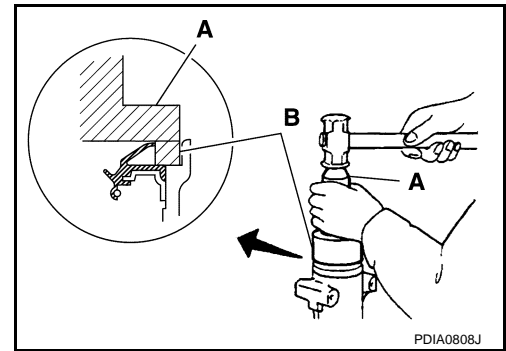

10. Install companion flange (1).

NOTE:

When reusing drive pinion, align the matching mark (B) of drive pinion with the matching mark (A) of companion flange, and then install companion flange (1).

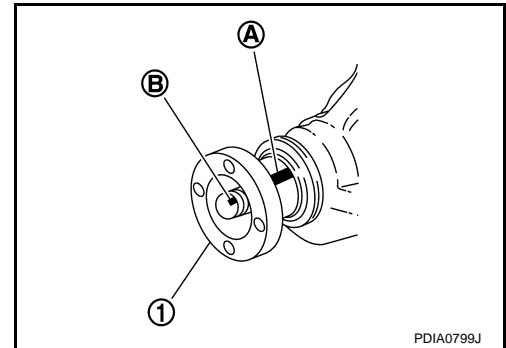

11. Apply anti-corrosion oil to the thread and seat of new drive pinion lock nut, and temporarily tighten drive pinion lock nut to drive pinion.

CAUTION:

Never reuse drive pinion lock nut.

12. Tighten to drive pinion lock nut, while adjusting pinion bearing preload torque.

A: Preload gauge [SST: ST3127S000 (J-25765-A)]

Standard

Pinion bearing preload : Refer to [DLN-150. "Pre-load Torque"](#).

CAUTION:

- Adjust to the lower limit of the drive pinion lock nut tightening torque first.
- After adjustment, rotate drive pinion back and forth 2 to 3 times to check for unusual noise, rotation malfunction, and other malfunctions.

13. Install differential case assembly. Refer to [DLN-132. "Assembly"](#).

CAUTION:

Never install carrier cover yet.

14. Check and adjust drive gear runout, tooth contact, drive gear to drive pinion backlash, and companion flange runout. Refer to [DLN-136. "Adjustment"](#) and [DLN-146. "Adjustment"](#).
Recheck above items. Readjust the above description, if necessary.

15. Check total preload torque. Refer to [DLN-136. "Adjustment"](#).

16. Install carrier cover. Refer to [DLN-132. "Assembly"](#).

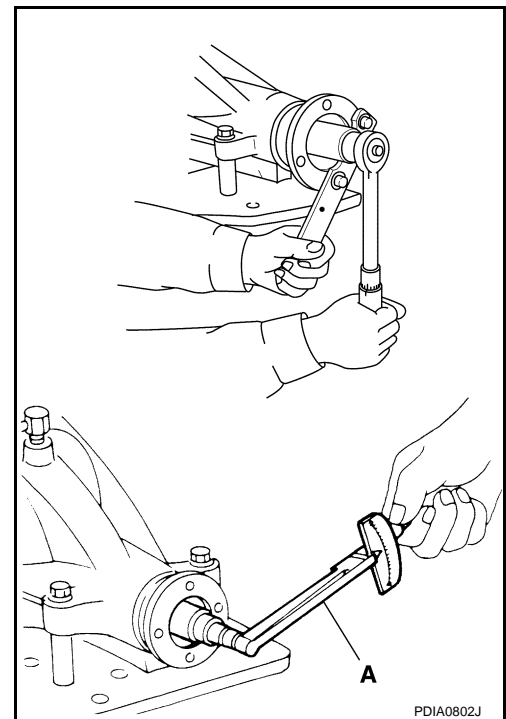

Adjustment

INFOID:000000005649731

PINION GEAR HEIGHT

If the hypoid gear set has been replaced, select the pinion height adjusting washer.

DRIVE PINION

< UNIT DISASSEMBLY AND ASSEMBLY >

[FRONT FINAL DRIVE: F160A]

1. Use the formula below to calculate pinion height adjusting washer thickness.

Washer selection equation:

$$T = T_0 + (t_1 - t_2)$$

T: Correct washer thickness

T₀: Removed washer thickness

t₁: Old drive pinion head letter "H × 0.01"
("H": machined tolerance 1/100 mm × 100)

t₂: New drive pinion head letter "H × 0.01"
("H": machined tolerance 1/100 mm × 100)

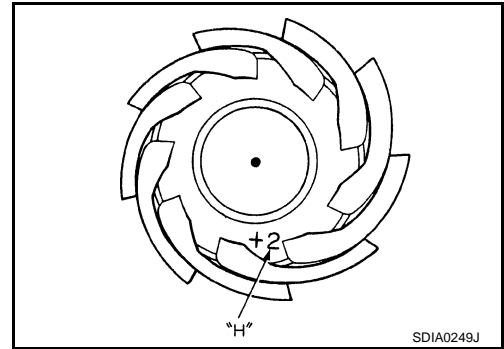

Example:

$$T = 3.21 + [(2 \times 0.01) - (-1 \times 0.01)] = 3.24$$

T₀: 3.21

t₁: +2

t₂: -1

2. Select the proper pinion height adjusting washer.
If unable to find a washer of desired thickness, use a washer with thickness closest to the calculated value.

Example:

Calculated value... T = 3.22 mm

Used washer... T = 3.21 mm

PINION BEARING PRELOAD

Assemble the drive pinion parts if they are disassembled. Refer to [DLN-144, "Assembly"](#).

1. Make sure all parts are clean. Also, make sure the bearings are well lubricated with gear oil.
2. Install companion flange (1).

NOTE:

When reusing drive pinion, align the matching mark (B) of drive pinion with the matching mark (A) of companion flange, and then install companion flange (1).

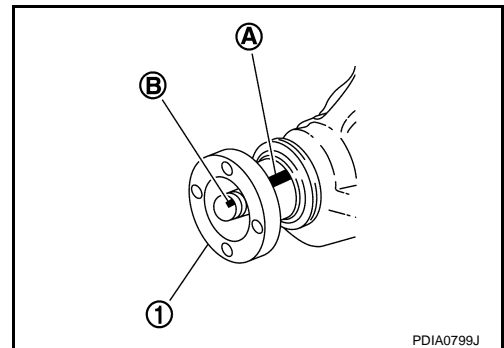

DRIVE PINION

< UNIT DISASSEMBLY AND ASSEMBLY >

[FRONT FINAL DRIVE: F160A]

- Temporarily tighten removed drive pinion lock nut to drive pinion.
NOTE:
Use removed drive pinion lock nut only for the preload measurement.
- Rotate drive pinion at least 20 times to check for smooth operation of the bearing.
- Tighten to drive pinion lock nut, while adjust pinion bearing preload torque.

A: Preload gauge [SST: ST3127S000 (J-25765-A)]

Standard

Pinion bearing preload : Refer to [DLN-150, "Pre-load Torque"](#).

CAUTION:

- Adjust to the lower limit of the drive pinion lock nut tightening torque first.
 - After adjustment, rotate drive pinion back and forth 2 to 3 times to check for unusual noise, rotation malfunction, and other malfunctions.
- If the pinion bearing preload torque is outside the specification, use a thicker/thinner drive pinion bearing adjusting washer and drive pinion adjusting washer to adjust.

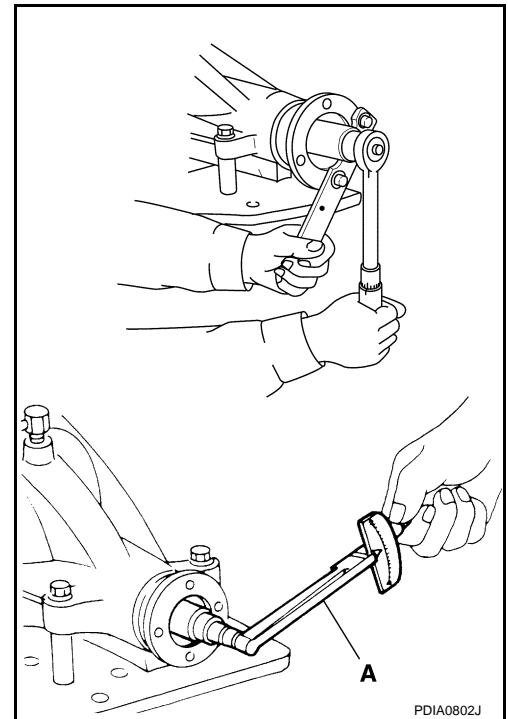

When the preload torque is large:

Decrease the drive pinion bearing adjusting washer and drive pinion adjusting washer thickness. For select parts refer to parts information.

When the preload is small:

Increase the drive pinion bearing adjusting washer and drive pinion adjusting washer thickness. For select parts refer to parts information.

- Remove companion flange, after adjustment.

COMPANION FLANGE RUNOUT

- Fit a dial indicator onto the companion flange face (inner side of the propeller shaft mounting bolt holes).
- Rotate companion flange to check for runout.

Limit

Companion flange runout : Refer to [DLN-150, "Companion Flange Runout"](#).

- Fit a test indicator to the inner side of companion flange (socket diameter).
- Rotate companion flange to check for runout.

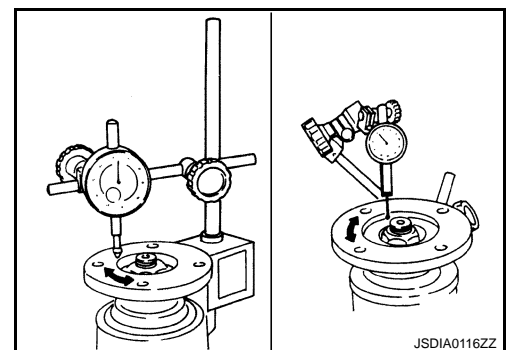

Limit

Companion flange runout : Refer to [DLN-150, "Companion Flange Runout"](#).

- If the runout value is outside the runout limit, follow the procedure below to adjust.
 - Check for runout while changing the phase between companion flange and drive pinion by 90° step, and search for the position where the runout is the minimum.
 - If the runout value is still outside of the limit after the phase has been changed, possible cause will be an assembly malfunction of drive pinion and pinion bearing and malfunction of pinion bearing. Check for these items and repair if necessary.

DRIVE PINION

< UNIT DISASSEMBLY AND ASSEMBLY >

[FRONT FINAL DRIVE: F160A]

- c. If the runout value is still outside of the limit after the check and repair, replace companion flange.

Inspection After Disassembly

INFOID:000000005649732

DRIVE GEAR AND DRIVE PINION

- Clean up the disassembled parts.
- If the gear teeth never mesh or line-up correctly, determine the cause and adjust or replace as necessary.
- If the gears are worn, cracked, damaged, pitted or chipped (by friction) noticeably, replace with new drive gear and drive pinion as a set.

BEARING

- Clean up the disassembled parts.
- If any chipped (by friction), pitted, worn, rusted or scratched marks, or unusual noise from the bearing is observed, replace as a bearing assembly (as a new set).

SIDE GEAR AND PINION MATE GEAR

- Clean up the disassembled parts.
- If any cracks or damage on the surface of the tooth is found, replace.
- If any worn or chipped mark on the contact sides of the thrust washer is found, replace.

SIDE GEAR THRUST WASHER AND PINION MATE THRUST WASHER

- Clean up the disassembled parts.
- If it is chipped (by friction), damaged, or unusually worn, replace.

OIL SEAL

- Whenever disassembled, replace.
- If wear, deterioration of adherence (sealing force lips), or damage is detected on the lips, replace them.

DIFFERENTIAL CASE

- Clean up the disassembled parts.
- If any wear or crack on the contact sides of the differential case is found, replace.

COMPANION FLANGE

- Clean up the disassembled parts.
- If any chipped mark [about 0.1 mm, (0.004 in)] or other damage on the contact sides of the lips of the companion flange is found, replace.

A

B

C

DLN

E

F

G

H

I

J

K

L

M

N

O

P

SERVICE DATA AND SPECIFICATIONS (SDS)

< SERVICE DATA AND SPECIFICATIONS (SDS)

[FRONT FINAL DRIVE: F160A]

SERVICE DATA AND SPECIFICATIONS (SDS)

SERVICE DATA AND SPECIFICATIONS (SDS)

General Specifications

INFOID:000000005649733

Applied model	AWD
	VQ37VHR
	A/T
Final drive model	F160A
Gear ratio	3.357
Number of teeth (Drive gear/Drive pinion)	47/14
Oil capacity (Approx.) ℓ (US pt, Imp pt)	0.65 (1-3/8, 1-1/8)
Number of pinion gears	2
Drive pinion adjustment spacer type	Solid

Drive Gear Runout

INFOID:000000005649734

Unit: mm (in)

Item	Limit
Drive gear back face runout	0.05 (0.0020)

Differential Side Gear Clearance

INFOID:000000005649735

Unit: mm (in)

Item	Standard
Side gear backlash (Clearance between side gear and differential case)	0.2 (0.008) or less (Each gear should rotate smoothly without excessive resistance during differential motion.)

Preload Torque

INFOID:000000005649736

Unit: N·m (kg·m, in·lb)

Item	Standard
Pinion bearing (P1)	0.78 – 1.57 (0.08 – 0.16, 7 – 13)
Side bearing (P2)	0.78 – 1.08 (0.08 – 0.11, 7 – 9)
Side bearing to pinion bearing (Total preload) (Total preload = P1 + P2)	1.56 – 2.65 (0.16 – 0.27, 14 – 23)

Backlash

INFOID:000000005649737

Unit: mm (in)

Item	Standard
Drive gear to drive pinion gear	0.10 – 0.15 (0.0039 – 0.0059)

Companion Flange Runout

INFOID:000000005649738

Unit: mm (in)

Item	Limit
Companion flange face runout	0.18 (0.0071)
Inner side of the companion flange runout	0.13 (0.0051)

REAR FINAL DRIVE ASSEMBLY

< SYSTEM DESCRIPTION >

[REAR FINAL DRIVE: R200]

SYSTEM DESCRIPTION

REAR FINAL DRIVE ASSEMBLY

System Diagram

INFOID:000000005649739

CROSS-SECTIONAL VIEW

2WD

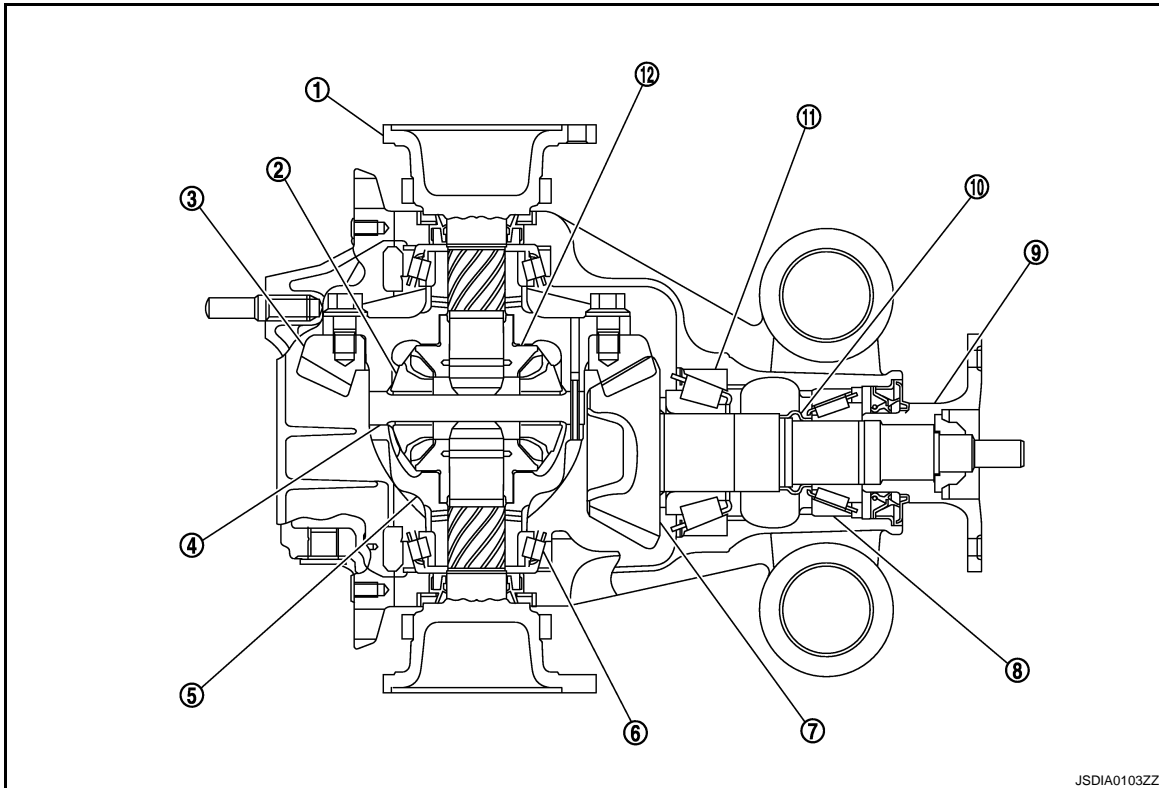

- | | | |
|------------------------|-------------------------|---------------------|
| 1. Side flange | 2. Pinion mate gear | 3. Drive gear |
| 4. Pinion mate shaft | 5. Differential case | 6. Side bearing |
| 7. Drive pinion | 8. Pinion front bearing | 9. Companion flange |
| 10. Collapsible spacer | 11. Pinion rear bearing | 12. Side gear |

A

B

C

DLN

E

F

G

H

I

J

K

L

M

N

O

P

REAR FINAL DRIVE ASSEMBLY

< SYSTEM DESCRIPTION >

[REAR FINAL DRIVE: R200]

AWD

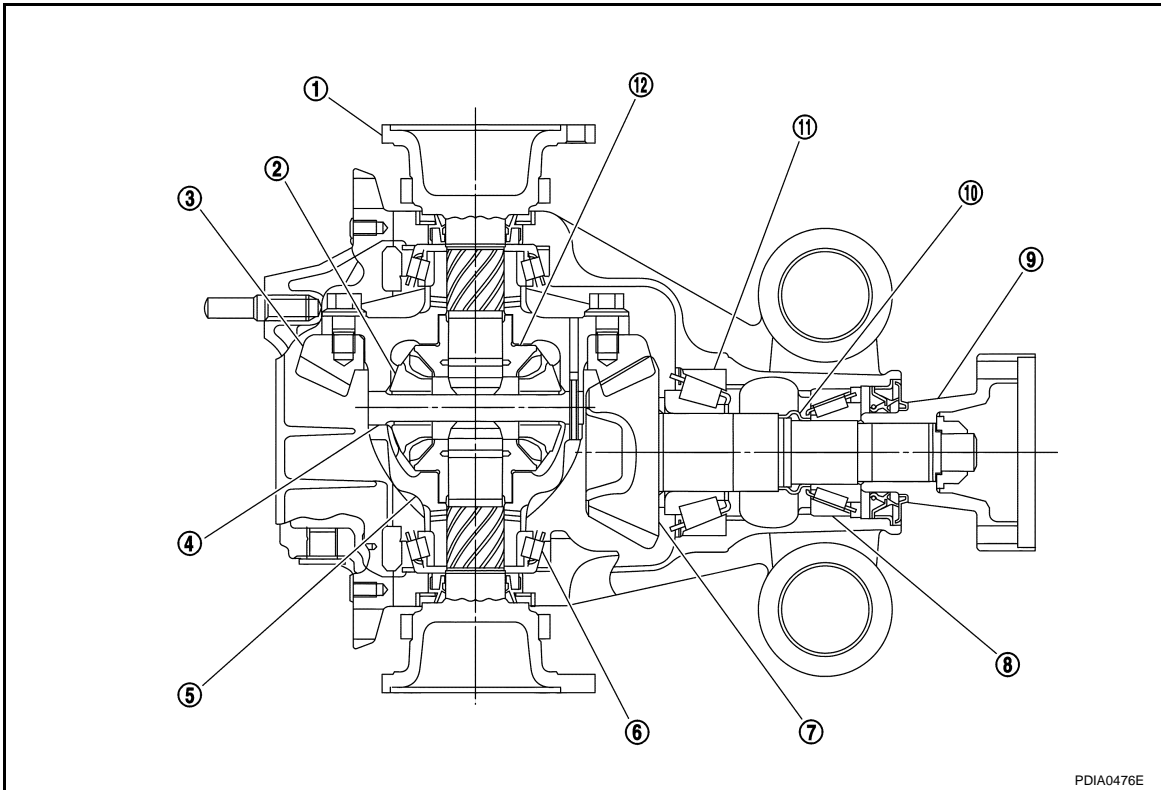

PDIA0476E

- | | | |
|------------------------|-------------------------|---------------------|
| 1. Side flange | 2. Pinion mate gear | 3. Drive gear |
| 4. Pinion mate shaft | 5. Differential case | 6. Side bearing |
| 7. Drive pinion | 8. Pinion front bearing | 9. Companion flange |
| 10. Collapsible spacer | 11. Pinion rear bearing | 12. Side gear |

NOISE, VIBRATION AND HARSHNESS (NVH) TROUBLESHOOTING

< SYMPTOM DIAGNOSIS >

[REAR FINAL DRIVE: R200]

SYMPTOM DIAGNOSIS

NOISE, VIBRATION AND HARSHNESS (NVH) TROUBLESHOOTING

NVH Troubleshooting Chart

INFOID:000000005649740

2WD

Use the chart below to find the cause of the symptom. If necessary, repair or replace these parts.

Reference	Possible cause and SUSPECTED PARTS	Symptom
DLN-191, "2WD : Inspection After Disassembly"	Gear tooth rough	Noise x
DLN-186, "2WD : Adjustment"	Gear contact improper	x
DLN-191, "2WD : Inspection After Disassembly"	Tooth surfaces worn	x
DLN-186, "2WD : Adjustment"	Backlash incorrect	x
DLN-186, "2WD : Adjustment"	Companion flange excessive runout	x
DLN-160, "Inspection"	Gear oil improper	x
NVH in DLN section.	PROPELLER SHAFT	x
NVH in FAX, RAX, FSU and RSU sections.	AXLE AND SUSPENSION	x
NVH in WT section.	TIRE	x
NVH in WT section.	ROAD WHEEL	x
NVH in RAX section.	DRIVE SHAFT	x
NVH in BR section.	BRAKE	x
NVH in ST section.	STEERING	x

x: Applicable

AWD

Use the chart below to find the cause of the symptom. If necessary, repair or replace these parts.

A
B
C
DLN
E
F
G
H
I
J
K
L
M
N
O
P

NOISE, VIBRATION AND HARSHNESS (NVH) TROUBLESHOOTING

< SYMPTOM DIAGNOSIS >

[REAR FINAL DRIVE: R200]

Symptom		Noise														
Possible cause and SUSPECTED PARTS			×	×	×	×	×	×	×	×	×	×	×	×		
		Gear tooth rough	×	×	×	×	×	×	×	×	×	×	×	×		
		Gear contact improper	×	×	×	×	×	×	×	×	×	×	×	×	×	
		Tooth surfaces worn	×	×	×	×	×	×	×	×	×	×	×	×	×	
		Backlash incorrect	×	×	×	×	×	×	×	×	×	×	×	×	×	
		Companion flange excessive runout	×	×	×	×	×	×	×	×	×	×	×	×	×	×
		Gear oil improper	×	×	×	×	×	×	×	×	×	×	×	×	×	×
		PROPELLER SHAFT	×	×	×	×	×	×	×	×	×	×	×	×	×	×
		AXLE AND SUSPENSION	×	×	×	×	×	×	×	×	×	×	×	×	×	×
		TIRE	×	×	×	×	×	×	×	×	×	×	×	×	×	×
ROAD WHEEL	×	×	×	×	×	×	×	×	×	×	×	×	×	×		
DRIVE SHAFT	×	×	×	×	×	×	×	×	×	×	×	×	×	×		
BRAKE	×	×	×	×	×	×	×	×	×	×	×	×	×	×		
STEERING	×	×	×	×	×	×	×	×	×	×	×	×	×	×		

×: Applicable

PRECAUTION

PRECAUTIONS

Service Notice or Precautions for Rear Final Drive

INFOID:000000005649741

- Check for the correct installation status prior to removal or disassembly. If matching marks are required, be certain they never interfere with the function of the parts when applied.
- Overhaul should be done in a clean work area, it is preferable to work in dustproof area.
- Before disassembly, using steam or white gasoline, completely remove sand and mud from the exterior of the unit, preventing them from entering into the unit during disassembly or assembly.
- Check appearance of the disassembled parts for damage, deformation, and unusual wear. Replace them with new ones, if necessary.
- Gaskets, seals and O-rings should be replaced any time when the unit is disassembled.
- In principle, tighten bolts or nuts gradually in several steps working diagonally from inside to outside. If tightening sequence is specified, observe it.
- Clean and flush the parts sufficiently and blow-dry them.
- Be careful not to damage sliding surfaces and mating surfaces.
- When applying sealant, remove the old sealant from the mounting surface; then remove any moisture, oil, and foreign materials from the application and mounting surfaces.
- Always use shop paper for cleaning the inside of components.
- Never use cotton gloves or shop rags to prevent entering of lint.
- During assembly, observe the specified tightening torque, and apply new gear oil, petroleum jelly, or multi-purpose grease as specified for each vehicle, if necessary.

A
B
C
DLN
E
F
G
H
I
J
K
L
M
N
O
P



PREPARATION

< PREPARATION >

[REAR FINAL DRIVE: R200]

PREPARATION

PREPARATION

Special Service Tools

INFOID:000000005649742

The actual shapes of Kent-Moore tools may differ from those of special service tools illustrated here.

Tool number (Kent-Moore No.) Tool name	Description
KV40104100 (—) Attachment	Removing side flange
ST36230000 (J-25840-A) Sliding hammer	Removing side flange
ST3127S000 (J-25765-A) Preload gauge	Measuring pinion bearing preload and total preload
KV381054S0 (J-34286) Puller	Removing front oil seal
ST30720000 (J-25405) Drift a: 77 mm (3.03 in) dia. b: 55.5 mm (2.185 in) dia.	<ul style="list-style-type: none"> • Installing front oil seal • Installing pinion rear bearing outer race
KV38107900 (J-39352) Protector	Installing side flange

PREPARATION

< PREPARATION >



[REAR FINAL DRIVE: R200]

Tool number (Kent-Moore No.) Tool name	Description	
KV38100200 (J-26233) Drift a: 65 mm (2.56 in) dia. b: 49 mm (1.93 in) dia. <div data-bbox="613 310 899 449" data-label="Image"> </div> <div data-bbox="846 470 915 485" data-label="Text"> <p>ZZA1143D</p> </div>	Installing side oil seal	A B C
KV10111100 (J-37228) Seal cutter <div data-bbox="708 569 834 705" data-label="Image"> </div> <div data-bbox="846 722 906 737" data-label="Text"> <p>S-NT046</p> </div>	Removing rear cover	DLN E F
KV38100800 (J-25604-01) Attachment A: 541 mm (21.30 in) B: 200 mm (7.87 in) <div data-bbox="646 800 818 974" data-label="Image"> </div> <div data-bbox="846 974 922 989" data-label="Text"> <p>SDIA0267E</p> </div>	Fixing unit assembly	G H
ST3306S001 (J-22888-D) Differential side bearing puller set 1: ST33051001 (J-22888-20) Puller 2: ST33061000 (J-8107-2) Base a: 28.5 mm (1.122 in) dia. b: 38 mm (1.50 in) dia. <div data-bbox="607 1062 932 1276" data-label="Image"> </div> <div data-bbox="846 1255 894 1270" data-label="Text"> <p>NT072</p> </div>	Removing and installing side bearing inner race	I J K
KV10112100 (BT-8653-A) Angle wrench <div data-bbox="683 1398 867 1524" data-label="Image"> </div> <div data-bbox="846 1541 915 1556" data-label="Text"> <p>ZZA0120D</p> </div>	Tightening drive gear bolt	L M N
KV38100300 (J-25523) Drift a: 54 mm (2.13 in) dia. b: 46 mm (1.81 in) dia. c: 32 mm (1.26 in) dia. <div data-bbox="613 1633 932 1793" data-label="Image"> </div> <div data-bbox="846 1793 915 1808" data-label="Text"> <p>ZZA1046D</p> </div>	Installing side bearing inner race	O P

PREPARATION

< PREPARATION >

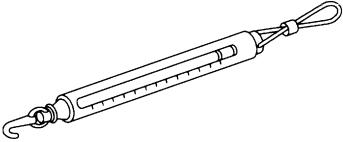
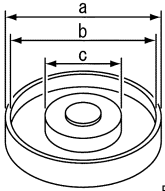
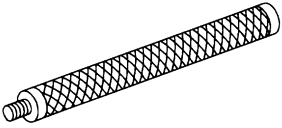
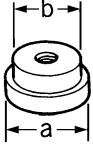
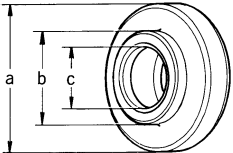
[REAR FINAL DRIVE: R200]

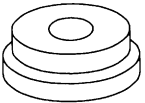
Tool number (Kent-Moore No.) Tool name	Description
<p>— (J-8129) Spring gauge</p> <div style="text-align: center;">  <p>NT127</p> </div>	<p>Measuring turning torque</p>
<p>KV40105230 (—) Drift a: 92 mm (3.62 in) dia. b: 86 mm (3.39 in) dia. c: 45 mm (1.77 in) dia.</p> <div style="text-align: center;">  <p>PDIA0591E</p> </div>	<p>Installing pinion rear bearing outer race</p>
<p>ST30611000 (J-25742-1) Drift bar</p> <div style="text-align: center;">  <p>S-NT090</p> </div>	<p>Installing pinion front bearing outer race (Use with ST30613000)</p>
<p>ST30613000 (J-25742-3) Drift a: 72 mm (2.83 in) dia. b: 48 mm (1.89 in) dia.</p> <div style="text-align: center;">  <p>ZZA1000D</p> </div>	<p>Installing pinion front bearing outer race</p>
<p>ST30901000 (J-26010-01) Drift a: 79 mm (3.11 in) dia. b: 45 mm (1.77 in) dia. c: 35.2 mm (1.386 in) dia.</p> <div style="text-align: center;">  <p>ZZA0978D</p> </div>	<p>Installing pinion rear bearing inner race</p>
<p>— (J-34309) Differential shim selector tool</p> <div style="text-align: center;">  <p>NT134</p> </div>	<p>Adjusting bearing preload and pinion gear height</p>
<p>— (J-25269-4) Side bearing disc (2 Req'd)</p> <div style="text-align: center;">  <p>NT136</p> </div>	<p>Selecting pinion height adjusting washer</p>



PREPARATION

< PREPARATION >

[REAR FINAL DRIVE: R200]

Commercial Service Tools

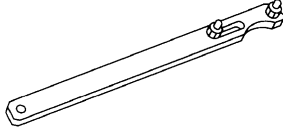
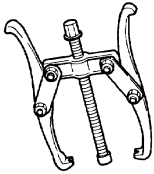
INFOID:000000005649743

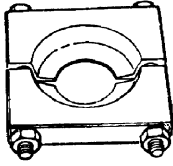
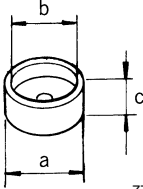
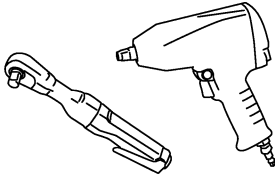
Tool name	Description
Flange wrench  NT035	Removing and installing drive pinion lock nut
Puller  ZZA0119D	Removing companion flange
Sliding hammer  NT125	Removing differential case assembly
Replacer  ZZA0700D	Removing pinion rear bearing inner race
Spacer a: 60 mm (2.36 in) dia. b: 36 mm (1.42 in) dia. c: 30 mm (1.18 in)  ZZA1133D	Installing pinion front bearing inner race
Power tool  PBIC0190E	Loosening bolts and nuts

A
B
C
DLN
E
F
G
H
I
J
K
L
M
N
O
P

PERIODIC MAINTENANCE

REAR DIFFERENTIAL GEAR OIL

Inspection

INFOID:000000005649744

OIL LEAKAGE

Make sure that oil is not leaking from final drive assembly or around it.

OIL LEVEL

- Remove filler plug (1) and check oil level from filler plug mounting hole as shown in the figure.

CAUTION:

Never start engine while checking oil level.

- Set a gasket on filler plug (1) and install it on final drive assembly. Refer to [DLN-179. "2WD : Exploded View"](#) (2WD), [DLN-192. "AWD : Exploded View"](#) (AWD).

CAUTION:

Never reuse gasket.

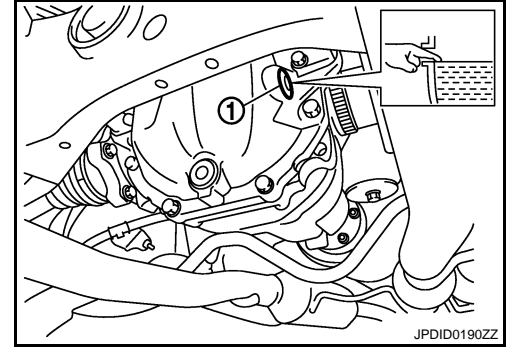

INFOID:000000005649745

Draining

- Stop the engine.
- Remove drain plug (1) and drain gear oil.
- Set a gasket on drain plug (1) and install it to final drive assembly and tighten to the specified torque. Refer to [DLN-179. "2WD : Exploded View"](#) (2WD), [DLN-192. "AWD : Exploded View"](#) (AWD).

CAUTION:

Never reuse gasket.

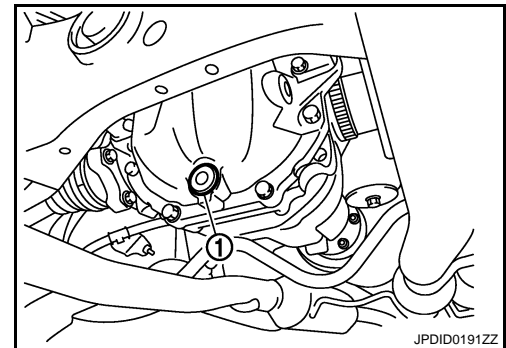

INFOID:000000005649746

Refilling

- Remove filler plug (1). Fill with new gear oil until oil level reaches the specified level near filler plug mounting hole.

Oil grade and viscosity : Refer to [MA-10. "Fluids and Lubricants"](#).

Oil capacity : Refer to [DLN-223. "General Specification"](#).

- After refilling oil, check oil level. Set a gasket to filler plug (1), then install it to final drive assembly. Refer to [DLN-179. "2WD : Exploded View"](#) (2WD), [DLN-192. "AWD : Exploded View"](#) (AWD).

CAUTION:

Never reuse gasket.

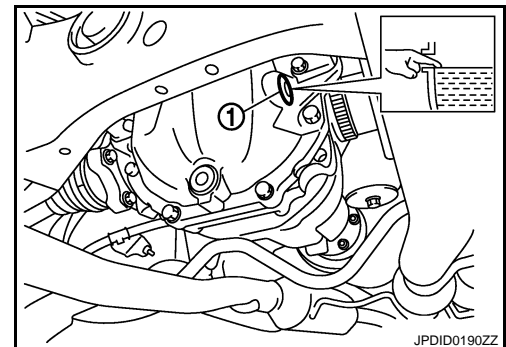

FRONT OIL SEAL

< REMOVAL AND INSTALLATION >

[REAR FINAL DRIVE: R200]

REMOVAL AND INSTALLATION

FRONT OIL SEAL

2WD

2WD : Exploded View

INFOID:000000005649747

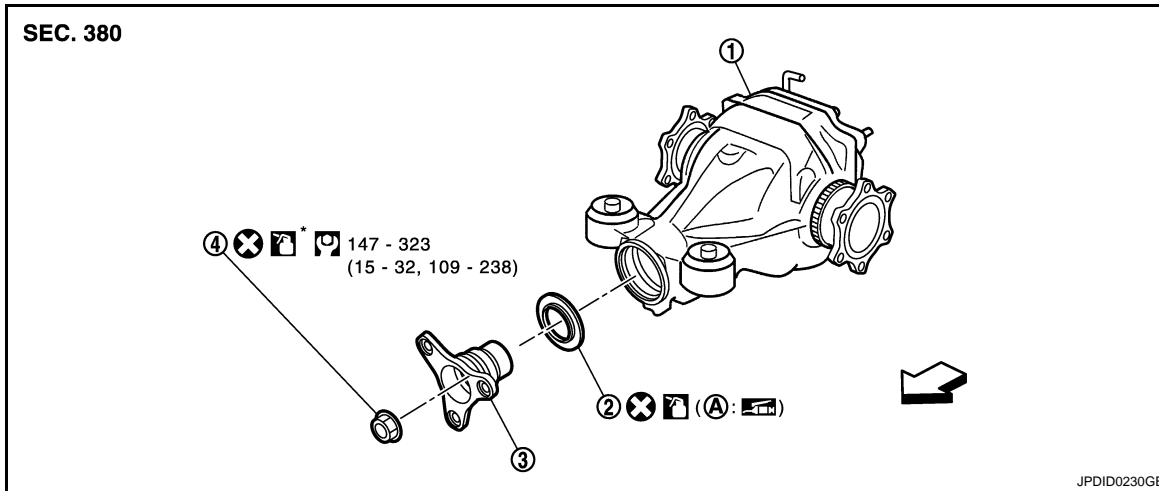

1. Final drive assembly

2. Front oil seal

3. Companion flange

4. Drive pinion lock nut

A. Oil seal lip

←: Vehicle front

: Apply gear oil.

: Apply anti-corrosion oil.

Refer to [GI-4, "Components"](#) for symbols not described on the above.

2WD : Removal and Installation

INFOID:000000005649748

REMOVAL

CAUTION:

Verify identification stamp of replacement frequency put in the lower part of gear carrier to determine replacement for collapsible spacer when replacing front oil seal. Refer to "Identification stamp of replacement frequency of front oil seal". If collapsible spacer replacement is necessary, remove final drive assembly and disassemble it to replace front oil seal and collapsible spacer. Refer to [DLN-175, "2WD : Removal and Installation"](#) and [DLN-180, "2WD : Disassembly"](#).

NOTE:

The reuse of collapsible spacer is prohibited in principle. However, it is reusable on a one-time basis only in cases when replacing front oil seal.

Identification stamp of replacement frequency of front oil seal

- The diagonally shaded area in the figure shows stamping point for replacement frequency of front oil seal.
- The following table shows if collapsible spacer replacement is needed before replacing front oil seal.
When collapsible spacer replacement is required, disassemble final drive assembly to replace collapsible spacer and front oil seal. Refer to [DLN-180, "2WD : Disassembly"](#).

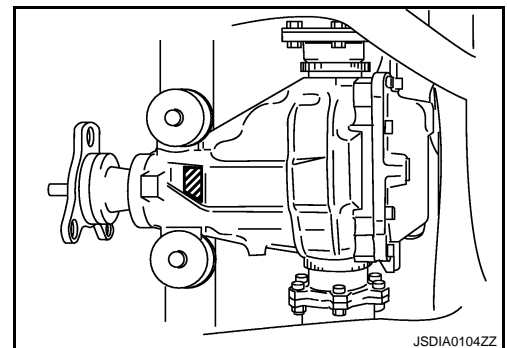

FRONT OIL SEAL

< REMOVAL AND INSTALLATION >

[REAR FINAL DRIVE: R200]

Stamp	collapsible spacer replacement
No stamp	Not required
"0" or "0" on the far right of stamp	Required
"01" or "1" on the far right of stamp	Not required

CAUTION:

Make a stamping after replacing front oil seal.

- After replacing front oil seal, make a stamping on the stamping point in accordance with the table below in order to identify replacement frequency.

CAUTION:

Make a stamping from left to right.

Stamp before stamping	Stamping on the far right	Stamping
No stamp	0	0
"0" (Front oil seal was replaced once.)	1	01
"01" (Collapsible spacer and front oil seal were replaced last time.)	0	010
"0" is on the far right. (Only front oil seal was replaced last time.)	1	...01
"1" is on the far right. (Collapsible spacer and front oil seal were replaced last time.)	0	...010

1. Drain gear oil. Refer to [DLN-160, "Draining"](#).
2. Make a judgment if a collapsible spacer replacement is required.
3. Remove center muffler with a power tool. Refer to [EX-5, "Exploded View"](#).
4. Remove rear wheel sensor. Refer to [BRC-103, "Exploded View"](#).
5. Remove drive shaft from final drive. Then suspend it by wire, etc. Refer to [RAX-10, "Exploded View"](#).
6. Install attachment to side flange, and then pull out the side flange with the sliding hammer.

- A : Attachment [SST: KV40104100 (—)]
- B : Sliding hammer [SST: ST36230000 (J-25840-A)]

7. Remove rear propeller shaft. Refer to [DLN-100, "Exploded View"](#).

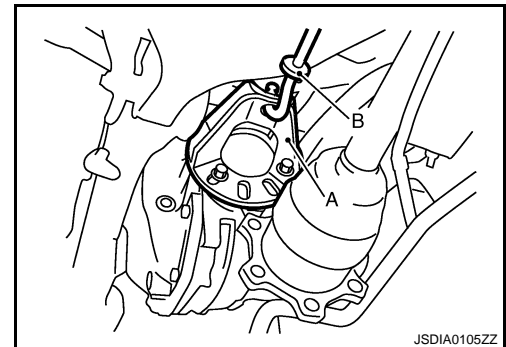

8. Measure the total preload with the preload gauge (A) [SST: ST3127S000 (J-25765-A)].

NOTE:

Record the preload measurement.

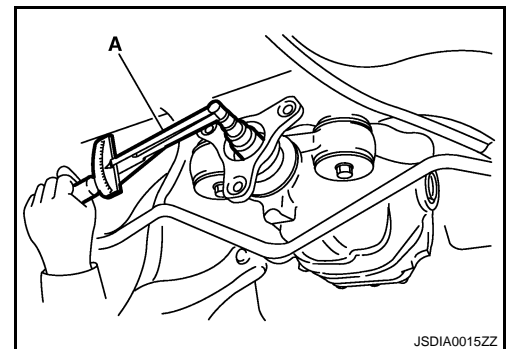

FRONT OIL SEAL

< REMOVAL AND INSTALLATION >

[REAR FINAL DRIVE: R200]

9. Put matching mark (B) on the end of the drive pinion. The matching mark (B) should be in line with the matching mark (A) on companion flange (1).

CAUTION:

For matching mark, use paint. Never damage companion flange and drive pinion.

NOTE:

The matching mark (A) on the final drive companion flange (1) indicates the maximum vertical runout position.

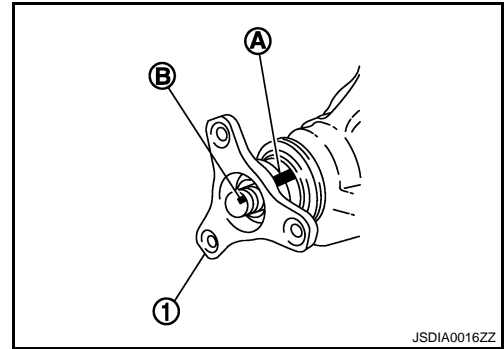

10. Remove drive pinion lock nut using the flange wrench.

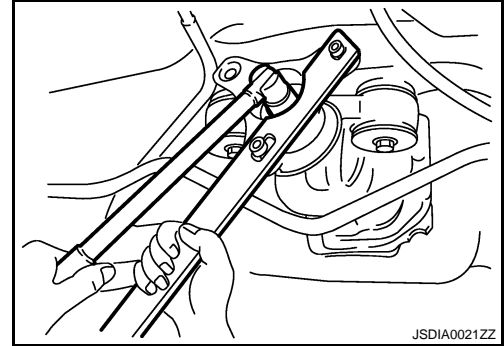

11. Remove companion flange using pullers.

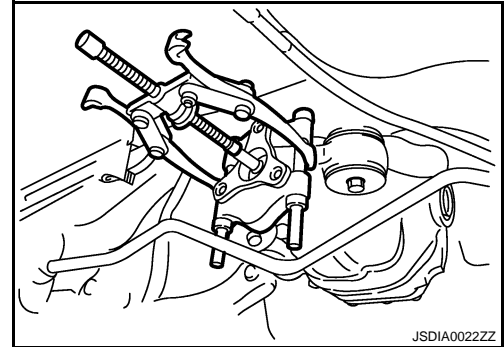

12. Remove front oil seal using the puller (A) [SST: KV381054S0 (J-34286)].

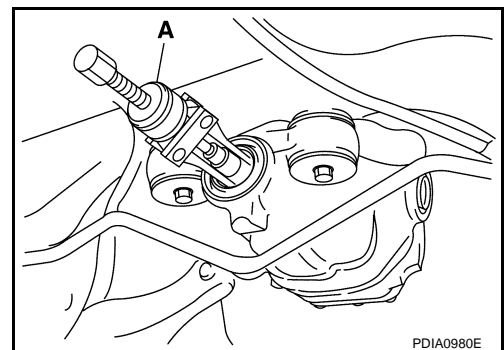

INSTALLATION

1. Apply multi-purpose grease to front oil seal lips.

A
B
C
DLN
E
F
G
H
I
J
K
L
M
N
O
P

FRONT OIL SEAL

< REMOVAL AND INSTALLATION >

[REAR FINAL DRIVE: R200]

2. Install front oil seal using the drift (A) [SST: ST30720000 (J-25405)] as shown in figure.

CAUTION:

- Never reuse oil seal.
- Never incline oil seal when installing.

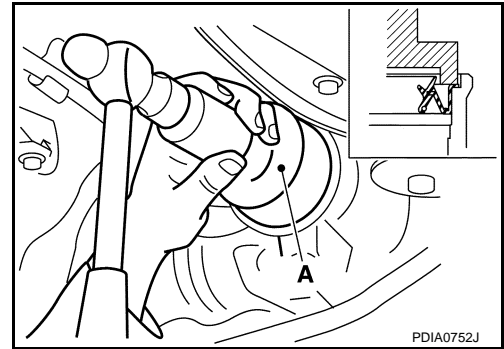

3. Align the matching mark (B) of drive pinion with the matching mark (A) of companion flange (1), and then install the companion flange (1).

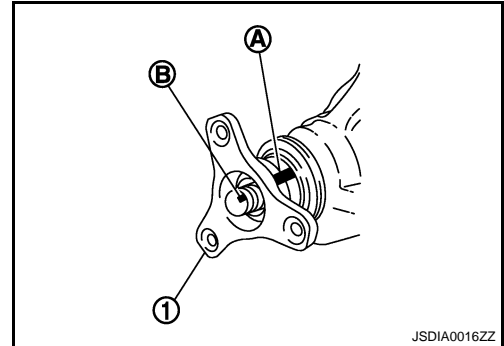

4. Apply anti-corrosion oil to the thread and seat of new drive pinion lock nut, and temporarily tighten drive pinion lock nut to drive pinion.

CAUTION:

Never reuse drive pinion lock nut.

5. Tighten drive pinion lock nut within the limits of specified torque so as to keep the pinion bearing preload within a standard values.

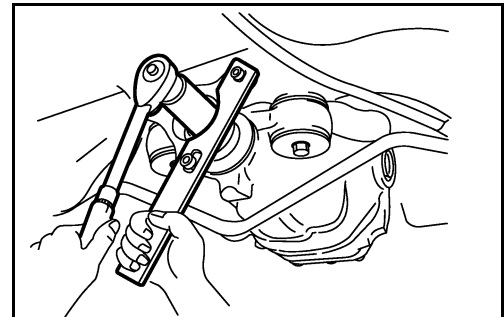

A : Preload gauge [SST: ST3127S000 (J-25765-A)]

Standard

Total preload torque : A value that add 0.1 – 0.4 N·m (0.01 – 0.04 kg·m, 0.9 – 3.5 in·lb) to the measured value before removing.

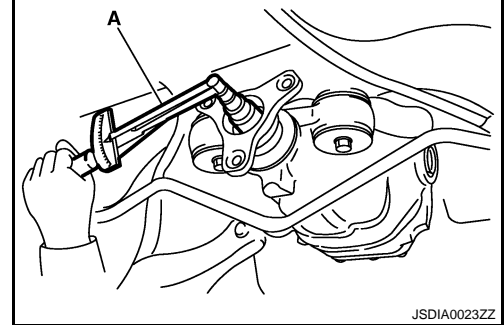

CAUTION:

- Adjust to the lower limit of the drive pinion lock nut tightening torque first.
- If the preload torque exceeds the specified value, replace collapsible spacer and tighten it again to adjust. Never loosen drive pinion lock nut to adjust the preload torque.

6. Set a dial indicator (A) vertically to the tip of the drive pinion.

7. Rotate drive pinion to check for runout.

Limit

Drive pinion runout : Refer to [DLN-223, "Drive Pinion Runout \(2WD\)"](#).

- If the runout value is still outside of the limit after the phase has been changed, possible causes are an assembly malfunction of drive pinion and pinion bearing and malfunction of pinion bearing. Check for these items and repair if necessary.

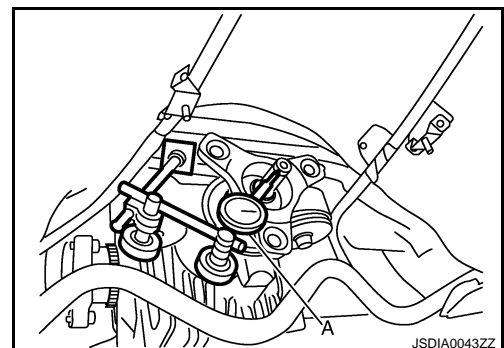

FRONT OIL SEAL

< REMOVAL AND INSTALLATION >

[REAR FINAL DRIVE: R200]

8. Make a stamping for identification of front oil seal replacement frequency. Refer to "Identification stamp of replacement frequency of front oil seal".

CAUTION:

Make a stamping after replacing front oil seal.

9. Install rear propeller shaft. Refer to [DLN-100, "Exploded View"](#).
10. Install side flange with the following procedure.
 - a. Attach the protector [SST: KV38107900 (J-39352)] to side oil seal.
 - b. After the side flange is inserted and the serrated part of side gear has engaged the serrated part of flange, remove the protector.
 - c. Put a suitable drift on the center of side flange, then drive it until sound changes.

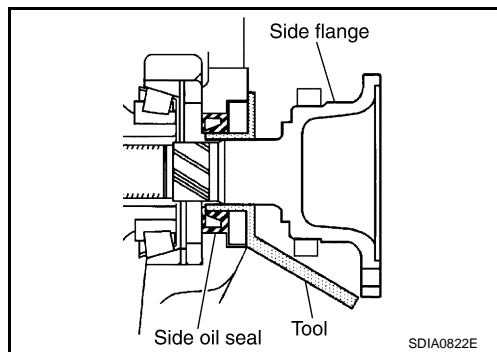

NOTE:

When installation is completed, driving sound of the side flange turns into a sound that seems to affect the whole final drive.

- d. Confirm that the dimension of the side flanges (1) installation measurement (A) in the figure comes into the following.

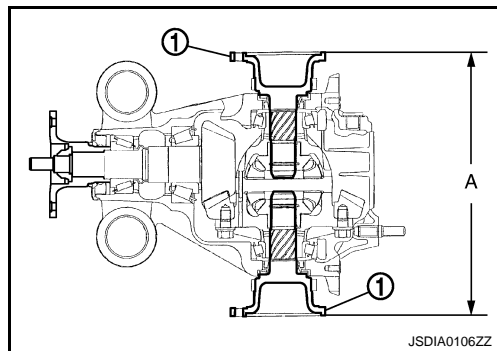

Standard

A : 326 – 328 mm (12.83 – 12.91 in)

11. Install drive shaft. Refer to [RAX-10, "Exploded View"](#).
12. Install rear wheel sensor. Refer to [BRC-103, "Exploded View"](#).
13. Install center muffler. Refer to [EX-5, "Exploded View"](#).
14. Refill gear oil to the final drive and check oil level. Refer to [DLN-160, "Refilling"](#).
15. Check the final drive for oil leakage. Refer to [DLN-160, "Inspection"](#).

AWD

AWD : Exploded View

INFOID:000000005649749

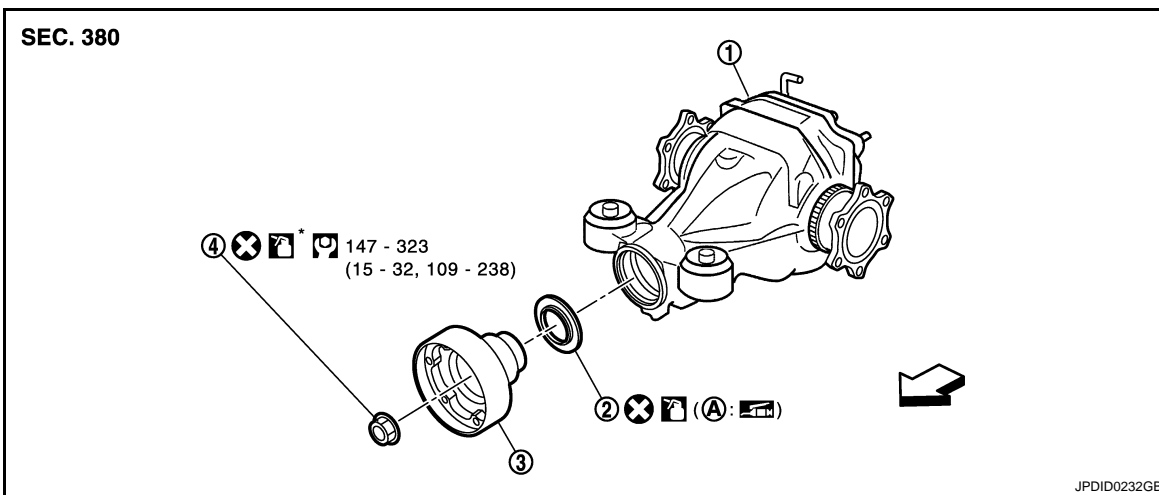



1. Final drive assembly
 2. Front oil seal
 3. Companion flange
 4. Drive pinion lock nut
 - A. Oil seal lip
- ↔ Vehicle front

FRONT OIL SEAL

< REMOVAL AND INSTALLATION >

[REAR FINAL DRIVE: R200]

: Apply gear oil.

*: Apply anti-corrosion oil.

Refer to [GI-4, "Components"](#) for symbols not described on the above.

AWD : Removal and Installation

INFOID:000000005649750

REMOVAL

CAUTION:

Verify identification stamp of replacement frequency put in the lower part of gear carrier to determine replacement for collapsible spacer when replacing front oil seal. Refer to "Identification stamp of replacement frequency of front oil seal". If collapsible spacer replacement is necessary, remove final drive assembly and disassemble it to replace front oil seal and collapsible spacer. Refer to [DLN-177, "AWD : Removal and Installation"](#) and [DLN-192, "AWD : Disassembly"](#).

NOTE:

The reuse of collapsible spacer is prohibited in principle. However, it is reusable on a one-time basis only in cases when replacing front oil seal.

Identification stamp of replacement frequency of front oil seal

- The diagonally shaded area in the figure shows stamping point for replacement frequency of front oil seal.
- The following table shows if collapsible spacer replacement is needed before replacing front oil seal.
When collapsible spacer replacement is required, disassemble final drive assembly to replace collapsible spacer and front oil seal. Refer to [DLN-192, "AWD : Disassembly"](#).

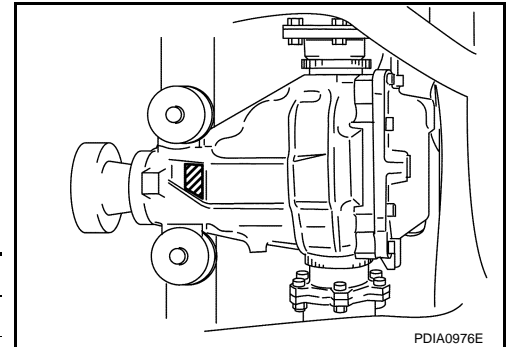

Stamp	collapsible spacer replacement
No stamp	Not required
"0" or "0" on the far right of stamp	Required
"01" or "1" on the far right of stamp	Not required

CAUTION:

Make a stamping after replacing front oil seal.

- After replacing front oil seal, make a stamping on the stamping point in accordance with the table below in order to identify replacement frequency.

CAUTION:

Make a stamping from left to right.

Stamp before stamping	Stamping on the far right	Stamping
No stamp	0	0
"0" (Front oil seal was replaced once.)	1	01
"01" (Collapsible spacer and front oil seal were replaced last time.)	0	010
"0" is on the far right. (Only front oil seal was replaced last time.)	1	...01
"1" is on the far right. (Collapsible spacer and front oil seal were replaced last time.)	0	...010

1. Drain gear oil. Refer to [DLN-160, "Draining"](#).
2. Make a judgment if a collapsible spacer replacement is required.
3. Remove center muffler with a power tool. Refer to [EX-5, "Exploded View"](#).
4. Remove rear wheel sensor. Refer to [BRC-103, "Exploded View"](#).
5. Remove drive shaft from final drive. Then suspend it by wire, etc. Refer to [RAX-10, "Exploded View"](#).

FRONT OIL SEAL

< REMOVAL AND INSTALLATION >

[REAR FINAL DRIVE: R200]

6. Install attachment to side flange, and then pull out the side flange with the sliding hammer.

- A : Attachment [SST: KV40104100 (—)]
B : Sliding hammer [SST: ST36230000 (J-25840-A)]

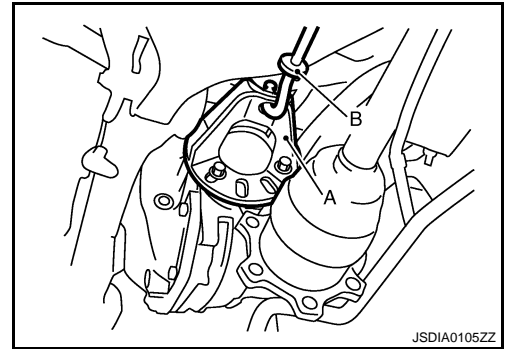

7. Remove rear propeller shaft. Refer to [DLN-108, "Exploded View"](#).
8. Measure the total preload with the preload gauge (A) [SST: ST3127S000 (J-25765-A)].

NOTE:

Record the preload measurement.

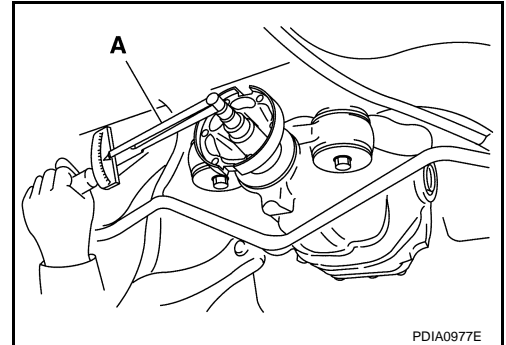

9. Put matching mark (B) on the end of the drive pinion. The matching mark should be in line with the matching mark (A) on companion flange (1).

CAUTION:

For matching mark, use paint. Never damage companion flange and drive pinion.

NOTE:

The matching mark on the final drive companion flange indicates the maximum vertical runout position.

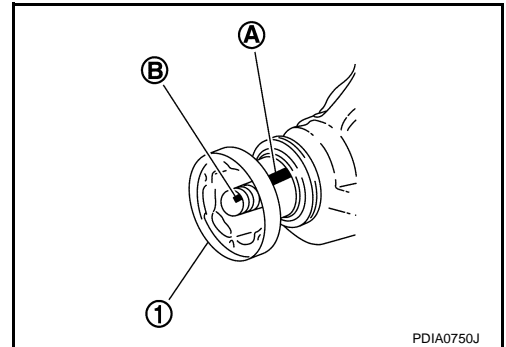

10. Remove drive pinion lock nut using the flange wrench.

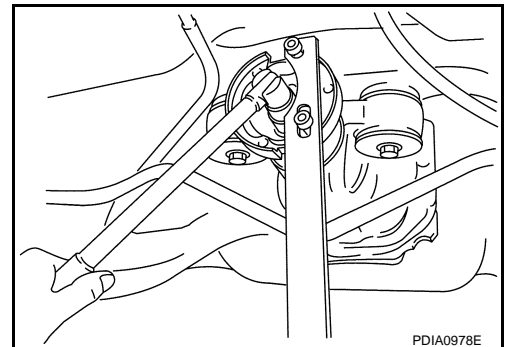

A
B
C
DLN
E
F
G
H
I
J
K
L
M
N
O
P

FRONT OIL SEAL

< REMOVAL AND INSTALLATION >

[REAR FINAL DRIVE: R200]

11. Remove companion flange using pullers.

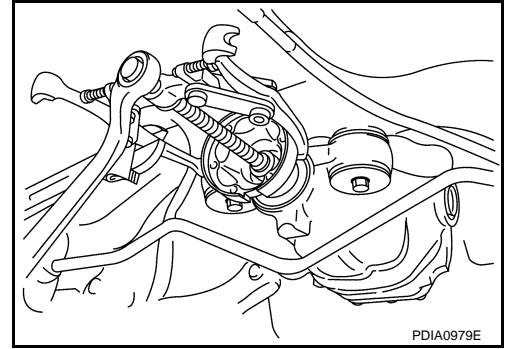

12. Remove front oil seal using the puller (A) [SST: KV381054S0 (J-34286)].

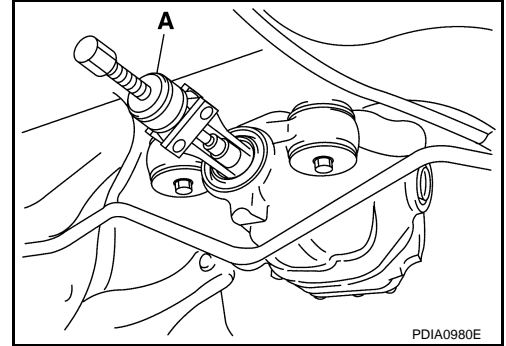

INSTALLATION

1. Apply multi-purpose grease to front oil seal lips.
2. Install front oil seal using the drift (A) [SST: ST30720000 (J-25405)] as shown in figure.

CAUTION:

- Never reuse oil seal.
- Never incline oil seal when installing.

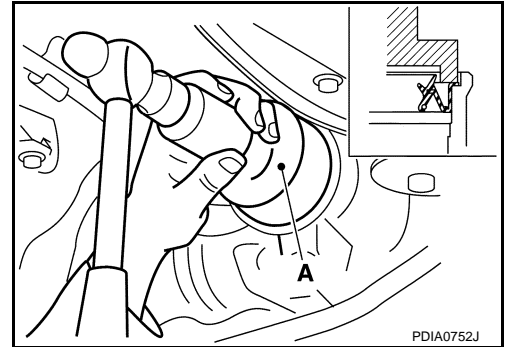

3. Align the matching mark (B) of drive pinion with the matching mark (A) of companion flange (1), and then install the companion flange.

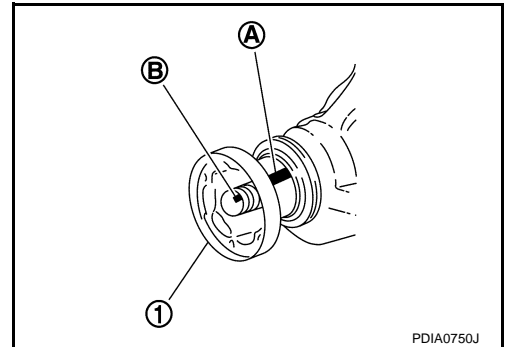

FRONT OIL SEAL

< REMOVAL AND INSTALLATION >

[REAR FINAL DRIVE: R200]

4. Apply anti-corrosion oil to the thread and seat of new drive pinion lock nut, and temporarily tighten drive pinion lock nut to drive pinion.

CAUTION:

Never reuse drive pinion lock nut.

5. Tighten drive pinion lock nut within the limits of specified torque so as to keep the pinion bearing preload within a standard values.

A : Preload gauge [SST: ST3127S000 (J-25765-A)]

Standard

Total preload torque : A value that add 0.1 – 0.4 N·m (0.01 – 0.04 kg·m, 0.9 – 3.5 in·lb) to the measured value before removing.

CAUTION:

- Adjust to the lower limit of the drive pinion lock nut tightening torque first.
- If the preload torque exceeds the specified value, replace collapsible spacer and tighten it again to adjust. Never loosen drive pinion lock nut to adjust the preload torque.

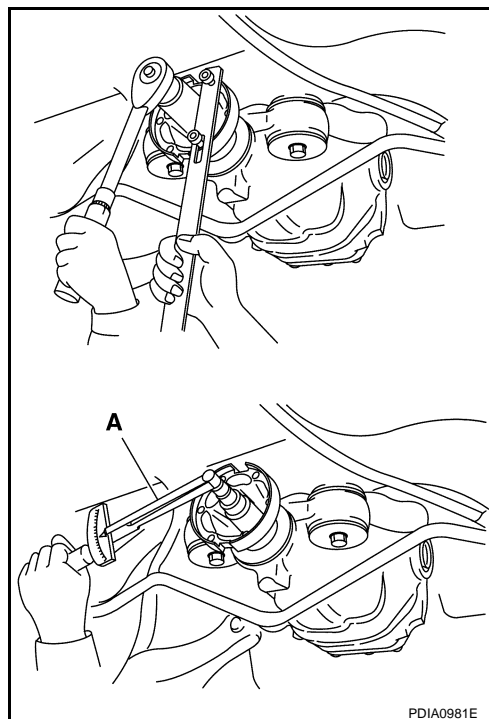

6. Fit a test indicator to the inner side of companion flange (socket diameter).
7. Rotate companion flange to check for runout.

Limit

Companion flange runout : Refer to [DLN-223, "Companion Flange Runout \(AWD\)"](#).

- If the runout value is outside the runout limit, follow the procedure below to adjust.
 - Check for runout while changing the phase between companion flange and drive pinion by 90° step, and search for the position where the runout is the minimum.
 - If the runout value is still outside of the limit after the phase has been changed, possible cause will be an assembly malfunction of drive pinion and pinion bearing and malfunction of pinion bearing. Check for these items and repair if necessary.
 - If the runout value is still outside of the limit after the check and repair, replace companion flange.

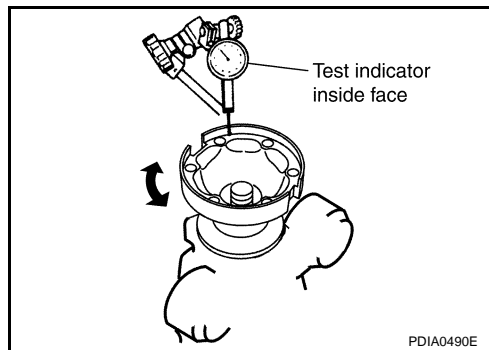

8. Make a stamping for identification of front oil seal replacement frequency. Refer to "Identification stamp of replacement frequency of front oil seal".

CAUTION:

Make a stamping after replacing front oil seal.

9. Install rear propeller shaft. Refer to [DLN-108, "Exploded View"](#).
10. Install side flange with the following procedure.
 - a. Attach the protector [SST: KV38107900 (J-39352)] to side oil seal.
 - b. After the side flange is inserted and the serrated part of side gear has engaged the serrated part of flange, remove the protector.
 - c. Put a suitable drift on the center of side flange, then drive it until sound changes.

NOTE:

When installation is completed, driving sound of the side flange turns into a sound that seems to affect the whole final drive.

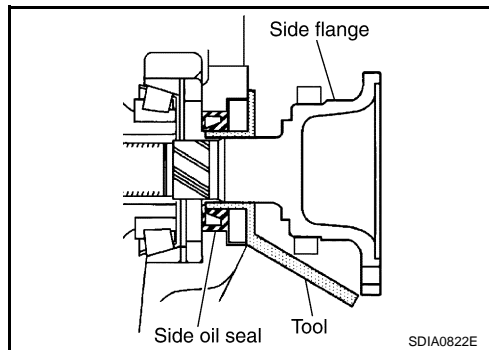

A
B
C
DLN
E
F
G
H
I
J
K
L
M
N
O
P

FRONT OIL SEAL

< REMOVAL AND INSTALLATION >

[REAR FINAL DRIVE: R200]

- d. Confirm that the dimension of the side flanges installation measurement (A) in the figure comes into the following.

Standard

A : 326 – 328 mm (12.83 – 12.91 in)

11. Install drive shaft. Refer to [RAX-10, "Exploded View"](#).
12. Install rear wheel sensor. Refer to [BRC-103, "Exploded View"](#).
13. Install center muffler. Refer to [EX-5, "Exploded View"](#).
14. Refill gear oil to the final drive and check oil level. Refer to [DLN-160, "Refilling"](#).
15. Check the final drive for oil leakage. Refer to [DLN-160, "Inspection"](#).

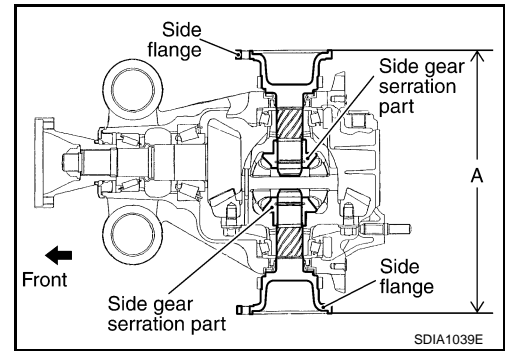

SIDE OIL SEAL

< REMOVAL AND INSTALLATION >

[REAR FINAL DRIVE: R200]

SIDE OIL SEAL

2WD

2WD : Exploded View

INFOID:000000005649751

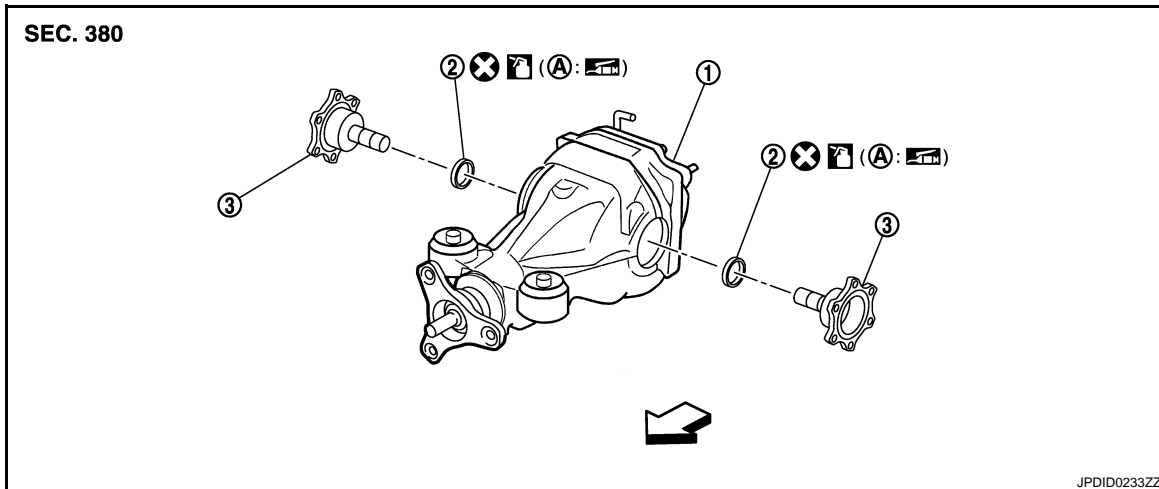

1. Final drive assembly

2. Side oil seal

3. Side flange

A. Oil seal lip

←: Vehicle front

: Apply gear oil.

Refer to [GI-4, "Components"](#) for symbols not described on the above.

2WD : Removal and Installation

INFOID:000000005649752

REMOVAL

1. Remove center muffler with a power tool. Refer to [EX-5, "Exploded View"](#).
2. Remove rear wheel sensor. Refer to [BRC-103, "Exploded View"](#).
3. Remove drive shaft from final drive with a power tool. Then suspend it by wire, etc. Refer to [RAX-10, "Exploded View"](#).
4. Install attachment to side flange, and then pull out the side flange with the sliding hammer.

A : Attachment [SST: KV40104100 (—)]

B : Sliding hammer [SST: ST36230000 (J-25840-A)]

5. Remove side oil seal, using a suitable tool.

CAUTION:

Never damage gear carrier.

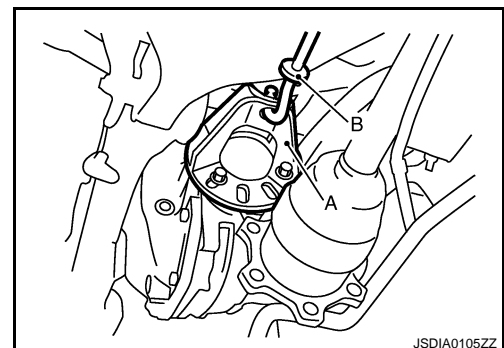

INSTALLATION

1. Apply multi-purpose grease to side oil seal lips.

SIDE OIL SEAL

< REMOVAL AND INSTALLATION >

[REAR FINAL DRIVE: R200]

2. Install side oil seal until it becomes flush with the case end, using the drift [SST: KV38100200 (J-26233)].

CAUTION:

- Never reuse oil seal.
- When installing, never incline oil seal.

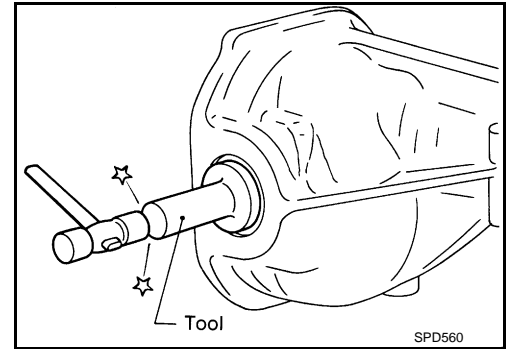

3. Install side flange with the following procedure.
 - a. Attach the protector [SST: KV38107900 (J-39352)] to side oil seal.
 - b. After the side flange is inserted and the serrated part of side gear has engaged the serrated part of flange, remove the protector.
 - c. Put a suitable drift on the center of side flange, then drive it until sound changes.

NOTE:

When installation is completed, driving sound of the side flange turns into a sound that seems to affect the whole final drive.

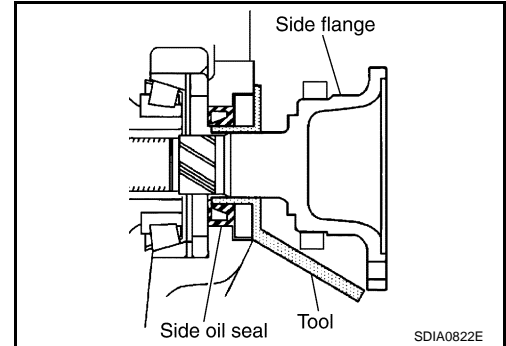

- d. Confirm that the dimension of the side flange (1) installation measurement (A) in the figure comes into the following.

Standard

A : 326 – 328 mm (12.83 – 12.91 in)

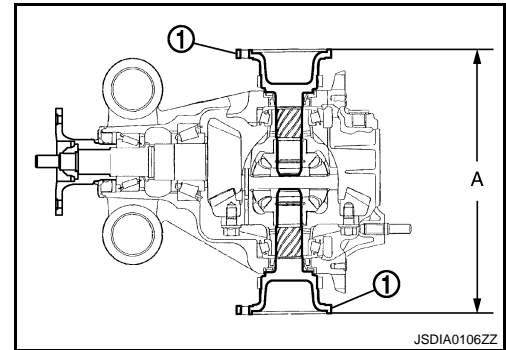

4. Install drive shaft. Refer to [RAX-10, "Exploded View"](#).
5. Install rear wheel sensor. Refer to [BRC-103, "Exploded View"](#).
6. Install center muffler. Refer to [EX-5, "Exploded View"](#).
7. When oil leaks while removing, check oil level after the installation. Refer to [DLN-160, "Inspection"](#).

AWD

AWD : Exploded View

INFOID:000000005649753

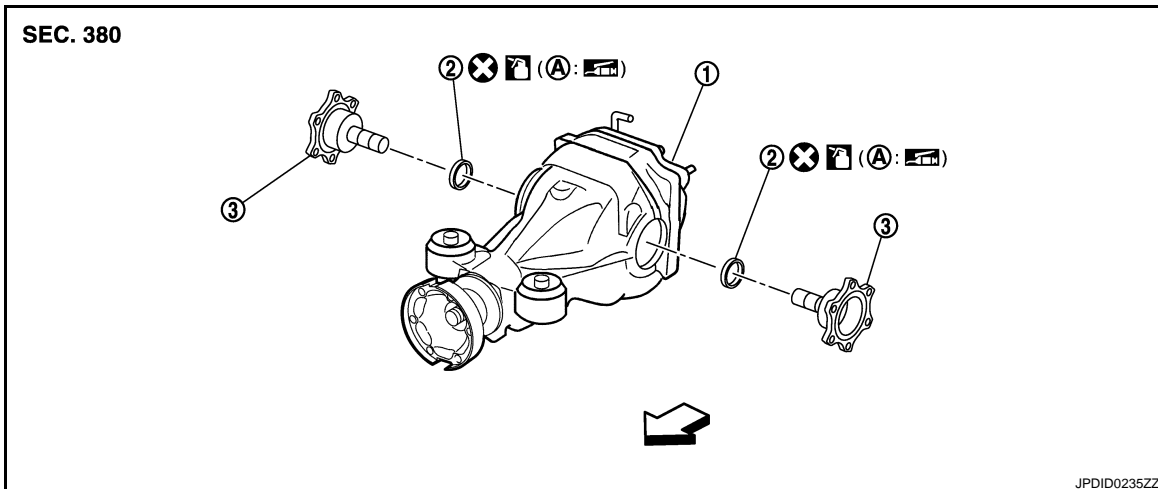

SIDE OIL SEAL

< REMOVAL AND INSTALLATION >

[REAR FINAL DRIVE: R200]

1. Final drive assembly
 2. Side oil seal
 3. Side flange
- A. Oil seal lip
- ↶: Vehicle front

: Apply gear oil.

Refer to [GI-4, "Components"](#) for symbols not described on the above.

AWD : Removal and Installation

INFOID:000000005649754

REMOVAL

1. Remove center muffler with a power tool. Refer to [EX-5, "Exploded View"](#).
2. Remove rear wheel sensor. Refer to [BRC-103, "Exploded View"](#).
3. Remove drive shaft from final drive with a power tool. Then suspend it by wire, etc. Refer to [RAX-10, "Exploded View"](#).
4. Install attachment to side flange, and then pull out the side flange with the sliding hammer.

- A : Attachment [SST: KV40104100 (—)]
B : Sliding hammer [SST: ST36230000 (J-25840-A)]

5. Remove side oil seal, using a suitable tool.

CAUTION:

Never damage gear carrier.

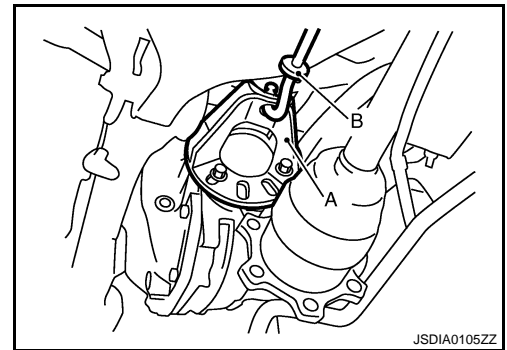

INSTALLATION

1. Apply multi-purpose grease to side oil seal lips.
2. Install side oil seal until it becomes flush with the case end, using the drift [SST: KV38100200 (J-26233)].

CAUTION:

- **Never reuse oil seal.**
- **When installing, never incline oil seal.**

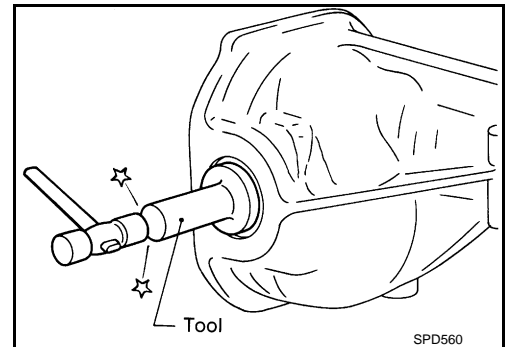

3. Install side flange with the following procedure.
 - a. Attach the protector [SST: KV38107900 (J-39352)] to side oil seal.
 - b. After the side flange is inserted and the serrated part of side gear has engaged the serrated part of flange, remove the protector.
 - c. Put a suitable drift on the center of side flange, then drive it until sound changes.

NOTE:

When installation is completed, driving sound of the side flange turns into a sound that seems to affect the whole final drive.

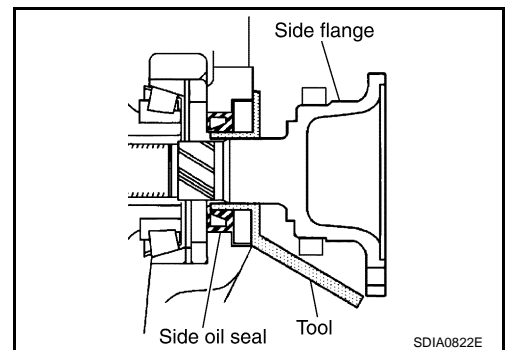

SIDE OIL SEAL

< REMOVAL AND INSTALLATION >

[REAR FINAL DRIVE: R200]

- d. Confirm that the dimension of the side flange (1) installation measurement (A) in the figure comes into the following.

Standard

A : 326 – 328 mm (12.83 – 12.91 in)

4. Install drive shaft. Refer to [RAX-10, "Exploded View"](#).
5. Install rear wheel sensor. Refer to [BRC-103, "Exploded View"](#).
6. Install center muffler. Refer to [EX-5, "Exploded View"](#).
7. When oil leaks while removing, check oil level after the installation. Refer to [DLN-160, "Inspection"](#).

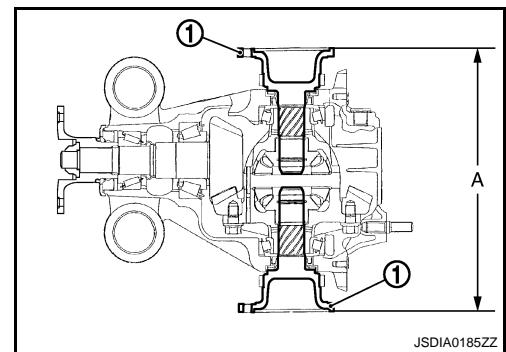

REAR FINAL DRIVE ASSEMBLY

< UNIT REMOVAL AND INSTALLATION >

[REAR FINAL DRIVE: R200]

UNIT REMOVAL AND INSTALLATION

REAR FINAL DRIVE ASSEMBLY

2WD

2WD : Exploded View

INFOID:000000005649755

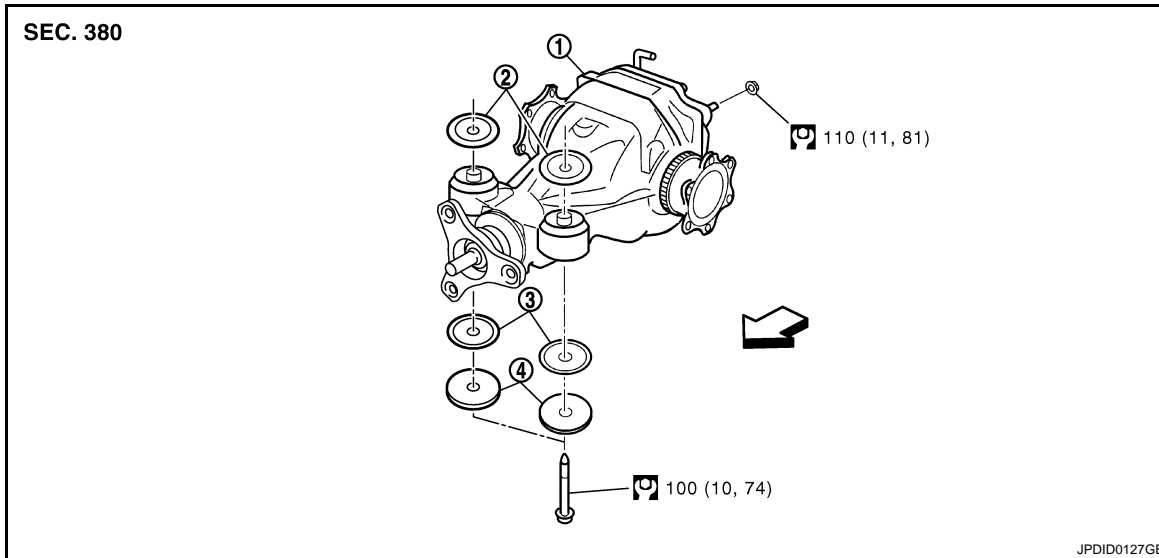

1. Rear final drive assembly
2. Upper stopper
3. Lower stopper
4. Washer

↔: Vehicle front

Refer to [GI-4, "Components"](#) for symbols in the figure.

2WD : Removal and Installation

INFOID:000000005649756

REMOVAL

1. Remove center muffler with a power tool. Refer to [EX-5, "Exploded View"](#).
2. Remove stabilizer bar with a power tool. Refer to [RSU-21, "Exploded View"](#).
3. Remove rear propeller shaft from the final drive. Refer to [DLN-100, "Exploded View"](#).
4. Remove drive shaft from final drive with a power tool. Then suspend it by wire, etc. Refer to [RAX-10, "Exploded View"](#).
5. Remove breather hose from the final drive.
6. Remove rear wheel sensor. Refer to [BRC-103, "Exploded View"](#).

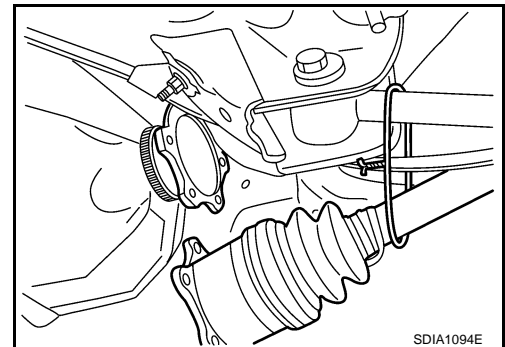

REAR FINAL DRIVE ASSEMBLY

< UNIT REMOVAL AND INSTALLATION >

[REAR FINAL DRIVE: R200]

7. Set a suitable jack to rear final drive assembly.

CAUTION:

Never place a jack on the rear cover (aluminum case).

8. Remove the mounting bolts and nuts connecting to the suspension member with a power tool. And then, remove rear final drive assembly.

CAUTION:

Secure rear final drive assembly to a suitable jack while removing it.

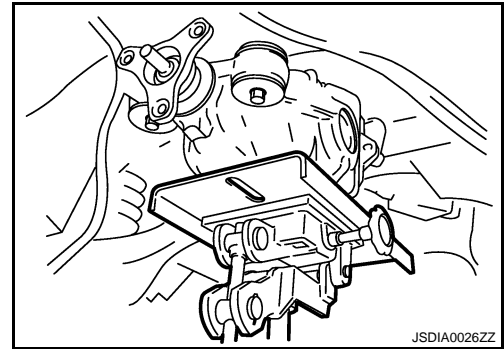

INSTALLATION

Note the following, and installation is in the reverse order of removal.

CAUTION:

Make sure there are no pinched or restricted areas on the breather hose caused by bending or winding when installing it.

- Install the breather hose (1) to breather connector until dimension (A) shown as follows.

A:

Final drive side : 20 mm (0.79 in)

**Suspension member : 20.5 mm (0.807 in)
side**

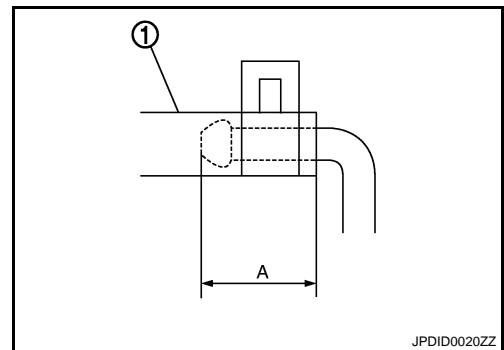

CAUTION:

- **Never reuse hose clamp.**
- **Install the hose clamp at the final drive side, with the tab facing downward.**
- **Install the hose clamp at the suspension member side, with the tab facing downward.**

- If remove breather connector, install breather hose (1) as shown in the figure.
- For installation, insert the breather connector to suspension member (2). Install metal connector (3) to rear cover with aiming painted marking to the front of vehicle.

⇐: Vehicle front

CAUTION:

Never reuse breather connector and metal connector.

- When oil leaks while removing final drive assembly, check oil level after the installation. Refer to [DLN-160. "Inspection"](#).

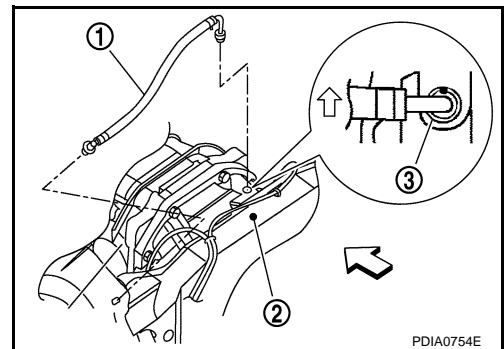

AWD

REAR FINAL DRIVE ASSEMBLY

< UNIT REMOVAL AND INSTALLATION >

[REAR FINAL DRIVE: R200]

AWD : Exploded View

INFOID:000000005649757

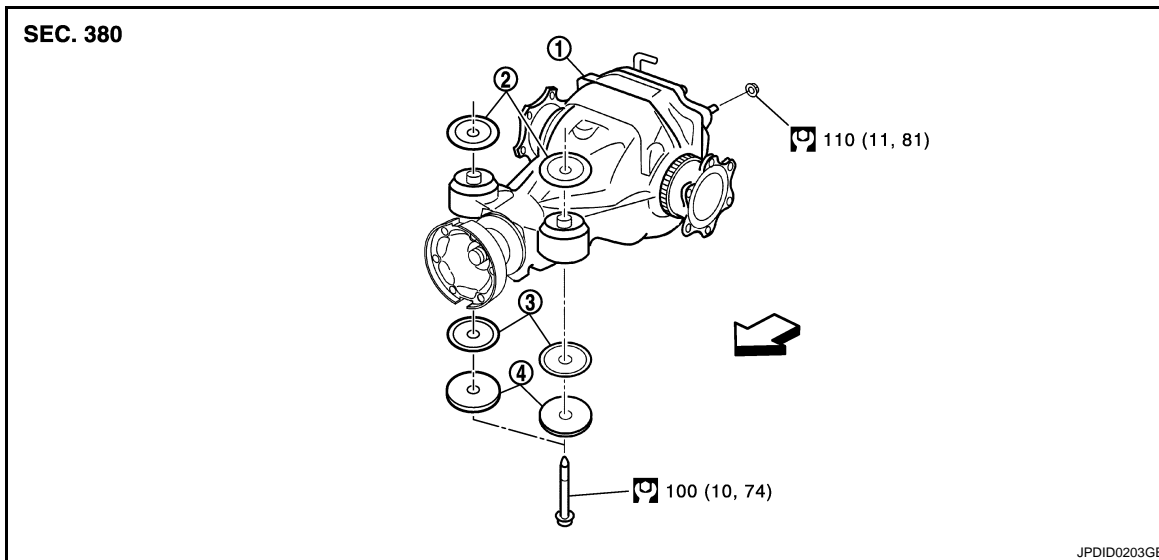

- 1. Rear final drive assembly
- 2. Upper stopper
- 3. Lower stopper
- 4. Washer

←: Vehicle front

Refer to [GI-4, "Components"](#) for symbols in the figure.

AWD : Removal and Installation

INFOID:000000005649758

REMOVAL

1. Remove center muffler with a power tool. Refer to [EX-5, "Exploded View"](#).
2. Remove stabilizer bar with a power tool. Refer to [RSU-21, "Exploded View"](#).
3. Remove rear propeller shaft from the final drive. Refer to [DLN-108, "Exploded View"](#).
4. Remove drive shaft from final drive with a power tool. Then suspend it by wire, etc. Refer to [RAX-10, "Exploded View"](#).
5. Remove breather hose from the final drive.
6. Remove rear wheel sensor. Refer to [BRC-103, "Exploded View"](#).

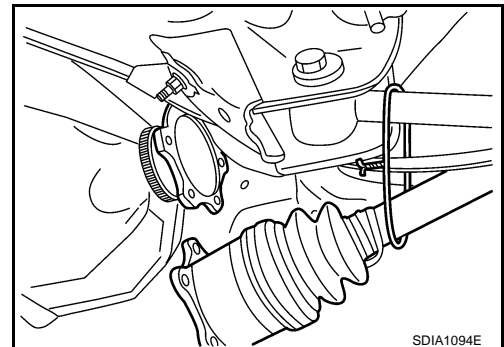

7. Set a suitable jack to rear final drive assembly.
CAUTION:
Never place a jack on the rear cover (aluminum case).
8. Remove the mounting bolts and nuts connecting to the suspension member, and remove rear final drive assembly with a power tool.
CAUTION:
Secure rear final drive assembly to a suitable jack while removing it.

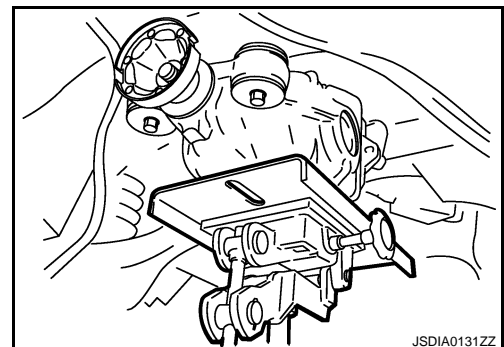

INSTALLATION

A
B
C
DLN
E
F
G
H
I
J
K
L
M
N
O
P

REAR FINAL DRIVE ASSEMBLY

< UNIT REMOVAL AND INSTALLATION >

[REAR FINAL DRIVE: R200]

Note the following, and installation is in the reverse order of removal.

CAUTION:

Make sure there are no pinched or restricted areas on the breather hose caused by bending or winding when installing it.

- Install the breather hose (1) to breather connector until dimension (A) shown as follows.

A:

Final drive side : 20 mm (0.79 in)

Suspension member side : 20.5 mm (0.807 in)

CAUTION:

- Never reuse hose clamp.
 - Install the hose clamp at the final drive side, with the tab facing downward.
 - Install the hose clamp at the suspension member side, with the tab facing downward.
-
- If remove breather connector, install breather hose (1) as shown in the figure.
 - For installation, insert the breather connector to suspension member (2). Install metal connector (3) to rear cover with aiming painted marking to the front of vehicle.

⇐: Vehicle front

CAUTION:

Never reuse breather connector and metal connector.

- When oil leaks while removing final drive assembly, check oil level after the installation. Refer to [DLN-160, "Inspection"](#).

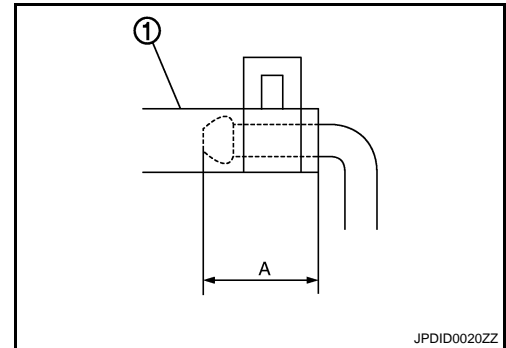

JPDID0020ZZ

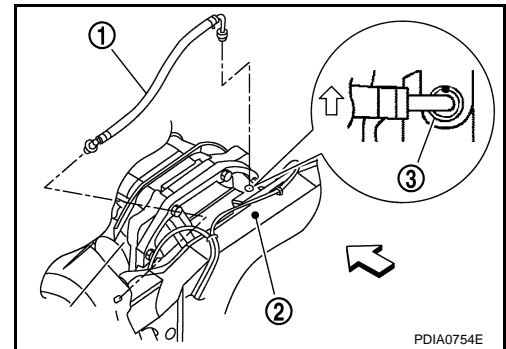

PDIA0754E

DIFFERENTIAL ASSEMBLY

< UNIT DISASSEMBLY AND ASSEMBLY >

[REAR FINAL DRIVE: R200]

UNIT DISASSEMBLY AND ASSEMBLY

DIFFERENTIAL ASSEMBLY

2WD

2WD : Exploded View

INFOID:000000005649759

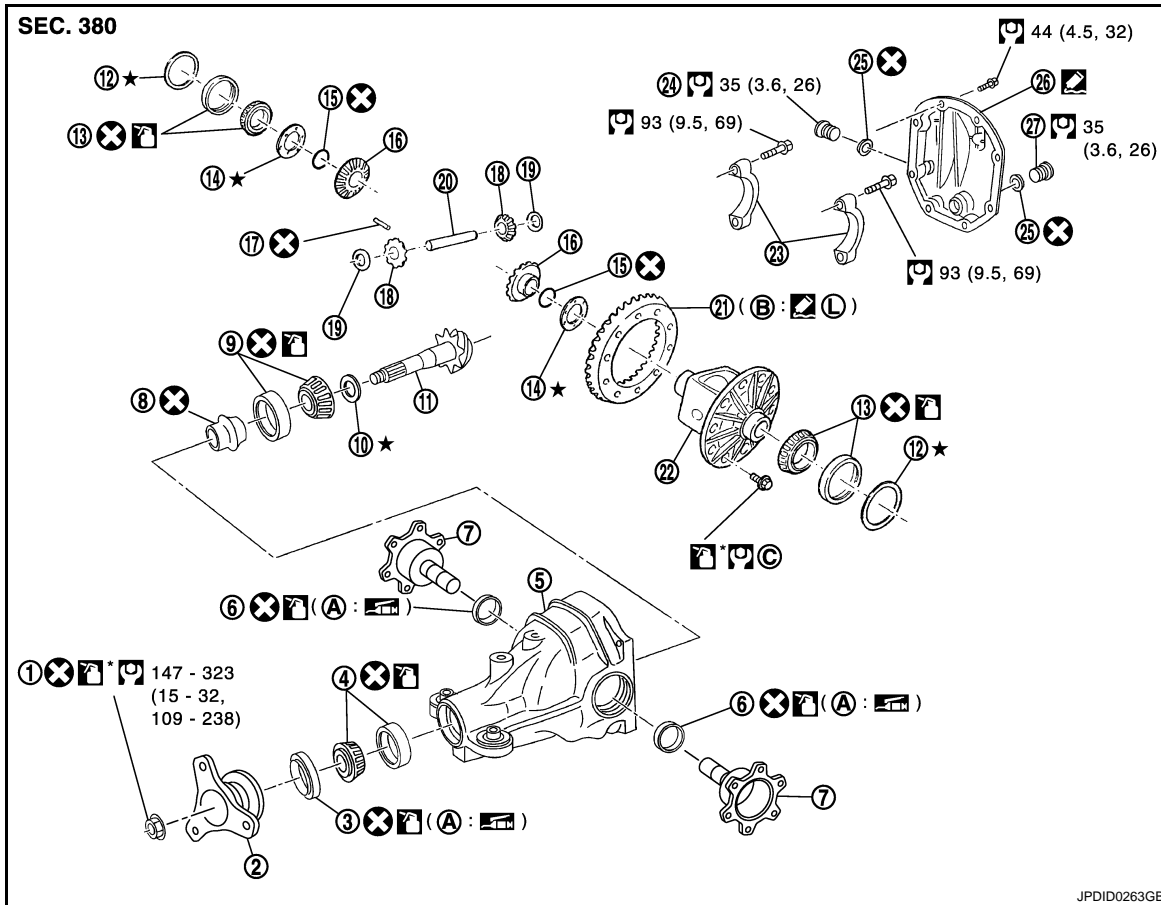

- | | | |
|------------------------------------|-----------------------------|-----------------------------------|
| 1. Drive pinion lock nut | 2. Companion flange | 3. Front oil seal |
| 4. Pinion front bearing | 5. Gear carrier | 6. Side oil seal |
| 7. Side flange | 8. Collapsible spacer | 9. Pinion rear bearing |
| 10. Pinion height adjusting washer | 11. Drive pinion | 12. Side bearing adjusting washer |
| 13. Side bearing | 14. Side gear thrust washer | 15. Circular clip |
| 16. Side gear | 17. Lock pin | 18. Pinion mate gear |
| 19. Pinion mate thrust washer | 20. Pinion mate shaft | 21. Drive gear |
| 22. Differential case | 23. Bearing cap | 24. Filler plug |
| 25. Gasket | 26. Rear cover | 27. Drain plug |
- A. Oil seal lip
B. Screw hole
C. Comply with the assembly procedure when tightening. Refer to [DLN-182, "2WD : Assembly"](#).

: Apply gear oil.

: Apply anti-corrosion oil.

: Apply Genuine Silicone RTV or equivalent. Refer to [GI-18, "Recommended Chemical Products and Sealants"](#).

DIFFERENTIAL ASSEMBLY

< UNIT DISASSEMBLY AND ASSEMBLY >

[REAR FINAL DRIVE: R200]

 L: Apply Genuine High Strength Thread Locking Sealant or equivalent. Refer to [GI-18. "Recommended Chemical Products and Sealants"](#).

Refer to [GI-4. "Components"](#) for symbols not described on the above.

2WD : Disassembly

INFOID:000000005649760

1. Drain gear oil, if necessary.
2. Remove side flanges.
3. Remove rear cover mounting bolts.
4. Remove rear cover to insert the seal cutter (A) [SST: KV10111100 (J-37228)] between gear carrier and rear cover.

CAUTION:

- Never damage the mating surface.
- Never insert flat-bladed screwdriver, this may damage the mating surface.

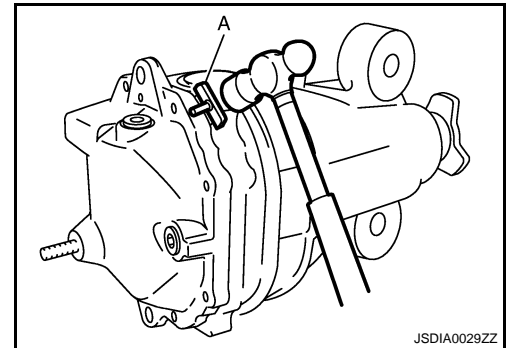

5. Using two spacers, mount carrier on the attachment (A) [SST: KV38100800 (J-25604-01)].

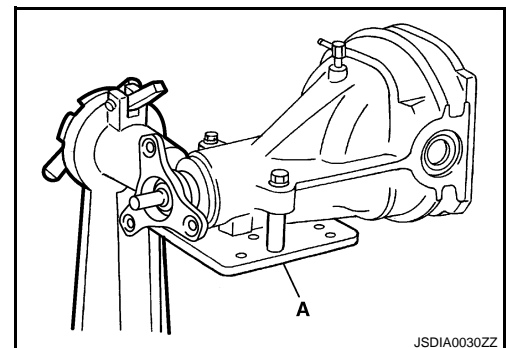

6. For proper reinstallation, paint matching marks on one side of the bearing cap.

CAUTION:

- For matching marks, use paint. Never damage bearing caps and gear carrier.
- Bearing caps are manufactured as integral molding. Use the matching marks to them in their original positions.

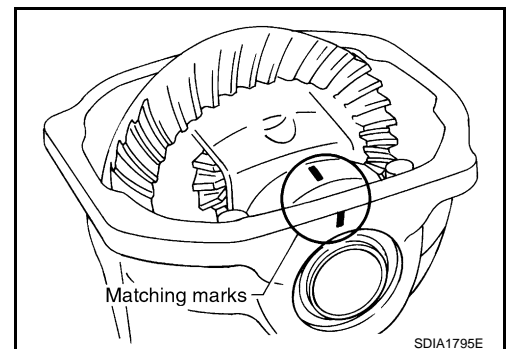

7. Remove bearing caps.

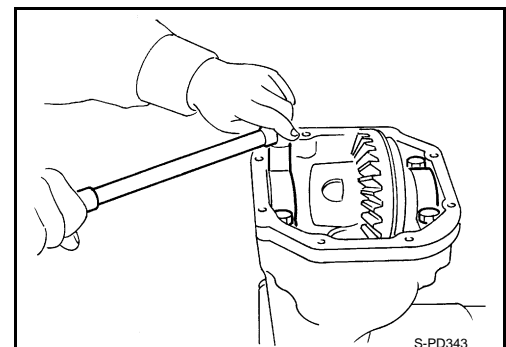

DIFFERENTIAL ASSEMBLY

< UNIT DISASSEMBLY AND ASSEMBLY >

[REAR FINAL DRIVE: R200]

8. Lift differential case assembly out with a suitable tool.

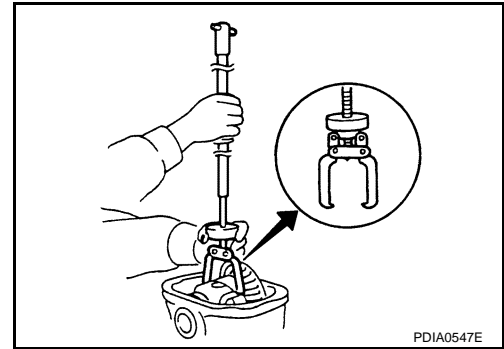

- Keep side bearing outer races together with inner race. Never mix them up.
Also, keep side bearing adjusting washers together with bearings.

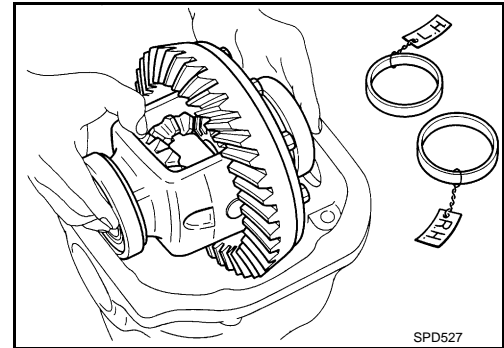

9. Remove side bearing inner race.
To prevent damage to bearing, engage puller jaws in groove (←).

A : Puller [SST: ST33051001 (J-22888-20)]

B : Base [SST: ST33061000 (J-8107-2)]

CAUTION:

- To prevent damage to the side bearing and drive gear, place copper plates between these parts and vise.
- It is not necessary to remove side bearing inner race except when it is replaced.

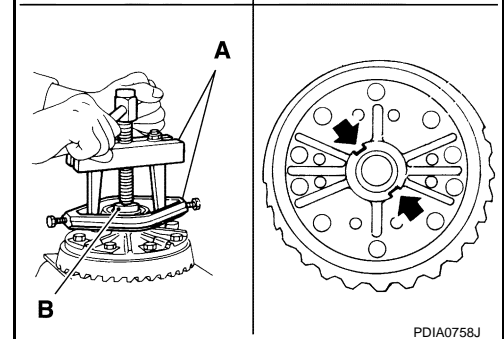
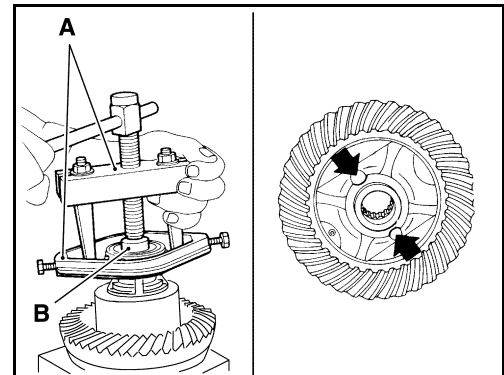

10. For proper reinstallation, paint matching marks on one differential case assembly.

CAUTION:

For matching marks, use paint. Never damage differential case and drive gear.

11. Remove drive gear mounting bolts.

12. Tap drive gear off differential case assembly with a soft hammer.

CAUTION:

Tap evenly all around to keep drive gear from bending.

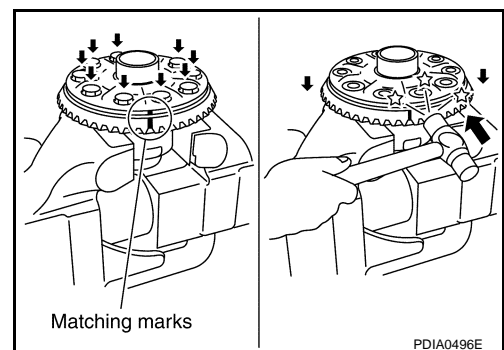

A
B
C
DLN
E
F
G
H
I
J
K
L
M
N
O
P

DIFFERENTIAL ASSEMBLY

< UNIT DISASSEMBLY AND ASSEMBLY >

[REAR FINAL DRIVE: R200]

13. Remove lock pin of pinion mate shaft with a punch from drive gear side.

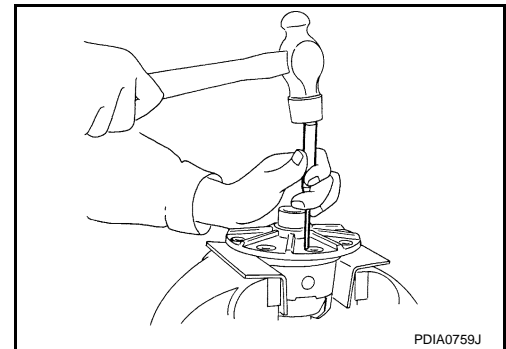

14. Remove pinion mate shaft.

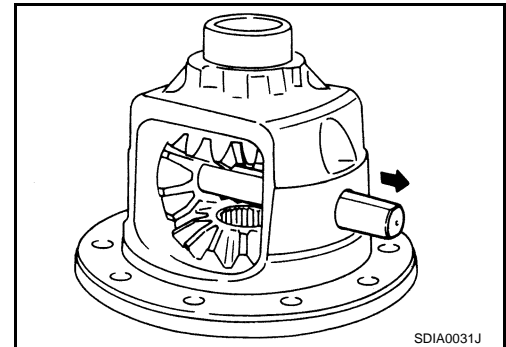

15. Turn pinion mate gear, then remove pinion mate gear, pinion mate thrust washer, side gear and side gear thrust washer from differential case.
16. Remove circular clip from side gear.
CAUTION:
Never damage side gear.
17. Remove side oil seal, using a suitable tool.
CAUTION:
Never damage gear carrier.

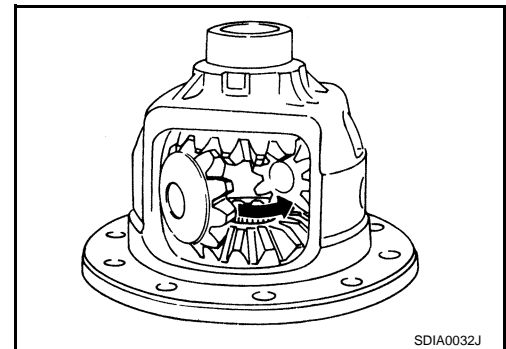

2WD : Assembly

1. Install circular clip to side gear.
CAUTION:
Never damage side gear.
2. Install side gear thrust washers with the same thickness as the ones installed prior to disassembly or reinstall the old ones on the side gears.

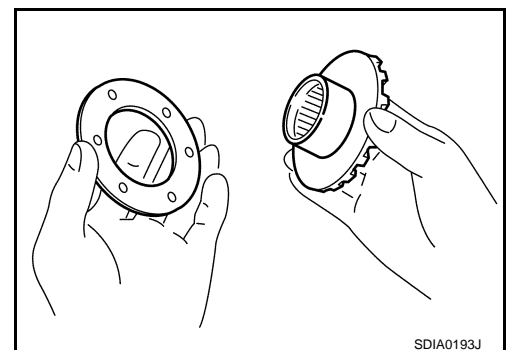

INFOID:000000005649761

DIFFERENTIAL ASSEMBLY

< UNIT DISASSEMBLY AND ASSEMBLY >

[REAR FINAL DRIVE: R200]

3. Install side gears and thrust washers into differential case.
CAUTION:
Make sure that the circular clip is installed to side gears.
4. Align 2 pinion mate gears in diagonally opposite positions, then rotate and install them into differential case after installing thrust washer to pinion mate gear.

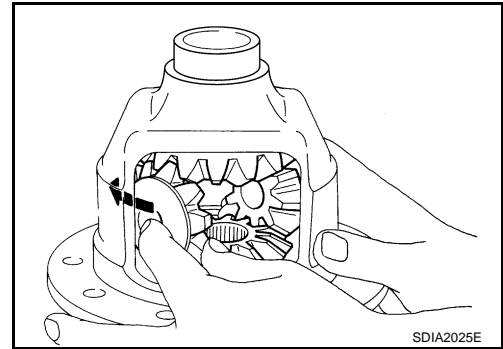

5. Align the lock pin holes on differential case with shaft, and install pinion mate shaft.

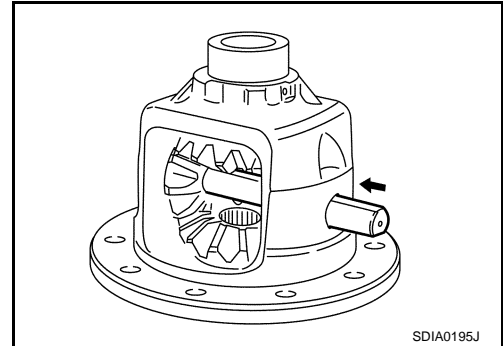

6. Measure side gear end play. If necessary, select the appropriate side gear thrust washers.
 - a. Place differential case straight up so that side gear to be measured comes upward.

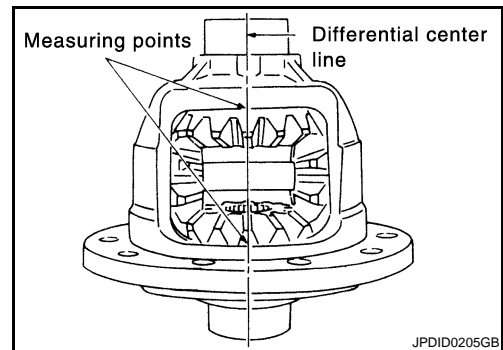

A
B
C
DLN
E
F
G
H
I
J
K
L
M
N
O
P

DIFFERENTIAL ASSEMBLY

< UNIT DISASSEMBLY AND ASSEMBLY >

[REAR FINAL DRIVE: R200]

- b. Using feeler gauge, measure the clearance between side gear back and differential case at 3 different points, while rotating side gear. Average the 3 readings, and then measure the clearance of the other side as well.

Standard

Side gear back clearance : Refer to [DLN-223, "Differential Side Gear Clearance"](#).

CAUTION:

To prevent side gear from tilting, insert feeler gauges with the same thickness from both sides.

- c. If the back clearance is outside the specification, use a thicker/thinner side gear thrust washer to adjust.

When the back clearance is large: Use a thicker thrust washer.

When the back clearance is small: Use a thinner thrust washer.

CAUTION:

Select a side gear thrust washer for right and left individually.

7. Drive a lock pin into pinion mate shaft, using a punch. Make sure lock pin is flush with differential case.

CAUTION:

Never reuse lock pin.

8. Apply thread locking sealant into the thread hole of drive gear. Use Genuine High Strength Thread Locking Sealant or equivalent. Refer to [GI-18, "Recommended Chemical Products and Sealants"](#).

CAUTION:

Clean and degrease drive gear back and threaded holes sufficiently.

9. Install the drive gear to differential case.

CAUTION:

Align the matching marks of differential case and drive gear.

10. Tighten the mounting bolts with the following procedure.

CAUTION:

Apply anti-corrosion oil to the thread and seat of mounting bolts.

- a. Tighten the bolts in a crisscross fashion to the specified torque.

Drive gear mounting bolts tightening torque : 78.5 N•m (8.0 kg-m, 58 ft-lb)

- b. Tighten the bolts additionally at the specified angle.

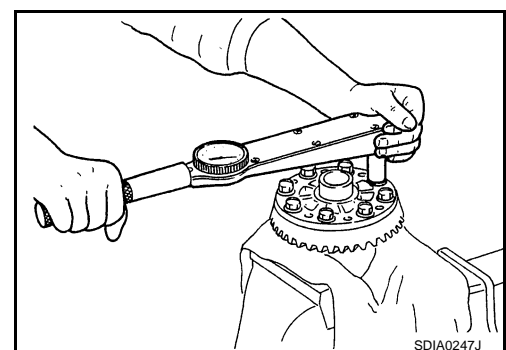
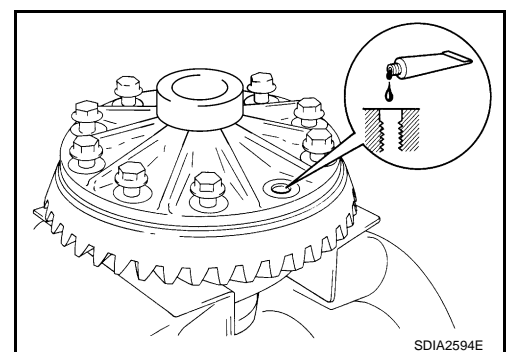
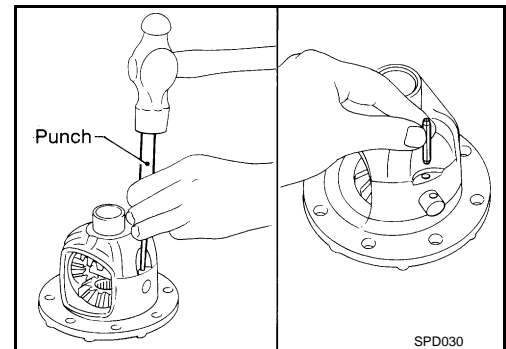
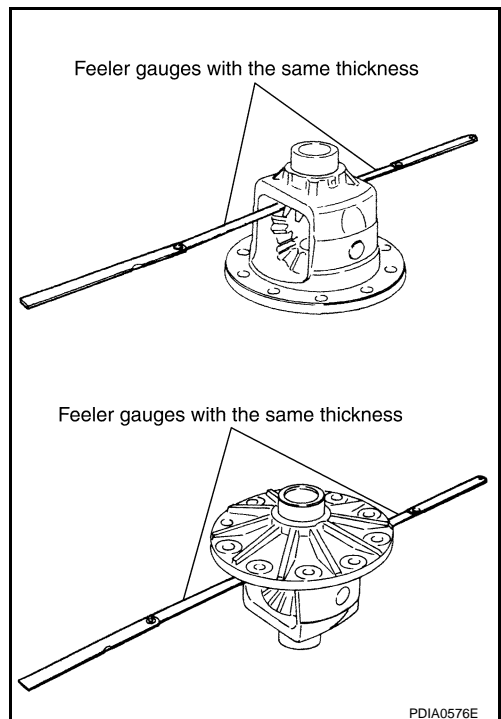

DIFFERENTIAL ASSEMBLY

< UNIT DISASSEMBLY AND ASSEMBLY >

[REAR FINAL DRIVE: R200]

Drive gear mounting : 31 to 36 degree
bolts tightening angle

CAUTION:

Check the tightening angle using the angle wrench [SST: KV10112100(BT-8653-A)]. Never make judgment by visual inspection.

11. Press side bearing inner races to differential case, using the drift and the base.

A : Drift [SST: KV38100300 (J-25523)]

B : Base [SST: ST33061000 (J-8107-2)]

CAUTION:

Never reuse side bearing inner race.

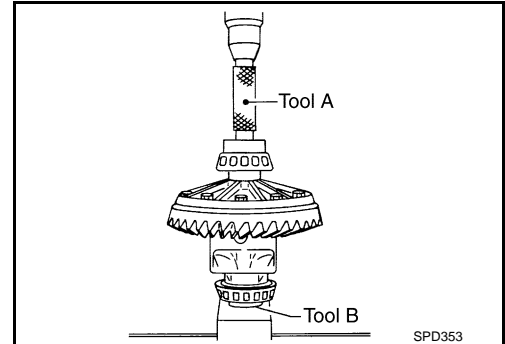

12. Install differential case assembly with side bearing outer races into gear carrier.
13. Measure side bearing preload. If necessary, select the appropriate side bearing adjusting washers. Refer to [DLN-186. "2WD : Adjustment"](#).

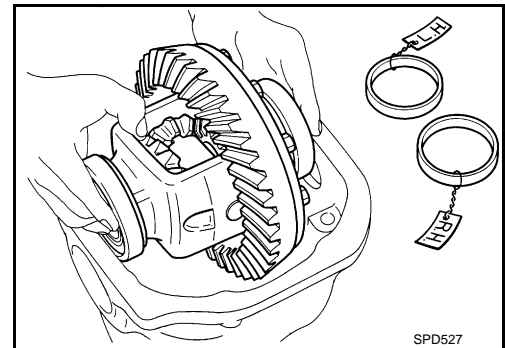

14. Insert selected left and right side bearing adjusting washers in place between side bearings and gear carrier. Refer to [DLN-186. "2WD : Adjustment"](#).

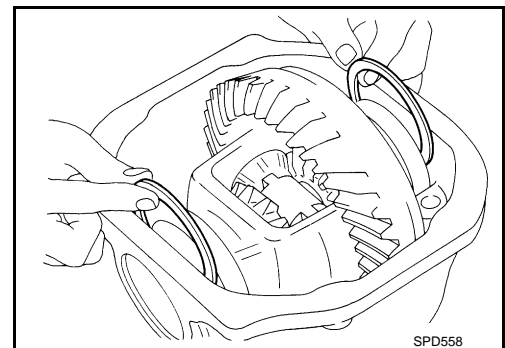

15. Align matching marks on bearing cap with that on gear carrier.
16. Install bearing caps and tighten bearing cap mounting bolts.

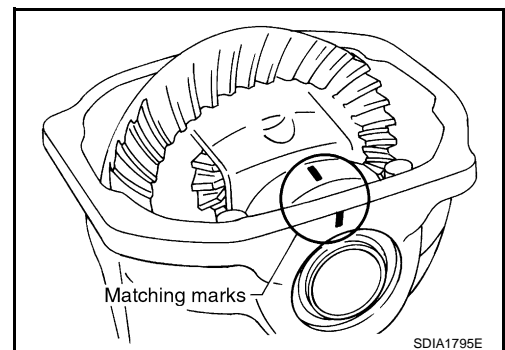

A
B
C
DLN
E
F
G
H
I
J
K
L
M
N
O
P

DIFFERENTIAL ASSEMBLY

< UNIT DISASSEMBLY AND ASSEMBLY >

[REAR FINAL DRIVE: R200]

17. Using the drift [SST: KV38100200 (J-26233)], drive side oil seals until it becomes flush with the case end.

CAUTION:

- Never reuse oil seal.
- When installing, never incline oil seal.
- Apply multi-purpose grease onto oil seal lips, and gear oil onto the circumference of oil seal.

18. Check and adjust drive gear runout, tooth contact, drive gear to drive pinion backlash, and total preload torque. Refer to [DLN-186. "2WD : Adjustment"](#).

Recheck above items. Readjust the above description, if necessary.

19. Apply sealant to mating surface of rear cover. Use Genuine Silicone RTV or equivalent. Refer to [GI-18. "Recommended Chemical Products and Sealants"](#).

CAUTION:

Remove old sealant adhering to mounting surfaces. Also remove any moisture, oil, or foreign material adhering to application and mounting surfaces.

20. Install rear cover on gear carrier and tighten mounting bolts.

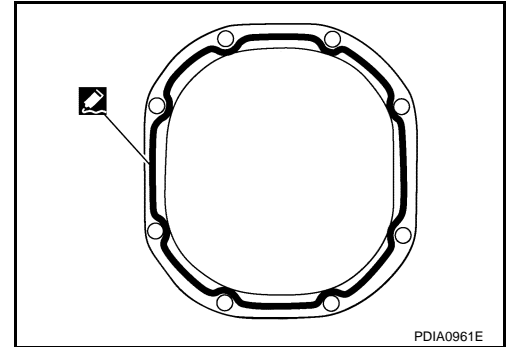
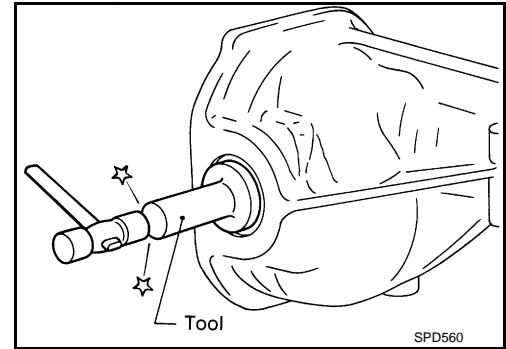

21. Install side flange with the following procedure.

- Attach the protector [SST: KV38107900 (J-39352)] to side oil seal.
- After the side flanges is inserted and the serrated part of side gear has engaged the serrated part of flange, remove the protector.

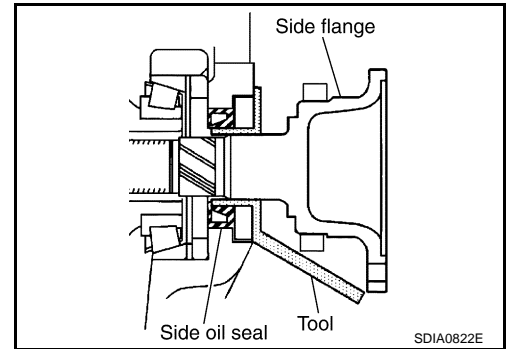

- Put a suitable drift on the center of side flange, then drive it until sound changes.

NOTE:

When installation is completed, driving sound of the side flange turns into a sound that seems to affect the whole final drive.

- Confirm that the dimension of the side flanges (1) installation measurement (A) in the figure comes into the following.

Standard

A : 326 – 328 mm (12.83 – 12.91 in)

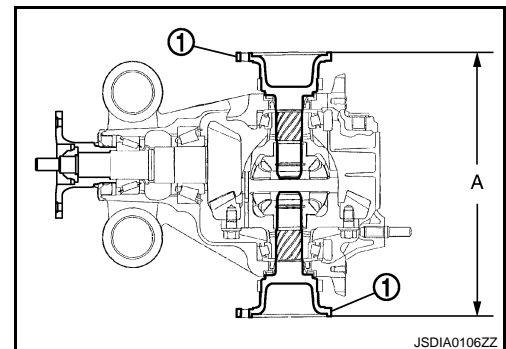

2WD : Adjustment

INFOID:000000005649762

TOTAL PRELOAD TORQUE

Before inspection and adjustment, drain gear oil.

- Secure final drive assembly onto an attachment [SST: KV38100800 (J-25604-01)].
- Remove side flanges.

DIFFERENTIAL ASSEMBLY

< UNIT DISASSEMBLY AND ASSEMBLY >

[REAR FINAL DRIVE: R200]

3. Rotate drive pinion back and forth 2 to 3 times to check for unusual noise and rotation malfunction.
4. Rotate drive pinion at least 20 times to check for smooth operation of the bearing.
5. Measure total preload with the preload gauge (A) [SST: ST3127S000 (J-25765-A)].

Standard

Total preload torque

: Refer to [DLN-223, "Pre-load Torque"](#).

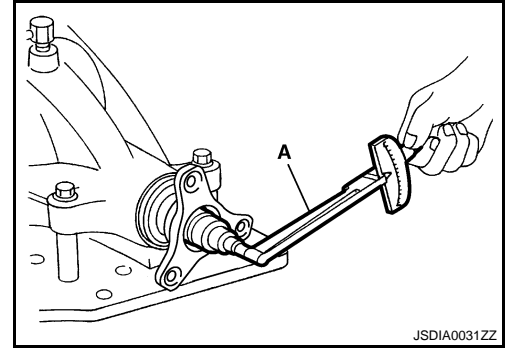

NOTE:

Total preload torque = Pinion bearing preload torque + Side bearing preload torque

- If measured value is out of the specification, disassemble it to check and adjust each part. Adjust the pinion bearing preload and side bearing preload. Adjust the pinion bearing preload first, then adjust the side bearing preload.

When the preload torque is large

On pinion bearings: Replace the collapsible spacer.

On side bearings: Use thinner side bearing adjusting washers by the same amount to each side.

When the preload is small

On pinion bearings: Tighten the drive pinion lock nut.

On side bearings: Use thicker side bearing adjusting washers by the same amount to each side.

SIDE BEARING PRELOAD

Before inspection and adjustment, drain gear oil.

1. Remove rear cover. Refer to [DLN-180, "2WD : Disassembly"](#).
2. Make sure all parts are clean. Also, make sure the bearings are well lubricated with gear oil.
3. Place the differential case, with side bearings and bearing races installed, into gear carrier.

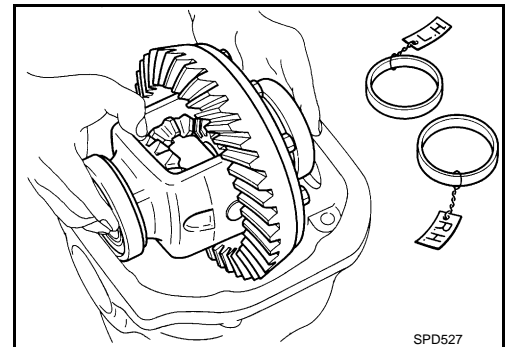

4. Insert left and right original side bearing adjusting washers in place between side bearings and gear carrier.

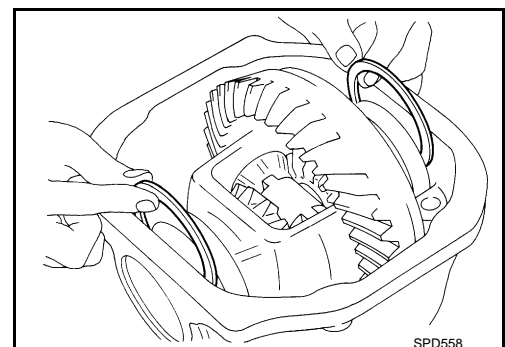

DIFFERENTIAL ASSEMBLY

< UNIT DISASSEMBLY AND ASSEMBLY >

[REAR FINAL DRIVE: R200]

5. Install bearing caps in their correct locations and tighten bearing cap mounting bolts.
6. Turn the carrier several times to seat the bearings.

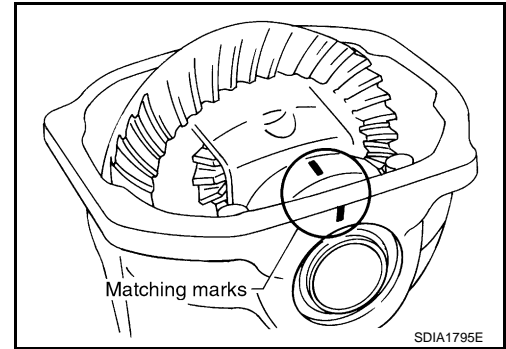

7. Measure the turning torque of the carrier at the drive gear mounting bolts with a spring gauge [SST: — (J-8129)].

Standard

Specification

: 34.2 – 39.2 N (3.5 – 4.0 kg, 7.7 – 8.8 lb) of pulling force at the drive gear bolt

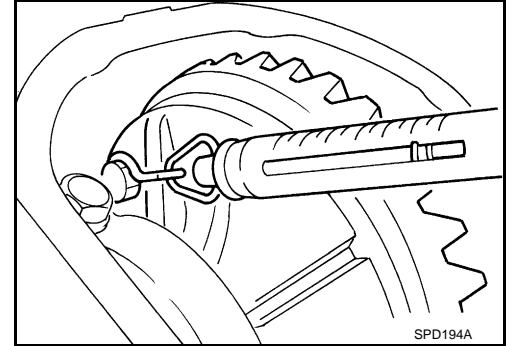

8. If the turning torque is outside the specification, use a thicker/thinner side bearing adjusting washer to adjust.

If the turning torque is less than the specified range:

Use a thicker thrust washer.

If the turning torque is greater than the specification:

Use a thinner thrust washer.

CAUTION:

Select a side bearing adjusting washer for right and left individually.

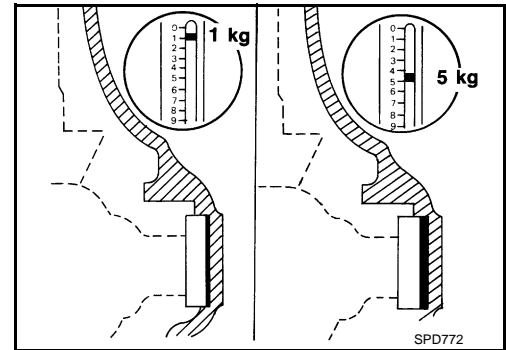

9. Record the total amount of washer thickness required for the correct carrier side bearing preload.

DRIVE GEAR RUNOUT

1. Remove rear cover. Refer to [DLN-180, "2WD : Disassembly"](#).
2. Fit a dial indicator to the drive gear back face.
3. Rotate the drive gear to measure runout.

Limit

Drive gear runout

: Refer to [DLN-223, "Drive Gear Runout"](#).

- If the runout is outside of the repair limit, check drive gear assembly condition; foreign material may be caught between drive gear and differential case, or differential case or drive gear may be deformed, etc.

CAUTION:

Replace drive gear and drive pinion gear as a set.

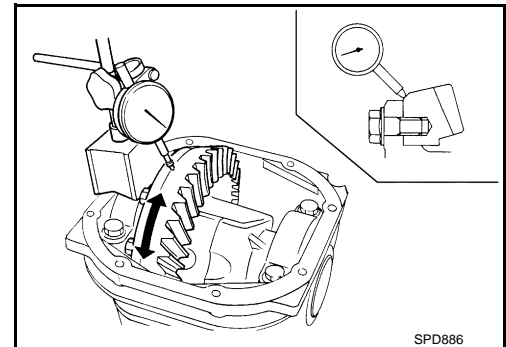

TOOTH CONTACT

Before inspection and adjustment, drain gear oil.

1. Remove rear cover. Refer to [DLN-180, "2WD : Disassembly"](#).

DIFFERENTIAL ASSEMBLY

< UNIT DISASSEMBLY AND ASSEMBLY >

[REAR FINAL DRIVE: R200]

2. Apply red lead to drive gear.

CAUTION:

Apply red lead to both the faces of 3 to 4 gears at 4 locations evenly spaced on drive gear.

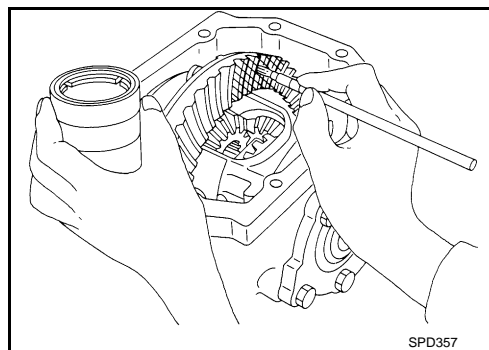

3. Rotate drive gear back and forth several times, check drive pinion gear to drive gear tooth contact.

CAUTION:

Check tooth contact on drive side and reverse side.

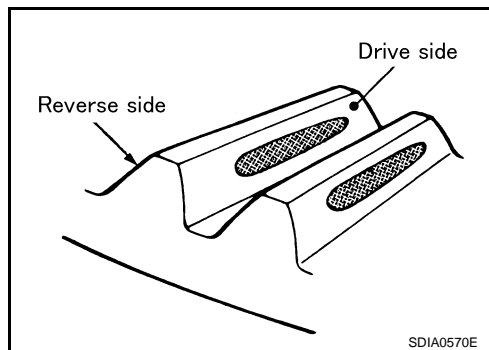

Tooth contact condition		Pinion height adjusting washer selection valve [mm (in)]	Adjustment (Yes/No)	Possible cause
Drive side	Back side			
Heel side 	Toe side Heel side 	↑ Thicker	Yes	Occurrence of noise and scoring sound in all speed ranges.
				+0.06 (+0.0024)
		+0.03 (+0.0012)	No	-
		0		
		↓ Thinner	Yes	Occurrence of noise at constant speed and decreasing speed.
		-0.06 (-0.0024)	Yes	Occurrence of noise and scoring sound in all speed ranges.
		-0.09 (-0.0035)		

SDIA0207E

A
B
C
DLN
E
F
G
H
I
J
K
L
M
N
O
P

DIFFERENTIAL ASSEMBLY

< UNIT DISASSEMBLY AND ASSEMBLY >

[REAR FINAL DRIVE: R200]

4. If tooth contact is improperly adjusted, follow the procedure below to adjust the pinion height [dimension (X)].

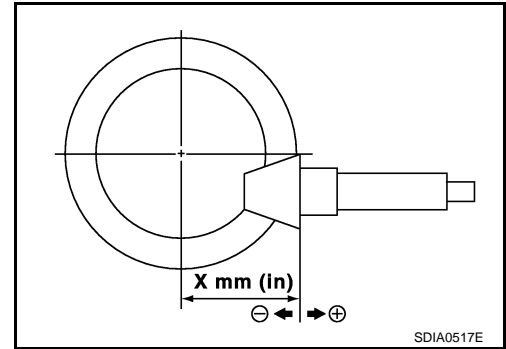

- If the tooth contact is near the face (face contact), or near the heel (heel contact), thicken pinion height adjusting washers to move drive pinion closer to drive gear.

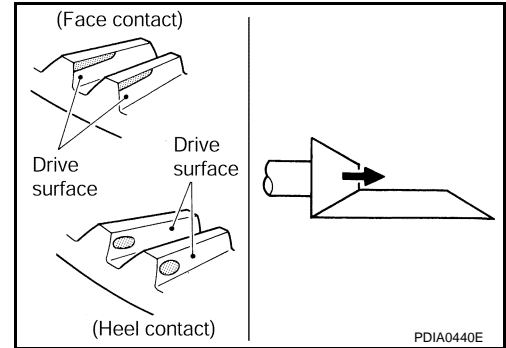

- If the tooth contact is near the flank (flank contact), or near the toe (toe contact), thin pinion height adjusting washers to move drive pinion farther from drive gear.

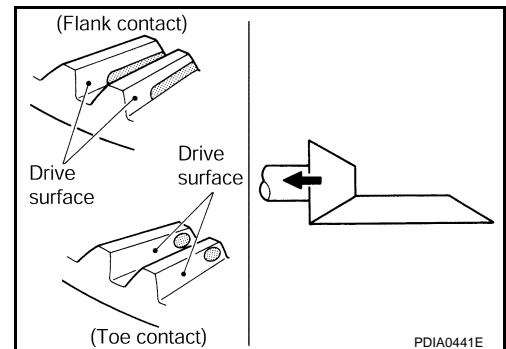

BACKLASH

Before inspection and adjustment, drain gear oil.

1. Remove rear cover. Refer to [DLN-180, "2WD : Disassembly"](#).
2. Fit a dial indicator to the drive gear face to measure the backlash.

Standard Backlash

: Refer to [DLN-223, "Backlash"](#).

- If the backlash is outside of the specified value, change the thickness of side bearing adjusting washer.

When the backlash is large:

Make drive gear back side adjusting washer thicker, and drive gear tooth side adjusting washer thinner by the same amount.

When the backlash is small:

Make drive gear back side adjusting washer thinner, and drive gear tooth side adjusting washer thicker by the same amount.

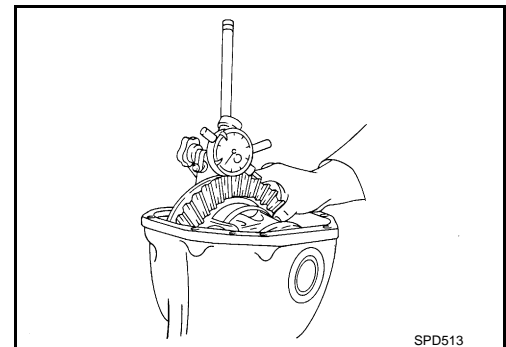

DIFFERENTIAL ASSEMBLY

< UNIT DISASSEMBLY AND ASSEMBLY >

[REAR FINAL DRIVE: R200]

CAUTION:

Never change the total amount of washers as it changes the bearing preload.

2WD : Inspection After Disassembly

INFOID:000000005649763

DRIVE GEAR AND DRIVE PINION

- Clean up the disassembled parts.
- If the gear teeth never mesh or line-up correctly, determine the cause and adjust or replace as necessary.
- If the gears are worn, cracked, damaged, pitted or chipped (by friction) noticeably, replace with new drive gear and drive pinion as a set.

BEARING

- Clean up the disassembled parts.
- If any chipped (by friction), pitted, worn, rusted or scratched marks, or unusual noise from the bearing is observed, replace as a bearing assembly (as a new set).

SIDE GEAR AND PINION MATE GEAR

- Clean up the disassembled parts.
- If any cracks or damage on the surface of the tooth is found, replace.
- If any worn or chipped mark on the contact sides of the thrust washer is found, replace.

SIDE GEAR THRUST WASHER AND PINION MATE THRUST WASHER

- Clean up the disassembled parts.
- If it is chipped (by friction), damaged, or unusually worn, replace.

OIL SEAL

- Whenever disassembled, replace.
- If wear, deterioration of adherence (sealing force lips), or damage is detected on the lips, replace them.

DIFFERENTIAL CASE

- Clean up the disassembled parts.
- If any wear or crack on the contact sides of the differential case is found, replace.

COMPANION FLANGE

- Clean up the disassembled parts.
- If any chipped mark [about 0.1 mm, (0.004 in)] or other damage on the contact sides of the lips of the companion flange is found, replace.

AWD

A

B

C

DLN

E

F

G

H

I

J

K

L

M

N

O

P

DIFFERENTIAL ASSEMBLY

< UNIT DISASSEMBLY AND ASSEMBLY >

[REAR FINAL DRIVE: R200]

AWD : Exploded View

INFOID:000000005649764

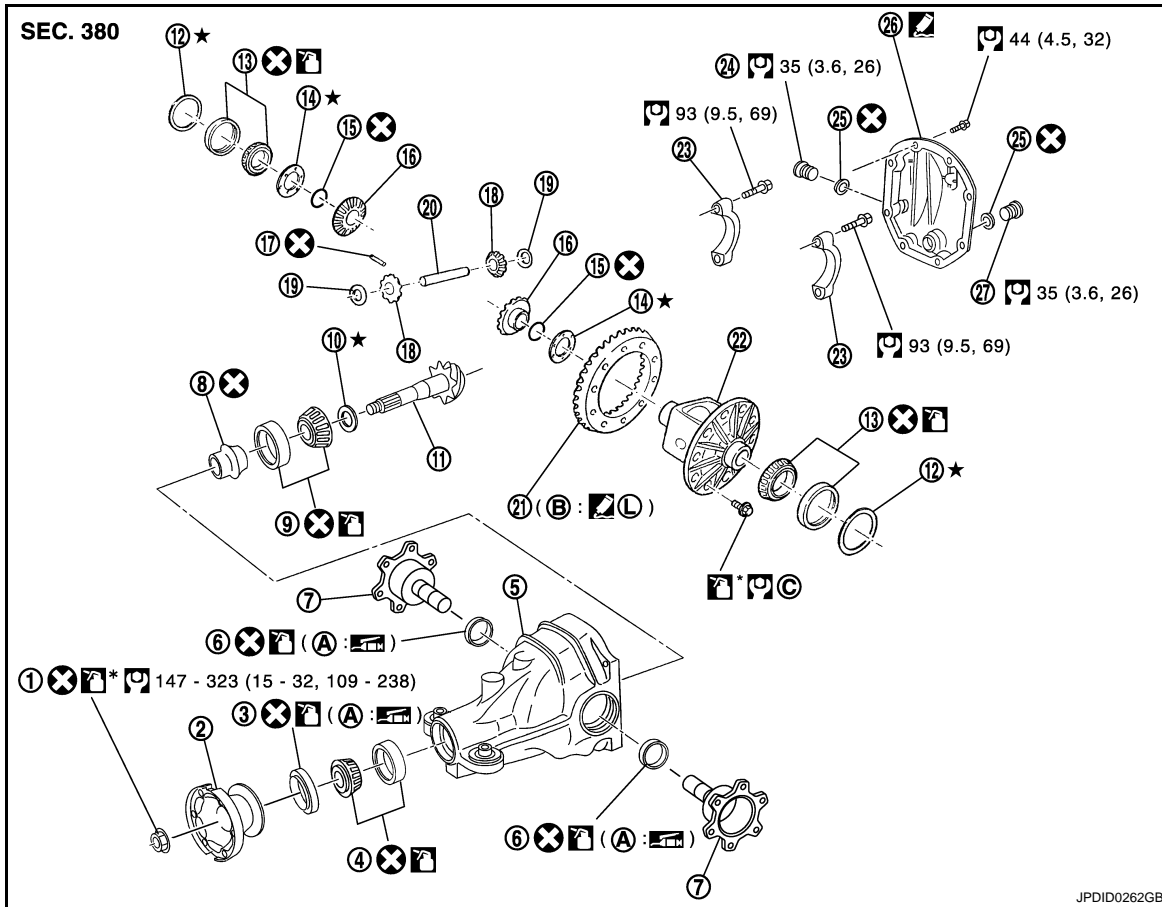

- | | | |
|------------------------------------|-----------------------------|---|
| 1. Drive pinion lock nut | 2. Companion flange | 3. Front oil seal |
| 4. Pinion front bearing | 5. Gear carrier | 6. Side oil seal |
| 7. Side flange | 8. Collapsible spacer | 9. Pinion rear bearing |
| 10. Pinion height adjusting washer | 11. Drive pinion | 12. Side bearing adjusting washer |
| 13. Side bearing | 14. Side gear thrust washer | 15. Circular clip |
| 16. Side gear | 17. Lock pin | 18. Pinion mate gear |
| 19. Pinion mate thrust washer | 20. Pinion mate shaft | 21. Drive gear |
| 22. Differential case | 23. Bearing cap | 24. Filler plug |
| 25. Gasket | 26. Rear cover | 27. Drain plug |
| A. Oil seal lip | B. Screw hole | C. Comply with the assembly procedure when tightening. Refer to DLN-195, "AWD : Assembly" . |

: Apply gear oil.

: Apply anti-corrosion oil.

: Apply Genuine Silicone RTV or equivalent. Refer to [GI-18, "Recommended Chemical Products and Sealants"](#).

: Apply Genuine High Strength Thread Locking Sealant or equivalent. Refer to [GI-18, "Recommended Chemical Products and Sealants"](#).

Refer to [GI-4, "Components"](#) for symbols not described on the above.

AWD : Disassembly

INFOID:000000005649765

1. Drain gear oil, if necessary.

DIFFERENTIAL ASSEMBLY

< UNIT DISASSEMBLY AND ASSEMBLY >

[REAR FINAL DRIVE: R200]

2. Remove side flanges.
3. Remove rear cover mounting bolts.
4. Remove rear cover to insert the seal cutter (A) [SST: KV10111100 (J-37228)] between gear carrier and rear cover.

CAUTION:

- Never damage the mating surface.
- Never insert flat-bladed screwdriver, this may damage the mating surface.

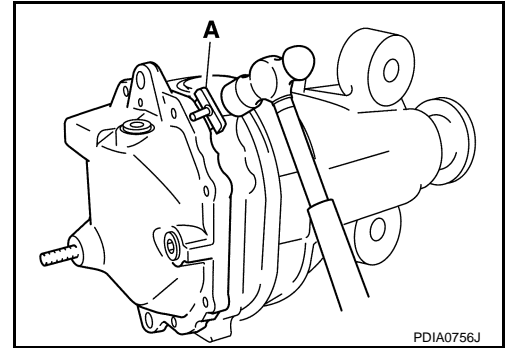

5. Using two spacers, mount carrier on the attachment (A) [SST: KV38100800 (J-25604-01)].

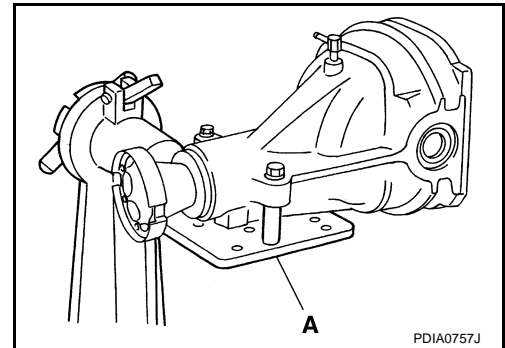

6. For proper reinstallation, paint matching marks on one side of the bearing cap.

CAUTION:

- For matching marks, use paint. Never damage bearing caps and gear carrier.
- Bearing caps are manufactured as integral molding. Use the matching marks to them in their original positions.

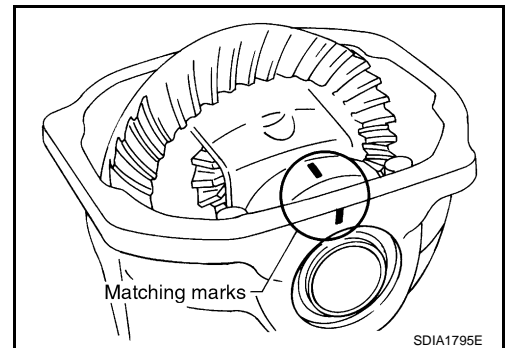

7. Remove bearing caps.

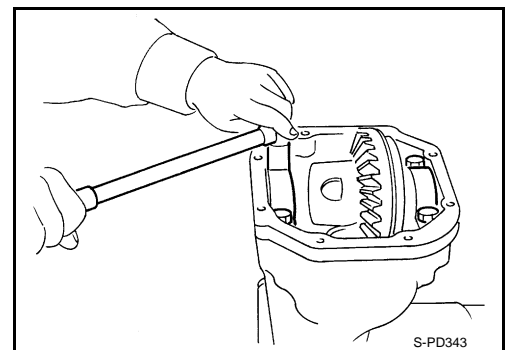

A
B
C
DLN
E
F
G
H
I
J
K
L
M
N
O
P

DIFFERENTIAL ASSEMBLY

< UNIT DISASSEMBLY AND ASSEMBLY >

[REAR FINAL DRIVE: R200]

8. Lift differential case assembly out with a suitable tool.

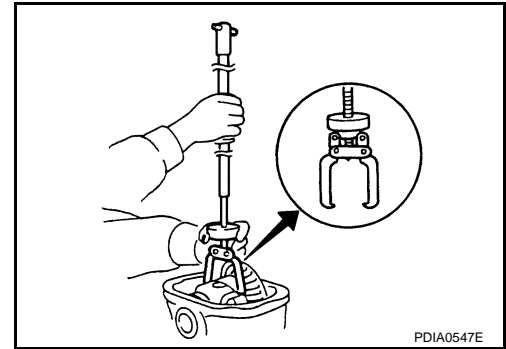

- Keep side bearing outer races together with inner race. Never mix them up.
Also, keep side bearing adjusting washers together with bearings.

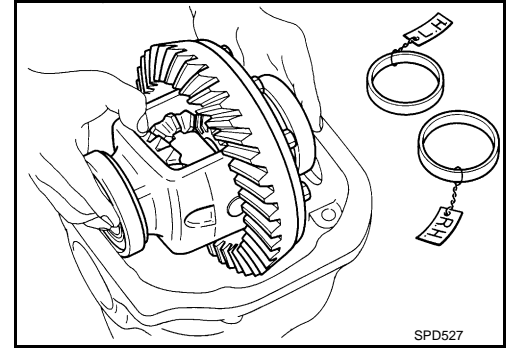

9. Remove side bearing inner race.
To prevent damage to bearing, engage puller jaws in groove (←).

A : Puller [SST: ST33051001 (J-22888-20)]

B : Base [SST: ST33061000 (J-8107-2)]

CAUTION:

- To prevent damage to the side bearing and drive gear, place copper plates between these parts and vise.
- It is not necessary to remove side bearing inner race except when it is replaced.

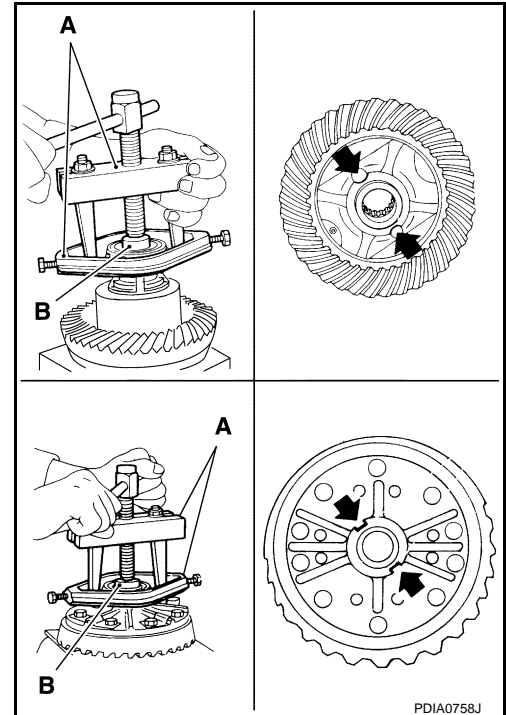

10. For proper reinstallation, paint matching marks on one differential case assembly.

CAUTION:

For matching marks, use paint. Never damage differential case and drive gear.

11. Remove drive gear mounting bolts.

12. Tap drive gear off differential case assembly with a soft hammer.

CAUTION:

Tap evenly all around to keep drive gear from bending.

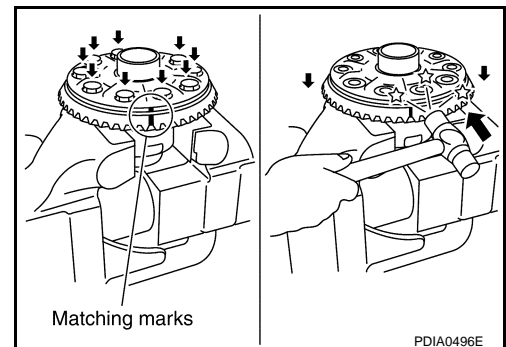

DIFFERENTIAL ASSEMBLY

< UNIT DISASSEMBLY AND ASSEMBLY >

[REAR FINAL DRIVE: R200]

13. Remove lock pin of pinion mate shaft with a punch from drive gear side.

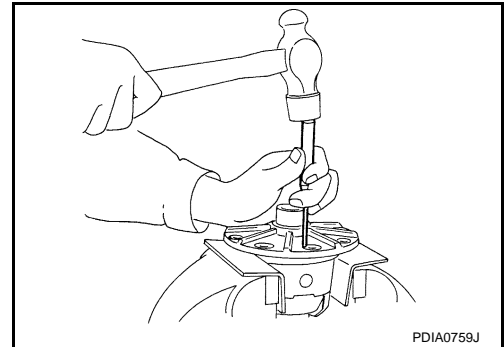

14. Remove pinion mate shaft.

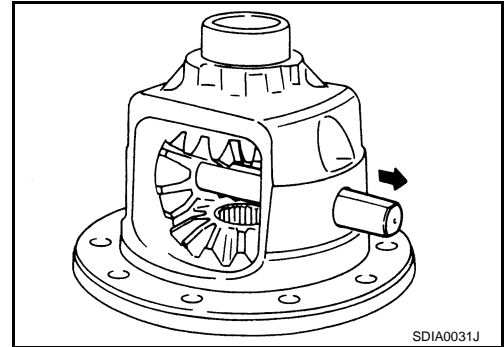

15. Turn pinion mate gear, then remove pinion mate gear, pinion mate thrust washer, side gear and side gear thrust washer from differential case.
16. Remove circular clip from side gear.
CAUTION:
Never damage side gear.
17. Remove side oil seal, using a suitable tool.
CAUTION:
Never damage gear carrier.

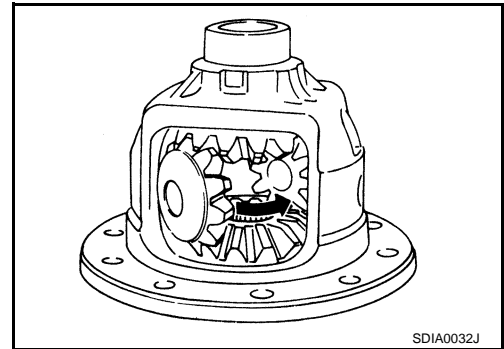

AWD : Assembly

1. Install circular clip to side gear.
CAUTION:
Never damage side gear.
2. Install side gear thrust washers with the same thickness as the ones installed prior to disassembly or reinstall the old ones on the side gears.

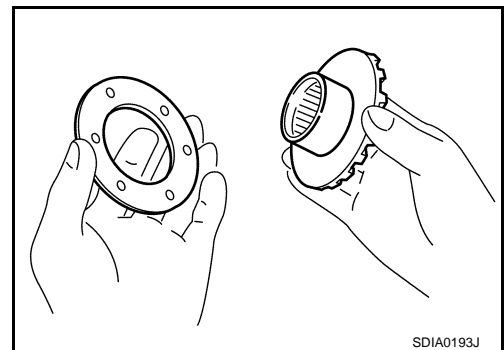

INFOID:000000005649766

A
B
C
DLN
E
F
G
H
I
J
K
L
M
N
O
P

DIFFERENTIAL ASSEMBLY

< UNIT DISASSEMBLY AND ASSEMBLY >

[REAR FINAL DRIVE: R200]

3. Install side gears and thrust washers into differential case.

CAUTION:

Make sure that the circular clip is installed to side gears.

4. Align 2 pinion mate gears in diagonally opposite positions, then rotate and install them into differential case after installing thrust washer to pinion mate gear.

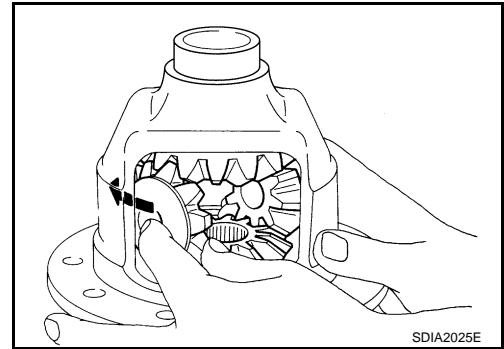

5. Align the lock pin holes on differential case with shaft, and install pinion mate shaft.

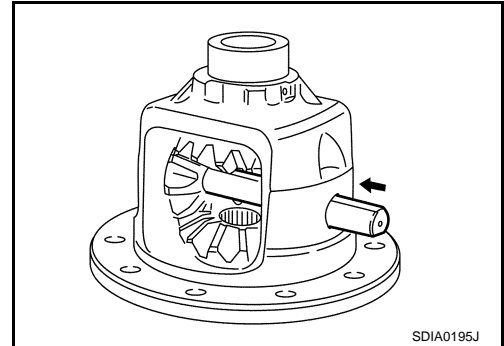

6. Measure side gear end play. If necessary, select the appropriate side gear thrust washers.

- a. Place differential case straight up so that side gear to be measured comes upward.

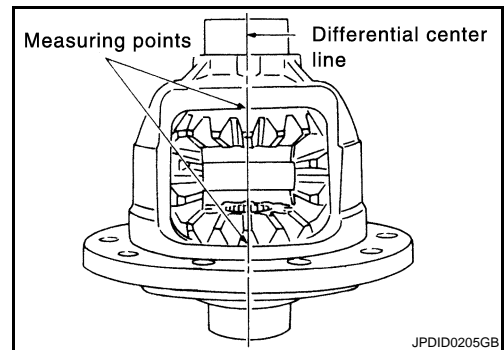

DIFFERENTIAL ASSEMBLY

< UNIT DISASSEMBLY AND ASSEMBLY >

[REAR FINAL DRIVE: R200]

- b. Using feeler gauge, measure the clearance between side gear back and differential case at 3 different points, while rotating side gear. Average the 3 readings, and then measure the clearance of the other side as well.

Standard

Side gear back clearance : Refer to [DLN-223, "Differential Side Gear Clearance"](#).

CAUTION:

To prevent side gear from tilting, insert feeler gauges with the same thickness from both sides.

- c. If the back clearance is outside the specification, use a thicker/thinner side gear thrust washer to adjust.

When the back clearance is large: Use a thicker thrust washer.

When the back clearance is small: Use a thinner thrust washer.

CAUTION:

Select a side gear thrust washer for right and left individually.

7. Drive a lock pin into pinion mate shaft, using a punch. Make sure lock pin is flush with differential case.

CAUTION:

Never reuse lock pin.

8. Apply thread locking sealant into the thread hole of drive gear. Use Genuine High Strength Thread Locking Sealant or equivalent. Refer to [GI-18, "Recommended Chemical Products and Sealants"](#).

CAUTION:

Clean and degrease drive gear back and threaded holes sufficiently.

9. Install the drive gear to differential case.

CAUTION:

Align the matching marks of differential case and drive gear.

10. Tighten the mounting bolts with the following procedure.

CAUTION:

Apply anti-corrosion oil to the thread and seat of mounting bolts.

- a. Tighten the bolts in a crisscross fashion to the specified torque.

Drive gear mounting bolts tightening torque : 78.5 N•m (8.0 kg-m, 58 ft-lb)

- b. Tighten the bolts additionally at the specified angle.

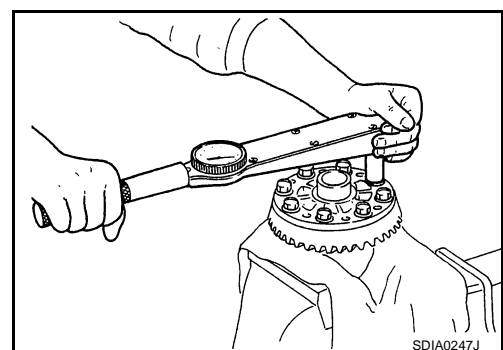
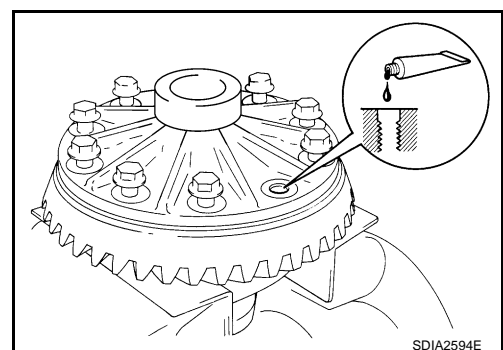
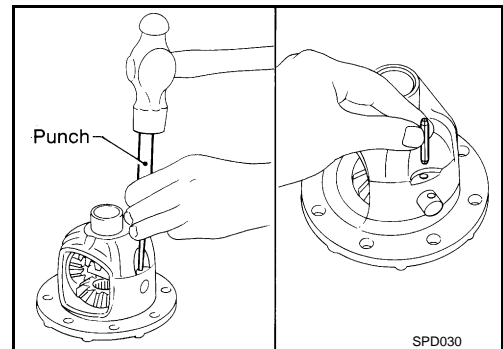
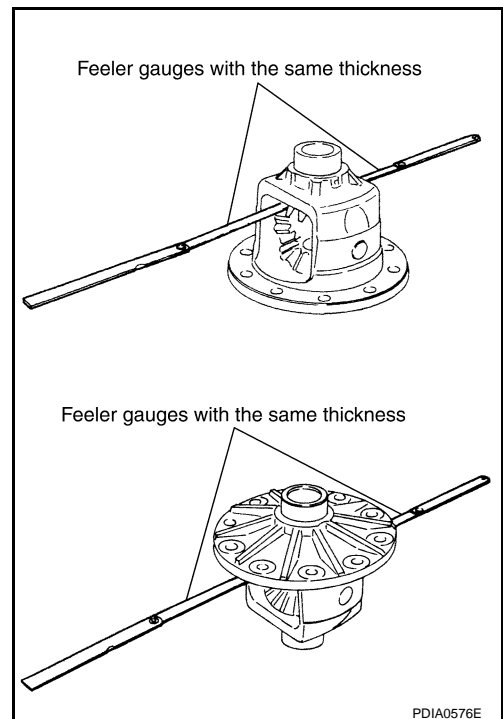

A

B

C

DLN

E

F

G

H

I

J

K

L

M

N

O

P

DIFFERENTIAL ASSEMBLY

< UNIT DISASSEMBLY AND ASSEMBLY >

[REAR FINAL DRIVE: R200]

Drive gear mounting bolts tightening angle : 31 to 36 degree

CAUTION:

Check the tightening angle using the angle wrench [SST: KV10112100(BT-8653-A)]. Never make judgment by visual inspection.

11. Press side bearing inner races to differential case, using the drift and the base.

- A : Drift [SST: KV38100300 (J-25523)]
- B : Base [SST: ST33061000 (J-8107-2)]

CAUTION:

Never reuse side bearing inner race.

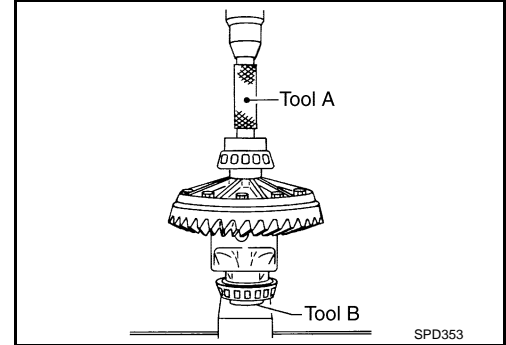

12. Install differential case assembly with side bearing outer races into gear carrier.
13. Measure side bearing preload. If necessary, select the appropriate side bearing adjusting washers. Refer to [DLN-199, "AWD : Adjustment"](#).

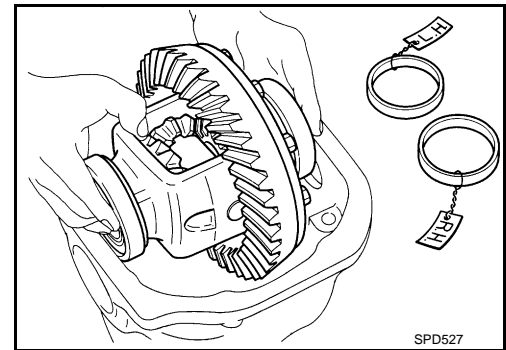

14. Insert selected left and right side bearing adjusting washers in place between side bearings and gear carrier. Refer to [DLN-199, "AWD : Adjustment"](#).

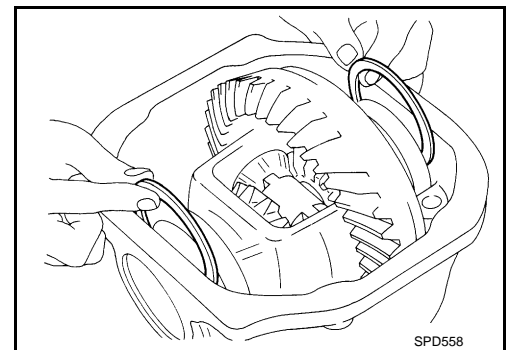

15. Align matching marks on bearing cap with that on gear carrier.
16. Install bearing caps and tighten bearing cap mounting bolts.

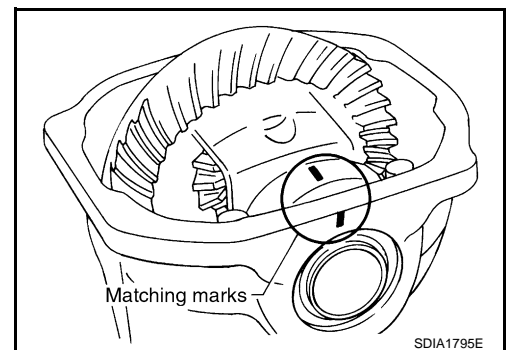

DIFFERENTIAL ASSEMBLY

< UNIT DISASSEMBLY AND ASSEMBLY >

[REAR FINAL DRIVE: R200]

17. Using the drift [SST: KV38100200 (J-26233)], drive side oil seals until it becomes flush with the case end.

CAUTION:

- Never reuse oil seal.
- When installing, never incline oil seal.
- Apply multi-purpose grease onto oil seal lips, and gear oil onto the circumference of oil seal.

18. Check and adjust drive gear runout, tooth contact, drive gear to drive pinion backlash, and total preload torque. Refer to [DLN-199. "AWD : Adjustment"](#).
Recheck above items. Readjust the above description, if necessary.

19. Apply sealant to mating surface of rear cover. Use Genuine Silicone RTV or equivalent. Refer to [GI-18. "Recommended Chemical Products and Sealants"](#).

CAUTION:

Remove old sealant adhering to mounting surfaces. Also remove any moisture, oil, or foreign material adhering to application and mounting surfaces.

20. Install rear cover on gear carrier and tighten mounting bolts.

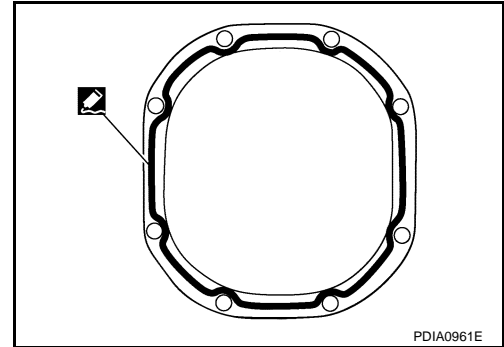
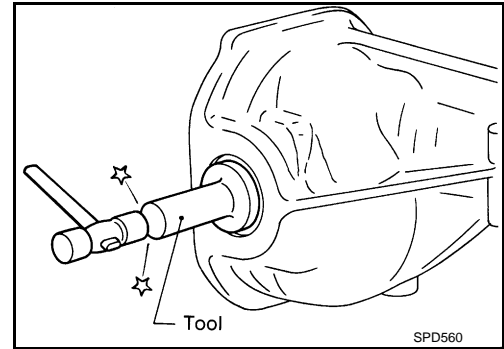

21. Install side flanges with the following procedure.

- a. Attach the protector [SST: KV38107900 (J-39352)] to side oil seal.
- b. After the side flange is inserted and the serrated part of side gear has engaged the serrated part of flange, remove the protector.

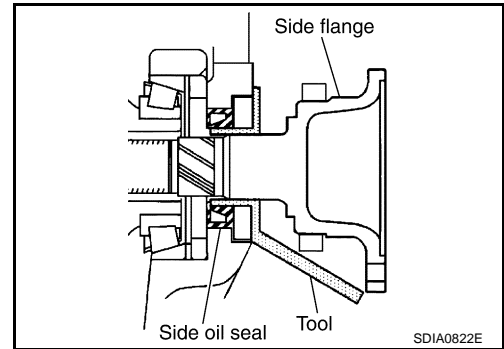

- c. Put a suitable drift on the center of side flange, then drive it until sound changes.

NOTE:

When installation is completed, driving sound of the side flange turns into a sound that seems to affect the whole final drive.

- d. Confirm that the dimension of the side flanges (1) installation measurement (A) in the figure comes into the following.

Standard

A : 326 – 328 mm (12.83 – 12.91 in)

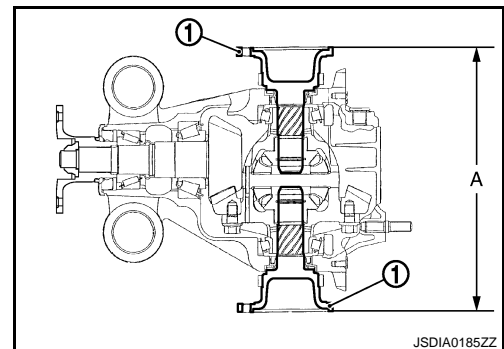

AWD : Adjustment

INFOID:000000005649767

TOTAL PRELOAD TORQUE

Before inspection and adjustment, drain gear oil.

1. Secure final drive assembly onto an attachment [SST: KV38100800 (J-25604-01)].
2. Remove side flanges.

DIFFERENTIAL ASSEMBLY

< UNIT DISASSEMBLY AND ASSEMBLY >

[REAR FINAL DRIVE: R200]

3. Rotate drive pinion back and forth 2 to 3 times to check for unusual noise and rotation malfunction.
4. Rotate drive pinion at least 20 times to check for smooth operation of the bearing.
5. Measure total preload with the preload gauge (A) [SST: ST3127S000 (J-25765-A)].

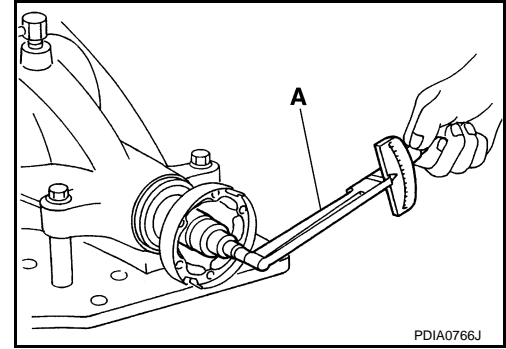

Standard

Total preload torque : Refer to [DLN-223, "Pre-load Torque"](#).

NOTE:

Total preload torque = Pinion bearing preload torque + Side bearing preload torque

- If measured value is out of the specification, disassemble it to check and adjust each part. Adjust the pinion bearing preload and side bearing preload. Adjust the pinion bearing preload first, then adjust the side bearing preload.

When the preload torque is large

On pinion bearings: Replace the collapsible spacer.

On side bearings: Use thinner side bearing adjusting washers by the same amount to each side.

When the preload is small

On pinion bearings: Tighten the drive pinion lock nut.

On side bearings: Use thicker side bearing adjusting washers by the same amount to each side.

SIDE BEARING PRELOAD

Before inspection and adjustment, drain gear oil.

1. Remove rear cover. Refer to [DLN-192, "AWD : Disassembly"](#).
2. Make sure all parts are clean. Also, make sure the bearings are well lubricated with gear oil.
3. Place the differential case, with side bearings and bearing races installed, into gear carrier.

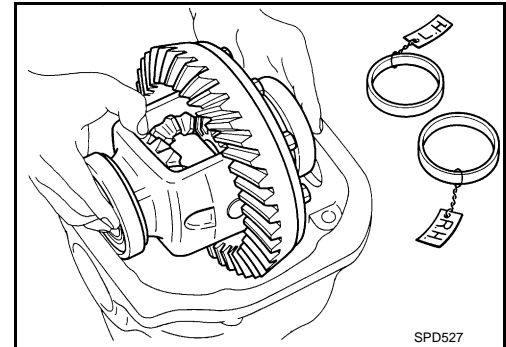

4. Insert left and right original side bearing adjusting washers in place between side bearings and gear carrier.

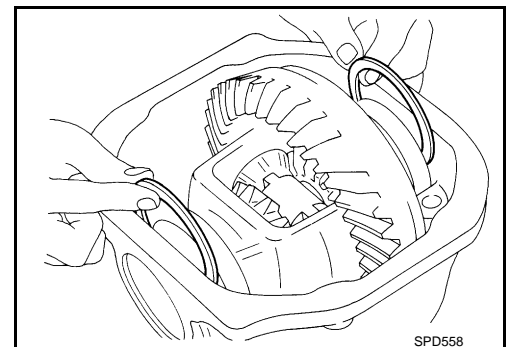

DIFFERENTIAL ASSEMBLY

< UNIT DISASSEMBLY AND ASSEMBLY >

[REAR FINAL DRIVE: R200]

5. Install bearing caps in their correct locations and tighten bearing cap mounting bolts.
6. Turn the carrier several times to seat the bearings.

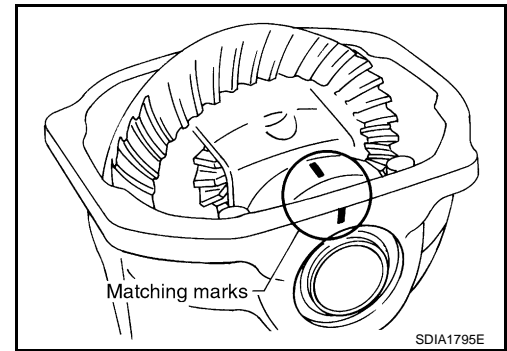

7. Measure the turning torque of the carrier at the drive gear mounting bolts with a spring gauge [SST: — (J-8129)].

Standard

Specification

: 34.2 – 39.2 N (3.5 – 4.0 kg, 7.7 – 8.8 lb) of pulling force at the drive gear bolt

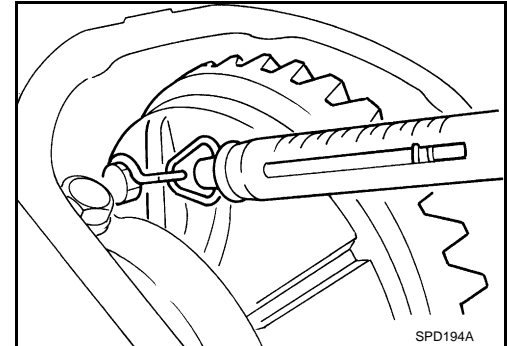

8. If the turning torque is outside the specification, use a thicker/thinner side bearing adjusting washer to adjust.

If the turning torque is less than the specified range:

Use a thicker thrust washer.

If the turning torque is greater than the specification:

Use a thinner thrust washer.

CAUTION:

Select a side bearing adjusting washer for right and left individually.

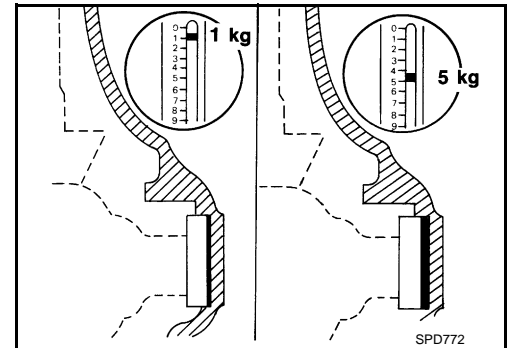

9. Record the total amount of washer thickness required for the correct carrier side bearing preload.

DRIVE GEAR RUNOUT

1. Remove rear cover. Refer to [DLN-192, "AWD : Disassembly"](#).
2. Fit a dial indicator to the drive gear back face.
3. Rotate the drive gear to measure runout.

Limit

Drive gear runout

: Refer to [DLN-223, "Drive Gear Runout"](#).

- If the runout is outside of the repair limit, check drive gear assembly condition; foreign material may be caught between drive gear and differential case, or differential case or drive gear may be deformed, etc.

CAUTION:

Replace drive gear and drive pinion gear as a set.

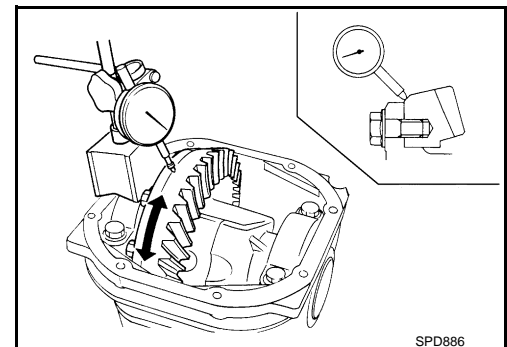

TOOTH CONTACT

Before inspection and adjustment, drain gear oil.

1. Remove rear cover. Refer to [DLN-192, "AWD : Disassembly"](#).

A
B
C
DLN
E
F
G
H
I
J
K
L
M
N
O
P

DIFFERENTIAL ASSEMBLY

< UNIT DISASSEMBLY AND ASSEMBLY >

[REAR FINAL DRIVE: R200]

2. Apply red lead to drive gear.

CAUTION:

Apply red lead to both the faces of 3 to 4 gears at 4 locations evenly spaced on drive gear.

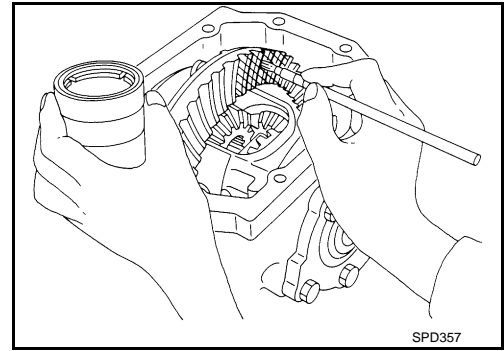

SPD357

3. Rotate drive gear back and forth several times, check drive pinion gear to drive gear tooth contact.

CAUTION:

Check tooth contact on drive side and reverse side.

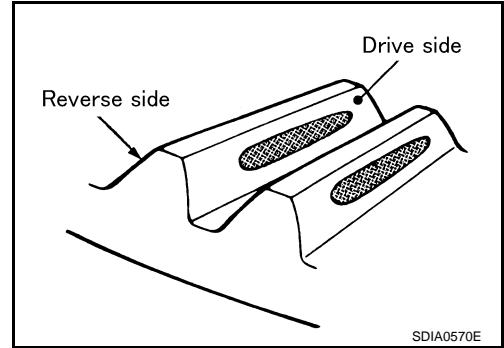

SDIA0570E

Tooth contact condition		Pinion height adjusting washer selection valve [mm (in)]	Adjustment (Yes/No)	Possible cause	
Drive side	Back side				
Heel side Toe side 	Toe side Heel side 	↑ Thicker	Yes	Occurrence of noise and scoring sound in all speed ranges.	
				+0.09 (+0.0035)	Occurrence of noise when accelerating.
				+0.06 (+0.0024)	
		↓ Thinner	No	-	
					+0.03 (+0.0012)
					0
					-0.03 (-0.0012)
					-0.06 (-0.0024)
		-0.09 (-0.0035)	Yes	Occurrence of noise and scoring sound in all speed ranges.	

SDIA0207E

DIFFERENTIAL ASSEMBLY

< UNIT DISASSEMBLY AND ASSEMBLY >

[REAR FINAL DRIVE: R200]

4. If tooth contact is improperly adjusted, follow the procedure below to adjust the pinion height [dimension (X)].

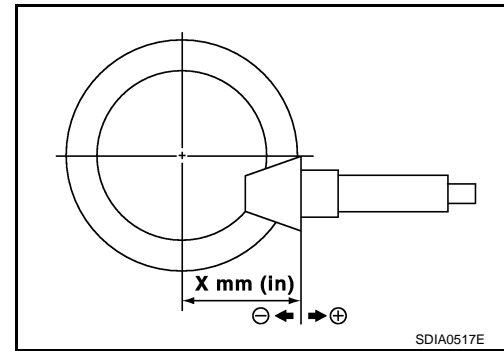

- If the tooth contact is near the face (face contact), or near the heel (heel contact), thicken pinion height adjusting washers to move drive pinion closer to drive gear.

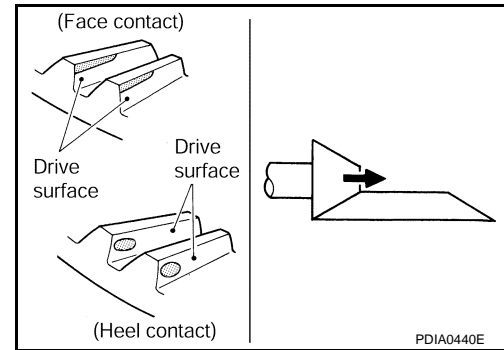

- If the tooth contact is near the flank (flank contact), or near the toe (toe contact), thin pinion height adjusting washers to move drive pinion farther from drive gear.

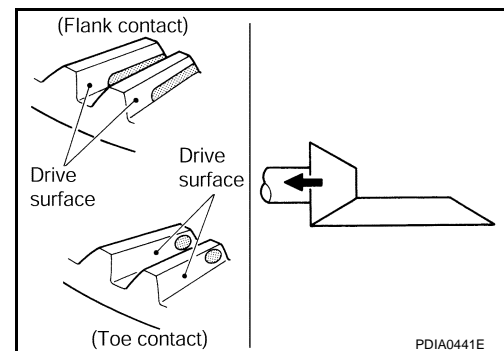

BACKLASH

Before inspection and adjustment, drain gear oil.

1. Remove rear cover. Refer to [DLN-192, "AWD : Disassembly"](#).
2. Fit a dial indicator to the drive gear face to measure the backlash.

Standard Backlash

: Refer to [DLN-223, "Backlash"](#).

- If the backlash is outside of the specified value, change the thickness of side bearing adjusting washer.

When the backlash is large:

Make drive gear back side adjusting washer thicker, and drive gear tooth side adjusting washer thinner by the same amount.

When the backlash is small:

Make drive gear back side adjusting washer thinner, and drive gear tooth side adjusting washer thicker by the same amount.

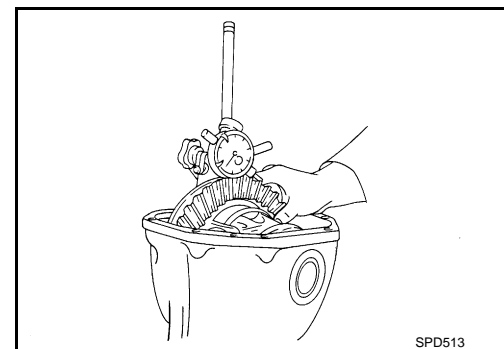

A
B
C
DLN
E
F
G
H
I
J
K
L
M
N
O
P

DIFFERENTIAL ASSEMBLY

< UNIT DISASSEMBLY AND ASSEMBLY >

[REAR FINAL DRIVE: R200]

CAUTION:

Never change the total amount of washers as it changes the bearing preload.

AWD : Inspection After Disassembly

INFOID:000000005649768

DRIVE GEAR AND DRIVE PINION

- Clean up the disassembled parts.
- If the gear teeth never mesh or line-up correctly, determine the cause and adjust or replace as necessary.
- If the gears are worn, cracked, damaged, pitted or chipped (by friction) noticeably, replace with new drive gear and drive pinion as a set.

BEARING

- Clean up the disassembled parts.
- If any chipped (by friction), pitted, worn, rusted or scratched marks, or unusual noise from the bearing is observed, replace as a bearing assembly (as a new set).

SIDE GEAR AND PINION MATE GEAR

- Clean up the disassembled parts.
- If any cracks or damage on the surface of the tooth is found, replace.
- If any worn or chipped mark on the contact sides of the thrust washer is found, replace.

SIDE GEAR THRUST WASHER AND PINION MATE THRUST WASHER

- Clean up the disassembled parts.
- If it is chipped (by friction), damaged, or unusually worn, replace.

OIL SEAL

- Whenever disassembled, replace.
- If wear, deterioration of adherence (sealing force lips), or damage is detected on the lips, replace them.

DIFFERENTIAL CASE

- Clean up the disassembled parts.
- If any wear or crack on the contact sides of the differential case is found, replace.

COMPANION FLANGE

- Clean up the disassembled parts.
- If any chipped mark [about 0.1 mm, (0.004 in)] or other damage on the contact sides of the lips of the companion flange is found, replace.

DRIVE PINION

< UNIT DISASSEMBLY AND ASSEMBLY >

[REAR FINAL DRIVE: R200]

DRIVE PINION

2WD

2WD : Exploded View

INFOID:000000005846247

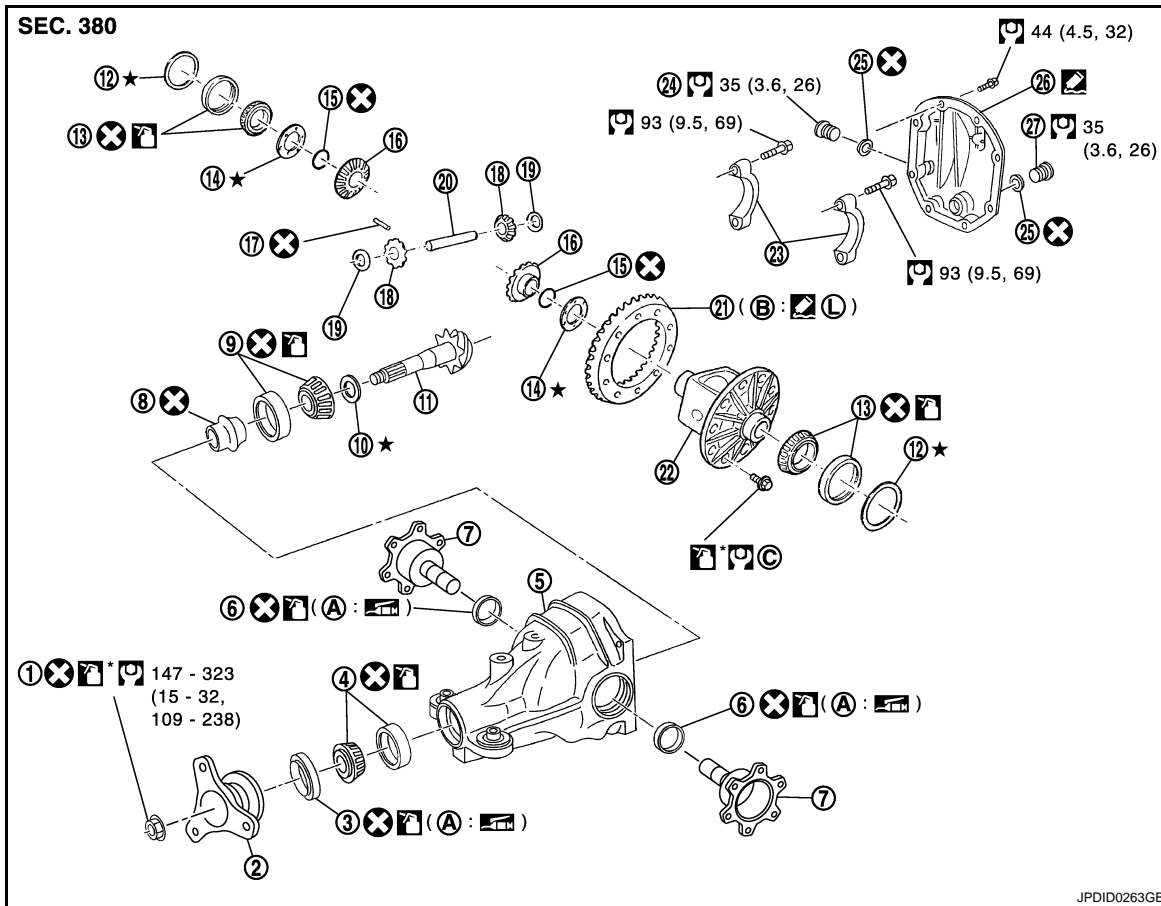

- | | | |
|------------------------------------|-----------------------------|-----------------------------------|
| 1. Drive pinion lock nut | 2. Companion flange | 3. Front oil seal |
| 4. Pinion front bearing | 5. Gear carrier | 6. Side oil seal |
| 7. Side flange | 8. Collapsible spacer | 9. Pinion rear bearing |
| 10. Pinion height adjusting washer | 11. Drive pinion | 12. Side bearing adjusting washer |
| 13. Side bearing | 14. Side gear thrust washer | 15. Circular clip |
| 16. Side gear | 17. Lock pin | 18. Pinion mate gear |
| 19. Pinion mate thrust washer | 20. Pinion mate shaft | 21. Drive gear |
| 22. Differential case | 23. Bearing cap | 24. Filler plug |
| 25. Gasket | 26. Rear cover | 27. Drain plug |
- A. Oil seal lip
B. Screw hole
C. Comply with the assembly procedure when tightening. Refer to [DLN-182, "2WD : Assembly"](#).

: Apply gear oil.

: Apply anti-corrosion oil.

: Apply Genuine Silicone RTV or equivalent. Refer to [GI-18, "Recommended Chemical Products and Sealants"](#).

: Apply Genuine High Strength Thread Locking Sealant or equivalent. Refer to [GI-18, "Recommended Chemical Products and Sealants"](#).

Refer to [GI-4, "Components"](#) for symbols not described on the above.

DRIVE PINION

< UNIT DISASSEMBLY AND ASSEMBLY >

[REAR FINAL DRIVE: R200]

INFOID:00000005649770

2WD : Disassembly

1. Remove differential case assembly. Refer to [DLN-180. "2WD : Disassembly"](#).
2. Remove drive pinion lock nut with the flange wrench.

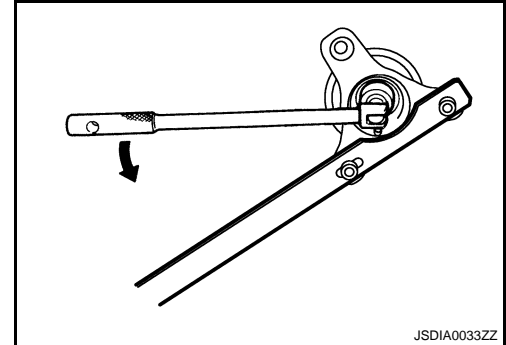

3. Put matching mark (B) on the end of drive pinion. The matching mark should be in line with the matching mark (A) on companion flange (1).

CAUTION:

For matching mark, use paint. Never damage companion flange and drive pinion.

NOTE:

The matching mark on the final drive companion flange indicates the maximum vertical runout position. When replacing companion flange, matching mark is not necessary.

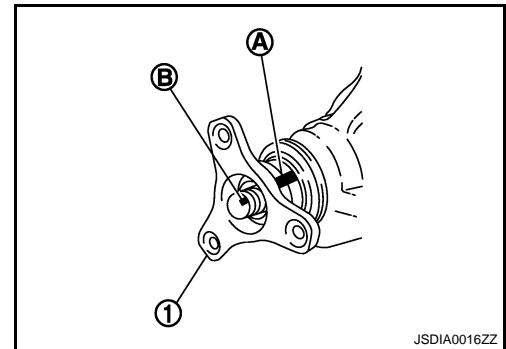

4. Remove companion flange using the suitable pullers.

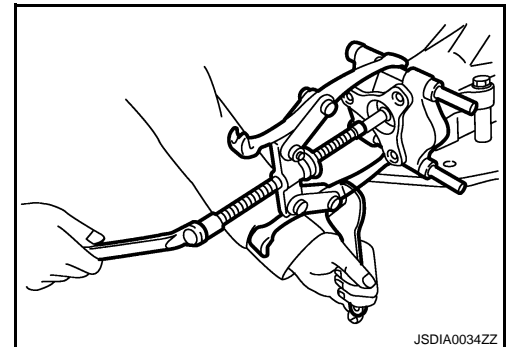

5. Press drive pinion assembly out of gear carrier.

CAUTION:

Never drop drive pinion assembly.

6. Remove front oil seal.
7. Remove side oil seal.
8. Remove pinion front bearing inner race.
9. Remove collapsible spacer.

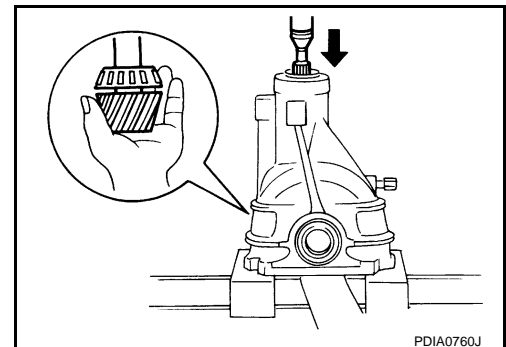

DRIVE PINION

< UNIT DISASSEMBLY AND ASSEMBLY >

[REAR FINAL DRIVE: R200]

10. Remove pinion rear bearing inner race and pinion height adjusting washer with the replacer (A) (commercial service tool).

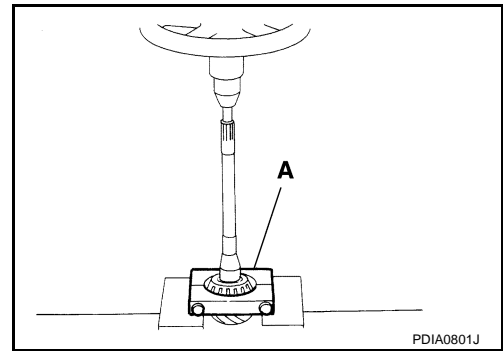

11. Tap pinion front/rear bearing outer races uniformly using a brass rod or equivalent to remove them.

CAUTION:

Never damage gear carrier.

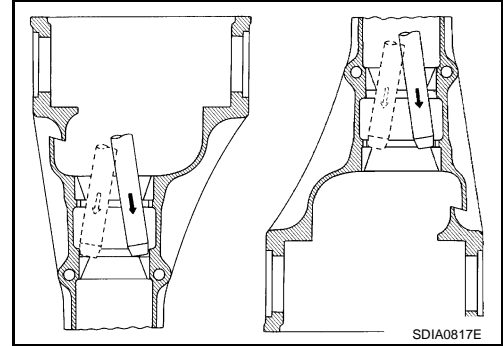

2WD : Assembly

1. Install front bearing outer race (1) and rear bearing outer race (2) using drifts.

- A : Drift [SST: ST30720000 (J-25405)]
- B : Drift [SST: KV40105230 (—)]
- C : Drift bar [SST: ST30611000 (J-25742-1)]
- D : Drift [SST: ST30613000 (J-25742-3)]

CAUTION:

- At first, using a hammer, tap bearing outer race until it becomes flat to gear carrier.
- Never reuse pinion front and rear bearing outer race.

2. Select drive pinion height adjusting washer. Refer to [DLN-209](#), "[2WD : Adjustment](#)".

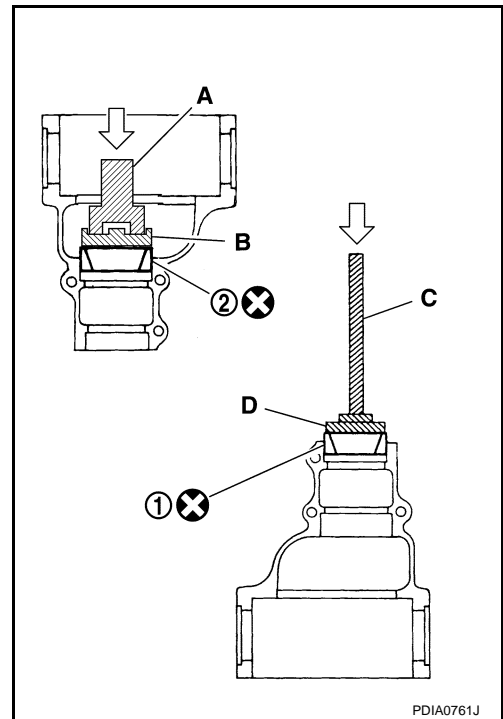

DRIVE PINION

< UNIT DISASSEMBLY AND ASSEMBLY >

[REAR FINAL DRIVE: R200]

3. Install selected drive pinion height adjusting washer (2) to drive pinion. Press pinion rear bearing inner race (1) to it, using drift (A) [SST: ST30901000 (J-26010-01)].

CAUTION:

- Be careful of the direction of pinion height adjusting washer. (Assemble as shown in the figure.)
- Never reuse pinion rear bearing inner race.

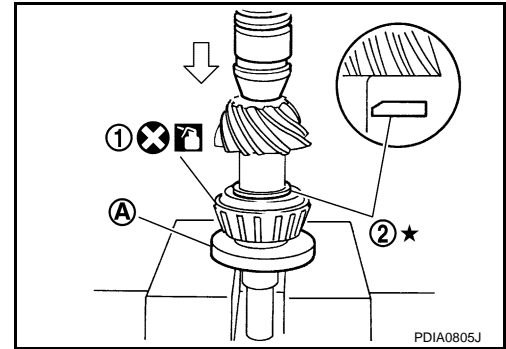

4. Assemble collapsible spacer to drive pinion.

CAUTION:

Never reuse collapsible spacer.

5. Apply gear oil to pinion rear bearing, and assemble drive pinion into gear carrier.
6. Apply gear oil to pinion front bearing, and assemble pinion front bearing inner race to drive pinion assembly.

CAUTION:

Never reuse pinion front bearing inner race.

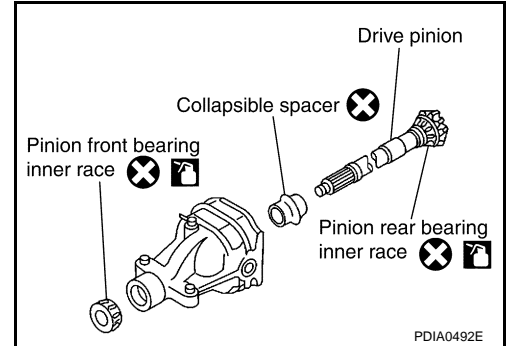

7. Using suitable spacer (A), press the pinion front bearing inner race to drive pinion as far as drive pinion nut can be tightened.

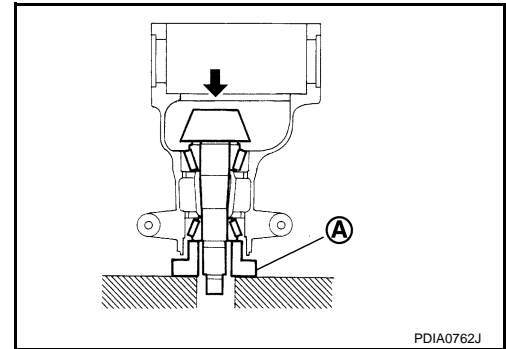

8. Using the drift (A) [SST: ST30720000 (J-25405)], install front oil seal as shown in figure.

CAUTION:

- Never reuse oil seal.
- When installing, never incline oil seal.
- Apply multi-purpose grease onto oil seal lips, and gear oil onto the circumference of oil seal.

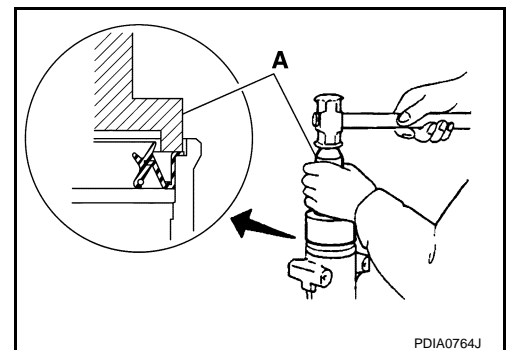

9. Install companion flange (1).

NOTE:

When reusing drive pinion, align the matching mark (B) of drive pinion with the matching mark (A) of companion flange, and then install companion flange (1).

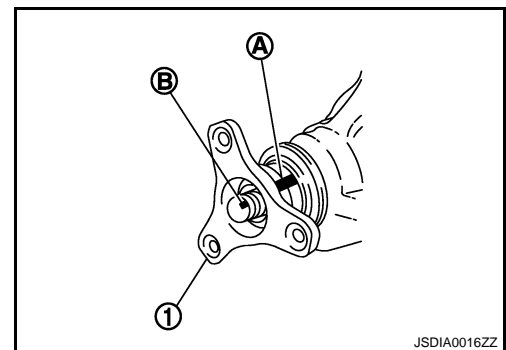

DRIVE PINION

< UNIT DISASSEMBLY AND ASSEMBLY >

[REAR FINAL DRIVE: R200]

10. Apply anti-corrosion oil to the thread and seat of drive pinion lock nut, and temporarily tighten drive pinion lock nut to drive pinion.

CAUTION:

Never reuse drive pinion lock nut.

11. Adjust to the drive pinion lock nut tightening torque and pinion bearing preload torque.

A : Preload gauge [SST: ST3127S000 (J-25765-A)]

Standard

Pinion bearing preload : Refer to [DLN-223, "Pre-load Torque"](#).

CAUTION:

- Adjust to the lower limit of the drive pinion lock nut tightening torque first.
- If the preload torque exceeds the specified value, replace collapsible spacer and tighten it again to adjust. Never loosen drive pinion lock nut to adjust the preload torque.
- After adjustment, rotate drive pinion back and forth 2 to 3 times to check for unusual noise, rotation malfunction, and other malfunctions.

12. Install differential case assembly. Refer to [DLN-182, "2WD : Assembly"](#).

CAUTION:

Never install rear cover at this timing.

13. Check and adjust drive gear runout, tooth contact, drive gear to drive pinion backlash, and companion flange runout. Refer to [DLN-186, "2WD : Adjustment"](#) and [DLN-209, "2WD : Adjustment"](#). Recheck above items. Readjust the above description, if necessary.
14. Check total preload torque. Refer to [DLN-186, "2WD : Adjustment"](#).
15. Install rear cover. Refer to [DLN-182, "2WD : Assembly"](#).

2WD : Adjustment

INFOID:000000005649772

PINION GEAR HEIGHT

1. Make sure all parts are clean and that the bearings are well lubricated.
2. Assemble the pinion gear bearings into the differential shim selector tool [SST: — (J-34309)].

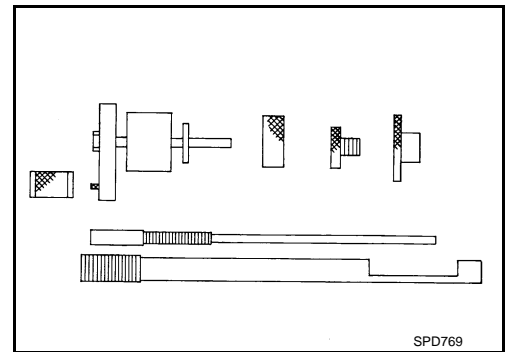
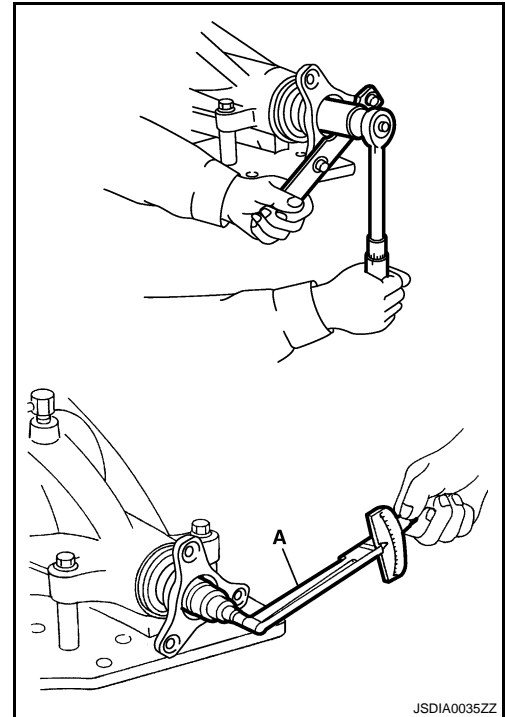

A
B
C
DLN
E
F
G
H
I
J
K
L
M
N
O
P

DRIVE PINION

< UNIT DISASSEMBLY AND ASSEMBLY >

[REAR FINAL DRIVE: R200]

- **Pinion front bearing;** make sure the J-34309-3 pinion front bearing seat is secured tightly against the J-34309-2 gauge anvil. Then turn the pinion front bearing pilot, J-34309-5, to secure the bearing in its proper position.
 - **Pinion rear bearing;** the pinion rear bearing pilot, J-34309-8, is used to center the pinion rear bearing only. The pinion rear bearing locking seat, J-34309-4, is used to lock the bearing to the assembly.
 - **Installation of J-34309-9 and J-34309-16;** place a suitable 2.5 mm (0.098 in) thick plain washer between J-34309-9 and J-34309-16. Both surfaces of J-34309-9 and J-34309-16 must be parallel with a clearance of 2.5 mm (0.098 in).
3. Install the pinion rear bearing inner race into gear carrier. Then place the pinion preload shim selector tool, J-34309-1, gauge screw assembly.

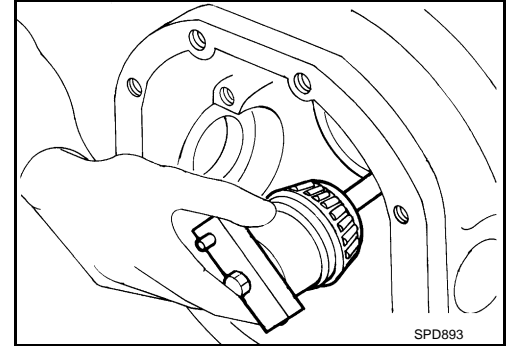
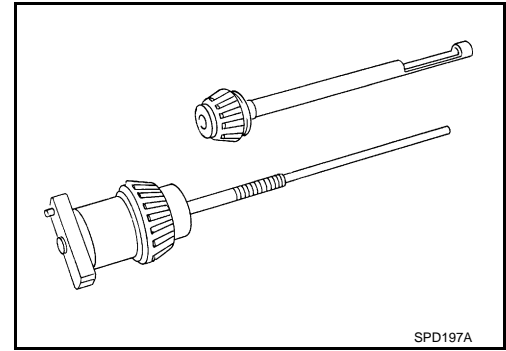

4. Assemble the pinion front bearing inner race and the J-34309-2 gauge anvil. Assemble them together with the J-34309-1 gauge screw in gear carrier. Make sure that the pinion height gauge plate, J-34309-16, turns a full 360 degrees. Tighten the two sections together by hand.

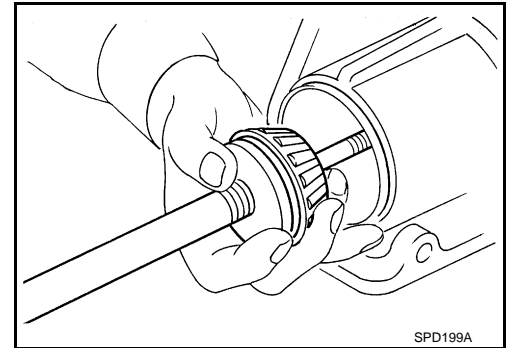

5. Turn the assembly several times to seat the bearings.

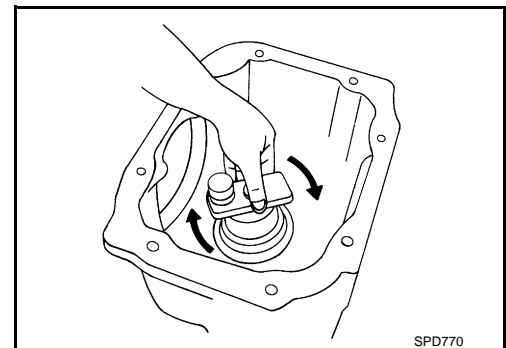

6. Measure the turning torque at the end of the J-34309-2 gauge anvil using preload gauge [SST: ST3127S000 (J-25765-A)].

Standard

Turning torque specification : 1.0 – 1.3 N·m (0.11 – 0.13 kg·m, 9 – 11 in·lb)

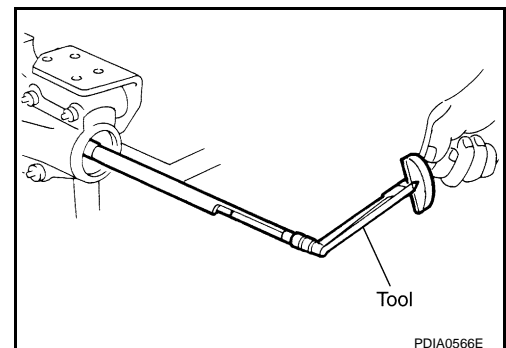

DRIVE PINION

< UNIT DISASSEMBLY AND ASSEMBLY >

[REAR FINAL DRIVE: R200]

7. Place the J-34309-11 "R200A" pinion height adapter onto the gauge plate and tighten it by hand.

CAUTION:

Make sure all machined surfaces are clean.

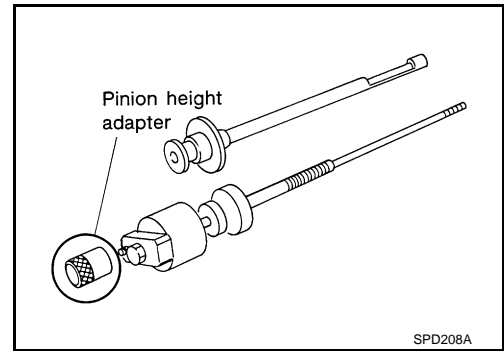

8. Position the side bearing discs, J-25269-4, and arbor firmly into the side bearing bores. Install the bearing caps and tighten bearing cap mounting bolts to the specified torque. Refer to [DLN-205, "2WD : Exploded View"](#).

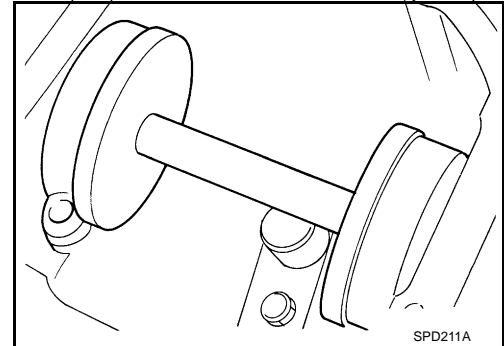

9. Select the correct standard pinion height adjusting washer thickness. Select by using a standard gauge of 3 mm (0.12 in) and J-34309-101 feeler gauge. Measure the distance between the J-34309-11 pinion height adapter including the standard gauge and the arbor.

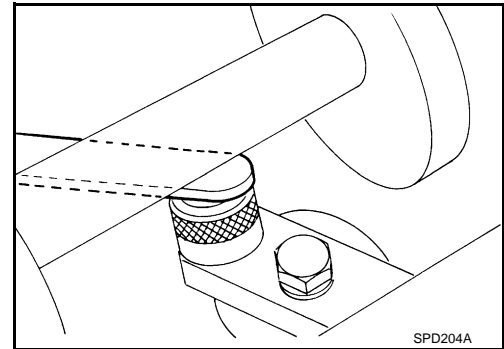

10. Write down exact measurement (the value of feeler gauge).

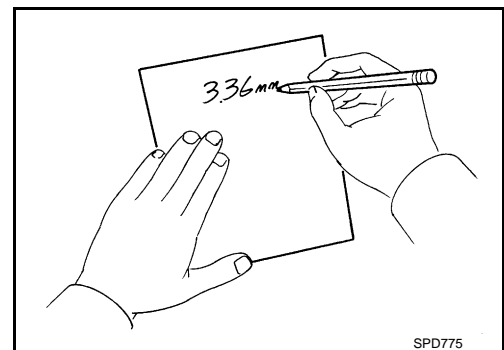

11. Correct the pinion height washer size by referring to the "pinion head number".

There are two numbers painted on the drive pinion. The first one refers to the drive pinion and drive gear as a matched set. This number should be the same as the number on the drive gear. The second number is the "pinion head height number". It refers to the ideal pinion height from standard for quietest operation. Use the following chart to determine the correct pinion height washer.

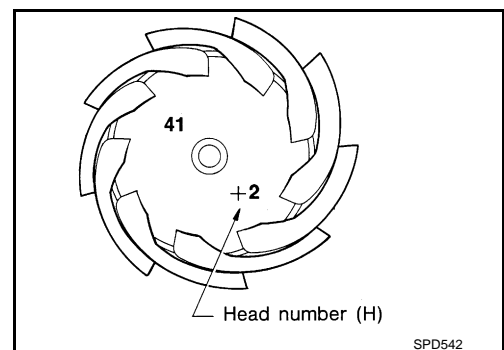

A

B

C

DLN

E

F

G

H

I

J

K

L

M

N

O

P

DRIVE PINION

< UNIT DISASSEMBLY AND ASSEMBLY >

[REAR FINAL DRIVE: R200]

Pinion head height number	Add or remove from the standard pinion height adjusting washer thickness measurement
-6	Add 0.06 mm (0.0024 in)
-5	Add 0.05 mm (0.0020 in)
-4	Add 0.04 mm (0.0016 in)
-3	Add 0.03 mm (0.0012 in)
-2	Add 0.02 mm (0.0008 in)
-1	Add 0.01 mm (0.0004 in)
0	Use the selected washer thickness
+1	Subtract 0.01 mm (0.0004 in)
+2	Subtract 0.02 mm (0.0008 in)
+3	Subtract 0.03 mm (0.0012 in)
+4	Subtract 0.04 mm (0.0016 in)
+5	Subtract 0.05 mm (0.0020 in)
+6	Subtract 0.06 mm (0.0024 in)

12. Select the correct pinion height adjusting washer.
13. Remove the J-34309 differential shim selector tool from the final drive housing. Then disassemble to retrieve the pinion bearings.

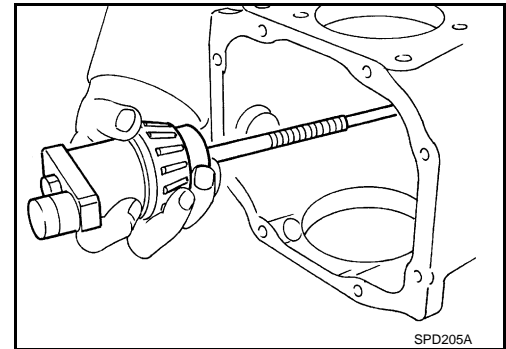

DRIVE PINION RUNOUT

1. Set a dial indicator (A) vertically to the tip of the drive pinion.
2. Rotate drive pinion to check for runout.

Limit

Drive pinion runout : Refer to [DLN-223, "Drive Pinion Runout \(2WD\)"](#).

3. If the runout value is outside of the limit, possible causes are an assembly malfunction of drive pinion and pinion bearing and malfunction of pinion bearing. Check for these items and repair if necessary.

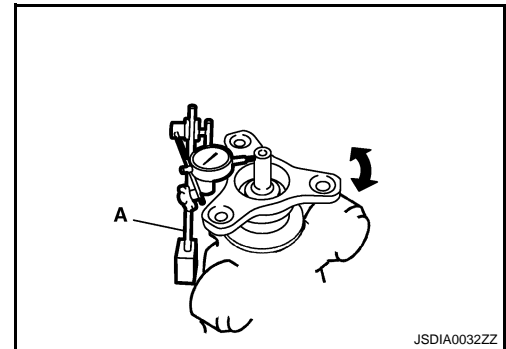

2WD : Inspection After Disassembly

INFOID:000000005649773

DRIVE GEAR AND DRIVE PINION

- Clean up the disassembled parts.
- If the gear teeth never mesh or line-up correctly, determine the cause and adjust or replace as necessary.
- If the gears are worn, cracked, damaged, pitted or chipped (by friction) noticeably, replace with new drive gear and drive pinion as a set.

BEARING

- Clean up the disassembled parts.
- If any chipped (by friction), pitted, worn, rusted or scratched marks, or unusual noise from the bearing is observed, replace as a bearing assembly (as a new set).

SIDE GEAR AND PINION MATE GEAR

- Clean up the disassembled parts.
- If any cracks or damage on the surface of the tooth is found, replace.
- If any worn or chipped mark on the contact sides of the thrust washer is found, replace.

SIDE GEAR THRUST WASHER AND PINION MATE THRUST WASHER

DRIVE PINION

< UNIT DISASSEMBLY AND ASSEMBLY >

[REAR FINAL DRIVE: R200]

- Clean up the disassembled parts.
- If it is chipped (by friction), damaged, or unusually worn, replace.

OIL SEAL

- Whenever disassembled, replace.
- If wear, deterioration of adherence (sealing force lips), or damage is detected on the lips, replace them.

DIFFERENTIAL CASE

- Clean up the disassembled parts.
- If any wear or crack on the contact sides of the differential case is found, replace.

COMPANION FLANGE

- Clean up the disassembled parts.
- If any chipped mark [about 0.1 mm, (0.004 in)] or other damage on the contact sides of the lips of the companion flange is found, replace.

AWD

AWD : Exploded View

INFOID:000000005846248

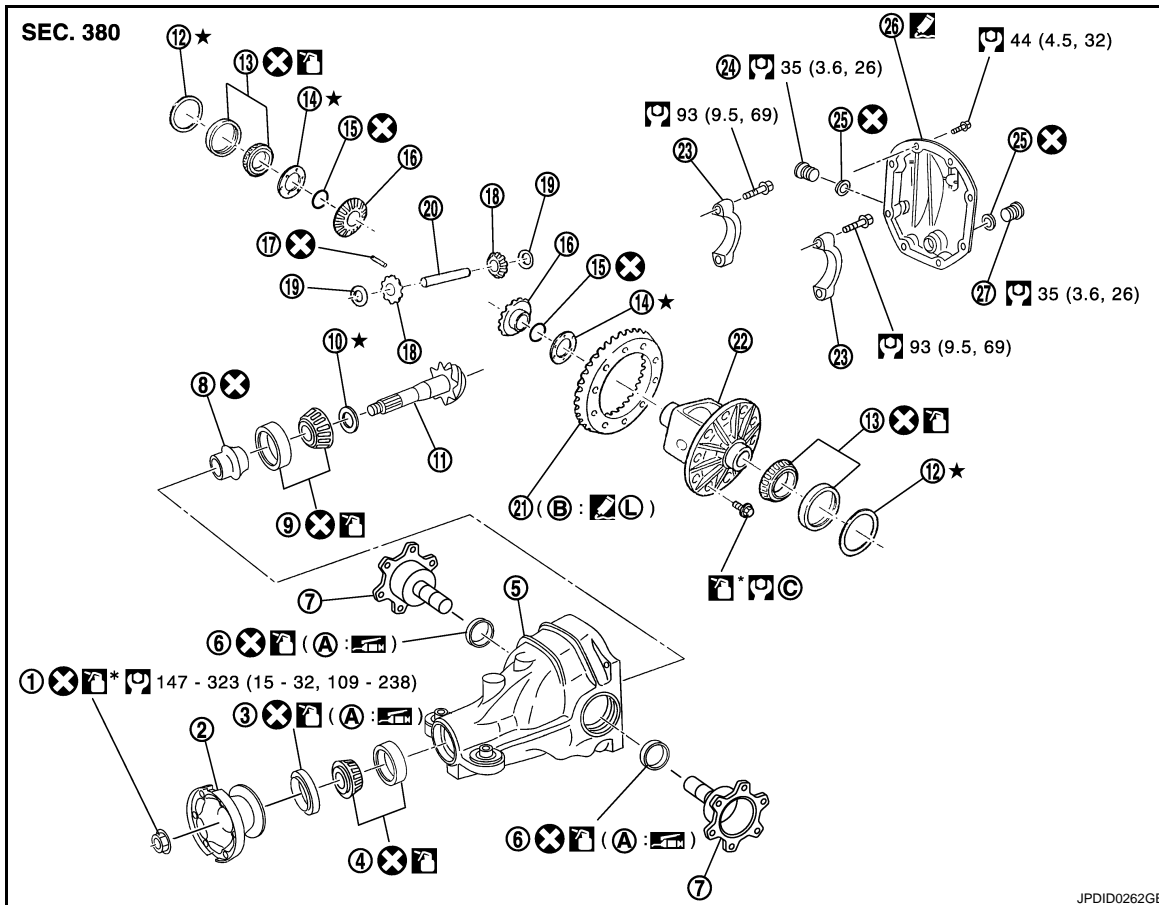

- | | | |
|------------------------------------|-----------------------------|-----------------------------------|
| 1. Drive pinion lock nut | 2. Companion flange | 3. Front oil seal |
| 4. Pinion front bearing | 5. Gear carrier | 6. Side oil seal |
| 7. Side flange | 8. Collapsible spacer | 9. Pinion rear bearing |
| 10. Pinion height adjusting washer | 11. Drive pinion | 12. Side bearing adjusting washer |
| 13. Side bearing | 14. Side gear thrust washer | 15. Circular clip |
| 16. Side gear | 17. Lock pin | 18. Pinion mate gear |
| 19. Pinion mate thrust washer | 20. Pinion mate shaft | 21. Drive gear |
| 22. Differential case | 23. Bearing cap | 24. Filler plug |

DRIVE PINION

< UNIT DISASSEMBLY AND ASSEMBLY >

[REAR FINAL DRIVE: R200]

- | | | |
|-----------------|----------------|---|
| 25. Gasket | 26. Rear cover | 27. Drain plug |
| A. Oil seal lip | B. Screw hole | C. Comply with the assembly procedure when tightening. Refer to DLN-195, "AWD : Assembly" . |

: Apply gear oil.

*: Apply anti-corrosion oil.

: Apply Genuine Silicone RTV or equivalent. Refer to [GI-18, "Recommended Chemical Products and Sealants"](#).

L: Apply Genuine High Strength Thread Locking Sealant or equivalent. Refer to [GI-18, "Recommended Chemical Products and Sealants"](#).

Refer to [GI-4, "Components"](#) for symbols not described on the above.

AWD : Disassembly

INFOID:000000005649775

1. Remove differential case assembly. Refer to [DLN-192, "AWD : Disassembly"](#).
2. Remove drive pinion lock nut with the flange wrench (commercial service tool).

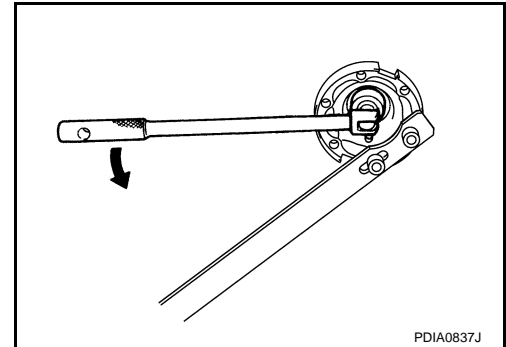

3. Put matching mark (B) on the end of drive pinion. The matching mark should be in line with the matching mark (A) on companion flange (1).

CAUTION:

For matching mark, use paint. Never damage companion flange and drive pinion.

NOTE:

The matching mark on the final drive companion flange indicates the maximum vertical runout position.

When replacing companion flange, matching mark is not necessary.

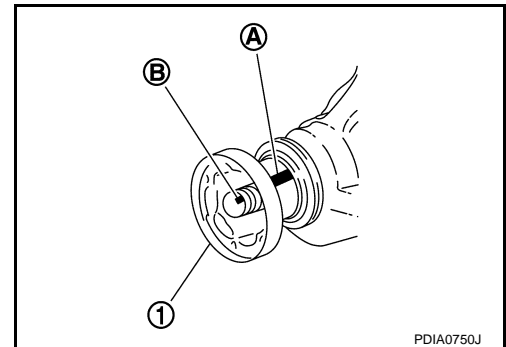

4. Remove companion flange using the suitable pullers.

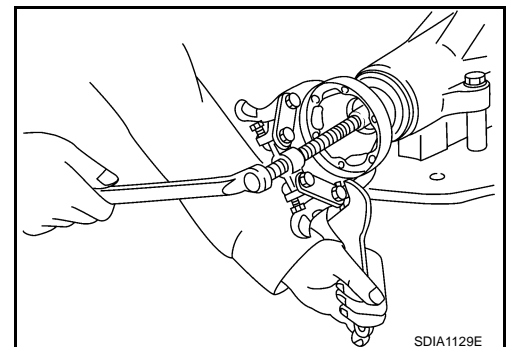

DRIVE PINION

< UNIT DISASSEMBLY AND ASSEMBLY >

[REAR FINAL DRIVE: R200]

5. Press drive pinion assembly out of gear carrier.

CAUTION:

Never drop drive pinion assembly.

6. Remove front oil seal.
7. Remove side oil seal.
8. Remove pinion front bearing inner race.
9. Remove collapsible spacer.

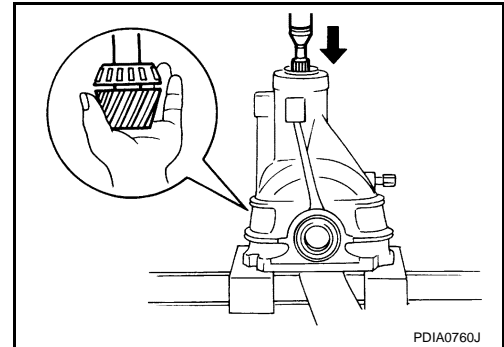

10. Remove pinion rear bearing inner race and pinion height adjusting washer with the replacer (A) (commercial service tool).

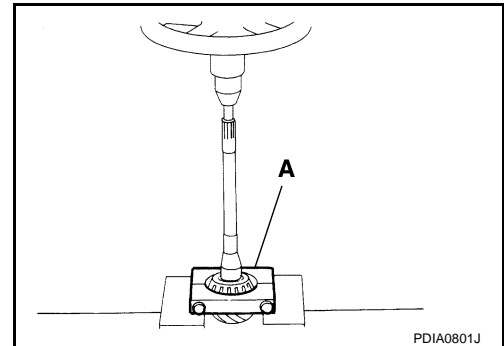

11. Tap pinion front/rear bearing outer races uniformly using a brass rod or equivalent to remove them.

CAUTION:

Never damage gear carrier.

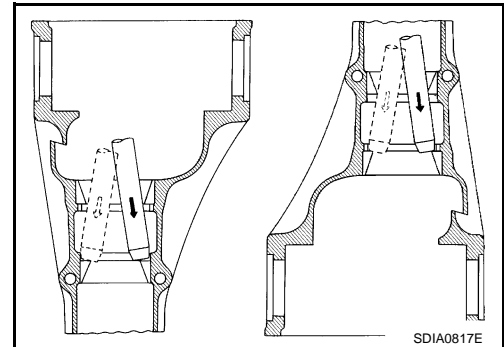

A
B
C
DLN
E
F
G
H
I
J
K
L
M
N
O
P

DRIVE PINION

< UNIT DISASSEMBLY AND ASSEMBLY >

[REAR FINAL DRIVE: R200]

AWD : Assembly

INFOID:000000005649776

1. Install front bearing outer race (1) and rear bearing outer race (2) using drifts.

- A : Drift [SST: ST30720000 (J-25405)]
- B : Drift [SST: KV40105230 (—)]
- C : Drift bar [SST: ST30611000 (J-25742-1)]
- D : Drift [SST: ST30613000 (J-25742-3)]

CAUTION:

- At first, using a hammer, tap bearing outer race until it becomes flat to gear carrier.
- Never reuse pinion front and rear bearing outer race.

2. Select drive pinion height adjusting washer. Refer to [DLN-218](#), "[AWD : Adjustment](#)".

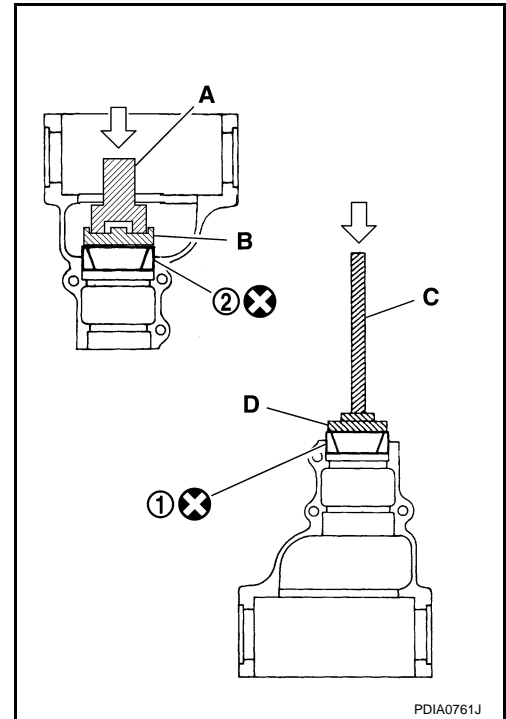

3. Install selected drive pinion height adjusting washer (2) to drive pinion. Press pinion rear bearing inner race (1) to it, using drift (A) [SST: ST30901000 (J-26010-01)].

CAUTION:

- Be careful of the direction of pinion height adjusting washer. (Assemble as shown in the figure.)
- Never reuse pinion rear bearing inner race.

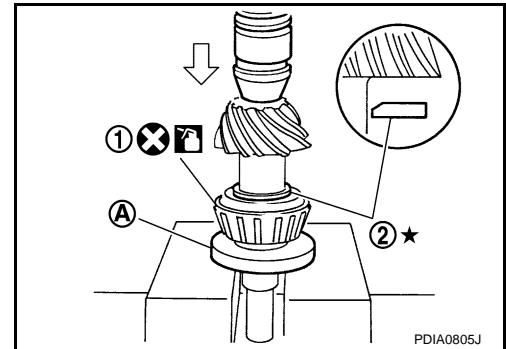

4. Assemble collapsible spacer to drive pinion.

CAUTION:

Never reuse collapsible spacer.

5. Apply gear oil to pinion rear bearing, and assemble drive pinion into gear carrier.
6. Apply gear oil to pinion front bearing, and assemble pinion front bearing inner race to drive pinion assembly.

CAUTION:

Never reuse pinion front bearing inner race.

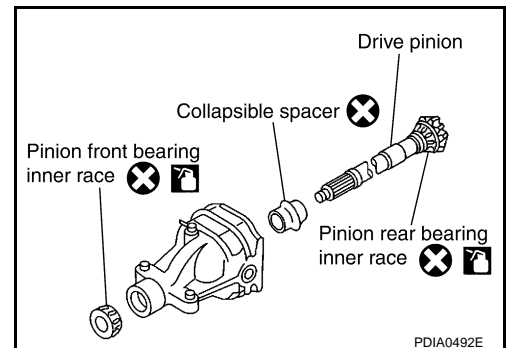

DRIVE PINION

< UNIT DISASSEMBLY AND ASSEMBLY >

[REAR FINAL DRIVE: R200]

7. Using suitable spacer (A), press the pinion front bearing inner race to drive pinion as far as drive pinion nut can be tightened.

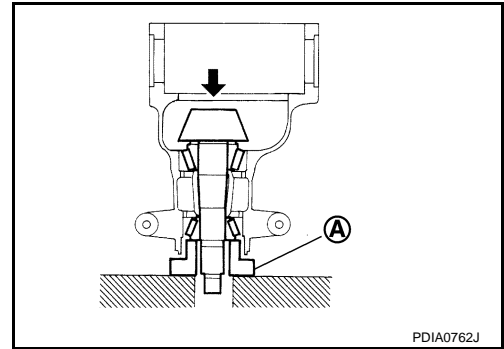

8. Using the drift (A) [SST: ST30720000 (J-25405)], install front oil seal as shown in figure.

CAUTION:

- Never reuse oil seal.
- When installing, never incline oil seal.
- Apply multi-purpose grease onto oil seal lips, and gear oil onto the circumference of oil seal.

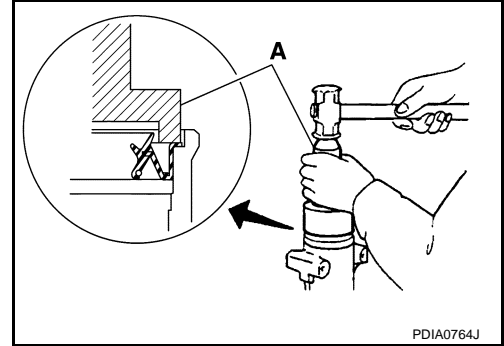

9. Install companion flange (1).

NOTE:

When reusing drive pinion, align the matching mark (B) of drive pinion with the matching mark (A) of companion flange, and then install companion flange.

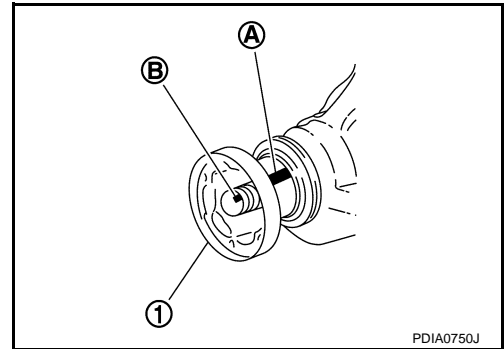

10. Apply anti-corrosion oil to the thread and seat of drive pinion lock nut, and temporarily tighten drive pinion lock nut to drive pinion.

CAUTION:

Never reuse drive pinion lock nut.

11. Adjust to the drive pinion lock nut tightening torque and pinion bearing preload torque.

A : Preload gauge [SST: ST3127S000 (J-25765-A)]

Standard

Pinion bearing preload : Refer to [DLN-223, "Pre-load Torque"](#).

CAUTION:

- Adjust to the lower limit of the drive pinion lock nut tightening torque first.
- If the preload torque exceeds the specified value, replace collapsible spacer and tighten it again to adjust. Never loosen drive pinion lock nut to adjust the preload torque.
- After adjustment, rotate drive pinion back and forth 2 to 3 times to check for unusual noise, rotation malfunction, and other malfunctions.

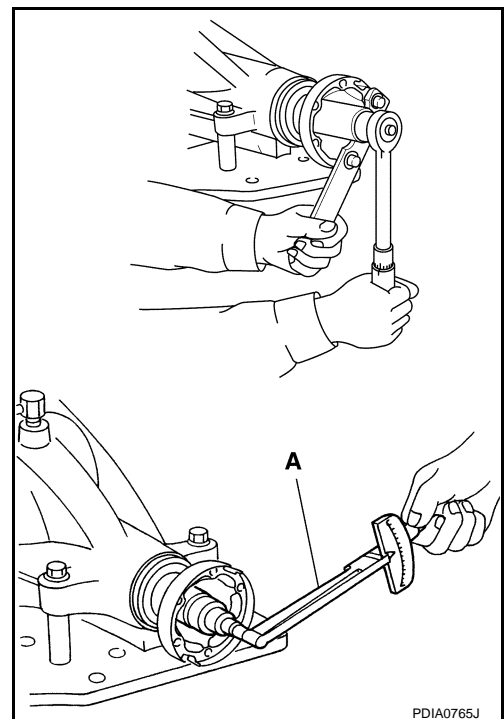

A

B

C

DLN

E

F

G

H

I

J

K

L

M

N

O

P

DRIVE PINION

< UNIT DISASSEMBLY AND ASSEMBLY >

[REAR FINAL DRIVE: R200]

12. Install differential case assembly. Refer to [DLN-195, "AWD : Assembly"](#).

CAUTION:

Never install rear cover at this timing.

13. Check and adjust drive gear runout, tooth contact, drive gear to drive pinion backlash, and companion flange runout. Refer to [DLN-199, "AWD : Adjustment"](#) and [DLN-218, "AWD : Adjustment"](#).
Recheck above items. Readjust the above description, if necessary.

14. Check total preload torque. Refer to [DLN-199, "AWD : Adjustment"](#).

15. Install rear cover. Refer to [DLN-195, "AWD : Assembly"](#).

AWD : Adjustment

INFOID:000000005649777

PINION GEAR HEIGHT

1. Make sure all parts are clean and that the bearings are well lubricated.
2. Assemble the pinion gear bearings into the differential shim selector tool [SST: — (J-34309)].

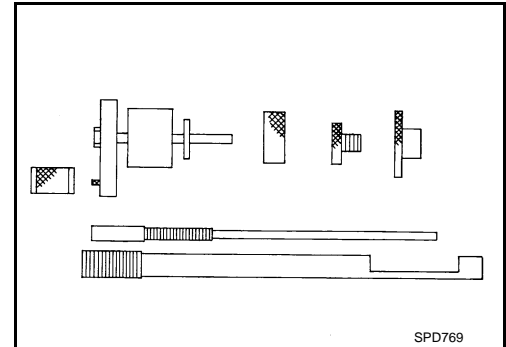

- **Pinion front bearing;** make sure the J-34309-3 pinion front bearing seat is secured tightly against the J-34309-2 gauge anvil. Then turn the pinion front bearing pilot, J-34309-5, to secure the bearing in its proper position.
- **Pinion rear bearing;** the pinion rear bearing pilot, J-34309-8, is used to center the pinion rear bearing only. The pinion rear bearing locking seat, J-34309-4, is used to lock the bearing to the assembly.
- **Installation of J-34309-9 and J-34309-16;** place a suitable 2.5 mm (0.098 in) thick plain washer between J-34309-9 and J-34309-16. Both surfaces of J-34309-9 and J-34309-16 must be parallel with a clearance of 2.5 mm (0.098 in).

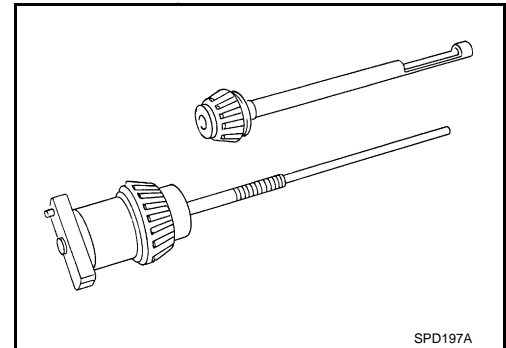

3. Install the pinion rear bearing inner race into gear carrier. Then place the pinion preload shim selector tool, J-34309-1, gauge screw assembly.

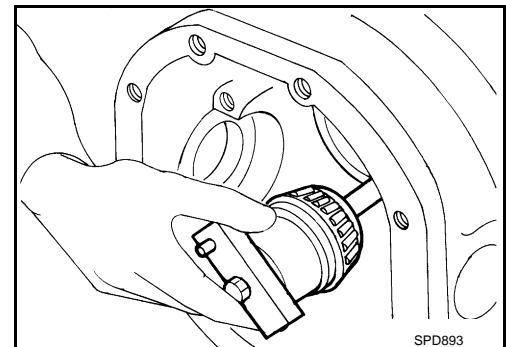

DRIVE PINION

< UNIT DISASSEMBLY AND ASSEMBLY >

[REAR FINAL DRIVE: R200]

4. Assemble the pinion front bearing inner race and the J-34309-2 gauge anvil. Assemble them together with the J-34309-1 gauge screw in gear carrier. Make sure that the pinion height gauge plate, J-34309-16, turns a full 360 degrees. Tighten the two sections together by hand.

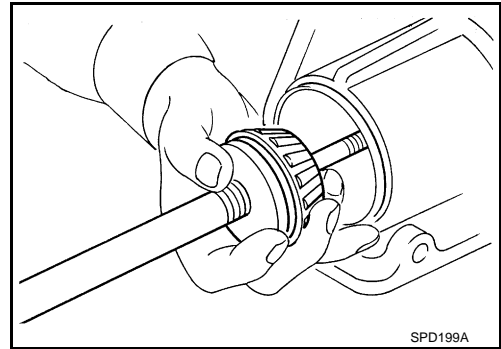

5. Turn the assembly several times to seat the bearings.

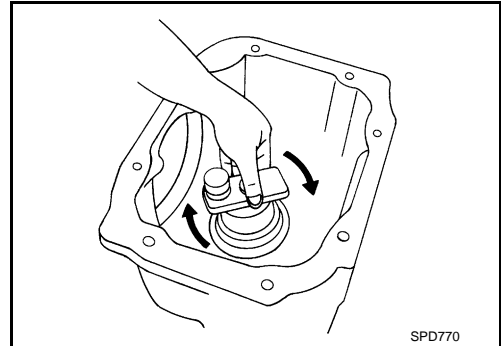

6. Measure the turning torque at the end of the J-34309-2 gauge anvil using preload gauge [SST: ST3127S000 (J-25765-A)].

Standard

Turning torque specification : 1.0 – 1.3 N·m (0.11 – 0.13 kg·m, 9 – 11 in·lb)

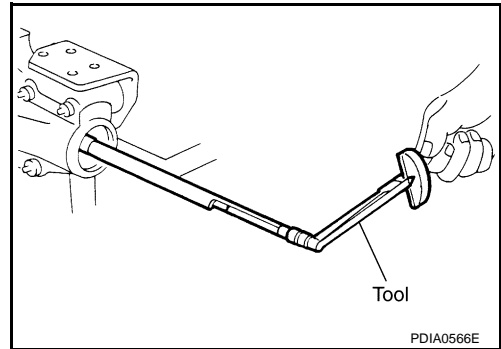

7. Place the J-34309-11 "R200A" pinion height adapter onto the gauge plate and tighten it by hand.

CAUTION:

Make sure all machined surfaces are clean.

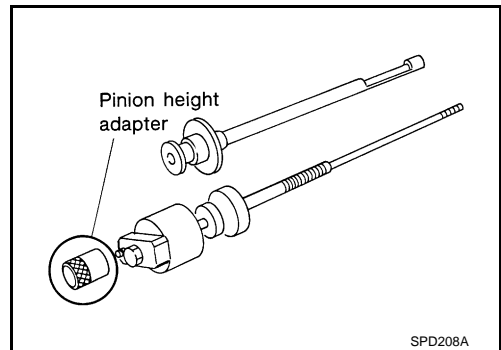

8. Position the side bearing discs, J-25269-4, and arbor firmly into the side bearing bores. Install the bearing caps and tighten bearing cap mounting bolts to the specified torque. Refer to [DLN-213, "AWD : Exploded View"](#).

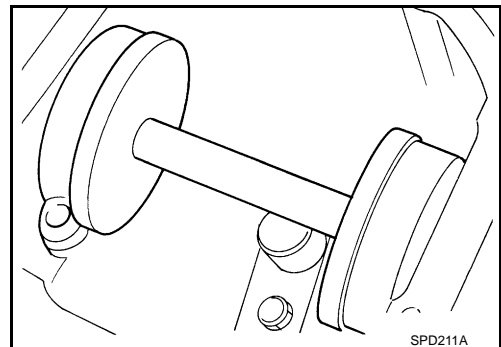

A
B
C
DLN
E
F
G
H
I
J
K
L
M
N
O
P

DRIVE PINION

< UNIT DISASSEMBLY AND ASSEMBLY >

[REAR FINAL DRIVE: R200]

9. Select the correct standard pinion height adjusting washer thickness. Select by using a standard gauge of 3 mm (0.12 in) and J-34309-101 feeler gauge. Measure the distance between the J-34309-11 pinion height adapter including the standard gauge and the arbor.

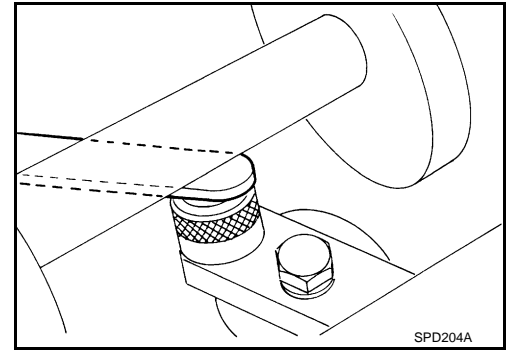

10. Write down exact measurement (the value of feeler gauge).

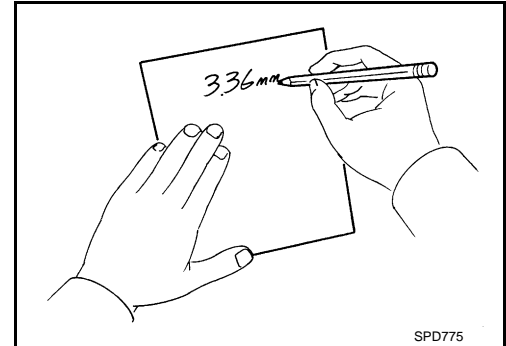

11. Correct the pinion height washer size by referring to the “pinion head number”.

There are two numbers painted on the drive pinion. The first one refers to the drive pinion and drive gear as a matched set. This number should be the same as the number on the drive gear. The second number is the “pinion head height number”. It refers to the ideal pinion height from standard for quietest operation. Use the following chart to determine the correct pinion height washer.

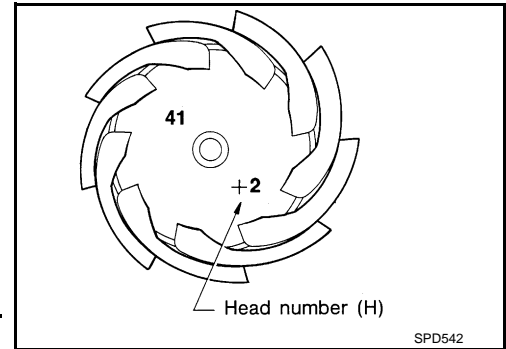

Pinion head height number	Add or remove from the standard pinion height adjusting washer thickness measurement
-6	Add 0.06 mm (0.0024 in)
-5	Add 0.05 mm (0.0020 in)
-4	Add 0.04 mm (0.0016 in)
-3	Add 0.03 mm (0.0012 in)
-2	Add 0.02 mm (0.0008 in)
-1	Add 0.01 mm (0.0004 in)
0	Use the selected washer thickness
+1	Subtract 0.01 mm (0.0004 in)
+2	Subtract 0.02 mm (0.0008 in)
+3	Subtract 0.03 mm (0.0012 in)
+4	Subtract 0.04 mm (0.0016 in)
+5	Subtract 0.05 mm (0.0020 in)
+6	Subtract 0.06 mm (0.0024 in)

12. Select the correct pinion height adjusting washer.

DRIVE PINION

< UNIT DISASSEMBLY AND ASSEMBLY >

[REAR FINAL DRIVE: R200]

13. Remove the J-34309 differential shim selector tool from the final drive housing. Then disassemble to retrieve the pinion bearings.

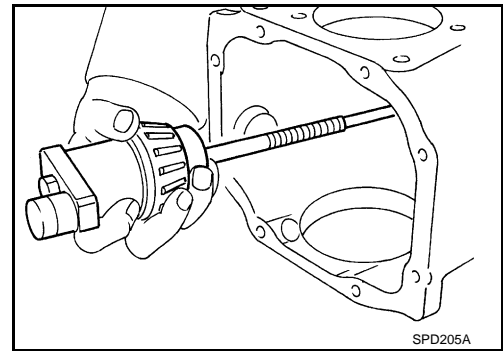

COMPANION FLANGE RUNOUT

1. Fit a test indicator to the inner side of companion flange (socket diameter).
2. Rotate companion flange to check for runout.

Limit

Companion flange runout : Refer to [DLN-223, "Companion Flange Runout \(AWD\)"](#).

3. If the runout value is outside the runout limit, follow the procedure below to adjust.
 - a. Check for runout while changing the phase between companion flange and drive pinion by 90° step, and search for the position where the runout is the minimum.
 - b. If the runout value is still outside of the limit after the phase has been changed, possible cause will be an assembly malfunction of drive pinion and pinion bearing and malfunction of pinion bearing. Check for these items and repair if necessary.
 - c. If the runout value is still outside of the limit after the check and repair, replace companion flange.

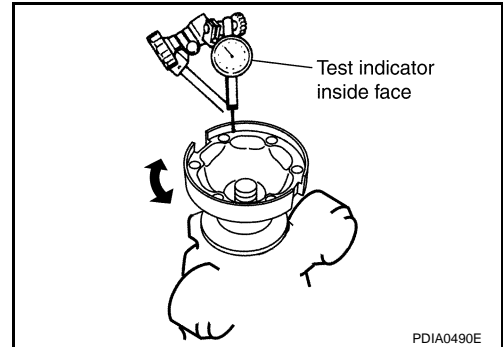

AWD : Inspection After Disassembly

INFOID:000000005649778

DRIVE GEAR AND DRIVE PINION

- Clean up the disassembled parts.
- If the gear teeth never mesh or line-up correctly, determine the cause and adjust or replace as necessary.
- If the gears are worn, cracked, damaged, pitted or chipped (by friction) noticeably, replace with new drive gear and drive pinion as a set.

BEARING

- Clean up the disassembled parts.
- If any chipped (by friction), pitted, worn, rusted or scratched marks, or unusual noise from the bearing is observed, replace as a bearing assembly (as a new set).

SIDE GEAR AND PINION MATE GEAR

- Clean up the disassembled parts.
- If any cracks or damage on the surface of the tooth is found, replace.
- If any worn or chipped mark on the contact sides of the thrust washer is found, replace.

SIDE GEAR THRUST WASHER AND PINION MATE THRUST WASHER

- Clean up the disassembled parts.
- If it is chipped (by friction), damaged, or unusually worn, replace.

OIL SEAL

- Whenever disassembled, replace.
- If wear, deterioration of adherence (sealing force lips), or damage is detected on the lips, replace them.

DIFFERENTIAL CASE

- Clean up the disassembled parts.
- If any wear or crack on the contact sides of the differential case is found, replace.

DRIVE PINION

< UNIT DISASSEMBLY AND ASSEMBLY >

[REAR FINAL DRIVE: R200]

COMPANION FLANGE

- Clean up the disassembled parts.
- If any chipped mark [about 0.1 mm, (0.004 in)] or other damage on the contact sides of the lips of the companion flange is found, replace.

SERVICE DATA AND SPECIFICATIONS (SDS)

< SERVICE DATA AND SPECIFICATIONS (SDS)

[REAR FINAL DRIVE: R200]

SERVICE DATA AND SPECIFICATIONS (SDS)

SERVICE DATA AND SPECIFICATIONS (SDS)

General Specification

INFOID:0000000005649779

	2WD	AWD
Applied model	VQ37VHR	
	A/T	
Final drive model	R200	
Gear ratio	3.357	
Number of teeth (Drive gear/Drive pinion)	47/14	
Oil capacity (Approx.) ℓ (US pt, Imp pt)	1.4 (3, 2-1/2)	
Number of pinion gears	2	
Drive pinion adjustment spacer type	Collapsible	

Drive Gear Runout

INFOID:0000000005649780

Unit: mm (in)

Item	Limit
Drive gear back face runout	0.05 (0.0020)

Differential Side Gear Clearance

INFOID:0000000005649781

Unit: mm (in)

Item	Standard
Side gear backlash (Clearance between side gear and differential case)	0.20 (0.0079) or less (Each gear should rotate smoothly without excessive resistance during differential motion.)

Preload Torque

INFOID:0000000005649782

Unit: N·m (kg·m, in·lb)

Item	Standard
Pinion bearing (P1)	2.65 – 3.23 (0.27 – 0.32, 24 – 28)
Side bearing (P2)	0.20 – 0.52 (0.02 – 0.05, 2 – 4)
Side bearing to pinion bearing (Total preload) (Total preload = P1 + P2)	2.85 – 3.75 (0.29 – 0.38, 26 – 33)

Backlash

INFOID:0000000005649783

Unit: mm (in)

Item	Standard
Drive gear to drive pinion gear	0.10 – 0.15 (0.0039 – 0.0059)

Drive Pinion Runout (2WD)

INFOID:0000000005649784

Unit: mm (in)

Item	Limit
Tip of drive pinion runout	0.8 (0.031)

Companion Flange Runout (AWD)

INFOID:0000000005649785

Unit: mm (in)

SERVICE DATA AND SPECIFICATIONS (SDS)

< SERVICE DATA AND SPECIFICATIONS (SDS)

[REAR FINAL DRIVE: R200]

Item	Limit
Inner side of the companion flange runout	0.08 (0.0031)

REAR FINAL DRIVE ASSEMBLY

< SYSTEM DESCRIPTION >

[REAR FINAL DRIVE: R200V]

SYSTEM DESCRIPTION

REAR FINAL DRIVE ASSEMBLY

System Diagram

INFOID:000000005649786

CROSS-SECTION VIEW

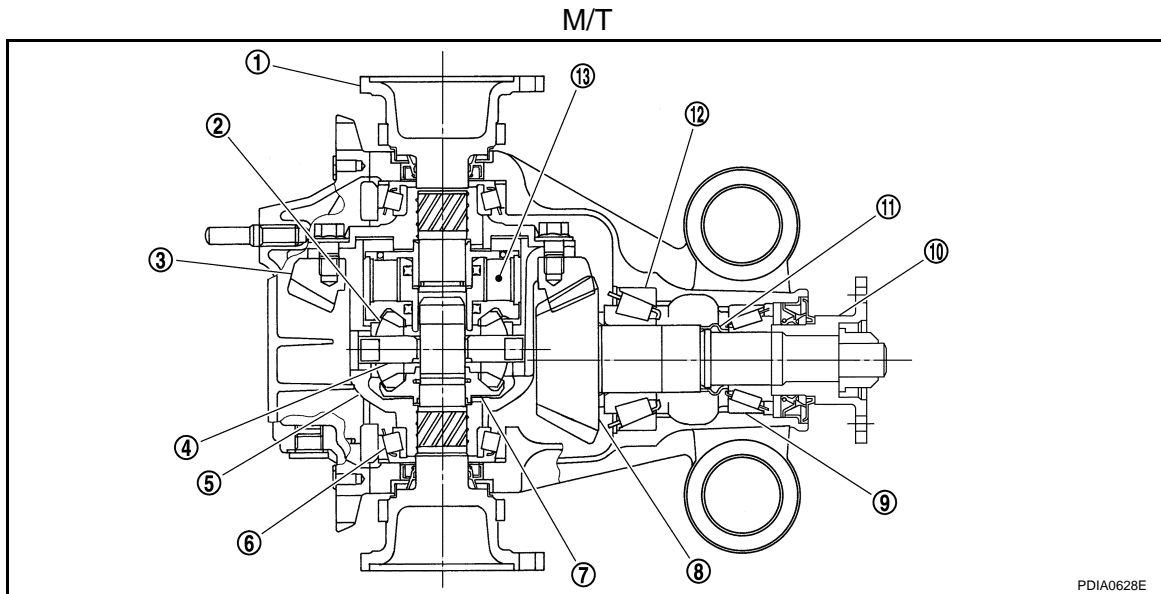

- | | | |
|----------------------|------------------------|-------------------------|
| 1. Side flange | 2. Pinion mate gear | 3. Drive gear |
| 4. Pinion mate shaft | 5. Differential case | 6. Side bearing |
| 7. Side gear | 8. Drive pinion | 9. Pinion front bearing |
| 10. Companion flange | 11. Collapsible spacer | 12. Pinion rear bearing |
| 13. Viscous coupling | | |

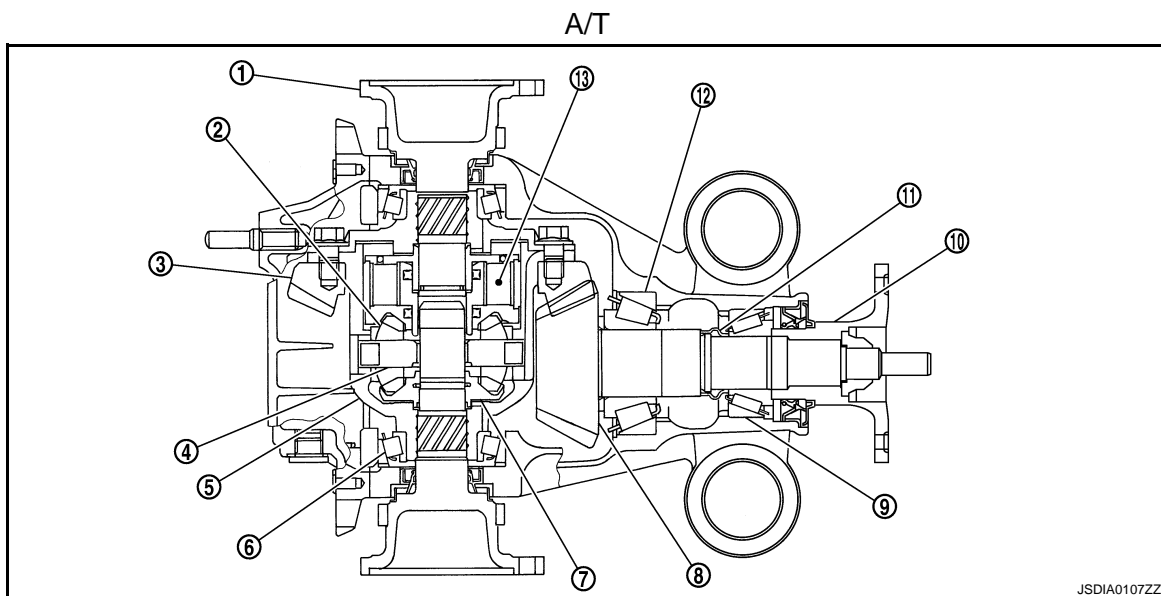

- | | | |
|----------------------|------------------------|-------------------------|
| 1. Side flange | 2. Pinion mate gear | 3. Drive gear |
| 4. Pinion mate shaft | 5. Differential case | 6. Side bearing |
| 7. Side gear | 8. Drive pinion | 9. Pinion front bearing |
| 10. Companion flange | 11. Collapsible spacer | 12. Pinion rear bearing |
| 13. Viscous coupling | | |

A
B
C
DLN
E
F
G
H
I
J
K
L
M
N
O
P

NOISE, VIBRATION AND HARSHNESS (NVH) TROUBLESHOOTING

< SYMPTOM DIAGNOSIS >

[REAR FINAL DRIVE: R200V]

SYMPTOM DIAGNOSIS

NOISE, VIBRATION AND HARSHNESS (NVH) TROUBLESHOOTING

NVH Troubleshooting Chart

INFOID:000000005649787

M/T MODELS

Use the chart below to find the cause of the symptom. If necessary, repair or replace these parts.

Symptom	Noise	Reference	Possible cause and SUSPECTED PARTS
	×	DLN-285, "M/T : Inspection After Disassembly"	Gear tooth rough
	×	DLN-259, "M/T : Adjustment"	Gear contact improper
	×	DLN-285, "M/T : Inspection After Disassembly"	Tooth surfaces worn
	×	DLN-259, "M/T : Adjustment"	Backlash incorrect
	×	DLN-259, "M/T : Adjustment"	Companion flange excessive runout
	×	DLN-233, "Inspection"	Gear oil improper
	×	NVH in DLN section.	PROPELLER SHAFT
	×	NVH in FAX, RAX, FSU and RSU sections.	AXLE AND SUSPENSION
	×	NVH in WT section.	TIRES
	×	NVH in WT section.	ROAD WHEEL
	×	NVH in RAX section.	DRIVE SHAFT
	×	NVH in BR section.	BRAKES
	×	NVH in ST section.	STEERING

×: Applicable

A/T MODELS

Use the chart below to find the cause of the symptom. If necessary, repair or replace these parts.

PRECAUTION

PRECAUTIONS

Service Notice or Precautions for Rear Final Drive

INFOID:000000005649788

- Check for the correct installation status prior to removal or disassembly. If matching marks are required, be certain they never interfere with the function of the parts when applied.
- Overhaul should be done in a clean work area, it is preferable to work in dustproof area.
- Before disassembly, using steam or white gasoline, completely remove sand and mud from the exterior of the unit, preventing them from entering into the unit during disassembly or assembly.
- Check appearance of the disassembled parts for damage, deformation, and unusual wear. Replace them with new ones, if necessary.
- Gaskets, seals and O-rings should be replaced any time when the unit is disassembled.
- In principle, tighten bolts or nuts gradually in several steps working diagonally from inside to outside. If tightening sequence is specified, observe it.
- Clean and flush the parts sufficiently and blow-dry them.
- Be careful not to damage sliding surfaces and mating surfaces.
- When applying sealant, remove the old sealant from the mounting surface; then remove any moisture, oil, and foreign materials from the application and mounting surfaces.
- Always use shop paper for cleaning the inside of components.
- Never use cotton gloves or shop rags to prevent entering of lint.
- During assembly, observe the specified tightening torque, and apply new gear oil, petroleum jelly, or multi-purpose grease as specified for each vehicle, if necessary.

PREPARATION

< PREPARATION >

[REAR FINAL DRIVE: R200V]

PREPARATION

PREPARATION

Special Service Tools

INFOID:000000005649789

The actual shapes of Kent-Moore tools may differ from those of special service tools illustrated here.

Tool number (Kent-Moore No.) Tool name	Description
KV40104100 (—) Attachment	Removing side flange
ST36230000 (J-25840-A) Sliding hammer	Removing side flange
ST3127S000 (J-25765-A) Preload gauge	Measuring pinion bearing preload and total preload
KV381054S0 (J-34286) Puller	Removing front oil seal
ST30720000 (J-25405) Drift a: 77 mm (3.03 in) dia. b: 55.5 mm (2.185 in) dia.	<ul style="list-style-type: none"> • Installing front oil seal • Installing pinion rear bearing outer race
KV38107900 (J-39352) Protector	Installing side flange

A

B

C

DLN

E

F

G

H

I

J

K

L

M

N

O

P

PREPARATION

< PREPARATION >

[REAR FINAL DRIVE: R200V]

Tool number (Kent-Moore No.) Tool name	Description
KV38100200 (J-26233) Drift a: 65 mm (2.56 in) dia. b: 49 mm (1.93 in) dia.	Installing side oil seal
KV10111100 (J-37228) Seal cutter	Removing rear cover
KV38100800 (J-25604-01) Attachment A: 541 mm (21.30 in) B: 200 mm (7.87 in)	Fixing unit assembly
ST3306S001 (J-22888-D) Differential side bearing puller set 1: ST33051001 (J-22888-20) Puller 2: ST33061000 (J-8107-2) Base a: 28.5 mm (1.122 in) dia. b: 38 mm (1.50 in) dia.	Removing and installing side bearing inner race
KV10112100 (BT-8653-A) Angle wrench	Tightening drive gear bolt
KV38100300 (J-25523) Drift a: 54 mm (2.13 in) dia. b: 46 mm (1.81 in) dia. c: 32 mm (1.26 in) dia.	Installing side bearing inner race

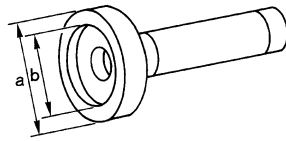

ZZA1143D

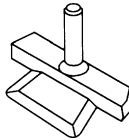

S-NT046

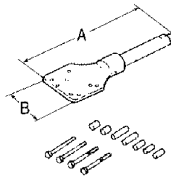

SDIA0267E

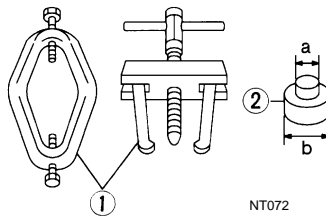

NT072

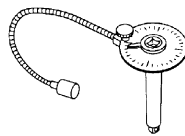

ZZA0120D

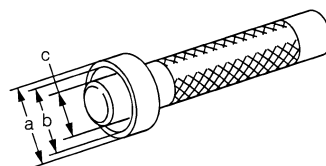



ZZA1046D

PREPARATION

< PREPARATION >

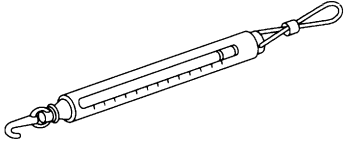
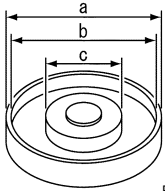
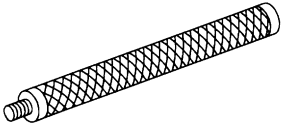
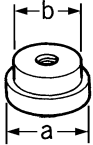
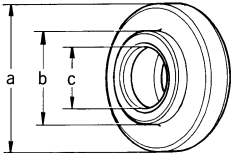
[REAR FINAL DRIVE: R200V]

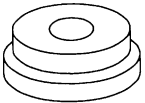
Tool number (Kent-Moore No.) Tool name	Description	
— (J-8129) Spring gauge	Measuring turning torque	A B C
 NT127		
KV40105230 (—) Drift a: 92 mm (3.62 in) dia. b: 86 mm (3.39 in) dia. c: 45 mm (1.77 in) dia.	Installing pinion rear bearing outer race	DLN E F
 PDIA0591E		
ST30611000 (J-25742-1) Drift bar	Installing pinion front bearing outer race (Use with ST30613000)	G H
 S-NT090		
ST30613000 (J-25742-3) Drift a: 72 mm (2.83 in) dia. b: 48 mm (1.89 in) dia.	Installing pinion front bearing outer race	I J
 ZZA1000D		
ST30901000 (J-26010-01) Drift a: 79 mm (3.11 in) dia. b: 45 mm (1.77 in) dia. c: 35.2 mm (1.386 in) dia.	Installing pinion rear bearing inner race	K L M
 ZZA0978D		
— (J-34309) Differential shim selector tool	Adjusting bearing preload and pinion gear height	N O
 NT134		
— (J-25269-4) Side bearing disc (2 Req'd)	Selecting pinion height adjusting washer	P
 NT136		

PREPARATION

< PREPARATION >

[REAR FINAL DRIVE: R200V]

Commercial Service Tools

INFOID:000000005649790

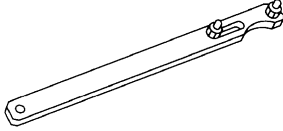
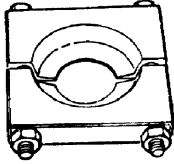
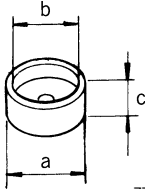
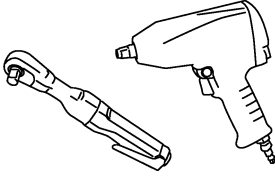
Tool name	Description
<p>Flange wrench</p>  <p style="text-align: right;">NT035</p>	<p>Removing and installing drive pinion lock nut</p>
<p>Replacer</p>  <p style="text-align: right;">ZZA0700D</p>	<p>Removing pinion rear bearing inner race</p>
<p>Spacer</p> <p>a: 60 mm (2.36 in) dia. b: 36 mm (1.42 in) dia. c: 30 mm (1.18 in)</p>  <p style="text-align: right;">ZZA1133D</p>	<p>Installing pinion front bearing inner race</p>
<p>Power tool</p>  <p style="text-align: right;">PBIC0190E</p>	<p>Loosening bolts and nuts</p>

PERIODIC MAINTENANCE

REAR DIFFERENTIAL GEAR OIL

Inspection

INFOID:000000005649791

OIL LEAKAGE

- Make sure that oil is not leaking from final drive assembly or around it.

OIL LEVEL

- Remove filler plug (1) and check oil level from filler plug mounting hole as shown in the figure.

CAUTION:

Never start engine while checking oil level.

- Set a gasket on filler plug (1) and install it on final drive assembly. Refer to [DLN-252, "M/T : Exploded View"](#) (M/T models), [DLN-264, "A/T : Exploded View"](#) (A/T models).

CAUTION:

Never reuse gasket.

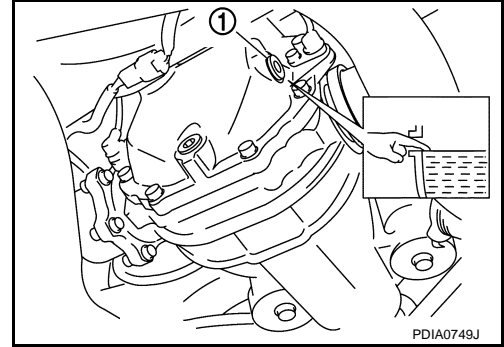

PDIA0749J

Draining

INFOID:000000005649792

1. Stop engine.
2. Remove drain plug (1) and drain gear oil.
3. Set a gasket on drain plug (1) and install it to final drive assembly and tighten to the specified torque. Refer to [DLN-252, "M/T : Exploded View"](#) (M/T models), [DLN-264, "A/T : Exploded View"](#) (A/T models).

CAUTION:

Never reuse gasket.

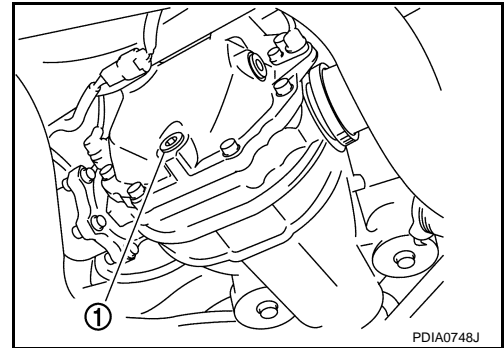

PDIA0748J

Refilling

INFOID:000000005649793

1. Remove filler plug (1). Fill with new gear oil until oil level reaches the specified level near filler plug mounting hole.

Oil grade and viscosity : Refer to [MA-10, "Fluids and Lubricants"](#).

Oil capacity : Refer to [DLN-295, "General Specification"](#).

2. After refilling oil, check oil level. Set a gasket to filler plug (1), then install it to final drive assembly. Refer to [DLN-252, "M/T : Exploded View"](#) (M/T models), [DLN-264, "A/T : Exploded View"](#) (A/T models).

CAUTION:

Never reuse gasket.

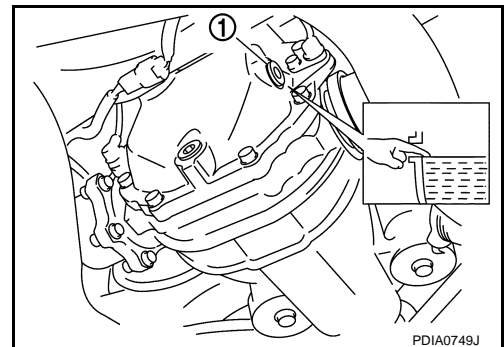

PDIA0749J

A
B
C
DLN
E
F
G
H
I
J
K
L
M
N
O
P

FRONT OIL SEAL

< REMOVAL AND INSTALLATION >

[REAR FINAL DRIVE: R200V]

REMOVAL AND INSTALLATION

FRONT OIL SEAL

M/T

M/T : Exploded View

INFOID:000000005649794

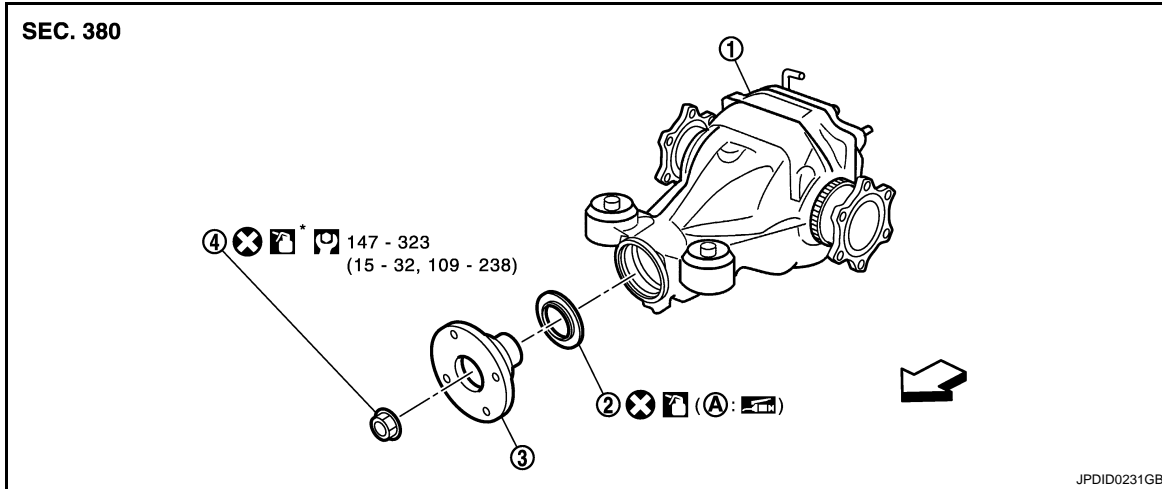

1. Final drive assembly 2. Front oil seal 3. Companion flange

4. Drive pinion lock nut

A. Oil seal lip

↶: Vehicle front

: Apply gear oil.

: Apply anti-corrosion oil.

Refer to [GI-4, "Components"](#) for symbols not described above.

M/T : Removal and Installation

INFOID:000000005649795

REMOVAL

CAUTION:

Verify identification stamp of replacement frequency put in the lower part of gear carrier to determine replacement for collapsible spacer when replacing front oil seal. Refer to "Identification stamp of replacement frequency of front oil seal". If collapsible spacer replacement is necessary, remove final drive assembly and disassemble it to replace front oil seal and collapsible spacer. Refer to [DLN-248, "M/T : Removal and Installation"](#) and [DLN-253, "M/T : Disassembly"](#).

NOTE:

The reuse of collapsible spacer is prohibited in principle. However, it is reusable on a one-time basis only in cases when replacing front oil seal.

Identification stamp of replacement frequency of front oil seal

- The diagonally shaded area in the figure shows stamping point for replacement frequency of front oil seal.
- The following table shows if collapsible spacer replacement is needed before replacing front oil seal.
When collapsible spacer replacement is required, disassemble final drive assembly to replace collapsible spacer and front oil seal. Refer to [DLN-253, "M/T : Disassembly"](#).

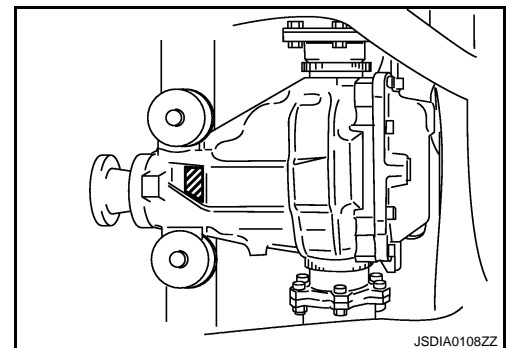

FRONT OIL SEAL

< REMOVAL AND INSTALLATION >

[REAR FINAL DRIVE: R200V]

Stamp	collapsible spacer replacement
No stamp	Not required
"0" or "0" on the far right of stamp	Required
"01" or "1" on the far right of stamp	Not required

A
B
C

CAUTION:

Make a stamping after replacing front oil seal.

- After replacing front oil seal, make a stamping on the stamping point in accordance with the table below in order to identify replacement frequency.

CAUTION:

Make a stamping made from left to right.

DLN

Stamp before stamping	Stamping on the far right	Stamping
No stamp	0	0
"0" (Front oil seal was replaced once.)	1	01
"01" (Collapsible spacer and front oil seal were replaced last time.)	0	010
"0" is on the far right. (Only front oil seal was replaced last time.)	1	...01
"1" is on the far right. (Collapsible spacer and front oil seal were replaced last time.)	0	...010

E
F
G

1. Drain gear oil. Refer to [DLN-233, "Draining"](#).
2. Make a judgment if a collapsible spacer replacement is required.
3. Remove center muffler with a power tool. Refer to [EX-5, "Exploded View"](#).
4. Remove rear wheel sensor. Refer to [BRC-103, "Exploded View"](#).
5. Remove drive shaft from final drive. Then suspend it by wire, etc. Refer to [RAX-10, "Exploded View"](#).

6. Install attachment (A) [SST: KV40104100 (—)] to side flange, and then pull out the side flange with the sliding hammer (B) [SST: ST36230000 (J-25840-A)].

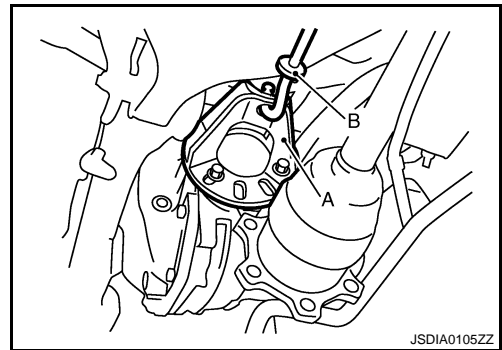

H
I
J

NOTE:

Circular clip installation position: Final drive side

7. Remove propeller shaft. Refer to [DLN-92, "Exploded View"](#).

K
L
M

8. Measure the total preload with the preload gauge (A) [SST: ST3127S000 (J-25765-A)].

NOTE:

Record the preload measurement.

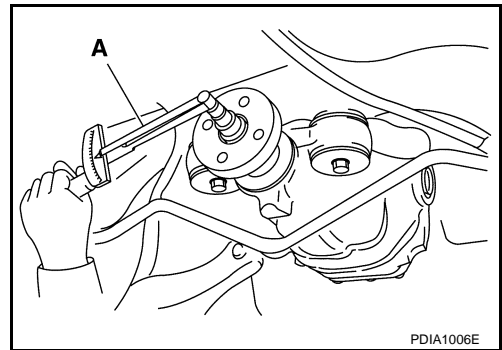

N
O
P

FRONT OIL SEAL

< REMOVAL AND INSTALLATION >

[REAR FINAL DRIVE: R200V]

9. Put matching mark (B) on the end of the drive pinion. The matching mark (B) should be in line with the matching mark (A) on companion flange (1).

CAUTION:

For matching mark, use paint. Never damage companion flange and drive pinion.

NOTE:

The matching mark (A) on the final drive companion flange (1) indicates the maximum vertical runout position.

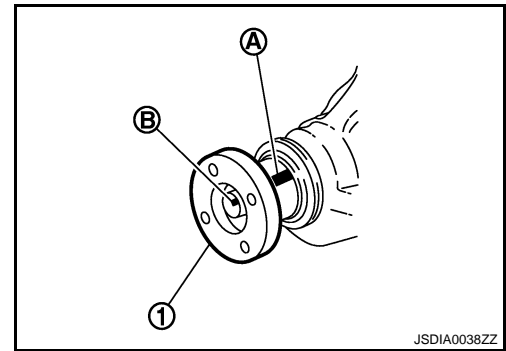

JSDIA0038ZZ

10. Remove drive pinion lock nut using the flange wrench.

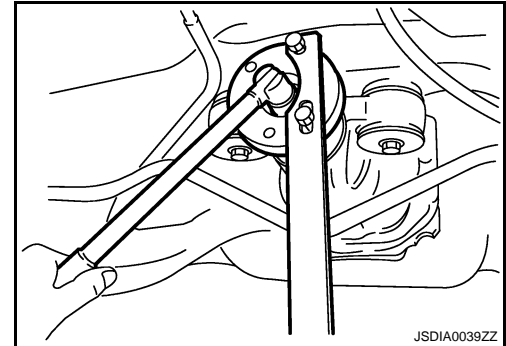

JSDIA0039ZZ

11. Remove companion flange using a puller.

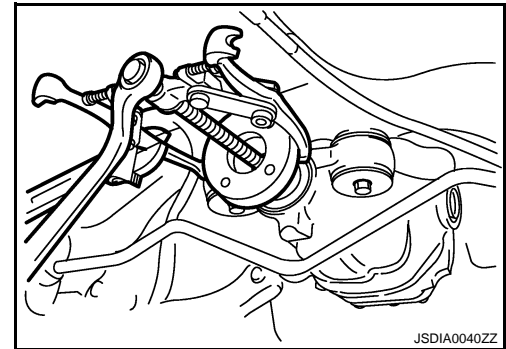

JSDIA0040ZZ

12. Remove front oil seal using the puller (A) [SST: KV381054S0 (J-34286)].

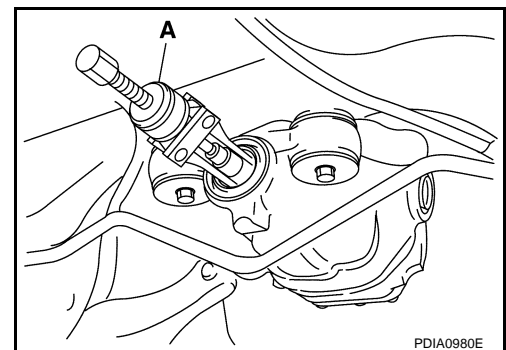

PDIA0980E

INSTALLATION

1. Apply multi-purpose grease to front oil seal lips.

FRONT OIL SEAL

< REMOVAL AND INSTALLATION >

[REAR FINAL DRIVE: R200V]

2. Install front oil seal using the drift (A) [SST: ST30720000 (J-25405)] as shown in figure.

CAUTION:

- Never reuse oil seal.
- Never incline oil seal when installing.

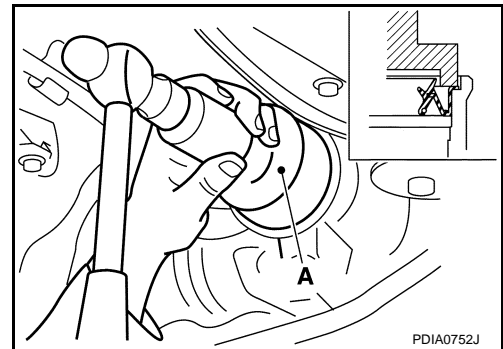

3. Align the matching mark (B) of drive pinion with the matching mark (A) of companion flange (1), and then install the companion flange (1).

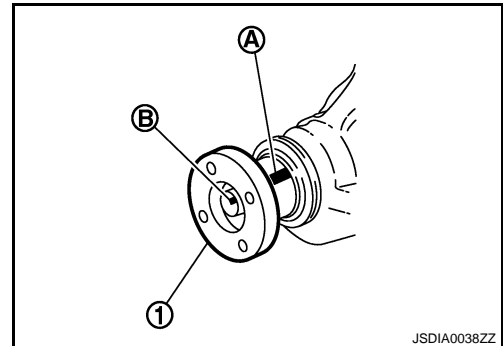

4. Apply anti-corrosion oil to the thread and seat of new drive pinion lock nut, and temporarily tighten drive pinion lock nut to drive pinion.

CAUTION:

Never reuse drive pinion lock nut.

5. Tighten drive pinion lock nut within the limits of specified torque so as to keep the pinion bearing preload within a standard values.

A: Preload gauge [SST: ST3127S000 (J-25765-A)]

Total preload torque : A value that add 0.1– 0.4 N·m (0.01 – 0.04 kg·m) to the measured value when removing.

CAUTION:

- Adjust to the lower limit of the drive pinion lock nut tightening torque first.
- If the preload torque exceeds the specified value, replace collapsible spacer and tighten it again to adjust. Never loosen drive pinion lock nut to adjust the preload torque.

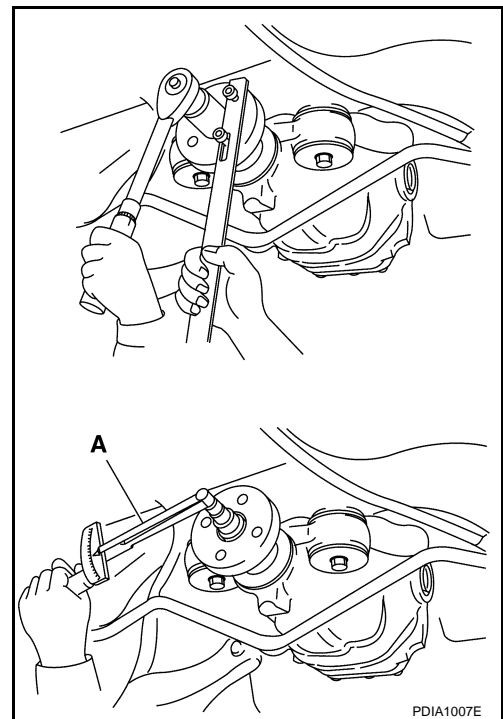

6. Fit a dial indicator onto the companion flange face (inner side of the propeller shaft mounting bolt holes).
7. Rotate the companion flange to check for runout.

Limit

Companion flange runout : Refer to [DLN-295, "Companion flange Runout \(M/T Models\)"](#).

8. Fit a test indicator to the inner side of the companion flange (socket diameter).

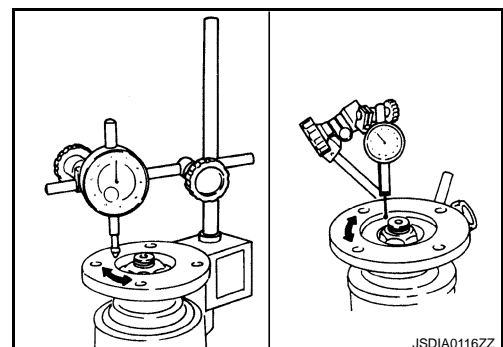

A

B

C

DLN

E

F

G

H

I

J

K

L

M

N

O

P

FRONT OIL SEAL

< REMOVAL AND INSTALLATION >

[REAR FINAL DRIVE: R200V]

9. Rotate the companion flange to check for runout.

Limit

Companion flange runout : Refer to [DLN-295, "Companion flange Runout \(M/T Models\)"](#).

10. If the runout value is outside the repair limit, follow the procedure below to adjust.
 - a. Check for runout while changing the phase between companion flange and drive pinion gear by 90° step, and search for the position where the runout is the minimum.
 - b. If the runout value is still outside of the limit after the phase has been changed, possible causes are be an assembly malfunction of drive pinion and pinion bearing and malfunction of pinion bearing. Check for these items and repair if necessary.
 - c. If the runout value is still outside of the limit after the check and repair, replace companion flange.
11. Make a stamping for identification of front oil seal replacement frequency. Refer to "Identification stamp of replacement frequency of front oil seal".

CAUTION:

Make a stamping after replacing front oil seal.

12. Install propeller shaft. Refer to [DLN-92, "Exploded View"](#).
13. Install side flange with the following procedure.
 - a. Attach the protector [SST: KV38107900 (J-39352)] to side oil seal.
 - b. After the side flange is inserted and the serrated part of side gear has engaged the serrated part of flange, remove the protector.

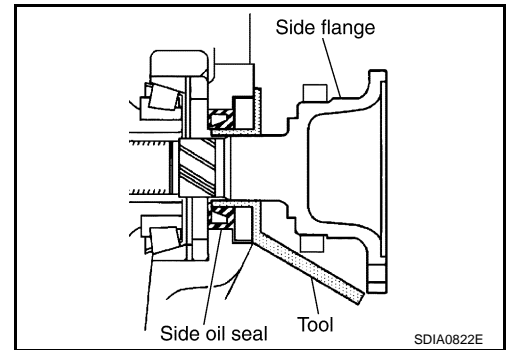

- c. Put a suitable drift on the center of side flange, then drive it until sound changes.

NOTE:

When installation is completed, driving sound of the side flange turns into a sound that seems to affect the whole final drive.

- d. Confirm that the dimension of the side flange (1) installation (Measurement A) in the figure comes into the following.

Measurement "A" : 326 – 328 mm (12.83 – 12.91 in)

14. Install drive shaft. Refer to [RAX-10, "Exploded View"](#).
15. Install rear wheel sensor. Refer to [BRC-103, "Exploded View"](#).
16. Install center muffler. Refer to [EX-5, "Exploded View"](#).
17. Refill gear oil to the final drive and check oil level. Refer to [DLN-233, "Refilling"](#).
18. Check the final drive for oil leakage. Refer to [DLN-233, "Inspection"](#).

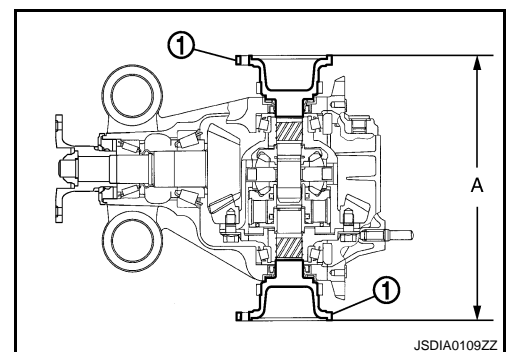

A/T

FRONT OIL SEAL

< REMOVAL AND INSTALLATION >

[REAR FINAL DRIVE: R200V]

A/T : Exploded View

INFOID:000000005649796

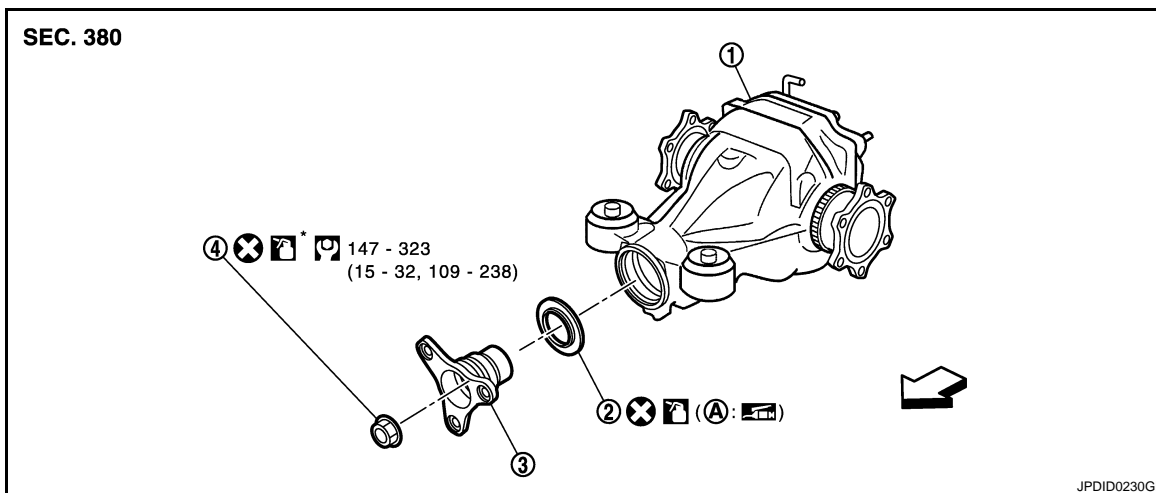

- 1. Final drive assembly
 - 2. Front oil seal
 - 3. Companion flange
 - 4. Drive pinion lock nut
 - A. Oil seal lip
- ↔: Vehicle front

: Apply gear oil.

: Apply anti-corrosion oil.

Refer to [GI-4, "Components"](#) for symbols not described above.

A/T : Removal and Installation

INFOID:000000005649797

REMOVAL

CAUTION:

Verify identification stamp of replacement frequency put in the lower part of gear carrier to determine replacement for collapsible spacer when replacing front oil seal. Refer to "Identification stamp of replacement frequency of front oil seal". If collapsible spacer replacement is necessary, remove final drive assembly and disassemble it to replace front oil seal and collapsible spacer. Refer to [DLN-250, "A/T : Removal and Installation"](#) and [DLN-265, "A/T : Disassembly"](#).

NOTE:

The reuse of collapsible spacer is prohibited in principle. However, it is reusable on a one-time basis only in cases when replacing front oil seal.

Identification stamp of replacement frequency of front oil seal

- The diagonally shaded area in the figure shows stamping point for replacement frequency of front oil seal.
- The following table shows if collapsible spacer replacement is needed before replacing front oil seal. When collapsible spacer replacement is required, disassemble final drive assembly to replace collapsible spacer and front oil seal. Refer to [DLN-265, "A/T : Disassembly"](#).

Stamp	collapsible spacer replacement
No stamp	Not required
"0" or "0" on the far right of stamp	Required
"01" or "1" on the far right of stamp	Not required

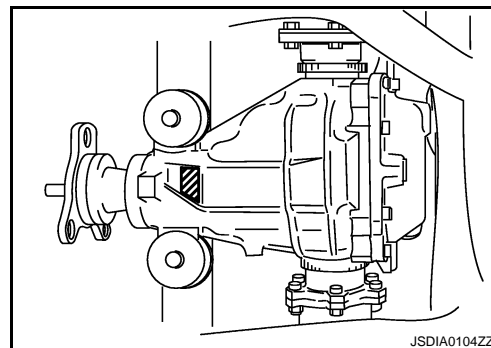

CAUTION:

Make a stamping after replacing front oil seal.

FRONT OIL SEAL

< REMOVAL AND INSTALLATION >

[REAR FINAL DRIVE: R200V]

- After replacing front oil seal, make a stamping on the stamping point in accordance with the table below in order to identify replacement frequency.

CAUTION:

Make a stamping from left to right.

Stamp before stamping	Stamping on the far right	Stamping
No stamp	0	0
"0" (Front oil seal was replaced once.)	1	01
"01" (Collapsible spacer and front oil seal were replaced last time.)	0	010
"0" is on the far right. (Only front oil seal was replaced last time.)	1	...01
"1" is on the far right. (Collapsible spacer and front oil seal were replaced last time.)	0	...010

- Drain gear oil. Refer to [DLN-233, "Draining"](#).
- Make a judgment if a collapsible spacer replacement is required.
- Remove center muffler with a power tool. Refer to [EX-5, "Exploded View"](#).
- Remove rear wheel sensor. Refer to [BRC-103, "Exploded View"](#).
- Remove drive shaft from final drive. Then suspend it by wire, etc. Refer to [RAX-10, "Exploded View"](#).

- Install attachment (A) [SST: KV40104100 (—)] to side flange, and then pull out the side flange with the sliding hammer (B) [SST: ST36230000 (J-25840-A)].

NOTE:

Circular clip installation position: Final drive side

- Remove propeller shaft. Refer to [DLN-100, "Exploded View"](#).

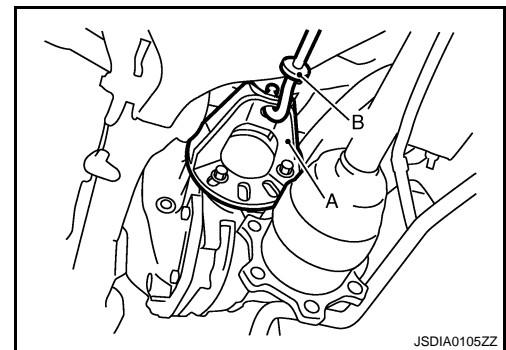

- Measure the total preload with the preload gauge (A) [SST: ST3127S000 (J-25765-A)].

NOTE:

Record the preload measurement.

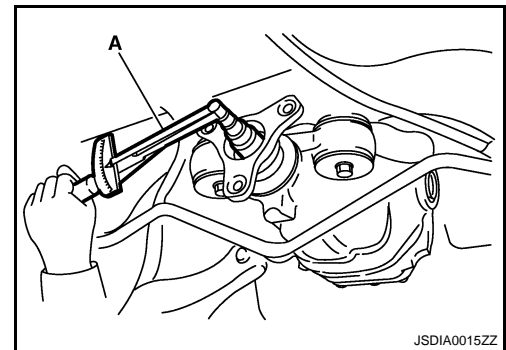

- Put matching mark (B) on the end of the drive pinion. The matching mark (B) should be in line with the matching mark (A) on companion flange (1).

CAUTION:

For matching mark, use paint. Never damage companion flange and drive pinion.

NOTE:

The matching mark (A) on the final drive companion flange (1) indicates the maximum vertical runout position.

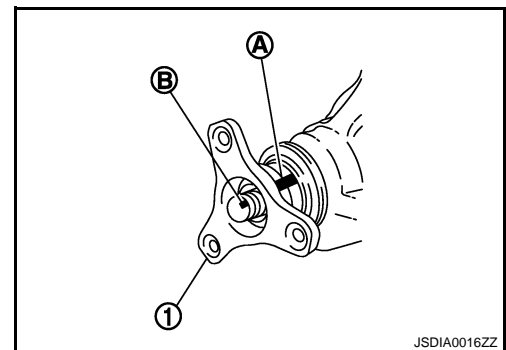

FRONT OIL SEAL

< REMOVAL AND INSTALLATION >

[REAR FINAL DRIVE: R200V]

10. Remove drive pinion lock nut using the flange wrench.

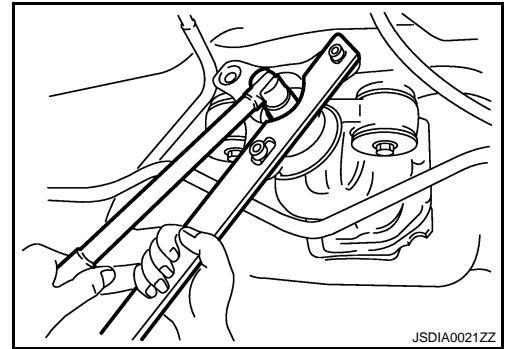

11. Remove companion flange using pullers.

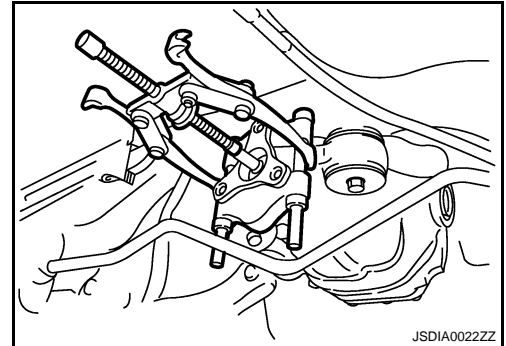

12. Remove front oil seal using the puller (A) [SST: KV381054S0 (J-34286)].

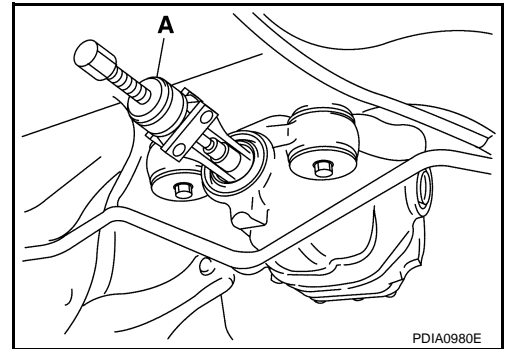

INSTALLATION

1. Apply multi-purpose grease to front oil seal lips.
2. Install front oil seal using the drift (A) [SST: ST30720000 (J-25405)] as shown in figure.

CAUTION:

- Never reuse oil seal.
- Never incline oil seal when installing.

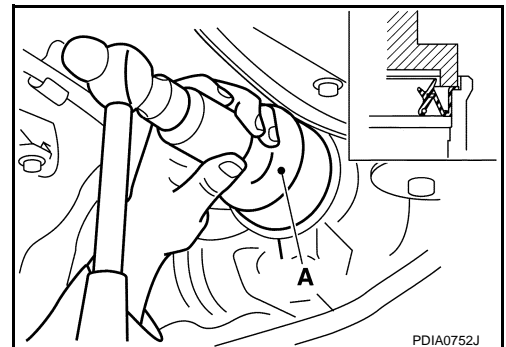

A
B
C
DLN
E
F
G
H
I
J
K
L
M
N
O
P

FRONT OIL SEAL

< REMOVAL AND INSTALLATION >

[REAR FINAL DRIVE: R200V]

- Align the matching mark (B) of drive pinion with the matching mark (A) of companion flange (1), and then install the companion flange (1).

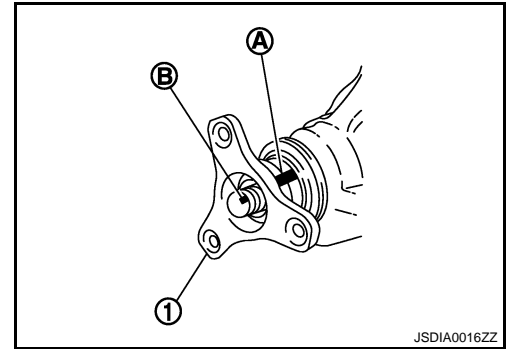

- Apply anti-corrosion oil to the thread and seat of new drive pinion lock nut, and temporarily tighten drive pinion lock nut to drive pinion.

CAUTION:

Never reuse drive pinion lock nut.

- Tighten drive pinion lock nut within the limits of specified torque so as to keep the pinion bearing preload within a standard values.

A: Preload gauge [SST: ST3127S000 (J-25765-A)]

Total preload torque : A value that add 0.1 – 0.4N·m (0.01–0.04 kg·m) to the measured value when removing.

CAUTION:

- Adjust to the lower limit of the drive pinion lock nut tightening torque first.
- If the preload torque exceeds the specified value, replace collapsible spacer and tighten it again to adjust. Never loosen drive pinion lock nut to adjust the preload torque.

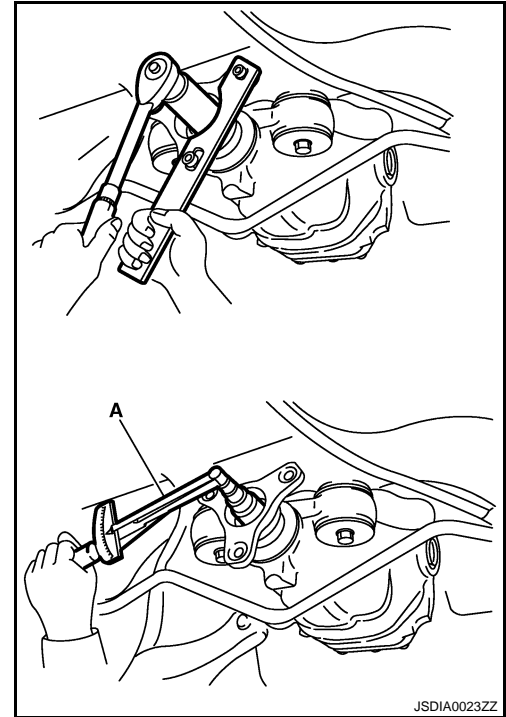

- Set a dial indicator (A) vertically to the tip of the drive pinion.
- Rotate drive pinion to check for runout.

Limit

Drive pinion runout : Refer to [DLN-296, "Drive Pinion Runout \(A/T Models\)"](#).

- If the runout value is still outside of the limit after the phase has been changed, possible causes are be an assembly malfunction of drive pinion and pinion bearing and malfunction of pinion bearing. Check for these items and repair if necessary.

- Make a stamping for identification of front oil seal replacement frequency. Refer to "Identification stamp of replacement frequency of front oil seal".

CAUTION:

Make a stamping after replacing front oil seal.

- Install propeller shaft. Refer to [DLN-100, "Exploded View"](#).

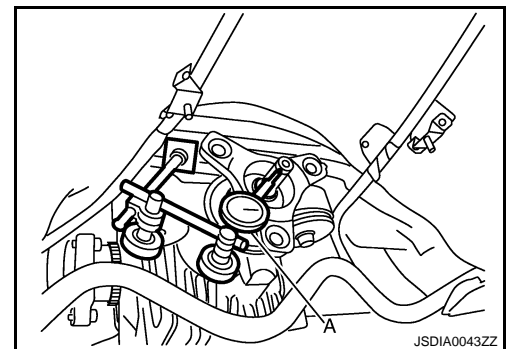

FRONT OIL SEAL

< REMOVAL AND INSTALLATION >

[REAR FINAL DRIVE: R200V]

10. Install side flange with the following procedure.
 - a. Attach the protector [SST: KV38107900 (J-39352)] to side oil seal.
 - b. After the side flange is inserted and the serrated part of side gear has engaged the serrated part of flange, remove the protector.

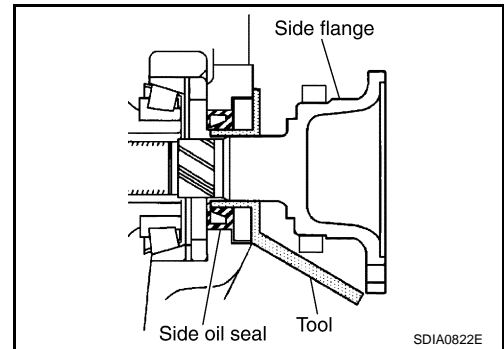

- c. Put a suitable drift on the center of side flange, then drive it until sound changes.

NOTE:

When installation is completed, driving sound of the side flange turns into a sound that seems to affect the whole final drive.

- d. Confirm that the dimension of the side flange (1) installation (Measurement A) in the figure comes into the following.

Measurement "A" : 326 – 328 mm (12.83 – 12.91 in)

11. Install drive shaft. Refer to [RAX-10, "Exploded View"](#).
12. Install rear wheel sensor. Refer to [BRC-103, "Exploded View"](#).
13. Install center muffler. Refer to [EX-5, "Exploded View"](#).
14. Refill gear oil to the final drive and check oil level. Refer to [DLN-233, "Refilling"](#).
15. Check the final drive for oil leakage. Refer to [DLN-233, "Inspection"](#).

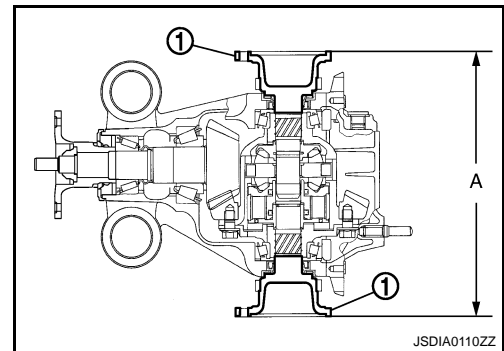

A

B

C

DLN

E

F

G

H

I

J

K

L

M

N

O

P

SIDE OIL SEAL

< REMOVAL AND INSTALLATION >

[REAR FINAL DRIVE: R200V]

SIDE OIL SEAL

M/T

M/T : Exploded View

INFOID:000000005649798

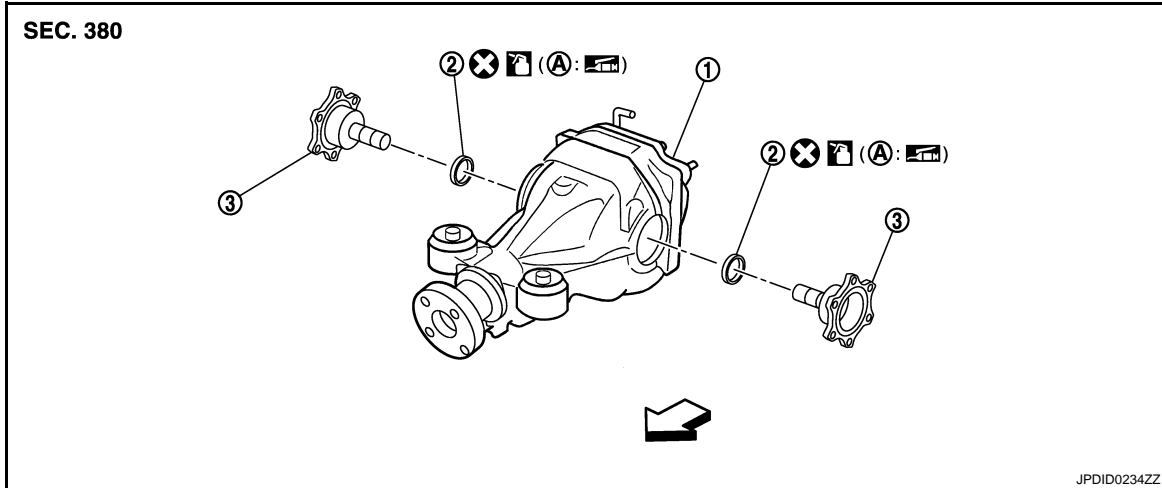

1. Final drive assembly

2. Side oil seal

3. Side flange

A. Oil seal lip

↔: Vehicle front

: Apply gear oil.

Refer to [GI-4, "Components"](#) for symbols not described above.

M/T : Removal and Installation

INFOID:000000005649799

REMOVAL

1. Remove center muffler with a power tool. Refer to [EX-5, "Exploded View"](#).
2. Remove rear wheel sensor. Refer to [BRC-103, "Exploded View"](#).
3. Remove drive shaft from final drive with a power tool. Then suspend it by wire, etc. Refer to [RAX-10, "Exploded View"](#).
4. Install attachment (A) [SST: KV40104100 (—)] to side flange, and then pull out the side flange with the sliding hammer (B) [SST: ST36230000 (J-25840-A)].

NOTE:

Circular clip installation position: Final drive side

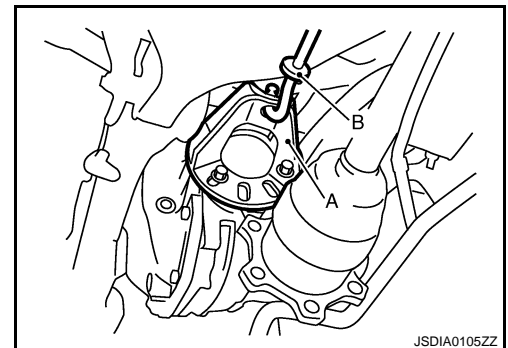

SIDE OIL SEAL

< REMOVAL AND INSTALLATION >

[REAR FINAL DRIVE: R200V]

5. Remove side oil seal, using a flat-bladed screwdriver.

CAUTION:

Never damage gear carrier.

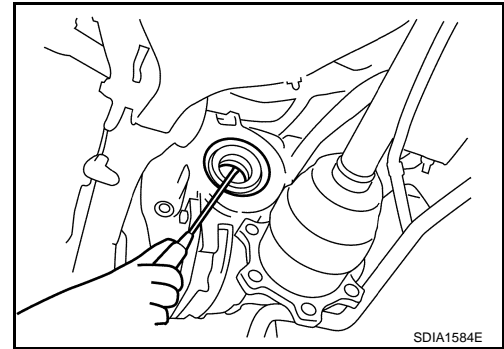

INSTALLATION

1. Apply multi-purpose grease to side oil seal lips.
2. Install side oil seal until it becomes flush with the case end, using the drift [SST: KV38100200 (J-26233)].

CAUTION:

- Never reuse oil seal.
- When installing, never incline oil seal.

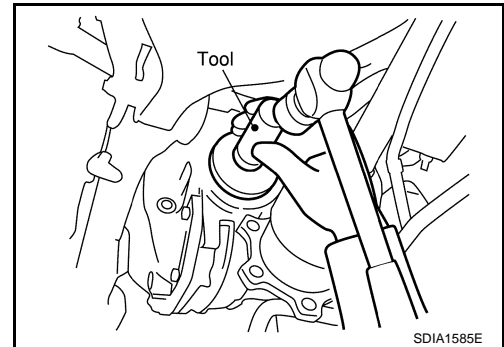

3. Install side flange with the following procedure.
 - a. Attach the protector [SST: KV38107900 (J-39352)] to side oil seal.
 - b. After the side flange is inserted and the serrated part of side gear has engaged the serrated part of flange, remove the protector.

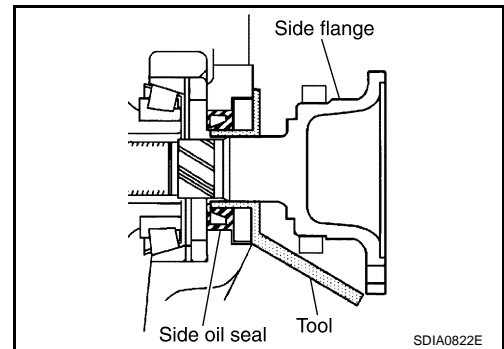

- c. Put a suitable drift on the center of side flange, then drive it until sound changes.

NOTE:

When installation is completed, driving sound of the side flange turns into a sound that seems to affect the whole final drive.

- d. Confirm that the dimension of the side flange (1) installation (Measurement A) in the figure comes into the following.

Measurement "A" : 326 – 328 mm (12.83 – 12.91 in)

4. Install drive shaft. Refer to [RAX-10. "Exploded View"](#).
5. Install rear wheel sensor. Refer to [BRC-103. "Exploded View"](#).
6. Install center muffler. Refer to [EX-5. "Exploded View"](#).
7. When oil leaks while removing, check oil level after the installation. Refer to [DLN-233. "Inspection"](#).

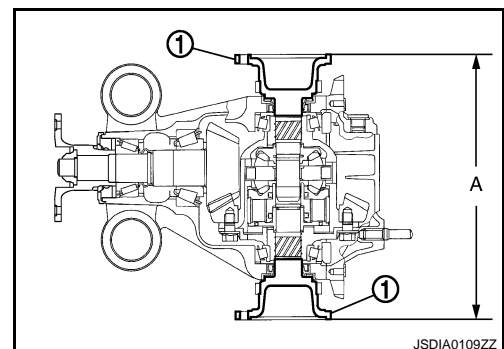

A/T

A
B
C
DLN
E
F
G
H
I
J
K
L
M
N
O
P

SIDE OIL SEAL

< REMOVAL AND INSTALLATION >

[REAR FINAL DRIVE: R200V]

A/T : Exploded View

INFOID:000000005649800

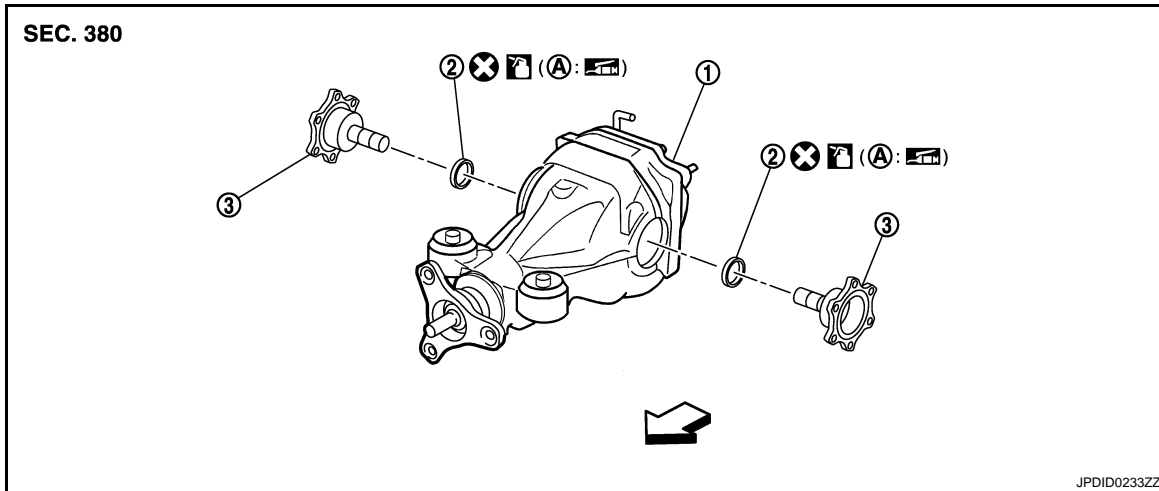

1. Final drive assembly 2. Side oil seal 3. Side flange

A. Oil seal lip

↔: Vehicle front

: Apply gear oil.

Refer to [GI-4, "Components"](#) for symbols not described above.

A/T : Removal and Installation

INFOID:000000005649801

REMOVAL

1. Remove center muffler with a power tool. Refer to [EX-5, "Exploded View"](#).
2. Remove rear wheel sensor. Refer to [BRC-103, "Exploded View"](#).
3. Remove drive shaft from final drive with a power tool. Then suspend it by wire, etc. Refer to [RAX-10, "Exploded View"](#).
4. Install attachment (A) [SST: KV40104100 (—)] to side flange, and then pull out the side flange with the sliding hammer (B) [SST: ST36230000 (J-25840-A)].

NOTE:

Circular clip installation position: Final drive side

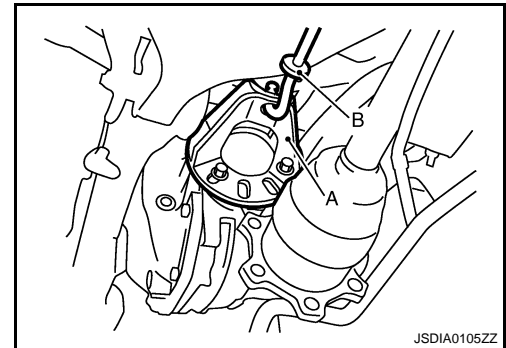

5. Remove side oil seal, using a flat-bladed screwdriver.

CAUTION:

Never damage gear carrier.

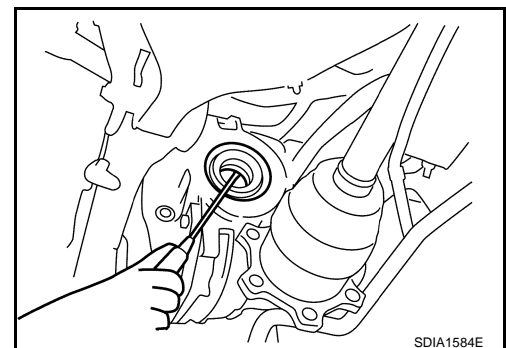

SIDE OIL SEAL

< REMOVAL AND INSTALLATION >

[REAR FINAL DRIVE: R200V]

INSTALLATION

1. Apply multi-purpose grease to side oil seal lips.
2. Install side oil seal until it becomes flush with the case end, using the drift [SST: KV38100200 (J-26233)].

CAUTION:

- Never reuse oil seal.
- When installing, never incline oil seal.

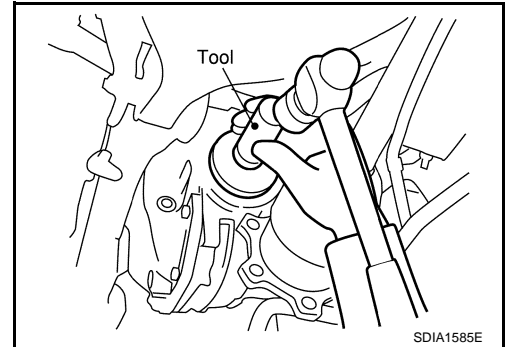

3. Install side flange with the following procedure.
 - a. Attach the protector [SST: KV38107900 (J-39352)] to side oil seal.
 - b. After the side flange is inserted and the serrated part of side gear has engaged the serrated part of flange, remove the protector.

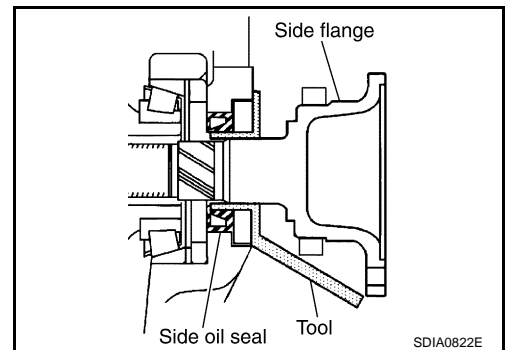

- c. Put a suitable drift on the center of side flange, then drive it until sound changes.

NOTE:

When installation is completed, driving sound of the side flange turns into a sound that seems to affect the whole final drive.

- d. Confirm that the dimension of the side flange (1) installation (Measurement A) in the figure comes into the following.

Measurement "A" : 326 – 328 mm (12.83 – 12.91 in)

4. Install drive shaft. Refer to [RAX-10, "Exploded View"](#).
5. Install rear wheel sensor. Refer to [BRC-103, "Exploded View"](#).
6. Install center muffler. Refer to [EX-5, "Exploded View"](#).
7. When oil leaks while removing, check oil level after the installation. Refer to [DLN-233, "Inspection"](#).

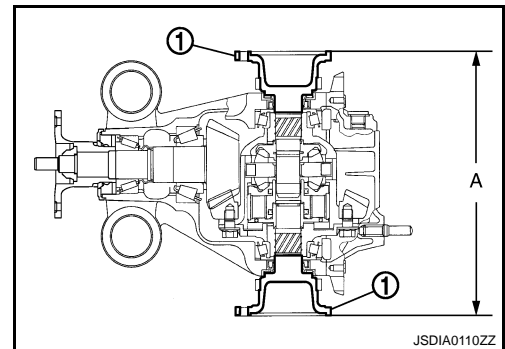

A
B
C
DLN
E
F
G
H
I
J
K
L
M
N
O
P

REAR FINAL DRIVE ASSEMBLY

< UNIT REMOVAL AND INSTALLATION >

[REAR FINAL DRIVE: R200V]

UNIT REMOVAL AND INSTALLATION

REAR FINAL DRIVE ASSEMBLY

M/T

M/T : Exploded View

INFOID:000000005649802

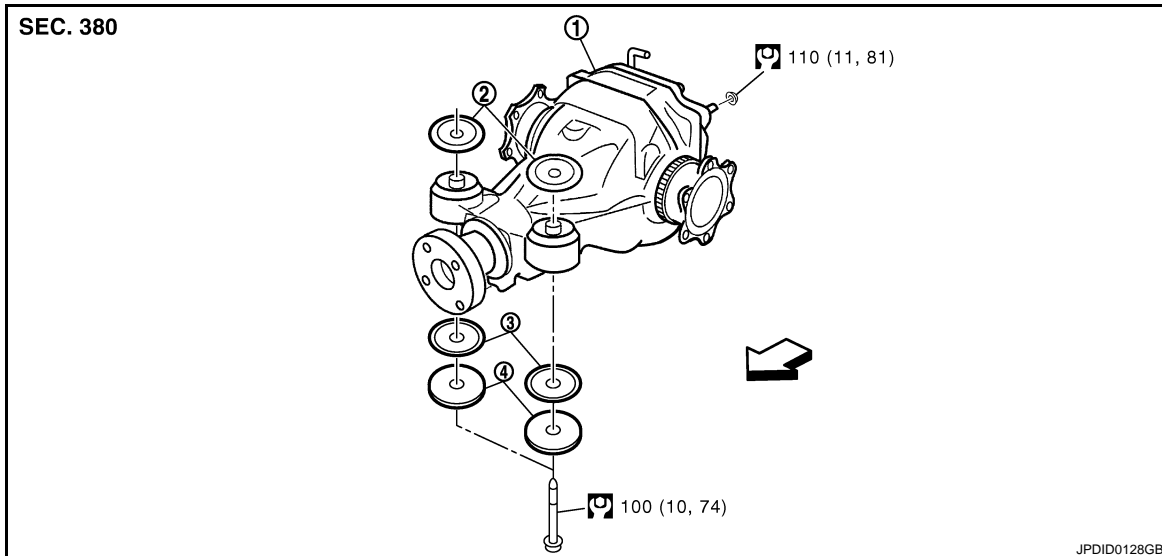

1. Rear final drive assembly
2. Upper stopper
3. Lower stopper
4. Washer

↩: Vehicle front

Refer to [GI-4. "Components"](#) for symbols in the figure.

M/T : Removal and Installation

INFOID:000000005649803

REMOVAL

1. Remove center muffler with a power tool. Refer to [EX-5. "Exploded View"](#).
2. Remove rear stabilizer bar with a power tool. Refer to [RSU-21. "Exploded View"](#).
3. Remove propeller shaft from the final drive. Refer to [DLN-92. "Exploded View"](#).
4. Remove drive shaft from final drive with a power tool. Then suspend it by wire, etc. Refer to [RAX-10. "Exploded View"](#).
5. Remove breather hose from the final drive.
6. Remove rear wheel sensor. Refer to [BRC-103. "Exploded View"](#).

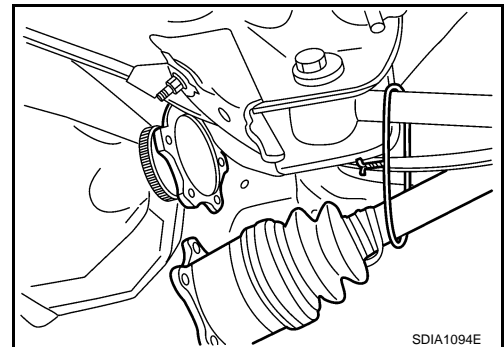

REAR FINAL DRIVE ASSEMBLY

[REAR FINAL DRIVE: R200V]

< UNIT REMOVAL AND INSTALLATION >

7. Set a suitable jack to rear final drive assembly.

CAUTION:

Never place a jack on the rear cover (aluminum case).

8. Remove the mounting bolts and nuts connecting to the suspension member, and remove rear final drive assembly with a power tool.

CAUTION:

Secure rear final drive assembly to a suitable jack while removing it.

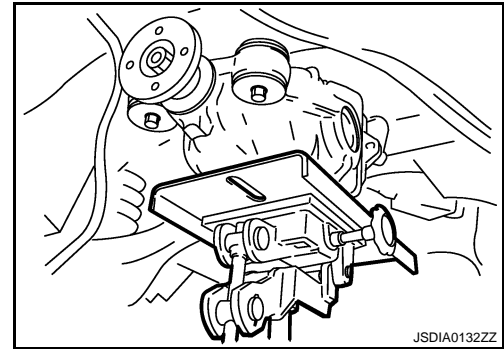

INSTALLATION

Note the following, and installation is in the reverse order of removal.

CAUTION:

Make sure there are no pinched or restricted areas on the breather hose caused by bending or winding when installing it.

- Install the breather hose (1) to breather connector until dimension (A) shown as follows.

A:

Final drive side : 20 mm (0.79 in)

**Suspension member : 20.5 mm (0.807 in)
side**

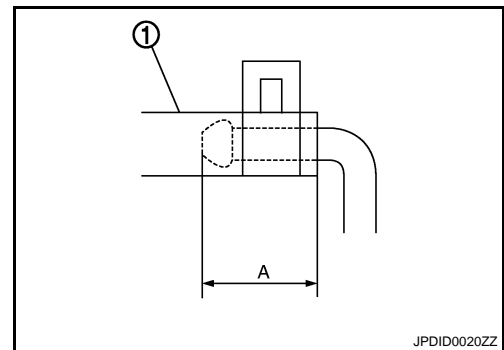

CAUTION:

- **Never reuse hose clamp.**
- **Install the hose clamp at the final drive side, with the tab facing downward.**
- **Install the hose clamp at the suspension member side, with the tab facing downward.**

- If remove breather connector, install breather hose (1) as shown in the figure.
- For installation, insert the breather connector to suspension member (2). Install metal connector (3) to rear cover with aiming painted marking to the front of vehicle.

←: Vehicle front

CAUTION:

Never reuse breather connector and metal connector.

- When oil leaks while removing final drive assembly, check oil level after the installation. Refer to [DLN-233. "Inspection"](#).

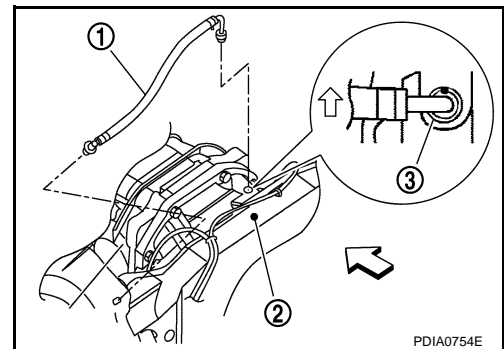

A/T

A
B
C
DLN
E
F
G
H
I
J
K
L
M
N
O
P

REAR FINAL DRIVE ASSEMBLY

< UNIT REMOVAL AND INSTALLATION >

[REAR FINAL DRIVE: R200V]

A/T : Exploded View

INFOID:000000005649804

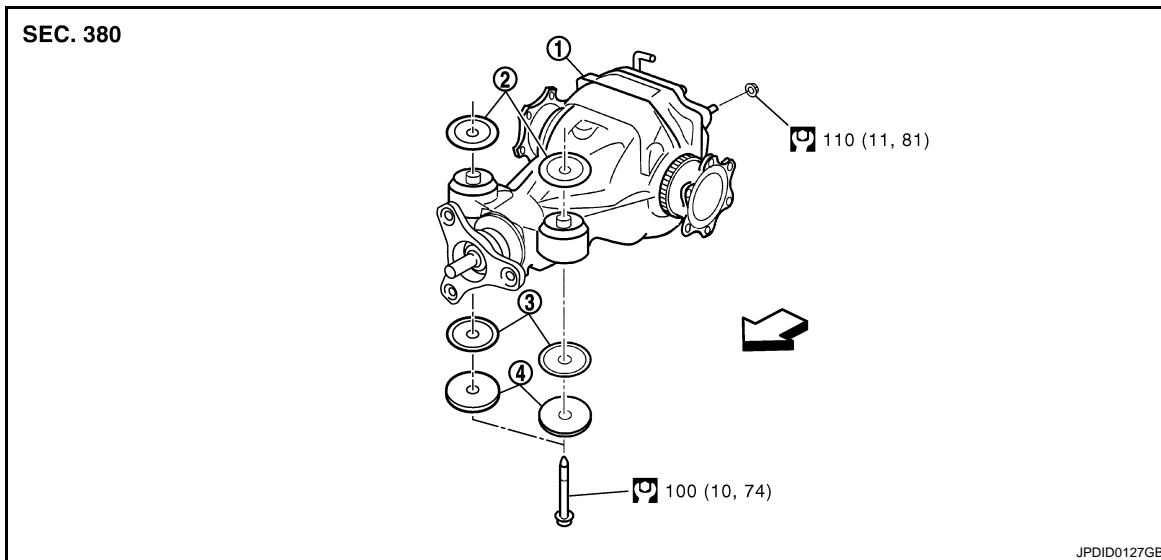

1. Rear final drive assembly
2. Upper stopper
3. Lower stopper
4. Washer

↶: Vehicle front

Refer to [GI-4, "Components"](#) for symbols in the figure.

A/T : Removal and Installation

INFOID:000000005649805

REMOVAL

1. Remove center muffler with a power tool. Refer to [EX-5, "Exploded View"](#).
2. Remove rear stabilizer bar with a power tool. Refer to [RSU-21, "Exploded View"](#).
3. Remove propeller shaft from the final drive. Refer to [DLN-100, "Exploded View"](#).
4. Remove drive shaft from final drive with a power tool. Then suspend it by wire, etc. Refer to [RAX-10, "Exploded View"](#).
5. Remove breather hose from the final drive.
6. Remove rear wheel sensor. Refer to [BRC-103, "Exploded View"](#).

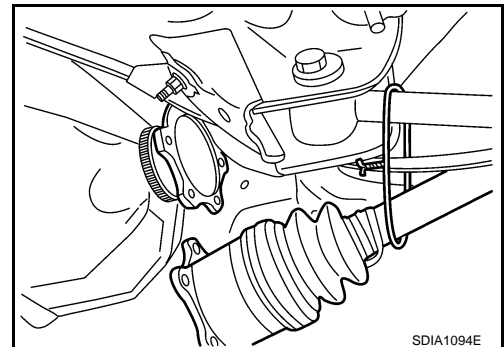

7. Set a suitable jack to rear final drive assembly.
CAUTION:
Never place a jack on the rear cover (aluminum case).
8. Remove the mounting bolts and nuts connecting to the suspension member, and remove rear final drive assembly with a power tool.
CAUTION:
Secure rear final drive assembly to a suitable jack while removing it.

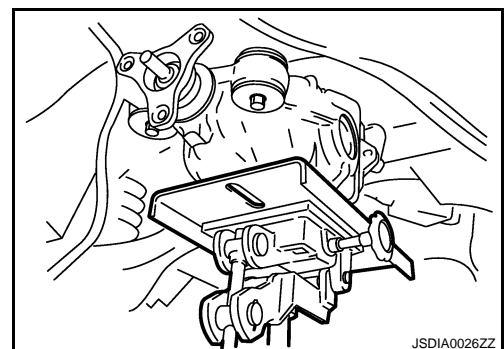

INSTALLATION

Revision: 2009 November

DLN-250

2010 G37 Coupe

REAR FINAL DRIVE ASSEMBLY

< UNIT REMOVAL AND INSTALLATION >

[REAR FINAL DRIVE: R200V]

Note the following, and installation is in the reverse order of removal.

CAUTION:

Make sure there are no pinched or restricted areas on the breather hose caused by bending or winding when installing it.

- Install the breather hose (1) to breather connector until dimension (A) shown as follows.

A:

Final drive side : 20 mm (0.79 in)

Suspension member side : 20.5 mm (0.807 in)

CAUTION:

- **Never reuse hose clamp.**
 - **Install the hose clamp at the final drive side, with the tab facing downward.**
 - **Install the hose clamp at the suspension member side, with the tab facing downward.**
-
- If remove breather connector, install breather hose (1) as shown in the figure.
 - For installation, insert the breather connector to suspension member (2). Install metal connector (3) to rear cover with aiming painted marking to the front of vehicle.

←: Vehicle front

CAUTION:

Never reuse breather connector and metal connector.

- When oil leaks while removing final drive assembly, check oil level after the installation. Refer to [DLN-233, "Inspection"](#).

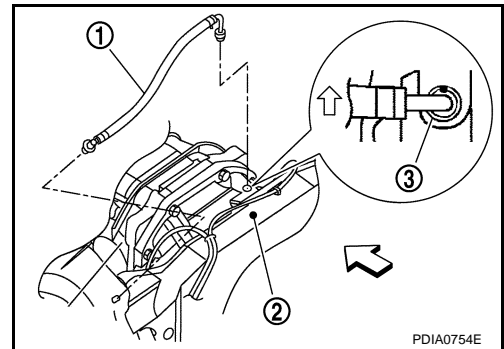
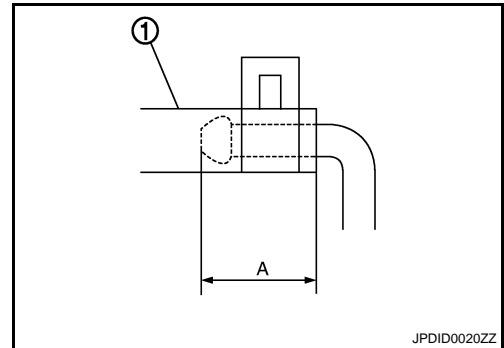

A
B
C
DLN
E
F
G
H
I
J
K
L
M
N
O
P

DIFFERENTIAL ASSEMBLY

< UNIT DISASSEMBLY AND ASSEMBLY >

[REAR FINAL DRIVE: R200V]

UNIT DISASSEMBLY AND ASSEMBLY

DIFFERENTIAL ASSEMBLY

M/T

M/T : Exploded View

INFOID:000000005649806

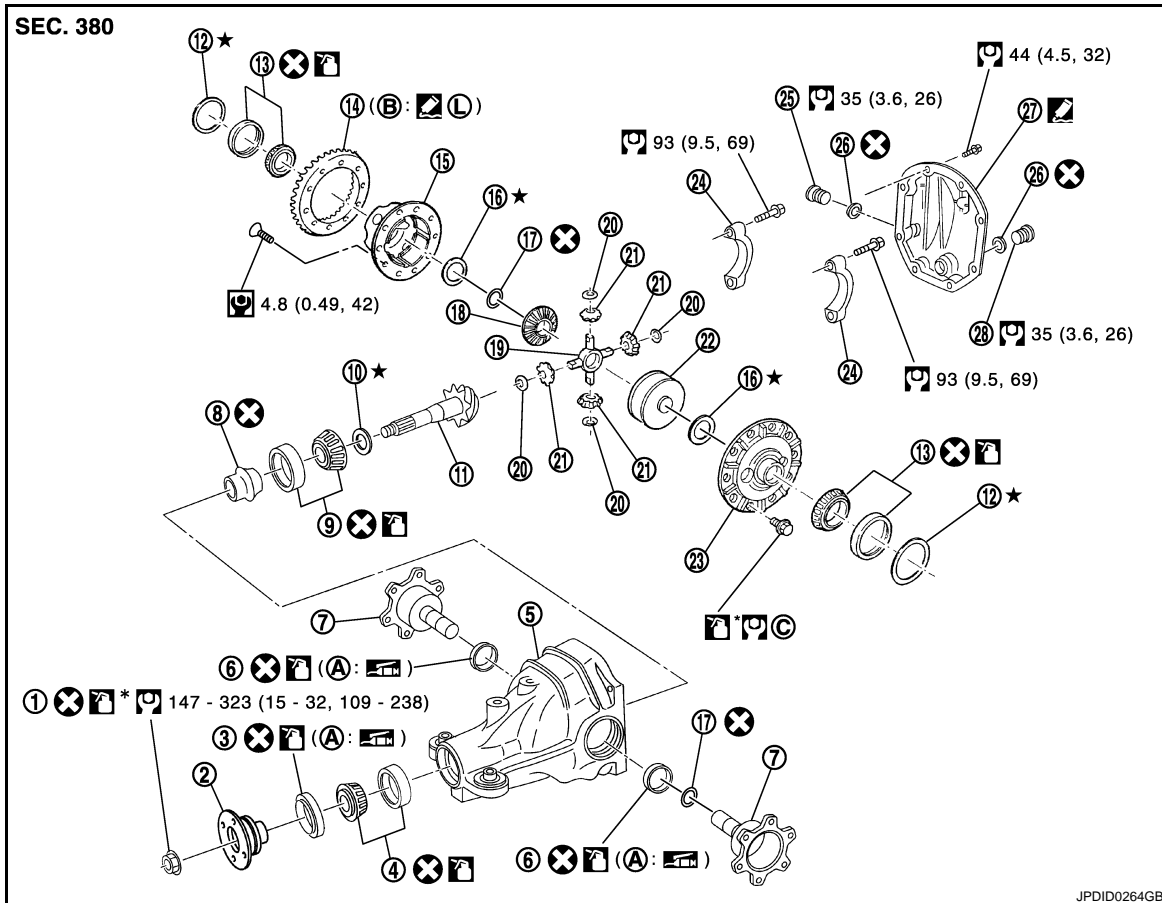

- | | | |
|------------------------------------|-------------------------------|-----------------------------------|
| 1. Drive pinion lock nut | 2. Companion flange | 3. Front oil seal |
| 4. Pinion front bearing | 5. Gear carrier | 6. Side oil seal |
| 7. Side flange | 8. Collapsible spacer | 9. Pinion rear bearing |
| 10. Pinion height adjusting washer | 11. Drive pinion | 12. Side bearing adjusting washer |
| 13. Side bearing | 14. Drive gear | 15. Differential case B |
| 16. Side gear thrust washer | 17. Circular clip | 18. Side gear |
| 19. Pinion mate shaft | 20. Pinion mate thrust washer | 21. Pinion mate gear |
| 22. Viscous coupling | 23. Differential case A | 24. Bearing cap |
| 25. Filler plug | 26. Gasket | 27. Rear cover |
| 28. Drain plug | | |
- A. Oil seal lip B. Screw hole C. Comply with the assembly procedure when tightening. Refer to [DLN-255, "M/T : Assembly"](#).



Apply gear oil.



Apply anti-corrosion oil.



Apply Genuine Silicone RTV or equivalent. Refer to [GI-18, "Recommended Chemical Products and Sealants"](#).

DIFFERENTIAL ASSEMBLY

< UNIT DISASSEMBLY AND ASSEMBLY >

[REAR FINAL DRIVE: R200V]

 Apply Genuine High Strength Thread Locking Sealant or equivalent. Refer to [GI-18. "Recommended Chemical Products and Sealants"](#).

Refer to [GI-4. "Components"](#) for symbols not described on the above.

M/T : Disassembly

INFOID:000000005649807

1. Drain gear oil, if necessary.
2. Remove side flange.
3. Remove rear cover mounting bolts.
4. Remove rear cover to insert the seal cutter (A) [SST: KV10111100 (J-37228)] between gear carrier and rear cover.

CAUTION:

- Never damage the mating surface.
- Never insert flat-bladed screwdriver, this may damage the mating surface.

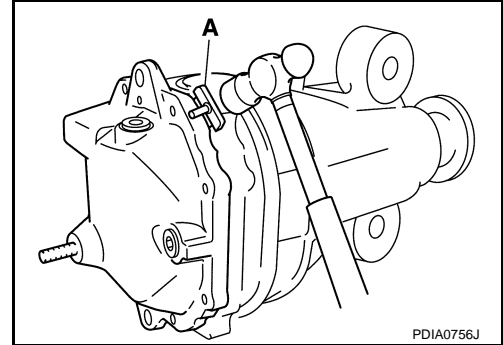

5. Using two 45 mm (1.77 in) spacers, mount carrier on the attachment (A) [SST: KV38100800 (J-25604-01)].

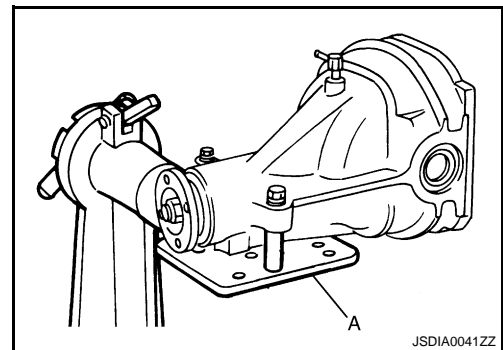

6. For proper reinstallation, paint matching marks on one side of the bearing cap.

CAUTION:

- For matching marks, use paint. Never damage bearing caps and gear carrier.
- Bearing caps are manufactured as integral molding. Use the matching marks to them in their original positions.

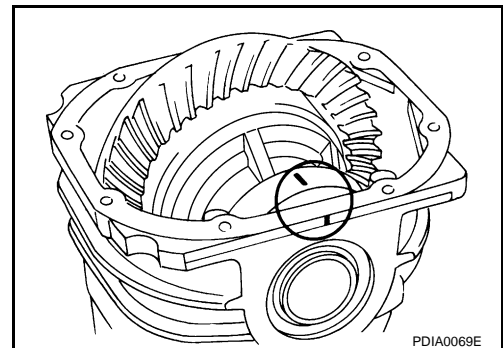

7. Remove bearing caps.

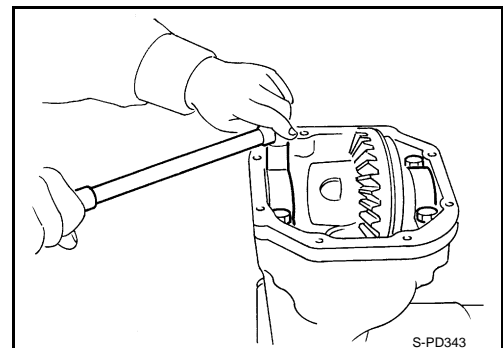

A

B

C

DLN

E

F

G

H

I

J

K

L

M

N

O

P

DIFFERENTIAL ASSEMBLY

< UNIT DISASSEMBLY AND ASSEMBLY >

[REAR FINAL DRIVE: R200V]

8. Lift differential case assembly out with a suitable tool.

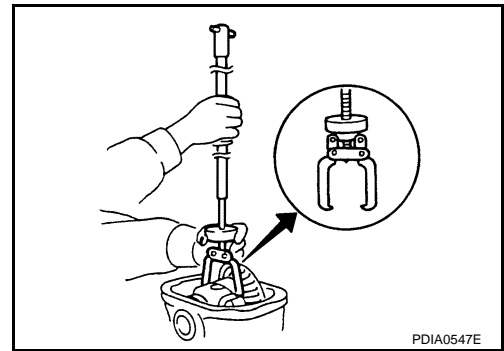

- Keep side bearing outer races together with inner race. Do not mix them up.
Also, keep side bearing adjusting washers together with bearings.

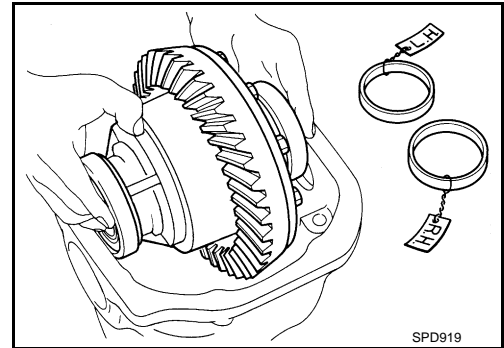

9. Remove side bearing inner race.
To prevent damage to bearing, engage puller jaws in groove (←).

A: Puller [SST: ST33051001 (J-22888-20)]

B: Base [SST: ST33061000 (J-8107-2)]

CAUTION:

- To prevent damage to the side bearing and drive gear, place copper plates between these parts and vise.
- It is not necessary to remove side bearing inner race except when it is replaced.

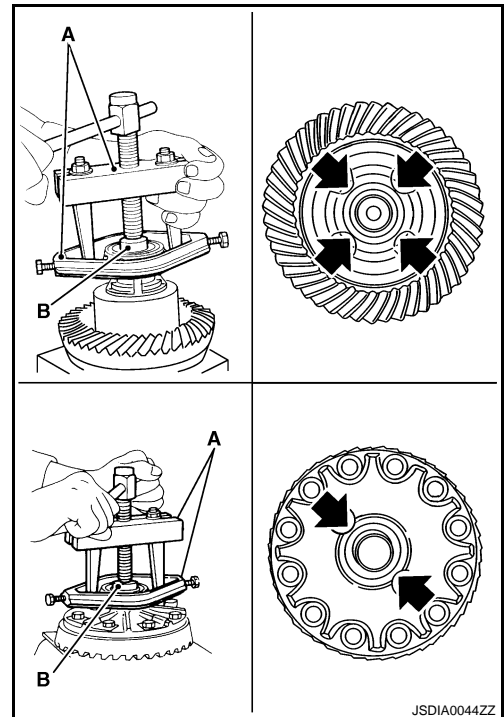

10. For proper reinstallation, paint matching marks on one differential case assembly.

CAUTION:

For matching marks, use paint. Never damage differential case and drive gear.

11. Remove drive gear mounting bolts.

12. Tap drive gear off differential case assembly with a soft hammer.

CAUTION:

Tap evenly all around to keep drive gear from bending.

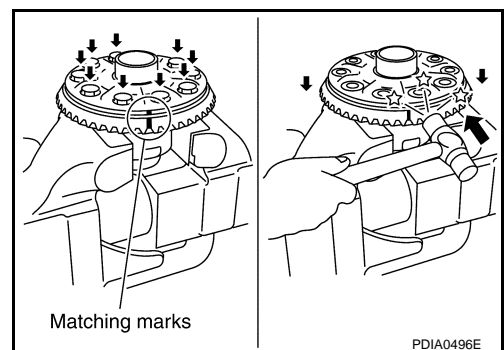

DIFFERENTIAL ASSEMBLY

< UNIT DISASSEMBLY AND ASSEMBLY >

[REAR FINAL DRIVE: R200V]

13. Put matching marks with paint.

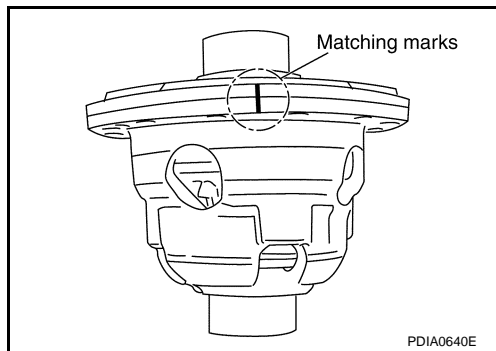

A
B
C

DLN

14. Loosen screws on differential cases A and B.

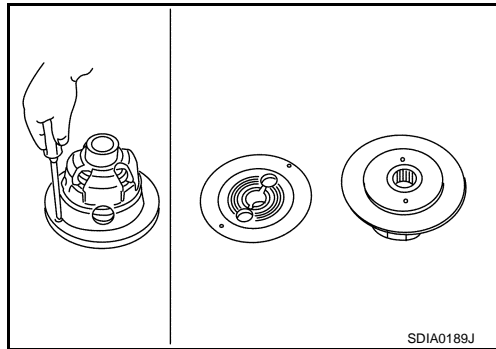

E
F
G

15. Separate differential case A and B, then remove viscous coupling, pinion mate gear, pinion mate thrust washer, side gear, pinion mate shaft, circular clip and side gear thrust washer from differential cases.

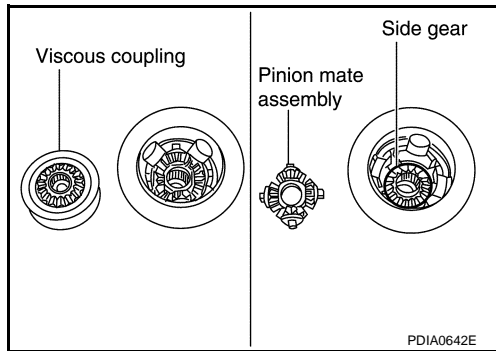

H
I
J

K

M/T : Assembly

INFOID:000000005649808

1. Install side gear thrust washer with the same thickness as the ones installed prior to disassembly or reinstall the old ones on the side gear.

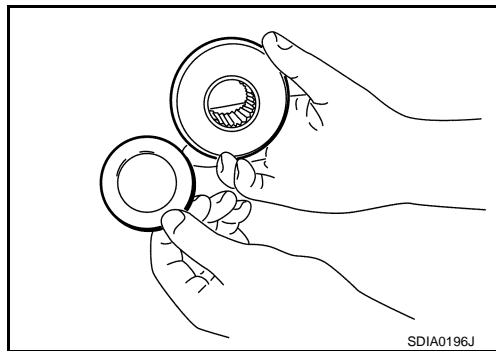

L
M
N

O

P

DIFFERENTIAL ASSEMBLY

< UNIT DISASSEMBLY AND ASSEMBLY >

[REAR FINAL DRIVE: R200V]

2. Install side gear and thrust washer into differential case B.
CAUTION:
Make sure that the circular clip is installed to side gear.
3. Install pinion mate assembly (pinion mate shaft, pinion mate gears and pinion mate thrust washers) into differential case B.
CAUTION:
Install the pinion mate shaft groove side to side gear.

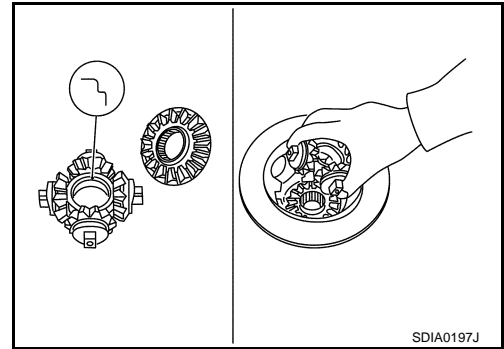

4. Install viscous coupling into differential case B.
5. Install side gear thrust washer with the same thickness as the ones installed prior to disassembly or reinstall the old ones on the viscous coupling.

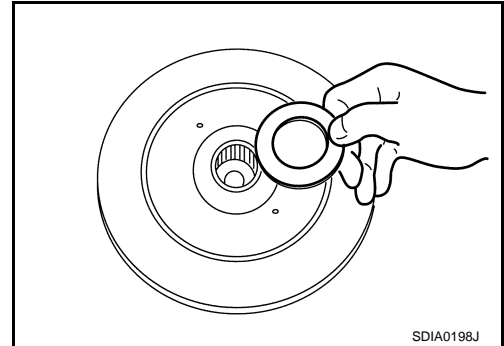

6. Align the matching marks and install differential case A into differential case B.

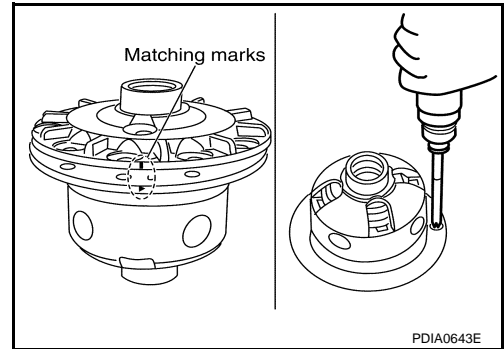

7. Measure side gear end play. If necessary, select the appropriate side gear thrust washer.
 - a. Place differential assembly so that right side gear is on the upper side.
 - b. Measure the clearance between right side gear back and differential case using feeler gauge, while rotating right side gear with a suitable tool attached to splines.

Standard

Side gear back clearance : Refer to [DLN-295, "Differential Side Gear Clearance"](#).

CAUTION:

- Never place feeler gauge at groove side of differential case.
 - To prevent side gear from tilting, insert feeler gauges with the same thickness from both sides.
- c. If the back clearance is outside the specification, use a thicker/thinner side gear thrust washer to adjust.

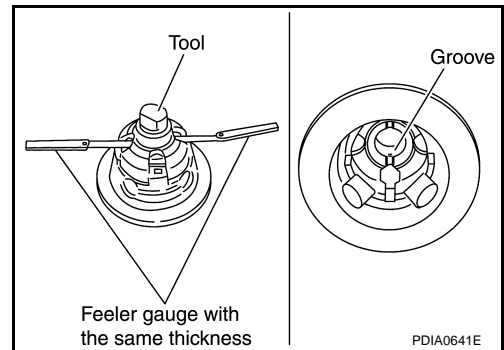

When the back clearance is large: Use a thicker thrust washer.

When the back clearance is small: Use a thinner thrust washer.

CAUTION:

DIFFERENTIAL ASSEMBLY

< UNIT DISASSEMBLY AND ASSEMBLY >

[REAR FINAL DRIVE: R200V]

- Adjust the clearance with the left side gear thrust washer only.
- Only one side gear thrust washer can be selected.

8. Align the matching mark of differential case with the mark of drive gear, then place drive gear.

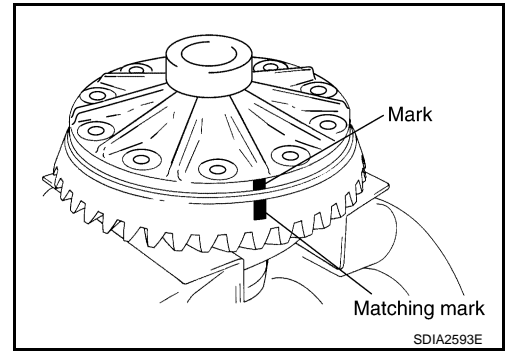

9. Apply thread locking sealant into the thread hole of drive gear. Use Genuine High Strength Thread Locking Sealant or equivalent. Refer to [GI-18, "Recommended Chemical Products and Sealants"](#).

CAUTION:

Clean and degrease drive gear back and threaded holes sufficiently.

10. Install the drive gear to differential case.

CAUTION:

Align the matching marks of differential case and drive gear.

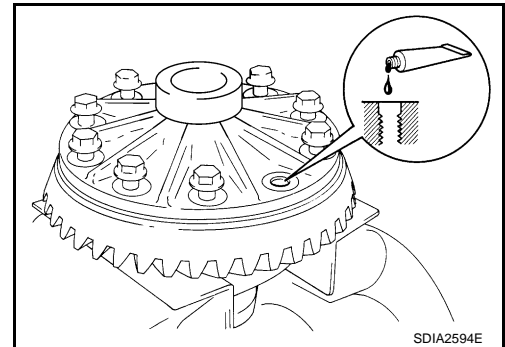

11. Tighten the mounting bolts with the following procedure.

CAUTION:

Apply anti-corrosion oil to the thread and seat of mounting bolts.

a. Tighten the bolts in a crisscross fashion to the specified torque.

Drive gear mounting bolts tightening torque : 78.5 N•m (8.0 kg-m, 58 ft-lb)

b. Tighten the bolts additionally at the specified angle.

Drive gear mounting bolts tightening angle : 31 to 36 degree

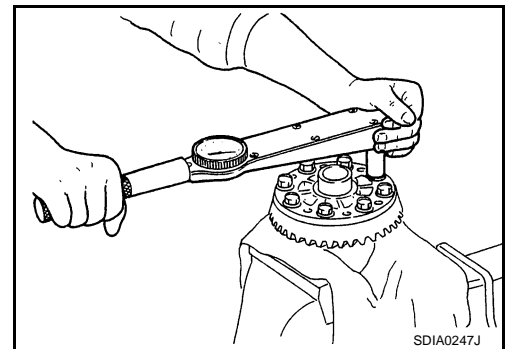

CAUTION:

Check the tightening angle using the angle wrench [SST: KV10112100(BT-8653-A)]. Never make judgment by visual inspection.

12. Press side bearing inner races to differential case, using the drift (A) [SST: KV38100300 (J-25523)] and the base (B) [SST: ST33061000 (J-8107-2)].

CAUTION:

Never reuse side bearing inner race.

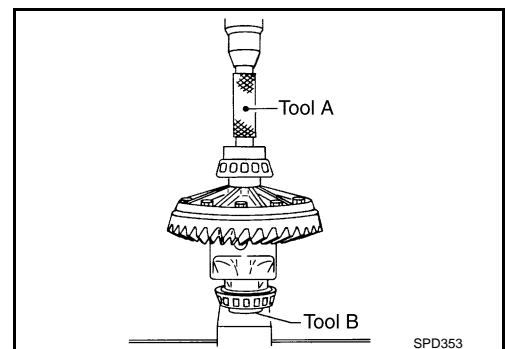

A
B
C
DLN
E
F
G
H
I
J
K
L
M
N
O
P

DIFFERENTIAL ASSEMBLY

< UNIT DISASSEMBLY AND ASSEMBLY >

[REAR FINAL DRIVE: R200V]

13. Install differential case assembly with side bearing outer races into gear carrier.
14. Measure side bearing preload. If necessary, select the appropriate side bearing adjusting washers. Refer to [DLN-259, "M/T : Adjustment"](#).

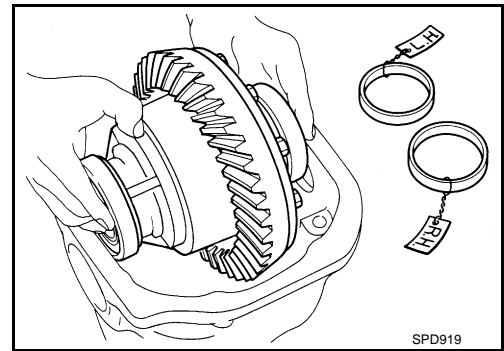

15. Insert selected left and right side bearing adjusting washers in place between side bearings and gear carrier. Refer to [DLN-259, "M/T : Adjustment"](#).

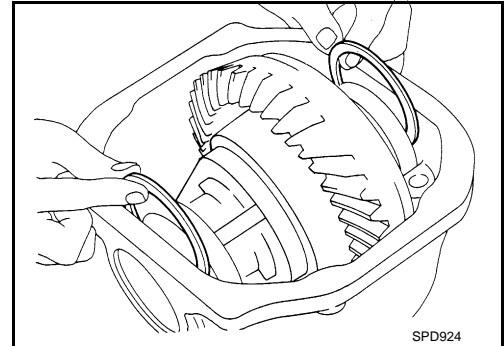

16. Align matching marks on bearing cap with that on gear carrier.
17. Install bearing caps and tighten bearing cap mounting bolts.

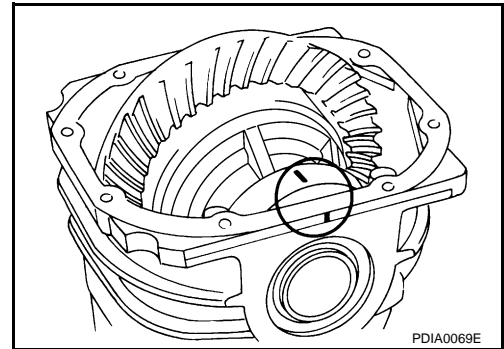

18. Using the drift [SST: KV38100200 (J-26233)], drive side oil seals until it becomes flush with the case end.

CAUTION:

- Never reuse oil seal.
- When installing, never incline oil seal.
- Apply multi-purpose grease onto oil seal lips, and gear oil onto the circumference of oil seal.

19. Check and adjust drive gear runout, tooth contact, drive gear to drive pinion backlash, and total preload torque. Refer to [DLN-259, "M/T : Adjustment"](#).

Recheck above items. Readjust the above description, if necessary.

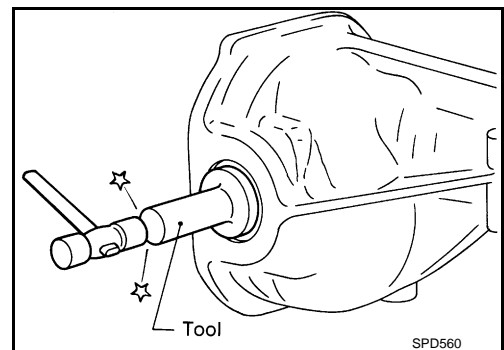

20. Apply sealant to mating surface of rear cover. Use Genuine Silicone RTV or equivalent. Refer to [GI-18, "Recommended Chemical Products and Sealants"](#).

CAUTION:

Remove old sealant adhering to mounting surfaces. Also remove any moisture, oil, or foreign material adhering to application and mounting surfaces.

21. Install rear cover on gear carrier and tighten mounting bolts.

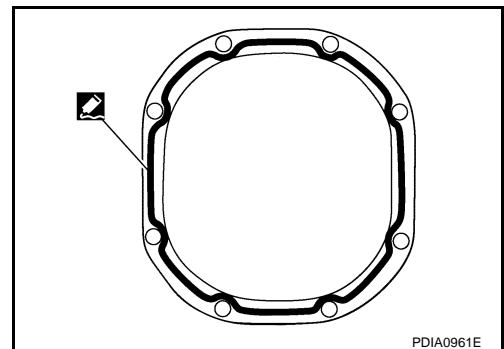

DIFFERENTIAL ASSEMBLY

< UNIT DISASSEMBLY AND ASSEMBLY >

[REAR FINAL DRIVE: R200V]

22. Install side flange with the following procedure.

- a. Attach the protector [SST: KV38107900 (J-39352)] to side oil seal.
- b. After the side flange is inserted and the serrated part of side gear has engaged the serrated part of flange, remove the protector.

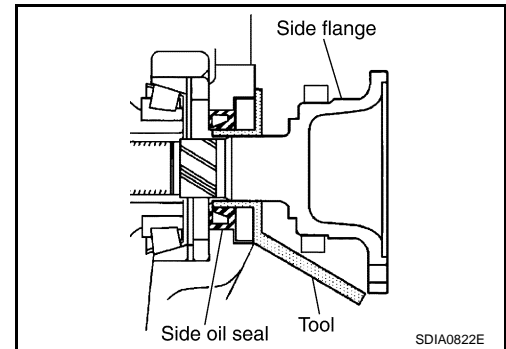

c. Put a suitable drift on the center of side flange, then drive it until sound changes.

NOTE:

When installation is completed, driving sound of the side flange turns into a sound that seems to affect the whole final drive.

d. Confirm that the dimension of the side flange (1) installation (Measurement A) in the figure comes into the following.

Measurement "A" : 326 – 328 mm (12.83 – 12.91 in)

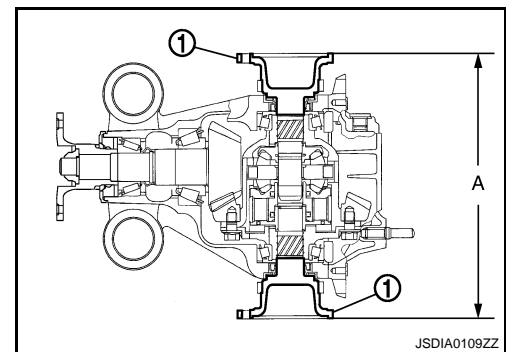

M/T : Adjustment

TOTAL PRELOAD TORQUE

• Before inspection and adjustment, drain gear oil.

1. Secure final drive assembly onto an attachment [SST: KV38100800 (J-25604-01)].
2. Remove side flanges.
3. Rotate drive pinion back and forth 2 to 3 times to check for unusual noise and rotation malfunction.
4. Rotate drive pinion at least 20 times to check for smooth operation of the bearing.
5. Measure total preload with the preload gauge (A) [SST: ST3127S000 (J-25765-A)].

Standard

Total preload torque : Refer to [DLN-295, "Pre-load Torque"](#).

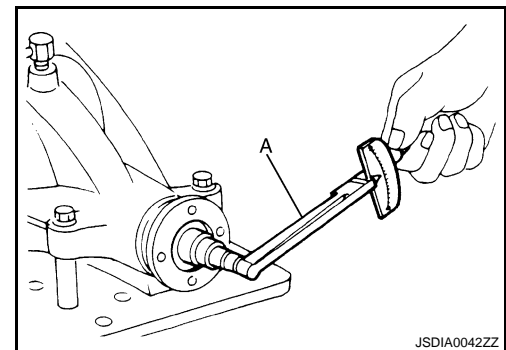

NOTE:

Total preload torque = Pinion bearing preload torque + Side bearing preload torque

- If measured value is out of the specification, disassemble it to check and adjust each part. Adjust the pinion bearing preload and side bearing preload. Adjust the pinion bearing preload first, then adjust the side bearing preload.

When the preload torque is large

On pinion bearings: Replace the collapsible spacer.

On side bearings: Use thinner side bearing adjusting washers by the same amount to each side.

A
B
C
DLN
E
F
G
H
I
J
K
L
M
N
O
P

DIFFERENTIAL ASSEMBLY

< UNIT DISASSEMBLY AND ASSEMBLY >

[REAR FINAL DRIVE: R200V]

When the preload is small

On pinion bearings: Tighten the drive pinion lock nut.

On side bearings: Use thicker side bearing adjusting washers by the same amount to each side.

SIDE BEARING PRELOAD

- Before inspection and adjustment, drain gear oil.
1. Remove rear cover. Refer to [DLN-253, "M/T : Disassembly"](#).
 2. Make sure all parts are clean. Also, make sure the bearings are well lubricated with gear oil.
 3. Place the differential case, with side bearings and bearing races installed, into gear carrier.
 4. Insert left and right original side bearing adjusting washers in place between side bearings and gear carrier.
 5. Install bearing caps in their correct locations and tighten bearing cap mounting bolts.
 6. Turn the carrier several times to seat the bearings.
 7. Measure the turning torque of the carrier at the drive gear mounting bolts with a spring gauge [SST: — (J-8129)].

Specification

: 34.2 – 39.2 N (3.5 – 4.0 kg, 7.7 – 8.8 lb) of pulling force at the drive gear bolt

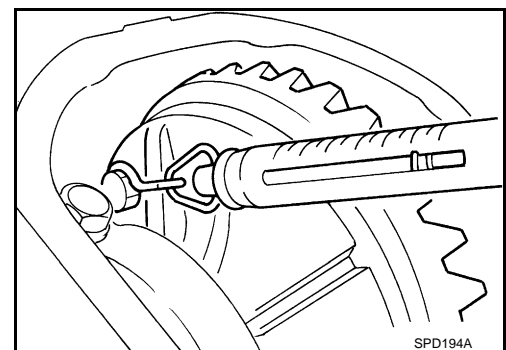
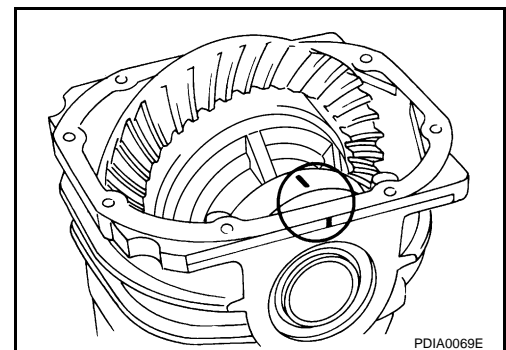
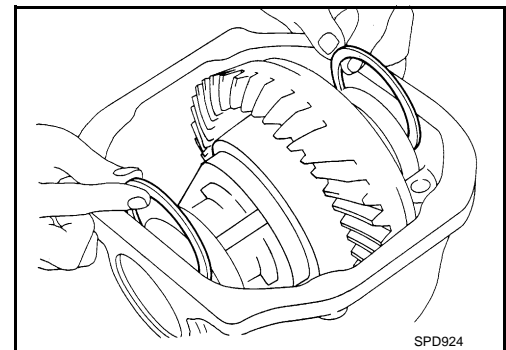
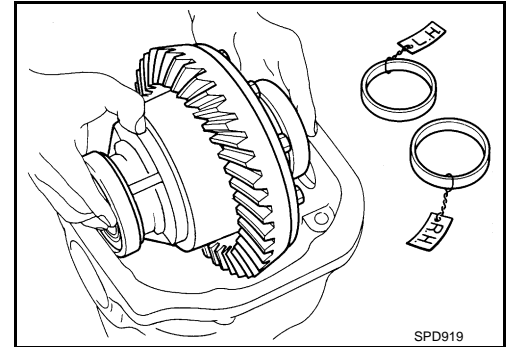

DIFFERENTIAL ASSEMBLY

< UNIT DISASSEMBLY AND ASSEMBLY >

[REAR FINAL DRIVE: R200V]

8. If the turning torque is outside the specification, use a thicker/thinner side bearing adjusting washer to adjust.

If the turning torque is less than the specified range:

Use a thicker thrust washer.

If the turning torque is greater than the specification:

Use a thinner thrust washer.

CAUTION:

Select a side bearing adjusting washer for right and left individually.

9. Record the total amount of washer thickness required for the correct carrier side bearing preload.

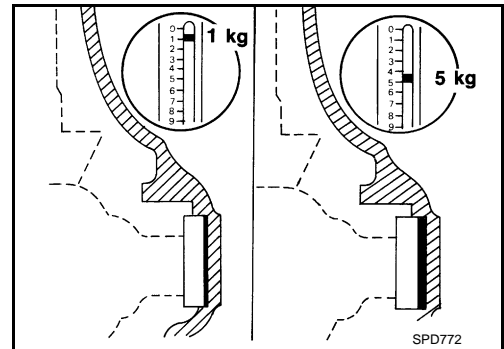

DRIVE GEAR RUNOUT

1. Remove rear cover. Refer to [DLN-253, "M/T : Disassembly"](#).
2. Fit a dial indicator to the drive gear back face.
3. Rotate the drive gear to measure runout.

Limit

Drive gear runout : Refer to [DLN-295, "Drive Gear Runout"](#).

- If the runout is outside of the repair limit, check drive gear assembly condition; foreign material may be caught between drive gear and differential case, or differential case or drive gear may be deformed, etc.

CAUTION:

Replace drive gear and drive pinion gear as a set.

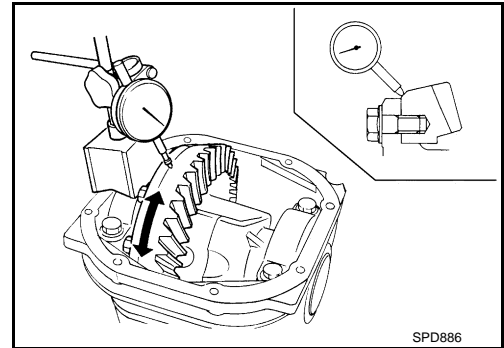

TOOTH CONTACT

- Before inspection and adjustment, drain gear oil.
1. Remove rear cover. Refer to [DLN-253, "M/T : Disassembly"](#).
 2. Apply red lead to drive gear.

CAUTION:

Apply red lead to both the faces of 3 to 4 gears at 4 locations evenly spaced on drive gear.

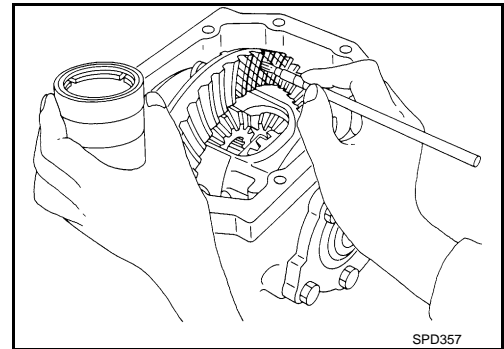

3. Rotate drive gear back and forth several times, check drive pinion gear to drive gear tooth contact.

CAUTION:

Check tooth contact on drive side and reverse side.

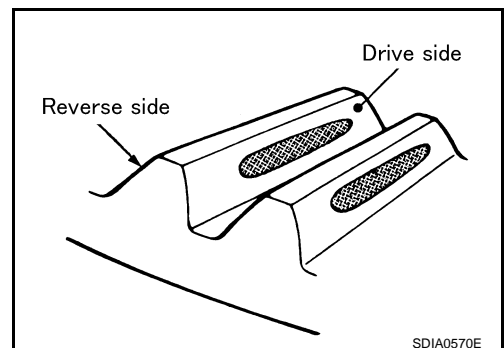









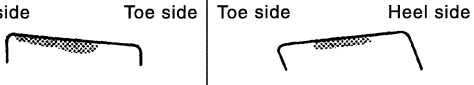
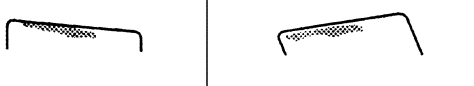

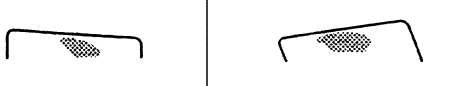

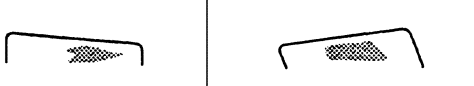
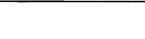
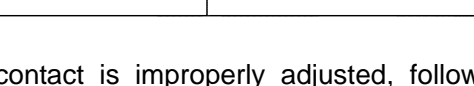
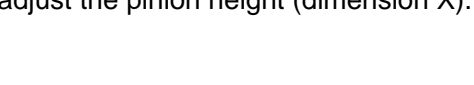
A
B
C
DLN
E
F
G
H
I
J
K
L
M
N
O
P

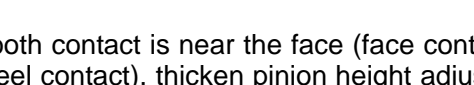
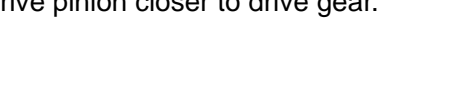
DIFFERENTIAL ASSEMBLY

< UNIT DISASSEMBLY AND ASSEMBLY >

[REAR FINAL DRIVE: R200V]

Tooth contact condition		Pinion height adjusting washer selection valve [mm (in)]	Adjustment (Yes/No)	Possible cause	
Drive side	Back side				
Heel side 	Toe side 	↑ Thicker	Yes	Occurrence of noise and scoring sound in all speed ranges.	
				+0.09 (+0.0035)	Occurrence of noise when accelerating.
				+0.06 (+0.0024)	
		↓ Thinner	No	-	
				+0.03 (+0.0012)	
				0	
				-0.03 (-0.0012)	
		-0.06 (-0.0024)	Yes	Occurrence of noise at constant speed and decreasing speed.	
		-0.09 (-0.0035)		Occurrence of noise and scoring sound in all speed ranges.	

SDIA0207E

4. If tooth contact is improperly adjusted, follow the procedure below to adjust the pinion height (dimension X).

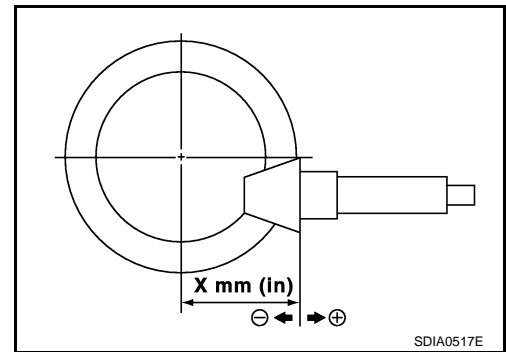

- If the tooth contact is near the face (face contact), or near the heel (heel contact), thicken pinion height adjusting washers to move drive pinion closer to drive gear.

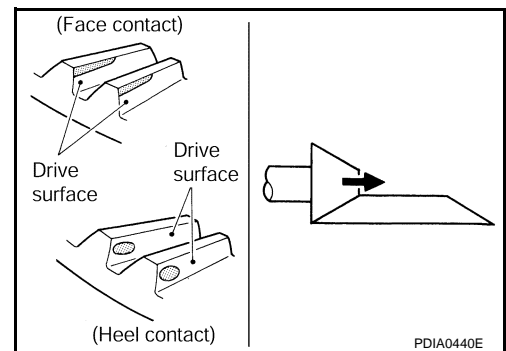

DIFFERENTIAL ASSEMBLY

< UNIT DISASSEMBLY AND ASSEMBLY >

[REAR FINAL DRIVE: R200V]

- If the tooth contact is near the flank (flank contact), or near the toe (toe contact), thin pinion height adjusting washers to move drive pinion farther from drive gear.

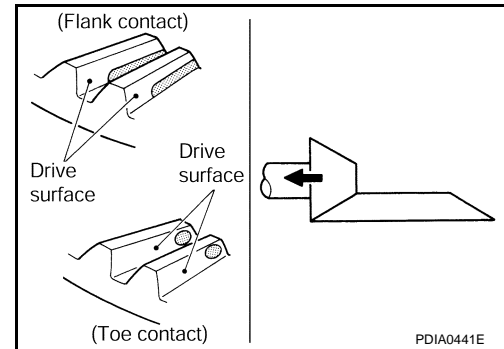

BACKLASH

- Before inspection and adjustment, drain gear oil.
1. Remove rear cover. Refer to [DLN-253. "M/T : Disassembly"](#).
 2. Fit a dial indicator to the drive gear face to measure the backlash.

**Standard
Backlash**

: Refer to [DLN-295. "Backlash"](#).

- If the backlash is outside of the specified value, change the thickness of side bearing adjusting washer.

When the backlash is large:

**Make drive gear back side adjusting washer thicker,
and drive gear tooth side adjusting washer thinner by
the same amount.**

When the backlash is small:

**Make drive gear back side adjusting washer thinner,
and drive gear tooth side adjusting washer thicker by
the same amount.**

CAUTION:

Never change the total amount of washers as it changes the bearing preload.

M/T : Inspection After Disassembly

INFOID:000000005649810

DRIVE GEAR AND DRIVE PINION

- Clean up the disassembled parts.
- If the gear teeth never mesh or line-up correctly, determine the cause and adjust or replace as necessary.
- If the gears are worn, cracked, damaged, pitted or chipped (by friction) noticeably, replace with new drive gear and drive pinion as a set.

BEARING

- Clean up the disassembled parts.
- If any chipped (by friction), pitted, worn, rusted or scratched marks, or unusual noise from the bearing is observed, replace as a bearing assembly (as a new set).

SIDE GEAR AND PINION MATE GEAR

- Clean up the disassembled parts.
- If any cracks or damage on the surface of the tooth is found, replace.
- If any worn or chipped mark on the contact sides of the thrust washer is found, replace.

SIDE GEAR THRUST WASHER AND PINION MATE THRUST WASHER

- Clean up the disassembled parts.
- If it is chipped (by friction), damaged, or unusually worn, replace.

OIL SEAL

- Whenever disassembled, replace.

A
B
C
DLN

E
F
G
H
I
J
K

L
M
N
O
P

DIFFERENTIAL ASSEMBLY

< UNIT DISASSEMBLY AND ASSEMBLY >

[REAR FINAL DRIVE: R200V]

- If wear, deterioration of adherence (sealing force lips), or damage is detected on the lips, replace them.

DIFFERENTIAL CASE

- Clean up the disassembled parts.
- If any wear or crack on the contact sides of the differential case is found, replace.

COMPANION FLANGE

- Clean up the disassembled parts.
- If any chipped mark [about 0.1 mm, (0.004 in)] or other damage on the contact sides of the lips of the companion flange is found, replace.

A/T

A/T : Exploded View

INFOID:000000005649811

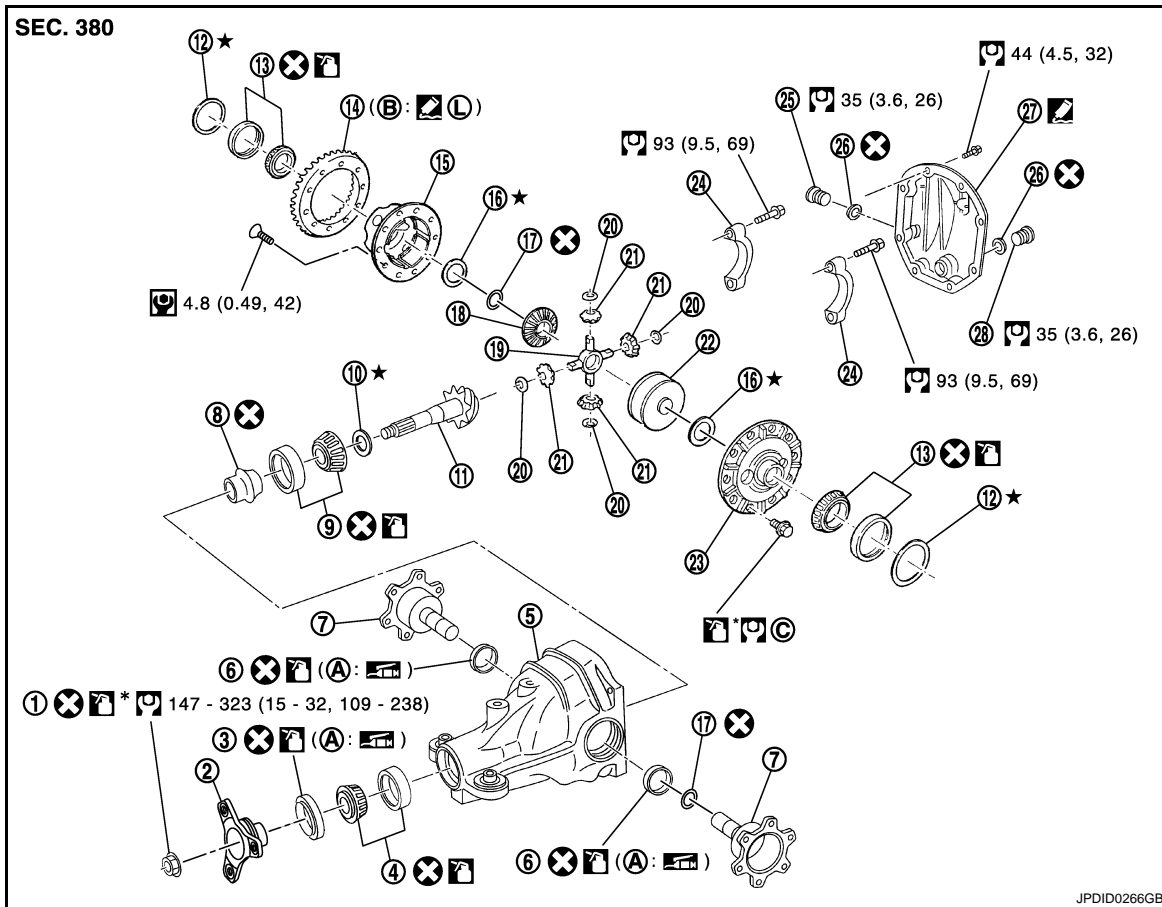





JPDID0266GB

- | | | |
|------------------------------------|-------------------------------|-----------------------------------|
| 1. Drive pinion lock nut | 2. Companion flange | 3. Front oil seal |
| 4. Pinion front bearing | 5. Gear carrier | 6. Side oil seal |
| 7. Side flange | 8. Collapsible spacer | 9. Pinion rear bearing |
| 10. Pinion height adjusting washer | 11. Drive pinion | 12. Side bearing adjusting washer |
| 13. Side bearing | 14. Drive gear | 15. Differential case B |
| 16. Side gear thrust washer | 17. Circular clip | 18. Side gear |
| 19. Pinion mate shaft | 20. Pinion mate thrust washer | 21. Pinion mate gear |
| 22. Viscous coupling | 23. Differential case A | 24. Bearing cap |
| 25. Filler plug | 26. Gasket | 27. Rear cover |
| 28. Drain plug | | |
- A. Oil seal lip
B. Screw hole
C. Comply with the assembly procedure when tightening. Refer to [DLN-268, "A/T : Assembly"](#).

DIFFERENTIAL ASSEMBLY

< UNIT DISASSEMBLY AND ASSEMBLY >

[REAR FINAL DRIVE: R200V]

-  Apply gear oil.
 - *: Apply anti-corrosion oil.
 -  Apply Genuine Silicone RTV or equivalent. Refer to [GI-18, "Recommended Chemical Products and Sealants"](#).
 - L: Apply Genuine High Strength Thread Locking Sealant or equivalent. Refer to [GI-18, "Recommended Chemical Products and Sealants"](#).
- Refer to [GI-4, "Components"](#) for symbols not described on the above.

A/T : Disassembly

INFOID:000000005649812

1. Drain gear oil, if necessary.
2. Remove side flange.
3. Remove rear cover mounting bolts.
4. Remove rear cover to insert the seal cutter (A) [SST: KV10111100 (J-37228)] between gear carrier and rear cover.

CAUTION:

- Never damage the mating surface.
- Never insert flat-bladed screwdriver, this may damage the mating surface.

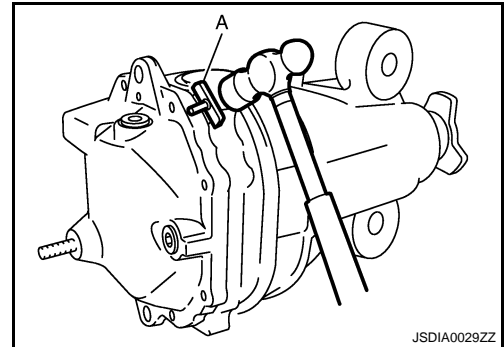

5. Using two 45 mm (1.77 in) spacers, mount carrier on the attachment (A) [SST: KV38100800 (J-25604-01)].

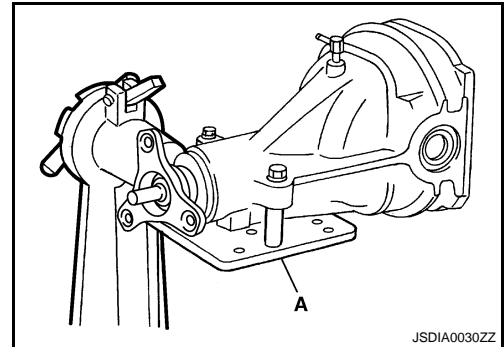

6. For proper reinstallation, paint matching marks on one side of the bearing cap.

CAUTION:

- For matching marks, use paint. Never damage bearing caps and gear carrier.
- Bearing caps are manufactured as integral molding. Use the matching marks to them in their original positions.

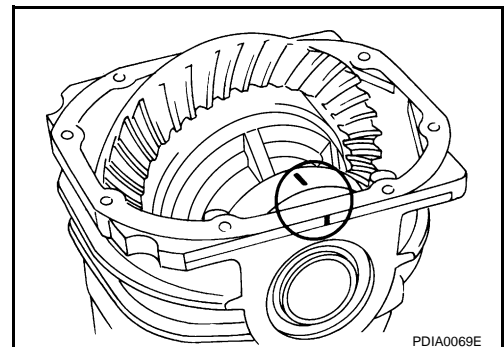

A
B
C
DLN
E
F
G
H
I
J
K
L
M
N
O
P

DIFFERENTIAL ASSEMBLY

< UNIT DISASSEMBLY AND ASSEMBLY >

[REAR FINAL DRIVE: R200V]

7. Remove bearing caps.

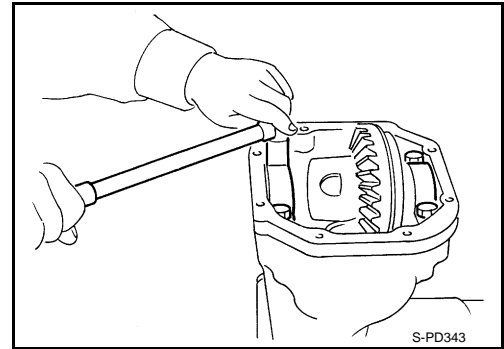

8. Lift differential case assembly out with a suitable tool.

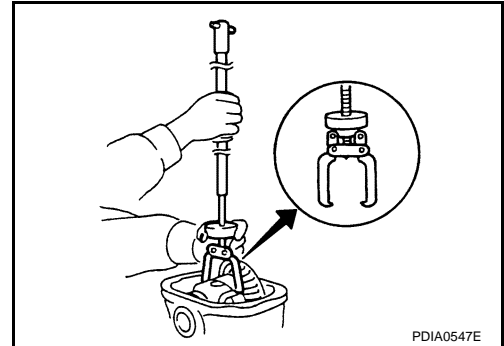

- Keep side bearing outer races together with inner race. Do not mix them up.
Also, keep side bearing adjusting washers together with bearings.

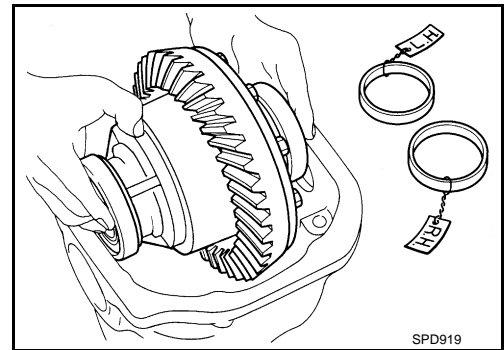

9. Remove side bearing inner race.
To prevent damage to bearing, engage puller jaws in groove (←).

A: Puller [SST: ST33051001 (J-22888-20)]

B: Base [SST: ST33061000 (J-8107-2)]

CAUTION:

- To prevent damage to the side bearing and drive gear, place copper plates between these parts and vise.
- It is not necessary to remove side bearing inner race except when it is replaced.

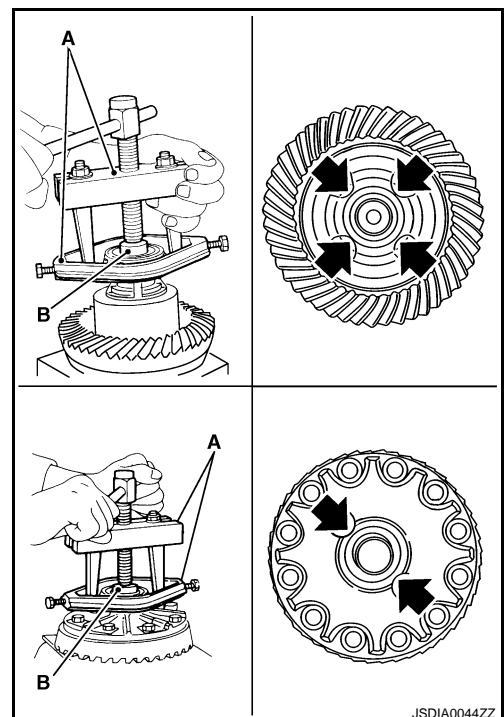

DIFFERENTIAL ASSEMBLY

< UNIT DISASSEMBLY AND ASSEMBLY >

[REAR FINAL DRIVE: R200V]

10. For proper reinstallation, paint matching marks on one differential case assembly.

CAUTION:

For matching marks, use paint. Never damage differential case and drive gear.

11. Remove drive gear mounting bolts.

12. Tap drive gear off differential case assembly with a soft hammer.

CAUTION:

Tap evenly all around to keep drive gear from bending.

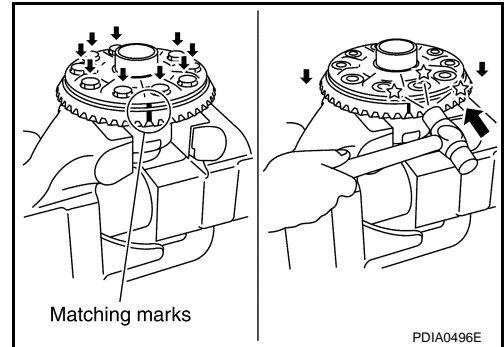

13. Put matching marks with paint.

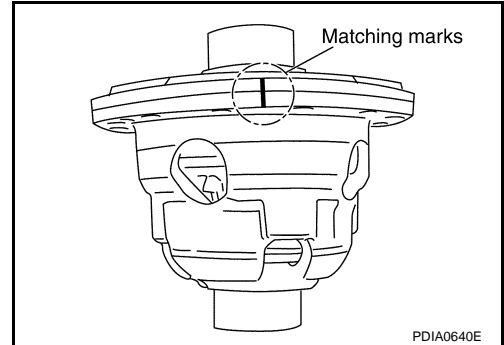

14. Loosen screws on differential cases A and B.

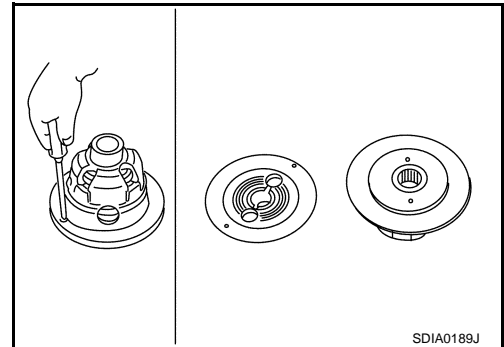

15. Separate differential case A and B, then remove viscous coupling, pinion mate gear, pinion mate thrust washer, side gear, pinion mate shaft, circular clip and side gear thrust washer from differential cases.

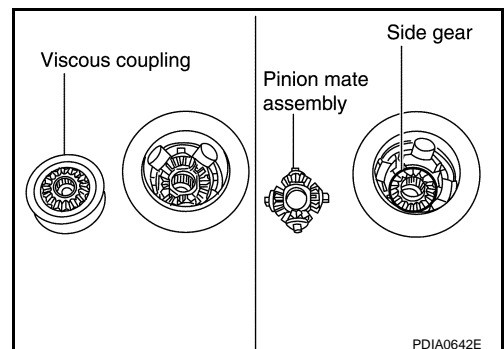

A
B
C
DLN
E
F
G
H
I
J
K
L
M
N
O
P

DIFFERENTIAL ASSEMBLY

< UNIT DISASSEMBLY AND ASSEMBLY >

[REAR FINAL DRIVE: R200V]

A/T : Assembly

INFOID:000000005649813

1. Install side gear thrust washer with the same thickness as the ones installed prior to disassembly or reinstall the old ones on the side gear.

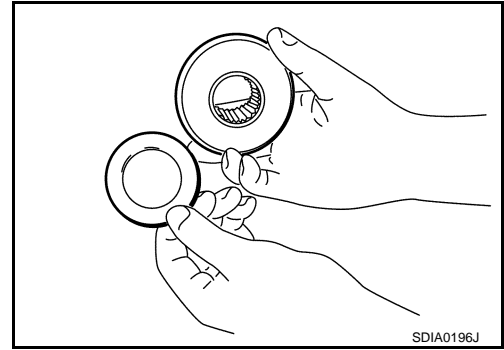

2. Install side gear and thrust washer into differential case B.
CAUTION:
Make sure that the circular clip is installed to side gear.
3. Install pinion mate assembly (pinion mate shaft, pinion mate gears and pinion mate thrust washers) into differential case B.
CAUTION:
Install the pinion mate shaft groove side to side gear.

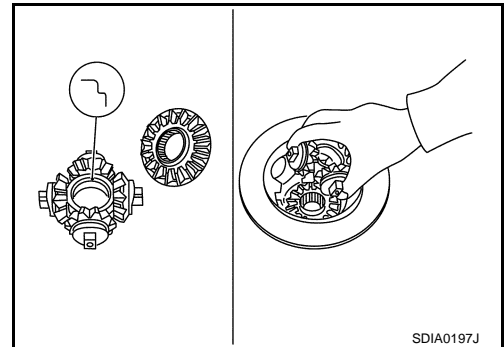

4. Install viscous coupling into differential case B.
5. Install side gear thrust washer with the same thickness as the ones installed prior to disassembly or reinstall the old ones on the viscous coupling.

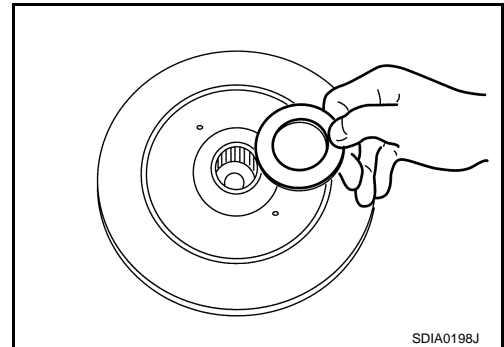

6. Align the matching marks and install differential case A into differential case B.

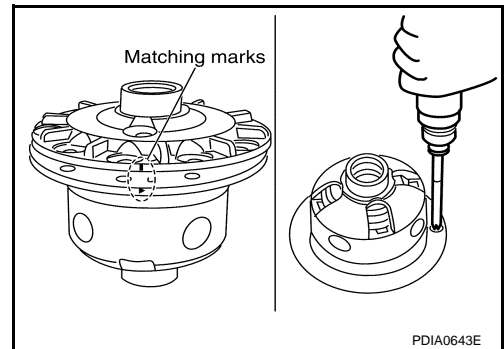

7. Measure side gear end play. If necessary, select the appropriate side gear thrust washer.
 - a. Place differential assembly so that right side gear is on the upper side.

DIFFERENTIAL ASSEMBLY

< UNIT DISASSEMBLY AND ASSEMBLY >

[REAR FINAL DRIVE: R200V]

- b. Measure the clearance between right side gear back and differential case using feeler gauge, while rotating right side gear with a suitable tool attached to splines.

Standard

Side gear back clearance : Refer to [DLN-295. "Differential Side Gear Clearance"](#).

CAUTION:

- Never place feeler gauge at groove side of differential case.
- To prevent side gear from tilting, insert feeler gauges with the same thickness from both sides.

- c. If the back clearance is outside the specification, use a thicker/thinner side gear thrust washer to adjust.

When the back clearance is large: Use a thicker thrust washer.

When the back clearance is small: Use a thinner thrust washer.

CAUTION:

- Adjust the clearance with the left side gear thrust washer only.
- Only one side gear thrust washer can be selected.

8. Align the matching mark of differential case with the mark of drive gear, then place drive gear.

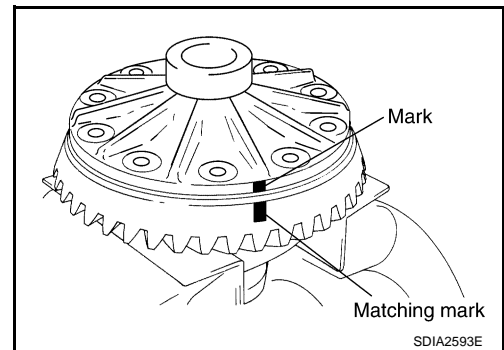
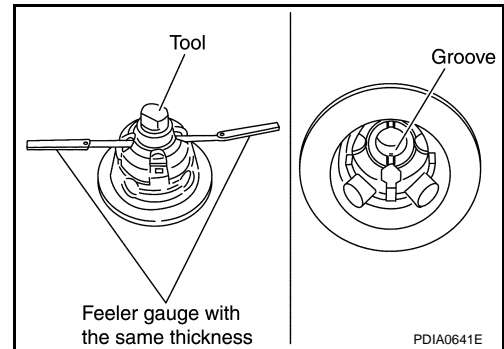

9. Apply thread locking sealant into the thread hole of drive gear. Use Genuine High Strength Thread Locking Sealant or equivalent. Refer to [GI-18. "Recommended Chemical Products and Sealants"](#).

CAUTION:

Clean and degrease drive gear back and threaded holes sufficiently.

10. Install the drive gear to differential case.

CAUTION:

Align the matching marks of differential case and drive gear.

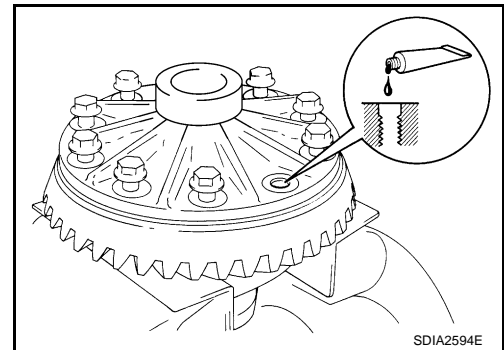

11. Tighten the mounting bolts with the following procedure.

CAUTION:

Apply anti-corrosion oil to the thread and seat of mounting bolts.

- a. Tighten the bolts in a crisscross fashion to the specified torque.

Drive gear mounting bolts tightening torque : 78.5 N•m (8.0 kg-m, 58 ft-lb)

- b. Tighten the bolts additionally at the specified angle.

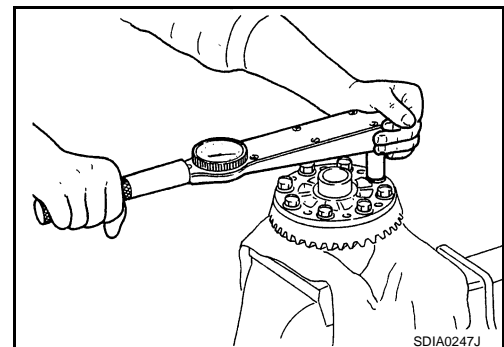

A

B

C

DLN

E

F

G

H

I

J

K

L

M

N

O

P

DIFFERENTIAL ASSEMBLY

< UNIT DISASSEMBLY AND ASSEMBLY >

[REAR FINAL DRIVE: R200V]

Drive gear mounting bolts tightening angle : 31 to 36 degree

CAUTION:

Check the tightening angle using the angle wrench [SST: KV10112100(BT-8653-A)]. Never make judgment by visual inspection.

12. Press side bearing inner races to differential case, using the drift (A) [SST: KV38100300 (J-25523)] and the base (B) [SST: ST33061000 (J-8107-2)].

CAUTION:

Never reuse side bearing inner race.

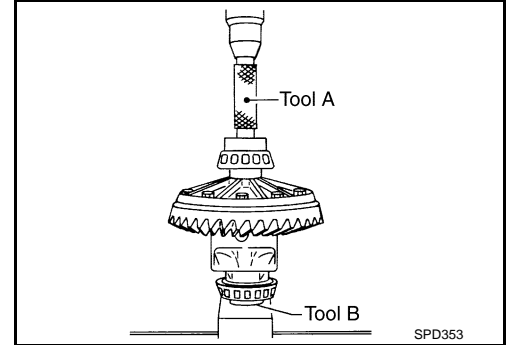

13. Install differential case assembly with side bearing outer races into gear carrier.
14. Measure side bearing preload. If necessary, select the appropriate side bearing adjusting washers. Refer to [DLN-271, "A/T: Adjustment"](#).

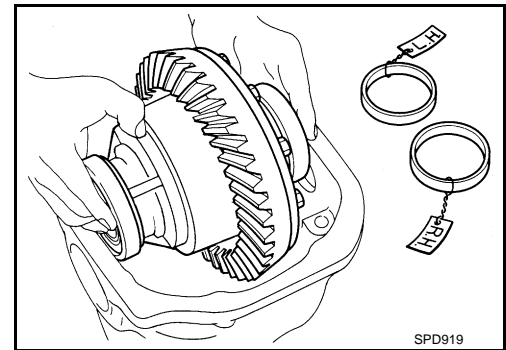

15. Insert selected left and right side bearing adjusting washers in place between side bearings and gear carrier.

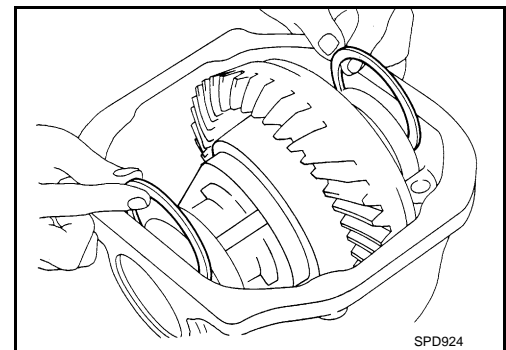

16. Align matching marks on bearing cap with that on gear carrier.
17. Install bearing caps and tighten bearing cap mounting bolts.

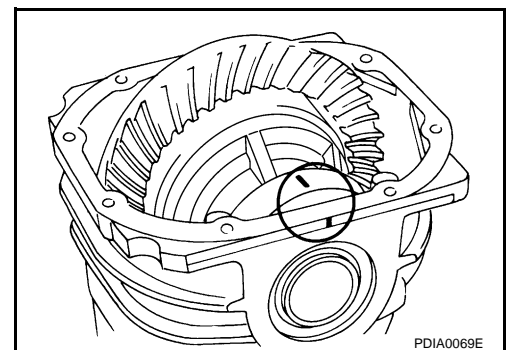

DIFFERENTIAL ASSEMBLY

< UNIT DISASSEMBLY AND ASSEMBLY >

[REAR FINAL DRIVE: R200V]

18. Using the drift [SST: KV38100200 (J-26233)], drive side oil seals until it becomes flush with the case end.

CAUTION:

- Never reuse oil seal.
- When installing, never incline oil seal.
- Apply multi-purpose grease onto oil seal lips, and gear oil onto the circumference of oil seal.

19. Check and adjust drive gear runout, tooth contact, drive gear to drive pinion backlash, and total preload torque. Refer to [DLN-271. "A/T : Adjustment"](#).

Recheck above items. Readjust the above description, if necessary.

20. Apply sealant to mating surface of rear cover. Use Genuine Silicone RTV or equivalent. Refer to [GI-18. "Recommended Chemical Products and Sealants"](#).

CAUTION:

Remove old sealant adhering to mounting surfaces. Also remove any moisture, oil, or foreign material adhering to application and mounting surfaces.

21. Install rear cover on gear carrier and tighten mounting bolts.

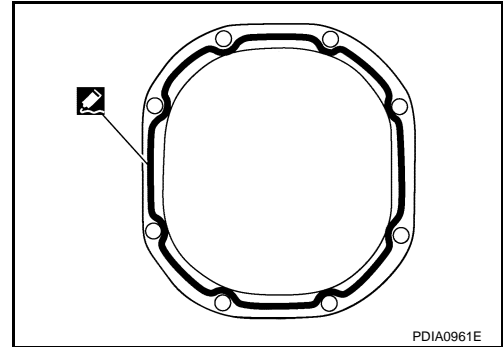
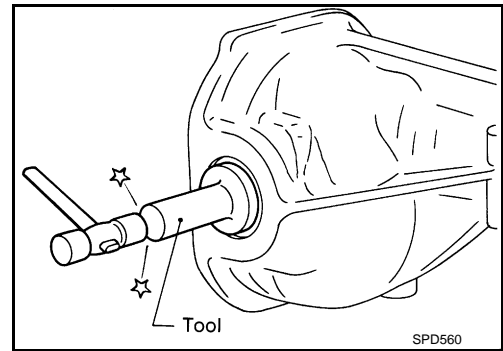

22. Install side flange with the following procedure.

- a. Attach the protector [SST: KV38107900 (J-39352)] to side oil seal.
- b. After the side flange is inserted and the serrated part of side gear has engaged the serrated part of flange, remove the protector.

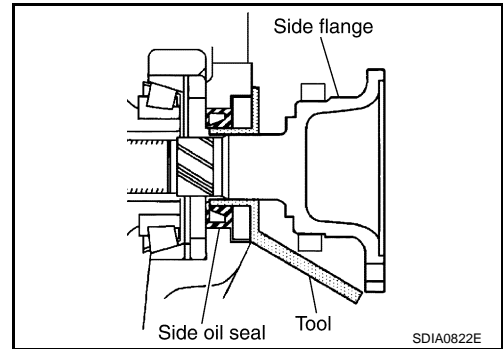

- c. Put a suitable drift on the center of side flange, then drive it until sound changes.

NOTE:

When installation is completed, driving sound of the side flange turns into a sound that seems to affect the whole final drive.

- d. Confirm that the dimension of the side flange (1) installation (Measurement A) in the figure comes into the following.

Measurement "A" : 326 – 328 mm (12.83 – 12.91 in)

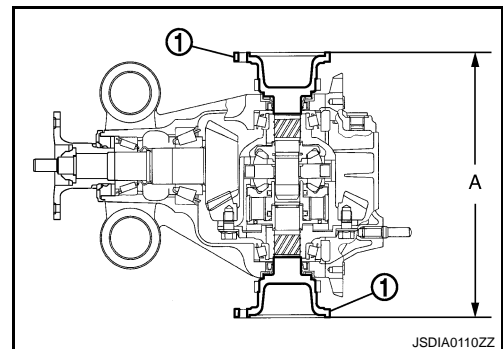

A/T : Adjustment

INFOID:000000005649814

TOTAL PRELOAD TORQUE

- Before inspection and adjustment, drain gear oil.
1. Secure final drive assembly onto an attachment [SST: KV38100800 (J-25604-01)].
 2. Remove side flanges.

DIFFERENTIAL ASSEMBLY

< UNIT DISASSEMBLY AND ASSEMBLY >

[REAR FINAL DRIVE: R200V]

3. Rotate drive pinion back and forth 2 to 3 times to check for unusual noise and rotation malfunction.
4. Rotate drive pinion at least 20 times to check for smooth operation of the bearing.
5. Measure total preload with the preload gauge (A) [SST: ST3127S000 (J-25765-A)].

Standard

Total preload torque : Refer to [DLN-295, "Pre-load Torque"](#).

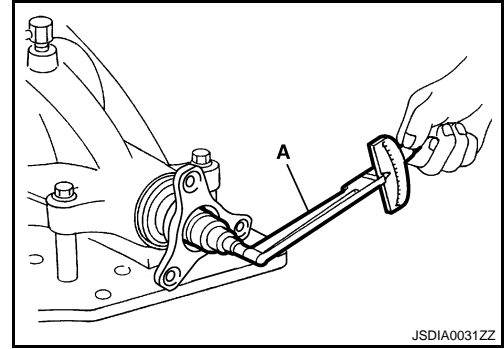

NOTE:

Total preload torque = Pinion bearing preload torque + Side bearing preload torque

- If measured value is out of the specification, disassemble it to check and adjust each part. Adjust the pinion bearing preload and side bearing preload. Adjust the pinion bearing preload first, then adjust the side bearing preload.

When the preload torque is large

On pinion bearings: Replace the collapsible spacer.

On side bearings: Use thinner side bearing adjusting washers by the same amount to each side.

When the preload is small

On pinion bearings: Tighten the drive pinion lock nut.

On side bearings: Use thicker side bearing adjusting washers by the same amount to each side.

SIDE BEARING PRELOAD

- Before inspection and adjustment, drain gear oil.
1. Remove rear cover. Refer to [DLN-265, "A/T : Disassembly"](#).
 2. Make sure all parts are clean. Also, make sure the bearings are well lubricated with gear oil.
 3. Place the differential case, with side bearings and bearing races installed, into gear carrier.

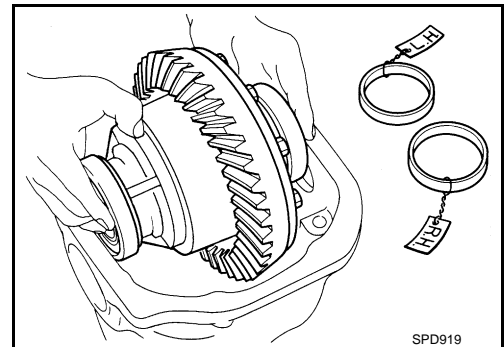

4. Insert left and right original side bearing adjusting washers in place between side bearings and gear carrier.

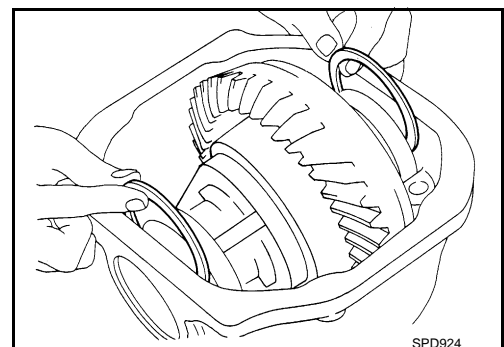

DIFFERENTIAL ASSEMBLY

< UNIT DISASSEMBLY AND ASSEMBLY >

[REAR FINAL DRIVE: R200V]

5. Install bearing caps in their correct locations and tighten bearing cap mounting bolts.
6. Turn the carrier several times to seat the bearings.

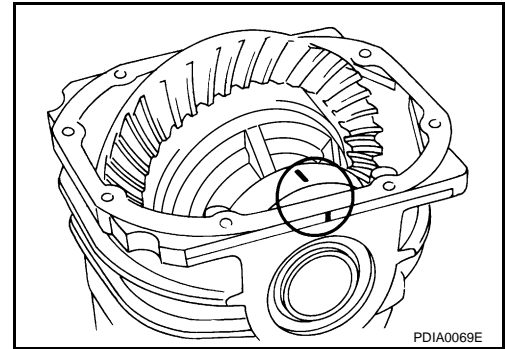

7. Measure the turning torque of the carrier at the drive gear mounting bolts with a spring gauge [SST: — (J-8129)].

Specification : 34.2 – 39.2 N (3.5 – 4.0 kg, 7.7 – 8.8 lb) of pulling force at the drive gear bolt

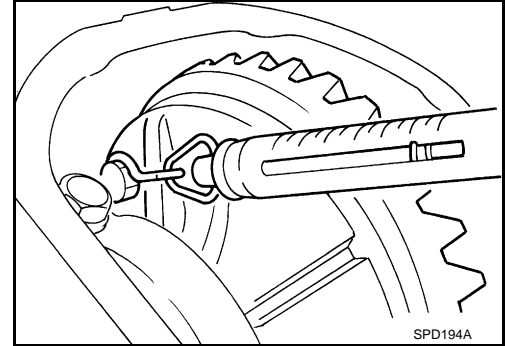

8. If the turning torque is outside the specification, use a thicker/thinner side bearing adjusting washer to adjust.

If the turning torque is less than the specified range:
Use a thicker thrust washer.
If the turning torque is greater than the specification:
Use a thinner thrust washer.

CAUTION:
Select a side bearing adjusting washer for right and left individually.

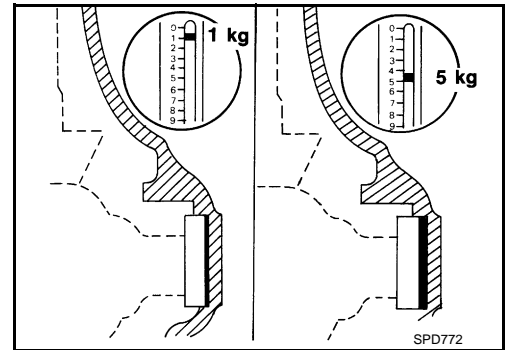

9. Record the total amount of washer thickness required for the correct carrier side bearing preload.

DRIVE GEAR RUNOUT

1. Remove rear cover. Refer to [DLN-265, "A/T : Disassembly"](#).
2. Fit a dial indicator to the drive gear back face.
3. Rotate the drive gear to measure runout.

Limit
Drive gear runout : Refer to [DLN-295, "Drive Gear Runout"](#).

- If the runout is outside of the repair limit, check drive gear assembly condition; foreign material may be caught between drive gear and differential case, or differential case or drive gear may be deformed, etc.

CAUTION:
Replace drive gear and drive pinion gear as a set.

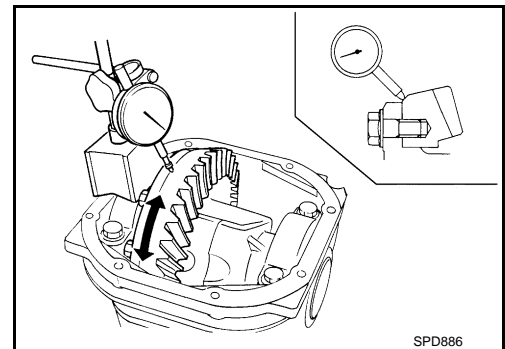

TOOTH CONTACT

- Before inspection and adjustment, drain gear oil.
1. Remove rear cover. Refer to [DLN-265, "A/T : Disassembly"](#).

A
B
C
DLN
E
F
G
H
I
J
K
L
M
N
O
P

DIFFERENTIAL ASSEMBLY

< UNIT DISASSEMBLY AND ASSEMBLY >

[REAR FINAL DRIVE: R200V]

2. Apply red lead to drive gear.

CAUTION:

Apply red lead to both the faces of 3 to 4 gears at 4 locations evenly spaced on drive gear.

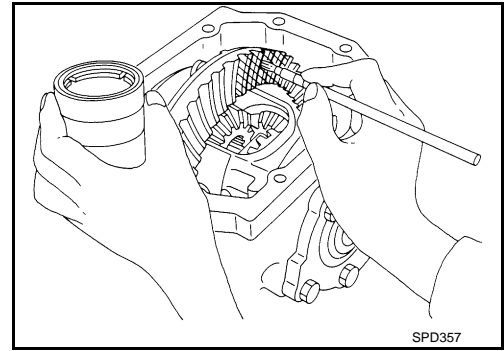

3. Rotate drive gear back and forth several times, check drive pinion gear to drive gear tooth contact.

CAUTION:

Check tooth contact on drive side and reverse side.

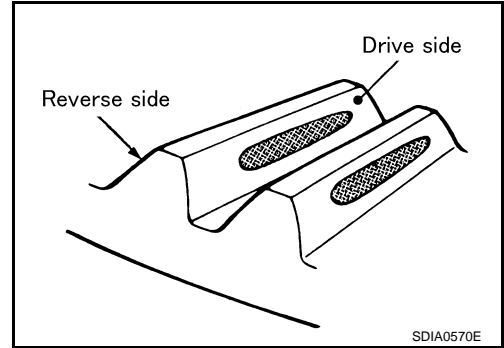

Tooth contact condition				Pinion height adjusting washer selection valve [mm (in)]	Adjustment (Yes/No)	Possible cause	
Drive side		Back side					
Heel side	Toe side	Toe side	Heel side				
				↑ Thicker	Yes	Occurrence of noise and scoring sound in all speed ranges.	
						+0.09 (+0.0035)	Occurrence of noise when accelerating.
						+0.06 (+0.0024)	
				+0.03 (+0.0012)	No	-	
				0			
				-0.03 (-0.0012)			
				↓ Thinner	Yes	Occurrence of noise at constant speed and decreasing speed.	
						-0.06 (-0.0024)	Occurrence of noise and scoring sound in all speed ranges.
				-0.09 (-0.0035)			

SDIA0207E

DIFFERENTIAL ASSEMBLY

< UNIT DISASSEMBLY AND ASSEMBLY >

[REAR FINAL DRIVE: R200V]

4. If tooth contact is improperly adjusted, follow the procedure below to adjust the pinion height (dimension X).

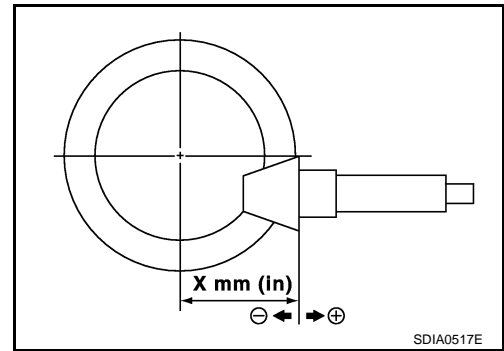

- If the tooth contact is near the face (face contact), or near the heel (heel contact), thicken pinion height adjusting washers to move drive pinion closer to drive gear.

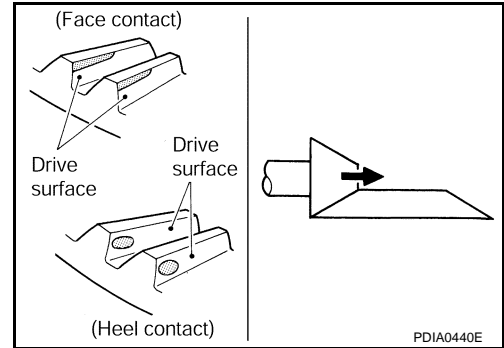

- If the tooth contact is near the flank (flank contact), or near the toe (toe contact), thin pinion height adjusting washers to move drive pinion farther from drive gear.

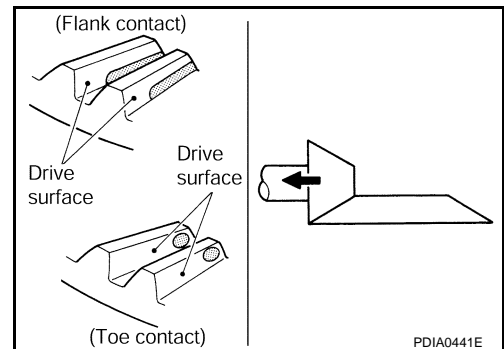

BACKLASH

- Before inspection and adjustment, drain gear oil.
1. Remove rear cover. Refer to [DLN-265, "A/T : Disassembly"](#).
 2. Fit a dial indicator to the drive gear face to measure the backlash.

Standard Backlash

: Refer to [DLN-295, "Backlash"](#).

- If the backlash is outside of the specified value, change the thickness of side bearing adjusting washer.

When the backlash is large:

Make drive gear back side adjusting washer thicker, and drive gear tooth side adjusting washer thinner by the same amount.

When the backlash is small:

Make drive gear back side adjusting washer thinner, and drive gear tooth side adjusting washer thicker by the same amount.

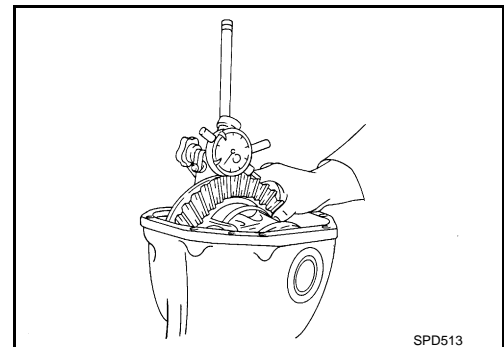

A
B
C
DLN
E
F
G
H
I
J
K
L
M
N
O
P

DIFFERENTIAL ASSEMBLY

< UNIT DISASSEMBLY AND ASSEMBLY >

[REAR FINAL DRIVE: R200V]

CAUTION:

Never change the total amount of washers as it changes the bearing preload.

A/T : Inspection After Disassembly

INFOID:000000005649815

DRIVE GEAR AND DRIVE PINION

- Clean up the disassembled parts.
- If the gear teeth never mesh or line-up correctly, determine the cause and adjust or replace as necessary.
- If the gears are worn, cracked, damaged, pitted or chipped (by friction) noticeably, replace with new drive gear and drive pinion as a set.

BEARING

- Clean up the disassembled parts.
- If any chipped (by friction), pitted, worn, rusted or scratched marks, or unusual noise from the bearing is observed, replace as a bearing assembly (as a new set).

SIDE GEAR AND PINION MATE GEAR

- Clean up the disassembled parts.
- If any cracks or damage on the surface of the tooth is found, replace.
- If any worn or chipped mark on the contact sides of the thrust washer is found, replace.

SIDE GEAR THRUST WASHER AND PINION MATE THRUST WASHER

- Clean up the disassembled parts.
- If it is chipped (by friction), damaged, or unusually worn, replace.

OIL SEAL

- Whenever disassembled, replace.
- If wear, deterioration of adherence (sealing force lips), or damage is detected on the lips, replace them.

DIFFERENTIAL CASE

- Clean up the disassembled parts.
- If any wear or crack on the contact sides of the differential case is found, replace.

COMPANION FLANGE

- Clean up the disassembled parts.
- If any chipped mark [about 0.1 mm, (0.004 in)] or other damage on the contact sides of the lips of the companion flange is found, replace.

DRIVE PINION

< UNIT DISASSEMBLY AND ASSEMBLY >

[REAR FINAL DRIVE: R200V]

DRIVE PINION

M/T

M/T : Exploded View

INFOID:000000005846249

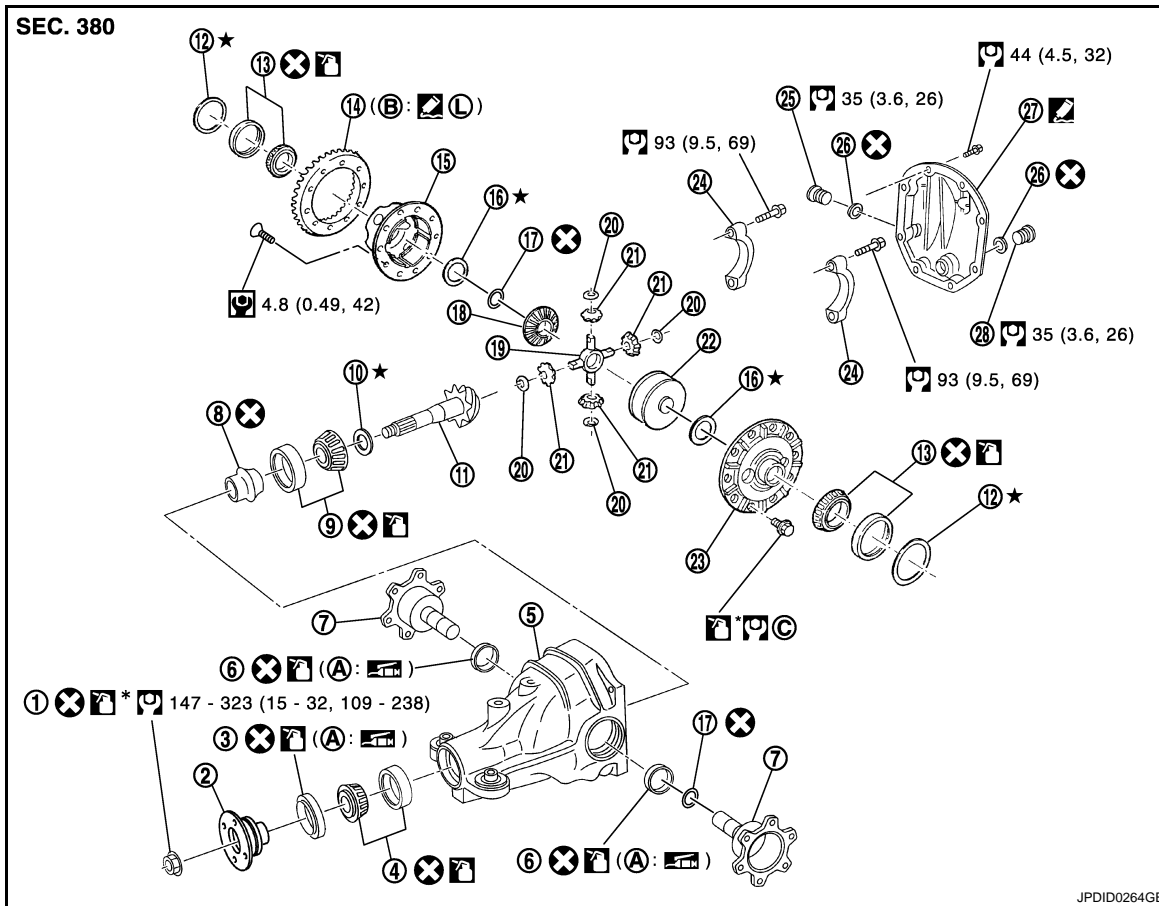

- | | | |
|------------------------------------|-------------------------------|-----------------------------------|
| 1. Drive pinion lock nut | 2. Companion flange | 3. Front oil seal |
| 4. Pinion front bearing | 5. Gear carrier | 6. Side oil seal |
| 7. Side flange | 8. Collapsible spacer | 9. Pinion rear bearing |
| 10. Pinion height adjusting washer | 11. Drive pinion | 12. Side bearing adjusting washer |
| 13. Side bearing | 14. Drive gear | 15. Differential case B |
| 16. Side gear thrust washer | 17. Circular clip | 18. Side gear |
| 19. Pinion mate shaft | 20. Pinion mate thrust washer | 21. Pinion mate gear |
| 22. Viscous coupling | 23. Differential case A | 24. Bearing cap |
| 25. Filler plug | 26. Gasket | 27. Rear cover |
| 28. Drain plug | | |
- A. Oil seal lip B. Screw hole C. Comply with the assembly procedure when tightening. Refer to [DLN-255, "M/T : Assembly"](#).

Apply gear oil.

Apply anti-corrosion oil.

Apply Genuine Silicone RTV or equivalent. Refer to [GI-18, "Recommended Chemical Products and Sealants"](#).

Apply Genuine High Strength Thread Locking Sealant or equivalent. Refer to [GI-18, "Recommended Chemical Products and Sealants"](#).

Refer to [GI-4, "Components"](#) for symbols not described on the above.

DRIVE PINION

< UNIT DISASSEMBLY AND ASSEMBLY >

[REAR FINAL DRIVE: R200V]

INFOID:000000005649817

M/T : Disassembly

1. Remove differential case assembly. Refer to [DLN-253. "M/T : Disassembly"](#).
2. Remove drive pinion lock nut with the flange wrench.

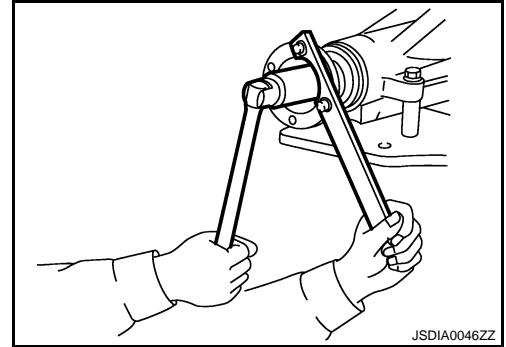

3. Put matching mark (B) on the end of drive pinion. The matching mark should be in line with the matching mark (A) on companion flange (1).

CAUTION:

For matching mark, use paint. Never damage companion flange and drive pinion.

NOTE:

The matching mark (A) on the final drive companion flange (1) indicates the maximum vertical runout position.

When replacing companion flange, matching mark is not necessary.

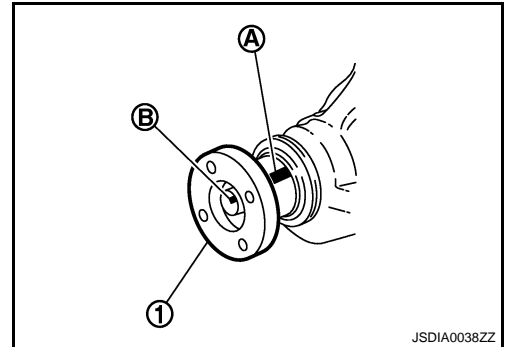

4. Remove companion flange using the suitable pullers.

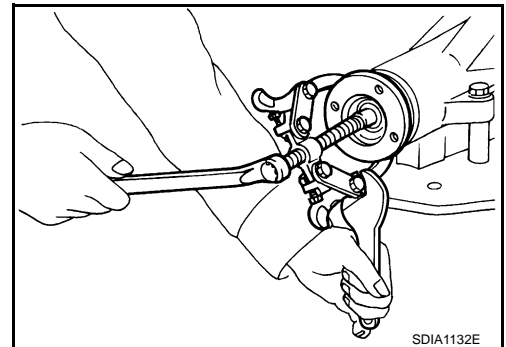

5. Press drive pinion assembly out of gear carrier.

CAUTION:

Never drop drive pinion assembly.

6. Remove front oil seal.
7. Remove side oil seal.
8. Remove pinion front bearing inner race.
9. Remove collapsible spacer.

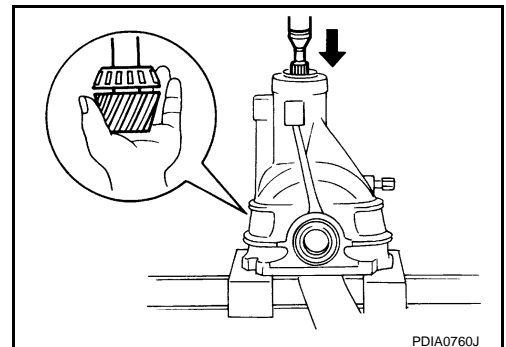

DRIVE PINION

< UNIT DISASSEMBLY AND ASSEMBLY >

[REAR FINAL DRIVE: R200V]

10. Remove pinion rear bearing inner race and pinion height adjusting washer with the replacer (A) (commercial service tool).

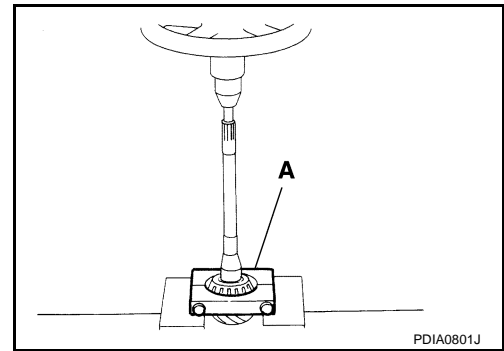

11. Tap pinion front/rear bearing outer races uniformly using a brass rod or equivalent to remove them.

CAUTION:

Never damage gear carrier.

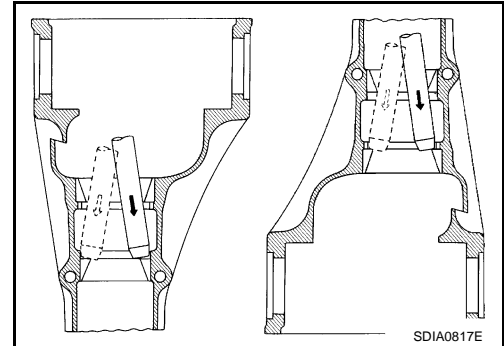

M/T : Assembly

1. Install front bearing outer race (1) and rear bearing outer race (2) using drifts.

A: Drift [SST: ST30720000 (J-25405)]

B: Drift [SST: KV40105230 (—)]

C: Drift bar [SST: ST30611000 (J-25742-1)]

D: Drift [SST: ST30613000 (J-25742-3)]

CAUTION:

- At first, using a hammer, tap bearing outer race until it becomes flat to gear carrier.
- Never reuse pinion front and rear bearing outer race.

2. Select drive pinion height adjusting washer. Refer to [DLN-281](#), "[M/T : Adjustment](#)".

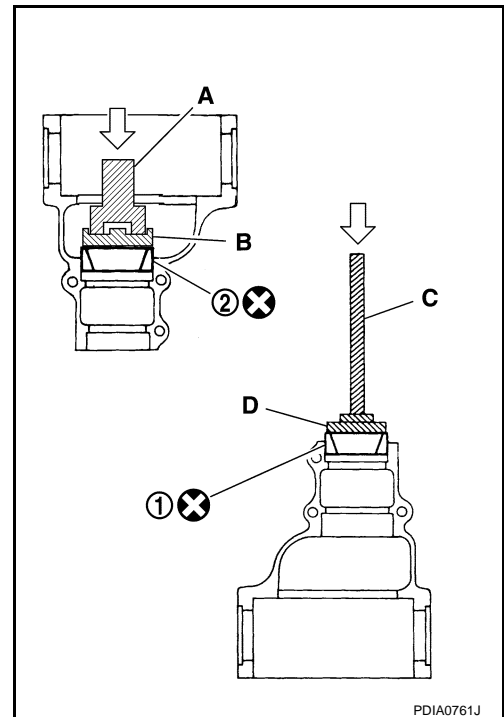

DRIVE PINION

< UNIT DISASSEMBLY AND ASSEMBLY >

[REAR FINAL DRIVE: R200V]

3. Install selected drive pinion height adjusting washer (2) to drive pinion. Press pinion rear bearing inner race (1) to it, using drift (A) [SST: ST30901000 (J-26010-01)].

CAUTION:

- Be careful of the direction of pinion height adjusting washer. (Assemble as shown in the figure.)
- Never reuse pinion rear bearing inner race.

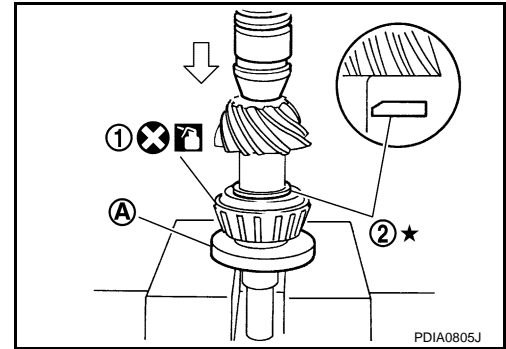

4. Assemble collapsible spacer to drive pinion.

CAUTION:

Never reuse collapsible spacer.

5. Apply gear oil to pinion rear bearing, and assemble drive pinion into gear carrier.
6. Apply gear oil to pinion front bearing, and assemble pinion front bearing inner race to drive pinion assembly.

CAUTION:

Never reuse pinion front bearing inner race.

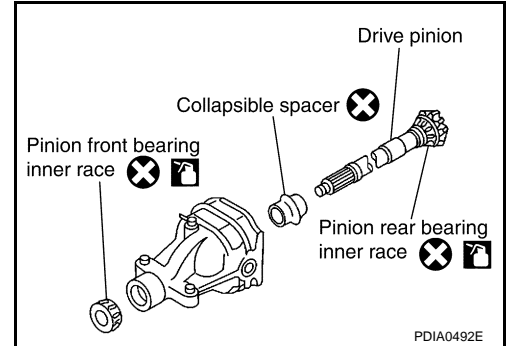

7. Using a spacer (A) (commercial service tool), press the pinion front bearing inner race to drive pinion as far as drive pinion nut can be tightened.

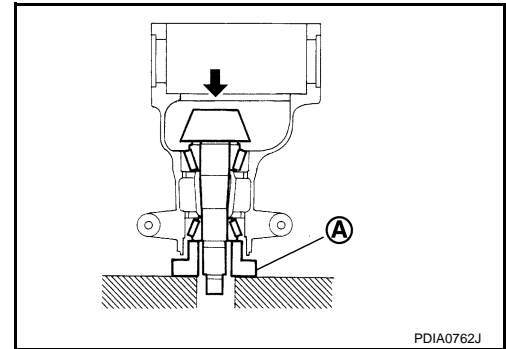

8. Using the drift (A) [SST: ST30720000 (J-25405)], install front oil seal as shown in figure.

CAUTION:

- Never reuse oil seal.
- When installing, never incline oil seal.
- Apply multi-purpose grease onto oil seal lips, and gear oil onto the circumference of oil seal.

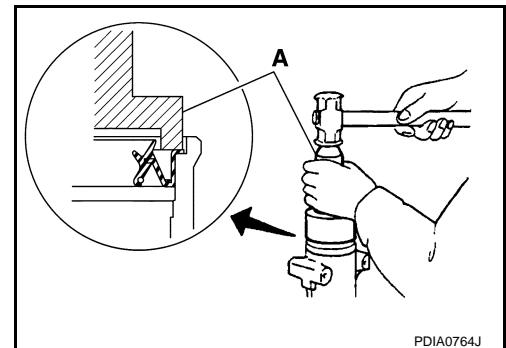

9. Install companion flange (1).

NOTE:

When reusing drive pinion, align the matching mark (B) of drive pinion with the matching mark (A) of companion flange, and then install companion flange (1).

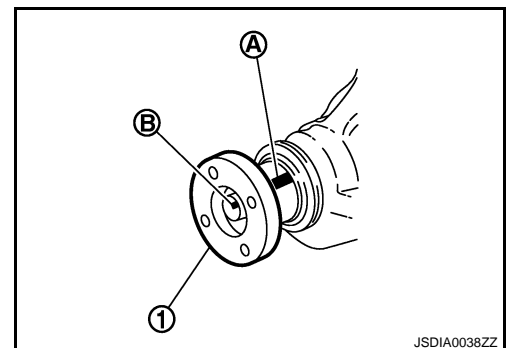

DRIVE PINION

< UNIT DISASSEMBLY AND ASSEMBLY >

[REAR FINAL DRIVE: R200V]

10. Apply anti-corrosion oil to the thread and seat of drive pinion lock nut, and temporarily tighten drive pinion lock nut to drive pinion.

CAUTION:

Never reuse drive pinion lock nut.

11. Adjust to the drive pinion lock nut tightening torque and pinion bearing preload torque.

A: Preload gauge [SST: ST3127S000 (J-25765-A)]

Standard

Pinion bearing preload : Refer to [DLN-295, "Pre-load Torque"](#).

CAUTION:

- Adjust to the lower limit of the drive pinion lock nut tightening torque first.
- If the preload torque exceeds the specified value, replace collapsible spacer and tighten it again to adjust. Never loosen drive pinion lock nut to adjust the preload torque.
- After adjustment, rotate drive pinion back and forth 2 to 3 times to check for unusual noise, rotation malfunction, and other malfunctions.

12. Install differential case assembly. Refer to [DLN-279, "M/T : Assembly"](#).

CAUTION:

Never install rear cover at the timing.

13. Check and adjust drive gear runout, tooth contact, drive gear to drive pinion backlash, and companion flange runout. Refer to [DLN-259, "M/T : Adjustment"](#) and [DLN-281, "M/T : Adjustment"](#). Recheck above items. Readjust the above description, if necessary.
14. Check total preload torque. Refer to [DLN-281, "M/T : Adjustment"](#).
15. Install rear cover. Refer to [DLN-279, "M/T : Assembly"](#).

M/T : Adjustment

INFOID:000000005649819

PINION GEAR HEIGHT

1. Make sure all parts are clean and that the bearings are well lubricated.
2. Assemble the pinion gear bearings into the differential shim selector tool [SST: — (J-34309)].

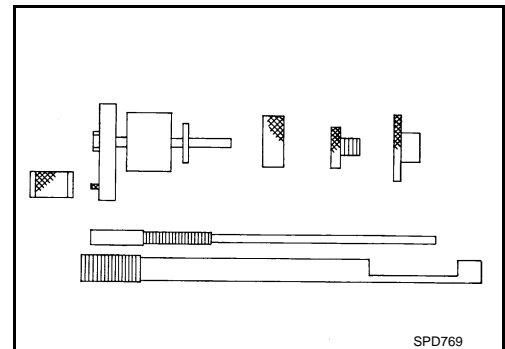
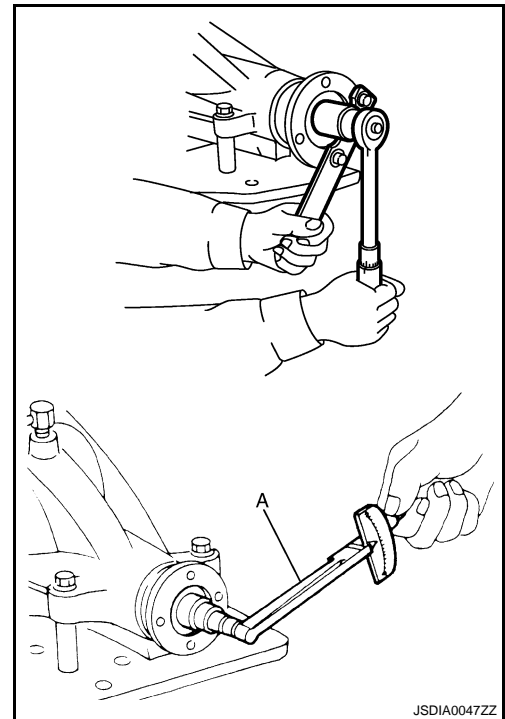

A
B
C
DLN
E
F
G
H
I
J
K
L
M
N
O
P

DRIVE PINION

< UNIT DISASSEMBLY AND ASSEMBLY >

[REAR FINAL DRIVE: R200V]

- **Pinion front bearing;** make sure the J-34309-3 pinion front bearing seat is secured tightly against the J-34309-2 gauge anvil. Then turn the pinion front bearing pilot, J-34309-5, to secure the bearing in its proper position.
 - **Pinion rear bearing;** the pinion rear bearing pilot, J-34309-8, is used to center the pinion rear bearing only. The pinion rear bearing locking seat, J-34309-4, is used to lock the bearing to the assembly.
 - **Installation of J-34309-9 and J-34309-16;** place a suitable 2.5 mm (0.098 in) thick plain washer between J-34309-9 and J-34309-16. Both surfaces of J-34309-9 and J-34309-16 must be parallel with a clearance of 2.5 mm (0.098 in).
3. Install the pinion rear bearing inner race into gear carrier. Then place the pinion preload shim selector tool, J-34309-1, gauge screw assembly.

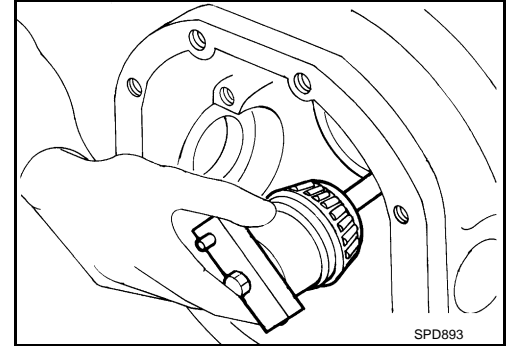
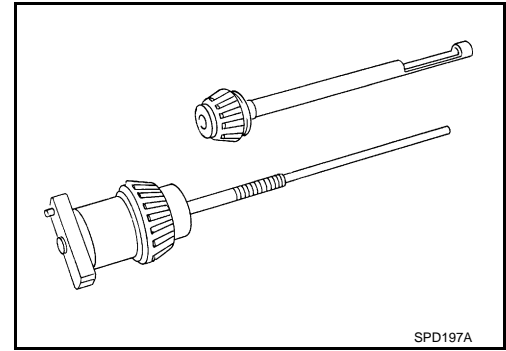

4. Assemble the pinion front bearing inner race and the J-34309-2 gauge anvil. Assemble them together with the J-34309-1 gauge screw in gear carrier. Make sure that the pinion height gauge plate, J-34309-16, turns a full 360 degrees. Tighten the two sections together by hand.

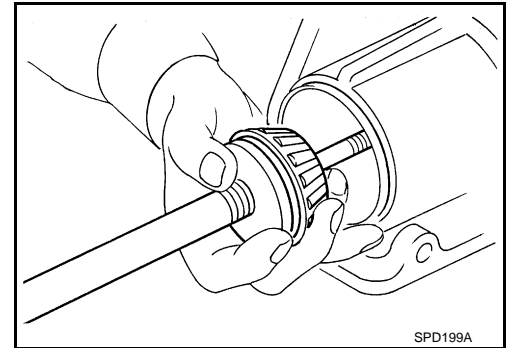

5. Turn the assembly several times to seat the bearings.

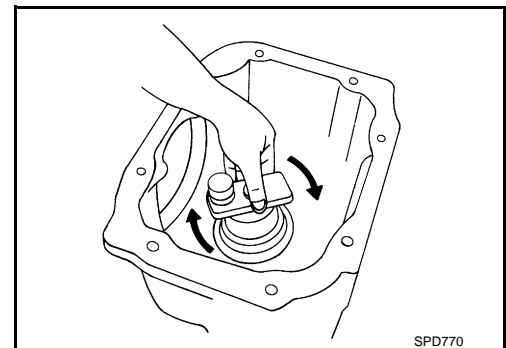

6. Measure the turning torque at the end of the J-34309-2 gauge anvil using preload gauge [SST: ST3127S000 (J-25765-A)].

Turning torque specification : 1.0 – 1.3 N·m (0.11 – 0.13 kg·m, 9 – 11 in·lb)

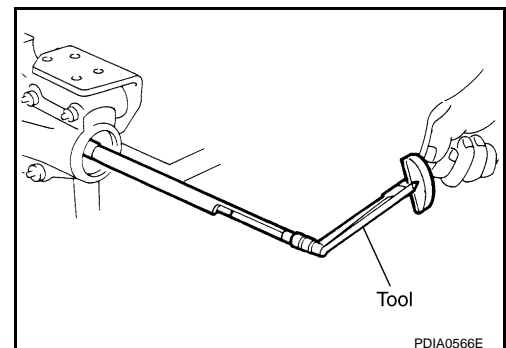

DRIVE PINION

< UNIT DISASSEMBLY AND ASSEMBLY >

[REAR FINAL DRIVE: R200V]

7. Place the J-34309-11 "R200A" pinion height adapter onto the gauge plate and tighten it by hand.

CAUTION:

Make sure all machined surfaces are clean.

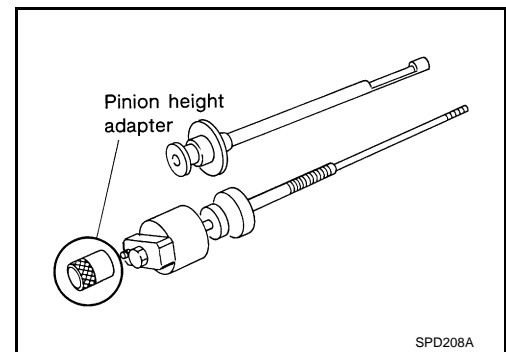

8. Position the side bearing discs, J-25269-4, and arbor firmly into the side bearing bores. Install the bearing caps and tighten bearing cap mounting bolts to the specified torque. Refer to [DLN-252, "M/T : Exploded View"](#).

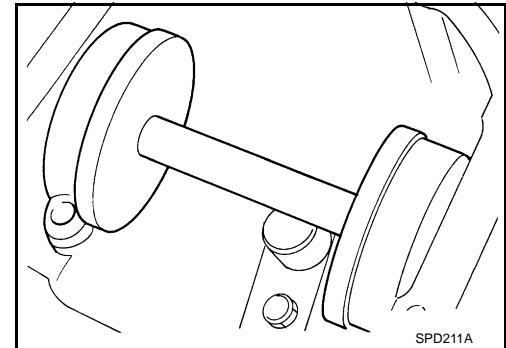

9. Select the correct standard pinion height adjusting washer thickness. Select by using a standard gauge of 3 mm (0.12 in) and J-34309-101 feeler gauge. Measure the distance between the J-34309-11 pinion height adapter including the standard gauge and the arbor.

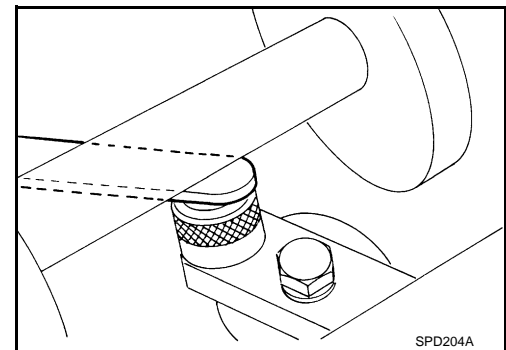

10. Write down exact measurement (the value of feeler gauge).

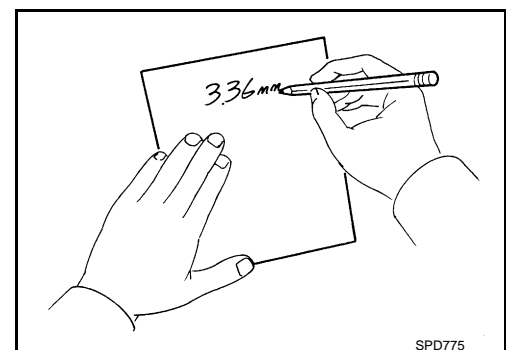

11. Correct the pinion height washer size by referring to the "pinion head number".

There are two numbers painted on the drive pinion. The first one refers to the drive pinion and drive gear as a matched set. This number should be the same as the number on the drive gear. The second number is the "pinion head height number". It refers to the ideal pinion height from standard for quietest operation. Use the following chart to determine the correct pinion height washer.

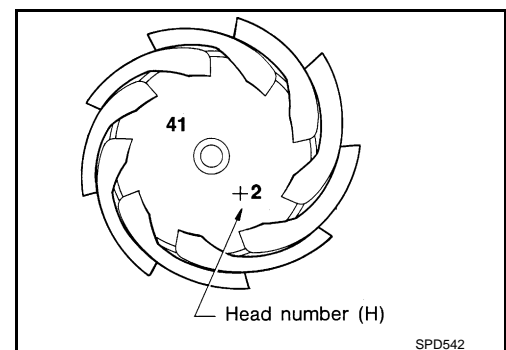

A

B

C

DLN

E

F

G

H

I

J

K

L

M

N

O

P

DRIVE PINION

< UNIT DISASSEMBLY AND ASSEMBLY >

[REAR FINAL DRIVE: R200V]

Pinion head height number	Add or remove from the standard pinion height adjusting washer thickness measurement
-6	Add 0.06 mm (0.0024 in)
-5	Add 0.05 mm (0.0020 in)
-4	Add 0.04 mm (0.0016 in)
-3	Add 0.03 mm (0.0012 in)
-2	Add 0.02 mm (0.0008 in)
-1	Add 0.01 mm (0.0004 in)
0	Use the selected washer thickness
+1	Subtract 0.01 mm (0.0004 in)
+2	Subtract 0.02 mm (0.0008 in)
+3	Subtract 0.03 mm (0.0012 in)
+4	Subtract 0.04 mm (0.0016 in)
+5	Subtract 0.05 mm (0.0020 in)
+6	Subtract 0.06 mm (0.0024 in)

12. Select the correct pinion height adjusting washer.
13. Remove the J-34309 differential shim selector tool from the final drive housing. Then disassemble to retrieve the pinion bearings.

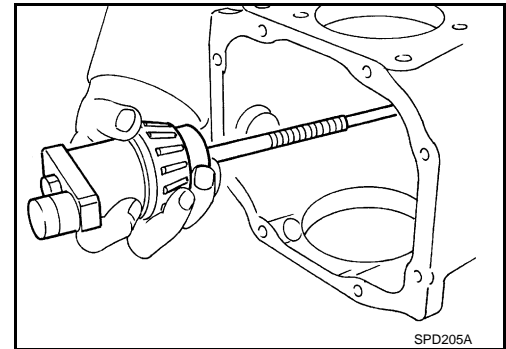

COMPANION FLANGE RUNOUT

1. Fit a dial indicator onto the companion flange face (inner side of the propeller shaft mounting bolt holes).
2. Rotate the companion flange to check for runout.

Limit

Companion flange runout : Refer to [DLN-295, "Companion flange Runout \(M/T Models\)"](#).

3. Fit a test indicator to the inner side of the companion flange (socket diameter).
4. Rotate the companion flange to check for runout.

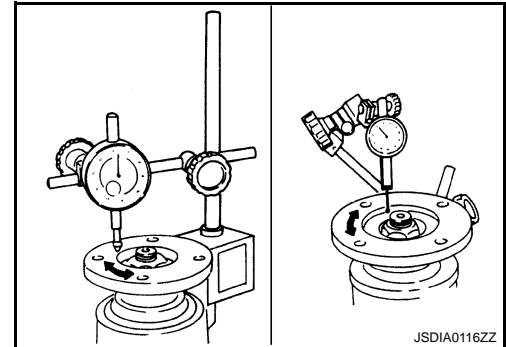

Limit

Companion flange runout : Refer to [DLN-295, "Companion flange Runout \(M/T Models\)"](#).

5. If the runout value is outside the repair limit, follow the procedure below to adjust.
 - a. Check for runout while changing the phase between companion flange and drive pinion gear by 90° step, and search for the position where the runout is the minimum.
 - b. If the runout value is still outside of the limit after the phase has been changed, possible causes are an assembly malfunction of drive pinion and pinion bearing and malfunction of pinion bearing. Check for these items and repair if necessary.
 - c. If the runout value is still outside of the limit after the check and repair, replace companion flange.

DRIVE PINION

< UNIT DISASSEMBLY AND ASSEMBLY >

[REAR FINAL DRIVE: R200V]

M/T : Inspection After Disassembly

INFOID:000000005649820

DRIVE GEAR AND DRIVE PINION

- Clean up the disassembled parts.
- If the gear teeth never mesh or line-up correctly, determine the cause and adjust or replace as necessary.
- If the gears are worn, cracked, damaged, pitted or chipped (by friction) noticeably, replace with new drive gear and drive pinion as a set.

BEARING

- Clean up the disassembled parts.
- If any chipped (by friction), pitted, worn, rusted or scratched marks, or unusual noise from the bearing is observed, replace as a bearing assembly (as a new set).

SIDE GEAR AND PINION MATE GEAR

- Clean up the disassembled parts.
- If any cracks or damage on the surface of the tooth is found, replace.
- If any worn or chipped mark on the contact sides of the thrust washer is found, replace.

SIDE GEAR THRUST WASHER AND PINION MATE THRUST WASHER

- Clean up the disassembled parts.
- If it is chipped (by friction), damaged, or unusually worn, replace.

OIL SEAL

- Whenever disassembled, replace.
- If wear, deterioration of adherence (sealing force lips), or damage is detected on the lips, replace them.

DIFFERENTIAL CASE

- Clean up the disassembled parts.
- If any wear or crack on the contact sides of the differential case is found, replace.

COMPANION FLANGE

- Clean up the disassembled parts.
- If any chipped mark [about 0.1 mm, (0.004 in)] or other damage on the contact sides of the lips of the companion flange is found, replace.

A/T

A

B

C

DLN

E

F

G

H

I

J

K

L

M

N

O

P

DRIVE PINION

< UNIT DISASSEMBLY AND ASSEMBLY >

[REAR FINAL DRIVE: R200V]

A/T : Exploded View

INFOID:000000005846250

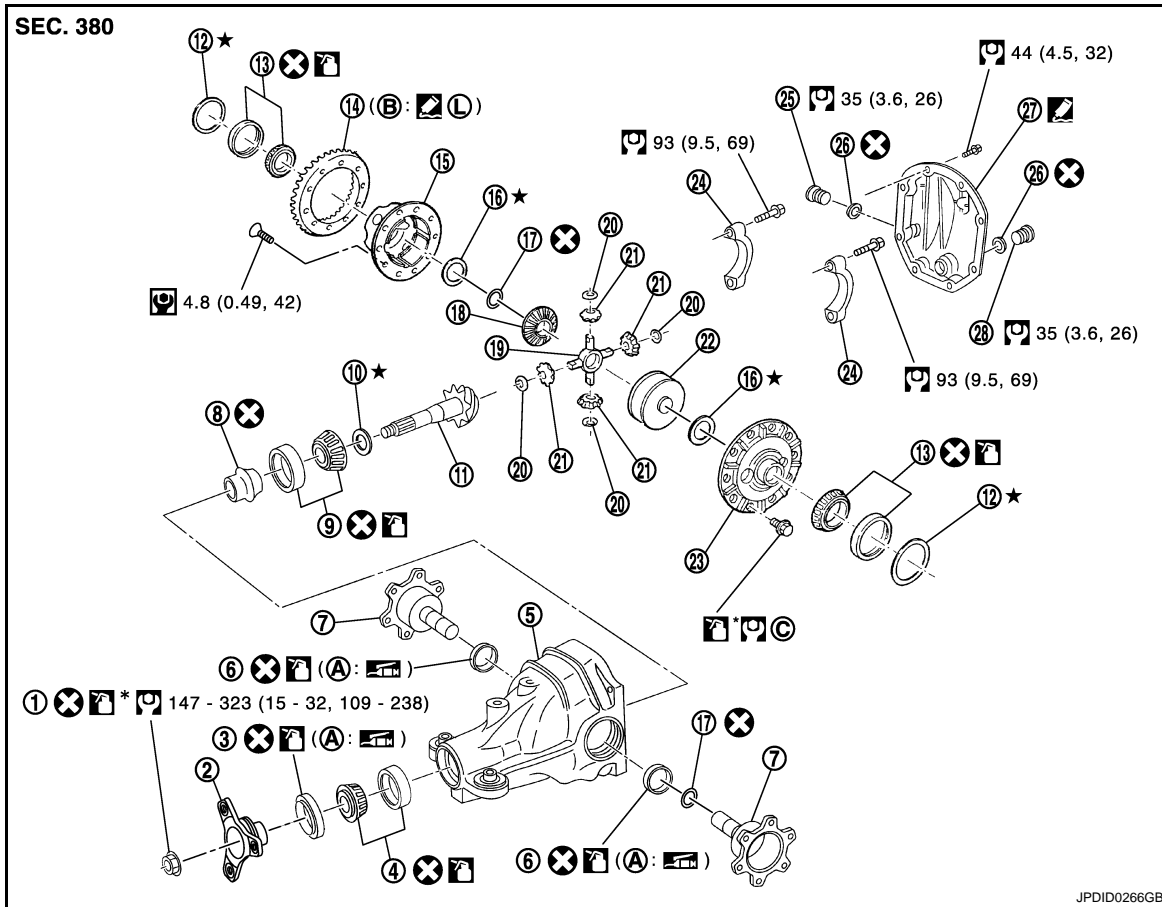

JPDID0266GB

- | | | |
|------------------------------------|-------------------------------|-----------------------------------|
| 1. Drive pinion lock nut | 2. Companion flange | 3. Front oil seal |
| 4. Pinion front bearing | 5. Gear carrier | 6. Side oil seal |
| 7. Side flange | 8. Collapsible spacer | 9. Pinion rear bearing |
| 10. Pinion height adjusting washer | 11. Drive pinion | 12. Side bearing adjusting washer |
| 13. Side bearing | 14. Drive gear | 15. Differential case B |
| 16. Side gear thrust washer | 17. Circular clip | 18. Side gear |
| 19. Pinion mate shaft | 20. Pinion mate thrust washer | 21. Pinion mate gear |
| 22. Viscous coupling | 23. Differential case A | 24. Bearing cap |
| 25. Filler plug | 26. Gasket | 27. Rear cover |
| 28. Drain plug | | |
- A. Oil seal lip B. Screw hole C. Comply with the assembly procedure when tightening. Refer to [DLN-268, "A/T : Assembly"](#).

- Apply gear oil.
- Apply anti-corrosion oil.
- Apply Genuine Silicone RTV or equivalent. Refer to [GI-18, "Recommended Chemical Products and Sealants"](#).
- Apply Genuine High Strength Thread Locking Sealant or equivalent. Refer to [GI-18, "Recommended Chemical Products and Sealants"](#).

Refer to [GI-4, "Components"](#) for symbols not described on the above.

A/T : Disassembly

INFOID:000000005649822

1. Remove differential case assembly. Refer to [DLN-265, "A/T : Disassembly"](#).

DRIVE PINION

< UNIT DISASSEMBLY AND ASSEMBLY >

[REAR FINAL DRIVE: R200V]

2. Remove drive pinion lock nut with the flange wrench.

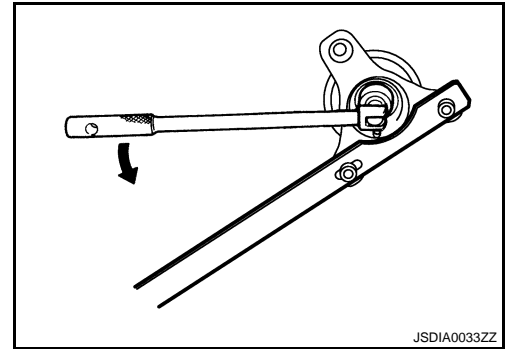

3. Put matching mark (B) on the end of drive pinion. The matching mark should be in line with the matching mark (A) on companion flange (1).

CAUTION:

For matching mark, use paint. Never damage companion flange and drive pinion.

NOTE:

The matching mark (A) on the final drive companion flange (1) indicates the maximum vertical runout position.

When replacing companion flange, matching mark is not necessary.

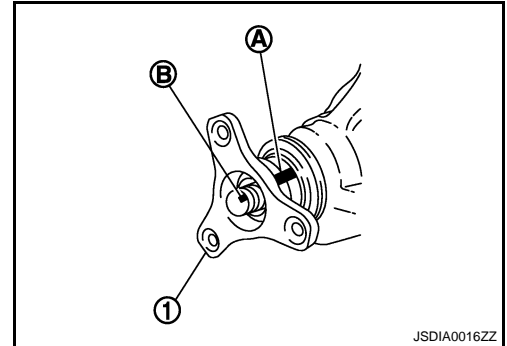

4. Remove companion flange using the suitable pullers.

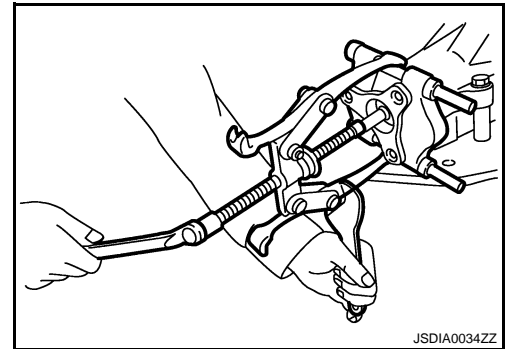

5. Press drive pinion assembly out of gear carrier.

CAUTION:

Never drop drive pinion assembly.

6. Remove front oil seal.
7. Remove side oil seal.
8. Remove pinion front bearing inner race.
9. Remove collapsible spacer.

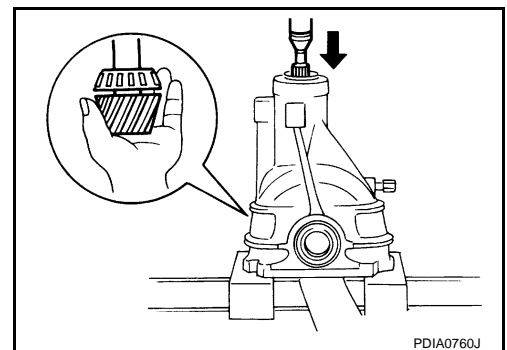

10. Remove pinion rear bearing inner race and pinion height adjusting washer with the replacer (A) (commercial service tool).

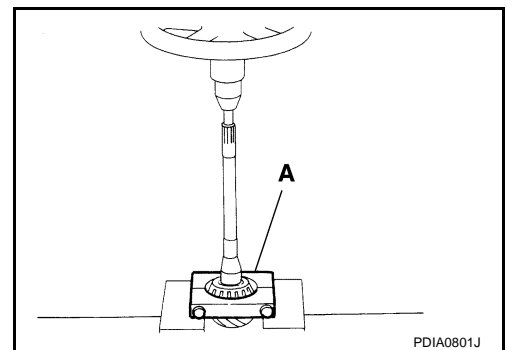

A
B
C
DLN
E
F
G
H
I
J
K
L
M
N
O
P

DRIVE PINION

< UNIT DISASSEMBLY AND ASSEMBLY >

[REAR FINAL DRIVE: R200V]

11. Tap pinion front/rear bearing outer races uniformly using a brass rod or equivalent to remove them.

CAUTION:

Never damage gear carrier.

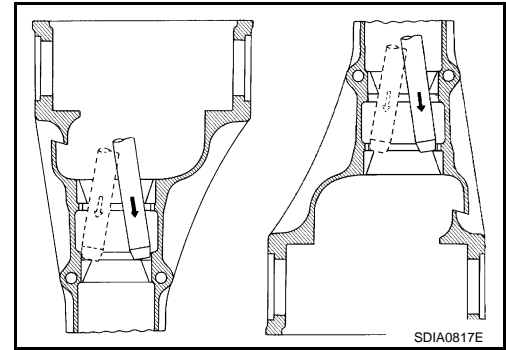

A/T : Assembly

INFOID:000000005649823

1. Install front bearing outer race (1) and rear bearing outer race (2) using drifts.

A: Drift [SST: ST30720000 (J-25405)]

B: Drift [SST: KV40105230 (—)]

C: Drift bar [SST: ST30611000 (J-25742-1)]

D: Drift [SST: ST30613000 (J-25742-3)]

CAUTION:

- At first, using a hammer, tap bearing outer race until it becomes flat to gear carrier.
- Never reuse pinion front and rear bearing outer race.

2. Select drive pinion height adjusting washer. Refer to [DLN-290](#), "[A/T : Adjustment](#)".

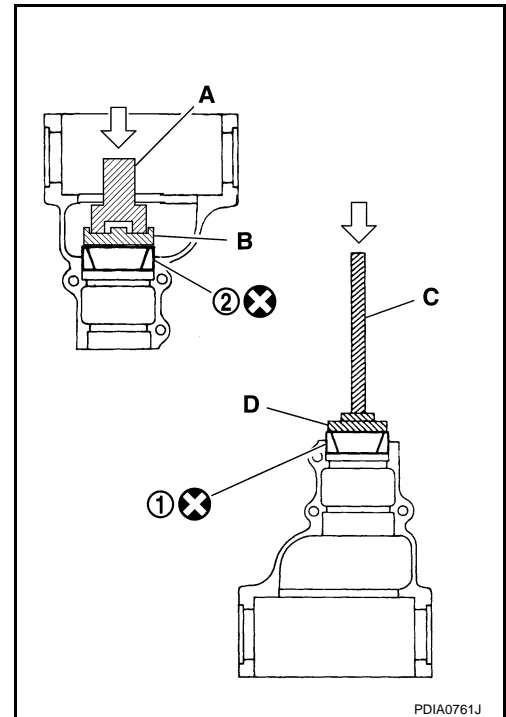

3. Install selected drive pinion height adjusting washer (2) to drive pinion. Press pinion rear bearing inner race (1) to it, using drift (A) [SST: ST30901000 (J-26010-01)].

CAUTION:

- Be careful of the direction of pinion height adjusting washer. (Assemble as shown in the figure.)
- Never reuse pinion rear bearing inner race.

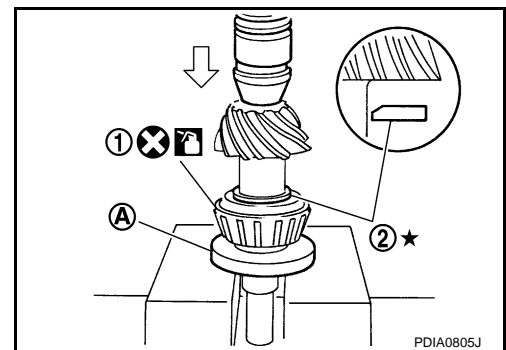

DRIVE PINION

< UNIT DISASSEMBLY AND ASSEMBLY >

[REAR FINAL DRIVE: R200V]

4. Assemble collapsible spacer to drive pinion.

CAUTION:

Never reuse collapsible spacer.

5. Apply gear oil to pinion rear bearing, and assemble drive pinion into gear carrier.

6. Apply gear oil to pinion front bearing, and assemble pinion front bearing inner race to drive pinion assembly.

CAUTION:

Never reuse pinion front bearing inner race.

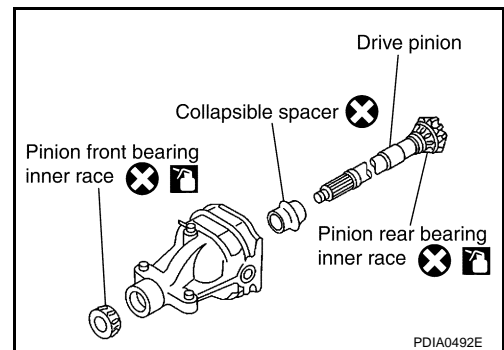

7. Using a spacer (A) (commercial service tool), press the pinion front bearing inner race to drive pinion as far as drive pinion nut can be tightened.

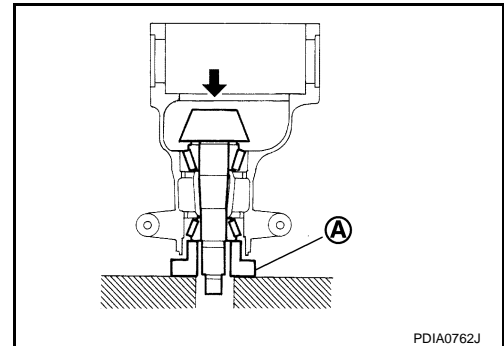

8. Using the drift (A) [SST: ST30720000 (J-25405)], install front oil seal as shown in figure.

CAUTION:

- Never reuse oil seal.
- When installing, never incline oil seal.
- Apply multi-purpose grease onto oil seal lips, and gear oil onto the circumference of oil seal.

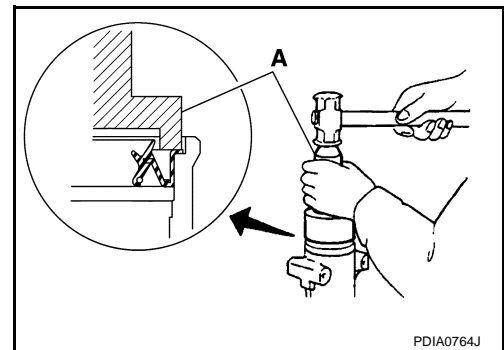

9. Install companion flange (1).

NOTE:

When reusing drive pinion, align the matching mark (B) of drive pinion with the matching mark (A) of companion flange, and then install companion flange (1).

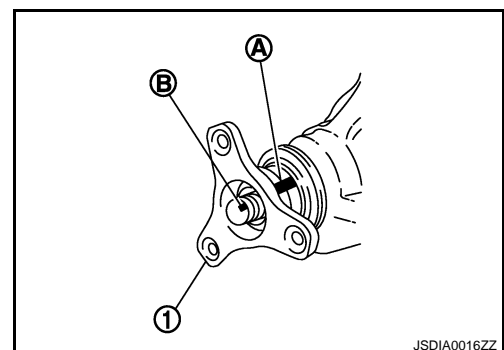

A
B
C
DLN
E
F
G
H
I
J
K
L
M
N
O
P

DRIVE PINION

< UNIT DISASSEMBLY AND ASSEMBLY >

[REAR FINAL DRIVE: R200V]

10. Apply anti-corrosion oil to the thread and seat of drive pinion lock nut, and temporarily tighten drive pinion lock nut to drive pinion.

CAUTION:

Never reuse drive pinion lock nut.

11. Adjust to the drive pinion lock nut tightening torque and pinion bearing preload torque.

A: Preload gauge [SST: ST3127S000 (J-25765-A)]

Standard

Pinion bearing preload : Refer to [DLN-295, "Pre-load Torque"](#).

CAUTION:

- Adjust to the lower limit of the drive pinion lock nut tightening torque first.
- If the preload torque exceeds the specified value, replace collapsible spacer and tighten it again to adjust. Never loosen drive pinion lock nut to adjust the preload torque.
- After adjustment, rotate drive pinion back and forth 2 to 3 times to check for unusual noise, rotation malfunction, and other malfunctions.

12. Install differential case assembly. Refer to [DLN-288, "A/T : Assembly"](#).

CAUTION:

Never install rear cover at the timing.

13. Check and adjust drive gear runout, tooth contact, drive gear to drive pinion backlash, and companion flange runout. Refer to [DLN-271, "A/T : Adjustment"](#) and [DLN-290, "A/T : Adjustment"](#).
Recheck above items. Readjust the above description, if necessary.
14. Check total preload torque. Refer to [DLN-290, "A/T : Adjustment"](#).
15. Install rear cover. Refer to [DLN-288, "A/T : Assembly"](#).

A/T : Adjustment

INFOID:000000005649824

PINION GEAR HEIGHT

1. Make sure all parts are clean and that the bearings are well lubricated.
2. Assemble the pinion gear bearings into the differential shim selector tool [SST: — (J-34309)].

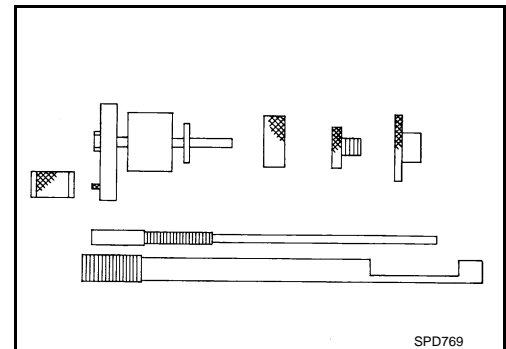
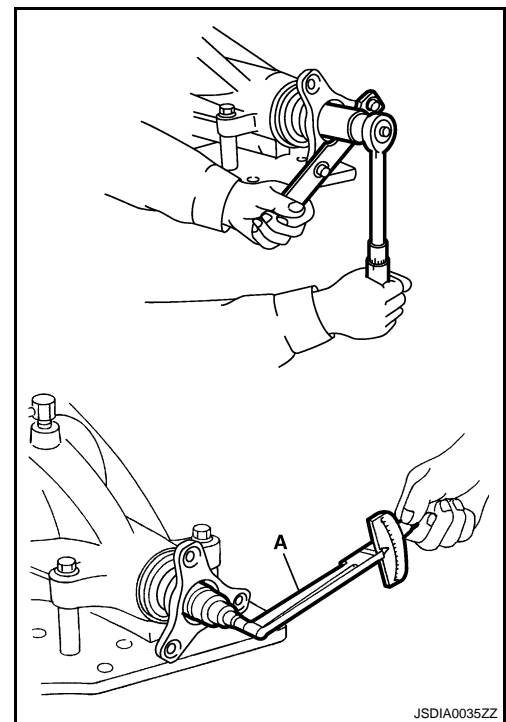

DRIVE PINION

< UNIT DISASSEMBLY AND ASSEMBLY >

[REAR FINAL DRIVE: R200V]

- **Pinion front bearing;** make sure the J-34309-3 pinion front bearing seat is secured tightly against the J-34309-2 gauge anvil. Then turn the pinion front bearing pilot, J-34309-5, to secure the bearing in its proper position.
 - **Pinion rear bearing;** the pinion rear bearing pilot, J-34309-8, is used to center the pinion rear bearing only. The pinion rear bearing locking seat, J-34309-4, is used to lock the bearing to the assembly.
 - **Installation of J-34309-9 and J-34309-16;** place a suitable 2.5 mm (0.098 in) thick plain washer between J-34309-9 and J-34309-16. Both surfaces of J-34309-9 and J-34309-16 must be parallel with a clearance of 2.5 mm (0.098 in).
3. Install the pinion rear bearing inner race into gear carrier. Then place the pinion preload shim selector tool, J-34309-1, gauge screw assembly.

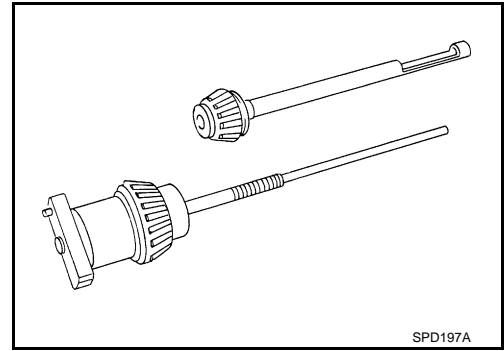

A
B
C

DLN

4. Assemble the pinion front bearing inner race and the J-34309-2 gauge anvil. Assemble them together with the J-34309-1 gauge screw in gear carrier. Make sure that the pinion height gauge plate, J-34309-16, turns a full 360 degrees. Tighten the two sections together by hand.

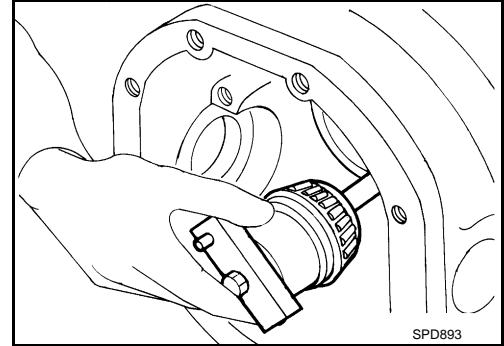

E
F
G

5. Turn the assembly several times to seat the bearings.

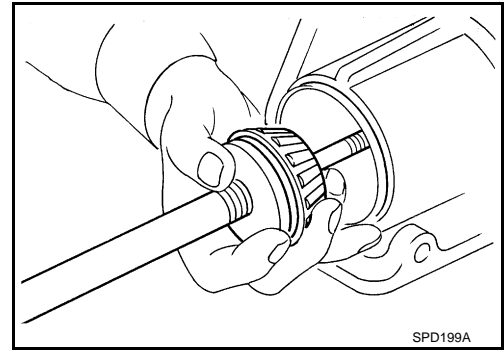

H
I
J

6. Measure the turning torque at the end of the J-34309-2 gauge anvil using preload gauge [SST: ST3127S000 (J-25765-A)].

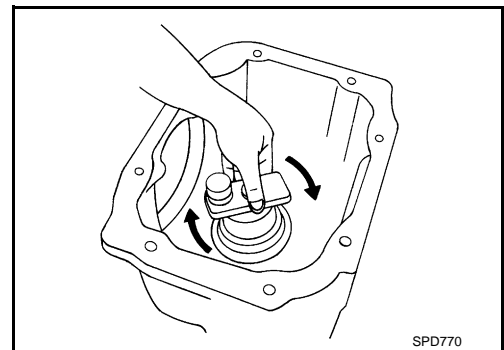

L
M
N

Turning torque specification : 1.0 – 1.3 N·m (0.11 – 0.13 kg·m, 9 – 11 in·lb)

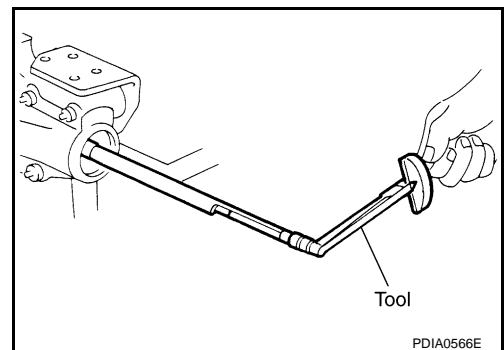

O
P

DRIVE PINION

< UNIT DISASSEMBLY AND ASSEMBLY >

[REAR FINAL DRIVE: R200V]

7. Place the J-34309-11 "R200A" pinion height adapter onto the gauge plate and tighten it by hand.

CAUTION:

Make sure all machined surfaces are clean.

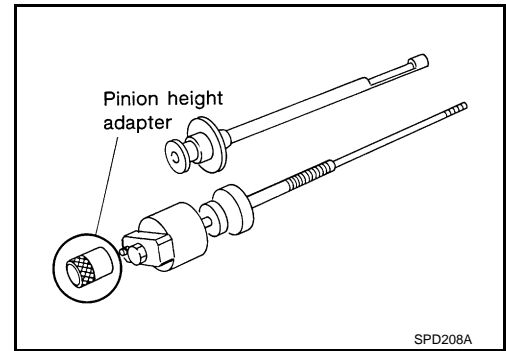

8. Position the side bearing discs, J-25269-4, and arbor firmly into the side bearing bores. Install the bearing caps and tighten bearing cap mounting bolts to the specified torque. Refer to [DLN-264, "A/T : Exploded View"](#).

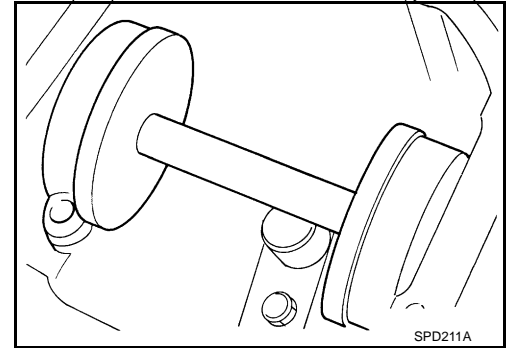

9. Select the correct standard pinion height adjusting washer thickness. Select by using a standard gauge of 3 mm (0.12 in) and your J-34309-101 feeler gauge. Measure the distance between the J-34309-11 pinion height adapter including the standard gauge and the arbor.

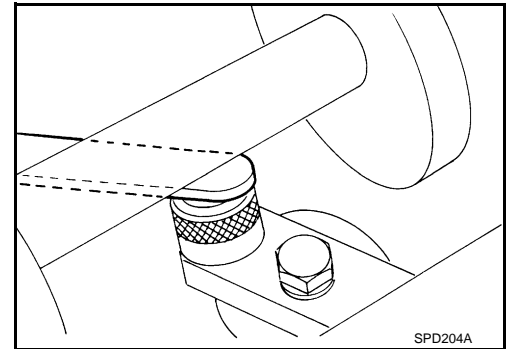

10. Write down exact measurement (the value of feeler gauge).

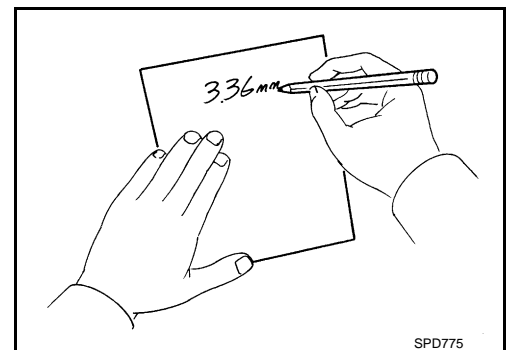

11. Correct the pinion height washer size by referring to the "pinion head number".

There are two numbers painted on the drive pinion. The first one refers to the drive pinion and drive gear as a matched set. This number should be the same as the number on the drive gear. The second number is the "pinion head height number". It refers to the ideal pinion height from standard for quietest operation. Use the following chart to determine the correct pinion height washer.

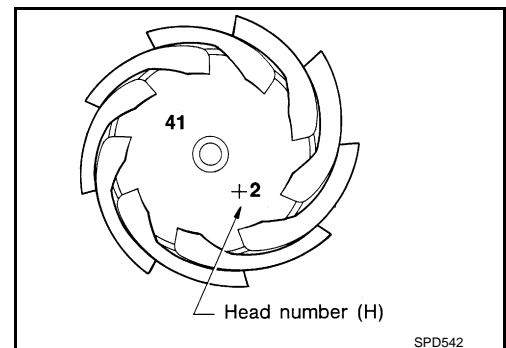

DRIVE PINION

< UNIT DISASSEMBLY AND ASSEMBLY >

[REAR FINAL DRIVE: R200V]

Pinion head height number	Add or remove from the standard pinion height adjusting washer thickness measurement
-6	Add 0.06 mm (0.0024 in)
-5	Add 0.05 mm (0.0020 in)
-4	Add 0.04 mm (0.0016 in)
-3	Add 0.03 mm (0.0012 in)
-2	Add 0.02 mm (0.0008 in)
-1	Add 0.01 mm (0.0004 in)
0	Use the selected washer thickness
+1	Subtract 0.01 mm (0.0004 in)
+2	Subtract 0.02 mm (0.0008 in)
+3	Subtract 0.03 mm (0.0012 in)
+4	Subtract 0.04 mm (0.0016 in)
+5	Subtract 0.05 mm (0.0020 in)
+6	Subtract 0.06 mm (0.0024 in)

- Select the correct pinion height adjusting washer.
- Remove the J-34309 differential shim selector tool from the final drive housing. Then disassemble to retrieve the pinion bearings.

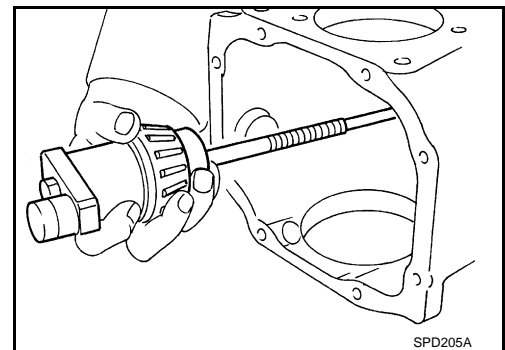

DRIVE PINION RUNOUT

- Set a dial indicator (A) vertically to the tip of the drive pinion.
- Rotate drive pinion to check for runout.

Limit

Drive pinion runout

: Refer to [DLN-296, "Drive Pinion Runout \(A/T Models\)"](#).

- If the runout value is outside of the limit, possible causes are an assembly malfunction of drive pinion and pinion bearing and malfunction of pinion bearing. Check for these items and repair if necessary.

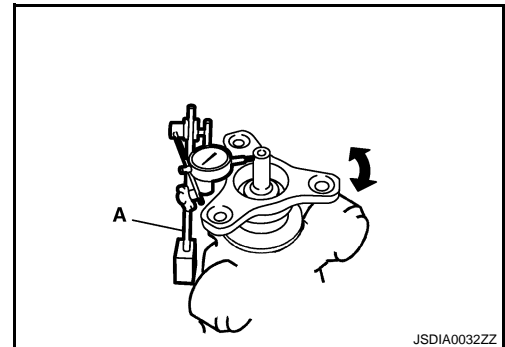

A/T : Inspection After Disassembly

INFOID:000000005649825

DRIVE GEAR AND DRIVE PINION

- Clean up the disassembled parts.
- If the gear teeth never mesh or line-up correctly, determine the cause and adjust or replace as necessary.
- If the gears are worn, cracked, damaged, pitted or chipped (by friction) noticeably, replace with new drive gear and drive pinion as a set.

BEARING

- Clean up the disassembled parts.
- If any chipped (by friction), pitted, worn, rusted or scratched marks, or unusual noise from the bearing is observed, replace as a bearing assembly (as a new set).

SIDE GEAR AND PINION MATE GEAR

- Clean up the disassembled parts.
- If any cracks or damage on the surface of the tooth is found, replace.
- If any worn or chipped mark on the contact sides of the thrust washer is found, replace.

DRIVE PINION

< UNIT DISASSEMBLY AND ASSEMBLY >

[REAR FINAL DRIVE: R200V]

SIDE GEAR THRUST WASHER AND PINION MATE THRUST WASHER

- Clean up the disassembled parts.
- If it is chipped (by friction), damaged, or unusually worn, replace.

OIL SEAL

- Whenever disassembled, replace.
- If wear, deterioration of adherence (sealing force lips), or damage is detected on the lips, replace them.

DIFFERENTIAL CASE

- Clean up the disassembled parts.
- If any wear or crack on the contact sides of the differential case is found, replace.

COMPANION FLANGE

- Clean up the disassembled parts.
- If any chipped mark [about 0.1 mm, (0.004 in)] or other damage on the contact sides of the lips of the companion flange is found, replace.

SERVICE DATA AND SPECIFICATIONS (SDS)

< SERVICE DATA AND SPECIFICATIONS (SDS)

[REAR FINAL DRIVE: R200V]

SERVICE DATA AND SPECIFICATIONS (SDS)

SERVICE DATA AND SPECIFICATIONS (SDS)

General Specification

INFOID:000000005649826

Applied model	2WD	
	VQ37VHR	
	M/T	A/T
Final drive model	R200V (With LSD)	
Gear ratio	3.692	3.357
Number of teeth (Drive gear/Drive pinion)	48/13	47/14
Oil capacity (Approx.)	ℓ (US pt, Imp pt)	1.4 (3, 2-1/2)
Number of pinion gears	4	
Drive pinion adjustment spacer type	Collapsible	

Drive Gear Runout

INFOID:000000005649827

Unit: mm (in)

Item	limit
Drive gear back face runout	0.05 (0.0020)

Differential Side Gear Clearance

INFOID:000000005649828

Unit: mm (in)

Item	Standard
Side gear backlash (Clearance between side gear and differential case)	0.15 (0.0059) or less (Each gear should rotate smoothly without excessive resistance during differential motion.)

Preload Torque

INFOID:000000005649829

Unit: N·m (kg·m, in·lb)

Item	Standard
Pinion bearing (P1)	2.65 – 3.23 (0.27 – 0.32, 24 – 28)
Side bearing (P2)	0.20 – 0.52 (0.02 – 0.05, 2 – 4)
Side bearing to pinion bearing (Total preload) (Total preload = P1 + P2)	2.85 – 3.75 (0.29 – 0.38, 26 – 33)

Backlash

INFOID:000000005649830

Unit: mm (in)

Item	Standard
Drive gear to drive pinion gear	0.10 – 0.15 (0.0039 – 0.0059)

Companion flange Runout (M/T Models)

INFOID:000000005649831

Unit: mm (in)

Item	Limit
Companion flange face runout	0.08 (0.0031)
Inner side of the companion flange runout	0.08 (0.0031)

SERVICE DATA AND SPECIFICATIONS (SDS)

< SERVICE DATA AND SPECIFICATIONS (SDS)

[REAR FINAL DRIVE: R200V]

Drive Pinion Runout (A/T Models)

INFOID:000000005649832

Unit: mm (in)

Item	Limit
Tip of drive pinion runout	0.8 (0.031)