

MWI

SECTION

METER, WARNING LAMP & INDICATOR

A
B
C
D
E
F
G
H
I
J
K
L
M
O
P

CONTENTS

BASIC INSPECTION	4	ODO/TRIP METER	19
DIAGNOSIS AND REPAIR WORKFLOW	4	ODO/TRIP METER : System Diagram	19
Work flow	4	ODO/TRIP METER : System Description	19
SYSTEM DESCRIPTION	6	ODO/TRIP METER : Component Parts Location	20
METER SYSTEM	6	ODO/TRIP METER : Component Description	20
METER SYSTEM	6	SHIFT POSITION INDICATOR	21
METER SYSTEM : System Diagram	6	SHIFT POSITION INDICATOR : System Diagram	21
METER SYSTEM : System Description	6	SHIFT POSITION INDICATOR : System Description	21
METER SYSTEM : Component Parts Location	10	SHIFT POSITION INDICATOR : Component Parts Location	22
METER SYSTEM : Component Description	10	SHIFT POSITION INDICATOR : Component Description	23
SPEEDOMETER	11	WARNING LAMPS/INDICATOR LAMPS	23
SPEEDOMETER : System Diagram	11	WARNING LAMPS/INDICATOR LAMPS : System Diagram	23
SPEEDOMETER : System Description	11	WARNING LAMPS/INDICATOR LAMPS : System Description	23
SPEEDOMETER : Component Parts Location	12	WARNING LAMPS/INDICATOR LAMPS : Component Parts Location	24
SPEEDOMETER : Component Description	12	WARNING LAMPS/INDICATOR LAMPS : Component Description	24
TACHOMETER	13	METER ILLUMINATION CONTROL	25
TACHOMETER : System Diagram	13	METER ILLUMINATION CONTROL : System Diagram	25
TACHOMETER : System Description	13	METER ILLUMINATION CONTROL : System Description	25
TACHOMETER : Component Parts Location	14	METER ILLUMINATION CONTROL : Component Parts Location	26
TACHOMETER : Component Description	14	METER ILLUMINATION CONTROL : Component Description	26
ENGINE COOLANT TEMPERATURE GAUGE	15	INFORMATION DISPLAY	27
ENGINE COOLANT TEMPERATURE GAUGE : System Diagram	15	INFORMATION DISPLAY : System Diagram	27
ENGINE COOLANT TEMPERATURE GAUGE : System Description	15	INFORMATION DISPLAY : System Description	27
ENGINE COOLANT TEMPERATURE GAUGE : Component Parts Location	16	INFORMATION DISPLAY : Component Parts Location	31
ENGINE COOLANT TEMPERATURE GAUGE : Component Description	16	INFORMATION DISPLAY : Component Description	31
FUEL GAUGE	17		
FUEL GAUGE : System Diagram	17		
FUEL GAUGE : System Description	17		
FUEL GAUGE : Component Parts Location	18		
FUEL GAUGE : Component Description	18		

MWI

COMPASS	33	IPDM E/R (INTELLIGENT POWER DISTRIBUTION MODULE ENGINE ROOM)	52
Description	33	IPDM E/R (INTELLIGENT POWER DISTRIBUTION MODULE ENGINE ROOM) : Diagnosis Procedure	52
Component Parts Location	34		
Special Repair Requirement	34		
CLOCK	35	FUEL LEVEL SENSOR SIGNAL CIRCUIT	54
Component Parts Location	35	Description	54
DIAGNOSIS SYSTEM (METER)	36	Component Function Check	54
Diagnosis Description	36	Diagnosis Procedure	55
DIAGNOSIS SYSTEM (UNIFIED METER AND A/C AMP.)	38	Component Inspection	56
CONSULT Function (METER/M&A)	38	METER CONTROL SWITCH SIGNAL CIRCUIT	58
DTC/CIRCUIT DIAGNOSIS	42	Description	58
U1000 CAN COMM CIRCUIT	42	Diagnosis Procedure	58
Description	42	Component Inspection	59
DTC Logic	42	OIL PRESSURE SWITCH SIGNAL CIRCUIT ...	60
Diagnosis Procedure	42	Description	60
U1010 CONTROL UNIT (CAN)	43	Component Function Check	60
Description	43	Diagnosis Procedure	60
DTC Logic	43	Component Inspection	60
Diagnosis Procedure	43	PARKING BRAKE SWITCH SIGNAL CIRCUIT	62
B2201 COMMUNICATION ERROR 1	44	Description	62
Description	44	Component Function Check	62
DTC Logic	44	Diagnosis Procedure (A/T models)	62
Diagnosis Procedure	44	Diagnosis Procedure (M/T models)	63
B2202 COMMUNICATION ERROR 2	46	Component Inspection	63
Description	46	WASHER LEVEL SWITCH SIGNAL CIRCUIT ..	65
DTC Logic	46	Description	65
Diagnosis Procedure	46	Diagnosis Procedure	65
B2205 VEHICLE SPEED	48	Component Inspection	65
Description	48	COMPASS	66
DTC Logic	48	Wiring Diagram - COMPASS -	66
Diagnosis Procedure	48	CLOCK	67
B2267 ENGINE SPEED	49	Wiring Diagram - CLOCK -	67
Description	49	ECU DIAGNOSIS INFORMATION	68
DTC Logic	49	COMBINATION METER	68
Diagnosis Procedure	49	Reference Value	68
B2268 WATER TEMP	50	Wiring Diagram - METER -	71
Description	50	Fail-safe	73
DTC Logic	50	DTC Index	74
Diagnosis Procedure	50	UNIFIED METER AND A/C AMP.	75
POWER SUPPLY AND GROUND CIRCUIT	51	Reference Value	75
COMBINATION METER	51	Wiring Diagram - METER -	82
COMBINATION METER : Diagnosis Procedure ...	51	Fail-safe	84
UNIFIED METER AND A/C AMP.	51	DTC Index	85
UNIFIED METER AND A/C AMP. : Diagnosis Procedure	51	IPDM E/R (INTELLIGENT POWER DISTRIBUTION MODULE ENGINE ROOM)	87
		Reference Value	87
		Wiring Diagram - IPDM E/R -	94

Fail-safe	96	THE AMBIENT TEMPERATURE DISPLAY IS INCORRECT	107	A
DTC Index	98	Description	107	
SYMPTOM DIAGNOSIS	99	Diagnosis Procedure	107	
THE FUEL GAUGE POINTER DOES NOT MOVE	99	NORMAL OPERATING CONDITION	108	B
Description	99	COMPASS	108	
Diagnosis Procedure	99	COMPASS : Description	108	C
THE METER CONTROL SWITCH IS INOPERATIVE	100	INFORMATION DISPLAY	108	
Description	100	INFORMATION DISPLAY : Description	108	D
Diagnosis Procedure	100	PRECAUTION	109	
THE OIL PRESSURE WARNING LAMP DOES NOT TURN ON	101	PRECAUTIONS	109	E
Description	101	Precaution for Supplemental Restraint System (SRS) "AIR BAG" and "SEAT BELT PRE-TENSIONER"	109	
Diagnosis Procedure	101	Precaution for Battery Service	109	F
THE OIL PRESSURE WARNING LAMP DOES NOT TURN OFF	102	PREPARATION	110	
Description	102	PREPARATION	110	G
Diagnosis Procedure	102	Commercial Service Tools	110	
THE PARKING BRAKE RELEASE WARNING CONTINUES DISPLAYING, OR DOES NOT DISPLAY	103	REMOVAL AND INSTALLATION	111	H
Description	103	COMBINATION METER	111	
Diagnosis Procedure	103	Exploded View	111	I
THE LOW WASHER FLUID WARNING CONTINUES DISPLAYING, or DOES NOT DISPLAY	104	Removal and Installation	112	
Description	104	Disassembly and Assembly	112	J
Diagnosis Procedure	104	UNIFIED METER AND A/C AMP.	113	
THE DOOR OPEN WARNING CONTINUES DISPLAYING, OR DOES NOT DISPLAY	105	Exploded View	113	K
Description	105	Removal and Installation	113	
Diagnosis Procedure	105	METER CONTROL SWITCH	114	L
THE TRUNK OPEN WARNING CONTINUES DISPLAYING, OR DOES NOT DISPLAY	106	Exploded View	114	
Description	106	Removal and Installation	114	M
Diagnosis Procedure	106	COMPASS	115	
		Exploded View	115	
		Removal and Installation	115	
		CLOCK	116	
		Exploded View	116	
		Removal and Installation	116	

MWI

DIAGNOSIS AND REPAIR WORKFLOW

< BASIC INSPECTION >

BASIC INSPECTION

DIAGNOSIS AND REPAIR WORKFLOW

Work flow

INFOID:000000007474214

OVERALL SEQUENCE

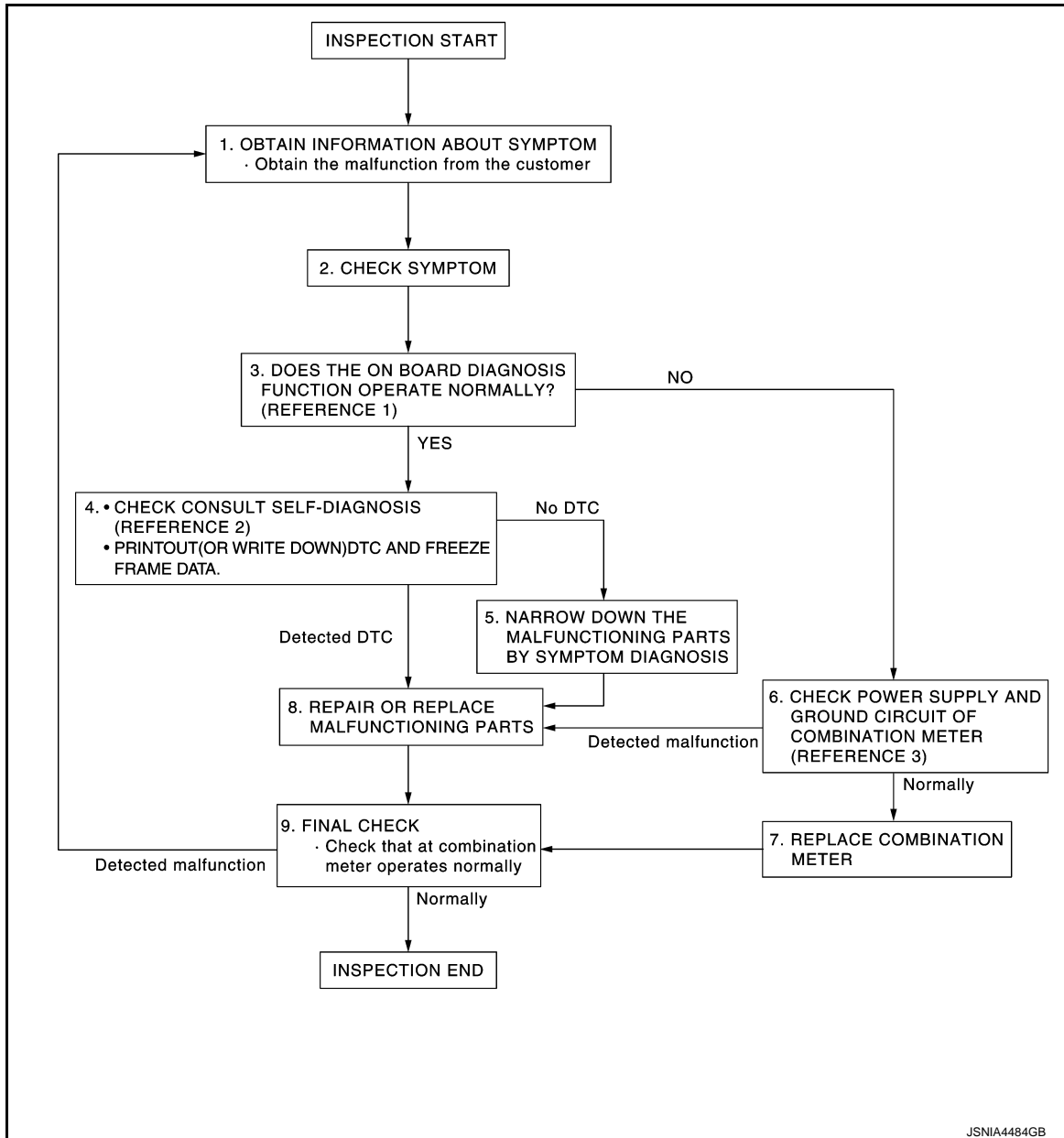

- Reference 1...[MWI-36, "Diagnosis Description"](#).
- Reference 2...[MWI-85, "DTC Index"](#).
- Reference 3...[MWI-51, "COMBINATION METER : Diagnosis Procedure"](#).

DETAILED FLOW

1.OBTAIN INFORMATION ABOUT SYMPTOM

Interview the customer to obtain as much information as possible about the conditions and environment under which the malfunction occurred.

>> GO TO 2.

2.CHECK SYMPTOM

DIAGNOSIS AND REPAIR WORKFLOW

< BASIC INSPECTION >

- Check the symptom based on the information obtained from the customer.
- Check that any other malfunctions are present.

>> GO TO 3.

3.CHECK ON BOARD DIAGNOSIS OPERATION

Check that the on board diagnosis function operates. Refer to [MWI-36, "Diagnosis Description"](#).

Does the on board diagnosis function operate normally?

YES >> GO TO 4.

NO >> GO TO 6.

4.CHECK CONSULT SELF-DIAGNOSIS RESULTS

1. Connect CONSULT and perform self-diagnosis. Refer to [MWI-85, "DTC Index"](#).

2. When DTC is detected, follow the instructions below:

- Record DTC and Freeze Frame Data.

Are self-diagnosis results normal?

YES >> GO TO 5.

NO >> GO TO 8.

5.NARROW DOWN THE MALFUNCTIONING PARTS BY SYMPTOM DIAGNOSIS

Perform symptom diagnosis and narrow down the malfunctioning parts.

>> GO TO 8.

6.CHECK COMBINATION METER POWER SUPPLY AND GROUND CIRCUITS

Check combination meter power supply and ground circuits. Refer to [MWI-51, "COMBINATION METER : Diagnosis Procedure"](#).

Is the inspection result normal?

YES >> GO TO 7.

NO >> GO TO 8.

7.REPLACE COMBINATION METER

Replace combination meter.

>> GO TO 9.

8.REPAIR OR REPLACE MALFUNCTIONING PARTS

Repair or replace the malfunctioning parts.

NOTE:

If DTC is displayed, erase DTC after repair or replace malfunctioning parts.

>> GO TO 9.

9.FINAL CHECK

Check that the combination meter operates normally.

Do they operate normally?

YES >> INSPECTION END

NO >> GO TO 1.

A

B

C

D

E

F

G

H

I

J

K

L

M

MWI

O

P

METER SYSTEM

< SYSTEM DESCRIPTION >

SYSTEM DESCRIPTION

METER SYSTEM

METER SYSTEM

METER SYSTEM : System Diagram

INFOID:000000007474215

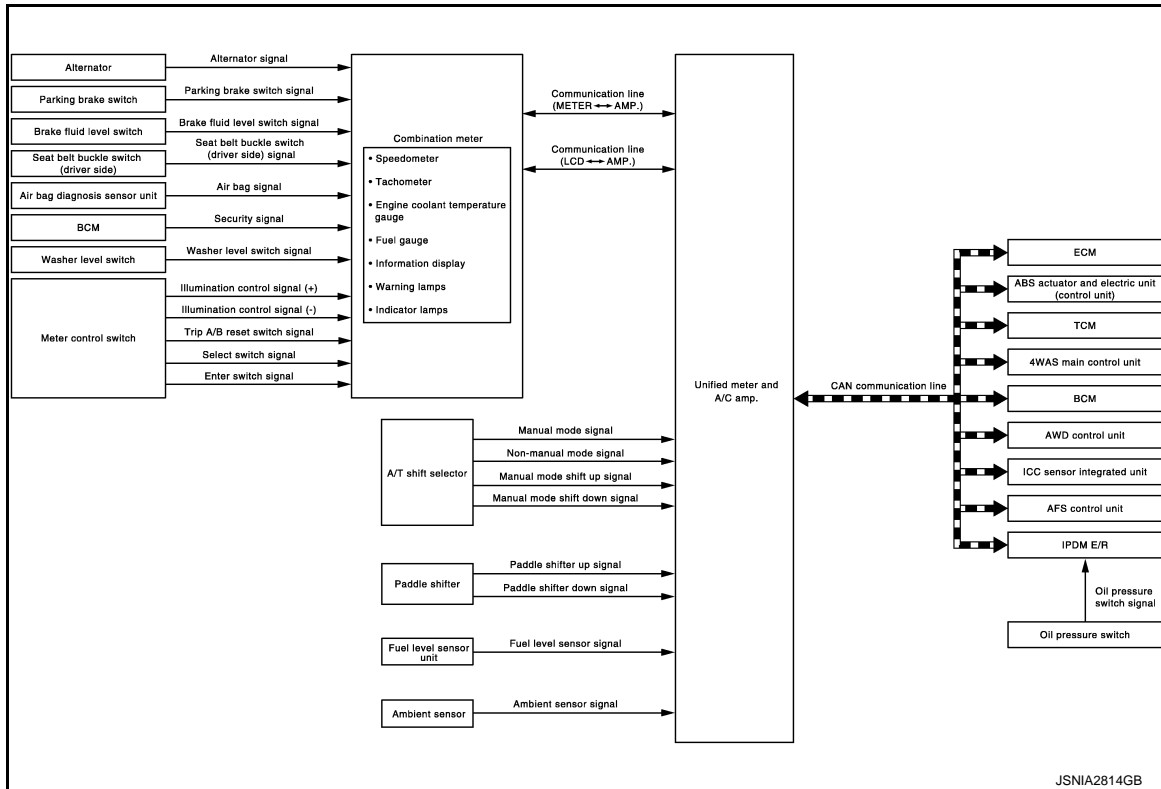

METER SYSTEM : System Description

INFOID:000000007474216

COMBINATION METER

- The combination meter retrieves the information required for controlling the operations of the meters, indicator lamps/warning lamps and information display from the communication signals from the unified meter and A/C amp. and the signals from various switches and sensors.
- The combination meter incorporates a trip computer that displays warnings and messages on the information display according to the information received from various units.
- The combination meter incorporates a buzzer function that sounds an audible alarm with the integrated buzzer device. Refer to [WCS-5. "WARNING CHIME SYSTEM : System Description"](#) for further details.
- The combination meter integrates the meter circuit check function and the segment check function that checks the information display operation.

UNIFIED METER AND A/C AMP.

- Receives information required by the combination meter from various units via CAN communication line and transmits it to the combination meter with communication line.
- The unified meter and A/C amp. incorporates a power saving control function that reduces the power consumption according to the vehicle status. Refer to [BCS-13. "System Description"](#) for details.
- The unified meter and A/C amp. incorporates a diagnosis function that allows the technician to perform diagnoses with CONSULT.

METER SYSTEM

< SYSTEM DESCRIPTION >

Between unified meter and A/C amp. and combination meter.

Unit	Communication line	Input from combination meter	Output to combination meter	
Unified meter and A/C amp.	Communication line (METER <-> AMP.)	<ul style="list-style-type: none"> • Parking brake switch signal • Washer level switch signal • Meter day/night condition signal • Illumination control switch signal • Refuel status signal • Low fuel warning lamp signal • Odo data signal 	<ul style="list-style-type: none"> • Vehicle speed signal • Turn indicator signal • High beam request signal • Engine speed signal • Fuel level sensor signal • Engine coolant temperature signal • A/T CHECK indicator signal • Oil pressure switch signal • Door switch signal • Buzzer output signal • AFS OFF indicator lamp signal • TPMS malfunction warning lamp signal • VDC OFF indicator signal • ABS warning lamp signal • Brake warning lamp signal • Malfunction indicator lamp signal • 4WAS warning lamp signal • Master warning signal • AWD warning lamp signal • Front fog light request signal • Position light request signal 	A B C D E F
	Communication line (LCD <-> AMP.)	<ul style="list-style-type: none"> • Average fuel consumption reset signal • Travel time reset signal • Possible driving distance reset signal • Average vehicle speed reset signal • Select switch signal • Enter switch signal • Trip A/B reset switch signal • Ambient air temperature display signal 	<ul style="list-style-type: none"> • Shift position signal • Meter display signal • Door switch signal • Trunk switch signal • Fuel level sensor signal • Parking brake switch signal • Washer level switch signal • Charge warning signal • Instantaneous fuel consumption display signal • Ambient air temperature display signal • Average fuel consumption display signal • Average vehicle speed display signal • Possible driving distance display signal • Engine speed signal • Vehicle speed signal • Low tire pressure warning lamp signal • Fuel filler cap warning display signal 	G H I J K

IPDM E/R

- IPDM E/R reads the ON/OFF signals of the oil pressure switch and transmits the oil pressure switch signal to the unified meter and A/C amp. via BCM with the CAN communication line.
- IPDM E/R is equipped with the diagnosis function. It can perform the operation check of oil pressure warning lamp with the auto active test and the diagnosis with CONSULT.

METER CONTROL FUNCTION LIST

X: Applicable

System		Description	Signal source	Via unified meter and A/C amp.
Meter/gauge	Speedometer	Receives vehicle speed signal and indicates vehicle speed.	ABS actuator and electric unit (control unit)	X
	Tachometer	Receives engine speed signal and indicates engine speed.	ECM	X
	Fuel gauge	Receives fuel level sensor signal and indicates fuel level.	Fuel level sensor unit	X
	Water temperature gauge	Receives engine coolant temperature signal and indicates coolant temperature.	ECM	X

METER SYSTEM

< SYSTEM DESCRIPTION >

System		Description	Signal source	Via unified meter and A/C amp.
Warning lamp/ indicator lamp	Oil pressure warning lamp	Receives oil pressure warning lamp signal and illuminates warning lamp.	IPDM E/R	X
	Master warning	Illuminates according to warning output on information display.	—	X
Information display	Door open warning	Receives door switch signals and displays warning.	BCM	X
	Trunk open warning	Receives trunk lid opener switch signal and displays warning.	BCM	X
	Parking brake release warning	Receives parking brake switch signal and vehicle speed signal and displays warnings.	Parking brake switch	
			ABS actuator and electric unit (control unit)	X
	Low fuel warning	Receives fuel gauge signal and displays warning if fuel level decreases to 15 ℓ (4 US gal, 3-1/4 Imp gal) or less.	Fuel level sensor unit	X
	Low washer fluid warning	Receives washer level switch signal and displays warning.	Washer level switch	
	Low outside temperature warning	Monitors ambient sensor signal and displays warning if ambient temperature decreases to 3°C (37°F) or less. (If enabled)	Ambient sensor	X
	Low tire pressure warning	Receives low tire pressure warning lamp signal and displays warning.	BCM	X
	Fuel filler cap warning	Receives fuel filler cap warning display signals and displays warning.	ECM	X
	Instantaneous fuel consumption	Calculates instantaneous fuel consumption based on received vehicle speed signals and fuel consumption monitor signal and displays it.	ECM	X
			ABS actuator and electric unit (control unit)	X
	Average fuel consumption	Calculates average fuel consumption in a reset-to-reset interval based on received vehicle speed signals and fuel consumption monitor signal and displays it.	ECM	X
			ABS actuator and electric unit (control unit)	X
	Average vehicle speed	Calculates average vehicle speed in a reset-to-reset interval based on received vehicle speed signals and displays it.	ABS actuator and electric unit (control unit)	X
	Travel time	Displays accumulated key switch ON time from reset to reset.	—	X
Travel distance	Calculates accumulated travel distance in a reset-to-reset interval based on received vehicle speed signals and displays it.	ABS actuator and electric unit (control unit)	X	
Possible driving distance	The unified meter and A/C amp. calculates the possible driving distance according to the vehicle speed signal and the fuel level sensor unit received with CAN communication line, and transmits it to the combination meter by means of communication line.	ABS actuator and electric unit (control unit)	X	
		Fuel level sensor unit	X	
Ambient air temperature	Corrects ambient air temperature value based on received ambient sensor signals and displays it.	Ambient sensor	X	

METER SYSTEM

< SYSTEM DESCRIPTION >

ARRANGEMENT OF COMBINATION METER

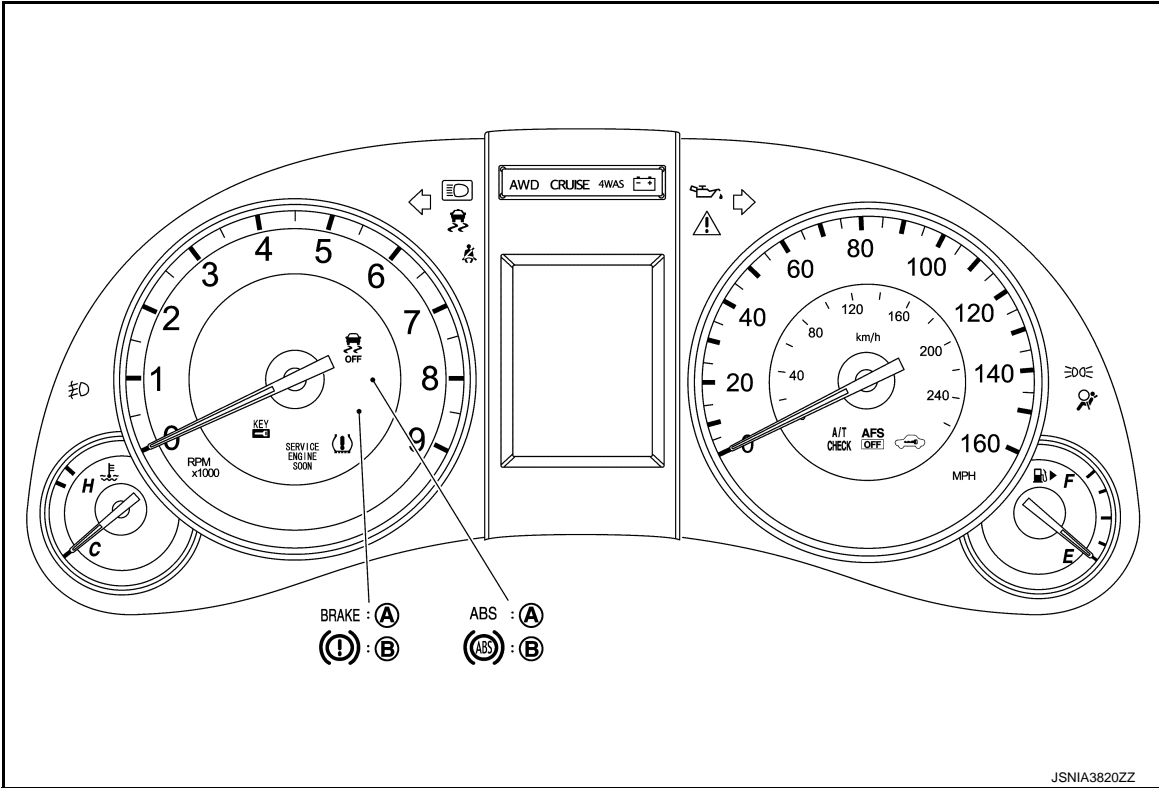

A. U.S.A.

B. Canada

A
B
C
D
E
F
G
H
I
J
K
L
M
N
O
P

MWI

METER SYSTEM

< SYSTEM DESCRIPTION >

METER SYSTEM : Component Parts Location

INFOID:000000007474217

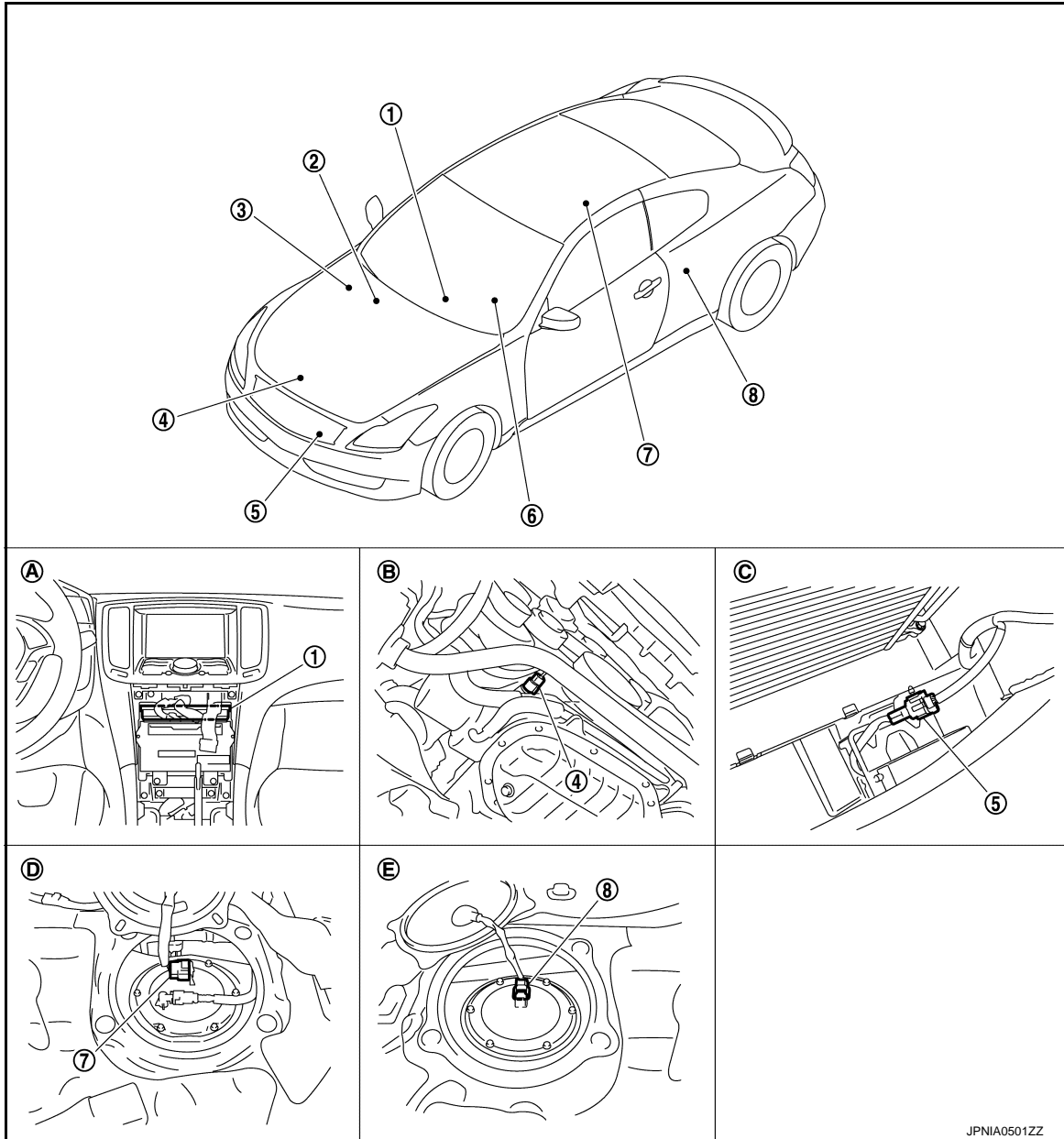

- | | | |
|--|---------------------------------|----------------------|
| 1. Unified meter and A/C amp. | 2. BCM | 3. IPDM E/R |
| 4. Oil pressure switch | 5. Ambient sensor | 6. Combination meter |
| 7. Fuel level sensor unit and fuel pump (main) | 8. Fuel level sensor unit (sub) | |
| A. Behind cluster lid C | B. Oil pan (upper) RH side | C. Condenser (front) |
| D. Rear seat (lower right) | E. Rear seat (lower left) | |

METER SYSTEM : Component Description

INFOID:000000007474218

Unit	Description
Combination meter	<p>Controls the following with the signals from the unified meter and A/C amp, switches and sensors.</p> <ul style="list-style-type: none"> • Speedometer • Water temperature gauge • Warning lamps • Information display • Tachometer • Fuel gauge • Indicator lamps • Warning chime

METER SYSTEM

< SYSTEM DESCRIPTION >

Unit	Description
Unified meter and A/C amp.	<ul style="list-style-type: none"> The combination meter receives the necessary information from various units via CAN communication line and transmits them to the unified meter and A/C amp. with the communication line that connects both of them. Transmits the fuel gauge signal from the fuel gauge unit with the communication line that connects the unified meter and A/C amp. and the combination meter. Reads the signals from the A/T shift selector and paddle shifter and transmits them to TCM with CAN communication line.
IPDM E/R	IPDM E/R reads the ON/OFF signals of the oil pressure switch and transmits the oil pressure switch signal to the unified meter and A/C amp. via BCM with CAN communication line.
Fuel level sensor unit	Refer to MWI-54, "Description" .
Oil pressure switch	Refer to MWI-60, "Description" .
ECM	Transmits the following signals to the unified meter and A/C amp. with CAN communication line. <ul style="list-style-type: none"> Engine speed signal Engine coolant temperature signal Fuel consumption monitor signal Fuel filler cap warning display signal
ABS actuator and electric unit (control unit)	Transmits the vehicle speed signal to the unified meter and A/C amp. with CAN communication line.
BCM	<ul style="list-style-type: none"> Transmits signals provided by various units to the unified meter and A/C amp. with CAN communication line. Transmits the security signal and low tire pressure warning lamp signal to the combination meter.
A/T shift selector	Transmits the following signals to the unified meter and A/C amp. <ul style="list-style-type: none"> Manual mode signal Non-manual mode signal Manual mode shift up signal Manual mode shift down signal
Paddle shifter	Transmits the paddle shifter up signal and paddle shifter down signal to the unified meter and A/C amp.
TCM	Transmits shift position signal to the unified meter and A/C amp.
Meter control switch	Refer to MWI-58, "Description" .
Washer level switch	Transmits the washer level switch signal to the combination meter.
Brake fluid level switch	Transmits the brake fluid level switch signal to the combination meter.
Parking brake switch	Refer to MWI-62, "Description" .

SPEEDOMETER

SPEEDOMETER : System Diagram

INFOID:000000007474219

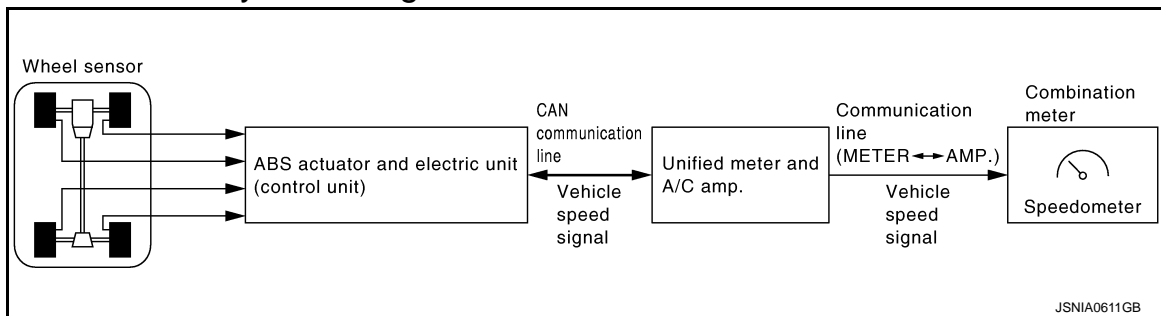

SPEEDOMETER : System Description

INFOID:000000007474220

- The ABS actuator and electric unit (control unit) converts the pulse signal provided by the wheel sensor to a vehicle speed signal and transmits it to the unified meter and A/C amp. with CAN communication line.
- The unified meter and A/C amp. receives the vehicle speed signal from the ABS actuator and electric unit (control unit) with CAN communication line and transmits it to the combination meter by means of communication line.
- The combination meter indicates the vehicle speed according to the vehicle speed signal received from the unified meter and A/C amp. by means of communication line.

METER SYSTEM

< SYSTEM DESCRIPTION >

SPEEDOMETER : Component Parts Location

INFOID:000000007616418

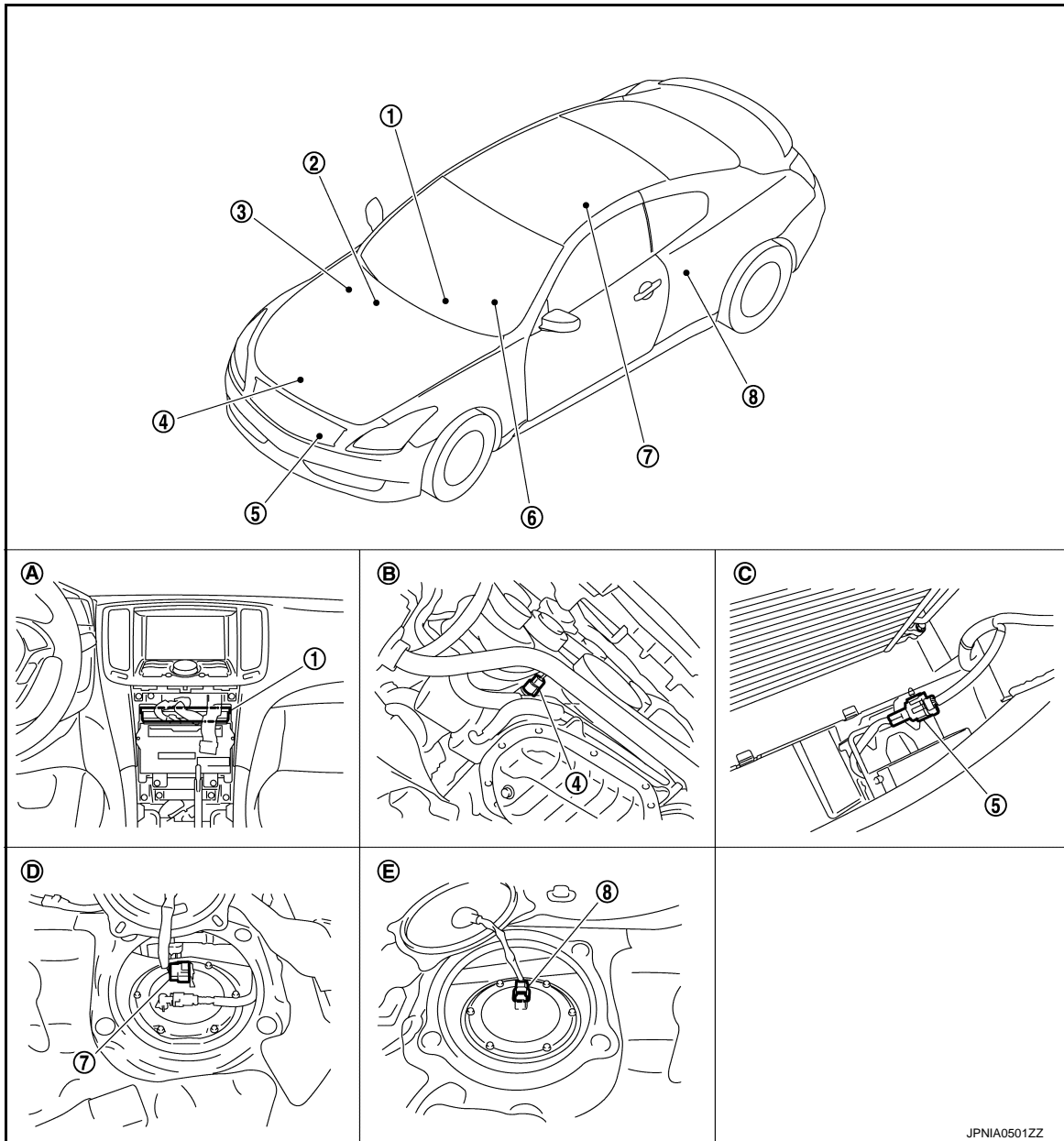

JPNIA0501ZZ

- | | | |
|--|---------------------------------|----------------------|
| 1. Unified meter and A/C amp. | 2. BCM | 3. IPDM E/R |
| 4. Oil pressure switch | 5. Ambient sensor | 6. Combination meter |
| 7. Fuel level sensor unit and fuel pump (main) | 8. Fuel level sensor unit (sub) | |
| A. Behind cluster lid C | B. Oil pan (upper) RH side | C. Condenser (front) |
| D. Rear seat (lower right) | E. Rear seat (lower left) | |

SPEEDOMETER : Component Description

INFOID:000000007474222

Unit	Description
Combination meter	Indicates the vehicle speed according to the vehicle speed signal received from the unified meter and A/C amp. by means of communication line.
Unified meter and A/C amp.	Transmits the vehicle speed signal received from ABS actuator and electric unit (control unit) with CAN communication line to the combination meter by means of communication line.
ABS actuator and electric unit (control unit)	Transmits the vehicle speed signal to the unified meter and A/C amp. with CAN communication line.

METER SYSTEM

< SYSTEM DESCRIPTION >

TACHOMETER

TACHOMETER : System Diagram

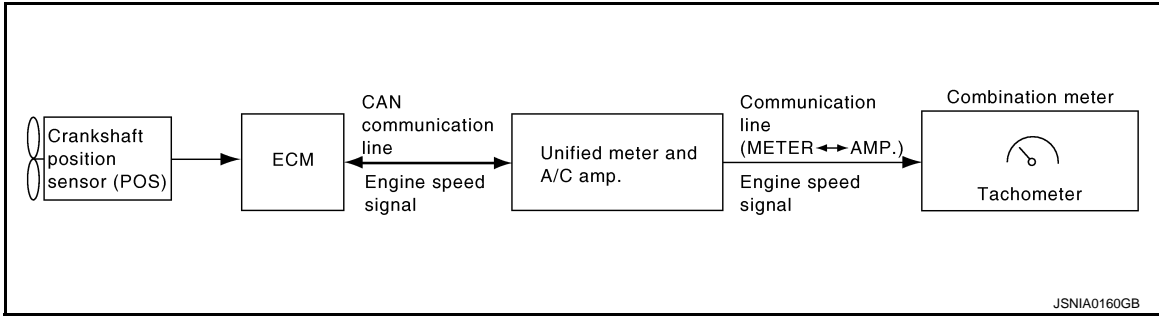

TACHOMETER : System Description

INFOID:000000007474224

- ECM converts the pulse signal provided by the crankshaft position sensor to an engine speed signal and transmits it to the unified meter and A/C amp. with CAN communication line.
- Unified meter and A/C amp. transmits engine speed signal to combination meter with communication line.
- The unified meter and A/C amp. receives the engine speed signal from ECM with CAN communication line and transmits it to the combination meter by means of communication line.
- Combination meter converses engine speed signal to the angle signal, and commands to tachometer.

A
B
C
D
E
F
G
H
I
J
K
L
M
N
O
P

MWI

METER SYSTEM

< SYSTEM DESCRIPTION >

TACHOMETER : Component Parts Location

INFOID:000000007616419

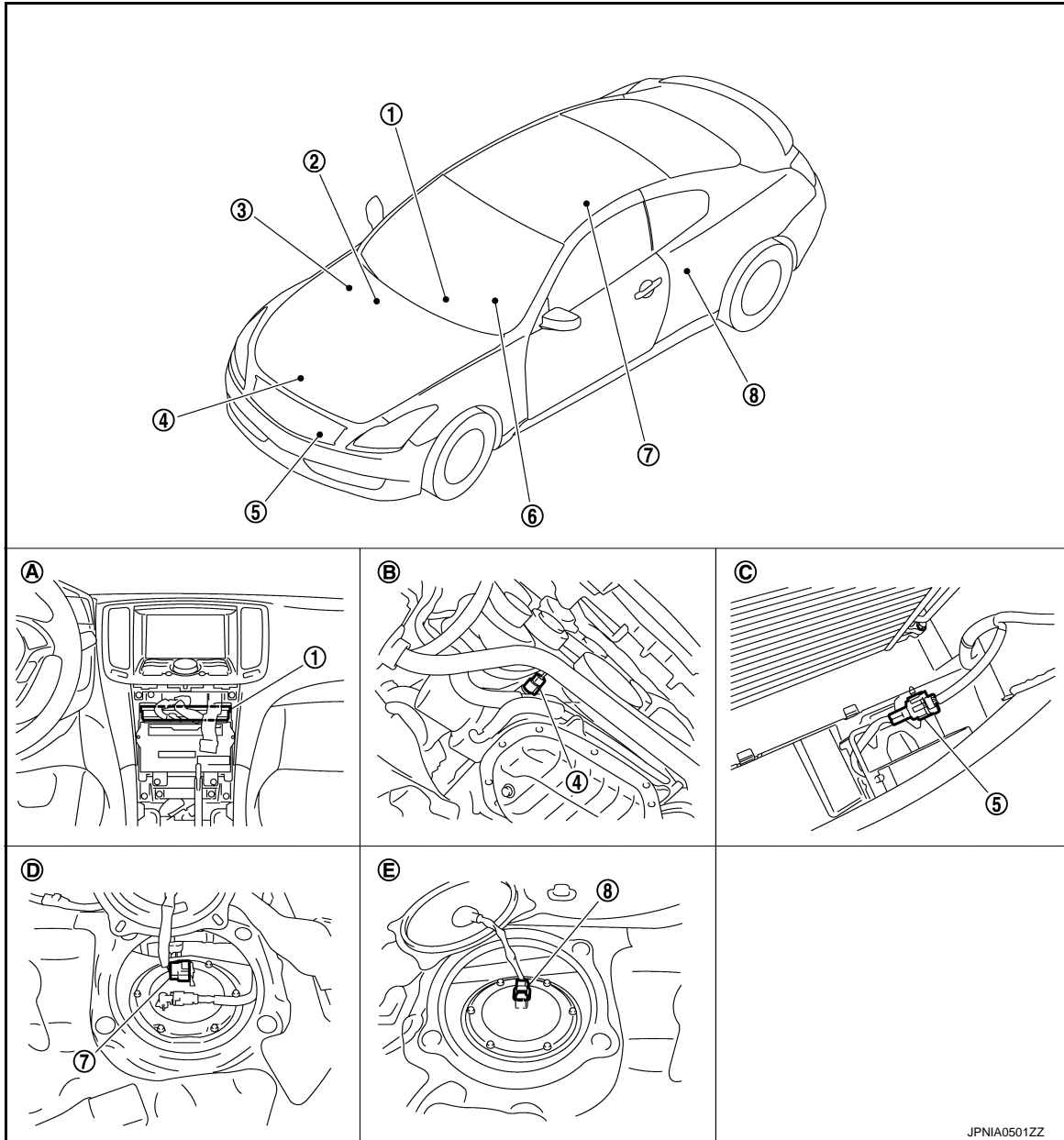

- | | | |
|--|---------------------------------|----------------------|
| 1. Unified meter and A/C amp. | 2. BCM | 3. IPDM E/R |
| 4. Oil pressure switch | 5. Ambient sensor | 6. Combination meter |
| 7. Fuel level sensor unit and fuel pump (main) | 8. Fuel level sensor unit (sub) | |
| A. Behind cluster lid C | B. Oil pan (upper) RH side | C. Condenser (front) |
| D. Rear seat (lower right) | E. Rear seat (lower left) | |

JPNIA0501ZZ

TACHOMETER : Component Description

INFOID:000000007474226

Unit	Description
Combination meter	Indicates the engine speed according to the engine speed signal received from the unified meter and A/C amp. by means of communication line.
Unified meter and A/C amp.	Transmits the engine speed signal received from ECM with CAN communication line to the combination meter by means of communication line.
ECM	Transmits the engine speed signal to the unified meter and A/C amp. with CAN communication line.

METER SYSTEM

< SYSTEM DESCRIPTION >

ENGINE COOLANT TEMPERATURE GAUGE

ENGINE COOLANT TEMPERATURE GAUGE : System Diagram

INFOID:000000007474227

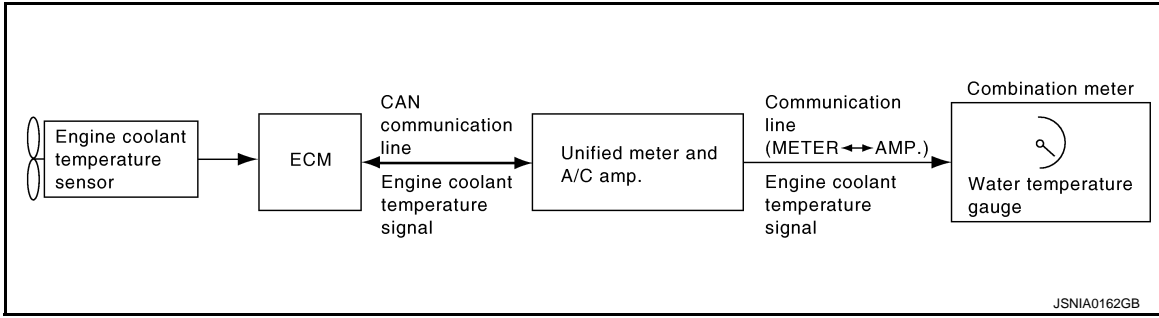

ENGINE COOLANT TEMPERATURE GAUGE : System Description

INFOID:000000007474228

- ECM converts a signal from engine coolant temperature sensor to engine coolant temperature signal, and transmits to unified meter and A/C amp. with CAN communication line.
- Unified meter and A/C amp. transmits engine coolant temperature signal to combination meter with communication line.
- Combination meter converts engine coolant temperature signal to the angle signal, and commands to engine coolant temperature gauge.

A
B
C
D
E
F
G
H
I
J
K
L
M
O
P

MWI

METER SYSTEM

< SYSTEM DESCRIPTION >

ENGINE COOLANT TEMPERATURE GAUGE : Component Parts Location

INFOID:000000007616420

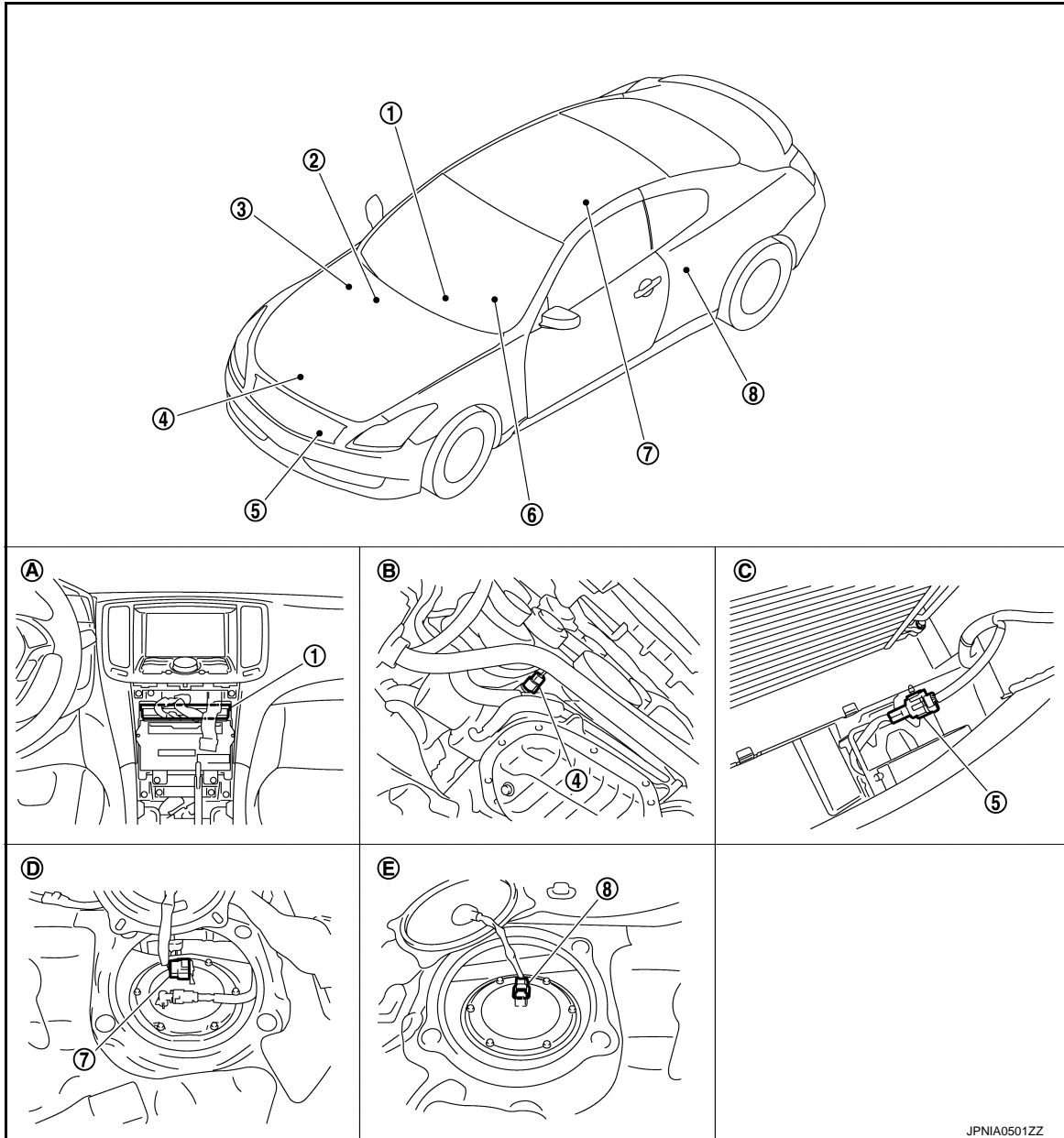

JPNIA0501ZZ

- | | | |
|--|---------------------------------|----------------------|
| 1. Unified meter and A/C amp. | 2. BCM | 3. IPDM E/R |
| 4. Oil pressure switch | 5. Ambient sensor | 6. Combination meter |
| 7. Fuel level sensor unit and fuel pump (main) | 8. Fuel level sensor unit (sub) | |
| A. Behind cluster lid C | B. Oil pan (upper) RH side | C. Condenser (front) |
| D. Rear seat (lower right) | E. Rear seat (lower left) | |

ENGINE COOLANT TEMPERATURE GAUGE : Component Description

INFOID:000000007474230

Unit	Description
Combination meter	Indicates the water temperature gauge according to the engine coolant temperature signal received from the unified meter and A/C amp. by means of communication line.

METER SYSTEM

< SYSTEM DESCRIPTION >

Unit	Description
Unified meter and A/C amp.	Transmits the engine coolant temperature signal received from ECM with CAN communication line to the combination meter by means of communication line.
ECM	Transmits the engine coolant temperature signal to the unified meter and A/C amp. with CAN communication line.

FUEL GAUGE

FUEL GAUGE : System Diagram

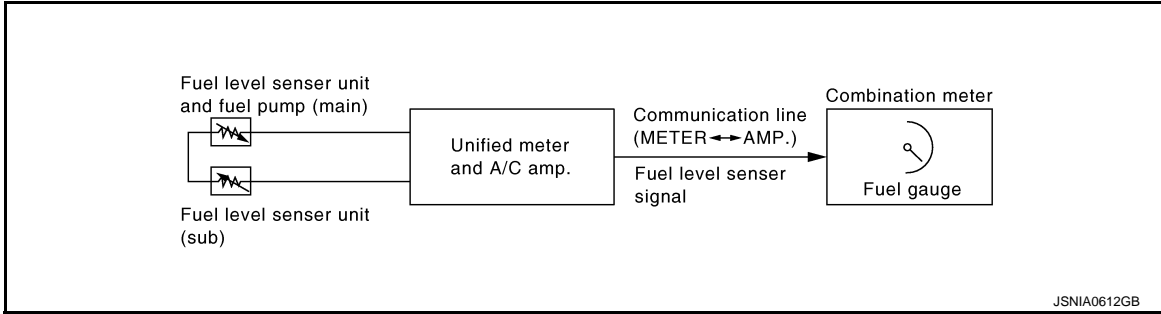

FUEL GAUGE : System Description

INFOID:000000007474232

CONTROL OUTLINE

- The unified meter and A/C amp. reads the fuel level sensor signal from the fuel gauge unit and transmits it to the combination meter with the communication line.
- The combination meter indicates the fuel level on the fuel gauge according to the received fuel level sensor signal.

REFUEL CONTROL

The unit judges that the driver is refueling the vehicle and accelerates the fuel gauge needle movement if the fuel level changes by 15 ℓ (4 US gal, 3-3/10 Imp gal) or more.

A
B
C
D
E
F
G
H
I
J
K
L
M
N
O
P

MWI

METER SYSTEM

< SYSTEM DESCRIPTION >

FUEL GAUGE : Component Parts Location

INFOID:000000007616421

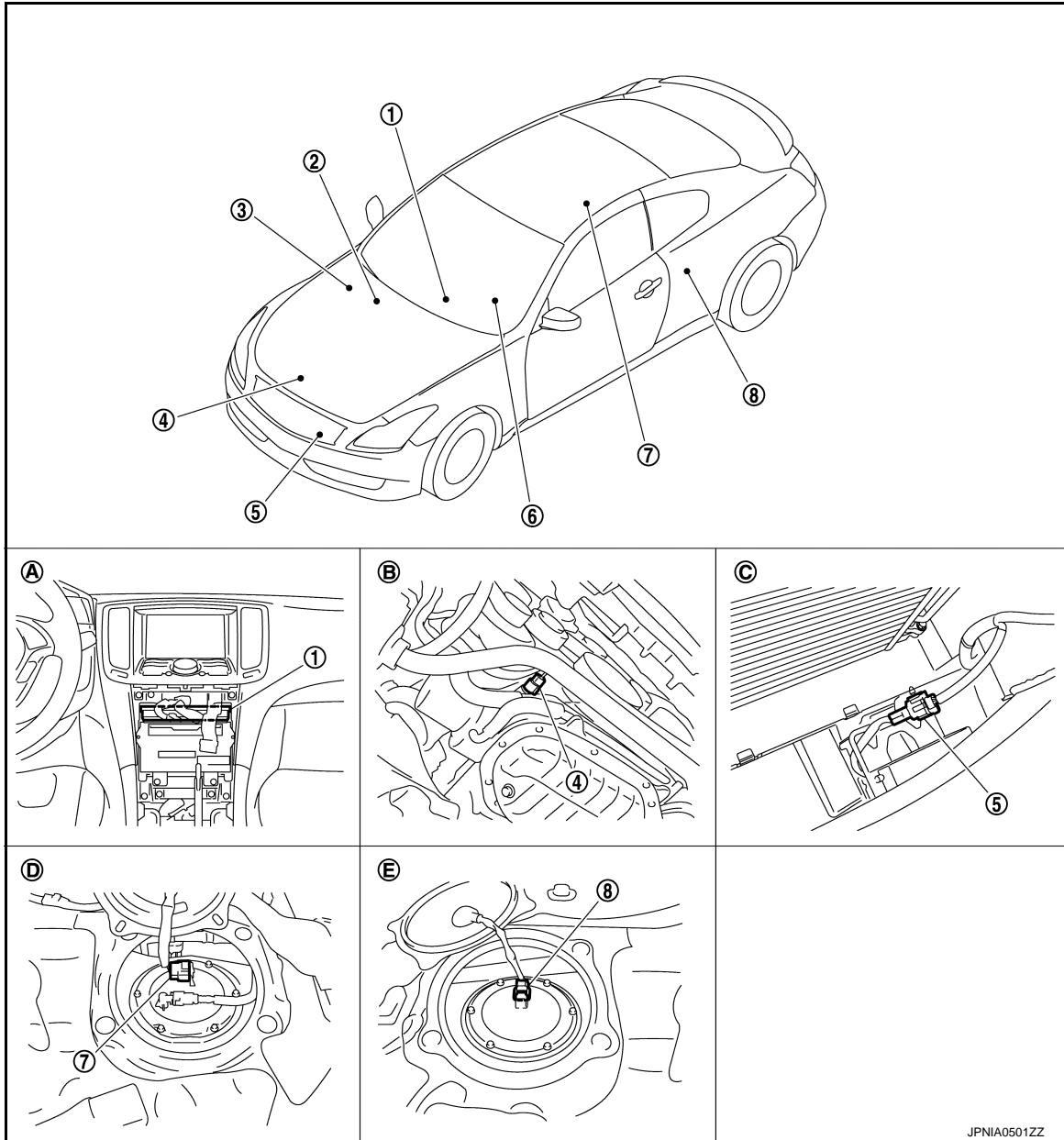

- | | | |
|--|---------------------------------|----------------------|
| 1. Unified meter and A/C amp. | 2. BCM | 3. IPDM E/R |
| 4. Oil pressure switch | 5. Ambient sensor | 6. Combination meter |
| 7. Fuel level sensor unit and fuel pump (main) | 8. Fuel level sensor unit (sub) | |
| A. Behind cluster lid C | B. Oil pan (upper) RH side | C. Condenser (front) |
| D. Rear seat (lower right) | E. Rear seat (lower left) | |

FUEL GAUGE : Component Description

INFOID:000000007474234

Unit	Description
Combination meter	Indicates the fuel gauge according to the fuel level sensor signal received from the unified meter and A/C amp. by means of communication line.
Unified meter and A/C amp.	Transmits the fuel level sensor signal from the fuel level sensor unit to the combination meter by means of communication line.
Fuel level sensor unit	Refer to MWI-54, "Description" .

METER SYSTEM

< SYSTEM DESCRIPTION >

ODO/TRIP METER

ODO/TRIP METER : System Diagram

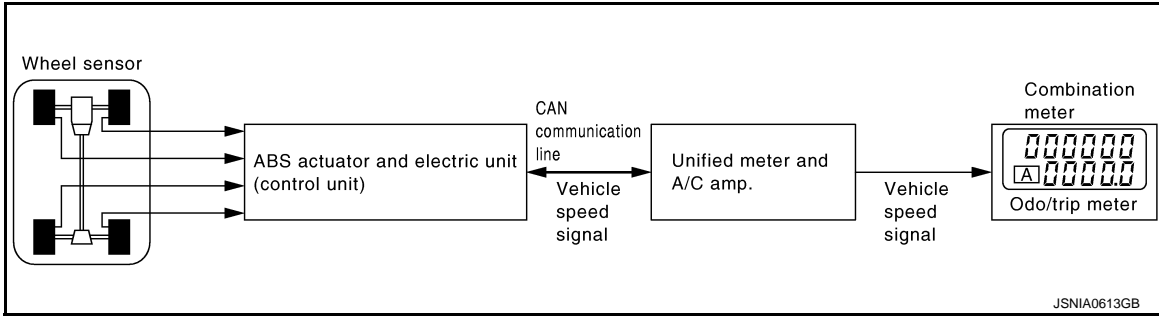

ODO/TRIP METER : System Description

INFOID:000000007474236

- The unified meter and A/C amp. transmits the vehicle speed signal from ABS actuator and electric unit (control unit) to the combination meter.
- The combination meter calculates the vehicle distance according to the vehicle speed signal. The vehicle distance is displayed.

A
B
C
D
E
F
G
H
I
J
K
L
M

MWI

O
P

METER SYSTEM

< SYSTEM DESCRIPTION >

ODO/TRIP METER : Component Parts Location

INFOID:000000007616422

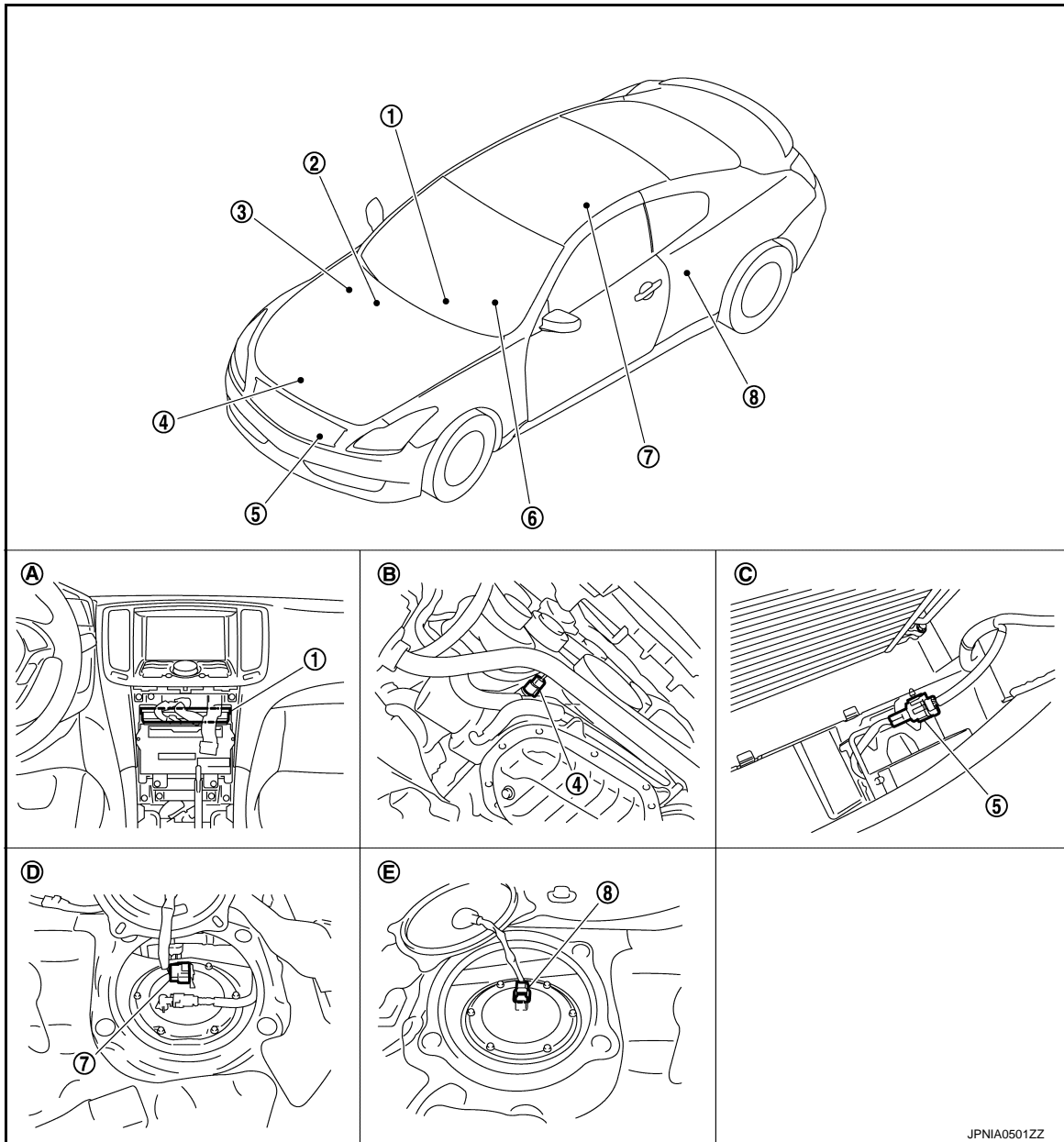

JPNIA0501ZZ

- | | | |
|--|---------------------------------|----------------------|
| 1. Unified meter and A/C amp. | 2. BCM | 3. IPDM E/R |
| 4. Oil pressure switch | 5. Ambient sensor | 6. Combination meter |
| 7. Fuel level sensor unit and fuel pump (main) | 8. Fuel level sensor unit (sub) | |
| A. Behind cluster lid C | B. Oil pan (upper) RH side | C. Condenser (front) |
| D. Rear seat (lower right) | E. Rear seat (lower left) | |

ODO/TRIP METER : Component Description

INFOID:000000007474238

Unit	Description
Combination meter	The combination meter calculates the vehicle distance according to the vehicle speed signal. The vehicle distance is displayed.
Unified meter and A/C amp.	The unified meter and A/C amp. transmits the vehicle speed signal from ABS actuator and electric unit (control unit) to the combination meter.
ABS actuator and electric unit (control unit)	Transmits the vehicle speed signal to the unified meter and A/C amp. with CAN communication line.

METER SYSTEM

< SYSTEM DESCRIPTION >

SHIFT POSITION INDICATOR

SHIFT POSITION INDICATOR : System Diagram

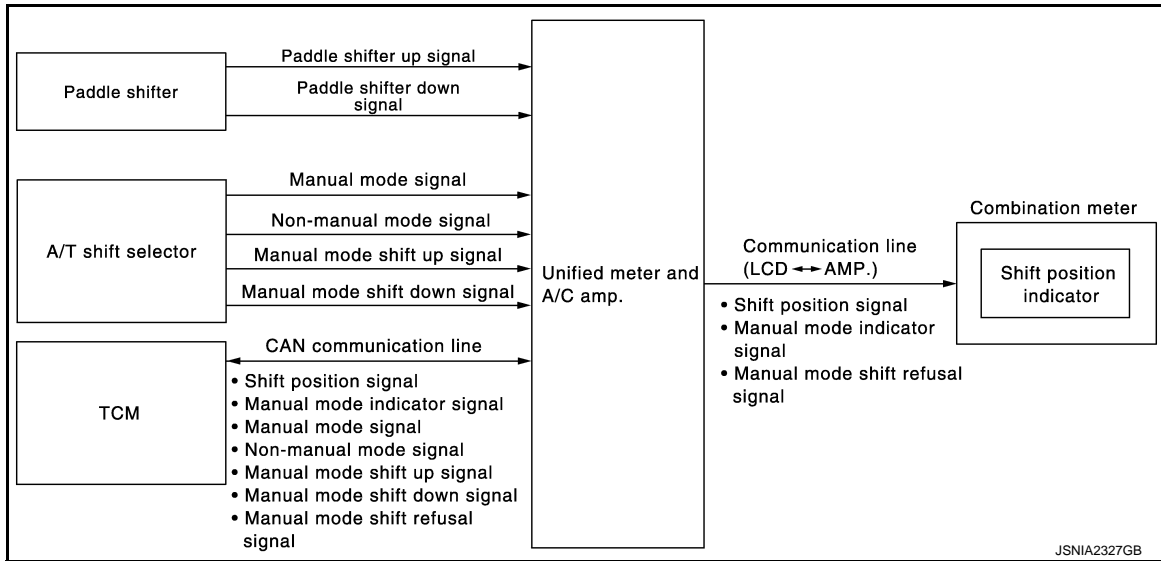

SHIFT POSITION INDICATOR : System Description

INFOID:000000007474240

Shift position is displayed in the information display LCD in the combination meter.

MANUAL MODE

When Operated with A/T Shift Selector

- Unified meter and A/C amp. inputs manual mode signal and manual mode shift-up/down signal from A/T shift selector (manual mode switch), and transmits the signals to TCM with CAN communication line.
- TCM processes manual mode signal and manual mode shift-up/down signal, and transmits manual mode indicator signal and shift position signal to unified meter and A/C amp. with CAN communication line.
- Unified meter and A/C amp. transmits manual mode indicator signal and shift position signal to combination meter with the communication line.
- Combination meter indicates A/T gear position and manual mode indicator, when receiving manual mode indicator signal and shift position signal.
- TCM transmits a manual mode shift refusal signal to the unified meter and A/C amp. via CAN communication line when gear shifting cannot be performed in manual mode.
- The unified meter and A/C amp. transmits a manual mode shift refusal signal to the combination meter via communication line.
- The combination meter blinks the shift position indicator and sounds a buzzer when receiving a manual mode shift refusal signal.

When Operated with Paddle Shifter

- Unified meter and A/C amp. inputs manual mode signal from A/T shift selector (manual mode switch) or the paddle shifter-up/down signal from the paddle shifter, and transmits the signals to TCM with communication line.
- TCM processes manual mode signal and paddle shifter-up/down signal, and transmits manual mode indicator signal and shift position signal to unified meter and A/C amp. with CAN communication line.
- Unified meter and A/C amp. transmits manual mode indicator signal and shift position signal to combination meter with the communication line.
- Combination meter indicates A/T gear position and manual mode indicator, when receiving manual mode indicator signal and shift position signal.
- TCM transmits a manual mode shift refusal signal to the unified meter and A/C amp. via CAN communication line when gear shifting cannot be performed in manual mode.
- The unified meter and A/C amp. transmits a manual mode shift refusal signal to the combination meter via communication line.
- The combination meter blinks the shift position indicator and sounds a buzzer when receiving a manual mode shift refusal signal.

NON-MANUAL MODE

A
B
C
D
E
F
G
H
I
J
K
L
M

MWI

O
P

METER SYSTEM

< SYSTEM DESCRIPTION >

- Unified meter and A/C amp. inputs non-manual mode signal from A/T shift selector (manual mode switch), and transmits the signals to TCM with CAN communication line.
- TCM transmits shift position signal to unified meter and A/C amp. with CAN communication line.
- Unified meter and A/C amp. transmits shift position signal to combination meter with the communication line.
- Combination meter indicates shift position when receiving shift position signal.

SHIFT POSITION INDICATOR : Component Parts Location

INFOID:000000007616423

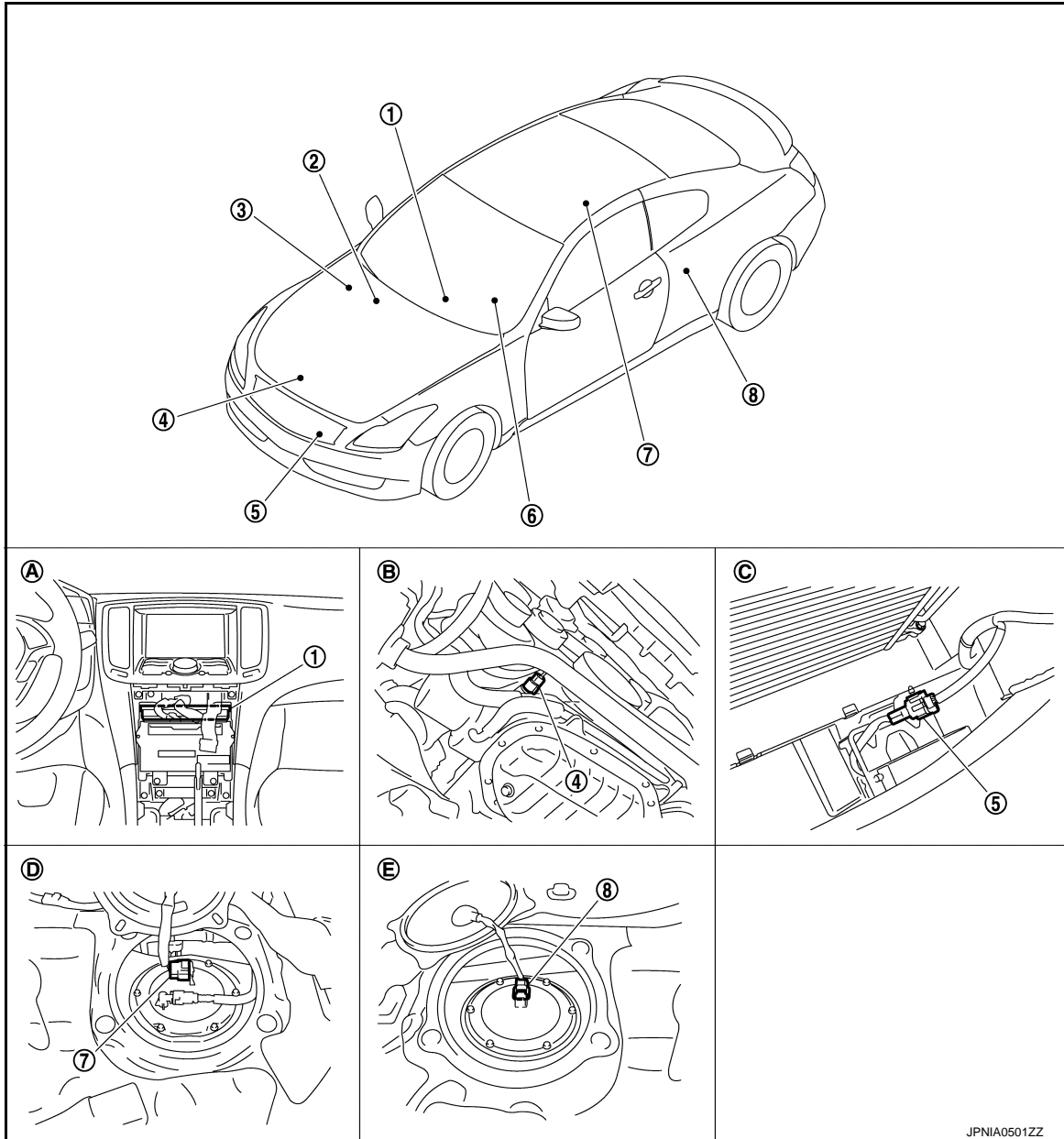

- | | | |
|--|---------------------------------|----------------------|
| 1. Unified meter and A/C amp. | 2. BCM | 3. IPDM E/R |
| 4. Oil pressure switch | 5. Ambient sensor | 6. Combination meter |
| 7. Fuel level sensor unit and fuel pump (main) | 8. Fuel level sensor unit (sub) | |
| A. Behind cluster lid C | B. Oil pan (upper) RH side | C. Condenser (front) |
| D. Rear seat (lower right) | E. Rear seat (lower left) | |

METER SYSTEM

< SYSTEM DESCRIPTION >

SHIFT POSITION INDICATOR : Component Description

INFOID:000000007474242

Unit	Description
Combination meter	<ul style="list-style-type: none"> Displays the shift position on the information display with shift position signal and manual mode indicator signal received from unified meter and A/C amp. The combination meter blinks the shift position indicator and sounds a buzzer when received manual mode shift refusal signal from unified meter and A/C amp.
Unified meter and A/C amp.	<ul style="list-style-type: none"> Transmits the signals from the A/T shift selector to TCM with CAN communication line. Transmits shift position signal, manual mode indicator signal and manual mode shift refusal signal received from TCM with CAN communication line to the combination meter by means of communication line.
A/T shift selector	Transmits the following signals to the unified meter and A/C amp. <ul style="list-style-type: none"> Manual mode signal Non-manual mode signal Manual mode shift up signal Manual mode shift down signal
TCM	Transmits shift position signal, manual mode indicator signal and manual mode shift refusal signal to the unified meter and A/C amp.

WARNING LAMPS/INDICATOR LAMPS

WARNING LAMPS/INDICATOR LAMPS : System Diagram

INFOID:000000007474243

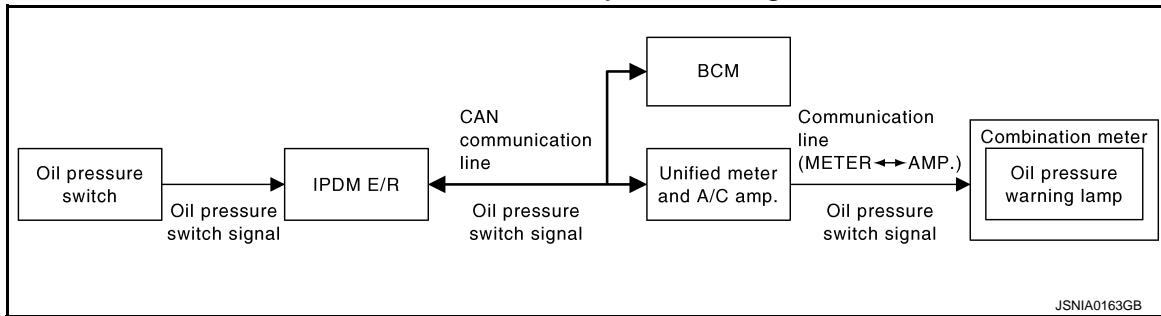

WARNING LAMPS/INDICATOR LAMPS : System Description

INFOID:000000007474244

OIL PRESSURE WARNING LAMP

- IPDM E/R inputs oil pressure switch signal from oil pressure switch, and transmits the signal to unified meter and A/C amp. through BCM with CAN communication line.
- Unified meter and A/C amp. transmits oil pressure switch signal to combination meter with communication line.
- Let the combination meter turn oil pressure warning lamp ON with received oil pressure switch signal.

A
B
C
D
E
F
G
H
I
J
K
L
M

MWI

METER SYSTEM

< SYSTEM DESCRIPTION >

WARNING LAMPS/INDICATOR LAMPS : Component Parts Location

INFOID:000000007616424

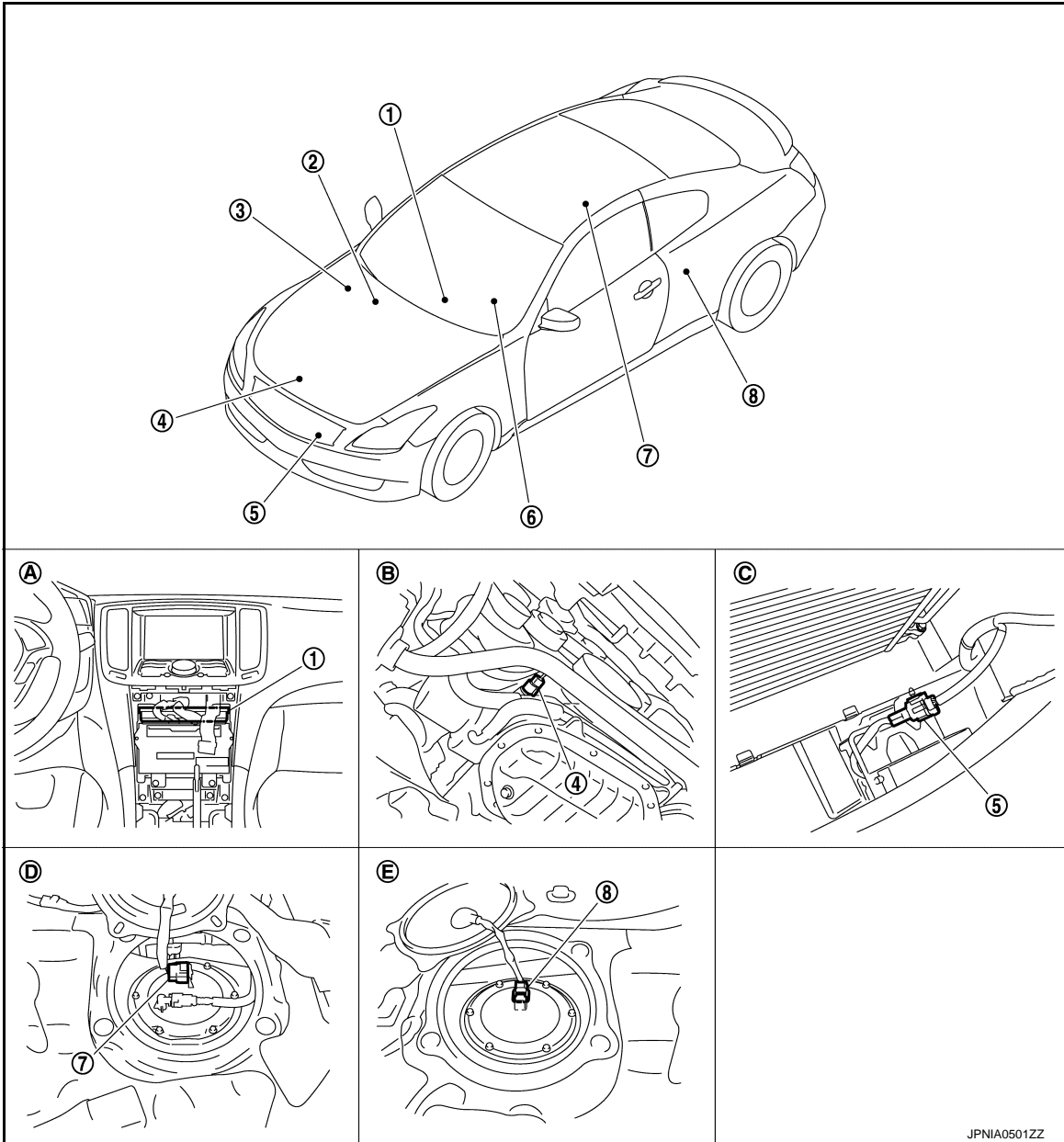

JPNIA0501ZZ

- | | | |
|--|---------------------------------|----------------------|
| 1. Unified meter and A/C amp. | 2. BCM | 3. IPDM E/R |
| 4. Oil pressure switch | 5. Ambient sensor | 6. Combination meter |
| 7. Fuel level sensor unit and fuel pump (main) | 8. Fuel level sensor unit (sub) | |
| A. Behind cluster lid C | B. Oil pan (upper) RH side | C. Condenser (front) |
| D. Rear seat (lower right) | E. Rear seat (lower left) | |

WARNING LAMPS/INDICATOR LAMPS : Component Description

INFOID:000000007474246

Unit	Description
Combination meter	Turns the oil pressure warning lamp ON/OFF according to the oil pressure switch signal received from the unified meter and A/C amp. by means of communication line.
Unified meter and A/C amp.	Transmits the oil pressure switch signal received from the IPDM E/R with BCM to the combination meter by means of communication line.
IPDM E/R	IPDM E/R reads the ON/OFF signals from the oil pressure switch and transmits the oil pressure switch signal to the unified meter and A/C amp. via BCM with the CAN communication line.

METER SYSTEM

< SYSTEM DESCRIPTION >

Unit	Description
Oil pressure switch	Refer to MWI-60, "Description" .
BCM	Transmits the oil pressure switch signal received from IPDM E/R via CAN communication to the unified meter and A/C amp. via CAN communication line.

METER ILLUMINATION CONTROL

METER ILLUMINATION CONTROL : System Diagram

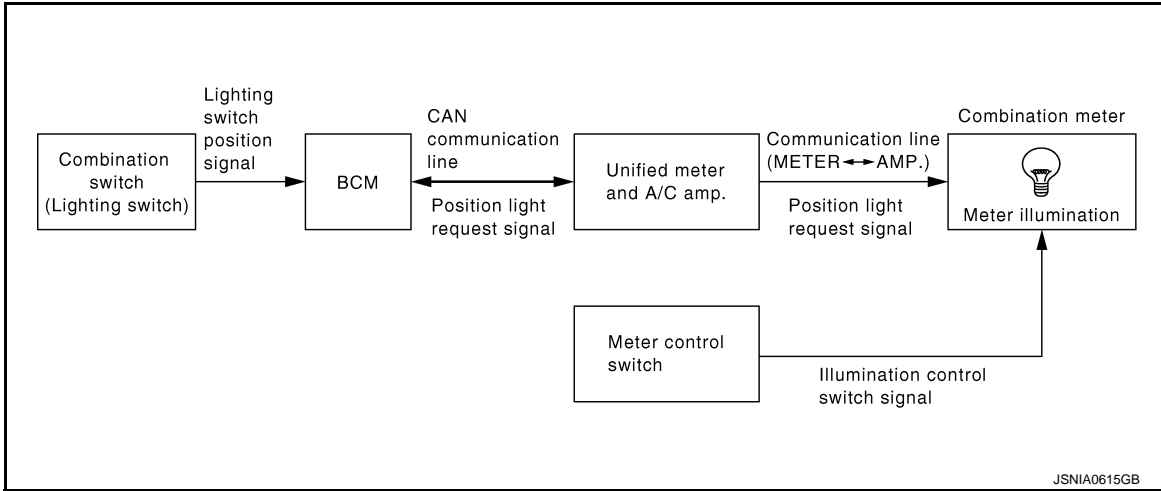

METER ILLUMINATION CONTROL : System Description

INFOID:000000007474248

SYSTEM DESCRIPTION

The combination meter controls the meter illumination by the illumination control switch signal from the meter control switch and the position light request signal transmitted by BCM with unified meter and A/C amp.

Daytime Mode

Meter illumination is adjusted to 5 steps by illumination control switch (1) in daytime mode.

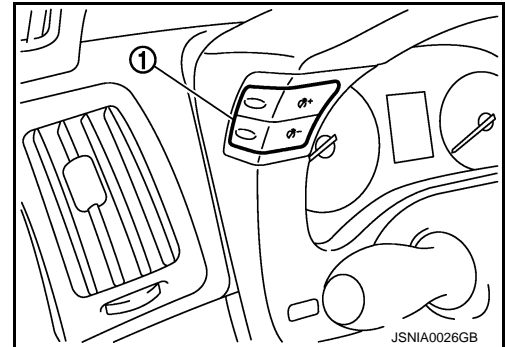

Nighttime Mode

- Combination meter is transferred to nighttime mode with position light request signal from BCM with CAN communication line.
- Meter illumination is adjusted to 22 steps by illumination control switch in nighttime.

A
B
C
D
E
F
G
H
I
J
K
L
M
O
P

MWI

METER SYSTEM

< SYSTEM DESCRIPTION >

METER ILLUMINATION CONTROL : Component Parts Location

INFOID:000000007616425

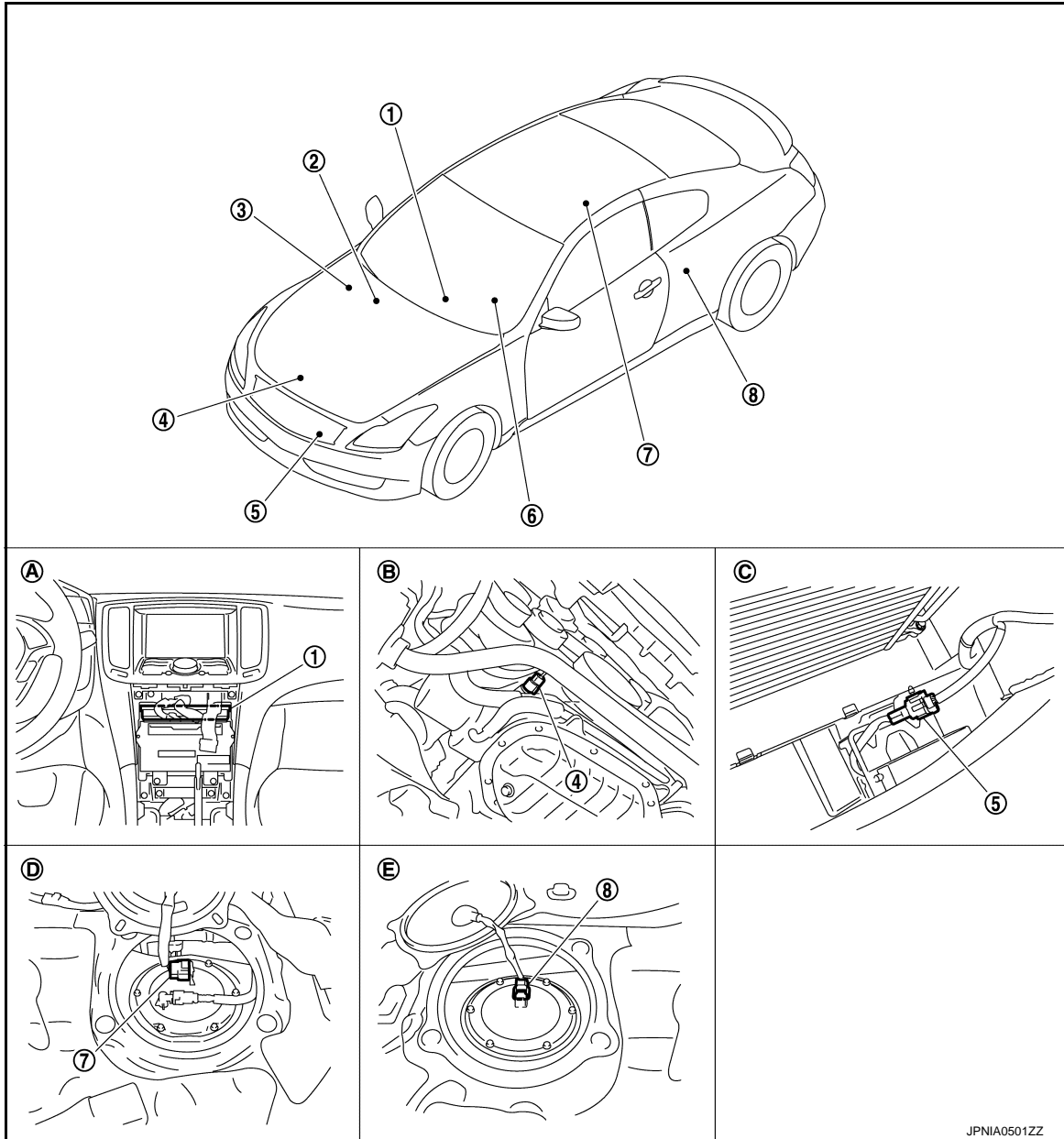

JPNIA0501ZZ

- | | | |
|--|---------------------------------|----------------------|
| 1. Unified meter and A/C amp. | 2. BCM | 3. IPDM E/R |
| 4. Oil pressure switch | 5. Ambient sensor | 6. Combination meter |
| 7. Fuel level sensor unit and fuel pump (main) | 8. Fuel level sensor unit (sub) | |
| A. Behind cluster lid C | B. Oil pan (upper) RH side | C. Condenser (front) |
| D. Rear seat (lower right) | E. Rear seat (lower left) | |

METER ILLUMINATION CONTROL : Component Description

INFOID:000000007474250

Unit	Description
Combination meter	Controls the meter illumination with the illumination control switch signal from the meter control switch and the position light request signal from unified meter and A/C amp.
Unified meter and A/C amp.	Transmits the position light request signal received from BCM via CAN communication to the combination meter by means of communication.

METER SYSTEM

< SYSTEM DESCRIPTION >

Unit	Description
Meter control switch	Transmits the following signals to the combination meter. <ul style="list-style-type: none"> • Illumination control switch signal (+) • Illumination control switch signal (-)

INFORMATION DISPLAY

INFORMATION DISPLAY : System Diagram

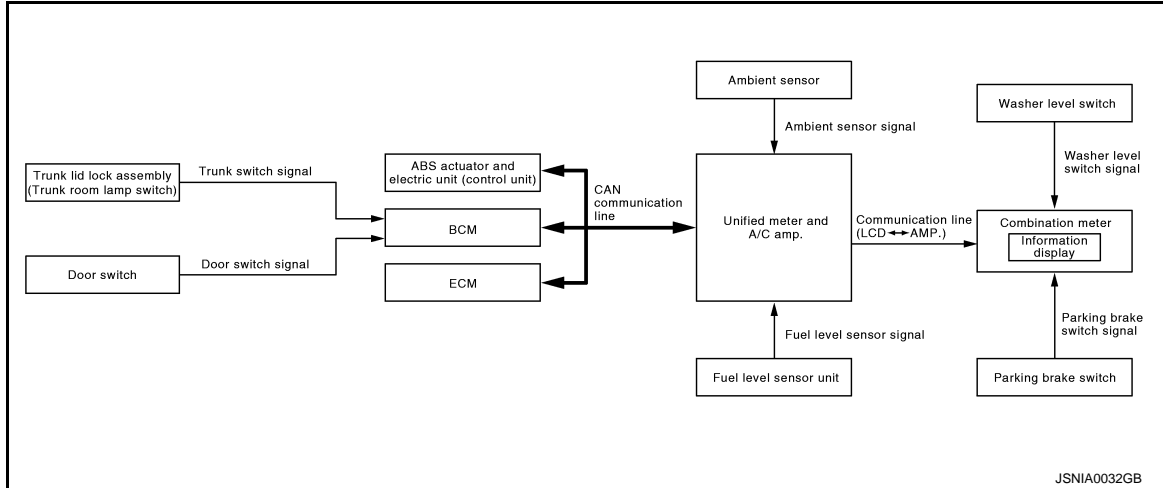

INFORMATION DISPLAY : System Description

INFOID:000000007474252

DESCRIPTION

- The combination meter retrieves the information required for controlling the operations of the information display from the communication signals from the unified meter and A/C amp., etc.
- The combination meter incorporates a trip computer that displays the warning / information according to the information received from various units.

PARKING BRAKE RELEASE WARNING

The combination meter indicates parking brake release warning judged with the vehicle speed signal received from the unified meter and A/C amp. by means of communication line and the parking brake switch signal from the parking brake switch.

Warning Operation Condition

Parking brake release warning is judged if all of the following conditions are fulfilled

- Vehicle speed is 7 km/h (4.3 MPH) or higher
- Parking brake switch ON

LOW FUEL WARNING

The combination meter indicates low fuel warning judged with the fuel level sensor signal received from the unified meter and A/C amp.

Warning Operation Condition

- Fuel level: Approx. 15 ℓ (4 US gal, 3-1/4 Imp gal) or less

LOW WASHER FLUID WARNING

The combination meter indicates low washer fluid warning judged with the signal from the washer level switch.

Warning Operation Condition

A
B
C
D
E
F
G
H
I
J
K
L
M
N
O
P

MWI

METER SYSTEM

< SYSTEM DESCRIPTION >

- Indicates the warning when it is in washer level switch ON condition for 180 seconds or more. Release the warning when it is in washer level switch OFF condition for 30 seconds or more.

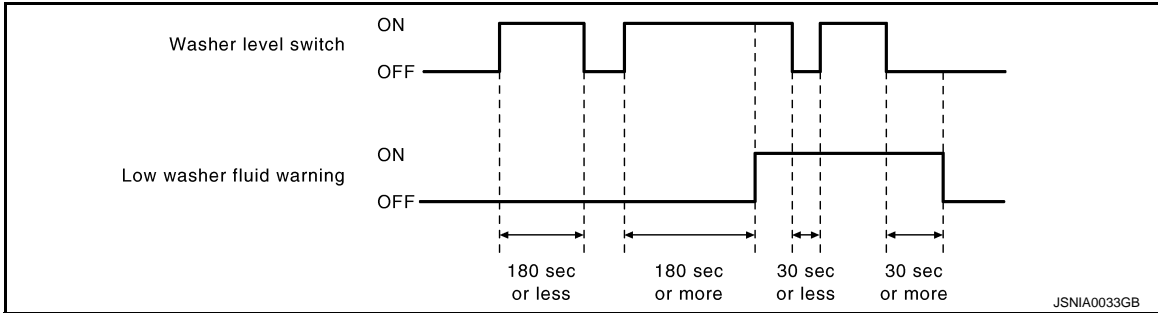

LOW TIRE PRESSURE WARNING

- The unified meter and A/C amp. receives remaining low tire pressure warning lamp signal from the BCM with CAN communication line.
- The unified meter and A/C amp. transmits remaining low tire pressure warning lamp signal to the combination meter with communication line.
- The combination meter indicates low tire pressure warning when receiving remaining low tire pressure warning lamp signal.
- The combination meter indicates low tire pressure warning judged with the low tire pressure warning lamp signal received from the unified meter and A/C amp.

For details, refer to [WT-7. "System Description"](#).

FUEL FILLER CAP WARNING

- The unified meter and A/C amp. receives remaining fuel filler cap warning display signal from the ECM with CAN communication line.
- The unified meter and A/C amp. transmits remaining fuel filler cap warning display signal to the combination meter with communication line.
- The combination meter indicates fuel filler cap warning when receiving remaining fuel filler cap warning display signal.
- The combination meter indicates fuel filler cap warning judged with the fuel filler cap warning display signal received from the unified meter and A/C amp.

For details, refer to [EC-114. "System Description"](#).

DOOR/TRUNK OPEN WARNING

- The combination meter indicates door open warning judged with each door switch signal received from the unified meter and A/C amp. by means of communication line.
- The combination meter indicates trunk open warning judged with the trunk switch signal received from the unified meter and A/C amp. by means of communication line.

INSTANTANEOUS FUEL CONSUMPTION

- The unified meter and A/C amp. receives the fuel consumption monitor signal from ECM and the vehicle speed signal from the ABS actuator and electric unit (control unit) with CAN communication line.
- The unified meter and A/C amp. calculates the instantaneous fuel consumption according to the fuel consumption monitor signal and the vehicle speed signal received with CAN communication line, and transmits it to the combination meter.

AVERAGE FUEL CONSUMPTION

- The unified meter and A/C amp. receives the fuel consumption monitor signal from ECM and the vehicle speed signal from the ABS actuator and electric unit (control unit) with CAN communication line.
- The unified meter and A/C amp. calculates the average fuel consumption according to the fuel consumption monitor signal and the vehicle speed signal received with CAN communication line, and transmits it to the combination meter.
- The average fuel consumption displayed on the information display is uploaded at approximately 30-second intervals.

NOTE:

“—” is displayed for approximately 30 seconds just after the reset operation and after the ignition switch is OFF → ON. It is displayed simultaneously until the vehicle drives approximately 500 m (0.31 mile).

AVERAGE VEHICLE SPEED

- The unified meter and A/C amp. receives the vehicle speed signal from the ABS actuator and electric unit (control unit) via CAN communication line.

METER SYSTEM

< SYSTEM DESCRIPTION >

- Measures the time during the ignition switch ON with the unified meter and A/C amp.
- The unified meter and A/C amp. calculates the average vehicle speed according to the above signals. These signals are transmitted to the combination meter with the communication line.
- The average vehicle speed displayed on the information display is uploaded at approximately 30-second intervals.

NOTE:

“—” is displayed for 30 seconds just after the reset operation and after the ignition switch is OFF → ON. It is displayed simultaneously until the vehicle drives approximately 500 m (0.31 mile).

TRAVEL TIME

Measures the time during the ignition switch ON with the unified meter and A/C amp, and transmits it to the combination meter by means of communication line.

TRAVEL DISTANCE

- The unified meter and A/C amp. transmits the vehicle speed signal from ABS actuator and electric unit (control unit) to the combination meter.
- The combination meter calculates the vehicle distance according to the vehicle speed signal. The vehicle distance is displayed.

POSSIBLE DRIVING DISTANCE

The unified meter and A/C amp. calculates possible driving distance according to the vehicle speed signal transmitted through CAN communication and the fuel level sensor signal transmitted from the fuel level sensor. These signals are transmitted to the combination meter with the communication line.

NOTE:

- “—” is displayed for 30 seconds after the ignition switch is OFF → ON. It is displayed simultaneously until the vehicle drives approximately 500 m (0.31 mile).
- The indicated values may not match each other when filling the fuel with the ignition switch ON. Refer to [MWI-108. "INFORMATION DISPLAY : Description"](#).

AMBIENT AIR TEMPERATURE

- The unified meter and A/C amp. receives the ambient sensor signal from the ambient sensor.
- The unified meter and A/C amp. calculates the ambient temperature according to the ambient sensor signal, and transmits it to the combination meter.
- The indicated temperature is corrected by the ignition switch signal, the ambient sensor detection temperature, and the vehicle speed signal. It does not increase if the vehicle speed is less than 20 km/h (12 MPH).

Correction Process (Ignition Switch OFF → ON)

The ambient temperature sensor detection temperature is not displayed in real time if all of the following conditions are fulfilled. The indicated temperature before the ignition switch OFF is displayed.

- The ignition switch OFF time is less than 3.5 hours.
- The ambient temperature sensor detection temperature is higher than the indicated temperature before the ignition switch OFF.

Correction Process (Ignition Switch ON)

Perform the following correction if the ambient sensor detection temperature is higher than the indicated temperature when the vehicle speed is 20 km/h (12 MPH) or more.

- Shorten the update time of the indicated temperature according to the increase of the vehicle speed.
- Increase the indicated temperature by 1°C (34°F) per 1 minute until it reaches to the ambient air temperature detection value when the ambient sensor detection temperature is higher than the indicated temperature at 8°C (46°F) or more.

NOTE:

The ambient sensor input value that is displayed on “Data Monitor” of CONSULT is the value before the correction. It may not match the indicated temperature on the information display.

SETTING

Setting item list

Items		Setting range	Setting unit	Description
ALERT	TIME TO REST	No setting - 6 hours	30 minutes, [60 minutes]*	Time to rest is displayed on the information display if the vehicle reached the set travel distance.
	ICY	ON/OFF	—	Low outside temperature is displayed on the information display if the ambient temperature is 3°C (37°F) or less.

METER SYSTEM

< SYSTEM DESCRIPTION >

Items		Setting range	Setting unit	Description
MAINTENANCE	ENGINE OIL	No setting - 18,500 miles, (No setting - 30,000 km)	250 miles (500 km), [500 miles (1000 km)]*	The engine oil replacement interval is displayed on the information display if the vehicle reached the set distance.
	OIL FILTER	No setting - 18,500 miles, (No setting - 30,000 km)	250 miles (500 km), [500 miles (1000 km)]*	The oil filter replacement interval is displayed on the information display if the vehicle reached the set distance.
	TIRE	No setting - 18,500 miles, (No setting - 30,000 km)	250 miles (500 km), [500 miles (1000 km)]*	The tire replacement interval is displayed on the information display if the vehicle reached the set distance.
	OTHER	No setting - 18,500 miles, (No setting - 30,000 km)	250 miles (500 km), [500 miles (1000 km)]*	The other replacement interval is displayed on the information display if the vehicle reached the set distance.
DISPLAY	LANGUAGE	ENGLISH/FRANCAIS	—	Changing the language setting can be performed.
	UNIT	US/METRIC	—	Changing the unit setting can be performed.

*: Press and hold the switch (1 second or more).

METER SYSTEM

< SYSTEM DESCRIPTION >

INFORMATION DISPLAY : Component Parts Location

INFOID:000000007616426

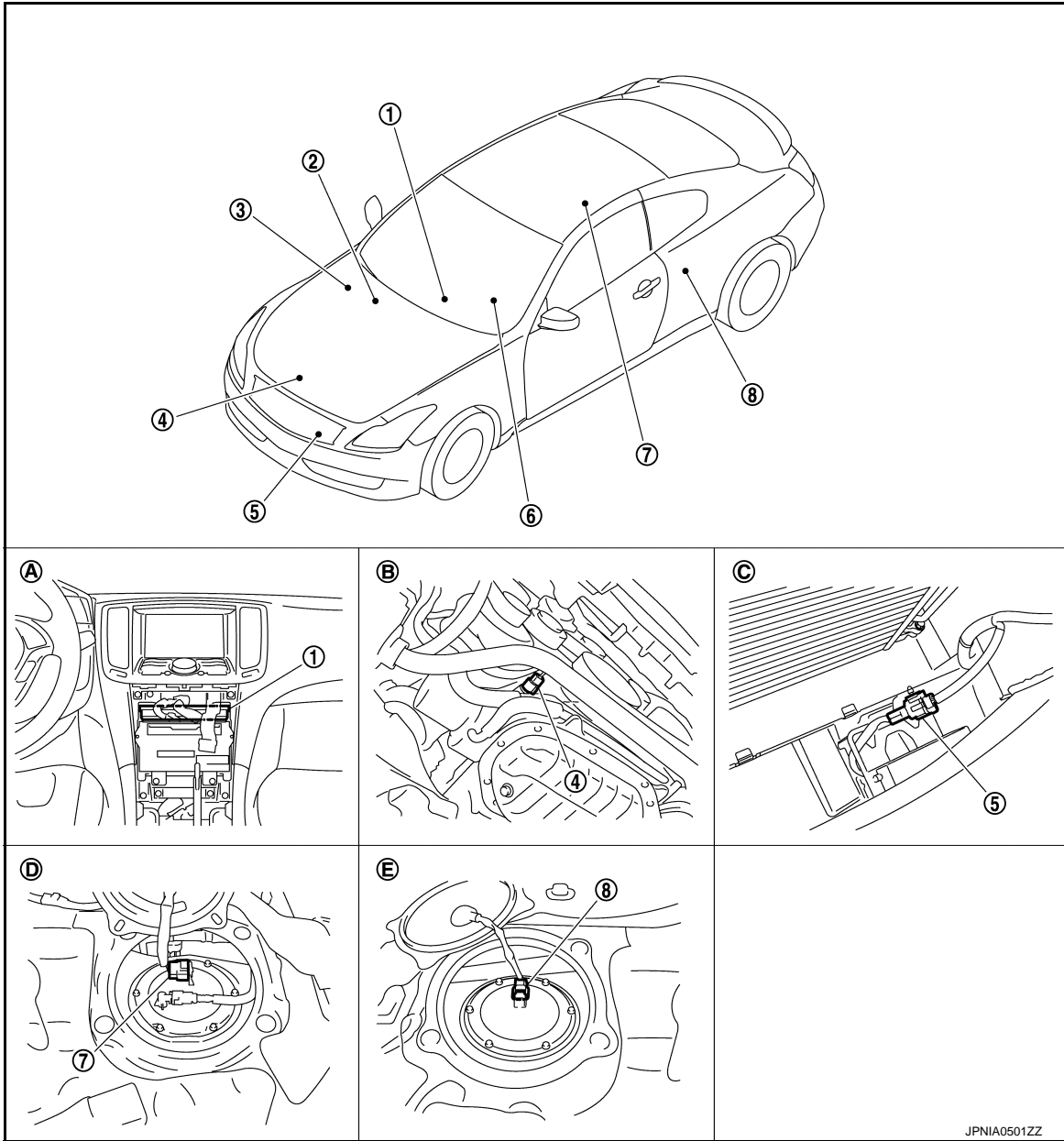

- | | | |
|--|---------------------------------|----------------------|
| 1. Unified meter and A/C amp. | 2. BCM | 3. IPDM E/R |
| 4. Oil pressure switch | 5. Ambient sensor | 6. Combination meter |
| 7. Fuel level sensor unit and fuel pump (main) | 8. Fuel level sensor unit (sub) | |
| A. Behind cluster lid C | B. Oil pan (upper) RH side | C. Condenser (front) |
| D. Rear seat (lower right) | E. Rear seat (lower left) | |

INFORMATION DISPLAY : Component Description

INFOID:000000007474254

Unit	Description
Combination meter	Controls the information display with the signals received from the unified meter and A/C amp. by means of communication and the signals from various switches and sensors.
Unified meter and A/C amp.	Transmits signals received from various units to the combination meter by means of communication.
Fuel level sensor unit	Refer to MWI-54, "Description" .

A
B
C
D
E
F
G
H
I
J
K
L
M
N
O
P



METER SYSTEM

< SYSTEM DESCRIPTION >

Unit	Description
ECM	Transmits the following signals to the unified meter and A/C amp. via CAN communication. <ul style="list-style-type: none">• Engine speed signal• Fuel consumption monitor signal• Fuel filler cap warning display signal
ABS actuator and electric unit (control unit)	Transmits the vehicle speed signal to the unified meter and A/C amp. via CAN communication.
BCM	Transmits signals provided by various units to the unified meter and A/C amp. via CAN communication.
Meter control switch	Transmits the following signals to the combination meter. <ul style="list-style-type: none">• Enter switch signal• Select switch signal
Washer level switch	Transmits the washer level switch signal to the combination meter.
Parking brake switch	Refer to MWI-62, "Description" .
Door switch	Transmits the door switch signals to BCM.
Trunk room lamp switch	Transmits the room lamp switch signal to BCM.
Ambient sensor	Detects the ambient air temperature and transmits the ambient sensor signal to the unified meter and A/C amp.

COMPASS

< SYSTEM DESCRIPTION >

COMPASS

Description

INFOID:000000007474255

DESCRIPTION

- This electronic compass is able to display 8 primary directions: N, NE, E, SE, S, SW, W, NW.
- The compass switch (1) is used to operate the compass.

Switch Operation

Press	Compass is turned ON/OFF
Press and hold (for 3 - 9 sec.)	Compass display (2) turns to zone variation change mode
Press and hold (for more than 9 sec.)	Compass display turns to calibration mode

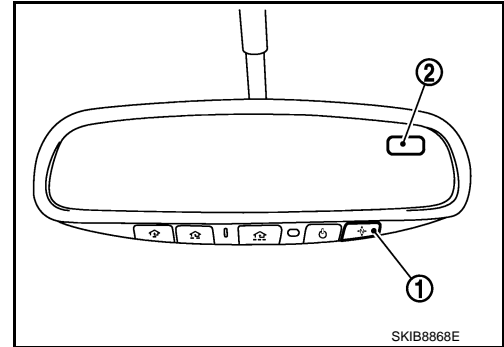

- All standard compasses determine direction relative to Magnetic North; however, this electronic compass is designed to display direction relative to True North.
- The difference between Magnetic North and True North varies from place to place across the surface of the earth.
- This electronic compass must be “told” approximately where it is on the earth’s surface so that the Magnetic North reading can be properly converted into a True North display.
- To tell the electronic compass where it’s at, the earth is separated into numbered “Zone Variances”. The Zone Variance number in which the compass is to function must be entered into this electronic compass.
- Each zone is magnetically about 4.2° wide. Typically, anything under 22.5° total zone change is not noticed on the electronic compass display. However, over 22.5°, a reading may be off by one or more primary directions.
- On long trips, a vehicle may leave its original zone and enter one or more new zones. Generally, you do not need to reset the compass zone if you travel between 3 or 4 zones, such as business travel or vacation. The typical driver will not notice any difference on the display within 3 or 4 zones. However, if the vehicle is “permanently” moved to a new location, it is recommended that the compass zone be reset.

ZONE VARIATION SETTING PROCEDURE

1. Press and hold the compass switch for 3 – 9 seconds.
2. The current zone setting appears on the compass display.
3. Find the current geographical location number in the Zone Variation Chart.
4. Select the new zone number. (Press the compass switch until the new zone number appears on the compass display.)
5. After select the new zone number, the compass display will automatically shows a direction within a few seconds.
6. Perform the following Calibration Procedure for more accurate indications.

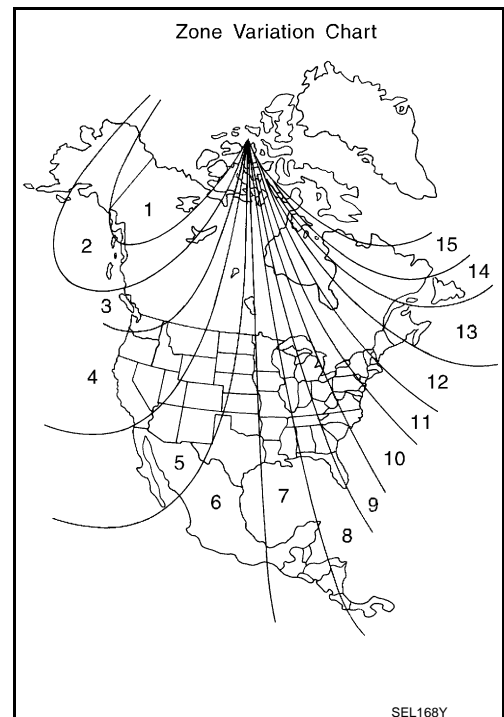

A
B
C
D
E
F
G
H
I
J
K
L
M
N
O
P

MWI

COMPASS

< SYSTEM DESCRIPTION >

CALIBRATION PROCEDURE

NOTE:

The compass calibrates itself under normal driving conditions. However, occasional circumstances may cause the compass to operate inaccurately. Example: Driving from rural (wide open) areas to crowded city areas, or if an aftermarket (i.e., non original equipment) antenna with a magnetic base is attached to the vehicle. Calibrate the mirror compass if the display shows only one direction or a limited number of directions.

NOTE:

- If “magnetic hats” are used in the dealership for vehicle identification, remove the hat from the vehicle before performing the following steps. Do not put the hat back on the vehicle after the procedure is completed.
- Drive the vehicle to an open level area; away from large metallic objects, structures, and overhead power lines.
- Turn off “non-essential” electrical accessories (rear window defrost, heater/air conditioning, wipers) and close the doors.

1. Verify the correct compass zone setting for the geographical location.
2. Press and hold the compass switch for more than 9 seconds.
3. “C” is displayed on the compass display, when calibration starts.
4. Drive slowly [less than 8 km/h (5 MPH)] in a circle until the “C / CAL” is replaced with primary headings (N, NE, E, SE, S, SW, W, or NW).

NOTE:

This will require driving at least 2 complete 360 degree circles; 3 complete circles may be required.

5. The compass calibration procedure is now complete. The compass should operate normally.

NOTE:

If at any time the compass continually displays the incorrect direction or the reading is erratic or locked, repeat the calibration procedure.

Component Parts Location

INFOID:000000007474256

- 1 : Compass switch
- 2 : Compass display

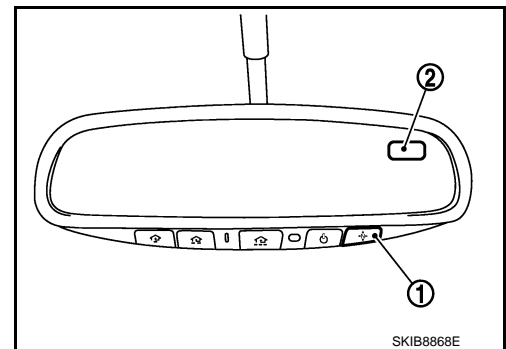

Special Repair Requirement

INFOID:000000007474257

1.PERFORM ZONE VARIATION SETTING

Perform the zone variation setting. Refer to [MWI-33. "Description"](#).

>> GO TO 2.

2.PERFORM CALIBRATION

Perform the calibration. Refer to [MWI-33. "Description"](#).

>> Setting completion

CLOCK

< SYSTEM DESCRIPTION >

CLOCK

Component Parts Location

INFOID:000000007474258

1 : Clock

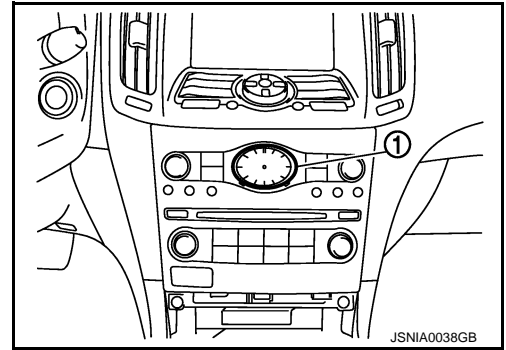

A
B
C
D
E
F
G
H
I
J
K
L
M
O
P

MWI

DIAGNOSIS SYSTEM (METER)

< SYSTEM DESCRIPTION >

DIAGNOSIS SYSTEM (METER)

Diagnosis Description

INFOID:000000007474259

SELF-DIAGNOSIS MODE

- Information display LCD segment operation can be checked in self-diagnosis mode.
- Meters/gauges can be checked in self-diagnosis mode.

OPERATION PROCEDURE

1. Turn ignition switch ON, and switch the trip meter to "trip A" or "trip B".

NOTE:

If the diagnosis function is activated with "trip A" displayed, the mileage on "trip A" is reset to "0000.0". (The same way for "trip B".)

2. Turn ignition switch OFF.
3. While pressing the trip A/B reset switch (1), turn ignition switch ON again.
4. Make sure that the trip meter displays "0000.0".
5. Press the trip A/B reset switch at least 3 times. (Within 7 seconds after the ignition switch is turned ON.)

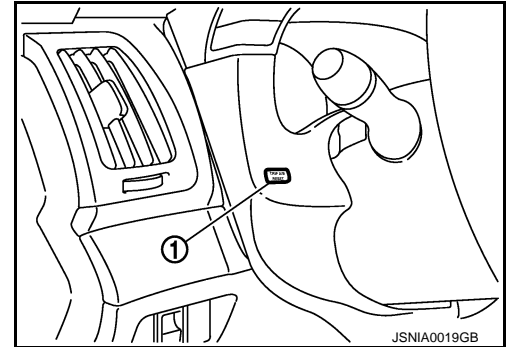

6. The unified meter control unit is turned to self-diagnosis mode.
 - Displays "888888" (1) and "8888.8" (2) in the information display LCD (3) for approximately 5 seconds and then blinks the segment dots of the information display LCD alternately.

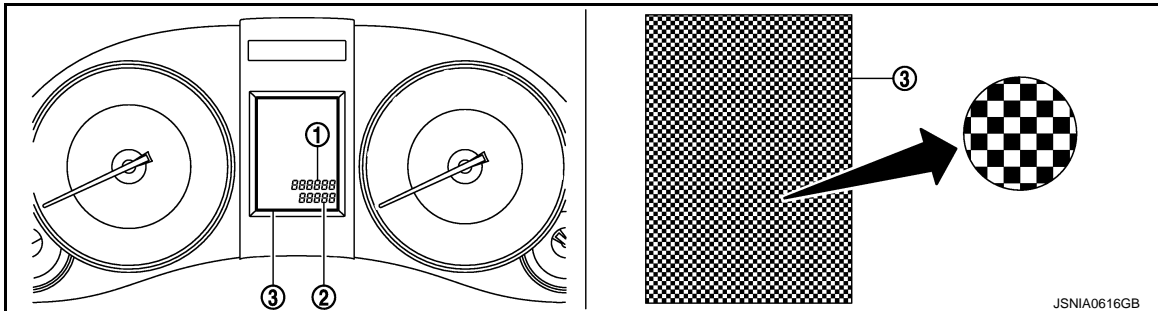

- Water temperature gauge and fuel gauge return to zero, and at the same time.

NOTE:

- Check trip A/B reset switch and combination meter power supply and ground circuit when self-diagnosis mode of combination meter does not start. Replace combination meter if they are normal.
- If any of the segments is not displayed, replace combination meter.

DIAGNOSIS SYSTEM (METER)

< SYSTEM DESCRIPTION >

7. Each meter activates during pressing trip A/B reset switch.

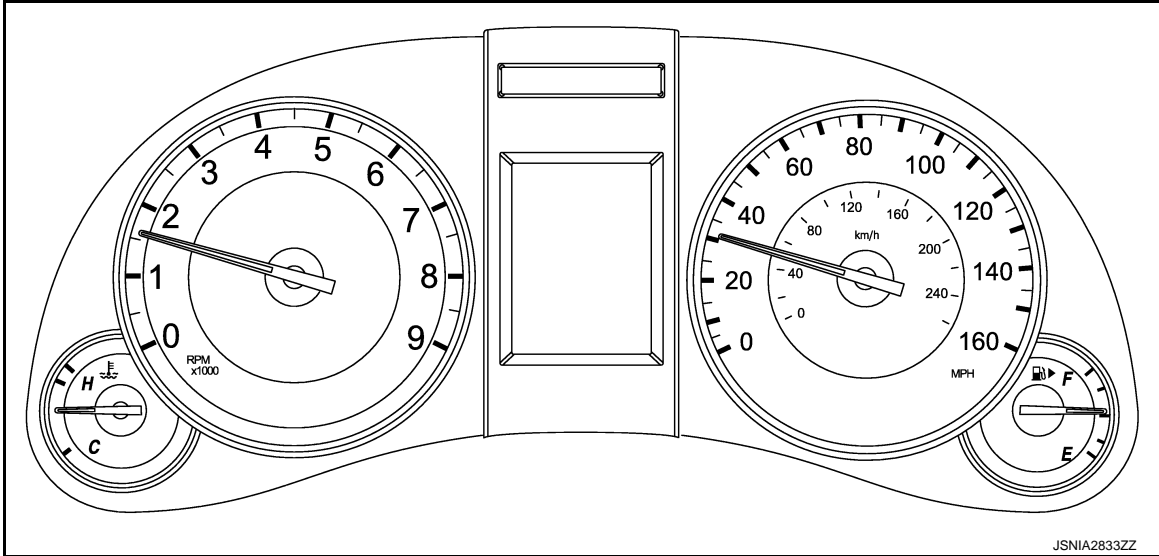

NOTE:

- If any of the meter and gages is not activated, replace combination meter.
- The figure is reference.

A
B
C
D
E
F
G
H
I
J
K
L
M
N
O
P

MWI

DIAGNOSIS SYSTEM (UNIFIED METER AND A/C AMP.)

< SYSTEM DESCRIPTION >

DIAGNOSIS SYSTEM (UNIFIED METER AND A/C AMP.)

CONSULT Function (METER/M&A)

INFOID:000000007474260

CONSULT APPLICATION ITEMS

CONSULT can perform the following diagnosis modes with CAN communication with the unified meter and A/C amp.

System	Diagnosis mode	Description
METER/M&A	Self Diagnostic Result	Unified meter and A/C amp. checks the conditions and displays memorized error.
	Data Monitor	Displays unified meter and A/C amp. input/output data in real time.

SELF DIAG RESULT

Refer to [MWI-85, "DTC Index"](#).

DATA MONITOR

Display Item List

X: Applicable

Display item [Unit]	MAIN SIGNALS	Description
SPEED METER [km/h]	X	Value of vehicle speed signal received from ABS actuator and electric unit (control unit) with CAN communication line. NOTE: 655.35 is displayed when the malfunction signal is received.
SPEED OUTPUT [km/h]	X	Vehicle speed signal value transmitted to other units with CAN communication line. NOTE: 655.35 is displayed when the malfunction signal is received.
ODO OUTPUT [km]		Odometer signal value transmitted to other units with CAN communication line.
TACHO METER [rpm]	X	Value of the engine speed signal received from ECM with CAN communication line. NOTE: 8191.875 is displayed when the malfunction signal is received.
FUEL METER [L]	X	Fuel level indicated on combination meter.
W TEMP METER [°C]	X	Value of engine coolant temperature signal received from ECM with CAN communication line. NOTE: 215 is displayed when the malfunction signal is input.
FUEL CAP W/L [On/Off]		Status of fuel filler cap warning display detected from fuel filler cap warning display signal received from ECM via CAN communication.
ABS W/L [On/Off]		Status of ABS warning lamp judged from ABS warning lamp signal received from ABS actuator and electric unit (control unit) with CAN communication line.
VDC/TCS IND [On/Off]		Status of VDC OFF indicator lamp judged from VDC OFF indicator lamp signal received from ABS actuator and electric unit (control unit) with CAN communication line.
SLIP IND [On/Off]		Status of VDC warning lamp judged from VDC warning lamp signal received from ABS actuator and electric unit (control unit) with CAN communication line.
BRAKE W/L [On/Off]		Status of brake warning lamp judged from brake warning lamp signal received from ABS actuator and electric unit (control unit) with CAN communication line. NOTE: Displays "Off" if the brake warning lamp is illuminated when the valve check starts, the parking brake switch is turned ON or the brake fluid level switch is turned ON.
DOOR W/L [On/Off]		Status of door warning judged from door switch signal received from BCM with CAN communication line.

DIAGNOSIS SYSTEM (UNIFIED METER AND A/C AMP.)

< SYSTEM DESCRIPTION >

Display item [Unit]	MAIN SIGNALS	Description	A
TRUNK/GLAS-H [On/Off]		Status of trunk warning judged from trunk switch signal received from BCM with CAN communication line.	A
HI-BEAM IND [On/Off]		Status of high beam indicator lamp judged from high beam request signal received from BCM with CAN communication line.	B
TURN IND [On/Off]		Status of turn indicator lamp judged from turn indicator signal received from BCM with CAN communication line.	C
FR FOG IND [On/Off]		Status of front fog lamp indicator lamp judged from front fog light request signal received from BCM with CAN communication line.	
RR FOG IND [Off]		This item is displayed, but cannot be monitored.	D
LIGHT IND [On/Off]		Status of tail lamp indicator lamp judged from position light request signal received from BCM with CAN communication line.	E
OIL W/L [On/Off]		Status of oil pressure warning lamp judged from oil pressure switch signal received from IPDM E/R with CAN communication line.	
MIL [On/Off]		Status of malfunction indicator lamp judged from malfunctioning indicator lamp signal received from ECM with CAN communication line.	F
GLOW IND [On/Off]		This item is displayed, but cannot be monitored.	G
C-ENG2 W/L [On/Off]		This item is displayed, but cannot be monitored.	G
CRUISE IND [On/Off]		Status of CRUISE indicator judged from ASCD status signal received from ECM with CAN communication line.	H
SET IND [On/Off]		Status of SET indicator judged from ASCD SET indicator signal received from ECM with CAN communication line.	I
CRUISE W/L [On/Off]		Status of CRUISE warning lamp judged from ASCD status signal received from ECM with CAN communication line.	I
BA W/L [Off]		This item is displayed, but cannot be monitored.	J
ATC/T-AMT W/L [On/Off]		Status of A/T check warning lamp judged from A/T check indicator signal received from TCM with CAN communication line.	K
4WD W/L [On/Off]		Status of AWD warning lamp judged from AWD warning lamp signal received from AWD control unit with CAN communication line.	K
4WD LOCK IND [Off]		This item is displayed, but cannot be monitored.	L
FUEL W/L [On/Off]		Low-fuel warning lamp status judged by the identified fuel level.	
WASHER W/L [On/Off]		Status of washer warning lamp judged from washer level switch input to combination meter.	M
AIR PRES W/L [On/Off]		Status of low tire pressure warning lamp judged from TPMS malfunction warning lamp signal received from BCM with CAN communication line.	MWI
KEY G/Y W/L [On/Off]		Status of key warning lamp (G/Y) judged from key warning signal received from BCM with CAN communication line.	
AFS OFF IND [On/Off]		Status of AFS OFF indicator lamp judged from AFS OFF indicator lamp signal received from AFS control unit with CAN communication line.	O
4WAS/RAS W/L [On/Off]		Status of 4WAS warning lamp judged from 4WAS warning lamp signal received from 4WAS main control unit with CAN communication line.	P
DDS W/L [On/Off]		This item is displayed, but cannot be monitored.	
LANE W/L [On/Off]		This item is displayed, but cannot be monitored.	
LDP IND [On/Off]		This item is displayed, but cannot be monitored.	

DIAGNOSIS SYSTEM (UNIFIED METER AND A/C AMP.)

< SYSTEM DESCRIPTION >

Display item [Unit]	MAIN SIGNALS	Description
LCD [B&P N, B&P I, ID NG, ROTAT, SFT P, INSRT, BATT, NO KY,OUTKY, LK WN, C&P N, C&P I]		Displays status of Intelligent Key system warning judged from meter display signal received from BCM with CAN communication line.
ACC TARGET [On/Off]		Status of vehicle ahead detection indicator judged from meter display signal received from ICC sensor integrated unit with CAN communication line.
ACC DISTANCE [Off, SHOR, MID, LONG]		Status of set distance indicator judged from meter display signal received from ICC sensor integrated unit with CAN communication line.
ACC OWN VHL [On/Off]		Status of own vehicle indicator judged from meter display signal received from ICC sensor integrated unit with CAN communication line.
ACC SET SPEED		Display ICC set vehicle speed from meter display signal received from ICC sensor integrated unit with CAN communication line.
ACC UNIT [On/Off]		Status of display unit judged from meter display signal received from ICC sensor integrated unit with CAN communication line.
O/D OFF SW [On/Off]		This item is displayed, but cannot be monitored.
SHIFT IND [P, R, N, D, M1, M2, M3, M4, M5, M6, M7]		Status of shift position indicator judged from shift position signal and manual mode indicator signal received from TCM with CAN communication line.
AT S MODE SW [On/Off]		Status of snow mode switch.
AT P MODE SW [On/Off]		This item is displayed, but cannot be monitored.
M RANGE SW [On/Off]		Status of manual mode switch.
NM RANGE SW [On/Off]		Status of not manual mode switch.
AT SFT UP SW [On/Off]		Status of A/T shift up switch.
AT SFT DWN SW [On/Off]		Status of A/T shift down switch.
ST SFT UP SW [On/Off]		Status of paddle shifter up switch.
ST SFT DWN SW [On/Off]		Status of paddle shifter down switch.
COMP F/B SIG [On/Off]		A/C compressor activation condition that ECM judges according to the water temperature and the acceleration degree.
4WD LOCK SW [Off]		This item is displayed, but cannot be monitored.
PKB SW [On/Off]		Status of parking brake switch.
BUCKLE SW [On/Off]		Status of seat belt buckle switch.
BRAKE OIL SW [On/Off]		Status of brake fluid level switch.
DISTANCE [km]		Value of possible driving distance calculated by unified meter and A/C amp.
OUTSIDE TEMP [°C or °F]		Ambient air temperature value converted from ambient sensor signal received from ambient sensor. NOTE: This may not match with the temperature value indicated on the information display. (Because the information display value is a corrected value from the ambient sensor input value.)

DIAGNOSIS SYSTEM (UNIFIED METER AND A/C AMP.)

< SYSTEM DESCRIPTION >

Display item [Unit]	MAIN SIGNALS	Description
FUEL LOW SIG [On/Off]		Status of fuel level low warning signal to output to AV control unit with CAN communication line.
BUZZER [On/Off]	X	Buzzer status (in the combination meter) is judged with the buzzer output signal received from each unit with CAN communication line and the warning output condition of the combination meter.

NOTE:

Some items are not available according to vehicle specification.

A
B
C
D
E
F
G
H
I
J
K
L
M
O
P

MWI

U1000 CAN COMM CIRCUIT

< DTC/CIRCUIT DIAGNOSIS >

DTC/CIRCUIT DIAGNOSIS

U1000 CAN COMM CIRCUIT

Description

INFOID:000000007474261

CAN (Controller Area Network) is a serial communication line for real time application. It is an on-vehicle multiplex communication line with high data communication speed and excellent error detection ability. Many electronic control units are equipped onto a vehicle, and each control unit shares information and links with other control units during operation (not independent). In CAN communication, control units are connected with two communication lines (CAN-H line, CAN-L line) allowing a high rate of information transmission with less wiring. Each control unit transmits/receives data but selectively reads required data only.

CAN Communication Signal Chart. Refer to [LAN-25, "CAN Communication Signal Chart"](#).

DTC Logic

INFOID:000000007474262

DTC DETECTION LOGIC

DTC	Display contents of CONSULT	Diagnostic item is detected when ...	Probable malfunction location
U1000	CAN COMM CIRCUIT	When unified meter and A/C amp. is not transmitting or receiving CAN communication signal for 2 seconds or more.	CAN communication system

Diagnosis Procedure

INFOID:000000007474263

1. PERFORM SELF DIAGNOSTIC

1. Turn ignition switch ON and wait for 2 seconds or more.
2. Check "Self Diagnostic Result" of "METER/M&A".

Is "CAN COMM CIRCUIT" displayed?

- YES >> Refer to [LAN-16, "Trouble Diagnosis Flow Chart"](#).
NO >> Refer to [GI-43, "Intermittent Incident"](#).

U1010 CONTROL UNIT (CAN)

< DTC/CIRCUIT DIAGNOSIS >

U1010 CONTROL UNIT (CAN)

Description

INFOID:000000007474264

Initial diagnosis of unified meter and A/C amp.

DTC Logic

INFOID:000000007474265

DTC DETECTION LOGIC

DTC	Display contents of CONSULT	Diagnostic item is detected when ...	Probable malfunction location
U1010	CONTROL UNIT (CAN)	If any malfunction is detected during initial diagnosis of unified meter and A/C amp. CAN controller	Unified meter and A/C amp.

Diagnosis Procedure

INFOID:000000007474266

1. REPLACE UNIFIED METER AND A/C AMP.

When DTC "U1010" is detected, replace unified meter and A/C amp.

>> INSPECTION END

A
B
C
D
E
F
G
H
I
J
K
L
M
O
P

MWI

B2201 COMMUNICATION ERROR 1

< DTC/CIRCUIT DIAGNOSIS >

B2201 COMMUNICATION ERROR 1

Description

INFOID:000000007474267

The communication line (LCD <-> AMP.) is used to communicate signals between the combination meter and the unified meter and A/C amp. in order to control the information display.

DTC Logic

INFOID:000000007474268

DTC DETECTION LOGIC

DTC	Display contents of CONSULT	Diagnostic item is detected when ...	Probable malfunction location
B2201	COMM ERROR 1	If a communication error is present in the communication line (LCD <-> AMP.) for 2 seconds or more	Communication line (LCD <-> AMP.) circuit

Diagnosis Procedure

INFOID:000000007474269

1. CHECK CONNECTOR

Check combination meter, unified meter and A/C amp. and terminals (combination meter side, unified meter and A/C amp. side, and harness side) for looseness or bent.

Is the inspection result normal?

YES >> GO TO 2.

NO >> Repair terminal or connector.

2. CHECK CONTINUITY COMMUNICATION CIRCUIT

1. Turn ignition switch OFF.
2. Disconnect combination meter connector and unified meter and A/C amp. connector.
3. Check continuity between combination meter harness connector terminal and unified meter and A/C amp. harness connector terminal.

Combination meter		Unified meter and A/C amp.		Continuity
Connector	Terminals	Connector	Terminals	
M53	24	M66	14	Existed
	25		34	

4. Check continuity between combination meter harness connector terminal and ground.

Combination meter		Ground	Continuity
Connector	Terminals		
M53	24		Not existed
	25		

Is the inspection result normal?

YES >> GO TO 3.

NO >> Repair harness or connector.

3. CHECK UNIFIED METER AND A/C AMP. OUTPUT VOLTAGE

1. Connect unified meter and A/C amp. connector.
2. Turn ignition switch ON.
3. Check voltage between unified meter and A/C amp. harness connector terminal and ground.

B2201 COMMUNICATION ERROR 1

< DTC/CIRCUIT DIAGNOSIS >

Terminal		(-)	Voltage (Approx.)
(+)			
Unified meter and A/C amp.		Ground	12 V
Connector	Terminal		
M66	14		

Is the inspection result normal?

YES >> GO TO 4.

NO >> Replace unified meter and A/C amp.

4. CHECK COMBINATION METER OUTPUT VOLTAGE

1. Turn ignition switch OFF.
2. Disconnect unified meter and A/C amp. connector.
3. Connect combination meter connector.
4. Turn ignition switch ON.
5. Check voltage between combination meter harness connector terminal and ground.

Terminal		(-)	Voltage (Approx.)
(+)			
Combination meter		Ground	5 V
Connector	Terminal		
M53	25		

Is the inspection result normal?

YES >> INSPECTION END

NO >> Replace combination meter.

A
B
C
D
E
F
G
H
I
J
K
L
M
O
P

MWI

B2202 COMMUNICATION ERROR 2

< DTC/CIRCUIT DIAGNOSIS >

B2202 COMMUNICATION ERROR 2

Description

INFOID:000000007474270

The communication line (METER <-> AMP.) is used to communicate signals between the combination meter and the unified meter and A/C amp. in order to control the combination meter.

DTC Logic

INFOID:000000007474271

DTC DETECTION LOGIC

DTC	Display contents of CONSULT	Diagnostic item is detected when ...	Probable malfunction location
B2202	COMM ERROR 2	If a communication error is present in the communication line (METER <-> AMP.) for 2 seconds or more	Communication line (METER <-> AMP.) circuit

Diagnosis Procedure

INFOID:000000007474272

1. CHECK CONNECTOR

Check combination meter, unified meter and A/C amp. and terminals (combination meter side, unified meter and A/C amp. side, and harness side) for looseness or bent.

Is the inspection result normal?

YES >> GO TO 2.

NO >> Repair terminal or connector.

2. CHECK CONTINUITY COMMUNICATION CIRCUIT

1. Turn ignition switch OFF.
2. Disconnect combination meter connector and unified meter and A/C amp. connector.
3. Check continuity between combination meter harness connector terminal and unified meter and A/C amp. harness connector terminal.

Combination meter		Unified meter and A/C amp.		Continuity
Connector	Terminals	Connector	Terminals	
M53	2	M66	27	Existed
	3		7	

4. Check continuity between combination meter harness connector terminal and ground.

Combination meter		Ground	Continuity
Connector	Terminals		
M53	2		Not existed
	3		

Is the inspection result normal?

YES >> GO TO 3.

NO >> Repair harness or connector.

3. CHECK UNIFIED METER AND A/C AMP. OUTPUT VOLTAGE

1. Connect unified meter and A/C amp. connector.
2. Turn ignition switch ON.
3. Check voltage between unified meter and A/C amp. harness connector terminal and ground.

B2202 COMMUNICATION ERROR 2

< DTC/CIRCUIT DIAGNOSIS >

Terminal		(-)	Voltage (Approx.)
(+)			
Unified meter and A/C amp.		Ground	5 V
Connector	Terminal		
M66	27		

Is the inspection result normal?

YES >> GO TO 4.

NO >> Replace unified meter and A/C amp.

4. CHECK COMBINATION METER OUTPUT VOLTAGE

1. Turn ignition switch OFF.
2. Disconnect unified meter and A/C amp. connector.
3. Connect combination meter connector.
4. Turn ignition switch ON.
5. Check voltage between combination meter harness connector terminal and ground.

Terminal		(-)	Voltage (Approx.)
(+)			
Combination meter		Ground	5 V
Connector	Terminal		
M53	3		

Is the inspection result normal?

YES >> INSPECTION END

NO >> Replace combination meter.

A
B
C
D
E
F
G
H
I
J
K
L
M
O
P

MWI

B2205 VEHICLE SPEED

< DTC/CIRCUIT DIAGNOSIS >

B2205 VEHICLE SPEED

Description

INFOID:000000007474273

Vehicle speed signal is transmitted from ABS actuator and electric unit (control unit) via CAN communication to unified meter and A/C amp.

DTC Logic

INFOID:000000007474274

DTC DETECTION LOGIC

DTC	Display contents of CONSULT	Diagnostic item is detected when ...	Probable malfunction location
B2205	VEHICLE SPEED	If the abnormal vehicle speed signal is input from ABS actuator and electric unit (control unit) for 2 seconds or more	<ul style="list-style-type: none">• Wheel sensor• ABS actuator and electric unit (control unit)

Diagnosis Procedure

INFOID:000000007474275

1. PERFORM SELF-DIAGNOSIS OF ABS ACTUATOR AND ELECTRIC UNIT (CONTROL UNIT)

Perform "Self Diagnostic Result" of ABS actuator and electric unit (control unit), and repair or replace malfunctioning parts.

>> Refer to [BRC-27, "CONSULT Function"](#).

B2267 ENGINE SPEED

< DTC/CIRCUIT DIAGNOSIS >

B2267 ENGINE SPEED

Description

INFOID:000000007474276

The engine speed signal is transmitted from ECM to the unified meter and A/C amp. with CAN communication.

DTC Logic

INFOID:000000007474277

DTC DETECTION LOGIC

DTC	Display contents of CONSULT	Diagnostic item is detected when ...	Probable malfunction location
B2267	ENGINE SPEED	If ECM continuously transmits abnormal engine speed signals for 2 seconds or more	<ul style="list-style-type: none">• Crankshaft position sensor (POS)• ECM

Diagnosis Procedure

INFOID:000000007474278

1. PERFORM SELF-DIAGNOSIS OF ECM

Perform "Self Diagnostic Result" of ECM, and repair or replace malfunctioning parts.

>> Refer to [EC-152. "CONSULT Function"](#) (VQ37VHR FOR USA AND CANADA) or [EC-732. "CONSULT Function"](#) (VQ37VHR FOR MEXICO).

A
B
C
D
E
F
G
H
I
J
K
L
M
O
P



B2268 WATER TEMP

< DTC/CIRCUIT DIAGNOSIS >

B2268 WATER TEMP

Description

INFOID:000000007474279

The engine coolant temperature signal is transmitted from ECM to the unified meter and A/C amp. via CAN communication.

DTC Logic

INFOID:000000007474280

DTC DETECTION LOGIC

DTC	Display contents of CONSULT	Diagnostic item is detected when ...	Probable malfunction location
B2268	WATER TEMP	If ECM continuously transmits abnormal engine coolant temperature signals for 60 seconds or more	<ul style="list-style-type: none">• Engine coolant temperature sensor• ECM

Diagnosis Procedure

INFOID:000000007474281

1. PERFORM SELF-DIAGNOSIS OF ECM

Perform "Self Diagnostic Result" of ECM, and repair or replace malfunctioning parts.

>> Refer to [EC-152. "CONSULT Function"](#) (VQ37VHR FOR USA AND CANADA) or [EC-732. "CONSULT Function"](#) (VQ37VHR FOR MEXICO).

POWER SUPPLY AND GROUND CIRCUIT

< DTC/CIRCUIT DIAGNOSIS >

POWER SUPPLY AND GROUND CIRCUIT COMBINATION METER

COMBINATION METER : Diagnosis Procedure

INFOID:000000007474282

1. CHECK FUSE

Check for blown fuses.

Power source	Fuse No.
Battery	11
Ignition switch ON or START	4

Is the inspection result normal?

YES >> GO TO 2.

NO >> Be sure to eliminate cause of malfunction before installing new fuse.

2. CHECK POWER SUPPLY CIRCUIT

Check voltage between combination meter harness connector terminal and ground.

Terminals		Ignition switch	Voltage (Approx.)
(+)	(-)		
Combination meter	Ground	OFF	Battery voltage
Connector		ON	
M53	1		
	21		

Is the inspection result normal?

YES >> GO TO 3.

NO >> Check harness between combination meter and fuse.

3. CHECK GROUND CIRCUIT

1. Turn ignition switch OFF.
2. Disconnect combination meter connector.
3. Check continuity between combination meter harness connector terminal and ground.

Combination meter		Ground	Continuity
Connector	Terminals		
M53	5	Ground	Existed
	15		
	22		

Is the inspection result normal?

YES >> INSPECTION END

NO >> Repair harness or connector.

UNIFIED METER AND A/C AMP.

UNIFIED METER AND A/C AMP. : Diagnosis Procedure

INFOID:000000007474283

1. CHECK FUSE

Check for blown fuses.

Power source	Fuse No.
Battery	11

A
B
C
D
E
F
G
H
I
J
K
L
M
N
O
P

MWI

POWER SUPPLY AND GROUND CIRCUIT

< DTC/CIRCUIT DIAGNOSIS >

Power source	Fuse No.
Ignition switch ACC or ON	19
Ignition switch ON or START	3

Is the inspection result normal?

YES >> GO TO 2.

NO >> Be sure to eliminate cause of malfunction before installing new fuse.

2.CHECK POWER SUPPLY CIRCUIT

Check voltage between unified meter and A/C amp. harness connector terminal and ground.

Terminals		Ignition switch	Voltage (Approx.)
(+)	(-)		
Unified meter and A/C amp.	Ground	OFF	Battery voltage
Connector		ACC	
Terminals		ON	
M67	54		
	41		
	53		

Is the inspection result normal?

YES >> GO TO 3.

NO >> Check harness between unified meter and A/C amp. and fuse.

3.CHECK GROUND CIRCUIT

1. Turn ignition switch OFF.
2. Disconnect unified meter and A/C amp. connector.
3. Check continuity between unified meter and A/C amp. harness connector terminal and ground.

Unified meter and A/C amp.		Ground	Continuity
Connector	Terminals		
M67	55		Existed
	71		

Is the inspection result normal?

YES >> INSPECTION END

NO >> Repair harness or connector.

IPDM E/R (INTELLIGENT POWER DISTRIBUTION MODULE ENGINE ROOM)

IPDM E/R (INTELLIGENT POWER DISTRIBUTION MODULE ENGINE ROOM) : Diagnosis Procedure

INFOID:000000007687404

1.CHECK FUSES AND FUSIBLE LINK

Check that the following IPDM E/R fuses or fusible links are not blown.

Signal name	Fuses and fusible link No.
Battery power supply	C
	50
	51

Is the fuse fusing?

YES >> Replace the blown fuse or fusible link after repairing the affected circuit if a fuse or fusible link is blown.

NO >> GO TO 2.

2.CHECK POWER SUPPLY CIRCUIT

POWER SUPPLY AND GROUND CIRCUIT

< DTC/CIRCUIT DIAGNOSIS >

1. Turn the ignition switch OFF.
2. Disconnect IPDM E/R connector.
3. Check voltage between IPDM E/R harness connector and the ground.

Terminals		Voltage (Approx.)
(+)	(-)	
IPDM E/R		Battery voltage
Connector	Terminal	
E4	1	

Is the measurement value normal?

YES >> GO TO 3.

NO >> Repair the harness or connector.

3.CHECK GROUND CIRCUIT

Check continuity between IPDM E/R harness connectors and the ground.

IPDM E/R		Ground	Continuity
Connector	Terminal		
E5	12		Existed
E6	41		

Does continuity exist?

YES >> INSPECTION END

NO >> Repair the harness or connector.

A
B
C
D
E
F
G
H
I
J
K
L
M
O
P

MWI

FUEL LEVEL SENSOR SIGNAL CIRCUIT

< DTC/CIRCUIT DIAGNOSIS >

FUEL LEVEL SENSOR SIGNAL CIRCUIT

Description

INFOID:000000007474285

The fuel level sensor unit and fuel pump (main) and the fuel level sensor unit (sub) detect the fuel level in the fuel tank and transmit the fuel gauge signal to the unified meter and A/C amp.

Component Function Check

INFOID:000000007474286

1. PERFORM SELF-DIAGNOSIS OF UNIFIED METER AND A/C AMP.

Perform "Self Diagnosis" of unified meter and A/C amp. with CONSULT.

Is any DTC detected?

YES >> Perform diagnosis on the detected DTC and repair or replace the malfunctioning parts. Refer to [MWI-85. "DTC Index"](#).

NO >> GO TO 2.

2. PERFORM COMPONENT FUNCTION CHECK (1)

1. Turn ignition switch OFF.
2. Disconnect fuel level sensor unit and fuel pump (main) and fuel level sensor unit (sub) connector.
3. Connect variable resistor between harness connector terminals located on the vehicle side of the fuel level sensor unit and fuel pump (main) and the fuel level sensor unit (sub).

Fuel level sensor unit and fuel pump (main)		Fuel level sensor unit (sub)	
Connector	Terminal	Connector	Terminal
B22	5	B21	1

4. Set variable resistor according to the resistance value shown in the following table and turn ignition switch ON.

Resistance (Ω) (Approx.)	Fuel gauge indication position (Approx.)
Less than 6.0	Full
25.5	3/4
45.5	2/4
66.0	1/4
More than 80.0	Empty

*: Reference resistance values used when the combination meter judges the indication position of the fuel gauge.

Is the inspection result normal?

YES >> GO TO 3.

NO >> GO TO 4.

3. PERFORM COMPONENT FUNCTION CHECK (2)

Check the fuel level sensor unit and fuel pump (main) and the fuel level sensor unit (sub). Refer to [MWI-56. "Component Inspection"](#).

Is the inspection result normal?

YES >> INSPECTION END

NO >> Replace fuel level sensor unit and fuel pump (main) or fuel level sensor unit (sub). Refer to [FL-6. "Removal and Installation"](#).

4. CHECK DATA MONITOR OF UNIFIED METER AND A/C AMP.

Select "FUEL METER" that is the data monitor item of "METER/M&A". Apply resistance according to the table below and check the monitor value.

FUEL LEVEL SENSOR SIGNAL CIRCUIT

< DTC/CIRCUIT DIAGNOSIS >

Resistance (Ω) (Approx.)	Reference value of data monitor [L] (Approx.)
Less than 6.0	75
25.5	58
45.5	41
66.0	22
More than 80.0	11

Is the inspection result normal?

- YES >> Replace combination meter. Refer to [MWI-112, "Removal and Installation"](#).
 NO >> Refer to [MWI-55, "Diagnosis Procedure"](#).

Diagnosis Procedure

INFOID:000000007474287

1. CHECK FUEL LEVEL SENSOR CIRCUIT

- Turn ignition switch OFF.
- Disconnect unified meter and A/C amp. connector and fuel level sensor unit (sub) connector.
- Check continuity between unified meter and A/C amp. harness connector and fuel level sensor unit (sub) harness connector.

Unified meter and A/C amp.		Fuel level sensor unit (sub)		Continuity
Connector	Terminal	Connector	Terminal	
M67	42	B21	1	Existed

- Check continuity between unified meter and A/C amp. harness connector and ground.

Unified meter and A/C amp.		Ground	Continuity
Connector	Terminal		
M67	42		Not existed

Is the inspection result normal?

- YES >> GO TO 2.
 NO >> Repair harness or connector.

2. CHECK FUEL LEVEL SENSOR UNIT (MAIN-SUB) CIRCUIT

- Disconnect fuel level sensor unit and fuel pump (main) connector.
- Check for continuity between the fuel level sensor unit (sub) harness connector and the fuel level sensor unit and fuel pump (main) harness connector.

Fuel level sensor unit (sub)		Fuel level sensor unit and fuel pump (main)		Continuity
Connector	Terminal	Connector	Terminal	
B21	2	B22	2	Existed

- Check for continuity between the fuel level sensor unit (sub) harness connector and the ground.

Fuel level sensor unit (sub)		Ground	Continuity
Connector	Terminal		
B21	2		Not existed

Is the inspection result normal?

- YES >> GO TO 3.
 NO >> Repair harness or connector.

3. CHECK FUEL LEVEL SENSOR GROUND CIRCUIT

A
B
C
D
E
F
G
H
I
J
K
L
M
O
P

MWI

FUEL LEVEL SENSOR SIGNAL CIRCUIT

< DTC/CIRCUIT DIAGNOSIS >

1. Check continuity between fuel level sensor unit and fuel pump (main) harness connector and unified meter and A/C amp. harness connector.

Fuel level sensor unit and fuel pump (main)		Unified meter and A/C amp.		Continuity
Connector	Terminal	Connector	Terminal	
B22	5	M67	58	Existed

2. Check for continuity between the fuel level sensor unit and fuel pump (main) harness connector and the ground.

Fuel level sensor unit and fuel pump (main)		Ground	Continuity
Connector	Terminal		
B22	5		Not existed

Is the inspection result normal?

- YES >> Replace unified meter and A/C amp. Refer to [MWI-113. "Removal and Installation"](#).
 NO >> Repair harness or connector.

Component Inspection

INFOID:000000007474288

1. REMOVE FUEL LEVEL SENSOR UNIT

Remove the fuel level sensor unit. Refer to [FL-6. "Removal and Installation"](#).

>> GO TO 2.

2. CHECK FUEL LEVEL SENSOR UNIT AND FUEL PUMP (MAIN)

Check the resistance between fuel level sensor unit and fuel pump (main).

Terminal	Float position	Resistance value (Ω)	
2	5	Full (A)	Approx. 3
		Empty (B)	Approx. 82

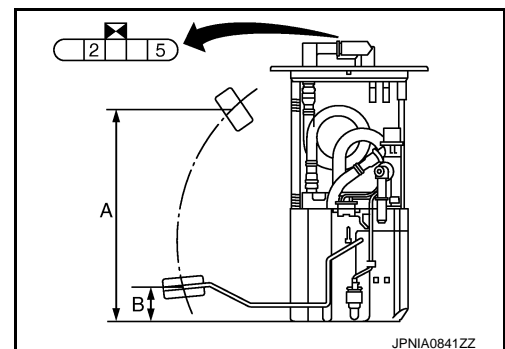

JPNIA0841ZZ

Standard float position

Float position [mm (in)]	
Full	Approx. 202 (7.95)
Empty	Approx. 37 (1.46)

Is the inspection result OK?

- YES >> GO TO 3.
 NO >> Replace fuel level sensor unit and fuel pump (main).

3. CHECK FUEL LEVEL SENSOR UNIT (SUB)

FUEL LEVEL SENSOR SIGNAL CIRCUIT

< DTC/CIRCUIT DIAGNOSIS >

Inspect the resistance of fuel level sensor unit (sub).

Terminal		Float position	Resistance value (Ω)
1	2	Full (A)	Approx. 3
		Empty (B)	Approx. 43

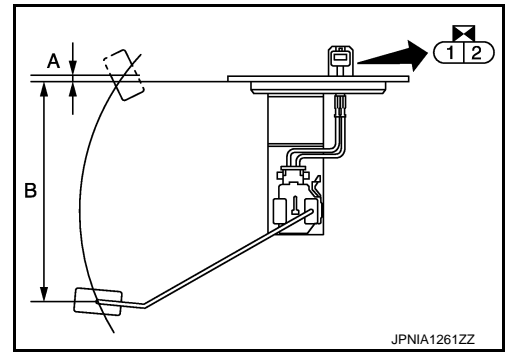

Standard float position

Float position [mm (in)]	
Full	Approx. 4 (0.16)
Empty	Approx. 174 (6.85)

Is the inspection result OK?

- YES >> INSPECTION END
- NO >> Replace fuel level sensor unit (sub).

A
B
C
D
E
F
G
H
I
J
K
L
M
N
O
P

MWI

METER CONTROL SWITCH SIGNAL CIRCUIT





< DTC/CIRCUIT DIAGNOSIS >

METER CONTROL SWITCH SIGNAL CIRCUIT

Description

INFOID:000000007474289

Transmits the following signals to the combination meter.





-  (Illumination control) switch signal (+)
-  (Illumination control) switch signal (-)
- Trip A/B reset switch signal
-  (select) switch signal
-  (enter) switch is pressed

Diagnosis Procedure

INFOID:000000007474290

1. CHECK METER CONTROL SWITCH INPUT SIGNAL

1. Turn the ignition switch ON.
2. Measure voltage between the following terminals of the combination meter.

Terminal No.	Condition	Voltage (Approx.)
36 - 16	When  (select) switch is pressed	0 V
	Other than the above	5 V
37 - 16	When  (enter) switch is pressed	0 V
	Other than the above	5 V
38 - 16	When trip A/B reset switch is pressed	0 V
	Other than the above	5 V
39 - 16	When  (illumination control) switch is pressed	0 V
	Other than the above	5 V
40 - 16	When  (illumination control) switch is pressed	0 V
	Other than the above	5 V

Is the inspection result normal?

- YES >> INSPECTION END
 NO >> GO TO 2.

2. CHECK METER CONTROL SWITCH SIGNAL CIRCUIT

1. Turn the ignition switch OFF.
2. Disconnect the combination meter and meter control switch connectors.
3. Check continuity between combination meter harness connector terminal and meter control switch harness connector terminal.

Combination meter		Meter control switch		Continuity
Connector	Terminals	Connector	Terminals	
M53	16	M54	7	Existed
	36		2	
	37		1	
	39		10	
	40		9	
	38		5	

4. Check continuity between combination meter harness connector terminal and ground.

METER CONTROL SWITCH SIGNAL CIRCUIT

< DTC/CIRCUIT DIAGNOSIS >

Combination meter		Ground	Continuity
Connector	Terminals		
M53	36	Ground	Not existed
	37		
	39		
	40		
	38		

Is the inspection result normal?

YES >> INSPECTION END





NO >> Repair harness or connector.

Component Inspection

INFOID:000000007474291

1. CHECK METER CONTROL SWITCH UNIT

1. Turn the ignition switch OFF.
2. Disconnect the meter control switch connector.
3. Check continuity of the meter control switch.

Connector	Terminal No.		Operation and status	Continuity
M54	2	7	When  (select) switch is pressed	Existed
			Other than the above	Not existed
	1	7	When  (enter) switch is pressed	Existed
			Other than the above	Not existed
	5	7	When trip A/B reset switch is pressed	Existed
			Other than the above	Not existed
	10	7	When  (illumination control) switch is pressed	Existed
			Other than the above	Not existed
	9	7	When  (illumination control) switch is pressed	Existed
			Other than the above	Not existed

Is the inspection result OK?

YES >> INSPECTION END

NO >> Replace the meter control switch.

MWI

OIL PRESSURE SWITCH SIGNAL CIRCUIT

< DTC/CIRCUIT DIAGNOSIS >

OIL PRESSURE SWITCH SIGNAL CIRCUIT

Description

INFOID:000000007474292

Detects the engine oil pressure and transmits the oil pressure switch signal to IPDM E/R.

Component Function Check

INFOID:000000007474293

1. CHECK UNIFIED METER AND A/C AMP. INPUT SIGNAL

1. Connect the CONSULT.
2. Select the "Data Monitor" for the "METER/M&A" and check the "OIL W/L" monitor value.

"OIL W/L"

Ignition switch ON : On

Engine running : Off

>> INSPECTION END

Diagnosis Procedure

INFOID:000000007474294

1. CHECK OIL PRESSURE SWITCH CIRCUIT

1. Turn ignition switch OFF.
2. Disconnect IPDM E/R connector and oil pressure switch connector.
3. Check continuity between IPDM E/R harness connector terminal and oil pressure switch harness connector terminal.

IPDM E/R		Oil pressure switch		Continuity
Connector	Terminal	Connector	Terminal	
E7	75	F37	1	Existed

4. Check continuity between IPDM E/R harness connector terminal and ground.

IPDM E/R		Ground	Continuity
Connector	Terminal		
E7	75		Not existed

Is the inspection result normal?

YES >> INSPECTION END

NO >> Repair harness or connector.

Component Inspection

INFOID:000000007474295

1. CHECK OIL PRESSURE SWITCH

Check continuity between oil pressure switch and ground.

Condition	Continuity
Engine stopped	Existed
Engine running	Not existed

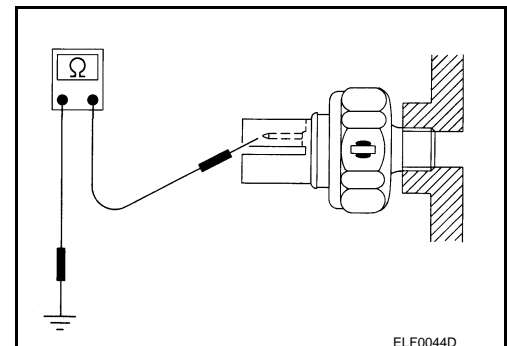

ELF0044D

Is the inspection result normal?

OIL PRESSURE SWITCH SIGNAL CIRCUIT

< DTC/CIRCUIT DIAGNOSIS >

YES >> INSPECTION END
NO >> Replace the oil pressure switch.

A

B

C

D

E

F

G

H

I

J

K

L

M

MWI

O

P

PARKING BRAKE SWITCH SIGNAL CIRCUIT

< DTC/CIRCUIT DIAGNOSIS >

PARKING BRAKE SWITCH SIGNAL CIRCUIT

Description

INFOID:000000007474296

Transmits the parking brake switch signal to the combination meter.

Component Function Check

INFOID:000000007474297

1. CHECK UNIFIED METER AND A/C AMP. INPUT SIGNAL

1. Connect the CONSULT.
2. Select the "Data Monitor" for the "METER/M&A" and check the "PKB SW" monitor value.

"PKB SW"

Parking brake is applied : On

Parking brake is released : Off

>> INSPECTION END

Diagnosis Procedure (A/T models)

INFOID:000000007474298

1. CHECK COMBINATION METER INPUT SIGNAL

1. Turn ignition switch ON.
2. Check the voltage and waveform between combination meter harness connector terminal and ground.

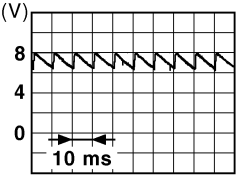
Terminal		(-)	Condition	Voltage (Approx.)
(+)				
Connector	Terminal			
M53	27	Ground	Parking brake applied	0 V
			Parking brake released	 <p style="text-align: right; font-size: small;">JSNIA0007GB</p>

Is the inspection result normal?

YES >> INSPECTION END

NO >> GO TO 2.

2. CHECK PARKING BRAKE SWITCH SIGNAL CIRCUIT

1. Turn ignition switch OFF.
2. Disconnect combination meter connector and parking brake switch connector.
3. Check continuity between combination meter harness connector terminal and parking brake switch harness connector terminal.

Combination meter		Parking brake switch		Continuity
Connector	Terminal	Connector	Terminal	
M53	27	E107	1	Existed

4. Check continuity between combination meter harness connector terminal and ground.

PARKING BRAKE SWITCH SIGNAL CIRCUIT

< DTC/CIRCUIT DIAGNOSIS >

Combination meter		Ground	Continuity
Connector	Terminal		
M53	27		Not existed

Is the inspection result normal?

- YES >> INSPECTION END
 NO >> Repair harness or connector.

Diagnosis Procedure (M/T models)

INFOID:000000007474299

1. CHECK COMBINATION METER INPUT SIGNAL

- Turn ignition switch ON.
- Check the voltage and waveform between combination meter harness connector terminal and ground.

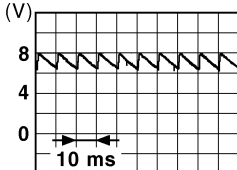
Terminals		Condition	Voltage (Approx.)
(+)			
Connector	Terminal		
		Parking brake applied	0 V
M53	27	Parking brake released	

JSNIA0007GB

Is the inspection result normal?

- YES >> INSPECTION END
 NO >> GO TO 2.

2. CHECK PARKING BRAKE SWITCH SIGNAL CIRCUIT

- Turn ignition switch OFF.
- Disconnect combination meter connector and parking brake switch connector.
- Check continuity between combination meter harness connector terminal and parking brake switch harness connector terminal.

Combination meter		Parking brake switch		Continuity
Connector	Terminal	Connector	Terminal	
M53	27	B14	1	Existed

- Check continuity between combination meter harness connector terminal and ground.

Combination meter		Ground	Continuity
Connector	Terminal		
M53	27		Not existed

Is the inspection result normal?

- YES >> INSPECTION END
 NO >> Repair harness or connector.

Component Inspection

INFOID:000000007474300

1. CHECK PARKING BRAKE SWITCH

A
B
C
D
E
F
G
H
I
J
K
L
M
N
O
P

MWI

PARKING BRAKE SWITCH SIGNAL CIRCUIT

< DTC/CIRCUIT DIAGNOSIS >

Check parking brake switch. Refer to [BRC-88. "Component Inspection"](#).

Is the inspection result normal?

YES >> INSPECTION END

NO >> Replace parking brake switch.

WASHER LEVEL SWITCH SIGNAL CIRCUIT

< DTC/CIRCUIT DIAGNOSIS >

WASHER LEVEL SWITCH SIGNAL CIRCUIT

Description

INFOID:000000007474301

Transmits the washer level switch signal to the combination meter.

Diagnosis Procedure

INFOID:000000007474302

1.CHECK WASHER LEVEL SWITCH SIGNAL CIRCUIT

1. Turn ignition switch OFF.
2. Disconnect combination meter connector and washer level switch connector.
3. Check continuity between combination meter harness connector terminal and washer level switch harness connector terminal.

Combination meter		Washer level switch		Continuity
Connector	Terminal	Connector	Terminal	
M53	31	E32	1	Existed

4. Check continuity between combination meter harness connector terminal and ground.

Combination meter		Ground	Continuity
Connector	Terminal		
M53	31		Not existed

Is the inspection result normal?

- YES >> INSPECTION END
NO >> Repair harness or connector.

Component Inspection

INFOID:000000007474303

1.CHECK WASHER LEVEL SWITCH

1. Turn ignition switch OFF.
2. Disconnect washer level switch connector.
3. Check washer level switch.

Terminal		Washer level switch	Continuity
1	2	ON	Existed
		OFF	Not existed

Is the inspection result normal?

- YES >> INSPECTION END
NO >> Replace washer level switch. Refer to [WW-48, "Removal and Installation"](#).

A
B
C
D
E
F
G
H
I
J
K
L
M
O
P

MWI

COMPASS

< DTC/CIRCUIT DIAGNOSIS >

COMPASS

Wiring Diagram - COMPASS -

INFOID:000000007474304

For connector terminal arrangements, harness layouts, and alphabets in a  (option abbreviation; if not described in wiring diagram), refer to [GI-12, "Connector Information"](#).

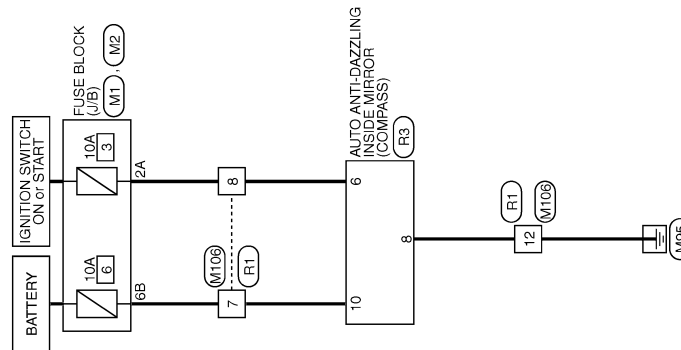

COMPASS

2009/11/05

JCNWM3854GB

CLOCK

< DTC/CIRCUIT DIAGNOSIS >

CLOCK

Wiring Diagram - CLOCK -

INFOID:000000007474305

For connector terminal arrangements, harness layouts, and alphabets in a  (option abbreviation; if not described in wiring diagram), refer to [GI-12, "Connector Information"](#).

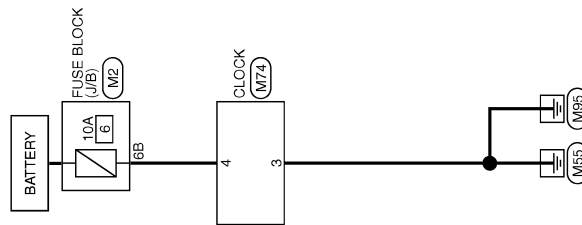

CLOCK

2008/08/22

JCNWM1761GB

A
B
C
D
E
F
G
H
I
J
K
L
M
N
O
P

MWI

COMBINATION METER

< ECU DIAGNOSIS INFORMATION >

ECU DIAGNOSIS INFORMATION

COMBINATION METER

Reference Value

INFOID:000000007474306

VALUES ON THE DIAGNOSIS TOOL

Refer to [MWI-75. "Reference Value"](#).

TERMINAL LAYOUT

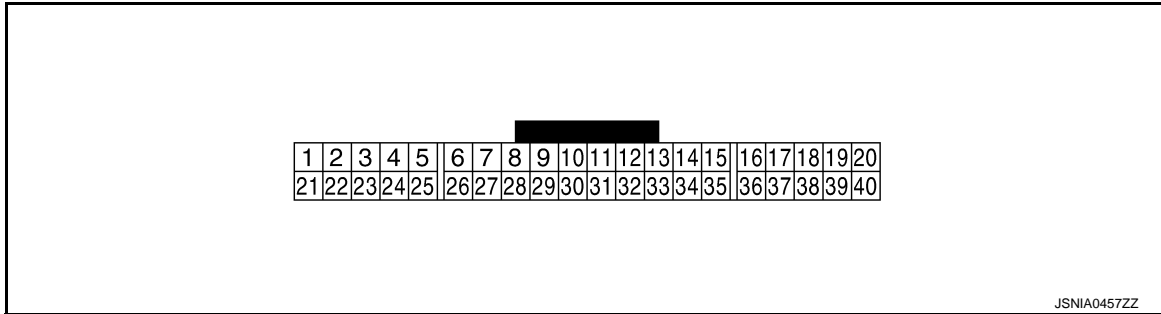

PHYSICAL VALUES

Terminal No. (Wire color)		Description		Condition		Value (Approx.)
+	-	Signal name	Input/ Output			
1 (V)	Ground	Battery power supply	Input	Ignition switch OFF	—	Battery voltage
2 (LG)	Ground	Communication signal (METER→ AMP.)	Output	Ignition switch ON	—	 JSNIA0027GB
3 (GR)	Ground	Communication signal (AMP.→ METER)	Input	Ignition switch ON	—	 JSNIA0027GB
5 (B)	Ground	Ground	—	Ignition switch ON	—	0 V
6 (W)	Ground	Alternator signal	Input	Ignition switch ON	Charge warning lamp ON	0 V
					Charge warning lamp OFF	12 V
7 (LG)	Ground	Air bag signal	Input	Ignition switch ON	Air bag warning lamp ON	4 V
					Air bag warning lamp OFF	0 V
10 (W)	Ground	Security signal	Input	Ignition switch OFF	Security warning lamp ON	0 V
					Security warning lamp OFF	12 V

COMBINATION METER

< ECU DIAGNOSIS INFORMATION >

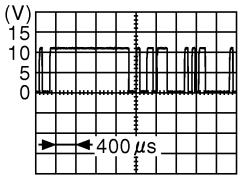
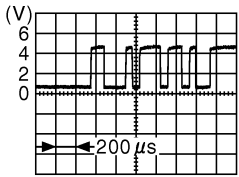
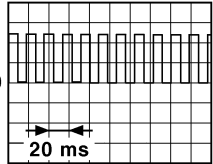
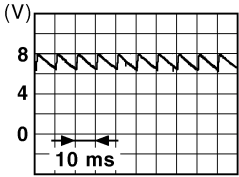
Terminal No. (Wire color)		Description		Condition		Value (Approx.)
+	-	Signal name	Input/ Output			
15 (B)	Ground	Ground	—	Ignition switch ON	—	0 V
16 (BR)	Ground	Meter control switch ground	—	Ignition switch ON	—	0 V
21 (G)	Ground	Ignition signal	Input	Ignition switch ON	—	12 V
22 (B)	Ground	Ground	—	Ignition switch ON	—	0 V
24 (BR)	Ground	Communication signal (LCD→ AMP.)	Output	Ignition switch ON	—	 <small>JSNIA0028GB</small>
25 (Y)	Ground	Communication signal (AMP.→ LCD)	Input	Ignition switch ON	—	 <small>JSNIA0027GB</small>
26 (R)	Ground	Vehicle speed signal (8-pulse)	Input	Ignition switch ON	Speedometer operated [When vehicle speed is ap- prox. 40 km/h (25 MPH)]	<p>NOTE: The maximum voltage varies de- pending on the specification (destination unit).</p>  <small>JSNIA0012GB</small>
27 (P)	Ground	Parking brake switch signal	Input	Ignition switch ON	Parking brake applied	0 V
					Parking brake released	 <small>JSNIA0007GB</small>

A
B
C
D
E
F
G
H
I
J
K
L
M
MWI
O
P

COMBINATION METER

< ECU DIAGNOSIS INFORMATION >

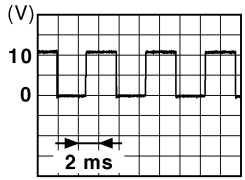
Terminal No. (Wire color)		Description		Condition	Value (Approx.)
+	-	Signal name	Input/ Output		
28 (SB)	Ground	Brake fluid level switch signal	Input	Ignition switch ON	Brake fluid level is normal.
					The brake fluid level is lower than the low level
29 (P)	Ground	Seat belt buckle switch signal (driver side)	Input	Ignition switch ON	When driver seat belt is fastened
					When driver seat belt is unfastened
30 (G)	Ground	Seat belt buckle switch signal (passenger side)	Input	Ignition switch ON	<ul style="list-style-type: none"> When getting in the passenger seat When passenger seat belt is fastened
					<ul style="list-style-type: none"> When getting in the passenger seat When passenger seat belt is unfastened
31 (L)	Ground	Washer level switch signal	Input	Ignition switch ON	Washer level switch ON
					Washer level switch OFF
33 (R)	Ground	Illumination control signal	Output	Ignition switch ON	Lighting switch ON, then operate the illumination control switch.
					NOTE: When brightness level is midway 
36 (LG)	16 (BR)	Select switch signal	Input	Ignition switch ON	When ● is pressed
					Other than the above
37 (Y)	16 (BR)	Enter switch signal	Input	Ignition switch ON	When □ is pressed
					Other than the above
38 (G)	16 (BR)	Trip A/B reset switch signal	Input	Ignition switch ON	When trip A/B reset switch is pressed
					Other than the above
39 (P)	16 (BR)	Illumination control switch signal (-)	Input	Ignition switch ON	When ⏻ switch is pressed
					Other than the above
40 (BG)	16 (BR)	Illumination control switch signal (+)	Input	Ignition switch ON	When ⏩ switch is pressed
					Other than the above

COMBINATION METER

< ECU DIAGNOSIS INFORMATION >

Wiring Diagram - METER -

INFOID:000000007474307

For connector terminal arrangements, harness layouts, and alphabets in a  (option abbreviation; if not described in wiring diagram), refer to [GI-12, "Connector Information"](#).

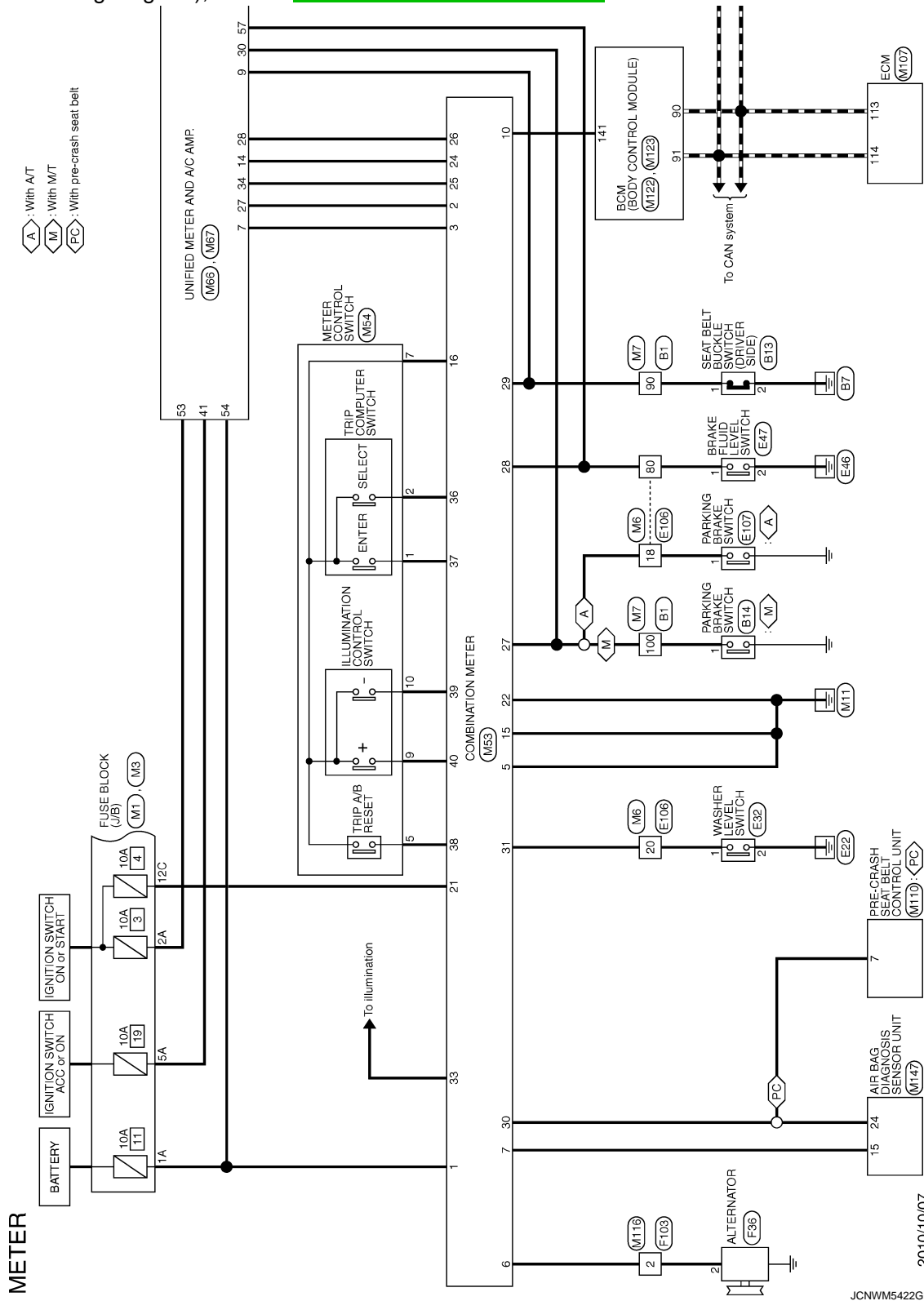

A
B
C
D
E
F
G
H
I
J
K
L
M
N
O
P



COMBINATION METER

< ECU DIAGNOSIS INFORMATION >

- : With 4WAS
- : With A/T
- : AWD models
- : With paddle shifter
- : With ICC

* : This connector is not shown in "Harness Layout".

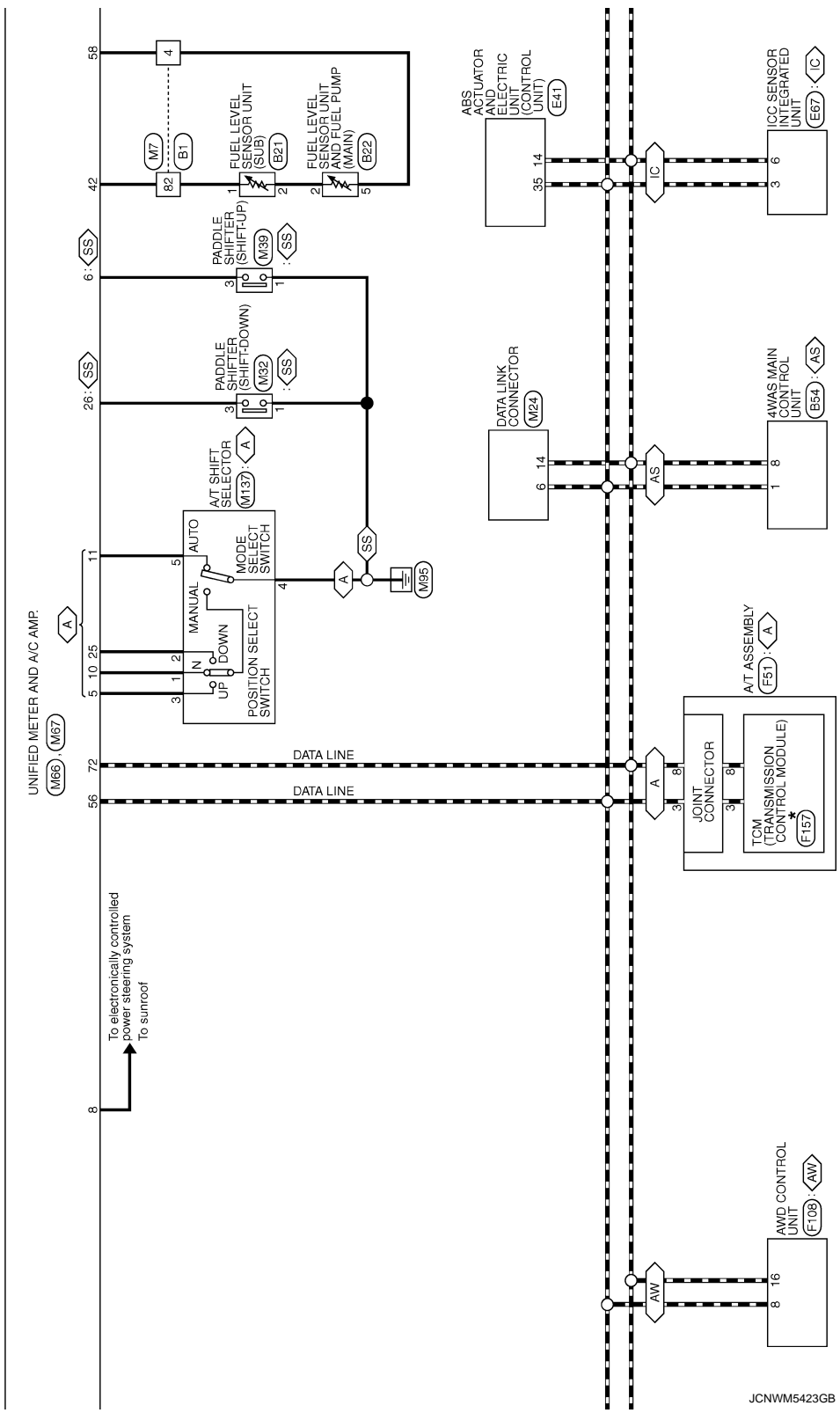

JCNWM5423GB

COMBINATION METER

< ECU DIAGNOSIS INFORMATION >

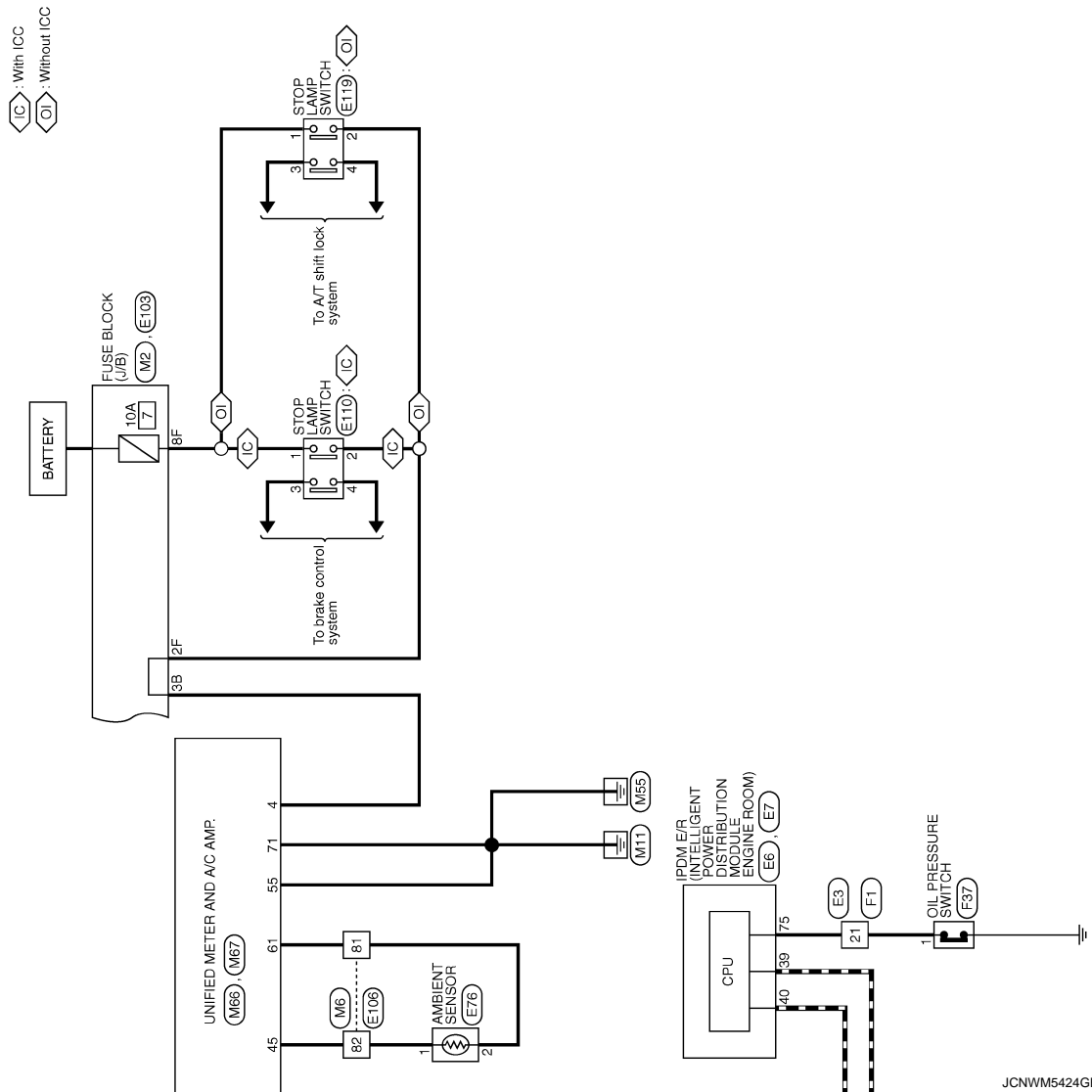

JCNWM5424GB

Fail-safe

FAIL SAFE

Combination meter performs fail-safe operation when unified meter and A/C amp. communication is malfunction.

Solution for communication error between the unified meter and A/C amp. and combination meter.

A
B
C
D
E
F
G
H
I
J
K
L
M
N
O
P



COMBINATION METER

< ECU DIAGNOSIS INFORMATION >

Function		Specifications
Speedometer		Reset to zero by suspending communication.
Tachometer		
Fuel gauge		
Water temperature gauge		
Illumination control		When suspending communication, change to nighttime mode.
Information display	Door open warning	The display turns off by suspending communication.
	Parking brake release warning	
	Low tire pressure warning	
	Fuel filler cap warning	
	Instantaneous fuel warning	<ul style="list-style-type: none"> • When reception time of an abnormal signal is 2 seconds or less, the last received datum is used for calculation to indicate the result. • When reception time of an abnormal signal is more than two seconds, the last result calculated during normal condition is indicated.
	Average fuel consumption	
	Average vehicle speed	
	Travel distance	
Buzzer		The buzzer turns off by suspending communication.
Warning lamp/indicator lamp	ABS warning lamp	The lamp turns on by suspending communication.
	VDC warning lamp	
	Brake warning lamp	
	CRUISE warning lamp	
	Malfunction indicator lamp	
	High beam indicator	
	Turn signal indicator lamp	The lamp turns off by suspending communication.
	Oil pressure warning lamp	
	A/T CHECK warning lamp	
	VDC OFF indicator lamp	
	Low tire pressure warning lamp	
	Key warning lamp	
	AFS OFF indicator lamp	
	4WAS warning lamp	
	Master warning lamp	
	AWD warning lamp	
Tail lamp indicator lamp		
Front fog lamp indicator lamp		

DTC Index

INFOID:000000007474309

Refer to [MWI-85, "DTC Index"](#).

UNIFIED METER AND A/C AMP.

< ECU DIAGNOSIS INFORMATION >

UNIFIED METER AND A/C AMP.

Reference Value

INFOID:000000007474310

VALUES ON THE DIAGNOSIS TOOL

CONSULT MONITOR ITEM

Monitor Item	Condition		Value/Status
SPEED METER [km/h]	Ignition switch ON	While driving	Equivalent to speedometer reading NOTE: 655.35 is displayed when the malfunction signal is received
SPEED OUTPUT [km/h]	Ignition switch ON	While driving	Equivalent to speedometer reading NOTE: 655.35 is displayed when the malfunction signal is received
ODO OUTPUT [km]	Ignition switch ON	—	Equivalent to odometer reading in combination meter
TACHO METER [rpm]	Ignition switch ON	While driving	Equivalent to tachometer reading NOTE: 8191.875 is displayed when the malfunction signal is received
FUEL METER [L]	Ignition switch ON	—	Values according to fuel level
W TEMP METER [°C]	Ignition switch ON	—	Values according to engine coolant temperature NOTE: 215 is displayed when the malfunction signal is input
FUEL CAP W/L	Ignition switch ON	Fuel filler cap warning display ON	On
		Fuel filler cap warning display OFF	Off
ABS W/L	Ignition switch ON	ABS warning lamp ON	On
		ABS warning lamp OFF	Off
VDC/TCS IND	Ignition switch ON	VDC OFF indicator lamp ON	On
		VDC OFF indicator lamp OFF	Off
SLIP IND	Ignition switch ON	VDC warning lamp ON	On
		VDC warning lamp OFF	Off
BRAKE W/L	Ignition switch ON	Blake warning lamp ON	On
		Blake warning lamp OFF	Off
DOOR W/L	Ignition switch ON	Door warning displayed	On
		Door warning not displayed	Off
TRUNK/GLAS-H	Ignition switch ON	Trunk warning displayed	On
		Trunk warning not displayed	Off
HI-BEAM IND	Ignition switch ON	Hi-beam indicator lamp ON	On
		Hi-beam indicator lamp OFF	Off
TURN IND	Ignition switch ON	Turn indicator lamp ON	On
		Turn indicator lamp OFF	Off
FR FOG IND	Ignition switch ON	Front fog lamp indicator lamp ON	On
		Front fog lamp indicator lamp OFF	Off
RR FOG IND	Ignition switch ON	NOTE: This item is displayed, but cannot be monitored.	Off

A

B

C

D

E

F

G

H

I

J

K

L

M

MWI

O

P

UNIFIED METER AND A/C AMP.

< ECU DIAGNOSIS INFORMATION >

Monitor Item	Condition		Value/Status
LIGHT IND	Ignition switch ON	Tail lamp indicator lamp ON	On
		Tail lamp indicator lamp OFF	Off
OIL W/L	Ignition switch ON	Oil pressure warning lamp ON	On
		Oil pressure warning lamp OFF	Off
MIL	Ignition switch ON	Malfunction warning lamp ON	On
		Malfunction warning lamp OFF	Off
GLOW IND	Ignition switch ON	NOTE: This item is displayed, but cannot be monitored.	Off
C-ENG2 W/L	Ignition switch ON	NOTE: This item is displayed, but cannot be monitored.	Off
CRUISE IND	Ignition switch ON	Cruise indicator displayed	On
		Cruise indicator not displayed	Off
SET IND	Ignition switch ON	Set indicator lamp ON	On
		Set indicator lamp OFF	Off
CRUISE W/L	Ignition switch ON	Cruise warning lamp ON	On
		Cruise warning lamp OFF	Off
BA W/L	Ignition switch ON	NOTE: This item is displayed, but cannot be monitored.	Off
ATC/T-AMT W/L	Ignition switch ON	A/T check warning lamp ON	On
		A/T check warning lamp OFF	Off
4WD W/L	Ignition switch ON	AWD warning lamp ON	On
		AWD warning lamp OFF	Off
4WD LOCK IND	Ignition switch ON	NOTE: This item is displayed, but cannot be monitored.	Off
FUEL W/L	Ignition switch ON	Low-fuel warning lamp displayed	On
		Low-fuel warning lamp not displayed	Off
WASHER W/L	Ignition switch ON	Washer warning displayed	On
		Washer warning not displayed	Off
AIR PRES W/L	Ignition switch ON	Low tire pressure lamp ON	On
		Low tire pressure lamp OFF	Off
KEY G/Y W/L	Ignition switch ON	Key warning lamp ON	On
		Key warning lamp OFF	Off
AFS OFF IND	Ignition switch ON	AFS OFF indicator lamp ON	On
		AFS OFF indicator lamp OFF	Off
4WAS/RAS W/L	Ignition switch ON	4WAS warning lamp ON	On
		4WAS warning lamp OFF	Off
DDS W/L	Ignition switch ON	NOTE: This item is displayed, but cannot be monitored.	Off
LANE W/L	Ignition switch ON	NOTE: This item is displayed, but cannot be monitored.	Off
LDP IND	Ignition switch ON	NOTE: This item is displayed, but cannot be monitored.	Off

UNIFIED METER AND A/C AMP.

< ECU DIAGNOSIS INFORMATION >

Monitor Item	Condition		Value/Status	
LCD	Ignition switch ON	Engine start information display (A/T model)	B&P I	A
		Engine start information display (M/T model)	C&P I	
	Ignition switch ACC	Engine start information display (A/T model)	B&P N	B
		Engine start information display (M/T model)	C&P N	
	Ignition switch LOCK	Key ID warning display	ID NG	C
	Ignition switch LOCK	Steering lock information display	ROTAT	
	Ignition switch LOCK	P position warning display	SFT P	D
	Ignition switch LOCK	Intelligent Key insert information display	INSRT	E
	Ignition switch LOCK	Intelligent Key low battery warning display	BATT	
	Ignition switch ON	Take away warning display	NO KY	F
	Ignition switch LOCK	Key warning display	OUTKY	G
Ignition switch ON	ICC sensor integrated unit warning display	LK WN		
ACC TARGET	Ignition switch ON	Vehicle ahead detection indicator displayed	On	H
		Vehicle ahead detection indicator not displayed	Off	
ACC DISTANCE	Ignition switch ON	When following distance set to "LONG"	LONG	I
		When following distance set to "MIDDLE"	MID	
		When following distance set to "SHORT"	SHORT	J
		Set distance indicator not displayed	Off	
ACC OWN VHL	Ignition switch ON	Own vehicle indicator displayed	On	
		Own vehicle indicator not displayed	Off	K
ACC SET SPEED	Ignition switch ON	ICC set vehicle speed display	Vehicle speed	
ACC UNIT	Ignition switch ON	Set vehicle speed indicator unit display ON	On	L
		Set vehicle speed indicator unit display OFF	Off	
O/D OFF SW	Ignition switch ON	NOTE: This item is displayed, but cannot be monitored.	Off	M
SHIFT IND	Ignition switch ON	Shift position indicator P display	P	MWI
		Shift position indicator R display	R	
		Shift position indicator N display	N	
		Shift position indicator D display	D	O
		Shift position indicator M1 display	M1	
		Shift position indicator M2 display	M2	
		Shift position indicator M3 display	M3	P
		Shift position indicator M4 display	M4	
		Shift position indicator M5 display	M5	
		Shift position indicator M6 display	M6	
Shift position indicator M7 display	M7			

UNIFIED METER AND A/C AMP.

< ECU DIAGNOSIS INFORMATION >

Monitor Item	Condition		Value/Status
AT S MODE SW	Ignition switch ON	Snow mode switch ON	On
		Snow mode switch OFF	Off
AT P MODE SW	Ignition switch ON	NOTE: This item is displayed, but cannot be monitored.	Off
M RANGE SW	Ignition switch ON	Selector lever DS position	On
		Other than the above	Off
NM RANGE SW	Ignition switch ON	Selector lever DS position	Off
		Other than the above	On
AT SFT UP SW	Ignition switch ON	Selector lever up position	On
		Other than the above	Off
AT SFT DWN SW	Ignition switch ON	Selector lever – position	On
		Other than the above	Off
ST SFT UP SW	Ignition switch ON	Paddle shifter up operation	On
		Other than the above	Off
ST SFT DWN SW	Ignition switch ON	Paddle shifter down operation	On
		Other than the above	Off
COMP F/B SIG	Ignition switch ON	A/C compressor activation condition	On
		A/C compressor deactivation condition	Off
4WD LOCK SW	Ignition switch ON	NOTE: This item is displayed, but cannot be monitored.	Off
PKB SW	Ignition switch ON	Parking brake applied	On
		Parking brake released	Off
BUCKLE SW	Ignition switch ON	Seat belt (driver side) unfastened	On
		Seat belt (driver side) fastened	Off
BRAKE OIL SW	Ignition switch ON	Brake fluid level is lower than the low level	On
		Brake fluid level is normal	Off
DISTANCE [km]	Ignition switch ON	—	Possible driving distance calculated by unified meter and A/C amp.
OUTSIDE TEMP [°C] or [°F]	Ignition switch ON	—	Equivalent to ambient temperature NOTE: This may not match the indicated value on the information display.
FUEL LOW SIG	Ignition switch ON	Low-fuel warning signal output	On
		Low-fuel warning signal not output	Off
BUZZER	Ignition switch ON	Buzzer ON	On
		Buzzer OFF	Off

NOTE:

Some items are not available according to vehicle specification.

TERMINAL LAYOUT

UNIFIED METER AND A/C AMP.

< ECU DIAGNOSIS INFORMATION >

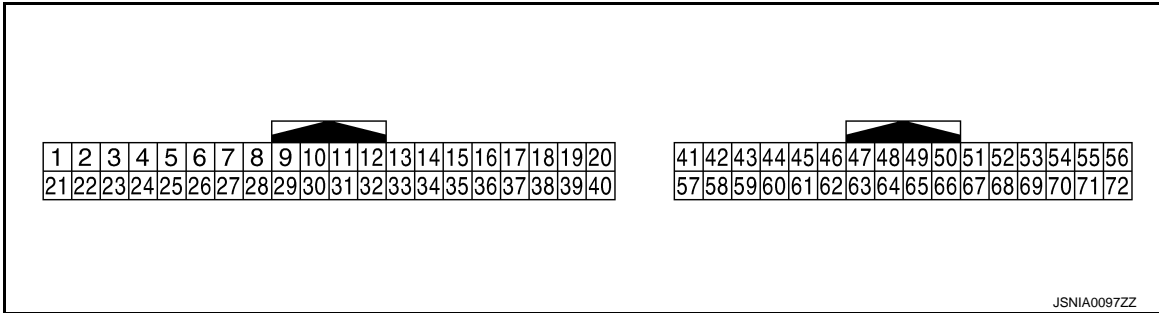

PHYSICAL VALUES

Terminal No. (Wire color)		Description		Condition		Value (Approx.)
+	-	Signal name	Input/ Output			
4 (G)	Ground	Stop lamp switch signal	Input	Ignition switch OFF	Brake pedal is depressed	12 V
					Other than the above	0 V
5 (L)	Ground	Manual mode shift up signal	Input	Ignition switch ON	Selector lever up position	0 V
					Other than the above	12 V
6 (BG)	Ground	Paddle shifter up signal	Input	Ignition switch ON	Paddle shifter up operation	0 V
					Other than the above	12 V
7 (GR)	Ground	Communication signal (AMP. → METER)	Output	Ignition switch ON	—	
8 (L)	Ground	Vehicle speed signal (2-pulse)	Output	Ignition switch ON	Speedometer operated [When vehicle speed is approx. 40 km/h (25 MPH)]	<p>NOTE: The maximum voltage varies depending on the specification (destination unit).</p>
9 (SB)	Ground	Seat belt buckle switch signal (driver side)	Input	Ignition switch ON	When seat belt (driver side) is fastened	12 V
					When seat belt (driver side) is unfastened	0 V
10 (W)	Ground	Manual mode signal	Input	Ignition switch ON	Selector lever DS position	0 V
					Other than the above	12 V
11 (G)	Ground	Non-manual mode signal	Input	Ignition switch ON	Selector lever DS position	12 V
					Other than the above	0 V

A
B
C
D
E
F
G
H
I
J
K
L
M
N
O
P

MWI

UNIFIED METER AND A/C AMP.

< ECU DIAGNOSIS INFORMATION >

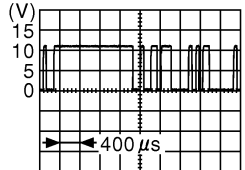
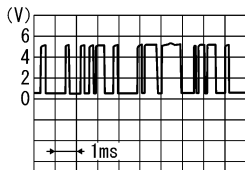
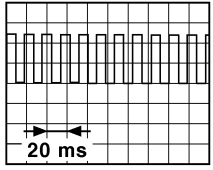
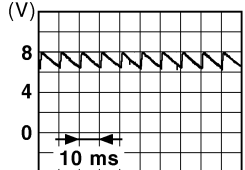
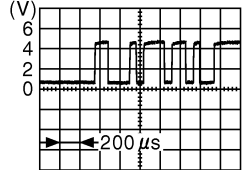
Terminal No. (Wire color)		Description		Condition		Value (Approx.)
+	-	Signal name	Input/ Output			
14 (BR)	Ground	Communication signal (LCD → AMP.)	Input	Ignition switch ON	—	 <small>JSNIA0028GB</small>
23 (Y)	Ground	A/T snow switch signal	Input	Ignition switch ON	Snow mode switch ON	12 V
					Snow mode switch OFF	0 V
25 (V)	Ground	Manual mode shift down signal	Input	Ignition switch ON	Selector lever down posi- tion	0 V
					Other than the above	12 V
26 (G)	Ground	Paddle shifter down signal	Input	Ignition switch ON	Paddle shifter down opera- tion	0 V
					Other than the above	12 V
27 (LG)	Ground	Communication signal (METER → AMP.)	Input	Ignition switch ON	—	 <small>SKIA3361E</small>
28 (R)	Ground	Vehicle speed signal (8-pulse)	Output	Ignition switch ON	Speedometer operated [When vehicle speed is ap- prox. 40 km/h (25 MPH)]	<p>NOTE: The maximum voltage varies de- pending on the specification (destination unit).</p>  <small>JSNIA0012GB</small>
30 (V)	Ground	Parking brake switch signal	Input	Ignition switch ON	Parking brake applied	0 V
					Parking brake released	 <small>JSNIA0007GB</small>
34 (Y)	Ground	Communication signal (AMP. → LCD)	Output	Ignition switch ON	—	 <small>JSNIA0027GB</small>

UNIFIED METER AND A/C AMP.

< ECU DIAGNOSIS INFORMATION >

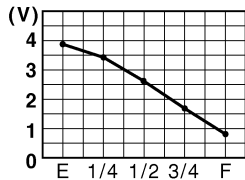
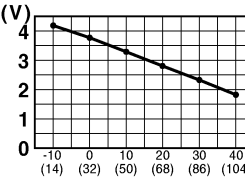
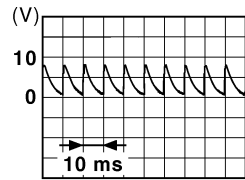
Terminal No. (Wire color)		Description		Condition		Value (Approx.)
+	-	Signal name	Input/ Output			
41 (L)	Ground	ACC power supply	Input	Ignition switch ACC	—	Battery voltage
42 (BR)	Ground	Fuel level sensor signal	Input	Ignition switch ON	—	 <p style="text-align: right; font-size: small;">JSNIA0013GB</p>
45 (V)	Ground	Ambient sensor signal	Input	—	—	 <p style="text-align: right; font-size: small;">JSNIA0014GB</p>
53 (W)	Ground	Ignition power supply	Input	Ignition switch ON	—	Battery voltage
54 (SB)	Ground	Battery power supply	Input	Ignition switch OFF	—	Battery voltage
55 (B)	Ground	Ground	—	Ignition switch ON	—	0 V
56 (L)	Ground	CAN-H	—	—	—	—
57 (LG)	Ground	Brake fluid level switch signal	Input	Ignition switch ON	Brake fluid level is normal.	 <p style="text-align: right; font-size: small;">JSNIA0008GB</p>
					The brake fluid level is lower than the low level	0 V
58 (Y)	Ground	Fuel level sensor ground	—	Ignition switch ON	—	0 V
61 (B)	Ground	Ambient sensor ground	—	Ignition switch ON	—	0 V
71 (GR)	Ground	Ground	—	Ignition switch ON	—	0 V
72 (P)	Ground	CAN-L	—	—	—	—

A
B
C
D
E
F
G
H
I
J
K
L
M
N
O
P

MWI

UNIFIED METER AND A/C AMP.

< ECU DIAGNOSIS INFORMATION >

Wiring Diagram - METER -

INFOID:000000007805129

For connector terminal arrangements, harness layouts, and alphabets in a  (option abbreviation; if not described in wiring diagram), refer to [GI-12, "Connector Information"](#).

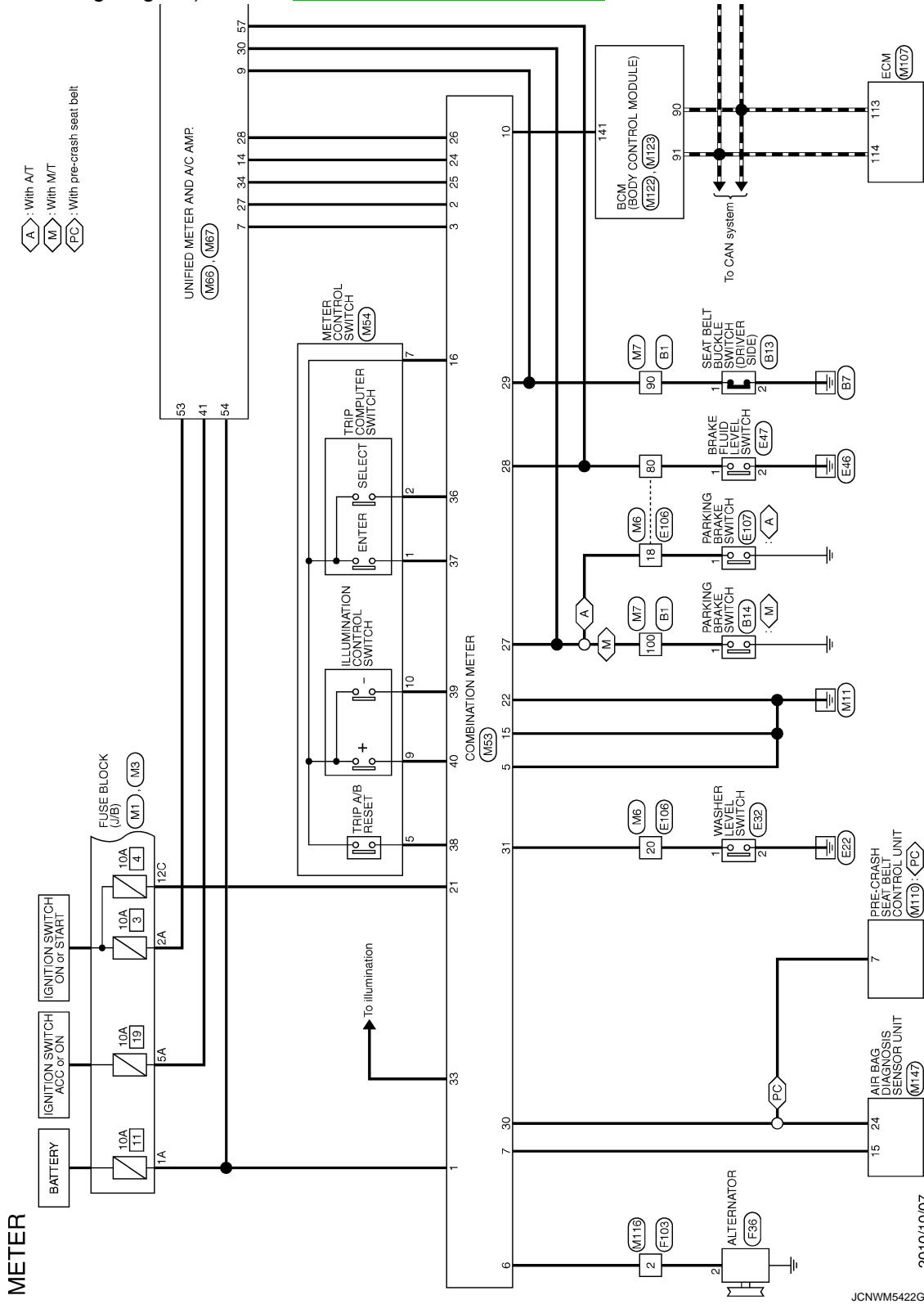

UNIFIED METER AND A/C AMP.

< ECU DIAGNOSIS INFORMATION >

- : With 4MAS
- : With paddle shifter
- : With AT
- : AWD models
- : With ICC

* : This connector is not shown in "Harness Layout".

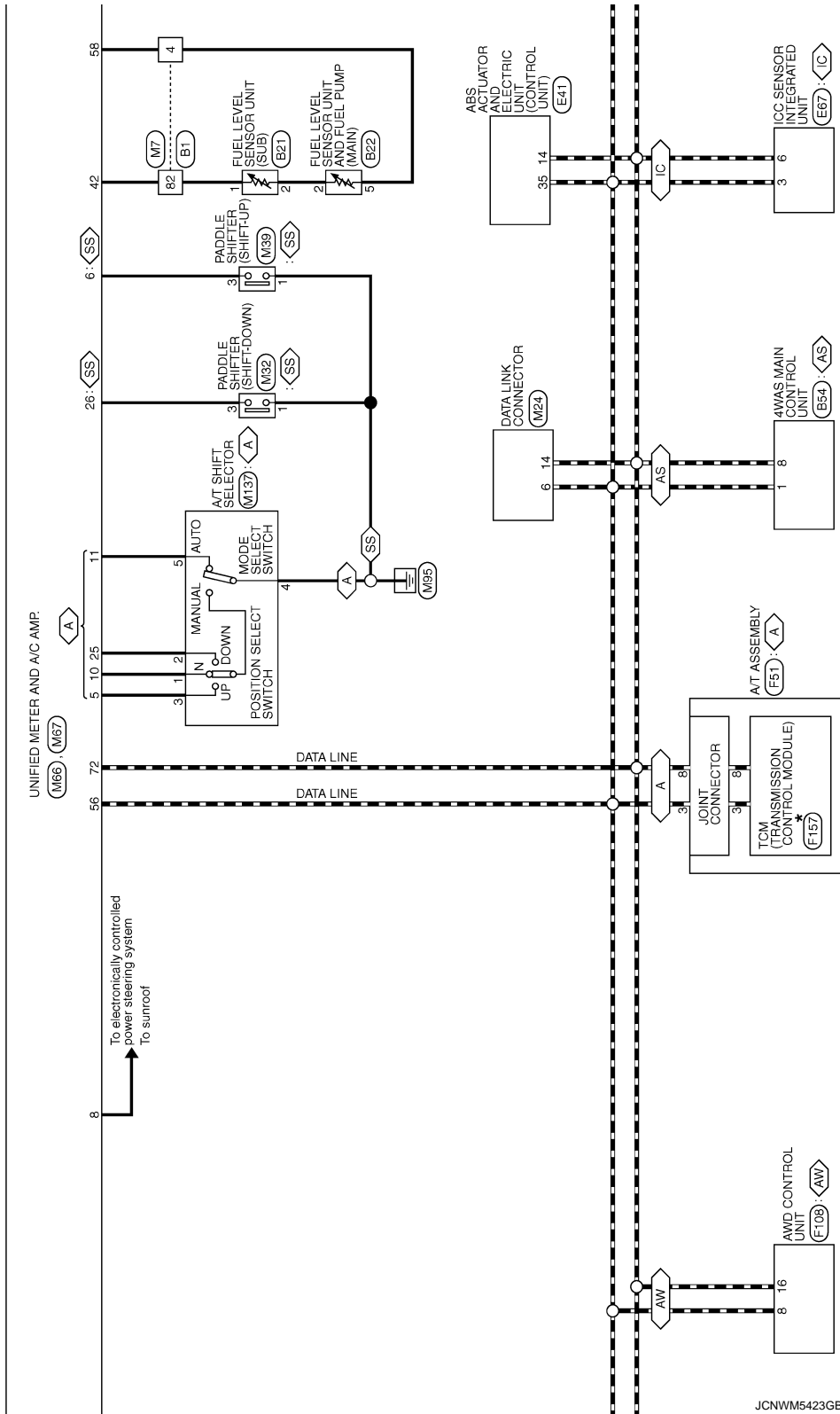

A
B
C
D
E
F
G
H
I
J
K
L
M
N
O
P

MWI

UNIFIED METER AND A/C AMP.

< ECU DIAGNOSIS INFORMATION >

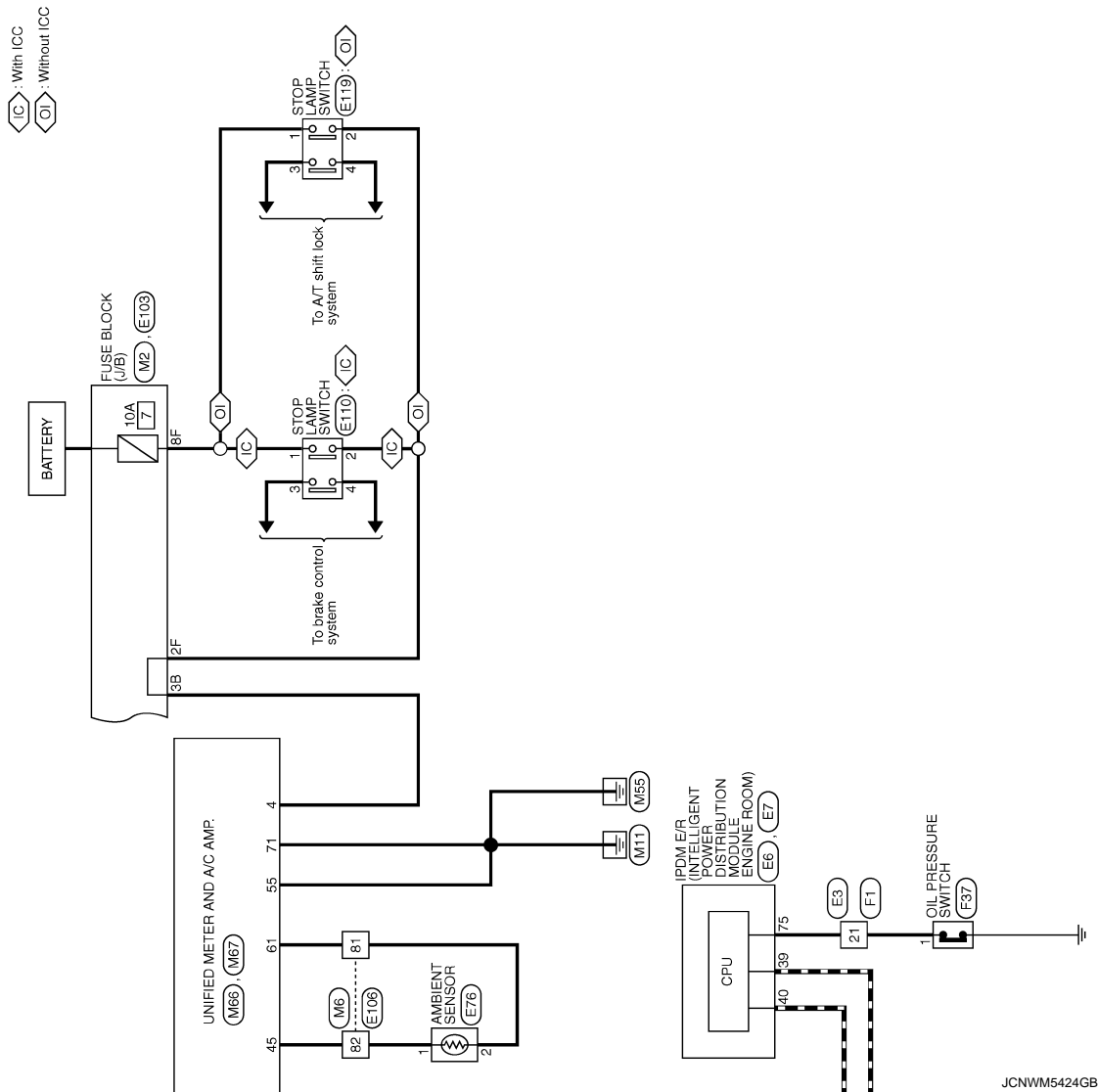

Fail-safe

INFOID:000000007474312

FAIL SAFE

Combination meter performs fail-safe operation when unified meter and A/C amp. communication is malfunction.

Solution for communication error between the unified meter and A/C amp. and combination meter.

UNIFIED METER AND A/C AMP.

< ECU DIAGNOSIS INFORMATION >

Function	Specifications			
Speedometer	Reset to zero by suspending communication.	A		
Tachometer		B		
Fuel gauge		C		
Water temperature gauge		D		
Illumination control	When suspending communication, change to nighttime mode.	E		
Information display	Door open warning	The display turns off by suspending communication.	F	
	Parking brake release warning		G	
	Low tire pressure warning		H	
	Fuel filler cap warning		I	
	Instantaneous fuel warning		<ul style="list-style-type: none"> When reception time of an abnormal signal is 2 seconds or less, the last received datum is used for calculation to indicate the result. When reception time of an abnormal signal is more than two seconds, the last result calculated during normal condition is indicated. 	J
	Average fuel consumption			K
	Average vehicle speed			L
Travel distance	M			
Buzzer	The buzzer turns off by suspending communication.	N		
Warning lamp/indicator lamp	ABS warning lamp	The lamp turns on by suspending communication.	O	
	VDC warning lamp		P	
	Brake warning lamp		Q	
	CRUISE warning lamp		R	
	Malfunction indicator lamp		S	
	High beam indicator	The lamp turns off by suspending communication.	T	
	Turn signal indicator lamp		U	
	Oil pressure warning lamp		V	
	A/T CHECK warning lamp		W	
	VDC OFF indicator lamp		X	
	Low tire pressure warning lamp		Y	
	Key warning lamp		Z	
	AFS OFF indicator lamp		AA	
	4WAS warning lamp		AB	
	Master warning lamp		AC	
AWD warning lamp	AD			
Tail lamp indicator lamp	AE			
Front fog lamp indicator lamp	AF			

DTC Index

INFOID:000000007474313

MWI

Display contents of CONSULT	Time		Diagnostic item is detected when...	Refer to	
U1000: CAN COMM CIRCUIT	CRNT	PAST	When unified meter and A/C amp. is not transmitting or receiving CAN communication signal for 2 seconds or more.	MWI-42	O
U1010: CONTROL UNIT (CAN)	CRNT	PAST	When detecting error during the initial diagnosis of CAN controller of unified meter and A/C amp.	MWI-43	P
B2201: COMM ERROR 1	CRNT	PAST	If a communication error is present in the communication line between unified meter and A/C amp. and combination meter for 2 seconds or more.	MWI-44	
B2202: COMM ERROR 2	CRNT	PAST	If a communication error is present in the communication line between unified meter and A/C amp. and combination meter for 2 seconds or more.	MWI-46	

UNIFIED METER AND A/C AMP.

< ECU DIAGNOSIS INFORMATION >

Display contents of CONSULT	Time		Diagnostic item is detected when...	Refer to
B2205: VEHICLE SPEED	CRNT	PAST	The abnormal vehicle speed signal is input from ABS actuator and electric unit (control unit) for 2 seconds or more.	MWI-48
B2267: ENGINE SPEED	CRNT	PAST	If ECM continuously transmits abnormal engine speed signals for 2 seconds or more.	MWI-49
B2268: WATER TEMP	CRNT	PAST	If ECM continuously transmits abnormal engine coolant temperature signals for 60 seconds or more.	MWI-50

NOTE:

The details of TIME display are as follows.

- CRNT: The malfunctions that are detected now.
- PAST: The malfunctions was detected in the past. IGN counter is displayed on FFD (Freeze Frame data).
- 1 - 39: The number is indicated when it is normal at present and a malfunction was detected in the past. It increases like 0 → 1 → 2 ... 38 → 39 after returning to the normal condition whenever IGN OFF → ON. It is fixed to 39 until the self-diagnosis results are erased if it is over 39. It returns to 0 when a malfunction is detected again in the process.

IPDM E/R (INTELLIGENT POWER DISTRIBUTION MODULE ENGINE ROOM)

< ECU DIAGNOSIS INFORMATION >

IPDM E/R (INTELLIGENT POWER DISTRIBUTION MODULE ENGINE ROOM)

Reference Value

INFOID:000000007687405

VALUES ON THE DIAGNOSIS TOOL

Monitor Item	Condition		Value/Status
RAD FAN REQ	Engine idle speed	Changes depending on engine coolant temperature, air conditioner operation status, vehicle speed, etc.	0 - 100 %
AC COMP REQ	Engine running	A/C switch OFF	Off
		A/C switch ON (Compressor is operating)	On
TAIL&CLR REQ	Lighting switch OFF		Off
	Lighting switch 1ST, 2ND, HI or AUTO (Light is illuminated)		On
HL LO REQ	Lighting switch OFF		Off
	Lighting switch 2ND HI or AUTO (Light is illuminated)		On
HL HI REQ	Lighting switch OFF		Off
	Lighting switch HI		On
FR FOG REQ	Lighting switch 2ND or AUTO (Light is illuminated)	Front fog lamp switch OFF	Off
		<ul style="list-style-type: none"> • Front fog lamp switch ON • Daytime running light activated (Only for Canada) 	On
FR WIP REQ	Ignition switch ON	Front wiper switch OFF	Stop
		Front wiper switch INT	1LOW
		Front wiper switch LO	Low
		Front wiper switch HI	Hi
WIP AUTO STOP	Ignition switch ON	Front wiper stop position	STOP P
		Any position other than front wiper stop position	ACT P
WIP PROT	Ignition switch ON	Front wiper operates normally	Off
		Front wiper stops at fail-safe operation	BLOCK
IGN RLY1 -REQ	Ignition switch OFF or ACC		Off
	Ignition switch ON		On
IGN RLY	Ignition switch OFF or ACC		Off
	Ignition switch ON		On
PUSH SW	Release the push-button ignition switch		Off
	Press the push-button ignition switch		On
INTER/NP SW	Ignition switch ON	Selector lever in any position other than P or N (A/T models)	Off
		Release clutch pedal (M/T models)	
	Ignition switch ON	Selector lever in P or N position (A/T models)	On
		Depress clutch pedal (M/T models)	
ST RLY CONT	Ignition switch ON		Off
	At engine cranking		On

IPDM E/R (INTELLIGENT POWER DISTRIBUTION MODULE ENGINE ROOM)

< ECU DIAGNOSIS INFORMATION >

Monitor Item	Condition	Value/Status
IHBT RLY -REQ	Ignition switch ON	Off
	At engine cranking	On
ST/INHI RLY	Ignition switch ON	Off
	At engine cranking	INHI ON → ST ON
	The status of starter relay or starter control relay cannot be recognized by the battery voltage malfunction, etc. when the starter relay is ON and the starter control relay is OFF	UNKWN
DETENT SW	Ignition switch ON	Off
	Release the selector button with selector lever in P position NOTE: Fixed On for M/T models	On
S/L RLY -REQ	NOTE: The item is indicated, but not monitored.	Off
S/L STATE	NOTE: The item is indicated, but not monitored.	UNLOCK
DTRL REQ	NOTE: The item is indicated, but not monitored.	Off
OIL P SW	Ignition switch OFF, ACC or engine running	Open
	Ignition switch ON	Close
HOOD SW	Close the hood	Off
	Open the hood	On
HL WASHER REQ	NOTE: The item is indicated, but not monitored.	Off
THFT HRN REQ	Not operation	Off
	<ul style="list-style-type: none"> • Panic alarm is activated • Horn is activated with VEHICLE SECURITY (THEFT WARNING) SYSTEM 	On
HORN CHIRP	Not operating	Off
	Door locking with Intelligent Key (horn chirp mode)	On
CRNRNG LMP REQ	NOTE: The item is indicated, but not monitored.	Off

IPDM E/R (INTELLIGENT POWER DISTRIBUTION MODULE ENGINE ROOM)

< ECU DIAGNOSIS INFORMATION >

TERMINAL LAYOUT

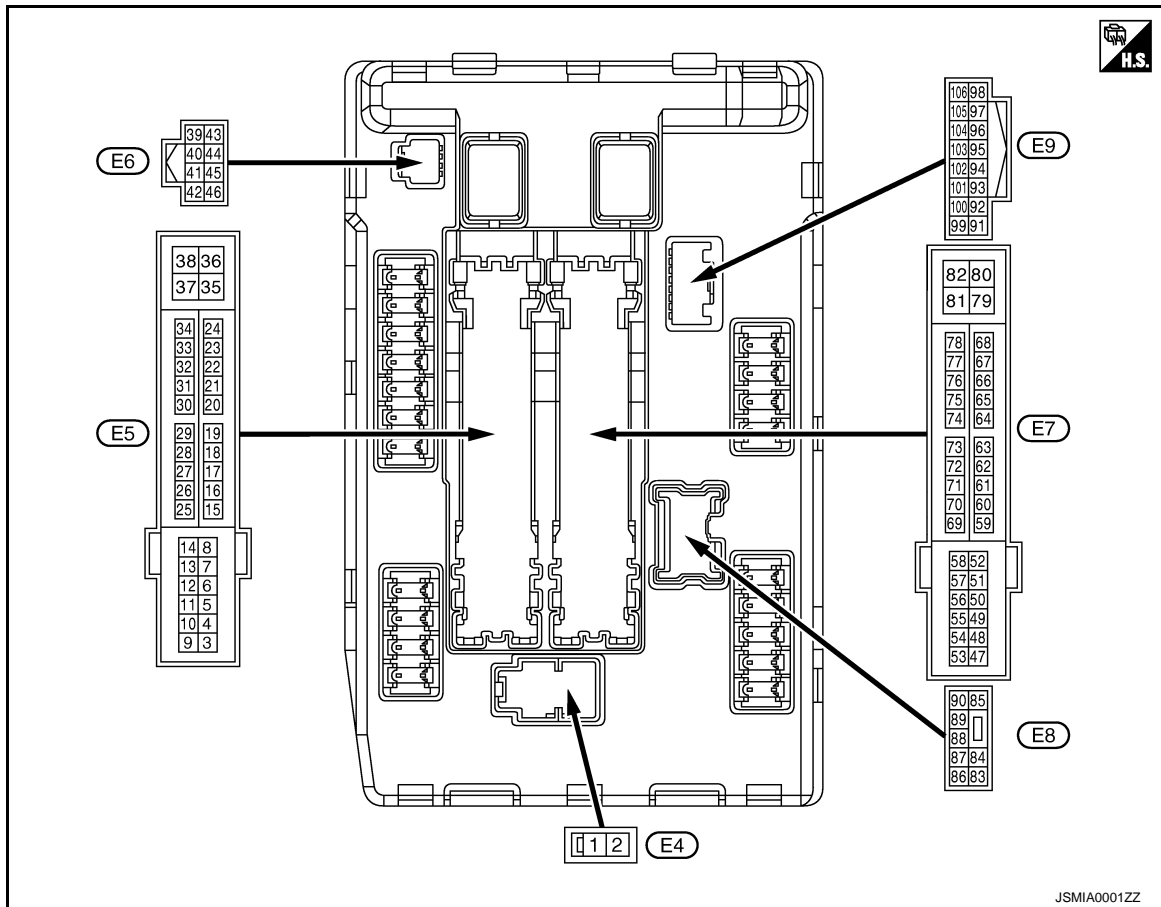

PHYSICAL VALUES

Terminal No. (Wire color)		Description		Condition		Value (Approx.)
+	-	Signal name	Input/ Output			
1 (W)	Ground	Battery power supply	Input	Ignition switch OFF		Battery voltage
2 (L)	Ground	Battery power supply	Input	Ignition switch OFF		Battery voltage
4 (V)	Ground	Front wiper LO	Output	Ignition switch ON	Front wiper switch OFF	0 V
					Front wiper switch LO	Battery voltage
5 (L)	Ground	Front wiper HI	Output	Ignition switch ON	Front wiper switch OFF	0 V
					Front wiper switch HI	Battery voltage
6*4 (SB)	Ground	Daytime running light relay	Input	Ignition switch OFF		Battery voltage
7 (R)	Ground	Tail, license plate lamps & illuminations	Output	Ignition switch ON	Lighting switch OFF	0 V
					Lighting switch 1ST	Battery voltage
12 (B/W)	Ground	Ground	—	Ignition switch ON		0 V
13 (Y)	Ground	Fuel pump power supply	Output	Approximately 1 second or more after turning the ignition switch ON		0 V
				<ul style="list-style-type: none"> Approximately 1 second after turning the ignition switch ON Engine running 		Battery voltage

IPDM E/R (INTELLIGENT POWER DISTRIBUTION MODULE ENGINE ROOM)

< ECU DIAGNOSIS INFORMATION >

Terminal No. (Wire color)		Description		Condition		Value (Approx.)
+	-	Signal name	Input/ Output			
16 (LG)	Ground	Front wiper auto stop	Input	Ignition switch ON	Front wiper stop position	0 V
					Any position other than front wiper stop position	Battery voltage
19 (W)	Ground	Ignition relay power supply	Output	Ignition switch OFF		0 V
				Ignition switch ON		Battery voltage
25 (G)	Ground	Ignition relay power supply	Output	Ignition switch OFF		0 V
				Ignition switch ON		Battery voltage
26*1 (R)	Ground	Ignition relay power supply	Output	Ignition switch OFF		0 V
				Ignition switch ON		Battery voltage
27 (BG)	Ground	Ignition relay monitor	Input	Ignition switch OFF or ACC		Battery voltage
				Ignition switch ON		0 V
28 (L)	Ground	Push-button ignition switch	Input	Press the push-button ignition switch		0 V
				Release the push-button ignition switch		Battery voltage
30 (GR)	Ground	Starter relay control	Input	A/T models	Selector lever in any position other than P or N (Ignition switch ON)	0 V
					Selector lever P or N (Ignition switch ON)	Battery voltage
				M/T models	Release the clutch pedal	0 V
					Depress the clutch pedal	Battery voltage
36 (G)	Ground	Battery power supply	Input	Ignition switch OFF		Battery voltage
39 (P)	—	CAN-L	Input/ Output	—		—
40 (L)	—	CAN-H	Input/ Output	—		—
41 (B/W)	Ground	Ground	—	Ignition switch ON		0 V
42 (Y)	Ground	Cooling fan relay control	Input	Ignition switch OFF or ACC		0 V
				Ignition switch ON		0.7 V
43*2 (SB)	Ground	A/T shift selector (Detention switch)	Input	Ignition switch ON	<ul style="list-style-type: none"> Press the selector button (selector lever P) Selector lever in any position other than P 	Battery voltage
					Release the selector button (selector lever P)	0 V
44 (LG)	Ground	Horn relay control	Input	The horn is deactivated		Battery voltage
				The horn is activated		0 V
45 (G)	Ground	Anti theft horn relay control	Input	The horn is deactivated		Battery voltage
				The horn is activated		0 V
46 (W)	Ground	Starter relay control	Input	A/T models	Selector lever in any position other than P or N (Ignition switch ON)	0 V
					Selector lever P or N (Ignition switch ON)	Battery voltage
				M/T models	Release the clutch pedal	0 V
					Depress the clutch pedal	Battery voltage

IPDM E/R (INTELLIGENT POWER DISTRIBUTION MODULE ENGINE ROOM)

< ECU DIAGNOSIS INFORMATION >

Terminal No. (Wire color)		Description		Condition		Value (Approx.)	
+	-	Signal name	Input/ Output				
48 (BR)	Ground	A/C relay power supply	Output	Engine running	A/C switch OFF	0 V	A
					A/C switch ON (A/C compressor is operating)	Battery voltage	B
49 (BG)	Ground	ECM relay power supply	Output	Ignition switch OFF (More than a few seconds after turning ignition switch OFF)		0 V	C
				<ul style="list-style-type: none"> Ignition switch ON Ignition switch OFF (For a few seconds after turning ignition switch OFF) 		Battery voltage	D
51 (Y)	Ground	Ignition relay power supply	Output	Ignition switch OFF		0 V	E
				Ignition switch ON		Battery voltage	F
53 (W)	Ground	ECM relay power supply	Output	Ignition switch OFF (More than a few seconds after turning ignition switch OFF)		0 V	F
				<ul style="list-style-type: none"> Ignition switch ON Ignition switch OFF (For a few seconds after turning ignition switch OFF) 		Battery voltage	G
54 (P)	Ground	Throttle control motor relay power supply	Output	Ignition switch OFF (More than a few seconds after turning ignition switch OFF)		0 V	H
				<ul style="list-style-type: none"> Ignition switch ON Ignition switch OFF (For a few seconds after turning ignition switch OFF) 		Battery voltage	I
55 (SB)	Ground	ECM power supply	Output	Ignition switch OFF		Battery voltage	J
56 (LG)	Ground	Ignition relay power supply	Output	Ignition switch OFF		0 V	K
				Ignition switch ON		Battery voltage	L
57 (G)	Ground	Ignition relay power supply	Output	Ignition switch OFF		0 V	L
				Ignition switch ON		Battery voltage	M
58*2 (GR)	Ground	Ignition relay power supply	Output	Ignition switch OFF		0 V	M
				Ignition switch ON		Battery voltage	M
69 (BR)	Ground	ECM relay control	Output	Ignition switch OFF (More than a few seconds after turning ignition switch OFF)		Battery voltage	MWI
				<ul style="list-style-type: none"> Ignition switch ON Ignition switch OFF (For a few seconds after turning ignition switch OFF) 		0 - 1.5 V	O
70 (BG)	Ground	Throttle control motor relay control	Output	Ignition switch ON → OFF		0 - 1.0 V ↓ Battery voltage ↓ 0 V	P
				Ignition switch ON		0 - 1.0 V	
73*3 (P)	Ground	Ignition relay power supply	Output	Ignition switch OFF		0 V	
				Ignition switch ON		Battery voltage	

IPDM E/R (INTELLIGENT POWER DISTRIBUTION MODULE ENGINE ROOM)

< ECU DIAGNOSIS INFORMATION >

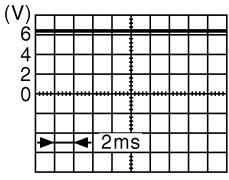
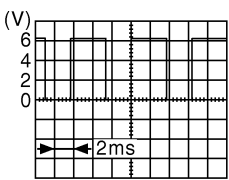
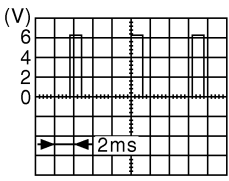
Terminal No. (Wire color)		Description		Condition		Value (Approx.)
+	-	Signal name	Input/ Output			
74 (G)	Ground	Ignition relay power supply	Output	Ignition switch OFF		0 V
				Ignition switch ON		Battery voltage
75 (SB)	Ground	Oil pressure switch	Input	Ignition switch ON	Engine stopped	0 V
					Engine running	Battery voltage
76 (Y)	Ground	Power generation command signal	Output	Ignition switch ON		 6.3 V
				40% is set on "ACTIVE TEST", "ALTERNATOR DUTY" of "ENGINE"		 3.8 V
				80% is set on "ACTIVE TEST", "ALTERNATOR DUTY" of "ENGINE"		 1.4 V
77 (R)	Ground	Fuel pump relay control	Output	<ul style="list-style-type: none"> Approximately 1 second after turning the ignition switch ON Engine running 		0 - 1.0 V
				Approximately 1 second or more after turning the ignition switch ON		Battery voltage
80 (W)	Ground	Starter motor	Output	At engine cranking		Battery voltage
83 (R)	Ground	Headlamp LO (RH)	Output	Ignition switch ON	Lighting switch OFF	0 V
					Lighting switch 2ND	Battery voltage
84 (P)	Ground	Headlamp LO (LH)	Output	Ignition switch ON	Lighting switch OFF	0 V
					Lighting switch 2ND	Battery voltage
86 (W)	Ground	Front fog lamp (RH)	Output	Lighting switch 2ND	Front fog lamp switch OFF	0 V
					<ul style="list-style-type: none"> Front fog lamp switch ON Daytime running light activated (Only for Canada) 	Battery voltage

IPDM E/R (INTELLIGENT POWER DISTRIBUTION MODULE ENGINE ROOM)

< ECU DIAGNOSIS INFORMATION >

Terminal No. (Wire color)		Description		Condition		Value (Approx.)
+	-	Signal name	Input/ Output			
87 (L)	Ground	Front fog lamp (LH)	Output	Lighting switch 2ND	Front fog lamp switch OFF	0 V
					<ul style="list-style-type: none"> • Front fog lamp switch ON • Daytime running light activated (Only for Canada) 	Battery voltage
88 (G)	Ground	Washer pump power sup- ply	Output	Ignition switch ON		Battery voltage
89 (BR)	Ground	Headlamp HI (RH)	Output	Ignition switch ON	Lighting switch OFF	0 V
					<ul style="list-style-type: none"> • Lighting switch HI • Lighting switch PASS 	Battery voltage
90 (LG)	Ground	Headlamp HI (LH)	Output	Ignition switch ON	Lighting switch OFF	0 V
					<ul style="list-style-type: none"> • Lighting switch HI • Lighting switch PASS 	Battery voltage
91 (P)	Ground	Parking lamp (RH)	Output	Ignition switch ON	Lighting switch OFF	0 V
					Lighting switch 1ST	Battery voltage
92 (BG)	Ground	Parking lamp (LH)	Output	Ignition switch ON	Lighting switch OFF	0 V
					Lighting switch 1ST	Battery voltage
97 (V)	Ground	Cooling fan control	Output	Engine idling		0 - 5 V
104 (LG)	Ground	Hood switch	Input	Close the hood		Battery voltage
				Open the hood		0 V
105*5 (L)	Ground	Daytime running light relay control	Output	<ul style="list-style-type: none"> • Parking lamp • License plate lamp • Tail lamp 	Turned OFF	Battery voltage
					Turned ON	

*1: Only for the models with ICC system

*2: A/T models only

*3: M/T models only

*4: Models with daytime running light system

MWI

IPDM E/R (INTELLIGENT POWER DISTRIBUTION MODULE ENGINE ROOM)

< ECU DIAGNOSIS INFORMATION >

Wiring Diagram - IPDM E/R -

INFOID:000000007687406

For connector terminal arrangements, harness layouts, and alphabets in a (option abbreviation; if not described in wiring diagram), refer to [GI-12, "Connector Information"](#).

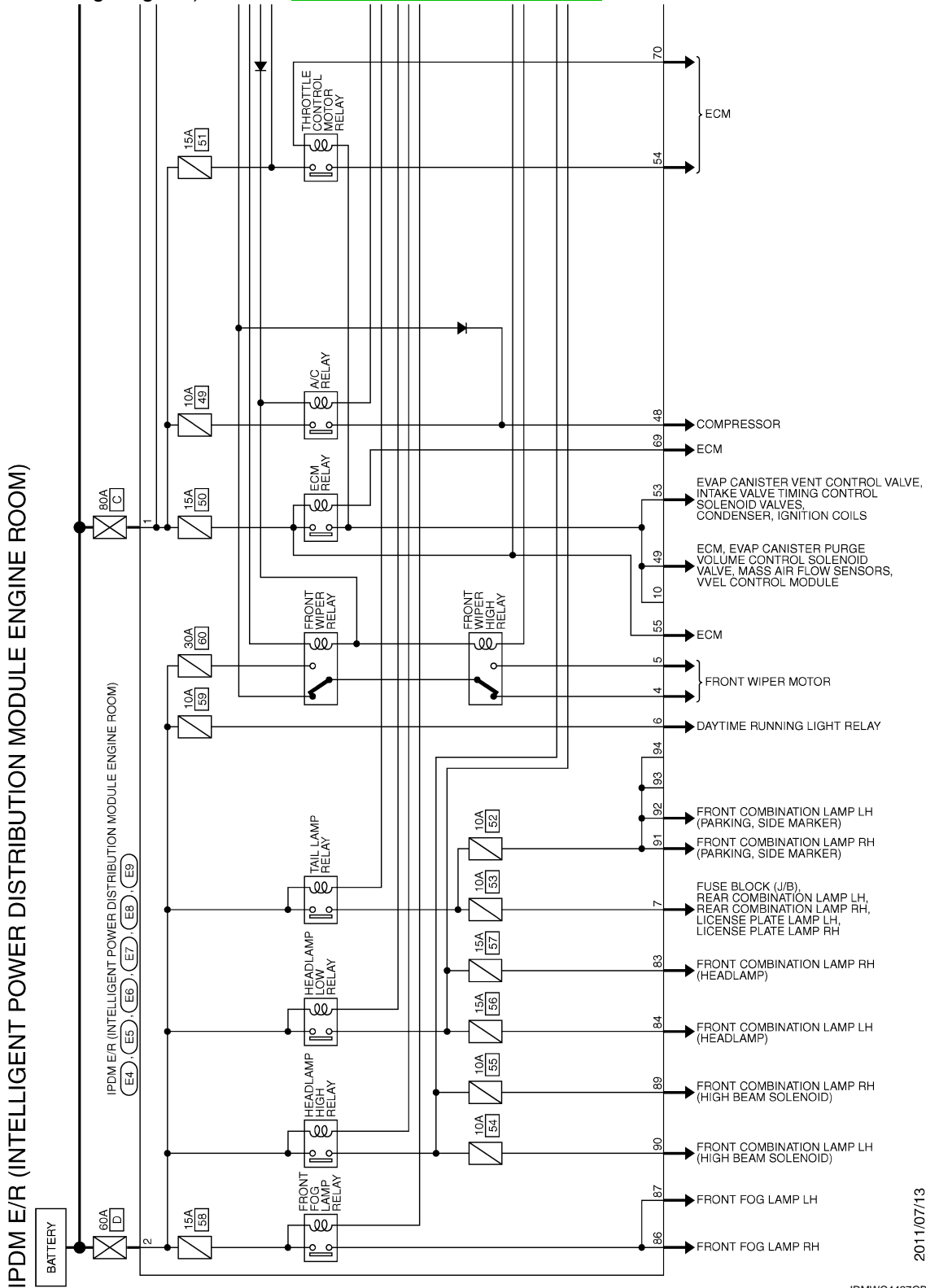

2011/07/13

JRMWC4427GB

IPDM E/R (INTELLIGENT POWER DISTRIBUTION MODULE ENGINE ROOM)

< ECU DIAGNOSIS INFORMATION >

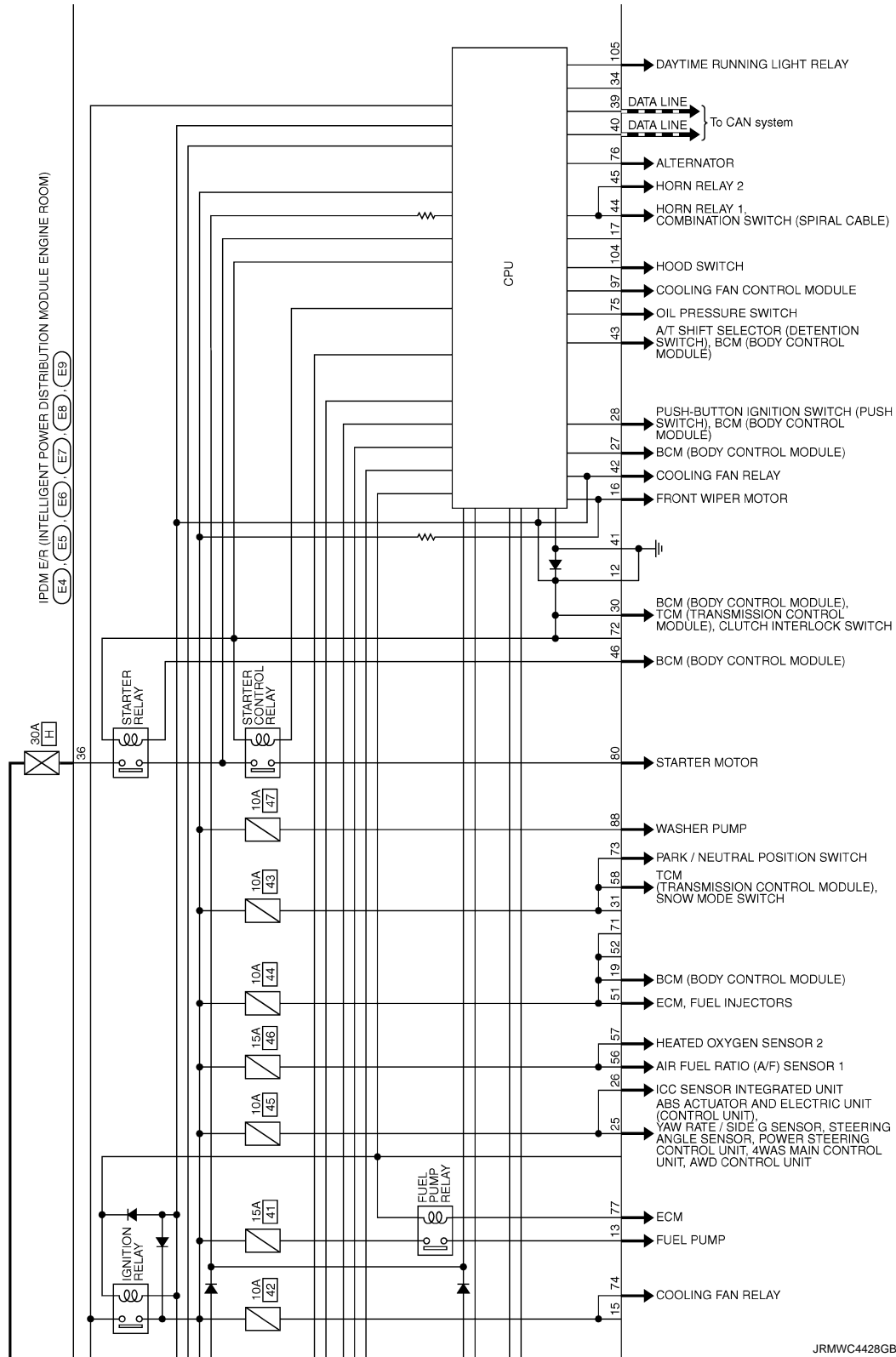

JRMWC4428GB

MWI

IPDM E/R (INTELLIGENT POWER DISTRIBUTION MODULE ENGINE ROOM)

< ECU DIAGNOSIS INFORMATION >

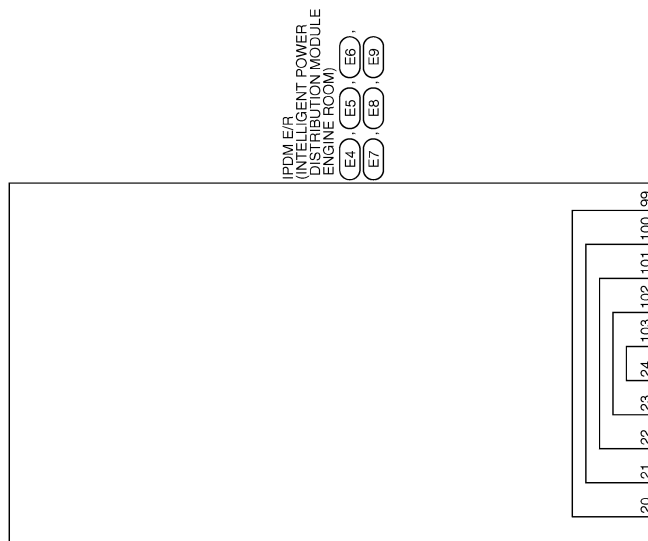

JRMWC4429GB

Fail-safe

INFOID:000000007687407

CAN COMMUNICATION CONTROL

When CAN communication with ECM and BCM is impossible, IPDM E/R performs fail-safe control. After CAN communication recovers normally, it also returns to normal control.

If No CAN Communication Is Available With ECM

IPDM E/R (INTELLIGENT POWER DISTRIBUTION MODULE ENGINE ROOM)

< ECU DIAGNOSIS INFORMATION >

Control part	Fail-safe operation
Cooling fan	<ul style="list-style-type: none"> Outputs the pulse duty signal (PWM signal) 100% when the ignition switch is turned ON Outputs the pulse duty signal (PWM signal) 0% when the ignition switch is turned OFF
A/C compressor	A/C relay OFF
Alternator	Outputs the power generation command signal (PWM signal) 0%

If No CAN Communication Is Available With BCM

Control part	Fail-safe operation
Headlamp	<ul style="list-style-type: none"> Turns ON the headlamp low relay when the ignition switch is turned ON Turns OFF the headlamp low relay when the ignition switch is turned OFF Headlamp high relay OFF
<ul style="list-style-type: none"> Parking lamps Side maker lamp License plate lamps Illuminations Tail lamps 	<ul style="list-style-type: none"> Turns ON the tail lamp relay when the ignition switch is turned ON Turns OFF the tail lamp relay when the ignition switch is turned OFF
Front wiper	<ul style="list-style-type: none"> The status just before activation of fail-safe control is maintained until the ignition switch is turned OFF while the front wiper is operating at LO or HI speed. The wiper is operated at LO speed until the ignition switch is turned OFF if the fail-safe control is activated while the front wiper is set in the INT mode and the front wiper motor is operating.
Horn	Horn relay OFF
Ignition relay	The status just before activation of fail-safe is maintained.
Starter motor	Starter control relay OFF

IGNITION RELAY MALFUNCTION DETECTION FUNCTION

- IPDM E/R monitors the voltage at the contact circuit and excitation coil circuit of the ignition relay inside it.
- IPDM E/R judges the ignition relay error if the voltage differs between the contact circuit and the excitation coil circuit.
- If the ignition relay cannot turn OFF due to contact seizure, it activates the tail lamp relay for 10 minutes to alert the user to the ignition relay malfunction when the ignition switch is turned OFF.

Voltage judgment		IPDM E/R judgment	Operation
Ignition relay contact side	Ignition relay excitation coil side		
ON	ON	Ignition relay ON normal	—
OFF	OFF	Ignition relay OFF normal	—
ON	OFF	Ignition relay ON stuck	<ul style="list-style-type: none"> Detects DTC "B2098: IGN RELAY ON" Turns ON the tail lamp relay for 10 minutes
OFF	ON	Ignition relay OFF stuck	Detects DTC "B2099: IGN RELAY OFF"

FRONT WIPER CONTROL

IPDM E/R detects front wiper stop position by a front wiper stop position signal.

When a front wiper stop position signal is in the conditions listed below, IPDM E/R stops power supply to wiper after repeating a front wiper 10 seconds activation and 20 seconds stop five times.

Ignition switch	Front wiper switch	Front wiper stop position signal
ON	OFF	The front wiper stop position signal (stop position) cannot be input for 10 seconds.
	ON	The front wiper stop position signal does not change for 10 seconds.

NOTE:

IPDM E/R (INTELLIGENT POWER DISTRIBUTION MODULE ENGINE ROOM)

< ECU DIAGNOSIS INFORMATION >

This operation status can be confirmed on the IPDM E/R “Data Monitor” that displays “BLOCK” for the item “WIP PROT” while the wiper is stopped.

STARTER MOTOR PROTECTION FUNCTION

IPDM E/R turns OFF the starter control relay to protect the starter motor when the starter control relay remains active for 90 seconds.

DTC Index

INFOID:000000007687408

NOTE:

- The details of time display are as follows.
 - CRNT: A malfunction is detected now.
 - PAST: A malfunction was detected in the past.
- IGN counter is displayed on FFD (Freeze Frame data).
 - The number is 0 when is detected now.
 - The number increases like 1 → 2 ... 38 → 39 after returning to the normal condition whenever IGN OFF → ON.
 - The number is fixed to 39 until the self-diagnosis results are erased if it is over 39.

×: Applicable

CONSULT display	Fail-safe	Refer to
No DTC is detected. further testing may be required.	—	—
U1000: CAN COMM CIRCUIT	×	PCS-14
B2098: IGN RELAY ON	×	PCS-15
B2099: IGN RELAY OFF	—	PCS-16
B210B: START CONT RLY ON	—	SEC-88
B210C: START CONT RLY OFF	—	SEC-89
B210D: STARTER RELAY ON	—	SEC-90
B210E: STARTER RELAY OFF	—	SEC-91
B210F: INTRLCK/PNP SW ON	—	SEC-93
B2110: INTRLCK/PNP SW OFF	—	SEC-95

THE FUEL GAUGE POINTER DOES NOT MOVE

< SYMPTOM DIAGNOSIS >

SYMPTOM DIAGNOSIS

THE FUEL GAUGE POINTER DOES NOT MOVE

Description

INFOID:000000007474318

Fuel gauge needle will not move from a certain position.

Diagnosis Procedure

INFOID:000000007474319

1. CONDUCTING THE COMBINATION METER SELF-DIAGNOSIS MODE

Perform the self-diagnosis mode of combination meter, and then check that the fuel gauge operates normally. Refer to [MWI-36, "Diagnosis Description"](#).

Is the inspection result normal?

YES >> GO TO 2.

NO >> Replace combination meter. Refer to [MWI-112, "Removal and Installation"](#).

2. CHECK FLOAT INTERFERENCE

Check that the float arm interferes with or binds to other components in the fuel tank.

Is the inspection result normal?

YES >> GO TO 3.

NO >> Repair or replace malfunctioning part.

3. CHECK FUEL LEVEL SENSOR SIGNAL CIRCUIT

Check the fuel level sensor signal circuit. Refer to [MWI-54, "Component Function Check"](#).

Is the inspection result normal?

YES >> Check intermittent incident. Refer to [GI-43, "Intermittent Incident"](#).

NO >> Repair or replace malfunctioning parts.

A
B
C
D
E
F
G
H
I
J
K
L
M
O
P

MWI

THE METER CONTROL SWITCH IS INOPERATIVE

< SYMPTOM DIAGNOSIS >

THE METER CONTROL SWITCH IS INOPERATIVE

Description

INFOID:000000007474320

If any of the following malfunctions is found for the meter control switch operation.

- All switches are inoperative.
- The specified switch cannot be operated.

Diagnosis Procedure

INFOID:000000007474321

1. CHECK METER CONTROL SWITCH SIGNAL CIRCUIT

Check the meter control switch signal circuit. Refer to [MWI-58, "Diagnosis Procedure"](#).

Is the inspection result normal?

YES >> GO TO 2.

NO >> Repair harness or connector.

2. CHECK METER CONTROL SWITCH

Check the meter control switch. Refer to [MWI-59, "Component Inspection"](#).

Is the inspection result normal?

YES >> Replace combination meter.

NG >> Replace meter control switch.

THE OIL PRESSURE WARNING LAMP DOES NOT TURN ON

< SYMPTOM DIAGNOSIS >

THE OIL PRESSURE WARNING LAMP DOES NOT TURN ON

Description

INFOID:000000007474322

The oil pressure warning lamp stays off when the ignition switch is turned ON.

Diagnosis Procedure

INFOID:000000007474323

1. CHECK OIL PRESSURE WARNING LAMP

Perform auto active test of IPDM E/R. Refer to [PCS-9, "Diagnosis Description"](#).

Is oil pressure warning lamp illuminated?

- YES >> GO TO 2.
- NO >> GO TO 4.

2. CHECK OIL PRESSURE SWITCH SIGNAL CIRCUIT

Check the oil pressure switch signal circuit. Refer to [MWI-60, "Diagnosis Procedure"](#).

Is the inspection result normal?

- YES >> GO TO 3.
- NO >> Repair harness or connector.

3. CHECK OIL PRESSURE SWITCH

Check the oil pressure switch. Refer to [MWI-60, "Component Inspection"](#).

Is the inspection result normal?

- YES >> Replace IPDM E/R.
- NO >> Replace oil pressure switch.

4. CHECK UNIFIED METER AND A/C AMP. INPUT SIGNAL

1. Connect the CONSULT.
2. Select the "Data Monitor" of the "METER/M&A" and check the "OIL W/L" monitor value. Refer to [MWI-60, "Component Function Check"](#).

Is the inspection result normal?

- YES >> Replace combination meter.
- NO >> Replace BCM. Refer to [BCS-78, "Removal and Installation"](#).

A
B
C
D
E
F
G
H
I
J
K
L
M
O
P

MWI

THE OIL PRESSURE WARNING LAMP DOES NOT TURN OFF

< SYMPTOM DIAGNOSIS >

THE OIL PRESSURE WARNING LAMP DOES NOT TURN OFF

Description

INFOID:000000007474324

The oil pressure warning lamp remains illuminated while the engine is running. (normal oil pressure)

Diagnosis Procedure

INFOID:000000007474325

1. CHECK OIL PRESSURE WARNING LAMP

Perform auto active test of IPDM E/R. Refer to [PCS-9, "Diagnosis Description"](#).

Is oil pressure warning lamp illuminated?

- YES >> GO TO 2.
- NO >> GO TO 5.

2. CHECK IPDM E/R OUTPUT VOLTAGE

1. Disconnect the oil pressure switch connector.
2. Turn ignition switch ON.
3. Check voltage between the oil pressure switch harness connector terminal and ground.

Terminals		Voltage (Approx.)
(+)	(-)	
Oil pressure switch		12 V
Connector	Terminal	
F37	1	
	Ground	

Is the inspection result normal?

- YES >> GO TO 3.
- NO >> GO TO 4.

3. CHECK OIL PRESSURE SWITCH

Check the oil pressure switch. Refer to [MWI-60, "Component Inspection"](#).

Is the inspection result normal?

- YES >> Replace IPDM E/R. Refer to [PCS-31, "Removal and Installation"](#).
- NO >> Replace oil pressure switch.

4. CHECK OIL PRESSURE SWITCH SIGNAL CIRCUIT

Check the oil pressure switch signal circuit. Refer to [MWI-60, "Diagnosis Procedure"](#).

Is the inspection result normal?

- YES >> GO TO 5.
- NO >> Repair harness or connector.

5. CHECK UNIFIED METER AND A/C AMP. INPUT SIGNAL

1. Connect the CONSULT.
2. Select the "Data Monitor" of the "METER/M&A" and check the "OIL W/L" monitor value. Refer to [MWI-60, "Component Function Check"](#).

Is the inspection result normal?

- YES >> Replace combination meter.
- NO >> Replace BCM. Refer to [BCS-78, "Removal and Installation"](#).

THE PARKING BRAKE RELEASE WARNING CONTINUES DISPLAYING, OR DOES NOT DISPLAY

< SYMPTOM DIAGNOSIS >

THE PARKING BRAKE RELEASE WARNING CONTINUES DISPLAYING, OR DOES NOT DISPLAY

Description

INFOID:000000007474326

- The parking brake warning is displayed during vehicle travel even though the parking brake is released.
- The parking brake warning is not displayed even though driving the vehicle with the parking brake applied.

Diagnosis Procedure

INFOID:000000007474327

1. CHECK UNIFIED METER AND A/C AMP. INPUT SIGNAL

1. Connect the CONSULT.
2. Select the "Data Monitor" of the "METER/M&A" and check the "PKB SW" monitor value. Refer to [MWI-62. "Component Function Check"](#).

Is the inspection result normal?

- YES >> Replace combination meter.
- NO >> GO TO 2.

2. CHECK PARKING BRAKE SWITCH SIGNAL CIRCUIT

Check the parking brake switch signal circuit. Refer to [MWI-62. "Diagnosis Procedure \(A/T models\)"](#) or [MWI-63. "Diagnosis Procedure \(M/T models\)"](#).

Is the inspection result normal?

- YES >> GO TO 3.
- NG >> Repair harness or connector.

3. CHECK PARKING BRAKE SWITCH

Check the parking brake switch. Refer to [BRC-88. "Component Inspection"](#).

Is the inspection result normal?

- YES >> Replace combination meter.
- NO >> Replace parking brake switch.

A
B
C
D
E
F
G
H
I
J
K
L
M
O
P

MWI

THE LOW WASHER FLUID WARNING CONTINUES DISPLAYING, OR DOES NOT DISPLAY

< SYMPTOM DIAGNOSIS >

THE LOW WASHER FLUID WARNING CONTINUES DISPLAYING, OR DOES NOT DISPLAY

Description

INFOID:000000007474328

- The warning is still displayed even after washer fluid is added.
- The warning is not displayed even though the washer tank is empty.

Diagnosis Procedure

INFOID:000000007474329

1.CHECK WASHER LEVEL SWITCH SIGNAL CIRCUIT

Check the washer level switch signal circuit. Refer to [MWI-65. "Diagnosis Procedure"](#).

Is the inspection result normal?

- YES >> GO TO 2.
NO >> Repair harness or connector.

2.CHECK WASHER LEVEL SWITCH

Check the washer level switch. Refer to [MWI-65. "Component Inspection"](#).

Is the inspection result normal?

- YES >> Replace combination meter.
NO >> Replace washer level switch. Refer to [WW-48. "Removal and Installation"](#).

THE DOOR OPEN WARNING CONTINUES DISPLAYING, OR DOES NOT DISPLAY

< SYMPTOM DIAGNOSIS >

THE DOOR OPEN WARNING CONTINUES DISPLAYING, OR DOES NOT DISPLAY

Description

INFOID:000000007474330

- The door ajar warning is displayed even though all of the doors are closed.
- The door ajar warning is not displayed even though a door is ajar.

Diagnosis Procedure

INFOID:000000007474331

1. CHECK BCM INPUT SIGNAL

1. Connect the CONSULT.
2. Check the BCM input signals. Refer to [DLK-62, "Component Function Check"](#).

Is the inspection result normal?

- YES >> GO TO 2.
- NO >> GO TO 3.

2. CHECK UNIFIED METER AND A/C AMP. INPUT SIGNAL

Select the "Data Monitor" for the "METER/M&A" and check the "DOOR W/L" monitor value.

"DOOR W/L"

Door open : On

Door closed : Off

Is the inspection result normal?

- YES >> Replace combination meter.
- NO >> Replace BCM. Refer to [BCS-78, "Removal and Installation"](#).

3. CHECK DOOR SWITCH SIGNAL CIRCUIT

Check the door switch signal circuit. Refer to [DLK-62, "Diagnosis Procedure"](#).

Is the inspection result normal?

- YES >> GO TO 4.
- NO >> Repair harness or connector.

4. CHECK DOOR SWITCH

Check the door switch. Refer to [DLK-63, "Component Inspection"](#).

Is the inspection result normal?

- YES >> Replace combination meter.
- NO >> Replace applicable door switch. Refer to [DLK-217, "Removal and Installation"](#).

A
B
C
D
E
F
G
H
I
J
K
L
M

MWI

O
P

THE TRUNK OPEN WARNING CONTINUES DISPLAYING, OR DOES NOT DISPLAY

< SYMPTOM DIAGNOSIS >

THE TRUNK OPEN WARNING CONTINUES DISPLAYING, OR DOES NOT DISPLAY

Description

INFOID:000000007474332

- The trunk ajar warning is displayed continuously even though the trunk lid is closed.
- The trunk ajar warning is not displayed even though the trunk lid is open.

Diagnosis Procedure

INFOID:000000007474333

1. CHECK BCM INPUT SIGNAL

1. Connect the CONSULT.
2. Check the BCM input signals. Refer to [DLK-71, "Component Function Check"](#).

Is the inspection result normal?

- YES >> GO TO 2.
- NO >> GO TO 3.

2. CHECK UNIFIED METER AND A/C AMP. INPUT SIGNAL

Select the "Data Monitor" for the "METER/M&A" and check the "TRUNK/GLAS-H" monitor value.

"TRUNK/GLAS-H"

Trunk lid open	: On
Trunk lid closed	: Off

Is the inspection result normal?

- YES >> Replace combination meter.
- NO >> Replace BCM.

3. CHECK TRUNK ROOM LAMP SWITCH SIGNAL CIRCUIT

Check the trunk room lamp switch signal circuit. Refer to [DLK-71, "Diagnosis Procedure"](#).

Is the inspection result normal?

- YES >> GO TO 4.
- NO >> Repair harness or connector.

4. CHECK TRUNK ROOM LAMP SWITCH

Check the trunk room lamp switch. Refer to [DLK-72, "Component Inspection"](#).

Is the inspection result normal?

- YES >> Replace combination meter.
- NO >> Replace trunk lid lock assembly. Refer to [DLK-215, "TRUNK LID LOCK : Removal and Installation"](#).

THE AMBIENT TEMPERATURE DISPLAY IS INCORRECT

< SYMPTOM DIAGNOSIS >

THE AMBIENT TEMPERATURE DISPLAY IS INCORRECT

Description

INFOID:000000007474334

- The displayed ambient air temperature is higher than the actual temperature.
- The displayed ambient air temperature is lower than the actual temperature.

Diagnosis Procedure

INFOID:000000007474335

NOTE:

Check that the symptom is not applicable to the normal operating condition before starting diagnosis. Refer to [MWI-108, "INFORMATION DISPLAY : Description"](#).

1.CHECK AMBIENT SENSOR SIGNAL CIRCUIT

Check the ambient sensor signal circuit. Refer to [HAC-90, "Diagnosis Procedure"](#).

Is the inspection result normal?

YES >> GO TO 2.

NO >> Repair harness or connector.

2.CHECK AMBIENT SENSOR

Check the ambient sensor. Refer to [HAC-91, "Component Inspection"](#).

Is the inspection result normal?

YES >> Replace unified meter and A/C amp.

NO >> Replace ambient sensor. Refer to [HAC-155, "Removal and Installation"](#).

A
B
C
D
E
F
G
H
I
J
K
L
M
O
P

MWI

NORMAL OPERATING CONDITION

< SYMPTOM DIAGNOSIS >

NORMAL OPERATING CONDITION COMPASS

COMPASS : Description

INFOID:000000007474336

COMPASS

- The electronic compass is highly protected from changes in most magnetic fields. However, some large changes in magnetic fields can affect it. Some examples are (but not limited to): high tension power lines, large steel buildings, subways, steel bridges, automatic car washes, large piles of scrap metal, etc. While this does not happen very often, it is possible.
- During normal operation, the Compass Mirror will continuously update the compass calibration to adjust for gradual changes in the vehicle's magnetic "remnant" field. If the vehicle is subjected to high magnetic influences, the compass may appear to indicate false headings, become locked, or appear that it is unable to be calibrated. If this occurs, perform the calibration procedure.
- If at any time the compass continually displays the incorrect direction or the reading is erratic or locked, verify the correct zone variance.

Symptom Chart

Symptom	Cause	Solution / Reference
The compass display reads "C".	<ul style="list-style-type: none">• Compass is not calibrated.• Incorrect zone variance setting.• Large change in magnetic field (Steel bridges, subways, concentrations of metal, carwashes, etc.)• Compass was calibrated incorrectly or in the presence of a strong magnetic field.	Perform Calibration. Refer to MWI-33, "Description" .
Compass shows the wrong direction.		
Compass does not change direction appears "Locked".		
Compass does not show all the directions, one or more is missing.		
The compass was calibrated but it "loses" calibration.		
On long trips the compass shows the wrong direction.	Perform Zone Variation Setting if correct reading is desired in that location. Refer to MWI-33, "Description" .	

INFORMATION DISPLAY

INFORMATION DISPLAY : Description

INFOID:000000007474337

AMBIENT AIR TEMPERATURE

The displayed ambient air temperature on the information display may differ from the actual temperature because it is a corrected value calculated from the ambient sensor signal by the unified meter and A/C amp. Refer to [MWI-27, "INFORMATION DISPLAY : System Description"](#) for details on the correction process.

POSSIBLE DRIVING DISTANCE

The calculated possible driving distance may differ from the actual distance to empty if the refueling amount is approximately 15 ℓ (4 US gal, 3-3/10 Imp gal) or less. This is because the refuel control (moves the fuel gauge needle quicker than normal judging that the driver is refueling the vehicle) is not performed in such a case.

PRECAUTIONS

< PRECAUTION >

PRECAUTION

PRECAUTIONS

Precaution for Supplemental Restraint System (SRS) "AIR BAG" and "SEAT BELT PRE-TENSIONER"

INFOID:000000007474338

The Supplemental Restraint System such as "AIR BAG" and "SEAT BELT PRE-TENSIONER", used along with a front seat belt, helps to reduce the risk or severity of injury to the driver and front passenger for certain types of collision. This system includes seat belt switch inputs and dual stage front air bag modules. The SRS system uses the seat belt switches to determine the front air bag deployment, and may only deploy one front air bag, depending on the severity of a collision and whether the front occupants are belted or unbelted. Information necessary to service the system safely is included in the "SRS AIR BAG" and "SEAT BELT" of this Service Manual.

WARNING:

Always observe the following items for preventing accidental activation.

- To avoid rendering the SRS inoperative, which could increase the risk of personal injury or death in the event of a collision that would result in air bag inflation, all maintenance must be performed by an authorized NISSAN/INFINITI dealer.
- Improper maintenance, including incorrect removal and installation of the SRS, can lead to personal injury caused by unintentional activation of the system. For removal of Spiral Cable and Air Bag Module, see "SRS AIR BAG".
- Never use electrical test equipment on any circuit related to the SRS unless instructed to in this Service Manual. SRS wiring harnesses can be identified by yellow and/or orange harnesses or harness connectors.

PRECAUTIONS WHEN USING POWER TOOLS (AIR OR ELECTRIC) AND HAMMERS

WARNING:

Always observe the following items for preventing accidental activation.

- When working near the Air Bag Diagnosis Sensor Unit or other Air Bag System sensors with the ignition ON or engine running, never use air or electric power tools or strike near the sensor(s) with a hammer. Heavy vibration could activate the sensor(s) and deploy the air bag(s), possibly causing serious injury.
- When using air or electric power tools or hammers, always switch the ignition OFF, disconnect the battery, and wait at least 3 minutes before performing any service.

Precaution for Battery Service

INFOID:000000007474339

Before disconnecting the battery, lower both the driver and passenger windows. This will prevent any interference between the window edge and the vehicle when the door is opened/closed. During normal operation, the window slightly raises and lowers automatically to prevent any window to vehicle interference. The automatic window function will not work with the battery disconnected.

A
B
C
D
E
F
G
H
I
J
K
L
M
O
P

MWI

PREPARATION

< PREPARATION >

PREPARATION

PREPARATION

Commercial Service Tools

INFOID:000000007474340

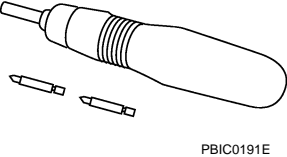
Tool name	Description
<p data-bbox="162 520 272 546">Power tool</p>  <p data-bbox="824 632 899 648">PBIC0191E</p>	<p data-bbox="1008 520 1192 546">Loosening screws</p>

COMBINATION METER

< REMOVAL AND INSTALLATION >

REMOVAL AND INSTALLATION

COMBINATION METER

Exploded View

INFOID:000000007474341

REMOVAL

Cluster lid A assembly

Refer to [IP-12. "A/T MODELS : Exploded View"](#) (A/T models) or [IP-23. "M/T MODELS : Exploded View"](#) (M/T models).

Combination meter

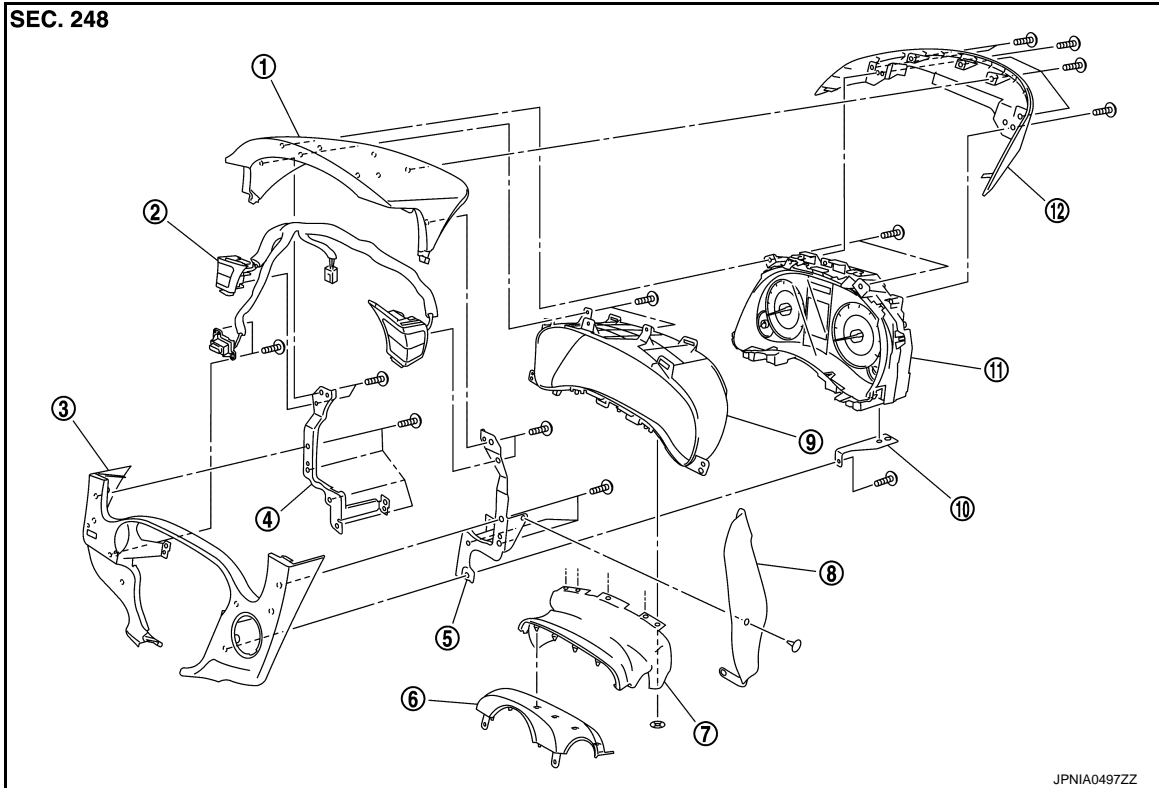

- | | | |
|----------------------------|-------------------------|--------------------------------|
| 1. Cluster lid A | 2. Meter control switch | 3. Cluster lid A under cover |
| 4. Bracket (LH) | 5. Bracket (RH) | 6. Steering column cover upper |
| 7. Steering column blind | 8. Blind | 9. Meter housing |
| 10. Combination meter stay | 11. Combination meter | 12. Cluster lid A cover |

DISASSEMBLY

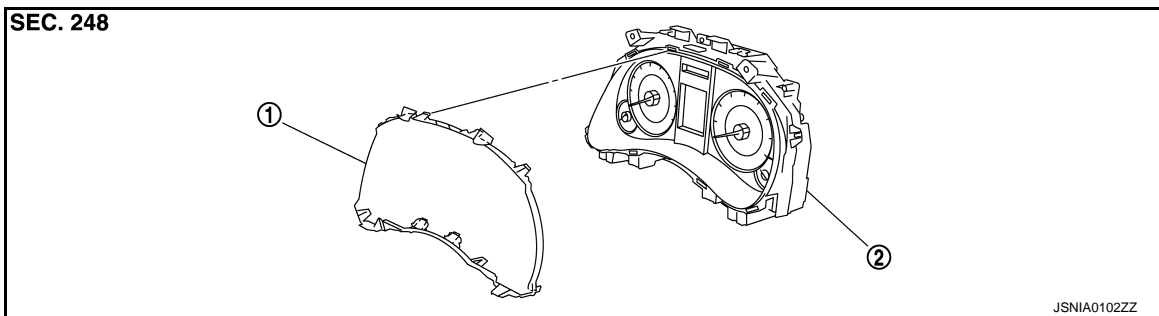

- | | |
|----------------|-------------------------------|
| 1. Front cover | 2. Unified meter control unit |
|----------------|-------------------------------|

A
B
C
D
E
F
G
H
I
J
K
L
M
N
O
P

MWI

COMBINATION METER

< REMOVAL AND INSTALLATION >

Removal and Installation

INFOID:000000007474342

REMOVAL

1. Remove cluster lid A assembly. Refer to [IP-13, "A/T MODELS : Removal and Installation"](#) (A/T models) or [IP-24, "M/T MODELS : Removal and Installation"](#) (M/T models).
2. Remove screw (A) and remove combination meter stay (1).
3. Remove screws (B) and remove cluster lid A cover (2).

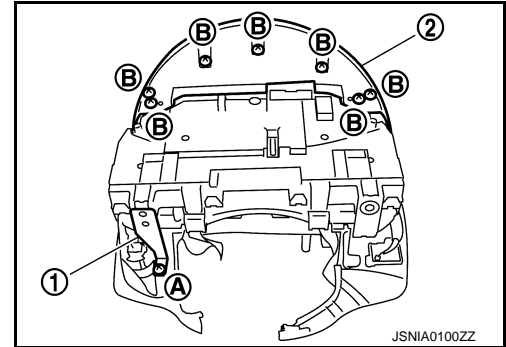

4. Remove screws (A), (B) and remove combination meter (1).
5. Remove meter control switch connector (2) from combination meter.

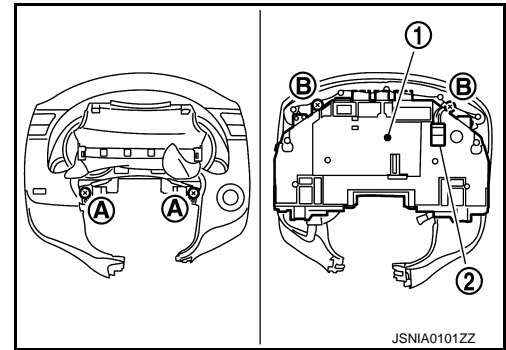

INSTALLATION

Install in the reverse order of removal.

Disassembly and Assembly

INFOID:000000007474343

DISASSEMBLY

Disengage the tabs to separate front cover.

ASSEMBLY

Assemble in the reverse order of disassembly.

UNIFIED METER AND A/C AMP.

< REMOVAL AND INSTALLATION >

UNIFIED METER AND A/C AMP.

Exploded View

INFOID:000000007474344

REMOVAL

Refer to [IP-12. "A/T MODELS : Exploded View"](#) (A/T models) or [IP-23. "M/T MODELS : Exploded View"](#) (M/T models).

DISASSEMBLY

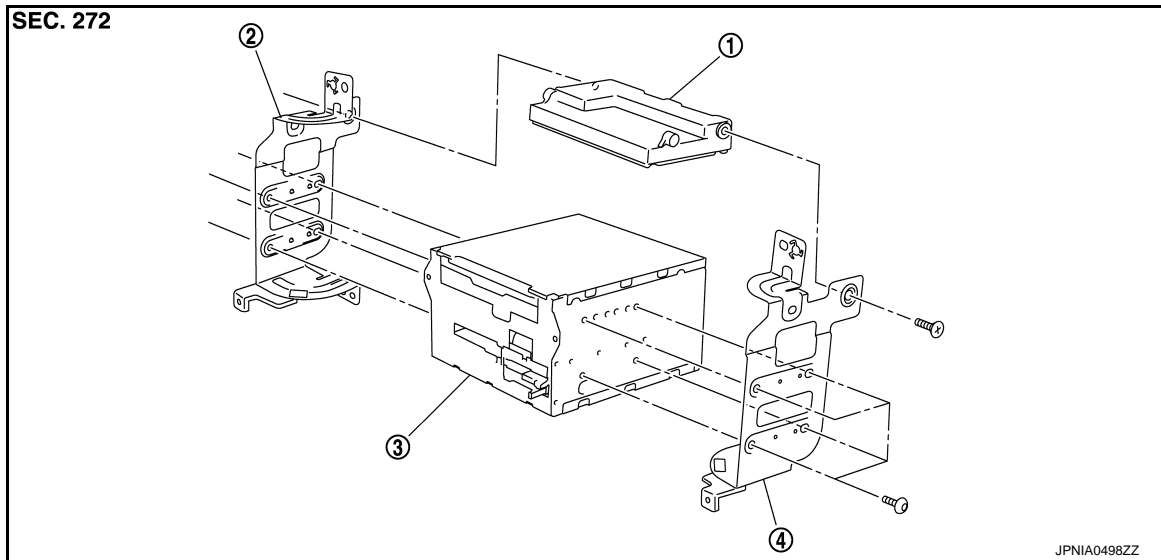

1. Unified meter and A/C amp.
2. Bracket (LH)
3. AV control unit
4. Bracket (RH)

Removal and Installation

INFOID:000000007474345

REMOVAL

1. Remove the display unit. Refer to [AV-84. "Removal and Installation"](#) (Base audio without rear view camera), [AV-187. "Removal and Installation"](#) (Base audio with rear view camera), [AV-303. "Removal and Installation"](#) (BOSE audio without navigation), or [AV-444. "Removal and Installation"](#) (BOSE audio with navigation).
2. Remove the unified meter and A/C amp and AV control unit as an assembly.
3. Remove the bracket screws and remove the unified meter and A/C amp.

INSTALLATION

Install in the reverse order of removal.

NOTE:

- Unified meter and A/C amp. screws are different from other screws. Never confuse them when installing.
- Since AV control unit connector and unified meter and A/C amp. connector have the same form, be careful not insert them wrongly.

A
B
C
D
E
F
G
H
I
J
K
L
M
O
P

MWI

METER CONTROL SWITCH

< REMOVAL AND INSTALLATION >

METER CONTROL SWITCH

Exploded View

INFOID:000000007474346

REMOVAL

Refer to [IP-12. "A/T MODELS : Exploded View"](#) (A/T models) or [IP-23. "M/T MODELS : Exploded View"](#) (M/T models).

DISASSEMBLY

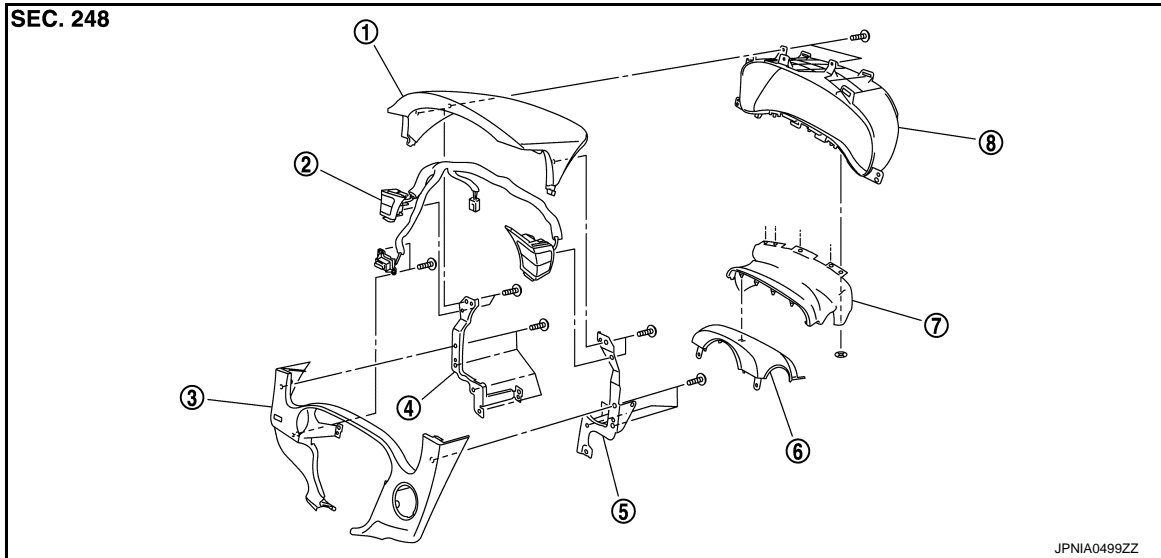

- | | | |
|--------------------------|-------------------------|--------------------------------|
| 1. Cluster lid A | 2. Meter control switch | 3. Cluster lid A under cover |
| 4. Bracket (LH) | 5. Bracket (RH) | 6. Steering column cover upper |
| 7. Steering column blind | 8. Meter housing | |

Removal and Installation

INFOID:000000007474347

REMOVAL

1. Remove combination meter.
2. Remove screws (A) and remove bracket RH (1), LH (2).
3. Remove screws (B) and remove meter control switch.

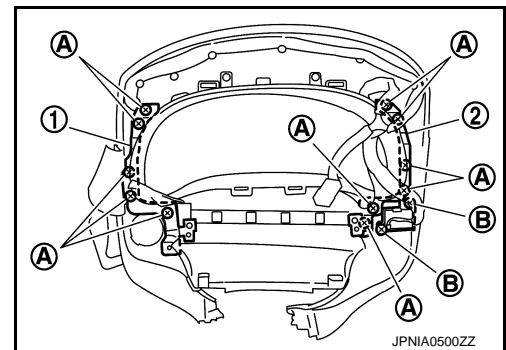

INSTALLATION

Install in the reverse order of removal.

COMPASS

< REMOVAL AND INSTALLATION >

COMPASS

Exploded View

INFOID:000000007474348

Refer to [MIR-34. "Exploded View"](#).

Removal and Installation

INFOID:000000007474349

Refer to [MIR-34. "Removal and Installation"](#).

A

B

C

D

E

F

G

H

I

J

K

L

M

MWI

O

P

CLOCK

< REMOVAL AND INSTALLATION >

CLOCK

Exploded View

INFOID:000000007474350

REMOVAL

Refer to [IP-12. "A/T MODELS : Exploded View"](#) (A/T models) or [IP-23. "M/T MODELS : Exploded View"](#) (M/T models).

DISASSEMBLY

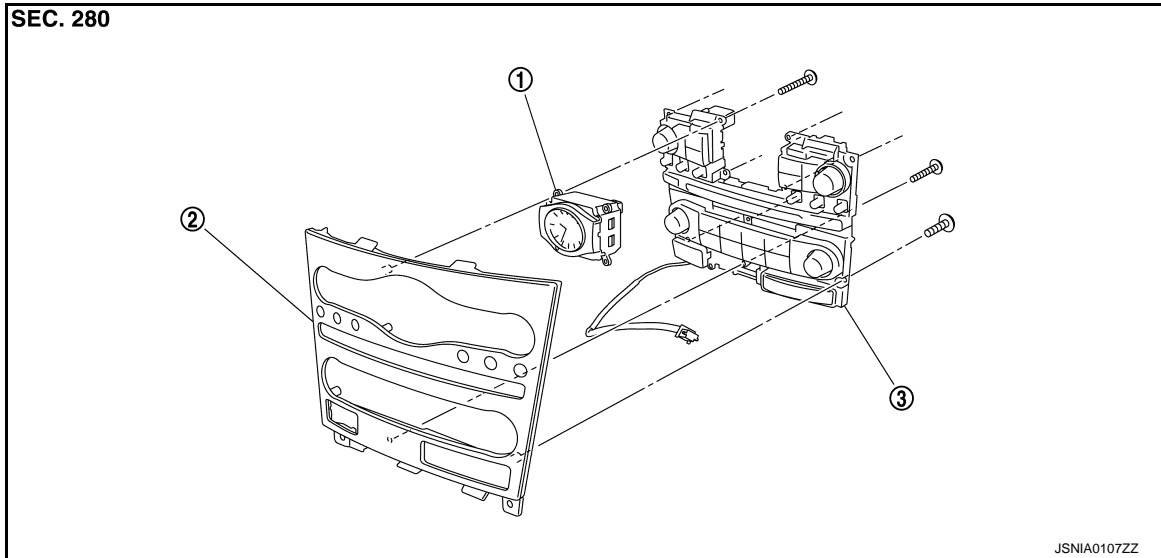

1. Clock

2. Cluster lid C

3. Preset switch

Removal and Installation

INFOID:000000007474351

REMOVAL

1. Remove cluster lid C assembly. Refer to [IP-13. "A/T MODELS : Removal and Installation"](#) (A/T models) or [IP-24. "M/T MODELS : Removal and Installation"](#) (M/T models).
2. Remove screws (A), (B), (C) and remove clock (1) in conjunction with preset switch (2) from cluster lid C.
3. Disengage the tabs to separate clock.

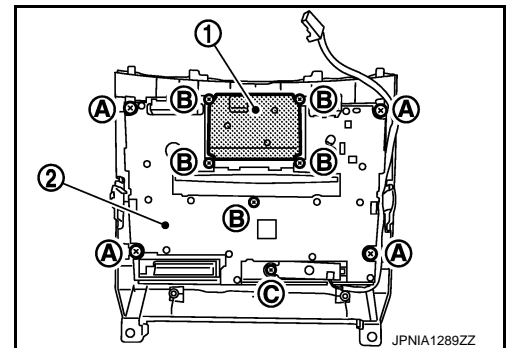

INSTALLATION

Install in the reverse order of removal.

NOTE:

Never confuse screws when installing.