

SECTION **SB**  
SEAT BELT

A  
B  
C  
D  
E  
F  
G  
SB  
I  
J  
K  
L  
M  
N  
O  
P

CONTENTS

<b>PRECAUTION</b> .....	2	SEAT BELT BUCKLE : Removal and Installation.....	8
<b>PRECAUTIONS</b> .....	2	<b>REAR SEAT BELT</b> .....	9
Precaution for Supplemental Restraint System (SRS) "AIR BAG" and "SEAT BELT PRE-TENSIONER" .....	2	<b>SEAT BELT RETRACTOR</b> .....	9
Precaution for Battery Service .....	2	SEAT BELT RETRACTOR : Inspection .....	9
Precaution for Seat Belt Service .....	2	SEAT BELT RETRACTOR : Exploded View .....	11
<b>REMOVAL AND INSTALLATION</b> .....	4	SEAT BELT RETRACTOR : Removal and Installation .....	11
<b>FRONT SEAT BELT</b> .....	4	<b>SEAT BELT BUCKLE</b> .....	11
<b>SEAT BELT RETRACTOR</b> .....	4	SEAT BELT BUCKLE : Inspection .....	12
SEAT BELT RETRACTOR : Inspection .....	4	SEAT BELT BUCKLE : Exploded View .....	12
SEAT BELT RETRACTOR : Exploded View .....	6	SEAT BELT BUCKLE : Removal and Installation.....	13
SEAT BELT RETRACTOR : Removal and Installation .....	6	<b>LATCH SYSTEM FOR CHILDREN</b> .....	14
<b>SEAT BELT BUCKLE</b> .....	7	Exploded View .....	14
SEAT BELT BUCKLE : Inspection .....	7	Removal and Installation .....	14
SEAT BELT BUCKLE : Exploded View .....	8	<b>TOP TETHER STRAP CHILD RESTRAINT</b> .....	15
		Exploded View .....	15
		Removal and Installation .....	15

# PRECAUTIONS

< PRECAUTION >

## PRECAUTION

### PRECAUTIONS

#### Precaution for Supplemental Restraint System (SRS) "AIR BAG" and "SEAT BELT PRE-TENSIONER"

INFOID:000000008160028

The Supplemental Restraint System such as "AIR BAG" and "SEAT BELT PRE-TENSIONER", used along with a front seat belt, helps to reduce the risk or severity of injury to the driver and front passenger for certain types of collision. This system includes seat belt switch inputs and dual stage front air bag modules. The SRS system uses the seat belt switches to determine the front air bag deployment, and may only deploy one front air bag, depending on the severity of a collision and whether the front occupants are belted or unbelted. Information necessary to service the system safely is included in the "SRS AIR BAG" and "SEAT BELT" of this Service Manual.

#### **WARNING:**

Always observe the following items for preventing accidental activation.

- To avoid rendering the SRS inoperative, which could increase the risk of personal injury or death in the event of a collision that would result in air bag inflation, all maintenance must be performed by an authorized NISSAN/INFINITI dealer.
- Improper maintenance, including incorrect removal and installation of the SRS, can lead to personal injury caused by unintentional activation of the system. For removal of Spiral Cable and Air Bag Module, see "SRS AIR BAG".
- Never use electrical test equipment on any circuit related to the SRS unless instructed to in this Service Manual. SRS wiring harnesses can be identified by yellow and/or orange harnesses or harness connectors.

#### PRECAUTIONS WHEN USING POWER TOOLS (AIR OR ELECTRIC) AND HAMMERS

#### **WARNING:**

Always observe the following items for preventing accidental activation.

- When working near the Air Bag Diagnosis Sensor Unit or other Air Bag System sensors with the ignition ON or engine running, never use air or electric power tools or strike near the sensor(s) with a hammer. Heavy vibration could activate the sensor(s) and deploy the air bag(s), possibly causing serious injury.
- When using air or electric power tools or hammers, always switch the ignition OFF, disconnect the battery, and wait at least 3 minutes before performing any service.

#### Precaution for Battery Service

INFOID:000000008160029

Before disconnecting the battery, lower both the driver and passenger windows. This will prevent any interference between the window edge and the vehicle when the door is opened/closed. During normal operation, the window slightly raises and lowers automatically to prevent any window to vehicle interference. The automatic window function will not work with the battery disconnected.

#### Precaution for Seat Belt Service

INFOID:000000008160030

#### **CAUTION:**

- Before removing the front seat belt pre-tensioner assembly, turn the ignition switch off, disconnect both battery cables and wait at least 3 minutes.
- Do not use electrical test equipment for front seat belt pre-tensioner connector.
- After replacing or reinstalling front seat belt pre-tensioner assembly, or reconnecting front seat belt pre-tensioner connector, check the system function. Refer to [SRC-17, "Diagnosis Description"](#).
- Do not use disassembled buckle or seat belt assembly.
- Replace anchor bolts if they are deformed or worn out.
- Never oil tongue and buckle.
- If any component of seat belt assembly is questionable, do not repair. Replace the entire seat belt assembly.
- If webbing is cut, frayed or damaged, replace seat belt assembly.
- When replacing seat belt assembly, use a genuine NISSAN seat belt assembly.

#### AFTER A COLLISION

#### **WARNING:**

# PRECAUTIONS

## < PRECAUTION >

**Inspect all seat belt assemblies including retractors and attached hardware after any collision. NISSAN recommends that all seat belt assemblies in use during a collision be replaced unless the collision was minor and the belts show no damage and continue to operate properly. Failure to do so could result in serious personal injury in an accident. Seat belt assemblies not in use during a collision should also be replaced if either damage or improper operation is noted. Seat belt pre-tensioners should be replaced even if the seat belts are not in use during a frontal collision in which the air bags are deployed.**

Replace any seat belt assembly (including anchor bolts) if:

- The seat belt was in use at the time of a collision (except for minor collisions and the belts, retractors and buckles show no damage and continue to operate properly).
- The seat belt was damaged in an accident (i.e. torn webbing, bent retractor or guide).
- The seat belt attaching point was damaged in an accident. Inspect the seat belt attaching area for damage or distortion and repair as necessary before installing a new seat belt assembly.
- Anchor bolts are deformed or worn out.
- The front seat belt pre-tensioner should be replaced even if the seat belts are not in use during the collision in which the air bags are deployed.

A  
B  
C  
D  
E  
F  
G  
I  
J  
K  
L  
M  
N  
O  
P

SB

# FRONT SEAT BELT

< REMOVAL AND INSTALLATION >

## REMOVAL AND INSTALLATION

### FRONT SEAT BELT

### SEAT BELT RETRACTOR

### SEAT BELT RETRACTOR : Inspection

INFOID:000000008160031

#### AFTER A COLLISION

#### **WARNING:**

**Inspect all seat belt assemblies including retractors and attached hardware after any collision.**

**NISSAN/INFINITI recommends that all seat belt assemblies in use during a collision be replaced unless the collision was minor and the belts show no damage and continue to operate properly. Failure to do so could result in serious personal injury in an accident. Seat belt assemblies not in use during a collision should also be replaced if either damage or improper operation is noted. Seat belt pre-tensioners must be replaced even if the seat belts are not in use during a frontal collision in which the air bags are deployed.**

Replace any seat belt assembly (including anchor bolts) if:

- The seat belt is in use at the time of a collision (except for minor collisions and the belts, retractors and buckles show no damage and continue to operate properly).
- The seat belt is damaged in an accident (i.e. torn webbing, bent retractor or guide, etc.).
- The seat belt attaching point is damaged in an accident. Inspect the seat belt attaching area for damage or distortion and repair as necessary before installing a new seat belt assembly.
- Anchor bolts are deformed or worn out.
- The seat belt pre-tensioners must be replaced even if the seat belts are not in use during the collision in which the air bags are deployed.

#### PRELIMINARY CHECKS

1. Check the seat belt warning lamp/chime for proper operation as follows:
  - a. Turn ignition switch ON. The seat belt warning lamp should illuminate. Also, the seat belt warning chime should sound for about six seconds.
  - b. Fasten driver seat belt. The seat belt warning lamp should turn off and the chime (if sounding) should stop.
2. If the air bag warning lamp is blinking, conduct self-diagnosis with CONSULT and air bag warning lamp. Refer to [SRC-17, "Diagnosis Description"](#).
3. Check that the seat belt retractor, seat belt anchor and buckle bolts are securely attached.
4. Check the shoulder seat belt guide and shoulder belt height adjuster for front seats. Ensure guide swivels freely and that webbing lays flat and does not bind in guide. Ensure height adjuster operates properly and holds securely.
5. Check retractor operation:
  - a. Fully extend the seat belt webbing and check for twists, tears or other damage.
  - b. Allow the seat belt to retract. Ensure that webbing returns smoothly and completely into the retractor. If the seat belt does not return smoothly, wipe the inside of the loops with a clean paper cloth. Because dirt build-up in the loops of the upper anchors can cause the seat belts to retract slowly.
  - c. Fasten the seat belt. Check that seat belt returns smoothly and completely to the retractor. If the webbing does not return smoothly, the cause may be an accumulation of dust or dirt. Use the "SEAT BELT TAPE SET" and perform the following steps.

Inspect the front seat belt through-anchor

1. Pull the seat belt out to a length of 500 mm (19.69 in) or more.
2. Fix the seat belt at the center pillar webbing opening with a clip or other device.
3. Pass a thin wire through the through-anchor webbing opening. Hold both ends of the wire and pull it tightly while moving it up and down several times along the webbing opening surface to remove dirt stuck there.
4. Any dirt that cannot be removed with the wire can be removed by cleaning the opening with a clean cloth.
5. Apply tape at the point where the webbing contacts the through-anchor webbing opening.

#### **NOTE:**

Apply the tape so that there is no looseness or wrinkling.

# FRONT SEAT BELT

## < REMOVAL AND INSTALLATION >

6. Remove the clip fixing the seat belt and check that the webbing returns smoothly.
6. Repeat steps above as necessary to check the other seat belts.

## SEAT BELT RETRACTOR ON-VEHICLE CHECK

Emergency Locking Retractors (ELR)

### NOTE:

All seat belt retractors are Emergency Locking Retractors (ELR) type. In an emergency (sudden stop) the retractor will lock and prevent the webbing from extending any further.

Check the seat belt retractors with the following test(s) to determine if a retractor assembly is operating properly.

ELR Function Stationary Check

Grasp the shoulder webbing and pull forward quickly. The retractor should lock and prevent the belt from extending further.

ELR Function Moving Check

### WARNING:

Perform the following test in a safe, open area clear of other vehicles and obstructions (for example, a large, empty parking lot). Road surface must be paved and dry. NEVER perform the following test on wet or gravel roads or on public streets and highways. This could result in an accident and serious personal injury. The driver and passenger must be prepared to brace themselves in the event that the retractor does not lock.

1. Fasten driver seat belt. Buckle a passenger into the seat for the belt that is to be tested.
2. Proceed to the designated safe area.
3. Drive the vehicle at approximately 16 km/h (10 MPH). Notify any passengers of a pending sudden stop and the driver and passenger must be prepared to brace themselves in the event that the retractor does not lock, apply brakes firmly and make a very hard stop.

During stop, seat belts should lock and not be extended. If the seat belt retractor assembly does not lock, perform the retractor off-vehicle check.

## SEAT BELT RETRACTOR OFF-VEHICLE CHECK

1. Remove the seat belt retractor.  
Remove the front seat belt assembly, refer to [SB-6, "SEAT BELT RETRACTOR : Removal and Installation"](#).
2. Slowly pull out webbing while tilting the retractor assembly forward from the mounted position without twisting the retractor assembly as shown in the figure.
  - The webbing can be pulled out when the angle (A) is 15 degrees or less.
  - The webbing cannot be pulled out when the angle (B) is 27 degrees or more.

A and B : Tilting angles

← : Vehicle front

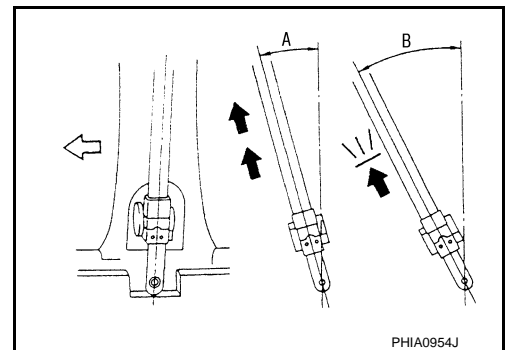

Replace the seat belt assembly if it does not operate normally.

# FRONT SEAT BELT

< REMOVAL AND INSTALLATION >

## SEAT BELT RETRACTOR : Exploded View

INFOID:000000008160032

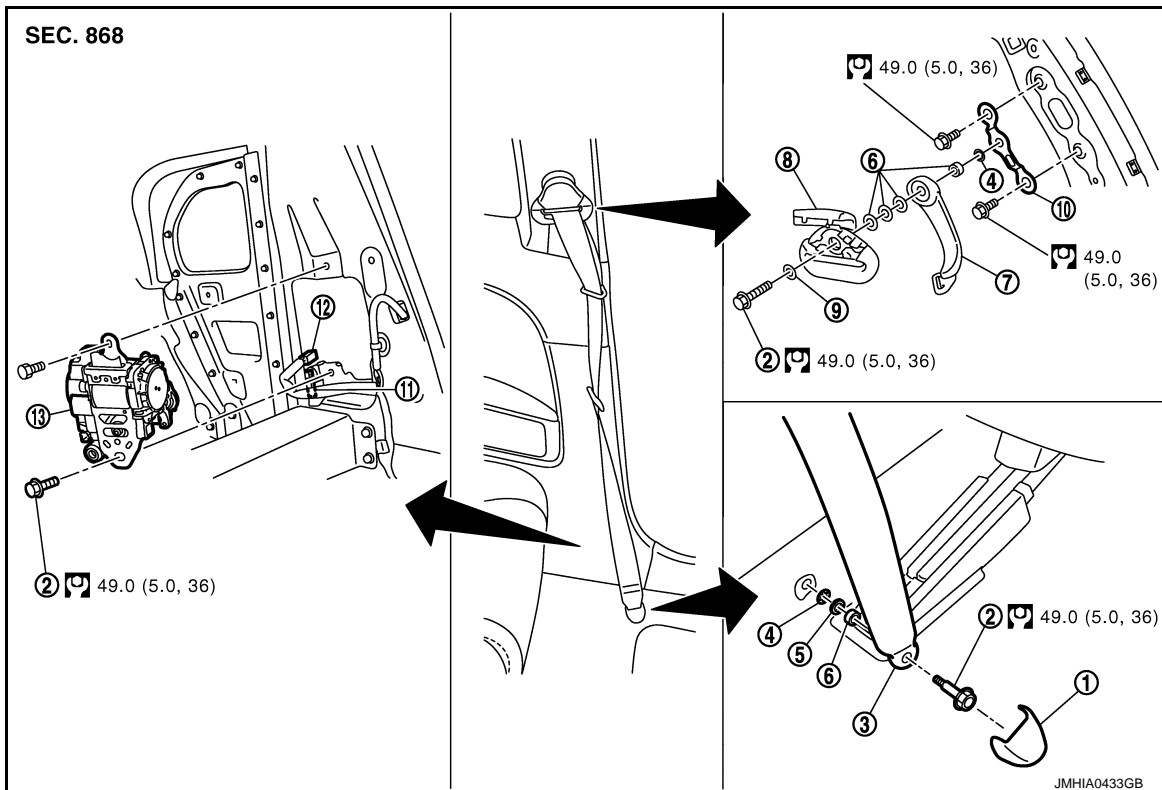

- |                                       |                                       |                                   |
|---------------------------------------|---------------------------------------|-----------------------------------|
| 1. Anchor cover                       | 2. Anchor bolt                        | 3. Outer anchor                   |
| 4. Retaining washer                   | 5. Spring washer                      | 6. Spacer                         |
| 7. Seat belt extension                | 8. Shoulder anchor                    | 9. Plastic washer                 |
| 10. Seat belt bracket                 | 11. Seat belt pre-tensioner connector | 12. Pre-crash seat belt connector |
| 13. Pre-tensioner seat belt retractor |                                       |                                   |

Refer to [GI-4. "Components"](#) for symbols in the figure.

## SEAT BELT RETRACTOR : Removal and Installation

INFOID:000000008160033

### REMOVAL

#### **CAUTION:**

**Before servicing SRS, turn the ignition switch OFF, disconnect battery negative terminal and wait at least 3 minutes.**

1. Remove the outer anchor.
  - Remove the outer anchor cover.
  - Remove the fixing anchor bolt of the outer anchor.
2. Remove the shoulder anchor.
  - Remove the shoulder anchor cover.
  - Remove the fixing anchor bolt of the shoulder anchor.
3. Remove the rear side finisher and rear pillar finisher. Refer to [INT-15. "Removal and Installation"](#).
4. Remove the seat belt bracket. Remove the fixing bolt of the seat belt bracket.
5. Remove the seat belt assembly.

## FRONT SEAT BELT

### < REMOVAL AND INSTALLATION >

- Disconnect the seat belt pre-tensioner connector.  
**NOTE:**
  - For installing/removing seat belt pre-tensioner connector, insert thin screwdriver wrapped in tape into notch, lift lock and remove connector.
  - Install connector with lock raised, and push lock into connector.
  - After installing the connector, check that the lock is pushed securely into it.

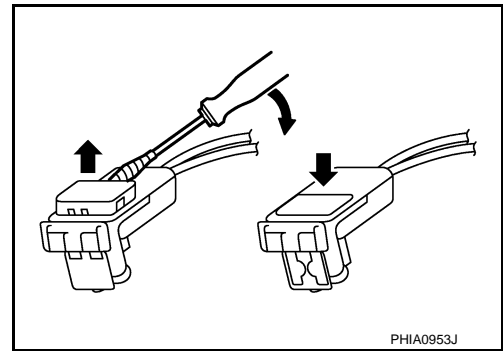

- Disconnect the pre-crash seat belt connector.
- Remove the fixing screw and anchor bolt of the pre-tensioner seat belt retractor.

### INSTALLATION

Install in the reverse order of removal.

### SEAT BELT BUCKLE

### SEAT BELT BUCKLE : Inspection

INFOID:000000008160034

### AFTER A COLLISION

#### **WARNING:**

**Inspect all seat belt assemblies including retractors and attached hardware after any collision.**

**NISSAN/INFINITI recommends that all seat belt assemblies in use during a collision be replaced unless the collision was minor and the belts show no damage and continue to operate properly. Failure to do so could result in serious personal injury in an accident. Seat belt assemblies not in use during a collision should also be replaced if either damage or improper operation is noted. Seat belt pre-tensioners must be replaced even if the seat belts are not in use during a frontal collision in which the air bags are deployed.**

Replace any seat belt assembly (including anchor bolts) if:

- The seat belt is in use at the time of a collision (except for minor collisions and the belts, retractors and buckles show no damage and continue to operate properly).
- The seat belt is damaged in an accident (i.e. torn webbing, bent retractor or guide, etc.).
- The seat belt attaching point is damaged in an accident. Inspect the seat belt attaching area for damage or distortion and repair as necessary before installing a new seat belt assembly.
- Anchor bolts are deformed or worn out.
- The seat belt pre-tensioner must be replaced even if the seat belts are not in use during the collision in which the air bags are deployed.

### PRELIMINARY CHECKS

1. Check the seat belt warning lamp/chime for proper operation as follows:
  - a. Turn ignition switch ON. The seat belt warning lamp should illuminate. Also, the seat belt warning chime should sound for about six seconds.
  - b. Fasten driver seat belt. The seat belt warning lamp should turn off and the chime (if sounding) should stop.
2. If the air bag warning lamp is blinking, conduct self-diagnosis using CONSULT and air bag warning lamp. Refer to [SRC-17, "Diagnosis Description"](#).
3. Check that the seat belt retractor, seat belt anchor and buckle bolts are securely attached.
4. Repeat steps above as necessary to check the other seat belts.

# FRONT SEAT BELT

< REMOVAL AND INSTALLATION >

## SEAT BELT BUCKLE : Exploded View

INFOID:000000008160035

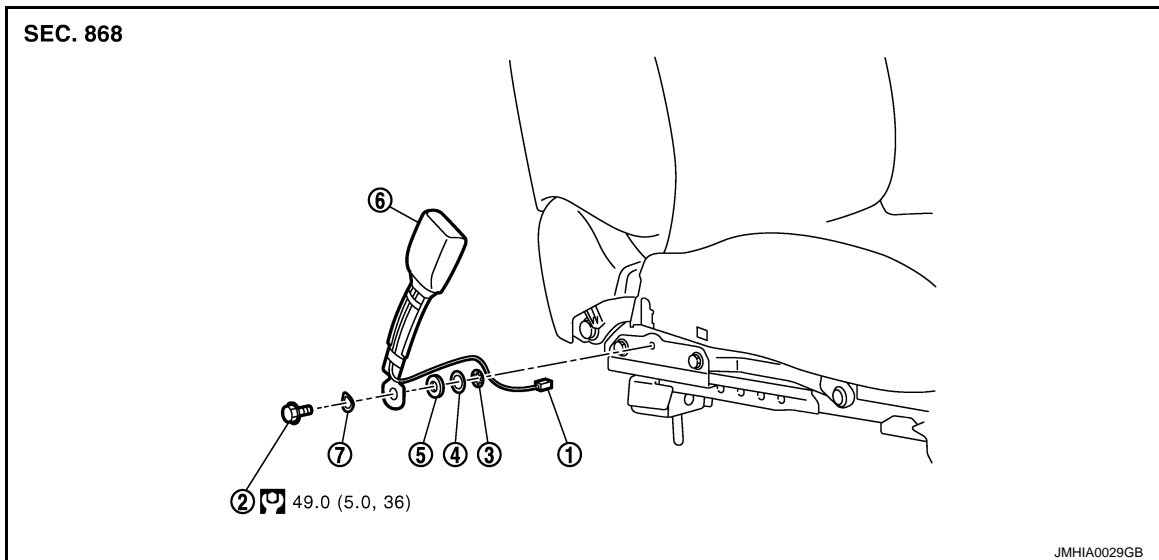

- |                                       |                |                     |
|---------------------------------------|----------------|---------------------|
| 1. Seat belt buckle harness connector | 2. Anchor bolt | 3. Retaining washer |
| 4. Washer                             | 5. Spacer      | 6. Seat belt buckle |
| 7. Wave washer                        |                |                     |

Refer to [GI-4, "Components"](#) for symbols in the figure.

## SEAT BELT BUCKLE : Removal and Installation

INFOID:000000008160036

### REMOVAL

Remove the seat belt buckle.

- Remove the front seat from vehicle. Refer to [SE-166, "Removal and Installation"](#) (for ease of tool operation in narrow space).
- Disconnect the seat belt buckle harness connector and harness clamp.
- Remove the fixing anchor bolt of the seat belt buckle.

### INSTALLATION

Install in the reverse order of removal.



# REAR SEAT BELT

< REMOVAL AND INSTALLATION >

## REAR SEAT BELT

### SEAT BELT RETRACTOR

#### SEAT BELT RETRACTOR : Inspection

INFOID:000000008160037

#### AFTER A COLLISION

##### **WARNING:**

**Inspect all seat belt assemblies including retractors and attached hardware after any collision. NISSAN/INFINITI recommends that all seat belt assemblies in use during a collision be replaced unless the collision was minor and the belts show no damage and continue to operate properly. Failure to do so could result in serious personal injury in an accident. Seat belt assemblies not in use during a collision should also be replaced if either damage or improper operation is noted. Seat belt pre-tensioners must be replaced even if the seat belts are not in use during a frontal collision in which the air bags are deployed.**

Replace any seat belt assembly (including anchor bolts) if:

- The seat belt is in use at the time of a collision (except for minor collisions and the belts, retractors and buckles show no damage and continue to operate properly).
- The seat belt is damaged in an accident (i.e. torn webbing, bent retractor or guide, etc.).
- The seat belt attaching point is damaged in an accident. Inspect the seat belt attaching area for damage or distortion and repair as necessary before installing a new seat belt assembly.
- Anchor bolts are deformed or worn out.
- The seat belt pre-tensioners must be replaced even if the seat belts are not in use during the collision in which the air bags are deployed.

#### PRELIMINARY CHECKS

1. Check the seat belt warning lamp/chime for proper operation as follows:
  - a. Turn ignition switch ON. The seat belt warning lamp should illuminate. Also, the seat belt warning chime should sound for about six seconds.
  - b. Fasten driver seat belt. The seat belt warning lamp should turn off and the chime (if sounding) should stop.
2. If the air bag warning lamp is blinking, conduct self-diagnosis with CONSULT and air bag warning lamp. Refer to [SRC-17, "Diagnosis Description"](#).
3. Check that the seat belt retractor, seat belt anchor and buckle bolts are securely attached.
4. Check retractor operation:
  - a. Fully extend the seat belt webbing and check for twists, tears or other damage.
  - b. Allow the seat belt to retract. Ensure that webbing returns smoothly and completely into the retractor. If the seat belt does not return smoothly, wipe the inside of the loops with a clean paper cloth. Because dirt build-up in the loops of that upper anchors can cause the seat belts to retract slowly.
  - c. Fasten the seat belt. Check the seat belt returns smoothly and completely to the retractor. If the webbing does not return smoothly, the cause may be an accumulation of dust or dirt. Use the "SEAT BELT TAPE SET" and perform the following steps.
5. Repeat steps above as necessary to check the other seat belts.

#### SEAT BELT RETRACTOR ON-VEHICLE CHECK

Emergency Locking Retractors (ELR) and Automatic Locking Retractors (ALR)

##### **NOTE:**

All seat belt retractors are Emergency Locking Retractors (ELR) type. In an emergency (sudden stop) the retractor will lock and prevent the webbing from extending any further. 3-point type seat belt retractors for rear seat have an Automatic Locking Retractors (ALR) mode. The ALR mode (also called child restraint mode) is used when installing child seats. The ALR mode is activated when the seat belt is fully extended. When the webbing is then retracted partially, the ALR mode automatically locks the seat belt in a specific position so the webbing cannot be extended any further. To cancel the ALR mode, allow the seat belt to fully wind back into the retractor.

Check the seat belt retractors with the following test(s) to determine if a retractor assembly is operating properly.

ELR Function Stationary Check

# REAR SEAT BELT

## < REMOVAL AND INSTALLATION >

Grasp the shoulder webbing and pull forward quickly. The retractor should lock and prevent the belt from extending further.

### ALR Function Stationary Check

1. Pull out the entire length of seat belt from retractor until a click is heard.
2. Retract the webbing partially. A clicking noise should be heard as the webbing retracts indicating that the retractor is in the Automatic Locking Retractors (ALR) mode.
3. Grasp the seat belt and try to pull out the retractor. The webbing must lock and not extend any further. If NG, replace the retractor assembly.
4. Allow the entire length of the webbing to retract to cancel the automatic locking mode.

### ELR Function Moving Check

#### **WARNING:**

**Perform the following test in a safe, open area clear of other vehicles and obstructions (for example, a large, empty parking lot). Road surface must be paved and dry. NEVER perform the following test on wet or gravel roads or on public streets and highways. This could result in an accident and serious personal injury. The driver and passenger must be prepared to brace themselves in the event that the retractor does not lock.**

1. Fasten driver seat belt. Buckle a passenger into the seat for the belt that is to be tested.
2. Proceed to the designated safe area.
3. Drive the vehicle at approximately 16 km/h (10 MPH). Notify any passengers of a pending sudden stop and the driver and passenger must be prepared to brace themselves in the event that the retractor does not lock, apply brakes firmly and make a very hard stop.

During stop, seat belts should lock and not be extended. If the seat belt retractor assembly does not lock, perform the retractor off-vehicle check.

### SEAT BELT RETRACTOR OFF-VEHICLE CHECK

1. Remove the seat belt retractor.  
Remove the rear seat belt assembly, refer to [SB-11, "SEAT BELT RETRACTOR : Removal and Installation"](#).
2. Slowly pull out webbing while tilting the retractor assembly forward from the mounted position without twisting the retractor assembly as shown in the figure.
  - The webbing can be pulled out when the angle (A) is 15 degrees or less.
  - The webbing cannot be pulled out when the angle (B) is 27 degrees or more.

A and B : Tilting angles

← : Vehicle front

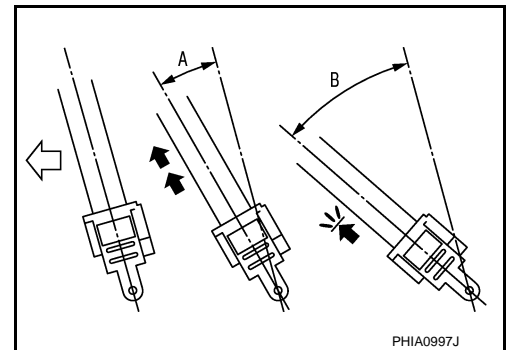

Replace the seat belt assembly if it does not operate normally.

# REAR SEAT BELT

< REMOVAL AND INSTALLATION >

## SEAT BELT RETRACTOR : Exploded View

INFOID:000000008160038

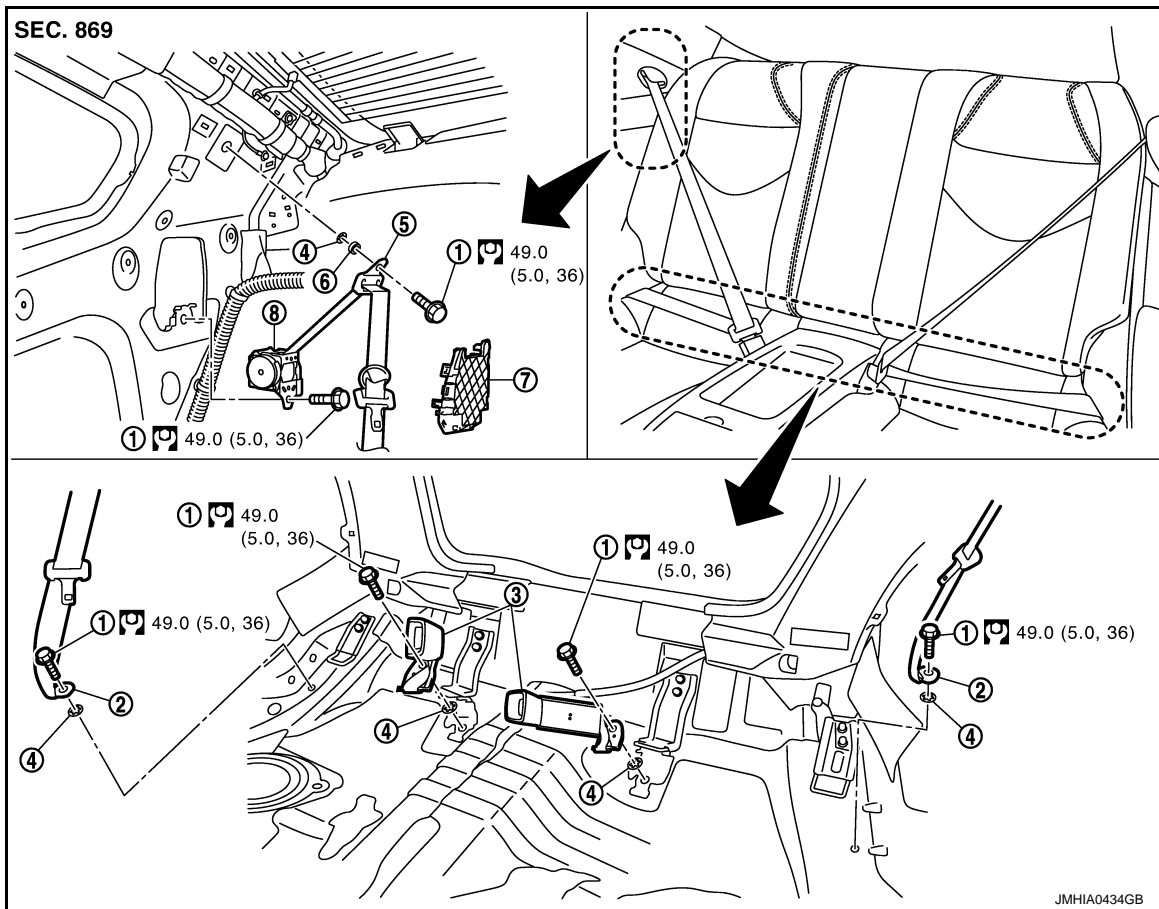

- |                     |                        |                     |
|---------------------|------------------------|---------------------|
| 1. Anchor bolt      | 2. Outer anchor        | 3. Seat belt buckle |
| 4. Retaining washer | 5. Shoulder anchor     | 6. Spacer           |
| 7. Retractor cover  | 8. Seat belt retractor |                     |

Refer to [GI-4, "Components"](#) for symbols in the figure.

## SEAT BELT RETRACTOR : Removal and Installation

INFOID:000000008160039

### REMOVAL

1. Remove the outer and inner anchors.
  - Remove the rear seat cushion. Refer to [SE-176, "Removal and Installation"](#).
  - Remove the outer anchor fixing anchor bolt.
2. Remove the seat belt assembly.
  - Remove the rear seatback. Refer to [SE-176, "Removal and Installation"](#).
  - Remove the kicking plate inner, the rear side finisher and the rear pillar finisher. Refer to [INT-15, "Removal and Installation"](#).
  - Remove the seat belt escutcheon from the rear pillar finisher. Refer to [INT-15, "Removal and Installation"](#).
  - Remove the retractor cover.
  - Remove the fixing anchor bolt of the seat belt retractor.

### INSTALLATION

Install in the reverse order of removal.

## SEAT BELT BUCKLE

# REAR SEAT BELT

< REMOVAL AND INSTALLATION >

## SEAT BELT BUCKLE : Inspection

INFOID:000000008160040

### AFTER A COLLISION

#### **WARNING:**

Inspect all seat belt assemblies including retractors and attached hardware after any collision. NISSAN/INFINITI recommends that all seat belt assemblies in use during a collision be replaced unless the collision was minor and the belts show no damage and continue to operate properly. Failure to do so could result in serious personal injury in an accident. Seat belt assemblies not in use during a collision should also be replaced if either damage or improper operation is noted. Seat belt pre-tensioners must be replaced even if the seat belts are not in use during a frontal collision in which the air bags are deployed.

Replace any seat belt assembly (including anchor bolts) if:

- The seat belt is in use at the time of a collision (except for minor collisions and the belts, retractors and buckles show no damage and continue to operate properly).
- The seat belt is damaged in an accident. (i.e. torn webbing, bent retractor or guide, etc.)
- The seat belt attaching point is damaged in an accident. Inspect the seat belt attaching area for damage or distortion and repair as necessary before installing a new seat belt assembly.
- Anchor bolts are deformed or worn out.
- The seat belt pre-tensioner must be replaced even if the seat belts are not in use during the collision in which the air bags are deployed.

### PRELIMINARY CHECKS

1. Check that the seat belt retractor, seat belt anchor and buckle bolts are securely attached.
2. Repeat step above as necessary to check the other seat belts.

## SEAT BELT BUCKLE : Exploded View

INFOID:000000008160041

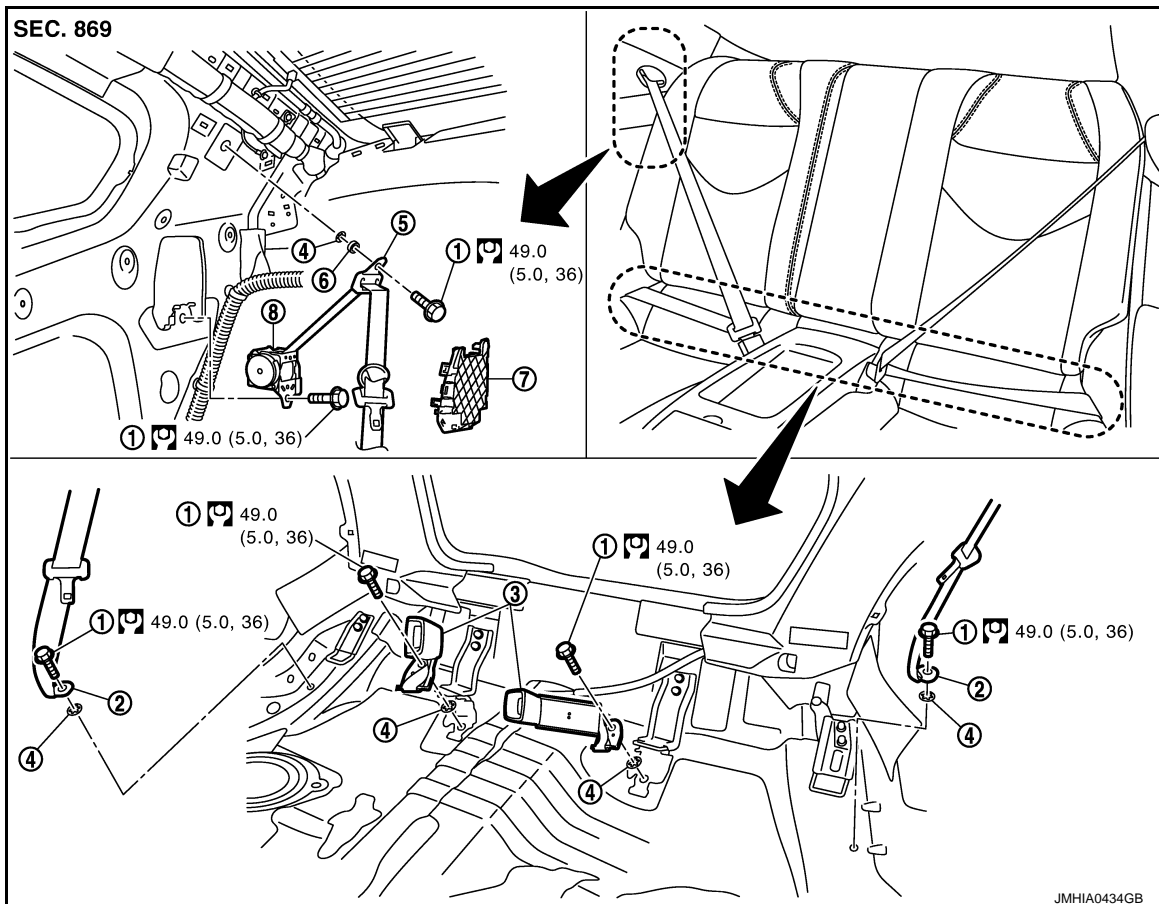

# REAR SEAT BELT

## < REMOVAL AND INSTALLATION >

---

- |                     |                        |                     |   |
|---------------------|------------------------|---------------------|---|
| 1. Anchor bolt      | 2. Outer anchor        | 3. Seat belt buckle | A |
| 4. Retaining washer | 5. Shoulder anchor     | 6. Spacer           |   |
| 7. Retractor cover  | 8. Seat belt retractor |                     |   |

Refer to [GI-4, "Components"](#) for symbols in the figure.

## SEAT BELT BUCKLE : Removal and Installation

INFOID:000000008160042

### REMOVAL

Remove the seat belt buckle.

- Remove the rear seat cushion. Refer to [SE-176, "Removal and Installation"](#).
- Remove the fixing anchor bolt of the inner anchor.

### INSTALLATION

Install in the reverse order of removal.

A  
B  
C  
D  
E  
F  
G  
SB  
I  
J  
K  
L  
M  
N  
O  
P

# LATCH SYSTEM FOR CHILDREN

< REMOVAL AND INSTALLATION >

## LATCH SYSTEM FOR CHILDREN

Exploded View

INFOID:000000008160043

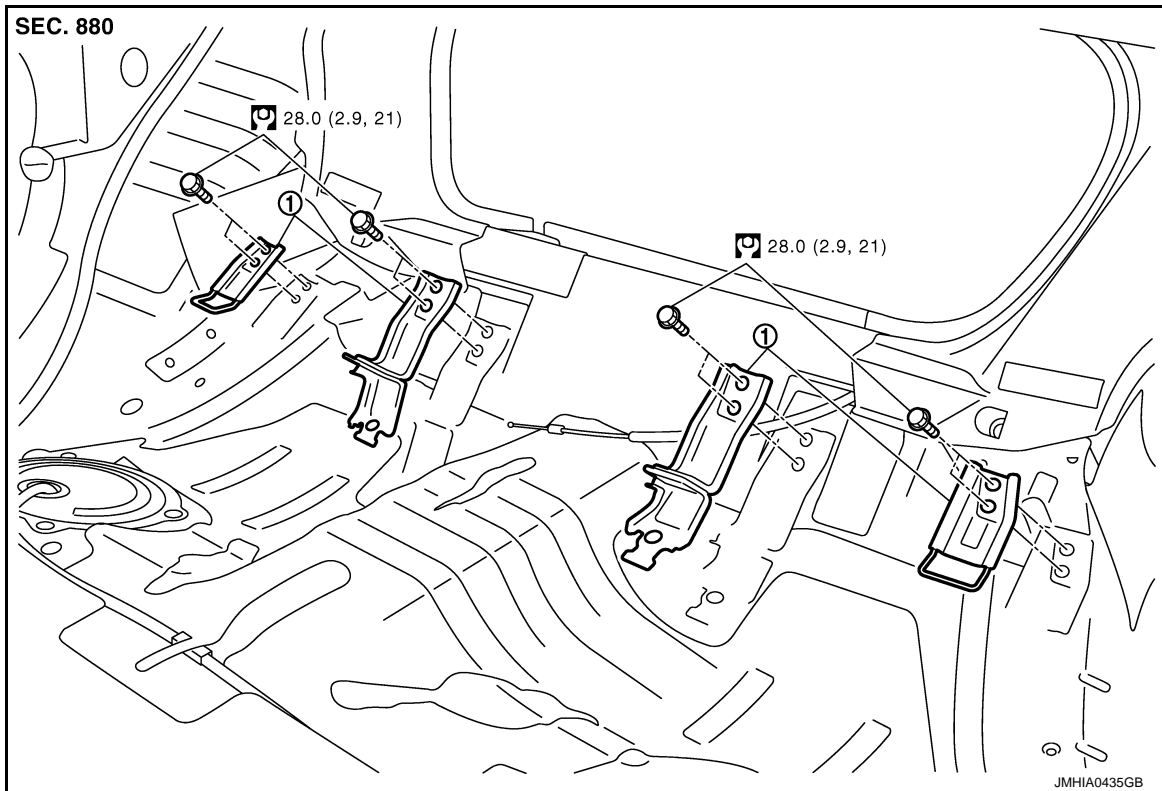

1. LATCH system

Refer to [GI-4, "Components"](#) for symbols in the figure.

## Removal and Installation

INFOID:000000008160044

### REMOVAL

#### **CAUTION:**

**Replace anchor bolts if they are deformed or worn out.**

1. Remove the rear seat cushion. Refer to [SE-176, "Removal and Installation"](#).
2. Remove LATCH (Lower Anchor and Tether for Children) system.

### INSTALLATION

Install in the reverse order of removal.

# TOP TETHER STRAP CHILD RESTRAINT

< REMOVAL AND INSTALLATION >

## TOP TETHER STRAP CHILD RESTRAINT

Exploded View

INFOID:000000008160045

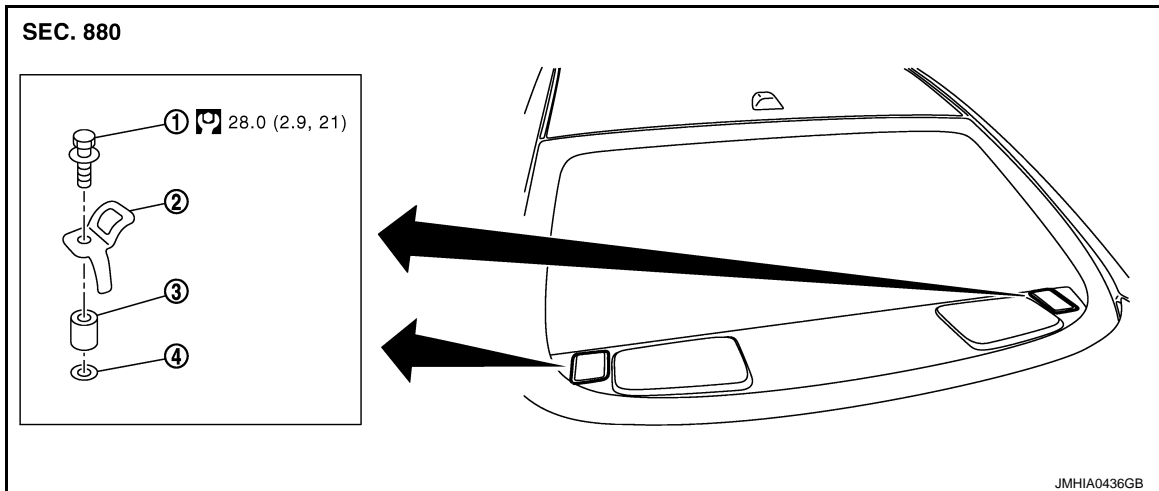

1. Anchor bolt

2. Anchor plate

3. Spacer

4. Fiber washer

Refer to [GI-4, "Components"](#) for symbols in the figure.

## Removal and Installation

INFOID:000000008160046

### REMOVAL

#### **CAUTION:**

**Replace anchor bolts if they are deformed or worn out.**

1. Remove the top tether strap child restraint cover (child anchor cover). Refer to [INT-19, "Exploded View"](#).
2. Remove the top tether strap child restraint.

### INSTALLATION

Install in the reverse order of removal.

A  
B  
C  
D  
E  
F  
G  
SB  
I  
J  
K  
L  
M  
N  
O  
P