

A  
B  
C

# SECTION **CL** CLUTCH

CL

## CONTENTS

<b>SYMPTOM DIAGNOSIS</b> ..... 2	Exploded View ..... 9	F
<b>NOISE, VIBRATION AND HARSHNESS (NVH) TROUBLESHOOTING</b> ..... 2	Removal and Installation ..... 9	
NVH Troubleshooting Chart ..... 2	Disassembly and Assembly ..... 11	G
<b>PRECAUTION</b> ..... 3	Inspection and Adjustment ..... 12	
<b>PRECAUTIONS</b> ..... 3	<b>CLUTCH PIPING</b> ..... 13	
Service Notice or Precautions for Clutch ..... 3	Exploded View ..... 13	H
<b>PREPARATION</b> ..... 4	Hydraulic Layout ..... 13	
<b>PREPARATION</b> ..... 4	Removal and Installation ..... 14	I
Special Service Tools ..... 4	Inspection and Adjustment ..... 14	
Commercial Service Tools ..... 4	<b>UNIT REMOVAL AND INSTALLATION</b> ..... 15	
<b>PERIODIC MAINTENANCE</b> ..... 5	<b>CSC (CONCENTRIC SLAVE CYLINDER)</b> ..... 15	J
<b>CLUTCH PEDAL</b> ..... 5	Exploded View ..... 15	
Inspection and Adjustment ..... 5	Removal and Installation ..... 15	K
<b>CLUTCH FLUID</b> ..... 6	Inspection and Adjustment ..... 18	
Inspection ..... 6	<b>CLUTCH DISC AND CLUTCH COVER</b> ..... 19	L
Air Bleeding Procedure ..... 6	Exploded View ..... 19	
<b>REMOVAL AND INSTALLATION</b> ..... 7	Removal and Installation ..... 19	M
<b>CLUTCH PEDAL</b> ..... 7	Inspection ..... 20	
Exploded View ..... 7	<b>SERVICE DATA AND SPECIFICATIONS (SDS)</b> ..... 22	N
Removal and Installation ..... 7	<b>SERVICE DATA AND SPECIFICATIONS (SDS)</b> ..... 22	O
Inspection and Adjustment ..... 8	Clutch Control System ..... 22	
<b>CLUTCH MASTER CYLINDER</b> ..... 9	Clutch Pedal ..... 22	P
	Clutch Master Cylinder ..... 22	
	Clutch Disc ..... 22	
	Clutch Cover ..... 22	

# NOISE, VIBRATION AND HARSHNESS (NVH) TROUBLESHOOTING

< SYMPTOM DIAGNOSIS >

## SYMPTOM DIAGNOSIS

### NOISE, VIBRATION AND HARSHNESS (NVH) TROUBLESHOOTING

#### NVH Troubleshooting Chart

INFOID:000000004243145

Use the chart below to find the cause of the symptom. The numbers indicate the order of the inspection. If necessary, repair or replace these parts.

SYMPTOM		SUSPECTED PARTS (Possible cause)																
		CLUTCH PEDAL (Inspection and adjustment)	CLUTCH LINE (Air in line)	MASTER CYLINDER PISTON CUP (Damaged)	ENGINE MOUNTING (Loose)	CSC (Concentric Slave Cylinder) (Worn, dirty or damaged)	CLUTCH DISC (Out of true)	CLUTCH DISC (Runout is excessive)	CLUTCH DISC (Lining broken)	CLUTCH DISC (Dirty or burned)	CLUTCH DISC (Oily)	CLUTCH DISC (Worn out)	CLUTCH DISC (Hardened)	CLUTCH DISC (Lack of spline grease)	DIAPHRAGM SPRING (Damaged)	DIAPHRAGM SPRING (Out of tip alignment)	PRESSURE PLATE (Distortion)	FLYWHEEL (Distortion)
Reference		CL-5	CL-6	CL-9	EM-69	CL-15	CL-19						EM-131					
Symptom	Clutch grabs/chatters				1			2			2	2	2			2		
	Clutch pedal spongy		1	2		2												
	Clutch noisy					1												
	Clutch slips	1									2	2			3		4	5
	Clutch does not disengage	1	2	3		4	4	4	4	4	4			4	5	5	6	

# PRECAUTIONS

< PRECAUTION >

## PRECAUTION

### PRECAUTIONS

#### Service Notice or Precautions for Clutch

INFOID:000000004243146

#### CAUTION:

- Clutch fluid use refer to [MA-10, "Fluids and Lubricants"](#).
- Never reuse drained clutch fluid.
- Never splash clutch fluid on painted areas.
- When removing clutch tube, use a flare nut wrench.
- When installing clutch tube, use a flare nut torque wrench [Commercial service tool].
- Use new clutch fluid to clean or wash all parts of master cylinder.
- Never use mineral oils such as gasoline or kerosene. It will ruin the rubber parts of the hydraulic system.
- Never reuse CSC (Concentric Slave Cylinder) body and CSC tube. Because CSC slides back to the original position every time when removing transmission assembly. At this timing, dust on the sliding parts may damage a seal of CSC and may cause clutch fluid leakage. Refer to [CL-15, "Removal and Installation"](#).
- Never disassemble CSC body.

#### WARNING:

After cleaning clutch disc, wipe it with a dust collector. Never use compressed air.

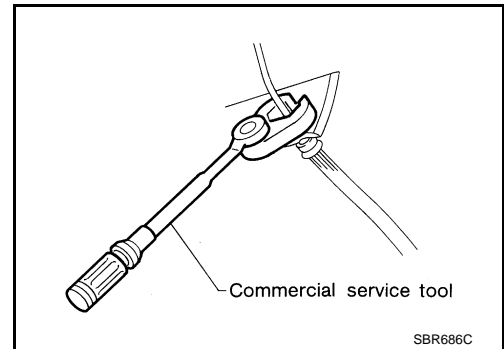

A

B

C

CL

E

F

G

H

I

J

K

L

M

N

O

P

# PREPARATION

< PREPARATION >

## PREPARATION

### PREPARATION

#### Special Service Tools

INFOID:000000004243147

The actual shapes of Kent-Moore tools may differ from those of special service tools illustrated here.

Tool number (Kent-Moore No.) Tool name	Description
ST20050240 (-) Diaphragm adjusting wrench  ZZA0508D	Adjusting unevenness of diaphragm spring of clutch cover

#### Commercial Service Tools

INFOID:000000004243148

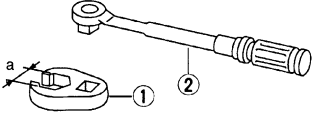
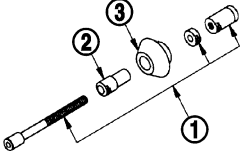
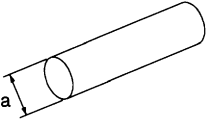
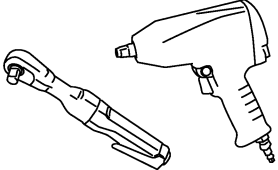
Tool name	Description
1. Flare nut crowfoot a: 10 mm (0.39 in) 2. Torque wrench  S-NT360	Installing clutch tube
Clutch aligner 1. Center shaft 2. Attachment 3. Guide  PCIB0017E	Installing clutch disc
Drift a: 10 mm (0.39 in) dia.  S-NT063	Removing bushing
Power tool  PBIC0190E	Loosening bolts and nuts

# CLUTCH PEDAL

< PERIODIC MAINTENANCE >

## PERIODIC MAINTENANCE

### CLUTCH PEDAL

#### Inspection and Adjustment

INFOID:000000004243149

#### INSPECTION

1. Make sure that clevis pin (1) floats freely in the bore of clutch pedal. It should not be bound by clevis or clutch pedal.
  - a. If clevis pin is not free, make sure that ASCD clutch switch (2) is not applying pressure to clutch pedal causing clevis pin to bind. To adjust, loosen lock nut (3) and turn ASCD clutch switch.
  - b. Tighten lock nut. Refer to [CL-7, "Exploded View"](#).
  - c. Make sure that clevis pin floats in the bore of clutch pedal. It should not be bound by clutch pedal.
  - d. If clevis pin is still not free, remove clevis pin and check for deformation or damage. Replace clevis pin if necessary. Leave clevis pin removed for step 2.
2. Check clutch pedal stroke for free range of movement.
  - a. With clevis pin removed, manually move clutch pedal up and down to determine if it moves freely.
  - b. If any sticking is found, replace related parts (bushing, clutch pedal assembly, etc.). Reassemble clutch pedal and again make sure that clevis pin floats freely in the bore of clutch pedal.
3. Check clutch hydraulic and system components (clutch master cylinder, CSC, etc.) for sticking or binding.
  - a. If any sticking or binding is found, repair or replace related parts as necessary.
  - b. If hydraulic system repair was necessary, bleed the clutch hydraulic system. Refer to [CL-6, "Air Bleeding Procedure"](#).

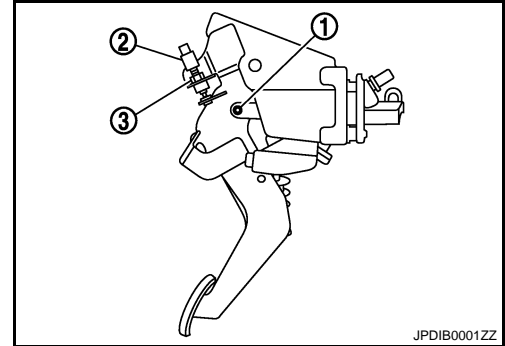

#### NOTE:

Do not use a vacuum assist or any other type of power bleeder on this system. Use of vacuum assist or power bleeder will not purge all the air from the system.

#### ADJUSTMENT

1. Adjust clutch interlock switch (1) position so that clearance between stopper rubber (2) and thread end (A) of clutch interlock switch with clutch pedal depressed is clearance "C".

#### Standard value

Clearance "C" : Refer to [CL-22, "Clutch Pedal"](#).

2. After adjusting clearance "C", tighten lock nut (3) to the specified torque. Refer to [CL-7, "Exploded View"](#).

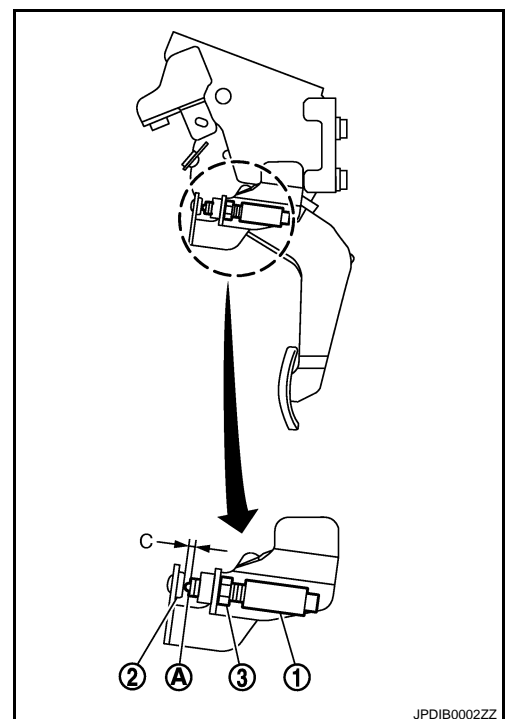

# CLUTCH FLUID

< PERIODIC MAINTENANCE >

## CLUTCH FLUID

### Inspection

INFOID:000000004243150

#### CLUTCH FLUID LEVEL

- Check that the fluid level in the reservoir tank is within the specified range (MAX – MIN lines).
- Visually check for any clutch fluid leakage around the reservoir tank.
- Check the clutch system for any leakage if the fluid level is extremely low (lower than MIN).

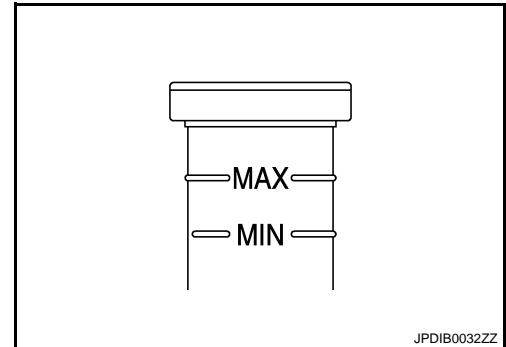

### Air Bleeding Procedure

INFOID:000000004243151

#### CAUTION:

- **Monitor clutch fluid level in reservoir tank to make sure it does not empty.**
- **Keep painted surface on the body or other parts free of clutch fluid. If it spills, wipe up immediately and wash the affected area with water.**

#### NOTE:

Do not use a vacuum assist or any other type of power bleeder on this system. Use of vacuum assist or power bleeder will not purge all the air from the system.

1. Fill master cylinder reservoir tank with new clutch fluid.
2. Connect a transparent vinyl hose to air bleeder valve.
3. Depress clutch pedal slowly and fully several times at an interval of 2 to 3 seconds and hold it.
4. With clutch pedal depressed, open air bleeder valve to release air.
5. Close air bleeder valve.
6. Release clutch pedal and wait for 5 seconds.
7. Repeat steps 3 to 6 until no bubbles can be observed in clutch fluid.
8. Tighten air bleeder valve to the specified torque. Refer to [CL-15, "Exploded View"](#).

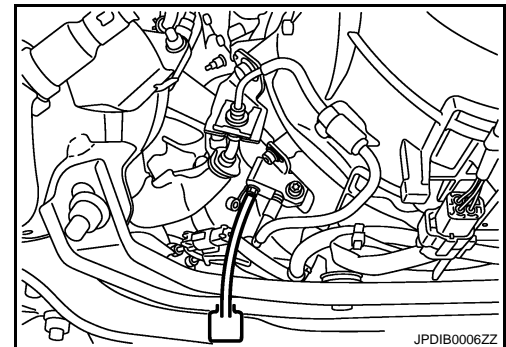

# CLUTCH PEDAL

< REMOVAL AND INSTALLATION >

## REMOVAL AND INSTALLATION

### CLUTCH PEDAL

#### Exploded View

INFOID:0000000004243152

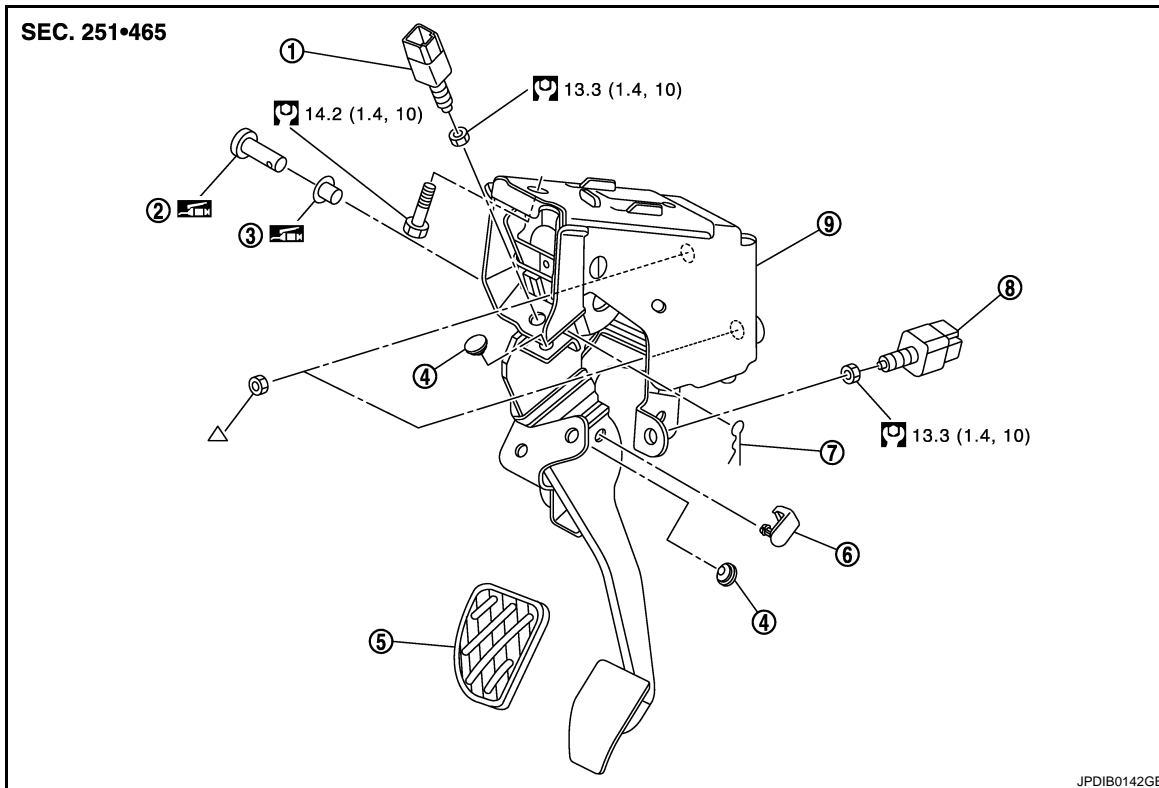

- |                       |                            |                          |
|-----------------------|----------------------------|--------------------------|
| 1. ASCD clutch switch | 2. Clevis pin              | 3. Bushing               |
| 4. Stopper rubber     | 5. Pedal pad               | 6. Pedal stopper rubber  |
| 7. Snap pin           | 8. Clutch interlock switch | 9. Clutch pedal assembly |

: Apply lithium-based grease including molybdenum disulphide.

△: Refer to [CL-9, "Exploded View"](#) for the tightening torque.

Refer to [GI-4, "Components"](#) for symbols not described on the above.

### Removal and Installation

INFOID:0000000004243153

#### REMOVAL

1. Remove front kicking plate inner and dash side finisher. Refer to [INT-14, "Removal and Installation"](#).
2. Remove instrument lower panel LH. Refer to [IP-12, "Removal and Installation"](#).
3. Remove bracket (1) and harness bracket (2).
4. Disconnect ASCD clutch switch and clutch interlock switch connectors and then remove clip of harness from clutch pedal assembly.
5. Remove snap pin and clevis pin.
6. Remove clutch pedal assembly.
7. Remove ASCD clutch switch, clutch interlock switch, and pedal pad.
8. Remove bushing using a suitable drift [Commercial service tool].
9. Remove stopper rubbers and pedal stopper rubber using a suitable remover.

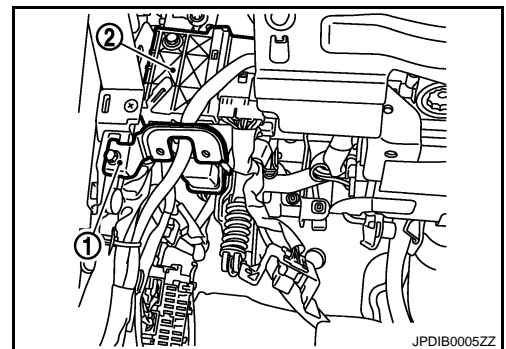

# CLUTCH PEDAL

## < REMOVAL AND INSTALLATION >

### INSTALLATION

Note the following, and install in the reverse order of removal.  
Apply recommended grease to clevis pin and bushing.

### Inspection and Adjustment

INFOID:000000004243154

### INSPECTION AFTER REMOVAL

Check the following items and replace clutch pedal if necessary.

- Check clutch pedal upper rivets (A) for deformation.

⇐ : Vehicle front

- Check the lapping length "L" of sub-bracket (B) and slide plate (C).

**Lapping length "L" : More than 5 mm (0.20 in)**

- Check clutch pedal for bend, damage, and cracks on the welded parts.

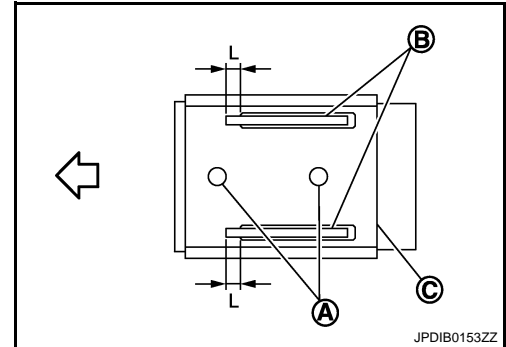

### INSPECTION AFTER INSTALLATION

Check the clutch pedal free play. Refer to [CL-5, "Inspection and Adjustment"](#).

### ADJUSTMENT AFTER INSTALLATION

Adjust the clutch interlock switch position. Refer to [CL-5, "Inspection and Adjustment"](#).



# CLUTCH MASTER CYLINDER

< REMOVAL AND INSTALLATION >

## CLUTCH MASTER CYLINDER

Exploded View

INFOID:000000004515712

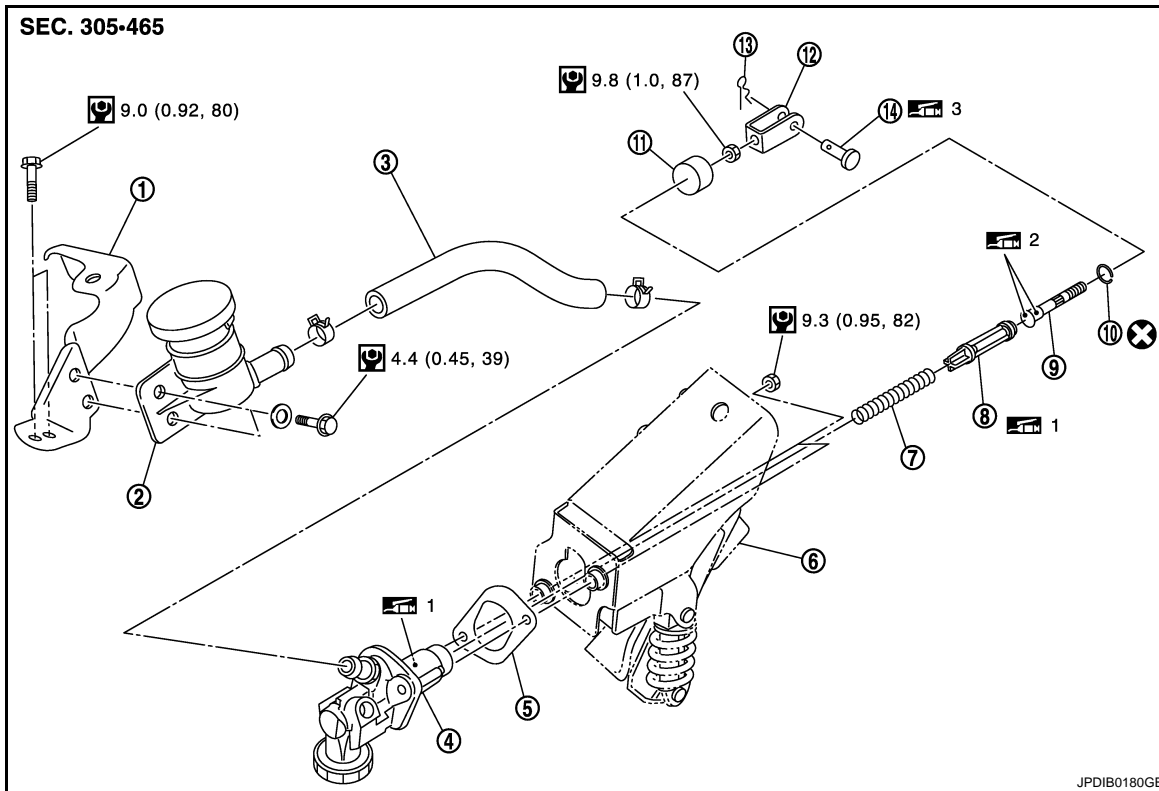

- |                  |                            |                          |
|------------------|----------------------------|--------------------------|
| 1. Bracket       | 2. Reservoir tank assembly | 3. Hose                  |
| 4. Cylinder body | 5. Packing                 | 6. Clutch pedal assembly |
| 7. Return spring | 8. Piston assembly         | 9. Push rod              |
| 10. Stopper ring | 11. Boot                   | 12. Clevis               |
| 13. Snap pin     | 14. Clevis pin             |                          |

 1: Apply rubber lubricant.

 2: Apply silicone grease.

 3: Apply lithium-based grease including molybdenum disulphide.

Refer to [GI-4, "Components"](#) for symbols not described on the above.

## Removal and Installation

INFOID:000000004515713

### REMOVAL

#### CAUTION:

Keep painted surface on the body or other parts free of clutch fluid. If it spills, wipe up immediately and wash the affected area with water.

1. Remove brake master cylinder cover. Refer to [EXT-20, "Removal and Installation"](#).
2. Remove brake booster pressure sensor. Refer to [BR-35, "Removal and Installation"](#).
3. Drain clutch fluid in reservoir tank assembly.

# CLUTCH MASTER CYLINDER

## < REMOVAL AND INSTALLATION >

4. Remove reservoir tank assembly.

← : Vehicle front

5. Remove hose and clips from cylinder body and reservoir tank assembly.
6. Remove mounting bolts and washers and then bracket from reservoir tank assembly.
7. Remove ABS actuator and electric unit (control unit). Refer to [BR-22. "FRONT : Removal and Installation"](#).
8. Remove clutch tube using a flare nut wrench.
9. Remove front kicking plate inner and dash side finisher. Refer to [INT-14. "Removal and Installation"](#).
10. Remove instrument lower panel LH. Refer to [IP-12. "Removal and Installation"](#).
11. Remove snap pin and clevis pin from clevis and then separate it from clutch pedal assembly.
12. Remove packing (1) and master cylinder assembly (2).

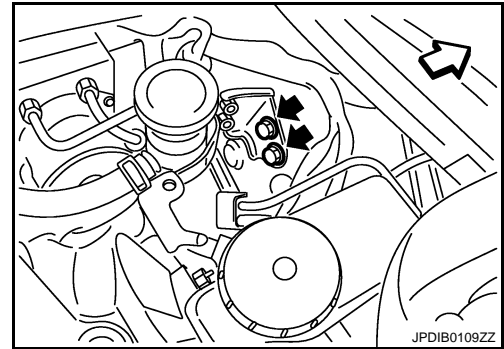

← : Vehicle front

### CAUTION:

Never damage packing, brake booster, and dash lower.

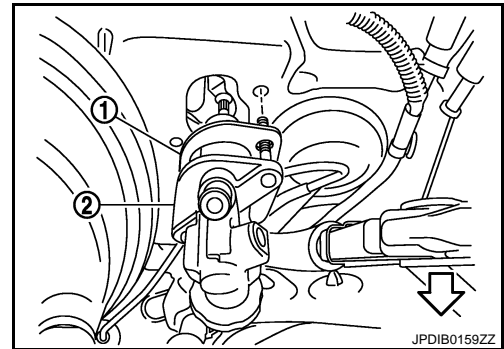

## INSTALLATION

### CAUTION:

Keep painted surface on the body or other parts free of clutch fluid. If it spills, wipe up immediately and wash the affected area with water.

1. Install packing (1) and master cylinder assembly (2).

← : Vehicle front

### CAUTION:

- Never damage packing, brake booster, and dash lower.

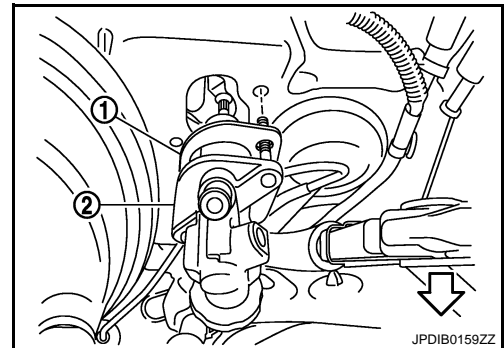

- Be careful with the orientation of packing. The figure is the view from the vehicle forward.

2. Connect clutch tube to master cylinder assembly and temporarily tighten flare nut.
3. Install master cylinder assembly and then tighten mounting nuts to the specified torque.
4. Set clevis to clutch pedal assembly.
5. Apply recommended grease to clevis pin and then insert clevis pin to clevis.
6. Attach snap pin to clevis pin.
7. Install instrument lower panel LH. Refer to [IP-12. "Removal and Installation"](#).
8. Install dash side finisher and front kicking plate inner. Refer to [INT-14. "Removal and Installation"](#).

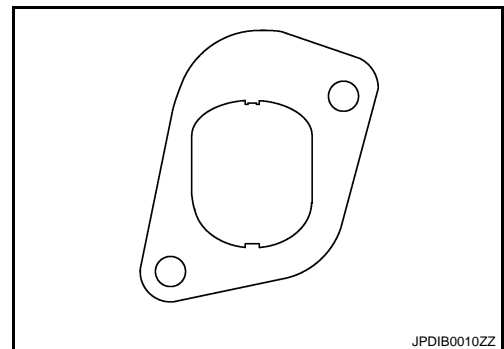

# CLUTCH MASTER CYLINDER

## < REMOVAL AND INSTALLATION >

9. Tighten clutch tube flare nut to the specified torque using a flare nut torque wrench [Commercial service tool]. Refer to [CL-13. "Exploded View"](#).
10. Install ABS actuator and electric unit (control unit). Refer to [BR-22. "FRONT : Removal and Installation"](#).
11. Install bracket, mounting bolts, and washers to reservoir tank assembly. Tighten mounting bolts to the specified torque.
12. Install hose (1) and clips to reservoir tank assembly (2) and cylinder body (3).

← : Painted mark

**CAUTION:**  
Set hose with painted mark facing upward.

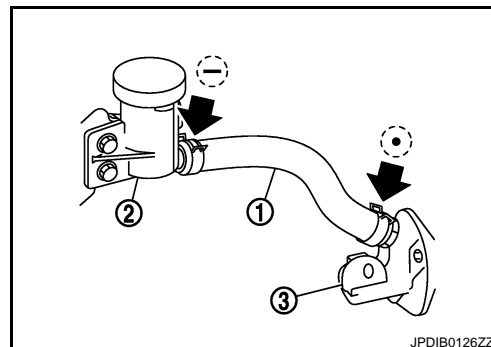

13. Install reservoir tank assembly.

↔ : Vehicle front

14. Install brake booster pressure sensor. Refer to [BR-35. "Removal and Installation"](#).
15. Install brake master cylinder cover. Refer to [EXT-20. "Removal and Installation"](#).

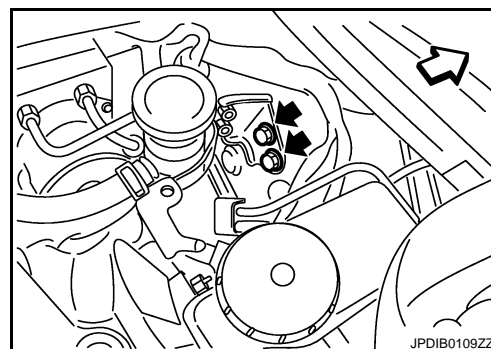

INFOID:000000004243157

## Disassembly and Assembly

### DISASSEMBLY

1. Loosen push rod lock nut and then remove clevis and push rod lock nut.  
**NOTE:**  
Clutch pedal height is controlled with position of clevis and cylinder body.
2. Remove boot.
3. Remove stopper ring while holding push rod.
4. Remove push rod, piston assembly, and return spring.

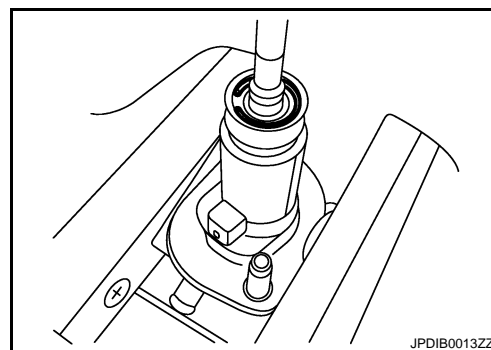

### ASSEMBLY

1. Apply rubber lubricant to the internal surface of cylinder body, the sliding surface and piston cup of piston assembly.
2. Insert return spring and piston assembly.
3. Apply silicon grease to push rod.
4. Install push rod.
5. Install stopper ring while holding push rod.  
**CAUTION:**  
Never reuse stopper ring.

A  
B  
C  
CL  
E  
F  
G  
H  
I  
J  
K  
L  
M  
N  
O  
P

# CLUTCH MASTER CYLINDER

## < REMOVAL AND INSTALLATION >

6. Install boot.
7. Install push rod lock nut and clevis to push rod.
8. Adjust the length "L" between clevis (1) and cylinder body (2) to the standard value. Then tighten lock nut (3) to the specified torque.

**Standard value**

**Length "L"**

: Refer to [CL-22, "Clutch Master Cylinder"](#).

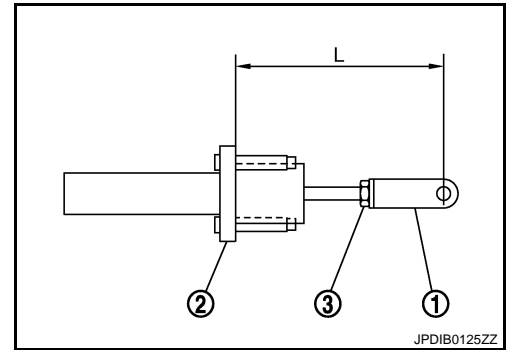

INFOID:000000004243158

## Inspection and Adjustment

### INSPECTION AFTER DISASSEMBLY

Check for any of the conditions shown below. If any malfunction is found, replace the part concerned.

- Damaged cylinder internal wall, foreign matter, wear, corrosion.
- Damaged or deformed reservoir tank.
- Settling of return spring.
- Cracked or deformed boot.
- Cracked or deformed packing.

### ADJUSTMENT BEFORE INSTALLATION

Check the length "L" between clevis (1) and cylinder body (2). If measurement is outside the standard value, adjust the length "L" between clevis and cylinder body to the standard value. Then tighten lock nut (3) to the specified torque.

**Standard value**

**Length "L"**

: Refer to [CL-22, "Clutch Master Cylinder"](#).

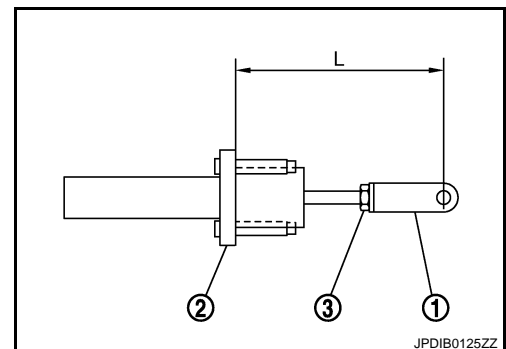

### ADJUSTMENT AFTER INSTALLATION

- Check and adjust the clutch pedal. Refer to [CL-5, "Inspection and Adjustment"](#).
- Bleed the air from the clutch hydraulic system. Refer to [CL-6, "Air Bleeding Procedure"](#).

### INSPECTION AFTER INSTALLATION

Check the clutch fluid leakage and clutch fluid level. Refer to [CL-6, "Inspection"](#).

# CLUTCH PIPING

< REMOVAL AND INSTALLATION >

## CLUTCH PIPING

Exploded View

INFOID:000000004243159

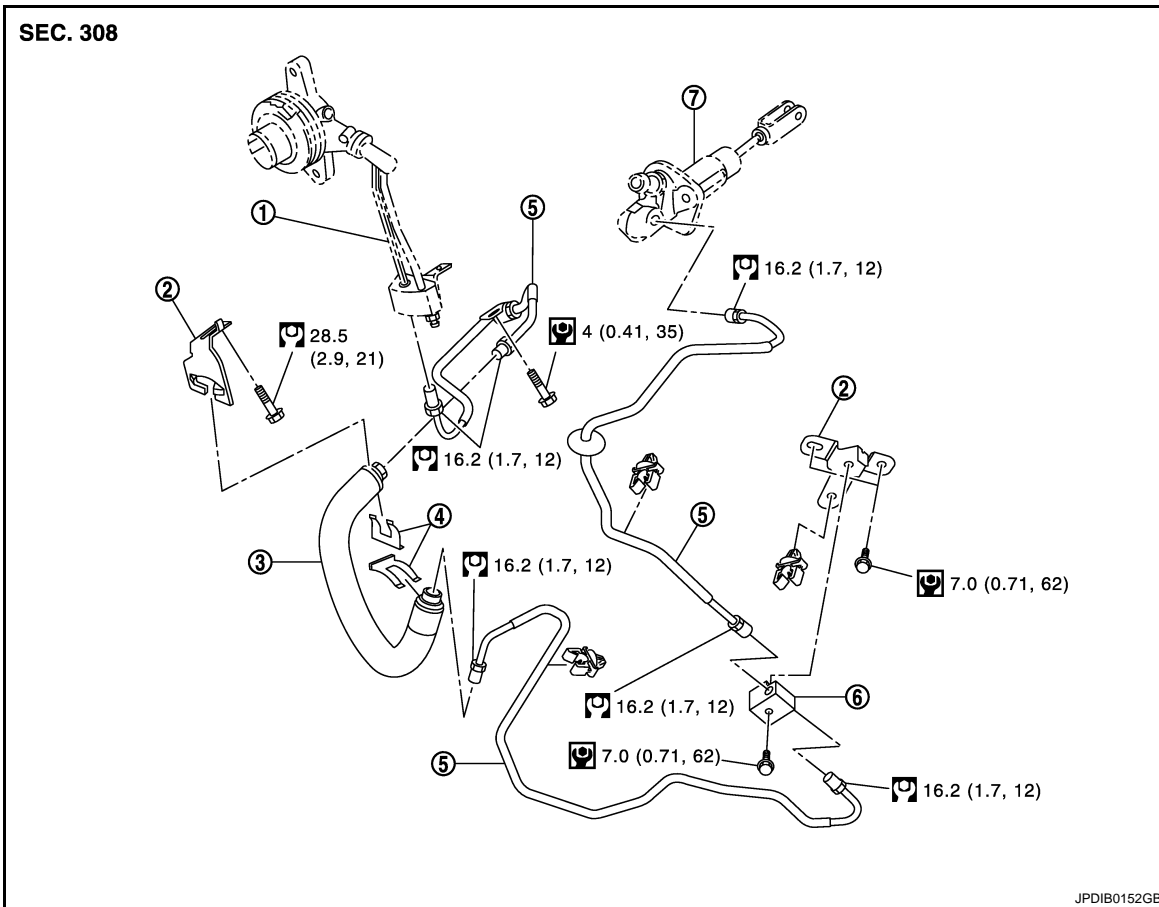

- |   |                |                |
|---|----------------|----------------|
| 1. CSC (Concentric Slave Cylinder) assembly | 2. Bracket     | 3. Clutch hose |
| 4. Lock plate                               | 5. Clutch tube | 6. Connector   |
| 7. Master cylinder assembly                 |                |                |

Refer to [GI-4, "Components"](#) for the symbols in the figure.

## Hydraulic Layout

INFOID:000000004243160

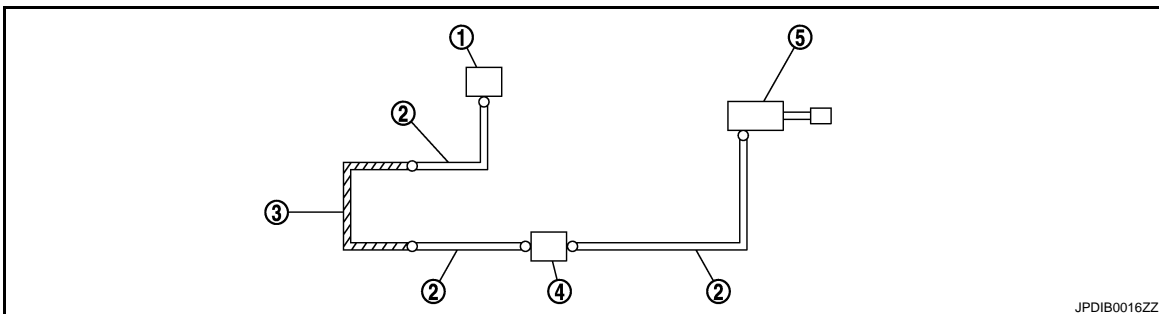

- |   |                             |                |
|---|-----------------------------|----------------|
| 1. CSC (Concentric Slave Cylinder) assembly | 2. Clutch tube              | 3. Clutch hose |
| 4. Connector                                | 5. Master cylinder assembly |                |

# CLUTCH PIPING

## < REMOVAL AND INSTALLATION >

### Removal and Installation

INFOID:000000004243161

#### **CAUTION:**

Keep painted surface on the body or other parts free of clutch fluid. If it spills, wipe up immediately and wash the affected area with water.

#### REMOVAL

Refer to [CL-13, "Exploded View"](#) for removal procedure.

#### INSTALLATION

Note the following, and refer to [CL-13, "Exploded View"](#) for installation procedure.

- To fix clutch hose on bracket, position clutch hose clasp on the emboss of bracket and drive lock plate vertically from above.

#### **CAUTION:**

- **Never bend or twist clutch hose.**
- **Never scratch or damage clutch hose.**
- Tighten clutch tube flare nut to the specified torque using a flare nut torque wrench [Commercial service tool].

#### **CAUTION:**

**Never damage flare nut and clutch tube.**

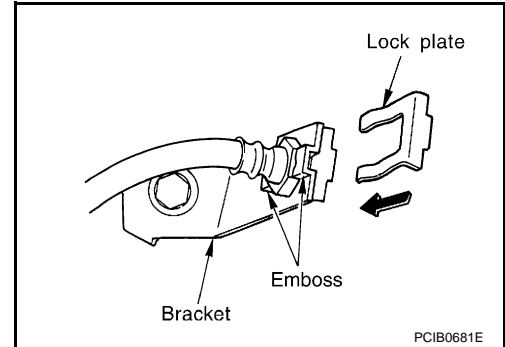

### Inspection and Adjustment

INFOID:000000004512962

#### ADJUSTMENT AFTER INSTALLATION

Bleed the air from the clutch hydraulic system. Refer to [CL-6, "Air Bleeding Procedure"](#).

#### INSPECTION AFTER INSTALLATION

Check the clutch fluid leakage and clutch fluid level. Refer to [CL-6, "Inspection"](#).

# CSC (CONCENTRIC SLAVE CYLINDER)

< UNIT REMOVAL AND INSTALLATION >

## UNIT REMOVAL AND INSTALLATION

### CSC (CONCENTRIC SLAVE CYLINDER)

Exploded View

INFOID:000000004243162

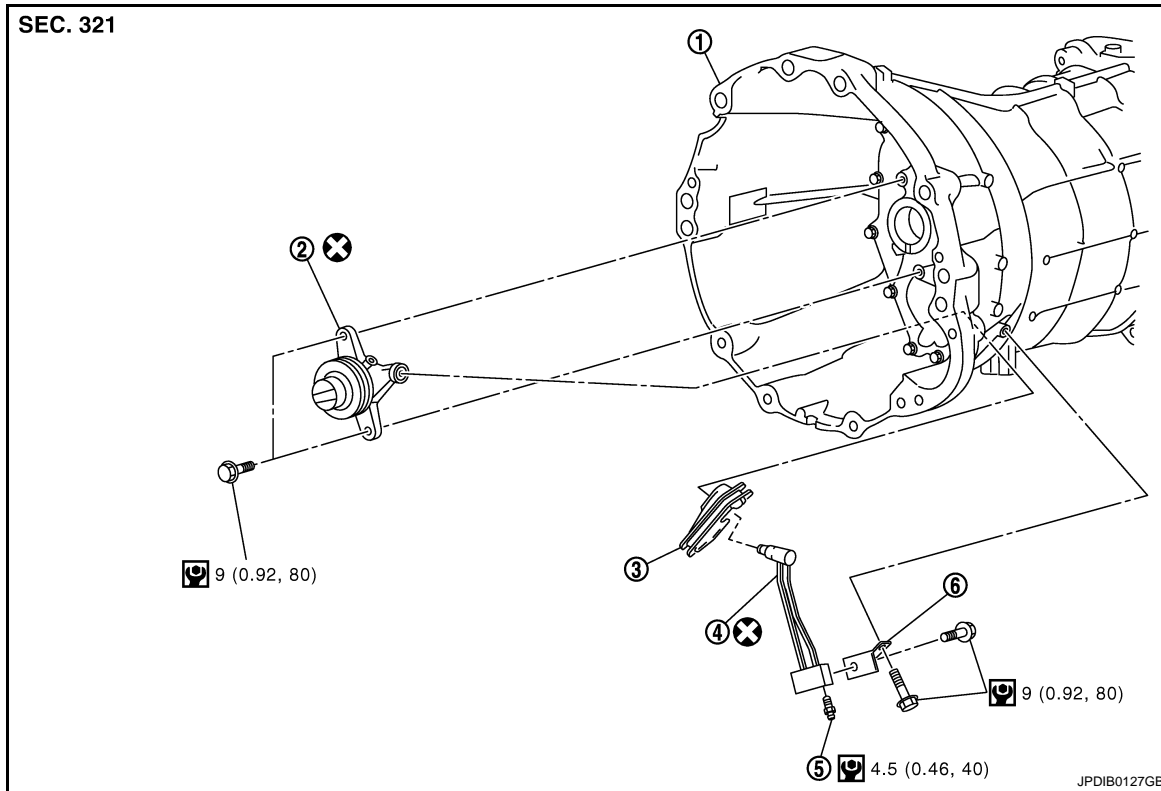

- |   |   |               |
|---|---|---------------|
| 1. Transmission assembly                | 2. CSC (Concentric Slave Cylinder) body | 3. Dust cover |
| 4. CSC (Concentric Slave Cylinder) tube | 5. Air bleeder valve                    | 6. Bracket    |

Refer to [GI-4, "Components"](#) for the symbols in the figure.

### Removal and Installation

INFOID:000000004243163

#### CAUTION:

- Never reuse CSC (Concentric Slave Cylinder) body and CSC tube. Because CSC slides back to the original position every time when removing transmission assembly. At this timing, dust on the sliding parts may damage a seal of CSC and may cause clutch fluid leakage.
- Never disassemble CSC body.
- Keep painted surface on the body or other parts free of clutch fluid. If it spills, wipe up immediately and wash the affected area with water.

#### REMOVAL

1. Remove transmission assembly from the engine. Refer to [TM-26, "Removal and Installation"](#).

## CSC (CONCENTRIC SLAVE CYLINDER)

### < UNIT REMOVAL AND INSTALLATION >

2. Remove bracket mounting bolt (←).

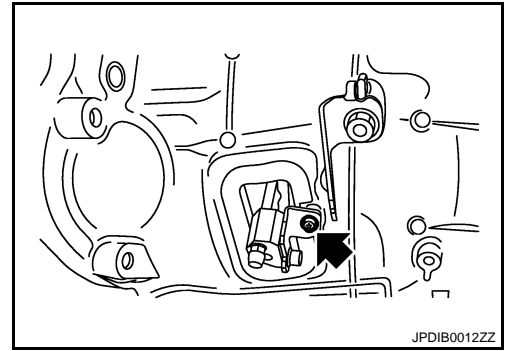

3. Pull up the lock pin of the CSC body.

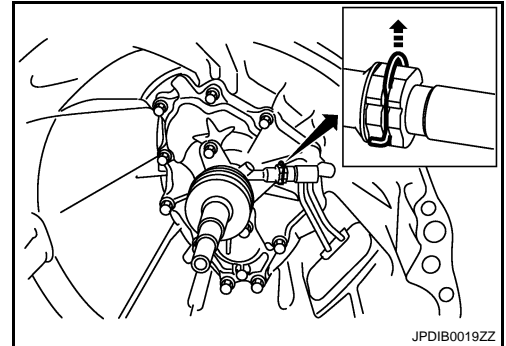

4. Pull out the CSC tube (1) from the CSC body (2).
5. Remove CSC tube and dust cover from transmission case.
6. Remove air bleeder valve and bracket from CSC tube.

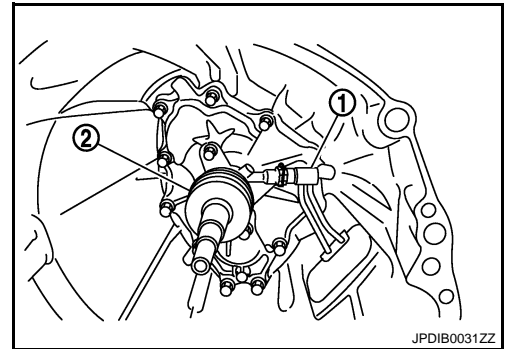

7. Remove CSC body from transmission case.

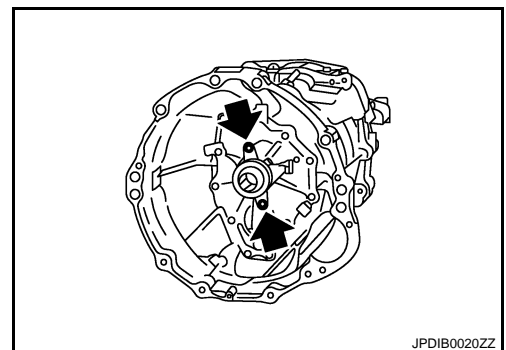

### INSTALLATION



# CSC (CONCENTRIC SLAVE CYLINDER)

## < UNIT REMOVAL AND INSTALLATION >

1. Install CSC body to transmission case and then tighten mounting bolts (←) to the specified torque.

**CAUTION:**

- Never reuse CSC body.
- Never insert and operate CSC body because piston and stopper of CSC body components may fall off.

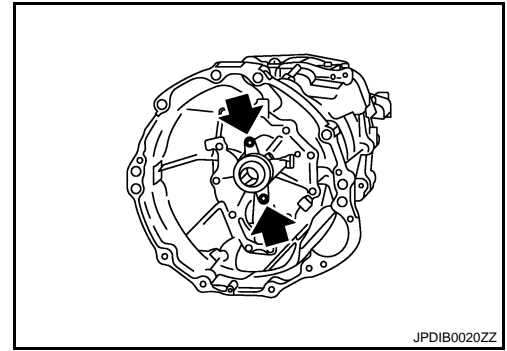

2. Install dust cover to transmission case.

← : Vehicle front

**CAUTION:**

**Be careful with the orientation of dust cover.**

3. Insert CSC tube to dust cover.

**CAUTION:**

- Never reuse CSC tube.
- Never damage O-ring of CSC tube.

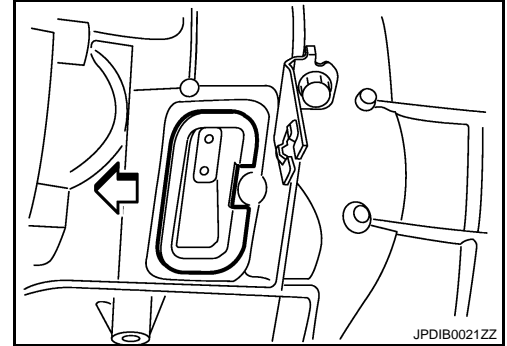

4. Press down the lock pin of the CSC body.

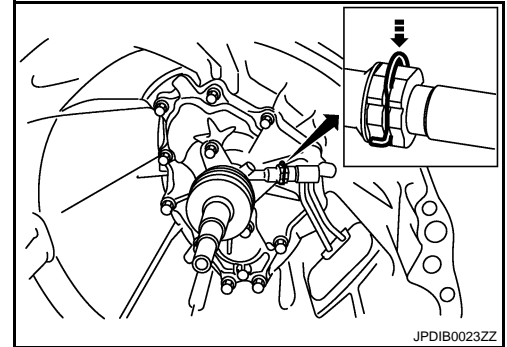

5. Insert the CSC tube (1) into the connector of the CSC body (2) until it clicks.

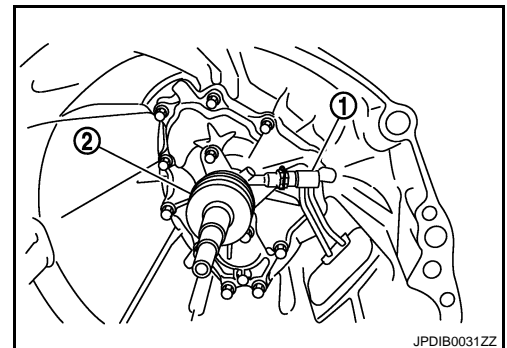

6. Install bracket mounting bolts (←) and then tighten mounting bolts to the specified torque in the order shown in the figure.

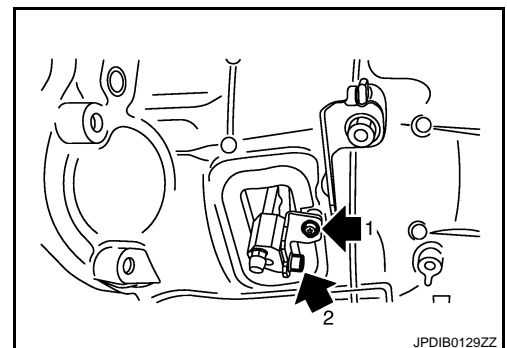

A

B

C

CL

E

F

G

H

I

J

K

L

M

N

O

P

## CSC (CONCENTRIC SLAVE CYLINDER)

### < UNIT REMOVAL AND INSTALLATION >

#### **CAUTION:**

- Check that CSC tube's (B) and bracket (1) are fit tightly before tightening the mounting bolt (A).
  - Tighten the mounting bolt within the range of bracket's mounting hole.
  - After replacing the CSC tube, the mounting bolt (C) is still temporary tightening. Never forget tightening the mounting bolt.
7. Install air bleeder valve to CSC tube and then tighten air bleeder valve to the specified torque.
  8. Install transmission assembly to the engine. Refer to [TM-26. "Removal and Installation"](#).

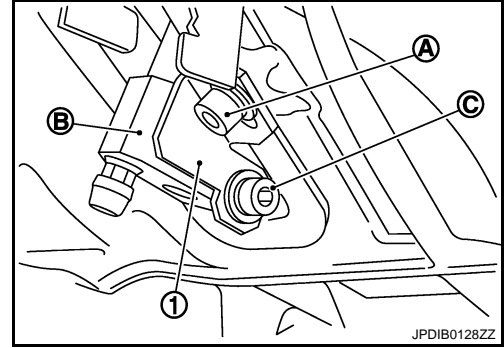

INFOID:000000004516161

### Inspection and Adjustment

#### ADJUSTMENT AFTER INSTALLATION

Bleed the air from the clutch hydraulic system. Refer to [CL-6. "Air Bleeding Procedure"](#).

#### INSPECTION AFTER INSTALLATION

Check the clutch fluid leakage and clutch fluid level. Refer to [CL-6. "Inspection"](#).

# CLUTCH DISC AND CLUTCH COVER

< UNIT REMOVAL AND INSTALLATION >

## CLUTCH DISC AND CLUTCH COVER

Exploded View

INFOID:000000004243164

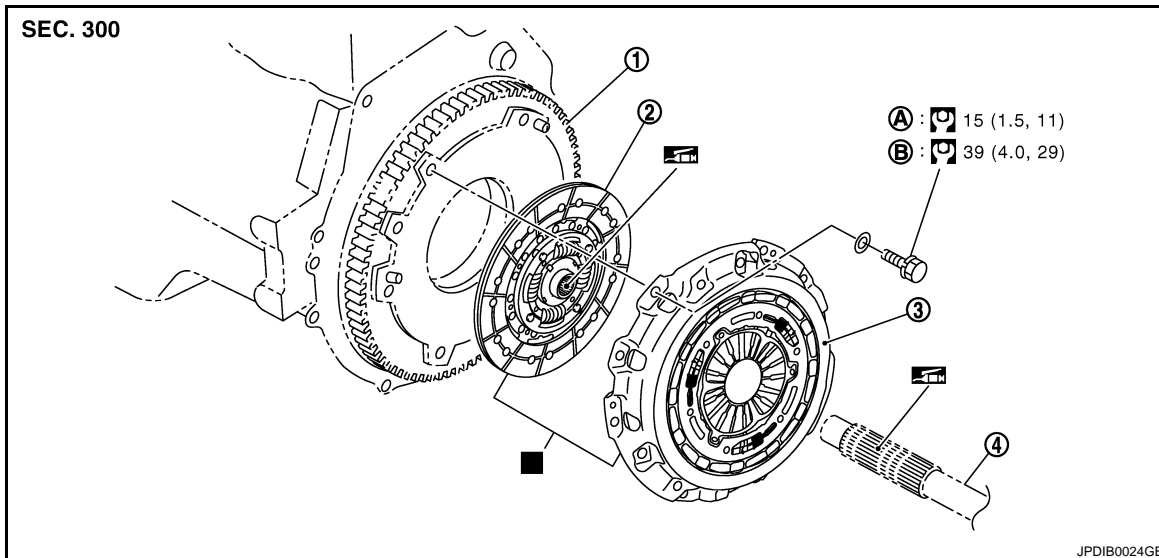

1. Flywheel
2. Clutch disc
3. Clutch cover
4. Main drive gear
- A. First step
- B. Final step

■ : Replace the parts as a set.

☑ : Apply lithium-based grease including molybdenum disulphide.

Refer to [GI-4, "Components"](#) for symbols not described on the above.

### CAUTION:

- Never reuse CSC (Concentric Slave Cylinder) body and CSC tube. Because CSC slides back to the original position every time when removing transmission assembly. At this timing, dust on the sliding parts may damage a seal of CSC and may cause clutch fluid leakage. Refer to [CL-15, "Removal and Installation"](#).
- Never bring any grease to the clutch disc facing, pressure plate surface and flywheel surface.
- When installing, be careful that grease applied to main drive gear does not adhere to clutch disc.
- Never clean clutch disc using solvent.
- If flywheel is removed, align dowel pin with the smallest hole of flywheel. Refer to [EM-122, "Disassembly and Assembly"](#).

## Removal and Installation

INFOID:000000004243165

### CAUTION:

Never reuse CSC (Concentric Slave Cylinder) body and CSC tube. Because CSC slides back to the original position every time when removing transmission assembly. At this timing, dust on the sliding parts may damage a seal of CSC and may cause clutch fluid leakage. Refer to [CL-15, "Removal and Installation"](#).

### REMOVAL

1. Remove transmission assembly from the engine. Refer to [TM-26, "Removal and Installation"](#).
2. Loosen clutch cover mounting bolts with power tool [Commercial service tool].
3. Remove clutch cover and clutch disc.

### CAUTION:

Never drop clutch disc.

### INSTALLATION

1. Clean clutch disc and main drive gear splines to remove grease and powder arisen from abrasion.
2. Apply recommended grease to clutch disc and main drive gear splines.

### CAUTION:

# CLUTCH DISC AND CLUTCH COVER

## < UNIT REMOVAL AND INSTALLATION >

Be sure to apply grease to the points specified. Otherwise, noise, poor disengagement, or damage to the clutch may result. Excessive grease may cause slip or judder. And if it adheres to seal of CSC body, it cause clutch fluid leakage. Wipe out excess grease. Wipe out any grease oozing from the parts.

3. Install clutch disc using a clutch aligner [Commercial service tool].

**CAUTION:**

If either clutch disc or clutch cover is needed to be replaced, replace them as a set.

4. Install clutch cover. Temporarily tighten clutch cover mounting bolts.

**CAUTION:**

If either clutch disc or clutch cover is needed to be replaced, replace them as a set.

5. Tighten clutch cover mounting bolts evenly in two steps in the order shown in the figure.

6. Install transmission assembly to the engine. Refer to [TM-26, "Removal and Installation"](#).

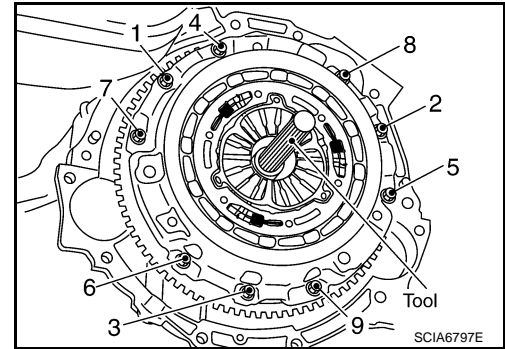

## Inspection

INFOID:000000004243166

### INSPECTION AFTER REMOVAL

#### CLUTCH DISC

- Measure circumferential runout relative to clutch disc center spline. If it is outside the specification, replace clutch disc and clutch cover as a set.

**Runout limit/diameter of the area to be measured** : Refer to [CL-22, "Clutch Disc"](#).

- Measure backlash to clutch disc spline and main drive gear spline at the circumference of clutch disc. If it is outside the specification, replace clutch disc and clutch cover as a set.

**Maximum allowable spline backlash (at outer edge of disc)** : Refer to [CL-22, "Clutch Disc"](#).

- Measure the depth "A" to clutch disc facing rivet heads using a calipers. If it exceeds the allowable wear limit, replace clutch disc and clutch cover as a set.

**Facing wear limit (depth to the rivet head) "A"** : Refer to [CL-22, "Clutch Disc"](#).

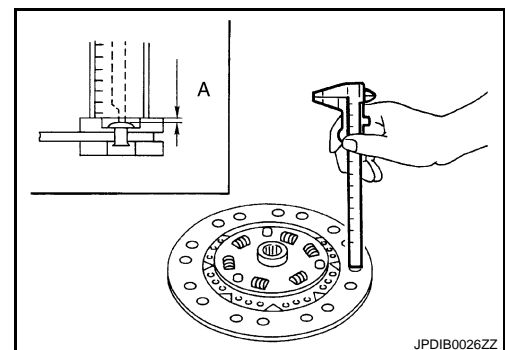
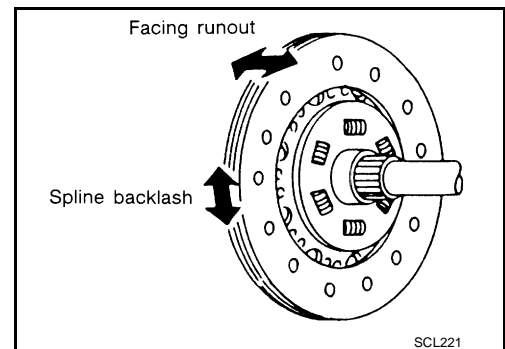

#### CLUTCH COVER

Check diaphragm spring lever claws for unevenness with the lever still on the vehicle. If they exceed the tolerance, adjust lever height using the diaphragm adjusting wrench [SST: ST20050240 (-)].

**Tolerance for diaphragm spring lever unevenness** : Refer to [CL-22, "Clutch Cover"](#).

- Check clutch cover thrust ring for wear or breakage. If wear or breakage is found, replace clutch disc and clutch cover as a set.

**NOTE:**

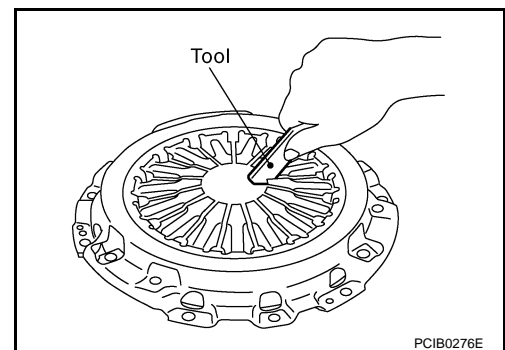

# CLUTCH DISC AND CLUTCH COVER

## < UNIT REMOVAL AND INSTALLATION >

---

- Worn thrust ring will generate a beating noise when tapped at the rivet with a hammer.
- Broken thrust ring will make a clinking sound when cover is shaken up and down.
- If a trace of burn or discoloration is found on the clutch cover pressure plate to clutch disc contact surface, repair the surface with sandpaper. If surface is damaged or distorted, replace clutch disc and clutch cover as a set.

A

B

C

**CL**

E

F

G

H

I

J

K

L

M

N

O

P

## SERVICE DATA AND SPECIFICATIONS (SDS)

< SERVICE DATA AND SPECIFICATIONS (SDS)

# SERVICE DATA AND SPECIFICATIONS (SDS)

## SERVICE DATA AND SPECIFICATIONS (SDS)

### Clutch Control System

INFOID:000000004243167

Type of clutch control	Hydraulic
------------------------	-----------

### Clutch Pedal

INFOID:000000004243168

Unit: mm (in)

Clearance "C" between pedal stopper rubber and clutch interlock switch threaded while clutch pedal is fully depressed.	0.1 – 1.0 (0.004 – 0.039)
--	---------------------------

### Clutch Master Cylinder

INFOID:000000004243169

Unit: mm (in)

Inner diameter	17.46 (11/16)
Standard length "L" between clevis and cylinder body	133.55 ± 0.5 (5.26 ± 0.020)

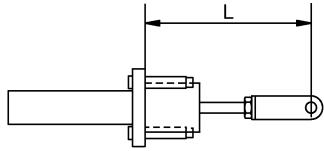

### Clutch Disc

INFOID:000000004243170

Unit: mm (in)

Facing size (Outer dia. × Inner dia. × Thickness)	240 × 160 × 3.8 (9.45 × 6.30 × 0.150)
Runout limit/diameter of the area to be measured	1.0 (0.039) / 230 (9.06) dia.
Maximum allowable spline backlash (at outer edge of disc)	1.0 (0.039)
Facing wear limit (depth to the rivet head)	0.3 (0.012)

### Clutch Cover

INFOID:000000004243171

Tolerance for diaphragm spring lever unevenness	0.8 mm (0.031 in) or less
Diaphragm spring lever height	44.6 – 46.8 mm (1.756 – 1.843 in)
Set-load	10,300 N (1,050.6 kg, 2,315.4 lb)