

SECTION **PWC**

POWER WINDOW CONTROL SYSTEM

A
B
C
D
E
F
G
H
I
J
PWC
L
M
N
O
P

CONTENTS

FRONT & REAR WINDOW ANTI-PINCH	POWER SUPPLY AND GROUND CIRCUIT16
BASIC INSPECTION 7	BCM16
DIAGNOSIS AND REPAIR WORK FLOW 7	BCM : Diagnosis Procedure16
Work Flow7	POWER WINDOW MAIN SWITCH16
INSPECTION AND ADJUSTMENT 8	POWER WINDOW MAIN SWITCH : Diagnosis
ADDITIONAL SERVICE WHEN REMOVING BATTERY NEGATIVE TERMINAL8	Procedure16
ADDITIONAL SERVICE WHEN REMOVING	FRONT POWER WINDOW SWITCH (PASSENGER SIDE)17
BATTERY NEGATIVE TERMINAL : Description8	FRONT POWER WINDOW SWITCH (PASSENGER SIDE) : Diagnosis Procedure17
ADDITIONAL SERVICE WHEN REMOVING	REAR POWER WINDOW SWITCH18
BATTERY NEGATIVE TERMINAL : Special Repair Requirement8	REAR POWER WINDOW SWITCH : Diagnosis
ADDITIONAL SERVICE WHEN REPLACING CONTROL UNIT8	Procedure18
ADDITIONAL SERVICE WHEN REPLACING	POWER WINDOW MOTOR20
CONTROL UNIT : Description8	DRIVER SIDE20
ADDITIONAL SERVICE WHEN REPLACING	DRIVER SIDE : Description20
CONTROL UNIT : Special Repair Requirement9	DRIVER SIDE : Component Function Check20
SYSTEM DESCRIPTION10	DRIVER SIDE : Diagnosis Procedure20
POWER WINDOW SYSTEM10	DRIVER SIDE : Component Inspection21
System Diagram10	PASSENGER SIDE21
System Description10	PASSENGER SIDE : Description21
Component Parts Location12	PASSENGER SIDE : Component Function Check
Component Description1221
DIAGNOSIS SYSTEM (BCM)14	PASSENGER SIDE : Diagnosis Procedure21
COMMON ITEM14	PASSENGER SIDE : Component Inspection22
COMMON ITEM : CONSULT-III Function (BCM - COMMON ITEM)14	REAR LH23
RETAIND PWR15	REAR LH : Description23
RETAIND PWR : CONSULT-III Function (BCM - RETAINED PWR)15	REAR LH : Component Function Check23
DTC/CIRCUIT DIAGNOSIS16	REAR LH : Diagnosis Procedure23
	REAR LH : Component Inspection24
	REAR RH24
	REAR RH : Description24
	REAR RH : Component Function Check24
	REAR RH : Diagnosis Procedure24

REAR RH : Component Inspection	25	POWER WINDOW MAIN SWITCH	78
ENCODER	27	Reference Value	78
DRIVER SIDE	27	Wiring Diagram - POWER WINDOW CONTROL SYSTEM -	80
DRIVER SIDE : Description	27	Fail-safe	84
DRIVER SIDE : Component Function Check	27	FRONT POWER WINDOW SWITCH	86
DRIVER SIDE : Diagnosis Procedure	27	Reference Value	86
PASSENGER SIDE	29	Wiring Diagram - POWER WINDOW CONTROL SYSTEM -	88
PASSENGER SIDE : Description	29	Fail-safe	92
PASSENGER SIDE : Component Function Check	29	REAR POWER WINDOW SWITCH	94
PASSENGER SIDE : Diagnosis Procedure	29	Reference Value	94
REAR LH	31	Wiring Diagram - POWER WINDOW CONTROL SYSTEM -	96
REAR LH : Description	31	Fail-safe	100
REAR LH : Component Function Check	31	SYMPTOM DIAGNOSIS	102
REAR LH : Diagnosis Procedure	31	POWER WINDOWS DO NOT OPERATE WITH ANY POWER WINDOW SWITCHES	102
REAR RH	33	Diagnosis Procedure	102
REAR RH : Description	33	DRIVER SIDE POWER WINDOW ALONE DOES NOT OPERATE	103
REAR RH : Component Function Check	33	Diagnosis Procedure	103
REAR RH : Diagnosis Procedure	34	FRONT PASSENGER SIDE POWER WINDOW DOES NOT OPERATE	104
POWER WINDOW SERIAL LINK	36	WHEN POWER WINDOW MAIN SWITCH IS OPERATED	104
POWER WINDOW MAIN SWITCH	36	WHEN POWER WINDOW MAIN SWITCH IS OPERATED : Diagnosis Procedure	104
POWER WINDOW MAIN SWITCH : Description ...	36	WHEN FRONT POWER WINDOW SWITCH (PASSENGER SIDE) IS OPERATED	104
POWER WINDOW MAIN SWITCH : Component Function Check	36	WHEN FRONT POWER WINDOW SWITCH (PASSENGER SIDE) IS OPERATED : Diagnosis Procedure	104
POWER WINDOW MAIN SWITCH : Diagnosis Procedure	36	WHEN BOTH POWER WINDOW MAIN SWITCH AND FRONT POWER WINDOW SWITCH ARE OPERATED	104
FRONT POWER WINDOW SWITCH (PASSENGER SIDE)	37	WHEN BOTH POWER WINDOW MAIN SWITCH AND FRONT POWER WINDOW SWITCH ARE OPERATED : Diagnosis Procedure	104
FRONT POWER WINDOW SWITCH (PASSENGER SIDE) : Description	37	REAR LH SIDE POWER WINDOW ALONE DOES NOT OPERATE	105
FRONT POWER WINDOW SWITCH (PASSENGER SIDE) : Component Function Check	37	WHEN POWER WINDOW MAIN SWITCH IS OPERATED	105
FRONT POWER WINDOW SWITCH (PASSENGER SIDE) : Diagnosis Procedure	38	WHEN POWER WINDOW MAIN SWITCH IS OPERATED : Diagnosis Procedure	105
REAR LH	39	WHEN REAR POWER WINDOW SWITCH LH IS OPERATED	105
REAR LH : Description	39	WHEN REAR POWER WINDOW SWITCH LH IS OPERATED : Diagnosis Procedure	105
REAR LH : Component Function Check	39		
REAR LH : Diagnosis Procedure	39		
REAR RH	40		
REAR RH : Description	40		
REAR RH : Component Function Check	40		
REAR RH : Diagnosis Procedure	40		
ECU DIAGNOSIS INFORMATION	42		
BCM (BODY CONTROL MODULE)	42		
Reference Value	42		
Wiring Diagram - BCM -	66		
Fail-safe	71		
DTC Inspection Priority Chart	73		
DTC Index	75		

WHEN BOTH POWER WINDOW MAIN SWITCH AND REAR POWER WINDOW SWITCH LH ARE OPERATED	105	DOOR KEY CYLINDER SWITCH DOES NOT OPERATE POWER WINDOWS	112	A
WHEN BOTH POWER WINDOW MAIN SWITCH AND REAR POWER WINDOW SWITCH LH ARE OPERATED : Diagnosis Procedure	105	Diagnosis Procedure	112	
REAR RH SIDE POWER WINDOW ALONE DOES NOT OPERATE	106	KEYLESS POWER WINDOW DOWN DOES NOT OPERATE	113	B
WHEN POWER WINDOW MAIN SWITCH IS OPERATED	106	Description	113	
WHEN POWER WINDOW MAIN SWITCH IS OPERATED : Diagnosis Procedure	106	Diagnosis Procedure	113	C
WHEN REAR POWER WINDOW SWITCH RH IS OPERATED	106	POWER WINDOW LOCK SWITCH DOES NOT FUNCTION	114	D
WHEN REAR POWER WINDOW SWITCH RH IS OPERATED : Diagnosis Procedure	106	Diagnosis Procedure	114	
WHEN BOTH POWER WINDOW MAIN SWITCH AND REAR POWER WINDOW SWITCH RH ARE OPERATED	106	POWER WINDOW SWITCH ILLUMINATION DOES NOT ILLUMINATE	115	E
WHEN BOTH POWER WINDOW MAIN SWITCH AND REAR POWER WINDOW SWITCH RH ARE OPERATED : Diagnosis Procedure	106	DRIVER SIDE	115	
ANTI-PINCH FUNCTION DOES NOT OPERATE NORMALLY	107	DRIVER SIDE : Diagnosis Procedure	115	F
DRIVER SIDE	107	PASSENGER SIDE	115	
DRIVER SIDE : Diagnosis Procedure	107	PASSENGER SIDE : Diagnosis Procedure	115	G
PASSENGER SIDE	107	REAR LH	115	
PASSENGER SIDE : Diagnosis Procedure	107	REAR LH : Diagnosis Procedure	115	H
REAR LH	107	REAR RH	115	
REAR LH : Diagnosis Procedure	107	REAR RH : Diagnosis Procedure	115	I
REAR RH	107	PRECAUTION	116	J
REAR RH : Diagnosis Procedure	107	PRECAUTIONS	116	
AUTO OPERATION DOES NOT OPERATE BUT MANUAL OPERATES NORMALLY	109	Precaution for Supplemental Restraint System (SRS) "AIR BAG" and "SEAT BELT PRE-TENSIONER"	116	
DRIVER SIDE	109	REMOVAL AND INSTALLATION	117	
DRIVER SIDE : Diagnosis Procedure	109	POWER WINDOW MAIN SWITCH	117	PWC
PASSENGER SIDE	109	Removal and Installation	117	
PASSENGER SIDE : Diagnosis Procedure	109	FRONT WINDOW ANTI-PINCH		
REAR LH	109	BASIC INSPECTION	118	L
REAR LH : Diagnosis Procedure	110	DIAGNOSIS AND REPAIR WORK FLOW	118	
REAR RH	110	Work Flow	118	M
REAR RH : Diagnosis Procedure	110	INSPECTION AND ADJUSTMENT	119	
POWER WINDOW RETAINED POWER FUNCTION DOES NOT OPERATE NORMALLY	111	ADDITIONAL SERVICE WHEN REMOVING BATTERY NEGATIVE TERMINAL	119	N
Diagnosis Procedure	111	ADDITIONAL SERVICE WHEN REMOVING BATTERY NEGATIVE TERMINAL : Description ..	119	
		ADDITIONAL SERVICE WHEN REMOVING BATTERY NEGATIVE TERMINAL : Special Repair Requirement	119	O
		ADDITIONAL SERVICE WHEN REPLACING CONTROL UNIT	119	P
		ADDITIONAL SERVICE WHEN REPLACING CONTROL UNIT : Description	119	
		ADDITIONAL SERVICE WHEN REPLACING CONTROL UNIT : Special Repair Requirement ...	120	

SYSTEM DESCRIPTION	121	REAR LH : Component Inspection	137
POWER WINDOW SYSTEM	121	REAR RH	137
System Diagram	121	REAR RH : Description	137
System Description	121	REAR RH : Component Function Check	137
Component Parts Location	123	REAR RH : Diagnosis Procedure	137
Component Description	123	REAR RH : Component Inspection	138
DIAGNOSIS SYSTEM (BCM)	125	ENCODER	140
COMMON ITEM	125	DRIVER SIDE	140
COMMON ITEM : CONSULT-III Function (BCM - COMMON ITEM)	125	DRIVER SIDE : Description	140
RETAINED PWR	126	DRIVER SIDE : Component Function Check	140
RETAINED PWR : CONSULT-III Function (BCM - RETAINED PWR)	126	DRIVER SIDE : Diagnosis Procedure	140
DTC/CIRCUIT DIAGNOSIS	127	PASSENGER SIDE	142
POWER SUPPLY AND GROUND CIRCUIT ..	127	PASSENGER SIDE : Description	142
BCM	127	PASSENGER SIDE : Component Function Check	142
BCM : Diagnosis Procedure	127	PASSENGER SIDE : Diagnosis Procedure	142
POWER WINDOW MAIN SWITCH	127	POWER WINDOW SERIAL LINK	145
POWER WINDOW MAIN SWITCH : Diagnosis Procedure	127	POWER WINDOW MAIN SWITCH	145
FRONT POWER WINDOW SWITCH (PASSEN- GER SIDE)	128	POWER WINDOW MAIN SWITCH : Description .	145
FRONT POWER WINDOW SWITCH (PASSEN- GER SIDE) : Diagnosis Procedure	128	POWER WINDOW MAIN SWITCH : Component Function Check	145
REAR POWER WINDOW SWITCH	129	POWER WINDOW MAIN SWITCH : Diagnosis Procedure	145
REAR POWER WINDOW SWITCH : Diagnosis Procedure	129	FRONT POWER WINDOW SWITCH (PASSEN- GER SIDE)	146
REAR POWER WINDOW SWITCH	131	FRONT POWER WINDOW SWITCH (PASSEN- GER SIDE) : Description	146
Description	131	FRONT POWER WINDOW SWITCH (PASSEN- GER SIDE) : Component Function Check	146
Component Function Check	131	FRONT POWER WINDOW SWITCH (PASSEN- GER SIDE) : Diagnosis Procedure	147
Diagnosis Procedure	131	ECU DIAGNOSIS INFORMATION	148
Component Inspection	132	BCM (BODY CONTROL MODULE)	148
POWER WINDOW MOTOR	133	Reference Value	148
DRIVER SIDE	133	Wiring Diagram - BCM -	172
DRIVER SIDE : Description	133	Fail-safe	177
DRIVER SIDE : Component Function Check	133	DTC Inspection Priority Chart	179
DRIVER SIDE : Diagnosis Procedure	133	DTC Index	181
DRIVER SIDE : Component Inspection	134	POWER WINDOW MAIN SWITCH	184
PASSENGER SIDE	134	Reference Value	184
PASSENGER SIDE : Description	134	Wiring Diagram - POWER WINDOW CONTROL SYSTEM -	186
PASSENGER SIDE : Component Function Check	134	Fail-safe	191
PASSENGER SIDE : Diagnosis Procedure	134	FRONT POWER WINDOW SWITCH	193
PASSENGER SIDE : Component Inspection	135	Reference Value	193
REAR LH	136	Wiring Diagram - POWER WINDOW CONTROL SYSTEM -	195
REAR LH : Description	136	Fail-safe	200
REAR LH : Component Function Check	136	SYMPTOM DIAGNOSIS	202
REAR LH : Diagnosis Procedure	136		

POWER WINDOWS DO NOT OPERATE WITH ANY POWER WINDOW SWITCHES 202		
Diagnosis Procedure	202	
DRIVER SIDE POWER WINDOW ALONE DOES NOT OPERATE	203	
Diagnosis Procedure	203	
FRONT PASSENGER SIDE POWER WINDOW DOES NOT OPERATE	204	
WHEN POWER WINDOW MAIN SWITCH IS OPERATED	204	
WHEN POWER WINDOW MAIN SWITCH IS OPERATED : Diagnosis Procedure	204	
WHEN FRONT POWER WINDOW SWITCH (PASSENGER SIDE) IS OPERATED	204	
WHEN FRONT POWER WINDOW SWITCH (PASSENGER SIDE) IS OPERATED : Diagnosis Procedure	204	
WHEN BOTH POWER WINDOW MAIN SWITCH AND FRONT POWER WINDOW SWITCH ARE OPERATED	204	
WHEN BOTH POWER WINDOW MAIN SWITCH AND FRONT POWER WINDOW SWITCH ARE OPERATED : Diagnosis Procedure	204	
REAR LH SIDE POWER WINDOW ALONE DOES NOT OPERATE	206	
WHEN POWER WINDOW MAIN SWITCH IS OPERATED	206	
WHEN POWER WINDOW MAIN SWITCH IS OPERATED : Diagnosis Procedure	206	
WHEN REAR POWER WINDOW SWITCH LH IS OPERATED	206	
WHEN REAR POWER WINDOW SWITCH LH IS OPERATED : Diagnosis Procedure	206	
WHEN BOTH POWER WINDOW MAIN SWITCH AND REAR POWER WINDOW SWITCH LH ARE OPERATED	206	
WHEN BOTH POWER WINDOW MAIN SWITCH AND REAR POWER WINDOW SWITCH LH ARE OPERATED : Diagnosis Procedure	206	
REAR RH SIDE POWER WINDOW ALONE DOES NOT OPERATE	207	
WHEN POWER WINDOW MAIN SWITCH IS OPERATED	207	
WHEN POWER WINDOW MAIN SWITCH IS OPERATED : Diagnosis Procedure	207	
WHEN REAR POWER WINDOW SWITCH RH IS OPERATED	207	
WHEN REAR POWER WINDOW SWITCH RH IS OPERATED : Diagnosis Procedure	207	
WHEN BOTH POWER WINDOW MAIN SWITCH AND REAR POWER WINDOW SWITCH RH ARE OPERATED	207	
WHEN BOTH POWER WINDOW MAIN SWITCH AND REAR POWER WINDOW SWITCH RH ARE OPERATED : Diagnosis Procedure	207	
ANTI-PINCH FUNCTION DOES NOT OPERATE NORMALLY	208	
DRIVER SIDE	208	
DRIVER SIDE : Diagnosis Procedure	208	
PASSENGER SIDE	208	
PASSENGER SIDE : Diagnosis Procedure	208	
AUTO OPERATION DOES NOT OPERATE BUT MANUAL OPERATES NORMALLY	209	
DRIVER SIDE	209	
DRIVER SIDE : Diagnosis Procedure	209	
PASSENGER SIDE	209	
PASSENGER SIDE : Diagnosis Procedure	209	
POWER WINDOW RETAINED POWER FUNCTION DOES NOT OPERATE NORMALLY	210	
Diagnosis Procedure	210	
DOOR KEY CYLINDER SWITCH DOES NOT OPERATE POWER WINDOWS	211	
Diagnosis Procedure	211	
KEYLESS POWER WINDOW DOWN DOES NOT OPERATE	212	
Description	212	
Diagnosis Procedure	212	
POWER WINDOW LOCK SWITCH DOES NOT FUNCTION	213	
Diagnosis Procedure	213	
POWER WINDOW SWITCH ILLUMINATION DOES NOT ILLUMINATE	214	
DRIVER SIDE	214	
DRIVER SIDE : Diagnosis Procedure	214	
PASSENGER SIDE	214	
PASSENGER SIDE : Diagnosis Procedure	214	
REAR LH	214	
REAR LH : Diagnosis Procedure	214	
REAR RH	214	
REAR RH : Diagnosis Procedure	214	
PRECAUTION	215	
PRECAUTIONS	215	

PWC

Precaution for Supplemental Restraint System (SRS) "AIR BAG" and "SEAT BELT PRE-TENSIONER"	215
--	-----

REMOVAL AND INSTALLATION	216
POWER WINDOW MAIN SWITCH	216
Removal and Installation	216

DIAGNOSIS AND REPAIR WORK FLOW

< BASIC INSPECTION >

[FRONT & REAR WINDOW ANTI-PINCH]

BASIC INSPECTION

DIAGNOSIS AND REPAIR WORK FLOW

Work Flow

INFOID:000000004240580

DETAILED FLOW

1.OBTAIN INFORMATION ABOUT SYMPTOM

Interview the customer to obtain the malfunction information (conditions and environment when the malfunction occurred) as much as possible when the customer brings the vehicle in.

>> GO TO 2.

2.REPRODUCE THE MALFUNCTION INFORMATION

Check the malfunction on the vehicle that the customer describes.
Inspect the relation of the symptoms and the condition when the symptoms occur.

>> GO TO 3.

3.IDENTIFY THE MALFUNCTIONING SYSTEM WITH "SYMPTOM DIAGNOSIS"

Use "Symptom diagnosis" from the symptom inspection result in step 2. Then identify where to start performing the diagnosis based on possible causes and symptoms.

>> GO TO 4.

4.IDENTIFY MALFUNCTIONING PARTS WITH "COMPONENT DIAGNOSIS"

Perform the diagnosis with "Component diagnosis" of the applicable system.

>> GO TO 5.

5.REPAIR OR REPLACE THE MALFUNCTIONING PARTS

Repair or replace the specified malfunctioning parts.

>> GO TO 6.

6.FINAL CHECK

Check that malfunctions are not reproduced when obtaining the malfunction information from the customer, referring to the symptom inspection result in step 2.

Is the malfunctioning part repaired or replaced?

YES >> Trouble diagnosis is completed.

NO >> GO TO 3.

A
B
C
D
E
F
G
H
I
J
PWC
L
M
N
O
P

INSPECTION AND ADJUSTMENT

< BASIC INSPECTION >

[FRONT & REAR WINDOW ANTI-PINCH]

INSPECTION AND ADJUSTMENT

ADDITIONAL SERVICE WHEN REMOVING BATTERY NEGATIVE TERMINAL

ADDITIONAL SERVICE WHEN REMOVING BATTERY NEGATIVE TERMINAL : Description

INFOID:000000004637319

When battery negative terminal is disconnected, initialization is necessary.

If any of the following operations are performed, initialization is necessary as well as when battery negative terminal is disconnected.

- Power supply to the power window control unit is cut off by the removal of battery terminal or the battery fuse is blown.
- Disconnection and connection of power window control unit harness connector.
- Removal and installation of motor from regulator assembly.
- Operation of regulator assembly as an independent unit.
- Removal and installation of rear power window control unit.
- Removal and installation of door glass.
- Removal and installation of door glass run.

The operations as per the following cannot be performed while initialization is not complete.

- AUTO-UP operation
- Anti-pinch function
- Door key cylinder power window function

ADDITIONAL SERVICE WHEN REMOVING BATTERY NEGATIVE TERMINAL : Special Repair Requirement

INFOID:000000004637320

INITIALIZATION PROCEDURE

1. Disconnect battery negative terminal or power window control unit connector. Reconnect it after a minute or more.
2. Turn ignition switch ON.
3. Operate power window switch to fully open door glass. (This operation is unnecessary if door glass is already fully open.)
4. Pull and hold power window switch UP (AUTO-UP operation). Even after door glass stops at the fully closed position, pull the switch for 2 seconds or more.
5. Initialization procedure is complete.
6. Inspect anti-pinch function.

CHECK ANTI-PINCH FUNCTION

1. Fully open door glass.
 2. Place a piece of wood near the fully closed position.
 3. Close door glass completely using AUTO-UP.
- Check that door glass lowers approximately 150 mm (5.9 in) without pinching piece of wood and stops.
 - Check that door glass does not rise when operating power window main switch while lowering.

CAUTION:

- Perform initialization when AUTO-UP operation or anti-pinch function does not operate normally.
- Check that AUTO-UP operates before inspection when initialization is performed.
- Never check with hands or other body parts because they may be pinched. Never get pinched.
- It may switch to the fail-safe mode if open/close operation is performed continuously without fully closing door glass. Perform initialization in the above situation. Refer to [PWC-84, "Fail-safe"](#).
- Finish initialization. Otherwise, the next operation cannot be done.

1. AUTO-UP operation
2. Anti-pinch function
3. Door key cylinder power window function

ADDITIONAL SERVICE WHEN REPLACING CONTROL UNIT

ADDITIONAL SERVICE WHEN REPLACING CONTROL UNIT : Description

INFOID:000000004637321

When the control unit is replaced, initialization is necessary.

If any of the following operations are performed, initialization is necessary as well as when the control unit is disconnected.

INSPECTION AND ADJUSTMENT

[FRONT & REAR WINDOW ANTI-PINCH]

< BASIC INSPECTION >

- Power supply to the power window control unit is cut off by the removal of battery terminal or the battery fuse is blown.
- Disconnection and connection of power window control unit harness connector.
- Removal and installation of motor from regulator assembly.
- Disconnection and connection of battery negative terminal.
- Removal and installation of rear power window control unit.
- Removal and installation of door glass.
- Removal and installation of door glass run.

The following specified operations cannot be performed while initialization is not complete.

- AUTO-UP operation
- Anti-pinch function
- Door key cylinder power window function

ADDITIONAL SERVICE WHEN REPLACING CONTROL UNIT : Special Repair Requirement

INFOID:000000004637322

INITIALIZATION PROCEDURE

1. Disconnect battery negative terminal or power window control unit connector. Reconnect it after a minute or more.
2. Turn ignition switch ON.
3. Operate power window switch to fully open door glass. (This operation is unnecessary if door glass is already fully open.)
4. Pull and hold power window switch UP (AUTO-UP operation). Even after door glass stops at the fully closed position, pull the switch for 2 seconds or more.
5. Initialization procedure is complete.
6. Inspect anti-pinch function.

CHECK ANTI-PINCH FUNCTION

1. Fully open door glass.
 2. Place a piece of wood near the fully closed position.
 3. Close door glass completely using AUTO-UP.
- Check that door glass lowers approximately 150 mm (5.9 in) without pinching piece of wood and stops.
 - Check that door glass does not rise when operating power window main switch while lowering.

CAUTION:

- **Perform initialization when AUTO-UP operation or anti-pinch function does not operate normally.**
 - **Check that AUTO-UP operates before inspection when initialization is performed.**
 - **Never check with hands or other body parts because they may be pinched. Never get pinched.**
 - **It may switch to the fail-safe mode if open/close operation is performed continuously without fully closing. Perform initialization in the above situation. Refer to [PWC-84, "Fail-safe"](#).**
 - **Finish initialization. Otherwise, the next operation cannot be done.**
1. AUTO-UP operation
 2. Anti-pinch function
 3. Door key cylinder power window function

A
B
C
D
E
F
G
H
I
J
L
M
N
O
P

PWC

POWER WINDOW SYSTEM

< SYSTEM DESCRIPTION >

[FRONT & REAR WINDOW ANTI-PINCH]

SYSTEM DESCRIPTION

POWER WINDOW SYSTEM

System Diagram

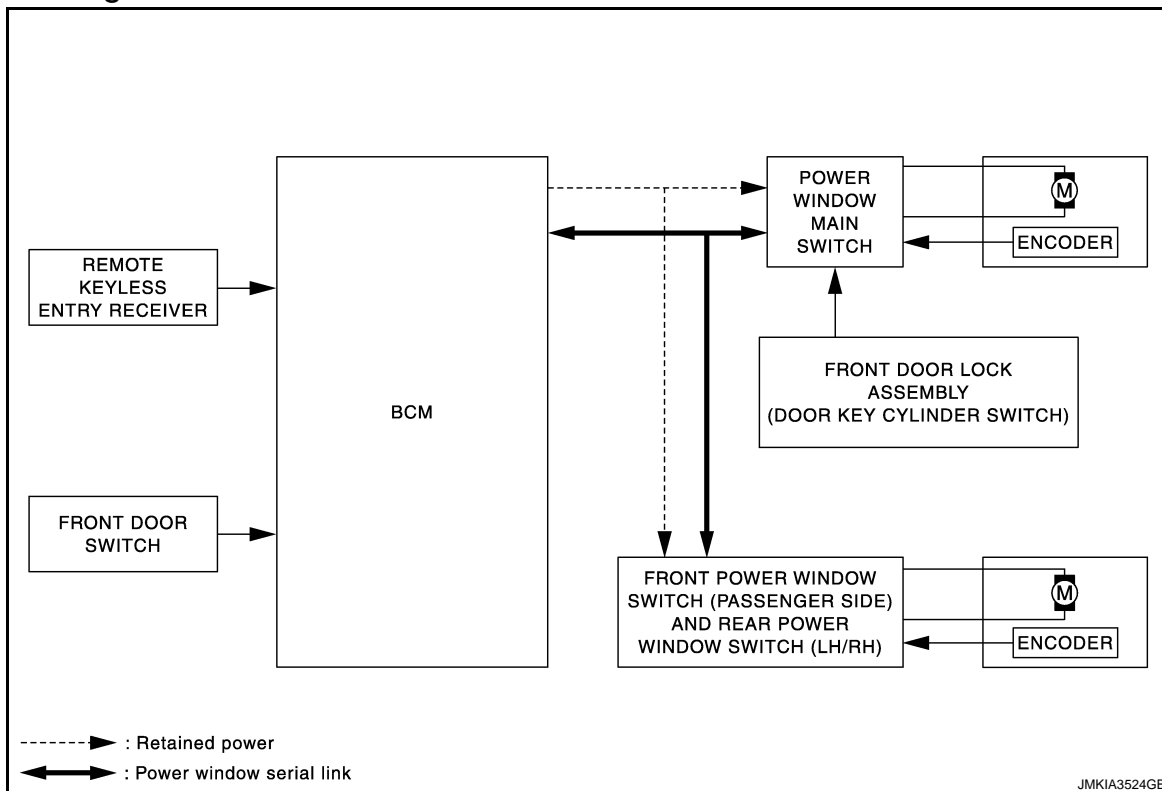

System Description

INFOID:000000004595168

POWER WINDOW SYSTEM

- Power window system is operable during the retained power operation timer after turning ignition switch OFF.
- Power window main switch can open/close door glass.
- Front and rear power window switch can open/close the corresponding door glass.
- AUTO UP/DOWN operation can be performed when front power window switch turns to AUTO.
- Power window serial link transmits the signals from power window main switch to each module.
- Power window lock switch can lock all power windows other than driver seat.
- If door glass receives resistance that is the specified value or more while power window of each seat is in AUTO-UP operation, power window of each seat operates in the reverse direction.
- Hold the door key cylinder to the LOCK or UNLOCK direction for 1 second or more to OPEN or CLOSE all power windows when ignition switch OFF.
- All power windows open when pressing Intelligent Key unlock button for 3 seconds.

POWER WINDOW AUTO-OPERATION

- AUTO UP/DOWN operation can be performed when each power window motor turns to AUTO.
- Encoder continues detecting the movement of power window motor and transmits to power window switch as the encoder pulse signal while power window motor is operating.
- Power window switch reads the changes of encoder signal and stops AUTO operation when door glass is at fully opened/closed position.
- Power window motor is operable in case encoder is malfunctioning.

RETAINED POWER OPERATION

Retained power operation is an additional power supply function that enables power window system to operate for 45 seconds after ignition switch turns OFF.

RETAINED POWER FUNCTION CANCEL CONDITIONS

POWER WINDOW SYSTEM

[FRONT & REAR WINDOW ANTI-PINCH]

< SYSTEM DESCRIPTION >

- Front door CLOSE (door switch OFF) → OPEN (door switch ON).
- When ignition switch turns ON again.
- When timer times out. (45 seconds)

POWER WINDOW LOCK FUNCTION

Ground circuit inside power window main switch shuts off when power window lock switch is ON. This inhibits power window switch operation except with the power window main switch.

POWER WINDOW SERIAL LINK

- All power window switches and BCM transmit and receive the power window serial link.
- Power window serial link transmits the power window main switch operation signals and IGN signal to power window main switch module, front power window switch (passenger side) module, and rear power window switches.

ANTI-PINCH OPERATION

- Pinch the foreign matter in the door glass during AUTO-UP operation is the anti-pinch function that lowers the door glass 150 mm (5.9 in) when detected.
- Encoder continues detecting the movement of power window motor and transmits to power window switch as the encoder pulse signal while power window motor is operating.
- Resistance is applied to the power window motor rotation that changes the frequency of encoder pulse signal if foreign material is trapped in the door glass.
- Power window switch controls to lower the door glass for 150 mm (5.9 in) after it detects encoder pulse signal frequency change.

OPERATION CONDITION

- When all door glass AUTO-UP operation is performed (anti-pinch function does not operate just before the door glass closes and is fully closed)

NOTE:

Depending on environment and driving conditions, if a similar impact or load is applied to the door glass, it may lower.

DOOR KEY CYLINDER SWITCH POWER WINDOW FUNCTION

Hold the door key cylinder to the LOCK or UNLOCK direction for 1.5 seconds or more to OPEN or CLOSE all power windows when ignition switch is OFF. In addition, it stops when key position is moved to NEUTRAL when operating.

OPERATION CONDITION

- Ignition switch OFF.
- Hold door key cylinder to LOCK position for 1.5 seconds or more to perform CLOSE operation of the door glass.
- Hold door key cylinder to UNLOCK position for 1.5 seconds or more to perform OPEN operation of the door glass.

KEYLESS POWER WINDOW DOWN FUNCTION

All power windows open when the unlock button on Intelligent Key is activated and kept pressed for more than 3* seconds with the ignition switch OFF. The windows keep opening if the unlock button is continuously pressed.

The power window opening stops when the following operations are performed.

- When the unlock button is kept pressed more than 15 seconds.
- When the ignition switch is turned ON while the power window opening is operated.
- When the unlock button is released.

While retained power operation activate, keyless power window down function cannot be operated.

Keyless power window down operation mode can be changed by "PW DOWN SET" mode in "WORK SUPPORT". Refer to [DLK-52, "INTELLIGENT KEY : CONSULT-III Function \(BCM - INTELLIGENT KEY\)".](#)

NOTE:

Use CONSULT-III to change settings.

MODE 1 (3 sec) / MODE 2 (OFF) / MODE 3 (5 sec)

A
B
C
D
E
F
G
H
I
J
L
M
N
O
P

PWC

POWER WINDOW SYSTEM

[FRONT & REAR WINDOW ANTI-PINCH]

< SYSTEM DESCRIPTION >

Component Parts Location

INFOID:000000004240587

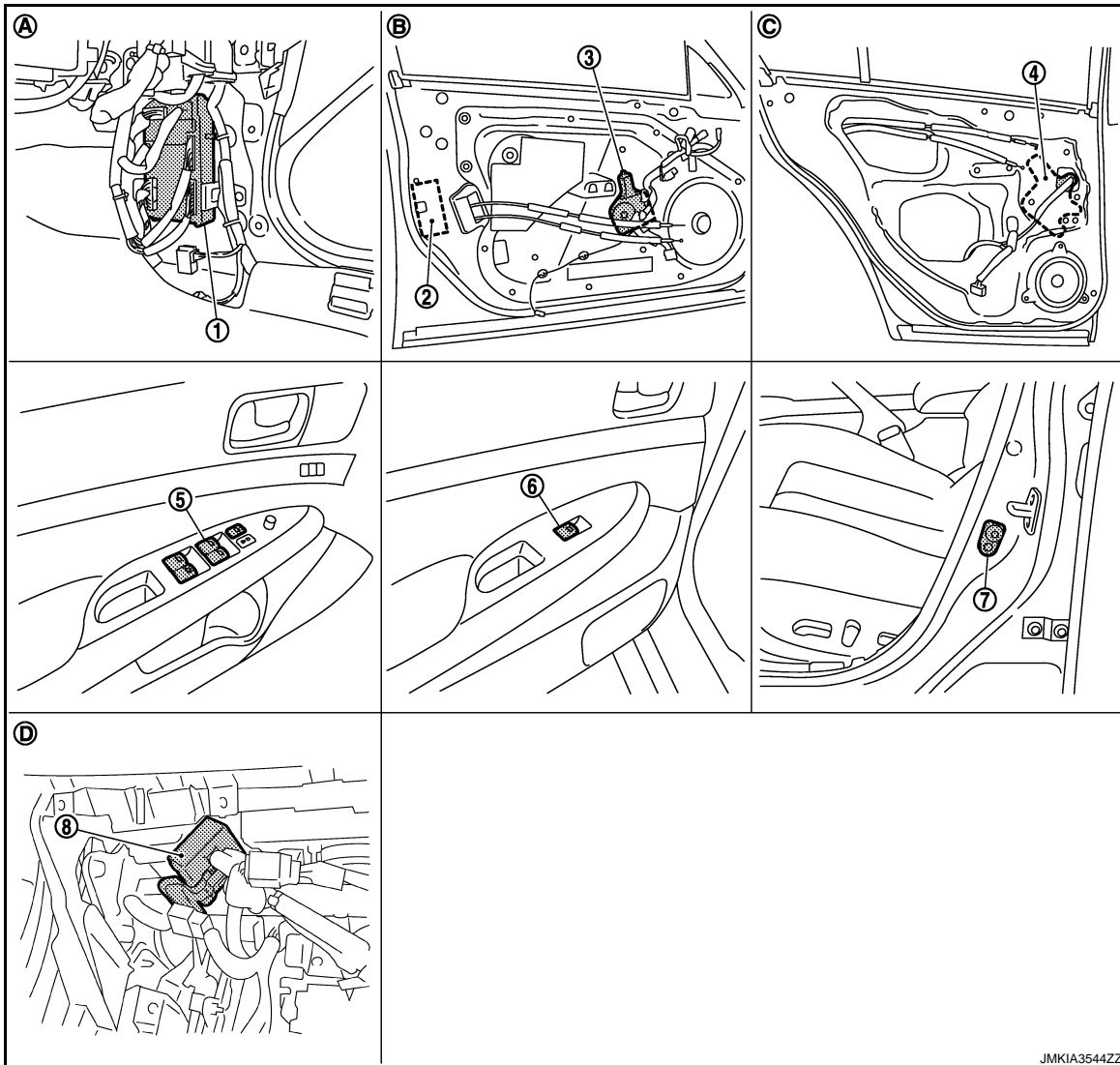

JMKIA3544ZZ

- | | | |
|--|--|---|
| 1. BCM M118,M119,M122,M123 | 2. Front door lock assembly (driver side) (door key cylinder switch) D15 | 3. Front power window motor (driver side) D10 |
| 4. Rear power window motor LH D52 | 5. Power window main switch D8,D9 | 6. Rear power window switch LH D57 |
| 7. Front door switch (driver side) B16 | 8. Remote keyless entry receiver M104 | |
| A. View with dash side lower (passenger side) | B. View with front door finisher removed | C. View with rear door finisher removed |
| D. View with instrument lower panel (passenger side) removed | | |

Component Description

INFOID:000000004240588

Component	Function
BCM	<ul style="list-style-type: none"> Supplies power supply to power window switch. Controls retained power function.
Power window main switch	<ul style="list-style-type: none"> Directly controls all power window motor of all doors. Controls anti-pinch operation of power window.
Front power window switch	<ul style="list-style-type: none"> Controls anti-pinch operation of power window. Controls power window motor of passenger door.

POWER WINDOW SYSTEM

[FRONT & REAR WINDOW ANTI-PINCH]

< SYSTEM DESCRIPTION >

Component	Function
Rear power window switch	<ul style="list-style-type: none">• Controls anti-pinch operation of power window.• Controls power window motor of rear right and left doors.
Power window motor	<ul style="list-style-type: none">• Integrates the ENCODER and WINDOW MOTOR.• Starts operating with signals from each power window switch.• Transmits power window motor rotation as a pulse signal to power window switch.
Front door lock assembly (door key cylinder switch)	Transmits operation condition of key cylinder switch to power window main switch.
Front door switch	Detects door open/close condition and transmits to BCM.
Remote keyless entry receiver	Receives lock/unlock signal from the intelligent Key, and then transmits to BCM.

A

B

C

D

E

F

G

H

I

J

PWC

L

M

N

O

P

DIAGNOSIS SYSTEM (BCM)

[FRONT & REAR WINDOW ANTI-PINCH]

< SYSTEM DESCRIPTION >

DIAGNOSIS SYSTEM (BCM)

COMMON ITEM

COMMON ITEM : CONSULT-III Function (BCM - COMMON ITEM)

INFOID:000000004667405

APPLICATION ITEM

CONSULT-III performs the following functions via CAN communication with BCM.

Diagnosis mode	Function Description
Work Support	Changes the setting for each system function.
Self Diagnostic Result	Displays the diagnosis results judged by BCM.
CAN Diag Support Monitor	Monitors the reception status of CAN communication viewed from BCM. Refer to CONSULT-III operation manual.
Data Monitor	The BCM input/output signals are displayed.
Active Test	The signals used to activate each device are forcibly supplied from BCM.
Ecu Identification	The BCM part number is displayed.
Configuration	This function is not used even though it is displayed.

SYSTEM APPLICATION

BCM can perform the following functions for each system.

NOTE:

It can perform the diagnosis modes except the following for all sub system selection items.

×: Applicable item

System	Sub system selection item	Diagnosis mode		
		Work Support	Data Monitor	Active Test
Door lock	DOOR LOCK	×	×	×
Rear window defogger	REAR DEFOGGER		×	×
Warning chime	BUZZER		×	×
Interior room lamp timer	INT LAMP	×	×	×
Exterior lamp	HEAD LAMP	×	×	×
Wiper and washer	WIPER	×	×	×
Turn signal and hazard warning lamps	FLASHER	×	×	×
—	AIR CONDITONER*			
<ul style="list-style-type: none"> • Intelligent Key system • Engine start system 	INTELLIGENT KEY	×	×	×
Combination switch	COMB SW		×	
Body control system	BCM	×		
IVIS - NATS	IMMU		×	×
Interior room lamp battery saver	BATTERY SAVER	×	×	×
Trunk lid open	TRUNK		×	×
Vehicle security system	THEFT ALM	×	×	×
RAP system	RETAINED PWR		×	
Signal buffer system	SIGNAL BUFFER		×	×
TPMS	TPMS (AIR PRESSURE MONITOR)	×	×	×

NOTE:

*: This item is displayed, but is not used.

FREEZE FRAME DATA (FFD)

The BCM records the following vehicle condition at the time a particular DTC is detected, and displays on CONSULT-III.

DIAGNOSIS SYSTEM (BCM)

[FRONT & REAR WINDOW ANTI-PINCH]

< SYSTEM DESCRIPTION >

CONSULT screen item	Indication/Unit	Description	
Vehicle Speed	km/h	Vehicle speed of the moment a particular DTC is detected	
Odo/Trip Meter	km	Total mileage (Odometer value) of the moment a particular DTC is detected	
Vehicle Condition	SLEEP>LOCK	Power position status of the moment a particular DTC is detected	While turning BCM status from low power consumption mode to normal mode (Power supply position is "LOCK")
	SLEEP>OFF		While turning BCM status from low power consumption mode to normal mode (Power supply position is "OFF".)
	LOCK>ACC		While turning power supply position from "LOCK" to "ACC"
	ACC>ON		While turning power supply position from "ACC" to "IGN"
	RUN>ACC		While turning power supply position from "RUN" to "ACC" (Vehicle is stopping and selector lever is except P position.)
	CRANK>RUN		While turning power supply position from "CRANKING" to "RUN" (From cranking up the engine to run it)
	RUN>URGENT		While turning power supply position from "RUN" to "ACC" (Emergency stop operation)
	ACC>OFF		While turning power supply position from "ACC" to "OFF"
	OFF>LOCK		While turning power supply position from "OFF" to "LOCK"
	OFF>ACC		While turning power supply position from "OFF" to "ACC"
	ON>CRANK		While turning power supply position from "IGN" to "CRANKING"
	OFF>SLEEP		While turning BCM status from normal mode (Power supply position is "OFF".) to low power consumption mode
	LOCK>SLEEP		While turning BCM status from normal mode (Power supply position is "LOCK".) to low power consumption mode
	LOCK		Power supply position is "LOCK" (Ignition switch OFF with steering is locked.)
	OFF		Power supply position is "OFF" (Ignition switch OFF with steering is unlocked.)
	ACC		Power supply position is "ACC" (Ignition switch ACC)
ON	Power supply position is "IGN" (Ignition switch ON with engine stopped)		
ENGINE RUN	Power supply position is "RUN" (Ignition switch ON with engine running)		
CRANKING	Power supply position is "CRANKING" (At engine cranking)		
IGN Counter	0 - 39	The number of times that ignition switch is turned ON after DTC is detected <ul style="list-style-type: none"> • The number is 0 when a malfunction is detected now. • The number increases like 1 → 2 → 3...38 → 39 after returning to the normal condition whenever ignition switch OFF → ON. • The number is fixed to 39 until the self-diagnosis results are erased if it is over 39. 	

RETAINED PWR

RETAINED PWR : CONSULT-III Function (BCM - RETAINED PWR)

INFOID:0000000004240590

Data monitor

Monitor Item	Description
DOOR SW-DR	Indicates [ON/OFF] condition of driver side door switch.
DOOR SW-AS	Indicates [ON/OFF] condition of passenger side door switch.

POWER SUPPLY AND GROUND CIRCUIT

< DTC/CIRCUIT DIAGNOSIS >

[FRONT & REAR WINDOW ANTI-PINCH]

DTC/CIRCUIT DIAGNOSIS

POWER SUPPLY AND GROUND CIRCUIT

BCM

BCM : Diagnosis Procedure

INFOID:000000004240591

1. CHECK FUSE AND FUSIBLE LINK

Check that the following fuse and fusible link are not blown.

Terminal No.	Signal name	Fuse and fusible link No.
1	Battery power supply	K (40 A)
11		10 (10A)

Is the fuse fusing?

YES >> Replace the blown fuse or fusible link after repairing the affected circuit if a fuse or fusible link is blown.

NO >> GO TO 2.

2. CHECK POWER SUPPLY CIRCUIT

1. Turn ignition switch OFF.
2. Disconnect BCM connectors.
3. Check voltage between BCM harness connector and ground.

(+)		(-)	Voltage (Approx.)
BCM			
Connector	Terminal	Ground	Battery voltage
M118	1		
M119	11		

Is the measurement value normal?

YES >> GO TO 3.

NO >> Repair harness or connector.

3. CHECK GROUND CIRCUIT

Check continuity between BCM harness connector and ground.

BCM		Ground	Continuity
Connector	Terminal		
M119	13		Existed

Does continuity exist?

YES >> INSPECTION END

NO >> Repair harness or connector.

POWER WINDOW MAIN SWITCH

POWER WINDOW MAIN SWITCH : Diagnosis Procedure

INFOID:000000004240592

1. CHECK POWER SUPPLY CIRCUIT 1

1. Turn ignition switch OFF.
2. Disconnect power window main switch connectors.
3. Turn ignition switch ON.
4. Check voltage between power window main switch harness connector and ground.

POWER SUPPLY AND GROUND CIRCUIT

< DTC/CIRCUIT DIAGNOSIS >

[FRONT & REAR WINDOW ANTI-PINCH]

(+)		(-)	Voltage (V) (Approx.)
Power window main switch			
Connector	Terminal	Ground	Battery voltage
D8	10		
D9	19		

Is the measurement value within the specification?

YES >> GO TO 3.

NO >> GO TO 2.

2. CHECK POWER SUPPLY CIRCUIT 2

1. Turn ignition switch OFF.
2. Disconnect BCM connector.
3. Check continuity between BCM harness connector and power window main switch harness connector.

BCM		Power window main switch		Continuity
Connector	Terminal	Connector	Terminal	
M118	2	D9	19	Existed
	3	D8	10	

4. Check continuity between BCM harness connector and ground.

BCM		Ground	Continuity
Connector	Terminal		
M118	2		Not existed
	3		

Is the inspection result normal?

YES >> Replace BCM. Refer to [BCS-82, "Exploded View"](#).

NO >> Repair or replace harness.

3. CHECK GROUND CIRCUIT

1. Turn ignition switch OFF.
2. Check continuity between power window main switch harness connector and ground.

Power window main switch		Ground	Continuity
Connector	Terminal		
D9	17		Existed

Is the inspection result normal?

YES >> INSPECTION END

NO >> Repair or replace harness.

FRONT POWER WINDOW SWITCH (PASSENGER SIDE)

FRONT POWER WINDOW SWITCH (PASSENGER SIDE) : Diagnosis Procedure

INFOID:000000004240593

1. CHECK POWER SUPPLY CIRCUIT 1

1. Turn ignition switch OFF.
2. Disconnect front power window switch (passenger side) connector.
3. Check voltage between front power window switch (passenger side) harness connector and ground.

POWER SUPPLY AND GROUND CIRCUIT

< DTC/CIRCUIT DIAGNOSIS >

[FRONT & REAR WINDOW ANTI-PINCH]

(+)		(-)	Voltage (V) (Approx.)
Front power window switch (passenger side)			
Connector	Terminal	Ground	Battery voltage
D38	10		

Is the measurement value within the specification?

YES >> GO TO 3.

NO >> GO TO 2.

2. CHECK POWER SUPPLY CIRCUIT 2

1. Disconnect BCM connector.
2. Check continuity between BCM harness connector and front power window switch (passenger side) harness connector.

BCM		Front power window switch (passenger side)		Continuity
Connector	Terminal	Connector	Terminal	
M118	2	D38	10	Existed

3. Check continuity between BCM harness connector and ground.

BCM		Ground	Continuity
Connector	Terminal		
M118	2		Not existed

Is the inspection result normal?

YES >> Replace BCM. Refer to [BCS-82, "Exploded View"](#).

NO >> Repair or replace harness.

3. CHECK GROUND CIRCUIT

Check continuity between front power window switch (passenger side) harness connector and ground.

Front power window switch (passenger side)		Ground	Continuity
Connector	Terminal		
D38	11		Existed

Is the inspection result normal?

YES >> INSPECTION END

NO >> Repair or replace harness.

REAR POWER WINDOW SWITCH

REAR POWER WINDOW SWITCH : Diagnosis Procedure

INFOID:000000004240594

1. CHECK POWER SUPPLY CIRCUIT 1

1. Turn ignition switch OFF.
2. Disconnect rear power window switch LH connector or power window switch RH connector.
3. Turn ignition switch ON.
4. Check voltage between rear power window switch harness connector and ground.

(+)		(-)	Voltage (V) (Approx.)
Rear power window switch			
Connector	Terminal	Ground	Battery voltage
LH	D57		
RH	D77		

POWER SUPPLY AND GROUND CIRCUIT

[FRONT & REAR WINDOW ANTI-PINCH]

< DTC/CIRCUIT DIAGNOSIS >

Is the measurement value within the specification?

YES >> GO TO 3.

NO >> GO TO 2.

2. CHECK POWER SUPPLY CIRCUIT 2

1. Turn ignition switch OFF.
2. Disconnect BCM connector.
3. Check continuity between BCM harness connector and rear power window switch harness connector.

BCM		Rear power window switch		Continuity
Connector	Terminal	Connector	Terminal	
M118	2	LH	D57	Existed
		RH	D77	

4. Check continuity between BCM harness connector and ground.

BCM		Ground	Continuity
Connector	Terminal		
M118	2		Not existed

Is the inspection result normal?

YES >> Replace BCM. Refer to [BCS-82. "Exploded View"](#).

NO >> Repair or replace harness.

3. CHECK GROUND CIRCUIT

1. Turn ignition switch OFF.
2. Check continuity between rear power window switch harness connector and ground.

Rear power window switch		Ground	Continuity
Connector	Terminal		
LH	D57	11	Existed
RH	D77		

Is the inspection result normal?

YES >> INSPECTION END

NO >> Repair or replace harness.

A
B
C
D
E
F
G
H
I
J
L
M
N
O
P

PWC

POWER WINDOW MOTOR

[FRONT & REAR WINDOW ANTI-PINCH]

< DTC/CIRCUIT DIAGNOSIS >

POWER WINDOW MOTOR

DRIVER SIDE

DRIVER SIDE : Description

INFOID:000000004240595

Door glass moves UP/DOWN by receiving the signal from power window main switch.

DRIVER SIDE : Component Function Check

INFOID:000000004240596

1.CHECK POWER WINDOW MOTOR (DRIVER SIDE) OPERATION

Check front power window motor (driver side) operation with power window main switch.

Is the inspection result normal?

YES >> Power window motor (driver side) is OK.

NO >> Refer to [PWC-20. "DRIVER SIDE : Diagnosis Procedure"](#).

DRIVER SIDE : Diagnosis Procedure

INFOID:000000004240597

1.CHECK FRONT POWER WINDOW MOTOR INPUT SIGNAL

1. Turn ignition switch OFF.
2. Disconnect front power window motor (driver side) connector.
3. Turn ignition switch ON.
4. Check voltage between front power window motor (driver side) harness connector and ground.

(+)		(-)	Condition	Voltage (V) (Approx.)	
Connector	Terminal				
D10	2	Ground	Power window main switch	UP	Battery voltage
				DOWN	0
	1		UP	0	
			DOWN	Battery voltage	

Is the measurement value within the specification?

YES >> GO TO 3.

NO >> GO TO 2.

2.CHECK POWER WINDOW MOTOR CIRCUIT

1. Turn ignition switch OFF.
2. Disconnect power window main switch connector.
3. Check continuity between power window main switch harness connector and front power window motor (driver side) harness connector.

Power window main switch		Front power window motor (driver side)		Continuity
Connector	Terminal	Connector	Terminal	
D8	8	D10	2	Existed
	11		1	

4. Check continuity between power window main switch harness connector and ground.

Power window main switch		Ground	Continuity
Connector	Terminal		
D8	8		Not existed
	11		

Is the inspection result normal?

YES >> Replace power window main switch. Refer to [PWC-117. "Removal and Installation"](#).

POWER WINDOW MOTOR

[FRONT & REAR WINDOW ANTI-PINCH]

< DTC/CIRCUIT DIAGNOSIS >

NO >> Repair or replace harness.

3.CHECK POWER WINDOW MOTOR

Check front power window motor (driver side).

Refer to [PWC-21, "DRIVER SIDE : Component Inspection"](#).

Is the inspection result normal?

YES >> GO TO 4.

NO >> Replace front power window motor (driver side). Refer to [GW-16, "Removal and Installation"](#).

4.CHECK INTERMITTENT INCIDENT

Refer to [GI-41, "Intermittent Incident"](#).

>> INSPECTION END

DRIVER SIDE : Component Inspection

INFOID:000000004240598

1.CHECK POWER WINDOW MOTOR (DRIVER SIDE)

1. Turn ignition switch OFF.
2. Disconnect front power window motor (driver side) connector.
3. Check motor operation by connecting the battery voltage directly to front power window motor (driver side) connector.

Front power window motor (driver side) connector	Terminal		Motor operation
	(+)	(-)	
D10	1	2	DOWN
	2	1	UP

Is the inspection result normal?

YES >> Driver side power window motor is OK.

NO >> Replace driver side power window motor. Refer to [GW-16, "Removal and Installation"](#).

PASSENGER SIDE

PASSENGER SIDE : Description

INFOID:000000004240599

Door glass moves UP/DOWN by receiving the signal power window main switch or front power window switch (passenger side).

PWC

PASSENGER SIDE : Component Function Check

INFOID:000000004240600

1. CHECK POWER WINDOW MOTOR (PASSENGER SIDE) OPERATION

Check front power window motor (passenger side) operation with power window main switch or front power window switch (passenger side).

Is the inspection result normal?

YES >> Power window motor (passenger side) is OK.

NO >> Refer to [PWC-21, "PASSENGER SIDE : Diagnosis Procedure"](#).

PASSENGER SIDE : Diagnosis Procedure

INFOID:000000004240601

1.CHECK FRONT POWER WINDOW MOTOR INPUT SIGNAL

1. Turn ignition switch OFF.
2. Disconnect front power window motor (passenger side) connector.
3. Turn ignition switch ON.
4. Check voltage between front power window motor (passenger side) harness connector and ground.

POWER WINDOW MOTOR

[FRONT & REAR WINDOW ANTI-PINCH]

< DTC/CIRCUIT DIAGNOSIS >

(+)		(-)	Condition	Voltage (V) (Approx.)	
Front power window motor (passenger side)					
Connector	Terminal				
D40	1	Ground	Front power window switch (passenger side)	UP	Battery voltage
				DOWN	0
	2			UP	0
				DOWN	Battery voltage

Is the measurement value within the specification?

YES >> GO TO 3.

NO >> GO TO 2.

2.CHECK POWER WINDOW MOTOR CIRCUIT

1. Turn ignition switch OFF.
2. Disconnect front power window switch (passenger side) connector.
3. Check continuity between front power window switch (passenger side) harness connector and front power window motor (passenger side) harness connector.

Front power window switch (passenger side)		Front power window motor (passenger side)		Continuity
Connector	Terminal	Connector	Terminal	
D38	9	D40	1	Existed
	8		2	

4. Check continuity between front power window switch (passenger side) connector and ground.

Front power window switch (passenger side)		Ground	Continuity
Connector	Terminal		
D38	8		Not existed
	9		

Is the inspection result normal?

YES >> Replace front power window switch (passenger side). Refer to [PWC-117, "Removal and Installation"](#).

NO >> Repair or replace harness.

3.CHECK POWER WINDOW MOTOR

Check front power window motor (passenger side).

Refer to [PWC-22, "PASSENGER SIDE : Component Inspection"](#).

Is the inspection result normal?

YES >> GO TO 4.

NO >> Replace front power window motor (passenger side). Refer to [GW-16, "Removal and Installation"](#).

4.CHECK INTERMITTENT INCIDENT

Refer to [GI-41, "Intermittent Incident"](#).

>> INSPECTION END

PASSENGER SIDE : Component Inspection

INFOID:000000004240602

1.CHECK POWER WINDOW MOTOR (PASSENGER SIDE)

1. Turn ignition switch OFF.
2. Disconnect front power window motor (passenger side) connector.
3. Check motor operation by connecting the battery voltage directly to front power window motor (passenger side) connector.

POWER WINDOW MOTOR

[FRONT & REAR WINDOW ANTI-PINCH]

< DTC/CIRCUIT DIAGNOSIS >

Front power window motor (passenger side) connector	Terminal		Motor condition
	(+)	(-)	
D40	2	1	DOWN
	1	2	UP

Is the inspection result normal?

YES >> Passenger side power window motor is OK.

NO >> Replace passenger side power window motor. Refer to [GW-16, "Removal and Installation"](#).

REAR LH

REAR LH : Description

INFOID:000000004240603

Door glass moves UP/DOWN by receiving the signal from power window main switch or rear power window switch LH.

REAR LH : Component Function Check

INFOID:000000004240604

1.CHECK POWER WINDOW MOTOR LH OPERATION

Check rear power window motor LH operation with power window main switch or rear power window switch LH.

Is the inspection result normal?

YES >> Power window motor LH is OK.

NO >> Refer to [PWC-23, "REAR LH : Diagnosis Procedure"](#).

REAR LH : Diagnosis Procedure

INFOID:000000004240605

1.CHECK REAR POWER WINDOW MOTOR INPUT SIGNAL

1. Turn ignition switch OFF.
2. Disconnect rear power window motor LH connector.
3. Turn ignition switch ON.
4. Check voltage between rear power window motor LH harness connector and ground.

(+) Rear power window motor LH Connector		Terminal	(-) Ground	Condition Rear power window switch LH	Voltage (V) (Approx.)
D52	1				
		DOWN	0		
	3	UP	0		
		DOWN	Battery voltage		

Is the measurement value within the specification?

YES >> GO TO 3.

NO >> GO TO 2.

2.CHECK POWER WINDOW MOTOR CIRCUIT

1. Turn ignition switch OFF.
2. Disconnect rear power window switch LH connector.
3. Check continuity between rear power window switch LH harness connector and rear power window motor LH harness connector.

Rear power window switch LH Connector		Terminal	Rear power window motor LH Connector		Continuity
Connector	Terminal		Connector	Terminal	
D57	8	D52	1	Existed	
	9		3		

4. Check continuity between rear power window switch LH harness connector and ground.

A
B
C
D
E
F
G
H
I
J
L
M
N
O
P

PWC

POWER WINDOW MOTOR

< DTC/CIRCUIT DIAGNOSIS >

[FRONT & REAR WINDOW ANTI-PINCH]

Rear power window switch LH		Ground	Continuity
Connector	Terminal		
D57	8		
	9		
			Not existed

Is the inspection result normal?

YES >> Replace rear power window switch LH. Refer to [PWC-117, "Removal and Installation"](#).

NO >> Repair or replace harness.

3. CHECK REAR POWER WINDOW MOTOR

Check rear power window motor LH.

Refer to [PWC-24, "REAR LH : Component Inspection"](#).

Is the inspection result normal?

YES >> GO TO 4.

NO >> Replace rear power window motor LH. Refer to [GW-22, "Removal and Installation"](#).

4. CHECK INTERMITTENT INCIDENT

Refer to [GI-41, "Intermittent Incident"](#).

>> INSPECTION END

REAR LH : Component Inspection

INFOID:000000004240606

1. CHECK REAR POWER WINDOW MOTOR LH

1. Turn ignition switch OFF.
2. Disconnect rear power window motor LH connector.
3. Check motor operation by connecting the battery voltage directly to rear power window motor LH connector.

Rear power window motor LH connector	Terminal		Motor condition
	(+)	(-)	
D52	1	3	UP
	3	1	DOWN

Is the inspection result normal?

YES >> Power window motor is OK.

NO >> Replace rear power window motor LH. Refer to [GW-22, "Removal and Installation"](#).

REAR RH

REAR RH : Description

INFOID:000000004240607

Door glass moves UP/DOWN by receiving the signal from power window main switch or rear power window switch RH.

REAR RH : Component Function Check

INFOID:000000004240608

1. CHECK POWER WINDOW MOTOR RH OPERATION

Check rear power window motor RH operation with power window main switch or rear power window switch RH.

Is the inspection result normal?

YES >> Power window motor RH is OK.

NO >> Refer to [PWC-24, "REAR RH : Diagnosis Procedure"](#).

REAR RH : Diagnosis Procedure

INFOID:000000004240609

1. CHECK REAR POWER WINDOW MOTOR INPUT SIGNAL

POWER WINDOW MOTOR

[FRONT & REAR WINDOW ANTI-PINCH]

< DTC/CIRCUIT DIAGNOSIS >

1. Turn ignition switch OFF.
2. Disconnect rear power window motor RH connector.
3. Turn ignition switch ON.
4. Check voltage between rear power window motor RH harness connector and ground.

(+)		(-)	Condition	Voltage (V) (Approx.)	
Connector	Terminal				
D72	1	Ground	Rear power window switch RH	UP	Battery voltage
			DOWN	0	
	3		UP	0	
			DOWN	Battery voltage	

Is the measurement value within the specification?

YES >> GO TO 3.

NO >> GO TO 2.

2.CHECK POWER WINDOW MOTOR CIRCUIT

1. Turn ignition switch OFF.
2. Disconnect rear power window switch RH connector.
3. Check continuity between rear power window switch RH harness connector and rear power window motor RH harness connector.

Rear power window switch RH		Rear power window motor RH		Continuity
Connector	Terminal	Connector	Terminal	
D77	8	D72	1	Existed
	9		3	

4. Check continuity between rear power window switch RH harness connector and ground.

Rear power window switch RH		Ground	Continuity
Connector	Terminal		
D77	8		Not existed
	9		

Is the inspection result normal?

YES >> Replace rear power window switch RH. Refer to [PWC-117, "Removal and Installation"](#).

NO >> Repair or replace harness.

3.CHECK REAR POWER WINDOW MOTOR RH

Check rear power window motor RH.

Refer to [PWC-25, "REAR RH : Component Inspection"](#).

Is the inspection result normal?

YES >> GO TO 4.

NO >> Replace rear power window motor RH. Refer to [GW-22, "Removal and Installation"](#).

4.CHECK INTERMITTENT INCIDENT

Refer to [GI-41, "Intermittent Incident"](#).

>> INSPECTION END

REAR RH : Component Inspection

INFOID:000000004240610

1.CHECK REAR POWER WINDOW MOTOR RH

1. Turn ignition switch OFF.
2. Disconnect rear power window motor RH connector.

POWER WINDOW MOTOR

[FRONT & REAR WINDOW ANTI-PINCH]

< DTC/CIRCUIT DIAGNOSIS >

3. Check motor operation by connecting the battery voltage directly to rear power window motor RH connector.

Rear power window motor RH connector	Terminal		Motor condition
	(+)	(-)	
D72	1	3	UP
	3	1	DOWN

Is the inspection result normal?

YES >> Power window motor is OK.

NO >> Replace rear power window motor RH. Refer to [GW-22. "Removal and Installation"](#).

ENCODER

< DTC/CIRCUIT DIAGNOSIS >

[FRONT & REAR WINDOW ANTI-PINCH]

ENCODER DRIVER SIDE

DRIVER SIDE : Description

INFOID:000000004240611

Detects condition of the front power window motor (driver side) operation and transmits to power window main switch as the pulse signal.

DRIVER SIDE : Component Function Check

INFOID:000000004240612

1.CHECK ENCODER OPERATION

Check driver side door glass perform AUTO open/close operation normally by power window main switch.

Is the inspection result normal?

YES >> Encoder operation is OK.

NO >> Refer to [PWC-27, "DRIVER SIDE : Diagnosis Procedure"](#).

DRIVER SIDE : Diagnosis Procedure

INFOID:000000004240613

1.CHECK ENCODER SIGNAL

1. Turn ignition switch ON.
2. Check signal between power window main switch harness connector and ground using oscilloscope.

(+)		(-)	Signal (Reference value)
Power window main switch			
Connector	Terminal	Ground	Refer to following signal
D8	9		
	13		

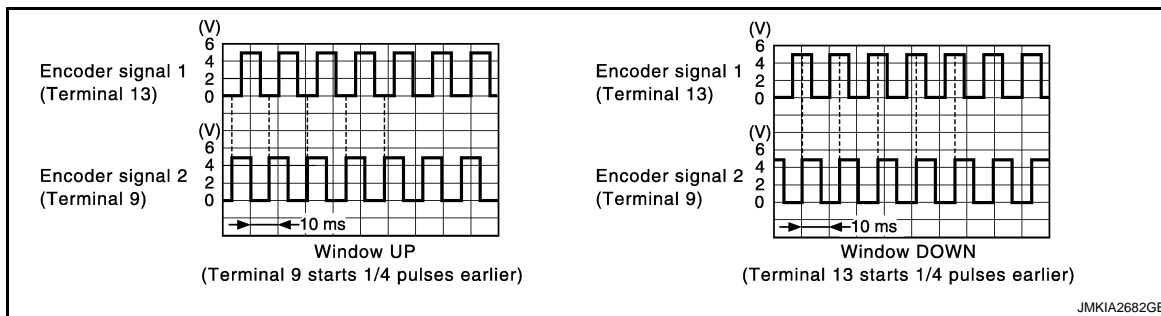

Is the inspection result normal?

YES >> Replace power window main switch. Refer to [PWC-117, "Removal and Installation"](#).

NO >> GO TO 2.

2.CHECK ENCODER SIGNAL CIRCUIT

1. Turn ignition switch OFF.
2. Disconnect power window main switch connector and front power window motor (driver side) connector.
3. Check continuity between power window main switch harness connector and front power window motor (driver side) harness connector.

Power window main switch		Front power window motor (driver side)		Continuity
Connector	Terminal	Connector	Terminal	
D8	9	D10	3	Existed
	13		5	

4. Check continuity between power window main switch harness connector and ground.

ENCODER

< DTC/CIRCUIT DIAGNOSIS >

[FRONT & REAR WINDOW ANTI-PINCH]

Power window main switch		Ground	Continuity
Connector	Terminal		
D8	9		
	13		Not existed

Is the inspection result normal?

YES >> GO TO 3.

NO >> Repair or replace harness.

3. CHECK ENCODER POWER SUPPLY CIRCUIT 1

1. Connect power window main switch connector.
2. Turn ignition switch ON.
3. Check voltage between front power window motor (driver side) harness connector and ground.

(+)		(-)	Voltage (V) (Approx.)
Front power window motor (driver side)			
Connector	Terminal		
D10	4	Ground	Battery voltage

Is the inspection result normal?

YES >> GO TO 5.

NO >> GO TO 4.

4. CHECK ENCODER POWER SUPPLY CIRCUIT 2

1. Turn ignition switch OFF.
2. Disconnect power window main switch connector.
3. Check continuity between power window main switch harness connector and front power window motor (driver side) harness connector.

Power window main switch		Front power window motor (driver side)		Continuity
Connector	Terminal	Connector	Terminal	
D8	15	D10	4	Existed

4. Check continuity between power window main switch harness connector and ground.

Power window main switch		Ground	Continuity
Connector	Terminal		
D8	15		

Is the inspection result normal?

YES >> Replace power window main switch. Refer to [PWC-117, "Removal and Installation"](#).

NO >> Repair or replace harness.

5. CHECK GROUND CIRCUIT 1

1. Turn ignition switch OFF.
2. Disconnect power window main switch connector.
3. Check continuity between power window main switch harness connector and front power window motor (driver side) harness connector.

Power window main switch		Front power window motor (driver side)		Continuity
Connector	Terminal	Connector	Terminal	
D8	2	D10	6	Existed

Is the inspection result normal?

YES >> GO TO 6.

NO >> Repair or replace harness.

6. CHECK GROUND CIRCUIT 2

ENCODER

< DTC/CIRCUIT DIAGNOSIS >

[FRONT & REAR WINDOW ANTI-PINCH]

1. Connect power window main switch connector.
2. Check continuity between power window main switch harness connector and ground.

Power window main switch		Ground	Continuity
Connector	Terminal		
D8	2		Existed

Is the inspection result normal?

YES >> Replace front power window motor (driver side). Refer to [GW-16. "Removal and Installation"](#).

NO >> Replace power window main switch. Refer to [PWC-117. "Removal and Installation"](#).

PASSENGER SIDE

PASSENGER SIDE : Description

INFOID:000000004240614

Detects condition of the front power window motor (passenger side) operation and transmits to front power window switch (passenger side) as the pulse signal.

PASSENGER SIDE : Component Function Check

INFOID:000000004240615

1.CHECK ENCODER OPERATION

Check passenger side door glass perform AUTO open/close operation normally by power window main switch or front power window switch (passenger side).

Is the inspection result normal?

YES >> Encoder operation is OK.

NO >> Refer to [PWC-29. "PASSENGER SIDE : Diagnosis Procedure"](#).

PASSENGER SIDE : Diagnosis Procedure

INFOID:000000004240616

1.CHECK ENCODER SIGNAL

1. Turn ignition switch ON.
2. Check signal between front power window switch (passenger side) harness connector and ground using oscilloscope.

(+)		(-)	Signal (Reference value)
Front power window switch (passenger side)			
Connector	Terminal	Ground	Refer to following signal
D38	12		
	15		

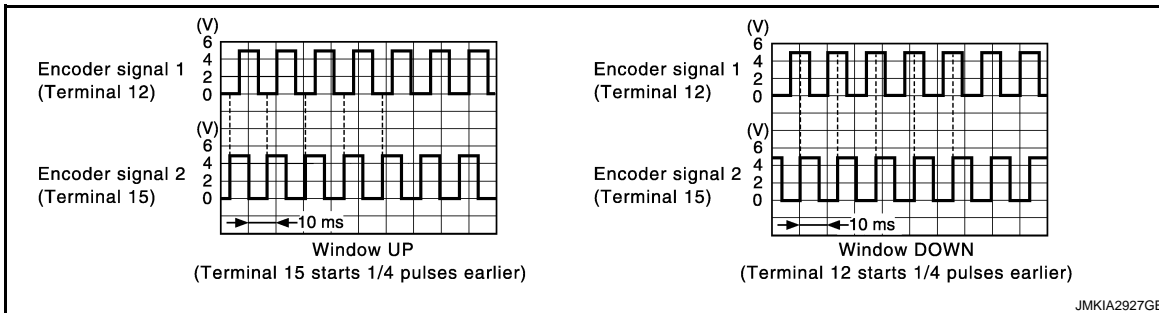

Is the inspection result normal?

YES >> Replace front power window switch (passenger side). Refer to [GW-16. "Removal and Installation"](#).

NO >> GO TO 2.

2.CHECK ENCODER SIGNAL CIRCUIT

1. Turn ignition switch OFF.

ENCODER

< DTC/CIRCUIT DIAGNOSIS >

[FRONT & REAR WINDOW ANTI-PINCH]

2. Disconnect front power window switch (passenger side) connector and front power window motor (passenger side) connector.
3. Check continuity between front power window switch (passenger side) harness connector and front power window motor (passenger side) harness connector.

Front power window switch (passenger side)		Front power window motor (passenger side)		Continuity
Connector	Terminal	Connector	Terminal	
D38	12	D40	5	Existed
	15		3	

4. Check continuity between front power window switch (passenger side) harness connector and ground.

Front power window switch (passenger side)		Ground	Continuity
Connector	Terminal		
D38	12		Not existed
	15		

Is the inspection result normal?

YES >> GO TO 3.

NO >> Repair or replace harness.

3.CHECK ENCODER POWER SUPPLY CIRCUIT 1

1. Connect front power window switch (passenger side) connector.
2. Turn ignition switch ON.
3. Check voltage between front power window motor (passenger side) harness connector and ground.

(+)		(-)	Voltage (V) (Approx.)
Front power window motor (passenger side)			
Connector	Terminal	Ground	Battery voltage
D40	4		

Is the inspection result normal?

YES >> GO TO 5.

NO >> GO TO 4.

4.CHECK ENCODER POWER SUPPLY CIRCUIT 2

1. Turn ignition switch OFF.
2. Disconnect front power window switch (passenger side) connector.
3. Check continuity between front power window switch (passenger side) harness connector and front power window motor (passenger side) harness connector.

Front power window switch (passenger side)		Front power window motor (passenger side)		Continuity
Connector	Terminal	Connector	Terminal	
D38	4	D40	4	Existed

4. Check continuity between front power window switch (passenger side) harness connector and ground.

Front power window switch (passenger side)		Ground	Continuity
Connector	Terminal		
D38	4		Not existed

Is the inspection result normal?

YES >> Replace front power window switch (passenger side). Refer to [PWC-117. "Removal and Installation"](#).

NO >> Repair or replace harness.

5.CHECK GROUND CIRCUIT 1

1. Turn ignition switch OFF.

ENCODER

< DTC/CIRCUIT DIAGNOSIS >

[FRONT & REAR WINDOW ANTI-PINCH]

2. Disconnect front power window switch (passenger side) connector.
3. Check continuity between front power window switch (passenger side) harness connector and front power window motor (passenger side) harness connector.

Front power window switch (passenger side)		Front power window motor (passenger side)		Continuity
Connector	Terminal	Connector	Terminal	
D38	3	D40	6	Existed

Is the inspection result normal?

- YES >> GO TO 6.
 NO >> Repair or replace harness.

6.CHECK GROUND CIRCUIT 2

1. Connect front power window switch (passenger side) connector.
2. Check continuity between front power window switch (passenger side) harness connector and ground.

Front power window switch (passenger side)		Ground	Continuity
Connector	Terminal		
D38	3		Existed

Is the inspection result normal?

- YES >> Replace front power window motor (passenger side). Refer to [GW-16, "Removal and Installation"](#).
 NO >> Replace front power window switch (passenger side). Refer to [PWC-117, "Removal and Installation"](#).

REAR LH

REAR LH : Description

INFOID:000000004240617

Detects condition of the rear power window motor LH operation and transmits to rear power window switch LH as the pulse signal.

REAR LH : Component Function Check

INFOID:000000004240619

1.CHECK ENCODER OPERATION

Check rear door LH glass perform AUTO open/close operation normally by power window main switch or rear power window switch LH.

PWC

Is the inspection result normal?

- YES >> Encoder operation is OK.
 NO >> Refer to [PWC-31, "REAR LH : Diagnosis Procedure"](#).

REAR LH : Diagnosis Procedure

INFOID:000000004240619

1.CHECK ENCODER SIGNAL

1. Turn ignition switch ON.
2. Check signal between rear power window switch LH harness connector and ground using oscilloscope.

(+)		(-)	Signal (Reference value)
Rear power window switch LH			
Connector	Terminal		
D57	12	Ground	Refer to following signal
	15		

ENCODER

< DTC/CIRCUIT DIAGNOSIS >

[FRONT & REAR WINDOW ANTI-PINCH]

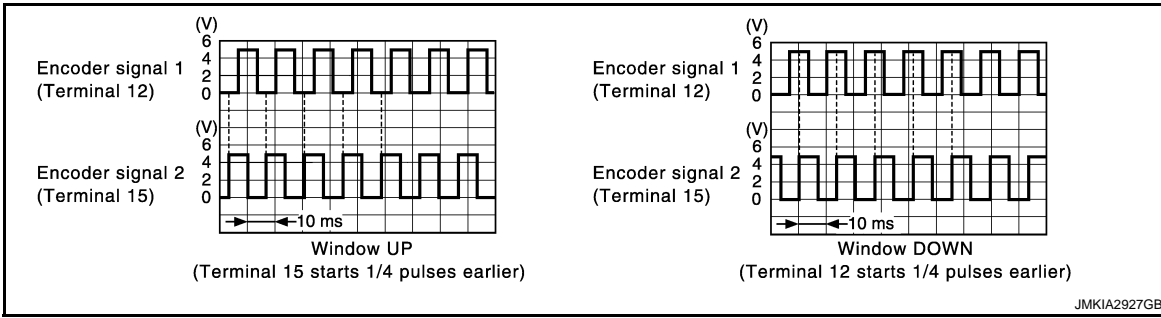

Is the inspection result normal?

- YES >> Replace rear power window switch LH. Refer to [PWC-117, "Removal and Installation"](#).
- NO >> GO TO 2.

2.CHECK ENCODER SIGNAL CIRCUIT

1. Turn ignition switch OFF.
2. Disconnect rear power window switch LH connector and rear power window motor LH connector.
3. Check continuity between rear power window switch LH harness connector and rear power window motor LH harness connector.

Rear power window switch LH		Rear power window motor LH		Continuity
Connector	Terminal	Connector	Terminal	
D57	12	D52	5	Existed
	15		6	

4. Check continuity rear power window switch LH harness connector and ground.

Rear power window switch LH		Ground	Continuity
Connector	Terminal		
D57	12		Not existed
	15		

Is the inspection result normal?

- YES >> GO TO 3.
- NO >> Repair or replace harness.

3.CHECK ENCODER POWER SUPPLY CIRCUIT 1

1. Connect rear power window switch LH connector.
2. Turn ignition switch ON.
3. Check voltage between rear power window motor LH harness connector and ground.

(+)		(-)	Voltage (V) (Approx.)
Rear power window motor LH			
Connector	Terminal		
D52	2	Ground	Battery voltage

Is the inspection result normal?

- YES >> GO TO 5.
- NO >> GO TO 4.

4.CHECK ENCODER POWER SUPPLY CIRCUIT 2

1. Turn ignition switch OFF.
2. Disconnect rear power window switch LH connector.
3. Check continuity between rear power window switch LH harness connector and rear power window motor LH harness connector.

ENCODER

< DTC/CIRCUIT DIAGNOSIS >

[FRONT & REAR WINDOW ANTI-PINCH]

Rear power window switch LH		Rear power window motor LH		Continuity
Connector	Terminal	Connector	Terminal	
D57	4	D52	2	Existed

4. Check continuity between rear power window switch LH harness connector and ground.

Rear power window switch LH		Ground	Continuity
Connector	Terminal		
D57	4		Not existed

Is the inspection result normal?

- YES >> Replace rear power window switch LH. Refer to [PWC-117, "Removal and Installation"](#).
NO >> Repair or replace harness.

5.CHECK GROUND CIRCUIT 1

- Turn ignition switch OFF.
- Disconnect rear power window switch LH harness connector.
- Check continuity between rear power window switch LH harness connector and rear power window motor LH harness connector.

Rear power window switch LH		Rear power window motor LH		Continuity
Connector	Terminal	Connector	Terminal	
D57	3	D52	4	Existed

Is the inspection result normal?

- YES >> GO TO 6.
NO >> Repair or replace harness.

6.CHECK GROUND CIRCUIT 2

- Connect rear power window switch LH harness connector.
- Check continuity between rear power window switch LH harness connector and ground.

Rear power window switch LH		Ground	Continuity
Connector	Terminal		
D57	3		Existed

Is the inspection result normal?

- YES >> Replace rear power window motor LH. Refer to [GW-22, "Removal and Installation"](#).
NO >> Replace rear power window switch LH. Refer to [PWC-117, "Removal and Installation"](#).

REAR RH

REAR RH : Description

INFOID:000000004240620

Detects condition of the rear power window motor RH operation and transmits to rear power window switch RH as the pulse signal.

REAR RH : Component Function Check

INFOID:000000004240621

1.CHECK ENCODER OPERATION

Check rear door RH glass perform AUTO open/close operation normally by power window main switch or rear power window switch RH.

Is the inspection result normal?

- YES >> Encoder operation is OK.
NO >> Refer to [PWC-34, "REAR RH : Diagnosis Procedure"](#).

ENCODER

< DTC/CIRCUIT DIAGNOSIS >

[FRONT & REAR WINDOW ANTI-PINCH]

REAR RH : Diagnosis Procedure

INFOID:000000004240622

1.CHECK ENCODER SIGNAL

1. Turn ignition switch ON.
2. Check signal between rear power window switch RH harness connector and ground using oscilloscope.

(+)		(-)	Signal (Reference value)
Rear power window switch RH			
Connector	Terminal	Ground	Refer to following signal
D77	12		
	15		

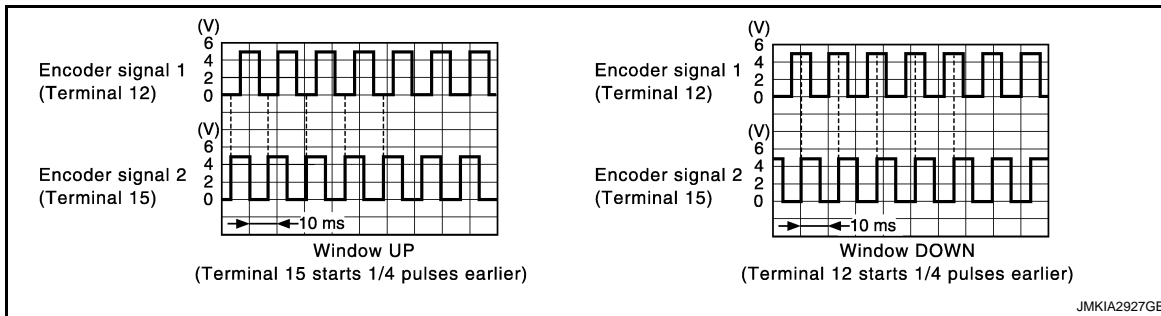

Is the inspection result normal?

- YES >> Replace rear power window switch RH. Refer to [PWC-117. "Removal and Installation"](#).
NO >> GO TO 2.

2.CHECK ENCODER SIGNAL CIRCUIT

1. Turn ignition switch OFF.
2. Disconnect rear power window switch RH connector and rear power window motor RH connector.
3. Check continuity between rear power window switch RH harness connector and rear power window motor RH harness connector.

Rear power window switch RH		Rear power window motor RH		Continuity
Connector	Terminal	Connector	Terminal	
D77	12	D72	5	Existed
	15		6	

4. Check continuity rear power window switch RH harness connector and ground.

Rear power window switch RH		Ground	Continuity
Connector	Terminal		
D77	12	Ground	Not existed
	15		

Is the inspection result normal?

- YES >> GO TO 3.
NO >> Repair or replace harness.

3.CHECK ENCODER POWER SUPPLY CIRCUIT 1

1. Connect rear power window switch RH connector.
2. Turn ignition switch ON.
3. Check voltage between rear power window motor RH harness connector and ground.

ENCODER

< DTC/CIRCUIT DIAGNOSIS >

[FRONT & REAR WINDOW ANTI-PINCH]

(+)		(-)	Voltage (V) (Approx.)
Rear power window motor RH			
Connector	Terminal		
D72	2	Ground	Battery voltage

Is the inspection result normal?

YES >> GO TO 5.

NO >> GO TO 4.

4.CHECK ENCODER POWER SUPPLY CIRCUIT 2

1. Turn ignition switch OFF.
2. Disconnect rear power window switch RH connector.
3. Check continuity between rear power window switch RH harness connector and rear power window motor RH harness connector.

Rear power window switch RH		Rear power window motor RH		Continuity
Connector	Terminal	Connector	Terminal	
D77	4	D72	2	Existed

4. Check continuity between rear power window switch RH harness connector and ground.

Rear power window switch RH		Ground	Continuity
Connector	Terminal		
D77	4		Not existed

Is the inspection result normal?

YES >> Replace rear power window switch RH. Refer to [PWC-117, "Removal and Installation"](#).

NO >> Repair or replace harness.

5.CHECK GROUND CIRCUIT 1

1. Turn ignition switch OFF.
2. Disconnect rear power window switch RH harness connector.
3. Check continuity between rear power window switch RH harness connector and rear power window motor RH harness connector.

Rear power window switch RH		Rear power window motor RH		Continuity
Connector	Terminal	Connector	Terminal	
D77	3	D72	4	Existed

Is the inspection result normal?

YES >> GO TO 6.

NO >> Repair or replace harness.

6.CHECK GROUND CIRCUIT 2

1. Connect rear power window switch RH harness connector.
2. Check continuity between rear power window switch RH harness connector and ground.

Rear power window switch RH		Ground	Continuity
Connector	Terminal		
D77	3		Existed

Is the inspection result normal?

YES >> Replace rear power window motor RH. Refer to [GW-22, "Removal and Installation"](#).

NO >> Replace rear power window switch RH. Refer to [PWC-117, "Removal and Installation"](#).

A
B
C
D
E
F
G
H
I
J
L
M
N
O
P

PWC

POWER WINDOW SERIAL LINK

[FRONT & REAR WINDOW ANTI-PINCH]

< DTC/CIRCUIT DIAGNOSIS >

POWER WINDOW SERIAL LINK

POWER WINDOW MAIN SWITCH

POWER WINDOW MAIN SWITCH : Description

INFOID:000000004638185

Power window main switch, front power window switch (passenger side), rear power window switch and BCM transmit and receive the signal by power window serial link.

The signal mentioned below is transmitted from BCM to power window main switch, front power window switch (passenger side) and rear power window switch.

- Keyless power window down signal

The signal mentioned below is transmitted from power window main switch to front power window switch (passenger side) and rear power window switch.

- Front passenger side door window and rear door window operation signal
- Power window control by key cylinder switch signal
- Power window lock switch signal
- Retained power operation signal

POWER WINDOW MAIN SWITCH : Component Function Check

INFOID:000000004638186

1.CHECK POWER WINDOW SWITCH OUTPUT SIGNAL

With CONSULT-III

Check ("CDL LOCK SW ", "CDL UNLOCK SW") in "DATA MONITOR" mode for "POWER DOOR LOCK SYSTEM" with CONSULT-III. Refer to [DLK-51, "DOOR LOCK : CONSULT-III Function \(BCM - DOOR LOCK\)"](#).

Monitor item	Condition
CDL LOCK SW	LOCK : ON
	UNLOCK : OFF
CDL UNLOCK SW	LOCK : OFF
	UNLOCK : ON

Is the inspection result normal?

YES >> Power window serial link is OK.

NO >> Refer to [PWC-36, "POWER WINDOW MAIN SWITCH : Diagnosis Procedure"](#).

POWER WINDOW MAIN SWITCH : Diagnosis Procedure

INFOID:000000004638187

1.CHECK POWER WINDOW SWITCH OUTPUT SIGNAL

1. Turn ignition switch ON.
2. Check signal between power window main switch harness connector and ground.

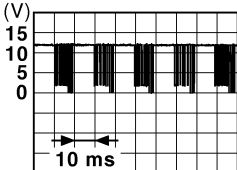
(+)		(-)	Signal (Reference value)
Connector	Terminal		
D8	14	Ground	 <p>JPMA0013GB</p>

Is the inspection result normal?

YES >> GO TO 4.

NO >> GO TO 2.

2.CHECK POWER WINDOW SERIAL LINK SIGNAL

POWER WINDOW SERIAL LINK

[FRONT & REAR WINDOW ANTI-PINCH]

< DTC/CIRCUIT DIAGNOSIS >

1. Turn ignition switch OFF.
2. Disconnect power window main switch connector.
3. Turn ignition switch ON.
4. Check voltage between power window main switch harness connector and ground.

(+)		(-)	Voltage (V) (Approx.)
Power window main switch			
Connector	Terminal	Ground	Battery voltage
D8	14		

Is the measurement value within the specification?

- YES >> Replace power window main switch. Refer to [PWC-117, "Removal and Installation"](#).
NO >> GO TO 3.

3.CHECK POWER WINDOW SERIAL LINK CIRCUIT

1. Turn ignition switch OFF.
2. Disconnect BCM connector.
3. Check continuity between BCM connector and power window main switch connector.

BCM		Power window main switch		Continuity
Connector	Terminal	Connector	Terminal	
M123	132	D8	14	Existed

4. Check continuity between BCM connector and ground.

BCM		Ground	Continuity
Connector	Terminal		
M123	132		Not existed

Is the inspection result normal?

- YES >> Replace BCM. Refer to [BCS-82, "Exploded View"](#).
NO >> Repair or replace harness.

4.CHECK INTERMITTENT INCIDENT

Refer to [GI-41, "Intermittent Incident"](#).

>> INSPECTION END

FRONT POWER WINDOW SWITCH (PASSENGER SIDE)

FRONT POWER WINDOW SWITCH (PASSENGER SIDE) : Description

INFOID:000000004638188

Power window main switch, front power window switch (passenger side), rear power window switch and BCM transmit and receive the signal by power window serial link.

The signal mentioned below is transmitted from BCM to power window main switch, front power window switch (passenger side) and rear power window switch.

- Keyless power window down signal

The signal mentioned below is transmitted from power window main switch to front power window switch (passenger side) and rear power window switch.

- Front passenger side door window and rear door window operation signal
- Power window control by key cylinder switch signal
- Power window lock switch signal
- Retained power operation signal

FRONT POWER WINDOW SWITCH (PASSENGER SIDE) : Component Function

Check

INFOID:000000004638189

1.CHECK POWER WINDOW SWITCH OUTPUT SIGNAL

POWER WINDOW SERIAL LINK

[FRONT & REAR WINDOW ANTI-PINCH]

< DTC/CIRCUIT DIAGNOSIS >

Ⓟ With CONSULT-III

Check ("CDL LOCK SW ", "CDL UNLOCK SW") in "DATA MONITOR" mode for "POWER DOOR LOCK SYSTEM" with CONSULT-III. Refer to [DLK-51, "DOOR LOCK : CONSULT-III Function \(BCM - DOOR LOCK\)"](#) .

Monitor item	Condition
CDL LOCK SW	LOCK : ON
	UNLOCK : OFF
CDL UNLOCK SW	LOCK : OFF
	UNLOCK : ON

Is the inspection result normal?

YES >> Power window serial link is OK.

NO >> Refer to [PWC-38, "FRONT POWER WINDOW SWITCH \(PASSENGER SIDE\) : Diagnosis Procedure"](#).

FRONT POWER WINDOW SWITCH (PASSENGER SIDE) : Diagnosis Procedure

INFOID:000000004638190

1. CHECK POWER WINDOW SWITCH OUTPUT SIGNAL

1. Turn ignition switch ON.
2. Check signal between front power window switch (passenger side) harness connector and ground.

(+)		(-)	Signal (Reference value)
Connector	Terminal		
D38	16	Ground	

Is the inspection result normal?

YES >> Replace front power window switch (passenger side). Refer to [PWC-117, "Removal and Installation"](#).

NO >> GO TO 2.

2. CHECK POWER WINDOW SERIAL LINK CIRCUIT

1. Turn ignition switch OFF.
2. Disconnect BCM connector and front power window switch (passenger side) connector.
3. Check continuity between BCM harness connector and front power window switch (passenger side) harness connector.

BCM		Front power window switch (passenger side)		Continuity
Connector	Terminal	Connector	Terminal	
M123	132	D38	16	Existed

4. Check continuity between BCM connector and ground.

BCM		Ground	Continuity
Connector	Terminal		
M123	132		Not existed

Is the inspection result normal?

YES >> Replace BCM. Refer to [BCS-82, "Exploded View"](#).

POWER WINDOW SERIAL LINK

[FRONT & REAR WINDOW ANTI-PINCH]

< DTC/CIRCUIT DIAGNOSIS >

NO >> Repair or replace harness.

REAR LH

REAR LH : Description

INFOID:000000004240629

Power window main switch, front power window switch (passenger side), rear power window switch and BCM transmit and receive the signal by power window serial link.

The signal mentioned below is transmitted from BCM to power window main switch, front power window switch (passenger side) and rear power window switch.

- Keyless power window down signal

The signal mentioned below is transmitted from power window main switch to front power window switch (passenger side) and rear power window switch.

- Front passenger side door window and rear door window operation signal
- Power window control by key cylinder switch signal
- Power window lock switch signal
- Retained power operation signal

REAR LH : Component Function Check

INFOID:000000004240630

1. CHECK POWER WINDOW SWITCH OUTPUT SIGNAL

With CONSULT-III

Check ("CDL LOCK SW ", "CDL UNLOCK SW") in "DATA MONITOR" mode for "POWER DOOR LOCK SYSTEM" with CONSULT-III. Refer to [DLK-51, "DOOR LOCK : CONSULT-III Function \(BCM - DOOR LOCK\)"](#).

Monitor item	Condition
CDL LOCK SW	LOCK : ON
	UNLOCK : OFF
CDL UNLOCK SW	LOCK : OFF
	UNLOCK : ON

Is the inspection result normal?

YES >> Power window serial link is OK.

NO >> Refer to [PWC-39, "REAR LH : Diagnosis Procedure"](#).

REAR LH : Diagnosis Procedure

INFOID:000000004240631

1. CHECK POWER WINDOW SWITCH OUTPUT SIGNAL

1. Turn ignition switch OFF.
2. Check signal between rear power window switch LH harness connector and ground.

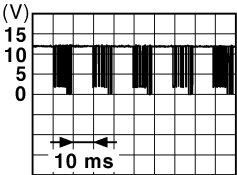
(+) Rear power window switch LH		(-)	Signal (Reference value)
Connector	Terminal		
D57	16	Ground	 <p style="text-align: right;">JPMA0013GB</p>

Is the inspection result normal?

YES >> Replace rear power window switch LH. Refer to [PWC-117, "Removal and Installation"](#).

NO >> GO TO 2.

POWER WINDOW SERIAL LINK

< DTC/CIRCUIT DIAGNOSIS >

[FRONT & REAR WINDOW ANTI-PINCH]

2. CHECK POWER WINDOW SERIAL LINK CIRCUIT

1. Turn ignition switch OFF.
2. Disconnect BCM connector and rear power window switch LH connector.
3. Check continuity between BCM harness connector and rear power window switch LH harness connector.

BCM		Rear power window switch LH		Continuity
Connector	Terminal	Connector	Terminal	
M123	132	D57	16	Existed

4. Check continuity between BCM harness connector and ground.

BCM		Ground	Continuity
Connector	Terminal		
M123	132		Not existed

Is the inspection result normal?

- YES >> Replace BCM. Refer to [BCS-82, "Exploded View"](#).
 NO >> Repair or replace harness.

REAR RH

REAR RH : Description

INFOID:000000004240632

Power window main switch, front power window switch (passenger side), rear power window switch and BCM transmit and receive the signal by power window serial link.

The signal mentioned below is transmitted from BCM to power window main switch, front power window switch (passenger side) and rear power window switch.

- Keyless power window down signal

The signal mentioned below is transmitted from power window main switch to front power window switch (passenger side) and rear power window switch.

- Front passenger side door window and rear door window operation signal
- Power window control by key cylinder switch signal
- Power window lock switch signal
- Retained power operation signal

REAR RH : Component Function Check

INFOID:000000004240633

1. CHECK POWER WINDOW SWITCH OUTPUT SIGNAL

④ With CONSULT-III

Check ("CDL LOCK SW", "CDL UNLOCK SW") in "DATA MONITOR" mode for "POWER DOOR LOCK SYSTEM" with CONSULT-III. Refer to [DLK-51, "DOOR LOCK : CONSULT-III Function \(BCM - DOOR LOCK\)"](#).

Monitor item	Condition
CDL LOCK SW	LOCK : ON
	UNLOCK : OFF
CDL UNLOCK SW	LOCK : OFF
	UNLOCK : ON

Is the inspection result normal?

- YES >> Power window serial link is OK.
 NO >> Refer to [PWC-40, "REAR RH : Diagnosis Procedure"](#).

REAR RH : Diagnosis Procedure

INFOID:000000004240634

1. CHECK POWER WINDOW SWITCH OUTPUT SIGNAL

1. Turn ignition switch OFF.
2. Check signal between rear power window switch RH harness connector and ground.

POWER WINDOW SERIAL LINK

[FRONT & REAR WINDOW ANTI-PINCH]

< DTC/CIRCUIT DIAGNOSIS >

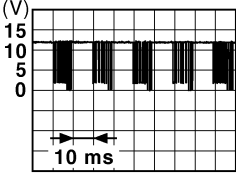
(+)		(-)	Signal (Reference value)
Rear power window switch RH			
Connector	Terminal		
D77	16	Ground	 <p style="text-align: right; font-size: small;">JPMA0013GB</p>

Is the inspection result normal?

- YES >> Replace rear power window switch RH. Refer to [PWC-117, "Removal and Installation"](#).
- NO >> GO TO 2.

2.CHECK POWER WINDOW SERIAL LINK CIRCUIT

1. Turn ignition switch OFF.
2. Disconnect BCM connector and rear power window switch RH connector.
3. Check continuity between BCM harness connector and rear power window switch RH harness connector.

BCM		Rear power window switch RH		Continuity
Connector	Terminal	Connector	Terminal	
M123	132	D77	16	Existed

4. Check continuity between BCM harness connector and ground.

BCM		Ground	Continuity
Connector	Terminal		
M123	132		Not existed

Is the inspection result normal?

- YES >> Replace BCM. Refer to [BCS-82, "Exploded View"](#).
- NO >> Repair or replace harness.

A
B
C
D
E
F
G
H
I
J
L
M
N
O
P

PWC

BCM (BODY CONTROL MODULE)

< ECU DIAGNOSIS INFORMATION >

[FRONT & REAR WINDOW ANTI-PINCH]

ECU DIAGNOSIS INFORMATION

BCM (BODY CONTROL MODULE)

Reference Value

INFOID:000000004667395

VALUES ON THE DIAGNOSIS TOOL

CONSULT-III MONITOR ITEM

Monitor Item	Condition	Value/Status
FR WIPER HI	Other than front wiper switch HI	Off
	Front wiper switch HI	On
FR WIPER LOW	Other than front wiper switch LO	Off
	Front wiper switch LO	On
FR WASHER SW	Front washer switch OFF	Off
	Front washer switch ON	On
FR WIPER INT	Other than front wiper switch INT	Off
	Front wiper switch INT	On
FR WIPER STOP	Front wiper is not in STOP position	Off
	Front wiper is in STOP position	On
INT VOLUME	Wiper intermittent dial is in a dial position 1 - 7	Wiper intermittent dial position
TURN SIGNAL R	Other than turn signal switch RH	Off
	Turn signal switch RH	On
TURN SIGNAL L	Other than turn signal switch LH	Off
	Turn signal switch LH	On
TAIL LAMP SW	Other than lighting switch 1ST and 2ND	Off
	Lighting switch 1ST or 2ND	On
HI BEAM SW	Other than lighting switch HI	Off
	Lighting switch HI	On
HEAD LAMP SW 1	Other than lighting switch 2ND	Off
	Lighting switch 2ND	On
HEAD LAMP SW 2	Other than lighting switch 2ND	Off
	Lighting switch 2ND	On
PASSING SW	Other than lighting switch PASS	Off
	Lighting switch PASS	On
AUTO LIGHT SW	Other than lighting switch AUTO	Off
	Lighting switch AUTO	On
FR FOG SW	Front fog lamp switch OFF	Off
	Front fog lamp switch ON	On
RR FOG SW	NOTE: The item is indicated, but not monitored.	Off
DOOR SW-DR	Driver door closed	Off
	Driver door opened	On
DOOR SW-AS	Passenger door closed	Off
	Passenger door opened	On
DOOR SW-RR	Rear RH door closed	Off
	Rear LH door opened	On

BCM (BODY CONTROL MODULE)

< ECU DIAGNOSIS INFORMATION >

[FRONT & REAR WINDOW ANTI-PINCH]

Monitor Item	Condition	Value/Status	
DOOR SW-RL	Rear LH door closed	Off	A
	Rear LH door opened	On	
DOOR SW-BK	NOTE: The item is indicated, but not monitored.	Off	B
CDL LOCK SW	Other than power door lock switch LOCK	Off	C
	Power door lock switch LOCK	On	
CDL UNLOCK SW	Other than power door lock switch UNLOCK	Off	D
	Power door lock switch UNLOCK	On	
KEY CYL LK-SW	Other than driver door key cylinder LOCK	Off	E
	Driver door key cylinder LOCK	On	
KEY CYL UN-SW	Other than driver door key cylinder UNLOCK	Off	F
	Driver door key cylinder LOCK	On	
KEY CYL SW-TR	NOTE: The item is indicated, but not monitored.	Off	F
HAZARD SW	Hazard switch is OFF	Off	G
	Hazard switch is ON	On	
REAR DEF SW	NOTE: The item is indicated, but not monitored.	Off	H
H/L WASH SW	NOTE: The item is indicated, but not monitored.	Off	H
TR CANCEL SW	Trunk lid opener cancel switch OFF	Off	I
	Trunk lid opener cancel switch ON	On	
TR/BD OPEN SW	Trunk lid opener switch OFF	Off	J
	While the trunk lid opener switch is turned ON	On	
TRNK/HAT MNTR	Trunk lid closed	Off	J
	Trunk lid opened	On	
RKE-LOCK	LOCK button of the Intelligent Key is not pressed	Off	PWC
	LOCK button of the Intelligent Key is pressed	On	
RKE-UNLOCK	UNLOCK button of the Intelligent Key is not pressed	Off	L
	UNLOCK button of the Intelligent Key is pressed	On	
RKE-TR/BD	TRUNK OPEN button of the Intelligent Key is not pressed	Off	M
	TRUNK OPEN button of the Intelligent Key is pressed	On	
RKE-PANIC	PANIC button of the Intelligent Key is not pressed	Off	N
	PANIC button of the Intelligent Key is pressed	On	
RKE-P/W OPEN	UNLOCK button of the Intelligent Key is not pressed	Off	O
	UNLOCK button of the Intelligent Key is pressed and held	On	
RKE-MODE CHG	LOCK/UNLOCK button of the Intelligent Key is not pressed and held simultaneously	Off	O
	LOCK/UNLOCK button of the Intelligent Key is pressed and held simultaneously	On	
OPTICAL SENSOR	Bright outside of the vehicle	Close to 5 V	P
	Dark outside of the vehicle	Close to 0 V	
REQ SW -DR	Driver door request switch is not pressed	Off	
	Driver door request switch is pressed	On	
REQ SW -AS	Passenger door request switch is not pressed	Off	
	Passenger door request switch is pressed	On	

BCM (BODY CONTROL MODULE)

< ECU DIAGNOSIS INFORMATION >

[FRONT & REAR WINDOW ANTI-PINCH]

Monitor Item	Condition	Value/Status
REQ SW -RR	NOTE: The item is indicated, but not monitored.	Off
REQ SW -RL	NOTE: The item is indicated, but not monitored.	Off
REQ SW -BD/TR	Trunk lid opener request switch is not pressed	Off
	Trunk lid opener request switch is pressed	On
PUSH SW	Push-button ignition switch (push switch) is not pressed	Off
	Push-button ignition switch (push switch) is pressed	On
IGN RLY2 -F/B	Ignition switch in OFF or ACC position	Off
	Ignition switch in ON position	On
ACC RLY -F/B	NOTE: The item is indicated, but not monitored.	Off
CLUCH SW	The clutch pedal is not depressed	Off
	The clutch pedal is depressed	On
BRAKE SW 1	The brake pedal is depressed when No. 7 fuse is blown	Off
	The brake pedal is not depressed when No. 7 fuse is blown, or No. 7 fuse is normal	On
BRAKE SW 2	The brake pedal is not depressed	Off
	The brake pedal is depressed	On
DETE/CANCL SW	<ul style="list-style-type: none"> • Selector lever in P position (Except M/T models) • The clutch pedal is depressed (M/T models) 	Off
	<ul style="list-style-type: none"> • Selector lever in any position other than P (Except M/T models) • The clutch pedal is not depressed (M/T models) 	On
SFT PN/N SW	Selector lever in any position other than P and N	Off
	Selector lever in P or N position	On
S/L -LOCK	Steering is unlocked	Off
	Steering is locked	On
S/L -UNLOCK	Steering is locked	Off
	Steering is unlocked	On
S/L RELAY-F/B	Ignition switch in OFF or ACC position	Off
	Ignition switch in ON position	On
UNLK SEN -DR	Driver door is unlocked	Off
	Driver door is locked	On
PUSH SW -IPDM	Push-button ignition switch (push-switch) is not pressed	Off
	Push-button ignition switch (push-switch) is pressed	On
IGN RLY1 -F/B	Ignition switch in OFF or ACC position	Off
	Ignition switch in ON position	On
DETE SW -IPDM	Selector lever in any position other than P	Off
	Selector lever in P position	On
SFT PN -IPDM	<ul style="list-style-type: none"> • Selector lever in any position other than P and N (Except M/T models) • The clutch pedal is not depressed (M/T models) 	Off
	<ul style="list-style-type: none"> • Selector lever in P or N position (Except M/T models) • The clutch pedal is depressed (M/T models) 	On
SFT P -MET	Selector lever in any position other than P	Off
	Selector lever in P position	On
SFT N -MET	Selector lever in any position other than N	Off
	Selector lever in N position	On

BCM (BODY CONTROL MODULE)

< ECU DIAGNOSIS INFORMATION >

[FRONT & REAR WINDOW ANTI-PINCH]

Monitor Item	Condition	Value/Status	
ENGINE STATE	Engine stopped	Stop	A
	While the engine stalls	Stall	
	At engine cranking	Crank	B
	Engine running	Run	
S/L LOCK-IPDM	Steering is unlocked	Off	
	Steering is locked	On	C
S/L UNLK-IPDM	Steering is locked	Off	
	Steering is unlocked	On	D
S/L RELAY-REQ	Steering lock system is not the LOCK condition and the changing condition from LOCK to UNLOCK	Off	
	Steering lock system is the LOCK condition or the changing condition from LOCK to UNLOCK	On	E
VEH SPEED 1	While driving	Equivalent to speedometer reading	F
VEH SPEED 2	While driving	Equivalent to speedometer reading	
DOOR STAT-DR	Driver door is locked	LOCK	G
	Wait with selective UNLOCK operation (60 seconds)	READY	
	Driver door is unlocked	UNLOCK	
DOOR STAT-AS	Passenger door is locked	LOCK	H
	Wait with selective UNLOCK operation (60 seconds)	READY	
	Passenger door is unlocked	UNLOCK	I
ID OK FLAG	Steering is locked	Reset	
	Steering is unlocked	Set	J
PRMT ENG STRT	The engine start is prohibited	Reset	
	The engine start is permitted	Set	
PRMT RKE STRT	NOTE: The item is indicated, but not monitored.	Reset	PWC
KEY SW -SLOT	The Intelligent Key is not inserted into key slot	Off	
	The Intelligent Key is inserted into key slot	On	L
RKE OPE COUN1	During the operation of the Intelligent Key	Operation frequency of the Intelligent Key	
RKE OPE COUN2	NOTE: The item is indicated, but not monitored.	—	M
CONFIRM ID ALL	The key ID that the key slot receives is not recognized by any key ID registered to BCM.	Yet	
	The key ID that the key slot receives is recognized by any key ID registered to BCM.	Done	N
CONFIRM ID4	The key ID that the key slot receives is not recognized by the fourth key ID registered to BCM.	Yet	O
	The key ID that the key slot receives is recognized by the fourth key ID registered to BCM.	Done	
CONFIRM ID3	The key ID that the key slot receives is not recognized by the third key ID registered to BCM.	Yet	P
	The key ID that the key slot receives is recognized by the third key ID registered to BCM.	Done	

BCM (BODY CONTROL MODULE)

< ECU DIAGNOSIS INFORMATION >

[FRONT & REAR WINDOW ANTI-PINCH]

Monitor Item	Condition	Value/Status
CONFIRM ID2	The key ID that the key slot receives is not recognized by the second key ID registered to BCM.	Yet
	The key ID that the key slot receives is recognized by the second key ID registered to BCM.	Done
CONFIRM ID1	The key ID that the key slot receives is not recognized by the first key ID registered to BCM.	Yet
	The key ID that the key slot receives is recognized by the first key ID registered to BCM.	Done
TP 4	The ID of fourth Intelligent Key is not registered to BCM	Yet
	The ID of fourth Intelligent Key is registered to BCM	Done
TP 3	The ID of third Intelligent Key is not registered to BCM	Yet
	The ID of third Intelligent Key is registered to BCM	Done
TP 2	The ID of second Intelligent Key is not registered to BCM	Yet
	The ID of second Intelligent Key is registered to BCM	Done
TP 1	The ID of first Intelligent Key is not registered to BCM	Yet
	The ID of first Intelligent Key is registered to BCM	Done
AIR PRESS FL	Ignition switch ON (Only when the signal from the transmitter is received)	Air pressure of front LH tire
AIR PRESS FR	Ignition switch ON (Only when the signal from the transmitter is received)	Air pressure of front RH tire
AIR PRESS RR	Ignition switch ON (Only when the signal from the transmitter is received)	Air pressure of rear RH tire
AIR PRESS RL	Ignition switch ON (Only when the signal from the transmitter is received)	Air pressure of rear LH tire
ID REGST FL1	ID of front LH tire transmitter is registered	Done
	ID of front LH tire transmitter is not registered	Yet
ID REGST FR1	ID of front RH tire transmitter is registered	Done
	ID of front RH tire transmitter is not registered	Yet
ID REGST RR1	ID of rear RH tire transmitter is registered	Done
	ID of rear RH tire transmitter is not registered	Yet
ID REGST RL1	ID of rear LH tire transmitter is registered	Done
	ID of rear LH tire transmitter is not registered	Yet
WARNING LAMP	Tire pressure indicator OFF	Off
	Tire pressure indicator ON	On
BUZZER	Tire pressure warning alarm is not sounding	Off
	Tire pressure warning alarm is sounding	On

BCM (BODY CONTROL MODULE)

< ECU DIAGNOSIS INFORMATION >

[FRONT & REAR WINDOW ANTI-PINCH]

TERMINAL LAYOUT

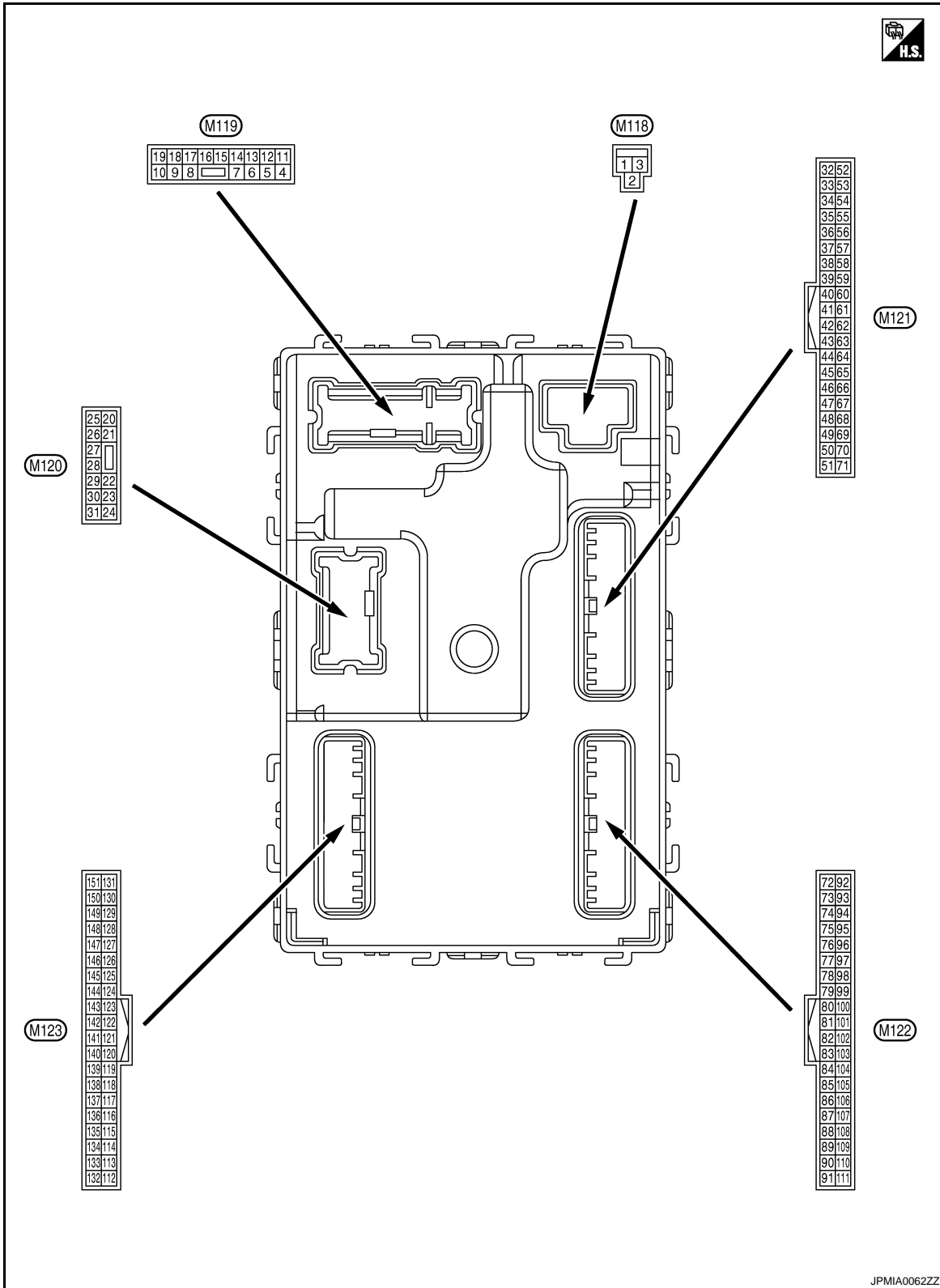

PHYSICAL VALUES

BCM (BODY CONTROL MODULE)

< ECU DIAGNOSIS INFORMATION >

[FRONT & REAR WINDOW ANTI-PINCH]

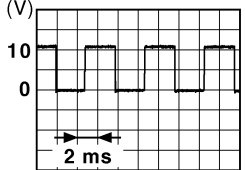
Terminal No. (Wire color)		Description		Condition		Value (Approx.)
		Signal name	Input/ Output			
+	-					
1 (W)	Ground	Battery power supply	Input	Ignition switch OFF		Battery voltage
2 (Y)	Ground	P/W power supply (BAT)	Output	Ignition switch OFF		12 V
3 (O)	Ground	P/W power supply (RAP)	Output	Ignition switch ON		12 V
4 (LG)	Ground	Interior room lamp power supply	Output	Interior room lamp battery saver is activated. (Cuts the interior room lamp power supply)		0 V
				Interior room lamp battery saver is not activated. (Outputs the interior room lamp power supply)		12 V
5 (P)	Ground	Passenger door UN- LOCK	Output	Passenger door	UNLOCK (Actuator is activated)	12 V
					Other than UNLOCK) Actuator is not activated	0 V
7 (BR)	Ground	Step lamp	Output	Step lamp	ON	0 V
					OFF	12 V
8 (V)	Ground	All doors, fuel lid LOCK	Output	All doors, fuel lid	LOCK (Actuator is activated)	12 V
					Other than LOCK (Actuator is not activated)	0 V
9 (G)	Ground	Driver door, fuel lid UNLOCK	Output	Driver door, fuel lid	UNLOCK (Actuator is activated)	12 V
					Other than UNLOCK (Actuator is not activated)	0 V
10 (BR)	Ground	Rear RH door and rear LH UNLOCK	Output	Rear RH door and rear LH door	UNLOCK (Actuator is activated)	12 V
					Other than UNLOCK (Actuator is not activated)	0 V
11 (R)	Ground	Battery power supply	Input	Ignition switch OFF		Battery voltage
13 (B)	Ground	Ground	—	Ignition switch ON		0 V
14 (W)	Ground	Push-button ignition switch illumination ground	Output	Tail lamp	OFF	0 V
					ON	<p>NOTE: When the illumination brightening/dimming level is in the neutral position</p>  <p style="text-align: right; font-size: small;">JSNIA0010GB</p>
15 (O)	Ground	ACC indicator lamp	Output	Ignition switch	OFF (LOCK indicator is not illuminated)	Battery voltage
					ACC	0 V

BCM (BODY CONTROL MODULE)

< ECU DIAGNOSIS INFORMATION >

[FRONT & REAR WINDOW ANTI-PINCH]

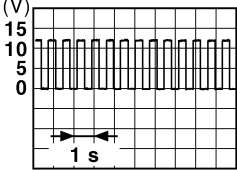
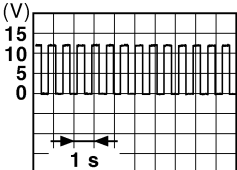
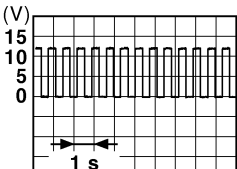
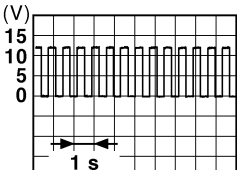
Terminal No. (Wire color)		Description		Condition	Value (Approx.)	
		Signal name	Input/ Output			
+	-					
17 (W)	Ground	Turn signal RH (Front)	Output	Ignition switch ON	Turn signal switch OFF	0 V
					Turn signal switch RH	 <p style="text-align: right; font-size: small;">PKID0926E</p>
18 (O)	Ground	Turn signal LH (Front)	Output	Ignition switch ON	Turn signal switch OFF	0 V
					Turn signal switch LH	 <p style="text-align: right; font-size: small;">PKID0926E</p>
19 (V)	Ground	Room lamp timer control	Output	Interior room lamp	OFF	12 V
					ON	0 V
20 (V)	Ground	Turn signal RH (Rear)	Output	Ignition switch ON	Turn signal switch OFF	0 V
					Turn signal switch RH	 <p style="text-align: right; font-size: small;">PKID0926E</p>
23 (L)	Ground	Trunk lid open	Output	Trunk lid	OPEN (Trunk lid opener actuator is activated)	12 V
					Other than OPEN (Trunk lid opener actuator is not activated)	0 V
25 (Y)	Ground	Turn signal LH (Rear)	Output	Ignition switch ON	Turn signal switch OFF	0 V
					Turn signal switch LH	 <p style="text-align: right; font-size: small;">PKID0926E</p>
30 (P)	Ground	Trunk room lamp	Output	Trunk room lamp	ON	0 V
					OFF	12 V

A
B
C
D
E
F
G
H
I
J
L
M
N
O
P



BCM (BODY CONTROL MODULE)

< ECU DIAGNOSIS INFORMATION >

[FRONT & REAR WINDOW ANTI-PINCH]

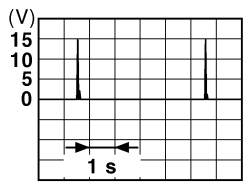
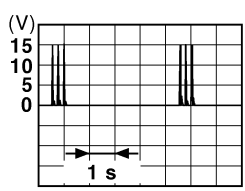
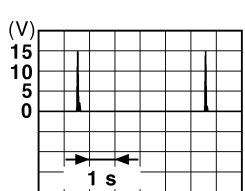
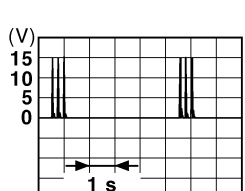
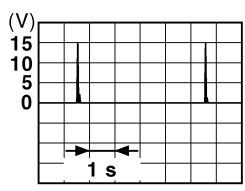
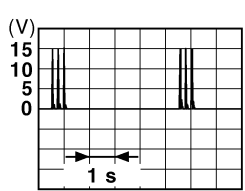
Terminal No. (Wire color)		Description		Condition	Value (Approx.)
+	-	Signal name	Input/ Output		
34 (SB)	Ground	Trunk room antenna (-)	Output	Ignition switch OFF	When Intelligent Key is in the passenger compart- ment  <small>JMKIA0062GB</small>
				When Intelligent Key is not in the passenger compart- ment  <small>JMKIA0063GB</small>	
35 (V)	Ground	Trunk room antenna (+)	Output	Ignition switch OFF	When Intelligent Key is in the passenger compart- ment  <small>JMKIA0062GB</small>
				When Intelligent Key is not in the passenger compart- ment  <small>JMKIA0063GB</small>	
38 (B)	Ground	Rear bumper anten- na (-)	Output	When the trunk lid opener re- quest switch is operated with ignition switch OFF	When Intelligent Key is in the antenna detection area  <small>JMKIA0062GB</small>
				When Intelligent Key is not in the antenna detection area  <small>JMKIA0063GB</small>	

BCM (BODY CONTROL MODULE)

< ECU DIAGNOSIS INFORMATION >

[FRONT & REAR WINDOW ANTI-PINCH]

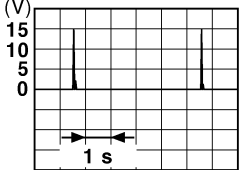
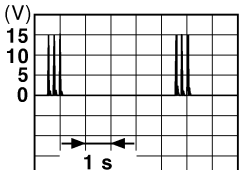
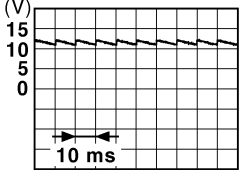
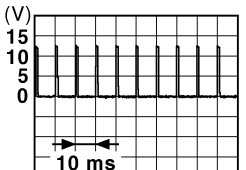
Terminal No. (Wire color)		Description		Condition	Value (Approx.)
		Signal name	Input/ Output		
+	-				
39 (W)	Ground	Rear bumper antenna (+)	Output	When Intelligent Key is in the antenna detection area	 <small>JMKIA0062GB</small>
				When the trunk lid opener request switch is operated with ignition switch OFF	 <small>JMKIA0063GB</small>
47 (Y)	Ground	Ignition relay (IPDM E/R) control	Output	Ignition switch OFF or ACC	12 V
				ON	0 V
50 (O)	Ground	Trunk room lamp switch	Input	Trunk room lamp switch OFF (Trunk lid is closed)	 <small>JPMIA0011GB</small>
				ON (Trunk lid is opened)	0 V
52 (SB)	Ground	Starter relay control	Output	Ignition switch ON (A/T models) When selector lever is in P or N position	12 V
				Ignition switch ON (A/T models) When selector lever is not in P or N position	0 V
				Ignition switch ON (M/T models) When the clutch pedal is depressed	Battery voltage
				Ignition switch ON (M/T models) When the clutch pedal is not depressed	0 V
61 (SB)	Ground	Trunk lid opener request switch	Input	Trunk lid opener request switch ON (Pressed)	0 V
				OFF (Not pressed)	 <small>JPMIA0016GB</small>
64 (G)	Ground	Intelligent Key warning buzzer (Engine room)	Output	Intelligent Key warning buzzer (Engine room) Sounding	0 V
				Not sounding	12 V

A
B
C
D
E
F
G
H
I
J
L
M
N
O
P

PWC

BCM (BODY CONTROL MODULE)

< ECU DIAGNOSIS INFORMATION >

[FRONT & REAR WINDOW ANTI-PINCH]

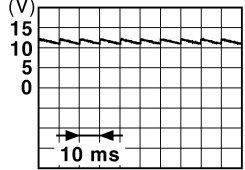
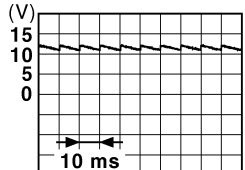
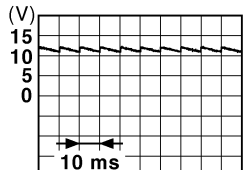
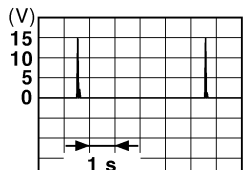
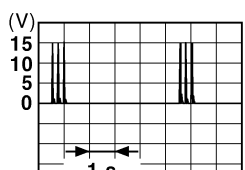
Terminal No. (Wire color)		Description		Condition	Value (Approx.)		
		Signal name	Input/ Output				
+	-						
67 (GR)	Ground	Trunk lid opener switch	Input	Trunk lid open- er switch	Pressed	0 V	
				Not pressed	 <p style="text-align: right; font-size: small;">JPMIA0011GB</p>	11.8 V	
68 (BR)	Ground	Rear RH door switch	Input	Rear RH door switch	OFF (When rear RH door closes)	 <p style="text-align: right; font-size: small;">JPMIA0011GB</p>	11.8 V
				ON (When rear RH door opens)	0 V		
69 (R)	Ground	Rear LH door switch	Input	Rear LH door switch	OFF (When rear LH door closes)	 <p style="text-align: right; font-size: small;">JPMIA0011GB</p>	11.8 V
				ON (When rear LH door opens)	0 V		
72 (R)	Ground	Room antenna 2 (-) (Center console)	Output	Ignition switch OFF	When Intelligent Key is in the passenger compart- ment	 <p style="text-align: right; font-size: small;">JMKIA0062GB</p>	
				When Intelligent Key is not in the passenger compart- ment	 <p style="text-align: right; font-size: small;">JMKIA0063GB</p>		

BCM (BODY CONTROL MODULE)

< ECU DIAGNOSIS INFORMATION >

[FRONT & REAR WINDOW ANTI-PINCH]

Terminal No. (Wire color)		Description		Condition	Value (Approx.)
+	-	Signal name	Input/ Output		
73 (G)	Ground	Room antenna 2 (+) (Center console)	Output	Ignition switch OFF	<p>JMKIA0062GB</p>
				When Intelligent Key is not in the passenger compart- ment	<p>JMKIA0063GB</p>
74 (SB)	Ground	Passenger door an- tenna (-)	Output	When the pas- senger door re- quest switch is operated with ignition switch OFF	<p>JMKIA0062GB</p>
				When Intelligent Key is not in the antenna detection area	<p>JMKIA0063GB</p>
75 (BR)	Ground	Passenger door an- tenna (+)	Output	When the pas- senger door re- quest switch is operated with ignition switch OFF	<p>JMKIA0062GB</p>
				When Intelligent Key is not in the antenna detection area	<p>JMKIA0063GB</p>

A
B
C
D
E
F
G
H
I
J
L
M
N
O
P

PWC

BCM (BODY CONTROL MODULE)

< ECU DIAGNOSIS INFORMATION >

[FRONT & REAR WINDOW ANTI-PINCH]

Terminal No. (Wire color)		Description		Condition	Value (Approx.)	
+	-	Signal name	Input/ Output			
76 (V)	Ground	Driver door antenna (-)	Output	When Intelligent Key is in the antenna detection area	<p>JMKIA0062GB</p>	
				When the driver door request switch is operated with ignition switch OFF	When Intelligent Key is not in the antenna detection area	<p>JMKIA0063GB</p>
77 (LG)	Ground	Driver door antenna (+)	Output	When Intelligent Key is in the antenna detection area	<p>JMKIA0062GB</p>	
				When the driver door request switch is operated with ignition switch OFF	When Intelligent Key is not in the antenna detection area	<p>JMKIA0063GB</p>
78 (Y)	Ground	Room antenna 1 (-) (Instrument panel)	Output	Ignition switch OFF	When Intelligent Key is in the passenger compartment	<p>JMKIA0062GB</p>
				When Intelligent Key is not in the passenger compartment	<p>JMKIA0063GB</p>	

BCM (BODY CONTROL MODULE)

< ECU DIAGNOSIS INFORMATION >

[FRONT & REAR WINDOW ANTI-PINCH]

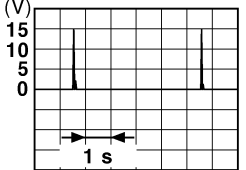
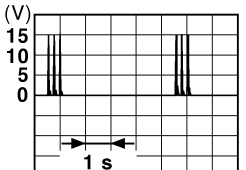
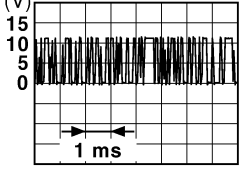
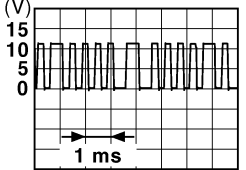
Terminal No. (Wire color)		Description		Condition	Value (Approx.)
+	-	Signal name	Input/ Output		
79 (BR)	Ground	Room antenna 1 (+) (Instrument panel)	Output	Ignition switch OFF	
				Ignition switch ON	
80 (GR)	Ground	NATS antenna amp (Built in key slot)	Input/ Output	During waiting	Ignition switch is pressed while inserting the Intelligent Key into the key slot. Pointer of tester should move.
81 (W)	Ground	NATS antenna amp (Built in key slot)	Input/ Output	During waiting	Ignition switch is pressed while inserting the Intelligent Key into the key slot. Pointer of tester should move.
82 (R)	Ground	Ignition relay [Fuse block (J/B)] control	Output	Ignition switch OFF or ACC	0 V
				ON	12 V
83 (Y)	Ground	Remote keyless entry receiver communication	Input/ Output	During waiting	
				When operating either button on the Intelligent Key	

A
B
C
D
E
F
G
H
I
J
L
M
N
O
P

PWC

BCM (BODY CONTROL MODULE)

< ECU DIAGNOSIS INFORMATION >



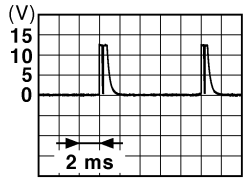
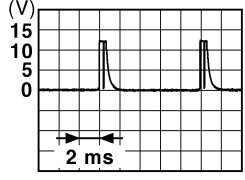

[FRONT & REAR WINDOW ANTI-PINCH]

Terminal No. (Wire color)		Description		Condition	Value (Approx.)
+	-	Signal name	Input/ Output		
87 (Y)	Ground	Combination switch INPUT 5	Input	All switches OFF (Wiper intermittent dial 4)	 <p style="text-align: right; font-size: small;">JPMIA0041GB</p> <p style="text-align: center;">1.4 V</p>
				Front fog lamp switch ON (Wiper intermittent dial 4)	 <p style="text-align: right; font-size: small;">JPMIA0037GB</p> <p style="text-align: center;">1.3 V</p>
				Any of the conditions below with all switches OFF <ul style="list-style-type: none"> • Wiper intermittent dial 1 • Wiper intermittent dial 2 • Wiper intermittent dial 6 • Wiper intermittent dial 7 	 <p style="text-align: right; font-size: small;">JPMIA0040GB</p> <p style="text-align: center;">1.3 V</p>

BCM (BODY CONTROL MODULE)

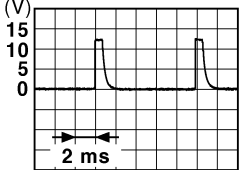
< ECU DIAGNOSIS INFORMATION >

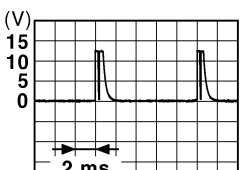
[FRONT & REAR WINDOW ANTI-PINCH]

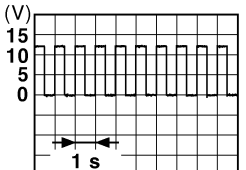
Terminal No. (Wire color)		Description		Condition	Value (Approx.)	
		Signal name	Input/ Output			
+	-					
88 (O)	Ground	Combination switch INPUT 3	Input	Combination switch	All switches OFF (Wiper intermittent dial 4)	 <small>JPMIA0041GB</small> 1.4 V
					Lighting switch HI (Wiper intermittent dial 4)	 <small>JPMIA0036GB</small> 1.3 V
					Lighting switch 2ND (Wiper intermittent dial 4)	 <small>JPMIA0037GB</small> 1.3 V
					Any of the conditions below with all switches OFF <ul style="list-style-type: none"> • Wiper intermittent dial 1 • Wiper intermittent dial 2 • Wiper intermittent dial 3 	 <small>JPMIA0040GB</small> 1.3 V
89 (BR)	Ground	Push-button ignition switch (Push switch)	Input	Push-button ignition switch (push switch)	Pressed	0 V
					Not pressed	Battery voltage
90 (P)	Ground	CAN-L	Input/ Output	—	—	
91 (L)	Ground	CAN-H	Input/ Output	—	—	
92 (LG)	Ground	Key slot illumination	Output	Key slot illumina- tion	OFF	0 V
					Blinking	 <small>JPMIA0015GB</small> 6.5 V
					ON	12 V

A
B
C
D
E
F
G
H
I
J
L
M
N
O
P

PWC

BCM (BODY CONTROL MODULE)

< ECU DIAGNOSIS INFORMATION >



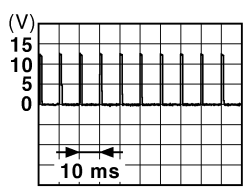
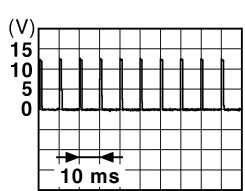

[FRONT & REAR WINDOW ANTI-PINCH]

Terminal No. (Wire color)		Description		Condition		Value (Approx.)
		Signal name	Input/ Output			
+	-					
93 (V)	Ground	ON indicator lamp	Output	Ignition switch	OFF (LOCK indicator is not illuminated)	Battery voltage
					ON	0 V
95 (O)	Ground	ACC relay control	Output	Ignition switch	OFF	0 V
					ACC or ON	12 V
96 (GR)	Ground	A/T shift selector (Detention switch) power supply	Output	—		12 V
97 (L)	Ground	Steering lock condition No. 1	Input	Steering lock	LOCK status	0 V
					UNLOCK status	12 V
98 (P)	Ground	Steering lock condition No. 2	Input	Steering lock	LOCK status	12 V
					UNLOCK status	0 V
99 (R)*1 (BR)*2	Ground	Selector lever P position switch (A/T models)	Input	Selector lever	P position	0 V
					Any position other than P	12 V
		ASCD clutch switch (M/T models without ICC)		ASCD clutch switch	OFF (Clutch pedal is depressed)	0 V
					ON (Clutch pedal is not depressed)	12 V
		ICC clutch switch (M/T models with ICC)		ICC clutch switch	OFF (Clutch pedal is depressed)	0 V
					ON (Clutch pedal is not depressed)	12 V
100 (Y)	Ground	Passenger door request switch	Input	Passenger door request switch	ON (Pressed)	0 V
					OFF (Not pressed)	 <p style="text-align: right; font-size: small;">JPMIA0016GB 1.0 V</p>
101 (P)	Ground	Driver door request switch	Input	Driver door request switch	ON (Pressed)	0 V
					OFF (Not pressed)	 <p style="text-align: right; font-size: small;">JPMIA0016GB 1.0 V</p>
102 (O)	Ground	Blower fan motor relay control	Output	Ignition switch	OFF or ACC	0 V
					ON	12 V
103 (L)	Ground	Remote keyless entry receiver power supply	Output	Ignition switch OFF		12 V
106 (W)	Ground	Steering lock unit power supply	Output	Ignition switch	OFF or ACC	12 V
					ON	0 V

BCM (BODY CONTROL MODULE)

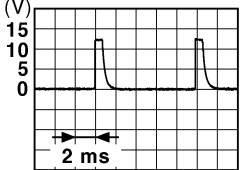
< ECU DIAGNOSIS INFORMATION >

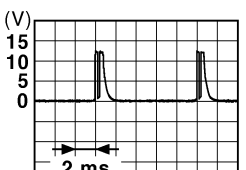
[FRONT & REAR WINDOW ANTI-PINCH]

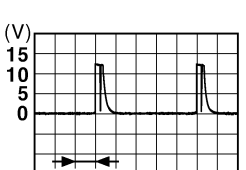
Terminal No. (Wire color)		Description		Condition	Value (Approx.)	
		Signal name	Input/ Output			
+	-					
107 (LG)	Ground	Combination switch INPUT 1	Input	Combination switch (Wiper intermit- tent dial 4)	All switches OFF	 1.4 V
					Turn signal switch LH	 1.3 V
					Turn signal switch RH	 1.3 V
					Front wiper switch LO	 1.3 V
					Front washer switch ON	 1.3 V

A
B
C
D
E
F
G
H
I
J
L
M
N
O
P

PWC

BCM (BODY CONTROL MODULE)

< ECU DIAGNOSIS INFORMATION >



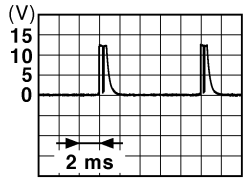
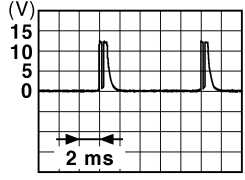
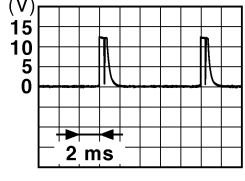

[FRONT & REAR WINDOW ANTI-PINCH]

Terminal No. (Wire color)		Description		Condition	Value (Approx.)
+	-	Signal name	Input/ Output		
108 (R)	Ground	Combination switch INPUT 4	Input	Combination switch	All switches OFF (Wiper intermittent dial 4) <div style="text-align: right;">  <p style="font-size: small; margin: 0;">JPMIA0041GB</p> <p style="margin: 0;">1.4 V</p> </div>
				Combination switch	Lighting switch AUTO (Wiper intermittent dial 4) <div style="text-align: right;">  <p style="font-size: small; margin: 0;">JPMIA0038GB</p> <p style="margin: 0;">1.3 V</p> </div>
				Combination switch	Lighting switch 1ST (Wiper intermittent dial 4) <div style="text-align: right;">  <p style="font-size: small; margin: 0;">JPMIA0036GB</p> <p style="margin: 0;">1.3 V</p> </div>
				Combination switch	Any of the conditions be- low with all switches OFF <ul style="list-style-type: none"> • Wiper intermittent dial 1 • Wiper intermittent dial 5 • Wiper intermittent dial 6 <div style="text-align: right;">  <p style="font-size: small; margin: 0;">JPMIA0039GB</p> <p style="margin: 0;">1.3 V</p> </div>

BCM (BODY CONTROL MODULE)

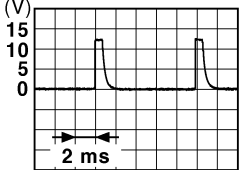
< ECU DIAGNOSIS INFORMATION >

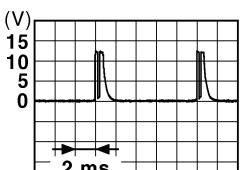
[FRONT & REAR WINDOW ANTI-PINCH]

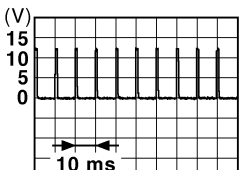
Terminal No. (Wire color)		Description		Condition	Value (Approx.)	
+	-	Signal name	Input/ Output			
109 (W)	Ground	Combination switch INPUT 2	Input	Combination switch (Wiper intermit- tent dial 4)	All switches OFF	 <p>1.4 V</p>
					Lighting switch PASS	 <p>1.3 V</p>
					Lighting switch 2ND	 <p>1.3 V</p>
					Front wiper switch INT	 <p>1.3 V</p>
					Front wiper switch HI	 <p>1.3 V</p>
					ON	0 V
110 (G)	Ground	Hazard switch	Input	Hazard switch	 <p>1.1 V</p>	
				OFF		

A
B
C
D
E
F
G
H
I
J
L
M
N
O
P

PWC

BCM (BODY CONTROL MODULE)

< ECU DIAGNOSIS INFORMATION >

[FRONT & REAR WINDOW ANTI-PINCH]

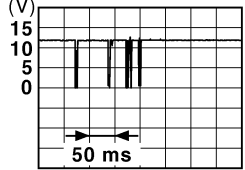
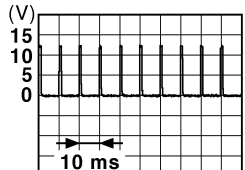
Terminal No. (Wire color)		Description		Condition	Value (Approx.)	
		Signal name	Input/ Output			
+	-					
111 (Y)	Ground	Steering lock unit communication	Input/ Output	Steering lock	LOCK status	12 V
					LOCK or UNLOCK	 <p style="text-align: right; font-size: small;">JMkia0066GB</p>
					For 15 seconds after UNLOCK	12 V
				15 seconds or later after UNLOCK	0 V	
113 (O)	Ground	Optical sensor	Input	Ignition switch ON	When bright outside of the vehicle	Close to 5 V
				When dark outside of the vehicle	Close to 0 V	
114 (R)	Ground	Clutch interlock switch	Input	Clutch interlock switch	OFF (Clutch pedal is not depressed)	0 V
				ON (Clutch pedal is depressed)	Battery voltage	
116 (SB)	Ground	Stop lamp switch 1	Input	—	Battery voltage	
118 (BR)	Ground	Stop lamp switch 2 (Without ICC)	Input	Stop lamp switch	OFF (Brake pedal is not depressed)	0 V
					ON (Brake pedal is depressed)	Battery voltage
		Stop lamp switch 2 (With ICC)		Stop lamp switch OFF (Brake pedal is not depressed) and ICC brake hold relay OFF	0 V	
				Stop lamp switch ON (Brake pedal is depressed) or ICC brake hold relay ON	Battery voltage	
119 (SB)	Ground	Front door lock assembly driver side (Unlock sensor)	Input	Driver door	LOCK status (Unlock sensor switch OFF)	 <p style="text-align: right; font-size: small;">JPMIA0012GB</p>
					UNLOCK status (Unlock switch sensor ON)	1.1 V
					0 V	
121 (SB)	Ground	Key slot switch	Input	When the Intelligent Key is inserted into key slot	12 V	
				When the Intelligent Key is not inserted into key slot	0 V	
123 (W)	Ground	IGN feedback	Input	Ignition switch	OFF or ACC	0 V
				ON	Battery voltage	

BCM (BODY CONTROL MODULE)

< ECU DIAGNOSIS INFORMATION >

[FRONT & REAR WINDOW ANTI-PINCH]

Terminal No. (Wire color)		Description		Condition	Value (Approx.)	
+	-	Signal name	Input/ Output			
124 (LG)	Ground	Passenger door switch	Input	Passenger door switch	OFF (Door close)	<p>JPMIA0011GB 11.8 V</p>
					ON (Door open)	0 V
129 (O)	Ground	Trunk lid opener cancel switch	Input	Trunk lid opener cancel switch	CANCEL	<p>JPMIA0012GB 1.1 V</p>
					ON	0 V
132 (V)	Ground	Power window switch communication	Input/ Output	Ignition switch ON		<p>JPMIA0013GB 10.2 V</p>
					Ignition switch OFF or ACC	12 V
133 (L)	Ground	Push-button ignition switch illumination	Output	Push-button ignition switch illumination	ON (Tail lamps OFF)	9.5 V
					ON (Tail lamps ON)	<p>NOTE: The pulse width of this wave is varied by the illumination brightening/dimming level.</p> <p>JPMIA0159GB</p>
					OFF	0 V
134 (LG)	Ground	LOCK indicator lamp	Output	LOCK indicator lamp	OFF	Battery voltage
					ON	0 V
137 (O)	Ground	Receiver and sensor ground	Input	Ignition switch ON		0 V
138 (V)	Ground	Receiver and sensor power supply	Output	Ignition switch	OFF	0 V
					ACC or ON	5.0 V

A
B
C
D
E
F
G
H
I
J
PWC
L
M
N
O
P

BCM (BODY CONTROL MODULE)

< ECU DIAGNOSIS INFORMATION >

[FRONT & REAR WINDOW ANTI-PINCH]

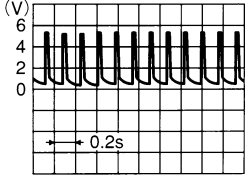
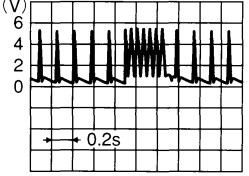
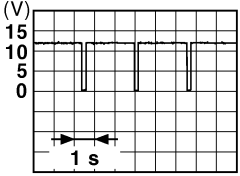
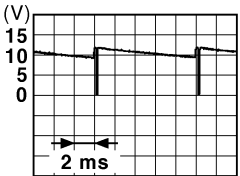
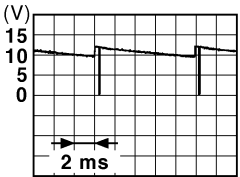
Terminal No. (Wire color)		Description		Condition	Value (Approx.)	
		Signal name	Input/ Output			
+	-					
139 (L)	Ground	Tire pressure receiver communication	Input/ Output	Ignition switch ON	Standby state	 OCC3881D
				When receiving the signal from the transmitter	 OCC3880D	
140 (GR)	Ground	Selector lever P/N position	Input	Selector lever	P or N position	12 V
				Except P and N positions	0 V	
141 (R)	Ground	Security indicator	Output	Security indicator	ON	0 V
					Blinking	 JPMIA0014GB
					OFF	12 V
142 (BR)	Ground	Combination switch OUTPUT 5	Output	Combination switch (Wiper intermittent dial 4)	All switches OFF	0 V
					Lighting switch 1ST	 JPMIA0031GB
					Lighting switch HI	
					Lighting switch 2ND	
Turn signal switch RH	10.7 V					
143 (P)	Ground	Combination switch OUTPUT 1	Output	Combination switch	All switches OFF (Wiper intermittent dial 4)	0 V
					Front wiper switch HI (Wiper intermittent dial 4)	 JPMIA0032GB
					Any of the conditions below with all switches OFF <ul style="list-style-type: none"> • Wiper intermittent dial 1 • Wiper intermittent dial 2 • Wiper intermittent dial 3 • Wiper intermittent dial 6 • Wiper intermittent dial 7 	

BCM (BODY CONTROL MODULE)

< ECU DIAGNOSIS INFORMATION >

[FRONT & REAR WINDOW ANTI-PINCH]

Terminal No. (Wire color)		Description		Condition	Value (Approx.)	
		Signal name	Input/ Output			
+	-					
144 (G)	Ground	Combination switch OUTPUT 2	Output	Combination switch	All switches OFF (Wiper intermittent dial 4)	0 V
					Front washer switch ON (Wiper intermittent dial 4)	
					Any of the conditions below with all switches OFF <ul style="list-style-type: none"> • Wiper intermittent dial 1 • Wiper intermittent dial 5 • Wiper intermittent dial 6 	
145 (L)	Ground	Combination switch OUTPUT 3	Output	Combination switch (Wiper intermit- tent dial 4)	All switches OFF	0 V
					Front wiper switch INT	
					Front wiper switch LO	
					Lighting switch AUTO	
146 (SB)	Ground	Combination switch OUTPUT 4	Output	Combination switch (Wiper intermit- tent dial 4)	All switches OFF	0 V
					Front fog lamp switch ON	
					Lighting switch 2ND	
					Lighting switch PASS	
					Turn signal switch LH	
149 (W)	Ground	Tire pressure warning check switch	Input	—	12 V	
150 (GR)	Ground	Driver door switch	Input	Driver door switch	OFF (Door close)	
					ON (Door open)	
151 (G)	Ground	Rear window defog- ger relay control	Output	Rear window defogger	Active	0 V
				Not activated	Battery voltage	

- *1: A/T models
- *2: M/T models

A
B
C
D
E
F
G
H
I
J
L
M
N
O
P

PWC

BCM (BODY CONTROL MODULE)

[FRONT & REAR WINDOW ANTI-PINCH]

< ECU DIAGNOSIS INFORMATION >

Wiring Diagram - BCM -

INFOID:000000004667396

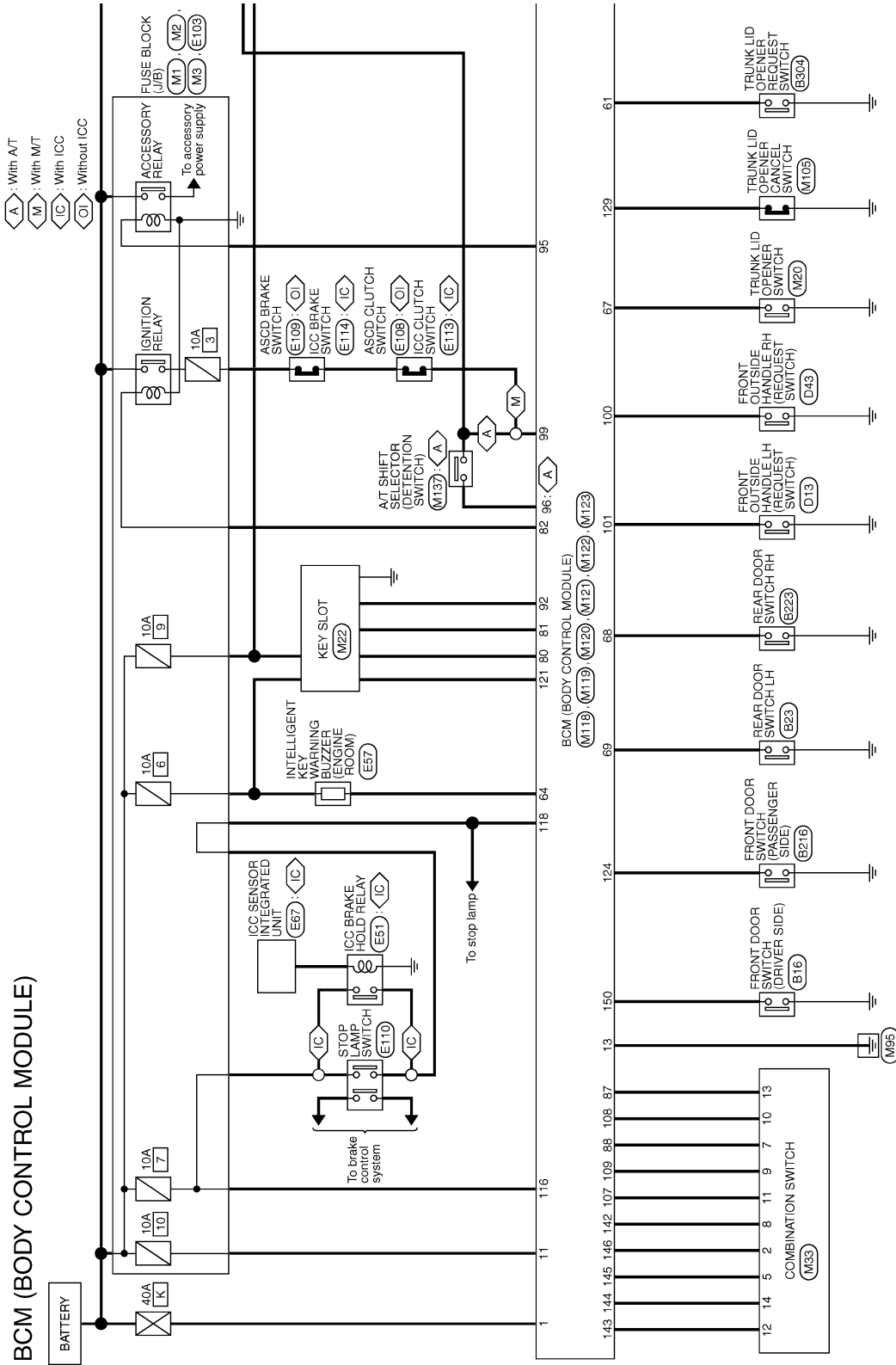

2008/08/07

JCMWA3019GE

BCM (BODY CONTROL MODULE)

< ECU DIAGNOSIS INFORMATION >

[FRONT & REAR WINDOW ANTI-PINCH]

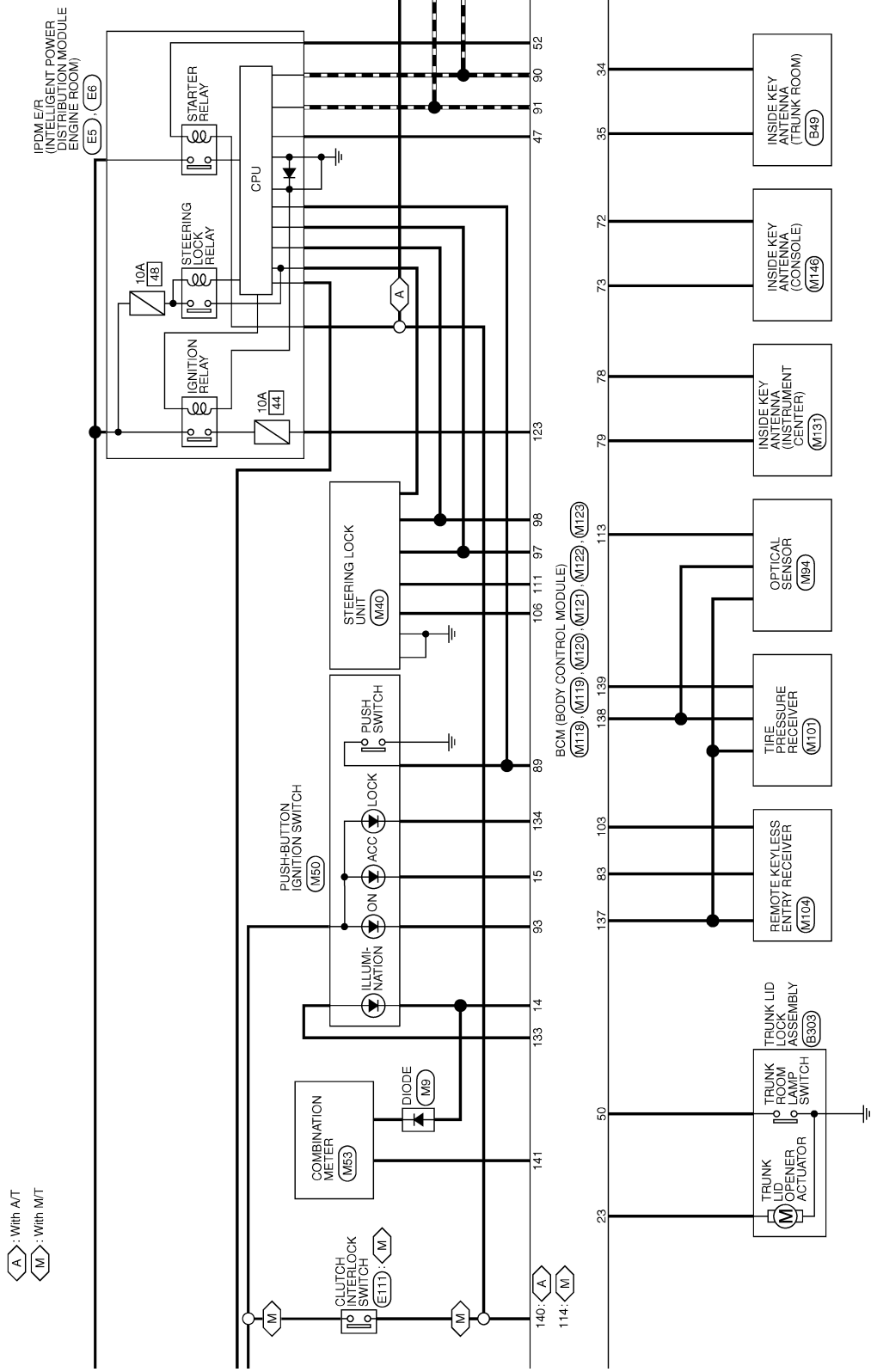

JCMWA3020GE

BCM (BODY CONTROL MODULE)

< ECU DIAGNOSIS INFORMATION >

[FRONT & REAR WINDOW ANTI-PINCH]

- ◁ A ▷ : With AT
- ◁ RF ▷ : With sunroof
- ◁ AN ▷ : With rear anti-pinch system
- ◁ OA ▷ : Without rear anti-pinch system
- ◁ SR ▷ : With sports seat without automatic drive positioner
- ◁ PM ▷ : With automatic drive positioner
- ◁ OP ▷ : Without automatic drive positioner

* : This connector is not shown in "Harness Layout".

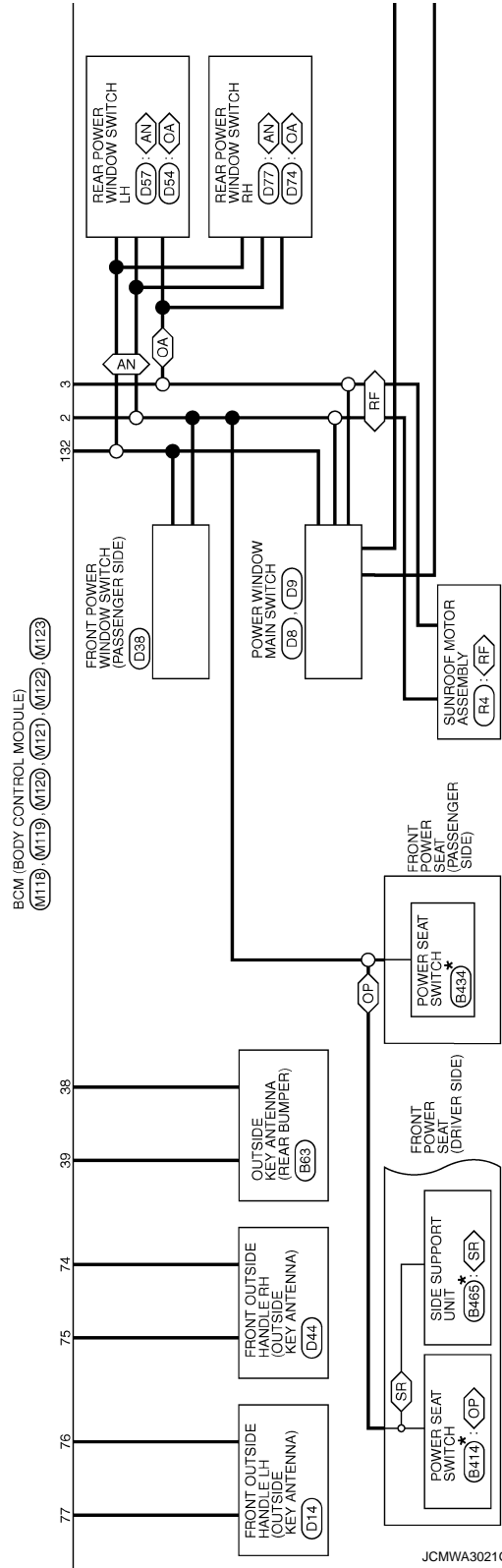
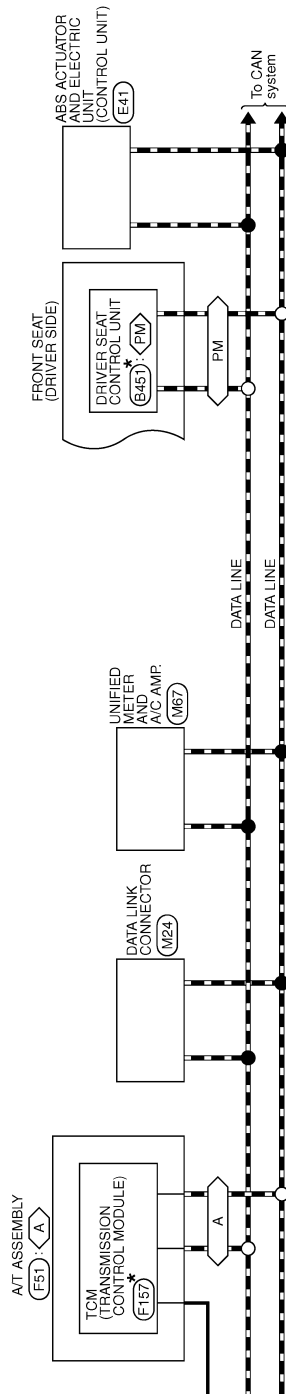

JCMWA3021Gf

BCM (BODY CONTROL MODULE)

< ECU DIAGNOSIS INFORMATION >

[FRONT & REAR WINDOW ANTI-PINCH]

BCM (BODY CONTROL MODULE)

Connector No.	M33
Connector Name	COMBINATION SWITCH
Connector Type	TH16FW-NH

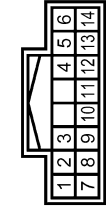

Terminal No.	Color of Wire	Signal Name [Specification]
2	SB	OUTPUT 4
5	L	OUTPUT 3
7	O	INPUT 3
8	BR	OUTPUT 5
9	W	INPUT 2
10	R	INPUT 4
11	LG	INPUT 1
12	P	OUTPUT 1
13	Y	INPUT 5
14	G	OUTPUT 2



Connector No.	M120
Connector Name	BCM (BODY CONTROL MODULE)
Connector Type	MS12PW-CS



Terminal No.	Color of Wire	Signal Name [Specification]
20	V	TURN SIGNAL RH (REAR)
23	L	TRUNK LID OPEN OUTPUT
25	Y	TURN SIGNAL LH (REAR)
30	P	TRUNK ROOM LAMP

Connector No.	M118
Connector Name	BCM (BODY CONTROL MODULE)
Connector Type	M03EB-LC



Terminal No.	Color of Wire	Signal Name [Specification]
1	W	BAT (E/L)
2	Y	POWER WINDOW POWER SUPPLY(BAT)
3	O	POWER WINDOW POWER SUPPLY(IRAP)

Connector No.	M121
Connector Name	BCM (BODY CONTROL MODULE)
Connector Type	TH40FGY-NH

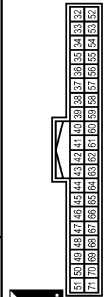

Terminal No.	Color of Wire	Signal Name [Specification]
34	SB	TRUNK ROOM ANT-
35	V	TRUNK ROOM ANT+
38	B	REAR BUMPER ANT-
39	W	REAR BUMPER ANT+
47	Y	IGN RELAY (PDM E/R) CONT
50	O	TRUNK ROOM LAMP SW
52	SR	STARTER RELAY CONT
61	SR	TRUNK LID OPENER REQUEST SW
64	G	IN-KEY WARN BUTTZEER (ENG ROOM)
67	GR	TRUNK LID OPENER SW
68	BR	REAR RH DOOR SW

Connector No.	M119
Connector Name	BCM (BODY CONTROL MODULE)
Connector Type	MS16FW-CS

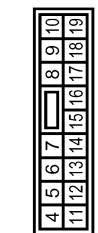

Terminal No.	Color of Wire	Signal Name [Specification]
4	LG	INTERIOR ROOM LAMP POWER SUPPLY
5	P	PASSENGER DOOR UNLOCK OUTPUT
7	BR	STEP LAMP OUTPUT
8	V	ALL DOOR. FUEL LID LOCK OUTPUT
9	G	DRIVER DOOR. FUEL LID UNLOCK OUTPUT
10	BR	REAR DOOR UNLOCK OUTPUT
11	R	BAT (FUSE)
13	B	GND
14	W	PUSH-BUTTON (IGNITION SW) ILL GND
15	O	ACC IND
17	W	TURN SIGNAL RH (FRONT)

69	R	REAR LH DOOR SW
----	---	-----------------

18	O	TURN SIGNAL LH (FRONT)
19	V	ROOM LAMP TIMER CONTROL

BCM (BODY CONTROL MODULE)

< ECU DIAGNOSIS INFORMATION >

[FRONT & REAR WINDOW ANTI-PINCH]

BCM (BODY CONTROL MODULE)

Connector No.	M122
Connector Name	BCM (BODY CONTROL MODULE)
Connector Type	TH40FB-NH



Terminal No.	Color of Wire	Signal Name [Specification]
72	R	ROOM ANT2-
73	G	ROOM ANT2+
74	SB	PASSENGER DOOR ANT-
75	BR	PASSENGER DOOR ANT+
76	V	DRIVER DOOR ANT-
77	LG	DRIVER DOOR ANT+
78	Y	ROOM ANTI-
79	BR	ROOM ANTI+
80	GR	IMMOBI ANTENNA CONTROL
81	W	IMMOBI ANTENNA SIGNAL
82	R	IGN RELAY (F/B) CONT

83	Y	KEYLESS ENTRY RECEIVER COMM
87	Y	COMBI SW INPUT 5
88	O	COMBI SW INPUT 3
89	BR	PUSH SW
90	P	GAH-L
91	L	GAH-H
92	LG	KEY SLOT ILL
93	V	ON IND
95	O	ACC RELAY CONT
96	GR	AT SHIFT SELECTOR POWER SUPPLY
97	L	S/L CONDITION 1
98	P	S/L CONDITION 2
99	BR	ASCD CLUTCH SW [With M/T without GC]
99	BR	IGCC CLUTCH SW [With M/T and GC]
99	R	SHIFT P [With A/T]
100	Y	PASSENGER DOOR REQUEST SW
101	P	DRIVER DOOR REQUEST SW
102	O	BLOWER FAN MOTOR RELAY CONT
103	L	KEYLESS ENTRY RECEIVER POWER SUPPLY
106	W	S/L UNIT POWER SUPPLY
107	LG	COMBI SW INPUT 1
108	R	COMBI SW INPUT 4
109	W	COMBI SW INPUT 2
110	G	HAZARD SW
111	Y	S/L UNIT COMM

Connector No.	M123
Connector Name	BCM (BODY CONTROL MODULE)
Connector Type	TH40FG-NH



Terminal No.	Color of Wire	Signal Name [Specification]
113	O	OPTICAL SENSOR
114	R	CLUTCH INTERLOCK SW
116	SB	STOP LAMP SW 1
118	BR	STOP LAMP SW 2
119	SB	DR DOOR UNLOCK SENSOR
121	SB	KEY SLOT SW
123	W	IGN F/B
124	LG	PASSENGER DOOR SW
129	O	TRUNK LID OPENER CANCEL SW
132	V	POWER WINDOW SW COMM
133	L	PUSH-BUTTON IGNITION SW ILL POWER

134	LG	LOCK IND
137	O	RECEIVER/SENSOR GND
138	V	RECEIVER/SENSOR POWER SUPPLY
139	L	TIRE PRESSURE RECEIVER COMM
140	GR	SHIFT LUP
141	R	SECURITY INDICATOR
142	BR	COMBI SW OUTPUT 5
143	P	COMBI SW OUTPUT 1
144	G	COMBI SW OUTPUT 2
145	L	COMBI SW OUTPUT 3
146	SB	COMBI SW OUTPUT 4
149	W	TIRE PRESSURE WARN CHECK SW
150	GR	DRIVER DOOR SW
151	G	REAR WINDOW DEFOGGER RELAY CONT

Fail-safe

FAIL-SAFE CONTROL BY DTC

BCM performs fail-safe control when any DTC are detected.

JCMWA3024GE

INFOID:000000004667397

A
B
C
D
E
F
G
H
I
J
K
L
M
N
O
P

PWC

BCM (BODY CONTROL MODULE)

< ECU DIAGNOSIS INFORMATION >

[FRONT & REAR WINDOW ANTI-PINCH]

Display contents of CONSULT	Fail-safe	Cancellation
B2013: ID DISCORD BCM-S/L	Inhibit engine cranking	Erase DTC
B2014: CHAIN OF S/L-BCM	Inhibit engine cranking	Erase DTC
B2190: NATS ANTENNA AMP	Inhibit engine cranking	Erase DTC
B2191: DIFFERENCE OF KEY	Inhibit engine cranking	Erase DTC
B2192: ID DISCORD BCM-ECM	Inhibit engine cranking	Erase DTC
B2193: CHAIN OF BCM-ECM	Inhibit engine cranking	Erase DTC
B2195: ANTI SCANNING	Inhibit engine cranking	Ignition switch ON → OFF
B2557: VEHICLE SPEED	Inhibit steering lock	When normal vehicle speed signals are received from ABS actuator and electric unit (control unit) for 500 ms
B2560: STARTER CONT RELAY	Inhibit engine cranking	500 ms after the following CAN signal communication status becomes consistent <ul style="list-style-type: none"> • Starter control relay signal • Starter relay status signal
B2601: SHIFT POSITION	Inhibit steering lock	500 ms after the following signal reception status becomes consistent <ul style="list-style-type: none"> • Selector lever P position switch signal • P range signal (CAN)
B2602: SHIFT POSITION	Inhibit steering lock	5 seconds after the following BCM recognition conditions are fulfilled <ul style="list-style-type: none"> • Ignition switch is in the ON position • Selector lever P position switch signal: Except P position (battery voltage) • Vehicle speed: 4 km/h (2.5 MPH) or more
B2603: SHIFT POSI STATUS	Inhibit steering lock	500 ms after the following BCM recognition conditions are fulfilled <ul style="list-style-type: none"> • Ignition switch is in the ON position • Selector lever P position switch signal: Except P position (battery voltage) • Selector lever P/N position signal: Except P and N positions (0 V)
B2604: PNP SW	Inhibit steering lock	500 ms after any of the following BCM recognition conditions are fulfilled <ul style="list-style-type: none"> • Status 1 <ul style="list-style-type: none"> - Ignition switch is in the ON position - Selector lever P/N position signal: P and N position (battery voltage) - P range signal or N range signal (CAN): ON • Status 2 <ul style="list-style-type: none"> - Ignition switch is in the ON position - Selector lever P/N position signal: Except P and N positions (0 V) - P range signal and N range signal (CAN): OFF
B2605: PNP SW	Inhibit steering lock	500 ms after any of the following BCM recognition conditions are fulfilled <ul style="list-style-type: none"> • Status 1 <ul style="list-style-type: none"> - Ignition switch is in the ON position - Selector lever P/N position signal: Except P and N positions (0 V) - Interlock/PNP switch signal (CAN): OFF • Status 2 <ul style="list-style-type: none"> - Ignition switch is in the ON position - Selector lever P/N position signal: P or N position (battery voltage) - PNP switch signal (CAN): ON
B2606: S/L RELAY	Inhibit engine cranking	500 ms after the following CAN signal communication status becomes consistent <ul style="list-style-type: none"> • Steering lock relay signal (Request signal) • Steering lock relay signal (Condition signal)

BCM (BODY CONTROL MODULE)

< ECU DIAGNOSIS INFORMATION >

[FRONT & REAR WINDOW ANTI-PINCH]

Display contents of CONSULT	Fail-safe	Cancellation
B2607: S/L RELAY	Inhibit engine cranking	500 ms after the following CAN signal communication status has becomes consistent <ul style="list-style-type: none"> Steering lock relay signal (Request signal) Steering lock relay signal (Condition signal)
B2608: STARTER RELAY	Inhibit engine cranking	500 ms after the following signal communication status becomes consistent <ul style="list-style-type: none"> Starter motor relay control signal Starter relay status signal (CAN)
B2609: S/L STATUS	<ul style="list-style-type: none"> Inhibit engine cranking Inhibit steering lock 	When the following steering lock conditions agree <ul style="list-style-type: none"> BCM steering lock control status Steering lock condition No. 1 signal status Steering lock condition No. 2 signal status
B260A: IGNITION RELAY	Inhibit engine cranking	500 ms after the following conditions are fulfilled <ul style="list-style-type: none"> IGN relay (IPDM E/R) control signal: OFF (Battery voltage) Ignition ON signal (CAN to IPDM E/R): OFF (Request signal) Ignition ON signal (CAN from IPDM E/R): OFF (Condition signal)
B260F: ENG STATE SIG LOST	Maintains the power supply position attained at the time of DTC detection	When any of the following conditions are fulfilled <ul style="list-style-type: none"> Power position changes to ACC Receives engine status signal (CAN)
B2612: S/L STATUS	<ul style="list-style-type: none"> Inhibit engine cranking Inhibit steering lock 	When any of the following conditions are fulfilled <ul style="list-style-type: none"> Steering lock unit status signal (CAN) is received normally The BCM steering lock control status matches the steering lock status recognized by the steering lock unit status signal (CAN from IPDM E/R)
B2617: STARTER RELAY CIRC	Inhibit engine cranking	1 second after the starter motor relay control inside BCM becomes normal
B2618: BCM	Inhibit engine cranking	1 second after the ignition relay (IPDM E/R) control inside BCM becomes normal
B2619: BCM	Inhibit engine cranking	1 second after the steering lock unit power supply output control inside BCM becomes normal
B261E: VEHICLE TYPE	Inhibit engine cranking	BCM initialization
B26E8: CLUTCH SW	Inhibit engine cranking	When any of the following BCM recognition conditions are fulfilled <ul style="list-style-type: none"> Status 1 <ul style="list-style-type: none"> Clutch switch signal (CAN from ECM): ON Clutch interlock switch signal: OFF (0 V) Status 2 <ul style="list-style-type: none"> Clutch switch signal (CAN from ECM): OFF Clutch interlock switch signal: ON (Battery voltage)
B26E9: S/L STATUS	<ul style="list-style-type: none"> Inhibit engine cranking Inhibit steering lock 	When BCM transmits the LOCK request signal to steering lock unit, and receives LOCK response signal from steering lock unit, the following conditions are fulfilled <ul style="list-style-type: none"> Steering condition No. 1 signal: LOCK (0 V) Steering condition No. 2 signal: LOCK (Battery voltage)

HIGH FLASHER OPERATION

BCM detects the turn signal lamp circuit status by the current value.

BCM increases the turn signal lamp blinking speed if the bulb or harness open is detected with the turn signal lamp operating.

NOTE:

The blinking speed is normal while activating the hazard warning lamp.

DTC Inspection Priority Chart

INFOID:000000004667398

If some DTCs are displayed at the same time, perform inspections one by one based on the following priority chart.

BCM (BODY CONTROL MODULE)

< ECU DIAGNOSIS INFORMATION >

[FRONT & REAR WINDOW ANTI-PINCH]

Priority	DTC
1	B2562: LOW VOLTAGE
2	<ul style="list-style-type: none">• U1000: CAN COMM• U1010: CONTROL UNIT(CAN)
3	<ul style="list-style-type: none">• B2190: NATS ANTENNA AMP• B2191: DIFFERENCE OF KEY• B2192: ID DISCORD BCM-ECM• B2193: CHAIN OF BCM-ECM• B2195: ANTI SCANNING
4	<ul style="list-style-type: none">• B2013: ID DISCORD BCM-S/L• B2014: CHAIN OF S/L-BCM• B2553: IGNITION RELAY• B2555: STOP LAMP• B2556: PUSH-BTN IGN SW• B2557: VEHICLE SPEED• B2560: STARTER CONT RELAY• B2601: SHIFT POSITION• B2602: SHIFT POSITION• B2603: SHIFT POSI STATUS• B2604: PNP SW• B2605: PNP SW• B2606: S/L RELAY• B2607: S/L RELAY• B2608: STARTER RELAY• B2609: S/L STATUS• B260A: IGNITION RELAY• B260B: STEERING LOCK UNIT• B260C: STEERING LOCK UNIT• B260D: STEERING LOCK UNIT• B260F: ENG STATE SIG LOST• B2612: S/L STATUS• B2614: ACC RELAY CIRC• B2615: BLOWER RELAY CIRC• B2616: IGN RELAY CIRC• B2617: STARTER RELAY CIRC• B2618: BCM• B2619: BCM• B261A: PUSH-BTN IGN SW• B261E: VEHICLE TYPE• B26E8: CLUTCH SW• B26E9: S/L STATUS• B26EA: KEY REGISTRATION• C1729: VHCL SPEED SIG ERR• U0415: VEHICLE SPEED SIG

BCM (BODY CONTROL MODULE)

< ECU DIAGNOSIS INFORMATION >

[FRONT & REAR WINDOW ANTI-PINCH]

Priority	DTC
5	<ul style="list-style-type: none"> • C1704: LOW PRESSURE FL • C1705: LOW PRESSURE FR • C1706: LOW PRESSURE RR • C1707: LOW PRESSURE RL • C1708: [NO DATA] FL • C1709: [NO DATA] FR • C1710: [NO DATA] RR • C1711: [NO DATA] RL • C1712: [CHECKSUM ERR] FL • C1713: [CHECKSUM ERR] FR • C1714: [CHECKSUM ERR] RR • C1715: [CHECKSUM ERR] RL • C1716: [PRESSDATA ERR] FL • C1717: [PRESSDATA ERR] FR • C1718: [PRESSDATA ERR] RR • C1719: [PRESSDATA ERR] RL • C1720: [CODE ERR] FL • C1721: [CODE ERR] FR • C1722: [CODE ERR] RR • C1723: [CODE ERR] RL • C1724: [BATT VOLT LOW] FL • C1725: [BATT VOLT LOW] FR • C1726: [BATT VOLT LOW] RR • C1727: [BATT VOLT LOW] RL • C1734: CONTROL UNIT
6	<ul style="list-style-type: none"> • B2621: INSIDE ANTENNA • B2622: INSIDE ANTENNA • B2623: INSIDE ANTENNA

DTC Index

INFOID:000000004667399

NOTE:

The details of time display are as follows.

- CRNT: A malfunction is detected now.
- PAST: A malfunction was detected in the past.

IGN counter is displayed on Freeze Frame Data. For details of Freeze Frame Data, refer to [PWC-125. "COMMON ITEM : CONSULT-III Function \(BCM - COMMON ITEM\)".](#)

CONSULT display	Fail-safe	Freeze Frame Data •Vehicle Speed •Odo/Trip Meter •Vehicle condition	Intelligent Key warning lamp ON	Tire pressure monitor warning lamp ON	Refer- ence page
No DTC is detected. further testing may be required.	—	—	—	—	—
U1000: CAN COMM	—	—	—	—	BCS-35
U1010: CONTROL UNIT(CAN)	—	—	—	—	BCS-36
U0415: VEHICLE SPEED SIG	—	—	—	—	BCS-37
B2013: ID DISCORD BCM-S/L	×	×	—	—	SEC-55
B2014: CHAIN OF S/L-BCM	×	×	—	—	SEC-56
B2190: NATS ANTENNA AMP	×	—	—	—	SEC-47
B2191: DIFFERENCE OF KEY	×	—	—	—	SEC-50
B2192: ID DISCORD BCM-ECM	×	—	—	—	SEC-51
B2193: CHAIN OF BCM-ECM	×	—	—	—	SEC-53
B2195: ANTI SCANNING	×	—	—	—	SEC-54
B2553: IGNITION RELAY	—	×	—	—	PCS-49
B2555: STOP LAMP	—	×	—	—	SEC-59

BCM (BODY CONTROL MODULE)

< ECU DIAGNOSIS INFORMATION >

[FRONT & REAR WINDOW ANTI-PINCH]

CONSULT display	Fail-safe	Freeze Frame Data •Vehicle Speed •Odo/Trip Meter •Vehicle condition	Intelligent Key warning lamp ON	Tire pressure monitor warning lamp ON	Refer- ence page
B2556: PUSH-BTN IGN SW	—	×	×	—	SEC-61
B2557: VEHICLE SPEED	×	×	×	—	SEC-63
B2560: STARTER CONT RELAY	×	×	×	—	SEC-64
B2562: LOW VOLTAGE	—	×	—	—	BCS-38
B2601: SHIFT POSITION	×	×	×	—	SEC-65
B2602: SHIFT POSITION	×	×	×	—	SEC-68
B2603: SHIFT POSI STATUS	×	×	×	—	SEC-70
B2604: PNP SW	×	×	×	—	SEC-73
B2605: PNP SW	×	×	×	—	SEC-75
B2606: S/L RELAY	×	×	×	—	SEC-77
B2607: S/L RELAY	×	×	×	—	SEC-78
B2608: STARTER RELAY	×	×	×	—	SEC-80
B2609: S/L STATUS	×	×	×	—	SEC-82
B260A: IGNITION RELAY	×	×	×	—	PCS-51
B260B: STEERING LOCK UNIT	—	×	×	—	SEC-86
B260C: STEERING LOCK UNIT	—	×	×	—	SEC-87
B260D: STEERING LOCK UNIT	—	×	×	—	SEC-88
B260F: ENG STATE SIG LOST	×	×	×	—	SEC-89
B2612: S/L STATUS	×	×	×	—	SEC-94
B2614: ACC RELAY CIRC	—	×	×	—	PCS-53
B2615: BLOWER RELAY CIRC	—	×	×	—	PCS-55
B2616: IGN RELAY CIRC	—	×	×	—	PCS-57
B2617: STARTER RELAY CIRC	×	×	×	—	SEC-98
B2618: BCM	×	×	×	—	PCS-59
B2619: BCM	×	×	×	—	SEC-100
B261A: PUSH-BTN IGN SW	—	×	×	—	PCS-60
B261E: VEHICLE TYPE	×	×	× (Turn ON for 15 seconds)	—	SEC-101
B2621: INSIDE ANTENNA	—	×	—	—	DLK-59
B2622: INSIDE ANTENNA	—	×	—	—	DLK-61
B2623: INSIDE ANTENNA	—	×	—	—	DLK-63
B26E8: CLUTCH SW	×	×	×	—	SEC-90
B26E9: S/L STATUS	×	×	× (Turn ON for 15 seconds)	—	SEC-92
B26EA: KEY REGISTRATION	—	×	× (Turn ON for 15 seconds)	—	SEC-93
C1704: LOW PRESSURE FL	—	—	—	×	WT-17
C1705: LOW PRESSURE FR	—	—	—	×	
C1706: LOW PRESSURE RR	—	—	—	×	
C1707: LOW PRESSURE RL	—	—	—	×	

BCM (BODY CONTROL MODULE)

< ECU DIAGNOSIS INFORMATION >

[FRONT & REAR WINDOW ANTI-PINCH]

CONSULT display	Fail-safe	Freeze Frame Data •Vehicle Speed •Odo/Trip Meter •Vehicle condition	Intelligent Key warning lamp ON	Tire pressure monitor warning lamp ON	Refer- ence page
C1708: [NO DATA] FL	—	—	—	×	WT-19
C1709: [NO DATA] FR	—	—	—	×	
C1710: [NO DATA] RR	—	—	—	×	
C1711: [NO DATA] RL	—	—	—	×	WT-21
C1712: [CHECKSUM ERR] FL	—	—	—	×	
C1713: [CHECKSUM ERR] FR	—	—	—	×	
C1714: [CHECKSUM ERR] RR	—	—	—	×	
C1715: [CHECKSUM ERR] RL	—	—	—	×	WT-24
C1716: [PRESSDATA ERR] FL	—	—	—	×	
C1717: [PRESSDATA ERR] FR	—	—	—	×	
C1718: [PRESSDATA ERR] RR	—	—	—	×	
C1719: [PRESSDATA ERR] RL	—	—	—	×	WT-26
C1720: [CODE ERR] FL	—	—	—	×	
C1721: [CODE ERR] FR	—	—	—	×	
C1722: [CODE ERR] RR	—	—	—	×	
C1723: [CODE ERR] RL	—	—	—	×	WT-29
C1724: [BATT VOLT LOW] FL	—	—	—	×	
C1725: [BATT VOLT LOW] FR	—	—	—	×	
C1726: [BATT VOLT LOW] RR	—	—	—	×	
C1727: [BATT VOLT LOW] RL	—	—	—	×	WT-32
C1729: VHCL SPEED SIG ERR	—	—	—	×	
C1734: CONTROL UNIT	—	—	—	×	WT-33

A
B
C
D
E
F
G
H
I
J
L
M
N
O
P

PWC

POWER WINDOW MAIN SWITCH

< ECU DIAGNOSIS INFORMATION >

[FRONT & REAR WINDOW ANTI-PINCH]

POWER WINDOW MAIN SWITCH

Reference Value

INFOID:000000004240642

TERMINAL LAYOUT

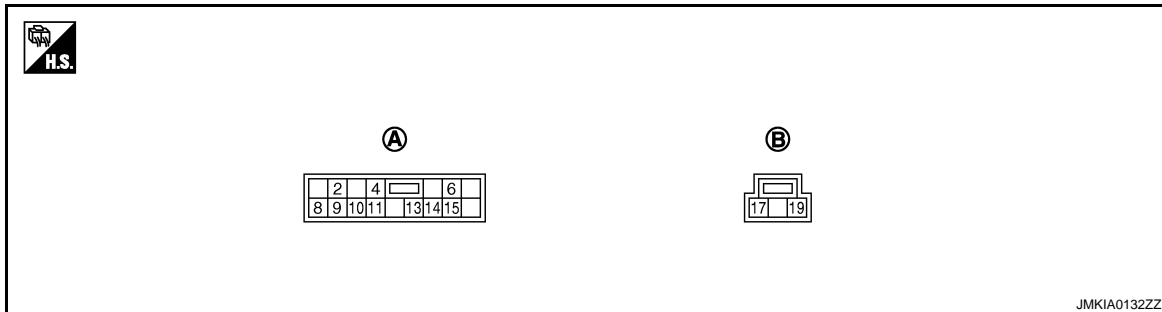

A. D8

B. D9

PHYSICAL VALUES

Power Window Main Switch

Terminal No. (wire color)		Description		Condition	Voltage (V) (Approx.)
+	-	Signal name	Input/ Output		
2 (LG)	Ground	Encoder ground	—	—	0
4 (V)	Ground	Door key cylinder switch LOCK signal	Input	Key position (Neutral → Locked)	5 → 0
6 (Y)	Ground	Door key cylinder switch UNLOCK signal	Input	Key position (Neutral → Unlocked)	5 → 0
8 (L)	Ground	Front driver side power win- dow motor UP signal	Output	When front LH switch in power window main switch is UP at operated.	Battery voltage
9 (O)	Ground	Encoder pulse signal 2	Input	When power window mo- tor operates.	
10 (SB)	Ground	Rap signal	Input	Ignition switch ON	Battery voltage
				Within 45 second after ig- nition switch is turned to OFF	Battery voltage
				When driver side or pas- senger side door is opened during retained power operation	0
11 (G)	Ground	Front driver side power win- dow motor DOWN signal	Output	When front LH switch in power window main switch is DOWN at operated.	Battery voltage

JMKIA0070GB

POWER WINDOW MAIN SWITCH

< ECU DIAGNOSIS INFORMATION >

[FRONT & REAR WINDOW ANTI-PINCH]

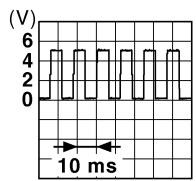
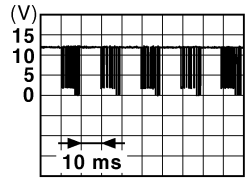
Terminal No. (wire color)		Description		Condition	Voltage (V) (Approx.)
+	-	Signal name	Input/ Output		
13 (P)	Ground	Encoder pulse signal 1	Input	When power window motor operates.	 <p style="text-align: right; font-size: small;">JMKIA0070GB</p>
14 (V)	Ground	Power window serial link	Input/ Output	Ignition switch ON or power window timer operating.	 <p style="text-align: right; font-size: small;">JPMIA0013GB</p>
15 (B)	Ground	Encoder power supply	Output	When ignition switch ON or power window timer operates.	Battery voltage
17 (B)	Ground	Ground	—	—	0
19 (Y)	Ground	Battery power supply	Input	—	Battery voltage

A
B
C
D
E
F
G
H
I
J
L
M
N
O
P

PWC

POWER WINDOW MAIN SWITCH

< ECU DIAGNOSIS INFORMATION >

[FRONT & REAR WINDOW ANTI-PINCH]

POWER WINDOW SYSTEM (WITH FRONT AND REAR POWER WINDOW ANTI-PINCH SYSTEM)

Connector No.	B1
Connector Name	WIRE TO WIRE
Connector Type	TH40FW-CS16-TM4

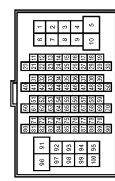

Terminal No.	Color of Wire	Signal Name [Specification]
8	W	
9	O	
87	B	

Connector No.	B16
Connector Name	FRONT DOOR SWITCH (DRIVER SIDE)
Connector Type	A09FW

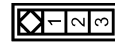

Terminal No.	Color of Wire	Signal Name [Specification]
2	B	

Connector No.	B18
Connector Name	WIRE TO WIRE
Connector Type	TK10FW-NS8

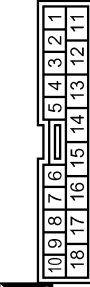

Terminal No.	Color of Wire	Signal Name [Specification]
12	O	- [With rear power window anti-pinch system]
13	W	
18	B	

Connector No.	B201
Connector Name	WIRE TO WIRE
Connector Type	TH40FW-CS16-TM4

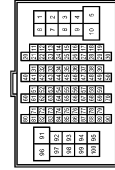

Terminal No.	Color of Wire	Signal Name [Specification]
92	Y	
93	W	
97	GR	

Connector No.	B216
Connector Name	FRONT DOOR SWITCH (PASSENGER SIDE)
Connector Type	A09FW

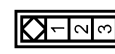

Terminal No.	Color of Wire	Signal Name [Specification]
2	GR	

Connector No.	B218
Connector Name	WIRE TO WIRE
Connector Type	TK10FW-NS8

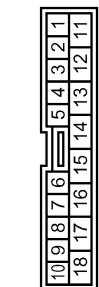

Terminal No.	Color of Wire	Signal Name [Specification]
12	Y	- [With rear power window anti-pinch system]
13	W	- [With rear power window anti-pinch system]
18	B	

Connector No.	D1
Connector Name	WIRE TO WIRE
Connector Type	TH40FW-CS15

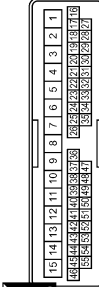

Terminal No.	Color of Wire	Signal Name [Specification]
8	SD	
13	B	
14	V	
15	Y	

Connector No.	D8
Connector Name	POWER WINDOW MAIN SWITCH
Connector Type	NS16FW-CS

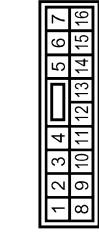

Terminal No.	Color of Wire	Signal Name [Specification]
2	LG	
4	V	
6	Y	
8	L	
9	O	
10	SB	
11	G	
13	P	
14	V	
15	B	

JCKWA1889GE

A
B
C
D
E
F
G
H
I
J
K
L
M
N
O
P

PWC

POWER WINDOW MAIN SWITCH

[FRONT & REAR WINDOW ANTI-PINCH]

< ECU DIAGNOSIS INFORMATION >

POWER WINDOW SYSTEM (WITH FRONT AND REAR POWER WINDOW ANTI-PINCH SYSTEM)

Connector No.	D9
Connector Name	POWER WINDOW MAIN SWITCH
Connector Type	NS08PW-CS



Terminal No.	Color of Wire	Signal Name [Specification]
17	B	-
18	Y	-

Connector No.	D10
Connector Name	FRONT POWER WINDOW MOTOR (DRIVER SIDE)
Connector Type	NS08PW-CS



Terminal No.	Color of Wire	Signal Name [Specification]
1	G	-
2	L	-
3	O	-
4	B	-
5	P	-
6	LG	-

Connector No.	D15
Connector Name	FRONT DOOR LOCK ASSEMBLY (DRIVER SIDE)
Connector Type	ED08FGY-RS

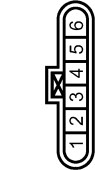

Terminal No.	Color of Wire	Signal Name [Specification]
4	B	-
5	Y	-
6	V	-

Connector No.	D31
Connector Name	WIRE TO WIRE
Connector Type	TH40FW-CS/5

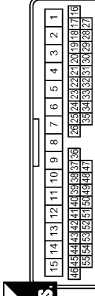

Terminal No.	Color of Wire	Signal Name [Specification]
13	B	-
14	V	-
15	Y	-

Connector No.	D38
Connector Name	FRONT POWER WINDOW SWITCH (PASSENGER SIDE)
Connector Type	NS18PW-CS



Terminal No.	Color of Wire	Signal Name [Specification]
3	LG	-
4	B	-
8	L	-
9	G	-
10	Y	-
11	B	-
12	P	-
15	O	-
16	V	-

Connector No.	D40
Connector Name	FRONT POWER WINDOW MOTOR (PASSENGER SIDE)
Connector Type	NS08PW-CS

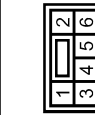

Terminal No.	Color of Wire	Signal Name [Specification]
1	G	-
2	L	-
3	O	-
4	B	-
5	P	-
6	LG	-

Connector No.	DE1
Connector Name	WIRE TO WIRE
Connector Type	TK10MK-NS

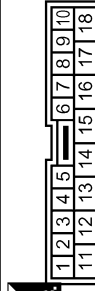

Terminal No.	Color of Wire	Signal Name [Specification]
12	R	-
13	W	- (With rear power window anti-pinch system)
18	B	-

Connector No.	D52
Connector Name	REAR POWER WINDOW MOTOR LH
Connector Type	RS08FG



Terminal No.	Color of Wire	Signal Name [Specification]
1	G	-
2	SB	-
3	L	-
4	W	-
5	GR	-
6	O	-















JCKWA1890GE

POWER WINDOW MAIN SWITCH

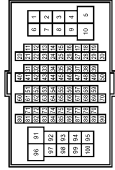
< ECU DIAGNOSIS INFORMATION >

[FRONT & REAR WINDOW ANTI-PINCH]

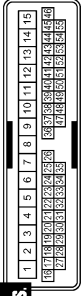
POWER WINDOW SYSTEM (WITH FRONT AND REAR POWER WINDOW ANTI-PINCH SYSTEM)

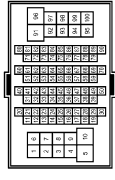
<table border="1"> <tr><td>Connector No.</td><td>D57</td></tr> <tr><td>Connector Name</td><td>REAR POWER WINDOW SWITCH LH (WITH REAR ANTI-PINCH SYSTEM)</td></tr> <tr><td>Connector Type</td><td>NS16FW-CS</td></tr> </table>   <table border="1"> <thead> <tr> <th>Terminal No.</th> <th>Color of Wire</th> <th>Signal Name [Specification]</th> </tr> </thead> <tbody> <tr><td>3</td><td>W</td><td>-</td></tr> <tr><td>4</td><td>SB</td><td>-</td></tr> <tr><td>8</td><td>G</td><td>-</td></tr> <tr><td>9</td><td>L</td><td>-</td></tr> <tr><td>10</td><td>W</td><td>-</td></tr> <tr><td>11</td><td>B</td><td>-</td></tr> <tr><td>12</td><td>GR</td><td>-</td></tr> <tr><td>15</td><td>O</td><td>-</td></tr> <tr><td>16</td><td>R</td><td>-</td></tr> </tbody> </table>	Connector No.	D57	Connector Name	REAR POWER WINDOW SWITCH LH (WITH REAR ANTI-PINCH SYSTEM)	Connector Type	NS16FW-CS	Terminal No.	Color of Wire	Signal Name [Specification]	3	W	-	4	SB	-	8	G	-	9	L	-	10	W	-	11	B	-	12	GR	-	15	O	-	16	R	-	<table border="1"> <tr><td>Connector No.</td><td>D71</td></tr> <tr><td>Connector Name</td><td>WIRE TO WIRE</td></tr> <tr><td>Connector Type</td><td>TK10MW-NBS</td></tr> </table>   <table border="1"> <thead> <tr> <th>Terminal No.</th> <th>Color of Wire</th> <th>Signal Name [Specification]</th> </tr> </thead> <tbody> <tr><td>12</td><td>R</td><td>-</td></tr> <tr><td>13</td><td>W</td><td>-</td></tr> <tr><td>18</td><td>B</td><td>-</td></tr> </tbody> </table>	Connector No.	D71	Connector Name	WIRE TO WIRE	Connector Type	TK10MW-NBS	Terminal No.	Color of Wire	Signal Name [Specification]	12	R	-	13	W	-	18	B	-	<table border="1"> <tr><td>Connector No.</td><td>D72</td></tr> <tr><td>Connector Name</td><td>REAR POWER WINDOW MOTOR RH</td></tr> <tr><td>Connector Type</td><td>RS06FG</td></tr> </table>   <table border="1"> <thead> <tr> <th>Terminal No.</th> <th>Color of Wire</th> <th>Signal Name [Specification]</th> </tr> </thead> <tbody> <tr><td>1</td><td>G</td><td>-</td></tr> <tr><td>2</td><td>SB</td><td>-</td></tr> <tr><td>3</td><td>L</td><td>-</td></tr> <tr><td>4</td><td>W</td><td>-</td></tr> <tr><td>5</td><td>GR</td><td>-</td></tr> <tr><td>6</td><td>O</td><td>-</td></tr> </tbody> </table>	Connector No.	D72	Connector Name	REAR POWER WINDOW MOTOR RH	Connector Type	RS06FG	Terminal No.	Color of Wire	Signal Name [Specification]	1	G	-	2	SB	-	3	L	-	4	W	-	5	GR	-	6	O	-	<table border="1"> <tr><td>Connector No.</td><td>D77</td></tr> <tr><td>Connector Name</td><td>REAR POWER WINDOW SWITCH RH (WITH REAR ANTI-PINCH SYSTEM)</td></tr> <tr><td>Connector Type</td><td>NS16FW-CS</td></tr> </table>   <table border="1"> <thead> <tr> <th>Terminal No.</th> <th>Color of Wire</th> <th>Signal Name [Specification]</th> </tr> </thead> <tbody> <tr><td>3</td><td>W</td><td>-</td></tr> <tr><td>4</td><td>SB</td><td>-</td></tr> <tr><td>8</td><td>G</td><td>-</td></tr> <tr><td>9</td><td>L</td><td>-</td></tr> <tr><td>10</td><td>W</td><td>-</td></tr> <tr><td>11</td><td>B</td><td>-</td></tr> <tr><td>12</td><td>GR</td><td>-</td></tr> <tr><td>15</td><td>O</td><td>-</td></tr> <tr><td>16</td><td>R</td><td>-</td></tr> </tbody> </table>	Connector No.	D77	Connector Name	REAR POWER WINDOW SWITCH RH (WITH REAR ANTI-PINCH SYSTEM)	Connector Type	NS16FW-CS	Terminal No.	Color of Wire	Signal Name [Specification]	3	W	-	4	SB	-	8	G	-	9	L	-	10	W	-	11	B	-	12	GR	-	15	O	-	16	R	-
Connector No.	D57																																																																																																																							
Connector Name	REAR POWER WINDOW SWITCH LH (WITH REAR ANTI-PINCH SYSTEM)																																																																																																																							
Connector Type	NS16FW-CS																																																																																																																							
Terminal No.	Color of Wire	Signal Name [Specification]																																																																																																																						
3	W	-																																																																																																																						
4	SB	-																																																																																																																						
8	G	-																																																																																																																						
9	L	-																																																																																																																						
10	W	-																																																																																																																						
11	B	-																																																																																																																						
12	GR	-																																																																																																																						
15	O	-																																																																																																																						
16	R	-																																																																																																																						
Connector No.	D71																																																																																																																							
Connector Name	WIRE TO WIRE																																																																																																																							
Connector Type	TK10MW-NBS																																																																																																																							
Terminal No.	Color of Wire	Signal Name [Specification]																																																																																																																						
12	R	-																																																																																																																						
13	W	-																																																																																																																						
18	B	-																																																																																																																						
Connector No.	D72																																																																																																																							
Connector Name	REAR POWER WINDOW MOTOR RH																																																																																																																							
Connector Type	RS06FG																																																																																																																							
Terminal No.	Color of Wire	Signal Name [Specification]																																																																																																																						
1	G	-																																																																																																																						
2	SB	-																																																																																																																						
3	L	-																																																																																																																						
4	W	-																																																																																																																						
5	GR	-																																																																																																																						
6	O	-																																																																																																																						
Connector No.	D77																																																																																																																							
Connector Name	REAR POWER WINDOW SWITCH RH (WITH REAR ANTI-PINCH SYSTEM)																																																																																																																							
Connector Type	NS16FW-CS																																																																																																																							
Terminal No.	Color of Wire	Signal Name [Specification]																																																																																																																						
3	W	-																																																																																																																						
4	SB	-																																																																																																																						
8	G	-																																																																																																																						
9	L	-																																																																																																																						
10	W	-																																																																																																																						
11	B	-																																																																																																																						
12	GR	-																																																																																																																						
15	O	-																																																																																																																						
16	R	-																																																																																																																						
<table border="1"> <tr><td>Connector No.</td><td>E108</td></tr> <tr><td>Connector Name</td><td>WIRE TO WIRE</td></tr> <tr><td>Connector Type</td><td>TH80FW-CS16-TM4</td></tr> </table>   <table border="1"> <thead> <tr> <th>Terminal No.</th> <th>Color of Wire</th> <th>Signal Name [Specification]</th> </tr> </thead> <tbody> <tr><td>91</td><td>W</td><td>-</td></tr> </tbody> </table>	Connector No.	E108	Connector Name	WIRE TO WIRE	Connector Type	TH80FW-CS16-TM4	Terminal No.	Color of Wire	Signal Name [Specification]	91	W	-	<table border="1"> <tr><td>Connector No.</td><td>M1</td></tr> <tr><td>Connector Name</td><td>FUSE BLOCK (J/B)</td></tr> <tr><td>Connector Type</td><td>NS06FW-M2</td></tr> </table>   <table border="1"> <thead> <tr> <th>Terminal No.</th> <th>Color of Wire</th> <th>Signal Name [Specification]</th> </tr> </thead> <tbody> <tr><td>7A</td><td>R</td><td>-</td></tr> </tbody> </table>	Connector No.	M1	Connector Name	FUSE BLOCK (J/B)	Connector Type	NS06FW-M2	Terminal No.	Color of Wire	Signal Name [Specification]	7A	R	-	<table border="1"> <tr><td>Connector No.</td><td>M5</td></tr> <tr><td>Connector Name</td><td>WIRE TO WIRE</td></tr> <tr><td>Connector Type</td><td>TH40MW-CS15</td></tr> </table>   <table border="1"> <thead> <tr> <th>Terminal No.</th> <th>Color of Wire</th> <th>Signal Name [Specification]</th> </tr> </thead> <tbody> <tr><td>8</td><td>O</td><td>-</td></tr> <tr><td>13</td><td>B</td><td>-</td></tr> <tr><td>14</td><td>V</td><td>-</td></tr> <tr><td>15</td><td>Y</td><td>-</td></tr> </tbody> </table>	Connector No.	M5	Connector Name	WIRE TO WIRE	Connector Type	TH40MW-CS15	Terminal No.	Color of Wire	Signal Name [Specification]	8	O	-	13	B	-	14	V	-	15	Y	-	<table border="1"> <tr><td>Connector No.</td><td>M6</td></tr> <tr><td>Connector Name</td><td>WIRE TO WIRE</td></tr> <tr><td>Connector Type</td><td>TH60MW-CS16-TM4</td></tr> </table>   <table border="1"> <thead> <tr> <th>Terminal No.</th> <th>Color of Wire</th> <th>Signal Name [Specification]</th> </tr> </thead> <tbody> <tr><td>91</td><td>W</td><td>-</td></tr> </tbody> </table>	Connector No.	M6	Connector Name	WIRE TO WIRE	Connector Type	TH60MW-CS16-TM4	Terminal No.	Color of Wire	Signal Name [Specification]	91	W	-																																																												
Connector No.	E108																																																																																																																							
Connector Name	WIRE TO WIRE																																																																																																																							
Connector Type	TH80FW-CS16-TM4																																																																																																																							
Terminal No.	Color of Wire	Signal Name [Specification]																																																																																																																						
91	W	-																																																																																																																						
Connector No.	M1																																																																																																																							
Connector Name	FUSE BLOCK (J/B)																																																																																																																							
Connector Type	NS06FW-M2																																																																																																																							
Terminal No.	Color of Wire	Signal Name [Specification]																																																																																																																						
7A	R	-																																																																																																																						
Connector No.	M5																																																																																																																							
Connector Name	WIRE TO WIRE																																																																																																																							
Connector Type	TH40MW-CS15																																																																																																																							
Terminal No.	Color of Wire	Signal Name [Specification]																																																																																																																						
8	O	-																																																																																																																						
13	B	-																																																																																																																						
14	V	-																																																																																																																						
15	Y	-																																																																																																																						
Connector No.	M6																																																																																																																							
Connector Name	WIRE TO WIRE																																																																																																																							
Connector Type	TH60MW-CS16-TM4																																																																																																																							
Terminal No.	Color of Wire	Signal Name [Specification]																																																																																																																						
91	W	-																																																																																																																						

JCKWA1891GE

A
B
C
D
E
F
G
H
I
J
L
M
N
O
P

PWC

POWER WINDOW MAIN SWITCH

< ECU DIAGNOSIS INFORMATION >

[FRONT & REAR WINDOW ANTI-PINCH]

POWER WINDOW SYSTEM (WITH FRONT AND REAR POWER WINDOW ANTI-PINCH SYSTEM)

Connector No.	Connector Name	Connector Type	Terminal No.	Color of Wire	Signal Name [Specification]
M117	WIRE TO WIRE	TH80MW-CS16-TM4	92	BR	—
M117	WIRE TO WIRE	TH80MW-CS16-TM4	93	V	—
M117	WIRE TO WIRE	TH80MW-CS16-TM4	97	LG	—
M118	BCM (BODY CONTROL MODULE)	M03FB-LG	1	W	BAT (F/L)
M118	BCM (BODY CONTROL MODULE)	M03FB-LG	2	Y	POWER WINDOW POWER SUPPLY(BAT)
M118	BCM (BODY CONTROL MODULE)	M03FB-LG	3	O	POWER WINDOW POWER SUPPLY(RAP)
M119	BCM (BODY CONTROL MODULE)	MS16FW-CS	8	G	—
M119	BCM (BODY CONTROL MODULE)	MS16FW-CS	9	Y	—
M119	BCM (BODY CONTROL MODULE)	MS16FW-CS	87	GR	—
M122	BCM (BODY CONTROL MODULE)	TH40FB-NH	1	O	GND
M122	BCM (BODY CONTROL MODULE)	TH40FB-NH	2	Y	SIGNAL OUTPUT
M122	BCM (BODY CONTROL MODULE)	TH40FB-NH	4	L	BATTERY
M123	BCM (BODY CONTROL MODULE)	TH40FG-NH	124	LG	PASSENGER DOOR SW
M123	BCM (BODY CONTROL MODULE)	TH40FG-NH	132	V	POWER WINDOW SW COMM
M123	BCM (BODY CONTROL MODULE)	TH40FG-NH	137	O	RECEIVER/SENSOR GND
M123	BCM (BODY CONTROL MODULE)	TH40FG-NH	150	GR	DRIVER DOOR SW
M124	WIRE TO WIRE	TH40MP-CS15	11	R	BAT (FUSE)
M124	WIRE TO WIRE	TH40MP-CS15	13	B	—
M124	WIRE TO WIRE	TH40MP-CS15	14	G	—
M124	WIRE TO WIRE	TH40MP-CS15	15	W	—

Fail-safe

FAIL-SAFE CONTROL

Switches to fail-safe control when malfunction is detected in encoder signal that detects up/down speed and direction of door glass. Switches to fail-safe control when a signal that is out of the specified value is detected between the fully closed position and the actual position of the glass.

JCKWA1892GE

INFOID:000000004679443

POWER WINDOW MAIN SWITCH

< ECU DIAGNOSIS INFORMATION >

[FRONT & REAR WINDOW ANTI-PINCH]

Malfunction	Malfunction condition
Pulse sensor malfunction	When one pulse signal that is the specified value or more is detected continuously for the specified time or more, while door glass is being operated UP or DOWN.
Both pulse sensors malfunction	When both pulse signals are not detected continuously for the specified time or more, while door glass is being operated UP or DOWN.
Pulse direction malfunction	When a pulse signal indicating that window is moving in the opposite direction against the power window motor is detected for the specified value or more, while door glass is being operated UP or DOWN.
Glass recognition position malfunction 1	When the actual door glass position that is out of specified value is detected compared to the door glass fully closed position memorized in module, while door glass is being operated UP or DOWN.
Glass recognition position malfunction 2	When pulse count that is out of the door glass full stroke value or more is detected, while door glass is being operated UP or DOWN.

If fail-safe control, the system changes to a non-initialized condition and the following function do not operate.

- Auto-up operation
- Anti-pinch function
- Door key cylinder switch power window function

When fail-safe control is activated, perform initialization procedure to recover. If a malfunction is detected in power window switch or more, fail-safe control is activated again.

A
B
C
D
E
F
G
H
I
J
L
M
N
O
P

PWC

FRONT POWER WINDOW SWITCH

< ECU DIAGNOSIS INFORMATION >

[FRONT & REAR WINDOW ANTI-PINCH]

FRONT POWER WINDOW SWITCH

Reference Value

INFOID:000000004240645

TERMINAL LAYOUT

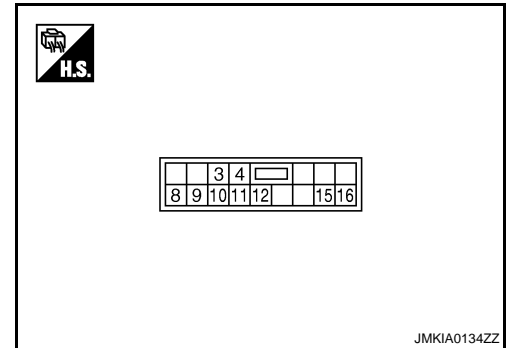

PHYSICAL VALUES

Front Power Window Switch

Terminal No. (wire color)		Description		Condition	Voltage (V) (Approx.)
+	-	Signal name	Input/ Output		
3 (LG)	Ground	Encoder ground	—	—	0
4 (B)	Ground	Encoder power supply	Output	When ignition switch ON or power window timer operates	Battery voltage
8 (L)	Ground	Power window motor DOWN signal	Output	When power window motor is DOWN at operated.	Battery voltage
9 (G)	Ground	Power window motor UP signal	Output	When power window motor is UP at operated.	Battery voltage
10 (Y)	Ground	Battery power supply	Input	—	Battery voltage
11 (B)	Ground	Ground	—	—	0
12 (P)	Ground	Encoder pulse signal 1	Input	When power window motor operates.	

JMKIA0070GB

FRONT POWER WINDOW SWITCH

< ECU DIAGNOSIS INFORMATION >

[FRONT & REAR WINDOW ANTI-PINCH]

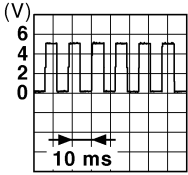
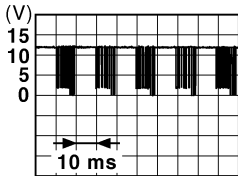
Terminal No. (wire color)		Description		Condition	Voltage (V) (Approx.)
+	-	Signal name	Input/ Output		
15 (O)	Ground	Encoder pulse signal 2	Input	When power window motor operates.	
16 (V)	Ground	Power window serial link	Input/ Output	Ignition switch ON or power window timer operating.	

A
B
C
D
E
F
G
H
I
J
L
M
N
O
P

PWC

FRONT POWER WINDOW SWITCH

< ECU DIAGNOSIS INFORMATION >

[FRONT & REAR WINDOW ANTI-PINCH]

POWER WINDOW SYSTEM (WITH FRONT AND REAR POWER WINDOW ANTI-PINCH SYSTEM)

Connector No.	B1
Connector Name	WIRE TO WIRE
Connector Type	TH40FW-CS16-TM4

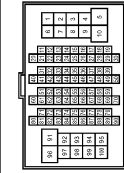

Terminal No.	Color of Wire	Signal Name [Specification]
8	W	-
9	O	-
87	B	-

Connector No.	B16
Connector Name	FRONT DOOR SWITCH (DRIVER SIDE)
Connector Type	A09FW

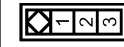

Terminal No.	Color of Wire	Signal Name [Specification]
2	B	-

Connector No.	B18
Connector Name	WIRE TO WIRE
Connector Type	TK10FW-NS8

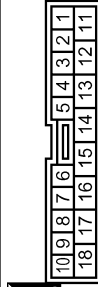

Terminal No.	Color of Wire	Signal Name [Specification]
12	O	- [With rear power window anti-pinch system]
13	W	-
18	B	-

Connector No.	B201
Connector Name	WIRE TO WIRE
Connector Type	TH40FW-CS16-TM4

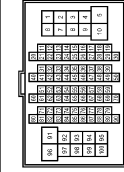

Terminal No.	Color of Wire	Signal Name [Specification]
92	Y	-
93	W	-
97	GR	-

Connector No.	B216
Connector Name	FRONT DOOR SWITCH (PASSENGER SIDE)
Connector Type	A09FW



Terminal No.	Color of Wire	Signal Name [Specification]
2	GR	-

Connector No.	B218
Connector Name	WIRE TO WIRE
Connector Type	TK10FW-NS8

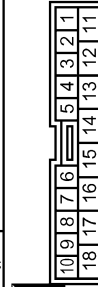

Terminal No.	Color of Wire	Signal Name [Specification]
12	Y	- [With rear power window anti-pinch system]
13	W	- [With rear power window anti-pinch system]
18	B	-

Connector No.	D1
Connector Name	WIRE TO WIRE
Connector Type	TH40FW-CS15

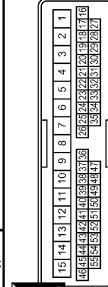

Terminal No.	Color of Wire	Signal Name [Specification]
8	SD	-
13	B	-
14	V	-
15	Y	-

Connector No.	D8
Connector Name	POWER WINDOW MAIN SWITCH
Connector Type	NS16FW-CS

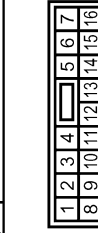

Terminal No.	Color of Wire	Signal Name [Specification]
2	LG	-
4	V	-
6	Y	-
8	L	-
9	O	-
10	SB	-
11	G	-
13	P	-
14	V	-
15	B	-

A
B
C
D
E
F
G
H
I
J
K
L
M
N
O
P

PWC

FRONT POWER WINDOW SWITCH

[FRONT & REAR WINDOW ANTI-PINCH]

< ECU DIAGNOSIS INFORMATION >

POWER WINDOW SYSTEM (WITH FRONT AND REAR POWER WINDOW ANTI-PINCH SYSTEM)

Connector No.	D39
Connector Name	POWER WINDOW MAIN SWITCH
Connector Type	NS38PW-CS



Terminal No.	Color of Wire	Signal Name [Specification]
17	B	-
18	Y	-

Connector No.	D10
Connector Name	FRONT POWER WINDOW MOTOR (DRIVER SIDE)
Connector Type	NS08FW-CS

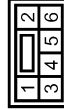

Terminal No.	Color of Wire	Signal Name [Specification]
1	G	-
2	L	-
3	O	-
4	B	-
5	P	-
6	LG	-

Connector No.	D15
Connector Name	FRONT DOOR LOCK ASSEMBLY (DRIVER SIDE)
Connector Type	ED08FGY-RS



Terminal No.	Color of Wire	Signal Name [Specification]
4	B	-
5	Y	-
6	V	-

Connector No.	D31
Connector Name	WIRE TO WIRE
Connector Type	TH40FW-CS/5

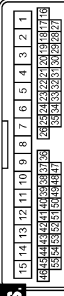

Terminal No.	Color of Wire	Signal Name [Specification]
13	B	-
14	V	-
15	Y	-

Connector No.	D38
Connector Name	FRONT POWER WINDOW SWITCH (PASSENGER SIDE)
Connector Type	NS18PW-CS



Terminal No.	Color of Wire	Signal Name [Specification]
3	LG	-
4	B	-
8	L	-
9	G	-
10	Y	-
11	B	-
12	P	-
15	O	-
16	V	-

Connector No.	D40
Connector Name	FRONT POWER WINDOW MOTOR (PASSENGER SIDE)
Connector Type	NS08PW-CS

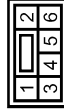

Terminal No.	Color of Wire	Signal Name [Specification]
1	G	-
2	L	-
3	O	-
4	B	-
5	P	-
6	LG	-

Connector No.	DE1
Connector Name	WIRE TO WIRE
Connector Type	TK10MK-NS

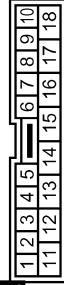

Terminal No.	Color of Wire	Signal Name [Specification]
12	R	-
13	W	- (With rear power window anti-pinch system)
18	B	-

Connector No.	D52
Connector Name	REAR POWER WINDOW MOTOR LH
Connector Type	RS08FG



Terminal No.	Color of Wire	Signal Name [Specification]
1	G	-
2	SB	-
3	L	-
4	W	-
5	GR	-
6	O	-

JCKWA1890GE

FRONT POWER WINDOW SWITCH

[FRONT & REAR WINDOW ANTI-PINCH]

< ECU DIAGNOSIS INFORMATION >

POWER WINDOW SYSTEM (WITH FRONT AND REAR POWER WINDOW ANTI-PINCH SYSTEM)

Connector No.	D57
Connector Name	REAR POWER WINDOW SWITCH LH (WITH REAR ANTI-PINCH SYSTEM)
Connector Type	NS16FW-CS

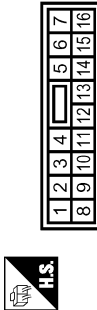

Terminal No.	Color of Wire	Signal Name [Specification]
3	W	-
4	SB	-
8	G	-
9	L	-
10	W	-
11	B	-
12	GR	-
15	O	-
16	R	-

Connector No.	D71
Connector Name	WIRE TO WIRE
Connector Type	TK10MW-NS

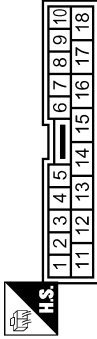

Terminal No.	Color of Wire	Signal Name [Specification]
12	R	-
13	W	-
18	B	-

Connector No.	D72
Connector Name	REAR POWER WINDOW MOTOR RH
Connector Type	RS06FG



Terminal No.	Color of Wire	Signal Name [Specification]
1	G	-
2	SB	-
3	L	-
4	W	-
5	GR	-
6	O	-

Connector No.	D77
Connector Name	REAR POWER WINDOW SWITCH RH (WITH REAR ANTI-PINCH SYSTEM)
Connector Type	NS16FW-CS

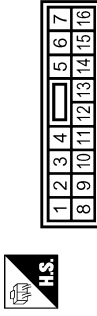

Terminal No.	Color of Wire	Signal Name [Specification]
3	W	-
4	SB	-
8	G	-
9	L	-
10	W	-
11	B	-
12	GR	-
15	O	-
16	R	-

Connector No.	E108
Connector Name	WIRE TO WIRE
Connector Type	TH80FW-CS16-TM4

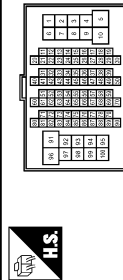

Terminal No.	Color of Wire	Signal Name [Specification]
91	W	-

Connector No.	M1
Connector Name	FUSE BLOCK (J/B)
Connector Type	NS06FW-M2

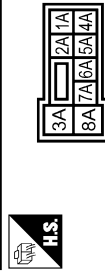

Terminal No.	Color of Wire	Signal Name [Specification]
7A	R	-

Connector No.	M5
Connector Name	WIRE TO WIRE
Connector Type	TH40MW-CS15

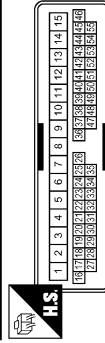

Terminal No.	Color of Wire	Signal Name [Specification]
8	O	-
13	B	-
14	V	-
15	Y	-

Connector No.	M6
Connector Name	WIRE TO WIRE
Connector Type	TH60MW-CS16-TM4



Terminal No.	Color of Wire	Signal Name [Specification]
91	W	-

JCKWA1891GE

A
B
C
D
E
F
G
H
I
J
L
M
N
O
P

PWC

FRONT POWER WINDOW SWITCH

< ECU DIAGNOSIS INFORMATION >

[FRONT & REAR WINDOW ANTI-PINCH]

POWER WINDOW SYSTEM (WITH FRONT AND REAR POWER WINDOW ANTI-PINCH SYSTEM)

Connector No.	M7
Connector Name	WIRE TO WIRE
Connector Type	TH80MW-CS16-TM4



Terminal No.	Color of Wire	Signal Name [Specification]
8	G	-
9	Y	-
87	GR	-

Connector No.	M104
Connector Name	REMOTE KEYLESS ENTRY RECEIVER
Connector Type	JA804EB

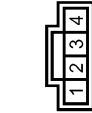

Terminal No.	Color of Wire	Signal Name [Specification]
1	O	GND
2	Y	SIGNAL OUTPUT
4	L	BATTERY

Connector No.	M117
Connector Name	WIRE TO WIRE
Connector Type	TH80MW-CS16-TM4



Terminal No.	Color of Wire	Signal Name [Specification]
92	BR	-
93	V	-
97	LG	-

Connector No.	M118
Connector Name	BCM (BODY CONTROL MODULE)
Connector Type	M03FB-LG



Terminal No.	Color of Wire	Signal Name [Specification]
1	W	BAT (F/L)
2	Y	POWER WINDOW POWER SUPPLY(BAT)
3	O	POWER WINDOW POWER SUPPLY(RAP)

Connector No.	M119
Connector Name	BCM (BODY CONTROL MODULE)
Connector Type	MS16FW-CS

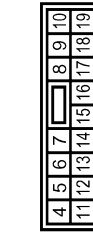

Terminal No.	Color of Wire	Signal Name [Specification]
11	R	BAT (FUSE)
13	B	GND

Connector No.	M122
Connector Name	BCM (BODY CONTROL MODULE)
Connector Type	TH40FB-NH

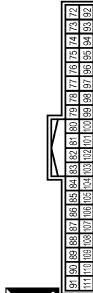

Terminal No.	Color of Wire	Signal Name [Specification]
83	Y	KEYLESS ENTRY RECEIVER COMM
103	L	KEYLESS ENTRY RECEIVER POWER SUPPLY

Connector No.	M123
Connector Name	BCM (BODY CONTROL MODULE)
Connector Type	TH40FG-NH

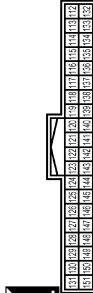

Terminal No.	Color of Wire	Signal Name [Specification]
124	LG	PASSENGER DOOR SW
132	V	POWER WINDOW SW COMM
137	O	RECEIVER/SENSOR GND
150	GR	DRIVER DOOR SW

Connector No.	M124
Connector Name	WIRE TO WIRE
Connector Type	TH40MP-CS15

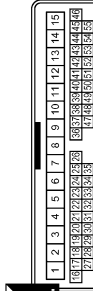

Terminal No.	Color of Wire	Signal Name [Specification]
13	B	-
14	G	-
15	W	-

Fail-safe

FAIL-SAFE CONTROL

Switches to fail-safe control when malfunction is detected in encoder signal that detects up/down speed and direction of door glass. Switches to fail-safe control when a signal that is out of the specified value is detected between the fully closed position and the actual position of the glass.

JCKWA1892GE

INFOID:000000004679444

FRONT POWER WINDOW SWITCH

< ECU DIAGNOSIS INFORMATION >

[FRONT & REAR WINDOW ANTI-PINCH]

Malfunction	Malfunction condition
Pulse sensor malfunction	When one pulse signal that is the specified value or more is detected continuously for the specified time or more, while door glass is being operated UP or DOWN.
Both pulse sensors malfunction	When both pulse signals are not detected continuously for the specified time or more, while door glass is being operated UP or DOWN.
Pulse direction malfunction	When a pulse signal indicating that window is moving in the opposite direction against the power window motor is detected for the specified value or more, while door glass is being operated UP or DOWN.
Glass recognition position malfunction 1	When the actual door glass position that is out of specified value is detected compared to the door glass fully closed position memorized in module, while door glass is being operated UP or DOWN.
Glass recognition position malfunction 2	When pulse count that is out of the door glass full stroke value or more is detected, while door glass is being operated UP or DOWN.

If fail-safe control, the system changes to a non-initialized condition and the following function do not operate.

- Auto-up operation
- Anti-pinch function
- Door key cylinder switch power window function

When fail-safe control is activated, perform initialization procedure to recover. If a malfunction is detected in power window switch or more, fail-safe control is activated again.

A
B
C
D
E
F
G
H
I
J
L
M
N
O
P

PWC

REAR POWER WINDOW SWITCH

< ECU DIAGNOSIS INFORMATION >

[FRONT & REAR WINDOW ANTI-PINCH]

REAR POWER WINDOW SWITCH

Reference Value

INFOID:000000004240648

TERMINAL LAYOUT

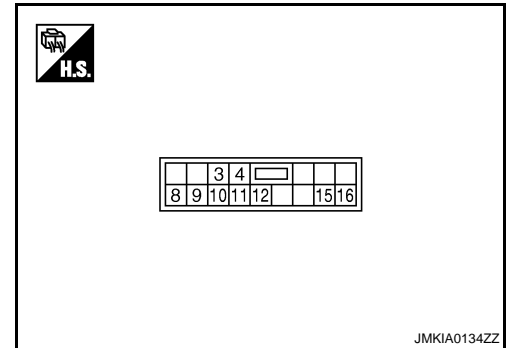

PHYSICAL VALUES

Rear Power Window Switch

Terminal No. (wire color)		Description		Condition	Voltage (V) (Approx.)
+	-	Signal name	Input/ Output		
3 (W)	Ground	Encoder ground	—	—	0
4 (SB)	Ground	Encoder power supply	Output	When ignition switch ON or power window timer operates	Battery voltage
8 (G)	Ground	Power window motor UP signal	Output	When power window motor is UP at operated.	Battery voltage
9 (L)	Ground	Power window motor DOWN signal	Output	When power window motor is DOWN at operated.	Battery voltage
10 (W)	Ground	Battery power supply	Input	—	Battery voltage
11 (B)	Ground	Ground	—	—	0
12 (GR)	Ground	Encoder pulse signal 1	Input	When power window motor operates.	

JMKIA0070GB

REAR POWER WINDOW SWITCH

< ECU DIAGNOSIS INFORMATION >

[FRONT & REAR WINDOW ANTI-PINCH]

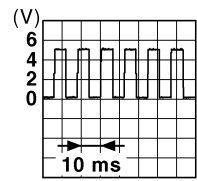
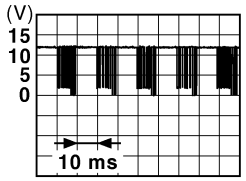
Terminal No. (wire color)		Description		Condition	Voltage (V) (Approx.)
+	-	Signal name	Input/ Output		
15 (O)	Ground	Encoder pulse signal 2	Input	When power window motor operates.	 <p style="text-align: right; font-size: small;">JMKIA0070GB</p>
16 (R)	Ground	Power window serial link	Input/ Output	Ignition switch ON or power window timer operating.	 <p style="text-align: right; font-size: small;">JPMIA0013GB</p>

A
B
C
D
E
F
G
H
I
J
L
M
N
O
P

PWC

REAR POWER WINDOW SWITCH

< ECU DIAGNOSIS INFORMATION >

[FRONT & REAR WINDOW ANTI-PINCH]

POWER WINDOW SYSTEM (WITH FRONT AND REAR POWER WINDOW ANTI-PINCH SYSTEM)

Connector No.	B1
Connector Name	WIRE TO WIRE
Connector Type	TH40FW-CS16-TM4

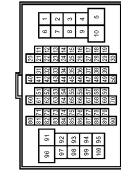

Terminal No.	Color of Wire	Signal Name [Specification]
8	W	-
9	O	-
87	B	-

Connector No.	B16
Connector Name	FRONT DOOR SWITCH (DRIVER SIDE)
Connector Type	A09FW

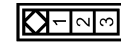

Terminal No.	Color of Wire	Signal Name [Specification]
2	B	-

Connector No.	B18
Connector Name	WIRE TO WIRE
Connector Type	TK10FW-NS8

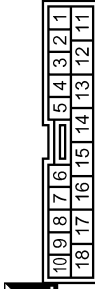

Terminal No.	Color of Wire	Signal Name [Specification]
12	O	- [With rear power window anti-pinch system]
13	W	-
18	B	-

Connector No.	B201
Connector Name	WIRE TO WIRE
Connector Type	TH40FW-CS16-TM4

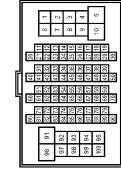

Terminal No.	Color of Wire	Signal Name [Specification]
92	Y	-
93	W	-
97	GR	-

Connector No.	B216
Connector Name	FRONT DOOR SWITCH (PASSENGER SIDE)
Connector Type	A09FW

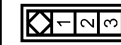

Terminal No.	Color of Wire	Signal Name [Specification]
2	GR	-

Connector No.	B218
Connector Name	WIRE TO WIRE
Connector Type	TK10FW-NS8

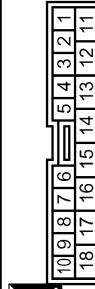

Terminal No.	Color of Wire	Signal Name [Specification]
12	Y	- [With rear power window anti-pinch system]
13	W	- [With rear power window anti-pinch system]
18	B	-

Connector No.	D1
Connector Name	WIRE TO WIRE
Connector Type	TH40FW-CS15

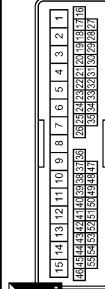

Terminal No.	Color of Wire	Signal Name [Specification]
8	SD	-
13	B	-
14	V	-
15	Y	-

Connector No.	D8
Connector Name	POWER WINDOW MAIN SWITCH
Connector Type	NS16FW-CS

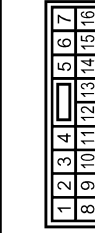

Terminal No.	Color of Wire	Signal Name [Specification]
2	LG	-
4	V	-
6	Y	-
8	L	-
9	O	-
10	SB	-
11	G	-
13	P	-
14	V	-
15	B	-

A
B
C
D
E
F
G
H
I
J
L
M
N
O
P

PWC

REAR POWER WINDOW SWITCH

< ECU DIAGNOSIS INFORMATION >

[FRONT & REAR WINDOW ANTI-PINCH]

POWER WINDOW SYSTEM (WITH FRONT AND REAR POWER WINDOW ANTI-PINCH SYSTEM)

Connector No.	D39
Connector Name	POWER WINDOW MAIN SWITCH
Connector Type	NS38PW-CS



Terminal No.	Color of Wire	Signal Name [Specification]
17	B	-
18	Y	-

Connector No.	D10
Connector Name	FRONT POWER WINDOW MOTOR (DRIVER SIDE)
Connector Type	NS08FW-CS

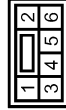

Terminal No.	Color of Wire	Signal Name [Specification]
1	G	-
2	L	-
3	O	-
4	B	-
5	P	-
6	LG	-

Connector No.	D15
Connector Name	FRONT DOOR LOCK ASSEMBLY (DRIVER SIDE)
Connector Type	ED08FGY-RS



Terminal No.	Color of Wire	Signal Name [Specification]
4	B	-
5	Y	-
6	V	-

Connector No.	D31
Connector Name	WIRE TO WIRE
Connector Type	TH40FW-CS/5

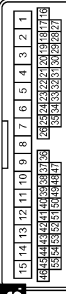

Terminal No.	Color of Wire	Signal Name [Specification]
13	B	-
14	V	-
15	Y	-

Connector No.	D38
Connector Name	FRONT POWER WINDOW SWITCH (PASSENGER SIDE)
Connector Type	NS18PW-CS



Terminal No.	Color of Wire	Signal Name [Specification]
3	LG	-
4	B	-
8	L	-
9	G	-
10	Y	-
11	B	-
12	P	-
15	O	-
16	V	-

Connector No.	D40
Connector Name	FRONT POWER WINDOW MOTOR (PASSENGER SIDE)
Connector Type	NS08PW-CS

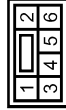

Terminal No.	Color of Wire	Signal Name [Specification]
1	G	-
2	L	-
3	O	-
4	B	-
5	P	-
6	LG	-

Connector No.	DE1
Connector Name	WIRE TO WIRE
Connector Type	TK10MK-NS



Terminal No.	Color of Wire	Signal Name [Specification]
12	R	-
13	W	- (With rear power window anti-pinch system)
18	B	-

Connector No.	D52
Connector Name	REAR POWER WINDOW MOTOR LH
Connector Type	RS08FG



Terminal No.	Color of Wire	Signal Name [Specification]
1	G	-
2	SB	-
3	L	-
4	W	-
5	GR	-
6	O	-

JCKWA1890GE

REAR POWER WINDOW SWITCH

[FRONT & REAR WINDOW ANTI-PINCH]

< ECU DIAGNOSIS INFORMATION >

POWER WINDOW SYSTEM (WITH FRONT AND REAR POWER WINDOW ANTI-PINCH SYSTEM)

Connector No.	D77
Connector Name	REAR POWER WINDOW SWITCH RH (WITH REAR ANTI-PINCH SYSTEM)
Connector Type	NSI6FW-CS



Terminal No.	Color of Wire	Signal Name [Specification]
3	W	-
4	SB	-
8	G	-
9	L	-
10	W	-
11	B	-
12	GR	-
15	O	-
16	R	-

Connector No.	D72
Connector Name	REAR POWER WINDOW MOTOR RH
Connector Type	RS06FG



Terminal No.	Color of Wire	Signal Name [Specification]
1	G	-
2	SB	-
3	L	-
4	W	-
5	GR	-
6	O	-

Connector No.	D71
Connector Name	WIRE TO WIRE
Connector Type	TK10MW-NS



Terminal No.	Color of Wire	Signal Name [Specification]
12	R	-
13	W	-
18	B	-

Connector No.	D57
Connector Name	REAR POWER WINDOW SWITCH LH (WITH REAR ANTI-PINCH SYSTEM)
Connector Type	NSI6FW-CS



Terminal No.	Color of Wire	Signal Name [Specification]
3	W	-
4	SB	-
8	G	-
9	L	-
10	W	-
11	B	-
12	GR	-
15	O	-
16	R	-

Connector No.	M6
Connector Name	WIRE TO WIRE
Connector Type	TH60MW-CS16-TM4



Terminal No.	Color of Wire	Signal Name [Specification]
91	W	-

Connector No.	M5
Connector Name	WIRE TO WIRE
Connector Type	TH40MW-CS15

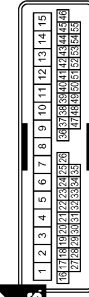

Terminal No.	Color of Wire	Signal Name [Specification]
8	O	-
13	B	-
14	V	-
15	Y	-

Connector No.	M1
Connector Name	FUSE BLOCK (J/B)
Connector Type	NS06FW-M2



Terminal No.	Color of Wire	Signal Name [Specification]
7A	R	-

Connector No.	E108
Connector Name	WIRE TO WIRE
Connector Type	TH09FW-CS16-TM4



Terminal No.	Color of Wire	Signal Name [Specification]
91	W	-

JCKWA1891GE

A
B
C
D
E
F
G
H
I
J
L
M
N
O
P

PWC

REAR POWER WINDOW SWITCH

< ECU DIAGNOSIS INFORMATION >

[FRONT & REAR WINDOW ANTI-PINCH]

POWER WINDOW SYSTEM (WITH FRONT AND REAR POWER WINDOW ANTI-PINCH SYSTEM)

Connector No.	M118
Connector Name	BCM (BODY CONTROL MODULE)
Connector Type	M33FB-LG



Terminal No.	Color of Wire	Signal Name [Specification]
1	W	BAT (F/L)
2	Y	POWER WINDOW POWER SUPPLY(BAT)
3	O	POWER WINDOW POWER SUPPLY(RAP)

Connector No.	M117
Connector Name	WIRE TO WIRE
Connector Type	TH40MM-CS16-TM4



Terminal No.	Color of Wire	Signal Name [Specification]
92	BR	-
93	V	-
97	LG	-

Connector No.	M104
Connector Name	REMOTE KEYLESS ENTRY RECEIVER
Connector Type	JA804EB

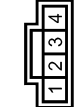

Terminal No.	Color of Wire	Signal Name [Specification]
1	O	GND
2	Y	SIGNAL OUTPUT
4	L	BATTERY

Connector No.	M7
Connector Name	WIRE TO WIRE
Connector Type	TH30MW-CS16-TM4



Terminal No.	Color of Wire	Signal Name [Specification]
8	G	-
9	Y	-
87	GR	-

Connector No.	M124
Connector Name	WIRE TO WIRE
Connector Type	TH40MM-CS15

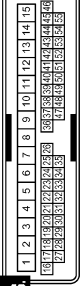

Terminal No.	Color of Wire	Signal Name [Specification]
13	B	-
14	G	-
15	W	-

Connector No.	M123
Connector Name	BCM (BODY CONTROL MODULE)
Connector Type	TH40FG-NH



Terminal No.	Color of Wire	Signal Name [Specification]
124	LG	PASSENGER DOOR SW
132	V	POWER WINDOW SW COMM
137	O	RECEIVER/SENSOR GND
150	GR	DRIVER DOOR SW

Connector No.	M122
Connector Name	BCM (BODY CONTROL MODULE)
Connector Type	TH40FB-NH

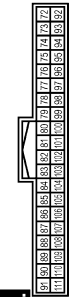

Terminal No.	Color of Wire	Signal Name [Specification]
83	Y	KEYLESS ENTRY RECEIVER COMM
103	L	KEYLESS ENTRY RECEIVER POWER SUPPLY

Connector No.	M119
Connector Name	BCM (BODY CONTROL MODULE)
Connector Type	MS16FW-CS



Terminal No.	Color of Wire	Signal Name [Specification]
11	R	BAT (FUSE)
13	B	GND

Fail-safe

FAIL-SAFE CONTROL

Switches to fail-safe control when malfunction is detected in encoder signal that detects up/down speed and direction of door glass. Switches to fail-safe control when a signal that is out of the specified value is detected between the fully closed position and the actual position of the glass.

JCKWA1892GE

INFOID:000000004679445

REAR POWER WINDOW SWITCH

< ECU DIAGNOSIS INFORMATION >

[FRONT & REAR WINDOW ANTI-PINCH]

Malfunction	Malfunction condition
Pulse sensor malfunction	When one pulse signal that is the specified value or more is detected continuously for the specified time or more, while door glass is being operated UP or DOWN.
Both pulse sensors malfunction	When both pulse signals are not detected continuously for the specified time or more, while door glass is being operated UP or DOWN.
Pulse direction malfunction	When a pulse signal indicating that window is moving in the opposite direction against the power window motor is detected for the specified value or more, while door glass is being operated UP or DOWN.
Glass recognition position malfunction 1	When the actual door glass position that is out of specified value is detected compared to the door glass fully closed position memorized in module, while door glass is being operated UP or DOWN.
Glass recognition position malfunction 2	When pulse count that is out of the door glass full stroke value or more is detected, while door glass is being operated UP or DOWN.

If fail-safe control, the system changes to a non-initialized condition and the following function do not operate.

- Auto-up operation
- Anti-pinch function
- Door key cylinder switch power window function

When fail-safe control is activated, perform initialization procedure to recover. If a malfunction is detected in power window switch or more, fail-safe control is activated again.

A
B
C
D
E
F
G
H
I
J
L
M
N
O
P

PWC

POWER WINDOWS DO NOT OPERATE WITH ANY POWER WINDOW SWITCHES

< SYMPTOM DIAGNOSIS >

[FRONT & REAR WINDOW ANTI-PINCH]

SYMPTOM DIAGNOSIS

POWER WINDOWS DO NOT OPERATE WITH ANY POWER WINDOW SWITCHES

Diagnosis Procedure

INFOID:000000004240651

1. CHECK BCM POWER SUPPLY AND GROUND CIRCUIT

Check BCM power supply and ground circuit.

[PWC-16, "BCM : Diagnosis Procedure"](#).

Is the inspection result normal?

YES >> GO TO 2.

NO >> Repair or replace the malfunctioning parts.

2. CHECK POWER WINDOW MAIN SWITCH SERIAL LINK CIRCUIT

Check power window serial link circuit.

Refer to [PWC-36, "POWER WINDOW MAIN SWITCH : Component Function Check"](#).

Is the inspection result normal?

YES >> GO TO 3.

NO >> Repair or replace the malfunctioning parts.

3. CONFIRM THE OPERATION

Confirm the operation again.

Is the result normal?

YES >> Check intermittent incident. Refer to [GI-41, "Intermittent Incident"](#).

NO >> GO TO 1.

DRIVER SIDE POWER WINDOW ALONE DOES NOT OPERATE

< SYMPTOM DIAGNOSIS >

[FRONT & REAR WINDOW ANTI-PINCH]

DRIVER SIDE POWER WINDOW ALONE DOES NOT OPERATE

Diagnosis Procedure

INFOID:000000004240652

1. CHECK POWER WINDOW MAIN SWITCH POWER SUPPLY AND GROUND CIRCUIT

Check power window switch power supply and ground circuit.

Refer to [PWC-16, "POWER WINDOW MAIN SWITCH : Diagnosis Procedure"](#).

Is the inspection result normal?

YES >> GO TO 2.

NO >> Repair or replace the malfunctioning parts.

2. CHECK DRIVER SIDE POWER WINDOW MOTOR

Check driver side power window motor.

Refer to [PWC-20, "DRIVER SIDE : Component Function Check"](#).

Is the measurement value within the specification?

YES >> GO TO 3.

NO >> Repair or replace the malfunctioning parts.

3. CONFIRM THE OPERATION

Confirm the operation again.

Is the result normal?

YES >> Check intermittent incident. Refer to [GI-41, "Intermittent Incident"](#).

NO >> GO TO 1.

A
B
C
D
E
F
G
H
I
J
L
M
N
O
P

PWC

FRONT PASSENGER SIDE POWER WINDOW DOES NOT OPERATE

< SYMPTOM DIAGNOSIS >

[FRONT & REAR WINDOW ANTI-PINCH]

FRONT PASSENGER SIDE POWER WINDOW DOES NOT OPERATE WHEN POWER WINDOW MAIN SWITCH IS OPERATED

WHEN POWER WINDOW MAIN SWITCH IS OPERATED : Diagnosis Procedure

INFOID:000000004240653

1. CHECK FRONT POWER WINDOW SWITCH (PASSENGER SIDE) SERIAL LINK CIRCUIT

Check front power window switch (passenger side) serial link circuit.

Refer to [PWC-37. "FRONT POWER WINDOW SWITCH \(PASSENGER SIDE\) : Component Function Check"](#).

Is the inspection result normal?

YES >> GO TO 2.

NO >> Repair or replace the malfunctioning parts.

2. CONFIRM THE OPERATION

Confirm the operation again.

Is the result normal?

YES >> Check intermittent incident. Refer to [GI-41. "Intermittent Incident"](#).

NO >> GO TO 1.

WHEN FRONT POWER WINDOW SWITCH (PASSENGER SIDE) IS OPERATED

WHEN FRONT POWER WINDOW SWITCH (PASSENGER SIDE) IS OPERATED :
Diagnosis Procedure

INFOID:000000004240654

1. REPLACE FRONT POWER WINDOW SWITCH (PASSENGER SIDE)

Replace front power window switch (passenger side).

Refer to [PWC-117. "Removal and Installation"](#)

>> INSPECTION END

WHEN BOTH POWER WINDOW MAIN SWITCH AND FRONT POWER WINDOW SWITCH ARE OPERATED

WHEN BOTH POWER WINDOW MAIN SWITCH AND FRONT POWER WINDOW
SWITCH ARE OPERATED : Diagnosis Procedure

INFOID:000000004240655

1. CHECK FRONT POWER WINDOW SWITCH (PASSENGER SIDE) POWER SUPPLY AND GROUND CIR- CUIT

Check front power window switch (passenger side) power supply and ground circuit.

Refer to [PWC-17. "FRONT POWER WINDOW SWITCH \(PASSENGER SIDE\) : Diagnosis Procedure"](#).

Is the inspection result normal?

YES >> GO TO 2.

NO >> Repair or replace the malfunctioning parts.

2. CHECK PASSENGER SIDE POWER WINDOW MOTOR CIRCUIT

Check passenger side power window motor circuit.

Refer to [PWC-21. "PASSENGER SIDE : Component Function Check"](#).

Is the inspection result normal?

YES >> GO TO 3.

NO >> Repair or replace the malfunctioning parts.

3. CONFIRM THE OPERATION

Confirm the operation again.

Is the result normal?

YES >> Check intermittent incident. Refer to [GI-41. "Intermittent Incident"](#).

NO >> GO TO 1.

REAR LH SIDE POWER WINDOW ALONE DOES NOT OPERATE

< SYMPTOM DIAGNOSIS >

[FRONT & REAR WINDOW ANTI-PINCH]

REAR LH SIDE POWER WINDOW ALONE DOES NOT OPERATE WHEN POWER WINDOW MAIN SWITCH IS OPERATED

WHEN POWER WINDOW MAIN SWITCH IS OPERATED : Diagnosis Procedure

INFOID:000000004240656

1. CHECK REAR POWER WINDOW SWITCH LH SERIAL LINK CIRCUIT

Check rear power window switch LH serial link circuit.

Refer to [PWC-39, "REAR LH : Component Function Check"](#).

Is the inspection result normal?

YES >> GO TO 2.

NO >> Repair or replace the malfunctioning parts.

2. CONFIRM THE OPERATION

Confirm the operation again.

Is the result normal?

YES >> Check intermittent incident. Refer to [GI-41, "Intermittent Incident"](#).

NO >> GO TO 1.

WHEN REAR POWER WINDOW SWITCH LH IS OPERATED

WHEN REAR POWER WINDOW SWITCH LH IS OPERATED : Diagnosis Procedure

INFOID:000000004240657

1. REPLACE REAR POWER WINDOW SWITCH LH

Replace rear power window switch LH.

Refer to [PWC-117, "Removal and Installation"](#)

>> INSPECTION END

WHEN BOTH POWER WINDOW MAIN SWITCH AND REAR POWER WINDOW SWITCH LH ARE OPERATED

WHEN BOTH POWER WINDOW MAIN SWITCH AND REAR POWER WINDOW
SWITCH LH ARE OPERATED : Diagnosis Procedure

INFOID:000000004240658

1. CHECK REAR POWER WINDOW SWITCH POWER SUPPLY AND GROUND CIRCUIT

Check rear power window switch power supply and ground circuit.

Refer to [PWC-18, "REAR POWER WINDOW SWITCH : Diagnosis Procedure"](#).

Is the inspection result normal?

YES >> GO TO 2.

NO >> Repair or replace the malfunctioning parts.

2. CHECK REAR POWER WINDOW MOTOR LH

Check rear power window motor LH.

Refer to [PWC-23, "REAR LH : Component Function Check"](#).

Is the inspection result normal?

YES >> GO TO 3.

NO >> Repair or replace the malfunctioning parts.

3. CONFIRM THE OPERATION

Confirm the operation again.

Is the result normal?

YES >> Check intermittent incident. Refer to [GI-41, "Intermittent Incident"](#).

NO >> GO TO 1.

A
B
C
D
E
F
G
H
I
J
L
M
N
O
P

PWC

REAR RH SIDE POWER WINDOW ALONE DOES NOT OPERATE

< SYMPTOM DIAGNOSIS >

[FRONT & REAR WINDOW ANTI-PINCH]

REAR RH SIDE POWER WINDOW ALONE DOES NOT OPERATE WHEN POWER WINDOW MAIN SWITCH IS OPERATED

WHEN POWER WINDOW MAIN SWITCH IS OPERATED : Diagnosis Procedure

INFOID:000000004240659

1. CHECK REAR POWER WINDOW SWITCH RH SERIAL LINK CIRCUIT

Check rear power window switch RH serial link circuit.

Refer to [PWC-40, "REAR RH : Component Function Check"](#).

Is the inspection result normal?

YES >> GO TO 2.

NO >> Repair or replace the malfunctioning parts.

2. CONFIRM THE OPERATION

Confirm the operation again.

Is the result normal?

YES >> Check intermittent incident. Refer to [GI-41, "Intermittent Incident"](#).

NO >> GO TO 1.

WHEN REAR POWER WINDOW SWITCH RH IS OPERATED

WHEN REAR POWER WINDOW SWITCH RH IS OPERATED : Diagnosis Procedure

INFOID:000000004240660

1. REPLACE REAR POWER WINDOW SWITCH RH

Replace rear power window switch RH.

Refer to [PWC-117, "Removal and Installation"](#)

>> INSPECTION END

WHEN BOTH POWER WINDOW MAIN SWITCH AND REAR POWER WINDOW SWITCH RH ARE OPERATED

WHEN BOTH POWER WINDOW MAIN SWITCH AND REAR POWER WINDOW
SWITCH RH ARE OPERATED : Diagnosis Procedure

INFOID:000000004240661

1. CHECK REAR POWER WINDOW SWITCH POWER SUPPLY AND GROUND CIRCUIT

Check rear power window switch power supply and ground circuit.

Refer to [PWC-18, "REAR POWER WINDOW SWITCH : Diagnosis Procedure"](#).

Is the inspection result normal?

YES >> GO TO 2.

NO >> Repair or replace the malfunctioning parts.

2. CHECK REAR POWER WINDOW MOTOR RH

Check rear power window motor RH.

Refer to [PWC-24, "REAR RH : Component Function Check"](#).

Is the inspection result normal?

YES >> GO TO 3.

NO >> Repair or replace the malfunctioning parts.

3. CONFIRM THE OPERATION

Confirm the operation again.

Is the result normal?

YES >> Check intermittent incident. Refer to [GI-41, "Intermittent Incident"](#).

NO >> GO TO 1.

ANTI-PINCH FUNCTION DOES NOT OPERATE NORMALLY

< SYMPTOM DIAGNOSIS >

[FRONT & REAR WINDOW ANTI-PINCH]

ANTI-PINCH FUNCTION DOES NOT OPERATE NORMALLY

DRIVER SIDE

DRIVER SIDE : Diagnosis Procedure

INFOID:000000004240662

1.CHECK POWER WINDOW AUTO OPERATION

Check power window auto operation.

Is the inspection result normal?

YES >> GO TO 2.

NO >> Refer to [PWC-109, "DRIVER SIDE : Diagnosis Procedure"](#).

2.CONFIRM THE OPERATION

Confirm the operation again.

Is the result normal?

YES >> Check intermittent incident. Refer to [GI-41, "Intermittent Incident"](#).

NO >> GO TO 1.

PASSENGER SIDE

PASSENGER SIDE : Diagnosis Procedure

INFOID:000000004240663

1.CHECK POWER WINDOW AUTO OPERATION

Check power window auto operation.

Is the inspection result normal?

YES >> GO TO 2.

NO >> Refer to [PWC-109, "PASSENGER SIDE : Diagnosis Procedure"](#).

2.CONFIRM THE OPERATION

Confirm the operation again.

Is the result normal?

YES >> Check intermittent incident. Refer to [GI-41, "Intermittent Incident"](#).

NO >> GO TO 1.

REAR LH

REAR LH : Diagnosis Procedure

INFOID:000000004240664

1.CHECK POWER WINDOW AUTO OPERATION

Check power window auto operation.

Is the inspection result normal?

YES >> GO TO 2.

NO >> Refer to [PWC-110, "REAR LH : Diagnosis Procedure"](#).

2.CONFIRM THE OPERATION

Confirm the operation again.

Is the result normal?

YES >> Check intermittent incident. Refer to [GI-41, "Intermittent Incident"](#).

NO >> GO TO 1.

REAR RH

REAR RH : Diagnosis Procedure

INFOID:000000004240665

1.CHECK POWER WINDOW AUTO OPERATION

Check power window auto operation.

Is the inspection result normal?

YES >> GO TO 2.

A
B
C
D
E
F
G
H
I
J
L
M
N
O
P

PWC

ANTI-PINCH FUNCTION DOES NOT OPERATE NORMALLY

< SYMPTOM DIAGNOSIS >

[FRONT & REAR WINDOW ANTI-PINCH]

NO >> Refer to [PWC-110. "REAR RH : Diagnosis Procedure"](#).

2. CONFIRM THE OPERATION

Confirm the operation again.

Is the result normal?

YES >> Check intermittent incident. Refer to [GI-41. "Intermittent Incident"](#).

NO >> GO TO 1.

AUTO OPERATION DOES NOT OPERATE BUT MANUAL OPERATES NORMALLY

< SYMPTOM DIAGNOSIS >

[FRONT & REAR WINDOW ANTI-PINCH]

AUTO OPERATION DOES NOT OPERATE BUT MANUAL OPERATES NORMALLY DRIVER SIDE

DRIVER SIDE : Diagnosis Procedure

INFOID:000000004240666

1.PERFORM INITIALIZATION PROCEDURE

Initialization procedure is executed and operation is confirmed.

Refer to [PWC-8, "ADDITIONAL SERVICE WHEN REMOVING BATTERY NEGATIVE TERMINAL : Special Repair Requirement"](#).

Is the inspection result normal?

- YES >> INSPECTION END
- NO >> GO TO 2.

2.CHECK ENCODER (DRIVER SIDE) CIRCUIT

Check encoder (driver side) circuit.

Refer to [PWC-27, "DRIVER SIDE : Component Function Check"](#).

Is the inspection result normal?

- YES >> GO TO 3.
- NO >> Repair or replace the malfunctioning parts.

3.CONFIRM THE OPERATION

Confirm the operation again.

Is the result normal?

- YES >> Check intermittent incident. Refer to [GI-41, "Intermittent Incident"](#).
- NO >> GO TO 1.

PASSENGER SIDE

PASSENGER SIDE : Diagnosis Procedure

INFOID:000000004240667

1.PERFORM INITIALIZAITON PROCEDURE

Initialization procedure is executed and operation is confirmed.

Refer to [PWC-8, "ADDITIONAL SERVICE WHEN REMOVING BATTERY NEGATIVE TERMINAL : Special Repair Requirement"](#).

Is the inspection result normal?

- YES >> INSPECTION END
- NO >> GO TO 2.

2.CHECK ENCODER (PASSENGER SIDE) CIRCUIT

Check encoder (passenger side) circuit.

Refer to [PWC-29, "PASSENGER SIDE : Component Function Check"](#).

Is the inspection result normal?

- YES >> GO TO 3.
- NO >> Repair or replace the malfunctioning parts.

3.CONFIRM THE OPERATION

Confirm the operation again.

Is the result normal?

- YES >> Check intermittent incident. Refer to [GI-41, "Intermittent Incident"](#).
- NO >> GO TO 1.

REAR LH

A
B
C
D
E
F
G
H
I
J
L
M
N
O
P

PWC

AUTO OPERATION DOES NOT OPERATE BUT MANUAL OPERATES NORMALLY

< SYMPTOM DIAGNOSIS >

[FRONT & REAR WINDOW ANTI-PINCH]

REAR LH : Diagnosis Procedure

INFOID:000000004240668

1. PERFORM INITIALIZATION PROCEDURE

Initialization procedure is executed and operation is confirmed.

Refer to [PWC-8. "ADDITIONAL SERVICE WHEN REMOVING BATTERY NEGATIVE TERMINAL : Special Repair Requirement"](#).

Is the inspection result normal?

YES >> INSPECTION END

NO >> GO TO 2.

2. CHECK ENCODER (REAR LH) CIRCUIT

Check encoder (rear LH) circuit.

Refer to [PWC-31. "REAR LH : Component Function Check"](#).

Is the inspection result normal?

YES >> GO TO 3.

NO >> Repair or replace the malfunctioning parts.

3. CONFIRM THE OPERATION

Confirm the operation again.

Is the result normal?

YES >> Check intermittent incident. Refer to [GI-41. "Intermittent Incident"](#).

NO >> GO TO 1.

REAR RH

REAR RH : Diagnosis Procedure

INFOID:000000004240669

1. PERFORM INITIALIZATION PROCEDURE

Initialization procedure is executed and operation is confirmed.

Refer to [PWC-8. "ADDITIONAL SERVICE WHEN REMOVING BATTERY NEGATIVE TERMINAL : Special Repair Requirement"](#).

Is the inspection result normal?

YES >> INSPECTION END

NO >> GO TO 2.

2. CHECK ENCODER (REAR RH) CIRCUIT

Check encoder (rear RH) circuit.

Refer to [PWC-33. "REAR RH : Component Function Check"](#).

Is the inspection result normal?

YES >> GO TO 3.

NO >> Repair or replace the malfunctioning parts.

3. CONFIRM THE OPERATION

Confirm the operation again.

Is the result normal?

YES >> Check intermittent incident. Refer to [GI-41. "Intermittent Incident"](#).

NO >> GO TO 1.

POWER WINDOW RETAINED POWER FUNCTION DOES NOT OPERATE NORMALLY

< SYMPTOM DIAGNOSIS >

[FRONT & REAR WINDOW ANTI-PINCH]

POWER WINDOW RETAINED POWER FUNCTION DOES NOT OPERATE NORMALLY

Diagnosis Procedure

INFOID:000000004240670

1. CHECK DOOR SWITCH

Check door switch.

Refer to [DLK-66, "Component Function Check"](#).

Is the inspection result normal?

YES >> GO TO 2.

NO >> Repair or replace the malfunctioning parts.

2. CONFIRM THE OPERATION

Confirm the operation again.

Is the result normal?

YES >> Check intermittent incident. Refer to [GI-41, "Intermittent Incident"](#).

NO >> GO TO 1.

A
B
C
D
E
F
G
H
I
J
L
M
N
O
P

PWC

DOOR KEY CYLINDER SWITCH DOES NOT OPERATE POWER WINDOWS

< SYMPTOM DIAGNOSIS >

[FRONT & REAR WINDOW ANTI-PINCH]

DOOR KEY CYLINDER SWITCH DOES NOT OPERATE POWER WINDOWS

Diagnosis Procedure

INFOID:000000004240671

1. PERFORM INITIALIZATION PROCEDURE

Initialization procedure is executed and operation is confirmed.

Refer to [PWC-8, "ADDITIONAL SERVICE WHEN REMOVING BATTERY NEGATIVE TERMINAL : Special Repair Requirement"](#).

Is the inspection result normal?

YES >> INSPECTION END

NO >> GO TO 2.

2. CHECK DRIVER SIDE DOOR LOCK ASSEMBLY (DOOR KEY CYLINDER SWITCH)

Check driver side door lock assembly (door key cylinder switch).

Refer to [DLK-80, "Component Function Check"](#).

Is the inspection result normal?

YES >> GO TO 3.

NO >> Repair or replace the malfunctioning parts.

3. CONFIRM THE OPERATION

Confirm the operation again.

Is the result normal?

YES >> Check intermittent incident. Refer to [GI-41, "Intermittent Incident"](#).

NO >> GO TO 1.

KEYLESS POWER WINDOW DOWN DOES NOT OPERATE

< SYMPTOM DIAGNOSIS >

[FRONT & REAR WINDOW ANTI-PINCH]

KEYLESS POWER WINDOW DOWN DOES NOT OPERATE

Description

INFOID:000000004596778

Power window down does not operate when pressing unlock button on Intelligent Key.

Diagnosis Procedure

INFOID:000000004596779

1. CHECK REMOTE KEYLESS ENTRY FUNCTION

Check remote keyless entry function.

Does door lock/unlock with Intelligent Key button?

YES >> GO TO 2.

NO >> Refer to [DLK-181, "Description"](#).

2. CHECK POWER WINDOW OPERATION

Check power window operation.

Does power window operate up/down using power window main switch?

YES >> GO TO 3.

NO >> Refer to [PWC-103, "Diagnosis Procedure"](#).

3. CHECK "PW DOWN SET" SETTING IN "WORK SUPPORT"

Check "PW DOWN SET" setting in "WORK SUPPORT".

Refer to [DLK-52, "INTELLIGENT KEY : CONSULT-III Function \(BCM - INTELLIGENT KEY\)"](#).

Is the inspection result normal?

YES >> GO TO 4.

NO >> Set "PW DOWN SET" setting in "WORK SUPPORT".

4. CONFIRM THE OPERATION

Confirm the operation again.

Is the result normal?

YES >> Check intermittent incident. Refer to [GI-41, "Intermittent Incident"](#).

NO >> GO TO 1.

A
B
C
D
E
F
G
H
I
J
L
M
N
O
P

PWC

POWER WINDOW LOCK SWITCH DOES NOT FUNCTION

< SYMPTOM DIAGNOSIS >

[FRONT & REAR WINDOW ANTI-PINCH]

POWER WINDOW LOCK SWITCH DOES NOT FUNCTION

Diagnosis Procedure

INFOID:000000004240672

1. REPLACE POWER WINDOW MAIN SWITCH

Replace power window main switch.

>> Refer to [PWC-117. "Removal and Installation"](#).

POWER WINDOW SWITCH ILLUMINATION DOES NOT ILLUMINATE

< SYMPTOM DIAGNOSIS >

[FRONT & REAR WINDOW ANTI-PINCH]

POWER WINDOW SWITCH ILLUMINATION DOES NOT ILLUMINATE

DRIVER SIDE

DRIVER SIDE : Diagnosis Procedure

INFOID:000000004240673

1. REPLACE POWER WINDOW MAIN SWITCH

Replace power window main switch.

Refer to [PWC-117, "Removal and Installation"](#).

>> INSPECTION END

PASSENGER SIDE

PASSENGER SIDE : Diagnosis Procedure

INFOID:000000004240674

1. REPLACE FRONT POWER WINDOW SWITCH (PASSENGER SIDE)

Replace front power window switch (passenger side).

Refer to [PWC-117, "Removal and Installation"](#).

>> INSPECTION END

REAR LH

REAR LH : Diagnosis Procedure

INFOID:000000004240675

1. REPLACE REAR POWER WINDOW SWITCH LH

Replace rear power window switch LH.

Refer to [PWC-117, "Removal and Installation"](#).

>> INSPECTION END

REAR RH

REAR RH : Diagnosis Procedure

INFOID:000000004240676

1. REPLACE REAR POWER WINDOW SWITCH RH

Replace rear power window switch RH.

Refer to [PWC-117, "Removal and Installation"](#).

>> INSPECTION END

A
B
C
D
E
F
G
H
I
J
L
M
N
O
P

PWC

PRECAUTION

PRECAUTIONS

Precaution for Supplemental Restraint System (SRS) "AIR BAG" and "SEAT BELT PRE-TENSIONER"

INFOID:000000004240677

The Supplemental Restraint System such as "AIR BAG" and "SEAT BELT PRE-TENSIONER", used along with a front seat belt, helps to reduce the risk or severity of injury to the driver and front passenger for certain types of collision. This system includes seat belt switch inputs and dual stage front air bag modules. The SRS system uses the seat belt switches to determine the front air bag deployment, and may only deploy one front air bag, depending on the severity of a collision and whether the front occupants are belted or unbelted. Information necessary to service the system safely is included in the "SRS AIR BAG" and "SEAT BELT" of this Service Manual.

WARNING:

- To avoid rendering the SRS inoperative, which could increase the risk of personal injury or death in the event of a collision which would result in air bag inflation, all maintenance must be performed by an authorized NISSAN/INFINITI dealer.
- Improper maintenance, including incorrect removal and installation of the SRS, can lead to personal injury caused by unintentional activation of the system. For removal of Spiral Cable and Air Bag Module, see the "SRS AIR BAG".
- Do not use electrical test equipment on any circuit related to the SRS unless instructed to in this Service Manual. SRS wiring harnesses can be identified by yellow and/or orange harnesses or harness connectors.

PRECAUTIONS WHEN USING POWER TOOLS (AIR OR ELECTRIC) AND HAMMERS

WARNING:

- When working near the Air Bag Diagnosis Sensor Unit or other Air Bag System sensors with the ignition ON or engine running, DO NOT use air or electric power tools or strike near the sensor(s) with a hammer. Heavy vibration could activate the sensor(s) and deploy the air bag(s), possibly causing serious injury.
- When using air or electric power tools or hammers, always switch the ignition OFF, disconnect the battery, and wait at least 3 minutes before performing any service.

POWER WINDOW MAIN SWITCH

< REMOVAL AND INSTALLATION >

[FRONT & REAR WINDOW ANTI-PINCH]

REMOVAL AND INSTALLATION

POWER WINDOW MAIN SWITCH

Removal and Installation

INFOID:000000004240678

REMOVAL

1. Remove the power window main switch finisher (2).
Refer to [INT-11, "Removal and Installation"](#).
2. Power window main switch (1) is removed from power window main switch finisher (2) using flat-head screw driver (A) etc.

 : Pawl

CAUTION:

Do not fold the pawl of power window main switch finisher.

NOTE:

The same procedure is also performed for front power window switch (passenger side) and rear power window switch (LH & RH).

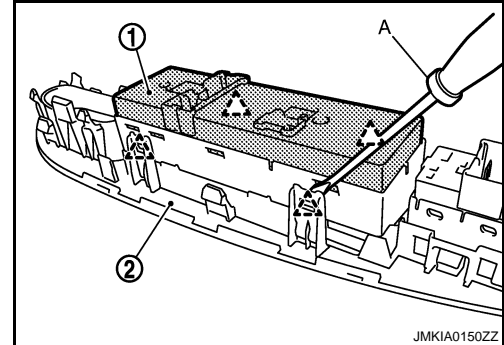

INSTALLATION

Install in the reverse order of removal.

NOTE:

Power window main switch is exchanged or is detached it is necessary to do the initialization procedure.
Refer to [PWC-9, "ADDITIONAL SERVICE WHEN REPLACING CONTROL UNIT : Special Repair Requirement"](#).

A
B
C
D
E
F
G
H
I
J
L
M
N
O
P

PWC

BASIC INSPECTION

DIAGNOSIS AND REPAIR WORK FLOW

Work Flow

INFOID:000000004240679

DETAILED FLOW

1.OBTAIN INFORMATION ABOUT SYMPTOM

Interview the customer to obtain the malfunction information (conditions and environment when the malfunction occurred) as much as possible when the customer brings the vehicle in.

>> GO TO 2.

2.REPRODUCE THE MALFUNCTION INFORMATION

Check the malfunction on the vehicle that the customer describes.
Inspect the relation of the symptoms and the condition when the symptoms occur.

>> GO TO 3.

3.IDENTIFY THE MALFUNCTIONING SYSTEM WITH "SYMPTOM DIAGNOSIS"

Use "Symptom diagnosis" from the symptom inspection result in step 2. Then identify where to start performing the diagnosis based on possible causes and symptoms.

>> GO TO 4.

4.IDENTIFY MALFUNCTIONING PARTS WITH "COMPONENT DIAGNOSIS"

Perform the diagnosis with "Component diagnosis" of the applicable system.

>> GO TO 5.

5.REPAIR OR REPLACE THE MALFUNCTIONING PARTS

Repair or replace the specified malfunctioning parts.

>> GO TO 6.

6.FINAL CHECK

Check that malfunctions are not reproduced when obtaining the malfunction information from the customer, referring to the symptom inspection result in step 2.

Is the malfunctioning part repaired or replaced?

YES >> Trouble diagnosis is completed.

NO >> GO TO 3.

INSPECTION AND ADJUSTMENT

< BASIC INSPECTION >

[FRONT WINDOW ANTI-PINCH]

INSPECTION AND ADJUSTMENT

ADDITIONAL SERVICE WHEN REMOVING BATTERY NEGATIVE TERMINAL

ADDITIONAL SERVICE WHEN REMOVING BATTERY NEGATIVE TERMINAL : Description

INFOID:000000004637761

When battery negative terminal is disconnected, initialization is necessary.

If any of the following operations are performed, initialization is necessary as well as when battery negative terminal is disconnected.

- Power supply to the power window control unit is cut off by the removal of battery terminal or the battery fuse is blown.
- Disconnection and connection of power window control unit harness connector.
- Removal and installation of motor from regulator assembly.
- Operation of regulator assembly as an independent unit.
- Removal and installation of rear power window control unit.
- Removal and installation of door glass.
- Removal and installation of door glass run.

The operations as per the following cannot be performed while initialization is not complete.

- AUTO-UP operation
- Anti-pinch function
- Door key cylinder power window function

ADDITIONAL SERVICE WHEN REMOVING BATTERY NEGATIVE TERMINAL : Special Repair Requirement

INFOID:000000004637762

INITIALIZATION PROCEDURE

1. Disconnect battery negative terminal or power window control unit connector. Reconnect it after a minute or more.
2. Turn ignition switch ON.
3. Operate power window switch to fully open door glass. (This operation is unnecessary if door glass is already fully open.)
4. Pull and hold power window switch UP (AUTO-UP operation). Even after door glass stops at the fully closed position, pull the switch for 2 seconds or more.
5. Initialization procedure is complete.
6. Inspect anti-pinch function.

CHECK ANTI-PINCH FUNCTION

1. Fully open door glass.
 2. Place a piece of wood near the fully closed position.
 3. Close door glass completely using AUTO-UP.
- Check that door glass lowers approximately 150 mm (5.9 in) without pinching piece of wood and stops.
 - Check that door glass does not rise when operating power window main switch while lowering.

CAUTION:

- Perform initialization when AUTO-UP operation or anti-pinch function does not operate normally.
- Check that AUTO-UP operates before inspection when initialization is performed.
- Never check with hands or other body parts because they may be pinched. Never get pinched.
- It may switch to the fail-safe mode if open/close operation is performed continuously without fully closing door glass. Perform initialization in the above situation. Refer to [PWC-191, "Fail-safe"](#).
- Finish initialization. Otherwise, the next operation cannot be done.

1. AUTO-UP operation
2. Anti-pinch function
3. Door key cylinder power window function

ADDITIONAL SERVICE WHEN REPLACING CONTROL UNIT

ADDITIONAL SERVICE WHEN REPLACING CONTROL UNIT : Description

INFOID:000000004637763

When the control unit is replaced, initialization is necessary.

If any of the following operations are performed, initialization is necessary as well as when the control unit is disconnected.

A
B
C
D
E
F
G
H
I
J
L
M
N
O
P

PWC

INSPECTION AND ADJUSTMENT

< BASIC INSPECTION >

[FRONT WINDOW ANTI-PINCH]

- Power supply to the power window control unit is cut off by the removal of battery terminal or the battery fuse is blown.
- Disconnection and connection of power window control unit harness connector.
- Removal and installation of motor from regulator assembly.
- Disconnection and connection of battery negative terminal.
- Removal and installation of rear power window control unit.
- Removal and installation of door glass.
- Removal and installation of door glass run.

The following specified operations cannot be performed while initialization is not complete.

- AUTO-UP operation
- Anti-pinch function
- Door key cylinder power window function

ADDITIONAL SERVICE WHEN REPLACING CONTROL UNIT : Special Repair Requirement

INFOID:000000004637764

INITIALIZATION PROCEDURE

1. Disconnect battery negative terminal or power window control unit connector. Reconnect it after a minute or more.
2. Turn ignition switch ON.
3. Operate power window switch to fully open door glass. (This operation is unnecessary if door glass is already fully open.)
4. Pull and hold power window switch UP (AUTO-UP operation). Even after door glass stops at the fully closed position, pull the switch for 2 seconds or more.
5. Initialization procedure is complete.
6. Inspect anti-pinch function.

CHECK ANTI-PINCH FUNCTION

1. Fully open door glass.
 2. Place a piece of wood near the fully closed position.
 3. Close door glass completely using AUTO-UP.
- Check that door glass lowers approximately 150 mm (5.9 in) without pinching piece of wood and stops.
 - Check that door glass does not rise when operating power window main switch while lowering.

CAUTION:

- **Perform initialization when AUTO-UP operation or anti-pinch function does not operate normally.**
 - **Check that AUTO-UP operates before inspection when initialization is performed.**
 - **Never check with hands or other body parts because they may be pinched. Never get pinched.**
 - **It may switch to the fail-safe mode if open/close operation is performed continuously without fully closing. Perform initialization in the above situation. Refer to [PWC-191, "Fail-safe"](#).**
 - **Finish initialization. Otherwise, the next operation cannot be done.**
1. **AUTO-UP operation**
 2. **Anti-pinch function**
 3. **Door key cylinder power window function**

SYSTEM DESCRIPTION

POWER WINDOW SYSTEM

System Diagram

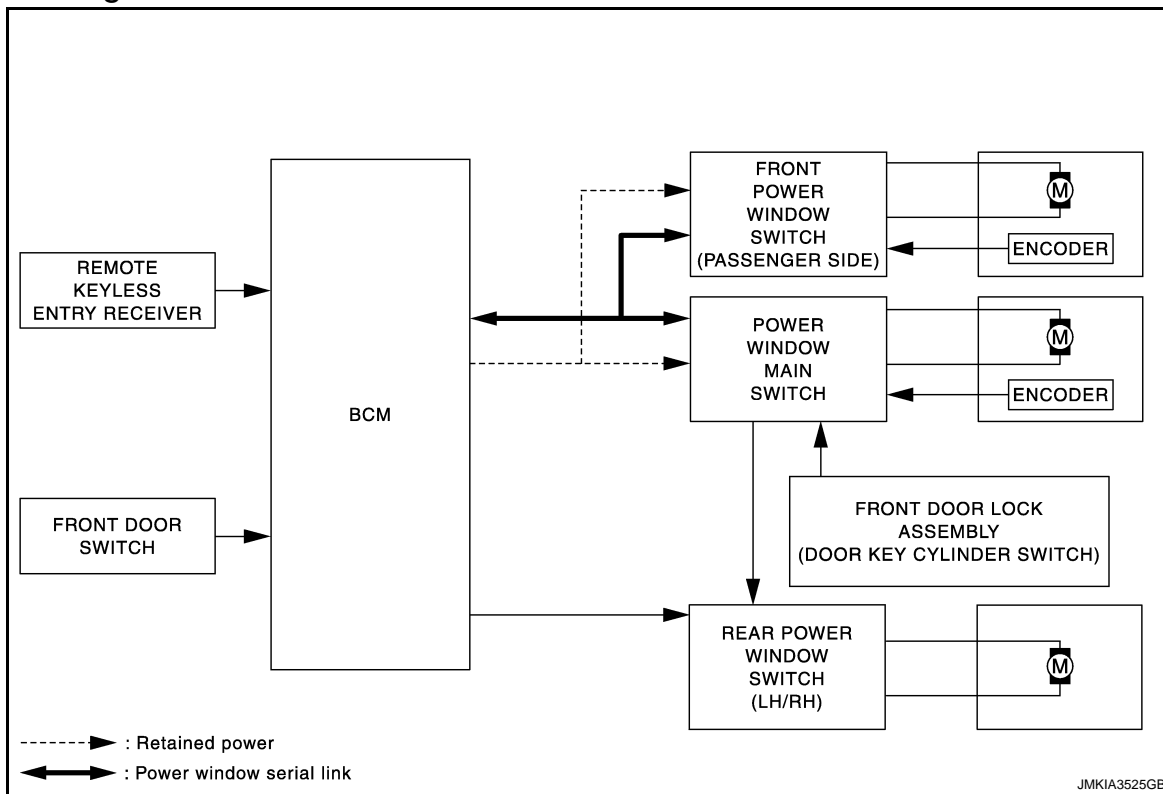

System Description

INFOID:000000004637758

POWER WINDOW SYSTEM

- Power window system is operable during the retained power operation timer after turning ignition switch OFF.
- Power window main switch can open/close door glass.
- Front and rear power window switch can open/close the corresponding door glass.
- AUTO UP/DOWN operation can be performed when front power window switch turns to AUTO.
- Power window lock switch can lock all power windows other than driver seat.
- Power window serial link transmits the signals from power window main switch to front power window switch (passenger side).
- If door glass receives resistance that is the specified value or more while power window of front seat is in AUTO-UP operation, power window of front seat operates in the reverse direction.
- Hold the door key cylinder to the LOCK or UNLOCK direction for 1 second or more to OPEN or CLOSE front power windows when ignition switch OFF.
- Front power windows open when pressing Intelligent Key unlock button for 3 seconds.

POWER WINDOW AUTO-OPERATION

- AUTO UP/DOWN operation can be performed when front power window motor turns to AUTO.
- Encoder continues detecting the movement of power window motor and transmits to power window switch as the encoder pulse signal while power window motor is operating.
- Power window switch reads the changes of encoder signal and stops AUTO operation when door glass is at fully opened/closed position.
- Power window motor is operable in case encoder is malfunctioning.

RETAINED POWER OPERATION

Retained power operation is an additional power supply function that enables power window system to operate for 45 seconds after ignition switch turns OFF.

A
B
C
D
E
F
G
H
I
J

PWC

L
M
N
O
P

POWER WINDOW SYSTEM

< SYSTEM DESCRIPTION >

[FRONT WINDOW ANTI-PINCH]

RETAINED POWER FUNCTION CANCEL CONDITIONS

- Front door CLOSE (door switch OFF) → OPEN (door switch ON).
- When ignition switch turns ON again.
- When timer times out. (45 seconds)

POWER WINDOW LOCK FUNCTION

Ground circuit inside power window main switch shuts off when power window lock switch is ON. This inhibits power window switch operation except with the power window main switch.

POWER WINDOW SERIAL LINK

- Front power window switches and BCM transmit and receive the power window serial link.
- Power window serial link transmits the power window main switch operation signals and IGN signal to power window main switch module, front power window switch (passenger side) module.

ANTI-PINCH OPERATION

- Pinch the foreign matter in the door glass during AUTO-UP operation is the anti-pinch function that lowers the door glass 150 mm (5.9 in) when detected.
- Encoder continues detecting the movement of power window motor and transmits to power window switch as the encoder pulse signal while power window motor is operating.
- Resistance is applied to the power window motor rotation that changes the frequency of encoder pulse signal if foreign material is trapped in the door glass.
- Power window switch controls to lower the door glass for 150 mm (5.9 in) after it detects encoder pulse signal frequency change.

OPERATION CONDITION

- When front door glass AUTO-UP operation is performed (anti-pinch function does not operate just before the door glass closes and is fully closed)

NOTE:

Depending on environment and driving conditions, if a similar impact or load is applied to the door glass, it may lower.

DOOR KEY CYLINDER SWITCH OPERATION

Hold the door key cylinder to the LOCK or UNLOCK direction for 1.5 seconds or more to OPEN or CLOSE front power windows when ignition switch is OFF. In addition, it stops when key position is moved to NEUTRAL when operating.

OPERATION CONDITION

- Ignition switch OFF.
- Hold door key cylinder to LOCK position for 1.5 seconds or more to perform CLOSE operation of the door glass.
- Hold door key cylinder to UNLOCK position for 1.5 seconds or more to perform OPEN operation of the door glass.

KEYLESS POWER WINDOW DOWN FUNCTION

Front power windows open when the unlock button on Intelligent Key is activated and kept pressed for more than 3* seconds with the ignition switch OFF. The windows keep opening if the unlock button is continuously pressed.

The power window opening stops when the following operations are performed.

- When the unlock button is kept pressed more than 15 seconds.
- When the ignition switch is turned ON while the power window opening is operated.
- When the unlock button is released.

While retained power operation activate, keyless power window down function cannot be operated.

Keyless power window down operation mode can be changed by "PW DOWN SET" mode in "WORK SUPPORT". Refer to [DLK-52, "INTELLIGENT KEY : CONSULT-III Function \(BCM - INTELLIGENT KEY\)".](#)

NOTE:

Use CONSULT-III to change settings.

MODE 1 (3 sec) / MODE 2 (OFF) / MODE 3 (5 sec)

POWER WINDOW SYSTEM

< SYSTEM DESCRIPTION >

[FRONT WINDOW ANTI-PINCH]

Component Parts Location

INFOID:000000004637759

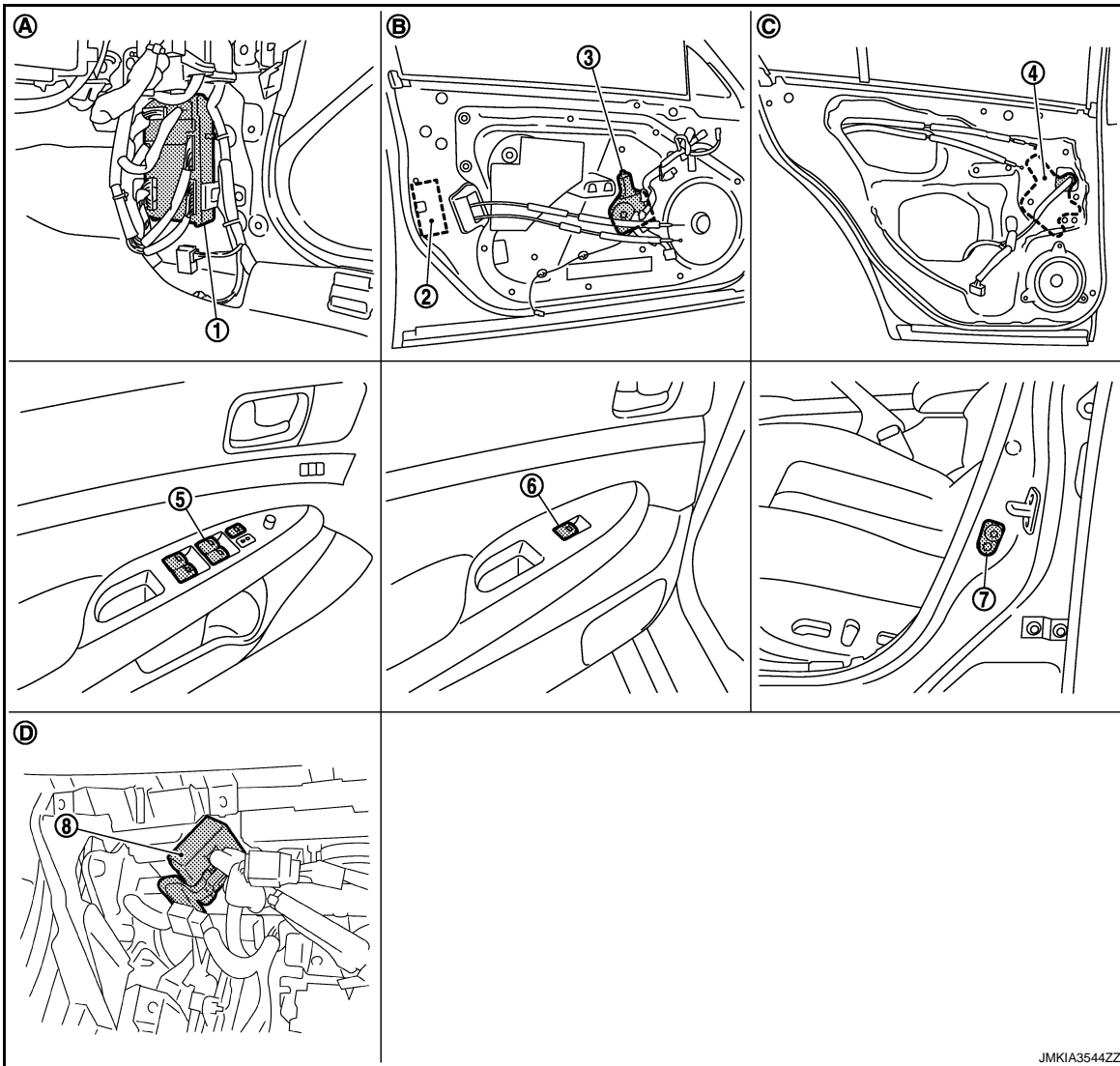

- | | | |
|--|--|---|
| 1. BCM M118,M119,M122,M123 | 2. Front door lock assembly (driver side) (door key cylinder switch) D15 | 3. Front power window motor (driver side) D10 |
| 4. Rear power window motor LH D52 | 5. Power window main switch D8,D9 | 6. Rear power window switch LH D54 |
| 7. Front door switch (driver side) B16 | 8. Remote keyless entry receiver M104 | |
| A. View with dash side lower (passenger side) | B. View with front door finisher removed | C. View with rear door finisher removed |
| D. View with instrument lower panel (passenger side) removed | | |

Component Description

INFOID:000000004637760

Component	Function
BCM	<ul style="list-style-type: none"> Supplies power supply to power window switch. Controls retained power function.
Power window main switch	<ul style="list-style-type: none"> Directly controls all power window motor of all doors. Controls anti-pinch operation of power window.
Front power window switch	<ul style="list-style-type: none"> Controls anti-pinch operation of power window. Controls power window motor of passenger door.

POWER WINDOW SYSTEM

< SYSTEM DESCRIPTION >

[FRONT WINDOW ANTI-PINCH]

Component	Function
Rear power window switch	Controls power window motor of rear right and left doors.
Power window motor	<ul style="list-style-type: none">• Integrates the ENCODER and WINDOW MOTOR.• Starts operating with signals from each power window switch.• Transmits power window motor rotation as a pulse signal to power window switch.
Front door lock assembly (door key cylinder switch)	Transmits operation condition of key cylinder switch to power window main switch.
Front door switch	Detects door open/close condition and transmits to BCM.
Remote keyless entry receiver	Receives lock/unlock signal from the intelligent Key, and then transmits to BCM.

DIAGNOSIS SYSTEM (BCM)

< SYSTEM DESCRIPTION >

[FRONT WINDOW ANTI-PINCH]

DIAGNOSIS SYSTEM (BCM)

COMMON ITEM

COMMON ITEM : CONSULT-III Function (BCM - COMMON ITEM)

INFOID:000000004667406

APPLICATION ITEM

CONSULT-III performs the following functions via CAN communication with BCM.

Diagnosis mode	Function Description
Work Support	Changes the setting for each system function.
Self Diagnostic Result	Displays the diagnosis results judged by BCM.
CAN Diag Support Monitor	Monitors the reception status of CAN communication viewed from BCM. Refer to CONSULT-III operation manual.
Data Monitor	The BCM input/output signals are displayed.
Active Test	The signals used to activate each device are forcibly supplied from BCM.
Ecu Identification	The BCM part number is displayed.
Configuration	This function is not used even though it is displayed.

SYSTEM APPLICATION

BCM can perform the following functions for each system.

NOTE:

It can perform the diagnosis modes except the following for all sub system selection items.

×: Applicable item

System	Sub system selection item	Diagnosis mode		
		Work Support	Data Monitor	Active Test
Door lock	DOOR LOCK	×	×	×
Rear window defogger	REAR DEFOGGER		×	×
Warning chime	BUZZER		×	×
Interior room lamp timer	INT LAMP	×	×	×
Exterior lamp	HEAD LAMP	×	×	×
Wiper and washer	WIPER	×	×	×
Turn signal and hazard warning lamps	FLASHER	×	×	×
—	AIR CONDITONER*			
• Intelligent Key system • Engine start system	INTELLIGENT KEY	×	×	×
Combination switch	COMB SW		×	
Body control system	BCM	×		
IVIS - NATS	IMMU		×	×
Interior room lamp battery saver	BATTERY SAVER	×	×	×
Trunk lid open	TRUNK		×	×
Vehicle security system	THEFT ALM	×	×	×
RAP system	RETAINED PWR		×	
Signal buffer system	SIGNAL BUFFER		×	×
TPMS	TPMS (AIR PRESSURE MONITOR)	×	×	×

NOTE:

*: This item is displayed, but is not used.

FREEZE FRAME DATA (FFD)

The BCM records the following vehicle condition at the time a particular DTC is detected, and displays on CONSULT-III.

DIAGNOSIS SYSTEM (BCM)

[FRONT WINDOW ANTI-PINCH]

< SYSTEM DESCRIPTION >

CONSULT screen item	Indication/Unit	Description	
Vehicle Speed	km/h	Vehicle speed of the moment a particular DTC is detected	
Odo/Trip Meter	km	Total mileage (Odometer value) of the moment a particular DTC is detected	
Vehicle Condition	SLEEP>LOCK	Power position status of the moment a particular DTC is detected	While turning BCM status from low power consumption mode to normal mode (Power supply position is "LOCK")
	SLEEP>OFF		While turning BCM status from low power consumption mode to normal mode (Power supply position is "OFF".)
	LOCK>ACC		While turning power supply position from "LOCK" to "ACC"
	ACC>ON		While turning power supply position from "ACC" to "IGN"
	RUN>ACC		While turning power supply position from "RUN" to "ACC" (Vehicle is stopping and selector lever is except P position.)
	CRANK>RUN		While turning power supply position from "CRANKING" to "RUN" (From cranking up the engine to run it)
	RUN>URGENT		While turning power supply position from "RUN" to "ACC" (Emergency stop operation)
	ACC>OFF		While turning power supply position from "ACC" to "OFF"
	OFF>LOCK		While turning power supply position from "OFF" to "LOCK"
	OFF>ACC		While turning power supply position from "OFF" to "ACC"
	ON>CRANK		While turning power supply position from "IGN" to "CRANKING"
	OFF>SLEEP		While turning BCM status from normal mode (Power supply position is "OFF".) to low power consumption mode
	LOCK>SLEEP		While turning BCM status from normal mode (Power supply position is "LOCK".) to low power consumption mode
	LOCK		Power supply position is "LOCK" (Ignition switch OFF with steering is locked.)
	OFF		Power supply position is "OFF" (Ignition switch OFF with steering is unlocked.)
	ACC		Power supply position is "ACC" (Ignition switch ACC)
	ON		Power supply position is "IGN" (Ignition switch ON with engine stopped)
ENGINE RUN	Power supply position is "RUN" (Ignition switch ON with engine running)		
CRANKING	Power supply position is "CRANKING" (At engine cranking)		
IGN Counter	0 - 39	<p>The number of times that ignition switch is turned ON after DTC is detected</p> <ul style="list-style-type: none"> • The number is 0 when a malfunction is detected now. • The number increases like 1 → 2 → 3...38 → 39 after returning to the normal condition whenever ignition switch OFF → ON. • The number is fixed to 39 until the self-diagnosis results are erased if it is over 39. 	

RETAINED PWR

RETAINED PWR : CONSULT-III Function (BCM - RETAINED PWR)

INFOID:000000004240689

Data monitor

Monitor Item	Description
DOOR SW-DR	Indicates [ON/OFF] condition of driver side door switch.
DOOR SW-AS	Indicates [ON/OFF] condition of passenger side door switch.

POWER SUPPLY AND GROUND CIRCUIT

< DTC/CIRCUIT DIAGNOSIS >

[FRONT WINDOW ANTI-PINCH]

DTC/CIRCUIT DIAGNOSIS

POWER SUPPLY AND GROUND CIRCUIT

BCM

BCM : Diagnosis Procedure

INFOID:000000004240690

1. CHECK FUSE AND FUSIBLE LINK

Check that the following fuse and fusible link are not blown.

Terminal No.	Signal name	Fuse and fusible link No.
1	Battery power supply	K (40 A)
11		10 (10 A)

Is the fuse fusing?

YES >> Replace the blown fuse or fusible link after repairing the affected circuit if a fuse or fusible link is blown.

NO >> GO TO 2.

2. CHECK POWER SUPPLY CIRCUIT

1. Turn ignition switch OFF.
2. Disconnect BCM connectors.
3. Check voltage between BCM harness connector and ground.

(+)		(-)	Voltage (Approx.)
BCM			
Connector	Terminal	Ground	Battery voltage
M118	1		
M119	11		

Is the measurement value normal?

YES >> GO TO 3.

NO >> Repair harness or connector.

3. CHECK GROUND CIRCUIT

Check continuity between BCM harness connector and ground.

BCM		Ground	Continuity
Connector	Terminal		
M119	13		Existed

Does continuity exist?

YES >> INSPECTION END

NO >> Repair harness or connector.

POWER WINDOW MAIN SWITCH

POWER WINDOW MAIN SWITCH : Diagnosis Procedure

INFOID:000000004240691

1. CHECK POWER SUPPLY CIRCUIT 1

1. Turn ignition switch OFF.
2. Disconnect power window main switch connectors.
3. Turn ignition switch ON.
4. Check voltage between power window main switch harness connector and ground.

A
B
C
D
E
F
G
H
I
J
L
M
N
O
P

PWC

POWER SUPPLY AND GROUND CIRCUIT

< DTC/CIRCUIT DIAGNOSIS >

[FRONT WINDOW ANTI-PINCH]

(+)		(-)	Voltage (V) (Approx.)
Power window main switch			
Connector	Terminal	Ground	Battery voltage
D8	10		
D9	19		

Is the measurement value within the specification?

YES >> GO TO 3.

NO >> GO TO 2.

2. CHECK POWER SUPPLY CIRCUIT 2

1. Turn ignition switch OFF.
2. Disconnect BCM connector.
3. Check continuity between BCM harness connector and power window main switch harness connector.

BCM		Power window main switch		Continuity
Connector	Terminal	Connector	Terminal	
M118	2	D9	19	Existed
	3	D8	10	

4. Check continuity between BCM harness connector and ground.

BCM		Ground	Continuity
Connector	Terminal		
M118	2		Not existed
	3		

Is the inspection result normal?

YES >> Replace BCM. Refer to [BCS-82, "Exploded View"](#).

NO >> Repair or replace harness.

3. CHECK GROUND CIRCUIT

1. Turn ignition switch OFF.
2. Check continuity between power window main switch harness connector and ground.

Power window main switch		Ground	Continuity
Connector	Terminal		
D9	17		Existed

Is the inspection result normal?

YES >> INSPECTION END

NO >> Repair or replace harness.

FRONT POWER WINDOW SWITCH (PASSENGER SIDE)

FRONT POWER WINDOW SWITCH (PASSENGER SIDE) : Diagnosis Procedure

INFOID:000000004240692

1. CHECK POWER SUPPLY CIRCUIT 1

1. Turn ignition switch OFF.
2. Disconnect front power window switch (passenger side) connector.
3. Check voltage between front power window switch (passenger side) harness connector and ground.

POWER SUPPLY AND GROUND CIRCUIT

< DTC/CIRCUIT DIAGNOSIS >

[FRONT WINDOW ANTI-PINCH]

(+)		(-)	Voltage (V) (Approx.)
Front power window switch (passenger side)			
Connector	Terminal	Ground	Battery voltage
D38	10		

Is the measurement value within the specification?

YES >> GO TO 3.

NO >> GO TO 2.

2.CHECK POWER SUPPLY CIRCUIT 2

1. Disconnect BCM connector.
2. Check continuity between BCM harness connector and front power window switch (passenger side) harness connector.

BCM		Front power window switch (passenger side)		Continuity
Connector	Terminal	Connector	Terminal	
M118	2	D38	10	Existed

3. Check continuity between BCM harness connector and ground.

BCM		Ground	Continuity
Connector	Terminal		
M118	2		Not existed

Is the inspection result normal?

YES >> Replace BCM. Refer to [BCS-82, "Exploded View"](#).

NO >> Repair or replace harness.

3.CHECK GROUND CIRCUIT

Check continuity between front power window switch (passenger side) harness connector and ground.

Front power window switch (passenger side)		Ground	Continuity
Connector	Terminal		
D38	11		Existed

Is the inspection result normal?

YES >> INSPECTION END

NO >> Repair or replace harness.

REAR POWER WINDOW SWITCH

REAR POWER WINDOW SWITCH : Diagnosis Procedure

INFOID:000000004240693

1.CHECK POWER SUPPLY CIRCUIT 1

1. Turn ignition switch OFF.
2. Disconnect rear power window switch LH connectors or rear power window switch RH.
3. Turn ignition switch ON.
4. Check voltage between rear power window switch harness connector and ground.

(+)		(-)	Voltage (V) (Approx.)
Rear power window switch			
Connector	Terminal	Ground	Battery voltage
LH	D54		
RH	D74		

POWER SUPPLY AND GROUND CIRCUIT

[FRONT WINDOW ANTI-PINCH]

< DTC/CIRCUIT DIAGNOSIS >

Is the measurement value within the specification?

YES >> GO TO 3.

NO >> GO TO 2.

2.CHECK POWER SUPPLY CIRCUIT 2

1. Turn ignition switch OFF.
2. Disconnect BCM connector.
3. Check continuity between BCM harness connector and rear power window switch harness connector.

BCM		Rear power window switch		Continuity
Connector	Terminal	Connector	Terminal	
M118	3	LH	D54	Existed
		RH	D74	

4. Check continuity between BCM harness connector and ground.

BCM		Ground	Continuity
Connector	Terminal		
M118	3		Not existed

Is the inspection result normal?

YES >> Replace BCM. Refer to [BCS-82. "Exploded View"](#).

NO >> Repair or replace harness.

3.CHECK GROUND CIRCUIT

Check continuity between rear power window switch harness connector and ground.

Rear power window switch		Ground	Continuity
Connector	Terminal		
LH	D54	7	Existed
RH	D74		

Is the inspection result normal?

YES >> INSPECTION END

NO >> Repair or replace harness.

REAR POWER WINDOW SWITCH

< DTC/CIRCUIT DIAGNOSIS >

[FRONT WINDOW ANTI-PINCH]

REAR POWER WINDOW SWITCH

Description

INFOID:000000004240694

- BCM supplies power.
- Rear power window motor will be operated if rear power window switch is operated. Rear power window switch.

Component Function Check

INFOID:000000004240695

1. CHECK REAR POWER WINDOW OPERATION

Check rear power window motor operation with rear power window switch.

Is the inspection result normal?

- YES >> Rear power window switch is OK.
 NO >> Refer to [PWC-131, "Diagnosis Procedure"](#).

Diagnosis Procedure

INFOID:000000004240696

1. CHECK REAR POWER WINDOW MOTOR INPUT SIGNAL

1. Turn ignition switch OFF.
2. Disconnect rear power window switch LH or rear power window switch RH.
3. Turn ignition switch ON.
4. Check voltage between rear power window switch harness connector and ground.

		(+)	(-)	Condition	Voltage (V) (Approx.)	
Rear power window switch						
Connector	Terminal					
LH	D54	2	Ground	Power window main switch (rear LH)	UP	Battery voltage
				DOWN	0	
		3		UP	0	
				DOWN	Battery voltage	
RH	D74	2		Power window main switch (rear RH)	UP	Battery voltage
					DOWN	0
		3			UP	0
					DOWN	Battery voltage

Is the measurement value within the specification?

- YES >> GO TO 3.
 NO >> GO TO 2.

2. CHECK REAR POWER WINDOW SWITCH CIRCUIT

1. Turn ignition switch OFF.
2. Disconnect power window main switch connector.
3. Check continuity between power window main switch harness connector and rear power window switch harness connector.

Power window main switch		Rear power window switch		Continuity
Connector	Terminal	Connector	Terminal	
D8	1	LH	D54	2
	3			3
	5	RH	D74	3
	7			2

4. Check continuity between power window main switch connector and ground.

A
B
C
D
E
F
G
H
I
J
K
L
M
N
O
P

PWC

REAR POWER WINDOW SWITCH

< DTC/CIRCUIT DIAGNOSIS >

[FRONT WINDOW ANTI-PINCH]

Power window main switch		Ground	Continuity
Connector	Terminal		
D8	1	Ground	Not existed
	3		
	5		
	7		

Is the inspection result normal?

- YES >> Replace power window main switch. Refer to [PWC-216. "Removal and Installation"](#).
 NO >> Repair or replace harness.

3.CHECK REAR POWER WINDOW SWITCH

Check rear power window switch.

Refer to [PWC-132. "Component Inspection"](#).

Is the inspection result normal?

- YES >> GO TO 4.
 NO >> Replace rear power window switch. Refer to [PWC-216. "Removal and Installation"](#).

4.CHECK INTERMITTENT INCIDENT

Refer to [GI-41. "Intermittent Incident"](#)

>> INSPECTION END

Component Inspection

INFOID:000000004240697

1.CHECK REAR POWER WINDOW SWITCH

1. Turn ignition switch OFF.
2. Disconnect rear power window switch terminals.
3. Check rear power window switch.

Rear power window switch	Terminal		Power window switch condition	Continuity
D54 (LH) D74 (RH)	1	5	UP	Existed
	3	4		
	3	4	NEUTRAL	
	5	2		
	1	4	DOWN	
	5	2		

Is the inspection result normal?

- YES >> Rear power window switch is OK.
 NO >> Replace rear power window switch. Refer to [PWC-216. "Removal and Installation"](#).

POWER WINDOW MOTOR

[FRONT WINDOW ANTI-PINCH]

< DTC/CIRCUIT DIAGNOSIS >

POWER WINDOW MOTOR DRIVER SIDE

DRIVER SIDE : Description

INFOID:000000004240698

Door glass moves UP/DOWN by receiving the signal from power window main switch.

DRIVER SIDE : Component Function Check

INFOID:000000004240699

1.CHECK FRONT POWER WINDOW MOTOR (DRIVER SIDE) OPERATION

Check front power window motor (driver side) operation with power window main switch.

Is the inspection result normal?

YES >> Power window motor (driver side) is OK.

NO >> Refer to [PWC-133, "DRIVER SIDE : Diagnosis Procedure"](#).

DRIVER SIDE : Diagnosis Procedure

INFOID:000000004240700

1.CHECK FRONT POWER WINDOW MOTOR INPUT SIGNAL

1. Turn ignition switch OFF.
2. Disconnect front power window motor (driver side) connector.
3. Turn ignition switch ON.
4. Check voltage between front power window motor (driver side) harness connector and ground.

(+)		(-)	Condition	Voltage (V) (Approx.)	
Front power window motor (driver side)					
Connector	Terminal				
D10	2	Ground	Power window main switch	UP	Battery voltage
				DOWN	0
	1			UP	0
				DOWN	Battery voltage

Is the measurement value within the specification?

YES >> GO TO 3.

NO >> GO TO 2.

2.CHECK FRONT POWER WINDOW MOTOR (DRIVER SIDE) CIRCUIT

1. Turn ignition switch OFF.
2. Disconnect power window main switch connector.
3. Check continuity between power window main switch harness connector and front power window motor (driver side) harness connector.

Power window main switch		Front power window motor (driver side)		Continuity
Connector	Terminal	Connector	Terminal	
D8	8	D10	2	Existed
	11		1	

4. Check continuity between power window main switch harness connector and ground.

Power window main switch		Ground	Continuity
Connector	Terminal		
D8	8		Not existed
	11		

Is the inspection result normal?

YES >> Replace power window main switch. Refer to [PWC-117, "Removal and Installation"](#).

A
B
C
D
E
F
G
H
I
J
L
M
N
O
P

PWC

POWER WINDOW MOTOR

[FRONT WINDOW ANTI-PINCH]

< DTC/CIRCUIT DIAGNOSIS >

NO >> Repair or replace harness.

3. CHECK FRONT POWER WINDOW MOTOR (DRIVER SIDE)

Check front power window motor (driver side).

Refer to [PWC-134, "DRIVER SIDE : Component Inspection"](#).

Is the inspection result normal?

YES >> GO TO 4.

NO >> Replace front power window motor (driver side). Refer to [GW-16, "Removal and Installation"](#).

4. CHECK INTERMITTENT INCIDENT

Refer to [GI-41, "Intermittent Incident"](#).

>> INSPECTION END

DRIVER SIDE : Component Inspection

INFOID:000000004240701

1. CHECK FRONT POWER WINDOW MOTOR (DRIVER SIDE)

1. Turn ignition switch OFF.
2. Disconnect front power window motor (driver side) connector.
3. Check motor operation by connecting the battery voltage directly to front power window motor (driver side) terminals.

Front power window motor (driver side) connector	Terminal		Motor operation
	(+)	(-)	
D10	1	2	DOWN
	2	1	UP

Is the inspection result normal?

YES >> Front power window motor (driver side) is OK.

NO >> Replace front power window motor (driver side). Refer to [GW-16, "Removal and Installation"](#).

PASSENGER SIDE

PASSENGER SIDE : Description

INFOID:000000004240702

Door glass moves UP/DOWN by receiving the signal power window main switch or front power window switch (passenger side).

PASSENGER SIDE : Component Function Check

INFOID:000000004240703

1. CHECK FRONT POWER WINDOW MOTOR (PASSENGER SIDE) OPERATION

Check front power window motor (passenger side) operation with power window main switch or front power window switch (passenger side).

Is the inspection result normal?

YES >> Power window motor (passenger side) is OK.

NO >> Refer to [PWC-134, "PASSENGER SIDE : Diagnosis Procedure"](#).

PASSENGER SIDE : Diagnosis Procedure

INFOID:000000004240704

1. CHECK FRONT POWER WINDOW MOTOR INPUT SIGNAL

1. Turn ignition switch OFF.
2. Disconnect front power window motor (passenger side) connector.
3. Turn ignition switch ON.
4. Check voltage between front power window motor (passenger side) harness connector and ground.

POWER WINDOW MOTOR

< DTC/CIRCUIT DIAGNOSIS >

[FRONT WINDOW ANTI-PINCH]

(+)		(-)	Condition	Voltage (V) (Approx.)	
Front power window motor (passenger side)					
Connector	Terminal				
D40	1	Ground	Front power window switch (passenger side)	UP	Battery voltage
				DOWN	0
	2			UP	0
				DOWN	Battery voltage

Is the measurement value within the specification?

YES >> GO TO 3.

NO >> GO TO 2.

2.CHECK POWER WINDOW MOTOR (PASSENGER SIDE) CIRCUIT

- Turn ignition switch OFF.
- Disconnect front power window switch (passenger side) connector.
- Check continuity between front power window switch (passenger side) harness connector and front power window motor (passenger side) harness connector.

Front power window switch (passenger side)		Front power window motor (passenger side)		Continuity
Connector	Terminal	Connector	Terminal	
D38	9	D40	1	Existed
	8		2	

- Check continuity between front power window switch (passenger side) connector and ground.

Front power window switch (passenger side)		Ground	Continuity
Connector	Terminal		
D38	8		Not existed
	9		

Is the inspection result normal?

YES >> Replace front power window switch (passenger side). Refer to [PWC-117, "Removal and Installation"](#).

NO >> Repair or replace harness.

3.CHECK FRONT POWER WINDOW MOTOR (PASSENGER SIDE)

Check front power window motor (passenger side).

Refer to [PWC-135, "PASSENGER SIDE : Component Inspection"](#).

Is the inspection result normal?

YES >> GO TO 4.

NO >> Replace front power window motor (passenger side). Refer to [GW-16, "Removal and Installation"](#).

4.CHECK INTERMITTENT INCIDENT

Refer to [GI-41, "Intermittent Incident"](#).

>> INSPECTION END

PASSENGER SIDE : Component Inspection

INFOID:000000004240705

1.CHECK FRONT POWER WINDOW MOTOR (PASSENGER SIDE)

- Turn ignition switch OFF.
- Disconnect front power window motor (passenger side) connector.
- Check motor operation by connecting the battery voltage directly to front power window motor (passenger side) terminals.

POWER WINDOW MOTOR

< DTC/CIRCUIT DIAGNOSIS >

[FRONT WINDOW ANTI-PINCH]

Front power window motor (passenger side) connector	Terminal		Motor condition
	(+)	(-)	
D40	2	1	DOWN
	1	2	UP

Is the inspection result normal?

YES >> Front power window motor (passenger side) is OK.

NO >> Replace front power window motor (passenger side). Refer to [GW-16, "Removal and Installation"](#).

REAR LH

REAR LH : Description

INFOID:000000004240706

Door glass moves UP/DOWN by receiving the signal from power window main switch or rear power window switch LH.

REAR LH : Component Function Check

INFOID:000000004240707

1.CHECK REAR POWER WINDOW MOTOR LH OPERATION

Check rear power window motor LH operation with power window main switch or rear power window switch LH.

Is the inspection result normal?

YES >> Power window motor LH is OK.

NO >> Refer to [PWC-136, "REAR LH : Diagnosis Procedure"](#)

REAR LH : Diagnosis Procedure

INFOID:000000004240708

1.CHECK REAR POWER WINDOW MOTOR INPUT SIGNAL

1. Turn ignition switch OFF.
2. Disconnect rear power window motor LH connector.
3. Turn ignition switch ON.
4. Check voltage between rear power window motor LH harness connector and ground.

(+) Rear power window motor LH Connector		Terminal	(-) Ground	Condition	Voltage (V) (Approx.)
D52	1				
		DOWN	0		
		3	Ground	UP	0
				DOWN	Battery voltage

Is the measurement value within the specification?

YES >> GO TO 3.

NO >> GO TO 2.

2.CHECK REAR POWER WINDOW MOTOR LH CIRCUIT

1. Turn ignition switch OFF.
2. Disconnect rear power window switch LH connector.
3. Check continuity between rear power window switch LH harness connector and rear power window motor LH harness connector.

Rear power window switch LH Connector		Terminal	Rear power window motor LH Connector		Continuity
Connector	Terminal		Connector	Terminal	
D54	5	D52	1	Existed	
	4		3		

4. Check continuity between rear power window switch LH harness connector and ground.

POWER WINDOW MOTOR

< DTC/CIRCUIT DIAGNOSIS >

[FRONT WINDOW ANTI-PINCH]

Rear power window switch LH		Ground	Continuity
Connector	Terminal		
D54	5		Not existed
	4		

Is the inspection result normal?

- YES >> Replace rear power window switch LH. Refer to [PWC-216, "Removal and Installation"](#).
NO >> Repair or replace harness.

3.CHECK REAR POWER WINDOW MOTOR LH

Check rear power window motor LH.

Refer to [PWC-137, "REAR LH : Component Inspection"](#).

Is the inspection result normal?

- YES >> GO TO 4.
NO >> Replace rear power window motor LH. Refer to [GW-22, "Removal and Installation"](#).

4.CHECK INTERMITTENT INCIDENT

Refer to [GI-41, "Intermittent Incident"](#).

>> INSPECTION END

REAR LH : Component Inspection

INFOID:000000004240709

1.CHECK REAR POWER WINDOW MOTOR LH

1. Turn ignition switch OFF.
2. Disconnect rear power window motor LH connector.
3. Check motor operation by connecting the battery voltage directly to rear power window motor LH terminals.

Rear power window motor LH connector	Terminal		Motor condition
	(+)	(-)	
D52	3	1	DOWN
	1	3	UP

Is the inspection result normal?

- YES >> Rear power window motor LH is OK.
NO >> Replace rear power window motor LH. Refer to [GW-22, "Removal and Installation"](#).

REAR RH

REAR RH : Description

INFOID:000000004240710

Door glass moves UP/DOWN by receiving the signal from power window main switch or rear power window switch RH.

REAR RH : Component Function Check

INFOID:000000004240711

1. CHECK REAR POWER WINDOW MOTOR RH OPERATION

Check rear power window motor RH operation with power window main switch or rear power window switch RH.

Is the inspection result normal?

- YES >> Power window motor RH is OK.
NO >> Refer to [PWC-137, "REAR RH : Diagnosis Procedure"](#).

REAR RH : Diagnosis Procedure

INFOID:000000004240712

1.CHECK REAR POWER WINDOW MOTOR INPUT SIGNAL

POWER WINDOW MOTOR

[FRONT WINDOW ANTI-PINCH]

< DTC/CIRCUIT DIAGNOSIS >

1. Turn ignition switch OFF.
2. Disconnect rear power window motor RH connector.
3. Turn ignition switch ON.
4. Check voltage between rear power window motor RH harness connector and ground.

(+)		(-)	Condition	Voltage (V) (Approx.)	
Connector	Terminal				
D72	1	Ground	Rear power window switch RH	UP	Battery voltage
			DOWN	0	
	3		UP	0	
			DOWN	Battery voltage	

Is the measurement value within the specification?

YES >> GO TO 3.

NO >> GO TO 2.

2.CHECK REAR POWER WINDOW MOTOR RH CIRCUIT

1. Turn ignition switch OFF.
2. Disconnect rear power window switch RH connector.
3. Check continuity between rear power window switch RH harness connector and rear power window motor RH harness connector.

Rear power window switch RH		Rear power window motor RH		Continuity
Connector	Terminal	Connector	Terminal	
D74	5	D72	1	Existed
	4		3	

4. Check continuity between rear power window switch RH harness connector and ground.

Rear power window switch RH		Ground	Continuity
Connector	Terminal		
D74	5		Not existed
	4		

Is the inspection result normal?

YES >> Replace rear power window switch RH. Refer to [PWC-216, "Removal and Installation"](#).

NO >> Repair or replace harness.

3.CHECK REAR POWER WINDOW MOTOR RH

Check rear power window motor RH.

Refer to [PWC-138, "REAR RH : Component Inspection"](#).

Is the inspection result normal?

YES >> GO TO 4.

NO >> Replace rear power window motor RH. Refer to [GW-22, "Removal and Installation"](#).

4.CHECK INTERMITTENT INCIDENT

Refer to [GI-41, "Intermittent Incident"](#).

>> INSPECTION END

REAR RH : Component Inspection

INFOID:000000004240713

1.CHECK REAR POWER WINDOW MOTOR RH

1. Turn ignition switch OFF.
2. Disconnect rear power window motor RH connector.

POWER WINDOW MOTOR

[FRONT WINDOW ANTI-PINCH]

< DTC/CIRCUIT DIAGNOSIS >

3. Check motor operation by connecting the battery voltage directly to rear power window motor RH terminals.

Rear power window motor RH connector	Terminal		Motor condition
	(+)	(-)	
D72	3	1	DOWN
	1	3	UP

Is the inspection result normal?

YES >> Rear power window motor RH is OK.

NO >> Replace rear power window motor RH. Refer to [GW-22. "Removal and Installation"](#).

A
B
C
D
E
F
G
H
I
J
L
M
N
O
P

PWC

ENCODER DRIVER SIDE

DRIVER SIDE : Description

INFOID:000000004240714

Detects condition of the front power window motor (driver side) operation and transmits to power window main switch as the pulse signal.

DRIVER SIDE : Component Function Check

INFOID:000000004240715

1.CHECK ENCODER OPERATION

Check driver side door glass perform AUTO open/close operation normally by power window main switch.

Is the inspection result normal?

- YES >> Encoder is OK.
- NO >> Refer to [PWC-140, "DRIVER SIDE : Diagnosis Procedure"](#).

DRIVER SIDE : Diagnosis Procedure

INFOID:000000004240716

1.CHECK ENCODER SIGNAL

1. Turn ignition switch ON.
2. Check signal between power window main switch harness connector and ground using oscilloscope.

(+)		(-)	Signal (Reference value)
Power window main switch			
Connector	Terminal	Ground	Refer to following signal
D8	9		
	13		

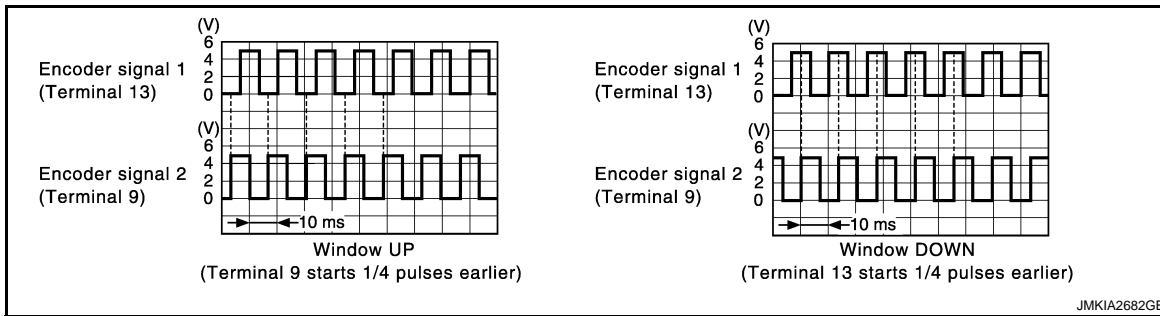

Is the inspection result normal?

- YES >> Replace power window main switch. Refer to [PWC-216, "Removal and Installation"](#).
- NO >> GO TO 2.

2.CHECK ENCODER SIGNAL CIRCUIT

1. Turn ignition switch OFF.
2. Disconnect power window main switch connector and front power window motor (driver side) connector.
3. Check continuity between power window main switch harness connector and front power window motor (driver side) harness connector.

Power window main switch		Front power window motor (driver side)		Continuity
Connector	Terminal	Connector	Terminal	
D8	9	D10	3	Existed
	13		5	

4. Check continuity between power window main switch harness connector and ground.

ENCODER

< DTC/CIRCUIT DIAGNOSIS >

[FRONT WINDOW ANTI-PINCH]

Power window main switch		Ground	Continuity
Connector	Terminal		
D8	9		
	13		Not existed

Is the inspection result normal?

YES >> GO TO 3.

NO >> Repair or replace harness.

3.CHECK ENCODER POWER SUPPLY CIRCUIT 1

1. Connect power window main switch connector.
2. Turn ignition switch ON.
3. Check voltage between front power window motor (driver side) harness connector and ground.

(+)		(-)	Voltage (V) (Approx.)
Front power window motor (driver side)			
Connector	Terminal		
D10	4	Ground	Battery voltage

Is the inspection result normal?

YES >> GO TO 5.

NO >> GO TO 4.

4.CHECK ENCODER POWER SUPPLY CIRCUIT 2

1. Turn ignition switch OFF.
2. Disconnect power window main switch connector.
3. Check continuity between power window main switch harness connector and front power window motor (driver side) harness connector.

Power window main switch		Front power window motor (driver side)		Continuity
Connector	Terminal	Connector	Terminal	
D8	15	D10	4	Existed

4. Check continuity between power window main switch harness connector and ground.

Power window main switch		Ground	Continuity
Connector	Terminal		
D8	15		

Is the inspection result normal?

YES >> Replace power window main switch. Refer to [PWC-216. "Removal and Installation"](#).

NO >> Repair or replace harness.

5.CHECK GROUND CIRCUIT 1

1. Turn ignition switch OFF.
2. Disconnect power window main switch connector.
3. Check continuity between power window main switch harness connector and front power window motor (driver side) harness connector.

Power window main switch		Front power window motor (driver side)		Continuity
Connector	Terminal	Connector	Terminal	
D8	2	D10	6	Existed

Is the inspection result normal?

YES >> GO TO 6.

NO >> Repair or replace harness.

6.CHECK GROUND CIRCUIT 2

A
B
C
D
E
F
G
H
I
J
L
M
N
O
P

PWC

ENCODER

< DTC/CIRCUIT DIAGNOSIS >

[FRONT WINDOW ANTI-PINCH]

1. Connect power window main switch connector.
2. Check continuity between power window main switch harness connector and ground.

Power window main switch		Ground	Continuity
Connector	Terminal		
D8	2		Existed

Is the inspection result normal?

- YES >> Replace front power window motor (driver side). Refer to [GW-16. "Removal and Installation"](#) .
 NO >> Replace power window main switch. Refer to [PWC-216. "Removal and Installation"](#) .

PASSENGER SIDE

PASSENGER SIDE : Description

INFOID:000000004240717

Detects condition of the front power window motor (passenger side) operation and transmits to front power window switch (passenger side) as the pulse signal.

PASSENGER SIDE : Component Function Check

INFOID:000000004240718

1.CHECK ENCODER OPERATION

Check passenger side door glass perform AUTO open/close operation normally by power window main switch or front power window switch (passenger side).

Is the inspection result normal?

- YES >> Encoder is OK.
 NO >> Refer to [PWC-142. "PASSENGER SIDE : Diagnosis Procedure"](#) .

PASSENGER SIDE : Diagnosis Procedure

INFOID:000000004240719

1.CHECK ENCODER SIGNAL

1. Turn ignition switch ON.
2. Check signal between front power window switch (passenger side) harness connector and ground using oscilloscope.

(+)		(-)	Signal (Reference value)
Front power window switch (passenger side)			
Connector	Terminal		
D38	12	Ground	Refer to following signal
	15		

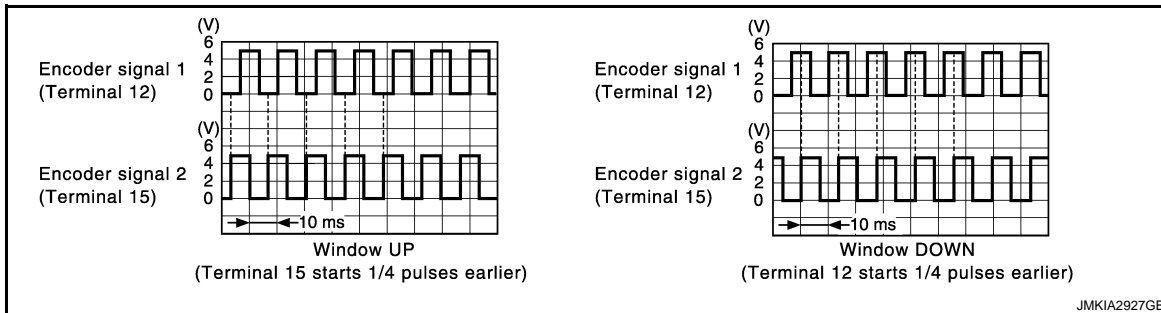

Is the inspection result normal?

- YES >> Replace front power window switch (passenger side). Refer to [PWC-216. "Removal and Installation"](#) .
 NO >> GO TO 2.

2.CHECK ENCODER SIGNAL CIRCUIT

1. Turn ignition switch OFF.

ENCODER

[FRONT WINDOW ANTI-PINCH]

< DTC/CIRCUIT DIAGNOSIS >

2. Disconnect front power window switch (passenger side) connector and front power window motor (passenger side) connector.
3. Check continuity between front power window switch (passenger side) harness connector and front power window motor (passenger side) harness connector.

Front power window switch (passenger side)		Front power window motor (passenger side)		Continuity
Connector	Terminal	Connector	Terminal	
D38	12	D40	5	Existed
	15		3	

4. Check continuity between front power window switch (passenger side) harness connector and ground.

Front power window switch (passenger side)		Ground	Continuity
Connector	Terminal		
D38	12		Not existed
	15		

Is the inspection result normal?

YES >> GO TO 3.

NO >> Repair or replace harness.

3.CHECK ENCODER POWER SUPPLY CIRCUIT 1

1. Connect front power window switch (passenger side) connector.
2. Turn ignition switch ON.
3. Check voltage between front power window motor (passenger side) harness connector and ground.

(+)		(-)	Voltage (V) (Approx.)
Front power window motor (passenger side)			
Connector	Terminal	Ground	Battery voltage
D40	4		

Is the inspection result normal?

YES >> GO TO 5.

NO >> GO TO 4.

4.CHECK ENCODER POWER SUPPLY CIRCUIT 2

1. Turn ignition switch OFF.
2. Disconnect front power window switch (passenger side) connector.
3. Check continuity between front power window switch (passenger side) harness connector and front power window motor (passenger side) harness connector.

Front power window switch (passenger side)		Front power window motor (passenger side)		Continuity
Connector	Terminal	Connector	Terminal	
D38	4	D40	4	Existed

4. Check continuity between front power window switch (passenger side) harness connector and ground.

Front power window switch (passenger side)		Ground	Continuity
Connector	Terminal		
D38	4		Not existed

Is the inspection result normal?

YES >> Replace front power window switch (passenger side). Refer to [PWC-216. "Removal and Installation"](#).

NO >> Repair or replace harness.

5.CHECK GROUND CIRCUIT 1

1. Turn ignition switch OFF.

A
B
C
D
E
F
G
H
I
J
L
M
N
O
P

PWC

ENCODER

< DTC/CIRCUIT DIAGNOSIS >

[FRONT WINDOW ANTI-PINCH]

2. Disconnect front power window switch (passenger side) connector.
3. Check continuity between front power window switch (passenger side) harness connector and front power window motor (passenger side) harness connector.

Front power window switch (passenger side)		Front power window motor (passenger side)		Continuity
Connector	Terminal	Connector	Terminal	
D38	3	D40	6	Existed

Is the inspection result normal?

YES >> GO TO 6.

NO >> Repair or replace harness.

6. CHECK GROUND CIRCUIT 2

1. Connect front power window switch (passenger side) connector.
2. Check continuity between front power window switch (passenger side) harness connector and ground.

Front power window switch (passenger side)		Ground	Continuity
Connector	Terminal		
D38	3		Existed

Is the inspection result normal?

YES >> Replace front power window motor (passenger side). Refer to [GW-16. "Removal and Installation"](#).

NO >> Replace front power window switch (passenger side). Refer to [PWC-216. "Removal and Installation"](#).

POWER WINDOW SERIAL LINK

[FRONT WINDOW ANTI-PINCH]

< DTC/CIRCUIT DIAGNOSIS >

POWER WINDOW SERIAL LINK

POWER WINDOW MAIN SWITCH

POWER WINDOW MAIN SWITCH : Description

INFOID:000000004639596

Power window main switch, front power window switch (passenger side) and BCM transmit and receive the signal by power window serial link.

The signal mentioned below is transmitted from BCM to power window main switch, front power window switch (passenger side).

- Keyless power window down signal

The signal mentioned below is transmitted from power window main switch to front power window switch (passenger side).

- Front passenger side door window operation signal
- Power window control by key cylinder switch signal
- Power window lock switch signal
- Retained power operation signal

POWER WINDOW MAIN SWITCH : Component Function Check

INFOID:000000004637391

1.CHECK POWER WINDOW SWITCH OUTPUT SIGNAL

With CONSULT-III

Check ("CDL LOCK SW ", "CDL UNLOCK SW") in "DATA MONITOR" mode for "POWER DOOR LOCK SYSTEM" with CONSULT-III. Refer to [DLK-51, "DOOR LOCK : CONSULT-III Function \(BCM - DOOR LOCK\)"](#).

Monitor item	Condition
CDL LOCK SW	LOCK : ON
	UNLOCK : OFF
CDL UNLOCK SW	LOCK : OFF
	UNLOCK : ON

Is the inspection result normal?

YES >> Power window serial link is OK.

NO >> Refer to [PWC-145, "POWER WINDOW MAIN SWITCH : Diagnosis Procedure"](#).

PWC

POWER WINDOW MAIN SWITCH : Diagnosis Procedure

INFOID:000000004637392

1.CHECK POWER WINDOW SWITCH OUTPUT SIGNAL

1. Turn ignition switch ON.
2. Check signal between power window main switch harness connector and ground.

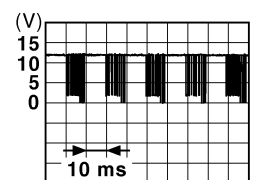
(+)		(-)	Signal (Reference value)
Connector	Terminal		
D8	12	Ground	 <p>JPMA0013GB</p>

Is the inspection result normal?

YES >> GO TO 4.

NO >> GO TO 2.

2.CHECK POWER WINDOW SERIAL LINK SIGNAL

POWER WINDOW SERIAL LINK

< DTC/CIRCUIT DIAGNOSIS >

[FRONT WINDOW ANTI-PINCH]

1. Turn ignition switch OFF.
2. Disconnect power window main switch connector.
3. Turn ignition switch ON.
4. Check voltage between power window main switch harness connector and ground.

(+)		(-)	Voltage (V) (Approx.)
Power window main switch			
Connector	Terminal	Ground	Battery voltage
D8	12		

Is the measurement value within the specification?

YES >> Replace power window main switch. Refer to [PWC-216, "Removal and Installation"](#).

NO >> GO TO 3.

3.CHECK POWER WINDOW SERIAL LINK CIRCUIT

1. Turn ignition switch OFF.
2. Disconnect BCM connector.
3. Check continuity between BCM connector and power window main switch connector.

BCM		Power window main switch		Continuity
Connector	Terminal	Connector	Terminal	
M123	132	D8	12	Existed

4. Check continuity between BCM connector and ground.

BCM		Ground	Continuity
Connector	Terminal		
M123	132		Not existed

Is the inspection result normal?

YES >> Replace BCM. Refer to [BCS-82, "Exploded View"](#).

NO >> Repair or replace harness.

4.CHECK INTERMITTENT INCIDENT

Refer to [GI-41, "Intermittent Incident"](#).

>> INSPECTION END

FRONT POWER WINDOW SWITCH (PASSENGER SIDE)

FRONT POWER WINDOW SWITCH (PASSENGER SIDE) : Description

INFOID:000000004639597

Power window main switch, front power window switch (passenger side) and BCM transmit and receive the signal by power window serial link.

The signal mentioned below is transmitted from BCM to power window main switch, front power window switch (passenger side).

- Keyless power window down signal

The signal mentioned below is transmitted from power window main switch to front power window switch (passenger side).

- Front passenger side door window operation signal
- Power window control by key cylinder switch signal
- Power window lock switch signal
- Retained power operation signal

FRONT POWER WINDOW SWITCH (PASSENGER SIDE) : Component Function

Check

INFOID:000000004637394

1.CHECK POWER WINDOW SWITCH OUTPUT SIGNAL

POWER WINDOW SERIAL LINK

< DTC/CIRCUIT DIAGNOSIS >

[FRONT WINDOW ANTI-PINCH]

With CONSULT-III

Check ("CDL LOCK SW", "CDL UNLOCK SW") in "DATA MONITOR" mode for "POWER DOOR LOCK SYSTEM" with CONSULT-III. Refer to [DLK-51, "DOOR LOCK : CONSULT-III Function \(BCM - DOOR LOCK\)"](#).

Monitor item	Condition
CDL LOCK SW	LOCK : ON
	UNLOCK : OFF
CDL UNLOCK SW	LOCK : OFF
	UNLOCK : ON

Is the inspection result normal?

YES >> Power window serial link is OK.

NO >> Refer to [PWC-147, "FRONT POWER WINDOW SWITCH \(PASSENGER SIDE\) : Diagnosis Procedure"](#).

FRONT POWER WINDOW SWITCH (PASSENGER SIDE) : Diagnosis Procedure

INFOID:000000004637395

1. CHECK POWER WINDOW SWITCH OUTPUT SIGNAL

- Turn ignition switch ON.
- Check signal between front power window switch (passenger side) harness connector and ground.

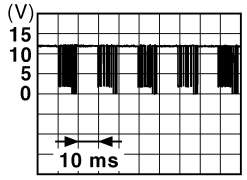
(+)		(-)	Signal (Reference value)
Connector	Terminal		
D38	16	Ground	 <p>JPMIA0013GB</p>

Is the inspection result normal?

YES >> Replace front power window switch (passenger side). Refer to [PWC-216, "Removal and Installation"](#).

NO >> GO TO 2.

2. CHECK POWER WINDOW SERIAL LINK CIRCUIT

- Turn ignition switch OFF.
- Disconnect BCM connector.
- Check continuity between BCM connector and front power window switch (passenger side) connector.

BCM		Front power window switch (passenger side)		Continuity
Connector	Terminal	Connector	Terminal	
M123	132	D38	16	Existed

- Check continuity between BCM connector and ground.

BCM		Ground	Continuity
Connector	Terminal		
M123	132		Not existed

Is the inspection result normal?

YES >> Replace BCM. Refer to [BCS-82, "Exploded View"](#).

NO >> Repair or replace harness.

BCM (BODY CONTROL MODULE)

< ECU DIAGNOSIS INFORMATION >

[FRONT WINDOW ANTI-PINCH]

ECU DIAGNOSIS INFORMATION

BCM (BODY CONTROL MODULE)

Reference Value

INFOID:000000004667400

VALUES ON THE DIAGNOSIS TOOL

CONSULT-III MONITOR ITEM

Monitor Item	Condition	Value/Status
FR WIPER HI	Other than front wiper switch HI	Off
	Front wiper switch HI	On
FR WIPER LOW	Other than front wiper switch LO	Off
	Front wiper switch LO	On
FR WASHER SW	Front washer switch OFF	Off
	Front washer switch ON	On
FR WIPER INT	Other than front wiper switch INT	Off
	Front wiper switch INT	On
FR WIPER STOP	Front wiper is not in STOP position	Off
	Front wiper is in STOP position	On
INT VOLUME	Wiper intermittent dial is in a dial position 1 - 7	Wiper intermittent dial position
TURN SIGNAL R	Other than turn signal switch RH	Off
	Turn signal switch RH	On
TURN SIGNAL L	Other than turn signal switch LH	Off
	Turn signal switch LH	On
TAIL LAMP SW	Other than lighting switch 1ST and 2ND	Off
	Lighting switch 1ST or 2ND	On
HI BEAM SW	Other than lighting switch HI	Off
	Lighting switch HI	On
HEAD LAMP SW 1	Other than lighting switch 2ND	Off
	Lighting switch 2ND	On
HEAD LAMP SW 2	Other than lighting switch 2ND	Off
	Lighting switch 2ND	On
PASSING SW	Other than lighting switch PASS	Off
	Lighting switch PASS	On
AUTO LIGHT SW	Other than lighting switch AUTO	Off
	Lighting switch AUTO	On
FR FOG SW	Front fog lamp switch OFF	Off
	Front fog lamp switch ON	On
RR FOG SW	NOTE: The item is indicated, but not monitored.	Off
DOOR SW-DR	Driver door closed	Off
	Driver door opened	On
DOOR SW-AS	Passenger door closed	Off
	Passenger door opened	On
DOOR SW-RR	Rear RH door closed	Off
	Rear LH door opened	On

BCM (BODY CONTROL MODULE)

< ECU DIAGNOSIS INFORMATION >

[FRONT WINDOW ANTI-PINCH]

Monitor Item	Condition	Value/Status	
DOOR SW-RL	Rear LH door closed	Off	A
	Rear LH door opened	On	
DOOR SW-BK	NOTE: The item is indicated, but not monitored.	Off	B
CDL LOCK SW	Other than power door lock switch LOCK	Off	C
	Power door lock switch LOCK	On	
CDL UNLOCK SW	Other than power door lock switch UNLOCK	Off	D
	Power door lock switch UNLOCK	On	
KEY CYL LK-SW	Other than driver door key cylinder LOCK	Off	E
	Driver door key cylinder LOCK	On	
KEY CYL UN-SW	Other than driver door key cylinder UNLOCK	Off	F
	Driver door key cylinder LOCK	On	
KEY CYL SW-TR	NOTE: The item is indicated, but not monitored.	Off	F
HAZARD SW	Hazard switch is OFF	Off	G
	Hazard switch is ON	On	
REAR DEF SW	NOTE: The item is indicated, but not monitored.	Off	G
H/L WASH SW	NOTE: The item is indicated, but not monitored.	Off	H
TR CANCEL SW	Trunk lid opener cancel switch OFF	Off	I
	Trunk lid opener cancel switch ON	On	
TR/BD OPEN SW	Trunk lid opener switch OFF	Off	J
	While the trunk lid opener switch is turned ON	On	
TRNK/HAT MNTR	Trunk lid closed	Off	J
	Trunk lid opened	On	
RKE-LOCK	LOCK button of the Intelligent Key is not pressed	Off	PWC
	LOCK button of the Intelligent Key is pressed	On	
RKE-UNLOCK	UNLOCK button of the Intelligent Key is not pressed	Off	L
	UNLOCK button of the Intelligent Key is pressed	On	
RKE-TR/BD	TRUNK OPEN button of the Intelligent Key is not pressed	Off	M
	TRUNK OPEN button of the Intelligent Key is pressed	On	
RKE-PANIC	PANIC button of the Intelligent Key is not pressed	Off	N
	PANIC button of the Intelligent Key is pressed	On	
RKE-P/W OPEN	UNLOCK button of the Intelligent Key is not pressed	Off	O
	UNLOCK button of the Intelligent Key is pressed and held	On	
RKE-MODE CHG	LOCK/UNLOCK button of the Intelligent Key is not pressed and held simultaneously	Off	O
	LOCK/UNLOCK button of the Intelligent Key is pressed and held simultaneously	On	
OPTICAL SENSOR	Bright outside of the vehicle	Close to 5 V	P
	Dark outside of the vehicle	Close to 0 V	
REQ SW -DR	Driver door request switch is not pressed	Off	
	Driver door request switch is pressed	On	
REQ SW -AS	Passenger door request switch is not pressed	Off	
	Passenger door request switch is pressed	On	

BCM (BODY CONTROL MODULE)

< ECU DIAGNOSIS INFORMATION >

[FRONT WINDOW ANTI-PINCH]

Monitor Item	Condition	Value/Status
REQ SW -RR	NOTE: The item is indicated, but not monitored.	Off
REQ SW -RL	NOTE: The item is indicated, but not monitored.	Off
REQ SW -BD/TR	Trunk lid opener request switch is not pressed	Off
	Trunk lid opener request switch is pressed	On
PUSH SW	Push-button ignition switch (push switch) is not pressed	Off
	Push-button ignition switch (push switch) is pressed	On
IGN RLY2 -F/B	Ignition switch in OFF or ACC position	Off
	Ignition switch in ON position	On
ACC RLY -F/B	NOTE: The item is indicated, but not monitored.	Off
CLUCH SW	The clutch pedal is not depressed	Off
	The clutch pedal is depressed	On
BRAKE SW 1	The brake pedal is depressed when No. 7 fuse is blown	Off
	The brake pedal is not depressed when No. 7 fuse is blown, or No. 7 fuse is normal	On
BRAKE SW 2	The brake pedal is not depressed	Off
	The brake pedal is depressed	On
DETE/CANCL SW	<ul style="list-style-type: none"> • Selector lever in P position (Except M/T models) • The clutch pedal is depressed (M/T models) 	Off
	<ul style="list-style-type: none"> • Selector lever in any position other than P (Except M/T models) • The clutch pedal is not depressed (M/T models) 	On
SFT PN/N SW	Selector lever in any position other than P and N	Off
	Selector lever in P or N position	On
S/L -LOCK	Steering is unlocked	Off
	Steering is locked	On
S/L -UNLOCK	Steering is locked	Off
	Steering is unlocked	On
S/L RELAY-F/B	Ignition switch in OFF or ACC position	Off
	Ignition switch in ON position	On
UNLK SEN -DR	Driver door is unlocked	Off
	Driver door is locked	On
PUSH SW -IPDM	Push-button ignition switch (push-switch) is not pressed	Off
	Push-button ignition switch (push-switch) is pressed	On
IGN RLY1 -F/B	Ignition switch in OFF or ACC position	Off
	Ignition switch in ON position	On
DETE SW -IPDM	Selector lever in any position other than P	Off
	Selector lever in P position	On
SFT PN -IPDM	<ul style="list-style-type: none"> • Selector lever in any position other than P and N (Except M/T models) • The clutch pedal is not depressed (M/T models) 	Off
	<ul style="list-style-type: none"> • Selector lever in P or N position (Except M/T models) • The clutch pedal is depressed (M/T models) 	On
SFT P -MET	Selector lever in any position other than P	Off
	Selector lever in P position	On
SFT N -MET	Selector lever in any position other than N	Off
	Selector lever in N position	On

BCM (BODY CONTROL MODULE)

< ECU DIAGNOSIS INFORMATION >

[FRONT WINDOW ANTI-PINCH]

Monitor Item	Condition	Value/Status	
ENGINE STATE	Engine stopped	Stop	A
	While the engine stalls	Stall	
	At engine cranking	Crank	B
	Engine running	Run	
S/L LOCK-IPDM	Steering is unlocked	Off	
	Steering is locked	On	C
S/L UNLK-IPDM	Steering is locked	Off	
	Steering is unlocked	On	D
S/L RELAY-REQ	Steering lock system is not the LOCK condition and the changing condition from LOCK to UNLOCK	Off	
	Steering lock system is the LOCK condition or the changing condition from LOCK to UNLOCK	On	E
VEH SPEED 1	While driving	Equivalent to speedometer reading	F
VEH SPEED 2	While driving	Equivalent to speedometer reading	
DOOR STAT-DR	Driver door is locked	LOCK	G
	Wait with selective UNLOCK operation (60 seconds)	READY	
	Driver door is unlocked	UNLOCK	
DOOR STAT-AS	Passenger door is locked	LOCK	H
	Wait with selective UNLOCK operation (60 seconds)	READY	
	Passenger door is unlocked	UNLOCK	
ID OK FLAG	Steering is locked	Reset	I
	Steering is unlocked	Set	
PRMT ENG STRT	The engine start is prohibited	Reset	J
	The engine start is permitted	Set	
PRMT RKE STRT	NOTE: The item is indicated, but not monitored.	Reset	PWC
KEY SW -SLOT	The Intelligent Key is not inserted into key slot	Off	
	The Intelligent Key is inserted into key slot	On	L
RKE OPE COUN1	During the operation of the Intelligent Key	Operation frequency of the Intelligent Key	
RKE OPE COUN2	NOTE: The item is indicated, but not monitored.	—	M
CONFIRM ID ALL	The key ID that the key slot receives is not recognized by any key ID registered to BCM.	Yet	
	The key ID that the key slot receives is recognized by any key ID registered to BCM.	Done	N
CONFIRM ID4	The key ID that the key slot receives is not recognized by the fourth key ID registered to BCM.	Yet	O
	The key ID that the key slot receives is recognized by the fourth key ID registered to BCM.	Done	
CONFIRM ID3	The key ID that the key slot receives is not recognized by the third key ID registered to BCM.	Yet	P
	The key ID that the key slot receives is recognized by the third key ID registered to BCM.	Done	

BCM (BODY CONTROL MODULE)

< ECU DIAGNOSIS INFORMATION >

[FRONT WINDOW ANTI-PINCH]

Monitor Item	Condition	Value/Status
CONFIRM ID2	The key ID that the key slot receives is not recognized by the second key ID registered to BCM.	Yet
	The key ID that the key slot receives is recognized by the second key ID registered to BCM.	Done
CONFIRM ID1	The key ID that the key slot receives is not recognized by the first key ID registered to BCM.	Yet
	The key ID that the key slot receives is recognized by the first key ID registered to BCM.	Done
TP 4	The ID of fourth Intelligent Key is not registered to BCM	Yet
	The ID of fourth Intelligent Key is registered to BCM	Done
TP 3	The ID of third Intelligent Key is not registered to BCM	Yet
	The ID of third Intelligent Key is registered to BCM	Done
TP 2	The ID of second Intelligent Key is not registered to BCM	Yet
	The ID of second Intelligent Key is registered to BCM	Done
TP 1	The ID of first Intelligent Key is not registered to BCM	Yet
	The ID of first Intelligent Key is registered to BCM	Done
AIR PRESS FL	Ignition switch ON (Only when the signal from the transmitter is received)	Air pressure of front LH tire
AIR PRESS FR	Ignition switch ON (Only when the signal from the transmitter is received)	Air pressure of front RH tire
AIR PRESS RR	Ignition switch ON (Only when the signal from the transmitter is received)	Air pressure of rear RH tire
AIR PRESS RL	Ignition switch ON (Only when the signal from the transmitter is received)	Air pressure of rear LH tire
ID REGST FL1	ID of front LH tire transmitter is registered	Done
	ID of front LH tire transmitter is not registered	Yet
ID REGST FR1	ID of front RH tire transmitter is registered	Done
	ID of front RH tire transmitter is not registered	Yet
ID REGST RR1	ID of rear RH tire transmitter is registered	Done
	ID of rear RH tire transmitter is not registered	Yet
ID REGST RL1	ID of rear LH tire transmitter is registered	Done
	ID of rear LH tire transmitter is not registered	Yet
WARNING LAMP	Tire pressure indicator OFF	Off
	Tire pressure indicator ON	On
BUZZER	Tire pressure warning alarm is not sounding	Off
	Tire pressure warning alarm is sounding	On

BCM (BODY CONTROL MODULE)

< ECU DIAGNOSIS INFORMATION >

[FRONT WINDOW ANTI-PINCH]

TERMINAL LAYOUT

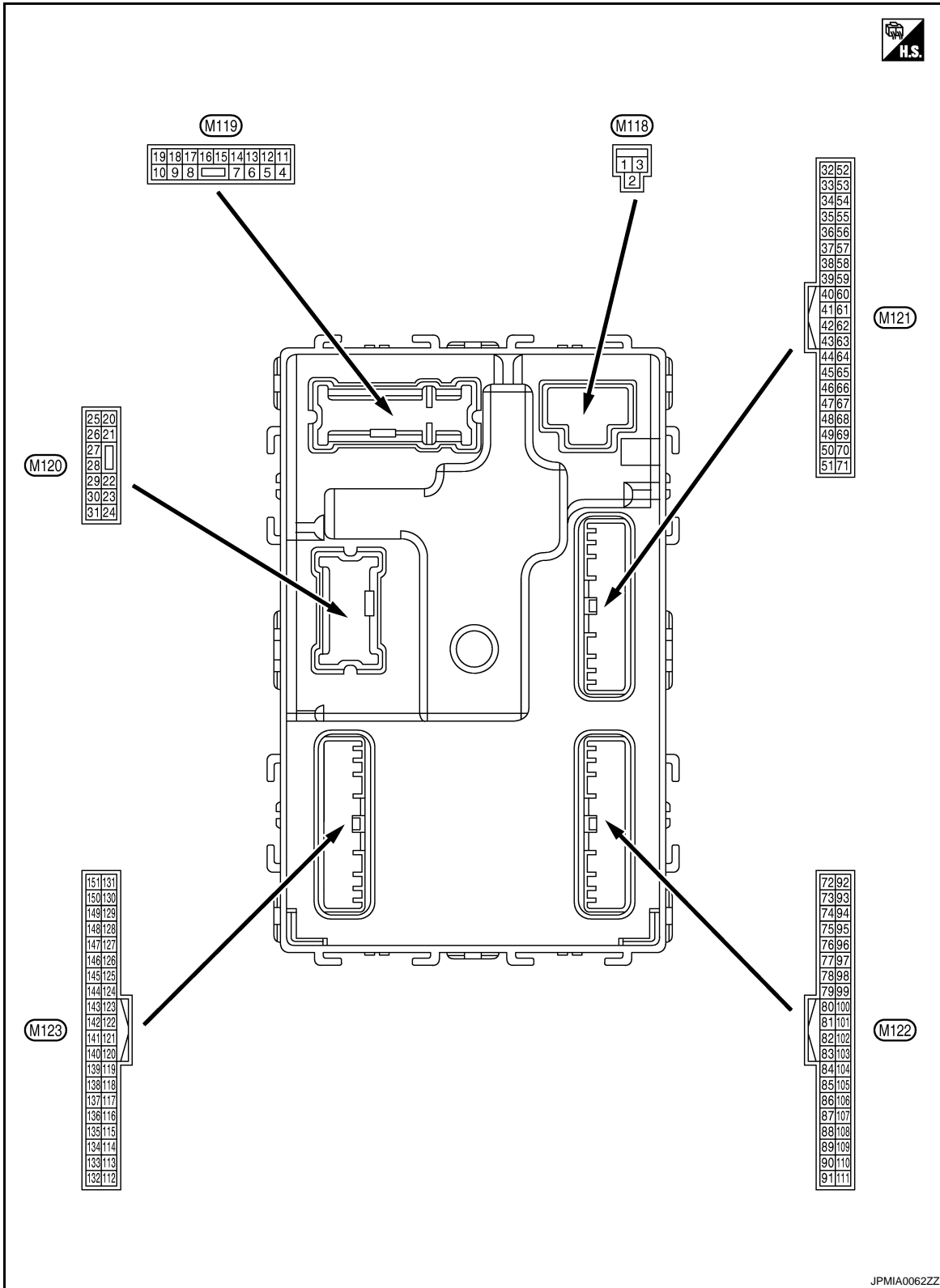

PHYSICAL VALUES

A
B
C
D
E
F
G
H
I
J
K
L
M
N
O
P

PWC

BCM (BODY CONTROL MODULE)

< ECU DIAGNOSIS INFORMATION >

[FRONT WINDOW ANTI-PINCH]

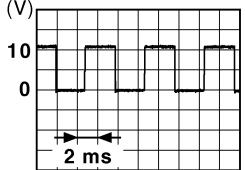
Terminal No. (Wire color)		Description		Condition		Value (Approx.)
		Signal name	Input/ Output			
+	-					
1 (W)	Ground	Battery power supply	Input	Ignition switch OFF		Battery voltage
2 (Y)	Ground	P/W power supply (BAT)	Output	Ignition switch OFF		12 V
3 (O)	Ground	P/W power supply (RAP)	Output	Ignition switch ON		12 V
4 (LG)	Ground	Interior room lamp power supply	Output	Interior room lamp battery saver is activated. (Cuts the interior room lamp power supply)		0 V
				Interior room lamp battery saver is not activated. (Outputs the interior room lamp power supply)		12 V
5 (P)	Ground	Passenger door UN- LOCK	Output	Passenger door	UNLOCK (Actuator is activated)	12 V
					Other than UNLOCK) Actuator is not activated	0 V
7 (BR)	Ground	Step lamp	Output	Step lamp	ON	0 V
					OFF	12 V
8 (V)	Ground	All doors, fuel lid LOCK	Output	All doors, fuel lid	LOCK (Actuator is activated)	12 V
					Other than LOCK (Actuator is not activated)	0 V
9 (G)	Ground	Driver door, fuel lid UNLOCK	Output	Driver door, fuel lid	UNLOCK (Actuator is activated)	12 V
					Other than UNLOCK (Actuator is not activated)	0 V
10 (BR)	Ground	Rear RH door and rear LH UNLOCK	Output	Rear RH door and rear LH door	UNLOCK (Actuator is activated)	12 V
					Other than UNLOCK (Actuator is not activated)	0 V
11 (R)	Ground	Battery power supply	Input	Ignition switch OFF		Battery voltage
13 (B)	Ground	Ground	—	Ignition switch ON		0 V
14 (W)	Ground	Push-button ignition switch illumination ground	Output	Tail lamp	OFF	0 V
					ON	<p>NOTE: When the illumination brightening/dimming level is in the neutral position</p>  <p style="text-align: right; font-size: small;">JSNIA0010GB</p>
15 (O)	Ground	ACC indicator lamp	Output	Ignition switch	OFF (LOCK indicator is not illuminated)	Battery voltage
					ACC	0 V

BCM (BODY CONTROL MODULE)

< ECU DIAGNOSIS INFORMATION >

[FRONT WINDOW ANTI-PINCH]

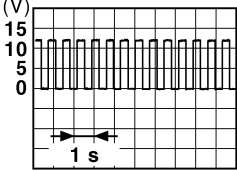
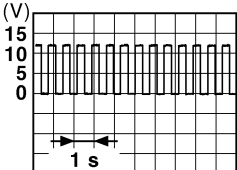
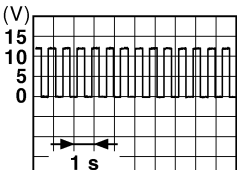
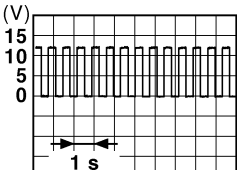
Terminal No. (Wire color)		Description		Condition	Value (Approx.)	
		Signal name	Input/ Output			
+	-					
17 (W)	Ground	Turn signal RH (Front)	Output	Ignition switch ON	Turn signal switch OFF	0 V
				Turn signal switch RH	 6.5 V	
18 (O)	Ground	Turn signal LH (Front)	Output	Ignition switch ON	Turn signal switch OFF	0 V
				Turn signal switch LH	 6.5 V	
19 (V)	Ground	Room lamp timer control	Output	Interior room lamp	OFF	12 V
				ON	0 V	
20 (V)	Ground	Turn signal RH (Rear)	Output	Ignition switch ON	Turn signal switch OFF	0 V
				Turn signal switch RH	 6.5 V	
23 (L)	Ground	Trunk lid open	Output	Trunk lid	OPEN (Trunk lid opener actuator is activated)	12 V
				Other than OPEN (Trunk lid opener actuator is not activated)	0 V	
25 (Y)	Ground	Turn signal LH (Rear)	Output	Ignition switch ON	Turn signal switch OFF	0 V
				Turn signal switch LH	 6.5 V	
30 (P)	Ground	Trunk room lamp	Output	Trunk room lamp	ON	0 V
				OFF	12 V	

A
B
C
D
E
F
G
H
I
J
L
M
N
O
P



BCM (BODY CONTROL MODULE)

< ECU DIAGNOSIS INFORMATION >

[FRONT WINDOW ANTI-PINCH]

Terminal No. (Wire color)		Description		Condition	Value (Approx.)
+	-	Signal name	Input/ Output		
34 (SB)	Ground	Trunk room antenna (-)	Output	Ignition switch OFF	<p>JMKIA0062GB</p>
				When Intelligent Key is not in the passenger compart- ment	<p>JMKIA0063GB</p>
35 (V)	Ground	Trunk room antenna (+)	Output	Ignition switch OFF	<p>JMKIA0062GB</p>
				When Intelligent Key is not in the passenger compart- ment	<p>JMKIA0063GB</p>
38 (B)	Ground	Rear bumper anten- na (-)	Output	When the trunk lid opener re- quest switch is operated with ignition switch OFF	<p>JMKIA0062GB</p>
				When Intelligent Key is not in the antenna detection area	<p>JMKIA0063GB</p>

BCM (BODY CONTROL MODULE)

< ECU DIAGNOSIS INFORMATION >

[FRONT WINDOW ANTI-PINCH]

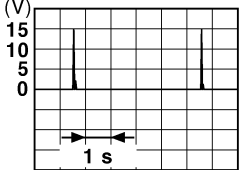
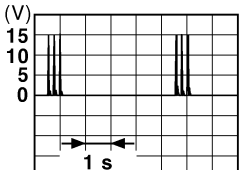
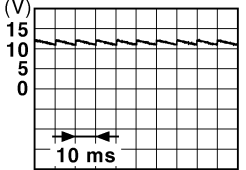
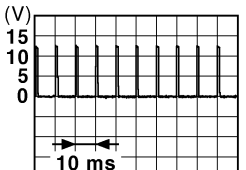
Terminal No. (Wire color)		Description		Condition	Value (Approx.)
		Signal name	Input/ Output		
+	-				
39 (W)	Ground	Rear bumper antenna (+)	Output	When Intelligent Key is in the antenna detection area	 <small>JMKIA0062GB</small>
				When the trunk lid opener request switch is operated with ignition switch OFF	 <small>JMKIA0063GB</small>
47 (Y)	Ground	Ignition relay (IPDM E/R) control	Output	Ignition switch OFF or ACC	12 V
				ON	0 V
50 (O)	Ground	Trunk room lamp switch	Input	Trunk room lamp switch OFF (Trunk lid is closed)	 <small>JPMIA0011GB</small>
				ON (Trunk lid is opened)	0 V
52 (SB)	Ground	Starter relay control	Output	Ignition switch ON (A/T models)	12 V
				When selector lever is in P or N position	0 V
				Ignition switch ON (M/T models)	Battery voltage
				When the clutch pedal is depressed	0 V
61 (SB)	Ground	Trunk lid opener request switch	Input	Trunk lid opener request switch ON (Pressed)	0 V
				OFF (Not pressed)	 <small>JPMIA0016GB</small>
64 (G)	Ground	Intelligent Key warning buzzer (Engine room)	Output	Intelligent Key warning buzzer (Engine room) Sounding	0 V
				Not sounding	12 V

A
B
C
D
E
F
G
H
I
J
L
M
N
O
P

PWC

BCM (BODY CONTROL MODULE)

< ECU DIAGNOSIS INFORMATION >

[FRONT WINDOW ANTI-PINCH]

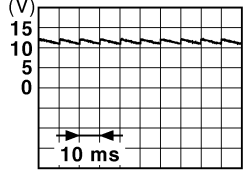
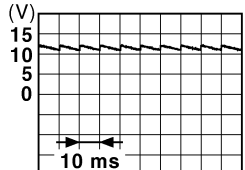
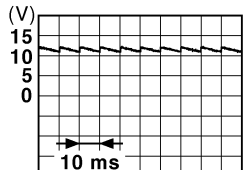
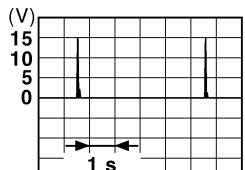
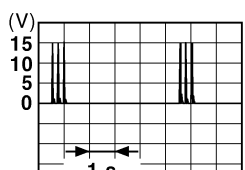
Terminal No. (Wire color)		Description		Condition	Value (Approx.)		
+	-	Signal name	Input/ Output				
67 (GR)	Ground	Trunk lid opener switch	Input	Trunk lid open- er switch	Pressed	0 V	
				Not pressed	 <p style="text-align: right; font-size: small;">JPMIA0011GB</p>	11.8 V	
68 (BR)	Ground	Rear RH door switch	Input	Rear RH door switch	OFF (When rear RH door closes)	 <p style="text-align: right; font-size: small;">JPMIA0011GB</p>	11.8 V
				ON (When rear RH door opens)	0 V		
69 (R)	Ground	Rear LH door switch	Input	Rear LH door switch	OFF (When rear LH door closes)	 <p style="text-align: right; font-size: small;">JPMIA0011GB</p>	11.8 V
				ON (When rear LH door opens)	0 V		
72 (R)	Ground	Room antenna 2 (-) (Center console)	Output	Ignition switch OFF	When Intelligent Key is in the passenger compart- ment	 <p style="text-align: right; font-size: small;">JMKIA0062GB</p>	
				When Intelligent Key is not in the passenger compart- ment	 <p style="text-align: right; font-size: small;">JMKIA0063GB</p>		

BCM (BODY CONTROL MODULE)

< ECU DIAGNOSIS INFORMATION >

[FRONT WINDOW ANTI-PINCH]

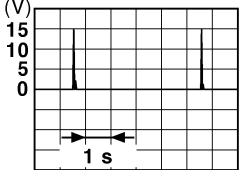
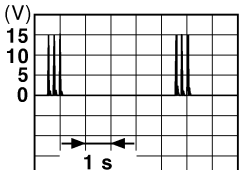
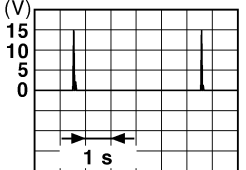
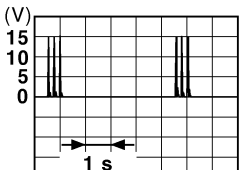
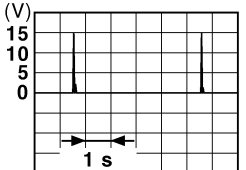
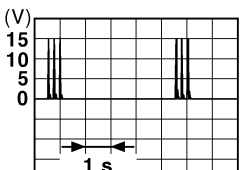
Terminal No. (Wire color)		Description		Condition	Value (Approx.)
+	-	Signal name	Input/ Output		
73 (G)	Ground	Room antenna 2 (+) (Center console)	Output	Ignition switch OFF	 <p style="text-align: right; font-size: small;">JMKIA0062GB</p>
				When Intelligent Key is not in the passenger compart- ment	 <p style="text-align: right; font-size: small;">JMKIA0063GB</p>
74 (SB)	Ground	Passenger door an- tenna (-)	Output	When the pas- senger door re- quest switch is operated with ignition switch OFF	 <p style="text-align: right; font-size: small;">JMKIA0062GB</p>
				When Intelligent Key is not in the antenna detection area	 <p style="text-align: right; font-size: small;">JMKIA0063GB</p>
75 (BR)	Ground	Passenger door an- tenna (+)	Output	When the pas- senger door re- quest switch is operated with ignition switch OFF	 <p style="text-align: right; font-size: small;">JMKIA0062GB</p>
				When Intelligent Key is not in the antenna detection area	 <p style="text-align: right; font-size: small;">JMKIA0063GB</p>

A
B
C
D
E
F
G
H
I
J
L
M
N
O
P

PWC

BCM (BODY CONTROL MODULE)

< ECU DIAGNOSIS INFORMATION >

[FRONT WINDOW ANTI-PINCH]

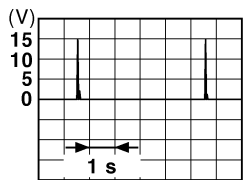
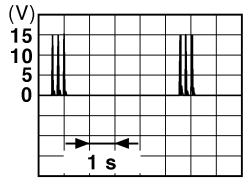
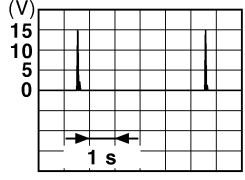
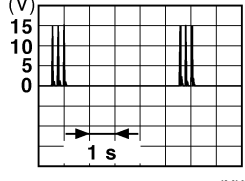
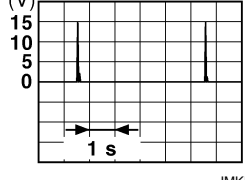
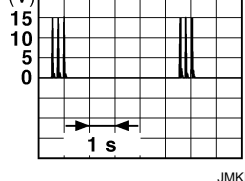
Terminal No. (Wire color)		Description		Condition	Value (Approx.)
+	-	Signal name	Input/ Output		
76 (V)	Ground	Driver door antenna (-)	Output	When the driver door request switch is operated with ignition switch OFF	When Intelligent Key is in the antenna detection area  <small>JMKIA0062GB</small>
				When Intelligent Key is not in the antenna detection area	 <small>JMKIA0063GB</small>
77 (LG)	Ground	Driver door antenna (+)	Output	When the driver door request switch is operated with ignition switch OFF	When Intelligent Key is in the antenna detection area  <small>JMKIA0062GB</small>
				When Intelligent Key is not in the antenna detection area	 <small>JMKIA0063GB</small>
78 (Y)	Ground	Room antenna 1 (-) (Instrument panel)	Output	Ignition switch OFF	When Intelligent Key is in the passenger compartment  <small>JMKIA0062GB</small>
				When Intelligent Key is not in the passenger compartment	 <small>JMKIA0063GB</small>

BCM (BODY CONTROL MODULE)

< ECU DIAGNOSIS INFORMATION >

[FRONT WINDOW ANTI-PINCH]

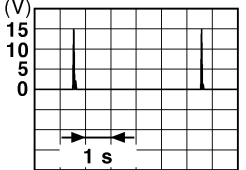
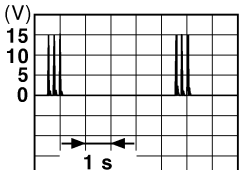
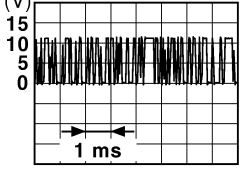
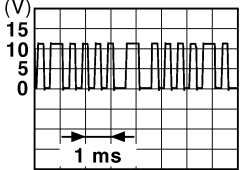
Terminal No. (Wire color)		Description		Condition	Value (Approx.)
		Signal name	Input/ Output		
+	-				
79 (BR)	Ground	Room antenna 1 (+) (Instrument panel)	Output	Ignition switch OFF	
				Ignition switch ON	
80 (GR)	Ground	NATS antenna amp (Built in key slot)	Input/ Output	During waiting	Ignition switch is pressed while inserting the Intelligent Key into the key slot. Pointer of tester should move.
81 (W)	Ground	NATS antenna amp (Built in key slot)	Input/ Output	During waiting	Ignition switch is pressed while inserting the Intelligent Key into the key slot. Pointer of tester should move.
82 (R)	Ground	Ignition relay [Fuse block (J/B)] control	Output	Ignition switch OFF or ACC	0 V
				ON	12 V
83 (Y)	Ground	Remote keyless entry receiver communication	Input/ Output	During waiting	
				When operating either button on the Intelligent Key	

A
B
C
D
E
F
G
H
I
J
L
M
N
O
P

PWC

BCM (BODY CONTROL MODULE)

< ECU DIAGNOSIS INFORMATION >



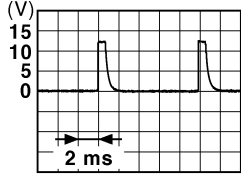
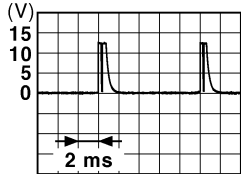
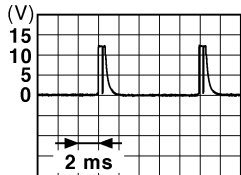

[FRONT WINDOW ANTI-PINCH]

Terminal No. (Wire color)		Description		Condition	Value (Approx.)	
+	-	Signal name	Input/ Output			
87 (Y)	Ground	Combination switch INPUT 5	Input	Combination switch	All switches OFF (Wiper intermittent dial 4)	 <p style="text-align: right; font-size: small;">JPMIA0041GB</p> <p style="text-align: center;">1.4 V</p>
					Front fog lamp switch ON (Wiper intermittent dial 4)	 <p style="text-align: right; font-size: small;">JPMIA0037GB</p> <p style="text-align: center;">1.3 V</p>
					Any of the conditions below with all switches OFF <ul style="list-style-type: none"> • Wiper intermittent dial 1 • Wiper intermittent dial 2 • Wiper intermittent dial 6 • Wiper intermittent dial 7 	 <p style="text-align: right; font-size: small;">JPMIA0040GB</p> <p style="text-align: center;">1.3 V</p>

BCM (BODY CONTROL MODULE)

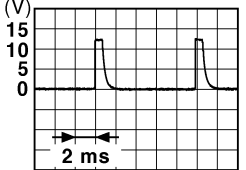
< ECU DIAGNOSIS INFORMATION >

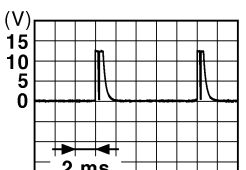
[FRONT WINDOW ANTI-PINCH]

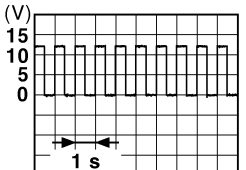
Terminal No. (Wire color)		Description		Condition	Value (Approx.)	
		Signal name	Input/ Output			
+	-					
88 (O)	Ground	Combination switch INPUT 3	Input	Combination switch	All switches OFF (Wiper intermittent dial 4)	 <small>JPMIA0041GB</small> 1.4 V
					Lighting switch HI (Wiper intermittent dial 4)	 <small>JPMIA0036GB</small> 1.3 V
					Lighting switch 2ND (Wiper intermittent dial 4)	 <small>JPMIA0037GB</small> 1.3 V
					Any of the conditions below with all switches OFF <ul style="list-style-type: none"> • Wiper intermittent dial 1 • Wiper intermittent dial 2 • Wiper intermittent dial 3 	 <small>JPMIA0040GB</small> 1.3 V
89 (BR)	Ground	Push-button ignition switch (Push switch)	Input	Push-button ignition switch (push switch)	Pressed	0 V
					Not pressed	Battery voltage
90 (P)	Ground	CAN-L	Input/ Output	—	—	
91 (L)	Ground	CAN-H	Input/ Output	—	—	
92 (LG)	Ground	Key slot illumination	Output	Key slot illumina- tion	OFF	0 V
					Blinking	 <small>JPMIA0015GB</small> 6.5 V
					ON	12 V

A
B
C
D
E
F
G
H
I
J
L
M
N
O
P

PWC

BCM (BODY CONTROL MODULE)

< ECU DIAGNOSIS INFORMATION >



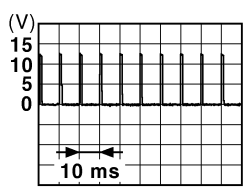
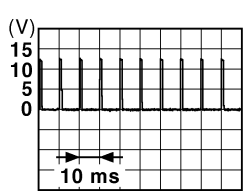

[FRONT WINDOW ANTI-PINCH]

Terminal No. (Wire color)		Description		Condition		Value (Approx.)
		Signal name	Input/ Output			
+	-					
93 (V)	Ground	ON indicator lamp	Output	Ignition switch	OFF (LOCK indicator is not illuminated)	Battery voltage
					ON	0 V
95 (O)	Ground	ACC relay control	Output	Ignition switch	OFF	0 V
					ACC or ON	12 V
96 (GR)	Ground	A/T shift selector (Detention switch) power supply	Output	—	—	12 V
97 (L)	Ground	Steering lock condition No. 1	Input	Steering lock	LOCK status	0 V
					UNLOCK status	12 V
98 (P)	Ground	Steering lock condition No. 2	Input	Steering lock	LOCK status	12 V
					UNLOCK status	0 V
99 (R)*1 (BR)*2	Ground	Selector lever P position switch (A/T models)	Input	Selector lever	P position	0 V
					Any position other than P	12 V
		ASCD clutch switch (M/T models without ICC)		ASCD clutch switch	OFF (Clutch pedal is depressed)	0 V
					ON (Clutch pedal is not depressed)	12 V
		ICC clutch switch (M/T models with ICC)		ICC clutch switch	OFF (Clutch pedal is depressed)	0 V
					ON (Clutch pedal is not depressed)	12 V
100 (Y)	Ground	Passenger door request switch	Input	Passenger door request switch	ON (Pressed)	0 V
					OFF (Not pressed)	 <p style="text-align: right; margin-right: 20px;">JPMIA0016GB</p> <p style="text-align: center;">1.0 V</p>
101 (P)	Ground	Driver door request switch	Input	Driver door request switch	ON (Pressed)	0 V
					OFF (Not pressed)	 <p style="text-align: right; margin-right: 20px;">JPMIA0016GB</p> <p style="text-align: center;">1.0 V</p>
102 (O)	Ground	Blower fan motor relay control	Output	Ignition switch	OFF or ACC	0 V
					ON	12 V
103 (L)	Ground	Remote keyless entry receiver power supply	Output	Ignition switch OFF	—	12 V
106 (W)	Ground	Steering lock unit power supply	Output	Ignition switch	OFF or ACC	12 V
					ON	0 V

BCM (BODY CONTROL MODULE)

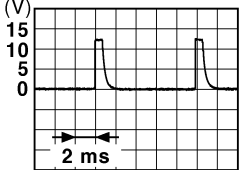
< ECU DIAGNOSIS INFORMATION >

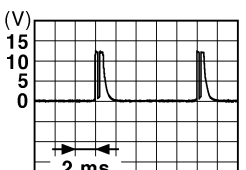
[FRONT WINDOW ANTI-PINCH]

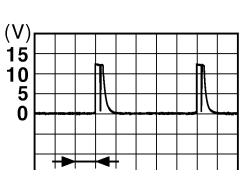
Terminal No. (Wire color)		Description		Condition	Value (Approx.)	
		Signal name	Input/ Output			
+	-					
107 (LG)	Ground	Combination switch INPUT 1	Input	Combination switch (Wiper intermit- tent dial 4)	All switches OFF	 1.4 V
					Turn signal switch LH	 1.3 V
					Turn signal switch RH	 1.3 V
					Front wiper switch LO	 1.3 V
					Front washer switch ON	 1.3 V

A
B
C
D
E
F
G
H
I
J
L
M
N
O
P

PWC

BCM (BODY CONTROL MODULE)

< ECU DIAGNOSIS INFORMATION >



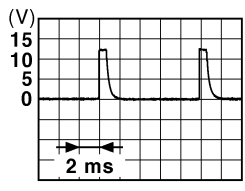
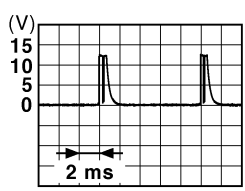
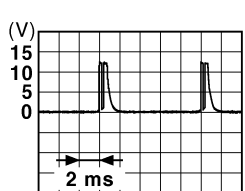
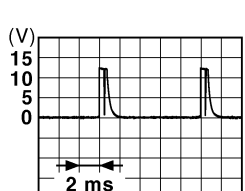

[FRONT WINDOW ANTI-PINCH]

Terminal No. (Wire color)		Description		Condition	Value (Approx.)
+	-	Signal name	Input/ Output		
108 (R)	Ground	Combination switch INPUT 4	Input	Combination switch	All switches OFF (Wiper intermittent dial 4) <div style="text-align: right;">  <p style="font-size: small; margin: 0;">JPMIA0041GB</p> <p style="margin: 0;">1.4 V</p> </div>
				Combination switch	Lighting switch AUTO (Wiper intermittent dial 4) <div style="text-align: right;">  <p style="font-size: small; margin: 0;">JPMIA0038GB</p> <p style="margin: 0;">1.3 V</p> </div>
				Combination switch	Lighting switch 1ST (Wiper intermittent dial 4) <div style="text-align: right;">  <p style="font-size: small; margin: 0;">JPMIA0036GB</p> <p style="margin: 0;">1.3 V</p> </div>
				Combination switch	Any of the conditions be- low with all switches OFF <ul style="list-style-type: none"> • Wiper intermittent dial 1 • Wiper intermittent dial 5 • Wiper intermittent dial 6 <div style="text-align: right;">  <p style="font-size: small; margin: 0;">JPMIA0039GB</p> <p style="margin: 0;">1.3 V</p> </div>

BCM (BODY CONTROL MODULE)

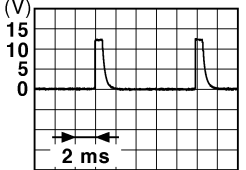
< ECU DIAGNOSIS INFORMATION >

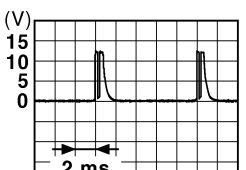
[FRONT WINDOW ANTI-PINCH]

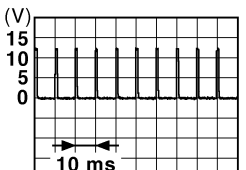
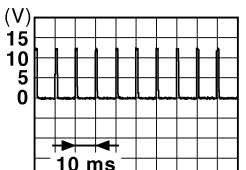
Terminal No. (Wire color)		Description		Condition	Value (Approx.)	
+	-	Signal name	Input/ Output			
109 (W)	Ground	Combination switch INPUT 2	Input	Combination switch (Wiper intermit- tent dial 4)	All switches OFF	 1.4 V
					Lighting switch PASS	 1.3 V
					Lighting switch 2ND	 1.3 V
					Front wiper switch INT	 1.3 V
					Front wiper switch HI	 1.3 V
					ON	0 V
110 (G)	Ground	Hazard switch	Input	Hazard switch	 1.1 V	
				OFF	 1.1 V	

A
B
C
D
E
F
G
H
I
J
L
M
N
O
P

PWC

BCM (BODY CONTROL MODULE)

< ECU DIAGNOSIS INFORMATION >

[FRONT WINDOW ANTI-PINCH]

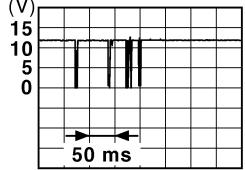
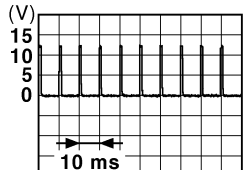
Terminal No. (Wire color)		Description		Condition	Value (Approx.)	
		Signal name	Input/ Output			
+	-					
111 (Y)	Ground	Steering lock unit communication	Input/ Output	Steering lock	LOCK status	12 V
					LOCK or UNLOCK	 <p style="text-align: right; font-size: small;">JMkia0066GB</p>
					For 15 seconds after UNLOCK	12 V
				15 seconds or later after UNLOCK	0 V	
113 (O)	Ground	Optical sensor	Input	Ignition switch ON	When bright outside of the vehicle	Close to 5 V
					When dark outside of the vehicle	Close to 0 V
114 (R)	Ground	Clutch interlock switch	Input	Clutch interlock switch	OFF (Clutch pedal is not depressed)	0 V
					ON (Clutch pedal is depressed)	Battery voltage
116 (SB)	Ground	Stop lamp switch 1	Input	—	Battery voltage	
118 (BR)	Ground	Stop lamp switch 2 (Without ICC)	Input	Stop lamp switch	OFF (Brake pedal is not depressed)	0 V
					ON (Brake pedal is depressed)	Battery voltage
		Stop lamp switch 2 (With ICC)		Stop lamp switch OFF (Brake pedal is not depressed) and ICC brake hold relay OFF	0 V	
				Stop lamp switch ON (Brake pedal is depressed) or ICC brake hold relay ON	Battery voltage	
119 (SB)	Ground	Front door lock assembly driver side (Unlock sensor)	Input	Driver door	LOCK status (Unlock sensor switch OFF)	 <p style="text-align: right; font-size: small;">JPMIA0012GB</p>
					UNLOCK status (Unlock switch sensor ON)	0 V
121 (SB)	Ground	Key slot switch	Input	When the Intelligent Key is inserted into key slot	12 V	
				When the Intelligent Key is not inserted into key slot	0 V	
123 (W)	Ground	IGN feedback	Input	Ignition switch	OFF or ACC	0 V
					ON	Battery voltage

BCM (BODY CONTROL MODULE)

< ECU DIAGNOSIS INFORMATION >

[FRONT WINDOW ANTI-PINCH]

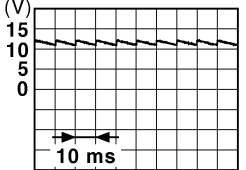
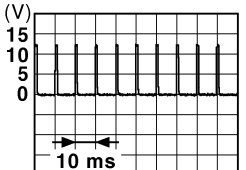
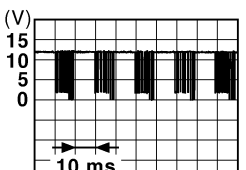
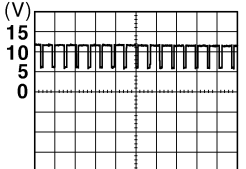
Terminal No. (Wire color)		Description		Condition	Value (Approx.)	
		Signal name	Input/ Output			
+	-					
124 (LG)	Ground	Passenger door switch	Input	Passenger door switch	OFF (Door close)	 <small>JPMIA0011GB</small> 11.8 V
					ON (Door open)	0 V
129 (O)	Ground	Trunk lid opener can- cel switch	Input	Trunk lid open- er cancel switch	CANCEL	 <small>JPMIA0012GB</small> 1.1 V
					ON	0 V
132 (V)	Ground	Power window switch communication	Input/ Output	Ignition switch ON	Ignition switch ON	 <small>JPMIA0013GB</small> 10.2 V
					Ignition switch OFF or ACC	12 V
133 (L)	Ground	Push-button ignition switch illumination	Output	Push-button ig- nition switch il- lumination	ON (Tail lamps OFF)	9.5 V
					ON (Tail lamps ON)	<p style="text-align: center;">NOTE: The pulse width of this wave is varied by the illumination bright- ening/dimming level.</p>  <small>JPMIA0159GB</small>
					OFF	0 V
134 (LG)	Ground	LOCK indicator lamp	Output	LOCK indicator lamp	OFF	Battery voltage
					ON	0 V
137 (O)	Ground	Receiver and sensor ground	Input	Ignition switch ON	Ignition switch ON	0 V
138 (V)	Ground	Receiver and sensor power supply	Output	Ignition switch	OFF	0 V
					ACC or ON	5.0 V



A
B
C
D
E
F
G
H
I
J
L
M
N
O
P

PWC

BCM (BODY CONTROL MODULE)

< ECU DIAGNOSIS INFORMATION >

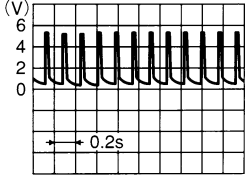
[FRONT WINDOW ANTI-PINCH]

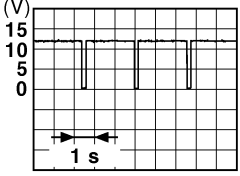
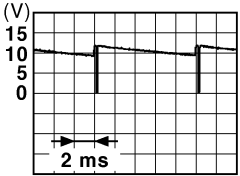
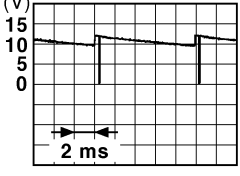
Terminal No. (Wire color)		Description		Condition	Value (Approx.)	
		Signal name	Input/ Output			
+	-					
139 (L)	Ground	Tire pressure receiver communication	Input/ Output	Ignition switch ON	Standby state	 OCC3881D
				When receiving the signal from the transmitter	 OCC3880D	
140 (GR)	Ground	Selector lever P/N position	Input	Selector lever	P or N position	12 V
				Except P and N positions	0 V	
141 (R)	Ground	Security indicator	Output	Security indicator	ON	0 V
					Blinking	 JPMIA0014GB
					OFF	12 V
142 (BR)	Ground	Combination switch OUTPUT 5	Output	Combination switch (Wiper intermittent dial 4)	All switches OFF	0 V
					Lighting switch 1ST	 JPMIA0031GB
					Lighting switch HI	
					Lighting switch 2ND	
Turn signal switch RH	10.7 V					
143 (P)	Ground	Combination switch OUTPUT 1	Output	Combination switch	All switches OFF (Wiper intermittent dial 4)	0 V
					Front wiper switch HI (Wiper intermittent dial 4)	 JPMIA0032GB
					Any of the conditions below with all switches OFF <ul style="list-style-type: none"> • Wiper intermittent dial 1 • Wiper intermittent dial 2 • Wiper intermittent dial 3 • Wiper intermittent dial 6 • Wiper intermittent dial 7 	

BCM (BODY CONTROL MODULE)

< ECU DIAGNOSIS INFORMATION >

[FRONT WINDOW ANTI-PINCH]

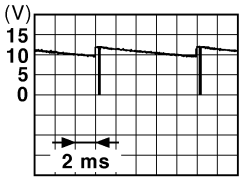
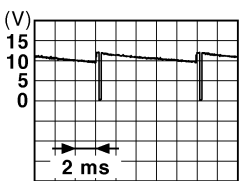
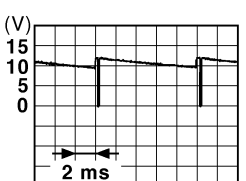
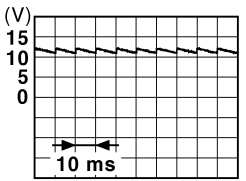
Terminal No. (Wire color)		Description		Condition	Value (Approx.)	
		Signal name	Input/ Output			
+	-					
144 (G)	Ground	Combination switch OUTPUT 2	Output	Combination switch	All switches OFF (Wiper intermittent dial 4)	0 V
					Front washer switch ON (Wiper intermittent dial 4)	
					Any of the conditions below with all switches OFF	
					<ul style="list-style-type: none"> • Wiper intermittent dial 1 • Wiper intermittent dial 5 • Wiper intermittent dial 6 	
145 (L)	Ground	Combination switch OUTPUT 3	Output	Combination switch (Wiper intermit- tent dial 4)	All switches OFF	0 V
					Front wiper switch INT	
					Front wiper switch LO	
					Lighting switch AUTO	
					10.7 V	
146 (SB)	Ground	Combination switch OUTPUT 4	Output	Combination switch (Wiper intermit- tent dial 4)	All switches OFF	0 V
					Front fog lamp switch ON	
					Lighting switch 2ND	
					Lighting switch PASS	
					Turn signal switch LH	
					10.7 V	
149 (W)	Ground	Tire pressure warning check switch	Input	—	12 V	
150 (GR)	Ground	Driver door switch	Input	Driver door switch	OFF (Door close)	
					ON (Door open)	
151 (G)	Ground	Rear window defog- ger relay control	Output	Rear window defogger	Active	0 V
					Not activated	Battery voltage

- *1: A/T models
- *2: M/T models

A
B
C
D
E
F
G
H
I
J
PWC
L
M
N
O
P

BCM (BODY CONTROL MODULE)

[FRONT WINDOW ANTI-PINCH]

< ECU DIAGNOSIS INFORMATION >

Wiring Diagram - BCM -

INFOID:000000004667401

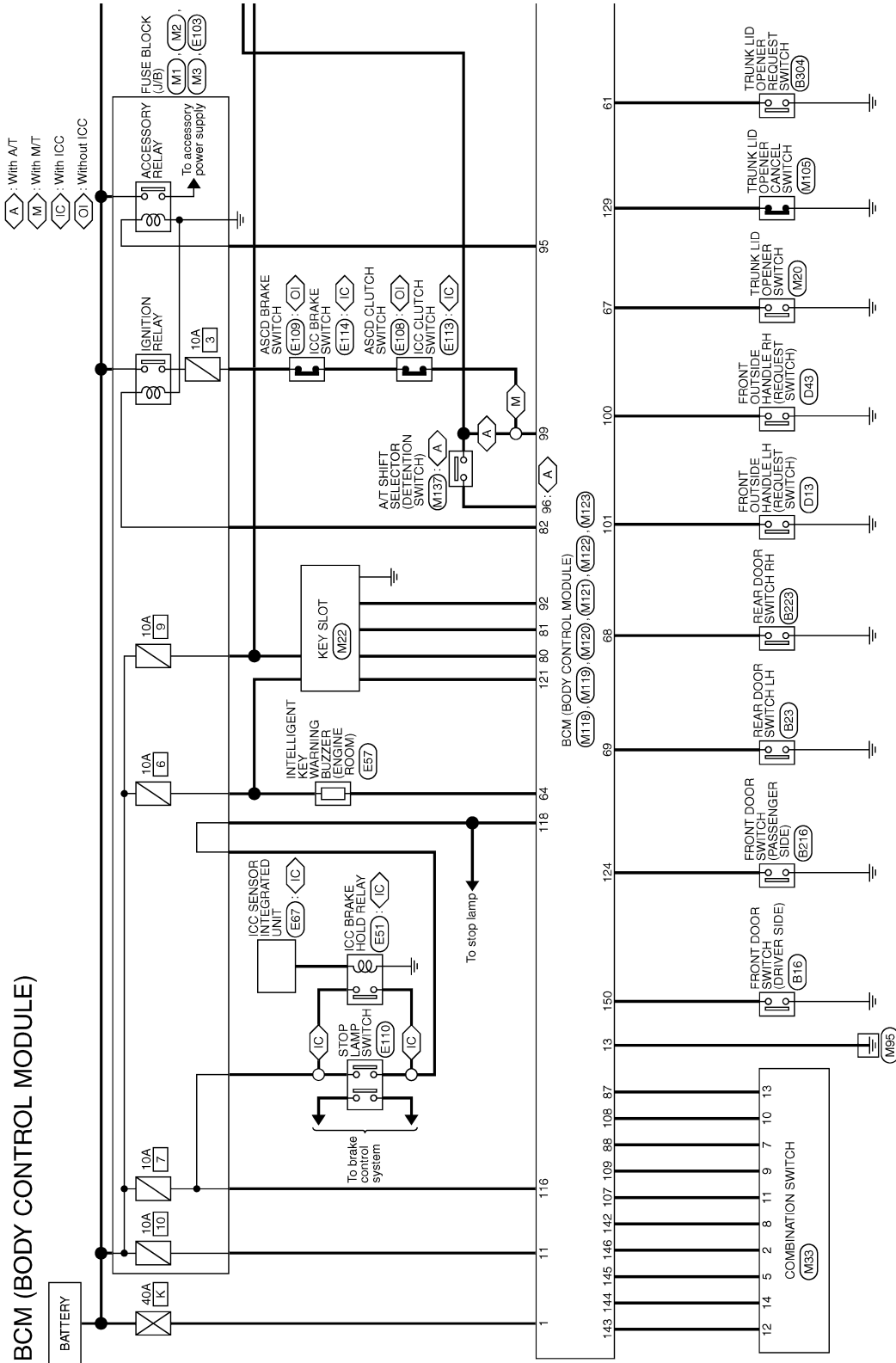

2008/08/07

JCMWA3019GE

BCM (BODY CONTROL MODULE)

< ECU DIAGNOSIS INFORMATION >

[FRONT WINDOW ANTI-PINCH]

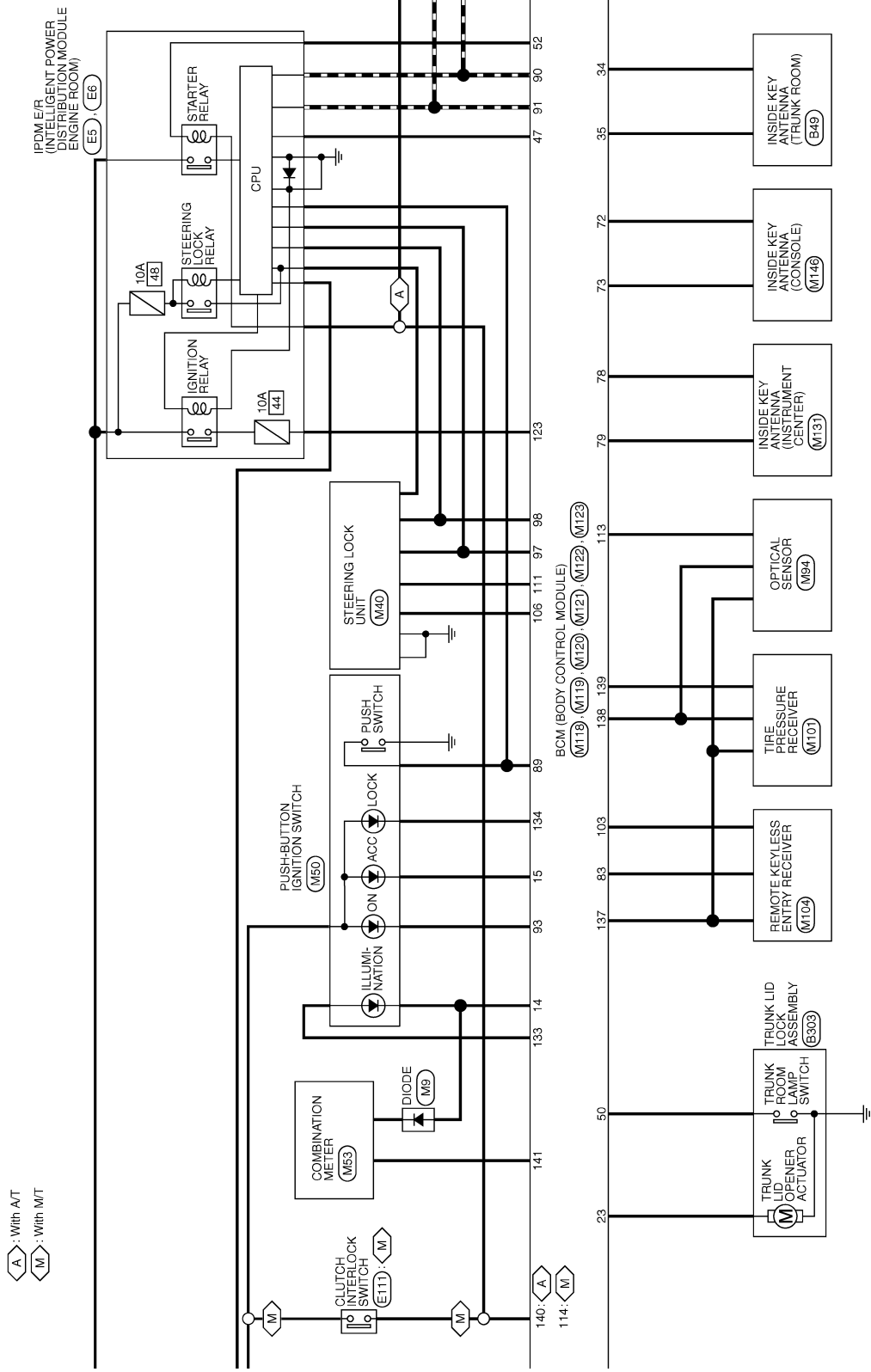

⬠ With A/T
⬠ With M/T

A
B
C
D
E
F
G
H
I
J
L
M
N
O
P

PWC

JCMWA3020GE

BCM (BODY CONTROL MODULE)

< ECU DIAGNOSIS INFORMATION >

[FRONT WINDOW ANTI-PINCH]

- ◁ A ▷ : With AT
- ◁ RF ▷ : With sunroof
- ◁ AN ▷ : With rear anti-pinch system
- ◁ OA ▷ : Without rear anti-pinch system
- ◁ SR ▷ : With sports seat without automatic drive positioner
- ◁ PM ▷ : With automatic drive positioner
- ◁ OP ▷ : Without automatic drive positioner

* : This connector is not shown in "Harness Layout".

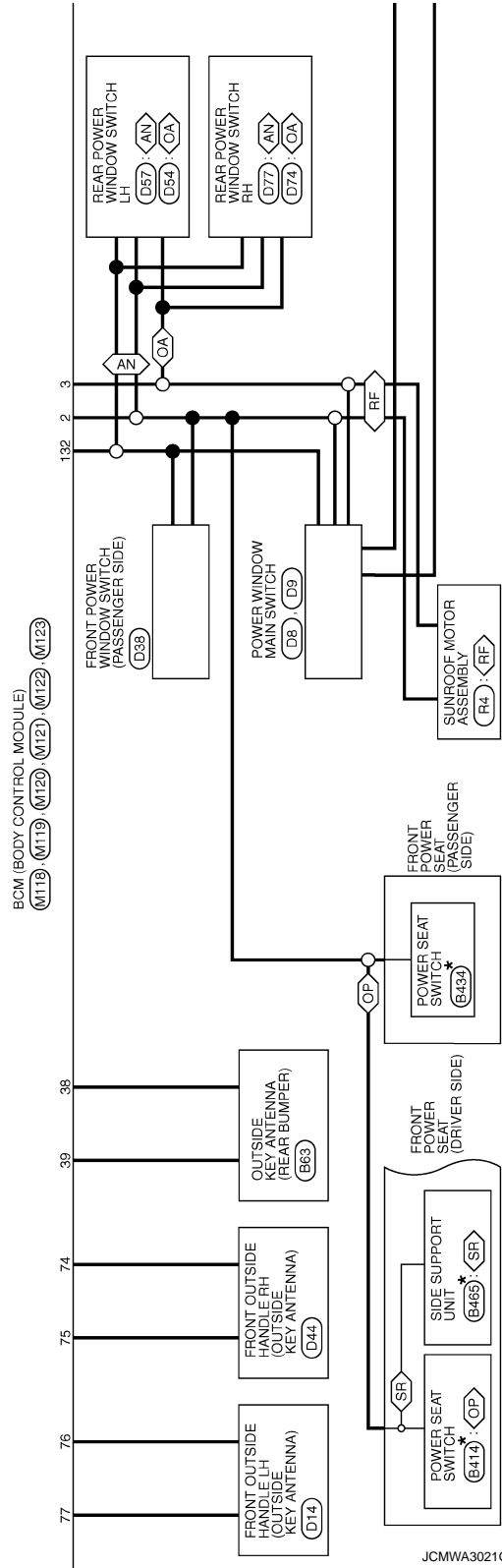
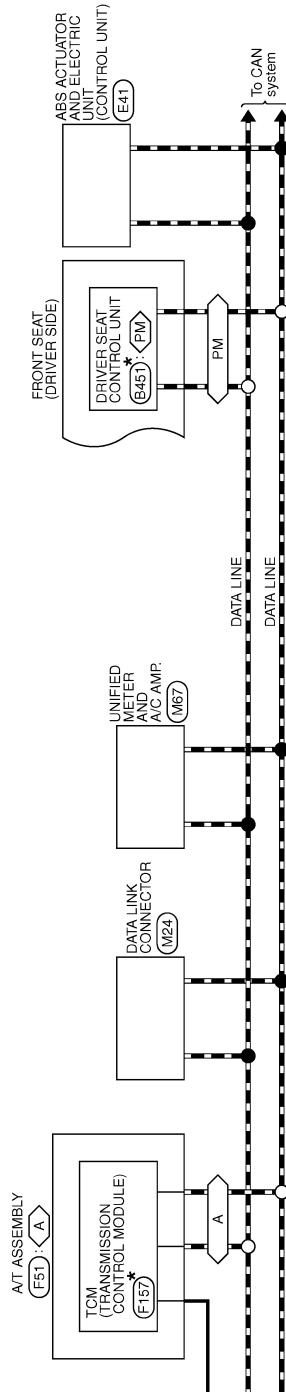

JCMWA3021Gf

BCM (BODY CONTROL MODULE)

< ECU DIAGNOSIS INFORMATION >

[FRONT WINDOW ANTI-PINCH]

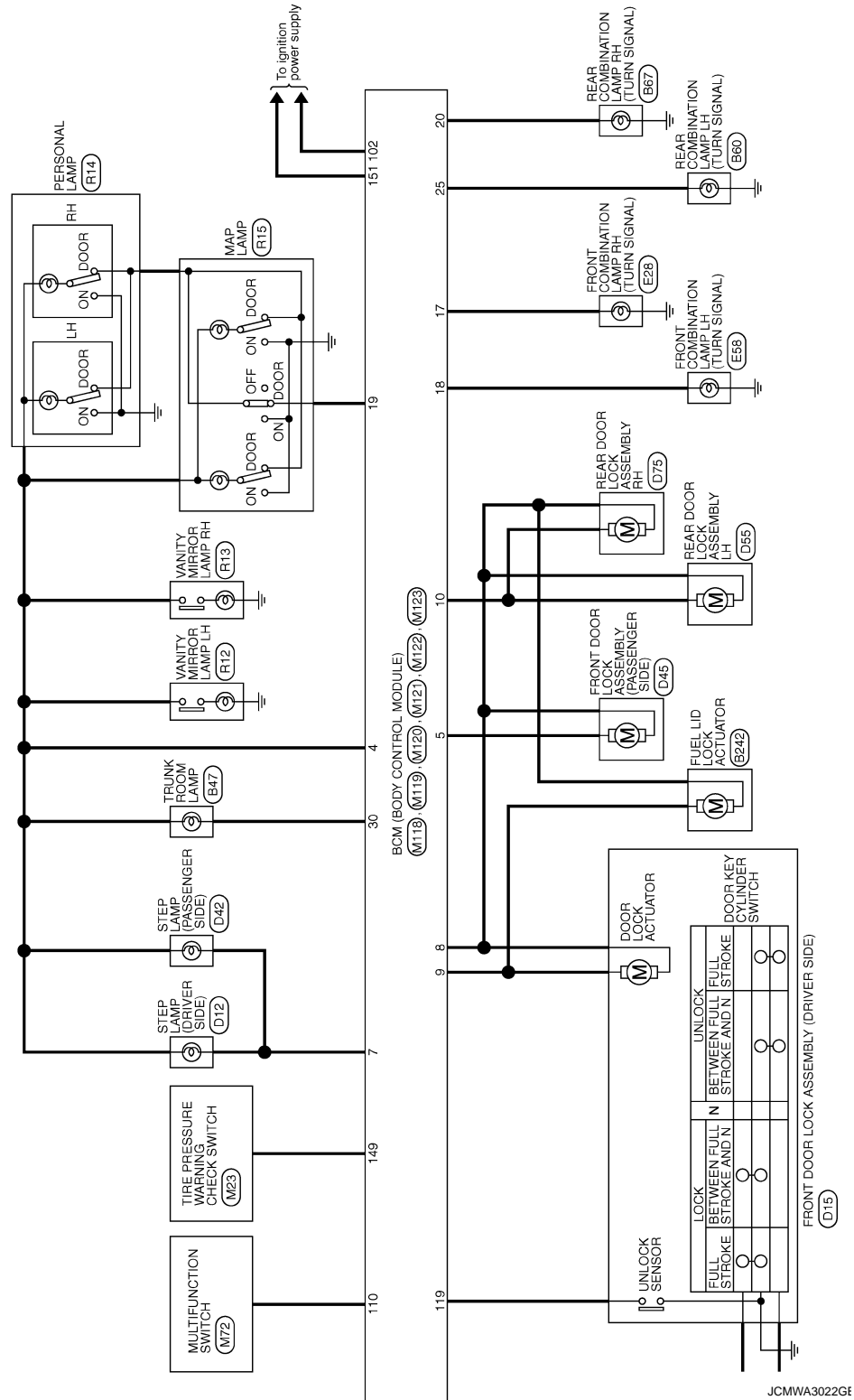

A
B
C
D
E
F
G
H
I
J
L
M
N
O
P



BCM (BODY CONTROL MODULE)

< ECU DIAGNOSIS INFORMATION >

[FRONT WINDOW ANTI-PINCH]

BCM (BODY CONTROL MODULE)

Connector No.	M33
Connector Name	COMBINATION SWITCH
Connector Type	TH16FW-NH

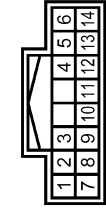

Terminal No.	Color of Wire	Signal Name [Specification]
2	SB	OUTPUT 4
5	L	OUTPUT 3
7	O	INPUT 3
8	BR	OUTPUT 5
9	W	INPUT 2
10	R	INPUT 4
11	LG	INPUT 1
12	P	OUTPUT 1
13	Y	INPUT 5
14	G	OUTPUT 2



Connector No.	M120
Connector Name	BCM (BODY CONTROL MODULE)
Connector Type	MS12PW-CS



Terminal No.	Color of Wire	Signal Name [Specification]
20	V	TURN SIGNAL RH (REAR)
23	L	TRUNK LID OPEN OUTPUT
25	Y	TURN SIGNAL LH (REAR)
30	P	TRUNK ROOM LAMP

Connector No.	M118
Connector Name	BCM (BODY CONTROL MODULE)
Connector Type	M03EB-LC



Terminal No.	Color of Wire	Signal Name [Specification]
1	W	BAT (E/L)
2	Y	POWER WINDOW POWER SUPPLY(BAT)
3	O	POWER WINDOW POWER SUPPLY(IRAP)

Connector No.	M121
Connector Name	BCM (BODY CONTROL MODULE)
Connector Type	TH40FGY-NH



Terminal No.	Color of Wire	Signal Name [Specification]
34	SB	TRUNK ROOM ANT-
35	V	TRUNK ROOM ANT+
38	B	REAR BUMPER ANT-
39	W	REAR BUMPER ANT+
47	Y	IGN RELAY (PDM E/R) CONT
50	O	TRUNK ROOM LAMP SW
52	SR	STARTER RELAY CONT
61	SR	TRUNK LID OPENER REQUEST SW
64	G	TR-KEY WARN BUTTEZ (ENG ROOM)
67	GR	TRUNK LID OPENER SW
68	BR	REAR RH DOOR SW

Connector No.	M119
Connector Name	BCM (BODY CONTROL MODULE)
Connector Type	MS16FW-CS

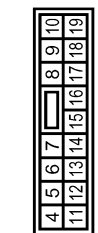

Terminal No.	Color of Wire	Signal Name [Specification]
4	LG	INTERIOR ROOM LAMP POWER SUPPLY
5	P	PASSENGER DOOR UNLOCK OUTPUT
7	BR	STEP LAMP OUTPUT
8	V	ALL DOOR. FUEL LID LOCK OUTPUT
9	G	DRIVER DOOR. FUEL LID UNLOCK OUTPUT
10	BR	REAR DOOR UNLOCK OUTPUT
11	R	BAT (FUSE)
13	B	GND
14	W	PUSH-BUTTON (IGNITION SW ILL GND
15	O	ACC IND
17	W	TURN SIGNAL RH (FRONT)

69	R	REAR LH DOOR SW
----	---	-----------------

18	O	TURN SIGNAL LH (FRONT)
19	V	ROOM LAMP TIMER CONTROL

BCM (BODY CONTROL MODULE)

< ECU DIAGNOSIS INFORMATION >

[FRONT WINDOW ANTI-PINCH]

BCM (BODY CONTROL MODULE)

Connector No.	M122
Connector Name	BCM (BODY CONTROL MODULE)
Connector Type	TH40FB-NH



1	2	3	4	5	6	7	8	9	10	11	12	13	14	15	16	17	18	19	20	21	22	23	24	25	26	27	28	29	30	31	32	33	34	35	36	37	38	39	40	41	42	43	44	45	46	47	48	49	50	51	52	53	54	55	56	57	58	59	60	61	62	63	64	65	66	67	68	69	70	71	72	73	74	75	76	77	78	79	80	81	82	83	84	85	86	87	88	89	90	91	92	93	94	95	96	97	98	99	100	101	102	103	104	105	106	107	108	109	110	111	112	113	114	115	116	117	118	119	120	121	122	123	124	125	126	127	128	129	130	131	132	133	134	135	136	137	138	139	140	141	142	143	144	145	146	147	148	149	150	151	152	153	154	155	156	157	158	159	160	161	162	163	164	165	166	167	168	169	170	171	172	173	174	175	176	177	178	179	180	181	182	183	184	185	186	187	188	189	190	191	192	193	194	195	196	197	198	199	200	201	202	203	204	205	206	207	208	209	210	211	212	213	214	215	216	217	218	219	220	221	222	223	224	225	226	227	228	229	230	231	232	233	234	235	236	237	238	239	240	241	242	243	244	245	246	247	248	249	250	251	252	253	254	255	256	257	258	259	260	261	262	263	264	265	266	267	268	269	270	271	272	273	274	275	276	277	278	279	280	281	282	283	284	285	286	287	288	289	290	291	292	293	294	295	296	297	298	299	300	301	302	303	304	305	306	307	308	309	310	311	312	313	314	315	316	317	318	319	320	321	322	323	324	325	326	327	328	329	330	331	332	333	334	335	336	337	338	339	340	341	342	343	344	345	346	347	348	349	350	351	352	353	354	355	356	357	358	359	360	361	362	363	364	365	366	367	368	369	370	371	372	373	374	375	376	377	378	379	380	381	382	383	384	385	386	387	388	389	390	391	392	393	394	395	396	397	398	399	400	401	402	403	404	405	406	407	408	409	410	411	412	413	414	415	416	417	418	419	420	421	422	423	424	425	426	427	428	429	430	431	432	433	434	435	436	437	438	439	440	441	442	443	444	445	446	447	448	449	450	451	452	453	454	455	456	457	458	459	460	461	462	463	464	465	466	467	468	469	470	471	472	473	474	475	476	477	478	479	480	481	482	483	484	485	486	487	488	489	490	491	492	493	494	495	496	497	498	499	500	501	502	503	504	505	506	507	508	509	510	511	512	513	514	515	516	517	518	519	520	521	522	523	524	525	526	527	528	529	530	531	532	533	534	535	536	537	538	539	540	541	542	543	544	545	546	547	548	549	550	551	552	553	554	555	556	557	558	559	560	561	562	563	564	565	566	567	568	569	570	571	572	573	574	575	576	577	578	579	580	581	582	583	584	585	586	587	588	589	590	591	592	593	594	595	596	597	598	599	600	601	602	603	604	605	606	607	608	609	610	611	612	613	614	615	616	617	618	619	620	621	622	623	624	625	626	627	628	629	630	631	632	633	634	635	636	637	638	639	640	641	642	643	644	645	646	647	648	649	650	651	652	653	654	655	656	657	658	659	660	661	662	663	664	665	666	667	668	669	670	671	672	673	674	675	676	677	678	679	680	681	682	683	684	685	686	687	688	689	690	691	692	693	694	695	696	697	698	699	700	701	702	703	704	705	706	707	708	709	710	711	712	713	714	715	716	717	718	719	720	721	722	723	724	725	726	727	728	729	730	731	732	733	734	735	736	737	738	739	740	741	742	743	744	745	746	747	748	749	750	751	752	753	754	755	756	757	758	759	760	761	762	763	764	765	766	767	768	769	770	771	772	773	774	775	776	777	778	779	780	781	782	783	784	785	786	787	788	789	790	791	792	793	794	795	796	797	798	799	800	801	802	803	804	805	806	807	808	809	810	811	812	813	814	815	816	817	818	819	820	821	822	823	824	825	826	827	828	829	830	831	832	833	834	835	836	837	838	839	840	841	842	843	844	845	846	847	848	849	850	851	852	853	854	855	856	857	858	859	860	861	862	863	864	865	866	867	868	869	870	871	872	873	874	875	876	877	878	879	880	881	882	883	884	885	886	887	888	889	890	891	892	893	894	895	896	897	898	899	900	901	902	903	904	905	906	907	908	909	910	911	912	913	914	915	916	917	918	919	920	921	922	923	924	925	926	927	928	929	930	931	932	933	934	935	936	937	938	939	940	941	942	943	944	945	946	947	948	949	950	951	952	953	954	955	956	957	958	959	960	961	962	963	964	965	966	967	968	969	970	971	972	973	974	975	976	977	978	979	980	981	982	983	984	985	986	987	988	989	990	991	992	993	994	995	996	997	998	999	1000	1001	1002	1003	1004	1005	1006	1007	1008	1009	1010	1011	1012	1013	1014	1015	1016	1017	1018	1019	1020	1021	1022	1023	1024	1025	1026	1027	1028	1029	1030	1031	1032	1033	1034	1035	1036	1037	1038	1039	1040	1041	1042	1043	1044	1045	1046	1047	1048	1049	1050	1051	1052	1053	1054	1055	1056	1057	1058	1059	1060	1061	1062	1063	1064	1065	1066	1067	1068	1069	1070	1071	1072	1073	1074	1075	1076	1077	1078	1079	1080	1081	1082	1083	1084	1085	1086	1087	1088	1089	1090	1091	1092	1093	1094	1095	1096	1097	1098	1099	1100	1101	1102	1103	1104	1105	1106	1107	1108	1109	1110	1111	1112	1113	1114	1115	1116	1117	1118	1119	1120	1121	1122	1123	1124	1125	1126	1127	1128	1129	1130	1131	1132	1133	1134	1135	1136	1137	1138	1139	1140	1141	1142	1143	1144	1145	1146	1147	1148	1149	1150	1151	1152	1153	1154	1155	1156	1157	1158	1159	1160	1161	1162	1163	1164	1165	1166	1167	1168	1169	1170	1171	1172	1173	1174	1175	1176	1177	1178	1179	1180	1181	1182	1183	1184	1185	1186	1187	1188	1189	1190	1191	1192	1193	1194	1195	1196	1197	1198	1199	1200	1201	1202	1203	1204	1205	1206	1207	1208	1209	1210	1211	1212	1213	1214	1215	1216	1217	1218	1219	1220	1221	1222	1223	1224	1225	1226	1227	1228	1229	1230	1231	1232	1233	1234	1235	1236	1237	1238	1239	1240	1241	1242	1243	1244	1245	1246	1247	1248	1249	1250	1251	1252	1253	1254	1255	1256	1257	1258	1259	1260	1261	1262	1263	1264	1265	1266	1267	1268	1269	1270	1271	1272	1273	1274	1275	1276	1277	1278	1279	1280	1281	1282	1283	1284	1285	1286	1287	1288	1289	1290	1291	1292	1293	1294	1295	1296	1297	1298	1299	1300	1301	1302	1303	1304	1305	1306	1307	1308	1309	1310	1311	1312	1313	1314	1315	1316	1317	1318	1319	1320	1321	1322	1323	1324	1325	1326	1327	1328	1329	1330	1331	1332	1333	1334	1335	1336	1337	1338	1339	1340	1341	1342	1343	1344	1345	1346	1347	1348	1349	1350	1351	1352	1353	1354	1355	1356	1357	1358	1359	1360	1361	1362	1363	1364	1365	1366	1367	1368	1369	1370	1371	1372	1373	1374	1375	1376	1377	1378	1379	1380	1381	1382	1383	1384	1385	1386	1387	1388	1389	1390	1391	1392	1393	1394	1395	1396	1397	1398	1399	1400	1401	1402	1403	1404	1405	1406	1407	1408	1409	1410	1411	1412	1413	1414	1415	1416	1417	1418	1419	1420	1421	1422	1423	1424	1425	1426	1427	1428	1429	1430	1431	1432	1433	1434	1435	1436	1437	1438	1439	1440	1441	1442	1443	1444	1445	1446	1447	1448	1449	1450	1451	1452	1453	1454	1455	1456	1457	14
---	---	---	---	---	---	---	---	---	----	----	----	----	----	----	----	----	----	----	----	----	----	----	----	----	----	----	----	----	----	----	----	----	----	----	----	----	----	----	----	----	----	----	----	----	----	----	----	----	----	----	----	----	----	----	----	----	----	----	----	----	----	----	----	----	----	----	----	----	----	----	----	----	----	----	----	----	----	----	----	----	----	----	----	----	----	----	----	----	----	----	----	----	----	----	----	----	----	----	-----	-----	-----	-----	-----	-----	-----	-----	-----	-----	-----	-----	-----	-----	-----	-----	-----	-----	-----	-----	-----	-----	-----	-----	-----	-----	-----	-----	-----	-----	-----	-----	-----	-----	-----	-----	-----	-----	-----	-----	-----	-----	-----	-----	-----	-----	-----	-----	-----	-----	-----	-----	-----	-----	-----	-----	-----	-----	-----	-----	-----	-----	-----	-----	-----	-----	-----	-----	-----	-----	-----	-----	-----	-----	-----	-----	-----	-----	-----	-----	-----	-----	-----	-----	-----	-----	-----	-----	-----	-----	-----	-----	-----	-----	-----	-----	-----	-----	-----	-----	-----	-----	-----	-----	-----	-----	-----	-----	-----	-----	-----	-----	-----	-----	-----	-----	-----	-----	-----	-----	-----	-----	-----	-----	-----	-----	-----	-----	-----	-----	-----	-----	-----	-----	-----	-----	-----	-----	-----	-----	-----	-----	-----	-----	-----	-----	-----	-----	-----	-----	-----	-----	-----	-----	-----	-----	-----	-----	-----	-----	-----	-----	-----	-----	-----	-----	-----	-----	-----	-----	-----	-----	-----	-----	-----	-----	-----	-----	-----	-----	-----	-----	-----	-----	-----	-----	-----	-----	-----	-----	-----	-----	-----	-----	-----	-----	-----	-----	-----	-----	-----	-----	-----	-----	-----	-----	-----	-----	-----	-----	-----	-----	-----	-----	-----	-----	-----	-----	-----	-----	-----	-----	-----	-----	-----	-----	-----	-----	-----	-----	-----	-----	-----	-----	-----	-----	-----	-----	-----	-----	-----	-----	-----	-----	-----	-----	-----	-----	-----	-----	-----	-----	-----	-----	-----	-----	-----	-----	-----	-----	-----	-----	-----	-----	-----	-----	-----	-----	-----	-----	-----	-----	-----	-----	-----	-----	-----	-----	-----	-----	-----	-----	-----	-----	-----	-----	-----	-----	-----	-----	-----	-----	-----	-----	-----	-----	-----	-----	-----	-----	-----	-----	-----	-----	-----	-----	-----	-----	-----	-----	-----	-----	-----	-----	-----	-----	-----	-----	-----	-----	-----	-----	-----	-----	-----	-----	-----	-----	-----	-----	-----	-----	-----	-----	-----	-----	-----	-----	-----	-----	-----	-----	-----	-----	-----	-----	-----	-----	-----	-----	-----	-----	-----	-----	-----	-----	-----	-----	-----	-----	-----	-----	-----	-----	-----	-----	-----	-----	-----	-----	-----	-----	-----	-----	-----	-----	-----	-----	-----	-----	-----	-----	-----	-----	-----	-----	-----	-----	-----	-----	-----	-----	-----	-----	-----	-----	-----	-----	-----	-----	-----	-----	-----	-----	-----	-----	-----	-----	-----	-----	-----	-----	-----	-----	-----	-----	-----	-----	-----	-----	-----	-----	-----	-----	-----	-----	-----	-----	-----	-----	-----	-----	-----	-----	-----	-----	-----	-----	-----	-----	-----	-----	-----	-----	-----	-----	-----	-----	-----	-----	-----	-----	-----	-----	-----	-----	-----	-----	-----	-----	-----	-----	-----	-----	-----	-----	-----	-----	-----	-----	-----	-----	-----	-----	-----	-----	-----	-----	-----	-----	-----	-----	-----	-----	-----	-----	-----	-----	-----	-----	-----	-----	-----	-----	-----	-----	-----	-----	-----	-----	-----	-----	-----	-----	-----	-----	-----	-----	-----	-----	-----	-----	-----	-----	-----	-----	-----	-----	-----	-----	-----	-----	-----	-----	-----	-----	-----	-----	-----	-----	-----	-----	-----	-----	-----	-----	-----	-----	-----	-----	-----	-----	-----	-----	-----	-----	-----	-----	-----	-----	-----	-----	-----	-----	-----	-----	-----	-----	-----	-----	-----	-----	-----	-----	-----	-----	-----	-----	-----	-----	-----	-----	-----	-----	-----	-----	-----	-----	-----	-----	-----	-----	-----	-----	-----	-----	-----	-----	-----	-----	-----	-----	-----	-----	-----	-----	-----	-----	-----	-----	-----	-----	-----	-----	-----	-----	-----	-----	-----	-----	-----	-----	-----	-----	-----	-----	-----	-----	-----	-----	-----	-----	-----	-----	-----	-----	-----	-----	-----	-----	-----	-----	-----	-----	-----	-----	-----	-----	-----	-----	-----	-----	-----	-----	-----	-----	-----	-----	-----	-----	-----	-----	-----	-----	-----	-----	-----	-----	-----	-----	-----	-----	-----	-----	-----	-----	-----	-----	-----	-----	-----	-----	-----	-----	-----	-----	-----	-----	-----	-----	-----	-----	-----	-----	-----	-----	-----	-----	-----	-----	-----	-----	-----	-----	-----	-----	-----	-----	-----	-----	-----	-----	-----	-----	-----	-----	-----	-----	-----	-----	-----	-----	-----	-----	-----	-----	-----	-----	-----	-----	-----	-----	-----	-----	-----	-----	-----	-----	-----	-----	-----	-----	-----	-----	-----	-----	-----	-----	-----	-----	-----	-----	-----	-----	-----	-----	-----	-----	-----	-----	-----	-----	-----	-----	-----	-----	-----	-----	-----	-----	-----	-----	-----	-----	-----	-----	-----	-----	-----	-----	-----	-----	-----	-----	-----	-----	-----	-----	-----	-----	-----	-----	-----	-----	-----	-----	-----	-----	-----	-----	-----	-----	-----	-----	-----	-----	-----	-----	-----	-----	-----	-----	-----	-----	-----	-----	-----	-----	-----	-----	-----	-----	-----	-----	-----	-----	-----	-----	-----	-----	-----	-----	-----	-----	-----	-----	-----	-----	-----	-----	-----	-----	-----	-----	-----	-----	-----	-----	-----	-----	-----	-----	-----	-----	-----	-----	-----	-----	-----	-----	-----	-----	-----	-----	-----	-----	-----	-----	-----	-----	-----	-----	-----	-----	-----	-----	-----	-----	-----	-----	-----	-----	-----	-----	-----	-----	-----	-----	-----	-----	-----	-----	-----	-----	-----	-----	-----	-----	-----	-----	-----	-----	-----	-----	-----	-----	-----	-----	-----	-----	------	------	------	------	------	------	------	------	------	------	------	------	------	------	------	------	------	------	------	------	------	------	------	------	------	------	------	------	------	------	------	------	------	------	------	------	------	------	------	------	------	------	------	------	------	------	------	------	------	------	------	------	------	------	------	------	------	------	------	------	------	------	------	------	------	------	------	------	------	------	------	------	------	------	------	------	------	------	------	------	------	------	------	------	------	------	------	------	------	------	------	------	------	------	------	------	------	------	------	------	------	------	------	------	------	------	------	------	------	------	------	------	------	------	------	------	------	------	------	------	------	------	------	------	------	------	------	------	------	------	------	------	------	------	------	------	------	------	------	------	------	------	------	------	------	------	------	------	------	------	------	------	------	------	------	------	------	------	------	------	------	------	------	------	------	------	------	------	------	------	------	------	------	------	------	------	------	------	------	------	------	------	------	------	------	------	------	------	------	------	------	------	------	------	------	------	------	------	------	------	------	------	------	------	------	------	------	------	------	------	------	------	------	------	------	------	------	------	------	------	------	------	------	------	------	------	------	------	------	------	------	------	------	------	------	------	------	------	------	------	------	------	------	------	------	------	------	------	------	------	------	------	------	------	------	------	------	------	------	------	------	------	------	------	------	------	------	------	------	------	------	------	------	------	------	------	------	------	------	------	------	------	------	------	------	------	------	------	------	------	------	------	------	------	------	------	------	------	------	------	------	------	------	------	------	------	------	------	------	------	------	------	------	------	------	------	------	------	------	------	------	------	------	------	------	------	------	------	------	------	------	------	------	------	------	------	------	------	------	------	------	------	------	------	------	------	------	------	------	------	------	------	------	------	------	------	------	------	------	------	------	------	------	------	------	------	------	------	------	------	------	------	------	------	------	------	------	------	------	------	------	------	------	------	------	------	------	------	------	------	------	------	------	------	------	------	------	------	------	------	------	------	------	------	------	------	------	------	------	------	------	------	------	------	------	------	------	------	------	------	------	------	------	------	------	------	------	------	------	------	------	------	------	------	------	------	------	------	------	------	------	------	------	------	------	------	------	------	------	------	------	------	------	------	------	------	------	------	----

BCM (BODY CONTROL MODULE)

< ECU DIAGNOSIS INFORMATION >

[FRONT WINDOW ANTI-PINCH]

Display contents of CONSULT	Fail-safe	Cancellation
B2013: ID DISCORD BCM-S/L	Inhibit engine cranking	Erase DTC
B2014: CHAIN OF S/L-BCM	Inhibit engine cranking	Erase DTC
B2190: NATS ANTENNA AMP	Inhibit engine cranking	Erase DTC
B2191: DIFFERENCE OF KEY	Inhibit engine cranking	Erase DTC
B2192: ID DISCORD BCM-ECM	Inhibit engine cranking	Erase DTC
B2193: CHAIN OF BCM-ECM	Inhibit engine cranking	Erase DTC
B2195: ANTI SCANNING	Inhibit engine cranking	Ignition switch ON → OFF
B2557: VEHICLE SPEED	Inhibit steering lock	When normal vehicle speed signals are received from ABS actuator and electric unit (control unit) for 500 ms
B2560: STARTER CONT RELAY	Inhibit engine cranking	500 ms after the following CAN signal communication status becomes consistent <ul style="list-style-type: none"> • Starter control relay signal • Starter relay status signal
B2601: SHIFT POSITION	Inhibit steering lock	500 ms after the following signal reception status becomes consistent <ul style="list-style-type: none"> • Selector lever P position switch signal • P range signal (CAN)
B2602: SHIFT POSITION	Inhibit steering lock	5 seconds after the following BCM recognition conditions are fulfilled <ul style="list-style-type: none"> • Ignition switch is in the ON position • Selector lever P position switch signal: Except P position (battery voltage) • Vehicle speed: 4 km/h (2.5 MPH) or more
B2603: SHIFT POSI STATUS	Inhibit steering lock	500 ms after the following BCM recognition conditions are fulfilled <ul style="list-style-type: none"> • Ignition switch is in the ON position • Selector lever P position switch signal: Except P position (battery voltage) • Selector lever P/N position signal: Except P and N positions (0 V)
B2604: PNP SW	Inhibit steering lock	500 ms after any of the following BCM recognition conditions are fulfilled <ul style="list-style-type: none"> • Status 1 <ul style="list-style-type: none"> - Ignition switch is in the ON position - Selector lever P/N position signal: P and N position (battery voltage) - P range signal or N range signal (CAN): ON • Status 2 <ul style="list-style-type: none"> - Ignition switch is in the ON position - Selector lever P/N position signal: Except P and N positions (0 V) - P range signal and N range signal (CAN): OFF
B2605: PNP SW	Inhibit steering lock	500 ms after any of the following BCM recognition conditions are fulfilled <ul style="list-style-type: none"> • Status 1 <ul style="list-style-type: none"> - Ignition switch is in the ON position - Selector lever P/N position signal: Except P and N positions (0 V) - Interlock/PNP switch signal (CAN): OFF • Status 2 <ul style="list-style-type: none"> - Ignition switch is in the ON position - Selector lever P/N position signal: P or N position (battery voltage) - PNP switch signal (CAN): ON
B2606: S/L RELAY	Inhibit engine cranking	500 ms after the following CAN signal communication status becomes consistent <ul style="list-style-type: none"> • Steering lock relay signal (Request signal) • Steering lock relay signal (Condition signal)

BCM (BODY CONTROL MODULE)

< ECU DIAGNOSIS INFORMATION >

[FRONT WINDOW ANTI-PINCH]

Display contents of CONSULT	Fail-safe	Cancellation
B2607: S/L RELAY	Inhibit engine cranking	500 ms after the following CAN signal communication status has becomes consistent <ul style="list-style-type: none"> Steering lock relay signal (Request signal) Steering lock relay signal (Condition signal)
B2608: STARTER RELAY	Inhibit engine cranking	500 ms after the following signal communication status becomes consistent <ul style="list-style-type: none"> Starter motor relay control signal Starter relay status signal (CAN)
B2609: S/L STATUS	<ul style="list-style-type: none"> Inhibit engine cranking Inhibit steering lock 	When the following steering lock conditions agree <ul style="list-style-type: none"> BCM steering lock control status Steering lock condition No. 1 signal status Steering lock condition No. 2 signal status
B260A: IGNITION RELAY	Inhibit engine cranking	500 ms after the following conditions are fulfilled <ul style="list-style-type: none"> IGN relay (IPDM E/R) control signal: OFF (Battery voltage) Ignition ON signal (CAN to IPDM E/R): OFF (Request signal) Ignition ON signal (CAN from IPDM E/R): OFF (Condition signal)
B260F: ENG STATE SIG LOST	Maintains the power supply position attained at the time of DTC detection	When any of the following conditions are fulfilled <ul style="list-style-type: none"> Power position changes to ACC Receives engine status signal (CAN)
B2612: S/L STATUS	<ul style="list-style-type: none"> Inhibit engine cranking Inhibit steering lock 	When any of the following conditions are fulfilled <ul style="list-style-type: none"> Steering lock unit status signal (CAN) is received normally The BCM steering lock control status matches the steering lock status recognized by the steering lock unit status signal (CAN from IPDM E/R)
B2617: STARTER RELAY CIRC	Inhibit engine cranking	1 second after the starter motor relay control inside BCM becomes normal
B2618: BCM	Inhibit engine cranking	1 second after the ignition relay (IPDM E/R) control inside BCM becomes normal
B2619: BCM	Inhibit engine cranking	1 second after the steering lock unit power supply output control inside BCM becomes normal
B261E: VEHICLE TYPE	Inhibit engine cranking	BCM initialization
B26E8: CLUTCH SW	Inhibit engine cranking	When any of the following BCM recognition conditions are fulfilled <ul style="list-style-type: none"> Status 1 <ul style="list-style-type: none"> Clutch switch signal (CAN from ECM): ON Clutch interlock switch signal: OFF (0 V) Status 2 <ul style="list-style-type: none"> Clutch switch signal (CAN from ECM): OFF Clutch interlock switch signal: ON (Battery voltage)
B26E9: S/L STATUS	<ul style="list-style-type: none"> Inhibit engine cranking Inhibit steering lock 	When BCM transmits the LOCK request signal to steering lock unit, and receives LOCK response signal from steering lock unit, the following conditions are fulfilled <ul style="list-style-type: none"> Steering condition No. 1 signal: LOCK (0 V) Steering condition No. 2 signal: LOCK (Battery voltage)

HIGH FLASHER OPERATION

BCM detects the turn signal lamp circuit status by the current value.

BCM increases the turn signal lamp blinking speed if the bulb or harness open is detected with the turn signal lamp operating.

NOTE:

The blinking speed is normal while activating the hazard warning lamp.

DTC Inspection Priority Chart

INFOID:000000004667403

If some DTCs are displayed at the same time, perform inspections one by one based on the following priority chart.

BCM (BODY CONTROL MODULE)

< ECU DIAGNOSIS INFORMATION >

[FRONT WINDOW ANTI-PINCH]

Priority	DTC
1	B2562: LOW VOLTAGE
2	<ul style="list-style-type: none">• U1000: CAN COMM• U1010: CONTROL UNIT(CAN)
3	<ul style="list-style-type: none">• B2190: NATS ANTENNA AMP• B2191: DIFFERENCE OF KEY• B2192: ID DISCORD BCM-ECM• B2193: CHAIN OF BCM-ECM• B2195: ANTI SCANNING
4	<ul style="list-style-type: none">• B2013: ID DISCORD BCM-S/L• B2014: CHAIN OF S/L-BCM• B2553: IGNITION RELAY• B2555: STOP LAMP• B2556: PUSH-BTN IGN SW• B2557: VEHICLE SPEED• B2560: STARTER CONT RELAY• B2601: SHIFT POSITION• B2602: SHIFT POSITION• B2603: SHIFT POSI STATUS• B2604: PNP SW• B2605: PNP SW• B2606: S/L RELAY• B2607: S/L RELAY• B2608: STARTER RELAY• B2609: S/L STATUS• B260A: IGNITION RELAY• B260B: STEERING LOCK UNIT• B260C: STEERING LOCK UNIT• B260D: STEERING LOCK UNIT• B260F: ENG STATE SIG LOST• B2612: S/L STATUS• B2614: ACC RELAY CIRC• B2615: BLOWER RELAY CIRC• B2616: IGN RELAY CIRC• B2617: STARTER RELAY CIRC• B2618: BCM• B2619: BCM• B261A: PUSH-BTN IGN SW• B261E: VEHICLE TYPE• B26E8: CLUTCH SW• B26E9: S/L STATUS• B26EA: KEY REGISTRATION• C1729: VHCL SPEED SIG ERR• U0415: VEHICLE SPEED SIG

BCM (BODY CONTROL MODULE)

< ECU DIAGNOSIS INFORMATION >

[FRONT WINDOW ANTI-PINCH]

Priority	DTC
5	<ul style="list-style-type: none"> • C1704: LOW PRESSURE FL • C1705: LOW PRESSURE FR • C1706: LOW PRESSURE RR • C1707: LOW PRESSURE RL • C1708: [NO DATA] FL • C1709: [NO DATA] FR • C1710: [NO DATA] RR • C1711: [NO DATA] RL • C1712: [CHECKSUM ERR] FL • C1713: [CHECKSUM ERR] FR • C1714: [CHECKSUM ERR] RR • C1715: [CHECKSUM ERR] RL • C1716: [PRESSDATA ERR] FL • C1717: [PRESSDATA ERR] FR • C1718: [PRESSDATA ERR] RR • C1719: [PRESSDATA ERR] RL • C1720: [CODE ERR] FL • C1721: [CODE ERR] FR • C1722: [CODE ERR] RR • C1723: [CODE ERR] RL • C1724: [BATT VOLT LOW] FL • C1725: [BATT VOLT LOW] FR • C1726: [BATT VOLT LOW] RR • C1727: [BATT VOLT LOW] RL • C1734: CONTROL UNIT
6	<ul style="list-style-type: none"> • B2621: INSIDE ANTENNA • B2622: INSIDE ANTENNA • B2623: INSIDE ANTENNA

DTC Index

INFOID:000000004667404

NOTE:

The details of time display are as follows.

- CRNT: A malfunction is detected now.
- PAST: A malfunction was detected in the past.

IGN counter is displayed on Freeze Frame Data. For details of Freeze Frame Data, refer to [PWC-125. "COMMON ITEM : CONSULT-III Function \(BCM - COMMON ITEM\)"](#).

CONSULT display	Fail-safe	Freeze Frame Data •Vehicle Speed •Odo/Trip Meter •Vehicle condition	Intelligent Key warning lamp ON	Tire pressure monitor warning lamp ON	Refer- ence page
No DTC is detected. further testing may be required.	—	—	—	—	—
U1000: CAN COMM	—	—	—	—	BCS-35
U1010: CONTROL UNIT(CAN)	—	—	—	—	BCS-36
U0415: VEHICLE SPEED SIG	—	—	—	—	BCS-37
B2013: ID DISCORD BCM-S/L	×	×	—	—	SEC-55
B2014: CHAIN OF S/L-BCM	×	×	—	—	SEC-56
B2190: NATS ANTENNA AMP	×	—	—	—	SEC-47
B2191: DIFFERENCE OF KEY	×	—	—	—	SEC-50
B2192: ID DISCORD BCM-ECM	×	—	—	—	SEC-51
B2193: CHAIN OF BCM-ECM	×	—	—	—	SEC-53
B2195: ANTI SCANNING	×	—	—	—	SEC-54
B2553: IGNITION RELAY	—	×	—	—	PCS-49
B2555: STOP LAMP	—	×	—	—	SEC-59

BCM (BODY CONTROL MODULE)

< ECU DIAGNOSIS INFORMATION >

[FRONT WINDOW ANTI-PINCH]

CONSULT display	Fail-safe	Freeze Frame Data •Vehicle Speed •Odo/Trip Meter •Vehicle condition	Intelligent Key warning lamp ON	Tire pressure monitor warning lamp ON	Refer- ence page
B2556: PUSH-BTN IGN SW	—	×	×	—	SEC-61
B2557: VEHICLE SPEED	×	×	×	—	SEC-63
B2560: STARTER CONT RELAY	×	×	×	—	SEC-64
B2562: LOW VOLTAGE	—	×	—	—	BCS-38
B2601: SHIFT POSITION	×	×	×	—	SEC-65
B2602: SHIFT POSITION	×	×	×	—	SEC-68
B2603: SHIFT POSI STATUS	×	×	×	—	SEC-70
B2604: PNP SW	×	×	×	—	SEC-73
B2605: PNP SW	×	×	×	—	SEC-75
B2606: S/L RELAY	×	×	×	—	SEC-77
B2607: S/L RELAY	×	×	×	—	SEC-78
B2608: STARTER RELAY	×	×	×	—	SEC-80
B2609: S/L STATUS	×	×	×	—	SEC-82
B260A: IGNITION RELAY	×	×	×	—	PCS-51
B260B: STEERING LOCK UNIT	—	×	×	—	SEC-86
B260C: STEERING LOCK UNIT	—	×	×	—	SEC-87
B260D: STEERING LOCK UNIT	—	×	×	—	SEC-88
B260F: ENG STATE SIG LOST	×	×	×	—	SEC-89
B2612: S/L STATUS	×	×	×	—	SEC-94
B2614: ACC RELAY CIRC	—	×	×	—	PCS-53
B2615: BLOWER RELAY CIRC	—	×	×	—	PCS-55
B2616: IGN RELAY CIRC	—	×	×	—	PCS-57
B2617: STARTER RELAY CIRC	×	×	×	—	SEC-98
B2618: BCM	×	×	×	—	PCS-59
B2619: BCM	×	×	×	—	SEC-100
B261A: PUSH-BTN IGN SW	—	×	×	—	PCS-60
B261E: VEHICLE TYPE	×	×	× (Turn ON for 15 seconds)	—	SEC-101
B2621: INSIDE ANTENNA	—	×	—	—	DLK-59
B2622: INSIDE ANTENNA	—	×	—	—	DLK-61
B2623: INSIDE ANTENNA	—	×	—	—	DLK-63
B26E8: CLUTCH SW	×	×	×	—	SEC-90
B26E9: S/L STATUS	×	×	× (Turn ON for 15 seconds)	—	SEC-92
B26EA: KEY REGISTRATION	—	×	× (Turn ON for 15 seconds)	—	SEC-93
C1704: LOW PRESSURE FL	—	—	—	×	WT-17
C1705: LOW PRESSURE FR	—	—	—	×	
C1706: LOW PRESSURE RR	—	—	—	×	
C1707: LOW PRESSURE RL	—	—	—	×	

BCM (BODY CONTROL MODULE)

< ECU DIAGNOSIS INFORMATION >

[FRONT WINDOW ANTI-PINCH]

CONSULT display	Fail-safe	Freeze Frame Data •Vehicle Speed •Odo/Trip Meter •Vehicle condition	Intelligent Key warning lamp ON	Tire pressure monitor warning lamp ON	Refer- ence page
C1708: [NO DATA] FL	—	—	—	×	WT-19
C1709: [NO DATA] FR	—	—	—	×	
C1710: [NO DATA] RR	—	—	—	×	
C1711: [NO DATA] RL	—	—	—	×	WT-21
C1712: [CHECKSUM ERR] FL	—	—	—	×	
C1713: [CHECKSUM ERR] FR	—	—	—	×	
C1714: [CHECKSUM ERR] RR	—	—	—	×	WT-24
C1715: [CHECKSUM ERR] RL	—	—	—	×	
C1716: [PRESSDATA ERR] FL	—	—	—	×	
C1717: [PRESSDATA ERR] FR	—	—	—	×	WT-26
C1718: [PRESSDATA ERR] RR	—	—	—	×	
C1719: [PRESSDATA ERR] RL	—	—	—	×	
C1720: [CODE ERR] FL	—	—	—	×	WT-29
C1721: [CODE ERR] FR	—	—	—	×	
C1722: [CODE ERR] RR	—	—	—	×	
C1723: [CODE ERR] RL	—	—	—	×	WT-32
C1724: [BATT VOLT LOW] FL	—	—	—	×	
C1725: [BATT VOLT LOW] FR	—	—	—	×	
C1726: [BATT VOLT LOW] RR	—	—	—	×	WT-33
C1727: [BATT VOLT LOW] RL	—	—	—	×	
C1729: VHCL SPEED SIG ERR	—	—	—	×	
C1734: CONTROL UNIT	—	—	—	×	

A
B
C
D
E
F
G
H
I
J
L
M
N
O
P

PWC

POWER WINDOW MAIN SWITCH

< ECU DIAGNOSIS INFORMATION >

[FRONT WINDOW ANTI-PINCH]

POWER WINDOW MAIN SWITCH

Reference Value

INFOID:000000004240733

TERMINAL LAYOUT

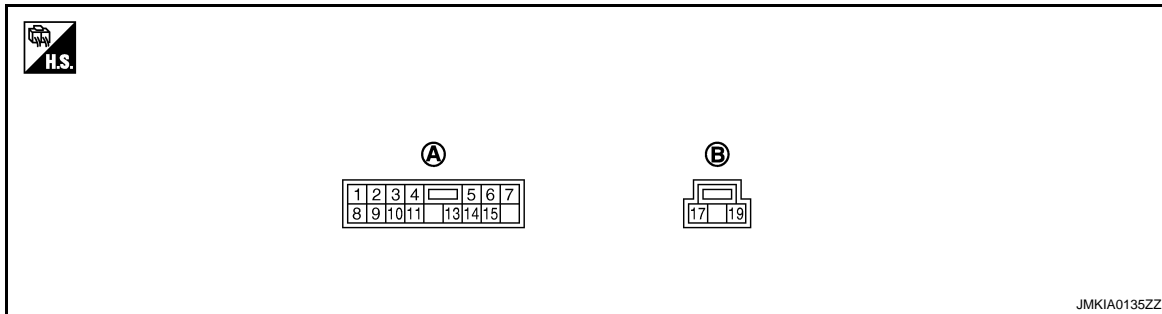

A. D8

B. D9

PHYSICAL VALUES

Power Window Main Switch



Terminal No. (wire color)		Description		Condition	Voltage (V) (Approx.)
+	-	Signal name	Input/ Output		
1 (W)	Ground	Rear power window motor LH DOWN signal	Output	When rear LH switch in power window main switch is DOWN at operated.	Battery voltage
2 (LG)	Ground	Encoder ground	—	—	0
3 (GR)	Ground	Rear power window motor LH UP signal	Output	When rear LH switch in power window main switch is UP at operated.	Battery voltage
4 (V)	Ground	Door key cylinder switch LOCK signal	Input	Key position (Neutral → Locked)	5 → 0
5 (O)	Ground	Rear power window motor RH UP signal	Output	When rear RH switch in power window main switch is UP at operated.	Battery voltage
6 (Y)	Ground	Door key cylinder switch UNLOCK signal	Input	Key position (Neutral → Unlocked)	5 → 0
7 (BR)	Ground	Rear power window motor RH DOWN signal	Output	When rear RH switch in power window main switch is DOWN at operated.	Battery voltage
8 (L)	Ground	Front driver side power window motor UP signal	Output	When front LH switch in power window main switch is UP at operated.	Battery voltage
9 (O)	Ground	Encoder pulse signal 2	Input	When power window motor operates.	

JMKIA0070GB

POWER WINDOW MAIN SWITCH

< ECU DIAGNOSIS INFORMATION >

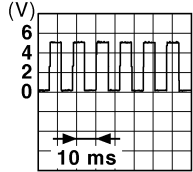
[FRONT WINDOW ANTI-PINCH]

Terminal No. (wire color)		Description		Condition	Voltage (V) (Approx.)
+	-	Signal name	Input/ Output		
10 (SB)	Ground	Rap signal	Input	Ignition switch ON	Battery voltage
				Within 45 second after ignition switch is turned to OFF	Battery voltage
				When driver side or passenger side door is opened during retained power operation	0
11 (G)	Ground	Front driver side power window motor DOWN signal	Output	When front LH switch in power window main switch is DOWN at operated.	Battery voltage
13 (P)	Ground	Encoder pulse signal 1	Input	When power window motor operates.	 <small>JMKIA0070GB</small>
14 (V)	Ground	Power window serial link	Input/ Output	Ignition switch ON or power window timer operating.	 <small>JPMIA0013GB</small>
15 (B)	Ground	Encoder power supply	Output	When ignition switch ON or power window timer operates.	Battery voltage
17 (B)	Ground	Ground	—	—	0
19 (Y)	Ground	Battery power supply	Input	—	Battery voltage

A
B
C
D
E
F
G
H
I
J
L
M
N
O
P

PWC

POWER WINDOW MAIN SWITCH

< ECU DIAGNOSIS INFORMATION >

[FRONT WINDOW ANTI-PINCH]

Wiring Diagram - POWER WINDOW CONTROL SYSTEM -

INFOID:000000004240734

POWER WINDOW SYSTEM (WITH FRONT POWER WINDOW ANTI-PINCH SYSTEM)

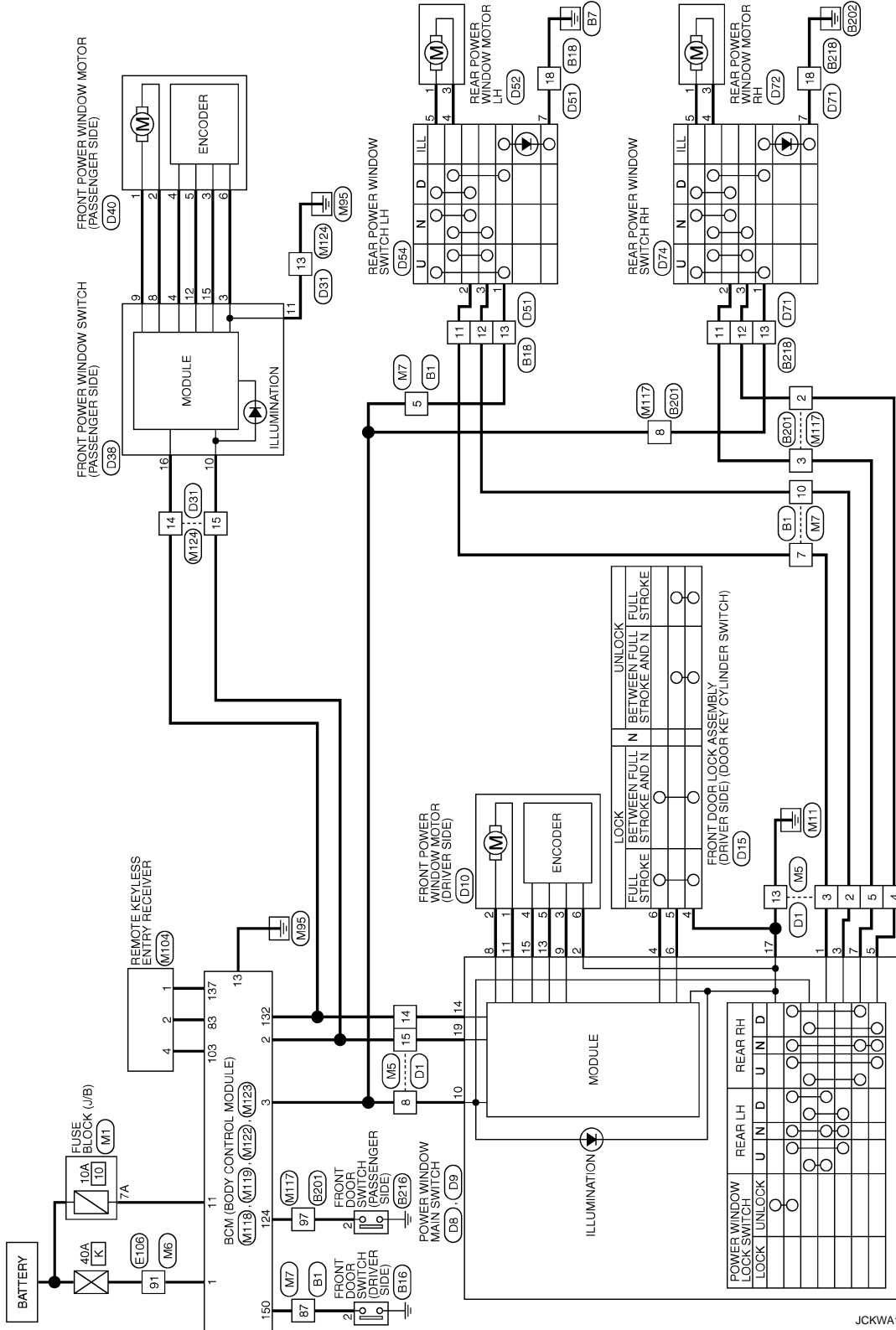

2008/08/07

JCKWA1893GE

POWER WINDOW MAIN SWITCH

< ECU DIAGNOSIS INFORMATION >

[FRONT WINDOW ANTI-PINCH]

POWER WINDOW SYSTEM (WITH FRONT POWER WINDOW ANTI-PINCH SYSTEM)

Connector No.	B1
Connector Name	WIRE TO WIRE
Connector Type	TH40FW-CS16-TM4

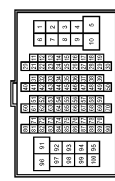

Terminal No.	Color of Wire	Signal Name [Specification]
5	W	-
7	P	-
10	GR	-
87	B	-

Connector No.	B16
Connector Name	FRONT DOOR SWITCH (DRIVER SIDE)
Connector Type	A08FW

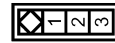

Terminal No.	Color of Wire	Signal Name [Specification]
2	B	-

Connector No.	B18
Connector Name	WIRE TO WIRE
Connector Type	TK10FW-NS8

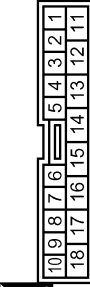

Terminal No.	Color of Wire	Signal Name [Specification]
11	P	-
12	GR	- [Without rear power window anti-pinch system]
13	W	-
18	B	-

Connector No.	B201
Connector Name	WIRE TO WIRE
Connector Type	TH40FW-CS16-TM4

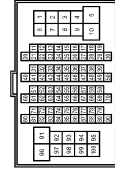

Terminal No.	Color of Wire	Signal Name [Specification]
2	R	-
3	W	-
8	BR	-
87	GR	-

Connector No.	B216
Connector Name	FRONT DOOR SWITCH (PASSENGER SIDE)
Connector Type	A08FW

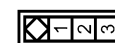

Terminal No.	Color of Wire	Signal Name [Specification]
2	GR	-

Connector No.	B218
Connector Name	WIRE TO WIRE
Connector Type	TK10FW-NS8

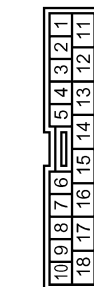

Terminal No.	Color of Wire	Signal Name [Specification]
11	W	-
12	R	- [Without rear power window anti-pinch system]
13	BR	- [Without rear power window anti-pinch system]
18	B	-

Connector No.	D1
Connector Name	WIRE TO WIRE
Connector Type	TH40FW-CS15

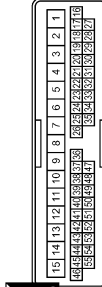

Terminal No.	Color of Wire	Signal Name [Specification]
2	GR	-
3	W	-
4	O	-
5	BR	-
8	SB	-
13	B	-
14	V	-
15	Y	-

A
B
C
D
E
F
G
H
I
J
K
L
M
N
O
P

PWC

JCKWA1894GE

POWER WINDOW MAIN SWITCH

< ECU DIAGNOSIS INFORMATION >

[FRONT WINDOW ANTI-PINCH]

POWER WINDOW SYSTEM (WITH FRONT POWER WINDOW ANTI-PINCH SYSTEM)

Connector No.	D10
Connector Name	FRONT POWER WINDOW MOTOR (DRIVER SIDE)
Connector Type	NS30FW-CS

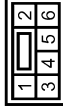

Terminal No.	Color of Wire	Signal Name [Specification]
1	G	-
2	L	-
3	O	-
4	B	-
5	P	-
6	LG	-

Connector No.	D9
Connector Name	POWER WINDOW MAIN SWITCH
Connector Type	NS30FW-CS



Terminal No.	Color of Wire	Signal Name [Specification]
17	B	-
19	Y	-

13	P
14	V
15	B

Connector No.	D8
Connector Name	POWER WINDOW MAIN SWITCH
Connector Type	NS16FW-CS



Terminal No.	Color of Wire	Signal Name [Specification]
1	W	-
2	LG	-
3	GR	-
4	V	-
5	O	-
6	Y	-
7	BR	-
8	L	-
9	O	-
10	SB	-
11	G	-

Connector No.	D10
Connector Name	FRONT POWER WINDOW MOTOR (PASSENGER SIDE)
Connector Type	NS30FW-CS

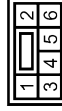

Terminal No.	Color of Wire	Signal Name [Specification]
1	G	-
2	L	-
3	O	-
4	B	-
5	P	-
6	LG	-

Connector No.	D38
Connector Name	FRONT POWER WINDOW SWITCH (PASSENGER SIDE)
Connector Type	NS16FW-CS

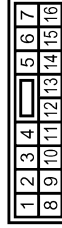

Terminal No.	Color of Wire	Signal Name [Specification]
3	LG	-
4	B	-
6	L	-
9	G	-
10	Y	-
11	B	-
12	P	-
15	O	-
16	V	-

Connector No.	D31
Connector Name	WIRE TO WIRE
Connector Type	TH40FW-CS15

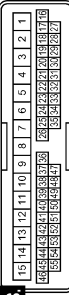

Terminal No.	Color of Wire	Signal Name [Specification]
13	B	-
14	V	-
15	Y	-

Connector No.	D15
Connector Name	FRONT DOOR LOCK ASSEMBLY (DRIVER SIDE)
Connector Type	E06FGY-RS



Terminal No.	Color of Wire	Signal Name [Specification]
4	B	-
5	Y	-
6	V	-

JCKWA1895GE

POWER WINDOW MAIN SWITCH

< ECU DIAGNOSIS INFORMATION >

[FRONT WINDOW ANTI-PINCH]

POWER WINDOW SYSTEM (WITH FRONT POWER WINDOW ANTI-PINCH SYSTEM)

Connector No.	D51
Connector Name	WIRE TO WIRE
Connector Type	TK (OMV-N5B)

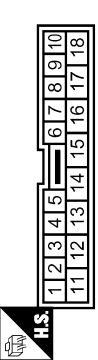

Terminal No.	Color of Wire	Signal Name [Specification]
11	V	-
12	R	-
13	Y	- [Without rear power window anti-pinch system]
18	B	-

Connector No.	D52
Connector Name	REAR POWER WINDOW MOTOR LH
Connector Type	RS08FG



Terminal No.	Color of Wire	Signal Name [Specification]
1	G	-
3	L	-

Connector No.	D54
Connector Name	REAR POWER WINDOW SWITCH LH (WITHOUT REAR ANTI-PINCH SYSTEM)
Connector Type	NS08FW-CS

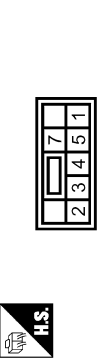

Terminal No.	Color of Wire	Signal Name [Specification]
1	Y	-
2	V	-
3	R	-
4	L	-
5	G	-
7	B	-

Connector No.	D71
Connector Name	WIRE TO WIRE
Connector Type	TK (OMV-N5B)

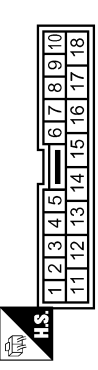

Terminal No.	Color of Wire	Signal Name [Specification]
11	V	-
12	R	-
13	W	-
18	B	-

Connector No.	D72
Connector Name	REAR POWER WINDOW MOTOR RH
Connector Type	RS08FG



Terminal No.	Color of Wire	Signal Name [Specification]
3	L	-

Connector No.	D74
Connector Name	REAR POWER WINDOW SWITCH RH (WITHOUT REAR ANTI-PINCH SYSTEM)
Connector Type	NS08FW-CS

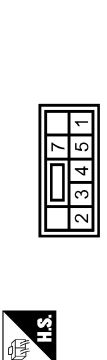

Terminal No.	Color of Wire	Signal Name [Specification]
1	W	-
2	V	-
3	R	-
4	L	-
5	G	-
7	B	-

Connector No.	E108
Connector Name	WIRE TO WIRE
Connector Type	TH08FW-CS (P-TM4)

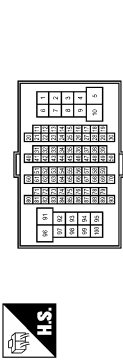

Terminal No.	Color of Wire	Signal Name [Specification]
91	W	-

Connector No.	M1
Connector Name	FUSE BLOCK (J/B)
Connector Type	NS08FW-M2

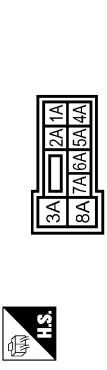

Terminal No.	Color of Wire	Signal Name [Specification]
7A	R	-

JCKWA1896GE

A
B
C
D
E
F
G
H
I
J
L
M
N
O
P

PWC

POWER WINDOW MAIN SWITCH

< ECU DIAGNOSIS INFORMATION >

[FRONT WINDOW ANTI-PINCH]

POWER WINDOW SYSTEM (WITH FRONT POWER WINDOW ANTI-PINCH SYSTEM)

Connector No.	M5
Connector Name	WIRE TO WIRE
Connector Type	TH80MW-CS15

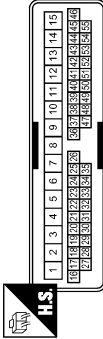

Terminal No.	Color of Wire	Signal Name [Specification]
2	G	-
3	W	-
4	LG	-
5	SB	-
8	O	-
13	B	-
14	V	-
15	Y	-

Connector No.	M6
Connector Name	WIRE TO WIRE
Connector Type	TH80MW-CS16-TM4

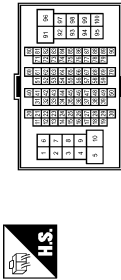

Terminal No.	Color of Wire	Signal Name [Specification]
9I	W	-

Connector No.	M7
Connector Name	WIRE TO WIRE
Connector Type	TH80MW-CS16-TM4

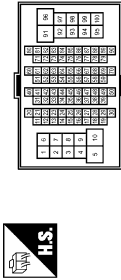

Terminal No.	Color of Wire	Signal Name [Specification]
5	Y	-
7	W	-
10	G	-
87	GR	-

Connector No.	M104
Connector Name	REMOTE KEYLESS ENTRY RECEIVER
Connector Type	JAB6AFB



Terminal No.	Color of Wire	Signal Name [Specification]
1	O	GND
2	Y	SIGNAL OUTPUT
4	L	BATTERY

Connector No.	M117
Connector Name	WIRE TO WIRE
Connector Type	TH80MW-CS16-TM4

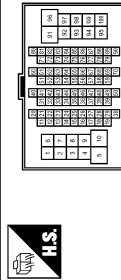

Terminal No.	Color of Wire	Signal Name [Specification]
2	LG	-
3	SB	-
8	W	-
97	LG	-

Connector No.	M118
Connector Name	BCM (BODY CONTROL MODULE)
Connector Type	MG3FB-LC



Terminal No.	Color of Wire	Signal Name [Specification]
1	W	BAT (F/L)
2	Y	POWER WINDOW POWER SUPPLY(BAT)
3	O	POWER WINDOW POWER SUPPLY(TRAP)

Connector No.	M119
Connector Name	BCM (BODY CONTROL MODULE)
Connector Type	NS16FW-CS

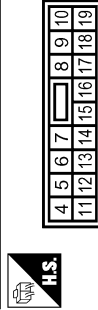

Terminal No.	Color of Wire	Signal Name [Specification]
11	R	BAT (FUSE)
13	B	GND

Connector No.	M122
Connector Name	BCM (BODY CONTROL MODULE)
Connector Type	TH46FB-NH

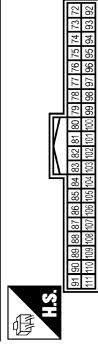

Terminal No.	Color of Wire	Signal Name [Specification]
83	Y	KEYLESS ENTRY RECEIVER COMM
103	L	KEYLESS ENTRY RECEIVER POWER SUPPLY

POWER WINDOW MAIN SWITCH

< ECU DIAGNOSIS INFORMATION >

[FRONT WINDOW ANTI-PINCH]

A
B
C
D
E
F
G
H
I
J
L
M
N
O
P

PWC

POWER WINDOW SYSTEM (WITH FRONT POWER WINDOW ANTI-PINCH SYSTEM)

Connector No.	M124
Connector Name	WIRE TO WIRE
Connector Type	TH40MW-CS15

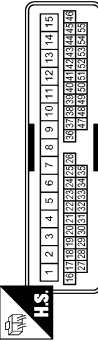

Terminal No.	Color of Wire	Signal Name (Specification)
13	B	-
14	G	-
15	W	-

Connector No.	M123
Connector Name	BCM (BODY CONTROL MODULE)
Connector Type	TH40FG-RH

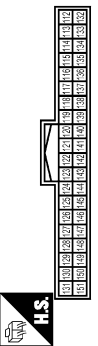

Terminal No.	Color of Wire	Signal Name (Specification)
124	LG	PASSENGER DOOR SW
132	V	POWER WINDOW SW COMM
137	O	RECEIVER/SENSOR GND
150	GR	DRIVER DOOR SW

Fail-safe

FAIL-SAFE CONTROL

Switches to fail-safe control when malfunction is detected in encoder signal that detects up/down speed and direction of door glass. Switches to fail-safe control when a signal that is out of the specified value is detected between the fully closed position and the actual position of the glass.

JCKWA1898GE

INFOID:000000004679446

POWER WINDOW MAIN SWITCH

< ECU DIAGNOSIS INFORMATION >

[FRONT WINDOW ANTI-PINCH]

Malfunction	Malfunction condition
Pulse sensor malfunction	When one pulse signal that is the specified value or more is detected continuously for the specified time or more, while door glass is being operated UP or DOWN.
Both pulse sensors malfunction	When both pulse signals are not detected continuously for the specified time or more, while door glass is being operated UP or DOWN.
Pulse direction malfunction	When a pulse signal indicating that window is moving in the opposite direction against the power window motor is detected for the specified value or more, while door glass is being operated UP or DOWN.
Glass recognition position malfunction 1	When the actual door glass position that is out of specified value is detected compared to the door glass fully closed position memorized in module, while door glass is being operated UP or DOWN.
Glass recognition position malfunction 2	When pulse count that is out of the door glass full stroke value or more is detected, while door glass is being operated UP or DOWN.

If fail-safe control, the system changes to a non-initialized condition and the following function do not operate.

- Auto-up operation
- Anti-pinch function
- Door key cylinder switch power window function

When fail-safe control is activated, perform initialization procedure to recover. If a malfunction is detected in power window switch or more, fail-safe control is activated again.

FRONT POWER WINDOW SWITCH

< ECU DIAGNOSIS INFORMATION >

[FRONT WINDOW ANTI-PINCH]

FRONT POWER WINDOW SWITCH

Reference Value

INFOID:000000004240736

TERMINAL LAYOUT

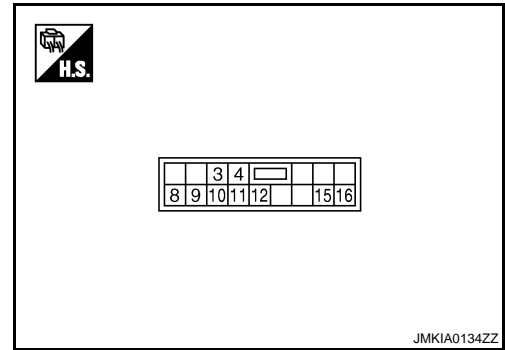

PHYSICAL VALUES

FRONT POWER WINDOW SWITCH

Terminal No. (wire color)		Description		Condition	Voltage (V) (Approx.)
+	-	Signal name	Input/ Output		
3 (LG)	Ground	Encoder ground	—	—	0
4 (B)	Ground	Encoder power supply	Output	When ignition switch ON or power window timer operates	Battery voltage
8 (L)	Ground	Power window motor DOWN signal	Output	When power window motor is DOWN at operated.	Battery voltage
9 (G)	Ground	Power window motor UP signal	Output	When power window motor is UP at operated.	Battery voltage
10 (Y)	Ground	Battery power supply	Input	—	Battery voltage
11 (B)	Ground	Ground	—	—	0
12 (P)	Ground	Encoder pulse signal 1	Input	When power window motor operates.	

PWC

JMKIA0070GB

FRONT POWER WINDOW SWITCH

< ECU DIAGNOSIS INFORMATION >

[FRONT WINDOW ANTI-PINCH]

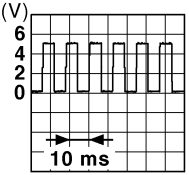
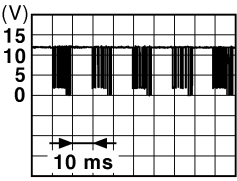
Terminal No. (wire color)		Description		Condition	Voltage (V) (Approx.)
+	-	Signal name	Input/ Output		
15 (O)	Ground	Encoder pulse signal 2	Input	When power window motor operates.	 <p style="text-align: right; font-size: small;">JMKIA0070GB</p>
16 (V)	Ground	Power window serial link	Input/ Output	Ignition switch ON or power window timer operating.	 <p style="text-align: right; font-size: small;">JPMIA0013GB</p>

FRONT POWER WINDOW SWITCH

[FRONT WINDOW ANTI-PINCH]

< ECU DIAGNOSIS INFORMATION >

Wiring Diagram - POWER WINDOW CONTROL SYSTEM -

INFOID:000000004704950

POWER WINDOW SYSTEM (WITH FRONT POWER WINDOW ANTI-PINCH SYSTEM)

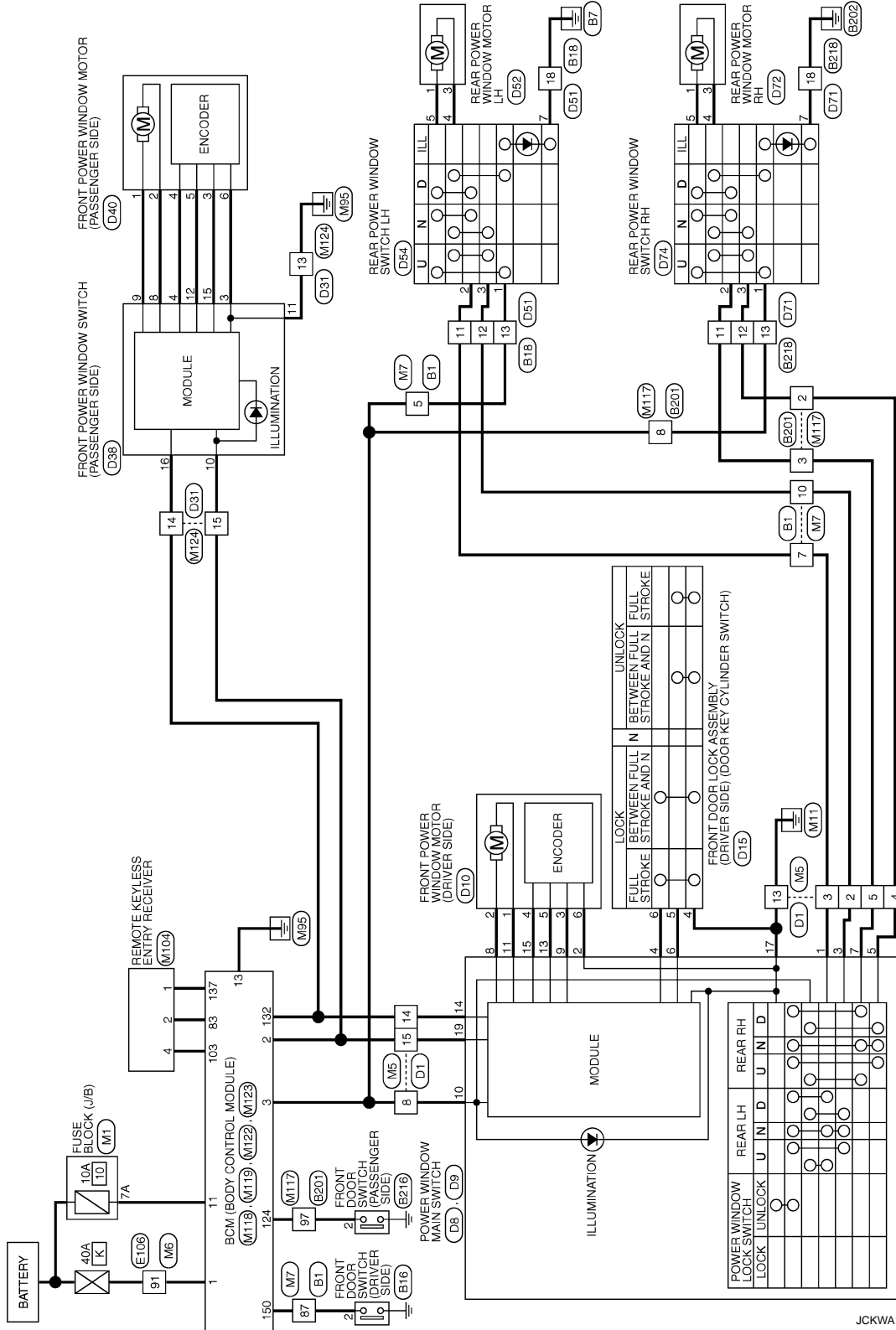

2008/08/07

JCKWA1893GE

A
B
C
D
E
F
G
H
I
J
K
L
M
N
O
P

PWC

FRONT POWER WINDOW SWITCH

< ECU DIAGNOSIS INFORMATION >

[FRONT WINDOW ANTI-PINCH]

POWER WINDOW SYSTEM (WITH FRONT POWER WINDOW ANTI-PINCH SYSTEM)

Connector No.	B1
Wire to Wire	WIRE TO WIRE
Connector Type	TH40PW-CS16-TM4



Terminal No.	Color of Wire	Signal Name [Specification]
5	W	-
7	P	-
10	GR	-
87	B	-

Connector No.	B16
Wire to Wire	FRONT DOOR SWITCH (DRIVER SIDE)
Connector Type	A03FW

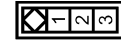

Terminal No.	Color of Wire	Signal Name [Specification]
2	B	-

Connector No.	B18
Wire to Wire	WIRE TO WIRE
Connector Type	TK10PW-NS8

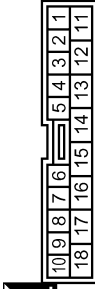

Terminal No.	Color of Wire	Signal Name [Specification]
11	P	-
12	GR	- [Without rear power window anti-pinch system]
13	W	-
18	B	-

Connector No.	B201
Wire to Wire	WIRE TO WIRE
Connector Type	TH40PW-CS16-TM4



Terminal No.	Color of Wire	Signal Name [Specification]
2	R	-
3	W	-
8	BR	-
97	GR	-

Connector No.	B216
Wire to Wire	FRONT DOOR SWITCH (PASSENGER SIDE)
Connector Type	A03FW

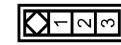

Terminal No.	Color of Wire	Signal Name [Specification]
2	GR	-

Connector No.	B218
Wire to Wire	WIRE TO WIRE
Connector Type	TK10PW-NS8

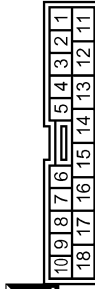

Terminal No.	Color of Wire	Signal Name [Specification]
11	W	-
12	R	- [Without rear power window anti-pinch system]
13	BR	- [Without rear power window anti-pinch system]
18	B	-

Connector No.	D1
Wire to Wire	WIRE TO WIRE
Connector Type	TH40PW-CS15

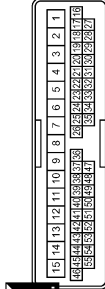

Terminal No.	Color of Wire	Signal Name [Specification]
2	GR	-
3	W	-
4	O	-
5	BR	-
6	SB	-
13	B	-
14	V	-
15	Y	-

FRONT POWER WINDOW SWITCH

< ECU DIAGNOSIS INFORMATION >

[FRONT WINDOW ANTI-PINCH]

POWER WINDOW SYSTEM (WITH FRONT POWER WINDOW ANTI-PINCH SYSTEM)

13	P	-
14	V	-
15	B	-

Connector No.	D8
Connector Name	POWER WINDOW MAIN SWITCH
Connector Type	NS16FW-CS



Terminal No.	Color of Wire	Signal Name [Specification]
1	W	-
2	LG	-
3	GR	-
4	V	-
5	O	-
6	Y	-
7	BR	-
8	L	-
9	O	-
10	SB	-
11	G	-

Connector No.	D9
Connector Name	POWER WINDOW MAIN SWITCH
Connector Type	NS33FW-CS



Terminal No.	Color of Wire	Signal Name [Specification]
17	B	-
19	Y	-

Connector No.	D10
Connector Name	FRONT POWER WINDOW MOTOR (DRIVER SIDE)
Connector Type	NS36FW-CS

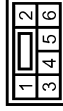

Terminal No.	Color of Wire	Signal Name [Specification]
1	G	-
2	L	-
3	O	-
4	B	-
5	P	-
6	LG	-

Connector No.	D31
Connector Name	WIRE TO WIRE
Connector Type	TH40FW-CS15



Terminal No.	Color of Wire	Signal Name [Specification]
13	B	-
14	V	-
15	Y	-

Connector No.	D38
Connector Name	FRONT POWER WINDOW SWITCH (PASSENGER SIDE)
Connector Type	NS16FW-CS



Terminal No.	Color of Wire	Signal Name [Specification]
3	LG	-
4	B	-
6	L	-
8	G	-
9	Y	-
10	B	-
11	P	-
12	O	-
15	O	-
16	V	-

Connector No.	D15
Connector Name	FRONT DOOR LOCK ASSEMBLY (DRIVER SIDE)
Connector Type	E08FY-RS



Terminal No.	Color of Wire	Signal Name [Specification]
4	B	-
5	Y	-
6	V	-

Connector No.	D10
Connector Name	FRONT POWER WINDOW MOTOR (PASSENGER SIDE)
Connector Type	NS36FW-CS



Terminal No.	Color of Wire	Signal Name [Specification]
1	G	-
2	L	-
3	O	-
4	B	-
5	P	-
6	LG	-

A
B
C
D
E
F
G
H
I
J
L
M
N
O
P

PWC

JCKWA1895GE

FRONT POWER WINDOW SWITCH

< ECU DIAGNOSIS INFORMATION >

[FRONT WINDOW ANTI-PINCH]

POWER WINDOW SYSTEM (WITH FRONT POWER WINDOW ANTI-PINCH SYSTEM)

Connector No.	D51
Connector Name	WIRE TO WIRE
Connector Type	TK(OMV-NS8)



Terminal No.	Color of Wire	Signal Name [Specification]
11	V	-
12	R	-
13	Y	- [Without rear power window anti-pinch system]
18	B	-

Connector No.	D52
Connector Name	REAR POWER WINDOW MOTOR LH
Connector Type	RS08FG



Terminal No.	Color of Wire	Signal Name [Specification]
1	G	-
3	L	-

Connector No.	D54
Connector Name	REAR POWER WINDOW SWITCH LH (WITHOUT REAR ANTI-PINCH SYSTEM)
Connector Type	NS308FW-CS



Terminal No.	Color of Wire	Signal Name [Specification]
1	Y	-
2	V	-
3	R	-
4	L	-
5	G	-
7	B	-

Connector No.	D71
Connector Name	WIRE TO WIRE
Connector Type	TK(OMV-NS8)



Terminal No.	Color of Wire	Signal Name [Specification]
11	V	-
12	R	-
13	W	-
18	B	-

Connector No.	D72
Connector Name	REAR POWER WINDOW MOTOR RH
Connector Type	RS08FG



Terminal No.	Color of Wire	Signal Name [Specification]
1	G	-
3	L	-

Connector No.	D74
Connector Name	REAR POWER WINDOW SWITCH RH (WITHOUT REAR ANTI-PINCH SYSTEM)
Connector Type	NS308PW-CS

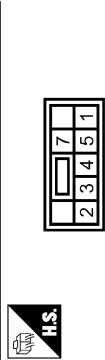

Terminal No.	Color of Wire	Signal Name [Specification]
1	W	-
2	V	-
3	R	-
4	L	-
5	G	-
7	B	-

Connector No.	E106
Connector Name	WIRE TO WIRE
Connector Type	TH80PW-CS (P-TM4)

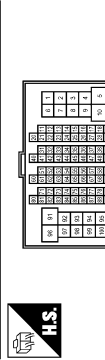

Terminal No.	Color of Wire	Signal Name [Specification]
91	W	-

Connector No.	M1
Connector Name	FUSE BLOCK (J/B)
Connector Type	NS308PW-M2

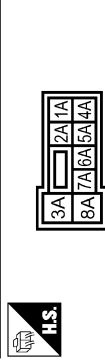

Terminal No.	Color of Wire	Signal Name [Specification]
7A	R	-

JCKWA1896GE

FRONT POWER WINDOW SWITCH

< ECU DIAGNOSIS INFORMATION >

[FRONT WINDOW ANTI-PINCH]

POWER WINDOW SYSTEM (WITH FRONT POWER WINDOW ANTI-PINCH SYSTEM)

Connector No.	M124
Connector Name	WIRE TO WIRE
Connector Type	TH40MW-C515

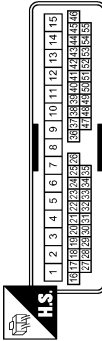

Terminal No.	Color of Wire	Signal Name [Specification]
13	B	
14	G	
15	W	

Connector No.	M123
Connector Name	ECM (BODY CONTROL MODULE)
Connector Type	TH40FG-RH

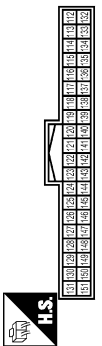

Terminal No.	Color of Wire	Signal Name [Specification]
124	LG	PASSENGER DOOR SW
132	V	POWER WINDOW SW COMM
137	O	RECEIVER/SENSOR GND
150	GR	DRIVER DOOR SW

Fail-safe

JCKWA1898GE

INFOID:000000004679447

FAIL-SAFE CONTROL

Switches to fail-safe control when malfunction is detected in encoder signal that detects up/down speed and direction of door glass. Switches to fail-safe control when a signal that is out of the specified value is detected between the fully closed position and the actual position of the glass.

FRONT POWER WINDOW SWITCH

< ECU DIAGNOSIS INFORMATION >

[FRONT WINDOW ANTI-PINCH]

Malfunction	Malfunction condition
Pulse sensor malfunction	When one pulse signal that is the specified value or more is detected continuously for the specified time or more, while door glass is being operated UP or DOWN.
Both pulse sensors malfunction	When both pulse signals are not detected continuously for the specified time or more, while door glass is being operated UP or DOWN.
Pulse direction malfunction	When a pulse signal indicating that window is moving in the opposite direction against the power window motor is detected for the specified value or more, while door glass is being operated UP or DOWN.
Glass recognition position malfunction 1	When the actual door glass position that is out of specified value is detected compared to the door glass fully closed position memorized in module, while door glass is being operated UP or DOWN.
Glass recognition position malfunction 2	When pulse count that is out of the door glass full stroke value or more is detected, while door glass is being operated UP or DOWN.

If fail-safe control, the system changes to a non-initialized condition and the following function do not operate.

- Auto-up operation
- Anti-pinch function
- Door key cylinder switch power window function

When fail-safe control is activated, perform initialization procedure to recover. If a malfunction is detected in power window switch or more, fail-safe control is activated again.

A
B
C
D
E
F
G
H
I
J
L
M
N
O
P

PWC

POWER WINDOWS DO NOT OPERATE WITH ANY POWER WINDOW SWITCHES

< SYMPTOM DIAGNOSIS >

[FRONT WINDOW ANTI-PINCH]

SYMPTOM DIAGNOSIS

POWER WINDOWS DO NOT OPERATE WITH ANY POWER WINDOW SWITCHES

Diagnosis Procedure

INFOID:000000004240739

1. CHECK BCM POWER SUPPLY AND GROUND CIRCUIT

Check BCM power supply and ground circuit.
Refer to [PWC-16, "BCM : Diagnosis Procedure"](#).

Is the inspection result normal?

- YES >> GO TO 2.
- NO >> Repair or replace the malfunctioning parts.

2. CONFIRM THE OPERATION

Confirm the operation again.

Is the result normal?

- YES >> Check intermittent incident. Refer to [GI-41, "Intermittent Incident"](#).
- NO >> GO TO 1.

DRIVER SIDE POWER WINDOW ALONE DOES NOT OPERATE

< SYMPTOM DIAGNOSIS >

[FRONT WINDOW ANTI-PINCH]

DRIVER SIDE POWER WINDOW ALONE DOES NOT OPERATE

Diagnosis Procedure

INFOID:000000004240740

1. CHECK POWER WINDOW MAIN SWITCH POWER SUPPLY AND GROUND CIRCUIT

Check power window switch power supply and ground circuit.

Refer to [PWC-127, "POWER WINDOW MAIN SWITCH : Diagnosis Procedure"](#).

Is the inspection result normal?

YES >> GO TO 2.

NO >> Repair or replace the malfunctioning parts.

2. CHECK DRIVER SIDE POWER WINDOW MOTOR

Check driver side power window motor.

Refer to [PWC-133, "DRIVER SIDE : Component Function Check"](#).

Is the measurement value within the specification?

YES >> GO TO 3.

NO >> Repair or replace the malfunctioning parts.

3. CONFIRM THE OPERATION

Confirm the operation again.

Is the result normal?

YES >> Check intermittent incident. Refer to [GI-41, "Intermittent Incident"](#).

NO >> GO TO 1.

A
B
C
D
E
F
G
H
I
J
L
M
N
O
P

PWC

FRONT PASSENGER SIDE POWER WINDOW DOES NOT OPERATE

< SYMPTOM DIAGNOSIS >

[FRONT WINDOW ANTI-PINCH]

FRONT PASSENGER SIDE POWER WINDOW DOES NOT OPERATE WHEN POWER WINDOW MAIN SWITCH IS OPERATED

WHEN POWER WINDOW MAIN SWITCH IS OPERATED : Diagnosis Procedure

INFOID:000000004240741

1. CHECK FRONT POWER WINDOW SWITCH (PASSENGER SIDE) SERIAL LINK CIRCUIT

Check front power window switch (passenger side) serial link circuit.

Refer to [PWC-146, "FRONT POWER WINDOW SWITCH \(PASSENGER SIDE\) : Component Function Check"](#).

Is the inspection result normal?

YES >> GO TO 2.

NO >> Repair or replace the malfunctioning parts.

2. CONFIRM THE OPERATION

Confirm the operation again.

Is the result normal?

YES >> Check intermittent incident. Refer to [GI-41, "Intermittent Incident"](#).

NO >> GO TO 1.

WHEN FRONT POWER WINDOW SWITCH (PASSENGER SIDE) IS OPERATED

WHEN FRONT POWER WINDOW SWITCH (PASSENGER SIDE) IS OPERATED :
Diagnosis Procedure

INFOID:000000004240742

1. REPLACE FRONT POWER WINDOW SWITCH (PASSENGER SIDE)

Replace front power window switch (passenger side).

Refer to [PWC-216, "Removal and Installation"](#)

>> INSPECTION END

WHEN BOTH POWER WINDOW MAIN SWITCH AND FRONT POWER WINDOW SWITCH ARE OPERATED

WHEN BOTH POWER WINDOW MAIN SWITCH AND FRONT POWER WINDOW
SWITCH ARE OPERATED : Diagnosis Procedure

INFOID:000000004240743

1. CHECK FRONT POWER WINDOW SWITCH (PASSENGER SIDE) POWER SUPPLY AND GROUND CIR- CUIT

Check front power window switch (passenger side) power supply and ground circuit.

Refer to [PWC-128, "FRONT POWER WINDOW SWITCH \(PASSENGER SIDE\) : Diagnosis Procedure"](#).

Is the inspection result normal?

YES >> GO TO 2.

NO >> Repair or replace the malfunctioning parts.

2. CHECK PASSENGER SIDE POWER WINDOW MOTOR CIRCUIT

Check passenger side power window motor circuit.

Refer to [PWC-134, "PASSENGER SIDE : Component Function Check"](#).

Is the inspection result normal?

YES >> GO TO 3.

NO >> Repair or replace the malfunctioning parts.

3. CONFIRM THE OPERATION

Confirm the operation again.

Is the result normal?

YES >> Check intermittent incident. Refer to [GI-41, "Intermittent Incident"](#).

FRONT PASSENGER SIDE POWER WINDOW DOES NOT OPERATE

< SYMPTOM DIAGNOSIS >

[FRONT WINDOW ANTI-PINCH]

NO >> GO TO 1.

A

B

C

D

E

F

G

H

I

J

PWC

L

M

N

O

P

REAR LH SIDE POWER WINDOW ALONE DOES NOT OPERATE

< SYMPTOM DIAGNOSIS >

[FRONT WINDOW ANTI-PINCH]

REAR LH SIDE POWER WINDOW ALONE DOES NOT OPERATE WHEN POWER WINDOW MAIN SWITCH IS OPERATED

WHEN POWER WINDOW MAIN SWITCH IS OPERATED : Diagnosis Procedure

INFOID:000000004240744

1.CHECK REAR POWER WINDOW SWITCH

Check rear power window switch .

Refer to [PWC-131, "Component Function Check"](#).

Is the inspection result normal?

YES >> GO TO 2.

NO >> Repair or replace the malfunctioning parts.

2.CONFIRM THE OPERATION

Confirm the operation again.

Is the result normal?

YES >> Check intermittent incident. Refer to [GI-41, "Intermittent Incident"](#).

NO >> GO TO 1.

WHEN REAR POWER WINDOW SWITCH LH IS OPERATED

WHEN REAR POWER WINDOW SWITCH LH IS OPERATED : Diagnosis Procedure

INFOID:000000004240745

1.CHECK REAR POWER WINDOW SWITCH POWER SUPPLY AND GROUND CIRCUIT

Check rear power window switch power supply and ground circuit.

Refer to [PWC-129, "REAR POWER WINDOW SWITCH : Diagnosis Procedure"](#).

Is the inspection result normal?

YES >> GO TO 2.

NO >> Repair or replace the malfunctioning parts.

2.REPLACE REAR POWER WINDOW SWITCH LH

Replace rear power window switch LH.

Refer to [PWC-216, "Removal and Installation"](#).

>> INSPECTION END

WHEN BOTH POWER WINDOW MAIN SWITCH AND REAR POWER WINDOW SWITCH LH ARE OPERATED

WHEN BOTH POWER WINDOW MAIN SWITCH AND REAR POWER WINDOW
SWITCH LH ARE OPERATED : Diagnosis Procedure

INFOID:000000004240746

1.CHECK REAR POWER WINDOW MOTOR LH

Check rear power window motor LH.

Refer to [PWC-136, "REAR LH : Component Function Check"](#).

Is the inspection result normal?

YES >> GO TO 2.

NO >> Repair or replace the malfunctioning parts.

2.CONFIRM THE OPERATION

Confirm the operation again.

Is the result normal?

YES >> Check intermittent incident. Refer to [GI-41, "Intermittent Incident"](#).

NO >> GO TO 1.

REAR RH SIDE POWER WINDOW ALONE DOES NOT OPERATE

< SYMPTOM DIAGNOSIS >

[FRONT WINDOW ANTI-PINCH]

REAR RH SIDE POWER WINDOW ALONE DOES NOT OPERATE WHEN POWER WINDOW MAIN SWITCH IS OPERATED

WHEN POWER WINDOW MAIN SWITCH IS OPERATED : Diagnosis Procedure

INFOID:000000004240747

1. CHECK REAR POWER WINDOW SWITCH

Check rear power window switch .

Refer to [PWC-131, "Component Function Check"](#).

Is the inspection result normal?

YES >> GO TO 2.

NO >> Repair or replace the malfunctioning parts.

2. CONFIRM THE OPERATION

Confirm the operation again.

Is the result normal?

YES >> Check intermittent incident. Refer to [GI-41, "Intermittent Incident"](#).

NO >> GO TO 1.

WHEN REAR POWER WINDOW SWITCH RH IS OPERATED

WHEN REAR POWER WINDOW SWITCH RH IS OPERATED : Diagnosis Procedure

INFOID:000000004240748

1. CHECK REAR POWER WINDOW SWITCH POWER SUPPLY AND GROUND CIRCUIT

Check rear power window switch power supply and ground circuit.

Refer to [PWC-129, "REAR POWER WINDOW SWITCH : Diagnosis Procedure"](#).

Is the inspection result normal?

YES >> GO TO 2.

NO >> Repair or replace the malfunctioning parts.

2. REPLACE REAR POWER WINDOW SWITCH RH

Replace rear power window switch RH.

Refer to [PWC-216, "Removal and Installation"](#).

>> INSPECTION END

WHEN BOTH POWER WINDOW MAIN SWITCH AND REAR POWER WINDOW SWITCH RH ARE OPERATED

WHEN BOTH POWER WINDOW MAIN SWITCH AND REAR POWER WINDOW
SWITCH RH ARE OPERATED : Diagnosis Procedure

INFOID:000000004240749

1. CHECK REAR POWER WINDOW MOTOR RH

Check rear power window motor RH.

Refer to [PWC-137, "REAR RH : Component Function Check"](#).

Is the inspection result normal?

YES >> GO TO 2.

NO >> Repair or replace the malfunctioning parts.

2. CONFIRM THE OPERATION

Confirm the operation again.

Is the result normal?

YES >> Check intermittent incident. Refer to [GI-41, "Intermittent Incident"](#).

NO >> GO TO 1.

A
B
C
D
E
F
G
H
I
J
L
M
N
O
P

PWC

ANTI-PINCH FUNCTION DOES NOT OPERATE NORMALLY

< SYMPTOM DIAGNOSIS >

[FRONT WINDOW ANTI-PINCH]

ANTI-PINCH FUNCTION DOES NOT OPERATE NORMALLY

DRIVER SIDE

DRIVER SIDE : Diagnosis Procedure

INFOID:000000004240750

1.CHECK POWER WINDOW AUTO OPERATION

Check power window auto operation.

Is the inspection result normal?

YES >> GO TO 2.

NO >> Refer to [PWC-209, "DRIVER SIDE : Diagnosis Procedure"](#).

2.CONFIRM THE OPERATION

Confirm the operation again.

Is the result normal?

YES >> Check intermittent incident. Refer to [GI-41, "Intermittent Incident"](#).

NO >> GO TO 1.

PASSENGER SIDE

PASSENGER SIDE : Diagnosis Procedure

INFOID:000000004240751

1.CHECK POWER WINDOW AUTO OPERATION

Check power window auto operation.

Is the inspection result normal?

YES >> GO TO 2.

NO >> Refer to [PWC-209, "PASSENGER SIDE : Diagnosis Procedure"](#).

2.CONFIRM THE OPERATION

Confirm the operation again.

Is the result normal?

YES >> Check intermittent incident. Refer to [GI-41, "Intermittent Incident"](#).

NO >> GO TO 1.

AUTO OPERATION DOES NOT OPERATE BUT MANUAL OPERATES NORMALLY

< SYMPTOM DIAGNOSIS >

[FRONT WINDOW ANTI-PINCH]

AUTO OPERATION DOES NOT OPERATE BUT MANUAL OPERATES NORMALLY DRIVER SIDE

DRIVER SIDE : Diagnosis Procedure

INFOID:000000004240752

1.PERFORM INITIALIZATION PROCEDURE

Initialization procedure is executed and operation is confirmed.

Refer to [PWC-119, "ADDITIONAL SERVICE WHEN REMOVING BATTERY NEGATIVE TERMINAL : Special Repair Requirement"](#).

Is the inspection result normal?

- YES >> INSPECTION END
- NO >> GO TO 2.

2.CHECK ENCODER (DRIVER SIDE) CIRCUIT

Check encoder (driver side) circuit.

Refer to [PWC-140, "DRIVER SIDE : Component Function Check"](#).

Is the inspection result normal?

- YES >> GO TO 3.
- NO >> Repair or replace the malfunctioning parts.

3.CONFIRM THE OPERATION

Confirm the operation again.

Is the result normal?

- YES >> Check intermittent incident. Refer to [GI-41, "Intermittent Incident"](#).
- NO >> GO TO 1.

PASSENGER SIDE

PASSENGER SIDE : Diagnosis Procedure

INFOID:000000004240753

1.PERFORM INITIALIZAITON PROCEDURE

Initialization procedure is executed and operation is confirmed.

Refer to [PWC-119, "ADDITIONAL SERVICE WHEN REMOVING BATTERY NEGATIVE TERMINAL : Special Repair Requirement"](#).

Is the inspection result normal?

- YES >> INSPECTION END
- NO >> GO TO 2.

2.CHECK ENCODER (PASSENGER SIDE) CIRCUIT

Check encoder (passenger side) circuit.

Refer to [PWC-142, "PASSENGER SIDE : Component Function Check"](#).

Is the inspection result normal?

- YES >> GO TO 3.
- NO >> Repair or replace the malfunctioning parts.

3.CONFIRM THE OPERATION

Confirm the operation again.

Is the result normal?

- YES >> Check intermittent incident. Refer to [GI-41, "Intermittent Incident"](#).
- NO >> GO TO 1.

A
B
C
D
E
F
G
H
I
J
L
M
N
O
P

PWC

POWER WINDOW RETAINED POWER FUNCTION DOES NOT OPERATE NORMALLY

< SYMPTOM DIAGNOSIS >

[FRONT WINDOW ANTI-PINCH]

POWER WINDOW RETAINED POWER FUNCTION DOES NOT OPERATE NORMALLY

Diagnosis Procedure

INFOID:000000004240754

1.CHECK DOOR SWITCH

Check door switch.

Refer to [DLK-66, "Component Function Check"](#).

Is the inspection result normal?

YES >> GO TO 2.

NO >> Repair or replace the malfunctioning parts.

2.CONFIRM THE OPERATION

Confirm the operation again.

Is the result normal?

YES >> Check intermittent incident. Refer to [GI-41, "Intermittent Incident"](#).

NO >> GO TO 1.

DOOR KEY CYLINDER SWITCH DOES NOT OPERATE POWER WINDOWS

< SYMPTOM DIAGNOSIS >

[FRONT WINDOW ANTI-PINCH]

DOOR KEY CYLINDER SWITCH DOES NOT OPERATE POWER WINDOWS

Diagnosis Procedure

INFOID:000000004240755

1.PERFORM INITIALIZATION PROCEDURE

Initialization procedure is executed and operation is confirmed.

Refer to [PWC-119. "ADDITIONAL SERVICE WHEN REMOVING BATTERY NEGATIVE TERMINAL : Special Repair Requirement"](#) .

Is the inspection result normal?

YES >> INSPECTION END
NO >> GO TO 2.

2.CHECK DRIVER SIDE DOOR LOCK ASSEMBLY (DOOR KEY CYLINDER SWITCH)

Check driver side door lock assembly (door key cylinder switch).

Refer to [DLK-80. "Component Function Check"](#).

Is the inspection result normal?

YES >> GO TO 3.
NO >> Repair or replace the malfunctioning parts.

3.CONFIRM THE OPERATION

Confirm the operation again.

Is the result normal?

YES >> Check intermittent incident. Refer to [GI-41. "Intermittent Incident"](#).
NO >> GO TO 1.

A
B
C
D
E
F
G
H
I
J
L
M
N
O
P

PWC

KEYLESS POWER WINDOW DOWN DOES NOT OPERATE

< SYMPTOM DIAGNOSIS >

[FRONT WINDOW ANTI-PINCH]

KEYLESS POWER WINDOW DOWN DOES NOT OPERATE

Description

INFOID:000000004596780

Power window down does not operate when pressing unlock button on Intelligent Key.

Diagnosis Procedure

INFOID:000000004596781

1. CHECK REMOTE KEYLESS ENTRY FUNCTION

Check remote keyless entry function.

Does door lock/unlock with Intelligent Key button?

YES >> GO TO 2.

NO >> Refer to [DLK-181, "Description"](#).

2. CHECK POWER WINDOW OPERATION

Check power window operation.

Does power window operate up/down using power window main switch?

YES >> GO TO 3.

NO >> Refer to [PWC-203, "Diagnosis Procedure"](#).

3. CHECK "PW DOWN SET" SETTING IN "WORK SUPPORT"

Check "PW DOWN SET" setting in "WORK SUPPORT".

Refer to [DLK-52, "INTELLIGENT KEY : CONSULT-III Function \(BCM - INTELLIGENT KEY\)"](#).

Is the inspection result normal?

YES >> GO TO 4.

NO >> Set "PW DOWN SET" setting in "WORK SUPPORT".

4. CONFIRM THE OPERATION

Confirm the operation again.

Is the result normal?

YES >> Check intermittent incident. Refer to [GI-41, "Intermittent Incident"](#).

NO >> GO TO 1.

POWER WINDOW LOCK SWITCH DOES NOT FUNCTION

< SYMPTOM DIAGNOSIS >

[FRONT WINDOW ANTI-PINCH]

POWER WINDOW LOCK SWITCH DOES NOT FUNCTION

Diagnosis Procedure

INFOID:000000004240756

1. REPLACE POWER WINDOW MAIN SWITCH

Replace power window main switch.

>> Refer to [PWC-216. "Removal and Installation"](#).

A
B
C
D
E
F
G
H
I
J
L
M
N
O
P

PWC

POWER WINDOW SWITCH ILLUMINATION DOES NOT ILLUMINATE

< SYMPTOM DIAGNOSIS >

[FRONT WINDOW ANTI-PINCH]

POWER WINDOW SWITCH ILLUMINATION DOES NOT ILLUMINATE DRIVER SIDE

DRIVER SIDE : Diagnosis Procedure

INFOID:000000004240757

1. REPLACE POWER WINDOW MAIN SWITCH

Replace power window main switch.
Refer to [PWC-216. "Removal and Installation"](#).

>> INSPECTION END

PASSENGER SIDE

PASSENGER SIDE : Diagnosis Procedure

INFOID:000000004240758

1. REPLACE FRONT POWER WINDOW SWITCH (PASSENGER SIDE)

Replace front power window switch (passenger side).
Refer to [PWC-216. "Removal and Installation"](#).

>> INSPECTION END

REAR LH

REAR LH : Diagnosis Procedure

INFOID:000000004240759

1. CHECK REAR POWER WINDOW SWITCH POWER SUPPLY AND GROUND CIRCUIT

Check rear power window switch power supply and ground circuit.
Refer to [PWC-129. "REAR POWER WINDOW SWITCH : Diagnosis Procedure"](#).

Is the inspection result normal?

- YES >> GO TO 2.
- NO >> Repair or replace harness.

2. REPLACE REAR POWER WINDOW SWITCH LH

Replace rear power window switch LH.
Refer to [PWC-216. "Removal and Installation"](#).

>> INSPECTION END

REAR RH

REAR RH : Diagnosis Procedure

INFOID:000000004240760

1. CHECK REAR POWER WINDOW SWITCH POWER SUPPLY AND GROUND CIRCUIT

Check rear power window switch power supply and ground circuit.
Refer to [PWC-129. "REAR POWER WINDOW SWITCH : Diagnosis Procedure"](#).

Is the inspection result normal?

- YES >> GO TO 2.
- NO >> Repair or replace harness.

2. REPLACE REAR POWER WINDOW SWITCH RH

Replace rear power window switch RH.
Refer to [PWC-216. "Removal and Installation"](#).

>> INSPECTION END

PRECAUTION

PRECAUTIONS

Precaution for Supplemental Restraint System (SRS) "AIR BAG" and "SEAT BELT PRE-TENSIONER"

INFOID:000000004240761

The Supplemental Restraint System such as "AIR BAG" and "SEAT BELT PRE-TENSIONER", used along with a front seat belt, helps to reduce the risk or severity of injury to the driver and front passenger for certain types of collision. This system includes seat belt switch inputs and dual stage front air bag modules. The SRS system uses the seat belt switches to determine the front air bag deployment, and may only deploy one front air bag, depending on the severity of a collision and whether the front occupants are belted or unbelted. Information necessary to service the system safely is included in the "SRS AIR BAG" and "SEAT BELT" of this Service Manual.

WARNING:

- To avoid rendering the SRS inoperative, which could increase the risk of personal injury or death in the event of a collision which would result in air bag inflation, all maintenance must be performed by an authorized NISSAN/INFINITI dealer.
- Improper maintenance, including incorrect removal and installation of the SRS, can lead to personal injury caused by unintentional activation of the system. For removal of Spiral Cable and Air Bag Module, see the "SRS AIR BAG".
- Do not use electrical test equipment on any circuit related to the SRS unless instructed to in this Service Manual. SRS wiring harnesses can be identified by yellow and/or orange harnesses or harness connectors.

PRECAUTIONS WHEN USING POWER TOOLS (AIR OR ELECTRIC) AND HAMMERS

WARNING:

- When working near the Air Bag Diagnosis Sensor Unit or other Air Bag System sensors with the ignition ON or engine running, DO NOT use air or electric power tools or strike near the sensor(s) with a hammer. Heavy vibration could activate the sensor(s) and deploy the air bag(s), possibly causing serious injury.
- When using air or electric power tools or hammers, always switch the ignition OFF, disconnect the battery, and wait at least 3 minutes before performing any service.

A
B
C
D
E
F
G
H
I
J
L
M
N
O
P

PWC

POWER WINDOW MAIN SWITCH

< REMOVAL AND INSTALLATION >

[FRONT WINDOW ANTI-PINCH]

REMOVAL AND INSTALLATION

POWER WINDOW MAIN SWITCH

Removal and Installation

INFOID:000000004240762

REMOVAL

1. Remove the power window main switch finisher (2).
Refer to [INT-11, "Removal and Installation"](#).
2. Power window main switch (1) is removed from power window main switch finisher (2) using flat-head screw driver (A) etc.

 : Pawl

CAUTION:

Do not fold the pawl of power window main switch finisher.

NOTE:

The same procedure is also performed for front power window switch (passenger side) and rear power window switch (LH & RH).

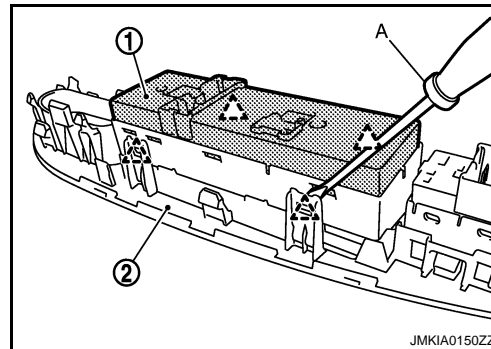

INSTALLATION

Install in the reverse order of removal.

NOTE:

Power window main switch is exchanged or is detached it is necessary to do the initialization procedure. Refer to [PWC-120, "ADDITIONAL SERVICE WHEN REPLACING CONTROL UNIT : Special Repair Requirement"](#).