

WT

SECTION

ROAD WHEELS & TIRES

A
B
C
D

WT

CONTENTS

BASIC INSPECTION	4	DTC Logic	17	F
DIAGNOSIS AND REPAIR WORK FLOW	4	Diagnosis Procedure	17	
Repair Work Flow	4	Special Repair Requirement	18	
INSPECTION AND ADJUSTMENT	6	C1708, C1709, C1710, C1711 TRANSMITTER	...19	G
TRANSMITTER WAKE UP OPERATION	6	Description	19	
TRANSMITTER WAKE UP OPERATION : De-		DTC Logic	19	H
scription	6	Diagnosis Procedure	19	
TRANSMITTER WAKE UP OPERATION : Spe-		Special Repair Requirement	20	
cial Repair Requirement	6	C1712, C1713, C1714, C1715 TRANSMITTER	...21	I
ID REGISTRATION PROCEDURE	6	Description	21	
ID REGISTRATION PROCEDURE : Description.....	6	DTC Logic	21	J
ID REGISTRATION PROCEDURE : Special Re-		Diagnosis Procedure	21	
pair Requirement	6	Special Repair Requirement	23	
SYSTEM DESCRIPTION	9	C1716, C1717, C1718, C1719 TRANSMITTER	...24	K
TPMS	9	Description	24	
System Diagram	9	DTC Logic	24	L
System Description	9	Diagnosis Procedure	24	
Component Parts Location	10	Component Inspection	25	
Component Description	10	Special Repair Requirement	25	M
DIAGNOSIS SYSTEM (BCM)	12	C1720, C1721, C1722, C1723 TRANSMITTER	...26	N
COMMON ITEM	12	Description	26	
COMMON ITEM : CONSULT-III Function (BCM -		DTC Logic	26	
COMMON ITEM)	12	Diagnosis Procedure	26	O
AIR PRESSURE MONITOR	13	Special Repair Requirement	28	
AIR PRESSURE MONITOR : Diagnosis Descrip-		C1724, C1725, C1726, C1727 TRANSMITTER	...29	P
tion	13	Description	29	
AIR PRESSURE MONITOR : CONSULT-III Func-		DTC Logic	29	
tion (BCM - AIR PRESSURE MONITOR)	15	Diagnosis Procedure	29	
DTC/CIRCUIT DIAGNOSIS	17	Special Repair Requirement	30	
C1704, C1705, C1706, C1707 LOW TIRE		C1729 VEHICLE SPEED SIGNAL	32	
PRESSURE	17			
Description	17			

Description	32	Description	86
DTC Logic	32	Diagnosis Procedure	86
Diagnosis Procedure	32		
Special Repair Requirement	32		
C1734 BCM	33	LOW TIRE PRESSURE WARNING LAMP	
Description	33	BLINKS	88
DTC Logic	33	Description	88
Diagnosis Procedure	33	Diagnosis Procedure	88
Special Repair Requirement	34		
TIRE PRESSURE RECEIVER	35	TURN SIGNAL LAMP BLINKS	90
Description	35	Description	90
Component Function Check	35	Diagnosis Procedure	90
Diagnosis Procedure	35		
TIRE PRESSURE WARNING CHECK		ID REGISTRATION CANNOT BE COMPLET-	
SWITCH	37	ED	91
Description	37	Description	91
Component Function Check	37	Diagnosis Procedure	91
Diagnosis Procedure	37		
LOW TIRE PRESSURE WARNING LAMP	39	NORMAL OPERATING CONDITION	92
Description	39	Description	92
Component Function Check	39		
Diagnosis Procedure	39	NOISE, VIBRATION AND HARSHNESS	
		(NVH) TROUBLESHOOTING	93
POWER SUPPLY AND GROUND CIRCUIT	40	NVH Troubleshooting Chart	93
BCM (BODY CONTROL MODULE)	40		
BCM (BODY CONTROL MODULE) : Diagnosis		PRECAUTION	94
Procedure	40	PRECAUTIONS	94
UNIFIED METER AND A/C AMP.	40	Precaution for Supplemental Restraint	
UNIFIED METER AND A/C AMP. : Diagnosis		System (SRS) "AIR BAG" and "SEAT BELT	
Procedure	40	PRE-TENSIONER"	94
TPMS	42	Service Notice or Precautions	94
Wiring Diagram - TIRE PRESSURE MONITOR-			
ING SYSTEM -	42	PREPARATION	95
ECU DIAGNOSIS INFORMATION	46	PREPARATION	95
BCM (BODY CONTROL MODULE)	46	Special Service Tool	95
Reference Value	46	Commercial Service Tool	95
Wiring Diagram - BCM -	70		
Fail-safe	75	PERIODIC MAINTENANCE	96
DTC Inspection Priority Chart	77	ROAD WHEEL	96
DTC Index	79	Inspection	96
SYMPTOM DIAGNOSIS	82	REMOVAL AND INSTALLATION	97
TPMS	82	ROAD WHEEL TIRE ASSEMBLY	97
Symptom Table	82	Adjustment	97
LOW TIRE PRESSURE WARNING LAMP		TRANSMITTER	100
DOES NOT TURN ON	85	Exploded View	100
Description	85	Removal and Installation	100
Diagnosis Procedure	85	TIRE PRESSURE RECEIVER	102
LOW TIRE PRESSURE WARNING LAMP		Exploded View	102
DOES NOT TURN OFF	86	Removal and Installation	102
		SERVICE DATA AND SPECIFICATIONS	
		(SDS)	103
		SERVICE DATA AND SPECIFICATIONS	
		(SDS)	103
		Road Wheel	103

- A
- B
- C
- D
- WT**
- F
- G
- H
- I
- J
- K
- L
- M
- N
- O
- P

DIAGNOSIS AND REPAIR WORK FLOW

< BASIC INSPECTION >

BASIC INSPECTION

DIAGNOSIS AND REPAIR WORK FLOW

Repair Work Flow

INFOID:000000004503708

DETAILED FLOW

1. VERIFY CUSTOMER COMPLAINTS

Interview the customer to obtain detailed information about the symptom.

>> GO TO 2.

2. DETERMINE REFERENCE ITEM RELATED TO SYMPTOM

Check the symptom on the vehicle from the information obtained. (cruise test, warning lamp illumination or blinking, etc.)

Is the symptom confirmed?

YES >> GO TO 3.

NO >> GO TO 4.

3. PRELIMINARY INSPECTION

1. Check all tire pressures. Refer to [WT-103, "Tire"](#).

2. Check the low tire pressure warning lamp for illumination or blinking. Refer to [WT-82, "Symptom Table"](#).

Is the malfunction finished?

YES >> INSPECTION END

NO >> GO TO 4.

4. PERFORM SELF-DIAGNOSIS

Perform self-diagnosis. Record any DTCs and data displayed on CONSULT-III.

Is there any DTC displayed?

YES >> GO TO 6.

NO >> GO TO 5.

5. CHECK SYMPTOM

Perform troubleshooting by symptom. Refer to [WT-82, "Symptom Table"](#).

Is the causal factor identified?

YES >> GO TO 7.

NO >> GO TO 9.

6. PERFORM THE SYSTEM DIAGNOSIS

Perform the diagnosis applicable to the displayed DTC. Refer to [WT-79, "DTC Index"](#).

>> GO TO 7.

7. REPAIR OR REPLACE MALFUNCTIONING PARTS

Repair or replace the applicable part.

>> GO TO 8.

8. CHECK SELF-DIAGNOSIS RESULT

1. Erase DTCs. Refer to [WT-13, "AIR PRESSURE MONITOR : Diagnosis Description"](#).

2. Perform self-diagnosis again.

Is any DTC displayed?

YES >> GO TO 6.

NO >> GO TO 9.

DIAGNOSIS AND REPAIR WORK FLOW

< BASIC INSPECTION >

9. FINAL CHECK

1. Perform a cruise test.
2. Check the warning lamp for illumination or blinking.

Is the malfunction corrected?

YES >> INSPECTION END
NO >> GO TO 4.

A

B

C

D

WT

F

G

H

I

J

K

L

M

N

O

P

INSPECTION AND ADJUSTMENT

< BASIC INSPECTION >

INSPECTION AND ADJUSTMENT TRANSMITTER WAKE UP OPERATION

TRANSMITTER WAKE UP OPERATION : Description

INFOID:000000004503709

This procedure must be done after replacement of a transmitter, BCM, or rotation of wheels.

TRANSMITTER WAKE UP OPERATION : Special Repair Requirement

INFOID:000000004503710

1. TRANSMITTER WAKE-UP PROCEDURE

1. Turn the ignition switch ON.
2. Contact the transmitter activation tool (J-45295) (1) to the side of the tire at the location to the transmitter.
3. Press and hold the activation tool button while pushing the tool to the tire surface. (approximately for 5 seconds)

CAUTION:

Perform the wake-up procedure starting from the vehicle front left wheel, then repeat the procedure in the order of the front right wheel, rear right wheel, and rear left wheel.

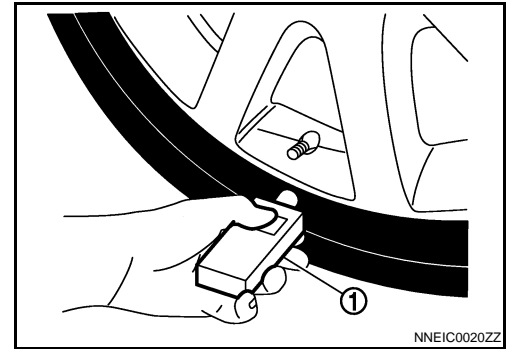

4. Check that the low tire pressure warning lamp blinks in the pattern shown as per the following. The pattern indicates that the transmitter wake-up procedure for the wheel is completed.

Low tire pressure warning lamp blinking timing	Activation tire position
	a : 0.3 sec. b : 1.3 sec. Front LH
	a : 0.3 sec. b : 1.3 sec. Front RH
	a : 0.3 sec. b : 1.3 sec. Rear RH
	a : 0.3 sec. b : 1.3 sec. Rear LH
	a : 2 sec. b : 0.2 sec. All tires

SEIA0762E

5. Check that the turn signal lamps blink twice when the transmitter wake-up procedure for all wheels is completed.
6. Check that the low tire pressure warning lamp turns OFF, after the transmitter wake-up procedure is completed for all wheels and turns OFF.

Is the transmitter wake-up procedure completed?

YES >> Perform the transmitter ID registration procedure. Refer to [WT-6, "ID REGISTRATION PROCEDURE : Special Repair Requirement"](#).

NO >> Perform trouble diagnosis for the transmitter. Refer to [WT-19, "Diagnosis Procedure"](#).

ID REGISTRATION PROCEDURE

ID REGISTRATION PROCEDURE : Description

INFOID:000000004503711

This procedure must be done after replacing or rotating wheels, replacing transmitter or BCM.

ID REGISTRATION PROCEDURE : Special Repair Requirement

INFOID:000000004503712

1. TRANSMITTER ID REGISTRATION PROCEDURE

With CONSULT-III.

INSPECTION AND ADJUSTMENT

< BASIC INSPECTION >

1. Display the "WORK SUPPORT" screen and select "ID REGIST".

Is the transmitter activation tool (J-45295) used for the transmitter ID registration procedure?

- YES >> GO TO 2.
NO >> GO TO 3.

2. TRANSMITTER ID REGISTRATION PROCEDURE (WITH TRANSMITTER ACTIVATION TOOL)

1. Turn the ignition switch ON.
2. Select the start button on the "ID REGIST" screen.
3. Contact the transmitter activation tool (J-45295) (1) to the side of the tire at the location to the transmitter.
4. Press and hold the activation tool button while pushing the tool to the tire surface. (approximately for 5 seconds)

CAUTION:

Perform the ID registration procedure starting from the vehicle front left wheel, then repeat the procedure in the order of the front right wheel, rear right wheel, and rear left wheel.

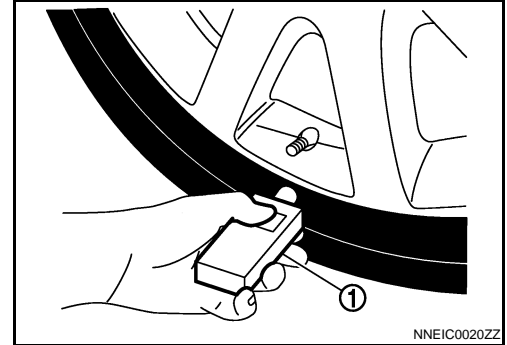

5. When ID registration is completed, check the following pattern at each wheel.

Se-quence	ID registration position	Turn signal lamp	CONSULT-III
1	Front left wheel	2 blinks	"Red" ↓ "Green"
2	Front right wheel		
3	Rear right wheel		
4	Rear left wheel		

6. After the ID registration procedure for all wheels is completed, press "END" to end ID registration, and check that ID registration for all wheels is completed.

Is the check result normal?

- YES >> ID registration END.
NO >> Performs trouble-diagnosis of the Tire Pressure Monitoring System (TPMS). Refer to [WT-19](#), "[Diagnosis Procedure](#)".

3. TRANSMITTER ID REGISTRATION PROCEDURE (WITHOUT TRANSMITTER ACTIVATION TOOL)

1. Adjust the tire pressure for all wheels to match the list below.

Tire position	Tire pressure kPa (kg/cm ² , psi)
Front LH	240 (2.4, 35)
Front RH	220 (2.2, 31)
Rear RH	200 (2.0, 29)
Rear LH	180 (1.8, 26)

2. Drive the vehicle at a speed at more than 40 km/h (25 MPH) for 3 minutes or more, then perform the transmitter ID registration procedure.
3. After ID registration for all wheels is completed, press "END" to end ID registration.

ID registration position	CONSULT-III
Front LH	"Red" ↓ "Green"
Front RH	
Rear RH	
Rear LH	

4. Adjust the tire pressures for all wheels to the specified value. Refer to [WT-103](#), "[Tire](#)".

INSPECTION AND ADJUSTMENT

< BASIC INSPECTION >

Is ID registrations for all wheels completed?

YES >> ID registration END.

NO >> Performs trouble-diagnosis of the Tire Pressure Monitoring System (TPMS). Refer to [WT-19](#), "[Diagnosis Procedure](#)".

TPMS

< SYSTEM DESCRIPTION >

SYSTEM DESCRIPTION

TPMS

System Diagram

INFOID:000000004503713

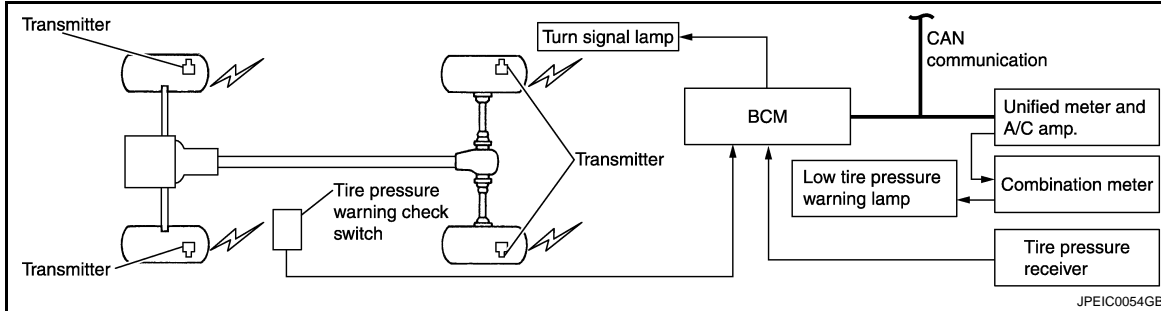

System Description

INFOID:000000004503714

DESCRIPTION

During driving, the TPMS (Tire Pressure Monitoring System) receives the signal transmitted from transmitter installed in each wheel. The BCM (Body Control Module) of this system has pressure judgment and trouble diagnosis functions. When the tire pressure monitoring system detects low inflation pressure or another unusual symptom, the low tire pressure warning lamps in the combination meter comes on.

TPMS

< SYSTEM DESCRIPTION >

Component Parts Location

INFOID:000000004503970

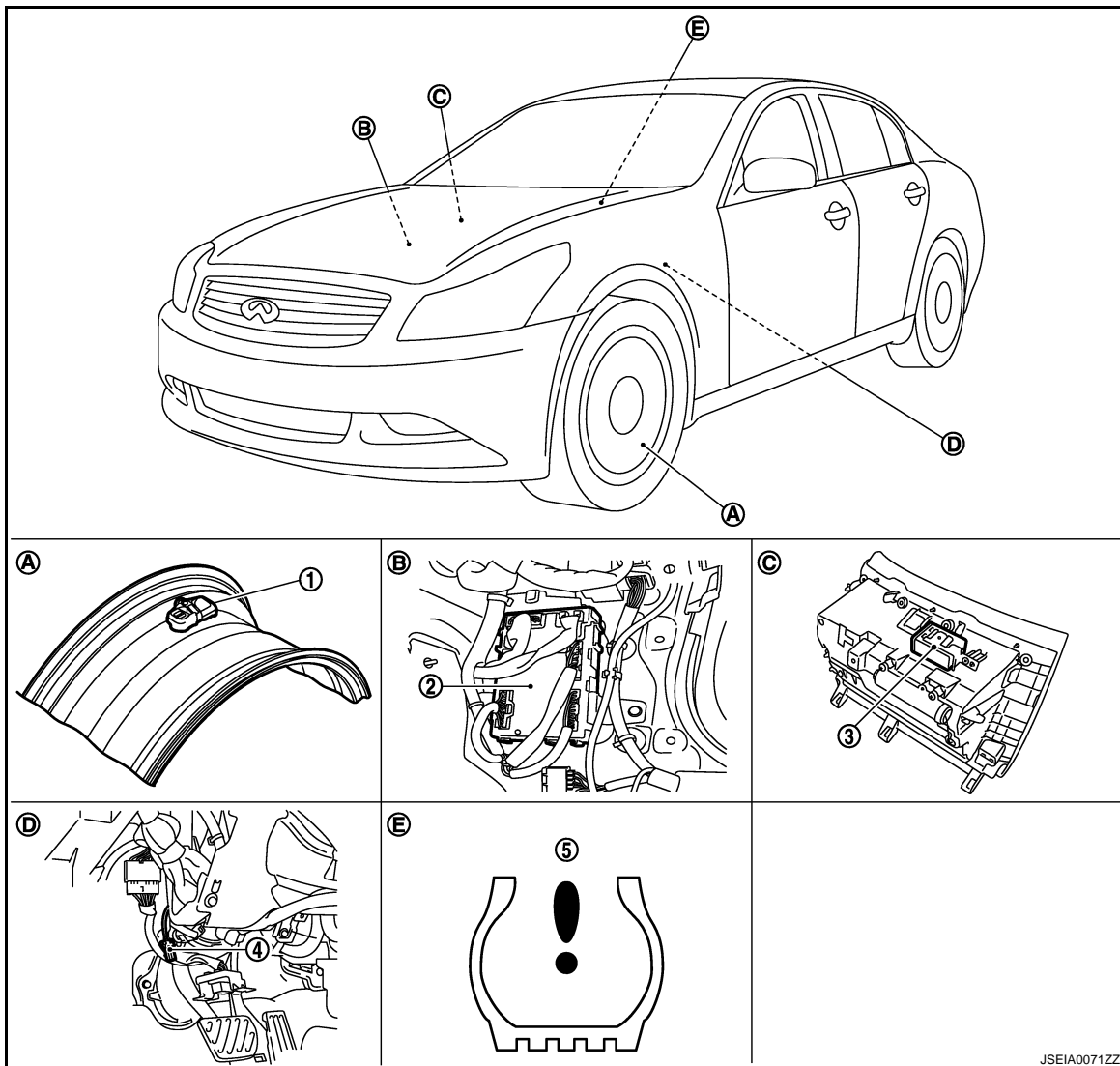

JSEIA0071ZZ

- | | | |
|---------------------------------------|-------------------------------------|------------------------------|
| 1. Transmitter | 2. BCM | 3. Tire pressure receiver |
| 4. Tire pressure warning check switch | 5. Low tire pressure warning lamp | |
| A. Wheel | B. Dash side lower (passenger side) | C. Instrument lower panel RH |
| D. Behind instrument lower panel LH | E. Inside combination meter | |

Component Description

INFOID:000000004503716

Component parts	Function
BCM (Body Control Module)	WT-33. "Description".
Transmitter	WT-19. "Description".
Tire pressure receiver	WT-35. "Description".
Tire pressure warning check switch	WT-37. "Description".
Turn signal lamp	ID registration of each wheel has been completed, turn signal lamp flashes.

TPMS

< SYSTEM DESCRIPTION >

Component parts	Function	
Unified meter and A/C amp.	Transmits the vehicle speed signal via CAN communication to BCM.	A
	Receives the following signals via CAN communication for BCM. <ul style="list-style-type: none">• Low tire pressure warning lamp signal• Hazard lamp signal• Buzzer signal	B
Low tire pressure warning lamp	Illuminates if malfunction is detected in electrical system of TPMS.	C

A

B

C

D

WT

F

G

H

I

J

K

L

M

N

O

P

DIAGNOSIS SYSTEM (BCM)

< SYSTEM DESCRIPTION >

DIAGNOSIS SYSTEM (BCM)

COMMON ITEM

COMMON ITEM : CONSULT-III Function (BCM - COMMON ITEM)

INFOID:000000004503904

APPLICATION ITEM

CONSULT-III performs the following functions via CAN communication with BCM.

Diagnosis mode	Function Description
Work Support	Changes the setting for each system function.
Self Diagnostic Result	Displays the diagnosis results judged by BCM.
CAN Diag Support Monitor	Monitors the reception status of CAN communication viewed from BCM. Refer to CONSULT-III operation manual.
Data Monitor	The BCM input/output signals are displayed.
Active Test	The signals used to activate each device are forcibly supplied from BCM.
Ecu Identification	The BCM part number is displayed.
Configuration	<ul style="list-style-type: none"> Read and save the vehicle specification. Write the vehicle specification when replacing BCM.

SYSTEM APPLICATION

BCM can perform the following functions for each system.

NOTE:

It can perform the diagnosis modes except the following for all sub system selection items.

×: Applicable item

System	Sub system selection item	Diagnosis mode		
		Work Support	Data Monitor	Active Test
Door lock	DOOR LOCK	×	×	×
Rear window defogger	REAR DEFOGGER		×	×
Warning chime	BUZZER		×	×
Interior room lamp timer	INT LAMP	×	×	×
Exterior lamp	HEAD LAMP	×	×	×
Wiper and washer	WIPER		×	×
Turn signal and hazard warning lamps	FLASHER	×	×	×
—	AIR CONDITONER*			
<ul style="list-style-type: none"> Intelligent Key system Engine start system 	INTELLIGENT KEY	×	×	×
Combination switch	COMB SW		×	
Body control system	BCM	×		
IVIS - NATS	IMMU		×	×
Interior room lamp battery saver	BATTERY SAVER	×	×	×
Trunk lid open	TRUNK		×	×
Vehicle security system	THEFT ALM	×	×	×
RAP system	RETAINED PWR		×	
Signal buffer system	SIGNAL BUFFER		×	×
TPMS	TPMS (AIR PRESSURE MONITOR)	×	×	×

NOTE:

*: This item is displayed, but is not used.

FREEZE FRAME DATA (FFD)

The BCM records the following vehicle condition at the time a particular DTC is detected, and displays on CONSULT-III.

DIAGNOSIS SYSTEM (BCM)

< SYSTEM DESCRIPTION >

CONSULT screen item	Indication/Unit	Description		
Vehicle Speed	km/h	Vehicle speed of the moment a particular DTC is detected		A
Odo/Trip Meter	km	Total mileage (Odometer value) of the moment a particular DTC is detected		B
Vehicle Condition	SLEEP>LOCK	Power position status of the moment a particular DTC is detected	While turning BCM status from low power consumption mode to normal mode (Power supply position is "LOCK")	C
	SLEEP>OFF		While turning BCM status from low power consumption mode to normal mode (Power supply position is "OFF".)	D
	LOCK>ACC		While turning power supply position from "LOCK" to "ACC"	WT
	ACC>ON		While turning power supply position from "ACC" to "IGN"	F
	RUN>ACC		While turning power supply position from "RUN" to "ACC" (Vehicle is stopping and selector lever is except P position.)	G
	CRANK>RUN		While turning power supply position from "CRANKING" to "RUN" (From cranking up the engine to run it)	H
	RUN>URGENT		While turning power supply position from "RUN" to "ACC" (Emergency stop operation)	I
	ACC>OFF		While turning power supply position from "ACC" to "OFF"	J
	OFF>LOCK		While turning power supply position from "OFF" to "LOCK"	K
	OFF>ACC		While turning power supply position from "OFF" to "ACC"	L
	ON>CRANK		While turning power supply position from "IGN" to "CRANKING"	M
	OFF>SLEEP		While turning BCM status from normal mode (Power supply position is "OFF".) to low power consumption mode	N
	LOCK>SLEEP		While turning BCM status from normal mode (Power supply position is "LOCK".) to low power consumption mode	O
	LOCK		Power supply position is "LOCK" (Ignition switch OFF with steering is locked.)	P
	OFF		Power supply position is "OFF" (Ignition switch OFF with steering is unlocked.)	
	ACC		Power supply position is "ACC" (Ignition switch ACC)	
	ON		Power supply position is "IGN" (Ignition switch ON with engine stopped)	
ENGINE RUN	Power supply position is "RUN" (Ignition switch ON with engine running)			
CRANKING	Power supply position is "CRANKING" (At engine cranking)			
IGN Counter	0 - 39	The number of times that ignition switch is turned ON after DTC is detected <ul style="list-style-type: none"> • The number is 0 when a malfunction is detected now. • The number increases like 1 → 2 → 3...38 → 39 after returning to the normal condition whenever ignition switch OFF → ON. • The number is fixed to 39 until the self-diagnosis results are erased if it is over 39. 		

AIR PRESSURE MONITOR

AIR PRESSURE MONITOR : Diagnosis Description

INFOID:000000004503905

DESCRIPTION

During driving, the TPMS receives the signal transmitted from the transmitter installed in each wheel, when the tire pressure becomes low. The control unit (BCM) of this system has pressure judgment and trouble diagnosis functions.

When the TPMS detects low inflation pressure or another unusual symptom, the low tire pressure warning lamps in the combination meter comes on.

SELF DIAGNOSTIC PROCEDURE (WITH CONSULT-III)

④ With CONSULT-III

Touch "SELF-DIAG RESULT" display shows malfunction experienced since the last erasing operation. Refer to [WT-79, "DTC Index"](#).

DIAGNOSIS SYSTEM (BCM)

< SYSTEM DESCRIPTION >

SELF DIAGNOSTIC PROCEDURE (WITHOUT CONSULT-III)

⊗ Without CONSULT-III

To start the self-diagnostic results mode, ground terminal of the tire pressure warning check connector. The malfunction location is indicated by the low tire pressure warning lamp blinking.

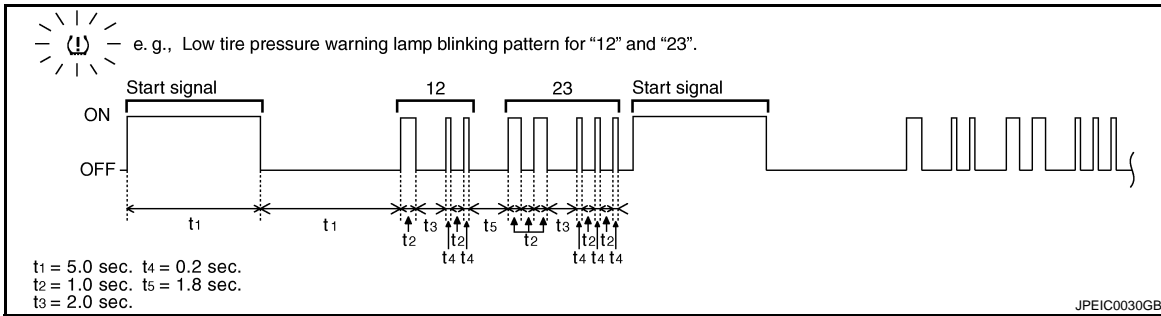

NOTE:

When the low tire pressure warning lamp blinks 5 Hz and continues repeating it, the system is normal.

Blinking pattern	Items	Diagnostic items detected when...	Check item
15	Tire pressure value (Front LH)	Front LH tire pressure drops to * kPa (* bar, * kg/cm ² , * psi) or less. [NOTE]	
16	Tire pressure value (Front RH)	Front RH tire pressure drops to * kPa (* bar, * kg/cm ² , * psi) or less. [NOTE]	
17	Tire pressure value (Rear RH)	Rear RH tire pressure drops to * kPa (* bar, * kg/cm ² , * psi) or less. [NOTE]	
18	Tire pressure value (Rear LH)	Rear LH tire pressure drops to * kPa (* bar, * kg/cm ² , * psi) or less. [NOTE]	
21	Transmitter no data (Front LH)	Data from front LH transmitter can not be receive.	WT-19
22	Transmitter no data (Front RH)	Data from front RH transmitter can not be receive.	
23	Transmitter no data (Rear RH)	Data from rear RH transmitter can not be receive.	
24	Transmitter no data (Rear LH)	Data from rear LH transmitter can not be receive.	
31	Transmitter checksum error (Front LH)	Checksum data from front LH transmitter is malfunctioning.	WT-21
32	Transmitter checksum error (Front RH)	Checksum data from front RH transmitter is malfunctioning.	
33	Transmitter checksum error (Rear RH)	Checksum data from rear RH transmitter is malfunctioning.	
34	Transmitter checksum error (Rear LH)	Checksum data from rear LH transmitter is malfunctioning.	
35	Transmitter pressure data error (Front LH)	Air pressure data from front LH transmitter is malfunction.	WT-24
36	Transmitter pressure data error (Front RH)	Air pressure data from front RH transmitter is malfunction.	
37	Transmitter pressure data error (Rear RH)	Air pressure data from rear RH transmitter is malfunction.	
38	Transmitter pressure data error (Rear LH)	Air pressure data from rear LH transmitter is malfunction.	

DIAGNOSIS SYSTEM (BCM)

< SYSTEM DESCRIPTION >

Blinking pattern	Items	Diagnostic items detected when...	Check item
41	Transmitter function code error (Front LH)	Function code data from front LH transmitter is malfunction.	WT-26
42	Transmitter function code error (Front RH)	Function code data from front RH transmitter is malfunction.	
43	Transmitter function code error (Rear RH)	Function code data from rear RH transmitter is malfunction.	
44	Transmitter function code error (Rear LH)	Function code data from rear LH transmitter is malfunction.	
45	Transmitter battery voltage low (Front LH)	Battery voltage of front LH transmitter drops.	WT-29
46	Transmitter battery voltage low (Front RH)	Battery voltage of front RH transmitter drops.	
47	Transmitter battery voltage low (Rear RH)	Battery voltage of rear RH transmitter drops.	
48	Transmitter battery voltage low (Rear LH)	Battery voltage of rear LH transmitter drops.	
52	Vehicle speed signal error	Vehicle speed signal error.	WT-32
53	Control unit	Tire pressure monitoring system malfunction in BCM.	WT-33
No blinking	Tire pressure warning check switch	Tire pressure warning switch circuit is open.	-

NOTE: 182.7 kPa (1.827 bar, 1.9 kg/cm², 26 psi): Standard air pressure is for 230 kPa (2.3 bar, 2.3 kg/cm², 33 psi) vehicles.

ERASE SELF-DIAGNOSIS

With CONSULT-III

1. Perform applicable inspection of malfunctioning item and then repair or replace.
2. Turn ignition switch ON and select "SELF-DIAG RESULTS" mode for "AIR PRESSURE MONITOR" with CONSULT-III.
3. Touch "ERASE" on CONSULT-III screen to erase memory.

Without CONSULT-III

- In order to make it easier to find the cause of hard-to-duplicate malfunctions, malfunction information is stored into the control unit as necessary during use by the user. This memory is not erased no matter how many times the ignition switch is turned ON and OFF.
- However, this information is erased by turning ignition switch OFF after performing self-diagnostic or by erasing the memory using the CONSULT-III.

AIR PRESSURE MONITOR : CONSULT-III Function (BCM - AIR PRESSURE MONITOR)

INFOID:000000004503906

WORK SUPPORT MODE

ID Read

The registered ID number is displayed.

ID Regist

Refer to [WT-6, "ID REGISTRATION PROCEDURE : Special Repair Requirement"](#).

SELF-DIAG RESULTS MODE

Operation Procedure

Refer to [WT-79, "DTC Index"](#).

DATA MONITOR MODE

Screen of data monitor mode is displayed.

NOTE:

When malfunction is detected, CONSULT-III perform REAL-TIME DIAGNOSIS. Also, any malfunction detected while in this mode will be displayed at real time.

DIAGNOSIS SYSTEM (BCM)

< SYSTEM DESCRIPTION >

Monitor item (Unit)	Remark
AIR PRESS FL (kPa/kg/cm ² /Psi)	Tire pressure
AIR PRESS FR (kPa/kg/cm ² /Psi)	
AIR PRESS RR (kPa/kg/cm ² /Psi)	
AIR PRESS RL (kPa/kg/cm ² /Psi)	
ID REGST FL1 (Green/Red)	Registration ID
ID REGST FR1 (Green/Red)	
ID REGST RR1 (Green/Red)	
ID REGST RL1 (Green/Red)	
WARNING LAMP (On/Off)	Low tire pressure warning lamp
BUZZER (On/Off)	Buzzer in combination meter

NOTE:

Before performing the self-diagnosis, be sure to register the ID, or erase the actual malfunction location may be different from that displayed on CONSULT-III.

ACTIVE TEST MODE

NOTE:

Before performing the self-diagnosis, be sure to register the ID, or erase the actual malfunction may be different from that displayed on CONSULT-III.

TEST ITEM LIST

Test item	Content
WARNING LAMP	This test is able to check to check that the low tire pressure warning lamp turns on.
ID REGIST WARNING	This test is able to check to check that the buzzer sounds or the low tire pressure warning lamp turns on.
FLASHER	This test is able to check to check that each turn signal lamp turns on.
HORN	This test is able to check to check that the horn sounds.

C1704, C1705, C1706, C1707 LOW TIRE PRESSURE

< DTC/CIRCUIT DIAGNOSIS >

DTC/CIRCUIT DIAGNOSIS

C1704, C1705, C1706, C1707 LOW TIRE PRESSURE

Description

INFOID:000000004503720

When the tire pressure monitoring system detects low inflation pressure, the low tire pressure warning lamps in the combination meter comes on.

DTC Logic

INFOID:000000004503721

DTC DETECTION LOGIC

DTC	Display item	Malfunction detected condition	Possible cause
C1704	LOW PRESSURE FL	Front LH tire pressure drops to * kPa (* kg/cm ² , * psi) or less. [NOTE]	Low tire pressure
C1705	LOW PRESSURE FR	Front RH tire pressure drops to * kPa (* kg/cm ² , * psi) or less. [NOTE]	
C1706	LOW PRESSURE RR	Rear RH tire pressure drops to * kPa (* kg/cm ² , * psi) or less. [NOTE]	
C1707	LOW PRESSURE RL	Rear LH tire pressure drops to * kPa (* kg/cm ² , * psi) or less. [NOTE]	

*: 182.7 kPa (1.9 kg/cm², 26 psi): Standard air pressure is for 230 kPa (2.3 kg/cm², 33 psi) vehicles.

DTC CONFIRMATION PROCEDURE

1. DTC REPRODUCTION PROCEDURE

Ⓜ With CONSULT-III

1. Drive at a speed of 40 km/h (25 MPH) or more, then drive normally for 10 minutes.
2. Perform BCM self-diagnosis.

Is DTC "C1704", "C1705", "C1706", "C1707" detected?

- YES >> Perform trouble diagnosis. Refer to [WT-17, "Diagnosis Procedure"](#).
NO >> INSPECTION END

Diagnosis Procedure

INFOID:000000004503722

1. CHECK TIRE AIR PRESSURE

1. Check the all tire air pressures.
2. Adjust all tire air pressures. Refer to [WT-103, "Tire"](#).

Does all tire pressure data meet the specification?

- YES >> GO TO 2.
NO >> Inspect or replace malfunctioning parts.

2. CHECK AIR PRESSURE SIGNAL

1. Start the engine.
2. Select "DATA MONITOR" mode for "AIR PRESSURE MONITOR" with CONSULT-III.
3. Read out the value of "AIR PRESS FL", "AIR PRESS FR", "AIR PRESS RR", "AIR PRESS RL".

Monitored item	Condition	Display value
AIR PRESS FL	Start the engine and drive at a 40 km/h (25 MPH) or more for several minutes.	Approximately equal to the indication on vehicle information display.
AIR PRESS FR		
AIR PRESS RR		
AIR PRESS RL		

Is inspection result normal?

- YES >> INSPECTION END
NO >> Repair or replace damaged parts (tire or wheel). Refer to [WT-94, "Service Notice or Precautions"](#).

C1704, C1705, C1706, C1707 LOW TIRE PRESSURE

< DTC/CIRCUIT DIAGNOSIS >

Special Repair Requirement

INFOID:000000004503723

1.CHECK TIRE AIR PRESSURE

Check all tire air pressures. Refer to [WT-103, "Tire"](#).

Does all tire pressure data meet the specification?

YES >> GO TO 2.

NO >> Inspect or repair the tires or wheels and adjust the tire pressure to the specification.

2.PERFORM ID REGISTRATION

Perform ID registration. Refer to [WT-6, "ID REGISTRATION PROCEDURE : Special Repair Requirement"](#).

>> END

C1708, C1709, C1710, C1711 TRANSMITTER

< DTC/CIRCUIT DIAGNOSIS >

C1708, C1709, C1710, C1711 TRANSMITTER

Description

INFOID:000000004503724

The transmitter integrated with a valve is installed on a wheel, and transmits a detected tire pressure signal by radio wave.

DTC Logic

INFOID:000000004503725

DTC DETECTION LOGIC

DTC	Display item	Malfunction detected condition	Possible cause
C1708	[NO DATA] FL	Data from front LH transmitter cannot received.	<ul style="list-style-type: none">• Harness or connector (Tire pressure receiver, BCM)• ID registration is not finished• Transmitter malfunction• BCM malfunction
C1709	[NO DATA] FR	Data from front RH transmitter cannot received.	
C1710	[NO DATA] RR	Data from rear RH transmitter cannot received.	
C1711	[NO DATA] RL	Data from rear LH transmitter cannot received.	

DTC CONFIRMATION PROCEDURE

1. DTC REPRODUCTION PROCEDURE

Ⓜ With CONSULT-III

1. Drive at a speed of 40 km/h (25 MPH) or more, then drive normally for 10 minutes.
2. Perform BCM self-diagnosis.

Is DTC "C1708", "C1709", "C1710", "C1711" detected?

- YES >> Perform trouble diagnosis. Refer to [WT-19, "Diagnosis Procedure"](#).
NO >> INSPECTION END

Diagnosis Procedure

INFOID:000000004503726

1. CHECK AIR PRESSURE SIGNAL

Ⓜ With CONSULT-III

1. Start the engine.
2. Select "DATA MONITOR" mode for "AIR PRESSURE MONITOR" with CONSULT-III.
3. Read out the value of "AIR PRESS FL", "AIR PRESS FR", "AIR PRESS RR", "AIR PRESS RL".

Monitored item	Condition	Display value
AIR PRESS FL	Start the engine and drive at a 40 km/h (25 MPH) or more for several minutes.	Approximately equal to the indication on vehicle information display.
AIR PRESS FR		
AIR PRESS RR		
AIR PRESS RL		

Are all tire pressures displayed 0 kPa?

- YES >> GO TO 2.
NO >> GO TO 4.

2. CHECK HARNESS BETWEEN BCM AND TIRE PRESSURE RECEIVER

1. Turn the ignition switch OFF.
2. Disconnect BCM harness connector and tire pressure receiver harness connector.
3. Check the continuity between BCM harness connector and tire pressure receiver harness connector.

BCM		Tire pressure receiver		Continuity
Connector	Terminal	Connector	Terminal	
M123	137	M101	1	Existed
	138		4	
	139		2	

C1708, C1709, C1710, C1711 TRANSMITTER

< DTC/CIRCUIT DIAGNOSIS >

4. Check the continuity between BCM harness connector and ground.

BCM		—	Continuity
Connector	Terminal		
M123	137	Ground	Not existed
	138		
	139		

Is the inspection result normal?

YES >> GO TO 3.

NO >> Repair or replace damaged parts.

3.CHECK TIRE PRESSURE RECEIVER

Check tire pressure receiver. Refer to [WT-35, "Diagnosis Procedure"](#).

Is the inspection result normal?

YES >> Check the BCM pin terminals for damage or loose connection with harness connector. If any items are damaged, repair or replace damaged parts.

NO >> Replace the tire pressure receiver.

4.CHECK ID REGISTRATION

Perform ID registration of all transmitters. Refer to [WT-6, "ID REGISTRATION PROCEDURE : Special Repair Requirement"](#).

Can ID registration of all transmitters be completed?

YES >> GO TO 5.

NO >> Replace malfunctioning transmitter.

5.CHECK TIRE PRESSURE MONITORING SYSTEM

Ⓢ With CONSULT-III

1. Drive at a speed of 40 km/h (25 MPH) or more for several minutes without stopping.

2. Check the all tire pressures with CONSULT-III "DATA MONITOR" within 15 minutes after stopped vehicle.

Monitored item	Condition	Display value
AIR PRESS FL	Start the engine and drive at 40 km/h (25MPH) or more for several minutes.	Approximately equal to the indication on vehicle information display.
AIR PRESS FR		
AIR PRESS RR		
AIR PRESS RL		

Is the inspection result normal?

YES >> INSPECTION END

NO >> Replace BCM.

Special Repair Requirement

INFOID:000000004503727

1.CHECK TIRE AIR PRESSURE

Check all tire air pressures. Refer to [WT-103, "Tire"](#).

Does all tire pressure data meet the specification?

YES >> GO TO 2.

NO >> Inspect or repair the tires or wheels and adjust the tire pressure to the specification.

2.PERFORM ID REGISTRATION

Perform ID registration. Refer to [WT-6, "ID REGISTRATION PROCEDURE : Special Repair Requirement"](#).

>> END

C1712, C1713, C1714, C1715 TRANSMITTER

< DTC/CIRCUIT DIAGNOSIS >

C1712, C1713, C1714, C1715 TRANSMITTER

Description

INFOID:000000004503728

The transmitter integrated with a valve is installed on a wheel, and transmits a detected tire pressure signal by radio wave.

DTC Logic

INFOID:000000004503729

DTC DETECTION LOGIC

DTC	Display item	Malfunction detected condition	Possible case
C1712	[CHECKSUM ERR] FL	Checksum data from front LH transmitter is malfunctioning.	<ul style="list-style-type: none">• Tire pressure receiver malfunction• Transmitter malfunction• BCM malfunction• Harness or connector
C1713	[CHECKSUM ERR] FR	Checksum data from front RH transmitter is malfunctioning.	
C1714	[CHECKSUM ERR] RR	Checksum data from rear RH transmitter is malfunctioning.	
C1715	[CHECKSUM ERR] RL	Checksum data from rear LH transmitter is malfunctioning.	

DTC CONFIRMATION PROCEDURE

1. DTC REPRODUCTION PROCEDURE

④ With CONSULT-III

1. Drive at a speed of 40 km/h (25 MPH) or more for several minutes without stopping.
2. Perform BCM self-diagnosis.

Is DTC "C1712", "C1713", "C1714", "C1715" detected?

- YES >> Perform trouble diagnosis. Refer to [WT-21, "Diagnosis Procedure"](#).
NO >> INSPECTION END

Diagnosis Procedure

INFOID:000000004503730

1. CHECK ID REGISTRATION

④ With CONSULT-III

1. Perform the ID registration of all transmitters. Refer to [WT-6, "ID REGISTRATION PROCEDURE : Special Repair Requirement"](#).
2. Drive at a speed of 40 km/h (25 MPH) or more, then drive normally for 10 minutes.
3. Check all tire pressure with CONSULT-III "DATA MONITOR" within 5 minutes.

Monitored item	Condition	Display value
AIR PRESS FL	Start the engine and drive at a 40 km/h (25 MPH) or more for 10 minutes.	Approximately equal to the indication on vehicle information display.
AIR PRESS FR		
AIR PRESS RR		
AIR PRESS RL		

Is the inspection result normal?

- YES >> GO TO 6.
NO >> GO TO 2.

2. CHECK AIR PRESSURE SIGNAL

④ With CONSULT-III

1. Start the engine.
2. Select "DATA MONITOR" mode for "AIR PRESSURE MONITOR" with CONSULT-III.
3. Read out the value of "AIR PRESS FL", "AIR PRESS FR", "AIR PRESS RR" and "AIR PRESS RL".

C1712, C1713, C1714, C1715 TRANSMITTER

< DTC/CIRCUIT DIAGNOSIS >

Monitored item	Condition	Display value
AIR PRESS FL	Start the engine and drive at a 40 km/h (25 MPH) or more for several minutes.	Approximately equal to the indication on vehicle information display.
AIR PRESS FR		
AIR PRESS RR		
AIR PRESS RL		

Are all tire pressures displayed 0 kPa?

YES >> GO TO 3.

NO >> GO TO 5.

3.CHECK HARNESS BETWEEN BCM AND TIRE PRESSURE RECEIVER

1. Turn the ignition switch OFF.
2. Disconnect BCM harness connector and tire pressure receiver harness connector.
3. Check the continuity between BCM harness connector and tire pressure receiver harness connector.

BCM		Tire pressure receiver		Continuity
Connector	Terminal	Connector	Terminal	
M123	137	M101	1	Existed
	138		4	
	139		2	

4. Check the continuity between BCM harness connector and ground.

BCM		—	Continuity
Connector	Terminal		
M123	137	Ground	Not existed
	138		
	139		

Is the inspection result normal?

YES >> GO TO 4.

NO >> Repair or replace damaged parts.

4.CHECK TIRE PRESSURE RECEIVER

Check the tire pressure receiver. Refer to [WT-35, "Diagnosis Procedure"](#).

Is the inspection result normal?

YES >> Check BCM pin terminals for damage or loose connection with harness connector. If any items are damaged, repair or replace damaged parts.

NO >> Replace the tire pressure receiver.

5.CHECK ID REGISTRATION

Perform ID registration of all transmitters. Refer to [WT-6, "ID REGISTRATION PROCEDURE : Special Repair Requirement"](#).

Can ID registration of all transmitters be completed?

YES >> GO TO 6.

NO >> Replace malfunctioning transmitter.

6.CHECK TIRE PRESSURE MONITORING SYSTEM

Ⓜ With CONSULT-III

1. Drive at a speed of 40 km/h (25 MPH) or more for several minutes without stopping.
2. Check the all tire pressure with CONSULT-III "DATA MONITOR" within 15 minutes after stopped vehicle.

C1712, C1713, C1714, C1715 TRANSMITTER

< DTC/CIRCUIT DIAGNOSIS >

Monitored item	Condition	Display value
AIR PRESS FL	Start the engine and drive at a 40 km/h (25 MPH) or more for several minutes.	Approximately equal to the indication on vehicle information display.
AIR PRESS FR		
AIR PRESS RR		
AIR PRESS RL		

Is the inspection result normal?

YES >> INSPECTION END

NO >> Replace BCM. Refer to [BCS-82, "Exploded View"](#).

Special Repair Requirement

INFOID:000000004503731

1. CHECK TIRE AIR PRESSURE

Check all tire air pressures. Refer to [WT-103, "Tire"](#).

Does all tire pressure data meet the specification?

YES >> GO TO 2.

NO >> Inspect or repair the tires or wheels and adjust the tire pressure to the specification.

2. PERFORM ID REGISTRATION

Perform ID registration. Refer to [WT-6, "ID REGISTRATION PROCEDURE : Special Repair Requirement"](#).

>> END

A
B
C
D
E
F
G
H
I
J
K
L
M
N
O
P

WT

C1716, C1717, C1718, C1719 TRANSMITTER

< DTC/CIRCUIT DIAGNOSIS >

C1716, C1717, C1718, C1719 TRANSMITTER

Description

INFOID:000000004503732

The transmitter integrated with a valve is installed on a wheel, and transmits a detected tire pressure signal by radio wave.

DTC Logic

INFOID:000000004503733

DTC DETECTION LOGIC

DTC	Display item	Malfunction detected condition	Possible case
C1716	[PRESSDATA ERR] FL	Air pressure data from front LH transmitter is malfunction.	<ul style="list-style-type: none">• ID registration is not finished• Transmitter malfunction
C1717	[PRESSDATA ERR] FR	Air pressure data from front RH transmitter is malfunction.	
C1718	[PRESSDATA ERR] RR	Air pressure data from rear RH transmitter is malfunction.	
C1719	[PRESSDATA ERR] RL	Air pressure data from rear LH transmitter is malfunction.	

DTC CONFIRMATION PROCEDURE

1. DTC REPRODUCTION PROCEDURE

Ⓜ With CONSULT-III

1. Drive at a speed of 40 km/h (25 MPH) or more, then drive normally for 10 minutes.
2. Perform BCM self- diagnosis.

Is DTC "C1716", "C1717", "C1718", "C1719" detected?

- YES >> Perform trouble diagnosis. Refer to [WT-24, "Diagnosis Procedure"](#).
NO >> INSPECTION END

Diagnosis Procedure

INFOID:000000004503734

1. CHECK TIRE PRESSURE

Ⓜ With CONSULT-III

1. Adjust tire pressure to specified value. Refer to [WT-103, "Tire"](#).
2. Perform the ID registration of all transmitters. Refer to [WT-6, "ID REGISTRATION PROCEDURE : Special Repair Requirement"](#).
3. Drive at a speed of 40 km/h (25 MPH) or more for several minutes without stopping.
4. Check the all tire pressure with CONSULT-III "DATA MONITOR" within 15 minutes after stopped vehicle.

Monitored item	Condition	Display value
AIR PRESS FL	Start the engine and drive at a 40 km/h (25 MPH) or more for several minutes.	Approximately equal to the indication on vehicle information display.
AIR PRESS FR		
AIR PRESS RR		
AIR PRESS RL		

Is tire pressure indicated as 438.60 kPa (4.47kg/cm², 63.60 psi) on the "DATA MONITOR" screen?

- YES >> Replace malfunctioning transmitter.
NO >> GO TO 2.

2. CHECK TIRE PRESSURE MONITORING SYSTEM

Ⓜ With CONSULT-III

1. Perform the ID registration of all transmitters. Refer to [WT-6, "ID REGISTRATION PROCEDURE : Special Repair Requirement"](#).
2. Drive at a speed of 40 km/h (25 MPH) or more for 10 minutes.
3. Check the all tire pressures with CONSULT-III "DATA MONITOR" within 5 minutes.

C1716, C1717, C1718, C1719 TRANSMITTER

< DTC/CIRCUIT DIAGNOSIS >

Monitored item	Condition	Display value
AIR PRESS FL	Start the engine and drive at a 40 km/h (25 MPH) or more for 10 minutes.	Approximately equal to the indication on vehicle information display.
AIR PRESS FR		
AIR PRESS RR		
AIR PRESS RL		

Is the inspection result normal?

YES >> INSPECTION END

NO >> Perform the self-diagnosis, inspect detected malfunction. Refer to [WT-13. "AIR PRESSURE MONITOR : Diagnosis Description"](#).

Component Inspection

INFOID:000000004503735

1.CHECK TRANSMITTER

Ⓜ With CONSULT-III

1. Adjust tire pressure to specified value. Refer to [WT-103. "Tire"](#).
2. Perform ID registration of all transmitters. Refer to [WT-6. "ID REGISTRATION PROCEDURE : Special Repair Requirement"](#).
3. Drive at a speed of 40 km/h (25 MPH) or more for several minutes without stopping.
4. Check the all tire pressure with CONSULT-III "DATA MONITOR" within 15 minutes after stopped vehicle.

Monitored item	Condition	Display value
AIR PRESSURE FL	Start the engine and drive at a 40 km/h (25 MPH) or more for several minutes.	Approximately equal to the indication on vehicle information display.
AIR PRESSURE FR		
AIR PRESSURE RR		
AIR PRESSURE RL		

Is tire pressure indicated as 438.60 kPa (4.47 kg/cm², 63.60 psi) on the "DATA MONITOR" screen?

YES >> Replace malfunctioning transmitter.

NO >> INSPECTION END

Special Repair Requirement

INFOID:000000004503736

1.CHECK TIRE AIR PRESSURE

Check all tire air pressures. Refer to [WT-103. "Tire"](#).

Does all tire pressure data meet the specification?

YES >> GO TO 2.

NO >> Inspect or repair the tires or wheels and adjust the tire pressure to the specification.

2.PERFORM ID REGISTRATION

Perform ID registration. Refer to [WT-6. "ID REGISTRATION PROCEDURE : Special Repair Requirement"](#).

>> END

C1720, C1721, C1722, C1723 TRANSMITTER

< DTC/CIRCUIT DIAGNOSIS >

C1720, C1721, C1722, C1723 TRANSMITTER

Description

INFOID:000000004503737

The transmitter integrated with a valve is installed on a wheel, and transmits a detected tire pressure signal by radio wave.

DTC Logic

INFOID:000000004503738

DTC DETECTION LOGIC

DTC	Display item	Malfunction detected condition	Possible case
C1720	[CODE ERR] FL	Function code data from front LH transmitter is malfunctioning.	<ul style="list-style-type: none">• Tire pressure receiver malfunction• Transmitter malfunction• BCM malfunction• Harness or connector
C1721	[CODE ERR] FR	Function code data from front RH transmitter is malfunctioning.	
C1722	[CODE ERR] RR	Function code data from rear RH transmitter is malfunctioning.	
C1723	[CODE ERR] RL	Function code data from rear LH transmitter is malfunctioning.	

DTC CONFIRMATION PROCEDURE

1. DTC REPRODUCTION PROCEDURE

④ With CONSULT-III

1. Driving at a speed of 40 km/h (25 MPH) or more, then drive normally for 10 minutes.
2. Perform BCM self-diagnosis.

Is DTC "C1720", "C1721", "C1722", "C1723" detected?

- YES >> Perform trouble diagnosis. Refer to [WT-26, "Diagnosis Procedure"](#).
NO >> INSPECTION END

Diagnosis Procedure

INFOID:000000004503739

1. CHECK ID REGISTRATION

④ With CONSULT-III

1. Perform the ID registration of all transmitters. Refer to [WT-6, "ID REGISTRATION PROCEDURE : Special Repair Requirement"](#).
2. Drive at a speed of 40 km/h (25 MPH) or more, then drive normally for 10 minutes.
3. Check all tire pressure with CONSULT-III "DATA MONITOR" within 5 minutes.

Monitored item	Condition	Display value
AIR PRESS FL	Start the engine and drive at a 40 km/h (25 MPH) or more for 10 minutes.	Approximately equal to the indication on vehicle information display.
AIR PRESS FR		
AIR PRESS RR		
AIR PRESS RL		

Is the inspection result normal?

- YES >> GO TO 6.
NO >> GO TO 2.

2. CHECK ALL TIRE PRESSURE SIGNAL

④ With CONSULT-III

1. Start the engine.
2. Select "DATA MONITOR" mode for "AIR PRESSURE MONITOR" with CONSULT-III.
3. Read out the value of "AIR PRESS FL", "AIR PRESS FR", "AIR PRESS RR" and "AIR PRESS RL".

C1720, C1721, C1722, C1723 TRANSMITTER

< DTC/CIRCUIT DIAGNOSIS >

Monitored item	Condition	Display value
AIR PRESS FL	Start the engine and drive at a 40 km/h (25 MPH) or more for several minutes.	Approximately equal to the indication on vehicle information display.
AIR PRESS FR		
AIR PRESS RR		
AIR PRESS RL		

Are all tire pressure displayed 0 kPa?

YES >> GO TO 3.

NO >> GO TO 5.

3. CHECK HARNESS BETWEEN BCM AND TIRE PRESSURE RECEIVER

1. Turn the ignition switch "OFF".
2. Disconnect BCM harness connector and tire pressure receiver harness connector.
3. Check continuity between BCM harness connector and tire pressure receiver harness connector.

BCM		Tire pressure receiver		Continuity
Connector	Terminal	Connector	Terminal	
M123	137	M101	1	Existed
	138		4	
	139		2	

4. Check continuity between BCM harness connector and ground.

BCM		—	Continuity
Connector	Terminal		
M123	137	Ground	Not existed
	138		
	139		

Is the inspection result normal?

YES >> GO TO 4.

NO >> Repair or replace damage parts.

4. CHECK TIRE PRESSURE RECEIVER

Check tire pressure receiver. Refer to [WT-35. "Diagnosis Procedure"](#).

Is the inspection result normal?

YES >> Check BCM pin terminals for damage or loose connection with harness connector. If any items are damaged, repair or replace damaged parts.

NO >> Replace the tire pressure receiver.

5. CHECK TIRE PRESSURE MONITORING SYSTEM

Ⓜ With CONSULT-III

1. Drive at a speed of 40 km/h (25 MPH) or more for several minutes without stopping.
2. Check all tire pressures with CONSULT-III "DATA MONITOR" within 15 minutes after stopped vehicle.

Monitored item	Condition	Display value
AIR PRESS FL	Start the engine and drive at a 40 km/h (25 MPH) or more for several minutes.	Approximately equal to the indication on vehicle information display.
AIR PRESS FR		
AIR PRESS RR		
AIR PRESS RL		

Is the inspection result normal?

YES >> GO TO 6.

NO >> Replace BCM. Refer to [BCS-82. "Exploded View"](#).

C1720, C1721, C1722, C1723 TRANSMITTER

< DTC/CIRCUIT DIAGNOSIS >

6.CHECK TRANSMITTER

④With CONSULT-III

1. Drive at a speed of 40 km/h (25 MPH) or more for several minutes without stopping.
2. Check all tire pressures with CONSULT-III "DATA MONITOR" within 5 minutes after stopped vehicle.

Monitored item	Condition	Display value
AIR PRESS FL	Start the engine and drive at a 40 km/h (25 MPH) or more for several minutes.	Approximately equal to the indication on vehicle information display.
AIR PRESS FR		
AIR PRESS RR		
AIR PRESS RL		

Is the inspection result normal?

- YES >> INSPECTION END
NO >> Replace malfunction transmitter.

Special Repair Requirement

INFOID:000000004503740

1.CHECK TIRE AIR PRESSURE

Check all tire air pressures. Refer to [WT-103, "Tire"](#).

Does all tire pressure data meet the specification?

- YES >> GO TO 2.
NO >> Inspect or repair the tires or wheels and adjust the tire pressure to the specification.

2.PERFORM ID REGISTRATION

Perform ID registration. Refer to [WT-6, "ID REGISTRATION PROCEDURE : Special Repair Requirement"](#).

>> END

C1724, C1725, C1726, C1727 TRANSMITTER

< DTC/CIRCUIT DIAGNOSIS >

C1724, C1725, C1726, C1727 TRANSMITTER

Description

INFOID:000000004503741

The transmitter integrated with a valve is installed on a wheel, and transmits a detected tire pressure signal by radio wave.

DTC Logic

INFOID:000000004503742

DTC DETECTION LOGIC

DTC	Display item	Malfunction detected condition	Possible case
C1724	[BATT VOLT LOW] FL	Battery voltage of front LH transmitter drops.	<ul style="list-style-type: none">• Transmitter malfunction• Tire pressure receiver malfunction• BCM malfunction• Harness or connector
C1725	[BATT VOLT LOW] FR	Battery voltage of front RH transmitter drops.	
C1726	[BATT VOLT LOW] RR	Battery voltage of rear RH transmitter drops.	
C1727	[BATT VOLT LOW] RL	Battery voltage of rear LH transmitter drops.	

DTC CONFIRMATION PROCEDURE

1. DTC REPRODUCTION PROCEDURE

Ⓜ With CONSULT-III

1. Driving at a speed of 40 km/h (25 MPH) or more, then drive normally for 10 minutes.
2. Perform BCM self-diagnosis.

Is DTC "C1724", "C1725", "C1726", "C1727" detected?

- YES >> Perform trouble diagnosis. Refer to [WT-29, "Diagnosis Procedure"](#).
NO >> INSPECTION END

Diagnosis Procedure

INFOID:000000004503743

1. CHECK ID REGISTRATION

Ⓜ With CONSULT-III

1. Perform the ID registration of all transmitters. Refer to [WT-6, "ID REGISTRATION PROCEDURE : Special Repair Requirement"](#).
2. Drive at a 40 km/h (25 MPH) or more, then drive normally for 10 minutes.
3. Check all tire pressure with CONSULT-III "DATA MONITOR" within 5 minutes.

Can ID registration of all transmitters be completed?

- YES >> GO TO 2.
NO >> GO TO 4.

2. CHECK AIR PRESSURE SIGNAL

Ⓜ With CONSULT-III

1. Start the engine.
2. Select "DATA MONITOR" mode for "AIR PRESSURE MONITOR" with CONSULT-III.
3. Read out the value of "AIR PRESS FL", "AIR PRESS FR", "AIR PRESS RR" and "AIR PRESS RL".

Monitored item	Condition	Display value
AIR PRESS FL	Start the engine and drive at a 40 km/h (25 MPH) or more for several minutes.	Approximately equal to the indication on vehicle information display.
AIR PRESS FR		
AIR PRESS RR		
AIR PRESS RL		

Are all tire pressures displayed 0 kPa?

- YES >> GO TO 3.
NO >> GO TO 5.

3. CHECK HARNESS BETWEEN BCM AND TIRE PRESSURE RECEIVER

1. Turn the ignition switch OFF.

C1724, C1725, C1726, C1727 TRANSMITTER

< DTC/CIRCUIT DIAGNOSIS >

2. Disconnect BCM harness connector and tire pressure receiver harness connector.
3. Check the continuity between BCM harness connector and tire pressure receiver harness connector.

BCM		Tire pressure receiver		Continuity
Connector	Terminal	Connector	Terminal	
M123	137	M101	1	Existed
	138		4	
	139		2	

4. Check continuity between BCM harness connector and ground.

BCM		—	Continuity
Connector	Terminal		
M123	137	Ground	Not existed
	138		
	139		

Is the inspection result normal?

- YES >> GO TO 4.
 NO >> Repair or replace damaged parts.

4.CHECK TIRE PRESSURE RECEIVER

Check the tire pressure receiver. Refer to [WT-35, "Diagnosis Procedure"](#).

Is the inspection result normal?

- YES >> Check the BCM pin terminals for damage or loose connection with harness connector. If any items are damaged, repair or replace damaged parts.
 NO >> Replace the tire pressure receiver.

5.CHECK ID REGISTRATION

Perform ID registration of all transmitters. Refer to [WT-6, "ID REGISTRATION PROCEDURE : Special Repair Requirement"](#).

Can ID registration of all transmitters be completed?

- YES >> GO TO 6.
 NO >> Replace malfunctioning transmitter.

6.CHECK TIRE PRESSURE MONITORING SYSTEM

With CONSULT-III

1. Drive at a speed of 40 km/h (25 MPH) or more for several minutes without stopping.
2. Check the all tire pressures with CONSULT-III "DATA MONITOR" within 15 minutes after stopped vehicle.

Monitored item	Condition	Display value
AIR PRESS FL	Start the engine and drive at a 40 km/h (25 MPH) or more for several minutes.	Approximately equal to the indication on vehicle information display.
AIR PRESS FR		
AIR PRESS RR		
AIR PRESS RL		

Is the inspection result normal?

- YES >> INSPECTION END
 NO >> Replace BCM. Refer to [BCS-82, "Exploded View"](#).

Special Repair Requirement

INFOID:000000004503744

1.CHECK TIRE AIR PRESSURE

Check all tire air pressures. Refer to [WT-103, "Tire"](#).

Does all tire pressure data meet the specification?

C1724, C1725, C1726, C1727 TRANSMITTER

< DTC/CIRCUIT DIAGNOSIS >

YES >> GO TO 2.

NO >> Inspect or repair the tires or wheels and adjust the tire pressure to the specification.

2.PERFORM ID REGISTRATION

Perform ID registration. Refer to [WT-6, "ID REGISTRATION PROCEDURE : Special Repair Requirement"](#).

>> END

A

B

C

D

WT

F

G

H

I

J

K

L

M

N

O

P

C1729 VEHICLE SPEED SIGNAL

< DTC/CIRCUIT DIAGNOSIS >

C1729 VEHICLE SPEED SIGNAL

Description

INFOID:000000004503745

BCM detects no vehicle speed signal.

DTC Logic

INFOID:000000004503746

DTC DETECTION LOGIC

DTC number	Trouble diagnosis name	DTC detecting condition	Possible case
C1729	VHCL SPEED SIG ERR	Vehicle speed signal error.	<ul style="list-style-type: none">CAN communication errorUnified meter and A/C amp. malfunction

DTC CONFIRMATION PROCEDURE

1. DTC REPRODUCTION PROCEDURE

Ⓜ With CONSULT-III

- Drive at a speed of 40 km/h (25 MPH) or more for several minutes without stopping.
- Perform BCM self-diagnosis.

Is DTC "C1729" detected?

- YES >> Perform trouble diagnosis. Refer to [WT-32, "Diagnosis Procedure"](#).
NO >> INSPECTION END

Diagnosis Procedure

INFOID:000000004503747

1. CHECK UNIFIED METER AND A/C AMP. SELF-DIAGNOSIS

Ⓜ With CONSULT-III

Perform unified meter and A/C amp. self-diagnosis.

Is any DTC detected?

- YES >> Check the DTC.
NO >> Check unified meter and A/C amp. [MWI-83, "Reference Value"](#).

Special Repair Requirement

INFOID:000000004503748

1. CHECK TIRE AIR PRESSURE

Check all tire air pressures. Refer to [WT-103, "Tire"](#).

Does all tire pressure data meet the specification?

- YES >> GO TO 2.
NO >> Inspect or repair the tires or wheels and adjust the tire pressure to the specification.

2. PERFORM ID REGISTRATION

Perform ID registration. Refer to [WT-6, "ID REGISTRATION PROCEDURE : Special Repair Requirement"](#).

>> END

C1734 BCM

< DTC/CIRCUIT DIAGNOSIS >

C1734 BCM

Description

INFOID:000000004503749

The BCM reads the tire pressure signal received by the tire pressure receiver, and controls the low tire pressure warning lamp and the buzzer operations. It also has a judgment function to detect a system malfunction.

DTC Logic

INFOID:000000004503750

DTC DETECTION LOGIC

DTC	Display item	Malfunction detected condition	Possible case
C1734	CONTROL UNIT	Tire pressure monitoring system malfunction in BCM	BCM malfunction

DTC CONFIRMATION PROCEDURE

1. DTC REPRODUCTION PROCEDURE

☐ With CONSULT-III

1. Drive at a speed of 40 km/h (25 MPH) or more for several minutes without stopping.
2. Perform BCM self-diagnosis with CONSULT-III "DATA MONITOR" within 15 minutes after stopped vehicle.

Is DTC "C1734" detected?

- YES >> Perform trouble diagnosis. Refer to [WT-33, "Diagnosis Procedure"](#).
 NO >> INSPECTION END

Diagnosis Procedure

INFOID:000000004503751

1. CHECK SELF-DIAGNOSTIC RESULTS

☐ With CONSULT-III

1. On "SELECT DIAG" mode, select the "SELF-DIAG RESULT" screen.
2. Check display contents in self-diagnostic results.

Does self-diagnostic results indicate any malfunction?

- YES >> Perform trouble diagnosis. Refer to [WT-79, "DTC Index"](#).
 NO >> GO TO 2.

2. CHECK BCM POWER SUPPLY CIRCUIT

1. Turn the ignition switch OFF.
2. Disconnect BCM harness connector.
3. Check voltage between BCM harness connector terminals and ground.

BCM		—	Voltage
Connector	Terminal		
M118	1	Ground	Battery voltage
M119	11		

Is the power supply normal?

- YES >> GO TO 3.
 NO >> Check the following. If any items are damaged, repair or replace damage parts.
- 40A fusible link [No. K located in the fuse block]. Refer to [PG-96, "Fuse and Fusible Link Arrangement"](#).
 - 10A fuse [No. 10 located in the fuse block (J/B)]. Refer to [PG-95, "Fuse, Connector and Terminal Arrangement"](#).
 - Harness for short or open between battery and BCM harness connector M118 terminal 1.
 - Harness for short or open between battery and BCM harness connector M119 terminal 11.
 - Check the Battery voltage.

3. CHECK BCM GROUND CIRCUIT

Check the continuity between BCM harness connector and ground.

C1734 BCM

< DTC/CIRCUIT DIAGNOSIS >

BCM		—	Continuity
Connector	Terminal		
M119	13	Ground	Existed

Is the inspection result normal?

YES >> GO TO 4.

NO >> Repair open circuit or short to power in harness or connectors.

4.CHECK HARNESS BETWEEN BCM AND TIRE PRESSURE RECEIVER

1. Disconnect tire pressure receiver harness connector.
2. Check the continuity between BCM harness connector and tire pressure receiver harness connector.

BCM		Tire pressure receiver		Continuity
Connector	Terminal	Connector	Terminal	
M123	137	M101	1	Existed
	138		4	
	139		2	

3. Check the continuity between BCM harness connector and ground.

BCM		—	Continuity
Connector	Terminal		
M123	137	Ground	Not existed
	138		
	139		

Is the inspection result normal?

YES >> GO TO 5.

NO >> Repair or replace damaged parts.

5.CHECK BCM

Check the BCM input/output signal. Refer to [WT-46, "Reference Value"](#).

Is the inspection result normal?

YES >> INSPECTION END

NO >> GO TO 6.

6.CHECK BCM HARNESS CONNECTOR

Check the BCM pin terminals for damage or loose connection with harness connector.

Is the inspection result normal?

YES >> Replace BCM. Refer to [BCS-82, "Exploded View"](#).

NO >> Repair or replace damaged parts.

Special Repair Requirement

INFOID:000000004503752

1.CHECK TIRE AIR PRESSURE

Check all tire air pressures. Refer to [WT-103, "Tire"](#).

Does all tire pressure data meet the specification?

YES >> GO TO 2.

NO >> Inspect or repair the tires or wheels and adjust the tire pressure to the specification.

2.PERFORM ID REGISTRATION

Perform ID registration. Refer to [WT-6, "ID REGISTRATION PROCEDURE : Special Repair Requirement"](#).

>> END

TIRE PRESSURE RECEIVER

< DTC/CIRCUIT DIAGNOSIS >

TIRE PRESSURE RECEIVER

Description

INFOID:000000004503753

The tire pressure receiver receives the tire pressure signal transmitted by the transmitter in each wheel.

Component Function Check

INFOID:000000004503754

1. TIRE PRESSURE MONITORING SYSTEM OPERATION

Ⓜ With CONSULT-III

1. Drive at a speed 40 km/h (25 MPH) or more, then drive normally for 10 minutes.
2. Check tire pressure with CONSULT-III "DATA MONITOR" within 5 minutes.

Monitored item	Condition	Display value
AIR PRESS FL	Start engine and drive at a 40 km/h (25MPH) or more for 10 minutes.	Approximately equal to the indication on vehicle information display.
AIR PRESS FR		
AIR PRESS RR		
AIR PRESS RL		

Is the inspection result normal?

- YES >> INSPECTION END
 NO-1 >> Perform BCM self-diagnosis. Refer to [WT-79, "DTC Index"](#).
 NO-2 >> Perform trouble diagnosis. Refer to [WT-35, "Diagnosis Procedure"](#).

Diagnosis Procedure

INFOID:000000004503755

1. CHECK TIRE PRESSURE RECEIVER SIGNAL

1. Turn the ignition switch ON.
CAUTION:
Never start the engine.
2. Check tire pressure receiver connector and ground signal with oscilloscope.

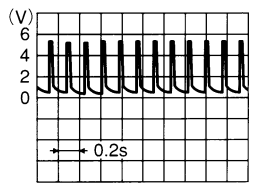
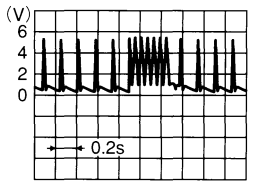
Tire pressure receiver		—	Condition	Voltage (Approx.)
Connector	Terminal			
M101	2	Ground	Standby state	
			When receiving the signal from the transmitter	

Is the inspection result normal?

- YES >> INSPECTION END
 NO >> GO TO 2.

2. CHECK TIRE PRESSURE RECEIVER INPUT VOLTAGE

1. Disconnect tire pressure receiver connector.
2. Check voltage between tire pressure receiver connector and ground.

TIRE PRESSURE RECEIVER

< DTC/CIRCUIT DIAGNOSIS >

Tire pressure receiver		—	Voltage (Approx.)
Connector	Terminal		
M101	4	Ground	5.0 V

Is the inspection result normal?

YES >> GO TO 3.

NO >> Check BCM harness and connector.

3. CHECK TIRE PRESSURE RECEIVER GROUND CIRCUIT

1. Disconnect BCM harness connector.
2. Check continuity between BCM harness connector and tire pressure receiver connector.

BCM		Tire pressure receiver		Continuity
Connector	Terminal	Connector	Terminal	
M123	137	M101	1	Existed

3. Check continuity between BCM harness connector and ground.

BCM		—	Continuity
Connector	Terminal		
M123	137	Ground	Not existed

Is the inspection result normal?

YES >> GO TO 4.

NO >> Repair or replace damaged parts.

4. CHECK BCM CIRCUIT

Inspect the BCM circuit. Refer to [WT-33, "Diagnosis Procedure"](#).

Is the BCM circuit normal?

YES >> Replace tire pressure receiver.

NO >> Repair or replace BCM circuit. Replace BCM. Refer to [BCS-82, "Exploded View"](#).

TIRE PRESSURE WARNING CHECK SWITCH

< DTC/CIRCUIT DIAGNOSIS >

TIRE PRESSURE WARNING CHECK SWITCH

Description

INFOID:000000004503756

Self-diagnosis can be performed by short-circuiting the tire pressure warning check switch to the ground. (Self-diagnosis indicates the location of the malfunction by the blinking of the low tire pressure warning lamp on the combination meter.)

NOTE:

If low tire pressure warning lamp blinks as shown in the figure, the system is normal.

- This mode shows transmitter status is in OFF-mode.
Perform transmitter wake up operation. Refer to [WT-6, "TRANSMITTER WAKE UP OPERATION : Special Repair Requirement"](#).

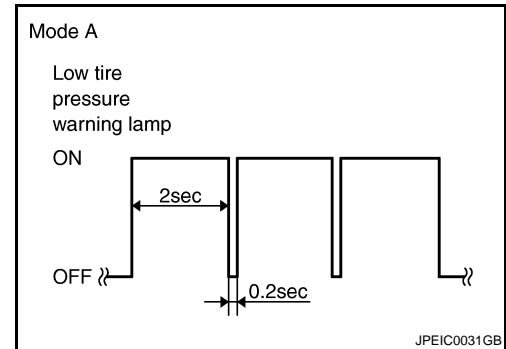

Component Function Check

INFOID:000000004503757

1. CHECK LOW TIRE PRESSURE WARNING LAMP OPERATION

Check if low tire pressure warning lamp blinks 1 second and then goes off after turning ignition switch ON.

Is inspection result normal?

YES >> GO TO 2.

NO >> Check the low tire pressure warning lamp. Refer to [WT-39, "Diagnosis Procedure"](#).

2. CHECK TIRE PRESSURE WARNING CHECK SWITCH OPERATION

- Ground the tire pressure warning check switch harness connector terminal.
- Check the low tire pressure warning lamp blinks.

Is the inspection result normal?

YES >> INSPECTION END

NO >> Perform trouble diagnosis. Refer to [WT-37, "Diagnosis Procedure"](#).

Diagnosis Procedure

INFOID:000000004503758

1. CHECK TIRE PRESSURE WARNING CHECK SWITCH POWER SUPPLY CIRCUIT

- Turn the ignition switch ON.
CAUTION:
Never start the engine.
- Check voltage between tire pressure warning check switch connector and ground.

Tire pressure warning check switch		—	Voltage (Approx.)
Connector	Terminal		
M23	1	Ground	5 V

Is the inspection result normal?

YES >> Repair or replace BCM circuit. Replace BCM. Refer to [BCS-82, "Exploded View"](#).

NO >> GO TO 2.

2. CHECK TIRE PRESSURE WARNING CHECK SWITCH CIRCUIT

- Turn the ignition switch OFF.
- Disconnect BCM harness connector
- Check the continuity between BCM harness connector and tire pressure warning check switch connector.

TIRE PRESSURE WARNING CHECK SWITCH

< DTC/CIRCUIT DIAGNOSIS >

BCM		Tire pressure warning check switch		Continuity
Connector	Terminal	Connector	Terminal	Existed
M123	149	M23	1	

4. Check the continuity between BCM harness connector and ground.

BCM			Continuity
Connector	Terminal		
M123	149	Ground	Not existed

Is the inspection result normal?

YES >> GO TO 3.

NO >> Repair or replace damaged parts.

3.CHECK BCM

Check the BCM input/output signal. Refer to [WT-46, "Reference Value"](#).

Is the inspection result normal?

YES >> INSPECTION END

NO >> Check the BCM pin terminals for damage or loose connection with harness connector. If any items are damaged, repair or replace damaged parts. Replace BCM. Refer to [BCS-82, "Exploded View"](#).

LOW TIRE PRESSURE WARNING LAMP

< DTC/CIRCUIT DIAGNOSIS >

LOW TIRE PRESSURE WARNING LAMP

Description

INFOID:000000004503759

The combination meter receives tire pressure status from the unified meter and A/C amp. via CAN communication. When BCM judges from a transmitter signal that tire pressure is insufficient, BCM transmits a signal to unified meter and A/C amp. via CAN communication. unified meter and A/C amp. turns on the low tire pressure warning lamp mounted on the combination meter.

Condition	Low tire pressure warning lamp
Ignition switch OFF	OFF
Ignition switch ON	Warning lamp turns on for 1second, then turns off.
Less than 182.7 kPa (1.9 kg/cm ² , 26 psi) [NOTE]	ON
Tire pressure monitoring system malfunction [Other diagnostic item]	Warning lamp blinks 1 min, then turns on.

NOTE: Standard air pressure is for 230 kPa (2.3 kg/cm², 33 psi) vehicles.

Component Function Check

INFOID:000000004503760

1.CHECK LOW TIRE PRESSURE WARNING LAMP

Check if low tire pressure warning lamp blinks for 1 second and then goes off after turning the ignition switch ON.

Is inspection result normal?

YES >> INSPECTION END

NO >> Perform trouble diagnosis. Refer to [WT-39. "Diagnosis Procedure"](#).

Diagnosis Procedure

INFOID:000000004503761

1.CHECK SELF DIAGNOSTIC RESULTS

Perform self-diagnosis of tire pressure monitoring system.

Is inspection result normal?

YES >> GO TO 2.

NO >> Check the DTC.

2.CHECK LOW TIRE PRESSURE WARNING LAMP

Check if low tire pressure warning lamp blinks 1 second and then goes off after turning the ignition switch ON.

Is inspection result normal?

YES >> INSPECTION END

NO >> Check the combination meter.

POWER SUPPLY AND GROUND CIRCUIT

< DTC/CIRCUIT DIAGNOSIS >

POWER SUPPLY AND GROUND CIRCUIT BCM (BODY CONTROL MODULE)

BCM (BODY CONTROL MODULE) : Diagnosis Procedure

INFOID:000000004503762

1. CHECK FUSE AND FUSIBLE LINK

Check that the following fuse and fusible link are not blown.

Signal name	Fuse and fusible link No.
Battery power supply	K
	10

Is the fuse fusing?

- YES >> Replace the blown fuse or fusible link after repairing the affected circuit if a fuse or fusible link is blown.
NO >> GO TO 2.

2. CHECK POWER SUPPLY CIRCUIT

1. Turn ignition switch OFF.
2. Disconnect BCM connectors.
3. Check voltage between BCM harness connector and ground.

Terminals		Voltage (Approx.)
(+)	(-)	
BCM		Ground Battery voltage
Connector	Terminal	
M118	1	
M119	11	

Is the measurement value normal?

- YES >> GO TO 3.
NO >> Repair harness or connector.

3. CHECK GROUND CIRCUIT

Check continuity between BCM harness connector and ground.

BCM		Ground	Continuity
Connector	Terminal		Existed
M119	13		

Does continuity exist?

- YES >> INSPECTION END
NO >> Repair harness or connector.

UNIFIED METER AND A/C AMP.

UNIFIED METER AND A/C AMP. : Diagnosis Procedure

INFOID:000000004503763

1. CHECK FUSE

Check for blown fuses.

Power source	Fuse No.
Battery	6
Ignition switch ACC or ON	19
Ignition switch ON or START	3

POWER SUPPLY AND GROUND CIRCUIT

< DTC/CIRCUIT DIAGNOSIS >

Is the inspection result normal?

YES >> GO TO 2.

NO >> Be sure to eliminate cause of malfunction before installing new fuse.

2.CHECK POWER SUPPLY CIRCUIT

Check voltage between unified meter and A/C amp. harness connector and ground.

Terminals			Ignition switch position	Value (Approx.)
(+)		(-)		
Unified meter and A/C amp.	Terminal		Signal name	
M67	54	Battery power supply	OFF	Battery voltage
	41	ACC power supply	ACC	Battery voltage
	53	Ignition signal	ON	Battery voltage

Is the inspection result normal?

YES >> GO TO 3.

NO >> Check harness between unified meter and A/C amp. and fuse.

3.CHECK GROUND CIRCUIT

1. Turn ignition switch OFF.
2. Disconnect unified meter and A/C amp. connector.
3. Check continuity between unified meter and A/C amp. harness connector and ground.

Unified meter and A/C amp.		Ground	Continuity
Connector	Terminal		
M67	55		Existed
	71		Existed

Is the inspection result normal?

YES >> INSPECTION END

NO >> Repair harness or connector.

A
B
C
D
WT
F
G
H
I
J
K
L
M
N
O
P

TPMS

< DTC/CIRCUIT DIAGNOSIS >

TPMS

Wiring Diagram - TIRE PRESSURE MONITORING SYSTEM -

INFOID:000000004503764

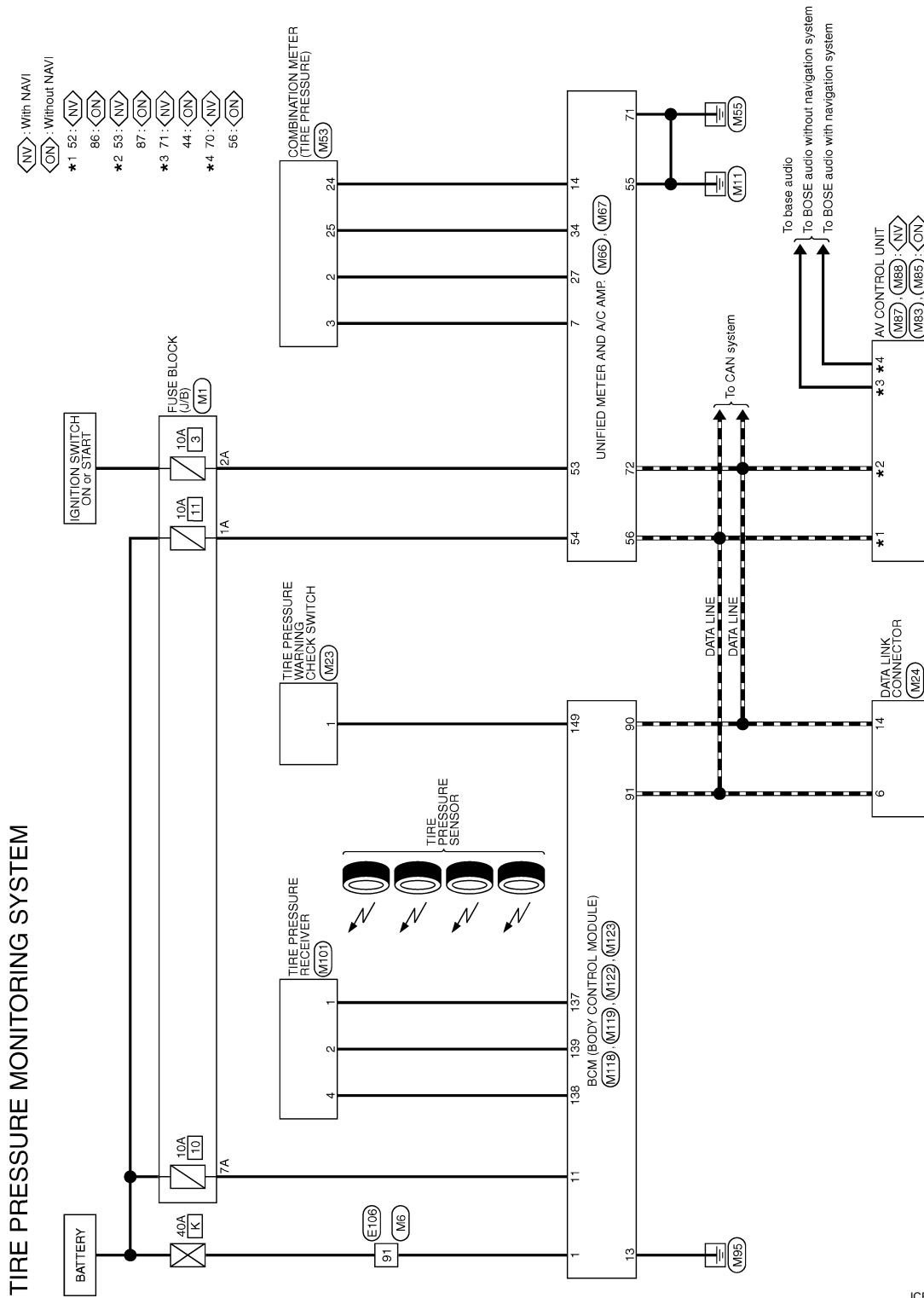

2008/08/07

JCEWA0083GE

TIRE PRESSURE MONITORING SYSTEM

Connector No.	E106
Connector Name	WIRE TO WIRE
Connector Type	TH80FW-CS16-TM4

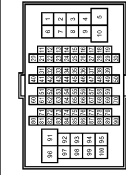

Terminal No.	91	W	Signal Name [Specification]

Connector No.	M1
Connector Name	FUSE BLOCK (J/B)
Connector Type	NS06FW-M2

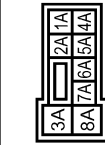

Terminal No.	1A	V	Signal Name [Specification]
	2A	G	
	7A	R	

Connector No.	M6
Connector Name	WIRE TO WIRE
Connector Type	TH80MM-CS16-TM4

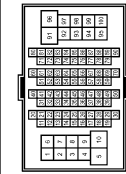

Terminal No.	91	W	Signal Name [Specification]

Connector No.	M23
Connector Name	TIRE PRESSURE WARNING CHECK SWITCH
Connector Type	TK02FW



Terminal No.	1	W	Signal Name [Specification]

Connector No.	M24
Connector Name	DATA LINK CONNECTOR
Connector Type	BD16FW-P

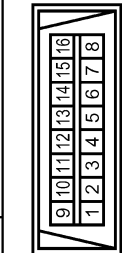

Terminal No.	6	L	Signal Name [Specification]
	14	P	

Connector No.	M53
Connector Name	COMBINATION METER
Connector Type	SAB0FW

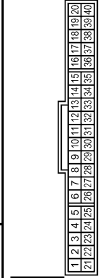

Terminal No.	2	LG	COMMUNICATION SIGNAL (METER->AMP)
	3	GR	COMMUNICATION SIGNAL (METER->METER)
	24	BR	COMMUNICATION SIGNAL (LCD->AMP)
	25	Y	COMMUNICATION SIGNAL (AMP->LCD)

Connector No.	M66
Connector Name	UNIFIED METER AND A/C AMP.
Connector Type	TH40FW-NH

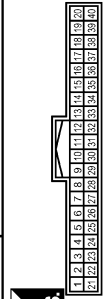

Terminal No.	7	GR	COMMUNICATION SIGNAL (AMP->METER)
	14	BR	COMMUNICATION SIGNAL (LCD->AMP)
	27	LG	COMMUNICATION SIGNAL (METER->AMP)
	34	Y	COMMUNICATION SIGNAL (AMP->LCD)

Connector No.	M67
Connector Name	UNIFIED METER AND A/C AMP.
Connector Type	TH62FW-NH

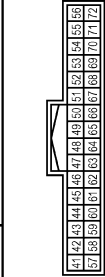

Terminal No.	53	W	IGNITION POWER SUPPLY
	54	Y	BATTERY POWER SUPPLY
	55	B	GROUND
	56	L	CAN-H
	71	GR	GROUND
	72	P	CAN-L

A
B
C
D
WT
F
G
H
I
J
K
L
M
N
O
P

TIRE PRESSURE MONITORING SYSTEM

Connector No.	M83
Connector Name	AV CONTROL UNIT (WITHOUT NAVI)
Connector Type	TH24FW-NH

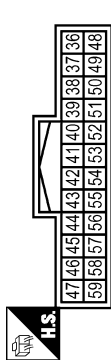

Terminal No.	Color of Wire	Signal Name [Specification]
44	BR	COMM (DISP->CONT)
56	Y	COMM (CONT->DISP)

Connector No.	M85
Connector Name	AV CONTROL UNIT (WITHOUT NAVI)
Connector Type	TH22FW-NH

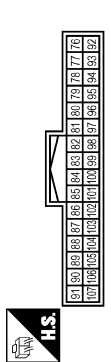

Terminal No.	Color of Wire	Signal Name [Specification]
86	L	CAN-H
87	P	CAN-L

Connector No.	M87
Connector Name	AV CONTROL UNIT (WITH NAVI)
Connector Type	TH40FW-NH

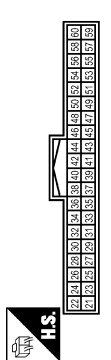

Terminal No.	Color of Wire	Signal Name [Specification]
44	SB	MODE CHANGE SIGNAL
52	L	CAN-H
53	P	CAN-L

Connector No.	M88
Connector Name	AV CONTROL UNIT (WITH NAVI)
Connector Type	TH42FW-NH

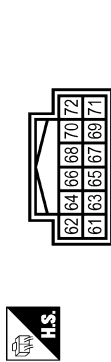

Terminal No.	Color of Wire	Signal Name [Specification]
70	L	COMM (CONT->DISP)
71	LG	COMM (DISP->CONT)

Connector No.	M101
Connector Name	TIRE PRESSURE RECEIVER
Connector Type	TK64FW

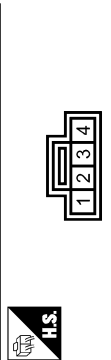

Terminal No.	Color of Wire	Signal Name [Specification]
1	P	GND
2	L	SIGNAL
4	V	BATTERY

Connector No.	M118
Connector Name	BCM (BODY CONTROL MODULE)
Connector Type	MG3FB-LC

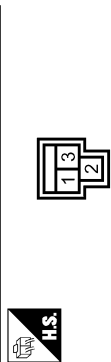

Terminal No.	Color of Wire	Signal Name [Specification]
1	W	BAT (F/L)

Connector No.	M119
Connector Name	BCM (BODY CONTROL MODULE)
Connector Type	NS16FW-CS

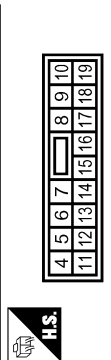

Terminal No.	Color of Wire	Signal Name [Specification]
11	R	BAT (FUSE)
13	B	GND

Connector No.	M122
Connector Name	BCM (BODY CONTROL MODULE)
Connector Type	TH40FB-NH

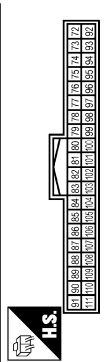

Terminal No.	Color of Wire	Signal Name [Specification]
90	P	CAN-L
91	L	CAN-H

A
B
C
D
WT
F
G
H
I
J
K
L
M
N
O
P

TIRE PRESSURE MONITORING SYSTEM

Connector No.	M123
Connector Name	BCM (BODY CONTROL MODULE)
Connector Type	TH40F-G-NH



Terminal No.	Color of Wire	Signal Name (Specification)
137	O	RECEIVER/SENSOR GND
138	V	RECEIVER/SENSOR POWER SUPPLY
139	L	TIRE PRESSURE RECEIVER COMM
149	W	TIRE PRESSURE WARN CHECK SW

JCEWA0086GE

BCM (BODY CONTROL MODULE)

< ECU DIAGNOSIS INFORMATION >

ECU DIAGNOSIS INFORMATION

BCM (BODY CONTROL MODULE)

Reference Value

INFOID:000000004503907

VALUES ON THE DIAGNOSIS TOOL

CONSULT-III MONITOR ITEM

Monitor Item	Condition	Value/Status
FR WIPER HI	Other than front wiper switch HI	Off
	Front wiper switch HI	On
FR WIPER LOW	Other than front wiper switch LO	Off
	Front wiper switch LO	On
FR WASHER SW	Front washer switch OFF	Off
	Front washer switch ON	On
FR WIPER INT	Other than front wiper switch INT	Off
	Front wiper switch INT	On
FR WIPER STOP	Front wiper is not in STOP position	Off
	Front wiper is in STOP position	On
INT VOLUME	Wiper intermittent dial is in a dial position 1 - 7	Wiper intermittent dial position
TURN SIGNAL R	Other than turn signal switch RH	Off
	Turn signal switch RH	On
TURN SIGNAL L	Other than turn signal switch LH	Off
	Turn signal switch LH	On
TAIL LAMP SW	Other than lighting switch 1ST and 2ND	Off
	Lighting switch 1ST or 2ND	On
HI BEAM SW	Other than lighting switch HI	Off
	Lighting switch HI	On
HEAD LAMP SW 1	Other than lighting switch 2ND	Off
	Lighting switch 2ND	On
HEAD LAMP SW 2	Other than lighting switch 2ND	Off
	Lighting switch 2ND	On
PASSING SW	Other than lighting switch PASS	Off
	Lighting switch PASS	On
AUTO LIGHT SW	Other than lighting switch AUTO	Off
	Lighting switch AUTO	On
FR FOG SW	Front fog lamp switch OFF	Off
	Front fog lamp switch ON	On
RR FOG SW	NOTE: The item is indicated, but not monitored.	Off
DOOR SW-DR	Driver door closed	Off
	Driver door opened	On
DOOR SW-AS	Passenger door closed	Off
	Passenger door opened	On
DOOR SW-RR	Rear RH door closed	Off
	Rear LH door opened	On

BCM (BODY CONTROL MODULE)

< ECU DIAGNOSIS INFORMATION >

Monitor Item	Condition	Value/Status	
DOOR SW-RL	Rear LH door closed	Off	A
	Rear LH door opened	On	
DOOR SW-BK	NOTE: The item is indicated, but not monitored.	Off	B
CDL LOCK SW	Other than power door lock switch LOCK	Off	C
	Power door lock switch LOCK	On	
CDL UNLOCK SW	Other than power door lock switch UNLOCK	Off	D
	Power door lock switch UNLOCK	On	
KEY CYL LK-SW	Other than driver door key cylinder LOCK	Off	E
	Driver door key cylinder LOCK	On	
KEY CYL UN-SW	Other than driver door key cylinder UNLOCK	Off	WT
	Driver door key cylinder LOCK	On	
KEY CYL SW-TR	NOTE: The item is indicated, but not monitored.	Off	F
HAZARD SW	Hazard switch is OFF	Off	G
	Hazard switch is ON	On	
REAR DEF SW	NOTE: The item is indicated, but not monitored.	Off	H
H/L WASH SW	NOTE: The item is indicated, but not monitored.	Off	H
TR CANCEL SW	Trunk lid opener cancel switch OFF	Off	I
	Trunk lid opener cancel switch ON	On	
TR/BD OPEN SW	Trunk lid opener switch OFF	Off	J
	While the trunk lid opener switch is turned ON	On	
TRNK/HAT MNTR	Trunk lid closed	Off	K
	Trunk lid opened	On	
RKE-LOCK	LOCK button of the Intelligent Key is not pressed	Off	L
	LOCK button of the Intelligent Key is pressed	On	
RKE-UNLOCK	UNLOCK button of the Intelligent Key is not pressed	Off	M
	UNLOCK button of the Intelligent Key is pressed	On	
RKE-TR/BD	TRUNK OPEN button of the Intelligent Key is not pressed	Off	N
	TRUNK OPEN button of the Intelligent Key is pressed	On	
RKE-PANIC	PANIC button of the Intelligent Key is not pressed	Off	O
	PANIC button of the Intelligent Key is pressed	On	
RKE-P/W OPEN	UNLOCK button of the Intelligent Key is not pressed	Off	P
	UNLOCK button of the Intelligent Key is pressed and held	On	
RKE-MODE CHG	LOCK/UNLOCK button of the Intelligent Key is not pressed and held simultaneously	Off	O
	LOCK/UNLOCK button of the Intelligent Key is pressed and held simultaneously	On	
OPTICAL SENSOR	Bright outside of the vehicle	Close to 5 V	P
	Dark outside of the vehicle	Close to 0 V	
REQ SW -DR	Driver door request switch is not pressed	Off	
	Driver door request switch is pressed	On	
REQ SW -AS	Passenger door request switch is not pressed	Off	
	Passenger door request switch is pressed	On	

BCM (BODY CONTROL MODULE)

< ECU DIAGNOSIS INFORMATION >

Monitor Item	Condition	Value/Status
REQ SW -RR	NOTE: The item is indicated, but not monitored.	Off
REQ SW -RL	NOTE: The item is indicated, but not monitored.	Off
REQ SW -BD/TR	Trunk lid opener request switch is not pressed	Off
	Trunk lid opener request switch is pressed	On
PUSH SW	Push-button ignition switch (push switch) is not pressed	Off
	Push-button ignition switch (push switch) is pressed	On
IGN RLY2 -F/B	Ignition switch in OFF or ACC position	Off
	Ignition switch in ON position	On
ACC RLY -F/B	NOTE: The item is indicated, but not monitored.	Off
CLUCH SW	The clutch pedal is not depressed	Off
	The clutch pedal is depressed	On
BRAKE SW 1	The brake pedal is depressed when No. 7 fuse is blown	Off
	The brake pedal is not depressed when No. 7 fuse is blown, or No. 7 fuse is normal	On
BRAKE SW 2	The brake pedal is not depressed	Off
	The brake pedal is depressed	On
DETE/CANCL SW	<ul style="list-style-type: none"> • Selector lever in P position (Except M/T models) • The clutch pedal is depressed (M/T models) 	Off
	<ul style="list-style-type: none"> • Selector lever in any position other than P (Except M/T models) • The clutch pedal is not depressed (M/T models) 	On
SFT PN/N SW	Selector lever in any position other than P and N	Off
	Selector lever in P or N position	On
S/L -LOCK	Steering is unlocked	Off
	Steering is locked	On
S/L -UNLOCK	Steering is locked	Off
	Steering is unlocked	On
S/L RELAY-F/B	Ignition switch in OFF or ACC position	Off
	Ignition switch in ON position	On
UNLK SEN -DR	Driver door is unlocked	Off
	Driver door is locked	On
PUSH SW -IPDM	Push-button ignition switch (push-switch) is not pressed	Off
	Push-button ignition switch (push-switch) is pressed	On
IGN RLY1 -F/B	Ignition switch in OFF or ACC position	Off
	Ignition switch in ON position	On
DETE SW -IPDM	Selector lever in any position other than P	Off
	Selector lever in P position	On
SFT PN -IPDM	<ul style="list-style-type: none"> • Selector lever in any position other than P and N (Except M/T models) • The clutch pedal is not depressed (M/T models) 	Off
	<ul style="list-style-type: none"> • Selector lever in P or N position (Except M/T models) • The clutch pedal is depressed (M/T models) 	On
SFT P -MET	Selector lever in any position other than P	Off
	Selector lever in P position	On
SFT N -MET	Selector lever in any position other than N	Off
	Selector lever in N position	On

BCM (BODY CONTROL MODULE)

< ECU DIAGNOSIS INFORMATION >

Monitor Item	Condition	Value/Status	
ENGINE STATE	Engine stopped	Stop	A
	While the engine stalls	Stall	
	At engine cranking	Crank	B
	Engine running	Run	
S/L LOCK-IPDM	Steering is unlocked	Off	
	Steering is locked	On	C
S/L UNLK-IPDM	Steering is locked	Off	
	Steering is unlocked	On	D
S/L RELAY-REQ	Steering lock system is not the LOCK condition and the changing condition from LOCK to UNLOCK	Off	
	Steering lock system is the LOCK condition or the changing condition from LOCK to UNLOCK	On	WT
VEH SPEED 1	While driving	Equivalent to speedometer reading	F
VEH SPEED 2	While driving	Equivalent to speedometer reading	
DOOR STAT-DR	Driver door is locked	LOCK	G
	Wait with selective UNLOCK operation (60 seconds)	READY	
	Driver door is unlocked	UNLOCK	
DOOR STAT-AS	Passenger door is locked	LOCK	H
	Wait with selective UNLOCK operation (60 seconds)	READY	
	Passenger door is unlocked	UNLOCK	I
ID OK FLAG	Steering is locked	Reset	
	Steering is unlocked	Set	
PRMT ENG STRT	The engine start is prohibited	Reset	J
	The engine start is permitted	Set	
PRMT RKE STRT	NOTE: The item is indicated, but not monitored.	Reset	K
KEY SW -SLOT	The Intelligent Key is not inserted into key slot	Off	
	The Intelligent Key is inserted into key slot	On	L
RKE OPE COUN1	During the operation of the Intelligent Key	Operation frequency of the Intelligent Key	
RKE OPE COUN2	NOTE: The item is indicated, but not monitored.	—	M
CONFIRM ID ALL	The key ID that the key slot receives is not recognized by any key ID registered to BCM.	Yet	
	The key ID that the key slot receives is recognized by any key ID registered to BCM.	Done	N
CONFIRM ID4	The key ID that the key slot receives is not recognized by the fourth key ID registered to BCM.	Yet	O
	The key ID that the key slot receives is recognized by the fourth key ID registered to BCM.	Done	
CONFIRM ID3	The key ID that the key slot receives is not recognized by the third key ID registered to BCM.	Yet	P
	The key ID that the key slot receives is recognized by the third key ID registered to BCM.	Done	

BCM (BODY CONTROL MODULE)

< ECU DIAGNOSIS INFORMATION >

Monitor Item	Condition	Value/Status
CONFIRM ID2	The key ID that the key slot receives is not recognized by the second key ID registered to BCM.	Yet
	The key ID that the key slot receives is recognized by the second key ID registered to BCM.	Done
CONFIRM ID1	The key ID that the key slot receives is not recognized by the first key ID registered to BCM.	Yet
	The key ID that the key slot receives is recognized by the first key ID registered to BCM.	Done
TP 4	The ID of fourth Intelligent Key is not registered to BCM	Yet
	The ID of fourth Intelligent Key is registered to BCM	Done
TP 3	The ID of third Intelligent Key is not registered to BCM	Yet
	The ID of third Intelligent Key is registered to BCM	Done
TP 2	The ID of second Intelligent Key is not registered to BCM	Yet
	The ID of second Intelligent Key is registered to BCM	Done
TP 1	The ID of first Intelligent Key is not registered to BCM	Yet
	The ID of first Intelligent Key is registered to BCM	Done
AIR PRESS FL	Ignition switch ON (Only when the signal from the transmitter is received)	Air pressure of front LH tire
AIR PRESS FR	Ignition switch ON (Only when the signal from the transmitter is received)	Air pressure of front RH tire
AIR PRESS RR	Ignition switch ON (Only when the signal from the transmitter is received)	Air pressure of rear RH tire
AIR PRESS RL	Ignition switch ON (Only when the signal from the transmitter is received)	Air pressure of rear LH tire
ID REGST FL1	ID of front LH tire transmitter is registered	Done
	ID of front LH tire transmitter is not registered	Yet
ID REGST FR1	ID of front RH tire transmitter is registered	Done
	ID of front RH tire transmitter is not registered	Yet
ID REGST RR1	ID of rear RH tire transmitter is registered	Done
	ID of rear RH tire transmitter is not registered	Yet
ID REGST RL1	ID of rear LH tire transmitter is registered	Done
	ID of rear LH tire transmitter is not registered	Yet
WARNING LAMP	Tire pressure indicator OFF	Off
	Tire pressure indicator ON	On
BUZZER	Tire pressure warning alarm is not sounding	Off
	Tire pressure warning alarm is sounding	On

BCM (BODY CONTROL MODULE)

< ECU DIAGNOSIS INFORMATION >

TERMINAL LAYOUT

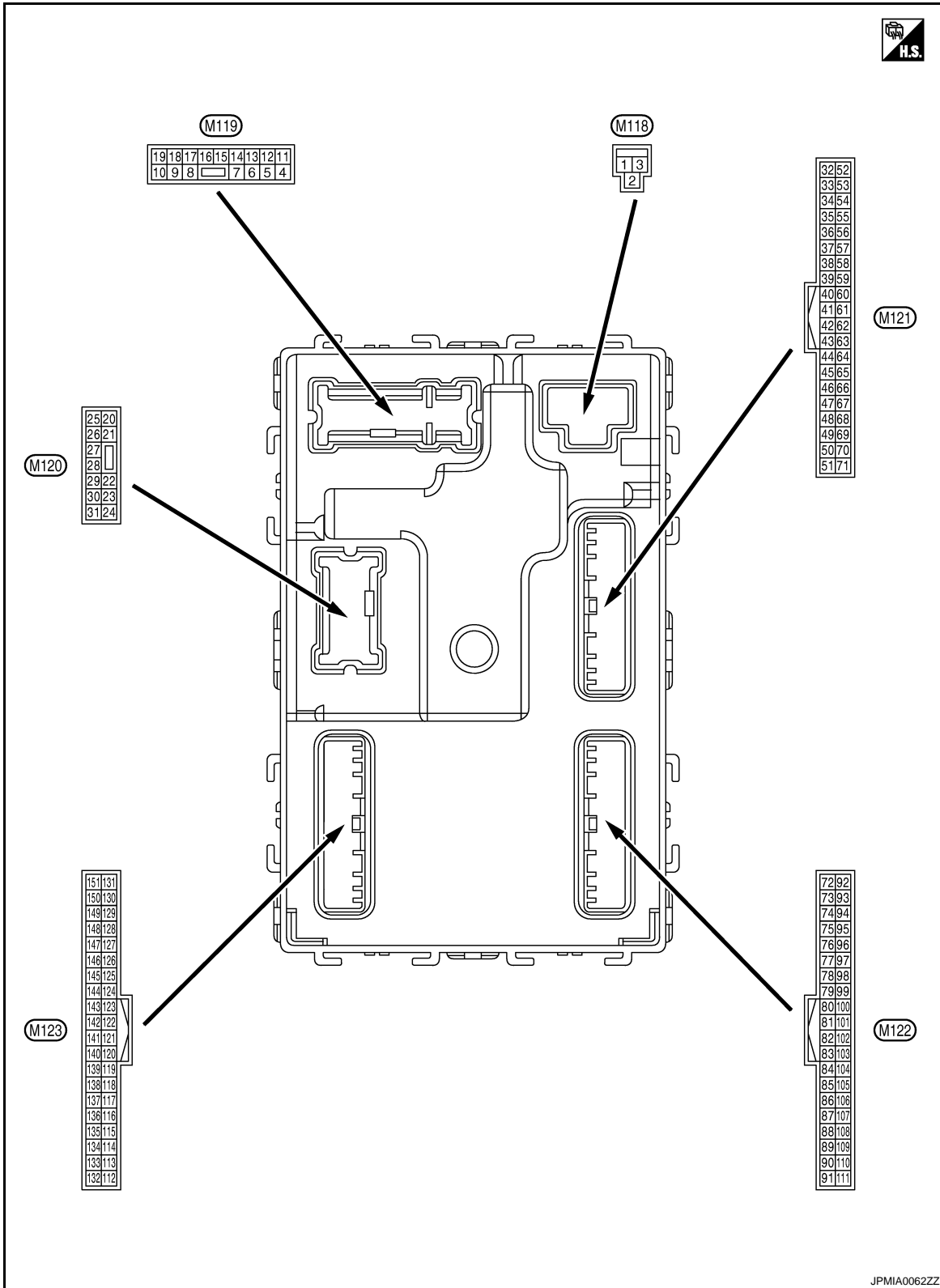

PHYSICAL VALUES

A
B
C
D
WT
F
G
H
I
J
K
L
M
N
O
P

BCM (BODY CONTROL MODULE)

< ECU DIAGNOSIS INFORMATION >

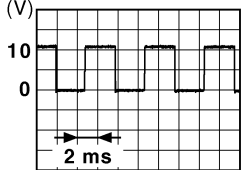
Terminal No. (Wire color)		Description		Condition		Value (Approx.)
		Signal name	Input/ Output			
+	-					
1 (W)	Ground	Battery power supply	Input	Ignition switch OFF		Battery voltage
2 (Y)	Ground	P/W power supply (BAT)	Output	Ignition switch OFF		12 V
3 (O)	Ground	P/W power supply (RAP)	Output	Ignition switch ON		12 V
4 (LG)	Ground	Interior room lamp power supply	Output	Interior room lamp battery saver is activated. (Cuts the interior room lamp power supply)		0 V
				Interior room lamp battery saver is not activated. (Outputs the interior room lamp power supply)		12 V
5 (P)	Ground	Passenger door UN- LOCK	Output	Passenger door	UNLOCK (Actuator is activated)	12 V
					Other than UNLOCK) Actuator is not activated	0 V
7 (BR)	Ground	Step lamp	Output	Step lamp	ON	0 V
					OFF	12 V
8 (V)	Ground	All doors, fuel lid LOCK	Output	All doors, fuel lid	LOCK (Actuator is activated)	12 V
					Other than LOCK (Actuator is not activated)	0 V
9 (G)	Ground	Driver door, fuel lid UNLOCK	Output	Driver door, fuel lid	UNLOCK (Actuator is activated)	12 V
					Other than UNLOCK (Actuator is not activated)	0 V
10 (BR)	Ground	Rear RH door and rear LH UNLOCK	Output	Rear RH door and rear LH door	UNLOCK (Actuator is activated)	12 V
					Other than UNLOCK (Actuator is not activated)	0 V
11 (R)	Ground	Battery power supply	Input	Ignition switch OFF		Battery voltage
13 (B)	Ground	Ground	—	Ignition switch ON		0 V
14 (W)	Ground	Push-button ignition switch illumination ground	Output	Tail lamp	OFF	0 V
					ON	<p>NOTE: When the illumination brightening/dimming level is in the neutral position</p>  <p style="text-align: right; font-size: small;">JSNIA0010GB</p>
15 (O)	Ground	ACC indicator lamp	Output	Ignition switch	OFF (LOCK indicator is not illuminated)	Battery voltage
					ACC	0 V

BCM (BODY CONTROL MODULE)

< ECU DIAGNOSIS INFORMATION >

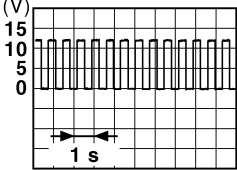
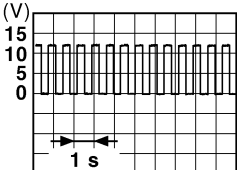
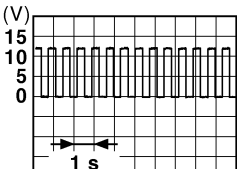
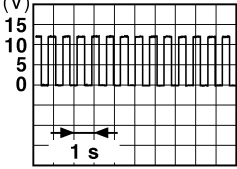
Terminal No. (Wire color)		Description		Condition	Value (Approx.)	
		Signal name	Input/ Output			
+	-					
17 (W)	Ground	Turn signal RH (Front)	Output	Ignition switch ON	Turn signal switch OFF	0 V
					Turn signal switch RH	 6.5 V
18 (O)	Ground	Turn signal LH (Front)	Output	Ignition switch ON	Turn signal switch OFF	0 V
					Turn signal switch LH	 6.5 V
19 (V)	Ground	Room lamp timer control	Output	Interior room lamp	OFF	12 V
					ON	0 V
20 (V)	Ground	Turn signal RH (Rear)	Output	Ignition switch ON	Turn signal switch OFF	0 V
					Turn signal switch RH	 6.5 V
23 (L)	Ground	Trunk lid open	Output	Trunk lid	OPEN (Trunk lid opener actuator is activated)	12 V
					Other than OPEN (Trunk lid opener actuator is not activated)	0 V
25 (Y)	Ground	Turn signal LH (Rear)	Output	Ignition switch ON	Turn signal switch OFF	0 V
					Turn signal switch LH	 6.5 V
30 (P)	Ground	Trunk room lamp	Output	Trunk room lamp	ON	0 V
					OFF	12 V

A
B
C
D
WT
F
G
H
I
J
K
L
M
N
O
P

BCM (BODY CONTROL MODULE)

< ECU DIAGNOSIS INFORMATION >

Terminal No. (Wire color)		Description		Condition	Value (Approx.)
+	-	Signal name	Input/ Output		
34 (SB)	Ground	Trunk room antenna (-)	Output	Ignition switch OFF	<p style="text-align: right; font-size: small;">JMKIA0062GB</p>
				When Intelligent Key is not in the passenger compart- ment	<p style="text-align: right; font-size: small;">JMKIA0063GB</p>
35 (V)	Ground	Trunk room antenna (+)	Output	Ignition switch OFF	<p style="text-align: right; font-size: small;">JMKIA0062GB</p>
				When Intelligent Key is not in the passenger compart- ment	<p style="text-align: right; font-size: small;">JMKIA0063GB</p>
38 (B)	Ground	Rear bumper anten- na (-)	Output	When the trunk lid opener re- quest switch is operated with ignition switch OFF	<p style="text-align: right; font-size: small;">JMKIA0062GB</p>
				When Intelligent Key is not in the antenna detection area	<p style="text-align: right; font-size: small;">JMKIA0063GB</p>

BCM (BODY CONTROL MODULE)

< ECU DIAGNOSIS INFORMATION >

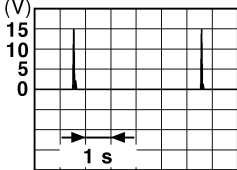
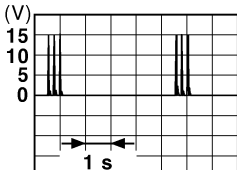
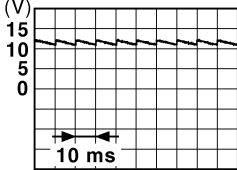
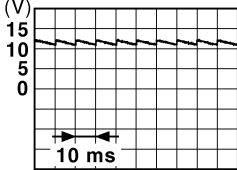
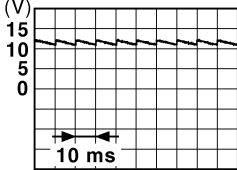
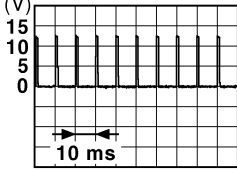
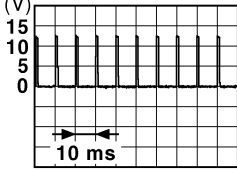
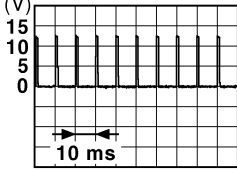
Terminal No. (Wire color)		Description		Condition	Value (Approx.)				
+	-	Signal name	Input/ Output						
39 (W)	Ground	Rear bumper antenna (+)	Output	When Intelligent Key is in the antenna detection area	 <small>JMKIA0062GB</small>				
				When the trunk lid opener request switch is operated with ignition switch OFF	 <small>JMKIA0063GB</small>				
47 (Y)	Ground	Ignition relay (IPDM E/R) control	Output	Ignition switch	<table border="1"> <tr> <td>OFF or ACC</td> <td>12 V</td> </tr> <tr> <td>ON</td> <td>0 V</td> </tr> </table>	OFF or ACC	12 V	ON	0 V
				OFF or ACC	12 V				
ON	0 V								
50 (O)	Ground	Trunk room lamp switch	Input	Trunk room lamp switch	<table border="1"> <tr> <td>OFF (Trunk lid is closed)</td> <td>  <small>JPMIA0011GB</small> </td> </tr> <tr> <td>ON (Trunk lid is opened)</td> <td>0 V</td> </tr> </table>	OFF (Trunk lid is closed)	 <small>JPMIA0011GB</small>	ON (Trunk lid is opened)	0 V
				OFF (Trunk lid is closed)	 <small>JPMIA0011GB</small>				
ON (Trunk lid is opened)	0 V								
52 (SB)	Ground	Starter relay control	Output	Ignition switch ON (A/T models)	<table border="1"> <tr> <td>When selector lever is in P or N position</td> <td>12 V</td> </tr> <tr> <td>When selector lever is not in P or N position</td> <td>0 V</td> </tr> </table>	When selector lever is in P or N position	12 V	When selector lever is not in P or N position	0 V
				When selector lever is in P or N position	12 V				
			When selector lever is not in P or N position	0 V					
			Ignition switch ON (M/T models)	<table border="1"> <tr> <td>When the clutch pedal is depressed</td> <td>Battery voltage</td> </tr> <tr> <td>When the clutch pedal is not depressed</td> <td>0 V</td> </tr> </table>	When the clutch pedal is depressed	Battery voltage	When the clutch pedal is not depressed	0 V	
When the clutch pedal is depressed	Battery voltage								
When the clutch pedal is not depressed	0 V								
61 (SB)	Ground	Trunk lid opener request switch	Input	Trunk lid opener request switch	<table border="1"> <tr> <td>ON (Pressed)</td> <td>0 V</td> </tr> <tr> <td>OFF (Not pressed)</td> <td>  <small>JPMIA0016GB</small> </td> </tr> </table>	ON (Pressed)	0 V	OFF (Not pressed)	 <small>JPMIA0016GB</small>
				ON (Pressed)	0 V				
OFF (Not pressed)	 <small>JPMIA0016GB</small>								
1.0 V									
64 (G)	Ground	Intelligent Key warning buzzer (Engine room)	Output	Intelligent Key warning buzzer (Engine room)	<table border="1"> <tr> <td>Sounding</td> <td>0 V</td> </tr> <tr> <td>Not sounding</td> <td>12 V</td> </tr> </table>	Sounding	0 V	Not sounding	12 V
				Sounding	0 V				
Not sounding	12 V								

A
B
C
D
WT
F
G
H
I
J
K
L
M
N
O
P

BCM (BODY CONTROL MODULE)

< ECU DIAGNOSIS INFORMATION >

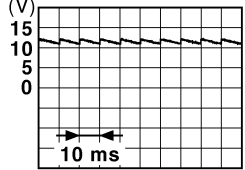
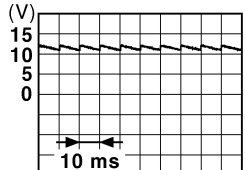
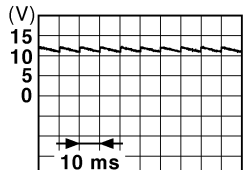
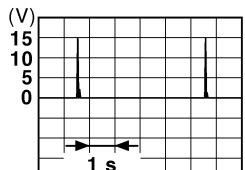
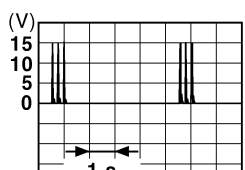
Terminal No. (Wire color)		Description		Condition	Value (Approx.)	
+	-	Signal name	Input/ Output			
67 (GR)	Ground	Trunk lid opener switch	Input	Trunk lid opener switch	Pressed	0 V
				Not pressed	Not pressed	 <p style="text-align: right; font-size: small;">JPMIA0011GB</p>
68 (BR)	Ground	Rear RH door switch	Input	Rear RH door switch	OFF (When rear RH door closes)	 <p style="text-align: right; font-size: small;">JPMIA0011GB</p>
				ON (When rear RH door opens)	ON (When rear RH door opens)	0 V
69 (R)	Ground	Rear LH door switch	Input	Rear LH door switch	OFF (When rear LH door closes)	 <p style="text-align: right; font-size: small;">JPMIA0011GB</p>
				ON (When rear LH door opens)	ON (When rear LH door opens)	0 V
72 (R)	Ground	Room antenna 2 (-) (Center console)	Output	Ignition switch OFF	When Intelligent Key is in the passenger compartment	 <p style="text-align: right; font-size: small;">JMKIA0062GB</p>
				When Intelligent Key is not in the passenger compartment	When Intelligent Key is not in the passenger compartment	 <p style="text-align: right; font-size: small;">JMKIA0063GB</p>

BCM (BODY CONTROL MODULE)

< ECU DIAGNOSIS INFORMATION >

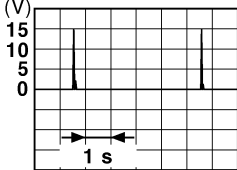
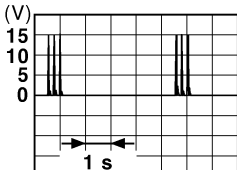
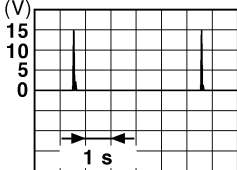
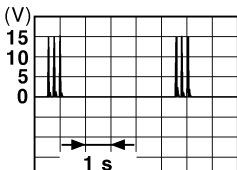
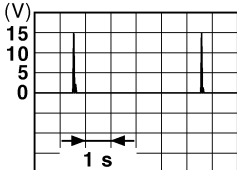
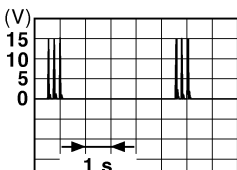
Terminal No. (Wire color)		Description		Condition	Value (Approx.)
		Signal name	Input/ Output		
+	-				
73 (G)	Ground	Room antenna 2 (+) (Center console)	Output	Ignition switch OFF	 <p style="text-align: right; font-size: small;">JMKIA0062GB</p>
				When Intelligent Key is not in the passenger compart- ment	 <p style="text-align: right; font-size: small;">JMKIA0063GB</p>
74 (SB)	Ground	Passenger door an- tenna (-)	Output	When the pas- senger door re- quest switch is operated with ignition switch OFF	 <p style="text-align: right; font-size: small;">JMKIA0062GB</p>
				When Intelligent Key is not in the antenna detection area	 <p style="text-align: right; font-size: small;">JMKIA0063GB</p>
75 (BR)	Ground	Passenger door an- tenna (+)	Output	When the pas- senger door re- quest switch is operated with ignition switch OFF	 <p style="text-align: right; font-size: small;">JMKIA0062GB</p>
				When Intelligent Key is not in the antenna detection area	 <p style="text-align: right; font-size: small;">JMKIA0063GB</p>

A
B
C
D
WT
F
G
H
I
J
K
L
M
N
O
P

BCM (BODY CONTROL MODULE)

< ECU DIAGNOSIS INFORMATION >

Terminal No. (Wire color)		Description		Condition	Value (Approx.)
+	-	Signal name	Input/ Output		
76 (V)	Ground	Driver door antenna (-)	Output	When Intelligent Key is in the antenna detection area	<p>JMKIA0062GB</p>
				When the driver door request switch is operated with ignition switch OFF	<p>JMKIA0063GB</p>
77 (LG)	Ground	Driver door antenna (+)	Output	When Intelligent Key is in the antenna detection area	<p>JMKIA0062GB</p>
				When the driver door request switch is operated with ignition switch OFF	<p>JMKIA0063GB</p>
78 (Y)	Ground	Room antenna 1 (-) (Instrument panel)	Output	Ignition switch OFF	<p>JMKIA0062GB</p>
				When Intelligent Key is in the passenger compartment	<p>JMKIA0063GB</p>

BCM (BODY CONTROL MODULE)

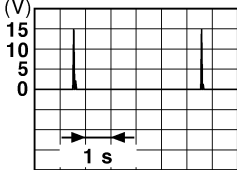
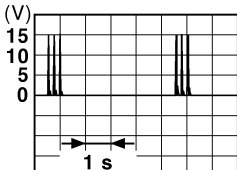
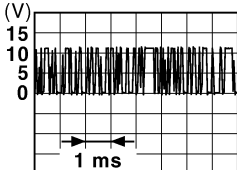
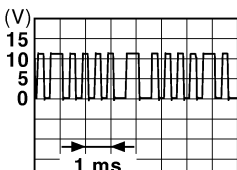

< ECU DIAGNOSIS INFORMATION >

Terminal No. (Wire color)		Description		Condition	Value (Approx.)
		Signal name	Input/ Output		
+	-				
79 (BR)	Ground	Room antenna 1 (+) (Instrument panel)	Output	Ignition switch OFF	
				Ignition switch ON	
80 (GR)	Ground	NATS antenna amp (Built in key slot)	Input/ Output	During waiting	Ignition switch is pressed while inserting the Intelligent Key into the key slot. Pointer of tester should move.
81 (W)	Ground	NATS antenna amp (Built in key slot)	Input/ Output	During waiting	Ignition switch is pressed while inserting the Intelligent Key into the key slot. Pointer of tester should move.
82 (R)	Ground	Ignition relay [Fuse block (J/B)] control	Output	Ignition switch OFF or ACC	0 V
				Ignition switch ON	12 V
83 (Y)	Ground	Remote keyless entry receiver communication	Input/ Output	During waiting	
				When operating either button on the Intelligent Key	

A
B
C
D
WT
F
G
H
I
J
K
L
M
N
O
P



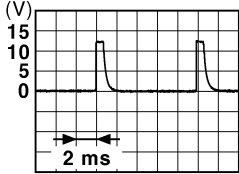

BCM (BODY CONTROL MODULE)

< ECU DIAGNOSIS INFORMATION >

Terminal No. (Wire color)		Description		Condition	Value (Approx.)	
		Signal name	Input/ Output			
+	-					
87 (Y)	Ground	Combination switch INPUT 5	Input	Combination switch	All switches OFF (Wiper intermittent dial 4)	 <p style="text-align: right; font-size: small;">JPMIA0041GB</p> <p style="text-align: center;">1.4 V</p>
				Combination switch	Front fog lamp switch ON (Wiper intermittent dial 4)	 <p style="text-align: right; font-size: small;">JPMIA0037GB</p> <p style="text-align: center;">1.3 V</p>
					Any of the conditions be- low with all switches OFF	<ul style="list-style-type: none"> • Wiper intermittent dial 1 • Wiper intermittent dial 2 • Wiper intermittent dial 6 • Wiper intermittent dial 7

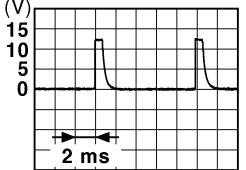
BCM (BODY CONTROL MODULE)

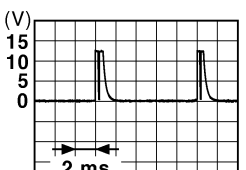
< ECU DIAGNOSIS INFORMATION >

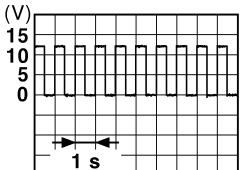
Terminal No. (Wire color)		Description		Condition	Value (Approx.)
+	-	Signal name	Input/ Output		
88 (O)	Ground	Combination switch INPUT 3	Input	Combination switch	All switches OFF (Wiper intermittent dial 4)  JPMIA0041GB 1.4 V
					Lighting switch HI (Wiper intermittent dial 4)  JPMIA0036GB 1.3 V
					Lighting switch 2ND (Wiper intermittent dial 4)  JPMIA0037GB 1.3 V
					Any of the conditions be- low with all switches OFF • Wiper intermittent dial 1 • Wiper intermittent dial 2 • Wiper intermittent dial 3  JPMIA0040GB 1.3 V
89 (BR)	Ground	Push-button ignition switch (Push switch)	Input	Push-button ig- nition switch (push switch)	Pressed 0 V
				Not pressed Battery voltage	
90 (P)	Ground	CAN-L	Input/ Output	—	—
91 (L)	Ground	CAN-H	Input/ Output	—	—
92 (LG)	Ground	Key slot illumination	Output	Key slot illumi- nation	OFF 0 V
					Blinking  JPMIA0015GB 6.5 V
					ON 12 V

A

B

C

D

WT

F

G

H

I

J

K

L

M

N

O

P

BCM (BODY CONTROL MODULE)

< ECU DIAGNOSIS INFORMATION >

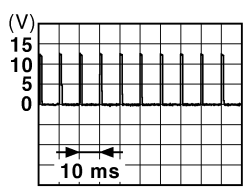
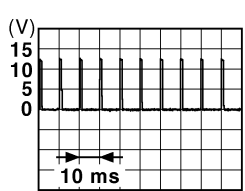
Terminal No. (Wire color)		Description		Condition		Value (Approx.)
		Signal name	Input/ Output			
+	-					
93 (V)	Ground	ON indicator lamp	Output	Ignition switch	OFF (LOCK indicator is not illuminated)	Battery voltage
					ON	0 V
95 (O)	Ground	ACC relay control	Output	Ignition switch	OFF	0 V
					ACC or ON	12 V
96 (GR)	Ground	A/T shift selector (Detention switch) power supply	Output	—		12 V
97 (L)	Ground	Steering lock condition No. 1	Input	Steering lock	LOCK status	0 V
					UNLOCK status	12 V
98 (P)	Ground	Steering lock condition No. 2	Input	Steering lock	LOCK status	12 V
					UNLOCK status	0 V
99 (R)*1 (BR)*2	Ground	Selector lever P position switch (A/T models)	Input	Selector lever	P position	0 V
					Any position other than P	12 V
		ASCD clutch switch (M/T models without ICC)		ASCD clutch switch	OFF (Clutch pedal is depressed)	0 V
					ON (Clutch pedal is not depressed)	12 V
		ICC clutch switch (M/T models with ICC)		ICC clutch switch	OFF (Clutch pedal is depressed)	0 V
					ON (Clutch pedal is not depressed)	12 V
100 (Y)	Ground	Passenger door request switch	Input	Passenger door request switch	ON (Pressed)	0 V
					OFF (Not pressed)	 <p style="text-align: right; font-size: small;">JPMIA0016GB</p>
101 (P)	Ground	Driver door request switch	Input	Driver door request switch	ON (Pressed)	0 V
					OFF (Not pressed)	 <p style="text-align: right; font-size: small;">JPMIA0016GB</p>
102 (O)	Ground	Blower fan motor relay control	Output	Ignition switch	OFF or ACC	0 V
					ON	12 V
103 (L)	Ground	Remote keyless entry receiver power supply	Output	Ignition switch OFF		12 V
106 (W)	Ground	Steering lock unit power supply	Output	Ignition switch	OFF or ACC	12 V
					ON	0 V

BCM (BODY CONTROL MODULE)

< ECU DIAGNOSIS INFORMATION >

Terminal No. (Wire color)		Description		Condition	Value (Approx.)	
		Signal name	Input/ Output			
+	-					
107 (LG)	Ground	Combination switch INPUT 1	Input	Combination switch (Wiper intermit- tent dial 4)	All switches OFF	<p style="text-align: center;">1.4 V</p>
					Turn signal switch LH	<p style="text-align: center;">1.3 V</p>
					Turn signal switch RH	<p style="text-align: center;">1.3 V</p>
					Front wiper switch LO	<p style="text-align: center;">1.3 V</p>
					Front washer switch ON	<p style="text-align: center;">1.3 V</p>

A
B
C
D
WT
F
G
H
I
J
K
L
M
N
O
P



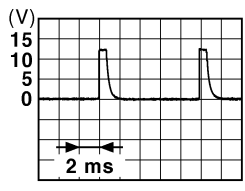
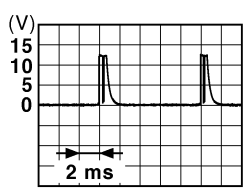
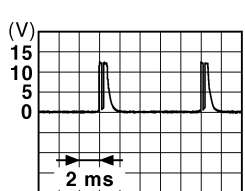
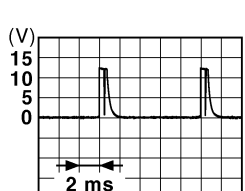

BCM (BODY CONTROL MODULE)

< ECU DIAGNOSIS INFORMATION >

Terminal No. (Wire color)		Description		Condition	Value (Approx.)
+	-	Signal name	Input/ Output		
108 (R)	Ground	Combination switch INPUT 4	Input	Combination switch	All switches OFF (Wiper intermittent dial 4) <div style="text-align: right;">  <p style="font-size: small; margin: 0;">JPMIA0041GB</p> <p style="margin: 0;">1.4 V</p> </div>
				Lighting switch AUTO (Wiper intermittent dial 4)	Lighting switch AUTO (Wiper intermittent dial 4) <div style="text-align: right;">  <p style="font-size: small; margin: 0;">JPMIA0038GB</p> <p style="margin: 0;">1.3 V</p> </div>
				Lighting switch 1ST (Wiper intermittent dial 4)	Lighting switch 1ST (Wiper intermittent dial 4) <div style="text-align: right;">  <p style="font-size: small; margin: 0;">JPMIA0036GB</p> <p style="margin: 0;">1.3 V</p> </div>
				Any of the conditions below with all switches OFF	Any of the conditions below with all switches OFF <ul style="list-style-type: none"> • Wiper intermittent dial 1 • Wiper intermittent dial 5 • Wiper intermittent dial 6 <div style="text-align: right;">  <p style="font-size: small; margin: 0;">JPMIA0039GB</p> <p style="margin: 0;">1.3 V</p> </div>

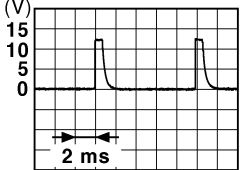
BCM (BODY CONTROL MODULE)

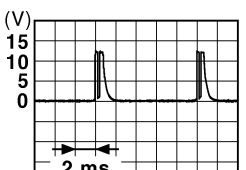
< ECU DIAGNOSIS INFORMATION >

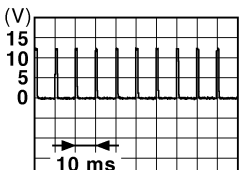
Terminal No. (Wire color)		Description		Condition	Value (Approx.)	
		Signal name	Input/ Output			
+	-					
109 (W)	Ground	Combination switch INPUT 2	Input	Combination switch (Wiper intermittent dial 4)	All switches OFF	 <small>JPMIA0041GB</small> 1.4 V
					Lighting switch PASS	 <small>JPMIA0037GB</small> 1.3 V
					Lighting switch 2ND	 <small>JPMIA0036GB</small> 1.3 V
					Front wiper switch INT	 <small>JPMIA0038GB</small> 1.3 V
					Front wiper switch HI	 <small>JPMIA0040GB</small> 1.3 V
					ON	0 V
110 (G)	Ground	Hazard switch	Input	Hazard switch	OFF	 <small>JPMIA0012GB</small> 1.1 V
				OFF	OFF	

A
B
C
D
WT
F
G
H
I
J
K
L
M
N
O
P

BCM (BODY CONTROL MODULE)

< ECU DIAGNOSIS INFORMATION >

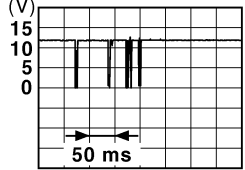
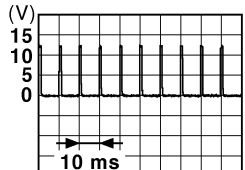
Terminal No. (Wire color)		Description		Condition	Value (Approx.)	
		Signal name	Input/ Output			
+	-					
111 (Y)	Ground	Steering lock unit communication	Input/ Output	Steering lock	LOCK status	12 V
					LOCK or UNLOCK	 <p style="text-align: right; font-size: small;">JMkia0066GB</p>
					For 15 seconds after UN- LOCK	12 V
					15 seconds or later after UNLOCK	0 V
113 (O)	Ground	Optical sensor	Input	Ignition switch ON	When bright outside of the vehicle	Close to 5 V
					When dark outside of the vehicle	Close to 0 V
114 (R)	Ground	Clutch interlock switch	Input	Clutch interlock switch	OFF (Clutch pedal is not depressed)	0 V
					ON (Clutch pedal is de- pressed)	Battery voltage
116 (SB)	Ground	Stop lamp switch 1	Input	—	Battery voltage	
118 (BR)	Ground	Stop lamp switch 2 (Without ICC)	Input	Stop lamp switch	OFF (Brake pedal is not depressed)	0 V
					ON (Brake pedal is de- pressed)	Battery voltage
		Stop lamp switch 2 (With ICC)		Stop lamp switch OFF (Brake pedal is not depressed) and ICC brake hold relay OFF	0 V	
				Stop lamp switch ON (Brake pedal is de- pressed) or ICC brake hold relay ON	Battery voltage	
119 (SB)	Ground	Front door lock as- sembly driver side (Unlock sensor)	Input	Driver door	LOCK status (Unlock sensor switch OFF)	 <p style="text-align: right; font-size: small;">JPMIA0012GB</p>
					UNLOCK status (Unlock switch sensor ON)	0 V
121 (SB)	Ground	Key slot switch	Input	When the Intelligent Key is inserted into key slot	12 V	
				When the Intelligent Key is not inserted into key slot	0 V	
123 (W)	Ground	IGN feedback	Input	Ignition switch	OFF or ACC	0 V
					ON	Battery voltage

BCM (BODY CONTROL MODULE)

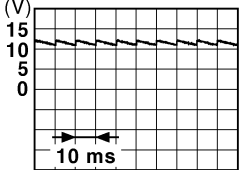
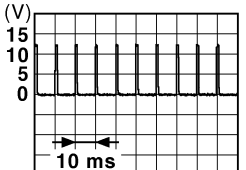
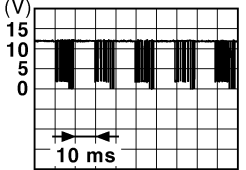
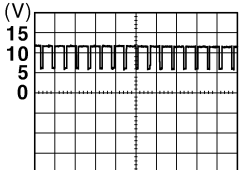

< ECU DIAGNOSIS INFORMATION >

Terminal No. (Wire color)		Description		Condition	Value (Approx.)	
		Signal name	Input/ Output			
+	-					
124 (LG)	Ground	Passenger door switch	Input	Passenger door switch	OFF (Door close)  <small>JPMIA0011GB</small> 11.8 V	
					ON (Door open)	0 V
129 (O)	Ground	Trunk lid opener cancel switch	Input	Trunk lid opener cancel switch	CANCEL  <small>JPMIA0012GB</small> 1.1 V	
					ON	0 V
132 (V)	Ground	Power window switch communication	Input/ Output	Ignition switch ON	 <small>JPMIA0013GB</small> 10.2 V	
					Ignition switch OFF or ACC	12 V
133 (L)	Ground	Push-button ignition switch illumination	Output	Push-button ignition switch illumination	ON (Tail lamps OFF) 9.5 V	
					ON (Tail lamps ON)	NOTE: The pulse width of this wave is varied by the illumination brightening/dimming level.  <small>JPMIA0159GB</small>
					OFF	0 V
134 (LG)	Ground	LOCK indicator lamp	Output	LOCK indicator lamp	OFF Battery voltage ON 0 V	
137 (O)	Ground	Receiver and sensor ground	Input	Ignition switch ON	0 V	
138 (V)	Ground	Receiver and sensor power supply	Output	Ignition switch	OFF 0 V ACC or ON 5.0 V	

A
B
C
D
WT
F
G
H
I
J
K
L
M
N
O
P

BCM (BODY CONTROL MODULE)

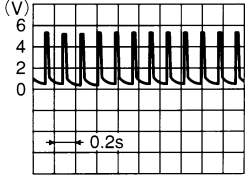
< ECU DIAGNOSIS INFORMATION >

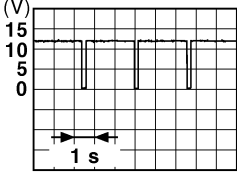
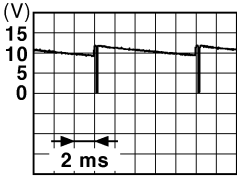
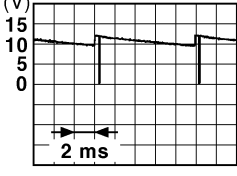
Terminal No. (Wire color)		Description		Condition	Value (Approx.)
+	-	Signal name	Input/ Output		
139 (L)	Ground	Tire pressure receiver communication	Input/ Output	Ignition switch ON	Standby state  OCC3881D
				When receiving the signal from the transmitter  OCC3880D	
140 (GR)	Ground	Selector lever P/N position	Input	Selector lever	P or N position 12 V
				Except P and N positions 0 V	
141 (R)	Ground	Security indicator	Output	Security indicator	ON 0 V
				Blinking  11.3 V	
				OFF 12 V	
142 (BR)	Ground	Combination switch OUTPUT 5	Output	Combination switch (Wiper intermittent dial 4)	All switches OFF 0 V
				Lighting switch 1ST	 10.7 V
				Lighting switch HI	
				Lighting switch 2ND	
Turn signal switch RH					
143 (P)	Ground	Combination switch OUTPUT 1	Output	Combination switch	All switches OFF (Wiper intermittent dial 4) 0 V
				Front wiper switch HI (Wiper intermittent dial 4)	 10.7 V
				Any of the conditions below with all switches OFF • Wiper intermittent dial 1 • Wiper intermittent dial 2 • Wiper intermittent dial 3 • Wiper intermittent dial 6 • Wiper intermittent dial 7	

BCM (BODY CONTROL MODULE)

< ECU DIAGNOSIS INFORMATION >

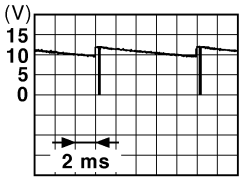
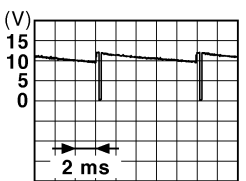
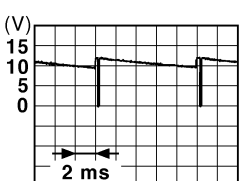
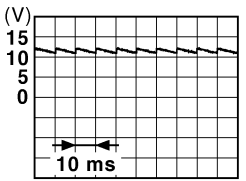
Terminal No. (Wire color)		Description		Condition	Value (Approx.)	
+	-	Signal name	Input/ Output			
144 (G)	Ground	Combination switch OUTPUT 2	Output	Combination switch	All switches OFF (Wiper intermittent dial 4)	0 V
					Front washer switch ON (Wiper intermittent dial 4)	
					Any of the conditions below with all switches OFF <ul style="list-style-type: none"> • Wiper intermittent dial 1 • Wiper intermittent dial 5 • Wiper intermittent dial 6 	
145 (L)	Ground	Combination switch OUTPUT 3	Output	Combination switch (Wiper intermittent dial 4)	All switches OFF	0 V
					Front wiper switch INT	
					Front wiper switch LO	
					Lighting switch AUTO	
146 (SB)	Ground	Combination switch OUTPUT 4	Output	Combination switch (Wiper intermittent dial 4)	All switches OFF	0 V
					Front fog lamp switch ON	
					Lighting switch 2ND	
					Lighting switch PASS	
					Turn signal switch LH	
149 (W)	Ground	Tire pressure warning check switch	Input	—	12 V	
150 (GR)	Ground	Driver door switch	Input	Driver door switch	OFF (Door close)	
					ON (Door open)	
151 (G)	Ground	Rear window defogger relay control	Output	Rear window defogger	Active	0 V
				Not activated	Battery voltage	

- *1: A/T models
- *2: M/T models

A
B
C
D
WT
F
G
H
I
J
K
L
M
N
O
P

BCM (BODY CONTROL MODULE)

< ECU DIAGNOSIS INFORMATION >

Wiring Diagram - BCM -

INFOID:000000004503908

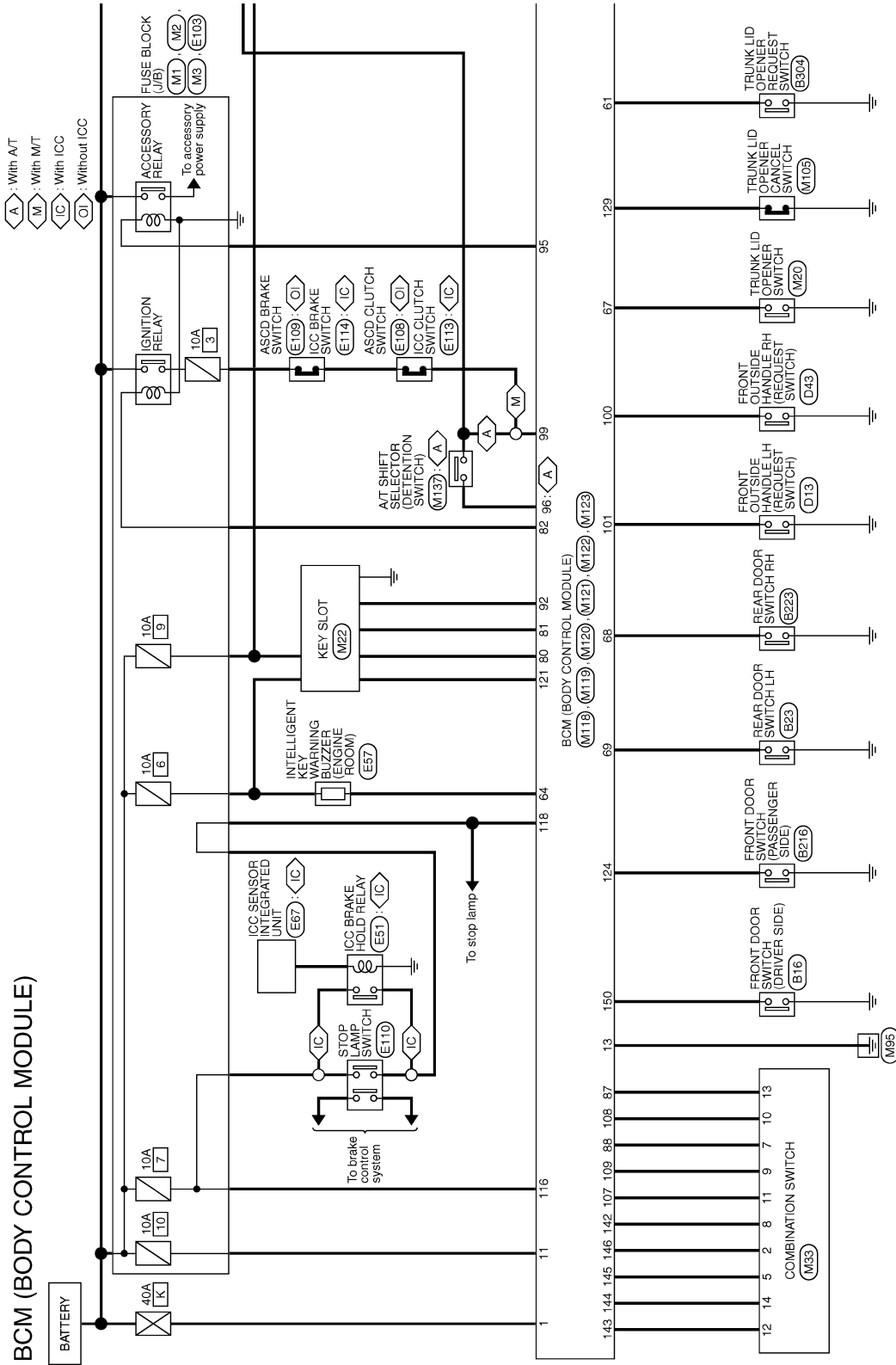

2008/08/07

JCMWA3019GE

BCM (BODY CONTROL MODULE)

< ECU DIAGNOSIS INFORMATION >

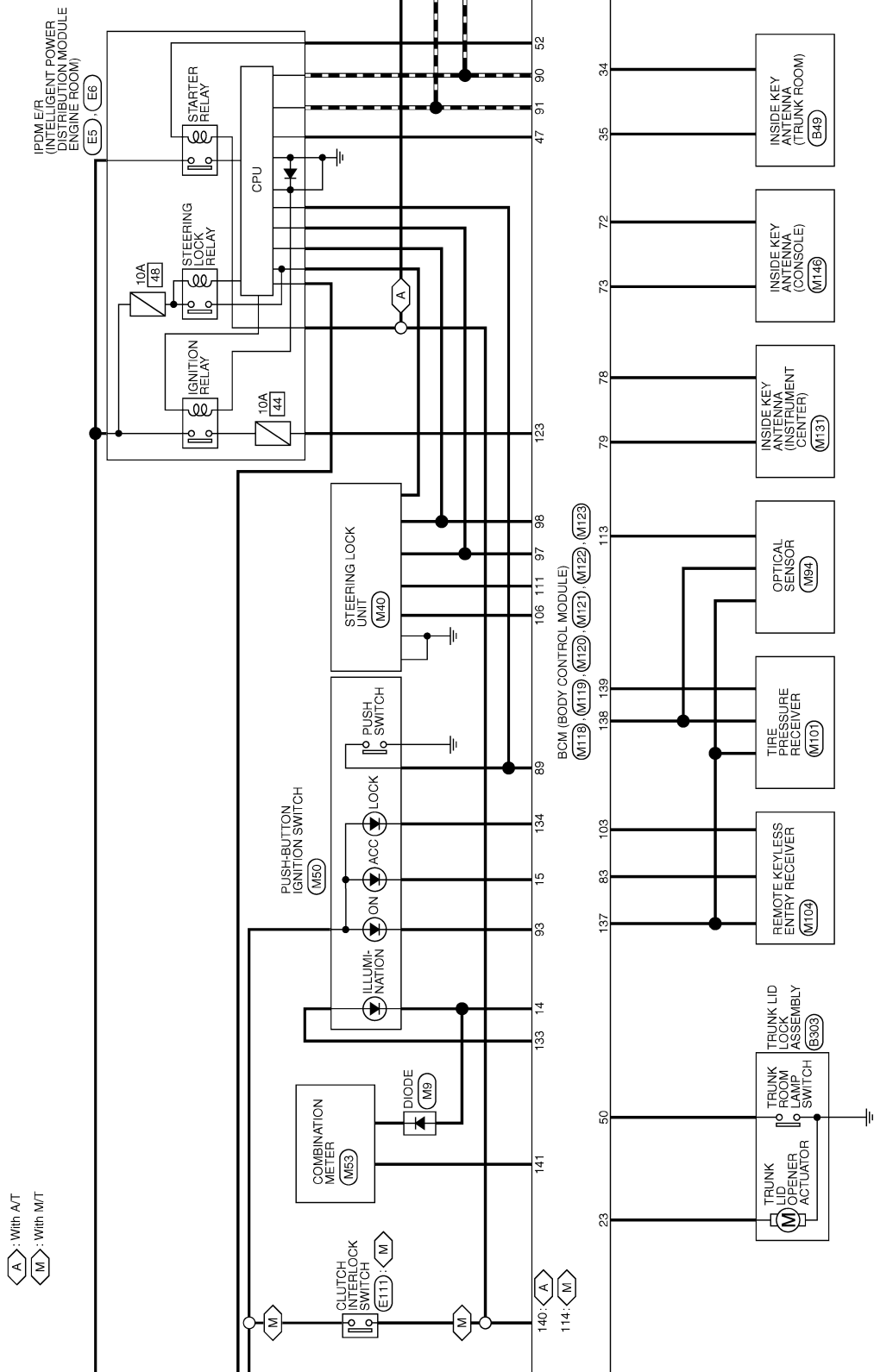

A : With A/T
M : With M/T

JCMWA3020GE

A
B
C
D
WT
F
G
H
I
J
K
L
M
N
O
P

BCM (BODY CONTROL MODULE)

< ECU DIAGNOSIS INFORMATION >

- ◁ A ▷ : With AT
- ◁ RF ▷ : With sunroof
- ◁ AN ▷ : With rear anti-pinch system
- ◁ OA ▷ : Without rear anti-pinch system
- ◁ SR ▷ : With sports seat without automatic drive positioner
- ◁ PM ▷ : With automatic drive positioner
- ◁ OP ▷ : Without automatic drive positioner

* : This connector is not shown in "Harness Layout".

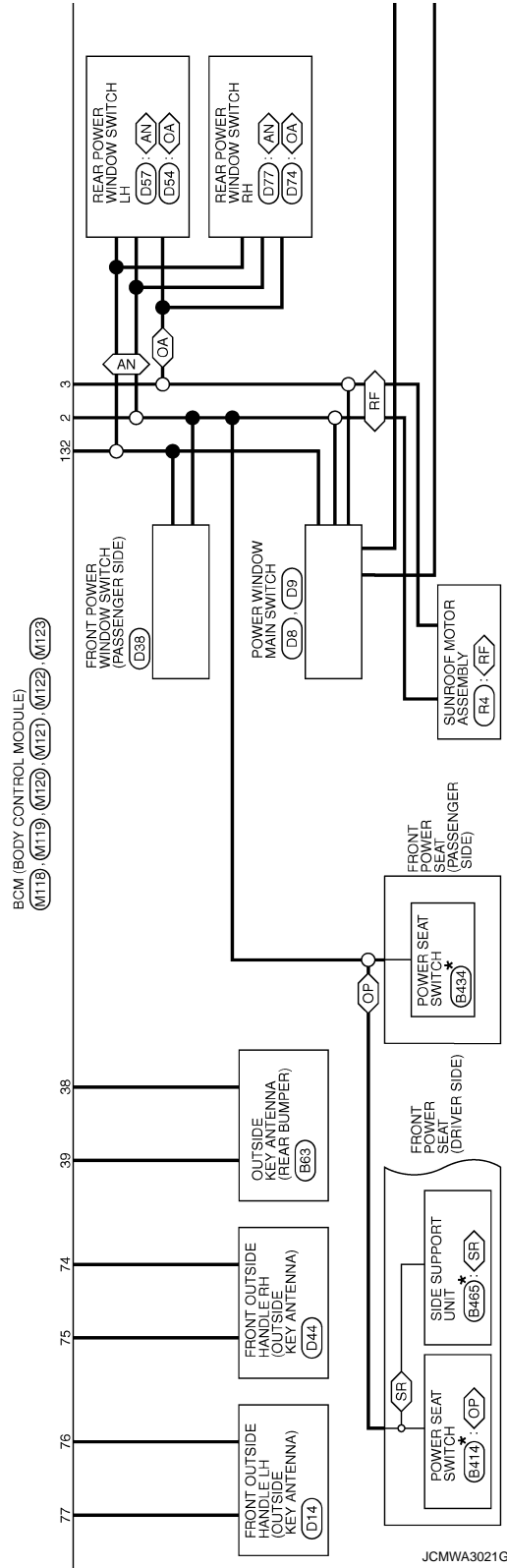
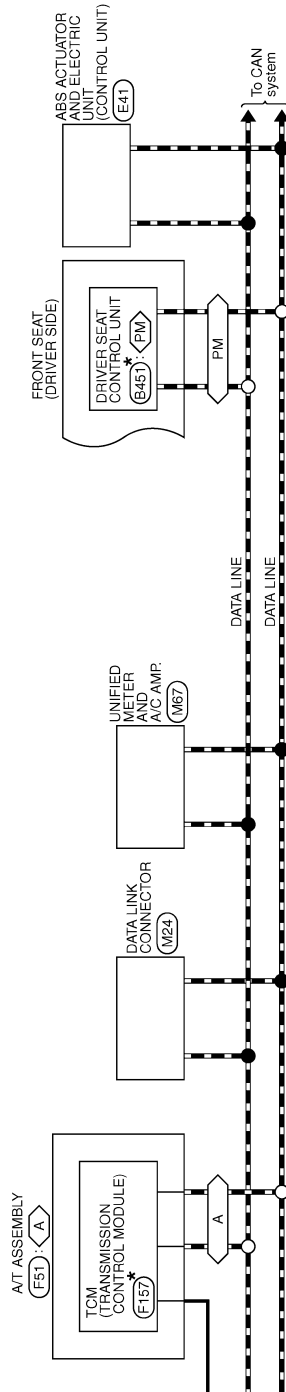

JCMWA3021G

BCM (BODY CONTROL MODULE)

< ECU DIAGNOSIS INFORMATION >

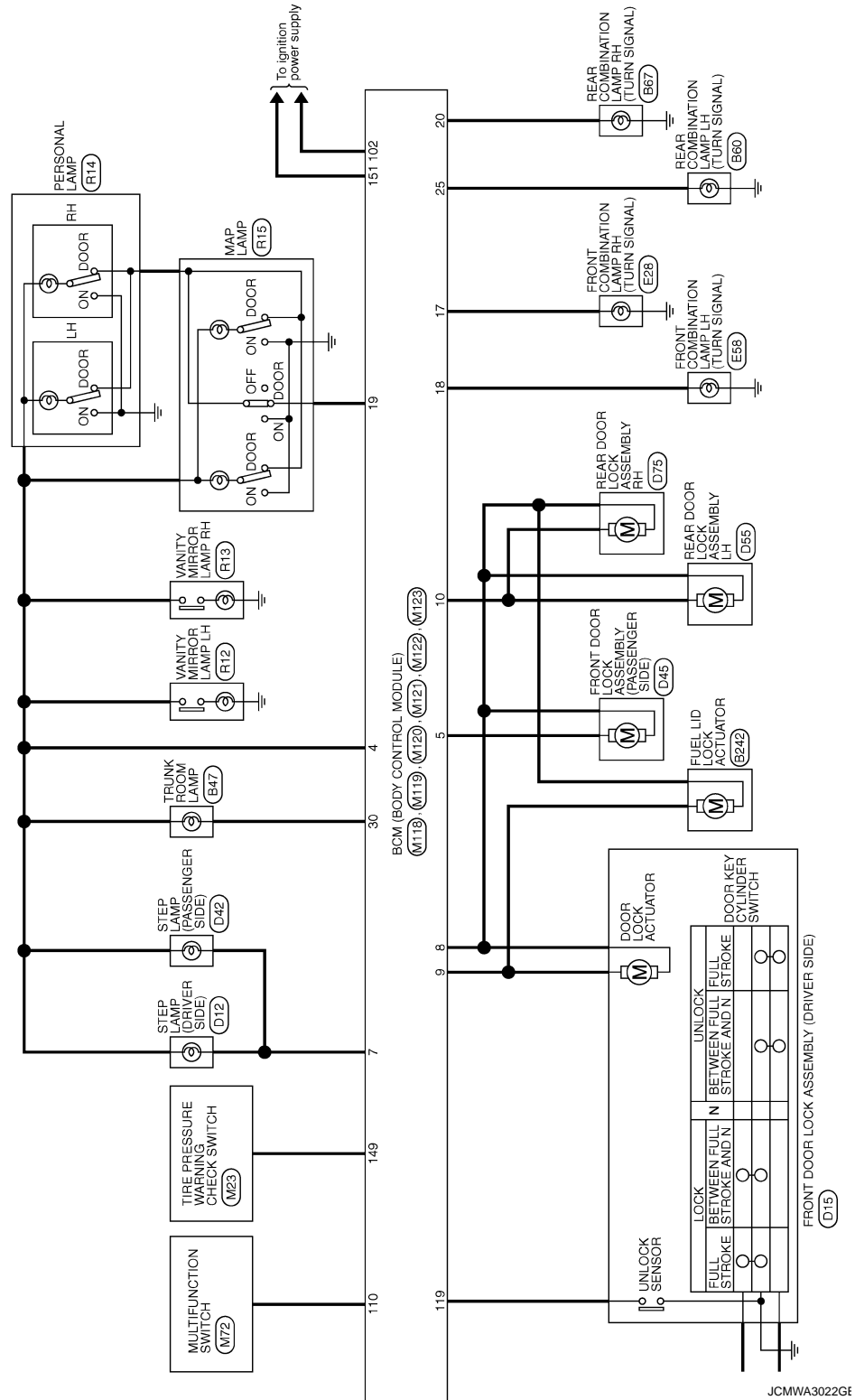

A
B
C
D
WT
F
G
H
I
J
K
L
M
N
O
P

BCM (BODY CONTROL MODULE)

< ECU DIAGNOSIS INFORMATION >

BCM (BODY CONTROL MODULE)

Connector No.	M33
Connector Name	COMBINATION SWITCH
Connector Type	TH16FW-NH



Terminal No.	Color of Wire	Signal Name [Specification]
2	SB	OUTPUT 4
5	L	OUTPUT 3
7	O	INPUT 3
8	BR	OUTPUT 5
9	W	INPUT 2
10	R	INPUT 4
11	LG	INPUT 1
12	P	OUTPUT 1
13	Y	INPUT 5
14	G	OUTPUT 2



Connector No.	M120
Connector Name	BCM (BODY CONTROL MODULE)
Connector Type	MS12PW-CS



Terminal No.	Color of Wire	Signal Name [Specification]
20	V	TURN SIGNAL RH (REAR)
23	L	TRUNK LID OPEN OUTPUT
25	Y	TURN SIGNAL LH (REAR)
30	P	TRUNK ROOM LAMP

Connector No.	M118
Connector Name	BCM (BODY CONTROL MODULE)
Connector Type	M03EB-LC



Terminal No.	Color of Wire	Signal Name [Specification]
1	W	BAT (E/L)
2	Y	POWER WINDOW POWER SUPPLY(BAT)
3	O	POWER WINDOW POWER SUPPLY(IRAP)

Connector No.	M121
Connector Name	BCM (BODY CONTROL MODULE)
Connector Type	TH40FGY-NH



Terminal No.	Color of Wire	Signal Name [Specification]
34	SB	TRUNK ROOM ANT-
35	V	TRUNK ROOM ANT+
38	B	REAR BUMPER ANT-
39	W	REAR BUMPER ANT+
47	Y	IGN RELAY (PDM E/R) CONT
50	O	TRUNK ROOM LAMP SW
52	SR	STARTER RELAY CONT
61	SR	TRUNK LID OPENER REQUEST SW
64	G	KEY WARN BUTTEZ (ENG ROOM)
67	GR	TRUNK LID OPENER SW
68	BR	REAR RH DOOR SW

Connector No.	M119
Connector Name	BCM (BODY CONTROL MODULE)
Connector Type	MS16FW-CS

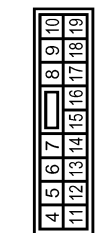

Terminal No.	Color of Wire	Signal Name [Specification]
4	LG	INTERIOR ROOM LAMP POWER SUPPLY
5	P	PASSENGER DOOR UNLOCK OUTPUT
7	BR	STEP LAMP OUTPUT
8	V	ALL DOOR. FUEL LID LOCK OUTPUT
9	G	DRIVER DOOR. FUEL LID UNLOCK OUTPUT
10	BR	REAR DOOR UNLOCK OUTPUT
11	R	BAT (FUSE)
13	B	GND
14	W	PUSH-BUTTON (IGNITION SW ILL GND
15	O	ACC IND
17	W	TURN SIGNAL RH (FRONT)

69	R	REAR LH DOOR SW
----	---	-----------------

18	O	TURN SIGNAL LH (FRONT)
19	V	ROOM LAMP TIMER CONTROL

BCM (BODY CONTROL MODULE)

< ECU DIAGNOSIS INFORMATION >

134	LG	LOCK IND
137	O	RECEIVER/SENSOR GND
138	V	RECEIVER/SENSOR POWER SUPPLY
139	L	TIRE PRESSURE RECEIVER COMM
140	GR	SHIFT UP/D
141	R	SECURITY INDICATOR
142	BR	COMBI SW OUTPUT 5
143	P	COMBI SW OUTPUT 1
144	G	COMBI SW OUTPUT 2
145	L	COMBI SW OUTPUT 3
146	SB	COMBI SW OUTPUT 4
149	W	TIRE PRESSURE WARN CHECK SW
150	GR	DRIVER DOOR SW
151	G	REAR WINDOW DEFOGGER RELAY CONT

Connector No.	M123
Connector Name	BCM (BODY CONTROL MODULE)
Connector Type	TH40FG-NH

Terminal No.	Color of Wire	Signal Name [Specification]
113	O	OPTICAL SENSOR
114	R	CLUTCH INTERLOCK SW
116	SB	STOP LAMP SW 1
118	BR	STOP LAMP SW 2
119	SB	DR DOOR UNLOCK SENSOR
121	SB	KEY SLOT SW
123	W	IGN F/B
124	LG	PASSENGER DOOR SW
129	O	TRUNK LID OPENER CANCEL SW
132	V	POWER WINDOW SW COMM
133	L	PUSH-BUTTON IGNITION SW ILL POWER

83	Y	KEYLESS ENTRY RECEIVER COMM
87	Y	COMBI SW INPUT 5
88	O	COMBI SW INPUT 3
89	BR	PUSH SW
90	P	GAH-L
91	L	GAH-H
92	LG	KEY SLOT ILL
93	V	ON IND
95	O	ACC RELAY CONT
96	GR	AT SHIFT SELECTOR POWER SUPPLY
97	L	S/L CONDITION 1
98	P	S/L CONDITION 2
99	BR	ASCD CLUTCH SW [With M/T without GC]
99	BR	IGCC CLUTCH SW [With M/T and GC]
99	R	SHIFT P [With A/T]
100	Y	PASSENGER DOOR REQUEST SW
101	P	DRIVER DOOR REQUEST SW
102	O	BLOWER FAN MOTOR RELAY CONT
103	L	KEYLESS ENTRY RECEIVER POWER SUPPLY
106	W	S/L UNIT POWER SUPPLY
107	LG	COMBI SW INPUT 1
108	R	COMBI SW INPUT 4
109	W	COMBI SW INPUT 2
110	G	HAZARD SW
111	Y	S/L UNIT COMM

BCM (BODY CONTROL MODULE)

Connector No.	M122
Connector Name	BCM (BODY CONTROL MODULE)
Connector Type	TH40FB-NH

Terminal No.	Color of Wire	Signal Name [Specification]
72	R	ROOM ANT2-
73	G	ROOM ANT2+
74	SB	PASSENGER DOOR ANT-
75	BR	PASSENGER DOOR ANT+
76	V	DRIVER DOOR ANT-
77	LG	DRIVER DOOR ANT+
78	Y	ROOM ANT1-
79	BR	ROOM ANT1+
80	GR	IMMOBI ANTENNA CONTROL
81	W	IMMOBI ANTENNA SIGNAL
82	R	IGN RELAY (F/B) CONT

Fail-safe

FAIL-SAFE CONTROL BY DTC

BCM performs fail-safe control when any DTC are detected.

JCMWA3024GE

INFOID:000000004503909

A
B
C
D
WT
F
G
H
I
J
K
L
M
N
O
P

BCM (BODY CONTROL MODULE)

< ECU DIAGNOSIS INFORMATION >

Display contents of CONSULT	Fail-safe	Cancellation
B2013: ID DISCORD BCM-S/L	Inhibit engine cranking	Erase DTC
B2014: CHAIN OF S/L-BCM	Inhibit engine cranking	Erase DTC
B2190: NATS ANTENNA AMP	Inhibit engine cranking	Erase DTC
B2191: DIFFERENCE OF KEY	Inhibit engine cranking	Erase DTC
B2192: ID DISCORD BCM-ECM	Inhibit engine cranking	Erase DTC
B2193: CHAIN OF BCM-ECM	Inhibit engine cranking	Erase DTC
B2195: ANTI SCANNING	Inhibit engine cranking	Ignition switch ON → OFF
B2557: VEHICLE SPEED	Inhibit steering lock	When normal vehicle speed signals are received from ABS actuator and electric unit (control unit) for 500 ms
B2560: STARTER CONT RELAY	Inhibit engine cranking	500 ms after the following CAN signal communication status becomes consistent <ul style="list-style-type: none"> • Starter control relay signal • Starter relay status signal
B2601: SHIFT POSITION	Inhibit steering lock	500 ms after the following signal reception status becomes consistent <ul style="list-style-type: none"> • Selector lever P position switch signal • P range signal (CAN)
B2602: SHIFT POSITION	Inhibit steering lock	5 seconds after the following BCM recognition conditions are fulfilled <ul style="list-style-type: none"> • Ignition switch is in the ON position • Selector lever P position switch signal: Except P position (battery voltage) • Vehicle speed: 4 km/h (2.5 MPH) or more
B2603: SHIFT POSI STATUS	Inhibit steering lock	500 ms after the following BCM recognition conditions are fulfilled <ul style="list-style-type: none"> • Ignition switch is in the ON position • Selector lever P position switch signal: Except P position (battery voltage) • Selector lever P/N position signal: Except P and N positions (0 V)
B2604: PNP SW	Inhibit steering lock	500 ms after any of the following BCM recognition conditions are fulfilled <ul style="list-style-type: none"> • Status 1 <ul style="list-style-type: none"> - Ignition switch is in the ON position - Selector lever P/N position signal: P and N position (battery voltage) - P range signal or N range signal (CAN): ON • Status 2 <ul style="list-style-type: none"> - Ignition switch is in the ON position - Selector lever P/N position signal: Except P and N positions (0 V) - P range signal and N range signal (CAN): OFF
B2605: PNP SW	Inhibit steering lock	500 ms after any of the following BCM recognition conditions are fulfilled <ul style="list-style-type: none"> • Status 1 <ul style="list-style-type: none"> - Ignition switch is in the ON position - Selector lever P/N position signal: Except P and N positions (0 V) - Interlock/PNP switch signal (CAN): OFF • Status 2 <ul style="list-style-type: none"> - Ignition switch is in the ON position - Selector lever P/N position signal: P or N position (battery voltage) - PNP switch signal (CAN): ON
B2606: S/L RELAY	Inhibit engine cranking	500 ms after the following CAN signal communication status becomes consistent <ul style="list-style-type: none"> • Steering lock relay signal (Request signal) • Steering lock relay signal (Condition signal)

BCM (BODY CONTROL MODULE)

< ECU DIAGNOSIS INFORMATION >

Display contents of CONSULT	Fail-safe	Cancellation
B2607: S/L RELAY	Inhibit engine cranking	500 ms after the following CAN signal communication status has becomes consistent <ul style="list-style-type: none"> • Steering lock relay signal (Request signal) • Steering lock relay signal (Condition signal)
B2608: STARTER RELAY	Inhibit engine cranking	500 ms after the following signal communication status becomes consistent <ul style="list-style-type: none"> • Starter motor relay control signal • Starter relay status signal (CAN)
B2609: S/L STATUS	<ul style="list-style-type: none"> • Inhibit engine cranking • Inhibit steering lock 	When the following steering lock conditions agree <ul style="list-style-type: none"> • BCM steering lock control status • Steering lock condition No. 1 signal status • Steering lock condition No. 2 signal status
B260A: IGNITION RELAY	Inhibit engine cranking	500 ms after the following conditions are fulfilled <ul style="list-style-type: none"> • IGN relay (IPDM E/R) control signal: OFF (Battery voltage) • Ignition ON signal (CAN to IPDM E/R): OFF (Request signal) • Ignition ON signal (CAN from IPDM E/R): OFF (Condition signal)
B260F: ENG STATE SIG LOST	Maintains the power supply position attained at the time of DTC detection	When any of the following conditions are fulfilled <ul style="list-style-type: none"> • Power position changes to ACC • Receives engine status signal (CAN)
B2612: S/L STATUS	<ul style="list-style-type: none"> • Inhibit engine cranking • Inhibit steering lock 	When any of the following conditions are fulfilled <ul style="list-style-type: none"> • Steering lock unit status signal (CAN) is received normally • The BCM steering lock control status matches the steering lock status recognized by the steering lock unit status signal (CAN from IPDM E/R)
B2617: STARTER RELAY CIRC	Inhibit engine cranking	1 second after the starter motor relay control inside BCM becomes normal
B2618: BCM	Inhibit engine cranking	1 second after the ignition relay (IPDM E/R) control inside BCM becomes normal
B2619: BCM	Inhibit engine cranking	1 second after the steering lock unit power supply output control inside BCM becomes normal
B261E: VEHICLE TYPE	Inhibit engine cranking	BCM initialization
B26E8: CLUTCH SW	Inhibit engine cranking	When any of the following BCM recognition conditions are fulfilled <ul style="list-style-type: none"> • Status 1 <ul style="list-style-type: none"> - Clutch switch signal (CAN from ECM): ON - Clutch interlock switch signal: OFF (0 V) • Status 2 <ul style="list-style-type: none"> - Clutch switch signal (CAN from ECM): OFF - Clutch interlock switch signal: ON (Battery voltage)
B26E9: S/L STATUS	<ul style="list-style-type: none"> • Inhibit engine cranking • Inhibit steering lock 	When BCM transmits the LOCK request signal to steering lock unit, and receives LOCK response signal from steering lock unit, the following conditions are fulfilled <ul style="list-style-type: none"> • Steering condition No. 1 signal: LOCK (0 V) • Steering condition No. 2 signal: LOCK (Battery voltage)

HIGH FLASHER OPERATION

BCM detects the turn signal lamp circuit status by the current value.

BCM increases the turn signal lamp blinking speed if the bulb or harness open is detected with the turn signal lamp operating.

NOTE:

The blinking speed is normal while activating the hazard warning lamp.

DTC Inspection Priority Chart

INFOID:000000004503910

If some DTCs are displayed at the same time, perform inspections one by one based on the following priority chart.

BCM (BODY CONTROL MODULE)

< ECU DIAGNOSIS INFORMATION >

Priority	DTC
1	B2562: LOW VOLTAGE
2	<ul style="list-style-type: none">• U1000: CAN COMM• U1010: CONTROL UNIT(CAN)
3	<ul style="list-style-type: none">• B2190: NATS ANTENNA AMP• B2191: DIFFERENCE OF KEY• B2192: ID DISCORD BCM-ECM• B2193: CHAIN OF BCM-ECM• B2195: ANTI SCANNING
4	<ul style="list-style-type: none">• B2013: ID DISCORD BCM-S/L• B2014: CHAIN OF S/L-BCM• B2553: IGNITION RELAY• B2555: STOP LAMP• B2556: PUSH-BTN IGN SW• B2557: VEHICLE SPEED• B2560: STARTER CONT RELAY• B2601: SHIFT POSITION• B2602: SHIFT POSITION• B2603: SHIFT POSI STATUS• B2604: PNP SW• B2605: PNP SW• B2606: S/L RELAY• B2607: S/L RELAY• B2608: STARTER RELAY• B2609: S/L STATUS• B260A: IGNITION RELAY• B260B: STEERING LOCK UNIT• B260C: STEERING LOCK UNIT• B260D: STEERING LOCK UNIT• B260F: ENG STATE SIG LOST• B2612: S/L STATUS• B2614: ACC RELAY CIRC• B2615: BLOWER RELAY CIRC• B2616: IGN RELAY CIRC• B2617: STARTER RELAY CIRC• B2618: BCM• B2619: BCM• B261A: PUSH-BTN IGN SW• B261E: VEHICLE TYPE• B26E8: CLUTCH SW• B26E9: S/L STATUS• B26EA: KEY REGISTRATION• C1729: VHCL SPEED SIG ERR• U0415: VEHICLE SPEED SIG

BCM (BODY CONTROL MODULE)

< ECU DIAGNOSIS INFORMATION >

Priority	DTC
5	<ul style="list-style-type: none"> • C1704: LOW PRESSURE FL • C1705: LOW PRESSURE FR • C1706: LOW PRESSURE RR • C1707: LOW PRESSURE RL • C1708: [NO DATA] FL • C1709: [NO DATA] FR • C1710: [NO DATA] RR • C1711: [NO DATA] RL • C1712: [CHECKSUM ERR] FL • C1713: [CHECKSUM ERR] FR • C1714: [CHECKSUM ERR] RR • C1715: [CHECKSUM ERR] RL • C1716: [PRESSDATA ERR] FL • C1717: [PRESSDATA ERR] FR • C1718: [PRESSDATA ERR] RR • C1719: [PRESSDATA ERR] RL • C1720: [CODE ERR] FL • C1721: [CODE ERR] FR • C1722: [CODE ERR] RR • C1723: [CODE ERR] RL • C1724: [BATT VOLT LOW] FL • C1725: [BATT VOLT LOW] FR • C1726: [BATT VOLT LOW] RR • C1727: [BATT VOLT LOW] RL • C1734: CONTROL UNIT
6	<ul style="list-style-type: none"> • B2621: INSIDE ANTENNA • B2622: INSIDE ANTENNA • B2623: INSIDE ANTENNA

DTC Index

INFOID:000000004503911

NOTE:

The details of time display are as follows.

- CRNT: A malfunction is detected now.
- PAST: A malfunction was detected in the past.

IGN counter is displayed on Freeze Frame Data. For details of Freeze Frame Data, refer to [WT-12. "COMMON ITEM : CONSULT-III Function \(BCM - COMMON ITEM\)"](#).

CONSULT display	Fail-safe	Freeze Frame Data •Vehicle Speed •Odo/Trip Meter •Vehicle condition	Intelligent Key warning lamp ON	Tire pressure monitor warning lamp ON	Refer- ence page
No DTC is detected. further testing may be required.	—	—	—	—	—
U1000: CAN COMM	—	—	—	—	BCS-35
U1010: CONTROL UNIT(CAN)	—	—	—	—	BCS-36
U0415: VEHICLE SPEED SIG	—	—	—	—	BCS-37
B2013: ID DISCORD BCM-S/L	×	×	—	—	SEC-55
B2014: CHAIN OF S/L-BCM	×	×	—	—	SEC-56
B2190: NATS ANTENNA AMP	×	—	—	—	SEC-47
B2191: DIFFERENCE OF KEY	×	—	—	—	SEC-50
B2192: ID DISCORD BCM-ECM	×	—	—	—	SEC-51
B2193: CHAIN OF BCM-ECM	×	—	—	—	SEC-53
B2195: ANTI SCANNING	×	—	—	—	SEC-54
B2553: IGNITION RELAY	—	×	—	—	PCS-49
B2555: STOP LAMP	—	×	—	—	SEC-59

BCM (BODY CONTROL MODULE)

< ECU DIAGNOSIS INFORMATION >

CONSULT display	Fail-safe	Freeze Frame Data •Vehicle Speed •Odo/Trip Meter •Vehicle condition	Intelligent Key warning lamp ON	Tire pressure monitor warning lamp ON	Refer- ence page
B2556: PUSH-BTN IGN SW	—	×	×	—	SEC-61
B2557: VEHICLE SPEED	×	×	×	—	SEC-63
B2560: STARTER CONT RELAY	×	×	×	—	SEC-64
B2562: LOW VOLTAGE	—	×	—	—	BCS-38
B2601: SHIFT POSITION	×	×	×	—	SEC-65
B2602: SHIFT POSITION	×	×	×	—	SEC-68
B2603: SHIFT POSI STATUS	×	×	×	—	SEC-70
B2604: PNP SW	×	×	×	—	SEC-73
B2605: PNP SW	×	×	×	—	SEC-75
B2606: S/L RELAY	×	×	×	—	SEC-77
B2607: S/L RELAY	×	×	×	—	SEC-78
B2608: STARTER RELAY	×	×	×	—	SEC-80
B2609: S/L STATUS	×	×	×	—	SEC-82
B260A: IGNITION RELAY	×	×	×	—	PCS-51
B260B: STEERING LOCK UNIT	—	×	×	—	SEC-86
B260C: STEERING LOCK UNIT	—	×	×	—	SEC-87
B260D: STEERING LOCK UNIT	—	×	×	—	SEC-88
B260F: ENG STATE SIG LOST	×	×	×	—	SEC-89
B2612: S/L STATUS	×	×	×	—	SEC-94
B2614: ACC RELAY CIRC	—	×	×	—	PCS-53
B2615: BLOWER RELAY CIRC	—	×	×	—	PCS-55
B2616: IGN RELAY CIRC	—	×	×	—	PCS-57
B2617: STARTER RELAY CIRC	×	×	×	—	SEC-98
B2618: BCM	×	×	×	—	PCS-59
B2619: BCM	×	×	×	—	SEC-100
B261A: PUSH-BTN IGN SW	—	×	×	—	PCS-60
B261E: VEHICLE TYPE	×	×	× (Turn ON for 15 seconds)	—	SEC-101
B2621: INSIDE ANTENNA	—	×	—	—	DLK-59
B2622: INSIDE ANTENNA	—	×	—	—	DLK-61
B2623: INSIDE ANTENNA	—	×	—	—	DLK-63
B26E8: CLUTCH SW	×	×	×	—	SEC-90
B26E9: S/L STATUS	×	×	× (Turn ON for 15 seconds)	—	SEC-92
B26EA: KEY REGISTRATION	—	×	× (Turn ON for 15 seconds)	—	SEC-93
C1704: LOW PRESSURE FL	—	—	—	×	WT-17
C1705: LOW PRESSURE FR	—	—	—	×	
C1706: LOW PRESSURE RR	—	—	—	×	
C1707: LOW PRESSURE RL	—	—	—	×	

BCM (BODY CONTROL MODULE)

< ECU DIAGNOSIS INFORMATION >

CONSULT display	Fail-safe	Freeze Frame Data •Vehicle Speed •Odo/Trip Meter •Vehicle condition	Intelligent Key warning lamp ON	Tire pressure monitor warning lamp ON	Refer- ence page	
C1708: [NO DATA] FL	—	—	—	×	WT-19	A
C1709: [NO DATA] FR	—	—	—	×		B
C1710: [NO DATA] RR	—	—	—	×		C
C1711: [NO DATA] RL	—	—	—	×	WT-21	D
C1712: [CHECKSUM ERR] FL	—	—	—	×		
C1713: [CHECKSUM ERR] FR	—	—	—	×		
C1714: [CHECKSUM ERR] RR	—	—	—	×		
C1715: [CHECKSUM ERR] RL	—	—	—	×	WT-24	WT
C1716: [PRESSDATA ERR] FL	—	—	—	×		
C1717: [PRESSDATA ERR] FR	—	—	—	×		
C1718: [PRESSDATA ERR] RR	—	—	—	×	WT-26	F
C1719: [PRESSDATA ERR] RL	—	—	—	×		
C1720: [CODE ERR] FL	—	—	—	×	WT-29	G
C1721: [CODE ERR] FR	—	—	—	×		
C1722: [CODE ERR] RR	—	—	—	×		
C1723: [CODE ERR] RL	—	—	—	×	WT-32	H
C1724: [BATT VOLT LOW] FL	—	—	—	×		
C1725: [BATT VOLT LOW] FR	—	—	—	×		
C1726: [BATT VOLT LOW] RR	—	—	—	×		
C1727: [BATT VOLT LOW] RL	—	—	—	×	WT-33	I
C1729: VHCL SPEED SIG ERR	—	—	—	×		
C1734: CONTROL UNIT	—	—	—	×		J

< SYMPTOM DIAGNOSIS >

SYMPTOM DIAGNOSIS

TPMS















Symptom Table

INFOID:000000004503771

LOW TIRE PRESSURE WARNING LAMP SYMPTOM CHART

TPMS

< SYMPTOM DIAGNOSIS >

Diagnosis items	Symptom (Ignition switch ON)	Low tire pressure warning lamp	Cause	Action
Low tire pressure warning lamp	The low tire pressure warning lamp illuminates for 1 second, then turns OFF.	  ON 1 sec > stays OFF <small>SEIA0592E</small>	Wake-up operation for all transmitters at wheels is completed.	No system malfunctions
	The low tire pressure warning lamp repeats blinking ON for 2 seconds and OFF for 0.2 seconds.	 Blinks:  ON 2 sec > OFF 0.2 sec <small>SEIA0593E</small>	Wake-up operation for all transmitters at wheels is not completed.	Perform the wake-up operation for all transmitters at wheels. Refer to WT-6, "TRANSMITTER WAKE UP OPERATION : Special Repair Requirement" .
	The low tire pressure warning lamp blinks once.	 Blinks 1 time ON 0.3 sec > OFF 1.3 sec <small>SEIA0594E</small>	The front left transmitter is not activated.	Perform the wake-up operation for the transmitter at front left wheel. Refer to WT-6, "TRANSMITTER WAKE UP OPERATION : Special Repair Requirement" .
	The low tire pressure warning lamp repeats blinking twice.	  Blinks 2 times ON 0.3 sec > OFF 0.3 sec <small>SEIA0595E</small>	The front right transmitter is not activated.	Perform the wake-up operation for the transmitter at front right wheel. Refer to WT-6, "TRANSMITTER WAKE UP OPERATION : Special Repair Requirement" .
	The low tire pressure warning lamp repeats blinking for 3 times.	   Blinks 3 times ON 0.3 sec > OFF 0.3 sec <small>SEIA0596E</small>	The rear right transmitter is not activated.	Perform the wake-up operation for the transmitter at rear right wheel. Refer to WT-6, "TRANSMITTER WAKE UP OPERATION : Special Repair Requirement" .
	The low tire pressure warning lamp repeats blinking for 4 times.	    Blinks 4 times ON 0.3 sec > OFF 0.3 sec <small>SEIA0597E</small>	The rear left transmitter is not activated.	Perform the wake-up operation for the transmitter at rear left wheel. Refer to WT-6, "TRANSMITTER WAKE UP OPERATION : Special Repair Requirement" .
	The low tire pressure warning lamp turns ON and stays illuminated.	 Comes ON and stays ON <small>SEIA0598E</small>	Low tire pressure	Check with CONSULT-III the tire pressure values. Refer to WT-15, "AIR PRESSURE MONITOR : CONSULT-III Function (BCM - AIR PRESSURE MONITOR)" .

A
B
C
D
WT
F
G
H
I
J
K
L
M
N
O
P

TPMS

< SYMPTOM DIAGNOSIS >

Diagnosis items	Symptom (Ignition switch ON)	Low tire pressure warning lamp	Cause	Action
Low tire pressure warning lamp	The low tire pressure warning lamp repeats blinking at 0.5-second intervals for 1 minute, and then stays illuminated.	 <p style="text-align: center;">Blinks 1 min</p> <p style="text-align: center;">ON 0.5 sec > OFF 0.5 sec and stays ON</p> <p style="text-align: right; font-size: small;">SEIA0788E</p>	The combination meter fuse is open or removed (or pulled out).	Check and install the combination meter fuse. If necessary, replace the fuse.
			The low tire pressure warning control unit harness connector is removed.	Check the connection conditions of the low tire pressure warning control unit harness connector, and repair if necessary.
			Tire Pressure Monitoring System (TPMS) malfunction.	<ul style="list-style-type: none"> • Perform CONSULT-III self-diagnosis. Refer to WT-15, "AIR PRES-SURE MONITOR : CON-SULT-III Function (BCM - AIR PRESSURE MONI-TOR)". • If necessary, perform transmitter ID registration. Refer to WT-6, "ID REGISTRATION PRO-CE-DURE : Special Re-pair Requirement".
Turn signal lamp	The turn signal lamps do not blink twice when the transmitter is activated. Or the buzzer does not sound.	—	<ol style="list-style-type: none"> 1. The transmitter activation tool (J-45295) does not activate. 2. The ignition switch is OFF when the transmitter wake-up operation is performed. 3. The transmitter activation tool (J-45295) is not used in the correct position. 4. The transmitter is already waked up. 	<ol style="list-style-type: none"> 1. Replace the battery in the transmitter activation tool (J-45295). 2. Turn the ignition switch ON when performing the transmitter wake-up operation. 3. Operate the transmitter activation tool (J-45295) in the correct position when performing the wake-up operation. 4. No procedure.

NOTE:

If transmitter wake-up operation is not completed for two or more transmitters, the applicable low tire pressure warning lamp blinking patterns are displayed continuously.

(Example: Blinks once/OFF/blinks 3 times = Wake-up operation is not completed at the front left wheel and rear right wheel transmitters.)

LOW TIRE PRESSURE WARNING LAMP DOES NOT TURN ON

< SYMPTOM DIAGNOSIS >

LOW TIRE PRESSURE WARNING LAMP DOES NOT TURN ON

Description

INFOID:000000004503772

DESCRIPTION

The low tire pressure warning lamp illuminates for approximately 1 second and then turns OFF when the ignition switch is turned ON. This is to check that no abnormal condition is present in the tire pressure monitoring system.

The lamp bulb may be burnt out or the tire pressure monitoring system may be malfunctioning if the low tire pressure warning lamp does not illuminate when the ignition switch is turned ON.

Diagnosis Procedure

INFOID:000000004503773

1. CHECK SELF-DIAGNOSIS RESULTS

④ With CONSULT-III

1. On the "SELECT DIAG" mode, select the "SELF-DIAG RESULTS" screen.
2. Check the display contents in self-diagnostic results.

Is "CAN COMM CIRCUIT" displayed in the self-diagnosis display items?

YES >> Perform trouble diagnosis for CAN communication system. Refer to [LAN-19, "Trouble Diagnosis Flow Chart"](#).

NO >> GO TO 2.

2. CHECK COMBINATION METER

Check the combination meter function. Refer to [MWI-38, "CONSULT-III Function \(METER/M&A\)"](#).

Is the inspection result normal?

YES >> GO TO 3.

NO >> Repair or replace damaged parts.

3. CHECK LOW TIRE PRESSURE WARNING LAMP

1. Turn the ignition switch OFF.
2. Disconnect BCM harness connectors.
3. Turn the ignition switch ON.

CAUTION:

Never start the engine.

Does low tire pressure warning lamp turn ON?

YES >> GO TO 4.

NO >> Check the combination meter and repair or replace. Refer to [MWI-36, "Diagnosis Description"](#).

4. CHECK SYMPTOM

Check the symptom again.

Is the inspection result normal?

YES >> INSPECTION END

NO >> GO TO 5.

5. CHECK BCM

Check the BCM input/output signal. Refer to [WT-46, "Reference Value"](#).

Is the inspection result normal?

YES >> GO TO 4.

NO >> GO TO 6.

6. CHECK BCM HARNESS CONNECTOR

Check the BCM pin terminals for damage or loose connection with harness connector.

Is the inspection result normal?

YES >> Replace BCM. Refer to [BCS-82, "Exploded View"](#).

NO >> Repair or replace damaged parts.

A

B

C

D

WT

F

G

H

I

J

K

L

M

N

O

P

LOW TIRE PRESSURE WARNING LAMP DOES NOT TURN OFF

< SYMPTOM DIAGNOSIS >

LOW TIRE PRESSURE WARNING LAMP DOES NOT TURN OFF

Description

INFOID:000000004503774

DESCRIPTION

The tire pressure monitoring system is checked and the warning lamp is illuminated for approximately 1 second when the ignition switch is turned ON. The low tire pressure warning lamp turns OFF after the system check finishes.

The system may be malfunctioning if the low tire pressure warning lamp does not turn off approximately 1 second after the ignition switch is turned ON.

Diagnosis Procedure

INFOID:000000004503775

1. CHECK SYSTEM FOR BCM

Ⓜ With CONSULT-III

1. On "SELF-DIAG" mode, select the "SELF-DIAG RESULTS" screen.
2. Check the display contents in self-diagnostic results.

Does self-diagnostic results indicate any malfunction?

YES >> Perform trouble diagnosis. Refer to [WT-15, "AIR PRESSURE MONITOR : CONSULT-III Function \(BCM - AIR PRESSURE MONITOR\)"](#).

NO >> GO TO 2.

2. CHECK ID REGISTRATION

Perform ID registration of all transmitters. Refer to [WT-6, "ID REGISTRATION PROCEDURE : Special Repair Requirement"](#).

Does low tire pressure warning lamp turn OFF?

YES >> INSPECTION END

NO >> GO TO 3.

3. CHECK BCM POWER SUPPLY CIRCUIT

1. Turn the ignition switch OFF.
2. Disconnect BCM harness connector.
3. Check the voltage between BCM harness connector and ground.

BCM		—	Voltage (Approx.)
Connector	Terminal		
M118	1	Ground	Battery voltage
M119	11		

Is the inspection result normal?

YES >> GO TO 4.

NO >> Check the following. If any items are damaged, repair or replace damaged parts.

- 40 A fusible link [No. K located in the fuse block]. Refer to [PG-96, "Fuse and Fusible Link Arrangement"](#).
- 10 A fuse [No. 10 located in the fuse block (J/B)]. Refer to [PG-95, "Fuse, Connector and Terminal Arrangement"](#).
- Harness for short or open between battery and BCM harness connector M118 terminal 1.
- Harness for short or open between battery and BCM harness connector M119 terminal 11.
- Check the battery voltage.

4. CHECK BCM GROUND CIRCUIT

Check continuity between BCM harness connector and ground.

BCM		—	Continuity
Connector	Terminal		
M119	13	Ground	Existed

Is the inspection result normal?

LOW TIRE PRESSURE WARNING LAMP DOES NOT TURN OFF

< SYMPTOM DIAGNOSIS >

- YES >> GO TO 5.
- NO >> Repair or replace damaged parts.

5.CHECK SYMPTOM

Check the symptom again.

Is the inspection result normal?

- YES >> INSPECTION END
- NO >> GO TO 6.

6.CHECK BCM

Check the BCM input/output signal. Refer to [WT-46, "Reference Value"](#).

Is the inspection result normal?

- YES >> GO TO 5.
- NO >> GO TO 7.

7.CHECK BCM HARNESS CONNECTOR

Check the BCM pin terminals for damage or loose connection with harness connector.

Is the inspection result normal?

- YES >> Replace BCM. Refer to [BCS-82, "Exploded View"](#).
- NO >> Repair or replace damaged parts.

A
B
C
D
WT
F
G
H
I
J
K
L
M
N
O
P

LOW TIRE PRESSURE WARNING LAMP BLINKS

< SYMPTOM DIAGNOSIS >

LOW TIRE PRESSURE WARNING LAMP BLINKS

Description

INFOID:000000004503776

DESCRIPTION

The low tire pressure warning lamp illuminates or blinks.

However, a check is necessary because the symptom may not be caused by a system malfunction. For example, the transmitter may not be initialized.

NOTE:

If low tire pressure warning lamp blinks as shown in the figure, the system is normal.

Blink Mode A

- This mode shows transmitter status is in OFF- mode. Perform transmitter wake up operation. Refer to [WT-6, "TRANSMITTER WAKE UP OPERATION : Special Repair Requirement"](#).

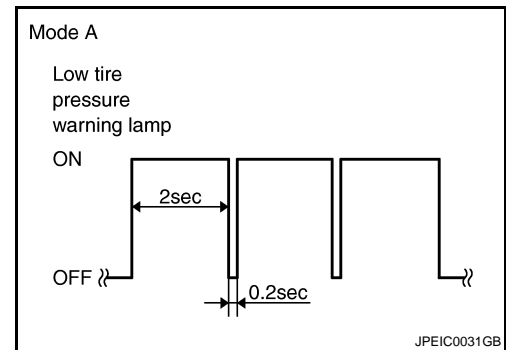

Diagnosis Procedure

INFOID:000000004503777

1. CHECK TIRE PRESSURE WARNING CHECK SWITCH POWER SUPPLY

1. Turn the ignition switch ON.

CAUTION:

Never start the engine.

2. Check voltage between tire pressure warning check switch connector and ground.

Tire pressure warning check switch		—	Voltage (Approx.)
Connector	Terminal		
M23	1	Ground	5 V

Is the inspection result normal?

YES >> GO TO 2.

NO >> Riper or replace error-detected damaged parts.

2. CHECK TIRE PRESSURE WARNING CHECK SWITCH CIRCUIT

1. Turn the ignition switch OFF.
2. Disconnect BCM harness connector.
3. Check the continuity between BCM harness connector and tire pressure warning check switch connector.

BCM		Tire pressure warning check switch		Continuity
Connector	Terminal	Connector	Terminal	
M123	149	M23	1	Existed

4. Check the continuity between BCM harness connector and ground.

BCM		—	Continuity
Connector	Terminal		
M123	149	Ground	Not existed

Is the inspection result normal?

YES >> GO TO 3.

NO >> Riper or replace error-detected damaged parts.

LOW TIRE PRESSURE WARNING LAMP BLINKS

< SYMPTOM DIAGNOSIS >

3.CHECK BCM

Check the BCM input/output signal. Refer to [WT-46. "Reference Value"](#).

Is the inspection result normal?

- YES >> Check the tire pressure warning check switch. Refer to [WT-37. "Diagnosis Procedure"](#).
- NO >> Repair or replace the BCM.

A
B
C
D
E
F
G
H
I
J
K
L
M
N
O
P

WT

TURN SIGNAL LAMP BLINKS

< SYMPTOM DIAGNOSIS >

TURN SIGNAL LAMP BLINKS

Description

INFOID:000000004503778

DESCRIPTION

The turn signal lamp blinks when the ignition switch is turned ON.
The BCM connector or circuit may have a malfunction.

Diagnosis Procedure

INFOID:000000004503779

1. CHECK TIRE PRESSURE WARNING CHECK SWITCH POWER SUPPLY CIRCUIT

1. Turn the ignition switch ON.

CAUTION:

Never start the engine.

2. Check voltage between tire pressure warning check switch connector and ground.

Tire pressure warning check switch		—	Voltage (Approx.)
Connector	Terminal		
M23	1	Ground	5 V

Is the inspection result normal?

YES >> GO TO 2.

NO >> Repair or replace damaged parts.

2. CHECK TIRE PRESSURE WARNING CHECK SWITCH CIRCUIT

1. Turn the ignition switch OFF.
2. Disconnect BCM harness connector.
3. Check the continuity between BCM harness connector and tire pressure warning check switch connector.

BCM		Tire pressure warning check switch		Continuity
Connector	Terminal	Connector	Terminal	
M123	149	M23	1	Existed

4. Check the continuity between BCM harness connector and ground.

BCM		—	Continuity
Connector	Terminal		
M123	149	Ground	Not existed

Is the inspection result normal?

YES >> Check the turn signal lamp operation. Refer to [BCS-31, "SIGNAL BUFFER : CONSULT-III Function \(BCM - SIGNAL BUFFER\)"](#).

NO >> Repair or replace damaged parts.

ID REGISTRATION CANNOT BE COMPLETED

< SYMPTOM DIAGNOSIS >

ID REGISTRATION CANNOT BE COMPLETED

Description

INFOID:000000004503780

DESCRIPTION

The ID of the transmitter installed in each wheel cannot be registered in the tire pressure monitoring system. Inspect the transmitter or the tire pressure monitoring system circuit.

Diagnosis Procedure

INFOID:000000004503781

1. CHECK ID REGISTRATION

1. Perform ID registration of all transmitters. Refer to [WT-6, "ID REGISTRATION PROCEDURE : Special Repair Requirement"](#).
2. Drive at a speed of 40 km/h (25 MPH) or more for 3 minutes, and then drive the vehicle at any speed for 10 minutes.
3. Check the all tire pressures with CONSULT-III "DATA MONITOR" within 5 minutes.

Monitored item	Condition	Display value
AIR PRESS FL	Start the engine and drive at 40 km/h (25 MPH) or more for several minutes.	Approximately equal to the indication on vehicle information display.
AIR PRESS FR		
AIR PRESS RR		
AIR PRESS RL		

Is the inspection result normal?

- YES >> INSPECTION END
NO >> GO TO 2.

2. CHECK TRANSMITTER

1. Perform trouble diagnosis for transmitters. Refer to [WT-19, "Diagnosis Procedure"](#).
2. Perform ID registration of all transmitters. Refer to [WT-6, "ID REGISTRATION PROCEDURE : Special Repair Requirement"](#).

Can ID registration of all transmitters be completed?

- YES >> INSPECTION END
NO >> Replace the transmitter. Refer to [WT-100, "Exploded View"](#).

NORMAL OPERATING CONDITION

< SYMPTOM DIAGNOSIS >

NORMAL OPERATING CONDITION

Description

INFOID:000000004503782

LOW TIRE PRESSURE WARNING LAMP BLINKS

The tire pressure monitoring system is not malfunctioning if the low tire pressure warning lamp blinks in the pattern as shown in the figure.

The incident occurs because the transmitter of each wheel is not wake up.

Perform transmitter wake up operation. Refer to [WT-6, "TRANSMITTER WAKE UP OPERATION : Special Repair Requirement"](#).

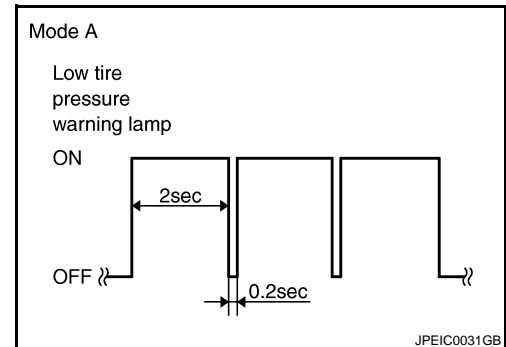

NOISE, VIBRATION AND HARSHNESS (NVH) TROUBLESHOOTING

< SYMPTOM DIAGNOSIS >

NOISE, VIBRATION AND HARSHNESS (NVH) TROUBLESHOOTING

NVH Troubleshooting Chart

INFOID:000000004503783

Use chart below to find the cause of the symptom. If necessary, repair or replace these parts.

Symptom		Possible cause and SUSPECTED PARTS																	
		Improper installation, looseness	Out-of-round	unbalance	Incorrect tire pressure	Uneven tire wear	Deformation or damage	Non-uniformity	Incorrect tire size	PROPELLER SHAFT	DIFFERENTIAL	FRONT AXLE AND FRONT SUSPENSION	REAR AXLE AND REAR SUSPENSION	TIRES	ROAD WHEELS	DRIVE SHAFT	BRAKE	STEERING	
Reference page	2WD models: FSU-9 , FSU-12 AWD models: FSU-31 , FSU-34																		
		WT-96, "Inspection"																	
	WT-97, "Adjustment"																		
	WT-103, "Tire"																		
	WT-103, "Tire"																		
	NVH in DLN section.																		
	NVH in DLN section.																		
	NVH in FAX and FSU sections.																		
NVH in RAX and RSU sections.																			
Refer to TIRES in this chart.																			
Refer to ROAD WHEEL in this chart.																			
NVH in FAX, RAX section.																			
NVH in BR section.																			
NVH in ST section.																			

x: Applicable

A
B
C
D
E
F
G
H
I
J
K
L
M
N
O
P

WT

PRECAUTIONS

< PRECAUTION >

PRECAUTION

PRECAUTIONS

Precaution for Supplemental Restraint System (SRS) "AIR BAG" and "SEAT BELT PRE-TENSIONER"

INFOID:000000004503903

The Supplemental Restraint System such as "AIR BAG" and "SEAT BELT PRE-TENSIONER", used along with a front seat belt, helps to reduce the risk or severity of injury to the driver and front passenger for certain types of collision. This system includes seat belt switch inputs and dual stage front air bag modules. The SRS system uses the seat belt switches to determine the front air bag deployment, and may only deploy one front air bag, depending on the severity of a collision and whether the front occupants are belted or unbelted. Information necessary to service the system safely is included in the "SRS AIR BAG" and "SEAT BELT" of this Service Manual.

WARNING:

- To avoid rendering the SRS inoperative, which could increase the risk of personal injury or death in the event of a collision which would result in air bag inflation, all maintenance must be performed by an authorized NISSAN/INFINITI dealer.
- Improper maintenance, including incorrect removal and installation of the SRS, can lead to personal injury caused by unintentional activation of the system. For removal of Spiral Cable and Air Bag Module, see the "SRS AIR BAG".
- Do not use electrical test equipment on any circuit related to the SRS unless instructed to in this Service Manual. SRS wiring harnesses can be identified by yellow and/or orange harnesses or harness connectors.

PRECAUTIONS WHEN USING POWER TOOLS (AIR OR ELECTRIC) AND HAMMERS

WARNING:

- When working near the Air Bag Diagnosis Sensor Unit or other Air Bag System sensors with the ignition ON or engine running, DO NOT use air or electric power tools or strike near the sensor(s) with a hammer. Heavy vibration could activate the sensor(s) and deploy the air bag(s), possibly causing serious injury.
- When using air or electric power tools or hammers, always switch the ignition OFF, disconnect the battery, and wait at least 3 minutes before performing any service.

Service Notice or Precautions

INFOID:000000004503788

- Low tire pressure warning lamp blinks for 1min, then turns ON when occurring any malfunction except low tire pressure. Delete the memory with CONSULT-III, or register the ID to turn low tire pressure warning lamp OFF. Refer to [WT-13. "AIR PRESSURE MONITOR : Diagnosis Description"](#), [WT-6. "ID REGISTRATION PROCEDURE : Special Repair Requirement"](#).
- ID registration is required when replacing or rotating wheels, replacing transmitter or BCM. Refer to [BCS-82. "Exploded View"](#).
- Replace grommet seal, valve core and cap of transmitter in TPMS every tire replacement by reaching wear limit of tire. Refer to [WT-100. "Exploded View"](#).

PREPARATION

< PREPARATION >

PREPARATION

PREPARATION

Special Service Tool

INFOID:000000004503789

The actual shapes of Kent-Moore tools may differ from those of special service tools illustrated here.

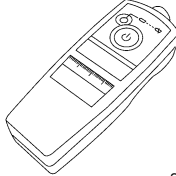
Tool number (Kent-Moore No.) Tool name	Description
- (J-45295) Transmitter activation tool  SEIA0462E	ID registration

A

B

C

D

WT

F

Commercial Service Tool

INFOID:000000004503790

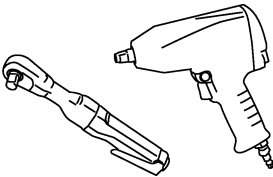
Tool name	Description
Power tool  PBIC0190E	Loosening wheel nuts

G

H

I

J

K

L

M

N

O

P

ROAD WHEEL

< PERIODIC MAINTENANCE >

PERIODIC MAINTENANCE

ROAD WHEEL

Inspection

INFOID:000000004503894

ALUMINUM WHEEL

1. Check tires for wear and improper inflation.
2. Check wheels for deformation, cracks and other damage. If deformed, remove wheel and check wheel runout.
 - a. Remove tire from aluminum wheel and mount on a tire balance machine.
 - b. Set dial indicator as shown in the figure.
 - c. If the lateral deflection (A) or vertical deflection (B) for radial runout value exceeds the limit, replace aluminum wheel.

Limit

A: Refer to [WT-103, "Road Wheel"](#).

B: Refer to [WT-103, "Road Wheel"](#).

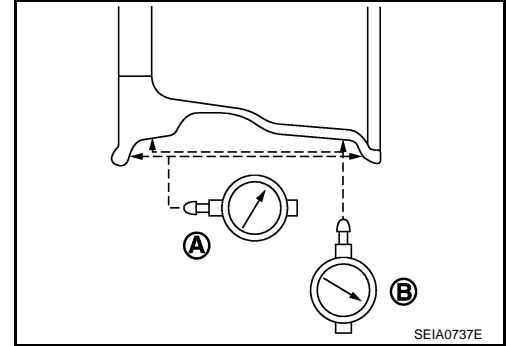

STEEL WHEEL

1. Check tires for were and improper inflation.
2. Check wheels for deformation, clacks and other damage. If deformed, remove wheel and check wheel runout.
 - a. Remove tire from steel wheel and mount wheel on a tire balance machine.
 - b. Set two dial indicators as shown in the illustration.
 - c. Set each dial indicator to "0".
 - d. Rotate wheel and check dial indicators at several points around the circumference of the wheel.
 - e. Calculate runout at each point as shown below.

Lateral runout limit (A): $(1+2)/2$

Radial runout limit (B): $(3+4)/2$

- f. Select maximum positive runout value and the maximum negative value. Add the two values to determine total runout.

CAUTION:

In case a positive or negative value is not available, use the maximum value (negative or positive) for total runout.

Limit

A: Refer to [WT-103, "Road Wheel"](#).

B: Refer to [WT-103, "Road Wheel"](#).

- g. If the total runout value exceeds limit, replace steel wheel.

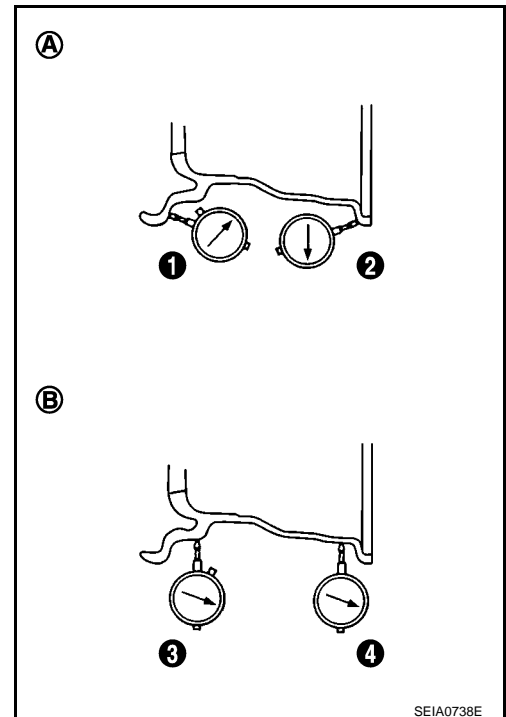

ROAD WHEEL TIRE ASSEMBLY

< REMOVAL AND INSTALLATION >

REMOVAL AND INSTALLATION

ROAD WHEEL TIRE ASSEMBLY

Adjustment

INFOID:000000004503895

BALANCING WHEELS (BONDING WEIGHT TYPE)

Preparation Before Adjustment

Using releasing agent, remove double-faced adhesive tape from the road wheel.

CAUTION:

- **Be careful not scratch the road wheel during removal.**
- **After removing double-faced adhesive tape, wipe clean traces of releasing agent from the road wheel.**

Wheel Balance Adjustment

- If a tire balance machine has adhesion balance weight mode settings and drive-in weight mode setting, select and adjust a drive-in weight mode suitable for road wheels.

1. Set road wheel on tire balance machine using the center hole as a guide. Start the tire balance machine.
2. When inner and outer unbalance values are shown on the tire balance machine indicator, multiply outer unbalance value by $5/3$ to determine balance weight that should be used. Select the outer balance weight with a value closest to the calculated value above and install in to the designated outer position of, or at the designated angle in relation to the road wheel.

CAUTION:

- **Never install the inner balance weight before installing the outer balance weight.**
- **Before installing the balance weight, be sure to clean the mating surface of the road wheel.**

- a. Indicated un balance value $\times 5/3 =$ balance weight to be installed

Calculation example:

$23 \text{ g (0.81 oz)} \times 5/3 = 38.33 \text{ g (1.35 oz)} \Rightarrow 37.5 \text{ g (1.32 oz)}$ balance weight (closer to calculated balance weight value)

NOTE:

Note that balance weight value must be closer to the calculated balance weight value.

Example:

$36.2 \Rightarrow 35 \text{ g (1.23 oz)}$

$36.3 \Rightarrow 37.5 \text{ g (1.32 oz)}$

- b. Installed balance weight in the position.

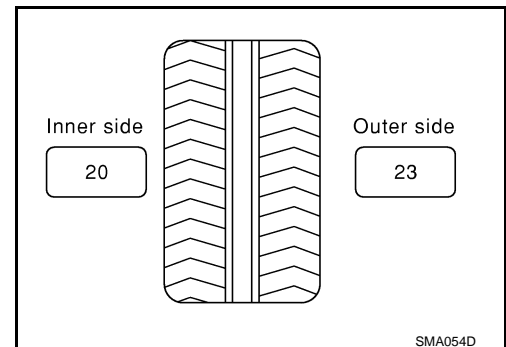

A
B
C
D
WT
F
G
H
I
J
K
L
M
N
O
P

ROAD WHEEL TIRE ASSEMBLY

< REMOVAL AND INSTALLATION >

- When installing balance weight (1) to road wheels, set it into the grooved area (A) on the inner wall of the road wheel as shown in the figure so that the balance weight center (B) is aligned with the tire balance machine indication position (angle)(C).

CAUTION:

- Always use genuine NISSAN adhesion balance weights.
- Balance weights are non-reusable; always replace with new ones.
- Never install more than three sheets of balance weight.

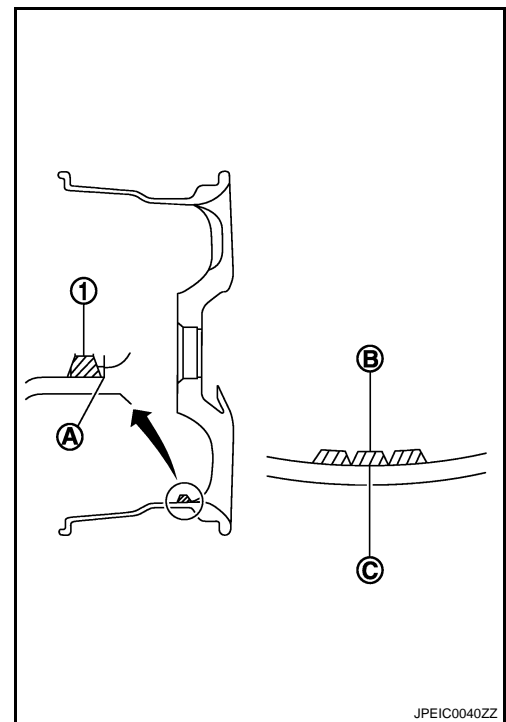

JPEIC0040ZZ

- If calculated balance weight value exceeds 50 g (1.76 oz), install two balance weight sheets in line with each other as shown in the figure.

CAUTION:

Never install one balance weight sheet on top another.

- Start tire balance machine again.
- Install drive-in balance weight on inner side of road wheel in the tire balance machine indication position (angle).

CAUTION:

Never install more than two balance weight.

- Start tire balance machine. Make sure that inner and outer residual unbalance values are 5 g (0.17 oz) each or below.
- If either residual unbalance value exceeds 5 g (0.17 oz), repeat installation procedures.

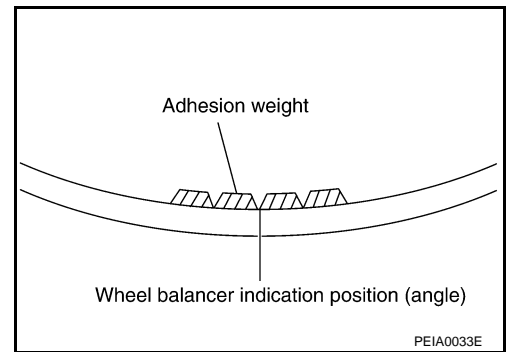

PEIA0033E

Wheel balance	Dynamic (At flange)	Static (At flange)
Maximum allowable unbalance	Refer to WT-103, "Road Wheel" .	

TIRE ROTATION (for 17 and 18 inch wheel models)

- Follow the maintenance schedule for tire rotation service intervals. Refer to [MA-4, "Explanation of General Maintenance"](#).
- When installing the wheel, tighten wheel nuts to the specified torque.

CAUTION:

- Never include the T-type spare tire when rotating the tires.
- When installing wheels, tighten them diagonally by dividing the work two to three times in order to prevent the wheels from developing any distortion.
- Be careful not to tighten wheel nut at torque exceeding the criteria for preventing strain of disc rotor.
- Use NISSAN genuine wheel nuts for aluminum wheels.

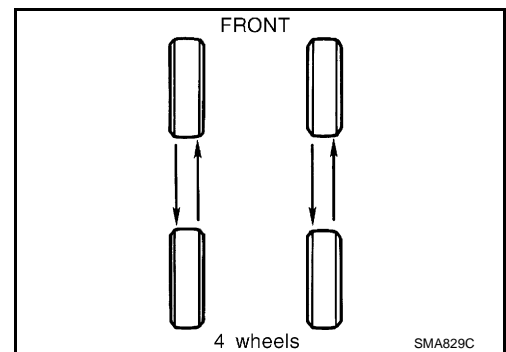

4 wheels

SMA829C

Wheel nuts tightening torque : Refer to [WT-103, "Road Wheel"](#).

ROAD WHEEL TIRE ASSEMBLY

< REMOVAL AND INSTALLATION >

- Perform the ID registration, after tire rotation. Refer to [WT-6. "ID REGISTRATION PROCEDURE : Special Repair Requirement"](#).

TIRE ROTATION (for 18 inch front and rear different tire size models)

- Tire cannot be rotated in vehicle, as front tire are different size from rear tire is fixed in each tire.

Wheel nuts tightening torque : Refer to [WT-103. "Road Wheel"](#).

CAUTION:

- **Never include the T-type spare tire when rotating the tires.**
- **Use NISSAN genuine wheel nuts for aluminum wheels.**

Safety Device Preventing from Being Incorrectly installed

FRONT BRAKE DISC ROTOR AND FRONT WHEEL

- Front and rear wheel size for this model differs, therefore special pin (1) is adopted to the front brake disc rotor (2). And a hole (3) that matches to this pin is adopted to the front wheel (4) (the rear wheel does not have this wheel). This structure prevents the rear wheel from being mistakenly installed on the front.

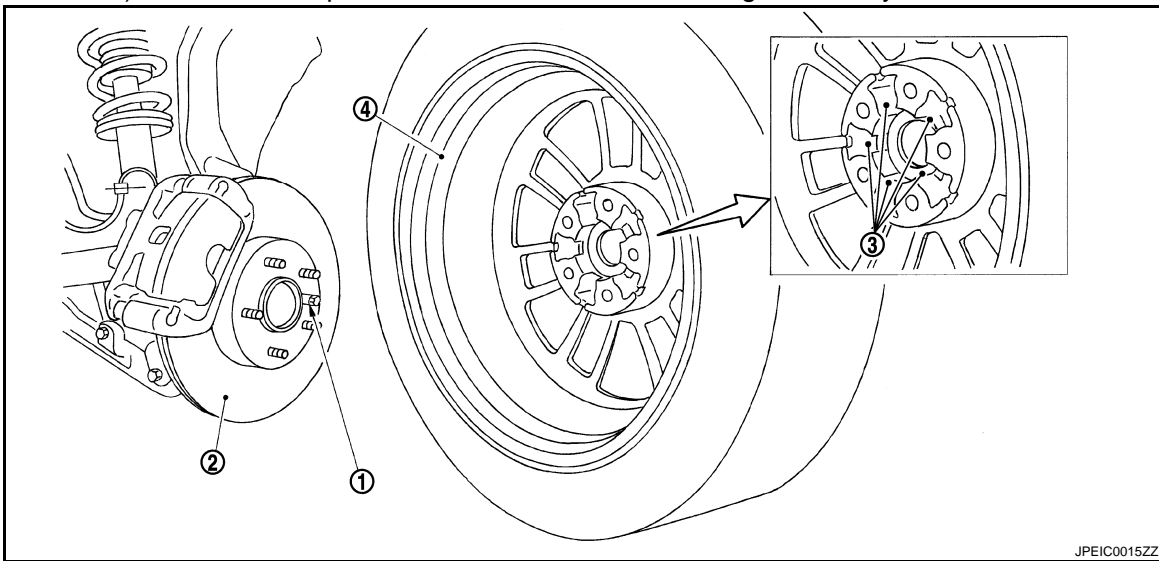

T-TYPE SPARE TIRE WHEEL

- Regarding spare tire (for emergency) wheel, wrong assembly protection pin through hole (1) has been set in addition to regular bolt holes (2) in order to enable installation to front wheel.

NOTE:

Protection pin through hole of 18 inch spare wheel is non-through type.

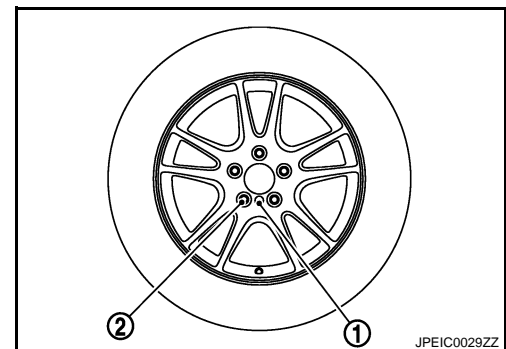

TRANSMITTER

< REMOVAL AND INSTALLATION >

TRANSMITTER

Exploded View

INFOID:000000004503896

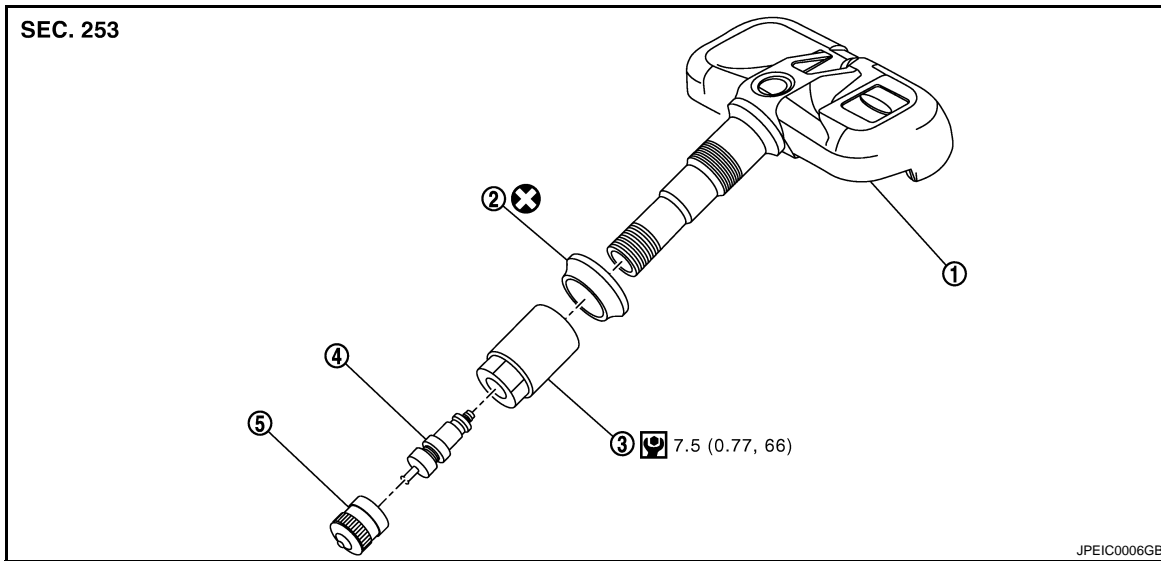

- | | | |
|----------------|-----------------|--------------|
| 1. Transmitter | 2. Grommet seal | 3. Valve nut |
| 4. Valve core | 5. Cap | |

Refer to [GI-4. "Components"](#) for symbols in figure.

Removal and Installation

INFOID:000000004503897

REMOVAL

1. Deflate tire. Unscrew transmitter retaining nut and allow transmitter to fall into tire.
2. Gently bounce tire so that transmitter falls to bottom of tire. Place on tire changing machine and break both tire beads ensuring that the transmitter remains at the bottom of the tire.

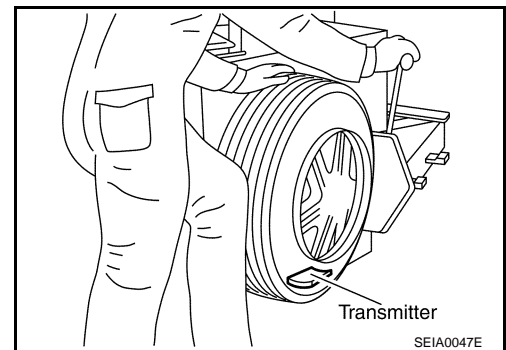

3. Turn tire so that valve hole is at bottom and bounce so that transmitter (1) is near valve hole. Carefully lift tire onto turntable and position valve hole (and transmitter) 270 degree from mounting/dismounting head (2).
4. Lubricate tire well and remove first side of the tire. Reach inside the tire and remove the transmitter.

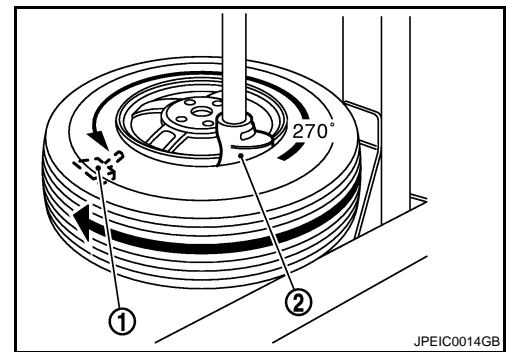

INSTALLATION

TRANSMITTER

< REMOVAL AND INSTALLATION >

1. Put first side of tire onto rim.

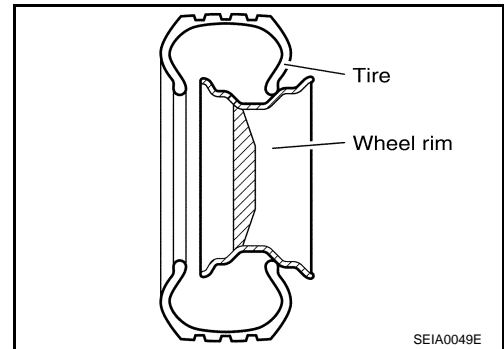

2. Mount transmitter on rim and tighten nut.

CAUTION:

Speed for tightening nut should be less than 15 rpm.

3. Place wheel on turntable of tire machine. Ensure that transmitter (1) is 270 degree from mounting head (2) when second side of tire is fitted.

NOTE:

Do not touch transmitter at mounting head.

4. Lubricate tire well and fit second side of tire as normal. Ensure that tire does not rotate relative to rim.
5. Inflate tire and fit to appropriate wheel position.

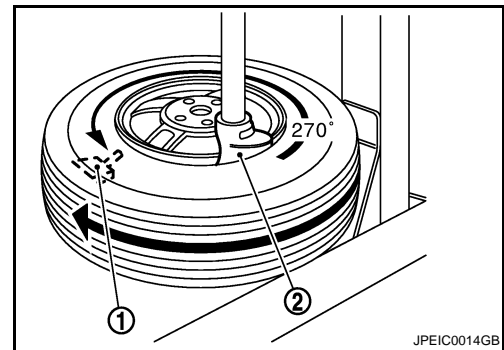

A
B
C
D
WT
F
G
H
I
J
K
L
M
N
O
P

TIRE PRESSURE RECEIVER

< REMOVAL AND INSTALLATION >

TIRE PRESSURE RECEIVER

Exploded View

INFOID:000000004503898

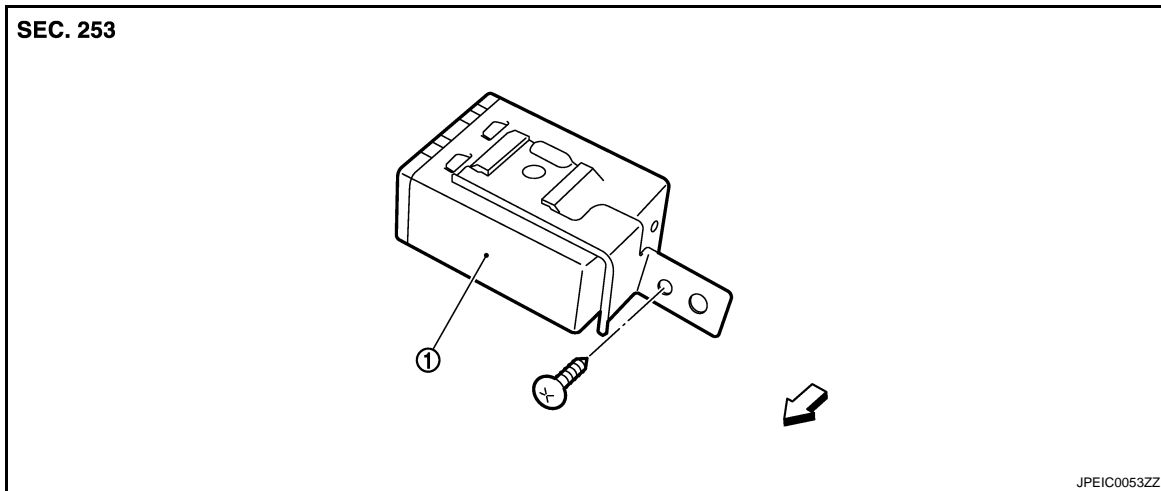

1. Tire pressure receiver

← Vehicle front

Removal and Installation

INFOID:000000004503899

REMOVAL

1. Remove the instrument lower cover. Refer to [IP-11, "Exploded View"](#).
2. Remove the glove box assembly.
3. Remove the instrument lower panel RH.
4. Disconnect tire pressure receiver harness connector.
5. Remove Tire pressure receiver mounting screw.
6. Remove tire pressure receiver.

INSTALLATION

Install is the reverse order of removal.

SERVICE DATA AND SPECIFICATIONS (SDS)

< SERVICE DATA AND SPECIFICATIONS (SDS)

SERVICE DATA AND SPECIFICATIONS (SDS)

SERVICE DATA AND SPECIFICATIONS (SDS)

Road Wheel

INFOID:000000004504026

ALUMINUM WHEEL (CONVENTIONAL)

Item		Limit
Radial runout	Lateral deflection	Less than 0.3 mm (0.012 in)
	Vertical deflection	
Allowable unbalance	Dynamic (At flange)	Less than 5 g (0.17 oz) (one side)
	Static (At flange)	Less than 10 g (0.35 oz)

STEEL WHEEL (FOR EMERGENCY USE)

Item		Limit
Radial runout	Lateral deflection	Less than 1.5 mm (0.059 in)
	Vertical deflection	
Allowable unbalance	Dynamic (At flange)	Less than 5 g (0.17 oz) (one side)
	Static (At flange)	Less than 10 g (0.35 oz)

Wheel Nut

INFOID:000000004503901

Item	Standard
Wheel nut tightening torque	108 N·m (11 kg·m, 80 ft·lb)

Tire

INFOID:000000004503913

Unit: kPa (kg/cm², psi)

Tire size	Air pressure	
	Front	Rear
P225/55R17 95V	230 (2.3, 33)	230 (2.3, 33)
P225/50R18 94V	230 (2.3, 33)	230 (2.3, 33)
225/50R18 95W	230 (2.3, 33)	-
245/45R18 96W	-	230 (2.3, 33)
T145/80D17	420 (4.2, 60)	420 (4.2, 60)
T145/70R18		