

A
B
C

SECTION **GW**

GLASS & WINDOW SYSTEM

CONTENTS

SYMPTOM DIAGNOSIS	2	Inspection	11	F
SQUEAK AND RATTLE TROUBLE DIAG- NOSES	2	REAR WINDOW GLASS	12	G
Work Flow	2	Exploded View	12	
Inspection Procedure	4	Removal and Installation	12	
Diagnostic Worksheet	6	Inspection	13	
PRECAUTION	8	FRONT DOOR GLASS	14	H
PRECAUTIONS	8	Exploded View	14	
Precaution for Supplemental Restraint System (SRS) "AIR BAG" and "SEAT BELT PRE-TEN- SIONER"	8	Removal and Installation	14	
Precaution for Procedure without Cowl Top Cover.....	8	Inspection and Adjustment	15	I
Handling for Adhesive and Primer	8	FRONT REGULATOR	16	J
PREPARATION	9	Exploded View	16	
PREPARATION	9	Removal and Installation	16	
Special Service Tools	9	Disassembly and Assembly	16	
Commercial Service Tools	9	Inspection and Installation	17	
REMOVAL AND INSTALLATION	10	REAR DOOR GLASS	18	GW
WINDSHIELD GLASS	10	Exploded View	18	
Exploded View	10	Removal and Installation	18	L
Removal and Installation	10	Inspection and Adjustment	19	
		REAR REGULATOR	21	M
		Exploded View	21	
		Removal and Installation	21	
		Disassembly and Assembly	22	N
		Inspection and Adjustment	22	O
				P

SQUEAK AND RATTLE TROUBLE DIAGNOSES

< SYMPTOM DIAGNOSIS >

SYMPTOM DIAGNOSIS

SQUEAK AND RATTLE TROUBLE DIAGNOSES

Work Flow

INFOID:000000006209060

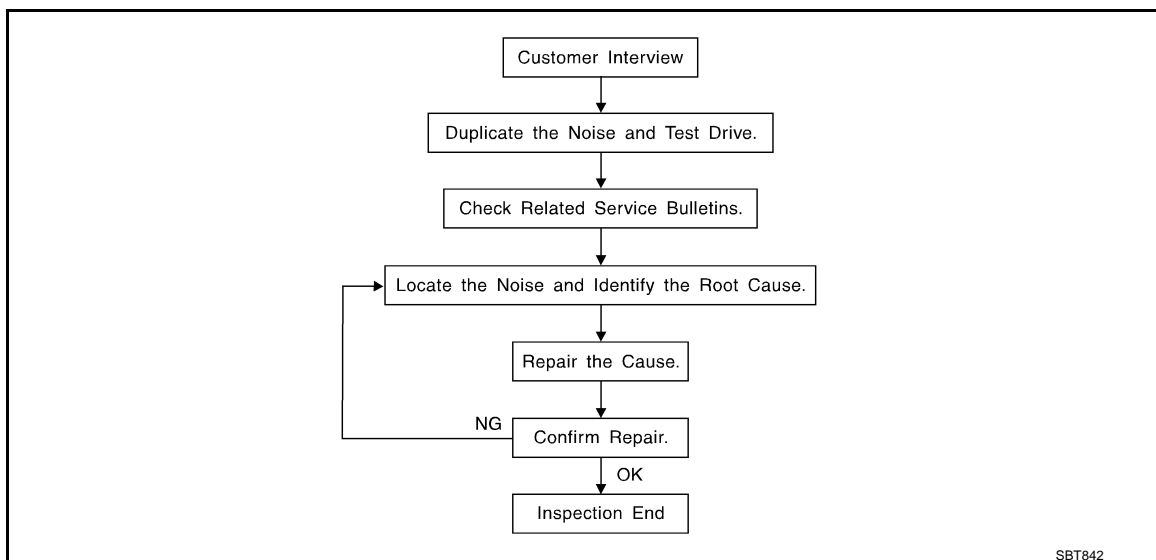

CUSTOMER INTERVIEW

Interview the customer if possible, to determine the conditions that exist when the noise occurs. Use the Diagnostic Worksheet during the interview to document the facts and conditions when the noise occurs and any customer comments. Refer to [GW-6. "Diagnostic Worksheet"](#). This information is necessary to duplicate the conditions that exist when the noise occurs.

- The customer may not be able to provide a detailed description or the location of the noise. Attempt to obtain all the facts and conditions that exist when the noise occurs (or does not occur).
- If there is more than one noise in the vehicle, perform a diagnosis and repair the noise that the customer is concerned about. This can be accomplished by performing a test drive with the customer.
- After identifying the type of noise, isolate the noise in terms of its characteristics. The noise characteristics are provided so that the customer, service adviser, and technician use the same language when describing the noise.
- Squeak – (Like tennis shoes on a clean floor)
Squeak characteristics include the light contact / fast movement / brought on by road conditions / hard surfaces = high-pitched noise / softer surfaces = low-pitched noises / edge to surface = chirping
- Creak – (Like walking on an old wooden floor)
Creak characteristics include firm contact / slow movement/twisting with a rotational movement / pitch dependent on materials / often brought on by activity.
- Rattle – (Like shaking a baby rattle)
Rattle characteristics include fast repeated contact / vibration or similar movement / loose parts/missing clip or fastener / incorrect clearance.
- Knock – (Like a knock on a door)
Knock characteristics include hollow sounds / sometimes repeating / often brought on by driver action.
- Tick – (Like a clock second hand)
Tick characteristics include gentle contacting of light materials / loose components / can be caused by driver action or road conditions.
- Thump – (Heavy, muffled knock noise)
Thump characteristics include softer knock / dull sounds often brought on by activity.
- Buzz – (Like a bumblebee)
Buzz characteristics include high frequency rattle / firm contact.
- Often the degree of acceptable noise level varies depending upon the person. A noise that a technician may judge as acceptable may be very irritating to a customer.
- Weather conditions, especially humidity and temperature, may have a great effect on noise level.

DUPLICATE THE NOISE AND TEST DRIVE

SQUEAK AND RATTLE TROUBLE DIAGNOSES

< SYMPTOM DIAGNOSIS >

If possible, drive the vehicle with the customer until the noise is duplicated. Note any additional information on the Diagnostic Worksheet regarding the conditions or location of the noise. This information can be used to duplicate the same conditions when the repair is reconfirmed.

If the noise can be duplicated easily during the test drive, do the following with the vehicle stopped to help identify the source of the noise.

- 1) Close a door.
 - 2) Tap or push/pull around the area where the noise appears to be coming from.
 - 3) Rev the engine.
 - 4) Use a floor jack to recreate vehicle "twist".
 - 5) At idle, apply engine load (electrical load, half-clutch on M/T models, drive position on A/T models).
 - 6) Raise the vehicle on a hoist and hit a tire with a rubber hammer.
- Drive the vehicle and attempt to duplicate the conditions the customer states exist when the noise occurs.
 - If it is difficult to duplicate the noise, drive the vehicle slowly on an undulating or rough road to stress the vehicle body.

CHECK RELATED SERVICE BULLETINS

After verifying the customer concern or symptom, check ASIST for Technical Service Bulletins (TSBs) related to the concern or symptom.

If a TSB relates to the symptom, follow the procedure to repair the noise.

LOCATE THE NOISE AND IDENTIFY THE ROOT CAUSE

1. Narrow down the noise to a general area. To help pinpoint the source of the noise, use a listening tool (Chassis ear: J-39570, engine ear, and mechanics stethoscope).
2. Narrow down the noise to a more specific area and identify the cause of the noise by:
 - Removing the component(s) in the area(s) that is / are suspected to be the cause of the noise. Do not use too much force when removing clips and fasteners, otherwise clips and fasteners can be broken or lost during the repair, creating a new noise.
 - Tapping or pushing/pulling the component(s) that is / are suspected to be the cause of the noise. Do not tap or push/pull the component(s) with excessive force, otherwise the noise is eliminated only temporarily.
 - Feeling for a vibration by hand by touching the component(s) that is / are suspected to be the cause of the noise.
 - Placing a piece of paper between components that are suspected to be the cause of the noise.
 - Looking for loose components and contact marks.
Refer to [GW-4. "Inspection Procedure"](#).

REPAIR THE CAUSE

- If the cause is a loose component, tighten the component securely.
- If the cause is insufficient clearance between components:
 - Separate components by repositioning or loosening and retightening the components, if possible.
 - Insulate components with a suitable insulator such as urethane pads, foam blocks, felt cloth tape, or urethane tape. A NISSAN Squeak and Rattle Kit (J-43980) is available through the authorized NISSAN Parts Department.

CAUTION:

Never use excessive force as many components are constructed of plastic and may be damaged.

NOTE:

Always check with the Parts Department for the latest parts information.

The following materials are contained in the NISSAN Squeak and Rattle Kit (J-43980). Each item can be ordered separately as needed.

URETHANE PADS [1.5 mm (0.059 in) thick]

Insulates connectors, harness, etc.

- 76268-9E005: 100 × 135 mm (3.937 × 5.315 in)
- 76884-71L01: 60 × 85 mm (2.362 × 3.346 in)
- 76884-71L02: 15 × 25 mm (0.591 × 0.984 in)

INSULATOR (Foam blocks)

Insulates components from contact. Can be used to fill space behind a panel.

- 73982-9E000: 45 mm (1.772 in) thick, 50 × 50 mm (1.969 × 1.969 in)
- 73982-50Y00: 10 mm (0.394 in) thick, 50 × 50 mm (1.969 × 1.969 in)

INSULATOR (Light foam block)

80845-71L00: 30 mm (1.18 in) thick, 30 × 50 mm (1.181 × 1.969 in)

FELT CLOTHTAPE

SQUEAK AND RATTLE TROUBLE DIAGNOSES

< SYMPTOM DIAGNOSIS >

Used to insulate where movement does not occur. Ideal for instrument panel applications.

- 68370-4B000: 15 × 25 mm (0.591 × 0.984 in) pad
- 68239-13E00: 5 mm (0.197 in) wide tape roll

The following materials, not found in the kit, can also be used to repair squeaks and rattles.

UHMW (TEFLON) TAPE

Insulates where slight movement is present. Ideal for instrument panel applications.

SILICONE GREASE

Used in place of UHMW tape that is visible or does not fit. Only lasts a few months.

SILICONE SPRAY

Used when grease cannot be applied.

DUCT TAPE

Used to eliminate movement.

CONFIRM THE REPAIR

After repair is complete, test drive the vehicle to confirm that the cause of noise is repaired by test driving the vehicle. Operate the vehicle under the same conditions as when the noise originally occurred. Refer to the notes on the Diagnostic Worksheet.

Inspection Procedure

INFOID:000000006209061

Refer to Table of Contents for specific component removal and installation information.

INSTRUMENT PANEL

Most incidents are caused by contact and movement between:

1. The cluster lid A and instrument panel
2. Acrylic lens and combination meter housing
3. Instrument panel to front pillar garnish
4. Instrument panel to windshield
5. Instrument panel mounting pins
6. Wiring harnesses behind the combination meter
7. A/C defroster duct and duct joint

These incidents can usually be located by tapping or moving the components to duplicate the noise or by pressing on the components while driving to stop the noise. Most of these incidents can be repaired by applying felt cloth tape or silicon spray (in hard to reach areas). Urethane pads can be used to insulate wiring harness.

CAUTION:

Never use silicone spray to isolate a squeak or rattle. If the area is saturated with silicone, the recheck of repair becomes impossible.

CENTER CONSOLE

Components to check include:

1. Shifter assembly cover to finisher
2. A/C control unit and cluster lid C
3. Wiring harnesses behind audio and A/C control unit

The instrument panel repair and isolation procedures also apply to the center console.

DOORS

Check the following items:

1. Finisher and inner panel making a slapping noise
2. Inside handle escutcheon connection to door finisher
3. Wiring harnesses tapping
4. Door striker out of alignment causing a popping noise on starts and stops

Tapping, moving the components, or pressing on them while driving to duplicate the conditions can isolate many of these incidents. The areas can usually be insulated with felt cloth tape or insulator foam blocks from the NISSAN Squeak and Rattle Kit (J-43980) to repair the noise.

TRUNK

Trunk noises are often caused by a loose jack or loose items put into the trunk by the customer.

In addition check for the following items:

SQUEAK AND RATTLE TROUBLE DIAGNOSES

< SYMPTOM DIAGNOSIS >

1. Trunk lid dumpers out of adjustment
2. Trunk lid striker out of adjustment
3. Trunk lid torsion bars knocking together
4. A loose license plate or bracket

Most of these incidents can be repaired by adjusting, securing, or insulating the item(s) or component(s) causing the noise.

SUNROOF/HEADLINING

Noises in the sunroof / headlining area can often be traced to one of the following items:

1. Sunroof lid, rail, linkage, or seals making a rattle or light knocking noise
2. Sunvisor shaft shaking in the holder
3. Front or rear windshield touching headlining and squeaking

Again, pressing on the components to stop the noise while duplicating the conditions can isolate most of these incidents. Repairs usually consist of insulating with felt cloth tape.

SEATS

When isolating seat noise it is important to note the position the seat is in and the load placed on the seat when the noise occurs. These conditions should be duplicated when verifying and isolating the cause of the noise.

Causes of seat noise include:

1. Headrest rods and holder
2. A squeak between the seat pad cushion and frame
3. The rear seatback lock and bracket

These noises can be isolated by moving or pressing on the suspected components while duplicating the conditions under which the noise occurs. Most of these incidents can be repaired by repositioning the component or applying urethane tape to the contact area.

UNDERHOOD

Some interior noise may be caused by components under the hood or on the engine wall. The noise is then transmitted into the passenger compartment.

Causes of transmitted underhood noise include:

1. Any component mounted to the engine wall
2. Components that pass through the engine wall
3. Engine wall mounts and connectors
4. Loose radiator mounting pins
5. Hood bumpers out of adjustment
6. Hood striker out of adjustment

These noises can be difficult to isolate since they cannot be reached from the interior of the vehicle. The best method is to secure, move, or insulate one component at a time and test drive the vehicle. Also, engine RPM or load can be changed to isolate the noise. Repairs can usually be made by moving, adjusting, securing, or insulating the component causing the noise.

A
B
C
D
E
F
G
H
I
J
L
M
N
O
P

GW

SQUEAK AND RATTLE TROUBLE DIAGNOSES

< SYMPTOM DIAGNOSIS >

Diagnostic Worksheet

INFOID:00000006209062



SQUEAK & RATTLE DIAGNOSTIC WORKSHEET

Dear Infiniti Customer:

We are concerned about your satisfaction with your Infiniti vehicle. Repairing a squeak or rattle sometimes can be very difficult. To help us fix your Infiniti right the first time, please take a moment to note the area of the vehicle where the squeak or rattle occurs and under what conditions. You may be asked to take a test drive with a service consultant or technician to ensure we confirm the noise you are hearing.

I. WHERE DOES THE NOISE COME FROM? (circle the area of the vehicle)

The illustrations are for reference only, and may not reflect the actual configuration of your vehicle.

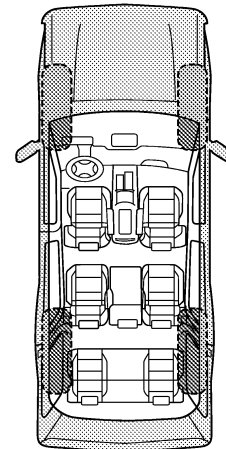
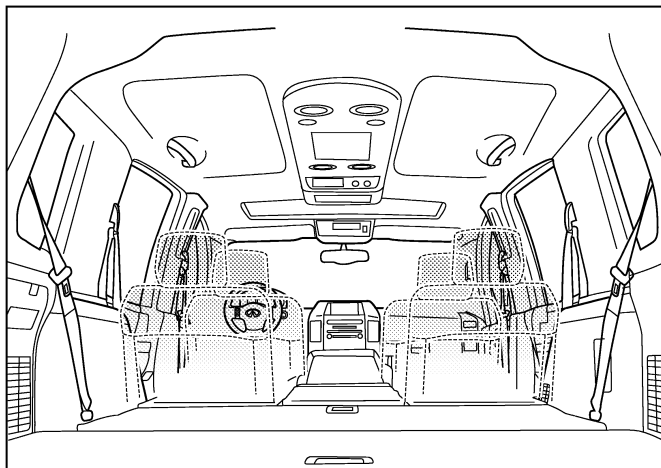
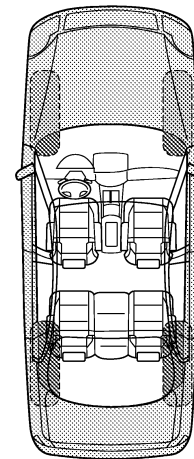
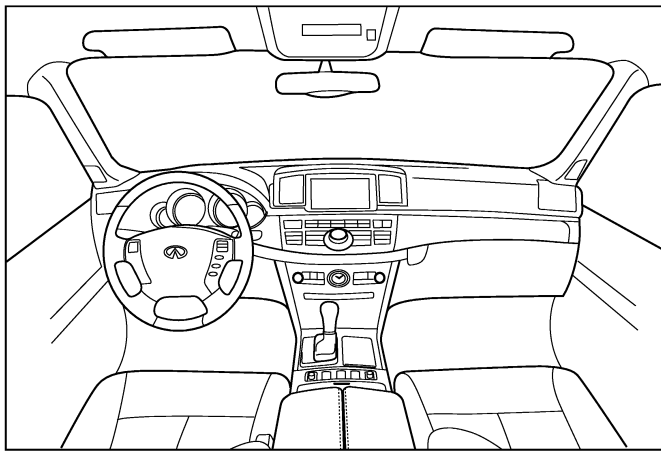

Continue to page 2 of the worksheet and briefly describe the location of the noise or rattle. In addition, please indicate the conditions which are present when the noise occurs.

PIIB8741E

SQUEAK AND RATTLE TROUBLE DIAGNOSES

< SYMPTOM DIAGNOSIS >

SQUEAK & RATTLE DIAGNOSTIC WORKSHEET - page 2

Briefly describe the location where the noise occurs:

II. WHEN DOES IT OCCUR? (please check the boxes that apply)

- | | |
|---|--|
| <input type="checkbox"/> anytime | <input type="checkbox"/> after sitting out in the rain |
| <input type="checkbox"/> 1st time in the morning | <input type="checkbox"/> when it is raining or wet |
| <input type="checkbox"/> only when it is cold outside | <input type="checkbox"/> dry or dusty conditions |
| <input type="checkbox"/> only when it is hot outside | <input type="checkbox"/> other: |

III. WHEN DRIVING:

- through driveways
- over rough roads
- over speed bumps
- only about ____ mph
- on acceleration
- coming to a stop
- on turns: left, right or either (circle)
- with passengers or cargo
- other: _____
- after driving ____ miles or ____ minutes

IV. WHAT TYPE OF NOISE

- squeak (like tennis shoes on a clean floor)
- creak (like walking on an old wooden floor)
- rattle (like shaking a baby rattle)
- knock (like a knock at the door)
- tick (like a clock second hand)
- thump (heavy, muffled knock noise)
- buzz (like a bumble bee)

TO BE COMPLETED BY DEALERSHIP PERSONNEL

Test Drive Notes:

	YES	NO	Initials of person performing
Vehicle test driven with customer	<input type="checkbox"/>	<input type="checkbox"/>	_____
- Noise verified on test drive	<input type="checkbox"/>	<input type="checkbox"/>	_____
- Noise source located and repaired	<input type="checkbox"/>	<input type="checkbox"/>	_____
- Follow up test drive performed to confirm repair	<input type="checkbox"/>	<input type="checkbox"/>	_____

VIN: _____ Customer Name: _____
W.O.# _____ Date: _____

This form must be attached to Work Order

PIIB8742E

A
B
C
D
E
F
G
H
I
J
L
M
N
O
P

GW

PRECAUTIONS

< PRECAUTION >

PRECAUTION

PRECAUTIONS

Precaution for Supplemental Restraint System (SRS) "AIR BAG" and "SEAT BELT PRE-TENSIONER"

INFOID:000000006209063

The Supplemental Restraint System such as "AIR BAG" and "SEAT BELT PRE-TENSIONER", used along with a front seat belt, helps to reduce the risk or severity of injury to the driver and front passenger for certain types of collision. This system includes seat belt switch inputs and dual stage front air bag modules. The SRS system uses the seat belt switches to determine the front air bag deployment, and may only deploy one front air bag, depending on the severity of a collision and whether the front occupants are belted or unbelted. Information necessary to service the system safely is included in the "SRS AIR BAG" and "SEAT BELT" of this Service Manual.

WARNING:

Always observe the following items for preventing accidental activation.

- To avoid rendering the SRS inoperative, which could increase the risk of personal injury or death in the event of a collision that would result in air bag inflation, all maintenance must be performed by an authorized NISSAN/INFINITI dealer.
- Improper maintenance, including incorrect removal and installation of the SRS, can lead to personal injury caused by unintentional activation of the system. For removal of Spiral Cable and Air Bag Module, see "SRS AIR BAG".
- Never use electrical test equipment on any circuit related to the SRS unless instructed to in this Service Manual. SRS wiring harnesses can be identified by yellow and/or orange harnesses or harness connectors.

PRECAUTIONS WHEN USING POWER TOOLS (AIR OR ELECTRIC) AND HAMMERS

WARNING:

Always observe the following items for preventing accidental activation.

- When working near the Air Bag Diagnosis Sensor Unit or other Air Bag System sensors with the ignition ON or engine running, never use air or electric power tools or strike near the sensor(s) with a hammer. Heavy vibration could activate the sensor(s) and deploy the air bag(s), possibly causing serious injury.
- When using air or electric power tools or hammers, always switch the ignition OFF, disconnect the battery, and wait at least 3 minutes before performing any service.

Precaution for Procedure without Cowl Top Cover

INFOID:000000006209064

When performing the procedure after removing cowl top cover, cover the lower end of windshield with urethane, etc to prevent damage to windshield.

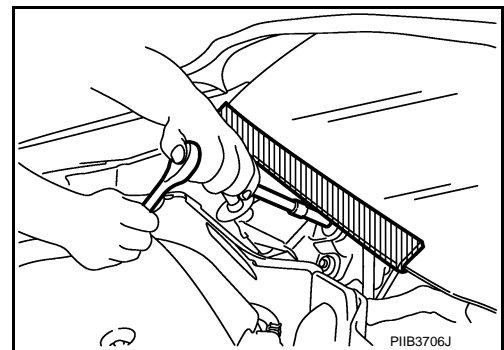

Handling for Adhesive and Primer

INFOID:000000006209065

- Do not use an adhesive which is past its usable date. Shelf life of this product is limited to six months after the date of manufacture. Carefully adhere to the expiration or manufacture date printed on the box.
- Keep primers and adhesive in a cool, dry place. Ideally, they should be stored in a refrigerator.
- Open the seal of the primer and adhesive just before application. Discard the remainder.
- Before application, be sure to shake the primer container to stir the contents. If any floating material is found, do not use it.
- If any primer or adhesive contacts the skin, wipe it off with gasoline or equivalent and wash the skin with soap.
- When using primer and adhesive, always observe the precautions in the instruction manual.

PREPARATION

< PREPARATION >

PREPARATION

PREPARATION

Special Service Tools

INFOID:000000006209066

The actual shapes of Kent-Moore tools may differ from those of special service tools illustrated here.

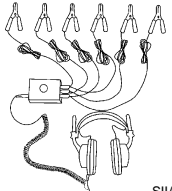
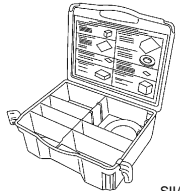
Tool number (Kent-Moore No.) Tool name	Description
(J-39570) Chassis ear  SIIA0993E	Locates the noise
(J-43980) NISSAN Squeak and Rattle Kit  SIIA0994E	Repairs the cause of noise

Commercial Service Tools

INFOID:000000006209067

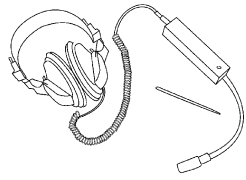
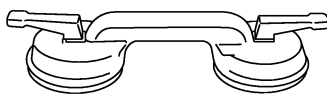
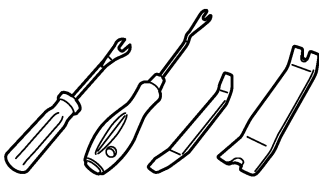
Tool name	Description
Engine ear  SIIA0995E	Locates the noise
Suction lifter  PIIB1805J	Holds the door glass
Remover tools  JMKIA3050ZZ	Removes the clips, pawls and metal clips

WINDSHIELD GLASS

< REMOVAL AND INSTALLATION >

REMOVAL AND INSTALLATION

WINDSHIELD GLASS

Exploded View

INFOID:000000006209068

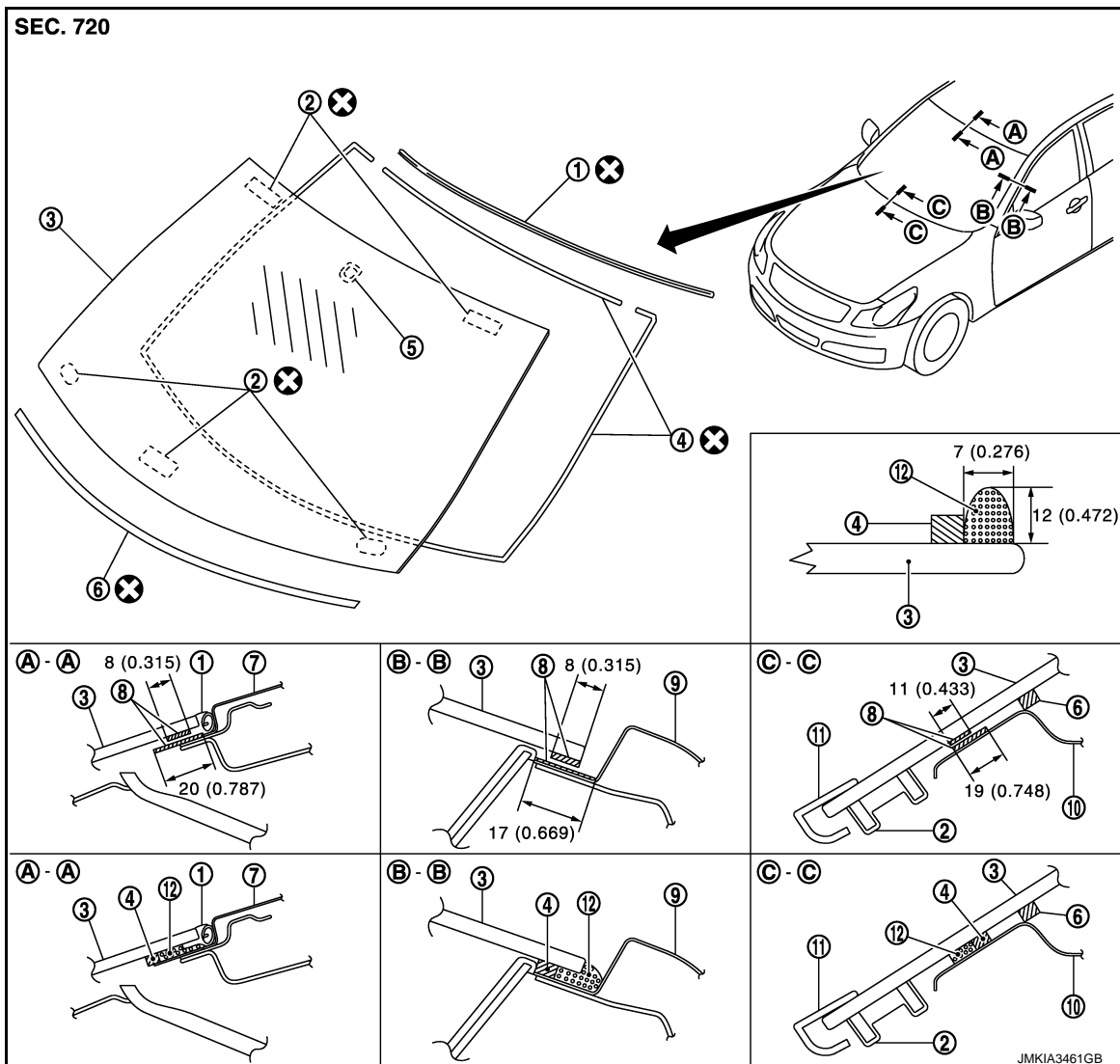

- | | | |
|------------------------------|--------------------|--------------------------|
| 1. Windshield molding | 2. Spacer | 3. Windshield glass |
| 4. Dam rubber (upper, lower) | 5. Mirror base | 6. Insulator |
| 7. Roof panel | 8. Primer | 9. Body side outer panel |
| 10. Dash upper cross member | 11. Cowl top cover | 12. Adhesive |

Unit: mm (in)

Refer to [GI-4. "Components"](#) for symbols in the figure.

Removal and Installation

INFOID:000000006209069

REMOVAL

1. Remove the front pillar garnish (LH/RH). Refer to [INT-15. "Removal and Installation"](#).
2. Remove partially the headlining (front edge). Refer to the following.
 - For normal roof. Refer to [INT-25. "NORMAL ROOF : Removal and Installation"](#).
 - For sunroof. Refer to [INT-27. "SUNROOF : Removal and Installation"](#).
3. Remove the front wiper arm and blade (LH/RH). Refer to [WW-102. "Removal and Installation"](#).
4. Remove the cowl top cover. Refer to [EXT-24. "Removal and Installation"](#).

WINDSHIELD GLASS

< REMOVAL AND INSTALLATION >

5. Remove the roof side molding (LH/RH). Refer to [EXT-34, "Removal and Installation"](#).
6. Apply protective tape around the windshield glass to protect the painted surface from damage.
7. Remove glass using piano wire or power cutting tool (A) and an inflatable pump bag (B) after removing moldings.

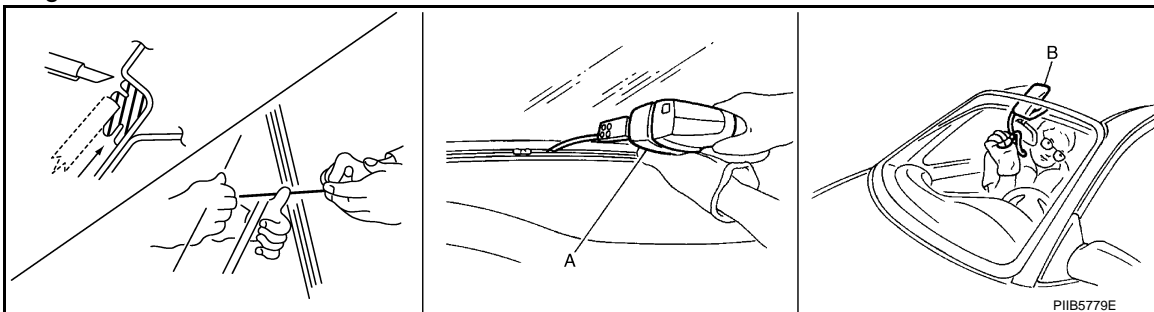

NOTE:

Mark the body and the glass with matching marks if the windshield glass is reused.

WARNING:

Always wear safety glasses and heavy gloves to help prevent glass splinters from entering your eyes or cutting your hands when cutting the glass from the vehicle.

CAUTION:

- Never use a cutting knife or power cutting tool when the windshield glass is reused.
- Be careful not to scratch the glass when removing.
- Never set or stand the glass on its edge. Small chips may develop into cracks.

INSTALLATION

- The dam rubber should be installed in position.
- Use a genuine Nissan Urethane Adhesive Kit (if available) or equivalent and follow the instructions furnished with it.
- Open a door window while the urethane adhesive is curing. This prevents the glass from being forced out by passenger room air pressure when all door windows are closed.
- The molding must be installed securely so that it is in position and leaves no clearance.
- Inform the customer that the vehicle should remain stationary until the urethane adhesive is completely cured (approximately 24 hours). Curing time varies with temperature and humidity.

WARNING:

- Keep heat and open flames away as primers and adhesive are flammable.
- The materials contained in the kit are harmful if swallowed, and may irritate skin and eyes. Never let them come in contact with the skin and eyes.
- Use in an open, well ventilated location. Never breathe the vapors. They may be harmful if inhaled. Move immediately to an area with fresh air if affected by vapor inhalation.
- Driving the vehicle before the urethane adhesive is completely cured may affect the performance of the windshield in case of an accident.

CAUTION:

- Perform adjustment of front wiper arms stop location. Refer to [WW-102, "Adjustment"](#).
- Never use an adhesive which is past its usable term. Shelf life of this product is limited to six months after the date of manufacture. Adhere carefully to the expiration or manufacture date printed on the box.
- Keep primers and adhesive in a cool, dry place. Ideally, they should be stored in a refrigerator.
- Never leave primers or adhesive cartridge unattended with their caps open or off.
- The vehicle should not be driven for at least 24 hours or until the urethane adhesive is completely cured. Curing time varies depending on temperature and humidity. The curing time increases under lower temperature and lower humidity.

Inspection

INFOID:000000006209070

REPAIRING WATER LEAKAGE FOR WINDSHIELD GLASS

Leakage can be repaired without removing and reinstalling glass.

If water is leaking between the urethane adhesive material and body or glass, determine the extent of leakage.

This can be done by applying water to the windshield area while pushing glass outward.

To stop the leakage, apply primer (if necessary) and then urethane adhesive to the leakage point.

REAR WINDOW GLASS

< REMOVAL AND INSTALLATION >

REAR WINDOW GLASS

Exploded View

INFOID:000000006209071

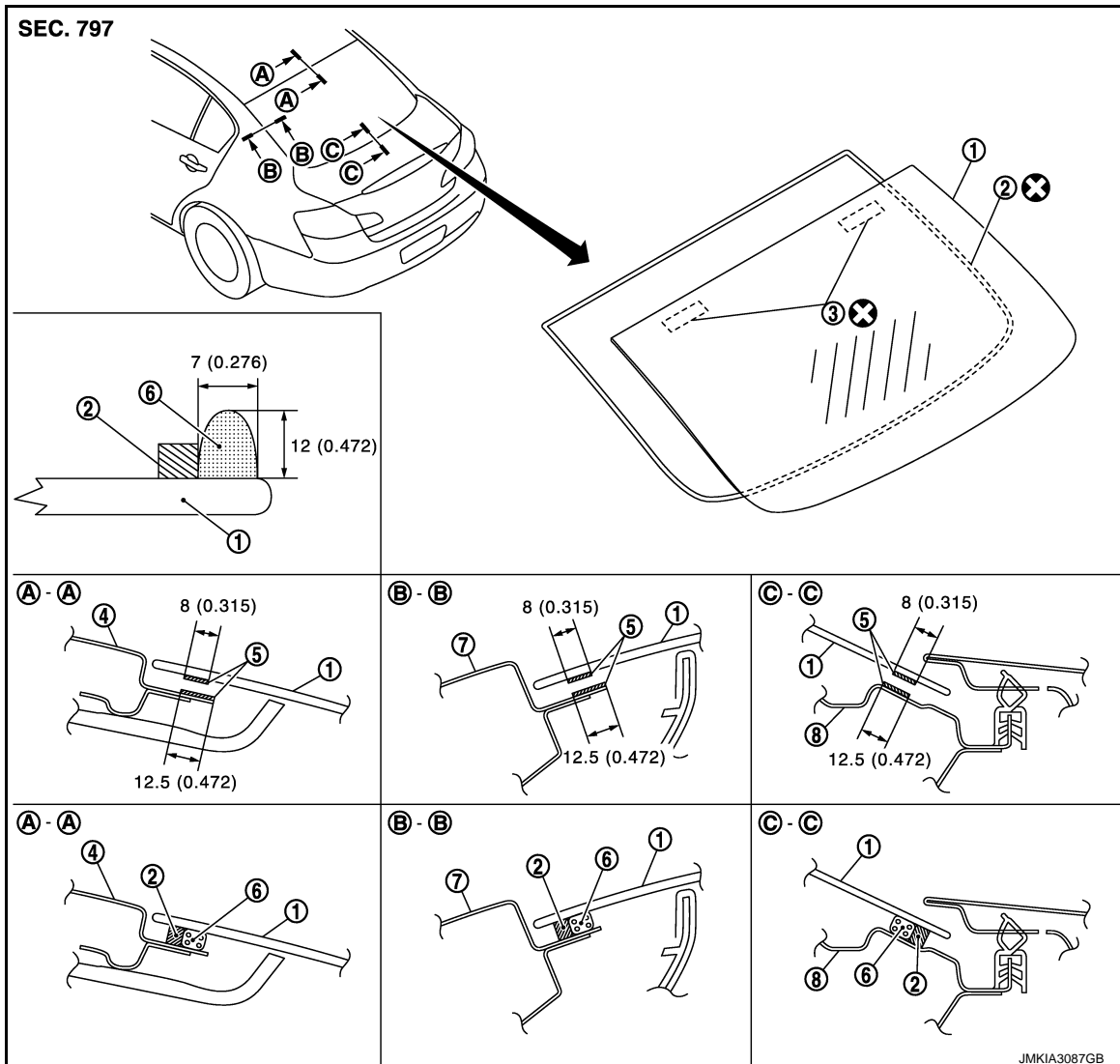

- | | | |
|--------------------------|---------------|-------------|
| 1. Rear window glass | 2. Dam rubber | 3. Spacer |
| 4. Roof panel | 5. Primer | 6. Adhesive |
| 7. Body side outer panel | 8. Waist rear | |

Unit: mm (in)

Refer to [GI-4. "Components"](#) for symbols in the figure.

Removal and Installation

INFOID:000000006209072

REMOVAL

1. Remove the rear seatback and rear seat cushion. Refer to [SE-133. "Removal and Installation"](#).
2. Remove the rear pillar finisher. Refer to [INT-15. "Removal and Installation"](#).
3. Remove the rear parcel shelf finisher. Refer to [INT-20. "Removal and Installation"](#).
4. Remove partially the headlining (rear edge). Refer to the following.
 - For normal roof. Refer to [INT-25. "NORMAL ROOF : Removal and Installation"](#)
 - For sunroof. Refer to [INT-27. "SUNROOF : Removal and Installation"](#).
5. Remove the connectors and grounds for the rear window defogger.

REAR WINDOW GLASS

< REMOVAL AND INSTALLATION >

6. Remove glass using piano wire or power cutting tool (A) and an inflatable pump bag (B) after removing molding using pliers.

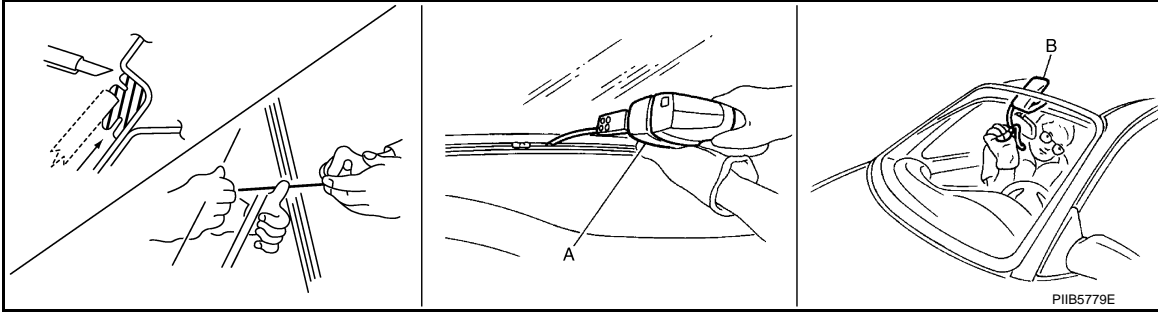

NOTE:

Mark the body and the glass with matching marks if a rear window glass is reused.

WARNING:

Always wear safety glasses and heavy gloves to help prevent glass splinters from entering your eyes or cutting your hands when cutting the glass from the vehicle.

CAUTION:

- Never use a cutting knife or power cutting tool when the rear window glass is reused.
- Be careful not to scratch the glass when removing.
- Never set or stand the glass on its edge. Small chips may develop into cracks.

INSTALLATION

- The dam rubber should be installed in position.
- Use a genuine Nissan Urethane Adhesive Kit (if available) or equivalent and follow the instructions furnished with it.
- Open a door window while the urethane adhesive is curing. This prevents the glass from being forced out by passenger compartment air pressure when all door windows are closed.
- The molding must be installed securely so that it is in position and leaves no clearance.
- Inform the customer that the vehicle should remain stationary until the urethane adhesive is completely cured (approximately 24 hours). Curing time varies with temperature and humidity.

WARNING:

- Keep heat and open flames away as primers and adhesive are flammable.
- The materials contained in the kit are harmful if swallowed, and may irritate skin and eyes. Never let them come in contact with the skin and eyes.
- Use in an open, well ventilated location. Never breathe the vapors. They may be harmful if inhaled. Move immediately to an area with fresh air if affected by vapor inhalation.
- Driving the vehicle before the urethane adhesive is completely cured may affect the performance of the rear window in case of an accident.

CAUTION:

- Never use an adhesive which is past its usable term. Shelf life of this product is limited to six months after the date of manufacture. Adhere carefully to the expiration or manufacture date printed on the box.
- Keep primers and adhesive in a cool, dry place. Ideally, they should be stored in a refrigerator.
- Never leave primers or adhesive cartridge unattended with their caps open or off.
- The vehicle should not be driven for at least 24 hours or until the urethane adhesive is completely cured. Curing time varies depending on temperature and humidity. The curing time increases under lower temperature and lower humidity.

Inspection

INFOID:000000006209073

REPAIRING WATER LEAKAGE FOR REAR WINDOW GLASS

Leakage can be repaired without removing and reinstalling glass.

If water is leaking between the urethane adhesive material and body or glass, determine the extent of leakage. This can be done by applying water to the side window area while pushing glass outward.

To stop the leakage, apply primer (if necessary) and then urethane adhesive to the leakage point.

FRONT DOOR GLASS

< REMOVAL AND INSTALLATION >

FRONT DOOR GLASS

Exploded View

INFOID:000000006209074

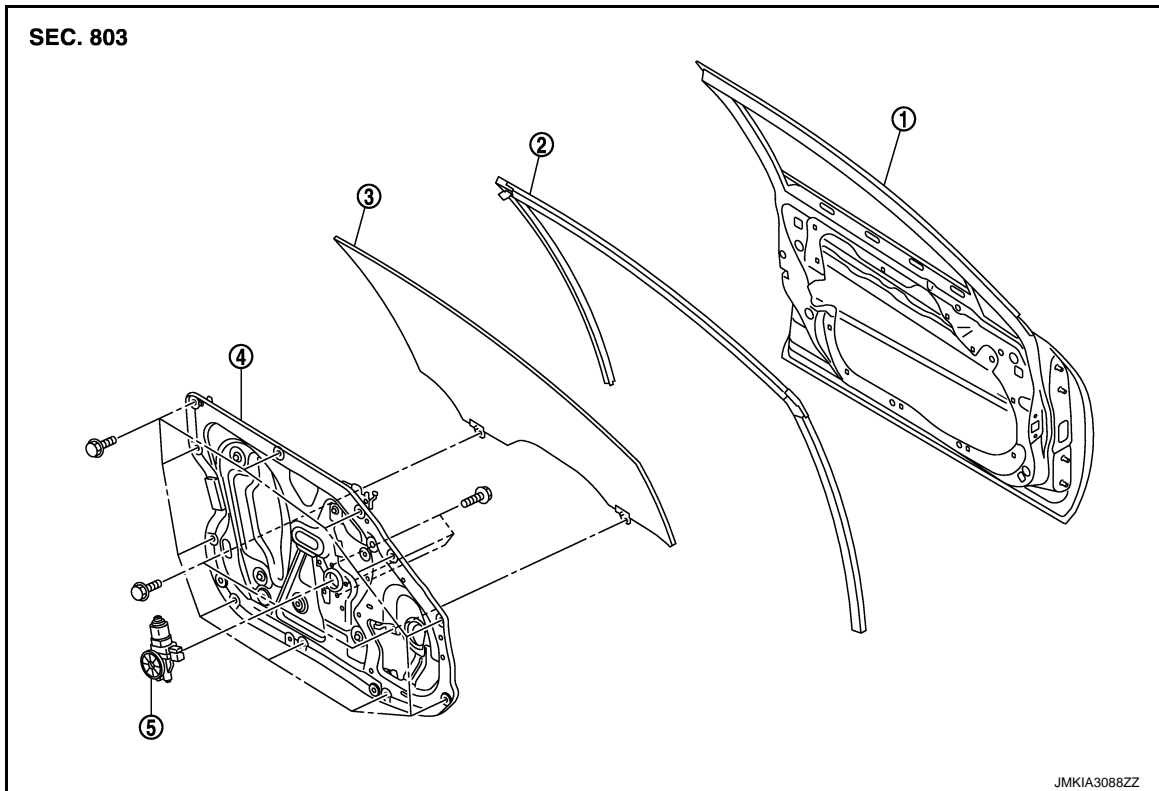

- 1. Front door panel
- 2. Door glass run
- 3. Door glass
- 4. Module assembly
- 5. Power window motor

Removal and Installation

INFOID:000000006209075

REMOVAL

1. Remove the front door finisher. Refer to [INT-12. "Removal and Installation"](#).
2. Remove the door inside seal.
3. Disconnect the front door speaker harness connector and remove the door speaker.
4. Reconnect the front power window control unit LH and the power window main switch finisher.
5. Operate the power window main switch to raise/lower the door window until the glass mounting bolts can be seen.
6. Remove the glass mounting bolts, shown by the arrows in the figure.

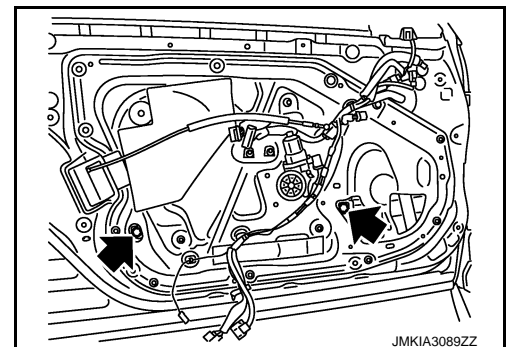

FRONT DOOR GLASS

< REMOVAL AND INSTALLATION >

7. While holding the door glass, raise it at the rear end to pull the glass out of the sash toward the inside of the door.

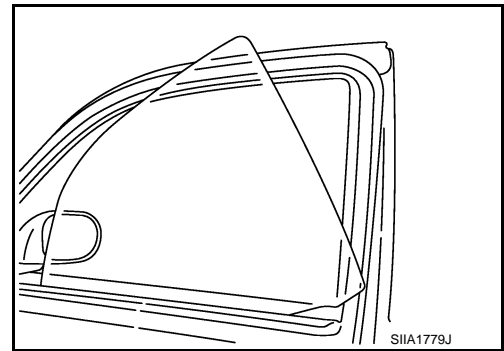

8. Remove the door glass run.

INSTALLATION

Install in the reverse order of removal.

Inspection and Adjustment

INFOID:000000006209076

SYSTEM INITIALIZATION

If any of the following work has been done, initialize the system.

- Electric power supply to power window switch or motor is interrupted by blown fuse or disconnecting battery cable, etc.
- Removal and installation of the regulator assembly.
- Removal and installation of the motor from the regulator assembly.
- Removal and installation of the harness connector of the power window switch.
- Operation of the regulator assembly as a unit.
- Removal and installation of the door glass.
- Removal and installation of the door glass run.

Initialization

After installing each component to the vehicle, follow the steps below.

1. Disconnect the minus terminal of battery or disconnect power window switch harness connector temporarily, then reconnect after at least 1 minute.
2. Turn ignition switch ON.
3. Operate power window switch to make over a half of the window area open.
4. Fully draw the power window switch in the up direction (auto close position) and hold, keep holding the switch even when window is completely closed and then release after 2 seconds have passed.
5. Inspect the anti-pinch system function.

NOTE:

Initialization may be cancelled with continuous opening and closing operation. In this case, initialize the system.

INSPECT THE FUNCTION OF THE ANTI-PINCH SYSTEM

1. Fully open the door glass.
 2. Place a wooden piece (wooden hammer handle, etc.) at near fully closed position.
 3. Perform fully closing operation with auto up switch.
- Check that the glass reverses without pinching the wooden piece, is lowered approximately 150 mm (5.906 in) or for 3 seconds and then stops.
 - The glass should not be raised with power window main switch operated while it is reversing or lowering.

CAUTION:

- **Be careful not to be pinched.**
- **Check that the auto up function is normal before the inspection following the system initialization.**

FITTING INSPECTION

- Check that the glass is securely fit into the glass run groove.
- Lower the glass slightly [approximately 10 to 20 mm (0.394 to 0.787 in)] and check that the clearance to the sash is parallel. If the clearance between the glass and sash is not parallel, loosen the regulator mounting bolts, guide rail mounting bolts, and glass and guide rail mounting bolts to correct the glass position.

FRONT REGULATOR

< REMOVAL AND INSTALLATION >

FRONT REGULATOR

Exploded View

INFOID:000000006209077

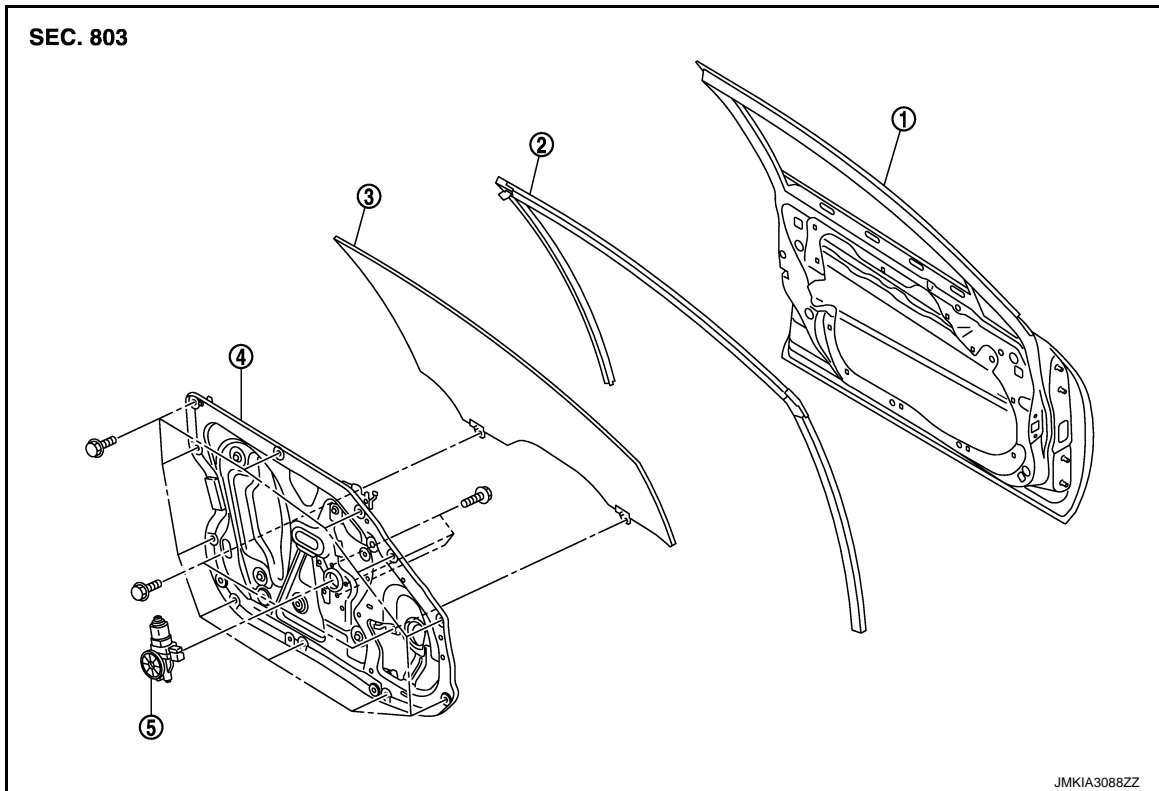

- | | | |
|---------------------|-----------------------|---------------|
| 1. Front door panel | 2. Door glass run | 3. Door glass |
| 4. Module assembly | 5. Power window motor | |

Removal and Installation

INFOID:000000006209078

REMOVAL

1. Remove the front door glass. Refer to [GW-14. "Removal and Installation"](#).
2. Disconnect the harness connector for the module assembly, and remove the harness clip.
3. Remove the module assembly mounting bolts shown by the arrows in the figure.
4. Remove the module assembly.

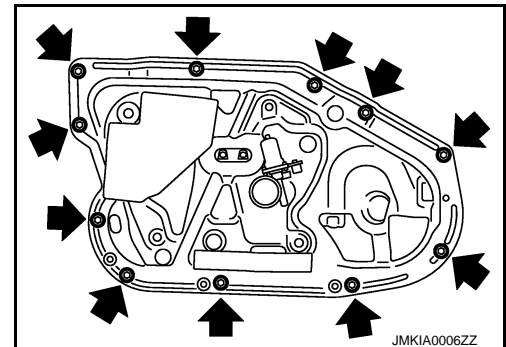

INSTALLATION

Install in the reverse order of removal.

Disassembly and Assembly

INFOID:000000006209079

DISASSEMBLY

1. Remove power window motor from module assembly.

FRONT REGULATOR

< REMOVAL AND INSTALLATION >

2. Remove regulator assembly from module assembly.

ASSEMBLY

Assemble in the reverse order of disassembly.

Inspection and Installation

INFOID:000000006209080

Inspection after Removal

Check the regulator assembly for the following items. If a malfunction is detected, replace or grease it.

- Wire wear
- Regulator deformation
- Grease condition for each sliding part

The arrows in the figure show the application points of the multi-purpose grease.

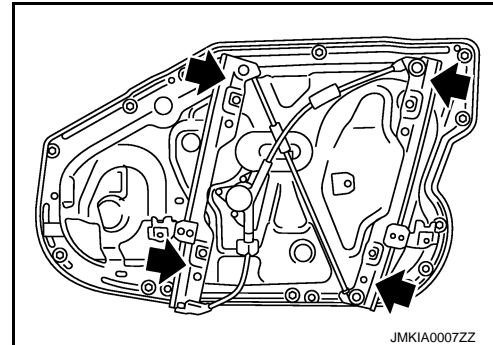

SYSTEM INITIALIZATION

If any of the following work has been done, initialize the system. Refer to [PWC-7, "ADDITIONAL SERVICE WHEN REMOVING BATTERY NEGATIVE TERMINAL : Description"](#).

Initialization

After installing each component to the vehicle, follow the steps below. Refer to [PWC-7, "ADDITIONAL SERVICE WHEN REMOVING BATTERY NEGATIVE TERMINAL : Special Repair Requirement"](#).

FITTING INSPECTION

- Check that the glass is securely fit into the glass run groove.
- Lower the glass slightly [approximately 10 to 20 mm (0.394 to 0.787 in)] and check that the clearance to the sash is parallel. If the clearance between the glass and sash is not parallel, loosen the regulator mounting bolts, guide rail mounting bolts, and glass and guide rail mounting bolts to correct the glass position.

A
B
C
D
E
F
G
H
I
J
L
M
N
O
P

GW

REAR DOOR GLASS

< REMOVAL AND INSTALLATION >

REAR DOOR GLASS

Exploded View

INFOID:000000006209081

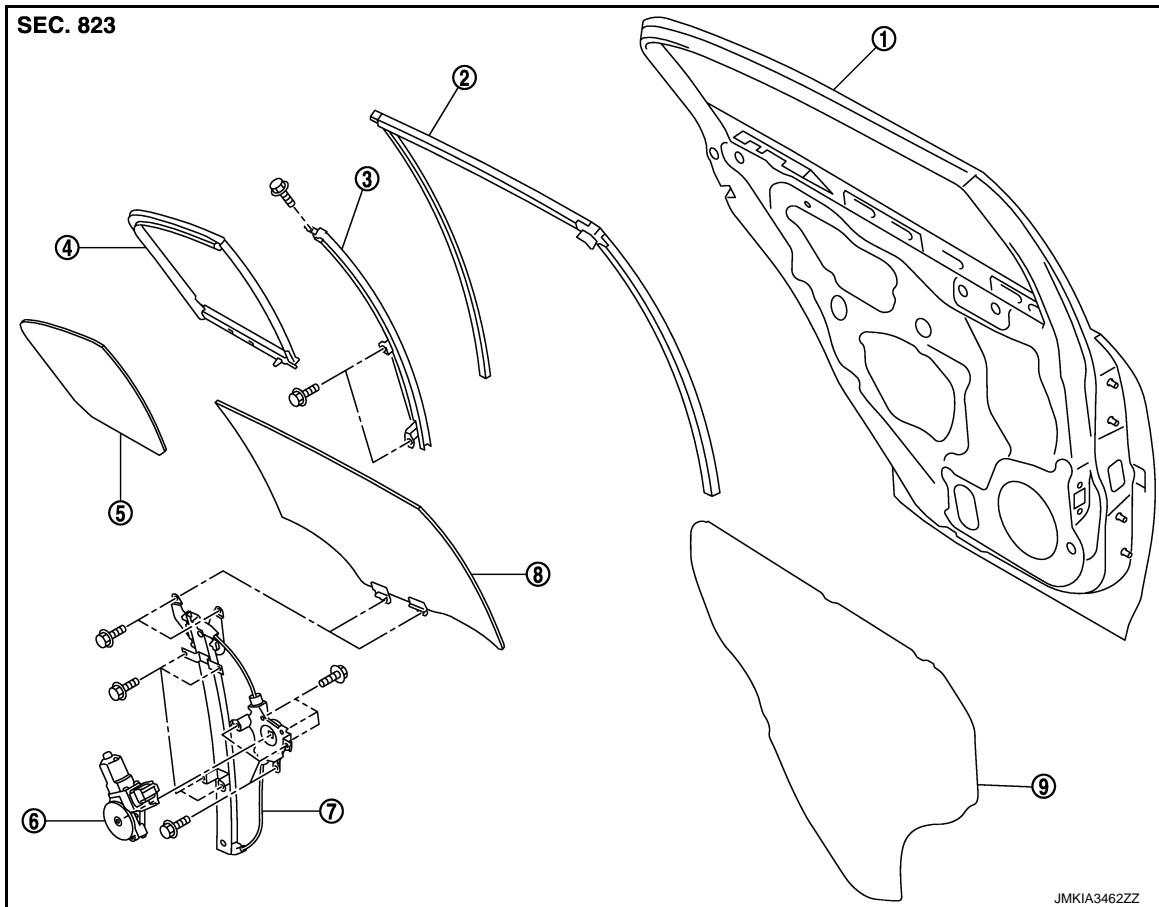

- | | | |
|------------------------|--------------------|-----------------------|
| 1. Rear door panel | 2. Door glass run | 3. Partition sash |
| 4. Partition glass run | 5. Partition glass | 6. Power window motor |
| 7. Regulator assembly | 8. Door glass | 9. Sealing screen |

Removal and Installation

INFOID:000000006209082

REMOVAL

1. Remove the rear door finisher. Refer to [INT-12, "Removal and Installation"](#).
2. Remove the rear door outside molding. Refer to [EXT-38, "Removal and Installation"](#).
3. Remove the rear door inside molding.
4. Remove partially the sealing screen.
5. Remove the door glass run (1) on the partition sash side.
6. Remove the partition sash (2) fixing bolts (shown by the arrows), and remove the partition sash.

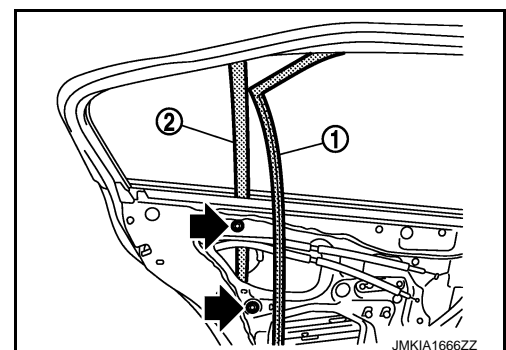

REAR DOOR GLASS

< REMOVAL AND INSTALLATION >

7. Reconnect the power window switch finisher.
8. Operate the power window switch to raise/lower the door window until the glass mounting bolts can be seen.
9. Remove the glass mounting bolts shown by the arrows in the figure.

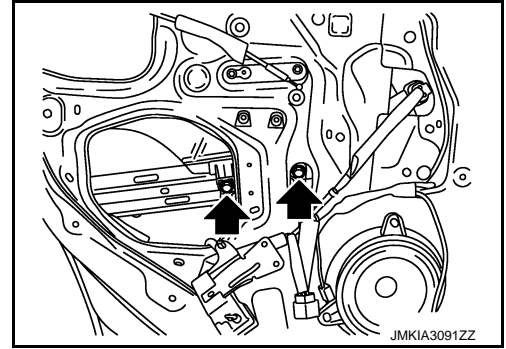

10. Remove the door glass from the inside of door panel.
11. Remove the door glass run.
12. Remove the partition glass from door panel.

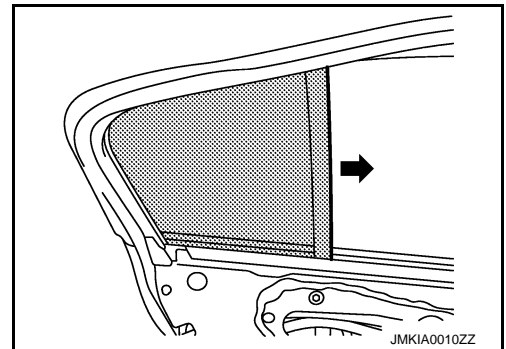

INSTALLATION

Install in the reverse order of removal.

Inspection and Adjustment

INFOID:000000006209083

SYSTEM INITIALIZATION OF ANTI-PINCH SYSTEM

If any of the following work has been done, initialize the system.

- Electric power source to power window switch or motor is interrupted by broken fuse or disconnecting battery cable, etc.
- Removal and installation of the regulator assembly.
- Removal and installation of the motor from the regulator assembly.
- Removal and installation of the harness connector of the power window switch.
- Operation of the regulator assembly as a unit.
- Removal and installation of the door glass.
- Removal and installation of the door glass run.

Initialization

After installing each component to the vehicle, follow the steps below.

1. Disconnect the minus terminal of battery or disconnect power window switch harness connector temporarily, then reconnect after at least 1 minute.
2. Turn ignition switch ON.
3. Open the window to its full width by operating the power window switch. (Exclude this procedure if the window is already fully opened)
4. Fully draw the power window switch in the up direction (auto close position) and hold, continue holding the switch even when window is completely closed and then release after 3 seconds have passed.
5. Inspection of the anti-pinch system function.

NOTE:

Initialization may be cancelled with continuous opening and closing operation. In this case, initialize the system.

INSPECT THE FUNCTION OF THE ANTI-PINCH SYSTEM

1. Fully open the door glass.

A
B
C
D
E
F
G
H
I
J

GW

L

M

N

O

P

REAR DOOR GLASS

< REMOVAL AND INSTALLATION >

2. Place a wooden piece (wooden hammer handle, etc.) at near fully closed position.
3. Perform fully closing operation with auto up switch.
 - Check that the glass reverses without pinching the wooden piece, is lowered approximately 150 mm (5.906 in) or for 2 seconds and then stops.
 - The glass should not be raised with power window main switch operated while it is reversing or lowering.

CAUTION:

- **Be careful not to be pinched.**
- **Check that the auto up function is normal before the inspection following the system initialization.**

FITTING INSPECTION

- Check that the glass is securely fit into the glass run groove.
- Lower the glass slightly [approximately 10 to 20 mm (0.394 to 0.787 in)], and check that the clearance to the sash is parallel. If the clearance between the glass and sash is not parallel, loosen the regulator mounting bolts, guide rail mounting bolts, and glass and carrier plate mounting bolts to correct the glass position.

REAR REGULATOR

< REMOVAL AND INSTALLATION >

REAR REGULATOR

Exploded View

INFOID:000000006209084

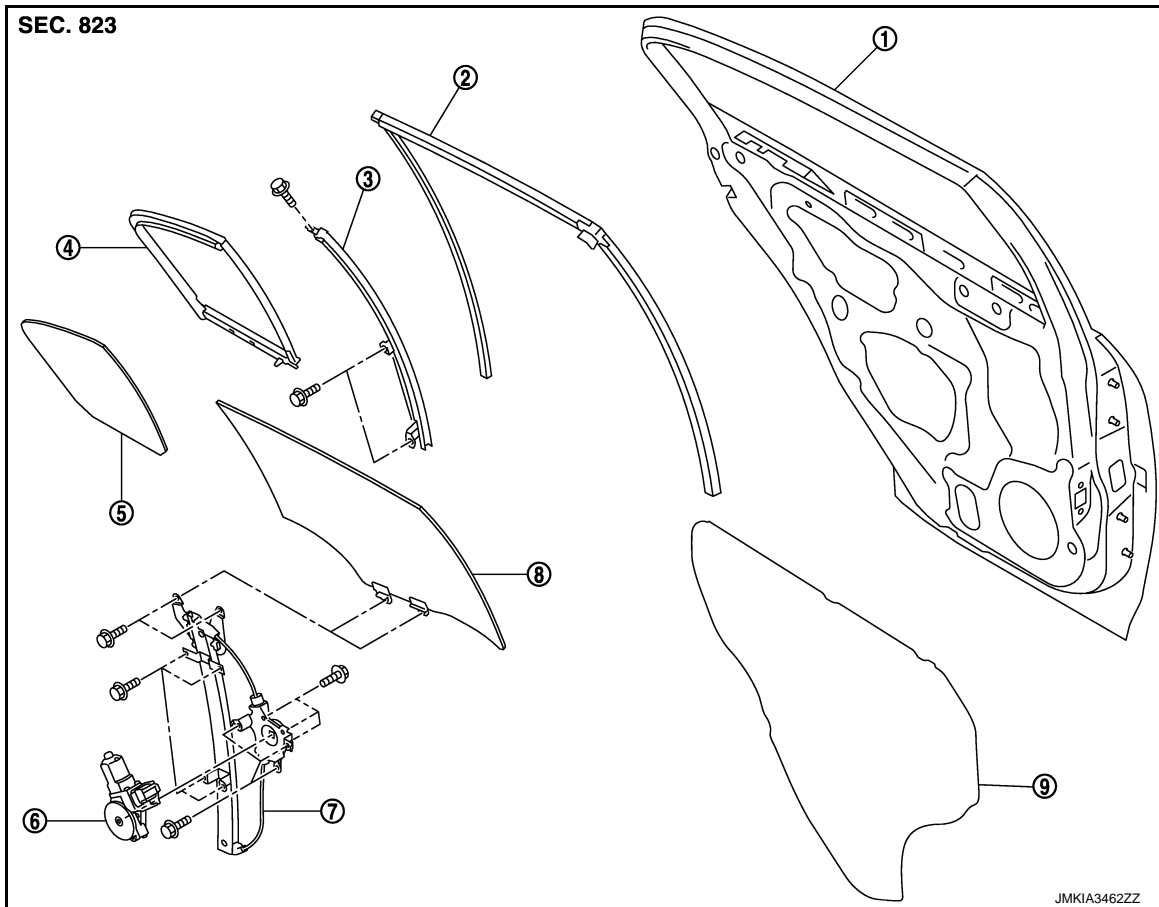

- | | | |
|------------------------|--------------------|-----------------------|
| 1. Rear door panel | 2. Door glass run | 3. Partition sash |
| 4. Partition glass run | 5. Partition glass | 6. Power window motor |
| 7. Regulator assembly | 8. Door glass | 9. Sealing screen |

Removal and Installation

INFOID:000000006209085

REMOVAL

1. Remove the rear door glass. Refer to [GW-18. "Removal and Installation"](#).
2. Remove the glass mounting bolts.
3. Disconnect the connector for the power window motor.
4. Remove the regulator mounting bolts shown by the arrows in the figure, and remove the regulator from the door panel.

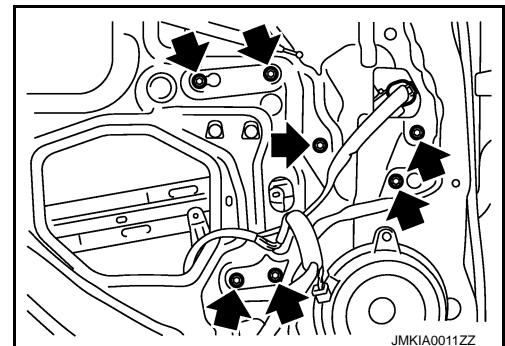

INSTALLATION

Install in the reverse order of removal.

A
B
C
D
E
F
G
H
I
J

GW

L

M

N

O

P

REAR REGULATOR

< REMOVAL AND INSTALLATION >

Disassembly and Assembly

INFOID:000000006209086

DISASSEMBLY

Remove power window motor from regulator assembly.

ASSEMBLY

Assemble in the reverse order of disassembly.

Inspection and Adjustment

INFOID:000000006209087

Inspection after Removal

Check the regulator assembly for the following items. If a malfunction is detected, replace or grease it.

- Gear wear
- Regulator deformation
- Grease condition for each sliding part

The arrows in the figure show the application points of the multi-purpose grease.

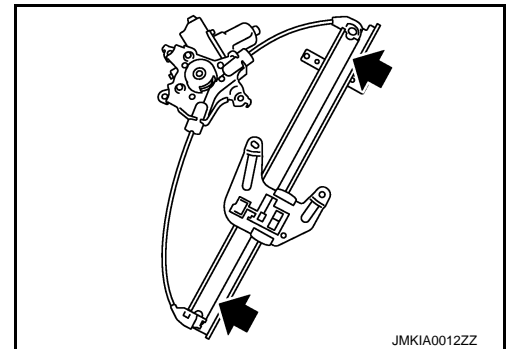

SYSTEM INITIALIZATION OF THE ANTI-PINCH SYSTEM

If any of the following work has been done, initialize the system. Refer to [PWC-7. "ADDITIONAL SERVICE WHEN REMOVING BATTERY NEGATIVE TERMINAL : Description"](#).

Initialization

After installing each component to the vehicle, follow the steps below. Refer to [PWC-7. "ADDITIONAL SERVICE WHEN REMOVING BATTERY NEGATIVE TERMINAL : Special Repair Requirement"](#).

FITTING INSPECTION

- Check that the glass is securely fit into the glass run groove.
- Lower the glass slightly [approximately 10 to 20 mm (0.394 to 0.787 in)], and check that the clearance to the sash is parallel. If the clearance between the glass and sash is not parallel, loosen the regulator mounting bolts, guide rail mounting bolts, and glass and carrier plate mounting bolts to correct the glass position.