

SECTION **SE**
SEAT

A
B
C
D
E
F
G
H
I
SE
K
L
M
N
O
P

CONTENTS

BASIC INSPECTION	4	HEATED SEAT SWITCH	16
DIAGNOSIS AND REPAIR WORK FLOW	4	DRIVER SIDE	16
Work Flow	4	DRIVER SIDE : Description	16
SYSTEM DESCRIPTION	5	DRIVER SIDE : Component Function Check	16
POWER SEAT	5	DRIVER SIDE : Diagnosis Procedure	16
System Description	5	DRIVER SIDE : Component Inspection	17
Component Parts Location	5	PASSENGER SIDE	17
Component Description	5	PASSENGER SIDE : Description	17
TILT&TELESCOPIC SYSTEM	6	PASSENGER SIDE :	
System Description	6	Component Function Check	17
Component Parts Location	6	PASSENGER SIDE : Diagnosis Procedure	18
Component Description	7	PASSENGER SIDE : Component Inspection	19
SIDE SUPPORT	8	HEATED SEAT RELAY	20
System Description	8	Description	20
Component Parts Location	8	Component Function Check	20
Component Description	8	Diagnosis Procedure	20
HEATED SEAT	9	Component Inspection	21
System Diagram	9	HEAT SENSOR	22
System Description	9	DRIVER SIDE	22
Component Parts Location	10	DRIVER SIDE : Description	22
Component Description	10	DRIVER SIDE : Component Function Check	22
DTC/CIRCUIT DIAGNOSIS	11	DRIVER SIDE : Diagnosis Procedure	22
POWER SUPPLY AND GROUND CIRCUIT	11	DRIVER SIDE : Component Inspection	23
AUTOMATIC DRIVE POSITIONER CONTROL UNIT	11	PASSENGER SIDE	24
AUTOMATIC DRIVE POSITIONER CONTROL UNIT : Diagnosis Procedure	11	PASSENGER SIDE : Description	24
HEATED SEAT CONTROL UNIT	11	PASSENGER SIDE : Component Function Check	24
HEATED SEAT CONTROL UNIT : Diagnosis Procedure	11	PASSENGER SIDE : Diagnosis Procedure	24
HEATED SEAT SWITCH	13	PASSENGER SIDE : Component Inspection	26
HEATED SEAT SWITCH : Diagnosis Procedure	13	SEAT CUSHION HEATER	27
		DRIVER SIDE	27
		DRIVER SIDE : Description	27
		DRIVER SIDE : Component Function Check	27
		DRIVER SIDE : Diagnosis Procedure	27
		DRIVER SIDE : Component Inspection	28

PASSENGER SIDE	28	ECU DIAGNOSIS INFORMATION	57
PASSENGER SIDE : Description	28	AUTOMATIC DRIVE POSITIONER CON-	
PASSENGER SIDE :		TROL UNIT	57
Component Function Check	28	Reference Value	57
PASSENGER SIDE : Diagnosis Procedure	28	Wiring Diagram - AUTOMATIC DRIVE POSI-	
PASSENGER SIDE : Component Inspection	30	TIONER CONTROL SYSTEM -	61
SEATBACK HEATER	31	HEATED SEAT CONTROL UNIT	72
DRIVER SIDE	31	DRIVER SIDE	72
DRIVER SIDE : Description	31	DRIVER SIDE : Reference Value	72
DRIVER SIDE : Component Function Check	31	DRIVER SIDE : Wiring Diagram - HEATED SEAT	
DRIVER SIDE : Diagnosis Procedure	31	SYSTEM (WITH M/T) -	73
PASSENGER SIDE	31	DRIVER SIDE : Wiring Diagram - HEATED SEAT	
PASSENGER SIDE : Description	31	SYSTEM (WITH A/T) -	80
PASSENGER SIDE :		PASSENGER SIDE	86
Component Function Check	31	PASSENGER SIDE : Reference Value	87
PASSENGER SIDE : Diagnosis Procedure	31	PASSENGER SIDE : Wiring Diagram - HEATED	
HEATED SEAT SWITCH INDICATOR	33	SEAT SYSTEM (WITH M/T) -	88
DRIVER SIDE	33	PASSENGER SIDE : Wiring Diagram - HEATED	
DRIVER SIDE : Description	33	SEAT SYSTEM (WITH A/T) -	95
DRIVER SIDE : Component Function Check	33	SYMPTOM DIAGNOSIS	102
DRIVER SIDE : Diagnosis Procedure	33	HEATED SEAT DOES NOT OPERATE	102
PASSENGER SIDE	33	BOTH SIDES	102
PASSENGER SIDE : Description	33	BOTH SIDES : Diagnosis Procedure	102
PASSENGER SIDE :		DRIVER SIDE	102
Component Function Check	33	DRIVER SIDE : Diagnosis Procedure	102
PASSENGER SIDE : Diagnosis Procedure	33	PASSENGER SIDE	103
TILT&TELESCOPIC SWITCH	35	PASSENGER SIDE : Diagnosis Procedure	103
Description	35	SEATBACK HEATER ONLY DOES NOT OP-	
Component Function Check	35	ERATE	104
Diagnosis Procedure	35	DRIVER SIDE	104
Component Inspection	36	DRIVER SIDE : Diagnosis Procedure	104
TILT&TELESCOPIC MOTOR	38	PASSENGER SIDE	104
Description	38	PASSENGER SIDE : Diagnosis Procedure	104
Component Function Check	38	CANNOT ADJUST HEATED SEAT TEMPER-	
Diagnosis Procedure	38	ATURE	105
Component Inspection	39	DRIVER SIDE	105
TILT&TELESCOPIC SENSOR	40	DRIVER SIDE : Diagnosis Procedure	105
Description	40	PASSENGER SIDE	105
Component Function Check	40	PASSENGER SIDE : Diagnosis Procedure	105
Diagnosis Procedure	40	HEATED SEAT SWITCH INDICATOR DOES	
POWER SEAT	42	NOT TURN ON	106
Wiring Diagram - POWER SEAT SYSTEM (DRIV-		DRIVER SIDE	106
ER SIDE) -	42	DRIVER SIDE : Diagnosis Procedure	106
Wiring Diagram - POWER SEAT SYSTEM (PAS-		PASSENGER SIDE	106
SENGER SIDE) -	46	PASSENGER SIDE : Diagnosis Procedure	106
SIDE SUPPORT	50		
Wiring Diagram - SIDE SUPPORT SYSTEM -	50		
TILT & TELESCOPIC SYSTEM	54		
Wiring Diagram - TILT&TELESCOPIC SYSTEM -	54		

STEERING POSITION FUNCTION DOES NOT OPERATE	107	REMOVAL AND INSTALLATION	120	A
Diagnosis Procedure	107	FRONT SEAT	120	B
TILT FUNCTION DOES NOT OPERATE	108	Exploded View	120	
Diagnosis Procedure	108	Removal and Installation	123	
TELESCOPIC FUNCTION DOES NOT OPERATE	109	Disassembly and Assembly	124	
Diagnosis Procedure	109	REAR SEAT	132	C
SQUEAK AND RATTLE TROUBLE DIAGNOSES	110	Exploded View	132	
Work Flow	110	Removal and Installation	133	
Inspection Procedure	112	Disassembly and Assembly	133	
Diagnostic Worksheet	114	AUTOMATIC DRIVE POSITIONER CONTROL UNIT	135	D
PRECAUTION	116	Removal and Installation	135	E
PRECAUTIONS	116	HEATED SEAT CONTROL UNIT	136	F
Precaution for Supplemental Restraint System (SRS) "AIR BAG" and "SEAT BELT PRE-TENSIONER"	116	Exploded View	136	
Service Notice	116	Removal and Installation	136	
Precaution for Work	116	POWER SEAT SWITCH	137	G
PREPARATION	118	Removal and Installation	137	
PREPARATION	118	SIDE SUPPORT SWITCH	138	H
Special Service Tool	118	Removal and Installation	138	
Commercial Service Tool	118	TILT&TELESCOPIC SWITCH	139	I
CLIP LIST	119	Removal and Installation	139	
Clip List	119	HEATED SEAT SWITCH	140	
		Exploded View	140	
		Removal and Installation	140	

SE

K

L

M

N

O

P

DIAGNOSIS AND REPAIR WORK FLOW

< BASIC INSPECTION >

BASIC INSPECTION

DIAGNOSIS AND REPAIR WORK FLOW

Work Flow

INFOID:000000006207321

DETAILED FLOW

1.OBTAIN INFORMATION ABOUT SYMPTOM

Interview the customer to obtain the malfunction information (conditions and environment when the malfunction occurred) as much as possible when the customer brings the vehicle in.

>> GO TO 2.

2.REPRODUCE THE MALFUNCTION INFORMATION

Check the malfunction on the vehicle that the customer describes.
Inspect the relation of the symptoms and the condition when the symptoms occur.

>> GO TO 3.

3.IDENTIFY THE MALFUNCTIONING SYSTEM WITH "SYMPTOM DIAGNOSIS"

Use "Symptom diagnosis" from the symptom inspection result in step 2. Then identify where to start performing the diagnosis based on possible causes and symptoms.

>> GO TO 4.

4.IDENTIFY MALFUNCTIONING PARTS WITH "COMPONENT DIAGNOSIS"

Perform the diagnosis with "Component diagnosis" of the applicable system.

>> GO TO 5.

5.REPAIR OR REPLACE THE MALFUNCTIONING PARTS

Repair or replace the specified malfunctioning parts.

>> GO TO 6.

6.FINAL CHECK

Is the malfunctioning part repaired or replaced?
(Check that malfunctions are not reproduced when obtaining the malfunction information from the customer, referring to the symptom inspection result in step 2.)

YES or NO

YES >> Trouble diagnosis is completed.
NO >> GO TO 2.

POWER SEAT

< SYSTEM DESCRIPTION >

SYSTEM DESCRIPTION

POWER SEAT

System Description

INFOID:000000006207322

BCM can operate regardless of the ignition switch position, because battery power is supplied at all times to power seat switch.

SLIDING OPERATION

While operating the sliding switch located in power seat switch, sliding motor operates and makes possible the seat front and back position adjustment.

RECLINING OPERATION

While operating the reclining switch located in power seat switch, reclining motor operates and makes possible the seat back forward and backward position adjustment.

LIFTING OPERATION

While operating the lifting switch located in power seat switch, lifting motor operates and makes possible the seat cushion up and down position adjustment.

Component Parts Location

INFOID:000000006207323

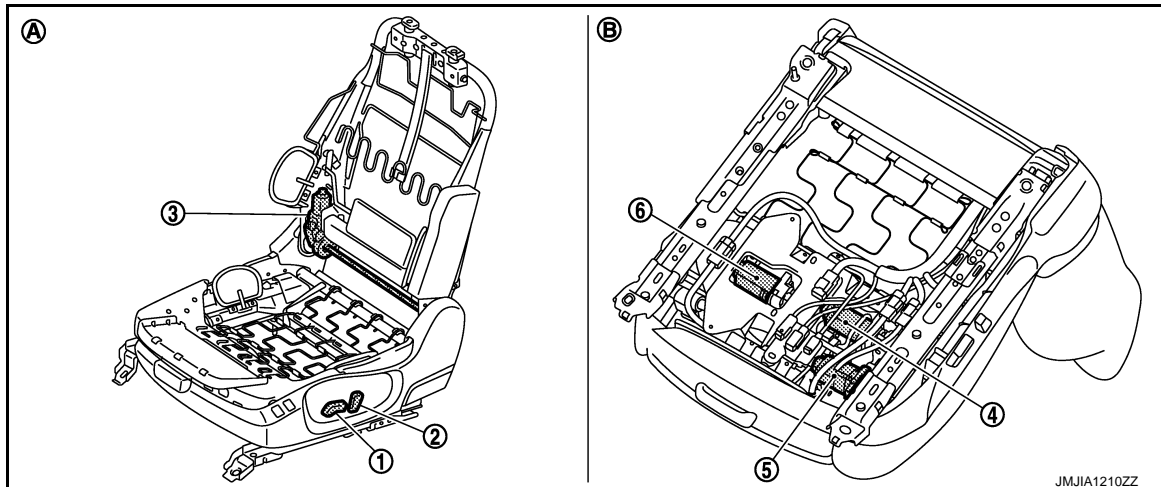

- | | | |
|---|--|---|
| 1. Sliding switch and lifting switch
B414 (driver side)
B434 (passenger side) | 2. Reclining switch
B414 (driver side)
B434 (passenger side) | 3. Reclining motor
B415 (driver side)
B435 (passenger side) |
| 4. Lifting motor (rear)
B418 (driver side)
B438 (passenger side) | 5. Sliding motor
B416 (driver side)
B436 (passenger side) | 6. Lifting motor (front)
B417 (driver side)
B437 (passenger side) |
| A. View with seat cushion pad and seat back pad are removed. | B. View with back side of seat cushion. | |

Component Description

INFOID:000000006207324

Item	Function
BCM	Supplies at all times the power received from battery to power seat switch.
Power seat switch	Built-in reclining switch, sliding switch and lifting switch, controls the power supplied to each motor.
Reclining motor	With the power supplied to power seat switch, operates the forward and backward movement of seatback.
Sliding motor	With the power supplied to power seat switch, operates the forward and backward slide of seat.
Lifting motor (front/rear)	With the power supplied to power seat switch, operates the up and down movement of seat cushion.

TILT&TELESCOPIC SYSTEM

< SYSTEM DESCRIPTION >

TILT&TELESCOPIC SYSTEM

System Description

INFOID:000000006207325

Power from battery is supplied at all times to automatic driver positioner control unit, tilt and telescopic system can operate regardless of the ignition switch position.

TILT OPERATION

- While operating the tilt and telescopic switch, tilt motor operates, and allows up or down position adjustment of steering wheel.
- During tilt motor operation tilt sensor detects the position of steering wheel and automatically cuts the power when the operation limit is reached.

TELESCOPIC OPERATION

- Operating the tilt and telescopic switch, telescopic motor operates and allows forward and backward position regulation of steering wheel.
- During telescopic motor operation telescopic sensor detects the position of steering wheel and automatically cuts the power when the operation limit is reached.

Component Parts Location

INFOID:000000006207326

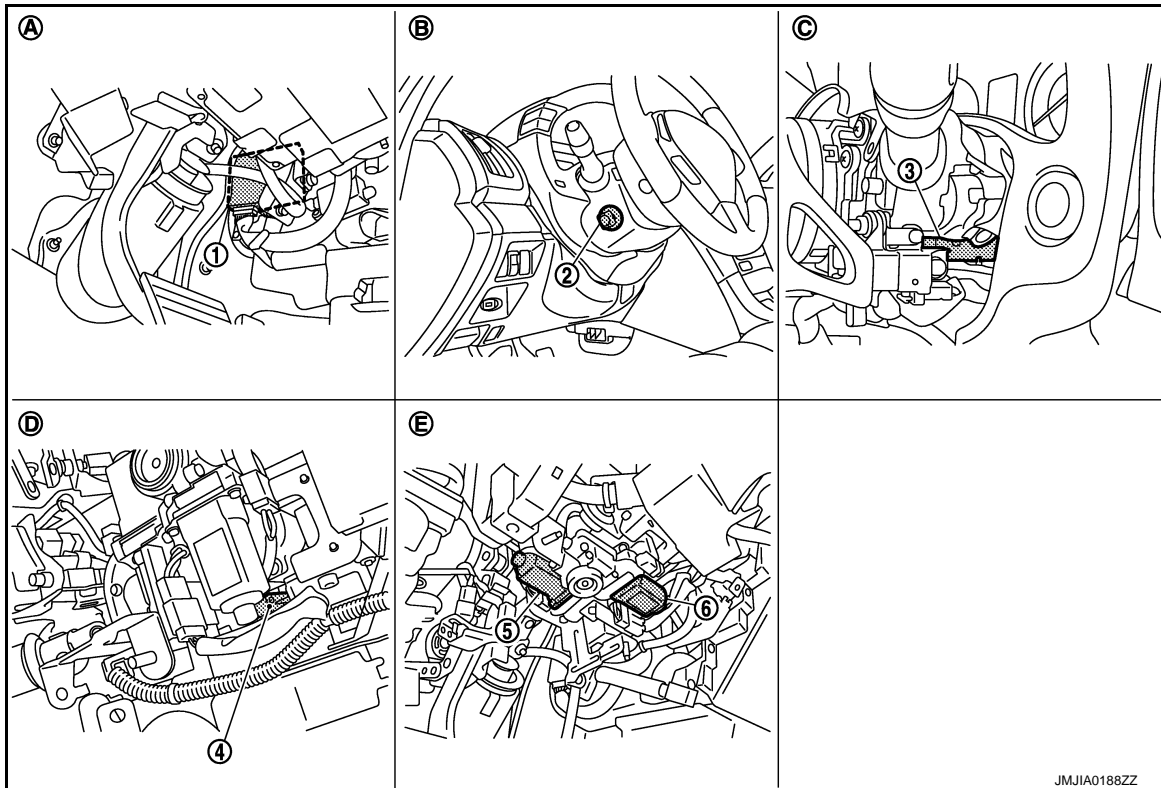

JMJIA018BZZ

1. Automatic drive positioner control unit M51, M52

4. Tilt sensor M48

A. View with instrument driver lower panel is removed.

D. View with steering column cover is removed.

2. Tilt & telescopic switch M31

5. Telescopic motor M49

B. Steering column cover

E. View with instrument lower cover is removed.

3. Telescopic sensor M48

6. Tilt motor M49

C. View with steering column cover is removed.

TILT&TELESCOPIC SYSTEM

< SYSTEM DESCRIPTION >

Component Description

INFOID:000000006207327

Item	Function
Automatic drive positioner control unit	Detects data input signal of tilt and telescopic switch and tilt and telescopic sensor, performs tilt and telescopic motor control.
Tilt and telescopic switch	Tilt switch and telescopic switch, as a unit, transmit switch operation signal to automatic drive positioner control unit.
Tilt and telescopic motor	Operates with the power received from automatic drive control unit.
Tilt and telescopic sensor	Detects the position of steering, send signal to automatic drive positioner control unit.

A

B

C

D

E

F

G

H

I

SE

K

L

M

N

O

P

SIDE SUPPORT

< SYSTEM DESCRIPTION >

SIDE SUPPORT

System Description

INFOID:000000006207328

- While operating the side support switch, the pump located inside side support unit operates and adjust the air pressure in seat cushion and seatback side support.
- It is possible to soften the side support, by allowing some air to escape, by deflating the solenoid located inside side support.
- It is possible to adjust seat cushion and seatback differently while inflating or deflating solenoid located in side support unit.

Component Parts Location

INFOID:000000006207329

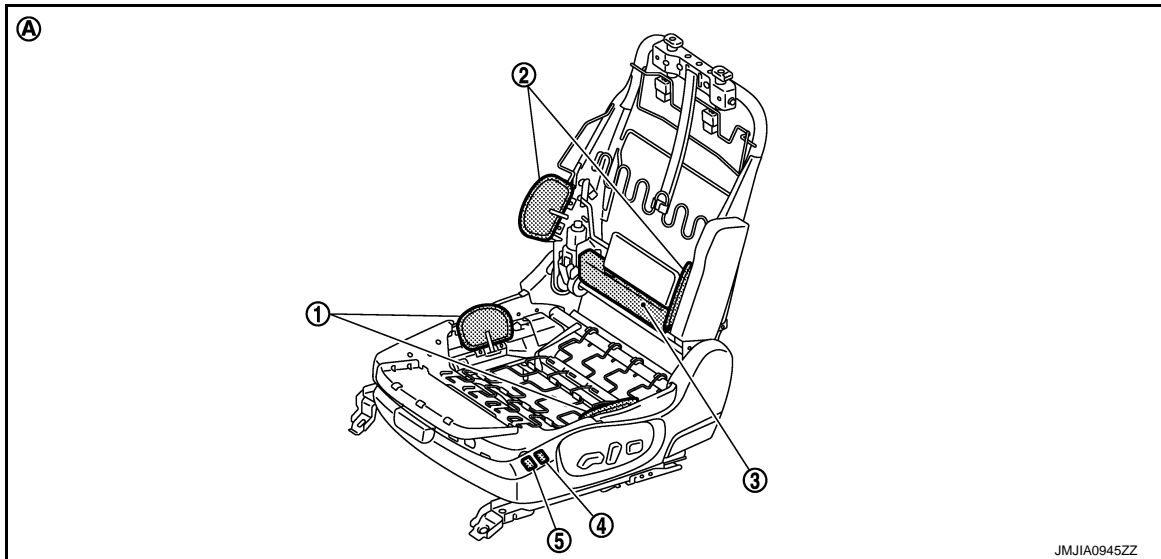

- | | | |
|--|---|---------------------------|
| 1. Side support (seat cushion)
(Side support unit B465) | 2. Side support (seat back)
(Side support unit B465) | 3. Side support unit B465 |
| 4. Side support switch (seat back side)
B464 | 5. Side support switch (cushion side)
B464 | |

A. View with seat cushion pad and seat back pad are removed.

Component Description

INFOID:000000006207330

Item	Function
Side support switch	With a built-in cushion side and seat back side, controls the power supplied to pump and to each solenoid.
Side support unit	Built-in pump, pump relay and solenoid, operates when pressing ON/OFF on side support switch.

HEATED SEAT

< SYSTEM DESCRIPTION >

HEATED SEAT

System Diagram

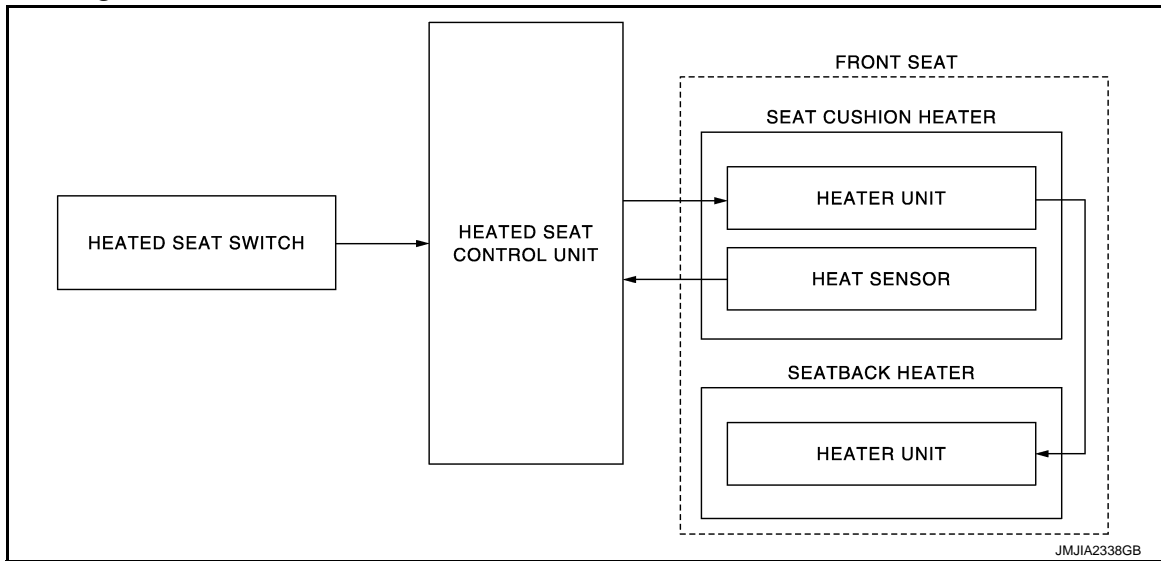

System Description

INFOID:000000006207332

- Heated seat is activated by heated seat switch while ignition switch is ON, and has the function to warm seat cushion and seatback.
- Heated seat equips the 6-stage temperature adjustment function that adjusts temperature by operating heated seat switch to the optimal position.
- Heated seat equips a thermostat in heater unit to prevent heater unit overheating.

OPERATION DESCRIPTION

- When operating heated seat switch to any position between 1 and 6 while ignition switch is ON, indicator illuminates, heated seat control unit supplies power supply to heater unit, and warms seat cushion and seatback.
- Heat sensor that is built in seat cushion heater detects seat cushion heater temperature and outputs to heated seat control unit.
- Heated seat control unit monitors the heated seat switch position and heater sensor temperature, and interrupts power supply to heater unit when the heat sensor temperature reaches preset temperature.
- Heated seat control unit adjusts temperature to preset temperature by supplying or interrupting power supply to heater unit.

A
B
C
D
E
F
G
H
I
SE
K
L
M
N
O
P

HEATED SEAT

< SYSTEM DESCRIPTION >

Component Parts Location

INFOID:000000006207333

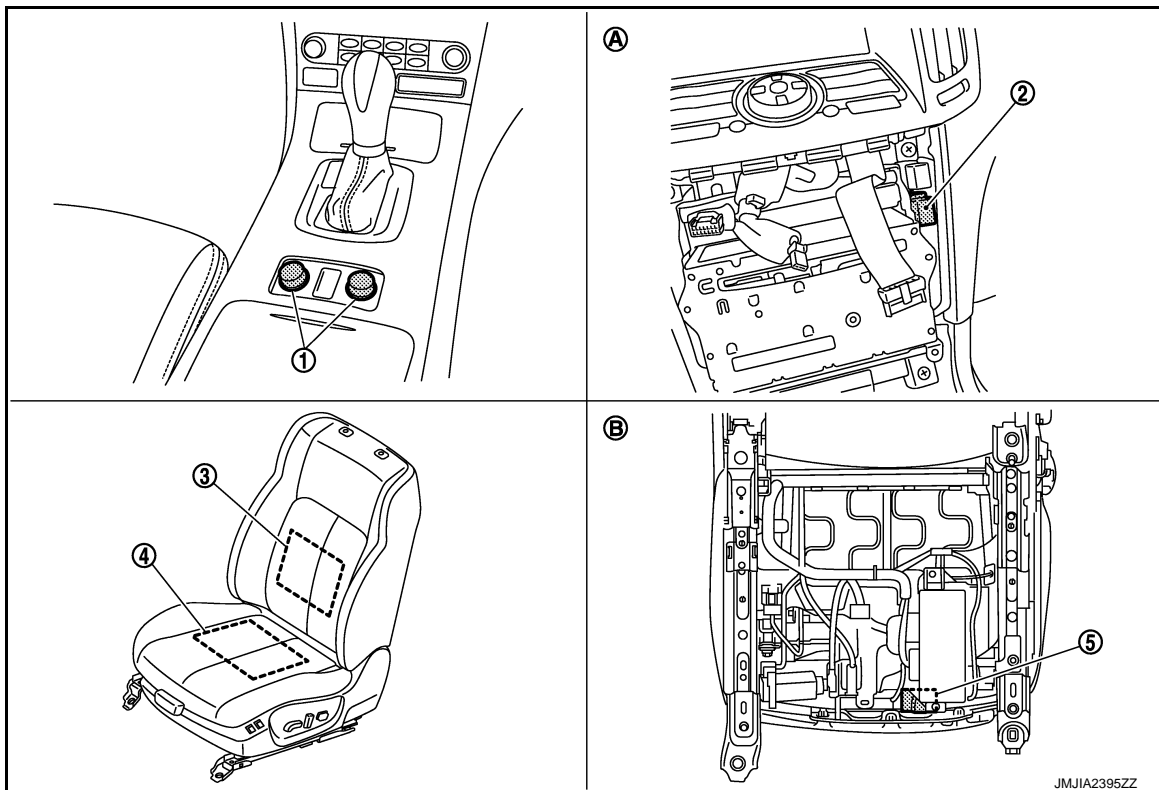

- | | | |
|---|---|---|
| <p>1. Heated seat switch</p> <ul style="list-style-type: none"> • Driver side - With A/T M141 - With M/T M175 • Passenger side - With A/T M142 - With M/T M176 <p>4. Seat cushion heater</p> <ul style="list-style-type: none"> • Driver side B467, B424 • Passenger side B441, B444 <p>A. Behind cluster lid C</p> | <p>2. Heated seat relay M70</p> <p>5. Heated seat control unit</p> <ul style="list-style-type: none"> • Driver side B466 • Passenger side B440 <p>B. Backside of seat cushion</p> | <p>3. Seatback heater</p> <ul style="list-style-type: none"> • Driver side B425 • Passenger side B445 |
|---|---|---|

Component Description

INFOID:000000006207334

Item	Function
Heated seat switch	<ul style="list-style-type: none"> • Adjusts heated seat temperature and deactivates heated seat • Equips indicator that indicates the operating condition
Seat cushion heater	<ul style="list-style-type: none"> • Warms seat cushion • Contains heater sensor that outputs seat cushion temperature to heated seat control unit
Seatback heater	Warms seatback
Heated seat control unit	Controls heated seat temperature and is independently placed in each seat cushion (driver seat and passenger seat)

POWER SUPPLY AND GROUND CIRCUIT

< DTC/CIRCUIT DIAGNOSIS >

DTC/CIRCUIT DIAGNOSIS

POWER SUPPLY AND GROUND CIRCUIT

AUTOMATIC DRIVE POSITIONER CONTROL UNIT

AUTOMATIC DRIVE POSITIONER CONTROL UNIT : Diagnosis Procedure

INFOID:000000006207338

1.CHECK FUSE AND FUSIBLE LINK

Check that the following fuse and fusible link are not fusing.

Terminal No.	Signal name	Fuse and fusible link No.
39	Battery power supply	K (40 A)
34		10 (10 A)

Is the inspection result normal?

YES >> GO TO 2.

NO >> Replace the blown fuse and fusible link after repairing the affected circuit if fuse and fusible link are blown.

2.CHECK POWER SUPPLY CIRCUIT

1. Turn ignition switch OFF.
2. Disconnect automatic drive positioner control unit connector.
3. Check voltage between automatic drive positioner control unit harness connector and ground.

(+)		(-)	Voltage (V) (Approx.)
Automatic drive positioner control unit	Terminal		
Connector	34	Ground	Battery voltage
M52	39		

Is the inspection result normal?

YES >> GO TO 3.

NO-1 >> Repair or replace harness.

NO-2 >> Check circuit breaker, and replace if NG.

3.CHECK GROUND CIRCUIT

Check continuity between automatic drive positioner control unit harness connector and ground.

Automatic drive positioner control unit		Ground	Continuity
Connector	Terminal		
M52	40		Existed
	48		

Is the inspection result normal?

YES >> INSPECTION END

NO >> Repair or replace harness.

HEATED SEAT CONTROL UNIT

HEATED SEAT CONTROL UNIT : Diagnosis Procedure

INFOID:000000006207339

1.CHECK FUSE

Check that the following fuses is not fusing.

Signal name	Fuse No.
Battery power supply	35 (15A)

POWER SUPPLY AND GROUND CIRCUIT

< DTC/CIRCUIT DIAGNOSIS >

Is the inspection result normal?

YES >> GO TO 2.

NO >> Replace the blown fuse after repairing the affected circuit if a fuse is blown.

2. CHECK POWER SUPPLY 1

1. Turn ignition switch OFF.
2. Disconnect heated seat control unit connector.
3. Turn ignition switch ON.
4. Check voltage between heated seat control unit harness connector and ground.

(+)			(-)	Voltage (V) (Approx.)
Heated seat control unit				
Connector	Terminal		Ground	Battery voltage
Driver side	B466	67		
Passenger side	B440	14		

Is the inspection result normal?

YES >> GO TO 4.

NO >> GO TO 3.

3. CHECK POWER SUPPLY CIRCUIT 1

1. Turn ignition switch OFF.
2. Disconnect heated seat relay.
3. Check continuity between heated seat control unit harness connector and heated seat relay terminal connector.

Heated seat control unit			Heated seat relay		Continuity
Connector	Terminal		Connector	Terminal	
Driver side	B466	67	M70	3	Existed
Passenger side	B440	14			

4. Check continuity between heated seat control unit harness connector and ground.

Heated seat control unit			Ground	Continuity
Connector	Terminal			
Driver side	B466	67		Not existed
Passenger side	B440	14		

Is the inspection result normal?

YES >> Repair or replace harness between heated seat relay and fuse holder.

NO >> Repair or replace harness between heated seat control unit and heated seat relay.

4. CHECK POWER SUPPLY 2

Check voltage between heated seat control unit harness connector and ground.

(+)			(-)	Condition	Voltage (V) (Approx.)
Heated seat control unit					
Connector	Terminal		Ground	Heated seat switch	
Driver side	B466	69			
Passenger side	B440	16			
			ON	Battery voltage	
			OFF	0	

Is the inspection result normal?

YES >> GO TO 7.

NO >> GO TO 5.

POWER SUPPLY AND GROUND CIRCUIT

< DTC/CIRCUIT DIAGNOSIS >

5.CHECK POWER SUPPLY CIRCUIT 2

1. Turn ignition switch OFF.
2. Disconnect heated seat switch connector.
3. Check continuity between heated seat control unit harness connector and heated seat switch harness connector.

Heated seat control unit		Heated seat switch		Continuity
Connector	Terminal	Connector	Terminal	
Driver side	B466	69	A/T models: M141 M/T models: M175	Existed
Passenger side	B440	16	A/T models: M142 M/T models: M176	

4. Check continuity between heated seat control unit harness connector and ground.

Heated seat control unit		Ground	Continuity
Connector	Terminal		
Driver side	B466	69	Not existed
Passenger side	B440	16	

Is the inspection result normal?

YES >> GO TO 6.

NO >> Repair or replace harness.

6.CHECK HEATED SEAT SWITCH

Check heated seat switch.

- Driver side: Refer to [SE-17, "DRIVER SIDE : Component Inspection"](#).
- Passenger side: Refer to [SE-19, "PASSENGER SIDE : Component Inspection"](#).

Is the inspection result normal?

YES >> GO TO 8.

NO >> Replace heated seat switch. Refer to [SE-140, "Removal and Installation"](#).

7.CHECK GROUND CIRCUIT

1. Turn ignition switch OFF.
2. Check continuity between heated seat control unit harness connector and ground.

Heated seat control unit		Ground	Continuity
Connector	Terminal		
Driver side	B466	48	Existed
Passenger side	B440	2	

Is the inspection result normal?

YES >> INSPECTION END

NO >> Repair or replace harness.

8.CHECK INTERMITTENT INCIDENT

Check intermittent incident.

Refer to [GI-43, "Intermittent Incident"](#).

>> INSPECTION END

HEATED SEAT SWITCH

HEATED SEAT SWITCH : Diagnosis Procedure

INFOID:000000006207340

1.CHECK FUSE

Check that the following fuses is not fusing.

POWER SUPPLY AND GROUND CIRCUIT

< DTC/CIRCUIT DIAGNOSIS >

Terminal No.	Signal name	Fuse No.
5	Ignition power supply	3 (10A)

Is the inspection result normal?

YES >> GO TO 2.

NO >> Replace the blown fuse after repairing the affected circuit if a fuse is blown.

2. CHECK POWER SUPPLY

1. Turn ignition switch OFF.
2. Disconnect heated seat switch connector.
3. Turn ignition switch ON.
4. Check voltage between heated seat switch harness connector and ground.

Heated seat switch		Terminal	(-)	Voltage (V) (Approx.)
Connector				
Driver side	A/T models: M141 M/T models: M175	5	Ground	Battery voltage
Passenger side	A/T models: M142 M/T models: M176			

Is the inspection result normal?

YES >> INSPECTION END

NO >> GO TO 3.

3. CHECK POWER SUPPLY CIRCUIT

1. Turn ignition switch OFF.
2. Disconnect fuse block (J/B) connector.
3. Check continuity between heated seat switch harness connector and fuse block (J/B) harness connector.

Heated seat switch		Terminal	Fuse block (J/B)		Continuity
Connector			Connector	Terminal	
Driver side	A/T models: M141 M/T models: M175	5	M1	2A	Existed
Passenger side	A/T models: M142 M/T models: M176				

4. Check continuity between heated seat switch harness connector and ground.

Heated seat switch		Terminal	Ground	Continuity
Connector				
Driver side	A/T models: M141 M/T models: M175	5	Ground	Not existed
Passenger side	A/T models: M142 M/T models: M176			

Is the inspection result normal?

YES >> GO TO 4.

NO >> Repair or replace harness.

4. CHECK FUSE BLOCK (J/B)

1. Turn ignition switch ON.
2. Check voltage between fuse block (J/B) connector (fuse block side) and ground.

POWER SUPPLY AND GROUND CIRCUIT

< DTC/CIRCUIT DIAGNOSIS >

(+)		(-)	Voltage (V) (Approx.)
Fuse block (J/B)			
Connector	Terminal		
M1	2A	Ground	Battery voltage

Is the inspection result normal?

YES >> GO TO 5.

NO >> Repair or replace fuse block (J/B).

5.CHECK INTERMITTENT INCIDENT

Check intermittent incident.

Refer to [GI-43, "Intermittent Incident"](#)

>> INSPECTION END

A
B
C
D
E
F
G
H
I
K
L
M
N
O
P

SE

HEATED SEAT SWITCH

< DTC/CIRCUIT DIAGNOSIS >

HEATED SEAT SWITCH DRIVER SIDE

DRIVER SIDE : Description

INFOID:000000006207341

Adjusts heated seat temperature and deactivates heated seat.

DRIVER SIDE : Component Function Check

INFOID:000000006207342

1. CHECK FUNCTION

Check that heated seat warms to preset temperature when operating heated seat switch to the optimal position.

Is the inspection result normal?

YES >> Heated seat switch function is OK.

NO >> Refer to [SE-16, "DRIVER SIDE : Diagnosis Procedure"](#).

DRIVER SIDE : Diagnosis Procedure

INFOID:000000006207343

1. CHECK HEATED SEAT CONTROL UNIT INPUT SIGNAL

1. Turn ignition switch OFF.
2. Disconnect heated seat control unit connector.
3. Turn ignition switch ON.
4. Check voltage between heated seat control unit harness connector and ground.

(+)		(-)	Condition	Voltage (V) (Approx.)	
Heated seat control unit					
Connector	Terminal				
B466	68	Ground	Heated seat switch position	OFF	0
				1 (Min. temperature)	12.24
				2	12.33
				3	12.49
				4	12.63
				5	12.76
			6 (Max. temperature)	12.90	

Is the inspection result normal?

YES >> Heated seat switch circuit is OK.

NO >> GO TO 2.

2. CHECK HEATED SEAT SWITCH CIRCUIT

1. Turn ignition switch OFF.
2. Disconnect heated seat switch connector.
3. Check continuity between heated seat switch harness connector and heated seat control unit harness connector.

Heated seat switch		Heated seat control unit		Continuity
Connector	Terminal	Connector	Terminal	
A/T models: M141 M/T models: M175	2	B466	68	Existed

4. Check continuity between heated seat switch harness connector and ground.

HEATED SEAT SWITCH

< DTC/CIRCUIT DIAGNOSIS >

Heated seat switch		Ground	Continuity
Connector	Terminal		
A/T models: M141 M/T models: M175	2		Not existed

Is the inspection result normal?

- YES >> GO TO 3.
NO >> Repair or replace harness.

3.CHECK HEATED SEAT SWITCH

Check heated seat switch.

Refer to [SE-17, "DRIVER SIDE : Component Inspection"](#).

Is the inspection result normal?

- YES >> GO TO 4.
NO >> Replace heated seat switch. Refer to [SE-140, "Removal and Installation"](#).

4.CHECK INTERMITTENT INCIDENT

Check intermittent incident.

Refer to [GI-43, "Intermittent Incident"](#).

>> INSPECTION END

DRIVER SIDE : Component Inspection

INFOID:000000006207344

1.CHECK HEATED SEAT SWITCH

- Turn ignition switch OFF.
- Disconnect heated seat switch connector.
- Check resistance between heated seat switch terminals.

Heated seat switch		Condition	Resistance (K Ω) (Approx.)
Connector	Terminal		
A/T models: M141 M/T models: M175	5	1	ON OFF
		2	Heated seat switch position
	2.400		
	1.800		
	1.200		
	0.910		
	0.620		
	0.348		

Is the inspection result normal?

- YES >> INSPECTION END
NO >> Replace heated seat switch. Refer to [SE-140, "Removal and Installation"](#).

PASSENGER SIDE

PASSENGER SIDE : Description

INFOID:000000006207345

Adjusts heated seat temperature and deactivates heated seat.

PASSENGER SIDE : Component Function Check

INFOID:000000006207346

1.CHECK FUNCTION

Check that heated seat warms to preset temperature when operating heated seat switch to the optimal position.

HEATED SEAT SWITCH

< DTC/CIRCUIT DIAGNOSIS >

Is the inspection result normal?

- YES >> Heated seat switch function is OK.
 NO >> Refer to [SE-18, "PASSENGER SIDE : Diagnosis Procedure"](#).

PASSENGER SIDE : Diagnosis Procedure

INFOID:000000006207347

1. CHECK HEATED SEAT CONTROL UNIT INPUT SIGNAL

1. Turn ignition switch OFF.
2. Disconnect heated seat control unit connector.
3. Turn ignition switch ON.
4. Check voltage between heated seat control unit harness connector and ground.

(+)		(-)	Condition	Voltage (V) (Approx.)	
Heated seat control unit					
Connector	Terminal				
B440	15	Ground	Heated seat switch position	OFF	0
				1 (Min. temperature)	12.24
				2	12.33
				3	12.49
				4	12.63
				5	12.76
				6 (Max. temperature)	12.90

Is the inspection result normal?

- YES >> Heated seat switch circuit is OK.
 NO >> GO TO 2.

2. CHECK HEATED SEAT SWITCH CIRCUIT

1. Turn ignition switch OFF.
2. Disconnect heated seat switch connector.
3. Check continuity between heated seat switch harness connector and heated seat control unit harness connector.

Heated seat switch		Heated seat control unit		Continuity
Connector	Terminal	Connector	Terminal	
A/T models: M142 M/T models: M176	2	B440	15	Existed

4. Check continuity between heated seat switch harness connector and ground.

Heated seat switch		Ground	Continuity
Connector	Terminal		
A/T models: M142 M/T models: M176	2		Not existed

Is the inspection result normal?

- YES >> GO TO 3.
 NO >> Repair or replace harness.

3. CHECK HEATED SEAT SWITCH

Check heated seat switch.
 Refer to [SE-19, "PASSENGER SIDE : Component Inspection"](#).

Is the inspection result normal?

- YES >> GO TO 4.
 NO >> Replace heated seat switch. Refer to [SE-140, "Removal and Installation"](#).

4. CHECK INTERMITTENT INCIDENT

HEATED SEAT SWITCH

< DTC/CIRCUIT DIAGNOSIS >

Check intermittent incident.
Refer to [GI-43, "Intermittent Incident"](#).

>> INSPECTION END

PASSENGER SIDE : Component Inspection

INFOID:000000006207348

1. CHECK HEATED SEAT SWITCH

1. Turn ignition switch OFF.
2. Disconnect heated seat switch connector.
3. Check resistance between heated seat switch terminals.

Heated seat switch		Condition	Resistance (KΩ) (Approx.)	
Connector	Terminal			
A/T models: M142 M/T models: M176	5	1	ON OFF	0 ∞
		2	1 (Min. temperature)	2.400
	2		1.800	
	3		1.200	
	4		0.910	
	5		0.620	
	6 (Max. temperature)	0.348		

Is the inspection result normal?

YES >> INSPECTION END

NO >> Replace heated seat switch. Refer to [SE-140, "Removal and Installation"](#).

A
B
C
D
E
F
G
H
I
K
L
M
N
O
P

SE

HEATED SEAT RELAY

< DTC/CIRCUIT DIAGNOSIS >

HEATED SEAT RELAY

Description

INFOID:000000006207349

Power is supplied to the heated seat using ignition power supply control.

Component Function Check

INFOID:000000006207350

1. CHECK FUNCTION

Check that heated seat warms to preset temperature when operating heated seat switch to the optimal position.

Is the inspection result normal?

- YES >> Heated seat relay function is OK.
- NO >> Refer to [SE-20, "Diagnosis Procedure"](#)

Diagnosis Procedure

INFOID:000000006207351

1. CHECK HEATED SEAT RELAY POWER SUPPLY

1. Turn ignition switch OFF.
2. Disconnect heated seat relay.
3. Turn ignition switch ON.
4. Check voltage between heated seat relay terminal connector and ground.

(+)		(-)	Voltage (V) (Approx.)
Heated seat relay			
Connector	Terminal	Ground	Battery voltage
M70	2		

Is the inspection result normal?

- YES >> GO TO 3.
- NO >> GO TO 2.

2. CHECK HEATED SEAT RELAY POWER SUPPLY CIRCUIT

1. Turn ignition switch OFF.
2. Disconnect fuse block (J/B) connector.
3. Check continuity between heated seat relay terminal connector and fuse block (J/B) harness connector.

Heated seat relay		Fuse block (J/B)		Continuity
Connector	Terminal	Connector	Terminal	
M70	2	M1	2A	Existed

4. Check continuity between heated seat relay terminal connector and ground.

Heated seat relay		Ground	Continuity
Connector	Terminal		
M70	2		Not existed

Is the inspection result normal?

- YES >> GO TO 5.
- NO >> Repair or replace harness.

3. CHECK HEATED SEAT RELAY GROUND CIRCUIT

1. Turn ignition switch OFF.
2. Check continuity between heated seat relay terminal connector and ground.

HEATED SEAT RELAY

< DTC/CIRCUIT DIAGNOSIS >

Heated seat relay		Ground	Continuity
Connector	Terminal		
M70	1		Existed

Is the inspection result normal?

- YES >> GO TO 4.
 NO >> Repair or replace harness.

4.CHECK HEATED SEAT RELAY

Check heated seat relay.

Refer to [SE-21, "Component Inspection"](#).

Is the inspection result normal?

- YES >> Heated seat relay is OK.
 NO >> Replace heated seat relay.

5.CHECK INTERMITTENT INCIDENT

Check intermittent incident.

Refer to [GI-43, "Intermittent Incident"](#)

>> INSPECTION END

Component Inspection

INFOID:000000006207352

1.CHECK HEATED SEAT RELAY

1. Turn ignition switch OFF.
2. Disconnect heated seat relay.
3. Check continuity between heated seat relay terminals.

heated seat relay		Condition	Continuity
Terminal			
3	5	12 V direct current supply between terminals 1 and 2.	Existed
		No current supply	Not existed

Is the inspection result normal?

- YES >> INSPECTION END
 NO >> Replace heated seat relay.

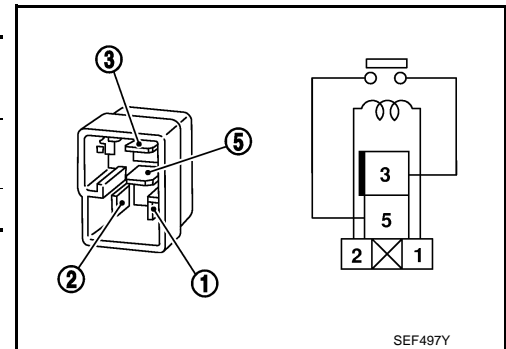

SEF497Y

HEAT SENSOR

< DTC/CIRCUIT DIAGNOSIS >

HEAT SENSOR

DRIVER SIDE

DRIVER SIDE : Description

INFOID:000000006207353

Detects seat cushion heater temperature and outputs to heated seat control unit.

DRIVER SIDE : Component Function Check

INFOID:000000006207354

1.CHECK FUNCTION

Check that heated seat warms to preset temperature when operating heated seat switch to the optimal position.

Is the inspection result normal?

YES >> Heat sensor function is OK.

NO >> Refer to [SE-22, "DRIVER SIDE : Diagnosis Procedure"](#)

DRIVER SIDE : Diagnosis Procedure

INFOID:000000006207355

1.CHECK HEAT SENSOR INPUT SIGNAL

1. Turn ignition switch ON.
2. Check voltage between heated seat control unit harness connector and ground.

(+)		(-)	Condition	Voltage (V) (Approx.)	
Heated seat control unit					
Connector	Terminal				
B466	71	Ground	Heated seat switch position	OFF	0
				1 (Min. temperature)	10.87 – 11.02
				2	10.93 – 11.07
				3	11.04 – 11.17
				4	11.13 – 11.26
				5	11.22 – 11.34
				6 (Max. temperature)	11.31 – 11.43

NOTE:

Voltage is repeated within the value shown as per the above list depending on heater unit temperature.

Is the inspection result normal?

YES >> heat sensor is OK.

NO >> GO TO 2.

2.CHECK HEAT SENSOR CIRCUIT

1. Turn ignition switch OFF.
2. Disconnect heated seat control unit connector and seat cushion heater connector.
3. Check continuity between heated seat control unit harness connector and seat cushion heater harness connector.

Heated seat control unit		Seat cushion heater		Continuity
Connector	Terminal	Connector	Terminal	
B466	71	B467	71	Existed

4. Check continuity between heated seat control unit harness connector and ground.

Heated seat control unit		Ground	Continuity
Connector	Terminal		
B466	71		Not existed

Is the inspection result normal?

HEAT SENSOR

< DTC/CIRCUIT DIAGNOSIS >

- YES >> GO TO 3.
NO >> Repair or replace harness.

3.CHECK HEAT SENSOR POWER SUPPLY

1. Turn ignition switch ON.
2. Heated seat switch ON.
3. Check voltage between seat cushion heater harness connector and ground.

(+)		(-)	Voltage (V) (Approx.)
Seat cushion heater			
Connector	Terminal		
B467	69	Ground	Battery voltage

Is the inspection result normal?

- YES >> GO TO 5.
NO >> GO TO 4.

4.CHECK HEAT SENSOR POWER SUPPLY CIRCUIT

1. Turn ignition switch OFF.
2. Disconnect heated seat switch connector.
3. Check continuity between heated seat control unit harness connector and seat cushion heater harness connector.

Heated seat control unit		Seat cushion heater		Continuity
Connector	Terminal	Connector	Terminal	
B466	69	B467	69	Existed

4. Check continuity between heated seat control unit harness connector and ground.

Heated seat control unit		Ground	Continuity
Connector	Terminal		
B466	69		Not existed

Is the inspection result normal?

- YES >> GO TO 6.
NO >> Repair or replace harness.

5.CHECK HEAT SENSOR

Check heat sensor. Refer to [SE-23. "DRIVER SIDE : Component Inspection"](#).

Is the inspection result normal?

- YES >> GO TO 6.
NO >> Replace seat cushion heater. Refer to [SE-120. "Exploded View"](#).

6.CHECK INTERMITTENT INCIDENT

Check intermittent incident.
Refer to [GI-43. "Intermittent Incident"](#)

>> INSPECTION END

DRIVER SIDE : Component Inspection

INFOID:000000006207356

1.CHECK HEAT SENSOR

1. Turn ignition switch OFF.
2. Disconnect seat cushion heater connector.
3. Check resistance between seat cushion heater terminals.

HEAT SENSOR

< DTC/CIRCUIT DIAGNOSIS >

Seat cushion heater			Condition	Resistance (KΩ) (Approx.)
Connector	Terminal			
B467	69	71	When heat sensor temperature is 25°C (77°F)	9.9 – 10.1

NOTE:

Resistance value changes according to temperature.

Is the inspection result normal?

YES >> INSPECTION END

NO >> Replace seat cushion heater. Refer to [SE-120, "Exploded View"](#).

PASSENGER SIDE

PASSENGER SIDE : Description

INFOID:000000006207357

Detects seat cushion heater temperature and outputs to heated seat control unit.

PASSENGER SIDE : Component Function Check

INFOID:000000006207358

1.CHECK FUNCTION

Check that heated seat warms to preset temperature when operating heated seat switch to the optimal position.

Is the inspection result normal?

YES >> Heat sensor function is OK.

NO >> Refer to [SE-24, "PASSENGER SIDE : Diagnosis Procedure"](#)

PASSENGER SIDE : Diagnosis Procedure

INFOID:000000006207359

1.CHECK HEAT SENSOR INPUT SIGNAL

1. Turn ignition switch ON.
2. Check voltage between heated seat control unit harness connector and ground.

(+) Heated seat control unit		(-)	Condition	Voltage (V) (Approx.)	
Connector	Terminal				
B440	18	Ground	Heated seat switch position	OFF	0
				1 (Min. temperature)	10.87 – 11.02
				2	10.93 – 11.07
				3	11.04 – 11.17
				4	11.13 – 11.26
				5	11.22 – 11.34
				6 (Max. temperature)	11.31 – 11.43

NOTE:

Voltage is repeated within the value shown as per the above list depending on heater unit temperature.

Is the inspection result normal?

YES >> heat sensor function is OK.

NO >> GO TO 2.

2.CHECK HEAT SENSOR CIRCUIT

1. Turn ignition switch OFF.
2. Disconnect heated seat control unit connector and seat cushion heater connector.
3. Check continuity between heated seat control unit harness connector and seat cushion heater harness connector.

HEAT SENSOR

< DTC/CIRCUIT DIAGNOSIS >

Heated seat control unit		Seat cushion heater		Continuity
Connector	Terminal	Connector	Terminal	
B440	18	B441	18	Existed

4. Check continuity between heated seat control unit harness connector and ground.

Heated seat control unit		Ground	Continuity
Connector	Terminal		
B440	18		Not existed

Is the inspection result normal?

YES >> GO TO 3.

NO >> Repair or replace harness.

3.CHECK HEAT SENSOR POWER SUPPLY

- Turn ignition switch ON.
- Heated seat switch ON.
- Check voltage between seat cushion heater harness connector and ground.

(+)		(-)	Voltage (V) (Approx.)
Seat cushion heater			
Connector	Terminal		
B441	16	Ground	Battery voltage

Is the inspection result normal?

YES >> GO TO 5.

NO >> GO TO 4.

4.CHECK HEAT SENSOR POWER SUPPLY CIRCUIT

- Turn ignition switch OFF.
- Disconnect heated seat switch connector.
- Check continuity between heated seat control unit harness connector and seat cushion heater harness connector.

Heated seat control unit		Seat cushion heater		Continuity
Connector	Terminal	Connector	Terminal	
B440	16	B441	16	Existed

4. Check continuity between heated seat control unit harness connector and ground.

Heated seat control unit		Ground	Continuity
Connector	Terminal		
B440	16		Not existed

Is the inspection result normal?

YES >> GO TO 6.

NO >> Repair or replace harness.

5.CHECK HEAT SENSOR

Check heat sensor. Refer to [SE-26, "PASSENGER SIDE : Component Inspection"](#).

Is the inspection result normal?

YES >> GO TO 6.

NO >> Replace seat cushion heater. Refer to [SE-120, "Exploded View"](#).

6.CHECK INTERMITTENT INCIDENT

Check intermittent incident.

Refer to [GI-43, "Intermittent Incident"](#)

HEAT SENSOR

< DTC/CIRCUIT DIAGNOSIS >

>> INSPECTION END

PASSENGER SIDE : Component Inspection

INFOID:000000006207360

1. CHECK HEAT SENSOR

1. Turn ignition switch OFF.
2. Disconnect seat cushion heater connector.
3. Check resistance between seat cushion heater terminals.

Seat cushion heater			Condition	Resistance (K Ω) (Approx.)
Connector	Terminal			
B441	16	18	When heat sensor temperature is 25°C (77°F)	9.9 – 10.1

NOTE:

Resistance value changes according to temperature.

Is the inspection result normal?

YES >> INSPECTION END

NO >> Replace seat cushion heater. Refer to [SE-120, "Exploded View"](#).

SEAT CUSHION HEATER

< DTC/CIRCUIT DIAGNOSIS >

SEAT CUSHION HEATER DRIVER SIDE

DRIVER SIDE : Description

INFOID:000000006207361

Warms the seat cushion.

DRIVER SIDE : Component Function Check

INFOID:000000006207362

1.CHECK FUNCTION

Check that heated seat warms to preset temperature when operating heated seat switch to the optimal position.

Is the inspection result normal?

- YES >> Seat cushion heater function is OK.
NO >> Refer to [SE-27, "DRIVER SIDE : Diagnosis Procedure"](#).

DRIVER SIDE : Diagnosis Procedure

INFOID:000000006207363

1.CHECK SEAT CUSHION HEATER INPUT SIGNAL

1. Turn ignition switch OFF.
2. Disconnect seat cushion heater connector.
3. Turn ignition switch ON.
4. Check voltage between seat cushion heater harness connector and ground.

(+)		(-)	Condition		Voltage (V) (Approx.)
Seat cushion heater					
Connector	Terminal				
B467	70	Ground	Heated seat	Operated	0 – Battery voltage
				Other than above	0

NOTE:

Voltage is repeated within the value shown as per the above list depending on heater unit temperature.

Is the inspection result normal?

- YES >> GO TO 3.
NO >> GO TO 2.

2.CHECK SEAT CUSHION HEATER CIRCUIT

1. Turn ignition switch OFF.
2. Disconnect heated seat control unit connector.
3. Check continuity between seat cushion heater harness connector and heated seat control unit harness connector.

Seat cushion heater		Heated seat control unit		Continuity
Connector	Terminal	Connector	Terminal	
B467	70	B466	70	Existed

4. Check continuity between seat cushion heater harness connector and ground.

Seat cushion heater		Ground	Continuity
Connector	Terminal		
B467	70		Not existed

Is the inspection result normal?

- YES >> Replace heated seat control unit. Refer to [SE-136, "Removal and Installation"](#).
NO >> Repair or replace harness.

3.CHECK SEAT CUSHION HEATER

SEAT CUSHION HEATER

< DTC/CIRCUIT DIAGNOSIS >

Check seat cushion heater.

Refer to [SE-28, "DRIVER SIDE : Component Inspection"](#).

Is the inspection result normal?

YES >> GO TO 4.

NO >> Replace seat cushion heater. Refer to [SE-120, "Exploded View"](#).

4.CHECK SEAT CUSHION HEATER GROUND CIRCUIT

Check continuity between seat cushion heater harness connector and ground.

Seat cushion heater		Ground	Continuity
Connector	Terminal		Existed
B467	48		

Is the inspection result normal?

YES >> GO TO 5.

NO >> Repair or replace harness.

5.CHECK INTERMITTENT INCIDENT

Check intermittent incident.

Refer to [GI-43, "Intermittent Incident"](#)

>> INSPECTION END

DRIVER SIDE : Component Inspection

INFOID:000000006207364

1.CHECK SEAT CUSHION HEATER

1. Turn ignition switch OFF.
2. Disconnect seat cushion heater connector and seatback heater connector.
3. Check resistance between seat cushion heater terminals.

Seat cushion heater		Condition	Resistance (Ω) (Approx.)
Connector	Terminal		
B467	48	70	When heat sensor temperature is 20°C (68°F) 2.6 – 3.0

NOTE:

Resistance value changes according to temperature.

Is the inspection result normal?

YES >> INSPECTION END

NO >> Replace seat cushion heater. Refer to [SE-120, "Exploded View"](#)

PASSENGER SIDE

PASSENGER SIDE : Description

INFOID:000000006207365

Warms the seat cushion.

PASSENGER SIDE : Component Function Check

INFOID:000000006207366

1.CHECK FUNCTION

Check that heated seat warms to preset temperature when operating heated seat switch to the optimal position.

Is the inspection result normal?

YES >> Seat cushion heater function is OK.

NO >> Refer to [SE-28, "PASSENGER SIDE : Diagnosis Procedure"](#).

PASSENGER SIDE : Diagnosis Procedure

INFOID:000000006207367

1.CHECK FRONT SEAT CUSHION HEATER INPUT SIGNAL

SEAT CUSHION HEATER

< DTC/CIRCUIT DIAGNOSIS >

1. Turn ignition switch OFF.
2. Disconnect seat cushion heater connector.
3. Turn ignition switch ON.
4. Check voltage between seat cushion heater harness connector and ground.

(+)		(-)	Condition	Voltage (V) (Approx.)	
Seat cushion heater					
Connector	Terminal				
B441	17	Ground	Heated seat	Operated	0 – Battery voltage
				Other than above	0

NOTE:

Voltage is repeated within the value shown as per the above list depending on heater unit temperature.

Is the inspection result normal?

- YES >> GO TO 3.
NO >> GO TO 2.

2.CHECK SEAT CUSHION HEATER CIRCUIT

1. Turn ignition switch OFF.
2. Disconnect heated seat control unit connector.
3. Check continuity between seat cushion heater harness connector and heated seat control unit harness connector.

Seat cushion heater		Heated seat control unit		Continuity
Connector	Terminal	Connector	Terminal	
B441	17	B440	17	Existed

4. Check continuity between seat cushion heater harness connector and ground.

Seat cushion heater		Ground	Continuity
Connector	Terminal		
B441	17		Not existed

Is the inspection result normal?

- YES >> Replace heated seat control unit. Refer to [SE-136. "Removal and Installation"](#).
NO >> Repair or replace harness.

3.CHECK SEAT CUSHION HEATER

Check seat cushion heater.
Refer to [SE-30. "PASSENGER SIDE : Component Inspection"](#).

Is the inspection result normal?

- YES >> GO TO 4.
NO >> Replace seat cushion heater. Refer to [SE-120. "Exploded View"](#).

4.CHECK SEAT CUSHION HEATER GROUND CIRCUIT

1. Turn ignition switch OFF.
2. Check continuity between seat cushion heater harness connector and ground.

Seat cushion heater		Ground	Continuity
Connector	Terminal		
B441	2		Existed

Is the inspection result normal?

- YES >> GO TO 5.
NO >> Repair or replace harness.

5.CHECK INTERMITTENT INCIDENT

Check intermittent incident.

SEAT CUSHION HEATER

< DTC/CIRCUIT DIAGNOSIS >

Refer to [GI-43. "Intermittent Incident"](#)

>> INSPECTION END

PASSENGER SIDE : Component Inspection

INFOID:000000006207368

1. CHECK SEAT CUSHION HEATER

1. Turn ignition switch OFF.
2. Disconnect seat cushion heater connector and seatback heater connector.
3. Check resistance between seat cushion heater terminals.

Seat cushion heater			Condition	Resistance (Ω) (Approx.)
Connector	Terminal			
B441	2	17	When heat sensor temperature is 20°C (68°F)	2.6 – 3.0

NOTE:

Resistance value changes according to temperature.

Is the inspection result normal?

YES >> INSPECTION END

NO >> Replace seat cushion heater. Refer to [SE-120. "Exploded View"](#).

SEATBACK HEATER

< DTC/CIRCUIT DIAGNOSIS >

SEATBACK HEATER DRIVER SIDE

DRIVER SIDE : Description

INFOID:000000006207369

Warms the seat cushion.

DRIVER SIDE : Component Function Check

INFOID:000000006207370

1.CHECK FUNCTION

Check that heated seat warms to preset temperature when operating heated seat switch to the optimal position.

Is the inspection result normal?

- YES >> Seatback heater function is OK.
NO >> Refer to [SE-31, "DRIVER SIDE : Diagnosis Procedure"](#).

DRIVER SIDE : Diagnosis Procedure

INFOID:000000006207371

1.CHECK SEATBACK HEATER

1. Turn ignition switch OFF.
2. Disconnect seatback heater connector.
3. Check resistance between seatback heater terminals.

Seatback heater		Condition	Resistance (Ω) (Approx.)
Connector	Terminal		
B425	1 2	When heat sensor temperature is 20°C (68°F)	4.0 – 4.7

NOTE:

Resistance value changes according to temperature.

Is the inspection result normal?

- YES >> Replace seat cushion heater. Refer to [SE-120, "Exploded View"](#).
NO >> Replace seatback heater. Refer to [SE-120, "Exploded View"](#).

PASSENGER SIDE

PASSENGER SIDE : Description

INFOID:000000006207372

Warms the seat cushion.

PASSENGER SIDE : Component Function Check

INFOID:000000006207373

1.CHECK FUNCTION

Check that heated seat warms to preset temperature when operating heated seat switch to the optimal position.

Is the inspection result normal?

- YES >> Seatback heater function is OK.
NO >> Refer to [SE-31, "PASSENGER SIDE : Diagnosis Procedure"](#).

PASSENGER SIDE : Diagnosis Procedure

INFOID:000000006207374

1.CHECK SEATBACK HEATER

1. Turn ignition switch OFF.
2. Disconnect seatback heater connector.
3. Check resistance between seatback heater terminals.

SEATBACK HEATER

< DTC/CIRCUIT DIAGNOSIS >

Seatback heater			Condition	Resistance (Ω) (Approx.)
Connector	Terminal			
B445	1	2	When heat sensor temperature is 20°C (68°F)	4.0 – 4.7

NOTE:

Resistance value changes according to temperature.

Is the inspection result normal?

- YES >> Replace seat cushion heater. Refer to [SE-120. "Exploded View"](#).
NO >> Replace seatback heater. Refer to [SE-120. "Exploded View"](#).

HEATED SEAT SWITCH INDICATOR

< DTC/CIRCUIT DIAGNOSIS >

HEATED SEAT SWITCH INDICATOR DRIVER SIDE

DRIVER SIDE : Description

INFOID:000000006207375

Illuminates the indicator that indicates the operating status of heated seat.

DRIVER SIDE : Component Function Check

INFOID:000000006207376

1.CHECK FUNCTION

Check that the related indicator lamp illuminates when heated seat switch is set to ON.

Is the inspection result normal?

- YES >> Heated seat switch indicator function is OK.
- NO >> Refer to [SE-33. "DRIVER SIDE : Diagnosis Procedure"](#).

DRIVER SIDE : Diagnosis Procedure

INFOID:000000006207377

1.CHECK HEATED SEAT SWITCH INDICATOR GROUND CIRCUIT

1. Turn ignition switch OFF
2. Disconnect heated seat switch connector.
3. Check continuity between heated seat switch harness connector and ground.

Heated seat switch		Ground	Continuity
Connector	Terminal		Existed
A/T models: M141 M/T models: M175	6		Existed

Is the inspection result normal?

- YES >> Replace heated seat switch. Refer to [SE-140. "Removal and Installation"](#).
- NO >> Repair or replace harness.

PASSENGER SIDE

PASSENGER SIDE : Description

INFOID:000000006207378

Illuminates the indicator that indicates the operating status of heated seat.

PASSENGER SIDE : Component Function Check

INFOID:000000006207379

1.CHECK FUNCTION

Check that the related indicator lamp illuminates when heated seat switch is set to ON.

Is the inspection result normal?

- YES >> Heated seat switch indicator function is OK.
- NO >> Refer to [SE-33. "PASSENGER SIDE : Diagnosis Procedure"](#).

PASSENGER SIDE : Diagnosis Procedure

INFOID:000000006207380

1.CHECK HEATED SEAT SWITCH INDICATOR GROUND CIRCUIT

1. Turn ignition switch OFF
2. Disconnect heated seat switch connector.
3. Check continuity between heated seat switch harness connector and ground.

Heated seat switch		Ground	Continuity
Connector	Terminal		Existed
A/T models: M142 M/T models: M176	6		Existed

Is the inspection result normal?

A
B
C
D
E
F
G
H
I
K
L
M
N
O
P

SE

HEATED SEAT SWITCH INDICATOR

< DTC/CIRCUIT DIAGNOSIS >

- YES >> Replace heated seat switch. Refer to [SE-140. "Removal and Installation"](#).
- NO >> Repair or replace harness.

TILT&TELESCOPIC SWITCH

< DTC/CIRCUIT DIAGNOSIS >

TILT&TELESCOPIC SWITCH

Description

INFOID:000000006207381

Tilt switch and telescopic switch as a unit, transmit switch operation signal to automatic drive positioner control unit.

Component Function Check

INFOID:000000006207382

1.CHECK TILT AND TELESCOPIC SWITCH FUNCTION

Check tilt and telescopic operation with tilt and telescopic switch.

Is the inspection results normal?

- YES >> Tilt and telescopic switch is OK.
 NO >> Refer to [SE-35. "Diagnosis Procedure"](#).

Diagnosis Procedure

INFOID:000000006207383

1.CHECK TILT AND TELESCOPIC SWITCH FUNCTION

Check voltage between tilt and telescopic switch and ground.

Tilt and telescopic switch		(-)	Switch condition	Voltage (V) Approx.
Connector	Terminal			
M31	2	Ground	Forward position	0
			Other than above	5
	3		Backward position	0
			Other than above	5
	4		Upward position	0
			Other than above	5
	5		Downward	0
			Other than above	5

Is the inspection result normal?

- YES >> Tilt and telescopic switch is OK.
 NO >> GO TO 2.

2.CHECK TILT AND TELESCOPIC SWITCH SIGNAL CIRCUIT

- Turn ignition switch OFF.
- Disconnect tilt and telescopic switch and automatic drive positioner control unit connectors.
- Check continuity between tilt and telescopic switch and automatic drive positioner control unit.

Tilt and telescopic switch connector	Terminal	Automatic drive positioner control unit	Terminal	Continuity
M31	2	M51	11	Existed
	3		27	
	4		1	
	5		17	

- Check continuity between tilt and telescopic switch and ground.

TILT&TELESCOPIC SWITCH

< DTC/CIRCUIT DIAGNOSIS >

Tilt and telescopic switch connector	Terminal		Continuity
M31	2	Ground	Not existed
	3		
	4		
	5		

Is the inspection result normal?

YES >> GO TO 3.

NO >> Repair or replace circuit.

3.CHECK TILT AND TELESCOPIC SWITCH GROUND CIRCUIT

Check continuity between tilt and telescopic switch and ground.

Tilt and telescopic switch connector	Terminal	Ground	Continuity
M31	1		Existed

Is the inspection result normal?

YES >> GO TO 4.

NO >> Repair or replace circuit.

4.CHECK TILT AND TELESCOPIC SWITCH

Check tilt and telescopic switch.

Refer to [SE-36, "Component Inspection"](#).

Is the inspection result normal?

YES >> GO TO 5.

NO >> Replace tilt and telescopic switch.

5.CHECK AUTOMATIC DRIVE POSITIONER CONTROL UNIT

1. Connect automatic drive positioner control unit connector.
2. Check voltage between automatic drive positioner control unit and ground.

Tilt and telescopic switch		(-)	Voltage (V) Approx.
Connector	Terminal		
M51	1	Ground	5
	11		
	17		
	27		

Is the inspection result normal?

YES >> GO TO 6.

NO >> Replace automatic drive positioner control unit. Refer to [SE-135, "Removal and Installation"](#).

6.CHECK INTERMITTENT INCIDENT

Check intermittent incident.

Refer to [GI-43, "Intermittent Incident"](#)

>> INSPECTION END

Component Inspection

INFOID:000000006207384

1.CHECK TILT SWITCH

1. Turn ignition switch OFF.
2. Remove tilt and telescopic switch.
3. Check continuity between tilt and telescopic switch terminals.

TILT&TELESCOPIC SWITCH

< DTC/CIRCUIT DIAGNOSIS >

Terminal		Switch condition	Continuity
2	1	Forward	Existed
		Other than above	Not existed
3		Backward	Existed
		Other than above	Not existed
4		Upward	Existed
		Other than above	Not existed
5		Downward	Existed
		Other than above	Not existed

Is the inspection result normal?

YES >> Tilt and telescopic switch is OK.

NO >> Replace tilt and telescopic switch. Refer to [SE-139. "Removal and Installation"](#).

A
B
C
D
E
F
G
H
I
K
L
M
N
O
P

SE

TILT&TELESCOPIC MOTOR

< DTC/CIRCUIT DIAGNOSIS >

TILT&TELESCOPIC MOTOR

Description

INFOID:000000006207385

Tilt and telescopic motor operates with the power received from automatic drive positioner control unit.

Component Function Check

INFOID:000000006207386

1.CHECK TILT AND TELESCOPIC MOTOR FUNCTION

Check tilt and telescopic operation with tilt and telescopic switch.

Is the inspection results normal?

- YES >> Tilt and telescopic motor are OK.
NO >> Refer to [SE-38, "Diagnosis Procedure"](#).

Diagnosis Procedure

INFOID:000000006207387

1.CHECK MALFUNCTIONING PART

Check malfunctioning part.

Is it tilt operation or telescopic operation?

- Tilt >> GO TO 2.
Telescopic>>GO TO 3.

2.CHECK TILT MOTOR POWER SUPPLY AND GROUND CIRCUIT

1. Turn ignition switch OFF.
2. Disconnect tilt motor and automatic drive positioner control unit.
3. Check continuity between tilt motor and automatic drive positioner control unit.

Tilt and telescopic motor connector	Terminal	Power seat switch connector	Terminal	Continuity
M49	3	M52	42	Existed
	4		35	

Is the inspection result normal?

- YES >> GO TO 4.
NO >> Repair or replace circuit.

3.CHECK TELESCOPIC MOTOR POWER SUPPLY AND GROUND CIRCUIT

1. Turn ignition switch OFF.
2. Disconnect telescopic motor and automatic drive positioner control unit.
3. Check continuity between telescopic motor and automatic drive positioner control unit.

Tilt and telescopic motor connector	Terminal	Power seat switch connector	Terminal	Continuity
M49	1	M52	44	Existed
	2		36	

Is the inspection result normal?

- YES >> GO TO 4.
NO >> Repair or replace circuit.

4.CHECK TILT AND TELESCOPIC MOTOR

Check tilt and telescopic motor.

Refer to [SE-39, "Component Inspection"](#).

Is the inspection result normal?

- YES >> GO TO 5.
NO >> Replace tilt and telescopic motor.

5.CHECK ADP CONTROL UNIT

TILT&TELESCOPIC MOTOR

< DTC/CIRCUIT DIAGNOSIS >

1. Connect automatic drive positioner control unit connector.
2. Check voltage between automatic drive positioner control unit and ground.

Tilt and telescopic switch		(-)	Tilt and telescopic switch condition	Voltage (V) Approx.
Connector	Terminal			
M51	35	Ground	Upward	Battery voltage
			Other than above	0
	36		Forward	Battery voltage
			Other than above	0
	42		Downward	Battery voltage
			Other than above	0
	44		Backward	Battery voltage
			Other than above	0

Is the inspection result normal?

YES >> GO TO 6.

NO >> Replace automatic drive positioner control unit. Refer to [SE-135. "Removal and Installation"](#).

6.CHECK INTERMITTENT INCIDENT

Check intermittent incident.

Refer to [GI-43. "Intermittent Incident"](#)

>> INSPECTION END

Component Inspection

INFOID:000000006207388

1.CHECK TILT AND TELESCOPIC MOTOR-I

Check visually the tilt and telescopic motor to see if any foreign object is not disturbing the functionment or if the tilt and telescopic motor is not broken.

Is the inspection result normal?

YES >> GO TO 2.

NO >> Repair or replace tilt and telescopic motor.

2.CHECK TILT AND TELESCOPIC MOTOR-II

1. Turn ignition switch OFF.
2. Disconnect tilt and telescopic motor connector.
3. Supply tilt and telescopic motor terminals with battery voltage and check operation.

Item	Terminal		Operation
	(+)	(-)	
Telescopic motor	1	2	Backward
	2	1	Forward
Tilt motor	3	4	Downward
	4	3	Upward

Is the inspection result normal?

YES >> Tilt and telescopic motor is OK.

NO >> Replace tilt and telescopic motor.

TILT&TELESCOPIC SENSOR

< DTC/CIRCUIT DIAGNOSIS >

TILT&TELESCOPIC SENSOR

Description

INFOID:000000006207389

Tilt and telescopic sensor detects the position of steering wheel and transmits signals to automatic drive positioner control unit.

Component Function Check

INFOID:000000006207390

1.CHECK TILT AND TELESCOPIC SENSOR FUNCTION

Check tilt and telescopic operation with tilt and telescopic switch.

Is the inspection results normal?

- YES >> Tilt and telescopic sensor is OK.
NO >> Refer to [SE-40. "Diagnosis Procedure"](#).

Diagnosis Procedure

INFOID:000000006207391

1.CHECK TILT AND TELESCOPIC SENSOR CIRCUIT

1. Turn ignition switch OFF.
2. Disconnect tilt and telescopic sensor and automatic drive positioner control unit connector.
3. Check continuity between tilt and telescopic sensor and automatic drive positioner control unit.

Tilt and telescopic sensor connector	Terminal	Automatic drive positioner control unit	Terminal	Continuity
M48	1	M51	33	Existed
	2		23	
	3		7	
	4	M52	41	

4. Check continuity between tilt and telescopic sensor and ground.

Tilt and telescopic sensor connector	Terminal		Continuity
M48	1	Ground	Not existed
	2		
	3		
	4		

Is the inspection result normal?

- YES >> GO TO 2.
NO >> Repair or replace circuit.

2.CHECK TILT AND TELESCOPIC SENSOR POWER SUPPLY

1. Connect automatic drive positioner control unit connector.
2. Check voltage between automatic drive positioner control unit and ground.

Tilt and telescopic sensor		Ground	Voltage
Connector	Terminal		
M52	33		Approx. 5V

Is the inspection result normal?

- YES >> GO TO 3.
NO >> Replace automatic drive positioner. Refer to [SE-135. "Removal and Installation"](#).

3.CHECK TILT AND TELESCOPIC SENSOR GROUND

Check continuity between automatic drive positioner control unit and ground.

TILT&TELESCOPIC SENSOR

< DTC/CIRCUIT DIAGNOSIS >

Tilt and telescopic sensor		Ground	Continuity
Connector	Terminal		Existed
M48	4		

Is the inspection result normal?

YES >> GO TO 4.

NO >> Replace automatic drive positioner. Refer to [SE-135, "Removal and Installation"](#).

4.CHECK INTERMITTENT INCIDENT

Check intermittent incident.

Refer to [GI-43, "Intermittent Incident"](#).

>> INSPECTION END

A
B
C
D
E
F
G
H
I
K
L
M
N
O
P

SE

POWER SEAT

< DTC/CIRCUIT DIAGNOSIS >

POWER SEAT

Wiring Diagram - POWER SEAT SYSTEM (DRIVER SIDE) -

INFOID:000000006207392

POWER SEAT FOR DRIVER SIDE

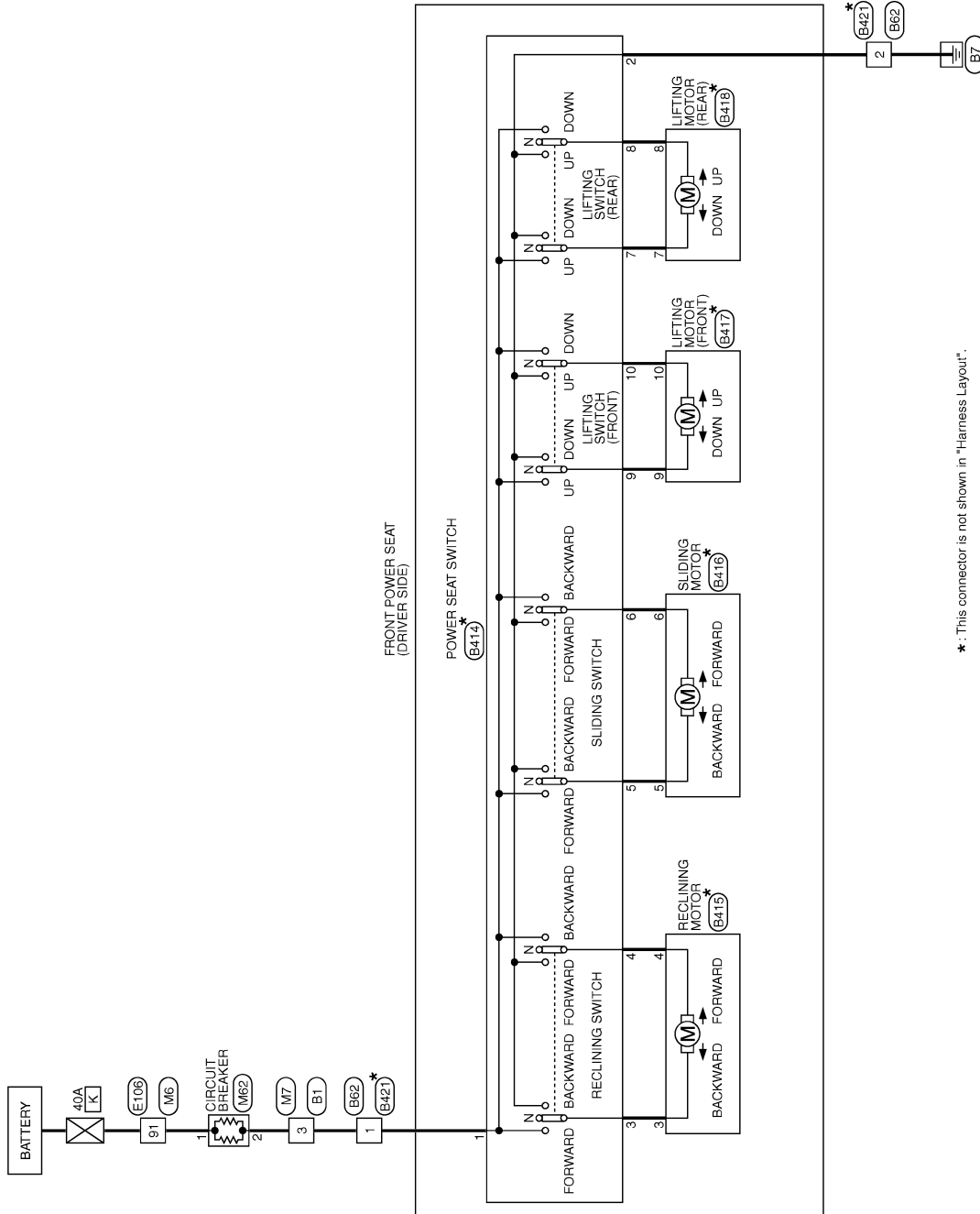

* : This connector is not shown in "Harness Layout".

2010/08/18

JCJWM1642GB

POWER SEAT

< DTC/CIRCUIT DIAGNOSIS >

POWER SEAT FOR DRIVER SIDE

Connector No.	B1
Connector Name	WIRE TO WIRE
Connector Type	TH80FW-CS16-TM4

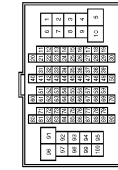

Terminal No.	Color of Wire	Signal Name [Specification]
1	GR	
2	BG	
3	L	
4	Y	
6	R	
7	P	
8	W	
9	LG	[With rear anti-pinch system]
9	GR	[Without rear anti-pinch system]
15	Y	
16	BR	
17	LG	
18	BG	
20	L	
21	P	
22	L	
23	P	
24	V	
25	SB	
26	G	
27	W	
28	R	
31	V	
32	SB	
33	SHIELD	
34	W	
35	BR	
36	Y	
37	SHIELD	
38	Y	
39	SB	
40	P	
41	L	
42	SHIELD	
43	R	
44	G	
45	SHIELD	
46	SB	

55	BR	
56	P	
58	V	
59	SB	
60	BR	
61	W	
62	R	
63	L	
64	Y	
65	SHIELD	
71	BG	
72	GR	
73	P	
74	L	
81	V	
82	B	
84	Y	
85	G	
86	W	
87	R	
88	BR	
89	Y	
90	SB	
91	BG	
92	BR	
93	P	
95	BG	
96	Y	
100	GR	

Connector No.	B62
Connector Name	WIRE TO WIRE
Connector Type	MO80FW-LG



Terminal No.	Color of Wire	Signal Name [Specification]
1	L	
2	B	
14	BG	
15	GR	
16	R	

Connector No.	B414
Connector Name	POWER SEAT SWITCH
Connector Type	NS10FW-CS

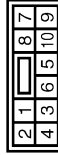

Terminal No.	Color of Wire	Signal Name [Specification]
1	R	
2	B	
3	G.Y	
4	P	
5	W	
6	V	
8	L.Y	
8	L	
9	L/R	
10	G/W	

Connector No.	B415
Connector Name	RECLINING MOTOR
Connector Type	NS10FW-CS



Terminal No.	Color of Wire	Signal Name [Specification]
3	G/Y	
4	P	

Connector No.	B416
Connector Name	SLIDING MOTOR
Connector Type	NS10FW-CS



Terminal No.	Color of Wire	Signal Name [Specification]
5	W	
6	V	

Connector No.	B417
Connector Name	LIFTING MOTOR (FRONT)
Connector Type	NS10FW-CS



Terminal No.	Color of Wire	Signal Name [Specification]
9	L/R	
10	G/W	

Connector No.	B418
Connector Name	LIFTING MOTOR (REAR)
Connector Type	NS10FW-CS



Terminal No.	Color of Wire	Signal Name [Specification]
7	L.Y	
8	L	

A
B
C
D
E
F
G
H
I
SE
K
L
M
N
O
P

JCJWM1643GB

POWER SEAT

< DTC/CIRCUIT DIAGNOSIS >

POWER SEAT FOR DRIVER SIDE

Connector No.	B421
Connector Name	WIRE TO WIRE
Connector Type	M08MW-LC



1	16
2	15 14

Terminal No.	Color of Wire	Signal Name [Specification]
1	R	
2	B	
14	R	
15	L/W	
16	R/W	

Connector No.	E106
Connector Name	WIRE TO WIRE
Connector Type	TH80FW-CS16-TM4



1	16
2	15 14
3	13
4	12
5	11
6	10
7	9
8	8
9	7
10	6
11	5
12	4
13	3
14	2
15	1

Terminal No.	Color of Wire	Signal Name [Specification]
1	GR	
3	EG	
6	Y	
7	V	
9	R	
10	W	
11	V	
12	R	
13	L	
14	GR	
15	P	
16	W	
17	SB	
18	EG	
19	SB	
20	LG	

30	BR	
31	L	
32	EG	
33	P	
34	V	
35	W	
36	SB	
37	Y	
38	R	
39	B	
40	G	
41	R	
42	LG	
43	G	
44	GR	
45	BR	
46	LG	
47	V	
48	P	
49	L	
50	B	
59	GR	
66	GR	
67	LG	
68	SB	
69	P	
70	G	
80	R	
81	P	
82	G	
83	V	
84	L	
85	W	
86	L	
87	BR	
88	GR	
89	W	
91	W	
93	V	
84	L	
86	L	
87	BR	
88	GR	
89	W	
91	W	
93	V	
95	Y	
97	SB	
98	SHIELD	
99	L	
100	P	

Connector No.	M6
Connector Name	WIRE TO WIRE
Connector Type	TH80MW-CS16-TM4



1	16
2	15 14
3	13
4	12
5	11
6	10
7	9
8	8
9	7
10	6
11	5
12	4
13	3
14	2
15	1

Terminal No.	Color of Wire	Signal Name [Specification]
1	BG	
3	R	
5	G	
6	LG	
7	W	
9	G	
10	W	
11	V	
12	R	
13	L	
14	GR	
15	P	
16	W	
17	BR	
18	P	
19	L	
20	L	
30	BR	
31	L	
32	Y	
33	BG	
34	W	
35	BR	
36	R	
37	Y	
38	R	
39	SB	
40	G	
41	V	
42	LG	
43	P	
44	B	- [With A/T]
44	R	- [With M/T]
45	BG	
46	G	
47	L	
48	P	
48	L	

59	B	
66	Y	
67	G	
68	R	
69	W	
70	G	
80	SB	
81	B	
82	V	
83	W	
84	L	
85	GR	
86	G	
87	R	
88	B	
89	LG	
91	W	
93	Y	
95	Y	
97	GR	
88	SHIELD	
99	V	
100	SB	

POWER SEAT

< DTC/CIRCUIT DIAGNOSIS >

POWER SEAT FOR DRIVER SIDE

Connector No.	M7
Connector Name	WIRE TO WIRE
Connector Type	TH80MW-CS (F-TM4)

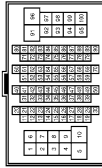

Terminal No.	Color of Wire	Signal Name [Specification]
1	GR	-
2	P	-
3	SB	- [With automatic drive positioner]
3	P	- [Without automatic drive positioner]
4	Y	-
5	L	-
6	L	-
7	W	-
8	G	- [With rear anti-pinch system]
8	Y	- [Without rear anti-pinch system]
9	Y	- [With rear anti-pinch system]
9	G	- [Without rear anti-pinch system]
15	R	-
16	BR	-
17	P	-
18	V	-
20	L	-
21	P	-
22	L	-
23	P	-
24	V	-
25	LG	-
26	BR	-
27	BG	-
28	LG	-
31	V	-
32	LG	-
33	SHIELD	-
34	GR	-
35	BR	-
36	Y	-
37	SHIELD	-
38	SB	-
39	LG	-
40	O	-
41	W	-
42	SHIELD	-
43	R	-
44	G	-

45	SHIELD	-
46	SB	-
55	W	-
56	B	-
58	V	-
59	Y	-
60	Y	-
61	W	-
62	R	-
63	G	-
64	B	-
65	SHIELD	-
71	V	-
72	P	-
73	SB	-
74	V	-
81	W	-
82	BR	-
84	LG	-
85	BG	-
86	SB	-
87	G	-
88	GR	-
89	L	-
90	P	-
91	BG	-
92	L	-
93	P	-
95	BG	-
96	Y	-
100	P	-

Connector No.	M82
Connector Name	CIRCUIT BREAKER
Connector Type	M02FW-LC



Terminal No.	Color of Wire	Signal Name [Specification]
1	L	- [With automatic drive positioner]
1	W	- [Without automatic drive positioner]
2	SB	- [With automatic drive positioner]
2	P	- [Without automatic drive positioner]

JCJWM1645GB

A
B
C
D
E
F
G
H
I
SE
K
L
M
N
O
P

POWER SEAT

< DTC/CIRCUIT DIAGNOSIS >

Wiring Diagram - POWER SEAT SYSTEM (PASSENGER SIDE) -

INFOID:000000006207393

POWER SEAT FOR PASSENGER SIDE

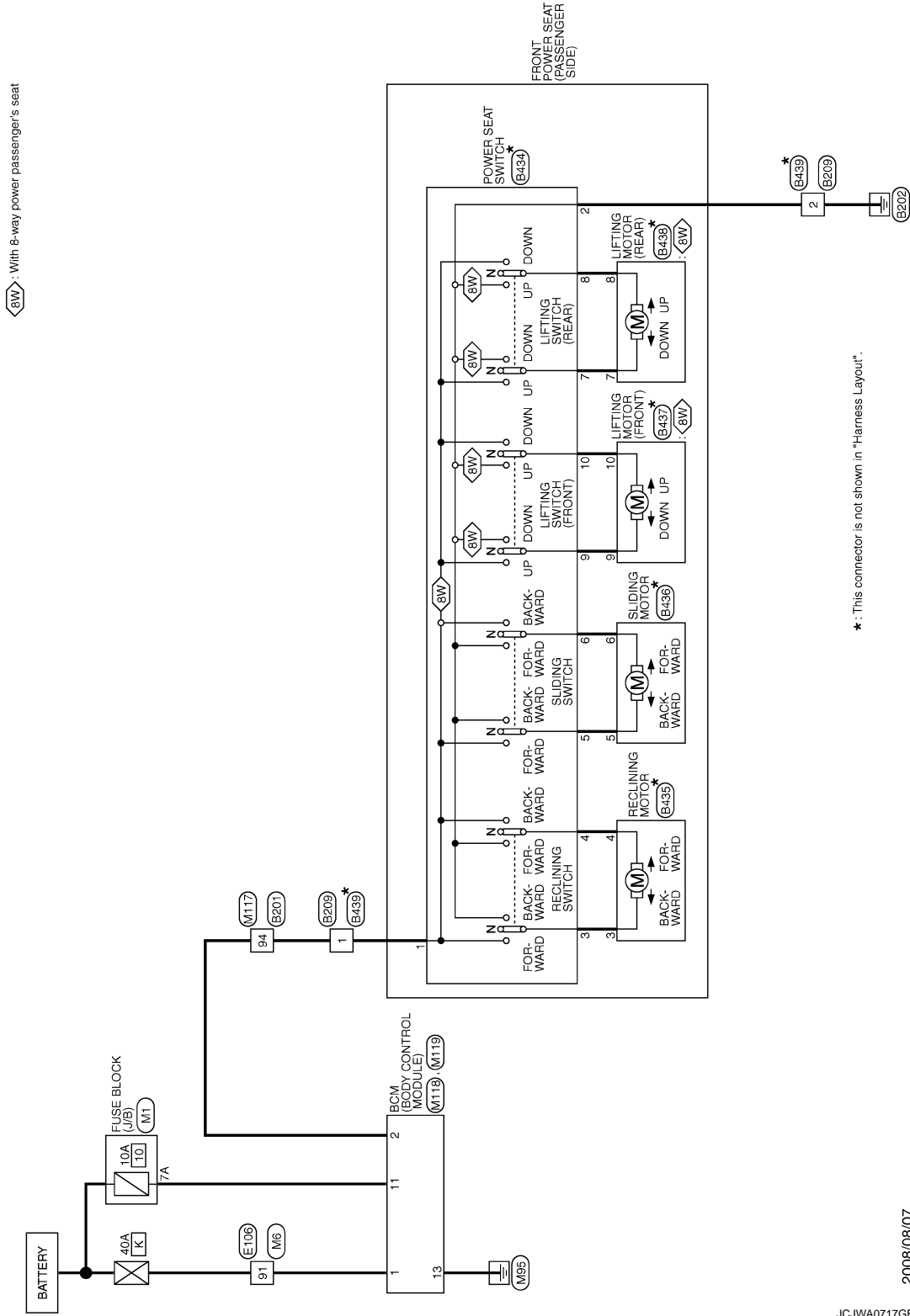

POWER SEAT

< DTC/CIRCUIT DIAGNOSIS >

POWER SEAT FOR PASSENGER SIDE

Connector No.	B201
Connector Name	WIRE TO WIRE
Connector Type	TH80FW-CS16-TM4

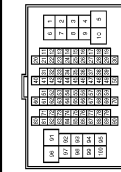

Terminal No.	Color of Wire	Signal Name [Specification]
1	BR	-
3	W	-
5	P	-
6	L	-
7	V	-
8	LG	-
10	L	-
31	L	-
32	P	-
33	G	-
34	R	-
40	GR	-
41	LG	-
42	BG	-
43	R	-
45	G	-
46	SHIELD	-
47	G	-
48	Y	-
48	SHIELD	-
50	W	-
71	R	-
72	V	-
80	BG	-
81	SHIELD	-
82	G	-
83	P	-
84	L	-
85	SHIELD	-
86	G	-
87	R	-
88	W	-
89	B	-
90	Y	-
91	V	-
92	W	- [With rear anti-pinch system]
92	R	- [Without rear anti-pinch system]
93	BG	- [With rear anti-pinch system]

93	BR	- [Without rear anti-pinch system]
94	R	-
95	SB	-
96	G	-
97	GR	-
98	BR	-
99	P	-
100	L	-

Connector No.	B209
Connector Name	WIRE TO WIRE
Connector Type	M06FW-LG



Terminal No.	Color of Wire	Signal Name [Specification]
1	R	-
2	B	-
14	L	-
15	V	-
16	BR	-

Connector No.	B434
Connector Name	POWER SEAT SWITCH
Connector Type	NS10FW-CS



Terminal No.	Color of Wire	Signal Name [Specification]
1	R	-
2	B	-
3	G/Y	-
4	P	-
5	W	-
6	V	-
7	L/Y	-

8	L	-
9	L/R	-
10	G/W	-

Connector No.	B435
Connector Name	RECLINING MOTOR
Connector Type	NS02FW-CS



Terminal No.	Color of Wire	Signal Name [Specification]
3	G/Y	-
4	P	-

Connector No.	B436
Connector Name	SLIDING MOTOR
Connector Type	6098-9239



Terminal No.	Color of Wire	Signal Name [Specification]
5	W	-
6	V	-

Connector No.	B437
Connector Name	LIFTING MOTOR (FRONT)
Connector Type	NS02FW-CS



Terminal No.	Color of Wire	Signal Name [Specification]
9	L/R	-
10	G/W	-

Connector No.	B438
Connector Name	LIFTING MOTOR (REAR)
Connector Type	NS02FW-CS



Terminal No.	Color of Wire	Signal Name [Specification]
7	L/Y	-
8	L	-

A
B
C
D
E
F
G
H
I
SE
K
L
M
N
O
P

JCJWM1646GB

POWER SEAT

< DTC/CIRCUIT DIAGNOSIS >

POWER SEAT FOR PASSENGER SIDE

Connector No.	B439
Connector Name	WIRE TO WIRE
Connector Type	M08MW-LC



1	16
2	15 14

Terminal No.	Color of Wire	Signal Name [Specification]
1	R	-
2	B	-
14	R	-
15	L/W	-
16	R/W	-

Connector No.	E106
Connector Name	WIRE TO WIRE
Connector Type	TH60FW-CS16-TM4



Terminal No.	Color of Wire	Signal Name [Specification]
1	GR	-
2	GR	-
3	EG	-
4	G	-
6	Y	-
7	V	-
9	R	-
10	W	-
11	V	-
12	R	-
13	L	-
14	GR	-
15	P	-
16	W	-
17	SB	-
18	EG	-
19	SB	-
20	LG	-

30	BR	-
31	L	-
32	EG	-
33	P	-
34	V	-
35	W	-
36	SB	-
37	Y	-
38	R	-
39	B	-
40	G	-
41	R	-
42	LG	-
43	G	-
44	GR	-
45	BR	-
46	LG	-
47	V	-
48	P	-
49	L	-
50	B	-
51	B	-
52	GR	-
53	GR	-
54	LG	-
55	SB	-
56	P	-
57	LG	-
58	SB	-
59	P	-
60	G	-
61	R	-
62	P	-
63	G	-
64	V	-
65	L	-
66	W	-
67	L	-
68	BR	-
69	GR	-
70	W	-
71	GR	-
72	GR	-
73	GR	-
74	GR	-
75	GR	-
76	GR	-
77	GR	-
78	GR	-
79	GR	-
80	GR	-
81	GR	-
82	GR	-
83	GR	-
84	L	-
85	W	-
86	L	-
87	BR	-
88	GR	-
89	V	-
90	W	-
91	W	-
92	GR	-
93	GR	-
94	LG	-
95	LG	-
96	SB	-
97	SHIELD	-
98	L	-
99	P	-
100	P	-

Connector No.	M1
Connector Name	FUSE BLOCK (U/B)
Connector Type	NS08FW-M2



3A	2A 1A
BA	7A 6A 5A 4A

Terminal No.	Color of Wire	Signal Name [Specification]
1A	V	-
2A	G	-
3A	L	-
4A	P	-
5A	L	-
6A	Y	-
7A	R	-
8A	L	-

Connector No.	M6
Connector Name	WIRE TO WIRE
Connector Type	TH60MW-CS16-TM4



Terminal No.	Color of Wire	Signal Name [Specification]
1	EG	-
3	R	-
5	G	-
6	LG	-
7	W	-
9	G	-
10	W	-
11	V	-
12	R	-
13	L	-
14	GR	-
15	P	-
16	W	-
17	BR	-

18	P	-
19	L	-
20	L	-
30	BR	-
31	L	-
32	Y	-
33	EG	-
34	W	-
35	BR	-
36	R	-
37	Y	-
38	R	-
39	SB	-
40	G	-
41	V	-
42	LG	-
43	P	-
44	B	-
44	R	-
45	EG	-
46	G	-
47	L	-
48	P	-
49	L	-
59	B	-
66	Y	-
67	G	-
68	R	-
69	W	-
70	G	-
80	SB	-
81	B	-
82	V	-
83	W	-
84	L	-
85	GR	-
86	G	-
87	R	-
88	B	-
89	LG	-
91	W	-
93	Y	-
95	Y	-
97	GR	-
98	SHIELD	-
99	V	-
100	SB	-

POWER SEAT

< DTC/CIRCUIT DIAGNOSIS >

POWER SEAT FOR PASSENGER SIDE

Connector No.	M117
Connector Name	WIRE TO WIRE
Connector Type	TH80MW-CS (F-TM4)

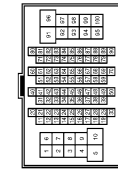

Terminal No.	Color of Wire	Signal Name [Specification]
1	LG	-
3	SB	-
5	P	-
6	G	-
7	SB	-
8	LG	-
10	L	-
31	SB	-
32	LG	-
33	SB	-
34	LG	-
40	Y	-
41	G	-
42	LG	-
43	R	-
45	G	-
46	SHIELD	-
48	L	-
48	SHIELD	-
50	W	-
71	R	-
72	L	-
80	W	-
81	SHIELD	-
82	P	-
83	L	-
84	G	-
85	SHIELD	-
86	W	-
87	B	-
88	R	-
89	G	-
90	Y	-
91	V	-
92	BR	- [With rear anti-pinch system]
92	LG	- [Without rear anti-pinch system]
93	V	- [With rear anti-pinch system]
		- [Without rear anti-pinch system]

93	W	-	[Without rear anti-pinch system]
94	Y	-	-
95	G	-	-
96	G	-	-
97	R	-	-
98	EG	-	-
99	P	-	-
100	L	-	-

Connector No.	M118
Connector Name	BCM (BODY CONTROL MODULE)
Connector Type	M03FB-LC



Terminal No.	Color of Wire	Signal Name [Specification]
1	W	BAT (F/L)
2	Y	POWER WINDOW POWER SUPPLY (BAT)
3	EG	POWER WINDOW POWER SUPPLY (RAP)

Connector No.	M119
Connector Name	BCM (BODY CONTROL MODULE)
Connector Type	NS16FW-CS



Terminal No.	Color of Wire	Signal Name [Specification]
4	LG	INTERIOR ROOM LAMP POWER SUPPLY
5	P	PASSENGER DOOR UNLOCK OUTPUT
7	SB	STEP LAMP OUTPUT
8	V	ALL DOOR FUEL LID LOCK OUTPUT
9	G	DRIVER DOOR FUEL LID UNLOCK OUTPUT
10	P	REAR DOOR UNLOCK OUTPUT
11	R	BAT (FUSE)
13	B	GND
14	W	PUSH-BUTTON (IGNITION SW ILL GND)

15	BG	AGC IND
17	W	TURN SIGNAL RH (FRONT)
18	BG	TURN SIGNAL LH (FRONT)
19	V	INT ROOM LAMP CONT

JCJWM1648GB

A
B
C
D
E
F
G
H
I
K
L
M
N
O
P

SE

SIDE SUPPORT

< DTC/CIRCUIT DIAGNOSIS >

SIDE SUPPORT

Wiring Diagram - SIDE SUPPORT SYSTEM -

INFOID:000000006207395

SIDE SUPPORT

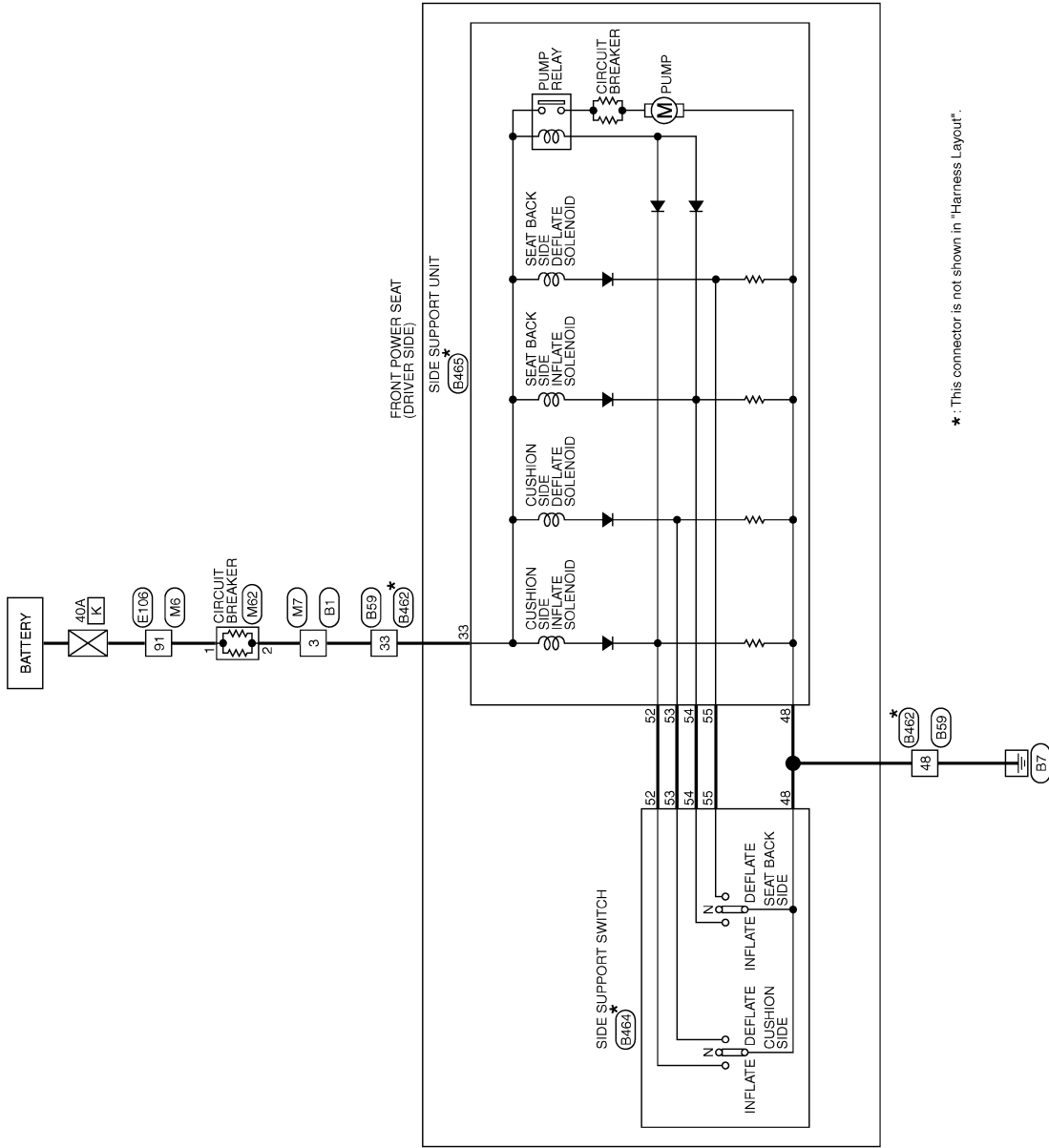

*: This connector is not shown in "Harness Layout".

2010/08/18

JCJWM1651GB

SIDE SUPPORT

< DTC/CIRCUIT DIAGNOSIS >

SIDE SUPPORT

Connector No.	B1
Connector Name	WIRE TO WIRE
Connector Type	TH80FW-CS16-TM4

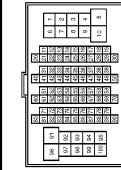

Terminal No.	Color of Wire	Signal Name [Specification]
1	GR	-
2	BG	-
3	L	-
4	Y	-
6	R	-
7	P	-
8	W	-
9	LG	- [With rear anti-pinch system] - [Without rear anti-pinch system]
15	Y	-
16	BR	-
17	LG	-
18	BG	-
20	L	-
21	P	-
22	L	-
23	P	-
24	V	-
25	SB	-
26	G	-
27	W	-
28	R	-
31	V	-
32	SB	-
33	SHIELD	-
34	W	-
35	BR	-
36	Y	-
37	SHIELD	-
38	Y	-
39	SB	-
40	P	-
41	L	-
42	SHIELD	-
43	R	-
44	G	-
45	SHIELD	-
46	SB	-

55	BR	-
56	P	-
58	V	-
59	SB	-
60	BR	-
61	W	-
62	R	-
63	L	-
64	Y	-
65	SHIELD	-
71	BG	-
72	GR	-
73	P	-
74	L	-
81	V	-
82	B	-
84	Y	-
85	G	-
86	W	-
87	R	-
88	BR	-
89	Y	-
90	SB	-
91	BG	-
92	BR	-
93	P	-
95	BG	-
96	Y	-
100	GR	-

Connector No.	B59
Connector Name	WIRE TO WIRE
Connector Type	NS10FW-CS



40	17	1	3	19
67	68	33	21	48
32	69	8		

Terminal No.	Color of Wire	Signal Name [Specification]
1	BG	-
3	L	-
8	Y	-
17	LG	-
19	P	-
21	Y	-
32	B	-

33	L	-
40	BR	-
48	B	-
67	BG	-
68	GR	-
69	R	-

Connector No.	B462
Connector Name	WIRE TO WIRE
Connector Type	NS10MW-LC



19	3	1	17	40
8	69	32	48	21
33	68	67		

Terminal No.	Color of Wire	Signal Name [Specification]
1	L/W	-
3	R/Y	-
8	LG	-
17	Y/R	-
19	V	-
21	L/Y	-
32	B/W	-
33	R	-
40	R/W	-
48	B	-
67	R	-
68	L	-
69	BR/W	-

Connector No.	B464
Connector Name	SIDE SUPPORT SWITCH
Connector Type	NS10FW-CS



55	64
53	52
48	

Terminal No.	Color of Wire	Signal Name [Specification]
48	B	-

52	G	- [With automatic drive positioner] - [Without automatic drive positioner]
53	B/R	- [With automatic drive positioner] - [Without automatic drive positioner]
54	W/R	- [With automatic drive positioner] - [Without automatic drive positioner]
55	BR	- [With automatic drive positioner] - [Without automatic drive positioner]
55	R/L	- [With automatic drive positioner] - [Without automatic drive positioner]
55	LG	- [Without automatic drive positioner]

Connector No.	B465
Connector Name	SIDE SUPPORT UNIT
Connector Type	NS10FW-CS



55	54
33	53
52	48

Terminal No.	Color of Wire	Signal Name [Specification]
33	R	-
48	B	-
52	G	- [With automatic drive positioner] - [Without automatic drive positioner]
53	B/R	- [With automatic drive positioner] - [Without automatic drive positioner]
54	W/W	- [With automatic drive positioner] - [Without automatic drive positioner]
54	BR	- [Without automatic drive positioner]
55	R/L	- [With automatic drive positioner] - [Without automatic drive positioner]
55	LG	- [Without automatic drive positioner]

A
B
C
D
E
F
G
H
I
SE
K
L
M
N
O
P

SIDE SUPPORT

< DTC/CIRCUIT DIAGNOSIS >

SIDE SUPPORT

Connector No.	E106
Connector Name	WIRE TO WIRE
Connector Type	TH80MW-CSI6-TM4

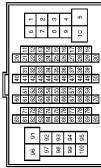

Terminal No.	Color of Wire	Signal Name [Specification]
1	GR	-
3	BG	-
5	G	-
6	Y	-
7	V	-
9	R	-
10	W	-
11	V	-
12	R	-
13	L	-
14	GR	-
15	P	-
16	W	-
17	SB	-
18	BG	-
19	SB	-
20	LG	-
30	BR	-
31	L	-
32	BG	-
33	P	-
34	V	-
35	W	-
36	SB	-
37	Y	-
38	R	-
39	B	-
40	G	-
41	R	-
42	LG	-
43	G	-
44	GR	-
45	BR	-
46	LG	-
47	V	-
48	P	-
49	L	-
59	B	-

66	GR	-
67	LG	-
68	SB	-
69	P	-
70	G	-
80	R	-
81	P	-
82	G	-
83	V	-
84	L	-
85	W	-
86	L	-
87	BR	-
88	GR	-
89	V	-
91	W	-
93	GR	-
95	LG	-
97	SR	-
98	SHIELD	-
99	L	-
100	P	-

Connector No.	M6
Connector Name	WIRE TO WIRE
Connector Type	TH80MW-CSI6-TM4



Terminal No.	Color of Wire	Signal Name [Specification]
1	BG	-
3	R	-
5	G	-
6	LG	-
7	W	-
9	G	-
10	W	-
11	V	-
12	R	-
13	L	-
14	GR	-
15	P	-
16	W	-
17	BR	-

18	P	-
19	L	-
20	L	-
30	BR	-
31	L	-
32	Y	-
33	BG	-
34	W	-
35	BR	-
36	R	-
37	Y	-
38	R	-
39	SB	-
40	G	-
41	V	-
42	LG	-
43	P	-
44	B	-
44	R	-
45	BG	-
46	G	-
47	L	-
48	P	-
49	L	-
66	Y	-
69	B	-
67	G	-
69	R	-
69	W	-
70	G	-
80	SB	-
81	B	-
82	V	-
83	W	-
84	L	-
84	L	-
85	GR	-
85	GR	-
88	G	-
87	R	-
88	B	-
89	LG	-
91	W	-
93	Y	-
95	Y	-
97	GR	-
98	SHIELD	-
99	V	-
100	SB	-

JCJWM1653GB

SIDE SUPPORT

< DTC/CIRCUIT DIAGNOSIS >

SIDE SUPPORT

Connector No.	M7
Connector Name	WIRE TO WIRE
Connector Type	TH80MW-CS (F-TM4)

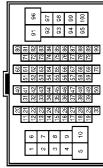

Terminal No.	Color of Wire	Signal Name [Specification]
1	GR	-
2	P	-
3	SB	- [With automatic drive positioner]
4	P	- [Without automatic drive positioner]
5	Y	-
6	L	-
7	W	-
8	G	- [With rear anti-pinch system]
8	Y	- [Without rear anti-pinch system]
9	Y	- [With rear anti-pinch system]
9	G	- [Without rear anti-pinch system]
15	R	-
16	BR	-
17	P	-
18	V	-
20	L	-
21	P	-
22	L	-
23	P	-
24	V	-
25	LG	-
26	BR	-
27	EG	-
28	LG	-
31	V	-
32	LG	-
33	SHIELD	-
34	GR	-
35	BR	-
36	Y	-
37	SHIELD	-
38	SB	-
39	LG	-
40	O	-
41	W	-
42	SHIELD	-
43	R	-
44	G	-

45	SHIELD	-
46	SB	-
55	W	-
56	B	-
58	V	-
59	Y	-
60	Y	-
61	W	-
62	R	-
63	G	-
64	B	-
65	SHIELD	-
71	V	-
72	P	-
73	SB	-
74	V	-
81	W	-
82	BR	-
84	LG	-
85	EG	-
86	SB	-
87	G	-
88	GR	-
89	L	-
90	P	-
91	BG	-
92	L	-
93	P	-
95	BG	-
96	Y	-
100	P	-

Connector No.	M82
Connector Name	CIRCUIT BREAKER
Connector Type	M02FW-LC



Terminal No.	Color of Wire	Signal Name [Specification]
1	L	- [With automatic drive positioner]
1	W	- [Without automatic drive positioner]
2	SB	- [With automatic drive positioner]
2	P	- [Without automatic drive positioner]

JCJWM1654GB

A
B
C
D
E
F
G
H
I
SE
K
L
M
N
O
P

TILT & TELESCOPIC SYSTEM

< DTC/CIRCUIT DIAGNOSIS >

TILT & TELESCOPIC SYSTEM

Wiring Diagram - TILT&TELESCOPIC SYSTEM -

INFOID:000000006207396

TILT & TELESCOPIC SYSTEM

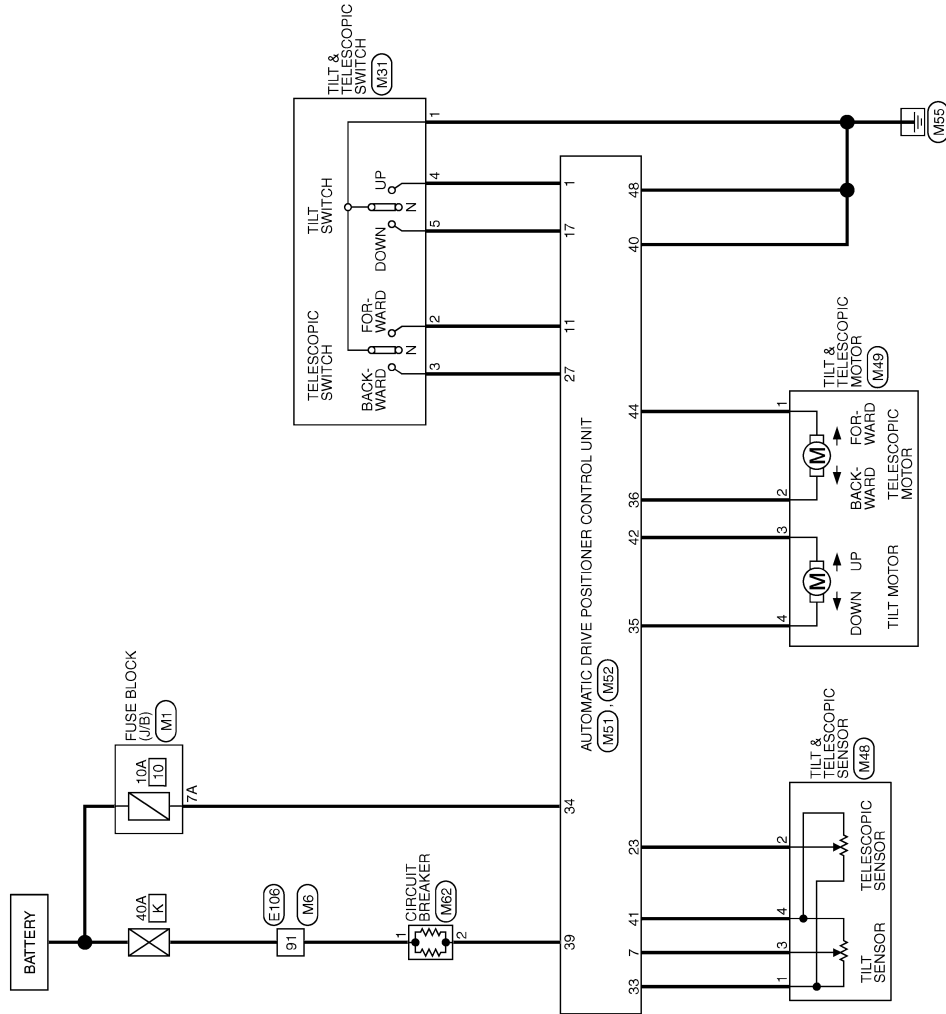

2008/08/07

JCJWA0720GB

TILT & TELESCOPIC SYSTEM

< DTC/CIRCUIT DIAGNOSIS >

TILT & TELESCOPIC SYSTEM

Connector No.	E106
Connector Name	WIRE TO WIRE
Connector Type	TH80FV-CS16-TM4

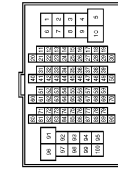

Terminal No.	Color of Wire	Signal Name [Specification]
1	GR	-
2	GR	-
3	EG	-
4	G	-
5	G	-
6	Y	-
7	V	-
8	R	-
9	W	-
10	W	-
11	V	-
12	R	-
13	L	-
14	GR	-
15	P	-
16	W	-
17	SB	-
18	BG	-
19	SB	-
20	LG	-
30	BR	-
31	L	-
32	BG	-
33	P	-
34	V	-
35	W	-
36	SB	-
37	Y	-
38	R	-
39	B	-
40	G	-
41	R	-
42	LG	-
43	G	-
44	GR	-
45	BR	-
46	LG	-
47	V	-
48	P	-
49	L	-
50	B	-

66	GR	-
67	LG	-
68	SB	-
69	P	-
70	G	-
80	R	-
81	P	-
82	G	-
83	V	-
84	L	-
85	W	-
86	L	-
87	BR	-
88	GR	-
89	V	-
91	W	-
93	GR	-
95	LG	-
97	SB	-
98	SHIELD	-
99	L	-
100	P	-

Connector No.	M1
Connector Name	FUSE BLOCK (J/B)
Connector Type	NS06FY-M2



Terminal No.	Color of Wire	Signal Name [Specification]
1A	V	-
2A	G	-
3A	L	-
4A	P	-
5A	L	-
6A	Y	-
7A	R	-
8A	L	-

Connector No.	M6
Connector Name	WIRE TO WIRE
Connector Type	TH80MW-CS16-TM4

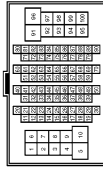

Terminal No.	Color of Wire	Signal Name [Specification]
1	BG	-
3	R	-
5	G	-
6	LG	-
7	W	-
8	G	-
10	W	-
11	V	-
12	R	-
13	L	-
14	GR	-
15	P	-
16	W	-
17	BR	-
18	P	-
19	L	-
20	L	-
30	BR	-
31	L	-
32	Y	-
33	BG	-
34	W	-
35	BR	-
36	R	-
37	Y	-
38	R	-
39	SB	-
40	G	-
41	V	-
42	LG	-
43	P	-
44	B	-
44	R	-
45	BG	-
46	G	-
47	L	-
48	P	-
49	L	-

59	B	-
66	Y	-
67	G	-
68	R	-
69	W	-
70	G	-
80	SB	-
81	B	-
82	V	-
83	W	-
84	L	-
85	GR	-
86	G	-
87	R	-
88	B	-
89	LG	-
91	W	-
93	Y	-
95	Y	-
97	GR	-
98	SHIELD	-
99	V	-
100	SB	-

Connector No.	M31
Connector Name	TILT & TELESCOPIC SWITCH
Connector Type	TK08FGY



Terminal No.	Color of Wire	Signal Name [Specification]
1	B	-
2	GR	-
3	G	-
4	Y	-
5	BR	-

JCJWM1649GB

A
B
C
D
E
F
G
H
I
SE
K
L
M
N
O
P

TILT & TELESCOPIC SYSTEM

< DTC/CIRCUIT DIAGNOSIS >

TILT & TELESCOPIC SYSTEM

Connector No.	M48
Connector Name	TILT & TELESCOPIC SENSOR
Connector Type	TK04FW

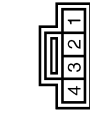

Terminal No.	Color of Wire	Signal Name [Specification]
1	W	-
2	P	-
3	EG	-
4	Y	-

Connector No.	M49
Connector Name	TILT & TELESCOPIC MOTOR
Connector Type	NS04FW-CS



Terminal No.	Color of Wire	Signal Name [Specification]
1	G	-
2	GR	-
3	EG	-
4	L	-

Connector No.	M51
Connector Name	AUTOMATIC DRIVE POSITIONER CONTROL UNIT
Connector Type	TH02FW-NH

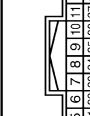

Terminal No.	Color of Wire	Signal Name [Specification]
1	Y	TILT SW (UPWARD)
2	LC	MIRROR SELECT SW (RH)
3	G	MIRROR SW (UPWARD)
4	Y	MIRROR SW (LEFTWARD)
5	R	MIRROR SENSOR (RH VERTICAL)
6	GR	MIRROR SENSOR (LH VERTICAL)
7	EG	TILT SENSOR
9	BR	ADDRESS 1
10	V	TX (UART)
11	GR	TELESCOPIC SW (FRONTWARD)
12	EG	IND 1
13	P	IND 2
14	W	MIRROR MOTOR (RH VERTICAL)
15	EG	MIRROR MOTOR (RH HORIZONTAL)
16	Y	MIRROR MOTOR (LH COMMON)
17	BR	TILT SW (DOWNWARD)
18	W	MIRROR SELECT SW (LH)
19	SB	MIRROR SW (DOWNWARD)
20	L	MIRROR SW (RIGHTWARD)
21	L	MIRROR SENSOR (RH HORIZONTAL)
22	B	MIRROR SENSOR (LH HORIZONTAL)
23	P	TELESCOPIC SENSOR
24	R	SET SW
25	V	ADDRESS 2
26	P	RX (UART)
27	G	TELESCOPIC SW (BACKWARD)
30	SB	MIRROR MOTOR (RH COMMON)
31	G	MIRROR MOTOR (LH VERTICAL)
32	L	MIRROR MOTOR (LH HORIZONTAL)

Connector No.	M52
Connector Name	AUTOMATIC DRIVE POSITIONER CONTROL UNIT
Connector Type	NS10FW-CS

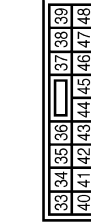

Terminal No.	Color of Wire	Signal Name [Specification]
33	W	POWER SUPPLY (SENSOR)
34	V	BAT (FUSE)
35	L	TILT MOTOR (UPWARD)
36	GR	TELESCOPIC MOTOR (FORWARD)
38	W	BAT (G/B)

40	B	GND (SIGNAL)
41	Y	GND (SENSOR)
42	EG	TILT MOTOR (DOWNWARD)
44	G	TELESCOPIC MOTOR (BACKWARD)
48	B	GND (POWER)

Connector No.	M62
Connector Name	CIRCUIT BREAKER
Connector Type	M02FW-LC



Terminal No.	Color of Wire	Signal Name [Specification]
1	L	- [With automatic drive positioner]
1	W	- [Without automatic drive positioner]
2	SB	- [With automatic drive positioner]
2	P	- [Without automatic drive positioner]

AUTOMATIC DRIVE POSITIONER CONTROL UNIT

< ECU DIAGNOSIS INFORMATION >

ECU DIAGNOSIS INFORMATION

AUTOMATIC DRIVE POSITIONER CONTROL UNIT

Reference Value

INFOID:000000006207397

TERMINAL LAYOUT

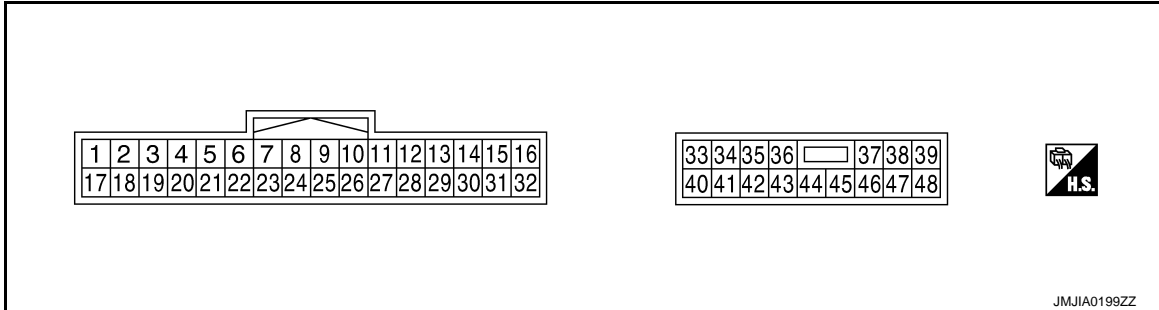

PHYSICAL VALUES

Terminal No. (Wire color)		Description		Condition		Voltage (V) (Approx.)
+	-	Signal name	Input/ Output			
1 (Y)	Ground	Tilt switch upward signal	Input	Tilt switch	Operate (upward)	0
					Other than above	5
2 (LG)	Ground	Changeover switch RH signal	Input	Changeover switch position	RH	0
					Neutral or LH	5
3 (G)	Ground	Mirror switch upward signal	Input	Mirror switch	Operated (upward)	0
					Other than above	5
4 (V)	Ground	Mirror switch leftward signal	Input	Mirror switch	Operated (leftward)	0
					Other than above	5
5 (R)	Ground	Door mirror sensor (RH) upward/downward signal	Input	Mirror face (door mirror RH)	Change between 3.4 (close to peak) 0.6 (close to valley)	
6 (GR)	Ground	Door mirror sensor (LH) upward/downward signal	Input	Mirror face (door mirror LH)	Change between 3.4 (close to peak) 0.6 (close to valley)	
7 (O)	Ground	Tilt sensor signal	Input	Tilt position	Change between 1.2 (close to top) 3.8 (close to bottom)	
9 (BR)	Ground	Memory switch 1 signal	Input	Memory switch 1	Press	0
					Other than above	5
10 (V)	Ground	UART communication (TX)	Output	Ignition switch ON		

AUTOMATIC DRIVE POSITIONER CONTROL UNIT

< ECU DIAGNOSIS INFORMATION >

Terminal No. (Wire color)		Description		Condition	Voltage (V) (Approx.)	
+	-	Signal name	Input/ Output			
11 (GR)	Ground	Telescopic switch forward signal	Input	Telescopic switch	Operate (forward)	0
					Other than above	5
12 (O)	Ground	Memory indicator 1 signal	Output	Memory indicator 1	Illuminate	1
					Other than above	Battery voltage
13 (P)	Ground	Memory indicator 2 signal	Output	Memory indicator 2	Illuminate	1
					Other than above	Battery voltage
14 (W)	Ground	Door mirror motor (RH) upward output	Output	Door mirror RH	Operate (upward)	Battery voltage
					Other than above	0
15 (O)	Ground	Door mirror motor (RH) leftward output	Output	Door mirror RH	Operate (leftward)	Battery voltage
					Other than above	0
16 (Y)	Ground	Door mirror motor (LH) downward output	Output	Door mirror (LH)	Operate (downward)	Battery voltage
					Other than above	0
		Door mirror motor (LH) rightward output			Operate (rightward)	Battery voltage
					Other than above	0
17 (BR)	Ground	Tilt switch downward signal	Input	Tilt switch	Operate (downward)	0
					Other than above	5
18 (P)	Ground	Changeover switch LH signal	Input	Changeover switch position	LH	0
					Neutral or RH	5
19 (SB)	Ground	Mirror switch downward signal	Input	Mirror switch	Operate (downward)	0
					Other than above	5
20 (BR)	Ground	Mirror switch rightward signal	Input	Mirror switch	Operate (rightward)	0
					Other than above	5
21 (L)	Ground	Door mirror sensor (RH) leftward/rightward signal	Input	Door mirror RH position	Change between 3.4 (close to left edge) 0.6 (close to right edge)	
22 (G)	Ground	Door mirror sensor (LH) leftward/rightward signal	Input	Door mirror LH position	Change between 0.6 (close to left edge) 3.4 (close to right edge)	
23 (P)	Ground	Telescopic sensor signal	Input	Telescopic position	Change between 0.8 (close to top) 4.4 (close to bottom)	

AUTOMATIC DRIVE POSITIONER CONTROL UNIT

< ECU DIAGNOSIS INFORMATION >

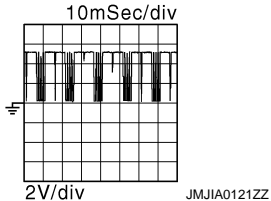
Terminal No. (Wire color)		Description		Condition	Voltage (V) (Approx.)	
+	-	Signal name	Input/ Output			
24 (R)	Ground	Set switch signal	Input	Set switch	Press	0
					Other than above	5
25 (V)	Ground	Memory switch 2 signal	Input	Memory switch 2	Press	0
					Other than above	5
26 (P)	Ground	UART communication (RX)	Input	Ignition switch ON		
27 (G)	Ground	Telescopic switch backward signal	Input	Telescopic switch	Operate (backward)	0
					Other than above	5
30 (SB)	Ground	Door mirror motor (RH) downward output	Output	Door mirror (RH)	Operate (downward)	Battery voltage
					Other than above	0
		Door mirror motor (RH) rightward output			Operate (rightward)	Battery voltage
					Other than above	0
31 (G)	Ground	Door mirror motor (LH) upward output	Output	Door mirror (LH)	Operate (upward)	Battery voltage
					Other than above	0
32 (L)	Ground	Door mirror motor (LH) leftward output	Output	Door mirror (LH)	Operate (leftward)	Battery voltage
					Other than above	0
33 (W)	Ground	Sensor power supply	Input	—	5	
34 (V)	Ground	Power source (Fuse)	Input	—	Battery voltage	
35 (L)	Ground	Tilt motor upward output	Output	Steering tilt	Operate (upward)	Battery voltage
					Other than above	0
36 (GR)	Ground	Telescopic motor forward output signal	Output	Steering telescopic	Operate (forward)	Battery voltage
					Other than above	0
39 (W)	Ground	Power source (C/B)	Input	—	Battery voltage	
40 (B)	Ground	Ground	—	—	0	

A
B
C
D
E
F
G
H
I
SE
K
L
M
N
O
P

AUTOMATIC DRIVE POSITIONER CONTROL UNIT

< ECU DIAGNOSIS INFORMATION >

Terminal No. (Wire color)		Description		Condition	Voltage (V) (Approx.)	
+	-	Signal name	Input/ Output			
41 (Y)	Ground	Sensor ground	—	—	0	
42 (O)	Ground	Tilt motor downward out- put	Output	Steering tilt	Operate (down- ward)	Battery voltage
					Other than above	0
44 (G)	Ground	Telescopic motor back- ward output	Output	Steering telescop- ic	Operate (backward)	Battery voltage
						Other than above
48 (B)	Ground	Ground	—	—	0	

AUTOMATIC DRIVE POSITIONER CONTROL UNIT

< ECU DIAGNOSIS INFORMATION >

Wiring Diagram - AUTOMATIC DRIVE POSITIONER CONTROL SYSTEM -

INFOID:000000006856844

AUTOMATIC DRIVE POSITIONER

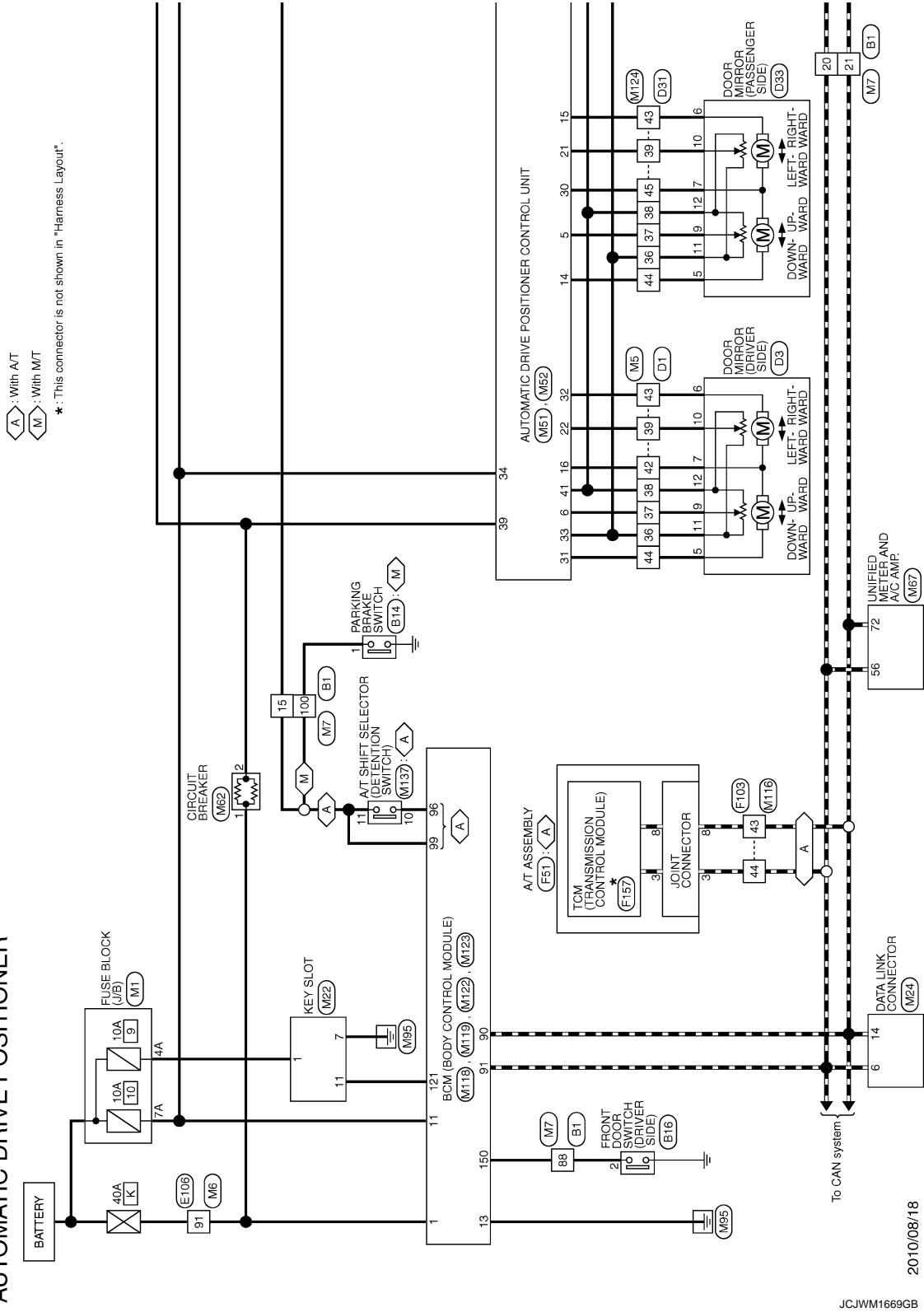

2010/08/18

JCJWM1669GB

A
B
C
D
E
F
G
H
I
SE
K
L
M
N
O
P

AUTOMATIC DRIVE POSITIONER CONTROL UNIT

< ECU DIAGNOSIS INFORMATION >

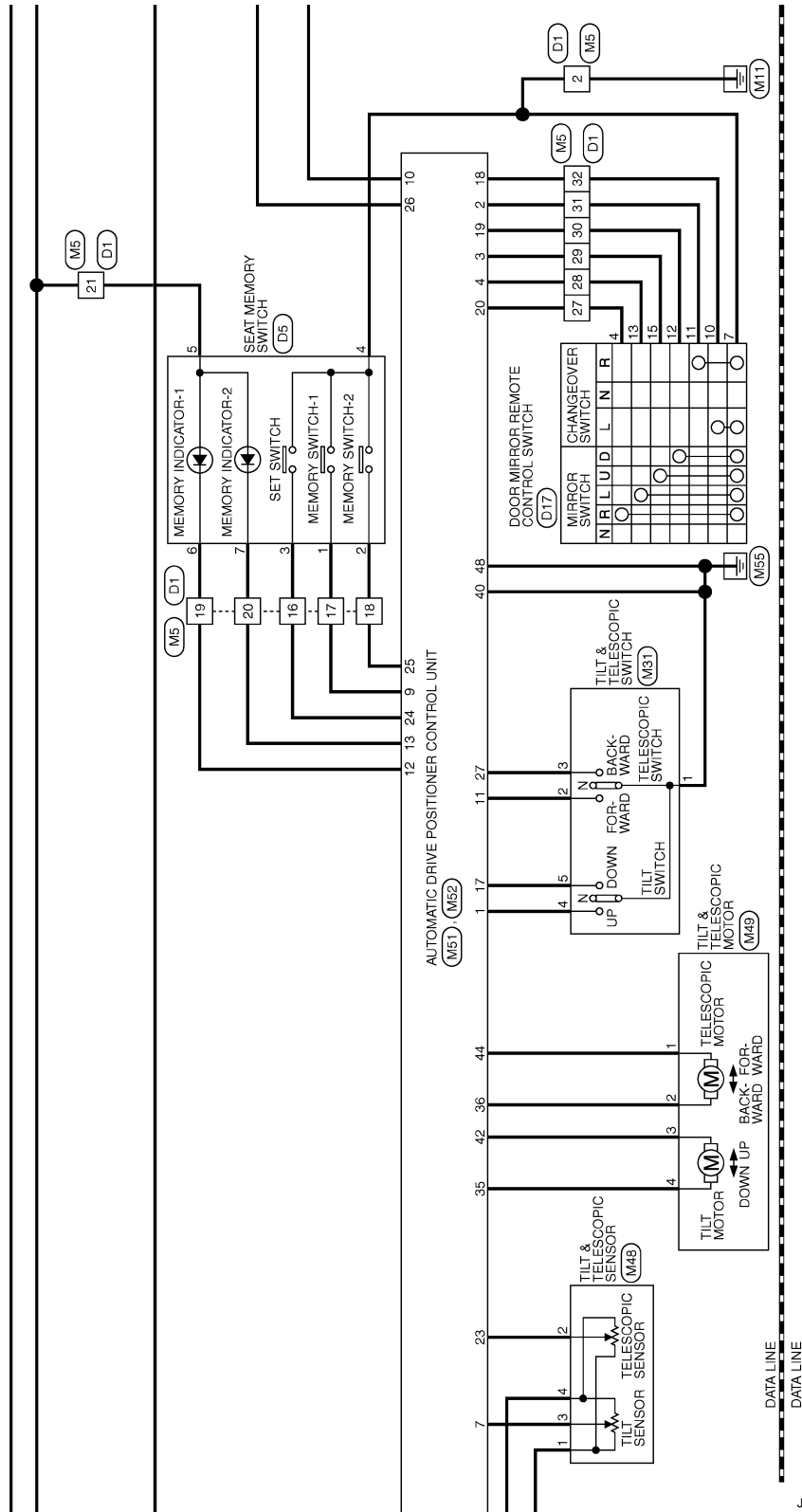

JCJWM1670GB

AUTOMATIC DRIVE POSITIONER CONTROL UNIT

< ECU DIAGNOSIS INFORMATION >

A : With A/T
M : With M/T
 * : This connector is not shown in "Harness Layout".

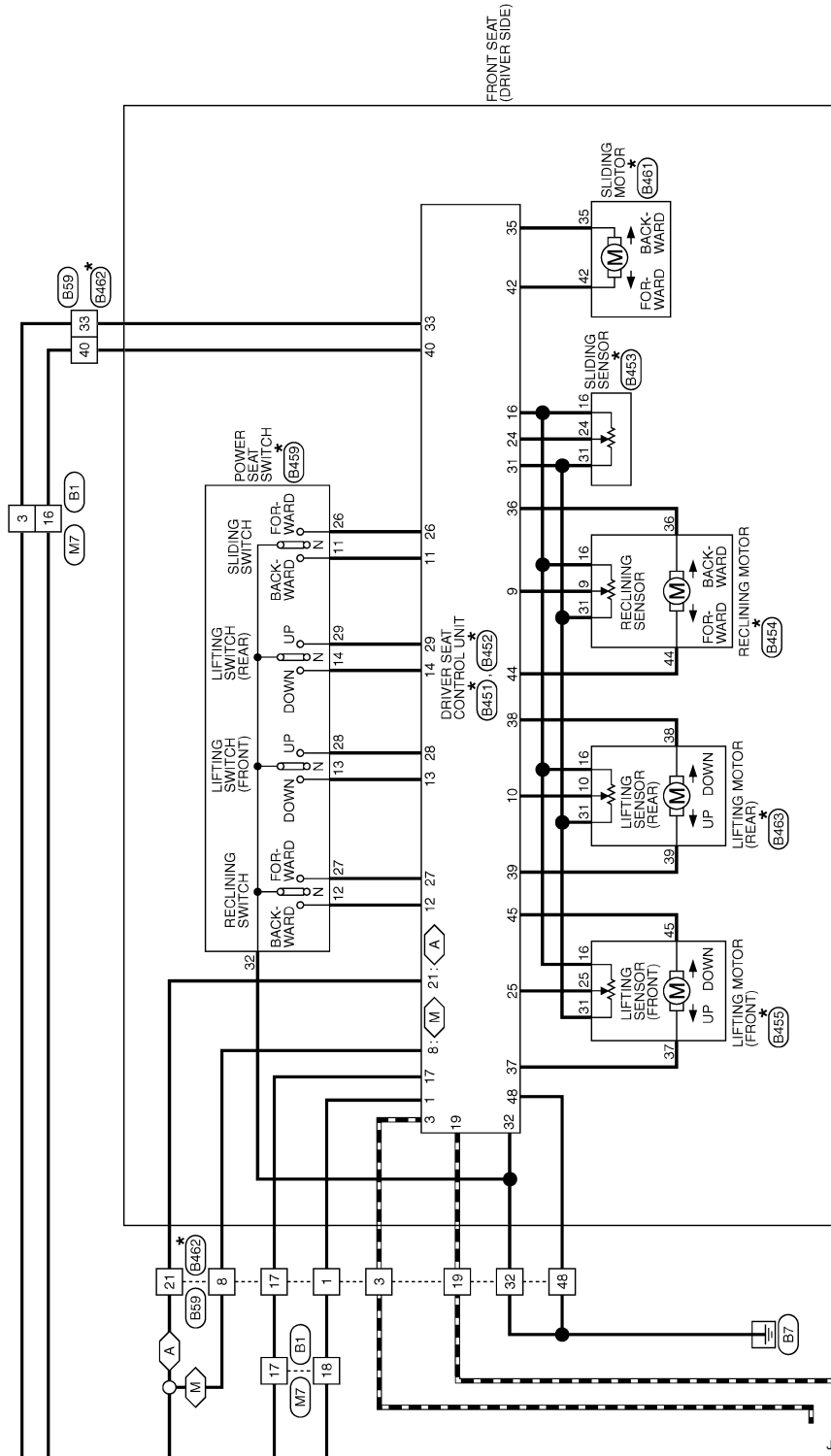

JCJWM1671GB

A
B
C
D
E
F
G
H
I
SE
K
L
M
N
O
P

AUTOMATIC DRIVE POSITIONER CONTROL UNIT

< ECU DIAGNOSIS INFORMATION >

AUTOMATIC DRIVE POSITIONER

Connector No.	B1
Connector Name	WIRE TO WIRE
Connector Type	THB07V-CS16-TM4

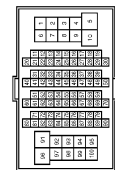

Terminal No.	Color of Wire	Signal Name [Specification]
1	GR	-
2	BG	-
3	L	-
4	Y	-
6	R	-
7	P	-
8	W	-
9	LG	- [With rear anti-pinch system]
9	GR	- [Without rear anti-pinch system]
15	Y	-
16	BR	-
17	LG	-
18	BG	-
20	L	-
21	P	-
22	L	-
23	P	-
24	V	-
25	SB	-
26	G	-
27	W	-
28	R	-
31	V	-
32	SB	-
33	SHIELD	-
34	W	-
35	BR	-
36	Y	-
37	SHIELD	-
38	Y	-
38	SB	-
40	P	-
41	L	-
42	SHIELD	-
43	R	-
44	G	-
45	SHIELD	-
46	SB	-

55	BR	-
56	R	-
58	V	-
59	SB	-
60	BR	-
61	W	-
62	R	-
63	L	-
64	Y	-
65	SHIELD	-
71	BG	-
72	GR	-
73	P	-
74	L	-
81	V	-
82	B	-
84	Y	-
85	G	-
86	W	-
87	R	-
88	BR	-
89	Y	-
90	SB	-
91	BG	-
92	BR	-
93	P	-
95	BG	-
96	Y	-
100	GR	-

Connector No.	B14
Connector Name	PARKING BRAKE SWITCH
Connector Type	PO1FB-A



Terminal No.	1	Color of Wire	GR	Signal Name [Specification]	-
--------------	---	---------------	----	-----------------------------	---

Connector No.	B16
Connector Name	FRONT DOOR SWITCH (DRIVER SIDE)
Connector Type	A03FW

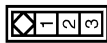

Terminal No.	2	Color of Wire	BR	Signal Name [Specification]	-
--------------	---	---------------	----	-----------------------------	---

Connector No.	B59
Connector Name	WIRE TO WIRE
Connector Type	NS18FW-CS



Terminal No.	Color of Wire	Signal Name [Specification]
1	BG	-
3	L	-
8	Y	-
17	LG	-
19	P	-
21	Y	-
21	B	-
32	L	-
33	BR	-
40	BR	-
48	B	-
67	BG	-
68	GR	-
69	R	-

Connector No.	B451
Connector Name	DRIVER SEAT CONTROL UNIT
Connector Type	TH22FW

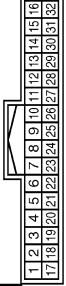

Terminal No.	Color of Wire	Signal Name [Specification]
1	L/W	RX
3	R/Y	CAN-H
8	LG	PARKING BRAKE SW
9	W/G	PULSE (RECLINING)
10	P/B	PULSE (RR LIFTING)
11	BR	SLIDING SW (BACKWARD)
12	SB	RECLINING SW (BACKWARD)
13	LG/R	FRONT LIFTING SW (DOWNWARD)
14	G/B	REAR LIFTING SW (DOWNWARD)
16	O	VCC
17	Y/R	TX
19	V	CAN-L
21	L/Y	P RANGE SW
24	R	PULSE (SLIDING)
25	Y/B	PULSE (FR LIFTING)
26	Y	SLIDING SW (FORWARD)
27	R/G	RECLINING SW (FORWARD)
28	W/B	FRONT LIFTING SW (UPWARD)
29	P/L	REAR LIFTING SW (UPWARD)
31	GR	SENSOR GND
32	B/W	GND (SIGNAL)

AUTOMATIC DRIVE POSITIONER CONTROL UNIT

< ECU DIAGNOSIS INFORMATION >

AUTOMATIC DRIVE POSITIONER

Connector No.	B462
Connector Name	DRIVER SEAT CONTROL UNIT
Connector Type	NS16FW-CS



33	34	35	36	37	38	39
40	41	42	43	44	45	46
47	48					

Terminal No.	Color of Wire	Signal Name [Specification]
33	R	BAT (C/B)
35	W/R	SLIDING MOTOR (FORWARD)
36	G/Y	RECLINING MOTOR (FORWARD)
37	G/W	FRONT LIFTING MOTOR (DOWNWARD)
38	L/Y	REAR LIFTING MOTOR (UPWARD)
38	R/B	REAR LIFTING MOTOR (BACKWARD)
40	R/W	BAT (FUSE)
42	W/B	SLIDING MOTOR (BACKWARD)
44	P	RECLINING MOTOR (BACKWARD)
45	L/R	FRONT LIFTING MOTOR (UPWARD)
48	B	GND (POWER)

Connector No.	B453
Connector Name	SLIDING SENSOR
Connector Type	8098-0241



24	31	16
----	----	----

Terminal No.	Color of Wire	Signal Name [Specification]
16	O	
24	R	
31	GR	

Connector No.	B454
Connector Name	RECLINING MOTOR
Connector Type	NS06FF-CS



36	44
16	31
9	

Terminal No.	Color of Wire	Signal Name [Specification]
9	W/G	
16	O	
31	GR	
36	G/Y	
44	P	

Connector No.	B455
Connector Name	LIFTING MOTOR (FRONT)
Connector Type	NS06FW-CS



45	37
16	31
25	

Terminal No.	Color of Wire	Signal Name [Specification]
16	O	
25	Y/B	
31	GR	
37	G/W	
45	L/R	

Connector No.	B459
Connector Name	POWER SEAT SWITCH
Connector Type	NS10FW-CS



32	14	29
12	27	11
26	13	28

Terminal No.	Color of Wire	Signal Name [Specification]
11	BR	
12	SB	
13	LG/R	
14	G/B	
26	Y	
27	R/G	
28	W/B	
29	P/L	
32	B/W	

Connector No.	B461
Connector Name	SLIDING MOTOR
Connector Type	8098-0239



42	35
----	----

Terminal No.	Color of Wire	Signal Name [Specification]
35	W/R	
42	W/B	

Connector No.	B462
Connector Name	WIRE TO WIRE
Connector Type	NS16MFL-C



19	3	1	17	40
8	69	32	48	21
				33
				68
				67

Terminal No.	Color of Wire	Signal Name [Specification]
1	L/W	
3	R/Y	
8	LG	
17	Y/R	
19	V	
21	L/Y	
32	B/W	
33	R	
40	R/W	
48	B	
67	R	
68	L	
69	BR/W	

Connector No.	B463
Connector Name	LIFTING MOTOR (REAR)
Connector Type	NS06FBR-CS



38	39
16	31
10	

Terminal No.	Color of Wire	Signal Name [Specification]
10	P/B	
16	O	
31	GR	
38	L/Y	
39	R/B	

A
B
C
D
E
F
G
H
I
SE
K
L
M
N
O
P

AUTOMATIC DRIVE POSITIONER CONTROL UNIT

< ECU DIAGNOSIS INFORMATION >

AUTOMATIC DRIVE POSITIONER

Connector No.	D1
Connector Name	WIRE TO WIRE
Connector Type	TH4DFW-CS15

Terminal No.	Color of Wire	Signal Name [Specification]
1	Y	
2	B	
3	SB	
4	V	
5	GR	
6	W	
7	BG	
8	L	
9	P	
10	LG	
11	BR	
12	L	
13	W	
14	G	
15	R	
16	GR	
17	L	
18	BR	
19	BG	
20	P	
21	R	
22	V	
23	R	
24	BR	
25	W	
26	Y	
27	LG	
28	B	
29	W	
30	G	
31	GR	
32	B	
33	W	
34	P	
35	V	
36	BR	
37	G	
38	GR	
39	B	
40	R	
41	W	
42	G	
43	GR	
44	BG	
45	V	

48	R	-
49	SB	-
50	W	-
51	P	-
52	V	-

Connector No.	D3
Connector Name	DOOR MIRROR (DRIVER SIDE)
Connector Type	TH12MW-NH

Terminal No.	Color of Wire	Signal Name [Specification]
1	Y	
2	B	
3	SB	
4	V	
5	GR	
6	W	
7	BG	
8	L	
9	P	
10	LG	
11	BR	
12	L	
13	W	
14	G	
15	R	
16	GR	
17	L	
18	BR	
19	BG	
20	P	
21	R	
22	V	

Connector No.	D5
Connector Name	SEAT MEMORY SWITCH
Connector Type	AB8FW

Terminal No.	Color of Wire	Signal Name [Specification]
1	L	
2	BR	
3	GR	
4	B	
5	R	
6	BG	

7	P	-
---	---	---

Connector No.	D17
Connector Name	DOOR MIRROR REMOTE CONTROL SWITCH
Connector Type	TK10FBR

Terminal No.	Color of Wire	Signal Name [Specification]
4	BR	
7	B	
8	B	
9	R	
10	GR	
11	LG	
12	G	
13	W	
15	Y	

Connector No.	D31
Connector Name	WIRE TO WIRE
Connector Type	TH4DFW-CS15

Terminal No.	Color of Wire	Signal Name [Specification]
1	Y	
2	V	
3	B	
7	LG	
8	P	
10	L	
11	W	
12	G	
13	R	
38	W	

37	P	-
38	V	-
39	BR	-
42	L	-
43	GR	-
44	BG	-
45	G	-
47	R	-
48	SB	-
49	W	-
50	P	-
51	V	-
52	GR	-
53	BG	-
54	G	-

Connector No.	D33
Connector Name	DOOR MIRROR (PASSENGER SIDE)
Connector Type	TH12MW-NH

Terminal No.	Color of Wire	Signal Name [Specification]
4	L	
5	BG	
6	GR	
7	G	
8	B	
9	P	
10	BR	
11	W	
12	V	

AUTOMATIC DRIVE POSITIONER CONTROL UNIT

< ECU DIAGNOSIS INFORMATION >

AUTOMATIC DRIVE POSITIONER

Connector No.	E106
Connector Name	WIRE TO WIRE
Connector Type	TH80PW-CS16-TM4

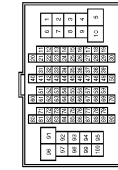

Terminal No.	Color of Wire	Signal Name [Specification]
1	GR	
3	EG	
5	G	
6	Y	
7	V	
8	R	
10	W	
11	V	
12	R	
13	L	
14	GR	
15	P	
16	W	
17	SB	
18	BG	
19	SB	
20	LG	
30	BR	
31	L	
32	BG	
33	P	
34	V	
35	W	
36	SB	
37	Y	
38	R	
39	B	
40	G	
41	R	
42	LG	
43	G	
44	GR	
45	BR	
46	LG	
47	V	
48	P	
49	L	
58	B	

66	GR	
67	LG	
68	SB	
69	P	
70	G	
80	R	
81	P	
82	G	
83	V	
84	L	
85	W	
86	L	
87	BR	
88	GR	
89	V	
91	W	
93	GR	
95	LG	
97	SB	
98	SHIELD	
99	L	
100	P	

Connector No.	FS1
Connector Name	A/T ASSEMBLY
Connector Type	RK1DFG-DGY

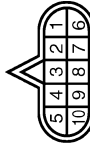

Terminal No.	Color of Wire	Signal Name [Specification]
1	Y	
2	GR	- [With VQ25HR engine]
3	L	- [With VQ37VHR engine]
4	V	
5	B	
6	Y	- [With VQ25HR engine]
6	G	- [With VQ37VHR engine]
7	R	
8	P	
9	GR	
10	B	

Connector No.	F103
Connector Name	WIRE TO WIRE
Connector Type	TK38FW-NS10

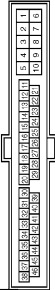

Terminal No.	Color of Wire	Signal Name [Specification]
2	G	
3	W	
4	R	
5	B	
9	G	- [With VQ25HR engine]
9	Y	- [With VQ37VHR engine]
10	L	- [With VQ25HR engine]
10	GR	- [With VQ37VHR engine]
19	BG	
20	Y	
28	B	
29	LG	
30	R	
31	R	
33	B	
34	B	
35	L	
36	P	
37	Y	
38	G	
41	O	
42	BR	
43	P	
44	L	
45	G	- [With VQ25HR engine]
45	V	- [With VQ37VHR engine]

Connector No.	F157
Connector Name	TOM (TRANSMISSION CONTROL MODULE)
Connector Type	SP10FG

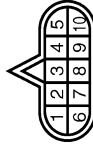

Terminal No.	Color of Wire	Signal Name [Specification]
1	-	VIGN
2	-	BAIT
3	-	GAN-H
4	-	K-LINE
5	-	GND
6	-	VIGN
7	-	REV LAMP RLY
8	-	CAV-L
9	-	STARTER RLY
10	-	GND

Connector No.	M1
Connector Name	FUSE BLOCK (J/B)
Connector Type	NS30FW-M2



Terminal No.	Color of Wire	Signal Name [Specification]
1A	V	
2A	G	
3A	L	
4A	P	
5A	L	
6A	Y	
7A	R	
8A	L	

A
B
C
D
E
F
G
H
I
SE
K
L
M
N
O
P

AUTOMATIC DRIVE POSITIONER CONTROL UNIT

< ECU DIAGNOSIS INFORMATION >

AUTOMATIC DRIVE POSITIONER

Connector No.	M5
Connector Name	WIRE TO WIRE
Connector Type	TH80MW-CS15

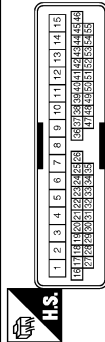

Terminal No.	Color of Wire	Signal Name [Specification]
1	Y	-
2	B	-
3	BG	-
4	V	-
5	G	-
6	W	-
7	LG	-
8	SB	-
9	G	-
10	V	-
11	SB	-
12	L	-
13	W	-
14	B	-
15	W	-
16	R	-
17	BR	-
18	V	-
19	BG	-
20	P	-
21	W	-
22	Y	-
23	G	-
24	L	-
25	Y	-
26	G	-
27	L	-
28	Y	-
29	G	-
30	SB	-
31	LG	-
32	W	-
33	B	-
36	W	-
37	GR	-
38	Y	-
39	B	-
42	Y	-
43	L	-
44	G	- [With automatic drive positioner] - [Without automatic drive positioner]
44	L	-

47	L	-	-
48	GR	-	-
49	SB	-	-
50	P	-	-
51	LG	-	-
52	V	-	-

Connector No.	M6
Connector Name	WIRE TO WIRE
Connector Type	TH80MW-CS16-TM4



Terminal No.	Color of Wire	Signal Name [Specification]
1	BG	-
3	R	-
5	G	-
6	LG	-
7	W	-
9	G	-
10	W	-
11	V	-
12	R	-
13	L	-
14	GR	-
15	P	-
16	W	-
17	BR	-
18	P	-
19	L	-
20	L	-
30	BR	-
31	L	-
32	Y	-
33	BG	-
34	W	-
35	BR	-
36	R	-
37	Y	-
38	R	-
39	SB	-
40	G	-
41	V	-
42	LG	-

43	P	-	-
44	B	-	- [With A/T] - [With M/T]
44	R	-	- [With M/T]
45	BG	-	-
46	G	-	-
47	L	-	-
48	P	-	-
49	L	-	-
59	B	-	-
66	Y	-	-
67	G	-	-
68	R	-	-
69	W	-	-
70	G	-	-
80	SB	-	-
81	B	-	-
82	V	-	-
83	W	-	-
84	L	-	-
85	GR	-	-
86	G	-	-
87	R	-	-
88	B	-	-
89	LG	-	-
91	W	-	-
93	Y	-	-
95	Y	-	-
97	GR	-	-
98	SHIELD	-	-
99	V	-	-
100	SB	-	-

AUTOMATIC DRIVE POSITIONER CONTROL UNIT

< ECU DIAGNOSIS INFORMATION >

AUTOMATIC DRIVE POSITIONER

Connector No.	M7
Connector Name	WIRE TO WIRE
Connector Type	TH80MW-CS (P-TM4)

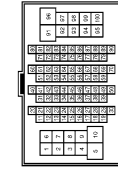

Terminal No.	Color of Wire	Signal Name [Specification]
1	GR	-
2	P	-
3	SB	- [With automatic drive positioner]
3	P	- [Without automatic drive positioner]
4	Y	-
6	L	-
7	W	-
8	G	- [With rear anti-pinch system]
8	Y	- [Without rear anti-pinch system]
9	Y	- [With rear anti-pinch system]
9	G	- [Without rear anti-pinch system]
15	R	-
16	BR	-
17	P	-
18	V	-
20	L	-
21	P	-
22	L	-
23	P	-
24	V	-
25	LG	-
26	BR	-
27	EG	-
28	LG	-
31	V	-
32	LG	-
33	SHIELD	-
34	GR	-
35	BR	-
36	Y	-
37	SHIELD	-
38	SB	-
39	LG	-
40	O	-
41	W	-
42	SHIELD	-
43	R	-
44	G	-

45	SHIELD	-
46	SB	-
55	W	-
56	B	-
58	V	-
59	Y	-
60	W	-
61	R	-
62	G	-
63	G	-
64	B	-
65	SHIELD	-
71	V	-
72	P	-
73	SB	-
74	V	-
81	W	-
82	BR	-
84	LG	-
85	EG	-
86	SB	-
87	G	-
88	GR	-
89	L	-
90	P	-
91	EG	-
92	L	-
93	P	-
95	EG	-
96	Y	-
100	P	-

Connector No.	M22
Connector Name	KEY SLOT
Connector Type	TH12FW-HH

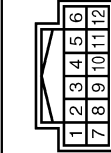

Terminal No.	Color of Wire	Signal Name [Specification]
1	R	BAT
2	GR	GLOCK
3	W	DATA
5	Y	ILL BAT
6	LG	ILL

7	B	GND
11	SB	KEY SWITCH SIGNAL

Connector No.	M24
Connector Name	DATA LINK CONNECTOR
Connector Type	BD16FW-P

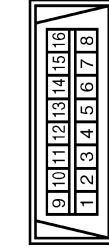

Terminal No.	Color of Wire	Signal Name [Specification]
3	LG	-
4	B	-
5	B	-
6	L	-
7	V	-
8	G	-
11	SB	-
14	P	-
16	R	-

Connector No.	M31
Connector Name	TILT & TELESCOPIC SWITCH
Connector Type	TK08FGY

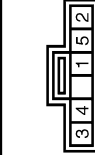

Terminal No.	Color of Wire	Signal Name [Specification]
1	B	-
2	GR	-
3	G	-
4	Y	-
5	BR	-

Connector No.	M48
Connector Name	TILT & TELESCOPIC SENSOR
Connector Type	TK03FW



Terminal No.	Color of Wire	Signal Name [Specification]
1	W	-
2	P	-
3	EG	-
4	Y	-

Connector No.	M49
Connector Name	TILT & TELESCOPIC MOTOR
Connector Type	INS04FW-CS



Terminal No.	Color of Wire	Signal Name [Specification]
1	G	-
2	GR	-
3	EG	-
4	L	-

A
B
C
D
E
F
G
H
I
SE
K
L
M
N
O
P

JCJWM1677GB

AUTOMATIC DRIVE POSITIONER CONTROL UNIT

< ECU DIAGNOSIS INFORMATION >

AUTOMATIC DRIVE POSITIONER

Connector No.	M51
Connector Name	AUTOMATIC DRIVE POSITIONER CONTROL UNIT
Connector Type	TH2FW-NH

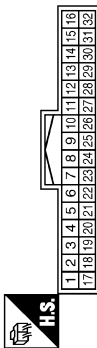

Terminal No.	Color of Wire	Signal Name [Specification]
1	Y	TILT SW (UPWARD)
2	LG	MIRROR SELECT SW (RH)
3	G	MIRROR SW (UPWARD)
4	Y	MIRROR SW (LEFTWARD)
5	R	MIRROR SENSOR (RH VERTICAL)
6	GR	MIRROR SENSOR (LH VERTICAL)
7	BG	TILT SENSOR
8	BR	ADDRESS 1
9	V	TX (UART)
10	GR	TELESCOPIC SW (FRONTWARD)
11	BG	IND 1
12	P	IND 2
13	P	MIRROR MOTOR (RH VERTICAL)
14	W	MIRROR MOTOR (RH HORIZONTAL)
15	BG	MIRROR MOTOR (RH COMMON)
16	Y	MIRROR MOTOR (LH COMMON)
17	BR	TILT SW (DOWNWARD)
18	W	MIRROR SELECT SW (LH)
19	SB	MIRROR SW (DOWNWARD)
20	L	MIRROR SW (RIGHTWARD)
21	L	MIRROR SENSOR (RH HORIZONTAL)
22	B	MIRROR SENSOR (LH HORIZONTAL)
23	P	TELESCOPIC SENSOR
24	R	SET SW
25	V	ADDRESS 2
26	P	RX (UART)
27	G	TELESCOPIC SW (BACKWARD)
30	SB	MIRROR MOTOR (RH COMMON)
31	G	MIRROR MOTOR (LH VERTICAL)
32	L	MIRROR MOTOR (LH HORIZONTAL)

Connector No.	M52
Connector Name	AUTOMATIC DRIVE POSITIONER CONTROL UNIT
Connector Type	NS16FW-CS

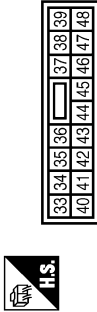

Terminal No.	Color of Wire	Signal Name [Specification]
33	W	POWER SUPPLY (SENSOR)
34	L	BAT (FUSE)
35	L	TILT MOTOR (UPWARD)
36	GR	TELESCOPIC MOTOR (FORWARD)
38	W	BAT (C/B)
40	B	GND (SIGNAL)
41	Y	GND (SENSOR)
42	BG	TILT MOTOR (DOWNWARD)
44	G	TELESCOPIC MOTOR (BACKWARD)
48	B	GND (POWER)

Connector No.	M62
Connector Name	CIRCUIT BREAKER
Connector Type	M02FW-LC



Terminal No.	Color of Wire	Signal Name [Specification]
1	L	- [With automatic drive positioner]
1	W	- [Without automatic drive positioner]
2	SB	- [With automatic drive positioner]
2	P	- [Without automatic drive positioner]

Connector No.	M67
Connector Name	UNIFIED METER AND A/C AMP.
Connector Type	TH2FW-NH

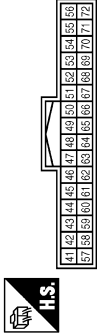

Terminal No.	Color of Wire	Signal Name [Specification]
41	L	ACC POWER SUPPLY
42	BR	FUEL LEVEL SENSOR SIGNAL
43	BR	INTAKE SENSOR SIGNAL
44	LG	IN-VEHICLE SENSOR SIGNAL
45	V	AMBIENT SENSOR SIGNAL
46	Y	SUNLOAD SENSOR SIGNAL
47	G	FANBLAST MOTOR (FORWARD) SENSOR SIGNAL
53	W	IGNITION POWER SUPPLY
54	SB	BATTERY POWER SUPPLY
55	B	GROUND
56	L	CAN-H
57	LG	BRAKE FLUID LEVEL SWITCH
58	Y	FUEL LEVEL SENSOR GROUND
59	GR	INTAKE SENSOR GROUND
60	W	IN-VEHICLE SENSOR GROUND
61	B	AMBIENT SENSOR GROUND
62	SB	SUNLOAD SENSOR GROUND
63	L	ION CONTROL MODE OUTPUT SIGNAL
65	BG	ECV SIGNAL
69	P	A/C LAN SIGNAL
70	R	EACH DOOR MOTOR POWER SUPPLY
71	GR	GROUND
72	P	CAN-L

Connector No.	M116
Connector Name	WIRE TO WIRE
Connector Type	TK38MW-NS10

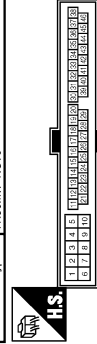

Terminal No.	Color of Wire	Signal Name [Specification]
2	W	-
3	BG	-
4	P	-
5	B	-
9	R	-
10	R	-
19	BG	-
20	Y	-
28	B	-
29	LG	-
30	LG	-
31	W	-
33	B	-
34	B	-
35	L	-
36	P	-
37	R	-
38	SB	-
41	BG	-
42	G	-
43	P	-
44	L	-
45	Y	-
46	SB	-

Connector No.	M118
Connector Name	ECM (BODY CONTROL MODULE)
Connector Type	M03FB-LC

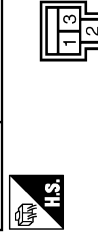

Terminal No.	Color of Wire	Signal Name [Specification]
1	W	BAT (F/L)
2	Y	POWER WINDOW POWER SUPPLY (BAT)
3	BG	POWER WINDOW POWER SUPPLY (RAP)

AUTOMATIC DRIVE POSITIONER CONTROL UNIT

< ECU DIAGNOSIS INFORMATION >

AUTOMATIC DRIVE POSITIONER

Connector No.	M119
Connector Name	BCM (BODY CONTROL MODULE)
Connector Type	MS16FW-CS



4	5	6	7	8	9	10		
11	12	13	14	15	16	17	18	19

Terminal No.	Color of Wire	Signal Name [Specification]
4	LG	INTERIOR ROOM LAMP POWER SUPPLY
5	P	PASSENGER DOOR UNLOCK OUTPUT
7	SB	STEP LAMP OUTPUT
8	V	ALL DOOR FUEL LID LOCK OUTPUT
9	G	DRIVER DOOR FUEL LID UNLOCK OUTPUT
10	P	REAR DOOR UNLOCK OUTPUT
11	R	BAT.(PUSE)
13	B	GND
14	W	PUSH-BUTTON IGNITION SW ILL GND
15	EG	ACC IND
17	W	TURN SIGNAL RH (FRONT)
18	EG	TURN SIGNAL LH (FRONT)
19	V	INT ROOM LAMP CONT

Connector No.	M122
Connector Name	BCM (BODY CONTROL MODULE)
Connector Type	TH40FB-NH



1	2	3	4	5	6	7	8	9	10	11	12	13	14	15	16	17	18	19																						
20	21	22	23	24	25	26	27	28	29	30	31	32	33	34	35	36	37	38	39	40	41	42	43	44	45	46	47	48	49	50	51	52	53	54	55	56	57	58	59	60

Terminal No.	Color of Wire	Signal Name [Specification]
72	R	ROOM ANT 2-
73	G	ROOM ANT 2+
74	SB	PASSENGER DOOR ANT-
75	BR	PASSENGER DOOR ANT+
76	V	DRIVER DOOR ANT-
77	LG	DRIVER DOOR ANT+
78	Y	ROOM ANT 1-
79	BR	ROOM ANT 1+
80	GR	MATS ANT AMP

81	W	MATS ANT AMP
82	SB	IGN RELAY (E/B) CONT
83	Y	KEYLESS ENTRY RECEIVER COMMI
87	Y	COMBI SW INPUT 3
88	EG	COMBI SW INPUT 3
89	BR	PUSH SW
90	P	CAN-L
91	L	CAN-H
92	LG	KEY SLOT ILL
93	GR	ON IND
95	EG	ACC RELAY CONT
96	GR	A/T SHIFT SELECTOR POWER SUPPLY
97	L	S/L CONDITION 1
98	P	S/L CONDITION 2
99	R	SHIFT P (Wth A/T)
99	BR	ASGD CLUTCH SW (Wth M/T)
100	Y	PASSENGER DOOR REQUEST SW
101	P	DRIVER DOOR REQUEST SW
102	EG	BLOWER FAN MOTOR RELAY CONT
103	P	KEYLESS ENTRY RECEIVER POWER SUPPLY
106	SB	S/L UNIT POWER SUPPLY
107	LG	COMBI SW INPUT 1
108	R	COMBI SW INPUT 4
109	W	COMBI SW INPUT 2
110	G	HAZARD SW
111	Y	S/L UNIT COMMI

Connector No.	M123
Connector Name	BCM (BODY CONTROL MODULE)
Connector Type	TH40FC-NH



1	2	3	4	5	6	7	8	9	10	11	12	13	14	15	16	17	18	19	20	21	22	23	24	25	26	27	28	29	30	31	32	33	34	35	36	37	38	39	40	41	42	43	44	45	46	47	48	49	50	51	52	53	54	55	56	57	58	59	60
---	---	---	---	---	---	---	---	---	----	----	----	----	----	----	----	----	----	----	----	----	----	----	----	----	----	----	----	----	----	----	----	----	----	----	----	----	----	----	----	----	----	----	----	----	----	----	----	----	----	----	----	----	----	----	----	----	----	----	----

Terminal No.	Color of Wire	Signal Name [Specification]
112	R	RAIN SENSOR SERIAL LINK
113	EG	OPTICAL SENSOR
114	R	CLUTCH INTERLOCK SW
116	SB	STOP LAMP SW 1
118	BR	STOP LAMP SW 2
119	SB	DR DOOR UNLOCK SENSOR
121	SB	KEY SLOT SW
123	V	IGN/F/B
124	R	PASSENGER DOOR SW
129	EG	TRUNK LID OPERER CANCEL SW

132	V	POWER WINDOW SW COMMI
133	L	PUSH-BUTTON IGNITION SW ILL POWER
134	LG	LOCK IND
137	EG	RECEIVER SENSOR GND
138	V	RECEIVER SENSOR POWER SUPPLY
139	L	TIRE PRESSURE RECEIVER COMMI
140	B	SHIFT IN/P
141	W	SECURITY INDICATOR LAMP
142	BR	COMBI SW OUTPUT 5
143	P	COMBI SW OUTPUT 1
144	G	COMBI SW OUTPUT 2
145	L	COMBI SW OUTPUT 3
146	SB	COMBI SW OUTPUT 4
150	GR	DRIVER DOOR SW
151	G	REAR WINDOW DEFOGGER RELAY CONT

Connector No.	M124
Connector Name	WIRE TO WIRE
Connector Type	TH40MW-CS15



1	2	3	4	5	6	7	8	9	10	11	12	13	14	15	16	17	18	19	20	21	22	23	24	25	26	27	28	29	30	31	32	33	34	35	36	37	38	39	40	41	42	43	44	45	46	47	48	49	50	51	52	53	54	55	56	57	58	59	60
---	---	---	---	---	---	---	---	---	----	----	----	----	----	----	----	----	----	----	----	----	----	----	----	----	----	----	----	----	----	----	----	----	----	----	----	----	----	----	----	----	----	----	----	----	----	----	----	----	----	----	----	----	----	----	----	----	----	----	----

Terminal No.	Color of Wire	Signal Name [Specification]
1	W	
2	GR	
3	B	
7	V	
8	B	
10	BR	
11	R	
12	G	
13	R	
38	G	
37	R	
38	GR	
39	L	
42	BG	
43	BG	
44	W	
45	SB	
47	LG	
48	P	
49	Y	
50	BR	

51	SB	
52	L	
53	L	
54	Y	

Connector No.	M137
Connector Name	A/T SHIFT SELECTOR
Connector Type	TH12FW-NH



1	2	3	4	5	6
7	8	9	10	11	12

Terminal No.	Color of Wire	Signal Name [Specification]
1	W	
2	V	
3	L	
4	B	
5	G	
7	Y	
8	LG	
9	B	
10	GR	
11	R	

HEATED SEAT CONTROL UNIT

< ECU DIAGNOSIS INFORMATION >

HEATED SEAT CONTROL UNIT DRIVER SIDE

DRIVER SIDE : Reference Value

INFOID:000000006207399

TERMINAL LAYOUT

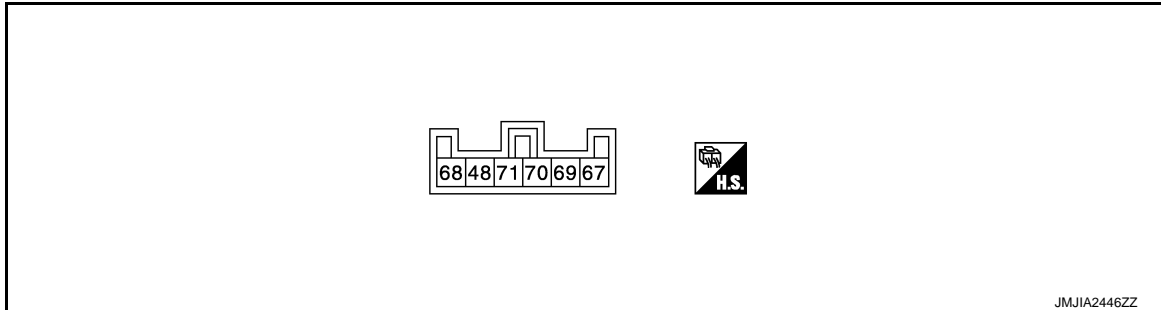

PHYSICAL VALUES

Terminal No. (Wire color)		Description		Condition		Voltage (V) (Approx.)
(+)	(-)	Signal name	Input/ Output			
48 (B)	Ground	Ground	-	Ignition switch ON		0
67 (R)	Ground	IGN power supply	Input	Ignition switch	OFF or ACC	0
					ON	Battery voltage
68 (L)* ¹ (L/W)* ²	Ground	Heated seat switch signal	Input	Heated seat switch	OFF	0
					1 (Min. temperature)	12.24
					2	12.33
					3	12.49
					4	12.63
					5	12.76
69 (BR/W)* ¹ (R/W)* ²	Ground	Heated seat operation signal	Input	Heated seat	Operate	Battery voltage
					Other than above	0
70 (L/W)* ¹ (R/L)* ²	Ground	Heater unit power supply	Output	Heated seat	Operate	0 – Battery voltage*
					Other than above	0
71 (R/B)	Ground	Heat sensor signal	Input	Heated seat switch	OFF	0
					1 (Min. temperature)	10.87 – 11.02*
					2	10.93 – 11.07*
					3	11.04 – 11.17*
					4	11.13 – 11.26*
					5	11.22 – 11.34*
		6 (Max. temperature)	11.31 – 11.43*			

*: Voltage is repeated within the value shown as per the following list depending on heater unit temperature.

*¹: With automatic drive positioner

*²: Without automatic drive positioner

HEATED SEAT CONTROL UNIT

< ECU DIAGNOSIS INFORMATION >

DRIVER SIDE : Wiring Diagram - HEATED SEAT SYSTEM (WITH M/T) - INFOID:000000006207400

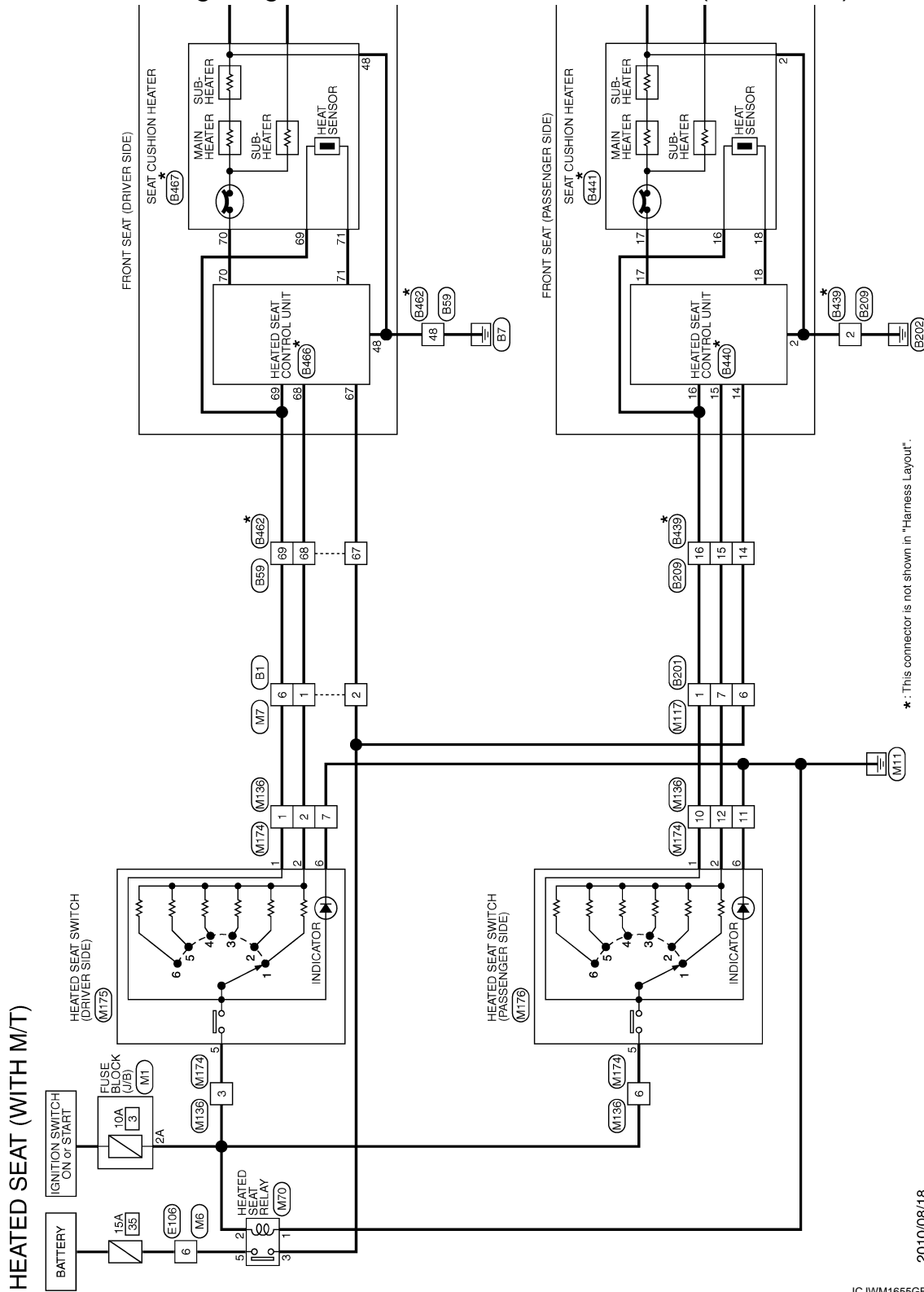

A
B
C
D
E
F
G
H
I
SE
K
L
M
N
O
P

HEATED SEAT CONTROL UNIT

< ECU DIAGNOSIS INFORMATION >

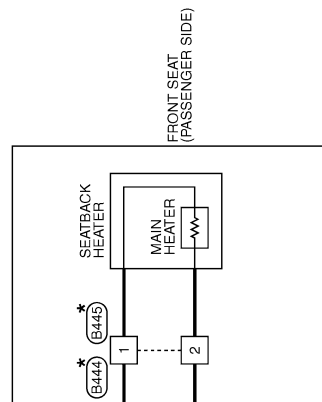
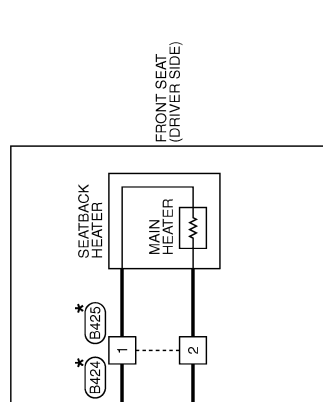

*: This connector is not shown in "Harness Layout".

JCJWM1656GB

HEATED SEAT CONTROL UNIT

< ECU DIAGNOSIS INFORMATION >

HEATED SEAT (WITH M/T)

Connector No.	B1
Connector Name	WIRE TO WIRE
Connector Type	TH80FW-CS16-TM4

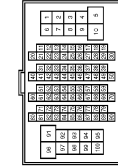

Terminal No.	Color of Wire	Signal Name [Specification]
1	GR	-
2	EG	-
3	L	-
4	Y	-
6	R	-
7	P	-
8	W	-
9	LG	- [With rear anti-pinch system] - [Without rear anti-pinch system]
15	Y	-
16	BR	-
17	LG	-
18	BG	-
20	L	-
21	P	-
22	L	-
23	P	-
24	V	-
25	SB	-
26	G	-
27	W	-
28	R	-
31	V	-
32	SB	-
33	SHIELD	-
34	W	-
35	BR	-
36	Y	-
37	SHIELD	-
38	Y	-
39	SB	-
40	P	-
41	L	-
42	SHIELD	-
43	R	-
44	G	-
45	SHIELD	-
46	SB	-

55	BR	-
56	P	-
58	V	-
59	SB	-
60	BR	-
61	W	-
62	R	-
63	L	-
64	Y	-
65	SHIELD	-
71	BG	-
72	GR	-
73	P	-
74	L	-
81	V	-
82	B	-
84	Y	-
85	G	-
86	W	-
87	R	-
88	BR	-
89	Y	-
90	SB	-
91	EG	-
92	BR	-
93	P	-
95	BG	-
96	Y	-
100	GR	-

Connector No.	B59
Connector Name	WIRE TO WIRE
Connector Type	NS10FW-CS



Terminal No.	Color of Wire	Signal Name [Specification]
1	BG	-
3	L	-
8	Y	-
17	LG	-
19	P	-
21	Y	-
32	B	-

33	L	-
40	BR	-
48	B	-
67	BG	-
68	GR	-
69	R	-

Connector No.	B201
Connector Name	WIRE TO WIRE
Connector Type	TH80FW-CS16-TM4

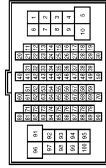

Terminal No.	Color of Wire	Signal Name [Specification]
1	BR	-
3	W	-
5	P	-
6	L	-
7	V	-
9	LG	-
10	L	-
31	L	-
32	P	-
33	G	-
34	R	-
40	GR	-
41	LG	-
42	BG	-
43	R	-
45	G	-
46	SHIELD	-
47	G	-
48	Y	-
49	SHIELD	-
50	W	-
71	R	-
72	V	-
80	BG	-
81	SHIELD	-
82	G	-
83	P	-
84	L	-
85	SHIELD	-
86	G	-

87	R	-
88	W	-
89	B	-
90	Y	-
91	V	-
92	W	- [With rear anti-pinch system] - [Without rear anti-pinch system]
93	BG	- [With rear anti-pinch system] - [Without rear anti-pinch system]
93	BR	- [Without rear anti-pinch system]
94	R	-
95	SB	-
96	G	-
97	GR	-
98	BR	-
99	P	-
100	L	-

Connector No.	B209
Connector Name	WIRE TO WIRE
Connector Type	MB8FW-LC



Terminal No.	Color of Wire	Signal Name [Specification]
1	R	-
2	B	-
14	L	-
15	V	-
16	BR	-

JCJWM1657GB

A
B
C
D
E
F
G
H
I
SE
K
L
M
N
O
P

HEATED SEAT CONTROL UNIT

< ECU DIAGNOSIS INFORMATION >

HEATED SEAT (WITH M/T)

Connector No.	B424
Connector Name	WIRE TO WIRE
Connector Type	MO2FW-LC



Terminal No.	Color of Wire	Signal Name [Specification]
1	-	-
2	-	-

Connector No.	B425
Connector Name	WIRE TO WIRE
Connector Type	MO2MW-LC



Terminal No.	Color of Wire	Signal Name [Specification]
1	-	-
2	-	-

Connector No.	B429
Connector Name	WIRE TO WIRE
Connector Type	MO3MW-LC



Terminal No.	Color of Wire	Signal Name [Specification]
1	R	-
2	B	-

Terminal No.	Color of Wire	Signal Name [Specification]
14	R	-
15	L/W	-
16	R/W	-

Connector No.	B440
Connector Name	HEATED SEAT CONTROL UNIT
Connector Type	174923-1



Terminal No.	Color of Wire	Signal Name [Specification]
2	B	GND
14	R	HEATER (-)
15	L/W	HEATER SW
16	R/W	THERMISTOR INPUT
17	R/L	HEATER (+)
18	R/B	THERMISTOR OUTPUT

Connector No.	B441
Connector Name	SEAT CUSHION HEATER
Connector Type	SO4FW



Terminal No.	Color of Wire	Signal Name [Specification]
2	B	-
16	R/W	-
17	R/L	-
18	R/B	-

Connector No.	B444
Connector Name	WIRE TO WIRE
Connector Type	MO2FW-LC



Terminal No.	Color of Wire	Signal Name [Specification]
1	-	-
2	-	-

Connector No.	B445
Connector Name	WIRE TO WIRE
Connector Type	MO2MW-LC



Terminal No.	Color of Wire	Signal Name [Specification]
1	-	-
2	-	-

Connector No.	B462
Connector Name	WIRE TO WIRE
Connector Type	MS16MW-LC



Terminal No.	Color of Wire	Signal Name [Specification]
1	L/W	-
3	R/Y	-

Terminal No.	Color of Wire	Signal Name [Specification]
8	LG	-
17	Y/R	-
19	V	-
21	L/Y	-
32	B/W	-
33	R	-
40	R/W	-
48	B	-
67	R	-
68	L	-
69	BR/W	-

Connector No.	B466
Connector Name	HEATED SEAT CONTROL UNIT
Connector Type	174923-1



Terminal No.	Color of Wire	Signal Name [Specification]
48	B	GND
67	R	HEATER (+)
68	L	HEATER SW [With automatic drive positioned]
69	BR/W	HEATER SW [Without automatic drive positioned]
70	R/W	THERMISTOR INPUT [With automatic drive positioned]
71	L/W	THERMISTOR INPUT [Without automatic drive positioned]
70	R/L	HEATER (-) [With automatic drive positioned]
71	R/B	HEATER (-) [Without automatic drive positioned]

JCJWM1658GB

HEATED SEAT CONTROL UNIT

< ECU DIAGNOSIS INFORMATION >

HEATED SEAT (WITH M/T)

Connector No.	E106
Connector Name	SEAT CUSHION HEATER
Connector Type	TH80FW



Terminal No.	Color of Wire	Signal Name [Specification]
48	B	-
69	BR/W	- [With automatic drive positioner]
70	R/W	- [Without automatic drive positioner]
71	R/B	- [With automatic drive positioner]
		- [Without automatic drive positioner]

Connector No.	E106
Connector Name	WIRE TO WIRE
Connector Type	TH80FW-CS16-TM4

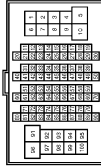

Terminal No.	Color of Wire	Signal Name [Specification]
1	GR	-
3	EG	-
5	G	-
6	Y	-
7	V	-
9	R	-
10	W	-
11	V	-
12	R	-
13	L	-
14	GR	-
15	P	-
16	W	-
17	SB	-
18	SB	-

20	LG	-
30	BR	-
31	L	-
32	EG	-
33	P	-
34	V	-
35	W	-
36	SB	-
37	Y	-
38	R	-
39	B	-
40	G	-
41	R	-
42	LG	-
43	G	-
44	GR	-
45	BR	-
46	LG	-
47	V	-
48	P	-
49	L	-
59	B	-
66	GR	-
67	LG	-
68	SB	-
69	P	-
70	G	-
80	R	-
81	P	-
82	G	-
83	V	-
84	L	-
85	W	-
86	L	-
87	BR	-
88	GR	-
89	V	-
91	W	-
93	GR	-
95	LG	-
97	SB	-
98	SHIELD	-
99	L	-
100	P	-

Connector No.	M1
Connector Name	FUSE BLOCK (L/R)
Connector Type	HS80FW-M2



Terminal No.	Color of Wire	Signal Name [Specification]
1A	V	-
2A	G	-
3A	L	-
4A	P	-
5A	L	-
6A	Y	-
7A	R	-
8A	L	-

Connector No.	M6
Connector Name	WIRE TO WIRE
Connector Type	TH80MW-CS16-TM4

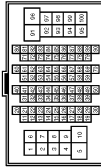

Terminal No.	Color of Wire	Signal Name [Specification]
1	EG	-
3	R	-
5	G	-
6	LG	-
7	W	-
9	G	-
10	W	-
11	V	-
12	R	-
13	L	-
14	GR	-
15	P	-
16	W	-
17	BR	-

18	P	-
19	L	-
20	L	-
30	BR	-
31	L	-
32	Y	-
33	EG	-
34	W	-
35	BR	-
36	R	-
37	Y	-
38	R	-
39	SB	-
40	G	-
41	V	-
42	LG	-
43	P	-
44	B	-
44	B	- [With A/T]
44	B	- [With M/T]
45	EG	-
46	G	-
47	L	-
48	P	-
49	L	-
59	B	-
66	Y	-
67	G	-
68	R	-
69	W	-
70	G	-
80	SB	-
81	B	-
82	V	-
83	W	-
84	L	-
85	GR	-
86	G	-
87	R	-
88	B	-
89	LG	-
91	W	-
93	Y	-
95	Y	-
97	GR	-
98	SHIELD	-
99	V	-
100	SB	-

A
B
C
D
E
F
G
H
I
SE
K
L
M
N
O
P

HEATED SEAT CONTROL UNIT

< ECU DIAGNOSIS INFORMATION >

HEATED SEAT (WITH M/T)

Connector No.	M7
Connector Name	WIRE TO WIRE
Connector Type	TH80MW-CS (6-TM4)



Terminal No.	Color of Wire	Signal Name [Specification]
1	GR	-
2	P	-
3	SB	- [With automatic drive positioner]
3	P	- [Without automatic drive positioner]
4	Y	-
6	L	-
7	W	-
8	G	- [With rear anti-pinch system]
8	Y	- [Without rear anti-pinch system]
9	Y	- [With rear anti-pinch system]
9	G	- [Without rear anti-pinch system]
15	R	-
16	BR	-
17	P	-
18	V	-
20	L	-
21	P	-
22	L	-
23	P	-
24	V	-
25	LG	-
26	BR	-
27	EG	-
28	LG	-
31	V	-
32	LG	-
33	SHIELD	-
34	GR	-
35	BR	-
36	Y	-
37	SHIELD	-
38	SB	-
39	LG	-
40	O	-
41	W	-
42	SHIELD	-
43	R	-
44	G	-

45	SHIELD	-
46	SB	-
55	W	-
56	B	-
58	V	-
59	Y	-
60	Y	-
61	W	-
62	R	-
63	G	-
64	B	-
65	SHIELD	-
71	V	-
72	P	-
73	SB	-
74	V	-
81	W	-
82	BR	-
84	LG	-
85	EG	-
86	SB	-
87	G	-
88	GR	-
89	L	-
90	P	-
91	EG	-
92	L	-
93	P	-
95	EG	-
96	Y	-
100	P	-

Connector No.	M70
Connector Name	HEATED SEAT RELAY
Connector Type	MS02PL-M2-LC



Terminal No.	Color of Wire	Signal Name [Specification]
1	G	-
3	G	-
5	LG	-

Connector No.	M117
Connector Name	WIRE TO WIRE
Connector Type	TH80MW-CS (6-TM4)

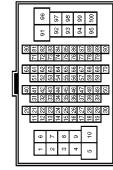

Terminal No.	Color of Wire	Signal Name [Specification]
1	LG	-
3	SB	-
5	P	-
6	G	-
7	SB	-
9	LG	-
10	L	-
31	SB	-
32	LG	-
33	SB	-
34	LG	-
40	Y	-
41	G	-
42	LG	-
43	R	-
45	G	-
46	SHIELD	-
47	P	-
48	L	-
48	SHIELD	-
50	V	-
71	R	-
72	L	-
80	W	-
81	SHIELD	-
82	P	-
83	L	-
84	G	-
85	SHIELD	-
86	W	-
87	B	-
88	R	-
89	G	-
90	Y	-
91	V	-
92	BR	- [With rear anti-pinch system]
92	LG	- [Without rear anti-pinch system]
93	V	- [With rear anti-pinch system]

93	W	- [Without rear anti-pinch system]
94	Y	-
95	G	-
96	G	-
97	R	-
98	EG	-
99	P	-
100	L	-

Connector No.	M138
Connector Name	WIRE TO WIRE
Connector Type	TH12FW-NH

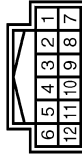

Terminal No.	Color of Wire	Signal Name [Specification]
1	L	-
2	GR	-
3	G	-
4	V	-
5	B	-
6	EG	-
7	B	-
8	R	-
9	B	-
10	LG	-
11	B	-
12	SB	-

HEATED SEAT CONTROL UNIT

< ECU DIAGNOSIS INFORMATION >

A
B
C
D
E
F
G
H
I
SE
K
L
M
N
O
P

HEATED SEAT (WITH M/T)

Connector No.	M174
Connector Name	WIRE TO WIRE
Connector Type	TH12MW-NH

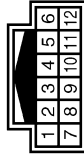

Terminal No.	Color of Wire	Signal Name [Specification]
1	L	-
2	GR	-
3	W	-
4	R	-
5	W	-
6	W	-
7	B	-
8	R	-
9	W	-
10	GR	-
11	GR	-
12	SB	-

Connector No.	M175
Connector Name	HEATED SEAT SWITCH (DRIVER SIDE)
Connector Type	TK10FW



Terminal No.	Color of Wire	Signal Name [Specification]
1	L	-
2	GR	-
3	R	-
4	W	-
5	W	-
6	B	-

Connector No.	M176
Connector Name	HEATED SEAT SWITCH (PASSENGER SIDE)
Connector Type	TK03FER



Terminal No.	Color of Wire	Signal Name [Specification]
1	GR	-
2	SB	-
3	R	-
4	W	-
5	W	-
6	GR	-

HEATED SEAT CONTROL UNIT

< ECU DIAGNOSIS INFORMATION >

DRIVER SIDE : Wiring Diagram - HEATED SEAT SYSTEM (WITH A/T) -

INFOID:000000006207401

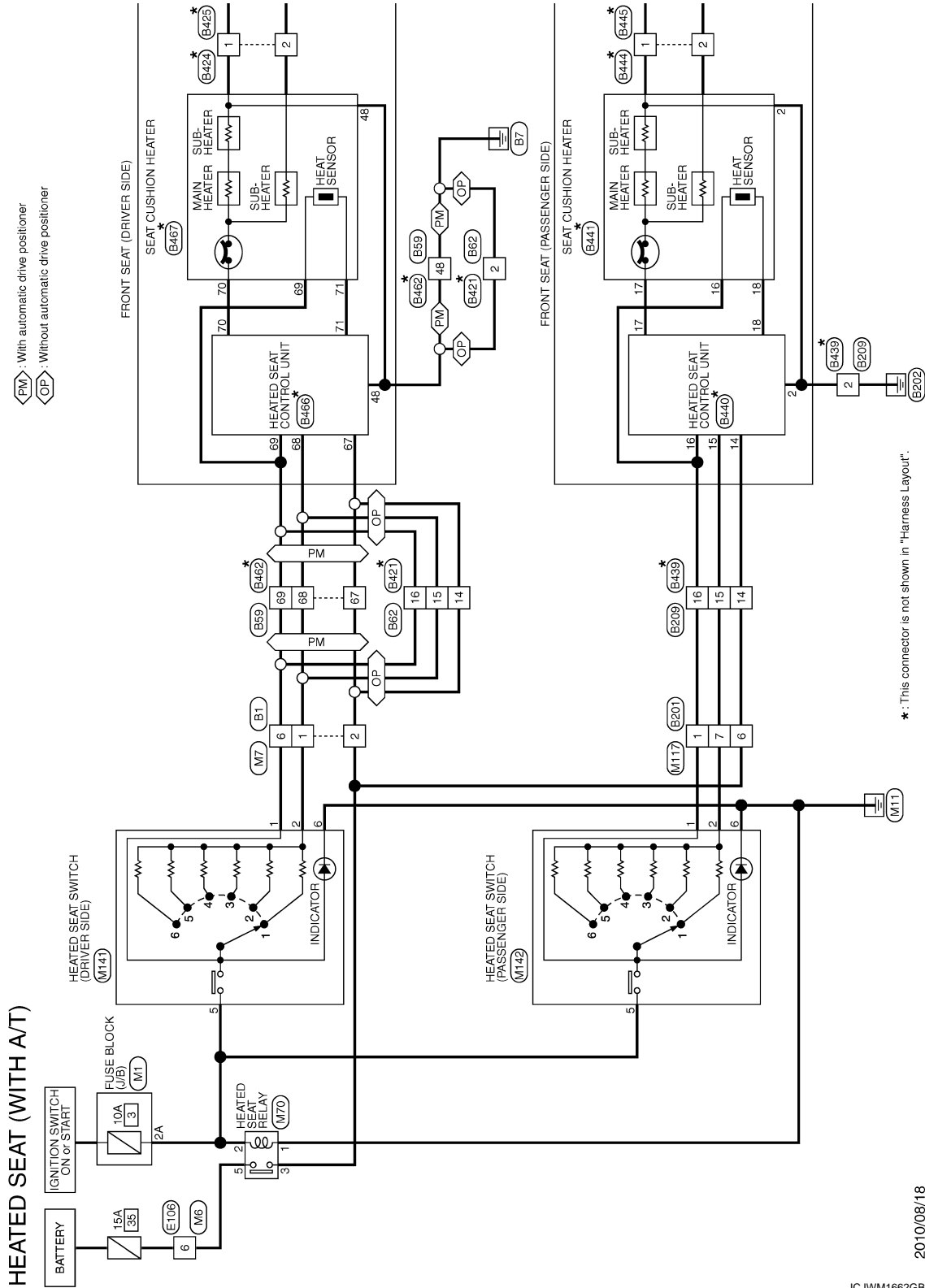

HEATED SEAT CONTROL UNIT

< ECU DIAGNOSIS INFORMATION >

A

B

C

D

E

F

G

H

I

SE

K

L

M

N

O

P

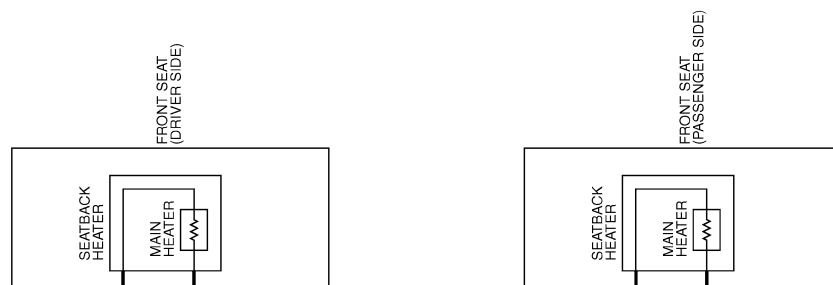

JCJWM1663GB

HEATED SEAT CONTROL UNIT

< ECU DIAGNOSIS INFORMATION >

HEATED SEAT (WITH A/T)

Connector No.	B1
Connector Name	WIRE TO WIRE
Connector Type	TH8DFW-CS16-TM4



Terminal No.	Color of Wire	Signal Name [Specification]
1	GR	-
2	BG	-
3	L	-
4	Y	-
6	R	-
7	P	-
8	W	-
9	LG	- [With rear anti-pinch system]
9	GR	- [Without rear anti-pinch system]
15	Y	-
16	BR	-
17	LG	-
18	BG	-
20	L	-
21	P	-
22	L	-
23	P	-
24	V	-
25	SB	-
26	G	-
27	W	-
28	R	-
31	V	-
32	SB	-
33	SHIELD	-
34	W	-
35	BR	-
36	Y	-
37	SHIELD	-
38	Y	-
38	SB	-
40	P	-
41	L	-
42	SHIELD	-
43	R	-
44	G	-
45	SHIELD	-
46	SB	-

55	BR	-
56	R	-
58	V	-
59	SB	-
60	BR	-
61	W	-
62	R	-
63	L	-
64	Y	-
65	SHIELD	-
71	BG	-
72	GR	-
73	P	-
74	L	-
81	V	-
82	B	-
84	Y	-
85	G	-
86	W	-
87	R	-
88	BR	-
89	Y	-
90	SB	-
91	BG	-
92	BR	-
93	P	-
95	BG	-
96	Y	-
100	GR	-

Connector No.	B59
Connector Name	WIRE TO WIRE
Connector Type	NS1DFW-CS



Terminal No.	Color of Wire	Signal Name [Specification]
1	BG	-
3	L	-
8	Y	-
17	LG	-
19	P	-
21	Y	-
32	B	-

33	L	-
40	BR	-
48	B	-
67	BG	-
68	GR	-
69	R	-

Connector No.	B82
Connector Name	WIRE TO WIRE
Connector Type	MD8FW-LC



Terminal No.	Color of Wire	Signal Name [Specification]
1	L	-
2	B	-
14	BG	-
15	GR	-
16	R	-

Connector No.	B201
Connector Name	WIRE TO WIRE
Connector Type	TH8DFW-CS16-TM4



Terminal No.	Color of Wire	Signal Name [Specification]
1	BR	-
3	W	-
5	P	-
6	L	-
7	V	-
9	LG	-
10	L	-
31	L	-
32	P	-

33	G	-
34	R	-
40	GR	-
41	LC	-
42	BG	-
43	R	-
45	G	-
46	SHIELD	-
47	G	-
48	Y	-
49	SHIELD	-
50	W	-
71	R	-
72	V	-
80	BG	-
81	SHIELD	-
82	G	-
83	P	-
84	L	-
85	SHIELD	-
86	G	-
87	R	-
88	W	-
89	B	-
90	Y	-
91	V	-
92	W	- [With rear anti-pinch system]
92	R	- [Without rear anti-pinch system]
93	BG	- [With rear anti-pinch system]
93	BR	- [Without rear anti-pinch system]
94	R	-
95	SB	-
96	G	-
97	GR	-
98	BR	-
99	P	-
100	L	-

HEATED SEAT CONTROL UNIT

< ECU DIAGNOSIS INFORMATION >

HEATED SEAT (WITH A/T)

Connector No.	B209	Connector No.	B424	Connector No.	B440	Connector No.	B444
Connector Name	WIRE TO WIRE	Connector Name	WIRE TO WIRE	Connector Name	HEATED SEAT CONTROL UNIT	Connector Name	WIRE TO WIRE
Connector Type	M02FW-LC	Connector Type	M02FW-LC	Connector Type	I74923-1	Connector Type	M02FW-LC
Terminal No.	1	Terminal No.	1	Terminal No.	15	Terminal No.	1
Color of Wire	R	Color of Wire	B	Color of Wire	B	Color of Wire	-
Signal Name [Specification]	-	Color of Wire	R	Color of Wire	L/W	Color of Wire	-
		Color of Wire	B	Color of Wire	R/W	Color of Wire	-
		Color of Wire	L	Color of Wire	-	Color of Wire	-
		Color of Wire	V	Color of Wire	-	Color of Wire	-
		Color of Wire	BR	Color of Wire	-	Color of Wire	-
Connector No.	B421	Connector No.	B425	Connector No.	B441	Connector No.	B445
Connector Name	WIRE TO WIRE	Connector Name	WIRE TO WIRE	Connector Name	SEAT CUSHION HEATER	Connector Name	WIRE TO WIRE
Connector Type	M06MW-LC	Connector Type	M02MW-LC	Connector Type	S04FW	Connector Type	M02MW-LC
Terminal No.	1	Terminal No.	1	Terminal No.	16	Terminal No.	1
Color of Wire	R	Color of Wire	B	Color of Wire	B	Color of Wire	-
Signal Name [Specification]	-	Color of Wire	R	Color of Wire	GND	Color of Wire	-
		Color of Wire	L/W	Color of Wire	HEATER (+)	Color of Wire	-
		Color of Wire	R/W	Color of Wire	HEATER SW	Color of Wire	-
		Color of Wire	L	Color of Wire	THERMISTOR INPUT	Color of Wire	-
		Color of Wire	V	Color of Wire	HEATER (-)	Color of Wire	-
		Color of Wire	BR	Color of Wire	THERMISTOR OUTPUT	Color of Wire	-
Connector No.	B439	Connector No.	B441	Connector No.	B441	Connector No.	B441
Connector Name	WIRE TO WIRE	Connector Name	SEAT CUSHION HEATER	Connector Name	SEAT CUSHION HEATER	Connector Name	SEAT CUSHION HEATER
Connector Type	M06MW-LC	Connector Type	M06MW-LC	Connector Type	S04FW	Connector Type	S04FW
Terminal No.	1	Terminal No.	1	Terminal No.	16	Terminal No.	1
Color of Wire	R	Color of Wire	B	Color of Wire	B	Color of Wire	-
Signal Name [Specification]	-	Color of Wire	R	Color of Wire	GND	Color of Wire	-
		Color of Wire	L/W	Color of Wire	HEATER (+)	Color of Wire	-
		Color of Wire	R/W	Color of Wire	HEATER SW	Color of Wire	-
		Color of Wire	L	Color of Wire	THERMISTOR INPUT	Color of Wire	-
		Color of Wire	V	Color of Wire	HEATER (-)	Color of Wire	-
		Color of Wire	BR	Color of Wire	THERMISTOR OUTPUT	Color of Wire	-
Connector No.	B439	Connector No.	B441	Connector No.	B441	Connector No.	B441
Connector Name	WIRE TO WIRE	Connector Name	SEAT CUSHION HEATER	Connector Name	SEAT CUSHION HEATER	Connector Name	SEAT CUSHION HEATER
Connector Type	M06MW-LC	Connector Type	M06MW-LC	Connector Type	S04FW	Connector Type	S04FW
Terminal No.	1	Terminal No.	1	Terminal No.	16	Terminal No.	1
Color of Wire	R	Color of Wire	B	Color of Wire	B	Color of Wire	-
Signal Name [Specification]	-	Color of Wire	R	Color of Wire	GND	Color of Wire	-
		Color of Wire	L/W	Color of Wire	HEATER (+)	Color of Wire	-
		Color of Wire	R/W	Color of Wire	HEATER SW	Color of Wire	-
		Color of Wire	L	Color of Wire	THERMISTOR INPUT	Color of Wire	-
		Color of Wire	V	Color of Wire	HEATER (-)	Color of Wire	-
		Color of Wire	BR	Color of Wire	THERMISTOR OUTPUT	Color of Wire	-

JCJWM1665GB

A
B
C
D
E
F
G
H
I
SE
K
L
M
N
O
P

HEATED SEAT CONTROL UNIT

< ECU DIAGNOSIS INFORMATION >

HEATED SEAT (WITH A/T)

Connector No.	B462
Connector Name	WIRE TO WIRE
Connector Type	HS16MW-LC



19	3	1	17	40
8	69	32	48	21
	68	68	67	

Terminal No.	Color of Wire	Signal Name [Specification]
1	L/W	-
3	R/Y	-
8	LG	-
17	Y/R	-
19	V	-
21	L/Y	-
32	B/W	-
33	R	-
40	R/W	-
48	B	-
67	R	-
68	L	-
69	BR/W	-

Connector No.	B465
Connector Name	HEATED SEAT CONTROL UNIT
Connector Type	I74923-1



68	48	71	69	67
----	----	----	----	----

Terminal No.	Color of Wire	Signal Name [Specification]
48	B	GND
67	R	HEATER (-)
68	L	HEATER SW [With automatic drive positioner]
68	L/W	HEATER SW [Without automatic drive positioner]
69	BR/W	THERMISTOR INPUT [With automatic drive positioner]
69	R/W	THERMISTOR INPUT [Without automatic drive positioner]
70	L/W	HEATER (+) [With automatic drive positioner]
70	R/L	HEATER (+) [Without automatic drive positioner]
71	R/B	THERMISTOR OUTPUT

Connector No.	B467
Connector Name	SEAT CUSHION HEATER
Connector Type	IS04FW



69	48
70	71

Terminal No.	Color of Wire	Signal Name [Specification]
48	B	-
69	BR/W	- [With automatic drive positioner]
69	R/W	- [Without automatic drive positioner]
70	L/W	- [With automatic drive positioner]
70	R/L	- [Without automatic drive positioner]
71	R/B	-

Connector No.	E108
Connector Name	WIRE TO WIRE
Connector Type	TH80FW-OS16-TM4



1	2	3	4	5	6	7	8	9	10	11	12	13	14	15	16	17	18	19	20	21	22	23	24	25	26	27	28	29	30	31	32	33	34	35	36	37	38	39	40	41	42	43	44	45	46	47	48	49	50	51	52	53	54	55	56	57	58	59	60	61	62	63	64	65	66	67	68	69	70	71	72	73	74	75	76	77	78	79	80	81	82	83	84	85	86	87	88	89	90	91	92	93	94	95	96	97	98	99	100
---	---	---	---	---	---	---	---	---	----	----	----	----	----	----	----	----	----	----	----	----	----	----	----	----	----	----	----	----	----	----	----	----	----	----	----	----	----	----	----	----	----	----	----	----	----	----	----	----	----	----	----	----	----	----	----	----	----	----	----	----	----	----	----	----	----	----	----	----	----	----	----	----	----	----	----	----	----	----	----	----	----	----	----	----	----	----	----	----	----	----	----	----	----	----	----	----	----	----	-----

Terminal No.	Color of Wire	Signal Name [Specification]
1	GR	-
3	BG	-
5	G	-
6	Y	-
7	V	-
9	R	-
10	W	-
11	V	-
12	R	-
13	L	-
14	GR	-
15	P	-
16	W	-
17	SB	-
18	BG	-
19	SB	-

Terminal No.	Color of Wire	Signal Name [Specification]
20	LG	-
30	BR	-
31	L	-
32	EG	-
33	P	-
34	V	-
35	W	-
36	SB	-
37	Y	-
38	R	-
39	B	-
40	G	-
41	R	-
42	LG	-
43	G	-
44	GR	-
45	BR	-
46	LG	-
47	V	-
48	P	-
48	L	-
48	B	-
59	B	-
67	LG	-
68	SB	-
69	P	-
70	G	-
80	R	-
81	P	-
82	G	-
83	V	-
84	L	-
85	W	-
86	L	-
87	BR	-
88	GR	-
89	V	-
91	W	-
93	GR	-
95	LG	-
97	SB	-
98	SHIELD	-
99	L	-
100	P	-

Connector No.	M1
Connector Name	FUSE BLOCK (J/B)
Connector Type	NS30FW-M2



3A	2A	1A
8A	7A	6A
	5A	4A

Terminal No.	Color of Wire	Signal Name [Specification]
1A	V	-
2A	G	-
3A	L	-
4A	P	-
5A	L	-
6A	Y	-
7A	R	-
8A	L	-

HEATED SEAT CONTROL UNIT

< ECU DIAGNOSIS INFORMATION >

HEATED SEAT (WITH A/T)

Connector No.	M6
Connector Name	WIRE TO WIRE
Connector Type	TH80MW-CS16-TM4

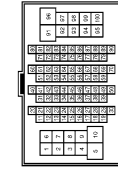

Terminal No.	Color of Wire	Signal Name [Specification]
1	BG	-
3	R	-
5	R	-
6	LG	-
7	W	-
8	G	-
10	W	-
11	V	-
12	R	-
13	L	-
14	GR	-
15	P	-
16	W	-
17	BR	-
18	P	-
19	L	-
20	L	-
30	BR	-
31	L	-
32	Y	-
33	BG	-
34	W	-
35	BR	-
36	R	-
37	Y	-
38	R	-
40	G	-
41	V	-
42	LG	-
43	P	-
44	R	- [With A/T] - [With M/T]
45	BG	-
46	G	-
47	L	-
48	P	-
48	L	-

59	B	-
66	Y	-
67	C	-
68	R	-
69	W	-
70	G	-
80	SB	-
81	B	-
82	V	-
83	W	-
84	L	-
85	GR	-
86	G	-
87	R	-
88	B	-
89	LG	-
91	W	-
96	Y	-
95	Y	-
97	GR	-
98	SHIELD	-
99	V	-
100	SB	-

Connector No.	M7
Connector Name	WIRE TO WIRE
Connector Type	TH80MW-CS16-TM4

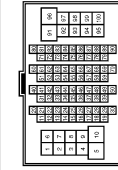

Terminal No.	Color of Wire	Signal Name [Specification]
1	GR	-
2	P	-
3	SB	- [With automatic drive positioner] - [Without automatic drive positioner]
4	Y	-
5	L	-
7	W	-
8	G	- [With rear anti-pinch system] - [Without rear anti-pinch system]
9	Y	- [With rear anti-pinch system] - [Without rear anti-pinch system]
9	G	-
15	R	-
16	BR	-

93	P	-
95	BG	-
96	V	-
100	P	-

Connector No.	M70
Connector Name	HEATED SEAT RELAY
Connector Type	MS02FL-M2-LC

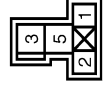

Terminal No.	Color of Wire	Signal Name [Specification]
1	G	-
2	P	-
3	G	-
5	LG	-

17	P	-
18	V	-
20	L	-
21	P	-
22	L	-
23	P	-
24	V	-
25	LG	-
26	BR	-
27	BG	-
28	LG	-
31	V	-
32	LG	-
33	SHIELD	-
34	GR	-
35	BR	-
36	Y	-
37	SHIELD	-
38	SB	-
39	G	-
40	O	-
41	W	-
42	SHIELD	-
43	R	-
44	G	-
45	SHIELD	-
46	SB	-
55	W	-
56	B	-
58	V	-
59	Y	-
60	Y	-
61	W	-
62	R	-
63	G	-
64	B	-
65	SHIELD	-
71	V	-
72	P	-
73	SB	-
74	V	-
81	W	-
82	BR	-
84	LG	-
85	BG	-
86	SB	-
87	G	-
88	GR	-
89	L	-
90	P	-
91	BG	-
92	L	-

A
B
C
D
E
F
G
H
I
SE
K
L
M
N
O
P

HEATED SEAT CONTROL UNIT

< ECU DIAGNOSIS INFORMATION >

HEATED SEAT (WITH A/T)

Connector No.	M117
Connector Name	WIRE TO WIRE
Connector Type	TH80MW-CS (6-TIM)



Terminal No.	Color of Wire	Signal Name [Specification]
1	LG	-
3	SB	-
5	P	-
6	G	-
7	SB	-
8	LG	-
10	L	-
31	SB	-
32	LG	-
33	SB	-
34	LG	-
40	Y	-
41	G	-
42	LG	-
43	R	-
45	G	-
46	SHIELD	-
47	P	-
48	L	-
48	SHIELD	-
50	V	-
71	R	-
72	L	-
80	W	-
81	SHIELD	-
82	P	-
83	L	-
84	G	-
85	SHIELD	-
86	W	-
87	B	-
88	R	-
89	G	-
90	Y	-
91	V	-
92	BR	- [With rear anti-pinch system]
92	LG	- [Without rear anti-pinch system]
93	V	- [With rear anti-pinch system]
93	V	- [Without rear anti-pinch system]

93	W	- [Without rear anti-pinch system]
94	Y	-
95	G	-
96	G	-
97	R	-
98	BG	-
99	P	-
100	L	-

Connector No.	M141
Connector Name	HEATED SEAT SWITCH (DRIVER SIDE)
Connector Type	TK10FW

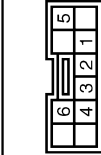

Terminal No.	Color of Wire	Signal Name [Specification]
1	L	-
2	GR	-
3	R	-
4	B	-
5	G	-
6	B	-

Connector No.	M142
Connector Name	HEATED SEAT SWITCH (PASSENGER SIDE)
Connector Type	TK08FBR

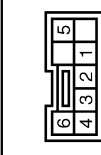

Terminal No.	Color of Wire	Signal Name [Specification]
1	LG	-
2	SB	-
3	V	-
4	B	-
5	BG	-
6	B	-

PASSENGER SIDE

JCJWM1668GB

HEATED SEAT CONTROL UNIT

< ECU DIAGNOSIS INFORMATION >

PASSENGER SIDE : Reference Value

INFOID:000000006207402

TERMINAL LAYOUT

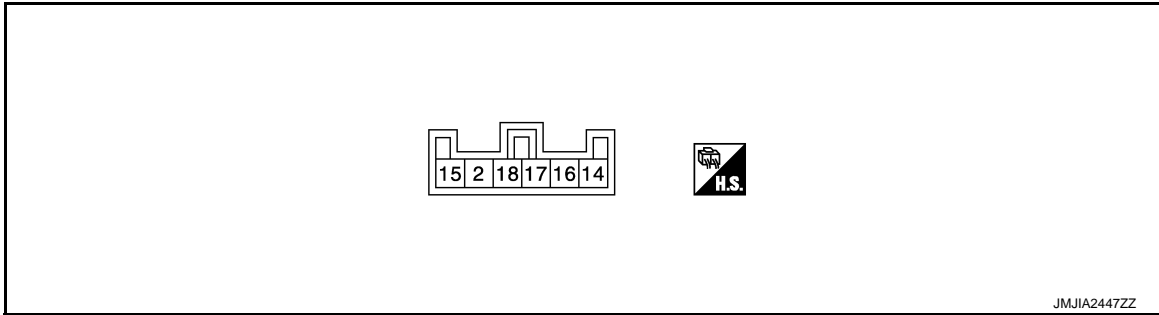

PHYSICAL VALUES

Terminal No. (Wire color)		Description		Condition		Voltage (V) (Approx.)
(+)	(-)	Signal name	Input/ Output			
2 (B)	Ground	Ground	-	Ignition switch ON		0
14 (R)	Ground	IGN power supply	Input	Ignition switch	OFF or ACC	0
					ON	Battery voltage
15 (L/W)	Ground	Heated seat switch signal	Input	Heated seat switch	OFF	0
					1 (Min. temperature)	12.24
					2	12.33
					3	12.49
					4	12.63
					5	12.76
					6 (Max. temperature)	12.90
16 (R/W)	Ground	Heated seat operation signal	Input	Heated seat	Operate	Battery voltage
					Other than above	0
17 (R/L)	Ground	Heater unit power supply	Output	Heated seat	Operate	0 – Battery voltage*
					Other than above	0
18 (R/B)	Ground	Heat sensor signal	Input	Heated seat switch	OFF	0
					1 (Min. temperature)	10.87 – 11.02*
					2	10.93 – 11.07*
					3	11.04 – 11.17*
					4	11.13 – 11.26*
					5	11.22 – 11.34*
					6 (Max. temperature)	11.31 – 11.43*

*: Voltage is repeated within the value shown as per the following list depending on heater unit temperature.

HEATED SEAT CONTROL UNIT

< ECU DIAGNOSIS INFORMATION >

PASSENGER SIDE : Wiring Diagram - HEATED SEAT SYSTEM (WITH M/T) -

INFOID:000000006856845

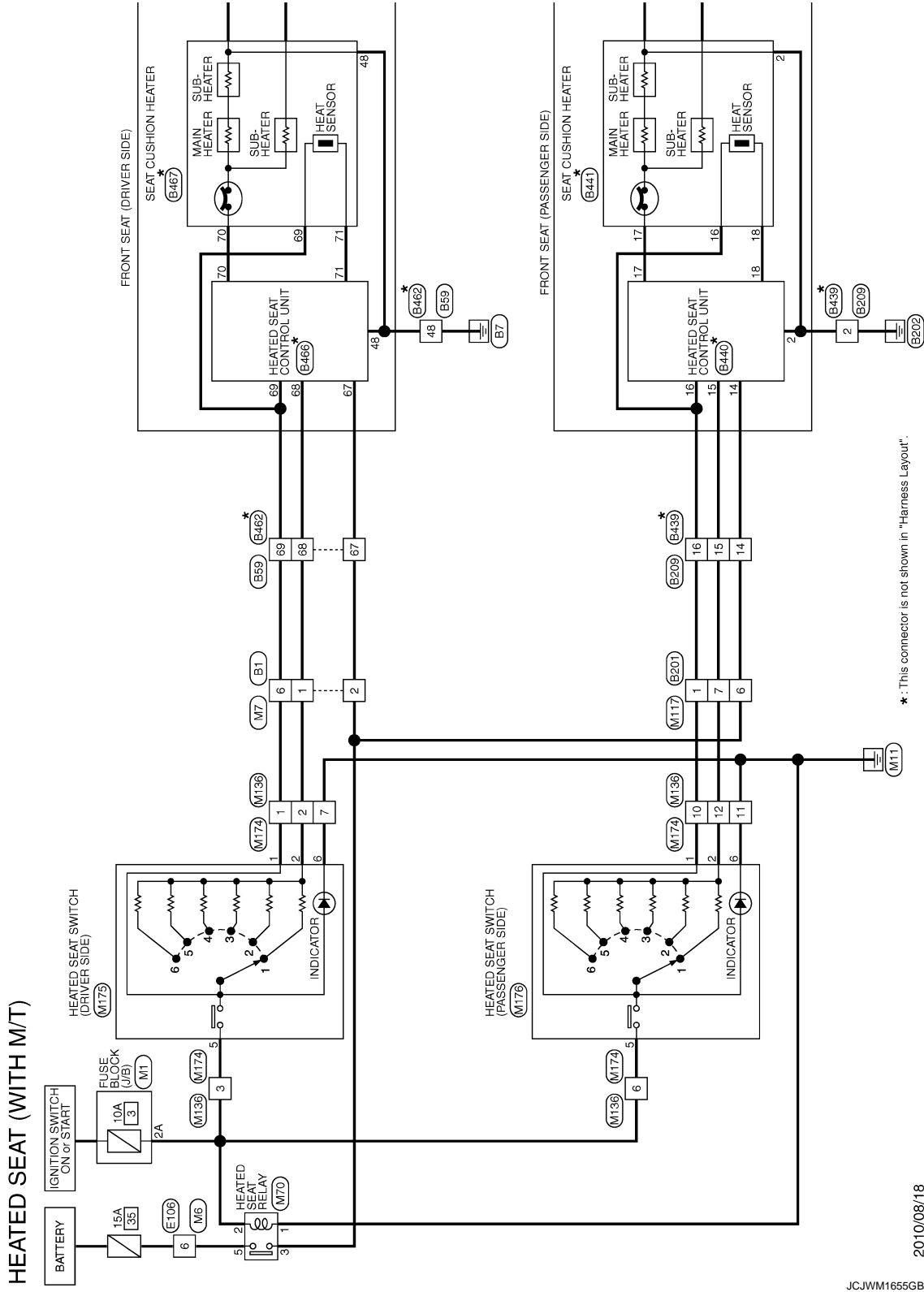

2010/08/18

JCJWM1655GB

HEATED SEAT CONTROL UNIT

< ECU DIAGNOSIS INFORMATION >

A

B

C

D

E

F

G

H

I

SE

K

L

M

N

O

P

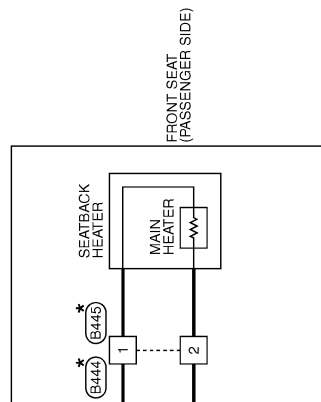
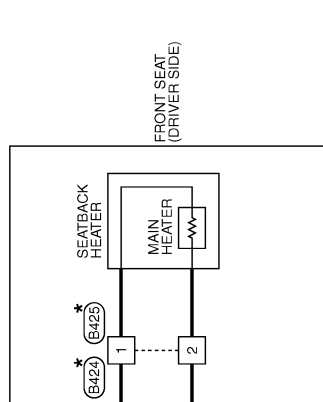

JCJWM1656GB

*: This connector is not shown in "Harness Layout".

HEATED SEAT CONTROL UNIT

< ECU DIAGNOSIS INFORMATION >

HEATED SEAT (WITH M/T)

Connector No.	B1
Connector Name	WIRE TO WIRE
Connector Type	TH80FW-CS16-TM4



Terminal No.	Color of Wire	Signal Name [Specification]
1	GR	-
2	BG	-
3	L	-
4	Y	-
6	R	-
7	P	-
8	W	-
9	LG	- [With rear anti-pinch system]
9	GR	- [Without rear anti-pinch system]
15	Y	-
16	BR	-
17	LG	-
18	BG	-
20	L	-
21	P	-
22	L	-
23	P	-
24	V	-
25	SB	-
26	G	-
27	W	-
28	R	-
31	V	-
32	SB	-
33	SHIELD	-
34	W	-
35	BR	-
36	Y	-
37	SHIELD	-
38	Y	-
38	SB	-
40	P	-
41	L	-
42	SHIELD	-
43	R	-
44	G	-
45	SHIELD	-
46	SB	-

55	BR	-
56	R	-
58	V	-
59	SB	-
60	BR	-
61	W	-
62	R	-
63	L	-
64	Y	-
65	SHIELD	-
71	BG	-
72	GR	-
73	P	-
74	L	-
81	V	-
82	B	-
84	Y	-
85	G	-
86	W	-
87	R	-
88	BR	-
89	Y	-
90	SB	-
91	BG	-
92	BR	-
93	P	-
95	BG	-
96	Y	-
100	GR	-

Connector No.	B59
Connector Name	WIRE TO WIRE
Connector Type	NS10FW-CS



Terminal No.	Color of Wire	Signal Name [Specification]
1	BG	-
3	L	-
8	Y	-
17	LG	-
19	P	-
21	Y	-
32	B	-

33	L	-
40	BR	-
48	B	-
67	BG	-
68	GR	-
69	R	-

Connector No.	B201
Connector Name	WIRE TO WIRE
Connector Type	TH80FW-CS16-TM4

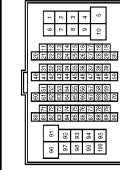

Terminal No.	Color of Wire	Signal Name [Specification]
1	BR	-
3	W	-
5	P	-
6	L	-
7	V	-
9	LG	-
10	L	-
31	L	-
32	P	-
33	R	-
34	GR	-
40	GR	-
41	LG	-
42	BG	-
43	R	-
44	G	-
46	SHIELD	-
47	G	-
48	Y	-
49	SHIELD	-
50	W	-
71	R	-
72	V	-
80	BG	-
81	SHIELD	-
92	G	-
93	P	-
84	L	-
85	SHIELD	-
86	G	-

87	R	-
88	W	-
89	B	-
90	Y	-
91	V	-
92	W	- [With rear anti-pinch system]
92	R	- [Without rear anti-pinch system]
93	BG	- [With rear anti-pinch system]
93	BR	- [Without rear anti-pinch system]
94	R	-
95	SB	-
96	G	-
97	GR	-
98	BR	-
99	P	-
100	L	-

Connector No.	B209
Connector Name	WIRE TO WIRE
Connector Type	MS8FW-LC



Terminal No.	Color of Wire	Signal Name [Specification]
1	R	-
2	B	-
14	L	-
15	V	-
16	BR	-

HEATED SEAT CONTROL UNIT

< ECU DIAGNOSIS INFORMATION >

HEATED SEAT (WITH M/T)

Connector No.	B424
Connector Name	WIRE TO WIRE
Connector Type	MO2PW-LC



Terminal No.	Color of Wire	Signal Name [Specification]
1	-	-
2	-	-

Connector No.	B425
Connector Name	WIRE TO WIRE
Connector Type	MO2MW-LC



Terminal No.	Color of Wire	Signal Name [Specification]
1	-	-
2	-	-

Connector No.	B429
Connector Name	WIRE TO WIRE
Connector Type	MO2MW-LC



Terminal No.	Color of Wire	Signal Name [Specification]
1	R	-
2	B	-

Terminal No.	Color of Wire	Signal Name [Specification]
14	R	-
15	L/W	-
16	R/W	-

Connector No.	B440
Connector Name	HEATED SEAT CONTROL UNIT
Connector Type	174923-1



Terminal No.	Color of Wire	Signal Name [Specification]
2	B	GND
14	R	HEATER (-)
15	L/W	HEATER SW
16	R/W	THERMISTOR INPUT
17	R/L	HEATER (+)
18	R/B	THERMISTOR OUTPUT

Connector No.	B441
Connector Name	SEAT CUSHION HEATER
Connector Type	SO4FW



Terminal No.	Color of Wire	Signal Name [Specification]
2	B	-
16	R/W	-
17	R/L	-
18	R/B	-

Connector No.	B444
Connector Name	WIRE TO WIRE
Connector Type	MO2PW-LC



Terminal No.	Color of Wire	Signal Name [Specification]
1	-	-
2	-	-

Connector No.	B445
Connector Name	WIRE TO WIRE
Connector Type	MO2MW-LC



Terminal No.	Color of Wire	Signal Name [Specification]
1	-	-
2	-	-

Connector No.	B462
Connector Name	WIRE TO WIRE
Connector Type	INS16MW-LC



Terminal No.	Color of Wire	Signal Name [Specification]
1	L/W	-
3	R/Y	-

Terminal No.	Color of Wire	Signal Name [Specification]
8	L/G	-
17	Y/R	-
19	V	-
21	L/Y	-
32	B/W	-
33	R	-
40	R/W	-
48	B	-
67	R	-
68	L	-
69	BR/W	-

Connector No.	B466
Connector Name	HEATED SEAT CONTROL UNIT
Connector Type	174923-1



Terminal No.	Color of Wire	Signal Name [Specification]
48	B	GND
67	R	HEATER (+)
68	L	HEATER SW [With automatic drive positional]
69	BR/W	HEATER SW [Without automatic drive positional]
70	R/W	THERMISTOR INPUT [With automatic drive positional]
71	L/W	THERMISTOR INPUT [Without automatic drive positional]
70	R/L	HEATER (-) [With automatic drive positional]
71	R/B	HEATER (-) [Without automatic drive positional]

A
B
C
D
E
F
G
H
I
SE
K
L
M
N
O
P

HEATED SEAT CONTROL UNIT

< ECU DIAGNOSIS INFORMATION >

HEATED SEAT (WITH M/T)

Connector No.	B467
Connector Name	SEAT CUSHION HEATER
Connector Type	SO4FW



Terminal No.	Color of Wire	Signal Name [Specification]
48	B	-
69	BR/W	- [With automatic drive positioner]
70	L/W	- [Without automatic drive positioner]
71	R/B	- [Without automatic drive positioner]

Connector No.	E106
Connector Name	WIRE TO WIRE
Connector Type	TH60FW-CS16-TM4

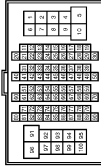

Terminal No.	Color of Wire	Signal Name [Specification]
1	GR	-
3	EG	-
6	Y	-
7	V	-
9	R	-
10	W	-
11	V	-
12	R	-
13	L	-
14	GR	-
15	P	-
16	W	-
17	SB	-
18	EG	-
19	SB	-

20	LG	-
30	BR	-
31	L	-
32	EG	-
33	P	-
34	V	-
35	W	-
36	SB	-
37	Y	-
38	R	-
39	B	-
40	G	-
41	R	-
42	LG	-
43	G	-
44	GR	-
45	R	-
46	LG	-
47	V	-
48	P	-
49	L	-
59	B	-
66	GR	-
67	LG	-
68	SB	-
69	P	-
70	G	-
80	R	-
81	P	-
82	G	-
83	V	-
84	L	-
85	W	-
86	L	-
87	BR	-
88	GR	-
89	V	-
91	W	-
93	GR	-
95	LG	-
97	SB	-
98	SHIELD	-
99	L	-
100	P	-

Connector No.	M1
Connector Name	FUSE BLOCK (U/B)
Connector Type	NS08FW-M2



Terminal No.	Color of Wire	Signal Name [Specification]
1A	V	-
2A	G	-
3A	L	-
4A	P	-
5A	L	-
6A	Y	-
7A	R	-
8A	L	-

Connector No.	M6
Connector Name	WIRE TO WIRE
Connector Type	TH60MW-CS16-TM4

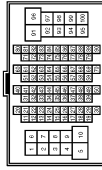

Terminal No.	Color of Wire	Signal Name [Specification]
1	EG	-
3	R	-
5	G	-
6	LG	-
7	W	-
9	G	-
10	W	-
11	V	-
12	R	-
13	L	-
14	GR	-
15	P	-
16	W	-
17	BR	-

18	P	-
19	L	-
20	L	-
30	BR	-
31	L	-
32	Y	-
33	EG	-
34	W	-
35	BR	-
36	R	-
37	Y	-
38	R	-
39	SB	-
40	G	-
41	V	-
42	LG	-
43	P	-
44	B	-
44	R	- [With A/T]
45	EG	- [With M/T]
46	G	-
47	L	-
48	P	-
49	L	-
59	B	-
66	Y	-
67	G	-
68	R	-
69	W	-
70	G	-
80	SB	-
81	B	-
82	V	-
83	W	-
84	L	-
85	GR	-
86	G	-
87	R	-
88	B	-
89	LG	-
91	W	-
93	Y	-
95	Y	-
97	GR	-
98	SHIELD	-
99	V	-
100	SB	-

HEATED SEAT CONTROL UNIT

< ECU DIAGNOSIS INFORMATION >

HEATED SEAT (WITH M/T)

Connector No.	M7
Connector Name	WIRE TO WIRE
Connector Type	TH80MW-CS16-TM4

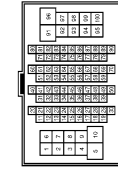

Terminal No.	Color of Wire	Signal Name [Specification]
1	GR	-
2	P	-
3	SB	- [With automatic drive positioner]
4	P	- [Without automatic drive positioner]
5	Y	-
6	L	-
7	W	-
8	G	- [With rear anti-pinch system]
8	Y	- [Without rear anti-pinch system]
9	Y	- [With rear anti-pinch system]
9	G	- [Without rear anti-pinch system]
15	R	-
16	BR	-
17	P	-
18	V	-
20	L	-
21	P	-
22	L	-
23	P	-
24	V	-
25	LG	-
26	BR	-
27	BG	-
31	V	-
32	LG	-
33	SHIELD	-
34	GR	-
35	BR	-
36	Y	-
37	SHIELD	-
38	SB	-
39	LG	-
40	O	-
41	W	-
42	SHIELD	-
43	R	-
44	G	-

45	SHIELD	-
46	SB	-
55	W	-
56	B	-
58	V	-
59	Y	-
60	Y	-
61	W	-
62	R	-
63	G	-
64	B	-
65	SHIELD	-
71	V	-
72	P	-
73	SB	-
74	V	-
81	W	-
82	BR	-
84	LG	-
85	BG	-
86	SB	-
87	G	-
88	GR	-
89	L	-
90	P	-
91	BG	-
92	L	-
93	P	-
95	BG	-
96	Y	-
100	P	-

Connector No.	M70
Connector Name	HEATED SEAT RELAY
Connector Type	MS02PL-M2-LC



Terminal No.	Color of Wire	Signal Name [Specification]
1	G	-
2	P	-
3	G	-
5	LG	-

Connector No.	M117
Connector Name	WIRE TO WIRE
Connector Type	TH80MW-CS16-TM4

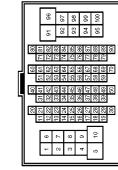

Terminal No.	Color of Wire	Signal Name [Specification]
1	LG	-
3	SB	-
5	P	-
6	G	-
7	SB	-
8	LG	-
10	L	-
31	SB	-
32	LG	-
33	SB	-
34	LG	-
40	Y	-
41	G	-
42	LG	-
43	R	-
45	G	-
46	SHIELD	-
47	P	-
48	L	-
48	SHIELD	-
50	V	-
71	R	-
72	L	-
80	W	-
81	SHIELD	-
82	P	-
83	L	-
84	G	-
85	SHIELD	-
86	W	-
87	B	-
88	R	-
89	G	-
90	Y	-
91	V	-
92	BR	- [With rear anti-pinch system]
92	LG	- [Without rear anti-pinch system]
93	V	- [With rear anti-pinch system]

93	W	- [Without rear anti-pinch system]
94	Y	-
95	G	-
96	R	-
97	BG	-
99	P	-
100	L	-

Connector No.	M138
Connector Name	WIRE TO WIRE
Connector Type	TH12FW-NH

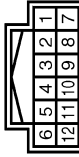

Terminal No.	Color of Wire	Signal Name [Specification]
1	L	-
2	GR	-
3	G	-
4	V	-
5	B	-
6	BG	-
7	B	-
8	R	-
9	B	-
10	LG	-
11	B	-
12	SB	-

A
B
C
D
E
F
G
H
I
SE
K
L
M
N
O
P

HEATED SEAT CONTROL UNIT

< ECU DIAGNOSIS INFORMATION >

HEATED SEAT (WITH M/T)

Connector No.	M174
Connector Name	WIRE TO WIRE
Connector Type	TH12MW-NH

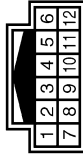

Terminal No.	Color of Wire	Signal Name [Specification]
1	L	-
2	GR	-
3	W	-
4	R	-
5	W	-
6	W	-
7	B	-
8	R	-
9	W	-
10	GR	-
11	GR	-
12	SB	-

Connector No.	M175
Connector Name	HEATED SEAT SWITCH (DRIVER SIDE)
Connector Type	TK10FW



Terminal No.	Color of Wire	Signal Name [Specification]
1	L	-
2	GR	-
3	R	-
4	W	-
5	B	-

Connector No.	M176
Connector Name	HEATED SEAT SWITCH (PASSENGER SIDE)
Connector Type	TK03FBR



Terminal No.	Color of Wire	Signal Name [Specification]
1	GR	-
2	SB	-
3	R	-
4	W	-
5	W	-
6	GR	-

JCJWM1661GB

HEATED SEAT CONTROL UNIT

< ECU DIAGNOSIS INFORMATION >

PASSENGER SIDE : Wiring Diagram - HEATED SEAT SYSTEM (WITH A/T) -

INFOID:0000000006856846

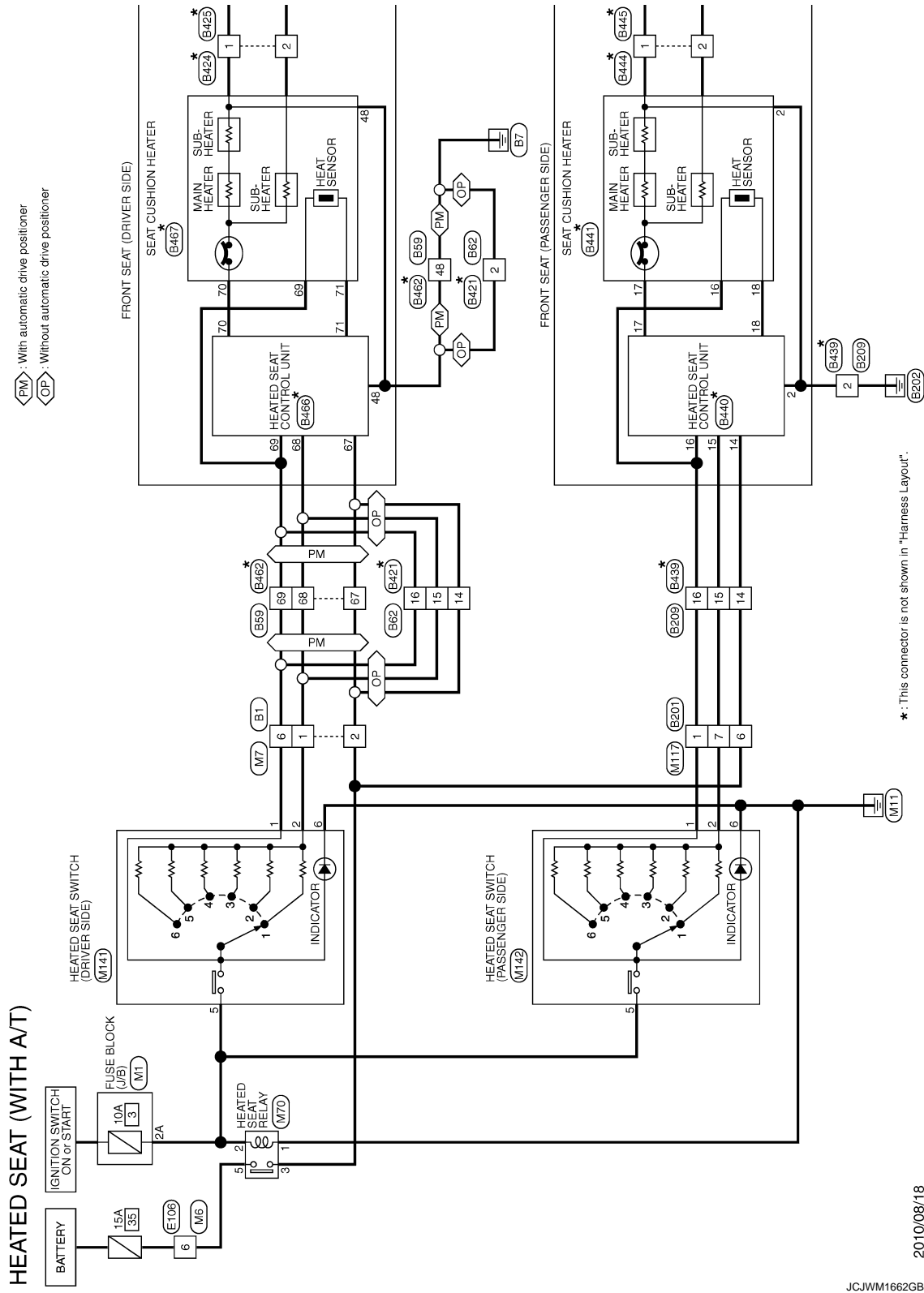

A
B
C
D
E
F
G
H
I
SE
K
L
M
N
O
P

HEATED SEAT CONTROL UNIT

< ECU DIAGNOSIS INFORMATION >

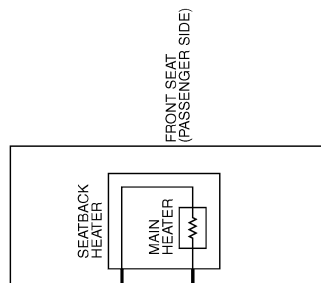
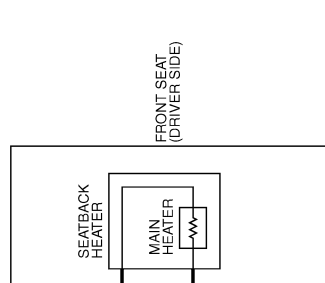

JCJWM1663GB

HEATED SEAT CONTROL UNIT

< ECU DIAGNOSIS INFORMATION >

HEATED SEAT (WITH A/T)

Connector No.	B1
Connector Name	WIRE TO WIRE
Connector Type	TH80FW-CS16-TM4

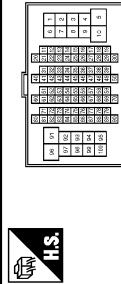

Terminal No.	Color of Wire	Signal Name [Specification]
1	GR	-
2	EG	-
3	L	-
4	Y	-
6	R	-
7	P	-
8	W	-
9	LG	- [With rear anti-pinch system] - [Without rear anti-pinch system]
9	GR	- [With rear anti-pinch system] - [Without rear anti-pinch system]
15	Y	-
16	BR	-
17	LG	-
18	BG	-
20	L	-
21	P	-
22	L	-
23	P	-
24	V	-
25	SB	-
26	G	-
27	W	-
28	R	-
31	V	-
32	SB	-
33	SHIELD	-
34	W	-
35	BR	-
36	Y	-
37	SHIELD	-
38	Y	-
39	SB	-
40	P	-
41	L	-
42	SHIELD	-
43	R	-
44	G	-
45	SHIELD	-
46	SB	-

55	BR	-
56	P	-
58	V	-
59	SB	-
60	GR	-
61	W	-
62	R	-
63	L	-
64	Y	-
65	SHIELD	-
71	BG	-
72	GR	-
73	P	-
74	L	-
81	V	-
82	B	-
84	Y	-
85	G	-
86	W	-
87	R	-
88	BR	-
89	Y	-
90	SB	-
91	EG	-
92	BR	-
93	P	-
95	BG	-
96	Y	-
100	GR	-

Connector No.	B59
Connector Name	WIRE TO WIRE
Connector Type	NS10FW-CS

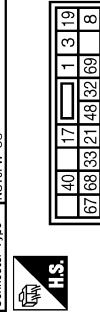

Terminal No.	Color of Wire	Signal Name [Specification]
1	BG	-
3	L	-
8	Y	-
17	LG	-
19	P	-
21	Y	-
32	B	-

33	L	-
40	BR	-
48	B	-
67	BG	-
68	GR	-
69	R	-

Connector No.	B82
Connector Name	WIRE TO WIRE
Connector Type	MD8FW-LC

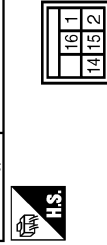

Terminal No.	Color of Wire	Signal Name [Specification]
1	L	-
2	B	-
14	BG	-
15	GR	-
16	R	-

Connector No.	B201
Connector Name	WIRE TO WIRE
Connector Type	TH80FW-CS16-TM4

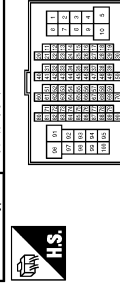

Terminal No.	Color of Wire	Signal Name [Specification]
1	BR	-
3	W	-
5	P	-
6	L	-
7	V	-
9	LG	-
10	L	-
31	L	-
32	P	-

33	G	-
34	R	-
40	GR	-
41	LG	-
42	BG	-
43	R	-
45	G	-
46	SHIELD	-
47	G	-
48	Y	-
49	SHIELD	-
50	W	-
71	R	-
72	V	-
80	BG	-
81	SHIELD	-
82	G	-
83	P	-
84	L	-
85	SHIELD	-
86	G	-
87	R	-
88	W	-
89	B	-
90	Y	-
91	V	-
92	W	- [With rear anti-pinch system] - [Without rear anti-pinch system]
93	BG	- [With rear anti-pinch system] - [Without rear anti-pinch system]
93	BR	- [Without rear anti-pinch system]
94	R	-
95	SB	-
96	G	-
97	GR	-
98	BR	-
69	P	-
100	L	-

A
B
C
D
E
F
G
H
I
SE
K
L
M
N
O
P

HEATED SEAT CONTROL UNIT

< ECU DIAGNOSIS INFORMATION >

HEATED SEAT (WITH A/T)

Terminal No.	Color of Wire	Signal Name [Specification]
1	R	-
2	B	-
14	L	-
15	V	-
16	BR	-

Connector No.	B209
Connector Name	WIRE TO WIRE
Connector Type	M08FW-LC

Terminal No.	1	2
Color of Wire	R	B

Connector No.	B423
Connector Name	WIRE TO WIRE
Connector Type	M02MW-LC

Terminal No.	1	2
Color of Wire	-	-

Connector No.	B424
Connector Name	WIRE TO WIRE
Connector Type	M02FW-LC

Terminal No.	1	2
Color of Wire	-	-

Connector No.	B425
Connector Name	WIRE TO WIRE
Connector Type	M02MW-LC

Terminal No.	1	2
Color of Wire	-	-

Connector No.	B426
Connector Name	WIRE TO WIRE
Connector Type	M02MW-LC

Terminal No.	1	2
Color of Wire	-	-

Connector No.	B427
Connector Name	WIRE TO WIRE
Connector Type	M02FW-LC

Terminal No.	1	2
Color of Wire	-	-

Connector No.	B428
Connector Name	WIRE TO WIRE
Connector Type	M02FW-LC

Terminal No.	1	2
Color of Wire	-	-

Connector No.	B429
Connector Name	WIRE TO WIRE
Connector Type	M08MW-LC

Terminal No.	1	2
Color of Wire	-	-

Connector No.	B440
Connector Name	HEATED SEAT CONTROL UNIT
Connector Type	174923-1

Terminal No.	2	4	14	16	17	18
Color of Wire	B	B	L/W	R/W	R/L	R/B
Signal Name [Specification]	GND	HEATER (+)	HEATER SW	THERMISTOR INPUT	HEATER (-)	THERMISTOR OUTPUT

Connector No.	B441
Connector Name	SEAT CUSHION HEATER
Connector Type	S04FW

Terminal No.	2	18
Color of Wire	B	R/W
Signal Name [Specification]	-	-

Connector No.	B444
Connector Name	WIRE TO WIRE
Connector Type	M02FW-LC

Terminal No.	1	2
Color of Wire	-	-
Signal Name [Specification]	-	-

Connector No.	B445
Connector Name	WIRE TO WIRE
Connector Type	M02MW-LC

Terminal No.	1	2
Color of Wire	-	-
Signal Name [Specification]	-	-

JCJWM1665GB

HEATED SEAT CONTROL UNIT

< ECU DIAGNOSIS INFORMATION >

HEATED SEAT (WITH A/T)

Connector No.	B462
Connector Name	WIRE TO WIRE
Connector Type	NS16MW-LC

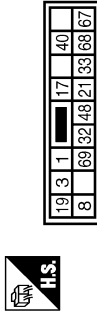

Terminal No.	Color of Wire	Signal Name [Specification]
1	L/W	-
3	R/Y	-
8	LG	-
17	Y/R	-
18	V	-
21	L/Y	-
32	BR/W	-
33	R	-
40	R/W	-
67	R	-
68	L	-
69	BR/W	-

Connector No.	B465
Connector Name	HEATED SEAT CONTROL UNIT
Connector Type	174923-1

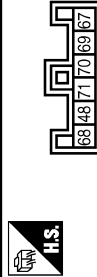

Terminal No.	Color of Wire	Signal Name [Specification]
48	B	GND
67	R	HEATER (+)
68	L/W	HEATER SW [With automatic drive positioner]
69	BR/W	HEATER SW [Without automatic drive positioner]
69	R/W	THERMISTOR INPUT [With automatic drive positioner]
70	L/W	THERMISTOR INPUT [Without automatic drive positioner]
70	R/L	HEATER (+) [With automatic drive positioner]
71	R/B	HEATER (+) [Without automatic drive positioner]
		THERMISTOR OUTPUT

Connector No.	B467
Connector Name	SEAT CUSHION HEATER
Connector Type	SO4FW



Terminal No.	Color of Wire	Signal Name [Specification]
48	B	-
69	BR/W	- [With automatic drive positioner]
69	R/W	- [Without automatic drive positioner]
70	L/W	- [With automatic drive positioner]
70	R/L	- [Without automatic drive positioner]
71	R/B	-

Connector No.	FE106
Connector Name	WIRE TO WIRE
Connector Type	TH86PW-OS16-TM4

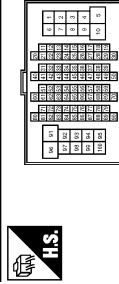

Terminal No.	Color of Wire	Signal Name [Specification]
1	GR	-
3	EG	-
5	G	-
6	Y	-
7	V	-
9	R	-
10	W	-
11	V	-
12	R	-
13	L	-
14	GR	-
15	P	-
16	W	-
17	SB	-
18	BG	-
19	SB	-

20	LG	-
30	BR	-
31	L	-
32	EG	-
33	P	-
34	V	-
35	W	-
36	SB	-
37	Y	-
38	R	-
39	B	-
40	G	-
41	R	-
42	LG	-
43	G	-
44	GR	-
45	BR	-
46	L	-
48	LG	-
47	V	-
48	P	-
49	L	-
59	B	-
66	GR	-
67	LG	-
68	SB	-
69	P	-
70	G	-
80	R	-
81	P	-
82	G	-
83	V	-
84	L	-
85	W	-
86	L	-
87	BR	-
88	GR	-
89	V	-
91	W	-
93	GR	-
95	LG	-
97	SB	-
98	SHIELD	-
99	L	-
100	P	-

Connector No.	MI
Connector Name	FUSE BLOCK (J/B)
Connector Type	NS30FW-M2



Terminal No.	Color of Wire	Signal Name [Specification]
1A	V	-
2A	G	-
3A	L	-
4A	P	-
5A	L	-
6A	Y	-
7A	R	-
8A	L	-

A
B
C
D
E
F
G
H
I
SE
K
L
M
N
O
P

HEATED SEAT CONTROL UNIT

< ECU DIAGNOSIS INFORMATION >

HEATED SEAT (WITH A/T)

Connector No.	M5
Connector Name	WIRE TO WIRE
Connector Type	TH80MW-CS16-TM4



Terminal No.	Color of Wire	Signal Name [Specification]
1	BG	-
3	R	-
5	G	-
6	LG	-
7	W	-
9	G	-
10	W	-
11	V	-
12	R	-
13	L	-
14	GR	-
15	P	-
16	W	-
17	BR	-
18	P	-
19	L	-
20	L	-
30	BR	-
31	L	-
32	Y	-
33	BG	-
34	W	-
35	BR	-
36	R	-
37	Y	-
38	R	-
40	G	-
41	V	-
42	LG	-
43	P	-
44	B	- [With A/T]
44	R	- [With M/T]
45	BG	-
46	G	-
47	L	-
48	P	-
48	L	-

59	B	-
66	Y	-
67	G	-
68	R	-
69	W	-
70	G	-
80	SB	-
81	B	-
82	V	-
83	W	-
84	L	-
85	GR	-
86	G	-
87	R	-
88	B	-
89	LG	-
91	W	-
93	Y	-
95	Y	-
97	GR	-
98	SHIELD	-
99	V	-
100	SB	-

Connector No.	M7
Connector Name	WIRE TO WIRE
Connector Type	TH80MW-CS16-TM4



Terminal No.	Color of Wire	Signal Name [Specification]
1	GR	-
2	P	-
3	SB	- [With automatic drive positioner]
3	P	- [Without automatic drive positioner]
4	Y	-
6	L	-
7	W	-
8	G	- [With rear anti-pinch system]
8	Y	- [Without rear anti-pinch system]
9	Y	- [With rear anti-pinch system]
9	G	- [Without rear anti-pinch system]
15	R	-
16	BR	-

93	P	-
95	BG	-
96	V	-
100	P	-

Connector No.	M70
Connector Name	HEATED SEAT RELAY
Connector Type	MS02FL-M2-LC



Terminal No.	Color of Wire	Signal Name [Specification]
1	G	-
2	P	-
3	G	-
5	LG	-

17	P	-
18	V	-
20	L	-
21	P	-
22	L	-
23	P	-
24	V	-
25	LG	-
26	BR	-
27	BG	-
28	LG	-
31	V	-
32	LG	-
33	SHIELD	-
34	GR	-
35	BR	-
36	Y	-
37	SHIELD	-
38	SB	-
39	LG	-
40	O	-
41	W	-
42	SHIELD	-
43	R	-
44	G	-
45	SHIELD	-
46	SB	-
55	W	-
56	B	-
58	V	-
59	Y	-
60	Y	-
61	W	-
62	R	-
63	G	-
64	B	-
65	SHIELD	-
71	V	-
72	P	-
73	SB	-
74	V	-
81	W	-
82	BR	-
84	LG	-
85	BG	-
86	SB	-
87	G	-
88	GR	-
89	L	-
90	P	-
91	BG	-
92	L	-

HEATED SEAT CONTROL UNIT

< ECU DIAGNOSIS INFORMATION >

HEATED SEAT (WITH A/T)

Connector No.	M117
Connector Name	WIRE TO WIRE
Connector Type	TH80MW-CS (F-TM4)

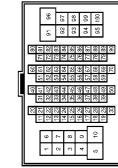

Terminal No.	Color of Wire	Signal Name [Specification]
1	LG	-
2	SB	-
3	P	-
4	G	-
5	SB	-
6	LG	-
7	L	-
8	L	-
9	L	-
10	L	-
31	SB	-
32	LG	-
33	SB	-
34	LG	-
40	Y	-
41	G	-
42	LG	-
43	R	-
45	G	-
46	SHIELD	-
47	P	-
48	L	-
48	SHIELD	-
50	V	-
71	R	-
72	L	-
80	W	-
81	SHIELD	-
82	P	-
83	L	-
84	G	-
85	SHIELD	-
86	W	-
87	B	-
88	R	-
89	G	-
90	Y	-
91	V	-
92	BR	- [With rear anti-pinch system]
92	LG	- [Without rear anti-pinch system]
93	V	- [With rear anti-pinch system]
		- [Without rear anti-pinch system]

93	W	- [Without rear anti-pinch system]
94	Y	-
95	G	-
96	G	-
97	R	-
98	EG	-
99	P	-
100	L	-

Connector No.	M141
Connector Name	HEATED SEAT SWITCH (DRIVER SIDE)
Connector Type	TK10FW

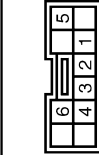

Terminal No.	Color of Wire	Signal Name [Specification]
1	L	-
2	GR	-
3	R	-
4	B	-
5	G	-
6	B	-

Connector No.	M142
Connector Name	HEATED SEAT SWITCH (PASSENGER SIDE)
Connector Type	TK08FBR

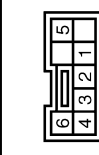

Terminal No.	Color of Wire	Signal Name [Specification]
1	LG	-
2	SB	-
3	V	-
4	B	-
5	EG	-
6	B	-

JCJWM1668GB

A
B
C
D
E
F
G
H
I
SE
K
L
M
N
O
P

HEATED SEAT DOES NOT OPERATE

< SYMPTOM DIAGNOSIS >

SYMPTOM DIAGNOSIS

HEATED SEAT DOES NOT OPERATE BOTH SIDES

BOTH SIDES : Diagnosis Procedure

INFOID:000000006207405

1. CHECK HEATED SEAT SWITCH POWER SUPPLY

Check heated seat switch power supply.

Refer to [SE-13, "HEATED SEAT SWITCH : Diagnosis Procedure"](#).

Is the inspection result normal?

YES >> GO TO 2.

NO >> Repair or replace the malfunctioning parts.

2. CHECK HEATED SEAT RELAY

Check heated seat relay.

Refer to [SE-20, "Component Function Check"](#).

Is the inspection result normal?

YES >> GO TO 3.

NO >> Repair or replace the malfunctioning parts.

3. CHECK HEATED SEAT CONTROL UNIT POWER SUPPLY AND GROUND CIRCUIT

Check heated seat switch power supply and ground circuit.

Refer to [SE-11, "HEATED SEAT CONTROL UNIT : Diagnosis Procedure"](#).

Is the inspection result normal?

YES >> GO TO 4.

NO >> Repair or replace the malfunctioning parts.

4. CONFIRM THE OPERATION

Confirm the operation again.

Is the inspection result normal?

YES >> Check intermittent incident. Refer to [GI-43, "Intermittent Incident"](#).

NO >> GO TO 1.

DRIVER SIDE

DRIVER SIDE : Diagnosis Procedure

INFOID:000000006207406

1. CHECK HEATED SEAT SWITCH POWER SUPPLY

Check heated seat switch power supply.

Refer to [SE-13, "HEATED SEAT SWITCH : Diagnosis Procedure"](#).

Is the inspection result normal?

YES >> GO TO 2.

NO >> Repair or replace the malfunctioning parts.

2. CHECK HEATED SEAT CONTROL UNIT POWER SUPPLY AND GROUND CIRCUIT

Check heated seat switch power supply and ground circuit.

Refer to [SE-11, "HEATED SEAT CONTROL UNIT : Diagnosis Procedure"](#).

Is the inspection result normal?

YES >> GO TO 3.

NO >> Repair or replace the malfunctioning parts.

3. CHECK HEATED SEAT SWITCH

Check heated seat switch.

Refer to [SE-16, "DRIVER SIDE : Component Function Check"](#).

Is the inspection result normal?

HEATED SEAT DOES NOT OPERATE

< SYMPTOM DIAGNOSIS >

- YES >> GO TO 4.
- NO >> Repair or replace the malfunctioning parts.

4.CHECK SEAT CUSHION HEATER

Check seat cushion heater.
Refer to [SE-27. "DRIVER SIDE : Component Function Check"](#).

Is the inspection result normal?

- YES >> GO TO 5.
- NO >> Repair or replace the malfunctioning parts.

5.CONFIRM THE OPERATION

Confirm the operation again.

Is the inspection result normal?

- YES >> Check intermittent incident. Refer to [GI-43. "Intermittent Incident"](#).
- NO >> GO TO 1.

PASSENGER SIDE

PASSENGER SIDE : Diagnosis Procedure

INFOID:000000006207407

1.CHECK HEATED SEAT SWITCH POWER SUPPLY

Check heated seat switch power supply.
Refer to [SE-13. "HEATED SEAT SWITCH : Diagnosis Procedure"](#).

Is the inspection result normal?

- YES >> GO TO 2.
- NO >> Repair or replace the malfunctioning parts.

2.CHECK HEATED SEAT CONTROL UNIT POWER SUPPLY AND GROUND CIRCUIT

Check heated seat switch power supply and ground circuit.
Refer to [SE-11. "HEATED SEAT CONTROL UNIT : Diagnosis Procedure"](#).

Is the inspection result normal?

- YES >> GO TO 3.
- NO >> Repair or replace the malfunctioning parts.

3.CHECK HEATED SEAT SWITCH

Check heated seat switch.
Refer to [SE-17. "PASSENGER SIDE : Component Function Check"](#).

Is the inspection result normal?

- YES >> GO TO 4.
- NO >> Repair or replace the malfunctioning parts.

4.CHECK SEAT CUSHION HEATER

Check seat cushion heater.
Refer to [SE-28. "PASSENGER SIDE : Component Function Check"](#).

Is the inspection result normal?

- YES >> GO TO 5.
- NO >> Repair or replace the malfunctioning parts.

5.CONFIRM THE OPERATION

Confirm the operation again.

Is the inspection result normal?

- YES >> Check intermittent incident. Refer to [GI-43. "Intermittent Incident"](#).
- NO >> GO TO 1.

A
B
C
D
E
F
G
H
I
K
L
M
N
O
P

SE

SEATBACK HEATER ONLY DOES NOT OPERATE

< SYMPTOM DIAGNOSIS >

SEATBACK HEATER ONLY DOES NOT OPERATE

DRIVER SIDE

DRIVER SIDE : Diagnosis Procedure

INFOID:000000006207408

1.CHECK SEATBACK HEATER

Check seatback heater.

Refer to [SE-31, "DRIVER SIDE : Component Function Check"](#).

Is the inspection result normal?

YES >> GO TO 2.

NO >> Repair or replace the malfunctioning parts.

2.CONFIRM THE OPERATION

Confirm the operation again.

Is the inspection result normal?

YES >> Check intermittent incident. Refer to [GI-43, "Intermittent Incident"](#).

NO >> GO TO 1.

PASSENGER SIDE

PASSENGER SIDE : Diagnosis Procedure

INFOID:000000006207409

1.CHECK SEATBACK HEATER

Check seatback heater.

Refer to [SE-31, "PASSENGER SIDE : Component Function Check"](#).

Is the inspection result normal?

YES >> GO TO 2.

NO >> Repair or replace the malfunctioning parts.

2.CONFIRM THE OPERATION

Confirm the operation again.

Is the inspection result normal?

YES >> Check intermittent incident. Refer to [GI-43, "Intermittent Incident"](#).

NO >> GO TO 1.

CANNOT ADJUST HEATED SEAT TEMPERATURE

< SYMPTOM DIAGNOSIS >

CANNOT ADJUST HEATED SEAT TEMPERATURE DRIVER SIDE

DRIVER SIDE : Diagnosis Procedure

INFOID:000000006207410

1.CHECK HEATED SEAT SWITCH

Check heated seat switch.

Refer to [SE-16, "DRIVER SIDE : Component Function Check"](#).

Is the inspection result normal?

YES >> GO TO 2.

NO >> Repair or replace the malfunctioning parts.

2.CHECK HEAT SENSOR

Check heat sensor.

Refer to [SE-22, "DRIVER SIDE : Component Function Check"](#).

Is the inspection result normal?

YES >> GO TO 3.

NO >> Repair or replace the malfunctioning parts.

3.CONFIRM THE OPERATION

Confirm the operation again.

Is the inspection result normal?

YES >> Check intermittent incident. Refer to [GI-43, "Intermittent Incident"](#).

NO >> Replace heated seat control unit. Refer to [SE-136, "Removal and Installation"](#).

PASSENGER SIDE

PASSENGER SIDE : Diagnosis Procedure

INFOID:000000006207411

1.CHECK HEATED SEAT SWITCH

Check heated seat switch.

Refer to [SE-17, "PASSENGER SIDE : Component Function Check"](#).

Is the inspection result normal?

YES >> GO TO 2.

NO >> Repair or replace the malfunctioning parts.

2.CHECK HEAT SENSOR

Check heat sensor.

Refer to [SE-24, "PASSENGER SIDE : Component Function Check"](#).

Is the inspection result normal?

YES >> GO TO 3.

NO >> Repair or replace the malfunctioning parts.

3.CONFIRM THE OPERATION

Confirm the operation again.

Is the inspection result normal?

YES >> Check intermittent incident. Refer to [GI-43, "Intermittent Incident"](#).

NO >> Replace heated seat control unit. Refer to [SE-136, "Removal and Installation"](#).

A
B
C
D
E
F
G
H
I
SE
K
L
M
N
O
P

HEATED SEAT SWITCH INDICATOR DOES NOT TURN ON

< SYMPTOM DIAGNOSIS >

HEATED SEAT SWITCH INDICATOR DOES NOT TURN ON DRIVER SIDE

DRIVER SIDE : Diagnosis Procedure

INFOID:000000006207412

1. CHECK HEATED SEAT SWITCH INDICATOR

Check heated seat switch indicator.

Refer to [SE-33, "DRIVER SIDE : Component Function Check"](#).

Is the inspection result normal?

YES >> GO TO 2.

NO >> Repair or replace the malfunctioning parts.

2. CONFIRM THE OPERATION

Confirm the operation again.

Is the inspection result normal?

YES >> Check intermittent incident. Refer to [GI-43, "Intermittent Incident"](#).

NO >> GO TO 1.

PASSENGER SIDE

PASSENGER SIDE : Diagnosis Procedure

INFOID:000000006207413

1. CHECK HEATED SEAT SWITCH INDICATOR

Check heated seat switch indicator.

Refer to [SE-33, "PASSENGER SIDE : Component Function Check"](#).

Is the inspection result normal?

YES >> GO TO 2.

NO >> Repair or replace the malfunctioning parts.

2. CONFIRM THE OPERATION

Confirm the operation again.

Is the inspection result normal?

YES >> Check intermittent incident. Refer to [GI-43, "Intermittent Incident"](#).

NO >> GO TO 1.

STEERING POSITION FUNCTION DOES NOT OPERATE

< SYMPTOM DIAGNOSIS >

STEERING POSITION FUNCTION DOES NOT OPERATE

Diagnosis Procedure

INFOID:000000006207414

1. CHECK AUTOMATIC DRIVE POSITIONER CONTROL UNIT POWER SUPPLY AND GROUND CIRCUIT

Check automatic drive positioner control unit power supply and ground circuit.

Refer to [ADP-66. "AUTOMATIC DRIVE POSITIONER CONTROL UNIT : Diagnosis Procedure"](#).

Is the inspection result normal?

YES >> GO TO 2.

NO >> Repair or replace the malfunctioning parts.

2. CHECK TILT AND TELESCOPIC SWITCH

Check tilt and telescopic switch.

Refer to [SE-35. "Component Function Check"](#).

Is the inspection result normal?

YES >> GO TO 3.

NO >> Repair or replace the malfunctioning parts.

3. CHECK TILT AND TELESCOPIC SENSOR

Check tilt and telescopic sensor.

Refer to [SE-40. "Component Function Check"](#).

Is the inspection result normal?

YES >> Check intermittent incident. Refer to [GI-43. "Intermittent Incident"](#).

NO >> Repair or replace the malfunctioning parts.

A
B
C
D
E
F
G
H
I
K
L
M
N
O
P

SE

TILT FUNCTION DOES NOT OPERATE

< SYMPTOM DIAGNOSIS >

TILT FUNCTION DOES NOT OPERATE

Diagnosis Procedure

INFOID:000000006207415

1. CHECK TILT AND TELESCOPIC SWITCH

Check tilt switch.

Refer to [SE-35, "Component Function Check"](#).

Is the inspection result normal?

YES >> GO TO 2.

NO >> Repair or replace the malfunctioning parts.

2. CHECK TILT AND TELESCOPIC MOTOR

Check tilt motor.

Refer to [SE-38, "Component Function Check"](#).

Is the inspection result normal?

YES >> GO TO 3.

NO >> Repair or replace the malfunctioning parts.

3. CHECK TILT AND TELESCOPIC SENSOR

Check tilt sensor.

Refer to [SE-40, "Component Function Check"](#).

Is the inspection result normal?

YES >> Check intermittent incident. Refer to [GI-43, "Intermittent Incident"](#).

NO >> Repair or replace the malfunctioning parts.

TELESCOPIC FUNCTION DOES NOT OPERATE

< SYMPTOM DIAGNOSIS >

TELESCOPIC FUNCTION DOES NOT OPERATE

Diagnosis Procedure

INFOID:000000006207416

1. CHECK TILT AND TELESCOPIC SWITCH

Check telescopic switch.

Refer to [SE-35. "Component Function Check"](#).

Is the inspection result normal?

YES >> GO TO 2.

NO >> Repair or replace the malfunctioning parts.

2. CHECK TILT AND TELESCOPIC MOTOR

Check telescopic motor.

Refer to [SE-38. "Component Function Check"](#).

Is the inspection result normal?

YES >> GO TO 3.

NO >> Repair or replace the malfunctioning parts.

3. CHECK TILT AND TELESCOPIC SENSOR

Check telescopic sensor.

Refer to [SE-40. "Component Function Check"](#).

Is the inspection result normal?

YES >> Check intermittent incident. Refer to [GI-43. "Intermittent Incident"](#).

NO >> Repair or replace the malfunctioning parts.

A
B
C
D
E
F
G
H
I
K
L
M
N
O
P

SE

SQUEAK AND RATTLE TROUBLE DIAGNOSES

< SYMPTOM DIAGNOSIS >

SQUEAK AND RATTLE TROUBLE DIAGNOSES

Work Flow

INFOID:000000006207417

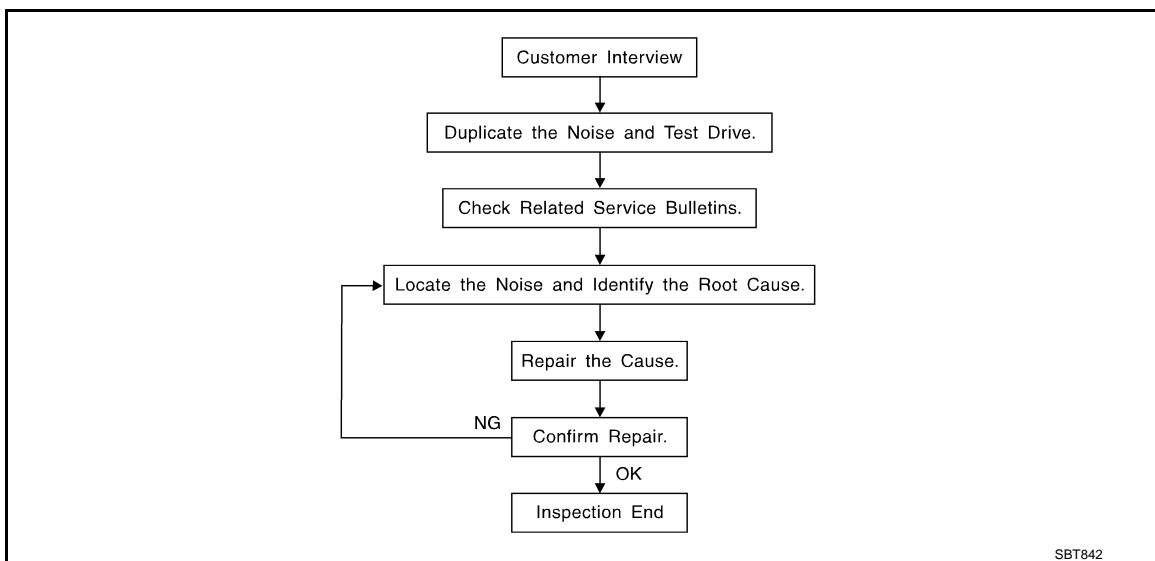

CUSTOMER INTERVIEW

Interview the customer if possible, to determine the conditions that exist when the noise occurs. Use the Diagnostic Worksheet during the interview to document the facts and conditions when the noise occurs and any of customer's comments; refer to [SE-114, "Diagnostic Worksheet"](#). This information is necessary to duplicate the conditions that exist when the noise occurs.

- The customer may not be able to provide a detailed description or the location of the noise. Attempt to obtain all the facts and conditions that exist when the noise occurs (or does not occur).
- If there is more than one noise in the vehicle, perform a diagnosis and repair the noise that the customer is concerned about. This can be accomplished by performing a cruise test on the vehicle with the customer.
- After identifying the type of noise, isolate the noise in terms of its characteristics. The noise characteristics are provided so the customer, service adviser and technician are all speaking the same language when defining the noise.
- Squeak – (Like tennis shoes on a clean floor)
Squeak characteristics include the light contact/fast movement/brought on by road conditions/hard surfaces = higher pitch noise/softer surfaces = lower pitch noises/edge to surface = chirping
- Creak – (Like walking on an old wooden floor)
Creak characteristics include firm contact/slow movement/twisting with a rotational movement/pitch dependent on materials/often brought on by activity.
- Rattle – (Like shaking a baby rattle)
Rattle characteristics include the fast repeated contact/vibration or similar movement/loose parts/missing clip or fastener/incorrect clearance.
- Knock – (Like a knock on a door)
Knock characteristics include hollow sounding/sometimes repeating/often brought on by driver action.
- Tick – (Like a clock second hand)
Tick characteristics include gentle contacting of light materials/loose components/can be caused by driver action or road conditions.
- Thump – (Heavy, muffled knock noise)
Thump characteristics include softer knock/dead sound often brought on by activity.
- Buzz – (Like a bumblebee)
Buzz characteristics include high frequency rattle/firm contact.
- Often the degree of acceptable noise level will vary depending up on the person. A noise that a technician may judge as acceptable may be very irritating to the customer.
- Weather conditions, especially humidity and temperature, may have a great effect on noise level.

DUPLICATE THE NOISE AND TEST DRIVE

If possible, drive the vehicle with the customer until the noise is duplicated. Note any additional information on the Diagnostic Worksheet regarding the conditions or location of the noise. This information can be used to duplicate the same conditions when the repair is reconfirmed.

SQUEAK AND RATTLE TROUBLE DIAGNOSES

< SYMPTOM DIAGNOSIS >

If the noise can be duplicated easily during the test drive, to help identify the source of the noise, try to duplicate the noise with the vehicle stopped by doing one or all of the following:

- 1) Close a door.
 - 2) Tap or push/pull around the area where the noise appears to be coming from.
 - 3) Rev the engine.
 - 4) Use a floor jack to recreate vehicle "twist".
 - 5) At idle, apply engine load (electrical load, half-clutch on M/T models, drive position on A/T models).
 - 6) Raise the vehicle on a hoist and hit a tire with a rubber hammer.
- Drive the vehicle and attempt to duplicate the conditions the customer states exist when the noise occurs.
 - If it is difficult to duplicate the noise, drive the vehicle slowly on an undulating or rough road to stress the vehicle body.

CHECK RELATED SERVICE BULLETINS

After verifying the customer concern or symptom, check ASIST for Technical Service Bulletins (TSBs) related to that concern or symptom.

If a TSB relates to the symptom, follow the procedure to repair the noise.

LOCATE THE NOISE AND IDENTIFY THE ROOT CAUSE

1. Narrow down the noise to a general area. To help pinpoint the source of the noise, use a listening tool (Chassis ear: J-39570, Engine ear and mechanics stethoscope).
2. Narrow down the noise to a more specific area and identify the cause of the noise by:
 - Removing the components in the area that is are suspected to be the cause of the noise.
Do not use too much force when removing clips and fasteners, otherwise clips and fastener can be broken or lost during the repair, resulting in the creation of new noise.
 - Tapping or pushing/pulling the component that is are suspected to be the cause of the noise.
Do not tap or push/pull the component with excessive force, otherwise the noise will be eliminated only temporarily.
 - Feeling for a vibration by hand by touching the component(s) that is are suspected to be the cause of the noise.
 - Placing a piece of paper between components that are suspected to be the cause of the noise.
 - Looking for loose components and contact marks.
Refer to [SE-112, "Inspection Procedure"](#).

REPAIR THE CAUSE

- If the cause is a loose component, tighten the component securely.
- If the cause is insufficient clearance between components:
 - Separate components by repositioning or loosening and retightening the component, if possible.
 - Insulate components with a suitable insulator such as urethane pads, foam blocks, felt cloth tape or urethane tape. A Nissan Squeak and Rattle Kit (J-43980) is available through the authorized Nissan Parts Department.

CAUTION:

Never use excessive force as many components are constructed of plastic and may be damaged.

NOTE:

Always check with the Parts Department for the latest parts information.

The following materials are contained in the Nissan Squeak and Rattle Kit (J-43980). Each item can be ordered separately as needed.

URETHANE PADS [1.5 mm (0.059 in) thick]

Insulates connectors, harness, etc.

76268-9E005: 100 × 135 mm (3.94 × 5.31 in)/76884-71L01: 60 × 85 mm (2.36 × 3.35 in)/76884-71L02: 15 × 25 mm (0.59 × 0.98 in)

INSULATOR (Foam blocks)

Insulates components from contact. Can be used to fill space behind a panel.

73982-9E000: 45 mm (1.77 in) thick, 50 × 50 mm (1.97 × 1.97 in)/73982-

50Y00: 10 mm (0.39 in) thick, 50 × 50 mm (1.97 × 1.97 in)

INSULATOR (Light foam block)

80845-71L00: 30 mm (1.18 in) thick, 30 × 50 mm (1.18 × 1.97in)

FELT CLOTHTAPE

Used to insulate where movement does not occur. Ideal for instrument panel applications.

68370-4B000: 15 × 25 mm (0.59 × 0.98 in) pad/68239-13E00: 5 mm (0.20 in) wide tape roll

The following materials, not found in the kit, can also be used to repair squeaks and rattles.

UHMW (TEFLON) TAPE

SQUEAK AND RATTLE TROUBLE DIAGNOSES

< SYMPTOM DIAGNOSIS >

Insulates where slight movement is present. Ideal for instrument panel applications.

SILICONE GREASE

Used in place of UHMW tape that is be visible or does not fit. Will only last a few months.

SILICONE SPRAY

Used when grease cannot be applied.

DUCT TAPE

Used to eliminate movement.

CONFIRM THE REPAIR

Confirm that the cause of a noise is repaired by test driving the vehicle. Operate the vehicle under the same conditions as when the noise originally occurred. Refer to the notes on the Diagnostic Worksheet.

Inspection Procedure

INFOID:000000006207418

Refer to Table of Contents for specific component removal and installation information.

INSTRUMENT PANEL

Most incidents are caused by contact and movement between:

1. The cluster lid A and instrument panel
2. Acrylic lens and combination meter housing
3. Instrument panel to front pillar garnish
4. Instrument panel to windshield
5. Instrument panel mounting pins
6. Wiring harnesses behind the combination meter
7. A/C defroster duct and duct joint

These incidents can usually be located by tapping or moving the components to duplicate the noise or by pressing on the components while driving to stop the noise. Most of these incidents can be repaired by applying felt cloth tape or silicon spray (in hard to reach areas). Urethane pads can be used to insulate wiring harness.

CAUTION:

Never use silicone spray to isolate a squeak or rattle. If the area is saturated with silicone, the recheck of repair becomes impossible.

CENTER CONSOLE

Components to pay attention to include:

1. Shifter assembly cover to finisher
2. A/C control unit and cluster lid C
3. Wiring harnesses behind audio and A/C control unit

The instrument panel repair and isolation procedures also apply to the center console.

DOORS

Pay attention to the following:

1. Finisher and inner panel making a slapping noise
2. Inside handle escutcheon to door finisher
3. Wiring harnesses tapping
4. Door striker out of alignment causing a popping noise on starts and stops

Tapping or moving the components or pressing on them while driving to duplicate the conditions can isolate many of these incidents. The areas can usually be insulated with felt cloth tape or insulator foam blocks from the Nissan Squeak and Rattle Kit (J-43980) to repair the noise.

TRUNK

Trunk noises are often caused by a loose jack or loose items put into the trunk by the customer.

In addition look for the following:

1. Trunk lid dumpers out of adjustment
2. Trunk lid striker out of adjustment
3. The trunk lid torsion bars knocking together
4. A loose license plate or bracket

SQUEAK AND RATTLE TROUBLE DIAGNOSES

< SYMPTOM DIAGNOSIS >

Most of these incidents can be repaired by adjusting, securing or insulating the item(s) or component(s) causing the noise.

SUNROOF/HEADLINING

Noises in the sunroof/headlining area can often be traced to one of the following:

1. Sunroof lid, rail, linkage or seals making a rattle or light knocking noise
2. Sunvisor shaft shaking in the holder
3. Front or rear windshield touching headlining and squeaking

Again, pressing on the components to stop the noise while duplicating the conditions can isolate most of these incidents. Repairs usually consist of insulating with felt cloth tape.

SEATS

When isolating seat noise it's important to note the position the seats in and the load placed on the seat when the noise occurs. These conditions should be duplicated when verifying and isolating the cause of the noise.

Cause of seat noise include:

1. Headrest rods and holder
2. A squeak between the seat pad cushion and frame
3. The rear seatback lock and bracket

These noises can be isolated by moving or pressing on the suspected components while duplicating the conditions under which the noise occurs. Most of these incidents can be repaired by repositioning the component or applying urethane tape to the contact area.

UNDERHOOD

Some interior noise may be caused by components under the hood or on the engine wall. The noise is then transmitted into the passenger compartment.

Causes of transmitted underhood noise include:

1. Any component mounted to the engine wall
2. Components that pass through the engine wall
3. Engine wall mounts and connectors
4. Loose radiator mounting pins
5. Hood bumpers out of adjustment
6. Hood striker out of adjustment

These noises can be difficult to isolate since they cannot be reached from the interior of the vehicle. The best method is to secure, move or insulate one component at a time and test drive the vehicle. Also, engine RPM or load can be changed to isolate the noise. Repairs can usually be made by moving, adjusting, securing, or insulating the component causing the noise.

A
B
C
D
E
F
G
H
I
K
L
M
N
O
P

SE

SQUEAK AND RATTLE TROUBLE DIAGNOSES

< SYMPTOM DIAGNOSIS >

Diagnostic Worksheet

INFOID:000000006207419



SQUEAK & RATTLE DIAGNOSTIC WORKSHEET

Dear Infiniti Customer:

We are concerned about your satisfaction with your Infiniti vehicle. Repairing a squeak or rattle sometimes can be very difficult. To help us fix your Infiniti right the first time, please take a moment to note the area of the vehicle where the squeak or rattle occurs and under what conditions. You may be asked to take a test drive with a service consultant or technician to ensure we confirm the noise you are hearing.

I. WHERE DOES THE NOISE COME FROM? (circle the area of the vehicle)

The illustrations are for reference only, and may not reflect the actual configuration of your vehicle.

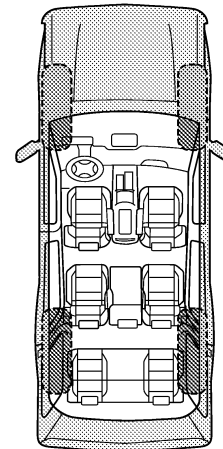
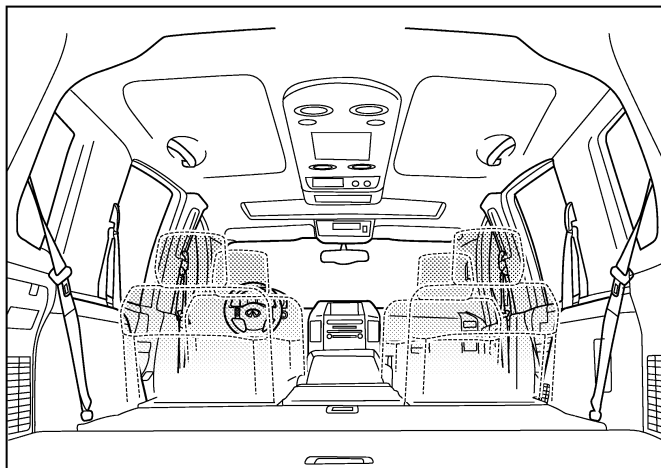
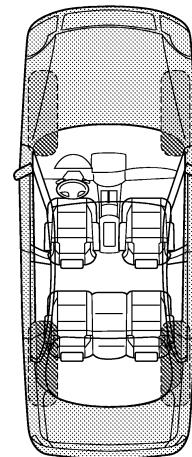
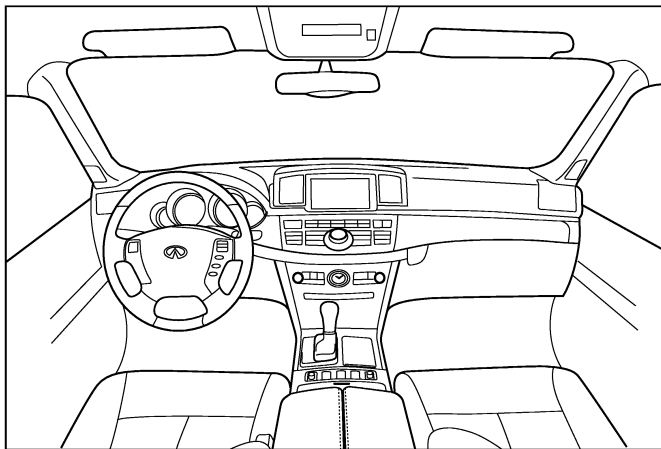

Continue to page 2 of the worksheet and briefly describe the location of the noise or rattle. In addition, please indicate the conditions which are present when the noise occurs.

PIIB8741E

SQUEAK AND RATTLE TROUBLE DIAGNOSES

< SYMPTOM DIAGNOSIS >

SQUEAK & RATTLE DIAGNOSTIC WORKSHEET - page 2

Briefly describe the location where the noise occurs:

II. WHEN DOES IT OCCUR? (please check the boxes that apply)

- | | |
|---|--|
| <input type="checkbox"/> anytime | <input type="checkbox"/> after sitting out in the rain |
| <input type="checkbox"/> 1st time in the morning | <input type="checkbox"/> when it is raining or wet |
| <input type="checkbox"/> only when it is cold outside | <input type="checkbox"/> dry or dusty conditions |
| <input type="checkbox"/> only when it is hot outside | <input type="checkbox"/> other: |

III. WHEN DRIVING:

- through driveways
- over rough roads
- over speed bumps
- only about ____ mph
- on acceleration
- coming to a stop
- on turns: left, right or either (circle)
- with passengers or cargo
- other: _____
- after driving ____ miles or ____ minutes

IV. WHAT TYPE OF NOISE

- squeak (like tennis shoes on a clean floor)
- creak (like walking on an old wooden floor)
- rattle (like shaking a baby rattle)
- knock (like a knock at the door)
- tick (like a clock second hand)
- thump (heavy, muffled knock noise)
- buzz (like a bumble bee)

TO BE COMPLETED BY DEALERSHIP PERSONNEL

Test Drive Notes:

	YES	NO	Initials of person performing
Vehicle test driven with customer	<input type="checkbox"/>	<input type="checkbox"/>	_____
- Noise verified on test drive	<input type="checkbox"/>	<input type="checkbox"/>	_____
- Noise source located and repaired	<input type="checkbox"/>	<input type="checkbox"/>	_____
- Follow up test drive performed to confirm repair	<input type="checkbox"/>	<input type="checkbox"/>	_____

VIN: _____ Customer Name: _____
W.O.# _____ Date: _____

This form must be attached to Work Order

PIIB8742E

A
B
C
D
E
F
G
H
I
SE
K
L
M
N
O
P

PRECAUTIONS

< PRECAUTION >

PRECAUTION

PRECAUTIONS

Precaution for Supplemental Restraint System (SRS) "AIR BAG" and "SEAT BELT PRE-TENSIONER"

INFOID:000000006207420

The Supplemental Restraint System such as "AIR BAG" and "SEAT BELT PRE-TENSIONER", used along with a front seat belt, helps to reduce the risk or severity of injury to the driver and front passenger for certain types of collision. This system includes seat belt switch inputs and dual stage front air bag modules. The SRS system uses the seat belt switches to determine the front air bag deployment, and may only deploy one front air bag, depending on the severity of a collision and whether the front occupants are belted or unbelted. Information necessary to service the system safely is included in the "SRS AIR BAG" and "SEAT BELT" of this Service Manual.

WARNING:

Always observe the following items for preventing accidental activation.

- To avoid rendering the SRS inoperative, which could increase the risk of personal injury or death in the event of a collision that would result in air bag inflation, all maintenance must be performed by an authorized NISSAN/INFINITI dealer.
- Improper maintenance, including incorrect removal and installation of the SRS, can lead to personal injury caused by unintentional activation of the system. For removal of Spiral Cable and Air Bag Module, see "SRS AIR BAG".
- Never use electrical test equipment on any circuit related to the SRS unless instructed to in this Service Manual. SRS wiring harnesses can be identified by yellow and/or orange harnesses or harness connectors.

PRECAUTIONS WHEN USING POWER TOOLS (AIR OR ELECTRIC) AND HAMMERS

WARNING:

Always observe the following items for preventing accidental activation.

- When working near the Air Bag Diagnosis Sensor Unit or other Air Bag System sensors with the ignition ON or engine running, never use air or electric power tools or strike near the sensor(s) with a hammer. Heavy vibration could activate the sensor(s) and deploy the air bag(s), possibly causing serious injury.
- When using air or electric power tools or hammers, always switch the ignition OFF, disconnect the battery, and wait at least 3 minutes before performing any service.

Service Notice

INFOID:000000006207421

- When removing or installing various parts, place a cloth or padding onto the vehicle body to prevent scratches.
- Handle trim, molding, instruments, grille, etc. carefully during removing or installing. Be careful not to oil or damage them.
- Apply sealing compound where necessary when installing parts.
- When applying sealing compound, be careful that the sealing compound does not protrude from parts.
- When replacing any metal parts (for example body outer panel, members, etc.), be sure to take rust prevention measures.

Precaution for Work

INFOID:000000006207422

- When removing or disassembling each component, be careful not to damage or deform it. If a component may be subject to interference, be sure to protect it with a shop cloth.
- When removing (disengaging) components with a screwdriver or similar tool, be sure to wrap the component with a shop cloth or vinyl tape to protect it.
- Protect the removed parts with a shop cloth and keep them.
- Replace a deformed or damaged clip.
- If a part is specified as a non-reusable part, always replace it with new one.
- Be sure to tighten bolts and nuts securely to the specified torque.
- After re-installation is completed, be sure to check that each part works normally.
- Follow the steps below to clean components.
 - Water soluble foul: Dip a soft cloth into lukewarm water, and wring the water out of the cloth to wipe the fouled area.

PRECAUTIONS

< PRECAUTION >

- Then rub with a soft and dry cloth.
- Oily foul: Dip a soft cloth into lukewarm water with mild detergent (concentration: within 2 to 3%), and wipe the fouled area.
Then dip a cloth into fresh water, and wring the water out of the cloth to wipe the detergent off. Then rub with a soft and dry cloth.
- Never use organic solvent such as thinner, benzene, alcohol, and gasoline.
- For genuine leather seats, use a genuine leather seat cleaner.

A

B

C

D

E

F

G

H

I

SE

K

L

M

N

O

P

PREPARATION

< PREPARATION >

PREPARATION

PREPARATION

Special Service Tool

INFOID:000000006207423

The actual shapes of Kent-Moore tools may differ from those of special service tools illustrated here.

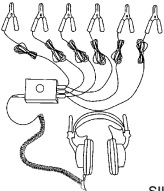
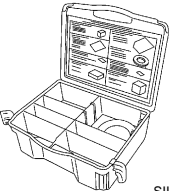
Tool number (Kent-Moore No.) Tool name	Description
<p>(J39570) Chassis ear</p>  <p>SIIA0993E</p>	<p>Locates the noise</p>
<p>(J43980) NISSAN Squeak and Rattle Kit</p>  <p>SIIA0994E</p>	<p>Repairs the cause of noise</p>

Commercial Service Tool

INFOID:000000006207424

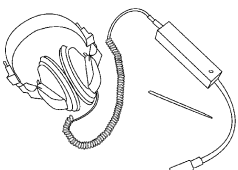
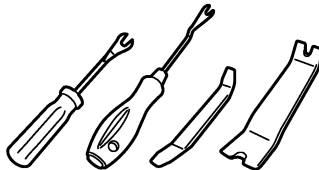
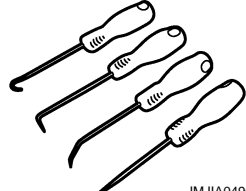
Tool name	Description
<p>Engine ear</p>  <p>SIIA0995E</p>	<p>Locates the noise</p>
<p>Remover tool</p>  <p>JMKIA3050ZZ</p>	<p>Removes the clips, pawls and metal clips</p>
<p>Hook and pick tool</p>  <p>JMJIA0490ZZ</p>	<p>Removes the snap pins</p>

CLIP LIST

< PREPARATION >

CLIP LIST

Clip List

INFOID:000000006207425

Shapes	Removal & Installation	Shapes	Removal & Installation
	<p>Removal: Remove by bending up with flat-bladed screwdrivers or clip remover.</p>		<p>Removal:</p>
	<p>Removal: Remove with a clip remover.</p>		<p>Removal:</p>
	<p>Removal: Push center pin to catching position. (Do not remove center pin by hitting it.)</p> <p>Installation:</p>		<p>Removal: Holder portion of clip must be spread out to remove rod.</p>
	<p>Removal: Remove by bending up with flat-bladed screwdrivers or clip remover.</p>		<p>Removal:</p> <ol style="list-style-type: none"> 1. Screw out with a Phillips screwdriver. 2. Remove female portion with flat-bladed screwdriver.
	<p>Removal:</p>		<p>Removal:</p> <p>Rotate 45° to remove.</p> <p>Installation:</p>
	<p>Removal:</p>		<p>Removal:</p>

JMJIA3734GB

A
B
C
D
E
F
G
H
I
SE
K
L
M
N
O
P

FRONT SEAT

< REMOVAL AND INSTALLATION >

REMOVAL AND INSTALLATION

FRONT SEAT

Exploded View

INFOID:000000006207426

DRIVER'S SEAT

SEC. 870

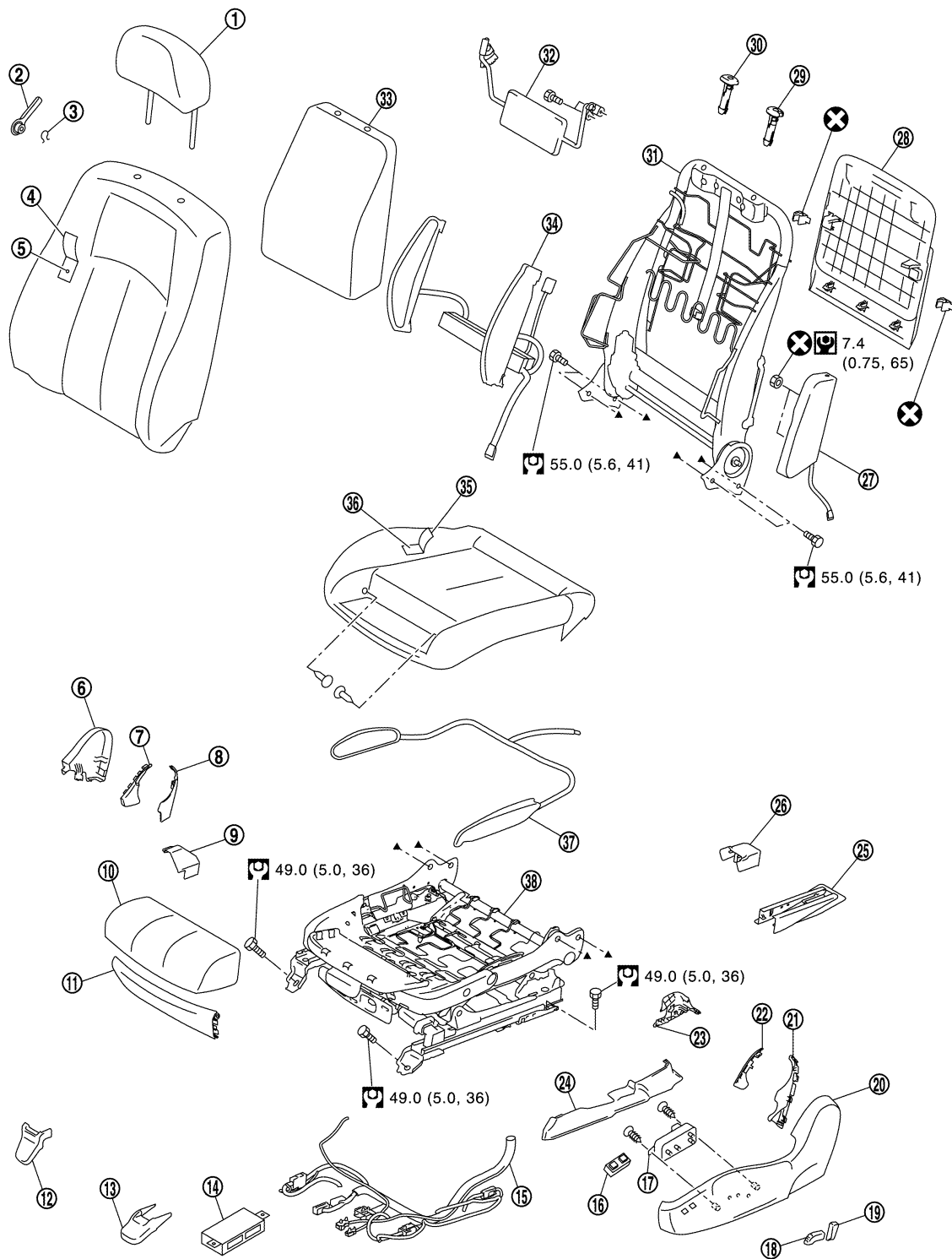

JMJIA5068GB

FRONT SEAT

< REMOVAL AND INSTALLATION >

- | | | | |
|--|--|---|---|
| 1. Headrest | 2. Lumbar support lever knob | 3. Snap ring | A |
| 4. Seatback trim | 5. Seatback pad | 6. Seat cushion inner finisher | |
| 7. Reclining device inner cover (front) | 8. Reclining device inner cover (rear) | 9. Seat slide inner finisher | |
| 10. Thigh extension pad | 11. Seat cushion front finisher | 12. Front inner slide cover | B |
| 13. Front outer slide cover | 14. Seat control unit | 15. Seat harness | |
| 16. Side support switch | 17. Seat control switch | 18. Seat slide and lifter switch knob | |
| 19. Seat reclining switch knob | 20. Seat cushion outer finisher | 21. Reclining device outer cover (rear) | C |
| 22. Reclining device outer cover (front) | 23. Seat slide outer finisher (inside) | 24. Seat slide outer finisher (outside) | |
| 25. Rear outer slide cover | 26. Rear inner slide cover | 27. Side air bag module | |
| 28. Seatback board | 29. Headrest holder (locked) | 30. Headrest holder (free) | D |
| 31. Seatback frame | 32. Lumbar support unit | 33. Seatback silencer | |
| 34. Seatback side support bag and unit | 35. Seat cushion trim | 36. Seat cushion pad | E |
| 37. Seat cushion side support bag | 38. Seat cushion frame | | |

Refer to [GI-4, "Components"](#) for symbols in the figure.

PASSENGER'S SEAT

F

G

H

I

SE

K

L

M

N

O

P

FRONT SEAT

< REMOVAL AND INSTALLATION >

SEC. 870

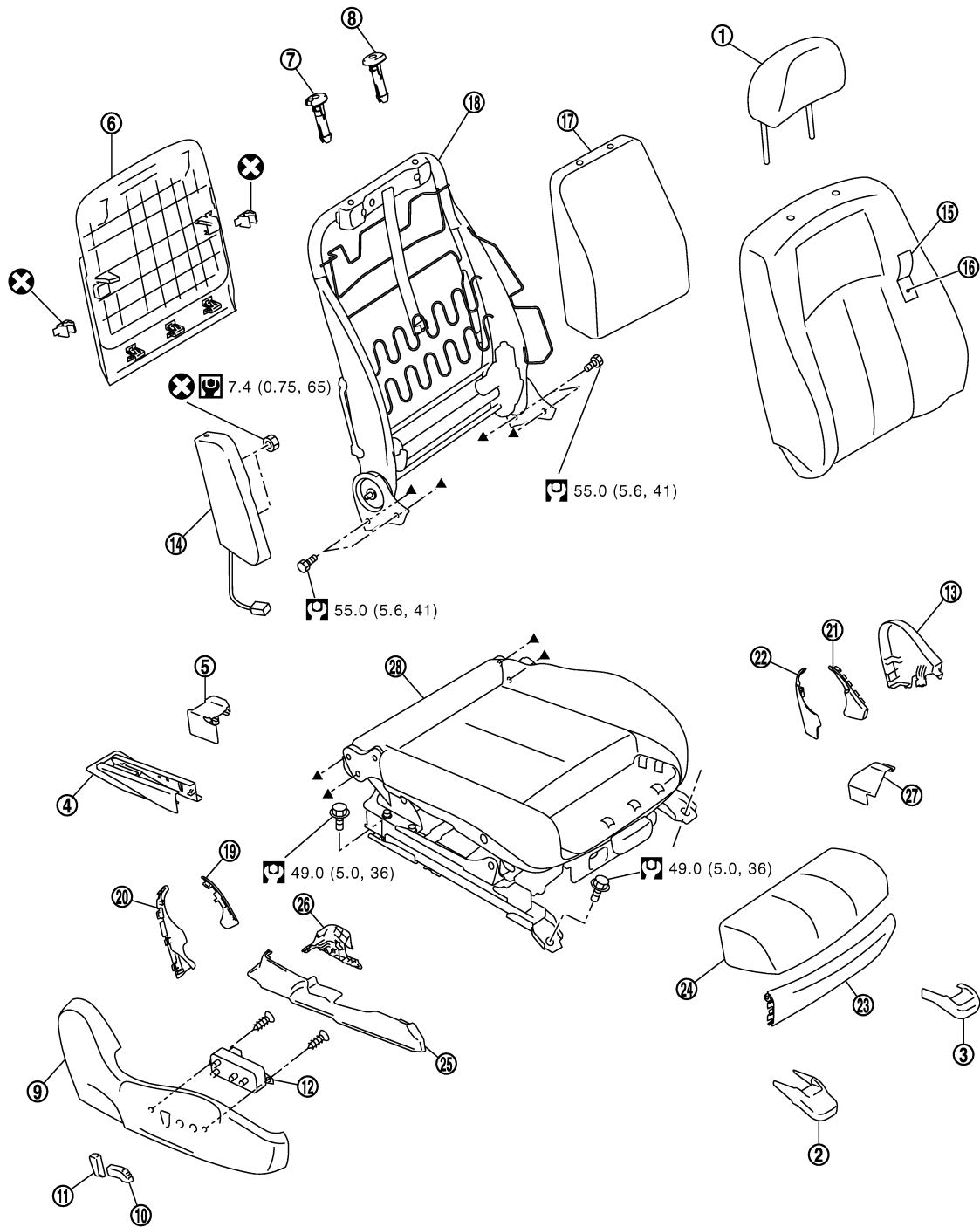

JMJIA1238GB

- | | | |
|---------------------------------------|--------------------------------|--------------------------------|
| 1. Headrest | 2. Front outer slide cover | 3. Front inner slide cover |
| 4. Rear outer slide cover | 5. Rear inner slide cover | 6. Seatback board |
| 7. Headrest holder (free) | 8. Headrest holder (locked) | 9. Seat cushion outer finisher |
| 10. Seat slide and lifter switch knob | 11. Seat reclining switch knob | 12. Seat control switch |
| 13. Seat cushion inner finisher | 14. Side air bag module | 15. Seatback trim |
| 16. Seatback pad | 17. Seatback silencer | 18. Seatback frame |

FRONT SEAT

< REMOVAL AND INSTALLATION >

- | | | |
|--|---|--|
| 19. Reclining device outer cover (front) | 20. Reclining device outer cover (rear) | 21. Reclining device inner cover (front) |
| 22. Reclining device inner cover (rear) | 23. Seat cushion front finisher | 24. Thigh extension pad |
| 25. Seat slide outer finisher (outside) | 26. Seat slide outer finisher (inside) | 27. Seat slide inner finisher |
| 28. Seat cushion assembly | | |

Refer to [GI-4. "Components"](#) for symbols in the figure.

Removal and Installation

INFOID:000000006207427

REMOVAL

CAUTION:

When removing and installing, use shop cloths to protect parts from damage.

1. Remove the headrest.
2. Remove the front slide cover.
 - a. Front outer slide cover
 - Slide the seat to the rearmost position.
 - Pull up the front edge of the front slide cover to release the pawls.
 - Slide the front slide cover forward to release the pawls.

 : Pawl

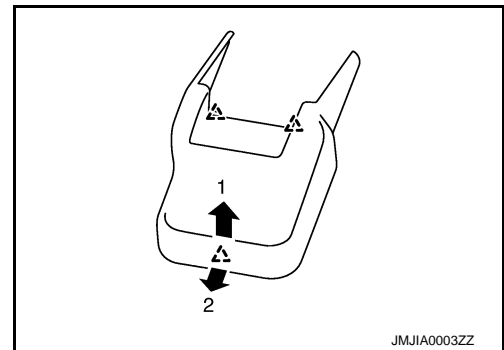

- b. Front inner slide cover
 - Slide the seat to the rearmost position.
 - Pull up the front edge of the front slide cover to release the pawls.
 - Slide the front slide cover forward to release the pawls.

 : Pawl

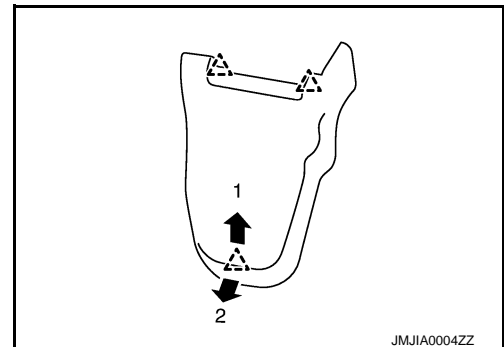

3. Remove the mounting bolts on the front side of the front seat.
4. Remove the rear slide cover.
 - a. Rear outer slide cover
 - Slide the seat to the foremost position.
 - Pull up the rear edge of the rear outer slide cover to release the pawls.
 - Open the front end of the rear outer slide cover to release the pawls.

 : Pawl

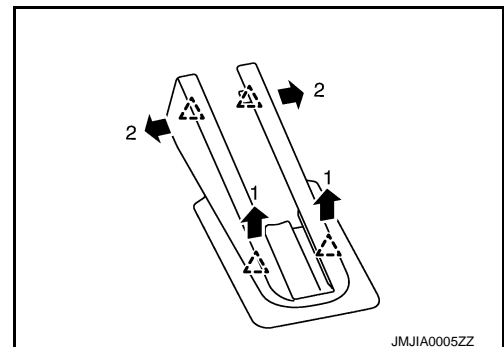

A
B
C
D
E
F
G
H
I
SE
K
L
M
N
O
P

FRONT SEAT

< REMOVAL AND INSTALLATION >

- b. Rear inner slide cover
- Slide the seat to the foremost position.
 - Pull up the rear edge of the rear inner slide cover to release the pawls.
 - Slide the rear inner slide cover rearward to release the pawls.

 : Pawl

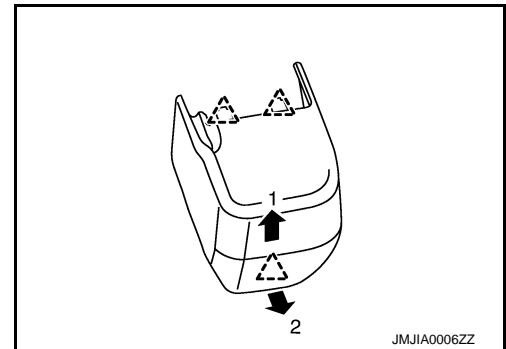

5. Remove the mounting bolts on the rear side of the front seat.
6. Set seatback in a standing position.
7. Disconnect harness connector under the seat and remove harness securing clips.

CAUTION:

Before removal, turn ignition switch OFF, disconnect battery negative terminal and then wait for at least 3 minutes.

8. Remove seat from the vehicle.

CAUTION:

When removing and installing, use shop cloths to protect parts from damage.

INSTALLATION

Install in the reverse order of removal.

CAUTION:

- **Before installation, turn ignition switch OFF, disconnect battery negative terminal and then wait for at least 3 minutes.**
- **Clamp the harness in position.**

NOTE:

After installing the driver seat, perform additional service when removing battery negative terminal. (Automatic drive positioner model only) Refer to [ADP-9, "ADDITIONAL SERVICE WHEN REMOVING BATTERY NEGATIVE TERMINAL : Special Repair Requirement"](#).

Disassembly and Assembly

INFOID:000000006207428

SEATBACK

Disassembly

1. Remove the seat cushion outer finisher.
- Remove the seat slide and lifter switch knob (1) and seat reclining switch knob (2). Using a remover tool (A).

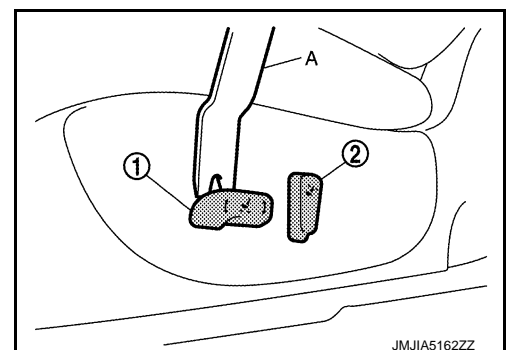

FRONT SEAT

< REMOVAL AND INSTALLATION >

- Remove the metal clips, clips and pawls, and then pull out seat cushion outer finisher.

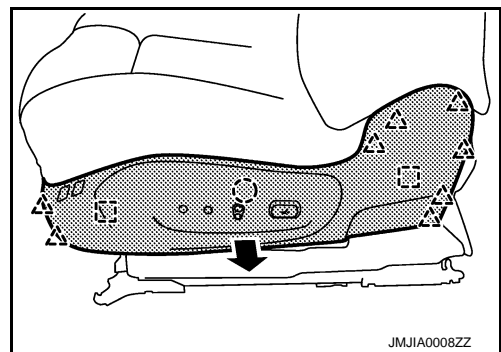
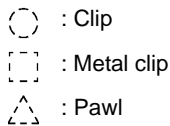

- Disconnect the seat control switch and side support switch harness connectors.
- Remove the reclining device outer cover (front, rear).

2. Remove the seat cushion inner finisher.

- Remove the reclining device inner covers (front, rear) by releasing the metal clip and pull it up together with the cover.
- Remove the reclining device inner covers (front, rear) from the seat cushion inner finisher by releasing the pawls.

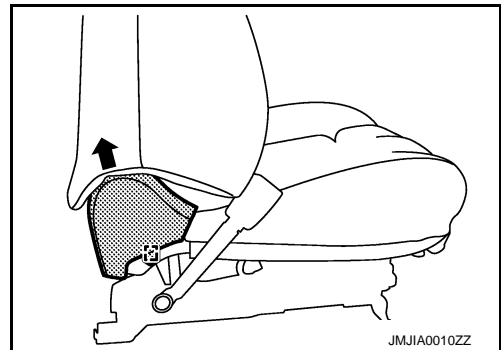
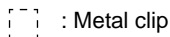

3. Remove the back board.

- Remove the metal clips and clips, and then pull out seatback board (1).
- Pull down the seatback board to release the upper pawls.

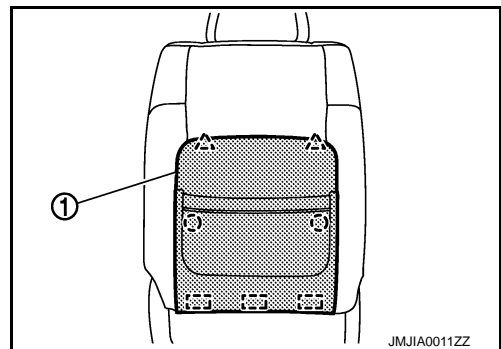
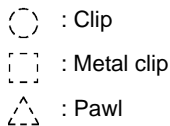

4. Remove the lumbar support lever knob.

- Pull snap ring (1) upward, and remove lumbar support lever knob (2) from seatback frame with hook and pick tool.

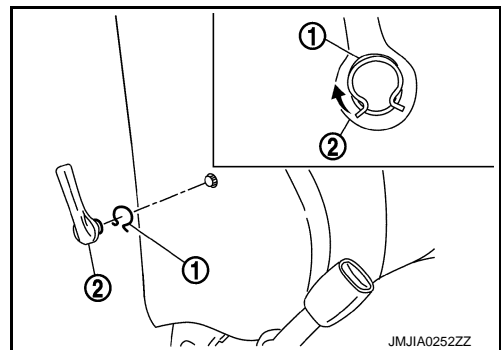

5. Remove the seatback pad and trim.

A
B
C
D
E
F
G
H
I
SE
K
L
M
N
O
P

FRONT SEAT

< REMOVAL AND INSTALLATION >

- Remove the seatback retainer (1) on the back side of the seatback.

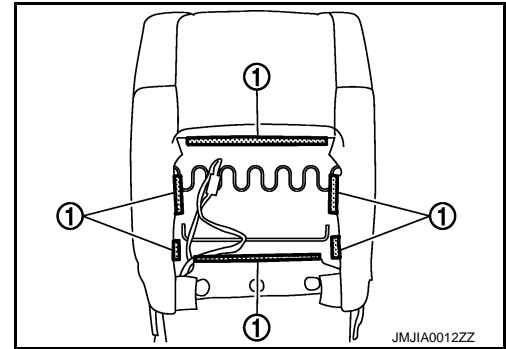

- Remove the headrest holder.

CAUTION:

Before installing headrest holder check its orientation. (front/rear and right/left)

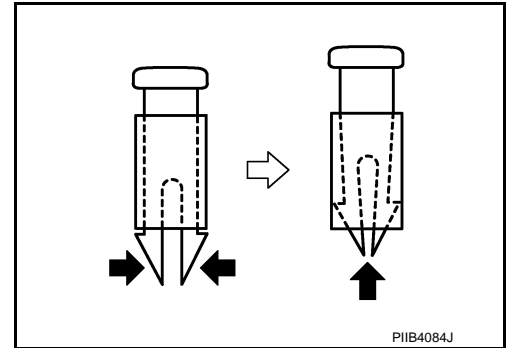

- Remove the side air bag module.
- Remove the side support hose joint (1) located under the seat cushion. (Side support model only.)

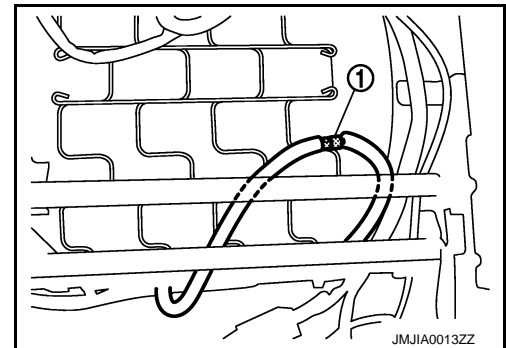

- Disconnect the seatback heater unit harness connector.
- Disconnect the reclining motor harness connector (1) and remove the harness clamp.
- Disconnect the side support unit harness connector (2) and remove the harness clamp. (Side support model only.)

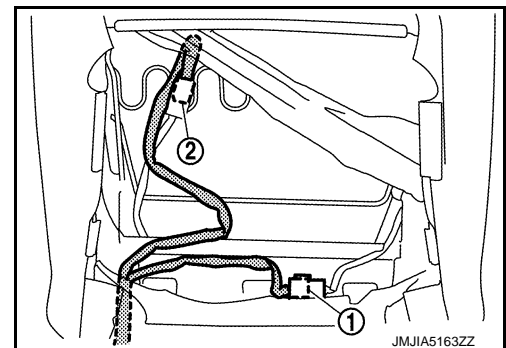

- Remove the seatback pad and seatback trim from the seatback frame.
- Remove the hog rings, and separate the trim and pad.

6. Remove the seatback silencer.
7. Remove the bolts, and then remove lumbar support unit.
8. Remove the side support bag and unit. (Side support model only.)

FRONT SEAT

< REMOVAL AND INSTALLATION >

- Remove the pawls, and then remove side support bag (1).
- Remove the side support unit.

 : Pawl

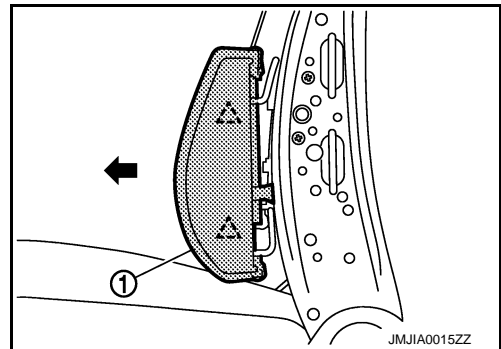

9. Remove the seatback frame.
Remove the seatback frame mounting bolts (A).

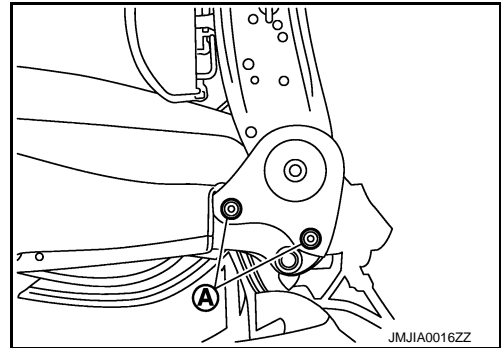

Assembly

Assemble in the reverse order of disassembly.

CAUTION:

Install the hog rings of seatback trim in position, and then securely connect the trim or trim cord with the pad side wire.

SEAT CUSHION

Disassembly

CAUTION:

- **Never disassemble front passenger seat cushion assembly.**
- **Always replace as an assembly.**
- **For front passenger seat service parts, refer to the service part catalogue.**

1. Remove the seat cushion outer finisher.
• Remove the seat slide and lifter switch knob (1) and seat reclining switch knob (2). Using a remover tool (A).

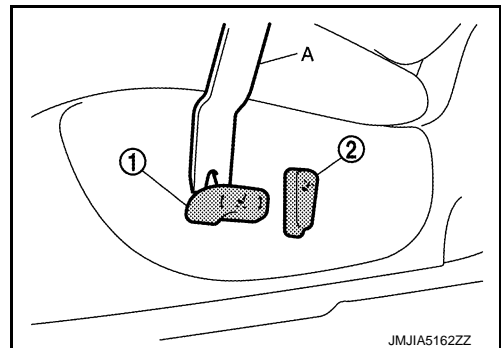



A
B
C
D
E
F
G
H
I
SE
K
L
M
N
O
P

FRONT SEAT

< REMOVAL AND INSTALLATION >

- Remove the metal clips, clips and pawls, and then pull out seat cushion outer finisher.

-  : Clip
-  : Metal clip
-  : Pawl

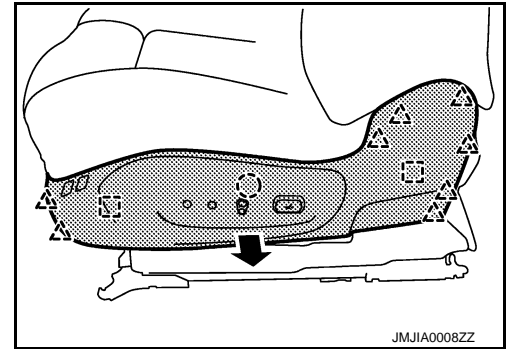

- Disconnect the seat control switch and side support switch harness connectors.
- Remove the reclining device outer cover (front, rear).

2. Remove the seat cushion inner finisher.

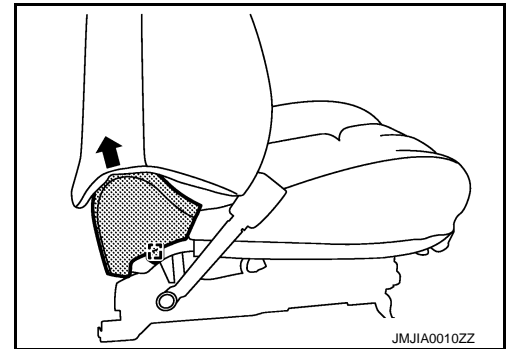

- Remove the reclining device inner covers (front, rear) by releasing the metal clip and pull it up together with the cover.
- Remove the reclining device inner covers (front, rear) from the seat cushion inner finisher by releasing the pawls.

-  : Metal clip



3. Remove the seat cushion front finisher.

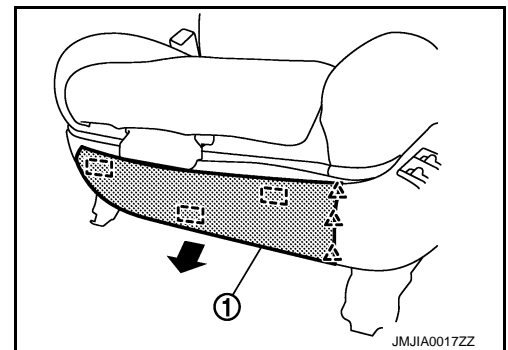

- Remove the metal clips, and then pull out seat cushion front finisher (1).

-  : Metal clip
-  : Pawl



4. Remove the seatback board.

- Remove the metal clips and clips, and then pull out seatback board (1).
- Pull down the seatback board to release the upper pawls.

-  : Clip
-  : Metal clip
-  : Pawl

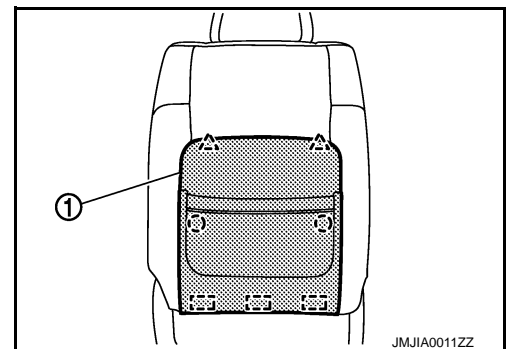

5. Remove the seatback assembly.

FRONT SEAT

< REMOVAL AND INSTALLATION >

- Disconnect the reclining motor harness connector (1) and remove the harness clamp.
- Disconnect the side support unit harness connector (2) and remove the harness clamp. (Side support model only.)

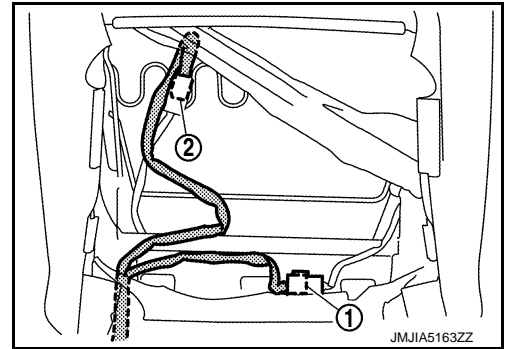

- Remove the seat cushion retainer, and then side air bag harness clamp and seatback heater unit harness connector.
- Remove the side support hose joint (1) located under the seat cushion. (Side support model only.)

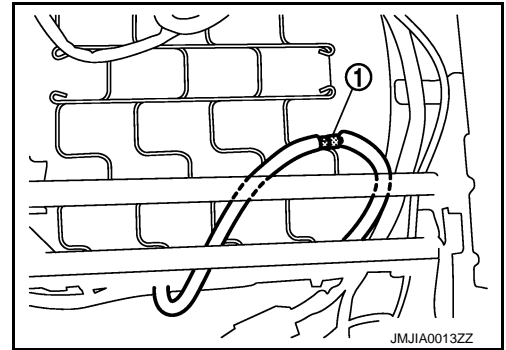

- Remove the seatback mounting bolts (A), and then remove the seatback assembly.

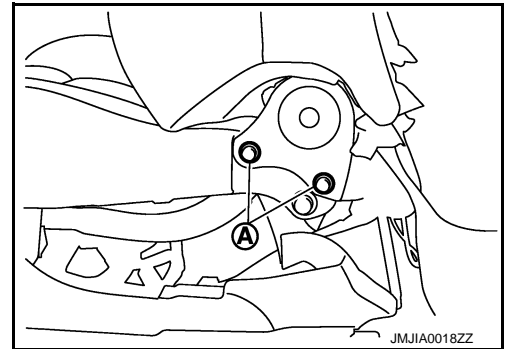

6. Remove the thigh extension. (Thigh extension model only.)
- Remove the retainer.

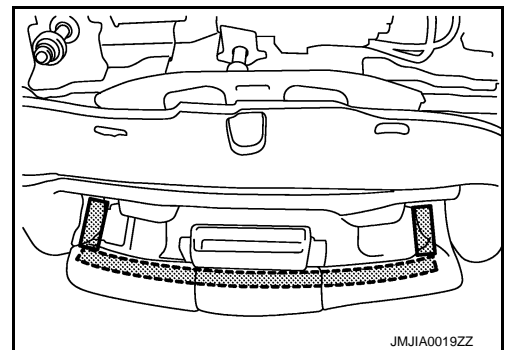

- Remove the thigh extension pad.

A
B
C
D
E
F
G
H
I
SE
K
L
M
N
O
P

FRONT SEAT

< REMOVAL AND INSTALLATION >

- Remove the mounting screws (A).
- Remove the seat cushion trim wire (1) from the hooks (2).
- Remove the thigh extension frame by sliding it.

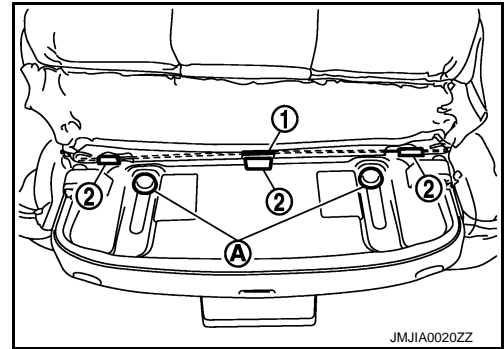

7. Remove the seat cushion pad and trim.
- Remove the clips (A). (Thigh extension model only.)

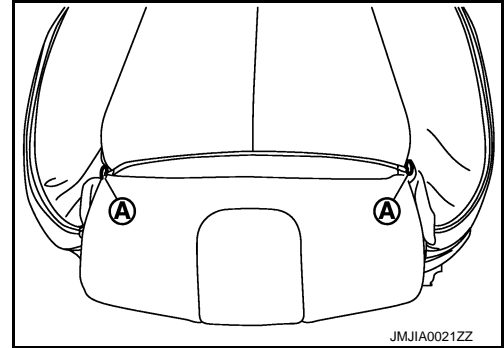

- Remove the retainer.
 - Disconnect the seat cushion heater unit harness connector.
 - Remove the hog rings, and separate the trim and pad.
8. Remove the side support bag. (Side support model only.)
- Remove the hose clamp.

- Remove the pawls, and then remove side support bag (1).

 : Pawl

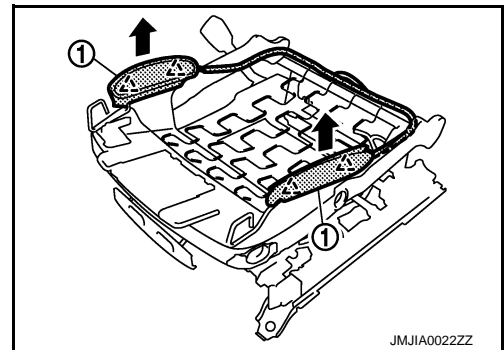

9. Remove the seat slide outer finisher.
- Remove the metal clips and pawls, and then pull out seat slide outer finisher (outside).
 - Remove the metal clip, and then pull out seat slide outer finisher (inside).

 : Metal clip

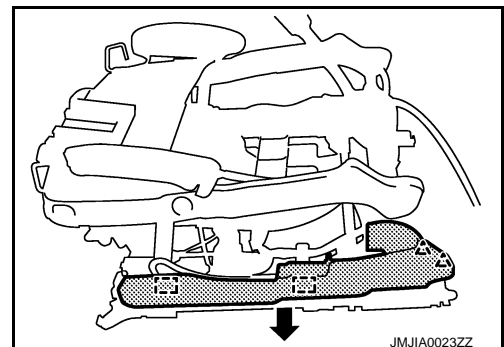

10. Remove the seat slide inner finisher.

FRONT SEAT

< REMOVAL AND INSTALLATION >

Remove the metal clip, and then pull out seat slide inner finisher.

 : Metal clip

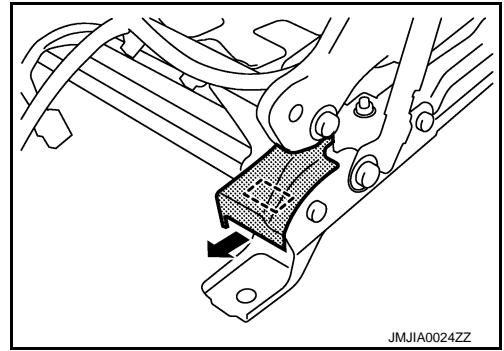

Assembly

Assemble in the reverse order of disassembly.

CAUTION:

Install the hog rings of seat cushion trim in position, and then securely connect the trim or trim cord with the pad side wire.

A
B
C
D
E
F
G
H
I
K
L
M
N
O
P

SE

REAR SEAT

< REMOVAL AND INSTALLATION >

REAR SEAT

Exploded View

INFOID:000000006207429

REAR SEAT

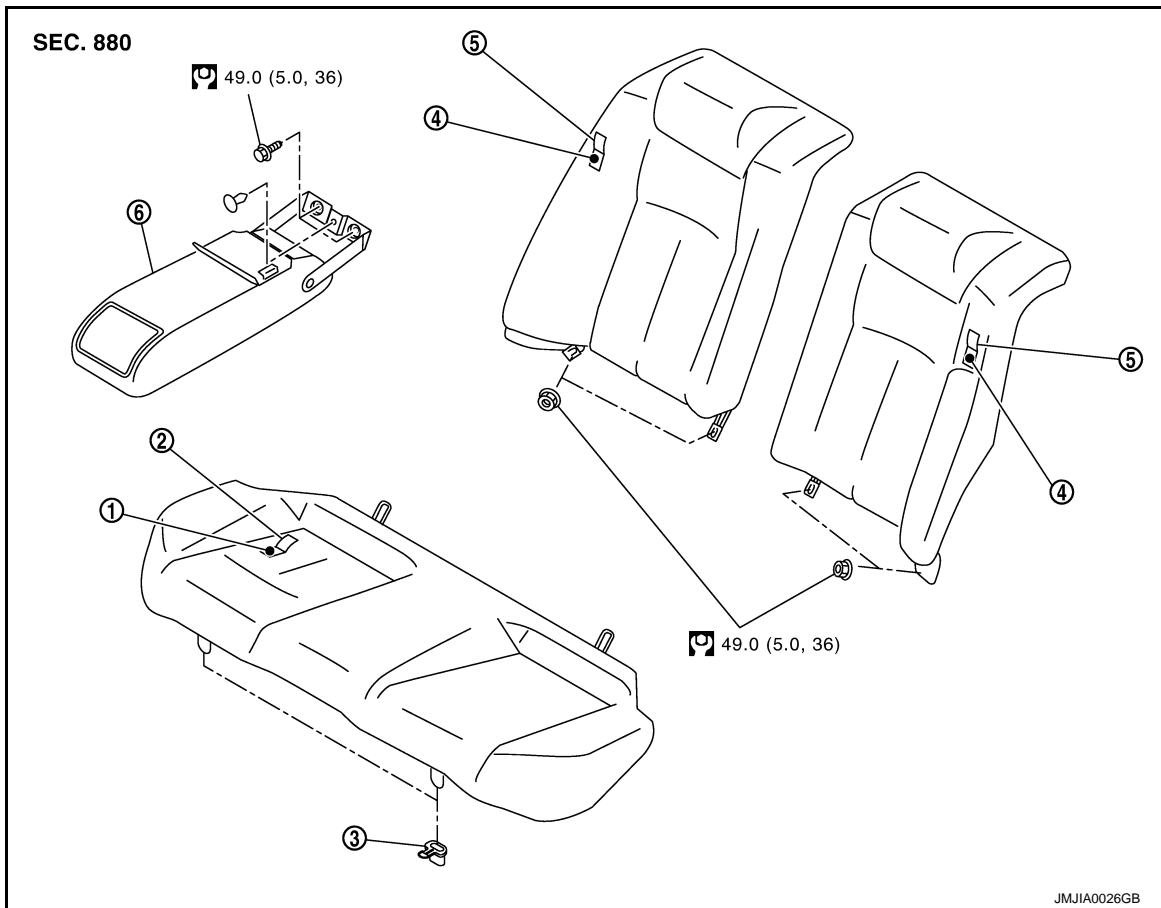

- 1. Seat cushion pad
- 2. Seat cushion trim
- 3. Seat cushion hook
- 4. Seatback pad
- 5. Seatback trim
- 6. Armrest assembly

Refer to [GI-4. "Components"](#) for symbols in the figure.

ARMREST

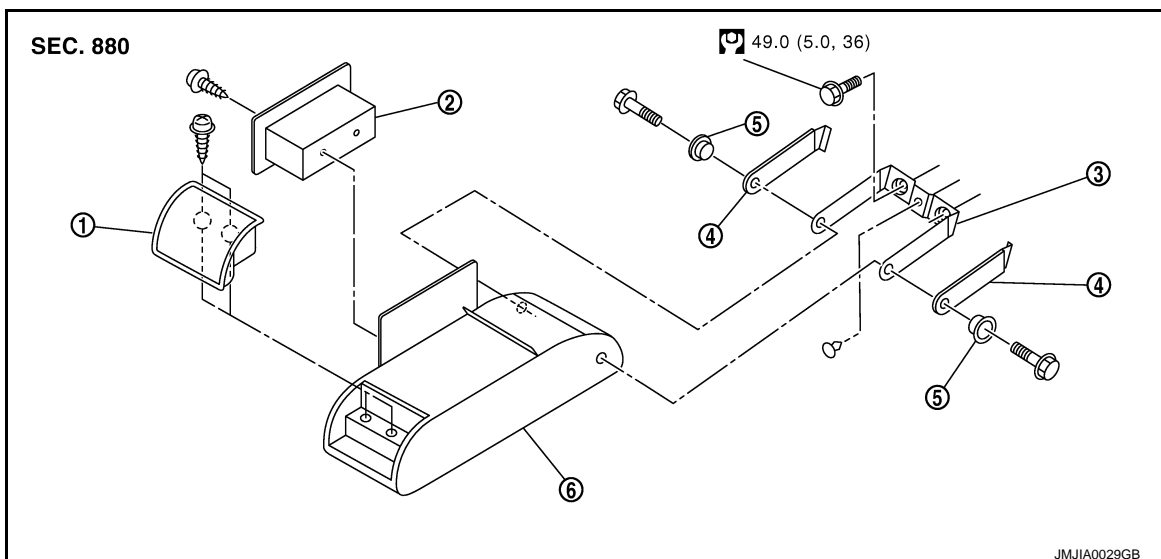

REAR SEAT

< REMOVAL AND INSTALLATION >

- | | | |
|--------------------------------|-------------------------|-------------------------|
| 1. Cup holder | 2. Armrest side console | 3. Armrest bracket |
| 4. Armrest bracket outer cover | 5. bushing | 6. Armrest trim and pad |

Refer to [GI-4, "Components"](#) for symbols in the figure.

Removal and Installation

INFOID:000000006207430

REMOVAL

CAUTION:

When removing and installing, use shop cloths to protect parts from damage.

1. Remove the seat cushion.
 - Pull the lock lever (1) at the front bottom of the seat cushion forward (1 for each side), and pull the seat cushion upward to release the wire (2) from the seat cushion hook. Then pull the seat cushion forward to remove.
 - Remove the seat cushion from the vehicle.

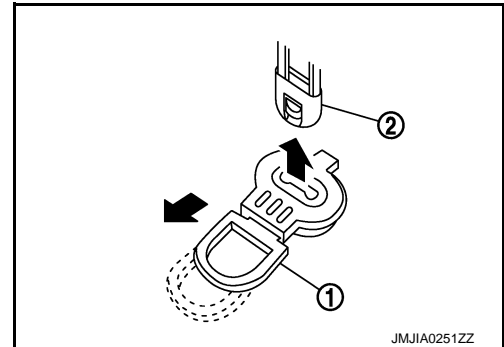

2. Remove the seatback.
 - Remove the nuts under seatback.
 - Lift up seatback from underneath, and then remove seatback from seatback hook that is fixed to the vehicle.
 - Remove the seatback from the vehicle.
3. Remove the armrest assembly.
 - Remove the fastener.
 - Remove the armrest mounting bolts.
 - Remove the clip.
 - Remove the armrest assembly from the vehicle.

INSTALLATION

Install in the reverse order of removal.

CAUTION:

When removing and installing, use shop cloths to protect parts from damage.

Disassembly and Assembly

INFOID:000000006207431

SEATBACK

Disassembly

Remove the hog rings, and separate the trim and pad.

Assembly

Assemble in the reverse order of disassembly.

SEAT CUSHION

Disassembly

Remove the hog rings, and separate the trim and pad.

Assembly

Assemble in the reverse order of disassembly.

ARMREST

Disassembly

1. Remove the screws, and then remove the cup holder.
2. Remove the screws, and then remove the armrest side console

REAR SEAT

< REMOVAL AND INSTALLATION >

3. Remove the bolts, and then remove the armrest bracket.
4. Remove the armrest bracket outer cover from armrest bracket.

Assembly

Assemble in the reverse order of disassembly.

AUTOMATIC DRIVE POSITIONER CONTROL UNIT

< REMOVAL AND INSTALLATION >

AUTOMATIC DRIVE POSITIONER CONTROL UNIT

Removal and Installation

INFOID:000000006207432

REMOVAL

1. Remove the instrument driver lower panel. Refer to [IP-13. "A/T MODELS : Removal and Installation"](#).
2. Remove the screws (A).
3. Remove automatic drive positioner control unit (1).

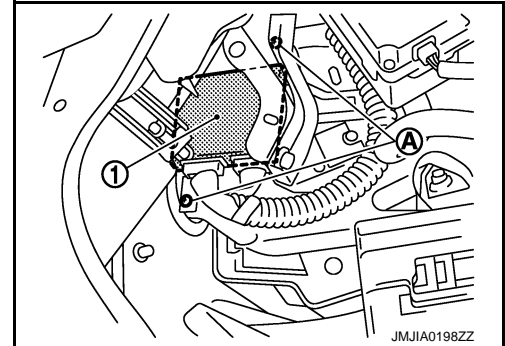

INSTALLATION

Install in the reverse order of removal.

CAUTION:

- Be sure to clamp the harness to the right place.

A
B
C
D
E
F
G
H
I
SE
K
L
M
N
O
P

HEATED SEAT CONTROL UNIT

< REMOVAL AND INSTALLATION >

HEATED SEAT CONTROL UNIT

Exploded View

INFOID:000000006207433

Refer to [SE-120, "Exploded View"](#).

Removal and Installation

INFOID:000000006207434

REMOVAL

CAUTION:

When removing and installing, use shop cloths to protect parts from damage.

1. Remove the front seat.
2. Disconnect heated seat control unit connector.
3. Remove the heated seat control unit from the heated seat control unit stay. Refer to [SE-120, "Exploded View"](#).

INSTALLATION

Install in the reverse order of removal.

CAUTION:

Always clamp the harness to the right place.

POWER SEAT SWITCH

< REMOVAL AND INSTALLATION >

POWER SEAT SWITCH

Removal and Installation

INFOID:000000006207435

REMOVAL

CAUTION:

When removing and installing, use shop cloths to protect parts from damage.

1. Remove the seat cushion outer finisher (1). Refer to [SE-123](#), "[Removal and Installation](#)".
2. Remove the screws (A).
3. Remove the power seat switch (2) from the seat cushion outer finisher (1).

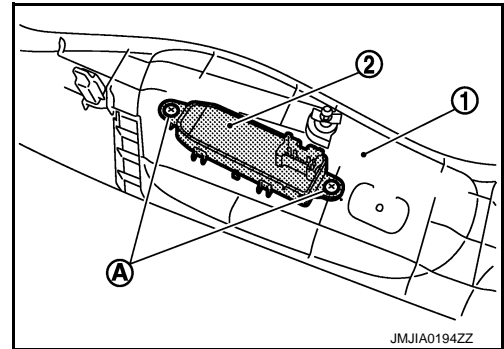

INSTALLATION

Install in the reverse order of removal.

CAUTION:

- Be sure to clamp the harness to the right place.

A
B
C
D
E
F
G
H
I
K
L
M
N
O
P

SE

SIDE SUPPORT SWITCH

< REMOVAL AND INSTALLATION >

SIDE SUPPORT SWITCH

Removal and Installation

INFOID:000000006207436

REMOVAL

CAUTION:

When removing and installing, use shop cloths to protect parts from damage.

1. Remove the seat cushion outer finisher (1). Refer to [SE-123. "Removal and Installation"](#).
2. Remove the screws (A).
3. Remove side support switch (2) from the seat cushion outer finisher.

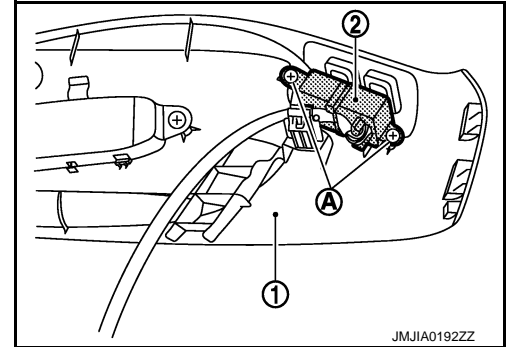

INSTALLATION

Install in the reverse order of removal.

CAUTION:

- Be sure to clamp the harness to the right place.

TILT&TELESCOPIC SWITCH

< REMOVAL AND INSTALLATION >

TILT&TELESCOPIC SWITCH

Removal and Installation

INFOID:000000006207438

REMOVAL

CAUTION:

When removing and installing, use shop cloths to protect parts from damage.

1. Disconnect battery negative terminal.
2. Remove the steering column mask (1). Refer to [IP-13. "A/T MODELS : Removal and Installation"](#).
3. Press pawls and remove tilt & telescopic switch (2) from the steering column mask (1).

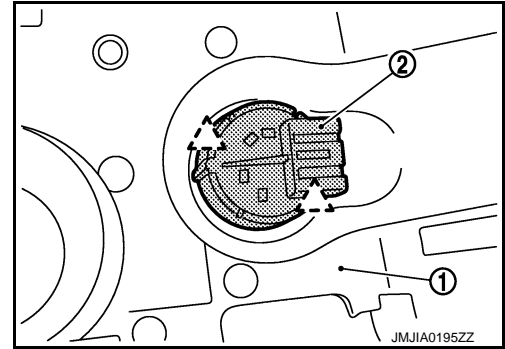

INSTALLATION

Install in the reverse order of removal.

CAUTION:

- Be sure to clamp the harness to the right place.

A
B
C
D
E
F
G
H
I
K
L
M
N
O
P

SE

HEATED SEAT SWITCH

< REMOVAL AND INSTALLATION >

HEATED SEAT SWITCH

Exploded View

INFOID:000000006207439

Refer to [IP-34. "A/T MODELS : Exploded View"](#).

Removal and Installation

INFOID:000000006207440

REMOVAL

CAUTION:

When removing and installing, use shop cloths to protect from damage.

1. Remove the console body assembly. Refer to [IP-35. "A/T MODELS : Removal and Installation"](#)
2. Remove heated seat switch (1) from switch bracket (2) with flat-bladed screwdriver (A).

 : Pawl

NOTE:

The same procedure is performed for passenger side.

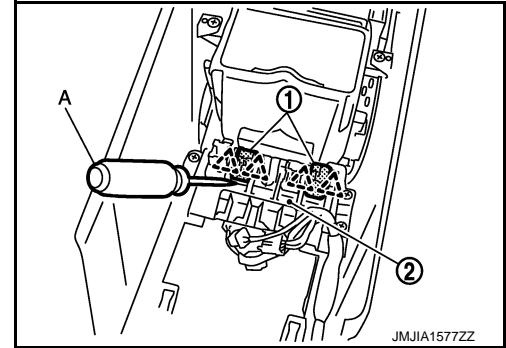

INSTALLATION

Install in the reverse order of removal.