

SECTION MA
MAINTENANCE

A
B
C
D
E
F
G
H
I
J
K
L
M
N
O
MA

CONTENTS

PREPARATION	4	DRIVE BELT	21
PREPARATION	4	DRIVE BELT : Exploded View	21
Special Service Tool	4	DRIVE BELT : Checking	21
Commercial Service Tool	4	DRIVE BELT : Tension Adjustment	21
PERIODIC MAINTENANCE	5	ENGINE COOLANT	21
GENERAL MAINTENANCE	5	ENGINE COOLANT : Draining	21
FOR NORTH AMERICA	5	ENGINE COOLANT : Refilling	22
FOR NORTH AMERICA : Explanation of General		ENGINE COOLANT : Flushing	24
Maintenance	5	FUEL LINES	25
FOR MEXICO	6	FUEL LINES : Inspection	25
FOR MEXICO : General Maintenance	7	AIR CLEANER FILTER	25
PERIODIC MAINTENANCE	9	AIR CLEANER FILTER : Removal and Installation	25
FOR NORTH AMERICA	9	25
FOR NORTH AMERICA : Introduction of Periodic		ENGINE OIL	25
Maintenance	9	ENGINE OIL : Draining	25
FOR NORTH AMERICA : Schedule 1	9	ENGINE OIL : Refilling	26
FOR NORTH AMERICA : Schedule 2	11	OIL FILTER	26
FOR MEXICO	13	OIL FILTER : Removal and Installation	26
FOR MEXICO : Periodic Maintenance	13	OIL FILTER : Inspection	28
RECOMMENDED FLUIDS AND LUBRI-		SPARK PLUG	28
CANTS	16	SPARK PLUG : Removal and Installation	28
FOR NORTH AMERICA	16	SPARK PLUG : Inspection	28
FOR NORTH AMERICA : Fluids and Lubricants	16	EVAP VAPOR LINES	29
FOR NORTH AMERICA : Engine Oil Recommen-		EVAP VAPOR LINES : Inspection	29
dation	17	ENGINE MAINTENANCE (VQ25HR)	30
FOR NORTH AMERICA : Anti-Freeze Coolant		DRIVE BELT	30
Mixture Ratio	17	DRIVE BELT : Inspection	30
FOR MEXICO	17	DRIVE BELT : Adjustment	30
FOR MEXICO : Fluids and Lubricants	18	ENGINE COOLANT	31
FOR MEXICO : SAE Viscosity Number	18	ENGINE COOLANT : Draining	31
FOR MEXICO : Engine Coolant Mixture Ratio	20	ENGINE COOLANT : Refilling	32
ENGINE MAINTENANCE (VQ37VHR)	21	ENGINE COOLANT : Flushing	34
		FUEL LINES	35



FUEL LINES : Inspection	35	REAR DIFFERENTIAL GEAR OIL: R200	46
AIR CLEANER FILTER	35	REAR DIFFERENTIAL GEAR OIL: R200 : Inspec-	46
AIR CLEANER FILTER : Removal and Installation	35	tion	46
ENGINE OIL	35	REAR DIFFERENTIAL GEAR OIL: R200 : Drain-	46
ENGINE OIL : Draining	35	ing	46
ENGINE OIL : Refilling	36	REAR DIFFERENTIAL GEAR OIL: R200 : Refill-	47
OIL FILTER	36	ing	47
OIL FILTER : Removal and Installation	36	REAR DIFFERENTIAL GEAR OIL: R200V	47
OIL FILTER : Inspection	38	REAR DIFFERENTIAL GEAR OIL: R200V : In-	47
SPARK PLUG	38	spection	47
SPARK PLUG : Removal and Installation	38	REAR DIFFERENTIAL GEAR OIL: R200V :	47
SPARK PLUG : Inspection	38	Draining	47
EVAP VAPOR LINES	39	REAR DIFFERENTIAL GEAR OIL: R200V : Refill-	48
EVAP VAPOR LINES : Inspection	39	ing	48
CHASSIS MAINTENANCE	40	WHEELS (BONDING WEIGHT TYPE)	48
EXHAUST SYSTEM	40	WHEELS (BONDING WEIGHT TYPE) : Adjust-	48
EXHAUST SYSTEM : Inspection	40	ment	48
GEAR OIL	40	BRAKE FLUID LEVEL AND LEAKS	50
GEAR OIL : Inspection	40	BRAKE FLUID LEVEL AND LEAKS : Inspection ...	50
GEAR OIL : Draining	40	BRAKE LINES AND CABLES	51
GEAR OIL : Refilling	41	BRAKE LINES AND CABLES : Inspection	51
CLUTCH FLUID	41	BRAKE FLUID	51
CLUTCH FLUID : Inspection	41	BRAKE FLUID : Changing	51
A/T FLUID	41	DISC BRAKE	51
A/T FLUID : Inspection	41	DISC BRAKE : Inspection	51
TRANSFER FLUID	41	DISC BRAKE : Front Disc Brake	52
TRANSFER FLUID : Inspection	41	DISC BRAKE : Rear Disc Brake	52
TRANSFER FLUID : Draining	42	STEERING GEAR AND LINKAGE	52
TRANSFER FLUID : Refilling	42	STEERING GEAR AND LINKAGE : Inspection	52
FRONT PROPELLER SHAFT: 2S56A	42	POWER STEERING FLUID AND LINES	53
FRONT PROPELLER SHAFT: 2S56A : Inspec-	42	POWER STEERING FLUID AND LINES : Inspec-	53
tion	42	tion	53
REAR PROPELLER SHAFT: 3S80A	43	AXLE AND SUSPENSION PARTS	53
REAR PROPELLER SHAFT: 3S80A : Inspection...	43	AXLE AND SUSPENSION PARTS : Inspection ...	53
REAR PROPELLER SHAFT: 3S80A-R	44	DRIVE SHAFT	54
REAR PROPELLER SHAFT: 3S80A-R : Inspec-	44	DRIVE SHAFT : Inspection	54
tion	44	BODY MAINTENANCE	55
REAR PROPELLER SHAFT: 3F80A-1VL107	44	LOCKS, HINGES AND HOOD LATCH	55
REAR PROPELLER SHAFT: 3F80A-1VL107 : In-	44	LOCKS, HINGES AND HOOD LATCH : Lubricat-	55
spection	44	ing	55
FRONT DIFFERENTIAL GEAR OIL: F160A	45	SEAT BELT, BUCKLES, RETRACTORS, AN-	55
FRONT DIFFERENTIAL GEAR OIL: F160A : In-	45	CHORS AND ADJUSTERS	55
spection	45	SEAT BELT, BUCKLES, RETRACTORS, AN-	55
FRONT DIFFERENTIAL GEAR OIL: F160A :	45	CHORS AND ADJUSTERS : Inspection	55
Draining	45	SERVICE DATA AND SPECIFICATIONS	56
FRONT DIFFERENTIAL GEAR OIL: F160A : Re-	46	(SDS)	56
filling	46	SERVICE DATA AND SPECIFICATIONS	56
		(SDS)	56

DRIVE BELT (VQ37VHR)	56	ENGINE OIL :		
DRIVE BELT (VQ37VHR) : Drive Belt	56	Periodical Maintenance Specification	56	A
DRIVE BELT (VQ25HR)	56	SPARK PLUG (VQ37VHR)	56	
DRIVE BELT (VQ25HR) : Drive Belt	56	SPARK PLUG (VQ37VHR) : Spark Plug	57	B
ENGINE COOLANT	56	SPARK PLUG (VQ25HR)	57	
ENGINE COOLANT :		SPARK PLUG (VQ25HR) : Spark Plug	57	C
Periodical Maintenance Specification	56	ROAD WHEEL	57	
ENGINE OIL	56	ROAD WHEEL : Road Wheel	57	D

E
F
G
H
I
J
K
L
M
N
O

PREPARATION

< PREPARATION >

PREPARATION

PREPARATION

Special Service Tool

INFOID:000000008294319

The actual shapes of Kent-Moore tools may differ from those of special service tools illustrated here.

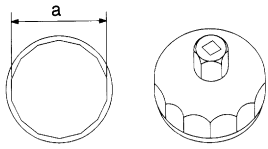
Tool number (Kent-Moore No.) Tool name	Description
KV10115801 (J-38956) Oil filter wrench <div style="text-align: center;">  <p>S-NT375</p> </div>	Removing and installing oil filter a: 64.3 mm (2.531 in)

Commercial Service Tool

INFOID:000000008294320

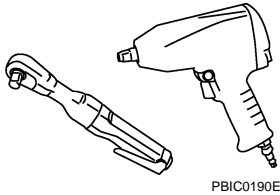
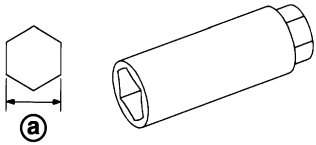
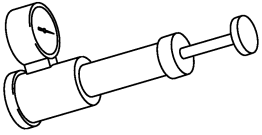
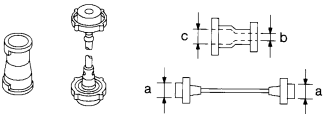
Tool name	Description
Power tool <div style="text-align: center;">  <p>PBIC0190E</p> </div>	Loosening nuts and bolts
Spark plug wrench <div style="text-align: center;">  <p>JPBIA0399ZZ</p> </div>	Removing and installing spark plug a : 14 mm (0.55 in)
Radiator cap tester <div style="text-align: center;">  <p>PBIC1982E</p> </div>	Checking radiator and radiator cap
Radiator cap tester adapter <div style="text-align: center;">  <p>S-NT564</p> </div>	Adapting radiator cap tester to radiator cap and water outlet (front) filler neck. a: 28 (1.10) dia. b: 31.4 (1.236) dia. c: 41.3 (1.626) dia. Unit: mm (in)

GENERAL MAINTENANCE

< PERIODIC MAINTENANCE >

PERIODIC MAINTENANCE

GENERAL MAINTENANCE FOR NORTH AMERICA

FOR NORTH AMERICA : Explanation of General Maintenance

INFOID:000000008294321

General maintenance includes those items which should be checked during the normal day-to-day operation of the vehicle. They are essential if the vehicle is to continue operating properly. The owners can perform checks and inspections themselves or have their **INFINITI** retailers do them.

OUTSIDE THE VEHICLE

The maintenance items listed here should be performed from time to time, unless otherwise specified.

Item		Reference page
Tires	Check the pressure with a gauge often and always prior to long distance trips. Adjust the pressure in all tires, including the spare, to the pressure specified. Check carefully for damage, cuts or excessive wear.	WT-49
Wheel nuts	When checking the tires, make sure no nuts are missing, and check for any loose nuts. Tighten if necessary.	—
Tire rotation	Tires should be rotated every 7,500 miles (12,000 km). If the vehicle is equipped with different sized tires in the front and rear, tires cannot be rotated.	MA-48
Tire Pressure Monitoring System (TPMS) transmitter components	Replace the TPMS transmitter grommet seal, valve core and cap when the tires are replaced due to wear or age.	WT-46
Wheel alignment and balance	If the vehicle should pull to either side while driving on a straight and level road, or if you detect uneven or abnormal tire wear, there may be a need for wheel alignment. If the steering wheel or seat vibrates at normal highway speeds, wheel balancing may be needed. For additional information regarding tires, refer to "Important Tire Safety Information" (US) or "Tire Safety Information" (Canada) in the INFINITI Warranty Information Booklet.	FSU-7 (2WD) FSU-29 (AWD) RSU-6 MA-48
Windshield	Clean the windshield on a regular basis. Check the windshield at least every six months for cracks or other damage. Repair as necessary.	—
Windshield wiper blades	Check for cracks or wear if they do not wipe properly.	—
Doors and engine hood	Check that all doors and the engine hood operate properly. Also make sure that all latches lock securely. Lubricate if necessary. Make sure that the secondary latch keeps the hood from opening when the primary latch is released. When driving in areas using road salt or other corrosive materials, check lubrication frequently.	MA-55
Lamps	Make sure that the headlamps, stop lamps, tail lamps, turn signal lamps, and other lamps are all operating properly and installed securely. Also check headlamp aim. Clean the headlamps on a regular basis.	—

INSIDE THE VEHICLE

The maintenance items listed here should be checked on a regular basis, such as when performing periodic maintenance, cleaning the vehicle, etc.

Item		Reference page
Warning lamps and chimes	Make sure that all warning lamps and chimes are operating properly.	—
Windshield wiper and washer	Check that the wipers and washer operate properly and that the wipers do not streak.	—
Windshield defroster	Check that the air comes out of the defroster outlets properly and in sufficient quantity when operating the heater or air conditioner.	—
Steering wheel	Check that it has the specified play. Check for changes in the steering condition, such as excessive play, hard steering or strange noises. Free play: Less than 35 mm (1.38 in)	—

GENERAL MAINTENANCE

< PERIODIC MAINTENANCE >

Item		Reference page
Seats	Check seat position controls such as seat adjusters, seatback recliner, etc. to make sure they operate smoothly and that all latches lock securely in every position. Check that the head restraints move up and down smoothly and that the locks (if equipped) hold securely in all latched positions. Check that the latches lock securely for folding-down rear seatbacks.	—
Seat belts	Check that all parts of the seat belt system (e.g. buckles, anchors, adjusters and retractors) operate properly and smoothly, and are installed securely. Check the belt webbing for cuts, fraying, wear or damage.	MA-55
Accelerator pedal	Check the pedal for smooth operation and make sure the pedal does not catch or require uneven effort. Keep the floor mats away from the pedal.	—
Brakes	Check that the brake does not pull the vehicle to one side when applied.	—
Brake pedal and booster	Check the pedal for smooth operation and make sure it has the proper distance under it when depressed fully. Check the brake booster function. Be sure to keep the floor mats away from the pedal.	BR-7 BR-13
Clutch pedal	Make sure the pedal operates smoothly and check that it has the proper free play.	CL-6
Parking brake	Check that the lever or pedal has the proper travel and make sure that the vehicle is held securely on a fairly steep hill when only the parking brake is applied.	PB-3 (PEDAL TYPE) PB-4 (LEVER TYPE)
Automatic transmission "Park" mechanism	Check that the lock release button on the selector lever operates properly and smoothly. On a fairly steep hill check that the vehicle is held securely with the selector lever in the P (Park) position without applying any brakes.	—

UNDER THE HOOD AND VEHICLE

The maintenance items listed here should be checked periodically (e.g. each time you check the engine oil or refuel).

Item		Reference page
Windshield washer fluid	Check that there is adequate fluid in the tank.	—
Engine coolant level	Check the coolant level when the engine is cold.	CO-9
Radiator and hoses	Check the front of the radiator and clean off any dirt, insects, leaves, etc., that may have accumulated. Make sure the hoses have no cracks, deformation, deterioration or loose connections.	—
Brake and clutch fluid levels	Make sure that the brake and clutch fluid levels are between the "MAX" and "MIN" lines on the reservoir(s).	MA-50 MA-41
Battery	Check the fluid level in each cell. It should be between the "MAX" and "MIN" lines. Vehicles operated in high temperatures or under severe conditions require frequent checks of the battery fluid level.	PG-3
Engine drive belts	Make sure that no belt is frayed, worn, cracked or oily.	MA-21
Engine oil level	Check the level on the oil level gauge after parking the vehicle on a level spot and turning off the engine.	LU-8
Power steering fluid level and lines	Check the level on the dipstick with the engine off. Check the lines for improper attachment, leaks, cracks, etc.	MA-53
Exhaust system	Make sure there are no loose supports, cracks or holes. If the sound of the exhaust seems unusual or there is a smell of exhaust fumes, immediately locate the trouble and correct it.	MA-40
Underbody	The underbody is frequently exposed to corrosive substances such as those used on icy roads or to control dust. It is very important to remove these substances, otherwise rust will form on the floor pan, frame, fuel lines and around the exhaust system. At the end of winter, the underbody should be thoroughly flushed with plain water, being careful to clean those areas where mud and dirt can easily accumulate.	—
Fluid leaks	Check under the vehicle for fuel, oil, water or other fluid leaks after the vehicle has been parked for a while. Water dripping from the air conditioner after use is normal. If you should notice any leaks or gasoline fumes are evident, check for the cause and correct it immediately.	—

FOR MEXICO

GENERAL MAINTENANCE

< PERIODIC MAINTENANCE >

FOR MEXICO : General Maintenance

INFOID:000000008793658

General maintenance includes those items which should be checked during the normal day-to-day operation of the vehicle. They are essential if the vehicle is to continue operating properly. The owners can perform the checks and inspections themselves or they can have their **INFINITI** dealers do them.

OUTSIDE THE VEHICLE

The maintenance items listed here should be performed from time to time, unless otherwise specified.

Item	Reference page
Doors and engine hood Check that all doors and the engine hood operate smoothly as well as the back door, trunk lid and hatch. Also make sure that all latches lock securely. Lubricate if necessary. Make sure that the secondary latch keeps the hood from opening when the primary latch is released. When driving in areas using road salt or other corrosive materials, check lubrication frequently.	MA-55
Lamps Clean the headlamps on a regular basis. Make sure that the headlamps, stop lamps, tail lamps, turn signal lamps, and other lamps are all operating properly installed securely. Also check the aim of the headlamps.	—
Tires Check the pressure with a gauge often and always prior to long distance trips. Adjust the pressure in all tires, including the spare, to the pressure specified. Check carefully for damage, cuts or excessive wear.	WT-49
Tire rotation In the case that Two-Wheel Drive (2WD) and front & rear tires are same size; Tires should be rotated every 10,000 km (6,000 miles). Tires marked with directional indicators can only be rotated between front and rear. Make sure that the directional indicators point in the direction of wheel rotation after the tire rotation is completed. In the case that Four-Wheel Drive (4WD) and front & rear tires are same size; Tires should be rotated every 5,000 km (3,000 miles). Tires marked with directional indicators can only be rotated between front and rear. Make sure that the directional indicators point in the direction of wheel rotation after the tire rotation is completed. In the case that front tires are different size from rear tires; Tires cannot be rotated. However, the timing for tire rotation may vary according to your driving habits and the road surface conditions.	MA-48
Tire Pressure Monitoring System (TPMS) transmitter components (if equipped) Replace the TPMS transmitter grommet seal, valve core and cap when the tires are replaced due to wear or age.	WT-46
Wheel alignment and balance If the vehicle should pull to either side while driving on a straight and level road, or if you detect uneven or abnormal tire wear, there may be a need for wheel alignment. If the steering wheel or seat vibrates at normal highway speeds, wheel balancing may be needed.	FSU-7 RSU-6 MA-48
Windshield Clean the windshield on a regular basis. Check the windshield at least every six months for cracks or other damage. Repairs necessary.	—
Wiper blades Check for cracks or wear if not functioning correctly.	—

INSIDE THE VEHICLE

The maintenance items listed here should be checked on a regular basis, such as when performing periodic maintenance, cleaning the vehicle, etc.

Item	Reference page
Accelerator pedal Check the pedal for smooth operation and make sure that the pedal does not catch or require uneven effort. Keep the floor mats away from the pedal.	—
Brake pedal Check the pedal for smooth operation and make sure that it attains the proper distance from the floor mat when depressed fully. Check the brake booster function. Be sure to keep the floor mats away from the pedal.	BR-7
Parking brake Check the parking brake operation regularly. Check that the lever (if equipped) or the pedal (if equipped) has the proper travel. Also make sure that the vehicle is held securely on a fairly steep hill when only the parking brake is applied.	PB-3 (PEDAL TYPE) PB-4 (LEVER TYPE)
Seat belts Check that all parts of the seat belt system (for example, buckles, anchors, adjusters and retractors) operate properly and smoothly, and are installed securely. Check the belt webbing for cuts, fraying, wear or damage.	MA-55

GENERAL MAINTENANCE

< PERIODIC MAINTENANCE >

	Item	Reference page
Steering wheel	Check for changes in the steering condition, such as excessive play, hard steering or strange noises. Check that it has the specified play. Free play: Less than 35 mm (1.38 in)	—
Warning lamps and chimes	Make sure that all warning lamps and chimes are operating properly.	—
Windshield defogger	Check that the air comes out of the defogger outlets properly and in good quantity when operating the heater or air conditioner.	—
Windshield wiper and washer	Check that the wipers and washer operate properly and that the wipers do not streak.	—

UNDER THE HOOD AND VEHICLE

The maintenance items listed here should be checked periodically (for example, each time you check the engine oil or refuel.)

	Item	Reference page
Battery	Except for maintenance free battery; Check the fluid level in each cell. It should be between the "UPPER" and "LOWER" lines. Vehicles operated in high temperatures or under severe conditions require frequent checks of the battery fluid level.	PG-3
Brake (and clutch) fluid level(s)	For Manual Transmission (MT) model; Make sure that the brake and clutch fluid levels are between the "MAX" and "MIN" lines on the reservoir(s). Except for Manual Transmission (MT) model; Make sure that the brake fluid level is between the "MAX" and "MIN" lines on the reservoir.	MA-50
Engine coolant level	Check the coolant level when the engine is cold. Make sure that the coolant level is between the "MAX" and "MIN" lines on the reservoir.	CO-9
Engine drive belt(s)	Make sure that drive belt(s) is/are not frayed, worn, cracked or oily.	MA-30 (VQ25HR) MA-21 (VQ37VHR)
Engine oil level	Check the level after parking the vehicle (on a level ground) and turning off the engine.	LU-8
Fluid leaks	Check under the vehicle for fuel, oil, water or other fluid leaks after the vehicle has been parked for a while. Water dripping from the air conditioner after use is normal. If you should notice any leaks or if fuel fumes are evident, check for cause and have it corrected immediately.	—
Power steering fluid level and lines	Check the level when the fluid is cold, with the engine off. Check the lines for proper attachment, leaks, cracks, etc.	MA-53
Windshield washer fluid	Check that there is adequate fluid in the reservoir tank.	—

PERIODIC MAINTENANCE

< PERIODIC MAINTENANCE >

PERIODIC MAINTENANCE FOR NORTH AMERICA

FOR NORTH AMERICA : Introduction of Periodic Maintenance

INFOID:000000008294323

Two different maintenance schedules are provided, and should be used, depending upon the conditions in which the vehicle is mainly operated. **After 60,000 miles (96,000 km) or 48 months, continue the periodic maintenance at the same mileage/time intervals.**

Schedule 1	Follow Periodic Maintenance Schedule 1 if the driving habits frequently include one or more of the following driving conditions: <ul style="list-style-type: none"> Repeated short trips of less than 5 miles (8 km). Repeated short trips of less than 10 miles (16 km) with outside temperatures remaining below freezing. Operating in hot weather in stop-and-go "rush hour" traffic. Extensive idling and/or low speed driving for long distances, such as police, taxi or door-to-door delivery use. Driving in dusty conditions. Driving on rough, muddy, or salt spread roads. Towing a trailer, using a camper or a car-top carrier. 	Emission Control System Maintenance	MA-9
		Chassis and Body Maintenance	
Schedule 2	Follow Periodic Maintenance Schedule 2 if none of driving conditions shown in Schedule 1 apply to the driving habits.	Emission Control System Maintenance	MA-11
		Chassis and Body Maintenance	

FOR NORTH AMERICA : Schedule 1

INFOID:000000008294324

EMISSION CONTROL SYSTEM

Abbreviations: R = Replace. I = Inspect. Correct or replace if necessary. []: At the mileage intervals only

MAINTENANCE OPERATION		MAINTENANCE INTERVAL								Reference Section - Page or Content Title
Perform at number of miles, kilometers or months, whichever comes first.	Miles x 1,000 (km x 1,000) Months	3.75 (6)	7.50 (12)	11.25 (18)	15 (24)	18.75 (30)	22.5 (36)	26.25 (42)	30 (48)	
Drive belts	NOTE (1)									MA-21
Air cleaner filter	NOTE (2)								[R]	MA-25
EVAP vapor lines									I*	MA-29
Fuel lines									I*	MA-25
Fuel filter	NOTE (3)									—
Engine coolant*	NOTE (4)(5)									MA-21
Engine oil		R	R	R	R	R	R	R	R	MA-25
Engine oil filter (Use genuine NISSAN engine oil filter or equivalent.)		R	R	R	R	R	R	R	R	MA-26
Spark plugs (Iridium-tipped type)		Replace every 105,000 miles (168,000 km).								MA-28
Intake & exhaust valve clearance*	NOTE (6)									EM-12

MAINTENANCE OPERATION		MAINTENANCE INTERVAL								Reference Section - Page or Content Title
Perform at number of miles, kilometers or months, whichever comes first.	Miles x 1,000 (km x 1,000) Months	33.75 (54)	37.5 (60)	41.25 (66)	45 (72)	48.75 (78)	52.5 (84)	56.25 (90)	60 (96)	
Drive belts	NOTE (1)								I*	MA-21
Air cleaner filter	NOTE (2)								[R]	MA-25
EVAP vapor lines									I*	MA-29

PERIODIC MAINTENANCE

< PERIODIC MAINTENANCE >

MAINTENANCE OPERATION		MAINTENANCE INTERVAL								Reference Section - Page or - Content Title
Perform at number of miles, kilometers or months, whichever comes first.	Miles x 1,000 (km x 1,000) Months	33.75 (54) 27	37.5 (60) 30	41.25 (66) 33	45 (72) 36	48.75 (78) 39	52.5 (84) 42	56.25 (90) 45	60 (96) 48	
Fuel lines									I*	MA-25
Fuel filter	NOTE (3)									—
Engine coolant*	NOTE (4)(5)									MA-21
Engine oil		R	R	R	R	R	R	R	R	MA-25
Engine oil filter (Use genuine NISSAN engine oil filter or equivalent.)		R	R	R	R	R	R	R	R	MA-26
Spark plugs (Iridium-tipped type)		Replace every 105,000 miles (168,000 km).								MA-28
Intake & exhaust valve clearance*	NOTE (6)									EM-12

NOTE:

(1) After 60,000 miles (96,000 km) or 48 months, inspect every 15,000 miles (24,000 km) or 12 months. Replace the drive belts if found damaged or if the auto belt tensioner reading reaches the maximum limit.

(2) If operating mainly in dusty conditions, more frequent maintenance may be required.

(3) Maintenance-free item. For service procedures, refer to FL section.

(4) First replacement intervals 105,000 miles (168,000 km) or 84 months. After first replacement, replace every 75,000 miles (120,000 km) or 60 months.

(5) Use only Genuine NISSAN Long Life Antifreeze / Coolant (blue) or equivalent with proper mixture ratio of 50% anti-freeze and 50% demineralized or distilled water. Mixing any other type of coolant or the use of non-distilled water will reduce the life expectancy of the factory-fill coolant.

(6) Periodic maintenance is not required. However, if valve noise increases, inspect valve clearance.

* Maintenance items and intervals with "*" are recommended by INFINITI for reliable vehicle operation. The owner need not perform such maintenance in order to maintain the emission warranty or manufacturer recall liability. Other maintenance items and intervals are required.

CHASSIS AND BODY

Abbreviations: R = Replace. I = Inspect. Correct or replace if necessary.

MAINTENANCE OPERATION		MAINTENANCE INTERVAL								Reference Section - Page or - Content Title
Perform at number of miles, kilometers or months, whichever comes first.	Miles x 1,000 (km x 1,000) Months	3.75 (6) 3	7.50 (12) 6	11.25 (18) 9	15 (24) 12	18.75 (30) 15	22.5 (36) 18	26.25 (42) 21	30 (48) 24	
Brake lines & cables					I				I	MA-51
Brake pads & rotors			I		I		I		I	MA-51
Brake fluid					R				R	MA-51
Manual transmission gear oil, transfer fluid & differential gear oil	NOTE (1)				I				I	MA-40 MA-41 MA-45 MA-46 MA-47
Automatic transmission fluid	NOTE (2)									—
Steering gear & linkage, axle & suspension parts			I		I		I		I	MA-52 MA-53
Tire rotation	NOTE (3)									MA-5 MA-48
Drive shaft boots and propeller shaft (AWD models)			I		I		I		I	MA-54 MA-42 MA-43 MA-44 MA-44
Exhaust system			I		I		I		I	MA-40

PERIODIC MAINTENANCE

< PERIODIC MAINTENANCE >

MAINTENANCE OPERATION		MAINTENANCE INTERVAL								Reference Section - Page or - Content Title
Perform at number of miles, kilometers or months, whichever comes first.	Miles x 1,000 (km x 1,000) Months	3.75 (6) 3	7.50 (12) 6	11.25 (18) 9	15 (24) 12	18.75 (30) 15	22.5 (36) 18	26.25 (42) 21	30 (48) 24	
In-cabin microfilter					R				R	VTL-8
Stop lamp switch & ASCD brake switch	NOTE (4)				I				I	BR-7

MAINTENANCE OPERATION		MAINTENANCE INTERVAL								Reference Section - Page or - Content Title
Perform at number of miles, kilometers or months, whichever comes first.	Miles x 1,000 (km x 1,000) Months	33.75 (54) 27	37.5 (60) 30	41.25 (66) 33	45 (72) 36	48.75 (78) 39	52.5 (84) 42	56.25 (90) 45	60 (96) 48	
Brake lines & cables					I				I	MA-51
Brake pads & rotors			I		I		I		I	MA-51
Brake fluid					R				R	MA-51
Manual transmission gear oil, transfer fluid & differential gear oil	NOTE (1)				I				I	MA-40 MA-41 MA-45 MA-46 MA-47
Automatic transmission fluid	NOTE (2)									—
Steering gear & linkage, axle & suspension parts			I		I		I		I	MA-52 MA-53
Tire rotation	NOTE (3)									MA-5 MA-48
Drive shaft boots and propeller shaft (AWD models)			I		I		I		I	MA-54 MA-42 MA-43 MA-44 MA-44
Exhaust system			I		I		I		I	MA-40
In-cabin microfilter					R				R	VTL-8
Stop lamp switch & ASCD brake switch	NOTE (4)				I				I	BR-7

NOTE:

- (1) If towing a trailer, using a camper or a car-top carrier, or driving on rough or muddy roads, change (not just inspect) fluid /oil at every 30,000 miles (48,000 km) or 24 months.
- (2) Automatic transmission fluid is maintenance-free.
- (3) Refer to "Tire rotation" under the "General maintenance" heading earlier in this section.
- (4) Inspect the clearance between the brake pedal and the switches.

FOR NORTH AMERICA : Schedule 2

INFOID:000000008294325

EMISSION CONTROL SYSTEM

Abbreviations: R = Replace. I = Inspect. Correct or replace if necessary. []: At the mileage intervals only

MAINTENANCE OPERATION		MAINTENANCE INTERVAL								Reference Section - Page or - Content Title
Perform at number of miles, kilometers or months, whichever comes first.	Miles x 1,000 (km x 1,000) Months	7.5 (12) 6	15 (24) 12	22.5 (36) 18	30 (48) 24	37.5 (60) 30	45 (72) 36	52.5 (84) 42	60 (96) 48	
Drive belts	NOTE (1)								I*	MA-21
Air cleaner filter					[R]				[R]	MA-25
EVAP vapor lines					I*				I*	MA-29
Fuel lines					I*				I*	MA-25

MA

PERIODIC MAINTENANCE

< PERIODIC MAINTENANCE >

MAINTENANCE OPERATION		MAINTENANCE INTERVAL								Reference Section - Page or - Content Title
Perform at number of miles, kilometers or months, whichever comes first.	Miles x 1,000 (km x 1,000) Months	7.5 (12) 6	15 (24) 12	22.5 (36) 18	30 (48) 24	37.5 (60) 30	45 (72) 36	52.5 (84) 42	60 (96) 48	
Fuel filter	NOTE (2)									—
Engine coolant*	NOTE (3)(4)									MA-21
Engine oil		R	R	R	R	R	R	R	R	MA-25
Engine oil filter (Use genuine NISSAN engine oil filter or equivalent.)		R	R	R	R	R	R	R	R	MA-26
Spark plugs (Iridium-tipped type)		Replace every 105,000 miles (168,000 km).								MA-28
Intake & exhaust valve clearance*	NOTE (5)									EM-12

NOTE:

(1) After 60,000 miles (96,000 km) or 48 months, inspect every 15,000 miles (24,000 km) or 12 months. Replace the drive belts if found damaged or if the auto belt tensioner reading reaches the maximum limit. (If auto belt tensioner is equipped)

(2) Maintenance-free item. For service procedures, refer to FL section.

(3) First replacement intervals 105,000 miles (168,000 km) or 84 months. After first replacement, replace every 75,000 miles (120,000 km) or 60 months.

(4) Use only Genuine NISSAN Long Life Antifreeze / Coolant (blue) or equivalent with proper mixture ratio of 50% anti-freeze and 50% demineralized or distilled water. Mixing any other type of coolant or the use of non-distilled water will reduce the life expectancy of the factory-fill coolant.

(5) Periodic maintenance is not required. However, if valve noise increases, inspect valve clearance.

* Maintenance items and intervals with "*" are recommended by INFINITI for reliable vehicle operation. The owner need not perform such maintenance in order to maintain the emission warranty or manufacturer recall liability. Other maintenance items and intervals are required.

CHASSIS AND BODY

Abbreviations: R = Replace. I = Inspect. Correct or replace if necessary.

MAINTENANCE OPERATION		MAINTENANCE INTERVAL								Reference Section - Page or - Content Title
Perform at number of miles, kilometers or months, whichever comes first.	Miles x 1,000 (km x 1,000) Months	7.5 (12) 6	15 (24) 12	22.5 (36) 18	30 (48) 24	37.5 (60) 30	45 (72) 36	52.5 (84) 42	60 (96) 48	
Brake lines & cables			I		I		I		I	MA-51
Brake pads & rotors			I		I		I		I	MA-51
Brake fluid					R				R	MA-51
Manual transmission gear oil, transfer fluid & differential gear oil			I		I		I		I	MA-40 MA-41 MA-45 MA-46 MA-47
Automatic transmission fluid	NOTE (1)									—
Steering gear & linkage, axle & suspension parts					I				I	MA-52 MA-53
Tire rotation	NOTE (2)									MA-5 MA-48
Drive shaft boots and propeller shaft (AWD models)			I		I		I		I	MA-54 MA-42 MA-43 MA-44 MA-44
Exhaust system					I				I	MA-40
In-cabin microfilter			R		R		R		R	VTL-8
Stop lamp switch & ASCD brake switch	NOTE (3)		I		I		I		I	BR-7

NOTE:

(1) Automatic transmission fluid is maintenance-free.

PERIODIC MAINTENANCE

< PERIODIC MAINTENANCE >

(2) Refer to "Tire rotation" under the "General maintenance" heading earlier in this section.

(3) Inspect the clearance between the brake pedal and the switches.

FOR MEXICO

FOR MEXICO : Periodic Maintenance

INFOID:000000008294326

The following tables show the normal maintenance schedule. Depending upon weather and atmospheric conditions, varying road surfaces, individual driving habits and vehicle usage, additional or more frequent maintenance may be required.

Periodic maintenance beyond the last period shown on the tables requires similar maintenance.

ENGINE AND EMISSION CONTROL MAINTENANCE

Abbreviations: I = Inspect and correct or replace as necessary, R = Replace, E = Check and correct the engine coolant mixture ratio.

MAINTENANCE OPERATION		MAINTENANCE INTERVAL								Reference page
Perform at a kilometers (miles) or month interval, whichever comes first.	km × 1,000 (Miles × 1,000) Months	10 (6) 6	20 (12) 12	30 (18) 18	40 (24) 24	50 (30) 30	60 (36) 36	70 (42) 42	80 (48) 48	
Underhood and under vehicle										
Intake & exhaust valve clearance	See NOTE (1)									EM-12 (VQ25HR) EM-154 (VQ37VHR)
Drive belt	See NOTE (2)				I				I	MA-21 (VQ37VHR) MA-30 (VQ25HR)
Engine oil (Use recommended oil.)★		R	R	R	R	R	R	R	R	MA-25 (VQ37VHR) MA-35 (VQ25HR)
Engine oil filter (Use genuine NISSAN engine oil filter or equivalent)★		R	R	R	R	R	R	R	R	MA-26 (VQ37VHR) MA-36 (VQ25HR)
Engine coolant	See NOTE (3)				E				E	MA-21 (VQ37VHR) MA-31 (VQ25HR)
Cooling system					I				I	CO-9 CO-13 CO-13
Fuel lines					I				I	MA-25 (VQ37VHR) MA-35 (VQ25HR)
Air cleaner filter (Viscous paper type)★					R				R	MA-25 (VQ37VHR) MA-35 (VQ25HR)
Fuel filter (In-tank type)	See NOTE (4)									—
Spark plugs (Iridium-tipped type)	See NOTE (5)	Replace every 100,000 km (60,000 miles)								MA-28 (VQ37VHR) MA-38 (VQ25HR)
EVAP vapor lines (With carbon canister)					I				I	MA-29 (VQ37VHR) MA-39 (VQ25HR)

PERIODIC MAINTENANCE

< PERIODIC MAINTENANCE >

NOTE:

- Maintenance items with “★” should be performed more frequently according to “Maintenance Under Severe Driving Conditions”.
- (1) Periodic maintenance is not required. However, if valve noise increases, check valve clearance.
- (2) Replace the drive belts if found damaged or if the auto belt tensioner reading reaches the maximum limit. (If auto belt tensioner is equipped)
- (3) Use Genuine NISSAN Engine Coolant (blue) or equivalent in its quality, in order to avoid possible aluminium corrosion within the engine cooling system caused by the use of non-genuine engine coolant. Check and correct the engine coolant mixture ratio every 40,000 km (24,000 miles) or 24 months. First replacement interval is 160,000 km (96,000 miles) or 96 months. After first replacement, replace every 80,000 km (48,000 miles) or 48 months.
- (4) Maintenance-free item.
- (5) Replace spark plug when the spark plug gap exceeds 1.4 mm (0.055 in) even if within specified periodic replacement mileage.

CHASSIS AND BODY MAINTENANCE

Abbreviations: I = Inspect and correct or replace as necessary, R = Replace

MAINTENANCE OPERATION		MAINTENANCE INTERVAL								Reference page
Perform at a kilometers (miles) or month interval, whichever comes first.	km × 1,000 (Miles × 1,000) Months	10 (6) 6	20 (12) 12	30 (18) 18	40 (24) 24	50 (30) 30	60 (36) 36	70 (42) 42	80 (48) 48	
Underhood and under vehicle										
Brake line & cables			I		I		I		I	MA-51
Brake fluid (For level & leaks)			I		I		I		I	MA-50
Brake fluid★					R				R	MA-51
Exhaust system					I				I	MA-40
Power steering fluid & lines (For level & leaks)			I		I		I		I	MA-53
Automatic transmission fluid	See NOTE (1)									—
Differential gear oil (For level & leaks)★			I		I		I		I	MA-46 MA-47
Steering gear & linkage, axle & suspension parts★					I				I	MA-52 MA-53
Outside and inside										
Wheel alignment (If necessary, balance wheels)			I		I		I		I	FSU-7 RSU-6 MA-48
Brake pads, rotors, drums & linings★			I		I		I		I	MA-51 BR-14 BR-16
Foot brake & parking brake (For free play, stroke & operation)			I		I		I		I	BR-7 PB-3 PB-4
Air conditioner filter★			R		R		R		R	VTL-8
Stop lamp switch & ASCD brake switch	See NOTE (2)		I		I		I		I	BR-7

NOTE:

- Maintenance items with “★” should be performed more frequently according to “Maintenance Under Severe Driving Conditions”.
- (1) Automatic transmission fluid is maintenance-free.
- (2) Inspect the clearance between the brake pedal and the switches.

MAINTENANCE UNDER SEVERE DRIVING CONDITIONS

PERIODIC MAINTENANCE

< PERIODIC MAINTENANCE >

The maintenance intervals shown on the preceding pages are for normal operating conditions. If the vehicle is mainly operated under severe driving conditions as shown below, more frequent maintenance must be performed on the following items as shown in the table.

Severe driving conditions

- A — Driving under dusty conditions
- B — Driving repeatedly short distances
- C — Towing a trailer or caravan
- D — Extensive idling
- E — Driving in extremely adverse weather conditions or in areas where ambient temperatures are either extremely low or extremely high
- F — Driving in high humidity or mountainous areas
- G — Driving in areas using salt or other corrosive areas
- H — Driving on rough and/or muddy roads or in the desert
- I — Driving with frequent use of braking or in mountainous areas
- J — Frequent driving in water

Maintenance operation: Inspect = Check and correct or replace as necessary.

Driving condition										Maintenance item	Maintenance operation	Maintenance interval	Reference page
A	Air cleaner filter (Viscous paper type)	Replace	More frequently	MA-25 (VQ37VHR) MA-35 (VQ25HR)
A	B	C	D	Engine oil & engine oil filter	Replace	Every 5,000 km (3,000 miles) or 3 months	MA-25 (VQ37VHR) MA-35 (VQ25HR) MA-26 (VQ37VHR) MA-36 (VQ25HR)
.	F	Brake fluid	Replace	Every 20,000 km (12,000 miles) or 12 months	MA-51
.	.	C	H	.	.	Differential gear oil	Replace	Every 40,000 km (24,000 miles) or 24 months	MA-46 MA-47
.	G	H	.	.	Steering gear & linkage, axle & suspension parts	Inspect	Every 20,000 km (12,000 miles) or 12 months	MA-52 MA-53
A	.	C	.	.	.	G	H	I	.	Brake pads, rotors, drums & linings	Inspect	Every 10,000 km (6,000 miles) or 6 months	MA-51 BR-14 BR-16
A	Air conditioner filter	Replace	More frequently	VTL-8

RECOMMENDED FLUIDS AND LUBRICANTS

< PERIODIC MAINTENANCE >

RECOMMENDED FLUIDS AND LUBRICANTS FOR NORTH AMERICA

FOR NORTH AMERICA : Fluids and Lubricants

INFOID:000000008294327

		Capacity (Approximate)			Recommended Fluids/Lubricants	
		Liter	Imp measure	US measure		
Engine oil drain and refill		With oil filter change	4.9	4-1/4 qt	5-1/8 qt	<ul style="list-style-type: none"> Engine oil with API Certification Mark^{*1, *2} Viscosity SAE 5W-30^{*1, *2}
		Without oil filter change	4.6	4 qt	4-7/8 qt	
Dry engine (Overhaul)			5.7	5 qt	6 qt	
Cooling system	With reservoir tank	A/T models	8.5	7-1/2 qt	9 qt	Pre-diluted Genuine NISSAN Long Life Antifreeze/ Coolant (blue) or equivalent
		M/T models	8.6	7-5/8 qt	9-1/8 qt	
	Reservoir tank		0.8	3/4 qt	7/8 qt	
Automatic transmission fluid			9.2 ^{*9}	8-1/8 qt ^{*9}	9-3/4 qt ^{*9}	Genuine NISSAN Matic S ATF ^{*3}
Manual transmission gear oil			2.83	5 pt	6 pt	Genuine NISSAN Manual Transmission Fluid (MTF) HQ Multi 75W-85 or API GL-4, Viscosity SAE 75W-85
Differential gear oil		Front	0.65	1-1/8 pt	1-3/8 pt	For 7A/T 2WD models: API GL-5 synthetic gear oil, Viscosity SAE 75W-90 ^{*5} Except for 7A/T 2WD models: Genuine NISSAN Differential Oil Hypoid Super GL-5 80W-90 or API GL-5, Viscosity SAE 80W-90 ^{*4}
		Rear	1.40	2-1/2 pt	3 pt	
Transfer fluid			1.0	1-3/4 pt	2-1/8 pt	Genuine NISSAN Matic J ATF ^{*6}
Power steering fluid (PSF)			1.0	7/8 qt	1-1/8 qt	Genuine NISSAN PSF or equivalent ^{*7}
Brake and clutch fluid			—	—	—	Genuine NISSAN Super Heavy Duty Brake Fluid ^{*8} or equivalent DOT 3 (US FMVSS No. 116)
Multi-purpose grease			—	—	—	NLGI No. 2 (Lithium soap base)
Windshield washer fluid			—	—	—	Genuine NISSAN Windshield Washer Concentrate Cleaner & Antifreeze or equivalent
Fuel recommendation			—	—	—	Refer to GI-33, "Fuel" .

*1: For additional information, see "Engine Oil Recommendation".

*2: INFINITI recommends Genuine NISSAN Ester Engine Oil available an INFINITI retailer.

*3: Using automatic transmission fluid other than Genuine NISSAN Matic S ATF will cause deterioration in driveability and automatic transmission durability, and may damage the automatic transmission, which is not covered by the INFINITI new vehicle limited warranty.

*4: For hot climates, viscosity SAE 90 is suitable for ambient temperatures above 32°F (0°C).

*5: See an INFINITI retailer for service for synthetic oil.

*6: Using transfer fluid other than Genuine NISSAN Matic J ATF will cause deterioration in driveability and transfer durability, and may damage the transfer, which is not covered by the INFINITI new vehicle limited warranty.

*7: DEXRON™ VI type ATF may also be used.

*8: Available in mainland U.S.A. through an INFINITI retailer.

*9: The fluid capacity is the reference value.

RECOMMENDED FLUIDS AND LUBRICANTS

< PERIODIC MAINTENANCE >

FOR NORTH AMERICA : Engine Oil Recommendation

INFOID:000000008294328

NISSAN recommends the use of an energy conserving oil in order to improve fuel economy. Select only engine oils that meet the American Petroleum Institute (API) certification and International Lubricant Standardization and Approval Committee (ILSAC) certification and SAE viscosity standard. These oils have the API certification mark on the front of the container. Oils which do not have the specified quality label should not be used as they could cause engine damage.

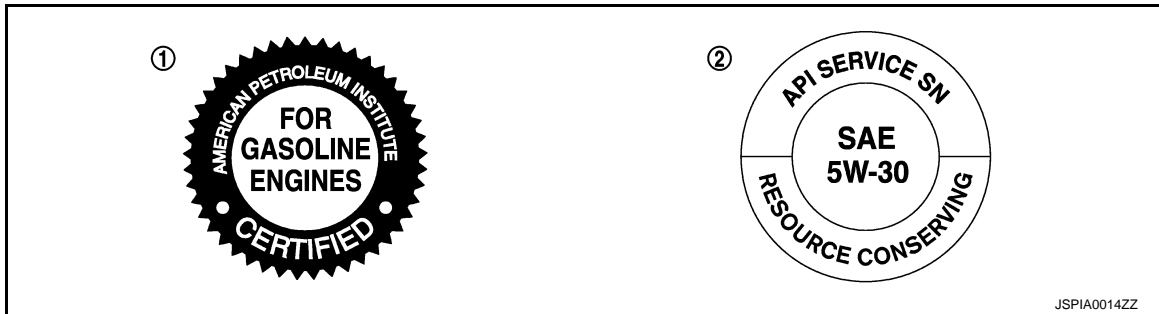

1. API certification mark
2. API service symbol

FOR NORTH AMERICA : Anti-Freeze Coolant Mixture Ratio

INFOID:000000008294329

The engine cooling system is filled at the factory with a pre-diluted mixture of 50% Genuine NISSAN Long Life Antifreeze/Coolant (blue) and 50% water to provide year-round anti-freeze and coolant protection. The anti-freeze solution contains rust and corrosion inhibitors. Additional engine cooling system additives are not necessary.

WARNING:

- Never remove the radiator or coolant reservoir cap when the engine is hot. Wait until the engine and radiator cool down. Serious burns could be caused by high pressure fluid escaping from the radiator.
- The radiator is equipped with a pressure type radiator cap. To prevent engine damage, use only a genuine NISSAN radiator cap.

CAUTION:

- When adding or replacing coolant, be sure to use only Genuine NISSAN Long Life Antifreeze/Coolant (blue) or equivalent. Genuine NISSAN Long Life Antifreeze/Coolant (blue) is pre-diluted to provide antifreeze protection to -34°F (-37°C). If additional freeze protection is needed due to weather where you operate your vehicle, add Genuine NISSAN Long Life Antifreeze/Coolant (blue) concentrate following the directions on the container. If an equivalent coolant other than Genuine NISSAN Long Life Antifreeze/Coolant (blue) is used, follow the coolant manufacturer's instructions to maintain minimum antifreeze protection to -34°F (-37°C). The use of other types of coolant solutions other than Genuine NISSAN Long Life Antifreeze/Coolant (blue) or equivalent may damage the engine cooling system.
- Mixing any other type of coolant other than Genuine NISSAN Long Life Antifreeze/Coolant (blue), including Genuine NISSAN Long Life Antifreeze/Coolant (green), or the use of non-distilled water will reduce the life expectancy of the factory-fill coolant.

FOR MEXICO

A
B
C
D
E
F
G
H
I
J
K
L
M
N
O

MA

RECOMMENDED FLUIDS AND LUBRICANTS

< PERIODIC MAINTENANCE >

FOR MEXICO : Fluids and Lubricants

INFOID:000000008294330

			Capacity (Approximate)		Recommended Fluids/Lubricants
			Liter	Imp measure	
Engine oil Drain and re- fill	With oil filter change	VQ25HR	4.7	4-1/8 qt	Genuine NISSAN engine oil API grade SL, SM or SN* ¹ ILSAC grade GF-2, GF-3, GF-4 or GF-5* ¹ Viscosity SAE 10W-30 except for VQ37 engine Viscosity SAE 5W-30 for VQ37 engine
		VQ37VHR	4.9	4-1/4 qt	
	Without oil filter change	VQ25HR	4.4	3-7/8 qt	
		VQ37VHR	4.6	4 qt	
Dry engine (engine overhaul)		VQ25HR	5.4	4-6/8 qt	
		VQ37VHR	5.7	5 qt	
Cooling system (with reservoir)		VQ25HR	8.3	7-2/8 qt	Genuine NISSAN Engine Coolant (blue) or equivalent* ²
		VQ37VHR	8.5	7-1/2 qt	
Reservoir tank			0.8	3/4 qt	
Automatic transmission fluid			9.2* ⁴	8-1/8 qt* ⁴	Genuine NISSAN Matic S ATF* ³
Differential gear oil			1.4	2-1/2 pt	Genuine NISSAN Differential Oil Hypoid Super-S GL-5 Synthetic 75W-90 or equivalent* ⁵
Power steering fluid (PSF)			1.0	7/8 qt	Genuine NISSAN PSF or equivalent* ⁶
Brake fluid			—	—	Genuine NISSAN Brake Fluid, or equivalent DOT 3 (US FMVSS No.116)
Multi-purpose grease			—	—	NLGI No. 2 (Lithium soap base)

*1: For additional information, see "SAE Viscosity Number".

*2: Use Genuine NISSAN Engine Coolant (blue) or equivalent in its quality, in order to avoid possible aluminum corrosion within the engine cooling system caused by the use of non-genuine engine coolant.

Note that any repairs for the incidents within the engine cooling system while using non-genuine engine coolant may not be covered by the warranty even if such incidents occurred during the warranty period.

*3: Using automatic transmission fluid other than Genuine NISSAN Matic S ATF will cause deterioration in driveability and automatic transmission durability, and may damage the automatic transmission, which is not covered by warranty.

*4: The fluid capacity is the reference value.

*5: See an INFINITI dealer for service for synthetic oil.

*6: DEXRON™ VI type ATF may also be used.

FOR MEXICO : SAE Viscosity Number

INFOID:000000008294331

GASOLINE ENGINE

RECOMMENDED FLUIDS AND LUBRICANTS

< PERIODIC MAINTENANCE >

Except for VQ37 engine

- 10W-30 is preferable.
- If 10W-30 is not available, select the viscosity, from the chart, that is suitable for the outside temperature range.

For VQ37 engine

- 5W-30 is preferable.
- If 5W-30 is not available, select the viscosity, from the chart, that is suitable for the outside temperature range.

Outside Temperature Range Anticipated Before Next Oil Change

GASOLINE ENGINE OIL

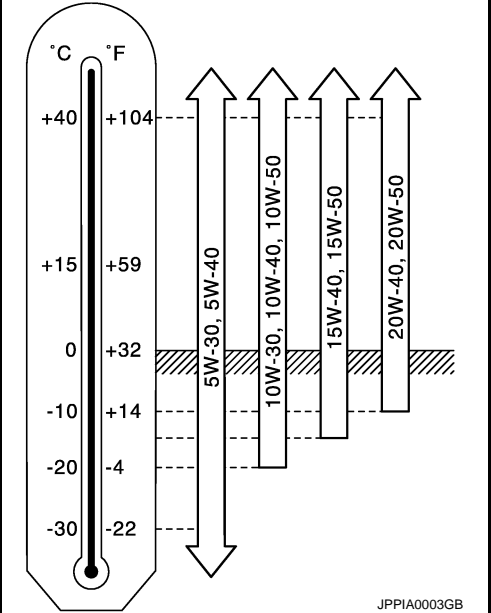

DIFFERENTIAL GEAR OIL

- 75W-90 for the differential gear is preferable.

Outside Temperature Range Anticipated Before Next Oil Change

DIFFERENTIAL GEAR OIL

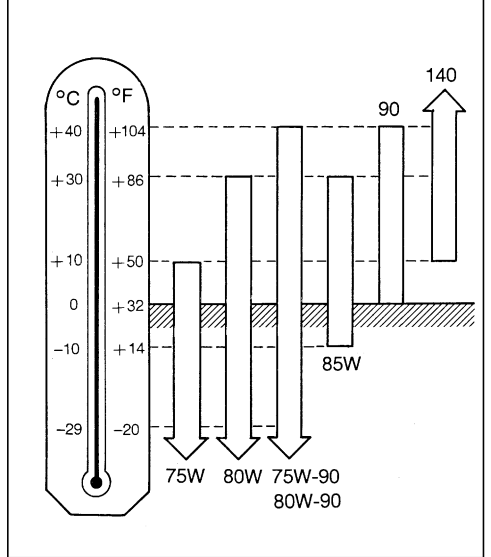

A
B
C
D
E
F
G
H
I
J
K
L
M
N
O

MA

RECOMMENDED FLUIDS AND LUBRICANTS

< PERIODIC MAINTENANCE >

FOR MEXICO : Engine Coolant Mixture Ratio

INFOID:000000008294332

The engine cooling system is filled at the factory with a high-quality, year-round and extended life engine coolant. The high quality engine coolant contains the specific solutions effective for the anti-corrosion and the anti-freeze function. Therefore, additional cooling system additives are not necessary.

CAUTION:

- When adding or replacing coolant, be sure to use only Genuine NISSAN Engine Coolant or equivalent in its quality with the proper mixture ratio. See the examples shown right.

The use of other types of engine coolant may damage the engine cooling system.

- When checking the engine coolant mixture ratio by the coolant hydrometer, use the chart below to correct your hydrometer reading (specific gravity) according to coolant temperature.

Outside temperature down to		Composition	
°C	°F	Engine coolant (Concentrated)	Demineralized water or distilled water
-15	5	30%	70%
-35	-30	50%	50%

SMA089D

Mixed coolant specific gravity

Unit: specific gravity

Engine coolant mixture ratio	Coolant temperature °C (°F)			
	15 (59)	25 (77)	35 (95)	45 (113)
30%	1.046 - 1.050	1.042 - 1.046	1.038 - 1.042	1.033 - 1.038
50%	1.076 - 1.080	1.070 - 1.076	1.065 - 1.071	1.059 - 1.065

WARNING:

Never remove the radiator cap when the engine is hot. Serious burns could be caused by high pressure fluid escaping from the radiator. Wait until the engine and radiator cool down.

ENGINE MAINTENANCE (VQ37VHR)

< PERIODIC MAINTENANCE >

ENGINE MAINTENANCE (VQ37VHR)

DRIVE BELT

DRIVE BELT : Exploded View

INFOID:000000008294333

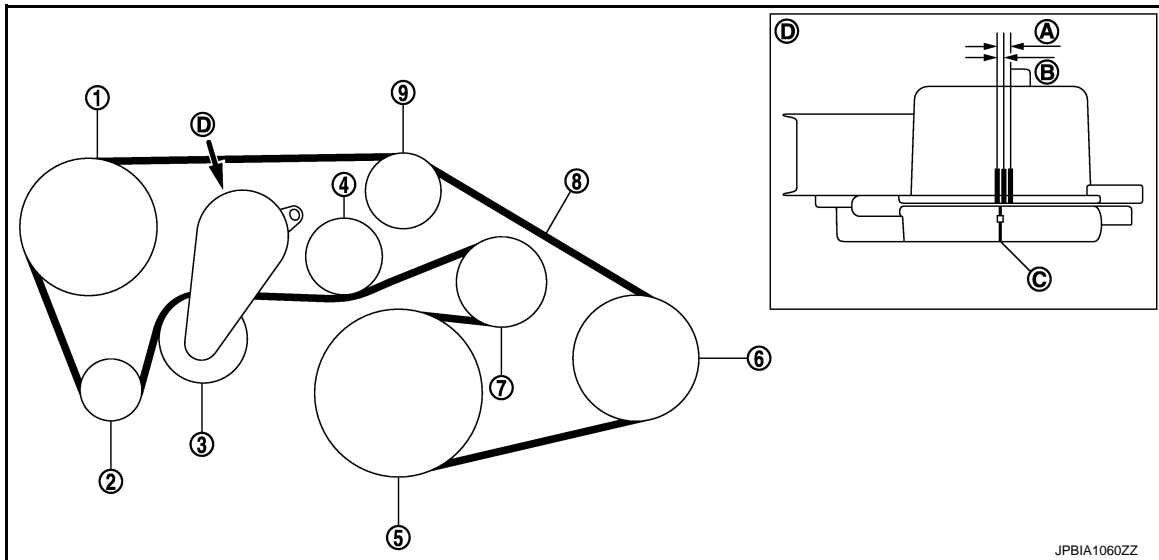

- | | | |
|----------------------------|---|------------------------------|
| 1. Power steering oil pump | 2. Alternator | 3. Drive belt auto-tensioner |
| 4. Idler pulley | 5. Crankshaft pulley | 6. A/C compressor |
| 7. Idler pulley | 8. Drive belt | 9. Idler pulley |
| A. Possible use range | B. Range when new drive belt is installed | C. Indicator |
| D. View D | | |

DRIVE BELT : Checking

INFOID:000000008294334

WARNING:

Be sure to perform the this step when engine is stopped.

- Check that the indicator (C) (notch on fixed side) of drive belt auto-tensioner is within the possible use range (A).

NOTE:

- Check the drive belt auto-tensioner indication when the engine is cold.
- When new drive belt is installed, the indicator (notch on fixed side) should be within the range (B) in the figure.
- Visually check the entire drive belt for wear, damage or crack.
- If the indicator (notch on fixed side) is out of the possible use range or belt is damaged, replace drive belt.

DRIVE BELT : Tension Adjustment

INFOID:000000008294335

Refer to [EM-291. "Drive Belt"](#).

ENGINE COOLANT

ENGINE COOLANT : Draining

INFOID:000000008294336

WARNING:

- To avoid being scalded, never change engine coolant when the engine is hot.
- Wrap a thick cloth around radiator cap and carefully remove radiator cap. First, turn radiator cap a quarter of a turn to release built-up pressure. Then turn radiator cap all the way.

A
B
C
D
E
F
G
H
I
J
K
L
M
N
O

MA

ENGINE MAINTENANCE (VQ37VHR)

< PERIODIC MAINTENANCE >

1. Connect drain hose.

NOTE:

Use a general-purpose hose with the dimensions shown in the figure.

- A : ϕ 15 - 16 mm (0.59 - 0.63 in)
B : 145 mm (5.71 in)

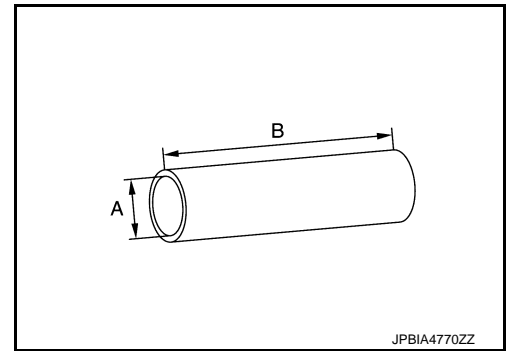

2. Open radiator drain plug (2) at the bottom of radiator, and then remove radiator cap.

- 1 : Engine under cover
A : Radiator drain plug hole
⇐ : Vehicle front

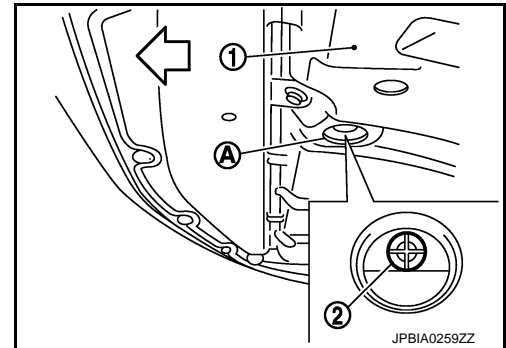

When draining all of engine coolant in the system, open water drain plugs on cylinder block. Refer to [EM-87, "Setting"](#) (VQ25HR) or [EM-222, "Setting"](#) (VQ37VHR).

3. Remove reservoir tank if necessary, and drain engine coolant and clean reservoir tank before installing.
4. Check drained engine coolant for contaminants such as rust, corrosion or discoloration.
If contaminated, flush the engine cooling system. Refer to [MA-24, "ENGINE COOLANT : Flushing"](#).

ENGINE COOLANT : Refilling

INFOID:000000008294337

CAUTION:

- Do not reuse O-rings.
- Do not put additive such as waterleak preventive, since it may cause cooling waterway clogging.
- When refilling use Genuine NISSAN Long Life Antifreeze/Coolant (blue) or equivalent in its quality mixed with water (distilled or demineralized). Refer to [MA-16, "FOR NORTH AMERICA : Fluids and Lubricants"](#) (FOR NORTH AMERICA) or [MA-18, "FOR MEXICO : Fluids and Lubricants"](#) (FOR MEXICO).

1. Remove air cleaner case (LH). Refer to [EM-28, "Exploded View"](#) (VQ25HR) or [EM-170, "Exploded View"](#) (VQ37VHR).
2. Install reservoir tank if removed, and radiator drain plug.

CAUTION:

Be sure to clean drain plug and install with new O-ring.

Tightening torque : Refer to [CO-15, "Exploded View"](#).

If water drain plugs on cylinder block are removed, close and tighten them. Refer to [EM-87, "Setting"](#) (VQ25HR) or [EM-222, "Setting"](#) (VQ37VHR).

3. Check that each hose clamp has been firmly tightened.

ENGINE MAINTENANCE (VQ37VHR)

< PERIODIC MAINTENANCE >

4. Remove air relief plug (2) on radiator left side.

- 1 : Reservoir tank
3 : Engine cover
↶ : Vehicle front

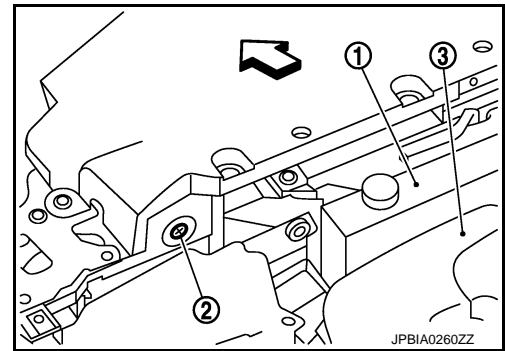

5. Remove air relief plug (1) on heater hose.

- 2 : Heater hose
↶ : Vehicle front

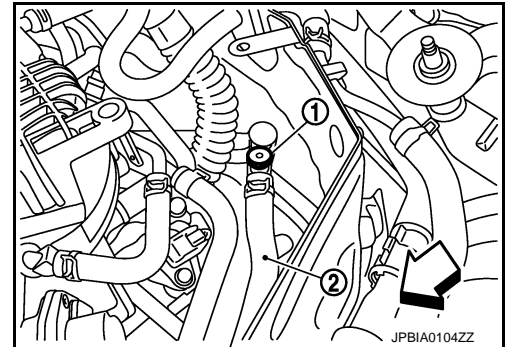

6. Fill radiator to specified level.

- Pour engine coolant through engine coolant filler neck slowly of less than 2 l (2-1/8 US qt, 1-3/4 Imp qt) a minute to allow air in system to escape.

Engine coolant capacity : Refer to [CO-33](#),
(With reservoir tank at "MAX" level) ["Periodical Maintenance Specification"](#).

7. Refill reservoir tank to "MAX" level line with engine coolant.

- A : MAX
B : MIN

Reservoir tank engine coolant capacity : Refer to [CO-33](#),
(At "MAX" level) ["Periodical Maintenance Specification"](#)

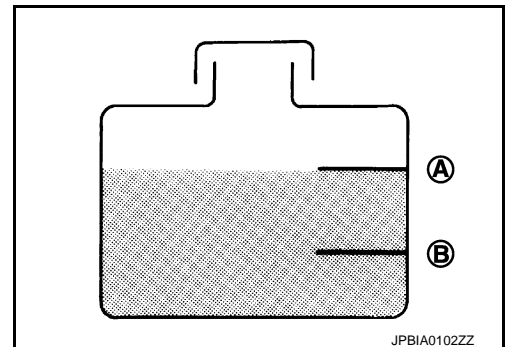

8. When engine coolant overflows air relief hole on radiator, install air relief plug with new O-ring.

Tightening torque : Refer to [CO-15](#), ["Exploded View"](#).

9. Repeat step 6 and 7.

10. When engine coolant overflows air relief hole on heater hose, install air relief plug with new O-ring. Then refill radiator with engine coolant.

 : **1.2 N·m (0.12 kg·m, 11 in·lb)**

11. Install air cleaner case (LH). Refer to [EM-28](#), ["Exploded View"](#) (VQ25HR) or [EM-170](#), ["Exploded View"](#) (VQ37VHR).

12. Install radiator cap.

13. Warm up engine until opening thermostat. Standard for warming-up time is approximately 10 minutes at 3,000 rpm.

ENGINE MAINTENANCE (VQ37VHR)

< PERIODIC MAINTENANCE >

- Check thermostat opening condition by touching radiator hose (lower) to see a flow of warm water.

CAUTION:

Watch water temperature gauge so as not to overheat engine.

14. Stop the engine and cool down to less than approximately 50°C (122°F).
 - Cool down using fan to reduce the time.
 - If necessary, refill radiator up to filler neck with engine coolant.
15. Refill reservoir tank to "MAX" level line with engine coolant, if necessary.
16. Repeat steps 12 through 15 two or more times with radiator cap installed until engine coolant level no longer drops.
17. Check cooling system for leakage with engine running.
18. Warm up the engine, and check for sound of engine coolant flow while running engine from idle up to 3,000 rpm with heater temperature controller set at several position between "COOL" and "WARM".
 - Sound may be noticeable at heater unit.
19. Repeat step 18 three times.
20. If sound is heard, bleed air from cooling system by repeating step 6, and steps from 12 to 19 until engine coolant level no longer drops.
21. Check that the reservoir tank cap is tightened.

ENGINE COOLANT : Flushing

INFOID:000000008294338

1. Install reservoir tank if removed, and radiator drain plug.

CAUTION:

Be sure to clean drain plug and install with new O-ring.

Tightening torque : Refer to [CO-15. "Exploded View"](#).

If water drain plugs on cylinder block are removed, close and tighten them. Refer to [EM-222. "Setting"](#).

2. Remove air relief plug (1) on heater hose (2).

← : Vehicle front

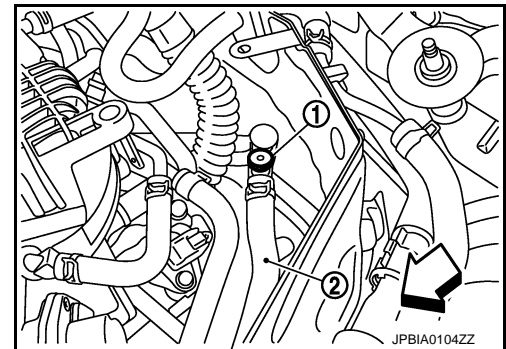

3. Remove air relief plug (2) on radiator.

1 : Reservoir tank

3 : Engine cover

← : Vehicle front

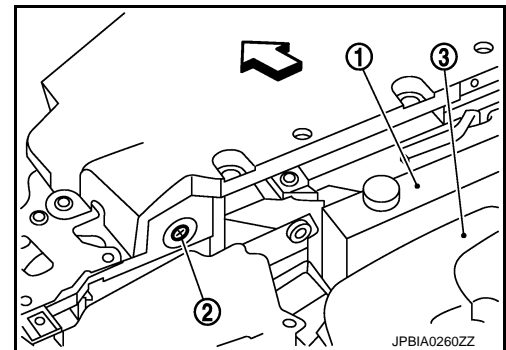

4. Fill radiator with water until water spills from the air relief holes, then close air relief plugs. Fill radiator and reservoir tank with water and reinstall radiator cap.

Tightening torque : Refer to [CO-15. "Exploded View"](#).

5. Run the engine and warm it up to normal operating temperature.

ENGINE MAINTENANCE (VQ37VHR)

< PERIODIC MAINTENANCE >

- Rev the engine two or three times under no-load.
- Stop the engine and wait until it cools down.
- Drain water from the system. Refer to [MA-21. "ENGINE COOLANT : Draining"](#).
- Repeat steps 1 through 8 until clear water begins to drain from radiator.
- Check that the reservoir tank cap is tightened.

FUEL LINES

FUEL LINES : Inspection

Inspect fuel lines, fuel filler cap and fuel tank for improper attachment, leakage, cracks, damage, loose connections, chafing or deterioration.

- A : Engine
- B : Fuel line
- C : Fuel tank

If necessary, repair or replace damaged parts.

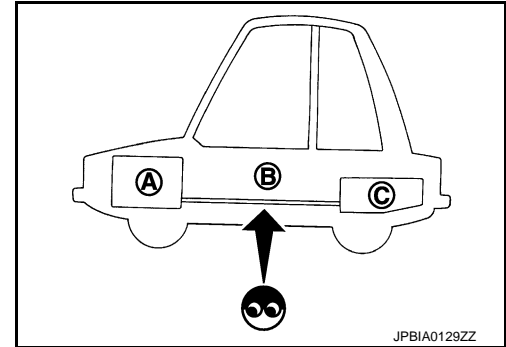

AIR CLEANER FILTER

AIR CLEANER FILTER : Removal and Installation

REMOVAL

- Unhook clips (A).

- 1 : Holder
- 2 : Air cleaner case

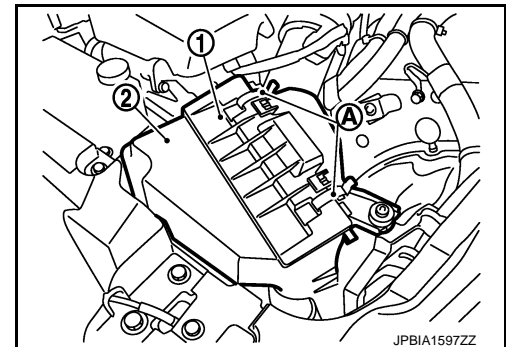

- Remove holder (3) from air cleaner case (2), and then remove air cleaner filter (1) from holder.

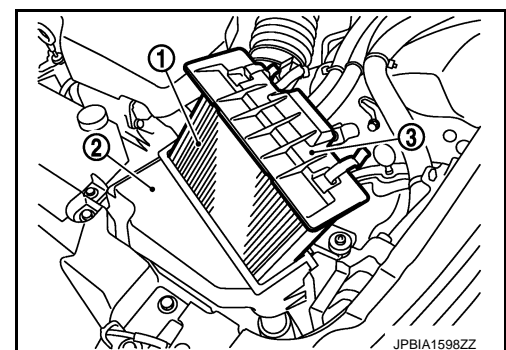

INSTALLATION

Note the following, and install in the reverse order of removal.

- Install the air cleaner filter by aligning the seal with the notch of air cleaner case.

ENGINE OIL

ENGINE OIL : Draining

WARNING:

ENGINE MAINTENANCE (VQ37VHR)

< PERIODIC MAINTENANCE >

- Be careful not to get burn yourself, as engine oil may be hot.
 - Prolonged and repeated contact with used engine oil may cause skin cancer. Try to avoid direct skin contact with used engine oil. If skin contact is made, wash thoroughly with soap or hand cleaner as soon as possible.
1. Warm up the engine, and check for engine oil leakage from engine components. Refer to [LU-8, "Inspection"](#).
 2. Stop the engine and wait for 10 minutes.
 3. Loosen oil filler cap.
 4. Remove undercover with power tool.
 5. Remove drain plug and then drain engine oil.

ENGINE OIL : Refilling

INFOID:000000008294342

1. Install drain plug with new washer. Refer to [EM-186, "Exploded View \(2WD\)"](#).
CAUTION:
Be sure to clean drain plug and install with new washer.

Tightening torque : Refer to [EM-186, "Exploded View \(2WD\)"](#).

2. Refill with new engine oil.
Engine oil specification and viscosity: Refer to [MA-16, "FOR NORTH AMERICA : Fluids and Lubricants"](#).

Engine oil capacity : Refer to [LU-19, "Periodical Maintenance Specification"](#).

CAUTION:

- When filling engine oil, do not pull out oil level gauge.
 - The refill capacity depends on the engine oil temperature and drain time. Use these specifications for reference only.
 - Always use oil level gauge to determine the proper amount of engine oil in engine.
3. Warm up the engine and check area around drain plug and oil filter for engine oil leakage.
 4. Stop the engine and wait for 10 minutes.
 5. Check the engine oil level. Refer to [LU-8, "Inspection"](#).

OIL FILTER

OIL FILTER : Removal and Installation

INFOID:000000008294343

REMOVAL

CAUTION:

- Oil filter is provided with relief valve. Use genuine NISSAN oil filter or equivalent.
- Never get burned when engine and engine oil may be hot.
- When removing, prepare a shop cloth to absorb any engine oil leakage or spillage.
- Never allow engine oil to adhere to drive belt.
- Completely wipe off any engine oil that adheres to engine and vehicle.

1. Remove engine undercover with power tool.
2. Using oil filter wrench [SST: KV10115801 (J-38956)], remove oil filter.
 - VQ25HR 2WD models

A : Vehicle under view

B : Oil filter wrench

⇐ : Engine front

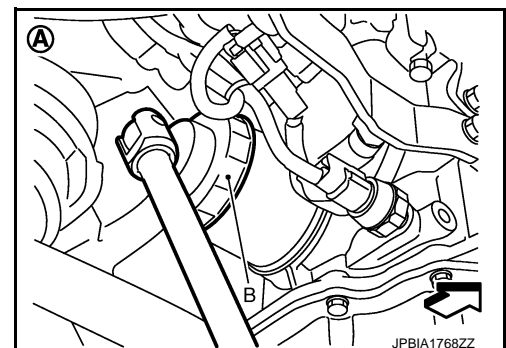

ENGINE MAINTENANCE (VQ37VHR)

< PERIODIC MAINTENANCE >

- VQ25HR AWD models

A : Oil filter wrench

⇐ : Engine front

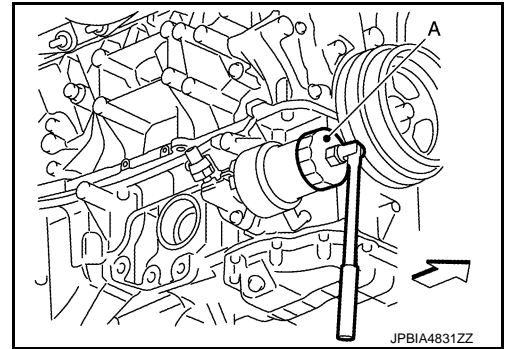

- VQ37VHR 2WD models

A : Vehicle under view

B : Oil filter wrench

⇐ : Engine front

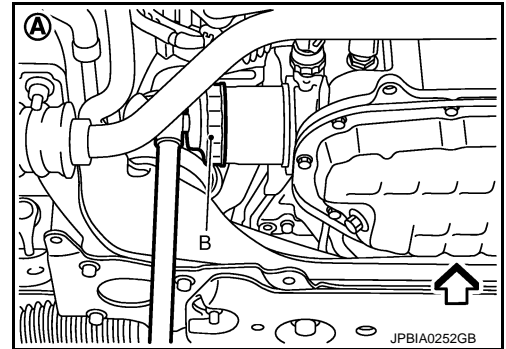

- VQ37VHR AWD models

A : Vehicle under view

B : Oil filter wrench

⇐ : Engine front

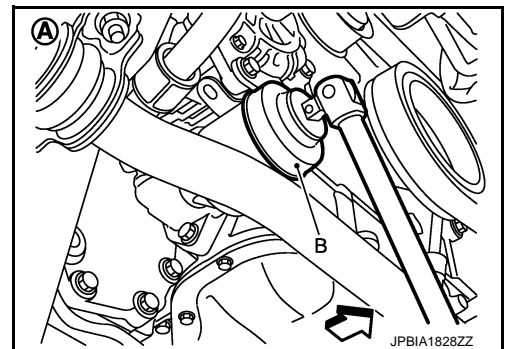

INSTALLATION

1. Remove foreign materials adhering to oil filter installation surface.
2. Apply engine oil to the oil seal contact surface of new oil filter.

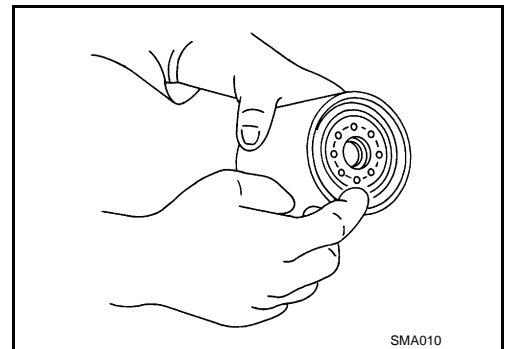

A
B
C
D
E
F
G
H
I
J
K
L
M
N
O
MA

ENGINE MAINTENANCE (VQ37VHR)

< PERIODIC MAINTENANCE >

3. Screw oil filter manually until it touches the installation surface, then tighten it by 2/3 turn (A). Or tighten to the specification.

Oil filter:

: 17.7 N·m (1.8 kg-m, 13 ft-lb)

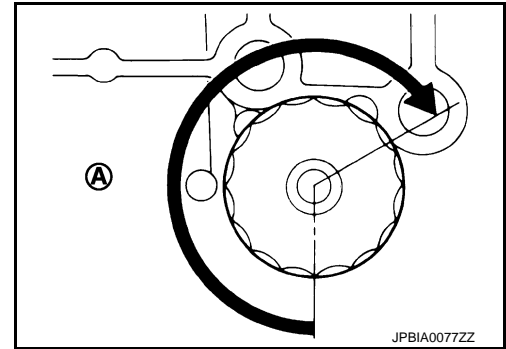

OIL FILTER : Inspection

INFOID:000000008294344

INSPECTION AFTER INSTALLATION

1. Check the engine oil level. Refer to [LU-8, "Inspection"](#).
2. Start the engine, and check there is no leak of engine oil.
3. Stop the engine and wait for 10 minutes.
4. Check the engine oil level, and adjust the level. Refer to [LU-8, "Inspection"](#).

SPARK PLUG

SPARK PLUG : Removal and Installation

INFOID:000000008294345

REMOVAL

1. Remove engine cover, using a power tool. Refer to [EM-168, "Exploded View"](#).
2. Remove air cleaner case and air duct (RH and LH). Refer to [EM-170, "Exploded View"](#).
3. Remove electric throttle control actuator. Refer to [EM-172, "Exploded View"](#).
4. Remove ignition coil. Refer to [EM-190, "Removal and Installation"](#).
5. Remove spark plug with a spark plug wrench (commercial service tool).

a : 14 mm (0.55 in)

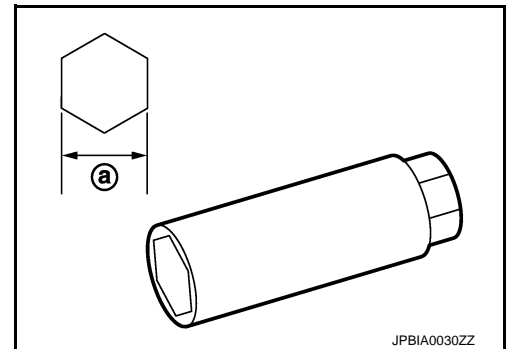

INSTALLATION

Installation is the reverse order of removal.

SPARK PLUG : Inspection

INFOID:000000008294346

INSPECTION AFTER REMOVAL

Use the standard type spark plug for normal condition.

Spark plug (Standard type) : Refer to [EM-291, "Spark Plug"](#).

CAUTION:

ENGINE MAINTENANCE (VQ37VHR)

< PERIODIC MAINTENANCE >

- Never drop or shock spark plug.
- Never use a wire brush for cleaning.
- If plug tip is covered with carbon, use spark plug cleaner to clean.

Cleaner air pressure

: Less than 588 kPa (6 kg/cm², 85 psi)

Cleaning time

: Less than 20 seconds

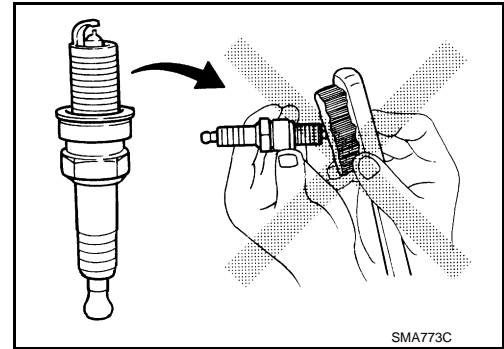

- Check and adjustment of plug gap is not required between change intervals.

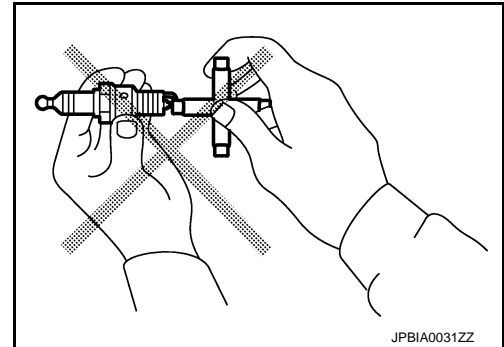

EVAP VAPOR LINES

EVAP VAPOR LINES : Inspection

INFOID:000000008294347

1. Visually inspect EVAP vapor lines for improper attachment and for cracks, damage, loose connections, chafing and deterioration. Refer to [EC-620, "Inspection"](#).
2. Inspect fuel tank filler cap vacuum relief valve for clogging, sticking, etc. Refer to [EC-366, "Component Inspection"](#).

A
B
C
D
E
F
G
H
I
J
K
L
M
N
O

MA

ENGINE MAINTENANCE (VQ25HR)

< PERIODIC MAINTENANCE >

ENGINE MAINTENANCE (VQ25HR) DRIVE BELT

DRIVE BELT : Inspection

INFOID:000000008294348

- Check the belt with the engine cold or after a lapse of 30 minutes or more after the engine is stopped.

- 1 : Power steering oil pump
- 2 : Alternator
- 3 : Idler pulley
- 4 : Crankshaft pulley
- 5 : A/C compressor

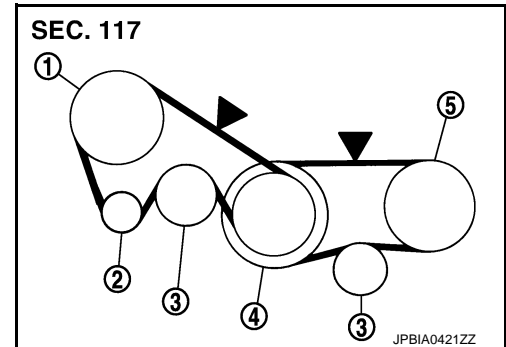

- Measure belt tension at the position ▼ as shown in the figure with the tension gauge [SST: KV99105600 (—)] (A). If it is difficult to measure the tension at the position ▼, then a nearby position can be measured.
- Apply the force of 98.1 N (10kg) at the ▼ position shown in the figure also when measuring by deflection amount.

CAUTION:

- To check belt tension right after belt installation, adjust belt tension to the reference value and rotate the crankshaft twice or more to prevent variations in the tension between pulleys. Measure belt tension again and adjust to the reference value.

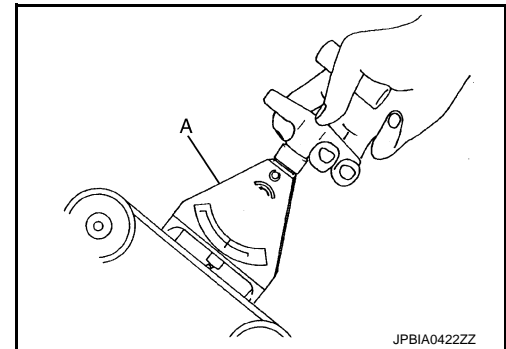

- Tighten Idler pulley lock nut by hand and measure tension in backlash-free condition.

**Auxiliary machine belt tension
Deflection amount of auxiliary
machine belt**

: Refer to [MA-56, "DRIVE BELT \(VQ25HR\) : Drive Belt"](#)

DRIVE BELT : Adjustment

INFOID:000000008294349

Portion	Belt tightening method for adjustment
Alternator·Power steering oil pump belt	Adjusting bolt of idler pulley
A/C compressor belt	Adjusting bolt of idler pulley

CAUTION:

- After replacing belt with a new one, adjust it to the value of "NEW" since new ones do not sufficiently fit in with pulley grooves.
- If the belt in use exceeds the value of "Limit of Retightening," adjust the belt to the value of "For Adjustment."
- To check belt tension right after belt installation, adjust belt tension to the reference value and rotate the crankshaft twice or more to prevent variations in the tension between pulleys. Measure belt tension again and adjust to the reference value.
- After installing belt, check that it is completely fit into the pulley groove.
- Never allow oil and coolant to adhere to the belt.
- Never twist or bend the belt.

Alternator ·power steering oil pump belt

1. Remove engine under cover with power tool.

ENGINE MAINTENANCE (VQ25HR)

< PERIODIC MAINTENANCE >

2. Loosening idler pulley rock nut (A).

- 1 : Alternator -power steering oil pump belt
- 2 : A/C compressor belt
- 3 : Power steering oil pump
- 4 : Idler pulley
- 5 : Alternator
- 6 : Crankshaft pulley
- 7 : A/C compressor
- C : Idler pulley rock nut
- D : Adjustment bolt

3. Adjust tension by turning adjusting bolt (B).

CAUTION:

Adjusting bolts are applied with grease. Never allow the grease to adhere to the belt.

- For adjustment value, refer to [MA-30. "DRIVE BELT : Inspection"](#).

4. Tightening idler pulley rock nut (A).

Tightening torque 34.8 N·m (3.5 kg·m)

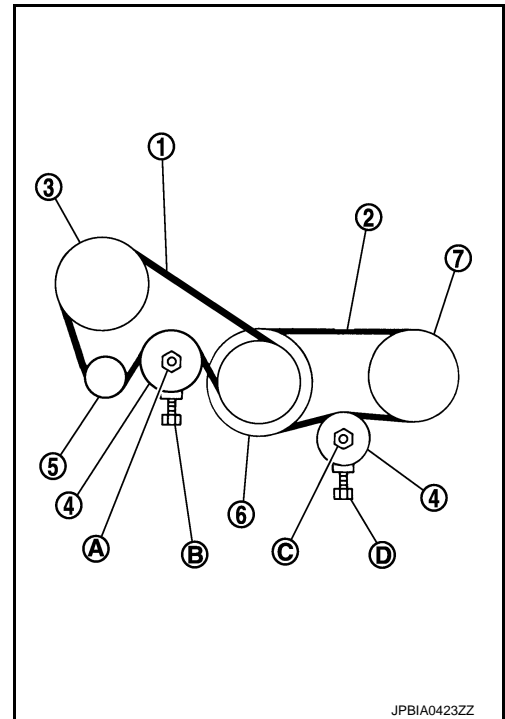

A/C compressor belt

1. Remove engine under cover with power tool.
2. Loosening idler pulley rock nut (C).

- 1 : Alternator -power steering oil pump belt
- 2 : A/C compressor belt
- 3 : Power steering oil pump
- 4 : Idler pulley
- 5 : Alternator
- 6 : Crankshaft pulley
- 7 : A/C compressor
- A : Idler pulley rock nut
- B : Adjustment bolt

3. Adjust tension by turning adjusting bolt (D).

CAUTION:

Adjusting bolts are applied with grease. Never allow the grease to adhere to the belt.

- For adjustment value, refer to [MA-30. "DRIVE BELT : Inspection"](#).

4. Tightening idler pulley rock nut (C).

Tightening torque 34.8 N·m (3.5 kg·m)

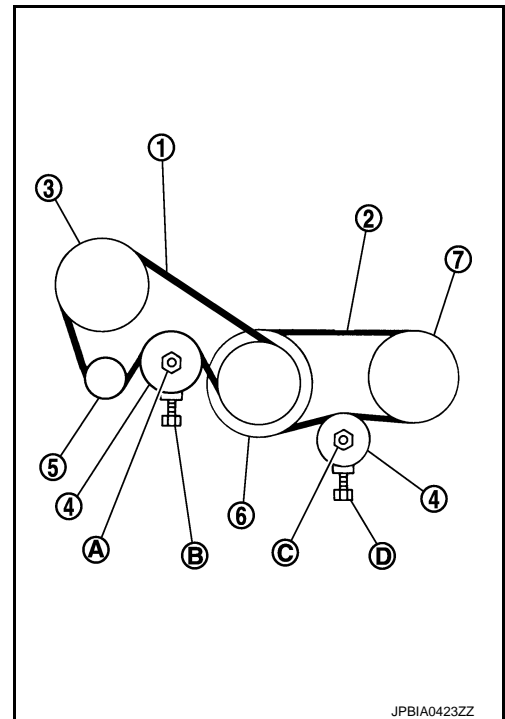

ENGINE COOLANT

ENGINE COOLANT : Draining

INFOID:000000008294350

WARNING:

- To avoid being scalded, never change engine coolant when the engine is hot.
- Wrap a thick cloth around radiator cap and carefully remove radiator cap. First, turn radiator cap a quarter of a turn to release built-up pressure. Then turn radiator cap all the way.

A
B
C
D
E
F
G
H
I
J
K
L
M
N
O

MA

ENGINE MAINTENANCE (VQ25HR)

< PERIODIC MAINTENANCE >

1. Connect drain hose.

NOTE:

Use a general-purpose hose with the dimensions shown in the figure.

- A : ϕ 15 - 16 mm (0.59 - 0.63 in)
B : 145 mm (5.71 in)

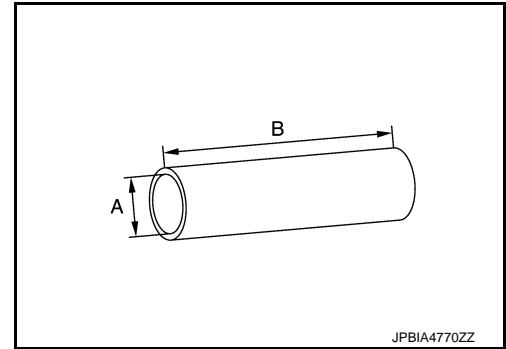

2. Open radiator drain plug (2) at the bottom of radiator, and then remove radiator cap.

- 1 : Engine under cover
A : Radiator drain plug hole
⇐ : Vehicle front

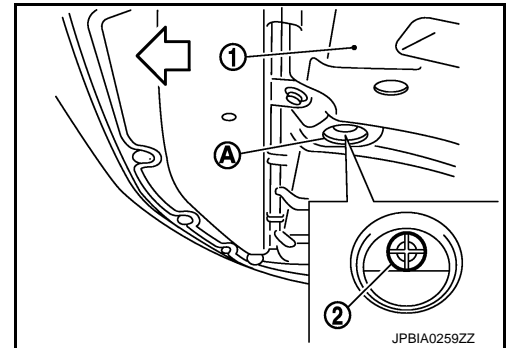

When draining all of engine coolant in the system, open water drain plugs on cylinder block. Refer to [EM-87, "Setting"](#) (VQ25HR) or [EM-222, "Setting"](#) (VQ37VHR).

3. Remove reservoir tank if necessary, and drain engine coolant and clean reservoir tank before installing.
4. Check drained engine coolant for contaminants such as rust, corrosion or discoloration.
If contaminated, flush the engine cooling system. Refer to [MA-24, "ENGINE COOLANT : Flushing"](#).

ENGINE COOLANT : Refilling

INFOID:000000008294351

CAUTION:

- Do not reuse O-rings.
- Do not put additive such as waterleak preventive, since it may cause cooling waterway clogging.
- When refilling use Genuine NISSAN Long Life Antifreeze/Coolant (blue) or equivalent in its quality mixed with water (distilled or demineralized). Refer to [MA-16, "FOR NORTH AMERICA : Fluids and Lubricants"](#) (FOR NORTH AMERICA) or [MA-18, "FOR MEXICO : Fluids and Lubricants"](#) (FOR MEXICO).

1. Remove air cleaner case (LH). Refer to [EM-28, "Exploded View"](#) (VQ25HR) or [EM-170, "Exploded View"](#) (VQ37VHR).
2. Install reservoir tank if removed, and radiator drain plug.

CAUTION:

Be sure to clean drain plug and install with new O-ring.

Tightening torque : Refer to [CO-15, "Exploded View"](#).

If water drain plugs on cylinder block are removed, close and tighten them. Refer to [EM-87, "Setting"](#) (VQ25HR) or [EM-222, "Setting"](#) (VQ37VHR).

3. Check that each hose clamp has been firmly tightened.

ENGINE MAINTENANCE (VQ25HR)

< PERIODIC MAINTENANCE >

4. Remove air relief plug (2) on radiator left side.

- 1 : Reservoir tank
3 : Engine cover
↶ : Vehicle front

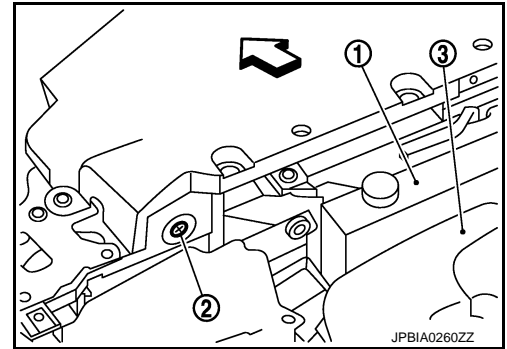

5. Remove air relief plug (1) on heater hose.

- 2 : Heater hose
↶ : Vehicle front

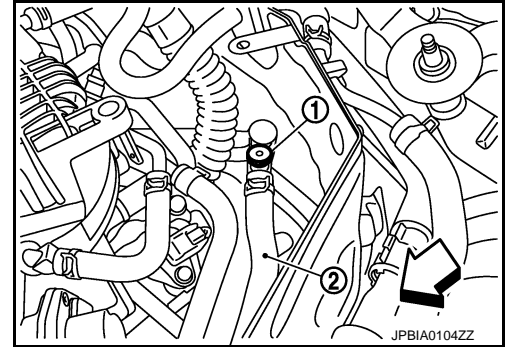

6. Fill radiator to specified level.

- Pour engine coolant through engine coolant filler neck slowly of less than 2 l (2-1/8 US qt, 1-3/4 Imp qt) a minute to allow air in system to escape.

Engine coolant capacity : Refer to [CO-33](#),
(With reservoir tank at "MAX" level) ["Periodical Maintenance Specification"](#).

7. Refill reservoir tank to "MAX" level line with engine coolant.

- A : MAX
B : MIN

Reservoir tank engine coolant capacity : Refer to [CO-33](#),
(At "MAX" level) ["Periodical Maintenance Specification"](#)

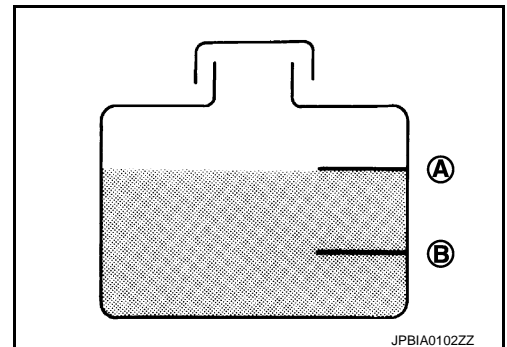

8. When engine coolant overflows air relief hole on radiator, install air relief plug with new O-ring.

Tightening torque : Refer to [CO-15](#), ["Exploded View"](#).

9. Repeat step 6 and 7.

10. When engine coolant overflows air relief hole on heater hose, install air relief plug with new O-ring. Then refill radiator with engine coolant.

 : **1.2 N·m (0.12 kg·m, 11 in·lb)**

11. Install air cleaner case (LH). Refer to [EM-28](#), ["Exploded View"](#) (VQ25HR) or [EM-170](#), ["Exploded View"](#) (VQ37VHR).

12. Install radiator cap.

13. Warm up engine until opening thermostat. Standard for warming-up time is approximately 10 minutes at 3,000 rpm.

ENGINE MAINTENANCE (VQ25HR)

< PERIODIC MAINTENANCE >

- Check thermostat opening condition by touching radiator hose (lower) to see a flow of warm water.

CAUTION:

Watch water temperature gauge so as not to overheat engine.

14. Stop the engine and cool down to less than approximately 50°C (122°F).
 - Cool down using fan to reduce the time.
 - If necessary, refill radiator up to filler neck with engine coolant.
15. Refill reservoir tank to "MAX" level line with engine coolant, if necessary.
16. Repeat steps 12 through 15 two or more times with radiator cap installed until engine coolant level no longer drops.
17. Check cooling system for leakage with engine running.
18. Warm up the engine, and check for sound of engine coolant flow while running engine from idle up to 3,000 rpm with heater temperature controller set at several position between "COOL" and "WARM".
 - Sound may be noticeable at heater unit.
19. Repeat step 18 three times.
20. If sound is heard, bleed air from cooling system by repeating step 6, and steps from 12 to 19 until engine coolant level no longer drops.
21. Check that the reservoir tank cap is tightened.

ENGINE COOLANT : Flushing

INFOID:000000008294352

1. Install reservoir tank if removed, and radiator drain plug.

CAUTION:

Be sure to clean drain plug and install with new O-ring.

Tightening torque : Refer to [CO-15. "Exploded View"](#).

If water drain plugs on cylinder block are removed, close and tighten them. Refer to [EM-222. "Setting"](#).

2. Remove air relief plug (1) on heater hose (2).

← : Vehicle front

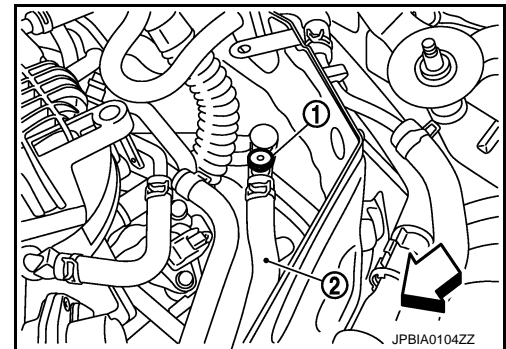

3. Remove air relief plug (2) on radiator.

1 : Reservoir tank

3 : Engine cover

← : Vehicle front

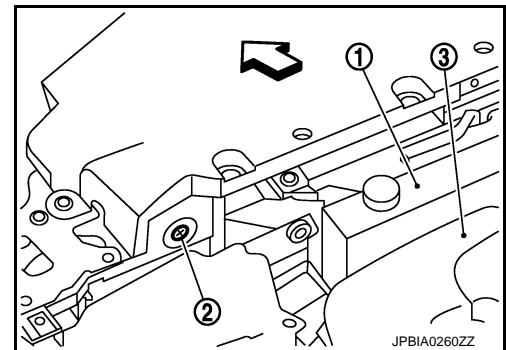

4. Fill radiator with water until water spills from the air relief holes, then close air relief plugs. Fill radiator and reservoir tank with water and reinstall radiator cap.

Tightening torque : Refer to [CO-15. "Exploded View"](#).

5. Run the engine and warm it up to normal operating temperature.

ENGINE MAINTENANCE (VQ25HR)

< PERIODIC MAINTENANCE >

6. Rev the engine two or three times under no-load.
7. Stop the engine and wait until it cools down.
8. Drain water from the system. Refer to [MA-21. "ENGINE COOLANT : Draining"](#).
9. Repeat steps 1 through 8 until clear water begins to drain from radiator.
10. Check that the reservoir tank cap is tightened.

FUEL LINES

FUEL LINES : Inspection

Inspect fuel lines, fuel filler cap and fuel tank for improper attachment, leakage, cracks, damage, loose connections, chafing or deterioration.

- A : Engine
- B : Fuel line
- C : Fuel tank

If necessary, repair or replace damaged parts.

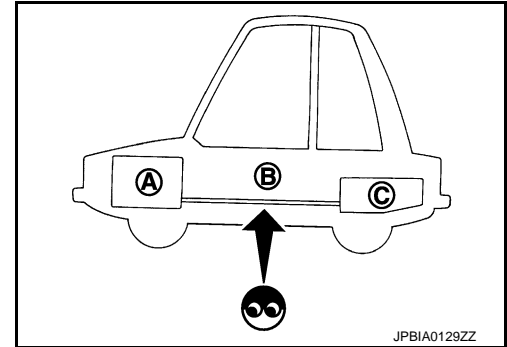

AIR CLEANER FILTER

AIR CLEANER FILTER : Removal and Installation

REMOVAL

1. Unhook clips (A).

- 1 : Holder
- 2 : Air cleaner case

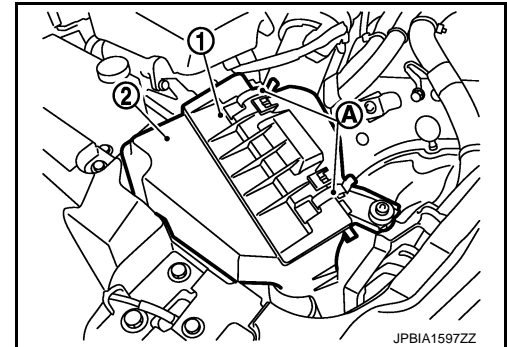

2. Remove air cleaner filter (1) from air cleaner case (2).

- 3 : Holder

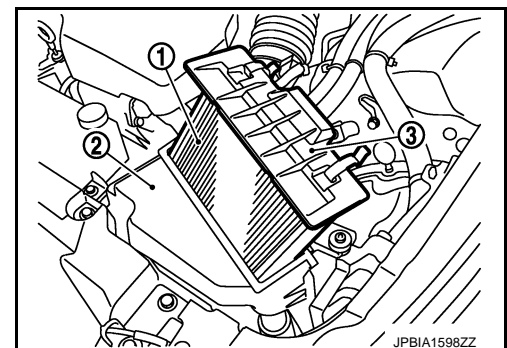

INSTALLATION

Note the following, and install in the reverse order of removal.

- Install the air cleaner filter by aligning the seal with the notch of air cleaner case.

ENGINE OIL

ENGINE OIL : Draining

WARNING:

A
B
C
D
E
F
G
H
I
J
K
L
M
N
O

MA

ENGINE MAINTENANCE (VQ25HR)

< PERIODIC MAINTENANCE >

- Be careful not to get burn yourself, as engine oil may be hot.
 - Prolonged and repeated contact with used engine oil may cause skin cancer. Try to avoid direct skin contact with used engine oil. If skin contact is made, wash thoroughly with soap or hand cleaner as soon as possible.
1. Warm up the engine, and check for engine oil leakage from engine components. Refer to [LU-8, "Inspection"](#).
 2. Stop the engine and wait for 10 minutes.
 3. Loosen oil filler cap.
 4. Remove undercover with power tool.
 5. Remove drain plug and then drain engine oil.

ENGINE OIL : Refilling

INFOID:000000008294356

1. Install drain plug with new washer. Refer to [EM-186, "Exploded View \(2WD\)"](#).
CAUTION:
Be sure to clean drain plug and install with new washer.

Tightening torque : Refer to [EM-186, "Exploded View \(2WD\)"](#).

2. Refill with new engine oil.
Engine oil specification and viscosity: Refer to [MA-16, "FOR NORTH AMERICA : Fluids and Lubricants"](#).

Engine oil capacity : Refer to [LU-19, "Periodical Maintenance Specification"](#).

CAUTION:

- When filling engine oil, do not pull out oil level gauge.
 - The refill capacity depends on the engine oil temperature and drain time. Use these specifications for reference only.
 - Always use oil level gauge to determine the proper amount of engine oil in engine.
3. Warm up the engine and check area around drain plug and oil filter for engine oil leakage.
 4. Stop the engine and wait for 10 minutes.
 5. Check the engine oil level. Refer to [LU-8, "Inspection"](#).

OIL FILTER

OIL FILTER : Removal and Installation

INFOID:000000008294357

REMOVAL

CAUTION:

- Oil filter is provided with relief valve. Use genuine NISSAN oil filter or equivalent.
- Never get burned when engine and engine oil may be hot.
- When removing, prepare a shop cloth to absorb any engine oil leakage or spillage.
- Never allow engine oil to adhere to drive belt.
- Completely wipe off any engine oil that adheres to engine and vehicle.

1. Remove engine undercover with power tool.
2. Using oil filter wrench [SST: KV10115801 (J-38956)], remove oil filter.
 - VQ25HR 2WD models

A : Vehicle under view

B : Oil filter wrench

⇐ : Engine front

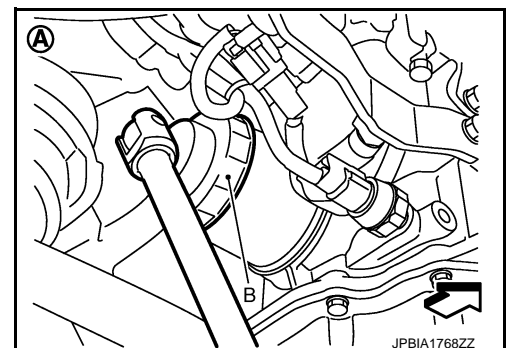

ENGINE MAINTENANCE (VQ25HR)

< PERIODIC MAINTENANCE >

- VQ25HR AWD models

A : Oil filter wrench

⇐ : Engine front

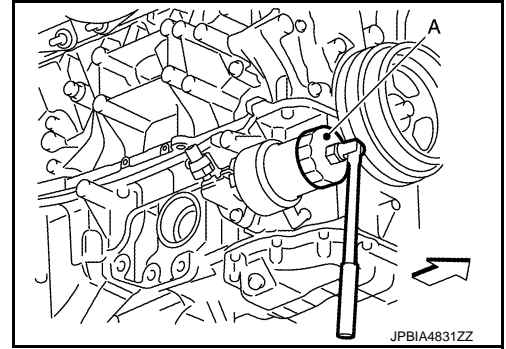

- VQ37VHR 2WD models

A : Vehicle under view

B : Oil filter wrench

⇐ : Engine front

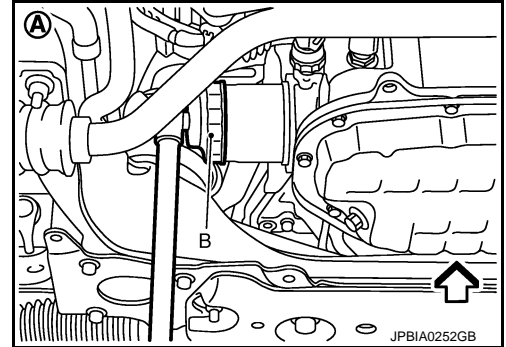

- VQ37VHR AWD models

A : Vehicle under view

B : Oil filter wrench

⇐ : Engine front

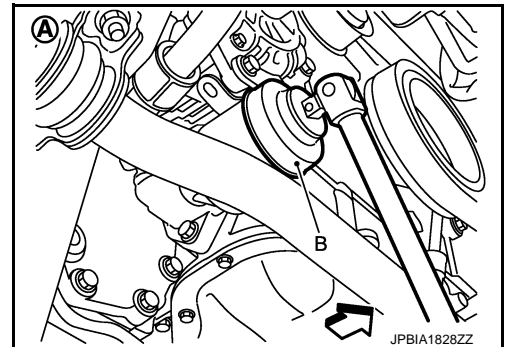

INSTALLATION

1. Remove foreign materials adhering to oil filter installation surface.
2. Apply engine oil to the oil seal contact surface of new oil filter.

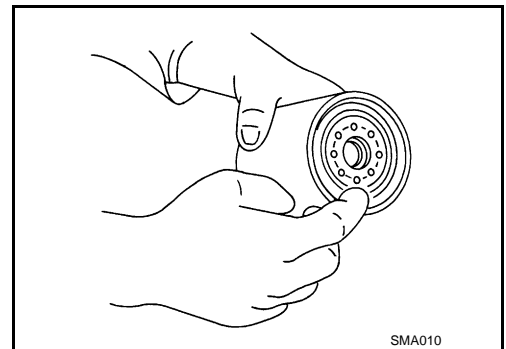

A
B
C
D
E
F
G
H
I
J
K
L
M
N
O
MA

ENGINE MAINTENANCE (VQ25HR)

< PERIODIC MAINTENANCE >

3. Screw oil filter manually until it touches the installation surface, then tighten it by 2/3 turn (A). Or tighten to the specification.

Oil filter:

: 17.7 N·m (1.8 kg-m, 13 ft-lb)

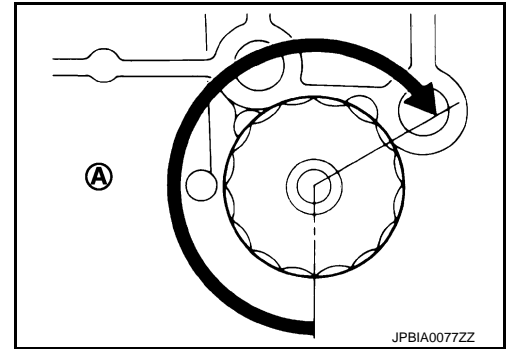

JPBIA0077ZZ

INFOID:000000008294358

OIL FILTER : Inspection

INSPECTION AFTER INSTALLATION

1. Check the engine oil level. Refer to [LU-8, "Inspection"](#).
2. Start the engine, and check there is no leak of engine oil.
3. Stop the engine and wait for 10 minutes.
4. Check the engine oil level, and adjust the level. Refer to [LU-8, "Inspection"](#).

SPARK PLUG

SPARK PLUG : Removal and Installation

INFOID:000000008294359

REMOVAL

1. Remove air cleaner case and air duct (RH and LH). Refer to [EM-28, "Exploded View"](#).
2. Remove ignition coil. Refer to [EM-47, "Removal and Installation"](#).
3. Remove spark plug with a spark plug wrench (commercial service tool).

a : 14 mm (0.55 in)

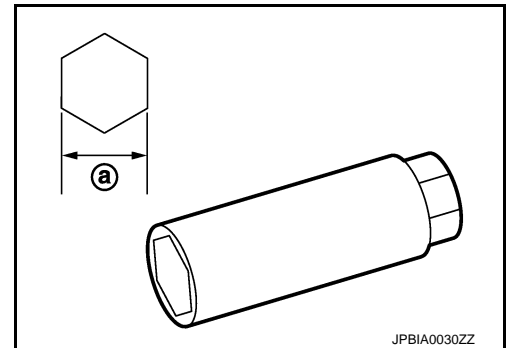

JPBIA0030ZZ

INSTALLATION

Installation is the reverse order of removal.

SPARK PLUG : Inspection

INFOID:000000008294360

INSPECTION AFTER REMOVAL

Use the standard type spark plug for normal condition.

Spark plug (Standard type) : Refer to [MA-57, "SPARK PLUG \(VQ25HR\) : Spark Plug"](#).

CAUTION:

ENGINE MAINTENANCE (VQ25HR)

< PERIODIC MAINTENANCE >

- Never drop or shock spark plug.
- Never use a wire brush for cleaning.
- If plug tip is covered with carbon, use spark plug cleaner to clean.

Cleaner air pressure

: Less than 588 kPa (6 kg/cm², 85 psi)

Cleaning time

: Less than 20 seconds

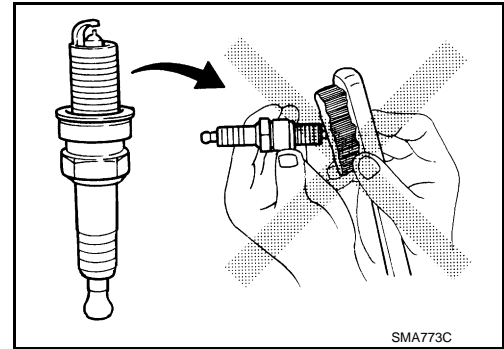

- Check and adjustment of plug gap is not required between change intervals.

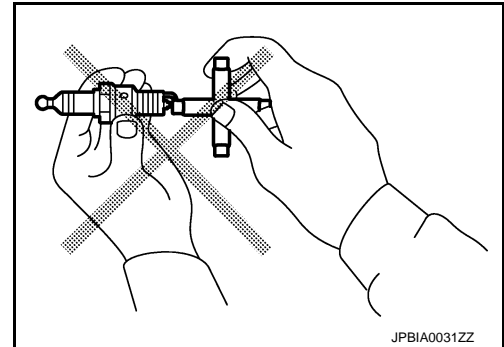

EVAP VAPOR LINES

EVAP VAPOR LINES : Inspection

INFOID:000000008294361

1. Visually inspect EVAP vapor lines for improper attachment and for cracks, damage, loose connections, chafing and deterioration. Refer to [EC-1040, "Inspection"](#).
2. Inspect fuel tank filler cap vacuum relief valve for clogging, sticking, etc. Refer to [EC-366, "Component Inspection"](#).

A
B
C
D
E
F
G
H
I
J
K
L
M
N
O

MA

CHASSIS MAINTENANCE

< PERIODIC MAINTENANCE >

CHASSIS MAINTENANCE

EXHAUST SYSTEM

EXHAUST SYSTEM : Inspection

INFOID:000000008294362

Check exhaust pipes, muffler and mounting for improper attachment, leaks, cracks, damage or deterioration.

- If anything is found, repair or replace damaged parts.

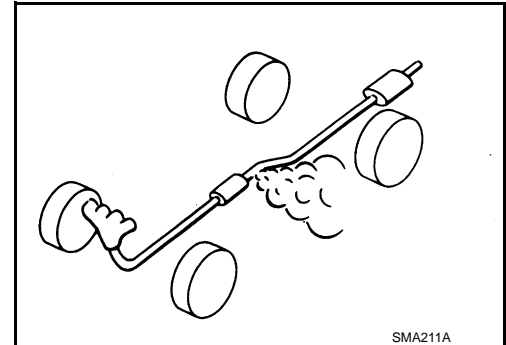

GEAR OIL

GEAR OIL : Inspection

INFOID:000000008294363

OIL LEAKAGE

Make sure that gear oil is not leaking from transmission or around it.

OIL LEVEL

1. Remove filler plug (1) and gasket from transmission case.
2. Check the oil level from filler plug mounting hole as shown in the figure.

CAUTION:

Never start engine while checking oil level.

3. Set a gasket on filler plug and then install it to transmission case.

CAUTION:

Never reuse gasket.

4. Tighten filler plug to the specified torque. Refer to [TM-32, "Exploded View"](#).

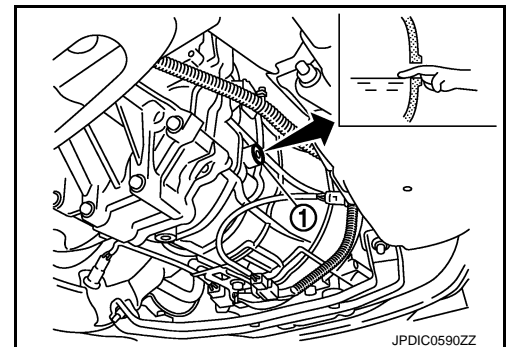

GEAR OIL : Draining

INFOID:000000008294364

1. Start the engine and let it run to warm up transmission.
2. Stop the engine.
3. Remove drain plug and gasket from transmission case and then drain gear oil.
4. Set a gasket on drain plug and install it to transmission case.

CAUTION:

Never reuse gasket.

5. Tighten drain plug to the specified torque. Refer to [TM-32, "Exploded View"](#).

CHASSIS MAINTENANCE

< PERIODIC MAINTENANCE >

GEAR OIL : Refilling

INFOID:000000008294365

1. Remove filler plug (1) and gasket from transmission case.
2. Fill with new gear oil to transmission as shown in the figure.

Oil grade and viscosity : Refer to [MA-16, "FOR NORTH AMERICA : Fluids and Lubricants"](#).

Oil capacity : Refer to [TM-94, "General Specifications"](#).

CAUTION:

Never reuse drained gear oil.

3. After refilling gear oil, check the oil level. Refer to [MA-40, "GEAR OIL : Inspection"](#).

4. Set a gasket on filler plug and then install it to transmission case.

CAUTION:

Never reuse gasket.

5. Tighten filler plug to the specified torque. Refer to [TM-32, "Exploded View"](#).

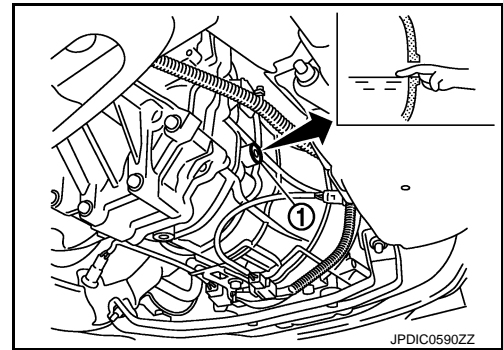

CLUTCH FLUID

CLUTCH FLUID : Inspection

INFOID:000000008294366

CLUTCH FLUID LEVEL

- Check that the fluid level in the reservoir tank is within the specified range (MAX – MIN lines).
- Visually check for any clutch fluid leakage around the reservoir tank.
- Check the clutch system for any leakage if the fluid level is extremely low (lower than MIN).

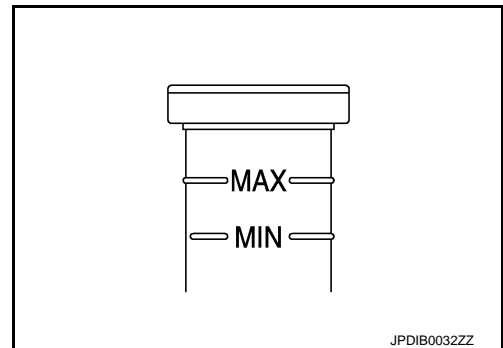

A/T FLUID

A/T FLUID : Inspection

INFOID:000000008294367

FLUID LEAKAGE

- Check transmission surrounding area (oil seal and plug etc.) for fluid leakage.
- If anything is found, repair or replace damaged parts and adjust A/T fluid level. Refer to [TM-263, "Adjustment"](#).

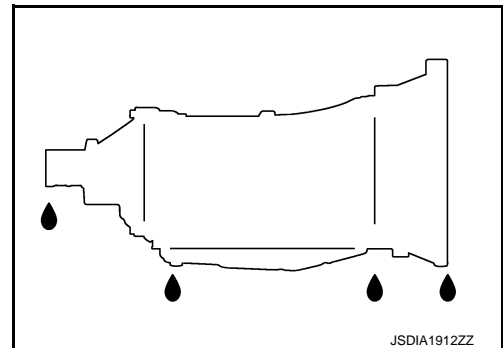

TRANSFER FLUID

TRANSFER FLUID : Inspection

INFOID:000000008294368

FLUID LEAKAGE

Check transfer surrounding area (oil seal, drain plug, and filler plug etc.) for fluid leakage.

A
B
C
D
E
F
G
H
I
J
K
L
M
N
O
MA

CHASSIS MAINTENANCE

< PERIODIC MAINTENANCE >

FLUID LEVEL

1. Remove filler plug (1) and gasket. Then check that fluid is filled up from mounting hole for the filler plug.

CAUTION:

Never start engine while checking fluid level.

2. Set a new gasket onto filler plug, and install it on transfer and tighten to the specified torque. Refer to [DLN-57, "Exploded View"](#).

CAUTION:

Never reuse gasket.

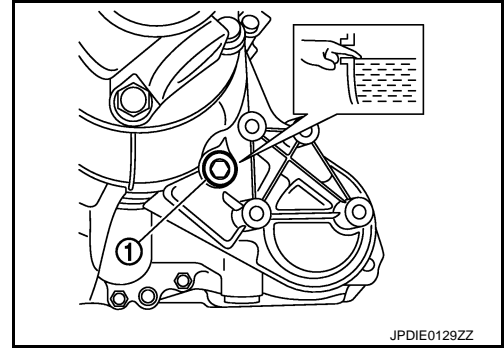

JPDIE0129ZZ

INFOID:000000008294369

TRANSFER FLUID : Draining

1. Run the vehicle to warm up the transfer unit sufficiently.
2. Stop the engine, and remove the drain plug (1) to drain the transfer fluid.
3. Set a new gasket onto the drain plug, and install it on the transfer and tighten to the specified torque. Refer to [DLN-57, "Exploded View"](#).

CAUTION:

Never reuse gasket.

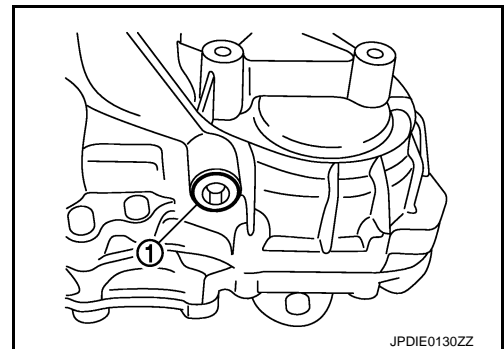

JPDIE0130ZZ

INFOID:000000008294370

TRANSFER FLUID : Refilling

1. Remove filler plug (1) and gasket. Then fill fluid up to mounting hole for the filler plug.

Fluid and viscosity

: Refer to [MA-16, "FOR NORTH AMERICA : Fluids and Lubricants"](#).

Fluid capacity

: Refer to [DLN-76, "General Specifications"](#).

CAUTION:

Carefully fill the fluid. (Fill up for approximately 3 minutes.)

2. Leave the vehicle for 3 minutes, and check the fluid level again.
3. Set a new gasket onto filler plug, and install it on transfer and tighten to the specified torque. Refer to [DLN-57, "Exploded View"](#).

CAUTION:

Never reuse gasket.

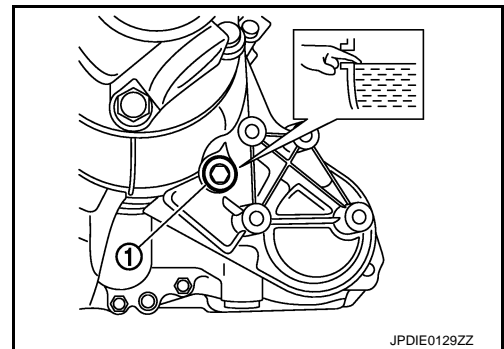

JPDIE0129ZZ

FRONT PROPELLER SHAFT: 2S56A

FRONT PROPELLER SHAFT: 2S56A : Inspection

INFOID:000000008294371

APPEARANCE AND NOISE

- Check the propeller shaft tube surface for dents or cracks. If damaged, replace propeller shaft assembly.
- If center bearing is noisy or damaged, replace propeller shaft assembly.

VIBRATION

If vibration is present at high speed, inspect propeller shaft runout first.

CHASSIS MAINTENANCE

< PERIODIC MAINTENANCE >

1. With a dial indicator, measure propeller shaft runout at runout measuring points by rotating final drive companion flange with hands.

← : Vehicle Front

Propeller shaft runout : Refer to [DLN-83, "Propeller Shaft Runout"](#).

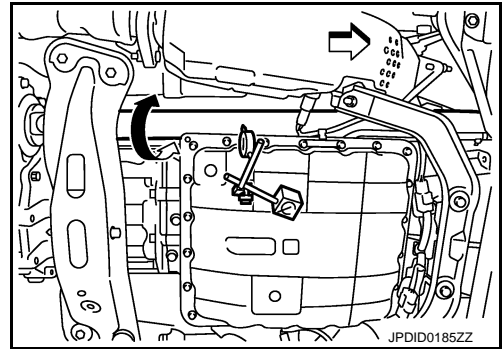

- Propeller shaft runout measuring point (Point "△")

Dimension A: 381.5 mm (15.02 in)

2. If runout still exceeds specifications, separate propeller shaft at final drive companion flange; then change the phase between companion flange and propeller shaft by the one bolt hole at a time and install propeller shaft.
3. Check runout again. If runout still exceeds specifications, replace propeller shaft assembly.
4. Check the vibration by driving vehicle.

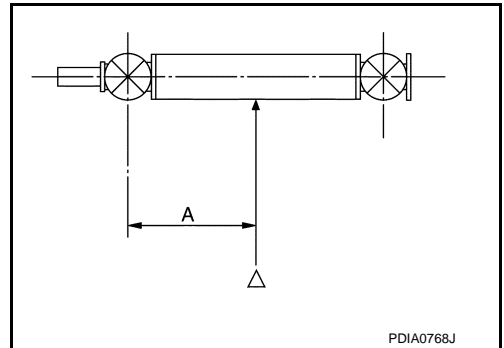

REAR PROPELLER SHAFT: 3S80A

REAR PROPELLER SHAFT: 3S80A : Inspection

INFOID:000000008294372

NOISE

- Check the propeller shaft tube surface for dents or cracks. If damaged, replace propeller shaft assembly.
- If center bearing is noisy or damaged, replace propeller shaft assembly.

VIBRATION

If vibration is present at high speed, inspect propeller shaft runout first.

1. With a dial indicator, measure propeller shaft runout at runout measuring points by rotating final drive companion flange with hands.

Propeller shaft runout : Refer to [DLN-91, "Propeller Shaft Runout"](#).

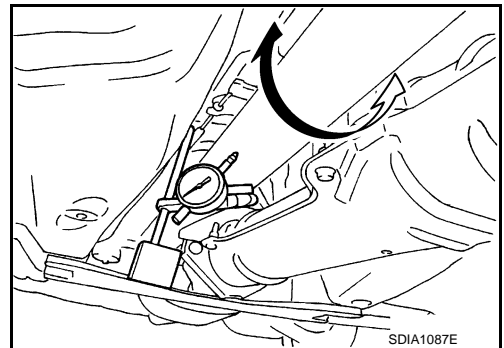

- Propeller shaft runout measuring point (Point "△")

← : Vehicle Front

Dimension
A: 192 mm (7.56 in)
B: 172 mm (6.77 in)
C: 170 mm (6.69 in)

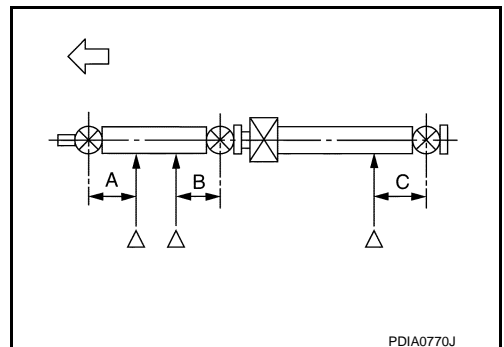

2. If runout still exceeds specifications, separate propeller shaft at final drive companion flange; then change the phase between companion flange and propeller shaft by the one bolt hole at a time and install propeller shaft.
3. Check runout again. If runout still exceeds specifications, replace propeller shaft assembly.

A
B
C
D
E
F
G
H
I
J
K
L
M
N
O

MA

CHASSIS MAINTENANCE

< PERIODIC MAINTENANCE >

4. Check the vibration by driving vehicle.

REAR PROPELLER SHAFT: 3S80A-R

REAR PROPELLER SHAFT: 3S80A-R : Inspection

INFOID:000000008294373

NOISE

- Check the propeller shaft tube surface for dents or cracks. If damaged, replace propeller shaft assembly.
- If center bearing is noisy or damaged, replace propeller shaft assembly.

VIBRATION

If vibration is present at high speed, inspect propeller shaft runout first.

1. With a dial indicator, measure propeller shaft runout at runout measuring points by rotating final drive companion flange with hands.

Propeller shaft runout : Refer to [DLN-100, "Propeller Shaft Runout"](#).

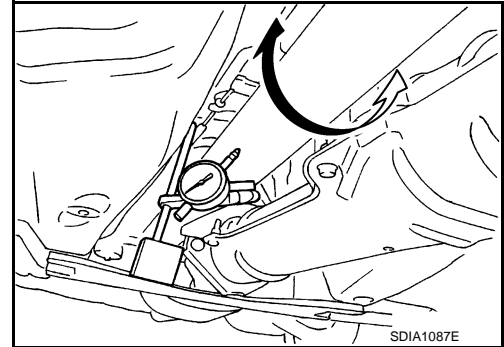

- Propeller shaft runout measuring point (Point "Δ")

⇐: Vehicle front

Dimension

A: 192 mm (7.56 in)
B: 172 mm (6.77 in)
C: 172 mm (6.77 in)

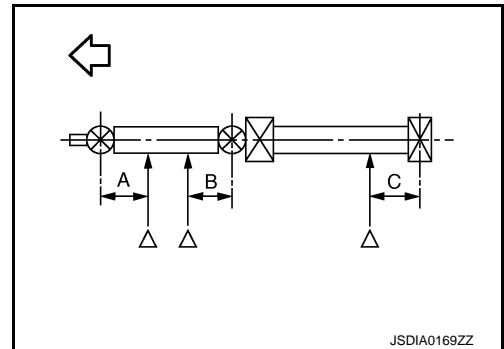

2. If runout still exceeds specifications, separate propeller shaft at final drive companion flange; then change the phase between companion flange and propeller shaft by the one bolt hole at a time and install propeller shaft.
3. Check runout again. If runout still exceeds specifications, replace propeller shaft assembly.
4. Check the vibration by driving vehicle.

REAR PROPELLER SHAFT: 3F80A-1VL107

REAR PROPELLER SHAFT: 3F80A-1VL107 : Inspection

INFOID:000000008294374

NOISE

- Check the propeller shaft tube surface for dents or cracks. If damaged, replace propeller shaft assembly.
- If center bearing is noisy or damaged, replace propeller shaft assembly.

VIBRATION

If vibration is present at high speed, inspect propeller shaft runout first.

1. With a dial indicator, measure propeller shaft runout at runout measuring points by rotating final drive companion flange with hands.

Propeller shaft runout : Refer to [DLN-109, "Propeller Shaft Runout"](#).

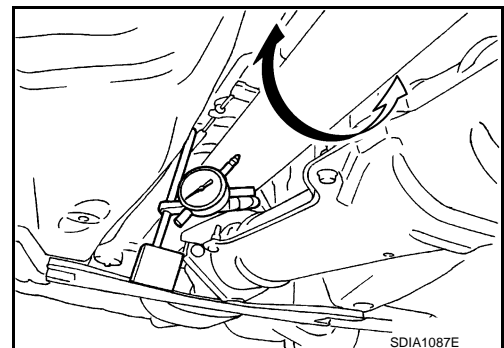

CHASSIS MAINTENANCE

< PERIODIC MAINTENANCE >

- Propeller shaft runout measuring point (Point “△”)

↔: Vehicle front

Standard

- A** : 162 mm (6.38 in)
- B** : 245 mm (9.65 in)
- C** : 185 mm (7.28 in)

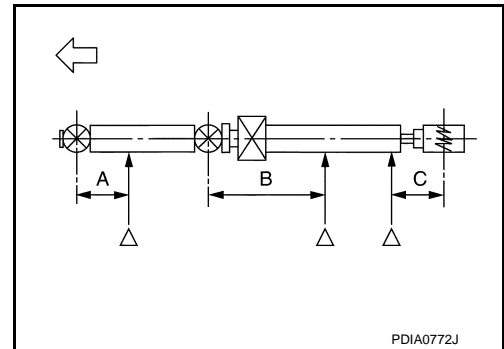

2. If runout still exceeds specifications, separate propeller shaft at final drive companion flange or transfer companion flange; then change the phase between companion flange and propeller shaft by the one bolt hole at a time and install propeller shaft.
3. Check runout again. If runout still exceeds specifications, replace propeller shaft assembly.
4. Check the vibration by driving vehicle.

FRONT DIFFERENTIAL GEAR OIL: F160A

FRONT DIFFERENTIAL GEAR OIL: F160A : Inspection

INFOID:000000008294375

OIL LEAKAGE

Make sure that oil is not leaking from final drive assembly or around it.

OIL LEVEL

- Remove filler plug (1) and check oil level from filler plug mounting hole as shown in the figure.

CAUTION:

Never start engine while checking oil level.

- Set a gasket on filler plug and install it on final drive assembly. Refer to [DLN-122, "Exploded View"](#).

CAUTION:

Never reuse gasket.

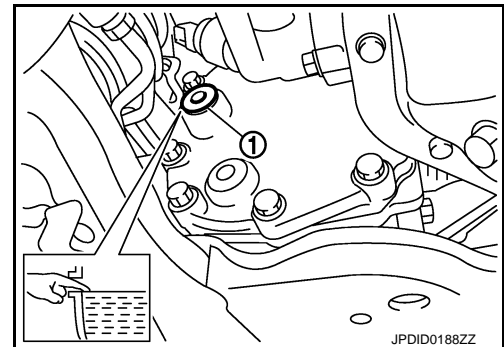

FRONT DIFFERENTIAL GEAR OIL: F160A : Draining

INFOID:000000008294376

1. Stop engine.
2. Remove drain plug (1) and drain gear oil.
3. Set a gasket on drain plug and install it to final drive assembly and tighten to the specified torque. Refer to [DLN-122, "Exploded View"](#).

CAUTION:

Never reuse gasket.

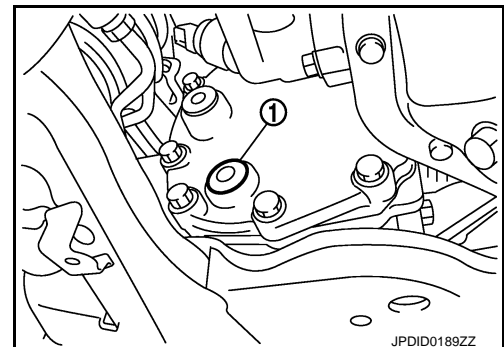

MA

CHASSIS MAINTENANCE

< PERIODIC MAINTENANCE >

FRONT DIFFERENTIAL GEAR OIL: F160A : Refilling

INFOID:000000008294377

1. Remove filler plug (1). Fill with new gear oil until oil level reaches the specified level near filler plug mounting hole.

Oil grade and Viscosity : Refer to [MA-16, "FOR NORTH AMERICA : Fluids and Lubricants"](#).

Oil capacity : Refer to [DLN-147, "General Specifications"](#).

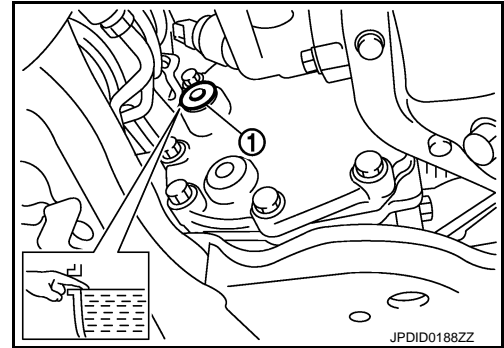

2. After refilling oil, check oil level. Set a gasket to filler plug, then install it to final drive assembly. Refer to [DLN-122, "Exploded View"](#).

CAUTION:

Never reuse gasket.

REAR DIFFERENTIAL GEAR OIL: R200

REAR DIFFERENTIAL GEAR OIL: R200 : Inspection

INFOID:000000008294378

OIL LEAKAGE

Make sure that oil is not leaking from final drive assembly or around it.

OIL LEVEL

- Remove filler plug (1) and check oil level from filler plug mounting hole as shown in the figure.

CAUTION:

Never start engine while checking oil level.

- Set a gasket on filler plug and install it on final drive assembly. Refer to [DLN-187, "2WD \(VQ25HR\) : Exploded View"](#) [2WD (VQ25HR)], [DLN-199, "2WD \(VQ37VHR\) : Exploded View"](#) [2WD (VQ37VHR)], [DLN-212, "AWD : Exploded View"](#) (AWD).

CAUTION:

Never reuse gasket.

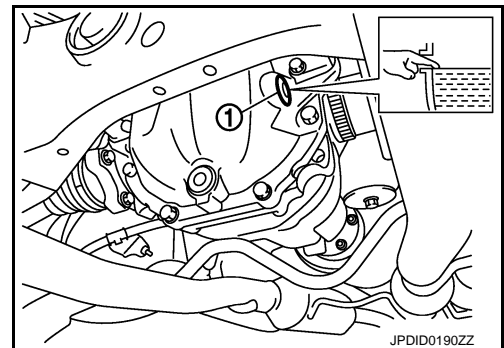

REAR DIFFERENTIAL GEAR OIL: R200 : Draining

INFOID:000000008294379

1. Stop the engine.
2. Remove drain plug (1) and drain gear oil.
3. Set a gasket on drain plug and install it to final drive assembly and tighten to the specified torque. Refer to [DLN-187, "2WD \(VQ25HR\) : Exploded View"](#) [2WD (VQ25HR)], [DLN-199, "2WD \(VQ37VHR\) : Exploded View"](#) [2WD (VQ37VHR)], [DLN-212, "AWD : Exploded View"](#) (AWD).

CAUTION:

Never reuse gasket.

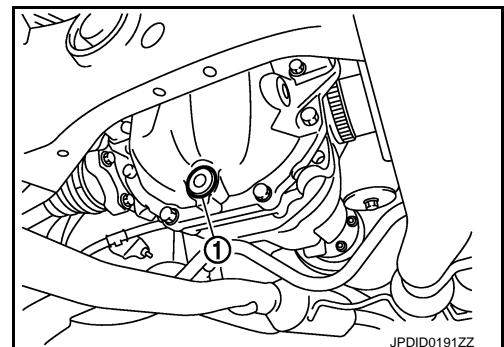

CHASSIS MAINTENANCE

< PERIODIC MAINTENANCE >

REAR DIFFERENTIAL GEAR OIL: R200 : Refilling

INFOID:000000008294381

1. Remove filler plug (1). Fill with new gear oil until oil level reaches the specified level near filler plug mounting hole.

Oil grade and viscosity : Refer to [MA-16, "FOR NORTH AMERICA : Fluids and Lubricants" \(For North America\)](#), [MA-18, "FOR MEXICO : Fluids and Lubricants" \(For Mexico\)](#).

Oil capacity : Refer to [DLN-249, "General Specification"](#).

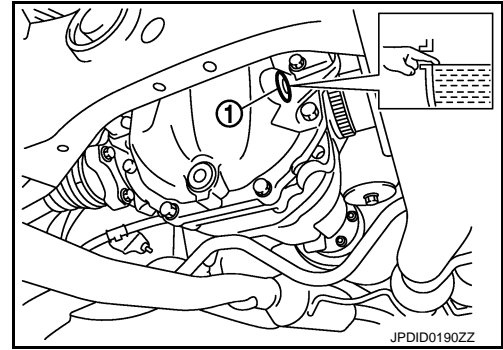

2. After refilling oil, check oil level. Set a gasket to filler plug, then install it to final drive assembly. Refer to [DLN-187, "2WD \(VQ25HR\) : Exploded View" \[2WD \(VQ25HR\)\]](#), [DLN-199, "2WD \(VQ37VHR\) : Exploded View" \[2WD \(VQ37VHR\)\]](#), [DLN-212, "AWD : Exploded View" \(AWD\)](#).

CAUTION:

Never reuse gasket.

REAR DIFFERENTIAL GEAR OIL: R200V

REAR DIFFERENTIAL GEAR OIL: R200V : Inspection

INFOID:000000008294381

OIL LEAKAGE

- Make sure that oil is not leaking from final drive assembly or around it.

OIL LEVEL

- Remove filler plug (1) and check oil level from filler plug mounting hole as shown in the figure.

CAUTION:

Never start engine while checking oil level.

- Set a gasket on filler plug and install it on final drive assembly. Refer to [DLN-278, "M/T : Exploded View" \(M/T models\)](#), [DLN-290, "A/T : Exploded View" \(A/T models\)](#).

CAUTION:

Never reuse gasket.

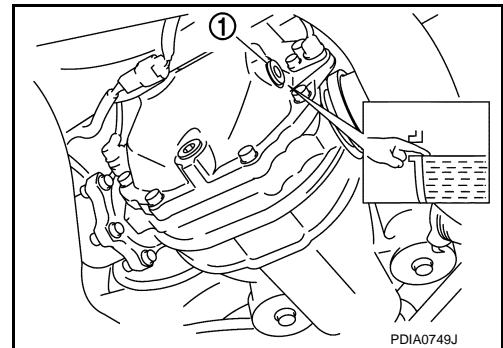

REAR DIFFERENTIAL GEAR OIL: R200V : Draining

INFOID:000000008294382

1. Stop engine.
2. Remove drain plug (1) and drain gear oil.
3. Set a gasket on drain plug and install it to final drive assembly and tighten to the specified torque. Refer to [DLN-278, "M/T : Exploded View" \(M/T models\)](#), [DLN-290, "A/T : Exploded View" \(A/T models\)](#).

CAUTION:

Never reuse gasket.

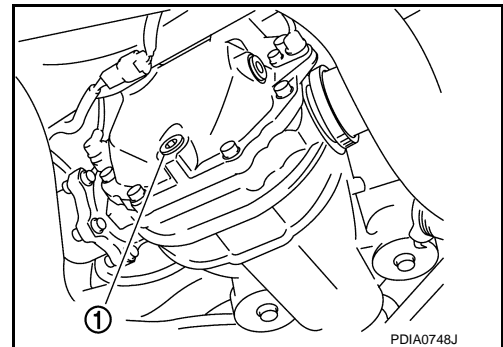

A
B
C
D
E
F
G
H
I
J
K
L
M
N
O

MA

CHASSIS MAINTENANCE

< PERIODIC MAINTENANCE >

REAR DIFFERENTIAL GEAR OIL: R200V : Refilling

INFOID:000000008294383

1. Remove filler plug (1). Fill with new gear oil until oil level reaches the specified level near filler plug mounting hole.

Oil grade and viscosity : Refer to [MA-16, "FOR NORTH AMERICA : Fluids and Lubricants"](#) (For North America), [MA-18, "FOR MEXICO : Fluids and Lubricants"](#) (For Mexico).

Oil capacity : Refer to [DLN-319, "General Specification"](#).

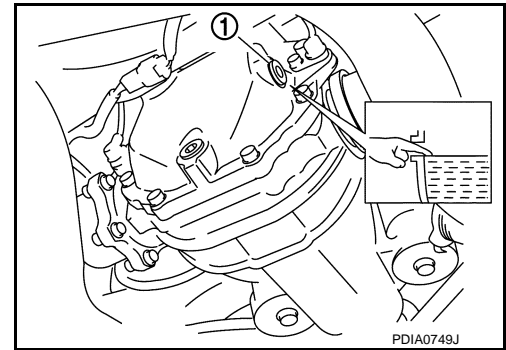

2. After refilling oil, check oil level. Set a gasket to filler plug, then install it to final drive assembly. Refer to [DLN-278, "M/T : Exploded View"](#) (M/T models), [DLN-290, "A/T : Exploded View"](#) (A/T models).

CAUTION:

Never reuse gasket.

WHEELS (BONDING WEIGHT TYPE)

WHEELS (BONDING WEIGHT TYPE) : Adjustment

INFOID:000000008294384

BALANCING WHEELS (BONDING WEIGHT TYPE)

Preparation Before Adjustment

Using releasing agent, remove double-faced adhesive tape from the road wheel.

CAUTION:

- Be careful not scratch the road wheel during removal.
- After removing double-faced adhesive tape, wipe clean traces of releasing agent from the road wheel.

Wheel Balance Adjustment

- If a tire balance machine has adhesion balance weight mode settings and drive-in weight mode setting, select and adjust a drive-in weight mode suitable for road wheels.

1. Set road wheel on tire balance machine using the center hole as a guide. Start the tire balance machine.
2. When inner and outer unbalance values are shown on the tire balance machine indicator, multiply outer unbalance value by 5/3 to determine balance weight that should be used. Select the outer balance weight with a value closest to the calculated value above and install in to the designated outer position of, or at the designated angle in relation to the road wheel.

CAUTION:

- Never install the inner balance weight before installing the outer balance weight.
- Before installing the balance weight, be sure to clean the mating surface of the road wheel.

- a. Indicated un balance value $\times 5/3 =$ balance weight to be installed

Calculation example:

$23 \text{ g (0.81 oz)} \times 5/3 = 38.33 \text{ g (1.35 oz)} \Rightarrow 37.5 \text{ g (1.32 oz)}$ balance weight (closer to calculated balance weight value)

NOTE:

Note that balance weight value must be closer to the calculated balance weight value.

Example:

$36.2 \Rightarrow 35 \text{ g (1.23 oz)}$

$36.3 \Rightarrow 37.5 \text{ g (1.32 oz)}$

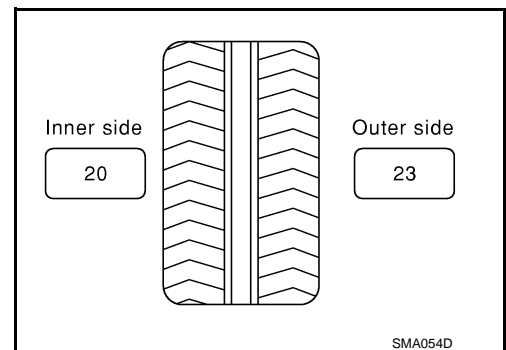

- b. Installed balance weight in the position.

CHASSIS MAINTENANCE

< PERIODIC MAINTENANCE >

- When installing balance weight (1) to road wheels, set it into the grooved area (A) on the inner wall of the road wheel as shown in the figure so that the balance weight center (B) is aligned with the tire balance machine indication position (angle) (C).

CAUTION:

- Always use genuine NISSAN adhesion balance weights.
- Balance weights are non-reusable; always replace with new ones.
- Never install more than three sheets of balance weight.

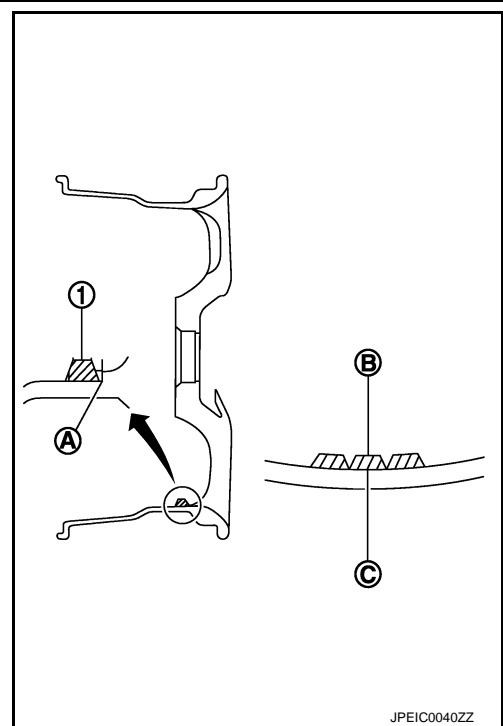

- c. If calculated balance weight value exceeds 50 g (1.76 oz), install two balance weight sheets in line with each other as shown in the figure.

CAUTION:

Never install one balance weight sheet on top another.

- Start tire balance machine again.
- Install drive-in balance weight on inner side of road wheel in the tire balance machine indication position (angle).

CAUTION:

Never install more than two balance weight.

- Start tire balance machine. Make sure that inner and outer residual unbalance values are 5 g (0.17 oz) each or below.
- If either residual unbalance value exceeds 5 g (0.17 oz), repeat installation procedures.

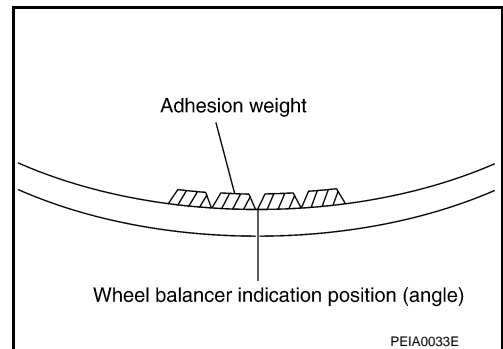

Limit

Dynamic (At flange) : Refer to [WT-49, "Road Wheel"](#).

Static (At flange) : Refer to [WT-49, "Road Wheel"](#).

TIRE ROTATION (for 17 and 18 inch wheel models)

- Follow the maintenance schedule for tire rotation service intervals. Refer to [MA-5, "FOR NORTH AMERICA : Explanation of General Maintenance"](#) (For North America), [MA-7, "FOR MEXICO : General Maintenance"](#) (For Mexico).
- When installing the wheel, tighten wheel nuts to the specified torque. Refer to [WT-44, "Exploded View"](#).

CAUTION:

- Never include the T-type spare tire when rotating the tires.
- When installing wheels, tighten them diagonally by dividing the work two to three times in order to prevent the wheels from developing any distortion.
- Be careful not to tighten wheel nut at torque exceeding the criteria for preventing strain of disc rotor.
- Use NISSAN genuine wheel nuts for aluminum wheels.
- Perform the ID registration, after tire rotation. Refer to [WT-18, "Work Procedure"](#).

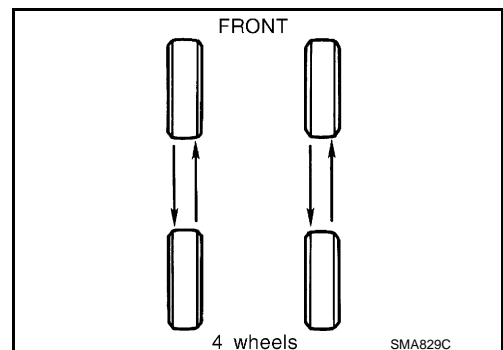

CHASSIS MAINTENANCE

< PERIODIC MAINTENANCE >

TIRE ROTATION (for 18 inch front and rear different tire size models)

- Tire cannot be rotated in vehicle, as front tire are different size from rear tire is fixed in each tire.

Wheel nuts tightening torque : Refer to [WT-44, "Exploded View"](#).

CAUTION:

- Never include the T-type spare tire when rotating the tires.
- Use NISSAN genuine wheel nuts for aluminum wheels.

Safety Device Preventing from Being Incorrectly installed

FRONT BRAKE DISC ROTOR AND FRONT WHEEL

- Front and rear wheel size for this model differs, therefore special pin (1) is adopted to the front brake disc rotor (2). And a hole (3) that matches to this pin is adopted to the front wheel (4) (the rear wheel does not have this wheel). This structure prevents the rear wheel from being mistakenly installed on the front.

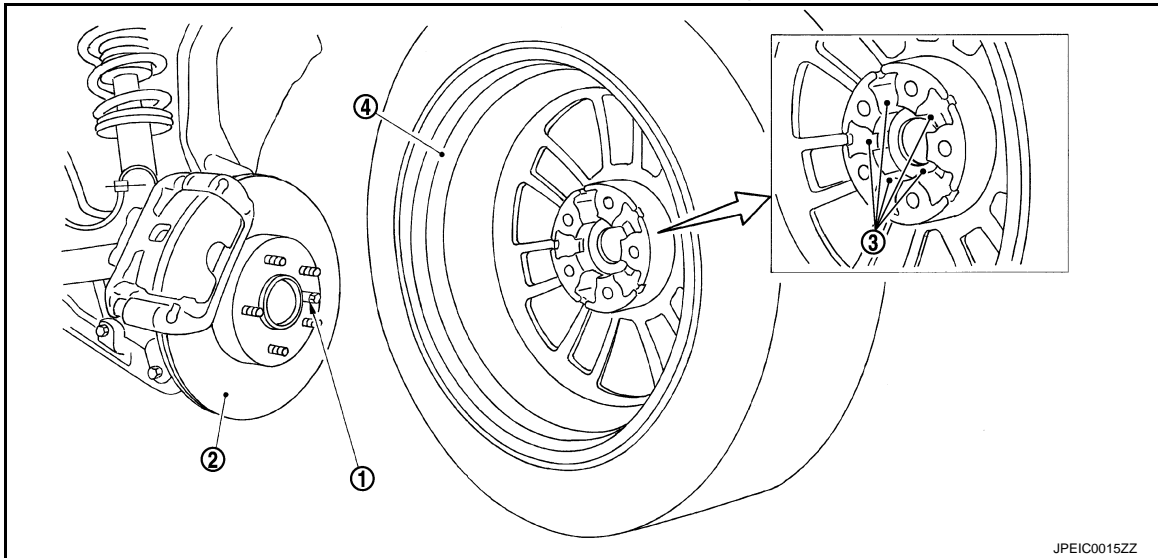

T-TYPE SPARE TIRE WHEEL

- Regarding spare tire (for emergency) wheel, wrong assembly protection pin hole (1) has been set in addition to regular bolt holes (2) in order to enable installation to front wheel.

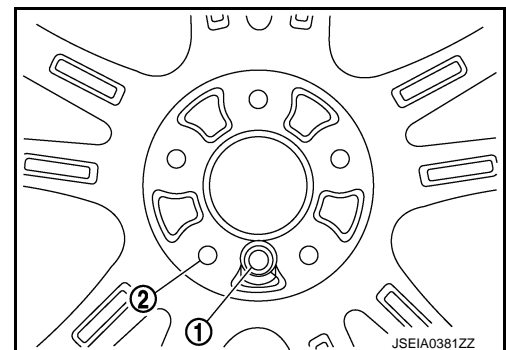

BRAKE FLUID LEVEL AND LEAKS

BRAKE FLUID LEVEL AND LEAKS : Inspection

- If fluid level is extremely low, check brake system for leaks.

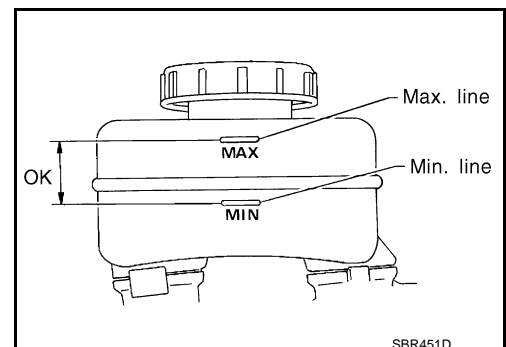

CHASSIS MAINTENANCE

< PERIODIC MAINTENANCE >

BRAKE LINES AND CABLES

BRAKE LINES AND CABLES : Inspection

INFOID:000000008294386

- Check brake fluid lines and parking brake cables for improper attachment, leaks, chafing, abrasions, deterioration, etc.

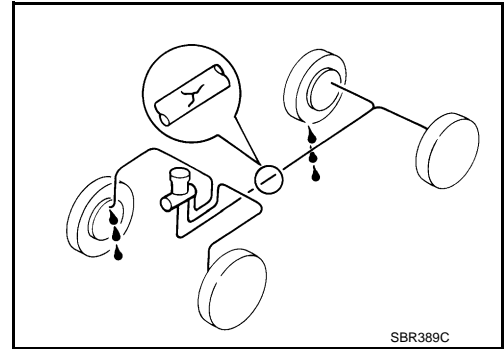

BRAKE FLUID

BRAKE FLUID : Changing

INFOID:000000008294387

1. Drain brake fluid from each bleed valve.
2. Refill until new brake fluid comes out from each bleed valve. Use same procedure as in bleeding hydraulic system to refill brake fluid.
Refer to [BR-11. "Bleeding Brake System"](#).
 - Refill with recommended Genuine NISSAN Super Heavy Duty Brake Fluid or equivalent DOT 3 (US FMVSS No. 116). Refer to [MA-16. "FOR NORTH AMERICA : Fluids and Lubricants"](#).
 - Never reuse drained brake fluid.
 - Be careful not to splash brake fluid on painted areas.

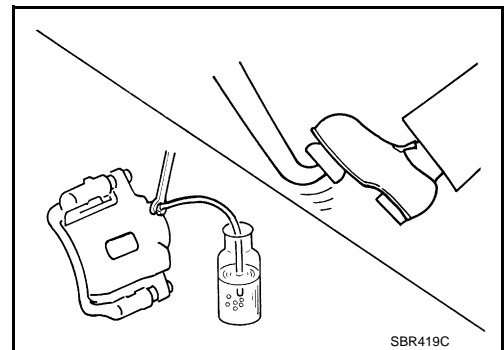

DISC BRAKE

DISC BRAKE : Inspection

INFOID:000000008294388

DISC ROTOR

Check condition, wear, and damage.

CALIPER

- Check for leakage.

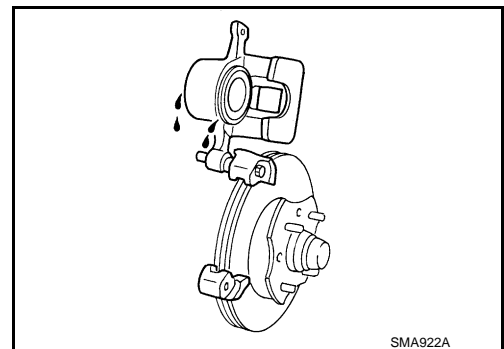

BRAKE PAD

A
B
C
D
E
F
G
H
I
J
K
L
M
N
O
MA

CHASSIS MAINTENANCE

< PERIODIC MAINTENANCE >

- Check for wear or damage.

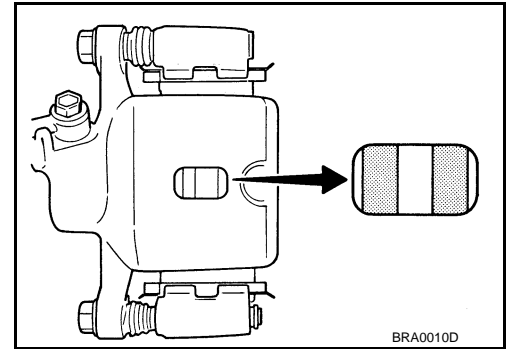

DISC BRAKE : Front Disc Brake

INFOID:000000008294389

2 PISTON TYPE

Unit: mm (in)

Item		Limit
Brake pad	Wear thickness	2.0 (0.079)
	Wear thickness	26.0 (1.024)
Disc rotor	Thickness variation (measured at 8 positions)	0.015 (0.0006)
	Runout (with it attached to the vehicle)	0.035 (0.0014)

4 PISTON TYPE

Unit: mm (in)

Item		Limit
Brake pad	Wear thickness	2.0 (0.079)
	Wear thickness	30.0 (1.181)
Disc rotor	Thickness variation (measured at 8 positions)	0.015 (0.0006)
	Runout (with it attached to the vehicle)	0.035 (0.0014)

DISC BRAKE : Rear Disc Brake

INFOID:000000008294390

1 PISTON TYPE

Unit: mm (in)

Item		Limit
Brake pad	Wear thickness	2.0 (0.079)
	Wear thickness	14.0 (0.551)
Disc rotor	Thickness variation (measured at 8 positions)	0.015 (0.0006)
	Runout (with it attached to the vehicle)	0.055 (0.0022)

2 PISTON TYPE

Unit: mm (in)

Item		Limit
Brake pad	Wear thickness	2.0 (0.079)
	Wear thickness	18.0 (0.709)
Disc rotor	Thickness variation (measured at 8 positions)	0.015 (0.0006)
	Runout (with it attached to the vehicle)	0.055 (0.0022)

STEERING GEAR AND LINKAGE

STEERING GEAR AND LINKAGE : Inspection

INFOID:000000008294391

STEERING GEAR

CHASSIS MAINTENANCE

< PERIODIC MAINTENANCE >

- Check gear housing and boots for looseness, damage and grease leakage.
- Check connection with steering column for looseness.

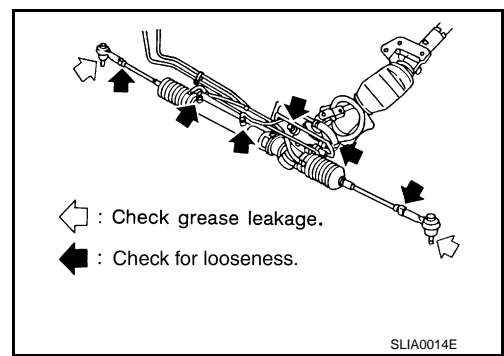

STEERING LINKAGE

Check ball joint, dust cover and other component parts for looseness, wear, damage and grease leakage.

POWER STEERING FLUID AND LINES

POWER STEERING FLUID AND LINES : Inspection

INFOID:000000008294392

Check fluid level in reservoir tank with engine off.

Use "HOT" range at fluid temperatures of 50 to 80°C (122 to 176°F) or "COLD" range at fluid temperatures of 0 to 30°C (32 to 86°F).

CAUTION:

- Do not overfill.
- Recommended fluid is Genuine NISSAN PSF or equivalent. Refer to [MA-16, "FOR NORTH AMERICA : Fluids and Lubricants"](#).

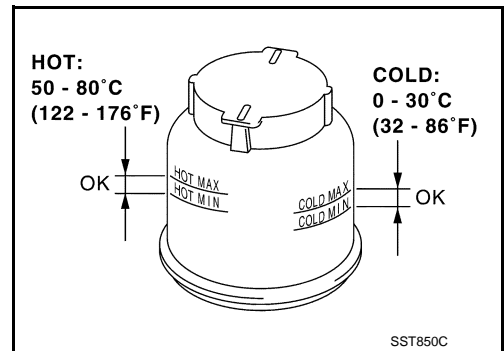

- Check lines for improper attachment, leaks, cracks, damage, loose connections, chafing and deterioration.
- Check rack boots for accumulation of power steering fluid.

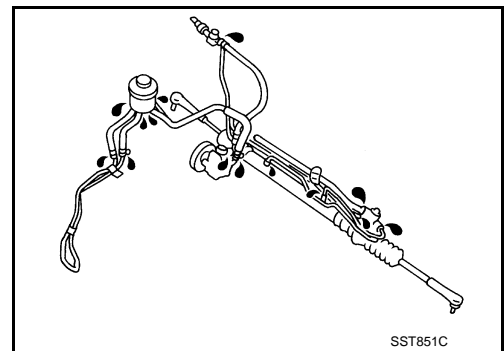

AXLE AND SUSPENSION PARTS

AXLE AND SUSPENSION PARTS : Inspection

INFOID:000000008294393

Check front and rear axle and suspension parts for excessive play, cracks, wear or other damage.

- Shake each wheel to check for excessive play.
- Check wheel bearings for smooth operation.
- Check axle and suspension nuts and bolts for looseness.
- Check strut (shock absorber) for oil leakage or other damage.
- Check suspension ball joint for grease leakage and ball joint dust cover for cracks or other damage.

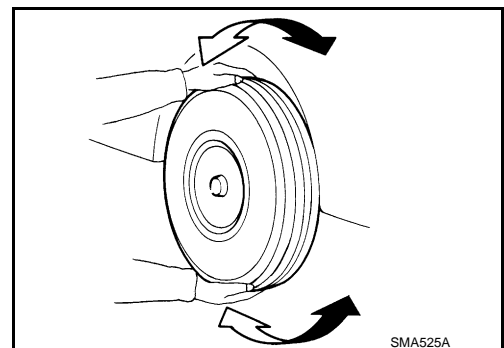

CHASSIS MAINTENANCE

< PERIODIC MAINTENANCE >

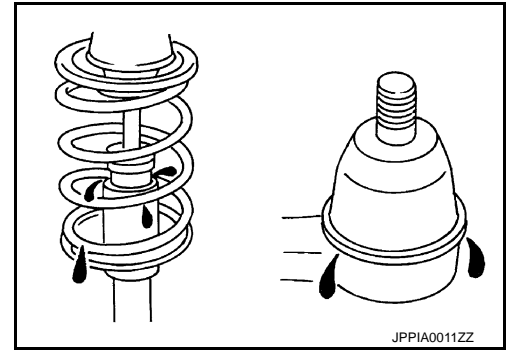

DRIVE SHAFT

DRIVE SHAFT : Inspection

Check boot and drive shaft for cracks, wear, damage and grease leakage.

INFOID:000000008294394

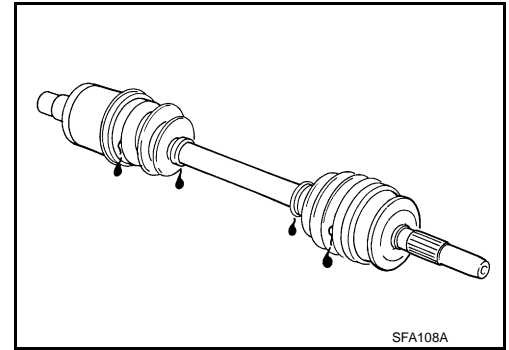

BODY MAINTENANCE

< PERIODIC MAINTENANCE >

BODY MAINTENANCE

LOCKS, HINGES AND HOOD LATCH

LOCKS, HINGES AND HOOD LATCH : Lubricating

INFOID:000000008294395

For hood lock illustration. Refer to [DLK-197, "HOOD ASSEMBLY : Exploded View"](#) and [DLK-200, "HOOD LOCK CONTROL : Exploded View"](#).

For door lock illustration. Refer to [DLK-213, "FRONT DOOR LOCK : Exploded View"](#) and [DLK-216, "REAR DOOR LOCK : Exploded View"](#).

For trunk lid lock illustration. Refer to [DLK-222, "TRUNK LID LOCK : Exploded View"](#).

SEAT BELT, BUCKLES, RETRACTORS, ANCHORS AND ADJUSTERS

SEAT BELT, BUCKLES, RETRACTORS, ANCHORS AND ADJUSTERS : Inspection

INFOID:000000008294396

For front seat belt illustration. Refer to [SB-6, "SEAT BELT RETRACTOR : Exploded View"](#).

For rear seat belt illustration. Refer to [SB-11, "SEAT BELT RETRACTOR : Exploded View"](#).

CAUTION:

- After any collision, inspect all seat belt assemblies, including retractors and other attached hardware (i.e. anchor bolt, guide rail set). Nissan recommends to replace all seat belt assemblies in use during a collision, unless not damaged and properly operating after minor collision.

Also inspect seat belt assemblies not in use during a collision, and replace if damaged or improperly operating.

Seat belt pre-tensioner should be replaced even if the seat belts are not in use during a frontal collision where the driver and passenger air bags are deployed.

- If any component of seat belt assembly is questionable, do not repair.

Replace as seat belt assembly.

- If webbing is cut, frayed, or damaged, replace belt assembly.

- Never oil tongue and buckle.

- Use a genuine NISSAN seat belt assembly.

For details, refer to [SB-4, "SEAT BELT RETRACTOR : Inspection"](#), [SB-9, "SEAT BELT RETRACTOR : Inspection"](#) in SB section.

- Check anchors for loose mounting
- Check belts for damage
- Check retractor for smooth operation
- Check function of buckles and tongues when buckled and released

A
B
C
D
E
F
G
H
I
J
K
L
M
N
O

MA

SERVICE DATA AND SPECIFICATIONS (SDS)

< SERVICE DATA AND SPECIFICATIONS (SDS)

SERVICE DATA AND SPECIFICATIONS (SDS)

SERVICE DATA AND SPECIFICATIONS (SDS)

DRIVE BELT (VQ37VHR)

DRIVE BELT (VQ37VHR) : Drive Belt

INFOID:000000008294397

DRIVE BELT

Tension of drive belt	Belt tension is not necessary, as it is automatically adjusted by drive belt auto-tensioner.
-----------------------	--

DRIVE BELT (VQ25HR)

DRIVE BELT (VQ25HR) : Drive Belt

INFOID:000000008294398

DRIVE BELT

PART	Belt spec	Tension [N (kg)]			Belt tension (mm) [When pushed at 98.1N (10 Kg)]		
		New	Adjustment	Rimit of retghtening	New	Adjustment	Rimit of retghtening
Alternator · power steering oil pump belt	V-ribbed belt (6 ribbs)	838 - 926 (85.5 - 94.5)	730 - 818 (74.5 - 83.5)	294 (30)	6 - 7	7 - 8	12
A/C compressor belt	V-ribbed belt (4 ribbs)	470 - 559 (48 - 57)	348 - 436 (35.5 - 4.5)	196 (20)	8 - 9	9 - 10	12

ENGINE COOLANT

ENGINE COOLANT : Periodical Maintenance Specification

INFOID:000000008294399

ENGINE COOLANT CAPACITY (APPROXIMATE)

Unit: ℓ (US qt, Imp qt)

Engine coolant capacity [With reservoir tank ("MAX" level)]	VQ25HR	2WD models	8.3 (8-6/8, 7-2/8)
		AWD models	8.8 (9-2/8, 7-6/8)
	VQ37VHR	A/T models	8.5 (9, 7-1/2)
		M/T models	8.6 (9-1/8, 7-5/8)
Reservoir tank engine coolant capacity (At "MAX" level)			0.8 (7/8, 3/4)

ENGINE OIL

ENGINE OIL : Periodical Maintenance Specification

INFOID:000000008294400

ENGINE OIL CAPACITY (APPROXIMATE)

Unit: ℓ (US qt, Imp qt)

Drain and refill	VQ25HR	With oil filter change	4.7 (5, 4-1/8)
		Without oil filter change	4.4 (4-5/8, 3-7/8)
	VQ37VHR	With oil filter change	4.9 (5-1/8, 4-1/4)
		Without oil filter change	4.6 (4-7/8, 4)
Dry engine (Overhaul)	VQ25HR	5.4 (5-6/8, 4-6/8)	
	VQ37VHR	5.7 (6, 5)	

SPARK PLUG (VQ37VHR)

SERVICE DATA AND SPECIFICATIONS (SDS)

< SERVICE DATA AND SPECIFICATIONS (SDS)

SPARK PLUG (VQ37VHR) : Spark Plug

INFOID:000000008294401

SPARK PLUG

Unit: mm (in)

Make	DENSO
Standard type	FXE24HR11
Gap (Nominal)	1.1 (0.043)

SPARK PLUG (VQ25HR)

SPARK PLUG (VQ25HR) : Spark Plug

INFOID:000000008294402

SPARK PLUG

Unit: mm (in)

Make	DENSO	
Standard type	FXE22HR11	
Gap	Standard	1.1 (0.043)
	Limit	1.4 (0.055)

ROAD WHEEL

ROAD WHEEL : Road Wheel

INFOID:000000008294403

ALUMINUM WHEEL (CONVENTIONAL)

Item	Limit	
Runout	Axial runout	Less than 0.3 mm (0.012 in)
	Radial runout	
Allowable unbalance	Dynamic (At flange)	Less than 5 g (0.17 oz) (one side)
	Static (At flange)	Less than 10 g (0.35 oz)

STEEL WHEEL (FOR EMERGENCY USE)

Item	Limit	
Runout	Axial runout (Average)	Less than 1.5 mm (0.059 in)
	Radial runout (Average)	

A
B
C
D
E
F
G
H
I
J
K
L
M
N
O

MA