

# SECTION **PWC**

## POWER WINDOW CONTROL SYSTEM

A  
B  
C  
D  
E  
F  
G  
H  
I  
J  
L  
M  
N  
O  
P

### CONTENTS

<p><b>FRONT &amp; REAR WINDOW ANTI-PINCH</b></p> <p><b>BASIC INSPECTION</b> ..... 6</p> <p><b>DIAGNOSIS AND REPAIR WORK FLOW</b> ..... 6 Work Flow .....6</p> <p><b>INSPECTION AND ADJUSTMENT</b> ..... 7</p> <p><b>ADDITIONAL SERVICE WHEN REMOVING BATTERY NEGATIVE TERMINAL</b> .....7 ADDITIONAL SERVICE WHEN REMOVING BATTERY NEGATIVE TERMINAL : Description .....7 ADDITIONAL SERVICE WHEN REMOVING BATTERY NEGATIVE TERMINAL : Special Repair Requirement .....7</p> <p><b>ADDITIONAL SERVICE WHEN REPLACING CONTROL UNIT</b> .....7 ADDITIONAL SERVICE WHEN REPLACING CONTROL UNIT : Description .....7 ADDITIONAL SERVICE WHEN REPLACING CONTROL UNIT : Special Repair Requirement .....8</p> <p><b>SYSTEM DESCRIPTION</b> ..... 9</p> <p><b>POWER WINDOW SYSTEM</b> ..... 9 System Diagram .....9 System Description .....9 Component Parts Location ..... 11 Component Description ..... 11</p> <p><b>DIAGNOSIS SYSTEM (BCM)</b> .....13</p> <p><b>COMMON ITEM</b> ..... 13 COMMON ITEM : CONSULT Function (BCM - COMMON ITEM) ..... 13</p> <p><b>RETAIND PWR</b> .....14 RETAIND PWR : CONSULT Function (BCM - RETAINED PWR) ..... 14</p> <p><b>DTC/CIRCUIT DIAGNOSIS</b> .....16</p>	<p><b>POWER SUPPLY AND GROUND CIRCUIT</b> ....16</p> <p><b>POWER WINDOW MAIN SWITCH</b> .....16 POWER WINDOW MAIN SWITCH : Diagnosis Procedure ..... 16</p> <p><b>FRONT POWER WINDOW SWITCH (PASSENGER SIDE)</b> .....16 FRONT POWER WINDOW SWITCH (PASSENGER SIDE) : Diagnosis Procedure .....17</p> <p><b>REAR POWER WINDOW SWITCH</b> .....17 REAR POWER WINDOW SWITCH : Diagnosis Procedure .....17</p> <p><b>POWER WINDOW MOTOR</b> .....19</p> <p><b>DRIVER SIDE</b> .....19 DRIVER SIDE : Description .....19 DRIVER SIDE : Component Function Check .....19 DRIVER SIDE : Diagnosis Procedure .....19</p> <p><b>PASSENGER SIDE</b> .....20 PASSENGER SIDE : Description .....20 PASSENGER SIDE : Component Function Check .....20 PASSENGER SIDE : Diagnosis Procedure .....20</p> <p><b>REAR LH</b> .....21 REAR LH : Description .....21 REAR LH : Component Function Check .....21 REAR LH : Diagnosis Procedure .....21</p> <p><b>REAR RH</b> .....22 REAR RH : Description .....22 REAR RH : Component Function Check .....22 REAR RH : Diagnosis Procedure .....22</p> <p><b>ENCODER</b> .....24</p> <p><b>DRIVER SIDE</b> .....24 DRIVER SIDE : Description .....24 DRIVER SIDE : Component Function Check .....24</p>
--	---

PWC

DRIVER SIDE : Diagnosis Procedure .....	24	<b>POWER WINDOW MAIN SWITCH .....</b>	<b>74</b>
<b>PASSENGER SIDE .....</b>	<b>26</b>	Reference Value .....	74
PASSENGER SIDE : Description .....	26	Wiring Diagram - POWER WINDOW CONTROL SYSTEM - .....	76
PASSENGER SIDE : Component Function Check .....	26	Fail-safe .....	76
PASSENGER SIDE : Diagnosis Procedure .....	26	<b>FRONT POWER WINDOW SWITCH .....</b>	<b>78</b>
<b>REAR LH .....</b>	<b>28</b>	Reference Value .....	78
REAR LH : Description .....	28	Wiring Diagram - POWER WINDOW CONTROL SYSTEM - .....	79
REAR LH : Component Function Check .....	28	Fail-safe .....	80
REAR LH : Diagnosis Procedure .....	28	<b>REAR POWER WINDOW SWITCH .....</b>	<b>81</b>
<b>REAR RH .....</b>	<b>30</b>	Reference Value .....	81
REAR RH : Description .....	30	Wiring Diagram - POWER WINDOW CONTROL SYSTEM - .....	82
REAR RH : Component Function Check .....	30	Fail-safe .....	83
REAR RH : Diagnosis Procedure .....	31	<b>SYMPTOM DIAGNOSIS .....</b>	<b>84</b>
<b>DOOR KEY CYLINDER SWITCH .....</b>	<b>33</b>	<b>POWER WINDOWS DO NOT OPERATE WITH ANY POWER WINDOW SWITCHES .....</b>	<b>84</b>
Description .....	33	Diagnosis Procedure .....	84
Component Function Check .....	33	<b>DRIVER SIDE POWER WINDOW DOES NOT OPERATE .....</b>	<b>85</b>
Diagnosis Procedure .....	33	Diagnosis Procedure .....	85
Component Inspection .....	34	<b>FRONT PASSENGER SIDE POWER WINDOW DOES NOT OPERATE .....</b>	<b>86</b>
<b>POWER WINDOW SERIAL LINK .....</b>	<b>35</b>	<b>WHEN POWER WINDOW MAIN SWITCH IS OPERATED .....</b>	<b>86</b>
<b>POWER WINDOW MAIN SWITCH .....</b>	<b>35</b>	WHEN POWER WINDOW MAIN SWITCH IS OPERATED : Diagnosis Procedure .....	86
POWER WINDOW MAIN SWITCH : Description ...	35	<b>WHEN FRONT POWER WINDOW SWITCH (PASSENGER SIDE) IS OPERATED .....</b>	<b>86</b>
POWER WINDOW MAIN SWITCH : Component Function Check .....	35	WHEN FRONT POWER WINDOW SWITCH (PASSENGER SIDE) IS OPERATED : Diagnosis Procedure .....	86
POWER WINDOW MAIN SWITCH : Diagnosis Procedure .....	35	<b>WHEN BOTH POWER WINDOW MAIN SWITCH AND FRONT POWER WINDOW SWITCH ARE OPERATED .....</b>	<b>86</b>
<b>FRONT POWER WINDOW SWITCH (PASSENGER SIDE) .....</b>	<b>36</b>	WHEN BOTH POWER WINDOW MAIN SWITCH AND FRONT POWER WINDOW SWITCH ARE OPERATED : Diagnosis Procedure .....	86
FRONT POWER WINDOW SWITCH (PASSENGER SIDE) : Description .....	36	<b>REAR LH SIDE POWER WINDOW DOES NOT OPERATE .....</b>	<b>87</b>
FRONT POWER WINDOW SWITCH (PASSENGER SIDE) : Component Function Check .....	36	<b>WHEN POWER WINDOW MAIN SWITCH IS OPERATED .....</b>	<b>87</b>
FRONT POWER WINDOW SWITCH (PASSENGER SIDE) : Diagnosis Procedure .....	37	WHEN POWER WINDOW MAIN SWITCH IS OPERATED : Diagnosis Procedure .....	87
<b>REAR LH .....</b>	<b>38</b>	<b>WHEN REAR POWER WINDOW SWITCH LH IS OPERATED .....</b>	<b>87</b>
REAR LH : Description .....	38	WHEN REAR POWER WINDOW SWITCH LH IS OPERATED : Diagnosis Procedure .....	87
REAR LH : Component Function Check .....	38		
REAR LH : Diagnosis Procedure .....	38		
<b>REAR RH .....</b>	<b>39</b>		
REAR RH : Description .....	39		
REAR RH : Component Function Check .....	39		
REAR RH : Diagnosis Procedure .....	39		
<b>ECU DIAGNOSIS INFORMATION .....</b>	<b>41</b>		
<b>BCM (BODY CONTROL MODULE) .....</b>	<b>41</b>		
Reference Value .....	41		
Wiring Diagram - BCM - .....	65		
Fail-safe .....	69		
DTC Inspection Priority Chart .....	70		
DTC Index .....	71		

<b>WHEN BOTH POWER WINDOW MAIN SWITCH AND REAR POWER WINDOW SWITCH LH ARE OPERATED</b> .....	87	Precaution for Supplemental Restraint System (SRS) "AIR BAG" and "SEAT BELT PRE-TENSIONER" .....	96	A
WHEN BOTH POWER WINDOW MAIN SWITCH AND REAR POWER WINDOW SWITCH LH ARE OPERATED : Diagnosis Procedure .....	87			
<b>REAR LH SIDE POWER WINDOW DOES NOT OPERATE</b> .....	88	<b>PREPARATION</b> .....	97	B
<b>WHEN POWER WINDOW MAIN SWITCH IS OPERATED</b> .....	88	<b>PREPARATION</b> .....	97	
WHEN POWER WINDOW MAIN SWITCH IS OPERATED : Diagnosis Procedure .....	88	Commercial Service Tools .....	97	
<b>WHEN REAR POWER WINDOW SWITCH RH IS OPERATED</b> .....	88	<b>REMOVAL AND INSTALLATION</b> .....	98	C
WHEN REAR POWER WINDOW SWITCH RH IS OPERATED : Diagnosis Procedure .....	88	<b>POWER WINDOW MAIN SWITCH</b> .....	98	D
<b>WHEN BOTH POWER WINDOW MAIN SWITCH AND REAR POWER WINDOW SWITCH RH ARE OPERATED</b> .....	88	Removal and Installation .....	98	
WHEN BOTH POWER WINDOW MAIN SWITCH AND REAR POWER WINDOW SWITCH RH ARE OPERATED : Diagnosis Procedure .....	88	<b>FRONT WINDOW ANTI-PINCH</b>		
<b>ANTI-PINCH FUNCTION DOES NOT OPERATE</b> .....	89	<b>BASIC INSPECTION</b> .....	99	E
Diagnosis Procedure .....	89	<b>DIAGNOSIS AND REPAIR WORKFLOW</b> .....	99	F
<b>AUTO OPERATION DOES NOT OPERATE BUT MANUAL OPERATES NORMALLY</b> .....	90	Work Flow .....	99	
Diagnosis Procedure .....	90	<b>INSPECTION AND ADJUSTMENT</b> .....	100	G
<b>POWER WINDOW RETAINED POWER FUNCTION DOES NOT OPERATE NORMALLY</b> .....	91	<b>ADDITIONAL SERVICE WHEN REMOVING BATTERY NEGATIVE TERMINAL</b> .....	100	H
Diagnosis Procedure .....	91	ADDITIONAL SERVICE WHEN REMOVING BATTERY NEGATIVE TERMINAL : Description ..	100	
<b>DOOR KEY CYLINDER SWITCH DOES NOT OPERATE POWER WINDOWS</b> .....	92	ADDITIONAL SERVICE WHEN REMOVING BATTERY NEGATIVE TERMINAL : Special Repair Requirement .....	100	I
Diagnosis Procedure .....	92	<b>ADDITIONAL SERVICE WHEN REPLACING CONTROL UNIT</b> .....	100	J
<b>KEYLESS POWER WINDOW DOWN DOES NOT OPERATE</b> .....	93	ADDITIONAL SERVICE WHEN REPLACING CONTROL UNIT : Description .....	100	
Description .....	93	ADDITIONAL SERVICE WHEN REPLACING CONTROL UNIT : Special Repair Requirement ..	101	
Diagnosis Procedure .....	93	<b>SYSTEM DESCRIPTION</b> .....	102	<b>PWC</b>
<b>POWER WINDOW LOCK SWITCH DOES NOT FUNCTION</b> .....	94	<b>POWER WINDOW SYSTEM</b> .....	102	L
Diagnosis Procedure .....	94	System Diagram .....	102	
<b>POWER WINDOW SWITCH ILLUMINATION DOES NOT ILLUMINATE</b> .....	95	System Description .....	102	M
Diagnosis Procedure .....	95	Component Parts Location .....	104	
<b>PRECAUTION</b> .....	96	Component Description .....	104	
<b>PRECAUTIONS</b> .....	96	<b>DIAGNOSIS SYSTEM (BCM)</b> .....	106	N
		<b>COMMON ITEM</b> .....	106	O
		COMMON ITEM : CONSULT Function (BCM - COMMON ITEM) .....	106	
		<b>RETAINED PWR</b> .....	107	P
		RETAINED PWR : CONSULT Function (BCM - RETAINED PWR) .....	107	
		<b>DTC/CIRCUIT DIAGNOSIS</b> .....	109	
		<b>POWER SUPPLY AND GROUND CIRCUIT</b> ..	109	
		<b>POWER WINDOW MAIN SWITCH</b> .....	109	
		POWER WINDOW MAIN SWITCH : Diagnosis Procedure .....	109	

<b>FRONT POWER WINDOW SWITCH (PASSENGER SIDE)</b> .....	110	POWER WINDOW MAIN SWITCH : Diagnosis Procedure .....	127
FRONT POWER WINDOW SWITCH (PASSENGER SIDE) : Diagnosis Procedure .....	110	<b>FRONT POWER WINDOW SWITCH (PASSENGER SIDE)</b> .....	128
<b>REAR POWER WINDOW SWITCH</b> .....	111	FRONT POWER WINDOW SWITCH (PASSENGER SIDE) : Description .....	128
REAR POWER WINDOW SWITCH : Diagnosis Procedure .....	111	FRONT POWER WINDOW SWITCH (PASSENGER SIDE) : Component Function Check .....	128
<b>REAR POWER WINDOW SWITCH</b> .....	113	FRONT POWER WINDOW SWITCH (PASSENGER SIDE) : Diagnosis Procedure .....	129
Description .....	113	<b>ECU DIAGNOSIS INFORMATION</b> .....	130
Component Function Check .....	113	<b>BCM (BODY CONTROL MODULE)</b> .....	130
Diagnosis Procedure .....	113	Reference Value .....	130
Component Inspection .....	114	Wiring Diagram - BCM - .....	154
<b>POWER WINDOW MOTOR</b> .....	115	Fail-safe .....	158
<b>DRIVER SIDE</b> .....	115	DTC Inspection Priority Chart .....	159
DRIVER SIDE : Description .....	115	DTC Index .....	160
DRIVER SIDE : Component Function Check .....	115	<b>POWER WINDOW MAIN SWITCH</b> .....	163
DRIVER SIDE : Diagnosis Procedure .....	115	Reference Value .....	163
<b>PASSENGER SIDE</b> .....	116	Wiring Diagram - POWER WINDOW CONTROL SYSTEM - .....	165
PASSENGER SIDE : Description .....	116	Fail-safe .....	165
PASSENGER SIDE : Component Function Check .....	116	<b>FRONT POWER WINDOW SWITCH</b> .....	167
PASSENGER SIDE : Diagnosis Procedure .....	116	Reference Value .....	167
<b>REAR LH</b> .....	117	Wiring Diagram - POWER WINDOW CONTROL SYSTEM - .....	168
REAR LH : Description .....	117	Fail-safe .....	169
REAR LH : Component Function Check .....	117	<b>SYMPTOM DIAGNOSIS</b> .....	170
REAR LH : Diagnosis Procedure .....	117	<b>POWER WINDOWS DO NOT OPERATE WITH ANY POWER WINDOW SWITCHES</b> ....	170
<b>REAR RH</b> .....	118	Diagnosis Procedure .....	170
REAR RH : Description .....	118	<b>DRIVER SIDE POWER WINDOW DOES NOT OPERATE</b> .....	171
REAR RH : Component Function Check .....	118	Diagnosis Procedure .....	171
REAR RH : Diagnosis Procedure .....	118	<b>FRONT PASSENGER SIDE POWER WINDOW DOES NOT OPERATE</b> .....	172
<b>ENCODER</b> .....	120	<b>WHEN POWER WINDOW MAIN SWITCH IS OPERATED</b> .....	172
<b>DRIVER SIDE</b> .....	120	WHEN POWER WINDOW MAIN SWITCH IS OPERATED : Diagnosis Procedure .....	172
DRIVER SIDE : Description .....	120	<b>WHEN FRONT POWER WINDOW SWITCH (PASSENGER SIDE) IS OPERATED</b> .....	172
DRIVER SIDE : Component Function Check .....	120	WHEN FRONT POWER WINDOW SWITCH (PASSENGER SIDE) IS OPERATED : Diagnosis Procedure .....	172
DRIVER SIDE : Diagnosis Procedure .....	120	<b>WHEN BOTH POWER WINDOW MAIN SWITCH AND FRONT POWER WINDOW SWITCH ARE OPERATED</b> .....	172
<b>PASSENGER SIDE</b> .....	122		
PASSENGER SIDE : Description .....	122		
PASSENGER SIDE : Component Function Check .....	122		
PASSENGER SIDE : Diagnosis Procedure .....	122		
<b>DOOR KEY CYLINDER SWITCH</b> .....	125		
Description .....	125		
Component Function Check .....	125		
Diagnosis Procedure .....	125		
Component Inspection .....	126		
<b>POWER WINDOW SERIAL LINK</b> .....	127		
<b>POWER WINDOW MAIN SWITCH</b> .....	127		
POWER WINDOW MAIN SWITCH : Description ..	127		
POWER WINDOW MAIN SWITCH : Component Function Check .....	127		

WHEN BOTH POWER WINDOW MAIN SWITCH AND FRONT POWER WINDOW SWITCH ARE OPERATED : Diagnosis Procedure .....	172	Diagnosis Procedure .....	176	
<b>REAR LH SIDE POWER WINDOW DOES NOT OPERATE .....</b>	<b>174</b>	<b>AUTO OPERATION DOES NOT OPERATE BUT MANUAL OPERATE NORMALLY .....</b>	<b>177</b>	<b>A</b>
WHEN POWER WINDOW MAIN SWITCH IS OPERATED .....	174	Diagnosis Procedure .....	177	B
WHEN POWER WINDOW MAIN SWITCH IS OPERATED : Diagnosis Procedure .....	174	<b>POWER WINDOW RETAINED POWER OPERATION DOES NOT OPERATE PROPERLY .....</b>	<b>178</b>	<b>C</b>
<b>WHEN REAR POWER WINDOW SWITCH LH IS OPERATED .....</b>	<b>174</b>	Diagnosis Procedure .....	178	
WHEN REAR POWER WINDOW SWITCH LH IS OPERATED : Diagnosis Procedure .....	174	<b>DOOR KEY CYLINDER SWITCH DOES NOT OPERATE POWER WINDOWS .....</b>	<b>179</b>	<b>D</b>
<b>WHEN BOTH POWER WINDOW MAIN SWITCH AND REAR POWER WINDOW SWITCH LH ARE OPERATED .....</b>	<b>174</b>	Diagnosis Procedure .....	179	E
WHEN BOTH POWER WINDOW MAIN SWITCH AND REAR POWER WINDOW SWITCH LH ARE OPERATED : Diagnosis Procedure .....	174	<b>KEYLESS POWER WINDOW DOWN DOES NOT OPERATE .....</b>	<b>180</b>	<b>F</b>
<b>REAR RH SIDE POWER WINDOW DOES NOT OPERATE .....</b>	<b>175</b>	Description .....	180	
WHEN POWER WINDOW MAIN SWITCH IS OPERATED .....	175	Diagnosis Procedure .....	180	
WHEN POWER WINDOW MAIN SWITCH IS OPERATED : Diagnosis Procedure .....	175	<b>POWER WINDOW LOCK SWITCH DOES NOT FUNCTION .....</b>	<b>181</b>	<b>G</b>
<b>WHEN REAR POWER WINDOW SWITCH RH IS OPERATED .....</b>	<b>175</b>	Diagnosis Procedure .....	181	
WHEN REAR POWER WINDOW SWITCH RH IS OPERATED : Diagnosis Procedure .....	175	<b>POWER WINDOW SWITCH ILLUMINATION DOES NOT ILLUMINATE .....</b>	<b>182</b>	<b>H</b>
<b>WHEN BOTH POWER WINDOW MAIN SWITCH AND REAR POWER WINDOW SWITCH RH ARE OPERATED .....</b>	<b>175</b>	Diagnosis Procedure .....	182	
WHEN BOTH POWER WINDOW MAIN SWITCH AND REAR POWER WINDOW SWITCH RH ARE OPERATED : Diagnosis Procedure .....	175	<b>PRECAUTION .....</b>	<b>183</b>	<b>I</b>
<b>ANTI-PINCH FUNCTION DOES NOT OPERATE .....</b>	<b>176</b>	<b>PRECAUTIONS .....</b>	<b>183</b>	<b>J</b>
		Precaution for Supplemental Restraint System (SRS) "AIR BAG" and "SEAT BELT PRE-TENSIONER" .....	183	
		<b>PREPARATION .....</b>	<b>184</b>	<b>PWC</b>
		<b>PREPARATION .....</b>	<b>184</b>	
		Commercial Service Tools .....	184	
		<b>REMOVAL AND INSTALLATION .....</b>	<b>185</b>	<b>L</b>
		<b>POWER WINDOW MAIN SWITCH .....</b>	<b>185</b>	<b>M</b>
		Removal and Installation .....	185	
				<b>N</b>
				<b>O</b>
				<b>P</b>

## BASIC INSPECTION

### DIAGNOSIS AND REPAIR WORK FLOW

#### Work Flow

INFOID:000000008290463

#### DETAILED FLOW

#### 1.OBTAIN INFORMATION ABOUT SYMPTOM

---

Interview the customer to obtain the malfunction information (conditions and environment when the malfunction occurred) as much as possible when the customer brings the vehicle in.

>> GO TO 2.

#### 2.REPRODUCE THE MALFUNCTION INFORMATION

---

Check the malfunction on the vehicle that the customer describes.  
Inspect the relation of the symptoms and the condition when the symptoms occur.

>> GO TO 3.

#### 3.IDENTIFY THE MALFUNCTIONING SYSTEM WITH "SYMPTOM DIAGNOSIS"

---

Use "Symptom diagnosis" from the symptom inspection result in step 2. Then identify where to start performing the diagnosis based on possible causes and symptoms.

>> GO TO 4.

#### 4.IDENTIFY MALFUNCTIONING PARTS WITH "DTC/CIRCUIT DIAGNOSIS"

---

Perform the diagnosis with "DTC/CIRCUIT DIAGNOSIS" of the applicable system.

>> GO TO 5.

#### 5.REPAIR OR REPLACE THE MALFUNCTIONING PARTS

---

Repair or replace the specified malfunctioning parts.

>> GO TO 6.

#### 6.FINAL CHECK

---

Check that malfunctions are not reproduced when obtaining the malfunction information from the customer, referring to the symptom inspection result in step 2.

Is the malfunctioning part repaired or replaced?

YES >> Trouble diagnosis is completed.

NO >> GO TO 3.

# INSPECTION AND ADJUSTMENT

< BASIC INSPECTION >

[FRONT & REAR WINDOW ANTI-PINCH]

## INSPECTION AND ADJUSTMENT

### ADDITIONAL SERVICE WHEN REMOVING BATTERY NEGATIVE TERMINAL

#### ADDITIONAL SERVICE WHEN REMOVING BATTERY NEGATIVE TERMINAL : Description

INFOID:000000008290464

When battery negative terminal is disconnected, initialization is necessary.

If any of the following operations are performed, initialization is necessary as well as when battery negative terminal is disconnected.

- Power supply to the power window control unit is cut off by the removal of battery terminal or the battery fuse is blown.
- Disconnection and connection of power window control unit harness connector.
- Removal and installation of motor from regulator assembly.
- Operation of regulator assembly as an independent unit.
- Removal and installation of rear power window control unit.
- Removal and installation of door glass.
- Removal and installation of door glass run.

The operations as per the following cannot be performed while initialization is not complete.

- AUTO-UP operation
- Anti-pinch function
- Door key cylinder power window function

#### ADDITIONAL SERVICE WHEN REMOVING BATTERY NEGATIVE TERMINAL : Special Repair Requirement

INFOID:000000008290465

#### INITIALIZATION PROCEDURE

1. Disconnect battery negative terminal or power window control unit connector. Reconnect it after a minute or more.
2. Turn ignition switch ON.
3. Operate power window switch to fully open door glass. (This operation is unnecessary if door glass is already fully open.)
4. Pull and hold power window switch UP (AUTO-UP operation). Even after door glass stops at the fully closed position, pull the switch for 2 seconds or more.
5. Initialization procedure is complete.
6. Inspect anti-pinch function.

#### CHECK ANTI-PINCH FUNCTION

1. Fully open door glass.
  2. Place a piece of wood near the fully closed position.
  3. Close door glass completely using AUTO-UP.
- Check that door glass lowers approximately 150 mm (5.9 in) without pinching piece of wood and stops.
  - Check that door glass does not rise when operating power window main switch while lowering.

#### **CAUTION:**

- **Perform initialization when AUTO-UP operation or anti-pinch function does not operate normally.**
- **Check that AUTO-UP operates before inspection when initialization is performed.**
- **Never check with hands or other body parts because they may be pinched. Never get pinched.**
- **Finish initialization. Otherwise, the next operation cannot be done.**

1. **AUTO-UP operation**
2. **Anti-pinch function**
3. **Door key cylinder power window function**

#### ADDITIONAL SERVICE WHEN REPLACING CONTROL UNIT

#### ADDITIONAL SERVICE WHEN REPLACING CONTROL UNIT : Description

INFOID:000000008290466

When the control unit is replaced, initialization is necessary.

If any of the following operations are performed, initialization is necessary as well as when the control unit is disconnected.

- Power supply to the power window control unit is cut off by the removal of battery terminal or the battery fuse is blown.

A  
B  
C  
D  
E  
F  
G  
H  
I  
J  
L  
M  
N  
O  
P

PWC

# INSPECTION AND ADJUSTMENT

## [FRONT & REAR WINDOW ANTI-PINCH]

### < BASIC INSPECTION >

- Disconnection and connection of power window control unit harness connector.
- Removal and installation of motor from regulator assembly.
- Disconnection and connection of battery negative terminal.
- Removal and installation of rear power window control unit.
- Removal and installation of door glass.
- Removal and installation of door glass run.

The following specified operations cannot be performed while initialization is not complete.

- AUTO-UP operation
- Anti-pinch function
- Door key cylinder power window function

### ADDITIONAL SERVICE WHEN REPLACING CONTROL UNIT : Special Repair Requirement

INFOID:000000008290467

#### INITIALIZATION PROCEDURE

1. Disconnect battery negative terminal or power window control unit connector. Reconnect it after a minute or more.
2. Turn ignition switch ON.
3. Operate power window switch to fully open door glass. (This operation is unnecessary if door glass is already fully open.)
4. Pull and hold power window switch UP (AUTO-UP operation). Even after door glass stops at the fully closed position, pull the switch for 2 seconds or more.
5. Initialization procedure is complete.
6. Inspect anti-pinch function.

#### CHECK ANTI-PINCH FUNCTION

1. Fully open door glass.
  2. Place a piece of wood near the fully closed position.
  3. Close door glass completely using AUTO-UP.
- Check that door glass lowers approximately 150 mm (5.9 in) without pinching piece of wood and stops.
  - Check that door glass does not rise when operating power window main switch while lowering.

#### **CAUTION:**

- **Perform initialization when AUTO-UP operation or anti-pinch function does not operate normally.**
  - **Check that AUTO-UP operates before inspection when initialization is performed.**
  - **Never check with hands or other body parts because they may be pinched. Never get pinched.**
  - **Finish initialization. Otherwise, the next operation cannot be done.**
1. **AUTO-UP operation**
  2. **Anti-pinch function**
  3. **Door key cylinder power window function**



# POWER WINDOW SYSTEM

[FRONT & REAR WINDOW ANTI-PINCH]

< SYSTEM DESCRIPTION >

## SYSTEM DESCRIPTION

### POWER WINDOW SYSTEM

#### System Diagram

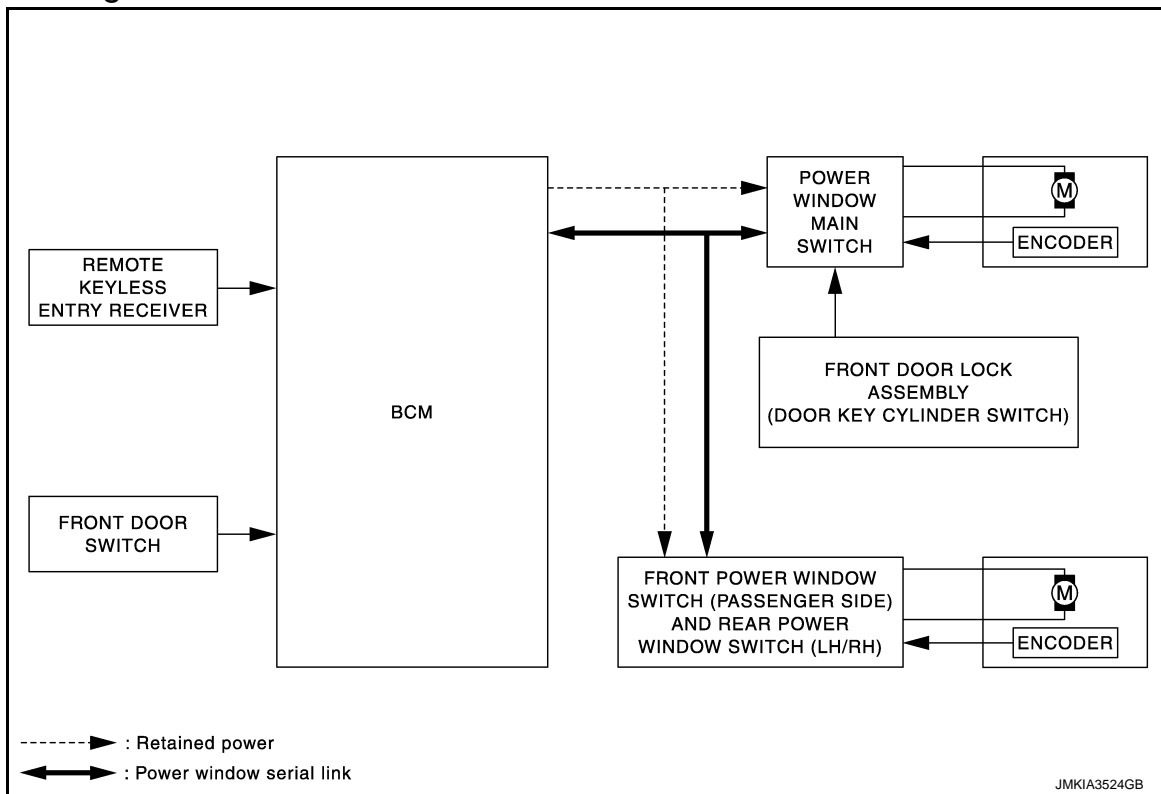

#### System Description

INFOID:000000008290469

- Power window system is activated by power window switch when ignition switch turns ON, or during the retained power operation after ignition switch turns OFF.
- Power window main switch opens/closes all door glass.
- Front and rear power window switch opens/closes the corresponding door glass.
- AUTO UP/DOWN operation can be performed when power window switch turns to AUTO.
- Power window serial link transmits the signals from power window main switch to each module.
- Power window lock switch can lock all power windows other than driver seat.
- If door glass receives resistance that is the specified value or more while power window of each seat is in AUTO-UP operation, power window of each seat operates in the reverse direction.
- Hold the door key cylinder to the LOCK or UNLOCK direction for 1 second or more to OPEN or CLOSE all power windows when ignition switch OFF.
- All power windows open when pressing Intelligent Key unlock button for 3 seconds.

#### POWER WINDOW AUTO-OPERATION

- AUTO UP/DOWN operation can be performed when each power window switch turns to AUTO.
- Encoder continues detecting the movement of power window motor and transmits to power window switch as the encoder pulse signal while power window motor is operating.
- Power window switch reads the changes of encoder signal and stops AUTO operation when door glass is at fully opened/closed position.
- Power window motor is operable in case encoder is malfunctioning.

#### RETAINED POWER OPERATION

Retained power operation is an additional power supply function that enables power window system to operate for 45 seconds after ignition switch turns OFF.

#### Retained Power Cancel Conditions

- Front door CLOSE (door switch OFF) → OPEN (door switch ON).
- When ignition switch turns ON again.

A  
B  
C  
D  
E  
F  
G  
H  
I  
J  
L  
M  
N  
O  
P

PWC

# POWER WINDOW SYSTEM

[FRONT & REAR WINDOW ANTI-PINCH]

## < SYSTEM DESCRIPTION >

- When timer times out (45 seconds).

### POWER WINDOW LOCK FUNCTION

Ground circuit inside power window main switch shuts off when power window lock switch is ON. This inhibits each power window switch operation except the power window main switch.

### POWER WINDOW SERIAL LINK

- All power window switches and BCM transmit and receive the power window serial link.
- Power window serial link transmits the power window main switch operation signals and IGN signal to power window main switch module, front power window switch (passenger side) module, and rear power window switches.

### ANTI-PINCH OPERATION

- Pinch the foreign matter in the door glass during AUTO-UP operation is the anti-pinch function that lowers the door glass 150 mm (5.9 in) when detected.
- Encoder continues detecting the movement of power window motor and transmits to power window switch as the encoder pulse signal while power window motor is operating.
- Resistance is applied to the power window motor rotation that changes the frequency of encoder pulse signal if foreign material is trapped in the door glass.
- Power window switch controls to lower the door glass for 150 mm (5.9 in) after it detects encoder pulse signal frequency change.

#### Operation Condition

When all door glass AUTO-UP operation is performed (anti-pinch function does not operate just before the door glass closes and is fully closed).

#### **NOTE:**

Depending on environment and driving conditions, if a similar impact or load is applied to the door glass, it may lower.

### DOOR KEY CYLINDER SWITCH POWER WINDOW FUNCTION

Hold the door key cylinder to the LOCK or UNLOCK direction for 1.5 seconds or more to OPEN or CLOSE all power windows when ignition switch is OFF. In addition, it stops when key position is moved to NEUTRAL when operating.

#### OPERATION CONDITION

- Ignition switch OFF.
- Hold door key cylinder to LOCK position for 1.5 seconds or more to perform CLOSE operation of the door glass.
- Hold door key cylinder to UNLOCK position for 1.5 seconds or more to perform OPEN operation of the door glass.

### KEYLESS POWER WINDOW DOWN FUNCTION

All power windows open when the unlock button on Intelligent Key is activated and kept pressed for more than 3 seconds with the ignition switch OFF. The windows keep opening if the unlock button is continuously pressed.

The power window opening stops when the following operations are performed.

- When the unlock button is kept pressed more than 15 seconds.
- When the ignition switch is turned ON while the power window opening is operated.
- When the unlock button is released.

While retained power operation activate, keyless power window down function cannot be operated.

Keyless power window down operation mode can be changed by "PW DOWN SET" mode in "WORK SUPPORT". Refer to [DLK-53, "INTELLIGENT KEY : CONSULT Function \(BCM - INTELLIGENT KEY\)"](#).

#### **NOTE:**

Use CONSULT to change settings.

MODE 1 (3 sec) / MODE 2 (OFF) / MODE 3 (5 sec)

# POWER WINDOW SYSTEM

[FRONT & REAR WINDOW ANTI-PINCH]

< SYSTEM DESCRIPTION >

## Component Parts Location

INFOID:000000008290470

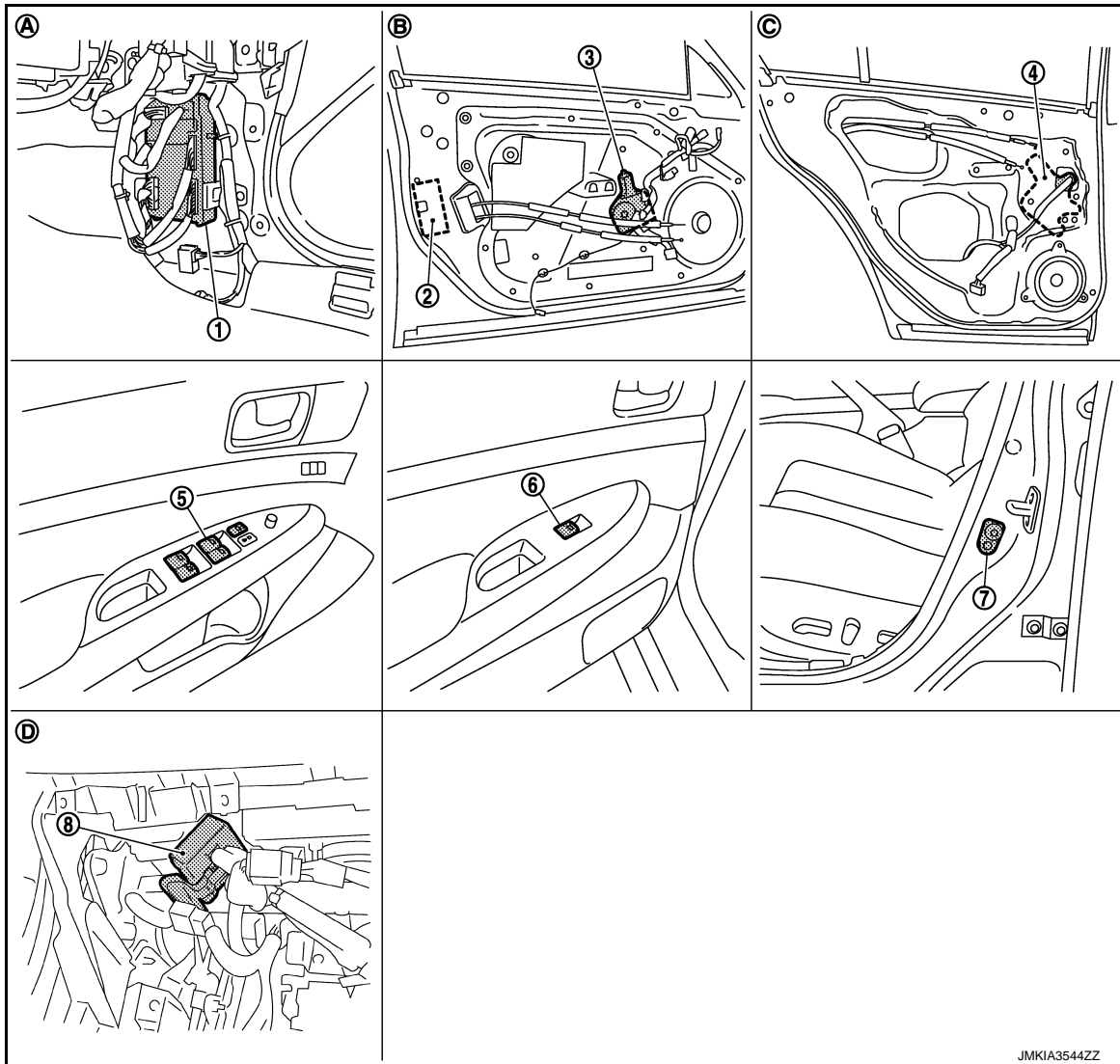

- |  |  |   |
|--|--|---|
| 1. BCM   | 2. Front door lock assembly (driver side) (door key cylinder switch) | 3. Front power window motor (driver side) |
| 4. Rear power window motor LH                                | 5. Power window main switch  | 6. Rear power window switch LH            |
| 7. Front door switch (driver side)                           | 8. Remote keyless entry receiver                                     |   |
| A. View with dash side lower (passenger side)                | B. View with front door finisher removed                             | C. View with rear door finisher removed   |
| D. View with instrument lower panel (passenger side) removed |  |   |

## Component Description

INFOID:000000008290471

Component	Function
BCM	<ul style="list-style-type: none"> <li>Supplies power supply to power window switch.</li> <li>Controls retained power function.</li> </ul>
Power window main switch	<ul style="list-style-type: none"> <li>Directly controls all power window motor of all doors.</li> <li>Controls anti-pinch operation of power window.</li> </ul>
Front power window switch (passenger side)	<ul style="list-style-type: none"> <li>Controls anti-pinch operation of power window.</li> <li>Controls power window motor of passenger door.</li> </ul>

## POWER WINDOW SYSTEM

[FRONT & REAR WINDOW ANTI-PINCH]

< SYSTEM DESCRIPTION >

Component	Function
Rear power window switch	<ul style="list-style-type: none"><li>• Controls anti-pinch operation of power window.</li><li>• Controls power window motor of rear right and left doors.</li></ul>
Power window motor	<ul style="list-style-type: none"><li>• Integrates the ENCODER and WINDOW MOTOR.</li><li>• Starts operating with signals from each power window switch.</li><li>• Transmits power window motor rotation as a pulse signal to power window switch.</li></ul>
Front door lock assembly (door key cylinder switch)	Transmits operation condition of key cylinder switch to power window main switch.
Front door switch	Detects door open/close condition and transmits to BCM.
Remote keyless entry receiver	Receives lock/unlock signal from the intelligent Key, and then transmits to BCM.

# DIAGNOSIS SYSTEM (BCM)

[FRONT & REAR WINDOW ANTI-PINCH]

< SYSTEM DESCRIPTION >

## DIAGNOSIS SYSTEM (BCM)

### COMMON ITEM

COMMON ITEM : CONSULT Function (BCM - COMMON ITEM)

INFOID:000000008781440

### APPLICATION ITEM

CONSULT performs the following functions via CAN communication with BCM.

Diagnosis mode	Function Description
Work Support	Changes the setting for each system function.
Self Diagnostic Result	Displays the diagnosis results judged by BCM.
CAN Diag Support Monitor	Monitors the reception status of CAN communication viewed from BCM.
Data Monitor	The BCM input/output signals are displayed.
Active Test	The signals used to activate each device are forcibly supplied from BCM.
Ecu Identification	The BCM part number is displayed.
Configuration	This function is not used even though it is displayed.

### SYSTEM APPLICATION

BCM can perform the following functions for each system.

#### NOTE:

It can perform the diagnosis modes except the following for all sub system selection items.

x: Applicable item

System	Sub system selection item	Diagnosis mode		
		Work Support	Data Monitor	Active Test
Door lock	DOOR LOCK	x	x	x
Rear window defogger	REAR DEFOGGER		x	x
Warning chime	BUZZER		x	x
Interior room lamp timer	INT LAMP	x	x	x
Exterior lamp	HEAD LAMP	x	x	x
Wiper and washer	WIPER	x	x	x
Turn signal and hazard warning lamps	FLASHER	x	x	x
—	AIR CONDITONER*			
<ul style="list-style-type: none"> <li>Intelligent Key system</li> <li>Engine start system</li> </ul>	INTELLIGENT KEY	x	x	x
Combination switch	COMB SW		x	
Body control system	BCM	x		
IVIS - NATS	IMMU		x	x
Interior room lamp battery saver	BATTERY SAVER	x	x	x
Trunk lid open	TRUNK		x	x
Vehicle security system	THEFT ALM	x	x	x
RAP system	RETAINED PWR		x	
Signal buffer system	SIGNAL BUFFER		x	x
TPMS	AIR PRESSURE MONITOR	x	x	x

#### NOTE:

\*: This item is displayed, but is not used.

### FREEZE FRAME DATA (FFD)

The BCM records the following vehicle condition at the time a particular DTC is detected, and displays on CONSULT.

# DIAGNOSIS SYSTEM (BCM)

## [FRONT & REAR WINDOW ANTI-PINCH]

### < SYSTEM DESCRIPTION >

CONSULT screen item	Indication/Unit	Description	
Vehicle Speed	km/h	Vehicle speed of the moment a particular DTC is detected	
Odo/Trip Meter	km	Total mileage (Odometer value) of the moment a particular DTC is detected	
Vehicle Condition	SLEEP>LOCK	Power position status of the moment a particular DTC is detected	While turning BCM status from low power consumption mode to normal mode (Power supply position is "LOCK"*)
	SLEEP>OFF		While turning BCM status from low power consumption mode to normal mode (Power supply position is "OFF".)
	LOCK>ACC		While turning power supply position from "LOCK"* to "ACC"
	ACC>ON		While turning power supply position from "ACC" to "IGN"
	RUN>ACC		While turning power supply position from "RUN" to "ACC" (Vehicle is stopping and selector lever is except P position.)
	CRANK>RUN		While turning power supply position from "CRANKING" to "RUN" (From cranking up the engine to run it)
	RUN>URGENT		While turning power supply position from "RUN" to "ACC" (Emergency stop operation)
	ACC>OFF		While turning power supply position from "ACC" to "OFF"
	OFF>LOCK		While turning power supply position from "OFF" to "LOCK"*
	OFF>ACC		While turning power supply position from "OFF" to "ACC"
	ON>CRANK		While turning power supply position from "IGN" to "CRANKING"
	OFF>SLEEP		While turning BCM status from normal mode (Power supply position is "OFF".) to low power consumption mode
	LOCK>SLEEP		While turning BCM status from normal mode (Power supply position is "LOCK"*. ) to low power consumption mode
	LOCK		Power supply position is "LOCK"*
	OFF		Power supply position is "OFF" (Ignition switch OFF)
	ACC		Power supply position is "ACC" (Ignition switch ACC)
	ON		Power supply position is "IGN" (Ignition switch ON with engine stopped)
ENGINE RUN	Power supply position is "RUN" (Ignition switch ON with engine running)		
CRANKING	Power supply position is "CRANKING" (At engine cranking)		
IGN Counter	0 - 39	The number of times that ignition switch is turned ON after DTC is detected <ul style="list-style-type: none"> <li>• The number is 0 when a malfunction is detected now.</li> <li>• The number increases like 1 → 2 → 3...38 → 39 after returning to the normal condition whenever ignition switch OFF → ON.</li> <li>• The number is fixed to 39 until the self-diagnosis results are erased if it is over 39.</li> </ul>	

#### NOTE:

\*: Power supply position shifts to "LOCK" from "OFF", when ignition switch is in the OFF position, selector lever is in the P position (A/T models), and any of the following conditions are met.

- Closing door
- Opening door
- Door is locked using door request switch
- Door is locked using Intelligent Key

The power supply position shifts to "ACC" when the push-button ignition switch (push switch) is pushed at "LOCK".

### RETAINED PWR

#### RETAINED PWR : CONSULT Function (BCM - RETAINED PWR)

INFOID:000000008290473

#### Data monitor

#### NOTE:

The following table includes information (items) inapplicable to this vehicle. For information (items) applicable to this vehicle, refer to CONSULT display items.

# DIAGNOSIS SYSTEM (BCM)

## [FRONT & REAR WINDOW ANTI-PINCH]

< SYSTEM DESCRIPTION >

Monitor Item	Description
DOOR SW-DR	Indicates [ON/OFF] condition of driver side door switch.
DOOR SW-AS	Indicates [ON/OFF] condition of passenger side door switch.

A

B

C

D

E

F

G

H

I

J

PWC

L

M

N

O

P

# POWER SUPPLY AND GROUND CIRCUIT

< DTC/CIRCUIT DIAGNOSIS >

[FRONT & REAR WINDOW ANTI-PINCH]

## DTC/CIRCUIT DIAGNOSIS

### POWER SUPPLY AND GROUND CIRCUIT

#### POWER WINDOW MAIN SWITCH

#### POWER WINDOW MAIN SWITCH : Diagnosis Procedure

INFOID:000000008290474

#### 1. CHECK POWER SUPPLY CIRCUIT 1

1. Turn ignition switch OFF.
2. Disconnect power window main switch connectors.
3. Turn ignition switch ON.
4. Check voltage between power window main switch harness connector and ground.

(+)		(-)	Voltage (V) (Approx.)
Power window main switch			
Connector	Terminal	Ground	12
D8	10		
D9	19		

Is the measurement value within the specification?

YES >> GO TO 3.

NO >> GO TO 2.

#### 2. CHECK POWER SUPPLY CIRCUIT 2

1. Turn ignition switch OFF.
2. Disconnect BCM connector.
3. Check continuity between BCM harness connector and power window main switch harness connector.

BCM		Power window main switch		Continuity
Connector	Terminal	Connector	Terminal	
M118	2	D9	19	Existed
	3	D8	10	

4. Check continuity between BCM harness connector and ground.

BCM		Ground	Continuity
Connector	Terminal		
M118	2		Not existed
	3		

Is the inspection result normal?

YES >> Replace BCM. Refer to [BCS-81. "Exploded View"](#).

NO >> Repair or replace harness.

#### 3. CHECK GROUND CIRCUIT

1. Turn ignition switch OFF.
2. Check continuity between power window main switch harness connector and ground.

Power window main switch		Ground	Continuity
Connector	Terminal		
D9	17		Existed

Is the inspection result normal?

YES >> INSPECTION END

NO >> Repair or replace harness.

#### FRONT POWER WINDOW SWITCH (PASSENGER SIDE)



# POWER SUPPLY AND GROUND CIRCUIT

< DTC/CIRCUIT DIAGNOSIS >

[FRONT & REAR WINDOW ANTI-PINCH]

## FRONT POWER WINDOW SWITCH (PASSENGER SIDE) : Diagnosis Procedure

INFOID:000000008290475

### 1. CHECK POWER SUPPLY CIRCUIT 1

1. Turn ignition switch OFF.
2. Disconnect front power window switch (passenger side) connector.
3. Turn ignition switch ON.
4. Check voltage between front power window switch (passenger side) harness connector and ground.

(+)		(-)	Voltage (V) (Approx.)
Connector	Terminal		
D38	10	Ground	12

Is the measurement value within the specification?

- YES >> GO TO 3.  
NO >> GO TO 2.

### 2. CHECK POWER SUPPLY CIRCUIT 2

1. Disconnect BCM connector.
2. Check continuity between BCM harness connector and front power window switch (passenger side) harness connector.

BCM		Front power window switch (passenger side)		Continuity
Connector	Terminal	Connector	Terminal	
M118	2	D38	10	Existed

3. Check continuity between BCM harness connector and ground.

BCM		Ground	Continuity
Connector	Terminal		
M118	2		Not existed

Is the inspection result normal?

- YES >> Replace BCM. Refer to [BCS-81, "Exploded View"](#).  
NO >> Repair or replace harness.

### 3. CHECK GROUND CIRCUIT

Check continuity between front power window switch (passenger side) harness connector and ground.

Front power window switch (passenger side)		Ground	Continuity
Connector	Terminal		
D38	11		Existed

Is the inspection result normal?

- YES >> INSPECTION END  
NO >> Repair or replace harness.

## REAR POWER WINDOW SWITCH

### REAR POWER WINDOW SWITCH : Diagnosis Procedure

INFOID:000000008290476

#### 1. CHECK POWER SUPPLY CIRCUIT 1

1. Turn ignition switch OFF.
2. Disconnect rear power window switch LH connector or power window switch RH connector.
3. Turn ignition switch ON.
4. Check voltage between rear power window switch harness connector and ground.

A  
B  
C  
D  
E  
F  
G  
H  
I  
J  
L  
M  
N  
O  
P

PWC

# POWER SUPPLY AND GROUND CIRCUIT

< DTC/CIRCUIT DIAGNOSIS >

[FRONT & REAR WINDOW ANTI-PINCH]

(+)		Terminal	(-)	Voltage (V) (Approx.)
Rear power window switch				
Connector				
LH	D57	10	Ground	12
RH	D77			

Is the measurement value within the specification?

YES >> GO TO 3.

NO >> GO TO 2.

## 2. CHECK POWER SUPPLY CIRCUIT 2

1. Turn ignition switch OFF.
2. Disconnect BCM connector.
3. Check continuity between BCM harness connector and rear power window switch harness connector.

BCM		Rear power window switch		Continuity
Connector	Terminal	Connector	Terminal	
M118	2	LH	D57	10
		RH	D77	

4. Check continuity between BCM harness connector and ground.

BCM		Ground	Continuity
Connector	Terminal		
M118	2		Not existed

Is the inspection result normal?

YES >> Replace BCM. Refer to [BCS-81, "Exploded View"](#).

NO >> Repair or replace harness.

## 3. CHECK GROUND CIRCUIT

1. Turn ignition switch OFF.
2. Check continuity between rear power window switch harness connector and ground.

Rear power window switch		Terminal	Ground	Continuity
Connector				
LH	D57	11	Ground	Existed
RH	D77			

Is the inspection result normal?

YES >> INSPECTION END

NO >> Repair or replace harness.

# POWER WINDOW MOTOR

[FRONT & REAR WINDOW ANTI-PINCH]

< DTC/CIRCUIT DIAGNOSIS >

## POWER WINDOW MOTOR

### DRIVER SIDE

#### DRIVER SIDE : Description

INFOID:000000008290477

Door glass moves UP/DOWN by receiving the signal from power window main switch.

#### DRIVER SIDE : Component Function Check

INFOID:000000008290478

### 1.CHECK FRONT POWER WINDOW MOTOR (DRIVER SIDE) OPERATION

Check front power window motor (driver side) operation with power window main switch.

Is the inspection result normal?

YES >> Power window motor (driver side) is OK.

NO >> Refer to [PWC-19, "DRIVER SIDE : Diagnosis Procedure"](#).

#### DRIVER SIDE : Diagnosis Procedure

INFOID:000000008290479

### 1.CHECK FRONT POWER WINDOW MOTOR (DRIVER SIDE) INPUT SIGNAL

1. Turn ignition switch OFF.
2. Disconnect front power window motor (driver side) connector.
3. Turn ignition switch ON.
4. Check voltage between front power window motor (driver side) harness connector and ground.

(+)		(-)	Condition	Voltage (V) (Approx.)
Connector	Terminal			
D10	1	Ground	Power window main switch NEUTRAL	0
			DOWN	12
	2		NEUTRAL	0
			UP	12

Is the measurement value within the specification?

YES >> Replace front power window motor (driver side).

NO >> GO TO 2.

### 2.CHECK FRONT POWER WINDOW MOTOR (DRIVER SIDE) CIRCUIT

1. Turn ignition switch OFF.
2. Disconnect power window main switch connector.
3. Check continuity between power window main switch harness connector and front power window motor (driver side) harness connector.

Power window main switch		Front power window motor (driver side)		Continuity
Connector	Terminal	Connector	Terminal	
D8	8	D10	2	Existed
	11		1	

4. Check continuity between power window main switch harness connector and ground.

Power window main switch		Ground	Continuity
Connector	Terminal		
D8	8		Not existed
	11		

Is the inspection result normal?

YES >> Replace power window main switch.

NO >> Repair or replace harness.

A  
B  
C  
D  
E  
F  
G  
H  
I  
J  
L  
M  
N  
O  
P

PWC

# POWER WINDOW MOTOR

[FRONT & REAR WINDOW ANTI-PINCH]

< DTC/CIRCUIT DIAGNOSIS >

## PASSENGER SIDE

### PASSENGER SIDE : Description

INFOID:000000008290480

Door glass moves UP/DOWN by receiving the signal power window main switch or front power window switch (passenger side).

### PASSENGER SIDE : Component Function Check

INFOID:000000008290481

#### 1. CHECK FRONT POWER WINDOW MOTOR (PASSENGER SIDE) OPERATION

Check front power window motor (passenger side) operation with power window main switch or front power window switch (passenger side).

Is the inspection result normal?

YES >> Power window motor (passenger side) is OK.

NO >> Refer to [PWC-20. "PASSENGER SIDE : Diagnosis Procedure"](#).

### PASSENGER SIDE : Diagnosis Procedure

INFOID:000000008290482

#### 1. CHECK FRONT POWER WINDOW MOTOR (PASSENGER SIDE) INPUT SIGNAL

1. Turn ignition switch OFF.
2. Disconnect front power window motor (passenger side) connector.
3. Turn ignition switch ON.
4. Check voltage between front power window motor (passenger side) harness connector and ground.

(+) Front power window motor (passenger side)		(-)	Condition	Voltage (V) (Approx.)	
Connector	Terminal				
D40	1	Ground	Front power window switch (passenger side)	NEUTRAL	0
				UP	12
	2			NEUTRAL	0
				DOWN	12

Is the measurement value within the specification?

YES >> Replace front power window motor (passenger side).

NO >> GO TO 2.

#### 2. CHECK FRONT POWER WINDOW MOTOR (PASSENGER SIDE) CIRCUIT

1. Turn ignition switch OFF.
2. Disconnect front power window switch (passenger side) connector.
3. Check continuity between front power window switch (passenger side) harness connector and front power window motor (passenger side) harness connector.

Front power window switch (passenger side)		Front power window motor (passenger side)		Continuity
Connector	Terminal	Connector	Terminal	
D38	8	D40	2	Existed
	9		1	

4. Check continuity between front power window switch (passenger side) connector and ground.

Front power window switch (passenger side)		Ground	Continuity
Connector	Terminal		
D38	8		Not existed
	9		

Is the inspection result normal?

YES >> Replace front power window switch (passenger side).

# POWER WINDOW MOTOR

[FRONT & REAR WINDOW ANTI-PINCH]

< DTC/CIRCUIT DIAGNOSIS >

NO >> Repair or replace harness.

## REAR LH

### REAR LH : Description

INFOID:000000008290483

Door glass moves UP/DOWN by receiving the signal from power window main switch or rear power window switch LH.

### REAR LH : Component Function Check

INFOID:000000008290484

#### 1.CHECK REAR POWER WINDOW MOTOR LH OPERATION

Check rear power window motor LH operation with power window main switch or rear power window switch LH.

Is the inspection result normal?

YES >> Power window motor LH is OK.

NO >> Refer to [PWC-21, "REAR LH : Diagnosis Procedure"](#).

### REAR LH : Diagnosis Procedure

INFOID:000000008290485

#### 1.CHECK REAR POWER WINDOW MOTOR LH INPUT SIGNAL

1. Turn ignition switch OFF.
2. Disconnect rear power window motor LH connector.
3. Turn ignition switch ON.
4. Check voltage between rear power window motor LH harness connector and ground.

(+)		(-)	Condition	Voltage (V) (Approx.)	
Connector	Terminal				
D52	1	Ground	Rear power window switch LH	NEUTRAL	0
			UP	12	
	3		NEUTRAL	0	
			DOWN	12	

Is the measurement value within the specification?

YES >> Replace rear power window motor LH.

NO >> GO TO 2.

#### 2.CHECK REAR POWER WINDOW MOTOR LH CIRCUIT

1. Turn ignition switch OFF.
2. Disconnect rear power window switch LH connector.
3. Check continuity between rear power window switch LH harness connector and rear power window motor LH harness connector.

Rear power window switch LH		Rear power window motor LH		Continuity
Connector	Terminal	Connector	Terminal	
D57	8	D52	1	Existed
	9		3	

4. Check continuity between rear power window switch LH harness connector and ground.

Rear power window switch LH		Ground	Continuity
Connector	Terminal		
D57	8		Not existed
	9		

Is the inspection result normal?

A  
B  
C  
D  
E  
F  
G  
H  
I  
J  
L  
M  
N  
O  
P

PWC

# POWER WINDOW MOTOR

[FRONT & REAR WINDOW ANTI-PINCH]

< DTC/CIRCUIT DIAGNOSIS >

YES >> Replace rear power window switch LH.

NO >> Repair or replace harness.

## REAR RH

### REAR RH : Description

INFOID:000000008290486

Door glass moves UP/DOWN by receiving the signal from power window main switch or rear power window switch RH.

### REAR RH : Component Function Check

INFOID:000000008290487

#### 1. CHECK REAR POWER WINDOW MOTOR RH OPERATION

Check rear power window motor RH operation with power window main switch or rear power window switch RH.

Is the inspection result normal?

YES >> Power window motor RH is OK.

NO >> Refer to [PWC-22, "REAR RH : Diagnosis Procedure"](#).

### REAR RH : Diagnosis Procedure

INFOID:000000008290488

#### 1. CHECK REAR POWER WINDOW MOTOR RH INPUT SIGNAL

1. Turn ignition switch OFF.
2. Disconnect rear power window motor RH connector.
3. Turn ignition switch ON.
4. Check voltage between rear power window motor RH harness connector and ground.

(+)		(-)	Condition	Voltage (V) (Approx.)	
Connector	Terminal				
D72	1	Ground	Rear power window switch RH	NEUTRAL	0
			UP	12	
	3		NEUTRAL	0	
			DOWN	12	

Is the measurement value within the specification?

YES >> Replace rear power window motor RH.

NO >> GO TO 2.

#### 2. CHECK REAR POWER WINDOW MOTOR RH CIRCUIT

1. Turn ignition switch OFF.
2. Disconnect rear power window switch RH connector.
3. Check continuity between rear power window switch RH harness connector and rear power window motor RH harness connector.

Rear power window switch RH		Rear power window motor RH		Continuity
Connector	Terminal	Connector	Terminal	
D77	8	D72	1	Existed
	9		3	

4. Check continuity between rear power window switch RH harness connector and ground.

Rear power window switch RH		Ground	Continuity
Connector	Terminal		
D77	8		Not existed
	9		

Is the inspection result normal?

# POWER WINDOW MOTOR

[FRONT & REAR WINDOW ANTI-PINCH]

< DTC/CIRCUIT DIAGNOSIS >

- YES >> Replace rear power window switch RH.
- NO >> Repair or replace harness.

A

B

C

D

E

F

G

H

I

J

**PWC**

L

M

N

O

P

# ENCODER

< DTC/CIRCUIT DIAGNOSIS >

[FRONT & REAR WINDOW ANTI-PINCH]

## ENCODER DRIVER SIDE

### DRIVER SIDE : Description

INFOID:000000008290489

Detects condition of the front power window motor (driver side) operation and transmits to power window main switch as the pulse signal.

### DRIVER SIDE : Component Function Check

INFOID:000000008290490

#### 1.CHECK ENCODER OPERATION

Check driver side door glass perform AUTO open/close operation normally by power window main switch.  
Is the inspection result normal?

- YES >> Encoder operation is OK.
- NO >> Refer to [PWC-24, "DRIVER SIDE : Diagnosis Procedure"](#).

### DRIVER SIDE : Diagnosis Procedure

INFOID:000000008290491

#### 1.CHECK ENCODER SIGNAL

1. Turn ignition switch ON.
2. Check signal between power window main switch harness connector and ground using oscilloscope.

(+)		(-)	Signal (Reference value)
Power window main switch			
Connector	Terminal	Ground	Refer to following signal
D8	9		
	13		

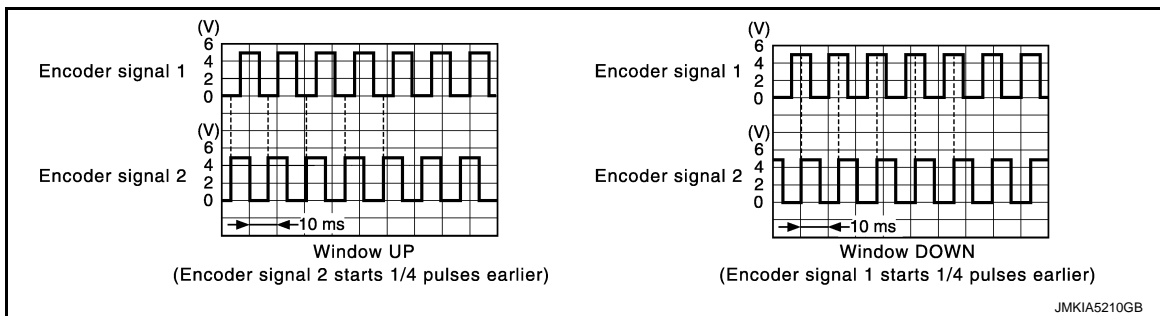

Is the inspection result normal?

- YES >> Replace power window main switch.
- NO >> GO TO 2.

#### 2.CHECK ENCODER SIGNAL CIRCUIT

1. Turn ignition switch OFF.
2. Disconnect power window main switch connector and front power window motor (driver side) connector.
3. Check continuity between power window main switch harness connector and front power window motor (driver side) harness connector.

Power window main switch		Front power window motor (driver side)		Continuity
Connector	Terminal	Connector	Terminal	
D8	9	D10	3	Existed
	13		5	

4. Check continuity between power window main switch harness connector and ground.



# ENCODER

< DTC/CIRCUIT DIAGNOSIS >

[FRONT & REAR WINDOW ANTI-PINCH]

Power window main switch		Ground	Continuity
Connector	Terminal		Not existed
D8	9		
	13		

Is the inspection result normal?

YES >> GO TO 3.

NO >> Repair or replace harness.

### 3. CHECK ENCODER POWER SUPPLY CIRCUIT 1

1. Connect power window main switch connector.
2. Turn ignition switch ON.
3. Check voltage between front power window motor (driver side) harness connector and ground.

(+)		(-)	Voltage (V) (Approx.)
Front power window motor (driver side)			
Connector	Terminal		
D10	4	Ground	12

Is the inspection result normal?

YES >> GO TO 5.

NO >> GO TO 4.

### 4. CHECK ENCODER POWER SUPPLY CIRCUIT 2

1. Turn ignition switch OFF.
2. Disconnect power window main switch connector.
3. Check continuity between power window main switch harness connector and front power window motor (driver side) harness connector.

Power window main switch		Front power window motor (driver side)		Continuity
Connector	Terminal	Connector	Terminal	
D8	15	D10	4	Existed

4. Check continuity between power window main switch harness connector and ground.

Power window main switch		Ground	Continuity
Connector	Terminal		Not existed
D8	15		

Is the inspection result normal?

YES >> Replace power window main switch.

NO >> Repair or replace harness.

### 5. CHECK GROUND CIRCUIT 1

1. Turn ignition switch OFF.
2. Disconnect power window main switch connector.
3. Check continuity between power window main switch harness connector and front power window motor (driver side) harness connector.

Power window main switch		Front power window motor (driver side)		Continuity
Connector	Terminal	Connector	Terminal	
D8	2	D10	6	Existed

Is the inspection result normal?

YES >> GO TO 6.

NO >> Repair or replace harness.

### 6. CHECK GROUND CIRCUIT 2

A  
B  
C  
D  
E  
F  
G  
H  
I  
J  
L  
M  
N  
O  
P

PWC

# ENCODER

< DTC/CIRCUIT DIAGNOSIS >

[FRONT & REAR WINDOW ANTI-PINCH]

1. Connect power window main switch connector.
2. Check continuity between power window main switch harness connector and ground.

Power window main switch		Ground	Continuity
Connector	Terminal		
D8	2		Existed

Is the inspection result normal?

- YES >> Replace front power window motor (driver side).  
 NO >> Replace power window main switch.

## PASSENGER SIDE

### PASSENGER SIDE : Description

INFOID:000000008290492

Detects condition of the front power window motor (passenger side) operation and transmits to front power window switch (passenger side) as the pulse signal.

### PASSENGER SIDE : Component Function Check

INFOID:000000008290493

#### 1.CHECK ENCODER OPERATION

Check passenger side door glass perform AUTO open/close operation normally by power window main switch or front power window switch (passenger side).

Is the inspection result normal?

- YES >> Encoder operation is OK.  
 NO >> Refer to [PWC-26, "PASSENGER SIDE : Diagnosis Procedure"](#).

### PASSENGER SIDE : Diagnosis Procedure

INFOID:000000008290494

#### 1.CHECK ENCODER SIGNAL

1. Turn ignition switch ON.
2. Check signal between front power window switch (passenger side) harness connector and ground using oscilloscope.

(+)		(-)	Signal (Reference value)
Front power window switch (passenger side)			
Connector	Terminal		
D38	12	Ground	Refer to following signal
	15		

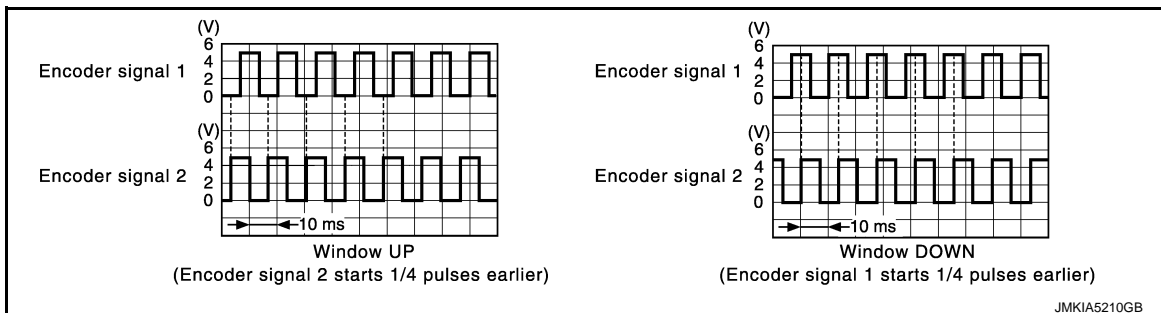

Is the inspection result normal?

- YES >> Replace front power window switch (passenger side).  
 NO >> GO TO 2.

#### 2.CHECK ENCODER SIGNAL CIRCUIT

1. Turn ignition switch OFF.
2. Disconnect front power window switch (passenger side) connector and front power window motor (passenger side) connector.

# ENCODER

## < DTC/CIRCUIT DIAGNOSIS >

## [FRONT & REAR WINDOW ANTI-PINCH]

3. Check continuity between front power window switch (passenger side) harness connector and front power window motor (passenger side) harness connector.

Front power window switch (passenger side)		Front power window motor (passenger side)		Continuity
Connector	Terminal	Connector	Terminal	
D38	12	D40	5	Existed
	15		3	

4. Check continuity between front power window switch (passenger side) harness connector and ground.

Front power window switch (passenger side)		Ground	Continuity
Connector	Terminal		
D38	12		Not existed
	15		

Is the inspection result normal?

YES >> GO TO 3.

NO >> Repair or replace harness.

### 3.CHECK ENCODER POWER SUPPLY CIRCUIT 1

1. Connect front power window switch (passenger side) connector.
2. Turn ignition switch ON.
3. Check voltage between front power window motor (passenger side) harness connector and ground.

(+)		(-)	Voltage (V) (Approx.)
Front power window motor (passenger side)			
Connector	Terminal	Ground	12
D40	4		

Is the inspection result normal?

YES >> GO TO 5.

NO >> GO TO 4.

### 4.CHECK ENCODER POWER SUPPLY CIRCUIT 2

1. Turn ignition switch OFF.
2. Disconnect front power window switch (passenger side) connector.
3. Check continuity between front power window switch (passenger side) harness connector and front power window motor (passenger side) harness connector.

Front power window switch (passenger side)		Front power window motor (passenger side)		Continuity
Connector	Terminal	Connector	Terminal	
D38	4	D40	4	Existed

4. Check continuity between front power window switch (passenger side) harness connector and ground.

Front power window switch (passenger side)		Ground	Continuity
Connector	Terminal		
D38	4		Not existed

Is the inspection result normal?

YES >> Replace front power window switch (passenger side).

NO >> Repair or replace harness.

### 5.CHECK GROUND CIRCUIT 1

1. Turn ignition switch OFF.
2. Disconnect front power window switch (passenger side) connector.
3. Check continuity between front power window switch (passenger side) harness connector and front power window motor (passenger side) harness connector.

PWC

# ENCODER

< DTC/CIRCUIT DIAGNOSIS >

[FRONT & REAR WINDOW ANTI-PINCH]

Front power window switch (passenger side)		Front power window motor (passenger side)		Continuity
Connector	Terminal	Connector	Terminal	
D38	3	D40	6	Existed

Is the inspection result normal?

YES >> GO TO 6.

NO >> Repair or replace harness.

## 6.CHECK GROUND CIRCUIT 2

1. Connect front power window switch (passenger side) connector.
2. Check continuity between front power window switch (passenger side) harness connector and ground.

Front power window switch (passenger side)		Ground	Continuity
Connector	Terminal		
D38	3		Existed

Is the inspection result normal?

YES >> Replace front power window motor (passenger side).

NO >> Replace front power window switch (passenger side).

## REAR LH

### REAR LH : Description

INFOID:000000008290495

Detects condition of the rear power window motor LH operation and transmits to rear power window switch LH as the pulse signal.

### REAR LH : Component Function Check

INFOID:000000008290496

## 1.CHECK ENCODER OPERATION

Check rear door LH glass perform AUTO open/close operation normally by power window main switch or rear power window switch LH.

Is the inspection result normal?

YES >> Encoder operation is OK.

NO >> Refer to [PWC-28, "REAR LH : Diagnosis Procedure"](#).

### REAR LH : Diagnosis Procedure

INFOID:000000008290497

## 1.CHECK ENCODER SIGNAL

1. Turn ignition switch ON.
2. Check signal between rear power window switch LH harness connector and ground using oscilloscope.

(+) Rear power window switch LH		(-)	Signal (Reference value)
Connector	Terminal		
D57	12	Ground	Refer to following signal
	15		

# ENCODER

< DTC/CIRCUIT DIAGNOSIS >

[FRONT & REAR WINDOW ANTI-PINCH]

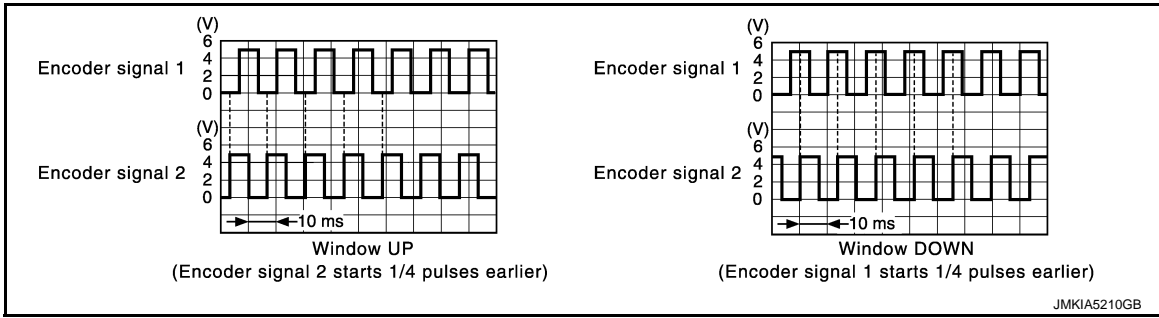

Is the inspection result normal?

- YES >> Replace rear power window switch LH.
- NO >> GO TO 2.

## 2.CHECK ENCODER SIGNAL CIRCUIT

1. Turn ignition switch OFF.
2. Disconnect rear power window switch LH connector and rear power window motor LH connector.
3. Check continuity between rear power window switch LH harness connector and rear power window motor LH harness connector.

Rear power window switch LH		Rear power window motor LH		Continuity
Connector	Terminal	Connector	Terminal	
D57	12	D52	5	Existed
	15		6	

4. Check continuity rear power window switch LH harness connector and ground.

Rear power window switch LH		Ground	Continuity
Connector	Terminal		
D57	12		Not existed
	15		

Is the inspection result normal?

- YES >> GO TO 3.
- NO >> Repair or replace harness.

## 3.CHECK ENCODER POWER SUPPLY CIRCUIT 1

1. Connect rear power window switch LH connector.
2. Turn ignition switch ON.
3. Check voltage between rear power window motor LH harness connector and ground.

(+)		(-)	Voltage (V) (Approx.)
Rear power window motor LH			
Connector	Terminal		
D52	2	Ground	12

Is the inspection result normal?

- YES >> GO TO 5.
- NO >> GO TO 4.

## 4.CHECK ENCODER POWER SUPPLY CIRCUIT 2

1. Turn ignition switch OFF.
2. Disconnect rear power window switch LH connector.
3. Check continuity between rear power window switch LH harness connector and rear power window motor LH harness connector.

# ENCODER

< DTC/CIRCUIT DIAGNOSIS >

[FRONT & REAR WINDOW ANTI-PINCH]

Rear power window switch LH		Rear power window motor LH		Continuity
Connector	Terminal	Connector	Terminal	
D57	4	D52	2	Existed

4. Check continuity between rear power window switch LH harness connector and ground.

Rear power window switch LH		Ground	Continuity
Connector	Terminal		
D57	4		Not existed

Is the inspection result normal?

YES >> Replace rear power window switch LH.

NO >> Repair or replace harness.

## 5.CHECK GROUND CIRCUIT 1

1. Turn ignition switch OFF.
2. Disconnect rear power window switch LH harness connector.
3. Check continuity between rear power window switch LH harness connector and rear power window motor LH harness connector.

Rear power window switch LH		Rear power window motor LH		Continuity
Connector	Terminal	Connector	Terminal	
D57	3	D52	4	Existed

Is the inspection result normal?

YES >> GO TO 6.

NO >> Repair or replace harness.

## 6.CHECK GROUND CIRCUIT 2

1. Connect rear power window switch LH harness connector.
2. Check continuity between rear power window switch LH harness connector and ground.

Rear power window switch LH		Ground	Continuity
Connector	Terminal		
D57	3		Existed

Is the inspection result normal?

YES >> Replace rear power window motor LH.

NO >> Replace rear power window switch LH.

## REAR RH

### REAR RH : Description

INFOID:000000008290498

Detects condition of the rear power window motor RH operation and transmits to rear power window switch RH as the pulse signal.

### REAR RH : Component Function Check

INFOID:000000008290499

## 1.CHECK ENCODER OPERATION

Check rear door RH glass perform AUTO open/close operation normally by power window main switch or rear power window switch RH.

Is the inspection result normal?

YES >> Encoder operation is OK.

NO >> Refer to [PWC-31, "REAR RH : Diagnosis Procedure"](#).

# ENCODER

< DTC/CIRCUIT DIAGNOSIS >

[FRONT & REAR WINDOW ANTI-PINCH]

## REAR RH : Diagnosis Procedure

INFOID:00000000290500

### 1.CHECK ENCODER SIGNAL

1. Turn ignition switch ON.
2. Check signal between rear power window switch RH harness connector and ground using oscilloscope.

(+)		(-)	Signal (Reference value)
Rear power window switch RH			
Connector	Terminal	Ground	Refer to following signal
D77	12		
	15		

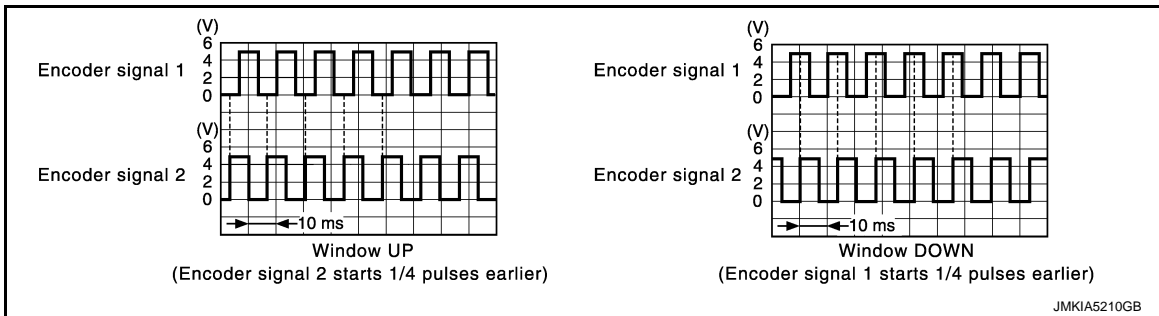

Is the inspection result normal?

- YES >> Replace rear power window switch RH.  
 NO >> GO TO 2.

### 2.CHECK ENCODER SIGNAL CIRCUIT

1. Turn ignition switch OFF.
2. Disconnect rear power window switch RH connector and rear power window motor RH connector.
3. Check continuity between rear power window switch RH harness connector and rear power window motor RH harness connector.

Rear power window switch RH		Rear power window motor RH		Continuity
Connector	Terminal	Connector	Terminal	
D77	12	D72	5	Existed
	15		6	

4. Check continuity rear power window switch RH harness connector and ground.

Rear power window switch RH		Ground	Continuity
Connector	Terminal		
D77	12		Not existed
	15		

Is the inspection result normal?

- YES >> GO TO 3.  
 NO >> Repair or replace harness.

### 3.CHECK ENCODER POWER SUPPLY CIRCUIT 1

1. Connect rear power window switch RH connector.
2. Turn ignition switch ON.
3. Check voltage between rear power window motor RH harness connector and ground.

# ENCODER

< DTC/CIRCUIT DIAGNOSIS >

[FRONT & REAR WINDOW ANTI-PINCH]

(+)		(-)	Voltage (V) (Approx.)
Rear power window motor RH			
Connector	Terminal	Ground	12
D72	2		

Is the inspection result normal?

YES >> GO TO 5.

NO >> GO TO 4.

## 4.CHECK ENCODER POWER SUPPLY CIRCUIT 2

1. Turn ignition switch OFF.
2. Disconnect rear power window switch RH connector.
3. Check continuity between rear power window switch RH harness connector and rear power window motor RH harness connector.

Rear power window switch RH		Rear power window motor RH		Continuity
Connector	Terminal	Connector	Terminal	
D77	4	D72	2	Existed

4. Check continuity between rear power window switch RH harness connector and ground.

Rear power window switch RH		Ground	Continuity
Connector	Terminal		
D77	4		Not existed

Is the inspection result normal?

YES >> Replace rear power window switch RH.

NO >> Repair or replace harness.

## 5.CHECK GROUND CIRCUIT 1

1. Turn ignition switch OFF.
2. Disconnect rear power window switch RH harness connector.
3. Check continuity between rear power window switch RH harness connector and rear power window motor RH harness connector.

Rear power window switch RH		Rear power window motor RH		Continuity
Connector	Terminal	Connector	Terminal	
D77	3	D72	4	Existed

Is the inspection result normal?

YES >> GO TO 6.

NO >> Repair or replace harness.

## 6.CHECK GROUND CIRCUIT 2

1. Connect rear power window switch RH harness connector.
2. Check continuity between rear power window switch RH harness connector and ground.

Rear power window switch RH		Ground	Continuity
Connector	Terminal		
D77	3		Existed

Is the inspection result normal?

YES >> Replace rear power window motor RH.

NO >> Replace rear power window switch RH.



# DOOR KEY CYLINDER SWITCH

< DTC/CIRCUIT DIAGNOSIS >

[FRONT & REAR WINDOW ANTI-PINCH]

## DOOR KEY CYLINDER SWITCH

### Description

INFOID:000000008290501

Power window main switch detects condition of the door key cylinder switch and transmits to BCM as the LOCK or UNLOCK signals.

### Component Function Check

INFOID:000000008290502

### 1. CHECK DOOR KEY CYLINDER SWITCH INPUT SIGNAL

Check ("KEY CYL LK-SW", "KEY CYL UN-SW") in "DATA MONITOR" mode for "POWER DOOR LOCK SYSTEM" with CONSULT. Refer to [DLK-51, "DOOR LOCK : CONSULT Function \(BCM - DOOR LOCK\)"](#).

Monitor item	Condition
KEY CYL LK-SW	Lock : ON
	Neutral / Unlock : OFF
KEY CYL UN-SW	Unlock : ON
	Neutral / Lock : OFF

Is the inspection result normal?

- YES >> Door key cylinder switch is OK.
- NO >> Refer to [PWC-33, "Diagnosis Procedure"](#).

### Diagnosis Procedure

INFOID:000000008290503

### 1. CHECK DOOR KEY CYLINDER SWITCH SIGNAL

1. Turn ignition switch OFF.
2. Disconnect front door lock assembly (driver side) (key cylinder switch) connect.
3. Turn ignition switch ON.
4. Check voltage between front door lock assembly (driver side) (key cylinder switch) harness connector and ground.

(+)		(-)	Voltage (V) (Approx.)
Front door lock assembly (driver side) (key cylinder switch)			
Connector	Terminal	Ground	5
D15	5		
	6		

Is the inspection result normal?

- YES >> GO TO 3.
- NO >> GO TO 2.

### 2. CHECK DOOR KEY CYLINDER SWITCH CIRCUIT

1. Turn ignition switch OFF.
2. Disconnect power window main switch connector.
3. Check continuity between power window main switch harness connector and front door lock assembly (driver side) (key cylinder switch) harness connector.

Power window main switch		Front door lock assembly (driver side) (key cylinder switch)		Continuity
Connector	Terminal	Connector	Terminal	
D8	4	D15	6	Existed
	6		5	

4. Check continuity between power window main switch harness connector and ground.

A  
B  
C  
D  
E  
F  
G  
H  
I  
J  
L  
M  
N  
O  
P

PWC

# DOOR KEY CYLINDER SWITCH

< DTC/CIRCUIT DIAGNOSIS >

[FRONT & REAR WINDOW ANTI-PINCH]

Power window main switch		Ground	Continuity
Connector	Terminal		
D8	4		
	6		Not existed

Is the inspection result normal?

YES >> Replace power window main switch.

NO >> Repair or replace harness.

## 3.CHECK DOOR KEY CYLINDER SWITCH GROUND CIRCUIT

Check continuity between front door lock assembly (driver side) (key cylinder switch) harness connector and ground.

Front door lock assembly (driver side) (key cylinder switch)		Ground	Continuity
Connector	Terminal		
D15	4		

Is the inspection result normal?

YES >> GO TO 4.

NO >> Repair or replace harness.

## 4.CHECK DOOR KEY CYLINDER SWITCH

Check front door lock assembly (driver side) (key cylinder switch).

Refer to [PWC-34. "Component Inspection"](#).

Is the inspection result normal?

YES >> GO TO 5.

NO >> Replace front door lock assembly (driver side) (key cylinder switch).

## 5.CHECK INTERMITTENT INCIDENT

Refer to [GI-43. "Intermittent Incident"](#).

>> INSPECTION END

## Component Inspection

INFOID:000000008290504

### COMPONENT INSPECTION

#### 1.CHECK DOOR KEY CYLINDER SWITCH

1. Turn ignition switch OFF.
2. Disconnect front door lock assembly (driver side) (key cylinder switch) connector.
3. Check front door lock assembly (driver side) (key cylinder switch) terminals under the following conditions.

Front door lock assembly (driver side) (key cylinder switch)		Key position	Continuity
Terminal			
5	4	Unlock	Existed
		Neutral / Lock	Not existed
6		Lock	Existed
		Neutral / Unlock	Not existed

Is the inspection result normal?

YES >> INSPECTION END

NO >> Replace front door lock assembly (driver side) (key cylinder switch).

# POWER WINDOW SERIAL LINK

[FRONT & REAR WINDOW ANTI-PINCH]

< DTC/CIRCUIT DIAGNOSIS >

## POWER WINDOW SERIAL LINK

### POWER WINDOW MAIN SWITCH

#### POWER WINDOW MAIN SWITCH : Description

INFOID:000000008290505

Power window main switch, front power window switch (passenger side), rear power window switch and BCM transmit and receive the signal by power window serial link.

The signal mentioned below is transmitted from BCM to power window main switch, front power window switch (passenger side) and rear power window switch.

- Keyless power window down signal

The signals mentioned below are transmitted from power window main switch to front power window switch (passenger side) and rear power window switch.

- Front passenger side door window and rear door window operation signal
- Power window control by key cylinder switch signal
- Power window lock switch signal
- Retained power operation signal

#### POWER WINDOW MAIN SWITCH : Component Function Check

INFOID:000000008290506

##### 1.CHECK POWER WINDOW SWITCH OUTPUT SIGNAL

###### With CONSULT

Check ("CDL LOCK SW ", "CDL UNLOCK SW") in "DATA MONITOR" mode for "POWER DOOR LOCK SYSTEM" with CONSULT. Refer to [DLK-51, "DOOR LOCK : CONSULT Function \(BCM - DOOR LOCK\)"](#).

Monitor item	Condition
CDL LOCK SW	LOCK : ON
	UNLOCK : OFF
CDL UNLOCK SW	LOCK : OFF
	UNLOCK : ON

Is the inspection result normal?

YES >> Power window serial link is OK.

NO >> Refer to [PWC-35, "POWER WINDOW MAIN SWITCH : Diagnosis Procedure"](#).

PWC

#### POWER WINDOW MAIN SWITCH : Diagnosis Procedure

INFOID:000000008290507

##### 1.CHECK POWER WINDOW SWITCH OUTPUT SIGNAL

1. Turn ignition switch ON.
2. Check signal between power window main switch harness connector and ground.

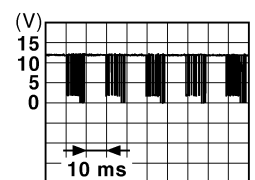
(+)		(-)	Signal (Reference value)
Connector	Terminal		
D8	14	Ground	 <p style="text-align: right; font-size: small;">JPMIA0013GB</p>

Is the inspection result normal?

YES >> GO TO 4.

NO >> GO TO 2.

##### 2.CHECK POWER WINDOW SERIAL LINK SIGNAL

# POWER WINDOW SERIAL LINK

[FRONT & REAR WINDOW ANTI-PINCH]

## < DTC/CIRCUIT DIAGNOSIS >

1. Turn ignition switch OFF.
2. Disconnect power window main switch connector.
3. Turn ignition switch ON.
4. Check voltage between power window main switch harness connector and ground.

(+)		(-)	Voltage (V) (Approx.)
Power window main switch			
Connector	Terminal	Ground	12
D8	14		

Is the measurement value within the specification?

YES >> Replace power window main switch.

NO >> GO TO 3.

## 3. CHECK POWER WINDOW SERIAL LINK CIRCUIT

1. Turn ignition switch OFF.
2. Disconnect BCM connector.
3. Check continuity between BCM connector and power window main switch connector.

BCM		Power window main switch		Continuity
Connector	Terminal	Connector	Terminal	
M123	132	D8	14	Existed

4. Check continuity between BCM connector and ground.

BCM		Ground	Continuity
Connector	Terminal		
M123	132		Not existed

Is the inspection result normal?

YES >> Replace BCM. Refer to [BCS-81, "Removal and Installation"](#).

NO >> Repair or replace harness.

## 4. CHECK INTERMITTENT INCIDENT

Refer to [GI-43, "Intermittent Incident"](#).

>> INSPECTION END

## FRONT POWER WINDOW SWITCH (PASSENGER SIDE)

### FRONT POWER WINDOW SWITCH (PASSENGER SIDE) : Description

INFOID:000000008290508

Power window main switch, front power window switch (passenger side), rear power window switch and BCM transmit and receive the signal by power window serial link.

The signal mentioned below is transmitted from BCM to power window main switch, front power window switch (passenger side) and rear power window switch.

- Keyless power window down signal

The signal mentioned below is transmitted from power window main switch to front power window switch (passenger side) and rear power window switch.

- Front passenger side door window and rear door window operation signal
- Power window control by key cylinder switch signal
- Power window lock switch signal
- Retained power operation signal

### FRONT POWER WINDOW SWITCH (PASSENGER SIDE) : Component Function

#### Check

INFOID:000000008290509

## 1. CHECK POWER WINDOW SWITCH OUTPUT SIGNAL

# POWER WINDOW SERIAL LINK

[FRONT & REAR WINDOW ANTI-PINCH]

< DTC/CIRCUIT DIAGNOSIS >

## With CONSULT

Check ("CDL LOCK SW", "CDL UNLOCK SW") in "DATA MONITOR" mode for "POWER DOOR LOCK SYSTEM" with CONSULT. Refer to [DLK-51, "DOOR LOCK : CONSULT Function \(BCM - DOOR LOCK\)"](#).

Monitor item	Condition
CDL LOCK SW	LOCK : ON
	UNLOCK : OFF
CDL UNLOCK SW	LOCK : OFF
	UNLOCK : ON

Is the inspection result normal?

YES >> Power window serial link is OK.

NO >> Refer to [PWC-37, "FRONT POWER WINDOW SWITCH \(PASSENGER SIDE\) : Diagnosis Procedure"](#).

## FRONT POWER WINDOW SWITCH (PASSENGER SIDE) : Diagnosis Procedure

INFOID:000000008290510

### 1. CHECK POWER WINDOW SWITCH OUTPUT SIGNAL

1. Turn ignition switch ON.
2. Check signal between front power window switch (passenger side) harness connector and ground.

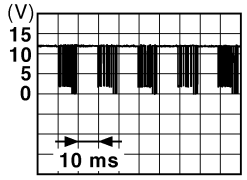
(+)		(-)	Signal (Reference value)
Connector	Terminal		
D38	16	Ground	 <p>JPMA0013GB</p>

Is the inspection result normal?

YES >> Replace front power window switch (passenger side).

NO >> GO TO 2.

### 2. CHECK POWER WINDOW SERIAL LINK CIRCUIT

1. Turn ignition switch OFF.
2. Disconnect power window main switch connector and front power window switch (passenger side) connector.
3. Check continuity between power window main switch harness connector and front power window switch (passenger side) harness connector.

Power window main switch		Front power window switch (passenger side)		Continuity
Connector	Terminal	Connector	Terminal	
D8	14	D38	16	Existed

4. Check continuity between power window main switch connector and ground.

Power window main switch		Ground	Continuity
Connector	Terminal		
D8	14		Not existed

Is the inspection result normal?

YES >> Replace power window main switch.

# POWER WINDOW SERIAL LINK

[FRONT & REAR WINDOW ANTI-PINCH]

< DTC/CIRCUIT DIAGNOSIS >

NO >> Repair or replace harness.

## REAR LH

### REAR LH : Description

INFOID:000000008290511

Power window main switch, front power window switch (passenger side), rear power window switch and BCM transmit and receive the signal by power window serial link.

The signal mentioned below is transmitted from BCM to power window main switch, front power window switch (passenger side) and rear power window switch.

- Keyless power window down signal

The signal mentioned below is transmitted from power window main switch to front power window switch (passenger side) and rear power window switch.

- Front passenger side door window and rear door window operation signal
- Power window control by key cylinder switch signal
- Power window lock switch signal
- Retained power operation signal

### REAR LH : Component Function Check

INFOID:000000008290512

#### 1.CHECK POWER WINDOW SWITCH OUTPUT SIGNAL

##### Ⓟ With CONSULT

Check ("CDL LOCK SW ", "CDL UNLOCK SW") in "DATA MONITOR" mode for "POWER DOOR LOCK SYSTEM" with CONSULT. Refer to [DLK-51, "DOOR LOCK : CONSULT Function \(BCM - DOOR LOCK\)"](#).

Monitor item	Condition
CDL LOCK SW	LOCK : ON
	UNLOCK : OFF
CDL UNLOCK SW	LOCK : OFF
	UNLOCK : ON

Is the inspection result normal?

YES >> Power window serial link is OK.

NO >> Refer to [PWC-38, "REAR LH : Diagnosis Procedure"](#).

### REAR LH : Diagnosis Procedure

INFOID:000000008290513

#### 1.CHECK POWER WINDOW SWITCH OUTPUT SIGNAL

1. Turn ignition switch ON.
2. Check signal between rear power window switch LH harness connector and ground.

(+)		(-)	Signal (Reference value)
Connector	Terminal		
D57	16	Ground	 JPMA0013GB

Is the inspection result normal?

YES >> Replace rear power window switch LH.

NO >> GO TO 2.

#### 2.CHECK POWER WINDOW SERIAL LINK CIRCUIT

# POWER WINDOW SERIAL LINK

[FRONT & REAR WINDOW ANTI-PINCH]

## < DTC/CIRCUIT DIAGNOSIS >

1. Turn ignition switch OFF.
2. Disconnect power window main switch connector and rear power window switch LH connector.
3. Check continuity between power window main switch harness connector and rear power window switch LH harness connector.

Power window main switch		Rear power window switch LH		Continuity
Connector	Terminal	Connector	Terminal	
D8	14	D57	16	Existed

4. Check continuity between power window main switch harness connector and ground.

Power window main switch		Ground	Continuity
Connector	Terminal		
D8	14		Not existed

Is the inspection result normal?

- YES >> Replace power window main switch.  
 NO >> Repair or replace harness.

## REAR RH

### REAR RH : Description

INFOID:000000008290514

Power window main switch, front power window switch (passenger side), rear power window switch and BCM transmit and receive the signal by power window serial link.

The signal mentioned below is transmitted from BCM to power window main switch, front power window switch (passenger side) and rear power window switch.

- Keyless power window down signal

The signal mentioned below is transmitted from power window main switch to front power window switch (passenger side) and rear power window switch.

- Front passenger side door window and rear door window operation signal
- Power window control by key cylinder switch signal
- Power window lock switch signal
- Retained power operation signal

### REAR RH : Component Function Check

INFOID:000000008290515

#### 1. CHECK POWER WINDOW SWITCH OUTPUT SIGNAL

##### With CONSULT

Check ("CDL LOCK SW ", "CDL UNLOCK SW") in "DATA MONITOR" mode for "POWER DOOR LOCK SYSTEM" with CONSULT. Refer to [DLK-51. "DOOR LOCK : CONSULT Function \(BCM - DOOR LOCK\)".](#)

Monitor item	Condition
CDL LOCK SW	LOCK : ON
	UNLOCK : OFF
CDL UNLOCK SW	LOCK : OFF
	UNLOCK : ON

Is the inspection result normal?

- YES >> Power window serial link is OK.  
 NO >> Refer to [PWC-39. "REAR RH : Diagnosis Procedure".](#)

### REAR RH : Diagnosis Procedure

INFOID:000000008290516

#### 1. CHECK POWER WINDOW SWITCH OUTPUT SIGNAL

1. Turn ignition switch ON.
2. Check signal between rear power window switch RH harness connector and ground.

# POWER WINDOW SERIAL LINK

< DTC/CIRCUIT DIAGNOSIS >

[FRONT & REAR WINDOW ANTI-PINCH]

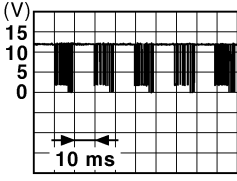
(+)		(-)	Signal (Reference value)
Rear power window switch RH			
Connector	Terminal		
D77	16	Ground	 <p style="text-align: right; font-size: small;">JPMIA0013GB</p>

Is the inspection result normal?

- YES >> Replace rear power window switch RH.  
 NO >> GO TO 2.

## 2. CHECK POWER WINDOW SERIAL LINK CIRCUIT

1. Turn ignition switch OFF.
2. Disconnect power window main switch connector and rear power window switch RH connector.
3. Check continuity between power window main switch harness connector and rear power window switch RH harness connector.

Power window main switch		Rear power window switch RH		Continuity
Connector	Terminal	Connector	Terminal	
D8	14	D77	16	Existed

4. Check continuity between power window main switch harness connector and ground.

Power window main switch		Ground	Continuity
Connector	Terminal		
D8	14		Not existed

Is the inspection result normal?

- YES >> Replace power window main switch.  
 NO >> Repair or replace harness.



# BCM (BODY CONTROL MODULE)

< ECU DIAGNOSIS INFORMATION >

[FRONT & REAR WINDOW ANTI-PINCH]

## ECU DIAGNOSIS INFORMATION

### BCM (BODY CONTROL MODULE)

#### Reference Value

INFOID:000000008781441

#### VALUES ON THE DIAGNOSIS TOOL

##### NOTE:

The following table includes information (items) inapplicable to this vehicle. For information (items) applicable to this vehicle, refer to CONSULT display items.

##### CONSULT MONITOR ITEM

Monitor Item	Condition	Value/Status
FR WIPER HI	Other than front wiper switch HI	Off
	Front wiper switch HI	On
FR WIPER LOW	Other than front wiper switch LO	Off
	Front wiper switch LO	On
FR WASHER SW	Front washer switch OFF	Off
	Front washer switch ON	On
FR WIPER INT	Other than front wiper switch INT/AUTO	Off
	Front wiper switch INT/AUTO	On
FR WIPER STOP	Front wiper is not in STOP position	Off
	Front wiper is in STOP position	On
INT VOLUME	Wiper volume dial is in a dial position 1 - 7	Wiper volume dial position
TURN SIGNAL R	Other than turn signal switch RH	Off
	Turn signal switch RH	On
TURN SIGNAL L	Other than turn signal switch LH	Off
	Turn signal switch LH	On
TAIL LAMP SW	Other than lighting switch 1ST and 2ND	Off
	Lighting switch 1ST or 2ND	On
HI BEAM SW	Other than lighting switch HI	Off
	Lighting switch HI	On
HEAD LAMP SW 1	Other than lighting switch 2ND	Off
	Lighting switch 2ND	On
HEAD LAMP SW 2	Other than lighting switch 2ND	Off
	Lighting switch 2ND	On
PASSING SW	Other than lighting switch PASS	Off
	Lighting switch PASS	On
AUTO LIGHT SW	Other than lighting switch AUTO	Off
	Lighting switch AUTO	On
FR FOG SW	Front fog lamp switch OFF	Off
	Front fog lamp switch ON	On
RR FOG SW	<b>NOTE:</b> The item is indicated, but not monitored.	Off
DOOR SW-DR	Driver door closed	Off
	Driver door opened	On
DOOR SW-AS	Passenger door closed	Off
	Passenger door opened	On

## BCM (BODY CONTROL MODULE)

< ECU DIAGNOSIS INFORMATION >

[FRONT & REAR WINDOW ANTI-PINCH]

Monitor Item	Condition	Value/Status
DOOR SW-RR	Rear RH door closed	Off
	Rear LH door opened	On
DOOR SW-RL	Rear LH door closed	Off
	Rear LH door opened	On
DOOR SW-BK	<b>NOTE:</b> The item is indicated, but not monitored.	Off
CDL LOCK SW	Other than power door lock switch LOCK	Off
	Power door lock switch LOCK	On
CDL UNLOCK SW	Other than power door lock switch UNLOCK	Off
	Power door lock switch UNLOCK	On
KEY CYL LK-SW	Other than driver door key cylinder LOCK	Off
	Driver door key cylinder LOCK	On
KEY CYL UN-SW	Other than driver door key cylinder UNLOCK	Off
	Driver door key cylinder LOCK	On
KEY CYL SW-TR	<b>NOTE:</b> The item is indicated, but not monitored.	Off
HAZARD SW	Hazard switch is OFF	Off
	Hazard switch is ON	On
REAR DEF SW	<b>NOTE:</b> The item is indicated, but not monitored.	Off
TR CANCEL SW	Trunk lid opener cancel switch OFF	Off
	Trunk lid opener cancel switch ON	On
TR/BD OPEN SW	Trunk lid opener switch OFF	Off
	While the trunk lid opener switch is turned ON	On
TRNK/HAT MNTR	Trunk lid closed	Off
	Trunk lid opened	On
REVERSE SW	<b>NOTE:</b> The item is indicated, but not monitored.	Off
RKE-LOCK	LOCK button of the Intelligent Key is not pressed	Off
	LOCK button of the Intelligent Key is pressed	On
RKE-UNLOCK	UNLOCK button of the Intelligent Key is not pressed	Off
	UNLOCK button of the Intelligent Key is pressed	On
RKE-TR/BD	TRUNK OPEN button of the Intelligent Key is not pressed	Off
	TRUNK OPEN button of the Intelligent Key is pressed	On
RKE-PANIC	PANIC button of the Intelligent Key is not pressed	Off
	PANIC button of the Intelligent Key is pressed	On
RKE-P/W OPEN	UNLOCK button of the Intelligent Key is not pressed	Off
	UNLOCK button of the Intelligent Key is pressed and held	On
RKE-MODE CHG	LOCK/UNLOCK button of the Intelligent Key is not pressed and held simultaneously	Off
	LOCK/UNLOCK button of the Intelligent Key is pressed and held simultaneously	On
OPTICAL SENSOR	Bright outside of the vehicle	Close to 5 V
	Dark outside of the vehicle	Close to 0 V
REQ SW -DR	Driver door request switch is not pressed	Off
	Driver door request switch is pressed	On

# BCM (BODY CONTROL MODULE)

< ECU DIAGNOSIS INFORMATION >

[FRONT & REAR WINDOW ANTI-PINCH]

Monitor Item	Condition	Value/Status	
REQ SW -AS	Passenger door request switch is not pressed	Off	A
	Passenger door request switch is pressed	On	
REQ SW -RR	<b>NOTE:</b> The item is indicated, but not monitored.	Off	B
REQ SW -RL	<b>NOTE:</b> The item is indicated, but not monitored.	Off	C
REQ SW -BD/TR	Trunk lid opener request switch is not pressed	Off	
	Trunk lid opener request switch is pressed	On	
PUSH SW	Push-button ignition switch (push switch) is not pressed	Off	D
	Push-button ignition switch (push switch) is pressed	On	
IGN RLY2 -F/B	<b>NOTE:</b> The item is indicated, but not monitored.	Off	E
ACC RLY -F/B	<b>NOTE:</b> The item is indicated, but not monitored.	Off	
CLUCH SW	The clutch pedal is not depressed	Off	F
	The clutch pedal is depressed	On	
BRAKE SW 1	The brake pedal is depressed when No. 7 fuse is blown	Off	
	The brake pedal is not depressed when No. 7 fuse is blown, or No. 7 fuse is normal	On	G
BRAKE SW 2	The brake pedal is not depressed	Off	H
	The brake pedal is depressed	On	
DETE/CANCL SW	<ul style="list-style-type: none"> <li>• Selector lever in P position (Except M/T models)</li> <li>• The clutch pedal is depressed (M/T models)</li> </ul>	Off	I
	<ul style="list-style-type: none"> <li>• Selector lever in any position other than P (Except M/T models)</li> <li>• The clutch pedal is not depressed (M/T models)</li> </ul>	On	
SFT PN/N SW	Selector lever in any position other than P and N	Off	J
	Selector lever in P or N position	On	
S/L -LOCK	<b>NOTE:</b> The item is indicated, but not monitored.	Off	PWC
S/L -UNLOCK	<b>NOTE:</b> The item is indicated, but not monitored.	Off	
S/L RELAY-F/B	<b>NOTE:</b> The item is indicated, but not monitored.	Off	L
UNLK SEN -DR	Driver door is unlocked	Off	
	Driver door is locked	On	M
PUSH SW -IPDM	Push-button ignition switch (push-switch) is not pressed	Off	
	Push-button ignition switch (push-switch) is pressed	On	N
IGN RLY1 -F/B	Ignition switch in OFF or ACC position	Off	
	Ignition switch in ON position	On	
DETE SW -IPDM	Selector lever in any position other than P	Off	O
	Selector lever in P position	On	
SFT PN -IPDM	<ul style="list-style-type: none"> <li>• Selector lever in any position other than P and N (Except M/T models)</li> <li>• The clutch pedal is not depressed (M/T models)</li> </ul>	Off	P
	<ul style="list-style-type: none"> <li>• Selector lever in P or N position (Except M/T models)</li> <li>• The clutch pedal is depressed (M/T models)</li> </ul>	On	
SFT P -MET	Selector lever in any position other than P	Off	
	Selector lever in P position	On	

# BCM (BODY CONTROL MODULE)

< ECU DIAGNOSIS INFORMATION >

[FRONT & REAR WINDOW ANTI-PINCH]

Monitor Item	Condition	Value/Status
SFT N -MET	Selector lever in any position other than N	Off
	Selector lever in N position	On
ENGINE STATE	Engine stopped	Stop
	While the engine stalls	Stall
	At engine cranking	Crank
	Engine running	Run
S/L LOCK-IPDM	<b>NOTE:</b> The item is indicated, but not monitored.	Off
S/L UNLK-IPDM	<b>NOTE:</b> The item is indicated, but not monitored.	Off
S/L RELAY-REQ	<b>NOTE:</b> The item is indicated, but not monitored.	Off
VEH SPEED 1	While driving	Equivalent to speedometer reading
VEH SPEED 2	While driving	Equivalent to speedometer reading
DOOR STAT-DR	Driver door is locked	LOCK
	Wait with selective UNLOCK operation (60 seconds)	READY
	Driver door is unlocked	UNLOCK
DOOR STAT-AS	Passenger door is locked	LOCK
	Wait with selective UNLOCK operation (60 seconds)	READY
	Passenger door is unlocked	UNLOCK
ID OK FLAG	Driver side door is open after ignition switch is turned OFF (Shift position is in the P position)	Reset
	Ignition switch ON	Set
PRMT ENG STRT	The engine start is prohibited	Reset
	The engine start is permitted	Set
PRMT RKE STRT	<b>NOTE:</b> The item is indicated, but not monitored.	Reset
KEY SW -SLOT	The Intelligent Key is not inserted into key slot	Off
	The Intelligent Key is inserted into key slot	On
RKE OPE COUN1	During the operation of the Intelligent Key	Operation frequency of the Intelligent Key
RKE OPE COUN2	<b>NOTE:</b> The item is indicated, but not monitored.	—
CONFIRM ID ALL	The key ID that the key slot receives is not recognized by any key ID registered to BCM.	Yet
	The key ID that the key slot receives is recognized by any key ID registered to BCM.	Done
CONFIRM ID4	The key ID that the key slot receives is not recognized by the fourth key ID registered to BCM.	Yet
	The key ID that the key slot receives is recognized by the fourth key ID registered to BCM.	Done
CONFIRM ID3	The key ID that the key slot receives is not recognized by the third key ID registered to BCM.	Yet
	The key ID that the key slot receives is recognized by the third key ID registered to BCM.	Done

# BCM (BODY CONTROL MODULE)

< ECU DIAGNOSIS INFORMATION >

[FRONT & REAR WINDOW ANTI-PINCH]

Monitor Item	Condition	Value/Status
CONFIRM ID2	The key ID that the key slot receives is not recognized by the second key ID registered to BCM.	Yet
	The key ID that the key slot receives is recognized by the second key ID registered to BCM.	Done
CONFIRM ID1	The key ID that the key slot receives is not recognized by the first key ID registered to BCM.	Yet
	The key ID that the key slot receives is recognized by the first key ID registered to BCM.	Done
TP 4	The ID of fourth Intelligent Key is not registered to BCM	Yet
	The ID of fourth Intelligent Key is registered to BCM	Done
TP 3	The ID of third Intelligent Key is not registered to BCM	Yet
	The ID of third Intelligent Key is registered to BCM	Done
TP 2	The ID of second Intelligent Key is not registered to BCM	Yet
	The ID of second Intelligent Key is registered to BCM	Done
TP 1	The ID of first Intelligent Key is not registered to BCM	Yet
	The ID of first Intelligent Key is registered to BCM	Done
AIR PRESS FL	Ignition switch ON (Only when the signal from the transmitter is received)	Air pressure of front LH tire
AIR PRESS FR	Ignition switch ON (Only when the signal from the transmitter is received)	Air pressure of front RH tire
AIR PRESS RR	Ignition switch ON (Only when the signal from the transmitter is received)	Air pressure of rear RH tire
AIR PRESS RL	Ignition switch ON (Only when the signal from the transmitter is received)	Air pressure of rear LH tire
ID REGST FL1	ID of front LH tire transmitter is registered	Done
	ID of front LH tire transmitter is not registered	Yet
ID REGST FR1	ID of front RH tire transmitter is registered	Done
	ID of front RH tire transmitter is not registered	Yet
ID REGST RR1	ID of rear RH tire transmitter is registered	Done
	ID of rear RH tire transmitter is not registered	Yet
ID REGST RL1	ID of rear LH tire transmitter is registered	Done
	ID of rear LH tire transmitter is not registered	Yet
WARNING LAMP	Tire pressure indicator OFF	Off
	Tire pressure indicator ON	On
BUZZER	Tire pressure warning alarm is not sounding	Off
	Tire pressure warning alarm is sounding	On

A  
B  
C  
D  
E  
F  
G  
H  
I  
J  
PWC  
L  
M  
N  
O  
P

# BCM (BODY CONTROL MODULE)

< ECU DIAGNOSIS INFORMATION >

[FRONT & REAR WINDOW ANTI-PINCH]

## TERMINAL LAYOUT

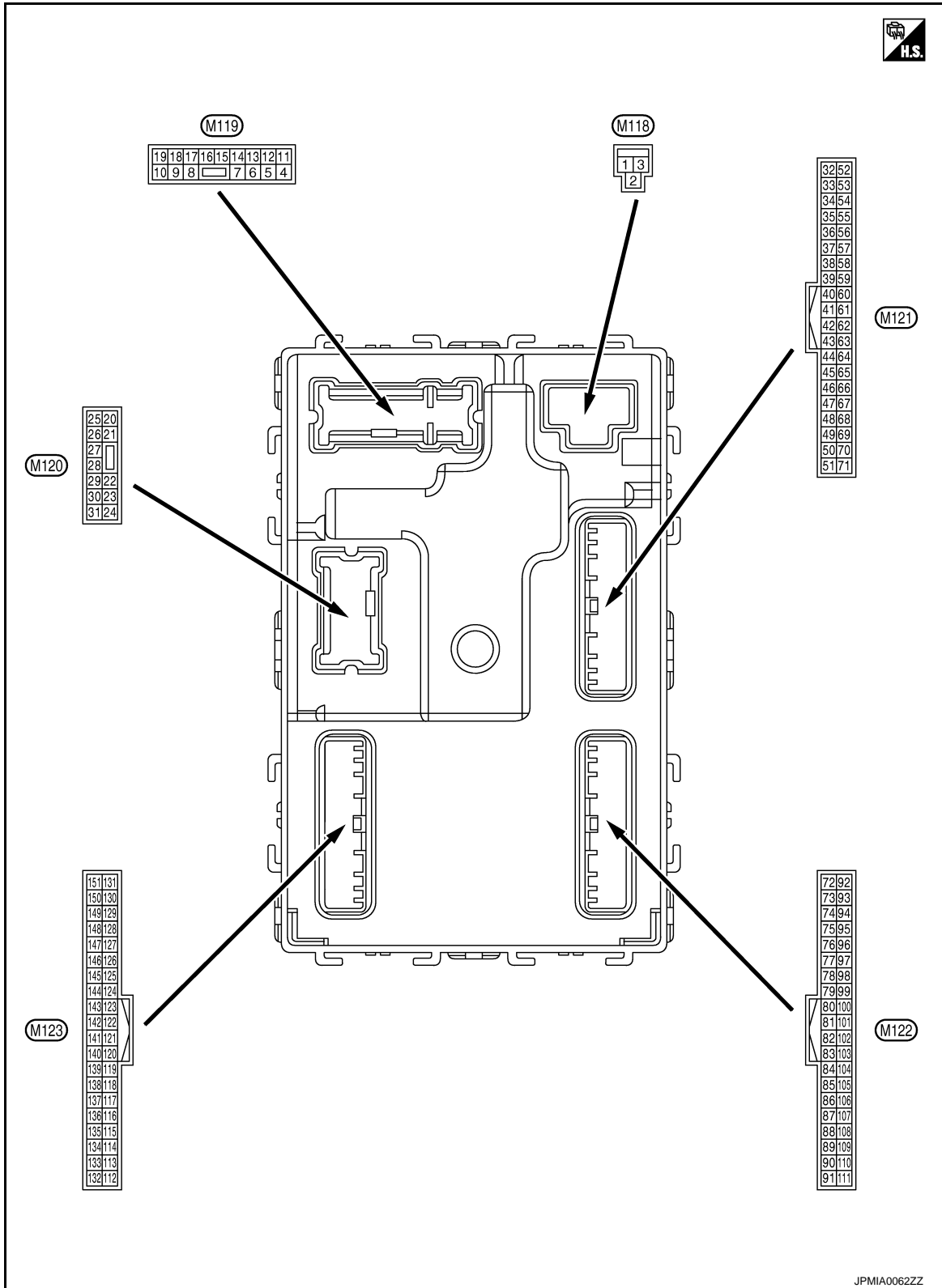

## PHYSICAL VALUES

# BCM (BODY CONTROL MODULE)

< ECU DIAGNOSIS INFORMATION >

[FRONT & REAR WINDOW ANTI-PINCH]

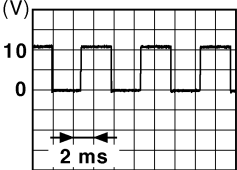
Terminal No. (Wire color)		Description		Condition		Value (Approx.)
		Signal name	Input/ Output			
+	-					
1 (W)	Ground	Battery power supply	Input	Ignition switch OFF		Battery voltage
2 (Y)	Ground	P/W power supply (BAT)	Output	Ignition switch OFF		12 V
3 (BG)	Ground	P/W power supply (RAP)	Output	Ignition switch ON		12 V
4 (LG)	Ground	Interior room lamp power supply	Output	Interior room lamp battery saver is activated. (Cuts the interior room lamp power supply)		0 V
				Interior room lamp battery saver is not activated. (Outputs the interior room lamp power supply)		12 V
5 (P)	Ground	Passenger door UN- LOCK	Output	Passenger door	UNLOCK (Actuator is activated)	12 V
					Other than UNLOCK) Ac- tuator is not activated	0 V
7 (SB)	Ground	Step lamp	Output	Step lamp	ON	0 V
					OFF	12 V
8 (V)	Ground	All doors, fuel lid LOCK	Output	All doors, fuel lid	LOCK (Actuator is activated)	12 V
					Other than LOCK (Actuator is not activated)	0 V
9 (G)	Ground	Driver door, fuel lid UNLOCK	Output	Driver door, fuel lid	UNLOCK (Actuator is activated)	12 V
					Other than UNLOCK (Actuator is not activated)	0 V
10 (P)	Ground	Rear RH door and rear LH door UN- LOCK	Output	Rear RH door and rear LH door	UNLOCK (Actuator is activated)	12 V
					Other than UNLOCK (Actuator is not activated)	0 V
11 (R)	Ground	Battery power supply	Input	Ignition switch OFF		Battery voltage
13 (B)	Ground	Ground	—	Ignition switch ON		0 V
14 (W)	Ground	Push-button ignition switch illumination ground	Output	Tail lamp	OFF	0 V
					ON	<p><b>NOTE:</b> When the illumination brightening/dimming level is in the neutral position.</p>  <p style="text-align: right; font-size: small;">JSNIA0010GB</p>
15 (BG)	Ground	ACC indicator lamp	Output	Ignition switch	OFF (LOCK indicator is not illuminated)	Battery voltage
					ACC	0 V

A  
B  
C  
D  
E  
F  
G  
H  
I  
J  
L  
M  
N  
O  
P

PWC

# BCM (BODY CONTROL MODULE)

< ECU DIAGNOSIS INFORMATION >

[FRONT & REAR WINDOW ANTI-PINCH]

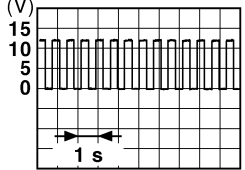
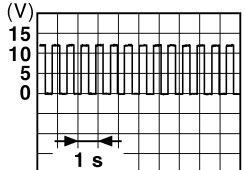
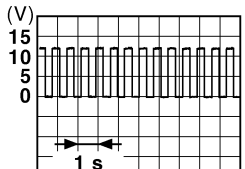
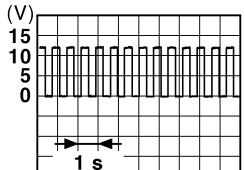
Terminal No. (Wire color)		Description		Condition	Value (Approx.)	
		Signal name	Input/ Output			
+	-					
17 (W)	Ground	Turn signal RH (Front)	Output	Ignition switch ON	Turn signal switch OFF	0 V
				Turn signal switch RH	 <p style="text-align: right; font-size: small;">PKID0926E</p>	
18 (BG)	Ground	Turn signal LH (Front)	Output	Ignition switch ON	Turn signal switch OFF	0 V
				Turn signal switch LH	 <p style="text-align: right; font-size: small;">PKID0926E</p>	
19 (V)	Ground	Interior room lamp control	Output	Interior room lamp	OFF	12 V
				ON	0 V	
20 (V)	Ground	Turn signal RH (Rear)	Output	Ignition switch ON	Turn signal switch OFF	0 V
				Turn signal switch RH	 <p style="text-align: right; font-size: small;">PKID0926E</p>	
23 (LG)	Ground	Trunk lid open	Output	Trunk lid	OPEN (Trunk lid opener actuator is activated)	12 V
				Other than OPEN (Trunk lid opener actuator is not activated)	0 V	
25 (Y)	Ground	Turn signal LH (Rear)	Output	Ignition switch ON	Turn signal switch OFF	0 V
				Turn signal switch LH	 <p style="text-align: right; font-size: small;">PKID0926E</p>	
30 (P)	Ground	Trunk room lamp	Output	Trunk room lamp	ON	0 V
				OFF	12 V	



# BCM (BODY CONTROL MODULE)

< ECU DIAGNOSIS INFORMATION >

[FRONT & REAR WINDOW ANTI-PINCH]

Terminal No. (Wire color)		Description		Condition	Value (Approx.)
+	-	Signal name	Input/ Output		
34 (SB)	Ground	Trunk room antenna (-)	Output	Ignition switch OFF	<p>JMKIA0062GB</p>
				When Intelligent Key is not in the passenger compart- ment	<p>JMKIA0063GB</p>
35 (V)	Ground	Trunk room antenna (+)	Output	Ignition switch OFF	<p>JMKIA0062GB</p>
				When Intelligent Key is not in the passenger compart- ment	<p>JMKIA0063GB</p>
38 (B)	Ground	Rear bumper anten- na (-)	Output	When the trunk lid opener re- quest switch is operated with ignition switch OFF	<p>JMKIA0062GB</p>
				When Intelligent Key is not in the antenna detection area	<p>JMKIA0063GB</p>

A  
B  
C  
D  
E  
F  
G  
H  
I  
J  
L  
M  
N  
O  
P

PWC

# BCM (BODY CONTROL MODULE)

< ECU DIAGNOSIS INFORMATION >

[FRONT & REAR WINDOW ANTI-PINCH]

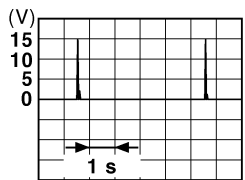
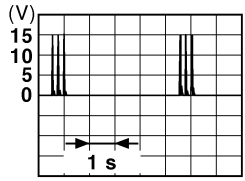
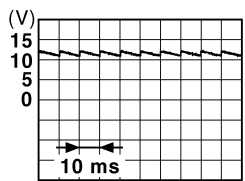
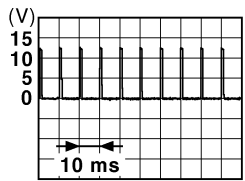
Terminal No. (Wire color)		Description		Condition	Value (Approx.)	
		Signal name	Input/ Output			
+	-					
39 (W)	Ground	Rear bumper antenna (+)	Output	When the trunk lid opener request switch is operated with ignition switch OFF	When Intelligent Key is in the antenna detection area	 <p style="text-align: right; font-size: small;">JMkia0062GB</p>
				When Intelligent Key is not in the antenna detection area	 <p style="text-align: right; font-size: small;">JMkia0063GB</p>	
47 (Y)	Ground	Ignition relay (IPDM E/R) control	Output	Ignition switch	OFF or ACC	12 V
					ON	0 V
50 (BG)	Ground	Trunk room lamp switch	Input	Trunk room lamp switch	OFF (Trunk lid is closed)	 <p style="text-align: right; font-size: small;">JPMIA0011GB</p>
					ON (Trunk lid is opened)	0 V
52 (R)	Ground	Starter relay control	Output	Ignition switch ON (A/T models)	When selector lever is in P or N position	12 V
					When selector lever is not in P or N position	0 V
				Ignition switch ON (M/T models)	When the clutch pedal is depressed	Battery voltage
					When the clutch pedal is not depressed	0 V
60 (BR)	Ground	Push-button ignition switch (Push switch)	Input	Push-button ignition switch (push switch)	Pressed	0 V
					Not pressed	Battery voltage
61 (SB)	Ground	Trunk lid opener request switch	Input	Trunk lid opener request switch	ON (Pressed)	0 V
					OFF (Not pressed)	 <p style="text-align: right; font-size: small;">JPMIA0016GB</p>
64 (G)	Ground	Intelligent Key warning buzzer (Engine room)	Output	Intelligent Key warning buzzer (Engine room)	Sounding	0 V
					Not sounding	12 V

# BCM (BODY CONTROL MODULE)

< ECU DIAGNOSIS INFORMATION >

[FRONT & REAR WINDOW ANTI-PINCH]

Terminal No. (Wire color)		Description		Condition	Value (Approx.)	
+	-	Signal name	Input/ Output			
67 (GR)	Ground	Trunk lid opener switch	Input	Trunk lid opener switch	Pressed	0 V
					Not pressed	 11.8 V
68 (BG)	Ground	Rear RH door switch	Input	Rear RH door switch	OFF (When rear RH door closes)	 11.8 V
					ON (When rear RH door opens)	0 V
69 (L)	Ground	Rear LH door switch	Input	Rear LH door switch	OFF (When rear LH door closes)	 11.8 V
					ON (When rear LH door opens)	0 V
72 (R)	Ground	Room antenna 2 (-) (Center console)	Output	Ignition switch OFF	When Intelligent Key is in the passenger compartment	 
					When Intelligent Key is not in the passenger compartment	 

A  
B  
C  
D  
E  
F  
G  
H  
I  
J  
L  
M  
N  
O  
P

PWC

# BCM (BODY CONTROL MODULE)

< ECU DIAGNOSIS INFORMATION >

[FRONT & REAR WINDOW ANTI-PINCH]

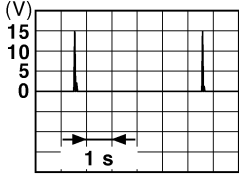
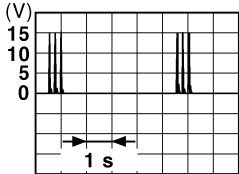
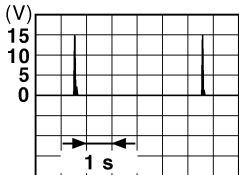
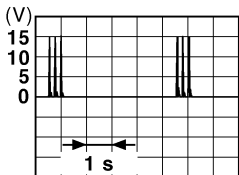
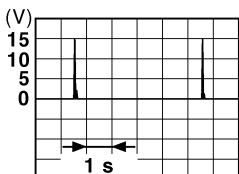
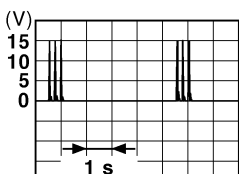
Terminal No. (Wire color)		Description		Condition	Value (Approx.)
+	-	Signal name	Input/ Output		
73 (G)	Ground	Room antenna 2 (+) (Center console)	Output	Ignition switch OFF	When Intelligent Key is in the passenger compart- ment   <small>JMKIA0062GB</small>
				When Intelligent Key is not in the passenger compart- ment   <small>JMKIA0063GB</small>	
74 (SB)	Ground	Passenger door an- tenna (-)	Output	When the pas- senger door re- quest switch is operated with ignition switch OFF	When Intelligent Key is in the antenna detection area   <small>JMKIA0062GB</small>
				When Intelligent Key is not in the antenna detection area   <small>JMKIA0063GB</small>	
75 (BR)	Ground	Passenger door an- tenna (+)	Output	When the pas- senger door re- quest switch is operated with ignition switch OFF	When Intelligent Key is in the antenna detection area   <small>JMKIA0062GB</small>
				When Intelligent Key is not in the antenna detection area   <small>JMKIA0063GB</small>	

# BCM (BODY CONTROL MODULE)

< ECU DIAGNOSIS INFORMATION >

[FRONT & REAR WINDOW ANTI-PINCH]

Terminal No. (Wire color)		Description		Condition	Value (Approx.)
+	-	Signal name	Input/ Output		
76 (V)	Ground	Driver door antenna (-)	Output	When the driver door request switch is operated with ignition switch OFF	<p>JMKIA0062GB</p>
				When Intelligent Key is not in the antenna detection area	<p>JMKIA0063GB</p>
77 (LG)	Ground	Driver door antenna (+)	Output	When the driver door request switch is operated with ignition switch OFF	<p>JMKIA0062GB</p>
				When Intelligent Key is not in the antenna detection area	<p>JMKIA0063GB</p>
78 (Y)	Ground	Room antenna 1 (-) (Instrument panel)	Output	Ignition switch OFF	<p>JMKIA0062GB</p>
				When Intelligent Key is not in the passenger compartment	<p>JMKIA0063GB</p>

A  
B  
C  
D  
E  
F  
G  
H  
I  
J  
L  
M  
N  
O  
P

PWC

# BCM (BODY CONTROL MODULE)

< ECU DIAGNOSIS INFORMATION >

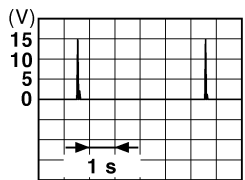
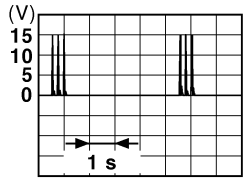
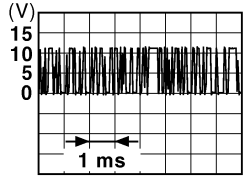
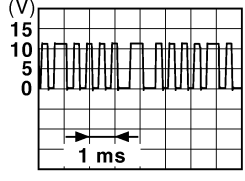

[FRONT & REAR WINDOW ANTI-PINCH]

Terminal No. (Wire color)		Description		Condition	Value (Approx.)	
		Signal name	Input/ Output			
+	-					
79 (BR)	Ground	Room antenna 1 (+) (Instrument panel)	Output	Ignition switch OFF	 <p style="text-align: right; font-size: small;">JMkia0062GB</p>	
				When Intelligent Key is not in the passenger compart- ment	 <p style="text-align: right; font-size: small;">JMkia0063GB</p>	
80 (GR)	Ground	NATS antenna amp.	Input/ Output	During waiting	Ignition switch is pressed while inserting the Intelli- gent Key into the key slot.	
81 (W)	Ground	NATS antenna amp.	Input/ Output	During waiting	Ignition switch is pressed while inserting the Intelli- gent Key into the key slot.	
82 (SB)	Ground	Ignition relay [Fuse block (J/B)] control	Output	Ignition switch	OFF or ACC	0 V
					ON	12 V
83 (Y)	Ground	Remote keyless entry receiver communica- tion	Input/ Output	During waiting	 <p style="text-align: right; font-size: small;">JMkia0064GB</p>	
				When operating either button on the Intelli- gent Key	 <p style="text-align: right; font-size: small;">JMkia0065GB</p>	

# BCM (BODY CONTROL MODULE)

< ECU DIAGNOSIS INFORMATION >

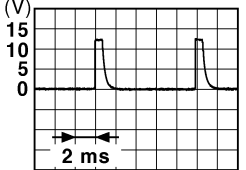
[FRONT & REAR WINDOW ANTI-PINCH]

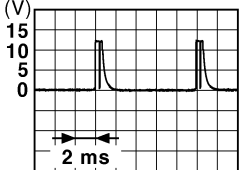
Terminal No. (Wire color)		Description		Condition	Value (Approx.)	
+	-	Signal name	Input/ Output			
87 (Y)	Ground	Combination switch INPUT 5	Input	Combination switch	All switches OFF (Wiper volume dial 4)	 <p style="text-align: right; font-size: small;">JPMA0041GB</p> <p style="text-align: center;">1.4 V</p>
				Combination switch	Front fog lamp switch ON (Wiper volume dial 4)	 <p style="text-align: right; font-size: small;">JPMA0037GB</p> <p style="text-align: center;">1.3 V</p>
				Combination switch	Any of the conditions below with all switches OFF <ul style="list-style-type: none"> <li>• Wiper volume dial 1</li> <li>• Wiper volume dial 2</li> <li>• Wiper volume dial 6</li> <li>• Wiper volume dial 7</li> </ul>	 <p style="text-align: right; font-size: small;">JPMA0040GB</p> <p style="text-align: center;">1.3 V</p>

A  
B  
C  
D  
E  
F  
G  
H  
I  
J



PWC

L  
M  
N  
O  
P

# BCM (BODY CONTROL MODULE)

< ECU DIAGNOSIS INFORMATION >

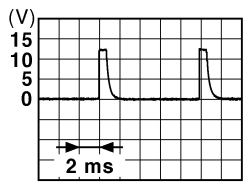
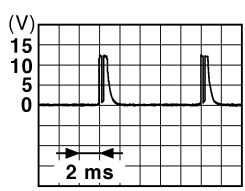
[FRONT & REAR WINDOW ANTI-PINCH]

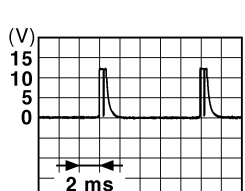
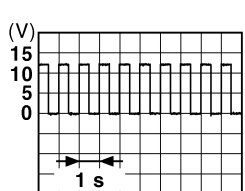
Terminal No. (Wire color)		Description		Condition	Value (Approx.)
		Signal name	Input/ Output		
+	-				
88 (BG)	Ground	Combination switch INPUT 3	Input	Combination switch	All switches OFF (Wiper volume dial 4) <div style="text-align: right;">  <p style="font-size: small; margin: 0;">JPMIA0041GB</p> <p style="margin: 0;">1.4 V</p> </div>
					Lighting switch HI (Wiper volume dial 4) <div style="text-align: right;">  <p style="font-size: small; margin: 0;">JPMIA0036GB</p> <p style="margin: 0;">1.3 V</p> </div>
					Lighting switch 2ND (Wiper volume dial 4) <div style="text-align: right;">  <p style="font-size: small; margin: 0;">JPMIA0037GB</p> <p style="margin: 0;">1.3 V</p> </div>
					Any of the conditions below with all switches OFF <ul style="list-style-type: none"> <li>• Wiper volume dial 1</li> <li>• Wiper volume dial 2</li> <li>• Wiper volume dial 3</li> </ul> <div style="text-align: right;">  <p style="font-size: small; margin: 0;">JPMIA0040GB</p> <p style="margin: 0;">1.3 V</p> </div>
90 (P)	Ground	CAN-L	Input/ Output	—	—
91 (L)	Ground	CAN-H	Input/ Output	—	—
92 (LG)	Ground	Key slot illumination	Output	Key slot illumi- nation	OFF <div style="text-align: right;"> <p style="margin: 0;">12 V</p> </div>
				Blinking	<div style="text-align: right;">  <p style="font-size: small; margin: 0;">JPMIA0015GB</p> <p style="margin: 0;">6.5 V</p> </div>
93 (GR)	Ground	ON indicator lamp	Output	Ignition switch	OFF (LOCK indicator is not illuminated) <div style="text-align: right;"> <p style="margin: 0;">Battery voltage</p> </div>
					ON <div style="text-align: right;"> <p style="margin: 0;">0 V</p> </div>



# BCM (BODY CONTROL MODULE)

< ECU DIAGNOSIS INFORMATION >

[FRONT & REAR WINDOW ANTI-PINCH]

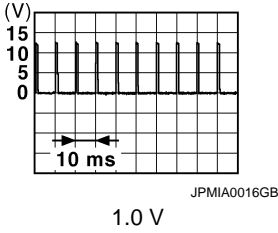
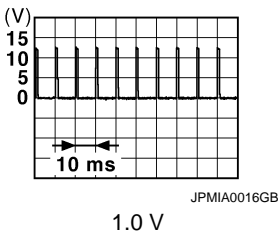
Terminal No. (Wire color)		Description		Condition		Value (Approx.)
		Signal name	Input/ Output			
+	-					
95 (BG)	Ground	ACC relay control	Output	Ignition switch	OFF	0 V
					ACC or ON	12 V
96 (GR)	Ground	A/T shift selector (Detention switch) power supply	Output	—		12 V
99 (R)*1 (BR)*2	Ground	Selector lever P position switch (A/T models)	Input	Selector lever	P position	0 V
					Any position other than P	12 V
		ASCD clutch switch (M/T models without ICC)		ASCD clutch switch	OFF (Clutch pedal is depressed)	0 V
					ON (Clutch pedal is not depressed)	12 V
		ICC clutch switch (M/T models with ICC)		ICC clutch switch	OFF (Clutch pedal is depressed)	0 V
					ON (Clutch pedal is not depressed)	12 V
100 (Y)	Ground	Passenger door request switch	Input	Passenger door request switch	ON (Pressed)	0 V
					OFF (Not pressed)	
101 (P)	Ground	Driver door request switch	Input	Driver door request switch	ON (Pressed)	0 V
					OFF (Not pressed)	
102 (BG)	Ground	Blower fan motor relay control	Output	Ignition switch	OFF or ACC	0 V
					ON	12 V
103 (P)	Ground	Remote keyless entry receiver power supply	Output	Ignition switch OFF		12 V

A  
B  
C  
D  
E  
F  
G  
H  
I  
J  
L  
M  
N  
O  
P

PWC

# BCM (BODY CONTROL MODULE)

< ECU DIAGNOSIS INFORMATION >

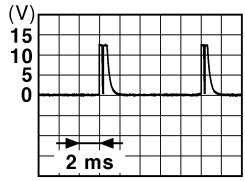
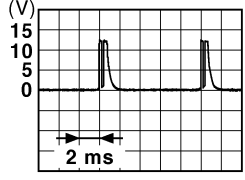
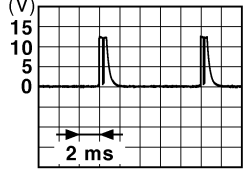
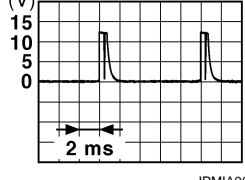

[FRONT & REAR WINDOW ANTI-PINCH]

Terminal No. (Wire color)		Description		Condition	Value (Approx.)	
+	-	Signal name	Input/ Output			
107 (LG)	Ground	Combination switch INPUT 1	Input	Combination switch (Wiper volume dial 4)	All switches OFF	 <p style="text-align: right; font-size: small;">JPMIA0041GB</p> <p style="text-align: center;">1.4 V</p>
					Turn signal switch LH	 <p style="text-align: right; font-size: small;">JPMIA0037GB</p> <p style="text-align: center;">1.3 V</p>
					Turn signal switch RH	 <p style="text-align: right; font-size: small;">JPMIA0036GB</p> <p style="text-align: center;">1.3 V</p>
					Front wiper switch LO	 <p style="text-align: right; font-size: small;">JPMIA0038GB</p> <p style="text-align: center;">1.3 V</p>
					Front washer switch ON	 <p style="text-align: right; font-size: small;">JPMIA0039GB</p> <p style="text-align: center;">1.3 V</p>

# BCM (BODY CONTROL MODULE)

< ECU DIAGNOSIS INFORMATION >

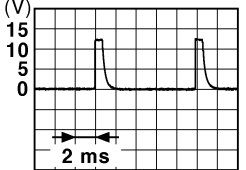
[FRONT & REAR WINDOW ANTI-PINCH]

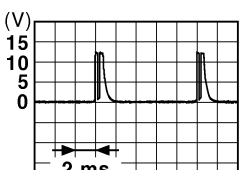
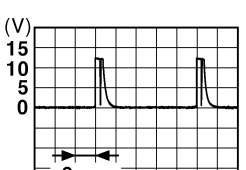
Terminal No. (Wire color)		Description		Condition	Value (Approx.)
		Signal name	Input/ Output		
+	-				
108 (R)	Ground	Combination switch INPUT 4	Input	Combination switch	All switches OFF (Wiper volume dial 4) <div style="text-align: right;">  <p style="font-size: small;">JPMIA0041GB</p> </div>
				Combination switch	Lighting switch AUTO (Wiper volume dial 4) <div style="text-align: right;">  <p style="font-size: small;">JPMIA0038GB</p> </div>
				Combination switch	Lighting switch 1ST (Wiper volume dial 4) <div style="text-align: right;">  <p style="font-size: small;">JPMIA0036GB</p> </div>
				Combination switch	Any of the conditions be- low with all switches OFF <ul style="list-style-type: none"> <li>• Wiper volume dial 1</li> <li>• Wiper volume dial 5</li> <li>• Wiper volume dial 6</li> </ul> <div style="text-align: right;">  <p style="font-size: small;">JPMIA0039GB</p> </div>

A  
B  
C  
D  
E  
F  
G  
H  
I  
J  
L  
M  
N  
O  
P

PWC

# BCM (BODY CONTROL MODULE)

< ECU DIAGNOSIS INFORMATION >

[FRONT & REAR WINDOW ANTI-PINCH]

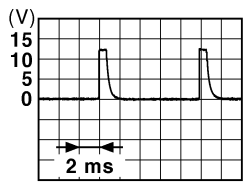
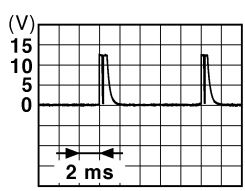
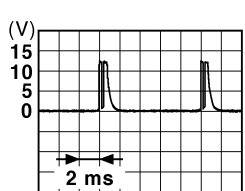
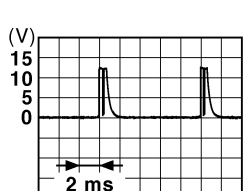
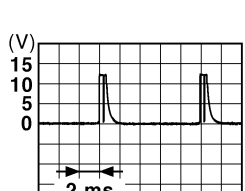
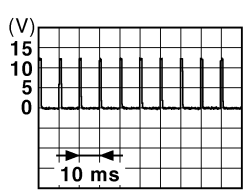
Terminal No. (Wire color)		Description		Condition	Value (Approx.)	
+	-	Signal name	Input/ Output			
109 (W)	Ground	Combination switch INPUT 2	Input	Combination switch (Wiper volume dial 4)	All switches OFF	 1.4 V
					Lighting switch PASS	 1.3 V
					Lighting switch 2ND	 1.3 V
					Front wiper switch INT/ AUTO	 1.3 V
					Front wiper switch HI	 1.3 V
					ON	0 V
110 (G)	Ground	Hazard switch	Input	Hazard switch	OFF	 1.1 V

# BCM (BODY CONTROL MODULE)

< ECU DIAGNOSIS INFORMATION >

[FRONT & REAR WINDOW ANTI-PINCH]

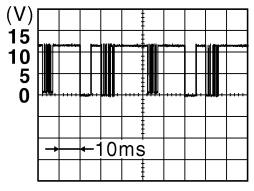
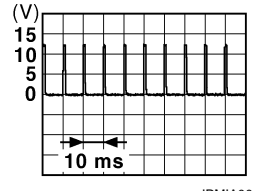
Terminal No. (Wire color)		Description		Condition	Value (Approx.)
		Signal name	Input/ Output		
+	-				
112 (R)	Ground	Rain sensor serial link	Input/ Output	Ignition switch ON	 <p style="text-align: center;">8.7 V</p>
113 (BG)	Ground	Optical sensor	Input	Ignition switch ON	When bright outside of the vehicle Close to 5 V
				Ignition switch ON	When dark outside of the vehicle Close to 0 V
114 (R)	Ground	Clutch interlock switch	Input	Clutch interlock switch	OFF (Clutch pedal is not depressed) 0 V
				Clutch interlock switch	ON (Clutch pedal is depressed) Battery voltage
116 (SB)	Ground	Stop lamp switch 1	Input	—	Battery voltage
118 (BR)	Ground	Stop lamp switch 2 (Without ICC)	Input	Stop lamp switch	OFF (Brake pedal is not depressed) 0 V
				Stop lamp switch	ON (Brake pedal is depressed) Battery voltage
		Stop lamp switch 2 (With ICC)		Stop lamp switch OFF (Brake pedal is not depressed) and ICC brake hold relay OFF 0 V	
				Stop lamp switch ON (Brake pedal is depressed) or ICC brake hold relay ON Battery voltage	
119 (SB)	Ground	Front door lock assembly driver side (Unlock sensor)	Input	Driver door	 <p style="text-align: center;">1.1 V</p>
				Driver door	UNLOCK status (Unlock switch sensor ON) 0 V
121 (SB)	Ground	Key slot switch	Input	When the Intelligent Key is inserted into key slot 12 V	
				When the Intelligent Key is not inserted into key slot 0 V	
123 (V)	Ground	IGN feedback	Input	Ignition switch	OFF or ACC 0 V
				Ignition switch	ON Battery voltage

A  
B  
C  
D  
E  
F  
G  
H  
I  
J  
L  
M  
N  
O  
P

PWC

# BCM (BODY CONTROL MODULE)

< ECU DIAGNOSIS INFORMATION >

[FRONT & REAR WINDOW ANTI-PINCH]

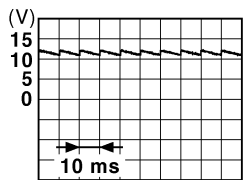
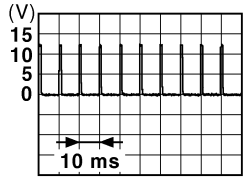
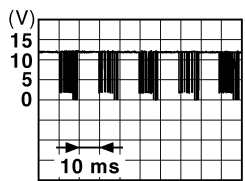
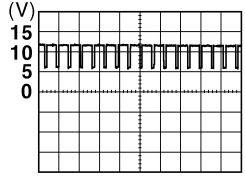
Terminal No. (Wire color)		Description		Condition	Value (Approx.)	
		Signal name	Input/ Output			
+	-					
124 (R)	Ground	Passenger door switch	Input	Passenger door switch	OFF (Door close)	 <small>JPMIA0011GB</small> 11.8 V
					ON (Door open)	0 V
129 (BG)	Ground	Trunk lid opener cancel switch	Input	Trunk lid open- er cancel switch	CANCEL	 <small>JPMIA0012GB</small> 1.1 V
					ON	0 V
132 (V)	Ground	Power window switch communication	Input/ Output	Ignition switch ON		 <small>JPMIA0013GB</small> 10.2 V
					Ignition switch OFF or ACC	12 V
133 (L)	Ground	Push-button ignition switch illumination	Output	Push-button ig- nition switch il- lumination	ON (Tail lamps OFF)	9.5 V
					ON (Tail lamps ON)	<p style="text-align: center;"><b>NOTE:</b> The pulse width of this wave is varied by the illumination bright- ening/dimming level.</p>  <small>JPMIA0159GB</small>
					OFF	0 V
134 (LG)	Ground	LOCK indicator lamp	Output	LOCK indicator lamp	OFF	Battery voltage
					ON	0 V
137 (BG)	Ground	Receiver and sensor ground	Input	Ignition switch ON		0 V
138 (V)	Ground	Receiver and sensor power supply	Output	Ignition switch	OFF	0 V
					ACC or ON	5.0 V

# BCM (BODY CONTROL MODULE)

< ECU DIAGNOSIS INFORMATION >

[FRONT & REAR WINDOW ANTI-PINCH]

Terminal No. (Wire color)		Description		Condition	Value (Approx.)
+	-	Signal name	Input/ Output		
139 (L)	Ground	Tire pressure receiver communication	Input/ Output	Ignition switch ON	<p>OCC3881D</p>
				When receiving the signal from the transmitter	<p>OCC3880D</p>
140 (B)	Ground	Selector lever P/N position	Input	Selector lever	P or N position: 12 V Except P and N positions: 0 V
				ON	0 V
141 (W)	Ground	Security indicator lamp	Output	Security indicator lamp	<p>JPMIA0014GB</p> <p>11.3 V</p>
				OFF	12 V
142 (BR)	Ground	Combination switch OUTPUT 5	Output	Combination switch (Wiper volume dial 4)	<p>JPMIA0031GB</p> <p>10.7 V</p>
				All switches OFF	0 V
				Lighting switch 1ST	
				Lighting switch HI	
143 (P)	Ground	Combination switch OUTPUT 1	Output	Combination switch	<p>JPMIA0032GB</p> <p>10.7 V</p>
				Any of the conditions below with all switches OFF <ul style="list-style-type: none"> <li>Wiper volume dial 1</li> <li>Wiper volume dial 2</li> <li>Wiper volume dial 3</li> <li>Wiper volume dial 6</li> <li>Wiper volume dial 7</li> </ul>	

A  
B  
C  
D  
E  
F  
G  
H  
I  
J  
L  
M  
N  
O  
P

PWC

# BCM (BODY CONTROL MODULE)

< ECU DIAGNOSIS INFORMATION >

[FRONT & REAR WINDOW ANTI-PINCH]

Terminal No. (Wire color)		Description		Condition	Value (Approx.)	
		Signal name	Input/ Output			
+	-					
144 (G)	Ground	Combination switch OUTPUT 2	Output	Combination switch	All switches OFF (Wiper volume dial 4)	0 V
					Front washer switch ON (Wiper volume dial 4)	
					Any of the conditions below with all switches OFF <ul style="list-style-type: none"> <li>• Wiper volume dial 1</li> <li>• Wiper volume dial 5</li> <li>• Wiper volume dial 6</li> </ul>	
145 (L)	Ground	Combination switch OUTPUT 3	Output	Combination switch (Wiper volume dial 4)	All switches OFF	0 V
					Front wiper switch INT/ AUTO	
					Lighting switch AUTO	
146 (SB)	Ground	Combination switch OUTPUT 4	Output	Combination switch (Wiper volume dial 4)	All switches OFF	0 V
					Front fog lamp switch ON	
					Lighting switch 2ND	
					Lighting switch PASS	
				Turn signal switch LH	10.7 V	
150 (GR)	Ground	Driver door switch	Input	Driver door switch	OFF (Door close)	
					ON (Door open)	0 V
151 (G)	Ground	Rear window defogger relay control	Output	Rear window defogger	Active	0 V
					Not activated	Battery voltage

- \*1: A/T models
- \*2: M/T models



# BCM (BODY CONTROL MODULE)

< ECU DIAGNOSIS INFORMATION >

[FRONT & REAR WINDOW ANTI-PINCH]

## Wiring Diagram - BCM -

INFOID:000000008781442

For connector terminal arrangements, harness layouts, and alphabets in a  (option abbreviation; if not described in wiring diagram), refer to [GI-12, "Connector Information"](#).

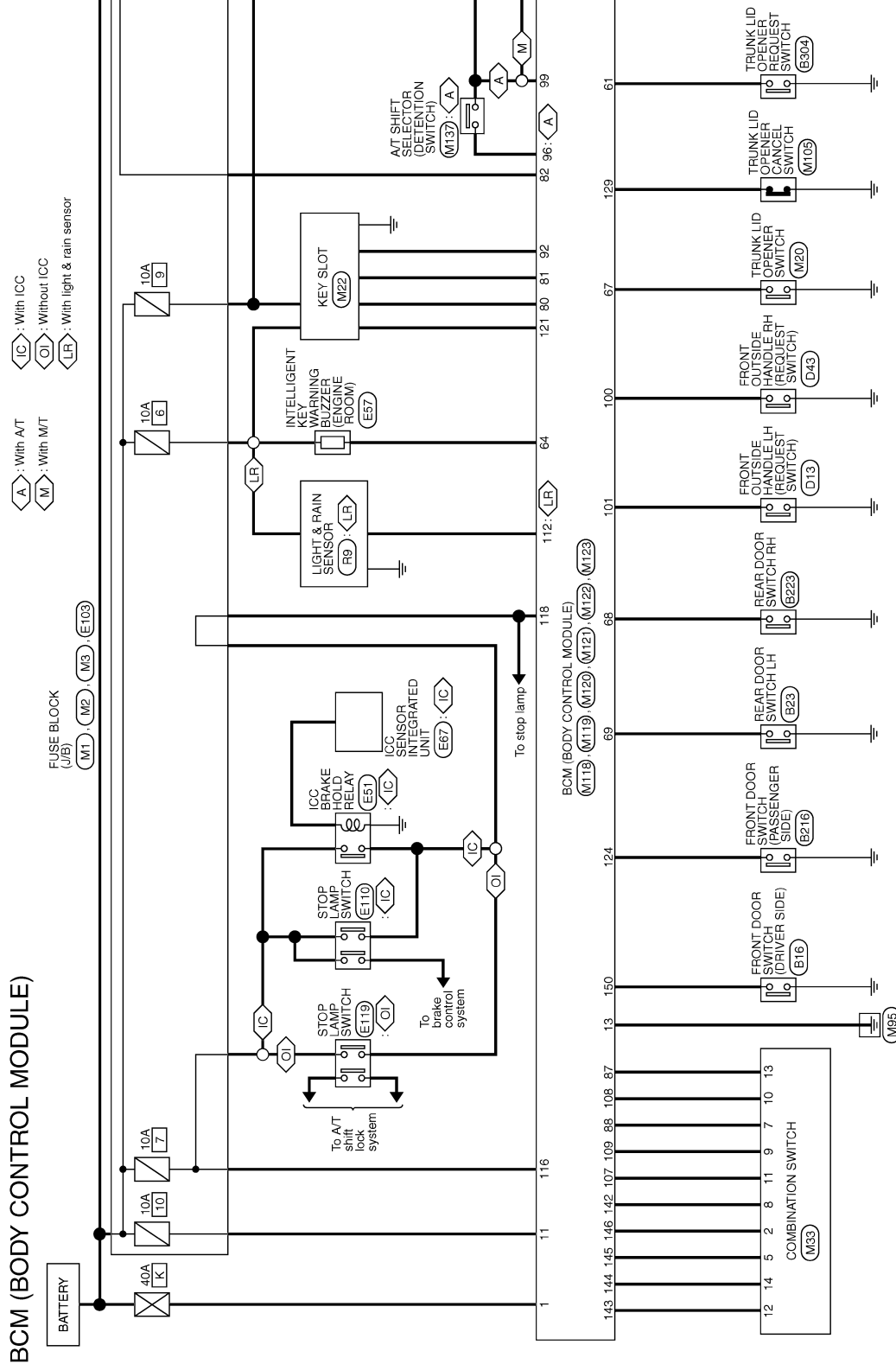

2012/07/10

JRMWD3146GB

A  
B  
C  
D  
E  
F  
G  
H  
I  
J  
K  
L  
M  
N  
O  
P

PWC

# BCM (BODY CONTROL MODULE)

< ECU DIAGNOSIS INFORMATION >

[FRONT & REAR WINDOW ANTI-PINCH]

A : With A/T  
W : With M/T  
IC : With ICC  
OI : Without ICC

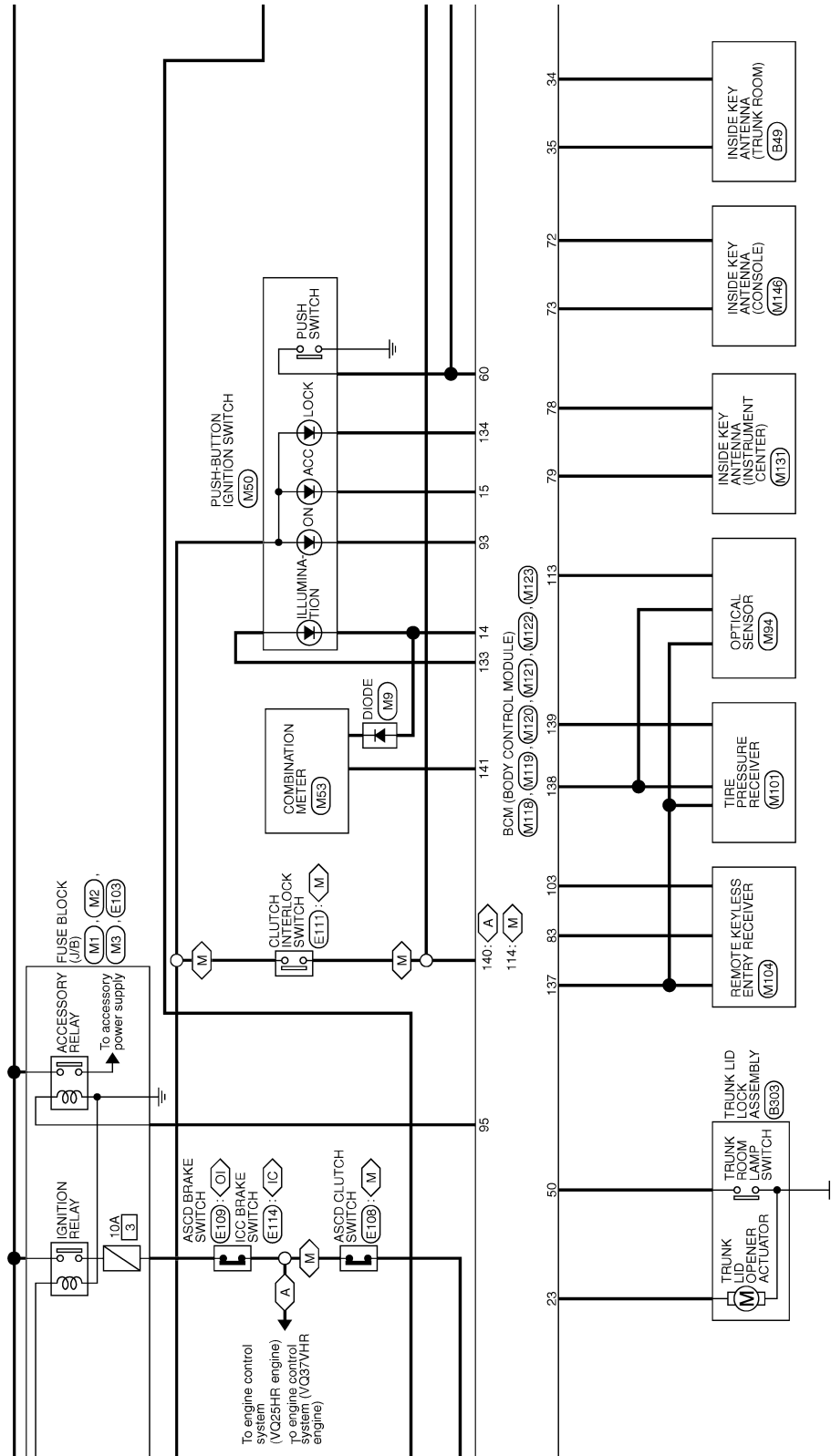

JRMWD3147GB

# BCM (BODY CONTROL MODULE)

< ECU DIAGNOSIS INFORMATION >

[FRONT & REAR WINDOW ANTI-PINCH]

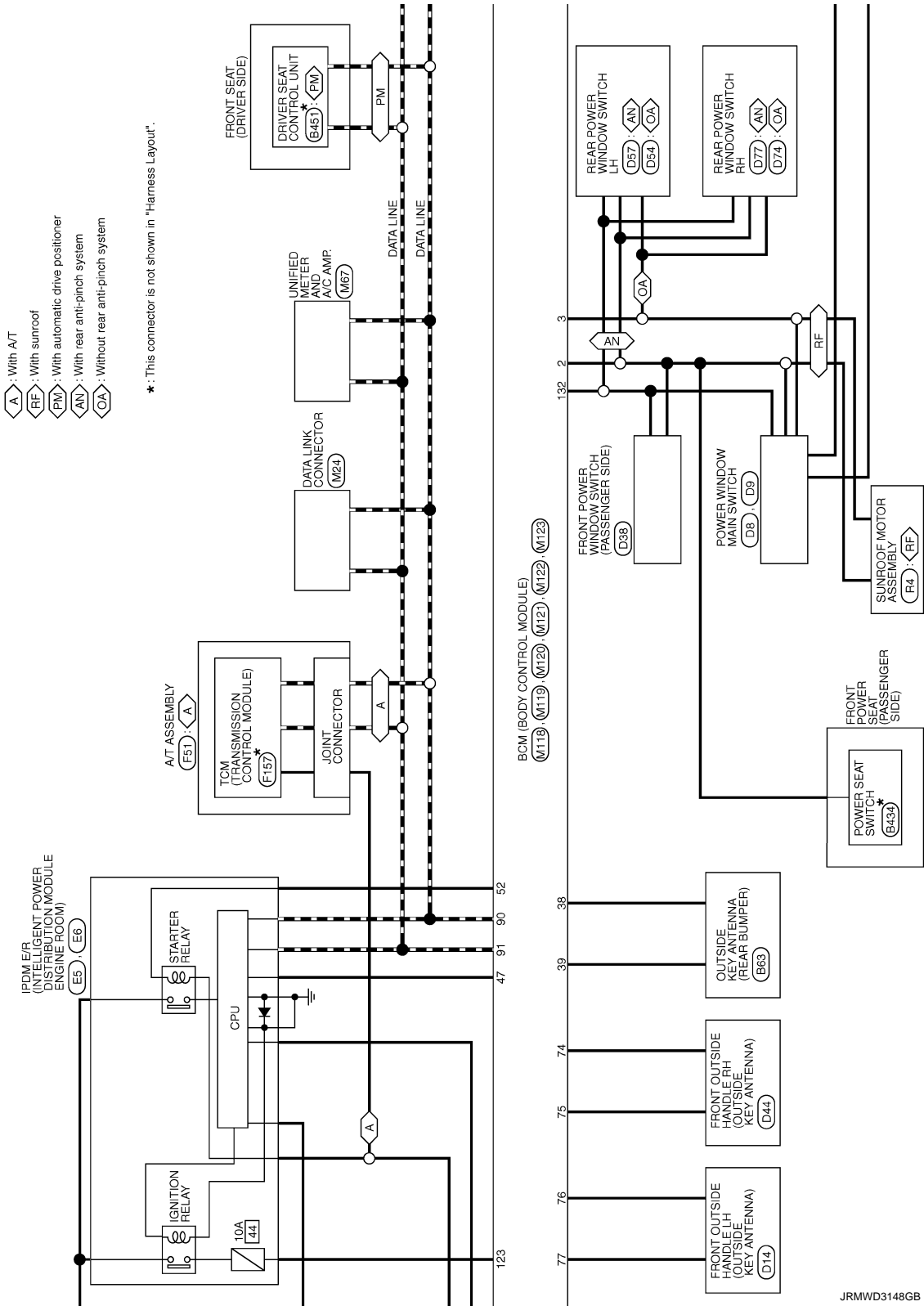

A  
B  
C  
D  
E  
F  
G  
H  
I  
J  
L  
M  
N  
O  
P

PWC

JRMWD3148GB

# BCM (BODY CONTROL MODULE)

< ECU DIAGNOSIS INFORMATION >

[FRONT & REAR WINDOW ANTI-PINCH]

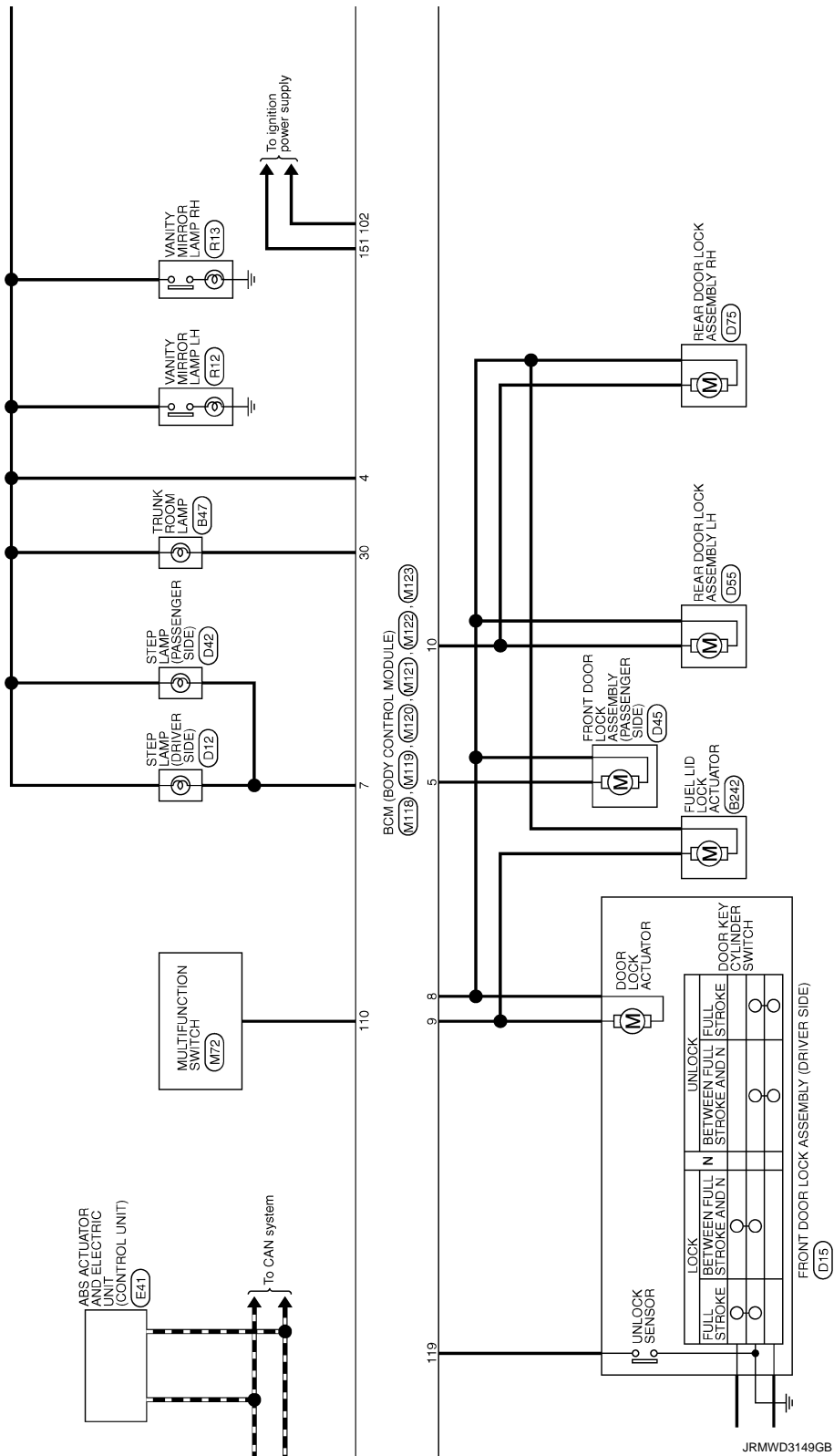

JRMWD3149GB

# BCM (BODY CONTROL MODULE)

< ECU DIAGNOSIS INFORMATION >

[FRONT & REAR WINDOW ANTI-PINCH]

A  
B  
C  
D  
E  
F  
G  
H  
I  
J  
L  
M  
N  
O  
P

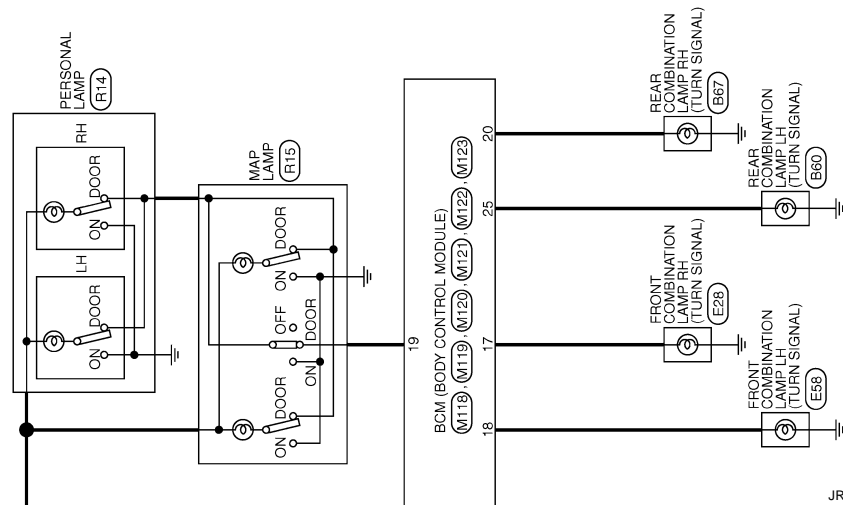

JRMWD3150GB

## Fail-safe

### FAIL-SAFE CONTROL BY DTC

BCM performs fail-safe control when any DTC are detected.

INFOID:000000008781443

PWC

# BCM (BODY CONTROL MODULE)

< ECU DIAGNOSIS INFORMATION >

[FRONT & REAR WINDOW ANTI-PINCH]

Display contents of CONSULT	Fail-safe	Cancellation
B2190: NATS ANTENNA AMP	Inhibit engine cranking	Erase DTC
B2191: DIFFERENCE OF KEY	Inhibit engine cranking	Erase DTC
B2192: ID DISCORD BCM-ECM	Inhibit engine cranking	Erase DTC
B2193: CHAIN OF BCM-ECM	Inhibit engine cranking	Erase DTC
B2195: ANTI-SCANNING	Inhibit engine cranking	Ignition switch ON → OFF
B2560: STARTER CONT RELAY	Inhibit engine cranking	500 ms after the following CAN signal communication status becomes consistent <ul style="list-style-type: none"> <li>• Starter control relay signal</li> <li>• Starter relay status signal</li> </ul>
B2608: STARTER RELAY	Inhibit engine cranking	500 ms after the following signal communication status becomes consistent <ul style="list-style-type: none"> <li>• Starter motor relay control signal</li> <li>• Starter relay status signal (CAN)</li> </ul>
B260A: IGNITION RELAY	Inhibit engine cranking	500 ms after the following conditions are fulfilled <ul style="list-style-type: none"> <li>• IGN relay (IPDM E/R) control signal: OFF (12 V)</li> <li>• Ignition ON signal (CAN to IPDM E/R): OFF (Request signal)</li> <li>• Ignition ON signal (CAN from IPDM E/R): OFF (Condition signal)</li> </ul>
B260F: ENG STATE SIG LOST	Maintains the power supply position attained at the time of DTC detection	When any of the following conditions are fulfilled <ul style="list-style-type: none"> <li>• Power position changes to ACC</li> <li>• Receives engine status signal (CAN)</li> </ul>
B2617: BCM	Inhibit engine cranking	1 second after the starter motor relay control inside BCM becomes normal
B2618: BCM	Inhibit engine cranking	1 second after the ignition relay (IPDM E/R) control inside BCM becomes normal
B261E: VEHICLE TYPE	Inhibit engine cranking	BCM initialization
B26E8: CLUTCH SW	Inhibit engine cranking	When any of the following BCM recognition conditions are fulfilled <ul style="list-style-type: none"> <li>• Status 1                             <ul style="list-style-type: none"> <li>- Clutch switch signal (CAN from ECM): ON</li> <li>- Clutch interlock switch signal: OFF (0 V)</li> </ul> </li> <li>• Status 2                             <ul style="list-style-type: none"> <li>- Clutch switch signal (CAN from ECM): OFF</li> <li>- Clutch interlock switch signal: ON (Battery voltage)</li> </ul> </li> </ul>

## DTC Inspection Priority Chart

INFOID:000000008781444

If some DTCs are displayed at the same time, perform inspections one by one based on the following priority chart.

Priority	DTC
1	B2562: LOW VOLTAGE
2	<ul style="list-style-type: none"> <li>• U1000: CAN COMM</li> <li>• U1010: CONTROL UNIT(CAN)</li> </ul>
3	<ul style="list-style-type: none"> <li>• B2190: NATS ANTENNA AMP</li> <li>• B2191: DIFFERENCE OF KEY</li> <li>• B2192: ID DISCORD BCM-ECM</li> <li>• B2193: CHAIN OF BCM-ECM</li> <li>• B2195: ANTI-SCANNING</li> </ul>

# BCM (BODY CONTROL MODULE)

< ECU DIAGNOSIS INFORMATION >

[FRONT & REAR WINDOW ANTI-PINCH]

Priority	DTC	
4	• B2553: IGNITION RELAY	A
	• B2555: STOP LAMP	B
	• B2556: PUSH-BTN IGN SW	
	• B2557: VEHICLE SPEED	C
	• B2560: STARTER CONT RELAY	
	• B2601: SHIFT POSITION	D
	• B2602: SHIFT POSITION	
	• B2603: SHIFT POSI STATUS	E
	• B2604: PNP/CLUTCH SW	
	• B2605: PNP/CLUTCH SW	F
	• B2608: STARTER RELAY	
	• B260A: IGNITION RELAY	G
	• B260F: ENG STATE SIG LOST	
	• B2614: BCM	
	• B2615: BCM	
	• B2616: BCM	
	• B2617: BCM	
	• B2618: BCM	
	• B261A: PUSH-BTN IGN SW	
	• B261E: VEHICLE TYPE	
• B26E8: CLUTCH SW		
• B26EA: KEY REGISTRATION		
• C1729: VHCL SPEED SIG ERR		
• U0415: VEHICLE SPEED		
5	• C1704: LOW PRESSURE FL	H
	• C1705: LOW PRESSURE FR	
	• C1706: LOW PRESSURE RR	I
	• C1707: LOW PRESSURE RL	
	• C1708: [NO DATA] FL	J
	• C1709: [NO DATA] FR	
	• C1710: [NO DATA] RR	
	• C1711: [NO DATA] RL	
	• C1716: [PRESSDATA ERR] FL	
	• C1717: [PRESSDATA ERR] FR	
	• C1718: [PRESSDATA ERR] RR	
	• C1719: [PRESSDATA ERR] RL	
	• C1734: CONTROL UNIT	
6	• B2621: INSIDE ANTENNA	
	• B2622: INSIDE ANTENNA	
	• B2623: INSIDE ANTENNA	

PWC

## DTC Index

INFOID:000000008781445

### NOTE:

The details of time display are as follows.

- CRNT: A malfunction is detected now.
- PAST: A malfunction was detected in the past.

IGN counter is displayed on Freeze Frame Data. For details of Freeze Frame Data, refer to [BCS-16. "COMMON ITEM : CONSULT Function \(BCM - COMMON ITEM\)"](#).

CONSULT display	Fail-safe	Freeze Frame Data •Vehicle Speed •Odo/Trip Meter •Vehicle condition	Intelligent Key warning lamp ON	Tire pressure monitor warning lamp ON	Refer- ence page
No DTC is detected. further testing may be required.	—	—	—	—	—
U1000: CAN COMM	—	—	—	—	<a href="#">BCS-36</a>
U1010: CONTROL UNIT(CAN)	—	—	—	—	<a href="#">BCS-37</a>
U0415: VEHICLE SPEED	—	—	—	—	<a href="#">BCS-38</a>
B2190: NATS ANTENNA AMP	×	—	—	—	<a href="#">SEC-44</a>

# BCM (BODY CONTROL MODULE)

< ECU DIAGNOSIS INFORMATION >

[FRONT & REAR WINDOW ANTI-PINCH]

CONSULT display	Fail-safe	Freeze Frame Data •Vehicle Speed •Odo/Trip Meter •Vehicle condition	Intelligent Key warning lamp ON	Tire pressure monitor warning lamp ON	Refer- ence page
B2191: DIFFERENCE OF KEY	×	—	—	—	<a href="#">SEC-47</a>
B2192: ID DISCORD BCM-ECM	×	—	—	—	<a href="#">SEC-48</a>
B2193: CHAIN OF BCM-ECM	×	—	—	—	<a href="#">SEC-50</a>
B2195: ANTI-SCANNING	×	—	—	—	<a href="#">SEC-51</a>
B2553: IGNITION RELAY	—	×	—	—	<a href="#">PCS-46</a>
B2555: STOP LAMP	—	×	—	—	<a href="#">SEC-52</a>
B2556: PUSH-BTN IGN SW	—	×	×	—	<a href="#">SEC-54</a>
B2557: VEHICLE SPEED	×	×	×	—	<a href="#">SEC-56</a>
B2560: STARTER CONT RELAY	×	×	×	—	<a href="#">SEC-57</a>
B2562: LOW VOLTAGE	—	×	—	—	<a href="#">BCS-39</a>
B2601: SHIFT POSITION	×	×	×	—	<a href="#">SEC-58</a>
B2602: SHIFT POSITION	×	×	×	—	<a href="#">SEC-61</a>
B2603: SHIFT POSI STATUS	×	×	×	—	<a href="#">SEC-64</a>
B2604: PNP/CLUTCH SW	×	×	×	—	<a href="#">SEC-67</a>
B2605: PNP/CLUTCH SW	×	×	×	—	<a href="#">SEC-69</a>
B2608: STARTER RELAY	×	×	×	—	<a href="#">SEC-71</a>
B260A: IGNITION RELAY	×	×	×	—	<a href="#">PCS-48</a>
B260F: ENG STATE SIG LOST	×	×	×	—	<a href="#">SEC-73</a>
B2614: BCM	—	×	×	—	<a href="#">PCS-50</a>
B2615: BCM	—	×	×	—	<a href="#">PCS-52</a>
B2616: BCM	—	×	×	—	<a href="#">PCS-54</a>
B2617: BCM	×	×	×	—	<a href="#">SEC-78</a>
B2618: BCM	×	×	×	—	<a href="#">PCS-56</a>
B261A: PUSH-BTN IGN SW	—	×	×	—	<a href="#">PCS-57</a>
B261E: VEHICLE TYPE	×	×	× (Turn ON for 15 seconds)	—	<a href="#">SEC-80</a>
B2621: INSIDE ANTENNA	—	×	—	—	<a href="#">DLK-59</a>
B2622: INSIDE ANTENNA	—	×	—	—	<a href="#">DLK-61</a>
B2623: INSIDE ANTENNA	—	×	—	—	<a href="#">DLK-63</a>
B26E8: CLUTCH SW	×	×	×	—	<a href="#">SEC-75</a>
B26EA: KEY REGISTRATION	—	×	× (Turn ON for 15 seconds)	—	<a href="#">SEC-77</a>
C1704: LOW PRESSURE FL	—	—	—	×	<a href="#">WT-20</a>
C1705: LOW PRESSURE FR	—	—	—	×	
C1706: LOW PRESSURE RR	—	—	—	×	
C1707: LOW PRESSURE RL	—	—	—	×	
C1708: [NO DATA] FL	—	—	—	×	<a href="#">WT-22</a>
C1709: [NO DATA] FR	—	—	—	×	
C1710: [NO DATA] RR	—	—	—	×	
C1711: [NO DATA] RL	—	—	—	×	



# BCM (BODY CONTROL MODULE)

< ECU DIAGNOSIS INFORMATION >

[FRONT & REAR WINDOW ANTI-PINCH]

CONSULT display	Fail-safe	Freeze Frame Data •Vehicle Speed •Odo/Trip Meter •Vehicle condition	Intelligent Key warning lamp ON	Tire pressure monitor warning lamp ON	Refer- ence page
C1716: [PRESSDATA ERR] FL	—	—	—	×	<a href="#">WT-25</a>
C1717: [PRESSDATA ERR] FR	—	—	—	×	
C1718: [PRESSDATA ERR] RR	—	—	—	×	
C1719: [PRESSDATA ERR] RL	—	—	—	×	<a href="#">WT-26</a>
C1729: VHCL SPEED SIG ERR	—	—	—	×	
C1734: CONTROL UNIT	—	—	—	×	<a href="#">WT-27</a>

A  
B  
C  
D  
E  
F  
G  
H  
I  
J  
L  
M  
N  
O  
P

PWC

# POWER WINDOW MAIN SWITCH

< ECU DIAGNOSIS INFORMATION >

[FRONT & REAR WINDOW ANTI-PINCH]

## POWER WINDOW MAIN SWITCH

Reference Value

INFOID:000000008290522

### TERMINAL LAYOUT

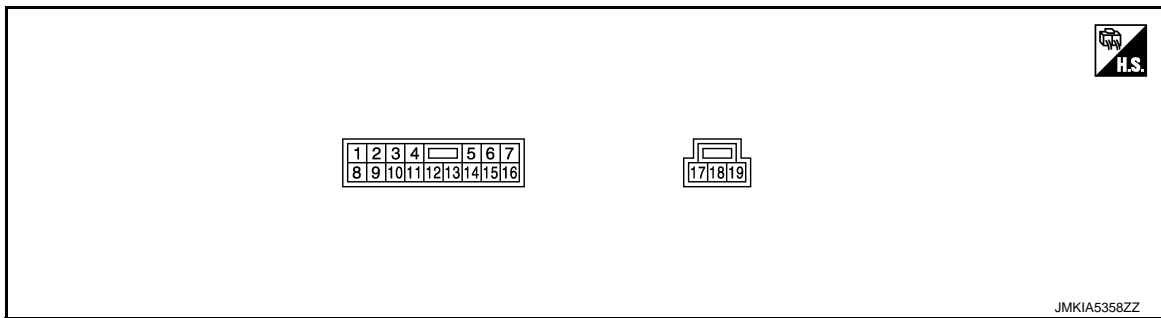

### PHYSICAL VALUES

Terminal No. (wire color)		Description		Condition	Voltage (V) (Approx.)
+	-	Signal name	Input/ Output		
2 (LG)	Ground	Encoder ground	—	—	0
4 (V)	Ground	Door key cylinder switch LOCK signal	Input	Key position (Neutral → Locked)	5 → 0
6 (Y)	Ground	Door key cylinder switch UNLOCK signal	Input	Key position (Neutral → Unlocked)	5 → 0
8 (L)	Ground	Front driver side power win- dow motor UP signal	Output	When front LH switch in power window main switch is UP at operated.	12
9 (BG)	Ground	Encoder pulse signal 2	Input	When power window mo- tor operates.	
10 (SB)	Ground	Rap signal	Input	Ignition switch ON	12
				Within 45 second after ig- nition switch is turned to OFF	12
				When driver side or pas- senger side door is opened during retained power operation	0
11 (G)	Ground	Front driver side power win- dow motor DOWN signal	Output	When front LH switch in power window main switch is DOWN at operated.	12

JMKIA0070GB

# POWER WINDOW MAIN SWITCH

< ECU DIAGNOSIS INFORMATION >

[FRONT & REAR WINDOW ANTI-PINCH]

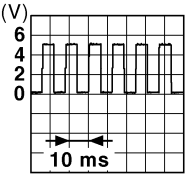
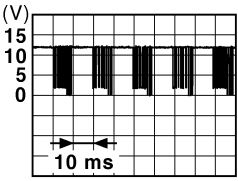
Terminal No. (wire color)		Description		Condition	Voltage (V) (Approx.)
+	-	Signal name	Input/ Output		
13 (P)	Ground	Encoder pulse signal 1	Input	When power window motor operates.	
14 (V)	Ground	Power window serial link	Input/ Output	Ignition switch ON or power window timer operating.	
15 (B)	Ground	Encoder power supply	Output	When ignition switch ON or power window timer operates.	12
17 (B)	Ground	Ground	—	—	0
19 (Y)	Ground	Battery power supply	Input	—	12

A  
B  
C  
D  
E  
F  
G  
H  
I  
J  
L  
M  
N  
O  
P

PWC



# POWER WINDOW MAIN SWITCH

< ECU DIAGNOSIS INFORMATION >

[FRONT & REAR WINDOW ANTI-PINCH]

Switches to fail-safe control when malfunction is detected in encoder signal that detects up/down speed and direction of door glass. Switches to fail-safe control when a signal that is out of the specified value is detected between the fully closed position and the actual position of the glass.

Malfunction	Malfunction condition
Pulse sensor malfunction	When one pulse signal that is the specified value or more is detected continuously for the specified time or more, while door glass is being operated UP or DOWN.
Both pulse sensors malfunction	When both pulse signals are not detected continuously for the specified time or more, while door glass is being operated UP or DOWN.
Pulse direction malfunction	When a pulse signal indicating that window is moving in the opposite direction against the power window motor is detected for the specified value or more, while door glass is being operated UP or DOWN.
Glass recognition position malfunction 1	When the actual door glass position that is out of specified value is detected compared to the door glass fully closed position memorized in module, while door glass is being operated UP or DOWN.
Glass recognition position malfunction 2	When pulse count that is out of the door glass full stroke value or more is detected, while door glass is being operated UP or DOWN.

If fail-safe control, the system changes to a non-initialized condition and the following function do not operate.

- Auto-up operation
- Anti-pinch function
- Door key cylinder switch power window function

When fail-safe control is activated, perform initialization procedure to recover. If a malfunction is detected in power window switch or more, fail-safe control is activated again.

A  
B  
C  
D  
E  
F  
G  
H  
I  
J  
L  
M  
N  
O  
P

PWC

# FRONT POWER WINDOW SWITCH

< ECU DIAGNOSIS INFORMATION >

[FRONT & REAR WINDOW ANTI-PINCH]

## FRONT POWER WINDOW SWITCH

Reference Value

INFOID:000000008290525

### TERMINAL LAYOUT

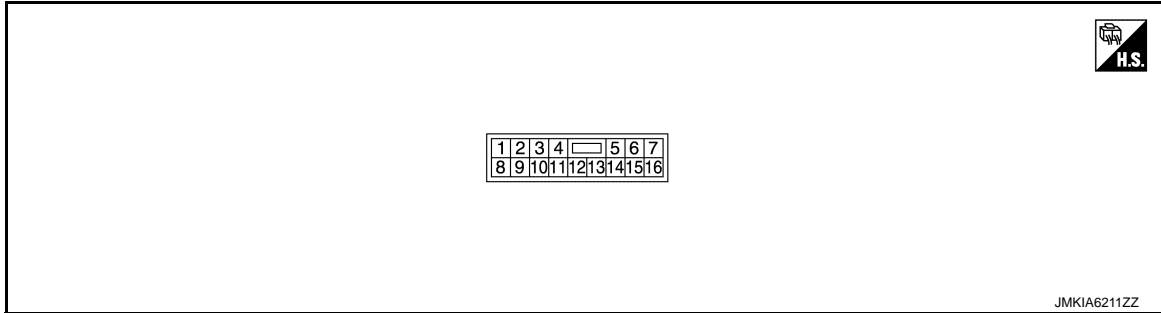

### PHYSICAL VALUES

Terminal No. (wire color)		Description		Condition	Voltage (V) (Approx.)
+	-	Signal name	Input/ Output		
3 (LG)	Ground	Encoder ground	—	—	0
4 (B)	Ground	Encoder power supply	Output	When ignition switch ON or power window timer operates	12
8 (L)	Ground	Power window motor DOWN signal	Output	When power window motor is DOWN at operated.	12
9 (G)	Ground	Power window motor UP signal	Output	When power window motor is UP at operated.	12
10 (Y)	Ground	Battery power supply	Input	—	12
11 (B)	Ground	Ground	—	—	0
12 (P)	Ground	Encoder pulse signal 1	Input	When power window motor operates.	
15 (BG)	Ground	Encoder pulse signal 2	Input	When power window motor operates.	
16 (V)	Ground	Power window serial link	Input/ Output	Ignition switch ON or power window timer operating.	



# FRONT POWER WINDOW SWITCH

< ECU DIAGNOSIS INFORMATION >

[FRONT & REAR WINDOW ANTI-PINCH]

## Fail-safe

INFOID:000000008290527

### FAIL-SAFE CONTROL

Switches to fail-safe control when malfunction is detected in encoder signal that detects up/down speed and direction of door glass. Switches to fail-safe control when a signal that is out of the specified value is detected between the fully closed position and the actual position of the glass.

Malfunction	Malfunction condition
Pulse sensor malfunction	When one pulse signal that is the specified value or more is detected continuously for the specified time or more, while door glass is being operated UP or DOWN.
Both pulse sensors malfunction	When both pulse signals are not detected continuously for the specified time or more, while door glass is being operated UP or DOWN.
Pulse direction malfunction	When a pulse signal indicating that window is moving in the opposite direction against the power window motor is detected for the specified value or more, while door glass is being operated UP or DOWN.
Glass recognition position malfunction 1	When the actual door glass position that is out of specified value is detected compared to the door glass fully closed position memorized in module, while door glass is being operated UP or DOWN.
Glass recognition position malfunction 2	When pulse count that is out of the door glass full stroke value or more is detected, while door glass is being operated UP or DOWN.

If fail-safe control, the system changes to a non-initialized condition and the following function do not operate.

- Auto-up operation
- Anti-pinch function
- Door key cylinder switch power window function

When fail-safe control is activated, perform initialization procedure to recover. If a malfunction is detected in power window switch or more, fail-safe control is activated again.



# REAR POWER WINDOW SWITCH

< ECU DIAGNOSIS INFORMATION >

[FRONT & REAR WINDOW ANTI-PINCH]

## REAR POWER WINDOW SWITCH

Reference Value

INFOID:000000008290528

### TERMINAL LAYOUT

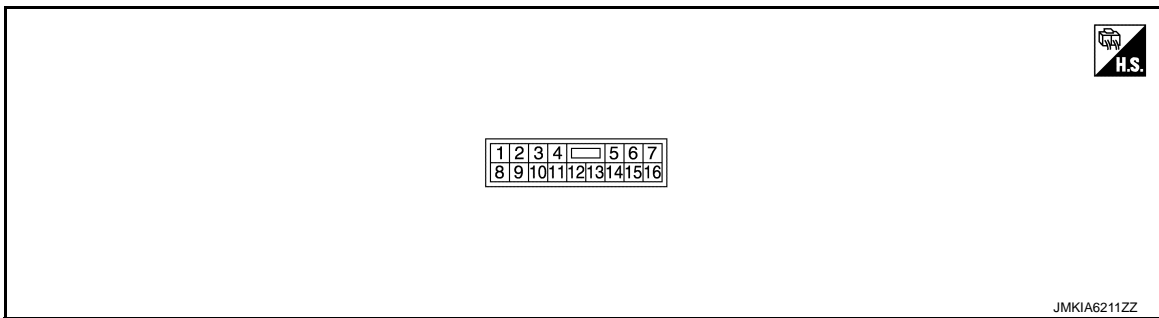

### PHYSICAL VALUES

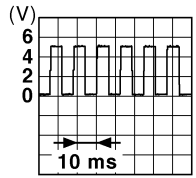
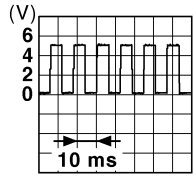
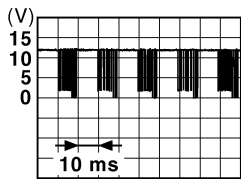
Terminal No. (wire color)		Description		Condition	Voltage (V) (Approx.)
+	-	Signal name	Input/ Output		
3 (BR)	Ground	Encoder ground	—	—	0
4 (SB)	Ground	Encoder power supply	Output	When ignition switch ON or power window timer operates	12
8 (W)	Ground	Power window motor UP signal	Output	When power window motor is UP at operated.	12
9 (L)	Ground	Power window motor DOWN signal	Output	When power window motor is DOWN at operated.	12
10 (W)	Ground	Battery power supply	Input	—	12
11 (B)	Ground	Ground	—	—	0
12 (GR)	Ground	Encoder pulse signal 1	Input	When power window motor operates.	
15 (BG)	Ground	Encoder pulse signal 2	Input	When power window motor operates.	
16 (Y)	Ground	Power window serial link	Input/ Output	Ignition switch ON or power window timer operating.	

A  
B  
C  
D  
E  
F  
G  
H  
I  
J  
L  
M  
N  
O  
P

PWC



# REAR POWER WINDOW SWITCH

< ECU DIAGNOSIS INFORMATION >

[FRONT & REAR WINDOW ANTI-PINCH]

## Fail-safe

INFOID:000000008290530

### FAIL-SAFE CONTROL

Switches to fail-safe control when malfunction is detected in encoder signal that detects up/down speed and direction of door glass. Switches to fail-safe control when a signal that is out of the specified value is detected between the fully closed position and the actual position of the glass.

Malfunction	Malfunction condition
Pulse sensor malfunction	When one pulse signal that is the specified value or more is detected continuously for the specified time or more, while door glass is being operated UP or DOWN.
Both pulse sensors malfunction	When both pulse signals are not detected continuously for the specified time or more, while door glass is being operated UP or DOWN.
Pulse direction malfunction	When a pulse signal indicating that window is moving in the opposite direction against the power window motor is detected for the specified value or more, while door glass is being operated UP or DOWN.
Glass recognition position malfunction 1	When the actual door glass position that is out of specified value is detected compared to the door glass fully closed position memorized in module, while door glass is being operated UP or DOWN.
Glass recognition position malfunction 2	When pulse count that is out of the door glass full stroke value or more is detected, while door glass is being operated UP or DOWN.

If fail-safe control, the system changes to a non-initialized condition and the following function do not operate.

- Auto-up operation
- Anti-pinch function
- Door key cylinder switch power window function

When fail-safe control is activated, perform initialization procedure to recover. If a malfunction is detected in power window switch or more, fail-safe control is activated again.

A  
B  
C  
D  
E  
F  
G  
H  
I  
J  
L  
M  
N  
O  
P

PWC

# POWER WINDOWS DO NOT OPERATE WITH ANY POWER WINDOW SWITCHES

< SYMPTOM DIAGNOSIS >

[FRONT & REAR WINDOW ANTI-PINCH]

## SYMPTOM DIAGNOSIS

### POWER WINDOWS DO NOT OPERATE WITH ANY POWER WINDOW SWITCHES

#### Diagnosis Procedure

INFOID:000000008290531

#### 1. CHECK BCM POWER SUPPLY AND GROUND CIRCUIT

---

Check BCM power supply and ground circuit.

[BCS-40, "Diagnosis Procedure"](#).

Is the inspection result normal?

YES >> GO TO 2.

NO >> Repair or replace the malfunctioning parts.

#### 2. CHECK POWER WINDOW MAIN SWITCH SERIAL LINK CIRCUIT

---

Check power window serial link circuit.

Refer to [PWC-35, "POWER WINDOW MAIN SWITCH : Component Function Check"](#).

Is the inspection result normal?

YES >> GO TO 3.

NO >> Repair or replace the malfunctioning parts.

#### 3. CONFIRM THE OPERATION

---

Confirm the operation again.

Is the result normal?

YES >> Check intermittent incident. Refer to [GI-43, "Intermittent Incident"](#).

NO >> GO TO 1.

# DRIVER SIDE POWER WINDOW DOES NOT OPERATE

< SYMPTOM DIAGNOSIS >

[FRONT & REAR WINDOW ANTI-PINCH]

## DRIVER SIDE POWER WINDOW DOES NOT OPERATE

### Diagnosis Procedure

INFOID:000000008290532

#### 1. CHECK POWER WINDOW MAIN SWITCH POWER SUPPLY AND GROUND CIRCUIT

Check power window switch power supply and ground circuit.

Refer to [PWC-16, "POWER WINDOW MAIN SWITCH : Diagnosis Procedure"](#).

Is the inspection result normal?

YES >> GO TO 2.

NO >> Repair or replace the malfunctioning parts.

#### 2. CHECK DRIVER SIDE POWER WINDOW MOTOR

Check driver side power window motor.

Refer to [PWC-19, "DRIVER SIDE : Component Function Check"](#).

Is the measurement value within the specification?

YES >> GO TO 3.

NO >> Repair or replace the malfunctioning parts.

#### 3. CONFIRM THE OPERATION

Confirm the operation again.

Is the result normal?

YES >> Check intermittent incident. Refer to [GI-43, "Intermittent Incident"](#).

NO >> GO TO 1.

A  
B  
C  
D  
E  
F  
G  
H  
I  
J  
L  
M  
N  
O  
P

PWC

## FRONT PASSENGER SIDE POWER WINDOW DOES NOT OPERATE

< SYMPTOM DIAGNOSIS >

[FRONT & REAR WINDOW ANTI-PINCH]

### FRONT PASSENGER SIDE POWER WINDOW DOES NOT OPERATE WHEN POWER WINDOW MAIN SWITCH IS OPERATED

WHEN POWER WINDOW MAIN SWITCH IS OPERATED : Diagnosis Procedure

INFOID:000000008290533

#### 1. CHECK FRONT POWER WINDOW SWITCH (PASSENGER SIDE) SERIAL LINK CIRCUIT

Check front power window switch (passenger side) serial link circuit.

Refer to [PWC-36. "FRONT POWER WINDOW SWITCH \(PASSENGER SIDE\) : Component Function Check"](#).

Is the inspection result normal?

YES >> GO TO 2.

NO >> Repair or replace the malfunctioning parts.

#### 2. CONFIRM THE OPERATION

Confirm the operation again.

Is the result normal?

YES >> Check intermittent incident. Refer to [GI-43. "Intermittent Incident"](#).

NO >> GO TO 1.

### WHEN FRONT POWER WINDOW SWITCH (PASSENGER SIDE) IS OPERATED

WHEN FRONT POWER WINDOW SWITCH (PASSENGER SIDE) IS OPERATED :  
Diagnosis Procedure

INFOID:000000008290534

#### 1. REPLACE FRONT POWER WINDOW SWITCH (PASSENGER SIDE)

Replace front power window switch (passenger side).

Refer to [PWC-98. "Removal and Installation"](#)

>> INSPECTION END

### WHEN BOTH POWER WINDOW MAIN SWITCH AND FRONT POWER WINDOW SWITCH ARE OPERATED

WHEN BOTH POWER WINDOW MAIN SWITCH AND FRONT POWER WINDOW  
SWITCH ARE OPERATED : Diagnosis Procedure

INFOID:000000008290535

#### 1. CHECK FRONT POWER WINDOW SWITCH (PASSENGER SIDE) POWER SUPPLY AND GROUND CIR- CUIT

Check front power window switch (passenger side) power supply and ground circuit.

Refer to [PWC-17. "FRONT POWER WINDOW SWITCH \(PASSENGER SIDE\) : Diagnosis Procedure"](#).

Is the inspection result normal?

YES >> GO TO 2.

NO >> Repair or replace the malfunctioning parts.

#### 2. CHECK PASSENGER SIDE POWER WINDOW MOTOR CIRCUIT

Check passenger side power window motor circuit.

Refer to [PWC-20. "PASSENGER SIDE : Component Function Check"](#).

Is the inspection result normal?

YES >> GO TO 3.

NO >> Repair or replace the malfunctioning parts.

#### 3. CONFIRM THE OPERATION

Confirm the operation again.

Is the result normal?

YES >> Check intermittent incident. Refer to [GI-43. "Intermittent Incident"](#).

NO >> GO TO 1.

# REAR LH SIDE POWER WINDOW DOES NOT OPERATE

< SYMPTOM DIAGNOSIS >

[FRONT & REAR WINDOW ANTI-PINCH]

## REAR LH SIDE POWER WINDOW DOES NOT OPERATE WHEN POWER WINDOW MAIN SWITCH IS OPERATED

WHEN POWER WINDOW MAIN SWITCH IS OPERATED : Diagnosis Procedure

INFOID:000000008290536

### 1. CHECK REAR POWER WINDOW SWITCH LH SERIAL LINK CIRCUIT

Check rear power window switch LH serial link circuit.

Refer to [PWC-38, "REAR LH : Component Function Check"](#).

Is the inspection result normal?

YES >> GO TO 2.

NO >> Repair or replace the malfunctioning parts.

### 2. CONFIRM THE OPERATION

Confirm the operation again.

Is the result normal?

YES >> Check intermittent incident. Refer to [GI-43, "Intermittent Incident"](#).

NO >> GO TO 1.

## WHEN REAR POWER WINDOW SWITCH LH IS OPERATED

WHEN REAR POWER WINDOW SWITCH LH IS OPERATED : Diagnosis Procedure

INFOID:000000008290537

### 1. REPLACE REAR POWER WINDOW SWITCH LH

Replace rear power window switch LH.

Refer to [PWC-98, "Removal and Installation"](#)

>> INSPECTION END

## WHEN BOTH POWER WINDOW MAIN SWITCH AND REAR POWER WINDOW SWITCH LH ARE OPERATED

WHEN BOTH POWER WINDOW MAIN SWITCH AND REAR POWER WINDOW  
SWITCH LH ARE OPERATED : Diagnosis Procedure

INFOID:000000008290538

PWC

### 1. CHECK REAR POWER WINDOW SWITCH POWER SUPPLY AND GROUND CIRCUIT

Check rear power window switch power supply and ground circuit.

Refer to [PWC-17, "REAR POWER WINDOW SWITCH : Diagnosis Procedure"](#).

Is the inspection result normal?

YES >> GO TO 2.

NO >> Repair or replace the malfunctioning parts.

### 2. CHECK REAR POWER WINDOW MOTOR LH

Check rear power window motor LH.

Refer to [PWC-21, "REAR LH : Component Function Check"](#).

Is the inspection result normal?

YES >> GO TO 3.

NO >> Repair or replace the malfunctioning parts.

### 3. CONFIRM THE OPERATION

Confirm the operation again.

Is the result normal?

YES >> Check intermittent incident. Refer to [GI-43, "Intermittent Incident"](#).

NO >> GO TO 1.

## REAR LH SIDE POWER WINDOW DOES NOT OPERATE

< SYMPTOM DIAGNOSIS >

[FRONT & REAR WINDOW ANTI-PINCH]

### REAR LH SIDE POWER WINDOW DOES NOT OPERATE WHEN POWER WINDOW MAIN SWITCH IS OPERATED

WHEN POWER WINDOW MAIN SWITCH IS OPERATED : Diagnosis Procedure

INFOID:000000008290539

#### 1. CHECK REAR POWER WINDOW SWITCH RH SERIAL LINK CIRCUIT

Check rear power window switch RH serial link circuit.

Refer to [PWC-39, "REAR RH : Component Function Check"](#).

Is the inspection result normal?

YES >> GO TO 2.

NO >> Repair or replace the malfunctioning parts.

#### 2. CONFIRM THE OPERATION

Confirm the operation again.

Is the result normal?

YES >> Check intermittent incident. Refer to [GI-43, "Intermittent Incident"](#).

NO >> GO TO 1.

### WHEN REAR POWER WINDOW SWITCH RH IS OPERATED

WHEN REAR POWER WINDOW SWITCH RH IS OPERATED : Diagnosis Procedure

INFOID:000000008290540

#### 1. REPLACE REAR POWER WINDOW SWITCH RH

Replace rear power window switch RH.

Refer to [PWC-98, "Removal and Installation"](#)

>> INSPECTION END

### WHEN BOTH POWER WINDOW MAIN SWITCH AND REAR POWER WINDOW SWITCH RH ARE OPERATED

WHEN BOTH POWER WINDOW MAIN SWITCH AND REAR POWER WINDOW  
SWITCH RH ARE OPERATED : Diagnosis Procedure

INFOID:000000008290541

#### 1. CHECK REAR POWER WINDOW SWITCH POWER SUPPLY AND GROUND CIRCUIT

Check rear power window switch power supply and ground circuit.

Refer to [PWC-17, "REAR POWER WINDOW SWITCH : Diagnosis Procedure"](#).

Is the inspection result normal?

YES >> GO TO 2.

NO >> Repair or replace the malfunctioning parts.

#### 2. CHECK REAR POWER WINDOW MOTOR RH

Check rear power window motor RH.

Refer to [PWC-22, "REAR RH : Component Function Check"](#).

Is the inspection result normal?

YES >> GO TO 3.

NO >> Repair or replace the malfunctioning parts.

#### 3. CONFIRM THE OPERATION

Confirm the operation again.

Is the result normal?

YES >> Check intermittent incident. Refer to [GI-43, "Intermittent Incident"](#).

NO >> GO TO 1.



# ANTI-PINCH FUNCTION DOES NOT OPERATE

< SYMPTOM DIAGNOSIS >

[FRONT & REAR WINDOW ANTI-PINCH]

## ANTI-PINCH FUNCTION DOES NOT OPERATE

### Diagnosis Procedure

INFOID:000000008290542

#### 1.CHECK POWER WINDOW AUTO OPERATION

Check AUTO operation when anti-pinch function does not operate.

Is the inspection result normal?

YES >> GO TO 2.

NO >> Refer to [PWC-90, "Diagnosis Procedure"](#).

#### 2.CONFIRM THE OPERATION

Confirm the operation again.

Is the result normal?

YES >> Check intermittent incident. Refer to [GI-43, "Intermittent Incident"](#).

NO >> GO TO 1.

A  
B  
C  
D  
E  
F  
G  
H  
I  
J  
L  
M  
N  
O  
P

PWC

# AUTO OPERATION DOES NOT OPERATE BUT MANUAL OPERATES NORMALLY

< SYMPTOM DIAGNOSIS >

[FRONT & REAR WINDOW ANTI-PINCH]

## AUTO OPERATION DOES NOT OPERATE BUT MANUAL OPERATES NORMALLY

### Diagnosis Procedure

INFOID:000000008290543

#### 1.PERFORM INITIALIZATION PROCEDURE

---

Initialization procedure is executed and operation is confirmed.

Refer to [PWC-7, "ADDITIONAL SERVICE WHEN REMOVING BATTERY NEGATIVE TERMINAL : Special Repair Requirement"](#).

Is the inspection result normal?

YES >> INSPECTION END  
NO >> GO TO 2.

#### 2.CHECK ENCODER CIRCUIT

---

Check encoder circuit. Refer to the following.

- Driver side: Refer to [PWC-24, "DRIVER SIDE : Component Function Check"](#).
- Passenger side: Refer to [PWC-26, "PASSENGER SIDE : Component Function Check"](#).
- Rear LH side: Refer to [PWC-28, "REAR LH : Component Function Check"](#).
- Rear RH side: Refer to [PWC-30, "REAR RH : Component Function Check"](#).

Is the inspection result normal?

YES >> GO TO 3.  
NO >> Repair or replace the malfunctioning parts.

#### 3.CONFIRM THE OPERATION

---

Confirm the operation again.

Is the result normal?

YES >> Check intermittent incident. Refer to [GI-43, "Intermittent Incident"](#).  
NO >> GO TO 1.

# POWER WINDOW RETAINED POWER FUNCTION DOES NOT OPERATE NORMALLY

< SYMPTOM DIAGNOSIS >

[FRONT & REAR WINDOW ANTI-PINCH]

## POWER WINDOW RETAINED POWER FUNCTION DOES NOT OPERATE NORMALLY

### Diagnosis Procedure

INFOID:000000008290544

#### 1. CHECK DOOR SWITCH

Check door switch.

Refer to [DLK-66, "Component Function Check"](#).

Is the inspection result normal?

YES >> GO TO 2.

NO >> Repair or replace the malfunctioning parts.

#### 2. CONFIRM THE OPERATION

Confirm the operation again.

Is the result normal?

YES >> Check intermittent incident. Refer to [GI-43, "Intermittent Incident"](#).

NO >> GO TO 1.

A  
B  
C  
D  
E  
F  
G  
H  
I  
J  
L  
M  
N  
O  
P

PWC

# DOOR KEY CYLINDER SWITCH DOES NOT OPERATE POWER WINDOWS

< SYMPTOM DIAGNOSIS >

[FRONT & REAR WINDOW ANTI-PINCH]

## DOOR KEY CYLINDER SWITCH DOES NOT OPERATE POWER WINDOWS

### Diagnosis Procedure

INFOID:000000008290545

#### 1.PERFORM INITIALIZATION PROCEDURE

---

Initialization procedure is executed and operation is confirmed.

Refer to [PWC-7, "ADDITIONAL SERVICE WHEN REMOVING BATTERY NEGATIVE TERMINAL : Special Repair Requirement"](#).

Is the inspection result normal?

YES >> INSPECTION END  
NO >> GO TO 2.

#### 2.CHECK DRIVER SIDE DOOR LOCK ASSEMBLY (DOOR KEY CYLINDER SWITCH)

---

Check driver side door lock assembly (door key cylinder switch).

Refer to [PWC-33, "Component Function Check"](#).

Is the inspection result normal?

YES >> GO TO 3.  
NO >> Repair or replace the malfunctioning parts.

#### 3.CONFIRM THE OPERATION

---

Confirm the operation again.

Is the result normal?

YES >> Check intermittent incident. Refer to [GI-43, "Intermittent Incident"](#).  
NO >> GO TO 1.

# KEYLESS POWER WINDOW DOWN DOES NOT OPERATE

< SYMPTOM DIAGNOSIS >

[FRONT & REAR WINDOW ANTI-PINCH]

## KEYLESS POWER WINDOW DOWN DOES NOT OPERATE

### Description

INFOID:000000008290546

Power window down does not operate when pressing unlock button on Intelligent Key.

### Diagnosis Procedure

INFOID:000000008290547

#### 1.CHECK REMOTE KEYLESS ENTRY FUNCTION

Check remote keyless entry function.

Does door lock/unlock with Intelligent Key button?

YES >> GO TO 2.

NO >> Refer to [DLK-160, "Description"](#).

#### 2.CHECK POWER WINDOW OPERATION

Check power window operation.

Does power window operate up/down using power window main switch?

YES >> GO TO 3.

NO >> Refer to [PWC-85, "Diagnosis Procedure"](#).

#### 3.CHECK "PW DOWN SET" SETTING IN "WORK SUPPORT"

Check "PW DOWN SET" setting in "WORK SUPPORT".

Refer to [DLK-53, "INTELLIGENT KEY : CONSULT Function \(BCM - INTELLIGENT KEY\)"](#).

Is the inspection result normal?

YES >> GO TO 4.

NO >> Set "PW DOWN SET" setting in "WORK SUPPORT".

#### 4.CONFIRM THE OPERATION

Confirm the operation again.

Is the result normal?

YES >> Check intermittent incident. Refer to [GI-43, "Intermittent Incident"](#).

NO >> GO TO 1.

A  
B  
C  
D  
E  
F  
G  
H  
I  
J  
L  
M  
N  
O  
P

PWC

## POWER WINDOW LOCK SWITCH DOES NOT FUNCTION

< SYMPTOM DIAGNOSIS >

[FRONT & REAR WINDOW ANTI-PINCH]

---

### POWER WINDOW LOCK SWITCH DOES NOT FUNCTION

#### Diagnosis Procedure

INFOID:000000008290548

#### 1. REPLACE POWER WINDOW MAIN SWITCH

---

Replace power window main switch.

>> Refer to [PWC-98. "Removal and Installation"](#).

# POWER WINDOW SWITCH ILLUMINATION DOES NOT ILLUMINATE

< SYMPTOM DIAGNOSIS >

[FRONT & REAR WINDOW ANTI-PINCH]

## POWER WINDOW SWITCH ILLUMINATION DOES NOT ILLUMINATE

### Diagnosis Procedure

INFOID:000000008290549

#### 1. REPLACE POWER WINDOW SWITCH

Replace power window switch.

Refer to [PWC-98, "Removal and Installation"](#).

>> INSPECTION END

A

B

C

D

E

F

G

H

I

J

PWC

L

M

N

O

P

## PRECAUTION

### PRECAUTIONS

#### Precaution for Supplemental Restraint System (SRS) "AIR BAG" and "SEAT BELT PRE-TENSIONER"

INFOID:000000008290550

The Supplemental Restraint System such as "AIR BAG" and "SEAT BELT PRE-TENSIONER", used along with a front seat belt, helps to reduce the risk or severity of injury to the driver and front passenger for certain types of collision. This system includes seat belt switch inputs and dual stage front air bag modules. The SRS system uses the seat belt switches to determine the front air bag deployment, and may only deploy one front air bag, depending on the severity of a collision and whether the front occupants are belted or unbelted. Information necessary to service the system safely is included in the "SRS AIR BAG" and "SEAT BELT" of this Service Manual.

**WARNING:**

Always observe the following items for preventing accidental activation.

- To avoid rendering the SRS inoperative, which could increase the risk of personal injury or death in the event of a collision that would result in air bag inflation, all maintenance must be performed by an authorized NISSAN/INFINITI dealer.
- Improper maintenance, including incorrect removal and installation of the SRS, can lead to personal injury caused by unintentional activation of the system. For removal of Spiral Cable and Air Bag Module, see "SRS AIR BAG".
- Never use electrical test equipment on any circuit related to the SRS unless instructed to in this Service Manual. SRS wiring harnesses can be identified by yellow and/or orange harnesses or harness connectors.

#### PRECAUTIONS WHEN USING POWER TOOLS (AIR OR ELECTRIC) AND HAMMERS

**WARNING:**

Always observe the following items for preventing accidental activation.

- When working near the Air Bag Diagnosis Sensor Unit or other Air Bag System sensors with the ignition ON or engine running, never use air or electric power tools or strike near the sensor(s) with a hammer. Heavy vibration could activate the sensor(s) and deploy the air bag(s), possibly causing serious injury.
- When using air or electric power tools or hammers, always switch the ignition OFF, disconnect the battery, and wait at least 3 minutes before performing any service.



# PREPARATION

< PREPARATION >

[FRONT & REAR WINDOW ANTI-PINCH]

## PREPARATION

### PREPARATION

#### Commercial Service Tools

INFOID:000000008290551

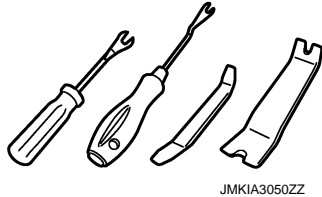
Tool name	Description
Remover tool  JMKIA3050ZZ	Removes the clips, pawls and metal clips

A  
B  
C  
D  
E  
F  
G  
H  
I  
J  
L  
M  
N  
O  
P

PWC

# POWER WINDOW MAIN SWITCH

< REMOVAL AND INSTALLATION >

[FRONT & REAR WINDOW ANTI-PINCH]

## REMOVAL AND INSTALLATION

### POWER WINDOW MAIN SWITCH

#### Removal and Installation

INFOID:000000008290552

#### REMOVAL

1. Remove the power window main switch finisher (2).  
Refer to [INT-11, "Removal and Installation"](#).
2. Power window main switch (1) is removed from power window main switch finisher (2) using remover tool (A).

 : Pawl

#### CAUTION:

**Do not fold the pawl of power window main switch finisher.**

#### NOTE:

The same procedure is also performed for front power window switch (passenger side) and rear power window switch (LH & RH).

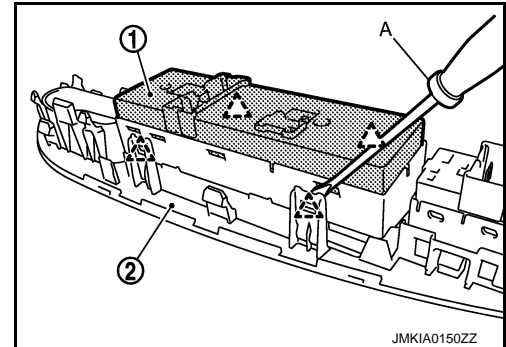

#### INSTALLATION

Install in the reverse order of removal.

#### NOTE:

Power window main switch is exchanged or is detached it is necessary to do the initialization procedure. Refer to [PWC-8, "ADDITIONAL SERVICE WHEN REPLACING CONTROL UNIT : Special Repair Requirement"](#).

## BASIC INSPECTION

### DIAGNOSIS AND REPAIR WORKFLOW

#### Work Flow

INFOID:000000008290553

#### DETAILED FLOW

#### 1.OBTAIN INFORMATION ABOUT SYMPTOM

Interview the customer to obtain as much malfunction information (conditions and environment when the malfunction occurred) as possible when the customer brings the vehicle in.

>> GO TO 2.

#### 2.REPRODUCE THE MALFUNCTION INFORMATION

Check the malfunction on the vehicle that the customer describes.  
Inspect the relation of the symptoms and the condition when the symptoms occur.

>> GO TO 3.

#### 3.IDENTIFY THE MALFUNCTIONING SYSTEM WITH "SYMPTOM DIAGNOSIS"

Use "Symptom diagnosis" from the symptom inspection result in step 2. Then identify where to start the diagnosis based on possible causes and symptoms.

>> GO TO 4.

#### 4.IDENTIFY MALFUNCTIONING PARTS WITH "DTC/CIRCUIT DIAGNOSIS"

Perform the diagnosis with "DTC/CIRCUIT DIAGNOSIS" of the applicable system.

>> GO TO 5.

#### 5.REPAIR OR REPLACE THE MALFUNCTIONING PARTS

Repair or replace the specified malfunctioning parts.

>> GO TO 6.

#### 6.FINAL CHECK

Check that malfunctions are not reproduced when obtaining the malfunction information from the customer, referring to the symptom inspection result in step 2.

Is the malfunctioning part repaired or replaced?

YES >> Trouble diagnosis is completed.

NO >> GO TO 3.

A  
B  
C  
D  
E  
F  
G  
H  
I  
J  
PWC  
L  
M  
N  
O  
P

# INSPECTION AND ADJUSTMENT

< BASIC INSPECTION >

[FRONT WINDOW ANTI-PINCH]

## INSPECTION AND ADJUSTMENT

### ADDITIONAL SERVICE WHEN REMOVING BATTERY NEGATIVE TERMINAL

#### ADDITIONAL SERVICE WHEN REMOVING BATTERY NEGATIVE TERMINAL : Description

INFOID:000000008290554

When the battery negative terminal is disconnected, the initialization is necessary.

If any of the following operations are performed, the initialization is necessary as well as when the negative terminal of battery is disconnected.

- Power supply to the power window main switch or power window motor is cut off by the removal of battery terminal or if the battery fuse is blown.
- Disconnection and connection of power window main switch harness connector.
- Removal and installation of motor from regulator assembly.
- Operation of regulator assembly as an independent unit.
- Removal and installation of glass.
- Removal and installation of door glass run.

The following specified operations can not be performed under the non-initialized condition.

- Auto-up operation
- Anti-pinch function

#### ADDITIONAL SERVICE WHEN REMOVING BATTERY NEGATIVE TERMINAL : Special Repair Requirement

INFOID:000000008290555

### INITIALIZATION PROCEDURE

1. Disconnect the battery negative terminal or power window main switch connector. Reconnect it after a minute or more.
2. Turn ignition switch ON.
3. Operate power window switch to fully open the window. (This operation is unnecessary if the window is already fully open)
4. Continue pulling the power window switch UP (AUTO-UP operation). Even after glass stops at the fully closed position, keep pulling the switch for 3 seconds or more.
5. Initializing procedure is completed.
6. Inspect anti-pinch function.

### CHECK ANTI-PINCH FUNCTION

1. Fully open the door window.
  2. Place a piece of wood near fully closed position.
  3. Close door glass completely with AUTO-UP.
- Check that glass lowers for approximately 150 mm (5.9 in) without pinching piece of wood and stops.
  - Check that glass does not rise when operating the power window main switch while lowering.

#### **CAUTION:**

- **Perform initial setting when auto-up operation or anti-pinch function does not operate normally.**
- **Check that AUTO-UP operates before inspection when system initialization is performed.**
- **Never check with hands or other body parts because they may be pinched. Never get pinched.**
- **Finish initial setting. Otherwise, next operation cannot be done.**

1. **Auto-up operation**
2. **Anti-pinch function**

### ADDITIONAL SERVICE WHEN REPLACING CONTROL UNIT

#### ADDITIONAL SERVICE WHEN REPLACING CONTROL UNIT : Description

INFOID:000000008290556

When the control unit replaced, the initialization is necessary.

If any of the following operations are performed, the initialization is necessary as well as when the control unit is disconnected.

- Power supply to the power window main switch or power window motor is cut off by the removal of battery terminal or if the battery fuse is blown.
- Disconnection and connection of power window main switch harness connector.
- Removal and installation of motor from regulator assembly.
- Disconnection and connection of battery negative terminal.

# INSPECTION AND ADJUSTMENT

## < BASIC INSPECTION >

## [FRONT WINDOW ANTI-PINCH]

- Removal and installation of glass.
- Removal and installation of door glass run.

The following specified operations can not be performed under the non-initialized condition.

- Auto-up operation
- Anti-pinch function

## ADDITIONAL SERVICE WHEN REPLACING CONTROL UNIT : Special Repair Requirement

INFOID:000000008290557

### INITIALIZATION PROCEDURE

1. Disconnect the battery negative terminal or power window main switch connector. Reconnect it after a minute or more.
2. Turn ignition switch ON.
3. Operate power window switch to fully open the window. (This operation is unnecessary if the window is already fully open)
4. Continue pulling the power window switch UP (AUTO-UP operation). Even after glass stops at the fully closed position, keep pulling the switch for 3 seconds or more.
5. Initializing procedure is completed.
6. Inspect anti-pinch function.

### CHECK ANTI-PINCH FUNCTION

1. Fully open the door window.
2. Place a piece of wood near fully closed position.
3. Close door glass completely with AUTO-UP.
  - Check that glass lowers for approximately 150 mm (5.9 in) without pinching piece of wood and stops.
  - Check that glass does not rise when operating the power window main switch while lowering.

#### **CAUTION:**

- Perform initial setting when auto-up operation or anti-pinch function does not operate normally.
  - Check that AUTO-UP operates before inspection when system initialization is performed.
  - Never check with hands or other body parts because they may be pinched. Never get pinched.
  - Finish initial setting. Otherwise, next operation cannot be done.
1. Auto-up operation
  2. Anti-pinch function

A  
B  
C  
D  
E  
F  
G  
H  
I  
J  
L  
M  
N  
O  
P

PWC

# SYSTEM DESCRIPTION

## POWER WINDOW SYSTEM

### System Diagram

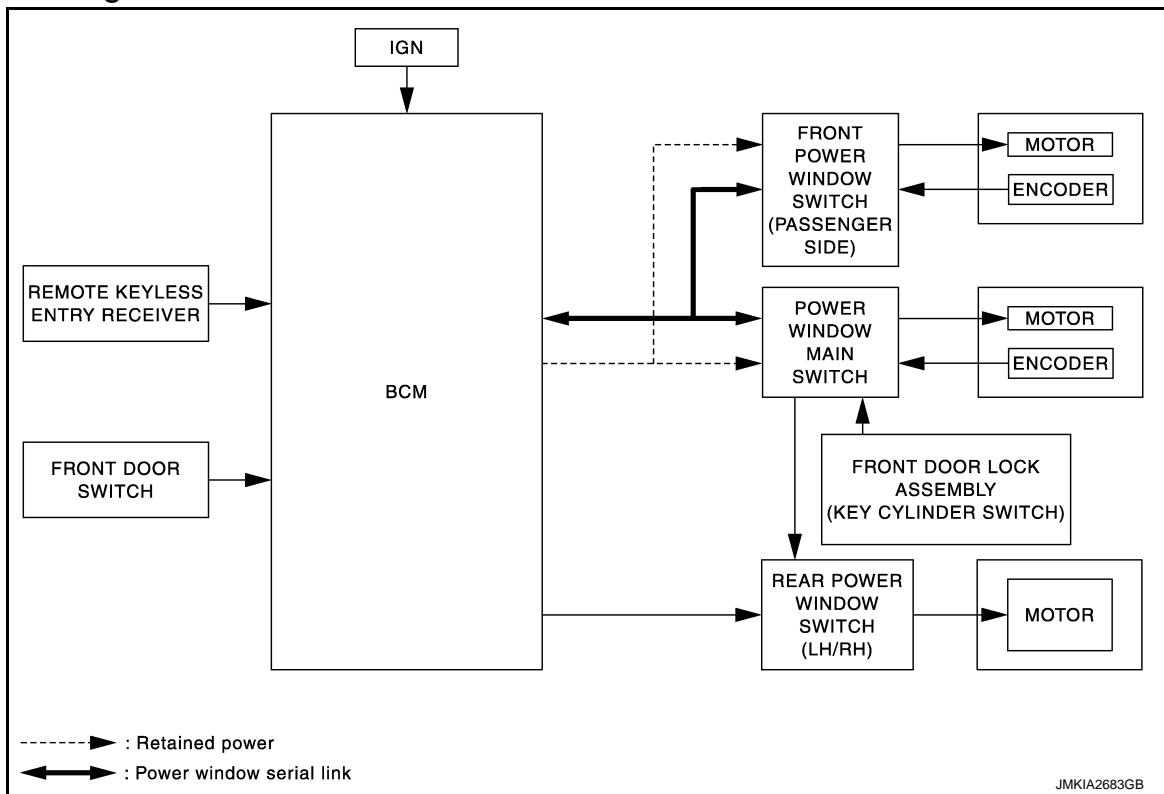

### System Description

INFOID:000000008290559

- Power window system is activated by power window switch when ignition switch turns ON, or during the retained power operation after ignition switch turns OFF.
- Power window main switch opens/closes all door glass.
- Front and rear power window switch opens/closes the corresponding door glass.
- AUTO UP/DOWN operation can be performed when power window main switch or front power window switch (passenger side) turns to AUTO.
- Power window serial link transmits the signals from power window main switch to front power window switch (passenger side).
- Power window lock switch can lock all power windows other than driver seat.
- If door glass receives resistance that is the specified value or more while power window of front seat is in AUTO-UP operation, power window of front seat operates in the reverse direction.
- Hold the door key cylinder to the LOCK or UNLOCK direction for 1 second or more to OPEN or CLOSE front power windows when ignition switch OFF.
- Front power windows open when pressing Intelligent Key unlock button for 3 seconds.

#### POWER WINDOW AUTO-OPERATION (FRONT DRIVER SIDE & PASSENGER SIDE)

- AUTO UP/DOWN operation can be performed when power window main switch or front power window switch (passenger side) turns to AUTO.
- Encoder continues detecting the movement of power window motor and transmits the encoder pulse signal to power window switch while power window motor is operating.
- Power window switch reads the changes of encoder signal and stops AUTO operation when door glass is at the fully opened/closed position.
- Power window motor is operable if encoder is malfunctioning.

#### RETAINED POWER OPERATION (FRONT DRIVER SIDE & PASSENGER SIDE)

Retained power operation is an additional power supply function that enables power window system to operate during the 45 seconds even when ignition switch is turned OFF

# POWER WINDOW SYSTEM

[FRONT WINDOW ANTI-PINCH]

## < SYSTEM DESCRIPTION >

### Retained Power Cancel Conditions

- Front door CLOSE (door switch OFF)→OPEN (door switch ON).
- When ignition switch is ON.
- When timer time passes (45 seconds).

### POWER WINDOW LOCK FUNCTION

Ground circuit inside power window main switch shuts off when power window lock switch is ON. This inhibits each power window switch operation except the power window main switch.

### POWER WINDOW SERIAL LINK (FRONT DRIVER SIDE & PASSENGER SIDE)

- Power window main switch, front power window switch (passenger side), and BCM transmit and receive the power window serial link.
- Power window serial link transmits the power window main switch operation signals and IGN signal to power window main switch module and front power window switch (passenger side) module.

### ANTI-PINCH OPERATION (FRONT DRIVER SIDE & PASSENGER SIDE)

- Pinch foreign matter in the door glass during AUTO-UP operation, and it is the anti-pinch function that lowers the door glass 150 mm (5.9 in) when detected.
- Encoder continues detecting the movement of power window motor and transmits to power window switch as the encoder pulse signal while power window motor is operating.
- Resistance is applied to the power window motor rotation that changes the frequency of encoder pulse signal if foreign material is trapped in the door glass.
- Power window switch controls to lower the door glass for 150 mm (5.9 in) after it detects encoder pulse signal frequency change.

### Operation Condition

When front door glass AUTO-UP operation is performed (anti-pinch function does not operate just before the door glass closes and is fully closed).

#### **NOTE:**

Depending on environment and driving conditions, if a similar impact or load is applied to the door glass, it may lower.

### DOOR KEY CYLINDER SWITCH OPERATION

Hold the door key cylinder to the LOCK or UNLOCK direction for 1.5 seconds or more to OPEN or CLOSE front power windows when ignition switch is OFF. In addition, it stops when key position is moved to NEUTRAL when operating.

#### OPERATION CONDITION

- Ignition switch OFF.
- Hold door key cylinder to LOCK position for 1.5 seconds or more to perform CLOSE operation of the door glass.
- Hold door key cylinder to UNLOCK position for 1.5 seconds or more to perform OPEN operation of the door glass.

### KEYLESS POWER WINDOW DOWN OPERATION (FRONT DRIVER SIDE & PASSENGER SIDE)

Front power windows open when the unlock button on Intelligent Key is activated and kept pressed for more than 3 seconds with the ignition switch OFF. The windows keep opening if the unlock button is continuously pressed.

The power window opening stops when the following operations are performed:

- When the unlock button is kept pressed more than 15 seconds.
- When the ignition switch is turned ON while the power window opening is operated.
- When the unlock button is released.

While retained power operation activate, keyless power window down function cannot be operated.

Keyless power window down operation mode can be changed by "PW DOWN SET" mode in "WORK SUPPORT". Refer to [DLK-53, "INTELLIGENT KEY : CONSULT Function \(BCM - INTELLIGENT KEY\)"](#).

#### **NOTE:**

Use CONSULT to change settings.

MODE 1 (3 sec) / MODE 2 (OFF) / MODE 3 (5 sec)

A  
B  
C  
D  
E  
F  
G  
H  
I  
J  
L  
M  
N  
O  
P

PWC

# POWER WINDOW SYSTEM

< SYSTEM DESCRIPTION >

[FRONT WINDOW ANTI-PINCH]

## Component Parts Location

INFOID:000000008290560

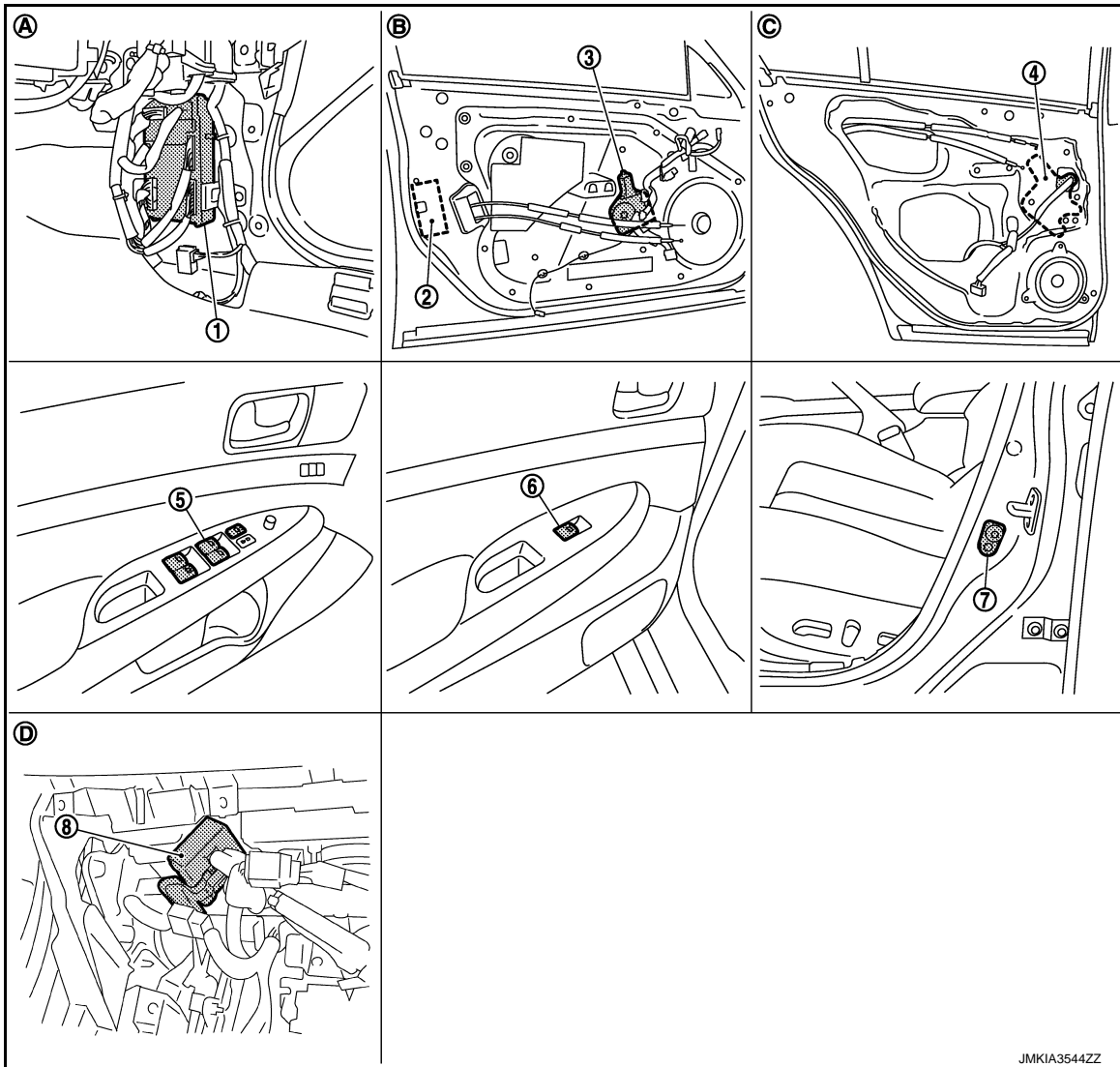

JMKIA3544ZZ

- |  |  |   |
|--|--|---|
| 1. BCM   | 2. Front door lock assembly (driver side) (door key cylinder switch) | 3. Front power window motor (driver side) |
| 4. Rear power window motor LH                                | 5. Power window main switch  | 6. Rear power window switch LH            |
| 7. Front door switch (driver side)                           | 8. Remote keyless entry receiver                                     |   |
| A. View with dash side lower (passenger side)                | B. View with front door finisher removed                             | C. View with rear door finisher removed   |
| D. View with instrument lower panel (passenger side) removed |  |   |

## Component Description

INFOID:000000008290561

Component	Function
BCM	<ul style="list-style-type: none"> <li>Supplies power supply to power window switch.</li> <li>Controls retained power.</li> </ul>
Power window main switch	<ul style="list-style-type: none"> <li>Directly controls all power window motor of all doors.</li> <li>Controls anti-pinch operation of power window.</li> </ul>
Front power window switch (passenger side)	<ul style="list-style-type: none"> <li>Controls power window motor of passenger door.</li> <li>Controls anti-pinch operation of power window.</li> </ul>



# POWER WINDOW SYSTEM

< SYSTEM DESCRIPTION >

[FRONT WINDOW ANTI-PINCH]

Component	Function
Rear power window switch	<ul style="list-style-type: none"><li>Controls power window motor of rear right and left doors.</li></ul>
Front power window motor	<ul style="list-style-type: none"><li>Integrates the ENCODER POWER and WINDOW MOTOR.</li><li>Starts operating with signals from power window main switch and front power window switch (passenger side).</li><li>Transmits power window motor rotation as a pulse signal to power window switch.</li></ul>
Rear power window motor	Starts operating with signals from power window main switch and rear power window switch.
Front door lock assembly (key cylinder switch)	Transmits operation condition of key cylinder switch to power window main switch.
Front door switch (driver side/passenger side)	Front door open/close condition and transmits to BCM.
Remote keyless entry receiver	Receives lock/unlock signal from the intelligent key, and then transmits to BCM.

A  
B  
C  
D  
E  
F  
G  
H  
I  
J  
L  
M  
N  
O  
P

PWC

# DIAGNOSIS SYSTEM (BCM)

< SYSTEM DESCRIPTION >

[FRONT WINDOW ANTI-PINCH]

## DIAGNOSIS SYSTEM (BCM)

### COMMON ITEM

COMMON ITEM : CONSULT Function (BCM - COMMON ITEM)

INFOID:000000008782235

### APPLICATION ITEM

CONSULT performs the following functions via CAN communication with BCM.

Diagnosis mode	Function Description
Work Support	Changes the setting for each system function.
Self Diagnostic Result	Displays the diagnosis results judged by BCM.
CAN Diag Support Monitor	Monitors the reception status of CAN communication viewed from BCM.
Data Monitor	The BCM input/output signals are displayed.
Active Test	The signals used to activate each device are forcibly supplied from BCM.
Ecu Identification	The BCM part number is displayed.
Configuration	This function is not used even though it is displayed.

### SYSTEM APPLICATION

BCM can perform the following functions for each system.

#### NOTE:

It can perform the diagnosis modes except the following for all sub system selection items.

×: Applicable item

System	Sub system selection item	Diagnosis mode		
		Work Support	Data Monitor	Active Test
Door lock	DOOR LOCK	×	×	×
Rear window defogger	REAR DEFOGGER		×	×
Warning chime	BUZZER		×	×
Interior room lamp timer	INT LAMP	×	×	×
Exterior lamp	HEAD LAMP	×	×	×
Wiper and washer	WIPER	×	×	×
Turn signal and hazard warning lamps	FLASHER	×	×	×
—	AIR CONDITONER*			
• Intelligent Key system • Engine start system	INTELLIGENT KEY	×	×	×
Combination switch	COMB SW		×	
Body control system	BCM	×		
IVIS - NATS	IMMU		×	×
Interior room lamp battery saver	BATTERY SAVER	×	×	×
Trunk lid open	TRUNK		×	×
Vehicle security system	THEFT ALM	×	×	×
RAP system	RETAINED PWR		×	
Signal buffer system	SIGNAL BUFFER		×	×
TPMS	AIR PRESSURE MONITOR	×	×	×

#### NOTE:

\*: This item is displayed, but is not used.

### FREEZE FRAME DATA (FFD)

The BCM records the following vehicle condition at the time a particular DTC is detected, and displays on CONSULT.

# DIAGNOSIS SYSTEM (BCM)

[FRONT WINDOW ANTI-PINCH]

< SYSTEM DESCRIPTION >

CONSULT screen item	Indication/Unit	Description	
Vehicle Speed	km/h	Vehicle speed of the moment a particular DTC is detected	
Odo/Trip Meter	km	Total mileage (Odometer value) of the moment a particular DTC is detected	
Vehicle Condition	SLEEP>LOCK	Power position status of the moment a particular DTC is detected	While turning BCM status from low power consumption mode to normal mode (Power supply position is "LOCK"*)
	SLEEP>OFF		While turning BCM status from low power consumption mode to normal mode (Power supply position is "OFF".)
	LOCK>ACC		While turning power supply position from "LOCK"* to "ACC"
	ACC>ON		While turning power supply position from "ACC" to "IGN"
	RUN>ACC		While turning power supply position from "RUN" to "ACC" (Vehicle is stopping and selector lever is except P position.)
	CRANK>RUN		While turning power supply position from "CRANKING" to "RUN" (From cranking up the engine to run it)
	RUN>URGENT		While turning power supply position from "RUN" to "ACC" (Emergency stop operation)
	ACC>OFF		While turning power supply position from "ACC" to "OFF"
	OFF>LOCK		While turning power supply position from "OFF" to "LOCK"*
	OFF>ACC		While turning power supply position from "OFF" to "ACC"
	ON>CRANK		While turning power supply position from "IGN" to "CRANKING"
	OFF>SLEEP		While turning BCM status from normal mode (Power supply position is "OFF".) to low power consumption mode
	LOCK>SLEEP		While turning BCM status from normal mode (Power supply position is "LOCK"*. ) to low power consumption mode
	LOCK		Power supply position is "LOCK"*
	OFF		Power supply position is "OFF" (Ignition switch OFF)
	ACC		Power supply position is "ACC" (Ignition switch ACC)
	ON		Power supply position is "IGN" (Ignition switch ON with engine stopped)
ENGINE RUN	Power supply position is "RUN" (Ignition switch ON with engine running)		
CRANKING	Power supply position is "CRANKING" (At engine cranking)		
IGN Counter	0 - 39	The number of times that ignition switch is turned ON after DTC is detected <ul style="list-style-type: none"> <li>• The number is 0 when a malfunction is detected now.</li> <li>• The number increases like 1 → 2 → 3...38 → 39 after returning to the normal condition whenever ignition switch OFF → ON.</li> <li>• The number is fixed to 39 until the self-diagnosis results are erased if it is over 39.</li> </ul>	

**NOTE:**

\*: Power supply position shifts to "LOCK" from "OFF", when ignition switch is in the OFF position, selector lever is in the P position (A/T models), and any of the following conditions are met.

- Closing door
- Opening door
- Door is locked using door request switch
- Door is locked using Intelligent Key

The power supply position shifts to "ACC" when the push-button ignition switch (push switch) is pushed at "LOCK".

## RETAINED PWR

### RETAINED PWR : CONSULT Function (BCM - RETAINED PWR)

INFOID:000000008290563

Data monitor

**NOTE:**

The following table includes information (items) inapplicable to this vehicle. For information (items) applicable to this vehicle, refer to CONSULT display items.

# DIAGNOSIS SYSTEM (BCM)

< SYSTEM DESCRIPTION >

[FRONT WINDOW ANTI-PINCH]

Monitor Item	Description
DOOR SW-DR	Indicates [ON/OFF] condition of driver side door switch.
DOOR SW-AS	Indicates [ON/OFF] condition of passenger side door switch.

# POWER SUPPLY AND GROUND CIRCUIT

< DTC/CIRCUIT DIAGNOSIS >

[FRONT WINDOW ANTI-PINCH]

## DTC/CIRCUIT DIAGNOSIS

### POWER SUPPLY AND GROUND CIRCUIT

#### POWER WINDOW MAIN SWITCH

#### POWER WINDOW MAIN SWITCH : Diagnosis Procedure

INFOID:000000008290564

#### 1. CHECK POWER SUPPLY CIRCUIT 1

1. Turn ignition switch OFF.
2. Disconnect power window main switch connectors.
3. Turn ignition switch ON.
4. Check voltage between power window main switch harness connector and ground.

(+)		(-)	Voltage (V) (Approx.)
Power window main switch			
Connector	Terminal	Ground	12
D8	10		
D9	19		

Is the inspection result normal?

- YES >> GO TO 2.  
NO >> GO TO 3.

#### 2. CHECK GROUND CIRCUIT

1. Turn ignition switch OFF.
2. Check continuity between power window main switch harness connector and ground.

Power window main switch		Ground	Continuity
Connector	Terminal		
D9	17		Existed

Is the inspection result normal?

- YES >> GO TO 4.  
NO >> Repair or replace harness.

#### 3. CHECK POWER SUPPLY CIRCUIT 2

1. Turn ignition switch OFF.
2. Disconnect BCM connector.
3. Check continuity between BCM harness connector and power window main switch harness connector.

BCM		Power window main switch		Continuity
Connector	Terminal	Connector	Terminal	
M118	2	D9	19	Existed
	3	D8	10	

4. Check continuity between BCM harness connector and ground.

BCM		Ground	Continuity
Connector	Terminal		
M118	2		Not existed
	3		

Is the inspection result normal?

- YES >> Replace BCM. Refer to [BCS-81, "Exploded View"](#).  
NO >> Repair or replace harness.

#### 4. CHECK INTERMITTENT INCIDENT

A  
B  
C  
D  
E  
F  
G  
H  
I  
J  
L  
M  
N  
O  
P

PWC

# POWER SUPPLY AND GROUND CIRCUIT

< DTC/CIRCUIT DIAGNOSIS >

[FRONT WINDOW ANTI-PINCH]

Refer to [GI-43. "Intermittent Incident"](#)

>> INSPECTION END

## FRONT POWER WINDOW SWITCH (PASSENGER SIDE)

### FRONT POWER WINDOW SWITCH (PASSENGER SIDE) : Diagnosis Procedure

INFOID:000000008290565

#### 1. CHECK POWER SUPPLY CIRCUIT 1

1. Turn ignition switch OFF.
2. Disconnect front power window switch (passenger side) connector.
3. Turn ignition switch ON.
4. Check voltage between front power window switch (passenger side) harness connector and ground.

(+)		(-)	Voltage (V) (Approx.)
Front power window switch (passenger side)			
Connector	Terminal	Ground	12
D38	10		

Is the inspection result normal?

- YES >> GO TO 2.  
NO >> GO TO 3.

#### 2. CHECK GROUND CIRCUIT

Check continuity between front power window switch (passenger side) harness connector and ground.

Front power window switch (passenger side)		Ground	Continuity
Connector	Terminal		
D38	11		Existed

Is the inspection result normal?

- YES >> GO TO 4.  
NO >> Repair or replace harness.

#### 3. CHECK POWER SUPPLY CIRCUIT 2

1. Disconnect BCM connector.
2. Check continuity between BCM harness connector and front power window switch (passenger side) harness connector.

BCM		Front power window switch (passenger side)		Continuity
Connector	Terminal	Connector	Terminal	
M118	2	D38	10	Existed

3. Check continuity between BCM harness connector and ground.

BCM		Ground	Continuity
Connector	Terminal		
M118	2		Not existed

Is the inspection result normal?

- YES >> Replace BCM. Refer to [BCS-81. "Exploded View"](#).  
NO >> Repair or replace harness.

#### 4. CHECK INTERMITTENT INCIDENT

Refer to [GI-43. "Intermittent Incident"](#)

# POWER SUPPLY AND GROUND CIRCUIT

< DTC/CIRCUIT DIAGNOSIS >

[FRONT WINDOW ANTI-PINCH]

>> INSPECTION END

## REAR POWER WINDOW SWITCH

### REAR POWER WINDOW SWITCH : Diagnosis Procedure

INFOID:000000008290566

#### 1.CHECK POWER SUPPLY CIRCUIT 1

1. Turn ignition switch OFF.
2. Disconnect rear power window switch connectors.
3. Turn ignition switch ON.
4. Check voltage between rear power window switch harness connector and ground.

(+)		Terminal	(-)	Voltage (V) (Approx.)
Rear power window switch				
Connector				
LH	D54	1	Ground	12
RH	D74			

Is the inspection result normal?

YES >> GO TO 2.

NO >> GO TO 3.

#### 2.CHECK GROUND CIRCUIT

Check continuity between rear power window switch harness connector and ground.

Rear power window switch		Terminal	Ground	Continuity
Connector				
LH	D54	7		Existed
RH	D74			

Is the inspection result normal?

YES >> GO TO 4.

NO >> Repair or replace harness.

#### 3.CHECK POWER SUPPLY CIRCUIT 2

1. Turn ignition switch OFF.
2. Disconnect BCM connector.
3. Check continuity between BCM harness connector and rear power window switch harness connector.

BCM		Rear power window switch		Continuity
Connector	Terminal	Connector	Terminal	
M118	3	LH	D54	Existed
		RH	D74	

4. Check continuity between BCM harness connector and ground.

BCM		Terminal	Ground	Continuity
Connector				
M118		3		Not existed

Is the inspection result normal?

YES >> Replace BCM. Refer to [BCS-81, "Exploded View"](#).

NO >> Repair or replace harness.

#### 4.CHECK INTERMITTENT INCIDENT

Refer to [GI-43, "Intermittent Incident"](#)

A  
B  
C  
D  
E  
F  
G  
H  
I  
J  
L  
M  
N  
O  
P

PWC

## POWER SUPPLY AND GROUND CIRCUIT

< DTC/CIRCUIT DIAGNOSIS >

[FRONT WINDOW ANTI-PINCH]

---

>> INSPECTION END



# REAR POWER WINDOW SWITCH

< DTC/CIRCUIT DIAGNOSIS >

[FRONT WINDOW ANTI-PINCH]

## REAR POWER WINDOW SWITCH

### Description

INFOID:000000008290567

- BCM supplies power.
- When power window switch is operated, corresponding power window motor is activated and rear door glass moves UP/DOWN.

### Component Function Check

INFOID:000000008290568

#### 1. CHECK REAR POWER WINDOW FUNCTION

Check rear power window motor operation with rear power window switch.

Is the inspection result normal?

- YES >> Rear power window switch is OK.  
 NO >> Refer to [PWC-113, "Diagnosis Procedure"](#).

### Diagnosis Procedure

INFOID:000000008290569

#### 1. CHECK REAR POWER WINDOW MOTOR INPUT SIGNAL

1. Turn ignition switch ON.
2. Check voltage between rear power window switch harness connector and ground.

(+)		Terminal	(-)	Condition	Voltage (V) (Approx.)			
Rear power window switch								
Connector								
LH	D54	2	Ground	Power window main switch (rear LH)	NEUTRAL	0		
		3			UP	12		
RH	D74			2	Power window main switch (rear RH)	NEUTRAL	0	
		3				DOWN	12	
								NEUTRAL

Is the inspection result normal?

- YES >> GO TO 2.  
 NO >> GO TO 3.

#### 2. CHECK REAR POWER WINDOW SWITCH

Check rear power window switch.

Refer to [PWC-114, "Component Inspection"](#).

Is the inspection result normal?

- YES >> GO TO 4.  
 NO >> Replace rear power window switch.

#### 3. CHECK HARNESS CONTINUITY

1. Turn ignition switch OFF.
2. Disconnect power window main switch connector and rear power window switch connector.
3. Check continuity between power window main switch harness connector and rear power window switch harness connector.



# REAR POWER WINDOW SWITCH

< DTC/CIRCUIT DIAGNOSIS >

[FRONT WINDOW ANTI-PINCH]

Power window main switch		Rear power window switch			Continuity
Connector	Terminal	Connector		Terminal	
D8	1	LH	D54	2	Existed
	3			3	
	5	RH	D74	3	
	7			2	

4. Check continuity between power window main switch connector and ground.

Power window main switch		Ground	Continuity
Connector	Terminal		
D8	1	Ground	Not existed
	3		
	5		
	7		

Is the inspection result normal?

YES >> Replace power window main switch.

NO >> Repair or replace harness.

## 4.CHECK INTERMITTENT INCIDENT

Refer to [GI-43, "Intermittent Incident"](#)

>> INSPECTION END

## Component Inspection

INFOID:000000008290570

### COMPONENT INSPECTION

#### 1.CHECK REAR POWER WINDOW SWITCH

1. Turn ignition switch OFF.
2. Disconnect rear power window switch connector.
3. Check rear power window switch terminals under the following conditions.

Rear power window switch		Condition	Continuity
Terminal			
1	5	UP	Existed
3	4		
3	4	NEUTRAL	
5	2	DOWN	
1	4		
5	2		

Is the inspection result normal?

YES >> Rear power window switch is OK.

NO >> Replace rear power window switch.

# POWER WINDOW MOTOR

[FRONT WINDOW ANTI-PINCH]

< DTC/CIRCUIT DIAGNOSIS >

## POWER WINDOW MOTOR DRIVER SIDE

### DRIVER SIDE : Description

INFOID:000000008290571

Door glass moves UP/DOWN by receiving the signal from power window main switch.

### DRIVER SIDE : Component Function Check

INFOID:000000008290572

#### 1. CHECK FRONT POWER WINDOW MOTOR (DRIVER SIDE) CIRCUIT

Check front power window motor (driver side) operation with power window main switch.

Is the inspection result normal?

- YES >> Front power window motor (driver side) is OK.
- NO >> Refer to [PWC-115. "DRIVER SIDE : Diagnosis Procedure"](#).

### DRIVER SIDE : Diagnosis Procedure

INFOID:000000008290573

#### 1. CHECK FRONT POWER WINDOW MOTOR (DRIVER SIDE) INPUT SIGNAL

1. Turn ignition switch OFF.
2. Disconnect front power window motor (driver side) connector.
3. Turn ignition switch ON.
4. Check voltage between front power window motor (driver side) harness connector and ground.

(+)		(-)	Condition	Voltage (V) (Approx.)	
Connector	Terminal				
D10	1	Ground	Power window main switch	NEUTRAL	0
				DOWN	12
	2			NEUTRAL	0
				UP	12

Is the inspection result normal?

- YES >> Replace front power window motor (driver side).
- NO >> GO TO 2.

#### 2. CHECK FRONT POWER WINDOW MOTOR (DRIVER SIDE) CIRCUIT

1. Turn ignition switch OFF.
2. Disconnect power window main switch connector.
3. Check continuity between power window main switch harness connector and front power window motor (driver side) harness connector.

Power window main switch		Front power window motor (driver side)		Continuity
Connector	Terminal	Connector	Terminal	
D8	8	D10	2	Existed
	11		1	

4. Check continuity between power window main switch harness connector and ground.

Power window main switch		Ground	Continuity
Connector	Terminal		
D8	8		Not existed
	11		

Is the inspection result normal?

- YES >> Replace power window main switch.
- NO >> Repair or replace harness.

A  
B  
C  
D  
E  
F  
G  
H  
I  
J  
L  
M  
N  
O  
P

PWC

# POWER WINDOW MOTOR

[FRONT WINDOW ANTI-PINCH]

< DTC/CIRCUIT DIAGNOSIS >

## PASSENGER SIDE

### PASSENGER SIDE : Description

INFOID:000000008290574

Door glass moves UP/DOWN by receiving the signal power window main switch or front power window switch (passenger side).

### PASSENGER SIDE : Component Function Check

INFOID:000000008290575

#### 1. CHECK FRONT POWER WINDOW MOTOR (PASSENGER SIDE) CIRCUIT

Check front power window motor (passenger side) operation with power window main switch or front power window switch (passenger side).

Is the inspection result normal?

YES >> Front power window motor (passenger side) is OK.

NO >> Refer to [PWC-116. "PASSENGER SIDE : Diagnosis Procedure"](#).

### PASSENGER SIDE : Diagnosis Procedure

INFOID:000000008290576

#### 1. CHECK FRONT POWER WINDOW MOTOR (PASSENGER SIDE) INPUT SIGNAL

1. Turn ignition switch OFF.
2. Disconnect front power window motor (passenger side) connector.
3. Turn ignition switch ON.
4. Check voltage between front power window motor (passenger side) harness connector and ground.

(+)		(-)	Condition	Voltage (V) (Approx.)	
Connector	Terminal				
D40	1	Ground	Front power window switch (passenger side)	NEUTRAL	0
				UP	12
	2			NEUTRAL	0
				DOWN	12

Is the inspection result normal?

YES >> Replace front power window motor (passenger side).

NO >> GO TO 2.

#### 2. CHECK FRONT POWER WINDOW MOTOR (PASSENGER SIDE) CIRCUIT

1. Turn ignition switch OFF.
2. Disconnect front power window switch (passenger side) connector.
3. Check continuity between front power window switch (passenger side) harness connector and front power window motor (passenger side) harness connector.

Front power window switch (passenger side)		Front power window motor (passenger side)		Continuity
Connector	Terminal	Connector	Terminal	
D38	8	D40	2	Existed
	9		1	

4. Check continuity between front power window switch (passenger side) connector and ground.

Front power window switch (passenger side)		Ground	Continuity
Connector	Terminal		
D38	8		Not existed
	9		

Is the inspection result normal?

YES >> Replace front power window switch (passenger side).

# POWER WINDOW MOTOR

[FRONT WINDOW ANTI-PINCH]

< DTC/CIRCUIT DIAGNOSIS >

NO >> Repair or replace harness.

## REAR LH

### REAR LH : Description

INFOID:000000008290577

Door glass moves UP/DOWN by receiving the signal from power window main switch or rear power window switch LH.

### REAR LH : Component Function Check

INFOID:000000008290578

#### 1.CHECK REAR POWER WINDOW MOTOR LH CURCUIT

Check rear power window motor LH operation with power window main switch or rear power window switch LH.

Is the inspection result normal?

YES >> Rear power window motor LH is OK.

NO >> Refer to [PWC-117. "REAR LH : Diagnosis Procedure"](#)

### REAR LH : Diagnosis Procedure

INFOID:000000008290579

#### 1.CHECK REAR POWER WINDOW MOTOR LH INPUT SIGNAL

1. Turn ignition switch OFF.
2. Disconnect rear power window motor LH connector.
3. Turn ignition switch ON.
4. Check voltage between rear power window motor LH harness connector and ground.

(+)		(-)	Condition	Voltage (V) (Approx.)	
Connector	Terminal				
D52	1	Ground	Rear power window switch LH	NEUTRAL	0
				UP	12
	3			NEUTRAL	0
				DOWN	12

Is the inspection result normal?

YES >> Replace rear power window motor LH.

NO >> GO TO 2.

#### 2.CHECK REAR POWER WINDOW MOTOR LH CIRCUIT

1. Turn ignition switch OFF.
2. Disconnect rear power window switch LH connector.
3. Check continuity between rear power window switch LH harness connector and rear power window motor LH harness connector.

Rear power window switch LH		Rear power window motor LH		Continuity
Connector	Terminal	Connector	Terminal	
D54	5	D52	1	Existed
	4		3	

4. Check continuity between rear power window switch LH harness connector and ground.

Rear power window switch LH		Ground	Continuity
Connector	Terminal		
D54	5		Not existed
	4		

Is the inspection result normal?

A  
B  
C  
D  
E  
F  
G  
H  
I  
J  
L  
M  
N  
O  
P

PWC

# POWER WINDOW MOTOR

[FRONT WINDOW ANTI-PINCH]

## < DTC/CIRCUIT DIAGNOSIS >

- YES >> Replace rear power window switch LH.
- NO >> Repair or replace harness.

### REAR RH

#### REAR RH : Description

INFOID:000000008290580

Door glass moves UP/DOWN by receiving the signal from power window main switch or rear power window switch RH.

#### REAR RH : Component Function Check

INFOID:000000008290581

### 1. CHECK REAR POWER WINDOW MOTOR RH CIRCUIT

Check rear power window motor RH operation with power window main switch or rear power window switch RH.

#### Is the inspection result normal?

- YES >> Rear power window motor RH is OK.
- NO >> Refer to [PWC-118, "REAR RH : Diagnosis Procedure"](#).

#### REAR RH : Diagnosis Procedure

INFOID:000000008290582

### 1. CHECK REAR POWER WINDOW MOTOR RH INPUT SIGNAL

1. Turn ignition switch OFF.
2. Disconnect rear power window motor RH connector.
3. Turn ignition switch ON.
4. Check voltage between rear power window motor RH harness connector and ground.

(+)		(-)	Condition	Voltage (V) (Approx.)	
Connector	Terminal				
D72	1	Ground	Rear power window switch RH	NEUTRAL	0
				UP	12
	3			NEUTRAL	0
				DOWN	12

#### Is the inspection result normal?

- YES >> Replace rear power window motor RH.
- NO >> GO TO 2.

### 2. CHECK REAR POWER WINDOW MOTOR RH CIRCUIT

1. Turn ignition switch OFF.
2. Disconnect rear power window switch RH connector.
3. Check continuity between rear power window switch RH harness connector and rear power window motor RH harness connector.

Rear power window switch RH		Rear power window motor RH		Continuity
Connector	Terminal	Connector	Terminal	
D74	5	D72	1	Existed
	4		3	

4. Check continuity between rear power window switch RH harness connector and ground.

Rear power window switch RH		Ground	Continuity
Connector	Terminal		
D74	5		Not existed
	4		

#### Is the inspection result normal?

# POWER WINDOW MOTOR

< DTC/CIRCUIT DIAGNOSIS >

[FRONT WINDOW ANTI-PINCH]

- YES >> Replace rear power window switch RH.
- NO >> Repair or replace harness.

A

B

C

D

E

F

G

H

I

J

**PWC**

L

M

N

O

P

## ENCODER DRIVER SIDE

### DRIVER SIDE : Description

INFOID:000000008290583

Detects condition of the front power window motor (driver side) operation and transmits to power window main switch as the pulse signal.

### DRIVER SIDE : Component Function Check

INFOID:000000008290584

#### 1.CHECK ENCODER

Check that driver side door glass performs AUTO open/close operation normally by power window main switch.

Is the inspection result normal?

YES >> Encoder is OK.

NO >> Refer to [PWC-120, "DRIVER SIDE : Diagnosis Procedure"](#).

### DRIVER SIDE : Diagnosis Procedure

INFOID:000000008290585

#### 1.CHECK ENCODER SIGNAL

1. Turn ignition switch ON.
2. Check signal between power window main switch harness connector and ground with oscilloscope.

(+)		(-)	Signal (Reference value)
Power window main switch			
Connector	Terminal	Ground	Refer to following signal
D8	9		
	13		

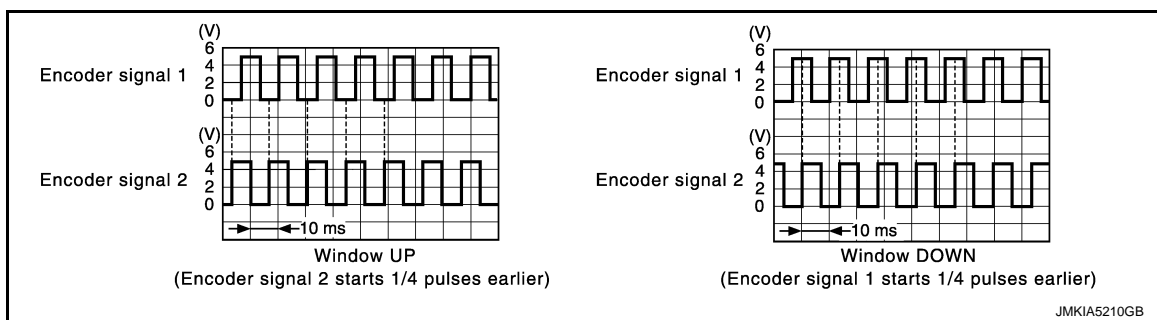

Is the inspection result normal?

YES >> Replace power window main switch.

NO >> GO TO 2.

#### 2.CHECK ENCODER SIGNAL CIRCUIT

1. Turn ignition switch OFF.
2. Disconnect power window main switch connector and front power window motor (driver side) connector.
3. Check continuity between power window main switch harness connector and front power window motor (driver side) harness connector.

Power window main switch		Front power window motor (driver side)		Continuity
Connector	Terminal	Connector	Terminal	
D8	9	D10	3	Existed
	13		5	

4. Check continuity between power window main switch harness connector and ground.



# ENCODER

< DTC/CIRCUIT DIAGNOSIS >

[FRONT WINDOW ANTI-PINCH]

Power window main switch		Ground	Continuity
Connector	Terminal		
D8	9		
	13	Not existed	

Is the inspection result normal?

YES >> GO TO 3.

NO >> Repair or replace harness.

### 3.CHECK ENCODER POWER SUPPLY CIRCUIT 1

1. Connect power window main switch connector.
2. Turn ignition switch ON.
3. Check voltage between front power window motor (driver side) harness connector and ground.

(+)		(-)	Voltage (V) (Approx.)
Front power window motor (driver side)			
Connector	Terminal		
D10	4	Ground	12

Is the inspection result normal?

YES >> GO TO 5.

NO >> GO TO 4.

### 4.CHECK ENCODER POWER SUPPLY CIRCUIT 2

1. Turn ignition switch OFF.
2. Disconnect power window main switch connector.
3. Check continuity between power window main switch harness connector and front power window motor (driver side) harness connector.

Power window main switch		Front power window motor (driver side)		Continuity
Connector	Terminal	Connector	Terminal	
D8	15	D10	4	Existed

4. Check continuity between power window main switch harness connector and ground.

Power window main switch		Ground	Continuity
Connector	Terminal		
D8	15		Not existed

Is the inspection result normal?

YES >> Replace power window main switch.

NO >> Repair or replace harness.

### 5.CHECK GROUND CIRCUIT 1

1. Turn ignition switch OFF.
2. Disconnect power window main switch connector.
3. Check continuity between power window main switch harness connector and front power window motor (driver side) harness connector.

Power window main switch		Front power window motor (driver side)		Continuity
Connector	Terminal	Connector	Terminal	
D8	2	D10	6	Existed

Is the inspection result normal?

YES >> GO TO 6.

NO >> Repair or replace harness.

### 6.CHECK GROUND CIRCUIT 2

A  
B  
C  
D  
E  
F  
G  
H  
I  
J  
L  
M  
N  
O  
P

PWC

# ENCODER

[FRONT WINDOW ANTI-PINCH]

## < DTC/CIRCUIT DIAGNOSIS >

1. Turn ignition switch OFF.
2. Check continuity between front power window motor (driver side) harness connector and ground.

Front power window motor (driver side)		Ground	Continuity
Connector	Terminal		Existed
D10	6		

Is the inspection result normal?

- YES >> Replace front power window motor (driver side).  
 NO >> Replace power window main switch.

## PASSENGER SIDE

### PASSENGER SIDE : Description

INFOID:000000008290586

Detects condition of the front power window motor (passenger side) operation and transmits to front power window switch (passenger side) as the pulse signal.

### PASSENGER SIDE : Component Function Check

INFOID:000000008290587

#### 1.CHECK ENCODER

Check that passenger side door glass performs AUTO open/close operation normally by power window main switch or front power window switch (passenger side).

Is the inspection result normal?

- YES >> Encoder is OK.  
 NO >> Refer to [PWC-122, "PASSENGER SIDE : Diagnosis Procedure"](#).

### PASSENGER SIDE : Diagnosis Procedure

INFOID:000000008290588

#### 1.CHECK ENCODER SIGNAL

1. Turn ignition switch ON.
2. Check signal between front power window switch (passenger side) harness connector and ground with oscilloscope.

(+)		(-)	Signal (Reference value)
Connector	Terminal		
D38	12	Ground	Refer to following signal
	15		

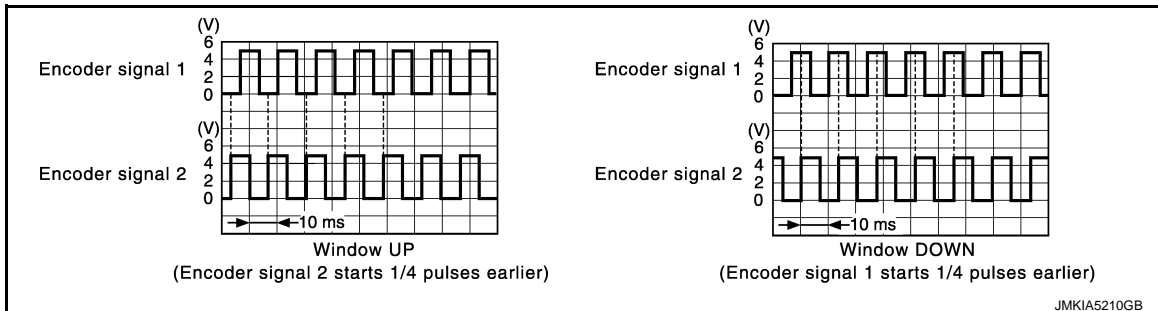

Is the inspection result normal?

- YES >> Replace front power window switch (passenger side).  
 NO >> GO TO 2.

#### 2.CHECK ENCODER SIGNAL CIRCUIT

1. Turn ignition switch OFF.
2. Disconnect front power window switch (passenger side) connector and front power window motor (passenger side) connector.

# ENCODER

## < DTC/CIRCUIT DIAGNOSIS >

## [FRONT WINDOW ANTI-PINCH]

3. Check continuity between front power window switch (passenger side) harness connector and front power window motor (passenger side) harness connector.

Front power window switch (passenger side)		Front power window motor (passenger side)		Continuity
Connector	Terminal	Connector	Terminal	
D38	12	D40	5	Existed
	15		3	

4. Check continuity between front power window switch (passenger side) harness connector and ground.

Front power window switch (passenger side)		Ground	Continuity
Connector	Terminal		
D38	12		Not existed
	15		

Is the inspection result normal?

YES >> GO TO 3.

NO >> Repair or replace harness.

### 3.CHECK ENCODER POWER SUPPLY CIRCUIT 1

1. Connect front power window switch (passenger side) connector.
2. Turn ignition switch ON.
3. Check voltage between front power window motor (passenger side) harness connector and ground.

(+)		(-)	Voltage (V) (Approx.)
Front power window motor (passenger side)			
Connector	Terminal	Ground	12
D40	4		

Is the inspection result normal?

YES >> GO TO 5.

NO >> GO TO 4.

### 4.CHECK ENCODER POWER SUPPLY CIRCUIT 2

1. Turn ignition switch OFF.
2. Disconnect front power window switch (passenger side) connector.
3. Check continuity between front power window switch (passenger side) harness connector and front power window motor (passenger side) harness connector.

Front power window switch (passenger side)		Front power window motor (passenger side)		Continuity
Connector	Terminal	Connector	Terminal	
D38	4	D40	4	Existed

4. Check continuity between front power window switch (passenger side) harness connector and ground.

Front power window switch (passenger side)		Ground	Continuity
Connector	Terminal		
D38	4		Not existed

Is the inspection result normal?

YES >> Replace front power window switch (passenger side).

NO >> Repair or replace harness.

### 5.CHECK GROUND CIRCUIT 1

1. Turn ignition switch OFF.
2. Disconnect front power window switch (passenger side) connector.
3. Check continuity between front power window switch (passenger side) harness connector and front power window motor (passenger side) harness connector.

# ENCODER

< DTC/CIRCUIT DIAGNOSIS >

[FRONT WINDOW ANTI-PINCH]

Front power window switch (passenger side)		Front power window motor (passenger side)		Continuity
Connector	Terminal	Connector	Terminal	
D38	3	D40	6	Existed

Is the inspection result normal?

YES >> GO TO 6.

NO >> Repair or replace harness.

## 6. CHECK GROUND CIRCUIT 2

1. Turn ignition switch OFF.
2. Check continuity between front power window motor (passenger side) harness connector and ground.

Front power window motor (passenger side)		Ground	Continuity
Connector	Terminal		
D40	6		Existed

Is the inspection result normal?

YES >> Replace front power window motor (passenger side).

NO >> Replace front power window switch (passenger side).

# DOOR KEY CYLINDER SWITCH

< DTC/CIRCUIT DIAGNOSIS >

[FRONT WINDOW ANTI-PINCH]

## DOOR KEY CYLINDER SWITCH

### Description

INFOID:000000008290589

Power window main switch detects condition of the door key cylinder switch and transmits to BCM as the LOCK or UNLOCK signals.

### Component Function Check

INFOID:000000008290590

### 1. CHECK DOOR KEY CYLINDER SWITCH INPUT SIGNAL

Check ("KEY CYL LK-SW", "KEY CYL UN-SW") in "DATA MONITOR" mode for "POWER DOOR LOCK SYSTEM" with CONSULT. Refer to [DLK-51, "DOOR LOCK : CONSULT Function \(BCM - DOOR LOCK\)"](#).

Monitor item	Condition
KEY CYL LK-SW	Lock : ON
	Neutral / Unlock : OFF
KEY CYL UN-SW	Unlock : ON
	Neutral / Lock : OFF

Is the inspection result normal?

- YES >> Door key cylinder switch is OK.
- NO >> Refer to [PWC-125, "Diagnosis Procedure"](#).

### Diagnosis Procedure

INFOID:000000008290591

### 1. CHECK DOOR KEY CYLINDER SWITCH SIGNAL

1. Turn ignition switch OFF.
2. Disconnect front door lock assembly (driver side) (key cylinder switch) connect.
3. Turn ignition switch ON.
4. Check voltage between front door lock assembly (driver side) (key cylinder switch) harness connector and ground.

(+)		(-)	Voltage (V) (Approx.)
Front door lock assembly (driver side) (key cylinder switch)			
Connector	Terminal	Ground	5
D15	5		
	6		

Is the inspection result normal?

- YES >> GO TO 3.
- NO >> GO TO 2.

### 2. CHECK DOOR KEY CYLINDER SWITCH CIRCUIT

1. Turn ignition switch OFF.
2. Disconnect power window main switch connector.
3. Check continuity between power window main switch harness connector and front door lock assembly (driver side) (key cylinder switch) harness connector.

Power window main switch		Front door lock assembly (driver side) (key cylinder switch)		Continuity
Connector	Terminal	Connector	Terminal	
D8	4	D15	6	Existed
	6		5	

4. Check continuity between power window main switch harness connector and ground.

# DOOR KEY CYLINDER SWITCH

< DTC/CIRCUIT DIAGNOSIS >

[FRONT WINDOW ANTI-PINCH]

Power window main switch		Ground	Continuity
Connector	Terminal		
D8	4		
	6		Not existed

Is the inspection result normal?

YES >> Replace power window main switch.

NO >> Repair or replace harness.

## 3.CHECK DOOR KEY CYLINDER SWITCH GROUND CIRCUIT

Check continuity between front door lock assembly (driver side) (key cylinder switch) harness connector and ground.

Front door lock assembly (driver side) (key cylinder switch)		Ground	Continuity
Connector	Terminal		
D15	4		

Is the inspection result normal?

YES >> GO TO 4.

NO >> Repair or replace harness.

## 4.CHECK DOOR KEY CYLINDER SWITCH

Check front door lock assembly (driver side) (key cylinder switch).

Refer to [PWC-126. "Component Inspection"](#).

Is the inspection result normal?

YES >> GO TO 5.

NO >> Replace front door lock assembly (driver side) (key cylinder switch).

## 5.CHECK INTERMITTENT INCIDENT

Refer to [GI-43. "Intermittent Incident"](#).

>> INSPECTION END

## Component Inspection

INFOID:000000008290592

### COMPONENT INSPECTION

#### 1.CHECK DOOR KEY CYLINDER SWITCH

1. Turn ignition switch OFF.
2. Disconnect front door lock assembly (driver side) (key cylinder switch) connector.
3. Check front door lock assembly (driver side) (key cylinder switch) terminals under the following conditions.

Front door lock assembly (driver side) (key cylinder switch)		Key position	Continuity
Terminal			
5	4	Unlock	Existed
		Neutral / Lock	Not existed
6		Lock	Existed
		Neutral / Unlock	Not existed

Is the inspection result normal?

YES >> INSPECTION END

NO >> Replace front door lock assembly (driver side) (key cylinder switch).

# POWER WINDOW SERIAL LINK

[FRONT WINDOW ANTI-PINCH]

< DTC/CIRCUIT DIAGNOSIS >

## POWER WINDOW SERIAL LINK

### POWER WINDOW MAIN SWITCH

#### POWER WINDOW MAIN SWITCH : Description

INFOID:000000008290593

Power window main switch, front power window switch (passenger side) and BCM transmit and receive the signal by power window serial link.

The signal mentioned below is transmitted from BCM to power window main switch and front power window switch (passenger side).

- Keyless power window down signal

The signals mentioned below are transmitted from power window main switch to front power window switch (passenger side).

- Front passenger side door window operation signal
- Power window control by key cylinder switch signal
- Power window lock switch signal
- Retained power operation signal

#### POWER WINDOW MAIN SWITCH : Component Function Check

INFOID:000000008290594

##### 1.CHECK POWER WINDOW SWITCH OUTPUT SIGNAL

###### With CONSULT

Check ("CDL LOCK SW ", "CDL UNLOCK SW") in "DATA MONITOR" mode for "POWER DOOR LOCK SYSTEM" with CONSULT. Refer to [DLK-51, "DOOR LOCK : CONSULT Function \(BCM - DOOR LOCK\)"](#).

Monitor item	Condition
CDL LOCK SW	LOCK : ON
	UNLOCK : OFF
CDL UNLOCK SW	LOCK : OFF
	UNLOCK : ON

Is the inspection result normal?

YES >> Power window serial link is OK.

NO >> Refer to [PWC-127, "POWER WINDOW MAIN SWITCH : Diagnosis Procedure"](#).

PWC

#### POWER WINDOW MAIN SWITCH : Diagnosis Procedure

INFOID:000000008290595

##### 1.CHECK POWER WINDOW SWITCH OUTPUT SIGNAL

1. Turn ignition switch ON.
2. Check signal between power window main switch harness connector and ground.

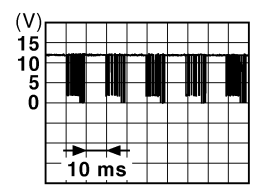
(+)		(-)	Signal (Reference value)
Connector	Terminal		
D8	14	Ground	 <p>JPMAI0013GB</p>

Is the inspection result normal?

YES >> GO TO 4.

NO >> GO TO 2.

##### 2.CHECK POWER WINDOW SERIAL LINK SIGNAL

# POWER WINDOW SERIAL LINK

[FRONT WINDOW ANTI-PINCH]

< DTC/CIRCUIT DIAGNOSIS >

1. Turn ignition switch OFF.
2. Disconnect power window main switch connector.
3. Turn ignition switch ON.
4. Check voltage between power window main switch harness connector and ground.

(+)		(-)	Voltage (V) (Approx.)
Power window main switch			
Connector	Terminal	Ground	12
D8	14		

Is the inspection result normal?

YES >> Replace power window main switch.

NO >> GO TO 3.

## 3. CHECK POWER WINDOW SERIAL LINK CIRCUIT

1. Disconnect BCM connector.
2. Check continuity between BCM harness connector and power window main switch harness connector.

BCM		Power window main switch		Continuity
Connector	Terminal	Connector	Terminal	
M123	132	D8	14	Existed

3. Check continuity between BCM harness connector and ground.

BCM		Ground	Continuity
Connector	Terminal		
M123	132		Not existed

Is the inspection result normal?

YES >> Replace BCM. Refer to [BCS-81. "Exploded View"](#).

NO >> Repair or replace harness.

## 4. CHECK INTERMITTENT INCIDENT

Refer to [GI-43. "Intermittent Incident"](#).

>> INSPECTION END

## FRONT POWER WINDOW SWITCH (PASSENGER SIDE)

### FRONT POWER WINDOW SWITCH (PASSENGER SIDE) : Description

INFOID:000000008290596

Power window main switch, front power window switch (passenger side) and BCM transmit and receive the signal by power window serial link.

The signal mentioned below is transmitted from BCM to power window main switch and front power window switch (passenger side).

- Keyless power window down signal

The signal mentioned below is transmitted from power window main switch to front power window switch (passenger side).

- Front passenger side door window operation signal
- Power window control by key cylinder switch signal
- Power window lock switch signal
- Retained power operation signal

### FRONT POWER WINDOW SWITCH (PASSENGER SIDE) : Component Function

#### Check

INFOID:000000008290597

## 1. CHECK POWER WINDOW SWITCH OUTPUT SIGNAL

 With CONSULT



# POWER WINDOW SERIAL LINK

[FRONT WINDOW ANTI-PINCH]

< DTC/CIRCUIT DIAGNOSIS >

Check ("CDL LOCK SW", "CDL UNLOCK SW") in "DATA MONITOR" mode for "POWER DOOR LOCK SYSTEM" with CONSULT. Refer to [DLK-51, "DOOR LOCK : CONSULT Function \(BCM - DOOR LOCK\)"](#).

Monitor item	Condition	
CDL LOCK SW	LOCK	: ON
	UNLOCK	: OFF
CDL UNLOCK SW	LOCK	: OFF
	UNLOCK	: ON

Is the inspection result normal?

YES >> Power window serial link is OK.

NO >> Refer to [PWC-129, "FRONT POWER WINDOW SWITCH \(PASSENGER SIDE\) : Diagnosis Procedure"](#).

## FRONT POWER WINDOW SWITCH (PASSENGER SIDE) : Diagnosis Procedure

INFOID:000000008290598

### 1. CHECK POWER WINDOW SWITCH OUTPUT SIGNAL

1. Turn ignition switch ON.
2. Check signal between front power window switch (passenger side) harness connector and ground.

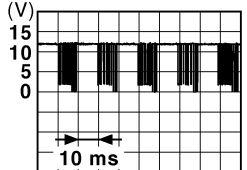
(+)		(-)	Signal (Reference value)
Connector	Terminal		
D38	16	Ground	 <p style="text-align: right; font-size: small;">JPMA0013GB</p>

Is the inspection result normal?

YES >> Replace front power window switch (passenger side).

NO >> GO TO 2.

### 2. CHECK POWER WINDOW SERIAL LINK CIRCUIT

1. Disconnect power window main switch connector.
2. Check continuity between power window main switch harness connector and front power window switch (passenger side) harness connector.

Power window main switch		Front power window switch (passenger side)		Continuity
Connector	Terminal	Connector	Terminal	
D8	14	D38	16	Existed

3. Check continuity between power window main switch harness connector and ground.

Power window main switch		Ground	Continuity
Connector	Terminal		
D8	14		Not existed

Is the inspection result normal?

YES >> Replace power window main switch.

NO >> Repair or replace harness.

# BCM (BODY CONTROL MODULE)

< ECU DIAGNOSIS INFORMATION >

[FRONT WINDOW ANTI-PINCH]

## ECU DIAGNOSIS INFORMATION

### BCM (BODY CONTROL MODULE)

#### Reference Value

INFOID:000000008782236

#### VALUES ON THE DIAGNOSIS TOOL

##### NOTE:

The following table includes information (items) inapplicable to this vehicle. For information (items) applicable to this vehicle, refer to CONSULT display items.

##### CONSULT MONITOR ITEM

Monitor Item	Condition	Value/Status
FR WIPER HI	Other than front wiper switch HI	Off
	Front wiper switch HI	On
FR WIPER LOW	Other than front wiper switch LO	Off
	Front wiper switch LO	On
FR WASHER SW	Front washer switch OFF	Off
	Front washer switch ON	On
FR WIPER INT	Other than front wiper switch INT/AUTO	Off
	Front wiper switch INT/AUTO	On
FR WIPER STOP	Front wiper is not in STOP position	Off
	Front wiper is in STOP position	On
INT VOLUME	Wiper volume dial is in a dial position 1 - 7	Wiper volume dial position
TURN SIGNAL R	Other than turn signal switch RH	Off
	Turn signal switch RH	On
TURN SIGNAL L	Other than turn signal switch LH	Off
	Turn signal switch LH	On
TAIL LAMP SW	Other than lighting switch 1ST and 2ND	Off
	Lighting switch 1ST or 2ND	On
HI BEAM SW	Other than lighting switch HI	Off
	Lighting switch HI	On
HEAD LAMP SW 1	Other than lighting switch 2ND	Off
	Lighting switch 2ND	On
HEAD LAMP SW 2	Other than lighting switch 2ND	Off
	Lighting switch 2ND	On
PASSING SW	Other than lighting switch PASS	Off
	Lighting switch PASS	On
AUTO LIGHT SW	Other than lighting switch AUTO	Off
	Lighting switch AUTO	On
FR FOG SW	Front fog lamp switch OFF	Off
	Front fog lamp switch ON	On
RR FOG SW	<b>NOTE:</b> The item is indicated, but not monitored.	Off
DOOR SW-DR	Driver door closed	Off
	Driver door opened	On
DOOR SW-AS	Passenger door closed	Off
	Passenger door opened	On

# BCM (BODY CONTROL MODULE)

< ECU DIAGNOSIS INFORMATION >

[FRONT WINDOW ANTI-PINCH]

Monitor Item	Condition	Value/Status	
DOOR SW-RR	Rear RH door closed	Off	A
	Rear LH door opened	On	
DOOR SW-RL	Rear LH door closed	Off	B
	Rear LH door opened	On	
DOOR SW-BK	<b>NOTE:</b> The item is indicated, but not monitored.	Off	C
CDL LOCK SW	Other than power door lock switch LOCK	Off	
	Power door lock switch LOCK	On	D
CDL UNLOCK SW	Other than power door lock switch UNLOCK	Off	
	Power door lock switch UNLOCK	On	D
KEY CYL LK-SW	Other than driver door key cylinder LOCK	Off	E
	Driver door key cylinder LOCK	On	
KEY CYL UN-SW	Other than driver door key cylinder UNLOCK	Off	F
	Driver door key cylinder LOCK	On	F
KEY CYL SW-TR	<b>NOTE:</b> The item is indicated, but not monitored.	Off	G
HAZARD SW	Hazard switch is OFF	Off	
	Hazard switch is ON	On	G
REAR DEF SW	<b>NOTE:</b> The item is indicated, but not monitored.	Off	H
TR CANCEL SW	Trunk lid opener cancel switch OFF	Off	
	Trunk lid opener cancel switch ON	On	I
TR/BD OPEN SW	Trunk lid opener switch OFF	Off	
	While the trunk lid opener switch is turned ON	On	J
TRNK/HAT MNTR	Trunk lid closed	Off	
	Trunk lid opened	On	
REVERSE SW	<b>NOTE:</b> The item is indicated, but not monitored.	Off	PWC
RKE-LOCK	LOCK button of the Intelligent Key is not pressed	Off	
	LOCK button of the Intelligent Key is pressed	On	L
RKE-UNLOCK	UNLOCK button of the Intelligent Key is not pressed	Off	
	UNLOCK button of the Intelligent Key is pressed	On	
RKE-TR/BD	TRUNK OPEN button of the Intelligent Key is not pressed	Off	M
	TRUNK OPEN button of the Intelligent Key is pressed	On	
RKE-PANIC	PANIC button of the Intelligent Key is not pressed	Off	N
	PANIC button of the Intelligent Key is pressed	On	
RKE-P/W OPEN	UNLOCK button of the Intelligent Key is not pressed	Off	O
	UNLOCK button of the Intelligent Key is pressed and held	On	
RKE-MODE CHG	LOCK/UNLOCK button of the Intelligent Key is not pressed and held simultaneously	Off	P
	LOCK/UNLOCK button of the Intelligent Key is pressed and held simultaneously	On	
OPTICAL SENSOR	Bright outside of the vehicle	Close to 5 V	
	Dark outside of the vehicle	Close to 0 V	
REQ SW -DR	Driver door request switch is not pressed	Off	
	Driver door request switch is pressed	On	

# BCM (BODY CONTROL MODULE)

< ECU DIAGNOSIS INFORMATION >

[FRONT WINDOW ANTI-PINCH]

Monitor Item	Condition	Value/Status
REQ SW -AS	Passenger door request switch is not pressed	Off
	Passenger door request switch is pressed	On
REQ SW -RR	<b>NOTE:</b> The item is indicated, but not monitored.	Off
REQ SW -RL	<b>NOTE:</b> The item is indicated, but not monitored.	Off
REQ SW -BD/TR	Trunk lid opener request switch is not pressed	Off
	Trunk lid opener request switch is pressed	On
PUSH SW	Push-button ignition switch (push switch) is not pressed	Off
	Push-button ignition switch (push switch) is pressed	On
IGN RLY2 -F/B	<b>NOTE:</b> The item is indicated, but not monitored.	Off
ACC RLY -F/B	<b>NOTE:</b> The item is indicated, but not monitored.	Off
CLUCH SW	The clutch pedal is not depressed	Off
	The clutch pedal is depressed	On
BRAKE SW 1	The brake pedal is depressed when No. 7 fuse is blown	Off
	The brake pedal is not depressed when No. 7 fuse is blown, or No. 7 fuse is normal	On
BRAKE SW 2	The brake pedal is not depressed	Off
	The brake pedal is depressed	On
DETE/CANCL SW	<ul style="list-style-type: none"> <li>• Selector lever in P position (Except M/T models)</li> <li>• The clutch pedal is depressed (M/T models)</li> </ul>	Off
	<ul style="list-style-type: none"> <li>• Selector lever in any position other than P (Except M/T models)</li> <li>• The clutch pedal is not depressed (M/T models)</li> </ul>	On
SFT PN/N SW	Selector lever in any position other than P and N	Off
	Selector lever in P or N position	On
S/L -LOCK	<b>NOTE:</b> The item is indicated, but not monitored.	Off
S/L -UNLOCK	<b>NOTE:</b> The item is indicated, but not monitored.	Off
S/L RELAY-F/B	<b>NOTE:</b> The item is indicated, but not monitored.	Off
UNLK SEN -DR	Driver door is unlocked	Off
	Driver door is locked	On
PUSH SW -IPDM	Push-button ignition switch (push-switch) is not pressed	Off
	Push-button ignition switch (push-switch) is pressed	On
IGN RLY1 -F/B	Ignition switch in OFF or ACC position	Off
	Ignition switch in ON position	On
DETE SW -IPDM	Selector lever in any position other than P	Off
	Selector lever in P position	On
SFT PN -IPDM	<ul style="list-style-type: none"> <li>• Selector lever in any position other than P and N (Except M/T models)</li> <li>• The clutch pedal is not depressed (M/T models)</li> </ul>	Off
	<ul style="list-style-type: none"> <li>• Selector lever in P or N position (Except M/T models)</li> <li>• The clutch pedal is depressed (M/T models)</li> </ul>	On
SFT P -MET	Selector lever in any position other than P	Off
	Selector lever in P position	On

# BCM (BODY CONTROL MODULE)

< ECU DIAGNOSIS INFORMATION >

[FRONT WINDOW ANTI-PINCH]

Monitor Item	Condition	Value/Status	
SFT N -MET	Selector lever in any position other than N	Off	A
	Selector lever in N position	On	
ENGINE STATE	Engine stopped	Stop	B
	While the engine stalls	Stall	
	At engine cranking	Crank	C
	Engine running	Run	
S/L LOCK-IPDM	<b>NOTE:</b> The item is indicated, but not monitored.	Off	D
S/L UNLK-IPDM	<b>NOTE:</b> The item is indicated, but not monitored.	Off	
S/L RELAY-REQ	<b>NOTE:</b> The item is indicated, but not monitored.	Off	E
VEH SPEED 1	While driving	Equivalent to speedometer reading	F
VEH SPEED 2	While driving	Equivalent to speedometer reading	
DOOR STAT-DR	Driver door is locked	LOCK	G
	Wait with selective UNLOCK operation (60 seconds)	READY	
	Driver door is unlocked	UNLOCK	
DOOR STAT-AS	Passenger door is locked	LOCK	H
	Wait with selective UNLOCK operation (60 seconds)	READY	
	Passenger door is unlocked	UNLOCK	
ID OK FLAG	Driver side door is open after ignition switch is turned OFF (Shift position is in the P position)	Reset	I
	Ignition switch ON	Set	J
PRMT ENG STRT	The engine start is prohibited	Reset	
	The engine start is permitted	Set	
PRMT RKE STRT	<b>NOTE:</b> The item is indicated, but not monitored.	Reset	PWC
KEY SW -SLOT	The Intelligent Key is not inserted into key slot	Off	L
	The Intelligent Key is inserted into key slot	On	
RKE OPE COUN1	During the operation of the Intelligent Key	Operation frequency of the Intelligent Key	
RKE OPE COUN2	<b>NOTE:</b> The item is indicated, but not monitored.	—	M
CONFIRM ID ALL	The key ID that the key slot receives is not recognized by any key ID registered to BCM.	Yet	N
	The key ID that the key slot receives is recognized by any key ID registered to BCM.	Done	
CONFIRM ID4	The key ID that the key slot receives is not recognized by the fourth key ID registered to BCM.	Yet	O
	The key ID that the key slot receives is recognized by the fourth key ID registered to BCM.	Done	P
CONFIRM ID3	The key ID that the key slot receives is not recognized by the third key ID registered to BCM.	Yet	
	The key ID that the key slot receives is recognized by the third key ID registered to BCM.	Done	

## BCM (BODY CONTROL MODULE)

< ECU DIAGNOSIS INFORMATION >

[FRONT WINDOW ANTI-PINCH]

Monitor Item	Condition	Value/Status
CONFIRM ID2	The key ID that the key slot receives is not recognized by the second key ID registered to BCM.	Yet
	The key ID that the key slot receives is recognized by the second key ID registered to BCM.	Done
CONFIRM ID1	The key ID that the key slot receives is not recognized by the first key ID registered to BCM.	Yet
	The key ID that the key slot receives is recognized by the first key ID registered to BCM.	Done
TP 4	The ID of fourth Intelligent Key is not registered to BCM	Yet
	The ID of fourth Intelligent Key is registered to BCM	Done
TP 3	The ID of third Intelligent Key is not registered to BCM	Yet
	The ID of third Intelligent Key is registered to BCM	Done
TP 2	The ID of second Intelligent Key is not registered to BCM	Yet
	The ID of second Intelligent Key is registered to BCM	Done
TP 1	The ID of first Intelligent Key is not registered to BCM	Yet
	The ID of first Intelligent Key is registered to BCM	Done
AIR PRESS FL	Ignition switch ON (Only when the signal from the transmitter is received)	Air pressure of front LH tire
AIR PRESS FR	Ignition switch ON (Only when the signal from the transmitter is received)	Air pressure of front RH tire
AIR PRESS RR	Ignition switch ON (Only when the signal from the transmitter is received)	Air pressure of rear RH tire
AIR PRESS RL	Ignition switch ON (Only when the signal from the transmitter is received)	Air pressure of rear LH tire
ID REGST FL1	ID of front LH tire transmitter is registered	Done
	ID of front LH tire transmitter is not registered	Yet
ID REGST FR1	ID of front RH tire transmitter is registered	Done
	ID of front RH tire transmitter is not registered	Yet
ID REGST RR1	ID of rear RH tire transmitter is registered	Done
	ID of rear RH tire transmitter is not registered	Yet
ID REGST RL1	ID of rear LH tire transmitter is registered	Done
	ID of rear LH tire transmitter is not registered	Yet
WARNING LAMP	Tire pressure indicator OFF	Off
	Tire pressure indicator ON	On
BUZZER	Tire pressure warning alarm is not sounding	Off
	Tire pressure warning alarm is sounding	On

# BCM (BODY CONTROL MODULE)

< ECU DIAGNOSIS INFORMATION >

[FRONT WINDOW ANTI-PINCH]

## TERMINAL LAYOUT

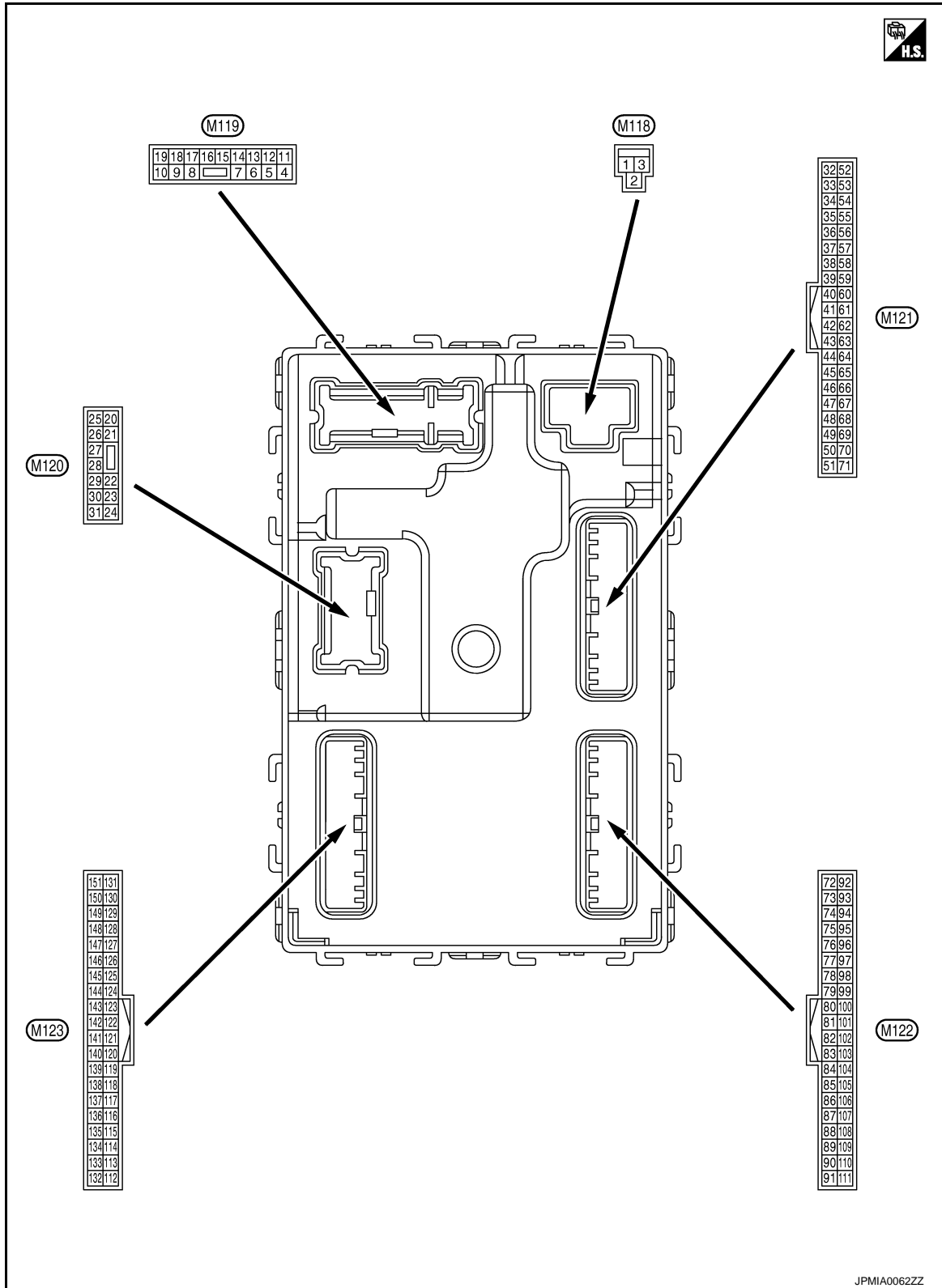

## PHYSICAL VALUES

# BCM (BODY CONTROL MODULE)

< ECU DIAGNOSIS INFORMATION >

[FRONT WINDOW ANTI-PINCH]

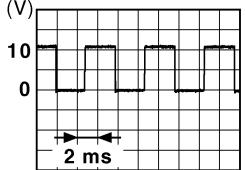
Terminal No. (Wire color)		Description		Condition		Value (Approx.)
		Signal name	Input/ Output			
+	-					
1 (W)	Ground	Battery power supply	Input	Ignition switch OFF		Battery voltage
2 (Y)	Ground	P/W power supply (BAT)	Output	Ignition switch OFF		12 V
3 (BG)	Ground	P/W power supply (RAP)	Output	Ignition switch ON		12 V
4 (LG)	Ground	Interior room lamp power supply	Output	Interior room lamp battery saver is activated. (Cuts the interior room lamp power supply)		0 V
				Interior room lamp battery saver is not activated. (Outputs the interior room lamp power supply)		12 V
5 (P)	Ground	Passenger door UN- LOCK	Output	Passenger door	UNLOCK (Actuator is activated)	12 V
					Other than UNLOCK) Actuator is not activated	0 V
7 (SB)	Ground	Step lamp	Output	Step lamp	ON	0 V
					OFF	12 V
8 (V)	Ground	All doors, fuel lid LOCK	Output	All doors, fuel lid	LOCK (Actuator is activated)	12 V
					Other than LOCK (Actuator is not activated)	0 V
9 (G)	Ground	Driver door, fuel lid UNLOCK	Output	Driver door, fuel lid	UNLOCK (Actuator is activated)	12 V
					Other than UNLOCK (Actuator is not activated)	0 V
10 (P)	Ground	Rear RH door and rear LH door UN- LOCK	Output	Rear RH door and rear LH door	UNLOCK (Actuator is activated)	12 V
					Other than UNLOCK (Actuator is not activated)	0 V
11 (R)	Ground	Battery power supply	Input	Ignition switch OFF		Battery voltage
13 (B)	Ground	Ground	—	Ignition switch ON		0 V
14 (W)	Ground	Push-button ignition switch illumination ground	Output	Tail lamp	OFF	0 V
					ON	<p><b>NOTE:</b> When the illumination brightening/dimming level is in the neutral position.</p>  <p style="text-align: right; font-size: small;">JSNIA0010GB</p>
15 (BG)	Ground	ACC indicator lamp	Output	Ignition switch	OFF (LOCK indicator is not illuminated)	Battery voltage
					ACC	0 V



# BCM (BODY CONTROL MODULE)

< ECU DIAGNOSIS INFORMATION >

[FRONT WINDOW ANTI-PINCH]

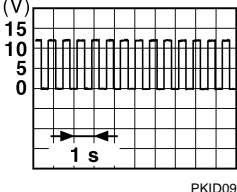
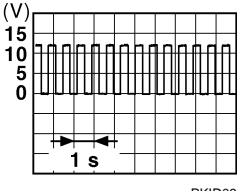
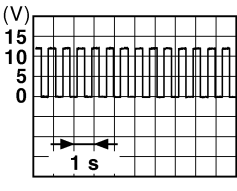
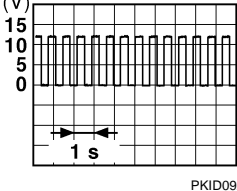
Terminal No. (Wire color)		Description		Condition	Value (Approx.)	
		Signal name	Input/ Output			
+	-					
17 (W)	Ground	Turn signal RH (Front)	Output	Ignition switch ON	Turn signal switch OFF	0 V
					Turn signal switch RH	
18 (BG)	Ground	Turn signal LH (Front)	Output	Ignition switch ON	Turn signal switch OFF	0 V
					Turn signal switch LH	
19 (V)	Ground	Interior room lamp control	Output	Interior room lamp	OFF	12 V
					ON	0 V
20 (V)	Ground	Turn signal RH (Rear)	Output	Ignition switch ON	Turn signal switch OFF	0 V
					Turn signal switch RH	
23 (LG)	Ground	Trunk lid open	Output	Trunk lid	OPEN (Trunk lid opener actuator is activated)	12 V
					Other than OPEN (Trunk lid opener actuator is not activated)	0 V
25 (Y)	Ground	Turn signal LH (Rear)	Output	Ignition switch ON	Turn signal switch OFF	0 V
					Turn signal switch LH	
30 (P)	Ground	Trunk room lamp	Output	Trunk room lamp	ON	0 V
					OFF	12 V

A  
B  
C  
D  
E  
F  
G  
H  
I  
J  
L  
M  
N  
O  
P



# BCM (BODY CONTROL MODULE)

< ECU DIAGNOSIS INFORMATION >

[FRONT WINDOW ANTI-PINCH]

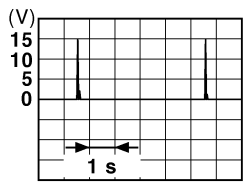
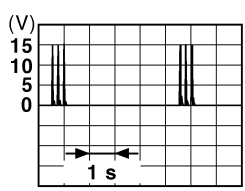
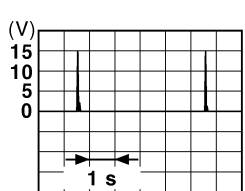
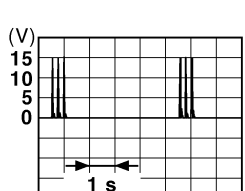
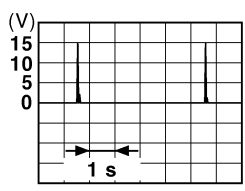
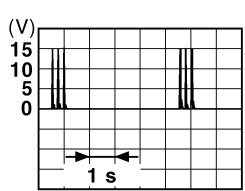
Terminal No. (Wire color)		Description		Condition	Value (Approx.)
		Signal name	Input/ Output		
+	-				
34 (SB)	Ground	Trunk room antenna (-)	Output	Ignition switch OFF	When Intelligent Key is in the passenger compart- ment  <p style="text-align: right; font-size: small;">JMKIA0062GB</p>
				Ignition switch OFF	When Intelligent Key is not in the passenger compart- ment  <p style="text-align: right; font-size: small;">JMKIA0063GB</p>
35 (V)	Ground	Trunk room antenna (+)	Output	Ignition switch OFF	When Intelligent Key is in the passenger compart- ment  <p style="text-align: right; font-size: small;">JMKIA0062GB</p>
				Ignition switch OFF	When Intelligent Key is not in the passenger compart- ment  <p style="text-align: right; font-size: small;">JMKIA0063GB</p>
38 (B)	Ground	Rear bumper anten- na (-)	Output	When the trunk lid opener re- quest switch is operated with ignition switch OFF	When Intelligent Key is in the antenna detection area  <p style="text-align: right; font-size: small;">JMKIA0062GB</p>
				Ignition switch OFF	When Intelligent Key is not in the antenna detection area  <p style="text-align: right; font-size: small;">JMKIA0063GB</p>

# BCM (BODY CONTROL MODULE)

< ECU DIAGNOSIS INFORMATION >

[FRONT WINDOW ANTI-PINCH]

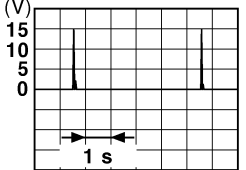
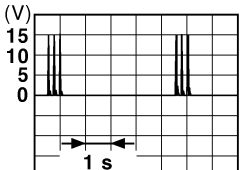
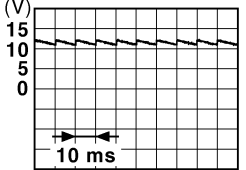
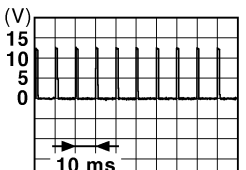
Terminal No. (Wire color)		Description		Condition	Value (Approx.)
		Signal name	Input/ Output		
+	-				
39 (W)	Ground	Rear bumper antenna (+)	Output	When the Intelligent Key is in the antenna detection area	
				When the trunk lid opener request switch is operated with ignition switch OFF	
47 (Y)	Ground	Ignition relay (IPDM E/R) control	Output	Ignition switch OFF or ACC	12 V
				ON	0 V
50 (BG)	Ground	Trunk room lamp switch	Input	Trunk room lamp switch OFF (Trunk lid is closed)	
				ON (Trunk lid is opened)	0 V
52 (R)	Ground	Starter relay control	Output	Ignition switch ON (A/T models) When selector lever is in P or N position	12 V
				Ignition switch ON (A/T models) When selector lever is not in P or N position	0 V
				Ignition switch ON (M/T models) When the clutch pedal is depressed	Battery voltage
				Ignition switch ON (M/T models) When the clutch pedal is not depressed	0 V
60 (BR)	Ground	Push-button ignition switch (Push switch)	Input	Push-button ignition switch (push switch) Pressed	0 V
				Not pressed	Battery voltage
61 (SB)	Ground	Trunk lid opener request switch	Input	Trunk lid opener request switch ON (Pressed)	0 V
				OFF (Not pressed)	
64 (G)	Ground	Intelligent Key warning buzzer (Engine room)	Output	Intelligent Key warning buzzer (Engine room) Sounding	0 V
				Not sounding	12 V

A  
B  
C  
D  
E  
F  
G  
H  
I  
J  
L  
M  
N  
O  
P

PWC

# BCM (BODY CONTROL MODULE)

< ECU DIAGNOSIS INFORMATION >

[FRONT WINDOW ANTI-PINCH]

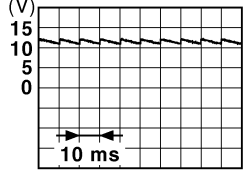
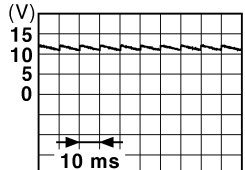
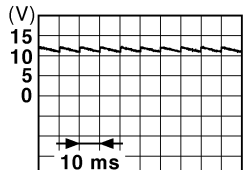
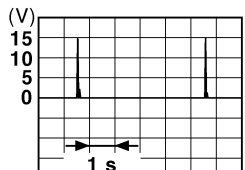
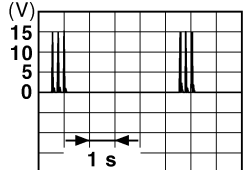
Terminal No. (Wire color)		Description		Condition	Value (Approx.)	
+	-	Signal name	Input/ Output			
67 (GR)	Ground	Trunk lid opener switch	Input	Trunk lid opener switch	Pressed	0 V
				Not pressed	Not pressed	 <p style="text-align: right; font-size: small;">JPMIA0011GB</p>
68 (BG)	Ground	Rear RH door switch	Input	Rear RH door switch	OFF (When rear RH door closes)	 <p style="text-align: right; font-size: small;">JPMIA0011GB</p>
				ON (When rear RH door opens)	ON (When rear RH door opens)	0 V
69 (L)	Ground	Rear LH door switch	Input	Rear LH door switch	OFF (When rear LH door closes)	 <p style="text-align: right; font-size: small;">JPMIA0011GB</p>
				ON (When rear LH door opens)	ON (When rear LH door opens)	0 V
72 (R)	Ground	Room antenna 2 (-) (Center console)	Output	Ignition switch OFF	When Intelligent Key is in the passenger compartment	 <p style="text-align: right; font-size: small;">JMKIA0062GB</p>
				Ignition switch OFF	When Intelligent Key is not in the passenger compartment	 <p style="text-align: right; font-size: small;">JMKIA0063GB</p>

# BCM (BODY CONTROL MODULE)

< ECU DIAGNOSIS INFORMATION >

[FRONT WINDOW ANTI-PINCH]

Terminal No. (Wire color)		Description		Condition	Value (Approx.)
+	-	Signal name	Input/ Output		
73 (G)	Ground	Room antenna 2 (+) (Center console)	Output	Ignition switch OFF	<p>JMKIA0062GB</p>
				When Intelligent Key is not in the passenger compart- ment	<p>JMKIA0063GB</p>
74 (SB)	Ground	Passenger door an- tenna (-)	Output	When the pas- senger door re- quest switch is operated with ignition switch OFF	<p>JMKIA0062GB</p>
				When Intelligent Key is not in the antenna detection area	<p>JMKIA0063GB</p>
75 (BR)	Ground	Passenger door an- tenna (+)	Output	When the pas- senger door re- quest switch is operated with ignition switch OFF	<p>JMKIA0062GB</p>
				When Intelligent Key is not in the antenna detection area	<p>JMKIA0063GB</p>

A  
B  
C  
D  
E  
F  
G  
H  
I  
J  
L  
M  
N  
O  
P

PWC

# BCM (BODY CONTROL MODULE)

< ECU DIAGNOSIS INFORMATION >

[FRONT WINDOW ANTI-PINCH]

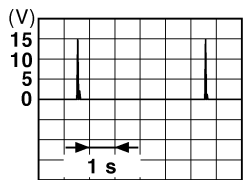
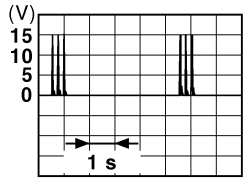
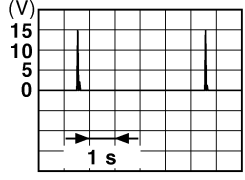
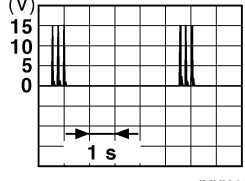
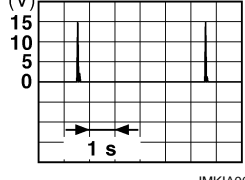
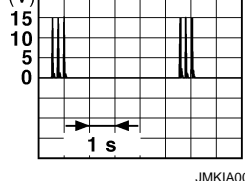
Terminal No. (Wire color)		Description		Condition	Value (Approx.)	
		Signal name	Input/ Output			
+	-					
76 (V)	Ground	Driver door antenna (-)	Output	When the driver door request switch is operated with ignition switch OFF	When Intelligent Key is in the antenna detection area	 <p style="text-align: right; font-size: small;">JMkia0062GB</p>
				When the driver door request switch is operated with ignition switch OFF	When Intelligent Key is not in the antenna detection area	 <p style="text-align: right; font-size: small;">JMkia0063GB</p>
77 (LG)	Ground	Driver door antenna (+)	Output	When the driver door request switch is operated with ignition switch OFF	When Intelligent Key is in the antenna detection area	 <p style="text-align: right; font-size: small;">JMkia0062GB</p>
				When the driver door request switch is operated with ignition switch OFF	When Intelligent Key is not in the antenna detection area	 <p style="text-align: right; font-size: small;">JMkia0063GB</p>
78 (Y)	Ground	Room antenna 1 (-) (Instrument panel)	Output	Ignition switch OFF	When Intelligent Key is in the passenger compartment	 <p style="text-align: right; font-size: small;">JMkia0062GB</p>
				Ignition switch OFF	When Intelligent Key is not in the passenger compartment	 <p style="text-align: right; font-size: small;">JMkia0063GB</p>

# BCM (BODY CONTROL MODULE)

< ECU DIAGNOSIS INFORMATION >

[FRONT WINDOW ANTI-PINCH]

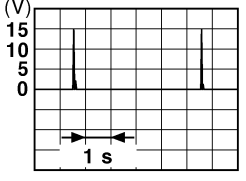
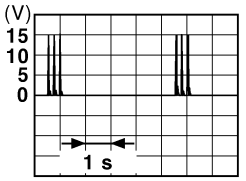
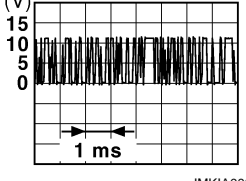
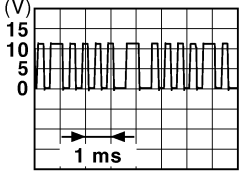
Terminal No. (Wire color)		Description		Condition	Value (Approx.)
+	-	Signal name	Input/ Output		
79 (BR)	Ground	Room antenna 1 (+) (Instrument panel)	Output	Ignition switch OFF	
				Ignition switch ON	
80 (GR)	Ground	NATS antenna amp.	Input/ Output	During waiting	Ignition switch is pressed while inserting the Intelligent Key into the key slot. Pointer of tester should move.
81 (W)	Ground	NATS antenna amp.	Input/ Output	During waiting	Ignition switch is pressed while inserting the Intelligent Key into the key slot. Pointer of tester should move.
82 (SB)	Ground	Ignition relay [Fuse block (J/B)] control	Output	Ignition switch OFF or ACC	0 V
				ON	12 V
83 (Y)	Ground	Remote keyless entry receiver communication	Input/ Output	During waiting	
				When operating either button on the Intelligent Key	

A  
B  
C  
D  
E  
F  
G  
H  
I  
J  
L  
M  
N  
O  
P

PWC

# BCM (BODY CONTROL MODULE)

< ECU DIAGNOSIS INFORMATION >

[FRONT WINDOW ANTI-PINCH]

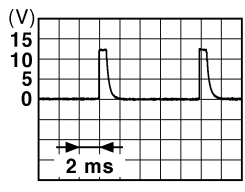
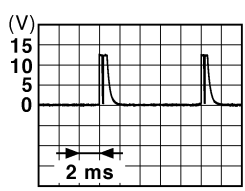
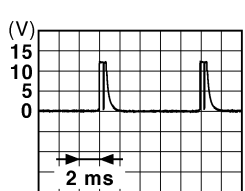



Terminal No. (Wire color)		Description		Condition	Value (Approx.)	
+	-	Signal name	Input/ Output			
87 (Y)	Ground	Combination switch INPUT 5	Input	Combination switch	All switches OFF (Wiper volume dial 4)	 1.4 V
				Combination switch	Front fog lamp switch ON (Wiper volume dial 4)	 1.3 V
				Any of the conditions be- low with all switches OFF	<ul style="list-style-type: none"> <li>• Wiper volume dial 1</li> <li>• Wiper volume dial 2</li> <li>• Wiper volume dial 6</li> <li>• Wiper volume dial 7</li> </ul>	 1.3 V

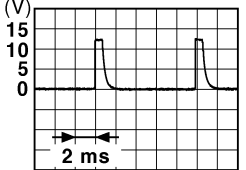

# BCM (BODY CONTROL MODULE)

< ECU DIAGNOSIS INFORMATION >

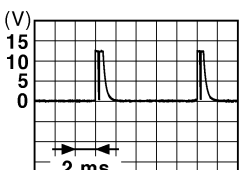
[FRONT WINDOW ANTI-PINCH]

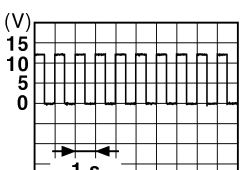
Terminal No. (Wire color)		Description		Condition	Value (Approx.)	
		Signal name	Input/ Output			
+	-					
88 (BG)	Ground	Combination switch INPUT 3	Input	Combination switch	All switches OFF (Wiper volume dial 4)	 <small>JPMIA0041GB</small> 1.4 V
				Combination switch	Lighting switch HI (Wiper volume dial 4)	 <small>JPMIA0036GB</small> 1.3 V
				Combination switch	Lighting switch 2ND (Wiper volume dial 4)	 <small>JPMIA0037GB</small> 1.3 V
				Combination switch	Any of the conditions below with all switches OFF <ul style="list-style-type: none"> <li>• Wiper volume dial 1</li> <li>• Wiper volume dial 2</li> <li>• Wiper volume dial 3</li> </ul>	 <small>JPMIA0040GB</small> 1.3 V
90 (P)	Ground	CAN-L	Input/ Output	—	—	
91 (L)	Ground	CAN-H	Input/ Output	—	—	
92 (LG)	Ground	Key slot illumination	Output	Key slot illuminati- on	OFF	12 V
				Key slot illuminati- on	Blinking	 <small>JPMIA0015GB</small> 6.5 V
93 (GR)	Ground	ON indicator lamp	Output	Ignition switch	OFF (LOCK indicator is not illuminated)	Battery voltage
				Ignition switch	ON	0 V

A  
B  
C  
D  
E  
F  
G  
H  
I  
J  
L  
M  
N  
O  
P

PWC

# BCM (BODY CONTROL MODULE)

< ECU DIAGNOSIS INFORMATION >



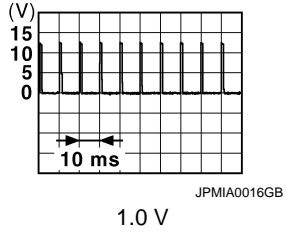
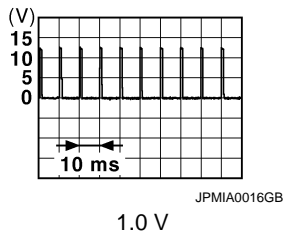

[FRONT WINDOW ANTI-PINCH]

Terminal No. (Wire color)		Description		Condition		Value (Approx.)
+	-	Signal name	Input/ Output			
95 (BG)	Ground	ACC relay control	Output	Ignition switch	OFF	0 V
					ACC or ON	12 V
96 (GR)	Ground	A/T shift selector (Detention switch) power supply	Output	—		12 V
99 (R)*1 (BR)*2	Ground	Selector lever P position switch (A/T models)	Input	Selector lever	P position	0 V
					Any position other than P	12 V
		ASCD clutch switch (M/T models without ICC)		ASCD clutch switch	OFF (Clutch pedal is depressed)	0 V
					ON (Clutch pedal is not depressed)	12 V
		ICC clutch switch (M/T models with ICC)		ICC clutch switch	OFF (Clutch pedal is depressed)	0 V
					ON (Clutch pedal is not depressed)	12 V
100 (Y)	Ground	Passenger door request switch	Input	Passenger door request switch	ON (Pressed)	0 V
					OFF (Not pressed)	
101 (P)	Ground	Driver door request switch	Input	Driver door request switch	ON (Pressed)	0 V
					OFF (Not pressed)	
102 (BG)	Ground	Blower fan motor relay control	Output	Ignition switch	OFF or ACC	0 V
					ON	12 V
103 (P)	Ground	Remote keyless entry receiver power supply	Output	Ignition switch OFF		12 V

# BCM (BODY CONTROL MODULE)

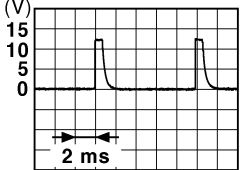
< ECU DIAGNOSIS INFORMATION >

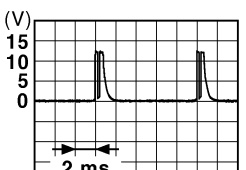
[FRONT WINDOW ANTI-PINCH]

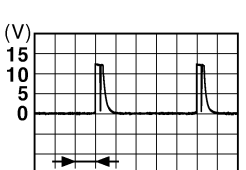
Terminal No. (Wire color)		Description		Condition	Value (Approx.)	
		Signal name	Input/ Output			
+	-					
107 (LG)	Ground	Combination switch INPUT 1	Input	Combination switch (Wiper volume dial 4)	All switches OFF	 1.4 V
					Turn signal switch LH	 1.3 V
					Turn signal switch RH	 1.3 V
					Front wiper switch LO	 1.3 V
					Front washer switch ON	 1.3 V

A  
B  
C  
D  
E  
F  
G  
H  
I  
J  
L  
M  
N  
O  
P

PWC

# BCM (BODY CONTROL MODULE)

< ECU DIAGNOSIS INFORMATION >



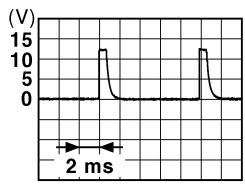
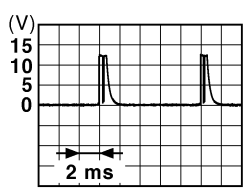
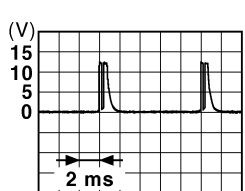
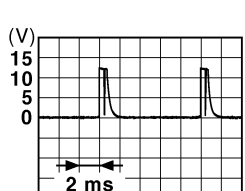

[FRONT WINDOW ANTI-PINCH]

Terminal No. (Wire color)		Description		Condition	Value (Approx.)
+	-	Signal name	Input/ Output		
108 (R)	Ground	Combination switch INPUT 4	Input	Combination switch	All switches OFF (Wiper volume dial 4) <div style="text-align: right;">  <p style="font-size: small; margin: 0;">JPMIA0041GB</p> <p style="margin: 0;">1.4 V</p> </div>
				Lighting switch AUTO (Wiper volume dial 4)	<div style="text-align: right;">  <p style="font-size: small; margin: 0;">JPMIA0038GB</p> <p style="margin: 0;">1.3 V</p> </div>
				Lighting switch 1ST (Wiper volume dial 4)	<div style="text-align: right;">  <p style="font-size: small; margin: 0;">JPMIA0036GB</p> <p style="margin: 0;">1.3 V</p> </div>
				Any of the conditions below with all switches OFF <ul style="list-style-type: none"> <li>• Wiper volume dial 1</li> <li>• Wiper volume dial 5</li> <li>• Wiper volume dial 6</li> </ul>	<div style="text-align: right;">  <p style="font-size: small; margin: 0;">JPMIA0039GB</p> <p style="margin: 0;">1.3 V</p> </div>

# BCM (BODY CONTROL MODULE)

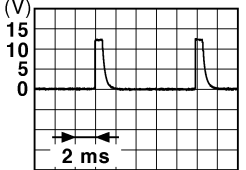
< ECU DIAGNOSIS INFORMATION >

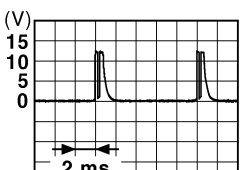
[FRONT WINDOW ANTI-PINCH]

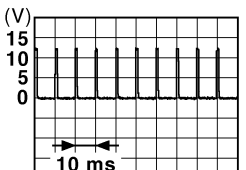
Terminal No. (Wire color)		Description		Condition	Value (Approx.)	
+	-	Signal name	Input/ Output			
109 (W)	Ground	Combination switch INPUT 2	Input	Combination switch (Wiper volume dial 4)	All switches OFF	 <small>JPMIA0041GB</small> 1.4 V
					Lighting switch PASS	 <small>JPMIA0037GB</small> 1.3 V
					Lighting switch 2ND	 <small>JPMIA0036GB</small> 1.3 V
					Front wiper switch INT/ AUTO	 <small>JPMIA0038GB</small> 1.3 V
					Front wiper switch HI	 <small>JPMIA0040GB</small> 1.3 V
					ON	0 V
110 (G)	Ground	Hazard switch	Input	Hazard switch	OFF	 <small>JPMIA0012GB</small> 1.1 V

A  
B  
C  
D  
E  
F  
G  
H  
I  
J  
L  
M  
N  
O  
P

PWC

# BCM (BODY CONTROL MODULE)

< ECU DIAGNOSIS INFORMATION >

[FRONT WINDOW ANTI-PINCH]

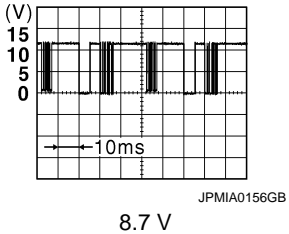
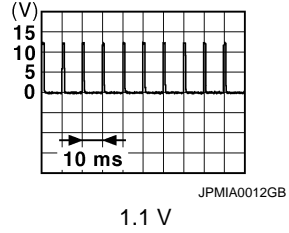
Terminal No. (Wire color)		Description		Condition		Value (Approx.)
+	-	Signal name	Input/ Output			
112 (R)	Ground	Rain sensor serial link	Input/ Output	Ignition switch ON		
113 (BG)	Ground	Optical sensor	Input	Ignition switch ON	When bright outside of the vehicle	Close to 5 V
					When dark outside of the vehicle	Close to 0 V
114 (R)	Ground	Clutch interlock switch	Input	Clutch interlock switch	OFF (Clutch pedal is not depressed)	0 V
					ON (Clutch pedal is depressed)	Battery voltage
116 (SB)	Ground	Stop lamp switch 1	Input	—		Battery voltage
118 (BR)	Ground	Stop lamp switch 2 (Without ICC)	Input	Stop lamp switch	OFF (Brake pedal is not depressed)	0 V
					ON (Brake pedal is depressed)	Battery voltage
		Stop lamp switch 2 (With ICC)		Stop lamp switch OFF (Brake pedal is not depressed) and ICC brake hold relay OFF		0 V
				Stop lamp switch ON (Brake pedal is depressed) or ICC brake hold relay ON		Battery voltage
119 (SB)	Ground	Front door lock assembly driver side (Unlock sensor)	Input	Driver door	LOCK status (Unlock sensor switch OFF)	
					UNLOCK status (Unlock switch sensor ON)	0 V
121 (SB)	Ground	Key slot switch	Input	When the Intelligent Key is inserted into key slot		12 V
				When the Intelligent Key is not inserted into key slot		0 V
123 (V)	Ground	IGN feedback	Input	Ignition switch	OFF or ACC	0 V
					ON	Battery voltage

# BCM (BODY CONTROL MODULE)

< ECU DIAGNOSIS INFORMATION >

[FRONT WINDOW ANTI-PINCH]

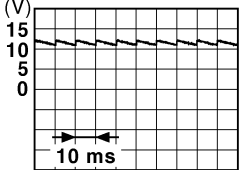
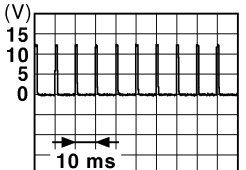
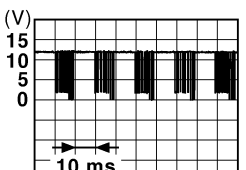
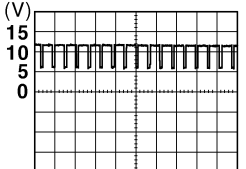
Terminal No. (Wire color)		Description		Condition	Value (Approx.)	
		Signal name	Input/ Output			
+	-					
124 (R)	Ground	Passenger door switch	Input	Passenger door switch	OFF (Door close)	 <small>JPMIA0011GB</small> 11.8 V
					ON (Door open)	0 V
129 (BG)	Ground	Trunk lid opener can- cel switch	Input	Trunk lid open- er cancel switch	CANCEL	 <small>JPMIA0012GB</small> 1.1 V
					ON	0 V
132 (V)	Ground	Power window switch communication	Input/ Output	Ignition switch ON	Ignition switch ON	 <small>JPMIA0013GB</small> 10.2 V
					Ignition switch OFF or ACC	12 V
133 (L)	Ground	Push-button ignition switch illumination	Output	Push-button ig- nition switch il- lumination	ON (Tail lamps OFF)	9.5 V
					ON (Tail lamps ON)	<p style="text-align: center;"><b>NOTE:</b> The pulse width of this wave is varied by the illumination bright- ening/dimming level.</p>  <small>JPMIA0159GB</small>
					OFF	0 V
134 (LG)	Ground	LOCK indicator lamp	Output	LOCK indicator lamp	OFF	Battery voltage
					ON	0 V
137 (BG)	Ground	Receiver and sensor ground	Input	Ignition switch ON	Ignition switch ON	0 V
138 (V)	Ground	Receiver and sensor power supply	Output	Ignition switch	OFF	0 V
					ACC or ON	5.0 V

A  
B  
C  
D  
E  
F  
G  
H  
I  
J  
L  
M  
N  
O  
P

PWC

# BCM (BODY CONTROL MODULE)

< ECU DIAGNOSIS INFORMATION >

[FRONT WINDOW ANTI-PINCH]

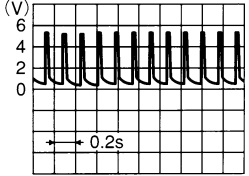
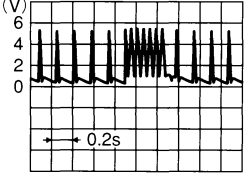
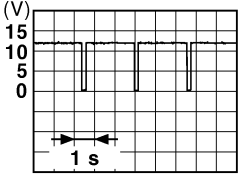
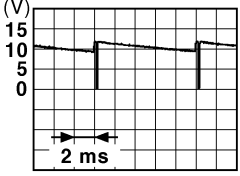
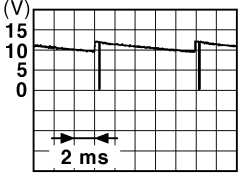
Terminal No. (Wire color)		Description		Condition	Value (Approx.)	
		Signal name	Input/ Output			
+	-					
139 (L)	Ground	Tire pressure receiver communication	Input/ Output	Ignition switch ON	Standby state	 OCC3881D
				When receiving the signal from the transmitter	 OCC3880D	
140 (B)	Ground	Selector lever P/N position	Input	Selector lever	P or N position	12 V
				Except P and N positions	0 V	
141 (W)	Ground	Security indicator lamp	Output	Security indicator lamp	ON	0 V
				Blinking	 JPMIA0014GB	11.3 V
				OFF	12 V	
142 (BR)	Ground	Combination switch OUTPUT 5	Output	Combination switch (Wiper volume dial 4)	All switches OFF	0 V
				Lighting switch 1ST	 JPMIA0031GB	10.7 V
				Lighting switch HI		
				Lighting switch 2ND		
Turn signal switch RH	10.7 V					
143 (P)	Ground	Combination switch OUTPUT 1	Output	Combination switch	All switches OFF (Wiper volume dial 4)	0 V
				Front wiper switch HI (Wiper volume dial 4)	 JPMIA0032GB	10.7 V
				Any of the conditions below with all switches OFF <ul style="list-style-type: none"> <li>• Wiper volume dial 1</li> <li>• Wiper volume dial 2</li> <li>• Wiper volume dial 3</li> <li>• Wiper volume dial 6</li> <li>• Wiper volume dial 7</li> </ul>		



# BCM (BODY CONTROL MODULE)

< ECU DIAGNOSIS INFORMATION >

[FRONT WINDOW ANTI-PINCH]

Terminal No. (Wire color)		Description		Condition	Value (Approx.)		
		Signal name	Input/ Output				
+	-						
144 (G)	Ground	Combination switch OUTPUT 2	Output	Combination switch	All switches OFF (Wiper volume dial 4)	0 V	
					Front washer switch ON (Wiper volume dial 4)		
					Any of the conditions below with all switches OFF		10.7 V
145 (L)	Ground	Combination switch OUTPUT 3	Output	Combination switch (Wiper volume dial 4)	All switches OFF	0 V	
					Front wiper switch INT/ AUTO		
					Front wiper switch LO		10.7 V
					Lighting switch AUTO		
146 (SB)	Ground	Combination switch OUTPUT 4	Output	Combination switch (Wiper volume dial 4)	All switches OFF	0 V	
					Front fog lamp switch ON		
					Lighting switch 2ND		10.7 V
					Lighting switch PASS		
150 (GR)	Ground	Driver door switch	Input	Driver door switch	OFF (Door close)		
					ON (Door open)		0 V
151 (G)	Ground	Rear window defogger relay control	Output	Rear window defogger	Active	0 V	
					Not activated	Battery voltage	

- \*1: A/T models
- \*2: M/T models

A  
B  
C  
D  
E  
F  
G  
H  
I  
J  
L  
M  
N  
O  
P

PWC



# BCM (BODY CONTROL MODULE)

< ECU DIAGNOSIS INFORMATION >

[FRONT WINDOW ANTI-PINCH]

A : With A/T  
M : With M/T  
IC : With ICC  
OI : Without ICC

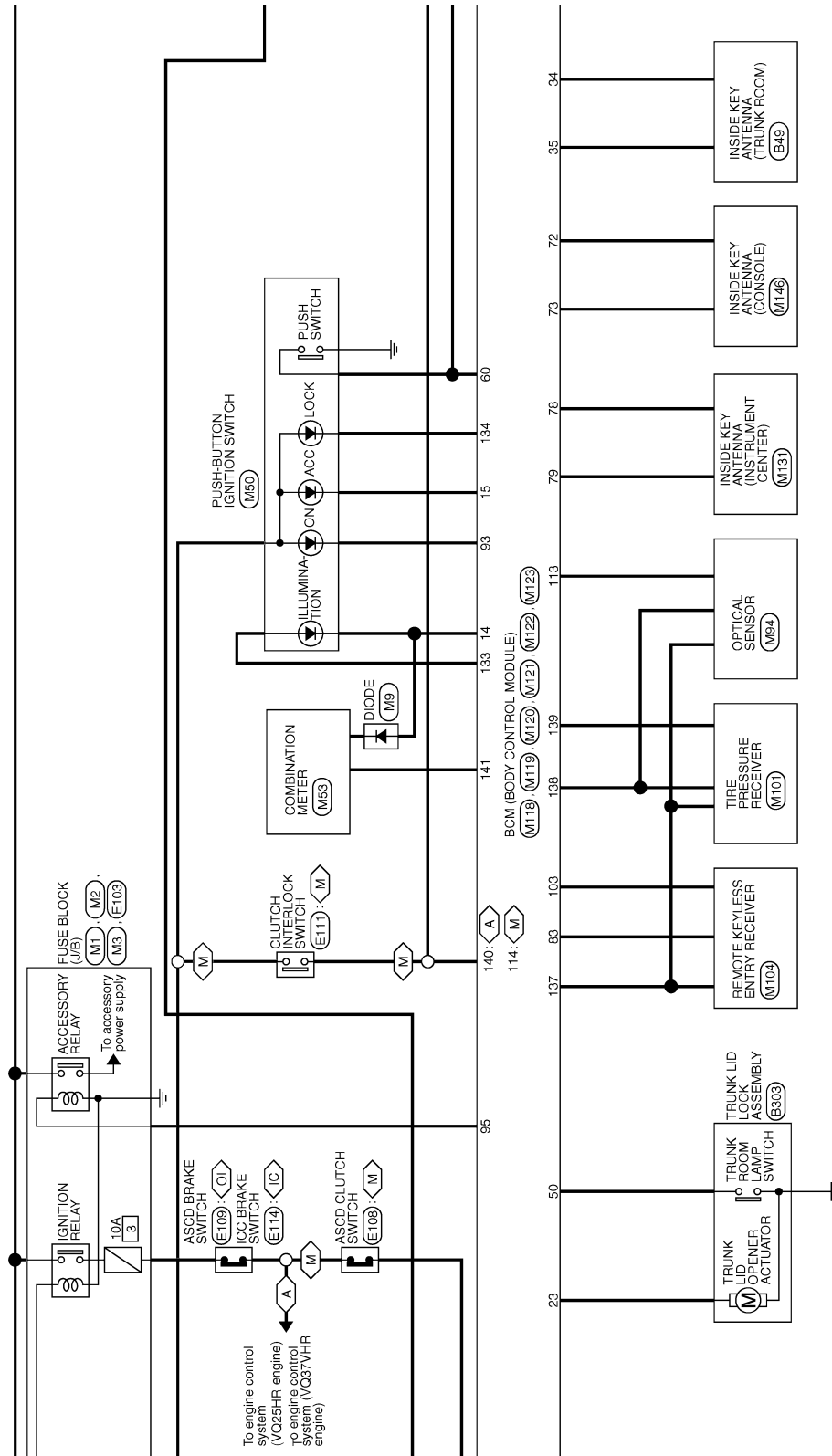

JRMWD3147GB

A  
B  
C  
D  
E  
F  
G  
H  
I  
J  
K  
L  
M  
N  
O  
P

PWC

# BCM (BODY CONTROL MODULE)

< ECU DIAGNOSIS INFORMATION >

[FRONT WINDOW ANTI-PINCH]

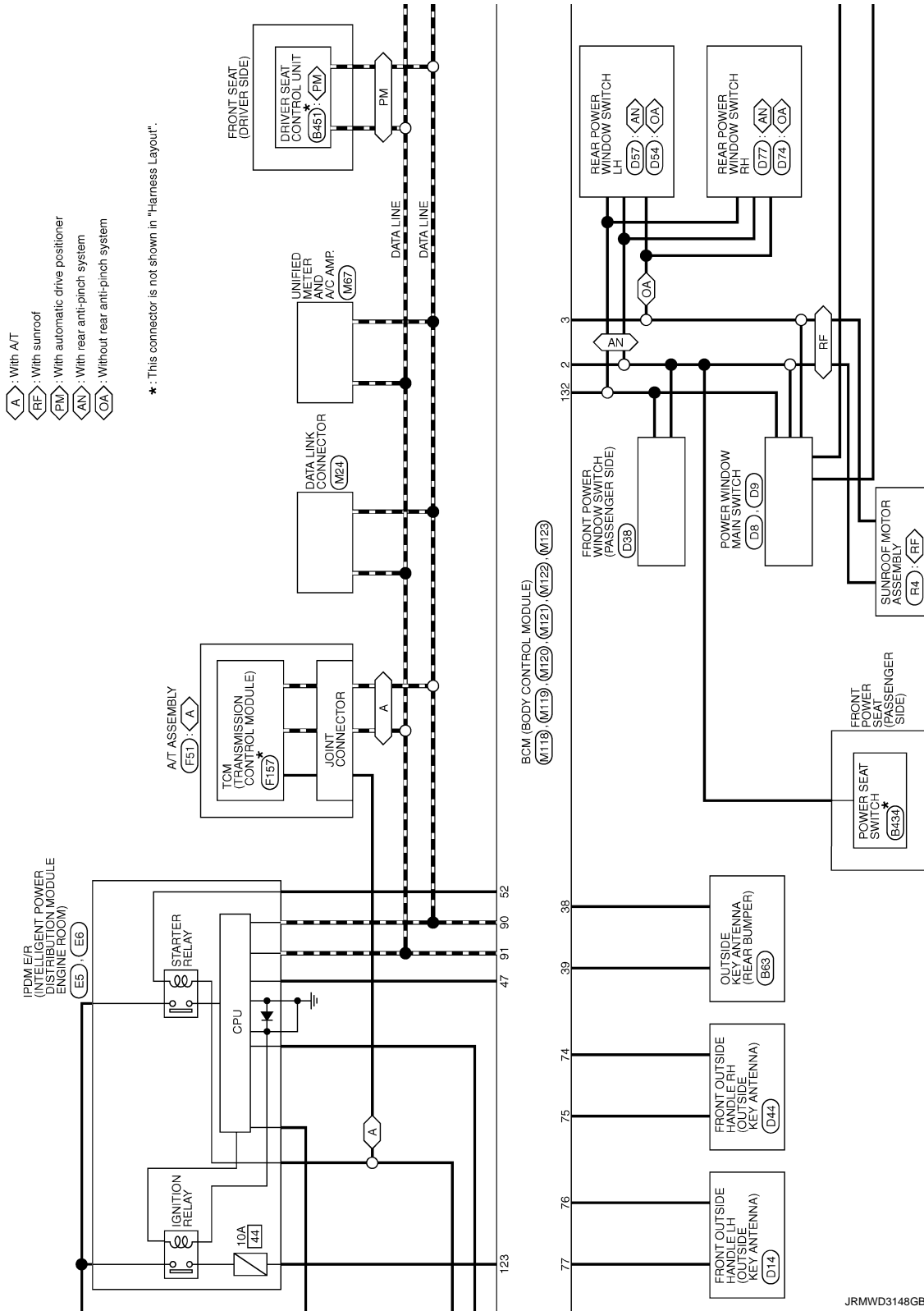

- ◊ A ◊ : With AT
- ◊ RE ◊ : With sunroof
- ◊ PM ◊ : With automatic drive positioner
- ◊ AN ◊ : With rear anti-pinch system
- ◊ OA ◊ : Without rear anti-pinch system

\*: This connector is not shown in "Harness Layout".

JRMWD3148GB

# BCM (BODY CONTROL MODULE)

< ECU DIAGNOSIS INFORMATION >

[FRONT WINDOW ANTI-PINCH]

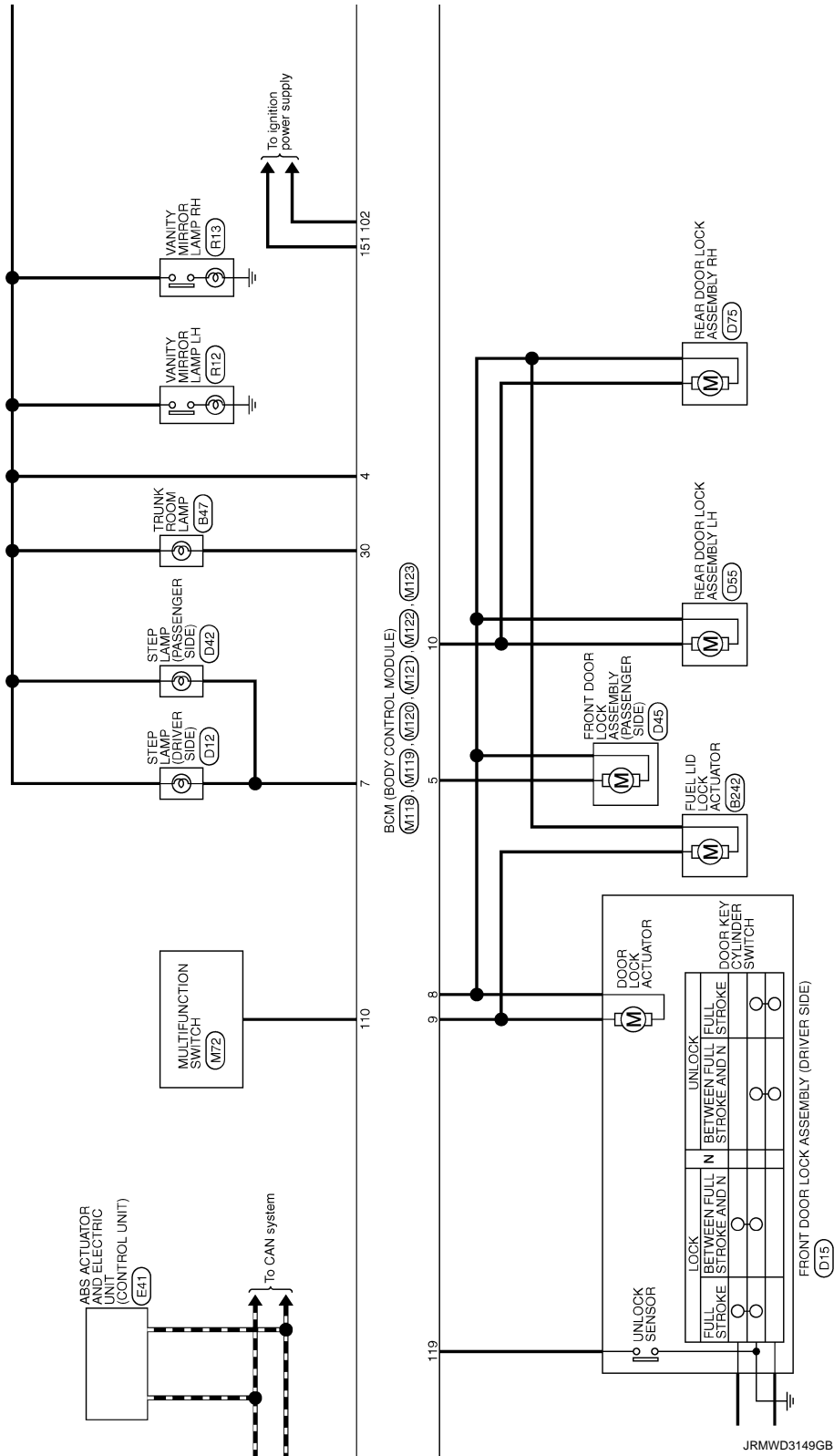

A  
B  
C  
D  
E  
F  
G  
H  
I  
J  
K  
L  
M  
N  
O  
P



# BCM (BODY CONTROL MODULE)

< ECU DIAGNOSIS INFORMATION >

[FRONT WINDOW ANTI-PINCH]

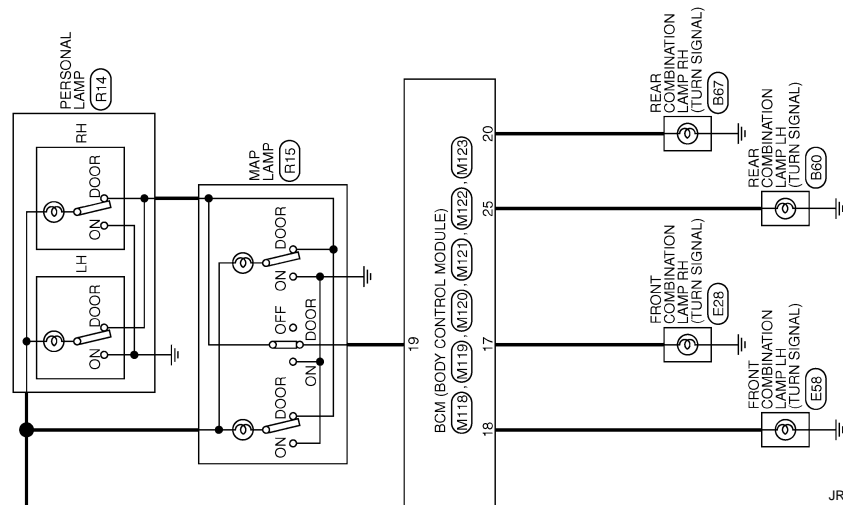

JRMWD3150GB

## Fail-safe

INFOID:000000008782238

### FAIL-SAFE CONTROL BY DTC

BCM performs fail-safe control when any DTC are detected.

# BCM (BODY CONTROL MODULE)

< ECU DIAGNOSIS INFORMATION >

[FRONT WINDOW ANTI-PINCH]

Display contents of CONSULT	Fail-safe	Cancellation
B2190: NATS ANTENNA AMP	Inhibit engine cranking	Erase DTC
B2191: DIFFERENCE OF KEY	Inhibit engine cranking	Erase DTC
B2192: ID DISCORD BCM-ECM	Inhibit engine cranking	Erase DTC
B2193: CHAIN OF BCM-ECM	Inhibit engine cranking	Erase DTC
B2195: ANTI-SCANNING	Inhibit engine cranking	Ignition switch ON → OFF
B2560: STARTER CONT RELAY	Inhibit engine cranking	500 ms after the following CAN signal communication status becomes consistent <ul style="list-style-type: none"> <li>• Starter control relay signal</li> <li>• Starter relay status signal</li> </ul>
B2608: STARTER RELAY	Inhibit engine cranking	500 ms after the following signal communication status becomes consistent <ul style="list-style-type: none"> <li>• Starter motor relay control signal</li> <li>• Starter relay status signal (CAN)</li> </ul>
B260A: IGNITION RELAY	Inhibit engine cranking	500 ms after the following conditions are fulfilled <ul style="list-style-type: none"> <li>• IGN relay (IPDM E/R) control signal: OFF (12 V)</li> <li>• Ignition ON signal (CAN to IPDM E/R): OFF (Request signal)</li> <li>• Ignition ON signal (CAN from IPDM E/R): OFF (Condition signal)</li> </ul>
B260F: ENG STATE SIG LOST	Maintains the power supply position attained at the time of DTC detection	When any of the following conditions are fulfilled <ul style="list-style-type: none"> <li>• Power position changes to ACC</li> <li>• Receives engine status signal (CAN)</li> </ul>
B2617: BCM	Inhibit engine cranking	1 second after the starter motor relay control inside BCM becomes normal
B2618: BCM	Inhibit engine cranking	1 second after the ignition relay (IPDM E/R) control inside BCM becomes normal
B261E: VEHICLE TYPE	Inhibit engine cranking	BCM initialization
B26E8: CLUTCH SW	Inhibit engine cranking	When any of the following BCM recognition conditions are fulfilled <ul style="list-style-type: none"> <li>• Status 1 <ul style="list-style-type: none"> <li>- Clutch switch signal (CAN from ECM): ON</li> <li>- Clutch interlock switch signal: OFF (0 V)</li> </ul> </li> <li>• Status 2 <ul style="list-style-type: none"> <li>- Clutch switch signal (CAN from ECM): OFF</li> <li>- Clutch interlock switch signal: ON (Battery voltage)</li> </ul> </li> </ul>

## DTC Inspection Priority Chart

INFOID:000000008782239

If some DTCs are displayed at the same time, perform inspections one by one based on the following priority chart.

Priority	DTC
1	B2562: LOW VOLTAGE
2	<ul style="list-style-type: none"> <li>• U1000: CAN COMM</li> <li>• U1010: CONTROL UNIT(CAN)</li> </ul>
3	<ul style="list-style-type: none"> <li>• B2190: NATS ANTENNA AMP</li> <li>• B2191: DIFFERENCE OF KEY</li> <li>• B2192: ID DISCORD BCM-ECM</li> <li>• B2193: CHAIN OF BCM-ECM</li> <li>• B2195: ANTI-SCANNING</li> </ul>

# BCM (BODY CONTROL MODULE)

< ECU DIAGNOSIS INFORMATION >

[FRONT WINDOW ANTI-PINCH]

Priority	DTC
4	<ul style="list-style-type: none"> <li>• B2553: IGNITION RELAY</li> <li>• B2555: STOP LAMP</li> <li>• B2556: PUSH-BTN IGN SW</li> <li>• B2557: VEHICLE SPEED</li> <li>• B2560: STARTER CONT RELAY</li> <li>• B2601: SHIFT POSITION</li> <li>• B2602: SHIFT POSITION</li> <li>• B2603: SHIFT POSI STATUS</li> <li>• B2604: PNP/CLUTCH SW</li> <li>• B2605: PNP/CLUTCH SW</li> <li>• B2608: STARTER RELAY</li> <li>• B260A: IGNITION RELAY</li> <li>• B260F: ENG STATE SIG LOST</li> <li>• B2614: BCM</li> <li>• B2615: BCM</li> <li>• B2616: BCM</li> <li>• B2617: BCM</li> <li>• B2618: BCM</li> <li>• B261A: PUSH-BTN IGN SW</li> <li>• B261E: VEHICLE TYPE</li> <li>• B26E8: CLUTCH SW</li> <li>• B26EA: KEY REGISTRATION</li> <li>• C1729: VHCL SPEED SIG ERR</li> <li>• U0415: VEHICLE SPEED</li> </ul>
5	<ul style="list-style-type: none"> <li>• C1704: LOW PRESSURE FL</li> <li>• C1705: LOW PRESSURE FR</li> <li>• C1706: LOW PRESSURE RR</li> <li>• C1707: LOW PRESSURE RL</li> <li>• C1708: [NO DATA] FL</li> <li>• C1709: [NO DATA] FR</li> <li>• C1710: [NO DATA] RR</li> <li>• C1711: [NO DATA] RL</li> <li>• C1716: [PRESSDATA ERR] FL</li> <li>• C1717: [PRESSDATA ERR] FR</li> <li>• C1718: [PRESSDATA ERR] RR</li> <li>• C1719: [PRESSDATA ERR] RL</li> <li>• C1734: CONTROL UNIT</li> </ul>
6	<ul style="list-style-type: none"> <li>• B2621: INSIDE ANTENNA</li> <li>• B2622: INSIDE ANTENNA</li> <li>• B2623: INSIDE ANTENNA</li> </ul>

## DTC Index

INFOID:000000008782240

### NOTE:

The details of time display are as follows.

- CRNT: A malfunction is detected now.
- PAST: A malfunction was detected in the past.

IGN counter is displayed on Freeze Frame Data. For details of Freeze Frame Data, refer to [BCS-16, "COMMON ITEM : CONSULT Function \(BCM - COMMON ITEM\)"](#).

CONSULT display	Fail-safe	Freeze Frame Data •Vehicle Speed •Odo/Trip Meter •Vehicle condition	Intelligent Key warning lamp ON	Tire pressure monitor warning lamp ON	Refer- ence page
No DTC is detected. further testing may be required.	—	—	—	—	—
U1000: CAN COMM	—	—	—	—	<a href="#">BCS-36</a>
U1010: CONTROL UNIT(CAN)	—	—	—	—	<a href="#">BCS-37</a>
U0415: VEHICLE SPEED	—	—	—	—	<a href="#">BCS-38</a>
B2190: NATS ANTENNA AMP	×	—	—	—	<a href="#">SEC-44</a>



# BCM (BODY CONTROL MODULE)

< ECU DIAGNOSIS INFORMATION >

[FRONT WINDOW ANTI-PINCH]

CONSULT display	Fail-safe	Freeze Frame Data •Vehicle Speed •Odo/Trip Meter •Vehicle condition	Intelligent Key warning lamp ON	Tire pressure monitor warning lamp ON	Refer- ence page
B2191: DIFFERENCE OF KEY	×	—	—	—	<a href="#">SEC-47</a>
B2192: ID DISCORD BCM-ECM	×	—	—	—	<a href="#">SEC-48</a>
B2193: CHAIN OF BCM-ECM	×	—	—	—	<a href="#">SEC-50</a>
B2195: ANTI-SCANNING	×	—	—	—	<a href="#">SEC-51</a>
B2553: IGNITION RELAY	—	×	—	—	<a href="#">PCS-46</a>
B2555: STOP LAMP	—	×	—	—	<a href="#">SEC-52</a>
B2556: PUSH-BTN IGN SW	—	×	×	—	<a href="#">SEC-54</a>
B2557: VEHICLE SPEED	×	×	×	—	<a href="#">SEC-56</a>
B2560: STARTER CONT RELAY	×	×	×	—	<a href="#">SEC-57</a>
B2562: LOW VOLTAGE	—	×	—	—	<a href="#">BCS-39</a>
B2601: SHIFT POSITION	×	×	×	—	<a href="#">SEC-58</a>
B2602: SHIFT POSITION	×	×	×	—	<a href="#">SEC-61</a>
B2603: SHIFT POSI STATUS	×	×	×	—	<a href="#">SEC-64</a>
B2604: PNP/CLUTCH SW	×	×	×	—	<a href="#">SEC-67</a>
B2605: PNP/CLUTCH SW	×	×	×	—	<a href="#">SEC-69</a>
B2608: STARTER RELAY	×	×	×	—	<a href="#">SEC-71</a>
B260A: IGNITION RELAY	×	×	×	—	<a href="#">PCS-48</a>
B260F: ENG STATE SIG LOST	×	×	×	—	<a href="#">SEC-73</a>
B2614: BCM	—	×	×	—	<a href="#">PCS-50</a>
B2615: BCM	—	×	×	—	<a href="#">PCS-52</a>
B2616: BCM	—	×	×	—	<a href="#">PCS-54</a>
B2617: BCM	×	×	×	—	<a href="#">SEC-78</a>
B2618: BCM	×	×	×	—	<a href="#">PCS-56</a>
B261A: PUSH-BTN IGN SW	—	×	×	—	<a href="#">PCS-57</a>
B261E: VEHICLE TYPE	×	×	× (Turn ON for 15 seconds)	—	<a href="#">SEC-80</a>
B2621: INSIDE ANTENNA	—	×	—	—	<a href="#">DLK-59</a>
B2622: INSIDE ANTENNA	—	×	—	—	<a href="#">DLK-61</a>
B2623: INSIDE ANTENNA	—	×	—	—	<a href="#">DLK-63</a>
B26E8: CLUTCH SW	×	×	×	—	<a href="#">SEC-75</a>
B26EA: KEY REGISTRATION	—	×	× (Turn ON for 15 seconds)	—	<a href="#">SEC-77</a>
C1704: LOW PRESSURE FL	—	—	—	×	<a href="#">WT-20</a>
C1705: LOW PRESSURE FR	—	—	—	×	
C1706: LOW PRESSURE RR	—	—	—	×	
C1707: LOW PRESSURE RL	—	—	—	×	
C1708: [NO DATA] FL	—	—	—	×	<a href="#">WT-22</a>
C1709: [NO DATA] FR	—	—	—	×	
C1710: [NO DATA] RR	—	—	—	×	
C1711: [NO DATA] RL	—	—	—	×	

A  
B  
C  
D  
E  
F  
G  
H  
I  
J  
PWC  
L  
M  
N  
O  
P

# BCM (BODY CONTROL MODULE)

< ECU DIAGNOSIS INFORMATION >

[FRONT WINDOW ANTI-PINCH]

CONSULT display	Fail-safe	Freeze Frame Data •Vehicle Speed •Odo/Trip Meter •Vehicle condition	Intelligent Key warning lamp ON	Tire pressure monitor warning lamp ON	Refer- ence page
C1716: [PRESSDATA ERR] FL	—	—	—	×	<a href="#">WT-25</a>
C1717: [PRESSDATA ERR] FR	—	—	—	×	
C1718: [PRESSDATA ERR] RR	—	—	—	×	
C1719: [PRESSDATA ERR] RL	—	—	—	×	
C1729: VHCL SPEED SIG ERR	—	—	—	×	<a href="#">WT-26</a>
C1734: CONTROL UNIT	—	—	—	×	<a href="#">WT-27</a>

# POWER WINDOW MAIN SWITCH

< ECU DIAGNOSIS INFORMATION >

[FRONT WINDOW ANTI-PINCH]

## POWER WINDOW MAIN SWITCH

Reference Value

INFOID:000000008290604

### TERMINAL LAYOUT

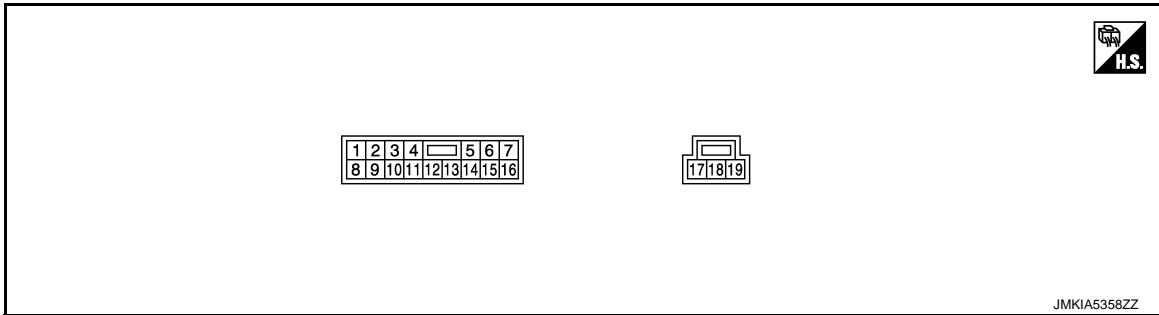

### PHYSICAL VALUES

Terminal No. (wire color)		Description		Condition	Voltage [V] (Approx.)
+	-	Signal name	Input/ Output		
1 (W)	Ground	Rear power window motor LH UP signal	Output	When rear LH switch in power window main switch is UP at operated.	12
2 (LG)	Ground	Encoder ground	—	—	0
3 (GR)	Ground	Rear power window motor LH DOWN signal	Output	When rear LH switch in power window main switch is DOWN at operated.	12
4 (V)	Ground	Door key cylinder switch LOCK signal	Input	Key position (Neutral → Locked)	5 → 0
5 (BG)	Ground	Rear power window motor RH DOWN signal	Output	When rear RH switch in power window main switch is DOWN at operated.	12
6 (Y)	Ground	Door key cylinder switch UNLOCK signal	Input	Key position (Neutral → Unlocked)	5 → 0
7 (BR)	Ground	Rear power window motor RH UP signal	Output	When rear RH switch in power window main switch is UP at operated.	12
8 (L)	Ground	Front driver side power window motor UP signal	Output	When front LH switch in power window main switch is UP at operated.	12
9 (BG)	Ground	Encoder pulse signal 2	Input	When power window motor operates.	

JMKIA0070GB

A  
B  
C  
D  
E  
F  
G  
H  
I  
J  
L  
M  
N  
O  
P

PWC

# POWER WINDOW MAIN SWITCH

< ECU DIAGNOSIS INFORMATION >

[FRONT WINDOW ANTI-PINCH]

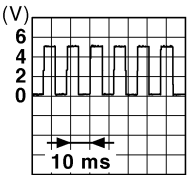
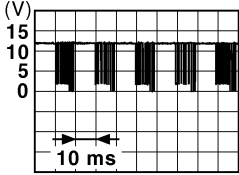
Terminal No. (wire color)		Description		Condition	Voltage [V] (Approx.)
+	-	Signal name	Input/ Output		
10 (SB)	Ground	Rap signal	Input	IGN SW ON	12
				Within 45 second after ignition switch is turned to OFF	12
				When driver side or passenger side door is opened during retained power operation	0
11 (G)	Ground	Front driver side power window motor DOWN signal	Output	When front LH switch in power window main switch is DOWN at operated.	12
13 (P)	Ground	Encoder pulse signal 1	Input	When power window motor operates.	 <p style="text-align: right; font-size: small;">JMKIA0070GB</p>
14 (V)	Ground	Power window serial link	Input/ Output	IGN SW ON or power window timer operating.	 <p style="text-align: right; font-size: small;">JPMIA0013GB</p>
15 (B)	Ground	Encoder power supply	Output	When ignition switch ON or power window timer operates.	12
17 (B)	Ground	Ground	—	—	0
19 (Y)	Ground	Battery power supply	Input	—	12



## POWER WINDOW MAIN SWITCH

< ECU DIAGNOSIS INFORMATION >

[FRONT WINDOW ANTI-PINCH]

Switches to fail-safe control when malfunction is detected in encoder signal that detects up/down speed and direction of door glass. Switches to fail-safe control when a signal that is out of the specified value is detected between the fully closed position and the actual position of the glass.

Malfunction	Malfunction condition
Pulse sensor malfunction	When one pulse signal that is the specified value or more is detected continuously for the specified time or more, while door glass is being operated UP or DOWN.
Both pulse sensors malfunction	When both pulse signals are not detected continuously for the specified time or more, while door glass is being operated UP or DOWN.
Pulse direction malfunction	When a pulse signal indicating that window is moving in the opposite direction against the power window motor is detected for the specified value or more, while door glass is being operated UP or DOWN.
Glass recognition position malfunction 1	When the actual door glass position that is out of specified value is detected compared to the door glass fully closed position memorized in module, while door glass is being operated UP or DOWN.
Glass recognition position malfunction 2	When pulse count that is out of the door glass full stroke value or more is detected, while door glass is being operated UP or DOWN.

If fail-safe control, the system changes to a non-initialized condition and the following function do not operate.

- Auto-up operation
- Anti-pinch function
- Retained power function

When fail-safe control is activated, perform initialization procedure to recover. If a malfunction is detected in power window switch or more, fail-safe control is activated again.

# FRONT POWER WINDOW SWITCH

< ECU DIAGNOSIS INFORMATION >

[FRONT WINDOW ANTI-PINCH]

## FRONT POWER WINDOW SWITCH

### Reference Value

INFOID:000000008290607

### TERMINAL LAYOUT

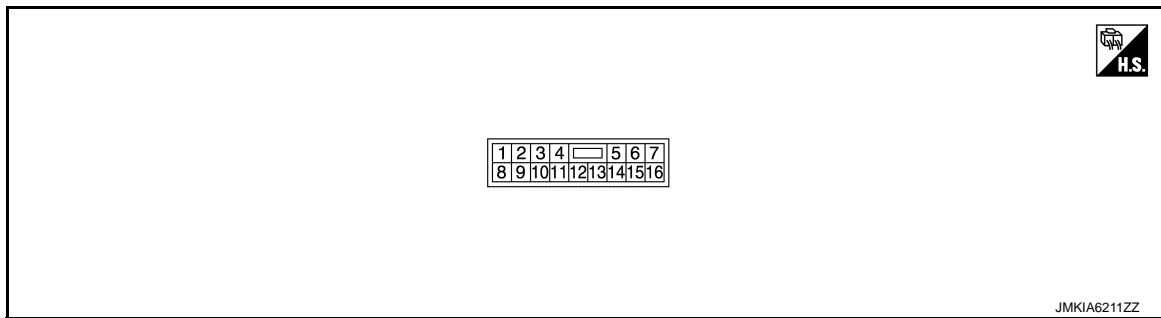

### PHYSICAL VALUES

Terminal No. (wire color)		Description		Condition	Voltage (V) (Approx.)
+	-	Signal name	Input/ Output		
3 (LG)	Ground	Encoder ground	—	—	0
4 (B)	Ground	Encoder power supply	Output	When ignition switch ON or power window timer operates	12
8 (L)	Ground	Power window motor DOWN signal	Output	When power window motor is DOWN at operated.	12
9 (G)	Ground	Power window motor UP signal	Output	When power window motor is UP at operated.	12
10 (Y)	Ground	Battery power supply	Input	—	12
11 (B)	Ground	Ground	—	—	0
12 (P)	Ground	Encoder pulse signal 1	Input	When power window motor operates.	 JMKIA0070GB
15 (BG)	Ground	Encoder pulse signal 2	Input	When power window motor operates.	 JMKIA0070GB
16 (V)	Ground	Power window serial link	Input/ Output	Ignition switch ON or power window timer operating.	 JPMIA0013GB

A  
B  
C  
D  
E  
F  
G  
H  
I  
J  
L  
M  
N  
O  
P

PWC





# FRONT POWER WINDOW SWITCH

< ECU DIAGNOSIS INFORMATION >

[FRONT WINDOW ANTI-PINCH]

## Fail-safe

INFOID:000000008290609

### FAIL-SAFE CONTROL

Switches to fail-safe control when malfunction is detected in encoder signal that detects up/down speed and direction of door glass. Switches to fail-safe control when a signal that is out of the specified value is detected between the fully closed position and the actual position of the glass.

Malfunction	Malfunction condition
Pulse sensor malfunction	When one pulse signal that is the specified value or more is detected continuously for the specified time or more, while door glass is being operated UP or DOWN.
Both pulse sensors malfunction	When both pulse signals are not detected continuously for the specified time or more, while door glass is being operated UP or DOWN.
Pulse direction malfunction	When a pulse signal indicating that window is moving in the opposite direction against the power window motor is detected for the specified value or more, while door glass is being operated UP or DOWN.
Glass recognition position malfunction 1	When the actual door glass position that is out of specified value is detected compared to the door glass fully closed position memorized in module, while door glass is being operated UP or DOWN.
Glass recognition position malfunction 2	When pulse count that is out of the door glass full stroke value or more is detected, while door glass is being operated UP or DOWN.

If fail-safe control, the system changes to a non-initialized condition and the following function do not operate.

- Auto-up operation
- Anti-pinch function
- Retained power function

When fail-safe control is activated, perform initialization procedure to recover. If a malfunction is detected in power window switch or more, fail-safe control is activated again.

A  
B  
C  
D  
E  
F  
G  
H  
I  
J  
L  
M  
N  
O  
P

PWC

# POWER WINDOWS DO NOT OPERATE WITH ANY POWER WINDOW SWITCHES

< SYMPTOM DIAGNOSIS >

[FRONT WINDOW ANTI-PINCH]

## SYMPTOM DIAGNOSIS

POWER WINDOWS DO NOT OPERATE WITH ANY POWER WINDOW SWITCHES

Diagnosis Procedure

INFOID:000000008290610

### 1. CHECK BCM POWER SUPPLY AND GROUND CIRCUIT

---

Check BCM power supply and ground circuit.

Refer to [BCS-40, "Diagnosis Procedure"](#).

Is the inspection result normal?

YES >> GO TO 2.

NO >> Repair or replace the malfunctioning parts.

### 2. CONFIRM THE OPERATION

---

Confirm the operation again.

Is the result normal?

YES >> Check intermittent incident. Refer to [GI-43, "Intermittent Incident"](#).

NO >> GO TO 1.

# DRIVER SIDE POWER WINDOW DOES NOT OPERATE

< SYMPTOM DIAGNOSIS >

[FRONT WINDOW ANTI-PINCH]

## DRIVER SIDE POWER WINDOW DOES NOT OPERATE

### Diagnosis Procedure

INFOID:000000008290611

#### 1. CHECK POWER WINDOW MAIN SWITCH POWER SUPPLY AND GROUND CIRCUIT

Check power window switch power supply and ground circuit.

Refer to [PWC-109, "POWER WINDOW MAIN SWITCH : Diagnosis Procedure"](#).

Is the inspection result normal?

YES >> GO TO 2.

NO >> Repair or replace the malfunctioning parts.

#### 2. CHECK DRIVER SIDE POWER WINDOW MOTOR

Check driver side power window motor.

Refer to [PWC-115, "DRIVER SIDE : Component Function Check"](#).

Is the measurement value within the specification?

YES >> GO TO 3.

NO >> Repair or replace the malfunctioning parts.

#### 3. CONFIRM THE OPERATION

Confirm the operation again.

Is the result normal?

YES >> Check intermittent incident. Refer to [GI-43, "Intermittent Incident"](#).

NO >> GO TO 1.

A  
B  
C  
D  
E  
F  
G  
H  
I  
J  
L  
M  
N  
O  
P

PWC

# FRONT PASSENGER SIDE POWER WINDOW DOES NOT OPERATE

< SYMPTOM DIAGNOSIS >

[FRONT WINDOW ANTI-PINCH]

## FRONT PASSENGER SIDE POWER WINDOW DOES NOT OPERATE WHEN POWER WINDOW MAIN SWITCH IS OPERATED

WHEN POWER WINDOW MAIN SWITCH IS OPERATED : Diagnosis Procedure

INFOID:000000008290612

### 1. CHECK FRONT POWER WINDOW SWITCH (PASSENGER SIDE) SERIAL LINK CIRCUIT

Check front power window switch (passenger side) serial link circuit.

Refer to [PWC-128, "FRONT POWER WINDOW SWITCH \(PASSENGER SIDE\) : Component Function Check"](#).

Is the inspection result normal?

YES >> GO TO 2.

NO >> Repair or replace the malfunctioning parts.

### 2. CONFIRM THE OPERATION

Confirm the operation again.

Is the result normal?

YES >> Check intermittent incident. Refer to [GI-43, "Intermittent Incident"](#).

NO >> GO TO 1.

WHEN FRONT POWER WINDOW SWITCH (PASSENGER SIDE) IS OPERATED

WHEN FRONT POWER WINDOW SWITCH (PASSENGER SIDE) IS OPERATED :  
Diagnosis Procedure

INFOID:000000008290613

### 1. REPLACE FRONT POWER WINDOW SWITCH (PASSENGER SIDE)

Replace front power window switch (passenger side).

Refer to [PWC-185, "Removal and Installation"](#)

>> INSPECTION END

WHEN BOTH POWER WINDOW MAIN SWITCH AND FRONT POWER WINDOW  
SWITCH ARE OPERATED

WHEN BOTH POWER WINDOW MAIN SWITCH AND FRONT POWER WINDOW  
SWITCH ARE OPERATED : Diagnosis Procedure

INFOID:000000008290614

### 1. CHECK FRONT POWER WINDOW SWITCH (PASSENGER SIDE) POWER SUPPLY AND GROUND CIR- CUIT

Check front power window switch (passenger side) power supply and ground circuit.

Refer to [PWC-110, "FRONT POWER WINDOW SWITCH \(PASSENGER SIDE\) : Diagnosis Procedure"](#).

Is the inspection result normal?

YES >> GO TO 2.

NO >> Repair or replace the malfunctioning parts.

### 2. CHECK PASSENGER SIDE POWER WINDOW MOTOR CIRCUIT

Check passenger side power window motor circuit.

Refer to [PWC-116, "PASSENGER SIDE : Component Function Check"](#).

Is the inspection result normal?

YES >> GO TO 3.

NO >> Repair or replace the malfunctioning parts.

### 3. CONFIRM THE OPERATION

Confirm the operation again.

Is the result normal?

YES >> Check intermittent incident. Refer to [GI-43, "Intermittent Incident"](#).

# FRONT PASSENGER SIDE POWER WINDOW DOES NOT OPERATE

< SYMPTOM DIAGNOSIS >

[FRONT WINDOW ANTI-PINCH]

NO >> GO TO 1.

A

B

C

D

E

F

G

H

I

J

**PWC**

L

M

N

O

P

## REAR LH SIDE POWER WINDOW DOES NOT OPERATE

< SYMPTOM DIAGNOSIS >

[FRONT WINDOW ANTI-PINCH]

### REAR LH SIDE POWER WINDOW DOES NOT OPERATE WHEN POWER WINDOW MAIN SWITCH IS OPERATED

WHEN POWER WINDOW MAIN SWITCH IS OPERATED : Diagnosis Procedure

INFOID:000000008290615

#### 1.CHECK REAR POWER WINDOW SWITCH

Check rear power window switch.

Refer to [PWC-113. "Component Function Check"](#).

Is the inspection result normal?

YES >> GO TO 2.

NO >> Repair or replace the malfunctioning parts.

#### 2.CONFIRM THE OPERATION

Confirm the operation again.

Is the result normal?

YES >> Check intermittent incident. Refer to [GI-43. "Intermittent Incident"](#).

NO >> GO TO 1.

### WHEN REAR POWER WINDOW SWITCH LH IS OPERATED

WHEN REAR POWER WINDOW SWITCH LH IS OPERATED : Diagnosis Procedure

INFOID:000000008290616

#### 1.CHECK REAR POWER WINDOW SWITCH POWER SUPPLY AND GROUND CIRCUIT

Check rear power window switch power supply and ground circuit.

Refer to [PWC-111. "REAR POWER WINDOW SWITCH : Diagnosis Procedure"](#).

Is the inspection result normal?

YES >> GO TO 2.

NO >> Repair or replace the malfunctioning parts.

#### 2.REPLACE REAR POWER WINDOW SWITCH LH

Replace rear power window switch LH.

Refer to [PWC-185. "Removal and Installation"](#).

>> INSPECTION END

### WHEN BOTH POWER WINDOW MAIN SWITCH AND REAR POWER WINDOW SWITCH LH ARE OPERATED

WHEN BOTH POWER WINDOW MAIN SWITCH AND REAR POWER WINDOW  
SWITCH LH ARE OPERATED : Diagnosis Procedure

INFOID:000000008290617

#### 1.CHECK REAR POWER WINDOW MOTOR LH

Check rear power window motor LH.

Refer to [PWC-117. "REAR LH : Component Function Check"](#).

Is the inspection result normal?

YES >> GO TO 2.

NO >> Repair or replace the malfunctioning parts.

#### 2.CONFIRM THE OPERATION

Confirm the operation again.

Is the result normal?

YES >> Check intermittent incident. Refer to [GI-43. "Intermittent Incident"](#).

NO >> GO TO 1.

## REAR RH SIDE POWER WINDOW DOES NOT OPERATE

< SYMPTOM DIAGNOSIS >

[FRONT WINDOW ANTI-PINCH]

### REAR RH SIDE POWER WINDOW DOES NOT OPERATE WHEN POWER WINDOW MAIN SWITCH IS OPERATED

WHEN POWER WINDOW MAIN SWITCH IS OPERATED : Diagnosis Procedure

INFOID:000000008290618

#### 1. CHECK REAR POWER WINDOW SWITCH

Check rear power window switch.

Refer to [PWC-113, "Component Function Check"](#).

Is the inspection result normal?

YES >> GO TO 2.

NO >> Repair or replace the malfunctioning parts.

#### 2. CONFIRM THE OPERATION

Confirm the operation again.

Is the result normal?

YES >> Check intermittent incident. Refer to [GI-43, "Intermittent Incident"](#).

NO >> GO TO 1.

### WHEN REAR POWER WINDOW SWITCH RH IS OPERATED

WHEN REAR POWER WINDOW SWITCH RH IS OPERATED : Diagnosis Procedure

INFOID:000000008290619

#### 1. CHECK REAR POWER WINDOW SWITCH POWER SUPPLY AND GROUND CIRCUIT

Check rear power window switch power supply and ground circuit.

Refer to [PWC-111, "REAR POWER WINDOW SWITCH : Diagnosis Procedure"](#).

Is the inspection result normal?

YES >> GO TO 2.

NO >> Repair or replace the malfunctioning parts.

#### 2. REPLACE REAR POWER WINDOW SWITCH RH

Replace rear power window switch RH.

Refer to [PWC-185, "Removal and Installation"](#).

>> INSPECTION END

### WHEN BOTH POWER WINDOW MAIN SWITCH AND REAR POWER WINDOW SWITCH RH ARE OPERATED

WHEN BOTH POWER WINDOW MAIN SWITCH AND REAR POWER WINDOW  
SWITCH RH ARE OPERATED : Diagnosis Procedure

INFOID:000000008290620

#### 1. CHECK REAR POWER WINDOW MOTOR RH

Check rear power window motor RH.

Refer to [PWC-118, "REAR RH : Component Function Check"](#).

Is the inspection result normal?

YES >> GO TO 2.

NO >> Repair or replace the malfunctioning parts.

#### 2. CONFIRM THE OPERATION

Confirm the operation again.

Is the result normal?

YES >> Check intermittent incident. Refer to [GI-43, "Intermittent Incident"](#).

NO >> GO TO 1.

A

B

C

D

E

F

G

H

I

J

PWC

L

M

N

O

P

# ANTI-PINCH FUNCTION DOES NOT OPERATE

< SYMPTOM DIAGNOSIS >

[FRONT WINDOW ANTI-PINCH]

---

## ANTI-PINCH FUNCTION DOES NOT OPERATE

### Diagnosis Procedure

INFOID:000000008290621

#### 1. CHECK POWER WINDOW AUTO OPERATION

---

Check AUTO operation when anti-pinch function does not operate.

Is the inspection result normal?

YES >> GO TO 2.

NO >> Refer to [PWC-177, "Diagnosis Procedure"](#).

#### 2. CONFIRM THE OPERATION

---

Confirm the operation again.

Is the result normal?

YES >> Check intermittent incident. Refer to [GI-43, "Intermittent Incident"](#).

NO >> GO TO 1.



# AUTO OPERATION DOES NOT OPERATE BUT MANUAL OPERATE NORMALLY

< SYMPTOM DIAGNOSIS >

[FRONT WINDOW ANTI-PINCH]

## AUTO OPERATION DOES NOT OPERATE BUT MANUAL OPERATE NORMALLY

### Diagnosis Procedure

INFOID:000000008290622

#### 1.PERFORM INITIALIZATION PROCEDURE

Initialization procedure is executed and operation is confirmed.

Refer to [PWC-100, "ADDITIONAL SERVICE WHEN REMOVING BATTERY NEGATIVE TERMINAL : Special Repair Requirement"](#).

Is the inspection result normal?

YES >> INSPECTION END  
NO >> GO TO 2.

#### 2.CHECK ENCODER CIRCUIT

Check encoder circuit. Refer to the following.

- Driver side: Refer to [PWC-120, "DRIVER SIDE : Component Function Check"](#).
- Passenger side: Refer to [PWC-122, "PASSENGER SIDE : Component Function Check"](#).

Is the inspection result normal?

YES >> GO TO 3.  
NO >> Repair or replace the malfunctioning parts.

#### 3.CONFIRM THE OPERATION

Confirm the operation again.

Is the result normal?

YES >> Check intermittent incident. Refer to [GI-43, "Intermittent Incident"](#).  
NO >> GO TO 1.

A  
B  
C  
D  
E  
F  
G  
H  
I  
J  
L  
M  
N  
O  
P

PWC

# POWER WINDOW RETAINED POWER OPERATION DOES NOT OPERATE PROPERLY

< SYMPTOM DIAGNOSIS >

[FRONT WINDOW ANTI-PINCH]

## POWER WINDOW RETAINED POWER OPERATION DOES NOT OPERATE PROPERLY

### Diagnosis Procedure

INFOID:000000008290623

#### 1. CHECK DOOR SWITCH

---

Check door switch.

Refer to [DLK-66, "Component Function Check"](#).

Is the inspection result normal?

YES >> GO TO 2.

NO >> Repair or replace the malfunctioning parts.

#### 2. CONFIRM THE OPERATION

---

Confirm the operation again.

Is the result normal?

YES >> Check intermittent incident. Refer to [GI-43, "Intermittent Incident"](#).

NO >> GO TO 1.

# DOOR KEY CYLINDER SWITCH DOES NOT OPERATE POWER WINDOWS

< SYMPTOM DIAGNOSIS >

[FRONT WINDOW ANTI-PINCH]

## DOOR KEY CYLINDER SWITCH DOES NOT OPERATE POWER WINDOWS

### Diagnosis Procedure

INFOID:000000008290624

#### 1.PERFORM INITIALIZATION PROCEDURE

Initialization procedure is executed and operation is confirmed.

Refer to [PWC-100, "ADDITIONAL SERVICE WHEN REMOVING BATTERY NEGATIVE TERMINAL : Special Repair Requirement"](#).

Is the inspection result normal?

YES >> INSPECTION END  
NO >> GO TO 2.

#### 2.CHECK DRIVER SIDE DOOR LOCK ASSEMBLY (KEY CYLINDER SWITCH)

Check driver side door lock assembly (key cylinder switch).

Refer to [PWC-125, "Component Function Check"](#).

Is the inspection result normal?

YES >> GO TO 3.  
NO >> Repair or replace the malfunctioning parts.

#### 3.CONFIRM THE OPERATION

Confirm the operation again.

Is the result normal?

YES >> Check intermittent incident. Refer to [GI-43, "Intermittent Incident"](#).  
NO >> GO TO 1.

A  
B  
C  
D  
E  
F  
G  
H  
I  
J  
L  
M  
N  
O  
P

PWC

# KEYLESS POWER WINDOW DOWN DOES NOT OPERATE

< SYMPTOM DIAGNOSIS >

[FRONT WINDOW ANTI-PINCH]

## KEYLESS POWER WINDOW DOWN DOES NOT OPERATE

### Description

INFOID:000000008290625

Power window down does not operate when pressing unlock button on Intelligent Key.

### Diagnosis Procedure

INFOID:000000008290626

#### 1. CHECK REMOTE KEYLESS ENTRY FUNCTION

---

Check remote keyless entry function.

Does door lock/unlock with Intelligent key button?

YES >> GO TO 2.

NO >> Refer to [DLK-160, "Description"](#).

#### 2. CHECK POWER WINDOW OPERATION

---

Check power window operation.

Does power window up/down with power window main switch?

YES >> GO TO 3.

NO >> Refer to [PWC-171, "Diagnosis Procedure"](#).

#### 3. CHECK "PW DOWN SET" SETTING IN "WORK SUPPORT"

---

Check "PW DOWN SET" setting in "WORK SUPPORT".

Refer to [DLK-51, "DOOR LOCK : CONSULT Function \(BCM - DOOR LOCK\)"](#).

Is the inspection result normal?

YES >> GO TO 4.

NO >> Set "PW DOWN SET" setting in "WORK SUPPORT".

#### 4. CONFIRM THE OPERATION

---

Confirm the operation again.

Is the result normal?

YES >> Check intermittent incident. Refer to [GI-43, "Intermittent Incident"](#).

NO >> GO TO 1.

# POWER WINDOW LOCK SWITCH DOES NOT FUNCTION

< SYMPTOM DIAGNOSIS >

[FRONT WINDOW ANTI-PINCH]

---

## POWER WINDOW LOCK SWITCH DOES NOT FUNCTION

### Diagnosis Procedure

INFOID:000000008290627

#### 1. REPLACE POWER WINDOW MAIN SWITCH

---

Replace power window main switch. Refer to [PWC-185, "Removal and Installation"](#).

>> INSPECTION END

A  
B  
C  
D  
E  
F  
G  
H  
I  
J  
L  
M  
N  
O  
P

PWC

# POWER WINDOW SWITCH ILLUMINATION DOES NOT ILLUMINATE

< SYMPTOM DIAGNOSIS >

[FRONT WINDOW ANTI-PINCH]

---

## POWER WINDOW SWITCH ILLUMINATION DOES NOT ILLUMINATE

### Diagnosis Procedure

INFOID:000000008290628

#### 1. REPLACE POWER WINDOW SWITCH

---

Replace power window switch.

Refer to [PWC-185, "Removal and Installation"](#).

>> INSPECTION END

# PRECAUTION

## PRECAUTIONS

### Precaution for Supplemental Restraint System (SRS) "AIR BAG" and "SEAT BELT PRE-TENSIONER"

INFOID:000000008290629

The Supplemental Restraint System such as "AIR BAG" and "SEAT BELT PRE-TENSIONER", used along with a front seat belt, helps to reduce the risk or severity of injury to the driver and front passenger for certain types of collision. This system includes seat belt switch inputs and dual stage front air bag modules. The SRS system uses the seat belt switches to determine the front air bag deployment, and may only deploy one front air bag, depending on the severity of a collision and whether the front occupants are belted or unbelted. Information necessary to service the system safely is included in the "SRS AIR BAG" and "SEAT BELT" of this Service Manual.

**WARNING:**

Always observe the following items for preventing accidental activation.

- To avoid rendering the SRS inoperative, which could increase the risk of personal injury or death in the event of a collision that would result in air bag inflation, all maintenance must be performed by an authorized NISSAN/INFINITI dealer.
- Improper maintenance, including incorrect removal and installation of the SRS, can lead to personal injury caused by unintentional activation of the system. For removal of Spiral Cable and Air Bag Module, see "SRS AIR BAG".
- Never use electrical test equipment on any circuit related to the SRS unless instructed to in this Service Manual. SRS wiring harnesses can be identified by yellow and/or orange harnesses or harness connectors.

### PRECAUTIONS WHEN USING POWER TOOLS (AIR OR ELECTRIC) AND HAMMERS

**WARNING:**

Always observe the following items for preventing accidental activation.

- When working near the Air Bag Diagnosis Sensor Unit or other Air Bag System sensors with the ignition ON or engine running, never use air or electric power tools or strike near the sensor(s) with a hammer. Heavy vibration could activate the sensor(s) and deploy the air bag(s), possibly causing serious injury.
- When using air or electric power tools or hammers, always switch the ignition OFF, disconnect the battery, and wait at least 3 minutes before performing any service.

A  
B  
C  
D  
E  
F  
G  
H  
I  
J  
L  
M  
N  
O  
P

PWC

PREPARATION

PREPARATION

Commercial Service Tools

INFOID:000000008290630

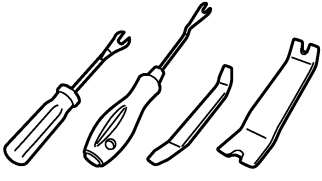
Tool name	Description
<p>Remover tool</p>  <p>JMKIA3050ZZ</p>	<p>Removes the clips, pawls and metal clips</p>



# POWER WINDOW MAIN SWITCH

< REMOVAL AND INSTALLATION >

[FRONT WINDOW ANTI-PINCH]

## REMOVAL AND INSTALLATION

### POWER WINDOW MAIN SWITCH

#### Removal and Installation

INFOID:000000008290631

#### REMOVAL

1. Remove the power window main switch finisher (2).  
Refer to [INT-11, "Removal and Installation"](#).
2. Power window main switch (1) is removed from power window main switch finisher (2) using remover tool (A).

 : Pawl

#### CAUTION:

**Do not fold the pawl of power window main switch finisher.**

#### NOTE:

The same procedure is also performed for front power window switch (passenger side) and rear power window switch (LH & RH).

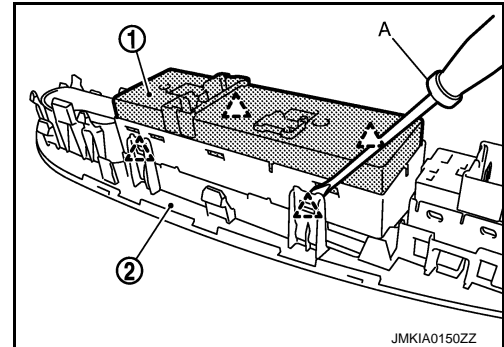

#### INSTALLATION

Install in the reverse order of removal.

#### NOTE:

Power window main switch is exchanged or is detached it is necessary to do the initialization procedure.  
Refer to [PWC-101, "ADDITIONAL SERVICE WHEN REPLACING CONTROL UNIT : Special Repair Requirement"](#).

A  
B  
C  
D  
E  
F  
G  
H  
I  
J  
L  
M  
N  
O  
P

PWC