

SECTION **SEC**

SECURITY CONTROL SYSTEM

A
B
C

CONTENTS

<p>BASIC INSPECTION 5</p> <p>DIAGNOSIS AND REPAIR WORK FLOW 5</p> <p style="padding-left: 20px;">Work Flow5</p> <p>INSPECTION AND ADJUSTMENT 8</p> <p>ECM RE-COMMUNICATING FUNCTION8</p> <p style="padding-left: 20px;">ECM RE-COMMUNICATING FUNCTION : De- scription8</p> <p style="padding-left: 20px;">ECM RE-COMMUNICATING FUNCTION : Spe- cial Repair Requirement8</p> <p>SYSTEM DESCRIPTION 9</p> <p>INTELLIGENT KEY SYSTEM/ENGINE START FUNCTION 9</p> <p style="padding-left: 20px;">System Diagram9</p> <p style="padding-left: 20px;">System Description9</p> <p style="padding-left: 20px;">Component Parts Location12</p> <p style="padding-left: 20px;">Component Description14</p> <p>INFINITI VEHICLE IMMOBILIZER SYSTEM- NATS15</p> <p style="padding-left: 20px;">System Diagram15</p> <p style="padding-left: 20px;">System Description15</p> <p style="padding-left: 20px;">Component Parts Location17</p> <p style="padding-left: 20px;">Component Description19</p> <p>VEHICLE SECURITY SYSTEM20</p> <p style="padding-left: 20px;">System Diagram20</p> <p style="padding-left: 20px;">System Description20</p> <p style="padding-left: 20px;">Component Parts Location22</p> <p style="padding-left: 20px;">Component Description24</p> <p>DIAGNOSIS SYSTEM (BCM)25</p> <p>COMMON ITEM25</p> <p style="padding-left: 20px;">COMMON ITEM : CONSULT Function (BCM - COMMON ITEM)25</p> <p>INTELLIGENT KEY26</p>	<p>INTELLIGENT KEY : CONSULT Function (BCM - INTELLIGENT KEY)26</p> <p>THEFT ALM30</p> <p style="padding-left: 20px;">THEFT ALM : CONSULT Function (BCM - THEFT)30</p> <p>IMMU31</p> <p style="padding-left: 20px;">IMMU : CONSULT Function (BCM - IMMU)31</p> <p>DTC/CIRCUIT DIAGNOSIS32</p> <p>U1000 CAN COMM CIRCUIT32</p> <p>BCM32</p> <p style="padding-left: 20px;">BCM : Description32</p> <p style="padding-left: 20px;">BCM : DTC Logic32</p> <p style="padding-left: 20px;">BCM : Diagnosis Procedure32</p> <p>IPDM E/R32</p> <p style="padding-left: 20px;">IPDM E/R : Description32</p> <p style="padding-left: 20px;">IPDM E/R : DTC Logic32</p> <p style="padding-left: 20px;">IPDM E/R : Diagnosis Procedure33</p> <p>U1010 CONTROL UNIT (CAN)34</p> <p>BCM34</p> <p style="padding-left: 20px;">BCM : DTC Logic34</p> <p style="padding-left: 20px;">BCM : Diagnosis Procedure34</p> <p>P1610 LOCK MODE35</p> <p style="padding-left: 20px;">Description35</p> <p style="padding-left: 20px;">DTC Logic35</p> <p style="padding-left: 20px;">Diagnosis Procedure35</p> <p>P1611 ID DISCORD, IMMU-ECM36</p> <p style="padding-left: 20px;">Description36</p> <p style="padding-left: 20px;">DTC Logic36</p> <p style="padding-left: 20px;">Diagnosis Procedure36</p> <p>P1612 CHAIN OF ECM-IMMU38</p> <p style="padding-left: 20px;">Description38</p> <p style="padding-left: 20px;">DTC Logic38</p>
---------------------------------------------------------------------------------------------------------------------------------------------------------------------------------------------------------------------------------------------------------------------------------------------------------------------------------------------------------------------------------------------------------------------------------------------------------------------------------------------------------------------------------------------------------------------------------------------------------------------------------------------------------------------------------------------------------------------------------------------------------------------------------------------------------------------------------------------------------------------------------------------------------------------------------------------------------------------------------------------------------------------------------------------------------------------------------------------------------------------------------------------------------------------------------------------------------------------------------------------------------------------------------------------------------------------------------------------------------------------------------------------------------------------------------------------------------------------------------------------------------------------------------------------------------------------------------------------------------------------------------------------------------------------------------------------------------	-----------------------------------------------------------------------------------------------------------------------------------------------------------------------------------------------------------------------------------------------------------------------------------------------------------------------------------------------------------------------------------------------------------------------------------------------------------------------------------------------------------------------------------------------------------------------------------------------------------------------------------------------------------------------------------------------------------------------------------------------------------------------------------------------------------------------------------------------------------------------------------------------------------------------------------------------------------------------------------------------------------------------------------------------------------------------------------------------------------------------------------------------------------------------------------------------------------------------------------------------------------------------------------------------------------------------------------------------------------------------------------------------------------------------------------------------------------------------------------------------------------------------------------------------------------------------------------------------------------------------------------------------------------------------------------------------

D
E

F
G

H
I

J
SEC

L
M

N
O

P

Diagnosis Procedure	38	Diagnosis Procedure	57
P1614 CHAIN OF IMMU-KEY	39	Component Inspection	59
Description	39	B2602 SHIFT POSITION	60
DTC Logic	39	Description	60
Diagnosis Procedure	39	DTC Logic	60
P1615 DIFFERENCE OF KEY	42	Diagnosis Procedure	60
Description	42	Component Inspection	61
DTC Logic	42	B2603 SHIFT POSITION	63
Diagnosis Procedure	42	Description	63
B2190 NATS ANTENNA AMP.	43	DTC Logic	63
Description	43	Diagnosis Procedure	63
DTC Logic	43	Component Inspection	65
Diagnosis Procedure	43	B2604 SHIFT POSITION	66
B2191 DIFFERENCE OF KEY	46	Description	66
Description	46	DTC Logic	66
DTC Logic	46	Diagnosis Procedure	66
Diagnosis Procedure	46	B2605 SHIFT POSITION	68
B2192 ID DISCORD, IMMUECM	47	Description	68
Description	47	DTC Logic	68
DTC Logic	47	Diagnosis Procedure	68
Diagnosis Procedure	47	B2608 STARTER RELAY	70
B2193 CHAIN OF ECM-IMMU	49	Description	70
Description	49	DTC Logic	70
DTC Logic	49	Diagnosis Procedure	70
Diagnosis Procedure	49	B260F ENGINE STATUS	72
B2195 ANTI-SCANNING	50	Description	72
Description	50	DTC Logic	72
DTC Logic	50	Diagnosis Procedure	72
Diagnosis Procedure	50	B26EA KEY REGISTRATION	73
B2555 STOP LAMP	51	Description	73
Description	51	DTC Logic	73
DTC Logic	51	Diagnosis Procedure	73
Diagnosis Procedure	51	B2617 STARTER RELAY CIRCUIT	74
Component Inspection	52	Description	74
B2556 PUSH-BUTTON IGNITION SWITCH	53	DTC Logic	74
Description	53	Diagnosis Procedure	74
DTC Logic	53	B261E VEHICLE TYPE	76
Diagnosis Procedure	53	Description	76
Component Inspection	54	DTC Logic	76
B2557 VEHICLE SPEED	55	Diagnosis Procedure	76
Description	55	B210B STARTER CONTROL RELAY	77
DTC Logic	55	Description	77
Diagnosis Procedure	55	DTC Logic	77
B2560 STARTER CONTROL RELAY	56	Diagnosis Procedure	77
Description	56	B210C STARTER CONTROL RELAY	78
DTC Logic	56	Description	78
Diagnosis Procedure	56	DTC Logic	78
B2601 SHIFT POSITION	57	Diagnosis Procedure	78
Description	57	B210D STARTER RELAY	80
DTC Logic	57	Description	80

DTC Logic	80	VEHICLE SECURITY SYSTEM	117	
Diagnosis Procedure	80	Wiring Diagram - VEHICLE SECURITY SYSTEM		A
B210E STARTER RELAY	82	-	117	
Description	82	ECU DIAGNOSIS INFORMATION	125	B
DTC Logic	82	BCM (BODY CONTROL MODULE)	125	
Diagnosis Procedure	82	Reference Value	125	C
B210F SHIFT POSITION/CLUTCH INTER-LOCK SWITCH	84	Wiring Diagram - BCM -	149	
Description	84	Fail-safe	162	D
DTC Logic	84	DTC Inspection Priority Chart	163	
Diagnosis Procedure	84	DTC Index	164	
B2110 SHIFT POSITION/CLUTCH INTER-LOCK SWITCH	86	IPDM E/R (INTELLIGENT POWER DISTRIBUTION MODULE ENGINE ROOM)	167	E
Description	86	Reference Value	167	
DTC Logic	86	Wiring Diagram - IPDM E/R -	174	F
Diagnosis Procedure	86	Fail-safe	177	
POWER SUPPLY AND GROUND CIRCUIT	88	DTC Index	179	
BCM	88	SYMPTOM DIAGNOSIS	180	G
BCM : Diagnosis Procedure	88	ENGINE DOES NOT START WHEN INTELLIGENT KEY IS INSIDE OF VEHICLE	180	
IPDM E/R	88	Description	180	H
IPDM E/R : Diagnosis Procedure	88	Diagnosis Procedure	180	
KEY SLOT	90	SECURITY INDICATOR LAMP DOES NOT TURN ON OR FLASH	181	I
Description	90	Description	181	
Component Function Check	90	Diagnosis Procedure	181	J
Diagnosis Procedure	90	VEHICLE SECURITY SYSTEM CANNOT BE SET	182	
KEY SLOT INDICATOR	91	INTELLIGENT KEY	182	SEC
Description	91	INTELLIGENT KEY : Description	182	
Component Function Check	91	INTELLIGENT KEY : Diagnosis Procedure	182	
Diagnosis Procedure	91	DOOR REQUEST SWITCH	182	L
HOOD SWITCH	93	DOOR REQUEST SWITCH : Description	182	
Description	93	DOOR REQUEST SWITCH : Diagnosis Procedure	182	M
Component Function Check	93	VEHICLE SECURITY ALARM DOES NOT ACTIVATE	184	N
Diagnosis Procedure	93	Description	184	
Component Inspection	94	Diagnosis Procedure	184	
SECURITY INDICATOR LAMP	95	INTELLIGENT KEY INSERT INFORMATION DOES NOT OPERATE	185	O
Description	95	Description	185	
Component Function Check	95	Diagnosis Procedure	185	P
Diagnosis Procedure	95	PRECAUTION	187	
KEY WARNING LAMP	97	PRECAUTIONS	187	
Description	97	Precaution for Supplemental Restraint System (SRS) "AIR BAG" and "SEAT BELT PRE-TENSIONER"	187	
Component Function Check	97	Precaution for Procedure without Cowl Top Cover.	187	
Diagnosis Procedure	97	VEHICLE SECURITY SYSTEM	117	
INTELLIGENT KEY SYSTEM/ENGINE START FUNCTION	98	Wiring Diagram - VEHICLE SECURITY SYSTEM		
Wiring Diagram - INTELLIGENT KEY SYSTEM/ENGINE START FUNCTION -	98	-	117	
INFINITI VEHICLE IMMOBILIZER SYSTEM-NATS	108	ECU DIAGNOSIS INFORMATION	125	
Wiring Diagram - IVIS -	108	BCM (BODY CONTROL MODULE)	125	

Precautions For Xenon Headlamp Service	187	Exploded View	189
Precautions for Removing Battery Terminal	188	Removal and Installation	189
REMOVAL AND INSTALLATION	189	PUSH BUTTON IGNITION SWITCH	190
KEY SLOT	189	Exploded View	190
		Removal and Installation	190

DIAGNOSIS AND REPAIR WORK FLOW

< BASIC INSPECTION >

BASIC INSPECTION

DIAGNOSIS AND REPAIR WORK FLOW

Work Flow

INFOID:0000000010993767

OVERALL SEQUENCE

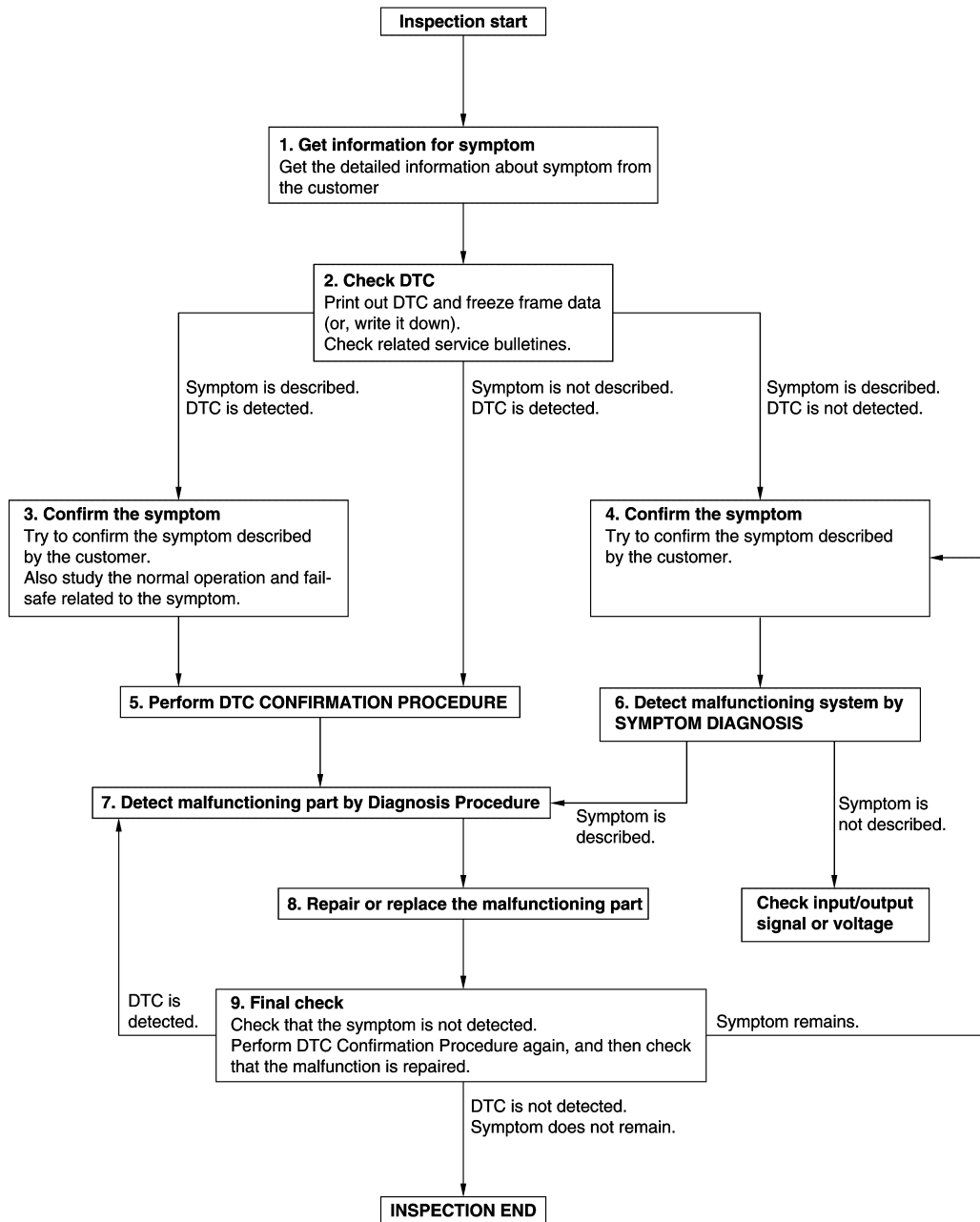

A
B
C
D
E
F
G
H
I
J
L
M
N
O
P

SEC

DETAILED FLOW

Revision: 2014 June

SEC-5

2014 Q40

JMKIA8652GB

DIAGNOSIS AND REPAIR WORK FLOW

< BASIC INSPECTION >

1. GET INFORMATION FOR SYMPTOM

1. Get detailed information from the customer about the symptom (the condition and the environment when the incident/malfunction occurs).
2. Check operation condition of the function that is malfunctioning.

>> GO TO 2.

2. CHECK DTC

1. Check DTC.
2. Perform the following procedure if DTC is detected.
 - Record DTC and freeze frame data (Print them out using CONSULT.)
 - Erase DTC.
 - Study the relationship between the cause detected by DTC and the symptom described by the customer.
3. Check related service bulletins for information.

Are any symptoms described and any DTC detected?

Symptom is described, DTC is detected>>GO TO 3.

Symptom is described, DTC is not detected>>GO TO 4.

Symptom is not described, DTC is detected>>GO TO 5.

3. CONFIRM THE SYMPTOM

Try to confirm the symptom described by the customer.

Also study the normal operation and fail-safe related to the symptom.

Verify relation between the symptom and the condition when the symptom is detected.

>> GO TO 5.

4. CONFIRM THE SYMPTOM

Try to confirm the symptom described by the customer.

Verify relation between the symptom and the condition when the symptom is detected.

>> GO TO 6.

5. PERFORM DTC CONFIRMATION PROCEDURE

Perform DTC CONFIRMATION PROCEDURE for the detected DTC, and then check that DTC is detected again. At this time, always connect CONSULT to the vehicle, and check self diagnostic results in real time.

If two or more DTCs are detected, refer to [BCS-83. "DTC Inspection Priority Chart"](#) (BCM) or [PCS-32. "DTC Index"](#) (IPDM E/R), and determine trouble diagnosis order.

NOTE:

- Freeze frame data is useful if the DTC is not detected.
- Perform Component Function Check if DTC CONFIRMATION PROCEDURE is not included on Service Manual. This simplified check procedure is an effective alternative though DTC cannot be detected during this check.
If the result of Component Function Check is NG, it is the same as the detection of DTC by DTC CONFIRMATION PROCEDURE.

Is DTC detected?

YES >> GO TO 7.

NO >> Check according to [GI-41. "Intermittent Incident"](#).

6. DETECT MALFUNCTIONING SYSTEM BY SYMPTOM DIAGNOSIS

Detect malfunctioning system according to SYMPTOM DIAGNOSIS based on the confirmed symptom in step 4, and determine the trouble diagnosis order based on possible causes and symptom.

Is the symptom described?

YES >> GO TO 7.

NO >> Monitor input data from related sensors or check voltage of related module terminals using CONSULT.

7. DETECT MALFUNCTIONING PART BY DIAGNOSIS PROCEDURE

DIAGNOSIS AND REPAIR WORK FLOW

< BASIC INSPECTION >

Inspect according to Diagnosis Procedure of the system.

Is malfunctioning part detected?

YES >> GO TO 8.

NO >> Check according to [GI-41. "Intermittent Incident"](#).

8. REPAIR OR REPLACE THE MALFUNCTIONING PART

1. Repair or replace the malfunctioning part.
2. Reconnect parts or connectors disconnected during Diagnosis Procedure again after repair and replacement.
3. Check DTC. If DTC is detected, erase it.

>> GO TO 9.

9. FINAL CHECK

When DTC is detected in step 2, perform DTC CONFIRMATION PROCEDURE again, and then check that the malfunction is repaired securely.

When symptom is described by the customer, refer to confirmed symptom in step 3 or 4, and check that the symptom is not detected.

Is DTC detected and does symptom remain?

YES-1 >> DTC is detected: GO TO 7.

YES-2 >> Symptom remains: GO TO 4.

NO >> Before returning the vehicle to the customer, always erase DTC.

A
B
C
D
E
F
G
H
I
J
L
M
N
O
P

SEC

INSPECTION AND ADJUSTMENT

< BASIC INSPECTION >

INSPECTION AND ADJUSTMENT ECM RE-COMMUNICATING FUNCTION

ECM RE-COMMUNICATING FUNCTION : Description

INFOID:000000010993768

Performing the following procedure can automatically activate recommunication of ECM and BCM, but only when the ECM is replaced with a new one*.

*: New one means a virgin ECM that is never energized on-board.

(In this step, initialization procedure by CONSULT is not necessary)

NOTE:

- When registering new Key IDs or replacing the ECM that is not brand new, follow the instruction of CONSULT display.
- If multiple keys are attached to the key holder, separate them before beginning work.
- Distinguish keys with unregistered key IDs from those with registered IDs.

ECM RE-COMMUNICATING FUNCTION : Special Repair Requirement

INFOID:000000010993769

1. PERFORM ECM RECOMMUNICATING FUNCTION

1. Install ECM.
2. Insert the registered Intelligent Key* into key slot, turn ignition switch to "ON".
*: To perform this step, use the key that is used before performing ECM replacement.
3. Maintain ignition switch in the "ON" position for 5 seconds or more.
4. Turn ignition switch to "OFF".
5. Start engine.

Can engine be started?

- YES >> Procedure is complete.
NO >> Initialize control unit.

INTELLIGENT KEY SYSTEM/ENGINE START FUNCTION

< SYSTEM DESCRIPTION >

SYSTEM DESCRIPTION

INTELLIGENT KEY SYSTEM/ENGINE START FUNCTION

System Diagram

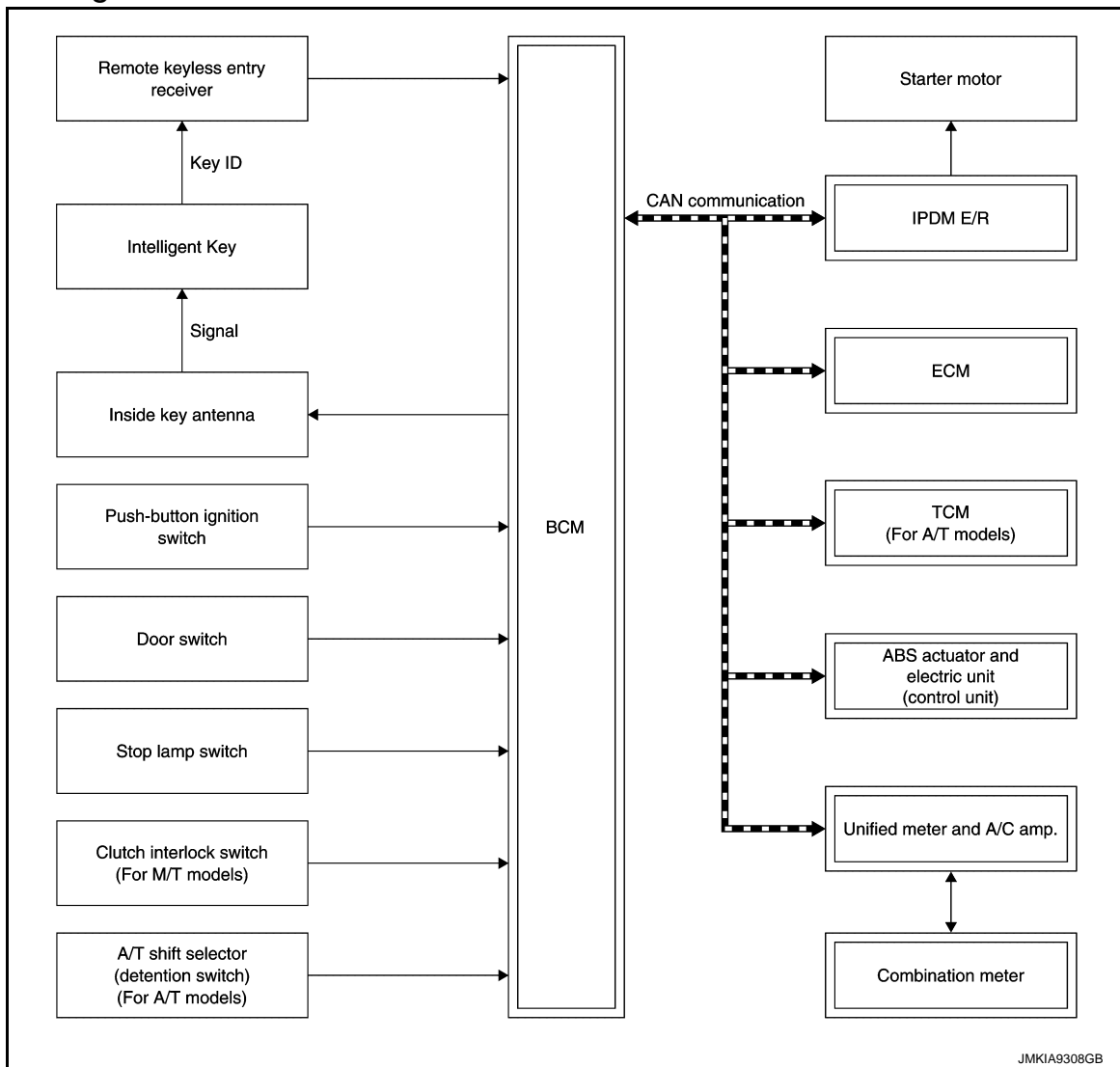

System Description

INFOID:000000010993771

SYSTEM DESCRIPTION

- The engine start function of Intelligent Key system is a system that makes it possible to start and stop the engine without removing the key. It verifies an electronic ID using two-way communication when pressing the push-button ignition switch while carrying the Intelligent Key, which operates based on the results of electronic ID verification of Intelligent Key using two-way communication between the Intelligent Key and the vehicle.

NOTE:

- The driver should carry the Intelligent Key at all times.
- Intelligent Key has 2 IDs [Intelligent Key and IVIS (NATS)]. It can perform the door lock/unlock operation and the push-button ignition switch operation when the registered Intelligent Key is carried.
- When the Intelligent Key battery is discharged, it can be used as emergency back-up by inserting the Intelligent Key to the key slot. At that time, perform the IVIS (NATS) ID verification. If it is used when the Intelligent Key is carried, perform the Intelligent Key ID verification.
- If the ID is successfully verified, and when push-button ignition switch is pressed, the engine can be started.
- Up to 4 Intelligent Keys can be registered (Including the standard Intelligent Key) upon request from the customer.

A
B
C
D
E
F
G
H
I
J
L
M
N
O
P

SEC

INTELLIGENT KEY SYSTEM/ENGINE START FUNCTION

< SYSTEM DESCRIPTION >

NOTE:

Refer to [DLK-16, "INTELLIGENT KEY SYSTEM : System Description"](#) for any functions other than engine start function of Intelligent Key system.

PRECAUTIONS FOR INTELLIGENT KEY SYSTEM

In the Intelligent Key system, the transponder [the chip for IVIS (NATS) ID verification] is integrated into the Intelligent Key. (For the conventional models, it is integrated into the mechanical key.) Therefore, the mechanical key cannot perform ID verification, and thus it cannot start the engine. Instead, IVIS (NATS) ID verification can be performed by inserting the Intelligent Key to the key slot, and then it can start the engine.

OPERATION WHEN INTELLIGENT KEY IS CARRIED

1. When the push-button ignition switch is pressed, the BCM activates the inside key antenna and transmits the request signal to the Intelligent Key.
2. The Intelligent Key receives the request signal and transmits the Intelligent Key ID signal to the BCM via the remote keyless entry receiver.
3. The Intelligent Key receives the Intelligent Key ID signal and verifies it with the registered ID.
4. BCM turns ACC relay ON and transmits the ignition power supply ON signal to IPDM E/R.
5. IPDM E/R turns the ignition relay ON and starts the ignition power supply.
6. BCM detects that the selector lever position and brake pedal operating condition.
7. BCM transmits the starter request signal via CAN communication to IPDM E/R and turns the starter relay in IPDM E/R ON if BCM judges that the engine start condition is satisfied.
8. IPDM E/R turns the starter control relay ON when receiving the starter request signal.
9. Power supply is supplied through the starter relay and the starter control relay to operate the starter motor and start cranking.

CAUTION:

If a malfunction is detected in the Intelligent Key system, the "KEY" warning lamp in the combination meter illuminates. At that time, the engine cannot be started.

10. When BCM receives feedback signal from ECM indicating that the engine is started, the BCM transmits a stop signal to IPDM E/R and stops cranking by turning OFF the starter motor relay. (If engine start is unsuccessful, cranking stops automatically within 5 seconds.)

CAUTION:

When the Intelligent Key is carried outside of the vehicle (inside key antenna detection area) while the power supply is in the ACC or ON position, even if the engine start condition* is satisfied, the engine cannot be started.

*: For the engine start condition, refer to "PUSH-BUTTON IGNITION SWITCH OPERATION PROCEDURE".

OPERATION RANGE

Engine can be started when Intelligent Key is inside the vehicle. However, sometimes engine may not start when Intelligent Key is on instrument panel or in glove box.

OPERATION WHEN KEY SLOT IS USED

When the Intelligent Key battery is discharged, it performs IVIS (NATS) ID verification between the integrated transponder and BCM by inserting the Intelligent Key into the key slot, and then the engine can be started. For details relating to starting the engine using key slot, refer to [SEC-15, "System Description"](#).

POWER SUPPLY POSITION CHANGE TABLE BY PUSH-BUTTON IGNITION SWITCH OPERATION

The power supply position changing operation can be performed with the following operations.

NOTE:

- When an Intelligent Key is within the detection area of inside key antenna and when it is inserted to the key slot, it is equivalent to the operations below.
- When starting the engine, the BCM monitors under the engine start conditions,

A/T models

- Brake pedal operating condition
- A/T selector lever position
- Vehicle speed

Vehicle speed: less than 4 km/h (2.5 MPH)

INTELLIGENT KEY SYSTEM/ENGINE START FUNCTION

< SYSTEM DESCRIPTION >

Power supply position	Engine start/stop condition		Push-button ignition switch operation frequency
	A/T models		
	Selector lever position	Brake pedal operation condition	
OFF → ACC	—	Not depressed	1
OFF → ACC → ON	—	Not depressed	2
OFF → ACC → ON → OFF	—	Not depressed	3
OFF → START ACC → START ON → START	P or N position	Depressed	1
Engine is running → OFF	—	—	1

Vehicle speed: 4 km/h (2.5 MPH) or more

Power supply position	Engine start/stop condition		Push-button ignition switch operation frequency
	A/T models		
	Selector lever position	Brake pedal operation condition	
Engine is running → ACC	—	—	Emergency stop operation
Engine stall return operation while driving	N position	Not depressed	1

Emergency stop operation

- Press and hold the push-button ignition switch for 2 seconds or more.
- Press the push-button ignition switch 3 times or more within 1.5 seconds.

A
B
C
D
E
F
G
H
I
J
L
M
N
O
P

SEC

INTELLIGENT KEY SYSTEM/ENGINE START FUNCTION

< SYSTEM DESCRIPTION >

Component Parts Location

INFOID:0000000110993772

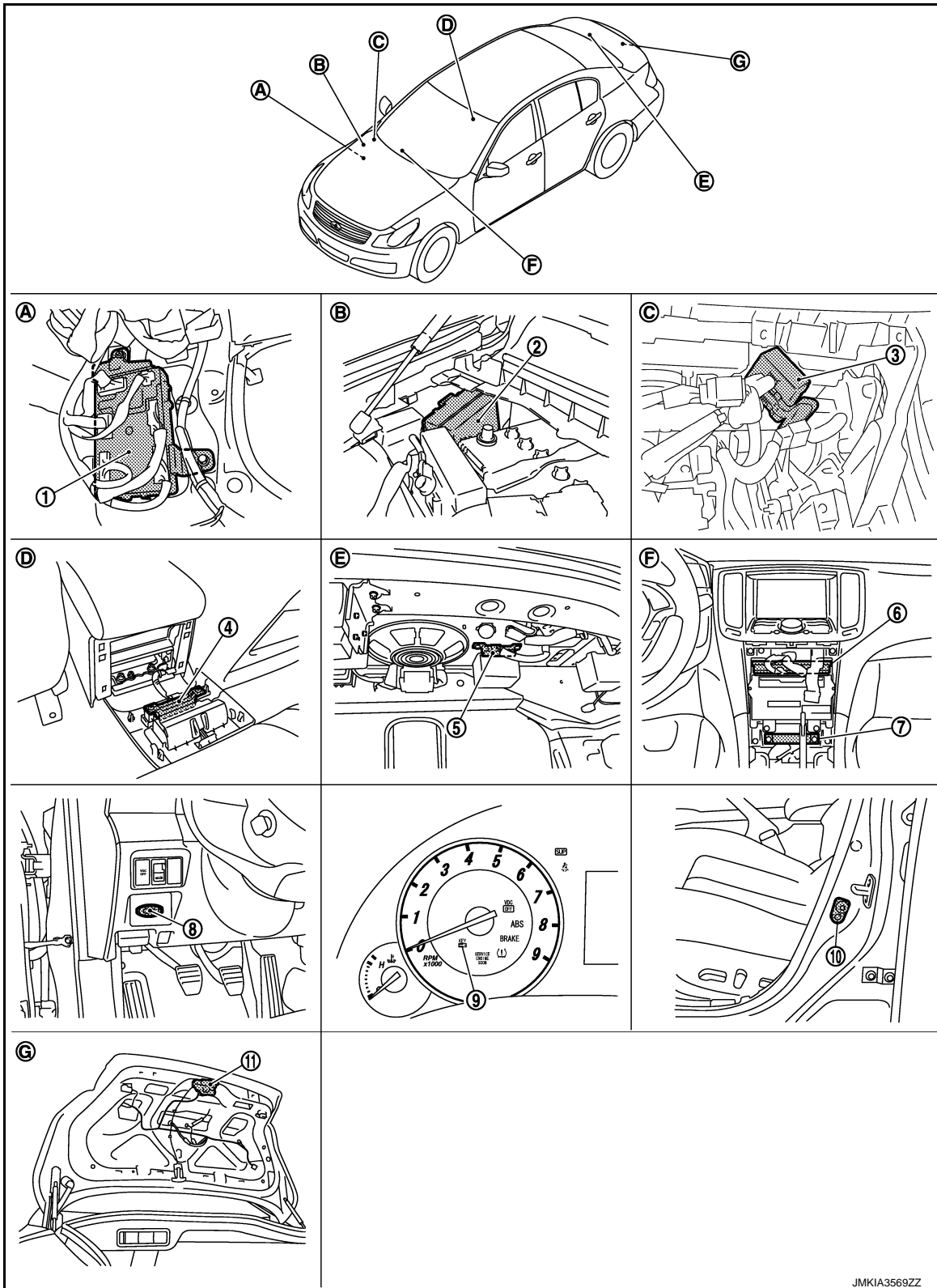

JMKIA3569ZZ

- | | | |
|-------------------------------------------|------------------------------------|-----------------------------------------|
| 1. BCM | 2. IPDM E/R | 3. Remote keyless entry receiver |
| 4. Inside key antenna (console) | 5. Inside key antenna (trunk room) | 6. Unified meter and A/C amp. |
| 7. Inside key antenna (instrument center) | 8. Key slot | 9. Combination meter (Key warning lamp) |

INTELLIGENT KEY SYSTEM/ENGINE START FUNCTION

< SYSTEM DESCRIPTION >

- | | | |
|---------------------------------------------|------------------------------------------------------|-----------------------------------------------------|
| 10. Driver side door switch | 11. Trunk lid lock assembly (trunk room lamp switch) | |
| A. Dash side lower (Passenger side). | B. Engine room dash panel (RH). | C. View with instrument assist lower panel removed. |
| D. View with console rear finisher removed. | E. View with trunk rear finisher (upper) removed. | F. Behind cluster lid C |
| G. View with trunk lid finisher removed. | | |

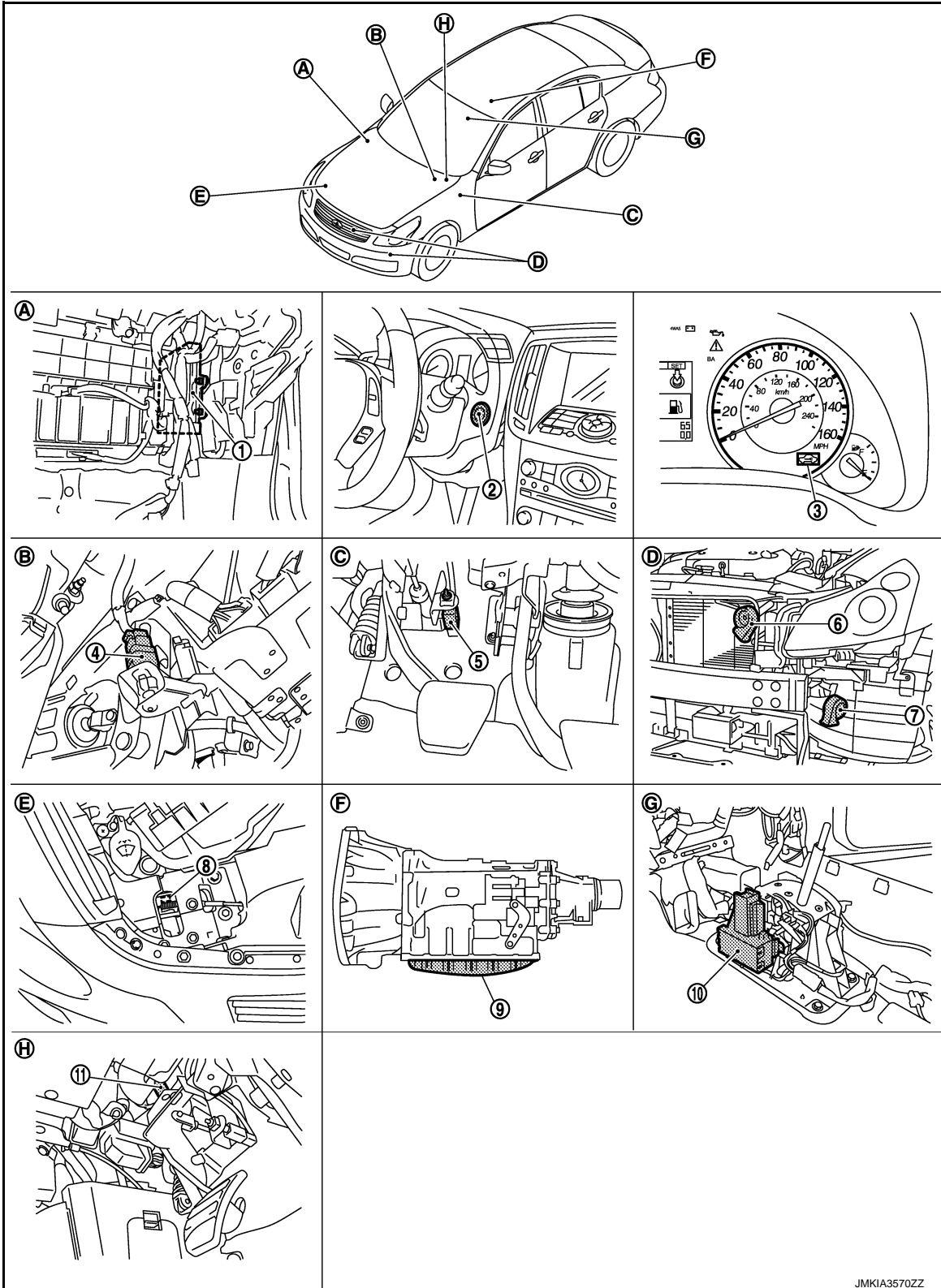

A
B
C
D
E
F
G
H
I
J
K
L
M
N
O
P

SEC

JMKIA3570ZZ

INTELLIGENT KEY SYSTEM/ENGINE START FUNCTION

< SYSTEM DESCRIPTION >

- | | | |
|-----------------------------------------------------|------------------------------------------------------------------------------|-----------------------------------------------------|
| 1. ECM | 2. Push-button ignition switch | 3. Combination meter (Security indicator) |
| 4. Stop lamp switch | 5. Clutch interlock switch* | 6. Horn (high) |
| 7. Horn (low) | 8. Hood switch | 9. TCM |
| 10. A/T shift selector (detention switch) | 11. • ASCD clutch switch (ASCD models)*
• ICC clutch switch (ICC models)* | |
| A. View with instrument assist lower panel removed. | B. View with instrument driver lower cover removed. | C. View with instrument driver lower cover removed. |
| D. View with front bumper removed. | E. View with hood switch incorporated into hood lock (RH). | F. Inside of A/T (built into A/T). |
| G. View with center console assembly removed. | H. View with instrument driver lower cover removed. | |

*: Not applicable

Component Description

INFOID:000000010993773

Component	Reference
Push-button ignition switch	SEC-53
Door switch	DLK-66
A/T shift selector (detention switch)	SEC-57
Inside key antenna	DLK-59
Remote keyless entry receiver	DLK-82
Stop lamp switch	SEC-51
TCM	SEC-66
Starter relay	SEC-70
Starter control relay	SEC-56
Security indicator lamp	SEC-95
Key warning lamp	SEC-97

INFINITI VEHICLE IMMOBILIZER SYSTEM-NATS

< SYSTEM DESCRIPTION >

INFINITI VEHICLE IMMOBILIZER SYSTEM-NATS

System Diagram

INFOID:000000010993774

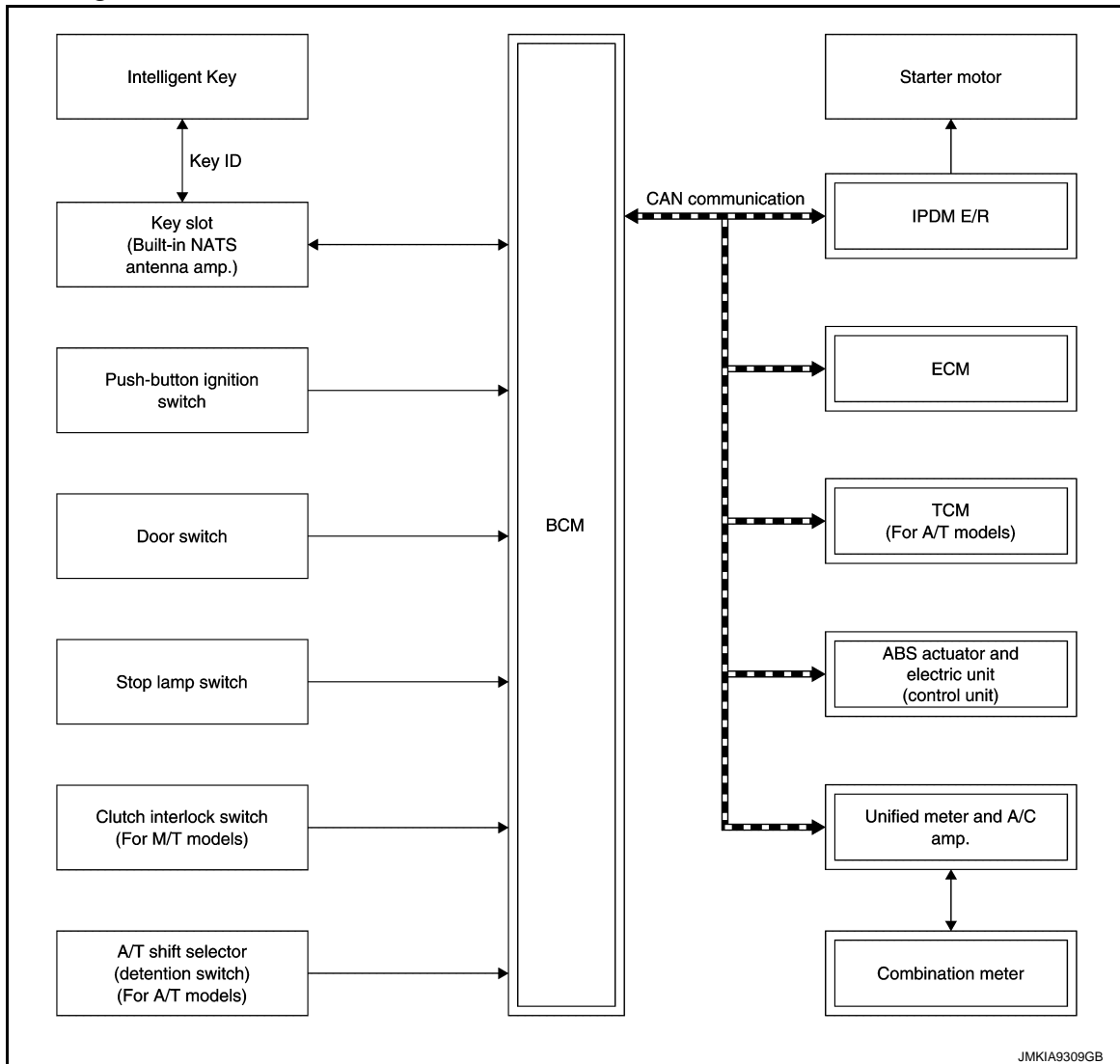

System Description

INFOID:000000010993775

SYSTEM DESCRIPTION

- The IVIS (NATS) is an anti-theft system that registers an Intelligent Key ID to the vehicle and prevents the engine from being started by an unregistered Intelligent Key. It has higher protection against auto theft involving the duplication of mechanical keys.
- It performs ID verification when starting the engine in the same way as the Intelligent Key system. But, it performs the IVIS (NATS) ID verification when inserting the Intelligent Key and performs the Intelligent Key ID verification when carrying the Intelligent Key.
- The mechanical key integrated in the Intelligent Key cannot start the engine. When the Intelligent Key battery is discharged, the IVIS (NATS) ID verification memorized to the transponder integrated with Intelligent Key is performed by inserting the Intelligent Key into the key slot. If the verification results are OK, the engine start operation can be performed by the push-button ignition switch operation.
- Locate the security indicator lamp and apply the anti-theft system equipment sticker that warns that the IVIS (NATS) is on board the model.
- Security indicator lamp always blinks when the power supply position is in the except ON position.
- Up to 4 Intelligent Keys can be registered (including the standard ignition key) upon request from the owner.
- Specified registration is required when replacing ECM, BCM, or Intelligent Key. For the registrations procedures for IVIS (NATS) and Intelligent Key when installing the BCM, follow the instruction of CONSULT display.

A
B
C
D
E
F
G
H
I
J

SEC

L

M

N

O

P

INFINITI VEHICLE IMMOBILIZER SYSTEM-NATS

< SYSTEM DESCRIPTION >

- Possible symptom of IVIS (NATS) malfunction is “Engine cannot start”. The engine can be started with the Intelligent Key system and IVIS (NATS). Identify the possible causes according to “Work Flow”. Refer to [SEC-5, "Work Flow"](#).
- If ECM other than genuine part is installed, the engine cannot be started. For ECM replacement procedure, refer to [EC-14, "BASIC INSPECTION : Special Repair Requirement"](#).

PRECAUTIONS FOR KEY REGISTRATION

- The key registration is a procedure that erases the current IVIS (NATS) ID once, and then registers a new ID operation. Therefore a registered Intelligent Key is necessary for this procedure. Before starting the registration operation collect all registered Intelligent Keys from the customer.
- When registering the Intelligent Key, perform only one procedure to simultaneously register both ID (IVIS “NATS” ID and Intelligent Key ID).
The IVIS (NATS) ID registration is the procedure that registers the ID stored into the transponder (integrated in Intelligent Key) to BCM.
The Intelligent key ID registration is the procedure that registers the ID to BCM.
- When performing the Intelligent Key system registration only, the engine cannot be started by inserting the key into the key slot. When performing the IVIS (NATS) registration only, the engine cannot be started by the operation when carrying the key. The registrations of both systems should be performed.

SECURITY INDICATOR LAMP

- Warns that the vehicle is equipped with IVIS (NATS).
- Security indicator lamp always blinks when the ignition switch is in the except ON position.

NOTE:

Because security indicator lamp is highly efficient, the battery is barely affected.

INFINITI VEHICLE IMMOBILIZER SYSTEM-NATS

< SYSTEM DESCRIPTION >

Component Parts Location

INFOID:0000000110993776

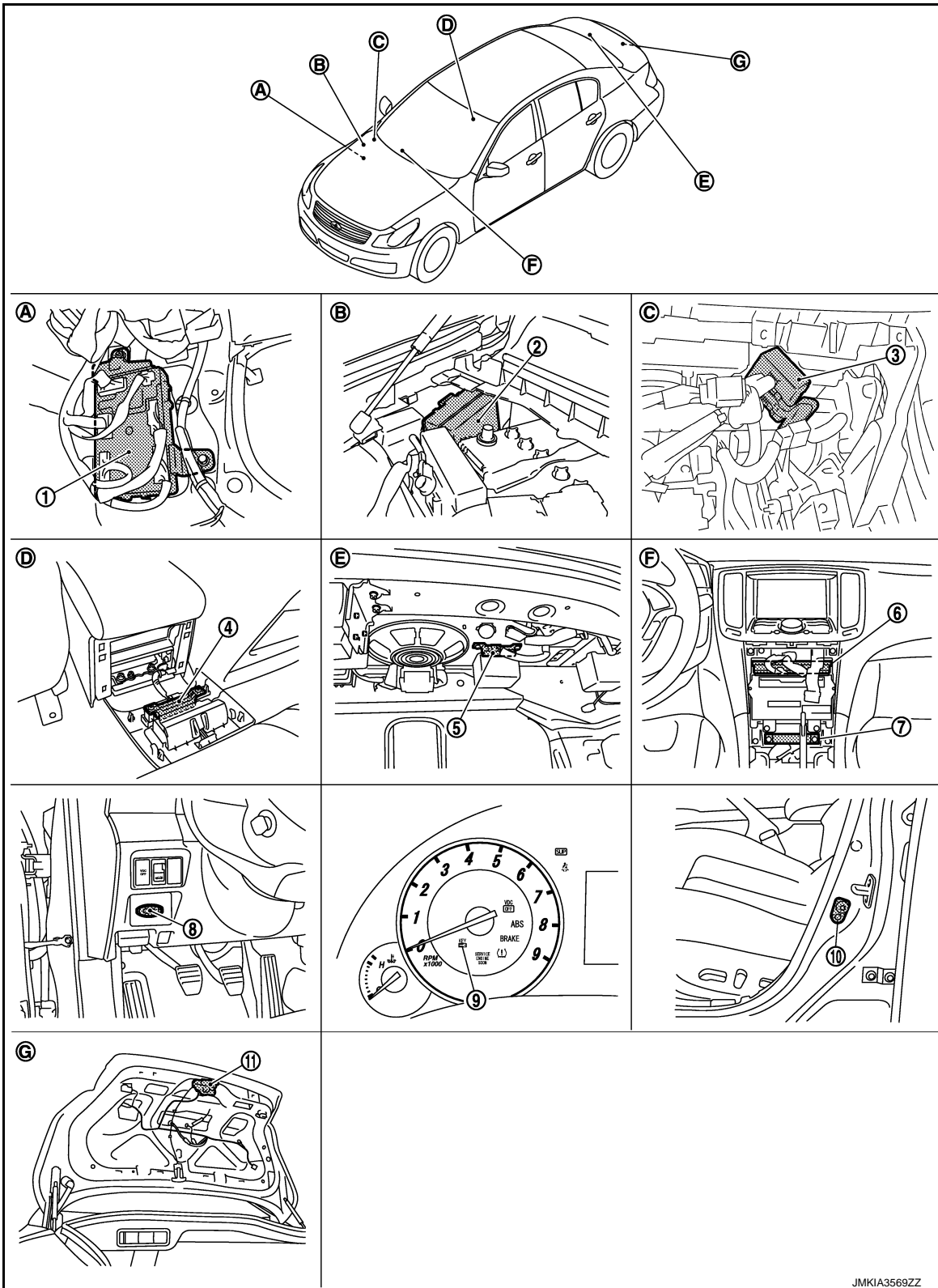

- 1. BCM
- 4. Inside key antenna (console)
- 7. Inside key antenna (instrument center)

- 2. IPDM E/R
- 5. Inside key antenna (trunk room)
- 8. Key slot

- 3. Remote keyless entry receiver
- 6. Unified meter and A/C amp.
- 9. Combination meter (Key warning lamp)

JMKIA3569ZZ

A
B
C
D
E
F
G
H
I
J
L
M
N
O
P

SEC

INFINITI VEHICLE IMMOBILIZER SYSTEM-NATS

< SYSTEM DESCRIPTION >

- 10. Driver side door switch
- 11. Trunk lid lock assembly (trunk room lamp switch)
- A. Dash side lower (Passenger side).
- B. Engine room dash panel (RH).
- C. View with instrument assist lower panel removed.
- D. View with console rear finisher removed.
- E. View with trunk rear finisher (upper) removed.
- F. Behind cluster lid C
- G. View with trunk lid finisher removed.

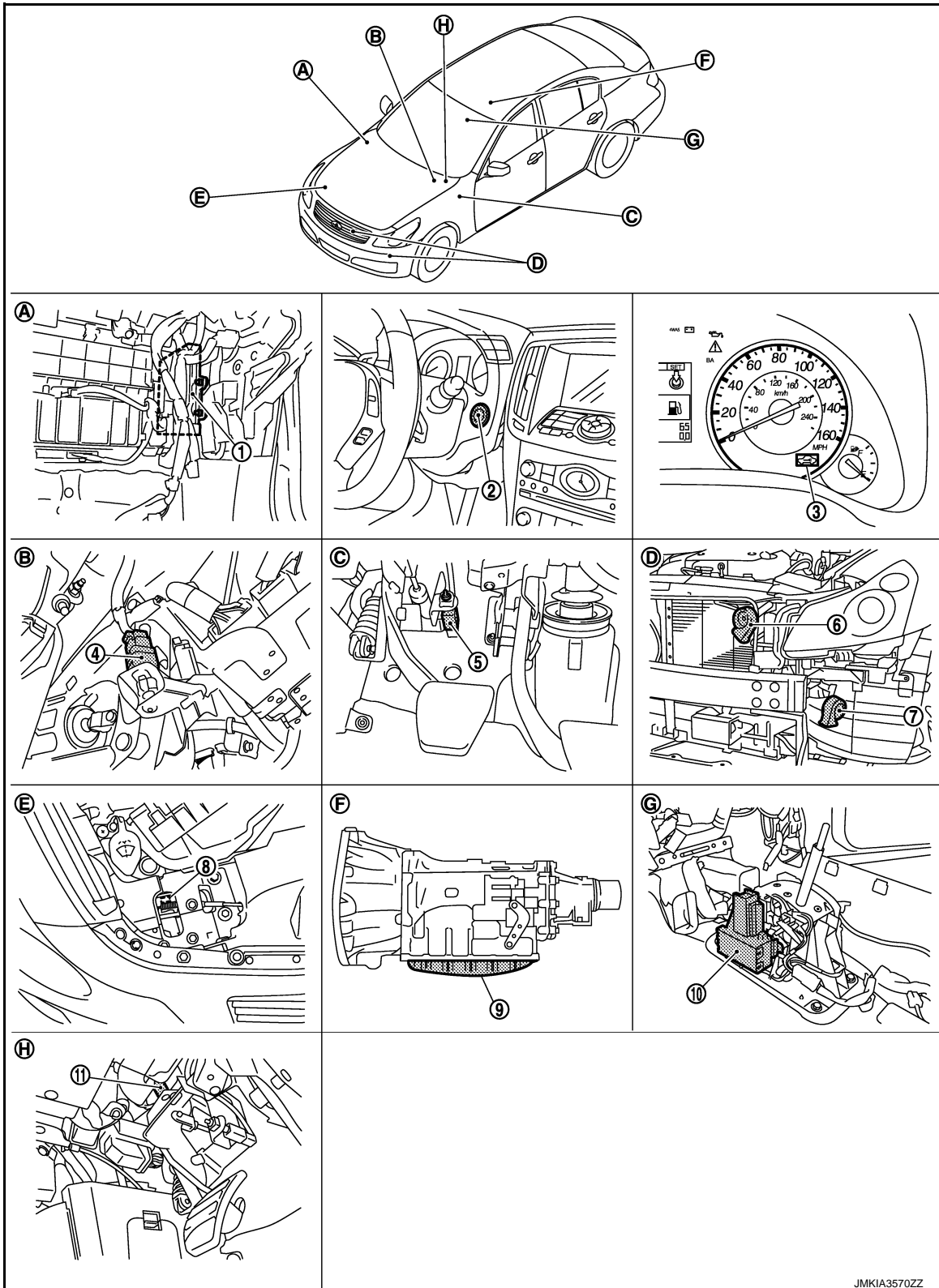

JMKIA3570ZZ

INFINITI VEHICLE IMMOBILIZER SYSTEM-NATS

< SYSTEM DESCRIPTION >

- | | | | |
|-----------------------------------------------------|------------------------------------------------------------------------------|-----------------------------------------------------|---|
| 1. ECM | 2. Push-button ignition switch | 3. Combination meter (Security indicator) | A |
| 4. Stop lamp switch | 5. Clutch interlock switch* | 6. Horn (high) | B |
| 7. Horn (low) | 8. Hood switch | 9. TCM | B |
| 10. A/T shift selector (detention switch) | 11. • ASCD clutch switch (ASCD models)*
• ICC clutch switch (ICC models)* | | C |
| A. View with instrument assist lower panel removed. | B. View with instrument driver lower cover removed. | C. View with instrument driver lower cover removed. | C |
| D. View with front bumper removed. | E. View with hood switch incorporated into hood lock (RH). | F. Inside of A/T (built into A/T). | D |
| G. View with center console assembly removed. | H. View with instrument driver lower cover removed. | | E |

*: Not applicable

Component Description

INFOID:000000010993777

Component	Reference
Push-button ignition switch	SEC-53
Door switch	DLK-66
Key slot	SEC-90
A/T shift selector (detention switch)	SEC-66
Stop lamp switch	SEC-51
TCM	SEC-66
Starter relay	SEC-70
Starter control relay	SEC-77
Security indicator lamp	SEC-95

SEC

L

M

N

O

P

VEHICLE SECURITY SYSTEM

< SYSTEM DESCRIPTION >

VEHICLE SECURITY SYSTEM

System Diagram

INFOID:000000010993778

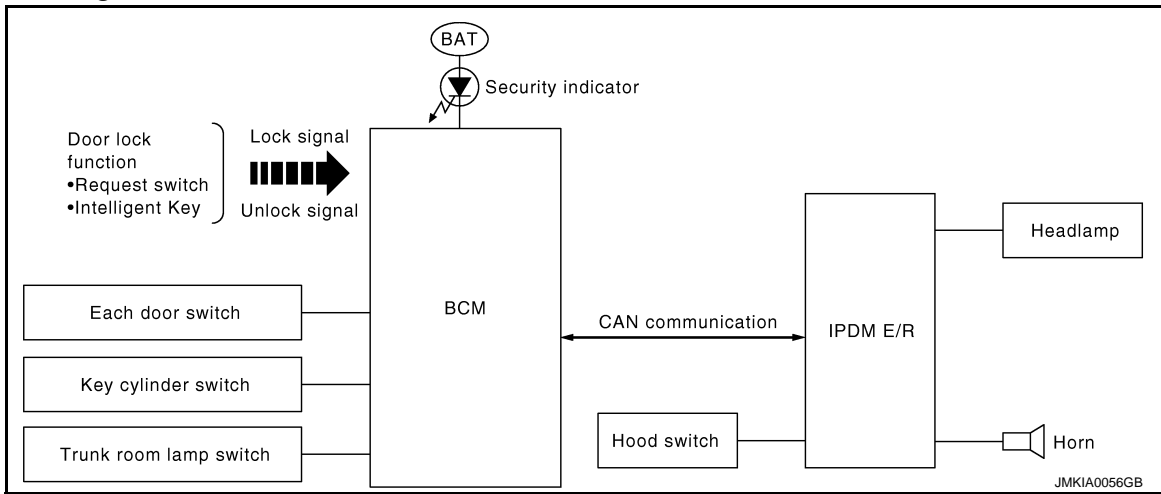

System Description

INFOID:000000010993779

OPERATION FLOW

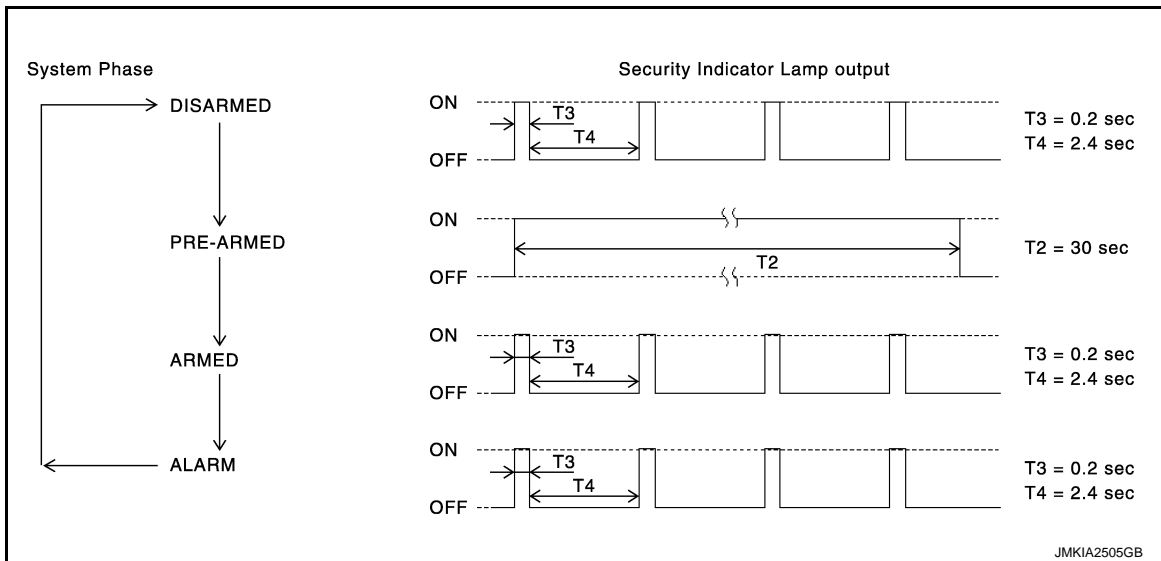

SETTING THE VEHICLE SECURITY SYSTEM

Initial Condition

Ignition switch is in OFF position.

Disarmed Phase

- When any door or trunk lid is open, the vehicle security system is set in the disarmed phase on the assumption that the owner is inside or near the vehicle.
- When the vehicle security system is in the disarmed phase, the security indicator lamp blinks every 2.4 seconds.

Pre-armed Phase and Armed Phase

When the following operation is performed, the vehicle security system turns into the "pre-armed" phase. (The security indicator lamp illuminates.)

1. BCM receives LOCK signal from door request switch or Intelligent Key, after all doors are closed.
2. Security indicator lamp illuminates for 30 seconds. Then, the system automatically shifts into the "armed" phase.

CANCELING THE SET VEHICLE SECURITY SYSTEM

VEHICLE SECURITY SYSTEM

< SYSTEM DESCRIPTION >

When one of the following operations is performed, the armed phase is canceled.

1. Unlock the all doors with the door request switch or Intelligent Key.
2. Turn ignition switch "ON" or "ACC" position.

CANCELING THE ALARM OPERATION OF THE VEHICLE SECURITY SYSTEM

When unlocking the all doors with the door request switch or Intelligent Key the alarm operation is canceled.

ACTIVATING THE ALARM OPERATION OF THE VEHICLE SECURITY SYSTEM

Check that the system is in the armed phase. (Security indicator lamp blinks every 2.4 seconds.)

When the following operation 1 or 2 is performed, the system sounds the horns and blinks the headlamps for about 50 seconds.

1. Trunk lid, any door or hood is opened during armed phase.
2. Disconnecting and connecting the battery connector before canceling armed phase.

A
B
C
D
E
F
G
H
I
J
L
M
N
O
P

SEC

VEHICLE SECURITY SYSTEM

< SYSTEM DESCRIPTION >

Component Parts Location

INFOID:0000000110993780

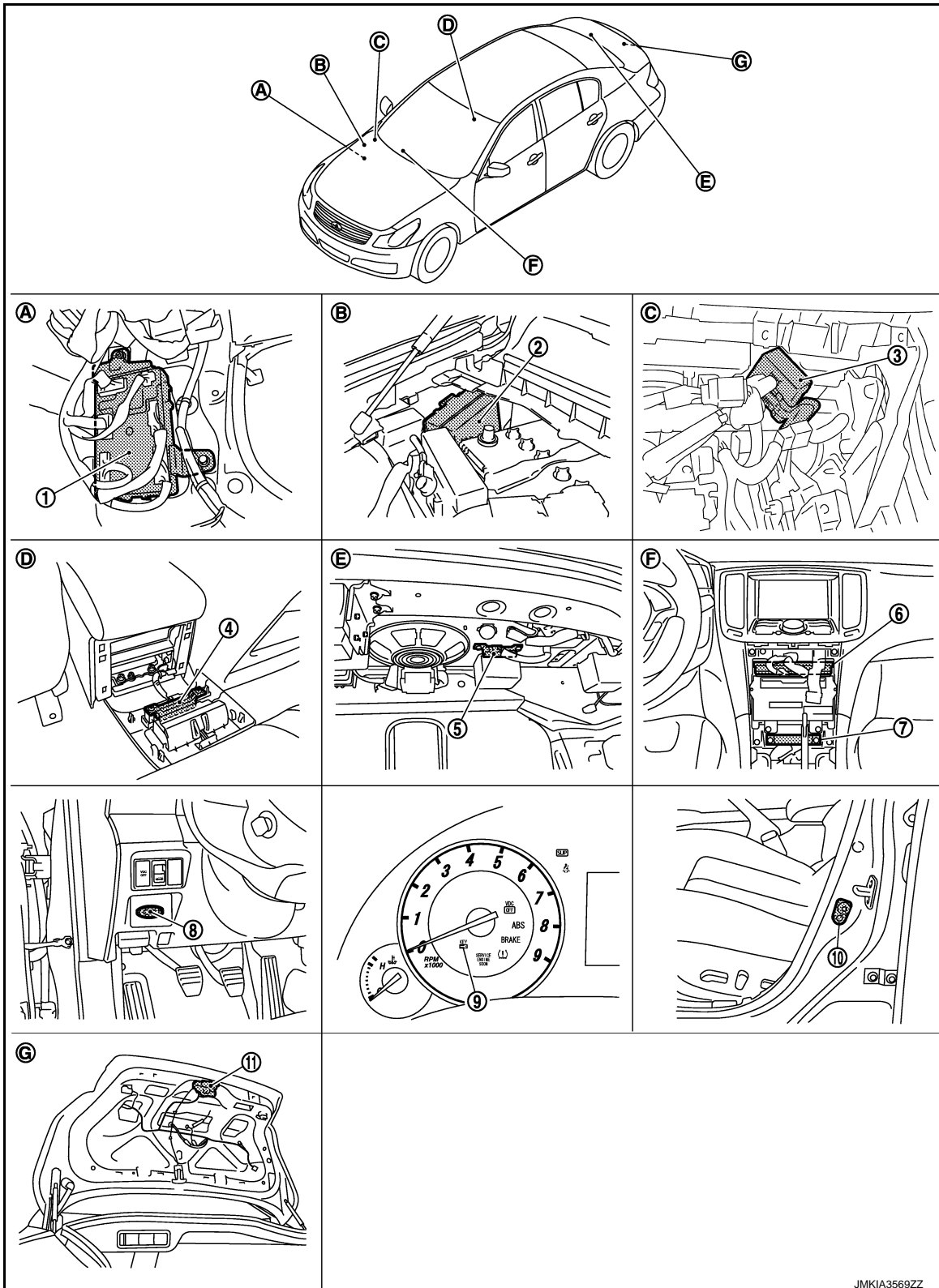

JMKIA3569ZZ

- | | | |
|-------------------------------------------|------------------------------------|-----------------------------------------|
| 1. BCM | 2. IPDM E/R | 3. Remote keyless entry receiver |
| 4. Inside key antenna (console) | 5. Inside key antenna (trunk room) | 6. Unified meter and A/C amp. |
| 7. Inside key antenna (instrument center) | 8. Key slot | 9. Combination meter (Key warning lamp) |

VEHICLE SECURITY SYSTEM

< SYSTEM DESCRIPTION >

- | | | |
|---------------------------------------------|------------------------------------------------------|-----------------------------------------------------|
| 10. Driver side door switch | 11. Trunk lid lock assembly (trunk room lamp switch) | |
| A. Dash side lower (Passenger side). | B. Engine room dash panel (RH). | C. View with instrument assist lower panel removed. |
| D. View with console rear finisher removed. | E. View with trunk rear finisher (upper) removed. | F. Behind cluster lid C |
| G. View with trunk lid finisher removed. | | |

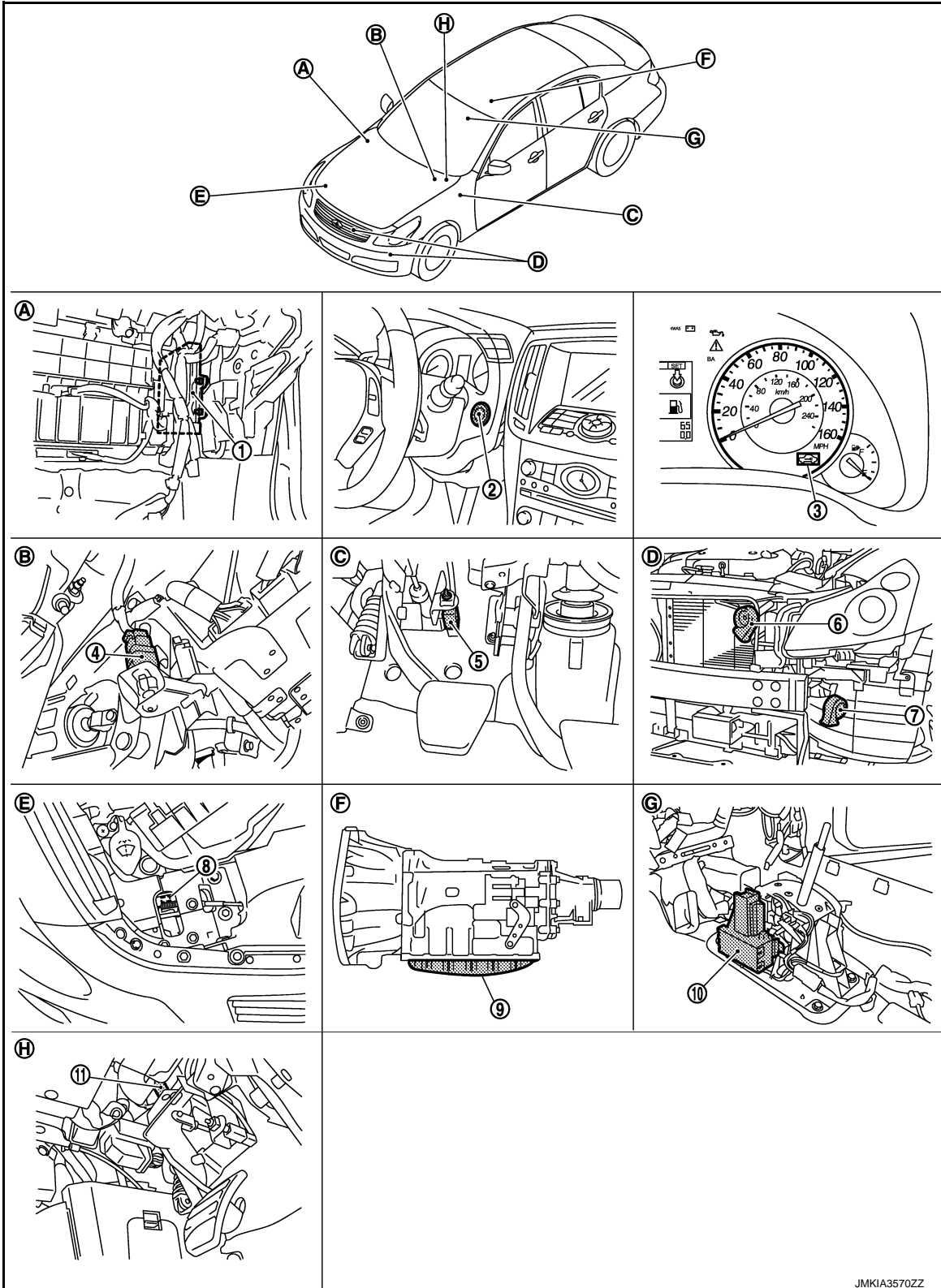

A
B
C
D
E
F
G
H
I
J
L
M
N
O
P

SEC

JMKIA3570ZZ

VEHICLE SECURITY SYSTEM

< SYSTEM DESCRIPTION >

- | | | |
|-----------------------------------------------------|------------------------------------------------------------------------------|-----------------------------------------------------|
| 1. ECM | 2. Push-button ignition switch | 3. Combination meter (Security indicator) |
| 4. Stop lamp switch | 5. Clutch interlock switch* | 6. Horn (high) |
| 7. Horn (low) | 8. Hood switch | 9. TCM |
| 10. A/T shift selector (detention switch) | 11. • ASCD clutch switch (ASCD models)*
• ICC clutch switch (ICC models)* | |
| A. View with instrument assist lower panel removed. | B. View with instrument driver lower cover removed. | C. View with instrument driver lower cover removed. |
| D. View with front bumper removed. | E. View with hood switch incorporated into hood lock (RH). | F. Inside of A/T (built into A/T). |
| G. View with center console assembly removed. | H. View with instrument driver lower cover removed. | |

*: Not applicable

Component Description

INFOID:000000010993781

Component	Reference
Security indicator lamp	SEC-95
Door switch	DLK-66
Trunk room lamp switch	DLK-78
Hood switch	SEC-93

DIAGNOSIS SYSTEM (BCM)

< SYSTEM DESCRIPTION >

DIAGNOSIS SYSTEM (BCM)

COMMON ITEM

COMMON ITEM : CONSULT Function (BCM - COMMON ITEM)

INFOID:0000000011413299

APPLICATION ITEM

CONSULT performs the following functions via CAN communication with BCM.

Diagnosis mode	Function Description
Work Support	Changes the setting for each system function.
Self Diagnostic Result	Displays the diagnosis results judged by BCM.
CAN Diag Support Monitor	Monitors the reception status of CAN communication viewed from BCM.
Data Monitor	The BCM input/output signals are displayed.
Active Test	The signals used to activate each device are forcibly supplied from BCM.
Ecu Identification	The BCM part number is displayed.
Configuration	This function is not used even though it is displayed.

SYSTEM APPLICATION

BCM can perform the following functions for each system.

NOTE:

It can perform the diagnosis modes except the following for all sub system selection items.

x: Applicable item

System	Sub system selection item	Diagnosis mode		
		Work Support	Data Monitor	Active Test
Door lock	DOOR LOCK	x	x	x
Rear window defogger	REAR DEFOGGER		x	x
Warning chime	BUZZER		x	x
Interior room lamp timer	INT LAMP	x	x	x
Exterior lamp	HEAD LAMP	x	x	x
Wiper and washer	WIPER	x	x	x
Turn signal and hazard warning lamps	FLASHER	x	x	x
—	AIR CONDITONER*			
• Intelligent Key system • Engine start system	INTELLIGENT KEY	x	x	x
Combination switch	COMB SW		x	
Body control system	BCM	x		
IVIS - NATS	IMMU		x	x
Interior room lamp battery saver	BATTERY SAVER	x	x	x
Trunk lid open	TRUNK		x	x
Vehicle security system	THEFT ALM	x	x	x
RAP system	RETAINED PWR		x	
Signal buffer system	SIGNAL BUFFER		x	x
TPMS	AIR PRESSURE MONITOR	x	x	x

NOTE:

*: This item is displayed, but is not used.

FREEZE FRAME DATA (FFD)

The BCM records the following vehicle condition at the time a particular DTC is detected, and displays on CONSULT.

DIAGNOSIS SYSTEM (BCM)

< SYSTEM DESCRIPTION >

CONSULT screen item	Indication/Unit	Description	
Vehicle Speed	km/h	Vehicle speed of the moment a particular DTC is detected	
Odo/Trip Meter	km	Total mileage (Odometer value) of the moment a particular DTC is detected	
Vehicle Condition	SLEEP>LOCK	Power position status of the moment a particular DTC is detected	While turning BCM status from low power consumption mode to normal mode (Power supply position is "LOCK"*)
	SLEEP>OFF		While turning BCM status from low power consumption mode to normal mode (Power supply position is "OFF".)
	LOCK>ACC		While turning power supply position from "LOCK"* to "ACC"
	ACC>ON		While turning power supply position from "ACC" to "IGN"
	RUN>ACC		While turning power supply position from "RUN" to "ACC" (Vehicle is stopping and selector lever is except P position.)
	CRANK>RUN		While turning power supply position from "CRANKING" to "RUN" (From cranking up the engine to run it)
	RUN>URGENT		While turning power supply position from "RUN" to "ACC" (Emergency stop operation)
	ACC>OFF		While turning power supply position from "ACC" to "OFF"
	OFF>LOCK		While turning power supply position from "OFF" to "LOCK"*
	OFF>ACC		While turning power supply position from "OFF" to "ACC"
	ON>CRANK		While turning power supply position from "IGN" to "CRANKING"
	OFF>SLEEP		While turning BCM status from normal mode (Power supply position is "OFF".) to low power consumption mode
	LOCK>SLEEP		While turning BCM status from normal mode (Power supply position is "LOCK"*.) to low power consumption mode
	LOCK		Power supply position is "LOCK"*
	OFF		Power supply position is "OFF" (Ignition switch OFF)
	ACC		Power supply position is "ACC" (Ignition switch ACC)
	ON		Power supply position is "IGN" (Ignition switch ON with engine stopped)
	ENGINE RUN		Power supply position is "RUN" (Ignition switch ON with engine running)
	CRANKING		Power supply position is "CRANKING" (At engine cranking)
IGN Counter	0 - 39	The number of times that ignition switch is turned ON after DTC is detected <ul style="list-style-type: none"> • The number is 0 when a malfunction is detected now. • The number increases like 1 → 2 → 3...38 → 39 after returning to the normal condition whenever ignition switch OFF → ON. • The number is fixed to 39 until the self-diagnosis results are erased if it is over 39. 	

NOTE:

*: Power supply position shifts to "LOCK" from "OFF", when ignition switch is in the OFF position, selector lever is in the P position (A/T models), and any of the following conditions are met.

- Closing door
- Opening door
- Door is locked using door request switch
- Door is locked using Intelligent Key

The power supply position shifts to "ACC" when the push-button ignition switch (push switch) is pushed at "LOCK".

INTELLIGENT KEY

INTELLIGENT KEY : CONSULT Function (BCM - INTELLIGENT KEY)

INFOID:000000010993783

WORK SUPPORT

DIAGNOSIS SYSTEM (BCM)

< SYSTEM DESCRIPTION >

Monitor item	Description	
CONFIRM KEY FOB ID	It can be checked whether Intelligent Key ID code is registered or not in this mode.	A
AUTO LOCK SET	Auto door lock time can be changed in this mode. <ul style="list-style-type: none"> • MODE 1: 1 minute • MODE 2: 5 minutes • MODE 3: 30 seconds • MODE 4: 2 minutes 	B
LOCK/UNLOCK BY I-KEY	Door lock/unlock function by door request switch (driver side and passenger side) mode can be changed to operate (ON) or not operate (OFF) in this mode.	C
ENGINE START BY I-KEY	Engine start function mode can be changed to operate (ON) or not operate (OFF) with this mode.	D
TRUNK/GLASS HATCH OPEN	Buzzer reminder function mode by trunk opener request switch can be changed to operate (ON) or not operate (OFF) with this mode.	E
PANIC ALARM SET	Panic alarm button pressing time on Intelligent Key remote control button can be selected from the following with this mode. <ul style="list-style-type: none"> • MODE 1: 0.5 sec. • MODE 2: Non-operation • MODE 3: 1.5 sec. 	F
PW DOWN SET	Unlock button pressing time on Intelligent Key button can be selected from the following with this mode. <ul style="list-style-type: none"> • MODE 1: 3 sec. • MODE 2: Non-operation • MODE 3: 5 sec. 	G
TRUNK OPEN DELAY	Trunk button pressing on Intelligent Key button can be selected as per the following in this mode. <ul style="list-style-type: none"> • MODE 1: Press and hold • MODE 2: Press twice • MODE 3: Press and hold, or press twice 	H
LO- BATT OF KEY FOB WARN	Intelligent Key low battery warning mode can be changed to operate (ON) or not operate (OFF) with this mode.	I
ANTI KEY LOCK IN FUNCTI	Key reminder function mode can be changed to operate (ON) or not operate (OFF) with this mode.	J
HAZARD ANSWER BACK	Hazard reminder function mode can be selected from the following with this mode. <ul style="list-style-type: none"> • LOCK ONLY: Door lock operation only • UNLOCK ONLY: Door unlock operation only • LOCK/UNLOCK: Lock/unlock operation • OFF: Non-operation 	SEC
ANS BACK I-KEY LOCK	Buzzer reminder function (lock operation) mode by door request switch (driver side and passenger side) can be selected from the following with this mode. <ul style="list-style-type: none"> • Horn chirp: Sound horn • Buzzer: Sound Intelligent Key warning buzzer • OFF: Non-operation 	L
ANS BACK I-KEY UNLOCK	Buzzer reminder function (unlock operation) mode by door request switch can be changed to operate (ON) or not operate (OFF) with this mode.	M
SHORT CRANKING OUTPUT	Starter motor can operate during the times below. <ul style="list-style-type: none"> • 70 msec • 100 msec • 200 msec 	N
INSIDE ANT DIAGNOSIS	This function allows inside key antenna self-diagnosis.	O
HORN WITH KEYLESS LOCK	Horn reminder function mode by Intelligent Key button can be changed to operate (ON) or not operate (OFF) with this mode.	P

SELF-DIAG RESULT

Refer to [BCS-84, "DTC Index"](#).

DATA MONITOR

NOTE:

DIAGNOSIS SYSTEM (BCM)

< SYSTEM DESCRIPTION >

The following table includes information (items) inapplicable to this vehicle. For information (items) applicable to this vehicle, refer to CONSULT display items.

Monitor Item	Condition
REQ SW -DR	Indicates [ON/OFF] condition of door request switch (driver side).
REQ SW -AS	Indicates [ON/OFF] condition of door request switch (passenger side).
REQ SW -BD/TR	Indicates [ON/OFF] condition of trunk opener request switch.
PUSH SW	Indicates [ON/OFF] condition of push-button ignition switch.
IGN RLY2 -F/B	Indicates [ON/OFF] condition of ignition relay 2.
ACC RLY-FB	NOTE: This item is displayed, but cannot be monitored.
CLUTCH SW*1	Indicates [ON/OFF] condition of clutch switch.
BRAKE SW 1	Indicates [ON/OFF]*2 condition of brake switch power supply.
BRAKE SW 2	Indicates [ON/OFF] condition of brake switch.
DETE/CANCL SW	Indicates [ON/OFF] condition of P position.
SFT PN/N SW	Indicates [ON/OFF] condition of P or N position.
S/L -LOCK	NOTE: This item is displayed, but can not be monitored.
S/L -UNLOCK	NOTE: This item is displayed, but can not be monitored.
S/L RELAY -F/B	NOTE: This item is displayed, but can not be monitored.
UNLK SEN -DR	Indicates [ON/OFF] condition of driver door UNLOCK status.
PUSH SW -IPDM	Indicates [ON/OFF] condition of push-button ignition switch.
IGN RLY1 -F/B	Indicates [ON/OFF] condition of ignition relay 1.
DETE SW -IPDM	Indicates [ON/OFF] condition of P position.
SFT PN -IPDM	Indicates [ON/OFF] condition of P or N position.
SFT P -MET	Indicates [ON/OFF] condition of P position.
SFT N -MET	Indicates [ON/OFF] condition of N position.
ENGINE STATE	Indicates [STOP/STALL/CRANK/RUN] condition of engine states.
S/L LOCK-IPDM	NOTE: This item is displayed, but can not be monitored.
S/L UNLK-IPDM	NOTE: This item is displayed, but can not be monitored.
S/L RELAY-REQ	NOTE: This item is displayed, but can not be monitored.
VEH SPEED 1	Display the vehicle speed signal received from combination meter by numerical value [Km/h].
VEH SPEED 2	Display the vehicle speed signal received from ABS or VDC or TCM by numerical value [Km/h].
DOOR STAT-DR	Indicates [LOCK/READY/UNLOCK] condition of driver side door status.
DOOR STAT-AS	Indicates [LOCK/READY/UNLOCK] condition of passenger side door status.
ID OK FLAG	Indicates [SET/RESET] condition of key ID.
PRMT ENG STRT	Indicates [SET/RESET] condition of engine start possibility.
PRMT RKE STRT	NOTE: This item is displayed, but cannot be monitored.
KEY SW -SLOT	Indicates [ON/OFF] condition of key slot.
TRNK/HAT MNTR	Indicates [ON/OFF] condition of trunk lid.
RKE-LOCK	Indicates [ON/OFF] condition of LOCK signal from Intelligent Key.
RKE-UNLOCK	Indicates [ON/OFF] condition of UNLOCK signal from Intelligent Key.

DIAGNOSIS SYSTEM (BCM)

< SYSTEM DESCRIPTION >

Monitor Item	Condition
RKE-TR/BD	Indicates [ON/OFF] condition of TRUNK OPEN signal from Intelligent Key.
RKE-PANIC	Indicates [ON/OFF] condition of PANIC button of Intelligent Key.
RKE-P/W OPEN	Indicates [ON/OFF] condition of P/W DOWN signal from Intelligent Key.
RKE-MODE CHG	Indicates [ON/OFF] condition of MODE CHANGE signal from Intelligent Key.
RKE OPE COUN1	When remote keyless entry receiver receives the signal transmitted while operating on Intelligent Key, the numerical value start changing.
RKE OPE COUN2	NOTE: This item is displayed, but cannot be monitored.

*1: It is displayed but does not operate on M/T models.

*2: OFF is displayed when brake pedal is depressed while brake switch power supply is OFF.

ACTIVE TEST

Test item	Description
BATTERY SAVER	This test is able to check interior room lamp operation. The interior room lamp is activated after "ON" on CONSULT screen is touched.
PW REMOTO DOWN SET	This test is able to check power window down operation. The power window down is activated after "ON" on CONSULT screen is touched.
OUTSIDE BUZZER	This test is able to check Intelligent Key warning buzzer operation. The Intelligent Key warning buzzer is activated after "ON" on CONSULT screen is touched.
INSIDE BUZZER	This test is able to check warning chime in combination meter operation. <ul style="list-style-type: none"> Take away warning chime sounds when "TAKE OUT" on CONSULT screen is touched. Key warning chime sounds when "KEY" on CONSULT screen is touched. OFF position warning chime sounds when "KNOB" on CONSULT screen is touched.
INDICATOR	This test is able to check warning lamp operation. <ul style="list-style-type: none"> "KEY" Warning lamp illuminates when "KEY ON" on CONSULT screen is touched. "KEY" Warning lamp blinks when "KEY IND" on CONSULT screen is touched.
INT LAMP	This test is able to check interior room lamp operation. The interior room lamp is activated after "ON" on CONSULT screen is touched.
LCD	This test is able to check meter display information <ul style="list-style-type: none"> Engine start information displays when "BP N" on CONSULT screen is touched. Engine start information displays when "BP I" on CONSULT screen is touched. Key ID warning displays when "ID NG" on CONSULT screen is touched. ROTAT: This item is displayed, but can not be monitored. P position warning displays when "SFT P" on CONSULT screen is touched. Intelligent Key insert information displays when "INSRT" on CONSULT screen is touched. Intelligent Key low battery warning displays when "BATT" on CONSULT screen is touched. Take away through window warning displays when "NO KY" on CONSULT screen is touched. Take away warning display when "OUTKEY" on CONSULT screen is touched. OFF position warning display when "LK WN" on CONSULT screen is touched.
TRUNK/GLASS HATCH	This test is able to check trunk lid opener actuator open operation. This actuator opens when "OPEN" on CONSULT screen is touched.
FLASHER	This test is able to check security hazard lamp operation. The hazard lamps are activated after "LH/RH/OFF" on CONSULT screen is touched.
HORN	This test is able to check horn operation. The horn is activated after "ON" on CONSULT screen is touched.
P RANGE	This test is able to check A/T shift selector power supply A/T shift selector power is supplied when "ON" on CONSULT screen is touched.
ENGINE SW ILLUMI	This test is able to check push-ignition switch illumination operation. Push-ignition switch illumination illuminates when "ON" on CONSULT screen is touched.
LOCK INDICATOR	This test is able to check LOCK indicator in push-ignition switch operation. LOCK indicator in push-ignition switch illuminates when "ON" on CONSULT screen is touched.
ACC INDICATOR	This test is able to check ACC indicator in push-ignition switch operation. ACC indicator in push-ignition switch illuminates when "ON" on CONSULT screen is touched.

DIAGNOSIS SYSTEM (BCM)

< SYSTEM DESCRIPTION >

Test item	Description
IGNITION ON IND	This test is able to check on indicator in push-ignition switch operation. ON indicator in push-ignition switch illuminates when "ON" on CONSULT screen is touched.
KEY SLOT ILLUMI	This test is able to check key slot illumination operation. Key slot illumination blinks when "ON" on CONSULT screen is touched.
TRUNK/BACK DOOR	This test is able to check trunk lid opener actuator open operation. This actuator opens when "OPEN" on CONSULT screen is touched.

THEFT ALM

THEFT ALM : CONSULT Function (BCM - THEFT)

INFOID:000000010993784

DATA MONITOR

NOTE:

The following table includes information (items) inapplicable to this vehicle. For information (items) applicable to this vehicle, refer to CONSULT display items.

Monitored Item	Description
REQ SW-DR	Indicates [ON/OFF] condition of door request switch (driver side).
REQ SW-AS	Indicates [ON/OFF] condition of door request switch (passenger side).
REQ SW-BD/TR	Indicates [ON/OFF] condition of trunk opener request switch.
PUSH SW	Indicates [ON/OFF] condition of push-button ignition switch
UNLK SEN-DR	Indicates [ON/OFF] condition of driver door UNLOCK status.
KEY SW -SLOT	Indicates [ON/OFF] condition of key slot.
DOOR SW-DR	Indicates [ON/OFF] condition of front door switch LH.
DOOR SW-AS	Indicates [ON/OFF] condition of front door switch RH.
DOOR SW-RR	Indicates [ON/OFF] condition of rear door switch RH.
DOOR SW-RL	Indicates [ON/OFF] condition of rear door switch LH.
DOOR SW-BK	This is displayed even when it is not equipped.
CDL LOCK SW	Indicates [ON/OFF] condition of lock signal from door lock/unlock switch LH and RH.
CDL UNLOCK SW	Indicates [ON/OFF] condition of unlock signal from door lock/unlock switch LH and RH.
KEY CYL LK-SW	Indicates [ON/OFF] condition of lock signal from front door key cylinder switch.
KEY CYL UN-SW	Indicates [ON/OFF] condition of unlock signal from front door key cylinder switch.
KEY CYL SW-TR	This is displayed even when it is not equipped.
TR/BD OPEN SW	Indicates [ON/OFF] condition of trunk lid opener switch.
TRNK/HAT MNTR	Indicates [ON/OFF] condition of trunk room lamp switch.
RKE-LOCK	Indicates [ON/OFF] condition of LOCK signal from Intelligent Key.
RKE-UNLOCK	Indicates [ON/OFF] condition of UNLOCK signal from Intelligent Key.
RKE-TR/BD	Indicates [ON/OFF] condition of TRUNK OPEN signal from Intelligent Key.

WORK SUPPORT

Test Item	Description
SECURITY ALARM SET	This mode is able to confirm and change security alarm ON-OFF setting.
THEFT ALM TRG	The switch which triggered vehicle security alarm is recorded. This mode is able to confirm and erase the record of vehicle security alarm. The trigger data can be erased by touching "CLEAR" on CONSULT screen.

ACTIVE TEST

DIAGNOSIS SYSTEM (BCM)

< SYSTEM DESCRIPTION >

Test Item	Description
THEFT IND	This test is able to check security indicator lamp operation. The lamp will be turned on when "ON" on CONSULT screen is touched.
VEHICLE SECURITY HORN	This test is able to check vehicle security horn operation. The horns will be activated for 0.5 seconds after "ON" on CONSULT screen is touched.
HEADLAMP(HI)	This test is able to check vehicle security lamp operation. The headlamps will be activated for 0.5 seconds after "ON" on CONSULT screen is touched.
FLASHER	This test is able to check vehicle security hazard lamp operation. The hazard lamps will be activated after "ON" on CONSULT screen is touched.

IMMU

IMMU : CONSULT Function (BCM - IMMU)

INFOID:0000000010993785

DATA MONITOR

NOTE:

The following table includes information (items) inapplicable to this vehicle. For information (items) applicable to this vehicle, refer to CONSULT display items.

Monitor item	Content
CONFIRM ID ALL	Indicates [YET] at all time. Switch to [DONE] when a registered Intelligent Key is inserted into the key slot.
CONFIRM ID4	
CONFIRM ID3	
CONFIRM ID2	
CONFIRM ID1	
TP 4	Indicates the number of ID which has been registered.
TP 3	
TP 2	
TP 1	
PUSH SW	Indicates [ON/OFF] condition of push-button ignition switch.
KEY SW -SLOT	Indicates [ON/OFF] condition of key slot.

ACTIVE TEST

Test item	Description
THEFT IND	This test is able to check security indicator lamp operation. The lamp will be turned on when "ON" on CONSULT screen touched.

A
B
C
D
E
F
G
H
I
J
L
M
N
O
P

SEC

U1000 CAN COMM CIRCUIT

< DTC/CIRCUIT DIAGNOSIS >

DTC/CIRCUIT DIAGNOSIS

U1000 CAN COMM CIRCUIT

BCM

BCM : Description

INFOID:0000000010993786

CAN (Controller Area Network) is a serial communication line for real time applications. It is an on-vehicle multiplex communication line with high data communication speed and excellent error detection ability. Modern vehicle is equipped with many electronic control unit, and each control unit shares information and links with other control units during operation (not independent). In CAN communication, control units are connected with 2 communication lines (CAN H-line, CAN L-line) allowing a high rate of information transmission with less wiring. Each control unit transmits/receives data but selectively reads required data only. CAN Communication Signal Chart. Refer to [LAN-22, "CAN Communication Signal Chart"](#).

BCM : DTC Logic

INFOID:0000000010993787

DTC DETECTION LOGIC

DTC	CONSULT display description	DTC Detection Condition	Possible cause
U1000	CAN COMM	When BCM cannot communicate CAN communication signal continuously for 2 seconds or more.	CAN communication system

BCM : Diagnosis Procedure

INFOID:0000000010993788

1. PERFORM SELF DIAGNOSTIC

1. Turn ignition switch ON and wait for 2 seconds or more.
2. Check "Self Diagnostic Result".

Is DTC "U1000" displayed?

- YES >> Refer to [LAN-13, "Trouble Diagnosis Flow Chart"](#).
NO >> Refer to [GI-41, "Intermittent Incident"](#).

IPDM E/R

IPDM E/R : Description

INFOID:0000000010993789

CAN (Controller Area Network) is a serial communication line for real time applications. It is an on-vehicle multiplex communication line with high data communication speed and excellent error detection ability. Modern vehicle is equipped with many electronic control unit, and each control unit shares information and links with other control units during operation (not independent). In CAN communication, control units are connected with 2 communication lines (CAN-H line, CAN-L line) allowing a high rate of information transmission with less wiring. Each control unit transmits/receives data but selectively reads required data only. CAN Communication Signal Chart. Refer to [LAN-5, "CAN Communication Control Circuit"](#).

IPDM E/R : DTC Logic

INFOID:0000000010993790

DTC DETECTION LOGIC

DTC	CONSULT display description	DTC Detection Condition	Possible cause
U1000	CAN COMM CIRCUIT	When IPDM E/R cannot communicate CAN communication signal continuously for 2 seconds or more	In CAN communication system, any item (or items) of the following listed below is malfunctioning. <ul style="list-style-type: none">• Transmission• Receiving (ECM)• Receiving (BCM)• Receiving (Unified meter and A/C amp.)

DTC CONFIRMATION PROCEDURE

U1000 CAN COMM CIRCUIT

< DTC/CIRCUIT DIAGNOSIS >

IPDM E/R : Diagnosis Procedure

INFOID:000000010993791

1.PERFORM SELF DIAGNOSTIC

1. Turn the ignition switch ON and wait for 2 seconds or more.
2. Check "Self Diagnostic Result" of IPDM E/R.

Is DTC "U1000" displayed?

- YES >> Refer to [LAN-13, "Trouble Diagnosis Flow Chart"](#).
NO >> Refer to [GI-41, "Intermittent Incident"](#).

A
B
C
D
E
F
G
H
I
J
L
M
N
O
P

SEC

U1010 CONTROL UNIT (CAN)

< DTC/CIRCUIT DIAGNOSIS >

U1010 CONTROL UNIT (CAN)

BCM

BCM : DTC Logic

INFOID:0000000010993792

DTC DETECTION LOGIC

DTC	CONSULT display de- scription	DTC Detection Condition	Possible cause
U1010	CONTROL UNIT(CAN)	BCM detected internal CAN communication circuit malfunction.	BCM

BCM : Diagnosis Procedure

INFOID:0000000010993793

1.REPLACE BCM

When DTC "U1010" is detected, replace BCM.

>> Replace BCM. Refer to [BCS-90. "Exploded View"](#).

P1610 LOCK MODE

< DTC/CIRCUIT DIAGNOSIS >

P1610 LOCK MODE

Description

INFOID:0000000010993794

When the starting operation is carried more than five times consecutively under the following conditions, NATS shifts to the mode that prevents the engine from being started.

- Unregistered Intelligent Key is used.
- BCM or ECM is malfunctioning.

DTC Logic

INFOID:0000000010993795

DTC DETECTION LOGIC

DTC No.	Trouble diagnosis name	DTC detecting condition	Possible cause
P1610	LOCK MODE	When the starting operation is carried out five or more times consecutively under the following conditions. <ul style="list-style-type: none">• Unregistered Intelligent Key• BCM or ECM is malfunctioning	—

DTC CONFIRMATION PROCEDURE

1.PERFORM DTC CONFIRMATION PROCEDURE

1. Turn ignition switch ON.
2. Check "Self-diagnostic result" using CONSULT.

Is DTC detected?

- YES >> Go to [SEC-35. "Diagnosis Procedure"](#).
NO >> INSPECTION END

Diagnosis Procedure

INFOID:0000000010993796

1.CHECK ENGINE START FUNCTION

1. Perform the check for DTC except DTC P1610.
2. Use CONSULT to erase DTC after fixing.
3. Turn ignition switch OFF.
4. Turn ignition switch ON when registered Intelligent Key is inserted into key slot and wait for 5 seconds.
5. Turn the ignition switch OFF and wait 5 seconds.
6. Repeat steps 4 and 5 twice (a total of 3 times).
7. Check that engine can start when registered Intelligent Key is inserted into key slot.

>> INSPECTION END

A
B
C
D
E
F
G
H
I
J
L
M
N
O
P

SEC

P1611 ID DISCORD, IMMUECM

< DTC/CIRCUIT DIAGNOSIS >

P1611 ID DISCORD, IMMUECM

Description

INFOID:000000010993797

BCM performs the ID verification with ECM that allows the engine to start. Start the engine if the ID is successfully verified. ECM prevents the engine from starting if the ID is not registered. BCM starts the communication with ECM if ignition switch is turned ON.

DTC Logic

INFOID:000000010993798

DTC DETECTION LOGIC

NOTE:

- If DTC P1611 is displayed with DTC U1000, first perform the trouble diagnosis for DTC U1000. Refer to [SEC-32, "BCM : DTC Logic"](#).
- If DTC P1611 is displayed with DTC U1010, first perform the trouble diagnosis for DTC U1010. Refer to [SEC-34, "BCM : DTC Logic"](#).

DTC No.	Trouble diagnosis name	DTC detecting condition	Possible cause
P1611	ID DISCORD, IMMUECM	The ID verification results between BCM and ECM are NG. Registration is necessary.	<ul style="list-style-type: none">• BCM• ECM

DTC CONFIRMATION PROCEDURE

1.PERFORM DTC CONFIRMATION PROCEDURE

1. Turn ignition switch ON under the following conditions.
 - Selector lever is in the P or N position
 - Do not depress brake pedal
2. Check "Self-diagnostic result" using CONSULT.

Is DTC detected?

- YES >> Go to [SEC-36, "Diagnosis Procedure"](#).
NO >> INSPECTION END

Diagnosis Procedure

INFOID:000000010993799

1.PERFORM INITIALIZATION

Perform initialization using CONSULT. Register all Intelligent Keys.
For initialization and registration of Intelligent Key, follow the instruction of CONSULT display.

Can the system be initialized and can the engine be started with registered Intelligent Key?

- YES >> INSPECTION END
NO >> GO TO 2.

2.REPLACE BCM

1. Replace BCM. Refer to [BCS-90, "Removal and Installation"](#).
2. Perform initialization using CONSULT.
For initialization, follow the instruction of CONSULT display.

Can the system be initialized and can the engine be started with registered Intelligent Key?

- YES >> INSPECTION END
NO >> GO TO 3.

3.REPLACE ECM

1. Replace ECM. Refer to [EC-17, "ADDITIONAL SERVICE WHEN REPLACING CONTROL UNIT \(ECM\) : Description"](#).
2. Perform initialization using CONSULT.
For initialization, follow the instruction of CONSULT display.

Can the system be initialized and can the engine be started with registered Intelligent Key?

- YES >> INSPECTION END
NO >> GO TO 4.

P1611 ID DISCORD, IMMUECM

< DTC/CIRCUIT DIAGNOSIS >

4.CHECK INTERMITTENT INCIDENT

Refer to [GI-41. "Intermittent Incident"](#).

>> INSPECTION END

A
B
C
D
E
F
G
H
I
J
L
M
N
O
P

SEC

P1612 CHAIN OF ECM-IMMU

< DTC/CIRCUIT DIAGNOSIS >

P1612 CHAIN OF ECM-IMMU

Description

INFOID:000000010993800

BCM performs ID verification with ECM that allows the engine to start. Start the engine if the ID is successfully verified. ECM prevents the engine from starting if the ID is not registered. BCM starts the communication with ECM if ignition switch is turned ON.

DTC Logic

INFOID:000000010993801

DTC DETECTION LOGIC

NOTE:

- If DTC P1612 is displayed with DTC U1000, first perform the trouble diagnosis for DTC U1000. Refer to [SEC-32, "BCM : DTC Logic"](#).
- If DTC P1612 is displayed with DTC U1010, first perform the trouble diagnosis for DTC U1010. Refer to [SEC-34, "BCM : DTC Logic"](#).

DTC No.	Trouble diagnosis name	DTC detecting condition	Possible cause
P1612	CHAIN OF ECM-IMMU	Inactive communication between ECM and BCM	<ul style="list-style-type: none">• Harness or connectors (The CAN communication line is open or shorted)• BCM• ECM

DTC CONFIRMATION PROCEDURE

1. PERFORM DTC CONFIRMATION PROCEDURE

1. Turn ignition switch ON under the following conditions.
 - Selector lever is in the P or N position
 - Do not depress brake pedal
2. Check "Self-diagnostic result" using CONSULT.

Is DTC detected?

- YES >> Go to [SEC-38, "Diagnosis Procedure"](#).
NO >> INSPECTION END

Diagnosis Procedure

INFOID:000000010993802

1. REPLACE BCM

1. Replace BCM. Refer to [BCS-90, "Removal and Installation"](#).
2. Perform initialization using CONSULT.
For initialization, follow the instruction of CONSULT display.

Does the engine start?

- YES >> INSPECTION END
NO >> GO TO 2.

2. REPLACE ECM

Replace ECM. Refer to [EC-17, "ADDITIONAL SERVICE WHEN REPLACING CONTROL UNIT \(ECM\) : Description"](#).

>> INSPECTION END

P1614 CHAIN OF IMMU-KEY

< DTC/CIRCUIT DIAGNOSIS >

P1614 CHAIN OF IMMU-KEY

Description

INFOID:000000010993803

Performs ID verification through BCM and Intelligent Key when push-button ignition switch is pressed. Prohibits start of engine when an unregistered ID of Intelligent Key is used.

DTC Logic

INFOID:000000010993804

DTC DETECTION LOGIC

DTC No.	Trouble diagnosis name	DTC detecting condition	Possible cause
P1614	CHAIN OF IMMU-KEY	Inactive communication between key slot and BCM.	<ul style="list-style-type: none">• Harness or connectors (The key slot circuit is open or shorted)• Key slot• BCM

DTC CONFIRMATION PROCEDURE

1. PERFORM DTC CONFIRMATION PROCEDURE 1

1. Insert Intelligent Key into the key slot.
2. Check "Self-diagnostic result" using CONSULT.

Is DTC detected?

- YES >> Go to [SEC-39, "Diagnosis Procedure"](#).
NO >> GO TO 2.

2. PERFORM DTC CONFIRMATION PROCEDURE 2

1. Press the push-button ignition switch.
2. Check "Self-diagnostic result" using CONSULT.

Is DTC detected?

- YES >> Go to [SEC-39, "Diagnosis Procedure"](#).
NO >> INSPECTION END

Diagnosis Procedure

INFOID:000000010993805

SEC

1. INSPECTION START

Perform inspection in accordance with procedure that confirms DTC.

Which procedure confirms DTC?

- DTC confirmation procedure 1 >> GO TO 2.
DTC confirmation procedure 2 >> GO TO 4.

2. CHECK KEY SLOT INPUT SIGNAL

1. Turn ignition switch OFF.
2. Disconnect key slot connector.
3. Check voltage between key slot harness connector and ground.

(+)		(-)	Voltage (V) (Approx.)
Key slot			
Connector	Terminal		
M22	2	Ground	Battery voltage

Is the inspection result normal?

- YES >> Replace key slot. Refer to [SEC-189, "Removal and Installation"](#).
NO >> GO TO 3.

3. CHECK KEY SLOT CIRCUIT

P1614 CHAIN OF IMMU-KEY

< DTC/CIRCUIT DIAGNOSIS >

1. Disconnect BCM connector.
2. Check continuity between key slot harness connector and BCM harness connector.

Key slot		BCM		Continuity
Connector	Terminal	Connector	Terminal	
M22	2	M122	80	Existed

3. Check continuity between key slot harness connector and ground.

Key slot		Ground	Continuity
Connector	Terminal		
M22	2		Not existed

Is the inspection result normal?

- YES >> Replace BCM. Refer to [BCS-90. "Removal and Installation"](#).
 NO >> Repair or replace harness.

4.CHECK PUSH-BUTTON IGNITION SWITCH OPERATION

Press push-button ignition switch and check if it turns ON.

Does ignition switch turn to ON?

- YES >> GO TO 5.
 NO >> GO TO 7.

5.CHECK KEY SLOT COMMUNICATION SIGNAL

1. Turn ignition switch OFF.
2. Disconnect key slot connector.
3. Check voltage between key slot harness connector and ground.

Key slot (+)		(-)	Voltage (V) (Approx.)
Connector	Terminal		
M22	3	Ground	Battery voltage

Is the inspection result normal?

- YES >> Replace key slot. Refer to [SEC-189. "Removal and Installation"](#).
 NO >> GO TO 6.

6.CHECK KEY SLOT COMMUNICATION SIGNAL CIRCUIT

1. Disconnect BCM connector.
2. Check continuity between key slot harness connector and BCM harness connector.

Key slot		BCM		Continuity
Connector	Terminal	Connector	Terminal	
M22	3	M122	81	Existed

3. Check continuity between key slot harness connector and ground.

Key slot		Ground	Continuity
Connector	Terminal		
M22	3		Not existed

Is the inspection result normal?

- YES >> Replace BCM. Refer to [BCS-90. "Removal and Installation"](#).
 NO >> Repair or replace harness.

7.CHECK KEY SLOT GROUND CIRCUIT

1. Turn ignition switch OFF.
2. Disconnect key slot connector.

P1614 CHAIN OF IMMU-KEY

< DTC/CIRCUIT DIAGNOSIS >

3. Check continuity between key slot harness connector and ground.

Key slot		Ground	Continuity
Connector	Terminal		
M22	7		Existed

Is the inspection result normal?

YES >> GO TO 8.

NO >> Repair or replace harness.

8. CHECK INTERMITTENT INCIDENT

Refer to [GI-41. "Intermittent Incident"](#).

>> INSPECTION END

A
B
C
D
E
F
G
H
I
J
L
M
N
O
P

SEC

P1615 DIFFERENCE OF KEY

< DTC/CIRCUIT DIAGNOSIS >

P1615 DIFFERENCE OF KEY

Description

INFOID:000000010993806

Performs ID verification through BCM and Intelligent Key when push-button ignition switch is pressed. Prohibits start of engine when an unregistered ID of Intelligent Key is used.

DTC Logic

INFOID:000000010993807

DTC DETECTION LOGIC

DTC No.	Trouble diagnosis name	DTC detecting condition	Possible cause
P1615	DIFFERENCE OF KEY	The ID verification results between BCM and Intelligent Key are NG. Registration is necessary.	Intelligent Key

DTC CONFIRMATION PROCEDURE

1.PERFORM DTC CONFIRMATION PROCEDURE

1. Press the push-button ignition switch.
2. Check "Self-diagnostic result" using CONSULT.

Is DTC detected?

- YES >> Go to [SEC-42, "Diagnosis Procedure"](#).
NO >> INSPECTION END

Diagnosis Procedure

INFOID:000000010993808

1.PERFORM INITIALIZATION

Perform initialization using CONSULT. Register all Intelligent Keys.
For initialization and registration of Intelligent Key, follow the instruction of CONSULT display.

Can the system be initialized and can the engine be started with registered Intelligent Key?

- YES >> INSPECTION END
NO >> GO TO 2.

2.REPLACE INTELLIGENT KEY

1. Replace Intelligent Key.
2. Perform initialization using CONSULT.
For initialization and registration of Intelligent Key, follow the instruction of CONSULT display.

Can the system be initialized and can the engine be started with registered Intelligent Key?

- YES >> INSPECTION END
NO >> GO TO 3.

3.CHECK INTERMITTENT INCIDENT

Refer to [GI-41, "Intermittent Incident"](#).

>> INSPECTION END

B2190 NATS ANTENNA AMP.

< DTC/CIRCUIT DIAGNOSIS >

B2190 NATS ANTENNA AMP.

Description

INFOID:0000000010993809

Performs ID verification through BCM and Intelligent Key when push-button ignition switch is pressed. Prohibits start of engine when an unregistered ID of Intelligent Key is used.

DTC Logic

INFOID:0000000010993810

DTC DETECTION LOGIC

DTC No.	Trouble diagnosis name	DTC detecting condition	Possible cause
B2190	NATS ANTENNA AMP	Inactive communication between key slot and BCM.	<ul style="list-style-type: none">• Harness or connectors (The key slot circuit is open or shorted)• Key slot• BCM

DTC CONFIRMATION PROCEDURE

1. PERFORM DTC CONFIRMATION PROCEDURE 1

1. Insert Intelligent Key into the key slot.
2. Check "Self-diagnostic result" using CONSULT.

Is DTC detected?

- YES >> Go to [SEC-43, "Diagnosis Procedure"](#).
NO >> GO TO 2.

2. PERFORM DTC CONFIRMATION PROCEDURE 2

1. Press the push-button ignition switch.
2. Check "Self-diagnostic result" using CONSULT.

Is DTC detected?

- YES >> Go to [SEC-43, "Diagnosis Procedure"](#).
NO >> INSPECTION END

Diagnosis Procedure

INFOID:0000000010993811

SEC

1. INSPECTION START

Perform inspection in accordance with the appropriate confirmation procedure DTC.

Which procedure confirms DTC?

- DTC confirmation procedure 1 >> GO TO 2.
DTC confirmation procedure 2 >> GO TO 4.

2. CHECK KEY SLOT INPUT SIGNAL

1. Turn ignition switch OFF.
2. Disconnect key slot connector.
3. Check voltage between key slot harness connector and ground.

(+)		(-)	Voltage (V) (Approx.)
Key slot			
Connector	Terminal		
M22	2	Ground	Battery voltage

Is the inspection result normal?

- YES >> Replace key slot. Refer to [SEC-189, "Removal and Installation"](#).
NO >> GO TO 3.

3. CHECK KEY SLOT CIRCUIT

B2190 NATS ANTENNA AMP.

< DTC/CIRCUIT DIAGNOSIS >

1. Disconnect BCM connector.
2. Check continuity between key slot harness connector and BCM harness connector.

Key slot		BCM		Continuity
Connector	Terminal	Connector	Terminal	
M22	2	M122	80	Existed

3. Check continuity between key slot harness connector and ground.

Key slot		Ground	Continuity
Connector	Terminal		
M22	2		Not existed

Is the inspection result normal?

- YES >> Replace BCM. Refer to [BCS-90. "Removal and Installation"](#).
 NO >> Repair or replace harness.

4. CHECK PUSH-BUTTON IGNITION SWITCH OPERATION

Press push-button ignition switch and check if it turns ON.

Does ignition switch turn to ON?

- YES >> GO TO 5.
 NO >> GO TO 7.

5. CHECK KEY SLOT COMMUNICATION SIGNAL

1. Turn ignition switch OFF.
2. Disconnect key slot connector.
3. Check voltage between key slot harness connector and ground.

(+)		(-)	Voltage (V) (Approx.)
Key slot			
Connector	Terminal		
M22	3	Ground	Battery voltage

Is the inspection result normal?

- YES >> Replace key slot. Refer to [SEC-189. "Removal and Installation"](#).
 NO >> GO TO 6.

6. CHECK KEY SLOT COMMUNICATION SIGNAL CIRCUIT

1. Disconnect BCM connector.
2. Check continuity between key slot harness connector and BCM harness connector.

Key slot		BCM		Continuity
Connector	Terminal	Connector	Terminal	
M22	3	M122	81	Existed

3. Check continuity between key slot harness connector and ground.

Key slot		Ground	Continuity
Connector	Terminal		
M22	3		Not existed

Is the inspection result normal?

- YES >> Replace BCM. Refer to [BCS-90. "Removal and Installation"](#).
 NO >> Repair or replace harness.

7. CHECK KEY SLOT GROUND CIRCUIT

1. Turn ignition switch OFF.
2. Disconnect key slot connector.

B2190 NATS ANTENNA AMP.

< DTC/CIRCUIT DIAGNOSIS >

3. Check continuity between key slot harness connector and ground.

Key slot		Ground	Continuity
Connector	Terminal		
M22	7		Existed

Is the inspection result normal?

YES >> GO TO 8.

NO >> Repair or replace harness.

8. CHECK INTERMITTENT INCIDENT

Refer to [GI-41. "Intermittent Incident"](#).

>> INSPECTION END

A
B
C
D
E
F
G
H
I
J
L
M
N
O
P

SEC

B2191 DIFFERENCE OF KEY

< DTC/CIRCUIT DIAGNOSIS >

B2191 DIFFERENCE OF KEY

Description

INFOID:000000010993812

Performs ID verification through BCM and Intelligent Key when push-button ignition switch is pressed. Prohibits start of engine when an unregistered ID of Intelligent Key is used.

DTC Logic

INFOID:000000010993813

DTC DETECTION LOGIC

DTC No.	Trouble diagnosis name	DTC detecting condition	Possible cause
B2191	DIFFERENCE OF KEY	The ID verification results between BCM and Intelligent Key are NG. Registration is necessary.	Intelligent Key

DTC CONFIRMATION PROCEDURE

1.PERFORM DTC CONFIRMATION PROCEDURE

1. Press the push-button ignition switch.
2. Check "Self-diagnostic result" using CONSULT.

Is DTC detected?

- YES >> Go to [SEC-46, "Diagnosis Procedure"](#).
NO >> INSPECTION END

Diagnosis Procedure

INFOID:000000010993814

1.PERFORM INITIALIZATION

Perform initialization using CONSULT. Register all Intelligent Keys.
For initialization and registration of Intelligent Key, follow the instruction of CONSULT display.

Can the system be initialized and can the engine be started with registered Intelligent Key?

- YES >> INSPECTION END
NO >> GO TO 2.

2.REPLACE INTELLIGENT KEY

1. Replace Intelligent Key.
2. Perform initialization using CONSULT.
For initialization and registration of Intelligent Key, follow the instruction of CONSULT display.

Can the system be initialized and can the engine be started with registered Intelligent Key?

- YES >> INSPECTION END
NO >> GO TO 3.

3.CHECK INTERMITTENT INCIDENT

Refer to [GI-41, "Intermittent Incident"](#).

>> INSPECTION END

B2192 ID DISCORD, IMMUECM

< DTC/CIRCUIT DIAGNOSIS >

B2192 ID DISCORD, IMMUECM

Description

INFOID:0000000010993815

BCM performs ID verification with ECM that allows the engine to start. Start the engine if the ID is successfully verified. ECM prevents the engine from starting if the ID is not registered. BCM starts the communication with ECM if ignition switch is turned ON.

DTC Logic

INFOID:0000000010993816

DTC DETECTION LOGIC

NOTE:

- If DTC B2192 is displayed with DTC U1000, first perform the trouble diagnosis for DTC U1000. Refer to [SEC-32, "BCM : DTC Logic"](#).
- If DTC B2192 is displayed with DTC U1010, first perform the trouble diagnosis for DTC U1010. Refer to [SEC-34, "BCM : DTC Logic"](#).

DTC No.	Trouble diagnosis name	DTC detecting condition	Possible cause
B2192	ID DISCORD, IMMUECM	The ID verification results between BCM and ECM are NG. Registration is necessary.	<ul style="list-style-type: none">• BCM• ECM

DTC CONFIRMATION PROCEDURE

1. PERFORM DTC CONFIRMATION PROCEDURE

1. Turn ignition switch ON under the following conditions.
 - Selector lever is in the P or N position
 - Do not depress brake pedal
2. Check "Self-diagnostic result" using CONSULT.

Is DTC detected?

- YES >> Go to [SEC-47, "Diagnosis Procedure"](#).
NO >> INSPECTION END

Diagnosis Procedure

INFOID:0000000010993817

1. PERFORM INITIALIZATION

Perform initialization using CONSULT. Register all Intelligent Keys.
For initialization and registration of Intelligent Key, follow the instruction of CONSULT display.

Can the system be initialized and can the engine be started with registered Intelligent Key?

- YES >> INSPECTION END
NO >> GO TO 2.

2. REPLACE BCM

1. Replace BCM. Refer to [BCS-90, "Removal and Installation"](#).
2. Perform initialization using CONSULT.
For initialization, follow the instruction of CONSULT display.

Can the system be initialized and can the engine be started with registered Intelligent Key?

- YES >> INSPECTION END
NO >> GO TO 3.

3. REPLACE ECM

1. Replace ECM. Refer to [EC-17, "ADDITIONAL SERVICE WHEN REPLACING CONTROL UNIT \(ECM\) : Description"](#).
2. Perform initialization using CONSULT.
For initialization, follow the instruction of CONSULT display.

Can the system be initialized and can the engine be started with registered Intelligent Key?

- YES >> INSPECTION END
NO >> GO TO 4.

A
B
C
D
E
F
G
H
I
J
L
M
N
O
P

SEC

B2192 ID DISCORD, IMMUECM

< DTC/CIRCUIT DIAGNOSIS >

4.CHECK INTERMITTENT INCIDENT

Refer to [GI-41, "Intermittent Incident"](#).

>> INSPECTION END

B2193 CHAIN OF ECM-IMMU

< DTC/CIRCUIT DIAGNOSIS >

B2193 CHAIN OF ECM-IMMU

Description

INFOID:0000000010993818

BCM performs the ID verification with ECM that allows the engine to start. Start the engine if the ID is successfully verified. ECM prevents the engine from starting if the ID is not registered. BCM starts the communication with ECM if ignition switch is turned ON.

DTC Logic

INFOID:0000000010993819

DTC DETECTION LOGIC

NOTE:

- If DTC B2193 is displayed with DTC U1000, first perform the trouble diagnosis for DTC U1000. Refer to [SEC-32, "BCM : DTC Logic"](#).
- If DTC B2193 is displayed with DTC U1010, first perform the trouble diagnosis for DTC U1010. Refer to [SEC-34, "BCM : DTC Logic"](#).

DTC No.	Trouble diagnosis name	DTC detecting condition	Possible cause
B2193	CHAIN OF ECM-IMMU	Inactive communication between ECM and BCM	<ul style="list-style-type: none">• Harness or connectors (The CAN communication line is open or shorted)• BCM• ECM

DTC CONFIRMATION PROCEDURE

1.PERFORM DTC CONFIRMATION PROCEDURE

1. Turn ignition switch ON under the following conditions.
 - Selector lever is in the P or N position
 - Do not depress brake pedal
2. Check "Self-diagnostic result" using CONSULT.

Is DTC detected?

- YES >> Go to [SEC-49, "Diagnosis Procedure"](#).
NO >> INSPECTION END

Diagnosis Procedure

INFOID:0000000010993820

SEC

1.REPLACE BCM

1. Replace BCM. Refer to [BCS-90, "Removal and Installation"](#).
2. Perform initialization using CONSULT.
For initialization, follow the instruction of CONSULT display.

Does the engine start?

- YES >> INSPECTION END
NO >> GO TO 2.

2.REPLACE ECM

Replace ECM. Refer to [EC-17, "ADDITIONAL SERVICE WHEN REPLACING CONTROL UNIT \(ECM\) : Description"](#).

>> INSPECTION END

B2195 ANTI-SCANNING

< DTC/CIRCUIT DIAGNOSIS >

B2195 ANTI-SCANNING

Description

INFOID:000000010993821

When ignition switch is turned ON, BCM performs ID verification with ECM. If ID verification that is out of the specified specification is detected, BCM prohibits further ID verification and engine cranking.

DTC Logic

INFOID:000000010993822

DTC DETECTION LOGIC

DTC No.	Trouble diagnosis name	DTC detecting condition	Possible cause
B2195	ANTI-SCANNING	ID verification between BCM and ECM that is out of the specified specification is detected	ID verification request out of the specified specification

DTC CONFIRMATION PROCEDURE

1. PERFORM DTC CONFIRMATION PROCEDURE

- Turn ignition switch ON under the following conditions.
 - Selector lever is in the P or N position
 - Do not depress brake pedal
- Check "Self-diagnostic result" using CONSULT.

Is DTC detected?

- YES >> Refer to [SEC-50. "Diagnosis Procedure"](#).
NO >> INSPECTION END.

Diagnosis Procedure

INFOID:000000010993823

1. CHECK SELF-DIAGNOSTIC RESULT-1

- Perform "Self-diagnostic result" of BCM using CONSULT.
- Erase DTC.
- Perform DTC Confirmation Procedure. Refer to [SEC-50. "DTC Logic"](#).

Is DTC 2195 detected?

- YES >> GO TO 2.
NO >> INSPECTION END

2. CHECK EQUIPMENT OF THE VEHICLE

Check that unspecified accessory part related to engine start is not installed.

Is unspecified accessory part related to engine start installed?

- YES >> GO TO 3.
NO >> Replace BCM. Refer to [BCS-90. "Removal and Installation"](#).

3. CHECK SELF-DIAGNOSTIC RESULT-2

- Obtain the customers approval to remove unspecified accessory part related to engine start, and then remove it.
- Perform "Self-diagnostic result" of BCM using CONSULT.
- Erase DTC.
- Perform DTC Confirmation Procedure. Refer to [SEC-50. "DTC Logic"](#).

Is DTC 2195 detected?

- YES >> Replace BCM. Refer to [BCS-90. "Removal and Installation"](#).
NO >> INSPECTION END

B2555 STOP LAMP

< DTC/CIRCUIT DIAGNOSIS >

B2555 STOP LAMP

Description

INFOID:0000000010993824

BCM detects the stop lamp status and confirms the stop lamp switch ON/OFF status. BCM confirms the engine start condition according to the stop lamp switch ON/OFF status.

DTC Logic

INFOID:0000000010993825

DTC DETECTION LOGIC

DTC No.	Trouble diagnosis name	DTC detecting condition	Possible cause
B2555	STOP LAMP	BCM makes a comparison between the upper voltage and lower voltage of stop lamp switch. It judges from their values to detect the malfunctioning circuit.	<ul style="list-style-type: none"> Harness or connectors (stop lamp switch circuit is open or shorted) Stop lamp switch Fuse

DTC CONFIRMATION PROCEDURE

1. PERFORM DTC CONFIRMATION PROCEDURE

- Depress the brake pedal and wait 1 second or more.
- Check "Self-diagnostic result" using CONSULT.

Is DTC detected?

- YES >> Go to [SEC-51, "Diagnosis Procedure"](#).
 NO >> INSPECTION END

Diagnosis Procedure

INFOID:0000000010993826

1. CHECK STOP LAMP SWITCH INPUT SIGNAL

- Turn ignition switch OFF.
- Disconnect BCM connector.
- Check voltage between BCM harness connector and ground.

(+)		(-)	Voltage (V) (Approx.)
BCM			
Connector	Terminal		
M123	116	Ground	Battery voltage

Is the inspection normal?

- YES >> GO TO 2.
 NO-1 >> Check 10 A fuse [No. 7, located in the fuse block (J/B)].
 NO-2 >> Check harness for open or short between BCM and fuse.

2. CHECK STOP LAMP SWITCH POWER SUPPLY CIRCUIT

- Disconnect stop lamp switch connector.
- Check voltage between stop lamp harness connector and ground.

(+)		(-)	Voltage (V) (Approx.)
Stop lamp switch			
Connector	Terminal		
E110 (With ICC) E119 (Without ICC)	1	Ground	Battery voltage

Is the inspection result normal?

- YES >> GO TO 3.
 NO >> Check harness for open or short to stop lamp switch.

B2555 STOP LAMP

< DTC/CIRCUIT DIAGNOSIS >

3.CHECK STOP LAMP SWITCH CIRCUIT

1. Check continuity between stop lamp switch harness connector and BCM harness connector.

Stop lamp switch		BCM		Continuity
Connector	Terminal	Connector	Terminal	
E110 (With ICC) E119 (Without ICC)	2	M123	118	Existed

2. Check continuity between stop lamp switch harness connector and ground.

Stop lamp switch		Ground	Continuity
Connector	Terminal		
E110 (With ICC) E119 (Without ICC)	2		Not existed

Is the inspection result normal?

- YES >> GO TO 4.
NO >> Repair or replace harness.

4.CHECK STOP LAMP SWITCH

Refer to [SEC-52, "Component Inspection"](#).

Is the inspection result normal?

- YES >> GO TO 5.
NO >> Replace stop lamp switch. Refer to [BR-20, "Exploded View"](#).

5.CHECK INTERMITTENT INCIDENT

Refer to [GI-41, "Intermittent Incident"](#).

>> INSPECTION END

Component Inspection

INFOID:0000000010993827

1.CHECK STOP LAMP SWITCH

1. Turn ignition switch OFF.
2. Disconnect stop lamp switch connector.
3. Check continuity between stop lamp switch terminals.

Stop lamp switch		Condition	Continuity	
Terminal				
1	2	Brake pedal	Not depressed	Not existed
			Depressed	Existed

Is the inspection result normal?

- YES >> INSPECTION END
NO >> Replace stop lamp switch. Refer to [BR-20, "Exploded View"](#).

B2556 PUSH-BUTTON IGNITION SWITCH

< DTC/CIRCUIT DIAGNOSIS >

B2556 PUSH-BUTTON IGNITION SWITCH

Description

INFOID:000000010993828

The switch changes the power supply position. BCM maintains the power supply position status. BCM changes the power supply position with the operation of the push-button ignition switch.

DTC Logic

INFOID:000000010993829

DTC DETECTION LOGIC

DTC No.	Trouble diagnosis name	DTC detecting condition	Possible cause
B2556	PUSH-BUTTON IGNITION SWITCH	BCM detects the push-button ignition switch stuck at ON for 100 seconds or more.	<ul style="list-style-type: none"> • Harness or connectors (Push-button ignition switch circuit is shorted.) • Push-button ignition switch • BCM

DTC CONFIRMATION PROCEDURE

1. PERFORM DTC CONFIRMATION PROCEDURE

1. Start the engine and wait 100 seconds or more.
2. Check "Self-diagnostic result" using CONSULT.

Is DTC detected?

- YES >> Go to [SEC-53, "Diagnosis Procedure"](#).
 NO >> INSPECTION END

Diagnosis Procedure

INFOID:000000010993830

1. CHECK PUSH-BUTTON IGNITION SWITCH INPUT SIGNAL

1. Turn ignition switch OFF.
2. Disconnect push-button ignition switch connector.
3. Check voltage between push-button ignition switch harness connector and ground.

(+)		(-)	Voltage (V) (Approx.)
Push-button ignition switch			
Connector	Terminal	Ground	Battery voltage
M50	4		

Is the inspection result normal?

- YES >> GO TO 3.
 NO >> GO TO 2.

2. CHECK PUSH-BUTTON IGNITION SWITCH CIRCUIT

1. Disconnect BCM connector and IPDM E/R connector.
2. Check continuity between push-button ignition switch harness connector and BCM harness connector.

Push-button ignition switch		BCM		Continuity
Connector	Terminal	Connector	Terminal	
M50	4	M122	60	Existed

3. Check continuity between push-button ignition switch harness connector and ground.

Push-button ignition switch		Ground	Continuity
Connector	Terminal		
M50	4		Not existed

Is the inspection result normal?

B2556 PUSH-BUTTON IGNITION SWITCH

< DTC/CIRCUIT DIAGNOSIS >

YES >> Replace BCM. Refer to [BCS-90, "Removal and Installation"](#).

NO >> Repair or replace harness.

3.CHECK PUSH-BUTTON IGNITION SWITCH GROUND CIRCUIT

Check continuity between push-button ignition switch harness connector and ground.

Push-button ignition switch		Ground	Continuity
Connector	Terminal		
M50	1		Existed

Is the inspection result normal?

YES >> GO TO 4.

NO >> Repair or replace harness.

4.CHECK PUSH-BUTTON IGNITION SWITCH

Refer to [SEC-54, "Component Inspection"](#).

Is the inspection result normal?

YES >> GO TO 5.

NO >> Replace push-button ignition switch. Refer to [SEC-190, "Removal and Installation"](#).

5.CHECK INTERMITTENT INCIDENT

Refer to [GI-41, "Intermittent Incident"](#).

>> INSPECTION END

Component Inspection

INFOID:000000010993831

1.CHECK PUSH-BUTTON IGNITION SWITCH

1. Turn ignition switch OFF.
2. Disconnect push-button ignition switch connector.
3. Check continuity between push-button ignition switch terminals.

Push-button ignition switch		Condition	Continuity
Terminal			
1	4	Push-button ignition switch	Pressed Existed
			Not pressed Not existed

Is the inspection result normal?

YES >> INSPECTION END

NO >> Replace push-button ignition switch. Refer to [SEC-190, "Removal and Installation"](#).

B2557 VEHICLE SPEED

< DTC/CIRCUIT DIAGNOSIS >

B2557 VEHICLE SPEED

Description

INFOID:0000000010993832

BCM receives 2 vehicle speed signals via CAN communication. 1 signal is transmitted by the “unified meter and A/C amp.”. Another signal is transmitted by “ABS actuator and electric unit (control unit.)”. BCM compares both signals to detect the vehicle speed.

DTC Logic

INFOID:0000000010993833

DTC DETECTION LOGIC

NOTE:

- If DTC B2557 is displayed with DTC U1000, first perform the trouble diagnosis for DTC U1000. Refer to [SEC-32, "BCM : DTC Logic"](#).
- If DTC B2557 is displayed with DTC U1010, first perform the trouble diagnosis for DTC U1010. Refer to [SEC-34, "BCM : DTC Logic"](#).

DTC No.	Self-diagnosis name	DTC detecting condition	Possible causes
B2557	VEHICLE SPEED	BCM detects the following difference between the vehicle speed signal from “unified meter and A/C amp.” and the one from “ABS actuator and electric unit” for 10 seconds continuously. <ul style="list-style-type: none">• One is 10 km/h (6.2 MPH) or more and the other is 4 km/h (2.5 MPH) or less	<ul style="list-style-type: none">• Wheel sensor• Unified meter and A/C amp.• ABS actuator and electric unit (control unit)

DTC CONFIRMATION PROCEDURE

1.PERFORM DTC CONFIRMATION PROCEDURE

1. Drive the vehicle at the vehicle speed of 10 km/h (6.2 MPH) or more and wait 10 seconds or more.
2. Check “Self-diagnostic result” using CONSULT.

Is DTC detected?

- YES >> Go to [SEC-55, "Diagnosis Procedure"](#).
NO >> INSPECTION END

Diagnosis Procedure

INFOID:0000000010993834

1.CHECK DTC WITH “ABS ACTUATOR AND ELECTRIC UNIT (CONTROL UNIT)”

Check “Self-diagnostic result” using CONSULT. Refer to [BRC-100, "DTC Index"](#).

Is the inspection result normal?

- YES >> GO TO 2.
NO >> Repair or replace the malfunctioning parts.

2.CHECK DTC WITH “COMBINATION METER”

Check “Self-diagnostic result” using CONSULT. Refer to [MWI-83, "DTC Index"](#).

Is the inspection result normal?

- YES >> GO TO 3.
NO >> Repair or replace the malfunctioning parts.

3.CHECK INTERMITTENT INCIDENT

Refer to [GI-41, "Intermittent Incident"](#).

>> INSPECTION END

A
B
C
D
E
F
G
H
I
J
L
M
N
O
P

SEC

B2560 STARTER CONTROL RELAY

< DTC/CIRCUIT DIAGNOSIS >

B2560 STARTER CONTROL RELAY

Description

INFOID:000000010993835

Starter control relay, integrated in IPDM E/R, permits the starter relay operation when in the N or P position. It is installed parallel to the starter relay.

DTC Logic

INFOID:000000010993836

DTC DETECTION LOGIC

NOTE:

- If DTC B2560 is displayed with DTC U1000, first perform the trouble diagnosis for DTC U1000. Refer to [SEC-32, "BCM : DTC Logic"](#).
- If DTC B2560 is displayed with DTC U1010, first perform the trouble diagnosis for DTC U1010. Refer to [SEC-34, "BCM : DTC Logic"](#).

DTC No.	Self-diagnosis name	DTC detecting condition	Possible causes
B2560	STARTER CONTROL RELAY	BCM detects a discrepancy between the OFF request of starter control relay to IPDM E/R and the feedback. (The feedback is ON instead of OFF.)	IPDM E/R

DTC CONFIRMATION PROCEDURE

1. PERFORM DTC CONFIRMATION PROCEDURE

1. Turn ignition switch ON under the following conditions and wait 2 seconds or more.
 - Selector lever is in the P or N position
 - Do not depress brake pedal
2. Check "Self-diagnostic result" using CONSULT.

Is DTC detected?

- YES >> Go to [SEC-56, "Diagnosis Procedure"](#).
NO >> INSPECTION END

Diagnosis Procedure

INFOID:000000010993837

1. CHECK DTC WITH IPDM E/R

Check "Self-diagnostic result" using CONSULT. Refer to [PCS-32, "DTC Index"](#).

Is the inspection result normal?

- YES >> GO TO 2.
NO >> Replace IPDM E/R. Refer to [PCS-34, "Removal and Installation"](#).

2. CHECK INTERMITTENT INCIDENT

Refer to [GI-41, "Intermittent Incident"](#).

>> INSPECTION END

B2601 SHIFT POSITION

< DTC/CIRCUIT DIAGNOSIS >

B2601 SHIFT POSITION

Description

INFOID:000000010993838

BCM confirms the shift position with the following 4 signals.

- Selector lever
- Transmission range switch
- P position signal from IPDM E/R (CAN)
- P position signal from TCM (CAN)

DTC Logic

INFOID:000000010993839

DTC DETECTION LOGIC

NOTE:

- If DTC B2601 is displayed with DTC U1000, first perform the trouble diagnosis for DTC U1000. Refer to [SEC-32, "BCM : DTC Logic"](#).
- If DTC B2601 is displayed with DTC U1010, first perform the trouble diagnosis for DTC U1010. Refer to [SEC-34, "BCM : DTC Logic"](#).

DTC No.	Trouble diagnosis name	DTC detecting condition	Possible cause
B2601	SHIFT POSITION	BCM detects when a difference between the shift P input signal and the shift position signal received from IPDM E/R via CAN communication continues for 2 seconds or more.	<ul style="list-style-type: none"> • Harness or connectors (A/T shift selector circuit is open or shorted) • A/T shift selector (detention switch)

DTC CONFIRMATION PROCEDURE

1. PERFORM DTC CONFIRMATION PROCEDURE

1. Turn ignition switch ON under the following conditions and wait 2 seconds or more.
 - Selector lever is in the P or N position
 - Do not depress brake pedal
2. Check "Self-diagnostic result" using CONSULT.

Is DTC detected?

- YES >> Go to [SEC-57, "Diagnosis Procedure"](#).
 NO >> INSPECTION END

Diagnosis Procedure

INFOID:000000010993840

1. CHECK A/T SHIFT SELECTOR POWER SUPPLY

1. Turn ignition switch OFF.
2. Disconnect A/T shift selector (detention switch) connector.
3. Check voltage between A/T shift selector (detention switch) harness connector and ground.

(+)		(-)	Voltage (V) (Approx.)
A/T shift selector (detention switch)			
Connector	Terminal		
M137	10	Ground	Battery voltage

Is the inspection result normal?

- YES >> GO TO 3.
 NO >> GO TO 2.

2. CHECK A/T SHIFT SELECTOR POWER SUPPLY CIRCUIT

1. Disconnect BCM connector.
2. Check continuity between A/T shift selector (detention switch) harness connector and BCM harness connector.

A
B
C
D
E
F
G
H
I
J
L
M
N
O
P

SEC

B2601 SHIFT POSITION

< DTC/CIRCUIT DIAGNOSIS >

A/T shift selector (detention switch)		BCM		Continuity
Connector	Terminal	Connector	Terminal	
M137	10	M122	96	Existed

3. Check continuity between A/T shift selector (detention switch) harness connector and ground.

A/T shift selector (detention switch)		Ground	Continuity
Connector	Terminal		
M137	10		Not existed

Is the inspection result normal?

YES >> Replace BCM. Refer to [BCS-90, "Removal and Installation"](#).

NO >> Repair or replace harness.

3.CHECK A/T SHIFT SELECTOR CIRCUIT (BCM)

1. Disconnect BCM connector and IPDM E/R connector.
2. Check continuity between A/T shift selector (detention switch) harness connector and BCM harness connector.

A/T shift selector (detention switch)		BCM		Continuity
Connector	Terminal	Connector	Terminal	
M137	11	M122	99	Existed

3. Check continuity between A/T shift selector (detention switch) harness connector and ground.

A/T shift selector (detention switch)		Ground	Continuity
Connector	Terminal		
M137	11		Not existed

Is the inspection result normal?

YES >> GO TO 4.

NO >> Repair or replace harness.

4.CHECK A/T SHIFT SELECTOR CIRCUIT (IPDM E/R)

Check continuity between A/T shift selector (detention switch) harness connector and IPDM E/R harness connector.

A/T shift selector (detention switch)		IPDM E/R		Continuity
Connector	Terminal	Connector	Terminal	
M137	11	E6	43	Existed

Is the inspection result normal?

YES >> GO TO 5.

NO >> Repair or replace harness.

5.CHECK A/T SHIFT SELECTOR (DETENTION SWITCH)

Refer to [SEC-59, "Component Inspection"](#).

Is the inspection result normal?

YES >> GO TO 6.

NO >> Replace A/T shift selector (detention switch). Refer to [TM-179, "2WD : Removal and Installation"](#) (2WD) or [TM-181, "AWD : Removal and Installation"](#) (AWD).

6.CHECK INTERMITTENT INCIDENT

Refer to [GI-41, "Intermittent Incident"](#).

>> INSPECTION END

B2601 SHIFT POSITION

< DTC/CIRCUIT DIAGNOSIS >

Component Inspection

INFOID:000000010993841

1. CHECK A/T SHIFT SELECTOR (DETENTION SWITCH)

1. Turn ignition switch OFF.
2. Disconnect A/T shift selector (detention switch) connector.
3. Check continuity between A/T shift selector (detention switch) terminals.

A/T shift selector (detention switch)		Condition		Continuity
Terminal				
10	11	Selector lever	P position	Not existed
			Other than above	Existed

Is the inspection result normal?

YES >> INSPECTION END

NO >> Replace A/T shift selector (detention switch). Refer to [TM-179, "2WD : Removal and Installation"](#) (2WD) or [TM-181, "AWD : Removal and Installation"](#) (AWD).

A
B
C
D
E
F
G
H
I
J
L
M
N
O
P

SEC

B2602 SHIFT POSITION

< DTC/CIRCUIT DIAGNOSIS >

B2602 SHIFT POSITION

Description

INFOID:000000010993842

BCM confirms the shift position with the following 4 signals.

- Selector lever
- Transmission range switch
- P position signal from IPDM E/R (CAN)
- P position signal from TCM (CAN)

DTC Logic

INFOID:000000010993843

DTC DETECTION LOGIC

NOTE:

- If DTC B2602 is displayed with DTC U1000, first perform the trouble diagnosis for DTC U1000. Refer to [SEC-32, "BCM : DTC Logic"](#).
- If DTC B2602 is displayed with DTC U1010, first perform the trouble diagnosis for DTC U1010. Refer to [SEC-34, "BCM : DTC Logic"](#).

DTC No.	Trouble diagnosis name	DTC detecting condition	Possible cause
B2602	SHIFT POSITION	BCM detects the following status for 10 seconds. <ul style="list-style-type: none">• Shift position is in the P position• Vehicle speed is 4 km/h (2.5 MPH) or more• Ignition switch is in the ON position	<ul style="list-style-type: none">• Harness or connectors (A/T shift selector circuit is open or shorted)• A/T shift selector (detention switch)• ABS actuator and electric unit (control unit)

DTC CONFIRMATION PROCEDURE

1. PERFORM DTC CONFIRMATION PROCEDURE

1. Start engine.
2. Drive vehicle at a speed of 4 km/h (2.5 MPH) or more for at least 10 seconds.
3. Check "Self-diagnostic result" using CONSULT.

Is DTC detected?

- YES >> Go to [SEC-60, "Diagnosis Procedure"](#).
NO >> INSPECTION END

Diagnosis Procedure

INFOID:000000010993844

1. CHECK DTC WITH "ABS ACTUATOR AND ELECTRIC UNIT"

Check "Self diagnostic result" using CONSULT. Refer to [BRC-100, "DTC Index"](#).

Is the inspection result normal?

- YES >> GO TO 2.
NO >> Repair or replace the malfunctioning parts.

2. CHECK A/T SHIFT SELECTOR POWER SUPPLY

1. Turn ignition switch OFF.
2. Disconnect A/T shift selector (detention switch) connector.
3. Check voltage between A/T shift selector (detention switch) harness connector and ground.

(+)		(-)	Voltage (V) (Approx.)
Connector	Terminal		
M137	10	Ground	Battery voltage

Is the inspection result normal?

- YES >> GO TO 4.

B2602 SHIFT POSITION

< DTC/CIRCUIT DIAGNOSIS >

NO >> GO TO 3.

3.CHECK A/T SHIFT SELECTOR POWER SUPPLY CIRCUIT

1. Disconnect BCM connector.
2. Check continuity between A/T shift selector (detention switch) harness connector and BCM harness connector.

A/T shift selector (detention switch)		BCM		Continuity
Connector	Terminal	Connector	Terminal	
M137	10	M122	96	Existed

3. Check continuity between A/T shift selector (detention switch) harness connector and ground.

A/T shift selector (detention switch)		Ground	Continuity
Connector	Terminal		
M137	10		Not existed

Is the inspection result normal?

YES >> Replace BCM. Refer to [BCS-90. "Removal and Installation"](#).

NO >> Repair or replace harness.

4.CHECK A/T SHIFT SELECTOR CIRCUIT

1. Disconnect BCM connector and IPDM E/R connector.
2. Check continuity between A/T shift selector (detention switch) harness connector and BCM harness connector.

A/T shift selector (detention switch)		BCM		Continuity
Connector	Terminal	Connector	Terminal	
M137	11	M122	99	Existed

3. Check continuity between A/T shift selector (detention switch) harness connector and ground.

A/T shift selector (detention switch)		Ground	Continuity
Connector	Terminal		
M137	11		Not existed

Is the inspection result normal?

YES >> GO TO 5.

NO >> Repair or replace harness.

5.CHECK A/T SHIFT SELECTOR (DETENTION SWITCH)

Refer to [SEC-61. "Component Inspection"](#).

Is the inspection result normal?

YES >> GO TO 6.

NO >> Replace A/T shift selector (detention switch). Refer to [TM-179. "2WD : Removal and Installation"](#) (2WD) or [TM-181. "AWD : Removal and Installation"](#) (AWD).

6.CHECK INTERMITTENT INCIDENT

Refer to [GI-41. "Intermittent Incident"](#).

>> INSPECTION END

Component Inspection

INFOID:000000010993845

1.CHECK A/T SHIFT SELECTOR (DETENTION SWITCH)

1. Turn ignition switch OFF.
2. Disconnect A/T shift selector (detention switch) connector.
3. Check continuity between A/T shift selector (detention switch) terminals.

B2602 SHIFT POSITION

< DTC/CIRCUIT DIAGNOSIS >

A/T shift selector (detention switch)		Condition		Continuity
Terminal				
10	11	Selector lever	P position	Not existed
			Other than above	Existed

Is the inspection result normal?

YES >> INSPECTION END

NO >> Replace A/T shift selector (detention switch). Refer to [TM-179, "2WD : Removal and Installation"](#) (2WD) or [TM-181, "AWD : Removal and Installation"](#) (AWD).

B2603 SHIFT POSITION

< DTC/CIRCUIT DIAGNOSIS >

B2603 SHIFT POSITION

Description

INFOID:0000000010993846

BCM confirms the shift position with the following 4 signals.

- Selector lever
- Transmission range switch
- P position signal from IPDM E/R (CAN)
- P position signal from TCM (CAN)

DTC Logic

INFOID:0000000010993847

DTC DETECTION LOGIC

NOTE:

- If DTC B2603 is displayed with DTC U1000, first perform the trouble diagnosis for DTC U1000. Refer to [SEC-32, "BCM : DTC Logic"](#).
- If DTC B2603 is displayed with DTC U1010, first perform the trouble diagnosis for DTC U1010. Refer to [SEC-34, "BCM : DTC Logic"](#).
- If DTC B2603 is displayed with DTC B2601, first perform the trouble diagnosis for DTC B2601. Refer to [SEC-57, "DTC Logic"](#).

DTC No.	Self-diagnosis name	DTC detecting condition	Possible causes
B2603	SHIFT POSITION STATUS	BCM detects the following status for 500 ms or more when shift is in the P position, and ignition switch is in the ON position. <ul style="list-style-type: none"> • Transmission range switch: approx. 0 V • A/T shift selector (detention switch): approx. 0 V 	<ul style="list-style-type: none"> • Harness or connector (A/T shift selector circuit is open or shorted) • Harness or connectors (TCM circuit is open or shorted) • A/T shift selector (detention switch) • TCM

DTC CONFIRMATION PROCEDURE

1. PERFORM DTC CONFIRMATION PROCEDURE

1. Start engine and wait 1 second or more.
2. Check "Self-diagnostic result" using CONSULT.

Is DTC detected?

- YES >> Go to [SEC-63, "Diagnosis Procedure"](#).
 NO >> INSPECTION END

Diagnosis Procedure

INFOID:0000000010993848

1. CHECK DTC WITH TCM

Check "Self diagnostic result" with CONSULT.

Are any DTC detected?

- YES >> Refer to [TM-153, "DTC Index"](#).
 NO >> GO TO 2.

2. CHECK TRANSMISSION RANGE SWITCH CIRCUIT 1

1. Turn ignition switch OFF.
2. Disconnect A/T assembly connector and BCM connector.
3. Check continuity between A/T assembly harness connector and BCM harness connector.

A/T assembly		BCM		Continuity
Connector	Terminal	Connector	Terminal	
F51	9	M123	140	Existed

4. Check continuity between A/T assembly harness connector and ground.

B2603 SHIFT POSITION

< DTC/CIRCUIT DIAGNOSIS >

A/T assembly		Ground	Continuity
Connector	Terminal		
F51	9		

Is the inspection result normal?

YES >> GO TO 3.

NO >> Repair or replace harness.

3. CHECK TRANSMISSION RANGE SWITCH CIRCUIT 2

1. Disconnect TCM connector.
2. Check continuity between TCM harness connector and A/T assembly harness connector.

TCM		A/T assembly		Continuity
Connector	Terminal	Connector	Terminal	
F157	9	F51	9	

3. Check continuity between TCM harness connector and ground.

TCM		Ground	Continuity
Connector	Terminal		
F157	9		

Is the inspection result normal?

YES >> GO TO 4.

NO >> Repair or replace harness.

4. CHECK A/T SHIFT SELECTOR POWER SUPPLY

1. Disconnect A/T shift selector (detention switch) connector.
2. Check voltage between A/T shift selector (detention switch) harness connector and ground.

(+)		(-)	Voltage (V) (Approx.)
A/T shift selector (detention switch)			
Connector	Terminal		
M137	10	Ground	Battery voltage

Is the inspection result normal?

YES >> GO TO 6.

NO >> GO TO 5.

5. CHECK A/T SHIFT SELECTOR POWER SUPPLY CIRCUIT

1. Disconnect BCM connector.
2. Check continuity between A/T shift selector (detention switch) harness connector and BCM harness connector.

A/T shift selector (detention switch)		BCM		Continuity
Connector	Terminal	Connector	Terminal	
M137	10	M122	96	

3. Check continuity between A/T shift selector (detention switch) harness connector and ground.

A/T shift selector (detention switch)		Ground	Continuity
Connector	Terminal		
M137	10		

Is the inspection result normal?

YES >> Replace BCM. Refer to [BCS-90, "Removal and Installation"](#).

NO >> Repair or replace harness.

B2603 SHIFT POSITION

< DTC/CIRCUIT DIAGNOSIS >

6. CHECK A/T SHIFT SELECTOR CIRCUIT

1. Disconnect BCM connector and IPDM E/R connector.
2. Check continuity between A/T shift selector (detention switch) harness connector and BCM harness connector.

A/T shift selector (detention switch)		BCM		Continuity
Connector	Terminal	Connector	Terminal	
M137	11	M122	99	Existed

3. Check continuity between A/T shift selector (detention switch) harness connector and ground.

A/T shift selector (detention switch)		Ground	Continuity
Connector	Terminal		
M137	11		Not existed

Is the inspection result normal?

- YES >> GO TO 7.
 NO >> Repair or replace harness.

7. CHECK A/T SHIFT SELECTOR (DETENTION SWITCH)

Refer to [SEC-65, "Component Inspection"](#).

Is the inspection result normal?

- YES >> GO TO 8.
 NO >> Replace A/T shift selector (detention switch). Refer to [TM-179, "2WD : Removal and Installation"](#) (2WD) or [TM-181, "AWD : Removal and Installation"](#) (AWD).

8. CHECK INTERMITTENT INCIDENT

Refer to [GI-41, "Intermittent Incident"](#).

>> INSPECTION END

Component Inspection

INFOID:000000010993849

1. CHECK A/T SHIFT SELECTOR (DETENTION SWITCH)

1. Turn ignition switch OFF.
2. Disconnect A/T shift selector (detention switch) connector.
3. Check continuity between A/T shift selector (detention switch) terminals.

A/T shift selector (detention switch)		Condition	Continuity	
Terminal				
10	11	Selector lever	P position	Not existed
			Other than above	Existed

Is the inspection result normal?

- YES >> INSPECTION END
 NO >> Replace A/T shift selector (detention switch). Refer to [TM-179, "2WD : Removal and Installation"](#) (2WD) or [TM-181, "AWD : Removal and Installation"](#) (AWD).

B2604 SHIFT POSITION

< DTC/CIRCUIT DIAGNOSIS >

B2604 SHIFT POSITION

Description

INFOID:000000010993850

BCM confirms the shift position with the following 4 signals.

- Selector lever
- Transmission range switch
- P position signal from IPDM E/R (CAN)
- P position signal from TCM (CAN)

DTC Logic

INFOID:000000010993851

DTC DETECTION LOGIC

NOTE:

- If DTC B2604 is displayed with DTC U1000, first perform the trouble diagnosis for DTC U1000. Refer to [SEC-32, "BCM : DTC Logic"](#).
- If DTC B2604 is displayed with DTC U1010, first perform the trouble diagnosis for DTC U1010. Refer to [SEC-34, "BCM : DTC Logic"](#).

DTC No.	Trouble diagnosis name	DTC detecting condition	Possible cause
B2604	PNP SWITCH	BCM detects the following status for 500 ms or more when the ignition switch is in the ON position. <ul style="list-style-type: none"> • N position input signal exists. Shift position signal from TCM does not exist. • N position input signal does not exist. Shift position signal from TCM exists. 	<ul style="list-style-type: none"> • Harness or connectors (TCM circuit is open or shorted) • TCM

DTC CONFIRMATION PROCEDURE

1. PERFORM DTC CONFIRMATION PROCEDURE

1. Start engine and wait 1 second or more.
2. Check "Self-diagnostic result" using CONSULT.

Is DTC detected?

- YES >> Go to [SEC-66, "Diagnosis Procedure"](#).
 NO >> INSPECTION END

Diagnosis Procedure

INFOID:000000010993852

1. CHECK DTC WITH TCM

Check "Self diagnostic result" using CONSULT.

Are any DTC detected?

- YES >> Refer to [TM-153, "DTC Index"](#).
 NO >> GO TO 2.

2. CHECK TRANSMISSION RANGE SWITCH CIRCUIT 1

1. Turn ignition switch OFF.
2. Disconnect A/T assembly connector and BCM connector.
3. Check continuity between A/T assembly harness connector and BCM harness connector.

A/T assembly		BCM		Continuity
Connector	Terminal	Connector	Terminal	
F51	9	M123	140	Existed

4. Check continuity between A/T assembly harness connector and ground.

B2604 SHIFT POSITION

< DTC/CIRCUIT DIAGNOSIS >

A/T assembly		Ground	Continuity
Connector	Terminal		
F51	9		Not existed

Is the inspection result normal?

YES >> GO TO 3.

NO >> Repair or replace harness.

3. CHECK TRANSMISSION RANGE SWITCH CIRCUIT 2

1. Disconnect TCM connector.
2. Check continuity between TCM harness connector and A/T assembly harness connector.

TCM		A/T assembly		Continuity
Connector	Terminal	Connector	Terminal	
F157	9	F51	9	Existed

3. Check continuity between TCM harness connector and ground.

TCM		Ground	Continuity
Connector	Terminal		
F157	9		Not existed

Is the inspection result normal?

YES >> GO TO 4.

NO >> Repair or replace harness.

4. CHECK INTERMITTENT INCIDENT

Refer to [GI-41. "Intermittent Incident"](#).

>> INSPECTION END

A
B
C
D
E
F
G
H
I
J
L
M
N
O
P

SEC

B2605 SHIFT POSITION

< DTC/CIRCUIT DIAGNOSIS >

B2605 SHIFT POSITION

Description

INFOID:000000010993853

BCM confirms the shift position with the following 4 signals.

- Selector lever
- Transmission range switch
- P position signal from IPDM E/R (CAN)
- P position signal from TCM (CAN)

DTC Logic

INFOID:000000010993854

DTC DETECTION LOGIC

NOTE:

- If DTC B2605 is displayed with DTC U1000, first perform the trouble diagnosis for DTC U1000. Refer to [SEC-32. "BCM : DTC Logic"](#).
- If DTC B2605 is displayed with DTC U1010, first perform the trouble diagnosis for DTC U1010. Refer to [SEC-34. "BCM : DTC Logic"](#).

DTC No.	Trouble diagnosis name	DTC detecting condition	Possible cause
B2605	PNP SWITCH	BCM detects the following status for 500 ms or more when the ignition switch is in the ON position <ul style="list-style-type: none">• N position input signal exists. Shift position signal from IPDM E/R does not exist.• N position input signal does not exist. Shift position signal from IPDM E/R exists.	<ul style="list-style-type: none">• Harness or connectors (TCM circuit is open or shorted)• TCM• IPDM E/R

DTC CONFIRMATION PROCEDURE

1. PERFORM DTC CONFIRMATION PROCEDURE

1. Turn ignition switch ON under the following conditions and wait 1 second or more.
 - Selector lever is in the P or N position
 - Do not depress brake pedal
2. Check "Self-diagnostic result" using CONSULT.

Is DTC detected?

- YES >> Go to [SEC-68. "Diagnosis Procedure"](#).
NO >> INSPECTION END

Diagnosis Procedure

INFOID:000000010993855

1. CHECK DTC WITH IPDM E/R

Check "Self diagnostic result" using CONSULT. Refer to [PCS-32. "DTC Index"](#).

Is the inspection result normal?

- YES >> GO TO 2.
NO >> Repair or replace the malfunctioning parts.

2. CHECK TRANSMISSION RANGE SWITCH CIRCUIT 1

1. Turn ignition switch OFF.
2. Disconnect A/T assembly connector and BCM connector.
3. Check continuity between A/T assembly harness connector and BCM harness connector.

A/T assembly		BCM		Continuity
Connector	Terminal	Connector	Terminal	
F51	9	M123	140	Existed

4. Check continuity between A/T assembly harness connector and ground.

B2605 SHIFT POSITION

< DTC/CIRCUIT DIAGNOSIS >

A/T assembly		Ground	Continuity
Connector	Terminal		
F51	9		Not existed

Is the inspection result normal?

YES >> GO TO 3.

NO >> Repair or replace harness.

3. CHECK TRANSMISSION RANGE SWITCH CIRCUIT 2

1. Disconnect TCM connector.
2. Check continuity between TCM harness connector and A/T assembly harness connector.

TCM		A/T assembly		Continuity
Connector	Terminal	Connector	Terminal	
F157	9	F51	9	Existed

3. Check continuity between TCM harness connector and ground.

TCM		Ground	Continuity
Connector	Terminal		
F157	9		Not existed

Is the inspection result normal?

YES >> GO TO 4.

NO >> Repair or replace harness.

4. CHECK INTERMITTENT INCIDENT

Refer to [GI-41. "Intermittent Incident"](#).

>> INSPECTION END

A
B
C
D
E
F
G
H
I
J
L
M
N
O
P

SEC

B2608 STARTER RELAY

< DTC/CIRCUIT DIAGNOSIS >

B2608 STARTER RELAY

Description

INFOID:0000000010993856

Located in IPDM E/R, the starter relay runs the starter motor. The starter relay is turned ON by the BCM when the ignition switch is in the START position. IPDM E/R transmits the starter relay ON signal to BCM via CAN communication.

DTC Logic

INFOID:0000000010993857

DTC DETECTION LOGIC

NOTE:

- If DTC B2608 is displayed with DTC U1000, first perform the trouble diagnosis for DTC U1000. Refer to [SEC-32, "BCM : DTC Logic"](#).
- If DTC B2608 is displayed with DTC U1010, first perform the trouble diagnosis for DTC U1010. Refer to [SEC-34, "BCM : DTC Logic"](#).
- If DTC B2608 is displayed with DTC B210D for IPDM E/R, first perform the trouble diagnosis for DTC B210D. Refer to [SEC-80, "DTC Logic"](#).

DTC No.	Trouble diagnosis name	DTC detecting condition	Possible cause
B2608	STARTER RELAY	BCM receives starter relay ON signal (CAN) from IPDM E/R even if BCM turns the starter relay OFF.	<ul style="list-style-type: none">• Harness or connectors (Starter relay circuit is open or shorted.)• IPDM E/R

DTC CONFIRMATION PROCEDURE

1. PERFORM DTC CONFIRMATION PROCEDURE

1. Turn ignition switch ON under the following conditions.
 - Selector lever is in the P or N position
 - Do not depress brake pedal
2. Check "Self-diagnostic result" using CONSULT.

Is DTC detected?

- YES >> Go to [SEC-70, "Diagnosis Procedure"](#).
NO >> INSPECTION END

Diagnosis Procedure

INFOID:0000000010993858

1. CHECK BCM POWER SUPPLY CIRCUIT

1. Turn ignition switch ON.
2. Check voltage between BCM harness connector and ground.

(+)		(-)	Condition	Voltage (V) (Approx.)	
BCM					
Connector	Terminal				
M121	52	Ground	Selector lever	N or P position	12
				Other than above	0

Is the measurement value within the specification?

- YES >> GO TO 3.
NO >> GO TO 2.

2. CHECK STARTER RELAY CIRCUIT

1. Turn ignition switch OFF.
2. Disconnect BCM connector and IPDM E/R connector.
3. Check continuity between IPDM E/R harness connector and BCM harness connector.

B2608 STARTER RELAY

< DTC/CIRCUIT DIAGNOSIS >

IPDM E/R		BCM		Continuity
Connector	Terminal	Connector	Terminal	
E6	46	M121	52	Existed

4. Check continuity between IPDM E/R harness connector and ground.

IPDM E/R		Ground	Continuity
Connector	Terminal		
E6	46		Not existed

Is the inspection result normal?

YES >> Replace IPDM E/R. Refer to [PCS-34, "Removal and Installation"](#).

NO >> Repair or replace harness.

3. CHECK INTERMITTENT INCIDENT

Refer to [GI-41, "Intermittent Incident"](#).

>> INSPECTION END

A
B
C
D
E
F
G
H
I
J
L
M
N
O
P

SEC

B260F ENGINE STATUS

< DTC/CIRCUIT DIAGNOSIS >

B260F ENGINE STATUS

Description

INFOID:000000010993859

BCM receives the engine status signal from ECM via CAN communication.

DTC Logic

INFOID:000000010993860

DTC DETECTION LOGIC

NOTE:

- If DTC B260F is displayed with DTC U1000, first perform the trouble diagnosis for DTC U1000. Refer to [SEC-32, "BCM : DTC Logic"](#).
- If DTC B260F is displayed with DTC U1010, first perform the trouble diagnosis for DTC U1010. Refer to [SEC-34, "BCM : DTC Logic"](#).

DTC No.	Trouble diagnosis name	DTC detecting condition	Possible cause
B260F	INTERRUPTION OF ENGINE STATUS SIGNAL	BCM has not yet received the engine status signal from ECM when ignition switch is in the ON position.	ECM

DTC CONFIRMATION PROCEDURE

1. PERFORM DTC CONFIRMATION PROCEDURE

1. Turn ignition switch ON under the following conditions.
 - Selector lever is in the P or N position
 - Do not depress brake pedal
2. Check "Self-diagnostic result" using CONSULT.

Is DTC detected?

- YES >> Go to [SEC-72, "Diagnosis Procedure"](#).
NO >> INSPECTION END

Diagnosis Procedure

INFOID:000000010993861

1. INSPECTION START

1. Turn ignition switch ON.
2. Check "Self-diagnostic result" using CONSULT.
3. Touch "ERASE".
4. **Perform DTC Confirmation Procedure.**
See [SEC-72, "DTC Logic"](#).

Is the DTC B260F displayed again?

- YES >> GO TO 2.
NO >> GO TO 3.

2. REPLACE ECM

Replace ECM. Refer to [EC-17, "ADDITIONAL SERVICE WHEN REPLACING CONTROL UNIT \(ECM\) : Description"](#).

>> INSPECTION END

3. CHECK INTERMITTENT INCIDENT

Refer to [GI-41, "Intermittent Incident"](#).

>> INSPECTION END

B26EA KEY REGISTRATION

< DTC/CIRCUIT DIAGNOSIS >

B26EA KEY REGISTRATION

Description

INFOID:000000010993866

When the registered Intelligent Key is carried, the door lock/unlock operation and the push-button ignition switch operation become possible.

DTC Logic

INFOID:000000010993867

DTC DETECTION LOGIC

DTC No.	Trouble diagnosis name	DTC detecting condition	Possible cause
B26EA	KEY REGISTRATION	Intelligent Key is not registered successfully.	<ul style="list-style-type: none">Improper registration operationIntelligent KeyBCM

DTC CONFIRMATION PROCEDURE

1. PERFORM DTC CONFIRMATION PROCEDURE

1. Perform initialization using CONSULT. Register all Intelligent Keys.
For initialization and registration of Intelligent Key, follow the instruction of CONSULT display.
2. Check "Self-diagnostic result" using CONSULT.

Is DTC detected?

YES >> Go to [SEC-73. "Diagnosis Procedure"](#)
NO >> INSPECTION END

Diagnosis Procedure

INFOID:000000010993868

1. PERFORM INITIALIZATION

1. Perform initialization using CONSULT. Register all Intelligent Keys.
For initialization and registration of Intelligent Key, follow the instruction of CONSULT display.
2. Check "Self-diagnostic result" using CONSULT.

Is DTC detected?

YES >> GO TO 2.
NO >> INSPECTION END

2. REPLACE INTELLIGENT KEY

1. Replace Intelligent Key. Register all Intelligent Keys
2. Perform initialization using CONSULT. For initialization, follow the instruction of CONSULT display.
3. Check "Self-diagnostic result" using CONSULT.

Is DTC detected?

YES >> Replace BCM. Refer to [BCS-90. "Removal and Installation"](#).
NO >> INSPECTION END

A
B
C
D
E
F
G
H
I
J
L
M
N
O
P

SEC

B2617 STARTER RELAY CIRCUIT

< DTC/CIRCUIT DIAGNOSIS >

B2617 STARTER RELAY CIRCUIT

Description

INFOID:000000010993869

Located in IPDM E/R, the starter relay runs the starter motor. The starter relay is turned ON by the BCM when the ignition switch is in the START position. IPDM E/R transmits the starter relay ON signal to BCM via CAN communication.

DTC Logic

INFOID:000000010993870

DTC DETECTION LOGIC

NOTE:

- If DTC B2617 is displayed with DTC U1000, first perform the trouble diagnosis for DTC U1000. Refer to [SEC-32, "BCM : DTC Logic"](#).
- If DTC B2617 is displayed with DTC U1010, first perform the trouble diagnosis for DTC U1010. Refer to [SEC-34, "BCM : DTC Logic"](#).
- If DTC B2617 is displayed with DTC B210E for IPDM E/R, first perform the trouble diagnosis for DTC B210E. Refer to [SEC-82, "DTC Logic"](#).

DTC No.	Trouble diagnosis name	DTC detecting condition	Possible cause
B2617	STARTER RELAY CIRCUIT	An immediate operation of starter relay is requested by BCM, but there is no response for more than 1 second.	<ul style="list-style-type: none">• Harness or connectors (Starter relay circuit is open or shorted.)• IPDM E/R

DTC CONFIRMATION PROCEDURE

1. PERFORM DTC CONFIRMATION PROCEDURE

1. Turn ignition switch ON under the following conditions and wait 1 second or more.
 - Selector lever is in the P or N position
 - Do not depress brake pedal
2. Check "Self-diagnostic result" using CONSULT.

Is DTC detected?

- YES >> Go to [SEC-74, "Diagnosis Procedure"](#).
NO >> INSPECTION END

Diagnosis Procedure

INFOID:000000010993871

1. CHECK STARTER RELAY

1. Turn ignition switch ON.
2. Check voltage between BCM harness connector and ground.

(+)		(-)	Condition	Voltage (V) (Approx.)	
BCM					
Connector	Terminal				
M121	52	Ground	Selector lever	N or P position	12
				Other than above	0

Is the measurement value within the specification.

- YES >> GO TO 3.
NO >> GO TO 2.

2. CHECK STARTER RELAY CIRCUIT

1. Turn ignition switch OFF.
2. Disconnect BCM connector and IPDM E/R connector.
3. Check continuity between IPDM E/R harness connector and BCM harness connector.

B2617 STARTER RELAY CIRCUIT

< DTC/CIRCUIT DIAGNOSIS >

IPDM E/R		BCM		Continuity
Connector	Terminal	Connector	Terminal	
E6	46	M121	52	Existed

4. Check continuity between IPDM E/R harness connector and ground.

IPDM E/R		Ground	Continuity
Connector	Terminal		
E6	46		Not existed

Is the inspection result normal?

YES >> Replace IPDM E/R. Refer to [PCS-34, "Removal and Installation"](#).

NO >> Repair or replace harness.

3. CHECK INTERMITTENT INCIDENT

Refer to [GI-41, "Intermittent Incident"](#).

>> INSPECTION END

A
B
C
D
E
F
G
H
I
J
L
M
N
O
P

SEC

B261E VEHICLE TYPE

< DTC/CIRCUIT DIAGNOSIS >

B261E VEHICLE TYPE

Description

INFOID:0000000010993872

There are two types of vehicles.

- HEV
- Conventional

DTC Logic

INFOID:0000000010993873

DTC DETECTION LOGIC

NOTE:

- If DTC B261E is displayed with DTC U1000, first perform the trouble diagnosis for DTC U1000. Refer to [SEC-32, "BCM : DTC Logic"](#).
- If DTC B261E is displayed with DTC U1010, first perform the trouble diagnosis for DTC U1010. Refer to [SEC-34, "BCM : DTC Logic"](#).

DTC No.	Trouble diagnosis name	DTC detecting condition	Possible cause
B261E	VEHICLE TYPE	Difference of BCM configuration.	BCM

DTC CONFIRMATION PROCEDURE

1. PERFORM DTC CONFIRMATION PROCEDURE

1. Turn ignition switch ON under the following conditions.
 - Selector lever is in the P or N position
 - Do not depress brake pedal
2. Check "Self-diagnostic result" using CONSULT.

Is DTC detected?

- YES >> Go to [SEC-76, "Diagnosis Procedure"](#).
NO >> INSPECTION END

Diagnosis Procedure

INFOID:0000000010993874

1. INSPECTION START

1. Turn ignition switch ON.
2. Check "Self-diagnostic result" using CONSULT.
3. Touch "ERASE".
4. **Perform DTC Confirmation Procedure.**
See [SEC-76, "DTC Logic"](#).

Is the 1st trip DTC B261E displayed again?

- YES >> Replace BCM. Refer to [BCS-90, "Removal and Installation"](#).
NO >> INSPECTION END

B210B STARTER CONTROL RELAY

< DTC/CIRCUIT DIAGNOSIS >

B210B STARTER CONTROL RELAY

Description

INFOID:000000010993879

Starter control relay, integrated in IPDM E/R, permits the starter relay operation when in the N or P position. It is installed parallel to the starter relay.

DTC Logic

INFOID:000000010993880

DTC DETECTION LOGIC

NOTE:

If DTC B210B is displayed with DTC U1000, first perform the trouble diagnosis for DTC U1000. Refer to [SEC-32, "IPDM E/R : DTC Logic"](#).

DTC No.	Trouble diagnosis name	DTC detecting condition	Possible cause
B210B	START CONT RLY ON CIRC	IPDM E/R detects that the relay is stuck in the ON position even if the following conditions are met for about 1 second. <ul style="list-style-type: none">• Starter control relay ON/OFF signal from BCM• Transmission range switch input signal	IPDM E/R

DTC CONFIRMATION PROCEDURE

1. PERFORM DTC CONFIRMATION PROCEDURE

1. Turn the power supply position to start under the following conditions and wait 1 second or more.
 - Selector lever is in the P or N position
 - Do not depress brake pedal
2. Check "Self-diagnostic result" using CONSULT.

Is DTC detected?

- YES >> Go to [SEC-77, "Diagnosis Procedure"](#).
NO >> INSPECTION END

Diagnosis Procedure

INFOID:000000010993881

1. CHECK SELF DIAGNOSTIC RESULT

Check "Self-diagnostic result" for IPDM E/R using CONSULT.

What is the display history of DTC "B210B"?

- "CRNT">> Replace IPDM E/R. Refer to [PCS-34, "Removal and Installation"](#).
"PAST">> GO TO 2.

2. CHECK INTERMITTENT INCIDENT

Refer to [GI-41, "Intermittent Incident"](#).

>> INSPECTION END

B210C STARTER CONTROL RELAY

< DTC/CIRCUIT DIAGNOSIS >

B210C STARTER CONTROL RELAY

Description

INFOID:000000010993882

Starter control relay, integrated in IPDM E/R, permits the starter relay operation when in the N or P position. It is installed parallel to the starter relay.

DTC Logic

INFOID:000000010993883

DTC DETECTION LOGIC

NOTE:

- If DTC B210C is displayed with DTC U1000, first perform the trouble diagnosis for DTC U1000. Refer to [SEC-32, "IPDM E/R : DTC Logic"](#).
- When IPDM E/R power supply voltage is low (Approx. 7 - 8 V for about 1 second), the DTC B210C may be detected.

DTC No.	Trouble diagnosis name	DTC detecting condition	Possible cause
B210C	START CONT RLY OFF CIRC	IPDM E/R detects that the relay is stuck in the OFF position even if the following conditions are met for about 1 second. <ul style="list-style-type: none">• Starter control relay ON/OFF signal from BCM• Transmission range switch input signal	<ul style="list-style-type: none">• IPDM E/R• Battery

DTC CONFIRMATION PROCEDURE

1.PERFORM DTC CONFIRMATION PROCEDURE

1. Turn the power supply position to start under the following conditions and wait 1 second or more.
 - Selector lever is in the P or N position
 - Do not depress brake pedal
2. Check "Self-diagnostic result" using CONSULT.

Is DTC detected?

- YES >> Go to [SEC-78, "Diagnosis Procedure"](#).
NO >> INSPECTION END

Diagnosis Procedure

INFOID:000000010993884

1.CHECK SELF DIAGNOSTIC RESULT

Check "Self-diagnostic result" for IPDM E/R using CONSULT.

What is the display history of DTC "B210C"?

- "CRNT">> GO TO 3.
"PAST">> GO TO 2.

2.CHECK BATTERY VOLTAGE

Measure the battery voltage.

Which is the measurement result?

- More than 12.4 V>>GO TO 5.
Less than 12.4 V>>Perform battery inspection. Refer to [PG-3, "How to Handle Battery"](#).

3.CHECK P/N POSITION SIGNAL CIRCUIT VOLTAGE

1. Turn ignition switch ON.
2. Selector lever is in P position.
3. Check the voltage between IPDM E/R harness connector and ground.

(+)		(-)	Voltage (Approx)
IPDM E/R			
Connector	Terminal		
E5	30	Ground	Battery voltage

B210C STARTER CONTROL RELAY

< DTC/CIRCUIT DIAGNOSIS >

Is the inspection result normal?

YES >> Replace IPDM E/R. Refer to [PCS-34, "Removal and Installation"](#).

NO >> GO TO 4.

4. CHECK P/N POSITION SIGNAL CIRCUIT

1. Turn ignition switch OFF.
2. Disconnect IPDM E/R connector and BCM connector.
3. Check continuity between IPDM E/R harness connector and BCM harness connector.

IPDM E/R		BCM		Continuity
Connector	Terminal	Connector	Terminal	
E5	30	M123	140	Existed

Is the inspection result normal?

YES >> Replace BCM. Refer to [BCS-90, "Removal and Installation"](#).

NO >> Repair or replace harness.

5. CHECK INTERMITTENT INCIDENT

Refer to [GI-41, "Intermittent Incident"](#).

>> INSPECTION END

A
B
C
D
E
F
G
H
I
J
L
M
N
O
P

SEC

B210D STARTER RELAY

< DTC/CIRCUIT DIAGNOSIS >

B210D STARTER RELAY

Description

INFOID:000000010993885

Located in IPDM E/R, the starter relay runs the starter motor. The starter relay is turned ON by the BCM when the ignition switch is in the START position. IPDM E/R transmits the starter relay ON signal to BCM via CAN communication.

DTC Logic

INFOID:000000010993886

DTC DETECTION LOGIC

NOTE:

- If DTC B210D is displayed with DTC U1000, first perform the trouble diagnosis for DTC U1000. Refer to [SEC-32, "IPDM E/R : DTC Logic"](#).
- If DTC B210D is displayed with DTC B2617, first perform the trouble diagnosis for DTC B2617. Refer to [SEC-74, "DTC Logic"](#).

DTC No.	Trouble diagnosis name	DTC detecting condition	Possible cause
B210D	STARTER RELAY ON CIRC	IPDM E/R detects that the relay is stuck in the ON position even if the following conditions are met for about 1 second. <ul style="list-style-type: none">• Starter control relay ON/OFF signal from BCM• Transmission range switch input	IPDM E/R

DTC CONFIRMATION PROCEDURE

1.PERFORM DTC CONFIRMATION PROCEDURE

1. Turn ignition switch ON under the following conditions and wait for 1 second or more.
 - Selector lever is in the P or N position
 - Do not depress brake pedal
2. Check "Self-diagnostic result" using CONSULT.

Is DTC detected?

- YES >> Go to [SEC-80, "Diagnosis Procedure"](#).
NO >> INSPECTION END

Diagnosis Procedure

INFOID:000000010993887

1.CHECK SELF DIAGNOSTIC RESULT

Check "Self-diagnostic result" for IPDM E/R using CONSULT.

What is the display history of DTC "B210D"?

- "CRNT">> GO TO 2.
"PAST">> GO TO 4.

2.CHECK STARTER RELAY CONTROL SIGNAL CIRCUIT VOLTAGE

Check the voltage between IPDM E/R harness connector and ground.

(+)		(-)	Condition	Voltage (Approx.)
IPDM E/R				
Connector	Terminal			
E6	46	Ground	Other than at engine cranking	Battery voltage

Is inspection result normal?

- YES >> Replace IPDM E/R. Refer to [PCS-34, "Removal and Installation"](#).
NO >> GO TO 3.

3.CHECK STARTER RELAY CONTROL SIGNAL CIRCUIT

1. Turn ignition switch OFF.
2. Disconnect IPDM E/R connector and BCM connector.
3. Check continuity between IPDM E/R harness connector and ground.

B210D STARTER RELAY

< DTC/CIRCUIT DIAGNOSIS >

IPDM E/R		Ground	Continuity
Connector	Terminal		
E6	46		Not existed

Is the inspection result normal?

YES >> Perform the diagnosis procedure for DTC B2608 of BCM. Refer to [SEC-70, "DTC Logic"](#).

NO >> Repair or replace harness.

4. CHECK INTERMITTENT INCIDENT

Refer to [GI-41, "Intermittent Incident"](#).

>> INSPECTION END

A
B
C
D
E
F
G
H
I
J
L
M
N
O
P

SEC

B210E STARTER RELAY

< DTC/CIRCUIT DIAGNOSIS >

B210E STARTER RELAY

Description

INFOID:000000010993888

Located in IPDM E/R, the starter relay runs the starter motor. The starter relay is turned ON by the BCM when the ignition switch is in the START position. IPDM E/R transmits the starter relay ON signal to BCM via CAN communication.

DTC Logic

INFOID:000000010993889

DTC DETECTION LOGIC

NOTE:

- If DTC B210E is displayed with DTC U1000, first perform the trouble diagnosis for DTC U1000. Refer to [SEC-32, "IPDM E/R : DTC Logic"](#).
- If DTC B210E is displayed with DTC B2110 for IPDM E/R, first perform the trouble diagnosis for DTC B2110. Refer to [SEC-86, "DTC Logic"](#).
- When IPDM E/R power supply voltage is low (Approx. 7 - 8 V for about 1 second), the DTC B210F may be detected.

DTC No.	Trouble diagnosis name	DTC detecting condition	Possible cause
B210E	STARTER RELAY OFF CIRC	IPDM E/R detects that the relay is stuck in the OFF position even if the following conditions are met for about 1 second. <ul style="list-style-type: none">• Starter control relay ON/OFF signal from BCM• Transmission range switch input	<ul style="list-style-type: none">• Harness or connector (Starter relay circuit is open or short)• IPDM E/R• Battery• BCM

DTC CONFIRMATION PROCEDURE

1. PERFORM DTC CONFIRMATION PROCEDURE

1. Turn ignition switch ON under the following conditions and wait 1 second or more.
 - Selector lever is in the P or N position
 - Do not depress brake pedal
2. Check "Self-diagnostic result" using CONSULT.

Is DTC detected?

- YES >> Go to [SEC-82, "Diagnosis Procedure"](#).
NO >> INSPECTION END

Diagnosis Procedure

INFOID:000000010993890

1. CHECK SELF DIAGNOSTIC RESULT

Check DTC in "Self Diagnostic Result" mode of "IPDM E/R" using CONSULT.

What is the display history of DTC "B210E"?

- "CRNT">> GO TO 3.
"PAST">> GO TO 2.

2. CHECK BATTERY VOLTAGE

Check the battery voltage.

Which is the measurement result?

- More than 12.4 V>>GO TO 5.
Less than 12.4 V>>Perform battery inspection. Refer to [PG-3, "How to Handle Battery"](#).

3. CHECK STARTER RELAY CONTROL SIGNAL

Check voltage between IPDM E/R harness connector and ground.

B210E STARTER RELAY

< DTC/CIRCUIT DIAGNOSIS >

(+)		(-)	Condition	Voltage (V) (Approx.)
IPDM E/R				
Connector	Terminal			
E6	46	Ground	Other than at engine cranking	Battery voltage

Is the inspection result normal?

YES >> GO TO 4.

NO >> Replace IPDM E/R. Refer to [PCS-34, "Removal and Installation"](#).

4.CHECK STARTER RELAY CONTROL SIGNAL CIRCUIT

1. Turn ignition switch OFF.
2. Disconnect IPDM E/R connector and BCM connector.
3. Check continuity between BCM harness connector and IPDM E/R harness connector.

BCM		IPDM E/R		Continuity
Connector	Terminal	Connector	Terminal	
M121	52	E6	46	Existed

Is the inspection result normal?

YES >> Replace BCM. Refer to [BCS-90, "Removal and Installation"](#).

NO >> Repair or replace harness.

5.CHECK INTERMITTENT INCIDENT

Refer to [GI-41, "Intermittent Incident"](#).

>> INSPECTION END

SEC

B210F SHIFT POSITION/CLUTCH INTERLOCK SWITCH

< DTC/CIRCUIT DIAGNOSIS >

B210F SHIFT POSITION/CLUTCH INTERLOCK SWITCH

Description

INFOID:0000000010993891

IPDM E/R confirms the shift position with the following signals.

- Transmission range switch
- Shift position signal from BCM (CAN)

DTC Logic

INFOID:0000000010993892

DTC DETECTION LOGIC

NOTE:

If DTC B210F is displayed with DTC U1000, first perform the trouble diagnosis for DTC U1000. Refer to [SEC-32. "IPDM E/R : DTC Logic"](#)

DTC No.	Trouble diagnosis name	DTC detecting condition	Possible cause
B210F	INTER LOCK/PNP SW ON	IPDM E/R detects the difference between the signals below for 1 second or more. <ul style="list-style-type: none">• Transmission range switch input signal• Shift position signal from BCM (CAN)	<ul style="list-style-type: none">• Harness or connectors (Transmission range switch circuit is open or shorted)• Transmission range switch• IPDM E/R• BCM

DTC CONFIRMATION PROCEDURE

1. PERFORM DTC CONFIRMATION PROCEDURE

1. Turn ignition switch ON under the following conditions and wait 1 second or more.
 - Selector lever is in the P or N position
 - Do not depress brake pedal
2. Check "Self-diagnostic result" using CONSULT.

Is DTC detected?

- YES >> Go to [SEC-84. "Diagnosis Procedure"](#).
NO >> INSPECTION END

Diagnosis Procedure

INFOID:0000000010993893

1. CHECK DTC WITH BCM

Check "Self-diagnostic result" using CONSULT. Refer to [BCS-84. "DTC Index"](#).

Is the inspection result normal?

- YES >> GO TO 2.
NO >> Repair or replace the malfunctioning parts.

2. CHECK TRANSMISSION RANGE SWITCH SIGNAL

1. Turn ignition switch OFF.
2. Disconnect IPDM E/R connector.
3. Turn ignition switch ON.
4. Check voltage between IPDM E/R harness connector and ground.

(+)		(-)	Condition	Voltage (V) (Approx.)
IPDM E/R				
Connector	Terminal			
E5	30	Ground	Selector lever	N or P position Battery voltage
				Other than above 0

Is the inspection result normal?

- YES >> Replace IPDM E/R. Refer to [PCS-34. "Removal and Installation"](#).
NO >> GO TO 3.

B210F SHIFT POSITION/CLUTCH INTERLOCK SWITCH

< DTC/CIRCUIT DIAGNOSIS >

3. CHECK TRANSMISSION RANGE SWITCH SIGNAL CIRCUIT

1. Disconnect BCM connector.
2. Check continuity between IPDM E/R harness connector and BCM harness connector.

IPDM E/R		BCM		Continuity
Connector	Terminal	Connector	Terminal	
E5	30	M123	140	Existed

3. Check continuity between IPDM E/R harness connector and ground.

IPDM E/R		Ground	Continuity
Connector	Terminal		
E5	30		Not existed

Is the inspection result normal?

- YES >> Replace BCM. Refer to [BCS-90. "Removal and Installation"](#).
NO >> Repair or replace harness.

A
B
C
D
E
F
G
H
I
J
L
M
N
O
P

SEC

B2110 SHIFT POSITION/CLUTCH INTERLOCK SWITCH

< DTC/CIRCUIT DIAGNOSIS >

B2110 SHIFT POSITION/CLUTCH INTERLOCK SWITCH

Description

INFOID:000000010993894

IPDM E/R confirms the shift position with the following signals.

- Transmission range switch
- Shift position signal from BCM (CAN)

DTC Logic

INFOID:000000010993895

DTC DETECTION LOGIC

NOTE:

If DTC B2110 is displayed with DTC U1000, first perform the trouble diagnosis for DTC U1000. Refer to [SEC-32, "IPDM E/R : DTC Logic"](#).

DTC No.	Trouble diagnosis name	DTC detecting condition	Possible cause
B2110	INTER LOCK/PNP SW	IPDM E/R detects the difference between the signals below for 1 second or more. <ul style="list-style-type: none">• Transmission range switch input signal• Shift position signal from BCM (CAN)	<ul style="list-style-type: none">• Harness or connectors (Transmission range switch circuit is open or shorted)• Transmission range switch• IPDM E/R• BCM

DTC CONFIRMATION PROCEDURE

1. PERFORM DTC CONFIRMATION PROCEDURE

1. Turn the ignition switch ON under the following conditions and wait 1 second or more.
 - Selector lever is in the P or N position
 - Do not depress brake pedal
2. Check "Self-diagnostic result" using CONSULT.

Is DTC detected?

- YES >> Go to [SEC-86, "Diagnosis Procedure"](#).
NO >> INSPECTION END

Diagnosis Procedure

INFOID:000000010993896

1. CHECK DTC WITH BCM

Check "Self-diagnostic result" using CONSULT. Refer to [BCS-84, "DTC Index"](#).

Is the inspection result normal?

- YES >> GO TO 2.
NO >> Repair or replace the malfunctioning parts.

2. CHECK TRANSMISSION RANGE SWITCH SIGNAL

1. Turn ignition switch OFF.
2. Disconnect IPDM E/R connector.
3. Turn ignition switch ON.
4. Check voltage between IPDM E/R harness connector and ground.

(+)		(-)	Condition	Voltage (V) (Approx.)
Connector	Terminal			
E5	30	Ground	Selector lever	N or P position Battery voltage
				Other than above 0

Is the inspection result normal?

- YES >> Replace IPDM E/R. Refer to [PCS-34, "Removal and Installation"](#).
NO >> GO TO 3.

B2110 SHIFT POSITION/CLUTCH INTERLOCK SWITCH

< DTC/CIRCUIT DIAGNOSIS >

3. CHECK TRANSMISSION RANGE SWITCH SIGNAL CIRCUIT

1. Disconnect BCM connector.
2. Check continuity between IPDM E/R harness connector and BCM harness connector.

IPDM E/R		BCM		Continuity
Connector	Terminal	Connector	Terminal	
E5	30	M123	140	Existed

3. Check continuity between IPDM E/R harness connector and ground.

IPDM E/R		Ground	Continuity
Connector	Terminal		
E5	30		Not existed

Is the inspection result normal?

- YES >> Replace BCM. Refer to [BCS-90. "Removal and Installation"](#).
NO >> Repair or replace harness.

A
B
C
D
E
F
G
H
I
J
L
M
N
O
P

SEC

POWER SUPPLY AND GROUND CIRCUIT

< DTC/CIRCUIT DIAGNOSIS >

POWER SUPPLY AND GROUND CIRCUIT

BCM

BCM : Diagnosis Procedure

INFOID:000000010993897

1. CHECK FUSE AND FUSIBLE LINK

Check that the following fuse and fusible link are not blown.

Signal name	Fuse and fusible link No.
Battery power supply	K
	10

Is the fuse fusing?

- YES >> Replace the blown fuse or fusible link after repairing the affected circuit if a fuse or fusible link is blown.
NO >> GO TO 2.

2. CHECK POWER SUPPLY CIRCUIT

1. Turn ignition switch OFF.
2. Disconnect BCM connectors.
3. Check voltage between BCM harness connector and ground.

Terminals		Voltage (Approx.)
(+)	(-)	
BCM		Ground Battery voltage
Connector	Terminal	
M118	1	
M119	11	

Is the measurement value normal?

- YES >> GO TO 3.
NO >> Repair harness or connector.

3. CHECK GROUND CIRCUIT

Check continuity between BCM harness connector and ground.

BCM		Ground	Continuity
Connector	Terminal		Existed
M119	13		

Does continuity exist?

- YES >> INSPECTION END
NO >> Repair harness or connector.

IPDM E/R

IPDM E/R : Diagnosis Procedure

INFOID:000000010993898

1. CHECK FUSES AND FUSIBLE LINK

Check that the following IPDM E/R fuses or fusible links are not blown.

Signal name	Fuses and fusible link No.
Battery power supply	C
	50
	51

POWER SUPPLY AND GROUND CIRCUIT

< DTC/CIRCUIT DIAGNOSIS >

Is the fuse fusing?

- YES >> Replace the blown fuse or fusible link after repairing the affected circuit if a fuse or fusible link is blown.
- NO >> GO TO 2.

2.CHECK POWER SUPPLY CIRCUIT

1. Turn the ignition switch OFF.
2. Disconnect IPDM E/R connector.
3. Check voltage between IPDM E/R harness connector and the ground.

Terminals		Voltage (Approx.)
(+)	(-)	
IPDM E/R		Battery voltage
Connector	Terminal	
E4	1	
	2	
		Ground

Is the measurement value normal?

- YES >> GO TO 3.
- NO >> Repair the harness or connector.

3.CHECK GROUND CIRCUIT

Check continuity between IPDM E/R harness connectors and the ground.

IPDM E/R		Ground	Continuity
Connector	Terminal		
E5	12		Existed
E6	41		

Does continuity exist?

- YES >> INSPECTION END
- NO >> Repair the harness or connector.

A
B
C
D
E
F
G
H
I
J
L
M
N
O
P

SEC

KEY SLOT

< DTC/CIRCUIT DIAGNOSIS >

KEY SLOT

Description

INFOID:0000000010993899

When the Intelligent Key battery is discharged, it performs the NVIS (NATS) ID verification between the integrated transponder and BCM by inserting the Intelligent Key into the key slot, and then the engine can be started.

Component Function Check

INFOID:0000000010993900

1. CHECK FUNCTION

1. Remove Intelligent Key battery from Intelligent Key.
2. Change power supply position when Intelligent Key insert into key slot and then press push-button ignition switch.

Is the inspection result normal?

- YES >> Key slot function is normal.
NO >> Go to [SEC-90, "Diagnosis Procedure"](#).

Diagnosis Procedure

INFOID:0000000010993901

1. CHECK KEY SLOT POWER SUPPLY CIRCUIT

1. Turn ignition switch OFF.
2. Disconnect key slot connector.
3. Check voltage between key slot harness connector and ground.

(+)		(-)	Voltage (V) (Approx.)
Key slot			
Connector	Terminal	Ground	Battery voltage
M22	1		
	5		

Is the inspection result normal?

- YES >> GO TO 2.
NO-1 >> Check 10 A fuse [No. 6 and 9 located in the fuse block (J/B)].
NO-2 >> Check harness for open or short between key slot and fuse.

2. CHECK KEY SLOT GROUND CIRCUIT

Check continuity between key slot harness connector and ground.

Key slot		Ground	Continuity
Connector	Terminal		
M22	7	Ground	Existed

Is the inspection result normal?

- YES >> Replace key slot. Refer to [SEC-189, "Removal and Installation"](#).
NO >> Repair or replace harness.

KEY SLOT INDICATOR

< DTC/CIRCUIT DIAGNOSIS >

KEY SLOT INDICATOR

Description

INFOID:000000010993902

Blinks when Intelligent Key insertion is required.

Component Function Check

INFOID:000000010993903

1.CHECK FUNCTION

Check key slot illumination ("KEY SLOT ILLUMI") Active Test mode.

Is the inspection result normal?

- YES >> Key slot function is normal.
NO >> Refer to [SEC-91, "Diagnosis Procedure"](#).

Diagnosis Procedure

INFOID:000000010993904

1.CHECK KEY SLOT INDICATOR OUTPUT SIGNAL

Check voltage between key slot harness connector and ground.

Key slot (+)		(-)	Condition	Key slot illumination	Voltage (V) (Approx.)
Connector	Terminal				
M22	6	Ground	Insert Intelligent Key into key slot	OFF	Battery voltage
			Remove Intelligent Key from key slot	ON	0

Is the inspection result normal?

- YES >> GO TO 5.
NO >> GO TO 2.

2.CHECK KEY SLOT POWER SUPPLY CIRCUIT

1. Turn ignition switch OFF.
2. Disconnect key slot connector.
3. Check voltage between key slot harness connector and ground.

Key slot (+)		(-)	Voltage (V) (Approx.)
Connector	Terminal		
M22	1	Ground	Battery voltage
	5		

Is the inspection result normal?

- YES >> GO TO 3.
NO-1 >> Check 10 A fuse [No. 6 and 9 located in the fuse block (J/B)].
NO-2 >> Check harness for open or short between key slot and fuse.

3.CHECK KEY SLOT GROUND CIRCUIT

Check continuity between key slot harness connector and ground.

Key slot		Ground	Continuity
Connector	Terminal		
M22	7		Existed

Is the inspection result normal?

- YES >> GO TO 4.

A
B
C
D
E
F
G
H
I
J
L
M
N
O
P

SEC

KEY SLOT INDICATOR

< DTC/CIRCUIT DIAGNOSIS >

NO >> Repair or replace key slot ground circuit.

4.CHECK KEY SLOT CIRCUIT

1. Turn ignition switch OFF.
2. Disconnect BCM connector.
3. Check continuity between BCM harness connector and key slot harness connector.

BCM		Key slot		Continuity
Connector	Terminal	Connector	Terminal	
M122	92	M22	6	Existed

4. Check continuity between BCM harness connector and ground.

BCM		Ground	Continuity
Connector	Terminal		
M122	92		Not existed

Is the inspection result normal?

YES >> Replace key slot. Refer to [SEC-189, "Removal and Installation"](#).

NO >> Repair or replace harness.

5.CHECK INTERMITTENT INCIDENT

Refer to [GI-41, "Intermittent Incident"](#).

>> INSPECTION END

HOOD SWITCH

< DTC/CIRCUIT DIAGNOSIS >

HOOD SWITCH

Description

INFOID:000000010993905

Hood switch is built into hood lock (RH) and connected to IPDM E/R which detects the open/close condition of hood.

Component Function Check

INFOID:000000010993906

1.CHECK FUNCTION

1. Select "HOOD SW" in the "Data Monitor" mode using CONSULT.
2. Check the hood switch signal under the following condition.

Test item	Condition		Status
HOOD SW	Hood	Open	ON
		Close	OFF

Is the indication normal?

- YES >> Hood switch is normal.
NO >> Go to [SEC-93. "Diagnosis Procedure"](#).

Diagnosis Procedure

INFOID:000000010993907

1.CHECK HOOD SWITCH SIGNAL

1. Turn ignition switch OFF.
2. Disconnect hood switch connector.
3. Check voltage between hood switch harness connector and ground.

(+)		(-)	Voltage (V) (Approx.)
Hood switch			
Connector	Terminal	Ground	Battery voltage
E30	2		

Is the inspection result normal?

- YES >> GO TO 3.
NO >> GO TO 2.

2.CHECK HOOD SWITCH CIRCUIT

1. Disconnect IPDM E/R connector.
2. Check continuity between IPDM E/R harness connector and hood switch harness connector.

IPDM E/R		Hood switch		Continuity
Connector	Terminal	Connector	Terminal	
E9	104	E30	2	Existed

3. Check continuity between IPDM E/R harness connector and ground.

IPDM E/R		Ground	Continuity
Connector	Terminal		
E9	104		Not existed

Is the inspection result normal?

- YES >> Replace IPDM E/R. Refer to [PCS-34. "Removal and Installation"](#).
NO >> Repair or replace harness.

3.CHECK HOOD SWITCH GROUND CIRCUIT

Check continuity between hood switch harness connector and ground.

HOOD SWITCH

< DTC/CIRCUIT DIAGNOSIS >

Hood switch		Ground	Continuity
Connector	Terminal		
E30	1		Existed

Is the inspection result normal?

- YES >> GO TO 4.
 NO >> Repair or replace harness.

4.CHECK HOOD SWITCH

Refer to [SEC-94, "Component Inspection"](#).

Is the inspection result normal?

- YES >> GO TO 5.
 NO >> Replace hood lock (RH). Refer to [DLK-232, "HOOD LOCK CONTROL : Exploded View"](#).

5.CHECK INTERMITTENT INCIDENT

Refer to [GI-41, "Intermittent Incident"](#).

>> INSPECTION END

Component Inspection

INFOID:000000010993908

1.CHECK HOOD SWITCH

- Turn ignition switch OFF.
- Disconnect hood switch connector.
- Check continuity between hood switch terminals.

Hood switch		Condition	Continuity
Terminal			
1	2	Hood switch	Pressed
			Released
			Not existed
			Existed

Is the inspection result normal?

- YES >> INSPECTION END
 NO >> Replace hood lock (RH). Refer to [DLK-232, "HOOD LOCK CONTROL : Exploded View"](#).

SECURITY INDICATOR LAMP

< DTC/CIRCUIT DIAGNOSIS >

SECURITY INDICATOR LAMP

Description

INFOID:0000000010993909

- Security indicator lamp is located on combination meter.
- IVIS (Nissan Vehicle Immobilizer System) and vehicle security system conditions are indicated by blink or illumination of security indicator lamp.

Component Function Check

INFOID:0000000010993910

1.CHECK FUNCTION

1. Perform "THEFT IND" in the "ACTIVE TEST" mode with CONSULT.
2. Check security indicator lamp operation.

Test item		Description	
THEFT IND	ON	Security indicator lamp	Illuminates
	OFF		Does not illuminate

Is the inspection result normal?

- YES >> INSPECTION END
NO >> Go to [SEC-95, "Diagnosis Procedure"](#).

Diagnosis Procedure

INFOID:0000000010993911

1.CHECK SECURITY INDICATOR LAMP POWER SUPPLY CIRCUIT

1. Turn ignition switch OFF.
2. Disconnect combination meter connector.
3. Check voltage between combination meter harness connector and ground.

(+)		(-)	Voltage (V) (Approx.)
Combination meter			
Connector	Terminal	Ground	Battery voltage
M53	1		

Is the inspection result normal?

- YES >> GO TO 2.
NO-1 >> 10A fuse [No. 11, located in the fuse block (J/B)].
NO-2 >> Harness for open or short between combination meter and fuse.

2.CHECK SECURITY INDICATOR LAMP SIGNAL

1. Connect combination meter connector.
2. Disconnect BCM connector.
3. Check voltage between BCM harness connector and ground.

(+)		(-)	Voltage (V) (Approx.)
BCM			
Connector	Terminal	Ground	Battery voltage
M123	141		

Is the inspection result normal?

- YES >> Replace BCM. Refer to [BCS-90, "Removal and Installation"](#).
NO >> GO TO 3.

3.CHECK COMBINATION METER CIRCUIT

1. Disconnect BCM connector.
2. Check continuity between combination meter harness connector and BCM harness connector.

SECURITY INDICATOR LAMP

< DTC/CIRCUIT DIAGNOSIS >

Combination meter		BCM		Continuity
Connector	Terminal	Connector	Terminal	
M53	10	M123	141	Existed

3. Check continuity between combination meter harness connector and ground.

Combination meter		Ground	Continuity
Connector	Terminal		
M53	10		Not existed

Is the inspection result normal?

- YES >> Replace combination meter. Refer to [MWI-130, "Removal and Installation"](#).
NO >> Repair or replace harness.

KEY WARNING LAMP

< DTC/CIRCUIT DIAGNOSIS >

KEY WARNING LAMP

Description

INFOID:000000010993912

Performs operation method guide and warning together with buzzer.

Component Function Check

INFOID:000000010993913

1.CHECK FUNCTION

Check the operation with "INDICATOR" in "Active Test" mode using CONSULT.

Test item	Condition	
INDICATOR	KEY ON	Key warning lamp illuminates
	KEY IND	Key warning lamp blinks

Is the inspection result normal?

YES >> Key warning lamp in combination meter is normal.

NO >> Refer to [SEC-97, "Diagnosis Procedure"](#).

Diagnosis Procedure

INFOID:000000010993914

1.CHECK KEY WARNING LAMP

Refer to [DLK-110, "Component Function Check"](#).

Is the inspection result normal?

YES >> GO TO 2.

NO >> Repair or replace harness.

2.CHECK INTERMITTENT INCIDENT

Refer to [GI-41, "Intermittent Incident"](#).

>> INSPECTION END

A
B
C
D
E
F
G
H
I
J
L
M
N
O
P

SEC

INTELLIGENT KEY SYSTEM/ENGINE START FUNCTION

< DTC/CIRCUIT DIAGNOSIS >

INTELLIGENT KEY SYSTEM/ENGINE START FUNCTION

Wiring Diagram - INTELLIGENT KEY SYSTEM/ENGINE START FUNCTION -

INFOID:000000010993915

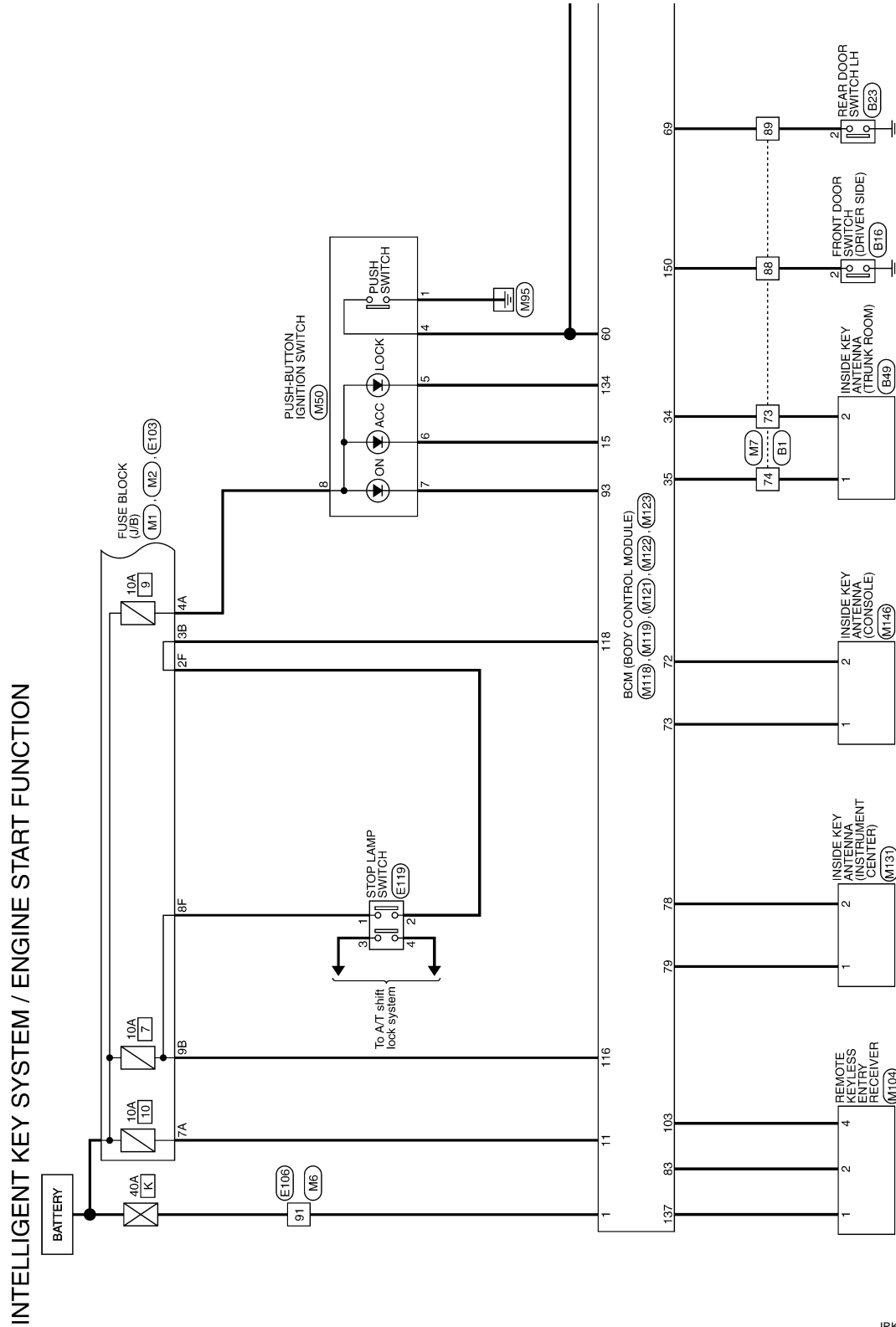

INTELLIGENT KEY SYSTEM/ENGINE START FUNCTION

< DTC/CIRCUIT DIAGNOSIS >

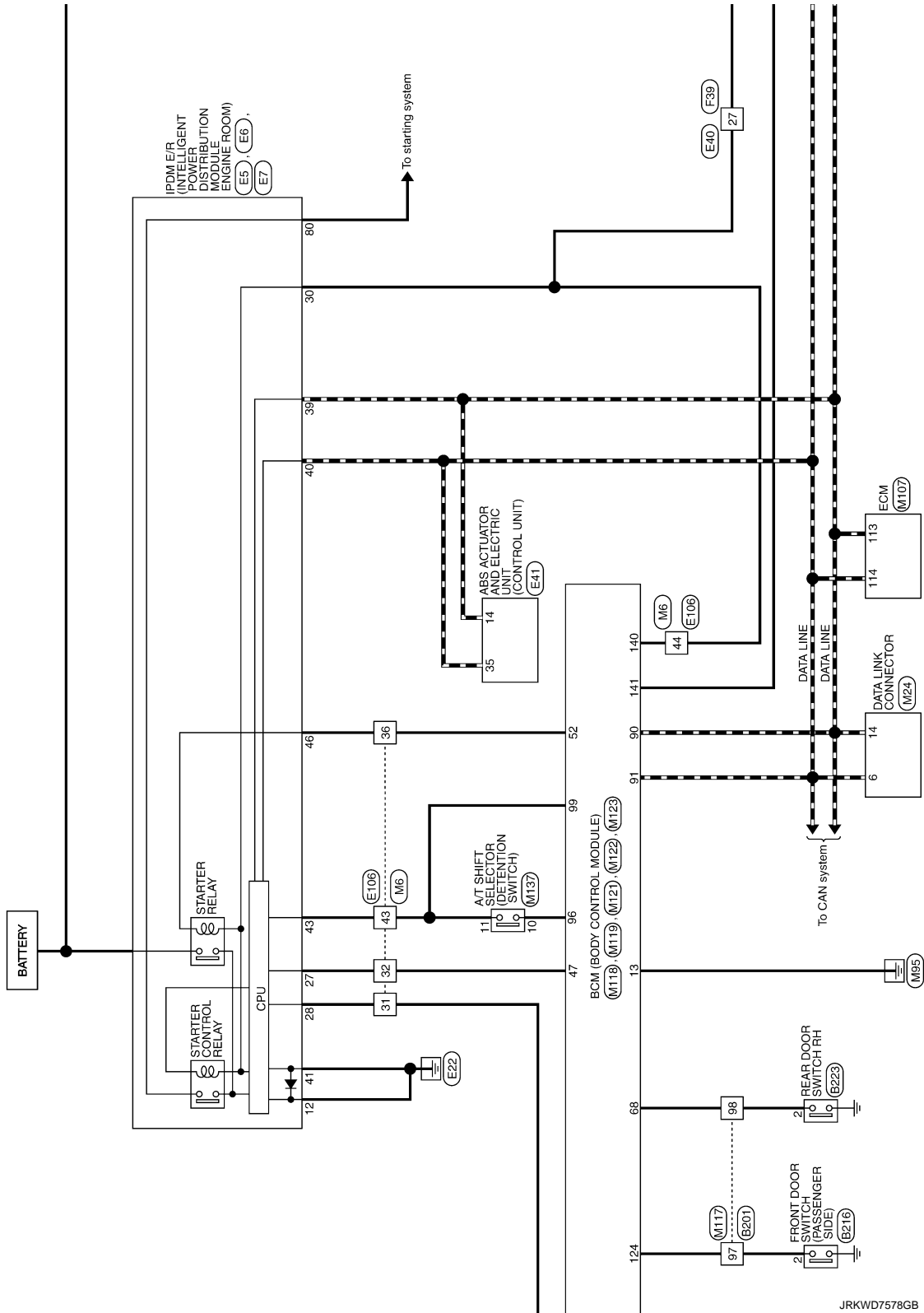

JRKWD7578GB

A
B
C
D
E
F
G
H
I
J
K
L
M
N
O
P

SEC

INTELLIGENT KEY SYSTEM/ENGINE START FUNCTION

< DTC/CIRCUIT DIAGNOSIS >

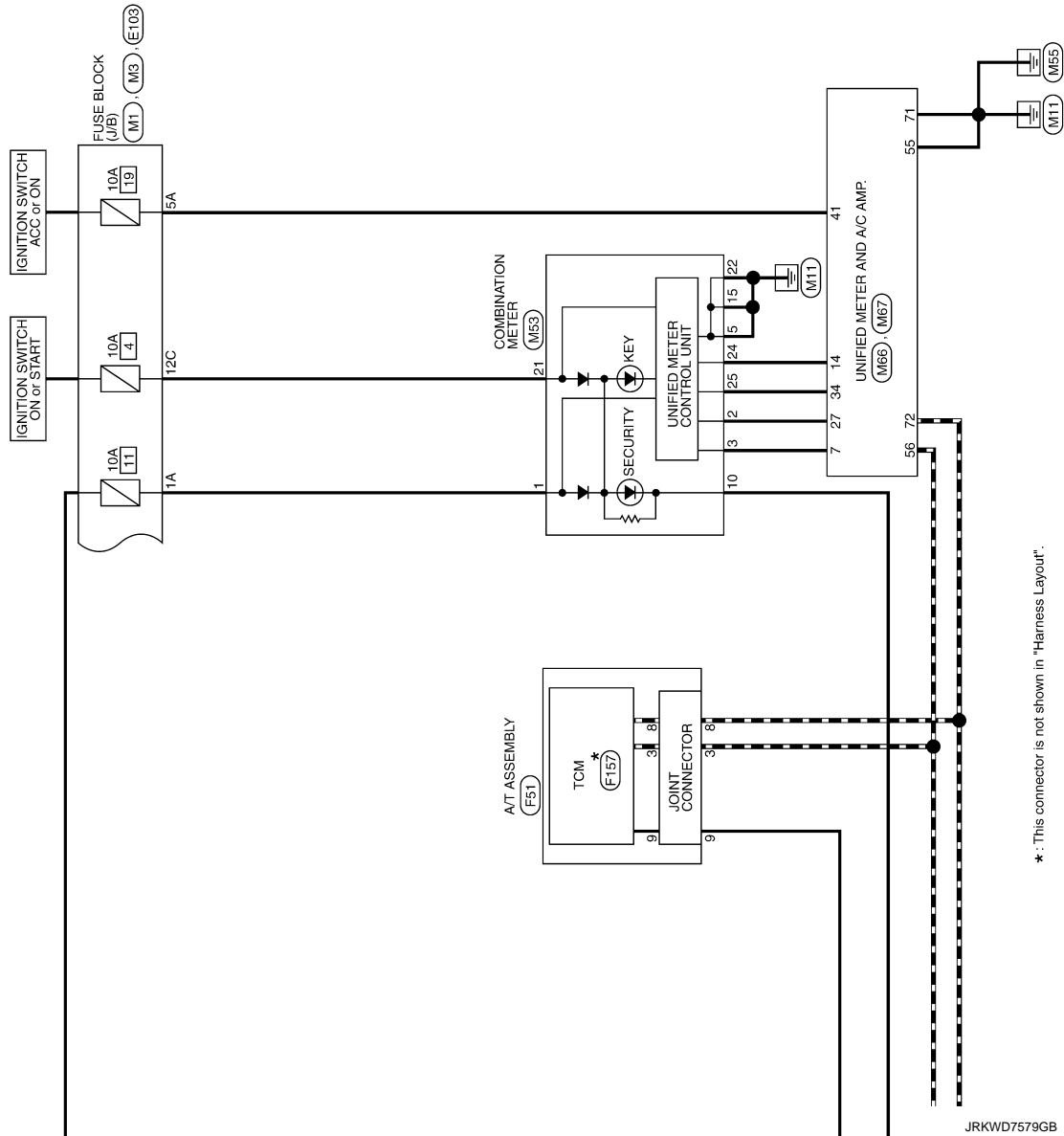

INTELLIGENT KEY SYSTEM/ENGINE START FUNCTION

< DTC/CIRCUIT DIAGNOSIS >

INTELLIGENT KEY SYSTEM / ENGINE START FUNCTION

Connector No.	B31
Connector Name	WIRE TO WIRE
Connector Type	TH88PFW-C516-TM4

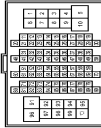

Terminal No.	Color Of Wire	Signal Name [Specification]
1	GR	-
2	BG	-
3	Y	-
4	Y	-
5	W	-
6	R	-
7	W	-
8	R	-
9	LG	-
24	V	-
25	SB	-
26	G	-
27	W	-
28	R	-
31	V	-
32	SB	-
33	SHIELD	-
34	BR	-
35	Y	-
36	Y	-
37	SHIELD	-
38	Y	-
39	SB	-
40	P	-
41	L	-
42	SHIELD	-
43	R	-
44	G	-
45	SHIELD	-
46	SB	-
48	BR	-
50	Y	-
55	SB	-
71	BG	-
72	GR	-
73	P	-

74	L	-
75	S	-
84	Y	-
85	G	-
86	W	-
87	R	-
88	BR	-
89	Y	-
90	SB	-
92	BR	-
93	P	-
95	BG	-

Connector No.	B16
Connector Name	FRONT DOOR SWITCH (DRIVER SIDE)
Connector Type	AG3FW

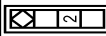

Terminal No.	Color Of Wire	Signal Name [Specification]
1	BR	-
2	BR	-

Connector No.	B23
Connector Name	REAR DOOR SWITCH LH
Connector Type	AG3FW

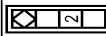

Terminal No.	Color Of Wire	Signal Name [Specification]
2	Y	-

Connector No.	B48
Connector Name	INSIDE KEY ANTENNA (TRUNK ROOM)
Connector Type	FRQ2FCY



Terminal No.	Color Of Wire	Signal Name [Specification]
1	L	-
2	P	-

Connector No.	B201
Connector Name	WIRE TO WIRE
Connector Type	TH88PFW-C516-TM4

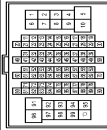

Terminal No.	Color Of Wire	Signal Name [Specification]
1	BR	-
6	L	-
7	V	-
31	L	-
32	P	-
33	G	-
34	R	-
40	GR	-
41	LG	-
42	BG	-
43	R	-
45	SHIELD	-
47	G	-
48	Y	-
49	SHIELD	-
50	W	-

71	R	-
72	BG	-
73	SHIELD	-
82	G	-
83	P	-
84	L	-
85	SHIELD	-
86	G	-
87	R	-
88	W	-
89	B	-
90	Y	-
91	V	-
92	W	-
93	BG	-
94	SB	-
95	G	-
96	SB	-
97	GR	-
98	BR	-
99	P	-
100	L	-

Connector No.	B218
Connector Name	FRONT DOOR SWITCH (PASSENGER SIDE)
Connector Type	AG3FW

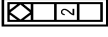

Terminal No.	Color Of Wire	Signal Name [Specification]
2	GR	-

JRKWD7637GB

A
B
C
D
E
F
G
H
I
J
L
M
N
O
P

SEC

INTELLIGENT KEY SYSTEM/ENGINE START FUNCTION

< DTC/CIRCUIT DIAGNOSIS >

INTELLIGENT KEY SYSTEM / ENGINE START FUNCTION

Connector No.	E323
Connector Name	REAR DOOR SWITCH RH
Connector Type	AQ3PW

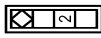

Terminal No.	Color Of Wire	Signal Name [Specification]
2	BR	-

Connector No.	E5
Connector Name	POWER INTELLIGENT POWER DISTRIBUTION MODULE ENGINE ROOM
Connector Type	TH20FW-CS12-M4-1V



Terminal No.	Color Of Wire	Signal Name [Specification]
4	V	-
5	L	-
6	SB	-
7	P	-
12	B/W	-
16	LG	-
19	R	-
25	G	-
27	BG	-
28	L	-
38	GR	-
38	G	-

Connector No.	E6
Connector Name	POWER INTELLIGENT POWER DISTRIBUTION MODULE ENGINE ROOM
Connector Type	TH88PW-M4



Terminal No.	Color Of Wire	Signal Name [Specification]
38	P	-
41	B/W	-
42	GR	-
43	G	-
44	LG	-
45	V	-
46	SB	-

Connector No.	E7
Connector Name	POWER INTELLIGENT POWER DISTRIBUTION MODULE ENGINE ROOM
Connector Type	TH20FW-CS12-M4

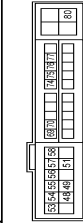

Terminal No.	Color Of Wire	Signal Name [Specification]
48	L	-
49	BG	-
51	Y	-
53	W	-
54	GR	-
55	SB	-
56	BR	-
57	G	-
58	GR	-
69	BR	-
70	BG	-
74	G	-

Terminal No.	76	SD	-
Terminal No.	78	Y	-
Terminal No.	77	R	-
Terminal No.	80	W	-

Connector No.	E40
Connector Name	WIRE TO WIRE
Connector Type	SAAA38MB-RSS-S4Z8

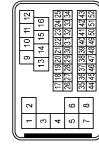

Terminal No.	Color Of Wire	Signal Name [Specification]
1	L/Y	-
2	SHIELD	-
3	L/B	-
4	SHIELD	-
5	BR	-
7	G	-
8	W	-
9	W	-
10	Y	-
12	SB	-
13	V	-
14	G	-
15	BG	-
16	BR	-
18	Y	-
19	BG	-
20	B	-
21	SB	-
22	W	-
23	L	-
24	GR	-
25	GR	-
26	G	-
28	V	-
29	P	-
30	R	-
31	BR	-
32	Y	-
33	G	-

Terminal No.	34	BG	-
Terminal No.	32	SHIELD	-
Terminal No.	33	L	-
Terminal No.	38	P	-
Terminal No.	40	R	-
Terminal No.	41	W	-
Terminal No.	42	LG	-
Terminal No.	43	G	-
Terminal No.	45	GR	-
Terminal No.	46	SHIELD	-
Terminal No.	47	W	-
Terminal No.	48	BR	-
Terminal No.	49	G	-
Terminal No.	50	B	-
Terminal No.	51	SB	-
Terminal No.	52	R	-

Connector No.	E41
Connector Name	ABS ACTUATOR AND ELECTRIC UNIT (CONTROL UNIT)
Connector Type	BAA4ZF8-AH24-LH



Terminal No.	Color Of Wire	Signal Name [Specification]
1	B	GROUND
2	GR	UBMR
3	BG	UBVR
4	B	GROUND
5	Y	DS FL
6	BG	DP RL
7	BR	DP RR
9	B	DS FR
10	W	DS FL
11	Y	DIAG-K
18	Y	SPS-L
26	LG	DS FL
27	GR	DS RL
28	G	UZ
29	P	DS RR
30	SB	BLS
31	R	VDC OFF SW

INTELLIGENT KEY SYSTEM/ENGINE START FUNCTION

< DTC/CIRCUIT DIAGNOSIS >

INTELLIGENT KEY SYSTEM / ENGINE START FUNCTION

3B	L	CAN-H
4B	B	BUS-H

Connector No.	E103
Connector Name	FUSE BLOCK (J/B)
Connector Type	NS16FW-C5

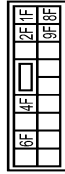

Terminal No.	Color Of Wire	Signal Name [Specification]
1F	SB	-
2F	W	-
4F	G	-
6F	BR	-
8F	L	-
9F	P	-

Connector No.	E106
Connector Name	WIRE TO WIRE
Connector Type	TR80PW-C516-TM4

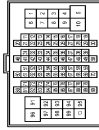

Terminal No.	Color Of Wire	Signal Name [Specification]
1	GR	-
3	BG	-
8	G	-
7	V	-
6	R	-
11	V	-
12	R	-
13	L	-
14	GR	-

15	P	-
17	SB	-
18	BG	-
20	LG	-
31	L	-
32	BG	-
36	SB	-
37	Y	-
38	R	-
39	B	-
41	R	-
42	LG	-
43	G	-
44	GR	-
45	BR	-
47	V	-
48	P	-
49	L	-
66	GR	-
67	LG	-
80	R	-
81	P	-
82	G	-
83	V	-
84	L	-
85	W	-
89	V	-
93	GR	-
95	LG	-
97	SB	-
98	SHIELD	-
99	L	-
100	P	-

Connector No.	E119
Connector Name	STOP LAMP SWITCH
Connector Type	NR4FW-LC



Terminal No.	Color Of Wire	Signal Name [Specification]
1	L	-
2	W	-
3	G	-
4	Y	-

Connector No.	F39
Connector Name	WIRE TO WIRE
Connector Type	SA43FB-R58-SH28

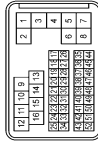

Terminal No.	Color Of Wire	Signal Name [Specification]
1	L/Y	-
2	SHIELD	-
3	L/B	-
4	SHIELD	-
5	BR	-
7	G	-
8	W	-
9	W	-
10	G	-
12	R	-
13	L	-
14	LG	-
15	R	-
16	O	-
18	Y	-

18	LG	-
19	O	-
20	G	-
21	BR	-
22	G	-
23	Y	-
24	LG	-
25	V	-
27	GR	-
28	BR	-
29	L	-
30	R	-
31	P	-
32	W	-
33	SB	-
34	BR	-
35	O	-
37	B	-
37	SHIELD	-
38	W	-
39	Y	-
40	G	-
41	B	-
42	GR	-
43	R	-
45	O	-
46	SHIELD	-
47	W/L	-
48	LG	-
49	V/Y	-
50	V/Y	-
51	W	-
52	L/G	-

Connector No.	F51
Connector Name	A/T ASSEMBLY
Connector Type	RK10FG-DG5



JRKWD7639GB

A
B
C
D
E
F
G
H
I
J
L
M
N
O
P

SEC



INTELLIGENT KEY SYSTEM/ENGINE START FUNCTION

< DTC/CIRCUIT DIAGNOSIS >

INTELLIGENT KEY SYSTEM / ENGINE START FUNCTION

Terminal No.	Color Of Wire	Signal Name [Specification]
1	Y	-
2	R	-
3	L	-
4	V	-
5	B	-
6	G	-
7	R	-
8	P	-
9	GR	-
10	B	-

Connector No.	FI57
Connector Name	TCM
Connector Type	SP10FG

Terminal No.	Color Of Wire	Signal Name [Specification]
1	SHIELD	VGN
2	SHIELD	RYT
3	SHIELD	CAN-H
4	SHIELD	K-LINE
5	SHIELD	GROUND
6	SHIELD	VGN
7	SHIELD	REV LAMP RLY
8	SHIELD	CAN-L
9	SHIELD	STARTER RLY
10	SHIELD	GROUND

Connector No.	M1
Connector Name	FUSE BLOCK (J/B)
Connector Type	NSRPFW-M2



Terminal No.	Color Of Wire	Signal Name [Specification]
7A	Y	-
7A	L	-
8A	R	-
7A	R	-
8A	L	-

Connector No.	M2
Connector Name	FUSE BLOCK (J/B)
Connector Type	HS10FW-ZS

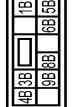
Terminal No.	Color Of Wire	Signal Name [Specification]
1B	SB	-
3B	P	-
4B	G	-
5B	EG	-
6B	R	-
7B	SS	-

Connector No.	M3
Connector Name	FUSE BLOCK (J/B)
Connector Type	NS17FW-CS



Terminal No.	Color Of Wire	Signal Name [Specification]
12C	L	-
12C	G	-
12C	G	-
6C	SB	-
7C	B	-
8C	W	-
9C	EG	-

Connector No.	M6
Connector Name	WIRE TO WIRE
Connector Type	TH80MW-CS1P-TM4



Terminal No.	Color Of Wire	Signal Name [Specification]
1	EG	-
3	R	-
5	G	-
6	LG	-
7	W	-
8	G	-
9	Y	-
12	R	-
13	L	-
14	GR	-
15	P	-
16	W	-
17	BR	-

18	P	-
37	L	-
37	L	-
32	Y	-
36	R	-
37	Y	-
38	R	-
39	SB	-
41	V	-
42	LG	-
43	P	-
44	B	-
45	EG	-
45	G	-
47	L	-
48	P	-
48	L	-
66	Y	-
67	G	-
80	SB	-
81	B	-
82	V	-
83	W	-
84	L	-
85	GR	-
89	LG	-
91	W	-
92	Y	-
93	Y	-
98	SHIELD	-
98	V	-
100	SB	-

Connector No.	M7
Connector Name	WIRE TO WIRE
Connector Type	TH80MW-CS1P-TM4





INTELLIGENT KEY SYSTEM/ENGINE START FUNCTION

< DTC/CIRCUIT DIAGNOSIS >

INTELLIGENT KEY SYSTEM / ENGINE START FUNCTION

Terminal No.	Color Of Wire	Signal Name [Specification]
1	GR	-
2	P	-
3	P	-
4	Y	-
6	L	-
8	G	-
9	Y	-
24	V	-
25	LG	-
26	BR	-
27	BG	-
28	LG	-
31	V	-
32	SHIELD	-
34	CR	-
35	BR	-
36	Y	-
37	SHIELD	-
38	SB	-
39	LG	-
40	O	-
41	W	-
42	SHIELD	-
43	R	-
44	G	-
45	SHIELD	-
46	W	-
47	W	-
48	B	-
58	V	-
59	Y	-
71	V	-
72	P	-
73	SB	-
74	V	-
81	W	-
82	BR	-
84	LG	-
85	BG	-
86	SB	-
87	BG	-
88	CR	-
89	L	-
90	L	-
92	L	-
93	P	-
95	BG	-

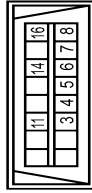
Connector No.	M54
Connector Name	DATA LINK CONNECTOR
Connector Type	BD16FW-P



Terminal No.	Color Of Wire	Signal Name [Specification]
3	LG	-
5	B	-
6	L	-
7	V	-
8	G	-
11	SB	-
14	P	-
16	R	-

Connector No.	M50
Connector Name	PUSH-BUTTON IGNITION SWITCH
Connector Type	TK08FBR

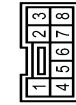

Terminal No.	Color Of Wire	Signal Name [Specification]
1	B	-
2	B	-
3	L	-
4	BR	-
6	BG	-
7	GR	-
8	P	-

Connector No.	M53
Connector Name	COMBINATION METER
Connector Type	SAB4FW

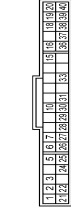

Terminal No.	Color Of Wire	Signal Name [Specification]
1	V	BATTERY POWER SUPPLY
2	LG	COMMUNICATION SIGNAL (METER-AMP)
3	GR	COMMUNICATION SIGNAL (METER-AMP)
5	B	GROUND
6	W	ALTERNATOR SIGNAL
7	LG	AIR BAG SIGNAL
10	W	SECURITY SIGNAL
15	B	GROUND
16	BR	METER CONTROL SWITCH GROUND
18	GR	ILL GND
19	B	ILL GND
20	R	ILL
21	G	IGNITION SIGNAL
22	B	GROUND
24	BR	COMMUNICATION SIGNAL (LGD-AMP)
25	B	COMMUNICATION SIGNAL (A-FUEL-SE)
27	P	PARKING BRAKE SWITCH SIGNAL
28	SB	BRAKE FLUID LEVEL SWITCH
29	P	SEAT BELT BUCKLE SW SIGNAL (DRIVER SIDE)
30	G	SEAT BELT BUCKLE SW SIGNAL (PASSENGER SIDE)
31	L	WASHER LEVEL SWITCH SIGNAL
33	R	ILLUMINATION CONTROL SIGNAL
36	LG	SELECT SWITCH SIGNAL
37	Y	ENTER SWITCH SIGNAL
38	G	TRIP A/B RESET SWITCH SIGNAL
39	P	ILLUMINATION CONTROL SWITCH SIGNAL (C)
40	BG	ILLUMINATION CONTROL SWITCH SIGNAL (D)

Connector No.	M65
Connector Name	UNIFIED METER AND A/C AMP.
Connector Type	TH40FW-RI



Terminal No.	Color Of Wire	Signal Name [Specification]
4	G	STOP LAMP SWITCH SIGNAL
7	G	MANUAL MODE SIGNAL
8	GR	COMMUNICATION SIGNAL (A-FUEL-SE)
8	L	VEHICLE SPEED SIGNAL (C-PULSE)
8	SB	SEAT BELT BUCKLE SWITCH SIGNAL (DRIVER SIDE)
10	W	MANUAL MODE SIGNAL
11	G	NON-MANUAL MODE SIGNAL
14	BR	COMMUNICATION SIGNAL (LGD-AMP)
23	Y	A/T SNOW SWITCH SIGNAL
25	V	MANUAL MODE SHIFT DOWN SIGNAL
27	LG	COMMUNICATION SIGNAL (METER-AMP)
28	R	VEHICLE SPEED SIGNAL (B-PULSE)
30	V	PARKING BRAKE SWITCH SIGNAL
34	Y	COMMUNICATION SIGNAL (AMP - LGD)
38	P	BLOWER MOTOR CONTROL SIGNAL

Connector No.	M67
Connector Name	UNIFIED METER AND A/C AMP.
Connector Type	TH42FW-NH



Terminal No.	Color Of Wire	Signal Name [Specification]
41	L	ACC POWER SUPPLY
42	BR	FUEL LEVEL SENSOR SIGNAL
43	BR	INTAKE SENSOR SIGNAL
44	LG	IN-VEHICLE SENSOR SIGNAL
45	V	AMBIENT SENSOR SIGNAL

A
B
C
D
E
F
G
H
I
J
K
L
M
N
O
P

SEC

INTELLIGENT KEY SYSTEM/ENGINE START FUNCTION

< DTC/CIRCUIT DIAGNOSIS >

INTELLIGENT KEY SYSTEM / ENGINE START FUNCTION

48	Y	SUNLOAD SENSOR SIGNAL
49	W	IGNITION POWER SUPPLY
50	SB	BATTERY POWER SUPPLY
53	B	GROUND
56	L	CAN-H
57	LG	BRAKE FLUID LEVEL SWITCH
58	Y	FUEL LEVEL SENSOR GROUND
59	GR	INTAKE SENSOR GROUND
60	W	IN-VEHICLE SENSOR GROUND
61	B	AMBIENT SENSOR GROUND
62	SB	SUNLOAD SENSOR GROUND
65	BG	ECV SIGNAL
70	R	A/C LAMP SIGNAL
71	GR	EACH DOOR MOTOR POWER SUPPLY
72	P	GROUND
		CAN-L

Connector No.	M104
Connector Name	REMOTE KEYLESS ENTRY RECEIVER
Connector Type	JAB04FE



Terminal No.	1	2	4
Color Of Wire	BG	Y	P
Signal Name [Specification]	GROUND	SIGNAL OUTPUT	BATTERY

Connector No.	M107
Connector Name	ECM
Connector Type	RH24EGV-R208-RH-1H-Z



Terminal No.	Color Of Wire	Signal Name [Specification]
98	R	ACCELERATOR PEDAL POSITION SENSOR 1
99	L	ACCELERATOR PEDAL POSITION SENSOR 2
100	W	SENSOR POWER SUPPLY
101	SB	ASCD STEERING SWITCH
102	LG	EVAP CONTROL SYSTEM PRESSURE SENSOR
103	GR	SENSOR POWER SUPPLY
104	V	SENSOR GROUND
105	L	REFRIGERANT PRESSURE SENSOR
106	W	FUEL TANK TEMPERATURE SENSOR
107	GR	SENSOR POWER SUPPLY
108	Y	SENSOR GROUND
109	G	PMP SWITCH
110	R	ENGINE SPEED OUTPUT SIGNAL
111	P	SENSOR GROUND
112	P	CAN COMMUNICATION LINE
113	L	CAN COMMUNICATION LINE
114	L	CAN COMMUNICATION LINE
117	V	DATA LINK CONNECTOR
121	LG	EVAP CANISTER VENT CONTROL VALVE
122	P	STOP LAMP SWITCH
123	B	ECM GROUND
124	B	ECM GROUND
125	R	POWER SUPPLY FOR ECM
126	BR	ASCD BRAKE SWITCH
127	B	ECM GROUND
128	B	ECM GROUND

Connector No.	M117
Connector Name	WIRE TO WIRE
Connector Type	TR80MM-C518-TM4



Terminal No.	Color Of Wire	Signal Name [Specification]
1	LG	SENSOR POWER SUPPLY
2	SB	SENSOR GROUND
31	SB	SENSOR GROUND
32	LG	ASCD STEERING SWITCH
33	SB	EVAP CONTROL SYSTEM PRESSURE SENSOR
34	LG	SENSOR POWER SUPPLY
40	Y	SENSOR GROUND
41	G	REFRIGERANT PRESSURE SENSOR
42	LG	FUEL TANK TEMPERATURE SENSOR
43	R	SENSOR POWER SUPPLY
45	G	SENSOR GROUND
46	SHIELD	PMP SWITCH
47	P	ENGINE SPEED OUTPUT SIGNAL
48	SHIELD	SENSOR GROUND
49	SHIELD	SENSOR GROUND
50	V	CAN COMMUNICATION LINE
59	R	DATA LINK CONNECTOR
71	R	EVAP CANISTER VENT CONTROL VALVE
80	W	STOP LAMP SWITCH
81	SHIELD	ECM GROUND
82	P	ECM GROUND
83	L	POWER SUPPLY FOR ECM
84	G	ASCD BRAKE SWITCH
85	SHIELD	ECM GROUND
86	W	ECM GROUND
87	B	ECM GROUND
88	R	ASCD BRAKE SWITCH
89	G	REFRIGERANT PRESSURE SENSOR
91	V	CAN COMMUNICATION LINE
92	BR	ASCD BRAKE SWITCH
93	V	ECM GROUND
94	Y	ECM GROUND
95	G	ECM GROUND
96	G	ECM GROUND

97	R	ASCD BRAKE SWITCH
98	BG	ECV SIGNAL
99	P	SENSOR POWER SUPPLY
100	L	SENSOR GROUND

Connector No.	M118
Connector Name	BCM (BODY CONTROL MODULE)
Connector Type	MD3FB-LC



Terminal No.	1	2	3
Color Of Wire	W	Y	BG
Signal Name [Specification]	BAT (F/L)	POWER WINDOW POWER SUPPLY (BAT)	POWER WINDOW POWER SUPPLY (RAP)

Connector No.	M119
Connector Name	BCM (BODY CONTROL MODULE)
Connector Type	NS (6PW-GS)



Terminal No.	4	5	6	7	8	9	10	11	13	14	15	17
Color Of Wire	LG	P	SB	R	G	P	R	B	W	BG	IND	W
Signal Name [Specification]	INTERIOR ROOM LAMP POWER SUPPLY	PASSENGER DOOR UNLOCK OUTPUT	STEP LAMP COOL	ALL DOOR LOCK OUTPUT	DRIVER DOOR FUEL LOCK CKA OUTPUT	REAR DOOR UNLOCK OUTPUT	BAT (ELSES)	GROUND	PUSH-BUTTON IGNITION SW ILL GND	ACC IND	TURN SIGNAL RH (FRONT)	TURN SIGNAL RH (FRONT)

INTELLIGENT KEY SYSTEM/ENGINE START FUNCTION

< DTC/CIRCUIT DIAGNOSIS >

INTELLIGENT KEY SYSTEM / ENGINE START FUNCTION

Terminal No.	Color of Wire	Signal Name [Specification]
18	BG	TURN SIGNAL LIT (FRONT)
19	V	INT ROOM LAMP CONT

Connector No.	M121
Connector Name	BCM (BODY CONTROL MODULE)
Connector Type	TH40FG-NH

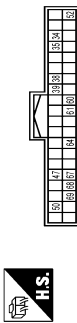

Terminal No.	Color of Wire	Signal Name [Specification]
34	SB	TRUNK ROOM ANT+
35	V	TRUNK ROOM ANT-
38	B	REAR BUMPER ANT+
39	W	REAR BUMPER ANT-
47	Y	IGN RELAY (IPDML/R) CONT
50	BG	TRUNK ROOM LAMP SW
52	R	STARTER RELAY CONT
60	BR	PUSH SW
61	SB	TRUNK LID OPENER REQUEST SW
64	G	F-KEY WARN BUZZER (ENG ROOM)
67	GR	TRUNK LID OPENER SW
68	BG	REAR TR DOOR SW
88	L	REAR LID DOOR SW

Connector No.	M122
Connector Name	BCM (BODY CONTROL MODULE)
Connector Type	TH40FB-NH



Terminal No.	Color of Wire	Signal Name [Specification]
72	R	ROOM ANT 2-
73	G	ROOM ANT 2+
74	SB	PASSENGER DOOR ANT-

Terminal No.	Color of Wire	Signal Name [Specification]
75	BR	PASSENGER DOOR ANT+
76	LG	DRIVER DOOR ANT-
77	LG	DRIVER DOOR ANT+
78	Y	ROOM ANT 1-
79	BR	ROOM ANT 1+
80	GR	NATS ANT AMP
81	W	NATS ANT
82	SB	IGN RELAY (F/B) CONT
83	Y	KEYLESS ENTRY RECEIVER COMM
87	Y	COMBI SW INPUT 5
88	BG	COMBI SW INPUT 3
90	P	CAN-L
91	L	CAN-H
92	LG	KEY SLOT LID CONT
93	GR	IGN IND
94	BG	LOCK REQUEST
95	GR	LOCK REQUEST
98	R	A/T SHIFT SELECT SW (DRIVER SUPPLY)
100	Y	PASSENGER DOOR REQUEST SW
101	P	DRIVER DOOR REQUEST SW
102	BG	BLOWER FAN MOTOR RELAY CONT
103	P	KEYLESS ENTRY RECEIVER POWER SUPPLY
107	LG	COMBI SW INPUT 1
108	R	COMBI SW INPUT 4
109	W	COMBI SW INPUT 2
110	G	HAZARD SW

Connector No.	M123
Connector Name	BCM (BODY CONTROL MODULE)
Connector Type	TH40FG-NH



Terminal No.	Color of Wire	Signal Name [Specification]
113	BG	OPTICAL SENSOR
114	BR	STOP LAMP SW 1
118	BR	STOP LAMP SW 2
119	SB	DR DOOR UNLOCK SENSOR
121	SB	KEY SLOT SW
123	V	IGN F/B
124	R	PASSENGER DOOR SW
129	BG	TRUNK LID OPENER CANCEL SW

Terminal No.	Color of Wire	Signal Name [Specification]
132	V	POWER WINDOW SW COMM
133	LG	PUSH-BUTTON IGNITION
134	LG	RECEIVER / SENSOR GND
137	BG	RECEIVER / SENSOR POWER SUPPLY
138	V	RECEIVER / SENSOR POWER SUPPLY
139	L	TIRE PRESSURE RECEIVER COMM
140	B	SHIFT N/P
141	W	SECURITY IND LAMP CONT
142	BR	COMBI SW OUTPUT 5
143	P	COMBI SW OUTPUT 1
144	G	COMBI SW OUTPUT 2
145	L	COMBI SW OUTPUT 3
146	SB	COMBI SW OUTPUT 4
150	GR	DRIVER DOOR SW
151	G	REAR WINDOW DEFOGGER RELAY CONT

Connector No.	M131
Connector Name	INSIDE KEY ANTENNA (INSTRUMENT CENTER)
Connector Type	RK02FGY



Terminal No.	Color of Wire	Signal Name [Specification]
1	Y	
2	Y	

Connector No.	M137
Connector Name	A/T SHIFT SELECTOR
Connector Type	TH12PW-NH



Terminal No.	Color of Wire	Signal Name [Specification]
1	W	
2	V	
3	L	
4	B	
5	G	
7	Y	
8	LG	
9	B	
10	GR	
11	R	

Connector No.	M146
Connector Name	INSIDE KEY ANTENNA (CONSOLE)
Connector Type	RK02FGY



Terminal No.	Color of Wire	Signal Name [Specification]
1	G	
2	R	

A B C D E F G H I J L M N O P

SEC

INFINITI VEHICLE IMMOBILIZER SYSTEM-NATS

< DTC/CIRCUIT DIAGNOSIS >

INFINITI VEHICLE IMMOBILIZER SYSTEM-NATS

Wiring Diagram - IVIS -

INFOID:000000010993916

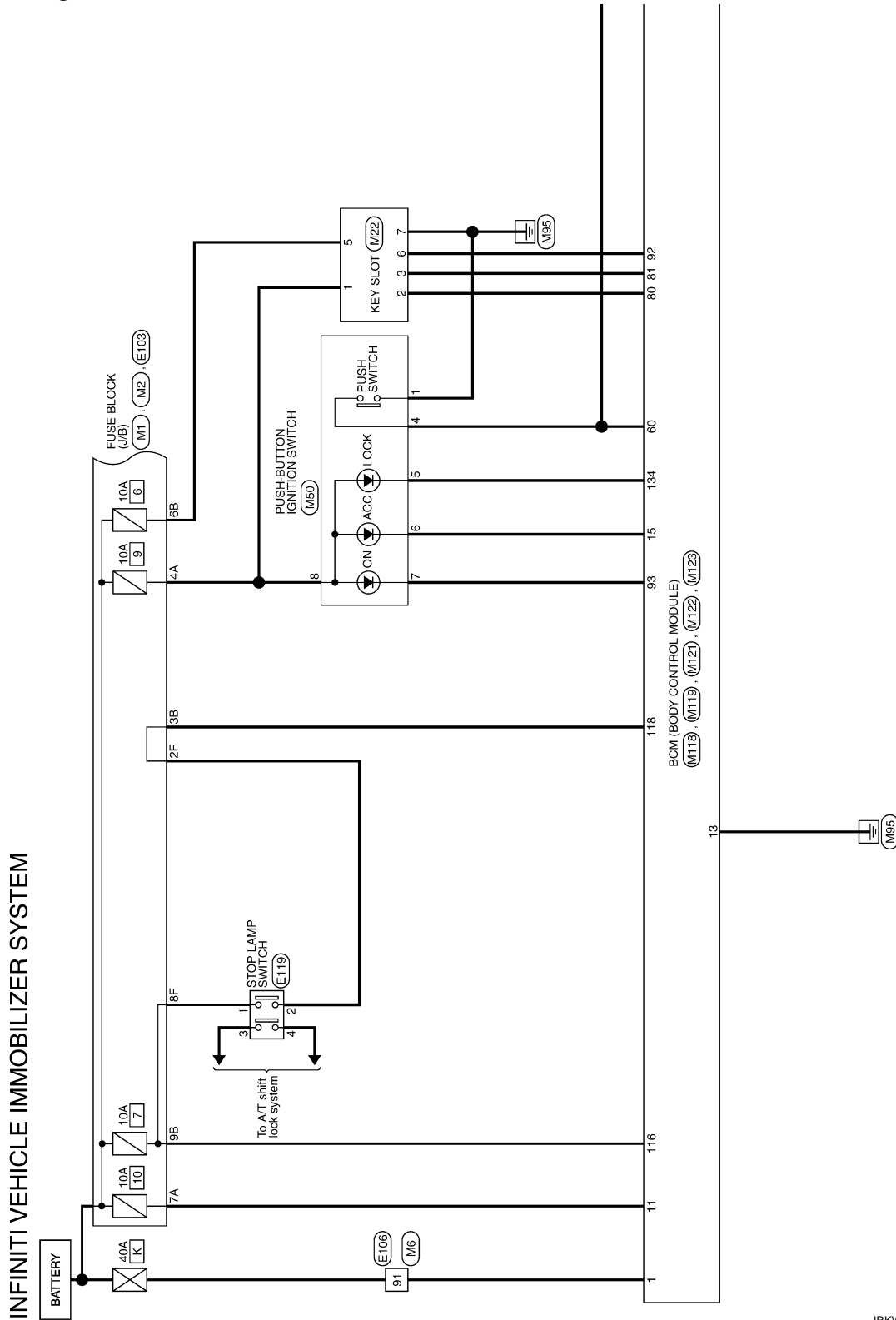

2014/06/09

JRKWD7580GB

INFINITI VEHICLE IMMOBILIZER SYSTEM-NATS

< DTC/CIRCUIT DIAGNOSIS >

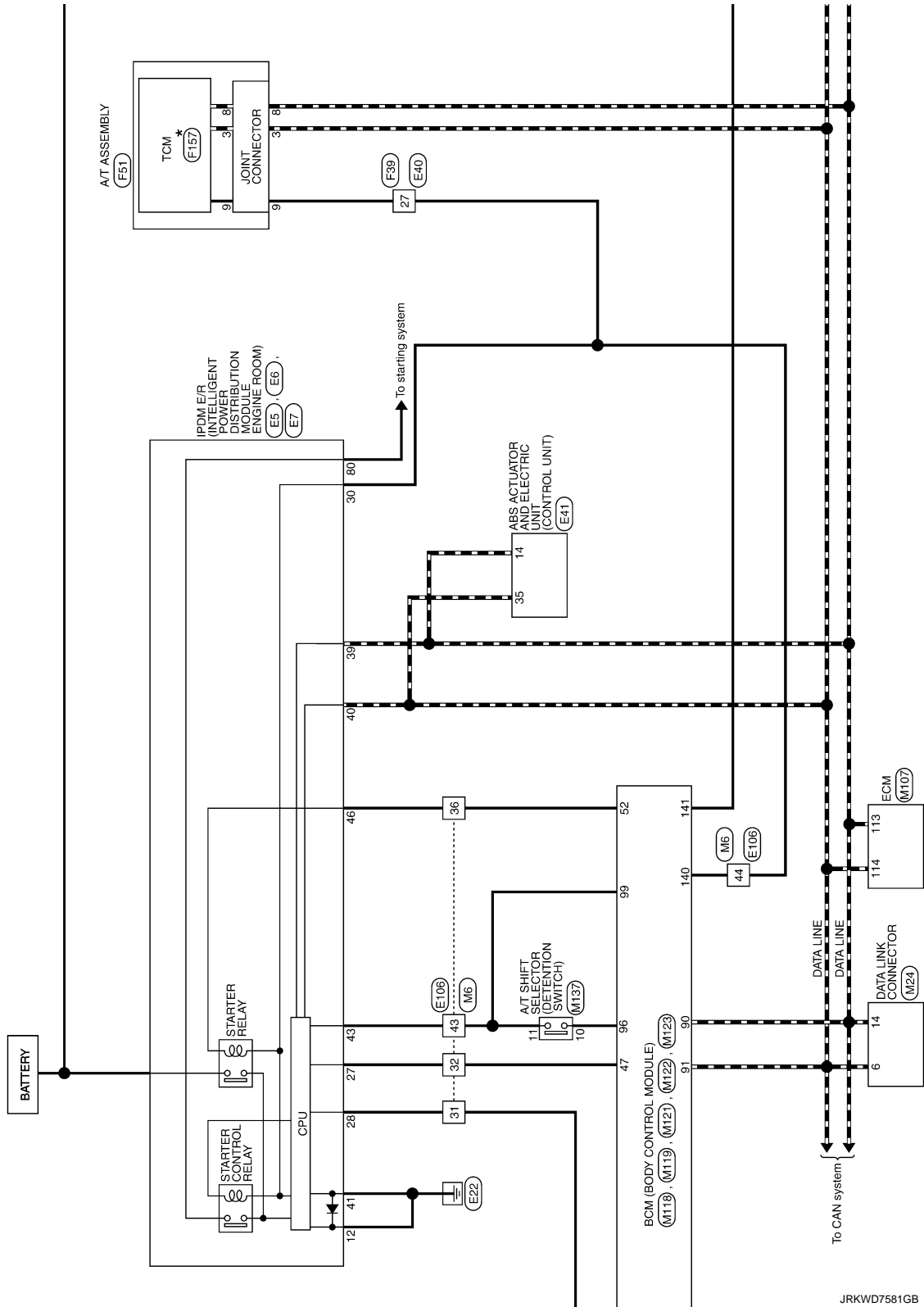

JRKWD7581GB

A
B
C
D
E
F
G
H
I
J
L
M
N
O
P

SEC

INFINITI VEHICLE IMMOBILIZER SYSTEM-NATS

< DTC/CIRCUIT DIAGNOSIS >

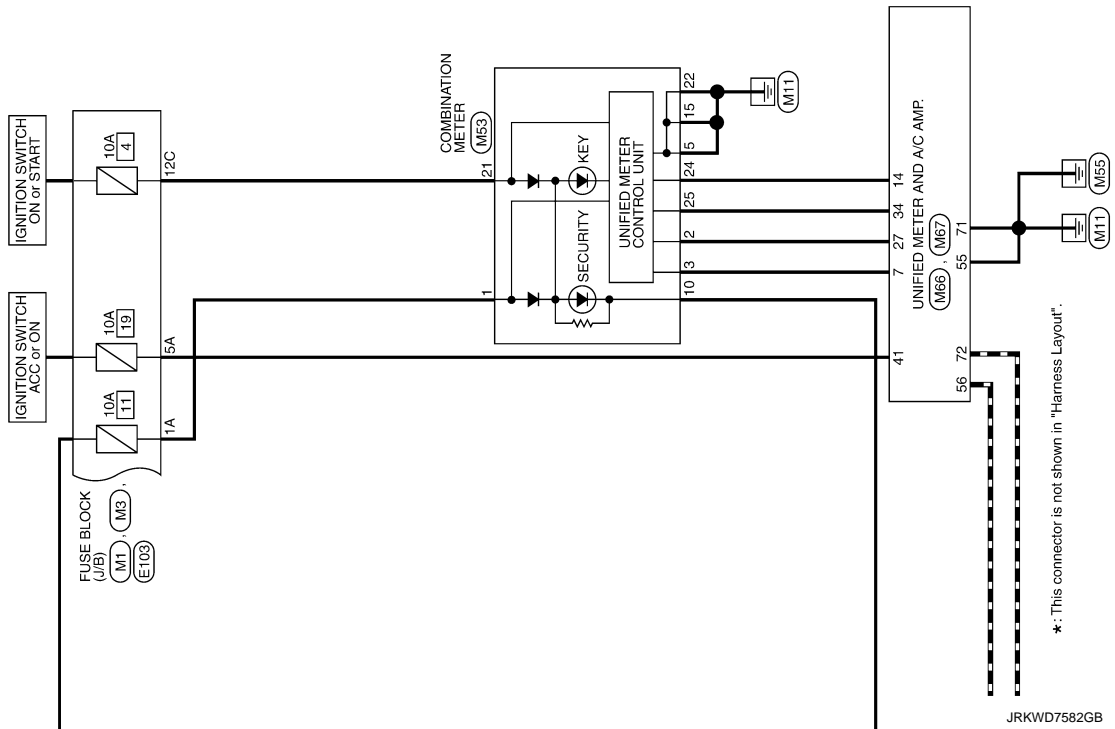

INFINITI VEHICLE IMMOBILIZER SYSTEM-NATS

< DTC/CIRCUIT DIAGNOSIS >

INFINITI VEHICLE IMMOBILIZER SYSTEM

Connector No.	E5		
Connector Name	IPM-E INTELLIGENT POWER DISTRIBUTION MODULE ENGINE		
Connector Type	TH80FW-CS12-M4-1V		



Terminal No.	Color Of Wire	Signal Name [Specification]
4	Y	
8	SB	
7	P	
12	B/W	
13	Y	
16	LG	
19	R	
25	G	
27	BG	
28	L	
30	GR	
36	G	

Connector No.	E6		
Connector Name	IPM-E INTELLIGENT POWER DISTRIBUTION MODULE ENGINE		
Connector Type	TH88FW-M4		



Terminal No.	Color Of Wire	Signal Name [Specification]
40	L	
41	B/W	
42	GR	
43	G	
44	LG	

45	V		
46	SB		

Connector No.	E7		
Connector Name	IPM-E INTELLIGENT POWER DISTRIBUTION MODULE ENGINE		
Connector Type	TH20FW-CS12-M4		

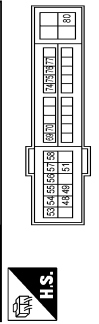

Terminal No.	Color Of Wire	Signal Name [Specification]
48	L	
49	BG	
51	Y	
53	W	
54	P	
55	SB	
56	BR	
57	G	
58	GR	
59	BR	
70	BG	
74	SB	
75	SB	
76	Y	
77	R	
80	W	

Connector No.	E40		
Connector Name	WIRE TO WIRE		
Connector Type	SAA38MB-RSS-SH28		

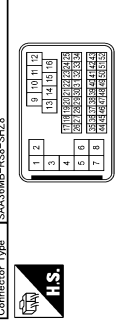

Terminal No.	Color Of Wire	Signal Name [Specification]
1	LT-Y	
2	SHIELD	
4	SHIELD	
5	BR	
7	G	
8	W	
9	W	
10	Y	
11	P	
12	SB	
13	L	
14	G	
15	BG	
16	BR	
18	BG	
20	B	
21	SB	
22	W	
23	L	
24	GR	
25	V	
27	GR	
28	V	
29	P	
30	R	
31	BR	
32	Y	
33	BG	
34	BG	
37	SHIELD	
38	L	
39	P	
40	R	

41	W		
42	G		
43	GR		
46	GR		
48	SHIELD		
47	W		
48	BR		
49	G		
50	B		
51	SB		
52	R		

Connector No.	E41		
Connector Name	ABS ACTUATOR AND ELECTRIC UNIT (CONTROL UNIT)		
Connector Type	SAA42FB-4H24-LH		

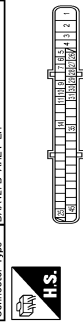

Terminal No.	Color Of Wire	Signal Name [Specification]
1	B	GROUND
2	GR	USMR
4	B	GRS
5	Y	GRS FL
6	BG	DP RL
7	BR	DP RR
9	B	DP FR
10	W	DS FR
11	V	DIAG-K
14	P	CAN-L
25	Y	BUS-L
26	LG	DP FL
27	GR	DS RL
28	G	UZ
29	B	DS RR
30	SB	DS RR
31	R	VCS SW
33	L	CAN-H
48	B	BUS-H

A
B
C
D
E
F
G
H
I
J
K
L
M
N
O
P

SEC

INFINITI VEHICLE IMMOBILIZER SYSTEM-NATS

< DTC/CIRCUIT DIAGNOSIS >

INFINITI VEHICLE IMMOBILIZER SYSTEM

Connector No.	E103
Connector Name	FUSE BLOCK (J/B)
Connector Type	NS16FW-GS



Terminal No.	Color Of Wire	Signal Name [Specification]
1F	SB	-
2F	GR	-
4F	LG	-
8F	BR	-
9F	L	-

Connector No.	E106
Connector Name	WIRE TO WIRE
Connector Type	T180FW-C516-TM4

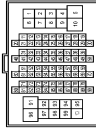

Terminal No.	Color Of Wire	Signal Name [Specification]
1	GR	-
3	BG	-
5	G	-
6	Y	-
7	V	-
9	R	-
11	R	-
13	L	-
14	GR	-
15	P	-
16	W	-
17	SB	-
18	BG	-

Terminal No.	Color Of Wire	Signal Name [Specification]
20	LG	-
21	W	-
32	BG	-
36	SB	-
37	Y	-
38	R	-
39	B	-
41	R	-
42	LG	-
43	G	-
44	GR	-
45	BR	-
46	LG	-
47	V	-
48	L	-
49	P	-
66	GR	-
67	LG	-
80	R	-
81	P	-
82	G	-
83	V	-
84	L	-
85	W	-
89	V	-
91	W	-
93	GR	-
95	LG	-
98	SHIELD	-
99	W	-
100	P	-

Connector No.	E119
Connector Name	STOP LAMP SWITCH
Connector Type	IM8FW-LC



Terminal No.	Color Of Wire	Signal Name [Specification]
2	W	-
3	G	-
4	V	-

Connector No.	F39
Connector Name	WIRE TO WIRE
Connector Type	SAAG3FB-R5B-SH2B

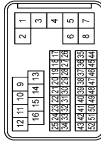

Terminal No.	Color Of Wire	Signal Name [Specification]
1	L/Y	-
2	SHIELD	-
3	L/B	-
4	SHIELD	-
5	BR	-
7	G	-
8	W	-
9	W	-
10	G	-
11	R	-
12	P	-
13	L	-
14	LG	-
15	R	-
16	O	-
18	Y	-
18	LG	-
19	P	-
20	O	-
21	BR	-
22	G	-
24	LG	-
25	V	-
27	GR	-
28	BR	-
29	L	-
30	R	-

Terminal No.	Color Of Wire	Signal Name [Specification]
31	P	-
32	W	-
33	SB	-
34	BR	-
34	O	-
37	B	-
37	SHIELD	-
38	W	-
39	Y	-
40	G	-
41	B	-
42	GR	-
43	R	-
43	O	-
45	SHIELD	-
45	LG	-
46	LG	-
48	O/L	-
50	L/Y	-
51	W	-
52	L/G	-

Connector No.	F51
Connector Name	A/T ASSEMBLY
Connector Type	RK10FG-DSY



Terminal No.	Color Of Wire	Signal Name [Specification]
1	Y	-
2	R	-
3	L	-
4	V	-
5	B	-
7	G	-
8	P	-
8	GR	-
10	B	-

INFINITI VEHICLE IMMOBILIZER SYSTEM-NATS

< DTC/CIRCUIT DIAGNOSIS >

INFINITI VEHICLE IMMOBILIZER SYSTEM

Connector No.	F157
Connector Name	TGM
Connector Type	SP10FG



Terminal No.	Color Of Wire	Signal Name [Specification]
1	SHIELD	VIGN
2	SHIELD	CAN-H
3	SHIELD	CAN-L
4	SHIELD	K-LINE
5	SHIELD	GROUND
6	SHIELD	VIGN
7	SHIELD	REV LAMP RLY
8	SHIELD	CAN-L
9	SHIELD	STARTER RLY
10	SHIELD	GROUND

Connector No.	M1
Connector Name	FUSE BLOCK (J/B)
Connector Type	NS36PW-MZ



Terminal No.	Color Of Wire	Signal Name [Specification]
1A	V	
2A	G	
3A	B	
4A	L	
5A	Y	
6A	R	
7A	L	
8A	L	

Connector No.	MZ
Connector Name	FUSE BLOCK (J/B)
Connector Type	NS10PW-GS

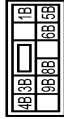

Terminal No.	Color Of Wire	Signal Name [Specification]
1B	SB	
2B	C	
3B	CG	
4B	RG	
5B	Y	
6B	R	
7B	R	
8B	SB	
9B	SB	

Connector No.	M3
Connector Name	FUSE BLOCK (J/B)
Connector Type	NS12PW-GS

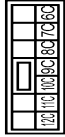

Terminal No.	Color Of Wire	Signal Name [Specification]
10C	L	
11C	LG	
12C	G	
13C	SB	
14C	B	
15C	W	
16C	Y	
17C	Y	
18C	Y	
19C	Y	
20C	Y	

Connector No.	M6
Connector Name	WIRE TO WIRE
Connector Type	TR80MH-CSP-TM4



Terminal No.	Color Of Wire	Signal Name [Specification]
1	EG	
2	R	
3	Y	
4	LG	
5	W	
6	W	
7	W	
8	G	
9	G	
10	V	
11	V	
12	R	
13	L	
14	GR	
15	P	
16	W	
17	BR	
18	P	
19	L	
20	L	
21	Y	
22	Y	
23	Y	
24	Y	
25	Y	
26	Y	
27	Y	
28	Y	
29	SB	
30	SB	
31	SB	
32	SB	
33	SB	
34	SB	
35	SB	
36	SB	
37	SB	
38	SB	
39	SB	
40	SB	
41	V	
42	LG	
43	P	
44	B	
45	EG	
46	G	
47	L	
48	P	
49	B	
50	W	
51	Y	
52	Y	
53	G	
54	G	
55	SB	
56	SB	
57	SB	
58	SB	
59	SB	
60	SB	
61	SB	
62	SB	
63	SB	
64	SB	
65	SB	
66	SB	
67	SB	
68	SB	
69	SB	
70	SB	
71	SB	
72	SB	
73	SB	
74	SB	
75	SB	
76	SB	
77	SB	
78	SB	
79	SB	
80	SB	
81	B	
82	V	
83	W	

84	L	
85	GR	
86	G	
87	W	
88	Y	
89	Y	
90	GR	
91	SHIELD	
92	SHIELD	
93	SHIELD	
94	SHIELD	
95	SHIELD	
96	SHIELD	
97	SHIELD	
98	SHIELD	
99	V	
100	SB	

Connector No.	M22
Connector Name	KEY SLOT
Connector Type	TR12PW-NH

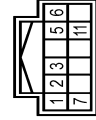

Terminal No.	Color Of Wire	Signal Name [Specification]
1	R	BAT
2	GR	CLOCK
3	W	DATA
4	L	ILBAT
5	LG	GROUND
6	B	KEY SWITCH SIGNAL
7	SB	
8	SB	
9	SB	
10	SB	
11	SB	

Connector No.	M24
Connector Name	DATA LINK CONNECTOR
Connector Type	BD16FW-P

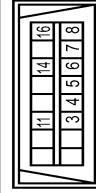

A
B
C
D
E
F
G
H
I
J
K
L
M
N
O
P

SEC

INFINITI VEHICLE IMMOBILIZER SYSTEM-NATS

< DTC/CIRCUIT DIAGNOSIS >

INFINITI VEHICLE IMMOBILIZER SYSTEM

Terminal No.	Color Of Wire	Signal Name [Specification]
3	LG	BATTERY POWER SUPPLY
4	B	BATTERY POWER SUPPLY
5	B	BATTERY POWER SUPPLY
6	L	BRAKE FLUID LEVEL SWITCH
7	V	FUEL LEVEL SENSOR GROUND
8	G	INTAKE SENSOR GROUND
11	SB	IN-VEHICLE SENSOR GROUND
14	P	SUNLOAD SENSOR GROUND
16	R	ECV SIGNAL

Connector No.	Signal Name [Specification]
M50	PUSH-BUTTON IGNITION SWITCH



Terminal No.	Color Of Wire	Signal Name [Specification]
1	B	GROUND
2	B	GROUND
3	B	GROUND
4	BR	COMMUNICATION SIGNAL (AMP-LCD)
5	LG	VEHICLE SPEED SIGNAL (8-PULSE)
6	BG	PARKING BRAKE SWITCH SIGNAL
7	GR	ILL GND
8	P	ILL GND

Connector No.	Signal Name [Specification]
M53	COMBINATION METER

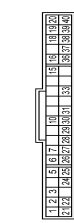

Terminal No.	Color Of Wire	Signal Name [Specification]
1	LG	BATTERY POWER SUPPLY
2	LG	COMMUNICATION SIGNAL (METER-AMP)
3	GR	COMMUNICATION SIGNAL (AMP-METER)
5	B	GROUND
6	W	ALTERNATOR SIGNAL
7	LG	AIR BAG SIGNAL
10	W	SECURITY SIGNAL
15	B	GROUND
16	BR	METER CONTROL SWITCH GROUND
18	GR	ILL GND
19	B	ILL GND
20	R	ILL
21	G	IGNITION SIGNAL
22	B	GROUND
23	BR	COMMUNICATION SIGNAL (LSD-AMP)
24	BR	COMMUNICATION SIGNAL (AMP-LCD)
26	R	VEHICLE SPEED SIGNAL (8-PULSE)
27	P	PARKING BRAKE SWITCH SIGNAL
28	SB	BRAKE FLUID LEVEL SWITCH
29	P	SEAT BELT BUCKLE SW SIGNAL (DRIVER SIDE)
30	G	SEAT BELT BUCKLE SWITCH SIGNAL (PASSENGER SIDE)
31	L	WASHER LEVEL SWITCH SIGNAL
33	R	ILLUMINATION CONTROL SIGNAL
36	LG	SELECT SWITCH SIGNAL
37	Y	ENTER SWITCH SIGNAL
39	G	TRIP A/B RESET SWITCH SIGNAL
40	EG	ILLUMINATION CONTROL SWITCH SIGNAL (-)

Connector No.	Signal Name [Specification]
M65	UNIFIED METER AND A/C AMP.



Terminal No.	Color Of Wire	Signal Name [Specification]
4	G	STOP LAMP SWITCH SIGNAL
7	L	MANUAL MODE SWITCH SIGNAL
8	GR	COMMUNICATION SIGNAL (AMP-METER)
9	L	VEHICLE SPEED SIGNAL (2-PULSE)
10	W	SEAT BELT BUCKLE SWITCH SIGNAL (DRIVER SIDE)
11	G	MANUAL MODE SIGNAL
14	BR	NON-MANUAL MODE SIGNAL
23	Y	A/T SNOW SWITCH SIGNAL
25	V	MANUAL MODE SHIFT DOWN SIGNAL
27	LG	COMMUNICATION SIGNAL (METER-AMP)
28	R	VEHICLE SPEED SIGNAL (8-PULSE)
30	V	PARKING BRAKE SWITCH SIGNAL
34	Y	COMMUNICATION SIGNAL (AMP-LCD)
38	P	BLOWER MOTOR CONTROL SIGNAL

Connector No.	Signal Name [Specification]
M67	UNIFIED METER AND A/C AMP.

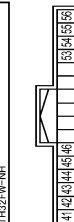

Terminal No.	Color Of Wire	Signal Name [Specification]
41	L	ACC POWER SUPPLY
42	BR	FUEL LEVEL SENSOR SIGNAL
43	BR	INTAKE SENSOR SIGNAL
44	LG	IN-VEHICLE SENSOR SIGNAL
45	V	AMBIENT SENSOR SIGNAL

Terminal No.	Color Of Wire	Signal Name [Specification]
46	Y	SUNLOAD SENSOR SIGNAL
52	W	IGNITION SENSOR SUPPLY
53	SB	BATTERY POWER SUPPLY
55	B	GROUND
56	L	CAN-H
57	LG	BRAKE FLUID LEVEL SWITCH
58	Y	FUEL LEVEL SENSOR GROUND
59	GR	INTAKE SENSOR GROUND
60	W	IN-VEHICLE SENSOR GROUND
61	B	AMBIENT SENSOR GROUND
62	SB	SUNLOAD SENSOR GROUND
65	BG	ECV SIGNAL
69	P	A/C LAM SIGNAL
70	R	EACH DOOR MOTOR POWER SUPPLY
71	GR	GROUND
72	P	CAN-L

Connector No.	Signal Name [Specification]
M107	ECM
RH24FCY-R28-R-LH-Z	

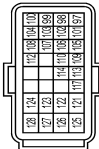

Terminal No.	Color Of Wire	Signal Name [Specification]
97	R	ACCELERATOR PEDAL POSITION SENSOR I
98	P	ACCELERATOR PEDAL POSITION SENSOR Z
99	L	SENSOR POWER SUPPLY
100	W	SENSOR GROUND
101	SB	ASCOD STEERING SWITCH
102	LG	EVAP CONTROL SYSTEM PRESSURE SENSOR
103	GR	SENSOR POWER SUPPLY
104	V	SENSOR GROUND
105	L	REFRIGERANT PRESSURE SENSOR
106	W	FUEL TANK TEMPERATURE SENSOR
107	GR	SENSOR POWER SUPPLY
108	G	SENSOR GROUND
109	G	PNP SWITCH
110	R	ENGINE SPEED OUTPUT SIGNAL
112	V	SENSOR GROUND
113	P	CAN COMMUNICATION LINE
114	L	CAN COMMUNICATION LINE
117	V	DATA LINK CONNECTOR

INFINITI VEHICLE IMMOBILIZER SYSTEM-NATS

< DTC/CIRCUIT DIAGNOSIS >

INFINITI VEHICLE IMMOBILIZER SYSTEM

121	LG	EVAP-CANISTER VENT CONTROL VALVE
122	B	STEERING WHEEL CONTROL SWITCH
123	B	ECM GROUND
124	B	ECM GROUND
125	R	POWER SUPPLY FOR ECM
126	BR	ASGD BRAKE SWITCH
127	B	ECM GROUND
128	B	ECM GROUND

Connector No.	MT18
Connector Name	BCM (BODY CONTROL MODULE)
Connector Type	HM3FB-LG



Terminal No.	Color of Wire	Signal Name [Specification]
1	W	BAT (F/L)
2	Y	POWER WINDOW POWER SUPPLY (BAT)
3	BG	POWER WINDOW POWER SUPPLY (RAP)

Connector No.	MT19
Connector Name	BCM (BODY CONTROL MODULE)
Connector Type	NS16FW-GS

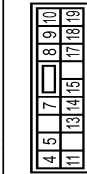

Terminal No.	Color of Wire	Signal Name [Specification]
4	LG	INTERIOR ROOM LAMP POWER SUPPLY
5	SB	PASSENGER DOOR UNLOCK OUTPUT
6	SB	STEER LAMP CONT
7	SB	STEER LAMP CONT
8	V	ALL DOOR FUEL LID LOCK OUTPUT
9	G	DRIVER DOOR FUEL LID UNLOCK OUTPUT
10	P	REAR DOOR UNLOCK OUTPUT
11	R	BAT (FUSE)

13	B	GROUND
14	B	PUSH-BUTTON LOCK SW ILL GND
15	BG	TRUNK LID OPENER SW ILL GND
16	W	TURN SIGNAL RH (FRONT)
17	W	TURN SIGNAL LH (FRONT)
18	BG	TURN SIGNAL LH (FRONT)
19	V	INT ROOM LAMP CONT

Connector No.	MT21
Connector Name	BCM (BODY CONTROL MODULE)
Connector Type	TH40FG-YH

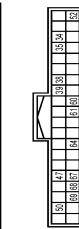

Terminal No.	Color of Wire	Signal Name [Specification]
34	SB	TRUNK ROOM ANT+
35	V	TRUNK ROOM ANT+
38	B	REAR BUMPER ANT+
39	W	REAR BUMPER ANT+
47	Y	IGN RELAY (JDM) E/R CONT
50	BG	TRUNK ROOM LAMP SW
52	R	STARTER RELAY CONT
53	R	STARTER RELAY CONT
54	SB	TRUNK LID OPENER REQUEST SW
64	G	F-KEY WARN BUZZER (ENG ROOM)
67	GR	TRUNK LID OPENER SW
68	BG	REAR LH DOOR SW
69	L	REAR LH DOOR SW

Connector No.	MT22
Connector Name	BCM (BODY CONTROL MODULE)
Connector Type	TH40FB-NH

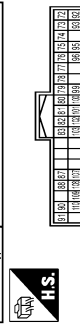

Terminal No.	Color of Wire	Signal Name [Specification]
72	R	ROOM ANT 2
73	G	ROOM ANT 2
74	SB	PASSENGER DOOR ANT+
75	BR	PASSENGER DOOR ANT+
76	V	DRIVER DOOR ANT+
77	LG	DRIVER DOOR ANT+
78	Y	ROOM ANT 1+
79	BR	ROOM ANT 1+
80	GR	NATS ANT AMP
81	W	NATS ANT AMP
82	SB	IGN RELAY (F/B) CONT
83	Y	KEYLESS ENTRY RECEIVER COMM
87	Y	COMBI SW INPUT 5
88	BG	COMBI SW INPUT 3
89	P	CAN-L
92	LG	KEY SELECT CONT
93	GR	ON IND
95	BG	ACC RELAY CONT
96	GR	A/T SHIFT SELECTOR POWER SUPPLY
99	R	SHIFT P
100	Y	PASSENGER DOOR REQUEST SW
101	P	DRIVER DOOR REQUEST SW
102	BG	BLOWER FAN MOTOR RELAY CONT
103	P	KEYLESS ENTRY RECEIVER POWER SUPPLY
107	LG	COMBI SW INPUT 1
108	R	COMBI SW INPUT 4
109	W	COMBI SW INPUT 2
110	G	HAZARD SW

Connector No.	MT23
Connector Name	BCM (BODY CONTROL MODULE)
Connector Type	TH40FG-RH



Terminal No.	Color of Wire	Signal Name [Specification]
113	BG	OPTICAL SENSOR
116	SB	STOP LAMP SW 2
118	SB	STOP LAMP SW 2
119	SB	DR DOOR UNLOCK SENSOR
121	SB	KEY SLOT SW
123	V	IGN F/B
124	R	PASSENGER DOOR SW
129	BG	TRUNK LID OPENER CANCEL SW
132	V	POWER WINDOW SW COMM
133	L	PUSH-BUTTON IGNITION SW ILL POWER
134	LG	LOCK IND
137	BG	RECEIVER / SENSOR GND
138	V	RECEIVER / SENSOR POWER SUPPLY
139	L	TIPE PRESSURE RECEIVER COMM
140	B	SHIFT N/P
142	BR	SECURITY RECEIVER COMM
143	P	COMBI SW OUTPUT 3
144	G	COMBI SW OUTPUT 1
145	L	COMBI SW OUTPUT 2
146	SB	COMBI SW OUTPUT 4
150	GR	DRIVER DOOR SW
151	G	REAR WINDOW DEFROGGER RELAY CONT

A
B
C
D
E
F
G
H
I
J
SEC
L
M
N
O
P

INFINITI VEHICLE IMMOBILIZER SYSTEM-NATS

< DTC/CIRCUIT DIAGNOSIS >

INFINITI VEHICLE IMMOBILIZER SYSTEM

Connector No.	IM137
Connector Name	A/T SHIFT SELECTOR
Connector Type	TH12FW-4H

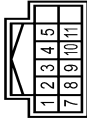

Terminal No.	Color	Wire	Signal Name [Specification]
1	Y	-	-
2	V	-	-
3	L	-	-
4	B	-	-
5	G	-	-
7	Y	-	-
8	LG	-	-
9	B	-	-
10	GR	-	-
11	R	-	-

JRKWD7649GB

VEHICLE SECURITY SYSTEM

< DTC/CIRCUIT DIAGNOSIS >

VEHICLE SECURITY SYSTEM

Wiring Diagram - VEHICLE SECURITY SYSTEM -

INFOID:000000010993917

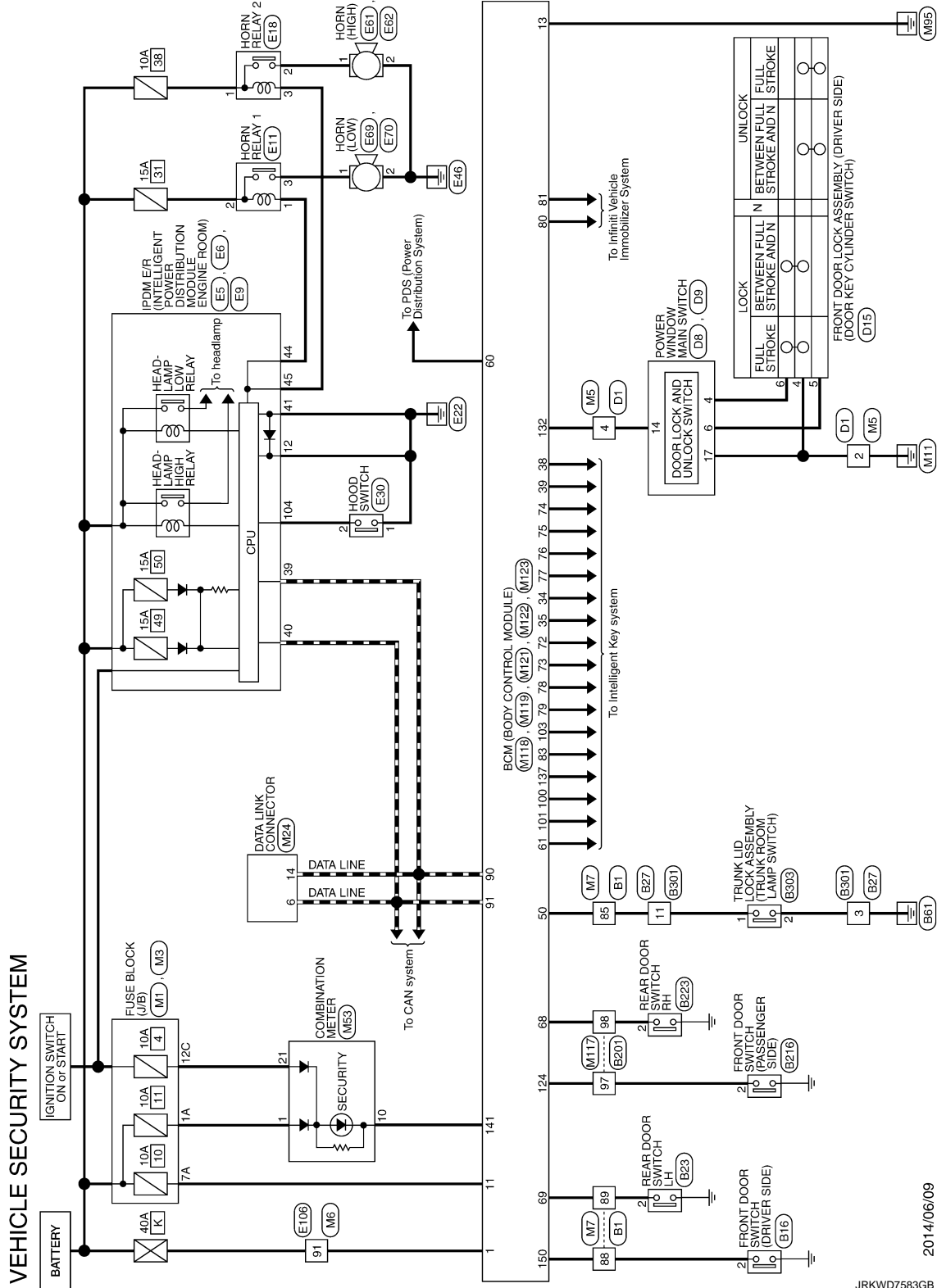

2014/06/09

JRKWD7583GB

A
B
C
D
E
F
G
H
I
J
K
L
M
N
O
P

SEC

VEHICLE SECURITY SYSTEM

< DTC/CIRCUIT DIAGNOSIS >

VEHICLE SECURITY SYSTEM

Connector No.	B21
Connector Name	WIRE TO WIRE
Connector Type	TH80FW-C516-TM4

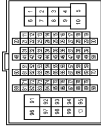

Terminal No.	Color Of Wire	Signal Name [Specification]
1	GR	-
2	BG	-
3	Y	-
4	Y	-
6	R	-
8	W	-
9	LG	-
24	V	-
25	SB	-
26	G	-
27	W	-
28	R	-
31	V	-
32	SB	-
33	SHIELD	-
35	BR	-
36	Y	-
37	SHIELD	-
38	Y	-
39	SB	-
40	P	-
41	L	-
42	SHIELD	-
43	R	-
44	G	-
45	SHIELD	-
46	SB	-
47	BR	-
48	BR	-
58	V	-
59	SB	-
71	BG	-
72	GR	-
73	P	-

Connector No.	B27
Connector Name	WIRE TO WIRE
Connector Type	NIS1BMV-CS

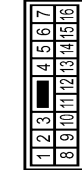

Terminal No.	Color Of Wire	Signal Name [Specification]
2	BG	-
4	Y	-
5	B	-
6	W	-
11	G	-
12	SHIELD	-
13	B	-
14	W	-
15	R	-

Connector No.	B201
Connector Name	WIRE TO WIRE
Connector Type	TH80FW-C516-TM4

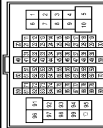

Terminal No.	Color Of Wire	Signal Name [Specification]
1	BR	-
6	L	-
31	Y	-
32	P	-
33	G	-
34	R	-
40	GR	-
41	LG	-

42	BG	-
43	G	-
45	G	-
46	SHIELD	-
47	G	-
48	Y	-
49	SHIELD	-
50	W	-
71	R	-
80	BG	-
81	SHIELD	-
82	G	-
83	P	-
84	SHIELD	-
85	P	-
86	R	-
88	W	-
89	B	-
90	Y	-
91	V	-
92	W	-
93	BG	-
94	R	-
95	SB	-
96	G	-
97	GR	-
98	BR	-
99	P	-
100	L	-

Connector No.	B216
Connector Name	FRONT DOOR SWITCH (PASSENGER SIDE)
Connector Type	A03FW

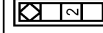

Terminal No.	Color Of Wire	Signal Name [Specification]
2	GR	-

JRKWD7650GB

VEHICLE SECURITY SYSTEM

< DTC/CIRCUIT DIAGNOSIS >

VEHICLE SECURITY SYSTEM

Connector No.	B223
Connector Name	REAR DOOR SWITCH RH
Connector Type	A03PW



Terminal No.	Color Of Wire	Signal Name [Specification]
2	BR	-

Connector No.	B301
Connector Name	WIRE TO WIRE
Connector Type	NS16FW-CS

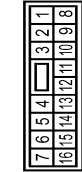

Terminal No.	Color Of Wire	Signal Name [Specification]
2	BG	-
3	B	-
4	G	-
5	B	-
6	W	-
11	V	-
12	SHIELD	-
13	Y	-
14	W	-
15	R	-

Connector No.	B033
Connector Name	TRUNK LID LOCK ASSEMBLY
Connector Type	TB03PW



Terminal No.	Color Of Wire	Signal Name [Specification]
1	V	-
2	B	-
3	G	-

Connector No.	D1
Connector Name	WIRE TO WIRE
Connector Type	TH40PW-CS15

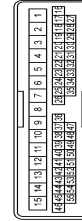

Terminal No.	Color Of Wire	Signal Name [Specification]
1	Y	-
2	B	-
3	S5	-
4	V	-
8	L	-
9	P	-
10	LG	-
12	GR	-
13	L	-
14	W	-
15	S	-
25	V	-
26	R	-
33	B	-
42	G	-
43	OR	-

44	BG	-
45	V	-
48	B	-
49	SB	-
50	W	-
51	P	-
52	V	-
53	G	-
54	R	-
55	SHIELD	-

Connector No.	B8
Connector Name	POWER WINDOW MAIN SWITCH
Connector Type	NS16PW-CS

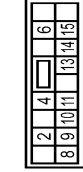

Terminal No.	Color Of Wire	Signal Name [Specification]
2	LG	-
4	V	-
6	Y	-
8	L	-
9	BG	-
10	SB	-
11	G	-
13	P	-
14	V	-
15	B	-

Connector No.	D9
Connector Name	POWER WINDOW MAIN SWITCH
Connector Type	NS30PW-CS



Terminal No.	Color Of Wire	Signal Name [Specification]
17	B	-
19	Y	-

Connector No.	D15
Connector Name	FRONT DOOR LOCK ASSEMBLY (DRIVER SIDE)
Connector Type	EB6FY-RS

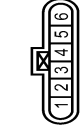

Terminal No.	Color Of Wire	Signal Name [Specification]
1	LG	-
2	P	-
3	L	-
4	B	-
5	Y	-
6	V	-

A
B
C
D
E
F
G
H
I
J
L
M
N
O
P

SEC

VEHICLE SECURITY SYSTEM

< DTC/CIRCUIT DIAGNOSIS >

VEHICLE SECURITY SYSTEM

Connector No.	E5	INTELLIGENT POWER DISTRIBUTION MODULE ENGINE ROOM
Connector Name		
Connector Type	TH20FW-C512-3M4-1V	



Terminal No.	Color Of Wire	Signal Name [Specification]
4	Y	-
5	SB	-
6	SB	-
7	P	-
12	B/W	-
13	Y	-
16	LG	-
19	R	-
25	G	-
27	BG	-
28	L	-
30	GR	-
36	G	-

Connector No.	E6	INTELLIGENT POWER DISTRIBUTION MODULE ENGINE ROOM
Connector Name		
Connector Type	TH88FW-NH	



Terminal No.	Color Of Wire	Signal Name [Specification]
38	P	-
40	L	-
41	B/W	-
42	GR	-
43	G	-
44	LG	-
45	V	-

46	SB	-
----	----	---

Connector No.	E8	INTELLIGENT POWER DISTRIBUTION MODULE ENGINE ROOM
Connector Name		
Connector Type	TH18FW-NH	

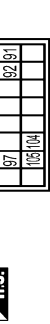

Terminal No.	Color Of Wire	Signal Name [Specification]
81	G	-
92	BG	-
97	V	-
104	LG	-
105	L	-

Connector No.	E11	HORN RELAY 1
Connector Name		
Connector Type	Z4381 7981A	



Terminal No.	Color Of Wire	Signal Name [Specification]
1	LG	-
2	SB	-
3	G	-

Connector No.	E18	HORN RELAY 2
Connector Name		
Connector Type	M33FW-R-LC	



Terminal No.	Color Of Wire	Signal Name [Specification]
1	P	-
2	Y	-
3	Y	-

Connector No.	E30	HOOD SWITCH
Connector Name		
Connector Type	RH02FB	



Terminal No.	Color Of Wire	Signal Name [Specification]
1	B	-
2	LG	-

Connector No.	E61	HORN (HIGH)
Connector Name		
Connector Type	PD1FB-BR-A	



Terminal No.	Color Of Wire	Signal Name [Specification]
1	Y	-

Connector No.	E62	HORN (HIGH)
Connector Name		
Connector Type	PD1FB-A	



Terminal No.	Color Of Wire	Signal Name [Specification]
2	B	-

Connector No.	E69	HORN (LOW)
Connector Name		
Connector Type	PD1FB-BR-A	



JRKWD7652GB

VEHICLE SECURITY SYSTEM

< DTC/CIRCUIT DIAGNOSIS >

VEHICLE SECURITY SYSTEM

Terminal No.	Color Of Wire	Signal Name [Specification]
1	G	-

Connector No.	E70
Connector Name	HORN (LOW)
Connector Type	PQ1FB-A



Terminal No.	Color Of Wire	Signal Name [Specification]
2	B	-

Connector No.	E10B
Connector Name	WIRE TO WIRE
Connector Type	TH80FW-C516-TM4

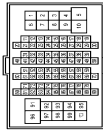

Terminal No.	Color Of Wire	Signal Name [Specification]
1	GR	-
3	BG	-
5	G	-
6	Y	-
7	V	-
9	R	-
11	W	-
12	LG	-
13	L	-
14	GR	-
15	P	-
16	W	-
17	SB	-
18	BG	-

20	LG	-
21	BG	-
22	SG	-
23	Y	-
24	G	-
25	GR	-
26	SB	-
27	W	-
28	R	-
29	B	-
30	LG	-
31	GR	-
32	G	-
33	V	-
34	L	-
35	W	-
36	P	-
37	SB	-
38	SHIELD	-
39	W	-
40	P	-
41	GR	-
42	LG	-
43	G	-
44	GR	-
45	BR	-
46	LG	-
47	V	-
48	P	-
49	SB	-
50	GR	-
51	LG	-
52	W	-
53	P	-
54	GR	-
55	SHIELD	-
56	W	-
57	P	-
58	GR	-
59	LG	-
60	R	-
61	P	-
62	G	-
63	V	-
64	L	-
65	W	-
66	V	-
67	GR	-
68	GR	-
69	LG	-
70	SB	-
71	SHIELD	-
72	W	-
73	P	-
74	GR	-
75	LG	-
76	W	-
77	P	-
78	GR	-
79	LG	-
80	W	-
81	P	-
82	G	-
83	V	-
84	L	-
85	W	-
86	V	-
87	GR	-
88	GR	-
89	LG	-
90	SB	-
91	SHIELD	-
92	W	-
93	P	-
94	GR	-
95	LG	-
96	SB	-
97	SHIELD	-
98	W	-
99	P	-
100	P	-

Connector No.	M1
Connector Name	FUSE BLOCK (J/B)
Connector Type	NS02FY-M2



Terminal No.	Color Of Wire	Signal Name [Specification]
1	Y	-
2	BG	-
3	EG	-
4	V	-
5	G	-
6	SB	-
7	W	-
8	R	-
9	B	-
10	Y	-
11	R	-
12	LG	-
13	L	-
14	GR	-
15	BR	-
16	LG	-
17	V	-
18	P	-
19	GR	-
20	SB	-
21	SHIELD	-
22	W	-
23	P	-
24	GR	-
25	LG	-
26	SB	-
27	SHIELD	-
28	W	-
29	P	-
30	GR	-
31	LG	-
32	W	-
33	BG	-
34	BG	-

Connector No.	M3
Connector Name	FUSE BLOCK (J/B)
Connector Type	NS12FY-CS

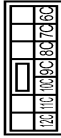

Terminal No.	Color Of Wire	Signal Name [Specification]
10C	L	-
11C	LG	-
12C	G	-
13C	SB	-
14C	W	-
15C	W	-
16C	BG	-
17C	BG	-

Connector No.	M5
Connector Name	WIRE TO WIRE
Connector Type	TH80FW-C516

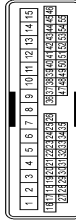

Terminal No.	Color Of Wire	Signal Name [Specification]
1	Y	-
2	BG	-
3	EG	-
4	V	-
5	G	-
6	SB	-
7	W	-
8	R	-
9	B	-
10	Y	-
11	R	-
12	LG	-
13	L	-
14	GR	-
15	BR	-
16	LG	-
17	V	-
18	P	-
19	GR	-
20	SB	-
21	SHIELD	-
22	W	-
23	P	-
24	GR	-
25	LG	-
26	SB	-
27	SHIELD	-
28	W	-
29	P	-
30	GR	-
31	LG	-
32	W	-
33	BG	-
34	BG	-
35	BG	-
36	BG	-
37	BG	-
38	BG	-
39	BG	-
40	BG	-
41	BG	-
42	BG	-
43	BG	-
44	BG	-
45	BG	-
46	BG	-
47	BG	-
48	GR	-
49	SB	-
50	P	-
51	LG	-
52	V	-
53	BR	-
54	Y	-
55	SHIELD	-

Connector No.	M6
Connector Name	WIRE TO WIRE
Connector Type	TH80FW-C516-TM4



Terminal No.	Color Of Wire	Signal Name [Specification]
1	BG	-
3	R	-
5	G	-
6	LG	-
7	W	-
9	G	-

A
B
C
D
E
F
G
H
I
J
L
M
N
O
P

SEC



VEHICLE SECURITY SYSTEM

< DTC/CIRCUIT DIAGNOSIS >

VEHICLE SECURITY SYSTEM

1	V	-
2	R	-
3	B	-
4	GR	-
5	P	-
6	W	-
7	BR	-
8	P	-
9	L	-
10	L	-
11	L	-
12	Y	-
13	R	-
14	Y	-
15	R	-
16	R	-
17	GR	-
18	GR	-
19	LG	-
20	LG	-
21	LG	-
22	LG	-
23	LG	-
24	LG	-
25	LG	-
26	LG	-
27	LG	-
28	LG	-
29	LG	-
30	SB	-
31	B	-
32	W	-
33	W	-
34	W	-
35	GR	-
36	GR	-
37	LG	-
38	W	-
39	Y	-
40	Y	-
41	GR	-
42	SHIELD	-
43	V	-
44	SB	-

Connector No.	M7
Connector Name	WIRE TO WIRE
Connector Type	TH8BMW-GS1P-TM4

Terminal No.	Color	Wire	Signal Name [Specification]
1	GR	GR	-
2	P	P	-
3	P	P	-
4	Y	Y	-
5	L	L	-
6	L	L	-
7	G	G	-
8	BG	BG	-
9	Y	Y	-
10	L	L	-
11	L	L	-
12	P	P	-
13	L	L	-
14	L	L	-
15	LG	LG	-
16	BR	BR	-
17	BG	BG	-
18	LG	LG	-
19	LG	LG	-
20	V	V	-
21	V	V	-
22	LG	LG	-
23	SHIELD	SHIELD	-
24	SHIELD	SHIELD	-
25	GR	GR	-
26	Y	Y	-
27	SHIELD	SHIELD	-
28	SB	SB	-
29	SB	SB	-
30	LG	LG	-
31	O	O	-
32	W	W	-
33	SHIELD	SHIELD	-
34	R	R	-
35	G	G	-
36	V	V	-
37	V	V	-
38	P	P	-
39	SB	SB	-
40	V	V	-



61	W	-
62	BR	-
63	LG	-
64	LG	-
65	BG	-
66	SB	-
67	G	-
68	GR	-
69	L	-
70	P	-
71	L	-
72	P	-
73	BG	-

Connector No.	M24
Connector Name	DATA LINK CONNECTOR
Connector Type	BD1BEV-P

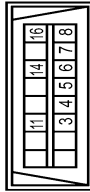
Terminal No.	Color	Wire	Signal Name [Specification]
3	LG	LG	-
4	B	B	-
5	B	B	-
6	L	L	-
7	V	V	-
8	G	G	-
9	SB	SB	-
10	SB	SB	-
11	SB	SB	-
12	P	P	-
13	R	R	-
14	P	P	-
15	R	R	-
16	R	R	-

Connector No.	M53
Connector Name	COMBINATION METER
Connector Type	SAB40EV

Terminal No.	Color	Wire	Signal Name [Specification]
1	G	G	BATTERY POWER SUPPLY
2	LG	LG	COMMUNICATION SIGNAL (METER-AMP)
3	GR	GR	COMMUNICATION SIGNAL (AMP-METER)
4	B	B	GROUND
5	B	B	ALTERNATOR SIGNAL
6	W	W	AIR BAG SIGNAL
7	LG	LG	SECURITY SIGNAL
8	W	W	GROUND
9	BR	BR	METER CONTROL SWITCH GROUND
10	GR	GR	ILL GND
11	B	B	ILL GND
12	R	R	ILL
13	G	G	GROUND
14	GR	GR	COMMUNICATION SIGNAL (GPS-AMP)
15	GR	GR	COMMUNICATION SIGNAL (AMP-LED)
16	R	R	VEHICLE SPEED SIGNAL (E-PULS SE)
17	P	P	PARKING BRAKE SWITCH SIGNAL
18	SB	SB	BRAKE FLUID LEVEL SWITCH
19	P	P	SEAT BELT BUCKLE SW SIGNAL (DRIVER SIDE)
20	G	G	SEAT BELT BUCKLE SWITCH SIGNAL (PASSENGER SIDE)
21	L	L	WASHER LEVEL SWITCH SIGNAL
22	R	R	ILLUMINATION CONTROL SIGNAL
23	LG	LG	SELECT SWITCH SIGNAL
24	Y	Y	ENTER SWITCH SIGNAL
25	G	G	TRIP A/B RESET SWITCH SIGNAL
26	P	P	ILLUMINATION CONTROL SWITCH SIGNAL (-)
27	BG	BG	ILLUMINATION CONTROL SWITCH SIGNAL (+)

JRKWD7654GB

VEHICLE SECURITY SYSTEM

< DTC/CIRCUIT DIAGNOSIS >

VEHICLE SECURITY SYSTEM

Connector No.	MT17
Wire TO WIRE	-
Connector Type	TH80MK-CS16-TM4



Terminal No.	Color Of Wire	Signal Name [Specification]
1	LG	-
2	SB	-
3	SB	-
31	SB	-
32	LG	-
33	SB	-
34	LG	-
40	Y	-
41	G	-
42	LG	-
43	R	-
45	G	-
46	SHIELD	-
47	P	-
48	SHIELD	-
50	Y	-
51	R	-
71	R	-
80	W	-
81	SHIELD	-
82	P	-
83	L	-
84	G	-
85	SHIELD	-
86	W	-
87	B	-
88	R	-
89	G	-
90	Y	-
92	Y	-
93	BR	-
94	Y	-
95	G	-
96	G	-

37	R	-
38	BG	-
39	P	-
100	L	-

Connector No.	MT18
Connector Name	BCM (BODY CONTROL MODULE)
Connector Type	M03FE-LC



Terminal No.	Color Of Wire	Signal Name [Specification]
1	W	BAT (7/L)
2	Y	POWER WINDOW POWER SUPPLY (BAT)
3	BG	POWER WINDOW POWER SUPPLY (RAP)

Connector No.	MT19
Connector Name	BCM (BODY CONTROL MODULE)
Connector Type	HS16FW-CS



Terminal No.	Color Of Wire	Signal Name [Specification]
4	LG	INTERIOR ROOM LAMP POWER SUPPLY
5	P	PASSENGER DOOR UNLOCK OUTPUT
7	SB	STEP LAMP CONT
8	V	ALL DOOR FUEL LID LOCK OUTPUT
9	P	DRIVER DOOR FUEL LID LOCK OUTPUT
10	P	REAR DOOR FUEL LID LOCK OUTPUT
11	R	BAT (GUSE)
13	B	GROUND
14	W	PUSH-BUTTON IGNITION SW ILL GND
15	BG	ACC I/O
17	W	TURN SIGNAL RH (FRONT)

18	BG	TURN SIGNAL LH (FRONT)
19	V	INT ROOM LAMP CONT

Connector No.	M121
Connector Name	BCM (BODY CONTROL MODULE)
Connector Type	TH40FG-NH

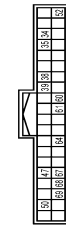

Terminal No.	Color Of Wire	Signal Name [Specification]
34	SB	TRUNK ROOM ANT-
35	V	TRUNK ROOM ANT+
38	B	REAR BUMPER ANT-
39	W	REAR BUMPER ANT+
47	Y	IGN RELAY (PDM E/R) CONT
50	BG	TRUNK ROOM LAMP SW
52	R	STARTER RELAY CONT
60	BR	PUSH SW
61	SB	TRUNK LID OPENER REQUEST SW
64	G	I-KEY/WARN BUZZER (ENG ROOM)
67	GR	TRUNK LID OPENER SW
68	BG	REAR LID DOOR SW
69	L	REAR LID DOOR SW

Connector No.	M122
Connector Name	BCM (BODY CONTROL MODULE)
Connector Type	TH40FE-NH



VEHICLE SECURITY SYSTEM

< DTC/CIRCUIT DIAGNOSIS >

VEHICLE SECURITY SYSTEM	
132	V POWER WINDOW SW COMM
133	V PUSH-BUTTON WINDOW SW STILL POWER
134	LG LOCK IND
137	BG RECEIVER // SENSOR GND
138	V RECEIVER // SENSOR POWER SUPPLY
139	L TIRE PRESSURE RECEIVER COMM
140	B SHIFT N/P
141	W SECURITY IND LAMP CONT
142	BR COMBI SW OUTPUT 5
143	P COMBI SW OUTPUT 1
144	G COMBI SW OUTPUT 2
145	L COMBI SW OUTPUT 3
146	SB COMBI SW OUTPUT 4
150	GR DRIVER DOOR SW
151	G REAR WINDOW DEFROSTER RELAY CONT

JRKWD7656GB

BCM (BODY CONTROL MODULE)

< ECU DIAGNOSIS INFORMATION >

ECU DIAGNOSIS INFORMATION

BCM (BODY CONTROL MODULE)

Reference Value

INFOID:0000000011433270

VALUES ON THE DIAGNOSIS TOOL

NOTE:

The following table includes information (items) inapplicable to this vehicle. For information (items) applicable to this vehicle, refer to CONSULT display items.

CONSULT MONITOR ITEM

Monitor Item	Condition	Value/Status
FR WIPER HI	Other than front wiper switch HI	Off
	Front wiper switch HI	On
FR WIPER LOW	Other than front wiper switch LO	Off
	Front wiper switch LO	On
FR WASHER SW	Front washer switch OFF	Off
	Front washer switch ON	On
FR WIPER INT	Other than front wiper switch INT/AUTO	Off
	Front wiper switch INT/AUTO	On
FR WIPER STOP	Front wiper is not in STOP position	Off
	Front wiper is in STOP position	On
INT VOLUME	Wiper volume dial is in a dial position 1 - 7	Wiper volume dial position
TURN SIGNAL R	Other than turn signal switch RH	Off
	Turn signal switch RH	On
TURN SIGNAL L	Other than turn signal switch LH	Off
	Turn signal switch LH	On
TAIL LAMP SW	Other than lighting switch 1ST and 2ND	Off
	Lighting switch 1ST or 2ND	On
HI BEAM SW	Other than lighting switch HI	Off
	Lighting switch HI	On
HEAD LAMP SW 1	Other than lighting switch 2ND	Off
	Lighting switch 2ND	On
HEAD LAMP SW 2	Other than lighting switch 2ND	Off
	Lighting switch 2ND	On
PASSING SW	Other than lighting switch PASS	Off
	Lighting switch PASS	On
AUTO LIGHT SW	Other than lighting switch AUTO	Off
	Lighting switch AUTO	On
FR FOG SW	Front fog lamp switch OFF	Off
	Front fog lamp switch ON	On
RR FOG SW	NOTE: The item is indicated, but not monitored.	Off
DOOR SW-DR	Driver door closed	Off
	Driver door opened	On
DOOR SW-AS	Passenger door closed	Off
	Passenger door opened	On

A
B
C
D
E
F
G
H
I
J
L
M
N
O
P

SEC

BCM (BODY CONTROL MODULE)

< ECU DIAGNOSIS INFORMATION >

Monitor Item	Condition	Value/Status
DOOR SW-RR	Rear RH door closed	Off
	Rear LH door opened	On
DOOR SW-RL	Rear LH door closed	Off
	Rear LH door opened	On
DOOR SW-BK	NOTE: The item is indicated, but not monitored.	Off
CDL LOCK SW	Other than power door lock switch LOCK	Off
	Power door lock switch LOCK	On
CDL UNLOCK SW	Other than power door lock switch UNLOCK	Off
	Power door lock switch UNLOCK	On
KEY CYL LK-SW	Other than driver door key cylinder LOCK	Off
	Driver door key cylinder LOCK	On
KEY CYL UN-SW	Other than driver door key cylinder UNLOCK	Off
	Driver door key cylinder LOCK	On
KEY CYL SW-TR	NOTE: The item is indicated, but not monitored.	Off
HAZARD SW	Hazard switch is OFF	Off
	Hazard switch is ON	On
REAR DEF SW	NOTE: The item is indicated, but not monitored.	Off
TR CANCEL SW	Trunk lid opener cancel switch OFF	Off
	Trunk lid opener cancel switch ON	On
TR/BD OPEN SW	Trunk lid opener switch OFF	Off
	While the trunk lid opener switch is turned ON	On
TRNK/HAT MNTR	Trunk lid closed	Off
	Trunk lid opened	On
REVERSE SW	NOTE: The item is indicated, but not monitored.	Off
RKE-LOCK	LOCK button of the Intelligent Key is not pressed	Off
	LOCK button of the Intelligent Key is pressed	On
RKE-UNLOCK	UNLOCK button of the Intelligent Key is not pressed	Off
	UNLOCK button of the Intelligent Key is pressed	On
RKE-TR/BD	TRUNK OPEN button of the Intelligent Key is not pressed	Off
	TRUNK OPEN button of the Intelligent Key is pressed	On
RKE-PANIC	PANIC button of the Intelligent Key is not pressed	Off
	PANIC button of the Intelligent Key is pressed	On
RKE-P/W OPEN	UNLOCK button of the Intelligent Key is not pressed	Off
	UNLOCK button of the Intelligent Key is pressed and held	On
RKE-MODE CHG	LOCK/UNLOCK button of the Intelligent Key is not pressed and held simultaneously	Off
	LOCK/UNLOCK button of the Intelligent Key is pressed and held simultaneously	On
OPTICAL SENSOR	Bright outside of the vehicle	Close to 5 V
	Dark outside of the vehicle	Close to 0 V
REQ SW -DR	Driver door request switch is not pressed	Off
	Driver door request switch is pressed	On

BCM (BODY CONTROL MODULE)

< ECU DIAGNOSIS INFORMATION >

Monitor Item	Condition	Value/Status	
REQ SW -AS	Passenger door request switch is not pressed	Off	A
	Passenger door request switch is pressed	On	
REQ SW -RR	NOTE: The item is indicated, but not monitored.	Off	B
REQ SW -RL	NOTE: The item is indicated, but not monitored.	Off	C
REQ SW -BD/TR	Trunk lid opener request switch is not pressed	Off	
	Trunk lid opener request switch is pressed	On	
PUSH SW	Push-button ignition switch (push switch) is not pressed	Off	D
	Push-button ignition switch (push switch) is pressed	On	
IGN RLY2 -F/B	NOTE: The item is indicated, but not monitored.	Off	E
ACC RLY -F/B	NOTE: The item is indicated, but not monitored.	Off	
CLUCH SW	NOTE: The item is indicated, but not monitored.	Off	F
BRAKE SW 1	The brake pedal is depressed when No. 7 fuse is blown	Off	
	The brake pedal is not depressed when No. 7 fuse is blown, or No. 7 fuse is normal	On	G
BRAKE SW 2	The brake pedal is not depressed	Off	H
	The brake pedal is depressed	On	
DETE/CANCL SW	Selector lever in P position	Off	
	Selector lever in any position other than P	On	I
SFT PN/N SW	Selector lever in any position other than P and N	Off	
	Selector lever in P or N position	On	J
S/L -LOCK	NOTE: The item is indicated, but not monitored.	Off	
S/L -UNLOCK	NOTE: The item is indicated, but not monitored.	Off	SEC
S/L RELAY-F/B	NOTE: The item is indicated, but not monitored.	Off	
UNLK SEN -DR	Driver door is unlocked	Off	L
	Driver door is locked	On	
PUSH SW -IPDM	Push-button ignition switch (push-switch) is not pressed	Off	M
	Push-button ignition switch (push-switch) is pressed	On	
IGN RLY1 -F/B	Ignition switch in OFF or ACC position	Off	
	Ignition switch in ON position	On	N
DETE SW -IPDM	Selector lever in any position other than P	Off	
	Selector lever in P position	On	O
SFT PN -IPDM	Selector lever in any position other than P and N	Off	
	Selector lever in P or N position	On	
SFT P -MET	Selector lever in any position other than P	Off	P
	Selector lever in P position	On	
SFT N -MET	Selector lever in any position other than N	Off	
	Selector lever in N position	On	

BCM (BODY CONTROL MODULE)

< ECU DIAGNOSIS INFORMATION >

Monitor Item	Condition	Value/Status
ENGINE STATE	Engine stopped	Stop
	While the engine stalls	Stall
	At engine cranking	Crank
	Engine running	Run
S/L LOCK-IPDM	NOTE: The item is indicated, but not monitored.	Off
S/L UNLK-IPDM	NOTE: The item is indicated, but not monitored.	Off
S/L RELAY-REQ	NOTE: The item is indicated, but not monitored.	Off
VEH SPEED 1	While driving	Equivalent to speedometer reading
VEH SPEED 2	While driving	Equivalent to speedometer reading
DOOR STAT-DR	Driver door is locked	LOCK
	Wait with selective UNLOCK operation (60 seconds)	READY
	Driver door is unlocked	UNLOCK
DOOR STAT-AS	Passenger door is locked	LOCK
	Wait with selective UNLOCK operation (60 seconds)	READY
	Passenger door is unlocked	UNLOCK
ID OK FLAG	Driver side door is open after ignition switch is turned OFF (Shift position is in the P position)	Reset
	Ignition switch ON	Set
PRMT ENG STRT	The engine start is prohibited	Reset
	The engine start is permitted	Set
PRMT RKE STRT	NOTE: The item is indicated, but not monitored.	Reset
KEY SW -SLOT	The Intelligent Key is not inserted into key slot	Off
	The Intelligent Key is inserted into key slot	On
RKE OPE COUN1	During the operation of the Intelligent Key	Operation frequency of the Intelligent Key
RKE OPE COUN2	NOTE: The item is indicated, but not monitored.	—
CONFIRM ID ALL	The key ID that the key slot receives is not recognized by any key ID registered to BCM.	Yet
	The key ID that the key slot receives is recognized by any key ID registered to BCM.	Done
CONFIRM ID4	The key ID that the key slot receives is not recognized by the fourth key ID registered to BCM.	Yet
	The key ID that the key slot receives is recognized by the fourth key ID registered to BCM.	Done
CONFIRM ID3	The key ID that the key slot receives is not recognized by the third key ID registered to BCM.	Yet
	The key ID that the key slot receives is recognized by the third key ID registered to BCM.	Done
CONFIRM ID2	The key ID that the key slot receives is not recognized by the second key ID registered to BCM.	Yet
	The key ID that the key slot receives is recognized by the second key ID registered to BCM.	Done

BCM (BODY CONTROL MODULE)

< ECU DIAGNOSIS INFORMATION >

Monitor Item	Condition	Value/Status
CONFIRM ID1	The key ID that the key slot receives is not recognized by the first key ID registered to BCM.	Yet
	The key ID that the key slot receives is recognized by the first key ID registered to BCM.	Done
TP 4	The ID of fourth Intelligent Key is not registered to BCM	Yet
	The ID of fourth Intelligent Key is registered to BCM	Done
TP 3	The ID of third Intelligent Key is not registered to BCM	Yet
	The ID of third Intelligent Key is registered to BCM	Done
TP 2	The ID of second Intelligent Key is not registered to BCM	Yet
	The ID of second Intelligent Key is registered to BCM	Done
TP 1	The ID of first Intelligent Key is not registered to BCM	Yet
	The ID of first Intelligent Key is registered to BCM	Done
AIR PRESS FL	Ignition switch ON (Only when the signal from the transmitter is received)	Air pressure of front LH tire
AIR PRESS FR	Ignition switch ON (Only when the signal from the transmitter is received)	Air pressure of front RH tire
AIR PRESS RR	Ignition switch ON (Only when the signal from the transmitter is received)	Air pressure of rear RH tire
AIR PRESS RL	Ignition switch ON (Only when the signal from the transmitter is received)	Air pressure of rear LH tire
ID REGST FL1	ID of front LH tire transmitter is registered	Done
	ID of front LH tire transmitter is not registered	Yet
ID REGST FR1	ID of front RH tire transmitter is registered	Done
	ID of front RH tire transmitter is not registered	Yet
ID REGST RR1	ID of rear RH tire transmitter is registered	Done
	ID of rear RH tire transmitter is not registered	Yet
ID REGST RL1	ID of rear LH tire transmitter is registered	Done
	ID of rear LH tire transmitter is not registered	Yet
WARNING LAMP	Tire pressure indicator OFF	Off
	Tire pressure indicator ON	On
BUZZER	Tire pressure warning alarm is not sounding	Off
	Tire pressure warning alarm is sounding	On

A
B
C
D
E
F
G
H
I
J
L
M
N
O
P

SEC

BCM (BODY CONTROL MODULE)

< ECU DIAGNOSIS INFORMATION >

TERMINAL LAYOUT

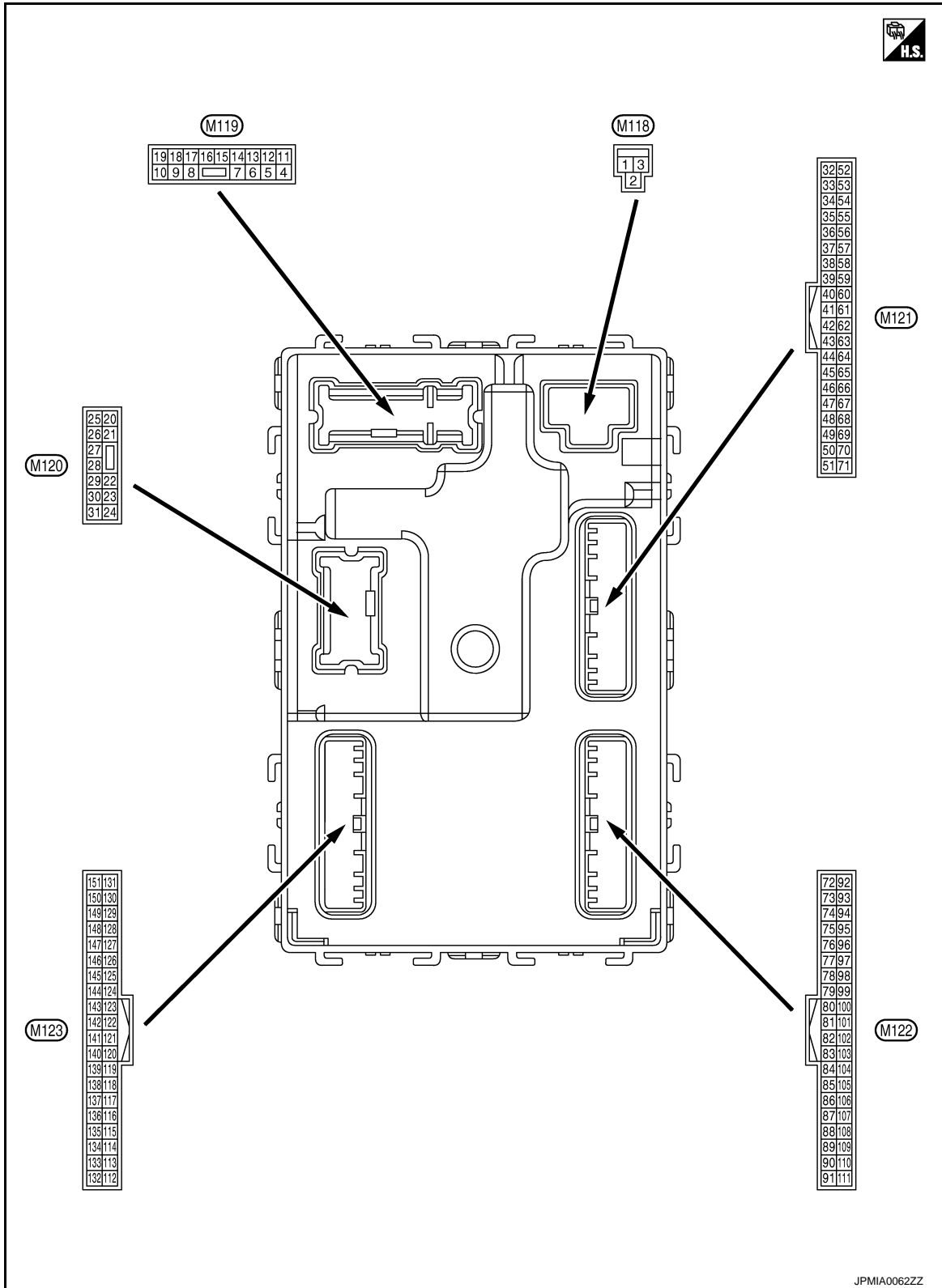

BCM (BODY CONTROL MODULE)

< ECU DIAGNOSIS INFORMATION >

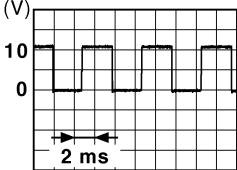
Terminal No. (Wire color)		Description		Condition		Value (Approx.)
		Signal name	Input/ Output			
+	-					
1 (W)	Ground	Battery power supply	Input	Ignition switch OFF		Battery voltage
2 (Y)	Ground	P/W power supply (BAT)	Output	Ignition switch OFF		12 V
3 (BG)	Ground	P/W power supply (RAP)	Output	Ignition switch ON		12 V
4 (LG)	Ground	Interior room lamp power supply	Output	Interior room lamp battery saver is activated. (Cuts the interior room lamp power supply)		0 V
				Interior room lamp battery saver is not activated. (Outputs the interior room lamp power supply)		12 V
5 (P)	Ground	Passenger door UN- LOCK	Output	Passenger door	UNLOCK (Actuator is activated)	12 V
					Other than UNLOCK) Ac- tuator is not activated	0 V
7 (SB)	Ground	Step lamp	Output	Step lamp	ON	0 V
					OFF	12 V
8 (V)	Ground	All doors, fuel lid LOCK	Output	All doors, fuel lid	LOCK (Actuator is activated)	12 V
					Other than LOCK (Actuator is not activated)	0 V
9 (G)	Ground	Driver door, fuel lid UNLOCK	Output	Driver door, fuel lid	UNLOCK (Actuator is activated)	12 V
					Other than UNLOCK (Actuator is not activated)	0 V
10 (P)	Ground	Rear RH door and rear LH door UN- LOCK	Output	Rear RH door and rear LH door	UNLOCK (Actuator is activated)	12 V
					Other than UNLOCK (Actuator is not activated)	0 V
11 (R)	Ground	Battery power supply	Input	Ignition switch OFF		Battery voltage
13 (B)	Ground	Ground	—	Ignition switch ON		0 V
14 (W)	Ground	Push-button ignition switch illumination ground	Output	Tail lamp	OFF	0 V
					ON	<p>NOTE: When the illumination brightening/dimming level is in the neutral position.</p>  <p style="text-align: right; font-size: small;">JSNIA0010GB</p>
15 (BG)	Ground	ACC indicator lamp	Output	Ignition switch	OFF (LOCK indicator is not illuminated)	Battery voltage
					ACC	0 V

A
B
C
D
E
F
G
H
I
J
K
L
M
N
O
P

SEC

BCM (BODY CONTROL MODULE)

< ECU DIAGNOSIS INFORMATION >

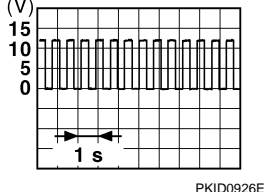
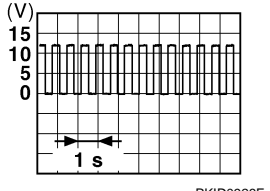
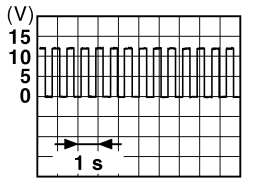
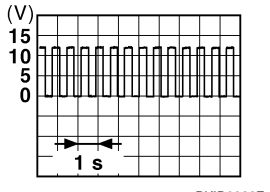
Terminal No. (Wire color)		Description		Condition	Value (Approx.)	
+	-	Signal name	Input/ Output			
17 (W)	Ground	Turn signal RH (Front)	Output	Ignition switch ON	Turn signal switch OFF	0 V
				Turn signal switch RH	 <p style="text-align: right; font-size: small;">PKID0926E</p>	6.5 V
18 (BG)	Ground	Turn signal LH (Front)	Output	Ignition switch ON	Turn signal switch OFF	0 V
				Turn signal switch LH	 <p style="text-align: right; font-size: small;">PKID0926E</p>	6.5 V
19 (V)	Ground	Interior room lamp control	Output	Interior room lamp	OFF	12 V
				ON	0 V	
20 (V)	Ground	Turn signal RH (Rear)	Output	Ignition switch ON	Turn signal switch OFF	0 V
				Turn signal switch RH	 <p style="text-align: right; font-size: small;">PKID0926E</p>	6.5 V
23 (LG)	Ground	Trunk lid open	Output	Trunk lid	OPEN (Trunk lid opener actuator is activated)	12 V
				Other than OPEN (Trunk lid opener actuator is not activated)	0 V	
25 (Y)	Ground	Turn signal LH (Rear)	Output	Ignition switch ON	Turn signal switch OFF	0 V
				Turn signal switch LH	 <p style="text-align: right; font-size: small;">PKID0926E</p>	6.5 V
30 (P)	Ground	Trunk room lamp	Output	Trunk room lamp	ON	0 V
				OFF	12 V	

BCM (BODY CONTROL MODULE)

< ECU DIAGNOSIS INFORMATION >

Terminal No. (Wire color)		Description		Condition	Value (Approx.)
+	-	Signal name	Input/ Output		
34 (SB)	Ground	Trunk room antenna (-)	Output	Ignition switch OFF	<p>JMKIA0062GB</p>
				When Intelligent Key is not in the passenger compart- ment	<p>JMKIA0063GB</p>
35 (V)	Ground	Trunk room antenna (+)	Output	Ignition switch OFF	<p>JMKIA0062GB</p>
				When Intelligent Key is not in the passenger compart- ment	<p>JMKIA0063GB</p>
38 (B)	Ground	Rear bumper anten- na (-)	Output	When the trunk lid opener re- quest switch is operated with ignition switch OFF	<p>JMKIA0062GB</p>
				When Intelligent Key is not in the antenna detection area	<p>JMKIA0063GB</p>

A
B
C
D
E
F
G
H
I
J
L
M
N
O
P

SEC

BCM (BODY CONTROL MODULE)

< ECU DIAGNOSIS INFORMATION >

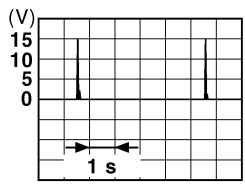
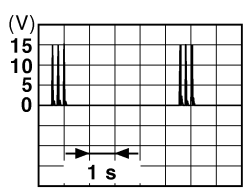
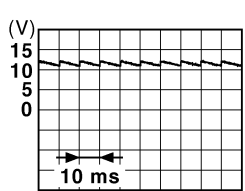
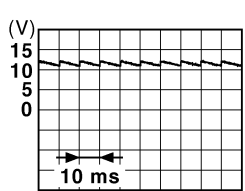
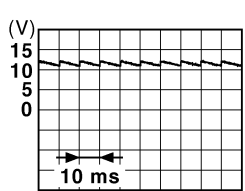
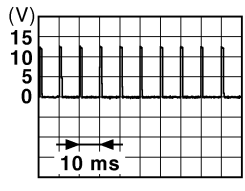
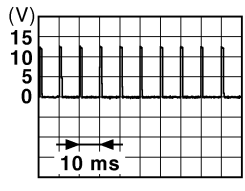
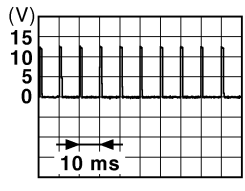
Terminal No. (Wire color)		Description		Condition	Value (Approx.)				
+	-	Signal name	Input/ Output						
39 (W)	Ground	Rear bumper antenna (+)	Output	When Intelligent Key is in the antenna detection area	 <p style="text-align: right; font-size: small;">JMKIA0062GB</p>				
				When Intelligent Key is not in the antenna detection area	 <p style="text-align: right; font-size: small;">JMKIA0063GB</p>				
47 (Y)	Ground	Ignition relay (IPDM E/R) control	Output	Ignition switch	<table border="1" style="width: 100%; border-collapse: collapse;"> <tr> <td>OFF or ACC</td> <td style="text-align: center;">12 V</td> </tr> <tr> <td>ON</td> <td style="text-align: center;">0 V</td> </tr> </table>	OFF or ACC	12 V	ON	0 V
				OFF or ACC	12 V				
ON	0 V								
50 (BG)	Ground	Trunk room lamp switch	Input	Trunk room lamp switch	<table border="1" style="width: 100%; border-collapse: collapse;"> <tr> <td>OFF (Trunk lid is closed)</td> <td>  <p style="text-align: right; font-size: small;">JPMIA0011GB</p> </td> </tr> <tr> <td>ON (Trunk lid is opened)</td> <td style="text-align: center;">0 V</td> </tr> </table>	OFF (Trunk lid is closed)	 <p style="text-align: right; font-size: small;">JPMIA0011GB</p>	ON (Trunk lid is opened)	0 V
				OFF (Trunk lid is closed)	 <p style="text-align: right; font-size: small;">JPMIA0011GB</p>				
ON (Trunk lid is opened)	0 V								
52 (R)	Ground	Starter relay control	Output	Ignition switch ON	<table border="1" style="width: 100%; border-collapse: collapse;"> <tr> <td>When selector lever is in P or N position</td> <td style="text-align: center;">12 V</td> </tr> <tr> <td>When selector lever is not in P or N position</td> <td style="text-align: center;">0 V</td> </tr> </table>	When selector lever is in P or N position	12 V	When selector lever is not in P or N position	0 V
				When selector lever is in P or N position	12 V				
When selector lever is not in P or N position	0 V								
60 (BR)	Ground	Push-button ignition switch (Push switch)	Input	Push-button ignition switch (push switch)	<table border="1" style="width: 100%; border-collapse: collapse;"> <tr> <td>Pressed</td> <td style="text-align: center;">0 V</td> </tr> <tr> <td>Not pressed</td> <td style="text-align: center;">Battery voltage</td> </tr> </table>	Pressed	0 V	Not pressed	Battery voltage
				Pressed	0 V				
Not pressed	Battery voltage								
61 (SB)	Ground	Trunk lid opener request switch	Input	Trunk lid opener request switch	<table border="1" style="width: 100%; border-collapse: collapse;"> <tr> <td>ON (Pressed)</td> <td style="text-align: center;">0 V</td> </tr> <tr> <td>OFF (Not pressed)</td> <td>  <p style="text-align: right; font-size: small;">JPMIA0016GB</p> </td> </tr> </table>	ON (Pressed)	0 V	OFF (Not pressed)	 <p style="text-align: right; font-size: small;">JPMIA0016GB</p>
				ON (Pressed)	0 V				
OFF (Not pressed)	 <p style="text-align: right; font-size: small;">JPMIA0016GB</p>								
64 (G)	Ground	Intelligent Key warning buzzer (Engine room)	Output	Intelligent Key warning buzzer (Engine room)	<table border="1" style="width: 100%; border-collapse: collapse;"> <tr> <td>Sounding</td> <td style="text-align: center;">0 V</td> </tr> <tr> <td>Not sounding</td> <td style="text-align: center;">12 V</td> </tr> </table>	Sounding	0 V	Not sounding	12 V
				Sounding	0 V				
Not sounding	12 V								

BCM (BODY CONTROL MODULE)

< ECU DIAGNOSIS INFORMATION >

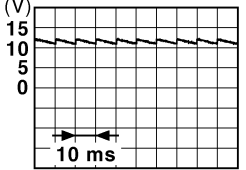
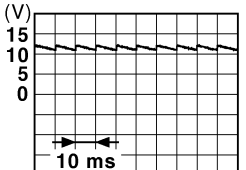
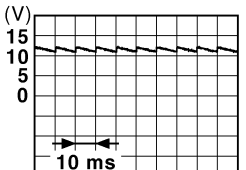
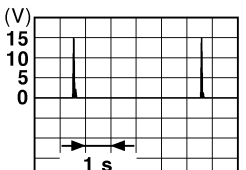
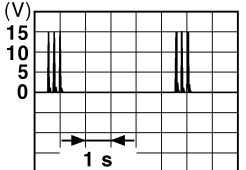
Terminal No. (Wire color)		Description		Condition	Value (Approx.)	
+	-	Signal name	Input/ Output			
67 (GR)	Ground	Trunk lid opener switch	Input	Trunk lid opener switch	Pressed	0 V
					Not pressed	 <p style="text-align: right; font-size: small;">JPMA0011GB</p>
68 (BG)	Ground	Rear RH door switch	Input	Rear RH door switch	OFF (When rear RH door closes)	 <p style="text-align: right; font-size: small;">JPMA0011GB</p>
					ON (When rear RH door opens)	0 V
69 (L)	Ground	Rear LH door switch	Input	Rear LH door switch	OFF (When rear LH door closes)	 <p style="text-align: right; font-size: small;">JPMA0011GB</p>
					ON (When rear LH door opens)	0 V
72 (R)	Ground	Room antenna 2 (-) (Center console)	Output	Ignition switch OFF	When Intelligent Key is in the passenger compartment	 <p style="text-align: right; font-size: small;">JMKIA0062GB</p>
					When Intelligent Key is not in the passenger compartment	 <p style="text-align: right; font-size: small;">JMKIA0063GB</p>

A
B
C
D
E
F
G
H
I
J
L
M
N
O
P

SEC

BCM (BODY CONTROL MODULE)

< ECU DIAGNOSIS INFORMATION >

Terminal No. (Wire color)		Description		Condition	Value (Approx.)
+	-	Signal name	Input/ Output		
73 (G)	Ground	Room antenna 2 (+) (Center console)	Output	Ignition switch OFF	<p style="text-align: right; font-size: small;">JMKIA0062GB</p>
				When Intelligent Key is not in the passenger compart- ment	<p style="text-align: right; font-size: small;">JMKIA0063GB</p>
74 (SB)	Ground	Passenger door an- tenna (-)	Output	When the pas- senger door re- quest switch is operated with ignition switch OFF	<p style="text-align: right; font-size: small;">JMKIA0062GB</p>
				When Intelligent Key is not in the antenna detection area	<p style="text-align: right; font-size: small;">JMKIA0063GB</p>
75 (BR)	Ground	Passenger door an- tenna (+)	Output	When the pas- senger door re- quest switch is operated with ignition switch OFF	<p style="text-align: right; font-size: small;">JMKIA0062GB</p>
				When Intelligent Key is not in the antenna detection area	<p style="text-align: right; font-size: small;">JMKIA0063GB</p>

BCM (BODY CONTROL MODULE)

< ECU DIAGNOSIS INFORMATION >

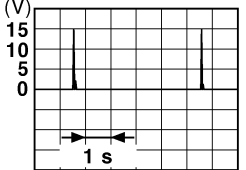
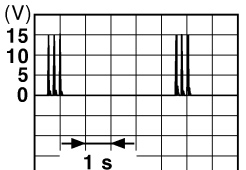
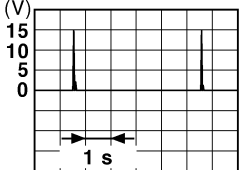
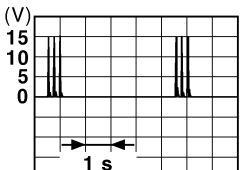
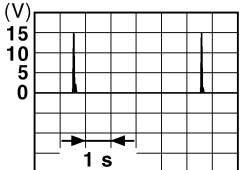
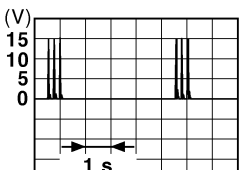
Terminal No. (Wire color)		Description		Condition	Value (Approx.)	
		Signal name	Input/ Output			
+	-					
76 (V)	Ground	Driver door antenna (-)	Output	When the driver door request switch is operated with ignition switch OFF	When Intelligent Key is in the antenna detection area	 <small>JMKIA0062GB</small>
				When the driver door request switch is operated with ignition switch OFF	When Intelligent Key is not in the antenna detection area	 <small>JMKIA0063GB</small>
77 (LG)	Ground	Driver door antenna (+)	Output	When the driver door request switch is operated with ignition switch OFF	When Intelligent Key is in the antenna detection area	 <small>JMKIA0062GB</small>
				When the driver door request switch is operated with ignition switch OFF	When Intelligent Key is not in the antenna detection area	 <small>JMKIA0063GB</small>
78 (Y)	Ground	Room antenna 1 (-) (Instrument panel)	Output	Ignition switch OFF	When Intelligent Key is in the passenger compartment	 <small>JMKIA0062GB</small>
				Ignition switch OFF	When Intelligent Key is not in the passenger compartment	 <small>JMKIA0063GB</small>

A
B
C
D
E
F
G
H
I
J
L
M
N
O
P

SEC



BCM (BODY CONTROL MODULE)

< ECU DIAGNOSIS INFORMATION >

Terminal No. (Wire color)		Description		Condition	Value (Approx.)	
+	-	Signal name	Input/ Output			
79 (BR)	Ground	Room antenna 1 (+) (Instrument panel)	Output	Ignition switch OFF		
				When Intelligent Key is not in the passenger compart- ment		
80 (GR)	Ground	NATS antenna amp.	Input/ Output	During waiting	Ignition switch is pressed while inserting the Intelli- gent Key into the key slot.	Just after pressing ignition switch. Pointer of tester should move.
81 (W)	Ground	NATS antenna amp.	Input/ Output	During waiting	Ignition switch is pressed while inserting the Intelli- gent Key into the key slot.	Just after pressing ignition switch. Pointer of tester should move.
82 (SB)	Ground	Ignition relay [Fuse block (J/B)] control	Output	Ignition switch	OFF or ACC	0 V
				ON		12 V
83 (Y)	Ground	Remote keyless entry receiver communica- tion	Input/ Output	During waiting		
				When operating either button on the Intelli- gent Key		

BCM (BODY CONTROL MODULE)

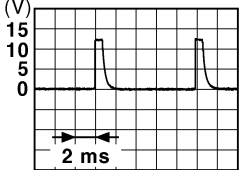
< ECU DIAGNOSIS INFORMATION >

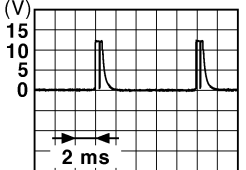
Terminal No. (Wire color)		Description		Condition	Value (Approx.)	
		Signal name	Input/ Output			
+	-					
87 (Y)	Ground	Combination switch INPUT 5	Input	Combination switch	All switches OFF (Wiper volume dial 4)	 1.4 V
				Combination switch	Front fog lamp switch ON (Wiper volume dial 4)	 1.3 V
					Any of the conditions be- low with all switches OFF	 1.3 V

A
B
C
D
E
F
G
H
I
J
L
M
N
O
P

SEC

BCM (BODY CONTROL MODULE)

< ECU DIAGNOSIS INFORMATION >

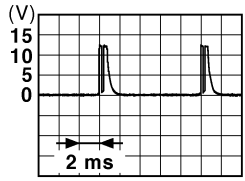
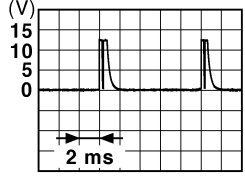
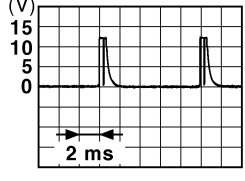
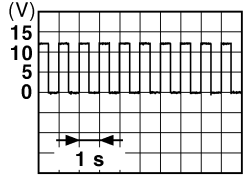
Terminal No. (Wire color)		Description		Condition	Value (Approx.)	
+	-	Signal name	Input/ Output			
88 (BG)	Ground	Combination switch INPUT 3	Input	Combination switch	All switches OFF (Wiper volume dial 4)	 <p style="text-align: right; font-size: small;">JP MIA0041GB</p> <p style="text-align: center;">1.4 V</p>
					Lighting switch HI (Wiper volume dial 4)	 <p style="text-align: right; font-size: small;">JP MIA0036GB</p> <p style="text-align: center;">1.3 V</p>
					Lighting switch 2ND (Wiper volume dial 4)	 <p style="text-align: right; font-size: small;">JP MIA0037GB</p> <p style="text-align: center;">1.3 V</p>
					Any of the conditions below with all switches OFF <ul style="list-style-type: none"> • Wiper volume dial 1 • Wiper volume dial 2 • Wiper volume dial 3 	 <p style="text-align: right; font-size: small;">JP MIA0040GB</p> <p style="text-align: center;">1.3 V</p>
90 (P)	Ground	CAN-L	Input/ Output	—	—	
91 (L)	Ground	CAN-H	Input/ Output	—	—	
92 (LG)	Ground	Key slot illumination	Output	Key slot illumi- nation	OFF	12 V
					Blinking	 <p style="text-align: right; font-size: small;">JP MIA0015GB</p> <p style="text-align: center;">6.5 V</p>
93 (GR)	Ground	ON indicator lamp	Output	Ignition switch	OFF (LOCK indicator is not illuminated)	Battery voltage
					ON	0 V

BCM (BODY CONTROL MODULE)

< ECU DIAGNOSIS INFORMATION >

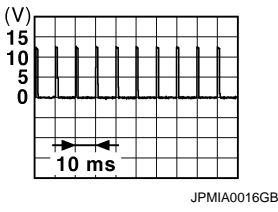
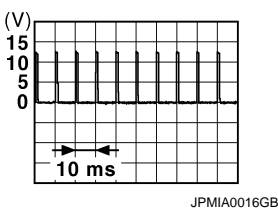



Terminal No. (Wire color)		Description		Condition		Value (Approx.)
+	-	Signal name	Input/ Output			
95 (BG)	Ground	ACC relay control	Output	Ignition switch	OFF	0 V
					ACC or ON	12 V
96 (GR)	Ground	A/T shift selector (Detention switch) power supply	Output	—		12 V
99 (R)	Ground	Selector lever P position switch	Input	Selector lever	P position	0 V
					Any position other than P	12 V
100 (Y)	Ground	Passenger door request switch	Input	Passenger door request switch	ON (Pressed)	0 V
					OFF (Not pressed)	 1.0 V JPMA0016GB
101 (P)	Ground	Driver door request switch	Input	Driver door request switch	ON (Pressed)	0 V
					OFF (Not pressed)	 1.0 V JPMA0016GB
102 (BG)	Ground	Blower fan motor relay control	Output	Ignition switch	OFF or ACC	0 V
					ON	12 V
103 (P)	Ground	Remote keyless entry receiver power supply	Output	Ignition switch OFF		12 V

A
B
C
D
E
F
G
H
I
J
L
M
N
O
P

SEC

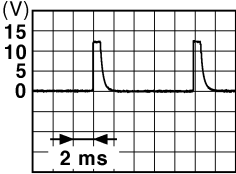

BCM (BODY CONTROL MODULE)

< ECU DIAGNOSIS INFORMATION >

Terminal No. (Wire color)		Description		Condition	Value (Approx.)	
		Signal name	Input/ Output			
+	-					
107 (LG)	Ground	Combination switch INPUT 1	Input	Combination switch (Wiper volume dial 4)	All switches OFF	 <p style="text-align: right;">1.4 V</p>
					Turn signal switch LH	 <p style="text-align: right;">1.3 V</p>
					Turn signal switch RH	 <p style="text-align: right;">1.3 V</p>
					Front wiper switch LO	 <p style="text-align: right;">1.3 V</p>
					Front washer switch ON	 <p style="text-align: right;">1.3 V</p>

BCM (BODY CONTROL MODULE)

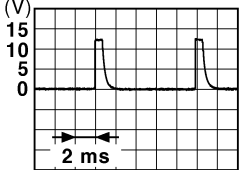
< ECU DIAGNOSIS INFORMATION >

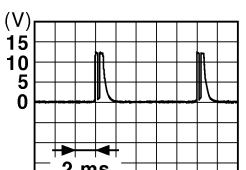
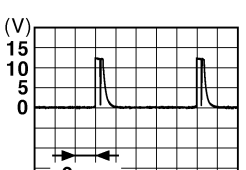
Terminal No. (Wire color)		Description		Condition	Value (Approx.)	
		Signal name	Input/ Output			
+	-					
108 (R)	Ground	Combination switch INPUT 4	Input	Combination switch	All switches OFF (Wiper volume dial 4)	 <p style="text-align: right; margin-right: 50px;">1.4 V</p>
					Lighting switch AUTO (Wiper volume dial 4)	 <p style="text-align: right; margin-right: 50px;">1.3 V</p>
					Lighting switch 1ST (Wiper volume dial 4)	 <p style="text-align: right; margin-right: 50px;">1.3 V</p>
					Any of the conditions below with all switches OFF <ul style="list-style-type: none"> • Wiper volume dial 1 • Wiper volume dial 5 • Wiper volume dial 6 	 <p style="text-align: right; margin-right: 50px;">1.3 V</p>

A
B
C
D
E
F
G
H
I
J
L
M
N
O
P

SEC

BCM (BODY CONTROL MODULE)

< ECU DIAGNOSIS INFORMATION >

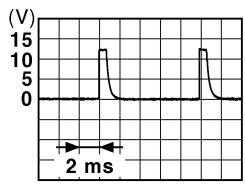
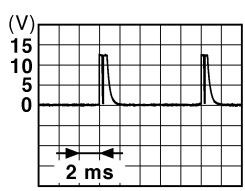
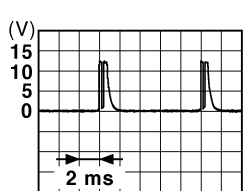
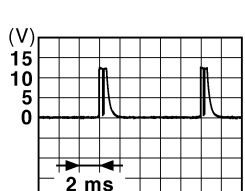
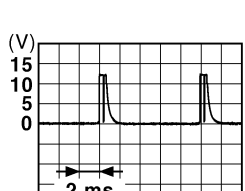
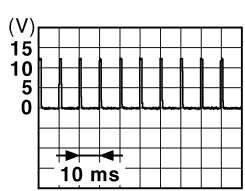
Terminal No. (Wire color)		Description		Condition	Value (Approx.)	
+	-	Signal name	Input/ Output			
109 (W)	Ground	Combination switch INPUT 2	Input	Combination switch (Wiper volume dial 4)	All switches OFF	 <p style="text-align: right; font-size: small;">JPMA0041GB</p> <p style="text-align: center;">1.4 V</p>
					Lighting switch PASS	 <p style="text-align: right; font-size: small;">JPMA0037GB</p> <p style="text-align: center;">1.3 V</p>
					Lighting switch 2ND	 <p style="text-align: right; font-size: small;">JPMA0036GB</p> <p style="text-align: center;">1.3 V</p>
					Front wiper switch INT/ AUTO	 <p style="text-align: right; font-size: small;">JPMA0038GB</p> <p style="text-align: center;">1.3 V</p>
					Front wiper switch HI	 <p style="text-align: right; font-size: small;">JPMA0040GB</p> <p style="text-align: center;">1.3 V</p>
110 (G)	Ground	Hazard switch	Input	Hazard switch	ON	0 V
					OFF	 <p style="text-align: right; font-size: small;">JPMA0012GB</p> <p style="text-align: center;">1.1 V</p>

BCM (BODY CONTROL MODULE)

< ECU DIAGNOSIS INFORMATION >

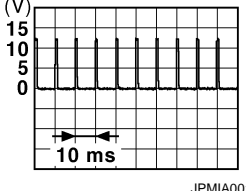
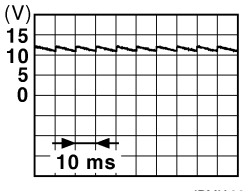
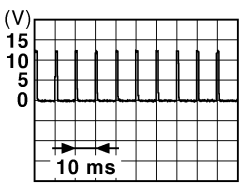
Terminal No. (Wire color)		Description		Condition		Value (Approx.)
+	-	Signal name	Input/ Output			
113 (BG)	Ground	Optical sensor	Input	Ignition switch ON	When bright outside of the vehicle	Close to 5 V
					When dark outside of the vehicle	Close to 0 V
116 (SB)	Ground	Stop lamp switch 1	Input	—		Battery voltage
118 (BR)	Ground	Stop lamp switch 2 (Without ICC)	Input	Stop lamp switch	OFF (Brake pedal is not depressed)	0 V
					ON (Brake pedal is depressed)	Battery voltage
		Stop lamp switch 2 (With ICC)		Stop lamp switch OFF (Brake pedal is not depressed) and ICC brake hold relay OFF		0 V
				Stop lamp switch ON (Brake pedal is depressed) or ICC brake hold relay ON		Battery voltage
119 (SB)	Ground	Front door lock assembly driver side (Unlock sensor)	Input	Driver door	LOCK status (Unlock sensor switch OFF)	 1.1 V
					UNLOCK status (Unlock switch sensor ON)	0 V
121 (SB)	Ground	Key slot switch	Input	When the Intelligent Key is inserted into key slot		12 V
				When the Intelligent Key is not inserted into key slot		0 V
123 (V)	Ground	IGN feedback	Input	Ignition switch	OFF or ACC	0 V
					ON	Battery voltage
124 (R)	Ground	Passenger door switch	Input	Passenger door switch	OFF (Door close)	 11.8 V
					ON (Door open)	0 V
129 (BG)	Ground	Trunk lid opener cancel switch	Input	Trunk lid opener cancel switch	CANCEL	 1.1 V
					ON	0 V

A
B
C
D
E
F
G
H
I
J
L
M
N
O
P

SEC



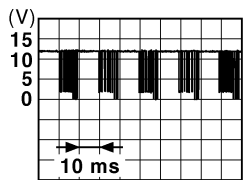
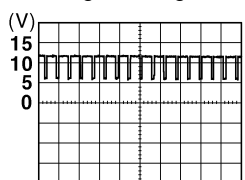
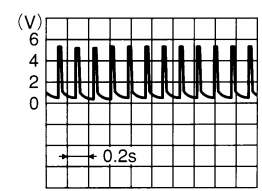
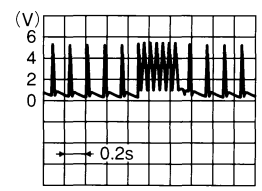

BCM (BODY CONTROL MODULE)

< ECU DIAGNOSIS INFORMATION >

Terminal No. (Wire color)		Description		Condition	Value (Approx.)	
+	-	Signal name	Input/ Output			
132 (V)	Ground	Power window switch communication	Input/ Output	Ignition switch ON	 <p style="text-align: right; font-size: small;">JPMA0013GB</p> <p style="text-align: center;">10.2 V</p>	
				Ignition switch OFF or ACC	12 V	
133 (L)	Ground	Push-button ignition switch illumination	Output	ON (Tail lamps OFF)	9.5 V	
				ON (Tail lamps ON)	<p style="text-align: center;">NOTE: The pulse width of this wave is varied by the illumination brightening/dimming level.</p>  <p style="text-align: right; font-size: small;">JPMA0159GB</p>	
				OFF	0 V	
134 (LG)	Ground	LOCK indicator lamp	Output	LOCK indicator lamp	OFF	Battery voltage
				ON	0 V	
137 (BG)	Ground	Receiver and sensor ground	Input	Ignition switch ON	0 V	
138 (V)	Ground	Receiver and sensor power supply	Output	Ignition switch	OFF	0 V
				ACC or ON	5.0 V	
139 (L)	Ground	Tire pressure receiver communication	Input/ Output	Ignition switch ON	 <p style="text-align: right; font-size: small;">OCC3881D</p>	
				When receiving the signal from the transmitter	 <p style="text-align: right; font-size: small;">OCC3880D</p>	
140 (B)	Ground	Selector lever P/N position	Input	Selector lever	P or N position	12 V
				Except P and N positions	0 V	

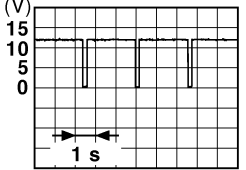
BCM (BODY CONTROL MODULE)

< ECU DIAGNOSIS INFORMATION >

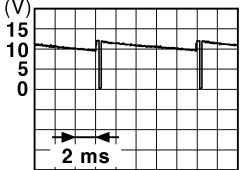
Terminal No. (Wire color)		Description		Condition	Value (Approx.)	
		Signal name	Input/ Output			
+	-					
141 (W)	Ground	Security indicator lamp	Output	Security indicator lamp	ON	0 V
				Security indicator lamp	Blinking	 <p style="text-align: right; font-size: small;">JPMAI0014GB</p>
				OFF	12 V	
142 (BR)	Ground	Combination switch OUTPUT 5	Output	Combination switch (Wiper volume dial 4)	All switches OFF	0 V
					Lighting switch 1ST	 <p style="text-align: right; font-size: small;">JPMAI0031GB</p>
					Lighting switch HI	
					Lighting switch 2ND	
					Turn signal switch RH	
				Turn signal switch RH	10.7 V	
143 (P)	Ground	Combination switch OUTPUT 1	Output	Combination switch	All switches OFF (Wiper volume dial 4)	0 V
					Front wiper switch HI (Wiper volume dial 4)	 <p style="text-align: right; font-size: small;">JPMAI0032GB</p>
					Any of the conditions below with all switches OFF	
					<ul style="list-style-type: none"> • Wiper volume dial 1 • Wiper volume dial 2 • Wiper volume dial 3 • Wiper volume dial 6 • Wiper volume dial 7 	10.7 V
144 (G)	Ground	Combination switch OUTPUT 2	Output	Combination switch	All switches OFF (Wiper volume dial 4)	0 V
					Front washer switch ON (Wiper volume dial 4)	 <p style="text-align: right; font-size: small;">JPMAI0033GB</p>
					Any of the conditions below with all switches OFF	
					<ul style="list-style-type: none"> • Wiper volume dial 1 • Wiper volume dial 5 • Wiper volume dial 6 	10.7 V
145 (L)	Ground	Combination switch OUTPUT 3	Output	Combination switch (Wiper volume dial 4)	All switches OFF	0 V
					Front wiper switch INT/AUTO	 <p style="text-align: right; font-size: small;">JPMAI0034GB</p>
					Front wiper switch LO	
					Lighting switch AUTO	10.7 V

A
B
C
D
E
F
G
H
I
J
L
M
N
O
P

SEC

BCM (BODY CONTROL MODULE)

< ECU DIAGNOSIS INFORMATION >

Terminal No. (Wire color)		Description		Condition	Value (Approx.)
+	-	Signal name	Input/ Output		
146 (SB)	Ground	Combination switch OUTPUT 4	Output	All switches OFF	0 V
				Front fog lamp switch ON	<p style="text-align: right; font-size: small;">JPMIA0035GB</p>
				Lighting switch 2ND	
				Lighting switch PASS	
				Turn signal switch LH	
150 (GR)	Ground	Driver door switch	Input	Driver door switch	<p style="text-align: right; font-size: small;">JPMIA0011GB</p>
				OFF (Door close)	
151 (G)	Ground	Rear window defog- ger relay control	Output	Rear window defogger	ON (Door open)
				Active	0 V
				Not activated	Battery voltage

BCM (BODY CONTROL MODULE)

< ECU DIAGNOSIS INFORMATION >

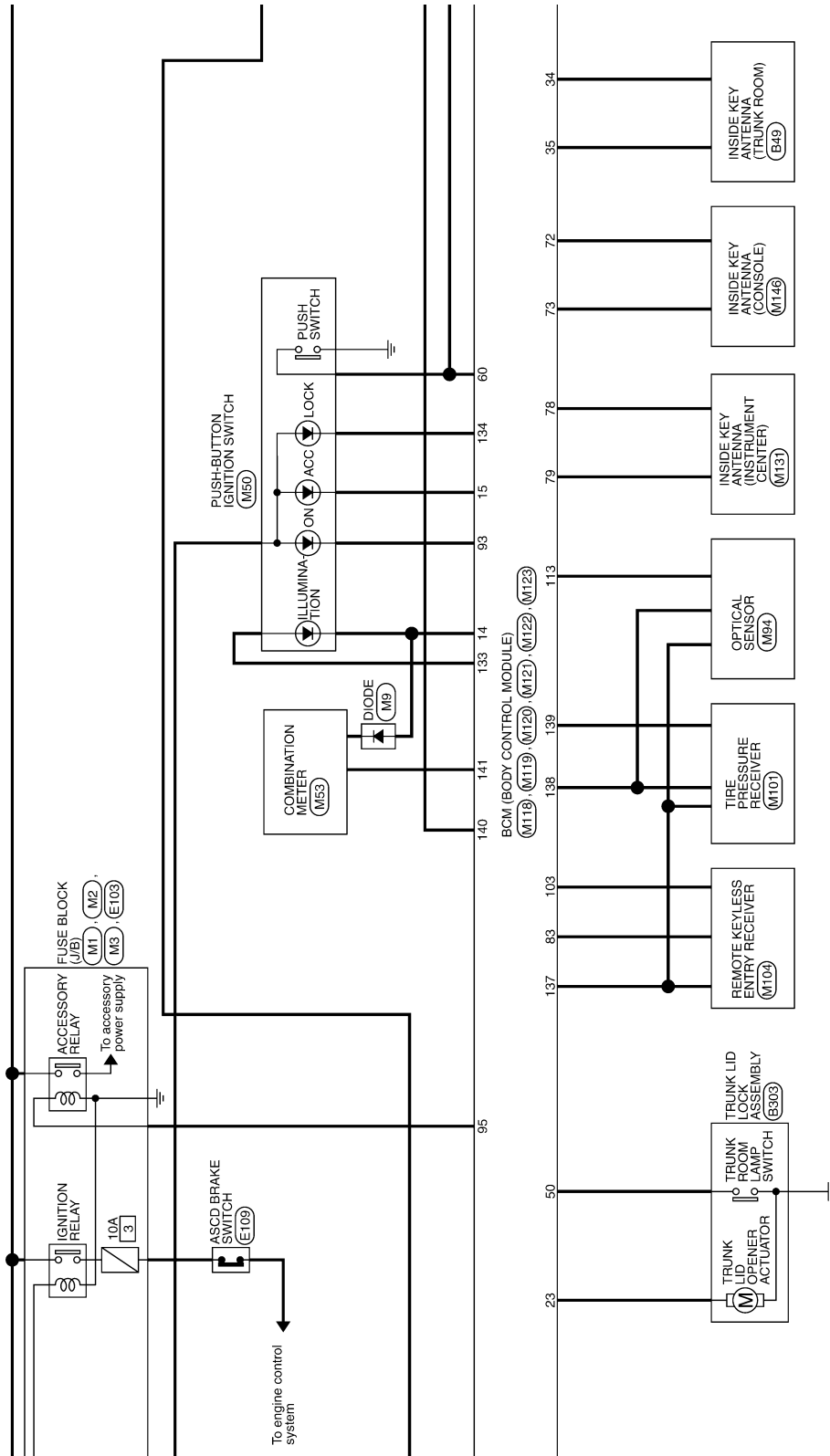

JRMWF9359GB

BCM (BODY CONTROL MODULE)

< ECU DIAGNOSIS INFORMATION >

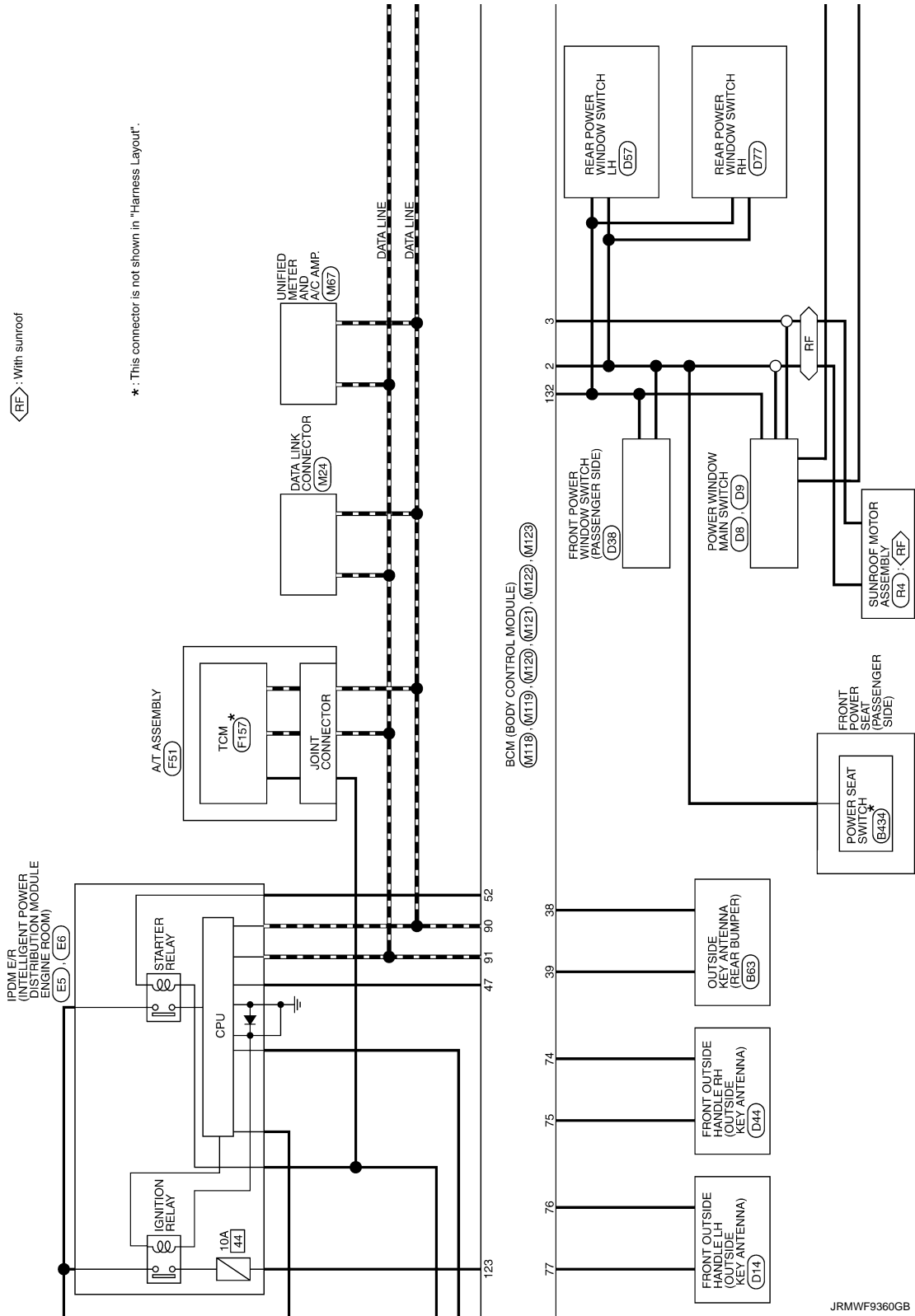

◁ RE ▷ : With sunroof

* : This connector is not shown in "Harness Layout".

A
B
C
D
E
F
G
H
I
J
L
M
N
O
P

SEC

JRMWF9380GB

BCM (BODY CONTROL MODULE)

< ECU DIAGNOSIS INFORMATION >

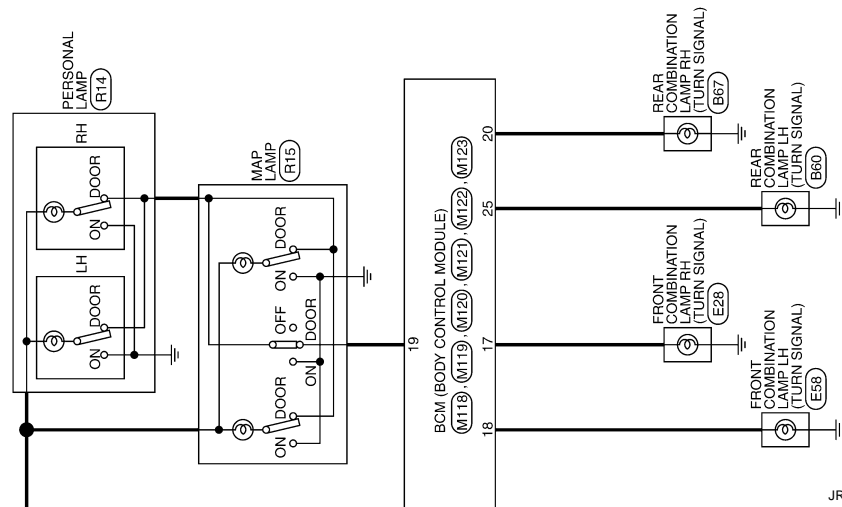

JRMWF9362GB

A
B
C
D
E
F
G
H
I
J
L
M
N
O
P

SEC

BCM (BODY CONTROL MODULE)

< ECU DIAGNOSIS INFORMATION >

BCM (BODY CONTROL MODULE)

Connector No.	B16	Signal Name [Specification]	
Connector Name	FRONT DOOR SWITCH (DRIVER SIDE)		
Connector Type	A03FW		
Terminal No.	1	Color Of Wire	BR
	2		GR
Terminal No.	1	Color Of Wire	BR
	2		GR
Connector No.	B23	Signal Name [Specification]	
Connector Name	REAR DOOR SWITCH LH		
Connector Type	A03FW		
Terminal No.	1	Color Of Wire	Y
	2		
Terminal No.	1	Color Of Wire	Y
	2		
Connector No.	B47	Signal Name [Specification]	
Connector Name	TRUNK ROOM LAMP		
Connector Type	S02FW		
Terminal No.	1	Color Of Wire	V
	2		LG
	3		SB
	4		B
Terminal No.	1	Color Of Wire	V
	2		LG
	3		SB
	4		B
Connector No.	B49	Signal Name [Specification]	
Connector Name	INSIDE KEY ANTENNA (TRUNK ROOM)		
Connector Type	RK02FCY		
Terminal No.	1	Color Of Wire	BC
	2		GR
Terminal No.	1	Color Of Wire	BC
	2		GR
Connector No.	B83	Signal Name [Specification]	
Connector Name	OUTSIDE KEY ANTENNA (REAR BUMPER)		
Connector Type	RK02FCY		
Terminal No.	1	Color Of Wire	BR
	2		R
Terminal No.	1	Color Of Wire	BR
	2		R
Connector No.	B223	Signal Name [Specification]	
Connector Name	REAR DOOR SWITCH RH		
Connector Type	A03FW		
Terminal No.	1	Color Of Wire	GR
	2		
Terminal No.	1	Color Of Wire	GR
	2		
Connector No.	B242	Signal Name [Specification]	
Connector Name	FUEL LID LOCK ACTUATOR		
Connector Type	MM0FW-LG		
Terminal No.	1	Color Of Wire	BR
	2		
Terminal No.	1	Color Of Wire	BR
	2		

JRMWF9505GB

BCM (BODY CONTROL MODULE)

< ECU DIAGNOSIS INFORMATION >

BCM (BODY CONTROL MODULE)

Connector No.	D1'S
Connector Name	FRONT DOOR LOCK ASSEMBLY (DRIVER SIDE)
Connector Type	EDFGY-RS

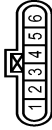

Terminal No.	Color Of Wire	Signal Name [Specification]
1	LG	-
2	L	-
3	L	-
4	B	-
5	Y	-
6	V	-

Connector No.	D3B
Connector Name	FRONT POWER WINDOW SWITCH (PASSENGER SIDE)
Connector Type	NS16FW-CS

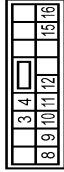

Terminal No.	Color Of Wire	Signal Name [Specification]
3	LG	-
4	B	-
8	L	-
9	G	-
10	Y	-
11	B	-
12	B	-
15	BG	-
16	V	-

Connector No.	D42
Connector Name	STEP LAMP (PASSENGER SIDE)
Connector Type	TR02FW



Terminal No.	Color Of Wire	Signal Name [Specification]
1	RS	-
2	SB	-

Connector No.	D43
Connector Name	FRONT OUTSIDE HANDLE RH (REQUEST SWITCH)
Connector Type	RK02FL



Terminal No.	Color Of Wire	Signal Name [Specification]
1	W	-
2	B	-

Connector No.	D44
Connector Name	FRONT OUTSIDE HANDLE RH (OUTSIDE KEY ANTENNA)
Connector Type	RK02MGY



Terminal No.	Color Of Wire	Signal Name [Specification]
1	P	-
2	V	-

Connector No.	D45
Connector Name	FRONT DOOR LOCK ASSEMBLY (PASSENGER SIDE)
Connector Type	EDFGY-RS



Terminal No.	Color Of Wire	Signal Name [Specification]
1	P	-
2	LG	-

Connector No.	D55
Connector Name	REAR DOOR LOCK ASSEMBLY LH
Connector Type	EDFGY-RS



Terminal No.	Color Of Wire	Signal Name [Specification]
1	Y	-
2	G	-

Connector No.	D57
Connector Name	REAR POWER WINDOW SWITCH LH
Connector Type	NS16FW-CS

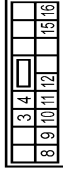

Terminal No.	Color Of Wire	Signal Name [Specification]
3	BR	-
4	SB	-
8	W	-
9	L	-
10	W	-
11	B	-
12	GR	-
15	BG	-
16	V	-

JRMWF9507GB

BCM (BODY CONTROL MODULE)

< ECU DIAGNOSIS INFORMATION >

BCM (BODY CONTROL MODULE)

Connector No.	D75
Connector Name	REAR DOOR LOCK ASSEMBLY RH
Connector Type	EG8FDY-RS



Terminal No.	Color Of Wire	Signal Name [Specification]
1	P	-
2	LG	-

Connector No.	D77
Connector Name	REAR POWER WINDOW SWITCH RH
Connector Type	NS18FW-CS



Terminal No.	Color Of Wire	Signal Name [Specification]
3	BR	-
4	SB	-
8	W	-
9	L	-
10	W	-
11	B	-
12	GR	-
15	BG	-
16	Y	-

Connector No.	E5
Connector Name	INTELLIGENT KEY WARNING BLOWER (ENGINE ROOM)
Connector Type	TH88PW-CS12-MA-TV

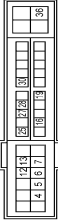

Terminal No.	Color Of Wire	Signal Name [Specification]
4	V	-
5	SB	-
7	P	-
12	B/W	-
16	LG	-
19	R	-
25	G	-
27	BG	-
28	L	-
30	GR	-
36	G	-

Connector No.	E5
Connector Name	INTELLIGENT KEY WARNING BLOWER (ENGINE ROOM)
Connector Type	TH88PW-RH



Terminal No.	Color Of Wire	Signal Name [Specification]
38	P	-
41	B/W	-
42	GR	-
43	G	-
44	LG	-
45	V	-

Connector No.	46
Connector Name	SB



Terminal No.	Color Of Wire	Signal Name [Specification]
3	B	-
4	B/W	-
5	R	-
6	V	-
7	BR	-
8	G	-

Connector No.	E41
Connector Name	ABS ACTUATOR AND ELECTRIC UNIT (CONTROL UNIT)
Connector Type	BAA42FB-AH24-LH



Terminal No.	Color Of Wire	Signal Name [Specification]
1	B	GROUND
2	GR	UBMR
3	BG	UBVR
4	B	GROUND
5	B	RS
6	BG	ES
7	BR	EP BR
9	B	DP GR
10	W	DS FR
11	V	DIAG-K
14	P	CAN-L

Terminal No.	25	V	BUS-L
Terminal No.	26	G	DP FL
Terminal No.	27	GR	DP RL
Terminal No.	28	G	UZ
Terminal No.	29	P	DS RR
Terminal No.	30	SB	BLS
Terminal No.	31	R	VDC OFF SW
Terminal No.	35	L	CAN-H
Terminal No.	45	B	BUS-H

Connector No.	E57
Connector Name	INTELLIGENT KEY WARNING BLOWER (ENGINE ROOM)
Connector Type	HK03FBR



Terminal No.	Color Of Wire	Signal Name [Specification]
1	GR	-
3	LG	-

Connector No.	E58
Connector Name	FRONT COMBINATION LAMP LH
Connector Type	RS08FB-PR



Terminal No.	Color Of Wire	Signal Name [Specification]
3	B	-
4	B/W	-
5	V	-
6	GR	-
7	P	-
8	BG	-

A
B
C
D
E
F
G
H
I
J
L
M
N
O
P

SEC

BCM (BODY CONTROL MODULE)

< ECU DIAGNOSIS INFORMATION >

BCM (BODY CONTROL MODULE)

Connector No.	E103
Connector Name	FUSE BLOCK (J/B)
Connector Type	NS10FW-CS

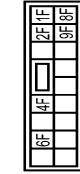

Terminal No.	Color Of Wire	Signal Name [Specification]
1F	SB	-
2F	V	-
4F	G	-
8F	BR	-
9F	P	-

Connector No.	E109
Connector Name	ASD BRAKE SWITCH
Connector Type	ISZFL



Terminal No.	Color Of Wire	Signal Name [Specification]
1	G	-
2	SB	-

Connector No.	E119
Connector Name	STOP LAMP SWITCH
Connector Type	MMHW-LC



Terminal No.	Color Of Wire	Signal Name [Specification]
1	L	-
2	G	-
3	V	-
4	V	-

Connector No.	F51
Connector Name	A/T ASSEMBLY
Connector Type	RK10FG-DGY



Terminal No.	Color Of Wire	Signal Name [Specification]
1	Y	-
2	R	-
3	L	-
4	V	-
5	B	-
6	G	-
7	R	-
8	P	-
9	GR	-
10	B	-

Connector No.	F157
Connector Name	TCM
Connector Type	SP10FG



Terminal No.	Color Of Wire	Signal Name [Specification]
1	SHIELD	VGN
2	SHIELD	RAM
3	SHIELD	CAH-H
4	SHIELD	K-LINE
5	SHIELD	GROUND
6	SHIELD	VGN
7	SHIELD	REV LAMP RLY
8	SHIELD	CAN-L
9	SHIELD	STARTER RLY
10	SHIELD	GROUND

Connector No.	M1
Connector Name	FUSE BLOCK (J/B)
Connector Type	NS08FW-M2



Terminal No.	Color Of Wire	Signal Name [Specification]
1A	V	-
2A	G	-
3A	L	-
4A	P	-
5A	L	-
6A	Y	-
7A	R	-
8A	L	-

Connector No.	M2
Connector Name	FUSE BLOCK (J/B)
Connector Type	NS10FW-CS

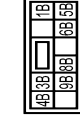

Terminal No.	Color Of Wire	Signal Name [Specification]
1B	SB	-
2B	G	-
3B	Y	-
4B	BR	-
5B	RG	-
6B	Y	-
7B	R	-
8B	SB	-

Connector No.	M3
Connector Name	FUSE BLOCK (J/B)
Connector Type	NS12FW-CS

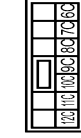

Terminal No.	Color Of Wire	Signal Name [Specification]
10C	L	-
11C	LG	-
12C	G	-
6C	SB	-
7C	B	-
8C	BB	-

JRMWF9509GB

BCM (BODY CONTROL MODULE)

< ECU DIAGNOSIS INFORMATION >

BCM (BODY CONTROL MODULE)

Connector No.	M19
Connector Name	DIODE
Connector Type	24335-C9900



Terminal No.	Color Of Wire	Signal Name [Specification]
1	R	-
2	R	-

Connector No.	M20
Connector Name	TRUNK LID OPENER SWITCH
Connector Type	T6045W



Terminal No.	Color Of Wire	Signal Name [Specification]
1	GR	-
2	B	-
3	LG	-
4	R	-

Connector No.	M22
Connector Name	KEY SLOT
Connector Type	TH12FH-NH

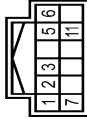

Terminal No.	Color Of Wire	Signal Name [Specification]
1	R	BAT
2	GR	GLOCK
3	Y	ILL BAT
4	Y	ILL BAT
5	Y	ILL BAT
6	LG	ILL
7	B	GROUND
11	SB	KEY SWITCH SIGNAL

Connector No.	M24
Connector Name	DATA LINK CONNECTOR
Connector Type	BD16FW-P

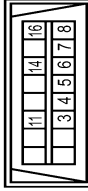

Terminal No.	Color Of Wire	Signal Name [Specification]
3	LG	-
4	B	-
5	B	-
6	L	-
7	V	-
8	V	-
14	SB	-
16	R	-

Connector No.	M33
Connector Name	COMBINATION SWITCH
Connector Type	TH16FW-NH

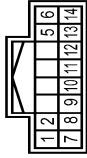

Terminal No.	Color Of Wire	Signal Name [Specification]
1	GR	FR WASHER (-)
2	SB	OUTPUT 4
3	SB	OUTPUT 4
4	GR	GROUND
5	B	GROUND
6	B	INPUT 3
7	EG	INPUT 3
8	BR	OUTPUT 5
9	W	INPUT 2
10	R	INPUT 4
11	LG	INPUT 1
12	P	OUTPUT 1
13	Y	INPUT 5
14	G	OUTPUT 2

Connector No.	M50
Connector Name	PUSH-BUTTON IGNITION SWITCH
Connector Type	TROBEER



Terminal No.	Color Of Wire	Signal Name [Specification]
1	B	-
2	B	-
3	B	-
4	BR	-
5	LG	-
6	EG	-
7	GR	-
8	P	-

Connector No.	M53
Connector Name	COMBINATION METER
Connector Type	SABOUP



Terminal No.	Color Of Wire	Signal Name [Specification]
1	V	BATTERY POWER SUPPLY
2	G	COMMUNICATION SIGNAL (WHEEL-AMS)
3	GR	COMMUNICATION SIGNAL (AMP-METER)
4	GR	GROUND
5	B	GROUND
6	W	ALTERNATOR SIGNAL
7	LG	AIR BAG SIGNAL
8	W	SECURITY SIGNAL
10	W	GROUND
15	B	GROUND
16	BR	METER CONTROL SWITCH GROUND
18	GR	ILL GND
19	B	ILL GND
20	R	ILL
21	G	IGNITION SIGNAL
22	B	GROUND
24	BR	COMMUNICATION SIGNAL (LGS-AMPS)
25	P	COMMUNICATION SIGNAL (LGS-AMPS)
26	R	VEHICLE SPEED SIGNAL (CAP-LED)
27	P	PARKING BRAKE SWITCH SIGNAL
28	SB	BRAKE FLUID LEVEL SWITCH
29	P	SEAT BELT BUCKLE SW SIGNAL (DRIVER SIDE)
30	G	SEAT BELT BUCKLE SWITCH SIGNAL (PASSENGER SIDE)
31	L	WASHER LEVEL SWITCH SIGNAL
33	R	ILLUMINATION CONTROL SIGNAL
36	LG	SELECT SWITCH SIGNAL
37	Y	ENTER SWITCH SIGNAL
38	G	TRIP A/B RESET SWITCH SIGNAL
39	P	ILLUMINATION CONTROL SWITCH SIGNAL (-)
40	EG	ILLUMINATION CONTROL SWITCH SIGNAL (+)

A
B
C
D
E
F
G
H
I
J
L
M
N
O
P

SEC

BCM (BODY CONTROL MODULE)

< ECU DIAGNOSIS INFORMATION >

BCM (BODY CONTROL MODULE)

Connector No.	M67
Connector Name	UNIFIED METER AND A.C. AMP.
Connector Type	TK32FW-N4

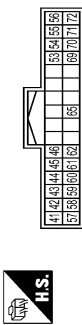

Terminal No.	Color Of Wire	Signal Name [Specification]
1	LG	A/C POWER SUPPLY
2	BR	FUEL LEVEL SENSOR SIGNAL
3	BR	FUEL LEVEL SENSOR SIGNAL
4	BR	VOLTAGE SENSOR SIGNAL
4	LG	IN-VEHICLE SENSOR SIGNAL
5	V	AMBIENT SENSOR SIGNAL
4	Y	SUNLOAD SENSOR SIGNAL
5	W	IGNITION POWER SUPPLY
5	SB	BATTERY POWER SUPPLY
5	B	GROUND
5	L	CAN-H
5	LG	BRAKE FLUID LEVEL SWITCH
5	Y	FUEL LEVEL SENSOR GROUND
5	GR	INTAKE SENSOR GROUND
5	W	IN-VEHICLE SENSOR GROUND
5	SB	AMBIENT SENSOR GROUND
5	SB	SUNLOAD SENSOR GROUND
5	SB	ECV SIGNAL
5	P	A/C LAN SIGNAL
5	GR	EACH DOOR MOTOR POWER SUPPLY
5	GR	GROUND
5	P	CAN-L

Connector No.	M72
Connector Name	MULTIFUNCTION SWITCH
Connector Type	TH16FW-N4

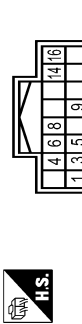

Terminal No.	Color Of Wire	Signal Name [Specification]
1	B	GROUND
2	P	LC
3	EG	ILL
4	B	ILL CONT
5	SB	AV COMM (H)
6	LG	AV COMM (L)
7	BR	SW GND
8	V	DISK EJECT SIGNAL
9	G	HAZARD ON

Connector No.	M64
Connector Name	OPTICAL SENSOR
Connector Type	TK63PW



Terminal No.	Color Of Wire	Signal Name [Specification]
1	Y	POWER
2	EG	OUTPUT
3	B	GROUND

Connector No.	M101
Connector Name	TIRE PRESSURE RECEIVER
Connector Type	TK04EW



Terminal No.	Color Of Wire	Signal Name [Specification]
1	P	GROUND
2	Y	SENSOR
3	Y	BATTERY
4	Y	BATTERY

Connector No.	M104
Connector Name	REMOTE KEYLESS ENTRY RECEIVER
Connector Type	JAB04FB



Terminal No.	Color Of Wire	Signal Name [Specification]
1	EG	GROUND
2	Y	SIGNAL OUTPUT
3	Y	BATTERY
4	P	BATTERY

Connector No.	M105
Connector Name	TRUNK LID OPENER CANCEL SWITCH
Connector Type	S02EW



Terminal No.	Color Of Wire	Signal Name [Specification]
1	EG	---
2	B	---

Connector No.	M118
Connector Name	BCM (BODY CONTROL MODULE)
Connector Type	M03FB-LC



Terminal No.	Color Of Wire	Signal Name [Specification]
1	W	BAT.(F/L)
2	Y	POWER WINDOW POWER SUPPLY (BAT)
3	BG	POWER WINDOW POWER SUPPLY (RWP)

JRMWF9511GB

BCM (BODY CONTROL MODULE)

< ECU DIAGNOSIS INFORMATION >

BCM (BODY CONTROL MODULE)

Connector No.	MT19
Connector Name	BCM (BODY CONTROL MODULE)
Connector Type	NS16PW-CS



Terminal No.	Color Of Wire	Signal Name [Specification]
4	LG	INTERIOR ROOM LAMP POWER SUPPLY
5	SB	PASSENGER DOOR UNLOCK OUTPUT
7	SB	REAR DOOR UNLOCK OUTPUT
8	V	ALL DOOR FUEL LID LOCK OUTPUT
9	P	DRIVER DOOR FUEL LID UNLOCK OUTPUT
10	G	REAR DOOR UNLOCK OUTPUT
11	R	BAT (FUSE)
13	B	GROUND
14	W	PUSH-BUTTON IGNITION SW ILL GND
15	EG	ACC IND
17	W	TURN SIGNAL RH (FRONT)
18	EG	TURN SIGNAL LH (FRONT)
19	V	INT ROOM LAMP CONT

Connector No.	MT20
Connector Name	BCM (BODY CONTROL MODULE)
Connector Type	NS12PW-CS

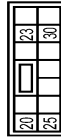

Terminal No.	Color Of Wire	Signal Name [Specification]
20	LG	TURN SIGNAL RH (REAR)
23	G	TRUNK LID OPEN OUTPUT
25	Y	TURN SIGNAL LH (REAR)
30	P	TRUNK ROOM LAMP CONT

Connector No.	MT21
Connector Name	BCM (BODY CONTROL MODULE)
Connector Type	TH4PFC-NH



Terminal No.	Color Of Wire	Signal Name [Specification]
24	SB	TRUNK ROOM ANT-
25	SB	TRUNK ROOM ANT+
26	S	REAR DOOR ANT-
27	W	REAR BUMPER ANT-
28	W	REAR BUMPER ANT+
29	Y	IGN RELAY (UPDM / RI) CONT
30	EG	TRUNK ROOM LAMP SW
32	R	STARTER RELAY CONT
60	BR	PUSH SW
61	SB	TRUNK LID OPENER REQUEST SW
64	G	I-KEY WARN BLIZZER (ENG ROOM)
67	GR	TRUNK LID OPENER SW
68	EG	REAR RH DOOR SW
69	L	REAR LH DOOR SW

Connector No.	MT22
Connector Name	BCM (BODY CONTROL MODULE)
Connector Type	TH4PFB-NH



Terminal No.	Color Of Wire	Signal Name [Specification]
72	C	ROOM ANT 2-
73	C	ROOM ANT 2+
74	SB	PASSENGER DOOR ANT-
75	BR	PASSENGER DOOR ANT+
76	V	DRIVER DOOR ANT-
77	LG	DRIVER DOOR ANT+
78	Y	ROOM ANT 1-

Terminal No.	Color Of Wire	Signal Name [Specification]
79	BR	ROOM ANT 1+
80	GR	MIS ANT AMP
81	W	IGN RELAY (E/C) CONT
82	SB	IGN RELAY (E/C) CONT
83	Y	KEYLESS ENTRY RECEIVER COMM
87	Y	COMBI SW INPUT 5
88	EG	COMBI SW INPUT 3
90	P	CAN-L
91	L	CAN-H
92	LG	KEY SLOT ILL CONT
93	GR	ON IND
95	EG	ACC RELAY CONT
96	GR	A/T SHIFT SELECTOR POWER SUPPLY
99	R	SHIFT P
100	Y	PASSENGER DOOR REQUEST SW
101	Y	DRIVER DOOR REQUEST SW
102	EG	BLUZZER REQUEST SW
103	P	KEYLESS ENTRY RECEIVER POWER SUPPLY
107	LG	COMBI SW INPUT 1
108	R	COMBI SW INPUT 4
109	W	COMBI SW INPUT 2
110	G	HAZARD SW

Connector No.	MT23
Connector Name	BCM (BODY CONTROL MODULE)
Connector Type	TH4PFC-NH



Terminal No.	Color Of Wire	Signal Name [Specification]
113	BG	OPTICAL SENSOR
116	SB	STOP LAMP SW 1
118	BR	STOP LAMP SW 2
119	SB	DR DOOR UNLOCK SENSOR
121	SB	KEY SLOT SW
122	Y	DRIVER DOOR SW
124	EG	PASSENGER DOOR SW
126	B	TRUNK LID OPENER CANCEL SW
132	V	POWER WINDOW SW COMM
133	L	PUSH-BUTTON IGNITION SW ILL POWER
134	LG	LOCK IND
137	BG	RECEIVER / SENSOR GND

Terminal No.	Color Of Wire	Signal Name [Specification]
138	V	RECEIVER / SENSOR POWER SUPPLY
139	L	TIME PRESSURE RELEASE RECEIVER COMM
140	B	SECURITY LAMP CONT
141	W	SECURITY LAMP CONT
142	BR	COMBI SW OUTPUT 5
143	P	COMBI SW OUTPUT 1
144	G	COMBI SW OUTPUT 2
145	L	COMBI SW OUTPUT 3
146	SB	COMBI SW OUTPUT 4
150	GR	DRIVER DOOR SW
151	G	REAR WINDOW DEFROGGER RELAY CONT

Connector No.	MT31
Connector Name	IN-BEDE KEY ANTENNA (INSTRUMENT CENTER)
Connector Type	RN02FCY



Terminal No.	Color Of Wire	Signal Name [Specification]
1	BR	-
2	Y	-

Connector No.	MT37
Connector Name	A/T SHIFT SELECTOR
Connector Type	TH12FW-NH

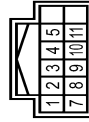

Terminal No.	Color Of Wire	Signal Name [Specification]
1	W	-
2	L	-
3	L	-
4	B	-
5	G	-

A
B
C
D
E
F
G
H
I
J
L
M
N
O
P

SEC

BCM (BODY CONTROL MODULE)

< ECU DIAGNOSIS INFORMATION >

BCM (BODY CONTROL MODULE)

7	Y	-
8	G	-
9	B	-
10	GR	-
11	R	-

Connector No.	MI46
Connector Name	INSIDE KEY ANTENNA (CONSOLE)
Connector Type	RK0ZFSY



Terminal No.	Color Of Wire	Signal Name [Specification]
1	G	-
2	R	-

Connector No.	RI4
Connector Name	SUNROOF MOTOR ASSEMBLY
Connector Type	YEA1MFSY

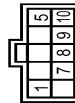

Terminal No.	Color Of Wire	Signal Name [Specification]
1	GR	SW-BIT 1
5	P	SW-BIT -
7	BR	PS
8	Y	SPEED SENSOR (SP)
9	Y	THRESHOLD (SH)
10	G	GROUND

Connector No.	RI2
Connector Name	VANITY MIRROR LAMP LH
Connector Type	MCADZFW



Terminal No.	Color Of Wire	Signal Name [Specification]
1	B	-
2	R	-

Connector No.	RI3
Connector Name	VANITY MIRROR LAMP RH
Connector Type	MCADZFW



Terminal No.	Color Of Wire	Signal Name [Specification]
1	B	-
2	R	-

Connector No.	RI4
Connector Name	PERSONAL LAMP
Connector Type	TH0EY-NH



Terminal No.	Color Of Wire	Signal Name [Specification]
1	R	-
3	B	-
2	Y	-

Connector No.	RI5
Connector Name	MAP LAMP
Connector Type	TR0BFCY



Terminal No.	Color Of Wire	Signal Name [Specification]
1	R	-
2	Y	-
3	Y	-
4	B	-
5	SHIELD	-
6	B	-

Fail-safe

FAIL-SAFE CONTROL BY DTC

BCM performs fail-safe control when any DTC are detected.

JRMWF9513GB

INFOID:000000011433272

BCM (BODY CONTROL MODULE)

< ECU DIAGNOSIS INFORMATION >

Display contents of CONSULT	Fail-safe	Cancellation
B2190: NATS ANTENNA AMP	Inhibit engine cranking	Erase DTC
B2191: DIFFERENCE OF KEY	Inhibit engine cranking	Erase DTC
B2192: ID DISCORD BCM-ECM	Inhibit engine cranking	Erase DTC
B2193: CHAIN OF BCM-ECM	Inhibit engine cranking	Erase DTC
B2195: ANTI-SCANNING	Inhibit engine cranking	Ignition switch ON → OFF
B2560: STARTER CONT RELAY	Inhibit engine cranking	500 ms after the following CAN signal communication status becomes consistent <ul style="list-style-type: none"> • Starter control relay signal • Starter relay status signal
B2608: STARTER RELAY	Inhibit engine cranking	500 ms after the following signal communication status becomes consistent <ul style="list-style-type: none"> • Starter motor relay control signal • Starter relay status signal (CAN)
B260A: IGNITION RELAY	Inhibit engine cranking	500 ms after the following conditions are fulfilled <ul style="list-style-type: none"> • IGN relay (IPDM E/R) control signal: OFF (12 V) • Ignition ON signal (CAN to IPDM E/R): OFF (Request signal) • Ignition ON signal (CAN from IPDM E/R): OFF (Condition signal)
B260F: ENG STATE SIG LOST	Maintains the power supply position attained at the time of DTC detection	When any of the following conditions are fulfilled <ul style="list-style-type: none"> • Power position changes to ACC • Receives engine status signal (CAN)
B2617: BCM	Inhibit engine cranking	1 second after the starter motor relay control inside BCM becomes normal
B2618: BCM	Inhibit engine cranking	1 second after the ignition relay (IPDM E/R) control inside BCM becomes normal
B261E: VEHICLE TYPE	Inhibit engine cranking	BCM initialization

DTC Inspection Priority Chart

INFOID:000000011433273

If some DTCs are displayed at the same time, perform inspections one by one based on the following priority chart.

Priority	DTC
1	B2562: LOW VOLTAGE
2	<ul style="list-style-type: none"> • U1000: CAN COMM • U1010: CONTROL UNIT(CAN)
3	<ul style="list-style-type: none"> • B2190: NATS ANTENNA AMP • B2191: DIFFERENCE OF KEY • B2192: ID DISCORD BCM-ECM • B2193: CHAIN OF BCM-ECM • B2195: ANTI-SCANNING

SEC

L

M

N

O

P

BCM (BODY CONTROL MODULE)

< ECU DIAGNOSIS INFORMATION >

Priority	DTC
4	<ul style="list-style-type: none"> • B2553: IGNITION RELAY • B2555: STOP LAMP • B2556: PUSH-BTN IGN SW • B2557: VEHICLE SPEED • B2560: STARTER CONT RELAY • B2601: SHIFT POSITION • B2602: SHIFT POSITION • B2603: SHIFT POSI STATUS • B2604: PNP/CLUTCH SW • B2605: PNP/CLUTCH SW • B2608: STARTER RELAY • B260A: IGNITION RELAY • B260F: ENG STATE SIG LOST • B2614: BCM • B2615: BCM • B2616: BCM • B2617: BCM • B2618: BCM • B261A: PUSH-BTN IGN SW • B261E: VEHICLE TYPE • B26EA: KEY REGISTRATION • C1729: VHCL SPEED SIG ERR • U0415: VEHICLE SPEED
5	<ul style="list-style-type: none"> • C1704: LOW PRESSURE FL • C1705: LOW PRESSURE FR • C1706: LOW PRESSURE RR • C1707: LOW PRESSURE RL • C1708: [NO DATA] FL • C1709: [NO DATA] FR • C1710: [NO DATA] RR • C1711: [NO DATA] RL • C1716: [PRESSDATA ERR] FL • C1717: [PRESSDATA ERR] FR • C1718: [PRESSDATA ERR] RR • C1719: [PRESSDATA ERR] RL • C1734: CONTROL UNIT
6	<ul style="list-style-type: none"> • B2621: INSIDE ANTENNA • B2622: INSIDE ANTENNA • B2623: INSIDE ANTENNA

DTC Index

INFOID:000000011433274

NOTE:

The details of time display are as follows.

- CRNT: A malfunction is detected now.
- PAST: A malfunction was detected in the past.

IGN counter is displayed on Freeze Frame Data. For details of Freeze Frame Data, refer to [BCS-16. "COMMON ITEM : CONSULT Function \(BCM - COMMON ITEM\)"](#).

CONSULT display	Fail-safe	Freeze Frame Data •Vehicle Speed •Odo/Trip Meter •Vehicle condition	Intelligent Key warning lamp ON	Tire pressure monitor warning lamp ON	Reference
No DTC is detected. further testing may be required.	—	—	—	—	—
U1000: CAN COMM	—	—	—	—	BCS-36
U1010: CONTROL UNIT(CAN)	—	—	—	—	BCS-37
U0415: VEHICLE SPEED	—	—	—	—	BCS-38
B2190: NATS ANTENNA AMP	×	—	—	—	SEC-43

BCM (BODY CONTROL MODULE)

< ECU DIAGNOSIS INFORMATION >

CONSULT display	Fail-safe	Freeze Frame Data •Vehicle Speed •Odo/Trip Meter •Vehicle condition	Intelligent Key warning lamp ON	Tire pressure monitor warning lamp ON	Reference
B2191: DIFFERENCE OF KEY	×	—	—	—	SEC-46
B2192: ID DISCORD BCM-ECM	×	—	—	—	SEC-47
B2193: CHAIN OF BCM-ECM	×	—	—	—	SEC-49
B2195: ANTI-SCANNING	×	—	—	—	SEC-50
B2553: IGNITION RELAY	—	×	—	—	PCS-49
B2555: STOP LAMP	—	×	—	—	SEC-51
B2556: PUSH-BTN IGN SW	—	×	×	—	SEC-53
B2557: VEHICLE SPEED	×	×	×	—	SEC-55
B2560: STARTER CONT RELAY	×	×	×	—	SEC-56
B2562: LOW VOLTAGE	—	×	—	—	BCS-39
B2601: SHIFT POSITION	×	×	×	—	SEC-57
B2602: SHIFT POSITION	×	×	×	—	SEC-60
B2603: SHIFT POSI STATUS	×	×	×	—	SEC-63
B2604: PNP/CLUTCH SW	×	×	×	—	SEC-66
B2605: PNP/CLUTCH SW	×	×	×	—	SEC-68
B2608: STARTER RELAY	×	×	×	—	SEC-70
B260A: IGNITION RELAY	×	×	×	—	PCS-51
B260F: ENG STATE SIG LOST	×	×	×	—	SEC-72
B2614: BCM	—	×	×	—	PCS-53
B2615: BCM	—	×	×	—	PCS-55
B2616: BCM	—	×	×	—	PCS-57
B2617: BCM	×	×	×	—	SEC-74
B2618: BCM	×	×	×	—	PCS-59
B261A: PUSH-BTN IGN SW	—	×	×	—	PCS-60
B261E: VEHICLE TYPE	×	×	× (Turn ON for 15 seconds)	—	SEC-76
B2621: INSIDE ANTENNA	—	×	—	—	DLK-59
B2622: INSIDE ANTENNA	—	×	—	—	DLK-61
B2623: INSIDE ANTENNA	—	×	—	—	DLK-63
B26EA: KEY REGISTRATION	—	×	× (Turn ON for 15 seconds)	—	SEC-73
C1704: LOW PRESSURE FL	—	—	—	×	WT-25
C1705: LOW PRESSURE FR	—	—	—	×	
C1706: LOW PRESSURE RR	—	—	—	×	
C1707: LOW PRESSURE RL	—	—	—	×	
C1708: [NO DATA] FL	—	—	—	×	WT-27
C1709: [NO DATA] FR	—	—	—	×	
C1710: [NO DATA] RR	—	—	—	×	
C1711: [NO DATA] RL	—	—	—	×	
C1716: [PRESSDATA ERR] FL	—	—	—	×	WT-30
C1717: [PRESSDATA ERR] FR	—	—	—	×	
C1718: [PRESSDATA ERR] RR	—	—	—	×	
C1719: [PRESSDATA ERR] RL	—	—	—	×	

A
B
C
D
E
F
G
H
I
J
SEC
L
M
N
O
P

BCM (BODY CONTROL MODULE)

< ECU DIAGNOSIS INFORMATION >

CONSULT display	Fail-safe	Freeze Frame Data •Vehicle Speed •Odo/Trip Meter •Vehicle condition	Intelligent Key warning lamp ON	Tire pressure monitor warning lamp ON	Reference
C1729: VHCL SPEED SIG ERR	—	—	—	×	WT-31
C1734: CONTROL UNIT	—	—	—	×	WT-32

IPDM E/R (INTELLIGENT POWER DISTRIBUTION MODULE ENGINE ROOM)

< ECU DIAGNOSIS INFORMATION >

IPDM E/R (INTELLIGENT POWER DISTRIBUTION MODULE ENGINE ROOM)

Reference Value

INFOID:000000011433346

VALUES ON THE DIAGNOSIS TOOL

NOTE:

The following table includes information (items) inapplicable to this vehicle. For information (items) applicable to this vehicle, refer to CONSULT display items.

Monitor Item	Condition		Value/Status
RAD FAN REQ	Engine idle speed	Changes depending on engine coolant temperature, air conditioner operation status, vehicle speed, etc.	0 - 100 %
AC COMP REQ	Engine running	A/C switch OFF	Off
		A/C switch ON (Compressor is operating)	On
TAIL&CLR REQ	Lighting switch OFF		Off
	Lighting switch 1ST, 2ND, HI or AUTO (Light is illuminated)		On
HL LO REQ	Lighting switch OFF		Off
	Lighting switch 2ND HI or AUTO (Light is illuminated)		On
HL HI REQ	Lighting switch OFF		Off
	Lighting switch HI		On
FR FOG REQ	Lighting switch 2ND or AUTO (Light is illuminated)	Front fog lamp switch OFF	Off
		Front fog lamp switch ON	On
FR WIP REQ	Ignition switch ON	Front wiper switch OFF	Stop
		Front wiper switch INT	1LOW
		Front wiper switch LO	Low
		Front wiper switch HI	Hi
WIP AUTO STOP	Ignition switch ON	Front wiper stop position	STOP P
		Any position other than front wiper stop position	ACT P
WIP PROT	Ignition switch ON	Front wiper operates normally	Off
		Front wiper stops at fail-safe operation	BLOCK
IGN RLY1 -REQ	Ignition switch OFF or ACC		Off
	Ignition switch ON		On
IGN RLY	Ignition switch OFF or ACC		Off
	Ignition switch ON		On
PUSH SW	Release the push-button ignition switch		Off
	Press the push-button ignition switch		On
INTER/NP SW	Ignition switch ON	Selector lever in any position other than P or N	Off
	Ignition switch ON	Selector lever in P or N position	On
ST RLY CONT	Ignition switch ON		Off
	At engine cranking		On
IHBT RLY -REQ	Ignition switch ON		Off
	At engine cranking		On

IPDM E/R (INTELLIGENT POWER DISTRIBUTION MODULE ENGINE ROOM)

< ECU DIAGNOSIS INFORMATION >

Monitor Item	Condition	Value/Status	
ST/INHI RLY	Ignition switch ON	Off	
	At engine cranking	INHI ON → ST ON	
	The status of starter relay or starter control relay cannot be recognized by the battery voltage malfunction, etc. when the starter relay is ON and the starter control relay is OFF	UNKWN	
DETENT SW	Ignition switch ON	<ul style="list-style-type: none"> • Press the selector button with selector lever in P position • Selector lever in any position other than P 	Off
	Release the selector button with selector lever in P position		On
S/L RLY -REQ	NOTE: The item is indicated, but not monitored.	Off	
S/L STATE	NOTE: The item is indicated, but not monitored.	UNLOCK	
DTRL REQ	NOTE: The item is indicated, but not monitored.	Off	
OIL P SW	Ignition switch OFF, ACC or engine running	Open	
	Ignition switch ON	Close	
HOOD SW	Close the hood	Off	
	Open the hood	On	
HL WASHER REQ	NOTE: The item is indicated, but not monitored.	Off	
THFT HRN REQ	Not operation	Off	
	<ul style="list-style-type: none"> • Panic alarm is activated • Horn is activated with VEHICLE SECURITY (THEFT WARNING) SYSTEM 	On	
HORN CHIRP	Not operating	Off	
	Door locking with Intelligent Key (horn chirp mode)	On	
CRNRNG LMP REQ	NOTE: The item is indicated, but not monitored.	Off	

IPDM E/R (INTELLIGENT POWER DISTRIBUTION MODULE ENGINE ROOM)

< ECU DIAGNOSIS INFORMATION >

TERMINAL LAYOUT

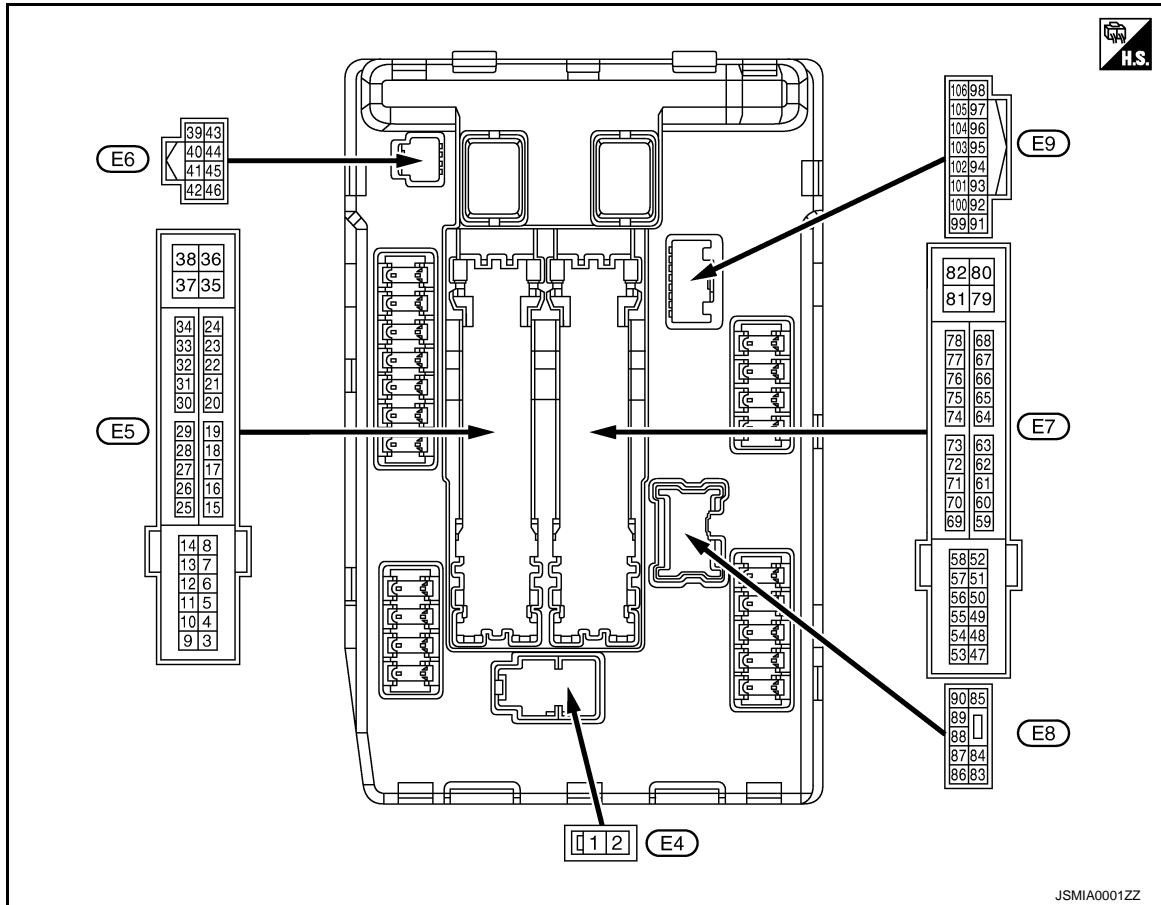

PHYSICAL VALUES

Terminal No. (Wire color)		Description		Condition		Value (Approx.)
+	-	Signal name	Input/ Output			
1 (W)	Ground	Battery power supply	Input	Ignition switch OFF		Battery voltage
2 (L)	Ground	Battery power supply	Input	Ignition switch OFF		Battery voltage
4 (V)	Ground	Front wiper LO	Output	Ignition switch ON	Front wiper switch OFF	0 V
					Front wiper switch LO	Battery voltage
5 (L)	Ground	Front wiper HI	Output	Ignition switch ON	Front wiper switch OFF	0 V
					Front wiper switch HI	Battery voltage
7 (P)	Ground	Tail, license plate lamps & interior lamps	Output	Ignition switch ON	Lighting switch OFF	0 V
					Lighting switch 1ST	Battery voltage
12 (B/W)	Ground	Ground	—	Ignition switch ON		0 V
13 (Y)	Ground	Fuel pump power supply	Output	Approximately 1 second or more after turning the ignition switch ON		0 V
				<ul style="list-style-type: none"> Approximately 1 second after turning the ignition switch ON Engine running 		Battery voltage
16 (LG)	Ground	Front wiper auto stop	Input	Ignition switch ON	Front wiper stop position	0 V
					Any position other than front wiper stop position	Battery voltage

A
B
C
D
E
F
G
H
I
J

SEC

L

M

N

O

P

IPDM E/R (INTELLIGENT POWER DISTRIBUTION MODULE ENGINE ROOM)

< ECU DIAGNOSIS INFORMATION >

Terminal No. (Wire color)		Description		Condition	Value (Approx.)	
+	-	Signal name	Input/ Output			
19 (R)	Ground	Ignition relay power supply	Output	Ignition switch OFF	0 V	
				Ignition switch ON	Battery voltage	
25 (G)	Ground	Ignition relay power supply	Output	Ignition switch OFF	0 V	
				Ignition switch ON	Battery voltage	
27 (BG)	Ground	Ignition relay monitor	Input	Ignition switch OFF or ACC	Battery voltage	
				Ignition switch ON	0 V	
28 (L)	Ground	Push-button ignition switch	Input	Press the push-button ignition switch	0 V	
				Release the push-button ignition switch	Battery voltage	
30 (GR)	Ground	Starter relay control	Input	Selector lever in any position other than P or N (Ignition switch ON)	0 V	
				Selector lever P or N (Ignition switch ON)	Battery voltage	
36 (G)	Ground	Battery power supply	Input	Ignition switch OFF	Battery voltage	
39 (P)	—	CAN-L	Input/ Output	—	—	
40 (L)	—	CAN-H	Input/ Output	—	—	
41 (B/W)	Ground	Ground	—	Ignition switch ON	0 V	
42 (GR)	Ground	Cooling fan relay control	Input	Ignition switch OFF or ACC	0 V	
				Ignition switch ON	0.7 V	
43 (G)	Ground	A/T shift selector (Detention switch)	Input	Ignition switch ON	<ul style="list-style-type: none"> Press the selector button (selector lever P) Selector lever in any position other than P 	Battery voltage
					Release the selector button (selector lever P)	0 V
44 (LG)	Ground	Horn relay control	Input	The horn is deactivated	Battery voltage	
				The horn is activated	0 V	
45 (V)	Ground	Anti theft horn relay control	Input	The horn is deactivated	Battery voltage	
				The horn is activated	0 V	
46 (SB)	Ground	Starter relay control	Input	Selector lever in any position other than P or N (Ignition switch ON)	0 V	
				Selector lever P or N (Ignition switch ON)	Battery voltage	
				Release the clutch pedal	0 V	
				Depress the clutch pedal	Battery voltage	
48 (L)	Ground	A/C relay power supply	Output	Engine running	A/C switch OFF	0 V
					A/C switch ON (A/C compressor is operating)	Battery voltage
49 (BG)	Ground	ECM relay power supply	Output	Ignition switch OFF (More than a few seconds after turning ignition switch OFF)	0 V	
				<ul style="list-style-type: none"> Ignition switch ON Ignition switch OFF (For a few seconds after turning ignition switch OFF) 	Battery voltage	

IPDM E/R (INTELLIGENT POWER DISTRIBUTION MODULE ENGINE ROOM)

< ECU DIAGNOSIS INFORMATION >

Terminal No. (Wire color)		Description		Condition	Value (Approx.)	
+	-	Signal name	Input/ Output			
51 (Y)	Ground	Ignition relay power supply	Output	Ignition switch OFF	0 V	A
				Ignition switch ON	Battery voltage	B
53 (W)	Ground	ECM relay power supply	Output	Ignition switch OFF (More than a few seconds after turning ignition switch OFF)	0 V	C
				<ul style="list-style-type: none"> Ignition switch ON Ignition switch OFF (For a few seconds after turning ignition switch OFF) 	Battery voltage	D
54 (P)	Ground	Throttle control motor relay power supply	Output	Ignition switch OFF (More than a few seconds after turning ignition switch OFF)	0 V	E
				<ul style="list-style-type: none"> Ignition switch ON Ignition switch OFF (For a few seconds after turning ignition switch OFF) 	Battery voltage	F
55 (SB)	Ground	ECM power supply	Output	Ignition switch OFF	Battery voltage	G
56 (BR)	Ground	Ignition relay power supply	Output	Ignition switch OFF	0 V	H
				Ignition switch ON	Battery voltage	
57 (G)	Ground	Ignition relay power supply	Output	Ignition switch OFF	0 V	I
				Ignition switch ON	Battery voltage	
58 (GR)	Ground	Ignition relay power supply	Output	Ignition switch OFF	0 V	J
				Ignition switch ON	Battery voltage	
69 (BR)	Ground	ECM relay control	Output	Ignition switch OFF (More than a few seconds after turning ignition switch OFF)	Battery voltage	SEC
				<ul style="list-style-type: none"> Ignition switch ON Ignition switch OFF (For a few seconds after turning ignition switch OFF) 	0 - 1.5 V	
70 (BG)	Ground	Throttle control motor relay control	Output	Ignition switch ON → OFF	0 - 1.0 V ↓ Battery voltage ↓ 0 V	L
				Ignition switch ON	0 - 1.0 V	M
74 (G)	Ground	Ignition relay power supply	Output	Ignition switch OFF	0 V	N
				Ignition switch ON	Battery voltage	
75 (SB)	Ground	Oil pressure switch	Input	Ignition switch ON	0 V	O
				Engine running	Battery voltage	

A
B
C
D
E
F
G
H
I
J
SEC
L
M
N
O
P

IPDM E/R (INTELLIGENT POWER DISTRIBUTION MODULE ENGINE ROOM)

< ECU DIAGNOSIS INFORMATION >

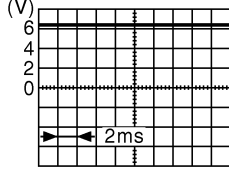
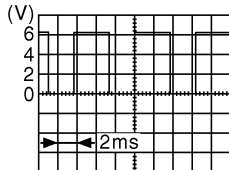
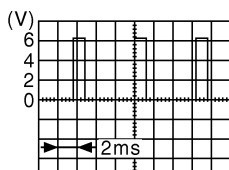
Terminal No. (Wire color)		Description		Condition		Value (Approx.)
+	-	Signal name	Input/ Output			
76 (Y)	Ground	Power generation command signal	Output	Ignition switch ON		 <p>6.3 V</p>
				40% is set on "ACTIVE TEST", "ALTERNATOR DUTY" of "ENGINE"		 <p>3.8 V</p>
				80% is set on "ACTIVE TEST", "ALTERNATOR DUTY" of "ENGINE"		 <p>1.4 V</p>
77 (R)	Ground	Fuel pump relay control	Output	<ul style="list-style-type: none"> Approximately 1 second after turning the ignition switch ON Engine running 		0 - 1.0 V
				Approximately 1 second or more after turning the ignition switch ON		Battery voltage
80 (W)	Ground	Starter motor	Output	At engine cranking		Battery voltage
83 (R)	Ground	Headlamp LO (RH)	Output	Ignition switch ON	Lighting switch OFF	0 V
					Lighting switch 2ND	Battery voltage
84 (V)	Ground	Headlamp LO (LH)	Output	Ignition switch ON	Lighting switch OFF	0 V
					Lighting switch 2ND	Battery voltage
86 (W)	Ground	Front fog lamp (RH)	Output	Lighting switch 2ND	Front fog lamp switch OFF	0 V
					Front fog lamp switch ON	Battery voltage
87 (L)	Ground	Front fog lamp (LH)	Output	Lighting switch 2ND	Front fog lamp switch OFF	0 V
					Front fog lamp switch ON	Battery voltage
88 (G)	Ground	Washer pump power supply	Output	Ignition switch ON		Battery voltage
89 (BR)	Ground	Headlamp HI (RH)	Output	Ignition switch ON	Lighting switch OFF	0 V
					<ul style="list-style-type: none"> Lighting switch HI Lighting switch PASS 	Battery voltage
90 (P)	Ground	Headlamp HI (LH)	Output	Ignition switch ON	Lighting switch OFF	0 V
					<ul style="list-style-type: none"> Lighting switch HI Lighting switch PASS 	Battery voltage

IPDM E/R (INTELLIGENT POWER DISTRIBUTION MODULE ENGINE ROOM)

< ECU DIAGNOSIS INFORMATION >

Terminal No. (Wire color)		Description		Condition		Value (Approx.)
+	-	Signal name	Input/ Output			
91 (G)	Ground	Parking lamp (RH)	Output	Ignition switch ON	Lighting switch OFF	0 V
					Lighting switch 1ST	Battery voltage
92 (BG)	Ground	Parking lamp (LH)	Output	Ignition switch ON	Lighting switch OFF	0 V
					Lighting switch 1ST	Battery voltage
97 (V)	Ground	Cooling fan control	Output	Engine idling		0 - 5 V
104 (LG)	Ground	Hood switch	Input	Close the hood		Battery voltage
				Open the hood		0 V

A

B

C

D

E

F

G

H

I

J

SEC

L

M

N

O

P

IPDM E/R (INTELLIGENT POWER DISTRIBUTION MODULE ENGINE ROOM)

< ECU DIAGNOSIS INFORMATION >

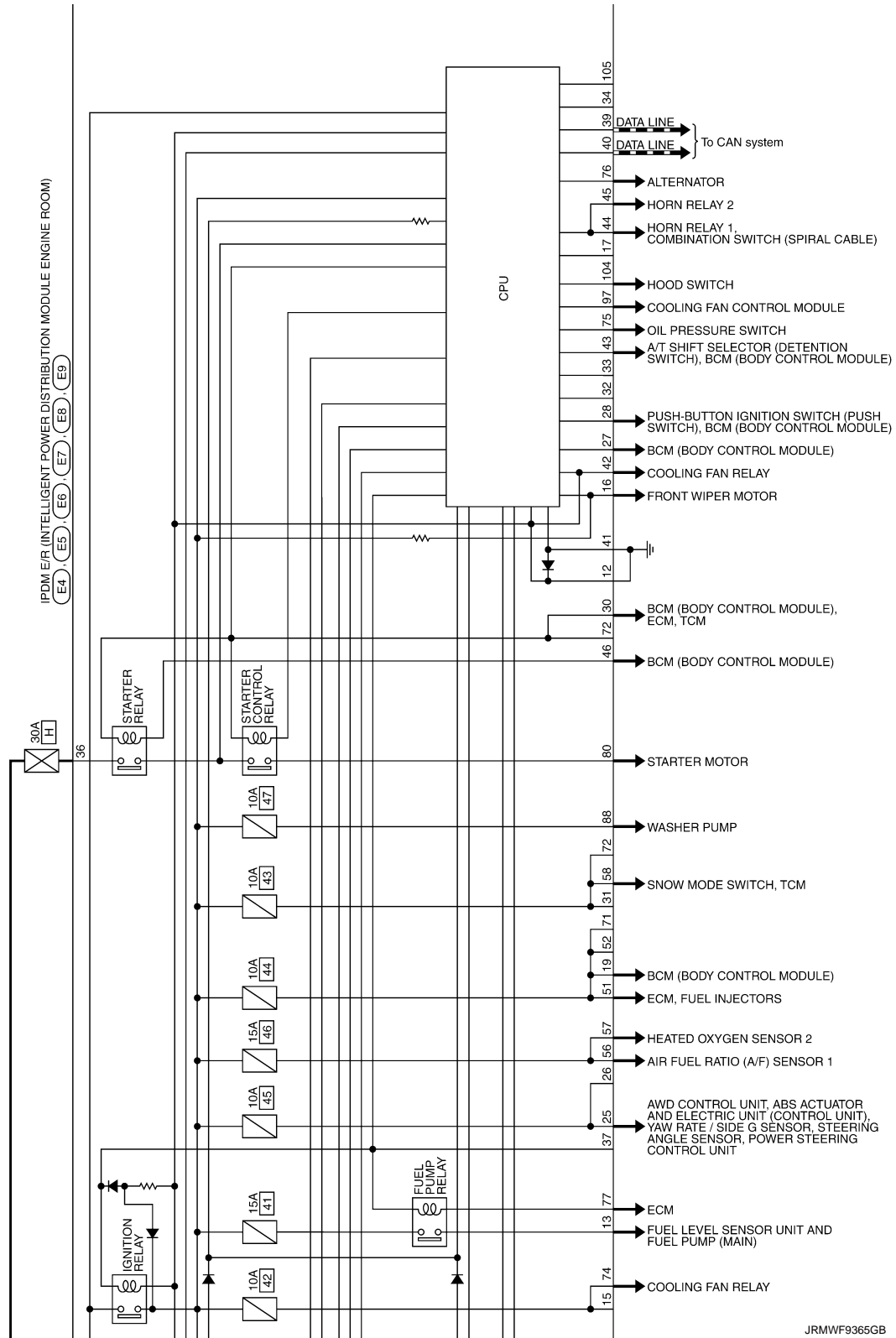

A
B
C
D
E
F
G
H
I
J
K
L
M
N
O
P

SEC

IPDM E/R (INTELLIGENT POWER DISTRIBUTION MODULE ENGINE ROOM)

< ECU DIAGNOSIS INFORMATION >

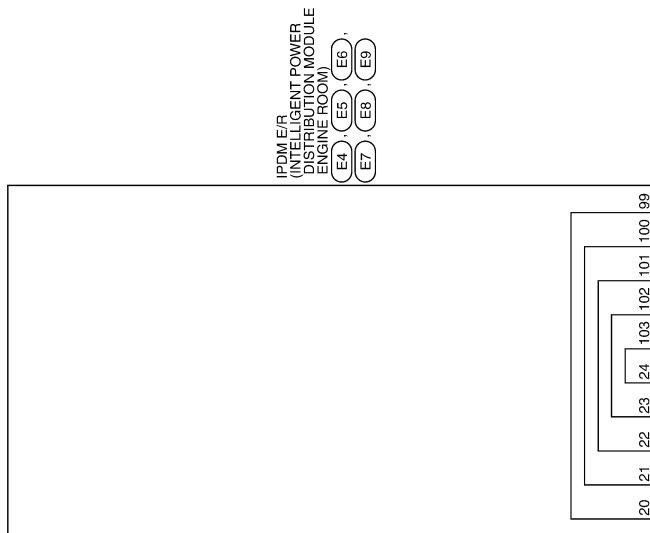

JRMWF9366GB

IPDM E/R (INTELLIGENT POWER DISTRIBUTION MODULE ENGINE ROOM)

< ECU DIAGNOSIS INFORMATION >

IPDM E/R (INTELLIGENT POWER DISTRIBUTION MODULE ENGINE ROOM)

Connector No.	E4
Connector Name	IPDM E/R INTELLIGENT POWER DISTRIBUTION MODULE ENGINE ROOM
Connector Type	10RFB-MC



Terminal No.	Color Of Wire	Signal Name [Specification]
1	W	-
2	L	-

Connector No.	E5
Connector Name	IPDM E/R INTELLIGENT POWER DISTRIBUTION MODULE ENGINE ROOM
Connector Type	TH20FW-CS12-M4-1V



Terminal No.	Color Of Wire	Signal Name [Specification]
4	V	-
5	L	-
6	SB	-
7	P	-
12	B/W	-
16	LG	-
19	R	-
25	G	-
27	BG	-
28	L	-
30	GR	-
30	G	-

Connector No.	E6
Connector Name	IPDM E/R INTELLIGENT POWER DISTRIBUTION MODULE ENGINE ROOM
Connector Type	TH8BFW-NH



Terminal No.	Color Of Wire	Signal Name [Specification]
38	P	-
41	P	-
42	B/W	-
43	GR	-
44	G	-
44	LG	-
45	V	-
46	SB	-

Connector No.	E7
Connector Name	IPDM E/R INTELLIGENT POWER DISTRIBUTION MODULE ENGINE ROOM
Connector Type	TH20FW-CS12-M4



Terminal No.	Color Of Wire	Signal Name [Specification]
48	L	-
49	BG	-
51	Y	-
53	W	-
54	B	-
55	BR	-
57	G	-
58	GR	-
69	BR	-
70	BG	-

74	G	-
75	SB	-
76	R	-
77	R	-
80	W	-

Connector No.	E8
Connector Name	IPDM E/R INTELLIGENT POWER DISTRIBUTION MODULE ENGINE ROOM
Connector Type	NS10BFW-CS



Terminal No.	Color Of Wire	Signal Name [Specification]
83	R	-
84	V	-
86	W	-
87	L	-
88	G	-
89	BR	-
90	P	-

Connector No.	E9
Connector Name	IPDM E/R INTELLIGENT POWER DISTRIBUTION MODULE ENGINE ROOM
Connector Type	TH18BFW-NH



Terminal No.	Color Of Wire	Signal Name [Specification]
92	EG	-
97	V	-
104	LG	-
105	L	-

Fail-safe

CAN COMMUNICATION CONTROL

When CAN communication with ECM and BCM is impossible, IPDM E/R performs fail-safe control. After CAN communication recovers normally, it also returns to normal control.

If No CAN Communication Is Available With ECM

JRMWF9518GB

INFOID:000000011433348

A
B
C
D
E
F
G
H
I
J
K
L
M
N
O
P

SEC

IPDM E/R (INTELLIGENT POWER DISTRIBUTION MODULE ENGINE ROOM)

< ECU DIAGNOSIS INFORMATION >

Control part	Fail-safe operation
Cooling fan	<ul style="list-style-type: none"> • Outputs the pulse duty signal (PWM signal) 100% when the ignition switch is turned ON • Outputs the pulse duty signal (PWM signal) 0% when the ignition switch is turned OFF
A/C compressor	A/C relay OFF
Alternator	Outputs the power generation command signal (PWM signal) 0%

If No CAN Communication Is Available With BCM

Control part	Fail-safe operation
Headlamp	<ul style="list-style-type: none"> • Turns ON the headlamp low relay when the ignition switch is turned ON • Turns OFF the headlamp low relay when the ignition switch is turned OFF • Headlamp high relay OFF
<ul style="list-style-type: none"> • Parking lamps • Side maker lamp • License plate lamps • Illuminations • Tail lamps 	<ul style="list-style-type: none"> • Turns ON the tail lamp relay when the ignition switch is turned ON • Turns OFF the tail lamp relay when the ignition switch is turned OFF
Front wiper	<ul style="list-style-type: none"> • The status just before activation of fail-safe control is maintained until the ignition switch is turned OFF while the front wiper is operating at LO or HI speed. • The wiper is operated at LO speed until the ignition switch is turned OFF if the fail-safe control is activated while the front wiper is set in the INT mode and the front wiper motor is operating.
Horn	Horn relay OFF
Ignition relay	The status just before activation of fail-safe is maintained.
Starter motor	Starter control relay OFF

IGNITION RELAY MALFUNCTION DETECTION FUNCTION

- IPDM E/R monitors the voltage at the contact circuit and excitation coil circuit of the ignition relay inside it.
- IPDM E/R judges the ignition relay error if the voltage differs between the contact circuit and the excitation coil circuit.
- If the ignition relay cannot turn OFF due to contact seizure, it activates the tail lamp relay for 10 minutes to alert the user to the ignition relay malfunction when the ignition switch is turned OFF.

Voltage judgment		IPDM E/R judgment	Operation
Ignition relay contact side	Ignition relay excitation coil side		
ON	ON	Ignition relay ON normal	—
OFF	OFF	Ignition relay OFF normal	—
ON	OFF	Ignition relay ON stuck	<ul style="list-style-type: none"> • Detects DTC “B2098: IGN RELAY ON CIRC” • Turns ON the tail lamp relay for 10 minutes
OFF	ON	Ignition relay OFF stuck	Detects DTC “B2099: IGN RELAY OFF CIRC”

FRONT WIPER CONTROL

IPDM E/R detects front wiper stop position by a front wiper stop position signal.

When a front wiper stop position signal is in the conditions listed below, IPDM E/R stops power supply to wiper after repeating a front wiper 10 seconds activation and 20 seconds stop five times.

Ignition switch	Front wiper switch	Front wiper stop position signal
ON	OFF	The front wiper stop position signal (stop position) cannot be input for 10 seconds.
	ON	The front wiper stop position signal does not change for 10 seconds.

NOTE:

This operation status can be confirmed on the IPDM E/R “Data Monitor” that displays “BLOCK” for the item “WIP PROT” while the wiper is stopped.

IPDM E/R (INTELLIGENT POWER DISTRIBUTION MODULE ENGINE ROOM)

< ECU DIAGNOSIS INFORMATION >

STARTER MOTOR PROTECTION FUNCTION

IPDM E/R turns OFF the starter control relay to protect the starter motor when the starter control relay remains active for 90 seconds.

DTC Index

INFOID:0000000011433349

NOTE:

- The details of time display are as follows.
 - CRNT: A malfunction is detected now.
 - PAST: A malfunction was detected in the past.
- IGN counter is displayed on FFD (Freeze Frame data).
 - The number is 0 when is detected now.
 - The number increases like 1 → 2 ... 38 → 39 after returning to the normal condition whenever IGN OFF → ON.
 - The number is fixed to 39 until the self-diagnosis results are erased if it is over 39.

x: Applicable

CONSULT display	Fail-safe	Refer to
No DTC is detected. further testing may be required.	—	—
U1000: CAN COMM CIRCUIT	×	PCS-14
B2098: IGN RELAY ON CIRC	×	PCS-15
B2099: IGN RELAY OFF CIRC	—	PCS-17
B210B: STR CONT RLY ON CIRC	—	SEC-77
B210C: STR CONT RLY OFF CIRC	—	SEC-78
B210D: STARTER RLY ON CIRC	—	SEC-80
B210E: STARTER RLY OFF CIRC	—	SEC-82
B210F: INTRLCK/PNP SW ON	—	SEC-84
B2110: INTRLCK/PNP SW OFF	—	SEC-86

SEC

ENGINE DOES NOT START WHEN INTELLIGENT KEY IS INSIDE OF VEHICLE

< SYMPTOM DIAGNOSIS >

SYMPTOM DIAGNOSIS

ENGINE DOES NOT START WHEN INTELLIGENT KEY IS INSIDE OF VEHICLE

Description

INFOID:0000000010993927

Engine does not start when push-button ignition switch is pressed while carrying Intelligent Key.

NOTE:

- Check that vehicle is under the condition shown in “Conditions of vehicle” before starting diagnosis, and check each symptom.
- The engine start function, door lock function, power distribution system, and NATS-IVIS/NVIS in the Intelligent Key system are closely related to each other regarding control. The vehicle security function can operate only when the door lock and power distribution system are operating normally.

Conditions of Vehicle (Operating Conditions)

- “ENGINE START BY I-KEY” in “WORK SUPPORT” is ON when setting on CONSULT.
- Intelligent Key is not inserted in key slot.
- One or more of Intelligent Keys with registered Intelligent Key ID is in the vehicle.

Diagnosis Procedure

INFOID:0000000010993928

1. CHECK INTELLIGENT KEY SYSTEM (DOOR LOCK FUNCTION)

Lock/unlock door with door request switch.

Refer to [DLK-21, "DOOR LOCK FUNCTION : System Description"](#).

Is the operation normal?

YES >> GO TO 2.

NO >> Check Intelligent Key system (door lock function). Refer to [DLK-189, "ALL DOOR : Diagnosis Procedure"](#).

2. PERFORM WORK SUPPORT

Perform “INSIDE ANT DIAGNOSIS” on Work Support in “INTELLIGENT KEY”.

Refer to [DLK-53, "INTELLIGENT KEY : CONSULT Function \(BCM - INTELLIGENT KEY\)"](#).

>> GO TO 3.

3. PERFORM SELF DIAGNOSTIC RESULT

Perform Self Diagnostic Result in “BCM”, and check whether or not DTC of inside key antenna is detected.

Is DTC detected?

YES >> Refer to [DLK-59, "DTC Logic"](#) (instrument center), [DLK-61, "DTC Logic"](#) (console) or [DLK-63, "DTC Logic"](#) (trunk room).

NO >> GO TO 4.

4. CHECK PUSH-BUTTON IGNITION SWITCH

Check push-button ignition switch.

Refer to [PCS-63, "Component Function Check"](#).

Is the operation normal?

YES >> GO TO 5.

NO >> Repair or replace malfunctioning parts.

5. CONFIRM THE OPERATION

Confirm the operation again.

Is the inspection normal?

YES >> Check intermittent incident. Refer to [GI-41, "Intermittent Incident"](#).

NO >> GO TO 1.

SECURITY INDICATOR LAMP DOES NOT TURN ON OR FLASH

< SYMPTOM DIAGNOSIS >

SECURITY INDICATOR LAMP DOES NOT TURN ON OR FLASH

Description

INFOID:000000010993929

Security indicator lamp does not blink when ignition switch is in a position other than ON

NOTE:

- Before performing the diagnosis, check "Work Flow". Refer to [SEC-5, "Work Flow"](#).
- Check that vehicle is under the condition shown in "Conditions of vehicle" before starting diagnosis, and check each symptom.

Conditions of Vehicle (Operating Conditions)

- Intelligent Key is not inserted in key slot.
- Ignition switch is not in the ON position.

Diagnosis Procedure

INFOID:000000010993930

1. CHECK SECURITY INDICATOR LAMP

Check security indicator lamp.

Refer to [SEC-95, "Component Function Check"](#).

Is the inspection result normal?

YES >> GO TO 2.

NO >> Repair or replace the malfunctioning parts.

2. CONFIRM THE OPERATION

Confirm the operation again.

Is the result normal?

YES >> Check intermittent incident. Refer to [GI-41, "Intermittent Incident"](#).

NO >> GO TO 1.

A
B
C
D
E
F
G
H
I
J
L
M
N
O
P

SEC

VEHICLE SECURITY SYSTEM CANNOT BE SET

< SYMPTOM DIAGNOSIS >

VEHICLE SECURITY SYSTEM CANNOT BE SET INTELLIGENT KEY

INTELLIGENT KEY : Description

INFOID:0000000010993931

Armed phase is not activated when door is locked using Intelligent Key.

NOTE:

Check that vehicle is under the condition shown in “Conditions of vehicle” before starting diagnosis, and check each symptom.

CONDITION OF VEHICLE (OPERATING CONDITION)

Confirm the setting of “SECURITY ALARM SET” in “WORK SUPPORT” in “THEFT ALM” using CONSULT.

INTELLIGENT KEY : Diagnosis Procedure

INFOID:0000000010993932

1. CHECK INTELLIGENT KEY SYSTEM (REMOTE KEYLESS ENTRY FUNCTION)

Lock/unlock door with Intelligent Key.

Refer to [DLK-21, "DOOR LOCK FUNCTION : System Description"](#).

Is the inspection result normal?

YES >> GO TO 2.

NO >> Check Intelligent Key system (remote keyless entry function). Refer to [DLK-191, "Diagnosis Procedure"](#).

2. CHECK HOOD SWITCH

Check hood switch.

Refer to [SEC-93, "Component Function Check"](#).

Is the inspection result normal?

YES >> GO TO 3.

NO >> Repair or replace the malfunctioning parts.

3. CONFIRM THE OPERATION

Confirm the operation again.

Is the result normal?

YES >> Check intermittent incident. Refer to [GI-41, "Intermittent Incident"](#).

NO >> GO TO 1.

DOOR REQUEST SWITCH

DOOR REQUEST SWITCH : Description

INFOID:0000000010993933

Armed phase is not activated when door is locked using door request switch.

NOTE:

Check that vehicle is under the condition shown in “Conditions of vehicle” before starting diagnosis, and check each symptom.

CONDITION OF VEHICLE (OPERATING CONDITION)

Confirm the setting of “SECURITY ALARM SET” in “WORK SUPPORT” in “THEFT ALM” using CONSULT.

DOOR REQUEST SWITCH : Diagnosis Procedure

INFOID:0000000010993934

1. CHECK INTELLIGENT KEY SYSTEM (DOOR LOCK FUNCTION)

Lock/unlock door with door request switch.

Refer to [DLK-21, "DOOR LOCK FUNCTION : System Description"](#).

Is the inspection result normal?

YES >> GO TO 2.

NO >> Check Intelligent Key system (door lock function). Refer to [DLK-191, "Diagnosis Procedure"](#).

2. CHECK HOOD SWITCH

Check hood switch.

VEHICLE SECURITY SYSTEM CANNOT BE SET

< SYMPTOM DIAGNOSIS >

Refer to [SEC-93, "Component Function Check"](#).

Is the inspection result normal?

YES >> GO TO 3.

NO >> Repair or replace the malfunctioning parts.

3.CONFIRM THE OPERATION

Confirm the operation again.

Is the result normal?

YES >> Check intermittent incident. Refer to [GI-41, "Intermittent Incident"](#).

NO >> GO TO 1.

A
B
C
D
E
F
G
H
I
J
L
M
N
O
P

SEC

VEHICLE SECURITY ALARM DOES NOT ACTIVATE

< SYMPTOM DIAGNOSIS >

VEHICLE SECURITY ALARM DOES NOT ACTIVATE

Description

INFOID:000000010993935

Alarm does not operate when alarm operating condition is satisfied.

NOTE:

Check that vehicle is under the condition shown in "Conditions of vehicle" before starting diagnosis, and check each symptom.

CONDITIONS OF VEHICLE (OPERATING CONDITIONS)

"SECURITY ALARM SET" in "WORK SUPPORT" of "THEFT ALM" is ON when setting on CONSULT.

Diagnosis Procedure

INFOID:000000010993936

1.CHECK DOOR SWITCH

Check door switch.

Refer to [DLK-66, "Component Function Check"](#).

Is the inspection result normal?

YES >> GO TO 2.

NO >> Replace the malfunctioning door switch

2.CHECK HOOD SWITCH

Check hood switch.

Refer to [SEC-93, "Component Function Check"](#).

Is the inspection result normal?

YES >> GO TO 3.

NO >> Repair or replace the malfunctioning parts.

3.CHECK HEADLAMP

Check headlamp.

Refer to [EXL-34, "Component Function Check"](#).

Is the inspection result normal?

YES >> GO TO 4.

NO >> Repair or replace the malfunctioning parts.

4.CHECK HORN

Check horn.

Refer to [HRN-2, "Wiring Diagram - HORN -"](#).

Is the inspection result normal?

YES >> GO TO 5.

NO >> Repair or replace the malfunctioning parts.

5.CONFIRM THE OPERATION

Confirm the operation again.

Is the result normal?

YES >> Check intermittent incident. Refer to [GI-41, "Intermittent Incident"](#).

NO >> GO TO 1.

INTELLIGENT KEY INSERT INFORMATION DOES NOT OPERATE

< SYMPTOM DIAGNOSIS >

INTELLIGENT KEY INSERT INFORMATION DOES NOT OPERATE

Description

INFOID:000000010993937

Intelligent Key insert information does not operate when push-button ignition switch is operated while Intelligent Key is not inside vehicle.

NOTE:

Warning functions operating condition is extremely complicated. During operation confirmation reconfirm the list above twice in order to ensure proper operation. Refer to [DLK-40, "WARNING FUNCTION : System Description"](#).

Diagnosis Procedure

INFOID:000000010993938

1.CHECK POWER POSITION

Check if ignition switch position is changing or not.

Does ignition switch position change?

YES >> GO TO 3.

NO >> GO TO 2.

2.CHECK PUSH-BUTTON IGNITION SWITCH

Check push-button ignition switch.

Refer to [PCS-63, "Component Function Check"](#).

Is the inspection result normal?

YES >> Check BCM for DTC. Refer to [BCS-84, "DTC Index"](#).

NO >> Repair or replace the malfunctioning parts.

3.CHECK DOOR SWITCH

Check door switch.

Refer to [DLK-66, "Component Function Check"](#).

Is the inspection result normal?

YES >> GO TO 4.

NO >> Repair or replace the malfunctioning parts.

4.CHECK KEY SLOT

Check key slot.

Refer to [SEC-90, "Component Function Check"](#).

Is the inspection result normal?

YES >> GO TO 5.

NO >> Repair or replace the malfunctioning parts.

5.CHECK COMBINATION METER DISPLAY

Check combination meter display.

Refer to [DLK-108, "Component Function Check"](#).

Is the inspection result normal?

YES >> GO TO 6.

NO >> Repair or replace the malfunctioning parts.

6.CHECK KEY SLOT INDICATOR

Check key slot indicator.

Refer to [SEC-91, "Component Function Check"](#).

Is the inspection result normal?

YES >> GO TO 7.

NO >> Repair or replace the malfunctioning parts.

7.CONFIRM THE OPERATION

Confirm the operation again.

Is the result normal?

A

B

C

D

E

F

G

H

I

J

SEC

L

M

N

O

P

INTELLIGENT KEY INSERT INFORMATION DOES NOT OPERATE

< SYMPTOM DIAGNOSIS >

YES >> Check intermittent incident. Refer to [GI-41, "Intermittent Incident"](#).
NO >> GO TO 1.

PRECAUTIONS

< PRECAUTION >

PRECAUTION

PRECAUTIONS

Precaution for Supplemental Restraint System (SRS) "AIR BAG" and "SEAT BELT PRE-TENSIONER"

INFOID:000000010993939

The Supplemental Restraint System such as "AIR BAG" and "SEAT BELT PRE-TENSIONER", used along with a front seat belt, helps to reduce the risk or severity of injury to the driver and front passenger for certain types of collision. This system includes seat belt switch inputs and dual stage front air bag modules. The SRS system uses the seat belt switches to determine the front air bag deployment, and may only deploy one front air bag, depending on the severity of a collision and whether the front occupants are belted or unbelted. Information necessary to service the system safely is included in the "SRS AIR BAG" and "SEAT BELT" of this Service Manual.

WARNING:

Always observe the following items for preventing accidental activation.

- To avoid rendering the SRS inoperative, which could increase the risk of personal injury or death in the event of a collision that would result in air bag inflation, all maintenance must be performed by an authorized NISSAN/INFINITI dealer.
- Improper maintenance, including incorrect removal and installation of the SRS, can lead to personal injury caused by unintentional activation of the system. For removal of Spiral Cable and Air Bag Module, see "SRS AIR BAG".
- Never use electrical test equipment on any circuit related to the SRS unless instructed to in this Service Manual. SRS wiring harnesses can be identified by yellow and/or orange harnesses or harness connectors.

PRECAUTIONS WHEN USING POWER TOOLS (AIR OR ELECTRIC) AND HAMMERS

WARNING:

Always observe the following items for preventing accidental activation.

- When working near the Air Bag Diagnosis Sensor Unit or other Air Bag System sensors with the ignition ON or engine running, never use air or electric power tools or strike near the sensor(s) with a hammer. Heavy vibration could activate the sensor(s) and deploy the air bag(s), possibly causing serious injury.
- When using air or electric power tools or hammers, always switch the ignition OFF, disconnect the battery, and wait at least 3 minutes before performing any service.

Precaution for Procedure without Cowl Top Cover

INFOID:000000010993940

When performing the procedure after removing cowl top cover, cover the lower end of windshield with urethane, etc to prevent damage to windshield.

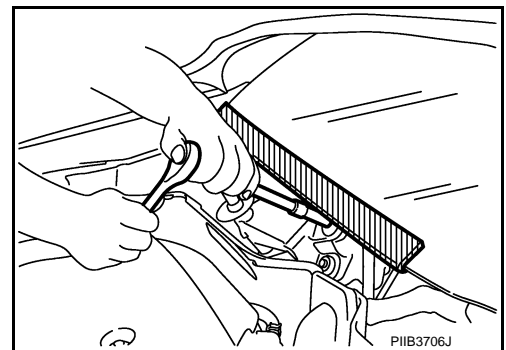

Precautions For Xenon Headlamp Service

INFOID:000000011404623

WARNING:

Comply with the following warnings to prevent any serious accident.

- Disconnect the battery cable (negative terminal) or the power supply fuse before installing, removing, or touching the xenon headlamp (bulb included). The xenon headlamp contains high-voltage generated parts.
- Never work with wet hands.
- Check the xenon headlamp ON-OFF status after assembling it to the vehicle. Never turn the xenon headlamp ON in other conditions. Connect the power supply to the vehicle-side connector.

A
B
C
D
E
F
G
H
I
J
K
L
M
N
O
P

SEC

PRECAUTIONS

< PRECAUTION >

(Turning it ON outside the lamp case may cause fire or visual impairments.)

- Never touch the bulb glass immediately after turning it OFF. It is extremely hot.

CAUTION:

Comply with the following cautions to prevent any error and malfunction.

- Install the xenon bulb securely. (Insufficient bulb socket installation may melt the bulb, the connector, the housing, etc. by high-voltage leakage or corona discharge.)
- Never perform HID circuit inspection with a tester.
- Never touch the xenon bulb glass with hands. Never put oil and grease on it.
- Dispose of the used xenon bulb after packing it in thick vinyl without breaking it.
- Never wipe out dirt and contamination with organic solvent (thinner, gasoline, etc.).

Precautions for Removing Battery Terminal

INFOID:000000011404624

- When removing the 12V battery terminal, turn OFF the ignition switch and wait at least 30 seconds.

NOTE:

ECU may be active for several tens of seconds after the ignition switch is turned OFF. If the battery terminal is removed before ECU stops, then a DTC detection error or ECU data corruption may occur.

- For vehicles with the 2-batteries, be sure to connect the main battery and the sub battery before turning ON the ignition switch.

NOTE:

If the ignition switch is turned ON with any one of the terminals of main battery and sub battery disconnected, then DTC may be detected.

- After installing the 12V battery, always check "Self Diagnosis Result" of all ECUs and erase DTC.

NOTE:

The removal of 12V battery may cause a DTC detection error.

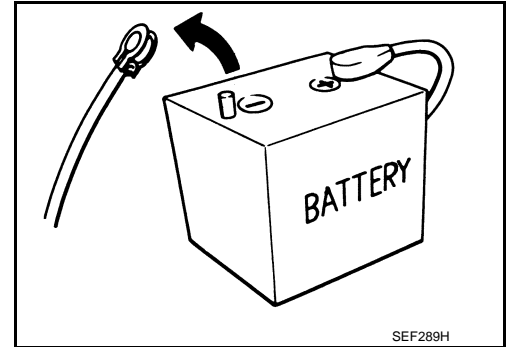

KEY SLOT

< REMOVAL AND INSTALLATION >

REMOVAL AND INSTALLATION

KEY SLOT

Exploded View

INFOID:0000000010993941

Refer to [IP-12, "Exploded View"](#).

Removal and Installation

INFOID:0000000010993942

REMOVAL

1. Remove the instrument driver lower panel. Refer to [IP-13, "Removal and Installation"](#).
2. Disconnect key slot connector.
3. Remove the key slot mounting screw (A), and then remove key slot (1) from instrument driver lower panel (2).

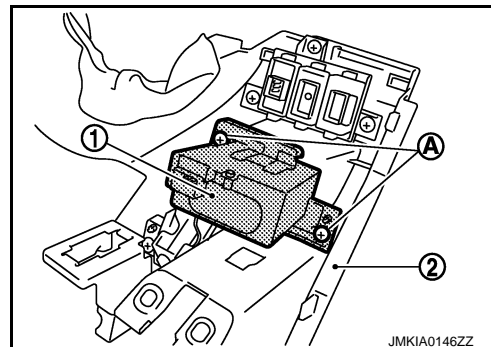

INSTALLATION

Install in the reverse order of removal.

A
B
C
D
E
F
G
H
I
J
L
M
N
O
P

SEC

PUSH BUTTON IGNITION SWITCH

< REMOVAL AND INSTALLATION >

PUSH BUTTON IGNITION SWITCH

Exploded View

INFOID:000000010993943

Refer to [IP-12. "Exploded View"](#).

Removal and Installation

INFOID:000000010993944

REMOVAL

1. Remove the cluster lid A assembly. Refer to [IP-13. "Removal and Installation"](#).
2. Remove the push-button ignition switch (1) from cluster lid A assembly, and then remove pawl (A). Press push-button ignition switch (1) back to disengage from cluster lid A assembly.

 : Pawl

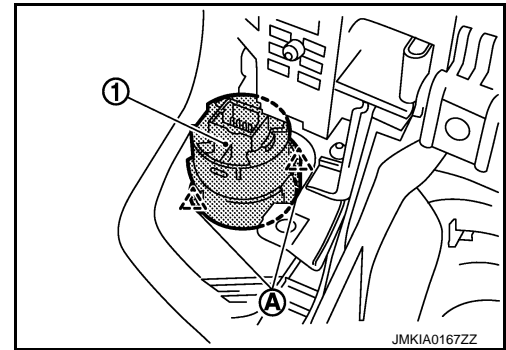

INSTALLATION

Install in the reverse order of removal.