

SECTION **RSU**
 REAR SUSPENSION

A
 B
 C
 D

RSU

CONTENTS

PRECAUTIONS	2	SUSPENSION ARM	11	F
Cautions	2	Removal and Installation	11	
PREPARATION	3	REMOVAL	11	G
Special Service Tools	3	INSPECTION AFTER REMOVAL	11	
Commercial Service Tools	3	INSTALLATION	12	
NOISE, VIBRATION AND HARSHNESS (NVH)		RADIUS ROD	13	H
TROUBLESHOOTING	4	Removal and Installation	13	
NVH Troubleshooting Chart	4	REMOVAL	13	
REAR SUSPENSION ASSEMBLY	5	INSPECTION AFTER REMOVAL	13	I
On-Vehicle Inspection and Service	5	INSTALLATION	13	
INSPECTION OF BALL JOINT END PLAY	5	FRONT LOWER LINK	14	J
SHOCK ABSORBER INSPECTION	5	Removal and Installation	14	
Wheel Alignment Inspection	5	REMOVAL	14	
DESCRIPTION	5	INSPECTION AFTER REMOVAL	14	
PRELIMINARY INSPECTION	5	INSTALLATION	14	
CAMBER INSPECTION	5	REAR LOWER LINK & COIL SPRING	15	K
TOE-IN	6	Removal and Installation	15	
Components	7	REMOVAL	15	
Removal and Installation	8	INSPECTION AFTER REMOVAL	15	
REMOVAL	8	INSTALLATION	15	L
INSTALLATION	8	STABILIZER BAR	16	
SHOCK ABSORBER	9	Removal and Installation	16	
Removal and Installation	9	REMOVAL	16	
REMOVAL	9	INSPECTION AFTER REMOVAL	16	M
INSPECTION AFTER REMOVAL	9	INSTALLATION	16	
INSTALLATION	9	REAR SUSPENSION MEMBER	17	
Disassembly and Assembly	9	Removal and Installation	17	
DISASSEMBLY	9	REMOVAL	17	
INSPECTION AFTER DISASSEMBLY	10	INSPECTION AFTER REMOVAL	17	
ASSEMBLY	10	INSTALLATION	17	
		SERVICE DATA	18	
		Wheel Alignment	18	
		Ball Joint	18	
		Wheelarch Height (Unladen*)	18	

PRECAUTIONS

PRECAUTIONS

PFP:00001

Cautions

AES000EA

- When installing rubber bushings, final tightening must be carried out under unladen condition with tires on level ground. Oil will shorten the life of rubber bushings. Be sure to wipe off any spilled oil.
- Unladen condition means that fuel, coolant and lubricant are full. Spare tire, jack, hand tools and mats in designated positions.
- After servicing suspension parts, be sure to check wheel alignment.
- Caulking nuts are not reusable. Always use new ones when installing. Since new caulking nuts are pre-oiled, tighten as they are.

PREPARATION

PREPARATION

PPF:00002

Special Service Tools

AES000EB

The actual shapes of Kent-Moore tools may differ from those of special service tools illustrated here.

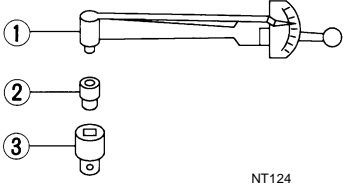
Tool number (Kent-Moore No.) Tool name	Description
ST3127S000 (See J25742-1) Preload Gauge 1. GC91030000 Torque wrench (J25765) 2. HT62940000 (—) Socket adapter (1/2") 3. HT62900000 (—) Socket adapter (3/8")	 NT124 Measuring rotating torque of ball joint

A
B
C
D
RSU

Commercial Service Tools

AES000EC

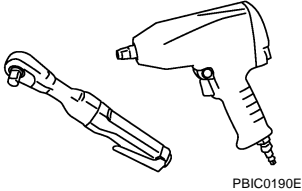
Tool name	Description
Power tool	 PBIC0190E <ul style="list-style-type: none"> ● Removing wheel nuts ● Removing brake caliper assembly ● Removing rear suspension component parts

F
G
H
I
J
K
L
M

NOISE, VIBRATION AND HARSHNESS (NVH) TROUBLESHOOTING

NOISE, VIBRATION AND HARSHNESS (NVH) TROUBLESHOOTING

PF0:00003

NVH Troubleshooting Chart

AES000ED

Use chart below to help you find the cause of the symptom. If necessary, repair or replace these parts.

Symptom		Possible cause and SUSPECTED PARTS													Reference page			
		Improper installation, looseness	Shock absorber deformation, damage or deflection	Bushing or mounting deterioration	Parts interference	Spring fatigue	Suspension looseness	Incorrect wheel alignment	Stabilizer bar fatigue	PROPELLER SHAFT	DIFFERENTIAL	FRONT AXLE AND FRONT SUSPENSION	TIRES	ROAD WHEEL	DRIVE SHAFT	BRAKES	STEERING	
REAR SUSPENSION	Noise	x	x	x	x	x	x			x	x	x	x	x	x	x	x	RSU-7.
	Shake	x	x	x	x		x			x		x	x	x	x	x	x	RSU-9.
	Vibration	x	x	x	x	x				x		x	x		x			—
	Shimmy	x	x	x	x			x				x	x	x		x	x	—
	Judder	x	x	x								x	x	x		x	x	—
	Poor quality ride or handling	x	x	x	x	x		x	x			x	x	x				RSU-7.
																		RSU-5.
																		RSU-16.
																		NVH in PR section.
																		NVH in RFD section.
																		NVH in FAX and FSU sections.
																		NVH in WT section.
																		NVH in WT section.
																		NVH in RAX section.
																		NVH in BR section.
																		NVH in PS section.

x: Applicable

REAR SUSPENSION ASSEMBLY

REAR SUSPENSION ASSEMBLY

PFP:55020

On-Vehicle Inspection and Service

AES000EF

Check that the mounting conditions (looseness, back lash) of each component and component status (wear, damage) are normal.

INSPECTION OF BALL JOINT END PLAY

- Measure axial end play by installing and moving up/down with an iron pry bar or something similar between suspension arm and axle.

Standard value

Axial end play : 0 mm (0 in)

CAUTION:

Be careful not to damage ball joint boot.

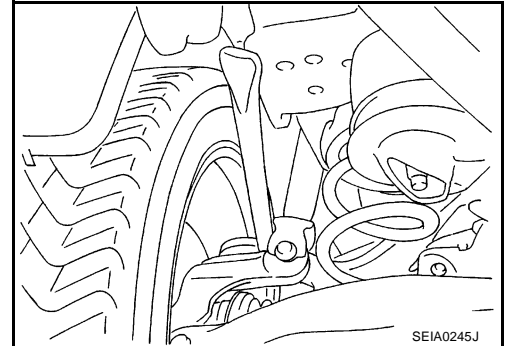

SHOCK ABSORBER INSPECTION

- Check shock absorber for oil leakage, damage and replace if necessary.

Wheel Alignment Inspection DESCRIPTION

AES000EG

- Measure wheel alignment under unladen conditions. "Unladen conditions" means that fuel, coolant, and lubricant are full. Spare tire, jack, hand tools and mats in designated positions.

PRELIMINARY INSPECTION

1. Check tires for improper air pressure and wear.
2. Check road wheels for runout.
3. Check wheel bearing axial end play.
4. Check ball joint axial end play of suspension arm.
5. Check shock absorber operation.
6. Check each mounting point of axle and suspension for looseness and deformation.
7. Check each link, arm and member for cracks, deformation, and other damage.
8. Check vehicle posture.

CAMBER INSPECTION

- Measure camber of both right and left wheels with a suitable alignment gauge and adjust in accordance with the following procedures.

Standard value

Camber : Refer to [RSU-18, "SERVICE DATA"](#).

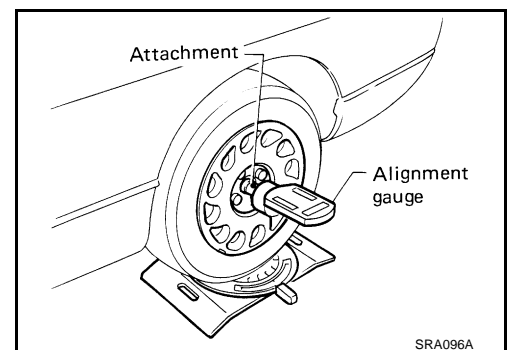

REAR SUSPENSION ASSEMBLY

If outside the standard value, adjust with adjusting bolt in front lower link.

CAUTION:

After adjusting camber, be sure to check toe-in.

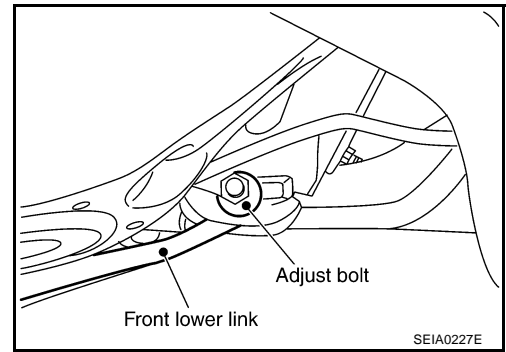

TOE-IN

Measure toe-in using following procedure. If out of specification, inspect and replace any damaged or worn rear suspension parts.

WARNING:

- Always perform following procedure on a flat surface.
 - Make sure that no person is in front of vehicle before pushing it.
1. Bounce rear of vehicle up and down to stabilize the posture.
 2. Push vehicle straight ahead about 5 m (16 ft).
 3. Put a mark on base line of the tread (rear side) of both tires at the same height of hub center. These are measuring point.
 4. Measure distance "A" (rear side).

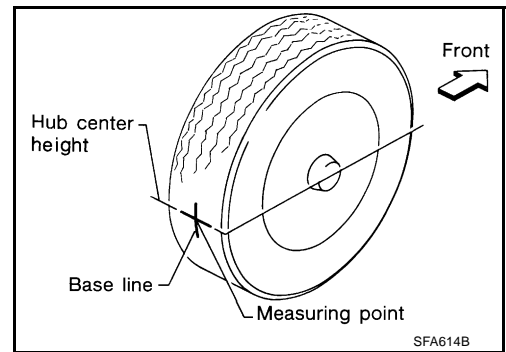

5. Push vehicle slowly ahead to rotate the wheels 180 degrees (1/2 turn).

If wheels have rotated more than 180 degrees (1/2 turn), try the above procedure again from the beginning. Never push vehicle backward.

6. Measure distance "B" (front side).

Standard value

Total toe-in : Refer to [RSU-18, "SERVICE DATA"](#) .

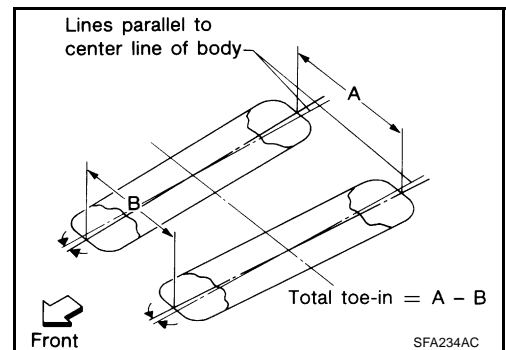

7. If outside the standard value, adjust with adjusting bolt in rear lower link.

CAUTION:

Be sure to adjust equally on RH and LH side with adjusting bolt.

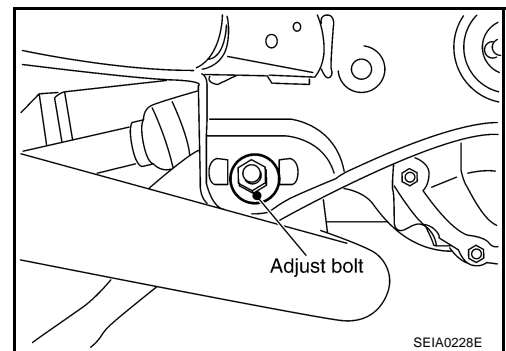

REAR SUSPENSION ASSEMBLY

Components

AES000EE

A
B
C
D
E
F
G
H
I
J
K
L
M

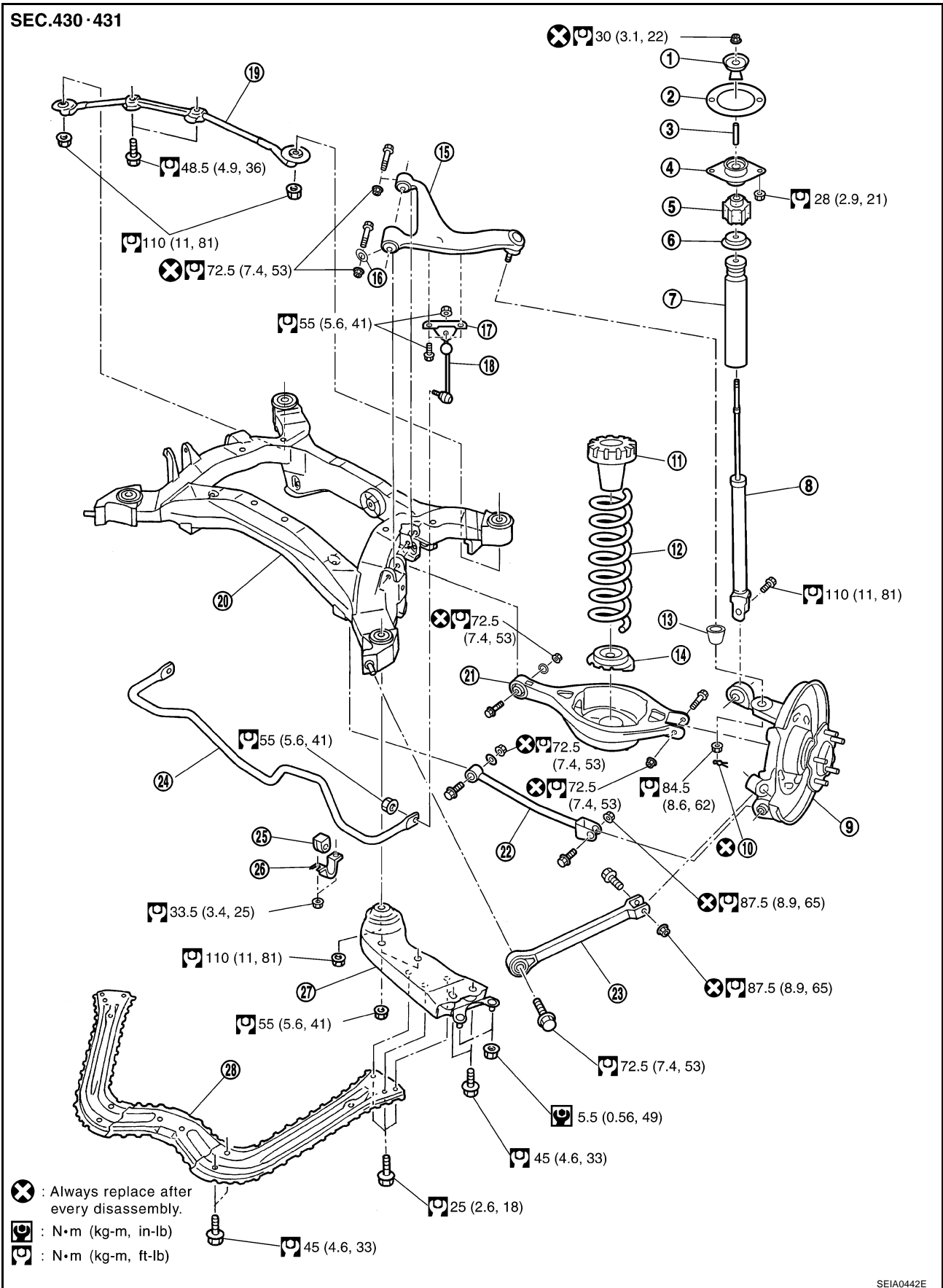

RSU

REAR SUSPENSION ASSEMBLY

- | | | |
|--------------------------|--|-------------------------------|
| 1. Bushing | 2. Mounting seal | 3. Distance tube |
| 4. Mounting seal bracket | 5. Bushing | 6. Bound bumper cover |
| 7. Bound bumper | 8. Shock absorber | 9. Axle |
| 10. Cotter pin | 11. Upper seat | 12. Coil spring |
| 13. Ball seat | 14. Rubber seat | 15. Suspension arm |
| 16. Stopper rubber | 17. Stabilizer connecting rod mounting bracket | 18. Stabilizer connecting rod |
| 19. Rear pin stay | 20. Rear suspension member | 21. Rear lower link |
| 22. Front lower link | 23. Radius rod | 24. Stabilizer bar |
| 25. Stabilizer bushing | 26. Stabilizer clamp | 27. Member stay |
| 28. Tunnel stay | | |

Removal and Installation

REMOVAL

AES000EH

1. Remove tire with power tool.
2. Remove brake caliper with power tool. Hang it in a place where it will not interfere with work. Refer to [BR-35, "REAR DISC BRAKE \(AD14VE TYPE\)"](#) , [BR-41, "REAR DISC BRAKE \(OPB13VB TYPE\)"](#) .

CAUTION:

Avoid depressing brake pedal while brake caliper is removed.

3. Remove disc rotor.
4. Remove stabilizer bar. Refer to [RSU-16, "STABILIZER BAR"](#) .
5. Remove rear exhaust tube. Refer to [EX-3, "EXHAUST SYSTEM"](#) .
6. Remove propeller shaft. Refer to [PR-4, "REAR PROPELLER SHAFT"](#) .
7. Separate the attachment between parking brake cable and vehicle and rear suspension member. Refer to [PB-6, "PARKING BRAKE CONTROL"](#) .
8. Remove wheel sensor connector from rear final drive.
9. Remove rear lower link and coil spring. Refer to [RSU-15, "REAR LOWER LINK & COIL SPRING"](#) .
10. Remove fixing nut in upper side of mounting seal bracket. Refer to [RSU-9, "SHOCK ABSORBER"](#) .
11. Set jack under rear final drive.
12. Remove tunnel stay and member stay from vehicle.
13. Remove fixing bolts and nuts of rear pin stay and then remove rear pin stay from vehicle.
14. Gradually lowering jack, remove rear suspension assembly.

INSTALLATION

- Refer to [RSU-7, "Components"](#) for tightening torque. Install in the reverse order of removal.

CAUTION:

Refer to component parts location and do not reuse non-reusable parts.

- Perform final tightening of installation position of links (rubber bushing) under unladen condition with tires on level ground. Check wheel alignment. Refer to [RSU-5, "Wheel Alignment Inspection"](#) .

SHOCK ABSORBER

SHOCK ABSORBER

PPF:56210

Removal and Installation

AES000EI

REMOVAL

1. Remove tire with power tool.
2. Remove fixing bolt in lower side of shock absorber with power tool.
3. Remove mounting seal bracket fixing nuts of shock absorber upper side with power tool and remove shock absorber from vehicle.

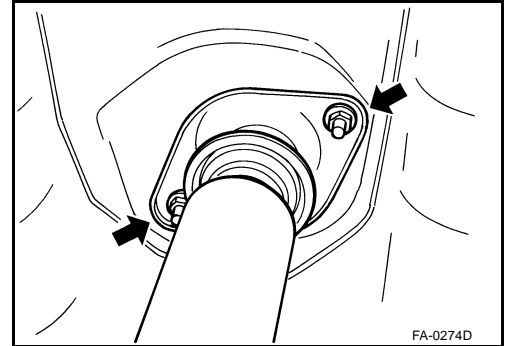

INSPECTION AFTER REMOVAL

- Check shock absorber for deformation, cracks, damage, and replace if necessary.
- Check piston rod for damage, uneven wear, distortion, and replace if necessary.
- Check welded and sealed areas for oil leakage, and replace if necessary.

INSTALLATION

- Refer to [RSU-7, "Components"](#) for tightening torque. Install in the reverse order of removal.

CAUTION:

Refer to component parts location and do not reuse non-reusable parts.

- Perform final tightening of shock absorber lower side (rubber bushing) under unladen condition with tires on level ground. Check wheel alignment. Refer to [RSU-18, "SERVICE DATA"](#).

Disassembly and Assembly

DISASSEMBLY

AES000EJ

CAUTION:

Make sure piston rod on shock absorber is not damaged when removing components from shock absorber.

1. Remove mounting seal from mounting seal bracket.
2. Wrap a shop cloth around lower side of shock absorber and fix it in a vise.

CAUTION:

Do not set the cylindrical part of shock absorber in vice.

3. Secure piston rod tip so that piston rod does not turn, and remove piston rod lock nut.

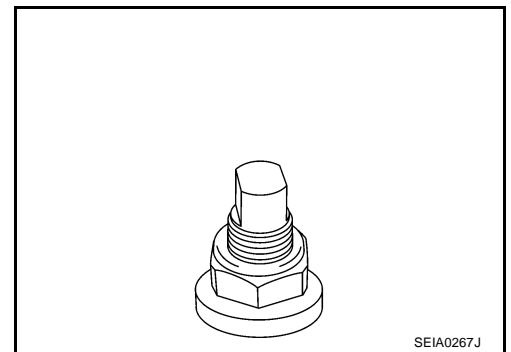

4. Remove bushing (Upper side), distance tube, mounting seal bracket, bushing (Lower side), bound bumper cover and bound bumper from shock absorber.

SHOCK ABSORBER

INSPECTION AFTER DISASSEMBLY

Bound Bumper and Bushing

- Check bound bumper and bushing for cracks, deformation or other damage. Replace if necessary.

ASSEMBLY

- Refer to [RSU-7, "Components"](#) for tightening torque. Install in the reverse order of removal.

CAUTION:

- Refer to component parts location and do not reuse non-reusable parts.
- Make sure piston rod on shock absorber is not damaged when attaching components to shock absorber.

SUSPENSION ARM

SUSPENSION ARM

PFP:55501

Removal and Installation

REMOVAL

1. Remove tire with power tool.
2. Remove drive shaft. Refer to [RAX-10, "REAR DRIVE SHAFT"](#).
3. Remove fixing nuts and bolts between suspension arm and rear suspension member.
4. Remove cotter pin of suspension arm ball joint, and loosen nut.
5. Use a ball joint remover (suitable tool) to remove suspension arm from axle. Be careful not to damage ball joint boot.

CAUTION:

To prevent damage to threads and to prevent ball joint remover (suitable tool) from coming off, temporarily tighten lock nuts.

INSPECTION AFTER REMOVAL

Visual Inspection

- Check suspension arm and bushing for deformation, cracks, or damage. If any non-standard condition is found, replace it.
- Check boot of ball joint for cracks, or damage, and also for grease leakage.

Ball Joint Inspection

- Manually move ball stud to confirm it moves smoothly with no binding.

Swing Torque Inspection

CAUTION:

Before measuring, move ball joint at least ten times by hand to check for smooth movement.

- Hook spring scale at cotter pin mounting hole. Confirm spring scale measurement value is within specifications when ball stud begins moving.

Standard value

Swing torque:

0.5 - 3.4 N·m (0.06 - 0.34 kg·m, 5 - 30 in-lb)

Measured value of spring scale:

8.06 - 54.8 N (0.83 - 5.5 kg, 1.81 - 12.32 lb)

- If it is outside the specified range, replace suspension arm assembly.

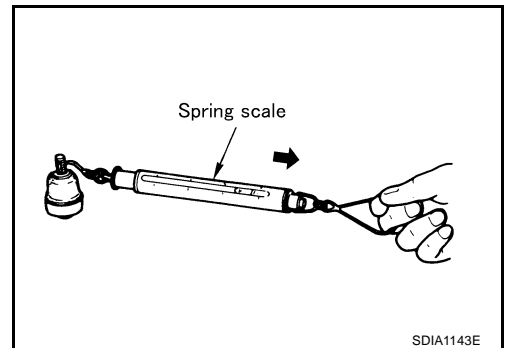

Rotating Torque Inspection

- Attach mounting nut to ball stud. Check that sliding torque is within specifications with a preload gauge (special service tool).

Standard value

Rotating torque:

0.5 - 3.4 N·m (0.06 - 0.34 kg·m, 5 - 30 in-lb)

- If it is outside the specified range, replace suspension arm assembly.

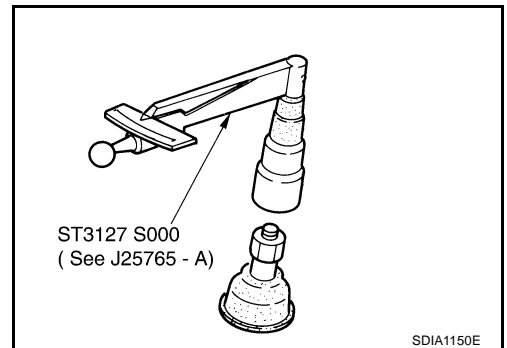

A
B
C
D
RSU
F
G
H
I
J
K
L
M

SUSPENSION ARM

Axial End Play Inspection

- Move tip of ball joint in axial direction to check for looseness.

Standard value

Axial end play : 0 mm (0 in)

- If it is outside the specified range, replace suspension arm assembly.

INSTALLATION

- Refer to [RSU-7, "Components"](#) for tightening torque. Install in the reverse order of removal.

CAUTION:

Refer to component parts location and do not reuse non-reusable parts.

- Perform final tightening of rear suspension member installation position (rubber bushing) under unladen condition with tires on level ground. Check wheel alignment. Refer to [RSU-5, "Wheel Alignment Inspection"](#) .

RADIUS ROD

RADIUS ROD

PPF:55110

Removal and Installation

AES000EL

REMOVAL

1. Remove tire with power tool.
2. Remove brake caliper with power tool. Hang it in a place where it will not interfere with work. Refer to [BR-35, "REAR DISC BRAKE \(AD14VE TYPE\)"](#) , [BR-41, "REAR DISC BRAKE \(OPB13VB TYPE\)"](#) .

CAUTION:

- **Avoid depressing brake pedal while brake caliper is removed.**

3. Remove fixing bolt and nut in axle side of radius rod with power tool.
4. Remove rear lower link and coil spring. Refer to [RSU-15, "REAR LOWER LINK & COIL SPRING"](#) .
5. Remove fixing bolt in lower side of shock absorber with power tool.
6. Remove fixing bolt and nut in axle side of front lower link with power tool.
7. Remove fixing bolt in rear suspension member side of radius rod with power tool, then remove radius rod from vehicle.

INSPECTION AFTER REMOVAL

- Check radius rod and bushing for any deformation, crack, or damage. Replace if necessary.

INSTALLATION

- Refer to [RSU-7, "Components"](#) for tightening torque. Install in the reverse order of removal.

CAUTION:

- **Refer to component parts location and do not reuse non-reusable parts.**

- Perform final tightening of rear suspension member and axle installation position (rubber bushing) under unladen condition with tires on level ground. Check wheel alignment. Refer to [RSU-5, "Wheel Alignment Inspection"](#) .

FRONT LOWER LINK

FRONT LOWER LINK

PFP:55110

Removal and Installation

AES000EM

REMOVAL

1. Remove tire with power tool.
2. Set jack under rear lower link.
3. Remove fixing nut and bolt between front lower link and rear suspension member with power tool.
4. Remove fixing nut and bolt between front lower link and axle with power tool.
5. Remove front lower link from vehicle.

INSPECTION AFTER REMOVAL

- Check front lower link and bushing for any deformation, crack, or damage. Replace if necessary.

INSTALLATION

- Refer to [RSU-7, "Components"](#) for tightening torque. Install in the reverse order of removal.

CAUTION:

Refer to component parts location and do not reuse non-reusable parts.

- Perform final tightening of rear suspension member and axle installation position (rubber bushing) under unladen condition with tires on level ground. Check wheel alignment. Refer to [RSU-5, "Wheel Alignment Inspection"](#) .

REAR LOWER LINK & COIL SPRING

REAR LOWER LINK & COIL SPRING

PF5:551B0

Removal and Installation

AES000EN

REMOVAL

1. Remove tire with power tool.
2. Set jack under rear lower link.
3. Loosen fixing bolt and nut of rear lower link in side of rear suspension member, and then remove fixing bolt and nut in side of axle with power tool.
4. Slowly lower jack, then remove upper seat, coil spring and rubber sheet from rear lower link.
5. Remove fixing bolt and nut in side of rear suspension member to remove rear lower link with power tool.

INSPECTION AFTER REMOVAL

- Check rear lower link, bushing and coil spring for deformation, cracks, and damage. Replace rear lower link and coil spring if necessary.

INSTALLATION

- Refer to [RSU-7, "Components"](#) for tightening torque. Install in the reverse order of removal.

CAUTION:

Refer to component parts location and do not reuse non-reusable parts.

- Check that upper seat is attached as shown in the figure.

CAUTION:

Insert bracket tabs (3) and the inside protrusion on upper seat into each other beforehand as shown in the figure.

- Match up rubber seat indentions and rear lower link grooves and attach.

CAUTION:

Make sure spring is not up side down. The top and bottom are indicated by paint color.

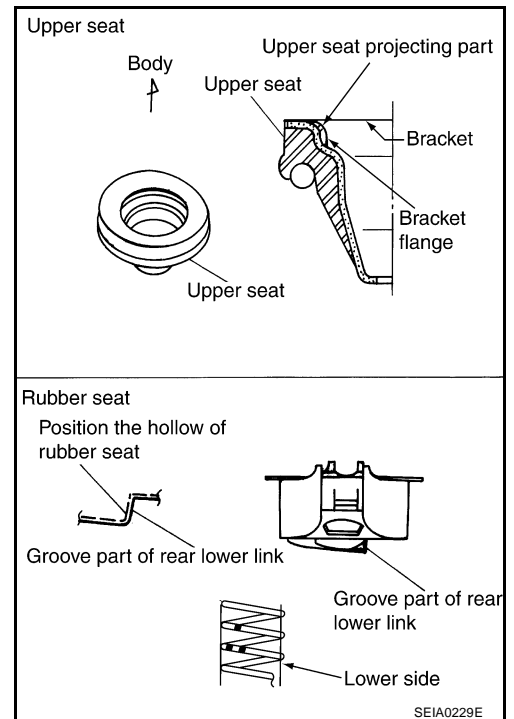

- Perform final tightening of rear suspension member and axle installation position (rubber bushing) under unladen condition with tires on level ground. Check wheel alignment. Refer to [RSU-5, "Wheel Alignment Inspection"](#).

STABILIZER BAR

STABILIZER BAR

PFP:56230

Removal and Installation

AES000EO

REMOVAL

1. Remove fixing nuts and remove stabilizer connecting rod mounting bracket from suspension arm.
2. Remove lower side fixing nut on stabilizer connecting rod and remove stabilizer connecting rod from stabilizer bar with power tool.
3. Remove fixing nut on stabilizer clamp and remove stabilizer from vehicle with power tool.

INSPECTION AFTER REMOVAL

- Check stabilizer bar, stabilizer bushing, stabilizer clamp, stabilizer connecting rod, stabilizer connecting rod mounting bracket for any deformation, crack or damage. Replace if necessary.

INSTALLATION

- Refer to [RSU-7, "Components"](#) for tightening torque. Install in the reverse order of removal.

CAUTION:

Refer to component parts location and do not reuse non-reusable parts.

- Stabilizer bar uses pillow ball type connecting rod, position ball joint with case on pillow ball head parallel to stabilizer bar.

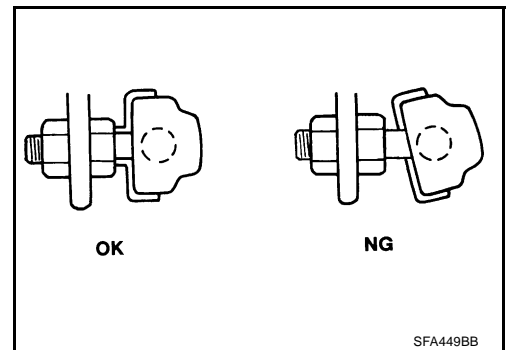

REAR SUSPENSION MEMBER

REAR SUSPENSION MEMBER

PFP:55501

Removal and Installation

AES000EV

REMOVAL

1. Remove tire with power tool.
2. Remove brake caliper with power tool. Hang it in a place where it will not interfere with work. Refer to [BR-35, "REAR DISC BRAKE \(AD14VE TYPE\)"](#) , [BR-41, "REAR DISC BRAKE \(OPB13VB TYPE\)"](#) .

CAUTION:

Avoid depressing brake pedal while brake caliper is removed.

3. Remove rear exhaust tube. Refer to [EX-3, "EXHAUST SYSTEM"](#) .
4. Remove stabilizer bar. Refer to [RSU-16, "STABILIZER BAR"](#) .
5. Remove drive shaft. Refer to [RAX-10, "REAR DRIVE SHAFT"](#) .
6. Remove final drive. Refer to [RFD-10, "REAR FINAL DRIVE ASSEMBLY"](#) .
7. Separate the attachment between parking brake cable and vehicle and rear suspension member. Refer to [PB-6, "PARKING BRAKE CONTROL"](#) .
8. Remove rear lower link and coil spring. Refer to [RSU-15, "REAR LOWER LINK & COIL SPRING"](#) .
9. Remove fixing bolt in lower side of shock absorber.
10. Set jack under rear suspension member.
11. Remove fixing bolts and nuts tunnel stay and member stay from vehicle.
12. Remove fixing bolts and nuts of rear pin stay and then remove rear pin stay from vehicle.
13. Slowly lowering jack, then remove rear suspension member, suspension arm, radius rod, front lower link and axle from vehicle as a unit.
14. Remove fixing bolts and nuts, then remove suspension arm, front lower link, radius rod from rear suspension member.

INSPECTION AFTER REMOVAL

- Check rear suspension member for deformation, cracks, and other damage and replace if necessary.

INSTALLATION

- Refer to [RSU-7, "Components"](#) , for tightening torque. Install in the reverse order of removal.

CAUTION:

Refer to component parts location and do not reuse non-reusable parts.

- Perform final tightening of installation position of links (rubber bushing) under unladen condition with tires on level ground. Check wheel alignment. Refer to [RSU-5, "Wheel Alignment Inspection"](#) .

SERVICE DATA

SERVICE DATA

PFP:00030

Wheel Alignment

AES000EP

Camber Degree minute (Decimal degree)	Minimum	- 2°00'(- 2.00°)	
	Nominal	- 1°30'(- 1.50°)	
	Maximum	- 1°00'(- 1.00°)	
Total toe-in	Distance (A - B)	Minimum	0 mm (0 in)
		Nominal	2.8 mm (0.110 in)
		Maximum	5.6 mm (0.220 in)

Ball Joint

AES000EQ

Axial end play	0 mm (0 in)
Swing torque	0.5 - 3.4 N·m (0.06 - 0.34 kg-m, 5 - 30 in-lb)
Measurement on spring balance (cotter pinhole position)	8.06 - 54.8 N (0.83 - 5.5 kg, 1.81 - 12.32 lb)
Rotating torque	0.5 - 3.4 N·m (0.06 - 0.34 kg-m, 5 - 30 in-lb)

Wheelarch Height (Unladen*)

AES000ER

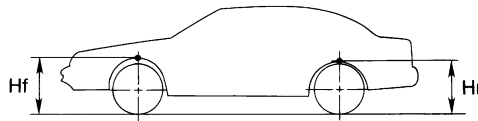

SFA818A

Applied model	225/50R17 (Front) 235/50R17 (Rear)	225/45R18 (Front) 245/45R18 (Rear)
Front (Hf)	691 mm (27.20 in)	694 mm (27.32 in)
Rear (Hr)	702 mm (27.64 in)	710 mm (27.95 in)

*: Fuel, radiator coolant and engine oil full. Spare tire, jack, hand tools and mats in designated positions.