

SECTION **MIR**  
MIRRORS

A  
B  
C  
D  
E  
F  
G  
H  
I  
J  
K  
M  
N  
O  
P

CONTENTS

<b>DTC/CIRCUIT DIAGNOSIS</b> .....	2	<b>PREPARATION</b> .....	16
<b>DOOR MIRROR SYSTEM</b> .....	2	Commercial Service Tools .....	16
Description .....	2	<b>REMOVAL AND INSTALLATION</b> .....	17
Wiring Diagram - DOOR MIRROR SYSTEM (WITHOUT AUTOMATIC DRIVE POSITIONER) .....	2	<b>INSIDE MIRROR</b> .....	17
Component Inspection .....	4	Exploded View .....	17
<b>AUTO ANTI-DAZZLING INSIDE MIRROR SYSTEM</b> .....	6	Removal and Installation .....	17
Description .....	6	<b>DOOR MIRROR</b> .....	19
Wiring Diagram - INSIDE MIRROR SYSTEM - .....	7	<b>DOOR MIRROR ASSEMBLY</b> .....	19
<b>SYMPTOM DIAGNOSIS</b> .....	9	DOOR MIRROR ASSEMBLY : Exploded View .....	19
<b>SQUEAK AND RATTLE TROUBLE DIAG- NOSES</b> .....	9	DOOR MIRROR ASSEMBLY : Removal and In- stallation .....	20
Work Flow .....	9	DOOR MIRROR ASSEMBLY : Disassembly and Assembly .....	20
Inspection Procedure .....	11	<b>GLASS MIRROR</b> .....	20
Diagnostic Worksheet .....	13	GLASS MIRROR : Exploded View .....	20
<b>PRECAUTION</b> .....	15	GLASS MIRROR : Disassembly and Assembly .....	21
<b>PRECAUTIONS</b> .....	15	<b>DOOR MIRROR COVER</b> .....	22
Precaution for Supplemental Restraint System (SRS) "AIR BAG" and "SEAT BELT PRE-TEN- SIONER" .....	15	DOOR MIRROR COVER : Exploded View .....	22
Service Procedure Precautions for Models with a Pop-up Roll Bar .....	15	DOOR MIRROR COVER : Disassembly and As- sembly .....	22
Precaution for Battery Service .....	15	<b>DOOR MIRROR REMOTE CONTROL SWITCH</b> .....	23
<b>PREPARATION</b> .....	16	Exploded View .....	23
		Removal and Installation .....	23

MIR

# DOOR MIRROR SYSTEM

< DTC/CIRCUIT DIAGNOSIS >

## DTC/CIRCUIT DIAGNOSIS

### DOOR MIRROR SYSTEM

#### Description

INFOID:000000005127820

In regards to the Automatic drive position with door mirror system, it refer to [ADP-14, "AUTOMATIC DRIVE POSITIONER SYSTEM : System Description"](#).

Component	Function
Door mirror remote control switch	It supplies power to mirror motor through mirror switch and changeover switch.
Door mirror	It makes mirror face operate from side to side and up and down with the mirror control switch operation.

#### Wiring Diagram - DOOR MIRROR SYSTEM (WITHOUT AUTOMATIC DRIVE POSI-

# DOOR MIRROR SYSTEM

< DTC/CIRCUIT DIAGNOSIS >

IGNITION SWITCH -

INFOID:000000005127824

## DOOR MIRROR (WITHOUT AUTOMATIC DRIVE POSITIONER)

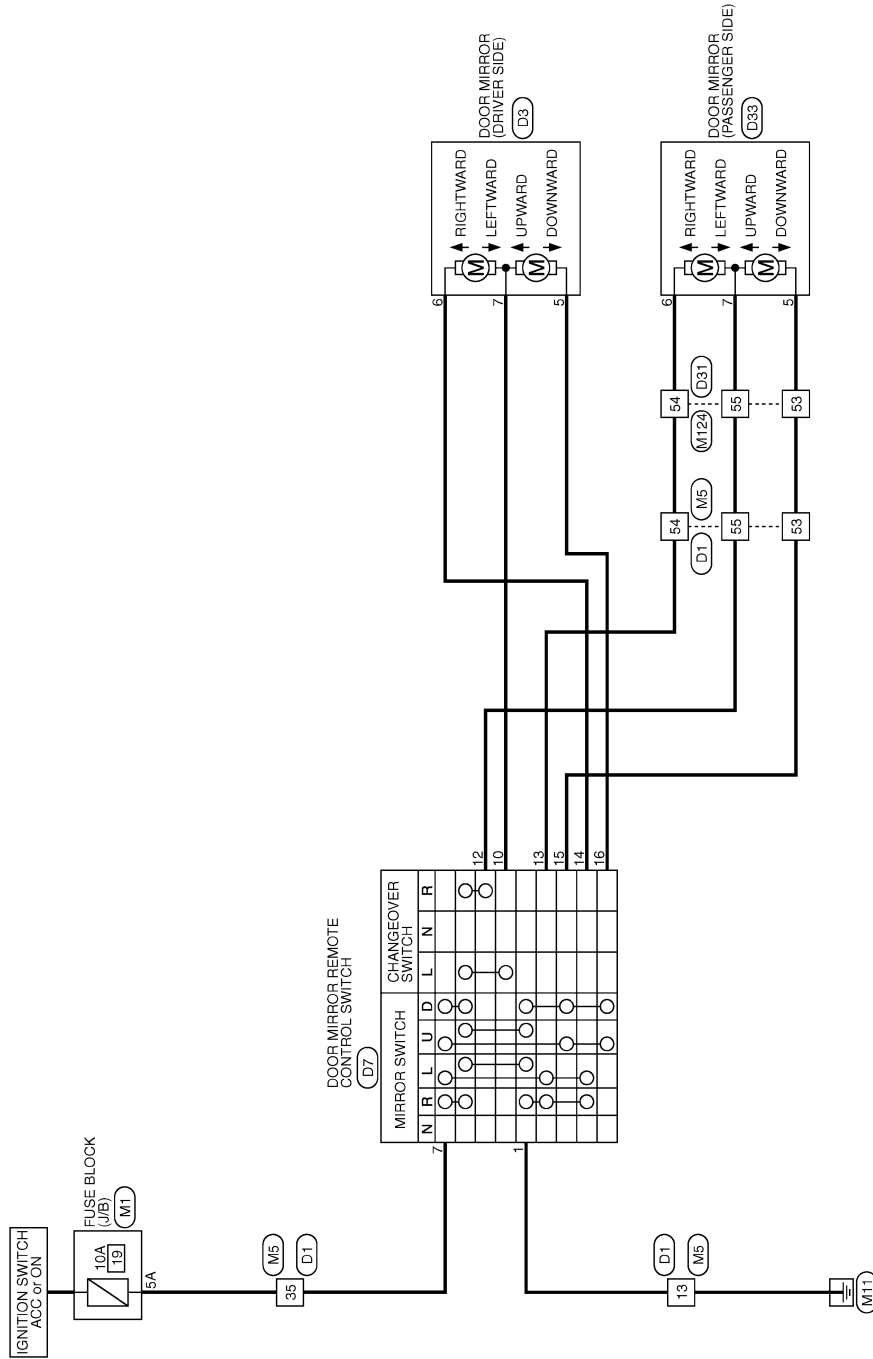

2009/02/27

JCLWA3340GB

A  
B  
C  
D  
E  
F  
G  
H  
I  
J  
K  
M  
N  
O  
P

MIR

# DOOR MIRROR SYSTEM

## < DTC/CIRCUIT DIAGNOSIS >

### DOOR MIRROR (WITHOUT AUTOMATIC DRIVE POSITIONER)

Connector No.	D1
Connector Name	WIRE TO WIRE
Connector Type	TH40FW-CS15

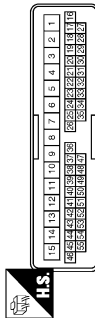

Terminal No.	Color of Wire	Signal Name [Specification]
13	B	-
35	V	-
53	O	-
54	GR	-
55	G	-

Connector No.	D3
Connector Name	DOOR MIRROR (DRIVER SIDE)
Connector Type	TH12MW-NH



Terminal No.	Color of Wire	Signal Name [Specification]
5	BR	- [Without automatic drive positioner]
6	L	- [Without automatic drive positioner]
7	Y	- [Without automatic drive positioner]

Connector No.	D7
Connector Name	DOOR MIRROR REMOTE CONTROL SWITCH (WITHOUT AUTOMATIC DRIVE POSITIONER)
Connector Type	TK18FW

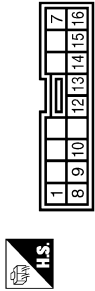

Terminal No.	Color of Wire	Signal Name [Specification]
1	B	-
7	V	-
10	Y	-
12	G	-
13	GR	-
14	L	-
15	O	-
16	BR	-

Connector No.	D31
Connector Name	WIRE TO WIRE
Connector Type	TH40FW-CS15

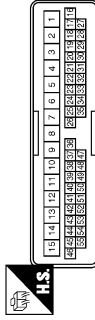

Terminal No.	Color of Wire	Signal Name [Specification]
53	O	-
54	GR	-
55	G	-

Connector No.	D33
Connector Name	DOOR MIRROR (PASSENGER SIDE)
Connector Type	TH12MW-NH



Terminal No.	Color of Wire	Signal Name [Specification]
5	O	-
6	GR	-
7	G	-

Connector No.	M1
Connector Name	FUSE BLOCK (J/B)
Connector Type	NS06FW-M2



Terminal No.	Color of Wire	Signal Name [Specification]
5A	L	-

Connector No.	M5
Connector Name	WIRE TO WIRE
Connector Type	TH40MW-CS15

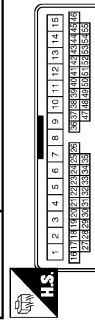

Terminal No.	Color of Wire	Signal Name [Specification]
13	B	-
35	Y	-
53	W	-
54	V	-
55	P	-

Connector No.	M124
Connector Name	WIRE TO WIRE
Connector Type	TH40MW-CS15

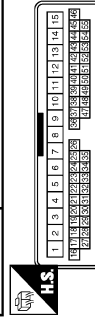

Terminal No.	Color of Wire	Signal Name [Specification]
53	W	-
54	V	-
55	P	-

## Component Inspection

### 1. CHECK DOOR MIRROR REMOTE CONTROL SWITCH

1. Turn ignition switch OFF.
2. Disconnect door mirror remote control switch connector.
3. Check door mirror remote control switch.

JCLWA3341GB

INFOID:000000005133250

# DOOR MIRROR SYSTEM

## < DTC/CIRCUIT DIAGNOSIS >

[Door mirror (driver side)]

Door mirror remote control switch		Mirror switch condition	Continuity
Connector	Terminal		
D7	7	10	Existed
	1	14	
	7	14	
	1	10	
	7	16	
	1	10	
	7	10	
	1	16	

[Door mirror (passenger side)]

Door mirror remote control switch		Mirror switch condition	Continuity
Connector	Terminal		
D7	7	12	Existed
	1	13	
	7	13	
	1	12	
	7	15	
	1	12	
	7	12	
	1	13	

Is the inspection result normal?

YES >> INSPECTION END.

NO >> Replace door mirror remote control switch. Refer to [MIR-23, "Removal and Installation"](#).

A  
B  
C  
D  
E  
F  
G  
H  
I  
J  
K  
L  
M  
N  
O  
P

MIR

# AUTO ANTI-DAZZLING INSIDE MIRROR SYSTEM

< DTC/CIRCUIT DIAGNOSIS >

---

## AUTO ANTI-DAZZLING INSIDE MIRROR SYSTEM

### Description

INFOID:000000005127822

Component	Function
Auto anti-dazzling inside mirror	It automatically changes the light transmittance according to the brightness of the light from the headlight of the vehicle behind.

# AUTO ANTI-DAZZLING INSIDE MIRROR SYSTEM

< DTC/CIRCUIT DIAGNOSIS >

## Wiring Diagram - INSIDE MIRROR SYSTEM -

INFOID:000000005127825

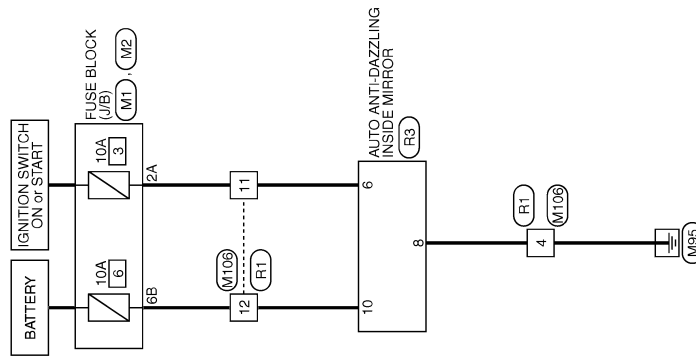

INSIDE MIRROR

2009/02/27

JCLWA3342GB

A  
B  
C  
D  
E  
F  
G  
H  
I  
J  
K  
M  
N  
O  
P

MIR

# AUTO ANTI-DAZZLING INSIDE MIRROR SYSTEM

## < DTC/CIRCUIT DIAGNOSIS >

### INSIDE MIRROR

Connector No.	M1
Connector Name	FUSE BLOCK (J/B)
Connector Type	NSDBFW-M2

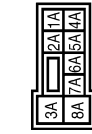

Terminal No.	2A	Color of Wire	G	Signal Name [Specification]	
--------------	----	---------------	---	-----------------------------	--

Connector No.	M2
Connector Name	FUSE BLOCK (J/B)
Connector Type	NSJDFW-CS



Terminal No.	6B	Color of Wire	Y	Signal Name [Specification]	
--------------	----	---------------	---	-----------------------------	--

Connector No.	M106
Connector Name	WIRE TO WIRE
Connector Type	TK10MW-NS5

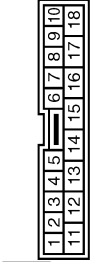

Terminal No.	4	Color of Wire	B	Signal Name [Specification]	
	11	Color of Wire	P	Signal Name [Specification]	
	12	Color of Wire	Y	Signal Name [Specification]	

Connector No.	R1
Connector Name	WIRE TO WIRE
Connector Type	TKJDFW-NS5

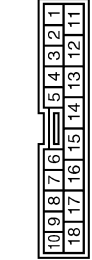

Terminal No.	4	Color of Wire	B	Signal Name [Specification]	
	11	Color of Wire	BR	Signal Name [Specification]	
	12	Color of Wire	G	Signal Name [Specification]	

Connector No.	R3
Connector Name	AUTO ANTI-DAZZLING INSIDE MIRROR
Connector Type	THJDFB-NH1

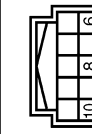

Terminal No.	6	Color of Wire	BR	Signal Name [Specification]	IGN
	8	Color of Wire	B	Signal Name [Specification]	GND
	10	Color of Wire	G	Signal Name [Specification]	BAT

JCLWA3343GB



# SQUEAK AND RATTLE TROUBLE DIAGNOSES

< SYMPTOM DIAGNOSIS >

## SYMPTOM DIAGNOSIS

### SQUEAK AND RATTLE TROUBLE DIAGNOSES

#### Work Flow

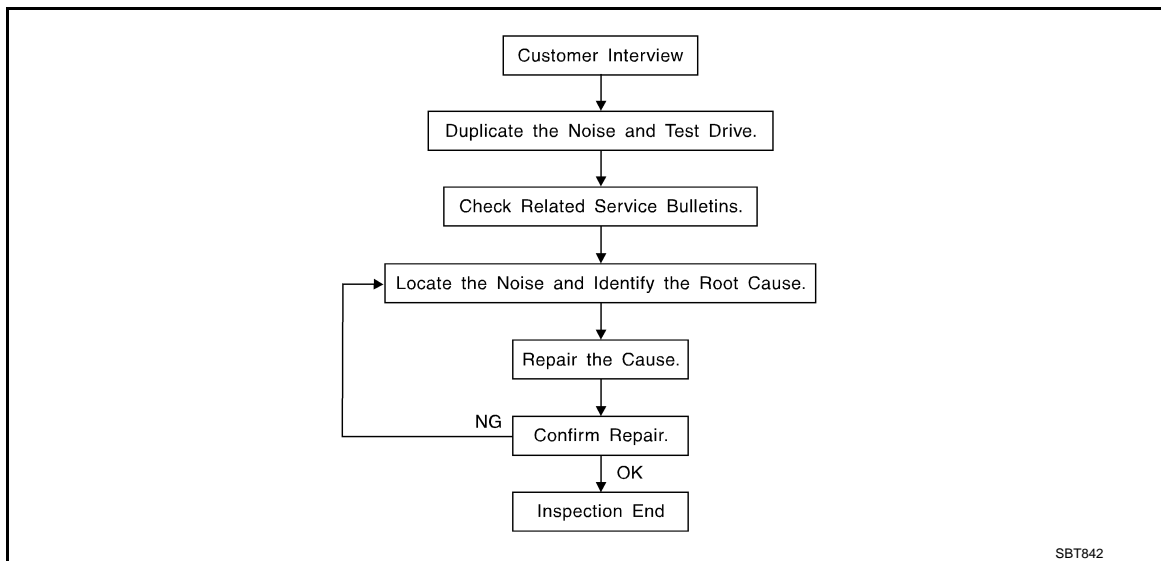

#### CUSTOMER INTERVIEW

Interview the customer if possible, to determine the conditions that exist when the noise occurs. Use the Diagnostic Worksheet during the interview to document the facts and conditions when the noise occurs and any of customer's comments; refer to [MIR-13. "Diagnostic Worksheet"](#). This information is necessary to duplicate the conditions that exist when the noise occurs.

- The customer may not be able to provide a detailed description or the location of the noise. Attempt to obtain all the facts and conditions that exist when the noise occurs (or does not occur).
- If there is more than one noise in the vehicle, perform a diagnosis and repair the noise that the customer is concerned about. This can be accomplished by performing a cruise test on the vehicle with the customer.
- After identifying the type of noise, isolate the noise in terms of its characteristics. The noise characteristics are provided so the customer, service adviser and technician are all speaking the same language when defining the noise.
- Squeak – (Like tennis shoes on a clean floor)  
Squeak characteristics include the light contact/fast movement/brought on by road conditions/hard surfaces = higher pitch noise/softer surfaces = lower pitch noises/edge to surface = chirping
- Creak – (Like walking on an old wooden floor)  
Creak characteristics include firm contact/slow movement/twisting with a rotational movement/pitch dependent on materials/often brought on by activity.
- Rattle – (Like shaking a baby rattle)  
Rattle characteristics include the fast repeated contact/vibration or similar movement/loose parts/missing clip or fastener/incorrect clearance.
- Knock – (Like a knock on a door)  
Knock characteristics include hollow sounding/sometimes repeating/often brought on by driver action.
- Tick – (Like a clock second hand)  
Tick characteristics include gentle contacting of light materials/loose components/can be caused by driver action or road conditions.
- Thump – (Heavy, muffled knock noise)  
Thump characteristics include softer knock/dead sound often brought on by activity.
- Buzz – (Like a bumblebee)  
Buzz characteristics include high frequency rattle/firm contact.
- Often the degree of acceptable noise level will vary depending up on the person. A noise that a technician may judge as acceptable may be very irritating to the customer.
- Weather conditions, especially humidity and temperature, may have a great effect on noise level.

#### DUPLICATE THE NOISE AND TEST DRIVE

# SQUEAK AND RATTLE TROUBLE DIAGNOSES

## < SYMPTOM DIAGNOSIS >

If possible, drive the vehicle with the customer until the noise is duplicated. Note any additional information on the Diagnostic Worksheet regarding the conditions or location of the noise. This information can be used to duplicate the same conditions when the repair is reconfirmed.

If the noise can be duplicated easily during the test drive, to help identify the source of the noise, try to duplicate the noise with the vehicle stopped by doing one or all of the following:

- 1) Close a door.
  - 2) Tap or push/pull around the area where the noise appears to be coming from.
  - 3) Rev the engine.
  - 4) Use a floor jack to recreate vehicle "twist".
  - 5) At idle, apply engine load (electrical load, half-clutch on M/T models, drive position on A/T models).
  - 6) Raise the vehicle on a hoist and hit a tire with a rubber hammer.
- Drive the vehicle and attempt to duplicate the conditions the customer states exist when the noise occurs.
  - If it is difficult to duplicate the noise, drive the vehicle slowly on an undulating or rough road to stress the vehicle body.

## CHECK RELATED SERVICE BULLETINS

After verifying the customer concern or symptom, check ASIST for Technical Service Bulletins (TSBs) related to that concern or symptom.

If a TSB relates to the symptom, follow the procedure to repair the noise.

## LOCATE THE NOISE AND IDENTIFY THE ROOT CAUSE

1. Narrow down the noise to a general area. To help pinpoint the source of the noise, use a listening tool (Chassis ear: J-39570, Engine ear and mechanics stethoscope).
2. Narrow down the noise to a more specific area and identify the cause of the noise by:
  - Removing the components in the area that is are suspected to be the cause of the noise.  
Do not use too much force when removing clips and fasteners, otherwise clips and fastener can be broken or lost during the repair, resulting in the creation of new noise.
  - Tapping or pushing/pulling the component that is are suspected to be the cause of the noise.  
Do not tap or push/pull the component with excessive force, otherwise the noise will be eliminated only temporarily.
  - Feeling for a vibration by hand by touching the component(s) that is are suspected to be the cause of the noise.
  - Placing a piece of paper between components that are suspected to be the cause of the noise.
  - Looking for loose components and contact marks.  
Refer to [MIR-11, "Inspection Procedure"](#).

## REPAIR THE CAUSE

- If the cause is a loose component, tighten the component securely.
- If the cause is insufficient clearance between components:
  - Separate components by repositioning or loosening and retightening the component, if possible.
  - Insulate components with a suitable insulator such as urethane pads, foam blocks, felt cloth tape or urethane tape. A Nissan Squeak and Rattle Kit (J-43980) is available through the authorized Nissan Parts Department.

### **CAUTION:**

**Never use excessive force as many components are constructed of plastic and may be damaged.**

### **NOTE:**

Always check with the Parts Department for the latest parts information.

The following materials are contained in the Nissan Squeak and Rattle Kit (J-43980). Each item can be ordered separately as needed.

URETHANE PADS [1.5 mm (0.059 in) thick]

Insulates connectors, harness, etc.

76268-9E005: 100 × 135 mm (3.94 × 5.31 in)/76884-71L01: 60 × 85 mm (2.36 × 3.35 in)/76884-71L02: 15 × 25 mm (0.59 × 0.98 in)

INSULATOR (Foam blocks)

Insulates components from contact. Can be used to fill space behind a panel.

73982-9E000: 45 mm (1.77 in) thick, 50 × 50 mm (1.97 × 1.97 in)/73982-

50Y00: 10 mm (0.39 in) thick, 50 × 50 mm (1.97 × 1.97 in)

INSULATOR (Light foam block)

80845-71L00: 30 mm (1.18 in) thick, 30 × 50 mm (1.18 × 1.97 in)

FELT CLOTH TAPE

Used to insulate where movement does not occur. Ideal for instrument panel applications.

# SQUEAK AND RATTLE TROUBLE DIAGNOSES

## < SYMPTOM DIAGNOSIS >

68370-4B000: 15 × 25 mm (0.59 × 0.98 in) pad/68239-13E00: 5 mm (0.20 in) wide tape roll

The following materials, not found in the kit, can also be used to repair squeaks and rattles.

### UHMW (TEFLON) TAPE

Insulates where slight movement is present. Ideal for instrument panel applications.

### SILICONE GREASE

Used in place of UHMW tape that is be visible or does not fit. Will only last a few months.

### SILICONE SPRAY

Used when grease cannot be applied.

### DUCT TAPE

Used to eliminate movement.

## CONFIRM THE REPAIR

Confirm that the cause of a noise is repaired by test driving the vehicle. Operate the vehicle under the same conditions as when the noise originally occurred. Refer to the notes on the Diagnostic Worksheet.

## Inspection Procedure

INFOID:000000005127827

Refer to Table of Contents for specific component removal and installation information.

## INSTRUMENT PANEL

Most incidents are caused by contact and movement between:

1. The cluster lid A and instrument panel
2. Acrylic lens and combination meter housing
3. Instrument panel to front pillar garnish
4. Instrument panel to windshield
5. Instrument panel mounting pins
6. Wiring harnesses behind the combination meter
7. A/C defroster duct and duct joint

These incidents can usually be located by tapping or moving the components to duplicate the noise or by pressing on the components while driving to stop the noise. Most of these incidents can be repaired by applying felt cloth tape or silicon spray (in hard to reach areas). Urethane pads can be used to insulate wiring harness.

### **CAUTION:**

**Never use silicone spray to isolate a squeak or rattle. If the area is saturated with silicone, the recheck of repair becomes impossible.**

## CENTER CONSOLE

Components to pay attention to include:

1. Shifter assembly cover to finisher
2. A/C control unit and cluster lid C
3. Wiring harnesses behind audio and A/C control unit

The instrument panel repair and isolation procedures also apply to the center console.

## DOORS

Pay attention to the following:

1. Finisher and inner panel making a slapping noise
2. Inside handle escutcheon to door finisher
3. Wiring harnesses tapping
4. Door striker out of alignment causing a popping noise on starts and stops

Tapping or moving the components or pressing on them while driving to duplicate the conditions can isolate many of these incidents. The areas can usually be insulated with felt cloth tape or insulator foam blocks from the Nissan Squeak and Rattle Kit (J-43980) to repair the noise.

## TRUNK

Trunk noises are often caused by a loose jack or loose items put into the trunk by the customer.

In addition look for the following:

1. Trunk lid dumpers out of adjustment
2. Trunk lid striker out of adjustment

A  
B  
C  
D  
E  
F  
G  
H  
I  
J  
K

MIR

M  
N  
O  
P

# SQUEAK AND RATTLE TROUBLE DIAGNOSES

## < SYMPTOM DIAGNOSIS >

---

3. The trunk lid torsion bars knocking together
4. A loose license plate or bracket

Most of these incidents can be repaired by adjusting, securing or insulating the item(s) or component(s) causing the noise.

## SUNROOF/HEADLINING

Noises in the sunroof/headlining area can often be traced to one of the following:

1. Sunroof lid, rail, linkage or seals making a rattle or light knocking noise
2. Sunvisor shaft shaking in the holder
3. Front or rear windshield touching headlining and squeaking

Again, pressing on the components to stop the noise while duplicating the conditions can isolate most of these incidents. Repairs usually consist of insulating with felt cloth tape.

## SEATS

When isolating seat noise it's important to note the position the seats in and the load placed on the seat when the noise occurs. These conditions should be duplicated when verifying and isolating the cause of the noise.

Cause of seat noise include:

1. Headrest rods and holder
2. A squeak between the seat pad cushion and frame
3. The rear seatback lock and bracket

These noises can be isolated by moving or pressing on the suspected components while duplicating the conditions under which the noise occurs. Most of these incidents can be repaired by repositioning the component or applying urethane tape to the contact area.

## UNDERHOOD

Some interior noise may be caused by components under the hood or on the engine wall. The noise is then transmitted into the passenger compartment.

Causes of transmitted underhood noise include:

1. Any component mounted to the engine wall
2. Components that pass through the engine wall
3. Engine wall mounts and connectors
4. Loose radiator mounting pins
5. Hood bumpers out of adjustment
6. Hood striker out of adjustment

These noises can be difficult to isolate since they cannot be reached from the interior of the vehicle. The best method is to secure, move or insulate one component at a time and test drive the vehicle. Also, engine RPM or load can be changed to isolate the noise. Repairs can usually be made by moving, adjusting, securing, or insulating the component causing the noise.

# SQUEAK AND RATTLE TROUBLE DIAGNOSES

< SYMPTOM DIAGNOSIS >

## Diagnostic Worksheet

INFOID:000000005127828



### SQUEAK & RATTLE DIAGNOSTIC WORKSHEET

Dear Infiniti Customer:

We are concerned about your satisfaction with your Infiniti vehicle. Repairing a squeak or rattle sometimes can be very difficult. To help us fix your Infiniti right the first time, please take a moment to note the area of the vehicle where the squeak or rattle occurs and under what conditions. You may be asked to take a test drive with a service consultant or technician to ensure we confirm the noise you are hearing.

#### I. WHERE DOES THE NOISE COME FROM? (circle the area of the vehicle)

The illustrations are for reference only, and may not reflect the actual configuration of your vehicle.

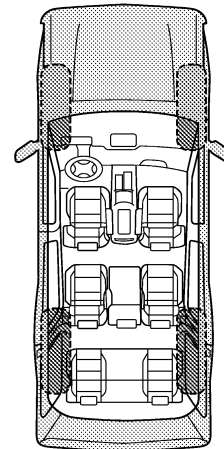
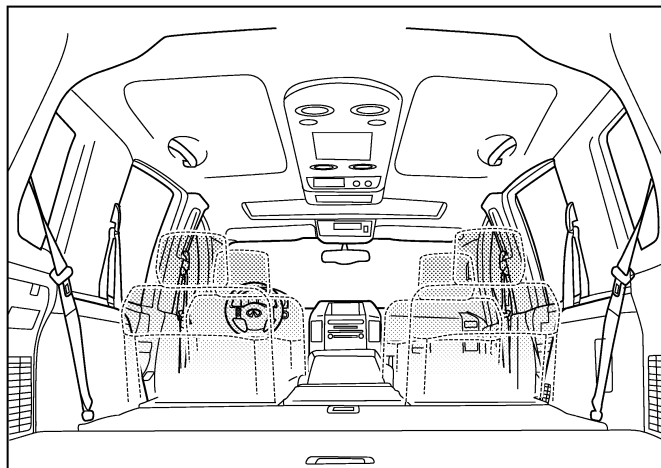
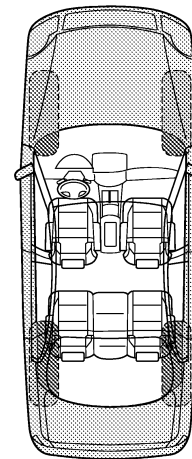
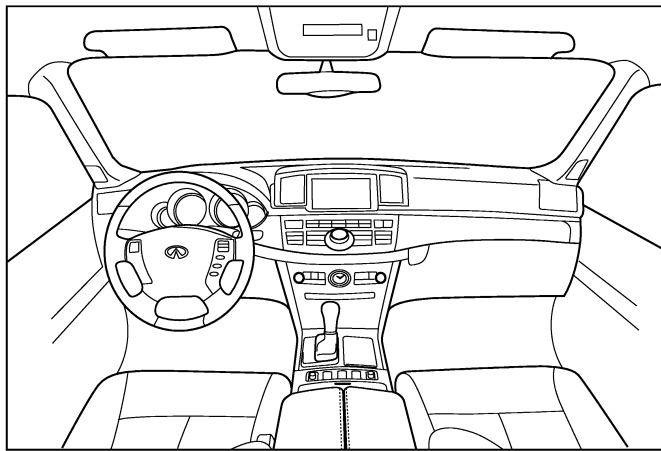

Continue to page 2 of the worksheet and briefly describe the location of the noise or rattle. In addition, please indicate the conditions which are present when the noise occurs.

PIIB8741E

A  
B  
C  
D  
E  
F  
G  
H  
I  
J  
K  
M  
N  
O  
P

MIR

# SQUEAK AND RATTLE TROUBLE DIAGNOSES

< SYMPTOM DIAGNOSIS >

## SQUEAK & RATTLE DIAGNOSTIC WORKSHEET - page 2

Briefly describe the location where the noise occurs:

---

---

### II. WHEN DOES IT OCCUR? (please check the boxes that apply)

- |   |  |
|---|--|
| <input type="checkbox"/> anytime                      | <input type="checkbox"/> after sitting out in the rain |
| <input type="checkbox"/> 1st time in the morning      | <input type="checkbox"/> when it is raining or wet     |
| <input type="checkbox"/> only when it is cold outside | <input type="checkbox"/> dry or dusty conditions       |
| <input type="checkbox"/> only when it is hot outside  | <input type="checkbox"/> other:                        |

### III. WHEN DRIVING:

- through driveways
- over rough roads
- over speed bumps
- only about \_\_\_\_ mph
- on acceleration
- coming to a stop
- on turns: left, right or either (circle)
- with passengers or cargo
- other: \_\_\_\_\_
- after driving \_\_\_\_ miles or \_\_\_\_ minutes

### IV. WHAT TYPE OF NOISE

- squeak (like tennis shoes on a clean floor)
- creak (like walking on an old wooden floor)
- rattle (like shaking a baby rattle)
- knock (like a knock at the door)
- tick (like a clock second hand)
- thump (heavy, muffled knock noise)
- buzz (like a bumble bee)

## TO BE COMPLETED BY DEALERSHIP PERSONNEL

### Test Drive Notes:

---

---

---

	YES	NO	Initials of person performing
Vehicle test driven with customer	<input type="checkbox"/>	<input type="checkbox"/>	_____
- Noise verified on test drive	<input type="checkbox"/>	<input type="checkbox"/>	_____
- Noise source located and repaired	<input type="checkbox"/>	<input type="checkbox"/>	_____
- Follow up test drive performed to confirm repair	<input type="checkbox"/>	<input type="checkbox"/>	_____

VIN: \_\_\_\_\_ Customer Name: \_\_\_\_\_  
W.O.# \_\_\_\_\_ Date: \_\_\_\_\_

This form must be attached to Work Order

PIIB8742E

# PRECAUTIONS

< PRECAUTION >

## PRECAUTION

### PRECAUTIONS

#### Precaution for Supplemental Restraint System (SRS) "AIR BAG" and "SEAT BELT PRE-TENSIONER"

INFOID:000000005157963

The Supplemental Restraint System such as "AIR BAG" and "SEAT BELT PRE-TENSIONER", used along with a front seat belt, helps to reduce the risk or severity of injury to the driver and front passenger for certain types of collision. This system includes seat belt switch inputs and dual stage front air bag modules. The SRS system uses the seat belt switches to determine the front air bag deployment, and may only deploy one front air bag, depending on the severity of a collision and whether the front occupants are belted or unbelted. Information necessary to service the system safely is included in the "SRS AIR BAG" and "SEAT BELT" of this Service Manual.

#### **WARNING:**

- To avoid rendering the SRS inoperative, which could increase the risk of personal injury or death in the event of a collision that would result in air bag inflation, all maintenance must be performed by an authorized NISSAN/INFINITI dealer.
- Improper maintenance, including incorrect removal and installation of the SRS, can lead to personal injury caused by unintentional activation of the system. For removal of Spiral Cable and Air Bag Module, see the "SRS AIR BAG".
- Do not use electrical test equipment on any circuit related to the SRS unless instructed to in this Service Manual. SRS wiring harnesses can be identified by yellow and/or orange harnesses or harness connectors.

#### PRECAUTIONS WHEN USING POWER TOOLS (AIR OR ELECTRIC) AND HAMMERS

#### **WARNING:**

- When working near the Air Bag Diagnosis Sensor Unit or other Air Bag System sensors with the ignition ON or engine running, DO NOT use air or electric power tools or strike near the sensor(s) with a hammer. Heavy vibration could activate the sensor(s) and deploy the air bag(s), possibly causing serious injury.
- When using air or electric power tools or hammers, always switch the ignition OFF, disconnect the battery, and wait at least 3 minutes before performing any service.

#### Service Procedure Precautions for Models with a Pop-up Roll Bar

INFOID:000000005157964

#### **WARNING:**

- Risk of passenger injury or death may increase if the pop-up roll bar does not deploy during a roll over collision. In order to reduce the chance of an incident where the pop-up roll bar is inoperative, all maintenance must be performed by a NISSAN or INFINITI dealer.
- Before removing and installing the pop-up roll bar component parts and harness, always turn the ignition switch OFF, disconnect the battery negative terminal, and wait for 3 minutes or more. (The purpose of this operation is to discharge electricity that is accumulated in the auxiliary power supply circuit in the air bag diagnosis sensor unit.)
- When repairing, removing, and installing a pop-up roll bar, always refer to SRS AIR BAG and SRS AIR BAG CONTROL warnings in the Service Manual.

#### Precaution for Battery Service

INFOID:000000005157965

Before disconnecting the battery, lower both the driver and passenger windows. This will prevent any interference between the window edge and the vehicle when the door is opened/closed. During normal operation, the window slightly raises and lowers automatically to prevent any window to vehicle interference. The automatic window function will not work with the battery disconnected.

A  
B  
C  
D  
E  
F  
G  
H  
I  
J  
K  
MIR  
M  
N  
O  
P

# PREPARATION

< PREPARATION >

## PREPARATION

### PREPARATION

#### Commercial Service Tools

INFOID:000000005127831

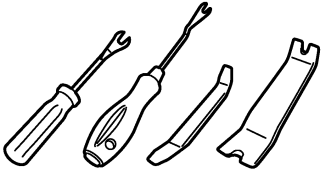
Tool name	Description
Remover tool  JMKIA3050ZZ	Removes the clips, pawls and metal clips



# INSIDE MIRROR

< REMOVAL AND INSTALLATION >

## REMOVAL AND INSTALLATION

### INSIDE MIRROR

Exploded View

INFOID:000000005127832

#### Manual anti-dazzling type

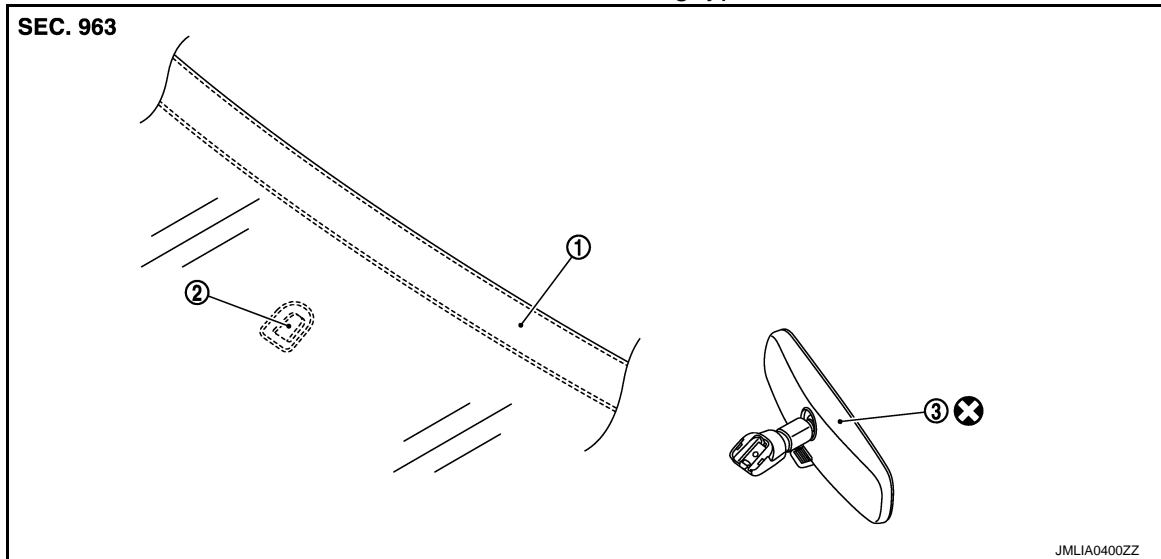

- 1. Windshield glass
- 2. Mirror base
- 3. Inside mirror

Refer to [GI-4, "Components"](#) for symbols in the figure.

#### Auto anti-dazzling type

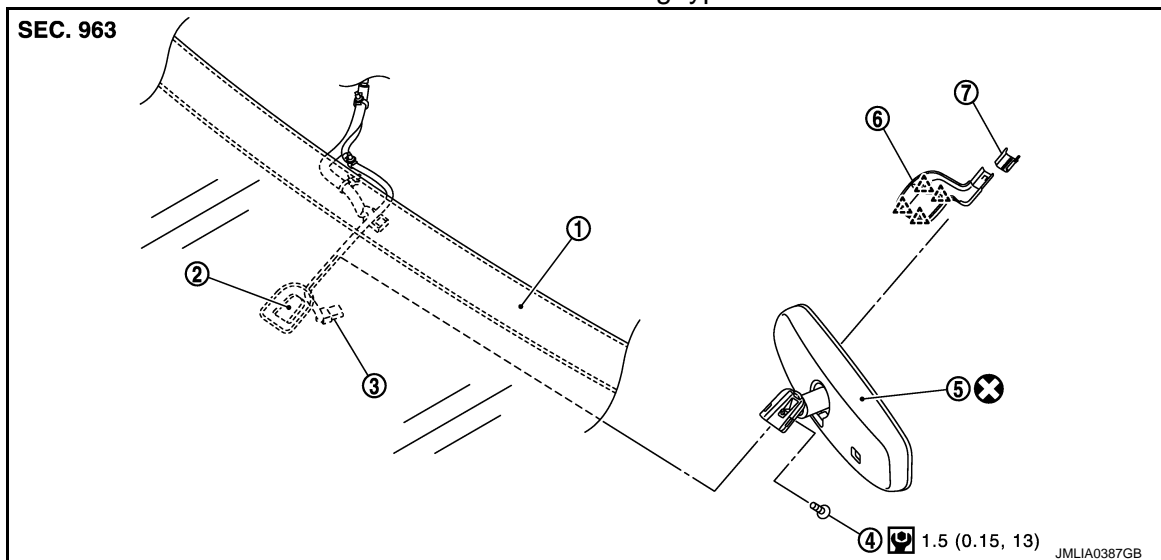

- 1. Windshield glass
- 2. Mirror base
- 3. Harness connector
- 4. TORX bolt
- 5. Inside mirror
- 6. Inside mirror cover (lower)
- 7. Inside mirror cover (upper)

△ : Pawl

Refer to [GI-4, "Components"](#) for symbols in the figure.

### Removal and Installation

INFOID:000000005127833

**CAUTION:**  
Never reuse the inside mirror disassembled from mirror base.

A  
B  
C  
D  
E  
F  
G  
H  
I  
J  
K  
MIR  
M  
N  
O  
P

## INSIDE MIRROR

### < REMOVAL AND INSTALLATION >

#### REMOVAL

Manual anti-dazzling type

Slide the inside mirror upward to remove.

**NOTE:**

Insert flat-bladed screwdriver (A) under the inside mirror (1).

Slide the inside mirror to the upper side while pushing the pawl downward.

**CAUTION:**

**Never use excessive force to remove the inside mirror because it is inserted tightly into the mirror base.**

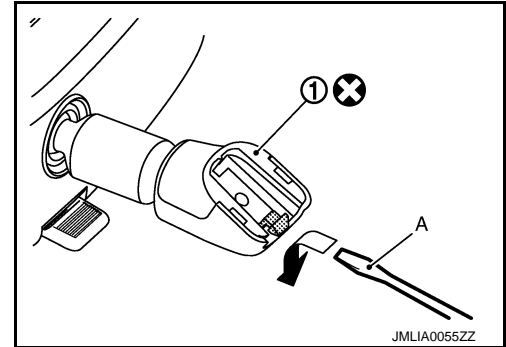

Auto anti-dazzling type

1. Remove inside mirror cover (upper/lower).
2. Disconnect harnessconnector from inside mirror.
3. Loosen TORX bolt and slide inside mirror upward to remove.

#### INSTALLATION

Install in the reverse order of removal.

# DOOR MIRROR

< REMOVAL AND INSTALLATION >

## DOOR MIRROR

### DOOR MIRROR ASSEMBLY

### DOOR MIRROR ASSEMBLY : Exploded View

INFOID:000000005127834

#### REMOVAL

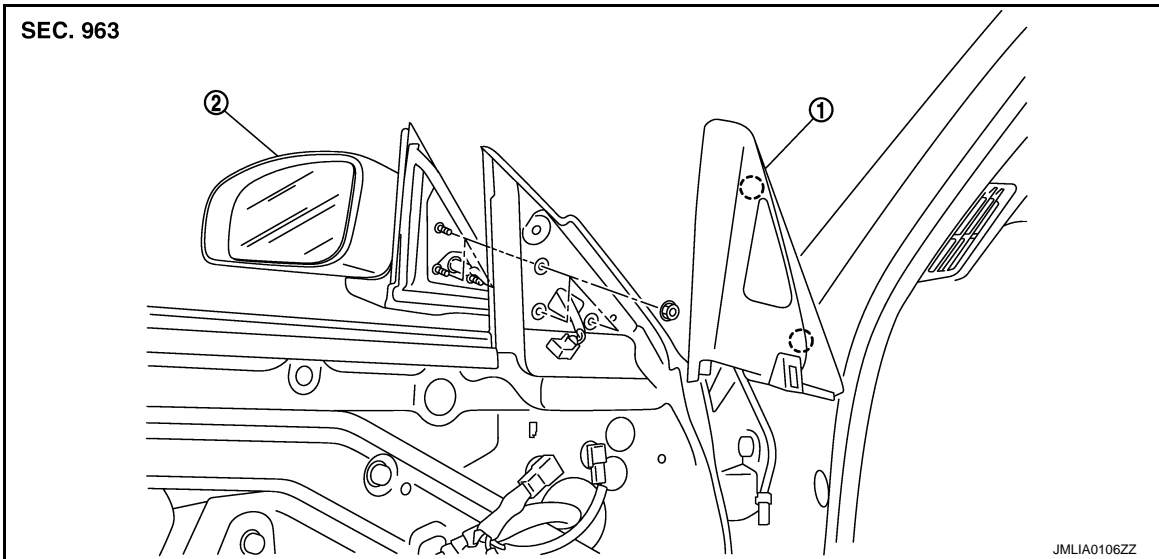

1. Corner cover

2. Door mirror assembly

○ : Clip

#### DISASSEMBLY

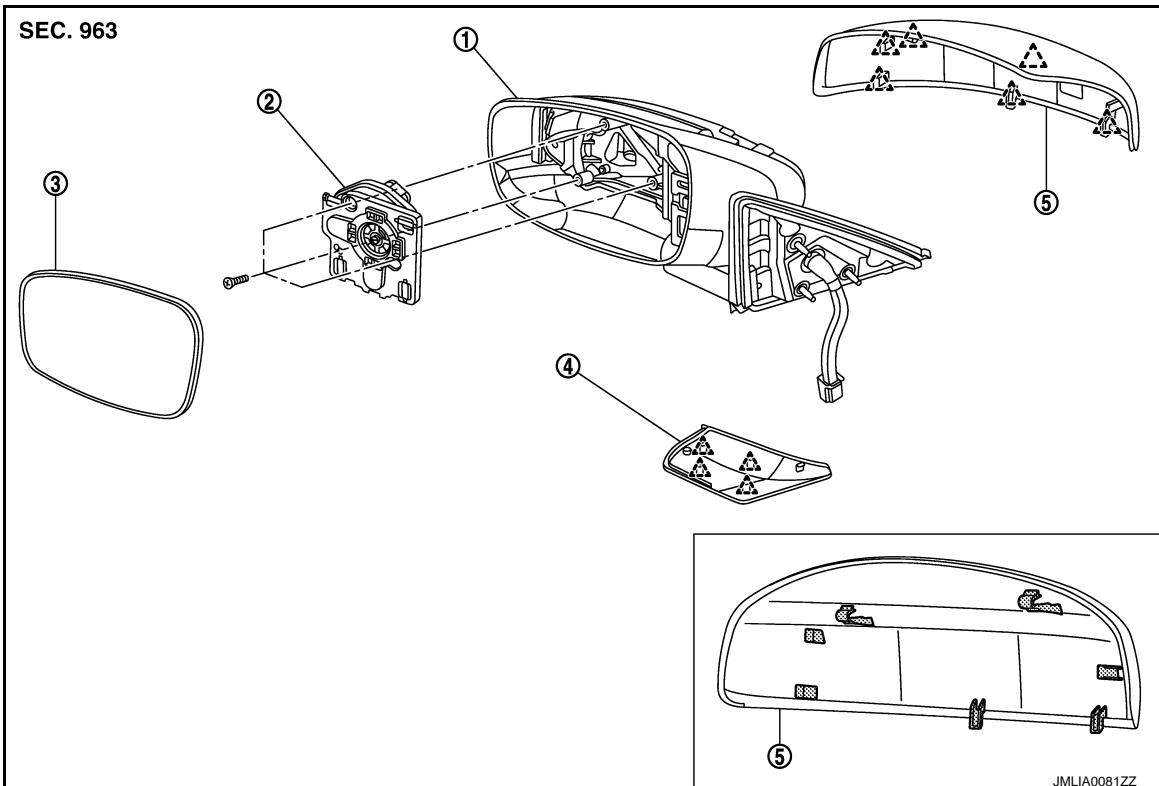

A  
B  
C  
D  
E  
F  
G  
H  
I  
J  
K  
L  
M  
N  
O  
P

MIR

# DOOR MIRROR

## < REMOVAL AND INSTALLATION >

---

- |                    |                         |                 |
|--------------------|-------------------------|-----------------|
| 1. Mirror assembly | 2. Door mirror actuator | 3. Glass mirror |
| 4. Base cover      | 5. Door mirror cover    |                 |

 : Pawl

### DOOR MIRROR ASSEMBLY : Removal and Installation

INFOID:000000005127835

#### REMOVAL

1. Remove the door finisher. Refer to [INT-12, "Removal and Installation"](#).
2. Remove the corner cover.
3. Disconnect the door mirror harness connector.
4. Remove the door mirror mounting nuts, and remove the door mirror assembly.

#### INSTALLATION

Install in the reverse order of removal.

### DOOR MIRROR ASSEMBLY : Disassembly and Assembly

INFOID:000000005127836

#### DISASSEMBLY

1. Remove the pawls and disassemble the base cover.
2. Remove the glass mirror. Refer to [MIR-21, "GLASS MIRROR : Disassembly and Assembly"](#).
3. Remove the mirror cover. Refer to [MIR-22, "DOOR MIRROR COVER : Disassembly and Assembly"](#).
4. Remove the screws and mirror actuator from the housing assembly.

#### ASSEMBLY

Assemble in the reverse order of disassemble.

#### **CAUTION:**

**After installation, visually check that pawls are securely engaged.**

### GLASS MIRROR

### GLASS MIRROR : Exploded View

INFOID:000000005127837

#### DISASSEMBLY

# DOOR MIRROR

## < REMOVAL AND INSTALLATION >

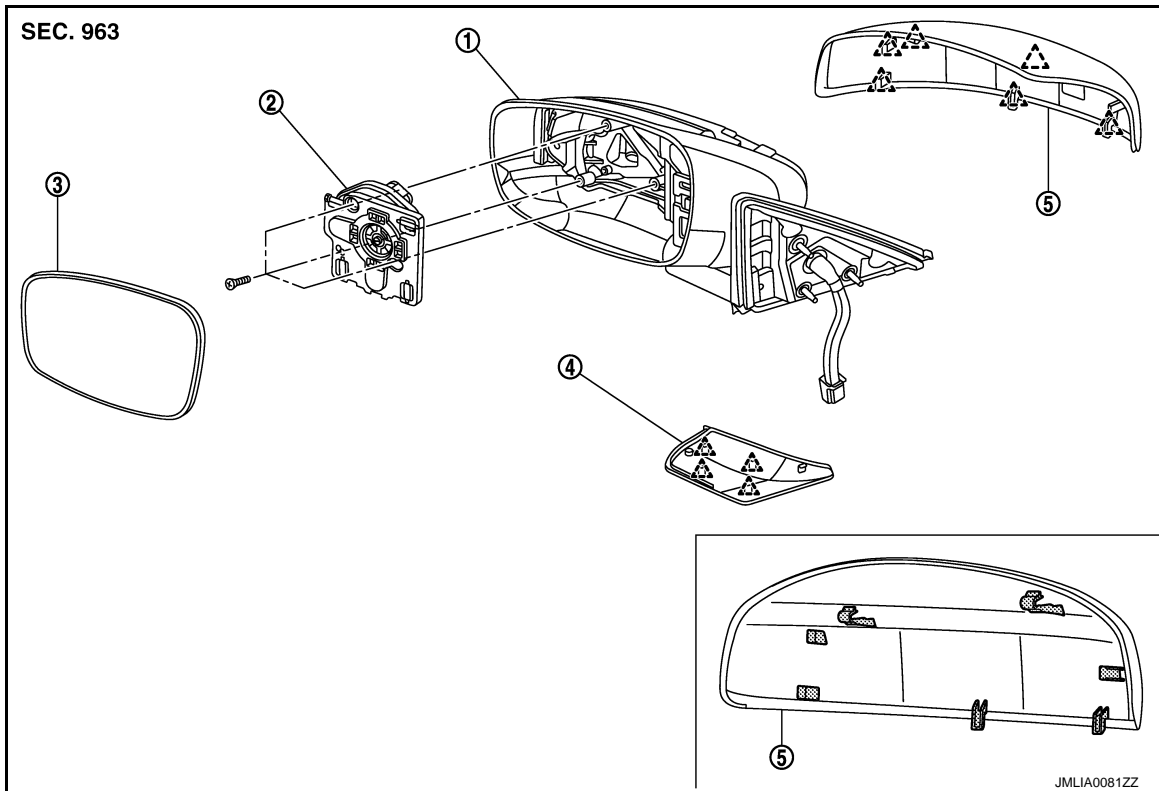

- |                    |                         |                 |
|--------------------|-------------------------|-----------------|
| 1. Mirror assembly | 2. Door mirror actuator | 3. Glass mirror |
| 4. Base cover      | 5. Door mirror cover    |                 |

△ : Pawl

## GLASS MIRROR : Disassembly and Assembly

INFOID:000000005127838

### DISASSEMBLY

1. Remove the pawls and disassemble the base cover.
2. Place the glass mirror upward.
3. Put a strip of protective tape (B) on housing assembly.
4. As shown in the figure, insert a small flat-bladed screwdriver (A) into the recess between glass mirror (1) and actuator (2). Push up two pawls (3) to remove glass mirror lower half side.

#### NOTE:

- When pushing up pawls do not attempt to use one recess only. Be sure to push up with both recesses.
- Insert a small flat-bladed screwdriver into recesses, and push up while rotating (twisting) to make work easier.

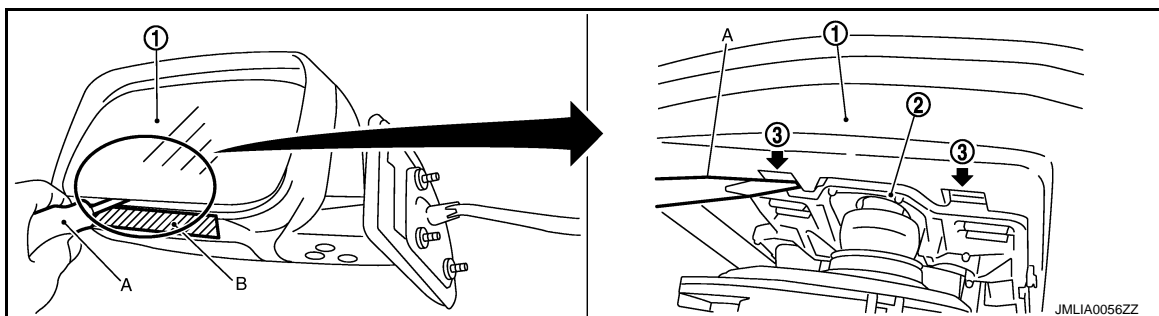

5. Remove both terminals of mirror heater attachment.
6. Lightly lift up lower side of glass mirror, and detach two pawls of upper side as if pulling it out. Disassemble glass mirror from actuator.

#### NOTE:

Be certain not to allow grease on sealing agent in center of mirror or back side of glass mirror.

# DOOR MIRROR

< REMOVAL AND INSTALLATION >

## ASSEMBLY

Assemble in the reverse order of disassemble.

### CAUTION:

After installation, visually check that pawls are securely engaged.

## DOOR MIRROR COVER

### DOOR MIRROR COVER : Exploded View

INFOID:000000005127839

## DISASSEMBLY

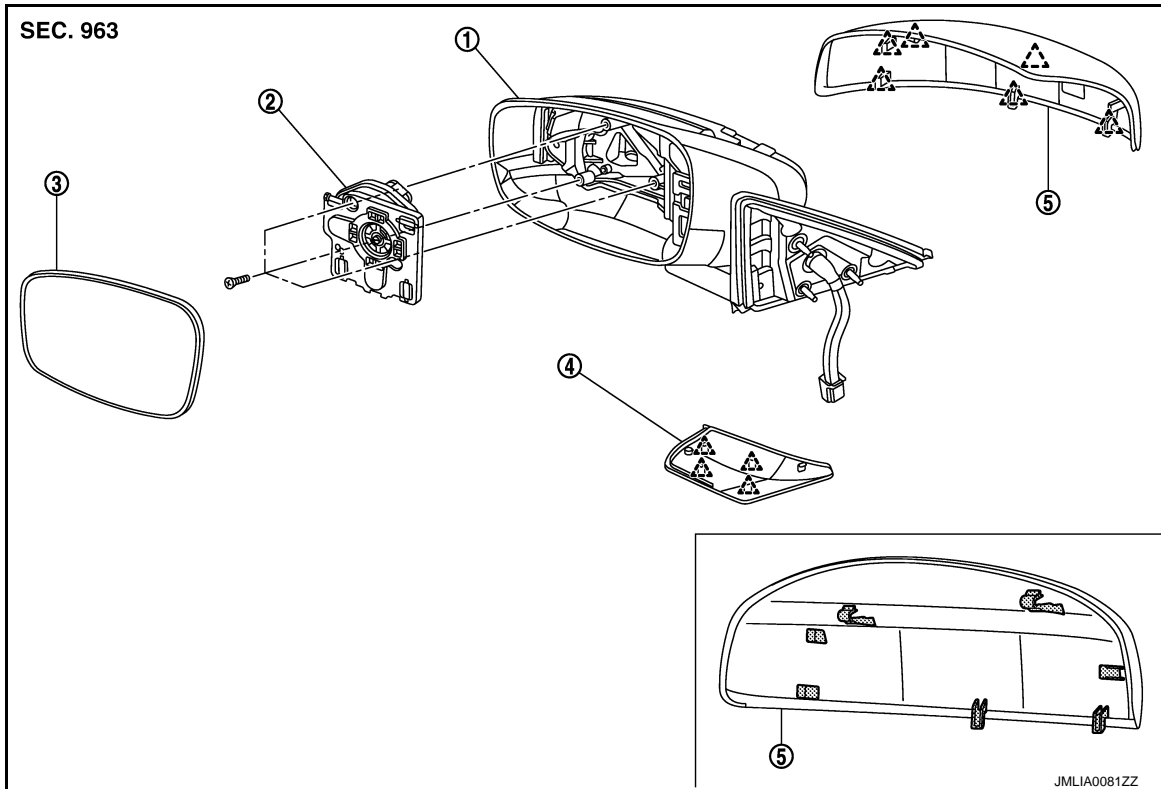

1. Mirror assembly

2. Door mirror actuator

3. Glass mirror

4. Base cover

5. Door mirror cover

 : Pawl

### DOOR MIRROR COVER : Disassembly and Assembly

INFOID:000000005127840

### CAUTION:

Never damage the mirror bodies.

## DISASSEMBLY

1. Remove the glass mirror. Refer to [MIR-21. "GLASS MIRROR : Disassembly and Assembly"](#).
2. Remove the pawls, and disassemble the door mirror cover from the mirror assembly.

## ASSEMBLY

Install in the reverse order of removal.

### CAUTION:

After installation, visually check that pawls are securely engaged.

# DOOR MIRROR REMOTE CONTROL SWITCH

< REMOVAL AND INSTALLATION >

## DOOR MIRROR REMOTE CONTROL SWITCH

### Exploded View

INFOID:000000005127841

Refer to [INT-12. "Exploded View"](#)

### Removal and Installation

INFOID:000000005127842

#### REMOVAL

1. Remove the power window main switch finisher.
2. Remove door mirror remote control switch (1) from power window main switch finisher (2) using flat-bladed screwdriver (A).

 : Pawl

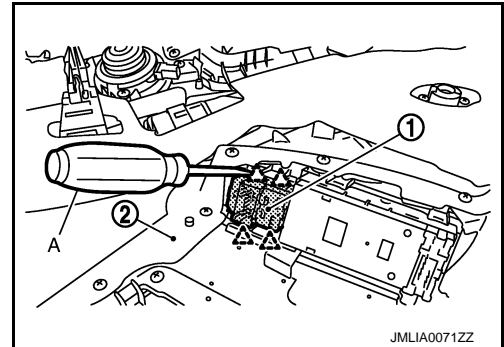

#### INSTALLATION

Install in the reverse order of removal.

A  
B  
C  
D  
E  
F  
G  
H  
I  
J  
K  
M  
N  
O  
P

MIR