

# SECTION **AV**

## AUDIO, VISUAL & NAVIGATION SYSTEM

A  
B  
C  
D  
E  
F  
G  
H  
I  
J  
K  
L  
M  
AV  
O  
P

### CONTENTS

<p><b>BASE AUDIO WITHOUT NAVIGATION</b></p> <p><b>PRECAUTION</b> ..... 9</p> <p><b>PRECAUTIONS</b> ..... 9</p> <p style="padding-left: 20px;">Precaution for Supplemental Restraint System (SRS) "AIR BAG" and "SEAT BELT PRE-TENSIONER" .....9</p> <p style="padding-left: 20px;">Precaution for Battery Service .....9</p> <p style="padding-left: 20px;">Service Procedure Precautions for Models with a Pop-up Roll Bar .....9</p> <p style="padding-left: 20px;">Cautions in Removing Battery Terminal and AV Control Unit (Models with AV Control Unit) .....9</p> <p style="padding-left: 20px;">Precaution for Trouble Diagnosis ..... 10</p> <p style="padding-left: 20px;">Precaution for Harness Repair ..... 10</p> <p><b>PREPARATION</b> .....11</p> <p><b>PREPARATION</b> .....11</p> <p style="padding-left: 20px;">Commercial Service Tools ..... 11</p> <p><b>SYSTEM DESCRIPTION</b> .....12</p> <p><b>COMPONENT PARTS</b> .....12</p> <p style="padding-left: 20px;">Component Parts Location ..... 12</p> <p style="padding-left: 20px;">Component Description ..... 13</p> <p><b>SYSTEM</b> .....15</p> <p><b>MULTI AV SYSTEM</b> ..... 15</p> <p style="padding-left: 20px;">MULTI AV SYSTEM : System Diagram ..... 15</p> <p style="padding-left: 20px;">MULTI AV SYSTEM : System Description ..... 15</p> <p><b>DIAGNOSIS SYSTEM (AV CONTROL UNIT)....18</b></p> <p style="padding-left: 20px;">Description ..... 18</p> <p style="padding-left: 20px;">On Board Diagnosis Function ..... 18</p> <p style="padding-left: 20px;">CONSULT - III Function ..... 27</p> <p><b>DIAGNOSIS SYSTEM (TEL ADAPTER UNIT)....30</b></p> <p style="padding-left: 20px;">On Board Diagnosis Function .....30</p> <p><b>ECU DIAGNOSIS INFORMATION</b> .....32</p>	<p><b>AV CONTROL UNIT</b> .....32</p> <p style="padding-left: 20px;">Reference Value .....32</p> <p style="padding-left: 20px;">DTC Index .....38</p> <p><b>DISPLAY UNIT</b> .....40</p> <p style="padding-left: 20px;">Reference Value .....40</p> <p><b>SATELLITE RADIO TUNER</b> .....43</p> <p style="padding-left: 20px;">Reference Value .....43</p> <p><b>TEL ADAPTER UNIT</b> .....45</p> <p style="padding-left: 20px;">Reference Value .....45</p> <p><b>WIRING DIAGRAM</b> .....47</p> <p><b>BASE AUDIO WITHOUT NAVIGATION</b> .....47</p> <p style="padding-left: 20px;">Wiring Diagram .....47</p> <p><b>BASIC INSPECTION</b> .....65</p> <p><b>DIAGNOSIS AND REPAIR WORKFLOW</b> .....65</p> <p style="padding-left: 20px;">Work Flow .....65</p> <p><b>ADDITIONAL SERVICE WHEN REPLACING (AV CONTROL UNIT)</b> .....67</p> <p style="padding-left: 20px;">Description .....67</p> <p style="padding-left: 20px;">Work Procedure .....67</p> <p><b>CONFIGURATION (AV CONTROL UNIT)</b> .....68</p> <p style="padding-left: 20px;">Description .....68</p> <p style="padding-left: 20px;">Work Procedure .....68</p> <p style="padding-left: 20px;">Configuration List .....68</p> <p><b>DTC/CIRCUIT DIAGNOSIS</b> .....70</p> <p><b>U1000 CAN COMM CIRCUIT</b> .....70</p> <p style="padding-left: 20px;">Description .....70</p> <p style="padding-left: 20px;">DTC Logic .....70</p> <p style="padding-left: 20px;">Diagnosis Procedure .....70</p> <p><b>U1010 CONTROL UNIT (CAN)</b> .....71</p> <p style="padding-left: 20px;">DTC Logic .....71</p>
---	---

<b>U1200 AV CONTROL UNIT</b> .....	<b>72</b>	<b>COMPOSITE IMAGE SIGNAL CIRCUIT</b> .....	<b>91</b>
DTC Logic .....	72	Description .....	91
<b>U1216 AV CONTROL UNIT</b> .....	<b>73</b>	Diagnosis Procedure .....	91
DTC Logic .....	73	<b>HORIZONTAL SYNCHRONIZING (HP) SIG-</b>	
<b>U1232 STEERING ANGLE SENSOR</b> .....	<b>74</b>	<b>NAL CIRCUIT</b> .....	<b>92</b>
DTC Logic .....	74	Description .....	92
Diagnosis Procedure .....	74	Diagnosis Procedure .....	92
<b>U1243 DISPLAY UNIT</b> .....	<b>75</b>	<b>VERTICAL SYNCHRONIZING (VP) SIGNAL</b>	
DTC Logic .....	75	<b>CIRCUIT</b> .....	<b>93</b>
Diagnosis Procedure .....	75	Description .....	93
<b>U1255 SATELLITE RADIO TUNER</b> .....	<b>77</b>	Diagnosis Procedure .....	93
DTC Logic .....	77	<b>DISK EJECT SIGNAL CIRCUIT</b> .....	<b>94</b>
Diagnosis Procedure .....	77	Description .....	94
<b>U1300 AV COMM CIRCUIT</b> .....	<b>79</b>	Diagnosis Procedure .....	94
Description .....	79	<b>MICROPHONE SIGNAL CIRCUIT</b> .....	<b>95</b>
<b>U1310 AV CONTROL UNIT</b> .....	<b>80</b>	Description .....	95
DTC Logic .....	80	Diagnosis Procedure .....	95
<b>POWER SUPPLY AND GROUND CIRCUIT</b> ....	<b>81</b>	<b>CONTROL SIGNAL CIRCUIT</b> .....	<b>97</b>
<b>AV CONTROL UNIT</b> .....	<b>81</b>	Description .....	97
AV CONTROL UNIT : Diagnosis Procedure .....	81	Diagnosis Procedure .....	97
<b>DISPLAY UNIT</b> .....	<b>81</b>	<b>STEERING SWITCH SIGNAL A CIRCUIT</b> .....	<b>98</b>
DISPLAY UNIT : Diagnosis Procedure .....	81	Description .....	98
<b>SATELLITE RADIO TUNER</b> .....	<b>82</b>	Diagnosis Procedure .....	98
SATELLITE RADIO TUNER : Diagnosis Proce-		Component Inspection .....	98
dure .....	82	<b>STEERING SWITCH SIGNAL B CIRCUIT</b> .....	<b>100</b>
<b>TEL ADAPTER UNIT</b> .....	<b>83</b>	Description .....	100
TEL ADAPTER UNIT : Diagnosis Procedure .....	83	Diagnosis Procedure .....	100
<b>RGB (R: RED) SIGNAL CIRCUIT</b> .....	<b>84</b>	Component Inspection .....	100
Description .....	84	<b>STEERING SWITCH GROUND CIRCUIT</b> .....	<b>102</b>
Diagnosis Procedure .....	84	Description .....	102
<b>RGB (G: GREEN) SIGNAL CIRCUIT</b> .....	<b>85</b>	Diagnosis Procedure .....	102
Description .....	85	Component Inspection .....	102
Diagnosis Procedure .....	85	<b>SYMPTOM DIAGNOSIS</b> .....	<b>104</b>
<b>RGB (B: BLUE) SIGNAL CIRCUIT</b> .....	<b>86</b>	<b>MULTI AV SYSTEM SYMPTOMS</b> .....	<b>104</b>
Description .....	86	Symptom Table .....	104
Diagnosis Procedure .....	86	<b>NORMAL OPERATING CONDITION</b> .....	<b>108</b>
<b>RGB SYNCHRONIZING SIGNAL CIRCUIT</b> ....	<b>87</b>	Description .....	108
Description .....	87	<b>REMOVAL AND INSTALLATION</b> .....	<b>110</b>
Diagnosis Procedure .....	87	<b>AV CONTROL UNIT</b> .....	<b>110</b>
<b>RGB AREA (YS) SIGNAL CIRCUIT</b> .....	<b>88</b>	Exploded View .....	110
Description .....	88	Removal and Installation .....	110
Diagnosis Procedure .....	88	<b>DISPLAY UNIT</b> .....	<b>112</b>
<b>CAMERA IMAGE SIGNAL CIRCUIT</b> .....	<b>89</b>	Exploded View .....	112
Description .....	89	Removal and Installation .....	112
Diagnosis Procedure .....	89	<b>DOOR SPEAKER</b> .....	<b>113</b>
		Exploded View .....	113
		Removal and Installation .....	

<b>REAR SPEAKER</b> .....	114	Cautions in Removing Battery Terminal and AV Control Unit (Models with AV Control Unit) .....	128	A
Exploded View .....	114	Precaution for Trouble Diagnosis .....	129	
Removal and Installation .....	114	Precaution for Harness Repair .....	129	
<b>TWEETER</b> .....	115	<b>PREPARATION</b> .....	130	B
Exploded View .....	115	<b>PREPARATION</b> .....	130	
Removal and Installation .....	115	Commercial Service Tools .....	130	C
<b>ANTENNA BASE</b> .....	116	<b>SYSTEM DESCRIPTION</b> .....	131	
Exploded View .....	116	<b>COMPONENT PARTS</b> .....	131	D
Removal and Installation .....	116	Component Parts Location .....	131	
<b>SATELLITE RADIO TUNER</b> .....	117	Component Description .....	132	E
Exploded View .....	117	<b>SYSTEM</b> .....	134	
Removal and Installation .....	117	<b>MULTI AV SYSTEM</b> .....	134	F
<b>MULTIFUNCTION SWITCH</b> .....	118	MULTI AV SYSTEM : System Diagram .....	134	
Exploded View .....	118	MULTI AV SYSTEM : System Description .....	134	
Removal and Installation .....	118	<b>DIAGNOSIS SYSTEM (AV CONTROL UNIT)</b> .	138	G
<b>PRESET SWITCH</b> .....	119	Description .....	138	
Exploded View .....	119	On Board Diagnosis Function .....	138	
Removal and Installation .....	119	CONSULT - III Function .....	148	H
<b>STEERING SWITCH</b> .....	120	<b>DIAGNOSIS SYSTEM (TEL ADAPTER UNIT)</b> .	153	
Exploded View .....	120	On Board Diagnosis Function .....	153	I
Removal and Installation .....	120	<b>ECU DIAGNOSIS INFORMATION</b> .....	155	
<b>USB CONNECTOR</b> .....	121	<b>AV CONTROL UNIT</b> .....	155	J
Exploded View .....	121	Reference Value .....	155	
Removal and Installation .....	121	DTC Index .....	161	
<b>MICROPHONE</b> .....	122	<b>DISPLAY UNIT</b> .....	163	K
Exploded View .....	122	Reference Value .....	163	
Removal and Installation .....	122	<b>BOSE AMP.</b> .....	166	L
<b>REAR VIEW CAMERA</b> .....	123	Reference Value .....	166	
Exploded View .....	123	<b>SATELLITE RADIO TUNER</b> .....	170	M
Removal and Installation .....	123	Reference Value .....	170	
Adjustment .....	123	<b>TEL ADAPTER UNIT</b> .....	172	
<b>STEERING ANGLE SENSOR</b> .....	125	Reference Value .....	172	
Exploded View .....	125	<b>WIRING DIAGRAM</b> .....	174	AV
Removal and Installation .....	125	<b>BOSE AUDIO WITHOUT NAVIGATION</b> .....	174	O
<b>TEL ADAPTER UNIT</b> .....	126	Wiring Diagram .....	174	
Exploded View .....	126	<b>BASIC INSPECTION</b> .....	196	
Removal and Installation .....	126	<b>DIAGNOSIS AND REPAIR WORKFLOW</b> .....	196	P
<b>ANTENNA FEEDER</b> .....	127	Work Flow .....	196	
Feeder Layout .....	127	<b>ADDITIONAL SERVICE WHEN REPLACING (AV CONTROL UNIT)</b> .....	198	
<b>BOSE AUDIO WITHOUT NAVIGATION</b>		Description .....	198	
<b>PRECAUTION</b> .....	128	Work Procedure .....	198	
<b>PRECAUTIONS</b> .....	128			
Precaution for Supplemental Restraint System (SRS) "AIR BAG" and "SEAT BELT PRE-TENSIONER" .....	128			
Precaution for Battery Service .....	128			
Service Procedure Precautions for Models with a Pop-up Roll Bar .....	128			



<b>DISK EJECT SIGNAL CIRCUIT</b> .....	<b>234</b>	Exploded View .....	257	
Description .....	234	Removal and Installation .....	257	A
Diagnosis Procedure .....	234			
<b>MICROPHONE SIGNAL CIRCUIT</b> .....	<b>235</b>	<b>HEADREST SPEAKER</b> .....	<b>258</b>	
Description .....	235	Exploded View .....	258	B
Diagnosis Procedure .....	235	Removal and Installation .....	258	
<b>CONTROL SIGNAL CIRCUIT</b> .....	<b>237</b>	<b>BOSE AMP.</b> .....	<b>259</b>	
Description .....	237	Exploded View .....	259	C
Diagnosis Procedure .....	237	Removal and Installation .....	259	
<b>STEERING SWITCH SIGNAL A CIRCUIT</b> .....	<b>238</b>	<b>AudioPilot™ MICROPHONE</b> .....	<b>260</b>	
Description .....	238	Exploded View .....	260	D
Diagnosis Procedure .....	238	Removal and Installation .....	260	
Component Inspection .....	238	<b>ANTENNA BASE</b> .....	<b>261</b>	
<b>STEERING SWITCH SIGNAL B CIRCUIT</b> .....	<b>240</b>	Exploded View .....	261	E
Description .....	240	Removal and Installation .....	261	
Diagnosis Procedure .....	240	<b>SATELLITE RADIO TUNER</b> .....	<b>262</b>	
Component Inspection .....	240	Exploded View .....	262	F
<b>STEERING SWITCH GROUND CIRCUIT</b> .....	<b>242</b>	Removal and Installation .....	262	
Description .....	242	<b>MULTIFUNCTION SWITCH</b> .....	<b>263</b>	
Diagnosis Procedure .....	242	Exploded View .....	263	G
Component Inspection .....	242	Removal and Installation .....	263	
<b>SYMPTOM DIAGNOSIS</b> .....	<b>244</b>	<b>PRESET SWITCH</b> .....	<b>264</b>	
<b>MULTI AV SYSTEM SYMPTOMS</b> .....	<b>244</b>	Exploded View .....	264	H
Symptom Table .....	244	Removal and Installation .....	264	
<b>NORMAL OPERATING CONDITION</b> .....	<b>248</b>	<b>STEERING SWITCH</b> .....	<b>265</b>	
Description .....	248	Exploded View .....	265	I
		Removal and Installation .....	265	
<b>REMOVAL AND INSTALLATION</b> .....	<b>250</b>	<b>USB CONNECTOR</b> .....	<b>266</b>	
<b>AV CONTROL UNIT</b> .....	<b>250</b>	Exploded View .....	266	J
Exploded View .....	250	Removal and Installation .....	266	
Removal and Installation .....	250	<b>MICROPHONE</b> .....	<b>267</b>	
<b>DISPLAY UNIT</b> .....	<b>252</b>	Exploded View .....	267	K
Exploded View .....	252	Removal and Installation .....	267	
Removal and Installation .....	252	<b>REAR VIEW CAMERA</b> .....	<b>268</b>	
<b>DOOR SQUAWKER</b> .....	<b>253</b>	Exploded View .....	268	L
Exploded View .....	253	Removal and Installation .....	268	
Removal and Installation .....	253	Adjustment .....	268	M
<b>DOOR WOOFER</b> .....	<b>254</b>	<b>STEERING ANGLE SENSOR</b> .....	<b>270</b>	
Exploded View .....	254	Exploded View .....	270	
Removal and Installation .....	254	Removal and Installation .....	270	O
<b>TWEETER</b> .....	<b>255</b>	<b>TEL ADAPTER UNIT</b> .....	<b>271</b>	
Exploded View .....	255	Exploded View .....	271	
Removal and Installation .....	255	Removal and Installation .....	271	P
<b>CENTER SPEAKER</b> .....	<b>256</b>	<b>SONAR CONTROL UNIT</b> .....	<b>272</b>	
Exploded View .....	256	Exploded View .....	272	
Removal and Installation .....	256	Removal and Installation .....	272	
<b>REAR WOOFER</b> .....	<b>257</b>	<b>ANTENNA FEEDER</b> .....	<b>273</b>	
		Feeder Layout .....	273	

<b>BOSE AUDIO WITH NAVIGATION</b>	<b>ADDITIONAL SERVICE WHEN REPLACING (AV CONTROL UNIT)</b> .....343
<b>PRECAUTION</b> .....274	Description ..... 343
<b>PRECAUTIONS</b> ..... 274	Work Procedure ..... 343
Precaution for Supplemental Restraint System (SRS) "AIR BAG" and "SEAT BELT PRE-TENSIONER" .....274	<b>CONFIGURATION (AV CONTROL UNIT)</b> .....344
Precaution for Battery Service .....274	Description ..... 344
Service Procedure Precautions for Models with a Pop-up Roll Bar .....274	Work Procedure ..... 344
Cautions in Removing Battery Terminal and AV Control Unit (Models with AV Control Unit) .....274	Configuration List ..... 344
Precaution for Trouble Diagnosis .....275	<b>DTC/CIRCUIT DIAGNOSIS</b> .....346
Precaution for Harness Repair .....275	<b>U1000 CAN COMM CIRCUIT</b> .....346
<b>PREPARATION</b> .....276	Description ..... 346
<b>PREPARATION</b> ..... 276	DTC Logic ..... 346
Commercial Service Tools .....276	Diagnosis Procedure ..... 346
<b>SYSTEM DESCRIPTION</b> .....277	<b>U1010 CONTROL UNIT (CAN)</b> .....347
<b>COMPONENT PARTS</b> ..... 277	DTC Logic ..... 347
Component Parts Location .....277	<b>U1200 AV CONTROL UNIT</b> .....348
Component Description .....278	DTC Logic ..... 348
<b>SYSTEM</b> ..... 280	<b>U1201 AV CONTROL UNIT</b> .....349
<b>MULTI AV SYSTEM</b> .....280	DTC Logic ..... 349
MULTI AV SYSTEM : System Diagram .....280	<b>U1202 AV CONTROL UNIT</b> .....350
MULTI AV SYSTEM : System Description .....280	DTC Logic ..... 350
MULTI AV SYSTEM : Fail-Safe .....285	<b>U1204 AV CONTROL UNIT</b> .....351
<b>DIAGNOSIS SYSTEM (AV CONTROL UNIT)</b> . 287	Description ..... 351
Description .....287	DTC Logic ..... 351
On Board Diagnosis Function .....287	Diagnosis Procedure ..... 351
CONSULT - III Function .....300	<b>U1205 AV CONTROL UNIT</b> .....352
<b>ECU DIAGNOSIS INFORMATION</b> .....305	Description ..... 352
<b>AV CONTROL UNIT</b> ..... 305	DTC Logic ..... 352
Reference Value .....305	Diagnosis Procedure ..... 352
Fail-Safe .....309	<b>U1206 AV CONTROL UNIT</b> .....353
DTC Index .....310	Description ..... 353
<b>DISPLAY UNIT</b> ..... 312	DTC Logic ..... 353
Reference Value .....312	Diagnosis Procedure ..... 353
<b>BOSE AMP.</b> ..... 314	<b>U1207 AV CONTROL UNIT</b> .....354
Reference Value .....314	Description ..... 354
<b>WIRING DIAGRAM</b> .....318	DTC Logic ..... 354
<b>BOSE AUDIO WITH NAVIGATION</b> ..... 318	Diagnosis Procedure ..... 354
Wiring Diagram .....318	<b>U1216 AV CONTROL UNIT</b> .....355
<b>BASIC INSPECTION</b> .....341	DTC Logic ..... 355
<b>DIAGNOSIS AND REPAIR WORKFLOW</b> ..... 341	<b>U1217 AV CONTROL UNIT</b> .....356
Work Flow .....341	DTC Logic ..... 356
	<b>U1218 AV CONTROL UNIT</b> .....357
	DTC Logic ..... 357
	Diagnosis Procedure ..... 357
	<b>U1219 AV CONTROL UNIT</b> .....358
	DTC Logic ..... 358
	Diagnosis Procedure ..... 358

<b>U121A AV CONTROL UNIT</b> .....	<b>359</b>	<b>U1264 ANTENNA AMP.</b> .....	<b>377</b>	A
DTC Logic .....	359	DTC Logic .....	377	
Diagnosis Procedure .....	359	Diagnosis Procedure .....	377	
<b>U121B AV CONTROL UNIT</b> .....	<b>360</b>	<b>U1300 AV COMM CIRCUIT</b> .....	<b>378</b>	B
DTC Logic .....	360	Description .....	378	
Diagnosis Procedure .....	360	<b>U1310 AV CONTROL UNIT</b> .....	<b>379</b>	C
<b>U121C AV CONTROL UNIT</b> .....	<b>361</b>	DTC Logic .....	379	
DTC Logic .....	361	<b>U1900 CENTER SPEAKER</b> .....	<b>380</b>	D
Diagnosis Procedure .....	361	DTC Logic .....	380	
<b>U121D AV CONTROL UNIT</b> .....	<b>362</b>	Diagnosis Procedure .....	380	
DTC Logic .....	362	<b>U1901, U1907 DOOR SQUAWKER/TWEET-</b>		E
Diagnosis Procedure .....	362	<b>ER</b> .....	<b>381</b>	
<b>U121E AV CONTROL UNIT</b> .....	<b>363</b>	DTC Logic .....	381	
DTC Logic .....	363	Diagnosis Procedure .....	381	
Diagnosis Procedure .....	363	<b>U1908, U1909 HEADREST SPEAKER</b> .....	<b>382</b>	F
<b>U1225 AV CONTROL UNIT</b> .....	<b>364</b>	DTC Logic .....	382	
DTC Logic .....	364	Diagnosis Procedure .....	382	
<b>U1227 AV CONTROL UNIT</b> .....	<b>365</b>	<b>U1910, U1911 REAR WOOFER</b> .....	<b>383</b>	G
DTC Logic .....	365	DTC Logic .....	383	
Diagnosis Procedure .....	365	Diagnosis Procedure .....	383	
<b>U1228 AV CONTROL UNIT</b> .....	<b>366</b>	<b>U190A, U190B HEADREST SPEAKER</b> .....	<b>384</b>	H
DTC Logic .....	366	DTC Logic .....	384	
<b>U1229 AV CONTROL UNIT</b> .....	<b>367</b>	Diagnosis Procedure .....	384	
DTC Logic .....	367	<b>U190C AudioPilot™ MICROPHONE</b> .....	<b>385</b>	I
<b>U122A AV CONTROL UNIT</b> .....	<b>368</b>	DTC Logic .....	385	
DTC Logic .....	368	Diagnosis Procedure .....	385	
Diagnosis Procedure .....	368	<b>U190F, U1912 DOOR WOOFER</b> .....	<b>386</b>	J
<b>U122E AV CONTROL UNIT</b> .....	<b>369</b>	DTC Logic .....	386	
DTC Logic .....	369	Diagnosis Procedure .....	386	
<b>U1231 BOSE AMP.</b> .....	<b>370</b>	<b>POWER SUPPLY AND GROUND CIRCUIT</b> ..	<b>387</b>	L
DTC Logic .....	370	<b>AV CONTROL UNIT</b> .....	<b>387</b>	
<b>U1232 STEERING ANGLE SENSOR</b> .....	<b>371</b>	AV CONTROL UNIT : Diagnosis Procedure .....	387	
DTC Logic .....	371	<b>DISPLAY UNIT</b> .....	<b>387</b>	M
Diagnosis Procedure .....	371	DISPLAY UNIT : Diagnosis Procedure .....	387	
<b>U1243 DISPLAY UNIT</b> .....	<b>372</b>	<b>BOSE AMP.</b> .....	<b>388</b>	AV
DTC Logic .....	372	BOSE AMP. : Diagnosis Procedure .....	388	
Diagnosis Procedure .....	372	<b>RGB DIGITAL IMAGE SIGNAL CIRCUIT</b> .....	<b>390</b>	O
<b>U1244 GPS ANTENNA</b> .....	<b>374</b>	Description .....	390	
DTC Logic .....	374	Diagnosis Procedure .....	390	
Diagnosis Procedure .....	374	<b>COMPOSITE IMAGE SIGNAL CIRCUIT</b> .....	<b>391</b>	P
<b>U1258 SATELLITE RADIO ANTENNA</b> .....	<b>375</b>	Description .....	391	
DTC Logic .....	375	Diagnosis Procedure .....	391	
Diagnosis Procedure .....	375	<b>DISK EJECT SIGNAL CIRCUIT</b> .....	<b>392</b>	
<b>U1263 USB</b> .....	<b>376</b>	Description .....	392	
DTC Logic .....	376	Diagnosis Procedure .....	392	
Diagnosis Procedure .....	376	<b>MICROPHONE SIGNAL CIRCUIT</b> .....	<b>393</b>	

Description .....	393	Removal and Installation .....	420
Diagnosis Procedure .....	393		
<b>CAMERA IMAGE SIGNAL CIRCUIT .....</b>	<b>395</b>	<b>HEADREST SPEAKER .....</b>	<b>421</b>
Description .....	395	Exploded View .....	421
Diagnosis Procedure .....	395	Removal and Installation .....	421
<b>STEERING SWITCH SIGNAL A CIRCUIT .....</b>	<b>397</b>	<b>BOSE AMP. ....</b>	<b>422</b>
Description .....	397	Exploded View .....	422
Diagnosis Procedure .....	397	Removal and Installation .....	422
Component Inspection .....	397	<b>AudioPilot™ MICROPHONE .....</b>	<b>423</b>
<b>STEERING SWITCH SIGNAL B CIRCUIT .....</b>	<b>399</b>	Exploded View .....	423
Description .....	399	Removal and Installation .....	423
Diagnosis Procedure .....	399	<b>ANTENNA BASE .....</b>	<b>424</b>
Component Inspection .....	399	Exploded View .....	424
<b>STEERING SWITCH GROUND CIRCUIT .....</b>	<b>401</b>	Removal and Installation .....	424
Description .....	401	<b>MULTIFUNCTION SWITCH .....</b>	<b>425</b>
Diagnosis Procedure .....	401	Exploded View .....	425
Component Inspection .....	401	Removal and Installation .....	425
<b>SYMPTOM DIAGNOSIS .....</b>	<b>403</b>	<b>PRESET SWITCH .....</b>	<b>426</b>
<b>MULTI AV SYSTEM SYMPTOMS .....</b>	<b>403</b>	Exploded View .....	426
Symptom Table .....	403	Removal and Installation .....	426
<b>NORMAL OPERATING CONDITION .....</b>	<b>407</b>	<b>STEERING SWITCH .....</b>	<b>427</b>
Description .....	407	Exploded View .....	427
<b>REMOVAL AND INSTALLATION .....</b>	<b>413</b>	Removal and Installation .....	427
<b>AV CONTROL UNIT .....</b>	<b>413</b>	<b>USB CONNECTOR .....</b>	<b>428</b>
Exploded View .....	413	Exploded View .....	428
Removal and Installation .....	413	Removal and Installation .....	428
<b>DISPLAY UNIT .....</b>	<b>415</b>	<b>MICROPHONE .....</b>	<b>429</b>
Exploded View .....	415	Exploded View .....	429
Removal and Installation .....	415	Removal and Installation .....	429
<b>DOOR SQUAWKER .....</b>	<b>416</b>	<b>GPS ANTENNA .....</b>	<b>430</b>
Exploded View .....	416	Exploded View .....	430
Removal and Installation .....	416	Feeder Layout .....	431
<b>DOOR WOOFER .....</b>	<b>417</b>	Removal and Installation .....	431
Exploded View .....	417	<b>REAR VIEW CAMERA .....</b>	<b>433</b>
Removal and Installation .....	417	Exploded View .....	433
<b>TWEETER .....</b>	<b>418</b>	Removal and Installation .....	433
Exploded View .....	418	Adjustment .....	433
Removal and Installation .....	418	<b>STEERING ANGLE SENSOR .....</b>	<b>435</b>
<b>CENTER SPEAKER .....</b>	<b>419</b>	Exploded View .....	435
Exploded View .....	419	Removal and Installation .....	435
Removal and Installation .....	419	<b>SONAR CONTROL UNIT .....</b>	<b>436</b>
<b>REAR WOOFER .....</b>	<b>420</b>	Exploded View .....	436
Exploded View .....	420	Removal and Installation .....	436
		<b>ANTENNA FEEDER .....</b>	<b>437</b>
		Feeder Layout .....	437



PRECAUTION

PRECAUTIONS

Precaution for Supplemental Restraint System (SRS) "AIR BAG" and "SEAT BELT PRE-TENSIONER"

INFOID:000000006472403

The Supplemental Restraint System such as "AIR BAG" and "SEAT BELT PRE-TENSIONER", used along with a front seat belt, helps to reduce the risk or severity of injury to the driver and front passenger for certain types of collision. This system includes seat belt switch inputs and dual stage front air bag modules. The SRS system uses the seat belt switches to determine the front air bag deployment, and may only deploy one front air bag, depending on the severity of a collision and whether the front occupants are belted or unbelted. Information necessary to service the system safely is included in the "SRS AIR BAG" and "SEAT BELT" of this Service Manual.

**WARNING:**

Always observe the following items for preventing accidental activation.

- To avoid rendering the SRS inoperative, which could increase the risk of personal injury or death in the event of a collision that would result in air bag inflation, all maintenance must be performed by an authorized NISSAN/INFINITI dealer.
- Improper maintenance, including incorrect removal and installation of the SRS, can lead to personal injury caused by unintentional activation of the system. For removal of Spiral Cable and Air Bag Module, see "SRS AIR BAG".
- Never use electrical test equipment on any circuit related to the SRS unless instructed to in this Service Manual. SRS wiring harnesses can be identified by yellow and/or orange harnesses or harness connectors.

PRECAUTIONS WHEN USING POWER TOOLS (AIR OR ELECTRIC) AND HAMMERS

**WARNING:**

Always observe the following items for preventing accidental activation.

- When working near the Air Bag Diagnosis Sensor Unit or other Air Bag System sensors with the ignition ON or engine running, never use air or electric power tools or strike near the sensor(s) with a hammer. Heavy vibration could activate the sensor(s) and deploy the air bag(s), possibly causing serious injury.
- When using air or electric power tools or hammers, always switch the ignition OFF, disconnect the battery, and wait at least 3 minutes before performing any service.

Precaution for Battery Service

INFOID:000000006472404

Before disconnecting the battery, lower both the driver and passenger windows. This will prevent any interference between the window edge and the vehicle when the door is opened/closed. During normal operation, the window slightly raises and lowers automatically to prevent any window to vehicle interference. The automatic window function will not work with the battery disconnected.

Service Procedure Precautions for Models with a Pop-up Roll Bar

INFOID:000000006472405

**WARNING:**

Always observe the following items for preventing accidental activation.

- Risk of passenger injury or death may increase if the pop-up roll bar does not deploy during a roll over collision. In order to reduce the chance of an incident where the pop-up roll bar is inoperative, all maintenance must be performed by a NISSAN or INFINITI dealer.
- Before removing and installing the pop-up roll bar component parts and harness, always turn the ignition switch OFF, disconnect the battery negative terminal, and wait for 3 minutes or more. (The purpose of this operation is to discharge electricity that is accumulated in the auxiliary power supply circuit in the air bag diagnosis sensor unit.)
- When repairing, removing, and installing a pop-up roll bar, always refer to SRS AIR BAG and SRS AIR BAG CONTROL warnings in the Service Manual.

Cautions in Removing Battery Terminal and AV Control Unit (Models with AV Control Unit)

INFOID:000000008116989

**CAUTION:**

A  
B  
C  
D  
E  
F  
G  
H  
I  
J  
K  
L  
M  
AV  
O  
P

# PRECAUTIONS

< PRECAUTION >

[BASE AUDIO WITHOUT NAVIGATION]

**Remove battery terminal and AV control unit after a lapse of 30 seconds or more after turning the ignition switch OFF.**

**NOTE:**

After the ignition switch is turned OFF, the AV control unit continues operating for approximately 30 seconds. Therefore, data corruption may occur if battery voltage is cut off within 30 seconds.

## Precaution for Trouble Diagnosis

INFOID:000000006472406

### AV COMMUNICATION SYSTEM

- Do not apply voltage of 7.0 V or higher to the measurement terminals.
- Use the tester with its open terminal voltage being 7.0 V or less.
- Be sure to turn ignition switch OFF and disconnect the battery cable from the negative terminal before checking the circuit.

## Precaution for Harness Repair

INFOID:000000006472407

### AV COMMUNICATION SYSTEM

- Solder the repaired parts, and wrap with tape. [Frays of twisted line must be within 110 mm (4.33 in).]

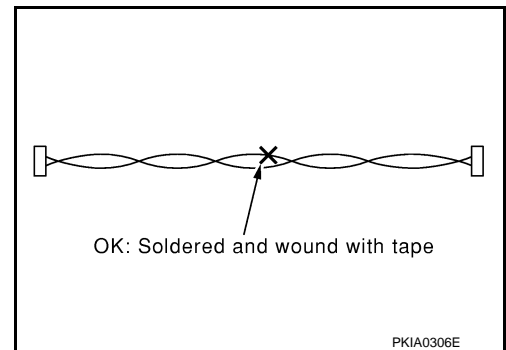

- Do not perform bypass wire connections for the repair parts. (The spliced wire will become separated and the characteristics of twisted line will be lost.)

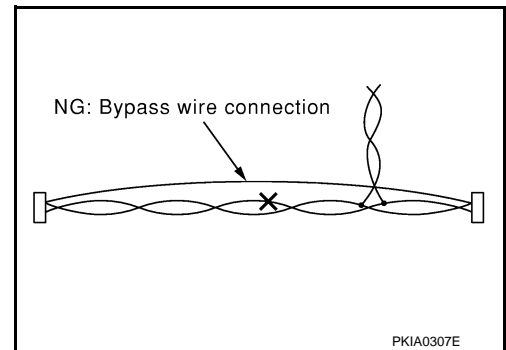

# PREPARATION

< PREPARATION >

[BASE AUDIO WITHOUT NAVIGATION]

## PREPARATION

### PREPARATION

#### Commercial Service Tools

INFOID:000000006472408

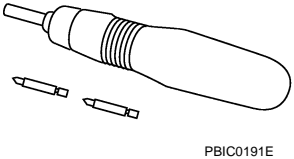
Tool	Description
<p>Power tool</p>  <p>PBIC0191E</p>	<p>Loosening screws</p>

A

B

C

D

E

F

G

H

I

J

K

L

M

AV

O

P

# COMPONENT PARTS

< SYSTEM DESCRIPTION >

[BASE AUDIO WITHOUT NAVIGATION]

## SYSTEM DESCRIPTION

### COMPONENT PARTS

#### Component Parts Location

INFOID:000000006472409

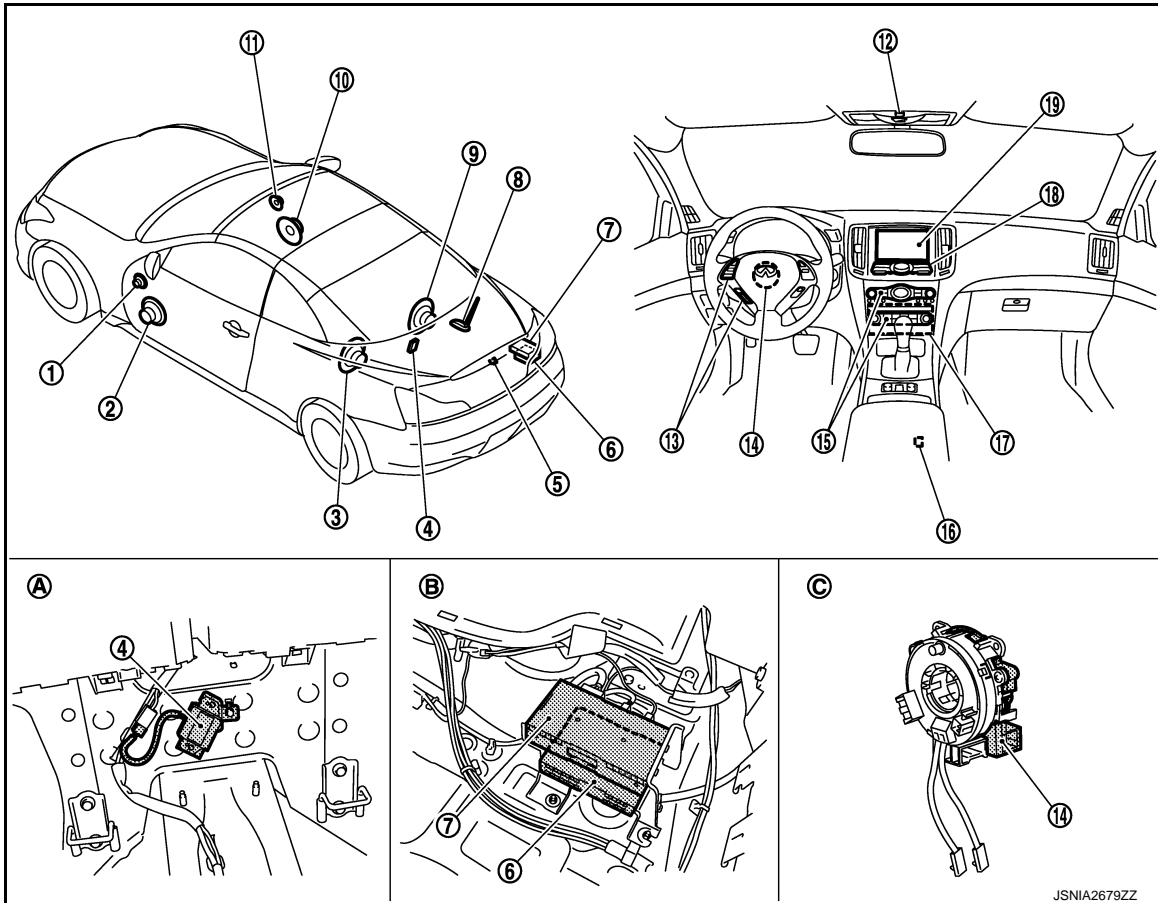

- |                                     |  |                                   |
|-------------------------------------|--|-----------------------------------|
| 1. Tweeter LH                       | 2. Door speaker LH                                   | 3. Rear speaker LH                |
| 4. TEL antenna                      | 5. Rear view camera                                  | 6. Satellite radio tuner          |
| 7. TEL adapter unit                 | 8. Antenna base (antenna amp. and satellite antenna) | 9. Rear speaker RH                |
| 10. Door speaker RH                 | 11. Tweeter RH                                       | 12. Microphone                    |
| 13. Steering switch                 | 14. Steering angle sensor                            | 15. Preset switch                 |
| 16. USB connector                   | 17. AV control unit                                  | 18. Multifunction switch          |
| 19. Display unit                    |  |                                   |
| A. Rear seat back removed condition | B. Trunk room RH                                     | C. Spiral cable removed condition |

# COMPONENT PARTS

[BASE AUDIO WITHOUT NAVIGATION]

< SYSTEM DESCRIPTION >

## Component Description

INFOID:000000006472410

Part name	Description
AV control unit	<ul style="list-style-type: none"> <li>It is the master unit of the MULTI AV system, and it is connected to each control unit by communication. It operates each system according to communication signals from the AV control unit.</li> <li>The AV control unit includes the audio, USB connection and vehicle information functions.</li> <li>It is connected to ECM and unified meter and A/C amp. via CAN communication to obtain necessary information for the vehicle information function.</li> <li>It is connected to the steering angle sensor and receives the steering angle sensor signal via CAN communication.</li> <li>It inputs the illumination signals that are required for the display dimming control.</li> <li>It inputs the signals for driving status recognition (vehicle speed, reverse and parking brake).</li> <li>TEL voice signal and voice guidance signal are input from TEL adapter unit.</li> </ul>
Door speaker	<ul style="list-style-type: none"> <li>Outputs sound signal from AV control unit.</li> <li>Outputs high, mid and low range sounds.</li> </ul>
Rear speaker	<ul style="list-style-type: none"> <li>Outputs sound signal from AV control unit.</li> <li>Outputs high, mid and low range sounds.</li> </ul>
Tweeter	<ul style="list-style-type: none"> <li>Outputs sound signal from AV control unit.</li> <li>Outputs high range sound.</li> </ul>
Display unit	<ul style="list-style-type: none"> <li>Display image is controlled by the serial communication from AV control unit.</li> <li>It receives the power (signal VCC and inverter VCC) from the AV control unit and operates.</li> <li>RGB image signal is input from AV control unit (RGB image, RGB area and RGB synchronizing).</li> <li>Composite image signals are input from AV control unit.</li> <li>Synchronizing signal (HP, VP) is output to AV control unit.</li> </ul>
Multifunction switch	<ul style="list-style-type: none"> <li>Operation panel is equipped with the centralized switch where audio operations are integrated.</li> <li>Connected with preset switch via cable, and operation signal is transmitted to AV control unit via AV communication.</li> </ul>
Preset switch	<ul style="list-style-type: none"> <li>Operation panel is equipped with the centralized switch where audio and air conditioner, etc. operations are integrated.</li> <li>Connected with multifunction switch via cable, and operation signal is transmitted to AV control unit via AV communication.</li> <li>The disk ejection operating signal is performed by hardwire.</li> </ul>
Rear view camera	<ul style="list-style-type: none"> <li>Camera power supply is input from AV control unit.</li> <li>The image of vehicle rear view is transmitted to AV control unit.</li> </ul>
Steering angle sensor	It is connected to the AV control unit and transmits the steering angle sensor signal via CAN communication.
Steering switch	<ul style="list-style-type: none"> <li>Operations for audio, hands-free phone and voice control, etc. are possible.</li> <li>Steering switch signal (operation signal) is output to AV control unit.</li> </ul>
Microphone	<ul style="list-style-type: none"> <li>Used for hands-free phone operation and voice recognition.</li> <li>Microphone signal is transmitted to TEL adapter unit.</li> <li>Power (Microphone VCC) is supplied from TEL adapter unit.</li> </ul>
Antenna base	<p>An antenna base integrated with radio antenna amp. and satellite radio antenna is adopted.</p> <p>ANTENNA AMP.</p> <ul style="list-style-type: none"> <li>Radio signal received by rod antenna is amplified and transmitted to AV control unit.</li> <li>Power (antenna amp. ON signal) is supplied from AV control unit.</li> </ul> <p>SATELLITE RADIO ANTENNA</p> <ul style="list-style-type: none"> <li>Receives the satellite radio waves and outputs it to AV control unit.</li> </ul>
Satellite radio tuner	<ul style="list-style-type: none"> <li>Inputs the satellite radio signal from satellite radio antenna and outputs the sound signal to the AV control unit.</li> <li>It is controlled with the AV control unit and serial communication (communication signal and request signal).</li> </ul>

A

B

C

D

E

F

G

H

I

J

K

L

M

AV

O

P

## COMPONENT PARTS

< SYSTEM DESCRIPTION >

[BASE AUDIO WITHOUT NAVIGATION]

Part name	Description
TEL adapter unit	<ul style="list-style-type: none"><li>• Inputs the TEL voice signal from TEL antenna and outputs it to the AV control unit.</li><li>• It is connected with the AV control unit via AV communication and controlled with the AV control unit.</li><li>• Inputs roof status signal from retractable hard top control unit.</li></ul>
TEL antenna	Receives the TEL voice signal and outputs it to the TEL adapter unit.
USB connector	Image signal <sup>*1</sup> and sound signal of USB input is transmitted to AV control unit.

\*1: Image signals cannot be received from iPod<sup>®</sup>.

< SYSTEM DESCRIPTION >

SYSTEM  
MULTI AV SYSTEM

MULTI AV SYSTEM : System Diagram

INFOID:000000006472411

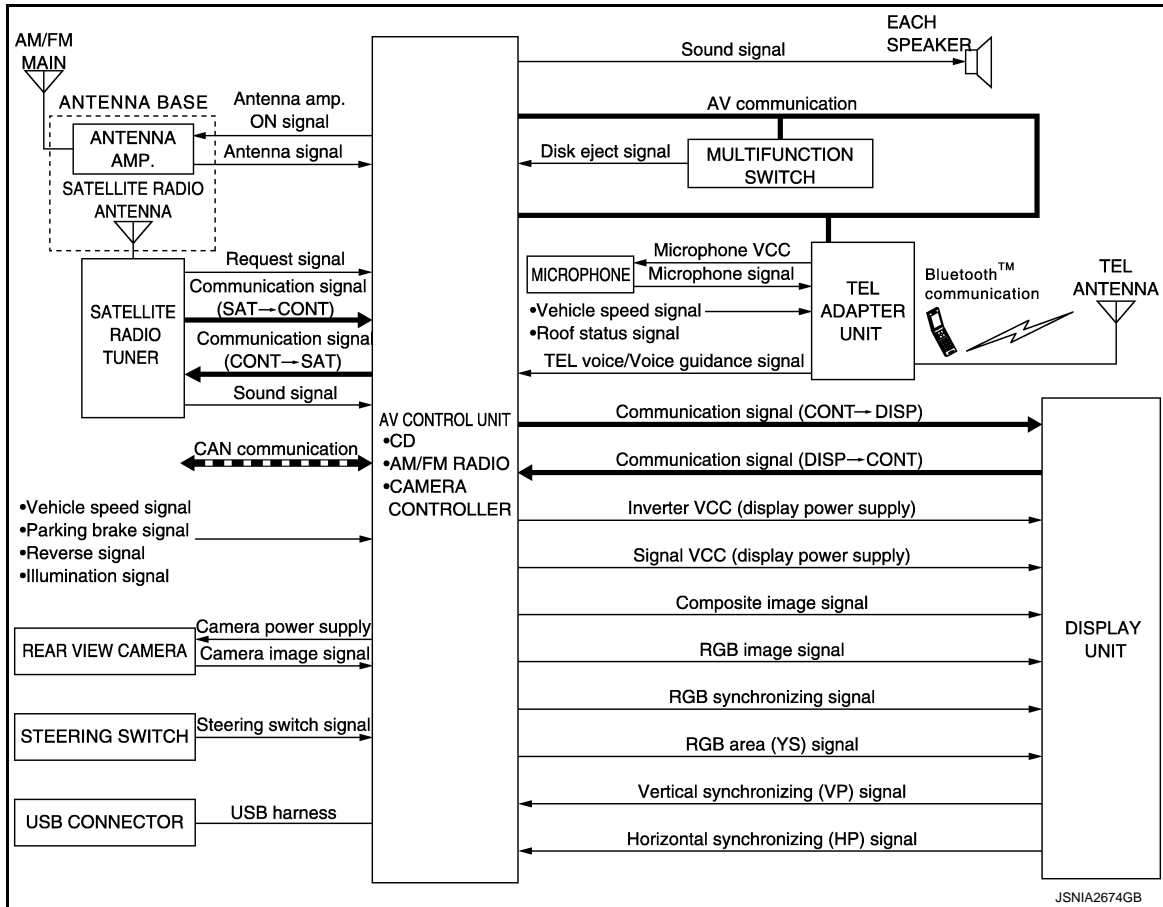

NOTE:

- The name MULTIFUNCTION SWITCH indicates the integration of PRESET SWITCH and MULTIFUNCTION SWITCH virtually.
- An antenna base integrated with radio antenna and satellite radio antenna is adopted.

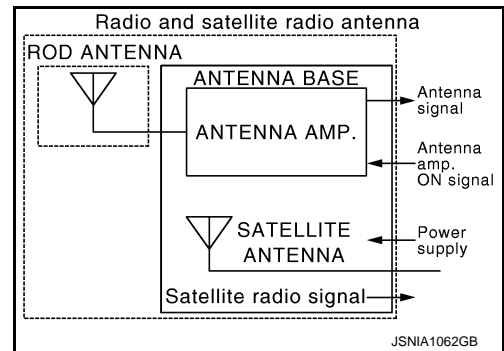

MULTI AV SYSTEM : System Description

INFOID:000000006472412

Multi AV system means that the following systems are integrated.

FUNCTION NAME
Audio function
Hands-free phone function
Rear view monitor function
Vehicle information function

# SYSTEM

< SYSTEM DESCRIPTION >

[BASE AUDIO WITHOUT NAVIGATION]

## COMMUNICATION SIGNAL

- AV control unit function by transmitting/receiving data one by one with each unit (slave unit) that configures them completely as a master unit by connecting between units that configure MULTI AV system with two AV communication lines (H, L).
- Two AV communication lines (H, L) adopt a twisted pair line that is resistant to noise.
- AV control unit is connected by CAN communication, and it receives data signal from ECM, unified meter and A/C amp. It computes and displays fuel economy information value with the obtained information.
- AV control unit is connected with display and serial communication, and it transmits the required signal of display and display control and receives the response signal from display.

## AUDIO FUNCTION

The audio system is equipped with the following functions. Each function is operated with multifunction switch, preset switch, steering switch. Operation status of audio is indicated at display.

FUNCTION
AM/FM radio
Satellite radio
CD
USB connection function

### Operating Signal

Audio system operation can be performed with multifunction switch, preset switch or steering switch.

- Operating signal is transmitted to AV control unit with AV communication when it is operated by multifunction switch or preset switch. The disk ejection operating signal is performed by hardwire.
- Operating signal is transmitted to AV control unit with steering switch signal when it is operated by steering switch.

### Screen Display

- Switching of display is performed with serial communication between display unit and AV control unit.
- The image signal to display operating condition is performed with RGB image signal, RGB area signal and RGB image synchronizing signal.

### AM/FM Radio Mode

- AM/FM radio tuner is built into AV control unit.
- Audio signal is received by rod antenna, next it is amplified by antenna amp., and finally it is input to AV control unit. Audio signal is outputs to each speaker.

### Satellite Radio Mode

- Satellite radio tuner is controlled by communication signal and request signal with AV control unit.
- Sound signal (satellite radio) is received by satellite antenna and transmitted to AV control unit. AV control unit is output the sound signal (satellite radio) to each speaker.

### CD Mode

- CD function is built into AV control unit.
- AV control unit outputs audio signal to each speaker when CD is inserted to AV control unit.

### USB Connection Function

- iPod or music files in USB memory can be played.
- iPod sound signals are transmitted from USB connector to the AV control unit and to each speaker.
- iPod® is recharged when connected to USB connector.

iPod® is a trademark of Apple inc., registered in the U.S. and other countries.

### NOTE:

Use the enclosed USB harness when connecting iPod® to USB connector.

## HANDS-FREE PHONE SYSTEM

- TEL adapter unit is controlled with AV communication from AV control unit.
- The connection between cellular phone and TEL adapter unit is performed with Bluetooth™ communication.
- The voice guidance signal is input from the TEL adapter unit to the AV control unit and output to the front speaker when operating the cellular phone.
- System operation is available only when the retractable hard top is closed.
- TEL adapter unit has the on board self-diagnosis function. Refer to [AV-30, "On Board Diagnosis Function"](#).



# SYSTEM

## < SYSTEM DESCRIPTION >

## [BASE AUDIO WITHOUT NAVIGATION]

### When A Call Is Originated

- Spoken voice sound output from the microphone (microphone signal) is input to TEL adapter unit.
- TEL adapter unit outputs to cellular phone with Bluetooth™ communication as a TEL voice signal.
- Voice sound is then heard at the other party.

A

### When Receiving A Call

- Voice sound is input to own cellular phone from the other party.
- TEL voice signal is input to TEL adapter unit by establishing Bluetooth™ communication from cellular phone, and the signal is output to front speaker.

B

C

### REAR VIEW MONITOR FUNCTION

- The AV control unit supplies power to the rear view camera when receiving a reverse signal.
- The rear view camera transmits camera images to the AV control unit when power is supplied from the AV control unit.
- The AV control unit transmits a warning message, fixed guide lines, and predictive course lines to the display unit by RGB image signal. Rear view monitor images are displayed by combining the RGB image signal and the camera image signals from the rear view camera.
- Predictive course lines are controlled by a steering angle sensor signal received the AV control unit via CAN communication.

D

E

F

### VEHICLE INFORMATION FUNCTION

- Status of audio, climate control system, fuel economy and maintenance are displayed.
- AV control unit displays the fuel consumption status while receiving data signal through CAN communication from ECM, unified meter and A/C amp.
- AV control unit is connected to BCM via CAN communication transmitting/receiving for the vehicle settings function.

G

H

I

J

K

L

M

AV

O

P

# DIAGNOSIS SYSTEM (AV CONTROL UNIT)

< SYSTEM DESCRIPTION >

[BASE AUDIO WITHOUT NAVIGATION]

## DIAGNOSIS SYSTEM (AV CONTROL UNIT)

### Description

INFOID:000000006472413

- The AV control unit diagnosis function starts up with multifunction switch operation and the AV control unit performs a diagnosis for each unit in the system during the on board diagnosis.
- Perform a CONSULT-III diagnosis if the on board diagnosis does not start, e.g., the screen does not display anything, the multifunction switch does not function, etc.

### On Board Diagnosis Function

INFOID:000000006472414

#### MULTIFUNCTION SWITCH AND PRESET SWITCH SELF-DIAGNOSIS FUNCTION

The ON/OFF operation (continuity) of each switch in the multifunction switch and preset switch can be checked.

##### Self-diagnosis Mode

- Press the “BACK” switch and the “UP” switch of the 4-direction switches within 10 seconds after turning the ignition switch from OFF to ACC and hold them for 3 seconds or more. Then the buzzer sounds, all indicators of the preset switch illuminate, and the self-diagnosis mode starts.
- The continuity of each switch at the ON position can be checked by pressing the switch. The buzzer sounds if the switch is normal.

**NOTE:**

The hazard switch and disk eject switch cannot be checked.

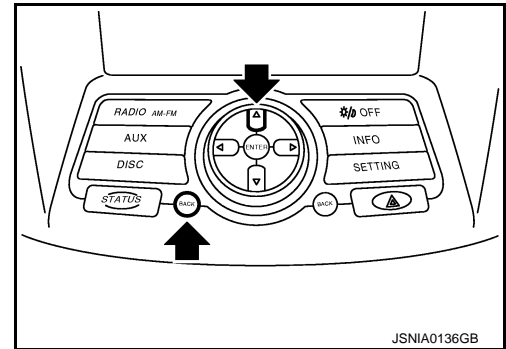

##### Finishing Self-diagnosis Mode

Self-diagnosis mode is canceled when turning the ignition switch OFF.

### ON BOARD DIAGNOSIS ITEM

#### Description

- The trouble diagnosis function has a self-diagnosis mode for conducting trouble diagnosis automatically and a confirmation/adjustment mode for operating manually.
- Self-diagnosis mode performs the AV control unit diagnosis and the connection diagnosis between each of the units that make up the system, and it indicates the results to the display unit.
- The confirmation/adjustment mode allows the technician to check, modify or adjust the vehicle signals and set values, as well as to monitor the system error records and system communication status. The checking, modifying or adjusting generally require human intervention and judgment (the system cannot make judgment automatically).

#### On Board Diagnosis Item

Mode	Description
Self Diagnosis	<ul style="list-style-type: none"><li>• AV control unit diagnosis.</li><li>• Diagnoses the connections across system components, between AV control unit and each unit.</li></ul>

# DIAGNOSIS SYSTEM (AV CONTROL UNIT)

< SYSTEM DESCRIPTION >

[BASE AUDIO WITHOUT NAVIGATION]

	Mode	Description
Confirmation/ Adjustment	Display Diagnosis	The following check functions are available: color tone check by color bar display and white display, light and shade check by gray scale display.
	Vehicle Signals	Diagnosis of signals can be performed for vehicle speed, parking brake, lights, ignition and reverse.
	Speaker Test	The connection of a speaker can be confirmed by test tone.
	Climate Control	Start auto air conditioner system self-diagnosis.
	Error History	The system malfunction and the frequency when occurring in the past are displayed. When the malfunctioning item is selected, the time and place that the selected malfunction last occurred are displayed.
	Camera Cont.	<ul style="list-style-type: none"> <li>Guiding line position that overlaps rear view camera image can be adjusted.</li> <li>Configuration stored in the AV control unit can be checked.</li> </ul>
	Vehicle CAN Diagnosis	The transmitting/receiving of CAN communication can be monitored.
	AV COMM Diagnosis	The communication condition of each unit of Multi AV system can be monitored.
	Delete Unit Connection Log	Erase the connection history of unit and error history.
Initialize Settings	Initializes the AV control unit memory.	

## METHOD OF STARTING

1. Start the engine.
2. Turn the audio system OFF.
3. While pressing the "SETTING" button, turn the volume control dial clockwise or counterclockwise for 40 clicks or more. (When the self-diagnosis mode is started, a short beep will be heard.)
  - Shifting from current screen to previous screen is performed by pressing "BACK" button.
4. The trouble diagnosis initial screen is displayed, and then the items of "Self Diagnosis" and "Confirmation/Adjustment" can be selected.

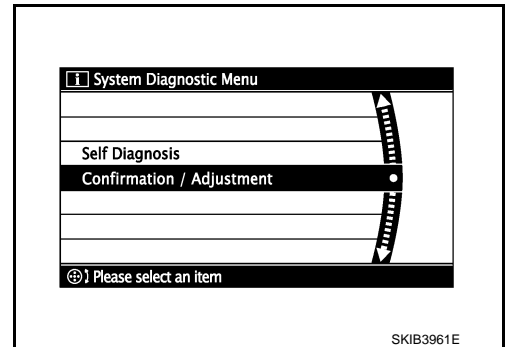
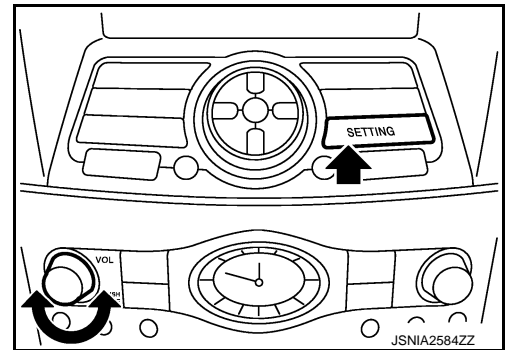

## SELF-DIAGNOSIS MODE

1. Start the self-diagnosis function and select "Self Diagnosis".
  - Self-diagnosis subdivision screen is displayed, and the self-diagnosis mode starts.
  - The bar graph visible on the center of the self-diagnosis subdivision screen indicates progress of the trouble diagnosis.

# DIAGNOSIS SYSTEM (AV CONTROL UNIT)

[BASE AUDIO WITHOUT NAVIGATION]

## < SYSTEM DESCRIPTION >

2. Diagnosis results are displayed after the self-diagnosis is completed. The unit names and the connection lines are color-coded according to the diagnostic results.

Diagnosis results	Unit	Connection line
Normal	Green	Green
Connection malfunction	Gray	Yellow
Unit malfunction <sup>Note</sup>	Red	Green

### NOTE:

Control unit (AV control unit) is displayed in red.

- Replace AV control unit if “Self-Diagnosis did not run because of a control unit malfunction” is indicated. The symptom is AV control unit internal error. Refer to [AV-110, "Exploded View"](#).
- If multiple errors occur at the same time for a single unit, the screen switch colors are determined according to the following order of priority: red > gray.

- The comments of the self-diagnosis results can be viewed with a component in the diagnosis result screen.

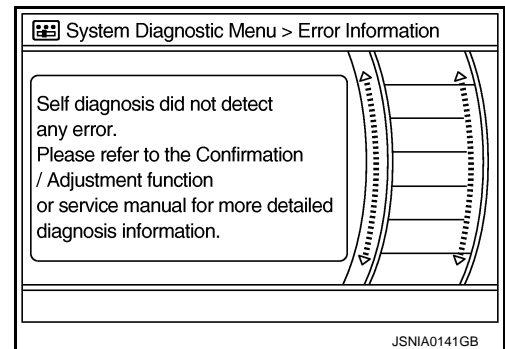
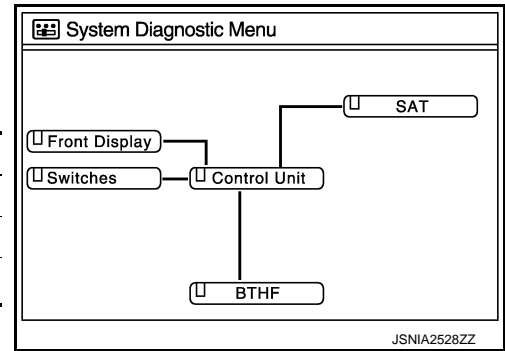

### Detection Range of Self-diagnosis Mode

- The self-diagnosis mode allows the technician to diagnose the connection in the communication line between AV control unit and each unit and the internal operation of the AV control unit.
- Because the start condition of diagnosis function is a switch operation, the on board diagnosis function cannot be started up if any malfunction is detected in the communication circuit between AV control unit and multifunction switch.

### SELF-DIAGNOSIS RESULTS

Check the applicable display at the following table, and then repair the malfunctioning parts.

Only Unit Part Is Displayed In Red.

Screen switch	Description	Possible malfunction location / Action to take
Control unit	Malfunction is detected in AV control unit power supply and ground circuits.	Check AV control unit power supply and ground circuits. When detecting no malfunction in those components, replace AV control unit. Refer to <a href="#">AV-110, "Exploded View"</a> .

A Connecting Cable Between Units Is Displayed In Yellow.

# DIAGNOSIS SYSTEM (AV CONTROL UNIT)

< SYSTEM DESCRIPTION >

[BASE AUDIO WITHOUT NAVIGATION]

Area with yellow connection lines	Description	Possible malfunction location / Action to take
Control unit ↔ Front Display	Malfunction is detected in serial communication circuits between AV control unit and display unit.	Serial communication circuits between AV control unit and display unit.
Control unit ↔ SAT	When either one of the following items is detected: <ul style="list-style-type: none"> <li>• satellite radio tuner power supply and ground circuit are malfunctioning.</li> <li>• communication circuits between AV control unit and satellite radio tuner are malfunctioning.</li> <li>• request signal circuit between AV control unit and satellite radio tuner are malfunctioning.</li> </ul>	<ul style="list-style-type: none"> <li>• Satellite radio tuner power supply and ground circuit.</li> <li>• Communication circuit between AV control unit and satellite radio tuner.</li> <li>• Request signal circuit between AV control unit and satellite radio tuner.</li> </ul>
Control unit ↔ BTHF	When either one of the following items is detected: <ul style="list-style-type: none"> <li>• TEL adapter unit power supply and ground circuits are malfunctioning.</li> <li>• AV communication circuits between AV control unit and TEL adapter unit are malfunctioning.</li> </ul>	<ul style="list-style-type: none"> <li>• TEL adapter unit power supply and ground circuits.</li> <li>• AV communication circuits between AV control unit and TEL adapter unit.</li> </ul>

## CONFIRMATION/ADJUSTMENT MODE

1. Start the diagnosis function and select “Confirmation/Adjustment”. The confirmation/adjustment mode indicates where each item can be checked or adjusted.
2. Select each switch on the “Confirmation/Adjustment Mode” screen to display the relevant trouble diagnosis screen. Press the “BACK” switch to return to the initial Confirmation/Adjustment Mode screen.

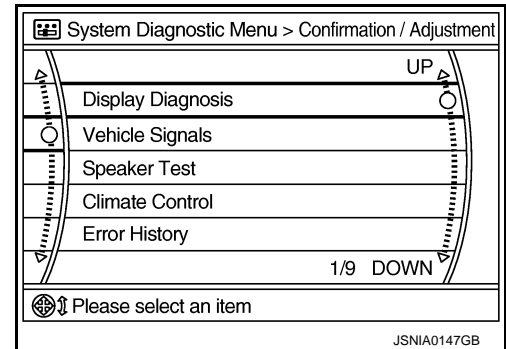

A  
B  
C  
D  
E  
F  
G  
H  
I  
J  
K  
L  
M  
N  
O  
P

AV

# DIAGNOSIS SYSTEM (AV CONTROL UNIT)

< SYSTEM DESCRIPTION >

[BASE AUDIO WITHOUT NAVIGATION]

## Display Diagnosis

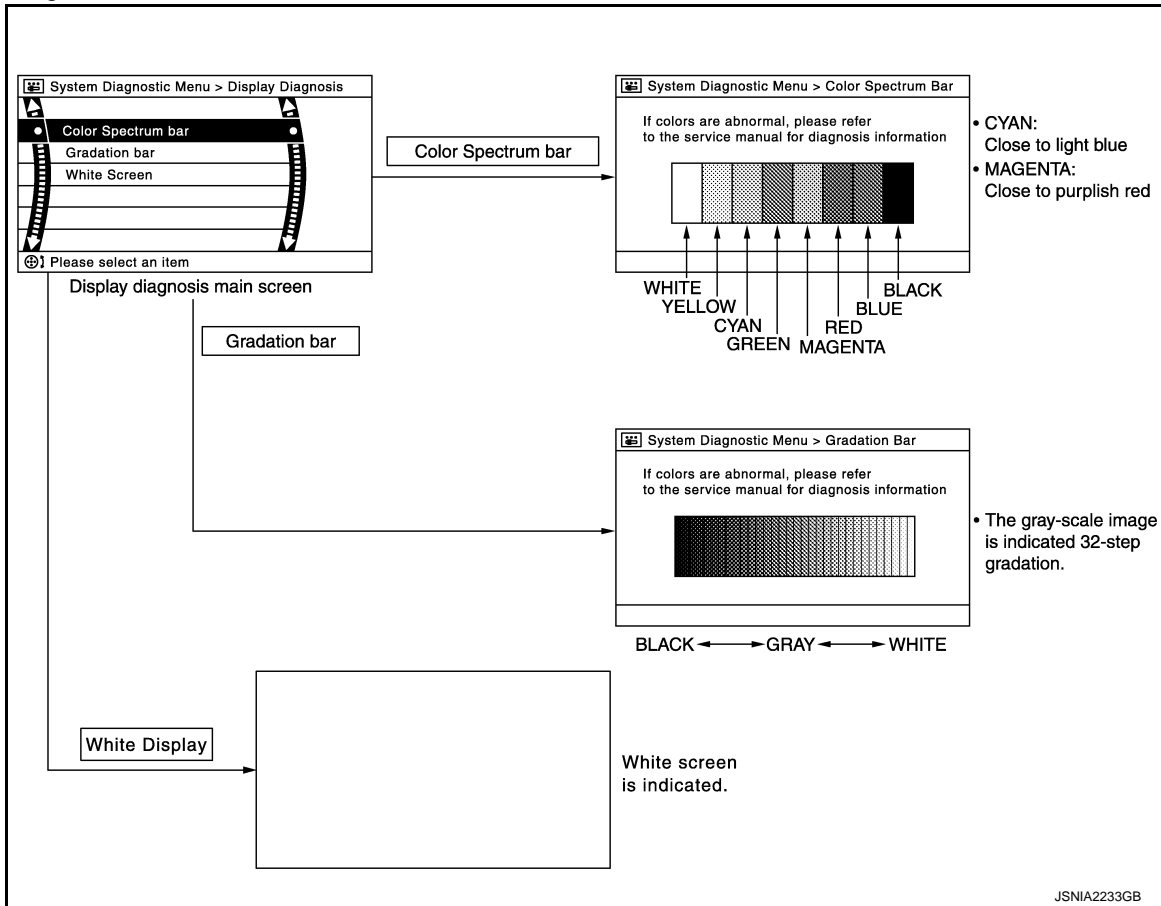

## Vehicle Signals

A comparison check can be made of each actual vehicle signal and the signals recognized by the system.

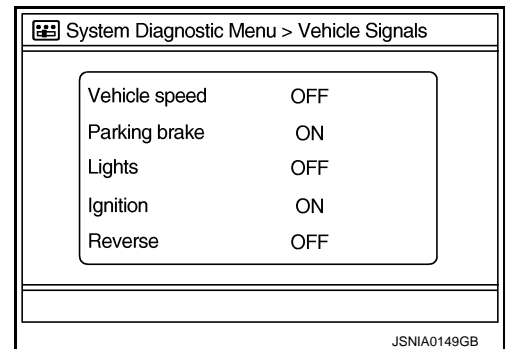

Diagnosis item	Display	Vehicle status	Remarks
Vehicle speed	ON	Vehicle speed > 0 km/h (0 MPH)	Changes in indication may be delayed. This is normal.
	OFF	Vehicle speed = 0 km/h (0 MPH)	
Parking brake	ON	Parking brake is applied.	
	OFF	Parking brake is released.	
Lights	ON	Light switch ON	—
	OFF	Light switch OFF	—
Ignition	ON	Ignition switch ON	—
	OFF	Ignition switch in ACC position	—

# DIAGNOSIS SYSTEM (AV CONTROL UNIT)

< SYSTEM DESCRIPTION >

[BASE AUDIO WITHOUT NAVIGATION]

Diagnosis item	Display	Vehicle status	Remarks
Reverse	ON	Shift the selector lever to "R" position	Changes in indication may be delayed. This is normal.
	OFF	Shift the selector lever other than "R" position	

## Speaker Test

Select "Speaker Test" to display the Speaker Diagnosis screen. Press "Start" to generate a test tone in a speaker. Press "Start" again to generate a test tone in the next speaker. Press "End" to stop the test tones.

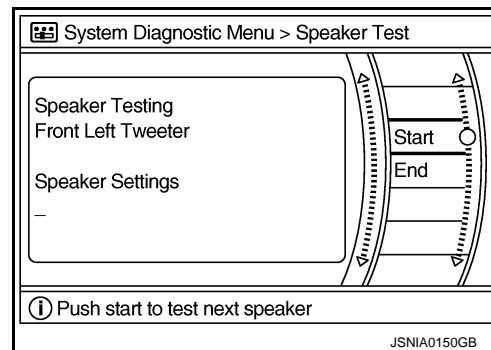

## Climate Control

Refer to "HEATER & AIR CONDITIONING CONTROL SYSTEM" for details.

## Error History

The self-diagnosis results are judged depending on whether any error occurs from when "Self-diagnosis" is selected until the self-diagnosis results are displayed.

However, the diagnosis results are judged normal if an error has occurred before the ignition switch is turned ON and then no error has occurred until the self-diagnosis start. Check the "Error Record" to detect any error that may have occurred before the self-diagnosis start because of this situation.

The frequency of occurrence is displayed in a count up manner. The actual count up method differs depending on the error item.

### Count up method A

- The counter resets to 0 if an error occurs when ignition switch is turned ON. The counter increases by 1 if the condition is normal at a next ignition ON cycle.
- The counter upper limit is 39. Any counts exceeding 39 are ignored. The counter can be reset (no error record display) with the "Delete log" switch or CONSULT-III.

### Count up method B

- The counter increases by 1 if an error occurs when ignition switch is ON. The counter will not decrease even if the condition is normal at the next ignition ON cycle.
- The counter upper limit is 50. Any counts exceeding 50 are ignored. The counter can be reset (no error record display) with the "Delete log" switch or CONSULT-III.

Display type of occurrence frequency	Error history display item
Count up method A	CAN communication line, control unit (CAN), AV communication line, control unit (AV)
Count up method B	Other than the above

# DIAGNOSIS SYSTEM (AV CONTROL UNIT)

< SYSTEM DESCRIPTION >

[BASE AUDIO WITHOUT NAVIGATION]

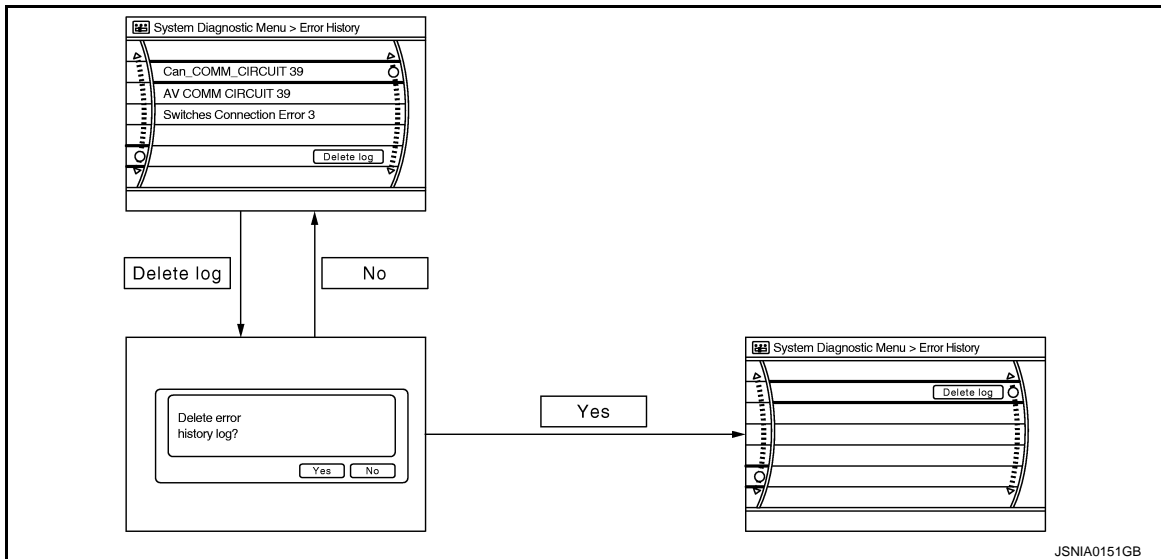

## Error item

Some error items may be displayed simultaneously according to the cause. If some error items are displayed simultaneously, the detection of the cause can be performed by the combination of display items

Error item	Description	Possible malfunction factor/Action to take
CAN COMM CIRCUIT	CAN communication malfunction is detected.	Perform diagnosis with CONSULT-III, and then repair the malfunctioning parts according to the diagnosis results. Refer to <a href="#">AV-27. "CONSULT - III Function"</a> .
CONTROL UNIT (CAN)	CAN initial diagnosis malfunction is detected.	Replace the AV control unit if the malfunction occurs constantly. Refer to <a href="#">AV-110. "Exploded View"</a> .
CONTROL UNIT (AV)	AV communication circuit initial diagnosis malfunction is detected.	
FLASH-ROM Error Of Control Unit CAN Controller Memory Error	AV control unit malfunction is detected.	
Steer. Angle Sensor Calibration	Predictive course line center position adjustment of the steering angle sensor is incomplete.	Adjust the predictive course line center position of the steering angle sensor. Refer to <a href="#">AV-27. "CONSULT - III Function"</a> .
Front Display Connection Error	When either one of the following items is detected: <ul style="list-style-type: none"> <li>display unit power supply and ground circuits are malfunctioning.</li> <li>communication circuits between AV control unit and display unit are malfunctioning.</li> </ul>	<ul style="list-style-type: none"> <li>Display unit power supply and ground circuits.</li> <li>Communication circuits between AV control unit and display unit.</li> </ul>
XM Connection Error	When either one of the following items is detected: <ul style="list-style-type: none"> <li>satellite radio tuner power supply and ground circuit are malfunctioning.</li> <li>communication circuits between AV control unit and satellite radio tuner are malfunctioning.</li> <li>request signal circuit between AV control unit and satellite radio tuner are malfunctioning.</li> </ul>	<ul style="list-style-type: none"> <li>Satellite radio tuner power supply and ground circuit.</li> <li>Communication circuit between AV control unit and satellite radio tuner.</li> <li>Request signal circuit between AV control unit and satellite radio tuner.</li> </ul>
<ul style="list-style-type: none"> <li>AV COMM CIRCUIT</li> <li>Switches Connection Error</li> </ul>	When either one of the following items is detected: <ul style="list-style-type: none"> <li>multifunction switch power supply and ground circuits are malfunctioning.</li> <li>AV communication circuits between AV control unit and multifunction switch are malfunctioning.</li> </ul>	<ul style="list-style-type: none"> <li>Multifunction switch power supply and ground circuits.</li> <li>AV communication circuits between AV control unit and multifunction switch.</li> </ul>



# DIAGNOSIS SYSTEM (AV CONTROL UNIT)

[BASE AUDIO WITHOUT NAVIGATION]

< SYSTEM DESCRIPTION >

Error item	Description	Possible malfunction factor/Action to take
<ul style="list-style-type: none"> <li>AV COMM CIRCUIT</li> <li>H/F Unit Connection Error</li> </ul>	When either one of the following items is detected: <ul style="list-style-type: none"> <li>TEL adapter unit power supply and ground circuits are malfunctioning.</li> <li>AV communication circuits between AV control unit and TEL adapter unit are malfunctioning.</li> </ul>	<ul style="list-style-type: none"> <li>TEL adapter unit power supply and ground circuits.</li> <li>AV communication circuits between AV control unit and TEL adapter unit.</li> </ul>
<ul style="list-style-type: none"> <li>AV COMM CIRCUIT</li> <li>Switches Connection Error</li> <li>H/F Unit Connection Error</li> </ul>	Malfunction is detected in AV communication circuits between AV control unit and multifunction switch.	AV communication circuits between AV control unit and multifunction switch.

## Camera Cont.

The two functions of “Correct Draw Line of Rear view Cam”, “Confirm Configuration” are available.

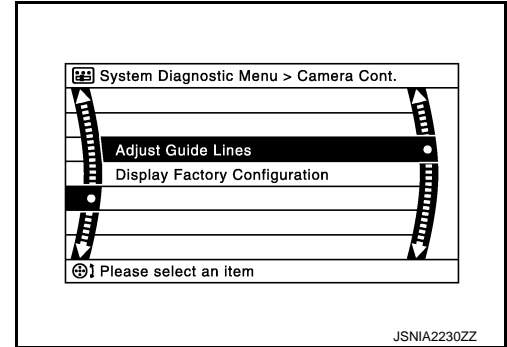

## Adjust Offset of Rear view Camera

- Use this mode to adjust the guide line display position of the rear view monitor if necessary after removing the rear view monitor camera.

### CAUTION:

After the adjustment, never perform other operations for one minute.

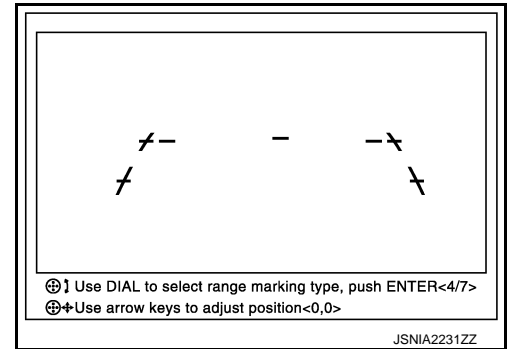

## Factory Configuration Confirmation

- Configuration stored in the AV control unit can be checked.

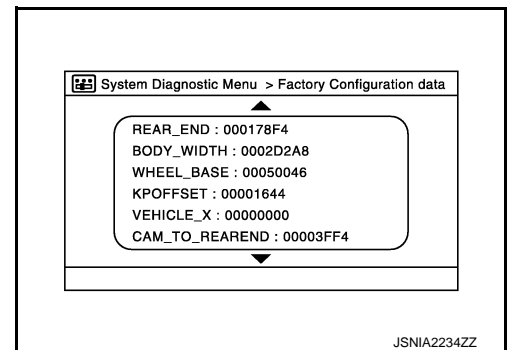

## Vehicle CAN Diagnosis

A  
B  
C  
D  
E  
F  
G  
H  
I  
J  
K  
L  
M  
AV  
O  
P

# DIAGNOSIS SYSTEM (AV CONTROL UNIT)

[BASE AUDIO WITHOUT NAVIGATION]

## < SYSTEM DESCRIPTION >

- CAN communication status and error counter is displayed.
- The error counter displays “OK” if any malfunction was not detected in the past and displays “0” if a malfunction is detected. It increases by 1 if the condition is normal at the next ignition switch ON cycle. The upper limit of the counter is 39.
- The error counter is erased if “Reset” is pressed.

Items	Display (Current)	Malfunction counter (Past)
Tx(HVAC)	OK / ???	OK / 0 – 39
Rx(ECM)	OK / ???	OK / 0 – 39
Rx(Cluster)	OK / ???	OK / 0 – 39
Rx(BCM)	OK / ???	OK / 0 – 39
Rx(HVAC)	OK / ???	OK / 0 – 39
Rx(USM)	OK / ???	OK / 0 – 39
Rx(VDC)	OK / ???	OK / 0 – 39
Rx(STRG)	OK / ???	OK / 0 – 39

**NOTE:**

“???” indicates UNKWN.

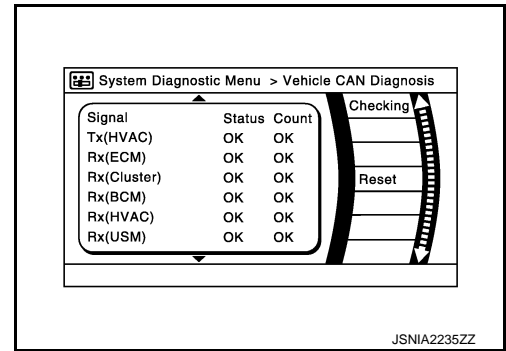

JSNIA2235ZZ

### AV COMM Diagnosis

- Displays the communication status between AV control unit (master unit) and each unit.
- The error counter displays “OK” if any malfunction was not detected in the past and displays “0” if a malfunction is detected. It increases by 1 if the condition is normal at the next ignition switch ON cycle. The upper limit of the counter is 39.
- The error counter is erased if “Reset” is pressed.

Items	Status (Current)	Counter (Past)
C Tx(ITM-SW)	OK / ???	OK / 0 – 39
C Rx(PrimarySW-ITM)	OK / ???	OK / 0 – 39
C Rx(BTHF-ITM)	OK / ???	OK / 0 – 39

**NOTE:**

“???” indicates UNKWN.

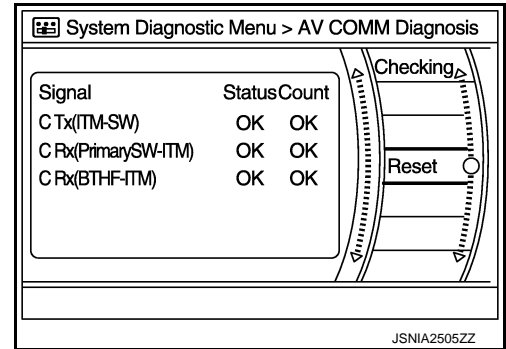

JSNIA2505ZZ

### Delete Unit Connection Log

Deletes any unit connection records and error records from the AV control unit memory. (Clear the records of the unit that has been removed.)

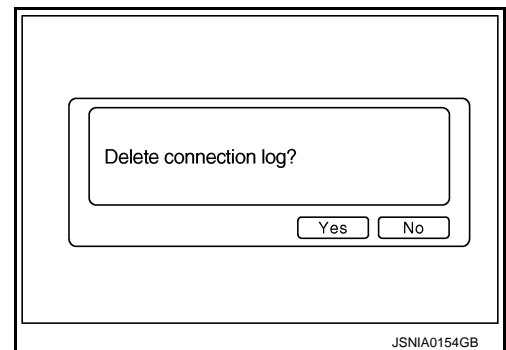

JSNIA0154GB

### Initialize Settings

# DIAGNOSIS SYSTEM (AV CONTROL UNIT)

[BASE AUDIO WITHOUT NAVIGATION]

< SYSTEM DESCRIPTION >

“User Data Initialization” and “Accessory Number Initialization” are possible.

**CAUTION:**

- Never perform Accessory Number Initialization except when configuration is unsuccessful.
- Accessory Number Initialization requires configuration. For details, refer to [AV-67, "Description"](#).

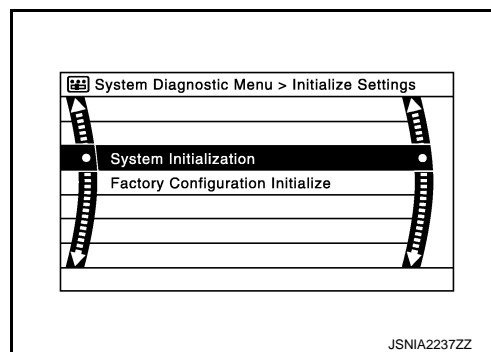

JSNIA2237ZZ

INFOID:000000006472415

## CONSULT - III Function

### CONSULT-III FUNCTIONS

CONSULT-III performs the following functions via the communication with the AV control unit.

Diagnosis mode	Description
Ecu Identification	The part number of AV control unit can be checked.
Self Diagnostic Result	Performs a diagnosis on the AV control unit and a connection diagnosis for the communication circuit of the Multi AV system, and displays the current and past malfunctions collectively.
Data Monitor	The diagnosis of vehicle signal that is input to the AV control unit can be performed.
Work Support	Steering angle sensor can be adjusted.
Configuration	<ul style="list-style-type: none"> <li>• Read and save the vehicle specification.</li> <li>• Write the vehicle specification when replacing AV control unit.</li> </ul>

### AV Communication

When “AV communication” of “CAN Diag Support Monitor” is selected, the following function will be performed.

AV communication	AV&NAVI C/U	Displays the communication status from AV control unit to each unit as well as the error counter.
	AUDIO	Displays the AV control unit communication status and the error counter.

### ECU IDENTIFICATION

The part number of AV control unit is displayed.

### SELF DIAGNOSIS RESULT

- In CONSULT-III self-diagnosis, self-diagnosis results and error history are displayed collectively.
- The current malfunction indicates “CRNT”. The past malfunction indicates “PAST”.
- The timing is displayed as “0” if any of the error codes [U1000], [U1010], [U1300] and [U1310] is detected. The counter increases by 1 if the condition is normal at the next ignition switch ON cycle.

### Self-diagnosis Results Display Item

Error item	Description	Possible malfunction factor/Action to take
CAN COMM CIRCUIT [U1000]	CAN communication malfunction is detected.	Refer to <a href="#">AV-70, "Diagnosis Procedure"</a> .
CONTROL UNIT (CAN) [U1010]	CAN initial diagnosis malfunction is detected.	Replace the AV control unit if the malfunction occurs constantly. Refer to <a href="#">AV-110, "Exploded View"</a> .
CONTROL UNIT (AV) [U1310]	AV communication circuit initial diagnosis malfunction is detected.	
Cont Unit [U1200] CAN CONT [U1216]	AV control unit malfunction is detected.	
ST ANGLE SEN CALIB [U1232]	Predictive course line center position adjustment of the steering angle sensor is incomplete.	Adjust the predictive course line center position of the steering angle sensor. Refer to <a href="#">BRC-9, "ADJUSTMENT OF STEERING ANGLE SENSOR NEUTRAL POSITION : Special Repair Requirement"</a> .

# DIAGNOSIS SYSTEM (AV CONTROL UNIT)

< SYSTEM DESCRIPTION >

[BASE AUDIO WITHOUT NAVIGATION]

Error item	Description	Possible malfunction factor/Action to take
FRONT DISP CONN [U1243]	When either one of the following items is detected: <ul style="list-style-type: none"> <li>• display unit power supply and ground circuits are malfunctioning.</li> <li>• communication circuits between AV control unit and display unit are malfunctioning.</li> </ul>	<ul style="list-style-type: none"> <li>• Display unit power supply and ground circuits.</li> <li>• Communication circuits between AV control unit and display unit.</li> </ul>
SAT CONN [U1255]	When either one of the following items is detected: <ul style="list-style-type: none"> <li>• satellite radio tuner power supply and ground circuit are malfunctioning.</li> <li>• communication circuits between AV control unit and satellite radio tuner are malfunctioning.</li> <li>• request signal circuit between AV control unit and satellite radio tuner are malfunctioning.</li> </ul>	<ul style="list-style-type: none"> <li>• Satellite radio tuner power supply and ground circuit.</li> <li>• Communication circuit between AV control unit and satellite radio tuner.</li> <li>• Request signal circuit between AV control unit and satellite radio tuner.</li> </ul>
<ul style="list-style-type: none"> <li>• AV COMM CIRCUIT [U1300]</li> <li>• SWITCH CONN [U1240]</li> </ul>	When either one of the following items is detected: <ul style="list-style-type: none"> <li>• multifunction switch power supply and ground circuits are malfunctioning.</li> <li>• AV communication circuits between AV control unit and multifunction switch are malfunctioning.</li> </ul>	<ul style="list-style-type: none"> <li>• Multifunction switch power supply and ground circuits.</li> <li>• AV communication circuits between AV control unit and multifunction switch.</li> </ul>
<ul style="list-style-type: none"> <li>• AV COMM CIRCUIT [U1300]</li> <li>• HAND FREE CONN [U1256]</li> </ul>	When either one of the following items is detected: <ul style="list-style-type: none"> <li>• TEL adapter unit power supply and ground circuits are malfunctioning.</li> <li>• AV communication circuits between AV control unit and TEL adapter unit are malfunctioning.</li> </ul>	<ul style="list-style-type: none"> <li>• TEL adapter unit power supply and ground circuits.</li> <li>• AV communication circuits between AV control unit and TEL adapter unit.</li> </ul>
<ul style="list-style-type: none"> <li>• AV COMM CIRCUIT [U1300]</li> <li>• SWITCH CONN [U1240]</li> <li>• HAND FREE CONN [U1256]</li> </ul>	Malfunction is detected in AV communication circuits between AV control unit and multifunction switch.	AV communication circuits between AV control unit and multifunction switch.

## DATA MONITOR

### ALL SIGNALS

- Displays the status of the following vehicle signals inputted into the AV control unit.
- For each signal, actual signal can be compared with the condition recognized on the system.

Display Item	Display	Vehicle status	Remarks	
VHCL SPD SIG	On	Vehicle speed > 0 km/h (0 MPH)	Changes in indication may be delayed. This is normal.	
	Off	Vehicle speed = 0 km/h (0 MPH)		
PKB SIG	On	Parking brake is applied.		
	Off	Parking brake is released.		
ILLUM SIG	On	Block the light beam from the auto light optical sensor when the light SW is ON.	—	
	Off	Expose the auto light optical sensor to light when the light SW is OFF or ON.		
IGN SIG	On	Ignition switch ON		
	Off	Ignition switch in ACC position		
REV SIG	On	Selector lever in R position		Changes in indication may be delayed. This is normal.
	Off	Selector lever in any position other than R		

# DIAGNOSIS SYSTEM (AV CONTROL UNIT)

< SYSTEM DESCRIPTION >

[BASE AUDIO WITHOUT NAVIGATION]

## SELECTION FROM MENU

Allows the technician to select which vehicle signals should be displayed and displays the status of the selected vehicle signals.

Item to be selected	Description
VHCL SPD SIG	The same as when "ALL SIGNALS" is selected.
PKB SIG	
ILLUM SIG	
IGN SIG	
REV SIG	

## WORK SUPPORT

Adjusts the neutral position of the steering angle sensor.

### **CAUTION:**

**For vehicles with VDC, adjust the steering angle sensor neutral position on the ABS actuator control unit side.**

Item	Description
ST ANGLE SENSOR ADJUSTMENT	Adjusts the neutral position of the steering angle sensor.

## CONFIGURATION

Configuration has three functions as follows.

Function	Description
READ CONFIGURATION	<ul style="list-style-type: none"><li>• Reads the vehicle configuration of current AV control unit.</li><li>• Saves the read vehicle configuration.</li></ul>
WRITE CONFIGURATION-Manual selection	Writes the vehicle configuration with manual selection.
WRITE CONFIGURATION-Config file	Writes the vehicle configuration with saved data.

A  
B  
C  
D  
E  
F  
G  
H  
I  
J  
K  
L  
M  
O  
P

AV

# DIAGNOSIS SYSTEM (TEL ADAPTER UNIT)

< SYSTEM DESCRIPTION >

[BASE AUDIO WITHOUT NAVIGATION]

## DIAGNOSIS SYSTEM (TEL ADAPTER UNIT)

### On Board Diagnosis Function

INFOID:000000006472416

#### HANDS-FREE PHONE SYSTEM ON BOARD DIAGNOSIS

During on board diagnosis the diagnosis function of TEL adapter unit starts with the operation of the steering switch and performs the diagnosis when ignition switch ACC.

#### ON BOARD DIAGNOSIS ITEM

The on board diagnosis has 3 modes: the self-diagnosis mode that performs the trouble diagnosis, the speaker adaptation data deleting mode and the hands-free phone system initialization mode.

#### CAUTION:

- Perform the diagnosis with the vehicle stopped.
- Perform STEP2 if necessary.

STEP	MODE	Description
STEP1	Self-diagnosis	The self-diagnosis mode performs the microphone test and the diagnosis of TEL adapter unit, TEL antenna and steering unit, and then reads out the results with the sound and indicates them on the display.
STEP2	Speaker adaptation data deleting	The speaker adaptation data deleting mode can delete the speaker adaptation data.
	Hands-free phone system initialization	Hands-free phone system initialization mode can perform the initialization of hands-free phone system.

#### Self-diagnosis results

Self-diagnosis mode reads out the self-diagnosis results.

#### NOTE:

- Error count is read out simultaneously when reading out the DTC name.
- The errors are read out continuously when some errors occur at the same time.

#### Self-diagnosis results

DTC	DTC name	Possible causes
DTC 10000	INTERNAL FAILURE	TEL adapter unit
DTC 01000	ANT. SHORT TO BATT OR OPEN	TEL antenna
DTC 00100	ANT. SHORT TO GROUND	
DTC 00010	STEERING REMOTE BUTTON STUCK A	Steering switch
DTC 00001	STEERING REMOTE BUTTON STUCK B	
DTC 00000	THERE ARE NO FAILURE RECORDS TO REPORT	—

#### The Details of Error Count

The error count guides "0" when the error occurs. The next time it counts up "1" if it is normal with the ignition switch ON. It continues the count up unless the initialization of hands-free phone system is performed.

# DIAGNOSIS SYSTEM (TEL ADAPTER UNIT)

< SYSTEM DESCRIPTION >

[BASE AUDIO WITHOUT NAVIGATION]

## FLOW CHART OF TROUBLE DIAGNOSIS

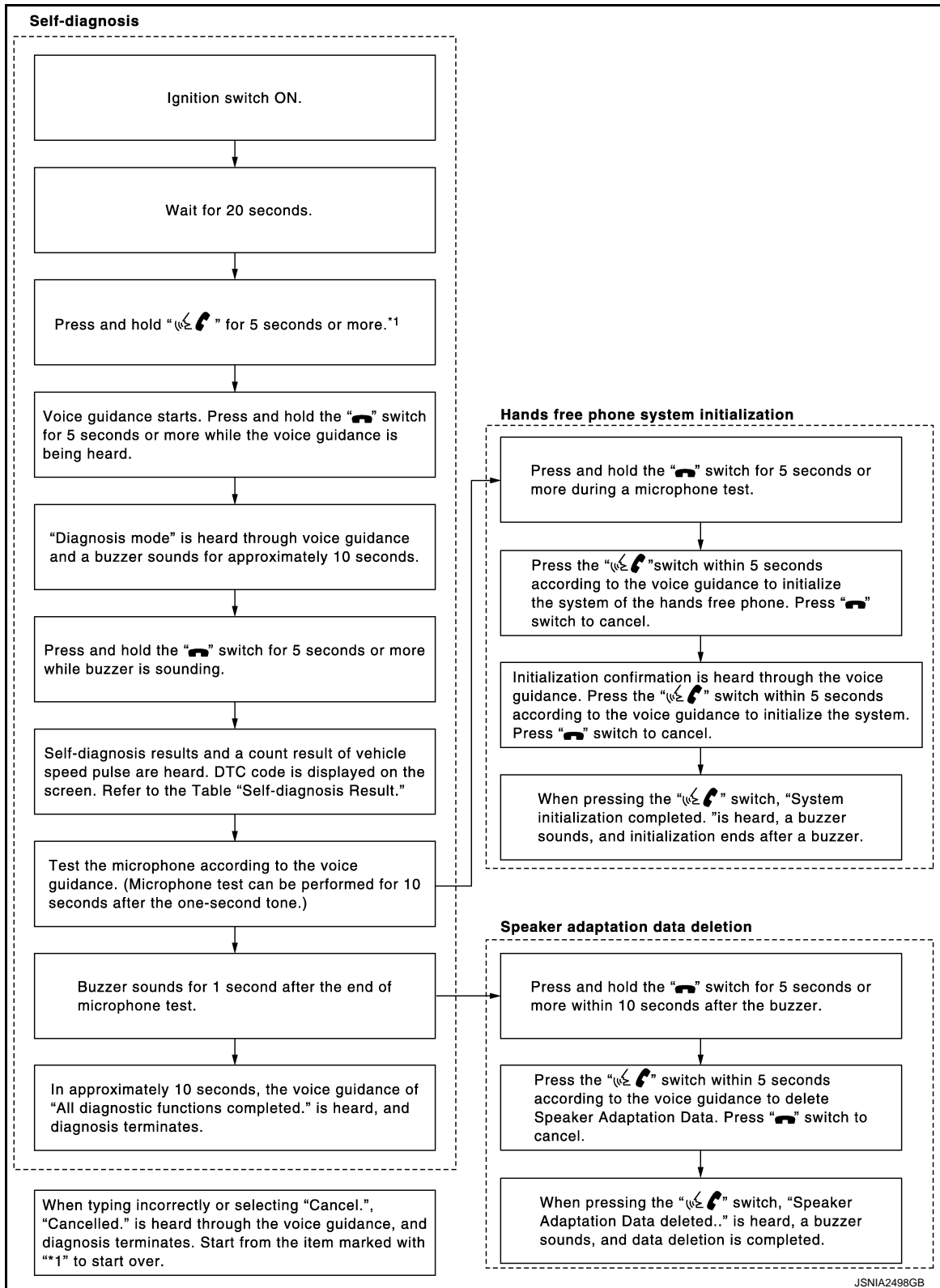

A  
B  
C  
D  
E  
F  
G  
H  
I  
J  
K  
L  
M  
AV  
O  
P

# AV CONTROL UNIT

< ECU DIAGNOSIS INFORMATION >

[BASE AUDIO WITHOUT NAVIGATION]

## ECU DIAGNOSIS INFORMATION

### AV CONTROL UNIT

#### Reference Value

INFOID:000000006472417

#### VALUES ON THE DIAGNOSIS TOOL

CONSULT-III MONITOR ITEM

Monitor Item	Condition		Value/Status
VHCL SPD SIG	Ignition switch ON	Vehicle speed > 0 km/h (0 MPH)	On
		Vehicle speed = 0 km/h (0 MPH)	Off
PKB SIG	Ignition switch ON	Parking brake is applied.	On
		Parking brake is released.	Off
ILLUM SIG	Ignition switch ON	Light switch ON	On
		Light switch OFF	Off
IGN SIG	Ignition switch ON	—	On
	Ignition switch ACC	—	Off
REV SIG	Ignition switch ON	Selector lever in R position	On
		Selector lever in any position other than R	Off

#### TERMINAL LAYOUT

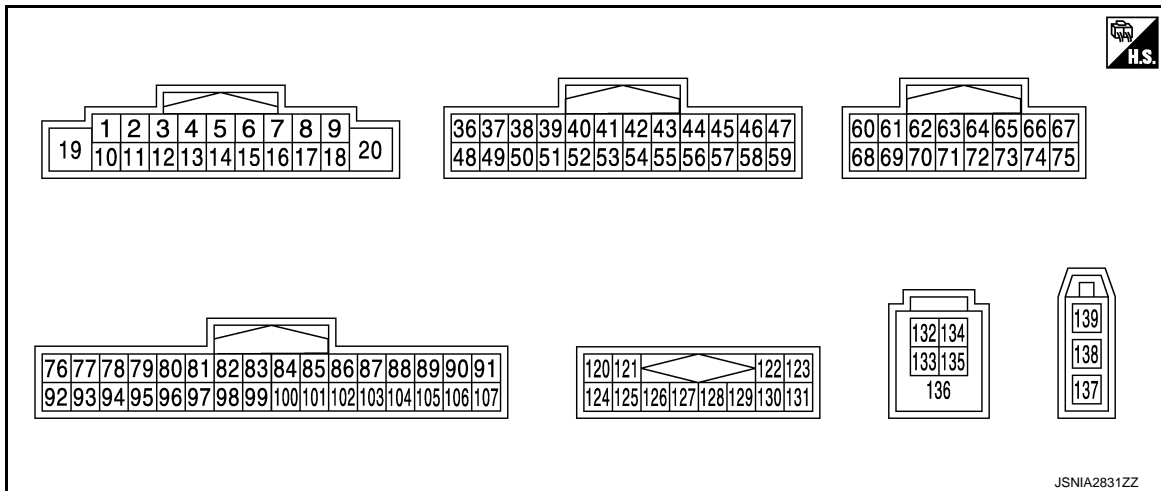



#### PHYSICAL VALUES



# AV CONTROL UNIT

< ECU DIAGNOSIS INFORMATION >

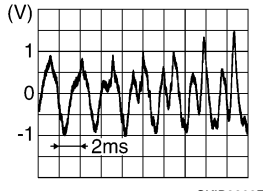
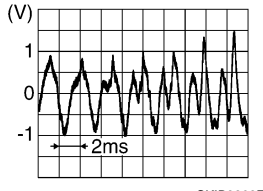
[BASE AUDIO WITHOUT NAVIGATION]

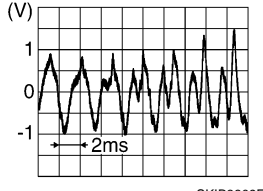
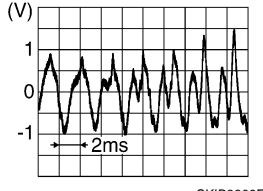
Terminal (Wire color)		Description		Condition		Reference value (Approx.)
+	-	Signal name	Input/ Output			
2 (L)	3 (W)	Sound signal front LH	Output	Ignition switch ON	Sound output	 <p style="text-align: right; font-size: small;">SKIB3609E</p>
4 (LG)	5 (SB)	Sound signal rear LH	Output	Ignition switch ON	Sound output	 <p style="text-align: right; font-size: small;">SKIB3609E</p>
6 (P)	15 (B)	Steering switch signal A	Input	Ignition switch ON	Keep pressing SOURCE switch.	0 V
					Keep pressing MENU UP switch.	0.7 V
					Keep pressing MENU DOWN switch.	1.3 V
					Keep pressing  switch	2.0 V
					Except for above.	3.3 V
7 (V)	Ground	ACC power supply	Input	Ignition switch ACC	—	Battery voltage
9 (L)	Ground	Illumination signal	Input	Ignition switch OFF	Lighting switch is OFF.	0 V
					Lighting switch is ON.	12.0 V
11 (BR)	12 (GR)	Sound signal front RH	Output	Ignition switch ON	Sound output	 <p style="text-align: right; font-size: small;">SKIB3609E</p>
13 (L)	14 (P)	Sound signal rear RH	Output	Ignition switch ON	Sound output	 <p style="text-align: right; font-size: small;">SKIB3609E</p>

A  
B  
C  
D  
E  
F  
G  
H  
I  
J  
K  
L  
M  
O  
P

AV

# AV CONTROL UNIT

< ECU DIAGNOSIS INFORMATION >

[BASE AUDIO WITHOUT NAVIGATION]

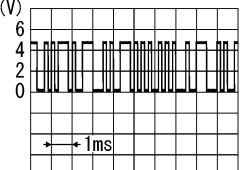
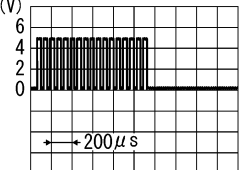
Terminal (Wire color)		Description		Condition		Reference value (Approx.)
+	-	Signal name	Input/ Output			
16 (L)	15 (B)	Steering switch signal B	Input	Ignition switch ON	Keep pressing VOL DOWN switch.	0 V
					Keep pressing VOL UP switch.	0.7 V
					Keep pressing  switch.	1.3 V
					Except for above.	3.3 V
18 (G)	Ground	Ground	—	Ignition switch ON	—	0 V
19 (BR)	Ground	Battery power supply	Input	Ignition switch OFF	—	Battery voltage
20 (B)	Ground	Ground	—	Ignition switch ON	—	0 V
36 (BG)	Ground	Signal VCC	Output	Ignition switch ACC	—	9.0 V
37 (LG)	Ground	Signal ground	—	Ignition switch OFF	—	0 V
38 (R)	Ground	Horizontal synchronizing (HP) signal	Input	Ignition switch ON	—	 <small>SKIB3601E</small>
39 (L)	Ground	Communication signal (DISP→CONT)	Input	Ignition switch ON	When adjusting display brightness.	 <small>PKIB5039J</small>
40 (B)	Ground	RGB area (YS) signal	Output	Ignition switch ON	At RGB image is displayed.	5.0 V
					At DVD image is displayed.	 <small>PKIB4948J</small>
41	—	Shield	—	—	—	—

# AV CONTROL UNIT

< ECU DIAGNOSIS INFORMATION >

[BASE AUDIO WITHOUT NAVIGATION]

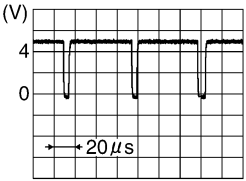
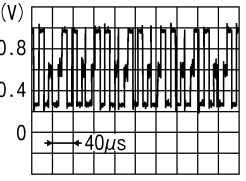
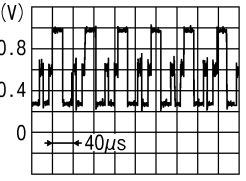
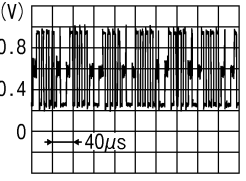
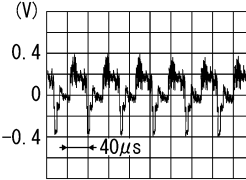
Terminal (Wire color)		Description		Condition		Reference value (Approx.)
+	-	Signal name	Input/ Output			
42 (W)	Ground	RGB synchronizing signal	Output	Ignition switch ON	—	 <small>SKIB3603E</small>
43 (G)	Ground	RGB signal (R: red)	Output	Ignition switch ON	Start Confirmation/Adjust- ment mode, and then dis- play color bar by selecting "Color Spectrum Bar" on Display Diagnosis screen.	 <small>JSNIA1029ZZ</small>
44 (L)	Ground	RGB signal (G: green)	Output	Ignition switch ON	Start Confirmation/Adjust- ment mode, and then dis- play color bar by selecting "Color Spectrum Bar" on Display Diagnosis screen.	 <small>JSNIA1030ZZ</small>
45 (P)	Ground	RGB signal (B: blue)	Output	Ignition switch ON	Start Confirmation/Adjust- ment mode, and then dis- play color bar by selecting "Color Spectrum Bar" on Display Diagnosis screen.	 <small>JSNIA1031ZZ</small>
46 (V)	Ground	Composite image ground	—	Ignition switch ON	—	0 V
47 (SB)	Ground	Composite image signal	Output	Ignition switch ON	At rear view camera image is displayed.	 <small>SKIB2251J</small>
48 (Y)	Ground	Inverter VCC	Output	Ignition switch ACC	—	9.0 V
49 (BR)	Ground	Inverter ground	—	Ignition switch OFF	—	0 V

A  
B  
C  
D  
E  
F  
G  
H  
I  
J  
K  
L  
M  
O  
P

AV

# AV CONTROL UNIT

< ECU DIAGNOSIS INFORMATION >

[BASE AUDIO WITHOUT NAVIGATION]

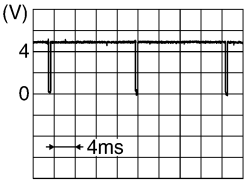
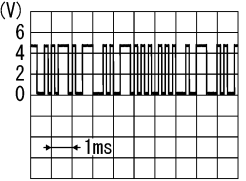
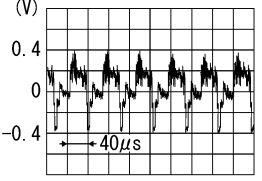
Terminal (Wire color)		Description		Condition		Reference value (Approx.)
+	-	Signal name	Input/ Output			
50 (G)	Ground	Vertical synchronizing (VP) signal	Input	Ignition switch ON	—	 <p style="text-align: right; font-size: small;">SKIB3598E</p>
51 (P)	Ground	Communication signal (CONT→DISP)	Output	Ignition switch ON	When adjusting display brightness.	 <p style="text-align: right; font-size: small;">PKIB5039J</p>
52	—	Shield	—	—	—	—
57	—	Shield	—	—	—	—
58	—	Shield	—	—	—	—
62 (W)	Ground	Camera image signal	Input	Ignition switch ON	At rear view camera image is displayed.	 <p style="text-align: right; font-size: small;">SKIB2251J</p>
71	—	Shield	—	—	—	—
72 (W)	Ground	Camera ground	—	Ignition switch ON	—	0 V
73 (R)	Ground	Camera power supply	Output	Ignition switch ON	At rear view camera image is displayed.	6.0 V
76 (LG)	—	AV communication signal (L)	Input/ Output	—	—	—
77 (SB)	—	AV communication signal (H)	Input/ Output	—	—	—
78 (LG)	—	AV communication signal (L)	Input/ Output	—	—	—
79 (SB)	—	AV communication signal (H)	Input/ Output	—	—	—
80 (P)	—	CAN-L	Input/ Output	—	—	—
81 (L)	—	CAN-H	Input/ Output	—	—	—
82 (BR)	Ground	Switch ground	—	Ignition switch ON	—	0 V
86	—	Shield	—	—	—	—

# AV CONTROL UNIT

< ECU DIAGNOSIS INFORMATION >

[BASE AUDIO WITHOUT NAVIGATION]

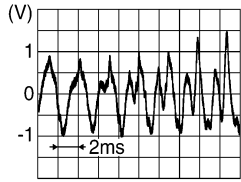
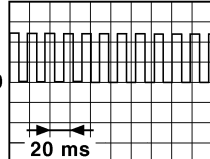
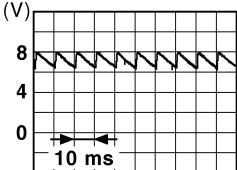
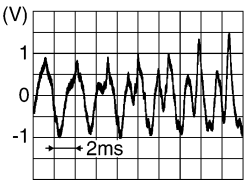
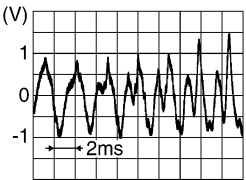
Terminal (Wire color)		Description		Condition		Reference value (Approx.)
+	-	Signal name	Input/ Output			
87 (L)	88 (P)	TEL voice signal	Input	Ignition switch ON	During voice guide output with the  switch pressed.	 SKIB3609E
92 (GR)	Ground	Vehicle speed signal (8-pulse)	Input	Ignition switch ON	When vehicle speed is approx. 40 km/h (25 MPH)	<b>NOTE:</b> The maximum voltage varies de- pending on the specification (destination unit).   JSNIA0012GB
93 (SB)	Ground	Parking brake signal	Input	Ignition switch ON	Parking brake is ON.	0 V
					Parking brake is OFF.	 JSNIA0007GB
94 (BG)	Ground	Reverse signal	Input	Ignition switch ON	R position	12.0 V
					Other than R position	0 V
95 (G)	Ground	Ignition signal	Input	Ignition switch ON	—	Battery voltage
96 (SB)	Ground	Disk eject signal	Input	Ignition switch ON	Pressing the eject switch.	0 V
					Except for above.	3.3 V
120 (B)	124 (W)	Satellite radio sound signal LH	Input	Ignition switch ON	When satellite radio mode is selected.	 SKIB3609E
121 (G)	125 (R)	Satellite radio sound signal RH	Input	Ignition switch ON	When satellite radio mode is selected.	 SKIB3609E

A  
B  
C  
D  
E  
F  
G  
H  
I  
J  
K  
L  
M  
AV  
O  
P

# AV CONTROL UNIT

< ECU DIAGNOSIS INFORMATION >

[BASE AUDIO WITHOUT NAVIGATION]

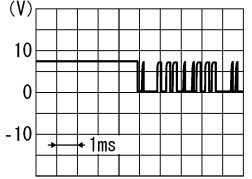
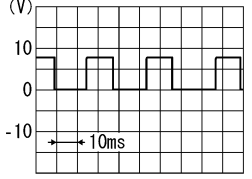
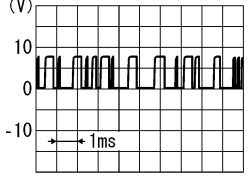
Terminal (Wire color)		Description		Condition		Reference value (Approx.)
+	-	Signal name	Input/ Output			
122 (L)	Ground	Communication signal (CONT→SAT)	Output	Ignition switch ON	When satellite radio mode is selected.	
126	—	Shield	—	—	—	—
127	—	Shield	—	—	—	—
129 (P)	Ground	Request signal (SAT→CONT)	Input	Ignition switch ON	When satellite radio mode is selected.	
130 (G)	Ground	Communication signal (SAT→CONT)	Input	Ignition switch ON	When satellite radio mode is selected.	
132 (G)	—	USB ground	—	—	—	—
133 (R)	—	USB D- signal	—	—	—	—
134 (W)	—	V BUS signal	—	—	—	—
135 (L)	—	USB D+ signal	—	—	—	—
136	—	Shield	—	—	—	—
138	—	Antenna signal	Input	—	—	—
139	Ground	Antenna amp. ON signal	Output	Ignition switch ACC	—	12.0 V

## DTC Index

INFOID:000000006472418

## SELF-DIAGNOSIS RESULTS DISPLAY ITEM

DTC	Display item	Refer to
U1000	CAN COMM CIRCUIT [U1000]	<a href="#">AV-70. "Diagnosis Procedure"</a>
U1010	CONTROL UNIT (CAN) [1010]	<a href="#">AV-71. "DTC Logic"</a>
U1200	Cont Unit [U1200]	<a href="#">AV-72. "DTC Logic"</a>
U1216	CAN CONT [U1216]	<a href="#">AV-73. "DTC Logic"</a>
U1232	ST ANGLE SEN CALIB [1232]	<a href="#">AV-74. "Diagnosis Procedure"</a>
U1243	FRONT DISP CONN [U1243]	<a href="#">AV-75. "Diagnosis Procedure"</a>

# AV CONTROL UNIT

< ECU DIAGNOSIS INFORMATION >

[BASE AUDIO WITHOUT NAVIGATION]

DTC	Display item	Refer to
U1255	SAT CONN [U1255]	<a href="#">AV-77, "Diagnosis Procedure"</a>
U1310	CONTROL UNIT (AV) [U1310]	<a href="#">AV-80, "DTC Logic"</a>
U1300 U1240	<ul style="list-style-type: none"> <li>• AV COMM CIRCUIT [U1300]</li> <li>• SWITCH CONN [U1240]</li> </ul>	<a href="#">AV-79, "Description"</a>
U1300 U1256	<ul style="list-style-type: none"> <li>• AV COMM CIRCUIT [U1300]</li> <li>• HAND FREE CONN [U1256]</li> </ul>	<a href="#">AV-79, "Description"</a>
U1300 U1240 U1256	<ul style="list-style-type: none"> <li>• AV COMM CIRCUIT [U1300]</li> <li>• SWITCH CONN [U1240]</li> <li>• HAND FREE CONN [U1256]</li> </ul>	<a href="#">AV-79, "Description"</a>

A  
B  
C  
D  
E  
F  
G  
H  
I  
J  
K  
L  
M  
O  
P

AV

# DISPLAY UNIT

< ECU DIAGNOSIS INFORMATION >

[BASE AUDIO WITHOUT NAVIGATION]

## DISPLAY UNIT

Reference Value

INFOID:000000006951850

TERMINAL LAYOUT

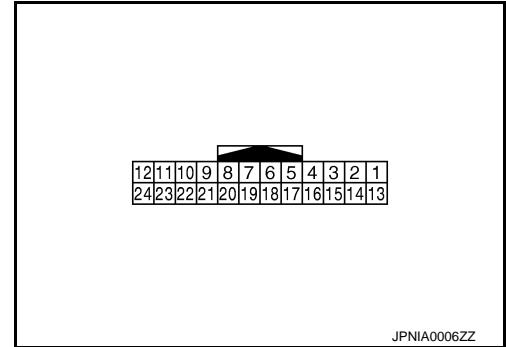

## PHYSICAL VALUES

Terminal (Wire color)		Description		Condition		Reference value (Approx.)
+	-	Signal name	Input/ Output			
1 (B)	Ground	Ground	—	Ignition switch ON	—	0 V
2 (Y)	Ground	Inverter VCC	Input	Ignition switch ACC	—	9.0 V
3 (BG)	Ground	Signal VCC	Input	Ignition switch ACC	—	9.0 V
4 (V)	Ground	Composite image ground	—	Ignition switch ON	—	0 V
5	—	Shield	—	—	—	—
6 (L)	Ground	RGB signal (G: green)	Input	Ignition switch ON	Start Confirmation/Adjust- ment mode, and then dis- play color bar by selecting "Color Spectrum Bar" on Display Diagnosis screen.	<p style="text-align: right;">JSNIA1030ZZ</p>
7	—	Shield	—	—	—	—
8 (R)	Ground	Horizontal synchronizing (HP) signal	Output	Ignition switch ON	—	<p style="text-align: right;">SKIB3601E</p>



# DISPLAY UNIT

< ECU DIAGNOSIS INFORMATION >

[BASE AUDIO WITHOUT NAVIGATION]

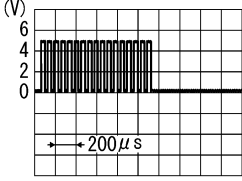
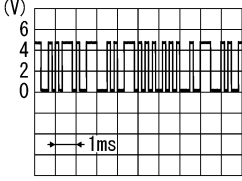
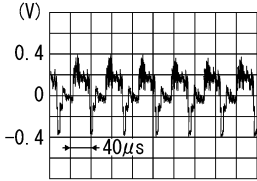
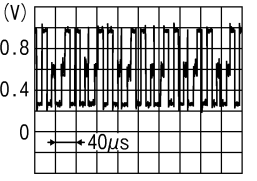
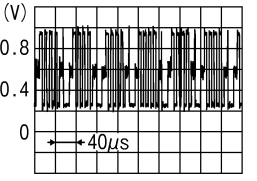
Terminal (Wire color)		Description		Condition	Reference value (Approx.)
+	-	Signal name	Input/ Output		
9 (B)	Ground	RGB area (YS) signal	Input	Ignition switch ON	At RGB image is displayed. 5.0 V
				Ignition switch ON	At DVD image is displayed.  PKIB4948J
11 (P)	Ground	Communication signal (CONT→DISP)	Input	Ignition switch ON	When adjusting display brightness.  PKIB5039J
13 (BR)	Ground	Inverter ground	—	Ignition switch ON	— 0 V
14 (LG)	Ground	Signal ground	—	Ignition switch ON	— 0 V
15 (SB)	Ground	Composite image signal	Input	Ignition switch ON	At rear view camera image is displayed.  SKIB2251J
17 (G)	Ground	RGB signal (R: red)	Input	Ignition switch ON	Start Confirmation/Adjustment mode, and then display color bar by selecting "Color Spectrum Bar" on Display Diagnosis screen.  JSNIA1029ZZ
18 (P)	Ground	RGB signal (B: blue)	Input	Ignition switch ON	Start Confirmation/Adjustment mode, and then display color bar by selecting "Color Spectrum Bar" on Display Diagnosis screen.  JSNIA1031ZZ

A  
B  
C  
D  
E  
F  
G  
H  
I  
J  
K  
L  
M  
AV  
O  
P

# DISPLAY UNIT

< ECU DIAGNOSIS INFORMATION >

[BASE AUDIO WITHOUT NAVIGATION]

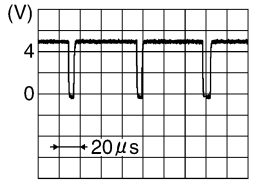
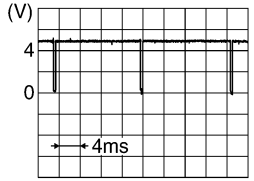
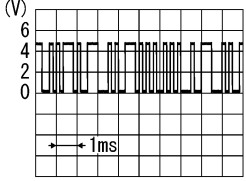
Terminal (Wire color)		Description		Condition		Reference value (Approx.)
+	-	Signal name	Input/ Output			
19 (W)	Ground	RGB synchronizing signal	Input	Ignition switch ON	—	 <p style="text-align: right;">SKIB3603E</p>
20 (G)	Ground	Vertical synchronizing (VP) signal	Output	Ignition switch On	—	 <p style="text-align: right;">SKIB3598E</p>
21	—	Shield	—	—	—	—
22 (L)	Ground	Communication signal (DISP→CONT)	Output	Ignition switch ON	When adjusting display brightness.	 <p style="text-align: right;">PKIB5039J</p>
23	—	Shield	—	—	—	—

# SATELLITE RADIO TUNER

< ECU DIAGNOSIS INFORMATION >

[BASE AUDIO WITHOUT NAVIGATION]

## SATELLITE RADIO TUNER

Reference Value

INFOID:000000006472420

TERMINAL LAYOUT

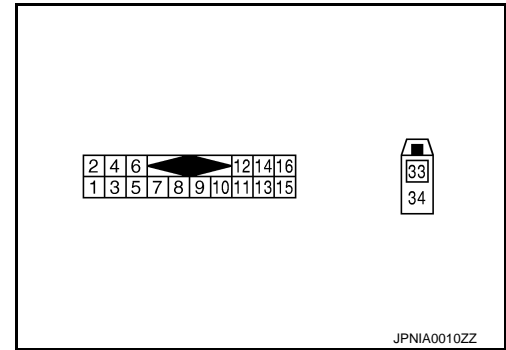

PHYSICAL VALUES

Terminal		Description		Condition		Reference value (Approx.)
+	-	Signal name	Input/Output			
2 (R)	1 (G)	Satellite radio sound signal LH	Output	Ignition switch ON	When satellite radio mode is selected.	
4 (B)	3 (W)	Satellite radio sound signal RH	Output	Ignition switch ON	When satellite radio mode is selected	
5	—	Shield	—	—	—	—
6	—	Shield	—	—	—	—
8 (Y)	Ground	Request signal (SAT→CONT)	Output	Ignition switch ON	When satellite radio mode is selected	
9 (O)	Ground	Communication signal (SAT→CONT)	Output	Ignition switch ON	When satellite radio mode is selected	

A  
B  
C  
D  
E  
F  
G  
H  
I  
J  
K  
L  
M  
O  
P

AV

# SATELLITE RADIO TUNER

< ECU DIAGNOSIS INFORMATION >

[BASE AUDIO WITHOUT NAVIGATION]

Terminal		Description		Condition		Reference value (Approx.)
+	-	Signal name	Input/ Output			
10 (BR)	Ground	Communication signal (CONT→SAT)	Input	Ignition switch ON	When satellite radio mode is selected	
12 (SB)	Ground	Battery power supply	Input	Ignition switch OFF	—	Battery voltage
15 (B)	Ground	Ground	—	Ignition switch ON	—	0 V
16 (V)	Ground	ACC power supply	Input	Ignition switch ACC	—	Battery voltage
33	—	Satellite antenna	Input	—	—	—
34	—	Shield	—	—	—	—

# TEL ADAPTER UNIT

< ECU DIAGNOSIS INFORMATION >

[BASE AUDIO WITHOUT NAVIGATION]

## TEL ADAPTER UNIT

Reference Value

INFOID:000000006472421

TERMINAL LAYOUT

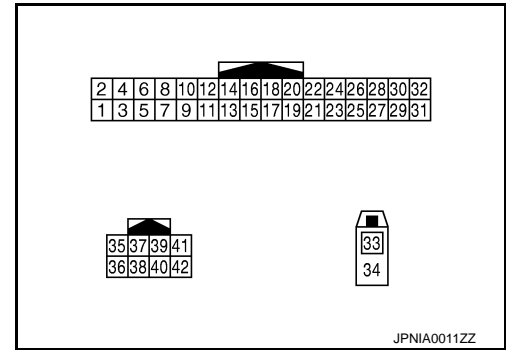

PHYSICAL VALUES

Terminal (Wire color)		Description		Condition		Reference value (Approx.)
+	-	Signal name	Input/Output			
1 (GR)	Ground	Battery power supply	Input	Ignition switch OFF	—	Battery voltage
2 (LG)	Ground	ACC power supply	Input	Ignition switch ACC	—	Battery voltage
3 (BG)	Ground	Ignition signal	Input	Ignition switch ON	—	Battery voltage
4 (B)	Ground	Ground	—	Ignition switch ON	—	0 V
5	—	Shield	—	—	—	—
7 (R)	8	Microphone signal	Input	Ignition switch ON	Give a voice	
9 (Y)	10 (G)	TEL voice signal	Output	Ignition switch ON	During voice guide output with the  switch pressed	
14 (B)	Ground	Ground	—	Ignition switch ON	—	0 V
16 (P)	Ground	Roof status signal	Input	Ignition switch ON	Retractable hard top is fully closed.	12.0 V
					Other than above.	0 V

# TEL ADAPTER UNIT

< ECU DIAGNOSIS INFORMATION >

[BASE AUDIO WITHOUT NAVIGATION]

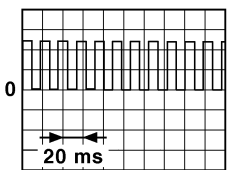
Terminal (Wire color)		Description		Condition		Reference value (Approx.)
+	-	Signal name	Input/ Output			
21 (B)	Ground	Control signal	Input	Ignition switch ON	—	0 V
23 (B)	Ground	Control signal	Input	Ignition switch ON	—	0 V
27 (B)	Ground	Control signal	Input	Ignition switch ON	—	0 V
28 (P)	Ground	Vehicle speed signal (8-pulse)	Input	Ignition switch ON	When vehicle speed is approx. 40 km/h (25 MPH)	<p><b>NOTE:</b> The maximum voltage varies de- pending on the specification (destination unit).</p>  <p style="text-align: right; font-size: small;">JSNIA0012GB</p>
29 (G)	8	Microphone VCC	Output	Ignition switch ON	—	5.0 V
33	—	TEL antenna	Input	—	—	—
34	—	Shield	—	—	—	—
35 (L)	—	AV communication signal (H)	Input/ Output	—	—	—
36 (P)	—	AV communication signal (L)	Input/ Output	—	—	—

# BASE AUDIO WITHOUT NAVIGATION

[BASE AUDIO WITHOUT NAVIGATION]

< WIRING DIAGRAM >

## WIRING DIAGRAM

### BASE AUDIO WITHOUT NAVIGATION

#### Wiring Diagram

INFOID:000000006472422

**NOTE:**

The name MULTIFUNCTION SWITCH indicates the integration of PRESET SWITCH and MULTIFUNCTION SWITCH virtually.

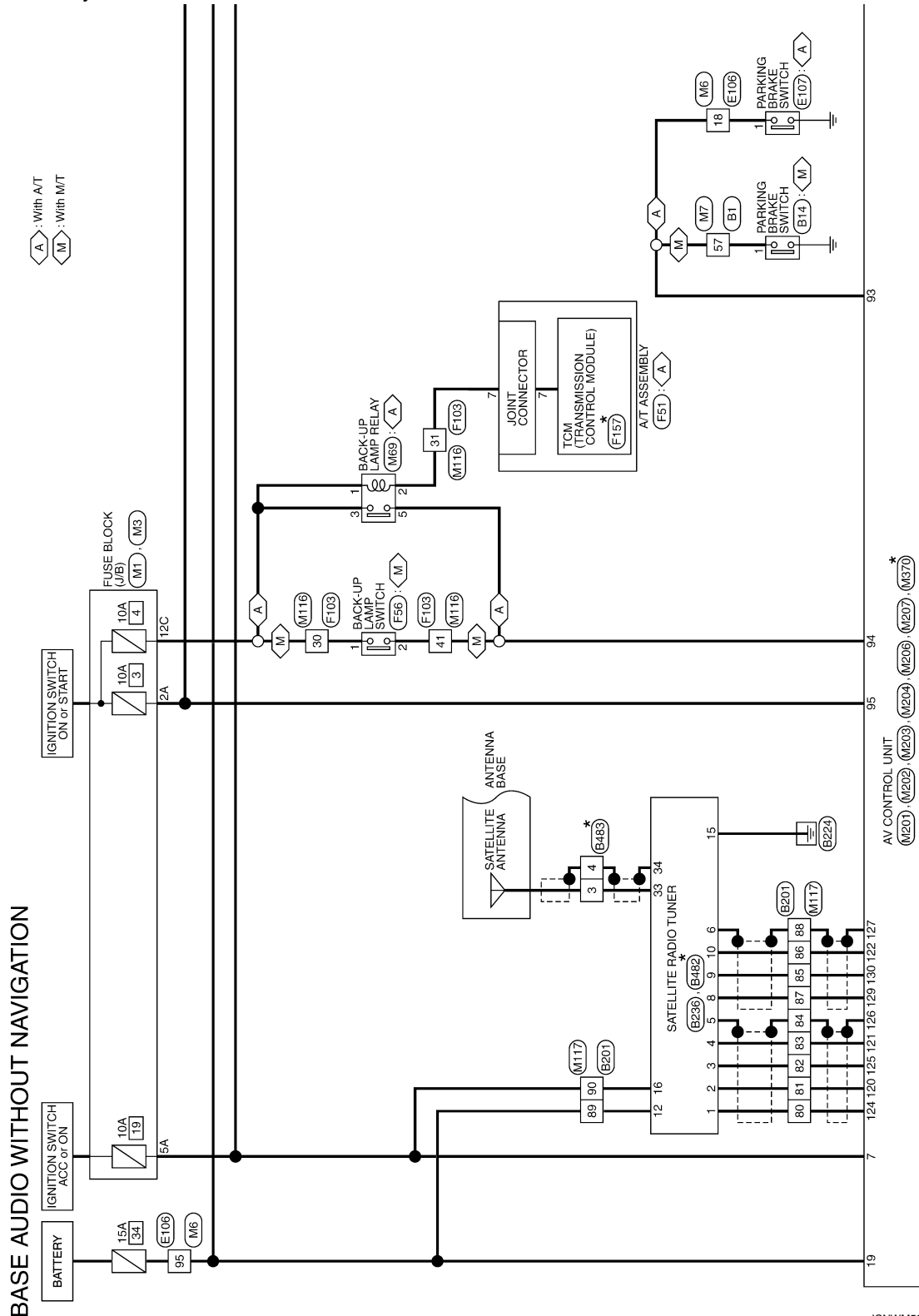

A  
B  
C  
D  
E  
F  
G  
H  
I  
J  
K  
L  
M  
N  
O  
P

AV

# BASE AUDIO WITHOUT NAVIGATION

[BASE AUDIO WITHOUT NAVIGATION]

< WIRING DIAGRAM >

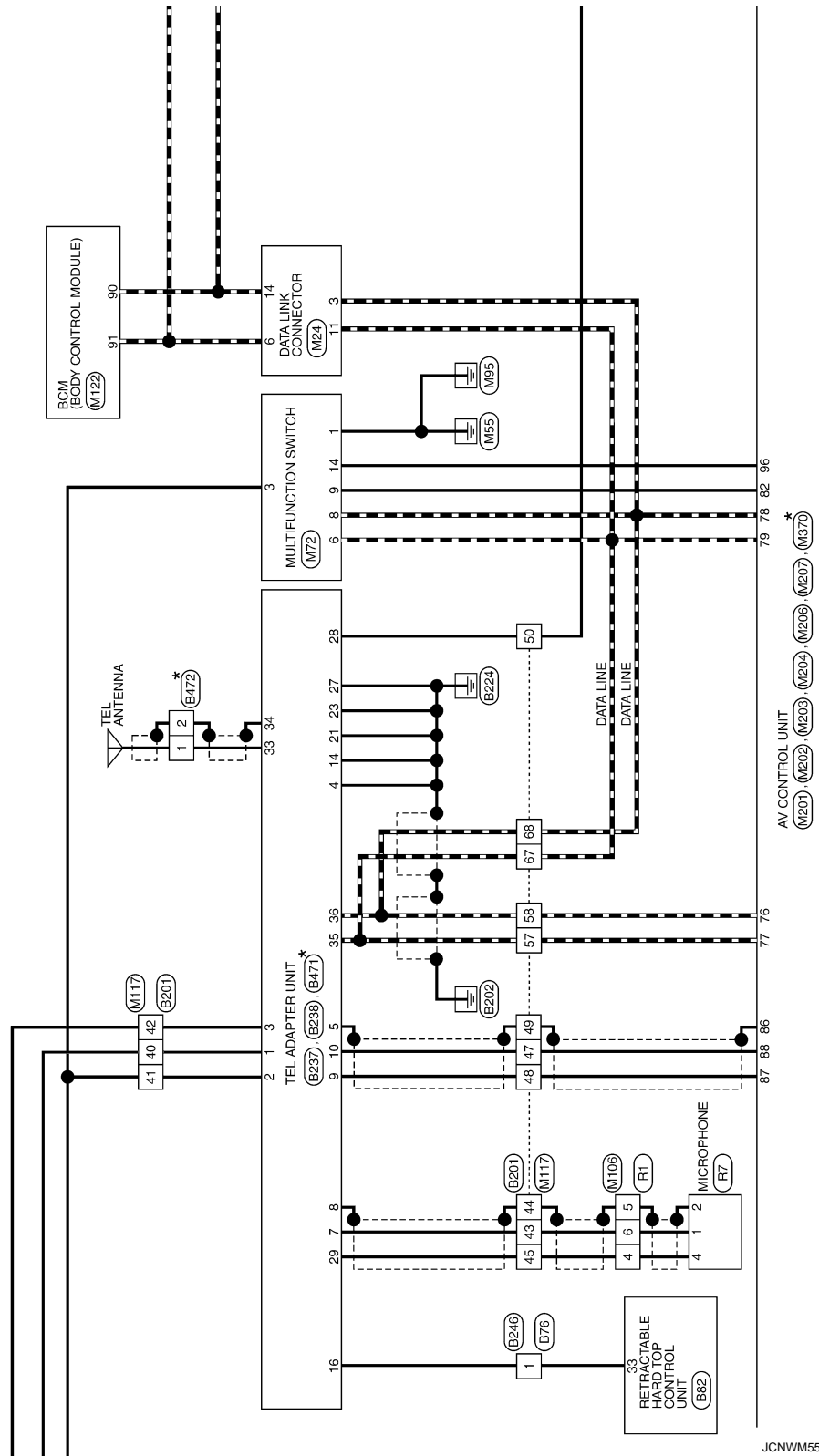

\*: This connector is not shown in "Harness Layout".

JCNWM5553GB



# BASE AUDIO WITHOUT NAVIGATION

[BASE AUDIO WITHOUT NAVIGATION]

< WIRING DIAGRAM >

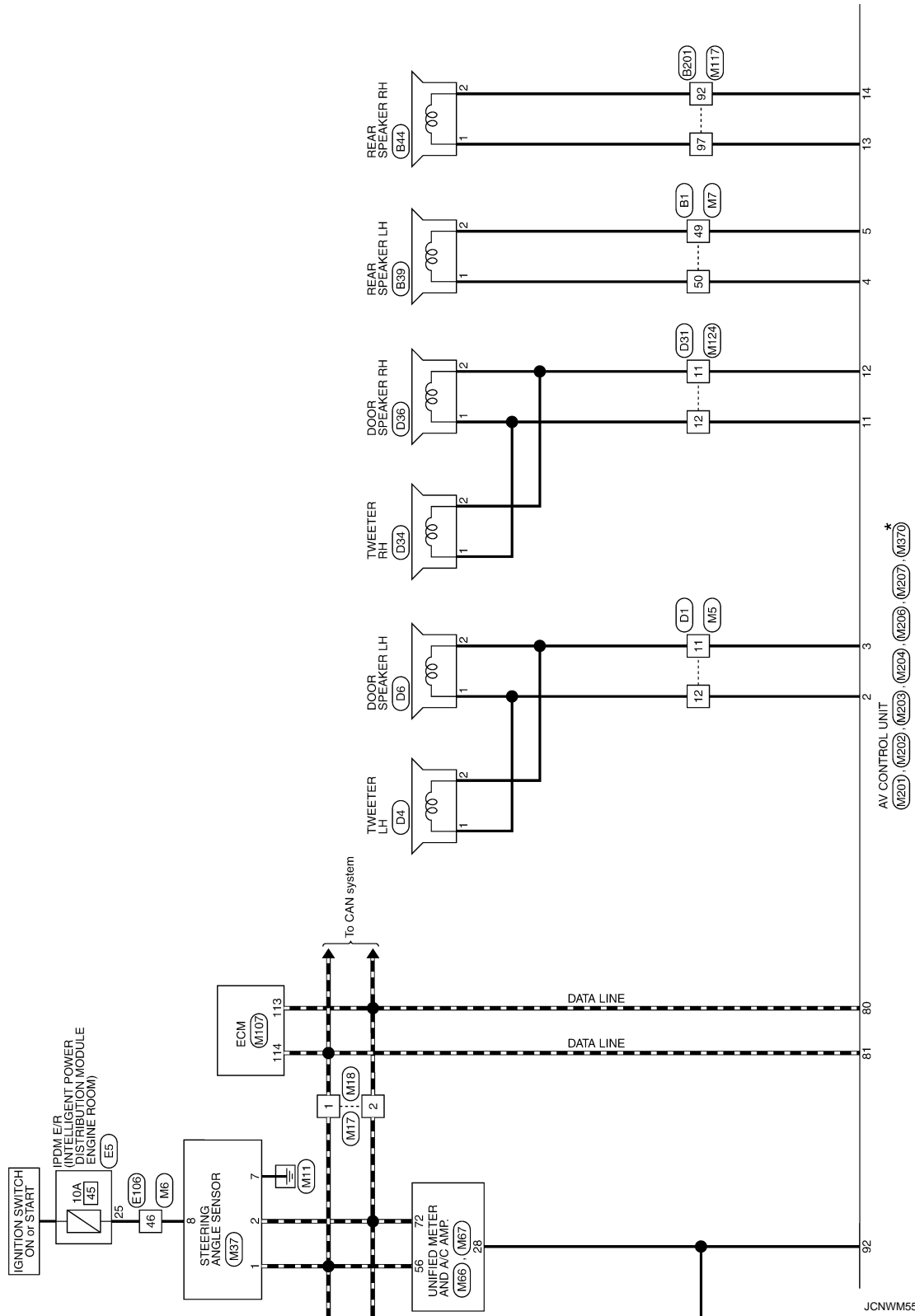

\*: This connector is not shown in "Harness Layout".

JCNWM5554GB

- A
- B
- C
- D
- E
- F
- G
- H
- I
- J
- K
- L
- M
- AV**
- O
- P

# BASE AUDIO WITHOUT NAVIGATION

[BASE AUDIO WITHOUT NAVIGATION]

< WIRING DIAGRAM >

A : With AT  
M : With MT

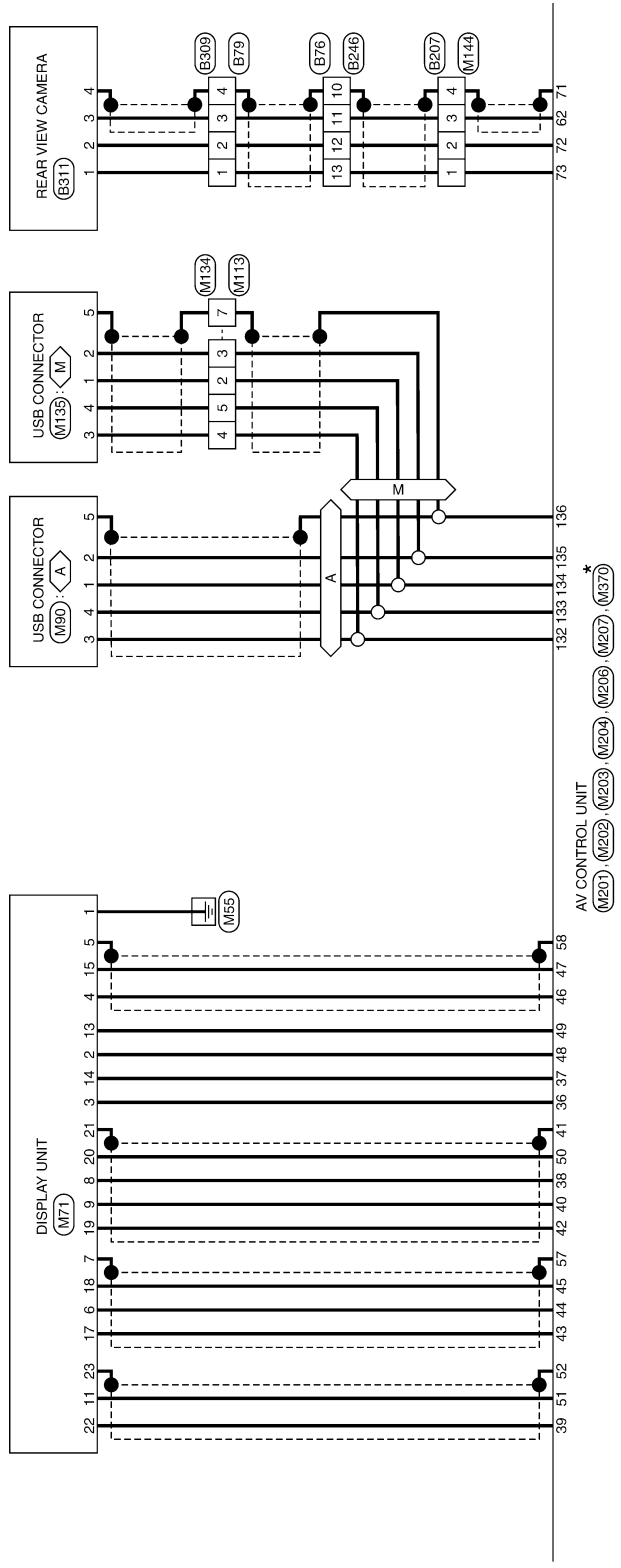

\* : This connector is not shown in "Harness Layout".

JCNWM5555GB

# BASE AUDIO WITHOUT NAVIGATION

< WIRING DIAGRAM >

[BASE AUDIO WITHOUT NAVIGATION]

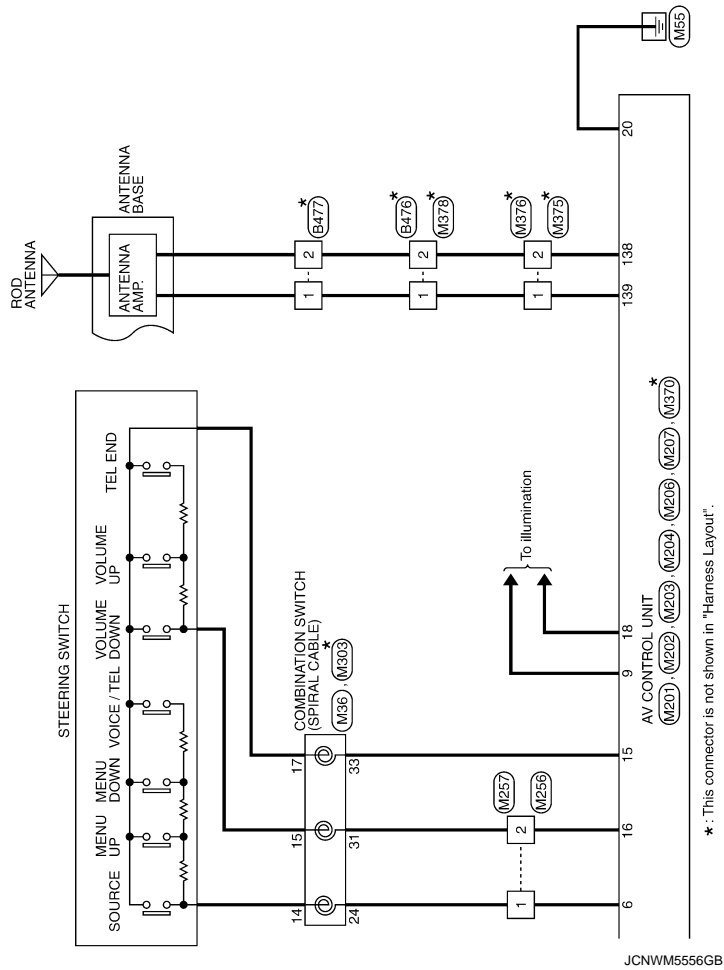

JCNWM5556GB

A  
B  
C  
D  
E  
F  
G  
H  
I  
J  
K  
L  
M  
N  
O  
P

AV

# BASE AUDIO WITHOUT NAVIGATION

[BASE AUDIO WITHOUT NAVIGATION]

< WIRING DIAGRAM >

## BASE AUDIO WITHOUT NAVIGATION

Connector No.	B1
Connector Name	WIRE TO WIRE
Connector Type	TH03PW-CS16-TM4



Terminal No.	Color of Wire	Signal Name [Specification]
1	W	
2	L	
3	R	
4	V	
5	W	
6	B	
7	G	
8	BR	
9	Y	
10	BR	
12	SHIELD	
13	Y	
14	L	
15	R	
16	W	
17	BR	
20	G	
21	SB	
22	GR	
23	W	
24	SB	
25	BR	
26	LG	
27	Y	
28	R	
29	V	
31	SHIELD	
32	G	
33	R	
34	BG	
35	GR	
36	BR	
37	P	- [With climate controlled seat]
37	Y	- [Without climate controlled seat]
38	V	- [With climate controlled seat]
38	GR	- [Without climate controlled seat]
40	SHIELD	
41	L	
42	P	
43	SHIELD	

44	SB	
45	V	
46	W	
47	SB	
48	LG	
49	LG	- [With BOSE system]
49	Y	- [Without BOSE system]
50	SB	- [With BOSE system]
50	LG	- [Without BOSE system]
51	SB	
52	G	
53	LG	
54	BR	
55	Y	
56	W	
57	V	
58	R	
60	R	
61	BG	
62	B	
63	L	
64	P	
65	B	
66	SB	
67	P	
68	L	
69	P	
70	L	
80	G	
81	V	
82	R	
83	BR	
84	G	
85	L	
86	Y	
87	GR	
91	R	
93	BG	
94	P	
95	GR	
96	GR	
97	SB	
99	Y	
100	Y/B	

Connector No.	B14
Connector Name	PARKING BRAKE SWITCH
Connector Type	F01FB-A



Terminal No.	Color of Wire	Signal Name [Specification]
1	V	

Connector No.	B39
Connector Name	REAR SPEAKER LH
Connector Type	NS02FW-CS



Terminal No.	Color of Wire	Signal Name [Specification]
1	LG	
2	Y	

Connector No.	B44
Connector Name	REAR SPEAKER RH
Connector Type	NS02FW-CS



Terminal No.	Color of Wire	Signal Name [Specification]
1	LG	
2	Y	

Connector No.	B76
Connector Name	WIRE TO WIRE
Connector Type	TH16MW-NH

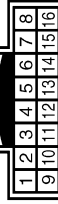

Terminal No.	Color of Wire	Signal Name [Specification]
1	V	
4	LG	
5	SR	
6	SHIELD	
7	B	
8	W	
10	SHIELD	
11	B	
12	W	
13	R	
14	SHIELD	
15	G	
16	Y	

Connector No.	B79
Connector Name	WIRE TO WIRE
Connector Type	TH09MW-NH



Terminal No.	Color of Wire	Signal Name [Specification]
1	R	
2	W	
3	B	
4	SHIELD	

JCNWM5557GB

# BASE AUDIO WITHOUT NAVIGATION

[BASE AUDIO WITHOUT NAVIGATION]

< WIRING DIAGRAM >

## BASE AUDIO WITHOUT NAVIGATION

Connector No.	B82
Connector Name	RETRACTABLE HARD TOP CONTROL UNIT
Connector Type	TH40PV-NH

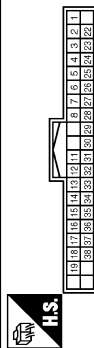

Terminal No.	Color of Wire	Signal Name [Specification]
1	G	ROOF OPEN / GLOSE SWITCH (OPEN)
2	BR	ROOF OPEN / GLOSE SWITCH (CLOSE)
3	B	FLIPPER DOOR LIMIT SWITCH GND
4	L	TONNEAU BOARD SWITCH
5	SB	TRUNK ROOM LAMP SWITCH
6	L	ROOF LATCH LIMIT SWITCH
7	W	FLIPPER DOOR LIMIT SWITCH (UP)
8	G	FLIPPER DOOR LIMIT SWITCH (DOWN)
9	W	RETAINED ACC POWER
10	Y	REVERSE SIGNAL
11	Y	REVERSE SIGNAL
12	Y	REVERSE SIGNAL
13	BG	PARCEL SHELF STATUS SENSOR POWER SUPPLY
14	P	TRUNK LINK SENSOR SIGNAL (LH)
15	SB	TRUNK LINK SENSOR SIGNAL (RH)
16	GR	ROOF LATCH STATUS SENSOR SIGNAL
17	G	ROOF LATCH LOCK SENSOR SIGNAL
18	LG	TRUNK STATUS SENSOR SIGNAL
19	V	ROOF STATUS SENSOR POWER SUPPLY
20	B	ROOF STATUS SENSOR GND
21	GR	PARCEL SHELF STATUS SENSOR SIGNAL (DRAWN)
22	R	PARCEL SHELF STATUS SENSOR SIGNAL (ROTATION)
23	P	ROOF STATUS SENSOR SIGNAL
24	Y	TRUNK LID OPEN REQUEST SIGNAL
25	BG	FLIPPER DOOR RELAY GND
26	V	LOCAL COMMUNICATION (BCM)
27	GR	LOCAL COMMUNICATION (POWER WINDOW)
28	L	CAN-L
29	P	ROOF STATUS SIGNAL (AUDIO)
30	V	ROOF WARNING BUZZER
31	B	HYDRAULIC MOTOR RELAY GND (RH)
32	Y	HYDRAULIC MOTOR RELAY GND (LH)
33	W	HYDRAULIC MOTOR RELAY POWER SUPPLY

Connector No.	B201
Connector Name	WIRE TO WIRE
Connector Type	TH80PFT-CS16-TM4

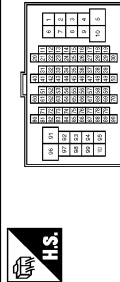

Terminal No.	Color of Wire	Signal Name [Specification]
1	W	-
2	B	-
3	B	-
4	W	-
5	W	-
6	R	-
7	B	-
8	G	-
9	BG	-
10	GR	-
11	LG	-
12	GR	-
13	LG	-
14	BG	-
15	R	-
16	SHIELD	-
17	G	-
18	G	-
19	Y	-
20	P	-
21	SB	-
22	LG	-
23	L	-
24	G	-
25	GR	-
26	LG	-
27	G	-
28	R	-
29	L	-
30	L	-
31	L	-
32	P	-
33	V	-
34	G	-
35	GR	-
36	LG	-
37	G	-
38	R	-
39	B	-
40	B	-
41	SHIELD	-
42	O	-
43	BR	-
44	Y	-
45	SHIELD	-

89	SB	-
90	V	-
91	GR	-
92	P	-
93	Y	-
94	SB	-
95	V	-
96	P	-
97	LG	-
98	Y/B	-
99	Y	-

Connector No.	B207
Connector Name	WIRE TO WIRE
Connector Type	TH40PV-NH

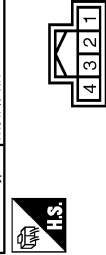

Terminal No.	Color of Wire	Signal Name [Specification]
1	R	-
2	W	-
3	B	-
4	SHIELD	-

Connector No.	B226
Connector Name	SATELLITE RADIO TUNER
Connector Type	A16FW

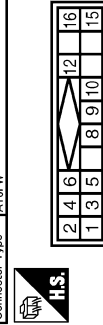

Terminal No.	Color of Wire	Signal Name [Specification]
1	G	SATELLITE RADIO SOUND SIGNAL LH (-)
2	R	SATELLITE RADIO SOUND SIGNAL LH (+)
3	W	SATELLITE RADIO SOUND SIGNAL RH (-)

4	B	SATELLITE RADIO SOUND SIGNAL RH (+)
5	SHIELD	SHIELD
6	SHIELD	SHIELD
7	Y	REQUEST (SAT->CONT)
8	O	COMM (SAT->CONT)
9	BR	COMM (CONT->SAT)
10	BR	BATTERY
11	B	GND
12	V	ACC

Connector No.	B237
Connector Name	TEL ADAPTER UNIT
Connector Type	TH42FW-NH

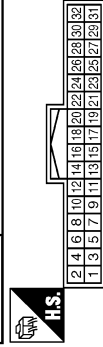

Terminal No.	Color of Wire	Signal Name [Specification]
1	GR	BATTERY
2	LG	ACC
3	BG	IGNITION
4	B	GND
5	SHIELD	SHIELD
6	R	MICROPHONE SIGNAL
7	R	MICROPHONE GND
8	Y	TEL VOICE SIGNAL (+)
9	Y	TEL VOICE SIGNAL (-)
10	G	GND
11	B	GND
12	P	ROOF STATUS SIGNAL (AUDIO)
13	B	CONTROL SIGNAL
14	B	CONTROL SIGNAL
15	B	CONTROL SIGNAL
16	P	VEHICLE SPEED (8-PULSE)
17	G	MICROPHONE VCC

A  
B  
C  
D  
E  
F  
G  
H  
I  
J  
K  
L  
M  
N  
O  
P

AV

# BASE AUDIO WITHOUT NAVIGATION

## [BASE AUDIO WITHOUT NAVIGATION]

< WIRING DIAGRAM >

### BASE AUDIO WITHOUT NAVIGATION

Connector No.	B238
Connector Name	TEL ADAPTER UNIT
Connector Type	TH08FV-NH

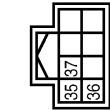

Terminal No.	Color of Wire	Signal Name [Specification]
35	L	AV COMM (H)
36	P	AV COMM (L)

Connector No.	B248
Connector Name	WIRE TO WIRE
Connector Type	TH16FV-NH

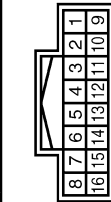

Terminal No.	Color of Wire	Signal Name [Specification]
1	P	-
4	P	-
5	L	-
6	SHIELD	-
7	B	-
8	W	-
10	SHIELD	-
11	B	-
12	W	-
13	R	-
14	SHIELD	-
15	G	-
16	Y	-

Connector No.	B309
Connector Name	WIRE TO WIRE
Connector Type	TH08FV-NH

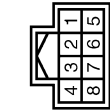

Terminal No.	Color of Wire	Signal Name [Specification]
1	R	-
2	W	-
3	Y	-
4	SHIELD	-

Connector No.	B311
Connector Name	REAR VIEW CAMERA
Connector Type	TH08MW-NH



Terminal No.	Color of Wire	Signal Name [Specification]
1	R	CAMERA POWER SUPPLY
2	W	CAMERA GND
3	Y	CAMERA IMAGE SIGNAL
4	SHIELD	-

Connector No.	B471
Connector Name	TEL ADAPTER UNIT
Connector Type	GT16C-IS-HU



Terminal No.	Color of Wire	Signal Name [Specification]
33	-	TEL ANTENNA
34	SHIELD	SHIELD

Connector No.	B472
Connector Name	TEL ANTENNA
Connector Type	GT16C-1PP-HU



Terminal No.	Color of Wire	Signal Name [Specification]
1	-	ANTENNA AMP. ON SIGNAL
2	-	AM-FM MAIN

Connector No.	B482
Connector Name	SATELLITE RADIO TUNER
Connector Type	FAKRA

Connector No.	B476
Connector Name	WIRE TO WIRE
Connector Type	GT13SS-1/IS-HU



Terminal No.	Color of Wire	Signal Name [Specification]
33	-	SATELLITE ANTENNA
34	SHIELD	SHIELD

Connector No.	B483
Connector Name	ANTENNA BASE
Connector Type	GT16C-1PP-HU

Terminal No.	Color of Wire	Signal Name [Specification]
1	-	-
2	-	-

Connector No.	B477
Connector Name	ANTENNA BASE
Connector Type	GT13SSN-1/IPP-HU



Terminal No.	Color of Wire	Signal Name [Specification]
1	-	ANTENNA AMP. ON SIGNAL
2	-	AM-FM MAIN

Connector No.	B482
Connector Name	SATELLITE RADIO TUNER
Connector Type	FAKRA

Connector No.	B483
Connector Name	ANTENNA BASE
Connector Type	GT16C-1PP-HU



Terminal No.	Color of Wire	Signal Name [Specification]
33	-	SATELLITE ANTENNA
34	SHIELD	SHIELD

Connector No.	B483
Connector Name	ANTENNA BASE
Connector Type	GT16C-1PP-HU

Terminal No.	Color of Wire	Signal Name [Specification]
3	-	-
4	SHIELD	-

Terminal No.	Color of Wire	Signal Name [Specification]
3	-	-
4	SHIELD	-

JCNWM5559GB

# BASE AUDIO WITHOUT NAVIGATION

[BASE AUDIO WITHOUT NAVIGATION]

< WIRING DIAGRAM >

## BASE AUDIO WITHOUT NAVIGATION

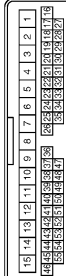

Connector No.	D1
Connector Name	WIRE TO WIRE
Connector Type	THMCPW-CS15

Terminal No.	Color of Wire	Signal Name [Specification]
4	BR	-
5	P	-
5	B	- [A/T models with automatic drive positioner]
6	SB	- [Except for A/T models with automatic drive positioner]
7	R	-
8	G	-
9	P	-
10	LG	-
11	W	-
12	L	-
13	B	-
14	V	-
15	Y	-
16	Y/B	-
17	Y	-
20	V	-
21	R	-
22	P	-
23	O	-
24	Y	-
25	SB	-
26	GR	-
27	GR	-
28	LG	-
29	G	-
30	Y	-
31	W	-
32	BR	-
33	L	-
34	R	-
35	V	-
37	B	-
38	O	-
39	GR	-
40	G	-
41	Y	-
42	LG	-
43	BR	-
44	P	-
45	P	-
46	P	-
47	V	-
48	P	-
49	W	-
50	SB	-
51	R	-
52	L	-
53	O	-
54	GR	-
55	G	-



44	V	-
45	P	-
46	W	-
47	V	-
48	P	-
49	W	-
50	SB	-
51	R	-
52	L	-

Connector No.	D4
Connector Name	TWEETER LH
Connector Type	TK02FBR

Terminal No.	Color of Wire	Signal Name [Specification]
1	L	-
2	W	-

Connector No.	D6
Connector Name	DOOR SPEAKER LH
Connector Type	NS02FW-CS



Terminal No.	Color of Wire	Signal Name [Specification]
1	L	-
2	W	-

Connector No.	B31
Connector Name	WIRE TO WIRE
Connector Type	THMCPW-CS15

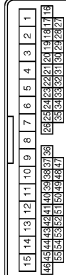

Terminal No.	Color of Wire	Signal Name [Specification]
6	BR	-
7	R	-
8	G	-
9	P	-
10	LG	-
11	W	-
12	L	-
13	B	-
14	Y	-
15	W	-
34	Y	-
35	Y/B	-
38	O	-
39	GR	-
40	G	-
41	Y	-
42	LG	-
43	BR	-
44	V	-
45	P	-
46	W	-
47	V	-
48	P	-
49	W	-
50	SB	-
51	R	-
52	L	-
53	O	-
54	GR	-
55	G	-

Connector No.	D34
Connector Name	TWEETER RH
Connector Type	TK02FBR

Terminal No.	Color of Wire	Signal Name [Specification]
1	L	-
2	W	-

Connector No.	D36
Connector Name	DOOR SPEAKER RH
Connector Type	NS02FW-CS

Terminal No.	Color of Wire	Signal Name [Specification]
1	L	-
2	W	-

JCNWM5560GB

A  
B  
C  
D  
E  
F  
G  
H  
I  
J  
K  
L  
M  
N  
O  
P

AV

# BASE AUDIO WITHOUT NAVIGATION

[BASE AUDIO WITHOUT NAVIGATION]

< WIRING DIAGRAM >

## BASE AUDIO WITHOUT NAVIGATION

Connector No.	E5
Connector Name	SMALL INDEPENDENT POWER DISTRIBUTION MODULE (PARKING BRAKE)
Connector Type	TH80FW-CS12-M4-TV

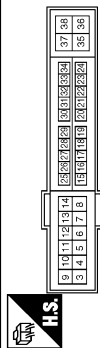

Terminal No.	Color of Wire	Signal Name [Specification]
4	V	
5	L	
6	SB	
7	R	
11	BR	
12	B/W	
13	Y	
16	LG	
19	W	
25	G	
26	R	
27	BG	
28	L	
30	GR	
32	V	
33	P	
36	G	

Connector No.	E106
Connector Name	WIRE TO WIRE
Connector Type	TH80FW-CS16-TM4

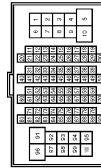

Terminal No.	Color of Wire	Signal Name [Specification]
1	GR	
3	BG	
4	B/W	
5	G	
6	BG	

7	LG	
8	G	
9	R	
10	W	
11	V	
12	R	
13	L	
14	GR	
15	P	
16	W	
17	V	
18	BG	
19	GR	
20	LG	
30	R	
31	L	
32	BG	
33	P	
34	V	
35	BR	
36	W	
37	Y	
38	R	
39	B	
40	G	
41	W	
42	LG	
43	SB	
44	GR	
45	BG	
46	LG	
47	V	
48	P	
49	L	
59	B	
66	LG	
67	SB	
68	R	
69	W	
70	G	
80	W	
81	P	
82	G	
83	V	
84	L	
85	BG	
86	LG	
87	Y	
88	GR	
89	W	
90	W	
91	G	

92	B	
93	GR	
94	L	
95	V	
97	BR	
98	SHIELD	
99	L	
100	P	

Connector No.	E107
Connector Name	PARKING BRAKE SWITCH
Connector Type	TB01FW



Terminal No.	Color of Wire	Signal Name [Specification]
1	BG	

Connector No.	F51
Connector Name	A/T ASSEMBLY
Connector Type	RK10FG-DCY

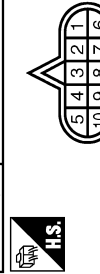

Terminal No.	Color of Wire	Signal Name [Specification]
1	Y	
2	R	
3	L	
4	V	
5	B	
6	Y	
7	R	
8	P	
9	GR	
10	B	

Connector No.	F66
Connector Name	BACK-UP LAMP SWITCH
Connector Type	RK02FB



Terminal No.	Color of Wire	Signal Name [Specification]
1	R	
2	O	

Connector No.	F103
Connector Name	WIRE TO WIRE
Connector Type	TK03FW-NS10

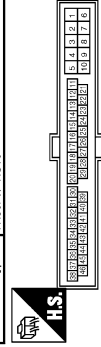

Terminal No.	Color of Wire	Signal Name [Specification]
2	G	
3	W	
4	R	
5	B	
8	V	
10	GR	
19	O	
20	Y	
28	B	
29	LG	
30	R	
31	R	
41	O	
42	BR	
43	P	
44	L	
45	Y	
46	V	



# BASE AUDIO WITHOUT NAVIGATION

< WIRING DIAGRAM >

[BASE AUDIO WITHOUT NAVIGATION]

## BASE AUDIO WITHOUT NAVIGATION

Connector No.	F157
Connector Name	TCM (TRANSMISSION CONTROL MODULE)
Connector Type	SP10FG

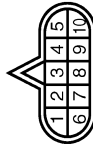

Terminal No.	Color of Wire	Signal Name [Specification]
1	-	VIGN
2	-	BATT
3	-	CAN-H
4	-	K-LINE
5	-	GND
6	-	GND
7	-	VIGN
8	-	REV LAMP-RLY
9	-	CAN-L
10	-	STARTER RLY
	-	GND

Connector No.	M1
Connector Name	FUSE BLOCK (J/B)
Connector Type	NS06FW-M2



Terminal No.	Color of Wire	Signal Name [Specification]
1A	V	-
2A	G	-
3A	L	-
4A	P	-
5A	BR	-
6A	Y	-
7A	GR	-
8A	L	-

Connector No.	M3
Connector Name	FUSE BLOCK (J/B)
Connector Type	NS12FF-CS

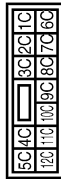

Terminal No.	Color of Wire	Signal Name [Specification]
6C	R	-
7C	B	-
8C	W	-
9C	BG	-
10C	L	-
11C	LG	-
12C	R	-

Connector No.	M5
Connector Name	WIRE TO WIRE
Connector Type	TH40MW-CS15

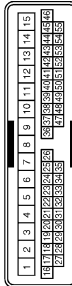

Terminal No.	Color of Wire	Signal Name [Specification]
4	R	-
5	B	-
6	BG	-
7	W	-
8	B	-
9	G	-
10	V	-
11	W	-
12	L	-
13	B	-
14	GR	-
15	Y	-
16	Y/B	-
17	Y	-
20	BG	-

21	W	-
22	P	-
23	BG	-
24	V	-
25	BR	-
26	R	-
27	P	-
28	LG	-
29	SB	-
30	G	-
31	V	-
32	BR	-
33	GR	-
34	G	-
35	L	-
37	B	-
38	G	-
39	L	-
40	Y	-
41	BR	-
42	R	-
43	G	-
44	Y	-
45	GR	-
46	BR	-
47	V	-
48	LG	-
49	P	-
50	SB	-
51	GR	-
52	L	-

JCNWM5562GB

A  
B  
C  
D  
E  
F  
G  
H  
I  
J  
K  
L  
M  
AV  
O  
P

# BASE AUDIO WITHOUT NAVIGATION

## [BASE AUDIO WITHOUT NAVIGATION]

< WIRING DIAGRAM >

### BASE AUDIO WITHOUT NAVIGATION

Connector No.	M7
Connector Name	WIRE TO WIRE
Connector Type	TH80MW-CS16-TM4

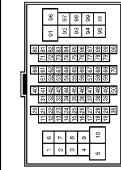

Terminal No.	Color of Wire	Signal Name [Specification]
1	BG	
3	R	
4	G	
5	G	
6	BR	
7	BR	
8	Y	
9	R	
10	W	
11	GR	
12	R	
13	L	
14	G	
15	P	
16	W	
17	BR	
18	V	
19	BG	
20	L	
30	R	
31	L	
32	Y	
33	GR	
34	P	
35	BR	
36	BR	
37	Y	
38	LG	
39	SB	
40	G	
41	W	
42	LG	
43	P	
44	GR	
44	R	- [With A/T]
45	BG	- [With M/T]
46	G	
47	P	

48	P	
49	L	
59	B	
66	Y	
67	G	
68	R	
69	W	
70	G	
80	SB	
81	R	
82	V	
83	W	
84	L	
85	BG	
86	G	
87	V	
88	B	
89	SB	
90	G	
91	W	
92	B	
93	G	
94	L	
95	BR	
97	P	
98	SHIELD	
99	V	
100	SB	

Connector No.	M7
Connector Name	WIRE TO WIRE
Connector Type	TH80MW-CS16-TM4

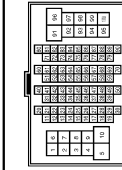

Terminal No.	Color of Wire	Signal Name [Specification]
1	BG	
2	LG	
3	G	
4	V	
5	L	
6	B	
9	L	
10	BR	

12	SHIELD	
13	V	
14	BR	
15	GR	
16	LG	
17	L	
20	BR	
21	G	
22	R	
23	SB	
24	B	
25	W	
26	L	
27	V	
28	P	
29	V	
31	SHIELD	
32	G	
33	R	
34	BG	
35	GR	
36	GR	
37	P	
37	L	- [With climate controlled seat]
38	V	- [With climate controlled seat]
38	GR	- [Without climate controlled seat]
40	SHIELD	
41	L	
42	P	
43	SHIELD	
44	Y	
45	BR	
46	SB	
47	SB	
48	LG	
49	LG	- [With BOSE system]
49	SB	- [Without BOSE system]
50	LG	- [With BOSE system]
50	LG	- [Without BOSE system]
51	R	
52	V	
53	P	
54	BR	
55	Y	- [With A/T]
55	BG	- [With M/T]
56	L	
57	V	
58	R	
60	LG	
61	BG	
62	B	
63	V	

64	SB	
65	BR	
66	Y	
67	P	
68	L	
69	P	
70	L	
80	G	
81	LG	
82	Y	
83	BR	
84	V	
85	L	
86	Y	
87	GR	
91	R	
93	G	
94	P	
95	GR	
96	Y	
97	SB	
99	Y	
100	Y/B	

Connector No.	M17
Connector Name	WIRE TO WIRE
Connector Type	TK02FW



Terminal No.	Color of Wire	Signal Name [Specification]
1	L	
2	P	

# BASE AUDIO WITHOUT NAVIGATION

## [BASE AUDIO WITHOUT NAVIGATION]

< WIRING DIAGRAM >

### BASE AUDIO WITHOUT NAVIGATION

Connector No.	M1B
Connector Name	WIRE TO WIRE
Connector Type	TK02NW



Terminal No.	Color of Wire	Signal Name [Specification]
1	L	-
2	P	-

Connector No.	M24
Connector Name	DATA LINK CONNECTOR
Connector Type	BD16FW



Terminal No.	Color of Wire	Signal Name [Specification]
3	LG	-
4	B	-
5	BR	-
6	L	-
7	V	-
8	G	-
11	SB	-
14	P	-
16	R	-

Connector No.	M35
Connector Name	COMBINATION SWITCH (SPIRAL CABLE)
Connector Type	TK03FY-1V



Terminal No.	Color of Wire	Signal Name [Specification]
24	P	-
25	SB	-
26	BR	-
31	L	-
32	Y	-
33	B	-
34	LG	-

Connector No.	M37
Connector Name	STEERING ANGLE SENSOR
Connector Type	TH08FY-NH

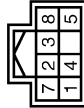

Terminal No.	Color of Wire	Signal Name [Specification]
1	L	CAN-H
2	P	CAN-L
7	B	GND
8	G	IGN

Connector No.	M66
Connector Name	UNIFIED METER AND A/C AMP.
Connector Type	TH42FY-NH

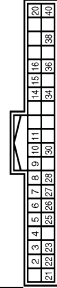

Terminal No.	Color of Wire	Signal Name [Specification]
4	G	STOP LAMP SWITCH
5	L	MANUAL MODE SHIFT UP SIGNAL
6	BG	PADDLE SHIFTER UP SIGNAL
7	GR	COMMUNICATION SIGNAL (AMP->METER)
8	L	VEHICLE SPEED (2-PULSE)
9	SB	SEAT BELT FROGILE SWITCH SIGNAL (DRIVER SIDE)
10	W	MANUAL MODE SIGNAL
11	G	NON-MANUAL MODE SIGNAL
14	SB	COMMUNICATION SIGNAL (LCD->AMP)
20	G	ION ON / OFF SIGNAL
25	V	MANUAL MODE SHIFT DOWN SIGNAL
26	G	PADDLE SHIFTER DOWN SIGNAL
27	LG	COMMUNICATION SIGNAL (METER->AMP)
28	R	VEHICLE SPEED (8-PULSE)
30	V	PARKING BRAKE SWITCH SIGNAL
34	B	COMMUNICATION SIGNAL (AMP->LCD)
38	P	BLOWER MOTOR CONTROL SIGNAL

Connector No.	M67
Connector Name	UNIFIED METER AND A/C AMP.
Connector Type	TH42FY-NH



Terminal No.	Color of Wire	Signal Name [Specification]
41	BR	ACC POWER SUPPLY
42	BR	FUEL LEVEL SENSOR SIGNAL
43	R	INTAKE SENSOR SIGNAL
44	LG	IN-VEHICLE SENSOR SIGNAL
45	V	AMBIENT SENSOR SIGNAL

46	BG	SUNLOAD SENSOR SIGNAL
47	G	EXHAUST GAS OXIDE SENSOR REFERENCE SENSOR SIGNAL
53	W	IGNITION POWER SUPPLY
54	BG	BATTERY POWER SUPPLY
55	B	GROUND
56	L	CAN-H
57	LG	BRAKE FLUID LEVEL SWITCH SIGNAL
58	Y	FUEL LEVEL SENSOR SIGNAL GROUND
59	GR	INTAKE SENSOR GROUND
60	L	IN-VEHICLE SENSOR GROUND
61	R	AMBIENT SENSOR GROUND
62	SB	SUNLOAD SENSOR GROUND
63	L	ION CONTROL MODE OUTPUT SIGNAL
65	BG	ECV SIGNAL
69	L	A/C LAM SIGNAL
70	R	EACH DOOR MOTOR POWER SUPPLY
71	GR	GROUND
72	P	CAN-L

Connector No.	M89
Connector Name	BACK-UP LAMP RELAY
Connector Type	MS02FL-M2-LC



Terminal No.	Color of Wire	Signal Name [Specification]
1	R	-
2	W	-
3	LG	-
5	BG	-

A  
B  
C  
D  
E  
F  
G  
H  
I  
J  
K  
L  
M  
AV  
O  
P

# BASE AUDIO WITHOUT NAVIGATION

## [BASE AUDIO WITHOUT NAVIGATION]

< WIRING DIAGRAM >

### BASE AUDIO WITHOUT NAVIGATION

Connector No.	M71
Connector Name	DISPLAY UNIT
Connector Type	TH16FW-RH

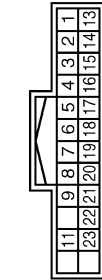

Terminal No.	Color of Wire	Signal Name [Specification]
1	B	GND
2	Y	INVERTER VCC
3	EG	SIGNAL VCC
4	V	COMPOSITE IMAGE GND
5	SHIELD	SHIELD
6	L	RGB (GREEN) SIGNAL
7	SHIELD	SHIELD
8	R	HP
9	B	RGB AREA (YS) SIGNAL
10	P	COMM (CONT->DISP)
11	P	INVERTER GND
12	LG	SIGNAL GND
13	BR	COMPOSITE IMAGE SIGNAL
14	LG	SIGNAL GND
15	SB	RGB (RED) SIGNAL
16	P	RGB (BLUE) SIGNAL
17	G	RGB SYNC
18	P	RGB SYNC
19	W	VP
20	G	SHIELD
21	SHIELD	SHIELD
22	L	COMM (DISP->CONT)
23	SHIELD	SHIELD

Connector No.	M72
Connector Name	MULTIFUNCTION SWITCH
Connector Type	TH16FW-RH

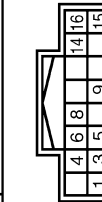

Terminal No.	Color of Wire	Signal Name [Specification]
1	B	GND
3	L	ACC

4	EG	ILL
5	V	ILL CONT
6	SB	AV COMM (H)
8	LG	AV COMM (L)
9	BR	SV GND
14	SB	DISK EJECT SIGNAL
16	G	HAZARD ON

Connector No.	M80
Connector Name	USB CONNECTOR
Connector Type	HAAD4FG

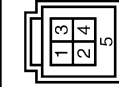

Terminal No.	Color of Wire	Signal Name [Specification]
1	W	
2	L	
3	G	
4	R	
5	SHIELD	

Connector No.	M106
Connector Name	WIRE TO WIRE
Connector Type	NH10MW-GS10

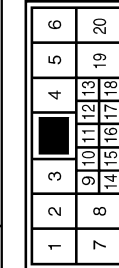

Terminal No.	Color of Wire	Signal Name [Specification]
1	B	
2	BR	
3	Y	
4	G	
5	SHIELD	
6	R	
7	B	
8	L	

9	R	
10	SB	
11	V	
12	LG	
18	B	
19	P	
20	Y	

Connector No.	M107
Connector Name	ECM
Connector Type	RH24FG-RZ8-R-LH-Z

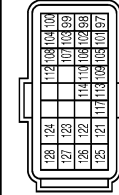

Terminal No.	Color of Wire	Signal Name [Specification]
97	R	APP SEN 1
98	P	APP SEN 2
99	L	SENSOR POWER SUPPLY
100	W	SENSOR GROUND
101	SB	ASCD/ICC STEERING SW
102	G	EVAP CONTROL SYSTEM PRESS SEN
103	G	SENSOR POWER SUPPLY
104	GR	SENSOR GROUND
105	L	REFRIGERANT PRESS SEN
106	LG	FUEL TANK TEMP SEN
107	BR	SENSOR POWER SUPPLY
108	Y	SENSOR GROUND
109	G	PNP SIGNAL
110	BR	ENGINE SPEED OUTPUT SIGNAL
112	R	SENSOR GROUND
113	P	CAN COMMUNICATION LINE
114	L	CAN COMMUNICATION LINE
117	V	DATA LINK CONNECTOR
121	LG	EVAP GANISTER VENT CONTROL VALVE
122	P	STOP LAMP SW
123	B	ECM GROUND
124	B	ECM GROUND
125	R	POWER SUPPLY FOR ECM
126	BR	ASCD/ICC BRAKE SW
127	B	ECM GROUND
128	B	ECM GROUND

Connector No.	M113
Connector Name	WIRE TO WIRE
Connector Type	CP06FG



Terminal No.	Color of Wire	Signal Name [Specification]
2	W	
3	L	
4	G	
5	R	
7	SHIELD	

# BASE AUDIO WITHOUT NAVIGATION

## [BASE AUDIO WITHOUT NAVIGATION]

< WIRING DIAGRAM >

### BASE AUDIO WITHOUT NAVIGATION

Connector No.	M116
Connector Name	WIRE TO WIRE
Connector Type	TK30MW-NS-0



Terminal No.	Color of Wire	Signal Name [Specification]
2	W	-
3	EG	-
4	R	-
5	B	-
6	R	-
7	R	-
8	R	-
9	R	-
10	R	-
11	EG	-
12	Y	-
13	GR	-
14	GR	-
15	LG	-
16	LG	-
17	W	-
18	W	-
19	W	-
20	Y	-
21	Y	-
22	Y	-
23	Y	-
24	Y	-
25	Y	-
26	Y	-
27	Y	-
28	Y	-
29	Y	-
30	Y	-
31	W	-
32	W	-
33	W	-
34	W	-
35	W	-
36	W	-
37	W	-
38	W	-
39	W	-
40	W	-
41	W	-
42	G	-
43	P	-
44	L	-
45	G	-
46	Y	-

Connector No.	M117
Connector Name	WIRE TO WIRE
Connector Type	TH30MW-CS (F-TM4)

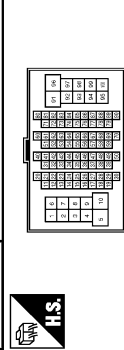

Terminal No.	Color of Wire	Signal Name [Specification]
1	Y	-
3	B	-
5	SB	-
6	R	-

7	G	-
8	SB	-
9	GR	-
10	LG	-
40	Y	-
41	G	-
42	LG	-
43	R	-
44	SHIELD	-
45	G	-
46	P	-
47	P	-
48	L	-
49	SHIELD	-
50	V	-
51	SB	-
52	EG	-
53	L	-
54	G	-
55	Y	-
56	LG	-
57	SB	-
58	LG	-
59	SB	-
67	GR	-
68	LG	-
80	W	-
81	B	-
82	R	-
83	G	-
84	SHIELD	-
85	G	-
86	L	-
87	P	-
88	SHIELD	-
89	Y	-
90	W	-
91	GR	-
92	P	-
93	W	-
94	EG	-
95	EG	-
96	P	-
97	L	-
98	Y/B	-
99	Y	-

Connector No.	M122
Connector Name	BCM (BODY CONTROL MODULE)
Connector Type	TH40FB-NH

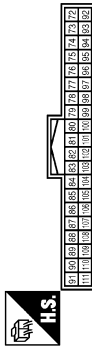

Terminal No.	Color of Wire	Signal Name [Specification]
72	R	ROOM ANT 2-
73	G	ROOM ANT 2+
74	SB	PASSENGER DOOR ANT-
75	BR	PASSENGER DOOR ANT+
76	V	DRIVER DOOR ANT-
77	LG	DRIVER DOOR ANT+
78	Y	ROOM ANT 1-
79	BR	ROOM ANT 1+
80	GR	NATS ANTENNA AMP-
81	W	NATS ANTENNA AMP+
82	R	IGN RELAY (F/B) CONT
83	Y	KEYLESS ENTRY RECEIVER COMM
87	Y	COMBI SW INPUT 5
88	BG	COMBI SW INPUT 3
89	BG	PUSH SW
90	P	CAN-L
91	L	CAN-H
92	LG	KEY SLOT ILL
93	V	ON IND
95	BG	ACC RELAY CONT
96	GR	A/T SHIFT SELECTOR POWER SUPPLY
97	L	S/L CONDITION 1
98	SB	S/L CONDITION 2
99	R	ASCD CLUTCH SW [W/M/T]
100	R	SHIFT P [W/M/T]
101	P	PASSENGER DOOR REQUEST SW
102	P	DRIVER DOOR REQUEST SW
103	BG	BLOWER FAN MOTOR RELAY CONT
104	LG	KEYLESS ENTRY RECEIVER POWER SUPPLY
106	W	S/L UNIT POWER SUPPLY
107	LG	COMBI SW INPUT 1
108	R	COMBI SW INPUT 4
109	W	COMBI SW INPUT 2
110	G	HAZARD SW
111	Y	S/L UNIT COMM

Connector No.	M124
Connector Name	WIRE TO WIRE
Connector Type	TH40MW-CS15

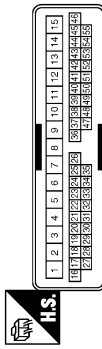

Terminal No.	Color of Wire	Signal Name [Specification]
6	BG	-
7	R	-
8	G	-
9	P	-
10	V	-
11	SB	- [With BOSE system]
11	GR	- [Without BOSE system]
12	BR	-
13	B	-
14	G	-
15	W	-
34	Y	-
35	Y/B	-
38	W	-
39	BG	-
40	S/S	-
41	G	- [With automatic drive positioner]
41	R	- [Without automatic drive positioner]
42	R	-
43	L	-
44	Y	-
45	R	-
46	W	-
47	SB	-
48	BR	-
49	Y	-
50	P	-
51	LG	-
52	BG	-
53	Y	-
54	L	-
55	L	-

A  
B  
C  
D  
E  
F  
G  
H  
I  
J  
K  
L  
M  
AV  
O  
P

# BASE AUDIO WITHOUT NAVIGATION

[BASE AUDIO WITHOUT NAVIGATION]

< WIRING DIAGRAM >

## BASE AUDIO WITHOUT NAVIGATION

Connector No.	M134
Connector Name	WIRE TO WIRE
Connector Type	CP08MGY-S

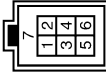

Terminal No.	Color of Wire	Signal Name [Specification]
2	W	-
3	L	-
4	G	-
5	R	-
7	SHIELD	-

Connector No.	M135
Connector Name	USB CONNECTOR
Connector Type	HAA0HFG



Terminal No.	Color of Wire	Signal Name [Specification]
1	W	-
2	L	-
3	G	-
4	R	-
5	SHIELD	-

Connector No.	M144
Connector Name	WIRE TO WIRE
Connector Type	TH04MP-NH



Terminal No.	Color of Wire	Signal Name [Specification]
1	R	-
2	W	-
3	W	-
4	SHIELD	-

Connector No.	M201
Connector Name	AV CONTROL UNIT
Connector Type	TH18FW-CSP



Terminal No.	Color of Wire	Signal Name [Specification]
2	L	SOUND SIGNAL FRONT LH (+)
3	W	SOUND SIGNAL FRONT LH (-)
4	LG	SOUND SIGNAL REAR LH (+)
5	SB	SOUND SIGNAL REAR LH (-)
6	P	STRG SW A
7	V	ACC
9	L	ILLUMINATION
11	BR	SOUND SIGNAL FRONT RH (-)
12	GR	SOUND SIGNAL FRONT RH (+)
13	L	SOUND SIGNAL REAR RH (+)
14	P	SOUND SIGNAL REAR RH (-)
15	B	STRG SW GND
16	L	STRG SW B
18	G	GND
19	BR	BATTERY
20	B	GND

Connector No.	M202
Connector Name	AV CONTROL UNIT
Connector Type	TH24FW-NH



Terminal No.	Color of Wire	Signal Name [Specification]
36	BG	SIGNAL VCC
37	LG	SIGNAL GND
38	R	HP
39	L	COMM (DISP->CONT)
40	B	RGB AREA (YS) SIGNAL
41	SHIELD	SHIELD
42	W	RGB SYNC
43	G	RGB (CRD) SIGNAL
44	L	RGB (GGREEN) SIGNAL
45	P	RGB (BBLUE) SIGNAL
46	V	COMPOSITE IMAGE GND
47	SB	COMPOSITE IMAGE SIGNAL
48	Y	INVERTER VCC
49	BR	INVERTER GND
50	G	VP
51	P	COMM (CONT->DISP)
52	SHIELD	SHIELD
57	SHIELD	SHIELD
58	SHIELD	SHIELD

Connector No.	M203
Connector Name	AV CONTROL UNIT
Connector Type	TH18FW-NH



Terminal No.	Color of Wire	Signal Name [Specification]
62	W	CAMERA IMAGE SIGNAL
71	SHIELD	SHIELD
72	W	CAMERA GND

Connector No.	73
Connector Name	CAMERA POWER SUPPLY

Connector No.	M204
Connector Name	AV CONTROL UNIT
Connector Type	TH22FW-NH

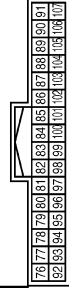

Terminal No.	Color of Wire	Signal Name [Specification]
76	LG	AV COMM (L)
77	SR	AV COMM (H)
78	LG	AV COMM (L)
79	SB	AV COMM (H)
80	P	CAN-L
81	L	CAN-H
82	BR	SW GND
86	SHIELD	SHIELD
87	L	TEL VOICE SIGNAL (+)
88	P	TEL VOICE SIGNAL (-)
92	GR	VEHICLE SPEED (G-PULSE)
93	SB	PARKING BRAKE
94	BG	REVERSE
95	G	IGNITION
96	SB	DISK EJECT SIGNAL

JCNWM5567GB

# BASE AUDIO WITHOUT NAVIGATION

[BASE AUDIO WITHOUT NAVIGATION]

< WIRING DIAGRAM >

## BASE AUDIO WITHOUT NAVIGATION

Connector No.	M206
Connector Name	AV CONTROL UNIT
Connector Type	A12FW



Terminal No.	Color of Wire	Signal Name [Specification]
120	B	SATELLITE RADIO SOUND SIGNAL LH (+)
121	G	SATELLITE RADIO SOUND SIGNAL RH (+)
122	L	COMM (CONT->SAT)
124	W	SATELLITE RADIO SOUND SIGNAL LH (-)
125	R	SATELLITE RADIO SOUND SIGNAL RH (-)
126	SHIELD	SHIELD
127	SHIELD	SHIELD
129	P	REQUEST (SAT->CONT)
130	G	COMM (SAT->CONT)

Connector No.	M207
Connector Name	AV CONTROL UNIT
Connector Type	HAAG4FL

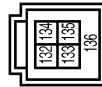

Terminal No.	Color of Wire	Signal Name [Specification]
132	G	USB GND
133	R	USB D- SIGNAL
134	W	V BUS SIGNAL
135	L	USB D+ SIGNAL
136	SHIELD	SHIELD

Connector No.	M256
Connector Name	WIRE TO WIRE
Connector Type	TR04MP-NH



Terminal No.	Color of Wire	Signal Name [Specification]
1	P	
2	L	

Connector No.	M257
Connector Name	WIRE TO WIRE
Connector Type	TR04FW-NH



Terminal No.	Color of Wire	Signal Name [Specification]
1	P	
2	L	

Connector No.	M303
Connector Name	COMBINATION SWITCH (SPIRAL CABLE)
Connector Type	TR08FBY



Terminal No.	Color of Wire	Signal Name [Specification]
13	-	
14	-	

15	-	
16	-	
17	-	
18	-	
19	-	
20	-	

Connector No.	M370
Connector Name	AV CONTROL UNIT
Connector Type	GT13SH-2/1S-HU

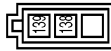

Terminal No.	Color of Wire	Signal Name [Specification]
138	-	ANTENNA SIGNAL
139	-	ANTENNA AMP ON SIGNAL

Connector No.	M375
Connector Name	WIRE TO WIRE
Connector Type	GT13SSN-1/1PP-HU



Terminal No.	Color of Wire	Signal Name [Specification]
1	-	
2	-	

Connector No.	M376
Connector Name	WIRE TO WIRE
Connector Type	GT13SS-1/1S-HU



Terminal No.	Color of Wire	Signal Name [Specification]
1	-	
2	-	

Connector No.	M378
Connector Name	WIRE TO WIRE
Connector Type	GT13SSN-1/1PP-HU



Terminal No.	Color of Wire	Signal Name [Specification]
1	-	
2	-	

A  
B  
C  
D  
E  
F  
G  
H  
I  
J  
K  
L  
M  
N  
O  
P

AV

JCNWM5568GB

# BASE AUDIO WITHOUT NAVIGATION

< WIRING DIAGRAM >

[BASE AUDIO WITHOUT NAVIGATION]

## BASE AUDIO WITHOUT NAVIGATION

Connector No.	R1
Connector Name	WIRE TO WIRE
Connector Type	HTUDV-C510

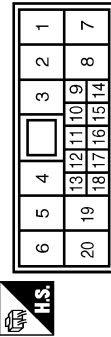

Terminal No.	Color of Wire	Signal Name [Specification]
1	B	-
2	BR	-
3	Y	-
4	W	-
5	SHIELD	-
6	O	-
7	B	-
8	L	-
9	Y	-
10	B	-
11	Y	-
12	R	-
13	B	-
14	B	-
15	BR	-
16	G	-
17	-	-
18	-	-
19	-	-
20	-	-

Connector No.	R7
Connector Name	MICROPHONE
Connector Type	TK04FW



Terminal No.	Color of Wire	Signal Name [Specification]
1	O	MICROPHONE SIGNAL
2	SHIELD	MICROPHONE SHIELD
4	W	MICROPHONE VCC

JCNWM5569GB



**BASIC INSPECTION**

DIAGNOSIS AND REPAIR WORKFLOW

Work Flow

INFOID:000000006472423

OVERALL SEQUENCE

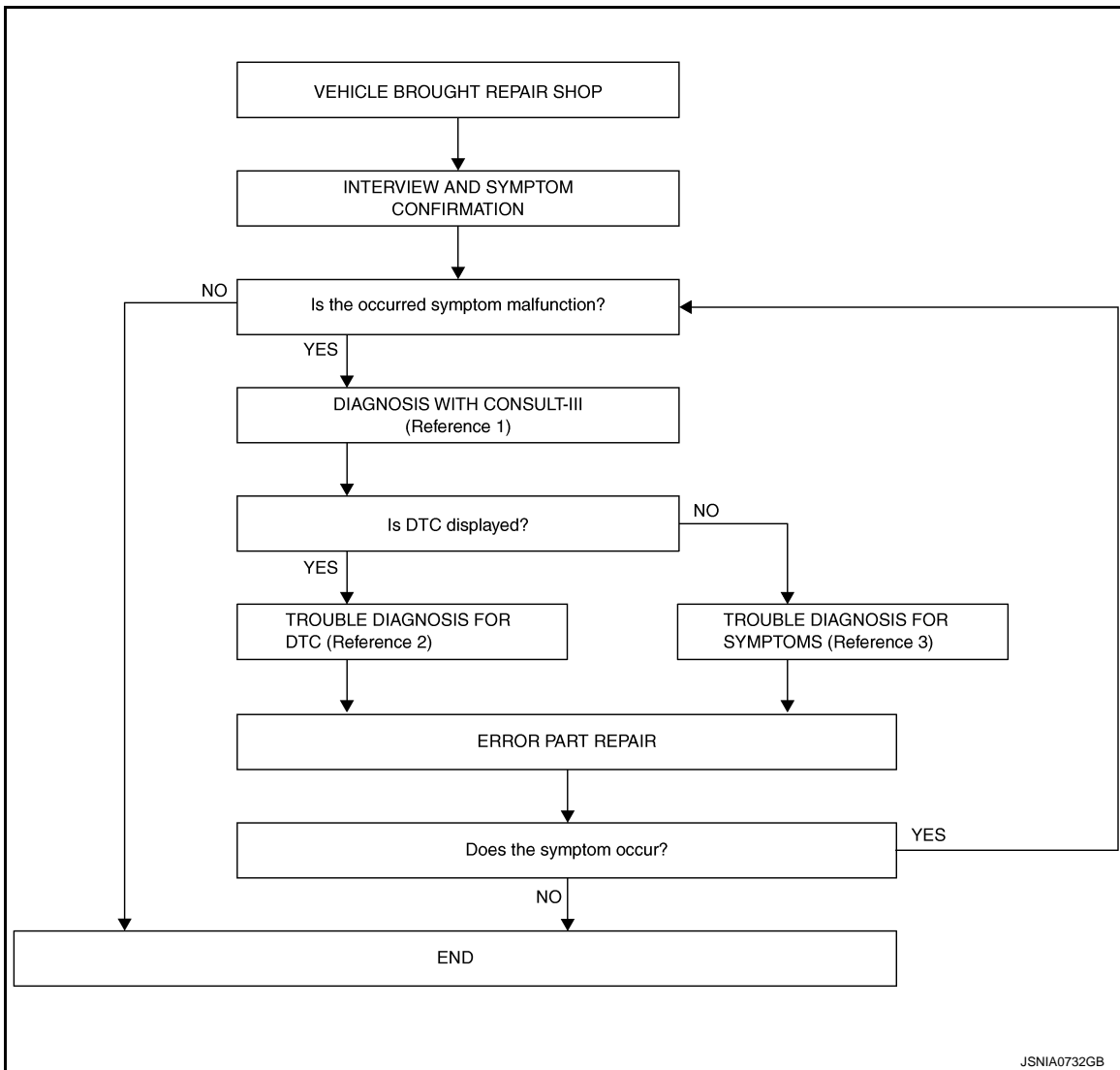

- Reference 1... Refer to [AV-27. "CONSULT - III Function"](#).
- Reference 2... Refer to [AV-38. "DTC Index"](#).
- Reference 3... Refer to [AV-104. "Symptom Table"](#).

DETAILED FLOW

**1. INTERVIEW AND SYMPTOM CONFIRMATION**

Check the malfunction symptoms by performing the following items.

- Interview the customer to obtain the malfunction information (conditions and environment when the malfunction occurred).
- Check the symptom.

Is the occurred symptom malfunction?

- YES >> GO TO 2.
- NO >> INSPECTION END

**2. DIAGNOSIS WITH CONSULT-III**

A  
B  
C  
D  
E  
F  
G  
H  
I  
J  
K  
L  
M  
AV

# DIAGNOSIS AND REPAIR WORKFLOW

< BASIC INSPECTION >

[BASE AUDIO WITHOUT NAVIGATION]

1. Connect CONSULT-III and perform a self-diagnosis for "MULTI AV". Refer to [AV-27, "CONSULT - III Function"](#).
- NOTE:**  
Skip to step 4 of the diagnosis procedure if "MULTI AV" is not displayed.
2. Check if any DTC is displayed in the "Self-Diagnosis Results".

Is DTC displayed?

- YES >> GO TO 3.  
NO >> GO TO 4.

## 3. TROUBLE DIAGNOSIS FOR DTC

---

1. Check the DTC indicated in the "Self-Diagnosis Results".
2. Perform the relevant diagnosis referring to the DTC Index. Refer to [AV-38, "DTC Index"](#).

>> GO TO 5.

## 4. TROUBLE DIAGNOSIS FOR SYMPTOMS

---

Perform the relevant diagnosis referring to the diagnosis chart by symptom. Refer to [AV-104, "Symptom Table"](#).

>> GO TO 5.

## 5. ERROR PART REPAIR

---

1. Repair or replace the identified malfunctioning parts.
  2. Perform a self-diagnosis for "MULTI AV" with CONSULT-III.
- NOTE:**  
Erase the stored self-diagnosis results after repairing or replacing the relevant components if any DTC has been indicated in the "Self-Diagnosis Results".
3. Check that the symptom does not occur.

Does the symptom occur?

- YES >> GO TO 1.  
NO >> INSPECTION END

# ADDITIONAL SERVICE WHEN REPLACING (AV CONTROL UNIT)

< BASIC INSPECTION >

[BASE AUDIO WITHOUT NAVIGATION]

## ADDITIONAL SERVICE WHEN REPLACING (AV CONTROL UNIT)

### Description

INFOID:000000006472424

#### BEFORE REPLACEMENT

When replacing AV control unit, save or print current vehicle specification with CONSULT-III configuration before replacement.

#### AFTER REPLACEMENT

##### **CAUTION:**

When replacing AV control unit, you must perform "WRITE CONFIGURATION" with CONSULT-III.

- Complete the procedure of "WRITE CONFIGURATION" in order.
- If you set incorrect "WRITE CONFIGURATION", incidents might occur.
- Configuration is different for each vehicle model. Confirm configuration of each vehicle model.

### Work Procedure

INFOID:000000006472425

#### 1. SAVING VEHICLE SPECIFICATION

##### Ⓜ-CONSULT-III Configuration

Perform "READ CONFIGURATION" to save or print current vehicle specification. Refer to [AV-68, "Description"](#).

##### **NOTE:**

If "READ CONFIGURATION" can not be used, use the "WRITE CONFIGURATION - Manual selection".

>> GO TO 2.

#### 2. REPLACE AV CONTROL UNIT

Replace AV control unit. Refer to [AV-110, "Exploded View"](#).

>> GO TO 3.

#### 3. WRITING VEHICLE SPECIFICATION

##### Ⓜ-CONSULT-III Configuration

Perform "WRITE CONFIGURATION - Config file" or "WRITE CONFIGURATION - Manual selection" to write vehicle specification. Refer to [AV-68, "Work Procedure"](#).

>> GO TO 4.

#### 4. OPERATION CHECK

Check that the operation of the AV control unit and camera images (fixed guide lines and predictive course lines) are normal.

>> WORK END

A  
B  
C  
D  
E  
F  
G  
H  
I  
J  
K  
L  
M  
O  
P

AV

# CONFIGURATION (AV CONTROL UNIT)

< BASIC INSPECTION >

[BASE AUDIO WITHOUT NAVIGATION]

## CONFIGURATION (AV CONTROL UNIT)

### Description

INFOID:000000006472426

- Since vehicle specifications are not included in the AV control unit after replacement, it is required to write vehicle specifications with CONSULT-III.
- Configuration has three functions as follows.

Function	Description
READ CONFIGURATION	<ul style="list-style-type: none"><li>• Reads the vehicle configuration of current AV control unit.</li><li>• Saves the read vehicle configuration.</li></ul>
WRITE CONFIGURATION-Manual selection	Writes the vehicle configuration with manual selection.
WRITE CONFIGURATION-Config file	Writes the vehicle configuration with saved data.

### Work Procedure

INFOID:000000006472427

#### NOTE:

If "WRITE CONFIGURATION" is unsuccessful, perform "Accessory Number Initialization". For details, refer to [AV-18, "On Board Diagnosis Function"](#).

After performing "Accessory Number Initialization", reboot the AV control unit to perform "WRITE CONFIGURATION".

#### 1. WRITING MODE SELECTION

ⓅCONSULT-III Configuration

Select "CONFIGURATION" of "MULTI AV".

When writing saved data>>GO TO 2.

When writing manually>>GO TO 3.

#### 2. PERFORM "WRITE CONFIGURATION-CONFIG FILE"

ⓅCONSULT-III Configuration

Perform "WRITE CONFIGURATION-Config file".

>> WORK END

#### 3. PERFORM "WRITE CONFIGURATION-MANUAL SELECTION"

ⓅCONSULT-III Configuration

Select "WRITE CONFIGURATION-Manual selection" to write vehicle specifications into the AV control unit.

For data to write, refer to [AV-68, "Configuration List"](#).

>> GO TO 4.

#### 4. OPERATION CHECK

Check that the operation of the AV control unit and camera images (fixed guide lines and predictive course lines) are normal.

>> WORK END

### Configuration List

INFOID:000000006472428

#### CAUTION:

**Check vehicle specifications before servicing.**

# CONFIGURATION (AV CONTROL UNIT)

< BASIC INSPECTION >

[BASE AUDIO WITHOUT NAVIGATION]

MANUAL SETTING ITEM		NOTE
Items	Setting value	
STEERING	LHD	—
	RHD	—
GRADE	MODE 1	not used
	MODE 2	Journey grade or premium grade
	MODE 3	Sport grade or sports premium grade
4WAS	WITHOUT	—
	WITH	—
SOUND SYSTEM	BASE	—
	BOSE	—

A  
B  
C  
D  
E  
F  
G  
H  
I  
J  
K  
L  
M  
N  
O  
P

AV

# U1000 CAN COMM CIRCUIT

< DTC/CIRCUIT DIAGNOSIS >

[BASE AUDIO WITHOUT NAVIGATION]

## DTC/CIRCUIT DIAGNOSIS

### U1000 CAN COMM CIRCUIT

#### Description

INFOID:000000006472429

CAN (Controller Area Network) is a serial communication line for real-time application. It is an on-vehicle multiplex communication line with high data communication speed and excellent error detection ability. Many electronic control units are equipped onto a vehicle, and each control unit shares information and links with other control units during operation (not independently). In CAN communication, control units are connected with 2 communication lines (CAN-H, CAN-L) allowing a high rate of information transmission with less wiring. Each control unit transmits/receives data but selectively reads required data only.

CAN Communication Signal Chart. Refer to [LAN-23, "CAN Communication Signal Chart"](#).

#### DTC Logic

INFOID:000000006472430

#### DTC DETECTION LOGIC

DTC	Display contents of CONSULT-III	DTC detection condition	Probable malfunction location
U1000	CAN COMM CIRCUIT [U1000]	AV control unit is not transmitting or receiving CAN communication signal for 2 seconds or more.	CAN communication system.

#### Diagnosis Procedure

INFOID:000000006472431

#### 1. PERFORM SELF-DIAGNOSTIC

1. Turn ignition switch ON and wait for 2 seconds or more.
2. Check "Self Diagnostic Result" of "MULTI AV".

Is "CAN COMM CIRCUIT" displayed?

- YES >> Refer to "LAN system". Refer to [LAN-14, "Trouble Diagnosis Flow Chart"](#).  
NO >> Refer to GI section. Refer to [GI-43, "Intermittent Incident"](#).

# U1010 CONTROL UNIT (CAN)

< DTC/CIRCUIT DIAGNOSIS >

[BASE AUDIO WITHOUT NAVIGATION]

## U1010 CONTROL UNIT (CAN)

### DTC Logic

INFOID:000000006472432

### DTC DETECTION LOGIC

DTC	Display contents of CONSULT-III	DTC detection condition	Probable malfunction factor
U1010	CONTROL UNIT (CAN) [U1010]	CAN initial diagnosis malfunction is detected.	Replace the AV control unit if the malfunction occurs constantly. Refer to <a href="#">AV-110, "Exploded View"</a> .

A  
B  
C  
D  
E  
F  
G  
H  
I  
J  
K  
L  
M  
N  
O  
P

AV

# U1200 AV CONTROL UNIT

< DTC/CIRCUIT DIAGNOSIS >

[BASE AUDIO WITHOUT NAVIGATION]

## U1200 AV CONTROL UNIT

### DTC Logic

INFOID:000000006472433

DTC	Display contents of CONSULT-III	DTC detection condition	Possible malfunction factor
U1200	Cont Unit [U1200]	AV control unit malfunction is detected.	Replace the AV control unit if the malfunction occurs constantly. Refer to <a href="#">AV-110. "Exploded View"</a> .



# U1216 AV CONTROL UNIT

< DTC/CIRCUIT DIAGNOSIS >

[BASE AUDIO WITHOUT NAVIGATION]

## U1216 AV CONTROL UNIT

### DTC Logic

INFOID:000000006472434

DTC	Display contents of CONSULT-III	DTC detection condition	Possible malfunction factor
U1216	CAN CONT [U1216]	AV control unit malfunction is detected.	Replace the AV control unit if the malfunction occurs constantly. Refer to <a href="#">AV-110. "Exploded View"</a> .

A  
B  
C  
D  
E  
F  
G  
H  
I  
J  
K  
L  
M  
N  
O  
P

AV

# U1232 STEERING ANGLE SENSOR

< DTC/CIRCUIT DIAGNOSIS >

[BASE AUDIO WITHOUT NAVIGATION]

## U1232 STEERING ANGLE SENSOR

### DTC Logic

INFOID:000000006472435

DTC	Display contents of CONSULT-III	DTC detection condition	Possible malfunction factor
U1232	ST ANGLE SEN CALIB [1232]	Predictive course line center position adjustment of the steering angle sensor is incomplete.	Adjust the predictive course line center position of the steering angle sensor.

### Diagnosis Procedure

INFOID:000000006472436

#### 1. ADJUST THE PREDICTIVE COURSE LINE CENTER POSITION OF THE STEERING ANGLE SENSOR

When U1232 is detected, adjust the predictive course line center position of the steering angle sensor.

>> Adjusts the steering angle sensor neutral position on ABS actuator and electrical unit (control unit) side. Refer to [BRC-9. "ADJUSTMENT OF STEERING ANGLE SENSOR NEUTRAL POSITION : Special Repair Requirement"](#).

# U1243 DISPLAY UNIT

< DTC/CIRCUIT DIAGNOSIS >

[BASE AUDIO WITHOUT NAVIGATION]

## U1243 DISPLAY UNIT

### DTC Logic

INFOID:000000006472437

DTC	Display contents of CONSULT-III	DTC detection condition	Possible malfunction factor
U1243	FRONT DISP CONN [U1243]	When either one of the following items is detected: <ul style="list-style-type: none"> <li>display unit power supply and ground circuit are malfunctioning.</li> <li>communication circuit between AV control unit and display unit are malfunctioning.</li> </ul>	<ul style="list-style-type: none"> <li>Display unit power supply and ground circuit.</li> <li>Communication circuit between AV control unit and display unit.</li> </ul>

### Diagnosis Procedure

INFOID:000000006472438

#### 1. CHECK DISPLAY UNIT POWER SUPPLY AND GROUND CIRCUIT

Check display unit power supply and ground circuit. Refer to [AV-81, "DISPLAY UNIT : Diagnosis Procedure"](#).

Is the inspection result normal?

YES >> GO TO 2.

NO >> Repair malfunctioning parts.

#### 2. CHECK CONTINUITY COMMUNICATION CIRCUIT

- Turn ignition switch OFF.
- Disconnect display unit connector and AV control unit connector.
- Check continuity between display unit harness connector and AV control unit harness connector.

Display unit		AV control unit		Continuity
Connector	Terminals	Connector	Terminals	
M71	11	M202	51	Existed
	22		39	

- Check continuity between display unit harness connector and ground.

Display unit		Ground	Continuity
Connector	Terminals		
M71	11		Not existed
	22		

Is the inspection result normal?

YES >> GO TO 3.

NO >> Repair harness or connector.

#### 3. CHECK COMMUNICATION SIGNAL

- Connect display unit connector and AV control unit connector.
- Turn ignition switch ON.
- Check signal between display unit harness connector and ground.

A  
B  
C  
D  
E  
F  
G  
H  
I  
J  
K  
L  
M  
AV  
O  
P

# U1243 DISPLAY UNIT

< DTC/CIRCUIT DIAGNOSIS >

[BASE AUDIO WITHOUT NAVIGATION]

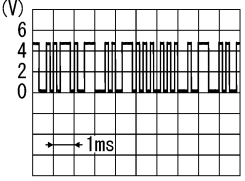
(+)		(-)	Condition	Reference value
Display unit				
Connector	Terminal			
M71	22	Ground	When adjusting display brightness.	 <p>PKIB5039J</p>

Is the inspection result normal?

YES >> GO TO 4.

NO >> Replace AV control unit. Refer to [AV-110. "Exploded View"](#).

## 4. CHECK COMMUNICATION SIGNAL

Check signal between display unit harness connector and ground.

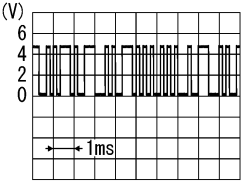
(+)		(-)	Condition	Reference value
Display unit				
Connector	Terminal			
M71	11	Ground	When adjusting display brightness.	 <p>PKIB5039J</p>

Is the inspection result normal?

YES >> INSPECTION END

NO >> Replace display unit. Refer to [AV-112. "Exploded View"](#).

# U1255 SATELLITE RADIO TUNER

< DTC/CIRCUIT DIAGNOSIS >

[BASE AUDIO WITHOUT NAVIGATION]

## U1255 SATELLITE RADIO TUNER

### DTC Logic

INFOID:000000006472439

DTC	Display contents of CONSULT-III	DTC Detection Condition	Possible malfunction factor
U1255	SAT CONN [U1255]	When either one of the following items is detected: <ul style="list-style-type: none"> <li>• satellite radio tuner power supply and ground circuit are malfunctioning.</li> <li>• communication circuits between AV control unit and satellite radio tuner are malfunctioning.</li> <li>• request signal circuit between AV control unit and satellite radio tuner are malfunctioning.</li> </ul>	<ul style="list-style-type: none"> <li>• Satellite radio tuner power supply and ground circuit.</li> <li>• Communication circuit between AV control unit and satellite radio tuner.</li> <li>• Request signal circuit between AV control unit and satellite radio tuner.</li> </ul>

### Diagnosis Procedure

INFOID:000000006472440

#### 1. CHECK SATELLITE RADIO TUNER POWER SUPPLY AND GROUND CIRCUIT

Check satellite radio tuner power supply and ground circuit. Refer to [AV-82. "SATELLITE RADIO TUNER : Diagnosis Procedure"](#).

Is the inspection result normal?

YES >> GO TO 2.

NO >> Repair malfunctioning parts.

#### 2. CHECK CONTINUITY COMMUNICATION CIRCUIT AND REQUEST SIGNAL CIRCUIT

1. Turn ignition switch OFF.
2. Disconnect AV control unit connector and satellite radio tuner connector.
3. Check continuity between AV control unit harness connector and satellite radio tuner harness connector.

AV control unit		Satellite radio tuner		Continuity
Connector	Terminals	Connector	Terminals	
M206	129	B236	8	Existed
	122		10	
	130		9	

4. Check continuity between AV control unit harness connector.

AV control unit		Ground	Continuity
Connector	Terminals		
M206	129	Ground	Not existed
	122		
	130		

Is the inspection result normal?

YES >> GO TO 3.

NO >> Repair harness or connector.

#### 3. CHECK AV CONTROL UNIT VOLTAGE

1. Connect AV control unit connector.
2. Turn ignition switch ON.
3. Check signal between AV control unit harness connector and ground.

(+)		(-)	Reference value (Approx.)
AV control unit			
Connector	Terminals		

## U1255 SATELLITE RADIO TUNER

< DTC/CIRCUIT DIAGNOSIS >

[BASE AUDIO WITHOUT NAVIGATION]

M206	129	Ground	7.0 V
	130	Ground	7.0 V

Is the inspection result normal?

YES >> GO TO 4.

NO >> Replace AV control unit. Refer to [AV-110, "Exploded View"](#).

### 4. CHECK SATELLITE RADIO TUNER VOLTAGE

1. Turn ignition switch OFF.
2. Disconnect AV control unit connector.
3. Connect satellite radio tuner.
4. Turn ignition switch ON.
5. Check signal between satellite radio tuner harness connector and ground.

(+)		(-)	Reference value (Approx.)
Satellite radio tuner			
Connector	Terminal		
B236	10	Ground	7.0 V

Is the inspection result normal?

YES >> INSPECTION END

NO >> Replace satellite radio tuner. Refer to [AV-117, "Exploded View"](#).

# U1300 AV COMM CIRCUIT

< DTC/CIRCUIT DIAGNOSIS >

[BASE AUDIO WITHOUT NAVIGATION]

## U1300 AV COMM CIRCUIT

### Description

INFOID:000000006472441

U1300 is indicated when malfunction occurs in communication signal of multi AV system. Indicated simultaneously, without fail, with the malfunction of control units connected to AV control unit with communication line. Determine the possible malfunction cause from the table below.

### SELF-DIAGNOSIS RESULTS DISPLAY ITEM

DTC	Display contents of CONSULT-III	DTC detection condition	Possible malfunction factor
U1300 U1240	<ul style="list-style-type: none"><li>• AV COMM CIRCUIT [U1300]</li><li>• SWITCH CONN [U1240]</li></ul>	When either one of the following items is detected: <ul style="list-style-type: none"><li>• multifunction switch power supply and ground circuits are malfunctioning.</li><li>• AV communication circuits between AV control unit and multifunction switch are malfunctioning.</li></ul>	<ul style="list-style-type: none"><li>• Multifunction switch power supply and ground circuits.</li><li>• AV communication circuits between AV control unit and multifunction switch.</li></ul>
U1300 U1256	<ul style="list-style-type: none"><li>• AV COMM CIRCUIT [U1300]</li><li>• HAND FREE CONN [U1256]</li></ul>	When either one of the following items is detected: <ul style="list-style-type: none"><li>• TEL adapter unit power supply and ground circuits are malfunctioning.</li><li>• AV communication circuits between AV control unit and TEL adapter unit are malfunctioning.</li></ul>	<ul style="list-style-type: none"><li>• TEL adapter unit power supply and ground circuits.</li><li>• AV communication circuits between AV control unit and TEL adapter unit.</li></ul>
U1300 U1240 U1256	<ul style="list-style-type: none"><li>• AV COMM CIRCUIT [U1300]</li><li>• SWITCH CONN [U1240]</li><li>• HAND FREE CONN [U1256]</li></ul>	Malfunction is detected in AV communication circuits between AV control unit and multifunction switch.	AV communication circuits between AV control unit and multifunction switch.

A  
B  
C  
D  
E  
F  
G  
H  
I  
J  
K  
L  
M  
N  
O  
P

AV

# U1310 AV CONTROL UNIT

< DTC/CIRCUIT DIAGNOSIS >

[BASE AUDIO WITHOUT NAVIGATION]

## U1310 AV CONTROL UNIT

### DTC Logic

INFOID:000000006472442

DTC	Display contents of CONSULT-III	DTC detection condition	Possible malfunction factor
U1310	CONTROL UNIT (AV) [U1310]	An initial diagnosis error is detected in AV communication circuit.	Replace AV control unit. If the malfunction occurs constantly. Refer to <a href="#">AV-110. "Exploded View"</a> .



# POWER SUPPLY AND GROUND CIRCUIT

< DTC/CIRCUIT DIAGNOSIS >

[BASE AUDIO WITHOUT NAVIGATION]

## POWER SUPPLY AND GROUND CIRCUIT

### AV CONTROL UNIT

#### AV CONTROL UNIT : Diagnosis Procedure

INFOID:000000006472443

#### 1.CHECK FUSE

Check for blown fuses.

Power source	Fuse No.
Battery	34
Ignition switch ACC or ON	19

Is the inspection result normal?

YES >> GO TO 2.

NO >> Be sure to eliminate cause of malfunction before installing new fuse.

#### 2.CHECK POWER SUPPLY CIRCUIT

Check voltage between AV control unit harness connectors and ground.

Signal name	Connector No.	Terminal No.	Ignition switch position	Value (Approx.)
Battery power supply	M201	19	OFF	Battery voltage
ACC power supply	M201	7	ACC	Battery voltage

Is the inspection result normal?

YES >> GO TO 3.

NO >> Check harness between AV control unit and fuse.

#### 3.CHECK GROUND CIRCUIT

1. Turn ignition switch OFF.
2. Disconnect AV control unit connectors.
3. Check continuity between AV control unit harness connectors and ground.

Signal name	Connector No.	Terminal No.	Ignition switch position	Continuity
Ground	M201	20	OFF	Existed

Is the inspection result normal?

YES >> INSPECTION END

NO >> Repair harness or connector.

## DISPLAY UNIT

#### DISPLAY UNIT : Diagnosis Procedure

INFOID:000000006472444

#### 1.CHECK POWER SUPPLY CIRCUIT (DISPLAY SIDE)

Check voltage between display unit harness connector and ground.

Signal name	Connector No.	Terminal No.	Ignition switch position	Value (Approx.)
Inverter VCC	M71	2	ACC	9.0 V
Signal VCC		3		

Is the inspection result normal?

YES >> GO TO 4.

NO >> GO TO 2.

#### 2.CHECK POWER SUPPLY CIRCUIT (CONTINUITY)

1. Turn ignition switch OFF.
2. Disconnect the harness connector between display unit and AV control unit.
3. Check continuity between display unit harness connector M71 and AV control unit harness connector.

A  
B  
C  
D  
E  
F  
G  
H  
I  
J  
K  
L  
M  
O  
P

AV

# POWER SUPPLY AND GROUND CIRCUIT

< DTC/CIRCUIT DIAGNOSIS >

[BASE AUDIO WITHOUT NAVIGATION]

Signal name	Display unit (M71)	AV control unit (M202)	Continuity
Inverter VCC	2	48	Existed
Signal VCC	3	36	Existed

4. Check continuity between display unit harness connector and ground.

Signal name	Display unit (M71)	—	Continuity
Inverter VCC	2	Ground	Not existed
Signal VCC	3	Ground	Not existed

Is the inspection result normal?

YES >> GO TO 3.

NO >> Repair harness or connector.

## 3.CHECK POWER SUPPLY CIRCUIT (AV CONTROL UNIT SIDE)

1. Connect the AV control unit harness connector.
2. Turn ignition switch ACC.
3. Check voltage between AV control unit harness connector and ground.

Signal name	Connector No.	Terminal No.	Ignition switch position	Value (Approx.)
Inverter VCC	M202	48	ACC	9.0 V
Signal VCC		36		

Is the inspection result normal?

YES >> INSPECTION END

NO >> Replacement of AV control unit.

## 4.CHECK GROUND CIRCUIT

1. Turn ignition switch OFF.
2. Disconnect display unit connector.
3. Check continuity between display unit harness connectors and ground.

Signal name	Connector No.	Terminal No.	Ignition switch position	Continuity
Ground	M71	1	OFF	Existed

Is the inspection result normal?

YES >> INSPECTION END

NO >> Repair harness or connector.

## SATELLITE RADIO TUNER

### SATELLITE RADIO TUNER : Diagnosis Procedure

INFOID:000000006472445

## 1.CHECK FUSE

Check for blown fuses.

Power source	Fuse No.
Battery	34
Ignition switch ACC or ON	19

Is the inspection result normal?

YES >> GO TO 2.

NO >> Be sure to eliminate cause of malfunction before installing new fuse.

## 2.CHECK POWER SUPPLY CIRCUIT

Check voltage between satellite radio tuner harness connector and ground.

# POWER SUPPLY AND GROUND CIRCUIT

< DTC/CIRCUIT DIAGNOSIS >

[BASE AUDIO WITHOUT NAVIGATION]

Signal name	Connector No.	Terminal No.	Ignition switch position	Value (Approx.)
Battery power supply	B236	12	OFF	Battery voltage
ACC power supply	B236	16	ACC	Battery voltage

Is the inspection result normal?

YES >> INSPECTION END

NO >> Check harness between satellite radio tuner and fuse.

## TEL ADAPTER UNIT

### TEL ADAPTER UNIT : Diagnosis Procedure

INFOID:000000006472446

#### 1.CHECK FUSE

Check for blown fuses.

Power source	Fuse No.
Battery	34
Ignition switch ACC or ON	19

Is the inspection result normal?

YES >> GO TO 2.

NO >> Be sure to eliminate cause of malfunction before installing new fuse.

#### 2.CHECK POWER SUPPLY CIRCUIT

Check voltage between TEL adapter unit harness connector and ground.

Signal name	Connector No.	Terminal No.	Ignition switch position	Value (Approx.)
Battery power supply	B237	1	OFF	Battery voltage
ACC power supply	B237	2	ACC	Battery voltage

Is the inspection result normal?

YES >> GO TO 3.

NO >> Check harness between TEL adapter unit and fuse.

#### 3.CHECK GROUND CIRCUIT

1. Turn ignition switch OFF.
2. Disconnect TEL adapter unit connector.
3. Check continuity between TEL adapter unit harness connector and ground.

Signal name	Connector No.	Terminal No.	Ignition switch position	Continuity
Ground	B237	4, 14	OFF	Existed

Is the inspection result normal?

YES >> INSPECTION END

NO >> Repair harness or connector.

# RGB (R: RED) SIGNAL CIRCUIT

< DTC/CIRCUIT DIAGNOSIS >

[BASE AUDIO WITHOUT NAVIGATION]

## RGB (R: RED) SIGNAL CIRCUIT

### Description

INFOID:000000006472447

Transmit the image displayed with AV control unit with RGB signal to the display unit.

### Diagnosis Procedure

INFOID:000000006472448

#### 1. CHECK CONTINUITY RGB (R: RED) SIGNAL CIRCUIT

1. Turn ignition switch OFF.
2. Disconnect display unit connector and AV control unit connector.
3. Check continuity between display unit harness connector and AV control unit harness connector.

Display unit		AV control unit		Continuity
Connector	Terminal	Connector	Terminal	
M71	17	M202	43	Existed

4. Check continuity between display unit harness connector and ground.

Display unit		Ground	Continuity
Connector	Terminal		
M71	17		Not existed

Is inspection result normal?

- YES >> GO TO 2.  
NO >> Repair harness or connector.

#### 2. CHECK RGB (R: RED) SIGNAL

1. Connect display unit connector and AV control unit connector.
2. Turn ignition switch ON.
3. Check signal between display unit harness connector and ground.

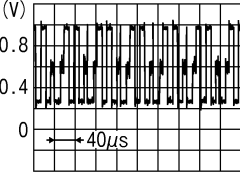
(+)		(-)	Condition	Reference value
Display unit				
Connector	Terminal			
M71	17	Ground	Start confirmation/adjustment mode, and then display color bar by selecting "Color Spectrum Bar" on DISPLAY DIAGNOSIS screen.	 JSNIA1029ZZ

Is inspection result normal?

- YES >> Replace display unit. Refer to [AV-112, "Exploded View"](#).  
NO >> Replace AV control unit. Refer to [AV-110, "Exploded View"](#).

# RGB (G: GREEN) SIGNAL CIRCUIT

< DTC/CIRCUIT DIAGNOSIS >

[BASE AUDIO WITHOUT NAVIGATION]

## RGB (G: GREEN) SIGNAL CIRCUIT

### Description

INFOID:000000006472449

Transmit the image displayed with AV control unit with RGB signal to the display unit.

### Diagnosis Procedure

INFOID:000000006472450

#### 1. CHECK CONTINUITY RGB (G: GREEN) SIGNAL CIRCUIT

1. Turn ignition switch OFF.
2. Disconnect display unit connector and AV control unit connector.
3. Check continuity between display unit harness connector and AV control unit harness connector.

Display unit		AV control unit		Continuity
Connector	Terminal	Connector	Terminal	
M71	6	M202	44	Existed

4. Check continuity between display unit harness connector and ground.

Display unit		Ground	Continuity
Connector	Terminal		
M71	6		Not existed

Is inspection result normal?

- YES >> GO TO 2.  
 NO >> Repair harness or connector.

#### 2. CHECK RGB (G: GREEN) SIGNAL

1. Connect display unit connector and AV control unit connector.
2. Turn ignition switch ON.
3. Check signal between display unit harness connector and ground.

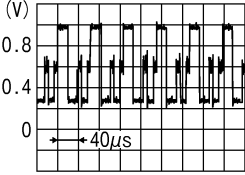
(+)		(-)	Condition	Reference value
Display unit				
Connector	Terminal			
M71	6	Ground	Start confirmation/adjustment mode, and then display color bar by selecting "Color Spectrum Bar" on DISPLAY DIAGNOSIS screen.	 <p style="text-align: right; font-size: small;">JSNIA1030ZZ</p>

Is inspection result normal?

- YES >> Replace display unit. Refer to [AV-112, "Exploded View"](#).  
 NO >> Replace AV control unit. Refer to [AV-110, "Exploded View"](#).

A  
B  
C  
D  
E  
F  
G  
H  
I  
J  
K  
L  
M  
AV  
O  
P

# RGB (B: BLUE) SIGNAL CIRCUIT

< DTC/CIRCUIT DIAGNOSIS >

[BASE AUDIO WITHOUT NAVIGATION]

## RGB (B: BLUE) SIGNAL CIRCUIT

### Description

INFOID:000000006472451

Transmit the image displayed with AV control unit with RGB signal to the display unit.

### Diagnosis Procedure

INFOID:000000006472452

#### 1. CHECK CONTINUITY RGB (B: BLUE) SIGNAL CIRCUIT

1. Turn ignition switch OFF.
2. Disconnect display unit connector and AV control unit connector.
3. Check continuity between display unit harness connector and AV control unit harness connector.

Display unit		AV control unit		Continuity
Connector	Terminal	Connector	Terminal	
M71	18	M202	45	Existed

4. Check continuity between display unit harness connector and ground.

Display unit		Ground	Continuity
Connector	Terminal		
M71	18		Not existed

Is inspection result normal?

- YES >> GO TO 2.  
 NO >> Repair harness or connector.

#### 2. CHECK RGB (B: BLUE) SIGNAL

1. Connect display unit connector and AV control unit connector.
2. Turn ignition switch ON.
3. Check signal between display unit harness connector and ground.

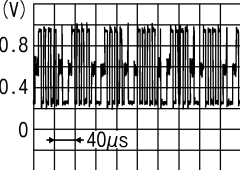
(+)		(-)	Condition	Reference value
Display unit				
Connector	Terminal			
M71	18	Ground	Start confirmation/adjustment mode, and then display color bar by selecting "Color Spectrum Bar" on DISPLAY DIAGNOSIS screen.	 <p style="text-align: right;">JSNIA1031ZZ</p>

Is inspection result normal?

- YES >> Replace display unit. Refer to [AV-112, "Exploded View"](#).  
 NO >> Replace AV control unit. Refer to [AV-110, "Exploded View"](#).

# RGB SYNCHRONIZING SIGNAL CIRCUIT

< DTC/CIRCUIT DIAGNOSIS >

[BASE AUDIO WITHOUT NAVIGATION]

## RGB SYNCHRONIZING SIGNAL CIRCUIT

### Description

INFOID:000000006472453

Transmit the RGB synchronizing signal to the display unit so as to synchronize the RGB image displayed with AV control unit.

### Diagnosis Procedure

INFOID:000000006472454

#### 1. CHECK CONTINUITY RGB SYNCHRONIZING SIGNAL CIRCUIT

1. Turn ignition switch OFF.
2. Disconnect display unit connector and AV control unit connector.
3. Check continuity between display unit harness connector and AV control unit harness connector.

Display unit		AV control unit		Continuity
Connector	Terminal	Connector	Terminal	
M71	19	M202	42	Existed

4. Check continuity between display unit harness connector and ground.

Display unit		Ground	Continuity
Connector	Terminal		
M71	19		Not existed

Is the inspection result normal?

YES >> GO TO 2.

NO >> Repair harness or connector.

#### 2. CHECK RGB SYNCHRONIZING SIGNAL

1. Connect display unit connector and AV control unit connector.
2. Turn ignition switch ON.
3. Check signal between display unit harness connector and ground.

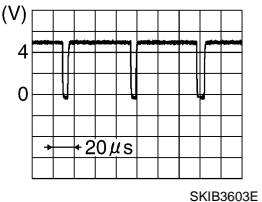
(+)		(-)	Reference value
Display unit			
Connector	Terminal		
M71	19	Ground	

Is the inspection result normal?

YES >> Replace display unit. Refer to [AV-112, "Exploded View"](#).

NO >> Replace AV control unit. Refer to [AV-110, "Exploded View"](#).

# RGB AREA (YS) SIGNAL CIRCUIT

< DTC/CIRCUIT DIAGNOSIS >

[BASE AUDIO WITHOUT NAVIGATION]

## RGB AREA (YS) SIGNAL CIRCUIT

### Description

INFOID:000000006472455

Transmits the display area of RGB image displayed by AV control unit with RGB area (YS) signal to display unit.

### Diagnosis Procedure

INFOID:000000006472456

#### 1. CHECK CONTINUITY RGB AREA (YS) SIGNAL CIRCUIT

1. Turn ignition switch OFF.
2. Disconnect display unit connector and AV control unit connector.
3. Check continuity between display unit harness connector and AV control unit harness connector.

Display unit		AV control unit		Continuity
Connector	Terminal	Connector	Terminal	
M71	9	M202	40	Existed

4. Check continuity between display unit harness connector and ground.

Display unit		Ground	Continuity
Connector	Terminal		
M71	9		Not existed

Is the inspection result normal?

- YES >> GO TO 2.  
 NO >> Repair harness or connector.

#### 2. CHECK RGB AREA (YS) SIGNAL

1. Connect display unit connector and AV control unit connector.
2. Turn ignition switch ON.
3. Check signal between display unit harness connector and ground.

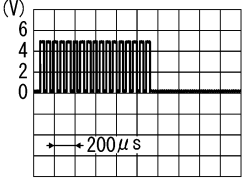
(+)		(-)	Condition	Reference value (Approx.)
Connector	Terminal			
M71	9	Ground	At RGB image is displayed.	5.0 V
			At camera image is displayed.	 <p style="text-align: right;">PKIB4948J</p>

Is the inspection result normal?

- YES >> Replace display unit. Refer to [AV-112, "Exploded View"](#).  
 NO >> Replace AV control unit. Refer to [AV-110, "Exploded View"](#).



# CAMERA IMAGE SIGNAL CIRCUIT

< DTC/CIRCUIT DIAGNOSIS >

[BASE AUDIO WITHOUT NAVIGATION]

## CAMERA IMAGE SIGNAL CIRCUIT

### Description

INFOID:000000006472457

- AV control unit outputs camera power supply to rear view camera and inputs rear view camera image signal from rear view camera when the reverse signal is input.
- The AV control unit that inputs the camera image signal transmits the camera image signal to the display unit.

### Diagnosis Procedure

INFOID:000000006472458

#### 1. CHECK CONTINUITY CAMERA POWER SUPPLY CIRCUIT

1. Turn ignition switch OFF.
2. Disconnect AV control unit connector and rear view camera connector.
3. Check continuity between AV control unit harness connector and rear view camera harness connector.

AV control unit		Rear view camera		Continuity
Connector	Terminal	Connector	Terminal	
M203	73	B311	1	Existed

4. Check continuity between AV control unit harness connector and ground.

AV control unit		Ground	Continuity
Connector	Terminal		
M203	73		Not existed

Is inspection result normal?

- YES >> GO TO 2.  
 NO >> Repair harness or connector.

#### 2. CHECK VOLTAGE CAMERA POWER SUPPLY

1. Connect AV control unit connector and rear view camera connector.
2. Turn ignition switch ON.
3. Shift the selector lever to "R".
4. Check voltage between AV control unit harness connector and ground.

(+)		(-)	Condition	Voltage (Approx.)
Connector	Terminal			
M203	73	Ground	Shift position is "R".	6.0 V

Is inspection result normal?

- YES >> GO TO 3.  
 NO >> Replace AV control unit. Refer to [AV-110, "Exploded View"](#).

#### 3. CHECK CONTINUITY CAMERA IMAGE SIGNAL CIRCUIT

1. Turn ignition switch OFF.
2. Disconnect AV control unit connector and rear view camera connector.
3. Check continuity between AV control unit harness connector and rear view camera harness connector.

AV control unit		Rear view camera		Continuity
Connector	Terminal	Connector	Terminal	
M203	62	B311	3	Existed

4. Check continuity between AV control unit harness connector and ground.

A  
B  
C  
D  
E  
F  
G  
H  
I  
J  
K  
L  
M  
O  
P

AV

# CAMERA IMAGE SIGNAL CIRCUIT

< DTC/CIRCUIT DIAGNOSIS >

[BASE AUDIO WITHOUT NAVIGATION]

AV control unit		Ground	Continuity
Connector	Terminal		
M203	62		Not existed

Is inspection result normal?

YES >> GO TO 4.

NO >> Repair harness or connector.

## 4. CHECK CAMERA IMAGE SIGNAL

1. Connect AV control unit connector and rear view camera connector.
2. Turn ignition switch ON.
3. Shift the selector lever to "R".
4. Check signal between AV control unit harness connector and ground.

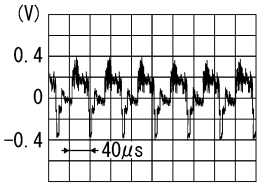
(+)		(-)	Condition	Reference value
AV control unit				
Connector	Terminal			
M203	62	Ground	At rear view camera image is displayed.	 <p style="text-align: right; font-size: small;">SKIB2251J</p>

Is inspection result normal?

YES >> Replace AV control unit. Refer to [AV-110, "Exploded View"](#).

NO >> Replace rear view camera. Refer to [AV-123, "Exploded View"](#).

# COMPOSITE IMAGE SIGNAL CIRCUIT

< DTC/CIRCUIT DIAGNOSIS >

[BASE AUDIO WITHOUT NAVIGATION]

## COMPOSITE IMAGE SIGNAL CIRCUIT

### Description

INFOID:000000006472459

AV control unit that inputs the camera image signal transmits the composite image signal to the display unit.

### Diagnosis Procedure

INFOID:000000006472460

#### 1. CHECK CONTINUITY COMPOSITE IMAGE SIGNAL CIRCUIT

1. Turn ignition switch OFF.
2. Disconnect AV control unit connector and display unit connector.
3. Check continuity between AV control unit harness connector and display unit harness connector.

AV control unit		Display unit		Continuity
Connector	Terminal	Connector	Terminal	
M202	47	M71	15	Existed

4. Check continuity between AV control unit harness connector and ground.

AV control unit		Ground	Continuity
Connector	Terminal		
M202	47		Not existed

Is the inspection result normal?

- YES >> GO TO 2.  
 NO >> Repair harness or connector.

#### 2. CHECK COMPOSITE IMAGE SIGNAL

1. Connect AV control unit connector and display unit connector.
2. Turn ignition switch ON.
3. Check signal between AV control unit harness connector and ground.

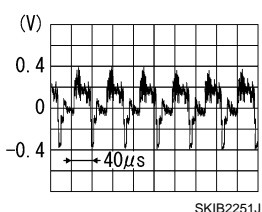
(+)		(-)	Condition	Reference value
AV control unit				
Connector	Terminal			
M202	47	Ground	At camera image is displayed.	

Is the inspection result normal?

- YES >> Replace display unit. Refer to [AV-112, "Exploded View"](#).  
 NO >> Replace AV control unit. Refer to [AV-110, "Exploded View"](#).

A  
B  
C  
D  
E  
F  
G  
H  
I  
J  
K  
L  
M  
AV  
O  
P

# HORIZONTAL SYNCHRONIZING (HP) SIGNAL CIRCUIT

< DTC/CIRCUIT DIAGNOSIS >

[BASE AUDIO WITHOUT NAVIGATION]

## HORIZONTAL SYNCHRONIZING (HP) SIGNAL CIRCUIT

### Description

INFOID:000000006472461

In composite image (camera image), transmit the vertical synchronizing (VP) signal and horizontal synchronizing (HP) signal from display unit to AV control unit so as to synchronize the RGB images displayed with AV control unit such as the image quality adjusting menu, etc.

### Diagnosis Procedure

INFOID:000000006472462

#### 1. CHECK CONTINUITY HORIZONTAL SYNCHRONIZING (HP) SIGNAL CIRCUIT

1. Turn ignition switch OFF.
2. Disconnect display unit connector and AV control unit connector.
3. Check continuity between display unit harness connector and AV control unit harness connector.

Display unit		AV control unit		Continuity
Connector	Terminal	Connector	Terminal	
M71	8	M202	38	Existed

4. Check continuity between display unit harness connector and ground.

Display unit		Ground	Continuity
Connector	Terminal		
M71	8		Not existed

Is the inspection result normal?

YES >> GO TO 2.

NO >> Repair harness or connector.

#### 2. CHECK HORIZONTAL SYNCHRONIZING (HP) SIGNAL

1. Connect display unit connector and AV control unit connector.
2. Turn ignition switch ON.
3. Check signal between display unit harness connector and ground.

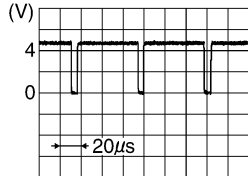
(+)		(-)	Reference value
Display unit			
Connector	Terminal		
M71	8	Ground	 SKIB3601E

Is the inspection result normal?

YES >> Replace AV control unit. Refer to [AV-110, "Exploded View"](#).

NO >> Replace display unit. Refer to [AV-112, "Exploded View"](#).

# VERTICAL SYNCHRONIZING (VP) SIGNAL CIRCUIT

< DTC/CIRCUIT DIAGNOSIS >

[BASE AUDIO WITHOUT NAVIGATION]

## VERTICAL SYNCHRONIZING (VP) SIGNAL CIRCUIT

### Description

INFOID:000000006472463

In composite image (camera image), transmit the vertical synchronizing (VP) signal and horizontal synchronizing (HP) signal from display unit to AV control unit so as to synchronize the RGB images displayed with AV control unit such as the image quality adjusting menu, etc.

### Diagnosis Procedure

INFOID:000000006472464

#### 1. CHECK CONTINUITY VERTICAL SYNCHRONIZING (VP) SIGNAL CIRCUIT

1. Turn ignition switch OFF.
2. Disconnect display unit connector and AV control unit connector.
3. Check continuity between display unit harness connector and AV control unit harness connector.

Display unit		AV control unit		Continuity
Connector	Terminal	Connector	Terminal	
M71	20	M202	50	Existed

4. Check continuity between display unit harness connector and ground.

Display unit		Ground	Continuity
Connector	Terminal		
M71	20		Not existed

Is the inspection result normal?

- YES >> GO TO 2.  
 NO >> Repair harness or connector.

#### 2. CHECK VERTICAL SYNCHRONIZING (VP) SIGNAL

1. Connect display unit connector and AV control unit connector.
2. Turn ignition switch ON.
3. Check signal between display unit harness connector and ground.

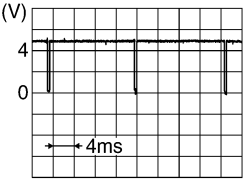
(+)		(-)	Reference value
Display unit			
Connector	Terminal		
M71	20	Ground	 <p style="text-align: right; font-size: small;">SKIB3598E</p>

Is the inspection result normal?

- YES >> Replace AV control unit. Refer to [AV-110, "Exploded View"](#).  
 NO >> Replace display unit. Refer to [AV-112, "Exploded View"](#).

AV

# DISK EJECT SIGNAL CIRCUIT

< DTC/CIRCUIT DIAGNOSIS >

[BASE AUDIO WITHOUT NAVIGATION]

## DISK EJECT SIGNAL CIRCUIT

### Description

INFOID:000000006472465

The eject signal is output to AV control unit when the eject switch of multifunction switch is pressed.

### Diagnosis Procedure

INFOID:000000006472466

#### 1. CHECK CONTINUITY DISK EJECT SIGNAL CIRCUIT

1. Turn ignition switch OFF.
2. Disconnect multifunction switch connector and AV control unit connector.
3. Check continuity between multifunction switch harness connector and AV control unit harness connector.

Multifunction switch		AV control unit		Continuity
Connector	Terminal	Connector	Terminal	
M72	14	M204	96	Existed

4. Check continuity between multifunction switch harness connector and ground.

Multifunction switch		Ground	Continuity
Connector	Terminal		
M72	14		Not existed

Is the inspection result normal?

- YES >> GO TO 2.  
NO >> Repair harness or connector.

#### 2. CHECK AV CONTROL UNIT VOLTAGE

1. Connect multifunction switch connector and AV control unit connector.
2. Turn ignition switch ON.
3. Check voltage between AV control unit harness connector and ground.

(+)		(-)	Condition	Voltage (Approx.)
AV control unit				
Connector	Terminal			
M204	96	Ground	Pressing the eject switch	0 V
			Except for above	3.3 V

Is the inspection result normal?

- YES >> Replace preset switch. Refer to [AV-119, "Exploded View"](#).  
NO >> Replace AV control unit. Refer to [AV-110, "Exploded View"](#).

# MICROPHONE SIGNAL CIRCUIT

< DTC/CIRCUIT DIAGNOSIS >

[BASE AUDIO WITHOUT NAVIGATION]

## MICROPHONE SIGNAL CIRCUIT

### Description

INFOID:000000006472467

Supply power from TEL adapter unit to microphone. The microphone transmits the sound/voice to the microphone.

### Diagnosis Procedure

INFOID:000000006472468

#### 1. CHECK CONTINUITY BETWEEN TEL ADAPTER UNIT AND MICROPHONE CIRCUIT

1. Turn ignition switch OFF.
2. Disconnect TEL adapter unit connector and microphone connector.
3. Check continuity between TEL adapter unit harness connector and microphone harness connector.

TEL adapter unit		Microphone		Continuity
Connector	Terminals	Connector	Terminals	
B237	7	R7	1	Existed
	8		2	
	29		4	

4. Check continuity between TEL adapter unit harness connector and ground.

TEL adapter unit		Ground	Continuity
Connector	Terminals		
M237	7		Not existed
	29		

Is the inspection result normal?

YES >> GO TO 2.

NO >> Repair harness or connector.

#### 2. CHECK VOLTAGE MICROPHONE VCC

1. Connect TEL adapter unit connector.
2. Turn ignition switch ON.
3. Check voltage between TEL adapter unit harness connector.

(+)		(-)		Voltage (Approx.)
TEL adapter unit		TEL adapter unit		
Connector	Terminal	Connector	Terminal	
B237	29	B237	8	5.0 V

Is the inspection result normal?

YES >> GO TO 3.

NO >> Replace TEL adapter unit. Refer to [AV-126. "Exploded View"](#).

#### 3. CHECK MICROPHONE SIGNAL

1. Connect microphone connector.
2. Check signal between TEL adapter unit harness connector.

A  
B  
C  
D  
E  
F  
G  
H  
I  
J  
K  
L  
M  
AV  
O  
P

# MICROPHONE SIGNAL CIRCUIT

< DTC/CIRCUIT DIAGNOSIS >

[BASE AUDIO WITHOUT NAVIGATION]

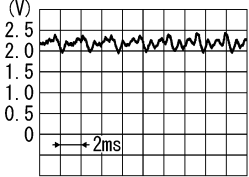
(+)		(-)		Condition	Reference value
TEL adapter unit		TEL adapter unit			
Connector	Terminal	Connector	Terminal		
B237	7	B237	8	give a voice.	 <p style="text-align: right;">PKIB5037J</p>

Is the inspection result normal?

- YES >> Replace TEL adapter unit. Refer to [AV-126, "Exploded View"](#).
- NO >> Replace microphone. Refer to [AV-122, "Exploded View"](#).



# CONTROL SIGNAL CIRCUIT

< DTC/CIRCUIT DIAGNOSIS >

[BASE AUDIO WITHOUT NAVIGATION]

## CONTROL SIGNAL CIRCUIT

### Description

INFOID:000000006472469

TEL adapter unit identifies the vehicle model according to the control signal and performs the control.

### Diagnosis Procedure

INFOID:000000006472470

#### 1. CHECK CONTINUITY CONTROL SIGNAL CIRCUIT

1. Turn ignition switch OFF.
2. Disconnect TEL adapter unit connector.
3. Check continuity between TEL adapter unit harness connector and ground.

TEL adapter unit		Ground	Continuity
Connector	Terminals		
B237	21	Ground	Existed
	23		
	27		

#### Is the inspection result normal?

- YES >> Replace TEL adapter unit. Refer to [AV-126, "Exploded View"](#).  
NO >> Repair harness or connector.

A  
B  
C  
D  
E  
F  
G  
H  
I  
J  
K  
L  
M

AV

O  
P

# STEERING SWITCH SIGNAL A CIRCUIT

< DTC/CIRCUIT DIAGNOSIS >

[BASE AUDIO WITHOUT NAVIGATION]

## STEERING SWITCH SIGNAL A CIRCUIT

### Description

INFOID:000000006472471

Transmits the steering switch signal to AV control unit.

### Diagnosis Procedure

INFOID:000000006472472

#### 1.CHECK STEERING SWITCH SIGNAL A CIRCUIT

1. Disconnect AV control unit connector and spiral cable connector.
2. Check continuity between AV control unit harness connector and spiral cable harness connector.

AV control unit		Spiral cable		Continuity
Connector	Terminal	Connector	Terminal	
M201	6	M36	24	Existed

3. Check continuity between AV control unit harness connector and ground.

AV control unit		Ground	Continuity
Connector	Terminal		
M201	6		Not existed

Is the inspection result normal?

- YES >> GO TO 2.  
NO >> Repair harness or connector.

#### 2.CHECK SPIRAL CABLE

Check spiral cable.

Is the inspection result normal?

- YES >> GO TO 3.  
NO >> Replace spiral cable.

#### 3.CHECK AV CONTROL UNIT VOLTAGE

1. Connect AV control unit connector and spiral cable connector.
2. Turn ignition switch ON.
3. Check voltage between AV control unit harness connector.

(+)		(-)		Voltage (Approx.)
AV control unit		AV control unit		
Connector	Terminal	Connector	Terminal	
M201	6	M201	15	3.3 V

Is the inspection result normal?

- YES >> GO TO 4.  
NO >> Replace AV control unit. Refer to [AV-110, "Exploded View"](#).

#### 4.CHECK STEERING SWITCH

1. Turn ignition switch OFF.
2. Check steering switch. Refer to [AV-98, "Component Inspection"](#).

Is the inspection result normal?

- YES >> INSPECTION END  
NO >> Replace steering switch. Refer to [ST-14, "Exploded View"](#).

### Component Inspection

INFOID:000000006472473

Measure the resistance between the steering switch connector terminals 14 to 17 and 15 to 17.

# STEERING SWITCH SIGNAL A CIRCUIT

[BASE AUDIO WITHOUT NAVIGATION]

## < DTC/CIRCUIT DIAGNOSIS >

### Standard

Between terminals 14 and 17

 switch ON	: 716 – 730 Ω
MENU DOWN switch ON	: 318 – 324 Ω
MENU UP switch ON	: 120 – 122 Ω
SOURCE switch ON	: 0 Ω

Between terminals 15 and 17

 switch ON	: 318 – 324 Ω
VOL UP switch ON	: 120 – 122 Ω
VOL DOWN switch ON	: 0 Ω

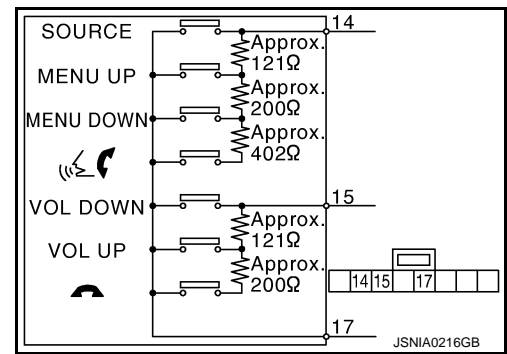

A  
B  
C  
D  
E  
F  
G  
H  
I  
J  
K  
L  
M

AV

O  
P

# STEERING SWITCH SIGNAL B CIRCUIT

< DTC/CIRCUIT DIAGNOSIS >

[BASE AUDIO WITHOUT NAVIGATION]

## STEERING SWITCH SIGNAL B CIRCUIT

### Description

INFOID:000000006472474

Transmits the steering switch signal to AV control unit.

### Diagnosis Procedure

INFOID:000000006472475

#### 1.CHECK STEERING SWITCH SIGNAL B CIRCUIT

1. Disconnect AV control unit connector and spiral cable connector.
2. Check continuity between AV control unit harness connector and spiral cable harness connector.

AV control unit		Spiral cable		Continuity
Connector	Terminal	Connector	Terminal	
M201	16	M36	31	Existed

3. Check continuity between AV control unit harness connector and ground.

AV control unit		Ground	Continuity
Connector	Terminal		
M201	16		Not existed

Is the inspection result normal?

- YES >> GO TO 2.  
NO >> Repair harness or connector.

#### 2.CHECK SPIRAL CABLE

Check spiral cable.

Is the inspection result normal?

- YES >> GO TO 3.  
NO >> Replace spiral cable.

#### 3.CHECK AV CONTROL UNIT VOLTAGE

1. Connect AV control unit connector and spiral cable connector.
2. Turn ignition switch ON.
3. Check voltage between AV control unit harness connector.

(+)		(-)		Voltage (Approx.)
AV control unit		AV control unit		
Connector	Terminal	Connector	Terminal	
M201	16	M201	15	3.3 V

Is the inspection result normal?

- YES >> GO TO 4.  
NO >> Replace AV control unit. Refer to [AV-110, "Exploded View"](#).

#### 4.CHECK STEERING SWITCH

1. Turn ignition switch OFF.
2. Check steering switch. Refer to [AV-100, "Component Inspection"](#).

Is the inspection result normal?

- YES >> INSPECTION END  
NO >> Replace steering switch. Refer to [ST-14, "Exploded View"](#).

### Component Inspection

INFOID:000000006472476

Measure the resistance between the steering switch connector terminals 14 to 17 and 15 to 17.

# STEERING SWITCH SIGNAL B CIRCUIT

[BASE AUDIO WITHOUT NAVIGATION]

## < DTC/CIRCUIT DIAGNOSIS >

### Standard

Between terminals 14 and 17

 switch ON	: 716 – 730 Ω
MENU DOWN switch ON	: 318 – 324 Ω
MENU UP switch ON	: 120 – 122 Ω
SOURCE switch ON	: 0 Ω

Between terminals 15 and 17

 switch ON	: 318 – 324 Ω
VOL UP switch ON	: 120 – 122 Ω
VOL DOWN switch ON	: 0 Ω

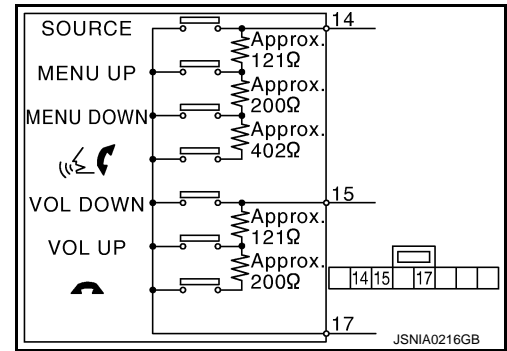

A  
B  
C  
D  
E  
F  
G  
H  
I  
J  
K  
L  
M

AV

O  
P

# STEERING SWITCH GROUND CIRCUIT

< DTC/CIRCUIT DIAGNOSIS >

[BASE AUDIO WITHOUT NAVIGATION]

## STEERING SWITCH GROUND CIRCUIT

### Description

INFOID:000000006472477

Transmits the steering switch signal to AV control unit.

### Diagnosis Procedure

INFOID:000000006472478

#### 1. CHECK STEERING SWITCH SIGNAL GND CIRCUIT

1. Disconnect AV control unit connector and spiral cable connector.
2. Check continuity between AV control unit harness connector and spiral cable harness connector.

AV control unit		Spiral cable		Continuity
Connector	Terminal	Connector	Terminal	
M201	15	M36	33	Existed

Is the inspection result normal?

- YES >> GO TO 2.  
NO >> Repair harness or connector.

#### 2. CHECK SPIRAL CABLE

Check spiral cable.

Is the inspection result normal?

- YES >> GO TO 3.  
NO >> Replace spiral cable.

#### 3. CHECK GROUND CIRCUIT

1. Connect AV control unit connector.
2. Check continuity between AV control unit harness connector and ground.

AV control unit		Ground	Continuity
Connector	Terminal		
M201	15		Existed

Is the inspection result normal?

- YES >> GO TO 4.  
NO >> Replace AV control unit. Refer to [AV-110, "Exploded View"](#).

#### 4. CHECK STEERING SWITCH

1. Turn ignition switch OFF.
2. Check steering switch. Refer to [AV-102, "Component Inspection"](#).

Is the inspection result normal?

- YES >> INSPECTION END  
NO >> Replace steering switch. Refer to [ST-14, "Exploded View"](#).

### Component Inspection

INFOID:000000006472479

Measure the resistance between the steering switch connector terminals 14 to 17 and 15 to 17.

# STEERING SWITCH GROUND CIRCUIT

[BASE AUDIO WITHOUT NAVIGATION]

< DTC/CIRCUIT DIAGNOSIS >

Standard

Between terminals 14 and 17

-  switch ON : 716 – 730 Ω
- MENU UP switch ON : 318 – 324 Ω
- MENU DOWN switch ON : 120 – 122 Ω
- SOURCE switch ON : 0 Ω

Between terminals 15 and 17

-  switch ON : 318 – 324 Ω
- VOL UP switch ON : 120 – 122 Ω
- VOL DOWN switch ON : 0 Ω

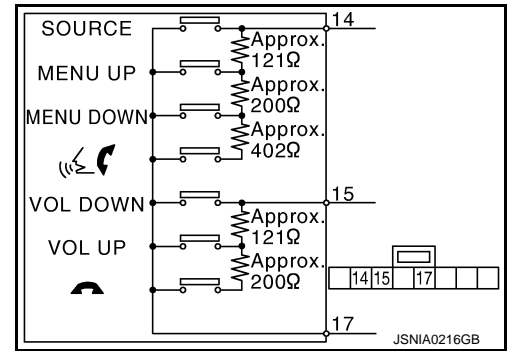

A  
B  
C  
D  
E  
F  
G  
H  
I  
J  
K  
L  
M

AV

O  
P

SYMPTOM DIAGNOSIS

MULTI AV SYSTEM SYMPTOMS

Symptom Table

INFOID:000000006472480

OPERATION

Symptoms	Check items	Possible malfunction location / Action to take
Multifunction switch and preset switch operation does not work.	<ul style="list-style-type: none"> <li>All switches cannot be operated.</li> <li>"MULTI AV" is displayed on system selection screen when the CONSULT-III is started.</li> </ul>	<ul style="list-style-type: none"> <li>Multifunction switch power supply and ground circuit.</li> <li>AV communication circuit between AV control unit and multifunction switch.</li> </ul> Perform "Self diagnosis Result" of "MULTI AV" with CONSULT-III. Refer to <a href="#">AV-27, "CONSULT - III Function"</a> .
	<ul style="list-style-type: none"> <li>All switches cannot be operated.</li> <li>"MULTI AV" is not displayed on system selection screen when the CONSULT-III is initialized.</li> </ul>	AV control unit power supply and ground circuit malfunction. Refer to <a href="#">AV-81, "AV CONTROL UNIT : Diagnosis Procedure"</a> .
	Only specified switch cannot be operated.	Multifunction switch or preset switch malfunction. Perform multifunction switch and preset switch self-diagnosis function. Refer to <a href="#">AV-18, "On Board Diagnosis Function"</a> .
Fuel economy display, vehicle setting operation is abnormal.	There is malfunction in the CONSULT-III self-diagnosis result. Refer to <a href="#">AV-27, "CONSULT - III Function"</a> .	Perform detected DTC diagnosis. Refer to <a href="#">AV-38, "DTC Index"</a> .
	There is no malfunction in the self-diagnosis results. Refer to <a href="#">AV-27, "CONSULT - III Function"</a> .	Ignition signal circuit malfunction. (AV control unit)

RELATED TO HANDS-FREE PHONE

Simple Check for Bluetooth™ Communication

If cellular phone and AV control unit cannot be connected with Bluetooth™ communication, following procedure allows the technician to judge which device has malfunction.

1. Turn on a cellular phone, not connecting Bluetooth™ communication.
2. Start CONSULT-III, then start Windows®.
3. Set CONSULT-III near a cellular phone.
4. When operated Bluetooth™ registration by cellular phone, check if CONSULT-III\* would be displayed on the device name. (If other Bluetooth™ device is located near cellular phone, a name of the device would be displayed also.)

**NOTE:**

\*:Displayed device name is "NISSAN-\*\*\*\*\*".

- If no device name is displayed, cellular phone is malfunctioning. Repair the cellular phone first, then perform diagnosis.
- If CONSULT-III is displayed on device name, cellular phone is normal. Perform diagnosis as per the following table.

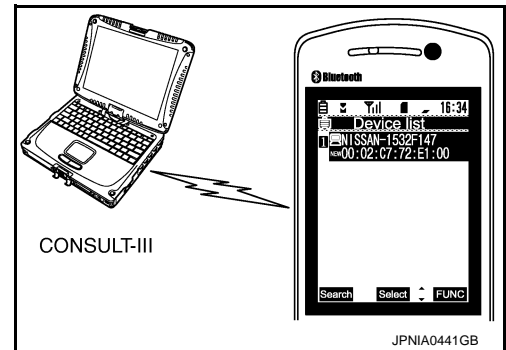

Trouble Diagnosis Chart by Symptom



# MULTI AV SYSTEM SYMPTOMS

< SYMPTOM DIAGNOSIS >

[BASE AUDIO WITHOUT NAVIGATION]

Symptoms	Check items	Probable malfunction location
Does not recognize cellular phone connection. (No connection is displayed on the display at the guide.)	Repeat the registration of cellular phone.	TEL adapter unit malfunction. Refer to <a href="#">AV-126, "Exploded View"</a> .
Hands-free phone cannot be established.	Both the reception and the speech cannot be performed	<ul style="list-style-type: none"> <li>Perform "Self diagnosis Result" of "MULTI AV" with CONSULT-III. Refer to <a href="#">AV-27, "CONSULT - III Function"</a>.</li> <li>No malfunction. TEL adapter unit malfunction. Refer to <a href="#">AV-126, "Exploded View"</a>.</li> <li>Malfunction is detected. Perform detected DTC diagnosis. Refer to <a href="#">AV-38, "DTC Index"</a>.</li> </ul>
The other party's voice cannot be heard by hands-free phone.	The operation of the "☞☜" switch can be performed.	TEL voice signal circuit malfunction between TEL adapter unit and AV control unit.
	The operation of the "☞☜" switch cannot be performed.	Control signal circuit. Refer to <a href="#">AV-97, "Diagnosis Procedure"</a> .
Originating sound is not heard by the other party with hands-free phone communication.	Sound operation function is normal.	TEL adapter unit. Refer to <a href="#">AV-126, "Exploded View"</a> .
	Sound operation function does not work.	Microphone signal circuit malfunction. Refer to <a href="#">AV-95, "Diagnosis Procedure"</a> .
The system cannot be operated.	<ul style="list-style-type: none"> <li>The retractable hard top is fully closed.</li> <li>"SOURCE", "MENU UP", and "MENU DOWN", but "☞☜" switches are not operated.</li> </ul>	<ul style="list-style-type: none"> <li>Check steering switch. Refer to <a href="#">AV-98, "Component Inspection"</a>.</li> <li>No malfunction. Roof status signal circuit malfunction.</li> <li>Malfunction is detected. Replace steering switch. Refer to <a href="#">ST-14, "Exploded View"</a>.</li> </ul>
	<ul style="list-style-type: none"> <li>The retractable hard top is fully closed.</li> <li>"SOURCE", "MENU UP", "MENU DOWN", and "☞☜" switches of steering switch are not operated.</li> </ul>	Steering switch signal B circuit malfunction. Refer to <a href="#">AV-100, "Diagnosis Procedure"</a>
	All steering switches do not work.	Steering switch ground circuit malfunction. Refer to <a href="#">AV-102, "Diagnosis Procedure"</a> .

## RELATED TO RGB IMAGE

Symptoms	Check items	Possible malfunction location / Action to take
RGB image is not shown.	There is malfunction in the CONSULT-III self-diagnosis result. Refer to <a href="#">AV-27, "CONSULT - III Function"</a> .	Perform detected DTC diagnosis. Refer to <a href="#">AV-38, "DTC Index"</a> .
	There is no malfunction in CONSULT-III self-diagnosis results. Refer to <a href="#">AV-27, "CONSULT - III Function"</a> .	Vertical synchronizing (VP) signal circuit. Refer to <a href="#">AV-93, "Diagnosis Procedure"</a> .
Color of RGB image is not proper.	Light blue (Cyan) tint.	RGB signal (R: red) circuit. Refer to <a href="#">AV-84, "Diagnosis Procedure"</a> .
	Purple (Magenta) tint.	RGB signal (G: green) circuit. Refer to <a href="#">AV-85, "Diagnosis Procedure"</a> .
	Screen looks yellowish.	RGB signal (B: blue) circuit. Refer to <a href="#">AV-86, "Diagnosis Procedure"</a> .
RGB screen is rolling.	—	RGB synchronizing signal circuit. Refer to <a href="#">AV-87, "Diagnosis Procedure"</a> .

## RELATED TO AUDIO

## MULTI AV SYSTEM SYMPTOMS

< SYMPTOM DIAGNOSIS >

[BASE AUDIO WITHOUT NAVIGATION]

Symptoms	Check items	Possible malfunction location / Action to take
The disk cannot be removed.	—	Disk eject signal circuit. Refer to <a href="#">AV-94, "Diagnosis Procedure"</a> .
Audio sound is not heard.	No sound from all speakers.	AV control unit malfunction. Refer to <a href="#">AV-110, "Exploded View"</a> .
	Sound is heard only from specific places.	Sound signals circuit of suspect system.
Satellite radio is not received.	There is no malfunction in CONSULT-III self-diagnosis results. Refer to <a href="#">AV-27, "CONSULT - III Function"</a> .	Perform the following inspection procedure. 1. Check satellite radio antenna (antenna base) mounting nut for looseness. <b>NOTE:</b> Tightening torque: 6.5 N·m (0.66 kg·m, 58 in·lb.) 2. Visually check for satellite radio antenna feeder.
	There is malfunction in the CONSULT-III self-diagnosis result. Refer to <a href="#">AV-27, "CONSULT - III Function"</a> .	Perform detected DTC diagnosis. Refer to <a href="#">AV-38, "DTC Index"</a> .
The sound of satellite radio is not heard.	Other audio sounds are normal.	Satellite radio sound signal circuit between AV control unit and satellite radio tuner.
It does not change to satellite radio mode.	There is malfunction in the CONSULT-III self-diagnosis result. Refer to <a href="#">AV-27, "CONSULT - III Function"</a> .	Perform detected DTC diagnosis. Refer to <a href="#">AV-38, "DTC Index"</a> .
AM/FM radio is not received.	Other audio sounds are normal.	<ul style="list-style-type: none"> <li>• Antenna amp. ON signal circuit.</li> <li>• Antenna base.</li> <li>• Antenna feeder.</li> </ul>

### RELATED TO USB

**NOTE:**

Check that there is no malfunction of USB equipment main body before performing a diagnosis.

Symptoms	Check items	Possible malfunction location / Action to take
iPod® or USB memory can not be recognized.	—	<ul style="list-style-type: none"> <li>• USB harness malfunction.</li> <li>• USB connector malfunction.</li> </ul>

iPod® is a trademark of Apple inc., registered in the U.S. and other countries.

### RELATED TO STEERING SWITCH

Symptoms	Probable malfunction location
None of the steering switch operations work.	Steering switch ground circuit malfunction. Refer to <a href="#">AV-102, "Diagnosis Procedure"</a> .
Only specified switch cannot be operated.	<ul style="list-style-type: none"> <li>• Check steering switch. Refer to <a href="#">AV-98, "Component Inspection"</a>.</li> <li>• Malfunction is detected. Replace steering switch. Refer to <a href="#">ST-14, "Exploded View"</a>.</li> </ul>
"SOURCE", "MENU UP", "MENU DOWN" and "⏪ ⏩" switches are not operated.	Steering switch signal A circuit. Refer to <a href="#">AV-98, "Diagnosis Procedure"</a> .
"VOL UP", "VOL DOWN" and "⏮ ⏭" switches are not operated.	Steering switch signal B circuit. Refer to <a href="#">AV-100, "Diagnosis Procedure"</a> .

### RELATED TO CAMERA

Trouble Diagnosis Chart by Symptom

# MULTI AV SYSTEM SYMPTOMS

< SYMPTOM DIAGNOSIS >

[BASE AUDIO WITHOUT NAVIGATION]

Symptoms	Check items	Probable malfunction location	
Camera image is not shown. (Vehicle width and possible route line is displayed.)	—	<ul style="list-style-type: none"> <li>• Camera image signal circuit. Refer to <a href="#">AV-89, "Diagnosis Procedure"</a>.</li> <li>• Composite image signal circuit. Refer to <a href="#">AV-91, "Diagnosis Procedure"</a>.</li> </ul>	A B
Camera image does not switch.	"Reverse" is not turned ON on "Vehicle Signals" screen of "Confirmation/Adjustment".	Reverse signal circuit malfunction.	C
	"Reverse" is turned ON on "Vehicle Signals" screen of "Confirmation/Adjustment".	AV control unit malfunction. Replace AV control unit. Refer to <a href="#">AV-110, "Exploded View"</a> .	D

E

F

G

H

I

J

K

L

M

AV

O

P

## NORMAL OPERATING CONDITION

< SYMPTOM DIAGNOSIS >

[BASE AUDIO WITHOUT NAVIGATION]

### NORMAL OPERATING CONDITION

#### Description

INFOID:000000006472481

#### BASIC OPERATIONS

Symptom	Possible cause	Possible solution
No image is displayed.	The brightness is at the lowest setting.	Adjust the brightness of the display.
	The systems in the video mode.	Press "DISC-AUX" to change the mode.
	The display is turned off.	Press "☀/☾ OFF" to turn on the display.
The screen is too dim. The movement is slow.	The temperature in the interior of the vehicle is low.	Wait until the interior of the vehicle has warmed up.
Some pixels in the display are darker or brighter than others.	This condition is an inherent characteristic of liquid crystal displays.	This is not a malfunction.
Some menu items cannot be selected.	Some menu items become unavailable while the vehicle is driven.	Park the vehicle in a safe location, and then operate the multi AV system.

#### RELATED TO VOICE RECOGNITION

##### Related to Telephone

The system should respond correctly to all voice commands without difficulty. If problems are encountered, try the following solutions.

Where the solutions are listed by number, try each solution in turn, starting with number 1, until the problem is resolved.

Symptom	Solution
System fails to interpret the command correctly.	1. Ensure that the command is valid.
	2. Ensure that the command is spoken after the tone.
	3. Speak clearly without pausing between words and at level appropriate to the ambient noise level in the vehicle.
	4. Ensure that the ambient noise level is not excessive (for example, windows open or defroster on). <b>NOTE:</b> If it is too noisy to use the phone, it is likely that the voice commands will not be recognized.
	5. If more than one command was said at a time, try saying the commands separately.
	6. If the system consistently fails to recognize commands, the voice training procedure should be carried out to improve the recognition response for the speaker. See "Speaker adaptation (SA) mode" earlier in this section. Refer to "OWNER'S MANUAL".
The system consistently selects the wrong voicetag	1. Ensure that the phone book entry name requested matches what was originally stored. This can be confirmed by using the "List Names" command.
	2. Replace one of the names being confused with a new name.
The system cannot be operated.	1. Make sure that the retractable hard top is usable. If the top is not working, contact an INFINITI dealer.
	2. Close the retractable hard top.
	3. Open and close the retractable hard top before operating the system.

#### RELATED TO AUDIO

- The majority of the audio malfunctions are the result of outside causes (bad CD, electromagnetic interference, etc.). Check the symptoms below to diagnose the malfunction.
- The vehicle itself can be a source of noise if noise prevention parts or electrical equipment is malfunctioning. Check if noise is caused and/or changed by engine speed, ignition switch turned to each position, and operation of each piece of electrical equipment, and then determine the cause.

##### NOTE:

- CD-R is not guaranteed to play because they can contain compressed audio (MP3, WMA, AAC, M4A) or could be incorrectly mastered by the customer on a computer.

## NORMAL OPERATING CONDITION

**[BASE AUDIO WITHOUT NAVIGATION]**

### < SYMPTOM DIAGNOSIS >

- Check if the CDs carry the Compact Disc Logo. If not, the disc is not mastered to the “red book” Compact Disc Standard and may not play.

Symptom	Cause and Counter measure
Cannot play	Check if the CD was inserted correctly.
	Check if the CD is scratched or dirty.
	Check if there is condensation inside the player, and if there is, wait until the condensation is gone (about 1 hour) before using the player.
	If there is a temperature increase error, the player will play correctly after it returns to the normal temperature.
	If there is a mixture of music CD files (CD-DA data) and MP3/WMA/AAC/M4A files on a CD, only the music CD files (CD-DA data) will be played.
	Files with extensions other than “.MP3”, “.WMA”, “.AAC”, “.M4A”, “.mp3”, “.wma”, “.aac” or “.m4a” cannot be played. In addition, the character codes and number of characters for folder names and file names should be in compliance with the specifications.
	Check if the disc or the file is generated in an irregular format, This may occur depending on the variation or the setting of MP3/WMA/AAC/M4A writing applications or other text editing applications.
	Check if the finalization process, such as session close and disc close, is done for the disc.
	Check if the CD is protected by copyright.
	Discs recorded in live file system format are not supported. (For Microsoft Windows Vista, check the settings.)
Poor sound quality	Check if the CD is scratched or dirty.
It takes a relatively long time before the music starts playing.	If there are many folder or file levels on the MP3/WMA/AAC/M4A CD, or if it is a multisession disc, some time may be required before the music starts playing.
Music cuts off or skips	The writing software and hardware combination might not match, or the writing speed, writing depth, writing width might not match the specifications. Try using the slowest writing speed.
Skipping with high bit rate files	Skipping may occur with large quantities if data such as for high bit rate data.
Move immediately to the next song when playing	When a non-MP3/WMA/AAC/M4A file has been given an extension of “.MP3”, “.WMA”, “.AAC”, “.M4A”, “.mp3”, “.wma”, “.aac” or “.m4a” or when play is prohibited by copyright protection, the player will skip to the next song.
The songs do not play back in the desired order.	The playback order is the order in which the files were written by the software, so the files might not play in the desired order.

Noise resulting from variations in field strength, such as fading noise and multi-path noise, or external noise from trains and other sources, is not a malfunction.

**NOTE:**

- Fading noise: This noise occurs because of variations in the field strength in a narrow range due to mountains or buildings blocking the signal.
- Multi-path noise: This noise results from a time difference between the broadcast waves directly from the station arriving at the antenna and the waves reflected by mountains or buildings.

A  
B  
C  
D  
E  
F  
G  
H  
I  
J  
K  
L  
M  
O  
P



# AV CONTROL UNIT

< REMOVAL AND INSTALLATION >

[BASE AUDIO WITHOUT NAVIGATION]

## REMOVAL AND INSTALLATION

### AV CONTROL UNIT

#### Exploded View

INFOID:000000006472482

#### CAUTION:

Before replacing AV control unit, perform "READ CONFIGURATION" to save or print current vehicle specification. For details, refer to [AV-67, "Description"](#).

#### REMOVAL

Refer to [IP-12, "A/T MODELS : Exploded View"](#) (A/T models) or [IP-23, "M/T MODELS : Exploded View"](#) (M/T models).

#### DISASSEMBLY

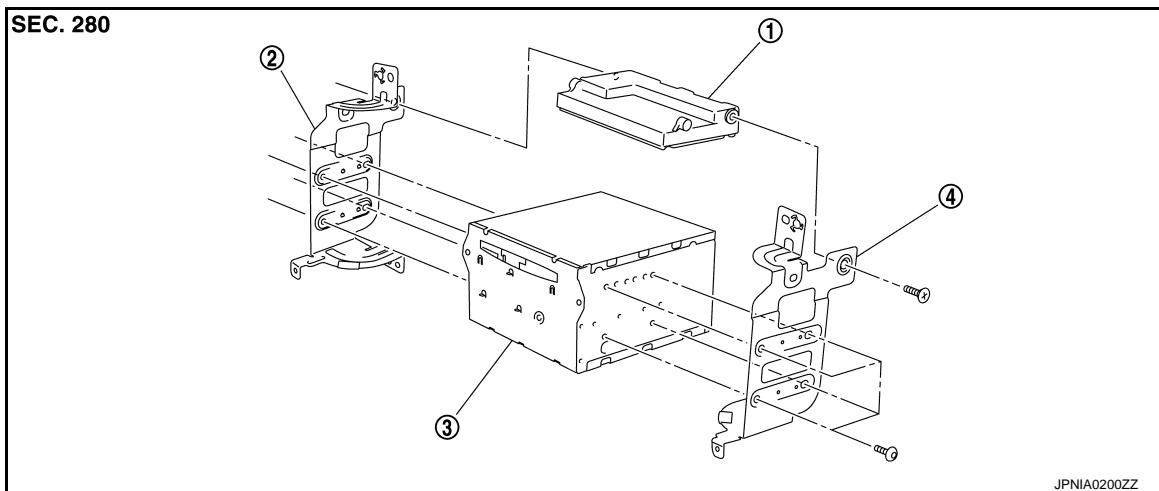

1. Unified meter and A/C amp.
2. Bracket LH
3. AV control unit
4. Bracket RH

### Removal and Installation

INFOID:000000006472483

#### REMOVAL

#### CAUTION:

- Before replacing AV control unit, perform "READ CONFIGURATION" to save or print current vehicle specification. For details, refer to [AV-67, "Description"](#).
- Remove battery terminal and AV control unit after a lapse of 30 seconds or more after turning the ignition switch OFF

#### NOTE:

After the ignition switch is turned OFF, the AV control unit continues operating for approximately 30 seconds. Therefore, data corruption may occur if battery voltage is cut off within 30 seconds.

1. Remove display unit. Refer to [AV-112, "Exploded View"](#).
2. Remove AV control unit with a unified meter and A/C amp. as a single unit from the body.
3. Remove bracket screws, and then remove AV control unit.

#### INSTALLATION

Install in the reverse order of removal.

#### CAUTION:

- Since AV control unit connector and unified meter and A/C amp. connector have the same form, be careful not to insert them wrongly.
- Be sure to perform "WRITE CONFIGURATION" when replacing AV control unit. For details, refer to [AV-68, "Work Procedure"](#).

# AV CONTROL UNIT

< REMOVAL AND INSTALLATION >

[BASE AUDIO WITHOUT NAVIGATION]

- Install AV control unit between connector (1) and connector (2) with the ferrite core (USB) orientated sideways to the vehicle. Incorrect installation may cause damage to the AV control unit.

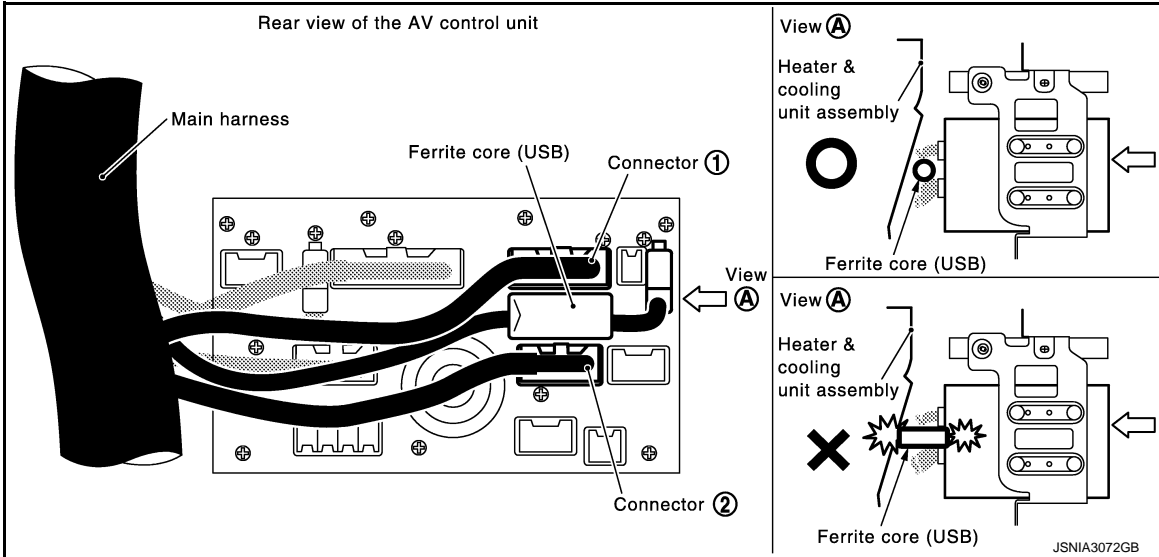

A  
B  
C  
D  
E  
F  
G  
H  
I  
J  
K  
L  
M  
O  
P

AV

## DISPLAY UNIT

### Exploded View

INFOID:000000006472484

Refer to [IP-12, "A/T MODELS : Exploded View"](#) (A/T models) or [IP-23, "M/T MODELS : Exploded View"](#) (M/T models).

### Removal and Installation

INFOID:000000006472485

#### REMOVAL

1. Remove cluster lid D. Refer to [IP-12, "A/T MODELS : Exploded View"](#) (A/T models) or [IP-23, "M/T MODELS : Exploded View"](#) (M/T models).
2. Remove display unit with bracket as a single unit.

#### INSTALLATION

Install in the reverse order of removal.



# DOOR SPEAKER

< REMOVAL AND INSTALLATION >

[BASE AUDIO WITHOUT NAVIGATION]

## DOOR SPEAKER

### Exploded View

INFOID:000000006472486

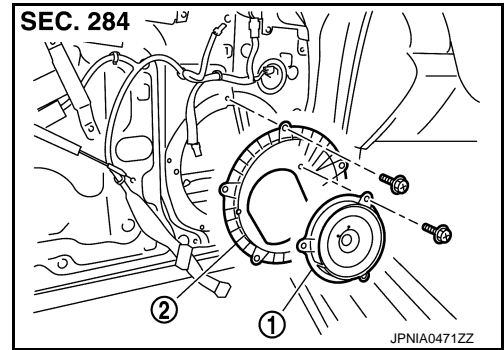

1. Door speaker
2. Speaker bracket

### Removal and Installation

INFOID:000000006472487

#### REMOVAL

1. Remove door finisher assembly. Refer to [INT-12. "Exploded View"](#).
2. Remove door speaker mounting bolts, disconnect the door speaker connector.
3. Remove door speaker.

#### INSTALLATION

Install in the reverse order of removal.

A  
B  
C  
D  
E  
F  
G  
H  
I  
J  
K  
L  
M  
AV  
O  
P

## REAR SPEAKER

< REMOVAL AND INSTALLATION >

[BASE AUDIO WITHOUT NAVIGATION]

### REAR SPEAKER

#### Exploded View

INFOID:000000006472488

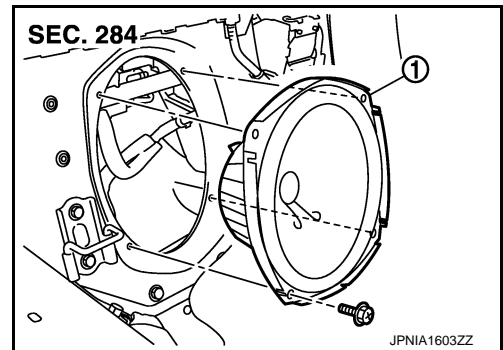

1. Rear speaker

#### Removal and Installation

INFOID:000000006472489

##### REMOVAL

1. Remove rear seatback. Refer to [SE-256. "Exploded View"](#).
2. Remove rear speaker mounting bolts, disconnect the speaker connector.
3. Remove rear speaker from the vehicle.

##### INSTALLATION

Install in the reverse order of removal.

# TWEETER

< REMOVAL AND INSTALLATION >

[BASE AUDIO WITHOUT NAVIGATION]

## TWEETER

### Exploded View

INFOID:000000006472490

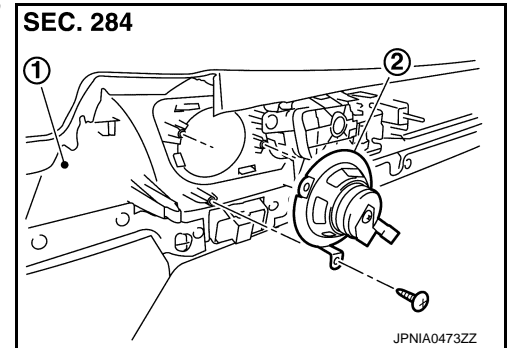

1. Door finisher assembly
2. Tweeter

### Removal and Installation

INFOID:000000006472491

#### REMOVAL

1. Remove door finisher assembly. Refer to [INT-12, "Exploded View"](#).
2. Remove the tweeter from the door finisher assembly.

#### INSTALLATION

Install in the reverse order of removal.

A  
B  
C  
D  
E  
F  
G  
H  
I  
J  
K  
L  
M  
O  
P

AV

# ANTENNA BASE

< REMOVAL AND INSTALLATION >

[BASE AUDIO WITHOUT NAVIGATION]

## ANTENNA BASE

### Exploded View

INFOID:000000006472492

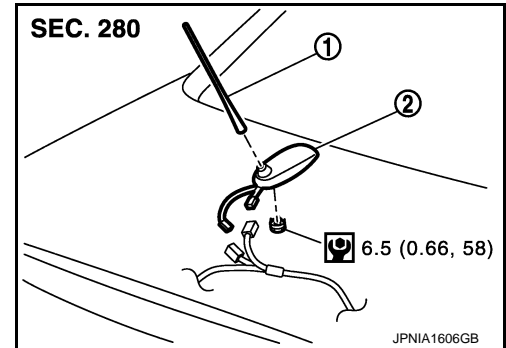

1. Antenna rod
2. Antenna base

Refer to [GI-4, "Components"](#) for symbols in the figure.

### Removal and Installation

INFOID:000000006472493

#### REMOVAL

1. Remove trunk lid finisher inner. Refer to [INT-26, "Exploded View"](#).
2. Remove antenna base mounting nut, disconnect the antenna base connector.
3. Remove antenna base.

#### INSTALLATION

Install in the reverse order of removal.

#### **CAUTION:**

**If the antenna base mounting nut is tightened looser than the specified torque, then this will lower the sensitivity of the antenna. On the other hand, if the nut is tightened tighter than the specified torque, then this will deform the trunk lid panel.**

# SATELLITE RADIO TUNER

< REMOVAL AND INSTALLATION >

[BASE AUDIO WITHOUT NAVIGATION]

## SATELLITE RADIO TUNER

### Exploded View

INFOID:000000006472494

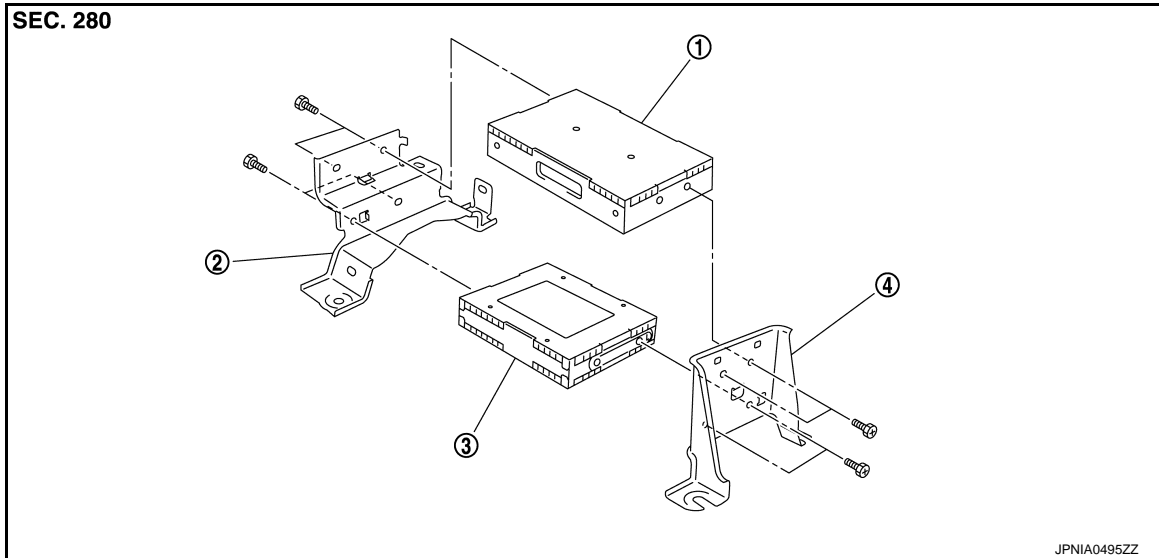

1. TEL adapter unit
2. Bracket (front)
3. Satellite radio tuner
4. Bracket (rear)

### Removal and Installation

INFOID:000000006472495

#### REMOVAL

1. Remove trunk floor spacer RH. Refer to [INT-23, "Exploded View"](#).
2. Remove nuts (A) from the trunk room RH, and remove TEL adapter unit and satellite radio tuner (1) from trunk room side.

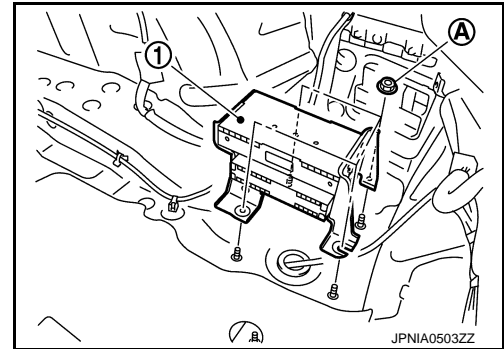

#### INSTALLATION

Install in the reverse order of removal.

A

B

C

D

E

F

G

H

I

J

K

L

M

AV

O

P

# MULTIFUNCTION SWITCH

< REMOVAL AND INSTALLATION >

[BASE AUDIO WITHOUT NAVIGATION]

## MULTIFUNCTION SWITCH

### Exploded View

INFOID:000000006472496

#### REMOVAL

Refer to [IP-12. "A/T MODELS : Exploded View"](#) (A/T models) or [IP-23. "M/T MODELS : Exploded View"](#) (M/T models).

#### DISASSEMBLY

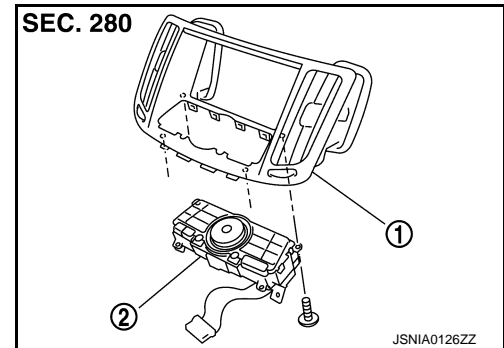

1. Center ventilator grille
2. Multifunction switch

### Removal and Installation

INFOID:000000006472497

#### REMOVAL

1. Remove cluster lid D. Refer to [IP-12. "A/T MODELS : Exploded View"](#) (A/T models) or [IP-23. "M/T MODELS : Exploded View"](#) (M/T models).
2. Remove multifunction switch with center ventilator grille as a single unit.
3. Remove multifunction switch from center ventilator.

#### INSTALLATION

Install in the reverse order of removal.

# PRESET SWITCH

< REMOVAL AND INSTALLATION >

[BASE AUDIO WITHOUT NAVIGATION]

## PRESET SWITCH

### Exploded View

INFOID:000000006472498

#### REMOVAL

Refer to [IP-12. "A/T MODELS : Exploded View"](#) (A/T models) or [IP-23. "M/T MODELS : Exploded View"](#) (M/T models).

#### DISASSEMBLY

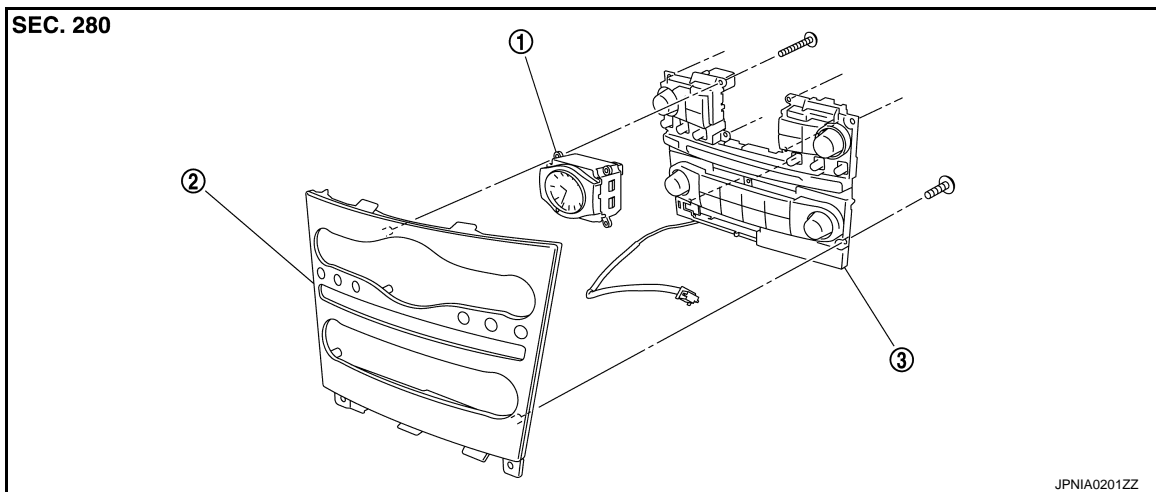

1. Clock

2. Cluster lid C

3. Preset switch

### Removal and Installation

INFOID:000000006472499

#### REMOVAL

1. Remove cluster lid C. Refer to [IP-12. "A/T MODELS : Exploded View"](#) (A/T models) or [IP-23. "M/T MODELS : Exploded View"](#) (M/T models).
2. Remove preset switch (2) from cluster lid C. Remove preset switch screws (A), (B) and (C), remove preset switch (2) from cluster lid C.

1. Clock

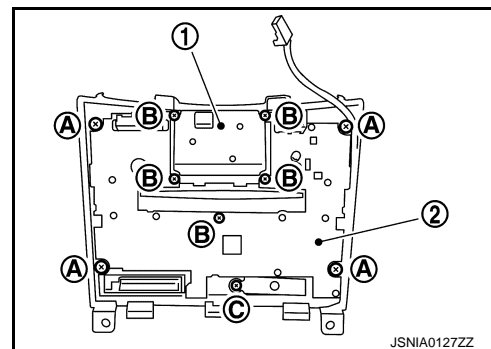

#### INSTALLATION

Install in the reverse order of removal.

#### NOTE:

When installing preset switch, do not allow the print wire that connects preset switch and multifunction switch to get caught in between AV control unit and preset switch.

## STEERING SWITCH

< REMOVAL AND INSTALLATION >

[BASE AUDIO WITHOUT NAVIGATION]

---

### STEERING SWITCH

#### Exploded View

INFOID:000000006472500

Refer to [ST-14, "Exploded View"](#).

#### Removal and Installation

INFOID:000000006472501

#### REMOVAL

Refer to [ST-14, "Removal and Installation"](#).

#### INSTALLATION

Install in the reverse order of removal.



# USB CONNECTOR

< REMOVAL AND INSTALLATION >

[BASE AUDIO WITHOUT NAVIGATION]

## USB CONNECTOR

### Exploded View

INFOID:000000006472502

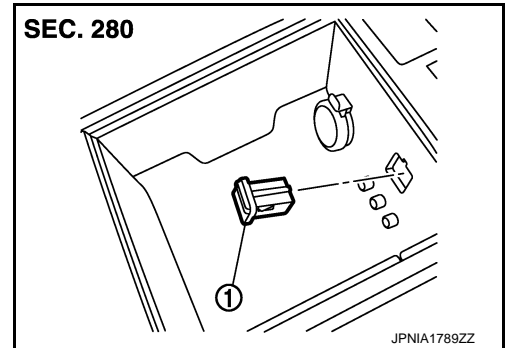

1. USB connector

### Removal and Installation

INFOID:000000006472503

#### REMOVAL

1. Remove center console. Refer to [IP-34. "A/T MODELS : Exploded View"](#) (A/T models) or [IP-39. "M/T MODELS : Exploded View"](#) (M/T models).
2. Push the pawl from the back of center console to remove USB connector.

#### INSTALLATION

Install in the reverse order of removal.

A  
B  
C  
D  
E  
F  
G  
H  
I  
J  
K  
L  
M  
O  
P

AV

# MICROPHONE

< REMOVAL AND INSTALLATION >

[BASE AUDIO WITHOUT NAVIGATION]

## MICROPHONE

### Exploded View

INFOID:000000006472504

#### REMOVAL

Refer to [INL-107, "Exploded View"](#).

#### DISASSEMBLY

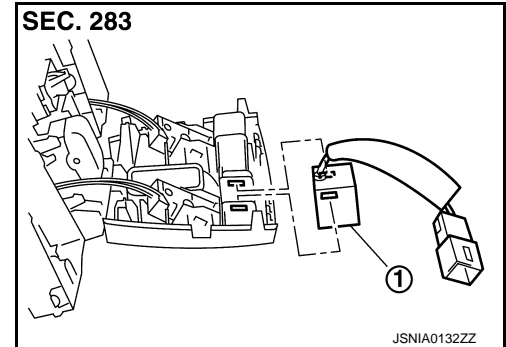

1. Microphone

### Removal and Installation

INFOID:000000006472505

#### REMOVAL

1. Remove map lamp. Refer to [INL-107, "Exploded View"](#).
2. Remove microphone from map lamp.

#### INSTALLATION

Install in the reverse order of removal.

# REAR VIEW CAMERA

< REMOVAL AND INSTALLATION >

[BASE AUDIO WITHOUT NAVIGATION]

## REAR VIEW CAMERA

### Exploded View

INFOID:000000006472506

#### REMOVAL

Refer to [EXT-38, "Exploded View"](#).

#### DISASSEMBLY

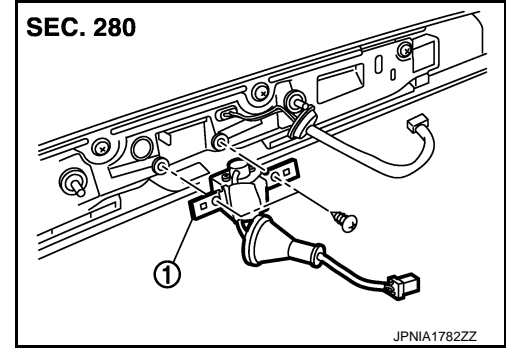

1. Rear view camera

### Removal and Installation

INFOID:000000006472507

#### REMOVAL

1. Remove trunk lid finisher outer. Refer to [EXT-38, "Exploded View"](#).
2. Remove rear view camera from trunk lid finisher outer.

#### INSTALLATION

Install in the reverse order of removal.

#### NOTE:

Adjust the guide line position if the guide line position is shifted after installing the rear view camera. Refer to [AV-123, "Adjustment"](#).

### Adjustment

INFOID:000000006472508

Adjust the guide line position if the guide line position is shifted after installing the rear view camera.

1. Draw lines on rearward area of the vehicle passing through the following points: 200 mm (7.87 in) from both sides of the vehicle, and 0.5 m (1.64 ft), 1.0 m (3.28 ft) from the rear end of the bumper.
2. Set into "Adjust Guide Lines" mode of "Confirmation/Adjustment" mode.

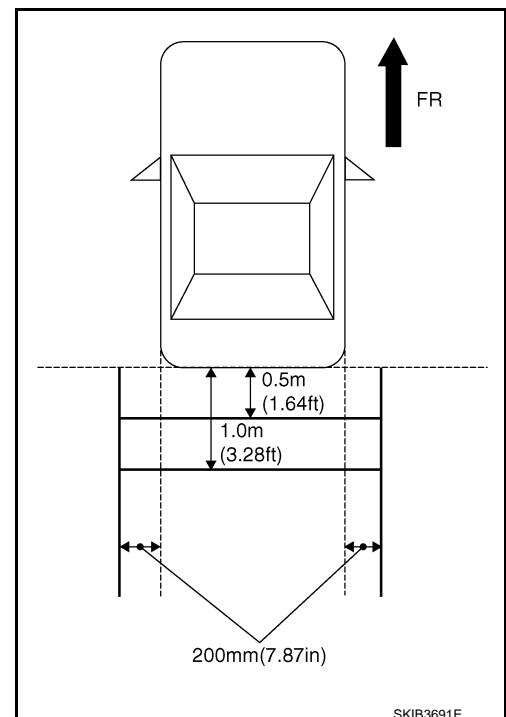

# REAR VIEW CAMERA

< REMOVAL AND INSTALLATION >

[BASE AUDIO WITHOUT NAVIGATION]

3. Rotate the center dial, and then select the guiding line pattern so that its angle is aligned with the correction line of the rear of the vehicle.

Selected pattern : 7

4. Make fine adjustment to the correction line of the rear of the vehicle with up/down/left/right switches so that its position is aligned with the guiding line. Press "OK" switch and record the adjusted guiding line position to the AV control unit.

Up/Down adjustment range : 20° – 20°

Left/Right adjustment range : 20° – 20°

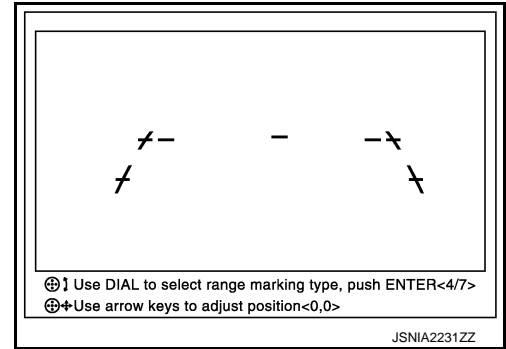

**CAUTION:**

**After the adjustment, never perform other operations for one minute.**

# STEERING ANGLE SENSOR

< REMOVAL AND INSTALLATION >

[BASE AUDIO WITHOUT NAVIGATION]

## STEERING ANGLE SENSOR

### Exploded View

INFOID:000000006472509

#### REMOVAL

Refer to [SR-15. "Exploded View"](#).

#### DISASSEMBLY

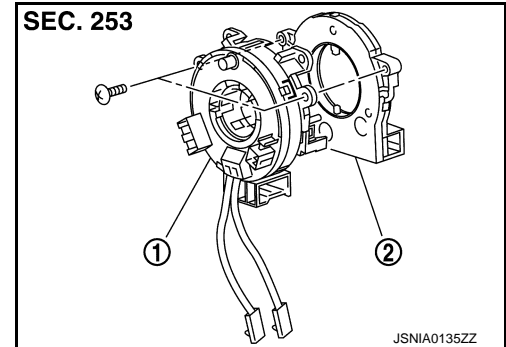

1. Spiral cable
2. Steering angle sensor

### Removal and Installation

INFOID:000000006472510

#### REMOVAL

1. Remove spiral cable.
2. Remove steering angle sensor from spiral cable.

#### INSTALLATION

Install in the reverse order of removal.

A  
B  
C  
D  
E  
F  
G  
H  
I  
J  
K  
L  
M  
O  
P

AV

# TEL ADAPTER UNIT

< REMOVAL AND INSTALLATION >

[BASE AUDIO WITHOUT NAVIGATION]

## TEL ADAPTER UNIT

Exploded View

INFOID:000000006472511

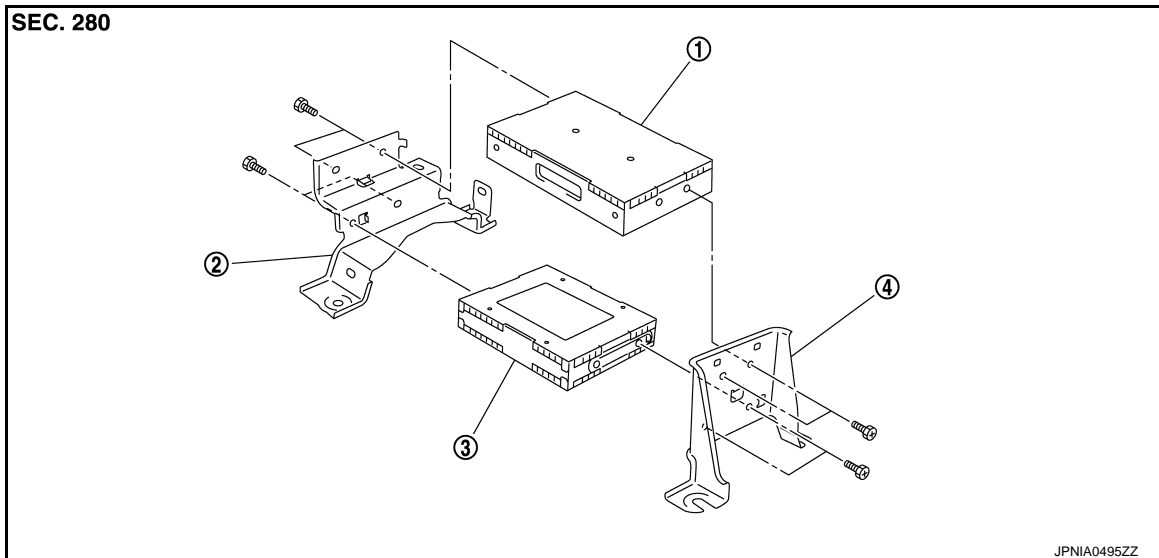

1. TEL adapter unit

2. Bracket (front)

3. Satellite radio tuner

4. Bracket (rear)

## Removal and Installation

INFOID:000000006472512

### REMOVAL

1. Remove trunk floor spacer RH. Refer to [INT-23, "Exploded View"](#).
2. Remove nuts (A) from the trunk room RH, and remove TEL adapter unit and satellite radio tuner (1) from trunk room side.

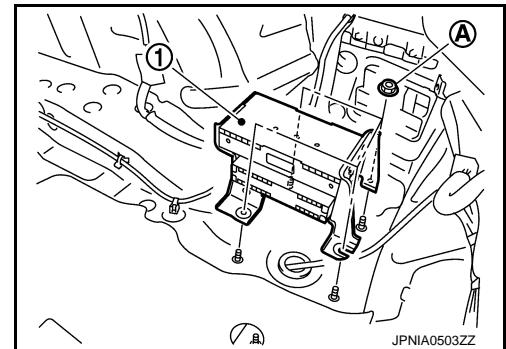

### INSTALLATION

Install in the reverse order of removal.



## PRECAUTION

### PRECAUTIONS

#### Precaution for Supplemental Restraint System (SRS) "AIR BAG" and "SEAT BELT PRE-TENSIONER"

INFOID:000000006472514

The Supplemental Restraint System such as "AIR BAG" and "SEAT BELT PRE-TENSIONER", used along with a front seat belt, helps to reduce the risk or severity of injury to the driver and front passenger for certain types of collision. This system includes seat belt switch inputs and dual stage front air bag modules. The SRS system uses the seat belt switches to determine the front air bag deployment, and may only deploy one front air bag, depending on the severity of a collision and whether the front occupants are belted or unbelted. Information necessary to service the system safely is included in the "SRS AIR BAG" and "SEAT BELT" of this Service Manual.

**WARNING:**

Always observe the following items for preventing accidental activation.

- To avoid rendering the SRS inoperative, which could increase the risk of personal injury or death in the event of a collision that would result in air bag inflation, all maintenance must be performed by an authorized NISSAN/INFINITI dealer.
- Improper maintenance, including incorrect removal and installation of the SRS, can lead to personal injury caused by unintentional activation of the system. For removal of Spiral Cable and Air Bag Module, see "SRS AIR BAG".
- Never use electrical test equipment on any circuit related to the SRS unless instructed to in this Service Manual. SRS wiring harnesses can be identified by yellow and/or orange harnesses or harness connectors.

#### PRECAUTIONS WHEN USING POWER TOOLS (AIR OR ELECTRIC) AND HAMMERS

**WARNING:**

Always observe the following items for preventing accidental activation.

- When working near the Air Bag Diagnosis Sensor Unit or other Air Bag System sensors with the ignition ON or engine running, never use air or electric power tools or strike near the sensor(s) with a hammer. Heavy vibration could activate the sensor(s) and deploy the air bag(s), possibly causing serious injury.
- When using air or electric power tools or hammers, always switch the ignition OFF, disconnect the battery, and wait at least 3 minutes before performing any service.

#### Precaution for Battery Service

INFOID:000000006472515

Before disconnecting the battery, lower both the driver and passenger windows. This will prevent any interference between the window edge and the vehicle when the door is opened/closed. During normal operation, the window slightly raises and lowers automatically to prevent any window to vehicle interference. The automatic window function will not work with the battery disconnected.

#### Service Procedure Precautions for Models with a Pop-up Roll Bar

INFOID:000000006472516

**WARNING:**

Always observe the following items for preventing accidental activation.

- Risk of passenger injury or death may increase if the pop-up roll bar does not deploy during a roll over collision. In order to reduce the chance of an incident where the pop-up roll bar is inoperative, all maintenance must be performed by a NISSAN or INFINITI dealer.
- Before removing and installing the pop-up roll bar component parts and harness, always turn the ignition switch OFF, disconnect the battery negative terminal, and wait for 3 minutes or more. (The purpose of this operation is to discharge electricity that is accumulated in the auxiliary power supply circuit in the air bag diagnosis sensor unit.)
- When repairing, removing, and installing a pop-up roll bar, always refer to SRS AIR BAG and SRS AIR BAG CONTROL warnings in the Service Manual.

#### Cautions in Removing Battery Terminal and AV Control Unit (Models with AV Control Unit)

INFOID:000000008116963

**CAUTION:**



# PRECAUTIONS

< PRECAUTION >

[BOSE AUDIO WITHOUT NAVIGATION]

Remove battery terminal and AV control unit after a lapse of 30 seconds or more after turning the ignition switch OFF.

**NOTE:**

After the ignition switch is turned OFF, the AV control unit continues operating for approximately 30 seconds. Therefore, data corruption may occur if battery voltage is cut off within 30 seconds.

## Precaution for Trouble Diagnosis

INFOID:000000006472517

### AV COMMUNICATION SYSTEM

- Do not apply voltage of 7.0 V or higher to the measurement terminals.
- Use the tester with its open terminal voltage being 7.0 V or less.
- Be sure to turn ignition switch OFF and disconnect the battery cable from the negative terminal before checking the circuit.

## Precaution for Harness Repair

INFOID:000000006472518

### AV COMMUNICATION SYSTEM

- Solder the repaired parts, and wrap with tape. [Frays of twisted line must be within 110 mm (4.33 in).]

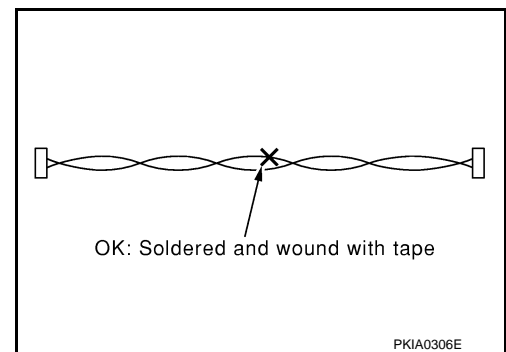

- Do not perform bypass wire connections for the repair parts. (The spliced wire will become separated and the characteristics of twisted line will be lost.)

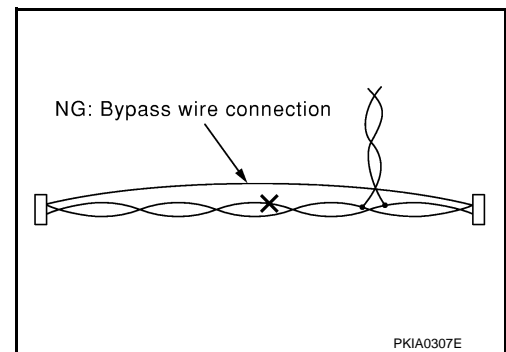

A  
B  
C  
D  
E  
F  
G  
H  
I  
J  
K  
L  
M  
O  
P

AV

# PREPARATION

< PREPARATION >

[BOSE AUDIO WITHOUT NAVIGATION]

## PREPARATION

### PREPARATION

#### Commercial Service Tools

INFOID:000000006472519

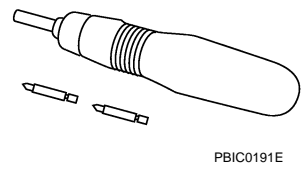
Tool	Description
<p data-bbox="162 514 276 546">Power tool</p>  <p data-bbox="820 619 901 651">PBIC0191E</p>	<p data-bbox="1006 514 1193 546">Loosening screws</p>

# COMPONENT PARTS

< SYSTEM DESCRIPTION >

[BOSE AUDIO WITHOUT NAVIGATION]

## SYSTEM DESCRIPTION

### COMPONENT PARTS

#### Component Parts Location

INFOID:000000006472520

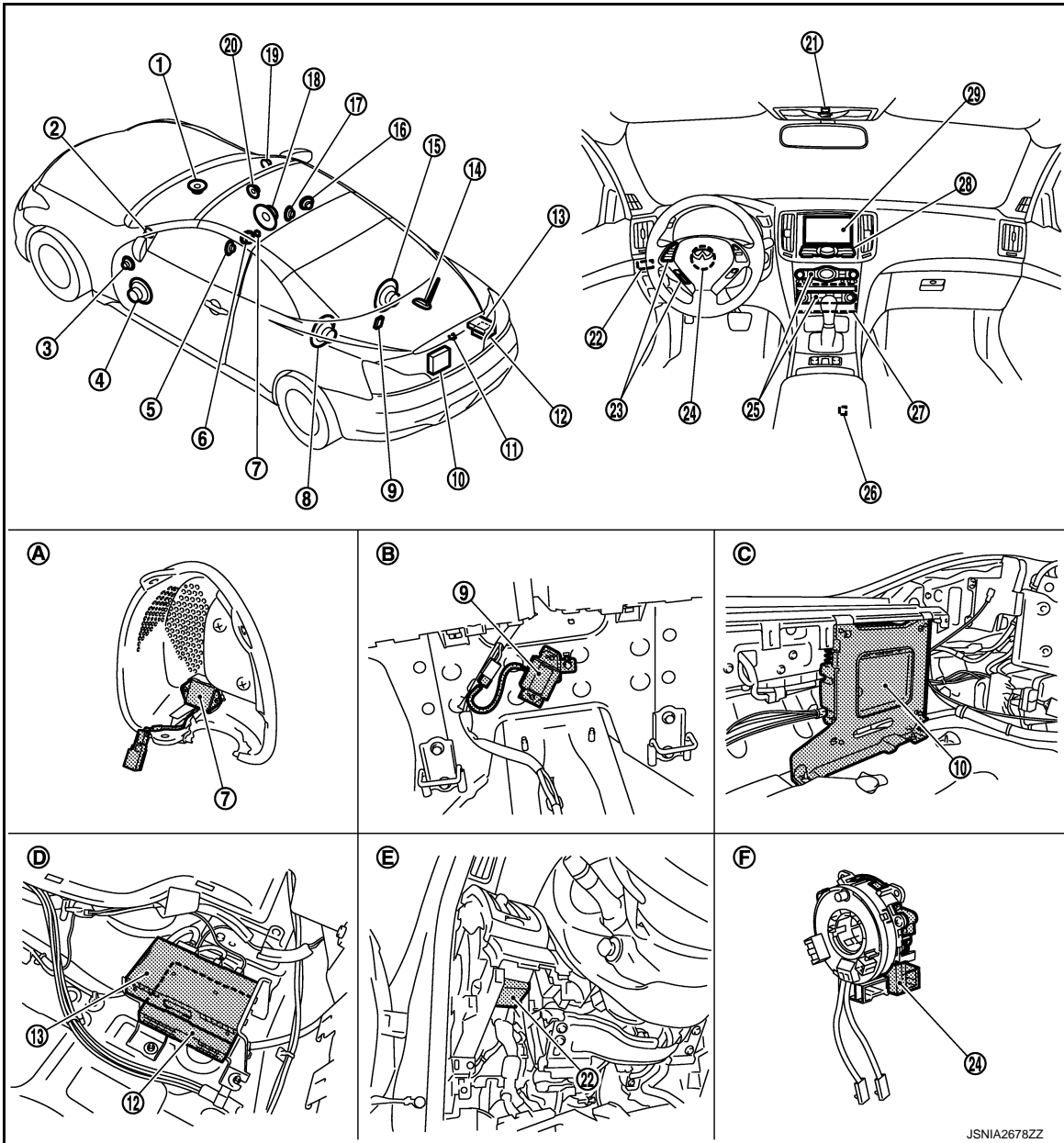

- |                                   |   |                               |
|-----------------------------------|---|-------------------------------|
| 1. Center speaker                 | 2. Tweeter LH   | 3. Door squawker LH           |
| 4. Door woofer LH                 | 5. Driver headrest speaker LH                         | 6. Driver headrest speaker RH |
| 7. Microphone (for AudioPilot®)   | 8. Rear woofer LH                                     | 9. TEL antenna                |
| 10. BOSE amp.                     | 11. Rear view camera                                  | 12. Satellite radio tuner     |
| 13. TEL adapter unit              | 14. Antenna base (antenna amp. and satellite antenna) | 15. Rear woofer RH            |
| 16. Passenger headrest speaker RH | 17. Passenger headrest speaker LH                     | 18. Door woofer RH            |
| 19. Tweeter RH                    | 20. Door squawker RH                                  | 21. Microphone                |
| 22. Sonar control unit            | 23. Steering switch                                   | 24. Steering angle sensor     |
| 25. Preset switch                 | 26. USB connector                                     | 27. AV control unit           |
| 28. Multifunction switch          | 29. Display unit                                      |                               |

# COMPONENT PARTS

[BOSE AUDIO WITHOUT NAVIGATION]

< SYSTEM DESCRIPTION >

- |                                   |  |                                       |
|-----------------------------------|--|---------------------------------------|
| A. Inner grille removed condition | B. Rear seat back removed condition                | C. Trunk rear plate removed condition |
| D. Trunk room RH                  | E. Instrument driver lower panel removed condition | F. Spiral cable removed condition     |

## Component Description

INFOID:000000006472521

Part name	Description
AV control unit	<ul style="list-style-type: none"> <li>Integrates flash memory allowing music data to be stored.</li> <li>It is the master unit of the MULTI AV system, and it is connected to each control unit by communication. It operates each system according to communication signals from the AV control unit.</li> <li>The AV control unit includes the audio, USB connection and vehicle information functions.</li> <li>It is connected to ECM and unified meter and A/C amp. via CAN communication to obtain necessary information for the vehicle information function.</li> <li>It is connected to the steering angle sensor and receives the steering angle sensor signal via CAN communication.</li> <li>It inputs the illumination signals that are required for the display dimming control.</li> <li>It inputs the signals for driving status recognition (vehicle speed, reverse and parking brake).</li> <li>TEL voice signal and voice guidance signal are input from TEL adapter unit.</li> </ul>
Display unit	<ul style="list-style-type: none"> <li>Display image is controlled by the serial communication from AV control unit.</li> <li>It receives the power (signal VCC and inverter VCC) from the AV control unit and operates.</li> <li>RGB image signal is input from AV control unit (RGB image, RGB area and RGB synchronizing).</li> <li>Composite image signals are input from AV control unit.</li> <li>Synchronizing signal (HP, VP) is output to AV control unit.</li> </ul>
BOSE amp.	<ul style="list-style-type: none"> <li>Inputs sound signal from AV control unit, and outputs sound signal to each speaker.</li> <li>Input microphone signal from microphone (AudioPilot™).</li> <li>Inputs roof status signal from retractable hard top control unit.</li> </ul>
Door woofer	<ul style="list-style-type: none"> <li>Outputs sound signal from BOSE amp.</li> <li>Outputs low range sound.</li> </ul>
Door squawker	<ul style="list-style-type: none"> <li>Outputs sound signal from BOSE amp.</li> <li>Outputs mid range sound.</li> </ul>
Tweeter	<ul style="list-style-type: none"> <li>Outputs sound signal from BOSE amp.</li> <li>Outputs high range sound.</li> </ul>
Center speaker	<ul style="list-style-type: none"> <li>Outputs sound signal from BOSE amp.</li> <li>Outputs mid range sounds.</li> </ul>
Rear woofer	<ul style="list-style-type: none"> <li>Outputs sound signal from BOSE amp.</li> <li>Outputs low range sound.</li> </ul>
Headrest speaker	<ul style="list-style-type: none"> <li>Outputs sound signal from BOSE amp.</li> <li>Outputs mid range sound.</li> </ul>
Microphone (for AudioPilot™)	<ul style="list-style-type: none"> <li>Used for AudioPilot™</li> <li>Microphone signal is transmitted to BOSE amp.</li> </ul>
Multifunction switch	<ul style="list-style-type: none"> <li>Operation panel is equipped with the centralized switch where audio operations are integrated.</li> <li>Connected with preset switch via cable, and operation signal is transmitted to AV control unit via AV communication.</li> </ul>
Preset switch	<ul style="list-style-type: none"> <li>Operation panel is equipped with the centralized switch where audio and air conditioner, etc. operations are integrated.</li> <li>Connected with multifunction switch via cable, and operation signal is transmitted to AV control unit via AV communication.</li> <li>The disk ejection operating signal is performed by hardwire.</li> </ul>
Rear view camera	<ul style="list-style-type: none"> <li>Camera power supply is input from AV control unit.</li> <li>The image of vehicle rear view is transmitted to AV control unit.</li> </ul>

## COMPONENT PARTS

< SYSTEM DESCRIPTION >

[BOSE AUDIO WITHOUT NAVIGATION]

Part name	Description
Steering angle sensor	It is connected to the AV control unit and transmits the steering angle sensor signal via CAN communication.
Sonar control unit	<ul style="list-style-type: none"> <li>• Controlled by AV communication transmitted from AV control unit.</li> <li>• Trouble diagnosis is supported with CONSULT-III (K-LINE).</li> </ul>
Steering switch	<ul style="list-style-type: none"> <li>• Operations for audio, hands-free phone and voice control, etc. are possible.</li> <li>• Steering switch signal (operation signal) is output to AV control unit.</li> </ul>
Microphone	<ul style="list-style-type: none"> <li>• Used for hands-free phone operation and voice recognition.</li> <li>• Microphone signal is transmitted to AV control unit.</li> <li>• Power (Microphone VCC) is supplied from AV control unit.</li> </ul>
Antenna base	<p>An antenna base integrated with radio antenna amp. and satellite radio antenna is adopted.</p> <p style="margin-left: 20px;">ANTENNA AMP.</p> <ul style="list-style-type: none"> <li>• Radio signal received by rod antenna is amplified and transmitted to AV control unit.</li> <li>• Power (antenna amp. ON signal) is supplied from AV control unit.</li> </ul> <p style="margin-left: 20px;">SATELLITE RADIO ANTENNA</p> <ul style="list-style-type: none"> <li>• Receives the satellite radio waves and outputs it to AV control unit.</li> </ul>
Satellite radio tuner	<ul style="list-style-type: none"> <li>• Inputs the satellite radio signal from satellite radio antenna and outputs the sound signal to the AV control unit.</li> <li>• It is controlled with the AV control unit and serial communication (communication signal and request signal).</li> </ul>
TEL adapter unit	<ul style="list-style-type: none"> <li>• Inputs the TEL voice signal from TEL antenna and outputs it to the AV control unit.</li> <li>• It is connected with the AV control unit via AV communication and controlled with the AV control unit.</li> <li>• Inputs roof status signal from retractable hard top control unit.</li> </ul>
TEL antenna	Receives the TEL voice signal and outputs it to the TEL adapter unit.
USB connector	Image signal <sup>*1</sup> and sound signal of USB input is transmitted to AV control unit.

\*1: Image signals cannot be received from iPod®.

A  
B  
C  
D  
E  
F  
G  
H  
I  
J  
K  
L  
M  
O  
P

AV

SYSTEM

MULTI AV SYSTEM

MULTI AV SYSTEM : System Diagram

INFOID:000000006472522

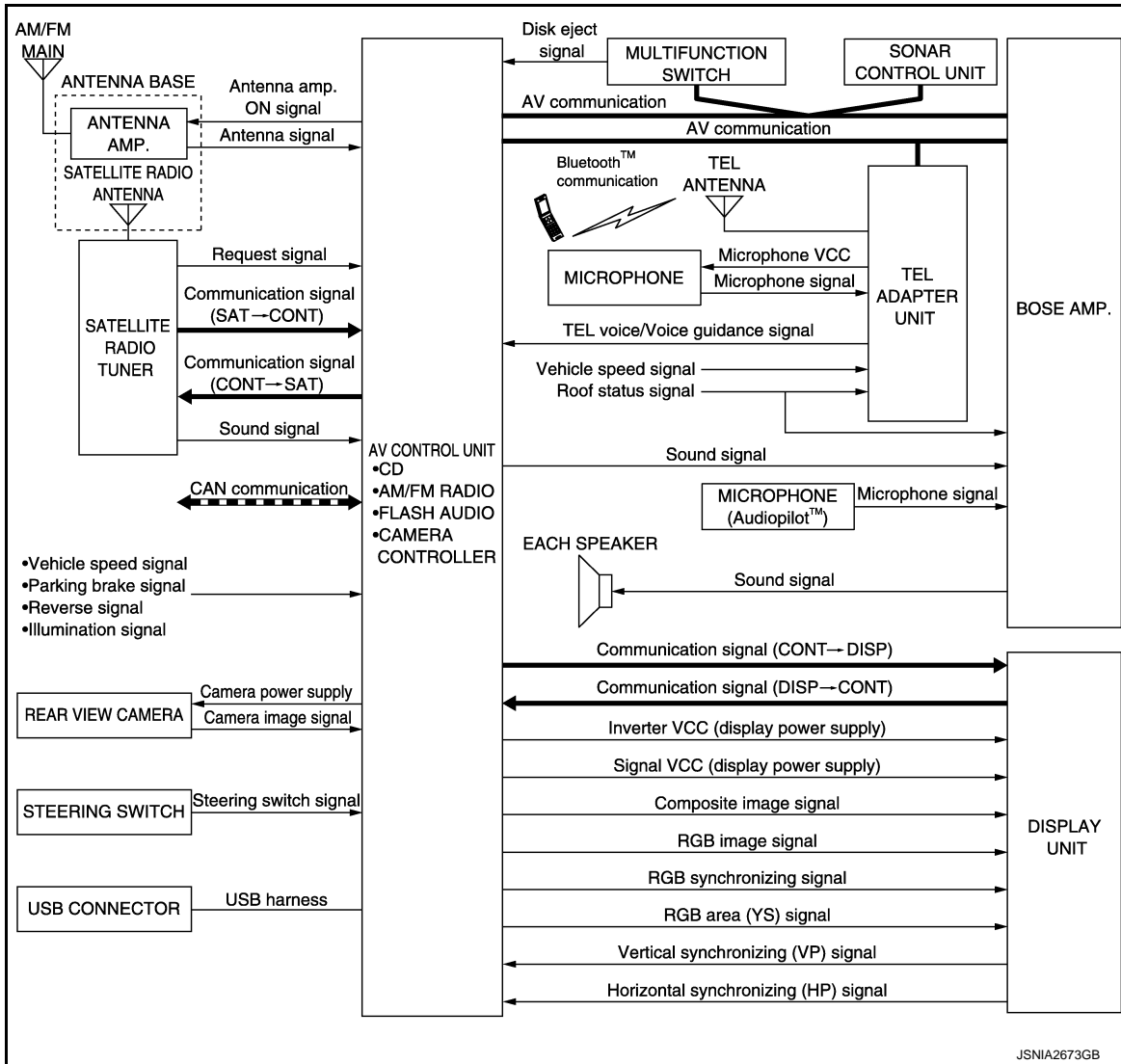

JSNIA2673GB

NOTE:

- The name MULTIFUNCTION SWITCH indicates the integration of PRESET SWITCH and MULTIFUNCTION SWITCH virtually.
- An antenna base integrated with radio antenna and satellite radio antenna is adopted.

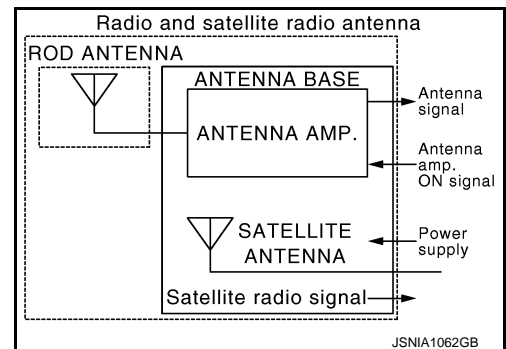

JSNIA1062GB

MULTI AV SYSTEM : System Description

INFOID:000000006472523

Multi AV system means that the following systems are integrated.

FUNCTION NAME
Audio function
Hands-free phone function
Rear view monitor function
Sonar function
Vehicle information function

A  
B  
C

### COMMUNICATION SIGNAL

- AV control unit function by transmitting/receiving data one by one with each unit (slave unit) that configures them completely as a master unit by connecting between units that configure MULTI AV system with two AV communication lines (H, L).
- Two AV communication lines (H, L) adopt a twisted pair line that is resistant to noise.
- AV control unit is connected by CAN communication, and it receives data signal from ECM, unified meter and A/C amp. It computes and displays fuel economy information value with the obtained information.
- AV control unit is connected with display and serial communication, and it transmits the required signal of display and display control and receives the response signal from display.

D  
E  
F

### AUDIO FUNCTION

The audio system is equipped with the following functions. Each function is operated with multifunction switch, preset switch, steering switch. Operation status of audio is indicated at display.

G

FUNCTION
AM/FM radio
Satellite radio
CD
Music Box (flash memory)
USB connection function
AudioPilot™
Sound equalizer automatic switching

H  
I  
J

#### Operating Signal

Audio system operation can be performed with multifunction switch, preset switch or steering switch.

- Operating signal is transmitted to AV control unit with AV communication when it is operated by multifunction switch or preset switch. The disk ejection operating signal is performed by hardware.
- Operating signal is transmitted to AV control unit with steering switch signal when it is operated by steering switch.

K  
L

#### Screen Display

- Switching of display is performed with serial communication between display unit and AV control unit.
- The image signal to display operating condition is performed with RGB image signal, RGB area signal and RGB image synchronizing signal.

M

#### AM/FM Radio Mode

- AM/FM radio tuner is built into AV control unit.
- Audio signal is received by rod antenna, next it is amplified by antenna amp., and finally it is input to AV control unit. Audio signal is input to BOSE amp., and BOSE amp. outputs to each speaker.

AV  
O

#### Satellite Radio Mode

- Satellite radio tuner is controlled by communication signal and request signal with AV control unit.
- Sound signal (satellite radio) is received by satellite antenna and transmitted to AV control unit. AV control unit is output the sound signal (satellite radio) to each speaker.

P

#### CD Mode

- CD function is built into AV control unit.
- AV control unit outputs audio signal to BOSE amp., and BOSE amp. outputs to each speaker when CD is inserted to AV control unit.

#### Music Box Mode

# SYSTEM

## < SYSTEM DESCRIPTION >

## [BOSE AUDIO WITHOUT NAVIGATION]

- Music CD data is stored on flash memory that is built into AV control unit, and it can be played.
- AV control unit outputs music (sound signal) that is stored on flash memory to BOSE amp., and BOSE amp. outputs to each speaker.

### USB Connection Function

- iPod or music files in USB memory can be played.
- iPod sound signals are transmitted from USB connector to the AV control unit and to each speaker.
- iPod® is recharged when connected to USB connector.

iPod® is a trademark of Apple inc., registered in the U.S. and other countries.

### NOTE:

Use the enclosed USB harness when connecting iPod® to USB connector.

### AudioPilot™

AudioPilot™ is a sound improving system that picks up by a microphone in a driver headrest any noises or the sound of music coming into the vehicle, and that uses the BOSE amp. to revise the frequency feature of music in real time in response to the frequency feature of the noise while driving and listening to music.

- If the low frequency area noise from the vehicle is loud, it adjusts the low frequency element of music to be larger than the vehicle noise.
- If the high frequency area noise from the vehicle is loud, it adjusts the high frequency element of music to be larger than the vehicle noise.
- If the vehicle noise is smaller than the setting volume, correction is not performed. This eliminates the vehicle noise when listening to music.

### Sound Equalizer Automatic Switching Function

Sound quality in a fully-open retractable hard top condition is improved by the correction for bringing the frequency characteristics in a fully-open retractable hard top condition closer to the characteristics in a fully-closed retractable hard top condition. When the retractable hard top is in a fully-open condition, sound pressure is reduced due to the absence of sound echo generated by sound reflection from the retractable hard top. BOSE amp. detects an open-close condition of the retractable hard top by receiving a roof status signal from the retractable hard top control unit and switches the equalizer to correct the frequency characteristics in a fully-open retractable hard top condition. During the switching of the equalizer, audio stops temporarily due to the temporary mute.

## HANDS-FREE PHONE SYSTEM

- TEL adapter unit is controlled with AV communication from AV control unit.
- The connection between cellular phone and TEL adapter unit is performed with Bluetooth™ communication.
- The voice guidance signal is input from the TEL adapter unit to the AV control unit and output via BOSE amp. to the front speaker when operating the cellular phone.
- System operation is available only when the retractable hard top is closed.
- TEL adapter unit has the on board self-diagnosis function. Refer to [AV-153. "On Board Diagnosis Function"](#).

### When A Call Is Originated

- Spoken voice sound output from the microphone (microphone signal) is input to TEL adapter unit.
- TEL adapter unit outputs to cellular phone with Bluetooth™ communication as a TEL voice signal.
- Voice sound is then heard at the other party.

### When Receiving A Call

- Voice sound is input to own cellular phone from the other party.
- TEL voice signal is input to TEL adapter unit by establishing Bluetooth™ communication from cellular phone, and the signal is output via BOSE amp. to front speaker.

## REAR VIEW MONITOR FUNCTION

- The AV control unit supplies power to the rear view camera when receiving a reverse signal.
- The rear view camera transmits camera images to the AV control unit when power is supplied from the AV control unit.
- The AV control unit transmits a warning message, fixed guide lines, and predictive course lines to the display unit by RGB image signal. Rear view monitor images are displayed by combining the RGB image signal and the camera image signals from the rear view camera.
- Predictive course lines are controlled by a steering angle sensor signal received the AV control unit via CAN communication.

## SONAR SYSTEM



# SYSTEM

## [BOSE AUDIO WITHOUT NAVIGATION]

### < SYSTEM DESCRIPTION >

For further information about the sonar system, refer to [SN-7, "System Description"](#).

### VEHICLE INFORMATION FUNCTION

- Status of audio, climate control system, fuel economy and maintenance are displayed.
- AV control unit displays the fuel consumption status while receiving data signal through CAN communication from ECM, unified meter and A/C amp.
- AV control unit is connected to BCM via CAN communication transmitting/receiving for the vehicle settings function.

A  
B  
C  
D  
E  
F  
G  
H  
I  
J  
K  
L  
M  
O  
P

AV

# DIAGNOSIS SYSTEM (AV CONTROL UNIT)

[BOSE AUDIO WITHOUT NAVIGATION]

< SYSTEM DESCRIPTION >

## DIAGNOSIS SYSTEM (AV CONTROL UNIT)

### Description

INFOID:000000006472524

- The AV control unit diagnosis function starts up with multifunction switch operation and the AV control unit performs a diagnosis for each unit in the system during the on board diagnosis.
- Perform a CONSULT-III diagnosis if the on board diagnosis does not start, e.g., the screen does not display anything, the multifunction switch does not function, etc.

### On Board Diagnosis Function

INFOID:000000006472525

#### MULTIFUNCTION SWITCH AND PRESET SWITCH SELF-DIAGNOSIS FUNCTION

The ON/OFF operation (continuity) of each switch in the multifunction switch and preset switch can be checked.

##### Self-diagnosis Mode

- Press the “BACK” switch and the “UP” switch of the 4-direction switches within 10 seconds after turning the ignition switch from OFF to ACC and hold them for 3 seconds or more. Then the buzzer sounds, all indicators of the preset switch illuminate, and the self-diagnosis mode starts.
- The continuity of each switch at the ON position can be checked by pressing the switch. The buzzer sounds if the switch is normal.

**NOTE:**

The hazard switch and disk eject switch cannot be checked.

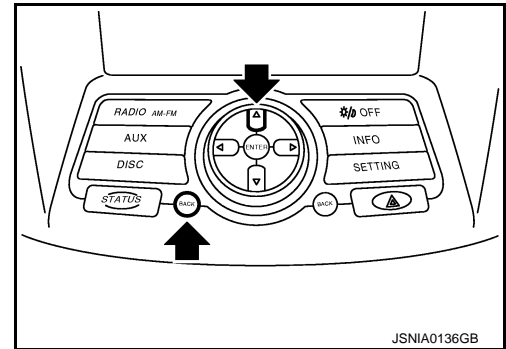

##### Finishing Self-diagnosis Mode

Self-diagnosis mode is canceled when turning the ignition switch OFF.

### ON BOARD DIAGNOSIS ITEM

#### Description

- The trouble diagnosis function has a self-diagnosis mode for conducting trouble diagnosis automatically and a confirmation/adjustment mode for operating manually.
- Self-diagnosis mode performs the AV control unit diagnosis and the connection diagnosis between each of the units that make up the system, and it indicates the results to the display unit.
- The confirmation/adjustment mode allows the technician to check, modify or adjust the vehicle signals and set values, as well as to monitor the system error records and system communication status. The checking, modifying or adjusting generally require human intervention and judgment (the system cannot make judgment automatically).

#### On Board Diagnosis Item

Mode	Description
Self Diagnosis	<ul style="list-style-type: none"><li>• AV control unit diagnosis.</li><li>• Diagnoses the connections across system components, between AV control unit and each unit.</li></ul>

# DIAGNOSIS SYSTEM (AV CONTROL UNIT)

[BOSE AUDIO WITHOUT NAVIGATION]

< SYSTEM DESCRIPTION >

	Mode	Description
Confirmation/ Adjustment	Display Diagnosis	The following check functions are available: color tone check by color bar display and white display, light and shade check by gray scale display.
	Vehicle Signals	Diagnosis of signals can be performed for vehicle speed, parking brake, lights, ignition and reverse.
	Speaker Test	The connection of a speaker can be confirmed by test tone.
	Climate Control	Start auto air conditioner system self-diagnosis.
	Error History	The system malfunction and the frequency when occurring in the past are displayed. When the malfunctioning item is selected, the time and place that the selected malfunction last occurred are displayed.
	Camera Cont.	<ul style="list-style-type: none"> <li>Guiding line position that overlaps rear view camera image can be adjusted.</li> <li>Configuration stored in the AV control unit can be checked.</li> </ul>
	Vehicle CAN Diagnosis	The transmitting/receiving of CAN communication can be monitored.
	AV COMM Diagnosis	The communication condition of each unit of Multi AV system can be monitored.
	Delete Unit Connection Log	Erase the connection history of unit and error history.
Initialize Settings	Initializes the AV control unit memory.	

## METHOD OF STARTING

1. Start the engine.
2. Turn the audio system OFF.
3. While pressing the "SETTING" button, turn the volume control dial clockwise or counterclockwise for 40 clicks or more. (When the self-diagnosis mode is started, a short beep will be heard.)
  - Shifting from current screen to previous screen is performed by pressing "BACK" button.
4. The trouble diagnosis initial screen is displayed, and then the items of "Self Diagnosis" and "Confirmation/Adjustment" can be selected.

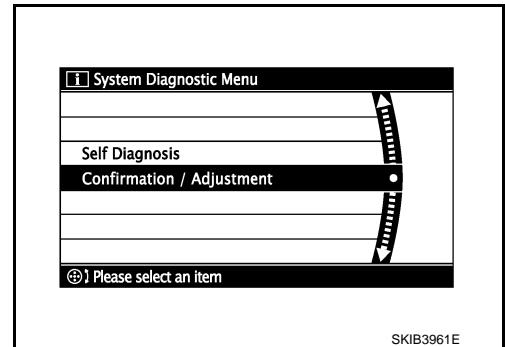
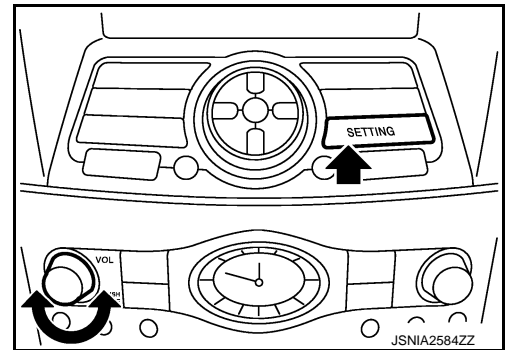

## SELF-DIAGNOSIS MODE

1. Start the self-diagnosis function and select "Self Diagnosis".
  - Self-diagnosis subdivision screen is displayed, and the self-diagnosis mode starts.
  - The bar graph visible on the center of the self-diagnosis subdivision screen indicates progress of the trouble diagnosis.

# DIAGNOSIS SYSTEM (AV CONTROL UNIT)

[BOSE AUDIO WITHOUT NAVIGATION]

## < SYSTEM DESCRIPTION >

2. Diagnosis results are displayed after the self-diagnosis is completed. The unit names and the connection lines are color-coded according to the diagnostic results.

Diagnosis results	Unit	Connection line
Normal	Green	Green
Connection malfunction	Gray	Yellow
Unit malfunction <sup>Note</sup>	Red	Green

### NOTE:

Control unit (AV control unit) and amplifier (BOSE amp.) are displayed in red.

- Replace AV control unit if "Self-Diagnosis did not run because of a control unit malfunction" is indicated. The symptom is AV control unit internal error. Refer to [AV-250, "Exploded View"](#).
- If multiple errors occur at the same time for a single unit, the screen switch colors are determined according to the following order of priority: red > gray.

- The comments of the self-diagnosis results can be viewed with a component in the diagnosis result screen.

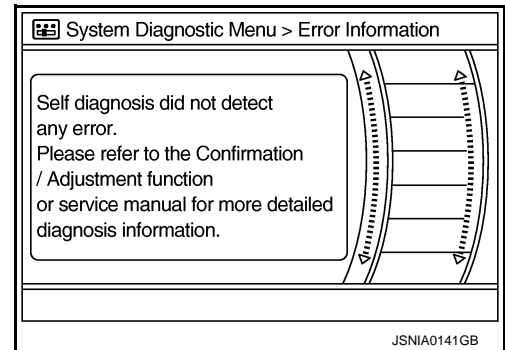
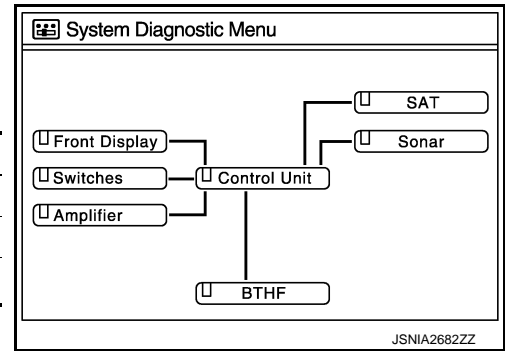

### Detection Range of Self-diagnosis Mode

- The self-diagnosis mode allows the technician to diagnose the connection in the communication line between AV control unit and each unit and the internal operation of the AV control unit.
- Because the start condition of diagnosis function is a switch operation, the on board diagnosis function cannot be started up if any malfunction is detected in the communication circuit between AV control unit and multifunction switch.

### SELF-DIAGNOSIS RESULTS

Check the applicable display at the following table, and then repair the malfunctioning parts.

Only Unit Part Is Displayed In Red.

Screen switch	Description	Possible malfunction location / Action to take
Control unit	Malfunction is detected in AV control unit power supply and ground circuits.	Check AV control unit power supply and ground circuits. When detecting no malfunction in those components, replace AV control unit. Refer to <a href="#">AV-250, "Exploded View"</a> .
Amplifier	When either one of the following items are detected: <ul style="list-style-type: none"> <li>• sound signal circuits between BOSE amp. and each speaker are malfunctioning.</li> <li>• BOSE amp. malfunction is detected.</li> </ul>	<ul style="list-style-type: none"> <li>• Malfunctioning speaker circuits</li> <li>• Replace BOSE amp. Refer to <a href="#">AV-259, "Exploded View"</a>.</li> </ul>

A Connecting Cable Between Units Is Displayed In Yellow.

# DIAGNOSIS SYSTEM (AV CONTROL UNIT)

< SYSTEM DESCRIPTION >

[BOSE AUDIO WITHOUT NAVIGATION]

Area with yellow connection lines	Description	Possible malfunction location / Action to take
Control unit ↔ Front Display	Malfunction is detected in serial communication circuits between AV control unit and display unit.	Serial communication circuits between AV control unit and display unit.
Control unit ↔ SAT	When either one of the following items is detected: <ul style="list-style-type: none"> <li>• satellite radio tuner power supply and ground circuit are malfunctioning.</li> <li>• communication circuits between AV control unit and satellite radio tuner are malfunctioning.</li> <li>• request signal circuit between AV control unit and satellite radio tuner are malfunctioning.</li> </ul>	<ul style="list-style-type: none"> <li>• Satellite radio tuner power supply and ground circuit.</li> <li>• Communication circuit between AV control unit and satellite radio tuner.</li> <li>• Request signal circuit between AV control unit and satellite radio tuner.</li> </ul>
Control unit ↔ Sonar	When either one of the following items is detected: <ul style="list-style-type: none"> <li>• sonar control unit power supply and ground circuits are malfunctioning.</li> <li>• AV communication circuits between AV control unit and sonar control unit are malfunctioning.</li> </ul>	<ul style="list-style-type: none"> <li>• Sonar control unit power supply and ground circuits.</li> <li>• AV communication circuits between AV control unit and sonar control unit.</li> </ul>
Control unit ↔ BTHF	When either one of the following items is detected: <ul style="list-style-type: none"> <li>• TEL adapter unit power supply and ground circuits are malfunctioning.</li> <li>• AV communication circuits between BOSE amp. and TEL adapter unit are malfunctioning.</li> </ul>	<ul style="list-style-type: none"> <li>• TEL adapter unit power supply and ground circuits.</li> <li>• AV communication circuits between BOSE amp. and TEL adapter unit.</li> </ul>
Control unit ↔ Amplifier	BOSE amp. power supply and ground circuits are malfunctioning.	BOSE amp. power supply and ground circuits.
<ul style="list-style-type: none"> <li>• Control unit ↔ BTHF</li> <li>• Control unit ↔ Amplifier</li> </ul>	AV communication circuits between sonar control unit and BOSE amp. are malfunctioning.	AV communication circuits between sonar control unit and BOSE amp.

## CONFIRMATION/ADJUSTMENT MODE

1. Start the diagnosis function and select “Confirmation/Adjustment”. The confirmation/adjustment mode indicates where each item can be checked or adjusted.
2. Select each switch on the “Confirmation/Adjustment Mode” screen to display the relevant trouble diagnosis screen. Press the “BACK” switch to return to the initial Confirmation/Adjustment Mode screen.

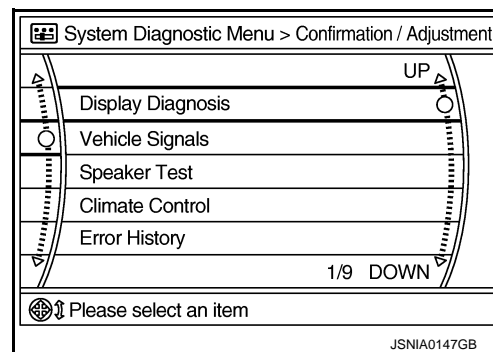

# DIAGNOSIS SYSTEM (AV CONTROL UNIT)

< SYSTEM DESCRIPTION >

[BOSE AUDIO WITHOUT NAVIGATION]

## Display Diagnosis

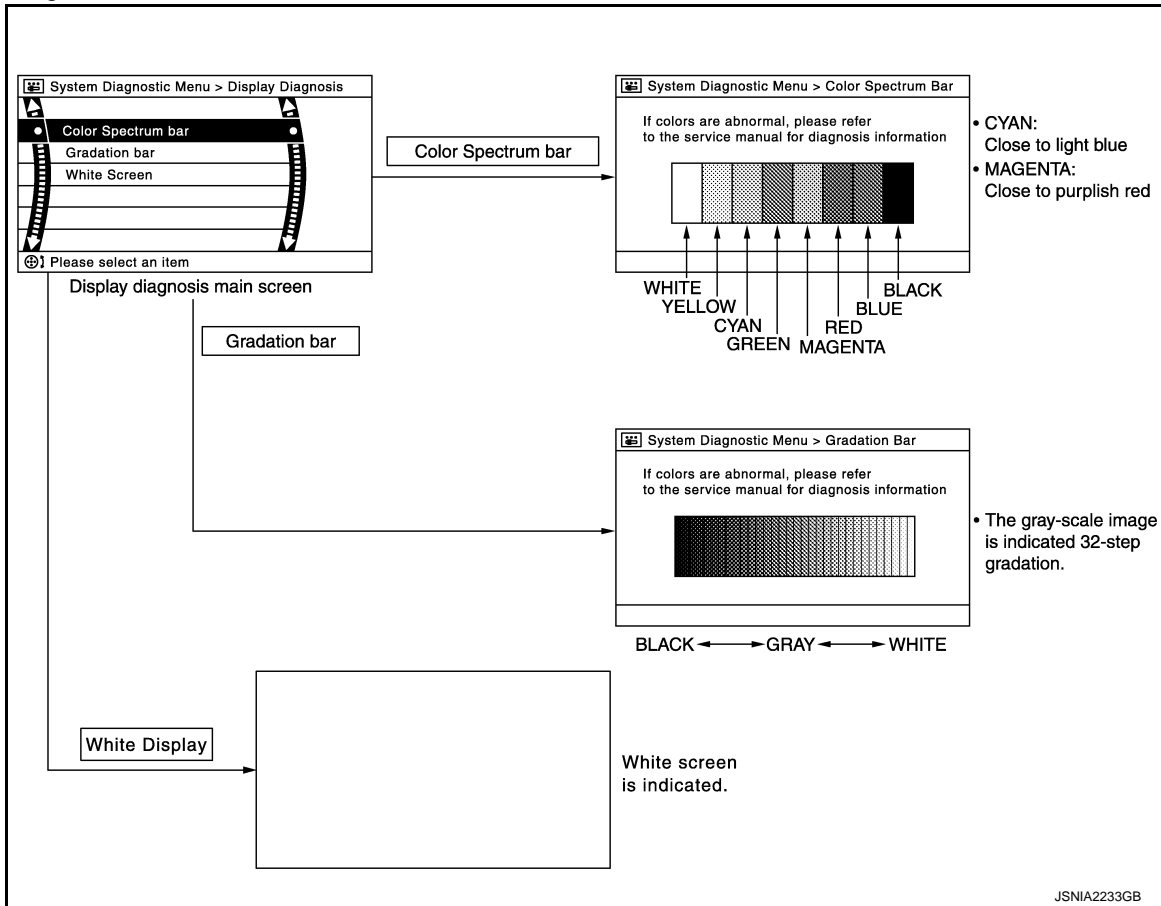

## Vehicle Signals

A comparison check can be made of each actual vehicle signal and the signals recognized by the system.

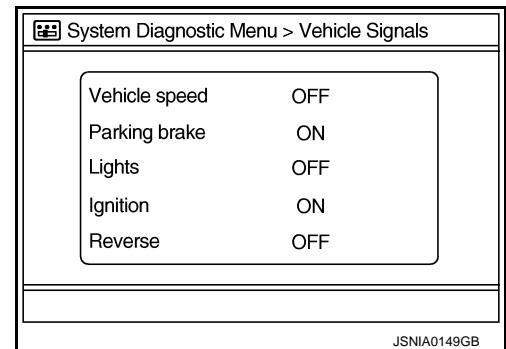

Diagnosis item	Display	Vehicle status	Remarks
Vehicle speed	ON	Vehicle speed > 0 km/h (0 MPH)	Changes in indication may be delayed. This is normal.
	OFF	Vehicle speed = 0 km/h (0 MPH)	
Parking brake	ON	Parking brake is applied.	
	OFF	Parking brake is released.	
Lights	ON	Light switch ON	—
	OFF	Light switch OFF	—
Ignition	ON	Ignition switch ON	—
	OFF	Ignition switch in ACC position	—

# DIAGNOSIS SYSTEM (AV CONTROL UNIT)

< SYSTEM DESCRIPTION >

[BOSE AUDIO WITHOUT NAVIGATION]

Diagnosis item	Display	Vehicle status	Remarks
Reverse	ON	Shift the selector lever to "R" position	Changes in indication may be delayed. This is normal.
	OFF	Shift the selector lever other than "R" position	

## Speaker Test

Select "Speaker Test" to display the Speaker Diagnosis screen. Press "Start" to generate a test tone in a speaker. Press "Start" again to generate a test tone in the next speaker. Press "End" to stop the test tones.

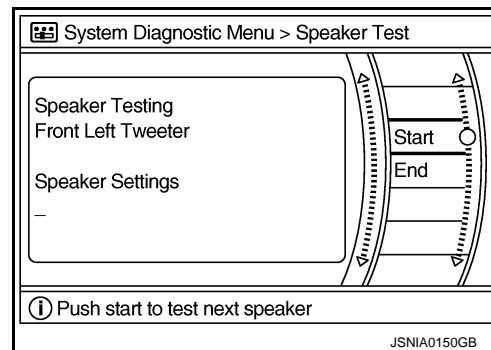

## Climate Control

Refer to "HEATER & AIR CONDITIONING CONTROL SYSTEM" for details.

## Error History

The self-diagnosis results are judged depending on whether any error occurs from when "Self-diagnosis" is selected until the self-diagnosis results are displayed.

However, the diagnosis results are judged normal if an error has occurred before the ignition switch is turned ON and then no error has occurred until the self-diagnosis start. Check the "Error Record" to detect any error that may have occurred before the self-diagnosis start because of this situation.

The frequency of occurrence is displayed in a count up manner. The actual count up method differs depending on the error item.

### Count up method A

- The counter resets to 0 if an error occurs when ignition switch is turned ON. The counter increases by 1 if the condition is normal at a next ignition ON cycle.
- The counter upper limit is 39. Any counts exceeding 39 are ignored. The counter can be reset (no error record display) with the "Delete log" switch or CONSULT-III.

### Count up method B

- The counter increases by 1 if an error occurs when ignition switch is ON. The counter will not decrease even if the condition is normal at the next ignition ON cycle.
- The counter upper limit is 50. Any counts exceeding 50 are ignored. The counter can be reset (no error record display) with the "Delete log" switch or CONSULT-III.

Display type of occurrence frequency	Error history display item
Count up method A	CAN communication line, control unit (CAN), AV communication line, control unit (AV)
Count up method B	Other than the above

# DIAGNOSIS SYSTEM (AV CONTROL UNIT)

< SYSTEM DESCRIPTION >

[BOSE AUDIO WITHOUT NAVIGATION]

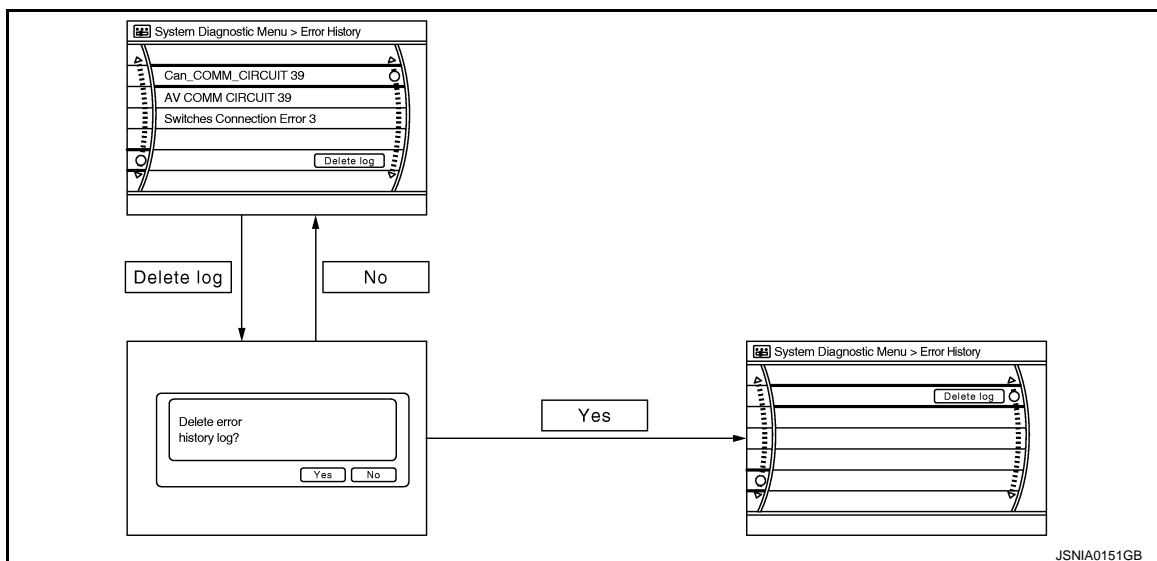

## Error item

Some error items may be displayed simultaneously according to the cause. If some error items are displayed simultaneously, the detection of the cause can be performed by the combination of display items

Error item	Description	Possible malfunction factor/Action to take
CAN COMM CIRCUIT	CAN communication malfunction is detected.	Perform diagnosis with CONSULT-III, and then repair the malfunctioning parts according to the diagnosis results. Refer to <a href="#">AV-148, "CONSULT - III Function"</a> .
CONTROL UNIT (CAN)	CAN initial diagnosis malfunction is detected.	Replace the AV control unit if the malfunction occurs constantly. Refer to <a href="#">AV-250, "Exploded View"</a> .
CONTROL UNIT (AV)	AV communication circuit initial diagnosis malfunction is detected.	
FLASH-ROM Error Of Control Unit CAN Controller Memory Error	AV control unit malfunction is detected.	
Steer. Angle Sensor Calibration	Predictive course line center position adjustment of the steering angle sensor is incomplete.	Adjust the predictive course line center position of the steering angle sensor. Refer to <a href="#">AV-148, "CONSULT - III Function"</a> .
Amplifier Temperature Error	BOSE amp. malfunction is detected.	Replace the BOSE amp. Refer to <a href="#">AV-259, "Exploded View"</a> .
Center speaker OUT: open Center speaker OUT: short Center speaker OUT: short to ground Center speaker OUT: short to battery	Malfunction is detected sound signal circuits between BOSE amp. and center speaker.	Sound signal circuits between BOSE amp. and center speaker.
FR speaker OUT: open FR speaker OUT: short FR speaker OUT: short to ground FR speaker OUT: short to battery	When either one of the following items is detected: • sound signal circuits between BOSE amp. and door squawker RH are malfunctioning. • sound signal circuits between BOSE amp. and tweeter RH are malfunctioning.	<ul style="list-style-type: none"> <li>• Sound signal circuits between BOSE amp. and door squawker RH.</li> <li>• Sound signal circuits between BOSE amp. and tweeter RH.</li> </ul>
RR speaker OUT: open RR speaker OUT: short RR speaker OUT: short to ground RR speaker OUT: short to battery	Malfunction is detected sound signal circuits between BOSE amp. and door woofer RH.	Sound signal circuits between BOSE amp. and door woofer RH.



# DIAGNOSIS SYSTEM (AV CONTROL UNIT)

## [BOSE AUDIO WITHOUT NAVIGATION]

### < SYSTEM DESCRIPTION >

Error item	Description	Possible malfunction factor/Action to take	
RR SR-speaker OUT: open	Malfunction is detected sound signal circuits between BOSE amp. and rear woofer RH.	Sound signal circuits between BOSE amp. and rear woofer RH.	A
RR SR-speaker OUT: short			
RR SR-speaker OUT: short to ground			B
RR SR-speaker OUT: short to battery			
RL SR-speaker OUT: open	Malfunction is detected sound signal circuits between BOSE amp. and rear woofer LH.	Sound signal circuits between BOSE amp. and rear woofer LH.	C
RL SR-speaker OUT: short			
RL SR-speaker OUT: short to ground			D
RL SR-speaker OUT: short to battery			
RL speaker OUT: open	Malfunction is detected sound signal circuits between BOSE amp. and door woofer LH.	Sound signal circuits between BOSE amp. and door woofer LH.	E
RL speaker OUT: short			
RL speaker OUT: short to ground			F
RL speaker OUT: short to battery			
FL speaker OUT: open	When either one of the following items is detected: <ul style="list-style-type: none"> <li>• sound signal circuits between BOSE amp. and door squawker LH are malfunctioning.</li> <li>• sound signal circuits between BOSE amp. and tweeter LH are malfunctioning.</li> </ul>	<ul style="list-style-type: none"> <li>• Sound signal circuits between BOSE amp. and door squawker LH.</li> <li>• Sound signal circuits between BOSE amp. and tweeter LH.</li> </ul>	G
FL speaker OUT: short			
FL speaker OUT: short to ground			H
FL speaker OUT: short to battery			
FL seat SP(L) OUT: open	Malfunction is detected sound signal circuits between BOSE amp. and driver headrest speaker LH.	Sound signal circuits between BOSE amp. and driver headrest speaker LH.	I
FL seat SP(L) OUT: short			
FL seat SP(L) OUT: short to ground			J
FL seat SP(L) OUT: short to battery			
FL seat SP(R) OUT: open	Malfunction is detected sound signal circuits between BOSE amp. and driver headrest speaker RH.	Sound signal circuits between BOSE amp. and driver headrest speaker RH.	K
FL seat SP(R) OUT: short			
FL seat SP(R) OUT: short to ground			L
FL seat SP(R) OUT: short to battery			
FR seat SP(L) OUT: open	Malfunction is detected sound signal circuits between BOSE amp. and passenger headrest speaker LH.	Sound signal circuits between BOSE amp. and passenger headrest speaker LH.	M
FR seat SP(L) OUT: short			
FR seat SP(L) OUT: short to ground			N
FR seat SP(L) OUT: short to battery			
FR seat SP(R) OUT: open	Malfunction is detected sound signal circuits between BOSE amp. and passenger headrest speaker RH.	Sound signal circuits between BOSE amp. and passenger headrest speaker RH.	O
FR seat SP(R) OUT: short			
FR seat SP(R) OUT: short to ground			P
FR seat SP(R) OUT: short to battery			
Compensat. mic IN: open	Malfunction is detected sound signal circuits between BOSE amp. and microphone (for AudioPilot™).	Sound signal circuits between BOSE amp. and microphone (for AudioPilot™).	Q
Compensat. mic IN: short			
Compensat. mic IN: short to ground			R
Compensat. mic IN: short to battery			
Front Display Connection Error	When either one of the following items is detected: <ul style="list-style-type: none"> <li>• display unit power supply and ground circuits are malfunctioning.</li> <li>• communication circuits between AV control unit and display unit are malfunctioning.</li> </ul>	<ul style="list-style-type: none"> <li>• Display unit power supply and ground circuits.</li> <li>• Communication circuits between AV control unit and display unit.</li> </ul>	S

# DIAGNOSIS SYSTEM (AV CONTROL UNIT)

< SYSTEM DESCRIPTION >

[BOSE AUDIO WITHOUT NAVIGATION]

Error item	Description	Possible malfunction factor/Action to take
XM Connection Error	When either one of the following items is detected: <ul style="list-style-type: none"> <li>• satellite radio tuner power supply and ground circuit are malfunctioning.</li> <li>• communication circuits between AV control unit and satellite radio tuner are malfunctioning.</li> <li>• request signal circuit between AV control unit and satellite radio tuner are malfunctioning.</li> </ul>	<ul style="list-style-type: none"> <li>• Satellite radio tuner power supply and ground circuit.</li> <li>• Communication circuit between AV control unit and satellite radio tuner.</li> <li>• Request signal circuit between AV control unit and satellite radio tuner.</li> </ul>
<ul style="list-style-type: none"> <li>• AV COMM CIRCUIT</li> <li>• Switches Connection Error</li> </ul>	When either one of the following items is detected: <ul style="list-style-type: none"> <li>• multifunction switch power supply and ground circuits are malfunctioning.</li> <li>• AV communication circuits between AV control unit and multifunction switch are malfunctioning.</li> </ul>	<ul style="list-style-type: none"> <li>• Multifunction switch power supply and ground circuits.</li> <li>• AV communication circuits between AV control unit and multifunction switch.</li> </ul>
<ul style="list-style-type: none"> <li>• AV COMM CIRCUIT</li> <li>• Sonar Connection Error</li> </ul>	When either one of the following items are detected: <ul style="list-style-type: none"> <li>• sonar control unit power supply and ground circuits are malfunctioning.</li> <li>• AV communication circuits between AV control unit and sonar control unit are malfunctioning.</li> </ul>	<ul style="list-style-type: none"> <li>• Sonar control unit power supply and ground circuits.</li> <li>• AV communication circuits between AV control unit and sonar control unit.</li> </ul>
<ul style="list-style-type: none"> <li>• AV COMM CIRCUIT</li> <li>• H/F Unit Connection Error</li> </ul>	When either one of the following items is detected: <ul style="list-style-type: none"> <li>• TEL adapter unit power supply and ground circuits are malfunctioning.</li> <li>• AV communication circuits between BOSE amp. and TEL adapter unit are malfunctioning.</li> </ul>	<ul style="list-style-type: none"> <li>• TEL adapter unit power supply and ground circuits.</li> <li>• AV communication circuits between BOSE amp. and TEL adapter unit.</li> </ul>
<ul style="list-style-type: none"> <li>• AV COMM CIRCUIT</li> <li>• Amplifier Connection Error</li> </ul>	BOSE amp. power supply and ground circuits are malfunctioning.	BOSE amp. power supply and ground circuits.
<ul style="list-style-type: none"> <li>• AV COMM CIRCUIT</li> <li>• H/F Unit Connection Error</li> <li>• Amplifier Connection Error</li> </ul>	Malfuction is detected in AV communication circuits between sonar control unit and BOSE amp. are malfunctioning.	AV communication circuits between sonar control unit and BOSE amp.
<ul style="list-style-type: none"> <li>• AV COMM CIRCUIT</li> <li>• Switches Connection Error</li> <li>• Sonar Connection Error</li> <li>• H/F Unit Connection Error</li> <li>• Amplifier Connection Error</li> </ul>	Malfuction is detected in AV communication circuits between AV control unit and multifunction switch are malfunctioning.	AV communication circuits between AV control unit and multifunction switch.

**Camera Cont.**

The two functions of “Correct Draw Line of Rear view Cam”, “Confirm Configuration” are available.

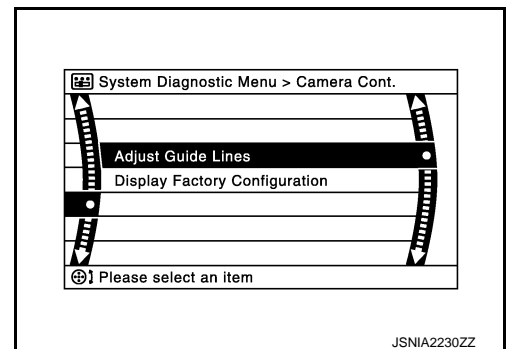

Adjust Offset of Rear view Camera

# DIAGNOSIS SYSTEM (AV CONTROL UNIT)

[BOSE AUDIO WITHOUT NAVIGATION]

## < SYSTEM DESCRIPTION >

- Use this mode to adjust the guide line display position of the rear view monitor if necessary after removing the rear view monitor camera.

**CAUTION:**

After the adjustment, never perform other operations for one minute.

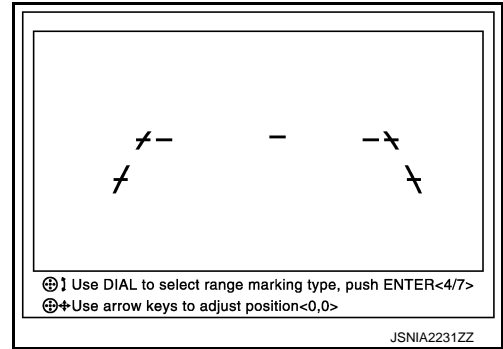

### Factory Configuration Confirmation

- Configuration stored in the AV control unit can be checked.

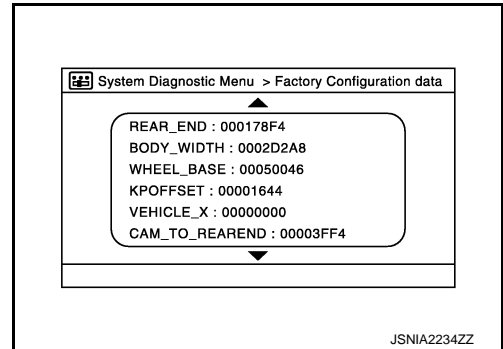

### Vehicle CAN Diagnosis

- CAN communication status and error counter is displayed.
- The error counter displays “OK” if any malfunction was not detected in the past and displays “0” if a malfunction is detected. It increases by 1 if the condition is normal at the next ignition switch ON cycle. The upper limit of the counter is 39.
- The error counter is erased if “Reset” is pressed.

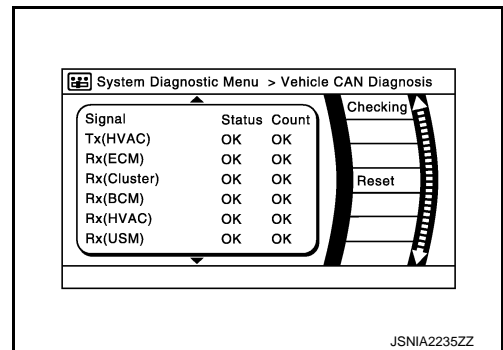

Items	Display (Current)	Malfunction counter (Past)
Tx(HVAC)	OK / ???	OK / 0 - 39
Rx(ECM)	OK / ???	OK / 0 - 39
Rx(Cluster)	OK / ???	OK / 0 - 39
Rx(BCM)	OK / ???	OK / 0 - 39
Rx(HVAC)	OK / ???	OK / 0 - 39
Rx(USM)	OK / ???	OK / 0 - 39
Rx(VDC)	OK / ???	OK / 0 - 39
Rx(STRG)	OK / ???	OK / 0 - 39

**NOTE:**

“???” indicates UNKWN.

### AV COMM Diagnosis

A  
B  
C  
D  
E  
F  
G  
H  
I  
J  
K  
L  
M  
AV  
O  
P

# DIAGNOSIS SYSTEM (AV CONTROL UNIT)

[BOSE AUDIO WITHOUT NAVIGATION]

## < SYSTEM DESCRIPTION >

- Displays the communication status between AV control unit (master unit) and each unit.
- The error counter displays “OK” if any malfunction was not detected in the past and displays “0” if a malfunction is detected. It increases by 1 if the condition is normal at the next ignition switch ON cycle. The upper limit of the counter is 39.
- The error counter is erased if “Reset” is pressed.

Items	Status (Current)	Counter (Past)
C Tx(ITM-SW)	OK / ???	OK / 0 – 39
C Rx(PrimarySW-ITM)	OK / ???	OK / 0 – 39
C Rx(Amp-ITM)	OK / ???	OK / 0 – 39
C Rx(Amp-Audio)	OK / ???	OK / 0 – 39
C Rx(BTHF-ITM)	OK / ???	OK / 0 – 39
C Rx(Sonar-ITM)	OK / ???	OK / 0 – 39

### NOTE:

“???” indicates UNKWN.

### Delete Unit Connection Log

Deletes any unit connection records and error records from the AV control unit memory. (Clear the records of the unit that has been removed.)

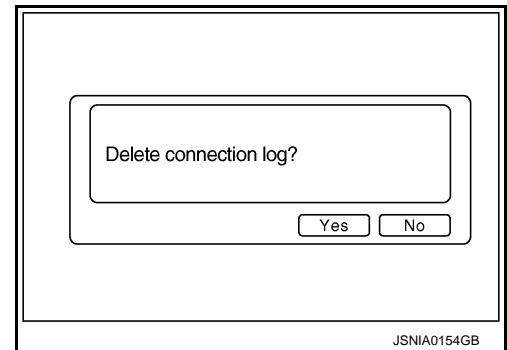
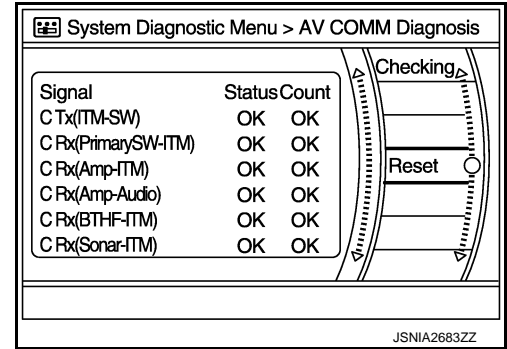

### Initialize Settings

“User Data Initialization” and “Accessory Number Initialization” are possible.

### CAUTION:

- **Never perform Accessory Number Initialization except when configuration is unsuccessful.**
- **Accessory Number Initialization requires configuration. For details, refer to [AV-198. "Description"](#).**

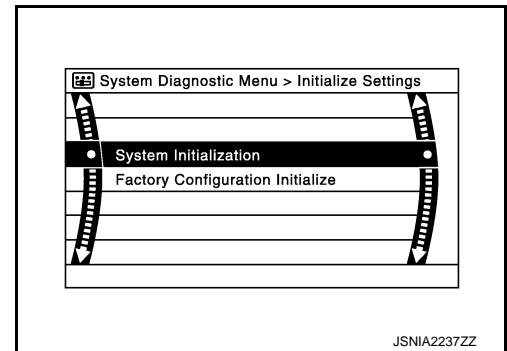

## CONSULT - III Function

INFOID:000000006472526

### APPLICATION ITEMS

CONSULT-III performs the following functions via the communication with the AV control unit.

Diagnosis mode	Description
Ecu Identification	The part number of AV control unit can be checked.
Self Diagnostic Result	Performs a diagnosis on the AV control unit and a connection diagnosis for the communication circuit of the Multi AV system, and displays the current and past malfunctions collectively.
Data Monitor	The diagnosis of vehicle signal that is input to the AV control unit can be performed.

# DIAGNOSIS SYSTEM (AV CONTROL UNIT)

< SYSTEM DESCRIPTION >

[BOSE AUDIO WITHOUT NAVIGATION]

Diagnosis mode	Description
Work Support	Steering angle sensor can be adjusted.
Configuration	<ul style="list-style-type: none"> <li>• Read and save the vehicle specification.</li> <li>• Write the vehicle specification when replacing AV control unit.</li> </ul>

## AV Communication

When "AV communication" of "CAN Diag Support Monitor" is selected, the following function will be performed.

AV communication	AV&NAVI C/U	Displays the communication status from AV control unit to each unit as well as the error counter.
	AUDIO	Displays the AV control unit communication status and the error counter.

## ECU IDENTIFICATION

The part number of AV control unit is displayed.

## SELF DIAGNOSIS RESULT

- In CONSULT-III self-diagnosis, self-diagnosis results and error history are displayed collectively.
- The current malfunction indicates "CRNT". The past malfunction indicates "PAST".
- The timing is displayed as "0" if any of the error codes [U1000], [U1010], [U1300] and [U1310] is detected. The counter increases by 1 if the condition is normal at the next ignition switch ON cycle.

## Self-diagnosis Results Display Item

Error item	Description	Possible malfunction factor/Action to take
CAN COMM CIRCUIT [U1000]	CAN communication malfunction is detected.	Refer to <a href="#">AV-201, "Diagnosis Procedure"</a> .
CONTROL UNIT (CAN) [U1010]	CAN initial diagnosis malfunction is detected.	Replace the AV control unit if the malfunction occurs constantly. Refer to <a href="#">AV-250, "Exploded View"</a> .
CONTROL UNIT (AV) [U1310]	AV communication circuit initial diagnosis malfunction is detected.	
Cont Unit [U1200] CAN CONT [U1216]	AV control unit malfunction is detected.	
ST ANGLE SEN CALIB [U1232]	Predictive course line center position adjustment of the steering angle sensor is incomplete.	Adjust the predictive course line center position of the steering angle sensor. Refer to <a href="#">BRC-9, "ADJUSTMENT OF STEERING ANGLE SENSOR NEUTRAL POSITION : Special Repair Requirement"</a> .
FRONT DISP CONN [U1243]	When either one of the following items is detected: <ul style="list-style-type: none"> <li>• display unit power supply and ground circuits are malfunctioning.</li> <li>• communication circuits between AV control unit and display unit are malfunctioning.</li> </ul>	<ul style="list-style-type: none"> <li>• Display unit power supply and ground circuits.</li> <li>• Communication circuits between AV control unit and display unit.</li> </ul>
AMP TEMP [U1231]	BOSE amp. malfunction is detected.	Replace the BOSE amp. if the malfunction occurs constantly. Refer to <a href="#">AV-259, "Exploded View"</a> .
SAT CONN [U1255]	When either one of the following items is detected: <ul style="list-style-type: none"> <li>• satellite radio tuner power supply and ground circuit are malfunctioning.</li> <li>• communication circuits between AV control unit and satellite radio tuner are malfunctioning.</li> <li>• request signal circuit between AV control unit and satellite radio tuner are malfunctioning.</li> </ul>	<ul style="list-style-type: none"> <li>• Satellite radio tuner power supply and ground circuit.</li> <li>• Communication circuit between AV control unit and satellite radio tuner.</li> <li>• Request signal circuit between AV control unit and satellite radio tuner.</li> </ul>
CENTER SPEAKER [OPEN, SHORT, GND-SHORT or VB-SHOR] [U1900]	Malfunction is detected sound signal circuits between BOSE amp. and center speaker.	Sound signal circuits between BOSE amp. and center speaker.

# DIAGNOSIS SYSTEM (AV CONTROL UNIT)

< SYSTEM DESCRIPTION >

[BOSE AUDIO WITHOUT NAVIGATION]

Error item	Description	Possible malfunction factor/Action to take
FR-DOOR SPEAKER [OPEN, SHORT, GND-SHORT or VB-SHOR] [U1901]	When either one of the following items are detected: <ul style="list-style-type: none"> <li>• sound signal circuits between BOSE amp. and door squawker RH are malfunctioning.</li> <li>• sound signal circuits between BOSE amp. and tweeter RH are malfunctioning.</li> </ul>	<ul style="list-style-type: none"> <li>• Sound signal circuits between BOSE amp. and door squawker RH.</li> <li>• Sound signal circuits between BOSE amp. and tweeter RH.</li> </ul>
RR WOOFER [OPEN, SHORT, GND-SHORT or VB-SHOR] [U1910]	Malfunction is detected sound signal circuits between BOSE amp. and rear woofer RH.	Sound signal circuits between BOSE amp. and rear woofer RH.
RL WOOFER [OPEN, SHORT, GND-SHORT or VB-SHOR] [U1911]	Malfunction is detected sound signal circuits between BOSE amp. and rear woofer LH.	Sound signal circuits between BOSE amp. and rear woofer LH.
FL-DOOR SPEAKER [OPEN, SHORT, GND-SHORT or VB-SHOR] [U1907]	When either one of the following items are detected: <ul style="list-style-type: none"> <li>• sound signal circuits between BOSE amp. and door squawker LH are malfunctioning.</li> <li>• sound signal circuits between BOSE amp. and tweeter LH are malfunctioning.</li> </ul>	<ul style="list-style-type: none"> <li>• Sound signal circuits between BOSE amp. and door squawker LH.</li> <li>• Sound signal circuits between BOSE amp. and tweeter LH.</li> </ul>
FL-SEAT L-SPEAKER [OPEN, SHORT, GND-SHORT or VB-SHOR] [U1908]	Malfunction is detected sound signal circuits between BOSE amp. and driver headrest speaker LH.	Sound signal circuits between BOSE amp. and driver headrest speaker LH.
FL-SEAT R-SPEAKER [OPEN, SHORT, GND-SHORT or VB-SHOR] [U1909]	Malfunction is detected sound signal circuits between BOSE amp. and driver headrest speaker RH.	Sound signal circuits between BOSE amp. and driver headrest speaker RH.
FR-SEAT L-SPEAKER [OPEN, SHORT, GND-SHORT or VB-SHOR] [U190A]	Malfunction is detected sound signal circuits between BOSE amp. and passenger headrest speaker LH.	Sound signal circuits between BOSE amp. and passenger headrest speaker LH.
FR-SEAT R-SPEAKER [OPEN, SHORT, GND-SHORT or VB-SHOR] [U190B]	Malfunction is detected sound signal circuits between BOSE amp. and passenger headrest speaker RH.	Sound signal circuits between BOSE amp. and passenger headrest speaker RH.
CORRECT MICROPHONE [OPEN, SHORT, GND-SHORT or VB-SHOR] [U190C]	Malfunction is detected sound signal circuits between BOSE amp. and microphone (for AudioPilot™).	Sound signal circuits between BOSE amp. and microphone (for AudioPilot™).
FR WOOFER [OPEN, SHORT, GND-SHORT or VB-SHOR] [U190F]	Malfunction is detected sound signal circuits between BOSE amp. and door woofer RH.	Sound signal circuits between BOSE amp. and door woofer RH.
FL WOOFER [OPEN, SHORT, GND-SHORT or VB-SHOR] [U1912]	Malfunction is detected sound signal circuits between BOSE amp. and door woofer LH.	Sound signal circuits between BOSE amp. and door woofer LH.
<ul style="list-style-type: none"> <li>• AV COMM CIRCUIT [U1300]</li> <li>• SWITCH CONN [U1240]</li> </ul>	When either one of the following items is detected: <ul style="list-style-type: none"> <li>• multifunction switch power supply and ground circuits are malfunctioning.</li> <li>• AV communication circuits between AV control unit and multifunction switch are malfunctioning.</li> </ul>	<ul style="list-style-type: none"> <li>• Multifunction switch power supply and ground circuits.</li> <li>• AV communication circuits between AV control unit and multifunction switch.</li> </ul>
<ul style="list-style-type: none"> <li>• AV COMM CIRCUIT [U1300]</li> <li>• HAND FREE CONN [U1256]</li> </ul>	When either one of the following items is detected: <ul style="list-style-type: none"> <li>• TEL adapter unit power supply and ground circuits are malfunctioning.</li> <li>• AV communication circuits between BOSE amp. and TEL adapter unit are malfunctioning.</li> </ul>	<ul style="list-style-type: none"> <li>• TEL adapter unit power supply and ground circuits.</li> <li>• AV communication circuits between BOSE amp. and TEL adapter unit.</li> </ul>

# DIAGNOSIS SYSTEM (AV CONTROL UNIT)

< SYSTEM DESCRIPTION >

[BOSE AUDIO WITHOUT NAVIGATION]

Error item	Description	Possible malfunction factor/Action to take
<ul style="list-style-type: none"> <li>• AV COMM CIRCUIT [U1300]</li> <li>• SONAR CONN [U125C]</li> </ul>	When either one of the following items are detected: <ul style="list-style-type: none"> <li>• sonar control unit power supply and ground circuits are malfunctioning.</li> <li>• AV communication circuits between AV control unit and sonar control unit are malfunctioning.</li> </ul>	<ul style="list-style-type: none"> <li>• Sonar control unit power supply and ground circuits.</li> <li>• AV communication circuits between AV control unit and sonar control unit.</li> </ul>
<ul style="list-style-type: none"> <li>• AV COMM CIRCUIT [U1300]</li> <li>• AMP CONN [U124E]</li> </ul>	BOSE amp. power supply and ground circuits are malfunctioning.	BOSE amp. power supply and ground circuits.
<ul style="list-style-type: none"> <li>• AV COMM CIRCUIT [U1300]</li> <li>• AMP CONN [U124E]</li> <li>• HAND FREE CONN [U1256]</li> </ul>	Malfuction is detected in AV communication circuits between sonar control unit and BOSE amp.	AV communication circuits between sonar control unit and BOSE amp.
<ul style="list-style-type: none"> <li>• AV COMM CIRCUIT [U1300]</li> <li>• SWITCH CONN [U1240]</li> <li>• AMP CONN [U124E]</li> <li>• SONAR CONN [U125C]</li> <li>• HAND FREE CONN [U1256]</li> </ul>	Malfuction is detected in AV communication circuits between AV control unit and multifunction switch.	AV communication circuits between AV control unit and multifunction switch.

## DATA MONITOR

### ALL SIGNALS

- Displays the status of the following vehicle signals inputted into the AV control unit.
- For each signal, actual signal can be compared with the condition recognized on the system.

Display Item	Display	Vehicle status	Remarks	
VHCL SPD SIG	On	Vehicle speed > 0 km/h (0 MPH)	Changes in indication may be delayed. This is normal.	
	Off	Vehicle speed = 0 km/h (0 MPH)		
PKB SIG	On	Parking brake is applied.		
	Off	Parking brake is released.		
ILLUM SIG	On	Block the light beam from the auto light optical sensor when the light SW is ON.	—	
	Off	Expose the auto light optical sensor to light when the light SW is OFF or ON.		
IGN SIG	On	Ignition switch ON		
	Off	Ignition switch in ACC position		
REV SIG	On	Selector lever in R position		Changes in indication may be delayed. This is normal.
	Off	Selector lever in any position other than R		

### SELECTION FROM MENU

Allows the technician to select which vehicle signals should be displayed and displays the status of the selected vehicle signals.

Item to be selected	Description
VHCL SPD SIG	The same as when "ALL SIGNALS" is selected.
PKB SIG	
ILLUM SIG	
IGN SIG	
REV SIG	

### WORK SUPPORT

Adjusts the neutral position of the steering angle sensor.

## DIAGNOSIS SYSTEM (AV CONTROL UNIT)

< SYSTEM DESCRIPTION >

[BOSE AUDIO WITHOUT NAVIGATION]

### CAUTION:

For vehicles with VDC, adjust the steering angle sensor neutral position on the ABS actuator control unit side.

Item	Description
ST ANGLE SENSOR ADJUSTMENT	Adjusts the neutral position of the steering angle sensor.

### CONFIGURATION

Configuration has three functions as follows.

Function	Description
READ CONFIGURATION	<ul style="list-style-type: none"><li>• Reads the vehicle configuration of current AV control unit.</li><li>• Saves the read vehicle configuration.</li></ul>
WRITE CONFIGURATION-Manual selection	Writes the vehicle configuration with manual selection.
WRITE CONFIGURATION-Config file	Writes the vehicle configuration with saved data.



# DIAGNOSIS SYSTEM (TEL ADAPTER UNIT)

< SYSTEM DESCRIPTION >

[BOSE AUDIO WITHOUT NAVIGATION]

## DIAGNOSIS SYSTEM (TEL ADAPTER UNIT)

### On Board Diagnosis Function

INFOID:000000006472527

#### HANDS-FREE PHONE SYSTEM ON BOARD DIAGNOSIS

During on board diagnosis the diagnosis function of TEL adapter unit starts with the operation of the steering switch and performs the diagnosis when ignition switch ACC.

#### ON BOARD DIAGNOSIS ITEM

The on board diagnosis has 3 modes: the self-diagnosis mode that performs the trouble diagnosis, the speaker adaptation data deleting mode and the hands-free phone system initialization mode.

#### CAUTION:

- Perform the diagnosis with the vehicle stopped.
- Perform STEP2 if necessary.

STEP	MODE	Description
STEP1	Self-diagnosis	The self-diagnosis mode performs the microphone test and the diagnosis of TEL adapter unit, TEL antenna and steering unit, and then reads out the results with the sound and indicates them on the display.
STEP2	Speaker adaptation data deleting	The speaker adaptation data deleting mode can delete the speaker adaptation data.
	Hands-free phone system initialization	Hands-free phone system initialization mode can perform the initialization of hands-free phone system.

#### Self-diagnosis results

Self-diagnosis mode reads out the self-diagnosis results.

#### NOTE:

- Error count is read out simultaneously when reading out the DTC name.
- The errors are read out continuously when some errors occur at the same time.

#### Self-diagnosis results

DTC	DTC name	Possible causes
DTC 10000	INTERNAL FAILURE	TEL adapter unit
DTC 01000	ANT. SHORT TO BATT OR OPEN	TEL antenna
DTC 00100	ANT. SHORT TO GROUND	
DTC 00010	STEERING REMOTE BUTTON STUCK A	Steering switch
DTC 00001	STEERING REMOTE BUTTON STUCK B	
DTC 00000	THERE ARE NO FAILURE RECORDS TO REPORT	—

#### The Details of Error Count

The error count guides "0" when the error occurs. The next time it counts up "1" if it is normal with the ignition switch ON. It continues the count up unless the initialization of hands-free phone system is performed.

A  
B  
C  
D  
E  
F  
G  
H  
I  
J  
K  
L  
M  
P

AV

# DIAGNOSIS SYSTEM (TEL ADAPTER UNIT)

[BOSE AUDIO WITHOUT NAVIGATION]

< SYSTEM DESCRIPTION >

## FLOW CHART OF TROUBLE DIAGNOSIS

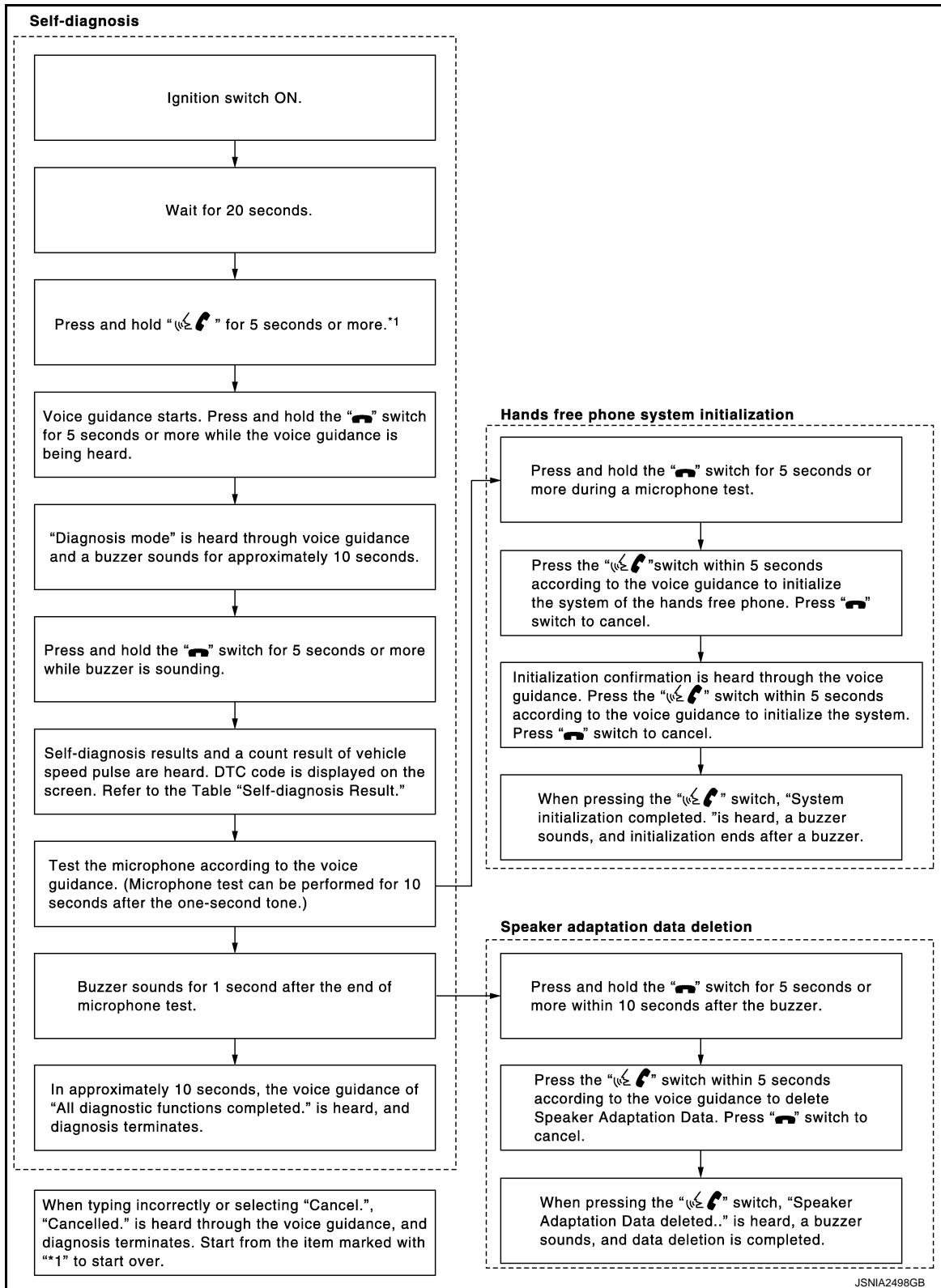

# AV CONTROL UNIT

< ECU DIAGNOSIS INFORMATION >

[BOSE AUDIO WITHOUT NAVIGATION]

## ECU DIAGNOSIS INFORMATION

### AV CONTROL UNIT

#### Reference Value

INFOID:000000006472528

#### VALUES ON THE DIAGNOSIS TOOL

CONSULT-III MONITOR ITEM

Monitor Item	Condition		Value/Status
VHCL SPD SIG	Ignition switch ON	Vehicle speed > 0 km/h (0 MPH)	On
		Vehicle speed = 0 km/h (0 MPH)	Off
PKB SIG	Ignition switch ON	Parking brake is applied.	On
		Parking brake is released.	Off
ILLUM SIG	Ignition switch ON	Light switch ON	On
		Light switch OFF	Off
IGN SIG	Ignition switch ON	—	On
	Ignition switch ACC	—	Off
REV SIG	Ignition switch ON	Selector lever in R position	On
		Selector lever in any position other than R	Off

#### TERMINAL LAYOUT

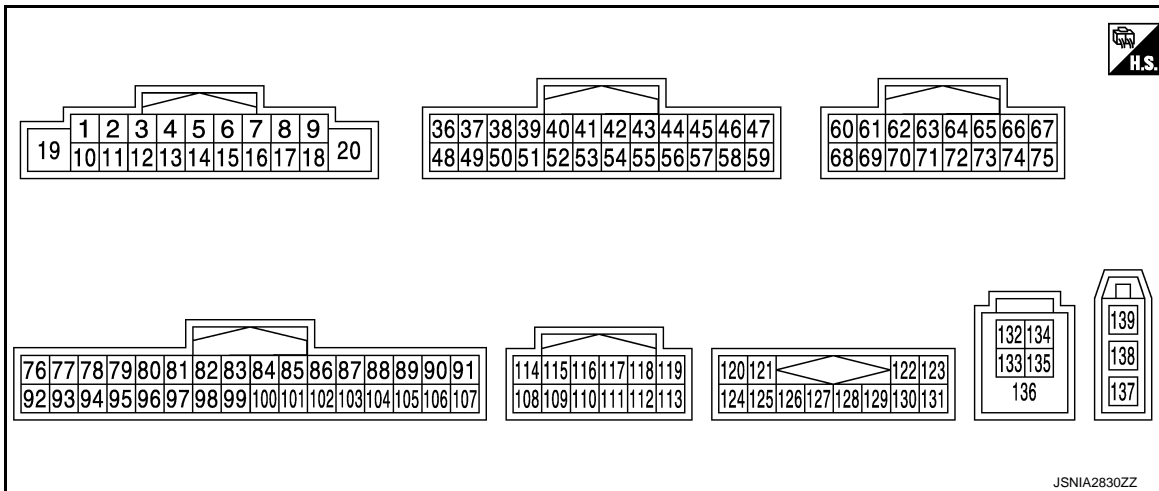

#### PHYSICAL VALUES

Terminal (Wire color)		Description		Condition	Reference value (Approx.)
+	-	Signal name	Input/Output		
6 (P)	15 (B)	Steering switch signal A	Input	Keep pressing SOURCE switch.	0 V
				Keep pressing MENU UP switch.	0.7 V
				Keep pressing MENU DOWN switch.	1.3 V
				Keep pressing  switch	2.0 V
				Except for above.	3.3 V

# AV CONTROL UNIT

< ECU DIAGNOSIS INFORMATION >

[BOSE AUDIO WITHOUT NAVIGATION]

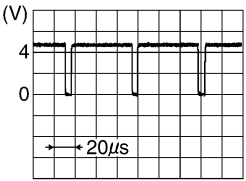
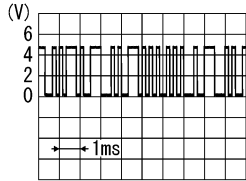
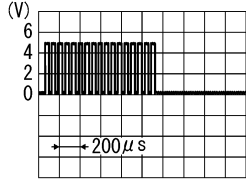
Terminal (Wire color)		Description		Condition		Reference value (Approx.)
+	-	Signal name	Input/ Output			
7 (V)	Ground	ACC power supply	Input	Ignition switch ACC	—	Battery voltage
9 (L)	Ground	Illumination signal	Input	Ignition switch OFF	Lighting switch is OFF.	0 V
					Lighting switch is ON.	12.0 V
16 (L)	15 (B)	Steering switch signal B	Input	Ignition switch ON	Keep pressing VOL DOWN switch.	0 V
					Keep pressing VOL UP switch.	0.7 V
					Keep pressing  switch.	1.3 V
					Except for above.	3.3 V
18 (G)	Ground	Ground	—	Ignition switch ON	—	0 V
19 (BR)	Ground	Battery power supply	Input	Ignition switch OFF	—	Battery voltage
20 (B)	Ground	Ground	—	Ignition switch ON	—	0 V
36 (BG)	Ground	Signal VCC	Output	Ignition switch ACC	—	9.0 V
37 (LG)	Ground	Signal ground	—	Ignition switch OFF	—	0 V
38 (R)	Ground	Horizontal synchronizing (HP) signal	Input	Ignition switch ON	—	 <small>SKIB3601E</small>
39 (L)	Ground	Communication signal (DISP→CONT)	Input	Ignition switch ON	When adjusting display brightness.	 <small>PKIB5039J</small>
40 (B)	Ground	RGB area (YS) signal	Output	Ignition switch ON	At RGB image is displayed.	5.0 V
					At DVD image is displayed.	 <small>PKIB4948J</small>
41	—	Shield	—	—	—	—

# AV CONTROL UNIT

< ECU DIAGNOSIS INFORMATION >

[BOSE AUDIO WITHOUT NAVIGATION]

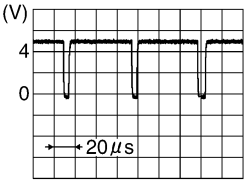
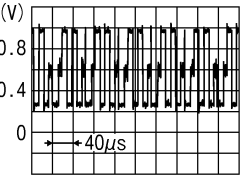
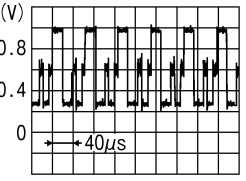
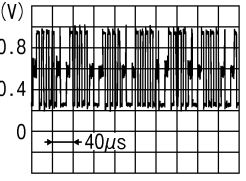
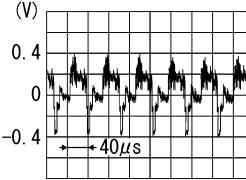
Terminal (Wire color)		Description		Condition		Reference value (Approx.)
+	-	Signal name	Input/ Output			
42 (W)	Ground	RGB synchronizing signal	Output	Ignition switch ON	—	 <p style="text-align: right; font-size: small;">SKIB3603E</p>
43 (G)	Ground	RGB signal (R: red)	Output	Ignition switch ON	Start Confirmation/Adjustment mode, and then display color bar by selecting "Color Spectrum Bar" on Display Diagnosis screen.	 <p style="text-align: right; font-size: small;">JSNIA1029ZZ</p>
44 (L)	Ground	RGB signal (G: green)	Output	Ignition switch ON	Start Confirmation/Adjustment mode, and then display color bar by selecting "Color Spectrum Bar" on Display Diagnosis screen.	 <p style="text-align: right; font-size: small;">JSNIA1030ZZ</p>
45 (P)	Ground	RGB signal (B: blue)	Output	Ignition switch ON	Start Confirmation/Adjustment mode, and then display color bar by selecting "Color Spectrum Bar" on Display Diagnosis screen.	 <p style="text-align: right; font-size: small;">JSNIA1031ZZ</p>
46 (V)	Ground	Composite image ground	—	Ignition switch ON	—	0 V
47 (SB)	Ground	Composite image signal	Output	Ignition switch ON	At rear view camera image is displayed.	 <p style="text-align: right; font-size: small;">SKIB2251J</p>
48 (Y)	Ground	Inverter VCC	Output	Ignition switch ACC	—	9.0 V
49 (BR)	Ground	Inverter ground	—	Ignition switch OFF	—	0 V

A  
B  
C  
D  
E  
F  
G  
H  
I  
J  
K  
L  
M  
O  
P

AV

# AV CONTROL UNIT

< ECU DIAGNOSIS INFORMATION >

[BOSE AUDIO WITHOUT NAVIGATION]

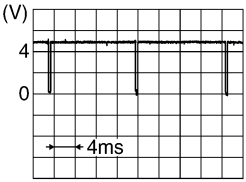
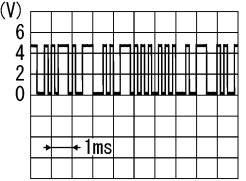
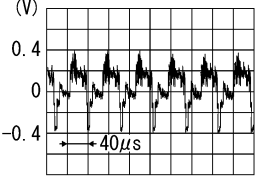
Terminal (Wire color)		Description		Condition		Reference value (Approx.)
+	-	Signal name	Input/ Output			
50 (G)	Ground	Vertical synchronizing (VP) signal	Input	Ignition switch ON	—	 <p style="text-align: right; font-size: small;">SKIB3598E</p>
51 (P)	Ground	Communication signal (CONT→DISP)	Output	Ignition switch ON	When adjusting display brightness.	 <p style="text-align: right; font-size: small;">PKIB5039J</p>
52	—	Shield	—	—	—	—
57	—	Shield	—	—	—	—
58	—	Shield	—	—	—	—
62 (W)	Ground	Camera image signal	Input	Ignition switch ON	At rear view camera image is displayed.	 <p style="text-align: right; font-size: small;">SKIB2251J</p>
71	—	Shield	—	—	—	—
72 (W)	Ground	Camera ground	—	Ignition switch ON	—	0 V
73 (R)	Ground	Camera power supply	Output	Ignition switch ON	At rear view camera image is displayed.	6.0 V
76 (LG)	—	AV communication signal (L)	Input/ Output	—	—	—
77 (SB)	—	AV communication signal (H)	Input/ Output	—	—	—
78 (LG)	—	AV communication signal (L)	Input/ Output	—	—	—
79 (SB)	—	AV communication signal (H)	Input/ Output	—	—	—
80 (P)	—	CAN-L	Input/ Output	—	—	—
81 (L)	—	CAN-H	Input/ Output	—	—	—
82 (BR)	Ground	Switch ground	—	Ignition switch ON	—	0 V
86	—	Shield	—	—	—	—

# AV CONTROL UNIT

< ECU DIAGNOSIS INFORMATION >

[BOSE AUDIO WITHOUT NAVIGATION]

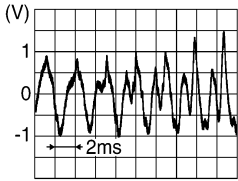
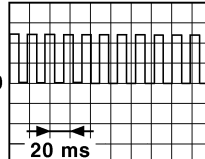
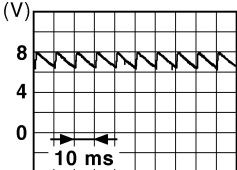
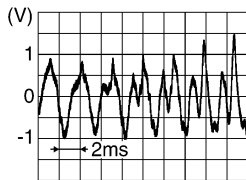
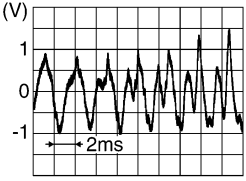
Terminal (Wire color)		Description		Condition		Reference value (Approx.)
+	-	Signal name	Input/ Output			
87 (L)	88 (P)	TEL voice signal	Input	Ignition switch ON	During voice guide output with the  switch pressed.	 SKIB3609E
92 (GR)	Ground	Vehicle speed signal (8-pulse)	Input	Ignition switch ON	When vehicle speed is approx. 40 km/h (25 MPH)	<p><b>NOTE:</b> The maximum voltage varies de- pending on the specification (destination unit).</p>  JSNIA0012GB
93 (SB)	Ground	Parking brake signal	Input	Ignition switch ON	Parking brake is ON.	0 V
					Parking brake is OFF.	 JSNIA0007GB
94 (BG)	Ground	Reverse signal	Input	Ignition switch ON	R position	12.0 V
					Other than R position	0 V
95 (G)	Ground	Ignition signal	Input	Ignition switch ON	—	Battery voltage
96 (SB)	Ground	Disk eject signal	Input	Ignition switch ON	Pressing the eject switch.	0 V
					Except for above.	3.3 V
109 (R)	115 (G)	Sound signal RH	Output	Ignition switch ON	Sound output	 SKIB3609E
111 (B)	—	Shield	—	—	—	—
113 (P)	119 (L)	Sound signal LH	Output	Ignition switch ON	Sound output	 SKIB3609E

A  
B  
C  
D  
E  
F  
G  
H  
I  
J  
K  
L  
M  
AV  
O  
P

# AV CONTROL UNIT

< ECU DIAGNOSIS INFORMATION >

[BOSE AUDIO WITHOUT NAVIGATION]

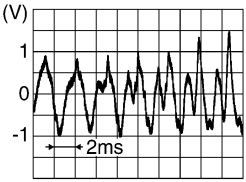
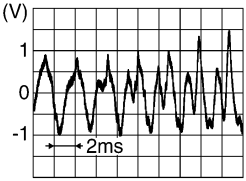
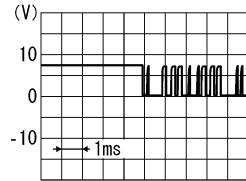
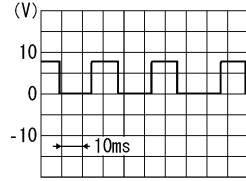
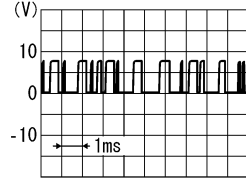
Terminal (Wire color)		Description		Condition		Reference value (Approx.)
+	-	Signal name	Input/ Output			
120 (B)	124 (W)	Satellite radio sound signal LH	Input	Ignition switch ON	When satellite radio mode is selected.	 <p style="text-align: right; font-size: small;">SKIB3609E</p>
121 (G)	125 (R)	Satellite radio sound signal RH	Input	Ignition switch ON	When satellite radio mode is selected.	 <p style="text-align: right; font-size: small;">SKIB3609E</p>
122 (L)	Ground	Communication signal (CONT→SAT)	Output	Ignition switch ON	When satellite radio mode is selected.	 <p style="text-align: right; font-size: small;">SKIA9301J</p>
126	—	Shield	—	—	—	—
127	—	Shield	—	—	—	—
129 (P)	Ground	Request signal (SAT→CONT)	Input	Ignition switch ON	When satellite radio mode is selected.	 <p style="text-align: right; font-size: small;">SKIA9299J</p>
130 (G)	Ground	Communication signal (SAT→CONT)	Input	Ignition switch ON	When satellite radio mode is selected.	 <p style="text-align: right; font-size: small;">SKIA9300J</p>
132 (G)	—	USB ground	—	—	—	—
133 (R)	—	USB D- signal	—	—	—	—
134 (W)	—	V BUS signal	—	—	—	—
135 (L)	—	USB D+ signal	—	—	—	—
136	—	Shield	—	—	—	—



# AV CONTROL UNIT

< ECU DIAGNOSIS INFORMATION >

[BOSE AUDIO WITHOUT NAVIGATION]

Terminal (Wire color)		Description		Condition		Reference value (Approx.)
+	-	Signal name	Input/ Output			
138	—	Antenna signal	Input	—	—	—
139	Ground	Antenna amp. ON signal	Output	Ignition switch ACC	—	12.0 V

## DTC Index

INFOID:000000006472529

## SELF-DIAGNOSIS RESULTS DISPLAY ITEM

DTC	Display item	Refer to
U1000	CAN COMM CIRCUIT [U1000]	<a href="#">AV-201, "Diagnosis Procedure"</a>
U1010	CONTROL UNIT (CAN) [1010]	<a href="#">AV-202, "DTC Logic"</a>
U1200	Cont Unit [U1200]	<a href="#">AV-203, "DTC Logic"</a>
U1216	CAN CONT [U1216]	<a href="#">AV-204, "DTC Logic"</a>
U1231	AMP TEMP [U1231]	<a href="#">AV-205, "DTC Logic"</a>
U1232	ST ANGLE SEN CALIB [1232]	<a href="#">AV-206, "Diagnosis Procedure"</a>
U1243	FRONT DISP CONN [U1243]	<a href="#">AV-207, "Diagnosis Procedure"</a>
U1255	SAT CONN [U1255]	<a href="#">AV-209, "Diagnosis Procedure"</a>
U1310	CONTROL UNIT (AV) [U1310]	<a href="#">AV-212, "DTC Logic"</a>
U1900	CENTER SPEAKER [OPEN, SHORT, GND-SHORT or VB-SHOR] [U1900]	<a href="#">AV-213, "Diagnosis Procedure"</a>
U1901	FR-DOOR SPEAKER [OPEN, SHORT, GND-SHORT or VB-SHOR] [U1901]	<a href="#">AV-214, "Diagnosis Procedure"</a>
U1907	FL-DOOR SPEAKER [OPEN, SHORT, GND-SHORT or VB-SHOR] [U1907]	<a href="#">AV-214, "Diagnosis Procedure"</a>
U1908	FL-SEAT L-SPEAKER [OPEN, SHORT, GND-SHORT or VB-SHOR] [U1908]	<a href="#">AV-215, "Diagnosis Procedure"</a>
U1909	FL-SEAT R-SPEAKER [OPEN, SHORT, GND-SHORT or VB-SHOR] [U1909]	<a href="#">AV-215, "Diagnosis Procedure"</a>
U1910	RR WOOFER [OPEN, SHORT, GND-SHORT or VB-SHOR] [U1910]	<a href="#">AV-216, "Diagnosis Procedure"</a>
U1911	RL WOOFER [OPEN, SHORT, GND-SHORT or VB-SHOR] [U1911]	<a href="#">AV-216, "Diagnosis Procedure"</a>
U190A	FR-SEAT L-SPEAKER [OPEN, SHORT, GND-SHORT or VB-SHOR] [U190A]	<a href="#">AV-217, "Diagnosis Procedure"</a>
U190B	FR-SEAT R-SPEAKER [OPEN, SHORT, GND-SHORT or VB-SHOR] [U190B]	<a href="#">AV-217, "Diagnosis Procedure"</a>
U190C	CORRECT MICROPHONE [OPEN, SHORT, GND-SHORT or VB-SHOR] [U190C]	<a href="#">AV-218, "Diagnosis Procedure"</a>

## AV CONTROL UNIT

< ECU DIAGNOSIS INFORMATION >

[BOSE AUDIO WITHOUT NAVIGATION]

DTC	Display item	Refer to
U190F	FR WOOFER [OPEN, SHORT, GND-SHORT or VB-SHOR] [U190F]	<a href="#">AV-219. "Diagnosis Procedure"</a>
U1912	FL WOOFER [OPEN, SHORT, GND-SHORT or VB-SHOR] [U1912]	<a href="#">AV-219. "Diagnosis Procedure"</a>
U1300 U1240	<ul style="list-style-type: none"> <li>• AV COMM CIRCUIT [U1300]</li> <li>• SWITCH CONN [U1240]</li> </ul>	<a href="#">AV-211. "Description"</a>
U1300 U1256	<ul style="list-style-type: none"> <li>• AV COMM CIRCUIT [U1300]</li> <li>• HAND FREE CONN [U1256]</li> </ul>	<a href="#">AV-211. "Description"</a>
U1300 U125C	<ul style="list-style-type: none"> <li>• AV COMM CIRCUIT [U1300]</li> <li>• SONAR CONN [U125C]</li> </ul>	<a href="#">AV-211. "Description"</a>
U1300 U124E	<ul style="list-style-type: none"> <li>• AV COMM CIRCUIT [U1300]</li> <li>• AMP CONN [U124E]</li> </ul>	<a href="#">AV-211. "Description"</a>
U1300 U124E U1256	<ul style="list-style-type: none"> <li>• AV COMM CIRCUIT [U1300]</li> <li>• AMP CONN [U124E]</li> <li>• HAND FREE CONN [U1256]</li> </ul>	<a href="#">AV-211. "Description"</a>
U1300 U1240 U124E U125C U1256	<ul style="list-style-type: none"> <li>• AV COMM CIRCUIT [U1300]</li> <li>• SWITCH CONN [U1240]</li> <li>• AMP CONN [U124E]</li> <li>• SONAR CONN [U125C]</li> <li>• HAND FREE CONN [U1256]</li> </ul>	<a href="#">AV-211. "Description"</a>

# DISPLAY UNIT

< ECU DIAGNOSIS INFORMATION >

[BOSE AUDIO WITHOUT NAVIGATION]

## DISPLAY UNIT

Reference Value

INFOID:000000006472530

TERMINAL LAYOUT

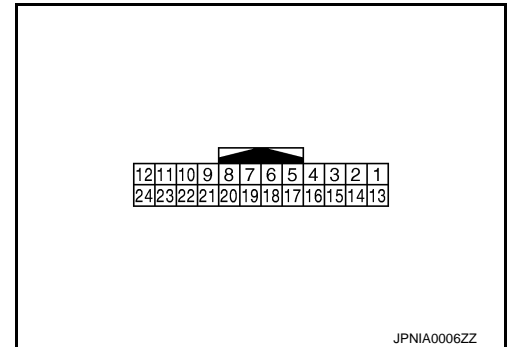

## PHYSICAL VALUES

Terminal (Wire color)		Description		Condition		Reference value (Approx.)
+	-	Signal name	Input/ Output			
1 (B)	Ground	Ground	—	Ignition switch ON	—	0 V
2 (Y)	Ground	Inverter VCC	Input	Ignition switch ACC	—	9.0 V
3 (BG)	Ground	Signal VCC	Input	Ignition switch ACC	—	9.0 V
4 (V)	Ground	Composite image ground	—	Ignition switch ON	—	0 V
5	—	Shield	—	—	—	—
6 (L)	Ground	RGB signal (G: green)	Input	Ignition switch ON	Start Confirmation/Adjust- ment mode, and then dis- play color bar by selecting "Color Spectrum Bar" on Display Diagnosis screen.	<p style="text-align: right;">JSNIA1030ZZ</p>
7	—	Shield	—	—	—	—
8 (R)	Ground	Horizontal synchronizing (HP) signal	Output	Ignition switch ON	—	<p style="text-align: right;">SKIB3601E</p>

A  
B  
C  
D  
E  
F  
G  
H  
I  
J  
K  
L  
M  
AV  
O  
P

# DISPLAY UNIT

< ECU DIAGNOSIS INFORMATION >

[BOSE AUDIO WITHOUT NAVIGATION]

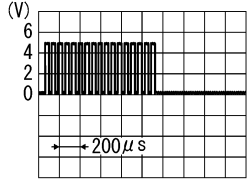
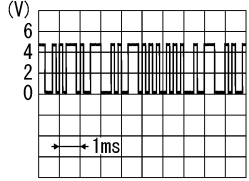
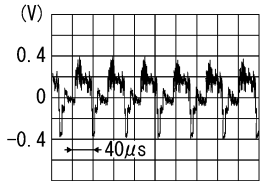
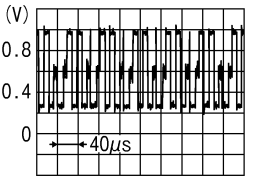
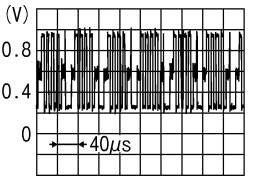
Terminal (Wire color)		Description		Condition	Reference value (Approx.)	
+	-	Signal name	Input/ Output			
9 (B)	Ground	RGB area (YS) signal	Input	Ignition switch ON	At RGB image is displayed. 5.0 V	
				At DVD image is displayed.	 <p>PKIB4948J</p>	
11 (P)	Ground	Communication signal (CONT→DISP)	Input	Ignition switch ON	When adjusting display brightness.	 <p>PKIB5039J</p>
13 (BR)	Ground	Inverter ground	—	Ignition switch ON	—	0 V
14 (LG)	Ground	Signal ground	—	Ignition switch ON	—	0 V
15 (SB)	Ground	Composite image signal	Input	Ignition switch ON	At rear view camera image is displayed.	 <p>SKIB2251J</p>
17 (G)	Ground	RGB signal (R: red)	Input	Ignition switch ON	Start Confirmation/Adjustment mode, and then display color bar by selecting "Color Spectrum Bar" on Display Diagnosis screen.	 <p>JSNIA1029ZZ</p>
18 (P)	Ground	RGB signal (B: blue)	Input	Ignition switch ON	Start Confirmation/Adjustment mode, and then display color bar by selecting "Color Spectrum Bar" on Display Diagnosis screen.	 <p>JSNIA1031ZZ</p>

# DISPLAY UNIT

< ECU DIAGNOSIS INFORMATION >

[BOSE AUDIO WITHOUT NAVIGATION]

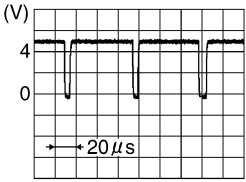
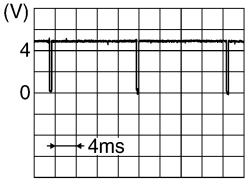
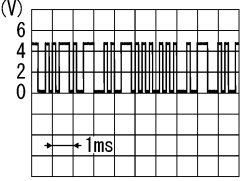
Terminal (Wire color)		Description		Condition		Reference value (Approx.)
+	-	Signal name	Input/ Output			
19 (W)	Ground	RGB synchronizing signal	Input	Ignition switch ON	—	 <p>SKIB3603E</p>
20 (G)	Ground	Vertical synchronizing (VP) signal	Output	Ignition switch On	—	 <p>SKIB3598E</p>
21	—	Shield	—	—	—	—
22 (L)	Ground	Communication signal (DISP→CONT)	Output	Ignition switch ON	When adjusting display brightness.	 <p>PKIB5039J</p>
23	—	Shield	—	—	—	—

A  
B  
C  
D  
E  
F  
G  
H  
I  
J  
K  
L  
M  
AV  
O  
P

AV

# BOSE AMP.

< ECU DIAGNOSIS INFORMATION >

[BOSE AUDIO WITHOUT NAVIGATION]

## BOSE AMP.

### Reference Value

INFOID:000000006472531

### TERMINAL LAYOUT

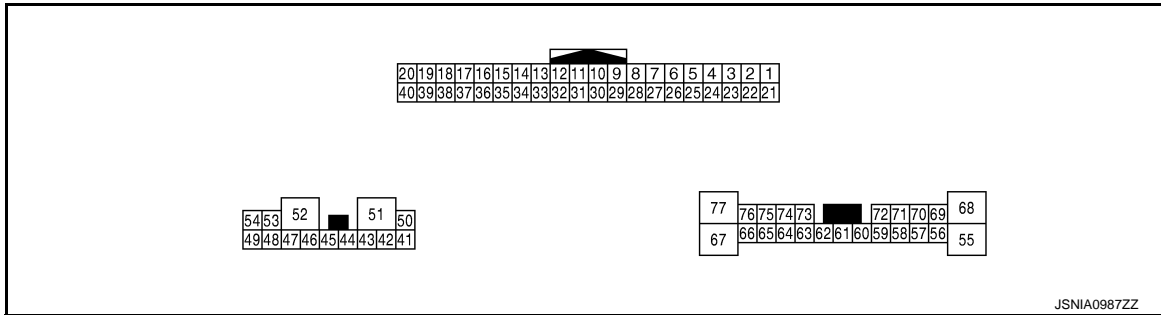

### PHYSICAL VALUES

Terminal (Wire color)		Description		Condition		Reference value (Approx.)
+	-	Signal name	Input/ Output			
14 (LG)	—	AV communication signal (L)	Input/ Output	—	—	—
15 (LG)	—	AV communication signal (L)	Input/ Output	—	—	—
16 (W)	Ground	ACC power supply	Input	Ignition switch ACC	—	12.0 V
29 (P)	9 (L)	Sound signal LH	Input	Ignition switch ON	Sound output	
30 (R)	10 (G)	Sound signal RH	Input	Ignition switch ON	Sound output	
31 (Y)	11 (G)	Microphone signal (for AudioPilot™)	Input	Ignition switch ON	When inputting noise.	
33	—	Shield	—	—	—	—
34 (SB)	—	AV communication signal (H)	Input/ Output	—	—	—
35 (SB)	—	AV communication signal (H)	Input/ Output	—	—	—

# BOSE AMP.

< ECU DIAGNOSIS INFORMATION >

[BOSE AUDIO WITHOUT NAVIGATION]

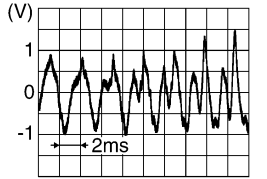
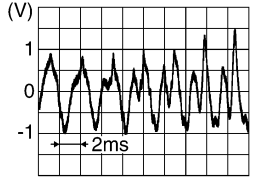
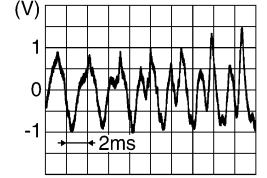
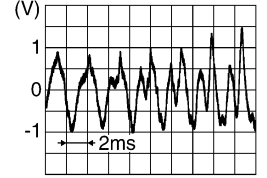
Terminal (Wire color)		Description		Condition		Reference value (Approx.)
+	-	Signal name	Input/ Output			
40 (V)	Ground	Roof status signal	Input	Ignition switch ON	Retractable hard top is fully closed.	12.0 V
					Other than above.	0 V
41 (B)	42 (W)	Sound signal door woofer LH	Output	Ignition switch ON	Sound output	 <small>SKIB3609E</small>
45 (G)	46 (R)	Sound signal door woofer RH	Output	Ignition switch ON	Sound output	 <small>SKIB3609E</small>
47 (B)	Ground	Ground	—	Ignition switch ON	—	0 V
50 (Y)	Ground	Battery power supply	Input	Ignition switch OFF	—	Battery voltage
51 (GR)	Ground	Battery power supply	Input	Ignition switch OFF	—	Battery voltage
52 (B)	Ground	Ground	—	Ignition switch ON	—	0 V
54 (L)	49 (P)	Sound signal rear woofer LH	Output	Ignition switch ON	Sound output	 <small>SKIB3609E</small>
56 (W)	69 (B)	Sound signal passenger headrest speaker LH	Output	Ignition switch ON	Sound output	 <small>SKIB3609E</small>

A  
B  
C  
D  
E  
F  
G  
H  
I  
J  
K  
L  
M  
AV  
O  
P

# BOSE AMP.

< ECU DIAGNOSIS INFORMATION >

[BOSE AUDIO WITHOUT NAVIGATION]

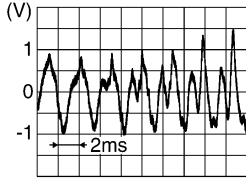
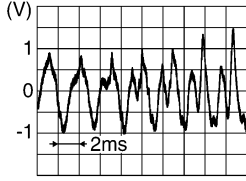
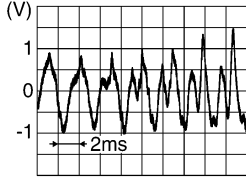
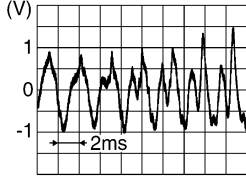
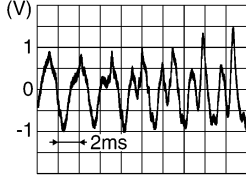
Terminal (Wire color)		Description		Condition		Reference value (Approx.)
+	-	Signal name	Input/ Output			
57 (BG)	58 (P)	Sound signal center speaker	Output	Ignition switch ON	Sound output	 <p>SKIB3609E</p>
59 (L)	72 (W)	Sound signal front LH	Output	Ignition switch ON	Sound output	 <p>SKIB3609E</p>
62 (V)	73 (LG)	Sound signal front RH	Output	Ignition switch ON	Sound output	 <p>SKIB3609E</p>
63 (G)	74 (Y)	Sound signal driver head-rest speaker LH	Output	Ignition switch ON	Sound output	 <p>SKIB3609E</p>
64 (W)	75 (B)	Sound signal driver head-rest speaker RH	Output	Ignition switch ON	Sound output	 <p>SKIB3609E</p>



# BOSE AMP.

< ECU DIAGNOSIS INFORMATION >

[BOSE AUDIO WITHOUT NAVIGATION]

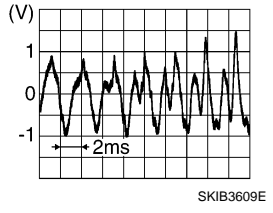
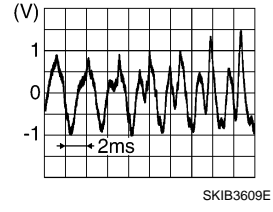
Terminal (Wire color)		Description		Condition		Reference value (Approx.)
+	-	Signal name	Input/ Output			
68 (LG)	55 (BG)	Sound signal rear woofer RH	Output	Ignition switch ON	Sound output	
71 (Y)	70 (G)	Sound signal passenger headrest speaker RH	Output	Ignition switch ON	Sound output	

A  
B  
C  
D  
E  
F  
G  
H  
I  
J  
K  
L  
M  
O  
P



# SATELLITE RADIO TUNER

< ECU DIAGNOSIS INFORMATION >

[BOSE AUDIO WITHOUT NAVIGATION]

## SATELLITE RADIO TUNER

Reference Value

INFOID:000000006472532

TERMINAL LAYOUT

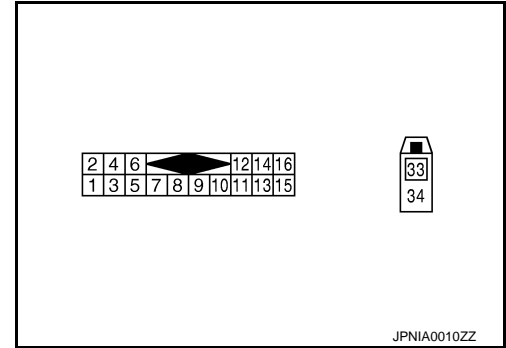

PHYSICAL VALUES

Terminal		Description		Condition		Reference value (Approx.)
+	-	Signal name	Input/Output			
2 (R)	1 (G)	Satellite radio sound signal LH	Output	Ignition switch ON	When satellite radio mode is selected.	
4 (B)	3 (W)	Satellite radio sound signal RH	Output	Ignition switch ON	When satellite radio mode is selected	
5	—	Shield	—	—	—	—
6	—	Shield	—	—	—	—
8 (Y)	Ground	Request signal (SAT→CONT)	Output	Ignition switch ON	When satellite radio mode is selected	
9 (O)	Ground	Communication signal (SAT→CONT)	Output	Ignition switch ON	When satellite radio mode is selected	

# SATELLITE RADIO TUNER

< ECU DIAGNOSIS INFORMATION >

[BOSE AUDIO WITHOUT NAVIGATION]

Terminal		Description		Condition		Reference value (Approx.)
+	-	Signal name	Input/Output			
10 (BR)	Ground	Communication signal (CONT→SAT)	Input	Ignition switch ON	When satellite radio mode is selected	
12 (SB)	Ground	Battery power supply	Input	Ignition switch OFF	—	Battery voltage
15 (B)	Ground	Ground	—	Ignition switch ON	—	0 V
16 (V)	Ground	ACC power supply	Input	Ignition switch ACC	—	Battery voltage
33	—	Satellite antenna	Input	—	—	—
34	—	Shield	—	—	—	—

A  
B  
C  
D  
E  
F  
G  
H  
I  
J  
K  
L  
M

AV

O  
P

# TEL ADAPTER UNIT

< ECU DIAGNOSIS INFORMATION >

[BOSE AUDIO WITHOUT NAVIGATION]

## TEL ADAPTER UNIT

Reference Value

INFOID:000000006472533

TERMINAL LAYOUT

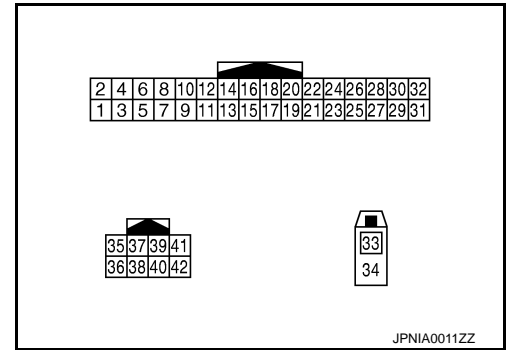

PHYSICAL VALUES

Terminal (Wire color)		Description		Condition		Reference value (Approx.)
+	-	Signal name	Input/ Output			
1 (GR)	Ground	Battery power supply	Input	Ignition switch OFF	—	Battery voltage
2 (LG)	Ground	ACC power supply	Input	Ignition switch ACC	—	Battery voltage
3 (BG)	Ground	Ignition signal	Input	Ignition switch ON	—	Battery voltage
4 (B)	Ground	Ground	—	Ignition switch ON	—	0 V
5	—	Shield	—	—	—	—
7 (R)	8	Microphone signal	Input	Ignition switch ON	Give a voice	<p style="text-align: right;">PKIB5037J</p>
9 (Y)	10 (G)	TEL voice signal	Output	Ignition switch ON	During voice guide output with the  switch pressed	<p style="text-align: right;">SKIB3609E</p>
14 (B)	Ground	Ground	—	Ignition switch ON	—	0 V
16 (P)	Ground	Roof status signal	Input	Ignition switch ON	Retractable hard top is fully closed.	12.0 V
					Other than above.	0 V

# TEL ADAPTER UNIT

< ECU DIAGNOSIS INFORMATION >

[BOSE AUDIO WITHOUT NAVIGATION]

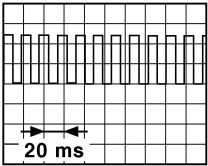
Terminal (Wire color)		Description		Condition		Reference value (Approx.)
+	-	Signal name	Input/ Output			
21 (B)	Ground	Control signal	Input	Ignition switch ON	—	0 V
23 (B)	Ground	Control signal	Input	Ignition switch ON	—	0 V
27 (B)	Ground	Control signal	Input	Ignition switch ON	—	0 V
28 (P)	Ground	Vehicle speed signal (8-pulse)	Input	Ignition switch ON	When vehicle speed is approx. 40 km/h (25 MPH)	<p><b>NOTE:</b> The maximum voltage varies depending on the specification (destination unit).</p>  <p style="text-align: right; font-size: small;">JSNIA0012GB</p>
29 (G)	8	Microphone VCC	Output	Ignition switch ON	—	5.0 V
33	—	TEL antenna	Input	—	—	—
34	—	Shield	—	—	—	—
35 (L)	—	AV communication signal (H)	Input/ Output	—	—	—
36 (P)	—	AV communication signal (L)	Input/ Output	—	—	—

A  
B  
C  
D  
E  
F  
G  
H  
I  
J  
K  
L  
M

AV

O  
P

# BOSE AUDIO WITHOUT NAVIGATION

[BOSE AUDIO WITHOUT NAVIGATION]

< WIRING DIAGRAM >

## WIRING DIAGRAM

### BOSE AUDIO WITHOUT NAVIGATION

#### Wiring Diagram

INFOID:000000006472534

**NOTE:**

The name MULTIFUNCTION SWITCH indicates the integration of PRESET SWITCH and MULTIFUNCTION SWITCH virtually.

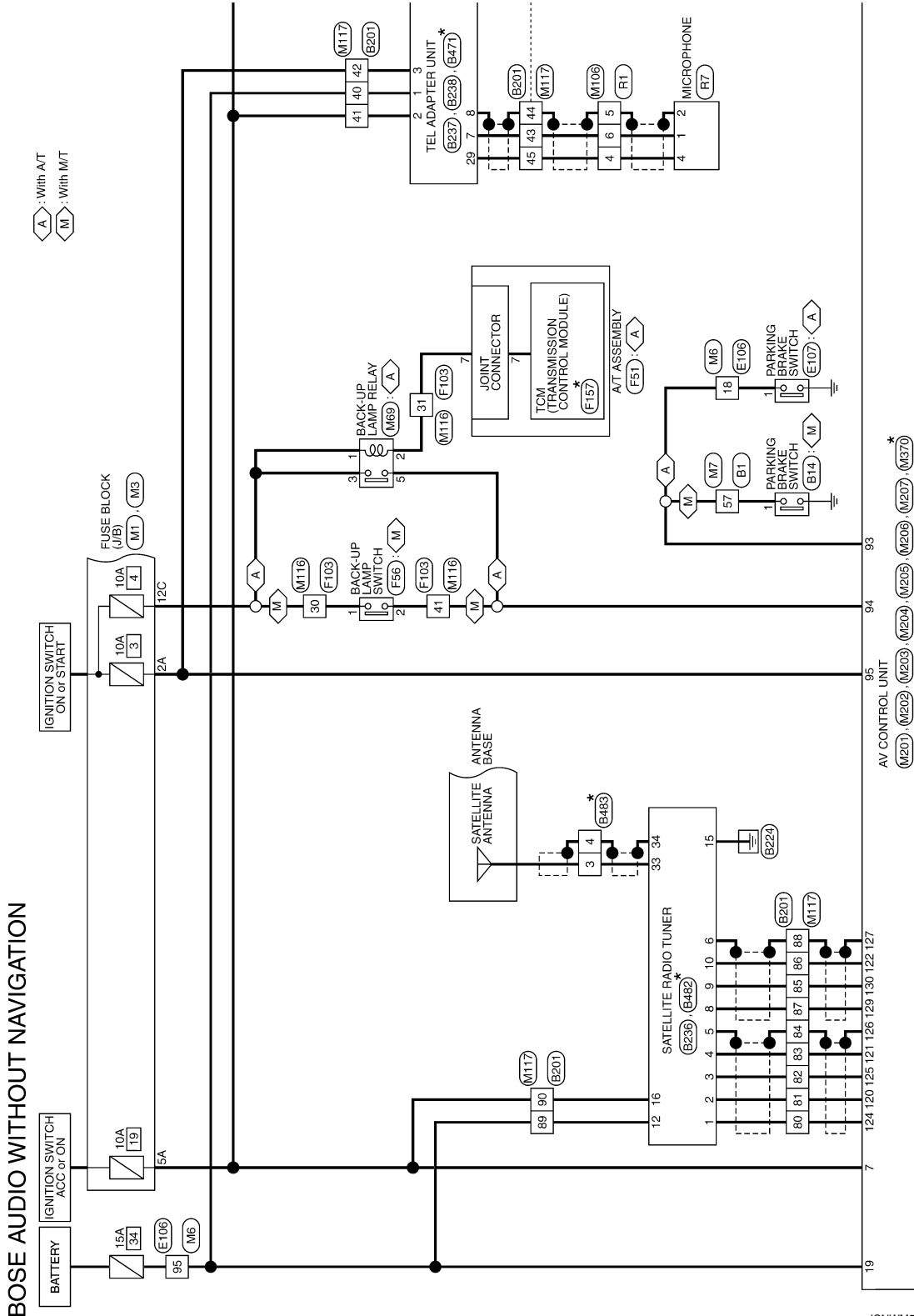

\*: This connector is not shown in "Harness Layout".

2010/10/12

JCNWM5570GB



# BOSE AUDIO WITHOUT NAVIGATION

[BOSE AUDIO WITHOUT NAVIGATION]

< WIRING DIAGRAM >

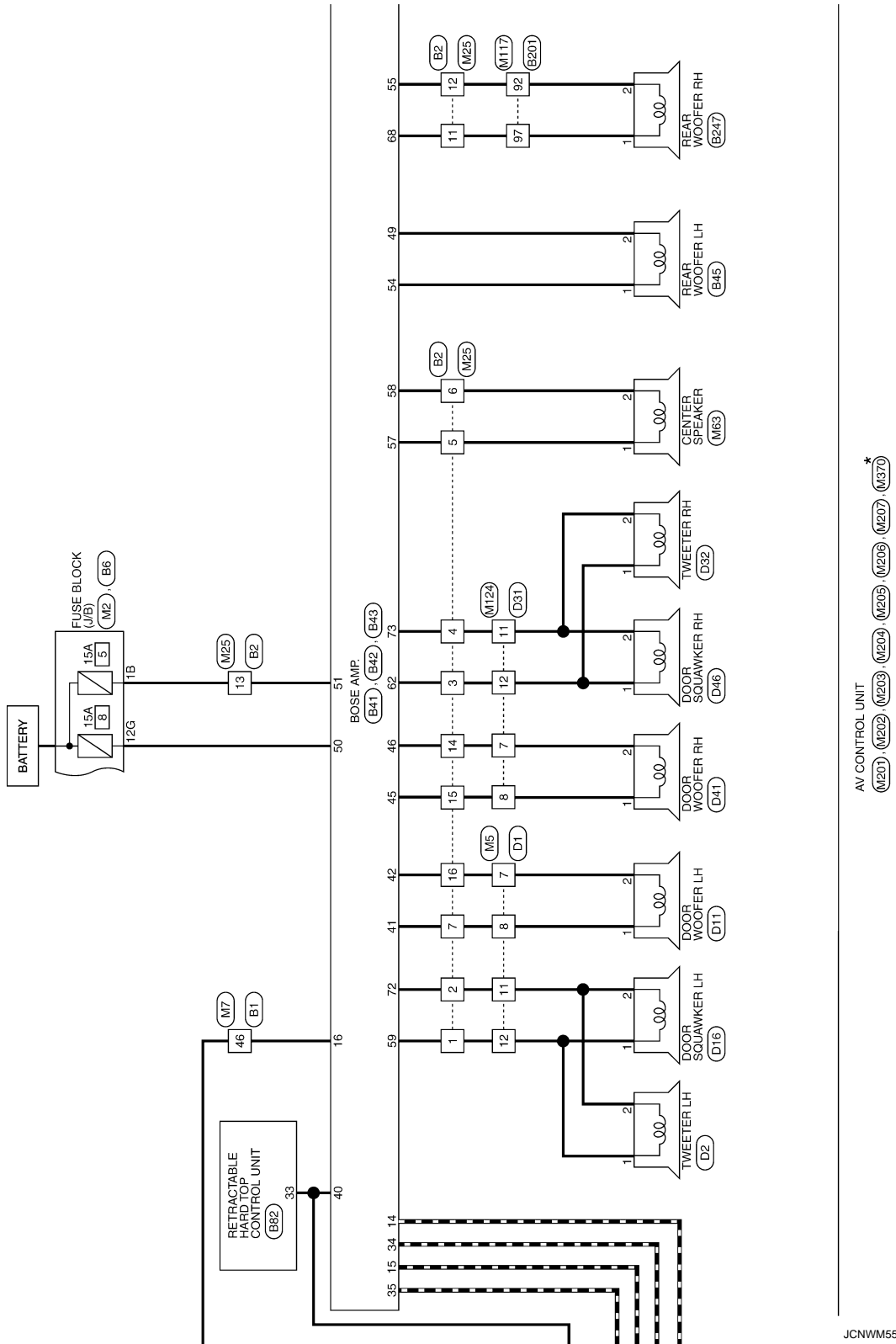

JCNWM5572GB



# BOSE AUDIO WITHOUT NAVIGATION

## [BOSE AUDIO WITHOUT NAVIGATION]

< WIRING DIAGRAM >

WS : With climate controlled seat  
 OS : Without climate controlled seat

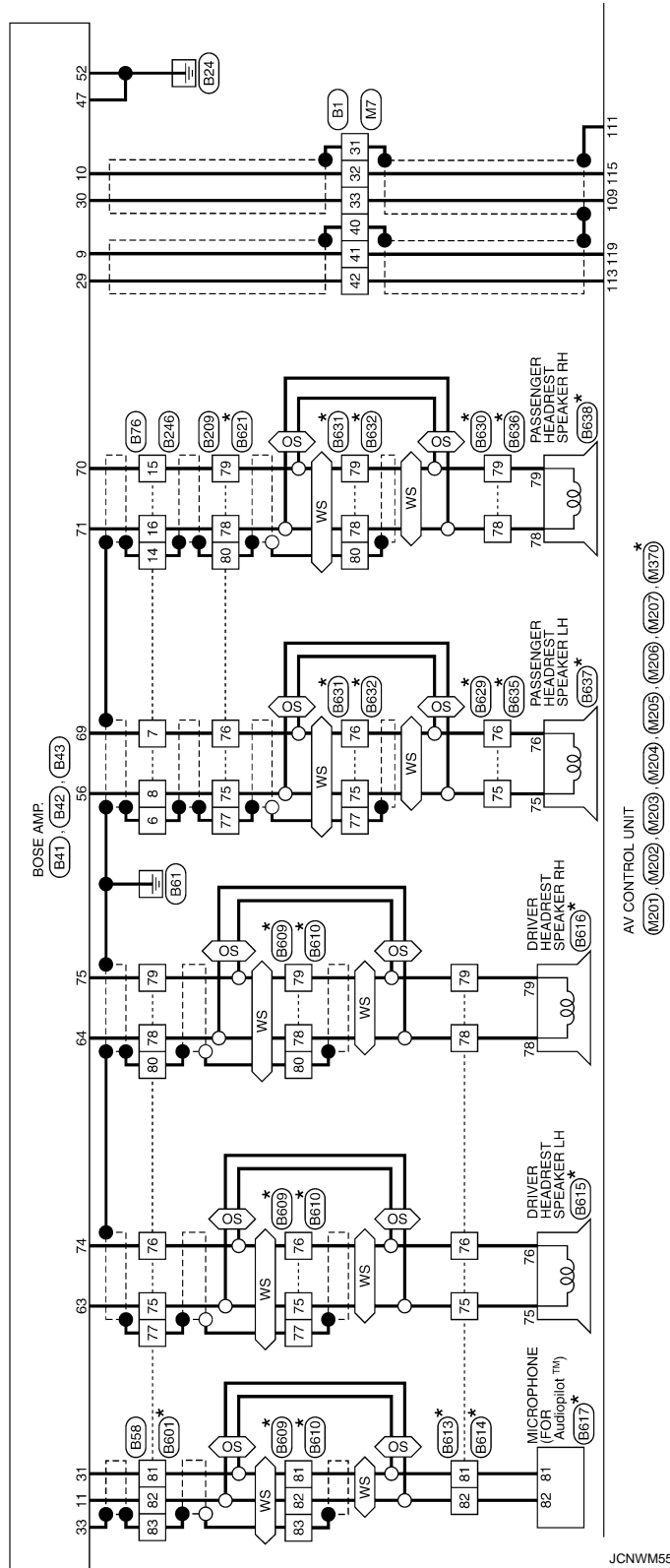

JCNWM5573GB

\* : This connector is not shown in "Harness Layout".

A  
 B  
 C  
 D  
 E  
 F  
 G  
 H  
 I  
 J  
 K  
 L  
 M  
 AV  
 O  
 P

# BOSE AUDIO WITHOUT NAVIGATION

## [BOSE AUDIO WITHOUT NAVIGATION]

< WIRING DIAGRAM >

A : With A/T  
M : With M/T

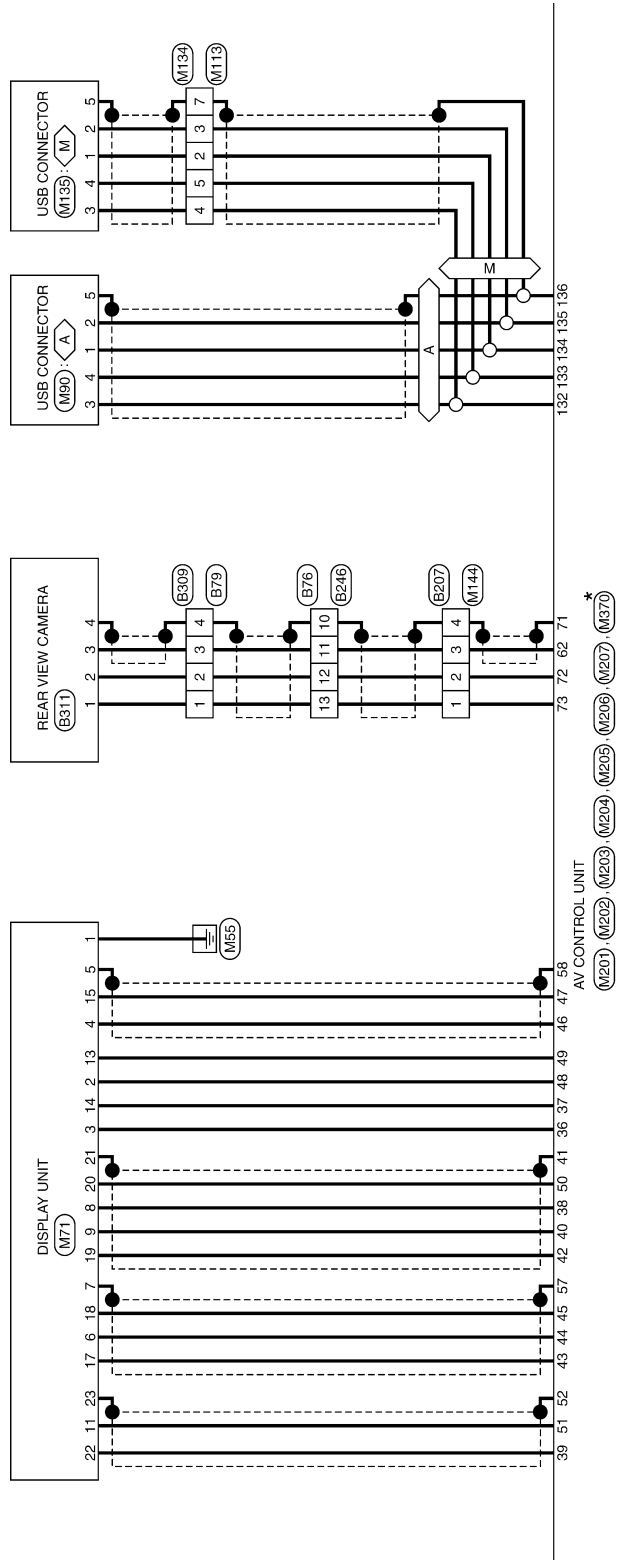

JCNWM5574GB

\* : This connector is not shown in "Harness Layout".

# BOSE AUDIO WITHOUT NAVIGATION

< WIRING DIAGRAM >

[BOSE AUDIO WITHOUT NAVIGATION]

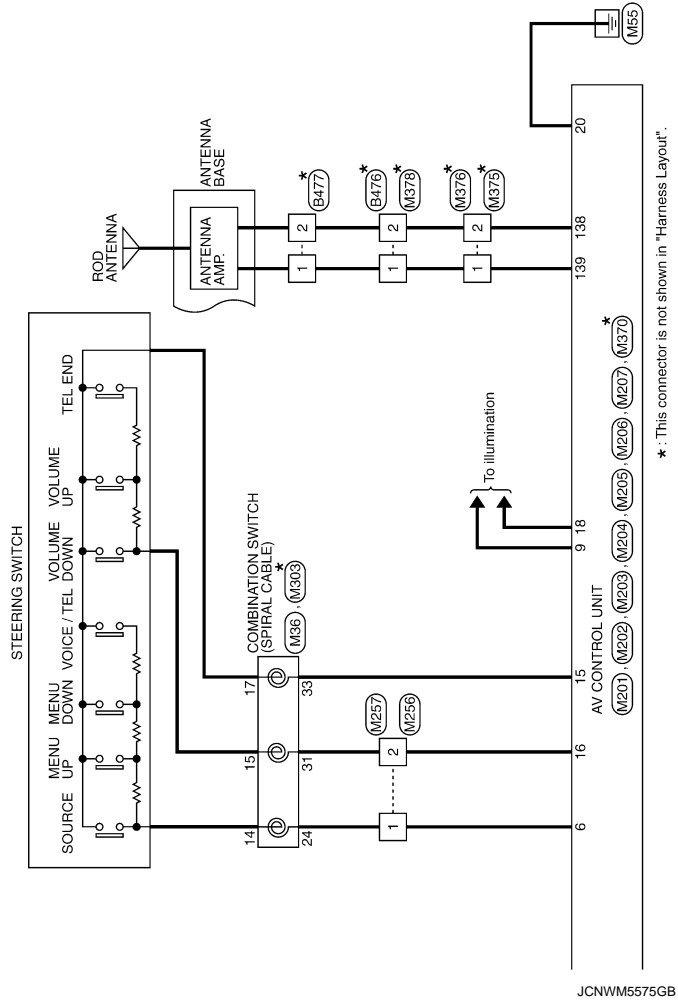

\* : This connector is not shown in "Harness Layout".

JCNWM5575GB

A  
B  
C  
D  
E  
F  
G  
H  
I  
J  
K  
L  
M  
N  
O  
P

AV

# BOSE AUDIO WITHOUT NAVIGATION

[BOSE AUDIO WITHOUT NAVIGATION]

< WIRING DIAGRAM >

## BOSE AUDIO WITHOUT NAVIGATION

Connector No.	B1
Connector Name	WIRE TO WIRE
Connector Type	THB07V-CS16-TM4



Terminal No.	Color of Wire	Signal Name [Specification]
1	W	-
2	L	-
3	R	-
4	V	-
5	W	-
6	B	-
7	G	-
8	BR	-
9	SHIELD	-
10	Y	-
11	R	-
12	W	-
13	W	-
14	W	-
15	W	-
16	W	-
17	BR	-
18	G	-
19	SB	-
20	GR	-
21	W	-
22	W	-
23	W	-
24	SB	-
25	BR	-
26	LG	-
27	Y	-
28	R	-
29	V	-
30	SHIELD	-
31	G	-
32	R	-
33	GR	-
34	BG	-
35	GR	-
36	BR	-
37	P	- [With climate controlled seat]
38	Y	- [Without climate controlled seat]
39	Y	- [With climate controlled seat]
40	GR	- [Without climate controlled seat]
41	SHIELD	-
42	L	-
43	SHIELD	-

44	SB	-
45	V	-
46	W	-
47	SB	-
48	LG	-
49	LG	- [With BOSE system]
50	SB	- [Without BOSE system]
51	LG	-
52	SB	-
53	G	-
54	LG	-
55	BR	-
56	Y	-
57	W	-
58	V	-
59	R	-
60	R	-
61	BG	-
62	B	-
63	L	-
64	P	-
65	B	-
66	SB	-
67	P	-
68	L	-
69	P	-
70	L	-
80	G	-
81	V	-
82	R	-
83	BR	-
84	G	-
85	L	-
86	Y	-
87	GR	-
88	GR	-
89	R	-
90	BG	-
91	P	-
92	GR	-
93	GR	-
94	P	-
95	GR	-
96	GR	-
97	SB	-
98	Y	-
99	Y	-
100	Y/B	-

Connector No.	B2
Connector Name	WIRE TO WIRE
Connector Type	NS18FW-CS



Terminal No.	Color of Wire	Signal Name [Specification]
1	L	-
2	W	-
3	V	-
4	LG	-
5	BG	-
6	B	-
7	B	-
8	LG	-
9	BG	-
10	GR	-
11	R	-
12	G	-
13	GR	-
14	R	-
15	G	-
16	W	-

Connector No.	B14
Connector Name	PARKING BRAKE SWITCH
Connector Type	P01FB-A



Terminal No.	Color of Wire	Signal Name [Specification]
1	V	-

Connector No.	B41
Connector Name	BOSE AMP.
Connector Type	TH40FW-NH

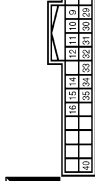

Terminal No.	Color of Wire	Signal Name [Specification]
9	L	SOUND SIGNAL LH (-)
10	G	SOUND SIGNAL RH (-)
11	G	MICROPHONE SIGNAL (-)
12	SR	VOICE GUIDANCE SIGNAL (-)
14	LG	AV COMM (L)
15	LG	AV COMM (L)
16	W	ACC
18	W	AV COMM (H)
29	P	SOUND SIGNAL LH (+)
30	R	SOUND SIGNAL RH (+)
31	Y	MICROPHONE SIGNAL (+)
32	V	VOICE GUIDANCE SIGNAL (+)
33	SHIELD	SHIELD
34	SB	AV COMM (H)
35	SB	AV COMM (H)
40	V	ROOF STATUS SIGNAL (AUDIO)

Connector No.	B6
Connector Name	FUSE BLOCK (J/B)
Connector Type	NS12FBR-CS

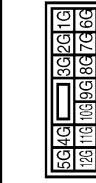

Terminal No.	Color of Wire	Signal Name [Specification]
5G	LG	-
6G	G	-
10G	P	-
11G	G	-
12G	Y	-

JCNWM5576GB

# BOSE AUDIO WITHOUT NAVIGATION

## [BOSE AUDIO WITHOUT NAVIGATION]

< WIRING DIAGRAM >

### BOSE AUDIO WITHOUT NAVIGATION

Connector No.	B42
Connector Name	BOSE AMP.
Connector Type	SCA12PFR-SJA2

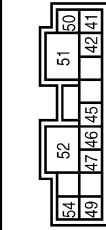

Terminal No.	Color of Wire	Signal Name [Specification]
41	B	SOUND SIGNAL DOOR WOOFER LH (-)
42	W	SOUND SIGNAL DOOR WOOFER LH (+)
45	G	SOUND SIGNAL DOOR WOOFER RH (-)
46	R	SOUND SIGNAL DOOR WOOFER RH (+)
47	B	SOUND SIGNAL DOOR WOOFER GND
48	P	SOUND SIGNAL REAR WOOFER LH (-)
50	Y	BATTERY
51	GR	BATTERY
52	B	GND
54	L	SOUND SIGNAL REAR WOOFER LH (+)

Connector No.	B43
Connector Name	BOSE AMP.
Connector Type	SCA12PFR-SGA4

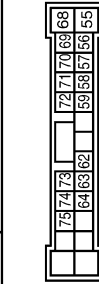

Terminal No.	Color of Wire	Signal Name [Specification]
55	BG	SOUND SIGNAL REAR WOOFER RH (-)
56	W	SOUND SIGNAL PASSENGER HEADREST SPEAKER LH (+)
57	BG	SOUND SIGNAL CENTER (+)
58	P	SOUND SIGNAL CENTER (-)
59	L	SOUND SIGNAL FRONT LH (+)
62	V	SOUND SIGNAL FRONT RH (+)
63	G	SOUND SIGNAL DRIVER HEADREST SPEAKER LH (+)
64	W	SOUND SIGNAL DRIVER HEADREST SPEAKER RH (+)
66	LG	SOUND SIGNAL REAR WOOFER RH (+)
68	B	SOUND SIGNAL PASSENGER HEADREST SPEAKER LH (-)
70	G	SOUND SIGNAL PASSENGER HEADREST SPEAKER RH (-)
71	Y	SOUND SIGNAL PASSENGER HEADREST SPEAKER RH (+)

72	W	SOUND SIGNAL FRONT LH (-)
73	LG	SOUND SIGNAL FRONT RH (-)
74	Y	SOUND SIGNAL DRIVER HEADREST SPEAKER LH (-)
75	B	SOUND SIGNAL DRIVER HEADREST SPEAKER RH (-)

Connector No.	B45
Connector Name	REAR WOOFER LH
Connector Type	NS02PFR-CS



Terminal No.	Color of Wire	Signal Name [Specification]
1	L	---
2	P	---

Connector No.	B53
Connector Name	WIRE TO WIRE
Connector Type	NS12PFR-CS

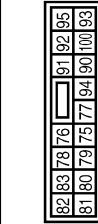

Terminal No.	Color of Wire	Signal Name [Specification]
76	Y	---
77	SHIELD	---
78	W	---
79	B	---
80	SHIELD	---
81	Y	---
82	G	---
83	SHIELD	---
90	B	---
91	P	---
92	V	---
93	G	---
94	BG	---

95	GR	---
100	BR	---

Connector No.	B76
Connector Name	WIRE TO WIRE
Connector Type	TH12BMW-NH



Terminal No.	Color of Wire	Signal Name [Specification]
1	V	---
4	LG	---
5	SB	---
6	SHIELD	---
7	B	---
8	W	---
10	SHIELD	---
11	B	---
12	W	---
13	R	---
14	SHIELD	---
15	G	---
16	Y	---

Connector No.	B79
Connector Name	WIRE TO WIRE
Connector Type	TH02BMW-NH

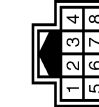

Terminal No.	Color of Wire	Signal Name [Specification]
1	R	---
2	W	---
3	B	---
4	SHIELD	---

Connector No.	B82
Connector Name	RETRACTABLE HARD TOP CONTROL UNIT
Connector Type	TH40PFR-NH

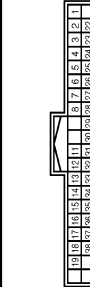

Terminal No.	Color of Wire	Signal Name [Specification]
1	G	ROOF OPEN / CLOSE SWITCH (OPEN)
2	BR	ROOF OPEN / CLOSE SWITCH (CLOSE)
3	B	FLIPPER DOOR LIMIT SWITCH (CLOSE)
4	L	TONNEAU BOARD SWITCH
5	SB	TRUNK ROOM LAMP SWITCH
6	L	ROOF LATCH LIMIT SWITCH
7	W	FLIPPER DOOR LIMIT SWITCH (UP)
8	G	FLIPPER DOOR LIMIT SWITCH (DOWN)
11	W	RETAINED ACC POWER
12	Y	REVERSE SIGNAL
13	BG	PARCEL SHELF STATUS SENSOR POWER SUPPLY
14	P	TRUNK LINK SENSOR SIGNAL (LH)
15	SB	TRUNK LINK SENSOR SIGNAL (RH)
16	GR	ROOF LATCH STATUS SENSOR SIGNAL
17	G	ROOF LATCH LOCK SENSOR SIGNAL
18	LG	TRUNK STATUS SENSOR SIGNAL
22	V	ROOF STATUS SENSOR POWER SUPPLY
23	B	ROOF STATUS SENSOR GND
24	GR	PARCEL SHELF STATUS SENSOR SIGNAL (DRAW)
25	R	PARCEL SHELF STATUS SENSOR SIGNAL (ROTATION)
26	P	ROOF STATUS SENSOR SIGNAL
27	Y	TRUNK LID OPEN REQUEST SIGNAL
28	BG	FLIPPER DOOR RELAY GND
29	V	LOCAL COMMUNICATION (EGW)
30	GR	LOCAL COMMUNICATION (POWER WINDOW)
31	L	CAN-L
32	P	---
33	V	ROOF STATUS SIGNAL (AUDIO)
35	B	ROOF WARNING BUZZER
36	Y	HYDRAULIC MOTOR RELAY GND (RH)
37	W	HYDRAULIC MOTOR RELAY GND (LH)
38	BR	HYDRAULIC MOTOR RELAY POWER SUPPLY

A B C D E F G H I J K L M O P



# BOSE AUDIO WITHOUT NAVIGATION

[BOSE AUDIO WITHOUT NAVIGATION]

< WIRING DIAGRAM >

## BOSE AUDIO WITHOUT NAVIGATION

Connector No.	B201
Connector Name	WIRE TO WIRE
Connector Type	TH80FW-CS16-TM44



Terminal No.	Color of Wire	Signal Name [Specification]
1	W	
2	B	
3	B	
4	W	
5	W	
6	R	
7	B	
7	G	
8	BG	
9	GR	
10	LG	
40	GR	
41	LG	
42	BG	
43	R	
44	SHIELD	
45	G	
47	G	
48	Y	
49	SHIELD	
50	P	
51	SB	
52	LG	
53	L	
54	G	
55	GR	
56	LG	
57	G	
58	R	
67	L	
68	P	
80	G	
81	R	
82	W	
83	B	
84	SHIELD	
85	O	
86	BR	
87	Y	
88	SHIELD	

89	SB	-
90	V	-
91	GR	-
92	P	- [With BOSE system]
92	Y	- [Without BOSE system]
93	L	-
94	SB	-
95	V	-
96	P	-
97	L	- [With BOSE system]
97	LG	- [Without BOSE system]
98	Y/B	-
99	Y	-

Connector No.	B207
Connector Name	WIRE TO WIRE
Connector Type	TH40FW-NH

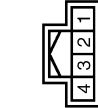

Terminal No.	Color of Wire	Signal Name [Specification]
1	R	
2	W	
3	B	
4	SHIELD	

Connector No.	B209
Connector Name	WIRE TO WIRE
Connector Type	NS1(FE)R-CS

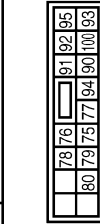

Terminal No.	Color of Wire	Signal Name [Specification]
75	W	
76	B	
77	SHIELD	

78	Y	-
79	G	-
80	SHIELD	-
80	B	-
80	LG	-
81	BG	-
82	G	-
93	W	-
94	SB	-
95	GR	-
100	LG	-

Connector No.	B236
Connector Name	SATELLITE RADIO TUNER
Connector Type	A16FW

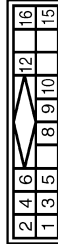

Terminal No.	Color of Wire	Signal Name [Specification]
1	G	SATELLITE RADIO SOUND SIGNAL LH (-)
2	R	SATELLITE RADIO SOUND SIGNAL LH (+)
3	W	SATELLITE RADIO SOUND SIGNAL RH (-)
4	B	SATELLITE RADIO SOUND SIGNAL RH (+)
5	SHIELD	
6	SHIELD	
8	Y	REQUEST (SAT->CONT)
9	O	COMM (SAT->CONT)
10	BR	COMM (CONT->SAT)
12	SB	BATTERY
15	B	GND
18	V	ACC

Connector No.	B237
Connector Name	TEL ADAPTER UNIT
Connector Type	TH52FW-NH



Terminal No.	Color of Wire	Signal Name [Specification]
1	GR	BATTERY
2	LG	ACC
3	BG	IGNITION
4	B	GND
5	SHIELD	SHIELD
7	R	MICROPHONE SIGNAL
8	SHIELD	MICROPHONE GND
9	Y	TEL VOICE SIGNAL (+)
10	G	TEL VOICE SIGNAL (-)
14	B	GND
16	P	ROOF STATUS SIGNAL (AUDIO)
21	B	CONTROL SIGNAL
23	B	CONTROL SIGNAL
27	B	CONTROL SIGNAL
28	P	VEHICLE SPEED (8-PULSE)
29	G	MICROPHONE VCC

Connector No.	B238
Connector Name	TEL ADAPTER UNIT
Connector Type	TH08FW-NH



Terminal No.	Color of Wire	Signal Name [Specification]
35	L	AV COMM (H)
38	P	AV COMM (L)

# BOSE AUDIO WITHOUT NAVIGATION

## [BOSE AUDIO WITHOUT NAVIGATION]

< WIRING DIAGRAM >

### BOSE AUDIO WITHOUT NAVIGATION

Connector No.	B246
Connector Name	WIRE TO WIRE
Connector Type	TH16FW-NH

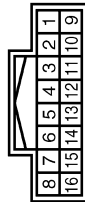

Terminal No.	Color of Wire	Signal Name [Specification]
1	P	
4	L	
5	L	
6	SHIELD	
7	B	
8	W	
10	SHIELD	
11	B	
12	W	
13	R	
14	SHIELD	
15	G	
16	Y	

Connector No.	B247
Connector Name	REAR WOOFER RH
Connector Type	NS02FW-CS



Terminal No.	Color of Wire	Signal Name [Specification]
1	L	
2	P	

Connector No.	B309
Connector Name	WIRE TO WIRE
Connector Type	TH06FW-NH

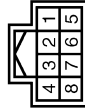

Terminal No.	Color of Wire	Signal Name [Specification]
1	R	
2	W	
3	Y	
4	SHIELD	

Connector No.	B311
Connector Name	REAR VIEW CAMERA
Connector Type	TH06MW-NH



Terminal No.	Color of Wire	Signal Name [Specification]
1	R	CAMERA POWER SUPPLY
2	W	CAMERA GND
3	Y	CAMERA IMAGE SIGNAL
4	SHIELD	SHIELD

Connector No.	B471
Connector Name	TEL ADAPTER UNIT
Connector Type	GT16C-1S-HU



Terminal No.	Color of Wire	Signal Name [Specification]
33	SHIELD	TEL ANTENNA
34	SHIELD	SHIELD

Connector No.	B474
Connector Name	WIRE TO WIRE
Connector Type	GT16C-1S-HU



Terminal No.	Color of Wire	Signal Name [Specification]
1	SHIELD	
2	SHIELD	

Connector No.	B475
Connector Name	WIRE TO WIRE
Connector Type	GT16C-1PP-HU



Terminal No.	Color of Wire	Signal Name [Specification]
1	SHIELD	
2	SHIELD	

Connector No.	B476
Connector Name	WIRE TO WIRE
Connector Type	GT13SS-1/S-HU



Terminal No.	Color of Wire	Signal Name [Specification]
1	-	
2	-	

Connector No.	B477
Connector Name	ANTENNA BASE
Connector Type	GT13SSN-1/PP-HU



Terminal No.	Color of Wire	Signal Name [Specification]
1	-	ANTENNA AMP. ON SIGNAL
2	-	AM-FM MAIN

Connector No.	B482
Connector Name	SATELLITE RADIO TUNER
Connector Type	FAPRA



Terminal No.	Color of Wire	Signal Name [Specification]
33	-	SATELLITE ANTENNA
34	SHIELD	SHIELD

A  
B  
C  
D  
E  
F  
G  
H  
I  
J  
K  
L  
M  
O  
P

AV

JCNWM5579GB

# BOSE AUDIO WITHOUT NAVIGATION

[BOSE AUDIO WITHOUT NAVIGATION]

< WIRING DIAGRAM >

## BOSE AUDIO WITHOUT NAVIGATION

Connector No.	B483
Connector Name	ANTENNA BASE
Connector Type	GT16C-1PP-HU



Terminal No.	Color of Wire	Signal Name [Specification]
3	-	-
4	SHIELD	-

Connector No.	B601
Connector Name	WIRE TO WIRE
Connector Type	NS16MBR-CS



Terminal No.	Color of Wire	Signal Name [Specification]
75	P	-
76	L	-
77	B/Y	-
78	R	-
79	C	-
80	B/W	-
81	B	-
82	W	-
83	B/R	-
90	L	-
91	W/B	-
92	W	-
93	Y	-
94	W/R	-
95	R/L	-
100	GR	-

Connector No.	B609
Connector Name	WIRE TO WIRE
Connector Type	NS16MH-CS



Terminal No.	Color of Wire	Signal Name [Specification]
75	P	-
76	L	-
77	B/Y	-
78	R	-
79	G	-
80	B/W	-
81	B	-
82	W	-
83	B/R	-
85	G	-
88	G/R	-
96	R/W	-
98	L	-
99	L/W	-
104	V/W	-
105	LG	-

Connector No.	B610
Connector Name	WIRE TO WIRE
Connector Type	NS16FH-CS



Terminal No.	Color of Wire	Signal Name [Specification]
75	P	-
76	L	-
77	B/Y	-
78	R	-
79	G	-
80	B/W	-

81	B	-
82	W	-
83	B/R	-
85	G	-
88	G/R	-
96	R/W	-
98	L	-
99	L/W	-
104	V/W	-
105	LG	-

Connector No.	B613
Connector Name	WIRE TO WIRE
Connector Type	A08MW



Terminal No.	Color of Wire	Signal Name [Specification]
75	P	-
76	L	-
78	R	-
79	G	-
81	B	-
82	W	-

Connector No.	B614
Connector Name	WIRE TO WIRE
Connector Type	A08FW



Terminal No.	Color of Wire	Signal Name [Specification]
75	-	-
76	-	-
78	-	-
79	-	-
81	-	-
82	-	-

81	-	-
82	-	-

Connector No.	B615
Connector Name	DRIVER HEADREST SPEAKER LH
Connector Type	TK02FGY



Terminal No.	Color of Wire	Signal Name [Specification]
75	-	-
76	-	-

Connector No.	B616
Connector Name	DRIVER HEADREST SPEAKER RH
Connector Type	TK02FEW



Terminal No.	Color of Wire	Signal Name [Specification]
78	-	-
79	-	-



# BOSE AUDIO WITHOUT NAVIGATION

[BOSE AUDIO WITHOUT NAVIGATION]

< WIRING DIAGRAM >

## BOSE AUDIO WITHOUT NAVIGATION

Connector No.	B617
Connector Name	MICROPHONE (FOR Audiopilot™)
Connector Type	TK02FBR



Terminal No.	Color of Wire	Signal Name [Specification]
81	-	-
82	-	-

Connector No.	B621
Connector Name	WIRE TO WIRE
Connector Type	NS16MBR-CS



Terminal No.	Color of Wire	Signal Name [Specification]
75	P	-
76	L	-
77	B/Y	-
78	R	-
79	G	-
80	B/W	-
90	L	-
91	W/B	-
92	W	-
93	Y	-
94	W/R	-
95	R/L	-
100	GR	-

Connector No.	B629
Connector Name	WIRE TO WIRE
Connector Type	TK02MGY



Terminal No.	Color of Wire	Signal Name [Specification]
75	P	-
76	L	-

Connector No.	B630
Connector Name	WIRE TO WIRE
Connector Type	TK02MW



Terminal No.	Color of Wire	Signal Name [Specification]
78	R	-
79	G	-

Connector No.	B631
Connector Name	WIRE TO WIRE
Connector Type	NS10MW-CS



Terminal No.	Color of Wire	Signal Name [Specification]
75	P	-
76	L	-

77	B/Y	-
78	R	-
79	G	-
80	B/W	-
81	G	-
88	G/R	-
104	V/W	-
106	LG	-

Connector No.	B632
Connector Name	WIRE TO WIRE
Connector Type	NS10FW-CS



Terminal No.	Color of Wire	Signal Name [Specification]
75	P	-
76	L	-
77	B/Y	-
78	R	-
79	G	-
80	B/W	-
85	G	-
88	G/R	-
104	V/W	-
106	LG	-

Connector No.	B635
Connector Name	WIRE TO WIRE
Connector Type	TK02FGY



Terminal No.	Color of Wire	Signal Name [Specification]
75	-	-
76	-	-

Connector No.	B636
Connector Name	WIRE TO WIRE
Connector Type	TK02FW



Terminal No.	Color of Wire	Signal Name [Specification]
78	-	-
79	-	-

Connector No.	B637
Connector Name	PASSENGER HEADREST SPEAKER LH
Connector Type	TK02FGY



Terminal No.	Color of Wire	Signal Name [Specification]
75	-	-
76	-	-

Connector No.	B638
Connector Name	PASSENGER HEADREST SPEAKER RH
Connector Type	TK02FW



Terminal No.	Color of Wire	Signal Name [Specification]
78	-	-
79	-	-

JCNWM5581GB

A  
B  
C  
D  
E  
F  
G  
H  
I  
J  
K  
L  
M  
O  
P

AV



# BOSE AUDIO WITHOUT NAVIGATION

## [BOSE AUDIO WITHOUT NAVIGATION]

< WIRING DIAGRAM >

### BOSE AUDIO WITHOUT NAVIGATION

Connector No.	D46
Connector Name	DOOR SQUAWKER RH
Connector Type	TK02FBR



Terminal No.	Color of Wire	Signal Name [Specification]
1	L	-
2	W	-

Connector No.	E5
Connector Name	INTELLIGENT POWER DISTRIBUTION MODULE (IPDM) (ENGINE ROOM)
Connector Type	TH20FW-CS12-MM-1V



Terminal No.	Color of Wire	Signal Name [Specification]
4	V	-
5	L	-
6	SB	-
7	BR	-
11	BR	-
12	B/W	-
13	Y	-
16	LG	-
19	W	-
25	G	-
26	R	-
27	BG	-
28	L	-
30	GR	-
32	V	-
33	P	-
36	G	-

Connector No.	E106
Connector Name	WIRE TO WIRE
Connector Type	TH80FW-CS16-TM4

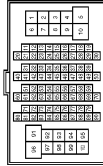

Terminal No.	Color of Wire	Signal Name [Specification]
1	GR	-
3	BG	-
4	B/W	-
5	G	-
6	BG	-
7	LG	-
8	G	-
9	R	-
10	W	-
11	V	-
12	R	-
13	L	-
14	GR	-
15	P	-
16	W	-
17	V	-
18	BG	-
19	GR	-
20	LG	-
30	R	-
31	L	-
32	BG	-
33	P	-
34	V	-
35	BR	-
36	W	-
37	Y	-
38	R	-
39	B	-
40	G	-
41	W	-
42	LG	-
43	SB	-
44	GR	-
45	BG	-
46	LG	-
47	V	-
48	P	-

Connector No.	F51
Connector Name	A/T ASSEMBLY
Connector Type	RK10FG-DGY

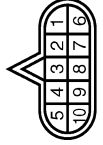

Terminal No.	Color of Wire	Signal Name [Specification]
1	Y	-
2	R	-
3	L	-
4	V	-
5	B	-
6	Y	-
7	R	-
8	P	-
9	GR	-
10	B	-

Connector No.	F56
Connector Name	BACK-UP LAMP SWITCH
Connector Type	RK02FB



Terminal No.	Color of Wire	Signal Name [Specification]
1	R	-
2	O	-

49	L	-
59	B	-
66	LG	-
67	SB	-
68	R	-
69	W	-
70	G	-
80	W	-
81	P	-
82	G	-
83	V	-
84	L	-
85	BG	-
86	LG	-
87	Y	-
88	GR	-
89	W	-
90	W	-
91	G	-
92	B	-
93	GR	-
94	L	-
95	Y	-
97	BR	-
98	SHIELD	-
99	L	-
100	P	-

Connector No.	E107
Connector Name	PARKING BRAKE SWITCH
Connector Type	TB01FW



Terminal No.	Color of Wire	Signal Name [Specification]
1	BG	-

JCNWM5583GB

A  
B  
C  
D  
E  
F  
G  
H  
I  
J  
K  
L  
M  
AV  
O  
P

# BOSE AUDIO WITHOUT NAVIGATION

[BOSE AUDIO WITHOUT NAVIGATION]

< WIRING DIAGRAM >

### BOSE AUDIO WITHOUT NAVIGATION

Connector No.	F103
Connector Name	WIRE TO WIRE
Connector Type	TK26FW-NS10

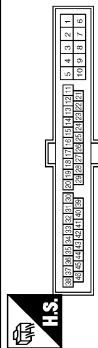

Terminal No.	Color of Wire	Signal Name [Specification]
2	G	-
3	W	-
4	R	-
5	B	-
9	Y	-
10	GR	-
18	O	-
20	Y	-
28	B	-
29	LG	-
30	R	-
31	R	-
41	O	-
42	BR	-
43	P	-
44	L	-
45	Y	-
46	V	-

Connector No.	F157
Connector Name	TCM (TRANSMISSION CONTROL MODULE)
Connector Type	SP10FG



Terminal No.	Color of Wire	Signal Name [Specification]
1	-	VIGN
2	-	BATT
3	-	CAN-H
4	-	K-LINE

5	-	GND
6	-	VIGN
7	-	REV LAMP RLY
8	-	CAN-L
9	-	STARTER RLY
10	-	GND

Connector No.	M1
Connector Name	FUSE BLOCK (J/B)
Connector Type	NS10FW-M2

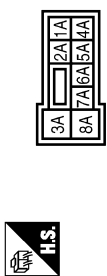

Terminal No.	Color of Wire	Signal Name [Specification]
1A	V	-
2A	G	-
3A	L	-
4A	P	-
5A	BR	-
6A	Y	-
7A	GR	-
8A	L	-

Connector No.	M2
Connector Name	FUSE BLOCK (J/B)
Connector Type	NS10FW-CS

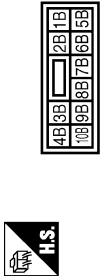

Terminal No.	Color of Wire	Signal Name [Specification]
1B	R	-
3B	P	-
4B	G	-
5B	BG	-
6B	Y	-
7B	P	-

9B	R	-
9B	SB	-

Connector No.	M3
Connector Name	FUSE BLOCK (J/B)
Connector Type	NS12FW-CS

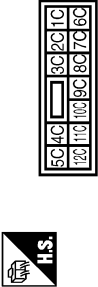

Terminal No.	Color of Wire	Signal Name [Specification]
6C	R	-
7C	B	-
8C	W	-
9C	BG	-
10C	L	-
11C	LG	-
12C	R	-

Connector No.	M5
Connector Name	WIRE TO WIRE
Connector Type	TH40MW-CS15

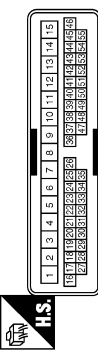

Terminal No.	Color of Wire	Signal Name [Specification]
4	R	-
5	B	-
6	BG	-
7	W	-
8	B	-
9	G	-
10	V	-
11	W	-
12	L	-
13	B	-
14	GR	-

15	Y	-
16	Y/B	-
17	V	-
20	BG	-
21	W	-
22	P	-
23	BG	-
24	V	-
25	BR	-
26	R	-
27	P	-
28	LG	-
29	SB	-
30	G	-
31	V	-
32	BR	-
33	GR	-
34	G	-
35	L	-
37	B	-
38	G	- [With automatic drive positioner]
38	L	- [Without automatic drive positioner]
39	BR	- [With automatic drive positioner]
39	L	- [Without automatic drive positioner]
40	Y	-
41	BR	- [With automatic drive positioner]
41	G	- [Without automatic drive positioner]
42	R	-
43	G	-
44	Y	-
45	GR	-
46	BR	-
47	V	-
48	LG	-
49	P	-
50	SB	-
51	GR	-
52	L	-

# BOSE AUDIO WITHOUT NAVIGATION

## [BOSE AUDIO WITHOUT NAVIGATION]

< WIRING DIAGRAM >

### BOSE AUDIO WITHOUT NAVIGATION

Connector No.	M6
Connector Name	WIRE TO WIRE
Connector Type	TH80MW-CS (F-TM4)

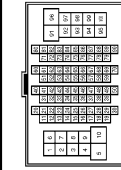

Terminal No.	Color of Wire	Signal Name [Specification]
1	EG	
3	R	
4	G	
5	G	
6	BR	
7	BR	
8	Y	
9	R	
10	W	
11	GR	
12	R	
13	L	
14	G	
15	P	
16	W	
17	BR	
18	V	
19	EG	
20	L	
30	R	
31	L	
32	Y	
33	GR	
34	P	
35	BR	
36	BR	
37	Y	
38	LG	
39	SB	
40	G	
41	W	
42	LG	
43	P	
44	GR	
44	R	- [With A/T]
45	EG	- [With M/T]
46	G	
47	P	

48	P	
49	L	
50	B	
50	Y	
57	L	
58	R	
59	W	
60	G	
60	SB	
61	R	
62	V	
63	L	
64	BG	
65	G	
67	V	
68	B	
69	SR	
70	G	
71	W	
72	B	
73	G	
74	L	
75	BR	
76	P	
77	SHIELD	
78	V	
79	SB	

Connector No.	M7
Connector Name	WIRE TO WIRE
Connector Type	TH80MW-CS (F-TM4)

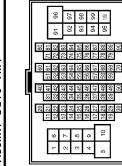

Terminal No.	Color of Wire	Signal Name [Specification]
1	BG	
2	LG	
3	G	
4	V	
5	L	
6	B	
9	L	
10	BR	

12	SHIELD	
13	V	
14	BR	
15	GR	
16	LG	
17	L	
20	BR	
21	G	
22	R	
23	SB	
24	B	
25	W	
26	Y	
27	V	
28	P	
29	V	
30	G	
31	SHIELD	
32	G	
33	B	
34	BG	
35	GR	
36	BR	
37	L	
37	P	
38	V	
39	GR	
40	SHIELD	
41	L	
42	P	
43	SHIELD	
44	Y	
45	BR	
46	SB	
47	SB	
48	LG	
48	LG	- [With BOSE system]
49	SB	- [Without BOSE system]
50	SB	- [With BOSE system]
50	LG	- [Without BOSE system]
51	R	
52	V	
53	P	
54	BR	
55	Y	- [With A/T]
55	BG	- [With M/T]
56	L	
57	V	
58	R	
60	LG	
61	BG	
62	B	
63	V	

64	SR	
65	BR	
66	Y	
67	P	
68	L	
69	P	
70	L	
80	G	
81	LG	
82	Y	
83	BR	
84	V	
85	L	
86	Y	
87	GR	
91	R	
93	G	
94	P	
95	GR	
96	Y	
97	SB	
99	Y	
100	Y/B	

Connector No.	M17
Connector Name	WIRE TO WIRE
Connector Type	TK02FW



Terminal No.	Color of Wire	Signal Name [Specification]
1	L	
2	P	

A  
B  
C  
D  
E  
F  
G  
H  
I  
J  
K  
L  
M  
N  
O  
P

AV

JCNWM5585GB

# BOSE AUDIO WITHOUT NAVIGATION

[BOSE AUDIO WITHOUT NAVIGATION]

< WIRING DIAGRAM >

## BOSE AUDIO WITHOUT NAVIGATION

Connector No.	M18
Connector Name	WIRE TO WIRE
Connector Type	TK02NW



Terminal No.	Color of Wire	Signal Name [Specification]
1	L	-
2	P	-

Connector No.	M24
Connector Name	DATA LINK CONNECTOR
Connector Type	BD16FW



Terminal No.	Color of Wire	Signal Name [Specification]
3	LG	-
4	B	-
5	BR	-
6	L	-
7	V	-
8	G	-
11	SB	-
14	P	-
16	R	-

Connector No.	M25
Connector Name	WIRE TO WIRE
Connector Type	NS16MH-OS



Terminal No.	Color of Wire	Signal Name [Specification]
1	L	-
2	W	-
3	BR	-
4	SB	-
5	Y	-
6	LG	-
7	B	-
11	L	-
12	P	-
13	R	-
14	R	-
15	G	-
16	W	-

Connector No.	M36
Connector Name	COMBINATOR SWITCH (SPPAL CABLE)
Connector Type	TK08FGY-1V

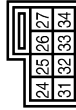

Terminal No.	Color of Wire	Signal Name [Specification]
24	P	-
25	SB	-
26	BR	-
31	L	-
32	Y	-
33	B	-
34	LG	-

Connector No.	M37
Connector Name	STEERING ANGLE SENSOR
Connector Type	TH08FW-NH



Terminal No.	Color of Wire	Signal Name [Specification]
1	L	CAN-H
2	P	CAN-L
7	B	GND
8	G	IGN

Connector No.	M44
Connector Name	SONAR CONTROL UNIT
Connector Type	TH04FW-NH

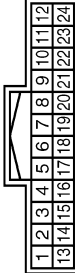

Terminal No.	Color of Wire	Signal Name [Specification]
1	G	CANCEL SW SIGNAL
2	SB	CORNER SENSOR SIGNAL REAR LH
5	LG	CORNER SENSOR SIGNAL REAR RH
6	L	CORNER SENSOR SIGNAL REAR LH
7	BR	CORNER SENSOR SIGNAL REAR RH
8	GR	CANCEL SW INDICATOR
11	BR	SENSOR GND
12	V	ACC
13	LG	R RANGE SIGNAL
17	BG	K LINE
18	V	AV COMM (H)
19	SB	AV COMM (L)
20	LG	GND
24	GR	GND

Connector No.	M63
Connector Name	CENTER SPEAKER
Connector Type	TK02FBR



Terminal No.	Color of Wire	Signal Name [Specification]
1	Y	-
2	LG	-

Connector No.	M66
Connector Name	UNIFIED METER AND A/C AMP.
Connector Type	TH04FW-NH



Terminal No.	Color of Wire	Signal Name [Specification]
4	G	STOP LAMP SWITCH
5	L	MANUAL MODE SHIFT UP SIGNAL
6	BG	PADDLE SHIFTER UP SIGNAL
7	GR	COMMUNICATION SIGNAL (AMP->METER)
8	L	VEHICLE SPEED (2-PULSE)
9	SB	SEAT BELT BUCKLE SWITCH SIGNAL (DRIVER SIDE)
10	W	MANUAL MODE SIGNAL
11	G	NON-MANUAL MODE SIGNAL
14	SB	COMMUNICATION SIGNAL (LDP->AMP)
20	G	IGN ON / OFF SIGNAL
25	V	MANUAL MODE SHIFT DOWN SIGNAL
26	G	PADDLE SHIFTER DOWN SIGNAL
27	LG	COMMUNICATION SIGNAL (METER->AMP)
28	R	VEHICLE SPEED (8-PULSE)
30	V	PARKING BRAKE SWITCH SIGNAL
34	B	COMMUNICATION SIGNAL (AMP->LCD)
38	P	BLOWER MOTOR CONTROL SIGNAL

# BOSE AUDIO WITHOUT NAVIGATION

[BOSE AUDIO WITHOUT NAVIGATION]

< WIRING DIAGRAM >

## BOSE AUDIO WITHOUT NAVIGATION

Connector No.	M67
Connector Name	UNIFIED METER AND A/C AMP.
Connector Type	TH2FV-NH

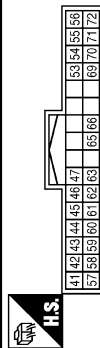

Terminal No.	Color of Wire	Signal Name [Specification]
41	BR	ACC POWER SUPPLY
42	BR	FUEL LEVEL SENSOR SIGNAL
43	R	INTAKE SENSOR SIGNAL
44	LG	IN-VEHICLE SENSOR SIGNAL
45	V	AMBIENT SENSOR SIGNAL
46	BG	SUNLOAD SENSOR SIGNAL
47	G	EXHAUST GAS OXIDISE SENSOR DETECTING SENSOR SIGNAL
53	W	IGNITION POWER SUPPLY
54	BG	BATTERY POWER SUPPLY
55	B	GROUND
56	L	CAN-H
57	LG	BRAKE FLUID LEVEL SWITCH SIGNAL
58	Y	FUEL LEVEL SENSOR SIGNAL GROUND
59	GR	INTAKE SENSOR GROUND
60	L	IN-VEHICLE SENSOR GROUND
61	R	AMBIENT SENSOR GROUND
62	SB	SUNLOAD SENSOR GROUND
63	L	ION CONTROL MODE OUTPUT SIGNAL
65	BG	ECV SIGNAL
68	L	A/C LAN SIGNAL
70	R	EACH DOOR MOTOR POWER SUPPLY
71	GR	GROUND
72	P	CAN-L

Connector No.	M69
Connector Name	BACK-UP LAMP RELAY
Connector Type	MS02FL-M2-LC

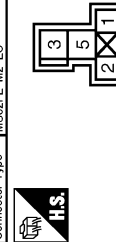

Terminal No.	Color of Wire	Signal Name [Specification]
1	R	---
2	W	---
3	LG	---
5	BG	---

Connector No.	M71
Connector Name	DISPLAY UNIT
Connector Type	TH2FV-NH

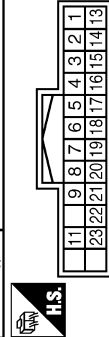

Terminal No.	Color of Wire	Signal Name [Specification]
1	B	---
2	Y	INVERTER VCC
3	BG	SIGNAL VCC
4	V	COMPOSITE IMAGE GND
5	SHIELD	SHIELD
6	L	RGB (G-GREEN) SIGNAL
7	SHIELD	SHIELD
8	R	HP
9	B	RGB AREA (YS) SIGNAL
11	P	COMM (CONT->DISP)
13	BR	INVERTER GND
14	LG	SIGNAL GND
15	SB	COMPOSITE IMAGE SIGNAL
17	G	RGB (R-RED) SIGNAL
18	P	RGB (B-BLUE) SIGNAL
19	W	RGB STANC
20	G	VP
21	SHIELD	SHIELD
22	L	COMM (DISP->CONT)
23	SHIELD	SHIELD

Connector No.	M72
Connector Name	MULTIFUNCTION SWITCH
Connector Type	TH16FN-NH

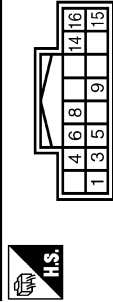

Terminal No.	Color of Wire	Signal Name [Specification]
1	B	GND
3	L	ACC
4	BG	ILL
5	V	ILL CONT
6	SB	AV COMM (H)
8	LG	AV COMM (L)
9	BR	SW GND
14	SB	DISK EJECT SIGNAL
16	G	HAZARD ON

Connector No.	M80
Connector Name	USB CONNECTOR
Connector Type	HA04FG

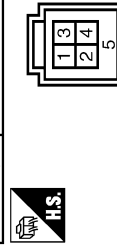

Terminal No.	Color of Wire	Signal Name [Specification]
1	W	---
2	L	---
3	G	---
4	R	---
5	SHIELD	---

Connector No.	M106
Connector Name	WIRE TO WIRE
Connector Type	NH10MP-CS10

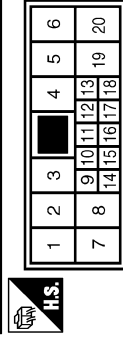

Terminal No.	Color of Wire	Signal Name [Specification]
1	B	---
2	BR	---
3	Y	---
4	G	---
5	SHIELD	---
6	R	---
7	B	---
8	L	---
9	R	---
10	SB	---
11	V	---
12	LG	---
18	B	---
19	P	---
20	Y	---

JCNWM5587GB

A  
B  
C  
D  
E  
F  
G  
H  
I  
J  
K  
L  
M  
N  
O  
P

AV

# BOSE AUDIO WITHOUT NAVIGATION

< WIRING DIAGRAM >

[BOSE AUDIO WITHOUT NAVIGATION]

## BOSE AUDIO WITHOUT NAVIGATION

Connector No.	M107
Connector Name	ECM
Connector Type	RH24FGY-R26-R-LH-Z

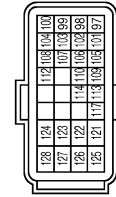

Terminal No.	Color of Wire	Signal Name [Specification]
97	R	APP SEN 1
98	P	APP SEN 2
99	L	SENSOR POWER SUPPLY
100	W	SENSOR GROUND
101	SB	ASCD/ICC STEERING SW
102	G	EVAP CONTROL SYSTEM PRESS SEN
103	G	SENSOR POWER SUPPLY
104	GR	SENSOR GROUND
105	L	REFRIGERANT PRESS SEN
106	LG	FUEL TANK TEMP SEN
107	BR	SENSOR POWER SUPPLY
108	Y	SENSOR GROUND
109	G	PNP SIGNAL
110	BR	ENGINE SPEED OUTPUT SIGNAL
112	R	SENSOR GROUND
113	P	CAN COMMUNICATION LINE
114	L	CAN COMMUNICATION LINE
117	V	DATA LINK CONNECTOR
121	LG	EVAP CANISTER VENT CONTROL VALVE
122	P	STOP LAMP SW
123	B	ECM GROUND
124	B	ECM GROUND
125	B	ECM GROUND
126	BR	POWER SUPPLY FOR ECM
127	B	ASCD/ICC BRAKE SW
128	B	ECM GROUND

Connector No.	M113
Connector Name	WIRE TO WIRE
Connector Type	CP06FCY

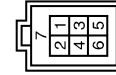

Terminal No.	Color of Wire	Signal Name [Specification]
2	W	
3	L	
4	G	
5	R	
7	SHIELD	

Connector No.	M116
Connector Name	WIRE TO WIRE
Connector Type	TK3BMW-NS10

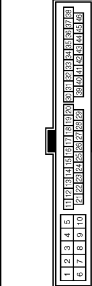

Terminal No.	Color of Wire	Signal Name [Specification]
2	W	
3	BG	
4	R	
5	B	
9	R	
10	R	
19	BG	
20	Y	
28	GR	
29	LG	
30	LG	
31	W	
41	BG	
42	G	
43	P	
44	L	
45	G	

46	Y	-
----	---	---

Connector No.	M117
Connector Name	WIRE TO WIRE
Connector Type	TH60MW-CS3-G-TM4



Terminal No.	Color of Wire	Signal Name [Specification]
1	Y	
3	B	
5	SB	
8	R	
9	SB	
10	GR	
40	Y	
41	G	
42	LG	
43	R	
44	SHIELD	
45	G	
47	P	
48	L	
49	SHIELD	
50	V	
51	SB	
52	BG	
33	L	
34	G	
55	Y	
56	LG	
57	SB	
58	LG	
67	SB	
68	LG	
80	W	
81	B	
92	R	
63	G	
84	SHIELD	
85	G	
86	L	

87	P	-
88	SHIELD	-
89	Y	-
90	W	-
91	GR	-
92	P	-
93	W	-
94	BG	-
95	BG	-
96	P	-
97	L	-
98	Y/B	-
99	Y	-



# BOSE AUDIO WITHOUT NAVIGATION

[BOSE AUDIO WITHOUT NAVIGATION]

< WIRING DIAGRAM >

## BOSE AUDIO WITHOUT NAVIGATION

Connector No.	M122
Connector Name	BCM BODY CONTROL MODULE
Connector Type	TH4CFB-NH

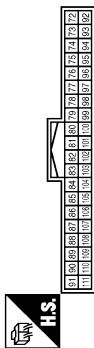

Terminal No.	Color of Wire	Signal Name [Specification]
72	R	ROOM ANT 2--
73	G	ROOM ANT 2+
74	SB	PASSENGER DOOR ANT--
75	BR	PASSENGER DOOR ANT+
76	V	DRIVER DOOR ANT--
77	LG	DRIVER DOOR ANT+
78	Y	ROOM ANT 1--
79	BR	ROOM ANT 1+
80	GR	NATS ANTENNA AMP
81	W	IGN RELAY (F/B) CONT
82	R	KEYLESS ENTRY RECEIVER COMM
83	Y	COMBI SW INPUT 5
87	Y	COMBI SW INPUT 5
88	BG	PUSH SW
89	BR	CAN-L
90	P	CAN-H
91	L	KEY SLOT ILL
92	LG	ON IND
93	V	ACC RELAY CONT
95	BG	A/T SHFT SELECTOR POWER SUPPLY
96	GR	S/L CONDITION 1
97	L	S/L CONDITION 2
98	SB	ASCD CLUTCH SW [Wth M/T]
99	R	SHIFT P [Wth A/T]
99	R	PASSENGER DOOR REQUEST SW
100	Y	BLOWER FAN MOTOR RELAY CONT
102	BG	KEYLESS ENTRY RECEIVER POWER SUPPLY
103	LG	S/L UNIT POWER SUPPLY
106	W	COMBI SW INPUT 1
107	LG	COMBI SW INPUT 4
108	R	HAZARD SW
109	W	S/L UNIT COMM
110	G	S/L UNIT COMM
111	Y	S/L UNIT COMM

Connector No.	M124
Connector Name	WIRE TO WIRE
Connector Type	TH4QMP-CS15

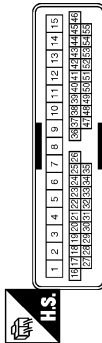

Terminal No.	Color of Wire	Signal Name [Specification]
6	BG	-- [With BOSE system]
7	R	-- [Without BOSE system]
8	G	--
9	P	--
10	V	--
11	SB	--
11	GR	--
12	BR	--
13	B	--
14	G	--
15	W	--
34	Y	--
35	Y/B	--
38	W	--
39	BG	--
40	SB	--
41	BR	-- [With automatic drive positioner]
41	G	-- [Without automatic drive positioner]
42	R	--
43	L	--
44	Y	--
45	R	--
46	W	--
47	SB	--
48	BR	--
49	Y	--
50	P	--
51	LG	--
52	BG	--
53	Y	--
54	L	--
55	L	--

Connector No.	M134
Connector Name	WIRE TO WIRE
Connector Type	CP8BAMGY-S



Terminal No.	Color of Wire	Signal Name [Specification]
2	W	--
3	R	--
4	G	--
5	R	--
7	SHIELD	--

Connector No.	M135
Connector Name	USB CONNECTOR
Connector Type	HAA04FG

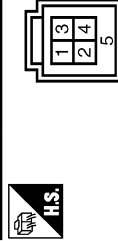

Terminal No.	Color of Wire	Signal Name [Specification]
1	W	--
2	L	--
3	G	--
4	R	--
5	SHIELD	--

Connector No.	M144
Connector Name	WIRE TO WIRE
Connector Type	TH6BMP-NH



Terminal No.	Color of Wire	Signal Name [Specification]
1	R	--
2	W	--
3	W	--
4	SHIELD	--

Connector No.	M201
Connector Name	AV CONTROL UNIT
Connector Type	TH18FW-CS2



Terminal No.	Color of Wire	Signal Name [Specification]
2	L	SOUND SIGNAL FRONT LH (+)
3	W	SOUND SIGNAL FRONT LH (-)
4	LG	SOUND SIGNAL REAR LH (+)
5	SB	SOUND SIGNAL REAR LH (-)
6	P	STRG SW A
7	V	ACC
9	L	ILLUMINATION
11	BR	SOUND SIGNAL FRONT RH (+)
12	GR	SOUND SIGNAL FRONT RH (-)
13	L	SOUND SIGNAL REAR RH (+)
14	P	SOUND SIGNAL REAR RH (-)
15	B	STRG SW GND
16	L	STRG SW B
18	G	GND
19	BR	BATTERY
20	B	GND

A  
B  
C  
D  
E  
F  
G  
H  
I  
J  
K  
L  
M  
N  
O  
P

AV

JCNWM5589GB

# BOSE AUDIO WITHOUT NAVIGATION

[BOSE AUDIO WITHOUT NAVIGATION]

< WIRING DIAGRAM >

## BOSE AUDIO WITHOUT NAVIGATION

Connector No.	M202
Connector Name	AV CONTROL UNIT
Connector Type	TH16PW-NH



36	37	38	39	40	41	42	43	44	45	46	47
48	49	50	51	52	53	54	55	56	57	58	59

Terminal No.	Color of Wire	Signal Name [Specification]
36	BG	SIGNAL VCC
37	LG	SIGNAL GND
38	R	HP
39	L	COMM (DISP->CONT)
40	B	RGB AREA (VS) SIGNAL
41	SHIELD	SHIELD
42	W	RGB SYNC
43	G	RGB (RED) SIGNAL
44	L	RGB (GREEN) SIGNAL
45	P	RGB (BLUE) SIGNAL
46	V	COMPOSITE IMAGE GND
47	SB	COMPOSITE IMAGE SIGNAL
48	Y	INVERTER VCC
49	BR	INVERTER GND
50	G	VP
51	P	COMM (CONT->DISP)
52	SHIELD	SHIELD
57	SHIELD	SHIELD
58	SHIELD	SHIELD

Connector No.	M203
Connector Name	AV CONTROL UNIT
Connector Type	TH16PW-NH



60	61	62	63	64	65	66	67
68	69	70	71	72	73	74	75

Terminal No.	Color of Wire	Signal Name [Specification]
62	W	CAMERA IMAGE SIGNAL
71	SHIELD	SHIELD
72	W	CAMERA GND

73	R	CAMERA POWER SUPPLY
----	---	---------------------

Connector No.	M204
Connector Name	AV CONTROL UNIT
Connector Type	TH16PW-NH



76	77	78	79	80	81	82	83	84	85	86	87	88	89	90	91
92	93	94	95	96	97	98	99	100	101	102	103	104	105	106	107

Terminal No.	Color of Wire	Signal Name [Specification]
76	LG	AV COMM (L)
77	SR	AV COMM (H)
78	LG	AV COMM (L)
79	SB	AV COMM (H)
80	P	CAN-L
81	L	CAN-H
82	BR	SHIELD
86	SHIELD	SHIELD
87	L	TEL VOICE SIGNAL (+)
88	P	TEL VOICE SIGNAL (-)
92	GR	VEHICLE SPEED (P-PULSE)
93	SB	PARKING BRAKE
94	BG	REVERSE
95	G	IGNITION
96	SB	DISK EJECT SIGNAL

Connector No.	M205
Connector Name	AV CONTROL UNIT
Connector Type	TH12PW-NH



108	109	110	111	112	113
114	115	116	117	118	119

Terminal No.	Color of Wire	Signal Name [Specification]
109	R	SOUND SIGNAL RH (+)
111	B	SHIELD
113	P	SOUND SIGNAL LH (+)
115	G	SOUND SIGNAL RH (-)

118	L	SOUND SIGNAL LH (-)
-----	---	---------------------

Connector No.	M206
Connector Name	AV CONTROL UNIT
Connector Type	A12PW



120	121	122	123
124	125	126	127
128	129	130	131

Terminal No.	Color of Wire	Signal Name [Specification]
120	B	SATELLITE RADIO SOUND SIGNAL LH (+)
121	G	SATELLITE RADIO SOUND SIGNAL RH (+)
122	L	COMM (CONT->SAT)
124	W	SATELLITE RADIO SOUND SIGNAL LH (-)
126	R	SATELLITE RADIO SOUND SIGNAL RH (-)
127	SHIELD	SHIELD
129	P	REQUEST (SAT->CONT)
130	G	COMM (SAT->CONT)

Connector No.	M207
Connector Name	AV CONTROL UNIT
Connector Type	HAA04FL



132	133	134	135
136			

Terminal No.	Color of Wire	Signal Name [Specification]
132	G	USB GND
133	R	USB D- SIGNAL
134	W	V BUS SIGNAL
135	L	USB D+ SIGNAL
136	SHIELD	SHIELD

Connector No.	M256
Connector Name	WIRE TO WIRE
Connector Type	TH104MW-NH



1	2	3	4
---	---	---	---

Terminal No.	Color of Wire	Signal Name [Specification]
1	P	
2	L	

Connector No.	M257
Connector Name	WIRE TO WIRE
Connector Type	TH104PW-NH



4	3	2	1
---	---	---	---

Terminal No.	Color of Wire	Signal Name [Specification]
1	P	
2	L	

# BOSE AUDIO WITHOUT NAVIGATION

## [BOSE AUDIO WITHOUT NAVIGATION]

< WIRING DIAGRAM >

### BOSE AUDIO WITHOUT NAVIGATION

Connector No.	M333
Connector Name	COMBINATION SWITCH (SPIRAL CABLE)
Connector Type	TK08FGY



Terminal No.	Color of Wire	Signal Name [Specification]
13	-	-
14	-	-
15	-	-
16	-	-
17	-	-
18	-	-
19	-	-
20	-	-

Connector No.	M370
Connector Name	AV CONTROL UNIT
Connector Type	GT13SH-2/1S-HU

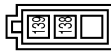

Terminal No.	Color of Wire	Signal Name [Specification]
139	-	ANTENNA SIGNAL
138	-	ANTENNA AMP. ON SIGNAL

Connector No.	M275
Connector Name	WIRE TO WIRE
Connector Type	GT13SSN-1/1PP-HU



Terminal No.	Color of Wire	Signal Name [Specification]
1	-	-
2	-	-

Connector No.	M276
Connector Name	WIRE TO WIRE
Connector Type	GT13SS-1/1S-HU



Terminal No.	Color of Wire	Signal Name [Specification]
1	-	-
2	-	-

Connector No.	M278
Connector Name	WIRE TO WIRE
Connector Type	GT13SSN-1/1PP-HU



Terminal No.	Color of Wire	Signal Name [Specification]
1	-	-
2	-	-

Connector No.	R1
Connector Name	WIRE TO WIRE
Connector Type	MH10FW-CS10

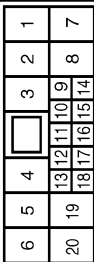

Terminal No.	Color of Wire	Signal Name [Specification]
1	B	-
2	BR	-
3	Y	-
4	W	-
5	SHIELD	-
6	O	-
7	B	-
8	L	-
9	Y	-
10	B	-
11	V	-
12	R	-
13	B	-
14	BR	-
15	G	-
16	-	-
17	-	-
18	-	-
19	-	-
20	-	-

Connector No.	R7
Connector Name	MICROPHONE
Connector Type	TK04FW



Terminal No.	Color of Wire	Signal Name [Specification]
1	O	MICROPHONE SIGNAL
2	SHIELD	MICROPHONE SHIELD
3	W	MICROPHONE VCC
4	-	-

JCNWM5591GB

A  
B  
C  
D  
E  
F  
G  
H  
I  
J  
K  
L  
M  
N  
O  
P

AV

## BASIC INSPECTION

### DIAGNOSIS AND REPAIR WORKFLOW

#### Work Flow

INFOID:000000006472535

#### OVERALL SEQUENCE

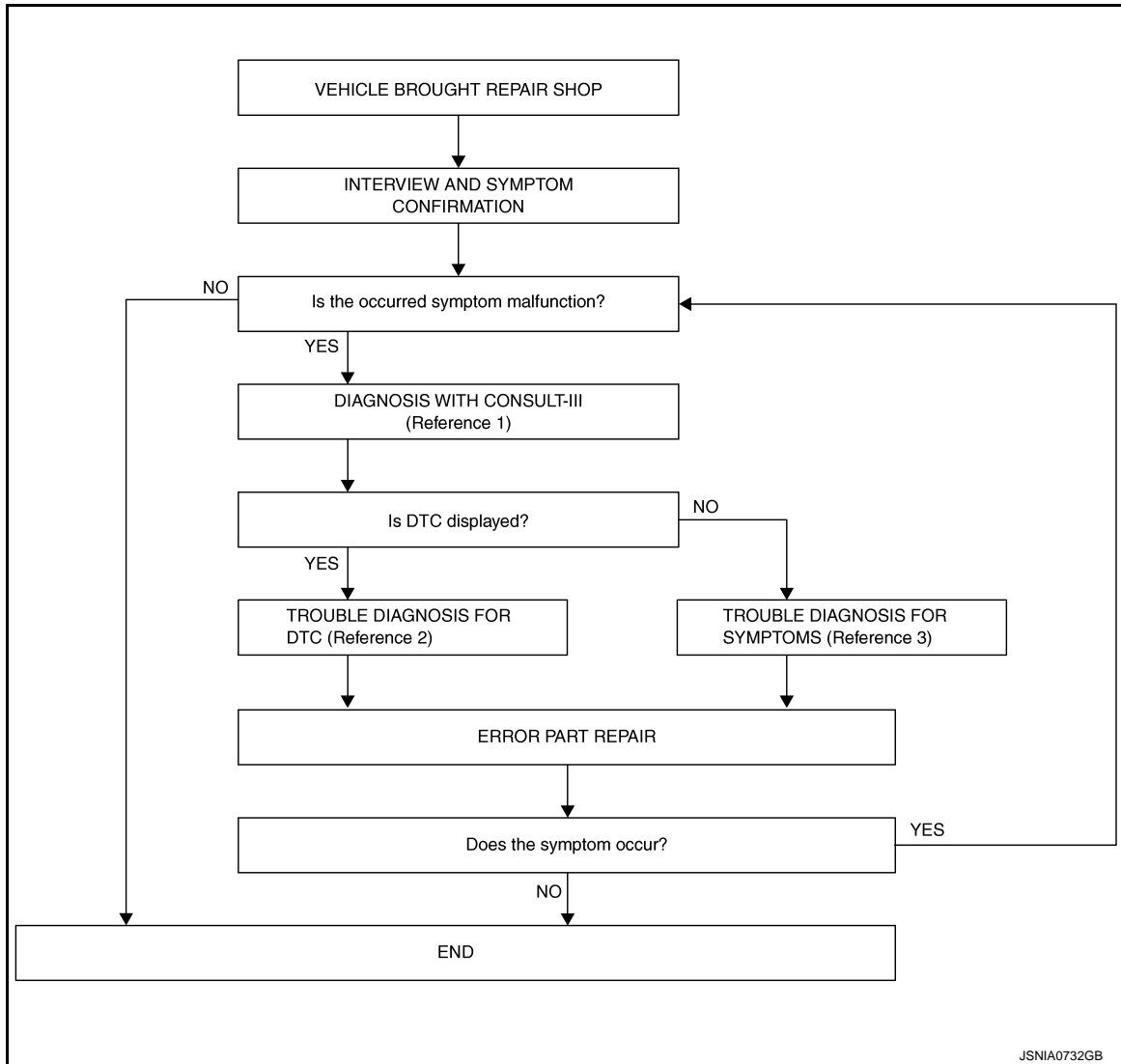

JSNIA0732GB

- Reference 1... Refer to [AV-148, "CONSULT - III Function"](#).
- Reference 2... Refer to [AV-161, "DTC Index"](#).
- Reference 3... Refer to [AV-244, "Symptom Table"](#).

#### DETAILED FLOW

##### 1. INTERVIEW AND SYMPTOM CONFIRMATION

Check the malfunction symptoms by performing the following items.

- Interview the customer to obtain the malfunction information (conditions and environment when the malfunction occurred).
- Check the symptom.

##### Is the occurred symptom malfunction?

YES >> GO TO 2.

NO >> INSPECTION END

##### 2. DIAGNOSIS WITH CONSULT-III

# DIAGNOSIS AND REPAIR WORKFLOW

[BOSE AUDIO WITHOUT NAVIGATION]

< BASIC INSPECTION >

1. Connect CONSULT-III and perform a self-diagnosis for "MULTI AV". Refer to [AV-148, "CONSULT - III Function"](#).

**NOTE:**

Skip to step 4 of the diagnosis procedure if "MULTI AV" is not displayed.

2. Check if any DTC is displayed in the "Self-Diagnosis Results".

Is DTC displayed?

YES >> GO TO 3.

NO >> GO TO 4.

## 3. TROUBLE DIAGNOSIS FOR DTC

1. Check the DTC indicated in the "Self-Diagnosis Results".
2. Perform the relevant diagnosis referring to the DTC Index. Refer to [AV-161, "DTC Index"](#).

>> GO TO 5.

## 4. TROUBLE DIAGNOSIS FOR SYMPTOMS

Perform the relevant diagnosis referring to the diagnosis chart by symptom. Refer to [AV-244, "Symptom Table"](#).

>> GO TO 5.

## 5. ERROR PART REPAIR

1. Repair or replace the identified malfunctioning parts.
2. Perform a self-diagnosis for "MULTI AV" with CONSULT-III.

**NOTE:**

Erase the stored self-diagnosis results after repairing or replacing the relevant components if any DTC has been indicated in the "Self-Diagnosis Results".

3. Check that the symptom does not occur.

Does the symptom occur?

YES >> GO TO 1.

NO >> INSPECTION END

A  
B  
C  
D  
E  
F  
G  
H  
I  
J  
K  
L  
M  
O  
P

AV

## ADDITIONAL SERVICE WHEN REPLACING (AV CONTROL UNIT)

< BASIC INSPECTION >

[BOSE AUDIO WITHOUT NAVIGATION]

### ADDITIONAL SERVICE WHEN REPLACING (AV CONTROL UNIT)

#### Description

INFOID:000000006472536

#### BEFORE REPLACEMENT

When replacing AV control unit, save or print current vehicle specification with CONSULT-III configuration before replacement.

#### AFTER REPLACEMENT

##### **CAUTION:**

When replacing AV control unit, you must perform "WRITE CONFIGURATION" with CONSULT-III.

- Complete the procedure of "WRITE CONFIGURATION" in order.
- If you set incorrect "WRITE CONFIGURATION", incidents might occur.
- Configuration is different for each vehicle model. Confirm configuration of each vehicle model.

#### Work Procedure

INFOID:000000006472537

### 1. SAVING VEHICLE SPECIFICATION

#### Ⓟ-CONSULT-III Configuration

Perform "READ CONFIGURATION" to save or print current vehicle specification. Refer to [AV-199, "Description"](#).

##### **NOTE:**

If "READ CONFIGURATION" can not be used, use the "WRITE CONFIGURATION - Manual selection".

>> GO TO 2.

### 2. REPLACE AV CONTROL UNIT

Replace AV control unit. Refer to [AV-250, "Exploded View"](#).

>> GO TO 3.

### 3. WRITING VEHICLE SPECIFICATION

#### Ⓟ-CONSULT-III Configuration

Perform "WRITE CONFIGURATION - Config file" or "WRITE CONFIGURATION - Manual selection" to write vehicle specification. Refer to [AV-199, "Work Procedure"](#).

>> GO TO 4.

### 4. OPERATION CHECK

Check that the operation of the AV control unit and camera images (fixed guide lines and predictive course lines) are normal.

>> WORK END

# CONFIGURATION (AV CONTROL UNIT)

< BASIC INSPECTION >

[BOSE AUDIO WITHOUT NAVIGATION]

## CONFIGURATION (AV CONTROL UNIT)

### Description

INFOID:000000006472538

- Since vehicle specifications are not included in the AV control unit after replacement, it is required to write vehicle specifications with CONSULT-III.
- Configuration has three functions as follows.

Function	Description
READ CONFIGURATION	<ul style="list-style-type: none"><li>• Reads the vehicle configuration of current AV control unit.</li><li>• Saves the read vehicle configuration.</li></ul>
WRITE CONFIGURATION-Manual selection	Writes the vehicle configuration with manual selection.
WRITE CONFIGURATION-Config file	Writes the vehicle configuration with saved data.

### Work Procedure

INFOID:000000006472539

#### NOTE:

If "WRITE CONFIGURATION" is unsuccessful, perform "Accessory Number Initialization". For details, refer to [AV-138, "On Board Diagnosis Function"](#).

After performing "Accessory Number Initialization", reboot the AV control unit to perform "WRITE CONFIGURATION".

#### 1. WRITING MODE SELECTION

ⓂCONSULT-III Configuration  
Select "CONFIGURATION" of "MULTI AV".

When writing saved data>>GO TO 2.

When writing manually>>GO TO 3.

#### 2. PERFORM "WRITE CONFIGURATION-CONFIG FILE"

ⓂCONSULT-III Configuration  
Perform "WRITE CONFIGURATION-Config file".

>> WORK END

#### 3. PERFORM "WRITE CONFIGURATION-MANUAL SELECTION"

ⓂCONSULT-III Configuration  
Select "WRITE CONFIGURATION-Manual selection" to write vehicle specifications into the AV control unit. For data to write, refer to [AV-199, "Configuration List"](#).

>> GO TO 4.

#### 4. OPERATION CHECK

Check that the operation of the AV control unit and camera images (fixed guide lines and predictive course lines) are normal.

>> WORK END

### Configuration List

INFOID:000000006472540

#### CAUTION:

Check vehicle specifications before servicing.

# CONFIGURATION (AV CONTROL UNIT)

< BASIC INSPECTION >

[BOSE AUDIO WITHOUT NAVIGATION]

MANUAL SETTING ITEM		NOTE
Items	Setting value	
STEERING	LHD	—
	RHD	—
GRADE	MODE 1	not used
	MODE 2	Journey grade or premium grade
	MODE 3	Sport grade or sports premium grade
4WAS	WITHOUT	—
	WITH	—
SOUND SYSTEM	BASE	—
	BOSE	—



# U1000 CAN COMM CIRCUIT

< DTC/CIRCUIT DIAGNOSIS >

[BOSE AUDIO WITHOUT NAVIGATION]

## DTC/CIRCUIT DIAGNOSIS

### U1000 CAN COMM CIRCUIT

#### Description

INFOID:000000006472541

CAN (Controller Area Network) is a serial communication line for real-time application. It is an on-vehicle multiplex communication line with high data communication speed and excellent error detection ability. Many electronic control units are equipped onto a vehicle, and each control unit shares information and links with other control units during operation (not independently). In CAN communication, control units are connected with 2 communication lines (CAN-H, CAN-L) allowing a high rate of information transmission with less wiring. Each control unit transmits/receives data but selectively reads required data only.

CAN Communication Signal Chart. Refer to [LAN-23, "CAN Communication Signal Chart"](#).

#### DTC Logic

INFOID:000000006472542

#### DTC DETECTION LOGIC

DTC	Display contents of CONSULT-III	DTC detection condition	Probable malfunction location
U1000	CAN COMM CIRCUIT [U1000]	AV control unit is not transmitting or receiving CAN communication signal for 2 seconds or more.	CAN communication system.

#### Diagnosis Procedure

INFOID:000000006472543

#### 1.PERFORM SELF-DIAGNOSTIC

1. Turn ignition switch ON and wait for 2 seconds or more.
2. Check "Self Diagnostic Result" of "MULTI AV".

Is "CAN COMM CIRCUIT" displayed?

- YES >> Refer to "LAN system". Refer to [LAN-14, "Trouble Diagnosis Flow Chart"](#).  
NO >> Refer to GI section. Refer to [GI-43, "Intermittent Incident"](#).

A  
B  
C  
D  
E  
F  
G  
H  
I  
J  
K  
L  
M  
O  
P

AV

# U1010 CONTROL UNIT (CAN)

< DTC/CIRCUIT DIAGNOSIS >

[BOSE AUDIO WITHOUT NAVIGATION]

## U1010 CONTROL UNIT (CAN)

### DTC Logic

INFOID:000000006472544

### DTC DETECTION LOGIC

DTC	Display contents of CONSULT-III	DTC detection condition	Probable malfunction factor
U1010	CONTROL UNIT (CAN) [U1010]	CAN initial diagnosis malfunction is detected.	Replace the AV control unit if the malfunction occurs constantly. Refer to <a href="#">AV-250, "Exploded View"</a> .

# U1200 AV CONTROL UNIT

< DTC/CIRCUIT DIAGNOSIS >

[BOSE AUDIO WITHOUT NAVIGATION]

## U1200 AV CONTROL UNIT

### DTC Logic

INFOID:000000006472545

DTC	Display contents of CONSULT-III	DTC detection condition	Possible malfunction factor
U1200	Cont Unit [U1200]	AV control unit malfunction is detected.	Replace the AV control unit if the malfunction occurs constantly. Refer to <a href="#">AV-250, "Exploded View"</a> .

A  
B  
C  
D  
E  
F  
G  
H  
I  
J  
K  
L  
M  
AV  
O  
P

# U1216 AV CONTROL UNIT

< DTC/CIRCUIT DIAGNOSIS >

[BOSE AUDIO WITHOUT NAVIGATION]

## U1216 AV CONTROL UNIT

### DTC Logic

INFOID:000000006472546

DTC	Display contents of CONSULT-III	DTC detection condition	Possible malfunction factor
U1216	CAN CONT [U1216]	AV control unit malfunction is detected.	Replace the AV control unit if the malfunction occurs constantly. Refer to <a href="#">AV-250, "Exploded View"</a> .

# U1231 BOSE AMP.

< DTC/CIRCUIT DIAGNOSIS >

[BOSE AUDIO WITHOUT NAVIGATION]

## U1231 BOSE AMP.

### DTC Logic

INFOID:000000006472547

DTC	Display contents of CONSULT-III	DTC detection condition	Possible malfunction factor
U1231	AMP TEMP [U1231]	BOSE amp. malfunction is detected.	Replace the BOSE amp. if the malfunction occurs constantly. Refer to <a href="#">AV-259, "Exploded View"</a> .

A  
B  
C  
D  
E  
F  
G  
H  
I  
J  
K  
L  
M  
AV  
O  
P



# U1232 STEERING ANGLE SENSOR

< DTC/CIRCUIT DIAGNOSIS >

[BOSE AUDIO WITHOUT NAVIGATION]

## U1232 STEERING ANGLE SENSOR

### DTC Logic

INFOID:000000006472548

DTC	Display contents of CONSULT-III	DTC detection condition	Possible malfunction factor
U1232	ST ANGLE SEN CALIB [1232]	Predictive course line center position adjustment of the steering angle sensor is incomplete.	Adjust the predictive course line center position of the steering angle sensor.

### Diagnosis Procedure

INFOID:000000006472549

#### 1. ADJUST THE PREDICTIVE COURSE LINE CENTER POSITION OF THE STEERING ANGLE SENSOR

When U1232 is detected, adjust the predictive course line center position of the steering angle sensor.

>> Adjusts the steering angle sensor neutral position on ABS actuator and electrical unit (control unit) side. Refer to [BRC-9. "ADJUSTMENT OF STEERING ANGLE SENSOR NEUTRAL POSITION : Special Repair Requirement"](#).

# U1243 DISPLAY UNIT

< DTC/CIRCUIT DIAGNOSIS >

[BOSE AUDIO WITHOUT NAVIGATION]

## U1243 DISPLAY UNIT

### DTC Logic

INFOID:000000006472550

DTC	Display contents of CONSULT-III	DTC detection condition	Possible malfunction factor
U1243	FRONT DISP CONN [U1243]	When either one of the following items is detected: <ul style="list-style-type: none"> <li>display unit power supply and ground circuit are malfunctioning.</li> <li>communication circuit between AV control unit and display unit are malfunctioning.</li> </ul>	<ul style="list-style-type: none"> <li>Display unit power supply and ground circuit.</li> <li>Communication circuit between AV control unit and display unit.</li> </ul>

### Diagnosis Procedure

INFOID:000000006472551

#### 1. CHECK DISPLAY UNIT POWER SUPPLY AND GROUND CIRCUIT

Check display unit power supply and ground circuit. Refer to [AV-220. "DISPLAY UNIT : Diagnosis Procedure"](#).  
Is the inspection result normal?

- YES >> GO TO 2.  
 NO >> Repair malfunctioning parts.

#### 2. CHECK CONTINUITY COMMUNICATION CIRCUIT

- Turn ignition switch OFF.
- Disconnect display unit connector and AV control unit connector.
- Check continuity between display unit harness connector and AV control unit harness connector.

Display unit		AV control unit		Continuity
Connector	Terminals	Connector	Terminals	
M71	11	M202	51	Existed
	22		39	

- Check continuity between display unit harness connector and ground.

Display unit		Ground	Continuity
Connector	Terminals		
M71	11		Not existed
	22		

Is the inspection result normal?

- YES >> GO TO 3.  
 NO >> Repair harness or connector.

#### 3. CHECK COMMUNICATION SIGNAL

- Connect display unit connector and AV control unit connector.
- Turn ignition switch ON.
- Check signal between display unit harness connector and ground.

A  
B  
C  
D  
E  
F  
G  
H  
I  
J  
K  
L  
M  
AV  
O  
P

# U1243 DISPLAY UNIT

< DTC/CIRCUIT DIAGNOSIS >

[BOSE AUDIO WITHOUT NAVIGATION]

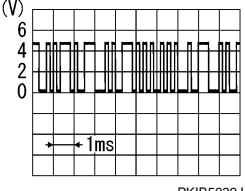
(+)		(-)	Condition	Reference value
Display unit				
Connector	Terminal			
M71	22	Ground	When adjusting display brightness.	

Is the inspection result normal?

YES >> GO TO 4.

NO >> Replace AV control unit. Refer to [AV-250. "Exploded View"](#).

## 4. CHECK COMMUNICATION SIGNAL

Check signal between display unit harness connector and ground.

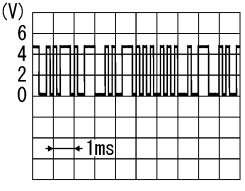
(+)		(-)	Condition	Reference value
Display unit				
Connector	Terminal			
M71	11	Ground	When adjusting display brightness.	

Is the inspection result normal?

YES >> INSPECTION END

NO >> Replace display unit. Refer to [AV-252. "Exploded View"](#).



# U1255 SATELLITE RADIO TUNER

< DTC/CIRCUIT DIAGNOSIS >

[BOSE AUDIO WITHOUT NAVIGATION]

## U1255 SATELLITE RADIO TUNER

### DTC Logic

INFOID:000000006472552

DTC	Display contents of CONSULT-III	DTC Detection Condition	Possible malfunction factor
U1255	SAT CONN [U1255]	When either one of the following items is detected: <ul style="list-style-type: none"> <li>• satellite radio tuner power supply and ground circuit are malfunctioning.</li> <li>• communication circuits between AV control unit and satellite radio tuner are malfunctioning.</li> <li>• request signal circuit between AV control unit and satellite radio tuner are malfunctioning.</li> </ul>	<ul style="list-style-type: none"> <li>• Satellite radio tuner power supply and ground circuit.</li> <li>• Communication circuit between AV control unit and satellite radio tuner.</li> <li>• Request signal circuit between AV control unit and satellite radio tuner.</li> </ul>

### Diagnosis Procedure

INFOID:000000006472553

#### 1. CHECK SATELLITE RADIO TUNER POWER SUPPLY AND GROUND CIRCUIT

Check satellite radio tuner power supply and ground circuit. Refer to [AV-222, "SATELLITE RADIO TUNER : Diagnosis Procedure"](#).

Is the inspection result normal?

YES >> GO TO 2.

NO >> Repair malfunctioning parts.

#### 2. CHECK CONTINUITY COMMUNICATION CIRCUIT AND REQUEST SIGNAL CIRCUIT

1. Turn ignition switch OFF.
2. Disconnect AV control unit connector and satellite radio tuner connector.
3. Check continuity between AV control unit harness connector and satellite radio tuner harness connector.

AV control unit		Satellite radio tuner		Continuity
Connector	Terminals	Connector	Terminals	
M206	129	B236	8	Existed
	122		10	
	130		9	

4. Check continuity between AV control unit harness connector.

AV control unit		Ground	Continuity
Connector	Terminals		
M206	129	Ground	Not existed
	122		
	130		

Is the inspection result normal?

YES >> GO TO 3.

NO >> Repair harness or connector.

#### 3. CHECK AV CONTROL UNIT VOLTAGE

1. Connect AV control unit connector.
2. Turn ignition switch ON.
3. Check signal between AV control unit harness connector and ground.

(+)		(-)	Reference value (Approx.)
AV control unit			
Connector	Terminals		

## U1255 SATELLITE RADIO TUNER

< DTC/CIRCUIT DIAGNOSIS >

[BOSE AUDIO WITHOUT NAVIGATION]

M206	129	Ground	7.0 V
	130	Ground	7.0 V

Is the inspection result normal?

YES >> GO TO 4.

NO >> Replace AV control unit. Refer to [AV-250, "Exploded View"](#).

### 4. CHECK SATELLITE RADIO TUNER VOLTAGE

1. Turn ignition switch OFF.
2. Disconnect AV control unit connector.
3. Connect satellite radio tuner.
4. Turn ignition switch ON.
5. Check signal between satellite radio tuner harness connector and ground.

(+)		(-)	Reference value (Approx.)
Satellite radio tuner			
Connector	Terminal		
B236	10	Ground	7.0 V

Is the inspection result normal?

YES >> INSPECTION END

NO >> Replace satellite radio tuner. Refer to [AV-262, "Exploded View"](#).

# U1300 AV COMM CIRCUIT

< DTC/CIRCUIT DIAGNOSIS >

[BOSE AUDIO WITHOUT NAVIGATION]

## U1300 AV COMM CIRCUIT

### Description

INFOID:000000006472554

U1300 is indicated when malfunction occurs in communication signal of multi AV system. Indicated simultaneously, without fail, with the malfunction of control units connected to AV control unit with communication line. Determine the possible malfunction cause from the table below.

### SELF-DIAGNOSIS RESULTS DISPLAY ITEM

DTC	Display contents of CONSULT-III	DTC detection condition	Possible malfunction factor
U1300 U1240	<ul style="list-style-type: none"> <li>AV COMM CIRCUIT [U1300]</li> <li>SWITCH CONN [U1240]</li> </ul>	When either one of the following items is detected: <ul style="list-style-type: none"> <li>multifunction switch power supply and ground circuits are malfunctioning.</li> <li>AV communication circuits between AV control unit and multifunction switch are malfunctioning.</li> </ul>	<ul style="list-style-type: none"> <li>Multifunction switch power supply and ground circuits.</li> <li>AV communication circuits between AV control unit and multifunction switch.</li> </ul>
U1300 U1256	<ul style="list-style-type: none"> <li>AV COMM CIRCUIT [U1300]</li> <li>HAND FREE CONN [U1256]</li> </ul>	When either one of the following items is detected: <ul style="list-style-type: none"> <li>TEL adapter unit power supply and ground circuits are malfunctioning.</li> <li>AV communication circuits between AV control unit and TEL adapter unit are malfunctioning.</li> </ul>	<ul style="list-style-type: none"> <li>TEL adapter unit power supply and ground circuits.</li> <li>AV communication circuits between AV control unit and TEL adapter unit.</li> </ul>
U1300 U125C	<ul style="list-style-type: none"> <li>AV COMM CIRCUIT [U1300]</li> <li>SONAR CONN [U125C]</li> </ul>	When either one of the following items are detected: <ul style="list-style-type: none"> <li>sonar control unit power supply and ground circuits are malfunctioning.</li> <li>AV communication circuits between AV control unit and sonar control unit are malfunctioning.</li> </ul>	<ul style="list-style-type: none"> <li>Sonar control unit power supply and ground circuits.</li> <li>AV communication circuits between AV control unit and sonar control unit.</li> </ul>
U1300 U124E	<ul style="list-style-type: none"> <li>AV COMM CIRCUIT [U1300]</li> <li>AMP CONN [U124E]</li> </ul>	BOSE amp. power supply and ground circuits are malfunctioning.	BOSE amp. power supply and ground circuits.
U1300 U124E U1256	<ul style="list-style-type: none"> <li>AV COMM CIRCUIT [U1300]</li> <li>AMP CONN [U124E]</li> <li>HAND FREE CONN [U1256]</li> </ul>	Malfunction is detected in AV communication circuits between sonar control unit and BOSE amp.	AV communication circuits between sonar control unit and BOSE amp.
U1300 U1240 U125C U1256	<ul style="list-style-type: none"> <li>AV COMM CIRCUIT [U1300]</li> <li>SWITCH CONN [U1240]</li> <li>AMP CONN [U124E]</li> <li>SONAR CONN [U125C]</li> <li>HAND FREE CONN [U1256]</li> </ul>	Malfunction is detected in AV communication circuits between AV control unit and multifunction switch.	AV communication circuits between AV control unit and multifunction switch.

A  
B  
C  
D  
E  
F  
G  
H  
I  
J  
K  
L  
M

AV

O  
P

# U1310 AV CONTROL UNIT

< DTC/CIRCUIT DIAGNOSIS >

[BOSE AUDIO WITHOUT NAVIGATION]

## U1310 AV CONTROL UNIT

### DTC Logic

INFOID:000000006472555

DTC	Display contents of CONSULT-III	DTC detection condition	Possible malfunction factor
U1310	CONTROL UNIT (AV) [U1310]	An initial diagnosis error is detected in AV communication circuit.	Replace AV control unit. If the malfunction occurs constantly. Refer to <a href="#">AV-250, "Exploded View"</a> .

# U1900 CENTER SPEAKER

< DTC/CIRCUIT DIAGNOSIS >

[BOSE AUDIO WITHOUT NAVIGATION]

## U1900 CENTER SPEAKER

### DTC Logic

INFOID:000000006472556

### DTC DETECTION LOGIC

DTC	Display contents of CONSULT-III	DTC detection condition	Possible malfunction factor
U1900	CENTER SPEAKER [OPEN, SHORT, GND-SHORT, or VB-SHORT] [U1900]	Malfunction is detected sound signal circuits between BOSE amp. and center speaker.	Sound signal circuits between BOSE amp. and center speaker.

### Diagnosis Procedure

INFOID:000000006472557

#### 1. PERFORM THE SELF-DIAGNOSIS

1. Delete the "self-diagnosis" results of "MULTI AV". Turn ignition switch OFF.
2. Turn ignition switch ON. perform the self-diagnosis again.
3. Check that the DTC is detected again.

#### Is any DTC detected?

- YES >> Check harnesses between BOSE amp. and center speaker.  
NO >> Refer to GI section. Refer to [GI-43, "Intermittent Incident"](#)

A  
B  
C  
D  
E  
F  
G  
H  
I  
J  
K  
L  
M  
O  
P

AV

# U1901, U1907 DOOR SQUAWKER

< DTC/CIRCUIT DIAGNOSIS >

[BOSE AUDIO WITHOUT NAVIGATION]

## U1901, U1907 DOOR SQUAWKER

### DTC Logic

INFOID:000000006472558

### DTC DETECTION LOGIC

DTC	Display contents of CONSULT-III	DTC detection condition	Possible malfunction factor
U1901	FR-DOOR SPEAKER [OPEN, SHORT, GND-SHORT or VB-SHOR] [U1901]	When either one of the following items are detected: <ul style="list-style-type: none"><li>• sound signal circuits between BOSE amp. and door squawker RH are malfunctioning.</li><li>• sound signal circuits between BOSE amp. and tweeter RH are malfunctioning.</li></ul>	<ul style="list-style-type: none"><li>• Sound signal circuits between BOSE amp. and door squawker RH.</li><li>• Sound signal circuits between BOSE amp. and tweeter RH.</li></ul>
U1907	FL-DOOR SPEAKER [OPEN, SHORT, GND-SHORT or VB-SHOR] [U1907]	When either one of the following items are detected: <ul style="list-style-type: none"><li>• sound signal circuits between BOSE amp. and door squawker LH are malfunctioning.</li><li>• sound signal circuits between BOSE amp. and tweeter LH are malfunctioning.</li></ul>	<ul style="list-style-type: none"><li>• Sound signal circuits between BOSE amp. and door squawker LH.</li><li>• Sound signal circuits between BOSE amp. and tweeter LH.</li></ul>

### Diagnosis Procedure

INFOID:000000006472559

#### 1. PERFORM THE SELF-DIAGNOSIS

1. Delete the "self-diagnosis" results of "MULTI AV". Turn ignition switch OFF.
2. Turn ignition switch ON. perform the self-diagnosis again.
3. Check that the DTC is detected again.

#### Is any DTC detected?

- YES-1 >> U1901: Check harnesses between BOSE amp. and door squawker RH and between BOSE amp. and tweeter RH.
- YES-2 >> U1907: Check harnesses between BOSE amp. and door squawker LH and between BOSE amp. and tweeter LH.
- NO >> Refer to GI section. Refer to [GI-43, "Intermittent Incident"](#).

# U1908, U1909 HEADREST SPEAKER

< DTC/CIRCUIT DIAGNOSIS >

[BOSE AUDIO WITHOUT NAVIGATION]

## U1908, U1909 HEADREST SPEAKER

### DTC Logic

INFOID:000000006472560

### DTC DETECTION LOGIC

DTC	Display contents of CONSULT-III	DTC detection condition	Possible malfunction factor
U1908	FL-SEAT L-SPEAKER [OPEN, SHORT, GND-SHORT or VB-SHOR] [U1908]	Malfunction is detected sound signal circuits between BOSE amp. and driver headrest speaker LH.	Sound signal circuits between BOSE amp. and driver headrest speaker LH.
U1909	FL-SEAT R-SPEAKER [OPEN, SHORT, GND-SHORT or VB-SHOR] [U1909]	Malfunction is detected sound signal circuits between BOSE amp. and driver headrest speaker RH.	Sound signal circuits between BOSE amp. and driver headrest speaker RH.

### Diagnosis Procedure

INFOID:000000006472561

#### 1. PERFORM THE SELF-DIAGNOSIS

1. Delete the "self-diagnosis" results of "MULTI AV". Turn ignition switch OFF.
2. Turn ignition switch ON. perform the self-diagnosis again.
3. Check that the DTC is detected again.

#### Is any DTC detected?

- YES-1 >> U1908: Check harnesses between BOSE amp. and driver headrest speaker LH.  
YES-2 >> U1909: Check harnesses between BOSE amp. and driver headrest speaker RH.  
NO >> Refer to GI section. Refer to [GI-43, "Intermittent Incident"](#).

A  
B  
C  
D  
E  
F  
G  
H  
I  
J  
K  
L  
M  
O  
P

AV

# U1910, U1911 REAR WOOFER

< DTC/CIRCUIT DIAGNOSIS >

[BOSE AUDIO WITHOUT NAVIGATION]

## U1910, U1911 REAR WOOFER

### DTC Logic

INFOID:000000006472562

### DTC DETECTION LOGIC

DTC	Display contents of CONSULT-III	DTC detection condition	Possible malfunction factor
U1910	RR WOOFER [OPEN, SHORT, GND-SHORT or VB-SHOR] [U1910]	Malfunction is detected sound signal circuits between BOSE amp. and rear woofer RH.	Sound signal circuits between BOSE amp. and rear woofer RH.
U1911	RL WOOFER [OPEN, SHORT, GND-SHORT or VB-SHOR] [U1911]	Malfunction is detected sound signal circuits between BOSE amp. and rear woofer LH.	Sound signal circuits between BOSE amp. and rear woofer LH.

### Diagnosis Procedure

INFOID:000000006472563

#### 1. PERFORM THE SELF-DIAGNOSIS

1. Delete the "self-diagnosis" results of "MULTI AV". Turn ignition switch OFF.
2. Turn ignition switch ON. perform the self-diagnosis again.
3. Check that the DTC is detected again.

#### Is any DTC detected?

- YES-1 >> U1910: Check harnesses between BOSE amp. and rear woofer RH.  
YES-2 >> U1911: Check harnesses between BOSE amp. and rear woofer LH.  
NO >> Refer to GI section. Refer to [GI-43, "Intermittent Incident"](#).



# U190A, U190B HEADREST SPEAKER

< DTC/CIRCUIT DIAGNOSIS >

[BOSE AUDIO WITHOUT NAVIGATION]

## U190A, U190B HEADREST SPEAKER

### DTC Logic

INFOID:000000006472564

### DTC DETECTION LOGIC

DTC	Display contents of CONSULT-III	DTC detection condition	Possible malfunction factor
U190A	FR-SEAT L-SPEAKER [OPEN, SHORT, GND-SHORT or VB-SHOR] [U190A]	Malfunction is detected sound signal circuits between BOSE amp. and passenger headrest speaker LH.	Sound signal circuits between BOSE amp. and passenger headrest speaker LH.
U190B	FR-SEAT R-SPEAKER [OPEN, SHORT, GND-SHORT or VB-SHOR] [U190B]	Malfunction is detected sound signal circuits between BOSE amp. and passenger headrest speaker RH.	Sound signal circuits between BOSE amp. and passenger headrest speaker RH.

### Diagnosis Procedure

INFOID:000000006472565

#### 1. PERFORM THE SELF-DIAGNOSIS

1. Delete the "self-diagnosis" results of "MULTI AV". Turn ignition switch OFF.
2. Turn ignition switch ON. perform the self-diagnosis again.
3. Check that the DTC is detected again.

#### Is any DTC detected?

- YES-1 >> U190A: Check harnesses between BOSE amp. and passenger headrest speaker LH.  
YES-2 >> U190B: Check harnesses between BOSE amp. and passenger headrest speaker RH.  
NO >> Refer to GI section. Refer to [GI-43, "Intermittent Incident"](#).

A  
B  
C  
D  
E  
F  
G  
H  
I  
J  
K  
L  
M  
AV  
O  
P



# U190C AUDIOPILOT™ MICROPHONE

< DTC/CIRCUIT DIAGNOSIS >

[BOSE AUDIO WITHOUT NAVIGATION]

## U190C AUDIOPILOT™ MICROPHONE

### DTC Logic

INFOID:000000006472566

DTC	Display contents of CONSULT-III	DTC detection condition	Possible malfunction factor
U190C	CORRECT MICROPHONE [OPEN, SHORT, GND-SHORT or VB-SHOR] [U190C]	Malfunction is detected sound signal circuits between BOSE amp. and microphone (for AudioPilot™).	Sound signal circuits between BOSE amp. and microphone (for AudioPilot™).

### Diagnosis Procedure

INFOID:000000006472567

#### 1. CHECK CONTINUITY BETWEEN BOSE AMP. AND MICROPHONE FOR AUDIOPILOT™ CIRCUIT

1. Turn ignition switch OFF.
2. Disconnect BOSE amp. connector and microphone for AudioPilot™ connector.
3. Check continuity between BOSE amp. harness connector and microphone for AudioPilot™ harness connector.

BOSE amp.		Microphone for AudioPilot™		Continuity
Connector	Terminals	Connector	Terminals	
B41	31	B617	81	Existed
	11		82	

4. Check continuity between BOSE amp. harness connector and ground.

BOSE amp.		Ground	Continuity
Connector	Terminals		
B41	31		Not existed
	11		

Is the inspection result normal?

- YES >> GO TO 2.  
NO >> Repair harness or connector.

#### 2. CHECK MICROPHONE SIGNAL

1. Connect BOSE amp. connector and microphone for AudioPilot™ connector.
2. Check signal between BOSE amp. harness connector.

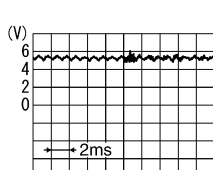
(+) BOSE amp.		(-) BOSE amp.		Condition	Reference value
Connector	Terminal	Connector	Terminal		
B41	31	B41	11	When inputting noise.	 <p>(reference value)</p>

PKIA2104E

Is the inspection result normal?

- YES >> Replace BOSE amp. Refer to [AV-259, "Exploded View"](#).  
NO >> Replace microphone for AudioPilot™. Refer to [AV-260, "Exploded View"](#).

# U190F, U1912 DOOR WOOFER

< DTC/CIRCUIT DIAGNOSIS >

[BOSE AUDIO WITHOUT NAVIGATION]

## U190F, U1912 DOOR WOOFER

### DTC Logic

INFOID:000000006472568

### DTC DETECTION LOGIC

DTC	Display contents of CONSULT-III	DTC detection condition	Possible malfunction factor
U190F	FR WOOFER [OPEN, SHORT, GND-SHORT or VB-SHOR] [U190F]	Malfunction is detected sound signal circuits between BOSE amp. and door woofer RH.	Sound signal circuits between BOSE amp. and door woofer RH.
U1912	FL WOOFER [OPEN, SHORT, GND-SHORT or VB-SHOR] [U1912]	Malfunction is detected sound signal circuits between BOSE amp. and door woofer LH.	Sound signal circuits between BOSE amp. and door woofer LH.

### Diagnosis Procedure

INFOID:000000006472569

#### 1. PERFORM THE SELF-DIAGNOSIS

1. Delete the "self-diagnosis" results of "MULTI AV". Turn ignition switch OFF.
2. Turn ignition switch ON. perform the self-diagnosis again.
3. Check that the DTC is detected again.

#### Is any DTC detected?

- YES-1 >> U1901F Check harnesses between BOSE amp. and door woofer RH.  
YES-2 >> U19012 Check harnesses between BOSE amp. and door woofer LH.  
NO >> Refer to GI section. Refer to [GI-43, "Intermittent Incident"](#).

A  
B  
C  
D  
E  
F  
G  
H  
I  
J  
K  
L  
M  
O  
P

AV

# POWER SUPPLY AND GROUND CIRCUIT

< DTC/CIRCUIT DIAGNOSIS >

[BOSE AUDIO WITHOUT NAVIGATION]

## POWER SUPPLY AND GROUND CIRCUIT

### AV CONTROL UNIT

#### AV CONTROL UNIT : Diagnosis Procedure

INFOID:000000006472570

#### 1.CHECK FUSE

Check for blown fuses.

Power source	Fuse No.
Battery	34
Ignition switch ACC or ON	19

Is the inspection result normal?

YES >> GO TO 2.

NO >> Be sure to eliminate cause of malfunction before installing new fuse.

#### 2.CHECK POWER SUPPLY CIRCUIT

Check voltage between AV control unit harness connectors and ground.

Signal name	Connector No.	Terminal No.	Ignition switch position	Value (Approx.)
Battery power supply	M201	19	OFF	Battery voltage
ACC power supply	M201	7	ACC	Battery voltage

Is the inspection result normal?

YES >> GO TO 3.

NO >> Check harness between AV control unit and fuse.

#### 3.CHECK GROUND CIRCUIT

1. Turn ignition switch OFF.
2. Disconnect AV control unit connectors.
3. Check continuity between AV control unit harness connectors and ground.

Signal name	Connector No.	Terminal No.	Ignition switch position	Continuity
Ground	M201	20	OFF	Existed

Is the inspection result normal?

YES >> INSPECTION END

NO >> Repair harness or connector.

## DISPLAY UNIT

#### DISPLAY UNIT : Diagnosis Procedure

INFOID:000000006472571

#### 1.CHECK POWER SUPPLY CIRCUIT (DISPLAY SIDE)

Check voltage between display unit harness connector and ground.

Signal name	Connector No.	Terminal No.	Ignition switch position	Value (Approx.)
Inverter VCC	M71	2	ACC	9.0 V
Signal VCC		3		

Is the inspection result normal?

YES >> GO TO 4.

NO >> GO TO 2.

#### 2.CHECK POWER SUPPLY CIRCUIT (CONTINUITY)

1. Turn ignition switch OFF.
2. Disconnect the harness connector between display unit and AV control unit.
3. Check continuity between display unit harness connector M71 and AV control unit harness connector.

# POWER SUPPLY AND GROUND CIRCUIT

< DTC/CIRCUIT DIAGNOSIS >

[BOSE AUDIO WITHOUT NAVIGATION]

Signal name	Display unit (M71)	AV control unit (M202)	Continuity
Inverter VCC	2	48	Existed
Signal VCC	3	36	Existed

4. Check continuity between display unit harness connector and ground.

Signal name	Display unit (M71)	—	Continuity
Inverter VCC	2	Ground	Not existed
Signal VCC	3	Ground	Not existed

Is the inspection result normal?

YES >> GO TO 3.

NO >> Repair harness or connector.

## 3.CHECK POWER SUPPLY CIRCUIT (AV CONTROL UNIT SIDE)

1. Connect the AV control unit harness connector.
2. Turn ignition switch ACC.
3. Check voltage between AV control unit harness connector and ground.

Signal name	Connector No.	Terminal No.	Ignition switch position	Value (Approx.)
Inverter VCC	M202	48	ACC	9.0 V
Signal VCC		36		

Is the inspection result normal?

YES >> INSPECTION END

NO >> Replacement of AV control unit.

## 4.CHECK GROUND CIRCUIT

1. Turn ignition switch OFF.
2. Disconnect display unit connector.
3. Check continuity between display unit harness connectors and ground.

Signal name	Connector No.	Terminal No.	Ignition switch position	Continuity
Ground	M71	1	OFF	Existed

Is the inspection result normal?

YES >> INSPECTION END

NO >> Repair harness or connector.

## BOSE AMP.

### BOSE AMP. : Diagnosis Procedure

INFOID:000000006472572

## 1.CHECK FUSE

Check for blown fuses.

Power source	Fuse No.
Battery	5, 8
Ignition switch ACC or ON	19

Is the inspection result normal?

YES >> GO TO 2.

NO >> Be sure to eliminate cause of malfunction before installing new fuse.

## 2.CHECK POWER SUPPLY CIRCUIT

Check voltage between BOSE amp. harness connector and ground.

# POWER SUPPLY AND GROUND CIRCUIT

< DTC/CIRCUIT DIAGNOSIS >

[BOSE AUDIO WITHOUT NAVIGATION]

Signal name	Connector No.	Terminal No.	Ignition switch position	Value (Approx.)
Battery power supply	B42	50, 51	OFF	Battery voltage
ACC power supply	B41	16	ACC	Battery voltage

Is the inspection result normal?

YES >> GO TO 3.

NO >> Check harness between BOSE amp. and fuse.

## 3.CHECK GROUND CIRCUIT

1. Turn ignition switch OFF.
2. Disconnect BOSE amp. connector.
3. Check continuity between BOSE amp. harness connector and ground.

Signal name	Connector No.	Terminal No.	Ignition switch position	Continuity
Ground	B42	47, 52	OFF	Existed

Is the inspection result normal?

YES >> INSPECTION END

NO >> Repair harness or connector.

## SATELLITE RADIO TUNER

### SATELLITE RADIO TUNER : Diagnosis Procedure

INFOID:000000006472573

#### 1.CHECK FUSE

Check for blown fuses.

Power source	Fuse No.
Battery	34
Ignition switch ACC or ON	19

Is the inspection result normal?

YES >> GO TO 2.

NO >> Be sure to eliminate cause of malfunction before installing new fuse.

#### 2.CHECK POWER SUPPLY CIRCUIT

Check voltage between satellite radio tuner harness connector and ground.

Signal name	Connector No.	Terminal No.	Ignition switch position	Value (Approx.)
Battery power supply	B236	12	OFF	Battery voltage
ACC power supply	B236	16	ACC	Battery voltage

Is the inspection result normal?

YES >> INSPECTION END

NO >> Check harness between satellite radio tuner and fuse.

## TEL ADAPTER UNIT

### TEL ADAPTER UNIT : Diagnosis Procedure

INFOID:000000006472574

#### 1.CHECK FUSE

Check for blown fuses.

Power source	Fuse No.
Battery	34
Ignition switch ACC or ON	19

Is the inspection result normal?

# POWER SUPPLY AND GROUND CIRCUIT

[BOSE AUDIO WITHOUT NAVIGATION]

< DTC/CIRCUIT DIAGNOSIS >

YES >> GO TO 2.

NO >> Be sure to eliminate cause of malfunction before installing new fuse.

## 2.CHECK POWER SUPPLY CIRCUIT

Check voltage between TEL adapter unit harness connector and ground.

Signal name	Connector No.	Terminal No.	Ignition switch position	Value (Approx.)
Battery power supply	B237	1	OFF	Battery voltage
ACC power supply	B237	2	ACC	Battery voltage

Is the inspection result normal?

YES >> GO TO 3.

NO >> Check harness between TEL adapter unit and fuse.

## 3.CHECK GROUND CIRCUIT

1. Turn ignition switch OFF.
2. Disconnect TEL adapter unit connector.
3. Check continuity between TEL adapter unit harness connector and ground.

Signal name	Connector No.	Terminal No.	Ignition switch position	Continuity
Ground	B237	4, 14	OFF	Existed

Is the inspection result normal?

YES >> INSPECTION END

NO >> Repair harness or connector.

A  
B  
C  
D  
E  
F  
G  
H  
I  
J  
K  
L  
M

AV

O  
P

# RGB (R: RED) SIGNAL CIRCUIT

< DTC/CIRCUIT DIAGNOSIS >

[BOSE AUDIO WITHOUT NAVIGATION]

## RGB (R: RED) SIGNAL CIRCUIT

### Description

INFOID:000000006472575

Transmit the image displayed with AV control unit with RGB signal to the display unit.

### Diagnosis Procedure

INFOID:000000006472576

#### 1. CHECK CONTINUITY RGB (R: RED) SIGNAL CIRCUIT

1. Turn ignition switch OFF.
2. Disconnect display unit connector and AV control unit connector.
3. Check continuity between display unit harness connector and AV control unit harness connector.

Display unit		AV control unit		Continuity
Connector	Terminal	Connector	Terminal	
M71	17	M202	43	Existed

4. Check continuity between display unit harness connector and ground.

Display unit		Ground	Continuity
Connector	Terminal		
M71	17		Not existed

Is inspection result normal?

- YES >> GO TO 2.  
 NO >> Repair harness or connector.

#### 2. CHECK RGB (R: RED) SIGNAL

1. Connect display unit connector and AV control unit connector.
2. Turn ignition switch ON.
3. Check signal between display unit harness connector and ground.

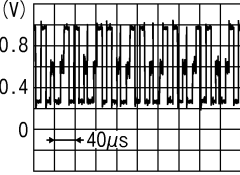
(+)		(-)	Condition	Reference value
Display unit				
Connector	Terminal			
M71	17	Ground	Start confirmation/adjustment mode, and then display color bar by selecting "Color Spectrum Bar" on DISPLAY DIAGNOSIS screen.	 <p style="text-align: right;">JSNIA1029ZZ</p>

Is inspection result normal?

- YES >> Replace display unit. Refer to [AV-252. "Exploded View"](#).  
 NO >> Replace AV control unit. Refer to [AV-250. "Exploded View"](#).



# RGB (G: GREEN) SIGNAL CIRCUIT

< DTC/CIRCUIT DIAGNOSIS >

[BOSE AUDIO WITHOUT NAVIGATION]

## RGB (G: GREEN) SIGNAL CIRCUIT

### Description

INFOID:000000006472577

Transmit the image displayed with AV control unit with RGB signal to the display unit.

### Diagnosis Procedure

INFOID:000000006472578

#### 1. CHECK CONTINUITY RGB (G: GREEN) SIGNAL CIRCUIT

1. Turn ignition switch OFF.
2. Disconnect display unit connector and AV control unit connector.
3. Check continuity between display unit harness connector and AV control unit harness connector.

Display unit		AV control unit		Continuity
Connector	Terminal	Connector	Terminal	
M71	6	M202	44	Existed

4. Check continuity between display unit harness connector and ground.

Display unit		Ground	Continuity
Connector	Terminal		
M71	6		Not existed

Is inspection result normal?

- YES >> GO TO 2.  
NO >> Repair harness or connector.

#### 2. CHECK RGB (G: GREEN) SIGNAL

1. Connect display unit connector and AV control unit connector.
2. Turn ignition switch ON.
3. Check signal between display unit harness connector and ground.

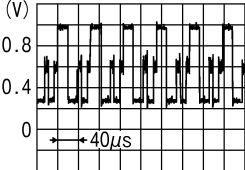
(+) Display unit		(-)	Condition	Reference value
Connector	Terminal			
M71	6	Ground	Start confirmation/adjustment mode, and then display color bar by selecting "Color Spectrum Bar" on DISPLAY DIAGNOSIS screen.	 <p>(V)</p> <p>0.8</p> <p>0.4</p> <p>0</p> <p>40µs</p> <p>JSNIA1030ZZ</p>

Is inspection result normal?

- YES >> Replace display unit. Refer to [AV-252, "Exploded View"](#).  
NO >> Replace AV control unit. Refer to [AV-250, "Exploded View"](#).

A  
B  
C  
D  
E  
F  
G  
H  
I  
J  
K  
L  
M  
AV  
O  
P

# RGB (B: BLUE) SIGNAL CIRCUIT

< DTC/CIRCUIT DIAGNOSIS >

[BOSE AUDIO WITHOUT NAVIGATION]

## RGB (B: BLUE) SIGNAL CIRCUIT

### Description

INFOID:000000006472579

Transmit the image displayed with AV control unit with RGB signal to the display unit.

### Diagnosis Procedure

INFOID:000000006472580

#### 1. CHECK CONTINUITY RGB (B: BLUE) SIGNAL CIRCUIT

1. Turn ignition switch OFF.
2. Disconnect display unit connector and AV control unit connector.
3. Check continuity between display unit harness connector and AV control unit harness connector.

Display unit		AV control unit		Continuity
Connector	Terminal	Connector	Terminal	
M71	18	M202	45	Existed

4. Check continuity between display unit harness connector and ground.

Display unit		Ground	Continuity
Connector	Terminal		
M71	18		Not existed

Is inspection result normal?

- YES >> GO TO 2.  
 NO >> Repair harness or connector.

#### 2. CHECK RGB (B: BLUE) SIGNAL

1. Connect display unit connector and AV control unit connector.
2. Turn ignition switch ON.
3. Check signal between display unit harness connector and ground.

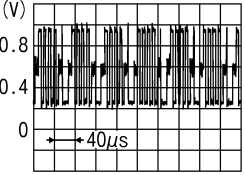
(+)		(-)	Condition	Reference value
Display unit				
Connector	Terminal			
M71	18	Ground	Start confirmation/adjustment mode, and then display color bar by selecting "Color Spectrum Bar" on DISPLAY DIAGNOSIS screen.	 <p style="text-align: right;">JSNIA1031ZZ</p>

Is inspection result normal?

- YES >> Replace display unit. Refer to [AV-252. "Exploded View"](#).  
 NO >> Replace AV control unit. Refer to [AV-250. "Exploded View"](#).

# RGB SYNCHRONIZING SIGNAL CIRCUIT

< DTC/CIRCUIT DIAGNOSIS >

[BOSE AUDIO WITHOUT NAVIGATION]

## RGB SYNCHRONIZING SIGNAL CIRCUIT

### Description

INFOID:000000006472581

Transmit the RGB synchronizing signal to the display unit so as to synchronize the RGB image displayed with AV control unit.

### Diagnosis Procedure

INFOID:000000006472582

#### 1. CHECK CONTINUITY RGB SYNCHRONIZING SIGNAL CIRCUIT

1. Turn ignition switch OFF.
2. Disconnect display unit connector and AV control unit connector.
3. Check continuity between display unit harness connector and AV control unit harness connector.

Display unit		AV control unit		Continuity
Connector	Terminal	Connector	Terminal	
M71	19	M202	42	Existed

4. Check continuity between display unit harness connector and ground.

Display unit		Ground	Continuity
Connector	Terminal		
M71	19		Not existed

Is the inspection result normal?

YES >> GO TO 2.

NO >> Repair harness or connector.

#### 2. CHECK RGB SYNCHRONIZING SIGNAL

1. Connect display unit connector and AV control unit connector.
2. Turn ignition switch ON.
3. Check signal between display unit harness connector and ground.

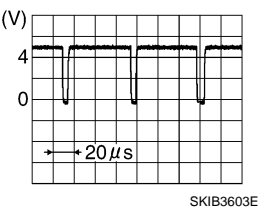
(+)		(-)	Reference value
Display unit			
Connector	Terminal		
M71	19	Ground	

Is the inspection result normal?

YES >> Replace display unit. Refer to [AV-252, "Exploded View"](#).

NO >> Replace AV control unit. Refer to [AV-250, "Exploded View"](#).

# RGB AREA (YS) SIGNAL CIRCUIT

< DTC/CIRCUIT DIAGNOSIS >

[BOSE AUDIO WITHOUT NAVIGATION]

## RGB AREA (YS) SIGNAL CIRCUIT

### Description

INFOID:000000006472583

Transmits the display area of RGB image displayed by AV control unit with RGB area (YS) signal to display unit.

### Diagnosis Procedure

INFOID:000000006472584

#### 1. CHECK CONTINUITY RGB AREA (YS) SIGNAL CIRCUIT

1. Turn ignition switch OFF.
2. Disconnect display unit connector and AV control unit connector.
3. Check continuity between display unit harness connector and AV control unit harness connector.

Display unit		AV control unit		Continuity
Connector	Terminal	Connector	Terminal	
M71	9	M202	40	Existed

4. Check continuity between display unit harness connector and ground.

Display unit		Ground	Continuity
Connector	Terminal		
M71	9		Not existed

Is the inspection result normal?

- YES >> GO TO 2.  
 NO >> Repair harness or connector.

#### 2. CHECK RGB AREA (YS) SIGNAL

1. Connect display unit connector and AV control unit connector.
2. Turn ignition switch ON.
3. Check signal between display unit harness connector and ground.

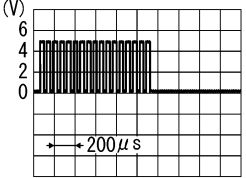
(+)		(-)	Condition	Reference value (Approx.)
Connector	Terminal			
M71	9	Ground	At RGB image is displayed.	5.0 V
			At camera image is displayed.	

Is the inspection result normal?

- YES >> Replace display unit. Refer to [AV-252, "Exploded View"](#).  
 NO >> Replace AV control unit. Refer to [AV-250, "Exploded View"](#).

# CAMERA IMAGE SIGNAL CIRCUIT

< DTC/CIRCUIT DIAGNOSIS >

[BOSE AUDIO WITHOUT NAVIGATION]

## CAMERA IMAGE SIGNAL CIRCUIT

### Description

INFOID:000000006472585

- AV control unit outputs camera power supply to rear view camera and inputs rear view camera image signal from rear view camera when the reverse signal is input.
- The AV control unit that inputs the camera image signal transmits the camera image signal to the display unit.

### Diagnosis Procedure

INFOID:000000006472586

#### 1. CHECK CONTINUITY CAMERA POWER SUPPLY CIRCUIT

1. Turn ignition switch OFF.
2. Disconnect AV control unit connector and rear view camera connector.
3. Check continuity between AV control unit harness connector and rear view camera harness connector.

AV control unit		Rear view camera		Continuity
Connector	Terminal	Connector	Terminal	
M203	73	B311	1	Existed

4. Check continuity between AV control unit harness connector and ground.

AV control unit		Ground	Continuity
Connector	Terminal		
M203	73		Not existed

Is inspection result normal?

- YES >> GO TO 2.  
NO >> Repair harness or connector.

#### 2. CHECK VOLTAGE CAMERA POWER SUPPLY

1. Connect AV control unit connector and rear view camera connector.
2. Turn ignition switch ON.
3. Shift the selector lever to "R".
4. Check voltage between AV control unit harness connector and ground.

(+)		(-)	Condition	Voltage (Approx.)
Connector	Terminal			
M203	73	Ground	Shift position is "R".	6.0 V

Is inspection result normal?

- YES >> GO TO 3.  
NO >> Replace AV control unit. Refer to [AV-250. "Exploded View"](#).

#### 3. CHECK CONTINUITY CAMERA IMAGE SIGNAL CIRCUIT

1. Turn ignition switch OFF.
2. Disconnect AV control unit connector and rear view camera connector.
3. Check continuity between AV control unit harness connector and rear view camera harness connector.

AV control unit		Rear view camera		Continuity
Connector	Terminal	Connector	Terminal	
M203	62	B311	3	Existed

4. Check continuity between AV control unit harness connector and ground.

A  
B  
C  
D  
E  
F  
G  
H  
I  
J  
K  
L  
M  
O  
P

AV

# CAMERA IMAGE SIGNAL CIRCUIT

< DTC/CIRCUIT DIAGNOSIS >

[BOSE AUDIO WITHOUT NAVIGATION]

AV control unit		Ground	Continuity
Connector	Terminal		
M203	62		Not existed

Is inspection result normal?

YES >> GO TO 4.

NO >> Repair harness or connector.

## 4. CHECK CAMERA IMAGE SIGNAL

1. Connect AV control unit connector and rear view camera connector.
2. Turn ignition switch ON.
3. Shift the selector lever to "R".
4. Check signal between AV control unit harness connector and ground.

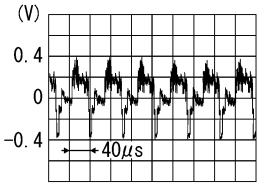
(+)		(-)	Condition	Reference value
AV control unit				
Connector	Terminal			
M203	62	Ground	At rear view camera image is displayed.	 <p style="text-align: right; font-size: small;">SKIB2251J</p>

Is inspection result normal?

YES >> Replace AV control unit. Refer to [AV-250, "Exploded View"](#).

NO >> Replace rear view camera. Refer to [AV-268, "Exploded View"](#).

# COMPOSITE IMAGE SIGNAL CIRCUIT

< DTC/CIRCUIT DIAGNOSIS >

[BOSE AUDIO WITHOUT NAVIGATION]

## COMPOSITE IMAGE SIGNAL CIRCUIT

### Description

INFOID:000000006472587

AV control unit that inputs the camera image signal transmits the composite image signal to the display unit.

### Diagnosis Procedure

INFOID:000000006472588

#### 1. CHECK CONTINUITY COMPOSITE IMAGE SIGNAL CIRCUIT

1. Turn ignition switch OFF.
2. Disconnect AV control unit connector and display unit connector.
3. Check continuity between AV control unit harness connector and display unit harness connector.

AV control unit		Display unit		Continuity
Connector	Terminal	Connector	Terminal	
M202	47	M71	15	Existed

4. Check continuity between AV control unit harness connector and ground.

AV control unit		Ground	Continuity
Connector	Terminal		
M202	47		Not existed

Is the inspection result normal?

- YES >> GO TO 2.  
 NO >> Repair harness or connector.

#### 2. CHECK COMPOSITE IMAGE SIGNAL

1. Connect AV control unit connector and display unit connector.
2. Turn ignition switch ON.
3. Check signal between AV control unit harness connector and ground.

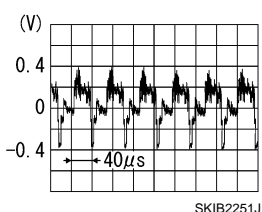
(+)		(-)	Condition	Reference value
AV control unit				
Connector	Terminal			
M202	47	Ground	At camera image is displayed.	

Is the inspection result normal?

- YES >> Replace display unit. Refer to [AV-252, "Exploded View"](#).  
 NO >> Replace AV control unit. Refer to [AV-250, "Exploded View"](#).

A  
B  
C  
D  
E  
F  
G  
H  
I  
J  
K  
L  
M  
O  
P

AV

# HORIZONTAL SYNCHRONIZING (HP) SIGNAL CIRCUIT

< DTC/CIRCUIT DIAGNOSIS >

[BOSE AUDIO WITHOUT NAVIGATION]

## HORIZONTAL SYNCHRONIZING (HP) SIGNAL CIRCUIT

### Description

INFOID:000000006472589

In composite image (camera image), transmit the vertical synchronizing (VP) signal and horizontal synchronizing (HP) signal from display unit to AV control unit so as to synchronize the RGB images displayed with AV control unit such as the image quality adjusting menu, etc.

### Diagnosis Procedure

INFOID:000000006472590

#### 1. CHECK CONTINUITY HORIZONTAL SYNCHRONIZING (HP) SIGNAL CIRCUIT

1. Turn ignition switch OFF.
2. Disconnect display unit connector and AV control unit connector.
3. Check continuity between display unit harness connector and AV control unit harness connector.

Display unit		AV control unit		Continuity
Connector	Terminal	Connector	Terminal	
M71	8	M202	38	Existed

4. Check continuity between display unit harness connector and ground.

Display unit		Ground	Continuity
Connector	Terminal		
M71	8		Not existed

Is the inspection result normal?

YES >> GO TO 2.

NO >> Repair harness or connector.

#### 2. CHECK HORIZONTAL SYNCHRONIZING (HP) SIGNAL

1. Connect display unit connector and AV control unit connector.
2. Turn ignition switch ON.
3. Check signal between display unit harness connector and ground.

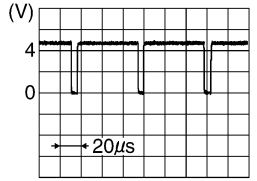
(+)		(-)	Reference value
Display unit			
Connector	Terminal		
M71	8	Ground	

Is the inspection result normal?

YES >> Replace AV control unit. Refer to [AV-250, "Exploded View"](#).

NO >> Replace display unit. Refer to [AV-252, "Exploded View"](#).



# VERTICAL SYNCHRONIZING (VP) SIGNAL CIRCUIT

< DTC/CIRCUIT DIAGNOSIS >

[BOSE AUDIO WITHOUT NAVIGATION]

## VERTICAL SYNCHRONIZING (VP) SIGNAL CIRCUIT

### Description

INFOID:000000006472591

In composite image (camera image), transmit the vertical synchronizing (VP) signal and horizontal synchronizing (HP) signal from display unit to AV control unit so as to synchronize the RGB images displayed with AV control unit such as the image quality adjusting menu, etc.

### Diagnosis Procedure

INFOID:000000006472592

#### 1. CHECK CONTINUITY VERTICAL SYNCHRONIZING (VP) SIGNAL CIRCUIT

1. Turn ignition switch OFF.
2. Disconnect display unit connector and AV control unit connector.
3. Check continuity between display unit harness connector and AV control unit harness connector.

Display unit		AV control unit		Continuity
Connector	Terminal	Connector	Terminal	
M71	20	M202	50	Existed

4. Check continuity between display unit harness connector and ground.

Display unit		Ground	Continuity
Connector	Terminal		
M71	20		Not existed

Is the inspection result normal?

YES >> GO TO 2.

NO >> Repair harness or connector.

#### 2. CHECK VERTICAL SYNCHRONIZING (VP) SIGNAL

1. Connect display unit connector and AV control unit connector.
2. Turn ignition switch ON.
3. Check signal between display unit harness connector and ground.

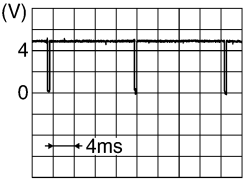
(+) Display unit		(-)	Reference value
Connector	Terminal		
M71	20	Ground	 <p>SKIB3598E</p>

Is the inspection result normal?

YES >> Replace AV control unit. Refer to [AV-250, "Exploded View"](#).

NO >> Replace display unit. Refer to [AV-252, "Exploded View"](#).

A  
B  
C  
D  
E  
F  
G  
H  
I  
J  
K  
L  
M  
O  
P

AV

# DISK EJECT SIGNAL CIRCUIT

< DTC/CIRCUIT DIAGNOSIS >

[BOSE AUDIO WITHOUT NAVIGATION]

## DISK EJECT SIGNAL CIRCUIT

### Description

INFOID:000000006472593

The eject signal is output to AV control unit when the eject switch of multifunction switch is pressed.

### Diagnosis Procedure

INFOID:000000006472594

#### 1. CHECK CONTINUITY DISK EJECT SIGNAL CIRCUIT

1. Turn ignition switch OFF.
2. Disconnect multifunction switch connector and AV control unit connector.
3. Check continuity between multifunction switch harness connector and AV control unit harness connector.

Multifunction switch		AV control unit		Continuity
Connector	Terminal	Connector	Terminal	
M72	14	M204	96	Existed

4. Check continuity between multifunction switch harness connector and ground.

Multifunction switch		Ground	Continuity
Connector	Terminal		
M72	14		Not existed

Is the inspection result normal?

- YES >> GO TO 2.  
NO >> Repair harness or connector.

#### 2. CHECK AV CONTROL UNIT VOLTAGE

1. Connect multifunction switch connector and AV control unit connector.
2. Turn ignition switch ON.
3. Check voltage between AV control unit harness connector and ground.

(+)		(-)	Condition	Voltage (Approx.)
AV control unit				
Connector	Terminal			
M204	96	Ground	Pressing the eject switch	0 V
			Except for above	3.3 V

Is the inspection result normal?

- YES >> Replace preset switch. Refer to [AV-264, "Exploded View"](#).  
NO >> Replace AV control unit. Refer to [AV-250, "Exploded View"](#).

# MICROPHONE SIGNAL CIRCUIT

< DTC/CIRCUIT DIAGNOSIS >

[BOSE AUDIO WITHOUT NAVIGATION]

## MICROPHONE SIGNAL CIRCUIT

### Description

INFOID:000000006472595

Supply power from TEL adapter unit to microphone. The microphone transmits the sound/voice to the microphone.

### Diagnosis Procedure

INFOID:000000006472596

#### 1.CHECK CONTINUITY BETWEEN TEL ADAPTER UNIT AND MICROPHONE CIRCUIT

1. Turn ignition switch OFF.
2. Disconnect TEL adapter unit connector and microphone connector.
3. Check continuity between TEL adapter unit harness connector and microphone harness connector.

TEL adapter unit		Microphone		Continuity
Connector	Terminals	Connector	Terminals	
B237	7	R7	1	Existed
	8		2	
	29		4	

4. Check continuity between TEL adapter unit harness connector and ground.

TEL adapter unit		Ground	Continuity
Connector	Terminals		
M237	7		Not existed
	29		

Is the inspection result normal?

YES >> GO TO 2.

NO >> Repair harness or connector.

#### 2.CHECK VOLTAGE MICROPHONE VCC

1. Connect TEL adapter unit connector.
2. Turn ignition switch ON.
3. Check voltage between TEL adapter unit harness connector.

(+)		(-)		Voltage (Approx.)
TEL adapter unit		TEL adapter unit		
Connector	Terminal	Connector	Terminal	
B237	29	B237	8	5.0 V

Is the inspection result normal?

YES >> GO TO 3.

NO >> Replace TEL adapter unit. Refer to [AV-271, "Exploded View"](#).

#### 3.CHECK MICROPHONE SIGNAL

1. Connect microphone connector.
2. Check signal between TEL adapter unit harness connector.

A  
B  
C  
D  
E  
F  
G  
H  
I  
J  
K  
L  
M  
AV  
O  
P

# MICROPHONE SIGNAL CIRCUIT

< DTC/CIRCUIT DIAGNOSIS >

[BOSE AUDIO WITHOUT NAVIGATION]

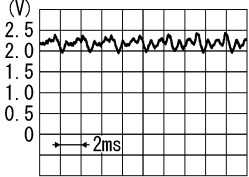
(+)		(-)		Condition	Reference value
TEL adapter unit		TEL adapter unit			
Connector	Terminal	Connector	Terminal		
B237	7	B237	8	give a voice.	 <p style="text-align: right;">PKIB5037J</p>

Is the inspection result normal?

- YES >> Replace TEL adapter unit. Refer to [AV-271, "Exploded View"](#).
- NO >> Replace microphone. Refer to [AV-267, "Exploded View"](#).

# CONTROL SIGNAL CIRCUIT

< DTC/CIRCUIT DIAGNOSIS >

[BOSE AUDIO WITHOUT NAVIGATION]

## CONTROL SIGNAL CIRCUIT

### Description

INFOID:000000006472597

TEL adapter unit identifies the vehicle model according to the control signal and performs the control.

### Diagnosis Procedure

INFOID:000000006472598

#### 1. CHECK CONTINUITY CONTROL SIGNAL CIRCUIT

1. Turn ignition switch OFF.
2. Disconnect TEL adapter unit connector.
3. Check continuity between TEL adapter unit harness connector and ground.

TEL adapter unit		Ground	Continuity
Connector	Terminals		
B237	21	Ground	Existed
	23		
	27		

#### Is the inspection result normal?

- YES >> Replace TEL adapter unit. Refer to [AV-271, "Exploded View"](#).
- NO >> Repair harness or connector.

A  
B  
C  
D  
E  
F  
G  
H  
I  
J  
K  
L  
M

AV

O  
P

# STEERING SWITCH SIGNAL A CIRCUIT

< DTC/CIRCUIT DIAGNOSIS >

[BOSE AUDIO WITHOUT NAVIGATION]

## STEERING SWITCH SIGNAL A CIRCUIT

### Description

INFOID:000000006472599

Transmits the steering switch signal to AV control unit.

### Diagnosis Procedure

INFOID:000000006472600

#### 1. CHECK STEERING SWITCH SIGNAL A CIRCUIT

1. Disconnect AV control unit connector and spiral cable connector.
2. Check continuity between AV control unit harness connector and spiral cable harness connector.

AV control unit		Spiral cable		Continuity
Connector	Terminal	Connector	Terminal	
M201	6	M36	24	Existed

3. Check continuity between AV control unit harness connector and ground.

AV control unit		Ground	Continuity
Connector	Terminal		
M201	6		Not existed

Is the inspection result normal?

- YES >> GO TO 2.  
NO >> Repair harness or connector.

#### 2. CHECK SPIRAL CABLE

Check spiral cable.

Is the inspection result normal?

- YES >> GO TO 3.  
NO >> Replace spiral cable.

#### 3. CHECK AV CONTROL UNIT VOLTAGE

1. Connect AV control unit connector and spiral cable connector.
2. Turn ignition switch ON.
3. Check voltage between AV control unit harness connector.

(+)		(-)		Voltage (Approx.)
AV control unit		AV control unit		
Connector	Terminal	Connector	Terminal	
M201	6	M201	15	3.3 V

Is the inspection result normal?

- YES >> GO TO 4.  
NO >> Replace AV control unit. Refer to [AV-250, "Exploded View"](#).

#### 4. CHECK STEERING SWITCH

1. Turn ignition switch OFF.
2. Check steering switch. Refer to [AV-238, "Component Inspection"](#).

Is the inspection result normal?

- YES >> INSPECTION END  
NO >> Replace steering switch. Refer to [ST-14, "Exploded View"](#).

### Component Inspection

INFOID:000000006472601

Measure the resistance between the steering switch connector terminals 14 to 17 and 15 to 17.

# STEERING SWITCH SIGNAL A CIRCUIT

[BOSE AUDIO WITHOUT NAVIGATION]

< DTC/CIRCUIT DIAGNOSIS >

Standard

Between terminals 14 and 17

-  switch ON : 716 – 730 Ω
- MENU DOWN switch ON : 318 – 324 Ω
- MENU UP switch ON : 120 – 122 Ω
- SOURCE switch ON : 0 Ω

Between terminals 15 and 17

-  switch ON : 318 – 324 Ω
- VOL UP switch ON : 120 – 122 Ω
- VOL DOWN switch ON : 0 Ω

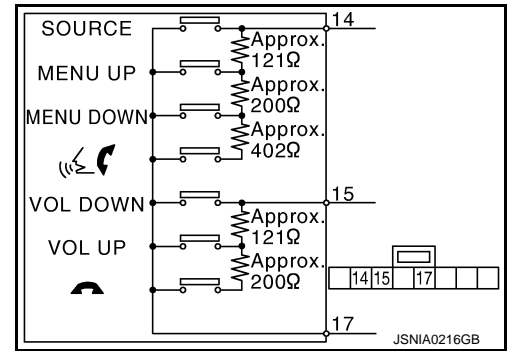

A  
B  
C  
D  
E  
F  
G  
H  
I  
J  
K  
L  
M

AV

O  
P

# STEERING SWITCH SIGNAL B CIRCUIT

< DTC/CIRCUIT DIAGNOSIS >

[BOSE AUDIO WITHOUT NAVIGATION]

## STEERING SWITCH SIGNAL B CIRCUIT

### Description

INFOID:000000006472602

Transmits the steering switch signal to AV control unit.

### Diagnosis Procedure

INFOID:000000006472603

#### 1.CHECK STEERING SWITCH SIGNAL B CIRCUIT

1. Disconnect AV control unit connector and spiral cable connector.
2. Check continuity between AV control unit harness connector and spiral cable harness connector.

AV control unit		Spiral cable		Continuity
Connector	Terminal	Connector	Terminal	
M201	16	M36	31	Existed

3. Check continuity between AV control unit harness connector and ground.

AV control unit		Ground	Continuity
Connector	Terminal		
M201	16		Not existed

Is the inspection result normal?

- YES >> GO TO 2.  
NO >> Repair harness or connector.

#### 2.CHECK SPIRAL CABLE

Check spiral cable.

Is the inspection result normal?

- YES >> GO TO 3.  
NO >> Replace spiral cable.

#### 3.CHECK AV CONTROL UNIT VOLTAGE

1. Connect AV control unit connector and spiral cable connector.
2. Turn ignition switch ON.
3. Check voltage between AV control unit harness connector.

(+)		(-)		Voltage (Approx.)
AV control unit		AV control unit		
Connector	Terminal	Connector	Terminal	
M201	16	M201	15	3.3 V

Is the inspection result normal?

- YES >> GO TO 4.  
NO >> Replace AV control unit. Refer to [AV-250, "Exploded View"](#).

#### 4.CHECK STEERING SWITCH

1. Turn ignition switch OFF.
2. Check steering switch. Refer to [AV-240, "Component Inspection"](#).

Is the inspection result normal?

- YES >> INSPECTION END  
NO >> Replace steering switch. Refer to [ST-14, "Exploded View"](#).

### Component Inspection

INFOID:000000006472604

Measure the resistance between the steering switch connector terminals 14 to 17 and 15 to 17.



# STEERING SWITCH SIGNAL B CIRCUIT

[BOSE AUDIO WITHOUT NAVIGATION]

## < DTC/CIRCUIT DIAGNOSIS >

### Standard

Between terminals 14 and 17

 switch ON	: 716 – 730 Ω
MENU DOWN switch ON	: 318 – 324 Ω
MENU UP switch ON	: 120 – 122 Ω
SOURCE switch ON	: 0 Ω

Between terminals 15 and 17

 switch ON	: 318 – 324 Ω
VOL UP switch ON	: 120 – 122 Ω
VOL DOWN switch ON	: 0 Ω

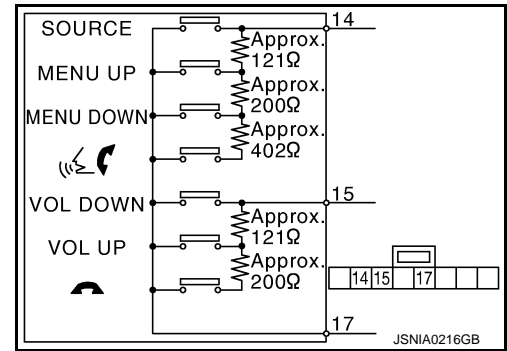

A  
B  
C  
D  
E  
F  
G  
H  
I  
J  
K  
L  
M

AV

O  
P

# STEERING SWITCH GROUND CIRCUIT

< DTC/CIRCUIT DIAGNOSIS >

[BOSE AUDIO WITHOUT NAVIGATION]

## STEERING SWITCH GROUND CIRCUIT

### Description

INFOID:000000006472605

Transmits the steering switch signal to AV control unit.

### Diagnosis Procedure

INFOID:000000006472606

#### 1. CHECK STEERING SWITCH SIGNAL GND CIRCUIT

1. Disconnect AV control unit connector and spiral cable connector.
2. Check continuity between AV control unit harness connector and spiral cable harness connector.

AV control unit		Spiral cable		Continuity
Connector	Terminal	Connector	Terminal	
M201	15	M36	33	Existed

Is the inspection result normal?

- YES >> GO TO 2.  
NO >> Repair harness or connector.

#### 2. CHECK SPIRAL CABLE

Check spiral cable.

Is the inspection result normal?

- YES >> GO TO 3.  
NO >> Replace spiral cable.

#### 3. CHECK GROUND CIRCUIT

1. Connect AV control unit connector.
2. Check continuity between AV control unit harness connector and ground.

AV control unit		Ground	Continuity
Connector	Terminal		
M201	15		Existed

Is the inspection result normal?

- YES >> GO TO 4.  
NO >> Replace AV control unit. Refer to [AV-250, "Exploded View"](#).

#### 4. CHECK STEERING SWITCH

1. Turn ignition switch OFF.
2. Check steering switch. Refer to [AV-242, "Component Inspection"](#).

Is the inspection result normal?

- YES >> INSPECTION END  
NO >> Replace steering switch. Refer to [ST-14, "Exploded View"](#).

### Component Inspection

INFOID:000000006472607

Measure the resistance between the steering switch connector terminals 14 to 17 and 15 to 17.

# STEERING SWITCH GROUND CIRCUIT

[BOSE AUDIO WITHOUT NAVIGATION]

< DTC/CIRCUIT DIAGNOSIS >

Standard

Between terminals 14 and 17

-  switch ON : 716 – 730 Ω
- MENU DOWN switch ON : 318 – 324 Ω
- MENU UP switch ON : 120 – 122 Ω
- SOURCE switch ON : 0 Ω

Between terminals 15 and 17

-  switch ON : 318 – 324 Ω
- VOL UP switch ON : 120 – 122 Ω
- VOL DOWN switch ON : 0 Ω

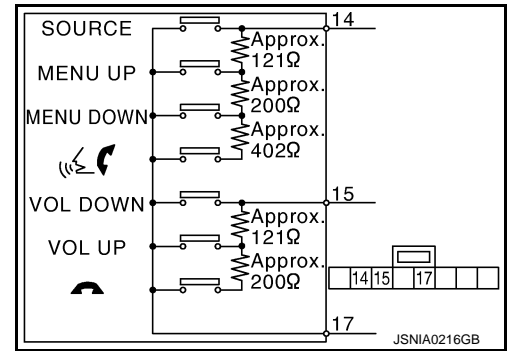

A  
B  
C  
D  
E  
F  
G  
H  
I  
J  
K  
L  
M

AV

O  
P

# MULTI AV SYSTEM SYMPTOMS

[BOSE AUDIO WITHOUT NAVIGATION]

< SYMPTOM DIAGNOSIS >

## SYMPTOM DIAGNOSIS

### MULTI AV SYSTEM SYMPTOMS

#### Symptom Table

INFOID:000000006472608

#### OPERATION

Symptoms	Check items	Possible malfunction location / Action to take
Multifunction switch and preset switch operation does not work.	<ul style="list-style-type: none"> <li>All switches cannot be operated.</li> <li>"MULTI AV" is displayed on system selection screen when the CONSULT-III is started.</li> </ul>	<ul style="list-style-type: none"> <li>Multifunction switch power supply and ground circuit.</li> <li>AV communication circuit between AV control unit and multifunction switch.</li> </ul> Perform "Self diagnosis Result" of "MULTI AV" with CONSULT-III. Refer to <a href="#">AV-148, "CONSULT - III Function"</a> .
	<ul style="list-style-type: none"> <li>All switches cannot be operated.</li> <li>"MULTI AV" is not displayed on system selection screen when the CONSULT-III is initialized.</li> </ul>	AV control unit power supply and ground circuit malfunction. Refer to <a href="#">AV-220, "AV CONTROL UNIT : Diagnosis Procedure"</a> .
	Only specified switch cannot be operated.	Multifunction switch or preset switch malfunction. Perform multifunction switch and preset switch self-diagnosis function. Refer to <a href="#">AV-138, "On Board Diagnosis Function"</a> .
Fuel economy display, vehicle setting operation is abnormal.	There is malfunction in the CONSULT-III self-diagnosis result. Refer to <a href="#">AV-148, "CONSULT - III Function"</a> .	Perform detected DTC diagnosis. Refer to <a href="#">AV-161, "DTC Index"</a> .
	There is no malfunction in the self-diagnosis results. Refer to <a href="#">AV-148, "CONSULT - III Function"</a> .	Ignition signal circuit malfunction. (AV control unit)

#### RELATED TO HANDS-FREE PHONE

##### Simple Check for Bluetooth™ Communication

If cellular phone and AV control unit cannot be connected with Bluetooth™ communication, following procedure allows the technician to judge which device has malfunction.

- Turn on a cellular phone, not connecting Bluetooth™ communication.
- Start CONSULT-III, then start Windows®.
- Set CONSULT-III near a cellular phone.
- When operated Bluetooth™ registration by cellular phone, check if CONSULT-III\* would be displayed on the device name. (If other Bluetooth™ device is located near cellular phone, a name of the device would be displayed also.)

**NOTE:**

\*:Displayed device name is "NISSAN-\*\*\*\*\*".

- If no device name is displayed, cellular phone is malfunctioning. Repair the cellular phone first, then perform diagnosis.
- If CONSULT-III is displayed on device name, cellular phone is normal. Perform diagnosis as per the following table.

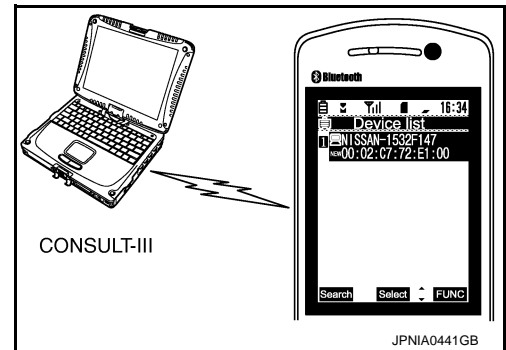

#### Trouble Diagnosis Chart by Symptom

# MULTI AV SYSTEM SYMPTOMS

[BOSE AUDIO WITHOUT NAVIGATION]

< SYMPTOM DIAGNOSIS >

Symptoms	Check items	Probable malfunction location
Does not recognize cellular phone connection. (No connection is displayed on the display at the guide.)	Repeat the registration of cellular phone.	TEL adapter unit malfunction. Refer to <a href="#">AV-271, "Exploded View"</a> .
Hands-free phone cannot be established.	Both the reception and the speech cannot be performed	<ul style="list-style-type: none"> <li>Perform "Self diagnosis Result" of "MULTI AV" with CONSULT-III. Refer to <a href="#">AV-148, "CONSULT - III Function"</a>.</li> <li>No malfunction. TEL adapter unit malfunction. Refer to <a href="#">AV-271, "Exploded View"</a>.</li> <li>Malfunction is detected. Perform detected DTC diagnosis. Refer to <a href="#">AV-161, "DTC Index"</a>.</li> </ul>
The other party's voice cannot be heard by hands-free phone.	The operation of the "☞" switch can be performed.	TEL voice signal circuit malfunction between TEL adapter unit and AV control unit.
	The operation of the "☞" switch cannot be performed.	Control signal circuit. Refer to <a href="#">AV-237, "Diagnosis Procedure"</a> .
Originating sound is not heard by the other party with hands-free phone communication.	Sound operation function is normal.	TEL adapter unit malfunction. Refer to <a href="#">AV-271, "Exploded View"</a> .
	Sound operation function does not work.	Microphone signal circuit malfunction. Refer to <a href="#">AV-235, "Diagnosis Procedure"</a> .
The system cannot be operated.	<ul style="list-style-type: none"> <li>The retractable hard top is fully closed.</li> <li>"SOURCE", "MENU UP", and "MENU DOWN", but "☞" switches are not operated.</li> </ul>	<ul style="list-style-type: none"> <li>Check steering switch. Refer to <a href="#">AV-238, "Component Inspection"</a>.</li> <li>No malfunction. Roof status signal circuit malfunction.</li> <li>Malfunction is detected. Replace steering switch. Refer to <a href="#">ST-14, "Exploded View"</a>.</li> </ul>
	<ul style="list-style-type: none"> <li>The retractable hard top is fully closed.</li> <li>"SOURCE", "MENU UP", "MENU DOWN" and "☞" switches of steering switch are not operated.</li> </ul>	Steering switch signal A circuit malfunction. Refer to <a href="#">AV-238, "Diagnosis Procedure"</a>
	All steering switches do not work.	Steering switch ground circuit malfunction. Refer to <a href="#">AV-242, "Diagnosis Procedure"</a> .

## RELATED TO RGB IMAGE

Symptoms	Check items	Possible malfunction location / Action to take
RGB image is not shown.	There is malfunction in the CONSULT-III self-diagnosis result. Refer to <a href="#">AV-148, "CONSULT - III Function"</a> .	Perform detected DTC diagnosis. Refer to <a href="#">AV-161, "DTC Index"</a> .
	There is no malfunction in CONSULT-III self-diagnosis results. Refer to <a href="#">AV-148, "CONSULT - III Function"</a> .	Vertical synchronizing (VP) signal circuit. Refer to <a href="#">AV-233, "Diagnosis Procedure"</a> .
Color of RGB image is not proper.	Light blue (Cyan) tint.	RGB signal (R: red) circuit. Refer to <a href="#">AV-224, "Diagnosis Procedure"</a> .
	Purple (Magenta) tint.	RGB signal (G: green) circuit. Refer to <a href="#">AV-225, "Diagnosis Procedure"</a> .
	Screen looks yellowish.	RGB signal (B: blue) circuit. Refer to <a href="#">AV-226, "Diagnosis Procedure"</a> .
RGB screen is rolling.	—	RGB synchronizing signal circuit. Refer to <a href="#">AV-227, "Diagnosis Procedure"</a> .

## RELATED TO AUDIO

## MULTI AV SYSTEM SYMPTOMS

< SYMPTOM DIAGNOSIS >

[BOSE AUDIO WITHOUT NAVIGATION]

Symptoms	Check items	Possible malfunction location / Action to take
The disk cannot be removed.	—	Disk eject signal circuit. Refer to <a href="#">AV-234, "Diagnosis Procedure"</a> .
Audio sound is not heard.	No sound from all speakers.	Perform CONSULT-III self-diagnosis. Refer to <a href="#">AV-148, "CONSULT - III Function"</a> .
	Sound is heard only from specific places.	Perform CONSULT-III self-diagnosis. Refer to <a href="#">AV-148, "CONSULT - III Function"</a> .
Satellite radio is not received.	There is no malfunction in CONSULT-III self-diagnosis results. Refer to <a href="#">AV-148, "CONSULT - III Function"</a> .	Perform the following inspection procedure. 1. Check satellite radio antenna (antenna base) mounting nut for looseness. <b>NOTE:</b> Tightening torque: 6.5 N·m (0.66 kg·m, 58 in·lb.) 2. Visually check for satellite radio antenna feeder.
	There is malfunction in the CONSULT-III self-diagnosis result. Refer to <a href="#">AV-148, "CONSULT - III Function"</a> .	Perform detected DTC diagnosis. Refer to <a href="#">AV-161, "DTC Index"</a> .
The sound of satellite radio is not heard.	Other audio sounds are normal.	Satellite radio sound signal circuit between AV control unit and satellite radio tuner.
It does not change to satellite radio mode.	There is malfunction in the CONSULT-III self-diagnosis result. Refer to <a href="#">AV-148, "CONSULT - III Function"</a> .	Perform detected DTC diagnosis. Refer to <a href="#">AV-161, "DTC Index"</a> .
AM/FM radio is not received.	Other audio sounds are normal.	<ul style="list-style-type: none"> <li>• Antenna amp. ON signal circuit.</li> <li>• Antenna base.</li> <li>• Antenna feeder.</li> </ul>

### RELATED TO USB

**NOTE:**

Check that there is no malfunction of USB equipment main body before performing a diagnosis.

Symptoms	Check items	Possible malfunction location / Action to take
iPod® or USB memory can not be recognized.	—	<ul style="list-style-type: none"> <li>• USB harness malfunction.</li> <li>• USB connector malfunction.</li> </ul>

iPod® is a trademark of Apple inc., registered in the U.S. and other countries.

### RELATED TO STEERING SWITCH

Symptoms	Probable malfunction location
None of the steering switch operations work.	Steering switch ground circuit malfunction. Refer to <a href="#">AV-242, "Diagnosis Procedure"</a> .
Only specified switch cannot be operated.	<ul style="list-style-type: none"> <li>• Check steering switch. Refer to <a href="#">AV-238, "Component Inspection"</a>.</li> <li>• Malfunction is detected. Replace steering switch. Refer to <a href="#">ST-14, "Exploded View"</a>.</li> </ul>
"SOURCE", "MENU UP", "MENU DOWN" and "⏪ ⏩" switches are not operated.	Steering switch signal A circuit. Refer to <a href="#">AV-238, "Diagnosis Procedure"</a> .
"VOL UP", "VOL DOWN" and "🔊" switches are not operated.	Steering switch signal B circuit. Refer to <a href="#">AV-240, "Diagnosis Procedure"</a> .

### RELATED TO CAMERA

Trouble Diagnosis Chart by Symptom

# MULTI AV SYSTEM SYMPTOMS

< SYMPTOM DIAGNOSIS >

[BOSE AUDIO WITHOUT NAVIGATION]

Symptoms	Check items	Probable malfunction location	
Camera image is not shown. (Vehicle width and possible route line is displayed.)	—	<ul style="list-style-type: none"> <li>• Camera image signal circuit. Refer to <a href="#">AV-229, "Diagnosis Procedure"</a>.</li> <li>• Composite image signal circuit. Refer to <a href="#">AV-231, "Diagnosis Procedure"</a>.</li> </ul>	A B
Camera image does not switch.	"Reverse" is not turned ON on "Vehicle Signals" screen of "Confirmation/Adjustment".	Reverse signal circuit malfunction.	C
	"Reverse" is turned ON on "Vehicle Signals" screen of "Confirmation/Adjustment".	AV control unit malfunction. Replace AV control unit. Refer to <a href="#">AV-250, "Exploded View"</a> .	D

A  
B  
C  
D  
E  
F  
G  
H  
I  
J  
K  
L  
M  
O  
P

AV

## NORMAL OPERATING CONDITION

< SYMPTOM DIAGNOSIS >

[BOSE AUDIO WITHOUT NAVIGATION]

### NORMAL OPERATING CONDITION

#### Description

INFOID:000000006472609

#### BASIC OPERATIONS

Symptom	Possible cause	Possible solution
No image is displayed.	The brightness is at the lowest setting.	Adjust the brightness of the display.
	The systems in the video mode.	Press "DISC-AUX" to change the mode.
	The display is turned off.	Press "☀/☾ OFF" to turn on the display.
The screen is too dim. The movement is slow.	The temperature in the interior of the vehicle is low.	Wait until the interior of the vehicle has warmed up.
Some pixels in the display are darker or brighter than others.	This condition is an inherent characteristic of liquid crystal displays.	This is not a malfunction.
Some menu items cannot be selected.	Some menu items become unavailable while the vehicle is driven.	Park the vehicle in a safe location, and then operate the multi AV system.

#### RELATED TO VOICE RECOGNITION

##### Related to Telephone

The system should respond correctly to all voice commands without difficulty. If problems are encountered, try the following solutions.

Where the solutions are listed by number, try each solution in turn, starting with number 1, until the problem is resolved.

Symptom	Solution
System fails to interpret the command correctly.	1. Ensure that the command is valid.
	2. Ensure that the command is spoken after the tone.
	3. Speak clearly without pausing between words and at level appropriate to the ambient noise level in the vehicle.
	4. Ensure that the ambient noise level is not excessive (for example, windows open or defroster on). <b>NOTE:</b> If it is too noisy to use the phone, it is likely that the voice commands will not be recognized.
	5. If more than one command was said at a time, try saying the commands separately.
	6. If the system consistently fails to recognize commands, the voice training procedure should be carried out to improve the recognition response for the speaker. See "Speaker adaptation (SA) mode" earlier in this section. Refer to "OWNER'S MANUAL".
The system consistently selects the wrong voicetag	1. Ensure that the phone book entry name requested matches what was originally stored. This can be confirmed by using the "List Names" command.
	2. Replace one of the names being confused with a new name.
The system cannot be operated.	1. Make sure that the retractable hard top is usable. If the top is not working, contact an INFINITI dealer.
	2. Close the retractable hard top.
	3. Open and close the retractable hard top before operating the system.

#### RELATED TO AUDIO

- The majority of the audio malfunctions are the result of outside causes (bad CD, electromagnetic interference, etc.). Check the symptoms below to diagnose the malfunction.
- The vehicle itself can be a source of noise if noise prevention parts or electrical equipment is malfunctioning. Check if noise is caused and/or changed by engine speed, ignition switch turned to each position, and operation of each piece of electrical equipment, and then determine the cause.

##### NOTE:

- CD-R is not guaranteed to play because they can contain compressed audio (MP3, WMA, AAC, M4A) or could be incorrectly mastered by the customer on a computer.



## NORMAL OPERATING CONDITION

### [BOSE AUDIO WITHOUT NAVIGATION]

#### < SYMPTOM DIAGNOSIS >

- Check if the CDs carry the Compact Disc Logo. If not, the disc is not mastered to the “red book” Compact Disc Standard and may not play.

Symptom	Cause and Counter measure
Cannot play	Check if the CD was inserted correctly.
	Check if the CD is scratched or dirty.
	Check if there is condensation inside the player, and if there is, wait until the condensation is gone (about 1 hour) before using the player.
	If there is a temperature increase error, the player will play correctly after it returns to the normal temperature.
	If there is a mixture of music CD files (CD-DA data) and MP3/WMA/AAC/M4A files on a CD, only the music CD files (CD-DA data) will be played.
	Files with extensions other than “.MP3”, “.WMA”, “.AAC”, “.M4A”, “.mp3”, “.wma”, “.aac” or “.m4a” cannot be played. In addition, the character codes and number of characters for folder names and file names should be in compliance with the specifications.
	Check if the disc or the file is generated in an irregular format, This may occur depending on the variation or the setting of MP3/WMA/AAC/M4A writing applications or other text editing applications.
	Check if the finalization process, such as session close and disc close, is done for the disc.
	Check if the CD is protected by copyright.
	Discs recorded in live file system format are not supported. (For Microsoft Windows Vista, check the settings.)
Poor sound quality	Check if the CD is scratched or dirty.
It takes a relatively long time before the music starts playing.	If there are many folder or file levels on the MP3/WMA/AAC/M4A CD, or if it is a multisession disc, some time may be required before the music starts playing.
Music cuts off or skips	The writing software and hardware combination might not match, or the writing speed, writing depth, writing width might not match the specifications. Try using the slowest writing speed.
Skipping with high bit rate files	Skipping may occur with large quantities if data such as for high bit rate data.
Move immediately to the next song when playing	When a non-MP3/WMA/AAC/M4A file has been given an extension of “.MP3”, “.WMA”, “.AAC”, “.M4A”, “.mp3”, “.wma”, “.aac” or “.m4a” or when play is prohibited by copyright protection, the player will skip to the next song.
The songs do not play back in the desired order.	The playback order is the order in which the files were written by the software, so the files might not play in the desired order.

Noise resulting from variations in field strength, such as fading noise and multi-path noise, or external noise from trains and other sources, is not a malfunction.

**NOTE:**

- Fading noise: This noise occurs because of variations in the field strength in a narrow range due to mountains or buildings blocking the signal.
- Multi-path noise: This noise results from a time difference between the broadcast waves directly from the station arriving at the antenna and the waves reflected by mountains or buildings.

A  
B  
C  
D  
E  
F  
G  
H  
I  
J  
K  
L  
M  
O  
P



# AV CONTROL UNIT

< REMOVAL AND INSTALLATION >

[BOSE AUDIO WITHOUT NAVIGATION]

## REMOVAL AND INSTALLATION

### AV CONTROL UNIT

#### Exploded View

INFOID:000000006472610

#### CAUTION:

Before replacing AV control unit, perform "READ CONFIGURATION" to save or print current vehicle specification. For details, refer to [AV-198, "Description"](#).

#### REMOVAL

Refer to [IP-12, "A/T MODELS : Exploded View"](#) (A/T models) or [IP-23, "M/T MODELS : Exploded View"](#) (M/T models).

#### DISASSEMBLY

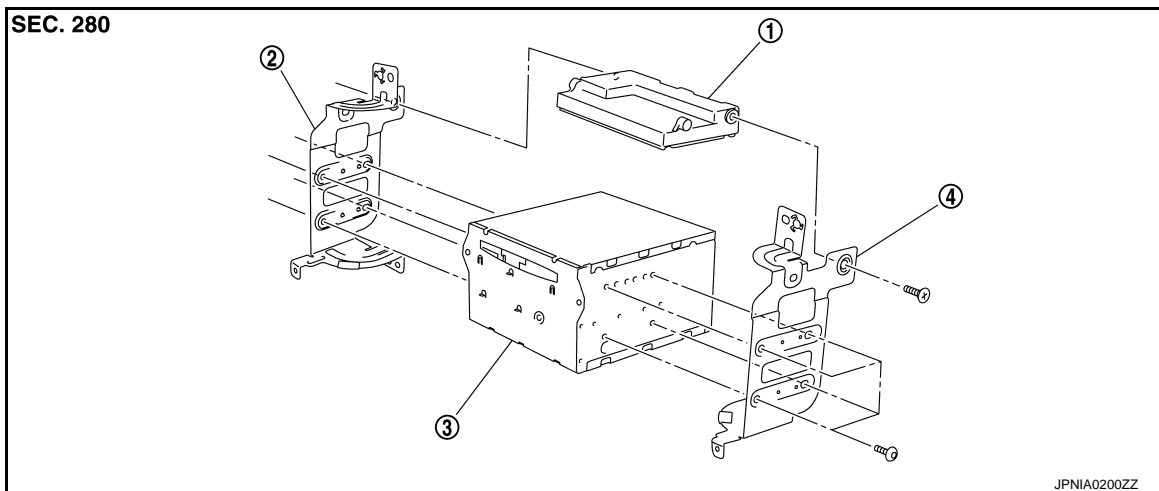

1. Unified meter and A/C amp.
2. Bracket LH
3. AV control unit
4. Bracket RH

### Removal and Installation

INFOID:000000006472611

#### REMOVAL

#### CAUTION:

- Before replacing AV control unit, perform "READ CONFIGURATION" to save or print current vehicle specification. For details, refer to [AV-198, "Description"](#).
- Remove battery terminal and AV control unit after a lapse of 30 seconds or more after turning the ignition switch OFF

#### NOTE:

After the ignition switch is turned OFF, the AV control unit continues operating for approximately 30 seconds. Therefore, data corruption may occur if battery voltage is cut off within 30 seconds.

1. Remove display unit. Refer to [AV-252, "Exploded View"](#).
2. Remove AV control unit with a unified meter and A/C amp. as a single unit from the body.
3. Remove bracket screws, and then remove AV control unit.

#### INSTALLATION

Install in the reverse order of removal.

#### CAUTION:

- Since AV control unit connector and unified meter and A/C amp. connector have the same form, be careful not to insert them wrongly.
- Be sure to perform "WRITE CONFIGURATION" when replacing AV control unit. For details, refer to [AV-199, "Work Procedure"](#).

# AV CONTROL UNIT

< REMOVAL AND INSTALLATION >

[BOSE AUDIO WITHOUT NAVIGATION]

- Install AV control unit between connector (1) and connector (2) with the ferrite core (USB) orientated sideways to the vehicle. Incorrect installation may cause damage to the AV control unit.

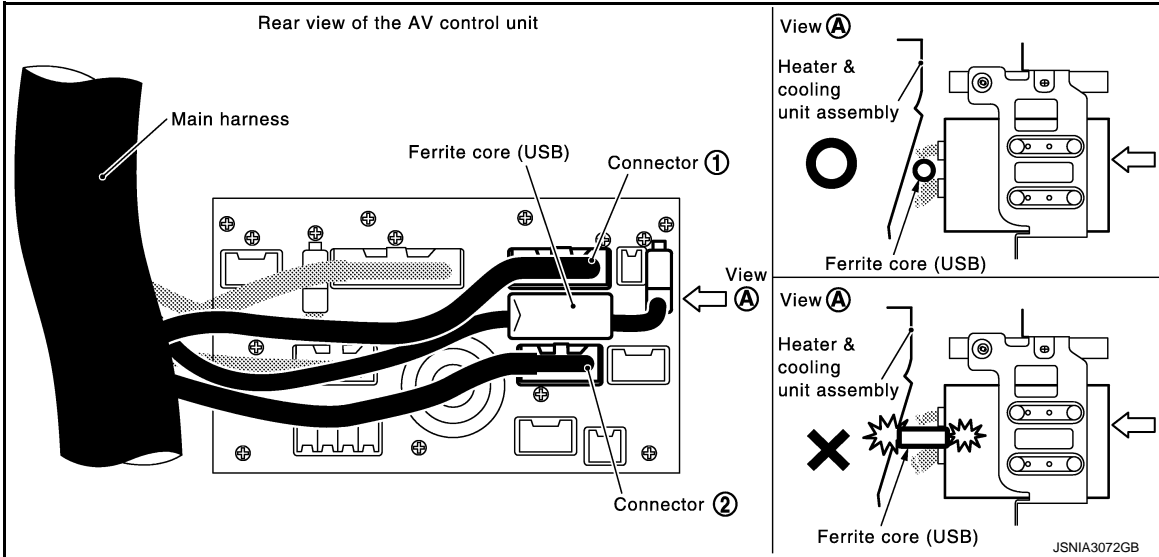

A  
B  
C  
D  
E  
F  
G  
H  
I  
J  
K  
L  
M  
O  
P

AV

## DISPLAY UNIT

### Exploded View

INFOID:000000006472612

Refer to [IP-12, "A/T MODELS : Exploded View"](#) (A/T models) or [IP-23, "M/T MODELS : Exploded View"](#) (M/T models).

### Removal and Installation

INFOID:000000006472613

#### REMOVAL

1. Remove cluster lid D. Refer to [IP-12, "A/T MODELS : Exploded View"](#) (A/T models) or [IP-23, "M/T MODELS : Exploded View"](#) (M/T models).
2. Remove display unit with bracket as a single unit.

#### INSTALLATION

Install in the reverse order of removal.

# DOOR SQUAWKER

< REMOVAL AND INSTALLATION >

[BOSE AUDIO WITHOUT NAVIGATION]

## DOOR SQUAWKER

### Exploded View

INFOID:000000006472614

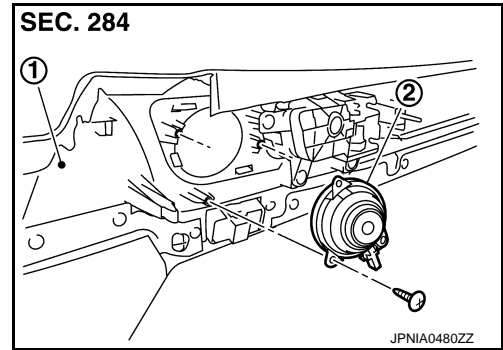

1. Door finisher assembly
2. Door squawker

### Removal and Installation

INFOID:000000006472615

#### REMOVAL

1. Remove door finisher assembly. Refer to [INT-12, "Exploded View"](#).
2. Remove door squawker from door finisher assembly.

#### INSTALLATION

Install in the reverse order of removal.

A  
B  
C  
D  
E  
F  
G  
H  
I  
J  
K  
L  
M  
O  
P

AV

# DOOR WOOFER

< REMOVAL AND INSTALLATION >

[BOSE AUDIO WITHOUT NAVIGATION]

## DOOR WOOFER

### Exploded View

INFOID:000000006472616

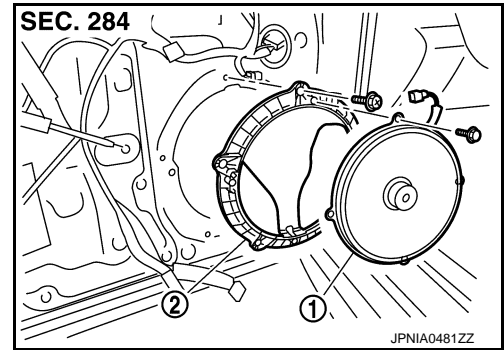

1. Door woofer
2. Woofer bracket

### Removal and Installation

INFOID:000000006472617

#### REMOVAL

1. Remove door finisher assembly. Refer to [INT-12, "Exploded View"](#).
2. Remove door woofer mounting bolts, disconnect the door woofer connector.
3. Remove door woofer.

#### INSTALLATION

Install in the reverse order of removal.

## TWEETER

## Exploded View

INFOID:000000006472618

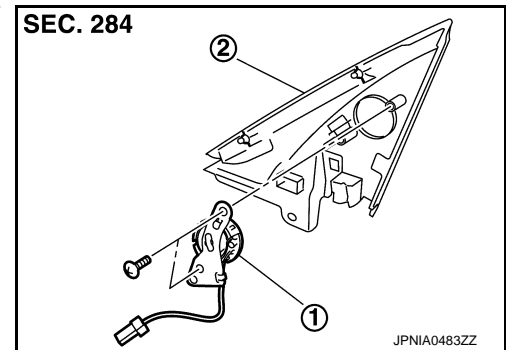

1. Tweeter
2. Corner cover

## Removal and Installation

INFOID:000000006472619

## REMOVAL

1. Remove corner cover. Refer to [MIR-20, "DOOR MIRROR ASSEMBLY : Exploded View"](#).
2. Remove tweeter from corner cover.

## INSTALLATION

Install in the reverse order of removal.

A  
B  
C  
D  
E  
F  
G  
H  
I  
J  
K  
L  
M  
AV  
O  
P

# CENTER SPEAKER

< REMOVAL AND INSTALLATION >

[BOSE AUDIO WITHOUT NAVIGATION]

## CENTER SPEAKER

### Exploded View

INFOID:000000006472620

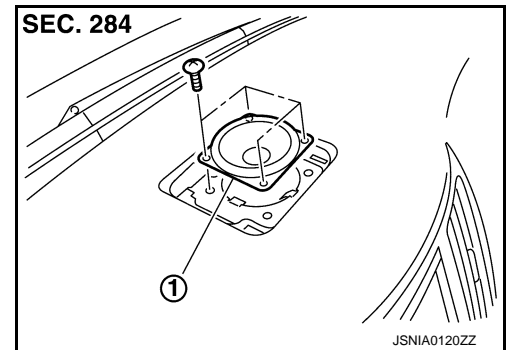

1. Center speaker

### Removal and Installation

INFOID:000000006472621

#### REMOVAL

1. Remove upper grille. Refer to [IP-12. "A/T MODELS : Exploded View"](#) (A/T models) or [IP-23. "M/T MOD-ELS : Exploded View"](#) (M/T models).
2. Remove center speaker mounting screws, disconnect the center speaker connector.
3. Remove center speaker.

#### INSTALLATION

Install in the reverse order of removal.



# REAR WOOFER

< REMOVAL AND INSTALLATION >

[BOSE AUDIO WITHOUT NAVIGATION]

## REAR WOOFER

### Exploded View

INFOID:000000006472622

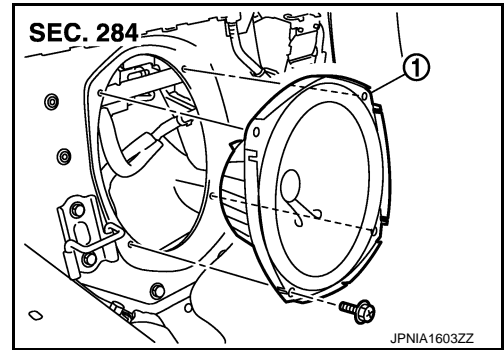

1. Rear woofer

### Removal and Installation

INFOID:000000006472623

#### REMOVAL

1. Remove rear seatback. Refer to [SE-256. "Exploded View"](#).
2. Remove rear woofer mounting bolts, disconnect the rear woofer connector.
3. Remove rear woofer from the vehicle.

#### INSTALLATION

Install in the reverse order of removal.

A  
B  
C  
D  
E  
F  
G  
H  
I  
J  
K  
L  
M  
N  
O  
P

AV

## HEADREST SPEAKER

< REMOVAL AND INSTALLATION >

[BOSE AUDIO WITHOUT NAVIGATION]

### HEADREST SPEAKER

#### Exploded View

INFOID:000000006472624

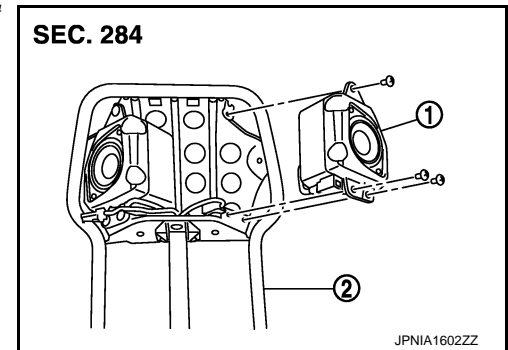

1. Headrest speaker
2. Headrest frame

#### Removal and Installation

INFOID:000000006472625

##### REMOVAL

1. Remove headrest frame. Refer to [SE-233. "Exploded View"](#).
2. Remove headrest speaker screws, then disconnect headrest speaker connector and remove headrest speaker.

##### INSTALLATION

Install in the reverse order of removal.

# BOSE AMP.

< REMOVAL AND INSTALLATION >

[BOSE AUDIO WITHOUT NAVIGATION]

## BOSE AMP.

### Exploded View

INFOID:000000006472626

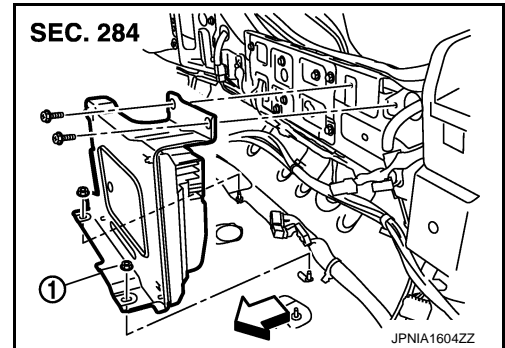

1. BOSE amp.

←: Vehicle front

### Removal and Installation

INFOID:000000006472627

#### REMOVAL

1. Remove net guard bracket assembly. Refer to [INT-23, "Exploded View"](#).
2. Remove BOSE amp. mounting bolts, disconnect the BOSE amp. connector.
3. Remove BOSE amp. from trunk room.

#### INSTALLATION

Install in the reverse order of removal.

A  
B  
C  
D  
E  
F  
G  
H  
I  
J  
K  
L  
M  
AV  
O  
P

# AUDIOPILOT™ MICROPHONE

< REMOVAL AND INSTALLATION >

[BOSE AUDIO WITHOUT NAVIGATION]

## AUDIOPILOT™ MICROPHONE

### Exploded View

INFOID:000000006472628

#### REMOVAL

Refer to [SE-233, "Exploded View"](#).

#### DISASSEMBLY

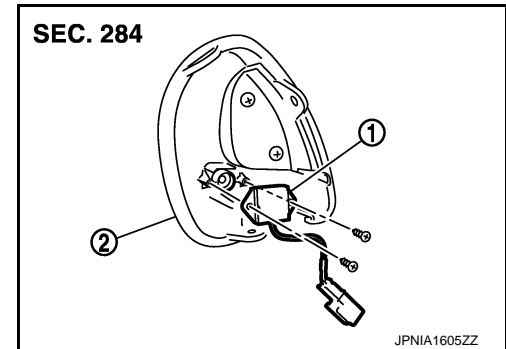

1. AudioPilot™ microphone
2. Headrest inner grille

### Removal and Installation

INFOID:000000006472629

#### REMOVAL

1. Remove headrest inner grille. Refer to [SE-233, "Exploded View"](#).
2. Remove AudioPilot™ microphone from headrest inner grille.

#### INSTALLATION

Install in the reverse order of removal.

# ANTENNA BASE

< REMOVAL AND INSTALLATION >

[BOSE AUDIO WITHOUT NAVIGATION]

## ANTENNA BASE

### Exploded View

INFOID:000000006472630

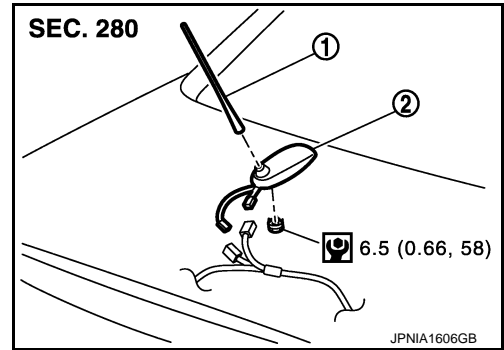

1. Antenna rod
2. Antenna base

Refer to [GI-4, "Components"](#) for symbols in the figure.

### Removal and Installation

INFOID:000000006472631

#### REMOVAL

1. Remove trunk lid finisher inner. Refer to [INT-26, "Exploded View"](#).
2. Remove antenna base mounting nut, disconnect the antenna base connector.
3. Remove antenna base.

#### INSTALLATION

Install in the reverse order of removal.

#### **CAUTION:**

**If the antenna base mounting nut is tightened looser than the specified torque, then this will lower the sensitivity of the antenna. On the other hand, if the nut is tightened tighter than the specified torque, then this will deform the trunk lid panel.**

A  
B  
C  
D  
E  
F  
G  
H  
I  
J  
K  
L  
M  
O  
P

AV

# SATELLITE RADIO TUNER

< REMOVAL AND INSTALLATION >

[BOSE AUDIO WITHOUT NAVIGATION]

## SATELLITE RADIO TUNER

### Exploded View

INFOID:000000006472632

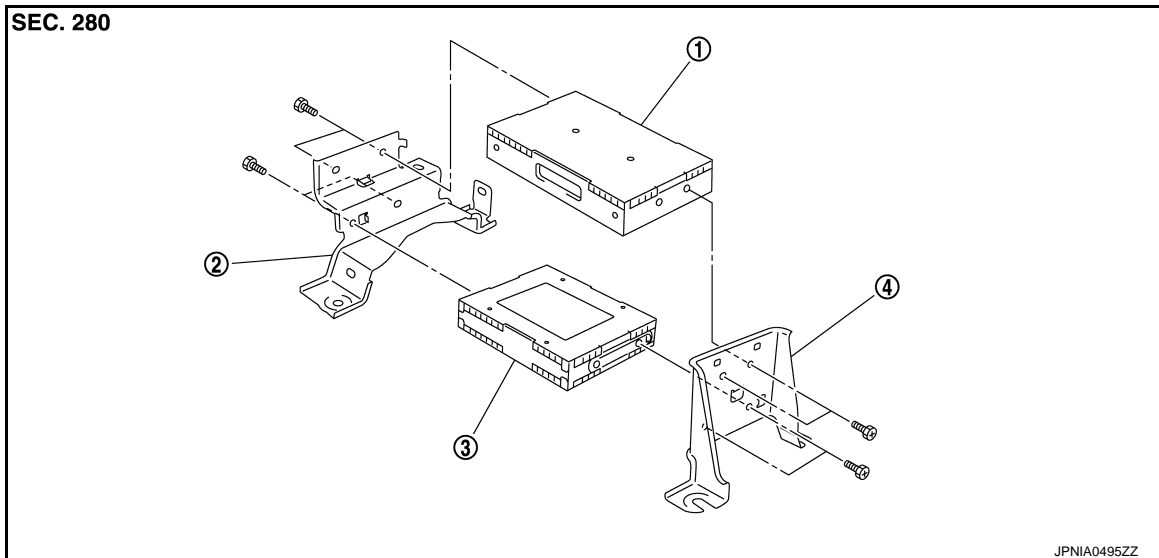

1. TEL adapter unit
2. Bracket (front)
3. Satellite radio tuner
4. Bracket (rear)

### Removal and Installation

INFOID:000000006472633

#### REMOVAL

1. Remove trunk floor spacer RH. Refer to [INT-23, "Exploded View"](#).
2. Remove nuts (A) from the trunk room RH, and remove TEL adapter unit and satellite radio tuner (1) from trunk room side.

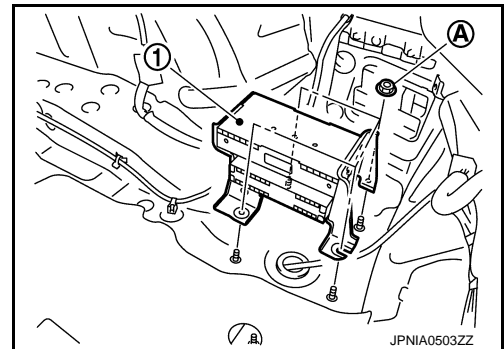

#### INSTALLATION

Install in the reverse order of removal.

# MULTIFUNCTION SWITCH

< REMOVAL AND INSTALLATION >

[BOSE AUDIO WITHOUT NAVIGATION]

## MULTIFUNCTION SWITCH

### Exploded View

INFOID:000000006472634

#### REMOVAL

Refer to [IP-12. "A/T MODELS : Exploded View"](#) (A/T models) or [IP-23. "M/T MODELS : Exploded View"](#) (M/T models).

#### DISASSEMBLY

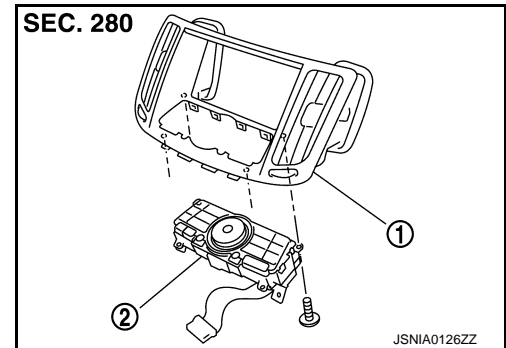

1. Center ventilator grille
2. Multifunction switch

### Removal and Installation

INFOID:000000006472635

#### REMOVAL

1. Remove cluster lid D. Refer to [IP-12. "A/T MODELS : Exploded View"](#) (A/T models) or [IP-23. "M/T MODELS : Exploded View"](#) (M/T models).
2. Remove multifunction switch with center ventilator grille as a single unit.
3. Remove multifunction switch from center ventilator.

#### INSTALLATION

Install in the reverse order of removal.

A  
B  
C  
D  
E  
F  
G  
H  
I  
J  
K  
L  
M  
O  
P

AV

# PRESET SWITCH

< REMOVAL AND INSTALLATION >

[BOSE AUDIO WITHOUT NAVIGATION]

## PRESET SWITCH

### Exploded View

INFOID:000000006472636

#### REMOVAL

Refer to [IP-12. "A/T MODELS : Exploded View"](#) (A/T models) or [IP-23. "M/T MODELS : Exploded View"](#) (M/T models).

#### DISASSEMBLY

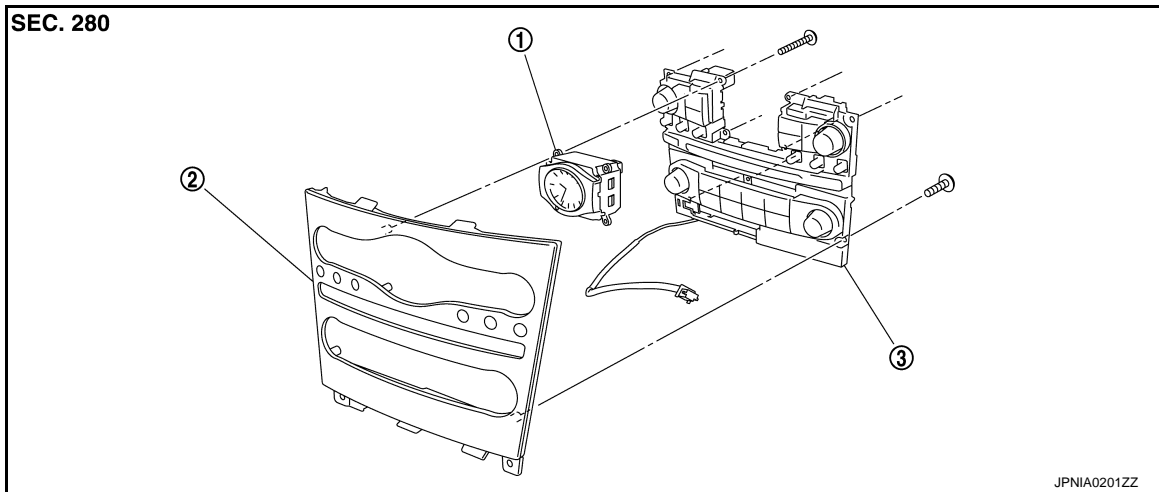

1. Clock

2. Cluster lid C

3. Preset switch

### Removal and Installation

INFOID:000000006472637

#### REMOVAL

1. Remove cluster lid C. Refer to [IP-12. "A/T MODELS : Exploded View"](#) (A/T models) or [IP-23. "M/T MODELS : Exploded View"](#) (M/T models).
2. Remove preset switch (2) from cluster lid C. Remove preset switch screws (A), (B) and (C), remove preset switch (2) from cluster lid C.

1. Clock

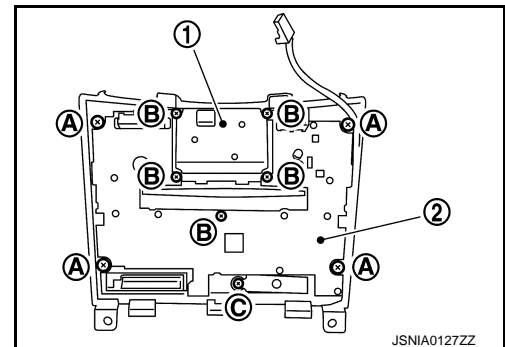

#### INSTALLATION

Install in the reverse order of removal.

#### NOTE:

When installing preset switch, do not allow the print wire that connects preset switch and multifunction switch to get caught in between AV control unit and preset switch.



# STEERING SWITCH

< REMOVAL AND INSTALLATION >

[BOSE AUDIO WITHOUT NAVIGATION]

## STEERING SWITCH

### Exploded View

INFOID:000000006472638

Refer to [ST-14. "Exploded View"](#).

### Removal and Installation

INFOID:000000006472639

#### REMOVAL

Refer to [ST-14. "Removal and Installation"](#).

#### INSTALLATION

Install in the reverse order of removal.

A

B

C

D

E

F

G

H

I

J

K

L

M

AV

O

P

# USB CONNECTOR

< REMOVAL AND INSTALLATION >

[BOSE AUDIO WITHOUT NAVIGATION]

## USB CONNECTOR

### Exploded View

INFOID:000000006472640

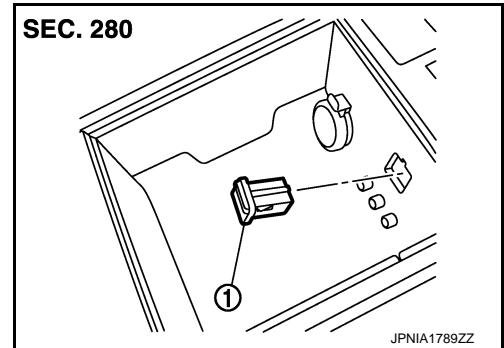

1. USB connector

### Removal and Installation

INFOID:000000006472641

#### REMOVAL

1. Remove center console. Refer to [IP-34. "A/T MODELS : Exploded View"](#) (A/T models) or [IP-39. "M/T MODELS : Exploded View"](#) (M/T models).
2. Push the pawl from the back of center console to remove USB connector.

#### INSTALLATION

Install in the reverse order of removal.

# MICROPHONE

< REMOVAL AND INSTALLATION >

[BOSE AUDIO WITHOUT NAVIGATION]

## MICROPHONE

### Exploded View

INFOID:000000006472642

#### REMOVAL

Refer to [INL-107, "Exploded View"](#).

#### DISASSEMBLY

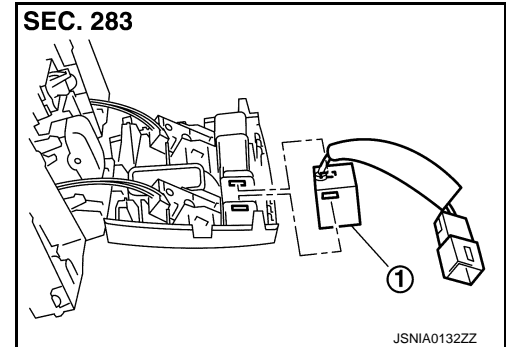

1. Microphone

### Removal and Installation

INFOID:000000006472643

#### REMOVAL

1. Remove map lamp. Refer to [INL-107, "Exploded View"](#).
2. Remove microphone from map lamp.

#### INSTALLATION

Install in the reverse order of removal.

A  
B  
C  
D  
E  
F  
G  
H  
I  
J  
K  
L  
M  
O  
P

AV

# REAR VIEW CAMERA

< REMOVAL AND INSTALLATION >

[BOSE AUDIO WITHOUT NAVIGATION]

## REAR VIEW CAMERA

### Exploded View

INFOID:000000006472644

#### REMOVAL

Refer to [EXT-38, "Exploded View"](#).

#### DISASSEMBLY

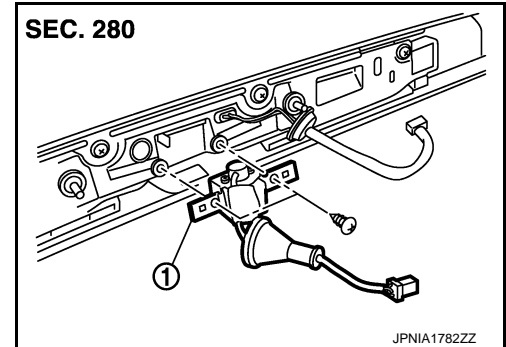

1. Rear view camera

### Removal and Installation

INFOID:000000006472645

#### REMOVAL

1. Remove trunk lid finisher outer. Refer to [EXT-38, "Exploded View"](#).
2. Remove rear view camera from trunk lid finisher outer.

#### INSTALLATION

Install in the reverse order of removal.

#### NOTE:

Adjust the guide line position if the guide line position is shifted after installing the rear view camera. Refer to [AV-268, "Adjustment"](#).

### Adjustment

INFOID:000000006472646

Adjust the guide line position if the guide line position is shifted after installing the rear view camera.

1. Draw lines on rearward area of the vehicle passing through the following points: 200 mm (7.87 in) from both sides of the vehicle, and 0.5 m (1.64 ft), 1.0 m (3.28 ft) from the rear end of the bumper.
2. Set into "Adjust Guide Lines" mode of "Confirmation/Adjustment" mode.

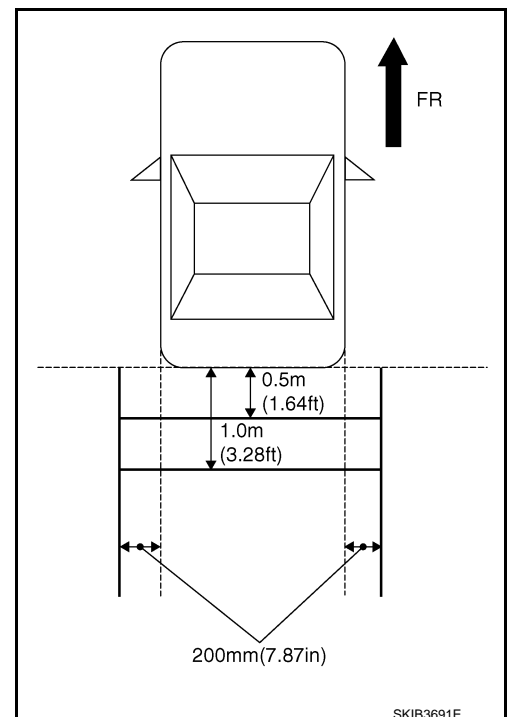

# REAR VIEW CAMERA

< REMOVAL AND INSTALLATION >

[BOSE AUDIO WITHOUT NAVIGATION]

3. Rotate the center dial, and then select the guiding line pattern so that its angle is aligned with the correction line of the rear of the vehicle.

Selected pattern : 7

4. Make fine adjustment to the correction line of the rear of the vehicle with up/down/left/right switches so that its position is aligned with the guiding line. Press "OK" switch and record the adjusted guiding line position to the AV control unit.

Up/Down adjustment range : 20° - 20°

Left/Right adjustment range : 20° - 20°

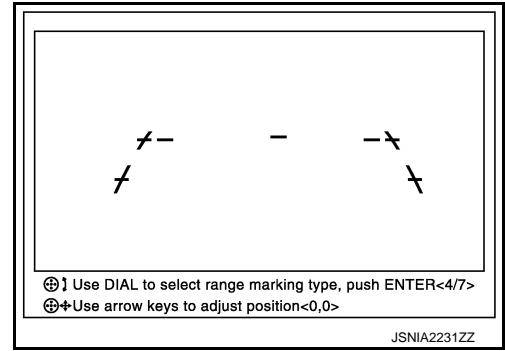

**CAUTION:**

**After the adjustment, never perform other operations for one minute.**

A  
B  
C  
D  
E  
F  
G  
H  
I  
J  
K  
L  
M  
O  
P

AV

# STEERING ANGLE SENSOR

< REMOVAL AND INSTALLATION >

[BOSE AUDIO WITHOUT NAVIGATION]

## STEERING ANGLE SENSOR

### Exploded View

INFOID:000000006472647

#### REMOVAL

Refer to [SR-15. "Exploded View"](#).

#### DISASSEMBLY

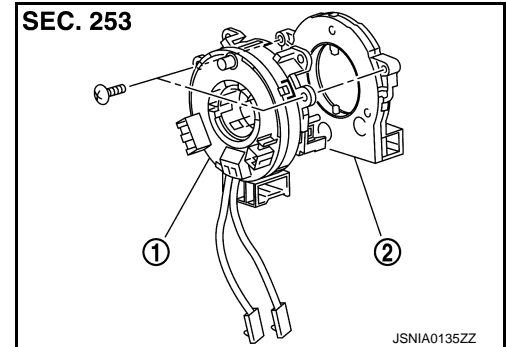

1. Spiral cable
2. Steering angle sensor

### Removal and Installation

INFOID:000000006472648

#### REMOVAL

1. Remove spiral cable.
2. Remove steering angle sensor from spiral cable.

#### INSTALLATION

Install in the reverse order of removal.

# TEL ADAPTER UNIT

< REMOVAL AND INSTALLATION >

[BOSE AUDIO WITHOUT NAVIGATION]

## TEL ADAPTER UNIT

### Exploded View

INFOID:000000006472649

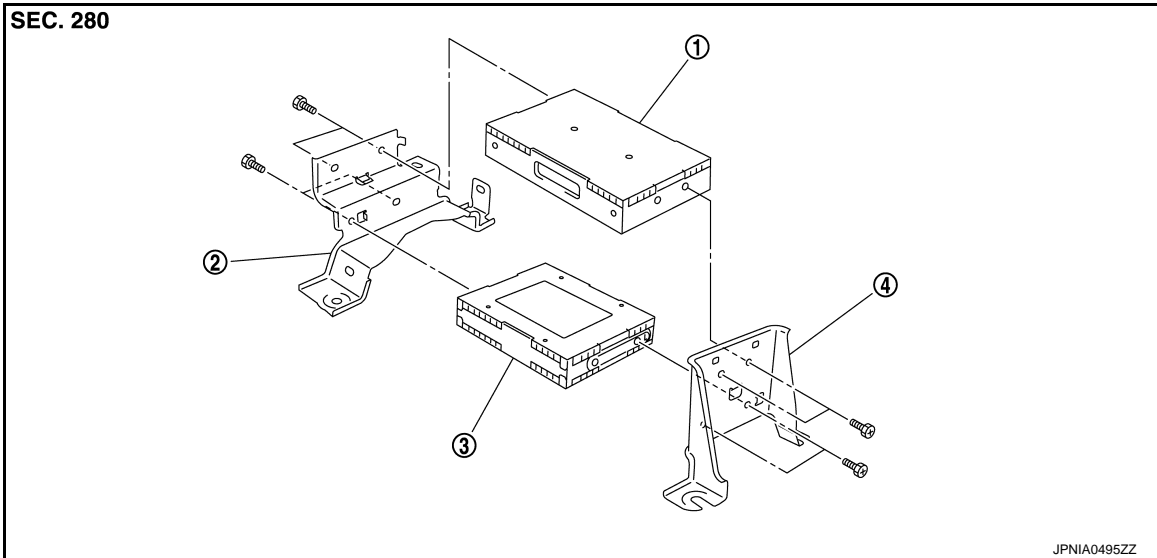

- 1. TEL adapter unit
- 2. Bracket (front)
- 3. Satellite radio tuner
- 4. Bracket (rear)

### Removal and Installation

INFOID:000000006472650

#### REMOVAL

1. Remove trunk floor spacer RH. Refer to [INT-23, "Exploded View"](#).
2. Remove nuts (A) from the trunk room RH, and remove TEL adapter unit and satellite radio tuner (1) from trunk room side.

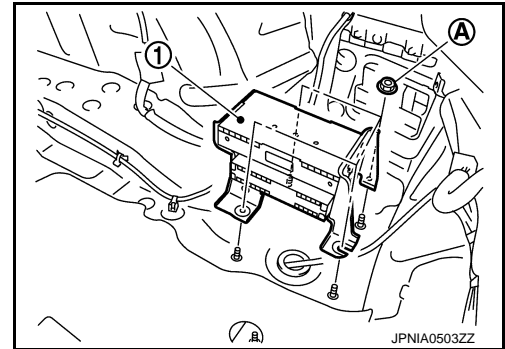

#### INSTALLATION

Install in the reverse order of removal.

A  
B  
C  
D  
E  
F  
G  
H  
I  
J  
K  
L  
M  
AV  
O  
P

# SONAR CONTROL UNIT

< REMOVAL AND INSTALLATION >

[BOSE AUDIO WITHOUT NAVIGATION]

## SONAR CONTROL UNIT

### Exploded View

INFOID:000000006472651

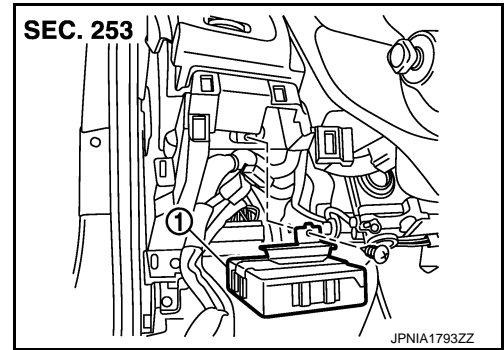

1. Sonar control unit

### Removal and Installation

INFOID:000000006472652

#### REMOVAL

1. Remove the instrument finisher A. Refer to [JP-12, "A/T MODELS : Exploded View"](#) (A/T models) or [JP-23, "M/T MODELS : Exploded View"](#) (M/T models).
2. Remove sonar control unit screw, then disconnect sonar control unit connector and remove the sonar control unit.

#### INSTALLATION

Install in the reverse order of removal.





## PRECAUTION

### PRECAUTIONS

#### Precaution for Supplemental Restraint System (SRS) "AIR BAG" and "SEAT BELT PRE-TENSIONER"

INFOID:000000006472654

The Supplemental Restraint System such as "AIR BAG" and "SEAT BELT PRE-TENSIONER", used along with a front seat belt, helps to reduce the risk or severity of injury to the driver and front passenger for certain types of collision. This system includes seat belt switch inputs and dual stage front air bag modules. The SRS system uses the seat belt switches to determine the front air bag deployment, and may only deploy one front air bag, depending on the severity of a collision and whether the front occupants are belted or unbelted. Information necessary to service the system safely is included in the "SRS AIR BAG" and "SEAT BELT" of this Service Manual.

**WARNING:**

Always observe the following items for preventing accidental activation.

- To avoid rendering the SRS inoperative, which could increase the risk of personal injury or death in the event of a collision that would result in air bag inflation, all maintenance must be performed by an authorized NISSAN/INFINITI dealer.
- Improper maintenance, including incorrect removal and installation of the SRS, can lead to personal injury caused by unintentional activation of the system. For removal of Spiral Cable and Air Bag Module, see "SRS AIR BAG".
- Never use electrical test equipment on any circuit related to the SRS unless instructed to in this Service Manual. SRS wiring harnesses can be identified by yellow and/or orange harnesses or harness connectors.

#### PRECAUTIONS WHEN USING POWER TOOLS (AIR OR ELECTRIC) AND HAMMERS

**WARNING:**

Always observe the following items for preventing accidental activation.

- When working near the Air Bag Diagnosis Sensor Unit or other Air Bag System sensors with the ignition ON or engine running, never use air or electric power tools or strike near the sensor(s) with a hammer. Heavy vibration could activate the sensor(s) and deploy the air bag(s), possibly causing serious injury.
- When using air or electric power tools or hammers, always switch the ignition OFF, disconnect the battery, and wait at least 3 minutes before performing any service.

#### Precaution for Battery Service

INFOID:000000006472655

Before disconnecting the battery, lower both the driver and passenger windows. This will prevent any interference between the window edge and the vehicle when the door is opened/closed. During normal operation, the window slightly raises and lowers automatically to prevent any window to vehicle interference. The automatic window function will not work with the battery disconnected.

#### Service Procedure Precautions for Models with a Pop-up Roll Bar

INFOID:000000006472656

**WARNING:**

Always observe the following items for preventing accidental activation.

- Risk of passenger injury or death may increase if the pop-up roll bar does not deploy during a roll over collision. In order to reduce the chance of an incident where the pop-up roll bar is inoperative, all maintenance must be performed by a NISSAN or INFINITI dealer.
- Before removing and installing the pop-up roll bar component parts and harness, always turn the ignition switch OFF, disconnect the battery negative terminal, and wait for 3 minutes or more. (The purpose of this operation is to discharge electricity that is accumulated in the auxiliary power supply circuit in the air bag diagnosis sensor unit.)
- When repairing, removing, and installing a pop-up roll bar, always refer to SRS AIR BAG and SRS AIR BAG CONTROL warnings in the Service Manual.

#### Cautions in Removing Battery Terminal and AV Control Unit (Models with AV Control Unit)

INFOID:000000008116962

**CAUTION:**

# PRECAUTIONS

< PRECAUTION >

[BOSE AUDIO WITH NAVIGATION]

**Remove battery terminal and AV control unit after a lapse of 30 seconds or more after turning the ignition switch OFF.**

**NOTE:**

After the ignition switch is turned OFF, the AV control unit continues operating for approximately 30 seconds. Therefore, data corruption may occur if battery voltage is cut off within 30 seconds.

## Precaution for Trouble Diagnosis

INFOID:000000006472657

### AV COMMUNICATION SYSTEM

- Do not apply voltage of 7.0 V or higher to the measurement terminals.
- Use the tester with its open terminal voltage being 7.0 V or less.
- Be sure to turn ignition switch OFF and disconnect the battery cable from the negative terminal before checking the circuit.

## Precaution for Harness Repair

INFOID:000000006472658

### AV COMMUNICATION SYSTEM

- Solder the repaired parts, and wrap with tape. [Frays of twisted line must be within 110 mm (4.33 in).]

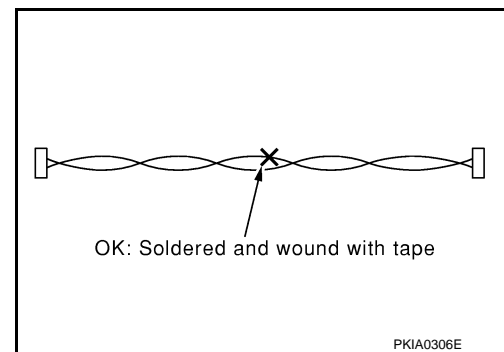

- Do not perform bypass wire connections for the repair parts. (The spliced wire will become separated and the characteristics of twisted line will be lost.)

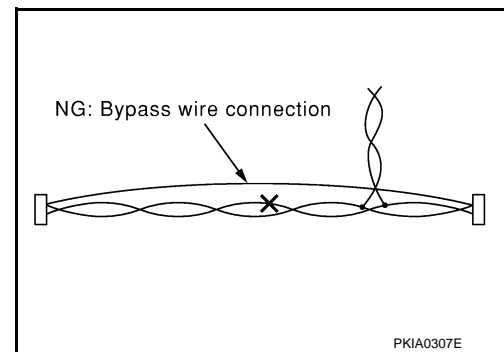

A  
B  
C  
D  
E  
F  
G  
H  
I  
J  
K  
L  
M

AV

O  
P

# PREPARATION

< PREPARATION >

[BOSE AUDIO WITH NAVIGATION]

## PREPARATION

### PREPARATION

#### Commercial Service Tools

INFOID:000000006472659

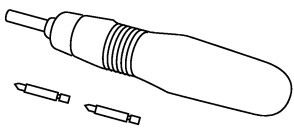
Tool	Description
<p data-bbox="162 514 267 546">Power tool</p>  <p data-bbox="820 619 901 651">PBIC0191E</p>	<p data-bbox="1006 514 1193 546">Loosening screws</p>

# COMPONENT PARTS

< SYSTEM DESCRIPTION >

[BOSE AUDIO WITH NAVIGATION]

## SYSTEM DESCRIPTION

### COMPONENT PARTS

#### Component Parts Location

INFOID:000000006472660

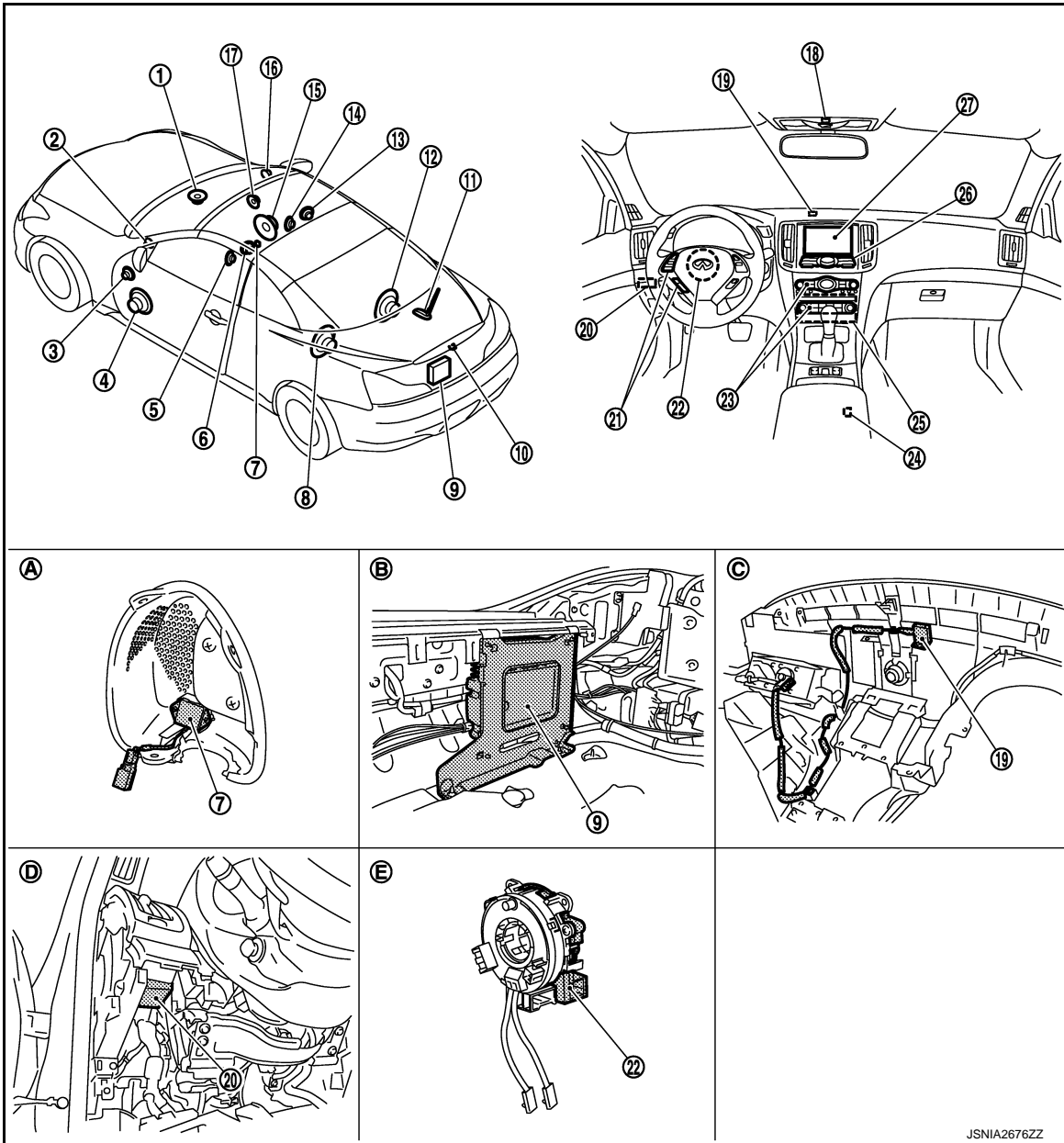

- |                                   |                                   |                               |
|-----------------------------------|-----------------------------------|-------------------------------|
| 1. Center speaker                 | 2. Tweeter LH                     | 3. Door squawker LH           |
| 4. Door woofer LH                 | 5. Driver headrest speaker LH     | 6. Driver headrest speaker RH |
| 7. Microphone (for AudioPilot™)   | 8. Rear woofer LH                 | 9. BOSE amp.                  |
| 10. Rear view camera              | 11. Antenna base                  | 12. Rear woofer RH            |
| 13. Passenger headrest speaker RH | 14. Passenger headrest speaker LH | 15. Door woofer RH            |
| 16. Tweeter RH                    | 17. Door squawker RH              | 18. Microphone                |
| 19. GPS antenna                   | 20. Sonar control unit            | 21. Steering switch           |
| 22. Steering angle sensor         | 23. Preset switch                 | 24. USB connector             |
| 25. AV control unit               | 26. Multifunction switch          | 27. Display unit              |

A  
B  
C  
D  
E  
F  
G  
H  
I  
J  
K  
L  
M  
AV  
O  
P

# COMPONENT PARTS

[BOSE AUDIO WITH NAVIGATION]

## < SYSTEM DESCRIPTION >

- |  |                                   |                               |
|--|-----------------------------------|-------------------------------|
| A. Inner grille removed condition                  | B. Rear plate removed condition   | C. Instrument panel rear side |
| D. Instrument driver lower panel removed condition | E. Spiral cable removed condition |                               |

## Component Description

INFOID:000000006472661

Part name	Description
AV control unit	<ul style="list-style-type: none"> <li>Integrates hard disk drive (HDD) allowing map data and music data to be stored.</li> <li>It is the master unit of the MULTI AV system, and it is connected to each control unit by communication. It operates each system according to communication signals from the AV control unit.</li> <li>The AV control unit includes the audio, hands-free phone, voice control, navigation, USB connection, DVD play, satellite radio and vehicle information functions.</li> <li>It is connected to ECM and unified meter and A/C amp. via CAN communication to obtain necessary information for the vehicle information function.</li> <li>It is connected to the steering angle sensor and receives the steering angle sensor signal via CAN communication.</li> <li>It inputs the illumination signals that are required for the display dimming control.</li> <li>It inputs the signals for driving status recognition (vehicle speed, reverse and parking brake).</li> <li>The RGB digital image signal and composite image signal are output to display unit.</li> <li>Update of map data is performed with the DVD-ROM.</li> </ul>
Display unit	<ul style="list-style-type: none"> <li>Display image is controlled by the serial communication from AV control unit.</li> <li>RGB digital image signal is input from AV control unit.</li> <li>Composite image signal is input from AV control unit.</li> <li>Camera image signal is input from rear view camera.</li> <li>Touch panel function can be operated for each system by touching a display directly.</li> </ul>
BOSE amp.	<ul style="list-style-type: none"> <li>Inputs sound signal from AV control unit, and outputs sound signal to each speaker.</li> <li>Input microphone signal from microphone (Audiopilot™).</li> <li>Inputs roof status signal from retractable hard top control unit.</li> </ul>
Door woofer	<ul style="list-style-type: none"> <li>Outputs sound signal from BOSE amp.</li> <li>Outputs low range sound.</li> </ul>
Door squawker	<ul style="list-style-type: none"> <li>Outputs sound signal from BOSE amp.</li> <li>Outputs mid range sound.</li> </ul>
Tweeter	<ul style="list-style-type: none"> <li>Outputs sound signal from BOSE amp.</li> <li>Outputs high range sound.</li> </ul>
Center speaker	<ul style="list-style-type: none"> <li>Outputs sound signal from BOSE amp.</li> <li>Outputs mid range sounds.</li> </ul>
Rear woofer	<ul style="list-style-type: none"> <li>Outputs sound signal from BOSE amp.</li> <li>Outputs low range sound.</li> </ul>
Headrest speaker	<ul style="list-style-type: none"> <li>Outputs sound signal from BOSE amp.</li> <li>Outputs mid range sound.</li> </ul>
Microphone (for AudioPilot™)	<ul style="list-style-type: none"> <li>Used for AudioPilot™</li> <li>Microphone signal is transmitted to BOSE amp.</li> </ul>
Multifunction switch	<ul style="list-style-type: none"> <li>Operation panel is equipped with the centralized switch where audio, auxiliary input and navigation, etc. operations are integrated.</li> <li>Connected with preset switch via cable, and operation signal is transmitted to AV control unit via AV communication.</li> </ul>
Preset switch	<ul style="list-style-type: none"> <li>Operation panel is equipped with the centralized switch where audio and air conditioner, etc. operations are integrated.</li> <li>Connected with multifunction switch via cable, and operation signal is transmitted to AV control unit via AV communication.</li> <li>The disk ejection operating signal is performed by hardwire.</li> </ul>
Rear view camera	<ul style="list-style-type: none"> <li>Camera power supply is input from AV control unit.</li> <li>The image of vehicle rear view is transmitted to display unit.</li> </ul>

## COMPONENT PARTS

< SYSTEM DESCRIPTION >

[BOSE AUDIO WITH NAVIGATION]

Part name	Description
Steering angle sensor	It is connected to the AV control unit and transmits the steering angle sensor signal via CAN communication.
Sonar control unit	<ul style="list-style-type: none"> <li>• Controlled by AV communication transmitted from AV control unit.</li> <li>• Trouble diagnosis is supported with CONSULT-III (K-LINE).</li> </ul>
Steering switch	<ul style="list-style-type: none"> <li>• Operations for audio, hands-free phone, voice control and navigation, etc. are possible.</li> <li>• Steering switch signal (operation signal) is output to AV control unit.</li> </ul>
Microphone	<ul style="list-style-type: none"> <li>• Used for hands-free phone operation and voice recognition.</li> <li>• Microphone signal is transmitted to AV control unit.</li> <li>• Power (Microphone VCC) is supplied from AV control unit.</li> </ul>
Antenna base	<p>An antenna base integrated with radio antenna amp. and satellite radio antenna is adopted.</p> <p style="margin-left: 20px;">ANTENNA AMP.</p> <ul style="list-style-type: none"> <li>• Radio signal received by rod antenna is amplified and transmitted to AV control unit.</li> <li>• Power (antenna amp. ON signal) is supplied from AV control unit.</li> </ul> <p style="margin-left: 20px;">SATELLITE RADIO ANTENNA</p> <ul style="list-style-type: none"> <li>• Receives the satellite radio waves and outputs it to AV control unit.</li> </ul>
GPS antenna	GPS signal is received and transmitted to AV control unit.
USB connector	Image signal <sup>*1</sup> and sound signal of USB input is transmitted to AV control unit.

\*1: Image signals cannot be received from iPod®.

A  
B  
C  
D  
E  
F  
G  
H  
I  
J  
K  
L  
M  
O  
P

AV

< SYSTEM DESCRIPTION >

SYSTEM

MULTI AV SYSTEM

MULTI AV SYSTEM : System Diagram

INFOID:000000006472662

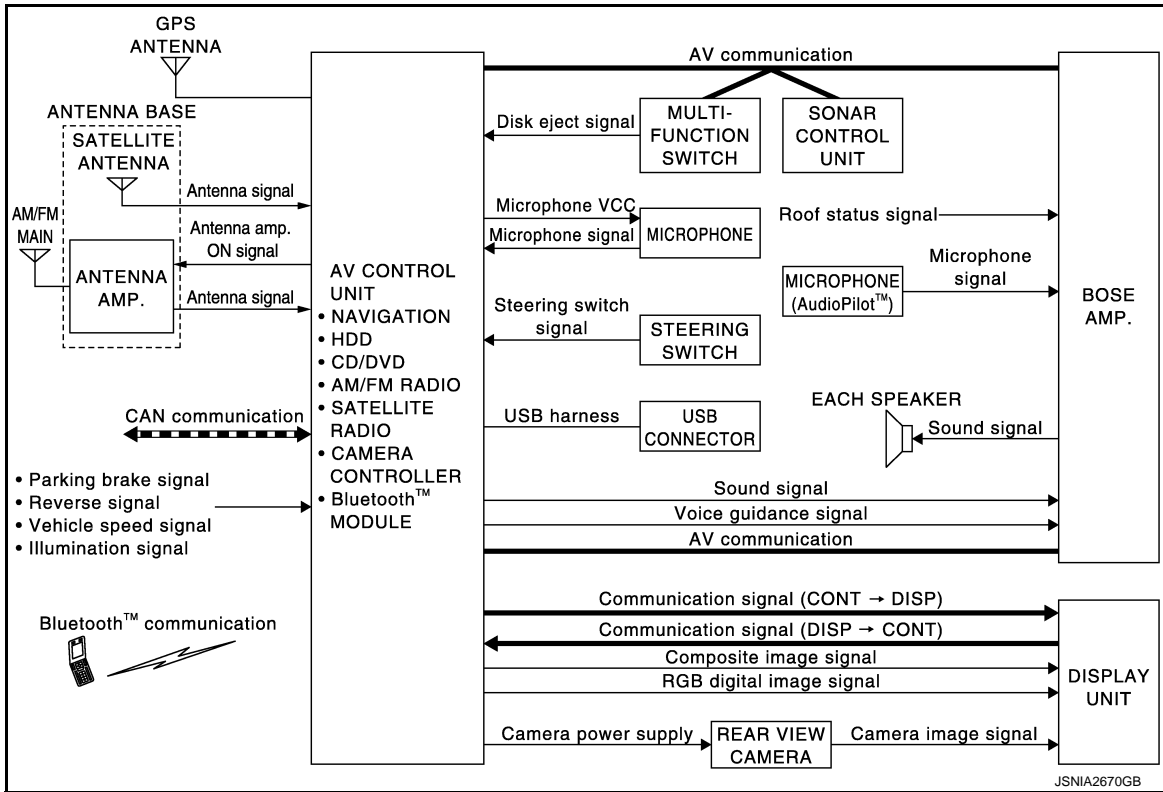

NOTE:

- The name MULTIFUNCTION SWITCH indicates the integration of PRESET SWITCH and MULTIFUNCTION SWITCH virtually.
- An antenna base integrated with radio antenna and satellite radio antenna is adopted.

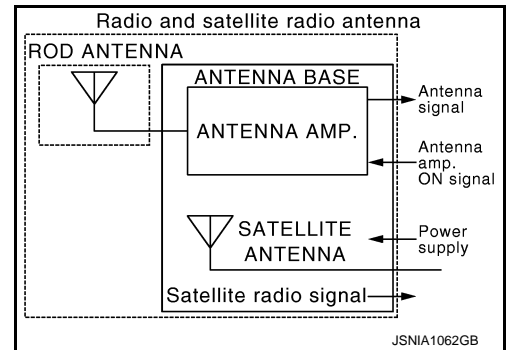

MULTI AV SYSTEM : System Description

INFOID:000000006472663

Multi AV system means that the following systems are integrated.

FUNCTION NAME
Navigation system function
Audio function
DVD play function
Hands-free phone function
USB connection function
Voice recognition function
Touch panel function



# SYSTEM

## < SYSTEM DESCRIPTION >

## [BOSE AUDIO WITH NAVIGATION]

FUNCTION NAME
Rear view monitor function
Sonar system
Vehicle information function

### COMMUNICATION SIGNAL

- AV control unit function by transmitting/receiving data one by one with each unit (slave unit) that configures them completely as a master unit by connecting between units that configure MULTI AV system with two AV communication lines (H, L).
- Two AV communication lines (H, L) adopt a twisted pair line that is resistant to noise.
- AV control unit is connected by CAN communication, and it receives data signal from ECM, unified meter and A/C amp. It computes and displays fuel economy information value with the obtained information.
- AV control unit is connected with display and serial communication, and it transmits the required signal of display and display control and receives the response signal from display.

### NAVIGATION SYSTEM FUNCTION

#### Description

- The AV control unit controls navigation function while GPS tuner has built-in map data, GYRO (angle speed sensor), on the HDD (Hard Disk Drive).
- The AV control unit inputs operation signal with communication signal, through display (touch panel) and multifunction switch and steering switch.
- Guide sound is output to front speaker through BOSE amp. from AV control unit when operating navigation system.
- A vehicle position is calculated with the GYRO (angle speed sensor), vehicle sensor, signal from GPS satellite and map data stored on HDD (Hard Disk Drive), and transmits the map image signal (RGB image, RGB area, RGB image synchronizing) to the display.

#### Position Detection Principle

The navigation system periodically calculates the current vehicle position according to the following three types of signals.

- Travel distance of the vehicle as determined by the vehicle speed sensor
- Vehicle turning angle determined by the gyroscope (angular speed sensor)
- The travel direction of the vehicle determined by the GPS antenna (GPS information)

The current position of the vehicle is then identified by comparing the calculated vehicle position with map data, which is stored in the HDD (Hard Disk Drive) (map-matching), and indicated on the screen with a current location mark. More accurate data is used by comparing position detection results from GPS to the map-matching.

The current position is calculated by detecting the travel distance from the previous calculation point, and its direction change.

- Travel distance

The travel distance is generated from the vehicle speed sensor input signal. The automatic distance correction function is adopted for preventing a miss-detection of the travel distance because of tire wear etc.

- Travel direction

The gyroscope (angular velocity sensor) and GPS antenna (GPS information) generate the change of the travel direction. Both have advantages and disadvantages as per the following descriptions.

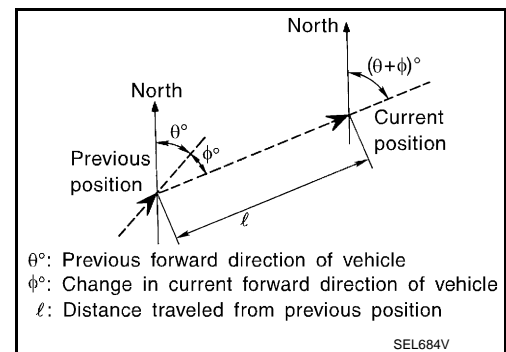
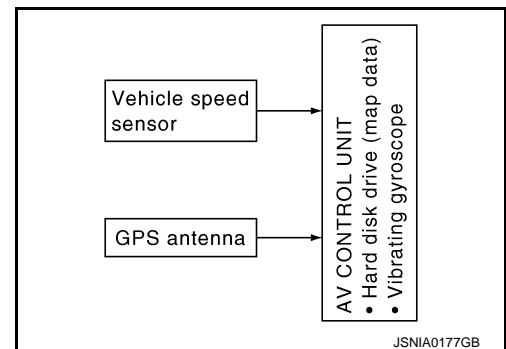

Type	Advantage	Disadvantage
Gyroscope (angular velocity sensor)	The turning angle is precisely detected.	Errors are accumulated when driving a long distance without stopping.
GPS antenna (GPS information)	The travel direction (North/South/East/West) is detected.	The travel direction is not precisely detected when driving slowly.

Input signals are prioritized in each situation. However, this order of priority may change in accordance with more detailed travel conditions so that the travel direction is detected more accurately.

### Map-matching

Map-matching repositions the vehicle on the road map when a new location is judged to be more accurate. This is done by comparing the current vehicle position (calculated by the normal position detection method) from the map data stored in the HDD (Hard Disk Drive).

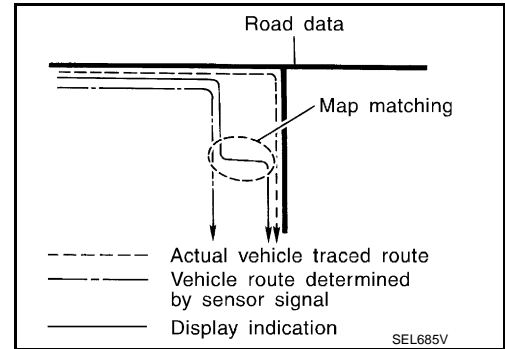

There is a possibility that the vehicle position may not be corrected in the following case, and when vehicle is driven over a certain distance or time in which GPS information is hard to receive. Correct manually the current location mark on the screen.

- In map-matching, several alternative routes are prepared and prioritized in addition to the road judged as currently driving on. Therefore, due to errors in the distance and/or direction, an incorrect road may be prioritized, and the current location mark may be repositioned to the incorrect road. If two roads are running in parallel, they are of the same priority. Therefore, the current location mark may appear on either of them alternately, depending on maneuvering of the steering wheel and configuration of the road, etc.

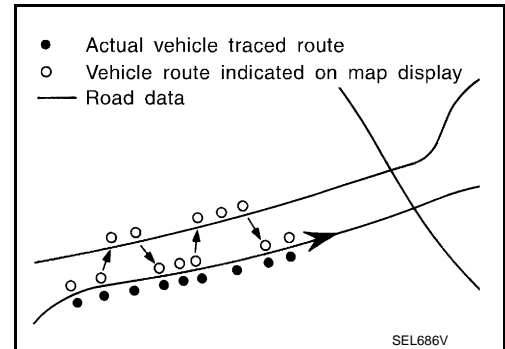

- Map-matching does not function correctly when road on which the vehicle is driving is new, etc. and not recorded in the map data. Also, map-matching does not function correctly when road pattern stored in the map data and the actual road pattern are different due to repair, etc.

Therefore, the map-matching function judges other road as a currently driving road if the road is not in the map, and displays the current location mark on it. Later, the current location mark may be repositioned to the road if the correct road is detected.

- Effective range for comparing the vehicle position and travel direction calculated by the distance and direction with the road data is limited. Therefore, correction by map-matching is not possible when there is an excessive gap between current vehicle position and the position on the map.

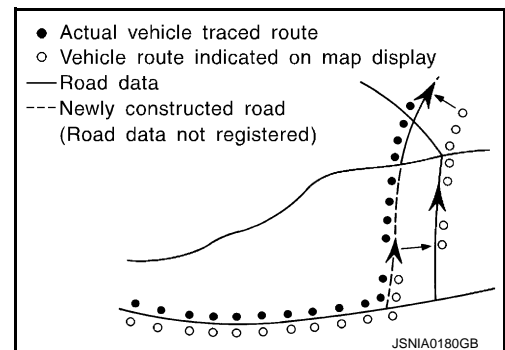

### GPS (Global Positioning System)

GPS (Global Positioning System) is developed for and is controlled by the US Department of Defense. The system utilizes GPS satellites (NAVSTAR), transmitting out radio waves while flying on an orbit around the earth at an altitude of approximately 21,000 km (13,049 mile).

The receiver calculates the travel position in three dimensions (latitude/longitude/altitude) according to the time lag of the radio waves that four or more GPS satellites transmit (three-dimensional positioning). The GPS receiver calculates the travel position in two dimensions (latitude/longitude) with the previous altitude data if the GPS receiver receives only three radio waves (two-dimensional positioning). GPS position correction is not performed while stopping the vehicle.

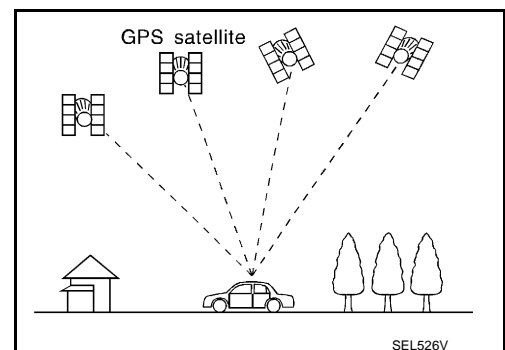

# SYSTEM

## < SYSTEM DESCRIPTION >

## [BOSE AUDIO WITH NAVIGATION]

Accuracy of the GPS will deteriorate under the following conditions:

- In two-dimensional positioning, GPS accuracy will deteriorate when altitude of the vehicle position changes.
- The position of GPS satellite affects GPS detection precision. The position detection may not be precisely performed.
- The position detection is not performed if GPS receiver does not receive radio waves from GPS satellites. (Inside a tunnel, parking in a building, under an elevated highway etc.) GPS receiver may not receive radio waves from GPS satellites if any object is placed on the GPS antenna.

### NOTE:

- The detection result has an error of approximately 10 m (32.81 ft) even with a high-precision three dimensional positioning.
- There may be cases when the accuracy is lowered and radio waves are stopped intentionally because the GPS satellite signal is controlled by the US trace control center.

## AUDIO FUNCTION

The audio system is equipped with the following functions. Each function is operated with multifunction switch, preset switch, touch panel, steering switch or audio recognition. Operation status of audio is indicated at display.

FUNCTION
AM/FM radio
Satellite radio
CD
Bluetooth™ audio
Music Box (Hard Disk Drive)
AudioPilot™
Sound equalizer automatic switching

### Operating Signal

Audio system operation can be performed with multifunction switch, preset switch, steering switch, touch panel function or voice recognition function.

- Operating signal is transmitted to AV control unit with AV communication when it is operated by multifunction switch or preset switch. The disk ejection operating signal is performed by hardware.
- Operating signal is transmitted to AV control unit with steering switch signal when it is operated by steering switch.

### Screen Display

Switching of display is performed with serial communication between display unit and AV control unit.

### AM/FM Radio Mode

- AM/FM radio tuner is built into AV control unit.
- Audio signal is received by rod antenna, next it is amplified by antenna amp., and finally it is input to AV control unit. Audio signal is input to BOSE amp., and BOSE amp. outputs to each speaker.

### Satellite Radio Mode

- Satellite radio tuner is built into AV control unit.
- Audio signal (satellite radio) is received by satellite antenna, and it is input to AV control unit. AV control unit outputs audio signal to BOSE amp. The signal is also outputted from BOSE amp. to both woofer and each speaker.

### CD Mode

- CD function is built into AV control unit.
- AV control unit outputs audio signal to BOSE amp., and BOSE amp. outputs to each speaker when CD is inserted to AV control unit.

### Bluetooth™ Audio Mode

- Bluetooth™ audio function is built into AV control unit.
- Bluetooth™ audio can play music data in the portable audio by means of Bluetooth™ communications between the portable audio and the AV control unit.
- AV control unit outputs audio signal to BOSE amp., and BOSE amp. outputs to each speaker.

A  
B  
C  
D  
E  
F  
G  
H  
I  
J  
K  
L  
M  
O  
P

AV

# SYSTEM

## < SYSTEM DESCRIPTION >

## [BOSE AUDIO WITH NAVIGATION]

### Music Box Mode

- Music CD data is stored on HDD that is built into AV control unit, and it can be played.
- AV control unit outputs music (sound signal) that is stored on HDD to BOSE amp., and BOSE amp. outputs to each speaker.

### AudioPilot™

AudioPilot™ is a sound improving system that picks up by a microphone in a driver headrest any noises or the sound of music coming into the vehicle, and that uses the BOSE amp. to revise the frequency feature of music in real time in response to the frequency feature of the noise while driving and listening to music.

- If the low frequency area noise from the vehicle is loud, it adjusts the low frequency element of music to be larger than the vehicle noise.
- If the high frequency area noise from the vehicle is loud, it adjusts the high frequency element of music to be larger than the vehicle noise.
- If the vehicle noise is smaller than the setting volume, correction is not performed. This eliminates the vehicle noise when listening to music.

### Sound Equalizer Automatic Switching Function

Sound quality in a fully-open retractable hard top condition is improved by the correction for bringing the frequency characteristics in a fully-open retractable hard top condition closer to the characteristics in a fully-closed retractable hard top condition. When the retractable hard top is in a fully-open condition, sound pressure is reduced due to the absence of sound echo generated by sound reflection from the retractable hard top. BOSE amp. detects an open-close condition of the retractable hard top by receiving a roof status signal from the retractable hard top control unit and switches the equalizer to correct the frequency characteristics in a fully-open retractable hard top condition. During the switching of the equalizer, audio stops temporarily due to the temporary mute.

### DVD PLAY FUNCTION

- DVD is played by inserting DVD into the AV control unit.
- DVD image signals are transmitted to the display unit and DVD sound signals are transmitted to each speaker via BOSE amp.

### HANDS-FREE PHONE FUNCTION

- AV control unit includes hands-free phone function.
- Hands-free communication can be operated by connecting using Bluetooth™ communication with cellular phone.
- Operation is performed by steering switch, and operating condition is indicated on display.
- Guide sound that is heard during operation is input from AV control unit to BOSE amp., and is output from front speaker and center speaker.
- System operation is available only when the retractable hard top is closed.

### When A Call Is Originated

Spoken voice sound output from the microphone (microphone signal) is input to AV control unit. AV control unit outputs to cellular phone with Bluetooth™ communication as a TEL voice signal. Voice sound is then heard at the other party.

### When Receiving A Call

Voice sound is input to own cellular phone from the other party. TEL voice signal is output to door speaker, and the signal is input to BOSE amp. via AV control unit by establishing Bluetooth™ communication from cellular phone.

### USB CONNECTION FUNCTION

- Connecting iPod® or USB memory allows the driver to play iPod® music files or USB memory-stored music files, video data, and image viewer data.
- Sound signals of music files stored in iPod® or USB memory are transmitted from the USB connector to the AV control unit. The AV control unit transmits the sound signals to the woofer and each speaker via BOSE amp.
- Video signals and image viewer file signals are transmitted from the USB connector to the AV control unit. The data and files are displayed on the front display unit screen.
- iPod® is recharged when connected to USB connector.
- Only files that meet the following conditions will be played.

# SYSTEM

< SYSTEM DESCRIPTION >

[BOSE AUDIO WITH NAVIGATION]

	Music file	Video file	Image viewer file
File format	"MP3", "WMA", "AAC", "M4A"	"DivX", "MPEG4 (ASF)"	"JPEG"
File extension	".mp3", ".wma", ".aac", ".m4a"	".divx", ".afs", ".avi"	".jpg", ".jpeg"
Maximum file size	2 GB	2 GB	2 MB

## NOTE:

- iPod® is a trademark of Apple inc., registered in the U.S. and other countries.
- Image signals cannot be received from iPod®.
- Use the enclosed USB harness when connecting iPod® to USB connector.

## VOICE RECOGNITION FUNCTION

- Each operation of multi AV system can be performed by inputting sound to microphone.
- Start of sound recognition system can be performed by steering switch.
- System operation is available only when the retractable hard top is closed.

## TOUCH PANEL SYSTEM

Each operation of multi AV system can be performed by directly touching a display.

## REAR VIEW MONITOR FUNCTION

- The AV control unit supplies power to the rear view camera when receiving a reverse signal.
- The rear view camera transmits camera images to the display unit when power is supplied from the AV control unit.
- The AV control unit transmits a warning message, fixed guide lines, and predictive course lines to the display unit by RGB digital image signal. Rear view monitor images are displayed by combining the RGB digital image signal and the camera image signals from the rear view camera.
- Predictive course lines are controlled by a steering angle sensor signal received the AV control unit via CAN communication.

## SONAR SYSTEM

For further information about the sonar system, refer to [SN-7. "System Description"](#).

## VEHICLE INFORMATION FUNCTION

- Status of audio, climate control system, fuel economy, maintenance and navigation are displayed.
- AV control unit displays the fuel consumption status while receiving data signal through CAN communication from ECM, unified meter and A/C amp.
- AV control unit is connected to BCM via CAN communication transmitting/receiving for the vehicle settings function.

## MULTI AV SYSTEM : Fail-Safe

INFOID:000000006472664

When the ambient temperature becomes extremely low or extremely high, AV control unit displays the message and limits the AV control unit function.

## FAIL-SAFE CONDITIONS

When the ambient temperature is -20°C (-4°F) or lower, or when it is 70°C (158°F) or higher

Display

The messages displayed on fail-safe conditions are as shown below:

Fail-safe mode	Display (display of the fail-safe condition)
When HDD temperature is low	HDD system is experiencing problems due to extreme low temperature. Normal operation will resume when temperature rises.
When HDD temperature is high	HDD system is experiencing problems due to extreme high temperature. Normal operation will resume when temperature drops.

## DESCRIPTION OF CONTROLS

A  
B  
C  
D  
E  
F  
G  
H  
I  
J  
K  
L  
M  
O  
P

AV

# SYSTEM

< SYSTEM DESCRIPTION >

[BOSE AUDIO WITH NAVIGATION]

Function		When Fail-safe Function is activated
Air conditioner	Operation	Only multifunction switch (preset switch) can be operated.
	Display	<ul style="list-style-type: none"><li>• LED of multifunction switch (preset switch) illuminates.</li><li>• Aired temperature, blow angle, and flow rate are displayed in simplified mode.</li></ul>
Audio	Operation	Only ON/OFF and volume control operations by multifunction switch (preset switch) are possible.
	Display	No display ("Fail-safe mode" is displayed)
Camera	Operation	Image tone cannot be controlled.
	Display	Cannot be superimposed. (warning display, tone control display)
Hands-free phone	Operation	Cannot be operated.
Navigation	Operation	Cannot be operated.
Self diagnosis		The display in simplified mode of fail-safe condition
CONSULT-III diagnosis		Cannot be operated.

## Ability Operation Mode

There is an ability operation mode for Fail-safes due to low or high ambient temperature.

If HDD data can be read, fail-safe is shown, then normal displays are displayed only for functions which can be operated.

## RELEASE CONDITIONS OF FAIL-SAFE

Fail-safe is released on following conditions and normal mode is restored.

When The Temperature of HDD Is Low or High

If the ambient temperature becomes out of fail-safe condition range, normal mode is restored.

# DIAGNOSIS SYSTEM (AV CONTROL UNIT)

[BOSE AUDIO WITH NAVIGATION]

< SYSTEM DESCRIPTION >

## DIAGNOSIS SYSTEM (AV CONTROL UNIT)

### Description

INFOID:000000006472665

- The AV control unit diagnosis function starts up with multifunction switch operation and the AV control unit performs a diagnosis for each unit in the system during the on board diagnosis.
- Perform a CONSULT-III diagnosis if the on board diagnosis does not start, e.g., the screen does not display anything, the multifunction switch does not function, etc.

### On Board Diagnosis Function

INFOID:000000006472666

#### MULTIFUNCTION SWITCH AND PRESET SWITCH SELF-DIAGNOSIS FUNCTION

The ON/OFF operation (continuity) of each switch in the multifunction switch and preset switch can be checked.

##### Self-diagnosis Mode

- Press the “BACK” switch and the “UP” switch of the 8-direction switches within 10 seconds after turning the ignition switch from OFF to ACC and hold them for 3 seconds or more. Then the buzzer sounds, all indicators of the preset switch illuminate, and the self-diagnosis mode starts.
- The continuity of each switch at the ON position can be checked by pressing the switch. The buzzer sounds if the switch is normal.

**NOTE:**

The hazard switch and disk eject switch cannot be checked.

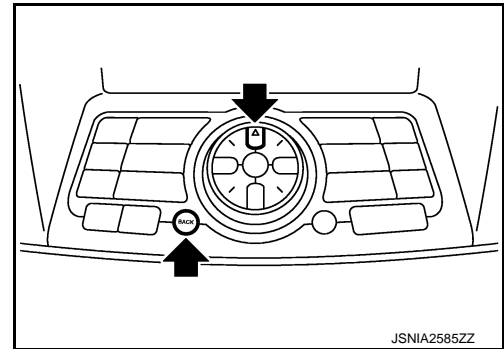

##### Finishing Self-diagnosis Mode

Self-diagnosis mode is canceled when turning the ignition switch OFF.

### ON BOARD DIAGNOSIS ITEM

#### Description

- The trouble diagnosis function has a self-diagnosis mode for conducting trouble diagnosis automatically and a confirmation/adjustment mode for operating manually.
- The self-diagnosis mode performs diagnoses on the AV control unit, connections between system components as well as connections between AV control unit and GPS antenna. Then it displays the diagnosis results on the display.
- The confirmation/adjustment mode allows the technician to check, modify or adjust the vehicle signals and set values, as well as to monitor the system error records and system communication status. The checking, modifying or adjusting generally require human intervention and judgment (the system cannot make judgment automatically).

#### On Board Diagnosis Item

Mode	Description
Self Diagnosis	<ul style="list-style-type: none"><li>• AV control unit diagnosis.</li><li>• Diagnoses the connections across system components, between AV control unit and GPS antenna.</li></ul>

A  
B  
C  
D  
E  
F  
G  
H  
I  
J  
K  
L  
M  
O  
P

AV

# DIAGNOSIS SYSTEM (AV CONTROL UNIT)

< SYSTEM DESCRIPTION >

[BOSE AUDIO WITH NAVIGATION]

Mode		Description	
Confirmation/ Adjustment	Display Diagnosis	The following check functions are available: color tone check by color bar display and white display, light and shade check by gray scale display and touch panel calibration response check.	
	Vehicle Signals	Diagnosis of signals can be performed for vehicle speed, parking brake, lights, ignition, reverse, side view switch and room lamp.	
	Climate Control	Start auto air conditioner system self-diagnosis.	
	Navigation	Steering Angle Adjustment	When there is a difference between the actual turning angle and the vehicle mark turning angle, it can be adjusted.
		Speed Calibration	When there is a difference between the current location mark and the actual location, it can be adjusted.
		XM SAT Subscription Status	The XM NavTraffic subscription status can be checked.
	Error History	The system malfunction and the frequency when occurring in the past are displayed. When the malfunctioning item is selected, the time and place that the selected malfunction last occurred are displayed.	
	Synchronizer FES Clock	-	
	Speaker Test	The connection of a speaker can be confirmed by test tone.	
	Vehicle CAN Diagnosis	The transmitting/receiving of CAN communication can be monitored.	
	AV COMM Diagnosis	The communication condition of each unit of Multi AV system can be monitored.	
	Hands-free Phone	The received volume adjustment of hands-free phone, microphone speaker check, and erase memory can be performed.	
	Camera Cont.	The signal connected to camera control unit can be checked and the guiding line position that overlaps rear view camera image can be adjusted.	
	XM	XM NaviTraffic	Change Channel
		XM NavWeather	• Any necessary channels required to receive traffic information from the satellite radio system can be set.
		XM CGS	Change Application ID
		Diag	• Any application ID's required to receive traffic information from the satellite radio system can be set.
Delete Unit Connection Log	Erase the connection history of unit and error history.		
Initialize Settings	Initializes the AV control unit memory.		
Version Information	Version information of the AV control unit is displayed.		

## METHOD OF STARTING

1. Start the engine.
2. Turn the audio system OFF.
3. While pressing the "SETTING" button, turn the volume control dial clockwise or counterclockwise for 40 clicks or more. (When the self-diagnosis mode is started, a short beep will be heard.)
  - Shifting from current screen to previous screen is performed by pressing "BACK" button.

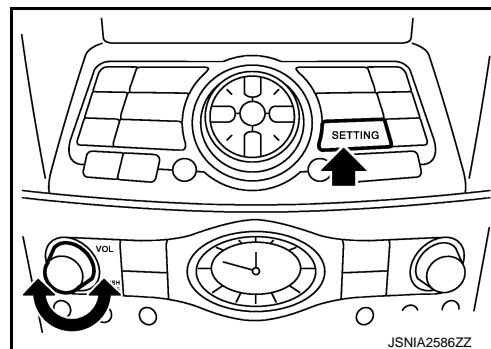



# DIAGNOSIS SYSTEM (AV CONTROL UNIT)

[BOSE AUDIO WITH NAVIGATION]

## < SYSTEM DESCRIPTION >

- The trouble diagnosis initial screen is displayed, and then the items of "Self Diagnosis" and "Confirmation/Adjustment" can be selected.

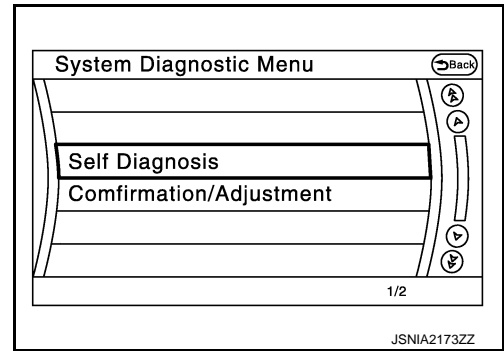

## SELF-DIAGNOSIS MODE

- Start the self-diagnosis function and select "Self Diagnosis".
  - Self-diagnosis subdivision screen is displayed, and the self-diagnosis mode starts.
  - The bar graph visible on the center of the self-diagnosis subdivision screen indicates progress of the trouble diagnosis.
- Diagnosis results are displayed after the self-diagnosis is completed. The unit names and the connection lines are color-coded according to the diagnostic results.

Diagnosis results	Unit	Connection line
Normal	Green	Green
Connection malfunction	Gray	Yellow
Unit malfunction <sup>Note</sup>	Red	Green

### NOTE:

Control unit (AV control unit) and amplifier (BOSE amp.) are displayed in red.

- Replace AV control unit if "Self-Diagnosis did not run because of a control unit malfunction" is indicated. The symptom is AV control unit internal error. Refer to [AV-413, "Exploded View"](#).
- If multiple errors occur at the same time for a single unit, the screen switch colors are determined according to the following order of priority: red > gray.

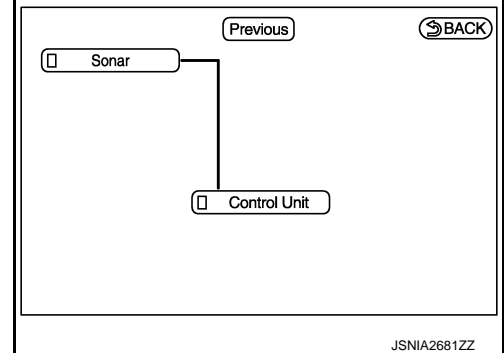
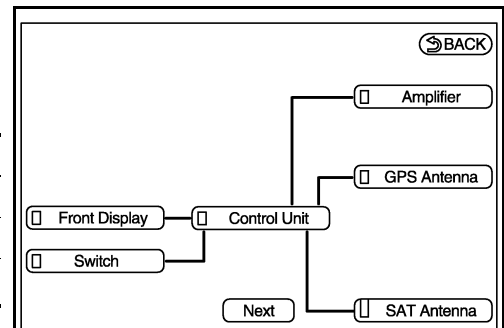

- The comments of the self-diagnosis results can be viewed with a component in the diagnosis result screen.

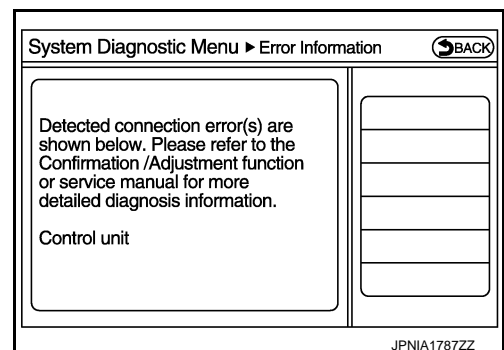

## Detection Range of Self-diagnosis Mode

- The self-diagnosis mode allows the technician to diagnose the connection in the communication line between AV control unit and each unit and the internal operation of the AV control unit.
- Because the start condition of diagnosis function is a switch operation, the on board diagnosis function cannot be started up if any malfunction is detected in the communication circuit between AV control unit and multifunction switch.

# DIAGNOSIS SYSTEM (AV CONTROL UNIT)

[BOSE AUDIO WITH NAVIGATION]

< SYSTEM DESCRIPTION >

## SELF-DIAGNOSIS RESULTS

Check the applicable display at the following table, and then repair the malfunctioning parts.

Only Unit Part Is Displayed In Red.

Screen switch	Description	Possible malfunction location / Action to take
Control Unit	Malfunction is detected in AV control unit power supply and ground circuits.	Check AV control unit power supply and ground circuits. When detecting no malfunction in those components, replace AV control unit. Refer to <a href="#">AV-413, "Exploded View"</a> .
Amplifier	When either one of the following items are detected: <ul style="list-style-type: none"> <li>• sound signal circuits between BOSE amp. and each speaker are malfunctioning.</li> <li>• BOSE amp. malfunction is detected.</li> </ul>	<ul style="list-style-type: none"> <li>• Malfunctioning speaker circuits</li> <li>• Replace BOSE amp. Refer to <a href="#">AV-422, "Exploded View"</a>.</li> </ul>

A Connecting Cable Between Units Is Displayed In Yellow.

Area with yellow connection lines	Description	Possible malfunction location / Action to take
Control unit ↔ Front Display	Malfunction is detected in serial communication circuits between AV control unit and display unit.	Serial communication circuits between AV control unit and display unit.
Control unit ↔ GPS Antenna	GPS antenna connection malfunctions detected.	GPS antenna
Control unit ↔ SAT Antenna	Satellite radio antenna connection malfunction is detected.	Satellite radio antenna disconnection
Control unit ↔ Sonar	When either one of the following items are detected: <ul style="list-style-type: none"> <li>• sonar control unit power supply and ground circuits are malfunctioning.</li> <li>• AV communication circuits between AV control unit and sonar control unit are malfunctioning.</li> </ul>	<ul style="list-style-type: none"> <li>• Sonar control unit power supply and ground circuits.</li> <li>• AV communication circuits between AV control unit and sonar control unit.</li> </ul>
Control unit ↔ Amplifier	When either one of the following items are detected: <ul style="list-style-type: none"> <li>• BOSE amp. power supply and ground circuits are malfunctioning.</li> <li>• AV communication circuits between sonar control unit and BOSE amp. are malfunctioning.</li> </ul>	<ul style="list-style-type: none"> <li>• BOSE amp. power supply and ground circuits.</li> <li>• AV communication circuits between sonar control unit and BOSE amp.</li> </ul>

## CONFIRMATION/ADJUSTMENT MODE

1. Start the diagnosis function and select "Confirmation/Adjustment". The confirmation/adjustment mode indicates where each item can be checked or adjusted.
2. Select each switch on the "Confirmation/Adjustment Mode" screen to display the relevant trouble diagnosis screen. Press the "Back" switch to return to the initial Confirmation/Adjustment Mode screen.

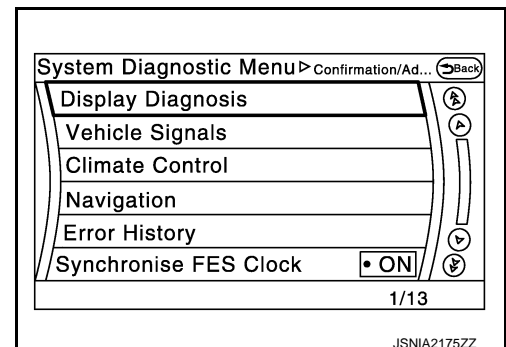

# DIAGNOSIS SYSTEM (AV CONTROL UNIT)

< SYSTEM DESCRIPTION >

[BOSE AUDIO WITH NAVIGATION]

## Display Diagnosis

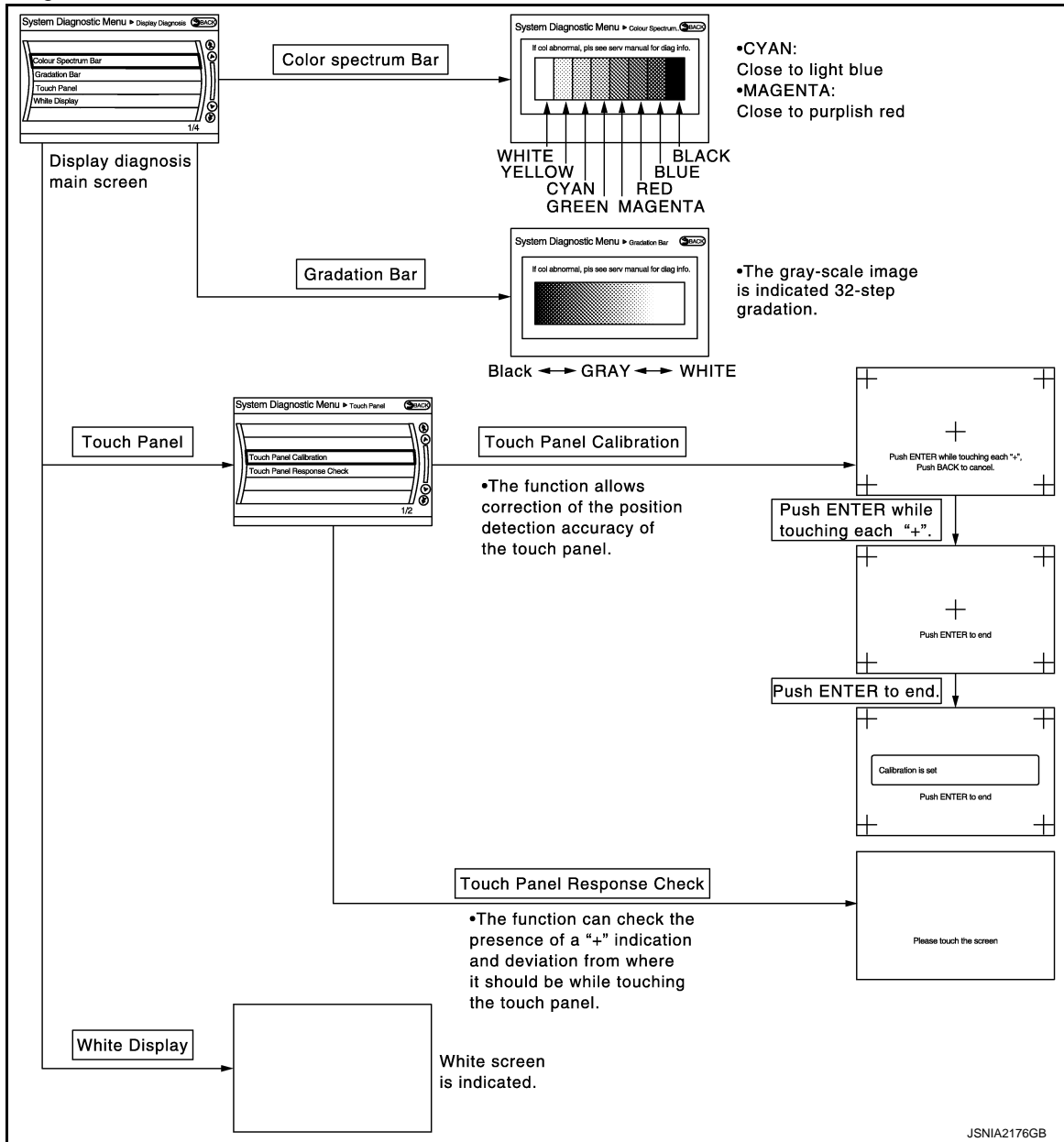

## Vehicle Signals

A comparison check can be made of each actual vehicle signal and the signals recognized by the system.

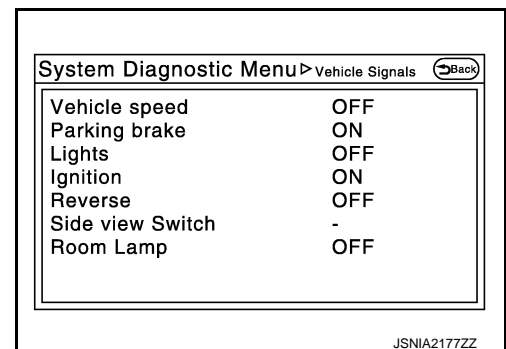

A  
B  
C  
D  
E  
F  
G  
H  
I  
J  
K  
L  
M  
AV  
O  
P

# DIAGNOSIS SYSTEM (AV CONTROL UNIT)

< SYSTEM DESCRIPTION >

[BOSE AUDIO WITH NAVIGATION]

Diagnosis item	Display	Vehicle status	Remarks
Vehicle speed	ON	Vehicle speed > 0 km/h (0 MPH)	Changes in indication may be delayed. This is normal.
	OFF	Vehicle speed = 0 km/h (0 MPH)	
Parking brake	ON	Parking brake is applied.	
	OFF	Parking brake is released.	
Lights	ON	Light switch ON	—
	OFF	Light switch OFF	—
Ignition	ON	Ignition switch ON	—
	OFF	Ignition switch in ACC position	—
Reverse	ON	Shift the selector lever to “R” position	Changes in indication may be delayed. This is normal.
	OFF	Shift the selector lever other than “R” position	
SIDE VIEW SW	—	—	This item is displayed, but cannot be monitored.
ROOM LAMP	OFF	—	This item is displayed, but cannot be monitored.

## Climate Control

Refer to “HEATER & AIR CONDITIONING CONTROL SYSTEM” for details.

## Navigation

### STEERING ANGLE ADJUSTMENT

The steering angle output value detected with the gyroscope is adjusted.

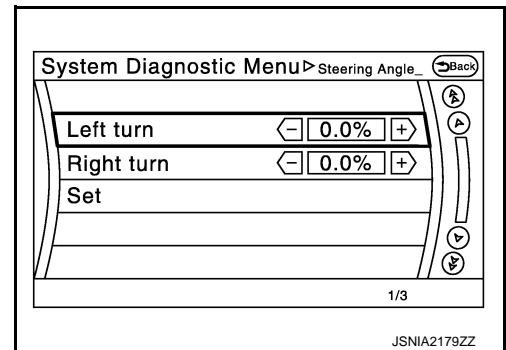

### SPEED CALIBRATION

During normal driving, distance error caused by tire wear and tire pressure change is automatically adjusted for by the automatic distance correction function. This function, on the other hand, is for immediate adjustment, in cases such as driving with tire chain fitted on tires.

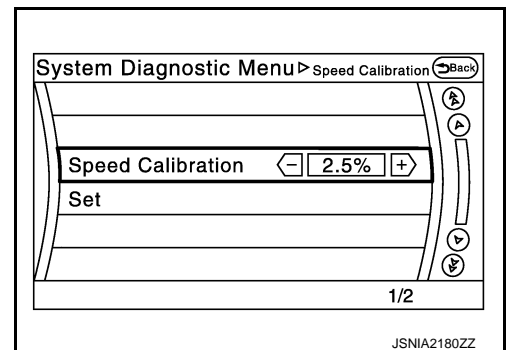

### XM SAT SUBSCRIPTION STATUS

The XM NavTraffic subscription status can be checked.

### Error History

The self-diagnosis results are judged depending on whether any error occurs from when “Self-diagnosis” is selected until the self-diagnosis results are displayed.

However, the diagnosis results are judged normal if an error has occurred before the ignition switch is turned ON and then no error has occurred until the self-diagnosis start. Check the “Error Record” to detect any error that may have occurred before the self-diagnosis start because of this situation.

# DIAGNOSIS SYSTEM (AV CONTROL UNIT)

[BOSE AUDIO WITH NAVIGATION]

## < SYSTEM DESCRIPTION >

The error record displays the time and place of the most recent occurrence of that error. However, take note of the following points.

- If there is a malfunction with the GPS antenna circuit board in the AV control unit, the correct date and time of occurrence may not be displayed.
- Place of the error occurrence is represented by the position of the current location mark at the time an error occurred. If current location mark has deviated from the correct position, then the place of the error occurrence cannot be located correctly.
- The frequency of occurrence is displayed in a count up manner. The actual count up method differs depending on the error item.

### Count up method A

- The counter resets to 0 if an error occurs when ignition switch is turned ON. The counter increases by 1 if the condition is normal at a next ignition ON cycle.
- The counter upper limit is 39. Any counts exceeding 39 are ignored. The counter can be reset (no error record display) with the "Delete log" switch or CONSULT-III.

### Count up method B

- The counter increases by 1 if an error occurs when ignition switch is ON. The counter will not decrease even if the condition is normal at the next ignition ON cycle.
- The counter upper limit is 50. Any counts exceeding 50 are ignored. The counter can be reset (no error record display) with the "Delete log" switch or CONSULT-III.

Display type of occurrence frequency	Error history display item
Count up method A	CAN communication line, control unit (CAN), AV communication line, control unit (AV)
Count up method B	Other than the above

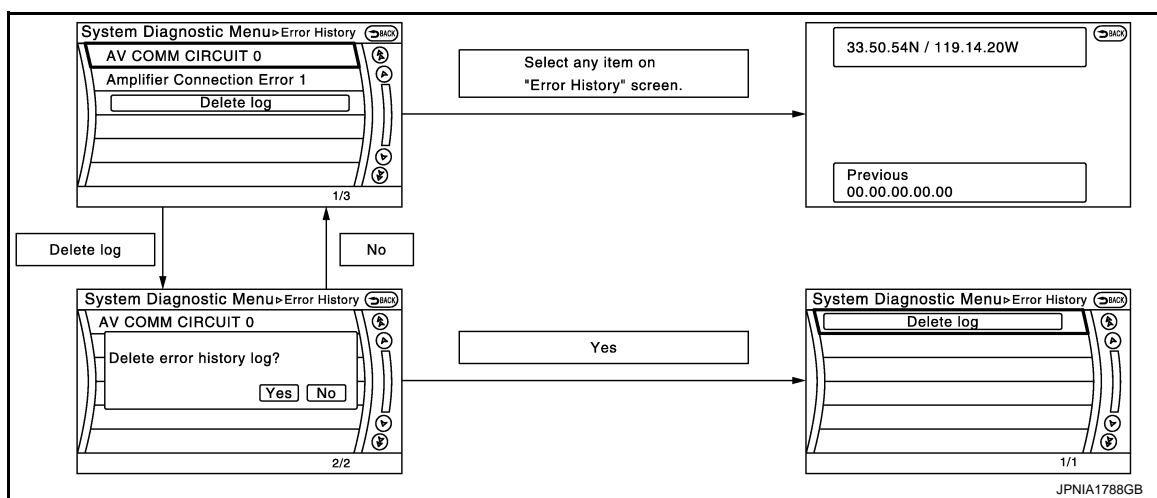

### Error item

Some error items may be displayed simultaneously according to the cause. If some error items are displayed simultaneously, the detection of the cause can be performed by the combination of display items

Error item	Description	Possible malfunction factor/Action to take
CAN COMM CIRCUIT	CAN communication malfunction is detected.	Perform diagnosis with CONSULT-III, and then repair the malfunctioning parts according to the diagnosis results. Refer to <a href="#">AV-300. "CONSULT - III Function"</a> .

# DIAGNOSIS SYSTEM (AV CONTROL UNIT)

< SYSTEM DESCRIPTION >

[BOSE AUDIO WITH NAVIGATION]

Error item	Description	Possible malfunction factor/Action to take
CONTROL UNIT (CAN)	CAN initial diagnosis malfunction is detected.	Replace the AV control unit if the malfunction occurs constantly. Refer to <a href="#">AV-413, "Exploded View"</a> .
CONTROL UNIT (AV)	AV communication circuit initial diagnosis malfunction is detected.	
FLASH-ROM Error Of Control Unit	AV control unit malfunction is detected.	
Connection Of Gyro		
Connection of G Sensor		
CAN Controller Memory Error		
Bluetooth Module Connection Error		
Sub CPU Connection Error		
iPod authentication chip error		
Audio connection error		
DSP Connection Error	AV control unit malfunction is detected.	<ul style="list-style-type: none"> <li>• If a disc can be played, then there is a possibility of the detection of a temporary malfunction.</li> <li>• Replace the AV control unit if the malfunction occurs constantly. Refer to <a href="#">AV-413, "Exploded View"</a>.</li> </ul>
DSP Communication Error		
HDD Connection Error	AV control unit malfunction is detected.	<ul style="list-style-type: none"> <li>• If the music box function has no malfunctions, then there is a possibility of the detection of a temporary malfunction.</li> <li>• Replace the AV control unit if the malfunction occurs constantly. Refer to <a href="#">AV-413, "Exploded View"</a>.</li> </ul>
HDD Read Error		
HDD Write Error		
HDD Communication Error		
HDD Access Error		
GPS Communication Error	GPS malfunction is detected.	An intermittent error caused by strong radio interference may be detected unless any symptom (GPS reception error, etc.) occurs. Replace the AV control unit if the malfunction occurs constantly. Refer to <a href="#">AV-413, "Exploded View"</a> .
GPS ROM Error		
GPS RAM Error		
GPS RTC Error		
Unfinished configuration	The writing of configuration data is incomplete.	Write configuration data with CONSULT-III. Refer to <a href="#">AV-300, "CONSULT - III Function"</a> .
USB Controller Communication Error	USB connection malfunction is detected.	Check that the connection to the USB connector is normal.
DVD Mechanism Communication Error	AV control unit malfunction is detected.	<ul style="list-style-type: none"> <li>• If DVD can be played, then there is a possibility of the detection of a temporary malfunction.</li> <li>• Replace the AV control unit if the malfunction occurs constantly. Refer to <a href="#">AV-413, "Exploded View"</a>.</li> </ul>
Steer. Angle Sensor Calibration	Predictive course line center position adjustment of the steering angle sensor is incomplete.	Adjust the predictive course line center position of the steering angle sensor. Refer to <a href="#">AV-300, "CONSULT - III Function"</a> .
Amplifier Temperature Error	BOSE amp. malfunction is detected.	Replace the BOSE amp. Refer to <a href="#">AV-422, "Exploded View"</a> .
Front Display Connection Error	When either one of the following items are detected: <ul style="list-style-type: none"> <li>• display unit power supply and ground circuits are malfunctioning.</li> <li>• communication circuits between AV control unit and display unit are malfunctioning.</li> </ul>	<ul style="list-style-type: none"> <li>• Display unit power supply and ground circuits.</li> <li>• Communication circuits between AV control unit and display unit.</li> </ul>
GPS Antenna Error	GPS antenna connection malfunction is detected.	Check the connection of the GPS antenna connector.

# DIAGNOSIS SYSTEM (AV CONTROL UNIT)

< SYSTEM DESCRIPTION >

[BOSE AUDIO WITH NAVIGATION]

Error item	Description	Possible malfunction factor/Action to take	
XM Antenna Connection Error	Satellite radio antenna connection malfunction is detected.	Satellite radio antenna disconnection.	A
USB electric current Error	Detection of overcurrent in USB connector.	Check USB harness between the AV control unit and USB connector.	B
AM/FM antenna amplifier short to ground	Antenna amp. ON signal circuit malfunction is detected.	Antenna amp. ON signal circuit between AV control unit and antenna base.	C
AM/FM antenna amplifier open			
Center speaker OUT: open	Malfunction is detected sound signal circuits between BOSE amp. and center speaker.	Sound signal circuits between BOSE amp. and center speaker.	D
Center speaker OUT: short			
Center speaker OUT: short to ground			
Center speaker OUT: short to battery			
FR speaker OUT: open	When either one of the following items is detected: <ul style="list-style-type: none"> <li>• sound signal circuits between BOSE amp. and door squawker RH are malfunctioning.</li> <li>• sound signal circuits between BOSE amp. and tweeter RH are malfunctioning.</li> </ul>	<ul style="list-style-type: none"> <li>• Sound signal circuits between BOSE amp. and door squawker RH.</li> <li>• Sound signal circuits between BOSE amp. and tweeter RH.</li> </ul>	E
FR speaker OUT: short			
FR speaker OUT: short to ground			
FR speaker OUT: short to battery			
FR sub woofer OUT: open	Malfunction is detected sound signal circuits between BOSE amp. and door woofer RH.	Sound signal circuits between BOSE amp. and door woofer RH.	G
FR sub woofer OUT: short			
FR sub woofer OUT: short to ground			
FR sub woofer OUT: short to battery			
RR sub woofer OUT: open	Malfunction is detected sound signal circuits between BOSE amp. and rear woofer RH.	Sound signal circuits between BOSE amp. and rear woofer RH.	I
RR sub woofer OUT: short			
RR sub woofer OUT: short to ground			
RR sub woofer OUT: short to battery			
RL sub woofer OUT: open	Malfunction is detected sound signal circuits between BOSE amp. and rear woofer LH.	Sound signal circuits between BOSE amp. and rear woofer LH.	J
RL sub woofer OUT: short			
RL sub woofer OUT: short to ground			
RL sub woofer OUT: short to battery			
FL sub woofer OUT: open	Malfunction is detected sound signal circuits between BOSE amp. and door woofer LH.	Sound signal circuits between BOSE amp. and door woofer LH.	L
FL sub woofer OUT: short			
FL sub woofer OUT: short to ground			
FL sub woofer OUT: short to battery			
FL speaker OUT: open	When either one of the following items is detected: <ul style="list-style-type: none"> <li>• sound signal circuits between BOSE amp. and door squawker LH are malfunctioning.</li> <li>• sound signal circuits between BOSE amp. and tweeter LH are malfunctioning.</li> </ul>	<ul style="list-style-type: none"> <li>• Sound signal circuits between BOSE amp. and door squawker LH.</li> <li>• Sound signal circuits between BOSE amp. and tweeter LH.</li> </ul>	M
FL speaker OUT: short			
FL speaker OUT: short to ground			
FL speaker OUT: short to battery			
FL seat SP(L) OUT: open	Malfunction is detected sound signal circuits between BOSE amp. and driver headrest speaker LH.	Sound signal circuits between BOSE amp. and driver headrest speaker LH.	O
FL seat SP(L) OUT: short			
FL seat SP(L) OUT: short to ground			
FL seat SP(L) OUT: short to battery			
FL seat SP(R) OUT: open	Malfunction is detected sound signal circuits between BOSE amp. and driver headrest speaker RH.	Sound signal circuits between BOSE amp. and driver headrest speaker RH.	P
FL seat SP(R) OUT: short			
FL seat SP(R) OUT: short to ground			
FL seat SP(R) OUT: short to battery			

A  
B  
C  
D  
E  
F  
G  
H  
I  
J  
K  
L  
M  
O  
P

AV

# DIAGNOSIS SYSTEM (AV CONTROL UNIT)

< SYSTEM DESCRIPTION >

[BOSE AUDIO WITH NAVIGATION]

Error item	Description	Possible malfunction factor/Action to take
FR seat SP(L) OUT: open	Malfunction is detected sound signal circuits between BOSE amp. and passenger headrest speaker LH.	Sound signal circuits between BOSE amp. and passenger headrest speaker LH.
FR seat SP(L) OUT: short		
FR seat SP(L) OUT: short to ground		
FR seat SP(L) OUT: short to battery		
FR seat SP(R) OUT: open	Malfunction is detected sound signal circuits between BOSE amp. and passenger headrest speaker RH.	Sound signal circuits between BOSE amp. and passenger headrest speaker RH.
FR seat SP(R) OUT: short		
FR seat SP(R) OUT: short to ground		
FR seat SP(R) OUT: short to battery		
Compensat. mic IN: open	Malfunction is detected sound signal circuits between BOSE amp. and microphone (for AudioPilot™).	Sound signal circuits between BOSE amp. and microphone (for AudioPilot™).
Compensat. mic IN: short		
Compensat. mic IN: short to ground		
Compensat. mic IN: short to battery		
<ul style="list-style-type: none"> <li>• AV COMM CIRCUIT</li> <li>• Switches Connection Error</li> </ul>	When either one of the following items are detected: <ul style="list-style-type: none"> <li>• multifunction switch power supply and ground circuits are malfunctioning.</li> <li>• AV communication circuits between AV control unit and multifunction switch are malfunctioning.</li> </ul>	<ul style="list-style-type: none"> <li>• Multifunction switch power supply and ground circuits.</li> <li>• AV communication circuits between AV control unit and multifunction switch.</li> </ul>
<ul style="list-style-type: none"> <li>• AV COMM CIRCUIT</li> <li>• Sonar Connection Error</li> </ul>	When either one of the following items are detected: <ul style="list-style-type: none"> <li>• sonar control unit power supply and ground circuits are malfunctioning.</li> <li>• AV communication circuits between AV control unit and sonar control unit are malfunctioning.</li> </ul>	<ul style="list-style-type: none"> <li>• Sonar control unit power supply and ground circuits.</li> <li>• AV communication circuits between AV control unit and sonar control unit.</li> </ul>
<ul style="list-style-type: none"> <li>• AV COMM CIRCUIT</li> <li>• Amplifier Connection Error</li> </ul>	When either one of the following items are detected: <ul style="list-style-type: none"> <li>• BOSE amp. power supply and ground circuits are malfunctioning.</li> <li>• AV communication circuits between sonar control unit and BOSE amp. are malfunctioning.</li> </ul>	<ul style="list-style-type: none"> <li>• BOSE amp. power supply and ground circuits.</li> <li>• AV communication circuits between sonar control unit and BOSE amp.</li> </ul>
<ul style="list-style-type: none"> <li>• AV COMM CIRCUIT</li> <li>• Switches Connection Error</li> <li>• Sonar Connection Error</li> <li>• Amplifier Connection Error</li> </ul>	AV communication circuits between AV control unit and multifunction switch are malfunctioning.	AV communication circuits between AV control unit and multifunction switch.

## Speaker Test

Select "SPEAKER DIAGNOSIS" to display the Speaker Diagnosis screen. Press "Start" to generate a test tone in a speaker. Press "Start" to generate a test tone in the next speaker. Press "Stop" to stop the test tones.

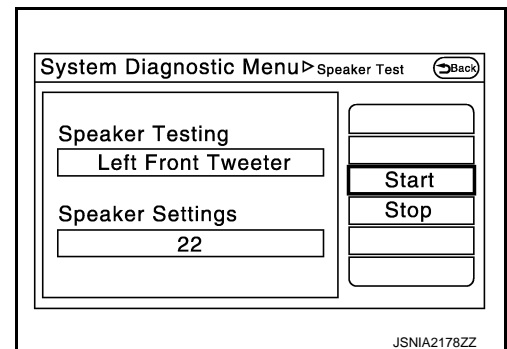

## Vehicle CAN Diagnosis



# DIAGNOSIS SYSTEM (AV CONTROL UNIT)

## [BOSE AUDIO WITH NAVIGATION]

### < SYSTEM DESCRIPTION >

- CAN communication status and error counter is displayed.
- The error counter displays “OK” if any malfunction was not detected in the past and displays “0” if a malfunction is detected. It increases by 1 if the condition is normal at the next ignition switch ON cycle. The upper limit of the counter is 39.
- The error counter is erased if “Reset” is pressed.

Items	Display (Current)	Malfunction counter (Past)
Tx(HVAC)	OK / ???	OK / 0 – 39
Rx(ECM)	OK / ???	OK / 0 – 39
Rx(Cluster)	OK / ???	OK / 0 – 39
Rx(HVAC)	OK / ???	OK / 0 – 39
Rx(USM)	OK / ???	OK / 0 – 39
Rx(STRG)	OK / ???	OK / 0 – 39
Rx(RCU)	OK / ???	OK / 0 – 39

**NOTE:**

“???” indicates UNKWN.

### AV COMM Diagnosis

- Displays the communication status between AV control unit (master unit) and each unit.
- The error counter displays “OK” if any malfunction was not detected in the past and displays “0” if a malfunction is detected. It increases by 1 if the condition is normal at the next ignition switch ON cycle. The upper limit of the counter is 39.
- The error counter is erased if “Reset” is pressed.

Items	Status (Current)	Counter (Past)
C Tx(ITM-PrimarySW)	OK / ???	OK / 0 – 39
C Rx(PrimarySW-ITM)	OK / ???	OK / 0 – 39
C Rx(Amp-ITM)	OK / ???	OK / 0 – 39
C Rx(Amp-Audio)	OK / ???	OK / 0 – 39
C Rx(Sonar-ITM)	OK / ???	OK / 0 – 39

**NOTE:**

“???” indicates UNKWN

### Hands-Free Phone

The hands-free phone reception volume adjustment and microphone and speaker test functions are also available.

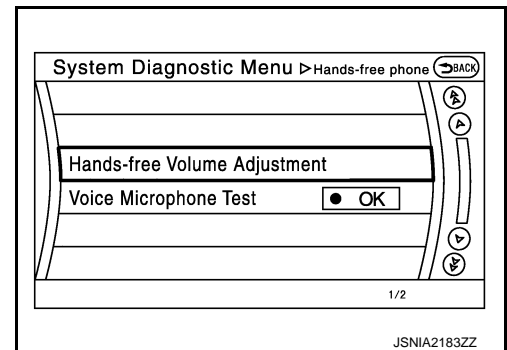
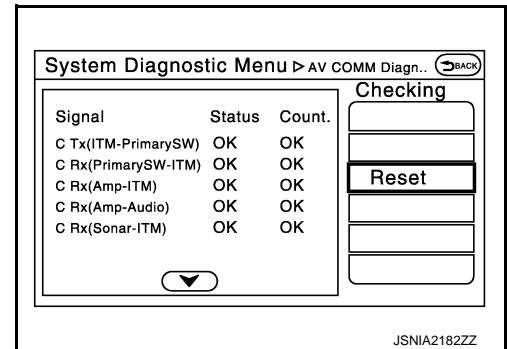
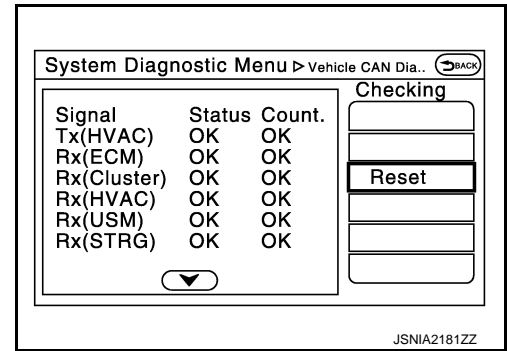

Camera Cont.

A  
B  
C  
D  
E  
F  
G  
H  
I  
J  
K  
L  
M  
AV  
O  
P

# DIAGNOSIS SYSTEM (AV CONTROL UNIT)

## < SYSTEM DESCRIPTION >

## [BOSE AUDIO WITH NAVIGATION]

The four functions of “Correct Draw Line of Rear view Camera”, “Alter/Confirm Configuration”, “Reset Configuration” and “Camera Syst Type” are available.

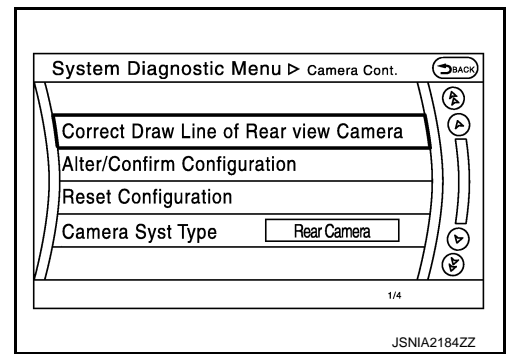

### Correct Draw Line of Rear view Camera

- Use this mode to adjust the guide line display position of the rear view monitor if necessary after removing the rear view monitor camera.

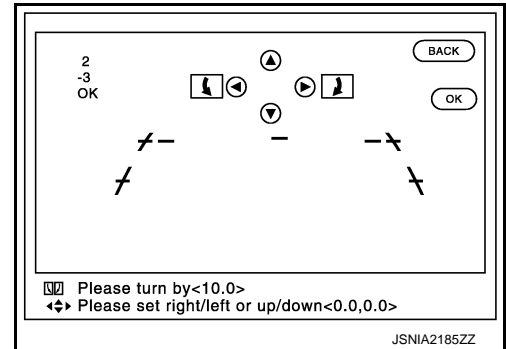

### Alter/Confirm Configuration

- Configuration stored in the AV control unit can be checked and modified.

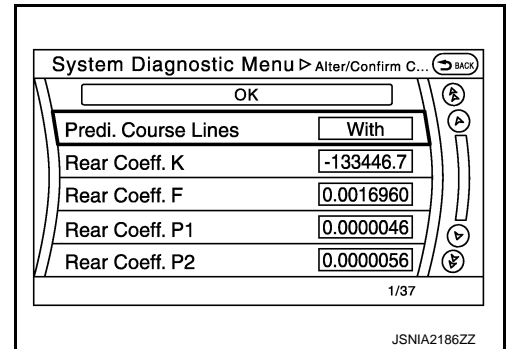

### Configuration list

Setting item	Setting	Setting item	Setting
Predi. Course Lines	With	Wheelbase	2.8499999
Rear Coeff. K	-133446.7	Total Length	0.0000000
Rear Coeff. F	0.0016960	Steering Gear Ratio	14.939999 <sup>*1</sup>
Rear Coeff. P1	0.0000046		16.884000 <sup>*2</sup>
Rear Coeff. P2	0.0000056	Side Coeff. K	0.0000000
Rear Coeff. C1	823.00000	Side Coeff. F	0.0000000
Rear Coeff. C2	480.00000	Side Coeff. P1	0.0000000
Rear Coeff. D1	800.00000	Side Coeff. P2	0.0000000
Rear Coeff. D2	494.00000	Side Coeff. C1	0.0000000
Car Width	1.8500000	Side Coeff. C2	0.0000000
Rear Offset	0.0000000	Side Coeff. D1	0.0000000
Rear Height	0.9852600	Side Coeff. D2	0.0000000
Rear L/R Angle	0.0000000	Side Offset	0.0000000

# DIAGNOSIS SYSTEM (AV CONTROL UNIT)

## < SYSTEM DESCRIPTION >

[BOSE AUDIO WITH NAVIGATION]

Setting item	Setting	Setting item	Setting
Rear Up/Dn Angle	47.869998	Overall Height	0.0000000
Rear Roll Angle	0.0000000	Side L/R Angle	0.0000000
Bumper Rear Dist.	0.1637200	Side Up/Dn Angle	0.0000000
Bumper Rear Ax Dist	0.9650000	Side Roll Angle	0.0000000
Steer. Max Angle	498.69720 <sup>*1</sup>	Side Front End Dist	0.0000000
	563.58789 <sup>*2</sup>	Total Width	0.0000000
Min. Turning Red.	5.5000000	—	—

- \*1: Sport grade or sports premium grade
- \*2: Except for above.

### Reset Configuration

- Configuration stored in the AV control unit can be initialized.

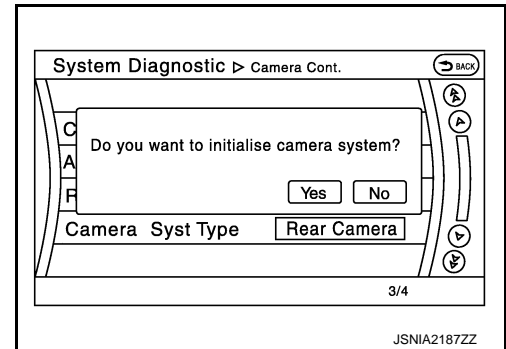

### Camera Syst Type

- Type of camera system is selectable.

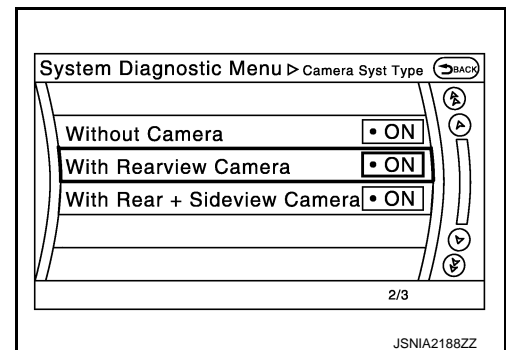

### XM

- Change Channel
  - Any necessary channels required to receive traffic information from the satellite radio system can be set.
- Change Application ID
  - Any application ID'-s required to receive traffic information from the satellite radio system can be set.

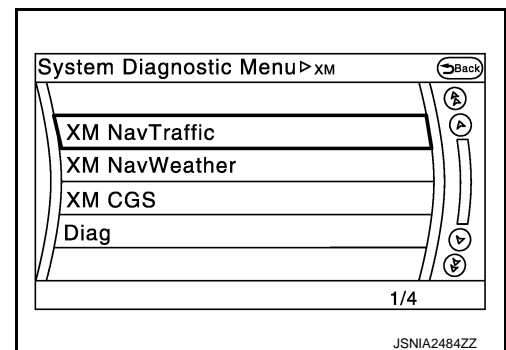

### Delete Unit Connection Log

A  
B  
C  
D  
E  
F  
G  
H  
I  
J  
K  
L  
M  
AV  
O  
P

# DIAGNOSIS SYSTEM (AV CONTROL UNIT)

[BOSE AUDIO WITH NAVIGATION]

## < SYSTEM DESCRIPTION >

Deletes any unit connection records and error records from the AV control unit memory. (Clear the records of the unit that has been removed.)

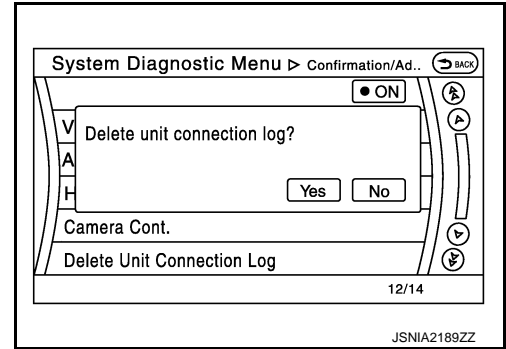

### Initialize Settings

“User Data Initialization” and “Accessory Number Initialization” are possible.

**CAUTION:**

- **Never perform Accessory Number Initialization except when configuration is unsuccessful.**
- **Accessory Number Initialization requires configuration. For details, refer to [AV-344, "Description"](#).**

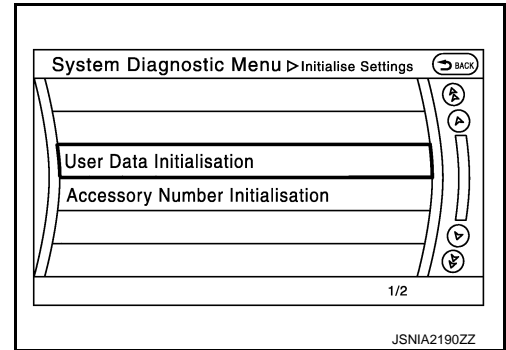

### Version Information

Version information of the AV control unit is displayed.

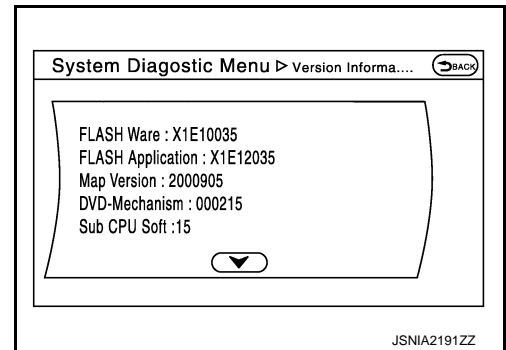

## CONSULT - III Function

INFOID:000000006472667

### APPLICATION ITEMS

CONSULT-III performs the following functions via the communication with the AV control unit.

Diagnosis mode	Description
Ecu Identification	The part number of AV control unit can be checked.
Self Diagnostic Result	Performs a diagnosis on the AV control unit and a connection diagnosis for the communication circuit of the Multi AV system, and displays the current and past malfunctions collectively.
Data Monitor	The diagnosis of vehicle signal that is input to the AV control unit can be performed.
Work Support	Steering angle sensor can be adjusted.
Configuration	<ul style="list-style-type: none"> <li>• Read and save the vehicle specification.</li> <li>• Write the vehicle specification when replacing AV control unit.</li> </ul>

### AV communication

When “AV communication” of “CAN Diag Support Monitor” is selected, the following function will be performed.

AV communication	AV&NAVI C/U	Displays the communication status from AV control unit to each unit as well as the error counter.
	AUDIO	Displays the AV control unit communication status and the error counter.

# DIAGNOSIS SYSTEM (AV CONTROL UNIT)

[BOSE AUDIO WITH NAVIGATION]

< SYSTEM DESCRIPTION >

## ECU IDENTIFICATION

The part number of AV control unit is displayed.

## SELF DIAGNOSIS RESULT

- In CONSULT-III self-diagnosis, self-diagnosis results and error history are displayed collectively.
- The current malfunction indicates “CRNT”. The past malfunction indicates “PAST”.
- The timing is displayed as “0” if any of the error codes [U1000], [U1010], [U1300] and [U1310] is detected. The counter increases by 1 if the condition is normal at the next ignition switch ON cycle.

Self-diagnosis Results Display Item

Error item	Description	Possible malfunction factor/Action to take
CAN COMM CIRCUIT [U1000]	CAN communication malfunction is detected.	Refer to <a href="#">AV-346, "Diagnosis Procedure"</a> .
CONTROL UNIT (CAN) [U1010]	CAN initial diagnosis malfunction is detected.	
CONTROL UNIT (AV) [U1310]	AV communication circuit initial diagnosis malfunction is detected.	
Cont Unit [U1200]	AV control unit malfunction is detected.	Replace the AV control unit if the malfunction occurs constantly. Refer to <a href="#">AV-413, "Exploded View"</a> .
GYRO NO CONN [U1201]		
G-SENSOR NO CONN [U1202]		
CAN CONT [U1216]		
BLUETOOTH MODULE [U1217]		
SUB CPU CONN [U1228]		
iPod CERTIFICATION [U1229]		
Built-in AUDIO CONN [U122E]		
HDD CONN [U1218]	AV control unit malfunction is detected.	<ul style="list-style-type: none"> <li>• If the music box function has no malfunctions, then there is a possibility of the detection of a temporary malfunction.</li> <li>• Replace the AV control unit if the malfunction occurs constantly. Refer to <a href="#">AV-413, "Exploded View"</a>.</li> </ul>
HDD READ [U1219]		
HDD WRITE [U121A]		
HDD COMM [U121B]		
HDD ACCESS [U121C]		
GPS COMM [U1204]	GPS malfunction is detected.	<p>An intermittent error caused by strong radio interference may be detected unless any symptom (GPS reception error, etc.) occurs.</p> <p>Replace the AV control unit if the malfunction occurs constantly. Refer to <a href="#">AV-413, "Exploded View"</a>.</p>
GPS ROM [U1205]		
GPS RAM [U1206]		
GPS RTC [U1207]		
USB CONTROLLER [U1225]	USB connection malfunction is detected.	Check that the connection to the USB connector is normal.
DSP CONN [U121D]	AV control unit malfunction is detected.	<ul style="list-style-type: none"> <li>• If a disc can be played, then there is a possibility of the detection of a temporary malfunction.</li> <li>• Replace the AV control unit if the malfunction occurs constantly. Refer to <a href="#">AV-413, "Exploded View"</a>.</li> </ul>
DSP COMM [U121E]		
DVD COMM [U1227]	AV control unit malfunction is detected.	<ul style="list-style-type: none"> <li>• If DVD can be played, then there is a possibility of the detection of a temporary malfunction.</li> <li>• Replace the AV control unit if the malfunction occurs constantly. Refer to <a href="#">AV-413, "Exploded View"</a>.</li> </ul>
CONFIG UNFINISH [U122A]	The writing of configuration data is incomplete.	Write configuration data with CONSULT-III. Refer to <a href="#">AV-343, "Description"</a> .

# DIAGNOSIS SYSTEM (AV CONTROL UNIT)

< SYSTEM DESCRIPTION >

[BOSE AUDIO WITH NAVIGATION]

Error item	Description	Possible malfunction factor/Action to take
AMP TEMP [U1231]	BOSE amp. malfunction is detected.	Replace the BOSE amp. if the malfunction occurs constantly. Refer to <a href="#">AV-422, "Exploded View"</a> .
ST ANGLE SEN CALIB [U1232]	Predictive course line center position adjustment of the steering angle sensor is incomplete.	Adjust the predictive course line center position of the steering angle sensor. Refer to <a href="#">BRC-9, "ADJUSTMENT OF STEERING ANGLE SENSOR NEUTRAL POSITION : Special Repair Requirement"</a> .
FRONT DISP CONN [U1243]	When either one of the following items are detected: <ul style="list-style-type: none"> <li>• display unit power supply and ground circuits are malfunctioning.</li> <li>• communication circuits between AV control unit and display unit are malfunctioning.</li> </ul>	<ul style="list-style-type: none"> <li>• Display unit power supply and ground circuits.</li> <li>• Communication circuits between AV control unit and display unit.</li> </ul>
GPS ANTENNA CONN [U1244]	GPS antenna connection malfunction is detected.	Check the connection of the GPS antenna connector.
XM ANTENNA CONN [U1258]	Satellite radio antenna connection malfunction is detected.	Satellite radio antenna disconnection.
USB OVERCURRENT [U1263]	Detection of overcurrent in USB connector.	Check USB harness between the AV control unit and USB connector.
ANTENNA AMP TERMINAL [OPEN or SHORT] [U1264]	Antenna amp. ON signal circuit malfunction is detected.	Antenna amp. ON signal circuit between AV control unit and antenna base.
CENTER SPEAKER [OPEN, SHORT, GND-SHORT or VB-SHOR] [U1900]	Malfunction is detected sound signal circuits between BOSE amp. and center speaker.	Sound signal circuits between BOSE amp. and center speaker.
FR-DOOR SPEAKER [OPEN, SHORT, GND-SHORT or VB-SHOR] [U1901]	When either one of the following items are detected: <ul style="list-style-type: none"> <li>• sound signal circuits between BOSE amp. and door squawker RH are malfunctioning.</li> <li>• sound signal circuits between BOSE amp. and tweeter RH are malfunctioning.</li> </ul>	<ul style="list-style-type: none"> <li>• Sound signal circuits between BOSE amp. and door squawker RH.</li> <li>• Sound signal circuits between BOSE amp. and tweeter RH.</li> </ul>
RR WOOFER [OPEN, SHORT, GND-SHORT or VB-SHOR] [U1910]	Malfunction is detected sound signal circuits between BOSE amp. and rear woofer RH.	Sound signal circuits between BOSE amp. and rear woofer RH.
RL WOOFER [OPEN, SHORT, GND-SHORT or VB-SHOR] [U1911]	Malfunction is detected sound signal circuits between BOSE amp. and rear woofer LH.	Sound signal circuits between BOSE amp. and rear woofer LH.
FL-DOOR SPEAKER [OPEN, SHORT, GND-SHORT or VB-SHOR] [U1907]	When either one of the following items are detected: <ul style="list-style-type: none"> <li>• sound signal circuits between BOSE amp. and door squawker LH are malfunctioning.</li> <li>• sound signal circuits between BOSE amp. and tweeter LH are malfunctioning.</li> </ul>	<ul style="list-style-type: none"> <li>• Sound signal circuits between BOSE amp. and door squawker LH.</li> <li>• Sound signal circuits between BOSE amp. and tweeter LH.</li> </ul>
FL-SEAT L-SPEAKER [OPEN, SHORT, GND-SHORT or VB-SHOR] [U1908]	Malfunction is detected sound signal circuits between BOSE amp. and driver headrest speaker LH.	Sound signal circuits between BOSE amp. and driver headrest speaker LH.
FL-SEAT R-SPEAKER [OPEN, SHORT, GND-SHORT or VB-SHOR] [U1909]	Malfunction is detected sound signal circuits between BOSE amp. and driver headrest speaker RH.	Sound signal circuits between BOSE amp. and driver headrest speaker RH.
FR-SEAT L-SPEAKER [OPEN, SHORT, GND-SHORT or VB-SHOR] [U190A]	Malfunction is detected sound signal circuits between BOSE amp. and passenger headrest speaker LH.	Sound signal circuits between BOSE amp. and passenger headrest speaker LH.

# DIAGNOSIS SYSTEM (AV CONTROL UNIT)

< SYSTEM DESCRIPTION >

[BOSE AUDIO WITH NAVIGATION]

Error item	Description	Possible malfunction factor/Action to take
FR-SEAT R-SPEAKER [OPEN, SHORT, GND-SHORT or VB-SHOR] [U190B]	Malfunction is detected sound signal circuits between BOSE amp. and passenger headrest speaker RH.	Sound signal circuits between BOSE amp. and passenger headrest speaker RH.
CORRECT MICROPHONE [OPEN, SHORT, GND-SHORT or VB-SHOR] [U190C]	Malfunction is detected sound signal circuits between BOSE amp. and microphone (for AudioPilot™).	Sound signal circuits between BOSE amp. and microphone (for AudioPilot™).
FR WOOFER [OPEN, SHORT, GND-SHORT or VB-SHOR] [U190F]	Malfunction is detected sound signal circuits between BOSE amp. and door woofer RH.	Sound signal circuits between BOSE amp. and door woofer RH.
FL WOOFER [OPEN, SHORT, GND-SHORT or VB-SHOR] [U1912]	Malfunction is detected sound signal circuits between BOSE amp. and door woofer LH.	Sound signal circuits between BOSE amp. and door woofer LH.
<ul style="list-style-type: none"> <li>• AV COMM CIRCUIT [U1300]</li> <li>• SWITCH CONN [U1240]</li> </ul>	When either one of the following items are detected: <ul style="list-style-type: none"> <li>• multifunction switch power supply and ground circuits are malfunctioning.</li> <li>• AV communication circuits between AV control unit and multifunction switch are malfunctioning.</li> </ul>	<ul style="list-style-type: none"> <li>• Multifunction switch power supply and ground circuits.</li> <li>• AV communication circuits between AV control unit and multifunction switch.</li> </ul>
<ul style="list-style-type: none"> <li>• AV COMM CIRCUIT [U1300]</li> <li>• SONAR CONN [U125C]</li> </ul>	When either one of the following items are detected: <ul style="list-style-type: none"> <li>• sonar control unit power supply and ground circuits are malfunctioning.</li> <li>• AV communication circuits between AV control unit and sonar control unit are malfunctioning.</li> </ul>	<ul style="list-style-type: none"> <li>• Sonar control unit power supply and ground circuits.</li> <li>• AV communication circuits between AV control unit and sonar control unit.</li> </ul>
<ul style="list-style-type: none"> <li>• AV COMM CIRCUIT [U1300]</li> <li>• AMP CONN [U124E]</li> </ul>	When either one of the following items are detected: <ul style="list-style-type: none"> <li>• BOSE amp. power supply and ground circuits are malfunctioning.</li> <li>• AV communication circuits between sonar control unit and BOSE amp. are malfunctioning.</li> </ul>	<ul style="list-style-type: none"> <li>• BOSE amp. power supply and ground circuits.</li> <li>• AV communication circuits between sonar control unit and BOSE amp.</li> </ul>
<ul style="list-style-type: none"> <li>• AV COMM CIRCUIT [U1300]</li> <li>• SWITCH CONN [U1240]</li> <li>• SONAR CONN [U125C]</li> <li>• AMP CONN [U124E]</li> </ul>	AV communication circuits between AV control unit and multifunction switch are malfunctioning.	AV communication circuits between AV control unit and multifunction switch.

## DATA MONITOR

### ALL SIGNALS

- Displays the status of the following vehicle signals inputted into the AV control unit.
- For each signal, actual signal can be compared with the condition recognized on the system.

Display Item	Display	Vehicle status	Remarks
VHCL SPD SIG	On	Vehicle speed > 0 km/h (0 MPH)	Changes in indication may be delayed. This is normal.
	Off	Vehicle speed = 0 km/h (0 MPH)	
PKB SIG	On	Parking brake is applied.	
	Off	Parking brake is released.	

## DIAGNOSIS SYSTEM (AV CONTROL UNIT)

< SYSTEM DESCRIPTION >

[BOSE AUDIO WITH NAVIGATION]

Display Item	Display	Vehicle status	Remarks	
ILLUM SIG	On	Block the light beam from the auto light optical sensor when the light SW is ON.	—	
	Off	Expose the auto light optical sensor to light when the light SW is OFF or ON.		
IGN SIG	On	Ignition switch ON		
	Off	Ignition switch in ACC position		
REV SIG	On	Selector lever in R position		Changes in indication may be delayed. This is normal.
	Off	Selector lever in any position other than R		
SIDE VIEW SW	Off	—	This item is displayed, but cannot be monitored.	
ROOM LAMP	Off	—	This item is displayed, but cannot be monitored.	

### SELECTION FROM MENU

Allows the technician to select which vehicle signals should be displayed and displays the status of the selected vehicle signals.

Item to be selected	Description
VHCL SPD SIG	The same as when "ALL SIGNALS" is selected.
PKB SIG	
ILLUM SIG	
IGN SIG	
REV SIG	
SIDE VIEW SW	
ROOM LAMP	

### WORK SUPPORT

Adjusts the neutral position of the steering angle sensor.

**CAUTION:**

**For vehicles with VDC, adjust the steering angle sensor neutral position on the ABS actuator control unit side.**

Item	Description
ST ANGLE SENSOR ADJUSTMENT	Adjusts the neutral position of the steering angle sensor.

### CONFIGURATION

Configuration has three functions as follows.

Function	Description
READ CONFIGURATION	<ul style="list-style-type: none"> <li>• Reads the vehicle configuration of current AV control unit.</li> <li>• Saves the read vehicle configuration.</li> </ul>
WRITE CONFIGURATION-Manual selection	Writes the vehicle configuration with manual selection.
WRITE CONFIGURATION-Config file	Writes the vehicle configuration with saved data.



# AV CONTROL UNIT

< ECU DIAGNOSIS INFORMATION >

[BOSE AUDIO WITH NAVIGATION]

## ECU DIAGNOSIS INFORMATION

### AV CONTROL UNIT

#### Reference Value

INFOID:000000006472668

#### VALUES ON THE DIAGNOSIS TOOL

CONSULT-III MONITOR ITEM

Monitor Item	Condition		Value/Status
VHCL SPD SIG	Ignition switch ON	Vehicle speed > 0 km/h (0 MPH)	On
		Vehicle speed = 0 km/h (0 MPH)	Off
PKB SIG	Ignition switch ON	Parking brake is applied.	On
		Parking brake is released.	Off
ILLUM SIG	Ignition switch ON	Light switch ON	On
		Light switch OFF	Off
IGN SIG	Ignition switch ON	—	On
	Ignition switch ACC	—	Off
REV SIG	Ignition switch ON	Selector lever in R position	On
		Selector lever in any position other than R	Off
SIDE VIEW SW*	Ignition switch ON	—	Off
ROOM LAMP*	Ignition switch ON	—	Off

\*: This item is displayed, but cannot be monitored.

#### TERMINAL LAYOUT

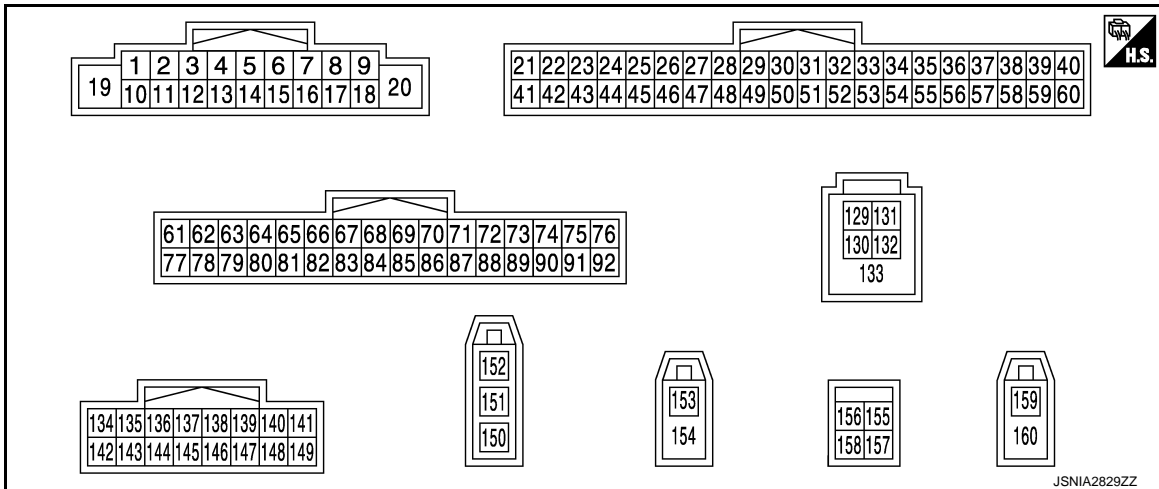





#### PHYSICAL VALUES

# AV CONTROL UNIT

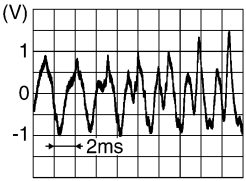
< ECU DIAGNOSIS INFORMATION >

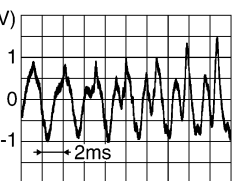
[BOSE AUDIO WITH NAVIGATION]

Terminal (Wire color)		Description		Condition		Reference value (Approx.)
+	-	Signal name	Input/ Output			
2 (P)	3 (L)	Sound signal LH	Output	Ignition switch ON	Sound output	 <p style="text-align: right; font-size: small;">SKIB3609E</p>
6 (P)	15 (B)	Steering switch signal A	Input	Ignition switch ON	Keep pressing SOURCE switch.	0 V
					Keep pressing MENU UP switch.	1.0 V
					Keep pressing MENU DOWN switch.	2.0 V
					Keep pressing  switch	3.0 V
					Keep pressing ENTER switch.	4.0 V
					Except for above.	5.0 V
7 (V)	Ground	ACC power supply	Input	Ignition switch ACC	—	Battery voltage
10 (B)	—	Shield	—	—	—	—
11 (R)	12 (G)	Sound signal RH	Output	Ignition switch ON	Sound output	 <p style="text-align: right; font-size: small;">SKIB3609E</p>
16 (L)	15 (B)	Steering switch signal B	Input	Ignition switch ON	Keep pressing VOL DOWN switch.	0 V
					Keep pressing VOL UP switch.	1.0 V
					Keep pressing  switch.	2.0 V
					Keep pressing  switch.	3.0 V
					Except for above.	5.0 V
19 (BR)	Ground	Battery power supply	Input	Ignition switch OFF	—	Battery voltage
20 (B)	Ground	Ground	—	Ignition switch ON	—	0 V
22 (R)	Ground	Camera power supply	Output	Ignition switch ON	At rear view camera image is displayed.	6.0 V
					Except for above.	0 V
29 (SB)	Ground	Disk eject signal	Input	Ignition switch ON	Pressing the eject switch.	0 V
					Except for above.	5.0 V

# AV CONTROL UNIT

< ECU DIAGNOSIS INFORMATION >

[BOSE AUDIO WITH NAVIGATION]

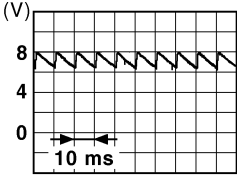
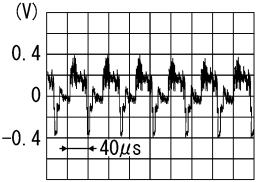
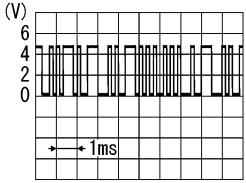
Terminal (Wire color)		Description		Condition		Reference value (Approx.)
+	-	Signal name	Input/ Output			
42 (W)	Ground	Camera ground	—	Ignition switch ON	—	0 V
49 (BR)	Ground	Switch ground	—	Ignition switch ON	—	0 V
65 (SB)	Ground	Parking brake signal	Input	Ignition switch ON	Parking brake is ON.	0 V
					Parking brake is OFF.	 <p style="text-align: right; font-size: small;">JSNIA0007GB</p>
67 (P)	Ground	Composite image ground	—	Ignition switch ON	—	0 V
68 (L)	Ground	Composite image signal	Output	Ignition switch ON	At DVD image is displayed.	 <p style="text-align: right; font-size: small;">SKIB2251J</p>
72 (G)	Ground	Microphone VCC	Output	Ignition switch ON	—	5.0 V
73 (P)	Ground	Communication signal (CONT→DISP)	Output	Ignition switch ON	When adjusting display brightness.	 <p style="text-align: right; font-size: small;">PKIB5039J</p>
74 (P)	—	CAN-L	Input/ Output	—	—	—
75 (LG)	—	AV communication signal (L)	Input/ Output	—	—	—
76 (LG)	—	AV communication signal (L)	Input/ Output	—	—	—
79 (L)	Ground	Illumination signal	Input	Ignition switch OFF	Lighting switch is OFF.	0 V
					Lighting switch is ON.	12.0 V
80 (G)	Ground	Ignition signal	Input	Ignition switch ON	—	Battery voltage
81 (BG)	Ground	Reverse signal	Input	Ignition switch ON	R position	12.0 V
					Other than R position	0 V

A  
B  
C  
D  
E  
F  
G  
H  
I  
J  
K  
L  
M

AV

O  
P

# AV CONTROL UNIT

< ECU DIAGNOSIS INFORMATION >

[BOSE AUDIO WITH NAVIGATION]

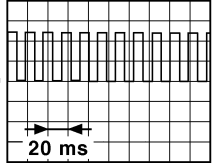
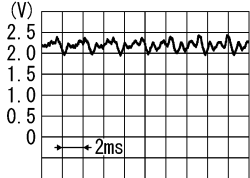
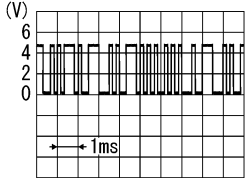
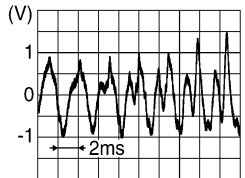
Terminal (Wire color)		Description		Condition		Reference value (Approx.)
+	-	Signal name	Input/ Output			
82 (GR)	Ground	Vehicle speed signal (8-pulse)	Input	Ignition switch ON	When vehicle speed is approx. 40 km/h (25 MPH)	<p><b>NOTE:</b> The maximum voltage varies de- pending on the specification (destination unit).</p>  <p style="text-align: right; font-size: small;">JSNIA0012GB</p>
83	—	Shield	—	—	—	—
87 (R)	71	Microphone signal	Input	Ignition switch ON	Give a voice	 <p style="text-align: right; font-size: small;">PKIB5037J</p>
88	—	Shield	—	—	—	—
89 (L)	Ground	Communication signal (DISP→CONT)	Input	Ignition switch ON	When adjusting display brightness.	 <p style="text-align: right; font-size: small;">PKIB5039J</p>
90 (L)	—	CAN-H	Input/ Output	—	—	—
91 (SB)	—	AV communication signal (H)	Input/ Output	—	—	—
92 (SB)	—	AV communication signal (H)	Input/ Output	—	—	—
129 (G)	—	USB ground	—	—	—	—
130 (R)	—	USB D- signal	—	—	—	—
131 (W)	—	V BUS signal	—	—	—	—
132 (L)	—	USB D+ signal	—	—	—	—
133	—	Shield	—	—	—	—
135 (BR)	136 (Y)	Voice guidance signal	Output	Ignition switch ON	Sound output	 <p style="text-align: right; font-size: small;">SKIB3609E</p>
151	—	AM-FM main	Input	—	—	—

# AV CONTROL UNIT

< ECU DIAGNOSIS INFORMATION >

[BOSE AUDIO WITH NAVIGATION]

Terminal (Wire color)		Description		Condition		Reference value (Approx.)
+	-	Signal name	Input/ Output			
152	Ground	Antenna amp. ON signal	Input	Ignition switch ON	—	12.0 V
153	Ground	GPS antenna signal	Input	Ignition switch ON	Not connected GPS antenna connector.	5.0 V
154	—	Shield	—	—	—	—
157	Ground	RGB digital image signal (-)	Output	Ignition switch ON	Not connected connector.	1.3 V
158	Ground	RGB digital image signal (+)	Output	Ignition switch ON	Not connected connector.	1.3 V
159	Ground	Satellite antenna signal	Input	Ignition switch ON	Not connected satellite antenna connector.	5.0 V
160	—	Shield	—	—	—	—

## Fail-Safe

INFOID:000000006472669

When the ambient temperature becomes extremely low or extremely high, AV control unit displays the message and limits the AV control unit function.

### FAIL-SAFE CONDITIONS

When the ambient temperature is  $-20^{\circ}\text{C}$  ( $-4^{\circ}\text{F}$ ) or lower, or when it is  $70^{\circ}\text{C}$  ( $158^{\circ}\text{F}$ ) or higher

#### Display

The messages displayed on fail-safe conditions are as shown below:

Fail-safe mode	Display (display of the fail-safe condition)
When HDD temperature is low	HDD system is experiencing problems due to extreme low temperature. Normal operation will resume when temperature rises.
When HDD temperature is high	HDD system is experiencing problems due to extreme high temperature. Normal operation will resume when temperature drops.

## DESCRIPTION OF CONTROLS

Function	When Fail-safe Function is activated	
Air conditioner	Operation	Only multifunction switch (preset switch) can be operated.
	Display	<ul style="list-style-type: none"> <li>• LED of multifunction switch (preset switch) illuminates.</li> <li>• Aired temperature, blow angle, and flow rate are displayed in simplified mode.</li> </ul>
Audio	Operation	Only ON/OFF and volume control operations by multifunction switch (preset switch) are possible.
	Display	No display ("Fail-safe mode" is displayed)
Camera	Operation	Image tone cannot be controlled.
	Display	Cannot be superimposed. (warning display, tone control display)
Hands-free phone	Operation	Cannot be operated.
Navigation	Operation	Cannot be operated.
Self diagnosis		The display in simplified mode of fail-safe condition
CONSULT-III diagnosis		Cannot be operated.

### Ability Operation Mode

There is an ability operation mode for Fail-safes due to low or high ambient temperature.

# AV CONTROL UNIT

< ECU DIAGNOSIS INFORMATION >

[BOSE AUDIO WITH NAVIGATION]

If HDD data can be read, fail-safe is shown, then normal displays are displayed only for functions which can be operated.

## RELEASE CONDITIONS OF FAIL-SAFE

Fail-safe is released on following conditions and normal mode is restored.

When The Temperature of HDD Is Low or High

If the ambient temperature becomes out of fail-safe condition range, normal mode is restored.

## DTC Index

INFOID:000000006472670

## SELF-DIAGNOSIS RESULTS DISPLAY ITEM

DTC	Display item	Refer to
U1000	CAN COMM CIRCUIT [U1000]	<a href="#">AV-346, "Diagnosis Procedure"</a>
U1010	CONTROL UNIT (CAN) [1010]	<a href="#">AV-347, "DTC Logic"</a>
U1200	Cont Unit [U1200]	<a href="#">AV-348, "DTC Logic"</a>
U1201	GYRO NO CONN [U1201]	<a href="#">AV-349, "DTC Logic"</a>
U1202	G-SENSOR NO CONN [U1202]	<a href="#">AV-350, "DTC Logic"</a>
U1204	GPS COMM [U1204]	<a href="#">AV-351, "Diagnosis Procedure"</a>
U1205	GPS ROM [U1205]	<a href="#">AV-352, "Diagnosis Procedure"</a>
U1206	GPS RAM [U1206]	<a href="#">AV-353, "Diagnosis Procedure"</a>
U1207	GPS RTC [U1207]	<a href="#">AV-354, "Diagnosis Procedure"</a>
U1216	CAN CONT [U1216]	<a href="#">AV-355, "DTC Logic"</a>
U1217	BLUETOOTH MODULE [U1217]	<a href="#">AV-356, "DTC Logic"</a>
U1218	HDD CONN [U1218]	<a href="#">AV-357, "Diagnosis Procedure"</a>
U1219	HDD READ [U1219]	<a href="#">AV-358, "Diagnosis Procedure"</a>
U121A	HDD WRITE [U121A]	<a href="#">AV-359, "Diagnosis Procedure"</a>
U121B	HDD COMM [U121B]	<a href="#">AV-360, "Diagnosis Procedure"</a>
U121C	HDD ACCESS [U121C]	<a href="#">AV-361, "Diagnosis Procedure"</a>
U121D	DSP CONN [U121D]	<a href="#">AV-362, "Diagnosis Procedure"</a>
U121E	DSP COMM [U121E]	<a href="#">AV-363, "Diagnosis Procedure"</a>
U1225	USB CONTROLLER [U1225]	<a href="#">AV-364, "DTC Logic"</a>
U1227	DVD COMM [U1227]	<a href="#">AV-365, "Diagnosis Procedure"</a>
U1228	SUB CPU CONN [U1228]	<a href="#">AV-366, "DTC Logic"</a>
U1229	iPod CERTIFICATION [U1229]	<a href="#">AV-367, "DTC Logic"</a>
U122A	CONFIG UNFINISH [U122A]	<a href="#">AV-368, "Diagnosis Procedure"</a>
U122E	Built-in AUDIO CONN [U122E]	<a href="#">AV-369, "DTC Logic"</a>
U1231	AMP TEMP [U1231]	<a href="#">AV-370, "DTC Logic"</a>
U1232	ST ANGLE SEN CALIB [1232]	<a href="#">AV-371, "Diagnosis Procedure"</a>
U1243	FRONT DISP CONN [U1243]	<a href="#">AV-372, "Diagnosis Procedure"</a>
U1244	GPS ANTENNA CONN [U1244]	<a href="#">AV-374, "Diagnosis Procedure"</a>
U1258	XM ANTENNA CONN [U1258]	<a href="#">AV-375, "Diagnosis Procedure"</a>
U1263	USB OVERCURRENT [U1263]	<a href="#">AV-376, "Diagnosis Procedure"</a>
U1264	ANTENNA AMP TERMINAL [OPEN or SHORT] [U1264]	<a href="#">AV-377, "Diagnosis Procedure"</a>
U1310	CONTROL UNIT (AV) [U1310]	<a href="#">AV-379, "DTC Logic"</a>
U1900	CENTER SPEAKER [OPEN, SHORT, GND-SHORT or VB-SHOR] [U1900]	<a href="#">AV-380, "Diagnosis Procedure"</a>

# AV CONTROL UNIT

< ECU DIAGNOSIS INFORMATION >

[BOSE AUDIO WITH NAVIGATION]

DTC	Display item	Refer to
U1901	FR-DOOR SPEAKER [OPEN, SHORT, GND-SHORT or VB-SHOR] [U1901]	<a href="#">AV-381, "Diagnosis Procedure"</a>
U1907	FL-DOOR SPEAKER [OPEN, SHORT, GND-SHORT or VB-SHOR] [U1907]	<a href="#">AV-381, "Diagnosis Procedure"</a>
U1908	FL-SEAT L-SPEAKER [OPEN, SHORT, GND-SHORT or VB-SHOR] [U1908]	<a href="#">AV-382, "Diagnosis Procedure"</a>
U1909	FL-SEAT R-SPEAKER [OPEN, SHORT, GND-SHORT or VB-SHOR] [U1909]	<a href="#">AV-382, "Diagnosis Procedure"</a>
U1910	RR WOOFER [OPEN, SHORT, GND-SHORT or VB-SHOR] [U1910]	<a href="#">AV-383, "Diagnosis Procedure"</a>
U1911	RL WOOFER [OPEN, SHORT, GND-SHORT or VB-SHOR] [U1911]	<a href="#">AV-383, "Diagnosis Procedure"</a>
U190A	FR-SEAT L-SPEAKER [OPEN, SHORT, GND-SHORT or VB-SHOR] [U190A]	<a href="#">AV-384, "Diagnosis Procedure"</a>
U190B	FR-SEAT R-SPEAKER [OPEN, SHORT, GND-SHORT or VB-SHOR] [U190B]	<a href="#">AV-384, "Diagnosis Procedure"</a>
U190C	CORRECT MICROPHONE [OPEN, SHORT, GND-SHORT or VB-SHOR] [U190C]	<a href="#">AV-385, "Diagnosis Procedure"</a>
U190F	FR WOOFER [OPEN, SHORT, GND-SHORT or VB-SHOR] [U190F]	<a href="#">AV-386, "Diagnosis Procedure"</a>
U1912	FL WOOFER [OPEN, SHORT, GND-SHORT or VB-SHOR] [U1912]	<a href="#">AV-386, "Diagnosis Procedure"</a>
U1300 U1240	<ul style="list-style-type: none"> <li>• AV COMM CIRCUIT [U1300]</li> <li>• SWITCH CONN [U1240]</li> </ul>	<a href="#">AV-378, "Description"</a>
U1300 U125C	<ul style="list-style-type: none"> <li>• AV COMM CIRCUIT [U1300]</li> <li>• SONAR CONN [U125C]</li> </ul>	<a href="#">AV-378, "Description"</a>
U1300 U125E	<ul style="list-style-type: none"> <li>• AV COMM CIRCUIT [U1300]</li> <li>• AMP CONN [U124E]</li> </ul>	<a href="#">AV-378, "Description"</a>
U1300 U1240 U125C U124E	<ul style="list-style-type: none"> <li>• AV COMM CIRCUIT [U1300]</li> <li>• SWITCH CONN [U1240]</li> <li>• SONAR CONN [U125C]</li> <li>• AMP CONN [U124E]</li> </ul>	<a href="#">AV-378, "Description"</a>

A  
B  
C  
D  
E  
F  
G  
H  
I  
J  
K  
L  
M  
O  
P

AV

# DISPLAY UNIT

< ECU DIAGNOSIS INFORMATION >

[BOSE AUDIO WITH NAVIGATION]

## DISPLAY UNIT

Reference Value

INFOID:00000006472671

### TERMINAL LAYOUT

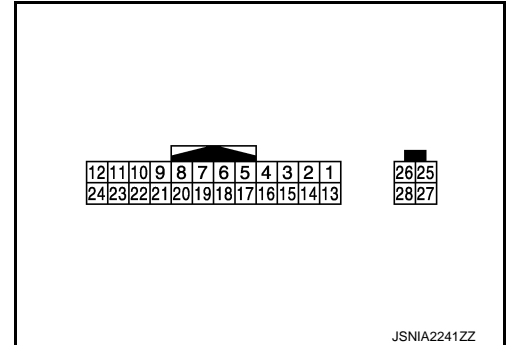

### PHYSICAL VALUES

Terminal (Wire color)		Description		Condition		Reference value (Approx.)
+	-	Signal name	Input/ Output			
6	—	Shield	—	—	—	—
7	—	Shield	—	—	—	—
8 (W)	Ground	Camera image signal	Input	Ignition switch ON	At rear view camera image is displayed.	 SKIB2251J
9 (L)	Ground	Communication signal (DISP→CONT)	Output	Ignition switch ON	When adjusting display brightness.	 PKIB5039J
10 (P)	Ground	Communication signal (CONT→DISP)	Input	Ignition switch ON	When adjusting display brightness.	 PKIB5039J
11 (Y)	Ground	Battery power supply	Input	Ignition switch OFF	—	Battery voltage
12 (B)	Ground	Ground	—	Ignition switch ON	—	0 V



# DISPLAY UNIT

< ECU DIAGNOSIS INFORMATION >

[BOSE AUDIO WITH NAVIGATION]

Terminal (Wire color)		Description		Condition		Reference value (Approx.)
+	-	Signal name	Input/ Output			
18 (L)	Ground	Composite image signal	Input	Ignition switch ON	At DVD image is displayed.	
19 (P)	Ground	Composite image ground	—	Ignition switch ON	—	0 V
22	—	Shield	—	—	—	—
23 (LG)	Ground	ACC power supply	Input	Ignition switch ACC	—	Battery voltage
27	—	RGB digital image signal (-)	Input	—	—	—
28	—	RGB digital image signal (+)	Input	—	—	—

A  
B  
C  
D  
E  
F  
G  
H  
I  
J  
K  
L  
M  
AV  
O  
P

AV

# BOSE AMP.

< ECU DIAGNOSIS INFORMATION >

[BOSE AUDIO WITH NAVIGATION]

## BOSE AMP.

### Reference Value

INFOID:000000006472672

### TERMINAL LAYOUT

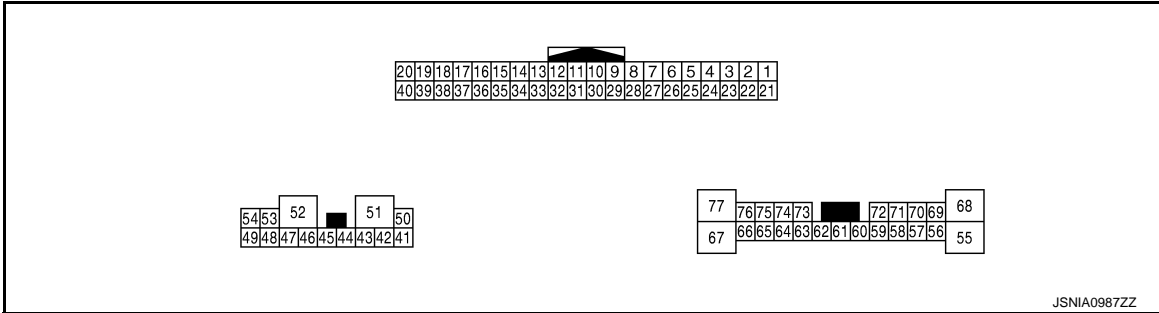

### PHYSICAL VALUES

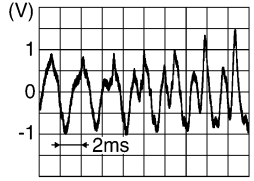
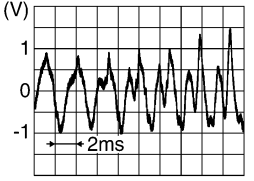
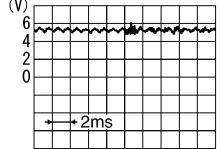
Terminal (Wire color)		Description		Condition		Reference value (Approx.)
+	-	Signal name	Input/Output			
14 (LG)	—	AV communication signal (L)	Input/Output	—	—	—
15 (LG)	—	AV communication signal (L)	Input/Output	—	—	—
16 (W)	Ground	ACC power supply	Input	Ignition switch ACC	—	12.0 V
29 (P)	9 (L)	Sound signal LH	Input	Ignition switch ON	Sound output	 <p>SKIB3609E</p>
30 (R)	10 (G)	Sound signal RH	Input	Ignition switch ON	Sound output	 <p>SKIB3609E</p>
31 (Y)	11 (G)	Microphone signal (for AudioPilot™)	Input	Ignition switch ON	When inputting noise.	 <p>(reference value) PKIA2104E</p>

# BOSE AMP.

< ECU DIAGNOSIS INFORMATION >

[BOSE AUDIO WITH NAVIGATION]

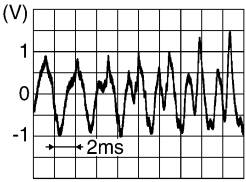
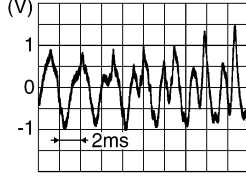
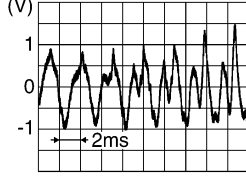
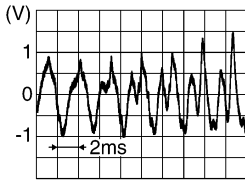
Terminal (Wire color)		Description		Condition		Reference value (Approx.)
+	-	Signal name	Input/ Output			
32 (V)	12 (SB)	Voice guidance signal	Input	Ignition switch ON	When inputting voice guid- ance.	 SKIB3609E
33	—	Shield	—	—	—	—
34 (SB)	—	AV communication signal (H)	Input/ Output	—	—	—
35 (SB)	—	AV communication signal (H)	Input/ Output	—	—	—
40 (V)	Ground	Roof status signal	Input	Ignition switch ON	Retractable hard top is fully closed.	12.0 V
					Other than above.	0 V
41 (B)	42 (W)	Sound signal door woofer LH	Output	Ignition switch ON	Sound output	 SKIB3609E
45 (G)	46 (R)	Sound signal door woofer RH	Output	Ignition switch ON	Sound output	 SKIB3609E
47 (B)	Ground	Ground	—	Ignition switch ON	—	0 V
50 (Y)	Ground	Battery power supply	Input	Ignition switch OFF	—	Battery voltage
51 (GR)	Ground	Battery power supply	Input	Ignition switch OFF	—	Battery voltage
52 (B)	Ground	Ground	—	Ignition switch ON	—	0 V
54 (L)	49 (P)	Sound signal rear woofer LH	Output	Ignition switch ON	Sound output	 SKIB3609E

A  
B  
C  
D  
E  
F  
G  
H  
I  
J  
K  
L  
M  
AV  
O  
P

# BOSE AMP.

< ECU DIAGNOSIS INFORMATION >

[BOSE AUDIO WITH NAVIGATION]

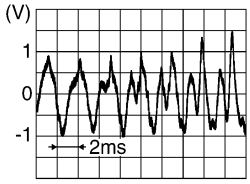
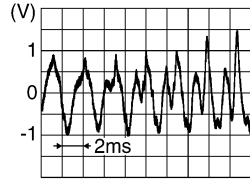
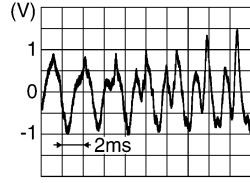
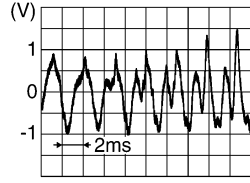
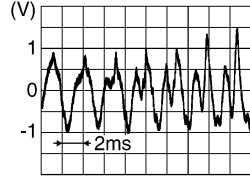
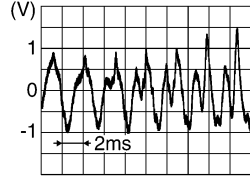
Terminal (Wire color)		Description		Condition		Reference value (Approx.)
+	-	Signal name	Input/ Output			
56 (W)	69 (B)	Sound signal passenger headrest speaker LH	Output	Ignition switch ON	Sound output	 <p style="text-align: right; font-size: small;">SKIB3609E</p>
57 (BG)	58 (P)	Sound signal center speak- er	Output	Ignition switch ON	Sound output	 <p style="text-align: right; font-size: small;">SKIB3609E</p>
59 (L)	72 (W)	Sound signal front LH	Output	Ignition switch ON	Sound output	 <p style="text-align: right; font-size: small;">SKIB3609E</p>
62 (V)	73 (LG)	Sound signal front RH	Output	Ignition switch ON	Sound output	 <p style="text-align: right; font-size: small;">SKIB3609E</p>
63 (G)	74 (Y)	Sound signal driver head- rest speaker LH	Output	Ignition switch ON	Sound output	 <p style="text-align: right; font-size: small;">SKIB3609E</p>
64 (W)	75 (B)	Sound signal driver head- rest speaker RH	Output	Ignition switch ON	Sound output	 <p style="text-align: right; font-size: small;">SKIB3609E</p>

# BOSE AMP.

< ECU DIAGNOSIS INFORMATION >

[BOSE AUDIO WITH NAVIGATION]

Terminal (Wire color)		Description		Condition		Reference value (Approx.)
+	-	Signal name	Input/ Output			
68 (LG)	55 (BG)	Sound signal rear woofer RH	Output	Ignition switch ON	Sound output	
71 (Y)	70 (G)	Sound signal passenger headrest speaker RH	Output	Ignition switch ON	Sound output	

A  
B  
C  
D  
E  
F  
G  
H  
I  
J  
K  
L  
M

AV

O  
P

< WIRING DIAGRAM >

# WIRING DIAGRAM

## BOSE AUDIO WITH NAVIGATION

### Wiring Diagram

INFOID:000000006472673

**NOTE:**

The name MULTIFUNCTION SWITCH indicates the integration of PRESET SWITCH and MULTIFUNCTION SWITCH virtually.

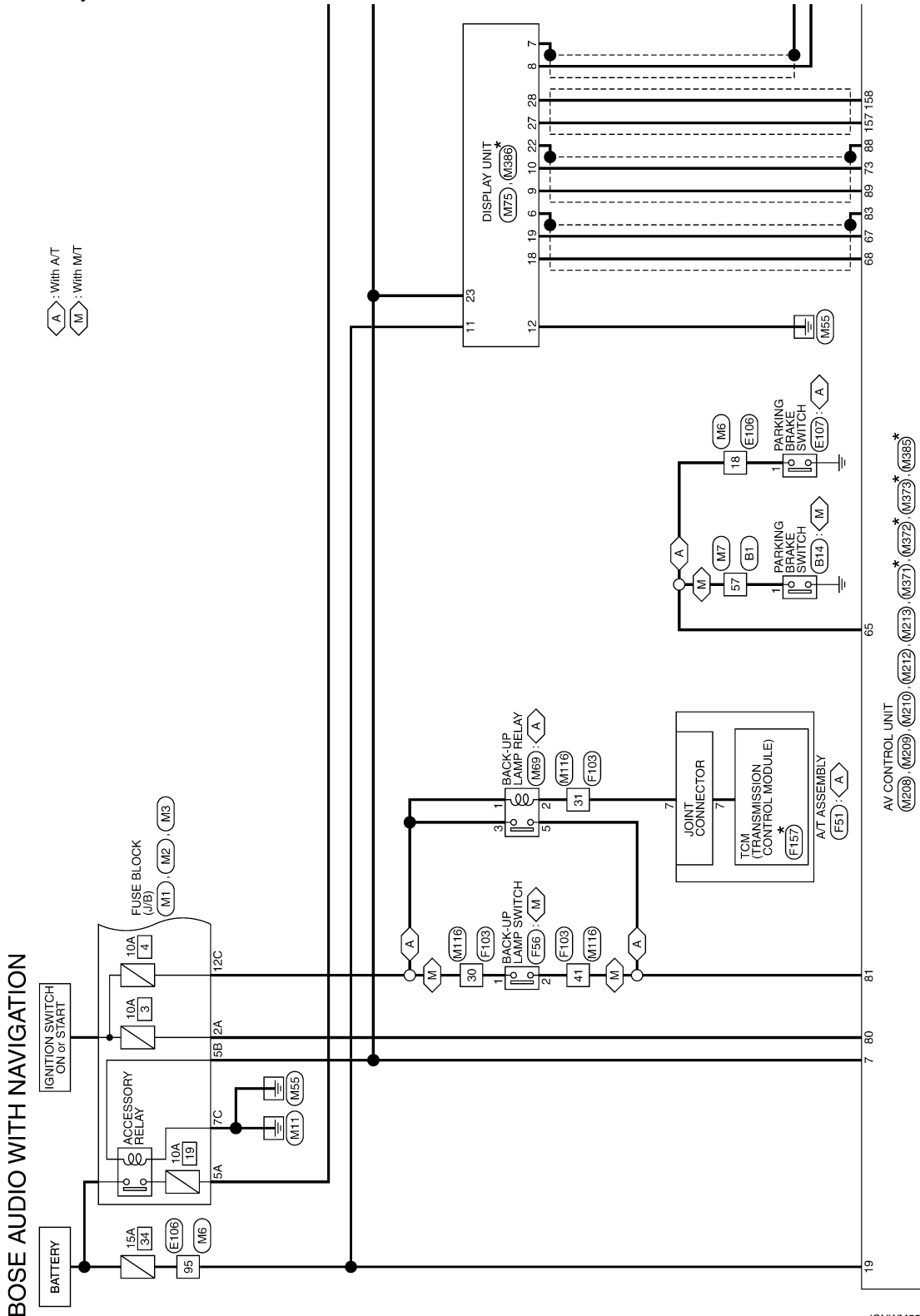

# BOSE AUDIO WITH NAVIGATION

## [BOSE AUDIO WITH NAVIGATION]

< WIRING DIAGRAM >

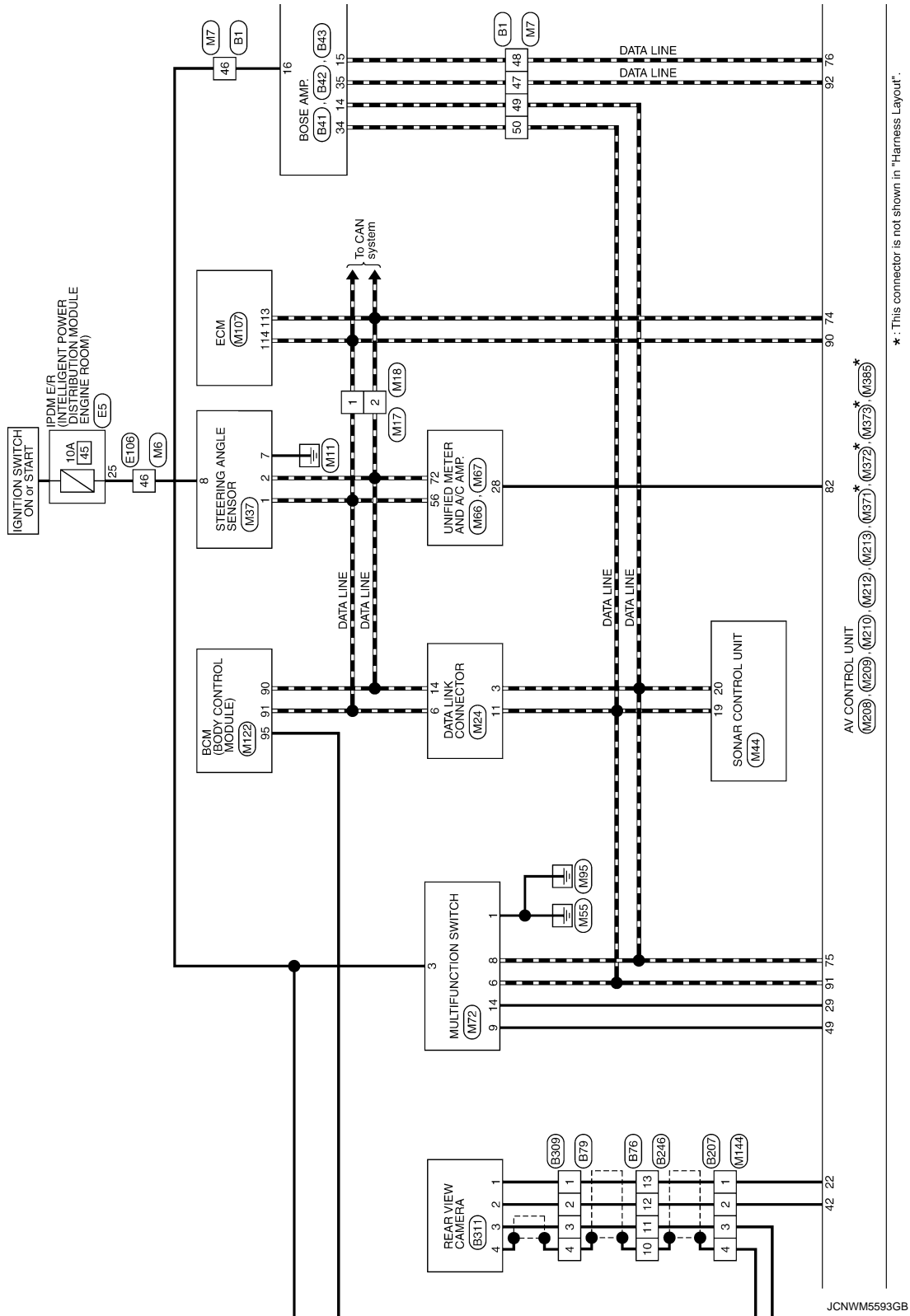

A  
B  
C  
D  
E  
F  
G  
H  
I  
J  
K  
L  
M  
N  
O  
P

AV

# BOSE AUDIO WITH NAVIGATION

[BOSE AUDIO WITH NAVIGATION]

< WIRING DIAGRAM >

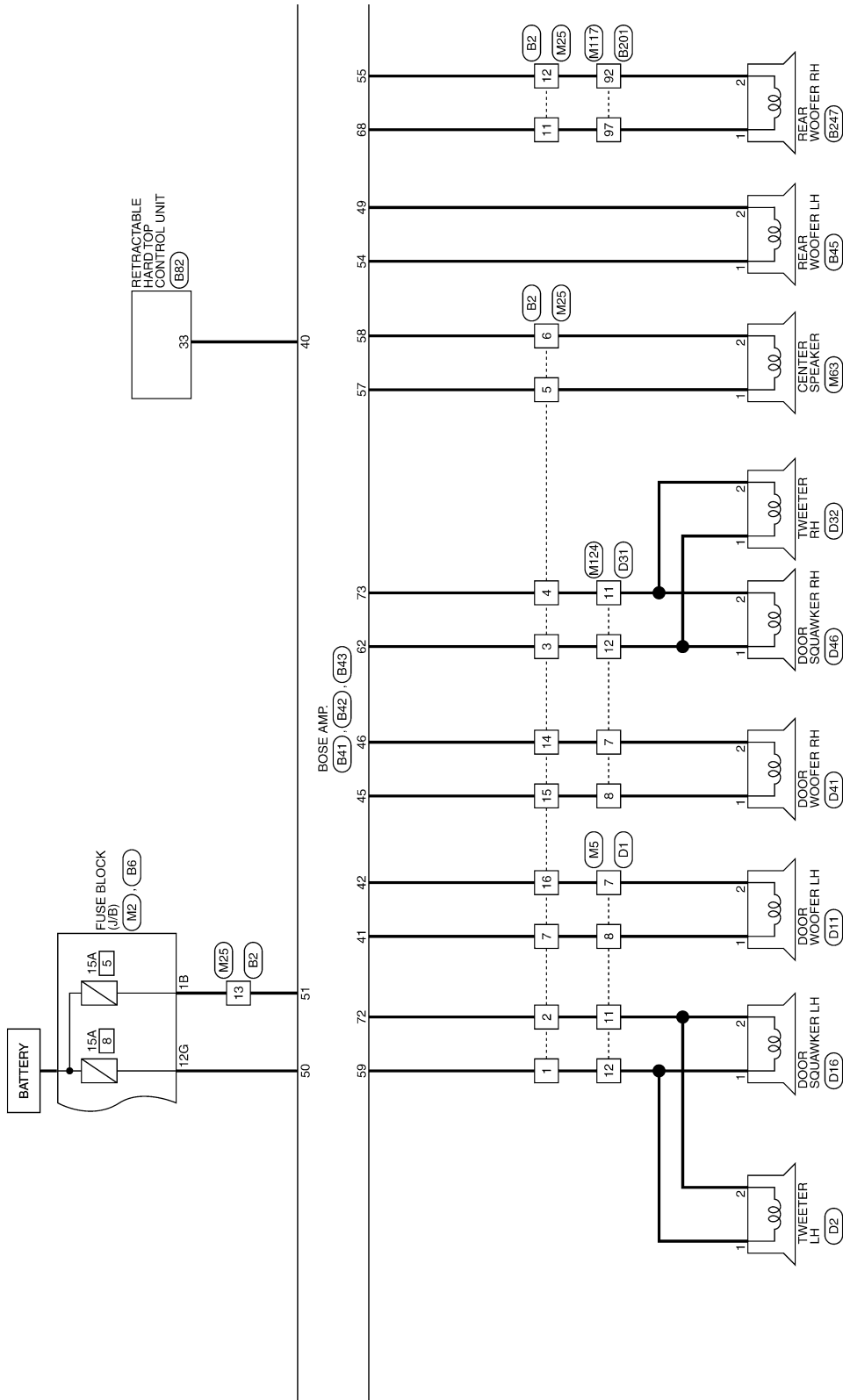

\* : This connector is not shown in "Harness Layout".

AV CONTROL UNIT  
(M209), (M209), (M210), (M212), (M213), (M371), (M372), (M373), (M385)

JCNWM5594GB



# BOSE AUDIO WITH NAVIGATION

## [BOSE AUDIO WITH NAVIGATION]

< WIRING DIAGRAM >

WS: With climate controlled seat  
 OS: Without climate controlled seat

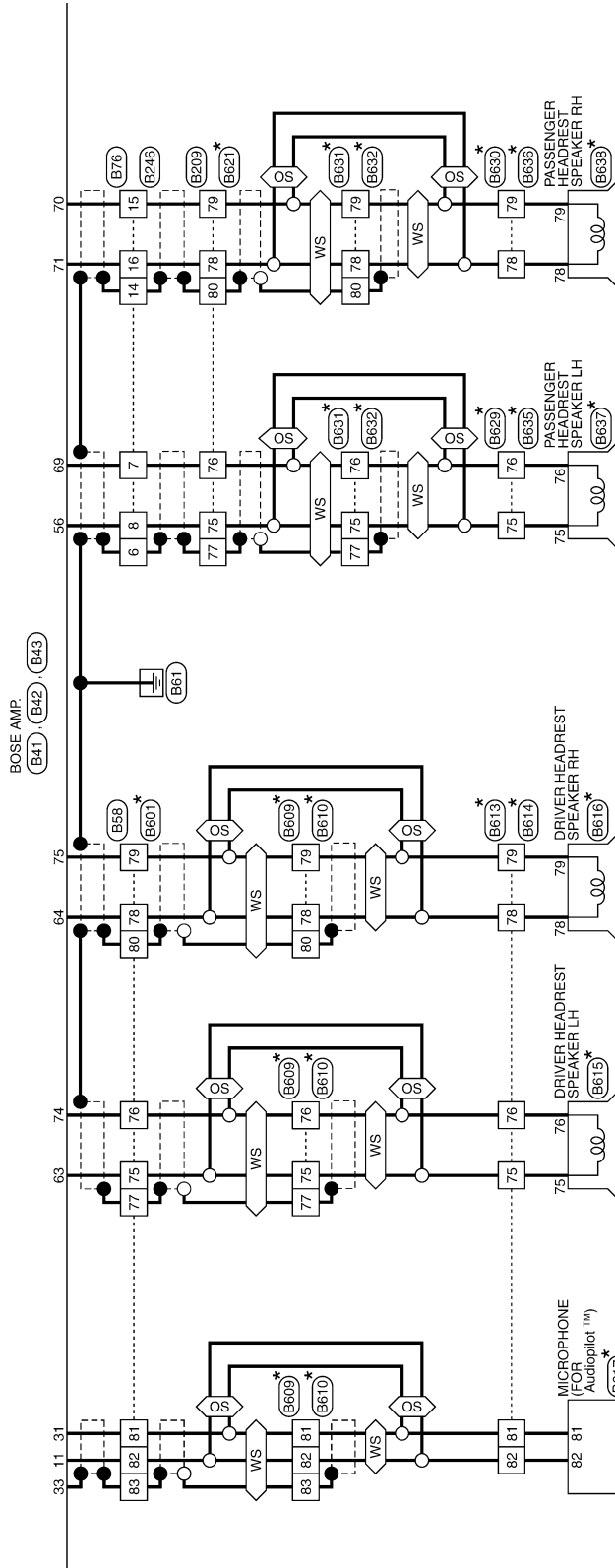

AV CONTROL UNIT  
 (M208) (M209) (M210) (M212) (M213) (M371) (M372) (M373) (M385)

\*: This connector is not shown in "Harness Layout".

JCNWM5595GB

A  
 B  
 C  
 D  
 E  
 F  
 G  
 H  
 I  
 J  
 K  
 L  
 M  
 N  
 O  
 P

AV

# BOSE AUDIO WITH NAVIGATION

[BOSE AUDIO WITH NAVIGATION]

< WIRING DIAGRAM >

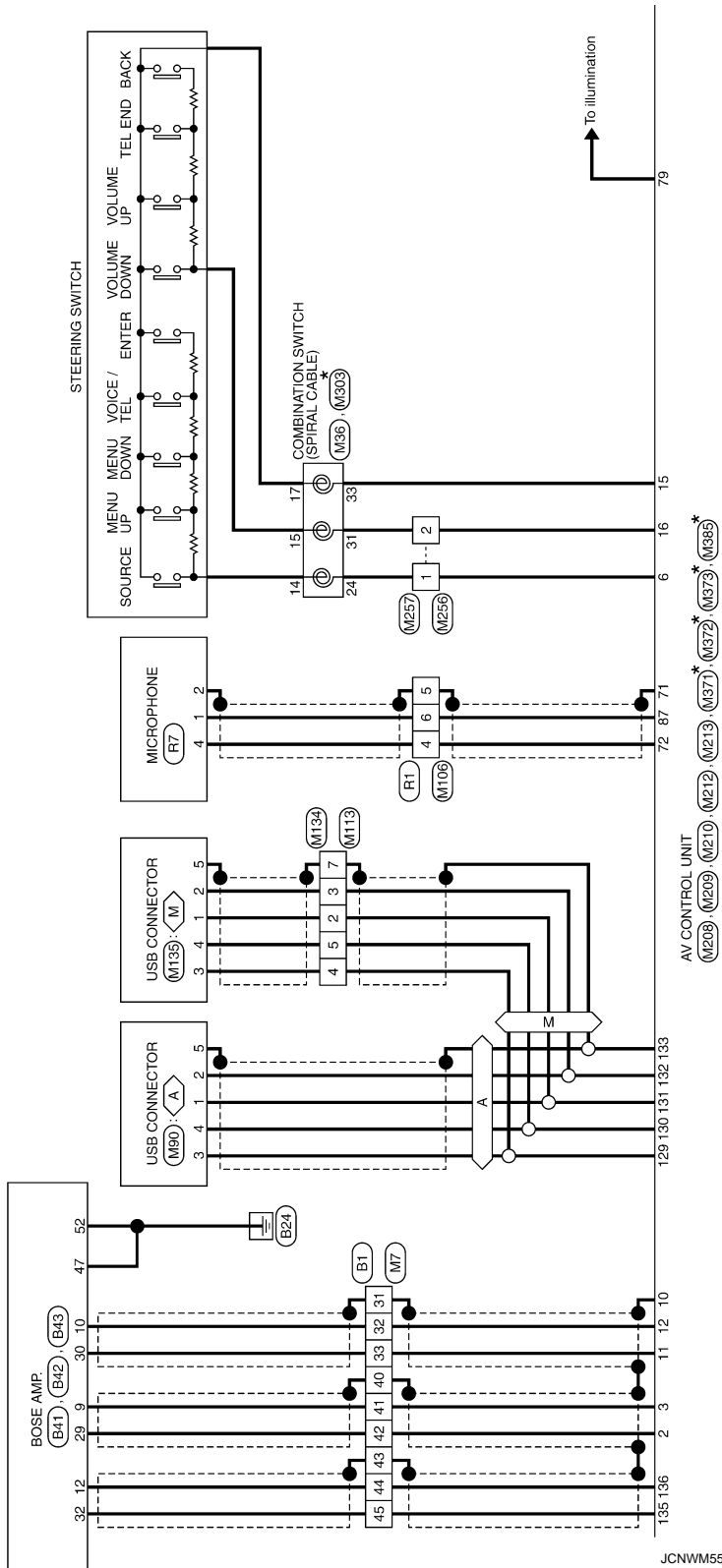

\* : This connector is not shown in "Harness Layout".

JCNWM5596GB

# BOSE AUDIO WITH NAVIGATION

< WIRING DIAGRAM >

[BOSE AUDIO WITH NAVIGATION]

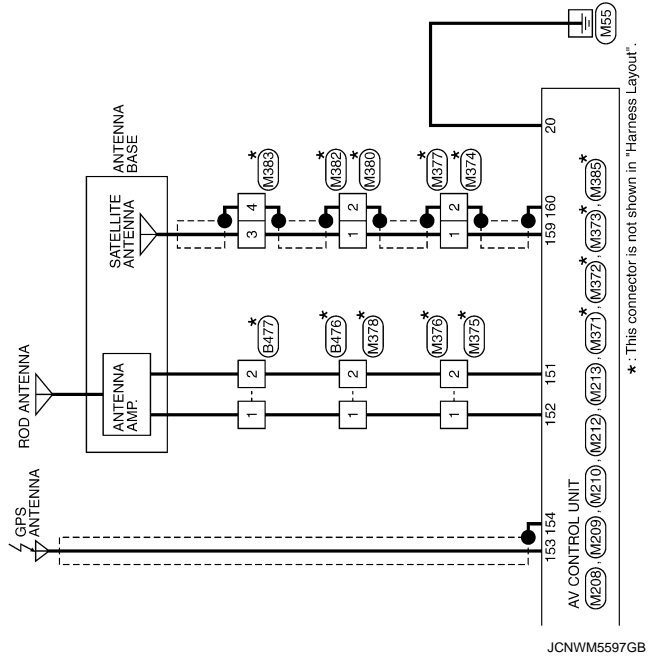

A  
B  
C  
D  
E  
F  
G  
H  
I  
J  
K  
L  
M  
N  
O  
P

AV

# BOSE AUDIO WITH NAVIGATION

[BOSE AUDIO WITH NAVIGATION]

< WIRING DIAGRAM >

## BOSE AUDIO WITH NAVIGATION

Connector No.	B1
Connector Name	WIRE TO WIRE
Connector Type	THB07V-CS16-TM4



Terminal No.	Color of Wire	Signal Name [Specification]
1	W	-
2	L	-
3	R	-
4	V	-
5	W	-
6	B	-
7	G	-
8	BR	-
9	SHIELD	-
10	Y	-
11	R	-
12	W	-
13	Y	-
14	L	-
15	R	-
16	W	-
17	BR	-
18	G	-
19	SB	-
20	GR	-
21	W	-
22	W	-
23	W	-
24	SB	-
25	BR	-
26	LG	-
27	Y	-
28	R	-
29	V	-
30	SHIELD	-
31	G	-
32	R	-
33	R	-
34	BG	-
35	GR	-
36	BR	-
37	P	- [With climate controlled seat]
38	Y	- [Without climate controlled seat]
39	Y	- [With climate controlled seat]
40	GR	- [Without climate controlled seat]
41	SHIELD	-
42	L	-
43	P	-
44	SHIELD	-

44	SB	-
45	V	-
46	W	-
47	SB	-
48	LG	-
49	LG	- [With BOSE system]
50	Y	- [Without BOSE system]
51	SB	-
52	LG	-
53	LG	-
54	BR	-
55	Y	-
56	W	-
57	V	-
58	R	-
59	R	-
60	R	-
61	BG	-
62	B	-
63	L	-
64	P	-
65	B	-
66	SB	-
67	P	-
68	L	-
69	P	-
70	L	-
80	G	-
81	V	-
82	R	-
83	BR	-
84	G	-
85	L	-
86	Y	-
87	GR	-
88	GR	-
89	R	-
90	BG	-
91	P	-
92	GR	-
93	GR	-
94	P	-
95	GR	-
96	GR	-
97	SB	-
98	Y	-
99	Y	-
100	Y/B	-

Connector No.	B2
Connector Name	WIRE TO WIRE
Connector Type	NS18FW-CS

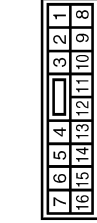

Terminal No.	Color of Wire	Signal Name [Specification]
1	L	-
2	W	-
3	V	-
4	LG	-
5	BG	-
6	P	-
7	B	-
8	P	-
9	LG	-
10	GR	-
11	GR	-
12	GR	-
13	GR	-
14	R	-
15	G	-
16	W	-

Connector No.	B14
Connector Name	PARKING BRAKE SWITCH
Connector Type	P01FB-A



Terminal No.	Color of Wire	Signal Name [Specification]
1	V	-

Connector No.	B41
Connector Name	BOSE AMP.
Connector Type	TH40FW-NH

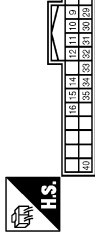

Terminal No.	Color of Wire	Signal Name [Specification]
9	L	SOUND SIGNAL LH (-)
10	G	SOUND SIGNAL RH (-)
11	G	MICROPHONE SIGNAL (-)
12	SR	VOICE GUIDANCE SIGNAL (-)
13	LG	AV COMM (L)
14	LG	AV COMM (L)
15	LG	ACC
16	W	ACC
17	W	ACC
18	P	SOUND SIGNAL LH (+)
19	P	SOUND SIGNAL RH (+)
20	R	MICROPHONE SIGNAL (+)
21	Y	VOICE GUIDANCE SIGNAL (+)
22	V	SHIELD
23	SHIELD	SHIELD
24	SB	AV COMM (H)
25	SB	AV COMM (H)
26	SB	AV COMM (H)
27	V	ROOF STATUS SIGNAL (AUDIO)

Connector No.	B6
Connector Name	FUSE BLOCK (J/B)
Connector Type	NS12FBR-CS

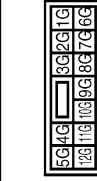

Terminal No.	Color of Wire	Signal Name [Specification]
5G	LG	-
6G	G	-
10G	P	-
11G	G	-
12G	Y	-

JCNWM5598GB

# BOSE AUDIO WITH NAVIGATION

[BOSE AUDIO WITH NAVIGATION]

< WIRING DIAGRAM >

## BOSE AUDIO WITH NAVIGATION

Connector No.	B42
Connector Name	BOSE AMP.
Connector Type	SCA12PFR-SJA2

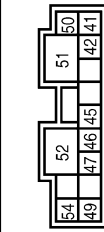

Terminal No.	Color of Wire	Signal Name [Specification]
41	B	SOUND SIGNAL DOOR WOOFER LH (+)
42	W	SOUND SIGNAL DOOR WOOFER LH (-)
45	G	SOUND SIGNAL DOOR WOOFER RH (+)
46	R	SOUND SIGNAL DOOR WOOFER RH (-)
47	B	GND
48	P	SOUND SIGNAL REAR WOOFER LH (+)
50	Y	BATTERY
51	GR	BATTERY
52	B	GND
54	L	SOUND SIGNAL REAR WOOFER LH (+)

Connector No.	B43
Connector Name	BOSE AMP.
Connector Type	SCA12PFR-SGA4

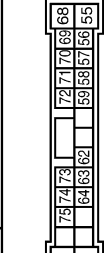

Terminal No.	Color of Wire	Signal Name [Specification]
55	BG	SOUND SIGNAL REAR WOOFER RH (-)
56	W	SOUND SIGNAL PASSENGER HEADREST SPEAKER LH (+)
57	BG	SOUND SIGNAL CENTER (+)
58	P	SOUND SIGNAL CENTER (-)
59	L	SOUND SIGNAL FRONT LH (+)
62	V	SOUND SIGNAL FRONT RH (+)
63	G	SOUND SIGNAL DRIVER HEADREST SPEAKER LH (+)
64	W	SOUND SIGNAL DRIVER HEADREST SPEAKER RH (+)
66	LG	SOUND SIGNAL REAR WOOFER RH (+)
68	B	SOUND SIGNAL PASSENGER HEADREST SPEAKER LH (+)
70	G	SOUND SIGNAL PASSENGER HEADREST SPEAKER RH (+)
71	Y	SOUND SIGNAL PASSENGER HEADREST SPEAKER RH (+)

72	W	SOUND SIGNAL FRONT LH (-)
73	LG	SOUND SIGNAL FRONT RH (-)
74	Y	SOUND SIGNAL DRIVER HEADREST SPEAKER LH (+)
75	B	SOUND SIGNAL DRIVER HEADREST SPEAKER RH (+)

Connector No.	B45
Connector Name	REAR WOOFER LH
Connector Type	NS02PFR-CS



Terminal No.	Color of Wire	Signal Name [Specification]
1	L	---
2	P	---

Connector No.	B53
Connector Name	WIRE TO WIRE
Connector Type	NS12PFR-CS

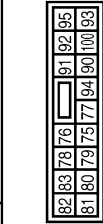

Terminal No.	Color of Wire	Signal Name [Specification]
76	Y	---
77	SHIELD	---
78	W	---
79	B	---
80	SHIELD	---
81	Y	---
82	G	---
83	SHIELD	---
90	B	---
91	P	---
92	V	---
93	G	---
94	BG	---

95	GR	---
100	BR	---

Connector No.	B76
Connector Name	WIRE TO WIRE
Connector Type	TH18MW-NH



Terminal No.	Color of Wire	Signal Name [Specification]
1	V	---
4	LG	---
5	SB	---
6	SHIELD	---
7	B	---
8	W	---
10	SHIELD	---
11	B	---
12	W	---
13	R	---
14	SHIELD	---
15	G	---
16	Y	---

Connector No.	B79
Connector Name	WIRE TO WIRE
Connector Type	TH08MW-NH

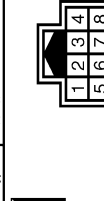

Terminal No.	Color of Wire	Signal Name [Specification]
1	R	---
2	W	---
3	B	---
4	SHIELD	---

Connector No.	B82
Connector Name	RETRACTABLE HARD TOP CONTROL UNIT
Connector Type	TH40PW-NH

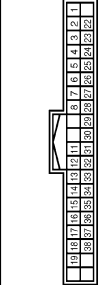

Terminal No.	Color of Wire	Signal Name [Specification]
1	G	ROOF OPEN / CLOSE SWITCH (OPEN)
2	BR	ROOF OPEN / CLOSE SWITCH (CLOSE)
3	B	FLIPPER DOOR LIMIT SWITCH (GND)
4	L	TONNEAU BOARD SWITCH
5	SB	TRUNK ROOM LAMP SWITCH
6	L	ROOF LATCH LIMIT SWITCH
7	W	FLIPPER DOOR LIMIT SWITCH (UP)
8	G	FLIPPER DOOR LIMIT SWITCH (DOWN)
11	W	RETAINED ACC POWER
12	Y	REVERSE SIGNAL
13	BG	PARCEL SHELF STATUS SENSOR POWER SUPPLY
14	P	TRUNK LINK SENSOR SIGNAL (LH)
15	SB	TRUNK LINK SENSOR SIGNAL (RH)
16	GR	ROOF LATCH STATUS SENSOR SIGNAL
17	G	ROOF LATCH LOCK SENSOR SIGNAL
18	LG	TRUNK STATUS SENSOR SIGNAL
22	V	ROOF STATUS SENSOR POWER SUPPLY
23	B	ROOF STATUS SENSOR GND
24	GR	PARCEL SHELF STATUS SENSOR SIGNAL (DRAW)
25	R	PARCEL SHELF STATUS SENSOR SIGNAL (ROTATION)
26	P	ROOF STATUS SENSOR SIGNAL
27	Y	TRUNK LID OPEN REQUEST SIGNAL
28	BG	FLIPPER DOOR RELAY GND
29	V	LOCAL COMMUNICATION (EGW)
30	GR	LOCAL COMMUNICATION (POWER WINDOW)
31	L	CAN-L
32	P	---
33	V	ROOF STATUS SIGNAL (AUDIO)
35	B	ROOF WARNING BUZZER
36	Y	HYDRAULIC MOTOR RELAY GND (RH)
37	W	HYDRAULIC MOTOR RELAY GND (LH)
38	BR	HYDRAULIC MOTOR RELAY POWER SUPPLY

A  
B  
C  
D  
E  
F  
G  
H  
I  
J  
K  
L  
M  
N  
O  
P

AV

# BOSE AUDIO WITH NAVIGATION

[BOSE AUDIO WITH NAVIGATION]

< WIRING DIAGRAM >

## BOSE AUDIO WITH NAVIGATION

Connector No.	B201
Connector Name	WIRE TO WIRE
Connector Type	TH80FW-CS16-TM44

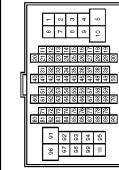

Terminal No.	Color of Wire	Signal Name [Specification]
1	W	
3	B	
5	W	
6	R	
7	B	
7	G	
8	BG	
9	GR	
10	LG	
40	GR	
41	LG	
42	BG	
43	R	
44	SHIELD	
45	G	
47	G	
48	Y	
48	SHIELD	
50	P	
51	SB	
52	LG	
53	L	
54	G	
55	GR	
56	LG	
57	G	
58	R	
67	L	
68	P	
80	G	
81	R	
82	W	
83	B	
84	SHIELD	
85	O	
86	BR	
87	Y	
88	SHIELD	

89	SB	-
90	V	-
91	GR	-
92	P	- [With BOSE system] - [Without BOSE system]
92	Y	-
93	L	-
94	SB	-
95	V	-
96	P	-
97	L	- [With BOSE system] - [Without BOSE system]
98	Y/B	-
99	Y	-

Connector No.	B207
Connector Name	WIRE TO WIRE
Connector Type	TH40FW-NH

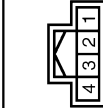

Terminal No.	Color of Wire	Signal Name [Specification]
1	R	
2	W	
3	B	
4	SHIELD	

Connector No.	B209
Connector Name	WIRE TO WIRE
Connector Type	NS16FER-CS



Terminal No.	Color of Wire	Signal Name [Specification]
75	W	
76	B	
77	SHIELD	

Connector No.	B247
Connector Name	REAR WOOFER RH
Connector Type	NS20FW-CS



Terminal No.	Color of Wire	Signal Name [Specification]
1	L	
2	P	

Connector No.	B209
Connector Name	WIRE TO WIRE
Connector Type	TH80FW-NH

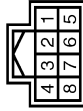

Terminal No.	Color of Wire	Signal Name [Specification]
1	R	
2	W	
3	Y	
4	SHIELD	

78	Y	-
79	G	-
80	SHIELD	-
80	B	-
81	L	-
92	G	-
93	W	-
94	SB	-
95	GR	-
100	LG	-

Connector No.	B246
Connector Name	WIRE TO WIRE
Connector Type	TH18FW-NH

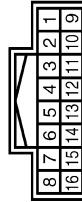

Terminal No.	Color of Wire	Signal Name [Specification]
1	P	
4	P	
5	L	
6	SHIELD	
7	B	
8	W	
10	SHIELD	
11	B	
12	W	
13	R	
14	SHIELD	
15	G	
16	Y	

JCNWM5600GB

# BOSE AUDIO WITH NAVIGATION

[BOSE AUDIO WITH NAVIGATION]

< WIRING DIAGRAM >

## BOSE AUDIO WITH NAVIGATION

Connector No.	B311
Connector Name	REAR VIEW CAMERA
Connector Type	TH04MW-NH



Terminal No.	Color of Wire	Signal Name [Specification]
1	R	CAMERA POWER SUPPLY
2	W	CAMERA GND
3	Y	CAMERA IMAGE SIGNAL
4	SHIELD	SHIELD

Connector No.	B476
Connector Name	WIRE TO WIRE
Connector Type	GT13SS-1/TS-HU



Terminal No.	Color of Wire	Signal Name [Specification]
1	--	--
2	--	--

Connector No.	B477
Connector Name	ANTENNA BASE
Connector Type	GT13SSN-1/IPP-HU



Terminal No.	Color of Wire	Signal Name [Specification]
1	--	--
2	--	--

1	--	ANTENNA AMP ON SIGNAL
2	--	AM-FM MAIN

Connector No.	B301
Connector Name	WIRE TO WIRE
Connector Type	NS16MB-C5



Terminal No.	Color of Wire	Signal Name [Specification]
75	P	--
76	L	--
77	B/Y	--
78	R	--
79	G	--
80	B/W	--
81	B	--
82	W	--
83	B/R	--
90	L	--
91	W/B	--
92	W	--
93	Y	--
94	W/R	--
95	R/L	--
100	GR	--

Connector No.	B309
Connector Name	WIRE TO WIRE
Connector Type	NS16MW-C5



Terminal No.	Color of Wire	Signal Name [Specification]
75	P	--
76	L	--

77	B/Y	--
78	R	--
79	G	--
80	B/W	--
81	B	--
82	W	--
83	B/R	--
85	G	--
88	G/R	--
96	R/W	--
98	L	--
99	L/W	--
104	V/W	--
105	LG	--

Connector No.	B310
Connector Name	WIRE TO WIRE
Connector Type	NS16FN-C5



Terminal No.	Color of Wire	Signal Name [Specification]
75	P	--
76	L	--
77	B/Y	--
78	R	--
79	G	--
80	B/W	--
81	B	--
82	W	--
83	B/R	--
85	G	--
88	G/R	--
96	R/W	--
98	L	--
99	L/W	--
104	V/W	--
105	LG	--

Connector No.	B313
Connector Name	WIRE TO WIRE
Connector Type	AG8MW



Terminal No.	Color of Wire	Signal Name [Specification]
75	P	--
76	L	--
78	R	--
79	G	--
81	B	--
82	W	--

Connector No.	B314
Connector Name	WIRE TO WIRE
Connector Type	AG8FW



Terminal No.	Color of Wire	Signal Name [Specification]
75	--	--
76	--	--
78	--	--
79	--	--
81	--	--
82	--	--

A  
B  
C  
D  
E  
F  
G  
H  
I  
J  
K  
L  
M  
N  
O  
P

AV

JCNWM5601GB

# BOSE AUDIO WITH NAVIGATION

[BOSE AUDIO WITH NAVIGATION]

< WIRING DIAGRAM >

## BOSE AUDIO WITH NAVIGATION

Connector No.	B615
Connector Name	DRIVER HEADREST SPEAKER LH
Connector Type	TK02FGY



Terminal No.	Color of Wire	Signal Name [Specification]
75	-	-
76	-	-

Connector No.	B616
Connector Name	DRIVER HEADREST SPEAKER RH
Connector Type	TK02FW



Terminal No.	Color of Wire	Signal Name [Specification]
78	-	-
79	-	-

Connector No.	B617
Connector Name	MICROPHONE (FOR Audiopilot™)
Connector Type	TK02FBR



Terminal No.	Color of Wire	Signal Name [Specification]
82	-	-

Connector No.	B621
Connector Name	WIRE TO WIRE
Connector Type	NS16MBR-CS



Terminal No.	Color of Wire	Signal Name [Specification]
75	P	-
76	L	-
77	B/Y	-
78	R	-
79	G	-
80	B/W	-
80	B/W	-
81	W/B	-
92	W	-
93	Y	-
94	W/R	-
95	R/L	-
100	GR	-

Connector No.	B629
Connector Name	WIRE TO WIRE
Connector Type	TK02MGY



Terminal No.	Color of Wire	Signal Name [Specification]
76	L	-
75	P	-

Connector No.	B630
Connector Name	WIRE TO WIRE
Connector Type	TK02MW



Terminal No.	Color of Wire	Signal Name [Specification]
78	R	-
79	G	-

Connector No.	B631
Connector Name	WIRE TO WIRE
Connector Type	NS10MW-CS



Terminal No.	Color of Wire	Signal Name [Specification]
75	P	-
76	L	-
77	B/Y	-
78	R	-
79	G	-
80	B/W	-
83	G	-
88	G/R	-
104	V/W	-
105	LG	-

Connector No.	B632
Connector Name	WIRE TO WIRE
Connector Type	NS10FW-CS



Terminal No.	Color of Wire	Signal Name [Specification]
75	P	-
76	L	-
77	B/Y	-
78	R	-
79	G	-
80	B/W	-
85	G	-
88	G/R	-
104	V/W	-
105	LG	-

Connector No.	B635
Connector Name	WIRE TO WIRE
Connector Type	TK02FGY



Terminal No.	Color of Wire	Signal Name [Specification]
75	-	-
76	-	-

JCNWM5602GB



# BOSE AUDIO WITH NAVIGATION

[BOSE AUDIO WITH NAVIGATION]

< WIRING DIAGRAM >

## BOSE AUDIO WITH NAVIGATION

Connector No.	B636
Connector Name	WIRE TO WIRE
Connector Type	TK02FW



Terminal No.	Color of Wire	Signal Name [Specification]
78	-	-
78	-	-

Connector No.	B637
Connector Name	PASSENGER HEADREST SPEAKER LH
Connector Type	TK02FY



Terminal No.	Color of Wire	Signal Name [Specification]
75	-	-
76	-	-

Connector No.	B638
Connector Name	PASSENGER HEADREST SPEAKER RH
Connector Type	TK02FW



Terminal No.	Color of Wire	Signal Name [Specification]
78	-	-
78	-	-

Connector No.	D1
Connector Name	WIRE TO WIRE
Connector Type	TH4PFT-CS15



Terminal No.	Color of Wire	Signal Name [Specification]
4	BR	-
5	P	- [A/T models with automatic drive positioner]
6	B	- [Except for A/T models with automatic drive positioner]
7	SR	-
8	G	-
9	P	-
10	LG	-
11	W	-
12	L	-
13	B	-
14	V	-
15	Y	-
16	Y/B	-
17	Y	-
20	V	-
21	R	-
22	P	-
23	O	-
24	Y	-
25	SR	-
26	GR	-
27	GR	-
28	LG	-
29	G	-
30	Y	-
31	W	-
32	BR	-
33	L	-
34	R	-
35	V	-
37	B	-
38	O	-
39	GR	-
40	G	-
41	Y	-
42	LG	-
43	BR	-

Connector No.	D2
Connector Name	TWEETER LH
Connector Type	TK02MRF-P



Terminal No.	Color of Wire	Signal Name [Specification]
1	L	-
2	W	-

Connector No.	D11
Connector Name	DOOR WOOFER LH
Connector Type	NS02FW-CS



Terminal No.	Color of Wire	Signal Name [Specification]
1	G	-
2	R	-

Connector No.	D16
Connector Name	DOOR SQUAWKER LH
Connector Type	TK02FBR



Terminal No.	Color of Wire	Signal Name [Specification]
1	L	-
2	W	-

A  
B  
C  
D  
E  
F  
G  
H  
I  
J  
K  
L  
M  
AV  
O  
P

# BOSE AUDIO WITH NAVIGATION

< WIRING DIAGRAM >

[BOSE AUDIO WITH NAVIGATION]

## BOSE AUDIO WITH NAVIGATION

Connector No.	D31
Connector Name	WIRE TO WIRE
Connector Type	TH40FW-CS15

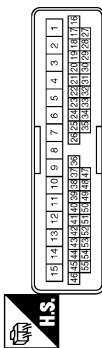

Terminal No.	Color of Wire	Signal Name [Specification]
6	BR	-
7	R	-
8	G	-
9	P	-
10	LG	-
11	W	-
12	L	-
13	B	-
14	Y	-
15	W	-
34	Y	-
35	Y/B	-
36	O	-
38	GR	-
40	G	-
41	Y	-
42	LG	-
43	BR	-
44	V	-
45	P	-
46	W	-
47	Y	-
48	P	-
49	W	-
50	SB	-
51	R	-
52	L	-
53	O	-
54	GR	-
55	G	-

Connector No.	D32
Connector Name	TWEETER RH
Connector Type	TK02MR-P

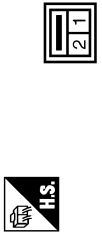

Terminal No.	Color of Wire	Signal Name [Specification]
1	L	-
2	W	-

Connector No.	D41
Connector Name	DOOR WOOFER RH
Connector Type	NS02FR-CS



Terminal No.	Color of Wire	Signal Name [Specification]
1	G	-
2	R	-

Connector No.	D46
Connector Name	DOOR SQUAWKER RH
Connector Type	TK02FR

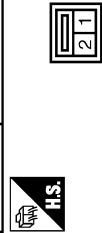

Terminal No.	Color of Wire	Signal Name [Specification]
1	L	-
2	W	-

Connector No.	E5
Connector Name	ENGINE INTELLIGENT POWER DISTRIBUTION MODULE ENGINE ROOM
Connector Type	TH40FW-CS12-MF-IV

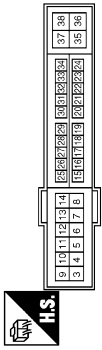

Terminal No.	Color of Wire	Signal Name [Specification]
4	V	-
5	L	-
6	SB	-
7	R	-
11	BR	-
12	B/W	-
13	Y	-
16	LG	-
19	W	-
25	G	-
26	R	-
27	BG	-
28	L	-
30	GR	-
32	V	-
33	P	-
36	G	-

JCNWM5604GB

# BOSE AUDIO WITH NAVIGATION

[BOSE AUDIO WITH NAVIGATION]

< WIRING DIAGRAM >

## BOSE AUDIO WITH NAVIGATION

Connector No.	E106
Connector Name	WIRE TO WIRE
Connector Type	TH80FW-CS16-TM4

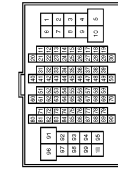

Terminal No.	Color of Wire	Signal Name [Specification]
1	GR	
2	EG	
3	B/W	
4	G	
5	EG	
6	GR	
7	LG	
8	G	
9	R	
10	W	
11	V	
12	R	
13	L	
14	GR	
15	P	
16	W	
17	V	
18	EG	
19	GR	
20	LG	
30	R	
31	L	
32	EG	
33	P	
34	V	
35	BR	
36	W	
37	Y	
38	R	
39	B	
40	G	
41	W	
42	LG	
43	SB	
44	GR	
45	EG	
46	LG	
47	V	
48	P	

49	L	
59	B	
66	LG	
67	SS	
68	R	
69	W	
70	G	
80	W	
81	P	
82	G	
83	V	
84	L	
85	BG	
86	LG	
87	Y	
88	GR	
89	W	
90	W	
91	G	
92	B	
93	GR	
94	L	
95	Y	
97	BR	
98	SHIELD	
99	L	
100	P	

Connector No.	E107
Connector Name	PARKING BRAKE SWITCH
Connector Type	TB01FW



Terminal No.	Color of Wire	Signal Name [Specification]
1	BG	

Connector No.	F51
Connector Name	A-7 ASSEMBLY
Connector Type	RK0FG-DCY



Terminal No.	Color of Wire	Signal Name [Specification]
1	Y	
2	R	
3	L	
4	V	
5	B	
6	Y	
7	R	
8	P	
9	GR	
10	B	

Connector No.	F56
Connector Name	BACK-UP LAMP SWITCH
Connector Type	RK02FB



Terminal No.	Color of Wire	Signal Name [Specification]
1	R	
2	O	

Connector No.	F103
Connector Name	WIRE TO WIRE
Connector Type	TK36FW-NS10

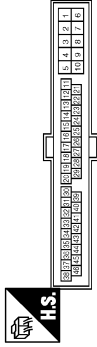

Terminal No.	Color of Wire	Signal Name [Specification]
2	G	
3	W	
4	R	
5	B	
6	Y	
7	Y	
8	Y	
9	Y	
10	GR	
19	O	
20	Y	
28	B	
29	LG	
30	R	
31	R	
41	O	
42	BR	
43	P	
44	L	
45	Y	
46	V	

JCNWM5605GB

A  
B  
C  
D  
E  
F  
G  
H  
I  
J  
K  
L  
M  
AV  
O  
P

# BOSE AUDIO WITH NAVIGATION

< WIRING DIAGRAM >

[BOSE AUDIO WITH NAVIGATION]

## BOSE AUDIO WITH NAVIGATION

Connector No.	F1B7
Connector Name	TOM (TRANSMISSION CONTROL MODULE)
Connector Type	SP10FG



Terminal No.	Color of Wire	Signal Name [Specification]
1	-	VIGN
2	-	BATT
3	-	CAN-H
4	-	K-LINE
5	-	GND
6	-	VIGN
7	-	REV LAMP RLY
8	-	CAN-L
9	-	STARTER RLY
10	-	GND

Connector No.	M1
Connector Name	FUSE BLOCK (J/B)
Connector Type	NS0BFW-MZ



Terminal No.	Color of Wire	Signal Name [Specification]
1A	Y	-
2A	G	-
3A	L	-
4A	P	-
5A	BR	-
6A	Y	-
7A	GR	-
8A	L	-

Connector No.	M2
Connector Name	FUSE BLOCK (J/B)
Connector Type	NS1ZFW-CS



Terminal No.	Color of Wire	Signal Name [Specification]
1B	R	-
3B	P	-
4B	G	-
5B	BG	-
6B	Y	-
7B	P	-
8B	R	-
9B	SB	-

Connector No.	M3
Connector Name	FUSE BLOCK (J/B)
Connector Type	NS1ZFW-CS

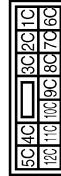

Terminal No.	Color of Wire	Signal Name [Specification]
6C	R	-
7C	B	-
8C	W	-
9C	BG	-
10C	L	-
11C	LG	-
12C	R	-

Connector No.	M5
Connector Name	WIRE TO WIRE
Connector Type	TH40MW-CS1.5

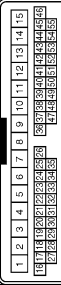

Terminal No.	Color of Wire	Signal Name [Specification]
4	R	-
5	B	-
6	BG	-
7	W	-
8	B	-
9	G	-
10	V	-
11	W	-
12	L	-
13	B	-
14	GR	-
15	Y	-
16	Y/B	-
17	Y	-
20	BG	-
21	W	-
22	P	-
23	BG	-
24	V	-
25	BR	-
26	R	-
27	P	-
28	LG	-
29	SB	-
30	G	-
31	V	-
32	BR	-
33	GR	-
34	G	-
35	L	-
37	B	-
38	G	- [With automatic drive positioner]
38	L	- [Without automatic drive positioner]
39	BR	- [With automatic drive positioner]
39	L	- [Without automatic drive positioner]
40	Y	-
41	BR	- [With automatic drive positioner]
41	G	- [Without automatic drive positioner]

42	R	-
43	G	-
44	Y	-
45	GR	-
46	BR	-
47	V	-
48	LG	-
49	P	-
50	SB	-
51	GR	-
52	L	-

# BOSE AUDIO WITH NAVIGATION

< WIRING DIAGRAM >

[BOSE AUDIO WITH NAVIGATION]

## BOSE AUDIO WITH NAVIGATION

Connector No.	M6
Connector Name	WIRE TO WIRE
Connector Type	TH80MW-CS (F-TM4)

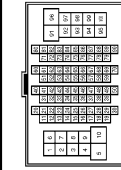

Terminal No.	Color of Wire	Signal Name [Specification]
1	EG	
2	R	
3	R	
4	G	
5	G	
6	BR	
7	BR	
8	Y	
9	R	
10	W	
11	GR	
12	R	
13	L	
14	G	
15	P	
16	W	
17	BR	
18	V	
19	EG	
20	L	
30	R	
31	L	
32	Y	
33	GR	
34	P	
35	BR	
36	BR	
37	Y	
38	LG	
39	SB	
40	G	
41	W	
42	LG	
43	P	
44	GR	
44	R	- [With A/T]
45	EG	- [With M/T]
46	G	
47	P	

48	P	
49	L	
50	B	
50	Y	
57	G	
58	R	
59	W	
60	G	
60	SB	
61	R	
62	V	
63	L	
64	BG	
65	G	
67	V	
68	B	
69	SR	
70	G	
80	G	
81	R	
82	V	
83	W	
84	L	
85	BG	
86	G	
87	V	
88	B	
89	SR	
90	G	
91	W	
92	B	
93	G	
94	L	
95	BR	
97	P	
98	SHIELD	
99	V	
100	SB	

Connector No.	M7
Connector Name	WIRE TO WIRE
Connector Type	TH80MW-CS (F-TM4)

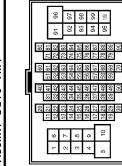

Terminal No.	Color of Wire	Signal Name [Specification]
1	BG	
2	LG	
3	G	
4	V	
5	L	
6	B	
9	L	
10	BR	

12	SHIELD	
13	V	
14	BR	
15	GR	
16	LG	
17	L	
20	BR	
21	G	
22	R	
23	SB	
24	B	
25	W	
26	Y	
27	V	
28	P	
29	V	
30	G	
31	SHIELD	
32	G	
33	B	
34	BG	
35	GR	
36	BR	
37	L	
37	P	
38	V	
39	GR	
40	SHIELD	
41	L	
42	P	
43	SHIELD	
44	Y	
45	BR	
46	SB	
47	SB	
48	LG	
48	LG	- [With BOSE system]
48	SB	- [Without BOSE system]
50	SB	- [With BOSE system]
50	LG	- [Without BOSE system]
51	R	
52	V	
53	P	
54	BR	
55	Y	- [With A/T]
55	BG	- [With M/T]
56	L	
57	V	
58	R	
60	LG	
61	BG	
62	B	
63	V	

64	SR	
65	BR	
66	Y	
67	P	
68	L	
69	P	
70	L	
80	G	
81	LG	
82	Y	
83	BR	
84	V	
85	L	
86	Y	
87	GR	
91	R	
93	G	
94	P	
95	GR	
96	Y	
97	SB	
99	Y	
100	Y/B	

Connector No.	M17
Connector Name	WIRE TO WIRE
Connector Type	TK02FW



Terminal No.	Color of Wire	Signal Name [Specification]
1	L	
2	P	

A  
B  
C  
D  
E  
F  
G  
H  
I  
J  
K  
L  
M  
N  
O  
P

AV

# BOSE AUDIO WITH NAVIGATION

[BOSE AUDIO WITH NAVIGATION]

< WIRING DIAGRAM >

## BOSE AUDIO WITH NAVIGATION

Connector No.	M18
Connector Name	WIRE TO WIRE
Connector Type	TK02NW



Terminal No.	Color of Wire	Signal Name [Specification]
1	L	-
2	P	-

Connector No.	M24
Connector Name	DATA LINK CONNECTOR
Connector Type	BD16FW



Terminal No.	Color of Wire	Signal Name [Specification]
3	LG	-
4	B	-
5	BR	-
6	L	-
7	V	-
8	G	-
11	SB	-
14	P	-
16	R	-

Connector No.	M25
Connector Name	WIRE TO WIRE
Connector Type	NS16MH-OS



Terminal No.	Color of Wire	Signal Name [Specification]
1	L	-
2	W	-
3	BR	-
4	SB	-
5	Y	-
6	LG	-
7	B	-
11	L	-
12	P	-
13	R	-
14	R	-
15	G	-
16	W	-

Connector No.	M36
Connector Name	COMBINATOR SWITCH (SPPAL CABLE)
Connector Type	TK08FGY-1V



Terminal No.	Color of Wire	Signal Name [Specification]
24	P	-
25	SB	-
26	BR	-
31	L	-
32	Y	-
33	B	-
34	LG	-

Connector No.	M37
Connector Name	STEERING ANGLE SENSOR
Connector Type	TH08FW-NH



Terminal No.	Color of Wire	Signal Name [Specification]
1	L	CAN-H
2	P	CAN-L
7	B	GND
8	G	IGN

Connector No.	M44
Connector Name	SONAR CONTROL UNIT
Connector Type	TH04FW-NH



Terminal No.	Color of Wire	Signal Name [Specification]
1	G	CANCEL SW SIGNAL
2	SB	CORNER SENSOR SIGNAL REAR LH
5	LG	CORNER SENSOR SIGNAL REAR RH
6	L	CORNER SENSOR SIGNAL REAR LH
7	BR	CORNER SENSOR SIGNAL REAR RH
8	GR	CANCEL SW INDICATOR
11	BR	SENSOR GND
12	V	ACC
13	LG	R RANGE SIGNAL
17	BG	K LINE
18	V	AV COMM (H)
19	SB	AV COMM (L)
20	LG	GND
24	GR	GND

Connector No.	M63
Connector Name	CENTER SPEAKER
Connector Type	TK02FBR



Terminal No.	Color of Wire	Signal Name [Specification]
1	Y	-
2	LG	-

Connector No.	M66
Connector Name	UNIFIED METER AND A/C AMP.
Connector Type	TH40FW-NH



Terminal No.	Color of Wire	Signal Name [Specification]
4	G	STOP LAMP SWITCH
5	L	MANUAL MODE SHIFT UP SIGNAL
6	BG	PADDLE SHIFTER UP SIGNAL
7	GR	COMMUNICATION SIGNAL (AMP->METER)
8	L	VEHICLE SPEED (2-PULSE)
9	SB	SEAT BELT BUCKLE SWITCH SIGNAL (DRIVER SIDE)
10	W	MANUAL MODE SIGNAL
11	G	NON-MANUAL MODE SIGNAL
14	SB	COMMUNICATION SIGNAL (LCP->AMP)
20	G	IGN ON / OFF SIGNAL
25	V	MANUAL MODE SHIFT DOWN SIGNAL
26	G	PADDLE SHIFTER DOWN SIGNAL
27	LG	COMMUNICATION SIGNAL (METER->AMP)
28	R	VEHICLE SPEED (8-PULSE)
30	V	PARKING BRAKE SWITCH SIGNAL
34	B	COMMUNICATION SIGNAL (AMP->LCD)
38	P	BLOWER MOTOR CONTROL SIGNAL

# BOSE AUDIO WITH NAVIGATION

[BOSE AUDIO WITH NAVIGATION]

< WIRING DIAGRAM >

## BOSE AUDIO WITH NAVIGATION

Connector No.	M67
Connector Name	UNIFIED METER AND A/C AMP.
Connector Type	TH22FN-NH

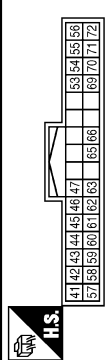

Terminal No.	Color of Wire	Signal Name [Specification]
1	R	BATTERY
2	W	COMPOSITE IMAGE SIGNAL
3	LG	COMPOSITE IMAGE GND
5	BG	SHIELD

Connector No.	M72
Connector Name	MULTIFUNCTION SWITCH
Connector Type	TH16FY-NH

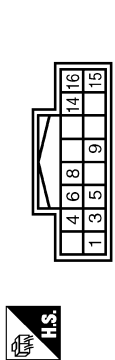

Terminal No.	Color of Wire	Signal Name [Specification]
1	B	GND
3	L	ACC
4	BG	ILL
5	V	ILL CONT
6	SB	AV COMM (H)
8	LG	AV COMM (L)
9	BR	SW GND
14	SB	DISK EJECT SIGNAL
16	G	HAZARD ON

Connector No.	M75
Connector Name	DISPLAY UNIT
Connector Type	TH22FN-NH

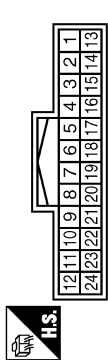

Terminal No.	Color of Wire	Signal Name [Specification]
6	SHIELD	SHIELD
7	SHIELD	SHIELD
8	W	CAMERA IMAGE SIGNAL
9	L	COMM (DISE->CONT)
10	P	COMM (CONT->DISEP)

Terminal No.	Color of Wire	Signal Name [Specification]
11	Y	BATTERY
12	B	GND
18	L	COMPOSITE IMAGE SIGNAL
19	P	COMPOSITE IMAGE GND
22	SHIELD	SHIELD
23	LG	ACC

Connector No.	M60
Connector Name	USB CONNECTOR
Connector Type	HAAD4FG

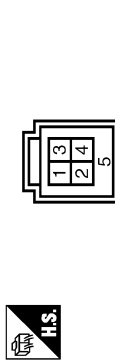

Terminal No.	Color of Wire	Signal Name [Specification]
1	W	
2	L	
3	G	
4	R	
5	SHIELD	

Connector No.	M106
Connector Name	WIRE TO WIRE
Connector Type	NH10MW-CS10

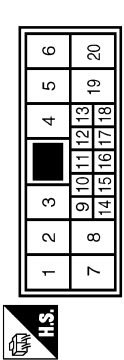

Terminal No.	Color of Wire	Signal Name [Specification]
1	B	
2	BR	
3	Y	
4	G	
5	SHIELD	
6	R	
7	B	
8	L	
9	R	

Terminal No.	Color of Wire	Signal Name [Specification]
10	SB	
11	V	
12	LG	
18	B	
19	P	
20	Y	

Connector No.	M107
Connector Name	ECM
Connector Type	RH24FCY-RZ8-F-LH-Z

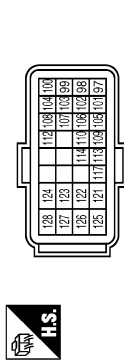

Terminal No.	Color of Wire	Signal Name [Specification]
97	R	APP SEN 1
98	P	APP SEN 2
99	L	SENSOR POWER SUPPLY
100	W	SENSOR GROUND
101	SB	ASC/DC STEERING SW
102	G	EVAP CONTROL SYSTEM PRESS SEN
103	G	SENSOR POWER SUPPLY
104	GR	SENSOR GROUND
105	L	REFRIGERANT PRESS SEN
106	LG	FUEL TANK TEMP SEN
107	BR	SENSOR POWER SUPPLY
108	Y	SENSOR GROUND
109	G	ENG SIGNAL
110	BR	ENGINE SPEED OUTPUT SIGNAL
112	R	SENSOR GROUND
113	P	CAN COMMUNICATION LINE
114	L	CAN COMMUNICATION LINE
117	V	DATA LINK CONNECTOR
121	LG	EVAP CANISTER VENT CONTROL VALVE
122	P	STOP LAMP SW
123	B	ECM GROUND
124	B	ECM GROUND
125	R	POWER SUPPLY FOR ECM
126	BR	ASC/DC BRAKE SW
127	B	ECM GROUND
128	B	ECM GROUND

A B C D E F G H I J K L M N O P

AV

JCNWM5609GB

# BOSE AUDIO WITH NAVIGATION

[BOSE AUDIO WITH NAVIGATION]

< WIRING DIAGRAM >

## BOSE AUDIO WITH NAVIGATION

Connector No.	M113
Connector Name	WIRE TO WIRE
Connector Type	CP06FGY

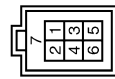

Terminal No.	Color of Wire	Signal Name [Specification]
2	W	
3	L	
4	G	
5	R	
7	SHIELD	

Connector No.	M116
Connector Name	WIRE TO WIRE
Connector Type	TK36MW-NS10



Terminal No.	Color of Wire	Signal Name [Specification]
2	W	
3	EG	
4	R	
5	B	
9	R	
10	R	
19	BG	
20	Y	
28	GR	
29	LG	
30	LG	
31	W	
41	BG	
42	G	
43	P	
44	L	
45	G	

46	Y	-
----	---	---

Connector No.	M117
Connector Name	WIRE TO WIRE
Connector Type	TH80MW-CST6-TM4

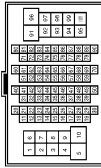

Terminal No.	Color of Wire	Signal Name [Specification]
1	Y	
3	B	
5	SB	
6	R	
7	G	
8	SB	
9	GR	
10	LG	
40	Y	
41	G	
42	LG	
43	R	
44	SHIELD	
45	G	
47	P	
48	L	
49	SHIELD	
50	V	
51	SB	
52	BG	
53	L	
54	G	
55	Y	
56	LG	
57	SB	
58	LG	
67	SB	
68	LG	
80	W	
81	B	
82	R	
83	G	
84	SHIELD	
85	G	
86	L	

87	P	SHIELD	-
88	Y	SHIELD	-
89	W	GR	-
90	GR	GR	-
92	P	GR	-
93	W	GR	-
94	BG	BG	-
95	BG	BG	-
96	P	P	-
97	L	L	-
98	Y/B	Y/B	-
99	Y	Y	-

Connector No.	M122
Connector Name	BCM (BODY CONTROL MODULE)
Connector Type	TH40FB-NH

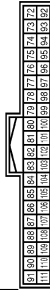

Terminal No.	Color of Wire	Signal Name [Specification]
72	R	ROOM ANT 2-
73	G	ROOM ANT 2+
74	SB	PASSENGER DOOR ANT-
75	BR	PASSENGER DOOR ANT+
76	V	DRIVER DOOR ANT-
77	LG	DRIVER DOOR ANT+
78	Y	ROOM ANT 1-
79	BR	ROOM ANT 1+
80	GR	NATS ANTENNA AMP
81	W	NATS ANTENNA AMP
82	R	IGN RELAY (P/B) CONT
83	Y	KEYLESS ENTRY RECEIVER COMM
87	Y	COMBI SW INPUT 5
88	BG	COMBI SW INPUT 3
89	BR	PUSH SW
90	P	CAN-L
91	L	CAN-H
92	LG	KEY SLOT ILL
93	V	ON IND
95	BG	ACC RELAY CONT
96	GR	A/T SHIFT SELECTOR POWER SUPPLY
97	L	S/L CONDITION 1
98	SB	S/L CONDITION 2

99	R	ASCD CLUTCH SW (Wgh, M/T)
99	R	SHIFT P (Wgh, A/T)
100	Y	PASSENGER DOOR REQUEST SW
101	P	DRIVER DOOR REQUEST SW
102	BG	BLOWER FAN MOTOR RELAY CONT
103	LG	KEYLESS ENTRY RECEIVER POWER SUPPLY
106	W	S/L UNIT POWER SUPPLY
107	LG	COMBI SW INPUT 1
108	R	COMBI SW INPUT 4
109	W	COMBI SW INPUT 2
110	G	HAZARD SW
111	Y	S/L UNIT COMM



# BOSE AUDIO WITH NAVIGATION

[BOSE AUDIO WITH NAVIGATION]

< WIRING DIAGRAM >

## BOSE AUDIO WITH NAVIGATION

Connector No.	M124
Connector Name	WIRE TO WIRE
Connector Type	TH40MW-CS 5

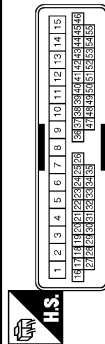

Terminal No.	Color of Wire	Signal Name [Specification]
6	BG	-
7	R	-
8	G	-
9	P	-
10	V	-
11	SB	- [With BOSE system]
11	GR	- [Without BOSE system]
12	BR	-
13	B	-
14	G	-
15	W	-
34	Y	-
35	Y/B	-
36	W	-
38	BG	-
40	SB	-
41	BR	- [With automatic drive positioner]
41	G	- [Without automatic drive positioner]
42	R	-
43	L	-
44	Y	-
45	R	-
46	W	-
47	SB	-
48	BR	-
49	Y	-
50	P	-
51	LG	-
52	BG	-
53	Y	-
54	L	-
55	L	-

Connector No.	M134
Connector Name	WIRE TO WIRE
Connector Type	CP30MGY-S

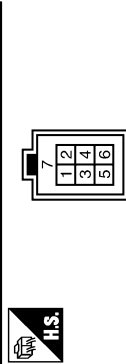

Terminal No.	Color of Wire	Signal Name [Specification]
2	W	-
3	L	-
4	G	-
5	R	-
7	SHIELD	-

Connector No.	M135
Connector Name	USB CONNECTOR
Connector Type	HAA04FG

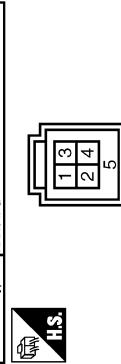

Terminal No.	Color of Wire	Signal Name [Specification]
1	W	-
2	L	-
3	G	-
4	R	-
5	SHIELD	-

Connector No.	M144
Connector Name	WIRE TO WIRE
Connector Type	TH40MW-NH



Terminal No.	Color of Wire	Signal Name [Specification]
1	R	-
2	W	-
3	W	-
4	SHIELD	-

Connector No.	M208
Connector Name	AV CONTROL UNIT
Connector Type	TH18FW-GS2

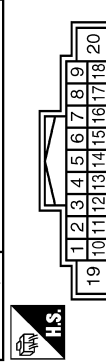

Terminal No.	Color of Wire	Signal Name [Specification]
2	P	SOUND SIGNAL LH (+)
3	L	SOUND SIGNAL LH (-)
6	P	STRG SW A
7	V	ACC
10	B	SHIELD
11	R	SOUND SIGNAL RH (+)
12	G	SOUND SIGNAL RH (-)
15	B	STRG SW GND
16	L	STRG SW B
19	BR	BATTERY
20	B	GND

Connector No.	M209
Connector Name	AV CONTROL UNIT
Connector Type	TH40FW-NH

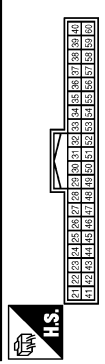

Terminal No.	Color of Wire	Signal Name [Specification]
22	R	CAMERA POWER SUPPLY
29	SB	DISK EJECT SIGNAL
42	W	CAMERA GND
49	BR	SW GND

A  
B  
C  
D  
E  
F  
G  
H  
I  
J  
K  
L  
M  
AV  
O  
P

JCNWM5611GB

# BOSE AUDIO WITH NAVIGATION

< WIRING DIAGRAM >

[BOSE AUDIO WITH NAVIGATION]

## BOSE AUDIO WITH NAVIGATION

Connector No.	M210
Connector Name	AV CONTROL UNIT
Connector Type	TH227V-NH



61	62	63	64	65	66	67	68	69	70	71	72	73	74	75	76	77	78	79	80	81	82	83	84	85	86	87	88	89	90	91	92
----	----	----	----	----	----	----	----	----	----	----	----	----	----	----	----	----	----	----	----	----	----	----	----	----	----	----	----	----	----	----	----

Terminal No.	Color of Wire	Signal Name [Specification]
65	SB	PARKING BRAKE
67	P	COMPOSITE IMAGE GND
68	L	COMPOSITE IMAGE SIGNAL
71	SHIELD	MICROPHONE SHIELD
72	G	MICROPHONE VCC
73	P	COMM (CONT->DISP)
74	P	CAN-L
75	LG	AV COMM (L)
76	LG	AV COMM (L)
79	L	ILLUMINATION
80	G	IGNITION
81	BG	REVERSE SIGNAL
82	GR	VEHICLE SPEED (8-PULSE)
83	SHIELD	SHIELD
87	R	MICROPHONE SIGNAL
88	SHIELD	SHIELD
89	L	COMM (DISP->CONT)
90	L	CAN-H
91	SB	AV COMM (H)
92	SB	AV COMM (H)

Connector No.	M212
Connector Name	AV CONTROL UNIT
Connector Type	HAADHFL



129	131	132	133
-----	-----	-----	-----

Terminal No.	Color of Wire	Signal Name [Specification]
129	G	USB GND
130	R	USB D- SIGNAL

131	W	V-BUS SIGNAL
132	L	USB D+ SIGNAL
133	SHIELD	SHIELD



Connector No.	M213
Connector Name	AV CONTROL UNIT
Connector Type	TH10FW-NH



134	135	136	137	138	139	140	141	142	143	144	145	146	147	148	149
-----	-----	-----	-----	-----	-----	-----	-----	-----	-----	-----	-----	-----	-----	-----	-----

Terminal No.	Color of Wire	Signal Name [Specification]
135	BR	VOICE GUIDANCE SIGNAL (+)
136	Y	VOICE GUIDANCE SIGNAL (-)

Connector No.	M256
Connector Name	WIRE TO WIRE
Connector Type	TH04MW-NH



1	2	3	4
---	---	---	---

Connector No.	M258
Connector Name	WIRE TO WIRE
Connector Type	TH04MW-NH

Connector No.	M257
Connector Name	WIRE TO WIRE
Connector Type	TH04FW-NH



4	3	2	1
---	---	---	---

Terminal No.	Color of Wire	Signal Name [Specification]
1	P	
2	L	

Connector No.	M303
Connector Name	COMBINATION SWITCH (SPIRAL CABLE)
Connector Type	TK08FGY



20	19	18	17	16	15	14	13
----	----	----	----	----	----	----	----

Terminal No.	Color of Wire	Signal Name [Specification]
13	-	
14	-	
15	-	
16	-	
17	-	
18	-	
19	-	
20	-	

Connector No.	M371
Connector Name	AV CONTROL UNIT
Connector Type	GT13SH-2 / IS-HU



152	151
-----	-----

Terminal No.	Color of Wire	Signal Name [Specification]
151	-	ANTENNA SIGNAL
152	-	ANTENNA AMP. ON SIGNAL

Connector No.	M372
Connector Name	AV CONTROL UNIT
Connector Type	FAKRA JACK



153	160
-----	-----

Terminal No.	Color of Wire	Signal Name [Specification]
159	-	SATELLITE ANTENNA
160	-	SHIELD

Connector No.	M373
Connector Name	AV CONTROL UNIT
Connector Type	GT5-1S-HU



153	154
-----	-----





















Terminal No.	Color of Wire	Signal Name [Specification]
153	-	GFS ANTENNA
154	-	SHIELD

# BOSE AUDIO WITH NAVIGATION

[BOSE AUDIO WITH NAVIGATION]

< WIRING DIAGRAM >

## BOSE AUDIO WITH NAVIGATION

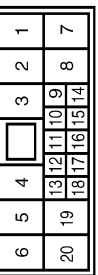
Connector No. M374	Connector Name WIRE TO WIRE	Connector Type FAKRA	 	Terminal No.	Color of Wire	Signal Name [Specification]
				1	-	-
				2	-	-
Connector No. M377	Connector Name WIRE TO WIRE	Connector Type FAKRA	 	Terminal No.	Color of Wire	Signal Name [Specification]
				1	-	-
				2	-	-
Connector No. M382	Connector Name WIRE TO WIRE	Connector Type FAKRA	 	Terminal No.	Color of Wire	Signal Name [Specification]
				1	-	-
				2	-	-
Connector No. M386	Connector Name DISPLAY UNIT	Connector Type GT17HN2-4DH-HU	 	Terminal No.	Color of Wire	Signal Name [Specification]
				27	-	RGB DIGITAL IMAGE SIGNAL (-)
				28	-	RGB DIGITAL IMAGE SIGNAL (+)
Connector No. M375	Connector Name WIRE TO WIRE	Connector Type GT13SSN-1/1PP-HU	 	Terminal No.	Color of Wire	Signal Name [Specification]
				1	-	-
				2	-	-
Connector No. M378	Connector Name WIRE TO WIRE	Connector Type GT13SSN-1/1PP-HU	 	Terminal No.	Color of Wire	Signal Name [Specification]
				1	-	-
				2	-	-
Connector No. M383	Connector Name ANTENNA BASE	Connector Type FAKRA	 	Terminal No.	Color of Wire	Signal Name [Specification]
				3	-	SATELLITE ANTENNA
				4	-	SHIELD
Connector No. M380	Connector Name WIRE TO WIRE	Connector Type FAKRA	 	Terminal No.	Color of Wire	Signal Name [Specification]
				1	-	-
				2	-	-
Connector No. M376	Connector Name WIRE TO WIRE	Connector Type GT13SS-1/1S-HU	 	Terminal No.	Color of Wire	Signal Name [Specification]
				1	-	-
				2	-	-
Connector No. M385	Connector Name AV CONTROL UNIT	Connector Type GT17HNN-4DS-HU	 	Terminal No.	Color of Wire	Signal Name [Specification]
				157	-	RGB DIGITAL IMAGE SIGNAL (-)
				158	-	RGB DIGITAL IMAGE SIGNAL (+)
Connector No. RT	Connector Name WIRE TO WIRE	Connector Type NH10FW-CSI0	 	Terminal No.	Color of Wire	Signal Name [Specification]
				6	B	-
				5	4	-
				4	W	-
				3	Y	-
				2	BR	-
				1	-	-
				20	19	-
				18	17	-
				16	15	-
				14	13	-
				12	11	-
				10	9	-
				8	7	-
				7	B	-
				6	O	-
				5	SHIELD	-
				4	W	-
				3	Y	-
				2	BR	-
				1	B	-
				20	G	-
				19	BR	-
				18	B	-
				17	R	-
				16	V	-
				15	B	-
				14	L	-
				13	Y	-
				12	B	-
				11	V	-
				10	B	-
				9	L	-
				8	Y	-
				7	B	-
				6	O	-
				5	SHIELD	-
				4	W	-
				3	Y	-
				2	BR	-
				1	B	-

JCNWM5613GB

A  
B  
C  
D  
E  
F  
G  
H  
I  
J  
K  
L  
M  
N  
O  
P

AV



# BOSE AUDIO WITH NAVIGATION

< WIRING DIAGRAM >

[BOSE AUDIO WITH NAVIGATION]

**BOSE AUDIO WITH NAVIGATION**

Connector No.	F7
Connector Name	MICROPHONE
Connector Type	TKCAF7W

Terminal No.	Color of Wire	Signal Name (Specification)
1	O	MICROPHONE SIGNAL
2	SHIELD	MICROPHONE SHIELD
4	W	MICROPHONE VCC

JCNWM5614GB

**BASIC INSPECTION**

DIAGNOSIS AND REPAIR WORKFLOW

Work Flow

INFOID:000000006472674

OVERALL SEQUENCE

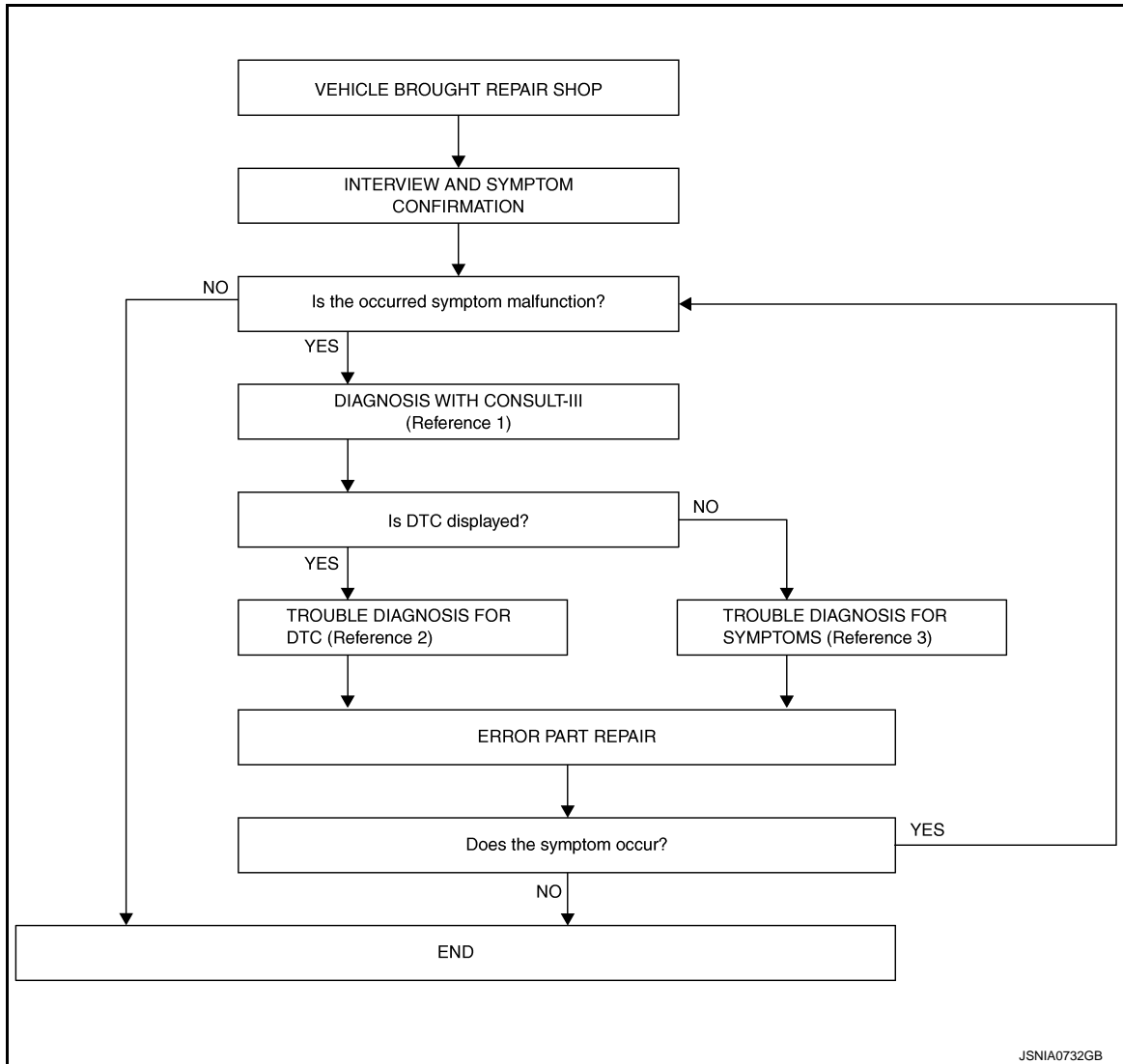

- Reference 1... Refer to [AV-300. "CONSULT - III Function"](#).
- Reference 2... Refer to [AV-310. "DTC Index"](#).
- Reference 3... Refer to [AV-403. "Symptom Table"](#).

DETAILED FLOW

**1. INTERVIEW AND SYMPTOM CONFIRMATION**

Check the malfunction symptoms by performing the following items.

- Interview the customer to obtain the malfunction information (conditions and environment when the malfunction occurred).
- Check the symptom.

Is the occurred symptom malfunction?

YES >> GO TO 2.

NO >> INSPECTION END

**2. DIAGNOSIS WITH CONSULT-III**

# DIAGNOSIS AND REPAIR WORKFLOW

[BOSE AUDIO WITH NAVIGATION]

< BASIC INSPECTION >

1. Connect CONSULT-III and perform a self-diagnosis for "MULTI AV". Refer to [AV-300, "CONSULT - III Function"](#).

**NOTE:**

Skip to step 4 of the diagnosis procedure if "MULTI AV" is not displayed.

2. Check if any DTC is displayed in the "Self-Diagnosis Results".

Is DTC displayed?

YES >> GO TO 3.

NO >> GO TO 4.

## 3. TROUBLE DIAGNOSIS FOR DTC

---

1. Check the DTC indicated in the "Self-Diagnosis Results".
2. Perform the relevant diagnosis referring to the DTC Index. Refer to [AV-310, "DTC Index"](#).

>> GO TO 5.

## 4. TROUBLE DIAGNOSIS FOR SYMPTOMS

---

Perform the relevant diagnosis referring to the diagnosis chart by symptom. Refer to [AV-403, "Symptom Table"](#).

>> GO TO 5.

## 5. ERROR PART REPAIR

---

1. Repair or replace the identified malfunctioning parts.
2. Perform a self-diagnosis for "MULTI AV" with CONSULT-III.

**NOTE:**

Erase the stored self-diagnosis results after repairing or replacing the relevant components if any DTC has been indicated in the "Self-Diagnosis Results".

3. Check that the symptom does not occur.

Does the symptom occur?

YES >> GO TO 1.

NO >> INSPECTION END

# ADDITIONAL SERVICE WHEN REPLACING (AV CONTROL UNIT)

< BASIC INSPECTION >

[BOSE AUDIO WITH NAVIGATION]

## ADDITIONAL SERVICE WHEN REPLACING (AV CONTROL UNIT)

### Description

INFOID:000000006472675

#### BEFORE REPLACEMENT

When replacing AV control unit, save or print current vehicle specification with CONSULT-III configuration before replacement.

#### AFTER REPLACEMENT

##### **CAUTION:**

When replacing AV control unit, you must perform "WRITE CONFIGURATION" with CONSULT-III.

- Complete the procedure of "WRITE CONFIGURATION" in order.
- If you set incorrect "WRITE CONFIGURATION", incidents might occur.
- Configuration is different for each vehicle model. Confirm configuration of each vehicle model.

### Work Procedure

INFOID:000000006472676

#### 1. SAVING VEHICLE SPECIFICATION

##### Ⓜ-CONSULT-III Configuration

Perform "READ CONFIGURATION" to save or print current vehicle specification. Refer to [AV-344, "Description"](#).

##### **NOTE:**

If "READ CONFIGURATION" can not be used, use the "WRITE CONFIGURATION - Manual selection".

>> GO TO 2.

#### 2. REPLACE AV CONTROL UNIT

Replace AV control unit. Refer to [AV-413, "Exploded View"](#).

>> GO TO 3.

#### 3. WRITING VEHICLE SPECIFICATION

##### Ⓜ-CONSULT-III Configuration

Perform "WRITE CONFIGURATION - Config file" or "WRITE CONFIGURATION - Manual selection" to write vehicle specification. Refer to [AV-344, "Work Procedure"](#).

>> GO TO 4.

#### 4. OPERATION CHECK

Check that the operation of the AV control unit and camera images (fixed guide lines and predictive course lines) are normal.

>> WORK END

A

B

C

D

E

F

G

H

I

J

K

L

M

AV

O

P

# CONFIGURATION (AV CONTROL UNIT)

< BASIC INSPECTION >

[BOSE AUDIO WITH NAVIGATION]

## CONFIGURATION (AV CONTROL UNIT)

### Description

INFOID:000000006472677

- Since vehicle specifications are not included in the AV control unit after replacement, it is required to write vehicle specifications with CONSULT-III.
- Configuration has three functions as follows.

Function	Description
READ CONFIGURATION	<ul style="list-style-type: none"><li>• Reads the vehicle configuration of current AV control unit.</li><li>• Saves the read vehicle configuration.</li></ul>
WRITE CONFIGURATION-Manual selection	Writes the vehicle configuration with manual selection.
WRITE CONFIGURATION-Config file	Writes the vehicle configuration with saved data.

### Work Procedure

INFOID:000000006472678

#### NOTE:

If "WRITE CONFIGURATION" is unsuccessful, perform "Accessory Number Initialization". For details, refer to [AV-287, "On Board Diagnosis Function"](#).

After performing "Accessory Number Initialization", reboot the AV control unit to perform "WRITE CONFIGURATION".

#### 1. WRITING MODE SELECTION

ⓅCONSULT-III Configuration

Select "CONFIGURATION" of "MULTI AV".

When writing saved data>>GO TO 2.

When writing manually>>GO TO 3.

#### 2. PERFORM "WRITE CONFIGURATION-CONFIG FILE"

ⓅCONSULT-III Configuration

Perform "WRITE CONFIGURATION-Config file".

>> WORK END

#### 3. PERFORM "WRITE CONFIGURATION-MANUAL SELECTION"

ⓅCONSULT-III Configuration

Select "WRITE CONFIGURATION-Manual selection" to write vehicle specifications into the AV control unit.

For data to write, refer to [AV-344, "Configuration List"](#).

>> GO TO 4.

#### 4. OPERATION CHECK

Check that the operation of the AV control unit and camera images (fixed guide lines and predictive course lines) are normal.

>> WORK END

### Configuration List

INFOID:000000006472679

#### CAUTION:

Check vehicle specifications before servicing.



# CONFIGURATION (AV CONTROL UNIT)

< BASIC INSPECTION >

[BOSE AUDIO WITH NAVIGATION]

MANUAL SETTING ITEM		NOTE
Items	Setting value	
STEERING	LHD	—
	RHD	—
GRADE	MODE 1	not used
	MODE 2	Journey grade or premium grade
	MODE 3	Sport grade or sports premium grade
4WAS	WITHOUT	—
	WITH	—
SOUND SYSTEM	BASE	—
	BOSE	—

A

B

C

D

E

F

G

H

I

J

K

L

M

AV

O

P

## DTC/CIRCUIT DIAGNOSIS

### U1000 CAN COMM CIRCUIT

#### Description

INFOID:000000006472680

CAN (Controller Area Network) is a serial communication line for real-time application. It is an on-vehicle multiplex communication line with high data communication speed and excellent error detection ability. Many electronic control units are equipped onto a vehicle, and each control unit shares information and links with other control units during operation (not independently). In CAN communication, control units are connected with 2 communication lines (CAN-H, CAN-L) allowing a high rate of information transmission with less wiring. Each control unit transmits/receives data but selectively reads required data only.

CAN Communication Signal Chart. Refer to [LAN-23, "CAN Communication Signal Chart"](#).

#### DTC Logic

INFOID:000000006472681

#### DTC DETECTION LOGIC

DTC	Display contents of CONSULT-III	DTC detection condition	Probable malfunction location
U1000	CAN COMM CIRCUIT [U1000]	AV control unit is not transmitting or receiving CAN communication signal for 2 seconds or more.	CAN communication system.

#### Diagnosis Procedure

INFOID:000000006472682

#### 1. PERFORM SELF-DIAGNOSTIC

1. Turn ignition switch ON and wait for 2 seconds or more.
2. Check "Self Diagnostic Result" of "MULTI AV".

Is "CAN COMM CIRCUIT" displayed?

- YES >> Refer to "LAN system". Refer to [LAN-14, "Trouble Diagnosis Flow Chart"](#).
- NO >> Refer to GI section. Refer to [GI-43, "Intermittent Incident"](#).

# U1010 CONTROL UNIT (CAN)

< DTC/CIRCUIT DIAGNOSIS >

[BOSE AUDIO WITH NAVIGATION]

## U1010 CONTROL UNIT (CAN)

### DTC Logic

INFOID:000000006472683

### DTC DETECTION LOGIC

DTC	Display contents of CONSULT-III	DTC detection condition	Probable malfunction factor
U1010	CONTROL UNIT (CAN) [U1010]	CAN initial diagnosis malfunction is detected.	Replace the AV control unit if the malfunction occurs constantly. Refer to <a href="#">AV-413, "Exploded View"</a> .

A

B

C

D

E

F

G

H

I

J

K

L

M

AV

O

P

# U1200 AV CONTROL UNIT

< DTC/CIRCUIT DIAGNOSIS >

[BOSE AUDIO WITH NAVIGATION]

## U1200 AV CONTROL UNIT

### DTC Logic

INFOID:000000006472684

DTC	Display contents of CONSULT-III	DTC detection condition	Possible malfunction factor
U1200	Cont Unit [U1200]	AV control unit malfunction is detected.	Replace the AV control unit if the malfunction occurs constantly. Refer to <a href="#">AV-413, "Exploded View"</a> .

# U1201 AV CONTROL UNIT

< DTC/CIRCUIT DIAGNOSIS >

[BOSE AUDIO WITH NAVIGATION]

## U1201 AV CONTROL UNIT

### DTC Logic

INFOID:000000006472685

DTC	Display contents of CONSULT-III	DTC detection condition	Possible malfunction factor
U1201	GYRO NO CONN [U1201]	AV control unit malfunction is detected.	Replace the AV control unit if the malfunction occurs constantly. Refer to <a href="#">AV-413, "Exploded View"</a> .

A

B

C

D

E

F

G

H

I

J

K

L

M

AV

O

P

# U1202 AV CONTROL UNIT

< DTC/CIRCUIT DIAGNOSIS >

[BOSE AUDIO WITH NAVIGATION]

## U1202 AV CONTROL UNIT

### DTC Logic

INFOID:000000006472686

DTC	Display contents of CONSULT-III	DTC detection condition	Possible malfunction factor
U1202	G-SENSOR NO CONN [U1202]	AV control unit malfunction is detected.	Replace the AV control unit if the malfunction occurs constantly. Refer to <a href="#">AV-413, "Exploded View"</a> .

# U1204 AV CONTROL UNIT

< DTC/CIRCUIT DIAGNOSIS >

[BOSE AUDIO WITH NAVIGATION]

## U1204 AV CONTROL UNIT

### Description

INFOID:000000006472687

An intermittent error caused by strong radio interference may be detected unless any symptoms (GPS reception error, etc.) occur. Replace the AV control unit if the malfunction occurs constantly. Refer to [AV-413, "Exploded View"](#).

### DTC Logic

INFOID:000000006472688

DTC	Display contents of CONSULT-III	DTC detection condition	Possible malfunction factor
U1204	GPS CONN [U1204]	GPS malfunction is detected.	An intermittent error caused by strong radio interference may be detected unless any symptom (GPS reception error, etc.) occurs. Replace the AV control unit if the malfunction occurs constantly. Refer to <a href="#">AV-413, "Exploded View"</a> .

### Diagnosis Procedure

INFOID:000000006472689

#### 1. PERFORM THE SELF-DIAGNOSIS

1. Delete the "Self-Diagnosis Results" of "MULTI AV". Turn ignition switch OFF.
2. Turn ignition switch ON. Perform the self-diagnosis again.
3. Check that the DTC is detected again.

#### Is any DTC detected?

- YES >> Replace AV control unit. Refer to [AV-413, "Exploded View"](#).
- NO >> An intermittent error caused by strong radio interference may be detected unless any symptom (GPS reception error, etc.) occurs.

A  
B  
C  
D  
E  
F  
G  
H  
I  
J  
K  
L  
M  
O  
P

AV

# U1205 AV CONTROL UNIT

< DTC/CIRCUIT DIAGNOSIS >

[BOSE AUDIO WITH NAVIGATION]

## U1205 AV CONTROL UNIT

### Description

INFOID:000000006472690

An intermittent error caused by strong radio interference may be detected unless any symptoms (GPS reception error, etc.) occur. Replace the AV control unit if the malfunction occurs constantly. Refer to [AV-413, "Exploded View"](#).

### DTC Logic

INFOID:000000006472691

DTC	Display contents of CONSULT-III	DTC detection condition	Possible malfunction factor
U1205	GPS ROM [U1205]	GPS malfunction is detected.	An intermittent error caused by strong radio interference may be detected unless any symptom (GPS reception error, etc.) occurs. Replace the AV control unit if the malfunction occurs constantly. Refer to <a href="#">AV-413, "Exploded View"</a> .

### Diagnosis Procedure

INFOID:000000006472692

#### 1. PERFORM THE SELF-DIAGNOSIS

1. Delete the "Self-Diagnosis Results" of "MULTI AV". Turn ignition switch OFF.
2. Turn ignition switch ON. Perform the self-diagnosis again.
3. Check that the DTC is detected again.

#### Is any DTC detected?

- YES >> Replace AV control unit. Refer to [AV-413, "Exploded View"](#).
- NO >> An intermittent error caused by strong radio interference may be detected unless any symptom (GPS reception error, etc.) occurs.



# U1206 AV CONTROL UNIT

< DTC/CIRCUIT DIAGNOSIS >

[BOSE AUDIO WITH NAVIGATION]

## U1206 AV CONTROL UNIT

### Description

INFOID:000000006472693

An intermittent error caused by strong radio interference may be detected unless any symptoms (GPS reception error, etc.) occur. Replace the AV control unit if the malfunction occurs constantly. Refer to [AV-413, "Exploded View"](#).

### DTC Logic

INFOID:000000006472694

DTC	Display contents of CONSULT-III	DTC detection condition	Possible malfunction factor
U1206	GPS RAM [U1206]	GPS malfunction is detected.	An intermittent error caused by strong radio interference may be detected unless any symptom (GPS reception error, etc.) occurs. Replace the AV control unit if the malfunction occurs constantly. Refer to <a href="#">AV-413, "Exploded View"</a> .

### Diagnosis Procedure

INFOID:000000006472695

#### 1. PERFORM THE SELF-DIAGNOSIS

1. Delete the "Self-Diagnosis Results" of "MULTI AV". Turn ignition switch OFF.
2. Turn ignition switch ON. Perform the self-diagnosis again.
3. Check that the DTC is detected again.

#### Is any DTC detected?

- YES >> Replace AV control unit. Refer to [AV-413, "Exploded View"](#).
- NO >> An intermittent error caused by strong radio interference may be detected unless any symptom (GPS reception error, etc.) occurs.

A  
B  
C  
D  
E  
F  
G  
H  
I  
J  
K  
L  
M  
O  
P

AV

# U1207 AV CONTROL UNIT

< DTC/CIRCUIT DIAGNOSIS >

[BOSE AUDIO WITH NAVIGATION]

## U1207 AV CONTROL UNIT

### Description

INFOID:000000006472696

An intermittent error caused by strong radio interference may be detected unless any symptoms (GPS reception error, etc.) occur. Replace the AV control unit if the malfunction occurs constantly. Refer to [AV-413, "Exploded View"](#).

### DTC Logic

INFOID:000000006472697

DTC	Display contents of CONSULT-III	DTC detection condition	Possible malfunction factor
U1207	GPS RTC [U1207]	GPS malfunction is detected.	An intermittent error caused by strong radio interference may be detected unless any symptom (GPS reception error, etc.) occurs. Replace the AV control unit if the malfunction occurs constantly. Refer to <a href="#">AV-413, "Exploded View"</a> .

### Diagnosis Procedure

INFOID:000000006472698

#### 1. PERFORM THE SELF-DIAGNOSIS

1. Delete the "Self-Diagnosis Results" of "MULTI AV". Turn ignition switch OFF.
2. Turn ignition switch ON. Perform the self-diagnosis again.
3. Check that the DTC is detected again.

#### Is any DTC detected?

- YES >> Replace AV control unit. Refer to [AV-413, "Exploded View"](#).
- NO >> An intermittent error caused by strong radio interference may be detected unless any symptom (GPS reception error, etc.) occurs.

# U1216 AV CONTROL UNIT

< DTC/CIRCUIT DIAGNOSIS >

[BOSE AUDIO WITH NAVIGATION]

## U1216 AV CONTROL UNIT

### DTC Logic

INFOID:000000006472699

DTC	Display contents of CONSULT-III	DTC detection condition	Possible malfunction factor
U1216	CAN CONT [U1216]	AV control unit malfunction is detected.	Replace the AV control unit if the malfunction occurs constantly. Refer to <a href="#">AV-413, "Exploded View"</a> .

A  
B  
C  
D  
E  
F  
G  
H  
I  
J  
K  
L  
M  
N  
O  
P

AV

# U1217 AV CONTROL UNIT

< DTC/CIRCUIT DIAGNOSIS >

[BOSE AUDIO WITH NAVIGATION]

## U1217 AV CONTROL UNIT

### DTC Logic

INFOID:000000006472700

DTC	Display contents of CONSULT-III	DTC detection condition	Possible malfunction factor
U1217	BLUETOOTH MODULE [U1217]	AV control unit malfunction is detected.	Replace the AV control unit if the malfunction occurs constantly. Refer to <a href="#">AV-413, "Exploded View"</a> .

# U1218 AV CONTROL UNIT

< DTC/CIRCUIT DIAGNOSIS >

[BOSE AUDIO WITH NAVIGATION]

## U1218 AV CONTROL UNIT

### DTC Logic

INFOID:000000006472701

DTC	Display contents of CONSULT-III	DTC detection condition	Possible malfunction factor
U1218	HDD CONN [U1218]	AV control unit malfunction is detected.	<ul style="list-style-type: none"><li>• If the music box function has no malfunctions, then there is a possibility of the detection of a temporary malfunction.</li><li>• Replace the AV control unit if the malfunction occurs constantly. Refer to <a href="#">AV-413. "Exploded View"</a>.</li></ul>

### Diagnosis Procedure

INFOID:000000006472702

#### 1. CHECK MUSIC BOX FUNCTION

##### Is music box function normal?

- YES >> Malfunction may be detected transitory.  
NO >> Replace AV control unit. Refer to [AV-413. "Exploded View"](#).

A  
B  
C  
D  
E  
F  
G  
H  
I  
J  
K  
L  
M  
O  
P

AV

# U1219 AV CONTROL UNIT

< DTC/CIRCUIT DIAGNOSIS >

[BOSE AUDIO WITH NAVIGATION]

## U1219 AV CONTROL UNIT

### DTC Logic

INFOID:000000006472703

DTC	Display contents of CONSULT-III	DTC detection condition	Possible malfunction factor
U1219	HDD READ [U1219]	AV control unit malfunction is detected.	<ul style="list-style-type: none"><li>• If the music box function has no malfunctions, then there is a possibility of the detection of a temporary malfunction.</li><li>• Replace the AV control unit if the malfunction occurs constantly. Refer to <a href="#">AV-413, "Exploded View"</a>.</li></ul>

### Diagnosis Procedure

INFOID:000000006472704

#### 1. CHECK MUSIC BOX FUNCTION

##### Is music box function normal?

YES >> Malfunction may be detected transitory.

NO >> Replace AV control unit. Refer to [AV-413, "Exploded View"](#).

# U121A AV CONTROL UNIT

< DTC/CIRCUIT DIAGNOSIS >

[BOSE AUDIO WITH NAVIGATION]

## U121A AV CONTROL UNIT

### DTC Logic

INFOID:000000006472705

DTC	Display contents of CONSULT-III	DTC detection condition	Possible malfunction factor
U121A	HDD WRITE [U121A]	AV control unit malfunction is detected.	<ul style="list-style-type: none"><li>• If the music box function has no malfunctions, then there is a possibility of the detection of a temporary malfunction.</li><li>• Replace the AV control unit if the malfunction occurs constantly. Refer to <a href="#">AV-413. "Exploded View"</a>.</li></ul>

### Diagnosis Procedure

INFOID:000000006472706

#### 1. CHECK MUSIC BOX FUNCTION

##### Is music box function normal?

- YES >> Malfunction may be detected transitory.  
NO >> Replace AV control unit. Refer to [AV-413. "Exploded View"](#).

A  
B  
C  
D  
E  
F  
G  
H  
I  
J  
K  
L  
M  
O  
P

AV

# U121B AV CONTROL UNIT

< DTC/CIRCUIT DIAGNOSIS >

[BOSE AUDIO WITH NAVIGATION]

## U121B AV CONTROL UNIT

### DTC Logic

INFOID:000000006472707

DTC	Display contents of CONSULT-III	DTC detection condition	Possible malfunction factor
U121B	HDD COMM [U121B]	AV control unit malfunction is detected.	<ul style="list-style-type: none"><li>• If the music box function has no malfunctions, then there is a possibility of the detection of a temporary malfunction.</li><li>• Replace the AV control unit if the malfunction occurs constantly. Refer to <a href="#">AV-413, "Exploded View"</a>.</li></ul>

### Diagnosis Procedure

INFOID:000000006472708

#### 1. CHECK MUSIC BOX FUNCTION

##### Is music box function normal?

YES >> Malfunction may be detected transitory.

NO >> Replace AV control unit. Refer to [AV-413, "Exploded View"](#).



# U121C AV CONTROL UNIT

< DTC/CIRCUIT DIAGNOSIS >

[BOSE AUDIO WITH NAVIGATION]

## U121C AV CONTROL UNIT

### DTC Logic

INFOID:000000006472709

DTC	Display contents of CONSULT-III	DTC detection condition	Possible malfunction factor
U121C	HDD ACCESS [U121C]	AV control unit malfunction is detected.	<ul style="list-style-type: none"><li>• If the music box function has no malfunctions, then there is a possibility of the detection of a temporary malfunction.</li><li>• Replace the AV control unit if the malfunction occurs constantly. Refer to <a href="#">AV-413. "Exploded View"</a>.</li></ul>

### Diagnosis Procedure

INFOID:000000006472710

#### 1. CHECK MUSIC BOX FUNCTION

Is music box function normal?

- YES >> Malfunction may be detected transitory.  
NO >> Replace AV control unit. Refer to [AV-413. "Exploded View"](#).

A  
B  
C  
D  
E  
F  
G  
H  
I  
J  
K  
L  
M  
O  
P

AV

# U121D AV CONTROL UNIT

< DTC/CIRCUIT DIAGNOSIS >

[BOSE AUDIO WITH NAVIGATION]

## U121D AV CONTROL UNIT

### DTC Logic

INFOID:000000006472711

DTC	Display contents of CONSULT-III	DTC detection condition	Possible malfunction factor
U121D	DSP CONN [U121D]	AV control unit malfunction is detected.	<ul style="list-style-type: none"><li>• If a disc can be played, then there is a possibility of the detection of a temporary malfunction.</li><li>• Replace the AV control unit if the malfunction occurs constantly. Refer to <a href="#">AV-413. "Exploded View"</a>.</li></ul>

### Diagnosis Procedure

INFOID:000000006472712

#### 1. CHECK PLAYBACK OF A DISK (CD)

##### Can a disk (CD) be played?

YES >> Malfunction may be detected transitory.

NO >> Replace AV control unit. Refer to [AV-413. "Exploded View"](#).

# U121E AV CONTROL UNIT

< DTC/CIRCUIT DIAGNOSIS >

[BOSE AUDIO WITH NAVIGATION]

## U121E AV CONTROL UNIT

### DTC Logic

INFOID:000000006472713

DTC	Display contents of CONSULT-III	DTC detection condition	Possible malfunction factor
U121E	DSP COMM [U121E]	AV control unit malfunction is detected.	<ul style="list-style-type: none"><li>• If a disc can be played, then there is a possibility of the detection of a temporary malfunction.</li><li>• Replace the AV control unit if the malfunction occurs constantly. Refer to <a href="#">AV-413. "Exploded View"</a>.</li></ul>

### Diagnosis Procedure

INFOID:000000006472714

#### 1. CHECK PLAYBACK OF A DISK (CD)

##### Can a disk (CD) be played?

- YES >> Malfunction may be detected transitory.  
NO >> Replace AV control unit. Refer to [AV-413. "Exploded View"](#).

A  
B  
C  
D  
E  
F  
G  
H  
I  
J  
K  
L  
M  
O  
P

AV

# U1225 AV CONTROL UNIT

< DTC/CIRCUIT DIAGNOSIS >

[BOSE AUDIO WITH NAVIGATION]

## U1225 AV CONTROL UNIT

### DTC Logic

INFOID:000000006472715

### DTC DETECTION LOGIC

DTC	Display contents of CONSULT-III	DTC detection condition	Possible malfunction factor
U1225	USB CONTROLLER [U1225]	USB connection malfunction is detected.	Check that the connection to the USB connector is normal.

# U1227 AV CONTROL UNIT

< DTC/CIRCUIT DIAGNOSIS >

[BOSE AUDIO WITH NAVIGATION]

## U1227 AV CONTROL UNIT

### DTC Logic

INFOID:000000006472716

DTC	Display contents of CONSULT-III	DTC detection condition	Possible malfunction factor
U1227	DVD COMM [U1227]	AV control unit malfunction is detected.	<ul style="list-style-type: none"><li>• If DVD can be played, then there is a possibility of the detection of a temporary malfunction.</li><li>• Replace the AV control unit if the malfunction occurs constantly. Refer to <a href="#">AV-413. "Exploded View"</a>.</li></ul>

### Diagnosis Procedure

INFOID:000000006472717

#### 1. CHECK PLAYBACK OF A DISK (DVD)

##### Can a disc (DVD) be played?

YES >> Malfunction may be detected transitory.

NO >> Replace AV control unit. Refer to [AV-413. "Exploded View"](#).

A  
B  
C  
D  
E  
F  
G  
H  
I  
J  
K  
L  
M  
O  
P

AV

# U1228 AV CONTROL UNIT

< DTC/CIRCUIT DIAGNOSIS >

[BOSE AUDIO WITH NAVIGATION]

## U1228 AV CONTROL UNIT

### DTC Logic

INFOID:000000006472718

### DTC DETECTION LOGIC

DTC	Display contents of CONSULT-III	DTC detection condition	Possible malfunction factor
U1228	SUB CPU CONN [U1228]	AV control unit malfunction is detected.	Replace the AV control unit if the malfunction occurs constantly. Refer to <a href="#">AV-413, "Exploded View"</a> .

# U1229 AV CONTROL UNIT

< DTC/CIRCUIT DIAGNOSIS >

[BOSE AUDIO WITH NAVIGATION]

## U1229 AV CONTROL UNIT

### DTC Logic

INFOID:000000006472719

### DTC DETECTION LOGIC

DTC	Display contents of CONSULT-III	DTC detection condition	Possible malfunction factor
U1229	iPod CERTIFICATION [U1229]	AV control unit malfunction is detected.	Replace the AV control unit if the malfunction occurs constantly. Refer to <a href="#">AV-413</a> , "Exploded View".

A  
B  
C  
D  
E  
F  
G  
H  
I  
J  
K  
L  
M  
O  
P

AV

# U122A AV CONTROL UNIT

< DTC/CIRCUIT DIAGNOSIS >

[BOSE AUDIO WITH NAVIGATION]

## U122A AV CONTROL UNIT

### DTC Logic

INFOID:000000006472720

DTC	Display contents of CONSULT-III	DTC detection condition	Action to take
U122A	CONFIG UNFINISH [U122A]	The writing of configuration data is incomplete.	Write configuration data with "MULTI AV" of CONSULT-III.

### Diagnosis Procedure

INFOID:000000006472721

#### 1.PERFORM THE SELF-DIAGNOSIS

When U122A is detected, write configuration data with "MULTI AV" of CONSULT-III.

>> Write configuration data with "MULTI AV" of CONSULT-III. Refer to [AV-344, "Work Procedure"](#).



# U122E AV CONTROL UNIT

< DTC/CIRCUIT DIAGNOSIS >

[BOSE AUDIO WITH NAVIGATION]

## U122E AV CONTROL UNIT

### DTC Logic

INFOID:000000006472722

### DTC DETECTION LOGIC

DTC	Display contents of CONSULT-III	DTC detection condition	Possible malfunction factor
U122E	Built-in AUDIO CONN [U122E]	AV control unit malfunction is detected.	Replace the AV control unit if the malfunction occurs constantly. Refer to <a href="#">AV-413, "Exploded View"</a> .

A

B

C

D

E

F

G

H

I

J

K

L

M

AV

O

P

# U1231 BOSE AMP.

< DTC/CIRCUIT DIAGNOSIS >

[BOSE AUDIO WITH NAVIGATION]

## U1231 BOSE AMP.

### DTC Logic

INFOID:000000006472723

DTC	Display contents of CONSULT-III	DTC detection condition	Possible malfunction factor
U1231	AMP TEMP [U1231]	BOSE amp. malfunction is detected.	Replace the BOSE amp. if the malfunction occurs constantly. Refer to <a href="#">AV-422. "Exploded View"</a> .

# U1232 STEERING ANGLE SENSOR

< DTC/CIRCUIT DIAGNOSIS >

[BOSE AUDIO WITH NAVIGATION]

## U1232 STEERING ANGLE SENSOR

### DTC Logic

INFOID:00000000647274

DTC	Display contents of CONSULT-III	DTC detection condition	Possible malfunction factor
U1232	ST ANGLE SEN CALIB [1232]	Predictive course line center position adjustment of the steering angle sensor is incomplete.	Adjust the predictive course line center position of the steering angle sensor.

### Diagnosis Procedure

INFOID:00000000647275

#### 1. ADJUST THE PREDICTIVE COURSE LINE CENTER POSITION OF THE STEERING ANGLE SENSOR

When U1232 is detected, adjust the predictive course line center position of the steering angle sensor.

>> Adjusts the steering angle sensor neutral position on ABS actuator and electrical unit (control unit) side. Refer to [BRC-9. "ADJUSTMENT OF STEERING ANGLE SENSOR NEUTRAL POSITION : Special Repair Requirement"](#).

A  
B  
C  
D  
E  
F  
G  
H  
I  
J  
K  
L  
M  
AV  
O  
P



# U1243 DISPLAY UNIT

< DTC/CIRCUIT DIAGNOSIS >

[BOSE AUDIO WITH NAVIGATION]

## U1243 DISPLAY UNIT

### DTC Logic

INFOID:000000006472726

DTC	Display contents of CONSULT-III	DTC detection condition	Possible malfunction factor
U1243	FRONT DISP CONN [U1243]	When either one of the following items is detected: <ul style="list-style-type: none"> <li>display unit power supply and ground circuit are malfunctioning.</li> <li>communication circuit between AV control unit and display unit are malfunctioning.</li> </ul>	<ul style="list-style-type: none"> <li>Display unit power supply and ground circuit.</li> <li>Communication circuit between AV control unit and display unit.</li> </ul>

### Diagnosis Procedure

INFOID:000000006472727

#### 1. CHECK DISPLAY UNIT POWER SUPPLY AND GROUND CIRCUIT

Check display unit power supply and ground circuit. Refer to [AV-387. "DISPLAY UNIT : Diagnosis Procedure"](#).

Is the inspection result normal?

YES >> GO TO 2.

NO >> Repair malfunctioning parts.

#### 2. CHECK CONTINUITY COMMUNICATION CIRCUIT

- Turn ignition switch OFF.
- Disconnect display unit connector and AV control unit connector.
- Check continuity between display unit harness connector and AV control unit harness connector.

Display unit		AV control unit		Continuity
Connector	Terminals	Connector	Terminals	
M75	9	M210	89	Existed
	10		73	

- Check continuity between display unit harness connector and ground.

Display unit		Ground	Continuity
Connector	Terminals		
M75	9		Not existed
	10		

Is the inspection result normal?

YES >> GO TO 3.

NO >> Repair harness or connector.

#### 3. CHECK COMMUNICATION SIGNAL

- Connect display unit connector and AV control unit connector.
- Turn ignition switch ON.
- Check signal between display unit harness connector and ground.

# U1243 DISPLAY UNIT

< DTC/CIRCUIT DIAGNOSIS >

[BOSE AUDIO WITH NAVIGATION]

(+)		(-)	Condition	Reference value
Display unit				
Connector	Terminal			
M75	9	Ground	When adjusting display brightness.	

Is the inspection result normal?

YES >> GO TO 4.

NO >> Replace AV control unit. Refer to [AV-413. "Exploded View"](#).

## 4. CHECK COMMUNICATION SIGNAL

Check signal between display unit harness connector and ground.

(+)		(-)	Condition	Reference value
Display unit				
Connector	Terminal			
M75	10	Ground	When adjusting display brightness.	

Is the inspection result normal?

YES >> INSPECTION END

NO >> Replace display unit. Refer to [AV-415. "Exploded View"](#).

A  
B  
C  
D  
E  
F  
G  
H  
I  
J  
K  
L  
M  
O  
P

AV

# U1244 GPS ANTENNA

< DTC/CIRCUIT DIAGNOSIS >

[BOSE AUDIO WITH NAVIGATION]

## U1244 GPS ANTENNA

### DTC Logic

INFOID:000000006472728

DTC	Display contents of CONSULT-III	DTC detection condition	Possible malfunction factor
U1244	GPS ANTENNA CONN [U1244]	GPS antenna connection malfunction is detected.	Check the connection of the GPS antenna connector.

### Diagnosis Procedure

INFOID:000000006472729

#### 1. GPS ANTENNA CHECK

Visually check GPS antenna and antenna feeder.

Is the inspection result normal?

YES >> GO TO 2.

NO >> Repair malfunctioning parts.

#### 2. CHECK AV CONTROL UNIT VOLTAGE

1. Disconnect GPS antenna connector.
2. Turn ignition switch ON.
3. Check voltage between AV control unit and ground.

(+)	(-)	Voltage (Approx.)
AV control unit		
Terminal		
153	Ground	5.0 V

Is the inspection result normal?

YES >> INSPECTION END

NO >> Replace AV control unit. Refer to [AV-413. "Exploded View"](#).

# U1258 SATELLITE RADIO ANTENNA

< DTC/CIRCUIT DIAGNOSIS >

[BOSE AUDIO WITH NAVIGATION]

## U1258 SATELLITE RADIO ANTENNA

### DTC Logic

INFOID:000000006472730

DTC	Display contents of CONSULT-III	DTC Detection Condition	Possible causes
U1258	XM ANTENNA CONN [U1258]	Satellite radio antenna connection malfunction is detected.	Satellite radio antenna disconnection.

### Diagnosis Procedure

INFOID:000000006472731

#### 1. SATELLITE RADIO ANTENNA CHECK

Visually check satellite radio antenna (antenna base) and antenna feeder.

Is the inspection result normal?

YES >> GO TO 2.

NO >> Repair malfunctioning parts.

#### 2. CHECK AV CONTROL UNIT VOLTAGE

1. Disconnect satellite radio antenna connector.
2. Turn ignition switch ON.
3. Check voltage between AV control unit and ground.

(+)	(-)	Voltage (Approx.)
AV control unit Terminal	Ground	5.0 V
159		

Is the inspection result normal?

YES >> INSPECTION END

NO >> Replace AV control unit. Refer to [AV-413, "Exploded View"](#).

A  
B  
C  
D  
E  
F  
G  
H  
I  
J  
K  
L  
M  
O  
P

AV

# U1263 USB

< DTC/CIRCUIT DIAGNOSIS >

[BOSE AUDIO WITH NAVIGATION]

## U1263 USB

### DTC Logic

INFOID:000000006472732

DTC	Display contents of CONSULT-III	DTC detection condition	Possible malfunction factor
U1263	USB OVERCURRENT [U1263]	Detection of overcurrent in USB connector.	Check USB harness between the AV control unit and USB connector.

### Diagnosis Procedure

INFOID:000000006472733

#### 1.CHECK USB HARNESS

Visually check USB harness.

Is the inspection result normal?

- YES >> Replace AV control unit. Refer to [AV-413, "Exploded View"](#).
- NO >> Replace USB harness.



# U1264 ANTENNA AMP.

< DTC/CIRCUIT DIAGNOSIS >

[BOSE AUDIO WITH NAVIGATION]

## U1264 ANTENNA AMP.

### DTC Logic

INFOID:000000006472734

DTC	Display contents of CONSULT-III	DTC detection condition	Possible malfunction factor
U1264	ANTENNA AMP TERMINAL [OPEN or SHORT] [U1264]	Antenna amp. ON circuit is open or shorted.	Check antenna amp. ON signal circuit between the AV control unit and antenna base.

### Diagnosis Procedure

INFOID:000000006472735

#### 1. CHECK CONTINUITY BETWEEN AV CONTROL UNIT AND ANTENNA BASE

- Turn ignition switch OFF.
- Disconnect antenna base connector and AV control unit connector.
- Check continuity between AV control unit harness connector and antenna base harness connector.

AV control unit		Antenna base		Continuity
Connector	Terminals	Connector	Terminals	
M371	152	M381	1	Existed

- Check continuity between AV control unit harness connector and ground.

AV control unit		Ground	Continuity
Connector	Terminals		
M371	152		Not existed

Is the inspection result normal?

- YES >> GO TO 2.  
 NO >> Repair harness or connector.

#### 2. CHECK VOLTAGE AV CONTROL UNIT

- Connect AV control unit connector.
- Turn ignition switch ON.
- Check voltage between AV control unit harness connector and ground.

AV control unit		(-)	Voltage (Approx.)
Connector	Terminals		
M371	152	Ground	12.0 V

Is the inspection result normal?

- YES >> Replace antenna base. Refer to [AV-424, "Exploded View"](#).  
 NO >> Replace AV control unit. Refer to [AV-413, "Exploded View"](#).

A  
B  
C  
D  
E  
F  
G  
H  
I  
J  
K  
L  
M  
O  
P

AV

# U1300 AV COMM CIRCUIT

< DTC/CIRCUIT DIAGNOSIS >

[BOSE AUDIO WITH NAVIGATION]

## U1300 AV COMM CIRCUIT

### Description

INFOID:000000006472736

U1300 is indicated when malfunction occurs in communication signal of multi AV system. Indicated simultaneously, without fail, with the malfunction of control units connected to AV control unit with communication line. Determine the possible malfunction cause from the table below.

### SELF-DIAGNOSIS RESULTS DISPLAY ITEM

DTC	Display contents of CONSULT-III	DTC detection condition	Possible malfunction factor
U1300 U1240	<ul style="list-style-type: none"> <li>• AV COMM CIRCUIT [U1300]</li> <li>• SWITCH CONN [U1240]</li> </ul>	When either one of the following items are detected: <ul style="list-style-type: none"> <li>• multifunction switch power supply and ground circuits are malfunctioning.</li> <li>• AV communication circuits between AV control unit and multifunction switch are malfunctioning.</li> </ul>	<ul style="list-style-type: none"> <li>• Multifunction switch power supply and ground circuits.</li> <li>• AV communication circuits between AV control unit and multifunction switch.</li> </ul>
U1300 U125C	<ul style="list-style-type: none"> <li>• AV COMM CIRCUIT [U1300]</li> <li>• SONAR CONN [U125C]</li> </ul>	When either one of the following items are detected: <ul style="list-style-type: none"> <li>• sonar control unit power supply and ground circuits are malfunctioning.</li> <li>• AV communication circuits between AV control unit and sonar control unit are malfunctioning.</li> </ul>	<ul style="list-style-type: none"> <li>• Sonar control unit power supply and ground circuits.</li> <li>• AV communication circuits between AV control unit and sonar control unit.</li> </ul>
U1300 U124E	<ul style="list-style-type: none"> <li>• AV COMM CIRCUIT [U1300]</li> <li>• AMP CONN [U124E]</li> </ul>	When either one of the following items are detected: <ul style="list-style-type: none"> <li>• BOSE amp. power supply and ground circuits are malfunctioning.</li> <li>• AV communication circuits between sonar control unit and BOSE amp. are malfunctioning.</li> </ul>	<ul style="list-style-type: none"> <li>• BOSE amp. power supply and ground circuits.</li> <li>• AV communication circuits between sonar control unit and BOSE amp.</li> </ul>
U1300 U1240 U125C U124E	<ul style="list-style-type: none"> <li>• AV COMM CIRCUIT [U1300]</li> <li>• SWITCH CONN [U1240]</li> <li>• SONAR CONN [U125C]</li> <li>• AMP CONN [U124E]</li> </ul>	AV communication circuits between AV control unit and multifunction switch are malfunctioning.	AV communication circuits between AV control unit and multifunction switch.

# U1310 AV CONTROL UNIT

< DTC/CIRCUIT DIAGNOSIS >

[BOSE AUDIO WITH NAVIGATION]

## U1310 AV CONTROL UNIT

### DTC Logic

INFOID:000000006472737

DTC	Display contents of CONSULT-III	DTC detection condition	Possible malfunction factor
U1310	CONTROL UNIT (AV) [U1310]	An initial diagnosis error is detected in AV communication circuit.	Replace AV control unit. If the malfunction occurs constantly. Refer to <a href="#">AV-413, "Exploded View"</a> .

A

B

C

D

E

F

G

H

I

J

K

L

M

AV

O

P

# U1900 CENTER SPEAKER

< DTC/CIRCUIT DIAGNOSIS >

[BOSE AUDIO WITH NAVIGATION]

## U1900 CENTER SPEAKER

### DTC Logic

INFOID:000000006472738

### DTC DETECTION LOGIC

DTC	Display contents of CONSULT-III	DTC detection condition	Possible malfunction factor
U1900	CENTER SPEAKER [OPEN, SHORT, GND-SHORT, or VB-SHORT] [U1900]	Malfunction is detected sound signal circuits between BOSE amp. and center speaker.	Sound signal circuits between BOSE amp. and center speaker.

### Diagnosis Procedure

INFOID:000000006472739

#### 1. PERFORM THE SELF-DIAGNOSIS

1. Delete the "self-diagnosis" results of "MULTI AV". Turn ignition switch OFF.
2. Turn ignition switch ON. perform the self-diagnosis again.
3. Check that the DTC is detected again.

#### Is any DTC detected?

- YES >> Check harnesses between BOSE amp. and center speaker.  
NO >> Refer to GI section. Refer to [GI-43, "Intermittent Incident"](#)

# U1901, U1907 DOOR SQUAWKER/TWEETER

< DTC/CIRCUIT DIAGNOSIS >

[BOSE AUDIO WITH NAVIGATION]

## U1901, U1907 DOOR SQUAWKER/TWEETER

### DTC Logic

INFOID:000000006472740

### DTC DETECTION LOGIC

DTC	Display contents of CONSULT-III	DTC detection condition	Possible malfunction factor
U1901	FR-DOOR SPEAKER [OPEN, SHORT, GND-SHORT or VB-SHOR] [U1901]	When either one of the following items are detected: <ul style="list-style-type: none"><li>• sound signal circuits between BOSE amp. and door squawker RH are malfunctioning.</li><li>• sound signal circuits between BOSE amp. and tweeter RH are malfunctioning.</li></ul>	<ul style="list-style-type: none"><li>• Sound signal circuits between BOSE amp. and door squawker RH.</li><li>• Sound signal circuits between BOSE amp. and tweeter RH.</li></ul>
U1907	FL-DOOR SPEAKER [OPEN, SHORT, GND-SHORT or VB-SHOR] [U1907]	When either one of the following items are detected: <ul style="list-style-type: none"><li>• sound signal circuits between BOSE amp. and door squawker LH are malfunctioning.</li><li>• sound signal circuits between BOSE amp. and tweeter LH are malfunctioning.</li></ul>	<ul style="list-style-type: none"><li>• Sound signal circuits between BOSE amp. and door squawker LH.</li><li>• Sound signal circuits between BOSE amp. and tweeter LH.</li></ul>

### Diagnosis Procedure

INFOID:000000006472741

#### 1. PERFORM THE SELF-DIAGNOSIS

1. Delete the "self-diagnosis" results of "MULTI AV". Turn ignition switch OFF.
2. Turn ignition switch ON. perform the self-diagnosis again.
3. Check that the DTC is detected again.

#### Is any DTC detected?

- YES-1 >> U1901: Check harnesses between BOSE amp. and door squawker RH and between BOSE amp. and tweeter RH.
- YES-2 >> U1907: Check harnesses between BOSE amp. and door squawker LH and between BOSE amp. and tweeter LH.
- NO >> Refer to GI section. Refer to [GI-43, "Intermittent Incident"](#).

A  
B  
C  
D  
E  
F  
G  
H  
I  
J  
K  
L  
M  
O  
P

AV

# U1908, U1909 HEADREST SPEAKER

< DTC/CIRCUIT DIAGNOSIS >

[BOSE AUDIO WITH NAVIGATION]

## U1908, U1909 HEADREST SPEAKER

### DTC Logic

INFOID:000000006472742

### DTC DETECTION LOGIC

DTC	Display contents of CONSULT-III	DTC detection condition	Possible malfunction factor
U1908	FL-SEAT L-SPEAKER [OPEN, SHORT, GND-SHORT or VB-SHOR] [U1908]	Malfunction is detected sound signal circuits between BOSE amp. and driver headrest speaker LH.	Sound signal circuits between BOSE amp. and driver headrest speaker LH.
U1909	FL-SEAT R-SPEAKER [OPEN, SHORT, GND-SHORT or VB-SHOR] [U1909]	Malfunction is detected sound signal circuits between BOSE amp. and driver headrest speaker RH.	Sound signal circuits between BOSE amp. and driver headrest speaker RH.

### Diagnosis Procedure

INFOID:000000006472743

#### 1. PERFORM THE SELF-DIAGNOSIS

1. Delete the "self-diagnosis" results of "MULTI AV". Turn ignition switch OFF.
2. Turn ignition switch ON. perform the self-diagnosis again.
3. Check that the DTC is detected again.

#### Is any DTC detected?

- YES-1 >> U1908: Check harnesses between BOSE amp. and driver headrest speaker LH.  
YES-2 >> U1909: Check harnesses between BOSE amp. and driver headrest speaker RH.  
NO >> Refer to GI section. Refer to [GI-43, "Intermittent Incident"](#).

# U1910, U1911 REAR WOOFER

< DTC/CIRCUIT DIAGNOSIS >

[BOSE AUDIO WITH NAVIGATION]

## U1910, U1911 REAR WOOFER

### DTC Logic

INFOID:000000006472744

### DTC DETECTION LOGIC

DTC	Display contents of CONSULT-III	DTC detection condition	Possible malfunction factor
U1910	RR WOOFER [OPEN, SHORT, GND-SHORT or VB-SHOR] [U1910]	Malfunction is detected sound signal circuits between BOSE amp. and rear woofer RH.	Sound signal circuits between BOSE amp. and rear woofer RH.
U1911	RL WOOFER [OPEN, SHORT, GND-SHORT or VB-SHOR] [U1911]	Malfunction is detected sound signal circuits between BOSE amp. and rear woofer LH.	Sound signal circuits between BOSE amp. and rear woofer LH.

### Diagnosis Procedure

INFOID:000000006472745

#### 1. PERFORM THE SELF-DIAGNOSIS

1. Delete the "self-diagnosis" results of "MULTI AV". Turn ignition switch OFF.
2. Turn ignition switch ON. perform the self-diagnosis again.
3. Check that the DTC is detected again.

#### Is any DTC detected?

- YES-1 >> U1910: Check harnesses between BOSE amp. and rear woofer RH.  
YES-2 >> U1911: Check harnesses between BOSE amp. and rear woofer LH.  
NO >> Refer to GI section. Refer to [GI-43, "Intermittent Incident"](#).

A  
B  
C  
D  
E  
F  
G  
H  
I  
J  
K  
L  
M  
O  
P

AV

# U190A, U190B HEADREST SPEAKER

< DTC/CIRCUIT DIAGNOSIS >

[BOSE AUDIO WITH NAVIGATION]

## U190A, U190B HEADREST SPEAKER

### DTC Logic

INFOID:000000006472746

### DTC DETECTION LOGIC

DTC	Display contents of CONSULT-III	DTC detection condition	Possible malfunction factor
U190A	FR-SEAT L-SPEAKER [OPEN, SHORT, GND-SHORT or VB-SHOR] [U190A]	Malfunction is detected sound signal circuits between BOSE amp. and passenger headrest speaker LH.	Sound signal circuits between BOSE amp. and passenger headrest speaker LH.
U190B	FR-SEAT R-SPEAKER [OPEN, SHORT, GND-SHORT or VB-SHOR] [U190B]	Malfunction is detected sound signal circuits between BOSE amp. and passenger headrest speaker RH.	Sound signal circuits between BOSE amp. and passenger headrest speaker RH.

### Diagnosis Procedure

INFOID:000000006472747

#### 1. PERFORM THE SELF-DIAGNOSIS

1. Delete the "self-diagnosis" results of "MULTI AV". Turn ignition switch OFF.
2. Turn ignition switch ON. perform the self-diagnosis again.
3. Check that the DTC is detected again.

#### Is any DTC detected?

- YES-1 >> U190A: Check harnesses between BOSE amp. and passenger headrest speaker LH.  
YES-2 >> U190B: Check harnesses between BOSE amp. and passenger headrest speaker RH.  
NO >> Refer to GI section. Refer to [GI-43, "Intermittent Incident"](#).



# U190C AUDIPILOT™ MICROPHONE

< DTC/CIRCUIT DIAGNOSIS >

[BOSE AUDIO WITH NAVIGATION]

## U190C AUDIPILOT™ MICROPHONE

### DTC Logic

INFOID:000000006472748

DTC	Display contents of CONSULT-III	DTC detection condition	Possible malfunction factor
U190C	CORRECT MICROPHONE [OPEN, SHORT, GND-SHORT or VB-SHOR] [U190C]	Malfunction is detected sound signal circuits between BOSE amp. and microphone (for AudioPilot™).	Sound signal circuits between BOSE amp. and microphone (for AudioPilot™).

### Diagnosis Procedure

INFOID:000000006472749

#### 1. CHECK CONTINUITY BETWEEN BOSE AMP. AND MICROPHONE FOR AUDIPILOT™ CIRCUIT

- Turn ignition switch OFF.
- Disconnect BOSE amp. connector and microphone for AudioPilot™ connector.
- Check continuity between BOSE amp. harness connector and microphone for AudioPilot™ harness connector.

BOSE amp.		Microphone for AudioPilot™		Continuity
Connector	Terminals	Connector	Terminals	
B41	31	B617	81	Existed
	11		82	

- Check continuity between BOSE amp. harness connector and ground.

BOSE amp.		Ground	Continuity
Connector	Terminals		
B41	31		Not existed
	11		

Is the inspection result normal?

- YES >> GO TO 2.  
NO >> Repair harness or connector.

#### 2. CHECK MICROPHONE SIGNAL

- Connect BOSE amp. connector and microphone for AudioPilot™ connector.
- Check signal between BOSE amp. harness connector.

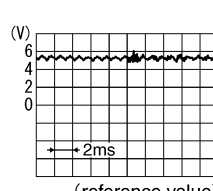
(+) BOSE amp.		(-) BOSE amp.		Condition	Reference value
Connector	Terminal	Connector	Terminal		
B41	31	B41	11	When inputting noise.	 <p>(reference value)</p> <p>PKIA2104E</p>

Is the inspection result normal?

- YES >> Replace BOSE amp. Refer to [AV-422. "Exploded View"](#).  
NO >> Replace microphone for AudioPilot™. Refer to [AV-423. "Exploded View"](#).

# U190F, U1912 DOOR WOOFER

< DTC/CIRCUIT DIAGNOSIS >

[BOSE AUDIO WITH NAVIGATION]

## U190F, U1912 DOOR WOOFER

### DTC Logic

INFOID:000000006472750

### DTC DETECTION LOGIC

DTC	Display contents of CONSULT-III	DTC detection condition	Possible malfunction factor
U190F	FR WOOFER [OPEN, SHORT, GND-SHORT or VB-SHOR] [U190F]	Malfunction is detected sound signal circuits between BOSE amp. and door woofer RH.	Sound signal circuits between BOSE amp. and door woofer RH.
U1912	FL WOOFER [OPEN, SHORT, GND-SHORT or VB-SHOR] [U1912]	Malfunction is detected sound signal circuits between BOSE amp. and door woofer LH.	Sound signal circuits between BOSE amp. and door woofer LH.

### Diagnosis Procedure

INFOID:000000006472751

#### 1. PERFORM THE SELF-DIAGNOSIS

1. Delete the "self-diagnosis" results of "MULTI AV". Turn ignition switch OFF.
2. Turn ignition switch ON. perform the self-diagnosis again.
3. Check that the DTC is detected again.

#### Is any DTC detected?

- YES-1 >> U1901F Check harnesses between BOSE amp. and door woofer RH.  
YES-2 >> U19012 Check harnesses between BOSE amp. and door woofer LH.  
NO >> Refer to GI section. Refer to [GI-43, "Intermittent Incident"](#).

# POWER SUPPLY AND GROUND CIRCUIT

< DTC/CIRCUIT DIAGNOSIS >

[BOSE AUDIO WITH NAVIGATION]

## POWER SUPPLY AND GROUND CIRCUIT

### AV CONTROL UNIT

#### AV CONTROL UNIT : Diagnosis Procedure

INFOID:000000006472752

#### 1.CHECK FUSE

Check for blown fuses.

Power source	Fuse No.
Battery	34

Is the inspection result normal?

YES >> GO TO 2.

NO >> Be sure to eliminate cause of malfunction before installing new fuse.

#### 2.CHECK BATTERY POWER SUPPLY CIRCUIT

Check voltage between AV control unit harness connector and ground.

Signal name	Connector No.	Terminal No.	Ignition switch position	Value (Approx.)
Battery power supply	M208	19	OFF	Battery voltage

Is the inspection result normal?

YES >> GO TO 3.

NO >> Check harness between AV control unit and fuse.

#### 3.CHECK ACC POWER SUPPLY CIRCUIT

Check voltage between AV control unit harness connector and ground.

Signal name	Connector No.	Terminal No.	Ignition switch position	Value (Approx.)
ACC power supply	M208	7	ACC	Battery voltage

Is the inspection result normal?

YES >> GO TO 4.

NO >> Check harness between AV control unit and BCM.

#### 4.CHECK GROUND CIRCUIT

1. Turn ignition switch OFF.
2. Disconnect AV control unit connectors.
3. Check continuity between AV control unit harness connectors and ground.

Signal name	Connector No.	Terminal No.	Ignition switch position	Continuity
Ground	M208	20	OFF	Existed

Is the inspection result normal?

YES >> INSPECTION END

NO >> Repair harness or connector.

### DISPLAY UNIT

#### DISPLAY UNIT : Diagnosis Procedure

INFOID:000000006472753

#### 1.CHECK FUSE

Check for blown fuses.

Power source	Fuse No.
Battery	34

Is the inspection result normal?

YES >> GO TO 2.

A  
B  
C  
D  
E  
F  
G  
H  
I  
J  
K  
L  
M  
O  
P

AV

# POWER SUPPLY AND GROUND CIRCUIT

[BOSE AUDIO WITH NAVIGATION]

< DTC/CIRCUIT DIAGNOSIS >

NO >> Be sure to eliminate cause of malfunction before installing new fuse.

## 2.CHECK BATTERY POWER SUPPLY CIRCUIT

Check voltage between display unit harness connector and ground.

Signal name	Connector No.	Terminal No.	Ignition switch position	Value (Approx.)
Battery power supply	M75	11	OFF	Battery voltage

Is the inspection result normal?

YES >> GO TO 3.

NO >> Check harness between display unit and fuse.

## 3.CHECK ACC POWER SUPPLY CIRCUIT

Check voltage between display unit harness connector and ground.

Signal name	Connector No.	Terminal No.	Ignition switch position	Value (Approx.)
ACC power supply	M75	23	ACC	Battery voltage

Is the inspection result normal?

YES >> GO TO 4.

NO >> Check harness between display unit and BCM.

## 4.CHECK GROUND CIRCUIT

1. Turn ignition switch OFF.
2. Disconnect display unit connector.
3. Check continuity between display unit harness connector and ground.

Signal name	Connector No.	Terminal No.	Ignition switch position	Continuity
Ground	M75	12	OFF	Existed

Is the inspection result normal?

YES >> INSPECTION END

NO >> Repair harness or connector.

## BOSE AMP.

### BOSE AMP. : Diagnosis Procedure

INFOID:000000006472754

## 1.CHECK FUSE

Check for blown fuses.

Power source	Fuse No.
Battery	5, 8
Ignition switch ACC or ON	19

Is the inspection result normal?

YES >> GO TO 2.

NO >> Be sure to eliminate cause of malfunction before installing new fuse.

## 2.CHECK POWER SUPPLY CIRCUIT

Check voltage between BOSE amp. harness connector and ground.

Signal name	Connector No.	Terminal No.	Ignition switch position	Value (Approx.)
Battery power supply	B42	50, 51	OFF	Battery voltage
ACC power supply	B41	16	ACC	Battery voltage

Is the inspection result normal?

YES >> GO TO 3.

NO >> Check harness between BOSE amp. and fuse.

# POWER SUPPLY AND GROUND CIRCUIT

< DTC/CIRCUIT DIAGNOSIS >

[BOSE AUDIO WITH NAVIGATION]

## 3. CHECK GROUND CIRCUIT

1. Turn ignition switch OFF.
2. Disconnect BOSE amp. connector.
3. Check continuity between BOSE amp. harness connector and ground.

Signal name	Connector No.	Terminal No.	Ignition switch position	Continuity
Ground	B42	47, 52	OFF	Existed

Is the inspection result normal?

- YES >> INSPECTION END  
NO >> Repair harness or connector.

A  
B  
C  
D  
E  
F  
G  
H  
I  
J  
K  
L  
M  
O  
P

AV

# RGB DIGITAL IMAGE SIGNAL CIRCUIT

< DTC/CIRCUIT DIAGNOSIS >

[BOSE AUDIO WITH NAVIGATION]

## RGB DIGITAL IMAGE SIGNAL CIRCUIT

### Description

INFOID:000000006472755

Transmit the image displayed with AV control unit with RGB digital image signal to the display unit.

### Diagnosis Procedure

INFOID:000000006472756

#### 1. CHECK CONTINUITY RGB DIGITAL IMAGE SIGNAL CIRCUIT

1. Turn ignition switch OFF.
2. Disconnect display unit connector and AV control unit connector.
3. Check continuity between display unit harness connector and AV control unit harness connector.

Display unit		AV control unit		Continuity
Connector	Terminals	Connector	Terminals	
M386	27	M385	157	Existed
	28		158	

4. Check continuity between display unit harness connector and ground.

Display unit		Ground	Continuity
Connector	Terminals		
M386	27		Not existed
	28		

Is the inspection result normal?

YES >> GO TO 2.

NO >> Repair harness or connector.

#### 2. CHECK RGB DIGITAL IMAGE SIGNAL

1. Connect AV control unit connector.
2. Turn ignition switch ON.
3. Check signal between display unit harness connector and ground.

(+) Display unit		(-) Ground	Condition	Voltage (Approx.)
Connector	Terminals			
M386	27		—	3.0 V
	28			

Is the inspection result normal?

YES >> Replace display unit. Refer to [AV-415, "Exploded View"](#).

NO >> Replace AV control unit. Refer to [AV-413, "Exploded View"](#).

# COMPOSITE IMAGE SIGNAL CIRCUIT

< DTC/CIRCUIT DIAGNOSIS >

[BOSE AUDIO WITH NAVIGATION]

## COMPOSITE IMAGE SIGNAL CIRCUIT

### Description

INFOID:000000006472757

AV control unit transmits the playback DVD image signal to the display unit.

### Diagnosis Procedure

INFOID:000000006472758

#### 1. CHECK CONTINUITY COMPOSITE IMAGE SIGNAL CIRCUIT

1. Turn ignition switch OFF.
2. Disconnect AV control unit connector and display unit connector.
3. Check continuity between AV control unit harness connector and display unit harness connector.

AV control unit		Display unit		Continuity
Connector	Terminal	Connector	Terminal	
M210	68	M75	18	Existed

4. Check continuity between AV control unit harness connector and ground.

AV control unit		Ground	Continuity
Connector	Terminal		
M210	68		Not existed

Is the inspection result normal?

- YES >> GO TO 2.  
 NO >> Repair harness or connector.

#### 2. CHECK COMPOSITE IMAGE SIGNAL

1. Connect AV control unit connector and display unit connector.
2. Turn ignition switch ON.
3. Check signal between AV control unit harness connector and ground.

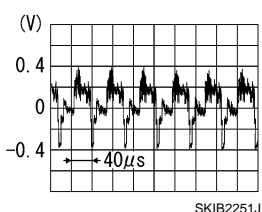
(+)		(-)	Condition	Reference value
AV control unit				
Connector	Terminal			
M210	68	Ground	At DVD image is displayed.	

Is the inspection result normal?

- YES >> Replace display unit. Refer to [AV-415. "Exploded View"](#).  
 NO >> Replace AV control unit. Refer to [AV-413. "Exploded View"](#).

A  
B  
C  
D  
E  
F  
G  
H  
I  
J  
K  
L  
M  
AV  
O  
P

# DISK EJECT SIGNAL CIRCUIT

< DTC/CIRCUIT DIAGNOSIS >

[BOSE AUDIO WITH NAVIGATION]

## DISK EJECT SIGNAL CIRCUIT

### Description

INFOID:000000006472759

The eject signal is output to AV control unit when the eject switch of multifunction switch is pressed.

### Diagnosis Procedure

INFOID:000000006472760

#### 1. CHECK CONTINUITY DISK EJECT SIGNAL CIRCUIT

1. Turn ignition switch OFF.
2. Disconnect multifunction switch connector and AV control unit connector.
3. Check continuity between multifunction switch harness connector and AV control unit harness connector.

Multifunction switch		AV control unit		Continuity
Connector	Terminal	Connector	Terminal	
M72	14	M209	29	Existed

4. Check continuity between multifunction switch harness connector and ground.

Multifunction switch		Ground	Continuity
Connector	Terminal		
M72	14		Not existed

Is the inspection result normal?

- YES >> GO TO 2.  
NO >> Repair harness or connector.

#### 2. CHECK AV CONTROL UNIT VOLTAGE

1. Connect multifunction switch connector and AV control unit connector.
2. Turn ignition switch ON.
3. Check voltage between AV control unit harness connector and ground.

(+)		(-)	Condition	Voltage (Approx.)
AV control unit				
Connector	Terminal			
M209	29	Ground	Pressing the eject switch	0 V
			Except for above	5.0 V

Is the inspection result normal?

- YES >> Replace preset switch. Refer to [AV-426, "Exploded View"](#).  
NO >> Replace AV control unit. Refer to [AV-413, "Exploded View"](#).



# MICROPHONE SIGNAL CIRCUIT

< DTC/CIRCUIT DIAGNOSIS >

[BOSE AUDIO WITH NAVIGATION]

## MICROPHONE SIGNAL CIRCUIT

### Description

INFOID:000000006472761

Supply power from AV control unit to microphone. The microphone transmits the sound/voice to the AV control unit.

### Diagnosis Procedure

INFOID:000000006472762

#### 1. CHECK CONTINUITY BETWEEN AV CONTROL UNIT AND MICROPHONE CIRCUIT

1. Turn ignition switch OFF.
2. Disconnect AV control unit connector and microphone connector.
3. Check continuity between AV control unit harness connector and microphone harness connector.

AV control unit		Microphone		Continuity
Connector	Terminals	Connector	Terminals	
M210	71	R7	2	Existed
	72		4	
	87		1	

4. Check continuity between AV control unit harness connector and ground.

AV control unit		Ground	Continuity
Connector	Terminals		
M210	72		Not existed
	87		

Is the inspection result normal?

YES >> GO TO 2.

NO >> Repair harness or connector.

#### 2. CHECK VOLTAGE MICROPHONE VCC

1. Connect AV control unit connector.
2. Turn ignition switch ON.
3. Check voltage between AV control unit harness connector.

(+)		(-)		Voltage (Approx.)
AV control unit		AV control unit		
Connector	Terminal	Connector	Terminal	
M210	72	M210	71	5.0 V

Is the inspection result normal?

YES >> GO TO 3.

NO >> Replace AV control unit. Refer to [AV-413, "Exploded View"](#).

#### 3. CHECK MICROPHONE SIGNAL

1. Connect microphone connector.
2. Check signal between AV control unit harness connector.

A  
B  
C  
D  
E  
F  
G  
H  
I  
J  
K  
L  
M  
O  
P

AV

# MICROPHONE SIGNAL CIRCUIT

< DTC/CIRCUIT DIAGNOSIS >

[BOSE AUDIO WITH NAVIGATION]

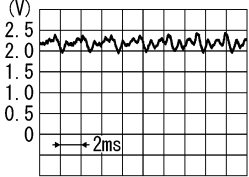
(+)		(-)		Condition	Reference value
AV control unit		AV control unit			
Connector	Terminal	Connector	Terminal		
M210	87	M210	71	Give a voice.	 <p style="text-align: right;">PKIB5037J</p>

Is the inspection result normal?

- YES >> Replace AV control unit. Refer to [AV-413, "Exploded View"](#).
- NO >> Replace microphone. Refer to [AV-429, "Exploded View"](#).

# CAMERA IMAGE SIGNAL CIRCUIT

< DTC/CIRCUIT DIAGNOSIS >

[BOSE AUDIO WITH NAVIGATION]

## CAMERA IMAGE SIGNAL CIRCUIT

### Description

INFOID:000000006472763

- The AV control unit supplies power to the rear view camera when receiving a reverse signal.
- The rear view camera transmits camera images to the display unit when power is supplied from the AV control unit.

### Diagnosis Procedure

INFOID:000000006472764

#### 1. CHECK CONTINUITY CAMERA POWER SUPPLY CIRCUIT

1. Turn ignition switch OFF.
2. Disconnect AV control unit connector and rear view camera connector.
3. Check continuity between AV control unit harness connector and rear view camera harness connector.

AV control unit		Rear view camera		Continuity
Connector	Terminal	Connector	Terminal	
M209	22	B311	1	Existed

4. Check continuity between AV control unit harness connector and ground.

AV control unit		Ground	Continuity
Connector	Terminal		
M209	22		Not existed

Is inspection result normal?

YES >> GO TO 2.

NO >> Repair harness or connector.

#### 2. CHECK VOLTAGE CAMERA POWER SUPPLY

1. Connect AV control unit connector and rear view camera connector.
2. Turn ignition switch ON.
3. Shift the selector lever to "R".
4. Check voltage between AV control unit harness connector and ground.

(+)		(-)	Condition	Voltage (Approx.)
AV control unit				
Connector	Terminal			
M209	22	Ground	Shift position is "R".	6.0 V

Is inspection result normal?

YES >> GO TO 3.

NO >> Replace AV control unit.

#### 3. CHECK CONTINUITY CAMERA IMAGE SIGNAL CIRCUIT

1. Turn ignition switch OFF.
2. Disconnect display unit connector and rear view camera connector.
3. Check continuity between display unit harness connector and rear view camera harness connector.

Display unit		Rear view camera		Continuity
Connector	Terminal	Connector	Terminal	
M75	8	B311	3	Existed

4. Check continuity between display unit harness connector and ground.

A  
B  
C  
D  
E  
F  
G  
H  
I  
J  
K  
L  
M  
N  
O  
P

AV

# CAMERA IMAGE SIGNAL CIRCUIT

< DTC/CIRCUIT DIAGNOSIS >

[BOSE AUDIO WITH NAVIGATION]

Display unit		Ground	Continuity
Connector	Terminal		
M75	8		Not existed

**Is inspection result normal?**

YES >> GO TO 4.

NO >> Repair harness or connector.

## 4. CHECK CAMERA IMAGE SIGNAL

1. Connect display unit connector and rear view camera connector.
2. Turn ignition switch ON.
3. Shift the selector lever to "R".
4. Check signal between display unit harness connector and ground.

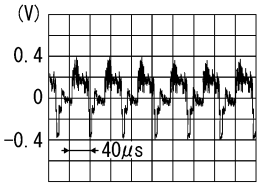
(+)		(-)	Condition	Reference value
Display unit				
Connector	Terminal			
M75	8	Ground	At rear view camera image is displayed.	 <p style="text-align: right; font-size: small;">SKIB2251J</p>

**Is inspection result normal?**

YES >> Replace display unit. Refer to [AV-415, "Exploded View"](#).

NO >> Replace rear view camera. Refer to [AV-433, "Exploded View"](#).

# STEERING SWITCH SIGNAL A CIRCUIT

< DTC/CIRCUIT DIAGNOSIS >

[BOSE AUDIO WITH NAVIGATION]

## STEERING SWITCH SIGNAL A CIRCUIT

### Description

INFOID:000000006472765

Transmits the steering switch signal to AV control unit.

### Diagnosis Procedure

INFOID:000000006472766

#### 1. CHECK STEERING SWITCH SIGNAL A CIRCUIT

1. Disconnect AV control unit connector and spiral cable connector.
2. Check continuity between AV control unit harness connector and spiral cable harness connector.

AV control unit		Spiral cable		Continuity
Connector	Terminal	Connector	Terminal	
M208	6	M36	24	Existed

3. Check continuity between AV control unit harness connector and ground.

AV control unit		Ground	Continuity
Connector	Terminal		
M208	6		Not existed

Is the inspection result normal?

- YES >> GO TO 2.  
 NO >> Repair harness or connector.

#### 2. CHECK SPIRAL CABLE

Check spiral cable.

Is the inspection result normal?

- YES >> GO TO 3.  
 NO >> Replace spiral cable.

#### 3. CHECK AV CONTROL UNIT VOLTAGE

1. Connect AV control unit connector and spiral cable connector.
2. Turn ignition switch ON.
3. Check voltage between AV control unit harness connector.

(+)		(-)		Voltage (Approx.)
AV control unit		AV control unit		
Connector	Terminal	Connector	Terminal	
M208	6	M208	15	5.0 V

Is the inspection result normal?

- YES >> GO TO 4.  
 NO >> Replace AV control unit. Refer to [AV-413, "Exploded View"](#)

#### 4. CHECK STEERING SWITCH

1. Turn ignition switch OFF.
2. Check steering switch. Refer to [AV-397, "Component Inspection"](#).

Is the inspection result normal?

- YES >> INSPECTION END  
 NO >> Replace steering switch. Refer to [ST-14, "Exploded View"](#).

### Component Inspection

INFOID:000000006472767

Measure the resistance between the steering switch connector terminals 14 to 17 and 15 to 17.

A  
B  
C  
D  
E  
F  
G  
H  
I  
J  
K  
L  
M  
O  
P

AV

# STEERING SWITCH SIGNAL A CIRCUIT

[BOSE AUDIO WITH NAVIGATION]

## < DTC/CIRCUIT DIAGNOSIS >

### Standard

Between terminals 14 and 17

ENTER switch ON	: 2003 – 2043 Ω
⏏ switch ON	: 716 – 730 Ω
MENU DOWN switch ON	: 318 – 324 Ω
MENU UP switch ON	: 120 – 122 Ω
SOURCE switch ON	: 0 Ω

Between terminals 15 and 17

↶ switch ON	: 716 – 730 Ω
↷ switch ON	: 318 – 324 Ω
VOL UP switch ON	: 120 – 122 Ω
VOL DOWN switch ON	: 0 Ω

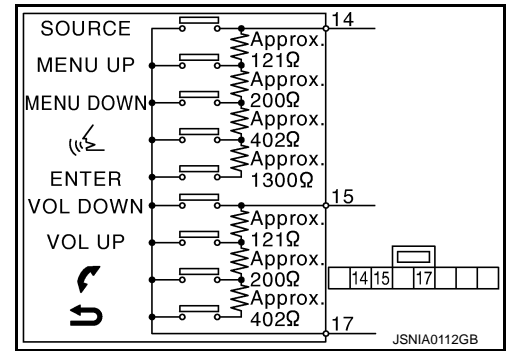

# STEERING SWITCH SIGNAL B CIRCUIT

< DTC/CIRCUIT DIAGNOSIS >

[BOSE AUDIO WITH NAVIGATION]

## STEERING SWITCH SIGNAL B CIRCUIT

### Description

INFOID:000000006472768

Transmits the steering switch signal to AV control unit.

### Diagnosis Procedure

INFOID:000000006472769

#### 1. CHECK STEERING SWITCH SIGNAL B CIRCUIT

1. Disconnect AV control unit connector and spiral cable connector.
2. Check continuity between AV control unit harness connector and spiral cable harness connector.

AV control unit		Spiral cable		Continuity
Connector	Terminal	Connector	Terminal	
M208	16	M36	31	Existed

3. Check continuity between AV control unit harness connector and ground.

AV control unit		Ground	Continuity
Connector	Terminal		
M208	16		Not existed

Is the inspection result normal?

- YES >> GO TO 2.  
 NO >> Repair harness or connector.

#### 2. CHECK SPIRAL CABLE

Check spiral cable.

Is the inspection result normal?

- YES >> GO TO 3.  
 NO >> Replace spiral cable.

#### 3. CHECK AV CONTROL UNIT VOLTAGE

1. Connect AV control unit connector and spiral cable connector.
2. Turn ignition switch ON.
3. Check voltage between AV control unit harness connector.

(+)		(-)		Voltage (Approx.)
AV control unit		AV control unit		
Connector	Terminal	Connector	Terminal	
M208	16	M208	15	5.0 V

Is the inspection result normal?

- YES >> GO TO 4.  
 NO >> Replace AV control unit. Refer to [AV-413, "Exploded View"](#).

#### 4. CHECK STEERING SWITCH

1. Turn ignition switch OFF.
2. Check steering switch. Refer to [AV-399, "Component Inspection"](#).

Is the inspection result normal?

- YES >> INSPECTION END  
 NO >> Replace steering switch. Refer to [ST-14, "Exploded View"](#).

### Component Inspection

INFOID:000000006472770

Measure the resistance between the steering switch connector terminals 14 to 17 and 15 to 17.

A  
B  
C  
D  
E  
F  
G  
H  
I  
J  
K  
L  
M  
O  
P

AV

# STEERING SWITCH SIGNAL B CIRCUIT

[BOSE AUDIO WITH NAVIGATION]

## < DTC/CIRCUIT DIAGNOSIS >

### Standard

Between terminals 14 and 17

ENTER switch ON	: 2003 – 2043 Ω
⏏ switch ON	: 716 – 730 Ω
MENU DOWN switch ON	: 318 – 324 Ω
MENU UP switch ON	: 120 – 122 Ω
SOURCE switch ON	: 0 Ω

Between terminals 15 and 17

↶ switch ON	: 716 – 730 Ω
↷ switch ON	: 318 – 324 Ω
VOL UP switch ON	: 120 – 122 Ω
VOL DOWN switch ON	: 0 Ω

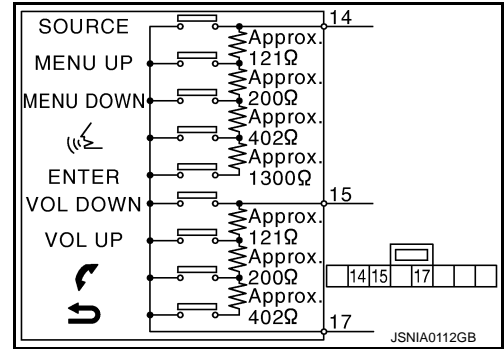



# STEERING SWITCH GROUND CIRCUIT

[BOSE AUDIO WITH NAVIGATION]

< DTC/CIRCUIT DIAGNOSIS >

## STEERING SWITCH GROUND CIRCUIT

### Description

INFOID:000000006472771

Transmits the steering switch signal to AV control unit.

### Diagnosis Procedure

INFOID:000000006472772

#### 1. CHECK STEERING SWITCH SIGNAL GROUND CIRCUIT

1. Disconnect AV control unit connector and spiral cable connector.
2. Check continuity between AV control unit harness connector and spiral cable harness connector.

AV control unit		Spiral cable		Continuity
Connector	Terminal	Connector	Terminal	
M208	15	M36	33	Existed

3. Connect AV control unit connector.

Is the inspection result normal?

- YES >> GO TO 2.  
NO >> Repair harness or connector.

#### 2. CHECK SPIRAL CABLE

Check spiral cable.

Is the inspection result normal?

- YES >> GO TO 3.  
NO >> Replace spiral cable.

#### 3. CHECK GROUND CIRCUIT

1. Connect AV control unit connector.
2. Check continuity between AV control unit harness connector and ground.

AV control unit		Ground	Continuity
Connector	Terminal		
M208	15		Existed

Is the inspection result normal?

- YES >> GO TO 4.  
NO >> Replace AV control unit. Refer to [AV-413, "Exploded View"](#)

#### 4. CHECK STEERING SWITCH

1. Turn ignition switch OFF.
2. Check steering switch. Refer to [AV-401, "Component Inspection"](#).

Is the inspection result normal?

- YES >> INSPECTION END  
NO >> Replace steering switch. Refer to [ST-14, "Exploded View"](#)

### Component Inspection

INFOID:000000006472773

Measure the resistance between the steering switch connector terminals 14 to 17 and 15 to 17.

A  
B  
C  
D  
E  
F  
G  
H  
I  
J  
K  
L  
M  
O  
P

AV

# STEERING SWITCH GROUND CIRCUIT

[BOSE AUDIO WITH NAVIGATION]

## < DTC/CIRCUIT DIAGNOSIS >

### Standard

Between terminals 14 and 17

ENTER switch ON	: 2003 – 2043 Ω
⏏ switch ON	: 716 – 730 Ω
MENU DOWN switch ON	: 318 – 324 Ω
MENU UP switch ON	: 120 – 122 Ω
SOURCE switch ON	: 0 Ω

Between terminals 15 and 17

↶ switch ON	: 716 – 730 Ω
↷ switch ON	: 318 – 324 Ω
VOL UP switch ON	: 120 – 122 Ω
VOL DOWN switch ON	: 0 Ω

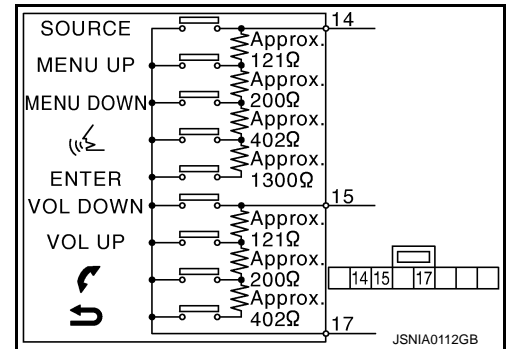

SYMPTOM DIAGNOSIS

MULTI AV SYSTEM SYMPTOMS

Symptom Table

INFOID:000000006472774

RELATED TO NAVIGATION

Symptoms	Check items	Probable malfunction location
Multifunction switch and preset switch operation does not work.	<ul style="list-style-type: none"> <li>All switches cannot be operated.</li> <li>"MULTI AV" is displayed on system selection screen when the CONSULT-III is started.</li> </ul>	<ul style="list-style-type: none"> <li>Multifunction switch power supply and ground circuit malfunction.</li> <li>AV communication circuit between AV control unit and multifunction switch. Perform CONSULT-III self-diagnosis. Refer to <a href="#">AV-300, "CONSULT - III Function"</a>.</li> </ul>
	<ul style="list-style-type: none"> <li>All switches cannot be operated.</li> <li>"MULTI AV" is not displayed on system selection screen when the CONSULT-III is initialized.</li> </ul>	AV control unit power supply and ground circuit malfunction. Refer to <a href="#">AV-387, "AV CONTROL UNIT : Diagnosis Procedure"</a> .
	Only specified switch cannot be operated.	Multifunction switch or preset switch malfunction. Perform multifunction switch and preset switch self-diagnosis function. Refer to <a href="#">AV-287, "On Board Diagnosis Function"</a> .
Fuel economy display, vehicle setting operation is abnormal.	There is malfunction in the CONSULT-III "self-diagnosis result" of "MULTI AV". Refer to <a href="#">AV-300, "CONSULT - III Function"</a> .	Perform detected DTC diagnosis. Refer to <a href="#">AV-310, "DTC Index"</a> .
	There is no malfunction in the CONSULT-III "self-diagnosis results" of "MULTI AV". Refer to <a href="#">AV-300, "CONSULT - III Function"</a> .	Ignition signal circuit malfunction.
Guide sound is not heard or too low.	On the setting display select "system sound (guide sound volume, etc.)," and confirm that guide sound is ON.	AV control unit malfunction. Replace AV control unit. Refer to <a href="#">AV-413, "Exploded View"</a> .

RELATED TO HANDS-FREE PHONE

Simple Check for Bluetooth™ Communication

If cellular phone and AV control unit cannot be connected with Bluetooth™ communication, following procedure allows the technician to judge which device has malfunction.

- Turn ON cellular phone, not connecting Bluetooth™ communication.
- Start CONSULT-III, then start Windows®.
- Set CONSULT-III near a cellular phone.
- When operated Bluetooth™ registration by cellular phone, check if CONSULT-III\* would be displayed on the device name. (If other Bluetooth™ device is located near cellular phone, a name of the device would be displayed also.)

NOTE:

\*:Displayed device name is "NISSAN-\*\*\*\*\*".

- If no device name is displayed, cellular phone is malfunctioning. Repair the cellular phone first, then perform diagnosis.
- If CONSULT-III is displayed on device name, cellular phone is normal. Perform diagnosis as per the following table.

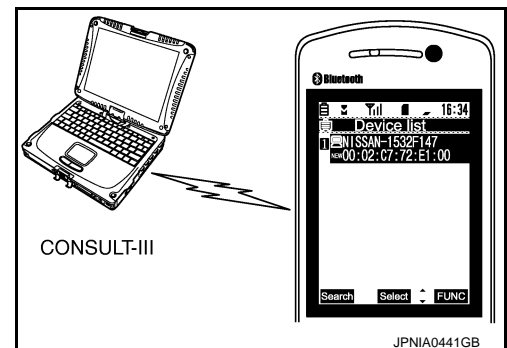

## MULTI AV SYSTEM SYMPTOMS

[BOSE AUDIO WITH NAVIGATION]

< SYMPTOM DIAGNOSIS >

Symptoms	Check items	Probable malfunction location
Does not recognize cellular phone connection. (no connection is displayed on the display at the guide.)	Repeat the registration of cellular phone.	
Hands-free phone cannot be established.	<ul style="list-style-type: none"> <li>Hands-free phone operation can be made, but the communication cannot be established.</li> <li>Hands-free phone operation can be performed, however, voice between each other cannot be heard during the conversation.</li> </ul>	AV control unit malfunction. Replace AV control unit. Refer to <a href="#">AV-413, "Exploded View"</a> .
The other party's voice cannot be heard by hands-free phone.	Check the "microphone speaker" in Inspection & Adjustment Mode if sound is heard.	
Originating sound is not heard by the other party with hands-free phone communication.	Sound operation function is normal.	
	Sound operation function does not work.	Microphone signal circuit malfunction. Refer to <a href="#">AV-393, "Diagnosis Procedure"</a> .
The system cannot be operated.	<ul style="list-style-type: none"> <li>The retractable hard top is fully closed.</li> <li>The voice recognition cannot be controlled.</li> </ul>	Roof status signal circuit malfunction.
	<ul style="list-style-type: none"> <li>The retractable hard top is fully closed.</li> <li>The voice recognition can be controlled.</li> <li>Steering switch's "VOL UP", "VOL DOWN", "↶" switch works, but "↷" it does not work.</li> </ul>	Steering switch malfunction. Replace steering switch. Refer to <a href="#">ST-14, "Exploded View"</a> .
	<ul style="list-style-type: none"> <li>The retractable hard top is fully closed.</li> <li>The voice recognition can be controlled.</li> <li>Steering switch's "↷", "VOL UP", "VOL DOWN", "↶" switches do not work.</li> </ul>	Steering switch signal B circuit malfunction. Refer to <a href="#">AV-399, "Diagnosis Procedure"</a> .
	All steering switches do not work.	Steering switch ground circuit malfunction. Refer to <a href="#">AV-401, "Diagnosis Procedure"</a> .

### RELATED TO RGB IMAGE

Symptoms	Check items	Probable malfunction location
RGB image is not shown.	—	RGB digital image signal circuit malfunction. Refer to <a href="#">AV-390, "Diagnosis Procedure"</a> .

### RELATED TO VOICE CONTROL

Symptoms	Check items	Probable malfunction location
The voice cannot be controlled even if the voice control screen is displayed.	Voice sounds at "Voice Microphone Test" of Confirmation/Adjustment mode.	AV control unit malfunction. Replace AV control unit. Refer to <a href="#">AV-413, "Exploded View"</a> .
	Voice does not sound at "Voice Microphone Test" of Confirmation/Adjustment mode.	Microphone circuit malfunction. Refer to <a href="#">AV-393, "Diagnosis Procedure"</a> .

# MULTI AV SYSTEM SYMPTOMS

[BOSE AUDIO WITH NAVIGATION]

< SYMPTOM DIAGNOSIS >

Symptoms	Check items	Probable malfunction location
The voice cannot be controlled (Voice control screen is not displayed).	<ul style="list-style-type: none"> <li>Steering switch's "SOURCE", "MENU UP", "MENU DOWN", "ENTER" switch works, but "⏮" it does not work.</li> <li>Hands-free phone system cannot be operated.</li> </ul>	Roof status signal circuit malfunction.
	<ul style="list-style-type: none"> <li>Steering switch's "SOURCE", "MENU UP", "MENU DOWN", "ENTER" switch works, but "⏮" it does not work.</li> <li>Hands-free phone system can be operated.</li> </ul>	Steering switch malfunction. Replace steering switch. Refer to <a href="#">ST-14, "Exploded View"</a> .
	Steering switch's "SOURCE", "MENU UP", "MENU DOWN", "⏮", "ENTER" switches do not work.	Steering switch signal A circuit malfunction. Refer to <a href="#">AV-397, "Diagnosis Procedure"</a> .
	All steering switches do not work.	Steering switch ground circuit malfunction. Refer to <a href="#">AV-401, "Diagnosis Procedure"</a> .

## RELATED TO AUDIO

Symptoms	Check items	Probable malfunction location
The disk cannot be removed.	—	Disk eject signal circuit malfunction. Refer to <a href="#">AV-392, "Diagnosis Procedure"</a> .
Audio sound is not heard.	No sound from all speakers.	Perform CONSULT-III self-diagnosis. Refer to <a href="#">AV-300, "CONSULT - III Function"</a> .
	Sound is heard only from specific places.	Perform CONSULT-III self-diagnosis. Refer to <a href="#">AV-300, "CONSULT - III Function"</a> .
Satellite radio is not received.	There is malfunction in the CONSULT-III self-diagnosis result. Refer to <a href="#">AV-300, "CONSULT - III Function"</a> .	Perform detected DTC diagnosis. Refer to <a href="#">AV-310, "DTC Index"</a> .
	There is no malfunction in the CONSULT-III self-diagnosis result. Refer to <a href="#">AV-300, "CONSULT - III Function"</a> .	Perform the following inspection procedure. 1. Check satellite radio antenna (antenna base) mounting nut for looseness. <b>NOTE:</b> Tightening torque: 6.5 N-m (0.66 kg-m, 58 in-lb) 2. Visually check for satellite radio antenna feeder.
AM/FM radio is not received.	Other audio sounds are normal.	<ul style="list-style-type: none"> <li>Antenna amp. ON signal circuit malfunction.</li> <li>Antenna feeder malfunction.</li> </ul>
Sound equalizer is not switched.	—	Roof status signal circuit malfunction.

## RELATED TO DVD MODE

Symptoms	Check items	Probable malfunction location
The disk cannot be removed.	—	Disk eject signal circuit malfunction. Refer to <a href="#">AV-392, "Diagnosis Procedure"</a> .
DVD image is not displayed.	—	Perform CONSULT-III self-diagnosis. Refer to <a href="#">AV-300, "CONSULT - III Function"</a> . When detecting no malfunction in those components, the following items are a possible cause. <ul style="list-style-type: none"> <li>Composite image signal circuits malfunction. Refer to <a href="#">AV-391, "Diagnosis Procedure"</a>.</li> </ul>
DVD sound is not heard.	No sound from all speakers.	Perform CONSULT-III self-diagnosis. Refer to <a href="#">AV-300, "CONSULT - III Function"</a> .
	Sound is heard only from specific places.	Perform CONSULT-III self-diagnosis. Refer to <a href="#">AV-300, "CONSULT - III Function"</a> .

## RELATED TO CAMERA

## MULTI AV SYSTEM SYMPTOMS

[BOSE AUDIO WITH NAVIGATION]

< SYMPTOM DIAGNOSIS >

### Trouble Diagnosis Chart by Symptom

Symptoms	Check items	Probable malfunction location
Camera image is not shown. (Vehicle width and predictive course line are displayed.)	—	Camera image signal circuit. Refer to <a href="#">AV-395, "Diagnosis Procedure"</a> .
Camera image does not switch.	Select "Camera Cont." of Confirmation/ Adjustment mode, Reverse Sensor is not turned ON at "Connection Confirmation".	Reverse signal circuit malfunction.
	Select "Camera Cont." of Confirmation/ Adjustment mode, Reverse Sensor is turned ON at "Connection Confirmation".	AV control unit malfunction. Replace AV control unit. Refer to <a href="#">AV-413, "Exploded View"</a> .

### RELATED TO USB

**NOTE:**

Check that there is no malfunction of USB equipment main body before performing a diagnosis.

Symptoms	Check items	Possible malfunction location / Action to take
iPod® or USB memory can not be recognized.	—	<ul style="list-style-type: none"> <li>• USB harness malfunction.</li> <li>• USB connector malfunction.</li> </ul>

iPod® is a trademark of Apple inc., registered in the U.S. and other countries.

### RELATED TO STEERING SWITCH

Symptoms	Probable malfunction location
None of the steering switch operations work.	Steering switch ground circuit malfunction. Refer to <a href="#">AV-401, "Diagnosis Procedure"</a> .
Only specified switch cannot be operated.	Steering switch malfunction. Replace steering switch. Refer to <a href="#">ST-14, "Exploded View"</a> .
Steering switch's "SOURCE", "MENU UP", "MENU DOWN", "↵", "ENTER" switches do not work.	Steering switch signal A circuit malfunction. Refer to <a href="#">AV-397, "Diagnosis Procedure"</a> .
Steering switch's "⤴", "VOL UP", "VOL DOWN", "⤵" switches do not work.	Steering switch signal B circuit malfunction. Refer to <a href="#">AV-399, "Diagnosis Procedure"</a> .

# NORMAL OPERATING CONDITION

< SYMPTOM DIAGNOSIS >

[BOSE AUDIO WITH NAVIGATION]

## NORMAL OPERATING CONDITION

### Description

INFOID:000000006472775

**NOTE:**

For Navigation system operation information, refer to Navigation system Owner's Manual.

### BASIC OPERATIONS

Symptom	Possible cause	Possible solution
No image is displayed.	The brightness is at the lowest setting.	Adjust the brightness of the display.
	The systems in the video mode.	Press "DISC-AUX" to change the mode.
	The display is turned off.	Press "☀/☾" to turn on the display.
	The interior of the vehicle becomes the a little less than 80°C (176°F) or high temperature, and the protection of the display acts, and a display is turned off.	Wait until the interior of the vehicle has cooled down.
Screen not clear.	Contrast setting is not appropriate.	Adjust the contrast of the display.
No voice guidance is available. Or The volume is too high or too low.	The volume is not set correctly, or it is turned off.	Adjust the volume of voice guidance.
	Voice guidance is not provided for certain streets (roads displayed in gray).	This is not a malfunction.
No map is displayed on the screen.	A screen other than map screen is displayed.	Press "MAP".
The screen is too dim. The movement is slow.	The temperature in the interior of the vehicle is low.	Wait until the interior of the vehicle has warmed up.
Some pixels in the display are darker or brighter than others.	This condition is an inherent characteristic of liquid crystal displays.	This is not a malfunction.
Some menu items cannot be selected.	Some menu items become unavailable while the vehicle is driven.	Park the vehicle in a safe location, and then operate the navigation system.

**NOTE:**

Locations stored in the Address Book and other memory functions may be lost if the vehicle's battery is disconnected or becomes discharged. If this occurs, service the vehicle's battery as necessary and re-enter the information in the Address Book.

### RELATED TO VOICE RECOGNITION

#### Related to Basic Operation

Symptom	Possible cause	Possible solution
The system does not recognize your command. or The system recognizes your command incorrectly	The interior of the vehicle is too noisy.	Close the windows or have other occupants quiet.
	The volume of your voice is too low.	Speak louder.
	The volume if your voice is too loud.	Speak softer.
	Your pronunciation is unclear.	Speak clearly.
	You are speaking before the voice recognition is ready	Press and release "☞" switch on the steering switch, and speak a command after the tone sounds.
	8 seconds or more have passed after you pressed and released "☞" switch on the steering switch.	Make sure to speak a command within 8 seconds after you press and release "☞" switch on the steering switch.
	Only a limited range of voice commands is usable for each screen.	Use a correct voice command appropriate for the current screen.
The system cannot be operated.	The fan of the air conditioner is too loud.	Lower the fan speed as necessary as voice command can be recognized more easily.
	The retractable hard top is open.	<ul style="list-style-type: none"> <li>Close the retractable hard top.</li> <li>Open and close the retractable hard top before operating the system.</li> </ul>

## NORMAL OPERATING CONDITION

< SYMPTOM DIAGNOSIS >

[BOSE AUDIO WITH NAVIGATION]

Related to Item Choice

The system should respond correctly to all voice commands without difficulty. If problems are encountered, follow the solutions given in this guide for the appropriate error.

Where the solutions are listed by number, try each solution in turn, starting with number one, until the problem is resolved.

Symptom/ error message	Solution
Displays "COMMAND NOT RECOGNIZED" or the system fails to interpret the command correctly.	1. Ensure that the command format is valid.
	2. Speak clearly without pausing between words and at a level appropriate to the ambient noise level.
	3. Ensure that the ambient noise level is not excessive, for example, windows open or defrost on. <b>NOTE:</b> If it is too noisy to use the phone, it is likely that voice commands will not be recognized.
	4. If optional words of the command have been omitted, then command should be tried with these in place.
The system consistently selects the wrong voicetag	1. Ensure that the voicetag requested matches what was originally stored. This can be confirmed by giving the "Addressbook" Directory or Phone Directory command.
	2. Replace one of the voicetags being confused with a different voicetag.

Related to Telephone

The system should respond correctly to all voice commands without difficulty. If problems are encountered, try the following solutions.

Where the solutions are listed by number, try each solution in turn, starting with number 1, until the problem is resolved.

Symptom	Solution
System fails to interpret the command correctly.	1. Ensure that the command is valid.
	2. Ensure that the command is spoken after the tone.
	3. Speak clearly without pausing between words and at level appropriate to the ambient noise level in the vehicle.
	4. Ensure that the ambient noise level is not excessive (for example, windows open or defroster on). <b>NOTE:</b> If it is too noisy to use the phone, it is likely that the voice commands will not be recognized.
	5. If more than one command was said at a time, try saying the commands separately.
	6. If the system consistently fails to recognize commands, the voice training procedure should be carried out to improve the recognition response for the speaker. See "Speaker adaptation (SA) mode" earlier in this section. Refer to "OWNER'S MANUAL".
The system consistently selects the wrong voicetag	1. Ensure that the phone book entry name requested matches what was originally stored. This can be confirmed by using the "List Names" command.
	2. Replace one of the names being confused with a new name.

### RELATED TO AUDIO

- The majority of the audio malfunctions are the result of outside causes (bad CD, electromagnetic interference, etc.). Check the symptoms below to diagnose the malfunction.
- The vehicle itself can be a source of noise if noise prevention parts or electrical equipment is malfunctioning. Check if noise is caused and/or changed by engine speed, ignition switch turned to each position, and operation of each piece of electrical equipment, and then determine the cause.

**NOTE:**

- CD-R is not guaranteed to play because they can contain compressed audio (MP3, WMA, AAC, M4A) or could be incorrectly mastered by the customer on a computer.
- Check if the CDs carry the Compact Disc Logo. If not, the disc is not mastered to the "red book" Compact Disc Standard and may not play.



# NORMAL OPERATING CONDITION

< SYMPTOM DIAGNOSIS >

[BOSE AUDIO WITH NAVIGATION]

Symptom	Cause and Counter measure	
Cannot play	Check if the CD was inserted correctly.	A
	Check if the CD is scratched or dirty.	B
	Check if there is condensation inside the player, and if there is, wait until the condensation is gone (about 1 hour) before using the player.	C
	If there is a temperature increase error, the player will play correctly after it returns to the normal temperature.	D
	If there is a mixture of music CD files (CD-DA data) and MP3/WMA/AAC/M4A files on a CD, only the music CD files (CD-DA data) will be played.	E
	Files with extensions other than ".MP3", ".WMA", ".AAC", ".M4A", ".mp3", ".wma", ".aac" or ".m4a" cannot be played. In addition, the character codes and number of characters for folder names and file names should be in compliance with the specifications.	F
	Check if the disc or the file is generated in an irregular format, This may occur depending on the variation or the setting of MP3/WMA/AAC/M4A writing applications or other text editing applications.	G
	Check if the finalization process, such as session close and disc close, is done for the disc.	H
	Check if the CD is protected by copyright.	I
Disks recorded in live file system format are not supported. (For Microsoft Windows Vista, check the settings.)	J	
Poor sound quality	Check if the CD is scratched or dirty.	K
It takes a relatively long time before the music starts playing.	If there are many folder or file levels on the MP3/WMA/AAC/M4A CD, or if it is a multisession disc, some time may be required before the music starts playing.	L
Music cuts off or skips	The writing software and hardware combination might not match, or the writing speed, writing depth, writing width might not match the specifications. Try using the slowest writing speed.	M
Skipping with high bit rate files	Skipping may occur with large quantities if data such as for high bit rate data.	N
Move immediately to the next song when playing	When a non-MP3/WMA/AAC/M4A file has been given an extension of ".MP3", ".WMA", ".AAC", ".M4A", ".mp3", ".wma", ".aac" or ".m4a", or when play is prohibited by copyright protection, the player will skip to the next song.	O
The songs do not play back in the desired order.	The playback order is the order in which the files were written by the software, so the files might not play in the desired order.	P

Noise resulting from variations in field strength, such as fading noise and multi-path noise, or external noise from trains and other sources, is not a malfunction.

**NOTE:**

- Fading noise: This noise occurs because of variations in the field strength in a narrow range due to mountains or buildings blocking the signal.
- Multi-path noise: This noise results from a time difference between the broadcast waves directly from the station arriving at the antenna and the waves reflected by mountains or buildings.

## RELATED TO DVD

Symptom	Possible cause	Possible solution	
Not working as operated	Some operations may be rejected or may not function as intended because of the manufacturer's intent, depending on DVD.	This is not a malfunction.	AV
Operation not accepted	If a requested operation is prohibited, then a message is displayed on the screen. (Message display depends on DVD.)	This is not a malfunction.	O

## NORMAL OPERATING CONDITION

< SYMPTOM DIAGNOSIS >

[BOSE AUDIO WITH NAVIGATION]

Symptom	Possible cause	Possible solution
DVD can not be played	Check that the DVD is inserted in the right place.	Upturn the DVD (facing the title upward).
	Check that there is no condensation inside the player.	Wait until the condensation evaporates (approximately one hour).
	DVD menu is displayed.	Select item to touch "ENTER".
	Insertion of a DVD with a different region code.	DVDs with a different region code can not be played. Check DVD.
	Some DVD softwares may not be played because not all DVD softwares fully comply in the standard.	This is not a malfunction.
Interruption during playback or flicker in the display	Check that the DVD has no scratches and dirt.	Errors may not be corrected depending on the size of scratches.
		Wipe and clean the dirt on the disc.
Subtitles not shown	Subtitle setting is OFF.	Set subtitle.
	Subtitle is not included in the software.	Check DVD.
Not played in set language	If a language is not included in the DVD, then the DVD is played in a recommended language.	Check DVD.
Not played with set subtitle	If a set subtitle is not included in the DVD, then the DVD is played with a recommended subtitle.	Check DVD.
Angle unchangeable	Plural angles are not recorded in the software.	Check if the DVD is multi-angle capable.
Unusual screen display	Display mode to the output aspect ratio for the DVD software is inappropriate.	Switch to the appropriate display mode.
Distortion in picture	In the process of fast-forward or fast-reverse.	This is not a malfunction.
Low sound quality	Check that the DVD has no scratches and dirt.	Wipe and clean the dirt on the disc.
Subtitle and language not selectable (not played with set subtitle or in set language)	The DVD is not multilanguage-capable.	The inclusion of the number of languages depends on DVD. Languages may be selectable on the Menu screen. Check DVD.
	The DVD has a priority language or setting.	If the DVD has a priority language or settings, then settings changed with this device are not reflected.
Playback time is indicated, but no sound comes out.	Playback of Mix mode Truck 1. (Mix mode: Format including Truck 1 with data other than music and Trucks from Truck 2 with music data.)	Play music data included in trucks from Truck 2.

### RELATED TO VEHICLE ICON

Symptom	Possible cause	Possible solution
Names of roads differ between Plan View and Birdview™.	This is because the quantity of the displayed information is reduced so that the screen does not become too crowded. There is also a chance that names of the roads may be displayed multiple times, and the names appearing on the screen may be different because of a processing procedure.	This is not a malfunction.
The vehicle icon is not displayed in the correct position.	The vehicle was transported after the ignition switch was pressed off, for example, by a ferry or car transporter.	Drive the vehicle for a while on a road where GPS signals can be received.
	The position and direction of the vehicle icon may be incorrect depending on the driving environments and the levels of positioning accuracy of the navigation system.	This is not a malfunction. Drive the vehicle for a while to automatically correct the position and direction of the vehicle icon.
When the vehicle is traveling on a new road, the vehicle icon is located on another road nearby.	Because the new road is not stored in the map data, the system automatically places the vehicle icon on the nearest road available.	Updated road information will be included in the next version of the map data.

## NORMAL OPERATING CONDITION

< SYMPTOM DIAGNOSIS >

[BOSE AUDIO WITH NAVIGATION]

Symptom	Possible cause	Possible solution
The screen does not switch to the night screen even after turning on the headlights.	The daytime screen was set the last time the headlights were turned on.	Set the screen to the night screen mode using <Day/Night> when you turn on the headlights.
The map does not scroll even when the vehicle is moving.	The current location map screen is not displayed.	Press "MAP".
The vehicle icon is not displayed.	The current location map screen is not displayed.	Press "MAP".
The location of the vehicle icon is misaligned from the actual position.	When using tire chains or replacing the tires, speed calculations based on the speed sensor may be incorrect.	Drive the vehicle for a while [at approximately 30 km/h (19 MPH) for about 30 minutes] to automatically correct the vehicle icon position. If this does not correct the vehicle icon position, contact an INFINITI dealer.
	The map data has a mistake or is incomplete (the vehicle icon position is always misaligned in the same area).	Updated road information will be included in the next version of the map data.

### RELATED TO ROUTE CALCULATION AND VISUAL GUIDANCE

Symptom	Possible cause	Possible solution
Waypoints are not included in the auto reroute calculation.	Waypoints that you have already passed are not included in the auto reroute calculation.	If you want to go to that waypoint again, you need to edit the route.
Route information is not displayed.	Route calculation has not yet been performed.	Set the destination and perform route calculation.
	You are not driving on the suggested route.	Drive on the suggested route.
	Route guidance is set to off.	Turn on route guidance.
	Route information is not provided for certain types of roads (roads displayed in gray).	This is not a malfunction.
The auto reroute calculation (or detour calculation) suggests the same route as the one previously suggested.	Route calculations took priority conditions into consideration, but the same route was calculated.	This is not a malfunction.
A waypoint cannot be added.	Five waypoints are already set on the route, including ones that you have already passed.	A maximum of 5 waypoints can be set on the route. If you want to go to 6 or more waypoints, perform route calculations multiple times as necessary.
The suggested route is not displayed.	Roads near the destination cannot be calculated.	Reset the destination to a main or ordinary road, and recalculate the route.
	The starting point and destination are too close.	Set a more distant destination.
	The starting point and destination are too far away.	Divide your trip by selecting one or two intermediate destinations, and perform route calculations multiple times.
	There are time restricted roads (by the day of the week, by time) near the current vehicle location or destination.	Set [Use Time Restricted Roads] to off.
The part of the route that you have already passed is deleted.	A route is managed by sections between waypoints. If you passed the first waypoint, the section between the starting point and the waypoint is deleted. (It may not be deleted depending on the area.)	This is not a malfunction.
An indirect route is suggested.	If there are restrictions (such as one-way streets) on roads close to the starting point or destination, the system may suggest an indirect route.	Adjust the location of the starting of the starting point or destination.
	The system may suggest an indirect route because route calculation does not take into consideration some areas such as narrow streets (gray roads.)	Reset the destination to a main or ordinary road, and recalculate the route.

## NORMAL OPERATING CONDITION

< SYMPTOM DIAGNOSIS >

[BOSE AUDIO WITH NAVIGATION]

Symptom	Possible cause	Possible solution
The landmark information does not correspond to the actual information.	This may be caused by insufficient or incorrect map data.	Updated information will be included in the next version of the data.
The suggested route does not exactly connect to the starting point, waypoints, or destination.	There is no data for route calculation closes to these locations.	Set the starting point, waypoints and destination on a main road, and perform route calculation.

### RELATED TO VOICE GUIDANCE

Symptom	Possible cause	Possible solution
Voice guidance is not available	Voice guidance is only available at certain intersections marked with In some case, voice guidance is not available even when the vehicle should make a turn.	This is not a malfunction.
	The vehicle has deviated from the suggested route.	Go back to the suggested route or request route calculation again
	Voice guide is set to off.	Turn on voice guidance.
	Route guidance is set to off.	Turn on voice guidance.
The guidance contact does not correspond to the actual condition.	The contact of voice guidance may vary, depending on the types of intersections at which turn are made.	Follow all traffic rules and regulations.

# AV CONTROL UNIT

< REMOVAL AND INSTALLATION >

[BOSE AUDIO WITH NAVIGATION]

## REMOVAL AND INSTALLATION

### AV CONTROL UNIT

#### Exploded View

INFOID:000000006472776

#### CAUTION:

Before replacing AV control unit, perform "READ CONFIGURATION" to save or print current vehicle specification. For details, refer to [AV-343, "Description"](#).

#### REMOVAL

Refer to [IP-12, "A/T MODELS : Exploded View"](#) (A/T models) or [IP-23, "M/T MODELS : Exploded View"](#) (M/T models).

#### DISASSEMBLY

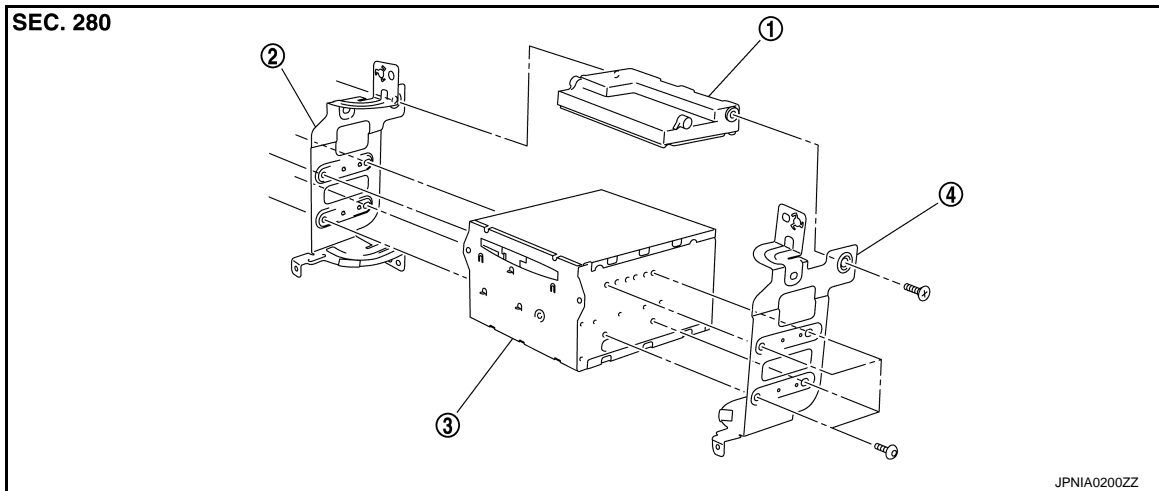

1. Unified meter and A/C amp.
2. Bracket LH
3. AV control unit
4. Bracket RH

#### Removal and Installation

INFOID:000000006472777

#### REMOVAL

#### CAUTION:

- Before replacing AV control unit, perform "READ CONFIGURATION" to save or print current vehicle specification. For details, refer to [AV-343, "Description"](#).
- Remove battery terminal and AV control unit after a lapse of 30 seconds or more after turning the ignition switch OFF

#### NOTE:

After the ignition switch is turned OFF, the AV control unit continues operating for approximately 30 seconds. Therefore, data corruption may occur if battery voltage is cut off within 30 seconds.

1. Remove display unit. Refer to [AV-415, "Exploded View"](#).
2. Remove AV control unit with a unified meter and A/C amp. as a single unit from the body.
3. Remove bracket screws, and then remove AV control unit.

#### INSTALLATION

Install in the reverse order of removal.

#### CAUTION:

- Since AV control unit connector and unified meter and A/C amp. connector have the same form, be careful not to insert them wrongly.
- Be sure to perform "WRITE CONFIGURATION" when replacing AV control unit. For details, refer to [AV-344, "Work Procedure"](#)

# AV CONTROL UNIT

< REMOVAL AND INSTALLATION >

[BOSE AUDIO WITH NAVIGATION]

- Install AV control unit between connector (1) and connector (2) with the ferrite core (USB) orientated sideways to the vehicle. Incorrect installation may cause damage to the AV control unit.

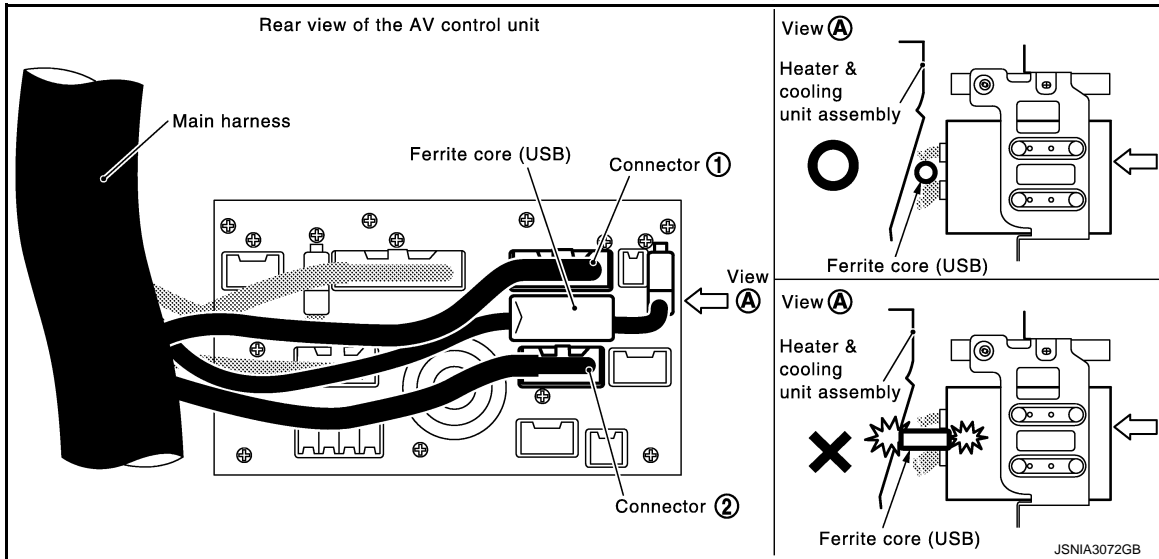

# DISPLAY UNIT

< REMOVAL AND INSTALLATION >

[BOSE AUDIO WITH NAVIGATION]

## DISPLAY UNIT

### Exploded View

INFOID:000000006472778

Refer to [IP-12. "A/T MODELS : Exploded View"](#) (A/T models) or [IP-23. "M/T MODELS : Exploded View"](#) (M/T models).

### Removal and Installation

INFOID:000000006472779

#### REMOVAL

1. Remove cluster lid D. Refer to [IP-12. "A/T MODELS : Exploded View"](#) (A/T models) or [IP-23. "M/T MODELS : Exploded View"](#) (M/T models).
2. Remove display unit with bracket as a single unit.

#### INSTALLATION

Install in the reverse order of removal.

A  
B  
C  
D  
E  
F  
G  
H  
I  
J  
K  
L  
M  
O  
P

AV

# DOOR SQUAWKER

< REMOVAL AND INSTALLATION >

[BOSE AUDIO WITH NAVIGATION]

## DOOR SQUAWKER

### Exploded View

INFOID:000000006472780

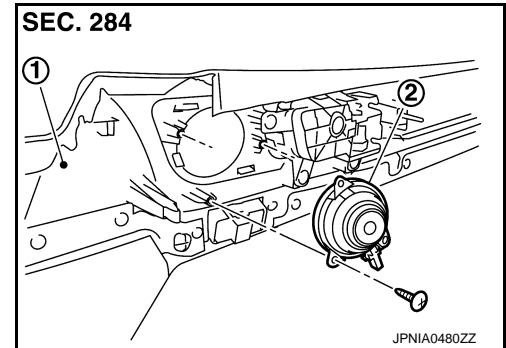

1. Door finisher assembly
2. Door squawker

### Removal and Installation

INFOID:000000006472781

#### REMOVAL

1. Remove door finisher assembly. Refer to [INT-12, "Exploded View"](#).
2. Remove door squawker from door finisher assembly.

#### INSTALLATION

Install in the reverse order of removal.



# DOOR WOOFER

< REMOVAL AND INSTALLATION >

[BOSE AUDIO WITH NAVIGATION]

## DOOR WOOFER

### Exploded View

INFOID:000000006472782

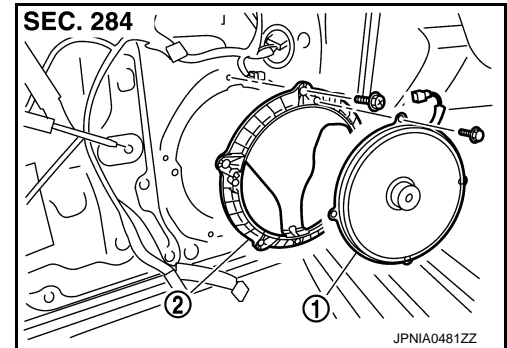

1. Door woofer
2. Woofer bracket

### Removal and Installation

INFOID:000000006472783

#### REMOVAL

1. Remove door finisher assembly. Refer to [INT-12. "Exploded View"](#).
2. Remove door woofer mounting bolts, disconnect the door woofer connector.
3. Remove door woofer.

#### INSTALLATION

Install in the reverse order of removal.

A  
B  
C  
D  
E  
F  
G  
H  
I  
J  
K  
L  
M  
N  
O  
P

AV

## TWEETER

### Exploded View

INFOID:000000006472784

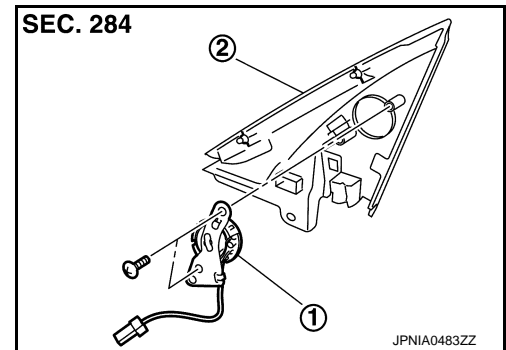

1. Tweeter
2. Corner cover

### Removal and Installation

INFOID:000000006472785

#### REMOVAL

1. Remove corner cover. Refer to [MIR-20. "DOOR MIRROR ASSEMBLY : Exploded View"](#).
2. Remove tweeter from corner cover.

#### INSTALLATION

Install in the reverse order of removal.

# CENTER SPEAKER

< REMOVAL AND INSTALLATION >

[BOSE AUDIO WITH NAVIGATION]

## CENTER SPEAKER

### Exploded View

INFOID:000000006472786

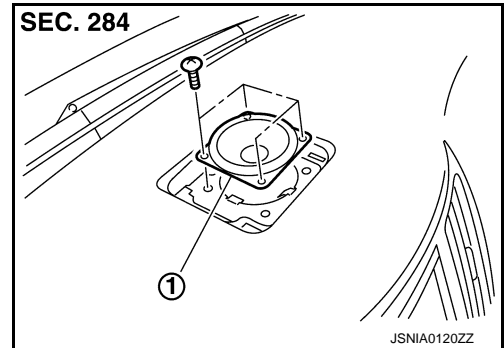

1. Center speaker

### Removal and Installation

INFOID:000000006472787

#### REMOVAL

1. Remove upper grille. Refer to [JP-12. "A/T MODELS : Exploded View"](#) (A/T models) or [JP-23. "M/T MODELS : Exploded View"](#) (M/T models).
2. Remove center speaker mounting screws, disconnect the center speaker connector.
3. Remove center speaker.

#### INSTALLATION

Install in the reverse order of removal.

A  
B  
C  
D  
E  
F  
G  
H  
I  
J  
K  
L  
M  
O  
P

AV

## REAR WOOFER

< REMOVAL AND INSTALLATION >

[BOSE AUDIO WITH NAVIGATION]

### REAR WOOFER

#### Exploded View

INFOID:000000006472788

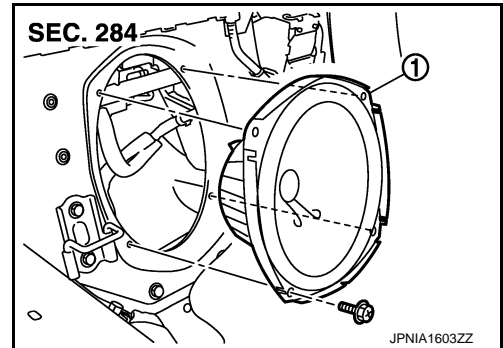

1. Rear woofer

#### Removal and Installation

INFOID:000000006472789

##### REMOVAL

1. Remove rear seatback. Refer to [SE-256. "Exploded View"](#).
2. Remove rear woofer mounting bolts, disconnect the rear woofer connector.
3. Remove rear woofer from the vehicle.

##### INSTALLATION

Install in the reverse order of removal.

# HEADREST SPEAKER

< REMOVAL AND INSTALLATION >

[BOSE AUDIO WITH NAVIGATION]

## HEADREST SPEAKER

### Exploded View

INFOID:000000006472790

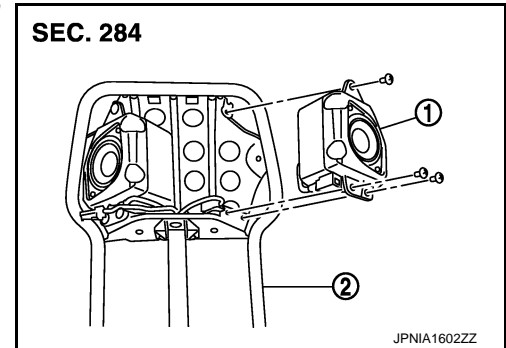

1. Headrest speaker
2. Headrest frame

### Removal and Installation

INFOID:000000006472791

#### REMOVAL

1. Remove headrest frame. Refer to [SE-233, "Exploded View"](#).
2. Remove headrest speaker screws, then disconnect headrest speaker connector and remove headrest speaker.

#### INSTALLATION

Install in the reverse order of removal.

A  
B  
C  
D  
E  
F  
G  
H  
I  
J  
K  
L  
M  
N  
O  
P

AV

# BOSE AMP.

< REMOVAL AND INSTALLATION >

[BOSE AUDIO WITH NAVIGATION]

## BOSE AMP.

### Exploded View

INFOID:000000006472792

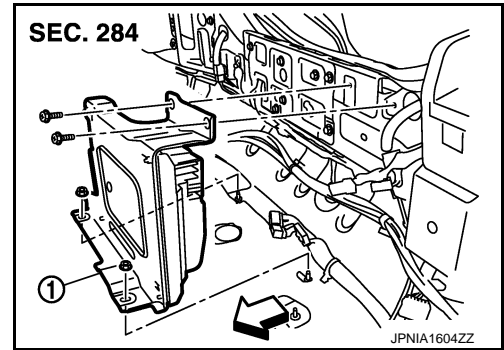

1. BOSE amp.

← Vehicle front

### Removal and Installation

INFOID:000000006472793

#### REMOVAL

1. Remove net guard bracket assembly. Refer to [INT-23, "Exploded View"](#).
2. Remove BOSE amp. mounting bolts, disconnect the BOSE amp. connector.
3. Remove BOSE amp. from trunk room.

#### INSTALLATION

Install in the reverse order of removal.

# AUDIOPILOT™ MICROPHONE

< REMOVAL AND INSTALLATION >

[BOSE AUDIO WITH NAVIGATION]

## AUDIOPILOT™ MICROPHONE

### Exploded View

INFOID:000000006472794

#### REMOVAL

Refer to [SE-233, "Exploded View"](#).

#### DISASSEMBLY

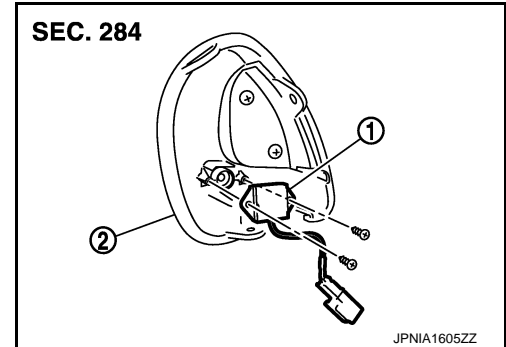

1. AudioPilot™ microphone
2. Headrest inner grille

### Removal and Installation

INFOID:000000006472795

#### REMOVAL

1. Remove headrest inner grille. Refer to [SE-233, "Exploded View"](#).
2. Remove AudioPilot™ microphone from headrest inner grille.

#### INSTALLATION

Install in the reverse order of removal.

A  
B  
C  
D  
E  
F  
G  
H  
I  
J  
K  
L  
M  
O  
P

AV

# ANTENNA BASE

< REMOVAL AND INSTALLATION >

[BOSE AUDIO WITH NAVIGATION]

## ANTENNA BASE

### Exploded View

INFOID:000000006472796

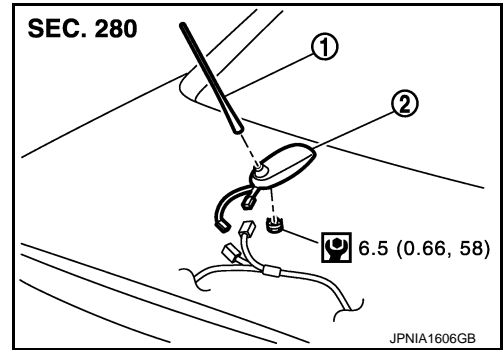

1. Antenna rod
2. Antenna base

Refer to [GI-4, "Components"](#) for symbols in the figure.

### Removal and Installation

INFOID:000000006472797

#### REMOVAL

1. Remove trunk lid finisher inner. Refer to [INT-26, "Exploded View"](#).
2. Remove antenna base mounting nut, disconnect the antenna base connector.
3. Remove antenna base.

#### INSTALLATION

Install in the reverse order of removal.

#### **CAUTION:**

**If the antenna base mounting nut is tightened looser than the specified torque, then this will lower the sensitivity of the antenna. On the other hand, if the nut is tightened tighter than the specified torque, then this will deform the trunk lid panel.**



# MULTIFUNCTION SWITCH

< REMOVAL AND INSTALLATION >

[BOSE AUDIO WITH NAVIGATION]

## MULTIFUNCTION SWITCH

### Exploded View

INFOID:000000006472798

#### REMOVAL

Refer to [IP-12. "A/T MODELS : Exploded View"](#) (A/T models) or [IP-23. "M/T MODELS : Exploded View"](#) (M/T models).

#### DISASSEMBLY

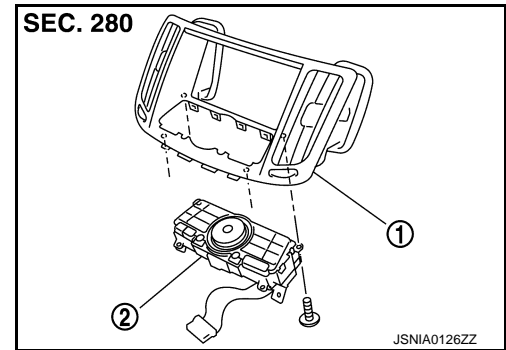

1. Center ventilator grille
2. Multifunction switch

### Removal and Installation

INFOID:000000006472799

#### REMOVAL

1. Remove cluster lid D. Refer to [IP-12. "A/T MODELS : Exploded View"](#) (A/T models) or [IP-23. "M/T MODELS : Exploded View"](#) (M/T models).
2. Remove multifunction switch with center ventilator grille as a single unit.
3. Remove multifunction switch from center ventilator.

#### INSTALLATION

Install in the reverse order of removal.

A  
B  
C  
D  
E  
F  
G  
H  
I  
J  
K  
L  
M  
O  
P

AV

# PRESET SWITCH

< REMOVAL AND INSTALLATION >

[BOSE AUDIO WITH NAVIGATION]

## PRESET SWITCH

### Exploded View

INFOID:000000006472800

#### REMOVAL

Refer to [IP-12. "A/T MODELS : Exploded View"](#) (A/T models) or [IP-23. "M/T MODELS : Exploded View"](#) (M/T models).

#### DISASSEMBLY

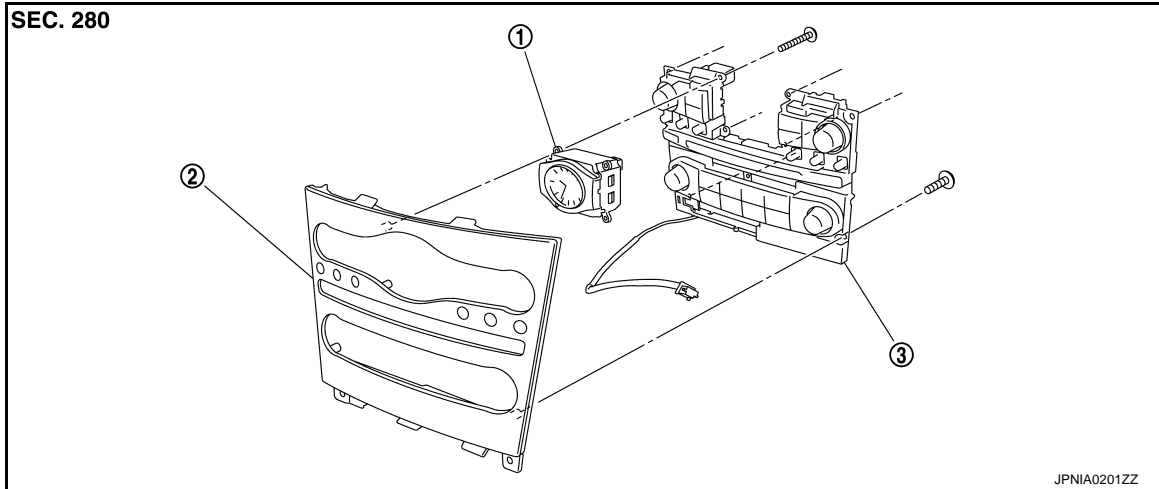

1. Clock

2. Cluster lid C

3. Preset switch

### Removal and Installation

INFOID:000000006472801

#### REMOVAL

1. Remove cluster lid C. Refer to [IP-12. "A/T MODELS : Exploded View"](#) (A/T models) or [IP-23. "M/T MODELS : Exploded View"](#) (M/T models).
2. Remove preset switch (2) from cluster lid C. Remove preset switch screws (A), (B) and (C), remove preset switch (2) from cluster lid C.

1. Clock

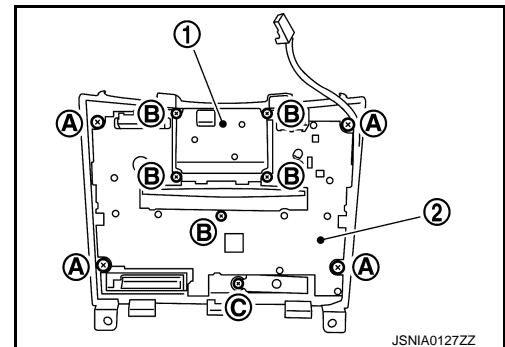

#### INSTALLATION

Install in the reverse order of removal.

#### NOTE:

When installing preset switch, do not allow the print wire that connects preset switch and multifunction switch to get caught in between AV control unit and preset switch.

# STEERING SWITCH

< REMOVAL AND INSTALLATION >

[BOSE AUDIO WITH NAVIGATION]

## STEERING SWITCH

### Exploded View

INFOID:000000006472802

Refer to [ST-14. "Exploded View"](#).

### Removal and Installation

INFOID:000000006472803

#### REMOVAL

Refer to [ST-14. "Removal and Installation"](#).

#### INSTALLATION

Install in the reverse order of removal.

A

B

C

D

E

F

G

H

I

J

K

L

M

AV

O

P

# USB CONNECTOR

< REMOVAL AND INSTALLATION >

[BOSE AUDIO WITH NAVIGATION]

## USB CONNECTOR

### Exploded View

INFOID:000000006472804

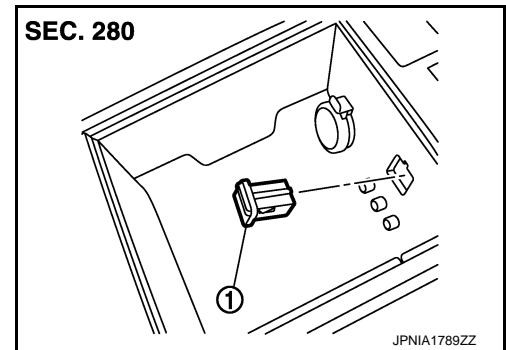

1. USB connector

### Removal and Installation

INFOID:000000006472805

#### REMOVAL

1. Remove center console. Refer to [IP-34. "A/T MODELS : Exploded View"](#) (A/T models) or [IP-39. "M/T MODELS : Exploded View"](#) (M/T models).
2. Push the pawl from the back of center console to remove USB connector.

#### INSTALLATION

Install in the reverse order of removal.

# MICROPHONE

< REMOVAL AND INSTALLATION >

[BOSE AUDIO WITH NAVIGATION]

## MICROPHONE

### Exploded View

INFOID:000000006472806

#### REMOVAL

Refer to [INL-107, "Exploded View"](#).

#### DISASSEMBLY

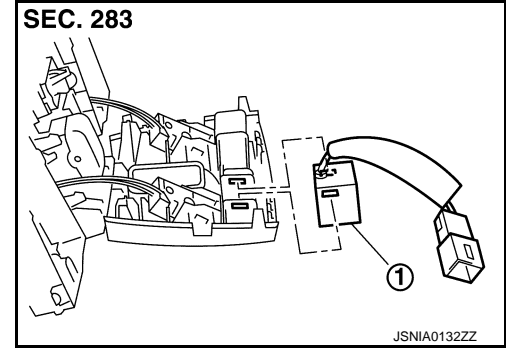

1. Microphone

### Removal and Installation

INFOID:000000006472807

#### REMOVAL

1. Remove map lamp. Refer to [INL-107, "Exploded View"](#).
2. Remove microphone from map lamp.

#### INSTALLATION

Install in the reverse order of removal.

A  
B  
C  
D  
E  
F  
G  
H  
I  
J  
K  
L  
M  
O  
P

AV

# GPS ANTENNA

< REMOVAL AND INSTALLATION >

[BOSE AUDIO WITH NAVIGATION]

## GPS ANTENNA

Exploded View

INFOID:000000006472808

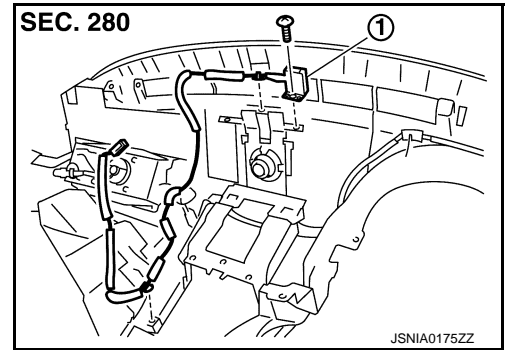

1. GPS antenna



## GPS ANTENNA

### < REMOVAL AND INSTALLATION >

[BOSE AUDIO WITH NAVIGATION]

2. Remove GPS antenna (1) from instrument panel.

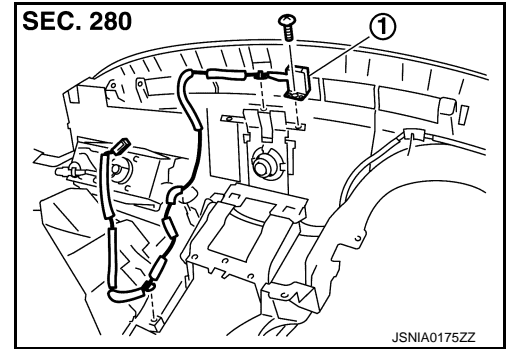

### INSTALLATION

Install in the reverse order of removal.



# REAR VIEW CAMERA

< REMOVAL AND INSTALLATION >

[BOSE AUDIO WITH NAVIGATION]

## REAR VIEW CAMERA

### Exploded View

INFOID:000000006472811

#### REMOVAL

Refer to [EXT-38, "Exploded View"](#).

#### DISASSEMBLY

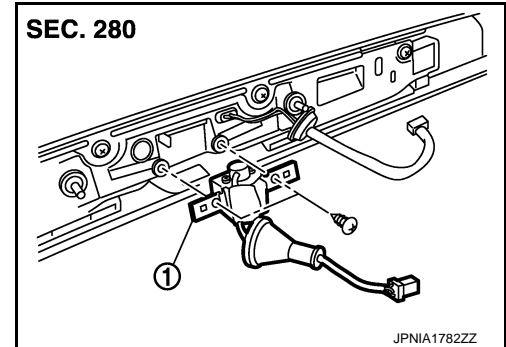

1. Rear view camera

### Removal and Installation

INFOID:000000006472812

#### REMOVAL

1. Remove trunk lid finisher outer. Refer to [EXT-38, "Exploded View"](#).
2. Remove rear view camera from trunk lid finisher outer.

#### INSTALLATION

Install in the reverse order of removal.

#### NOTE:

Adjust the guide line position if the guide line position is shifted after installing the rear view camera. Refer to [AV-433, "Adjustment"](#).

### Adjustment

INFOID:000000006472813

Adjust the guide line position if the guide line position is shifted after installing the rear view camera.

1. Draw lines on rearward area of the vehicle passing through the following points: 200 mm (7.87 in) from both sides of the vehicle, and 0.5 m (1.64 ft), 1.0 m (3.28 ft) from the rear end of the bumper.
2. Set into "Adjust offset of rear view camera" mode of Confirmation / Adjustment mode.

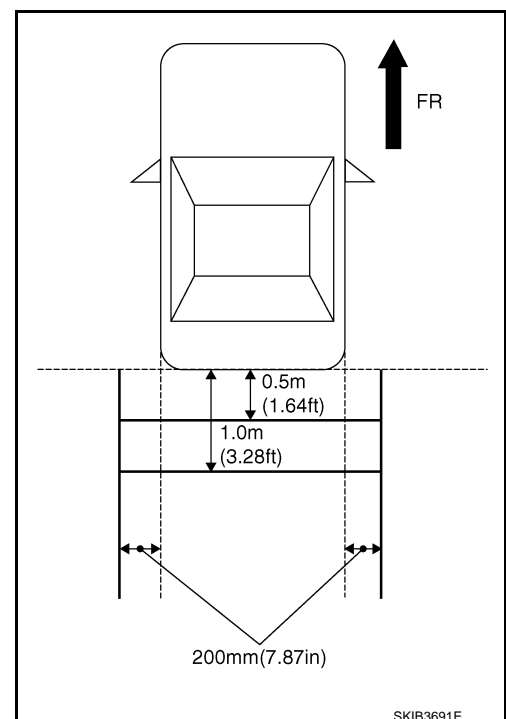

# REAR VIEW CAMERA

## < REMOVAL AND INSTALLATION >

[BOSE AUDIO WITH NAVIGATION]

3. Rotate the center dial, and then select the guiding line pattern so that its angle is aligned with the correction line of the rear of the vehicle.

Selected pattern : (-10° - (10°

4. Make fine adjustment to the correction line of the rear of the vehicle with up/down/left/right switches so that its position is aligned with the guiding line. Press "OK" switch and record the adjusted guiding line position to the camera control unit.

Up/Down adjustment range : (-10° - (10°

Left/Right adjustment range : (-10°) - (10°)

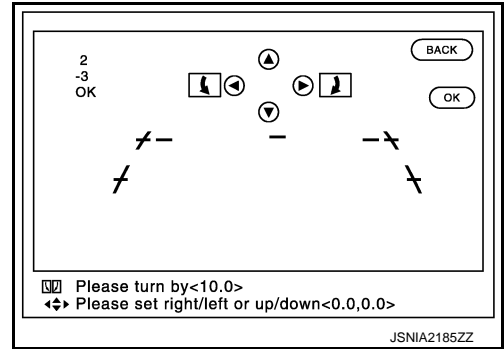

### CAUTION:

Never operate other function such as pressing BACK while writing index data.

# STEERING ANGLE SENSOR

< REMOVAL AND INSTALLATION >

[BOSE AUDIO WITH NAVIGATION]

## STEERING ANGLE SENSOR

### Exploded View

INFOID:000000006472814

### REMOVAL

Refer to [SR-15. "Exploded View"](#).

### DISASSEMBLY

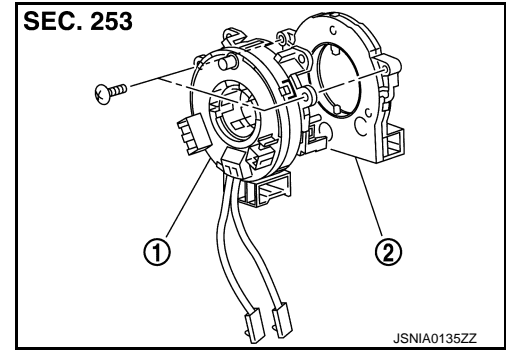

1. Spiral cable
2. Steering angle sensor

### Removal and Installation

INFOID:000000006472815

### REMOVAL

1. Remove spiral cable.
2. Remove steering angle sensor from spiral cable.

### INSTALLATION

Install in the reverse order of removal.

A  
B  
C  
D  
E  
F  
G  
H  
I  
J  
K  
L  
M  
O  
P

AV

# SONAR CONTROL UNIT

< REMOVAL AND INSTALLATION >

[BOSE AUDIO WITH NAVIGATION]

## SONAR CONTROL UNIT

### Exploded View

INFOID:000000006472816

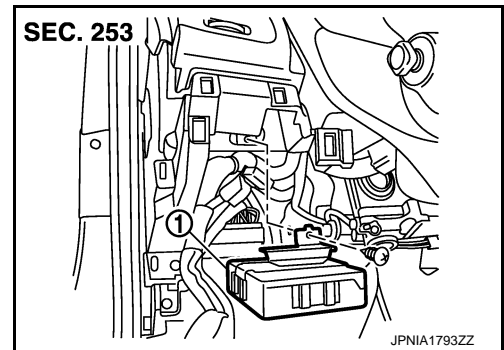

1. Sonar control unit

### Removal and Installation

INFOID:000000006472817

#### REMOVAL

1. Remove the instrument finisher A. Refer to [JP-12, "A/T MODELS : Exploded View"](#) (A/T models) or [JP-23, "M/T MODELS : Exploded View"](#) (M/T models).
2. Remove sonar control unit screw, then disconnect sonar control unit connector and remove the sonar control unit.

#### INSTALLATION

Install in the reverse order of removal.

