

SECTION **INT**
INTERIOR

A
B
C
D
E
F
G
H
I
INT
K
L
M
N
O
P

CONTENTS

SYMPTOM DIAGNOSIS	2	CLIP LIST	11
SQUEAK AND RATTLE TROUBLE DIAG- NOSES	2	Clip List	11
Work Flow	2	REMOVAL AND INSTALLATION	12
Inspection Procedure	4	DOOR FINISHER	12
Diagnostic Worksheet	6	Exploded View	12
PRECAUTION	8	Removal and Installation	12
PRECAUTIONS	8	BODY SIDE TRIM	15
Precaution for Supplemental Restraint System (SRS) "AIR BAG" and "SEAT BELT PRE-TEN- SIONER"	8	Exploded View	15
Service Procedure Precautions for Models with a Pop-up Roll Bar	8	Removal and Installation	15
Precautions Necessary for Steering Wheel Rota- tion After Battery Disconnection	8	FLOOR TRIM	19
Precaution for Battery Service	9	Exploded View	19
Precaution for Procedure without Cowl Top Cover.....	9	Removal and Installation	19
Precaution for Work	9	HEADLINING	21
PREPARATION	10	Exploded View	21
PREPARATION	10	Removal and Installation	21
Special Service Tools	10	TRUNK ROOM TRIM	23
Commercial Service Tools	10	Exploded View	23
		Removal and Installation	24
		TRUNK LID TRIM	26
		Exploded View	26
		Removal and Installation	26

SQUEAK AND RATTLE TROUBLE DIAGNOSES

< SYMPTOM DIAGNOSIS >

SYMPTOM DIAGNOSIS

SQUEAK AND RATTLE TROUBLE DIAGNOSES

Work Flow

INFOID:000000006469958

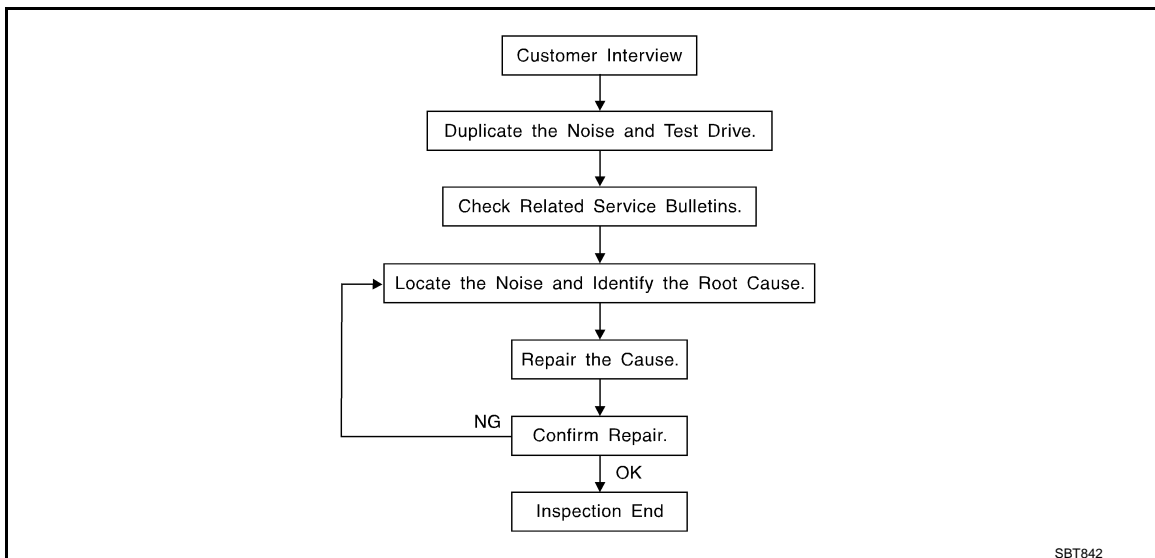

CUSTOMER INTERVIEW

Interview the customer if possible, to determine the conditions that exist when the noise occurs. Use the Diagnostic Worksheet during the interview to document the facts and conditions when the noise occurs and any customer comments. Refer to [INT-6. "Diagnostic Worksheet"](#). This information is necessary to duplicate the conditions that exist when the noise occurs.

- The customer may not be able to provide a detailed description or the location of the noise. Attempt to obtain all the facts and conditions that exist when the noise occurs (or does not occur).
- If there is more than one noise in the vehicle, perform a diagnosis and repair the noise that the customer is concerned about. This can be accomplished by performing a test drive with the customer.
- After identifying the type of noise, isolate the noise in terms of its characteristics. The noise characteristics are provided so that the customer, service adviser, and technician use the same language when describing the noise.
- Squeak – (Like tennis shoes on a clean floor)
Squeak characteristics include the light contact / fast movement / brought on by road conditions / hard surfaces = high-pitched noise / softer surfaces = low-pitched noises / edge to surface = chirping
- Creak – (Like walking on an old wooden floor)
Creak characteristics include firm contact / slow movement/twisting with a rotational movement / pitch dependent on materials / often brought on by activity.
- Rattle – (Like shaking a baby rattle)
Rattle characteristics include fast repeated contact / vibration or similar movement / loose parts/missing clip or fastener / incorrect clearance.
- Knock – (Like a knock on a door)
Knock characteristics include hollow sounds / sometimes repeating / often brought on by driver action.
- Tick – (Like a clock second hand)
Tick characteristics include gentle contacting of light materials / loose components / can be caused by driver action or road conditions.
- Thump – (Heavy, muffled knock noise)
Thump characteristics include softer knock / dull sounds often brought on by activity.
- Buzz – (Like a bumblebee)
Buzz characteristics include high frequency rattle / firm contact.
- Often the degree of acceptable noise level varies depending upon the person. A noise that a technician may judge as acceptable may be very irritating to a customer.
- Weather conditions, especially humidity and temperature, may have a great effect on noise level.

DUPLICATE THE NOISE AND TEST DRIVE

SQUEAK AND RATTLE TROUBLE DIAGNOSES

< SYMPTOM DIAGNOSIS >

If possible, drive the vehicle with the customer until the noise is duplicated. Note any additional information on the Diagnostic Worksheet regarding the conditions or location of the noise. This information can be used to duplicate the same conditions when the repair is reconfirmed.

If the noise can be duplicated easily during the test drive, to help identify the source of the noise, try to duplicate the noise with the vehicle stopped by doing one or all of the following items:

- 1) Close a door.
 - 2) Tap or push/pull around the area where the noise appears to be coming from.
 - 3) Rev the engine.
 - 4) Use a floor jack to recreate vehicle "twist".
 - 5) At idle, apply engine load (electrical load, half-clutch on M/T models, drive position on A/T models).
 - 6) Raise the vehicle on a hoist and hit a tire with a rubber hammer.
- Drive the vehicle and attempt to duplicate the conditions the customer states exist when the noise occurs.
 - If it is difficult to duplicate the noise, drive the vehicle slowly on an undulating or rough road to stress the vehicle body.

CHECK RELATED SERVICE BULLETINS

After verifying the customer concern or symptom, check ASIST for Technical Service Bulletins (TSBs) related to the concern or symptom.

If a TSB relates to the symptom, follow the procedure to repair the noise.

LOCATE THE NOISE AND IDENTIFY THE ROOT CAUSE

1. Narrow down the noise to a general area. To help pinpoint the source of the noise, use a listening tool (Chassis ear: J-39570, engine ear, and mechanics stethoscope).
2. Narrow down the noise to a more specific area and identify the cause of the noise by:
 - Removing the component(s) in the area that is / are suspected to be the cause of the noise. Do not use too much force when removing clips and fasteners, otherwise clips and fasteners can be broken or lost during the repair, resulting in the creation of new noise.
 - Tapping or pushing/pulling the component(s) that is / are suspected to be the cause of the noise. Do not tap or push/pull the component(s) with excessive force, otherwise the noise is eliminated only temporarily.
 - Feeling for a vibration by hand by touching the component(s) that is / are suspected to be the cause of the noise.
 - Placing a piece of paper between components that are suspected to be the cause of the noise.
 - Looking for loose components and contact marks.
Refer to [INT-4, "Inspection Procedure"](#).

REPAIR THE CAUSE

- If the cause is a loose component, tighten the component securely.
- If the cause is insufficient clearance between components:
 - Separate components by repositioning or loosening and retightening the components, if possible.
 - Insulate components with a suitable insulator such as urethane pads, foam blocks, felt cloth tape, or urethane tape. A NISSAN Squeak and Rattle Kit (J-43980) is available through the authorized NISSAN Parts Department.

CAUTION:

Never use excessive force as many components are constructed of plastic and may be damaged.

NOTE:

Always check with the Parts Department for the latest parts information.

The following materials are contained in the NISSAN Squeak and Rattle Kit (J-43980). Each item can be ordered separately as needed.

URETHANE PADS [1.5 mm (0.059 in) thick]

Insulates connectors, harness, etc.

- 76268-9E005: 100 × 135 mm (3.937 × 5.315 in)
- 76884-71L01: 60 × 85 mm (2.362 × 3.346 in)
- 76884-71L02: 15 × 25 mm (0.591 × 0.984 in)

INSULATOR (Foam blocks)

Insulates components from contact. Can be used to fill space behind a panel.

- 73982-9E000: 45 mm (1.772 in) thick, 50 × 50 mm (1.969 × 1.969 in)
- 73982-50Y00: 10 mm (0.394 in) thick, 50 × 50 mm (1.969 × 1.969 in)

INSULATOR (Light foam block)

80845-71L00: 30 mm (1.18 in) thick, 30 × 50 mm (1.181 × 1.969 in)

FELT CLOTHTAPE

SQUEAK AND RATTLE TROUBLE DIAGNOSES

< SYMPTOM DIAGNOSIS >

Used to insulate where movement does not occur. Ideal for instrument panel applications.

- 68370-4B000: 15 × 25 mm (0.591 × 0.984 in) pad
- 68239-13E00: 5 mm (0.197 in) wide tape roll

The following materials, not found in the kit, can also be used to repair squeaks and rattles.

UHMW (TEFLON) TAPE

Insulates where slight movement is present. Ideal for instrument panel applications.

SILICONE GREASE

Used in place of UHMW tape that is visible or does not fit. Only lasts a few months.

SILICONE SPRAY

Used when grease cannot be applied.

DUCT TAPE

Used to eliminate movement.

CONFIRM THE REPAIR

After repair is complete, test drive the vehicle to confirm that the cause of noise is repaired by test driving the vehicle. Operate the vehicle under the same conditions as when the noise originally occurred. Refer to the notes on the Diagnostic Worksheet.

Inspection Procedure

INFOID:000000006469959

Refer to Table of Contents for specific component removal and installation information.

INSTRUMENT PANEL

Most incidents are caused by contact and movement between:

1. The cluster lid A and instrument panel
2. Acrylic lens and combination meter housing
3. Instrument panel to front pillar garnish
4. Instrument panel to windshield
5. Instrument panel mounting pins
6. Wiring harnesses behind the combination meter
7. A/C defroster duct and duct joint

These incidents can usually be located by tapping or moving the components to duplicate the noise or by pressing on the components while driving to stop the noise. Most of these incidents can be repaired by applying felt cloth tape or silicon spray (in hard to reach areas). Urethane pads can be used to insulate wiring harness.

CAUTION:

Never use silicone spray to isolate a squeak or rattle. If the area is saturated with silicone, the recheck of repair becomes impossible.

CENTER CONSOLE

Components to check include:

1. Shifter assembly cover to finisher
2. A/C control unit and cluster lid C
3. Wiring harnesses behind audio and A/C control unit

The instrument panel repair and isolation procedures also apply to the center console.

DOORS

Check the following items:

1. Finisher and inner panel making a slapping noise
2. Inside handle escutcheon connection to door finisher
3. Wiring harnesses tapping
4. Door striker out of alignment causing a popping noise on starts and stops

Tapping, moving the components, or pressing on them while driving to duplicate the conditions can isolate many of these incidents. The areas can usually be insulated with felt cloth tape or insulator foam blocks from the NISSAN Squeak and Rattle Kit (J-43980) to repair the noise.

TRUNK

Trunk noises are often caused by a loose jack or loose items put into the trunk by the customer.

In addition check for the following items:

SQUEAK AND RATTLE TROUBLE DIAGNOSES

< SYMPTOM DIAGNOSIS >

1. Trunk lid dumpers out of adjustment
2. Trunk lid striker out of adjustment
3. Trunk lid torsion bars knocking together
4. A loose license plate or bracket

Most of these incidents can be repaired by adjusting, securing, or insulating the item(s) or component(s) causing the noise.

SUNROOF/HEADLINING

Noises in the sunroof / headlining area can often be traced to one of the following items:

1. Sunroof lid, rail, linkage, or seals making a rattle or light knocking noise
2. Sunvisor shaft shaking in the holder
3. Front or rear windshield touching headlining and squeaking

Again, pressing on the components to stop the noise while duplicating the conditions can isolate most of these incidents. Repairs usually consist of insulating with felt cloth tape.

SEATS

When isolating seat noise it is important to note the position the seat is in and the load placed on the seat when the noise occurs. These conditions should be duplicated when verifying and isolating the cause of the noise.

Causes of seat noise include:

1. Headrest rods and holder
2. A squeak between the seat pad cushion and frame
3. The rear seatback lock and bracket

These noises can be isolated by moving or pressing on the suspected components while duplicating the conditions under which the noise occurs. Most of these incidents can be repaired by repositioning the component or applying urethane tape to the contact area.

UNDERHOOD

Some interior noise may be caused by components under the hood or on the engine wall. The noise is then transmitted into the passenger compartment.

Causes of transmitted underhood noise include:

1. Any component mounted to the engine wall
2. Components that pass through the engine wall
3. Engine wall mounts and connectors
4. Loose radiator mounting pins
5. Hood bumpers out of adjustment
6. Hood striker out of adjustment

These noises can be difficult to isolate since they cannot be reached from the interior of the vehicle. The best method is to secure, move, or insulate one component at a time and test drive the vehicle. Also, engine RPM or load can be changed to isolate the noise. Repairs can usually be made by moving, adjusting, securing, or insulating the component causing the noise.

A

B

C

D

E

F

G

H

I

INT

K

L

M

N

O

P

SQUEAK AND RATTLE TROUBLE DIAGNOSES

< SYMPTOM DIAGNOSIS >

Diagnostic Worksheet

INFOID:000000006469960



SQUEAK & RATTLE DIAGNOSTIC WORKSHEET

Dear Infiniti Customer:

We are concerned about your satisfaction with your Infiniti vehicle. Repairing a squeak or rattle sometimes can be very difficult. To help us fix your Infiniti right the first time, please take a moment to note the area of the vehicle where the squeak or rattle occurs and under what conditions. You may be asked to take a test drive with a service consultant or technician to ensure we confirm the noise you are hearing.

I. WHERE DOES THE NOISE COME FROM? (circle the area of the vehicle)

The illustrations are for reference only, and may not reflect the actual configuration of your vehicle.

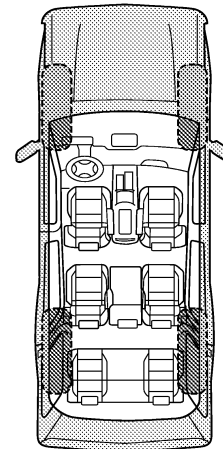
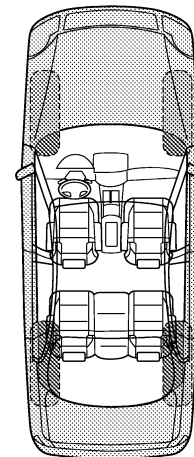

Continue to page 2 of the worksheet and briefly describe the location of the noise or rattle. In addition, please indicate the conditions which are present when the noise occurs.

PIIB8741E

SQUEAK AND RATTLE TROUBLE DIAGNOSES

< SYMPTOM DIAGNOSIS >

SQUEAK & RATTLE DIAGNOSTIC WORKSHEET - page 2

Briefly describe the location where the noise occurs:

II. WHEN DOES IT OCCUR? (please check the boxes that apply)

- | | |
|---|--|
| <input type="checkbox"/> anytime | <input type="checkbox"/> after sitting out in the rain |
| <input type="checkbox"/> 1st time in the morning | <input type="checkbox"/> when it is raining or wet |
| <input type="checkbox"/> only when it is cold outside | <input type="checkbox"/> dry or dusty conditions |
| <input type="checkbox"/> only when it is hot outside | <input type="checkbox"/> other: |

III. WHEN DRIVING:

- through driveways
- over rough roads
- over speed bumps
- only about ____ mph
- on acceleration
- coming to a stop
- on turns: left, right or either (circle)
- with passengers or cargo
- other: _____
- after driving ____ miles or ____ minutes

IV. WHAT TYPE OF NOISE

- squeak (like tennis shoes on a clean floor)
- creak (like walking on an old wooden floor)
- rattle (like shaking a baby rattle)
- knock (like a knock at the door)
- tick (like a clock second hand)
- thump (heavy, muffled knock noise)
- buzz (like a bumble bee)

TO BE COMPLETED BY DEALERSHIP PERSONNEL

Test Drive Notes:

	YES	NO	Initials of person performing
Vehicle test driven with customer	<input type="checkbox"/>	<input type="checkbox"/>	_____
- Noise verified on test drive	<input type="checkbox"/>	<input type="checkbox"/>	_____
- Noise source located and repaired	<input type="checkbox"/>	<input type="checkbox"/>	_____
- Follow up test drive performed to confirm repair	<input type="checkbox"/>	<input type="checkbox"/>	_____

VIN: _____ Customer Name: _____
W.O.# _____ Date: _____

This form must be attached to Work Order

PIIB8742E

A
B
C
D
E
F
G
H
I
INT
K
L
M
N
O
P

PRECAUTIONS

< PRECAUTION >

PRECAUTION

PRECAUTIONS

Precaution for Supplemental Restraint System (SRS) "AIR BAG" and "SEAT BELT PRE-TENSIONER"

INFOID:000000006469961

The Supplemental Restraint System such as "AIR BAG" and "SEAT BELT PRE-TENSIONER", used along with a front seat belt, helps to reduce the risk or severity of injury to the driver and front passenger for certain types of collision. This system includes seat belt switch inputs and dual stage front air bag modules. The SRS system uses the seat belt switches to determine the front air bag deployment, and may only deploy one front air bag, depending on the severity of a collision and whether the front occupants are belted or unbelted. Information necessary to service the system safely is included in the "SRS AIR BAG" and "SEAT BELT" of this Service Manual.

WARNING:

Always observe the following items for preventing accidental activation.

- To avoid rendering the SRS inoperative, which could increase the risk of personal injury or death in the event of a collision that would result in air bag inflation, all maintenance must be performed by an authorized NISSAN/INFINITI dealer.
- Improper maintenance, including incorrect removal and installation of the SRS, can lead to personal injury caused by unintentional activation of the system. For removal of Spiral Cable and Air Bag Module, see "SRS AIR BAG".
- Never use electrical test equipment on any circuit related to the SRS unless instructed to in this Service Manual. SRS wiring harnesses can be identified by yellow and/or orange harnesses or harness connectors.

PRECAUTIONS WHEN USING POWER TOOLS (AIR OR ELECTRIC) AND HAMMERS

WARNING:

Always observe the following items for preventing accidental activation.

- When working near the Air Bag Diagnosis Sensor Unit or other Air Bag System sensors with the ignition ON or engine running, never use air or electric power tools or strike near the sensor(s) with a hammer. Heavy vibration could activate the sensor(s) and deploy the air bag(s), possibly causing serious injury.
- When using air or electric power tools or hammers, always switch the ignition OFF, disconnect the battery, and wait at least 3 minutes before performing any service.

Service Procedure Precautions for Models with a Pop-up Roll Bar

INFOID:000000006469962

WARNING:

Always observe the following items for preventing accidental activation.

- Risk of passenger injury or death may increase if the pop-up roll bar does not deploy during a roll over collision. In order to reduce the chance of an incident where the pop-up roll bar is inoperative, all maintenance must be performed by a NISSAN or INFINITI dealer.
- Before removing and installing the pop-up roll bar component parts and harness, always turn the ignition switch OFF, disconnect the battery negative terminal, and wait for 3 minutes or more. (The purpose of this operation is to discharge electricity that is accumulated in the auxiliary power supply circuit in the air bag diagnosis sensor unit.)
- When repairing, removing, and installing a pop-up roll bar, always refer to SRS AIR BAG and SRS AIR BAG CONTROL warnings in the Service Manual.

Precautions Necessary for Steering Wheel Rotation After Battery Disconnection

INFOID:000000006469963

CAUTION:

Comply with the following cautions to prevent any error and malfunction.

- Before removing and installing any control units, first turn the ignition switch to the LOCK position, then disconnect both battery cables.
- After finishing work, confirm that all control unit connectors are connected properly, then re-connect both battery cables.
- Always use CONSULT to perform self-diagnosis as a part of each function inspection after finishing work. If a DTC is detected, perform trouble diagnosis according to self-diagnosis results.

PRECAUTIONS

< PRECAUTION >

For vehicle with steering lock unit, if the battery is disconnected or discharged, the steering wheel will lock and cannot be turned.

If turning the steering wheel is required with the battery disconnected or discharged, follow the operation procedure below before starting the repair operation.

OPERATION PROCEDURE

1. Connect both battery cables.

NOTE:

Supply power using jumper cables if battery is discharged.

2. Turn the ignition switch to ACC position.
(At this time, the steering lock will be released.)
3. Disconnect both battery cables. The steering lock will remain released with both battery cables disconnected and the steering wheel can be turned.
4. Perform the necessary repair operation.
5. When the repair work is completed, re-connect both battery cables. With the brake pedal released, turn the ignition switch from ACC position to ON position, then to LOCK position. (The steering wheel will lock when the ignition switch is turned to LOCK position.)
6. Perform self-diagnosis check of all control units using CONSULT.

Precaution for Battery Service

INFOID:000000006469964

Before disconnecting the battery, lower both the driver and passenger windows. This will prevent any interference between the window edge and the vehicle when the door is opened/closed. During normal operation, the window slightly raises and lowers automatically to prevent any window to vehicle interference. The automatic window function will not work with the battery disconnected.

Precaution for Procedure without Cowl Top Cover

INFOID:000000006469965

When performing the procedure after removing cowl top cover, cover the lower end of windshield with urethane, etc to prevent damage to windshield.

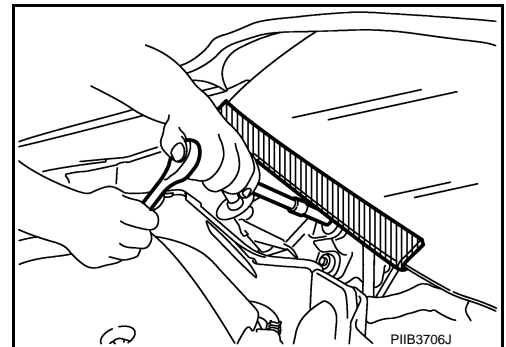

Precaution for Work

INFOID:000000006469966

- After removing and installing the opening/closing parts, be sure to carry out fitting adjustments to check their operation.
- Check the lubrication level, damage, and wear of each part. If necessary, grease or replace it.

A
B
C
D
E
F
G
H
I
INT
K
L
M
N
O
P

PREPARATION

< PREPARATION >

PREPARATION

PREPARATION

Special Service Tools

INFOID:000000006469967

The actual shapes of Kent-Moore tools may differ from those of special service tools illustrated here.

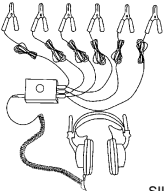
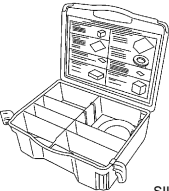
Tool number (Kent-Moore No.) Tool name	Description
<p>(J-39570) Chassis ear</p>  <p style="text-align: right;">SIIA0993E</p>	<p>Locates the noise</p>
<p>(J-43980) NISSAN Squeak and Rattle Kit</p>  <p style="text-align: right;">SIIA0994E</p>	<p>Repairs the cause of noise</p>

Commercial Service Tools

INFOID:000000006469968

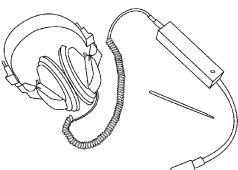
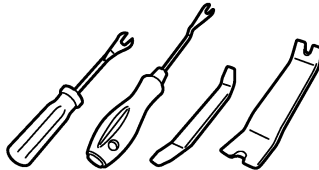
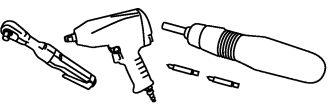
Tool name	Description
<p>Engine ear</p>  <p style="text-align: right;">SIIA0995E</p>	<p>Locates the noise</p>
<p>Remover tool</p>  <p style="text-align: right;">JMKIA3050ZZ</p>	<p>Removes clips, pawls and metal clips</p>
<p>Power tool</p>  <p style="text-align: right;">PIIB1407E</p>	

CLIP LIST

< PREPARATION >

CLIP LIST

Clip List

INFOID:000000006469969

Shapes	Removal & Installation	Shapes	Removal & Installation
	<p>Removal: Remove by bending up with flat-bladed screwdrivers or clip remover.</p>		<p>Removal:</p>
	<p>Removal: Remove with a clip remover.</p>		<p>Removal:</p>
	<p>Removal: Push center pin to catching position. (Do not remove center pin by hitting it.)</p> <p>Installation:</p>		<p>Removal: Holder portion of clip must be spread out to remove rod.</p>
	<p>Removal: Remove by bending up with flat-bladed screwdrivers or clip remover.</p>		<p>Removal:</p> <ol style="list-style-type: none"> Screw out with a Phillips screwdriver. Remove female portion with flat-bladed screwdriver.
	<p>Removal:</p>		<p>Removal:</p> <p>Rotate 45° to remove.</p> <p>Installation:</p>
	<p>Removal:</p>		<p>Removal:</p>

JMJIA3734GB

A
B
C
D
E
F
G
H
I
INT
K
L
M
N
O
P

DOOR FINISHER

< REMOVAL AND INSTALLATION >

REMOVAL AND INSTALLATION

DOOR FINISHER

Exploded View

INFOID:000000006469970

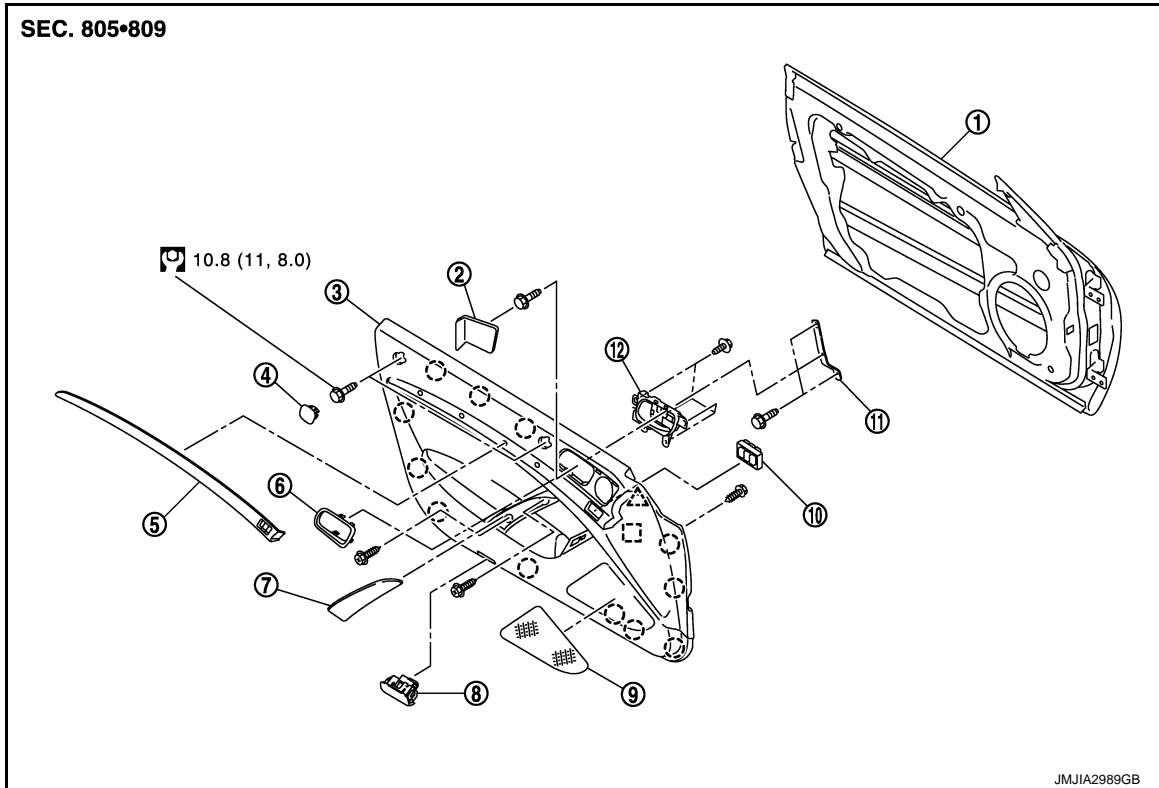

- | | | |
|------------------------|-----------------------------|-----------------------------|
| 1. Door panel assembly | 2. Inside handle escutcheon | 3. Door finisher assembly |
| 4. Bolt cover | 5. Finisher waist assembly | 6. Door finisher escutcheon |
| 7. Door grip cap | 8. Step lamp | 9. Speaker grille |
| 10. Seat memory switch | 11. Inside handle bracket | 12. Inside handle assembly |

○ : Clip

△ : Pawl

□ : Metal clip

Removal and Installation

INFOID:000000006469971

WARNING:

- Before servicing, turn ignition switch OFF, disconnect battery negative terminal and wait 3 minutes or more.
- Never use the air tools or electric tools for servicing.

REMOVAL

1. Fully open door window.

DOOR FINISHER

< REMOVAL AND INSTALLATION >

- Remove inside handle escutcheon with a remover tool, and then remove the bolt located behind inside handle escutcheon.

 : Pawl

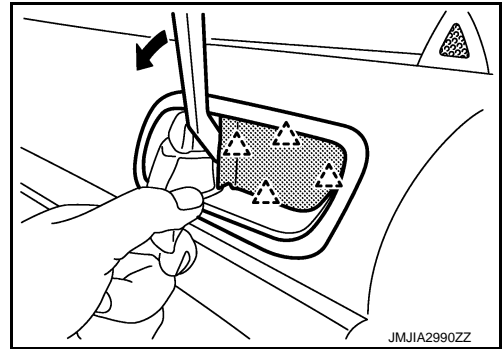

- Remove bolt cover with a remover tool, and then remove door-mounted curtain airbag module fixing bolts.

 : Pawl

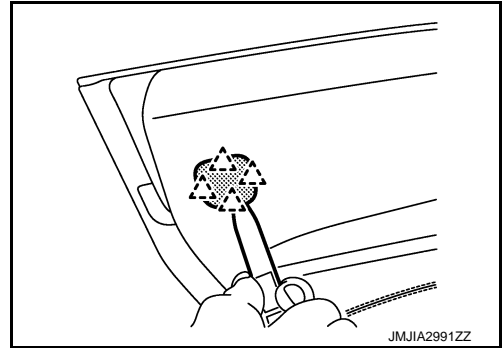

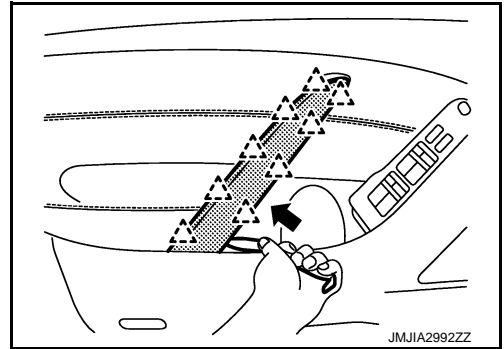

- Remove armrest cap with remover tool, and then remove the mounting bolts located behind the cap.

 : Pawl



- Remove step lamp. Refer to [INL-112. "Removal and Installation"](#).
- Insert a remover tool between the door panel and door finisher to disengage the clips, pawls and metal clips.

 : Clip

 : Pawl

 : Metal clip

CAUTION:

Insert a remover tool into the part shown in the figure. (Between the clips and the body side panel).

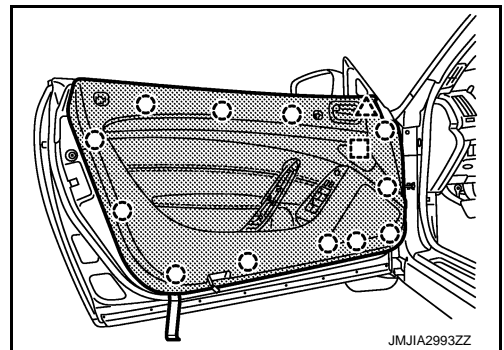

- Pull slightly the door finisher, and disconnect first the door-mounted curtain air bag harness connector before disconnecting others harness connectors.

CAUTION:

A
B
C
D
E
F
G
H
I
INT
K
L
M
N
O
P

DOOR FINISHER

< REMOVAL AND INSTALLATION >

- For installing/removing the door-mounted curtain air bag module harness connector, insert a flat-bladed screwdriver wrapped in tape into notch, lift lock and remove the connector.
- Install the connector with lock raised, and push lock into the connector.
- After installing the connector, check that the lock is pushed securely into it.

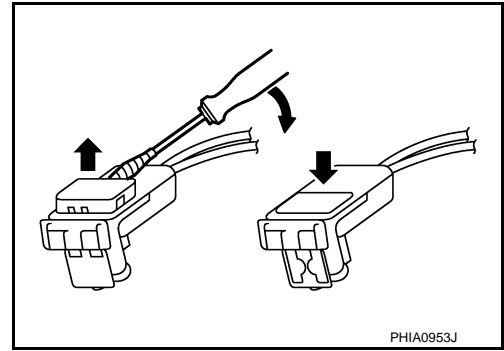

8. Disconnect lock knob cable and inside handle cable from inside handle.
9. Remove door finisher from door panel.
10. Remove the following parts after removing door finisher.
 - Door inside handle assembly. Refer to [DLK-285, "INSIDE HANDLE : Removal and Installation"](#).
 - Seat memory switch. Refer to [ADP-238, "Removal and Installation"](#).
 - Tweeter.
Refer to [AV-115, "Removal and Installation"](#) (with BASE AUDIO).
Refer to [AV-255, "Removal and Installation"](#) (with BOSE AUDIO).
 - Door squawker. Refer to [AV-253, "Removal and Installation"](#) (with BOSE AUDIO).

CAUTION:

- When removing, always use a remover tool that is made of plastic.
- Never impact the door-mounted curtain air bag module.
- Replace the door-mounted curtain air bag module if it has been dropped or sustained an impact.



- Never insert any foreign objects (screwdriver, etc.) into the door-mounted curtain air bag module.
- Never disassemble the door-mounted curtain air bag module.
- Never expose the door-mounted curtain air bag module to temperature exceeding 90 °C (194 °F).
- Never allow oil, grease, detergent, or water to come in contact with the door-mounted curtain air bag module.

INSTALLATION

Install in the reverse order of removal.

CAUTION:

- When removing door-mounted curtain airbag module from door finisher, never reuse door finisher.
- Never damage the harness while installing.
- When installing door finisher, check that clips, pawls and metal clip are securely fitted in panel holes on body, and then press them in.

BODY SIDE TRIM

< REMOVAL AND INSTALLATION >

BODY SIDE TRIM

Exploded View

INFOID:000000006469972

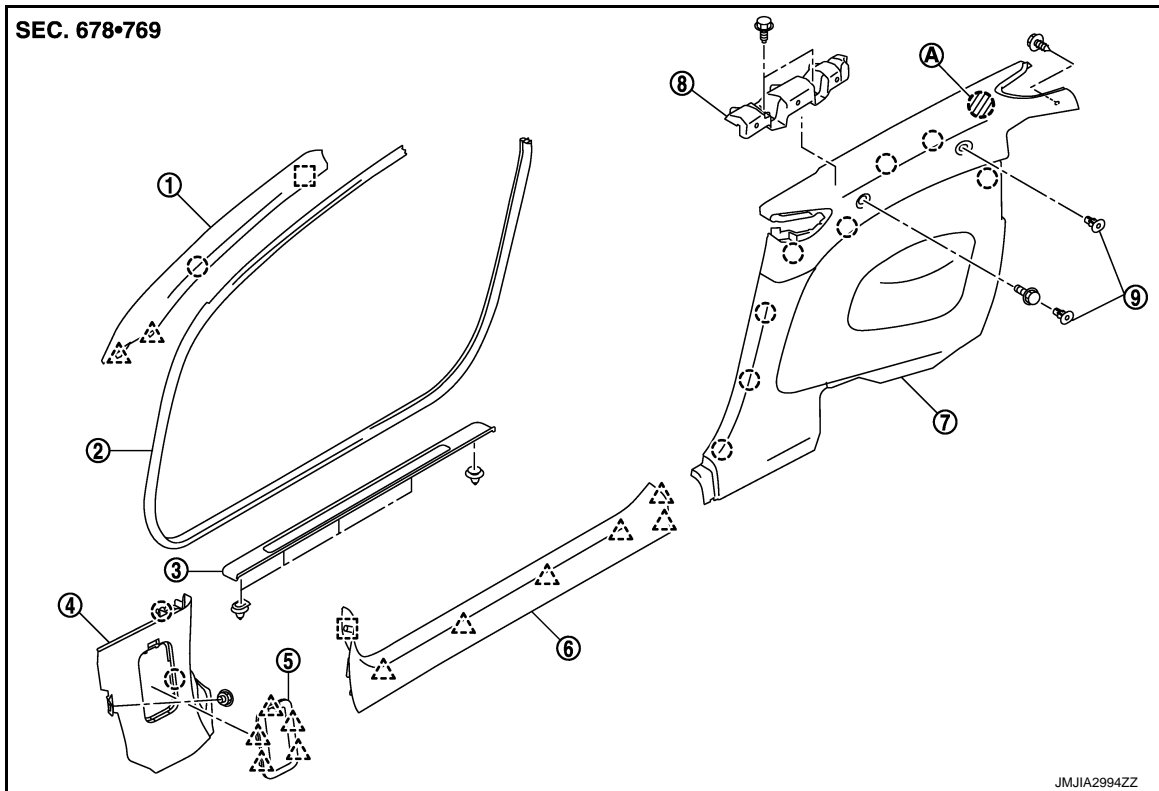

- | | | |
|-------------------------|-------------------------------|------------------------|
| 1. Front pillar garnish | 2. Body side welt | 3. Kicking plate outer |
| 4. Dash side finisher | 5. Dash side finisher lid | 6. Kicking plate inner |
| 7. Rear side finisher | 8. Rear side finisher bracket | 9. Cap |

A: Dual-lock fastener

○ : Clip

△ : Pawl

□ : Metal clip

Removal and Installation

INFOID:000000006469973

CAUTION:

- When removing, always use a remover tool that is made of plastic.
- Never damage the body.

REMOVAL

FRONT PILLAR GARNISH

1. Release front pillar portion of body side welt.

A
B
C
D
E
F
G
H
I
INT
K
L
M
N
O
P

BODY SIDE TRIM

< REMOVAL AND INSTALLATION >

2. Remove front pillar garnish (1) fixing clip and metal clip with a remover tool (A), and then remove front pillar garnish.

- : Clip
- : Metal clip

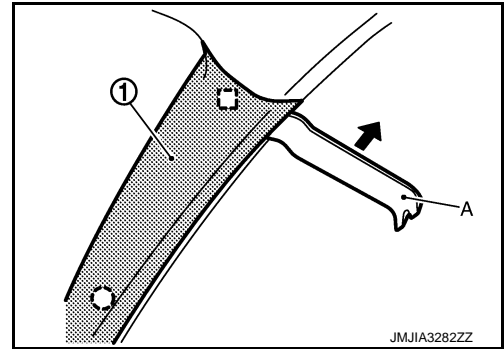

DASH SIDE FINISHER

1. Remove instrument passenger lower cover.
Refer to [IP-13. "A/T MODELS : Removal and Installation"](#) (A/T models).
Refer to [IP-24. "M/T MODELS : Removal and Installation"](#) (M/T models).
2. Remove kicking plate inner.
3. Remove clip (A).
4. Remove dash side finisher fixing clips with a remover tool (B), and then remove dash side finisher (1).

- : Clip

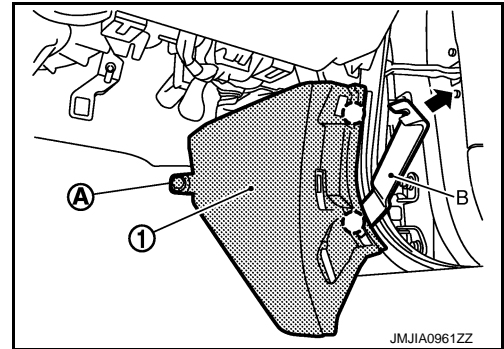

KICKING PLATE OUTER

Remove kicking plate outer fixing clips with a remover tool, and then remove kicking plate outer.

- : Clip

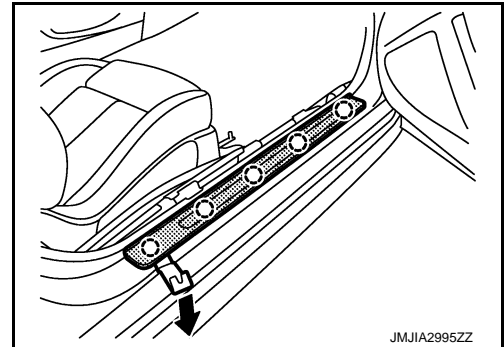

KICKING PLATE INNER

1. Pull up kicking plate inner to disengage pawls.

- △ : Pawl

2. Remove kicking plate inner (1).

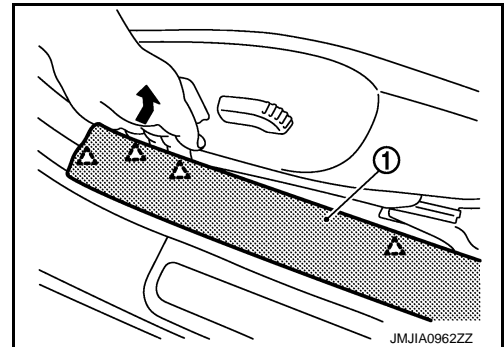

BODY SIDE WELT

1. Remove kicking plate inner.
2. Remove body side welt.

BODY SIDE TRIM

< REMOVAL AND INSTALLATION >

REAR SIDE FINISHER

1. Fully open hard top retractor roof.
2. Fully open trunk lid assembly.
3. Remove the wind deflector assembly. (If installed)

 : Pawl

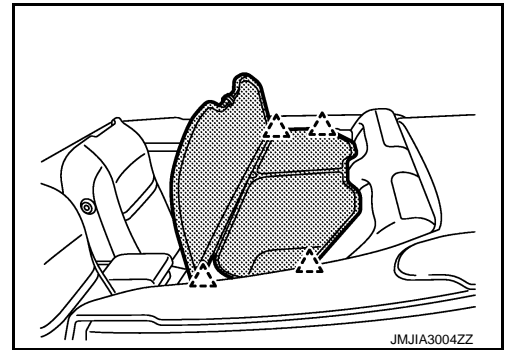

4. Disengage the body side molding fixing clips with a remover tool, and then remove the body side molding.

 : Clip

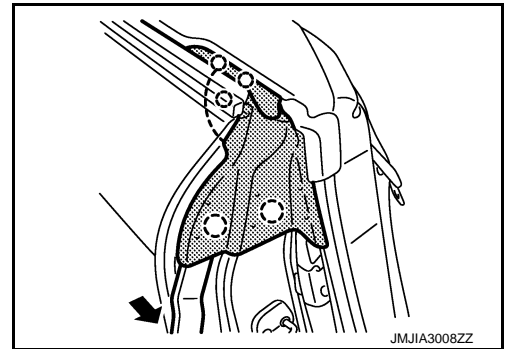

5. Remove kicking plate inner.
6. Remove body side welt.
7. Remove rear seat cushion and rear seatback. Refer to [SE-256. "Removal and Installation"](#).
8. Slide front seat assembly to the front most position.
9. Remove rear side finisher fixing clips(1) with a remover tool (A), and then remove the rear side finisher mounting bolt.

NOTE:

The rear side finisher mounting bolt is located behind the front side clip.

 : Pawls

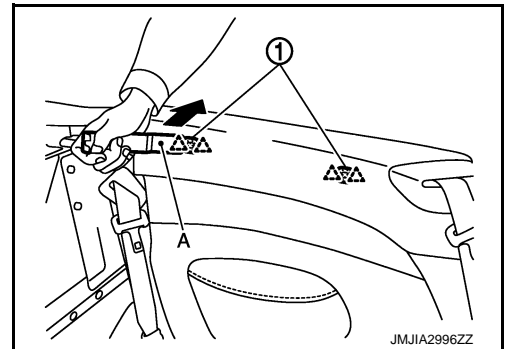

10. Remove the rear side finisher mounting bolt.
11. Remove front seatbelt anchor escutcheon. Refer to [SB-8. "SEAT BELT BUCKLE : Exploded View"](#).
12. Remove rear side finisher.
NOTE:
Pull up rear side finisher to remove the dual-lock fastener.
13. Remove rear side finisher bracket mounting bolts and then remove rear side finisher bracket.

INSTALLATION

Install in the reverse order of removal.

NOTE:

A
B
C
D
E
F
G
H
I
INT
K
L
M
N
O
P

BODY SIDE TRIM

< REMOVAL AND INSTALLATION >

Install the wind deflector assembly (1) in the rear side finisher (2) as shown by the figure below.

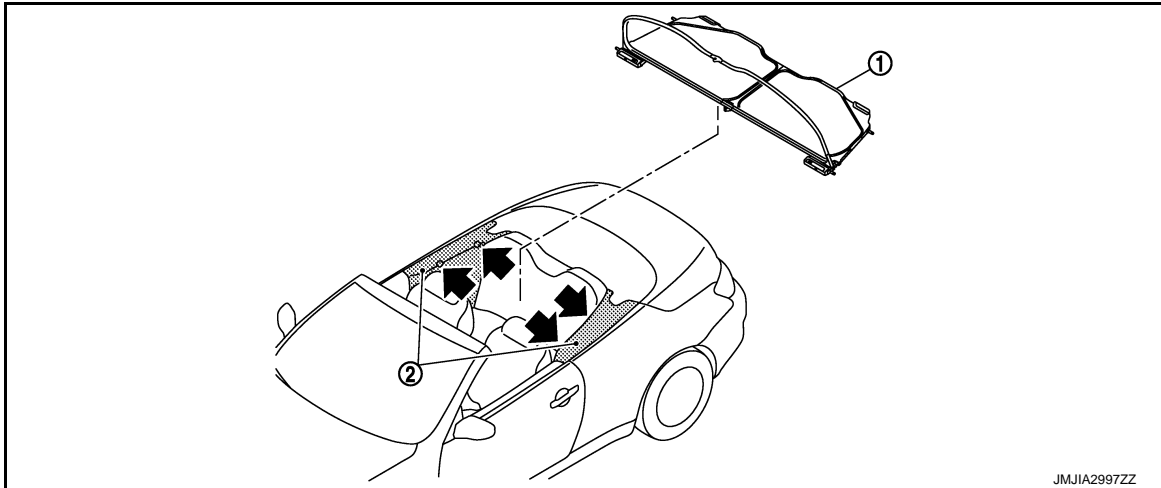

JMJIA2997ZZ

CAUTION:

Check that clips are securely fitted in panel holes on body when installing, and then press them in.

FLOOR TRIM

< REMOVAL AND INSTALLATION >

FLOOR TRIM

Exploded View

INFOID:000000006469974

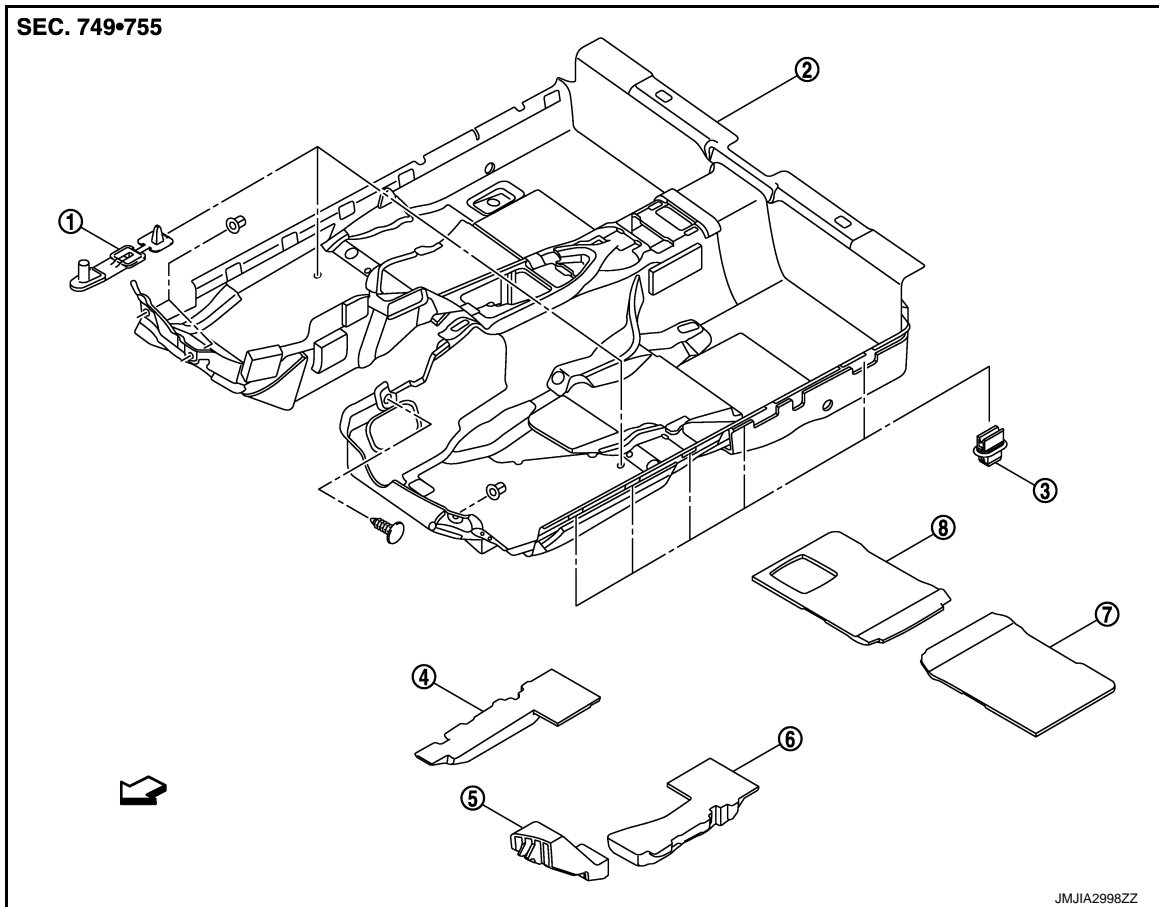

- | | | |
|--------------------------|-----------------------|--------------------------|
| 1. Floor hook | 2. Floor trim | 3. Fixing clip |
| 4. Front floor spacer RH | 5. Footrest | 6. Front floor spacer LH |
| 7. Rear floor felt LH | 8. Rear floor felt RH | |

↔ : Vehicle front

Removal and Installation

INFOID:000000006469975

REMOVAL

1. Remove front seat assembly (LH/RH). Refer to [SE-244, "Removal and Installation"](#).
2. Remove rear seat cushion. Refer to [SE-256, "Removal and Installation"](#).
3. Remove accelerator pedal pad. Refer to [ACC-3, "Removal and Installation"](#).
4. Disengage clip of floor hook (1) with remover tool (A).

○ : Clip

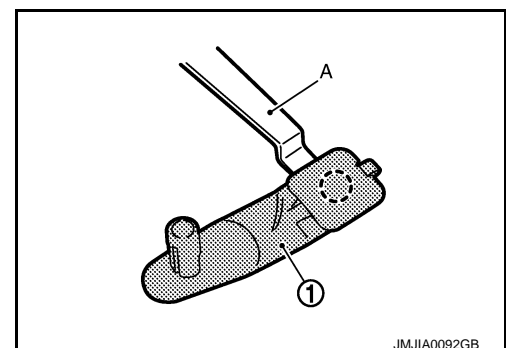

FLOOR TRIM

< REMOVAL AND INSTALLATION >

5. Remove foot grille. Refer to [VTL-13, "FOOT GRILLE : Removal and Installation"](#).
6. Remove front seat belt floor anchor bolt (LH/RH). Refer to [SB-8, "SEAT BELT BUCKLE : Exploded View"](#).
7. Remove center console assembly.
Refer to [IP-35, "A/T MODELS : Removal and Installation"](#) (A/T models).
Refer to [IP-40, "M/T MODELS : Removal and Installation"](#) (M/T models).
8. Remove front kicking plate inner (LH/RH), dash side finisher (LH/RH), and body side welt (LH/RH).
Refer to [INT-15, "Removal and Installation"](#).
9. Remove instrument passenger lower cover and instrument side panel (LH/RH).
Refer to [IP-13, "A/T MODELS : Removal and Installation"](#) (A/T models).
Refer to [IP-24, "M/T MODELS : Removal and Installation"](#) (M/T models).
10. Remove YAW RATE/G-SENSOR.
Refer to [BRC-120, "Removal and Installation"](#).
11. Remove diagnosis sensor unit.
Refer to [SR-30, "Removal and Installation"](#).
12. Remove console rear bracket.
Refer to [IP-35, "A/T MODELS : Removal and Installation"](#) (A/T models).
Refer to [IP-40, "M/T MODELS : Removal and Installation"](#) (M/T models).
13. Remove floor harness mounting clamps.
14. Remove floor trim mounting clips and fixing nuts.
15. Remove floor trim from floor trim fixing clips.
16. Remove partially the bottom side of rear side finisher, and the pull out floor carpet to remove

INSTALLATION

Install in the reverse order of removal.

HEADLINING

< REMOVAL AND INSTALLATION >

HEADLINING

Exploded View

INFOID:000000006469976

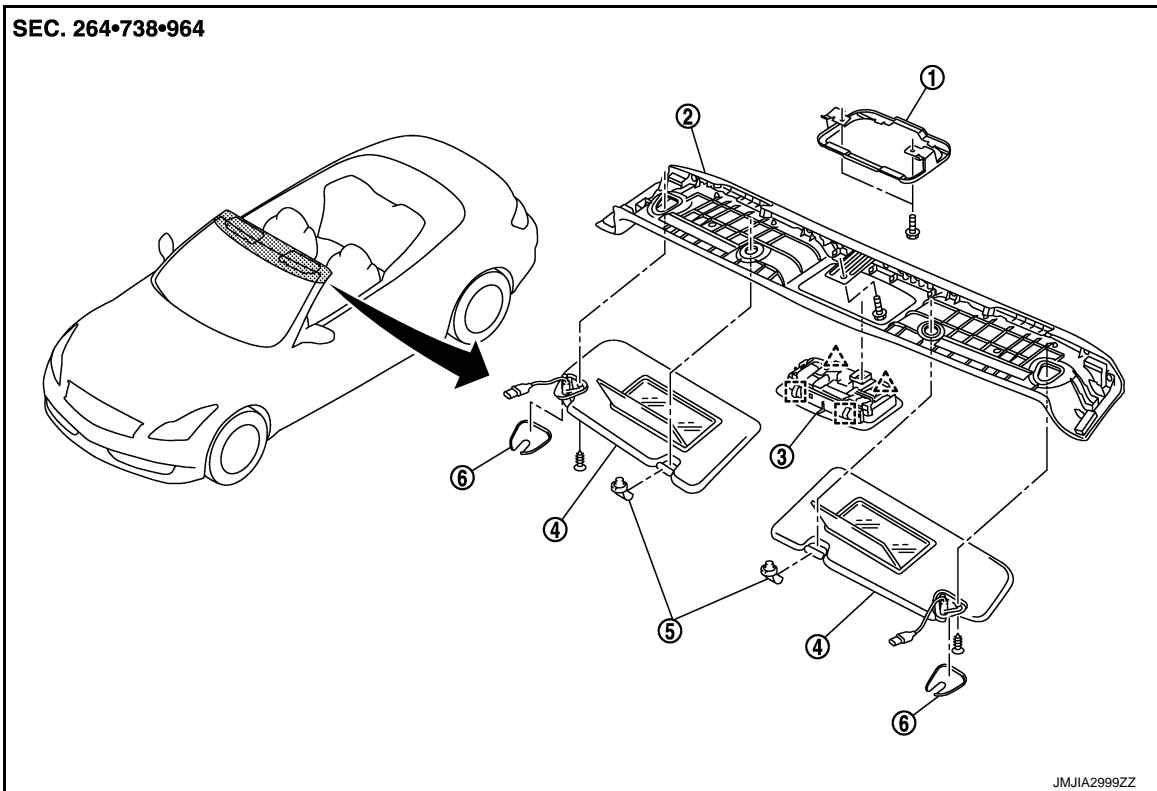

- | | | |
|----------------------|-----------------------------|----------------------|
| 1. Map lamp bracket | 2. Roof front finisher | 3. Map lamp assembly |
| 4. Sun-visor (LH/RH) | 5. Sun-visor holder (LH/RH) | 6. Sun-visor cap |

- △ : Pawl
- - - : Metal clip

Removal and Installation

INFOID:000000006469977

REMOVAL

1. Remove body side welt (LH/RH) and front pillar garnish (LH/RH). Refer to [INT-15, "Removal and Installation"](#).
2. Remove sunvisor assembly (LH/RH).
 - Remove sunvisor cover.
 - Remove sunvisor assembly fixing screws.
 - Disconnect vanity mirror lamp harness connectors.
3. Insert small flat-bladed screwdriver into the hole of sunvisor holder, press while rotating approximately 90 degrees to remove.

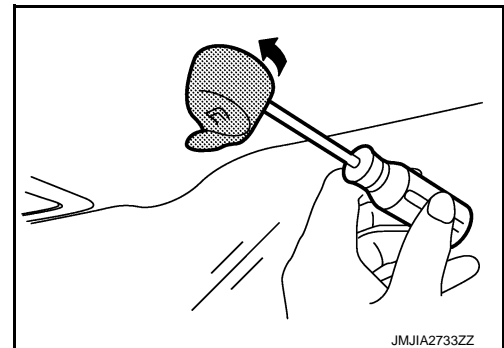

4. Remove map lamp assembly.

A
B
C
D
E
F
G
H
I

INT

K

L

M

N

O

P

HEADLINING

< REMOVAL AND INSTALLATION >

- Insert remover tool between map lamp assembly and roof front finisher assembly to disengage the fixing pawls and metal clips.
- Disconnect map lamp harness connector.
- Remove map lamp assembly.

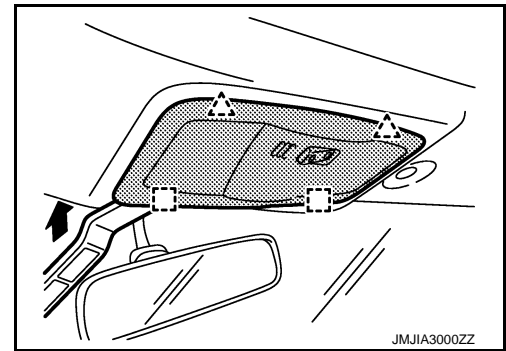
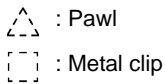

5. Remove the roof front finisher mounting bolt.
6. Remove roof front finisher as shown in the figure.
CAUTION:
Never bend roof front finisher when removing.

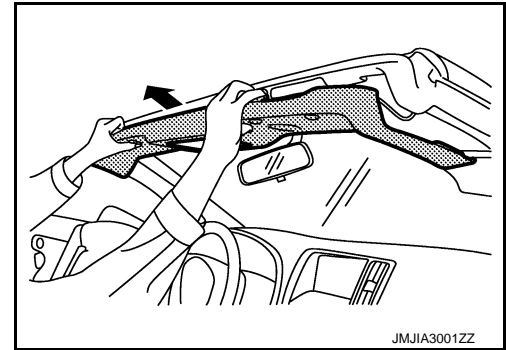

7. Remove map lamp bracket after removing roof front finisher.

INSTALLATION

Install in the reverse order of removal.

- CAUTION:**
Never bend roof front finisher when installing.

TRUNK ROOM TRIM

< REMOVAL AND INSTALLATION >

TRUNK ROOM TRIM

Exploded View

INFOID:000000006469978

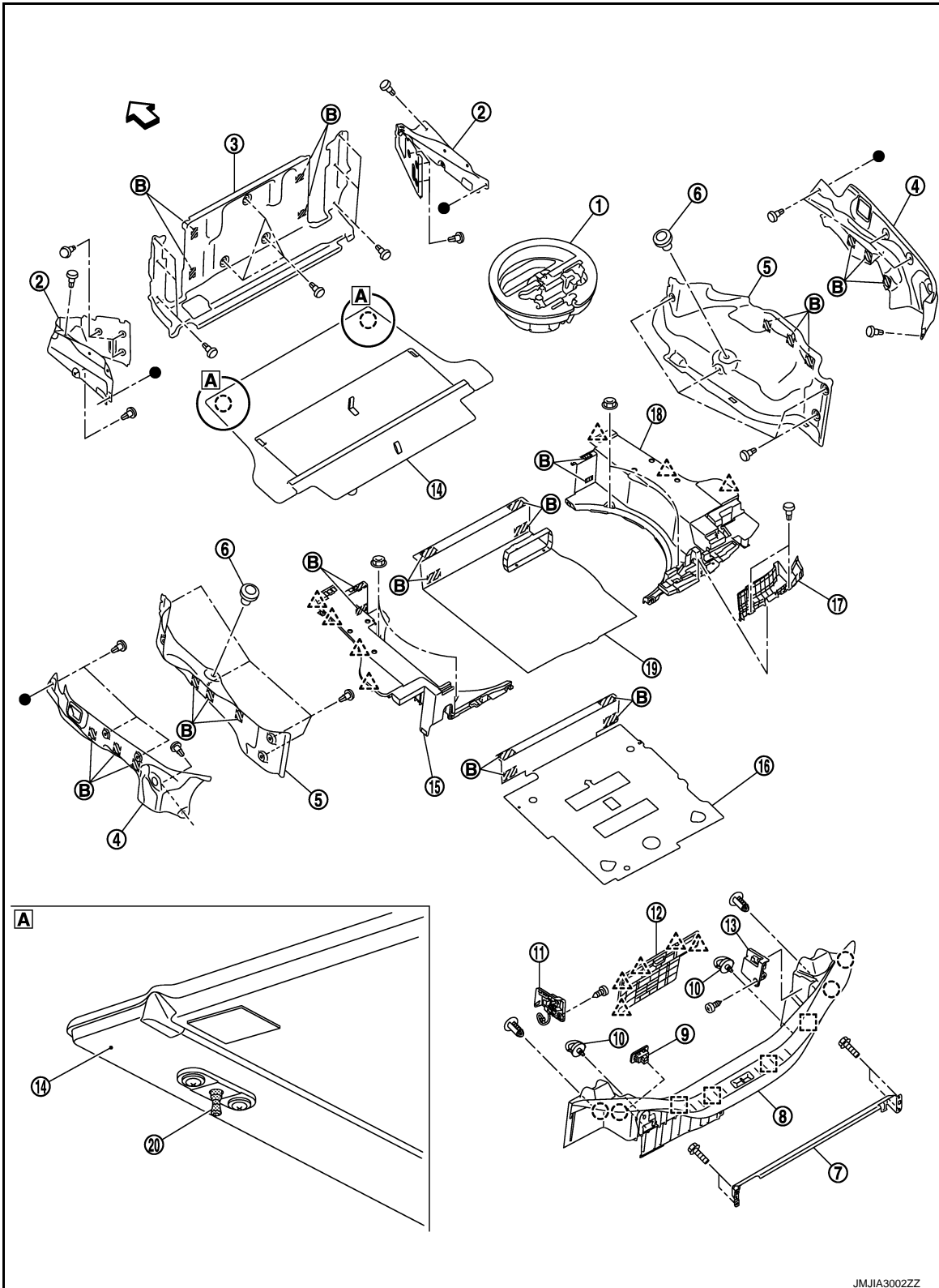

A
B
C
D
E
F
G
H
I
INT
K
L
M
N
O
P

- | | | |
|---------------------------------------|--------------------------------|-------------------------------|
| 1. Trunk center box (with spare tire) | 2. Trunk side finisher (LH/RH) | 3. Trunk lower finisher front |
| 4. Rear trunk finisher (LH/RH) | 5. Rear wheel finisher (LH/RH) | 6. Bumper rubber |
| 7. Net guard bracket assembly | 8. Trunk rear plate | 9. Trunk room lamp |

TRUNK ROOM TRIM

< REMOVAL AND INSTALLATION >

- | | | |
|---|--|---------------------------|
| 10. Hook | 11. Trunk room trim cap LH | 12. Jack lid assembly |
| 13. Trunk room trim cap RH | 14. Trunk floor board assembly | 15. Trunk floor spacer LH |
| 16. Spare tire pad (with spare tire) | 17. Rear trunk cover (with spare tire) | 18. Trunk floor spacer RH |
| 19. Trunk floor carpet (without spare tire) | 20. Clip | |

B: Dual lock fastener

 : Clip

 : Pawl

 : Metal clip

 : Vehicle front

Removal and Installation

INFOID:000000006469979

REMOVAL

TRUNK REAR PLATE

- Fully open trunk lid assembly.
- Remove trunk floor board assembly.
- Remove trunk floor carpet.
- Remove trunk center box.
- Remove spare tire.(With spare tire)
- Remove spare tire pad. (With spare tire)
- Remove trunk lid weather-strip. Refer to [DLK-281. "TRUNK LID WEATHERSTRIP : Removal and Installation"](#).
- Remove trunk room lamp. Refer to [INL-113. "Removal and Installation"](#).
- Remove trunk room trim cap LH (1).
 - Remove trunk room trim cap fixing screw (A).
 - Insert a remover tool (B) into the lower part to disengage the pawls.
 - Disconnect the harness connector.
 - Remove trunk room trim cap from trunk rear plate.

 : Pawl

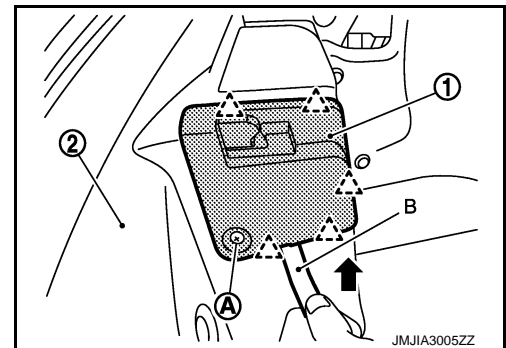

- Disengage jack lid assembly fixing pawls, and then remove jack lid assembly.
- Remove trunk rear plate fixing hooks and clips.
- Insert a remover tool between trunk panel and trunk rear plate to disengage the fixing clips and metal clips.

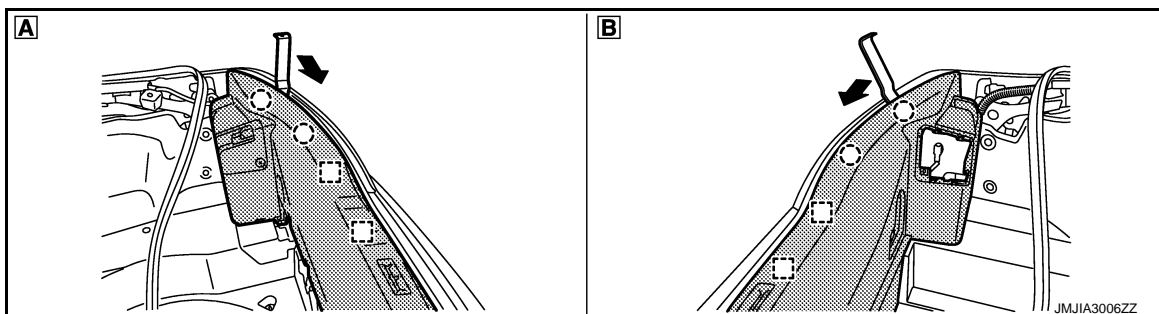

A :Trunk lid right side

B :Trunk lid left side

TRUNK ROOM TRIM

< REMOVAL AND INSTALLATION >

 : Clip

 : Metal clip

13. Pull up the trunk rear plate to remove.

14. Remove net guard bracket assembly mounting bolts, and then remove net guard bracket assembly.

TRUNK FLOOR SPACER

1. Remove trunk rear plate.

2. Remove rear trunk cover.

3. Remove the trunk floor spacer fixing nuts, and then remove the trunk floor spacer (LH/RH).

REAR WHEEL FINISHER

1. Remove trunk floor spacer.

2. Remove bumper rubber.

3. Remove rear wheel finisher trim fixing clips.

4. Pull rear wheel finisher to disengage it from dual lock fastener contact, and then remove.

REAR TRUNK FINISHER

1. Remove rear wheel finisher

2. Remove trunk hinge. Refer to [DLK-275, "TRUNK LID HINGE : Removal and Installation"](#).

3. Remove rear trunk finisher fixing clip and then remove rear trunk finisher.

TRUNK LOWER FINISHER FRONT

1. Remove rear wheel finisher.

2. Remove trunk lower finisher front fixing clips, and then remove trunk lower finisher front.

INSTALLATION

Install in the reverse order of removal.

CAUTION:

When installing, check that clips, pawls, metal clips are securely fitted in panel holes on body when installing, and then press them in.

A

B

C

D

E

F

G

H

I

INT

K

L

M

N

O

P

TRUNK LID TRIM

< REMOVAL AND INSTALLATION >

TRUNK LID TRIM

Exploded View

INFOID:000000006469980

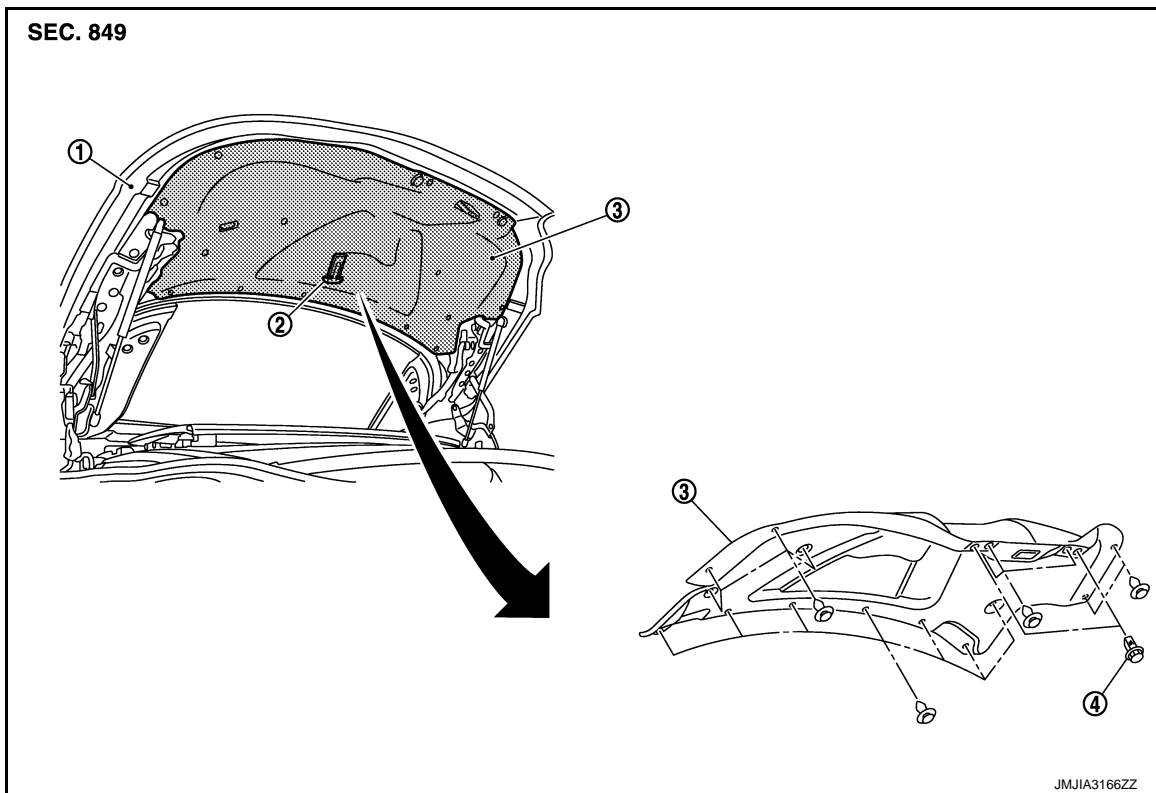

1. Trunk lid assembly
2. Emergency handle
3. Trunk lid finisher inner
4. Trunk lid bumper rubber

Removal and Installation

INFOID:000000006469981

REMOVAL

1. Fully open roof.
2. Fully open trunk lid assembly.
3. Remove trunk lid bumper rubber.
4. Remove trunk lid emergency handle holder (1).

 : Clip

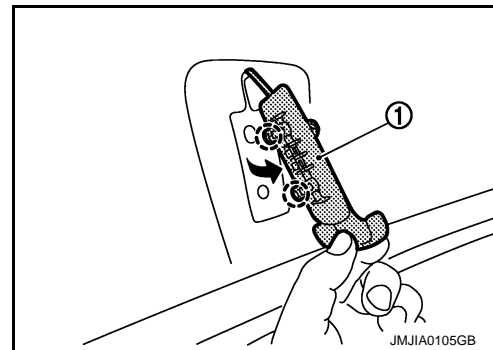

5. Remove trunk lid finisher fixing clips, and then remove trunk lid finisher inner.

INSTALLATION

Install in the reverse order of removal.