

SECTION MA
MAINTENANCE

A
B
C
D
E
F
G
H
I
J
K
L
M
N
O
MA

CONTENTS

PREPARATION	3	ENGINE OIL : Refilling	16
PREPARATION	3	OIL FILTER	17
Special Service Tool	3	OIL FILTER : Removal and Installation	17
Commercial Service Tool	3	OIL FILTER : Inspection	18
PERIODIC MAINTENANCE	4	SPARK PLUG	18
GENERAL MAINTENANCE	4	SPARK PLUG : Removal and Installation	18
Explanation of General Maintenance	4	SPARK PLUG : Inspection	18
PERIODIC MAINTENANCE	6	EVAP VAPOR LINES	19
Introduction of Periodic Maintenance	6	EVAP VAPOR LINES : Inspection	19
Schedule 1	6	CHASSIS MAINTENANCE	20
Schedule 2	8	EXHAUST SYSTEM	20
RECOMMENDED FLUIDS AND LUBRI- CANTS	10	EXHAUST SYSTEM : Inspection	20
Fluids and Lubricants	10	GEAR OIL	20
Engine Oil Recommendation	10	GEAR OIL : Inspection	20
Anti-Freeze Coolant Mixture Ratio	11	GEAR OIL : Draining	20
ENGINE MAINTENANCE	12	GEAR OIL : Refilling	21
DRIVE BELT	12	CLUTCH FLUID	21
DRIVE BELT : Exploded View	12	CLUTCH FLUID : Inspection	21
DRIVE BELT : Checking	12	A/T FLUID	21
DRIVE BELT : Tension Adjustment	12	A/T FLUID : Inspection	21
ENGINE COOLANT	12	REAR PROPELLER SHAFT: 3S80A	21
ENGINE COOLANT : Draining	12	REAR PROPELLER SHAFT: 3S80A : Inspection ...	22
ENGINE COOLANT : Refilling	13	REAR PROPELLER SHAFT: 3S80A-R	22
ENGINE COOLANT : Flushing	15	REAR PROPELLER SHAFT: 3S80A-R : Inspec- tion	22
FUEL LINES	15	REAR DIFFERENTIAL GEAR OIL: R200	23
FUEL LINES : Inspection	15	REAR DIFFERENTIAL GEAR OIL: R200 : Inspec- tion	23
AIR CLEANER FILTER	15	REAR DIFFERENTIAL GEAR OIL: R200 : Drain- ing	23
AIR CLEANER FILTER : Removal and Installation	15	REAR DIFFERENTIAL GEAR OIL: R200 : Refill- ing	24
ENGINE OIL	16		
ENGINE OIL : Draining	16		

WHEELS (BONDING WEIGHT TYPE)	24	LOCKS, HINGES AND HOOD LATCH : Lubricating	31
WHEELS (BONDING WEIGHT TYPE) : Adjustment	24	SEAT BELT, BUCKLES, RETRACTORS, ANCHORS AND ADJUSTERS	31
BRAKE FLUID LEVEL AND LEAKS	26	SEAT BELT, BUCKLES, RETRACTORS, ANCHORS AND ADJUSTERS : Inspection	31
BRAKE FLUID LEVEL AND LEAKS : Inspection ...	26	SERVICE DATA AND SPECIFICATIONS (SDS)	32
BRAKE LINES AND CABLES	26	SERVICE DATA AND SPECIFICATIONS (SDS)	32
BRAKE LINES AND CABLES : Inspection	27	DRIVE BELTS	32
BRAKE FLUID	27	DRIVE BELTS : Drive Belt	32
BRAKE FLUID : Changing	27	ENGINE COOLANT	32
DISC BRAKE	27	ENGINE COOLANT : Periodical Maintenance Specification	32
DISC BRAKE : Inspection	27	ENGINE OIL	32
DISC BRAKE : Front Disc Brake	28	ENGINE OIL : Periodical Maintenance Specification	32
DISC BRAKE : Rear Disc Brake	28	SPARK PLUG	32
STEERING GEAR AND LINKAGE	28	SPARK PLUG : Spark Plug	32
STEERING GEAR AND LINKAGE : Inspection	28	ROAD WHEEL	32
POWER STEERING FLUID AND LINES	29	ROAD WHEEL : Road Wheel	32
POWER STEERING FLUID AND LINES : Inspection	29		
AXLE AND SUSPENSION PARTS	29		
AXLE AND SUSPENSION PARTS : Inspection	29		
BODY MAINTENANCE	31		
LOCKS, HINGES AND HOOD LATCH	31		

PREPARATION

< PREPARATION >

PREPARATION

PREPARATION

Special Service Tool

INFOID:000000008154351

The actual shapes of Kent-Moore tools may differ from those of special service tools illustrated here.

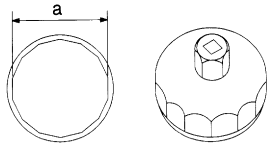
Tool number (Kent-Moore No.) Tool name	Description
KV10115801 (J38956) Oil filter wrench  <p style="text-align: center;">S-NT375</p>	Removing and installing oil filter a: 64.3 mm (2.531 in)

Commercial Service Tool

INFOID:000000008154352

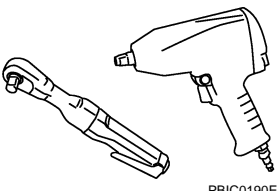
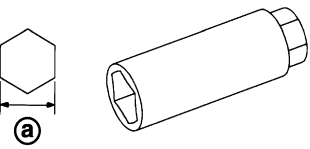
Tool name (Kent-Moore No.)	Description
Power tool (—)  <p style="text-align: center;">PBIC0190E</p>	Loosening nuts and bolts
Spark plug wrench (—)  <p style="text-align: center;">JPBIA0399ZZ</p>	Removing and installing spark plug a : 14 mm (0.55 in)

A
B
C
D
E
F
G
H
I
J
K
L
M
N
O

MA

GENERAL MAINTENANCE

< PERIODIC MAINTENANCE >

PERIODIC MAINTENANCE

GENERAL MAINTENANCE

Explanation of General Maintenance

INFOID:000000008154353

General maintenance includes those items which should be checked during the normal day-to-day operation of the vehicle. They are essential if the vehicle is to continue operating properly. The owners can perform checks and inspections themselves or have their **INFINITI** retailers do them.

OUTSIDE THE VEHICLE

The maintenance items listed here should be performed from time to time, unless otherwise specified.

Item		Reference page
Tires	Check the pressure with a gauge often and always prior to long distance trips. Adjust the pressure in all tires, including the spare, to the pressure specified. Check carefully for damage, cuts or excessive wear.	WT-50
Wheel nuts	When checking the tires, make sure no nuts are missing, and check for any loose nuts. Tighten if necessary.	—
Tire rotation	Tires cannot be rotated, as front tires are different size from rear tires and the direction of wheel rotation is fixed in each tire.	MA-24
Tire Pressure Monitoring System (TPMS) transmitter components	Replace the TPMS transmitter grommet seal, valve core and cap when the tires are replaced due to wear or age.	WT-47
Wheel alignment and balance	If the vehicle should pull to either side while driving on a straight and level road, or if you detect uneven or abnormal tire wear, there may be a need for wheel alignment. If the steering wheel or seat vibrates at normal highway speeds, wheel balancing may be needed. For additional information regarding tires, refer to "Important Tire Safety Information" (US) or "Tire Safety Information" (Canada) in the INFINITI Warranty Information Booklet.	FSU-7 RSU-6 MA-24
Windshield	Clean the windshield on a regular basis. Check the windshield at least every six months for cracks or other damage. Repair as necessary.	—
Windshield wiper blades	Check for cracks or wear if they do not wipe properly.	—
Doors and engine hood	Check that all doors and the engine hood operate properly. Also make sure that all latches lock securely. Lubricate if necessary. Make sure that the secondary latch keeps the hood from opening when the primary latch is released. When driving in areas using road salt or other corrosive materials, check for lubrication frequently.	MA-31
Lamps	Make sure that the headlamps, stop lamps, tail lamps, turn signal lamps, and other lamps are all operating properly and installed securely. Also check headlamp aim. Clean the headlamps on a regular basis.	—

INSIDE THE VEHICLE

The maintenance items listed here should be checked on a regular basis, such as when performing periodic maintenance, cleaning the vehicle, etc.

Item		Reference page
Warning lamps and chimes	Make sure that all warning lamps and chimes are operating properly.	—
Windshield wiper and washer	Check that the wipers and washer operate properly and that the wipers do not streak.	—
Windshield defroster	Check that the air comes out of the defroster outlets properly and in sufficient quantity when operating the heater or air conditioner.	—
Steering wheel	Check that it has the specified play. Check for changes in the steering condition, such as excessive play, hard steering or strange noises. Free play: Less than 35 mm (1.38 in)	—

GENERAL MAINTENANCE

< PERIODIC MAINTENANCE >

Item		Reference page	
Seats	Check seat position controls such as seat adjusters, seatback recliner, etc. to make sure they operate smoothly and that all latches lock securely in every position. Check that the head restraints move up and down smoothly and that the locks (if equipped) hold securely in all latched positions. Check that the latches lock securely for folding-down rear setbacks.	—	A B
Seat belts	Check that all parts of the seat belt system (e.g. buckles, anchors, adjusters and retractors) operate properly and smoothly, and are installed securely. Check the belt webbing for cuts, fraying, wear or damage.	MA-31	C
Accelerator pedal	Check the pedal for smooth operation and make sure the pedal does not catch or require uneven effort. Keep the floor mats away from the pedal.	—	D
Brakes	Check that the brake does not pull the vehicle to one side when applied.	—	E
Brake pedal and booster	Check the pedal for smooth operation and make sure it has the proper distance under it when depressed fully. Check the brake booster function. Be sure to keep the floor mats away from the pedal.	BR-7 BR-13	F
Clutch pedal	Make sure the pedal operates smoothly and check that it has the proper free play.	CL-6	G
Parking brake	Check that the lever or the pedal has the proper travel and make sure that the vehicle is held securely on a fairly steep hill when only the parking brake is applied.	PB-3 (PEDAL TYPE) PB-3 (LEVER TYPE)	H
Automatic transmission "Park" mechanism	Check that the lock release button on the selector lever operates properly and smoothly. On a fairly steep hill check that the vehicle is held securely with the selector lever in the P (Park) position without applying any brakes.	—	I

UNDER THE HOOD AND VEHICLE

The maintenance items listed here should be checked periodically (e.g. each time you check the engine oil or refuel).

Item		Reference page	
Windshield washer fluid	Check that there is adequate fluid in the tank.	—	J
Engine coolant level	Check the coolant level when the engine is cold.	CO-7	K
Radiator and hoses	Check the front of the radiator and clean off any dirt, insects, leaves, etc., that may have accumulated. Make sure the hoses have no cracks, deformation, deterioration or loose connections.	—	L
Brake and clutch fluid levels	Make sure that the brake and clutch fluid levels are(is) between the "MAX" and "MIN" lines on the reservoirs.	MA-26 MA-21	M
Battery	Check the fluid level in each cell. It should be between the "MAX" and "MIN" lines. Vehicles operated in high temperatures or under severe conditions require frequent checks of the battery fluid level.	PG-3	N
Engine drive belt	Make sure that no belt is frayed, worn, cracked or oily.	MA-12	O
Engine oil level	Check the level on the oil level gauge after parking the vehicle on a level spot and turning off the engine.	LU-7	P
Power steering fluid level and lines	Check the level on the dipstick with the engine off. Check the lines for improper attachment, leaks, cracks, etc.	MA-29	Q
Exhaust system	Make sure there are no loose supports, cracks or holes. If the sound of the exhaust seems unusual or there is a smell of exhaust fumes, immediately locate the trouble and correct it.	MA-20	R
Underbody	The underbody is frequently exposed to corrosive substances such as those used on icy roads or to control dust. It is very important to remove these substances, otherwise rust will form on the floor pan, frame, fuel lines and around the exhaust system. At the end of winter, the underbody should be thoroughly flushed with plain water, being careful to clean those areas where mud and dirt can easily accumulate.	—	S
Fluid leaks	Check under the vehicle for fuel, oil, water or other fluid leaks after the vehicle has been parked for a while. Water dripping from the air conditioner after use is normal. If you should notice any leaks or gasoline fumes are evident, check for the cause and correct it immediately.	—	T

MA

PERIODIC MAINTENANCE

< PERIODIC MAINTENANCE >

PERIODIC MAINTENANCE

Introduction of Periodic Maintenance

INFOID:000000008154354

Two different maintenance schedules are provided, and should be used, depending upon the conditions in which the vehicle is mainly operated. **After 60,000 miles (96,000 km) or 48 months, continue the periodic maintenance at the same mileage/time intervals.**

Schedule 1	Follow Periodic Maintenance Schedule 1 if the driving habits frequently include one or more of the following driving conditions: <ul style="list-style-type: none"> • Repeated short trips of less than 5 miles (8 km). • Repeated short trips of less than 10 miles (16 km) with outside temperatures remaining below freezing. • Operating in hot weather in stop-and-go “rush hour” traffic. • Extensive idling and/or low speed driving for long distances, such as police, taxi or door-to-door delivery use. • Driving in dusty conditions. • Driving on rough, muddy, or salt spread roads. • Towing a trailer, using a camper or a car-top carrier. 	Emission Control System Maintenance	MA-6
		Chassis and Body Maintenance	
Schedule 2	Follow Periodic Maintenance Schedule 2 if none of driving conditions shown in Schedule 1 apply to the driving habits.	Emission Control System Maintenance	MA-8
		Chassis and Body Maintenance	

Schedule 1

INFOID:000000008154355

EMISSION CONTROL SYSTEM MAINTENANCE

Abbreviations: R = Replace. I = Inspect. Correct or replace if necessary. []: At the mileage interval only

MAINTENANCE OPERATION		MAINTENANCE INTERVAL								Reference Section - Page or - Content Title	
Perform at number of miles, kilometers or months, whichever comes first.	Miles x 1,000 (km x 1,000) Months	3.75 (6)	7.50 (12)	11.25 (18)	15 (24)	18.75 (30)	22.5 (36)	26.25 (42)	30 (48)		
Drive belt(s)	NOTE (1)									[R]	MA-12
Air cleaner filter	NOTE (2)									[R]	MA-15
EVAP vapor lines										I*	MA-19
Fuel lines										I*	MA-15
Fuel filter	NOTE (3)										—
Engine coolant*	NOTE (4)(5)										MA-12
Engine oil		R	R	R	R	R	R	R	R	MA-16	
Engine oil filter (Use genuine NISSAN engine oil filter or equivalent.)		R	R	R	R	R	R	R	R	MA-17	
Spark plugs (Iridium-tipped type)(Except for G37IPL)	NOTE (6)	Replace every 105,000 miles (168,000 km).								MA-18	
Spark plugs (Iridium-tipped type)(For G37IPL)	NOTE (6)	Replace every 60,000 miles (96,000 km).								MA-18	
Intake & exhaust valve clearance*	NOTE (7)										EM-18

MAINTENANCE OPERATION		MAINTENANCE INTERVAL								Reference Section - Page or - Content Title	
Perform at number of miles, kilometers or months, whichever comes first.	Miles x 1,000 (km x 1,000) Months	33.75 (54)	37.5 (60)	41.25 (66)	45 (72)	48.75 (78)	52.5 (84)	56.25 (90)	60 (96)		
Drive belt(s)	NOTE (1)									I*	MA-12
Air cleaner filter	NOTE (2)									[R]	MA-15

PERIODIC MAINTENANCE

< PERIODIC MAINTENANCE >

MAINTENANCE OPERATION		MAINTENANCE INTERVAL								Reference Section - Page or - Content Title
		Miles x 1,000 (km x 1,000)	33.75 (54)	37.5 (60)	41.25 (66)	45 (72)	48.75 (78)	52.5 (84)	56.25 (90)	
Perform at number of miles, kilometers or months, whichever comes first.	Months	27	30	33	36	39	42	45	48	
EVAP vapor lines									I*	MA-19
Fuel lines									I*	MA-15
Fuel filter	NOTE (3)									—
Engine coolant*	NOTE (4)(5)									MA-12
Engine oil		R	R	R	R	R	R	R	R	MA-16
Engine oil filter (Use genuine NISSAN engine oil filter or equivalent.)		R	R	R	R	R	R	R	R	MA-17
Spark plugs (Iridium-tipped type)(Except for G37IPL)	NOTE (6)	Replace every 105,000 miles (168,000 km).								MA-18
Spark plugs (Iridium-tipped type)(For G37IPL)	NOTE (6)	Replace every 60,000 miles (96,000 km).								MA-18
Intake & exhaust valve clearance*	NOTE (7)									EM-18

NOTE:

- (1) After 60,000 miles (96,000 km) or 48 months, inspect every 15,000 miles (24,000 km) or 12 months. Replace the drive belt if found damaged or if the auto belt tensioner reading reaches the maximum limit.
- (2) If operating mainly in dusty conditions, more frequent maintenance may be required.
- (3) Maintenance-free item. For service procedures, refer to FL section.
- (4) First replacement intervals 105,000 miles (168,000 km) or 84 months. After first replacement, replace every 75,000 miles (120,000 km) or 60 months.
- (5) Use only Genuine NISSAN Long Life Antifreeze / Coolant (blue) or equivalent with proper mixture ratio of 50% anti-freeze and 50% demineralized or distilled water. Mixing any other type of coolant or the use of non-distilled water will reduce the life expectancy of the factory-fill coolant.
- (6) Replace spark plug when the spark plug gap exceeds 1.4 mm (0.055 in) even if within specified periodic replacement mileage.
- (7) Periodic maintenance is not required. However, if valve noise increases, inspect valve clearance.

* Maintenance items and intervals with "*" are recommended by INFINITI for reliable vehicle operation. The owner need not perform such maintenance in order to maintain the emission warranty or manufacturer recall liability. Other maintenance items and intervals are required.

CHASSIS AND BODY MAINTENANCE

Abbreviations: R = Replace. I = Inspect. Correct or replace if necessary.

MAINTENANCE OPERATION		MAINTENANCE INTERVAL								Reference Section - Page or - Content Title
		Miles x 1,000 (km x 1,000)	3.75 (6)	7.50 (12)	11.25 (18)	15 (24)	18.75 (30)	22.5 (36)	26.25 (42)	
Perform at number of miles, kilometers or months, whichever comes first.	Months	3	6	9	12	15	18	21	24	
Brake lines & cables					I				I	MA-27
Brake pads & rotors			I		I		I		I	MA-27
Brake fluid					R				R	MA-27
Automatic transmission fluid	NOTE (1)									—
Manual transmission gear oil & differential gear oil	NOTE (2)				I				I	MA-20 MA-23
Steering gear & linkage, axle & suspension parts			I		I		I		I	MA-28 MA-29
Tire rotation	NOTE (3)									MA-4 MA-24
Exhaust system			I		I		I		I	MA-20

PERIODIC MAINTENANCE

< PERIODIC MAINTENANCE >

MAINTENANCE OPERATION		MAINTENANCE INTERVAL								Reference Section - Page or - Content Title
Perform at number of miles, kilometers or months, whichever comes first.	Miles x 1,000 (km x 1,000) Months	3.75 (6) 3	7.50 (12) 6	11.25 (18) 9	15 (24) 12	18.75 (30) 15	22.5 (36) 18	26.25 (42) 21	30 (48) 24	
In-cabin microfilter					R				R	VTL-8
Stop lamp switch & ASCD brake switch	NOTE (4)				I				I	BR-7

MAINTENANCE OPERATION		MAINTENANCE INTERVAL								Reference Section - Page or - Content Title
Perform at number of miles, kilometers or months, whichever comes first.	Miles x 1,000 (km x 1,000) Months	33.75 (54) 27	37.5 (60) 30	41.25 (66) 33	45 (72) 36	48.75 (78) 39	52.5 (84) 42	56.25 (90) 45	60 (96) 48	
Brake lines & cables					I				I	MA-27
Brake pads & rotors			I		I		I		I	MA-27
Brake fluid					R				R	MA-27
Automatic transmission fluid	NOTE (1)									—
Manual transmission gear oil & differential gear oil	NOTE (2)				I				I	MA-20 MA-23
Steering gear & linkage, axle & suspension parts			I		I		I		I	MA-28 MA-29
Tire rotation	NOTE (3)									MA-4 MA-24
Exhaust system			I		I		I		I	MA-20
In-cabin microfilter					R				R	VTL-8
Stop lamp switch & ASCD brake switch	NOTE (4)				I				I	BR-7

NOTE:

- (1) Automatic transmission fluid is maintenance-free.
- (2) If towing a trailer, using a camper or a car-top carrier, or driving on rough or muddy roads, change (not just inspect) fluid/oil at every 30,000 miles (48,000 km) or 24 months.
- (3) Refer to "Tire rotation" under the "General maintenance" heading earlier in this section.
- (4) Inspect the clearance between the brake pedal and the switches.

Schedule 2

INFOID:000000008154356

EMISSION CONTROL SYSTEM MAINTENANCE

Abbreviations: R = Replace. I = Inspect. Correct or replace if necessary. []: At the mileage interval only

MAINTENANCE OPERATION		MAINTENANCE INTERVAL								Reference Section - Page or - Content Title
Perform at number of miles, kilometers or months, whichever comes first.	Miles x 1,000 (km x 1,000) Months	7.5 (12) 6	15 (24) 12	22.5 (36) 18	30 (48) 24	37.5 (60) 30	45 (72) 36	52.5 (84) 42	60 (96) 48	
Drive belt(s)	NOTE (1)								I*	MA-12
Air cleaner filter					[R]				[R]	MA-15
EVAP vapor lines					I*				I*	MA-19
Fuel lines					I*				I*	MA-15
Fuel filter	NOTE (2)									—
Engine coolant*	NOTE (3)(4)									MA-12
Engine oil		R	R	R	R	R	R	R	R	MA-16
Engine oil filter (Use genuine NISSAN engine oil filter or equivalent.)		R	R	R	R	R	R	R	R	MA-17

PERIODIC MAINTENANCE

< PERIODIC MAINTENANCE >

MAINTENANCE OPERATION		MAINTENANCE INTERVAL								Reference Section - Page or - Content Title
Perform at number of miles, kilometers or months, whichever comes first.	Miles x 1,000 (km x 1,000) Months	7.5 (12) 6	15 (24) 12	22.5 (36) 18	30 (48) 24	37.5 (60) 30	45 (72) 36	52.5 (84) 42	60 (96) 48	
Spark plugs (Iridium-tipped type) (Except for G37IPL)	NOTE (5)	Replace every 105,000 miles (168,000 km).								MA-18
Spark plugs (Iridium-tipped type)(For G37IPL)	NOTE (5)	Replace every 60,000 miles (96,000 km).								MA-18
Intake & exhaust valve clearance*	NOTE (6)									EM-18

NOTE:

- (1) After 60,000 miles (96,000 km) or 48 months, inspect every 15,000 miles (24,000 km) or 12 months. Replace the drive belt if found damaged or if the auto belt tensioner reading reaches the maximum limit.
- (2) Maintenance-free item. For service procedures, refer to FL section.
- (3) First replacement interval is 105,000 miles (168,000 km) or 84 months. After first replacement, replace every 75,000 miles (120,000 km) or 60 months.
- (4) Use only Genuine NISSAN Long Life Antifreeze / Coolant (blue) or equivalent with proper mixture ratio of 50% anti-freeze and 50% demineralized or distilled water. Mixing any other type of coolant or the use of non-distilled water will reduce the life expectancy of the factory-fill coolant.
- (5) Replace spark plug when the spark plug gap exceeds 1.4 mm (0.055 in) even if within specified periodic replacement mileage.
- (6) Periodic maintenance is not required. However, if valve noise increases, inspect valve clearance.

* Maintenance items and intervals with "*" are recommended by INFINITI for reliable vehicle operation. The owner need not perform such maintenance in order to maintain the emission warranty or manufacturer recall liability. Other maintenance items and intervals are required.

CHASSIS AND BODY MAINTENANCE

Abbreviations: R = Replace. I = Inspect. Correct or replace if necessary.

MAINTENANCE OPERATION		MAINTENANCE INTERVAL								Reference Section - Page or - Content Title
Perform at number of miles, kilometers or months, whichever comes first.	Miles x 1,000 (km x 1,000) Months	7.5 (12) 6	15 (24) 12	22.5 (36) 18	30 (48) 24	37.5 (60) 30	45 (72) 36	52.5 (84) 42	60 (96) 48	
Brake lines & cables			I		I		I		I	MA-26
Brake pads & rotors			I		I		I		I	MA-27
Brake fluid					R				R	MA-27
Automatic transmission fluid	NOTE (1)									—
Manual transmission gear oil & differential gear oil			I		I		I		I	MA-20 MA-23
Steering gear & linkage, axle & suspension parts					I				I	MA-28 MA-29
Tire rotation	NOTE (2)									MA-4 MA-24
Exhaust system					I				I	MA-20
In-cabin microfilter			R		R		R		R	VTL-8
Stop lamp switch & ASCD brake switch	NOTE (3)		I		I		I		I	BR-7

NOTE:

- (1) Automatic transmission fluid is maintenance-free.
- (2) Refer to "Tire rotation" under the "General maintenance" heading earlier in this section.
- (3) Inspect the clearance between the brake pedal and the switches.

RECOMMENDED FLUIDS AND LUBRICANTS

< PERIODIC MAINTENANCE >

RECOMMENDED FLUIDS AND LUBRICANTS

Fluids and Lubricants

INFOID:000000008154357

			Capacity (Approximate)			Recommended Fluids/Lubricants
			US mea- sure	Imp mea- sure	Liter	
Engine oil Drain and refill	With oil filter change		5-1/8 qt	4-1/4 qt	4.9	<ul style="list-style-type: none"> • Engine oil with API Certification Mark*¹ *² • Viscosity SAE 5W-30*¹ *²
	Without oil filter change		4-7/8 qt	4 qt	4.6	
Dry engine (Overhaul)			6 qt	5 qt	5.7	
Cooling system	With reservoir tank	A/T	9 qt	7-1/2 qt	8.5	Pre-diluted Genuine NISSAN Long Life Anti-freeze/ Coolant (blue) or equivalent
		M/T	9-1/8 qt	7-5/8 qt	8.6	
	Reservoir tank		7/8 qt	3/4 qt	0.8	
Automatic transmission fluid			9-3/4 qt* ⁷	8-1/8 qt* ⁷	9.2* ⁷	Genuine NISSAN Matic S ATF* ³
Manual transmission gear oil			6 pt	5 pt	2.83	Genuine NISSAN Manual Transmission Fluid (MTF) HQ Multi 75W-85 or API GL-4, Viscosity SAE 75W-85
Differential gear oil			3 pt	2-1/2 pt	1.40	API GL-5 Synthetic Gear Oil, Viscosity SAE 75W-90* ⁴
Power steering fluid (PSF)			1-1/8 qt	7/8 qt	1.0	Genuine NISSAN PSF or equivalent* ⁵
Brake and clutch fluid			—	—	—	Genuine NISSAN Super Heavy Duty Brake Fluid* ⁶ or equivalent DOT 3 (US FMVSS No. 116)
Multi-purpose grease			—	—	—	NLGI No. 2 (Lithium soap base)
Windshield washer fluid			—	—	—	Genuine NISSAN Windshield Washer Concentrate Cleaner & Antifreeze or equivalent
Fuel recommendation			—	—	—	Refer to GI-33. "Fuel" .

*1: For additional information, see "Engine Oil Recommendation".

*2: INFINITI recommends NISSAN Ester oil available at an INFINITI retailer.

*3: Using automatic transmission fluid other than Genuine NISSAN Matic S ATF will cause deterioration in driveability and automatic transmission durability, and may damage the automatic transmission, which is not covered by the INFINITI new vehicle limited warranty.

*4: See an INFINITI retailer for service for synthetic oil.

*5: DEXRON™ VI type ATF may also be used.

*6: Available in mainland U.S.A. through an INFINITI retailer.

*7: The fluid capacity is the reference value.

Engine Oil Recommendation

INFOID:000000008154358

NISSAN recommends the use of an energy conserving oil in order to improve fuel economy. Select only engine oils that meet the American Petroleum Institute (API) certification and International Lubricant Standardization and Approval Committee (ILSAC) certification and SAE viscosity standard. These oils have the API certification mark on the front of the container. Oils which do not have the specified quality label should not be used as they could cause engine damage.



JSPIA0014ZZ

RECOMMENDED FLUIDS AND LUBRICANTS

< PERIODIC MAINTENANCE >

1. API certification mark

2. API service symbol

Anti-Freeze Coolant Mixture Ratio

INFOID:000000008154359

The engine cooling system is filled at the factory with a pre-diluted mixture of 50% Genuine NISSAN Long Life Antifreeze/Coolant (blue) and 50% water to provide year-round anti-freeze and coolant protection. The anti-freeze solution contains rust and corrosion inhibitors. Additional engine cooling system additives are not necessary.

WARNING:

- Never remove the radiator or coolant reservoir cap when the engine is hot. Wait until the engine and radiator cool down. Serious burns could be caused by high pressure fluid escaping from the radiator.
- The radiator is equipped with a pressure type radiator cap. To prevent engine damage, use only a genuine NISSAN radiator cap.

CAUTION:

- When adding or replacing coolant, be sure to use only Genuine NISSAN Long Life Antifreeze/Coolant (blue) or equivalent. Genuine NISSAN Long Life Antifreeze/Coolant (blue) is pre-diluted to provide antifreeze protection to -34°F (-37°C). If additional freeze protection is needed due to weather where you operate your vehicle, add Genuine NISSAN Long Life Antifreeze/Coolant (blue) concentrate following the directions on the container. If an equivalent coolant other than Genuine NISSAN Long Life Antifreeze/Coolant (blue) is used, follow the coolant manufacturer's instructions to maintain minimum antifreeze protection to -34°F (-37°C). The use of other types of coolant solutions other than Genuine NISSAN Long Life Antifreeze/Coolant (blue) or equivalent may damage the engine cooling system.
- Mixing any other type of coolant other than Genuine NISSAN Long Life Antifreeze/Coolant (blue), including Genuine NISSAN Long Life Antifreeze/Coolant (green), or the use of non-distilled water will reduce the life expectancy of the factory-fill coolant.

A
B
C
D
E
F
G
H
I
J
K
L
M
N
O

MA

ENGINE MAINTENANCE

< PERIODIC MAINTENANCE >

ENGINE MAINTENANCE

DRIVE BELT

DRIVE BELT : Exploded View

INFOID:000000008154360

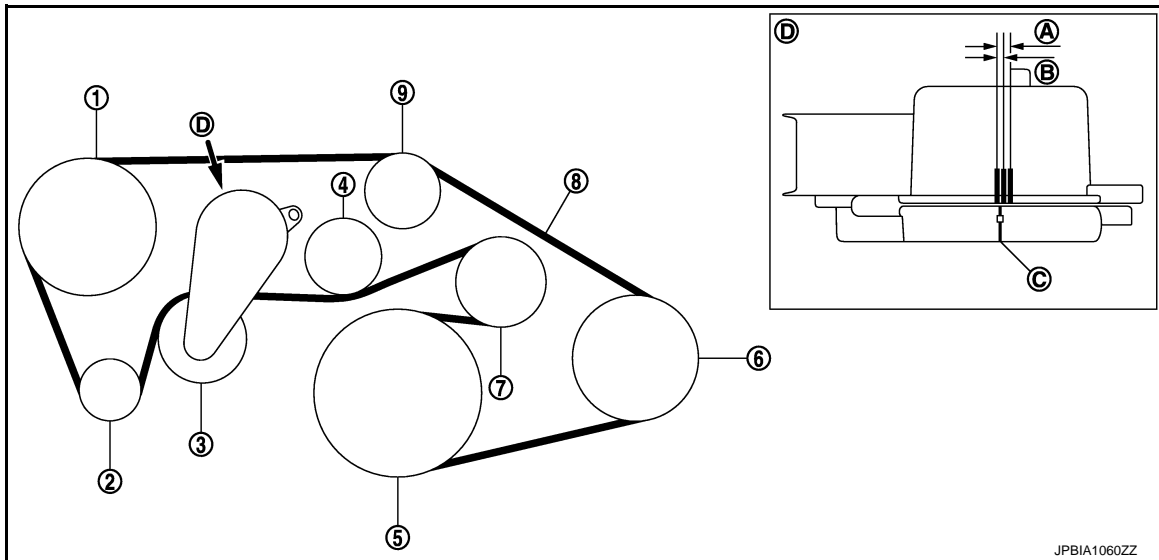

- | | | |
|----------------------------|-------------------------------------------|------------------------------|
| 1. Power steering oil pump | 2. Alternator | 3. Drive belt auto-tensioner |
| 4. Idler pulley | 5. Crankshaft pulley | 6. A/C compressor |
| 7. Idler pulley | 8. Drive belt | 9. Idler pulley |
| A. Possible use range | B. Range when new drive belt is installed | C. Indicator |
| D. View D | | |

DRIVE BELT : Checking

INFOID:000000008154361

WARNING:

Be sure to perform the this step when engine is stopped.

- Check that the indicator (C) (notch on fixed side) of drive belt auto-tensioner is within the possible use range (A).

NOTE:

- Check the drive belt auto-tensioner indication when the engine is cold.
- When new drive belt is installed, the indicator (notch on fixed side) should be within the range (B) in the figure.
- Visually check the entire drive belt for wear, damage or crack.
- If the indicator (notch on fixed side) is out of the possible use range or belt is damaged, replace drive belt.

DRIVE BELT : Tension Adjustment

INFOID:000000008154362

Refer to [EM-138. "Drive Belt"](#).

ENGINE COOLANT

ENGINE COOLANT : Draining

INFOID:000000008154363

WARNING:

- **Never change engine coolant when the engine is hot to avoid being scalded.**
- **Wrap a thick cloth around reservoir tank cap and carefully remove reservoir tank cap. First, turn reservoir tank cap a quarter of a turn to release built-up pressure. Then turn reservoir tank cap all the way.**

1. Connect drain hose.

NOTE:

ENGINE MAINTENANCE

< PERIODIC MAINTENANCE >

Use a general-purpose hose with the dimensions shown in the figure.

- A : $\phi 15 - 16$ mm (0.59 - 0.63 in)
 B : 145 mm (5.17 in)

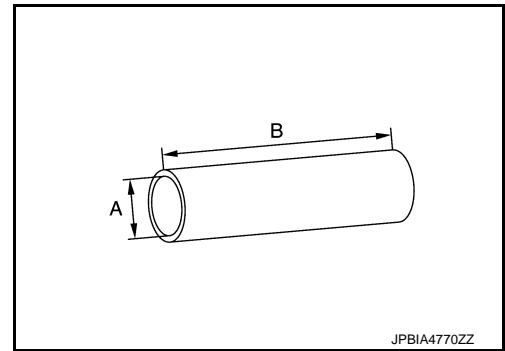

- Open radiator drain plug (2) at the bottom of radiator, and then remove reservoir tank cap and radiator cap.

- 1 : Engine under cover
 A : Radiator drain plug hole
 : Vehicle front

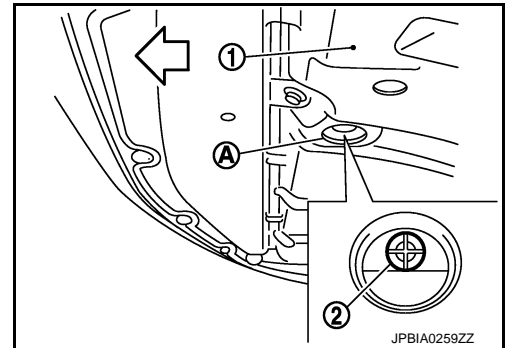

When draining all of engine coolant in the system, open water drain plugs on cylinder block. Refer to [EM-73](#).

- Remove reservoir tank if necessary, and drain engine coolant and clean reservoir tank before installing.
- Check drained engine coolant for contaminants such as rust, corrosion or discoloration. If contaminated, flush the engine cooling system. Refer to [CO-9, "Flushing"](#).
- Disconnect drain hose.

ENGINE COOLANT : Refilling

INFOID:000000008154364

CAUTION:

- Do not reuse O-rings.
- Do not put additive such as waterleak preventive, since it may cause cooling waterway clogging.
- When refilling use Genuine NISSAN Long Life Antifreeze/Coolant (blue) or equivalent in its quality mixed with water (distilled or demineralized). Refer to [MA-10, "Fluids and Lubricants"](#).

- Remove air cleaner case (LH). Refer to [EM-27, "Exploded View"](#).
- Install reservoir tank if removed, and radiator drain plug.

CAUTION:

Be sure to clean drain plug and install with new O-ring.

Tightening torque : Refer to [CO-13, "Exploded View"](#).

If water drain plugs on cylinder block are removed, close and tighten them. Refer to [EM-112, "Disassembly and Assembly"](#).

- Check that each hose clamp has been firmly tightened.
- Remove air relief plug (2) on radiator left side.

- 1 : Reservoir tank
 3 : Engine cover
 : Vehicle front

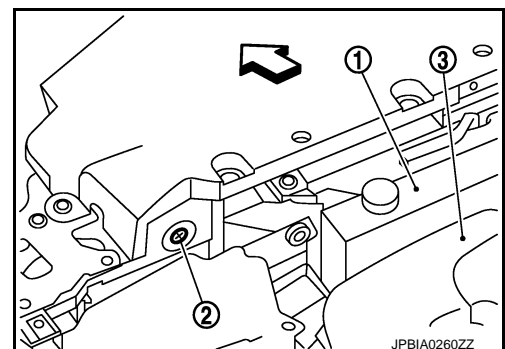

ENGINE MAINTENANCE

< PERIODIC MAINTENANCE >

5. Fill radiator, and reservoir tank if removed, to specified level.
Pour engine coolant through engine coolant filler neck slowly of less than 2 ℓ (2-1/8 US qt, 1-3/4 Imp qt) a minute to allow air in system to escape.

**Engine coolant capacity
(With reservoir tank at
"MAX" level)**

**: Refer to [CO-26,](#)
["Periodical Maintenance
e Specification".](#)**

**Reservoir tank engine
coolant capacity
(At "MAX" level)**

**:Refer to [CO-26,](#)
["Periodical Maintenance Sp
ecification"](#)**

A : MAX

B : MIN

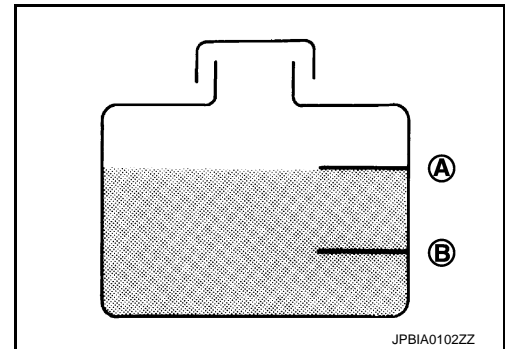
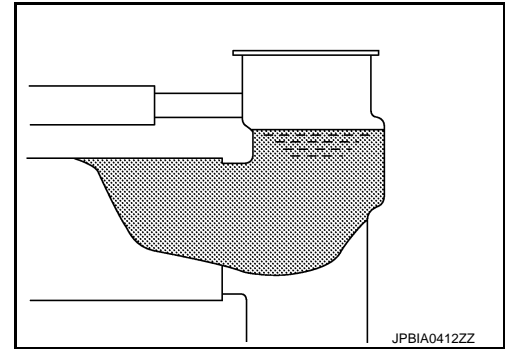

6. When engine coolant overflows air relief hole on radiator, install air relief plug with new O-ring.

CAUTION:
Do not reuse O-ring.

Tightening torque : Refer to [CO-13, "Exploded View".](#)

7. Repeat step 5.
8. Install air cleaner case (LH). Refer to [EM-27, "Exploded View".](#)
9. Install radiator cap.
10. Warm up engine until opening thermostat. Standard for warming-up time is approximately 10 minutes at 3,000 rpm.
- Check thermostat opening condition by touching radiator hose (lower) to see a flow of warm water.
- CAUTION:**
Watch water temperature gauge so as not to overheat engine.
11. Stop the engine and cool down to less than approximately 50°C (122°F).
- Cool down using fan to reduce the time.
 - If necessary, refill radiator up to filler neck with engine coolant.
12. Refill reservoir tank to "MAX" level line with engine coolant.
13. Repeat steps 9 through 12 two or more times with radiator cap installed until engine coolant level no longer drops.
14. Check cooling system for leakage with engine running.
15. Warm up the engine, and check for sound of engine coolant flow while running engine from idle up to 3,000 rpm with heater temperature controller set at several position between "COOL" and "WARM".
- Sound may be noticeable at heater unit.
16. Repeat step 15 three times.
17. If sound is heard, bleed air from cooling system by repeating step 5, and steps from 9 to 16 until engine coolant level no longer drops.
18. Check that the reservoir tank cap is tightened.

ENGINE MAINTENANCE

< PERIODIC MAINTENANCE >

ENGINE COOLANT : Flushing

INFOID:000000008154365

1. Install reservoir tank if removed, and radiator drain plug.

CAUTION:

Be sure to clean drain plug and install with new O-ring.

Tightening torque : Refer to [CO-13, "Exploded View"](#).

If water drain plugs on cylinder block are removed, close and tighten them. Refer to [EM-112, "Dis-assembly and Assembly"](#).

2. Remove air relief plug (2) on radiator.

- 1 : Reservoir tank
- 3 : Engine cover
- ⇐ : Vehicle front

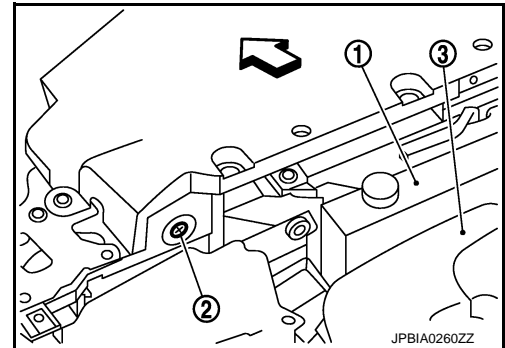

3. Fill radiator with water until water spills from the air relief hole, then close air relief plug. Fill radiator and reservoir tank with water and reinstall radiator cap.

Tightening torque : Refer to [CO-13, "Exploded View"](#).

4. Run the engine and warm it up to normal operating temperature.
5. Rev the engine two or three times under no-load.
6. Stop the engine and wait until it cools down.
7. Drain water from the system. Refer to [CO-7, "Draining"](#).
8. Repeat steps 1 through 8 until clear water begins to drain from radiator.
9. Check that the reservoir tank cap is tightened.

FUEL LINES

FUEL LINES : Inspection

INFOID:000000008154366

Inspect fuel lines, fuel filler cap and fuel tank for improper attachment, leakage, cracks, damage, loose connections, chafing or deterioration.

- A : Engine
- B : Fuel line
- C : Fuel tank

If necessary, repair or replace damaged parts.

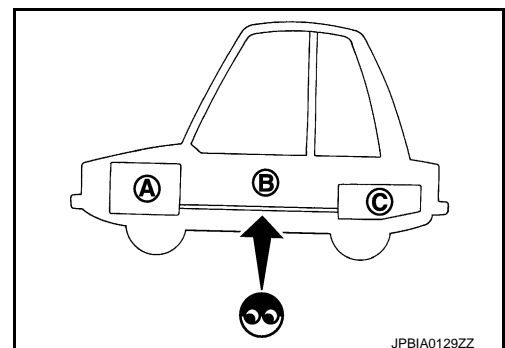

AIR CLEANER FILTER

AIR CLEANER FILTER : Removal and Installation

INFOID:000000008154367

REMOVAL

A
B
C
D
E
F
G
H
I
J
K
L
M
N
O

MA

ENGINE MAINTENANCE

< PERIODIC MAINTENANCE >

1. Unhook clips (A).

- 1 : Holder
- 2 : Air cleaner case

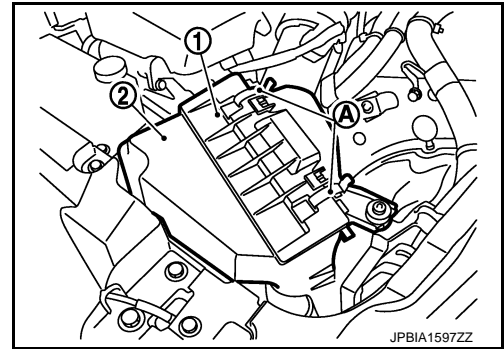

2. Remove holder (3) from air cleaner case (2), and then remove air cleaner filter (1) from holder.

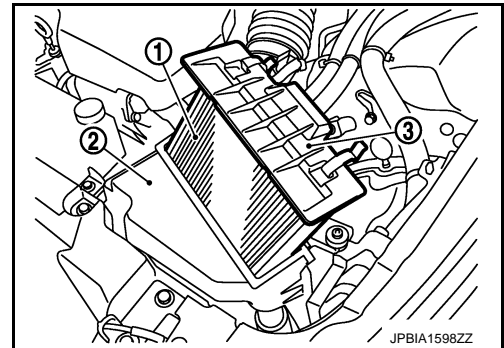

INSTALLATION

Note the following, and install in the reverse order of removal.

- Install the air cleaner filter by aligning the seal with the notch of air cleaner case.

ENGINE OIL

ENGINE OIL : Draining

INFOID:000000008154368

WARNING:

- Be careful not to get burn yourself, as engine oil may be hot.
- Prolonged and repeated contact with used engine oil may cause skin cancer. Try to avoid direct skin contact with used engine oil. If skin contact is made, wash thoroughly with soap or hand cleaner as soon as possible.

1. Warm up the engine, and check for engine oil leakage from engine components. Refer to [LU-7, "Inspection"](#).
2. Stop the engine and wait for 10 minutes.
3. Loosen oil filler cap.
4. Remove undercover with power tool.
5. Remove drain plug and then drain engine oil.

ENGINE OIL : Refilling

INFOID:000000008154369

1. Install drain plug with new washer. Refer to [EM-43, "Exploded View"](#).

CAUTION:

Be sure to clean drain plug and install with new washer.

Tightening torque : Refer to [EM-43, "Exploded View"](#).

2. Refill with new engine oil.
Engine oil specification and viscosity: Refer to [MA-10, "Fluids and Lubricants"](#).

Engine oil capacity : Refer to [LU-14, "Periodical Maintenance Specification"](#).

CAUTION:

- When filling engine oil, never pull out oil level gauge.

ENGINE MAINTENANCE

< PERIODIC MAINTENANCE >

- The refill capacity depends on the engine oil temperature and drain time. Use these specifications for reference only.
 - Always use oil level gauge to determine the proper amount of engine oil in engine.
3. Warm up the engine and check area around drain plug and oil filter for engine oil leakage.
 4. Stop the engine and wait for 10 minutes.
 5. Check the engine oil level. Refer to [LU-7, "Inspection"](#).

OIL FILTER

OIL FILTER : Removal and Installation

INFOID:000000008154370

REMOVAL

CAUTION:

- Oil filter is provided with relief valve. Use genuine NISSAN oil filter or equivalent.
- Be careful not to get burned when engine and engine oil may be hot.
- When removing, prepare a shop cloth to absorb any engine oil leakage or spillage.
- Never allow engine oil to adhere to drive belt.
- Completely wipe off any engine oil that adheres to engine and vehicle.

1. Remove engine undercover with power tool.
2. Using oil filter wrench [SST: KV10115801 (J-38956)] (A), remove oil filter.

⇐ : Engine front

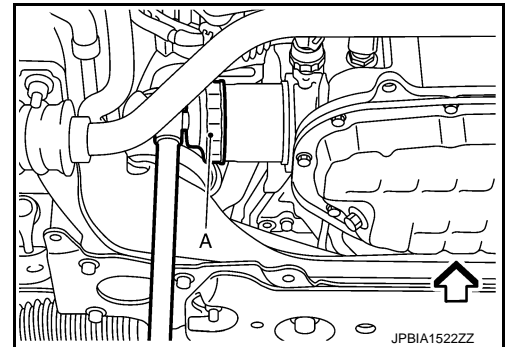

INSTALLATION

1. Remove foreign materials adhering to oil filter installation surface.
2. Apply engine oil to the oil seal contact surface of new oil filter.

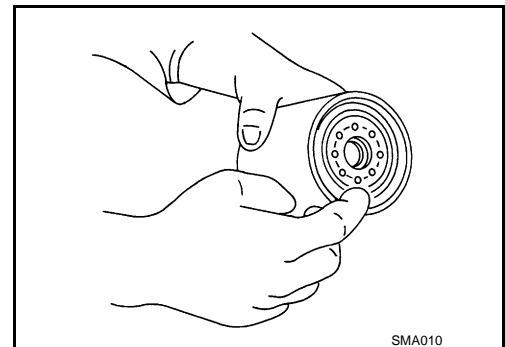

3. Screw oil filter manually until it touches the installation surface, then tighten it by 2/3 turn (A). Or tighten to the specification.

Oil filter:

: 17.7 N·m (1.8 kg·m, 13 ft·lb)

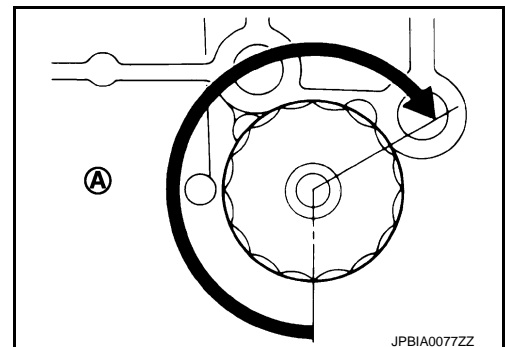

A
B
C
D
E
F
G
H
I
J
K
L
M
N
O
MA

ENGINE MAINTENANCE

< PERIODIC MAINTENANCE >

OIL FILTER : Inspection

INFOID:000000008154371

INSPECTION AFTER INSTALLATION

1. Check the engine oil level. Refer to [LU-7, "Inspection"](#).
2. Start the engine, and check there is no leakage of engine oil.
3. Stop the engine and wait for 10 minutes.
4. Check the engine oil level, and adjust the level. Refer to [LU-7, "Inspection"](#).

SPARK PLUG

SPARK PLUG : Removal and Installation

INFOID:000000008154372

REMOVAL

1. Remove engine cover with power tool. Refer to [EM-25, "Exploded View"](#).
2. Remove air cleaner case and air duct (RH and LH). Refer to [EM-27, "Exploded View"](#).
3. Remove electric throttle control actuator. Refer to [EM-29, "Exploded View"](#).
4. Remove ignition coil. Refer to [EM-46, "Removal and Installation"](#).
5. Remove spark plug with a spark plug wrench (commercial service tool).

a : 14 mm (0.55 in)

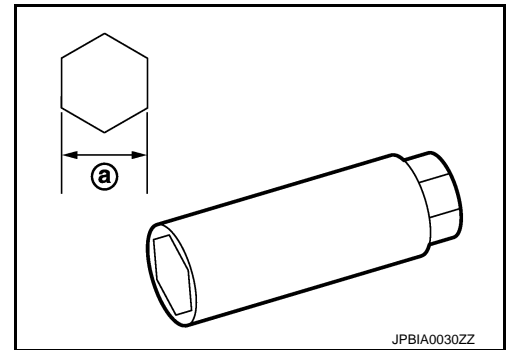

INSTALLATION

Installation is the reverse order of removal.

SPARK PLUG : Inspection

INFOID:000000008154373

INSPECTION AFTER REMOVAL

Use the standard type spark plug for normal condition.

Spark plug (Standard type) : Refer to [EM-138, "Spark Plug"](#).

CAUTION:

- Never drop or shock spark plug.
- Never use a wire brush for cleaning.
- If plug tip is covered with carbon, use spark plug cleaner to clean.

Cleaner air pressure

: Less than 588 kPa (6 kg/cm², 85 psi)

Cleaning time

: Less than 20 seconds

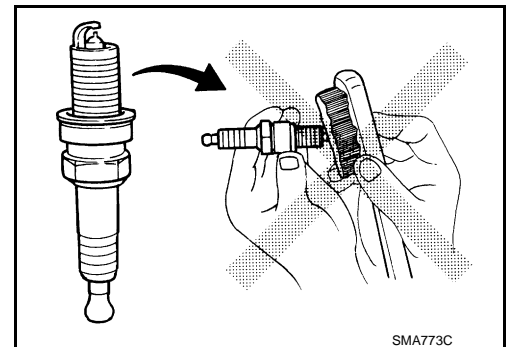

ENGINE MAINTENANCE

< PERIODIC MAINTENANCE >

- Spark plug gap adjustment is not required between replacement intervals.
- Measure spark plug gap. When it exceeds the limit, replace spark plug even if it is within the specified replacement mileage. Refer to [EM-138, "Spark Plug"](#).

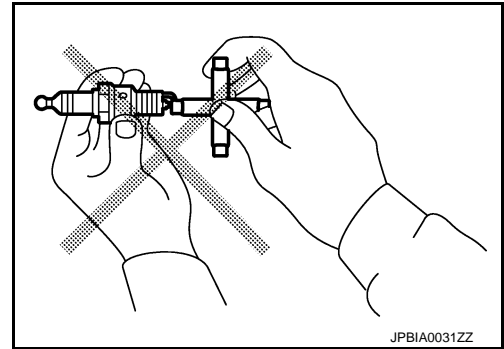

EVAP VAPOR LINES

EVAP VAPOR LINES : Inspection

INFOID:000000008154374

1. Visually inspect EVAP vapor lines for improper attachment and for cracks, damage, loose connections, chafing and deterioration. Refer to [EC-596, "Inspection"](#).
2. Inspect fuel tank filler cap vacuum relief valve for clogging, sticking, etc. Refer to [EC-347, "Component Inspection"](#).

A
B
C
D
E
F
G
H
I
J
K
L
M
N
O

MA

CHASSIS MAINTENANCE

< PERIODIC MAINTENANCE >

CHASSIS MAINTENANCE

EXHAUST SYSTEM

EXHAUST SYSTEM : Inspection

INFOID:000000008154375

Check exhaust pipes, muffler and mounting for improper attachment, leakage, cracks, damage or deterioration.

- If anything is found, repair or replace damaged parts.

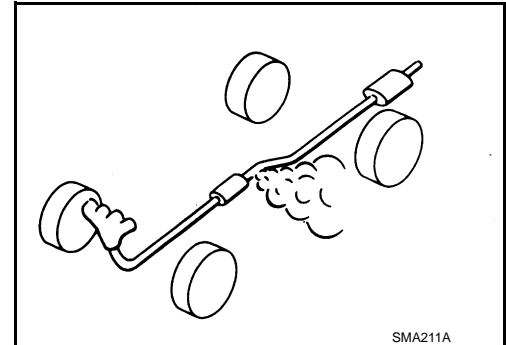

GEAR OIL

GEAR OIL : Inspection

INFOID:000000008154376

OIL LEAKAGE

Make sure that gear oil is not leaking from transmission or around it.

OIL LEVEL

1. Remove filler plug (1) and gasket from transmission case.
2. Check the oil level from filler plug mounting hole as shown in the figure.

CAUTION:

Never start engine while checking oil level.

3. Set a gasket on filler plug and then install it to transmission case.

CAUTION:

Never reuse gasket.

4. Tighten filler plug to the specified torque. Refer to [TM-38, "Exploded View"](#).

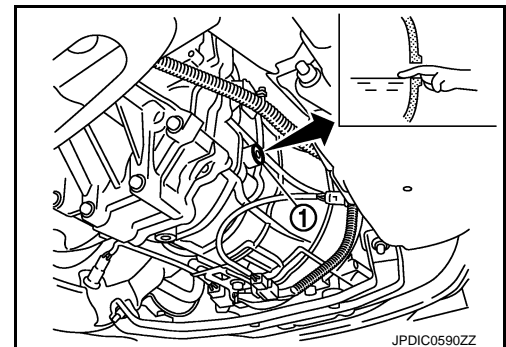

GEAR OIL : Draining

INFOID:000000008154377

1. Start the engine and let it run to warm up transmission.
2. Stop the engine.
3. Remove drain plug and gasket from transmission case and then drain gear oil.
4. Set a gasket on drain plug and install it to transmission case.

CAUTION:

Never reuse gasket.

5. Tighten drain plug to the specified torque. Refer to [TM-38, "Exploded View"](#).

CHASSIS MAINTENANCE

< PERIODIC MAINTENANCE >

GEAR OIL : Refilling

INFOID:000000008154378

1. Remove filler plug (1) and gasket from transmission case.
2. Fill with new gear oil to transmission as shown in the figure.

Oil grade and viscosity : Refer to [MA-10, "Fluids and Lubricants"](#).

Oil capacity : Refer to [TM-100, "General Specifications"](#).

CAUTION:

Never reuse drained gear oil.

3. After refilling gear oil, check the oil level. Refer to [MA-20, "GEAR OIL : Inspection"](#).

4. Set a gasket on filler plug and then install it to transmission case.

CAUTION:

Never reuse gasket.

5. Tighten filler plug to the specified torque. Refer to [TM-38, "Exploded View"](#).

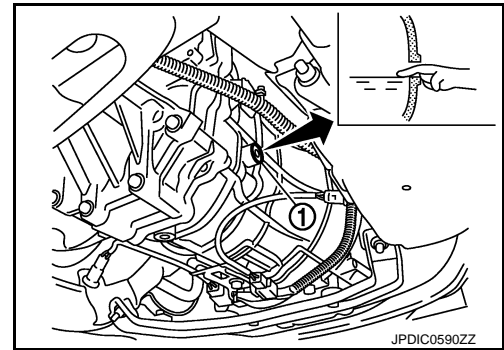

JPDIC0590ZZ

CLUTCH FLUID

CLUTCH FLUID : Inspection

INFOID:000000008154379

FLUID LEAKAGE

- Check clutch line (tubes and hoses) for cracks, deterioration or other damage. Replace any damaged parts.
- Check for fluid leakage by fully depressing clutch pedal while engine is running.

CAUTION:

If leakage occurs around joints, retighten or, if necessary, replace damaged parts.

FLUID LEVEL

- Check that the fluid level in the reservoir tank is within the specified range (MAX – MIN lines).
- Visually check for any fluid leakage around the reservoir tank.
- Check the clutch system for any leakage if the fluid level is extremely low (lower than MIN).

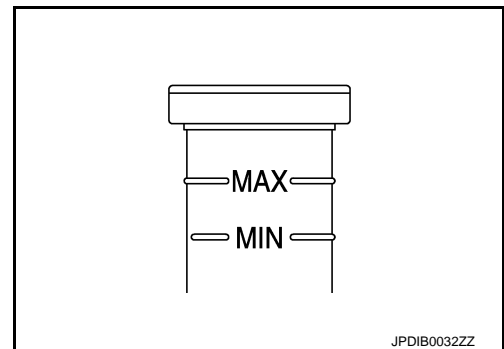

JPDIB0032ZZ

A/T FLUID

A/T FLUID : Inspection

INFOID:000000008154380

FLUID LEAKAGE

- Check transaxle surrounding area (oil seal and plug etc.) for fluid leakage.
- If anything is found, repair or replace damaged parts and adjust A/T fluid level. Refer to [TM-269, "Adjustment"](#).

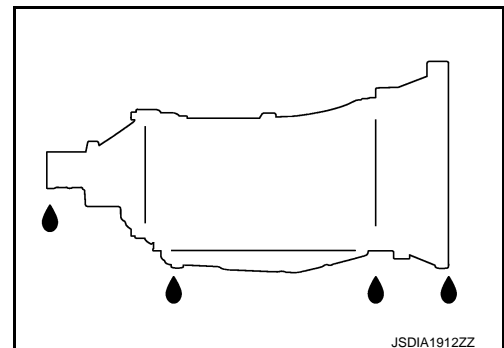

JSDIA1912ZZ

REAR PROPELLER SHAFT: 3S80A

A
B
C
D
E
F
G
H
I
J
K
L
M
N
O

MA

CHASSIS MAINTENANCE

< PERIODIC MAINTENANCE >

REAR PROPELLER SHAFT: 3S80A : Inspection

INFOID:000000008154381

NOISE

- Check the propeller shaft tube surface for dents or cracks. If damaged, replace propeller shaft assembly.
- If center bearing is noisy or damaged, replace propeller shaft assembly.

VIBRATION

If vibration is present at high speed, inspect propeller shaft runout first.

1. With a dial indicator, measure propeller shaft runout at runout measuring points by rotating final drive companion flange with hands.

Propeller shaft runout : Refer to [DLN-10. "Propeller Shaft Runout"](#).

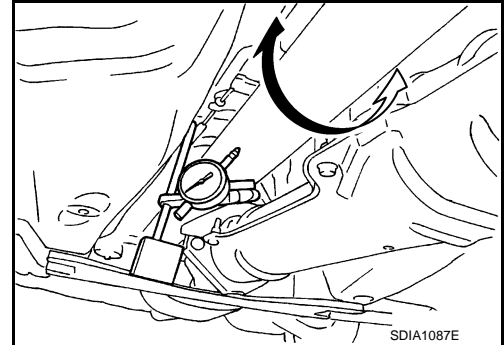

- Propeller shaft runout measuring point (Point "Δ").

← Vehicle front

Dimension

A: 192 mm (7.56 in)
B: 172 mm (6.77 in)
C: 170 mm (6.69 in)

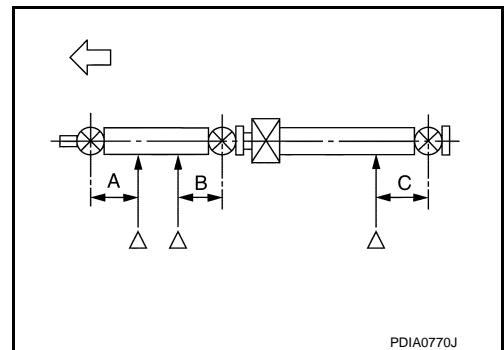

2. If runout still exceeds specifications, separate propeller shaft at final drive companion flange; then change the phase between companion flange and propeller shaft by the one bolt hole at a time and install propeller shaft.
3. If runout is more than the limit value, remove and check propeller shaft.
4. Check the vibration by driving vehicle.

REAR PROPELLER SHAFT: 3S80A-R

REAR PROPELLER SHAFT: 3S80A-R : Inspection

INFOID:000000008154382

NOISE

- Check the propeller shaft tube surface for dents or cracks. If damaged, replace propeller shaft assembly.
- If center bearing is noisy or damaged, replace propeller shaft assembly.

VIBRATION

If vibration is present at high speed, inspect propeller shaft runout first.

1. With a dial indicator, measure propeller shaft runout at runout measuring points by rotating final drive companion flange with hands.

Propeller shaft runout : Refer to [DLN-19. "Propeller Shaft Runout"](#).

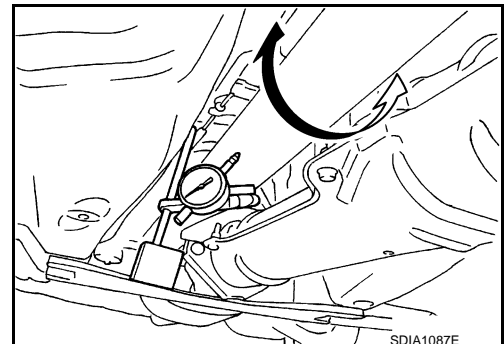

CHASSIS MAINTENANCE

< PERIODIC MAINTENANCE >

- Propeller shaft runout measuring point (Point “△”).

↔: Vehicle front

Dimension

A: 192 mm (7.56 in)

B: 172 mm (6.77 in)

C: 172 mm (6.77 in)

2. If runout still exceeds specifications, separate propeller shaft at final drive companion flange; then change the phase between companion flange and propeller shaft by the one bolt hole at a time and install propeller shaft.
3. If runout is more than the limit value, remove and check propeller shaft.
4. Check the vibration by driving vehicle.

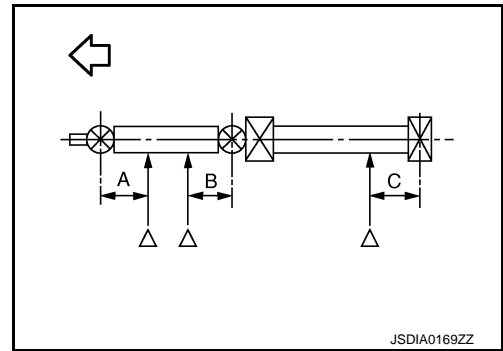

REAR DIFFERENTIAL GEAR OIL: R200

REAR DIFFERENTIAL GEAR OIL: R200 : Inspection

INFOID:000000008154383

OIL LEAKAGE

Make sure that oil is not leaking from final drive assembly or around it.

OIL LEVEL

- Remove filler plug (1) and check oil level from filler plug mounting hole as shown in the figure.

CAUTION:

Never start engine while checking oil level.

- Set a gasket on filler plug and install it on final drive assembly. Refer to [DLN-48. "M/T : Exploded View"](#) (M/T), [DLN-61. "A/T : Exploded View"](#) (A/T).

CAUTION:

Never reuse gasket.

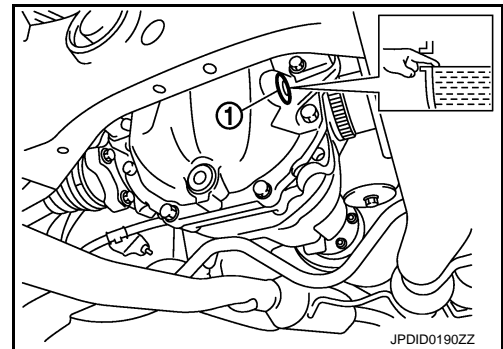

REAR DIFFERENTIAL GEAR OIL: R200 : Draining

INFOID:000000008154384

1. Stop the engine.
2. Remove drain plug (1) and drain gear oil.
3. Set a gasket on drain plug and install it to final drive assembly and tighten to the specified torque. Refer to [DLN-48. "M/T : Exploded View"](#) (M/T), [DLN-61. "A/T : Exploded View"](#) (A/T).

CAUTION:

Never reuse gasket.

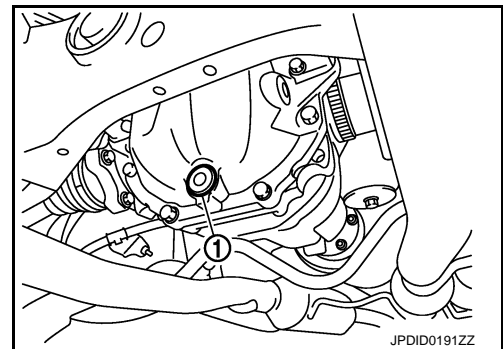

CHASSIS MAINTENANCE

< PERIODIC MAINTENANCE >

REAR DIFFERENTIAL GEAR OIL: R200 : Refilling

INFOID:000000008154385

1. Remove filler plug (1). Fill with new gear oil until oil level reaches the specified level near filler plug mounting hole.

Oil grade and viscosity : Refer to [MA-10, "Fluids and Lubricants"](#).

Oil capacity : Refer to [DLN-90, "General Specification"](#).

2. After refilling oil, check oil level. Set a gasket to filler plug, then install it to final drive assembly. Refer to [DLN-48, "M/T : Exploded View"](#) (M/T), [DLN-61, "A/T : Exploded View"](#) (A/T).

CAUTION:

Never reuse gasket.

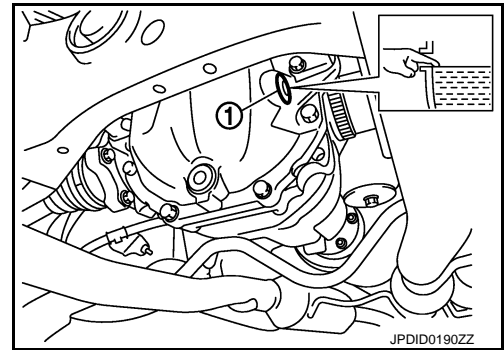

WHEELS (BONDING WEIGHT TYPE)

WHEELS (BONDING WEIGHT TYPE) : Adjustment

INFOID:000000008154386

BALANCING WHEELS (BONDING WEIGHT TYPE)

Preparation Before Adjustment

Using releasing agent, remove double-faced adhesive tape from the road wheel.

CAUTION:

- **Be careful not to scratch the road wheel during removal.**
- **After removing double-faced adhesive tape, wipe clean traces of releasing agent from the road wheel.**

Wheel Balance Adjustment

If a tire balance machine has adhesion balance weight mode settings and drive-in weight mode setting, select and adjust a drive-in weight mode suitable for road wheels.

1. Set road wheel on tire balance machine using the center hole as a guide. Start the tire balance machine.
2. When inner and outer unbalance values are shown on the tire balance machine indicator, multiply outer unbalance value by 5/3 to determine balance weight that should be used. Select the outer balance weight with a value closest to the calculated value above and install to the designated outer position of, or at the designated angle in relation to the road wheel.

CAUTION:

- **Do not install the inner balance weight before installing the outer balance weight.**
- **Before installing the balance weight, be sure to clean the mating surface of the road wheel.**

- a. Indicated unbalance value $\times 5/3$ = balance weight to be installed

Calculation example:

23 g (0.81 oz) $\times 5/3$ = 38.33 g (1.35 oz) \Rightarrow 37.5 g (1.32 oz) balance weight (closer to calculated balance weight value)

NOTE:

Note that balance weight value must be closer to the calculated balance weight value.

Example:

36.2 \Rightarrow 35 g (1.23 oz)

36.3 \Rightarrow 37.5 g (1.32 oz)

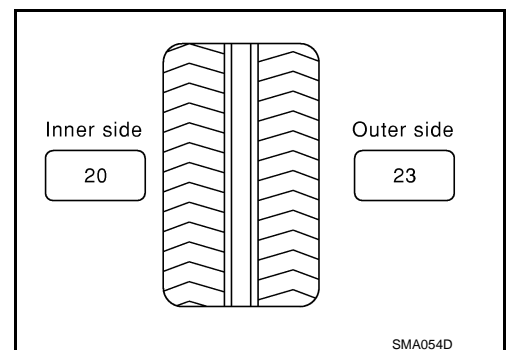

- b. Installed balance weight in the position.

CHASSIS MAINTENANCE

< PERIODIC MAINTENANCE >

- When installing balance weight (1) to road wheels, set it into the grooved area (A) on the inner wall of the road wheel as shown in the figure so that the balance weight center (B) is aligned with the tire balance machine indication position (angle) (C).

CAUTION:

- Always use genuine NISSAN adhesion balance weights.
- Balance weights are non-reusable; always replace with new ones.
- Do not install more than three sheets of balance weight.

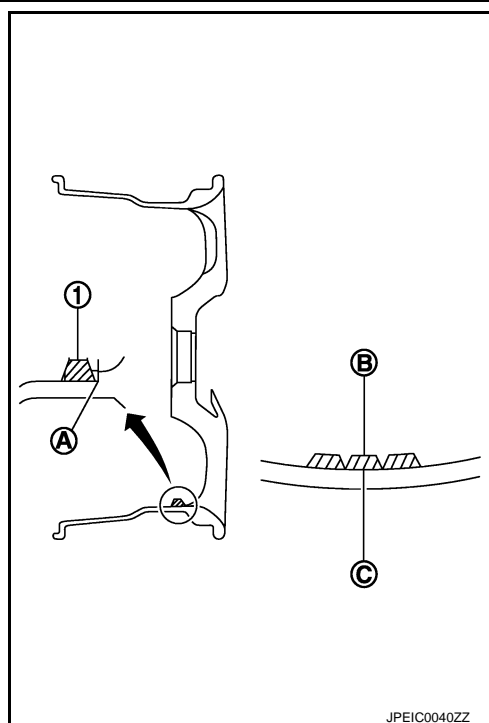

- c. If calculated balance weight value exceeds 50 g (1.76 oz), install two balance weight sheets in line with each other as shown in the figure.

CAUTION:

Do not install one balance weight sheet on top of another.

3. Start the tire balance machine again.
4. Install drive-in balance weight on inner side of road wheel in the tire balance machine indication position (angle).

CAUTION:

Do not install more than two balance weight.

5. Start the tire balance machine. Make sure that inner and outer residual unbalance values are 5 g (0.17 oz) each or below.
6. If either residual unbalance value exceeds 5 g (0.17 oz), repeat installation procedures.

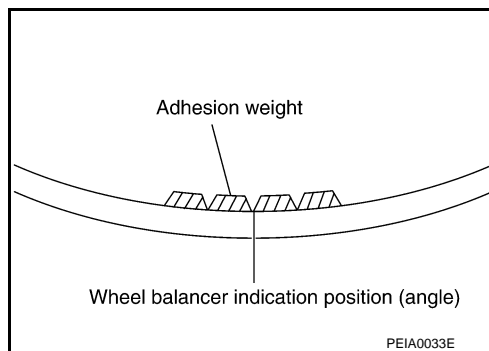

Limit

Dynamic (At flange) : Refer to [WT-50, "Road Wheel"](#).

Static (At flange) : Refer to [WT-50, "Road Wheel"](#).

TIRE ROTATION

- Tire cannot be rotated in vehicle, as front tire are different size from rear tire and the direction of wheel rotation is fixed in each tire.

Wheel nuts tightening torque : Refer to [WT-50, "Road Wheel"](#).

CAUTION:

- Never include the T-type spare tire when rotating the tires.
- Use NISSAN genuine wheel nuts for aluminum wheels.

Safety Device Preventing from Being Incorrectly installed

FRONT BRAKE DISC ROTOR AND FRONT WHEEL

CHASSIS MAINTENANCE

< PERIODIC MAINTENANCE >

- Front and rear wheel size for this model differs, therefore special pin (1) is adopted to the front brake disc rotor (2). And a hole (3) that matches to this pin is adopted to the front wheel (4) (the rear wheel does not have this wheel). This structure prevents the rear wheel from being mistakenly installed on the front.

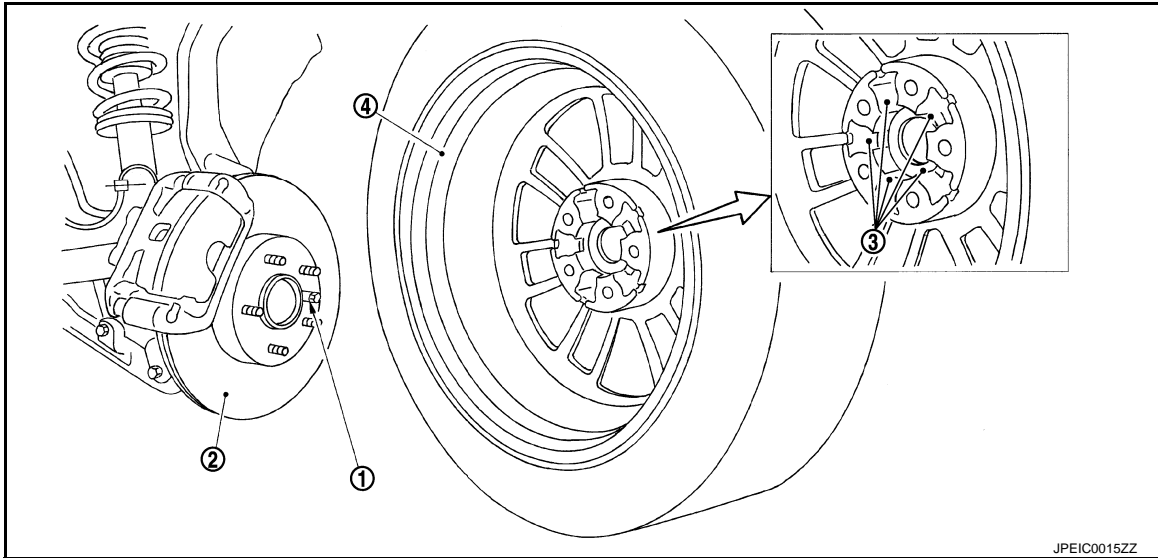

T-TYPE SPARE TIRE WHEEL

- Regarding spare tire (for emergency) wheel, wrong assembly protection pin through hole (1) has been set in addition to regular bolt holes (2) in order to enable installation to front wheel.

NOTE:

Protection pin through hole of 18 inch spare wheel is non-through type.

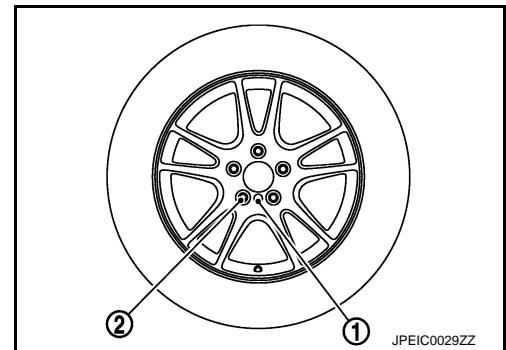

BRAKE FLUID LEVEL AND LEAKS

BRAKE FLUID LEVEL AND LEAKS : Inspection

- If fluid level is extremely low, check brake system for leaks.

INFOID:000000008154387

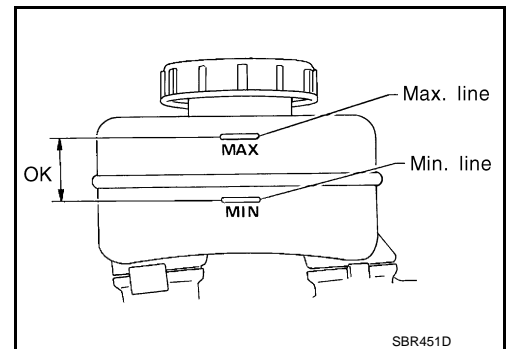

BRAKE LINES AND CABLES

CHASSIS MAINTENANCE

< PERIODIC MAINTENANCE >

BRAKE LINES AND CABLES : Inspection

INFOID:000000008154388

- Check brake fluid lines and parking brake cables for improper attachment, leaks, chafing, abrasions, deterioration, etc.

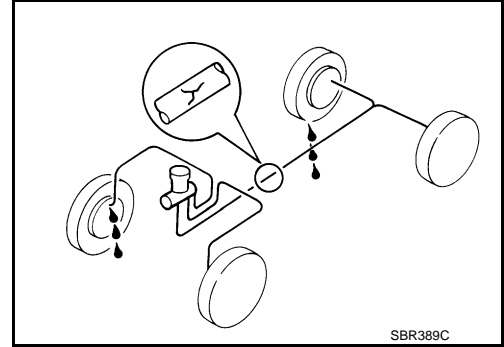

BRAKE FLUID

BRAKE FLUID : Changing

INFOID:000000008154389

1. Drain brake fluid from each bleed valve.
2. Refill until new brake fluid comes out from each bleed valve. Use same procedure as in bleeding hydraulic system to refill brake fluid.
Refer to [BR-11. "Bleeding Brake System"](#).
 - Refill with recommended Genuine NISSAN Super Heavy Duty Brake Fluid or equivalent DOT 3 (US FMVSS No. 116). Refer to [MA-10. "Fluids and Lubricants"](#).
 - Never reuse drained brake fluid.
 - Be careful not to splash brake fluid on painted areas.

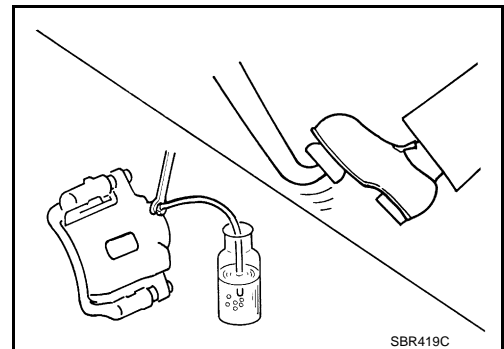

DISC BRAKE

DISC BRAKE : Inspection

INFOID:000000008154390

DISC ROTOR

Check condition, wear, and damage.

CALIPER

- Check for leakage.

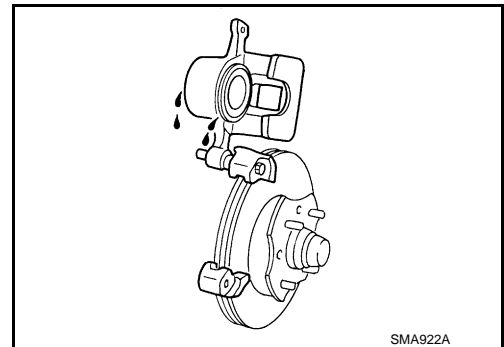

BRAKE PAD

A
B
C
D
E
F
G
H
I
J
K
L
M
N
O

MA

CHASSIS MAINTENANCE

< PERIODIC MAINTENANCE >

- Check for wear or damage.

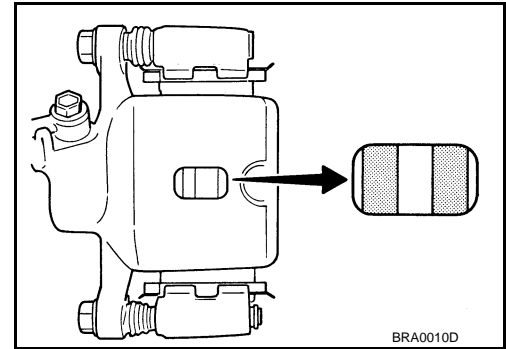

DISC BRAKE : Front Disc Brake

INFOID:000000008154391

1 PISTON TYPE

Unit: mm (in)

Item		Limit
Brake pad	Wear thickness	2.0 (0.079)
	Wear thickness	30.0 (1.181)
Disc rotor	Thickness variation (measured at 8 positions)	0.015 (0.0006)
	Runout (with it attached to the vehicle)	0.035 (0.0014)

4 PISTON TYPE

Unit: mm (in)

Item		Limit
Brake pad	Wear thickness	2.0 (0.079)
	Wear thickness	30.0 (1.181)
Disc rotor	Thickness variation (measured at 8 positions)	0.015 (0.0006)
	Runout (with it attached to the vehicle)	0.035 (0.0014)

DISC BRAKE : Rear Disc Brake

INFOID:000000008154392

1 PISTON TYPE

Unit: mm (in)

Item		Limit
Brake pad	Wear thickness	2.0 (0.079)
	Wear thickness	15.0 (0.591)
Disc rotor	Thickness variation (measured at 8 positions)	0.015 (0.0006)
	Runout (with it attached to the vehicle)	0.055 (0.0022)

2 PISTON TYPE

Unit: mm (in)

Item		Limit
Brake pad	Wear thickness	2.0 (0.079)
	Wear thickness	18.0 (0.709)
Disc rotor	Thickness variation (measured at 8 positions)	0.015 (0.0006)
	Runout (with it attached to the vehicle)	0.055 (0.0022)

STEERING GEAR AND LINKAGE

STEERING GEAR AND LINKAGE : Inspection

INFOID:000000008154393

STEERING GEAR

CHASSIS MAINTENANCE

< PERIODIC MAINTENANCE >

- Check gear housing and boots for looseness, damage and grease leakage.
- Check connection with steering column for looseness.

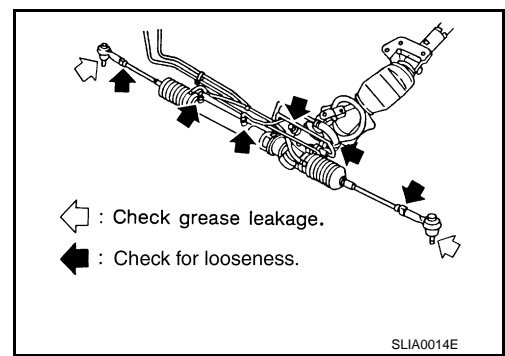

STEERING LINKAGE

Check ball joint, dust cover and other component parts for looseness, wear, damage and grease leakage.

POWER STEERING FLUID AND LINES

POWER STEERING FLUID AND LINES : Inspection

INFOID:000000008154394

Check fluid level in reservoir tank with engine off.

Use "HOT" range at fluid temperatures of 50 to 80°C (122 to 176°F) or "COLD" range at fluid temperatures of 0 to 30°C (32 to 86°F).

CAUTION:

- Do not overfill.
- Recommended fluid is Genuine NISSAN PSF or equivalent. Refer to [MA-10, "Fluids and Lubricants"](#).

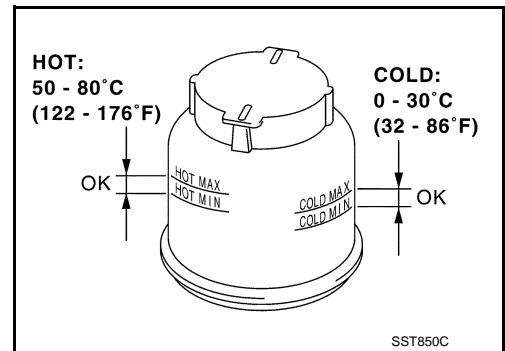

- Check lines for improper attachment, leaks, cracks, damage, loose connections, chafing and deterioration.
- Check rack boots for accumulation of power steering fluid.

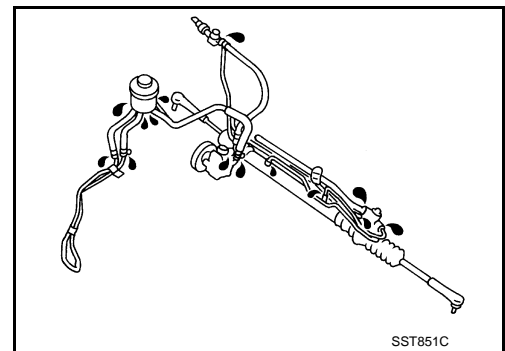

AXLE AND SUSPENSION PARTS

AXLE AND SUSPENSION PARTS : Inspection

INFOID:000000008154395

Check front and rear axle and suspension parts for excessive play, cracks, wear or other damage.

- Shake each wheel to check for excessive play.
- Check wheel bearings for smooth operation.
- Check axle and suspension nuts and bolts for looseness.
- Check strut (shock absorber) for oil leakage or other damage.
- Check suspension ball joint for grease leakage and ball joint dust cover for cracks or other damage.

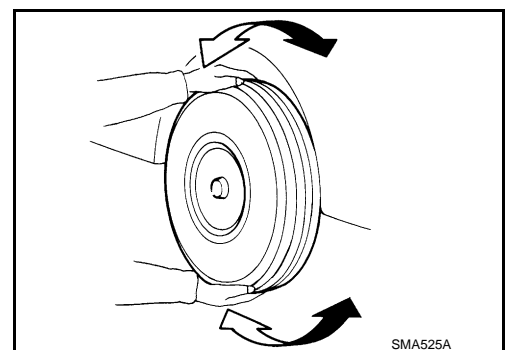

A
B
C
D
E
F
G
H
I
J
K
L
M
N
O

MA

CHASSIS MAINTENANCE

< PERIODIC MAINTENANCE >

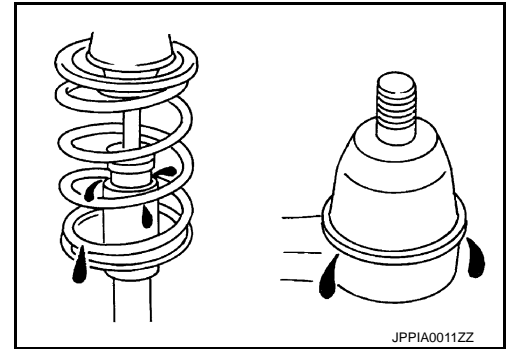

BODY MAINTENANCE

< PERIODIC MAINTENANCE >

BODY MAINTENANCE

LOCKS, HINGES AND HOOD LATCH

LOCKS, HINGES AND HOOD LATCH : Lubricating

INFOID:000000008154396

For hood lock illustration. Refer to [DLK-220, "HOOD ASSEMBLY : Exploded View"](#) and [DLK-223, "HOOD LOCK CONTROL : Exploded View"](#).

For door lock illustration. Refer to [DLK-230, "DOOR ASSEMBLY : Exploded View"](#).

For trunk lid lock illustration. Refer to [DLK-235, "TRUNK LID ASSEMBLY : Exploded View"](#).

SEAT BELT, BUCKLES, RETRACTORS, ANCHORS AND ADJUSTERS

SEAT BELT, BUCKLES, RETRACTORS, ANCHORS AND ADJUSTERS : Inspection

INFOID:000000008154397

For front seat belt illustration. Refer to [SB-6, "SEAT BELT RETRACTOR : Exploded View"](#).

For rear seat belt illustration. Refer to [SB-11, "SEAT BELT RETRACTOR : Exploded View"](#).

CAUTION:

- After any collision, inspect all seat belt assemblies, including retractors and other attached hardware (i.e. anchor bolt, guide rail set). Nissan recommends to replace all seat belt assemblies in use during a collision, unless not damaged and properly operating after minor collision. Also inspect seat belt assemblies not in use during a collision, and replace if damaged or improperly operating.

Seat belt pre-tensioner should be replaced even if the seat belts are not in use during a frontal collision where the driver and passenger air bags are deployed.

- If any component of seat belt assembly is questionable, do not repair.

Replace as seat belt assembly.

- If webbing is cut, frayed, or damaged, replace belt assembly.
- Never oil tongue and buckle.
- Use a genuine NISSAN seat belt assembly.

For details, refer to [SB-4, "SEAT BELT RETRACTOR : Inspection"](#), [SB-9, "SEAT BELT RETRACTOR : Inspection"](#) in SB section.

- Check anchors for loose mounting
- Check belts for damage
- Check retractor for smooth operation
- Check function of buckles and tongues when buckled and released

A
B
C
D
E
F
G
H
I
J
K
L
M
N
O

MA

SERVICE DATA AND SPECIFICATIONS (SDS)

< SERVICE DATA AND SPECIFICATIONS (SDS)

SERVICE DATA AND SPECIFICATIONS (SDS)

SERVICE DATA AND SPECIFICATIONS (SDS)

DRIVE BELTS

DRIVE BELTS : Drive Belt

INFOID:000000008154398

DRIVE BELT

Tension of drive belt	Belt tension is not necessary, as it is automatically adjusted by drive belt auto-tensioner.
-----------------------	----------------------------------------------------------------------------------------------

ENGINE COOLANT

ENGINE COOLANT : Periodical Maintenance Specification

INFOID:000000008154399

ENGINE COOLANT CAPACITY (APPROXIMATE)

Unit: ℓ (US qt, Imp qt)

Engine coolant capacity [With reservoir tank ("MAX" level)]	A/T models	8.5 (9, 7-1/2)
	M/T models	8.6 (9-1/8, 7-5/8)
Reservoir tank engine coolant capacity (At "MAX" level)		0.8 (7/8, 3/4)

ENGINE OIL

ENGINE OIL : Periodical Maintenance Specification

INFOID:000000008154400

ENGINE OIL CAPACITY (APPROXIMATE)

Unit: ℓ (US qt, Imp qt)

Drain and refill	With oil filter change	4.9 (5-1/8, 4-1/4)
	Without oil filter change	4.6 (4-7/8, 4)
Dry engine (Overhaul)		5.7 (6, 5)

SPARK PLUG

SPARK PLUG : Spark Plug

INFOID:000000008154401

SPARK PLUG

Unit: mm (in)

Make		DENSO
Standard type		FXE24HR11
Gap (Nominal)	Standard	1.1 (0.043)
	Limit	1.4 (0.055)

ROAD WHEEL

ROAD WHEEL : Road Wheel

INFOID:000000008154402

CONVENTIONAL

Item		Limit
Runout	Axial runout	Less than 0.3 mm (0.012 in)
	Radial runout	
Allowable unbalance	Dynamic (At flange)	Less than 5 g (0.17 oz) (one side)
	Static (At flange)	Less than 10 g (0.35 oz)

SERVICE DATA AND SPECIFICATIONS (SDS)

< SERVICE DATA AND SPECIFICATIONS (SDS)

EMERGENCY

Item		Limit
Runout	Axial runout	Less than 1.5 mm (0.059 in)
	Radial runout	

A

B

C

D

E

F

G

H

I

J

K

L

M

N

O

MA