

SECTION **FSU**
FRONT SUSPENSION

A
B
C
D

FSU

CONTENTS

<p>2WD</p> <p>SYMPTOM DIAGNOSIS 3</p> <p>NOISE, VIBRATION AND HARSHNESS (NVH) TROUBLESHOOTING 3</p> <p> NVH Troubleshooting Chart3</p> <p>PRECAUTION 4</p> <p>PRECAUTIONS 4</p> <p> Precaution for Supplemental Restraint System (SRS) "AIR BAG" and "SEAT BELT PRE-TENSIONER"4</p> <p> Precaution Necessary for Steering Wheel Rotation after Battery Disconnect4</p> <p> Precaution for Procedure without Cowl Top Cover.....5</p> <p> Precautions for Suspension5</p> <p>PREPARATION 6</p> <p>PREPARATION 6</p> <p> Special Service Tool6</p> <p> Commercial Service Tool6</p> <p>PERIODIC MAINTENANCE 7</p> <p>FRONT SUSPENSION ASSEMBLY 7</p> <p> Inspection7</p> <p>WHEEL ALIGNMENT 8</p> <p> Inspection8</p> <p>REMOVAL AND INSTALLATION 9</p> <p>FRONT COIL SPRING AND SHOCK ABSORBER 9</p> <p> Exploded View9</p> <p> Removal and Installation10</p> <p> Disassembly and Assembly10</p> <p> Inspection12</p>	<p>TRANSVERSE LINK14</p> <p> Exploded View14</p> <p> Removal and Installation15</p> <p> Inspection15</p> <p>UPPER LINK17</p> <p> Exploded View17</p> <p> Removal and Installation18</p> <p> Inspection18</p> <p>FRONT STABILIZER19</p> <p> Exploded View19</p> <p> Removal and Installation20</p> <p> Inspection20</p> <p>UNIT REMOVAL AND INSTALLATION21</p> <p>FRONT SUSPENSION MEMBER21</p> <p> Exploded View21</p> <p> Removal and Installation22</p> <p> Inspection22</p> <p>SERVICE DATA AND SPECIFICATIONS (SDS)23</p> <p>SERVICE DATA AND SPECIFICATIONS (SDS)23</p> <p> Wheel Alignment23</p> <p> Ball Joint23</p> <p> Wheelarch Height23</p> <p style="text-align: center;">AWD</p> <p>SYMPTOM DIAGNOSIS25</p> <p>NOISE, VIBRATION AND HARSHNESS (NVH) TROUBLESHOOTING25</p> <p> NVH Troubleshooting Chart25</p> <p>PRECAUTION26</p> <p>PRECAUTIONS26</p>	<p>F G H I J K L M N O P</p>
--	---	--

Precaution for Supplemental Restraint System (SRS) "AIR BAG" and "SEAT BELT PRE-TENSIONER"	26	TRANSVERSE LINK	36
Precaution Necessary for Steering Wheel Rotation after Battery Disconnect	26	Exploded View	36
Precaution for Procedure without Cowl Top Cover..	27	Removal and Installation	37
Precautions for Suspension	27	Inspection	37
PREPARATION	28	UPPER LINK	39
PREPARATION	28	Exploded View	39
Special Service Tool	28	Removal and Installation	40
Commercial Service Tool	28	Inspection	40
PERIODIC MAINTENANCE	29	FRONT STABILIZER	41
FRONT SUSPENSION ASSEMBLY	29	Exploded View	41
Inspection	29	Removal and Installation	42
WHEEL ALIGNMENT	30	Inspection	42
Inspection	30	UNIT REMOVAL AND INSTALLATION	43
REMOVAL AND INSTALLATION	31	FRONT SUSPENSION MEMBER	43
FRONT COIL SPRING AND SHOCK ABSORBER	31	Exploded View	43
Exploded View	31	Removal and Installation	44
Removal and Installation	32	Inspection	44
Disassembly and Assembly	32	SERVICE DATA AND SPECIFICATIONS (SDS)	45
Inspection	34	SERVICE DATA AND SPECIFICATIONS (SDS)	45
		Wheel Alignment	45
		Ball Joint	45
		Wheelarch Height	45

NOISE, VIBRATION AND HARSHNESS (NVH) TROUBLESHOOTING

< SYMPTOM DIAGNOSIS >

[2WD]

SYMPTOM DIAGNOSIS

NOISE, VIBRATION AND HARSHNESS (NVH) TROUBLESHOOTING

NVH Troubleshooting Chart

INFOID:000000004670198

Use chart below to find the cause of the symptom. If necessary, repair or replace these parts.

Symptom		Possible cause and SUSPECTED PARTS	Reference page													
			FSU-9, FSU-14, FSU-17, FSU-19, FSU-21	FSU-12	—	—	—	FSU-9, FSU-14, FSU-17, FSU-19, FSU-21	FSU-8	FSU-20	NVH in DLN section	NVH in FAX and FSU section	NVH in WT section	NVH in BR section	NVH in ST section	
FRONT SUSPENSION	Noise	Improper installation, looseness	x	x	x	x	x	x	x			x	x	x	x	x
	Shake	Shock absorber deformation, damage or deflection	x	x	x	x						x	x	x	x	x
	Vibration	Bushing or mounting deterioration	x	x	x	x	x									
	Shimmy	Parts interference	x	x	x	x										
	Judder	Spring fatigue	x	x												
	Poor quality ride or handling	Suspension looseness	x	x												
		Incorrect wheel alignment														
		Stabilizer bar fatigue														
		PROPELLER SHAFT														
		FRONT AXLE AND FRONT SUSPENSION														
		ROAD WHEEL														
		BRAKE														
		STEERING														

x: Applicable

A
B
C
D
E
F
G
H
I
J
K
L
M
N
O
P

FSU

PRECAUTION

PRECAUTIONS

Precaution for Supplemental Restraint System (SRS) "AIR BAG" and "SEAT BELT PRE-TENSIONER"

INFOID:000000004679096

The Supplemental Restraint System such as "AIR BAG" and "SEAT BELT PRE-TENSIONER", used along with a front seat belt, helps to reduce the risk or severity of injury to the driver and front passenger for certain types of collision. This system includes seat belt switch inputs and dual stage front air bag modules. The SRS system uses the seat belt switches to determine the front air bag deployment, and may only deploy one front air bag, depending on the severity of a collision and whether the front occupants are belted or unbelted. Information necessary to service the system safely is included in the "SRS AIR BAG" and "SEAT BELT" of this Service Manual.

WARNING:

- To avoid rendering the SRS inoperative, which could increase the risk of personal injury or death in the event of a collision which would result in air bag inflation, all maintenance must be performed by an authorized NISSAN/INFINITI dealer.
- Improper maintenance, including incorrect removal and installation of the SRS, can lead to personal injury caused by unintentional activation of the system. For removal of Spiral Cable and Air Bag Module, see the "SRS AIR BAG".
- Do not use electrical test equipment on any circuit related to the SRS unless instructed to in this Service Manual. SRS wiring harnesses can be identified by yellow and/or orange harnesses or harness connectors.

PRECAUTIONS WHEN USING POWER TOOLS (AIR OR ELECTRIC) AND HAMMERS

WARNING:

- When working near the Air Bag Diagnosis Sensor Unit or other Air Bag System sensors with the ignition ON or engine running, DO NOT use air or electric power tools or strike near the sensor(s) with a hammer. Heavy vibration could activate the sensor(s) and deploy the air bag(s), possibly causing serious injury.
- When using air or electric power tools or hammers, always switch the ignition OFF, disconnect the battery, and wait at least 3 minutes before performing any service.

Precaution Necessary for Steering Wheel Rotation after Battery Disconnect

INFOID:000000004679098

NOTE:

- Before removing and installing any control units, first turn the push-button ignition switch to the LOCK position, then disconnect both battery cables.
- After finishing work, confirm that all control unit connectors are connected properly, then re-connect both battery cables.
- Always use CONSULT-III to perform self-diagnosis as a part of each function inspection after finishing work. If a DTC is detected, perform trouble diagnosis according to self-diagnosis results.

For vehicle with steering lock unit, if the battery is disconnected or discharged, the steering wheel will lock and cannot be turned.

If turning the steering wheel is required with the battery disconnected or discharged, follow the operation procedure below before starting the repair operation.

OPERATION PROCEDURE

1. Connect both battery cables.

NOTE:

Supply power using jumper cables if battery is discharged.

2. Turn the push-button ignition switch to ACC position.
(At this time, the steering lock will be released.)
3. Disconnect both battery cables. The steering lock will remain released with both battery cables disconnected and the steering wheel can be turned.
4. Perform the necessary repair operation.

PRECAUTIONS

[2WD]

< PRECAUTION >

5. When the repair work is completed, re-connect both battery cables. With the brake pedal released, turn the push-button ignition switch from ACC position to ON position, then to LOCK position. (The steering wheel will lock when the push-button ignition switch is turned to LOCK position.)
6. Perform self-diagnosis check of all control units using CONSULT-III.

Precaution for Procedure without Cowl Top Cover

INFOID:000000004679101

When performing the procedure after removing cowl top cover, cover the lower end of windshield with urethane, etc.

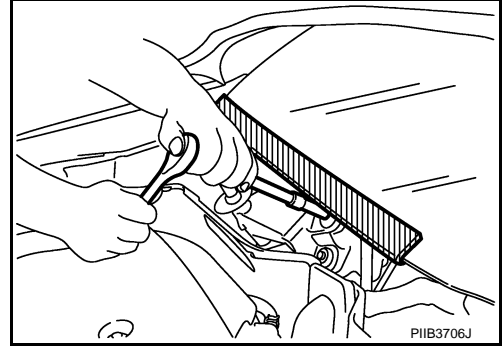

Precautions for Suspension

INFOID:000000004670202

- When installing rubber bushings, the final tightening must be carried out under unladen conditions with tires on ground. Spilled oil might shorten the life of rubber bushings. Be sure to wipe off any spilled oil.
- Unladen conditions mean that fuel, engine coolant and lubricant are full. Spare tire, jack, hand tools and mats are in designated positions.
- After servicing suspension parts, be sure to check wheel alignment.
- Self-lock nuts are not reusable. Always use new ones when installing. Since new self-lock nuts are pre-oiled, tighten as they are.

PREPARATION

< PREPARATION >

[2WD]

PREPARATION

PREPARATION

Special Service Tool

INFOID:000000004670203

The actual shapes of Kent-Moore tools may differ from those of special service tools illustrated here.

Tool number (Kent-Moore No.) Tool name	Description
ST35652000 (-) Shock absorber attachment	Disassembling and assembling shock absorber
ST3127S000 (J-25765-A) Preload gauge	Measuring rotating torque of ball joint

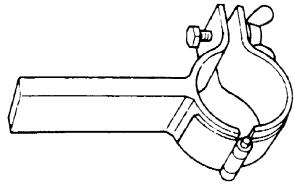

ZZA0807D

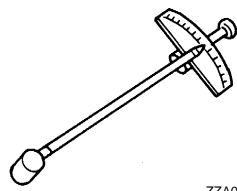

ZZA0806D

Commercial Service Tool

INFOID:000000004670204

Tool name	Description
Power tool	Loosening bolts and nuts
Spring compressor	Removing and installing coil spring

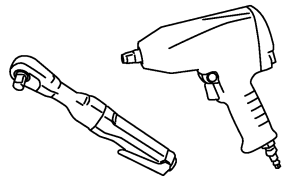

PBIC0190E

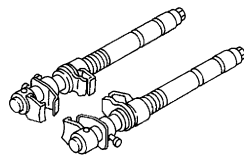

S-NT717

FRONT SUSPENSION ASSEMBLY

< PERIODIC MAINTENANCE >

[2WD]

PERIODIC MAINTENANCE

FRONT SUSPENSION ASSEMBLY

Inspection

INFOID:000000004670205

MOUNTING INSPECTION

Make sure the mounting conditions (looseness, backlash) of each component and component conditions (wear, damage) are normal.

BALL JOINT AXIAL END PLAY

1. Set front wheels in a straight-ahead position.

CAUTION:

Never depress brake pedal.

2. Place an iron bar or equivalent between transverse link or upper link and steering knuckle.
3. Measure axial end play by prying it up and down.

Standard

Axial end play : Refer to [FSU-23, "Ball Joint"](#).

CAUTION:

Be careful not to damage ball joint boot. never damage the installation position by applying excessive force.

SHOCK ABSORBER

Check for oil leakage, damage and replace if malfunction is detected.

A
B
C
D
E
F
G
H
I
J
K
L
M
N
O
P

FSU

WHEEL ALIGNMENT

Inspection

INFOID:000000004670206

DESCRIPTION

CAUTION:

- **Camber, caster, kingpin inclination angles cannot be adjusted.**
- **If camber, caster, or kingpin inclination angle is outside the standard, check front suspension parts for wear and damage. Replace suspect parts if a malfunction is detected.**
- **Kingpin inclination angle is reference value, no inspection is required.**
- **Measure wheel alignment under unladen conditions.**

NOTE:

“Unladen conditions” means that fuel, engine coolant, and lubricant are full. Spare tire, jack, hand tools and mats are in designated positions.

GENERAL INFORMATION AND RECOMMENDATIONS

- A four-wheel thrust alignment should be performed.
- This type of alignment is recommended for any NISSAN/INFINITI vehicle.
- The four-wheel “thrust” process helps ensure that the vehicle is properly aligned and the steering wheel is centered.
- The alignment rack itself should be capable of accepting any NISSAN/INFINITI vehicle.
- The rack should be checked to ensure that it is level.
- Make sure the machine is properly calibrated.
- Your alignment equipment should be regularly calibrated in order to give correct information.
- Check with the manufacturer of your specific equipment for their recommended Service/Calibration Schedule.

ALIGNMENT PROCESS

IMPORTANT:

Use only the alignment specifications listed in this Service Manual.

- When displaying the alignment settings, many alignment machines use “indicators”: (Green/red, plus or minus, Go/No Go). **Never use these indicators.**
- The alignment specifications programmed into your machine that operate these indicators may not be correct.
- This may result in an ERROR.
- Some newer alignment machines are equipped with an “optional Rolling Compensation” method to “compensate” the sensors (alignment targets or head units). **Never use this “Rolling Compensation” method.**
- Use the “Jacking Compensation Method”. After installing the alignment targets or head units, raise the vehicle and rotate the wheels 1/2 turn both ways.
- See Instructions in the alignment machine you're using for more information on this.

PRELIMINARY CHECK

Check the following:

- Tires for improper air pressure and wear.
- Road wheels for runout. Refer to [WT-95, "Inspection"](#).
- Wheel bearing axial end play. Refer to [FAX-5, "Inspection"](#).
- Transverse link or upper link ball joint axial end play. Refer to [FSU-23, "Ball Joint"](#), [FSU-18, "Inspection"](#).
- Shock absorber operation.
- Each mounting part of axle and suspension for looseness and deformation.
- Each of suspension member, shock absorber, upper link and transverse link for cracks, deformation and other damage.
- Vehicle height (posture).

FRONT COIL SPRING AND SHOCK ABSORBER

< REMOVAL AND INSTALLATION >

[2WD]

REMOVAL AND INSTALLATION

FRONT COIL SPRING AND SHOCK ABSORBER

Exploded View

INFOID:000000004670207

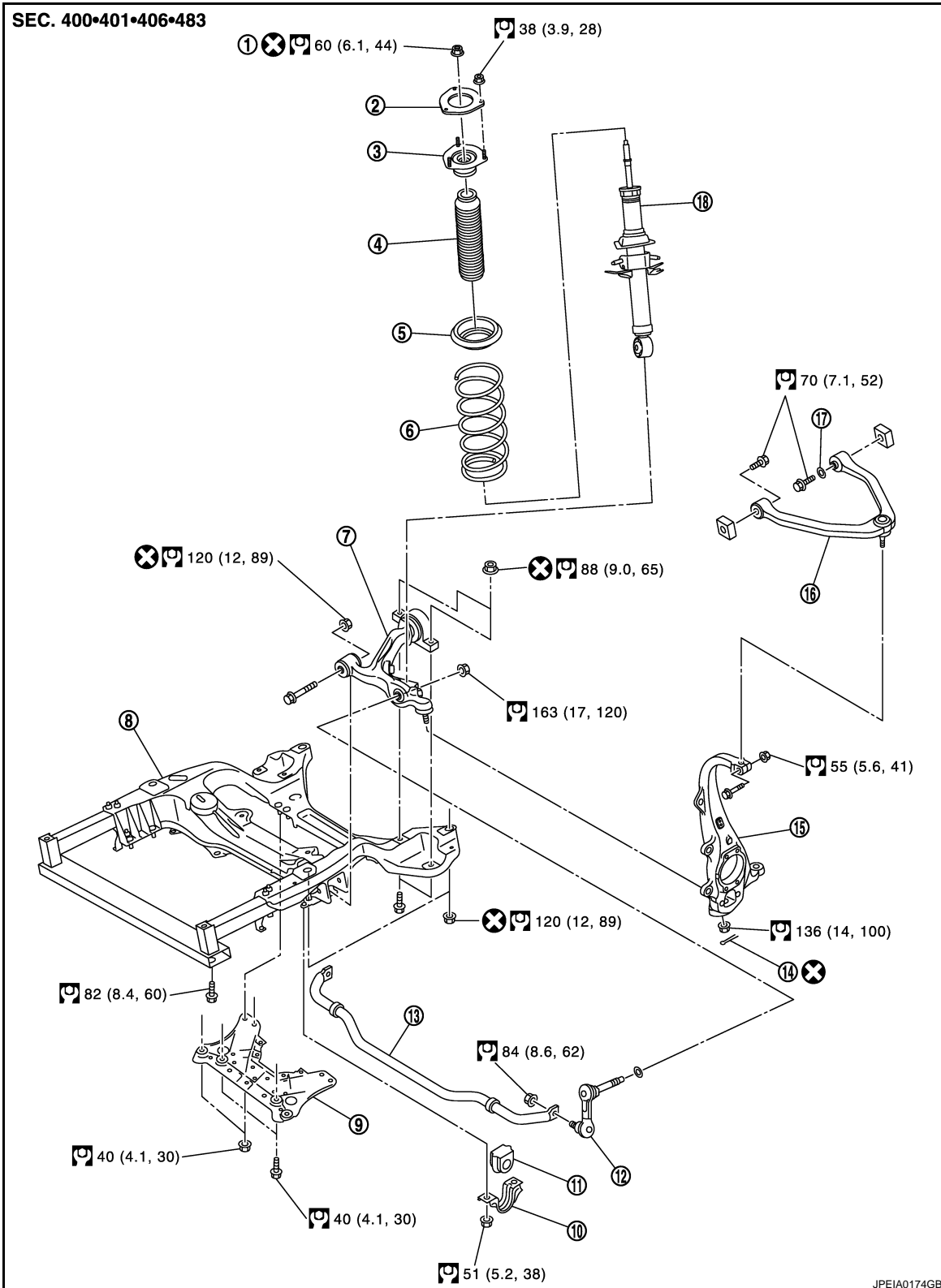

A
B
C
D
E
F
G
H
I
J
K
L
M
N
O
P

FSU

FRONT COIL SPRING AND SHOCK ABSORBER

< REMOVAL AND INSTALLATION >

[2WD]

- | | | |
|------------------------|----------------------------|------------------------------------|
| 1. Piston rod lock nut | 2. Mounting seal | 3. Shock absorber mounting bracket |
| 4. Bound bumper | 5. Rubber seat | 6. Coil spring |
| 7. Transverse link | 8. Front suspension member | 9. Suspension member stay |
| 10. Stabilizer clamp | 11. Stabilizer bushing | 12. Stabilizer connecting rod |
| 13. Stabilizer bar | 14. Cotter pin | 15. Steering knuckle |
| 16. Upper link | 17. Stopper rubber | 18. Shock absorber |

Refer to [GI-4, "Components"](#) for symbols in the figure.

Removal and Installation

INFOID:000000004670208

REMOVAL

1. Remove tires with power tool.
2. Remove harness of the wheel sensor from shock absorber. Refer to [BRC-100, "Exploded View"](#).
CAUTION:
Never pull on wheel sensor harness.
3. Remove brake hose bracket. Refer to [BR-21, "FRONT : Exploded View"](#).
4. Remove stabilizer connecting rod mounting nuts (lower side) with power tool.
5. Remove stabilizer connecting rod mounting nuts (upper side) with power tool, and then remove stabilizer connecting rod from transverse link.
6. Separate upper link from steering knuckle.
7. Remove mounting nuts of shock absorber mounting bracket, then remove shock absorber assembly.

INSTALLATION

Note the following, and install in the reverse order of removal.

- Never tap on the ball joint cap of the stabilizer connecting rod with a hammer or a similar item when inserting the stabilizer connecting rod into the transverse link.
- Perform final tightening of bolts and nuts at the shock absorber lower side (rubber bushing), under unladen conditions with tires on level ground.

Disassembly and Assembly

INFOID:000000004670209

DISASSEMBLY

CAUTION:

Never damage shock absorber piston rod when removing components from shock absorber.

1. Install shock absorber attachment (A) [SST: ST35652000 (-)] to shock absorber and secure it in a vise.

CAUTION:

When installing the shock absorber attachment to shock absorber, wrap a shop cloth around shock absorber to protect it from damage.

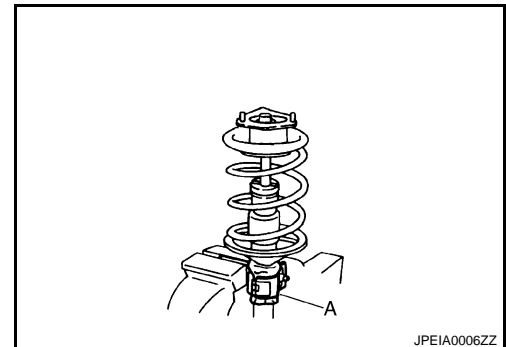

JPEIA0006ZZ

FRONT COIL SPRING AND SHOCK ABSORBER

< REMOVAL AND INSTALLATION >

[2WD]

- Using a spring compressor (A) (commercial service tool), compress coil spring between rubber seat and shock absorber until coil spring with a spring compressor is free.

CAUTION:

Be sure a spring compressor is securely attached coil spring. Compress coil spring.

- Make sure coil spring with a spring compressor between rubber seat and shock absorber is free and then remove piston rod lock nut while securing the piston rod tip so that piston rod does not turn.
- Remove mounting seal, shock absorber mounting bracket, rubber seat, bound bumper from shock absorber.
- Remove coil spring with a spring compressor, and then gradually release a spring compressor.

CAUTION:

Loosen while making sure coil spring attachment position does not move.

- Remove the shock absorber attachment from shock absorber.

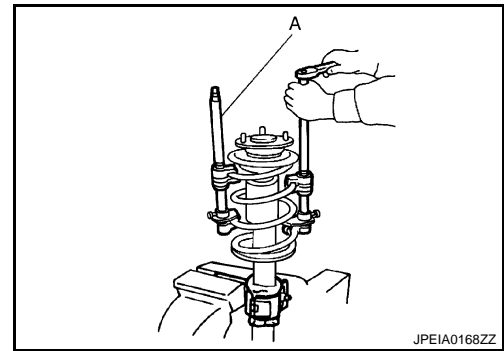

ASSEMBLY

- Install shock absorber attachment (A) [SST: ST35652000 (-)] to shock absorber and secure it in a vise.

CAUTION:

When installing the shock absorber attachment to shock absorber, wrap a shop cloth around shock absorber to protect it from damage.

- Compress coil spring using a spring compressor (commercial service tool), and install it onto shock absorber.

CAUTION:

- Install with the large-diameter side (A) facing up and the small-diameter side (B) facing down.
- Be sure a spring compressor is securely attached to coil spring. Compress coil spring.

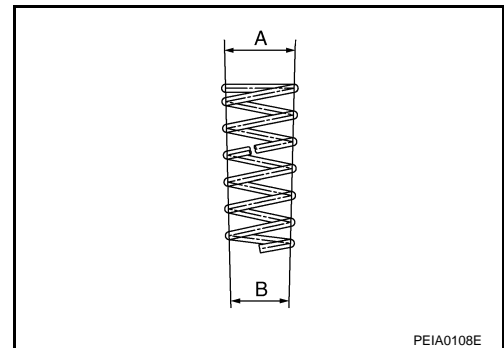

- Install the shock absorber mounting bracket and rubber seat.

CAUTION:

Align the paint mark (A) to the stud bolt (1) position when assembling.

- Apply soapy water to bound bumper.

CAUTION:

Never use machine oil.

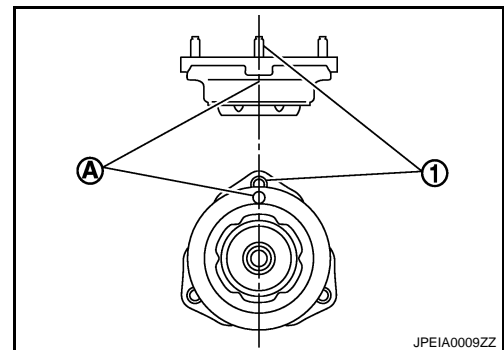

FRONT COIL SPRING AND SHOCK ABSORBER

< REMOVAL AND INSTALLATION >

[2WD]

5. Insert bound bumper into shock absorber mounting bracket, and then install it to shock absorber together with rubber seat.

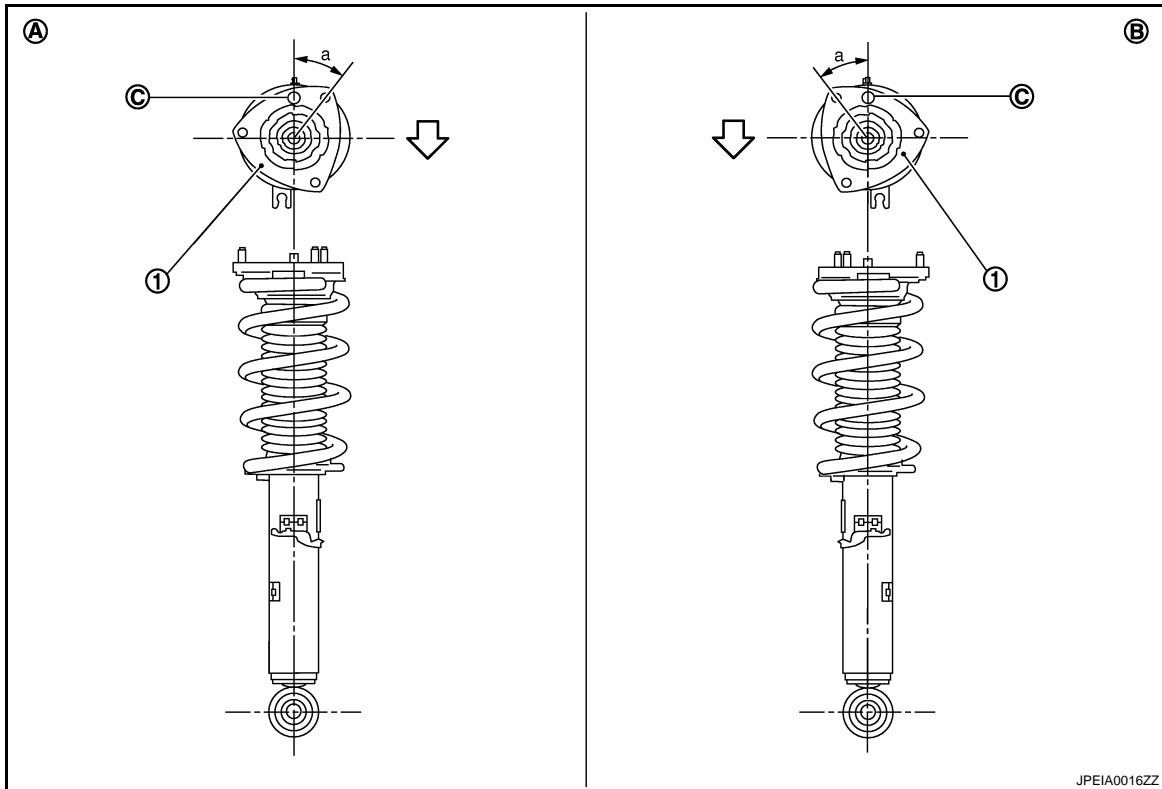

1. Shock absorber mounting bracket

A. Right side

B. Left side

C. Coil spring lower end position

⇐ : Vehicle front

- Install the shock absorber mounting bracket as shown in the figure.

Angle (a) : 35.4°

- Check that the lower end of the coil spring is positioned at the spring lower seat of the shock absorber.

6. Secure piston rod tip so that piston rod does not turn, then tighten piston rod lock nut with specified torque.
7. Gradually release a spring compressor, and remove coil spring.

CAUTION:

Loosen while making sure coil spring attachment position does not move.

8. Remove the shock absorber attachment from shock absorber.
9. Install the mounting seal to shock absorber mounting bracket.

Inspection

INFOID:000000004670210

INSPECTION AFTER DISASSEMBLY

Shock Absorber

Check the following items, and replace the part if necessary.

- Shock absorber for deformation, cracks or damage.
- Piston rod for damage, uneven wear or distortion.
- Oil leakage.

Shock Absorber Mounting Bracket and Rubber Parts Inspection

Check shock absorber mounting bracket for cracks and rubber parts for wear. Replace it if necessary.

Coil Spring

Check coil spring for cracks, wear or damage, and replace it if necessary.

FRONT COIL SPRING AND SHOCK ABSORBER

< REMOVAL AND INSTALLATION >

[2WD]

INSPECTION AFTER INSTALLATION

- Check wheel sensor harness for proper connection. Refer to [BRC-100. "Exploded View"](#).
- Check wheel alignment. Refer to [FSU-8. "Inspection"](#).
- Adjust neutral position of steering angle sensor. Refer to [BRC-8. "ADJUSTMENT OF STEERING ANGLE SENSOR NEUTRAL POSITION : Special Repair Requirement"](#).

A

B

C

D

FSU

F

G

H

I

J

K

L

M

N

O

P

TRANSVERSE LINK

< REMOVAL AND INSTALLATION >

[2WD]

TRANSVERSE LINK

Exploded View

INFOID:000000004670211

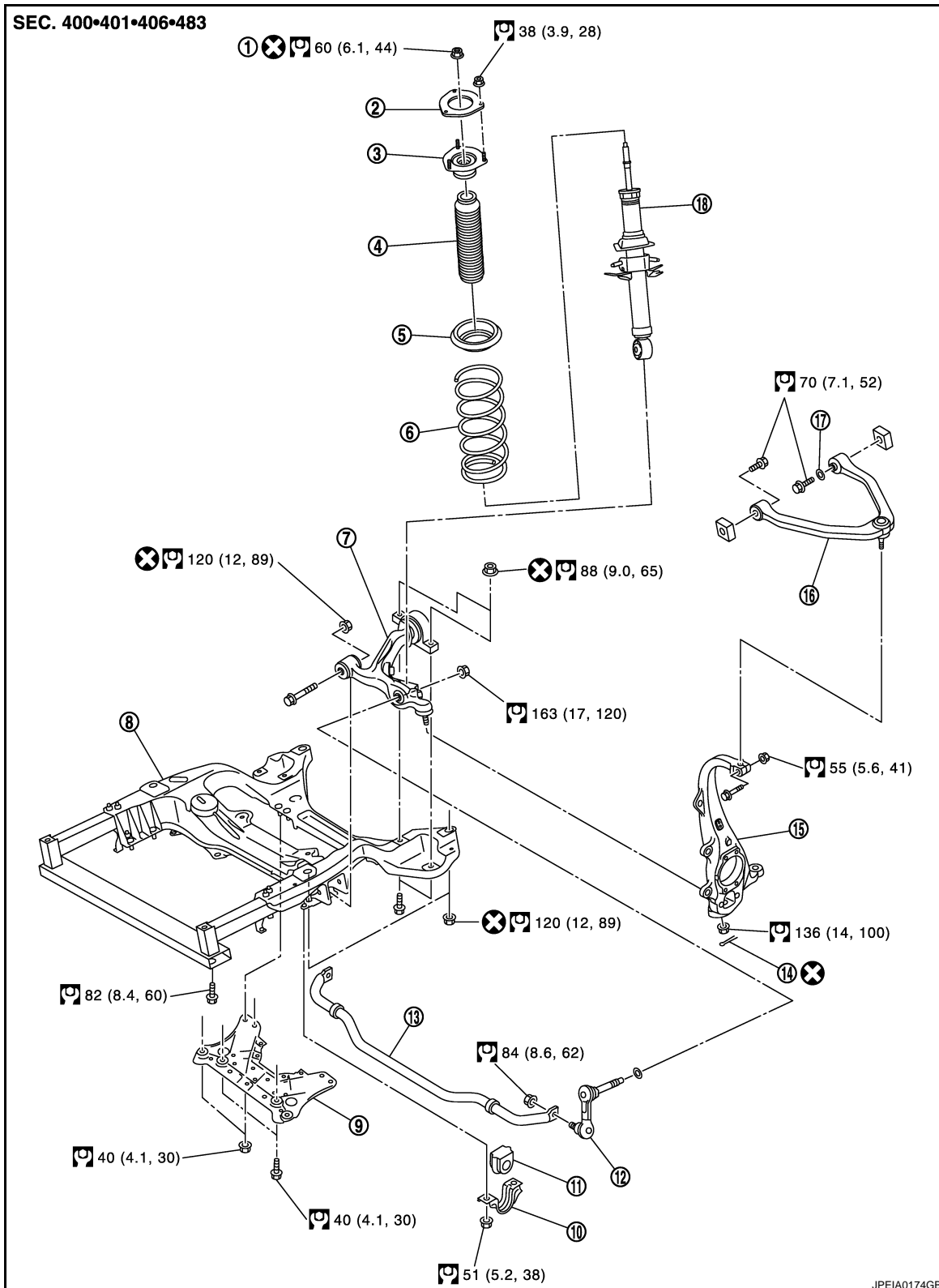

- | | | |
|------------------------|----------------------------|------------------------------------|
| 1. Piston rod lock nut | 2. Mounting seal | 3. Shock absorber mounting bracket |
| 4. Bound bumper | 5. Rubber seat | 6. Coil spring |
| 7. Transverse link | 8. Front suspension member | 9. Suspension member stay |

TRANSVERSE LINK

< REMOVAL AND INSTALLATION >

[2WD]

- | | | |
|----------------------|------------------------|-------------------------------|
| 10. Stabilizer clamp | 11. Stabilizer bushing | 12. Stabilizer connecting rod |
| 13. Stabilizer bar | 14. Cotter pin | 15. Steering knuckle |
| 16. Upper link | 17. Stopper rubber | 18. Shock absorber |
- Refer to [GI-4, "Components"](#) for symbols in the figure.

Removal and Installation

INFOID:000000004670212

REMOVAL

1. Remove tires with power tool.
2. Remove under cover with power tool.
3. Remove shock absorber. Refer to [FSU-9, "Exploded View"](#).
4. Remove steering outer socket from steering knuckle. Refer to [ST-30, "2WD : Exploded View"](#).
5. Remove transverse link from steering knuckle.
6. Set suitable jack under transverse link.
7. Remove mounting bolts and nuts, and then remove transverse link.

INSTALLATION

Note the following, and install in the reverse order of removal.

- Never tap on the ball joint cap of the stabilizer connecting rod with a hammer or a similar item when inserting the stabilizer connecting rod into the transverse link.
- Perform final tightening of bolts and nuts at the front suspension member installation and shock absorber lower side (rubber bushing), under unladen conditions with tires on level ground.
- Never reuse cotter pin.

Inspection

INFOID:000000004670213

INSPECTION AFTER REMOVAL

Appearance

Check the following items, and replace the part if necessary.

- Transverse link and bushing for deformation, cracks or damage.
- Ball joint boot for cracks or other damage, and also for grease leakage.

Ball Joint Inspection

Manually move ball stud to confirm it moves smoothly with no binding.

Swing Torque Inspection

NOTE:

Before measurement, move ball stud at least ten times by hand to check for smooth movement.

- Hook a spring balance (A) at cotter pin mounting hole. Confirm spring balance measurement value is within specifications when ball stud begins moving.

Standard

Swing torque

: Refer to [FSU-23, "Ball Joint"](#).

- If it is outside the specified range, replace transverse link assembly.

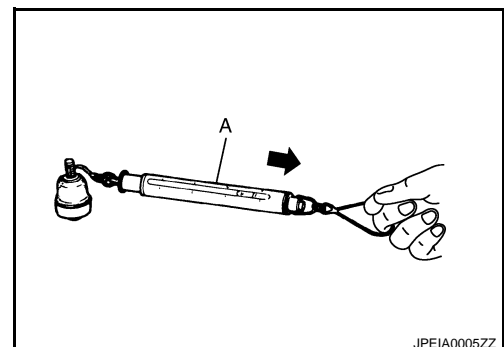

Rotating Torque Inspection

TRANSVERSE LINK

[2WD]

< REMOVAL AND INSTALLATION >

- Attach mounting nut to ball stud. Make sure that rotating torque is within specifications with a preload gauge (A) [SST: ST3127S000 (J-25765-A)].

Standard

Rotating torque : Refer to [FSU-23, "Ball Joint"](#).

- If it is outside the specified range, replace transverse link assembly.

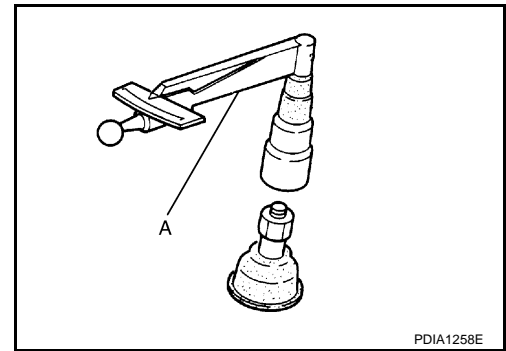

Axial End Play Inspection

- Move tip of ball stud in axial direction to check for looseness.

Standard

Axial end play : Refer to [FSU-23, "Ball Joint"](#).

- If it is outside the specified range, replace transverse link assembly.

INSPECTION AFTER INSTALLATION

- Check wheel sensor harness for proper connection. Refer to [BR-21, "FRONT : Exploded View"](#).
- Check wheel alignment. Refer to [FSU-8, "Inspection"](#).
- Adjust neutral position of steering angle sensor. Refer to [BRC-8, "ADJUSTMENT OF STEERING ANGLE SENSOR NEUTRAL POSITION : Special Repair Requirement"](#).

UPPER LINK

< REMOVAL AND INSTALLATION >

[2WD]

UPPER LINK

Exploded View

INFOID:000000004670214

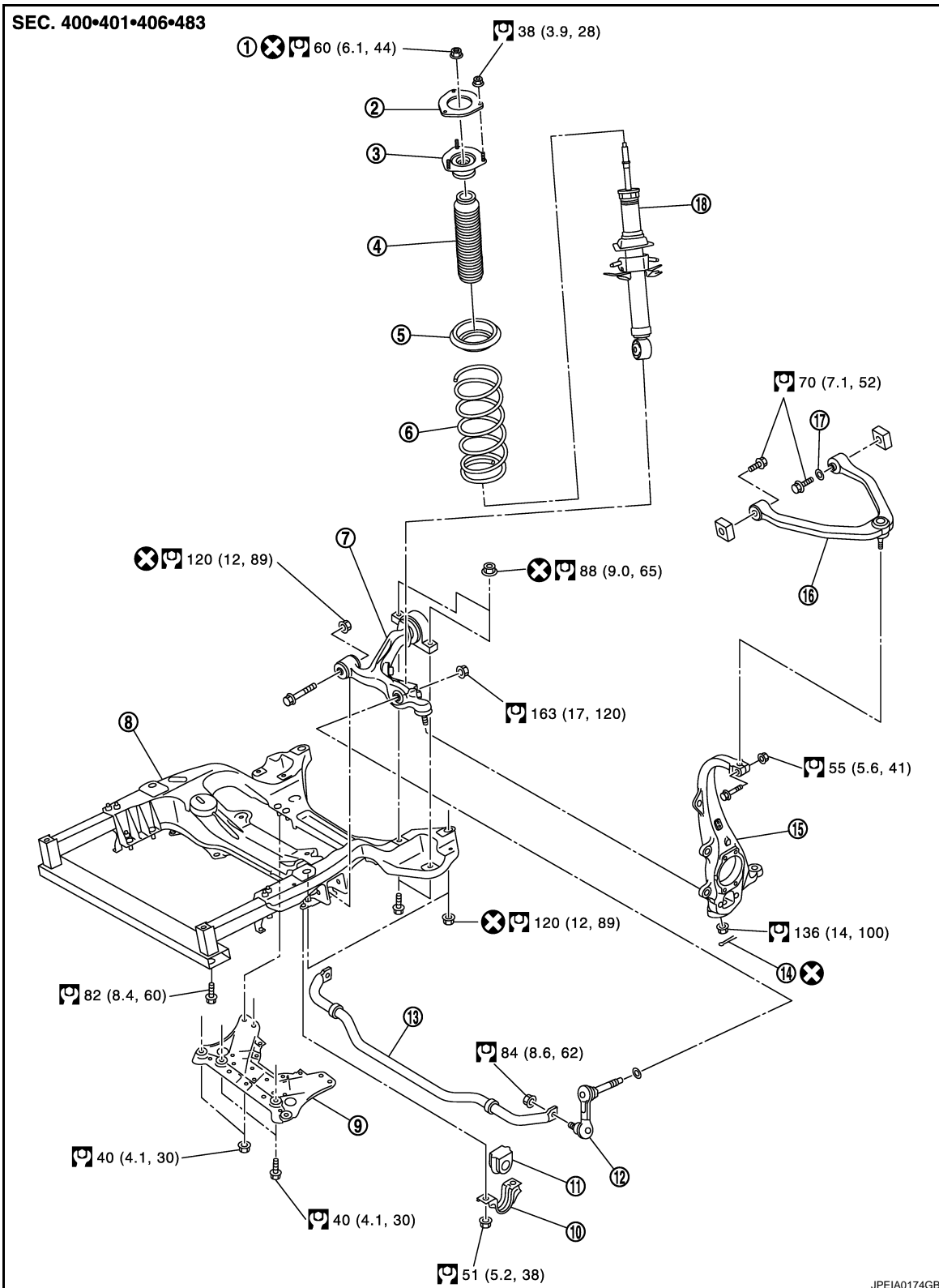

- | | | |
|------------------------|----------------------------|------------------------------------|
| 1. Piston rod lock nut | 2. Mounting seal | 3. Shock absorber mounting bracket |
| 4. Bound bumper | 5. Rubber seat | 6. Coil spring |
| 7. Transverse link | 8. Front suspension member | 9. Suspension member stay |

UPPER LINK

< REMOVAL AND INSTALLATION >

[2WD]

- | | | |
|----------------------|------------------------|-------------------------------|
| 10. Stabilizer clamp | 11. Stabilizer bushing | 12. Stabilizer connecting rod |
| 13. Stabilizer bar | 14. Cotter pin | 15. Steering knuckle |
| 16. Upper link | 17. Stopper rubber | 18. Shock absorber |
- Refer to [GI-4, "Components"](#) for symbols in the figure.

Removal and Installation

INFOID:000000004670215

REMOVAL

1. Remove tires with power tool.
2. Remove shock absorber. Refer to [FSU-9, "Exploded View"](#).
3. Remove mounting bolts and nuts with power tool, and then remove upper link from steering knuckle.
4. Remove mounting bolts and nuts, and then remove upper link and stopper rubber.

INSTALLATION

Note the following, and install in the reverse order of removal.

- Perform final tightening of bolts and nuts at the vehicle installation position (rubber bushing), under unladen conditions with tires on level ground.

Inspection

INFOID:000000004670216

INSPECTION AFTER REMOVAL

Appearance

Check the following items, and replace the part if necessary.

- Upper link and bushing for deformation, cracks or damage.
- Ball joint boot for cracks or other damage, and also for grease leakage.

Ball Joint Inspection

Manually move ball stud to confirm it moves smoothly with no binding.

Swing Torque Inspection

NOTE:

Before measurement, move ball stud at least ten times by hand to check for smooth movement.

- Hook a spring balance (A) at cutout on ball stud. Confirm spring balance measurement value is within specifications when ball stud begins moving.

Standard

Swing torque : Refer to [FSU-23, "Ball Joint"](#).

- If it is outside the specified range, replace upper link assembly.

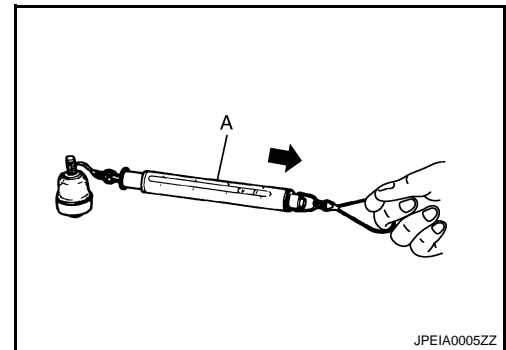

Axial End Play Inspection

- Move tip of ball stud in axial direction to check for looseness.

Standard

Axial end play : Refer to [FSU-23, "Ball Joint"](#).

- If it is outside the specified range, replace upper link assembly.

INSPECTION AFTER INSTALLATION

- Check wheel sensor harness for proper connection. Refer to [BR-21, "FRONT : Exploded View"](#).
- Check wheel alignment. Refer to [FSU-8, "Inspection"](#).
- Adjust neutral position of steering angle sensor. Refer to [BRC-8, "ADJUSTMENT OF STEERING ANGLE SENSOR NEUTRAL POSITION : Special Repair Requirement"](#).

FRONT STABILIZER

< REMOVAL AND INSTALLATION >

[2WD]

FRONT STABILIZER

Exploded View

INFOID:000000004670217

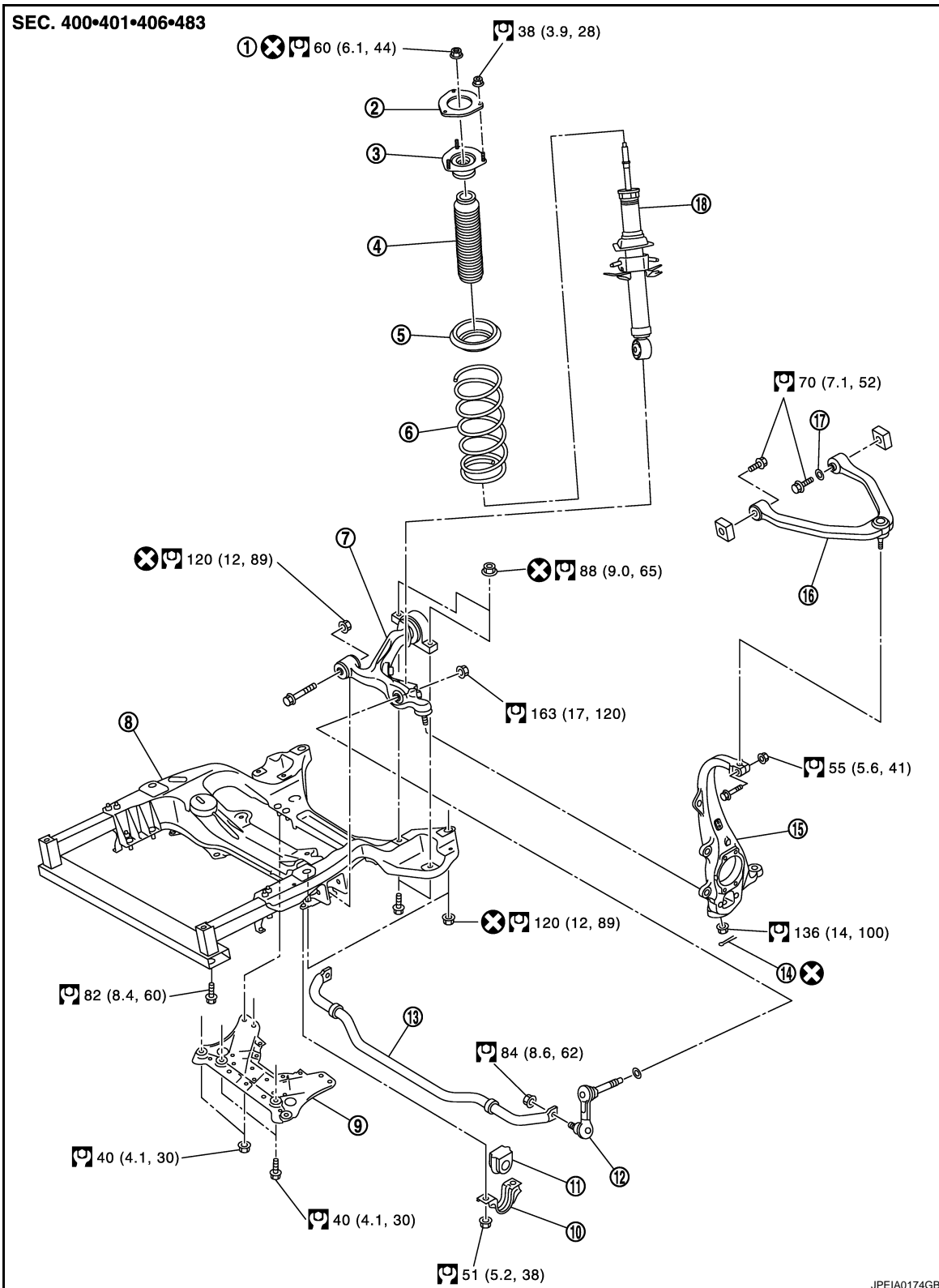

- | | | |
|------------------------|----------------------------|------------------------------------|
| 1. Piston rod lock nut | 2. Mounting seal | 3. Shock absorber mounting bracket |
| 4. Bound bumper | 5. Rubber seat | 6. Coil spring |
| 7. Transverse link | 8. Front suspension member | 9. Suspension member stay |

FRONT STABILIZER

< REMOVAL AND INSTALLATION >

[2WD]

- | | | |
|----------------------|------------------------|-------------------------------|
| 10. Stabilizer clamp | 11. Stabilizer bushing | 12. Stabilizer connecting rod |
| 13. Stabilizer bar | 14. Cotter pin | 15. Steering knuckle |
| 16. Upper link | 17. Stopper rubber | 18. Shock absorber |

Refer to [GI-4. "Components"](#) for symbols in the figure.

Removal and Installation

INFOID:000000004670218

REMOVAL

1. Remove tires with power tool.
2. Remove under cover with power tool.
3. Remove stabilizer connecting rod.

CAUTION:

Apply a matching mark to identify the installation position.

4. Remove the stabilizer clamp and stabilizer bushing.
5. Remove stabilizer bar.

INSTALLATION

Note the following, and install in the reverse order of removal.

- Check the mounting mark when installing.
- Tighten the mounting nut to the specified torque while holding a hexagonal part of stabilizer connecting rod side.

Inspection

INFOID:000000004670219

INSPECTION AFTER REMOVAL

Check stabilizer bar, stabilizer connecting rod, stabilizer bushing and stabilizer clamp for deformation, cracks or damage. Replace it if a malfunction is detected.

FRONT SUSPENSION MEMBER

< UNIT REMOVAL AND INSTALLATION >

[2WD]

UNIT REMOVAL AND INSTALLATION

FRONT SUSPENSION MEMBER

Exploded View

INFOID:000000004670220

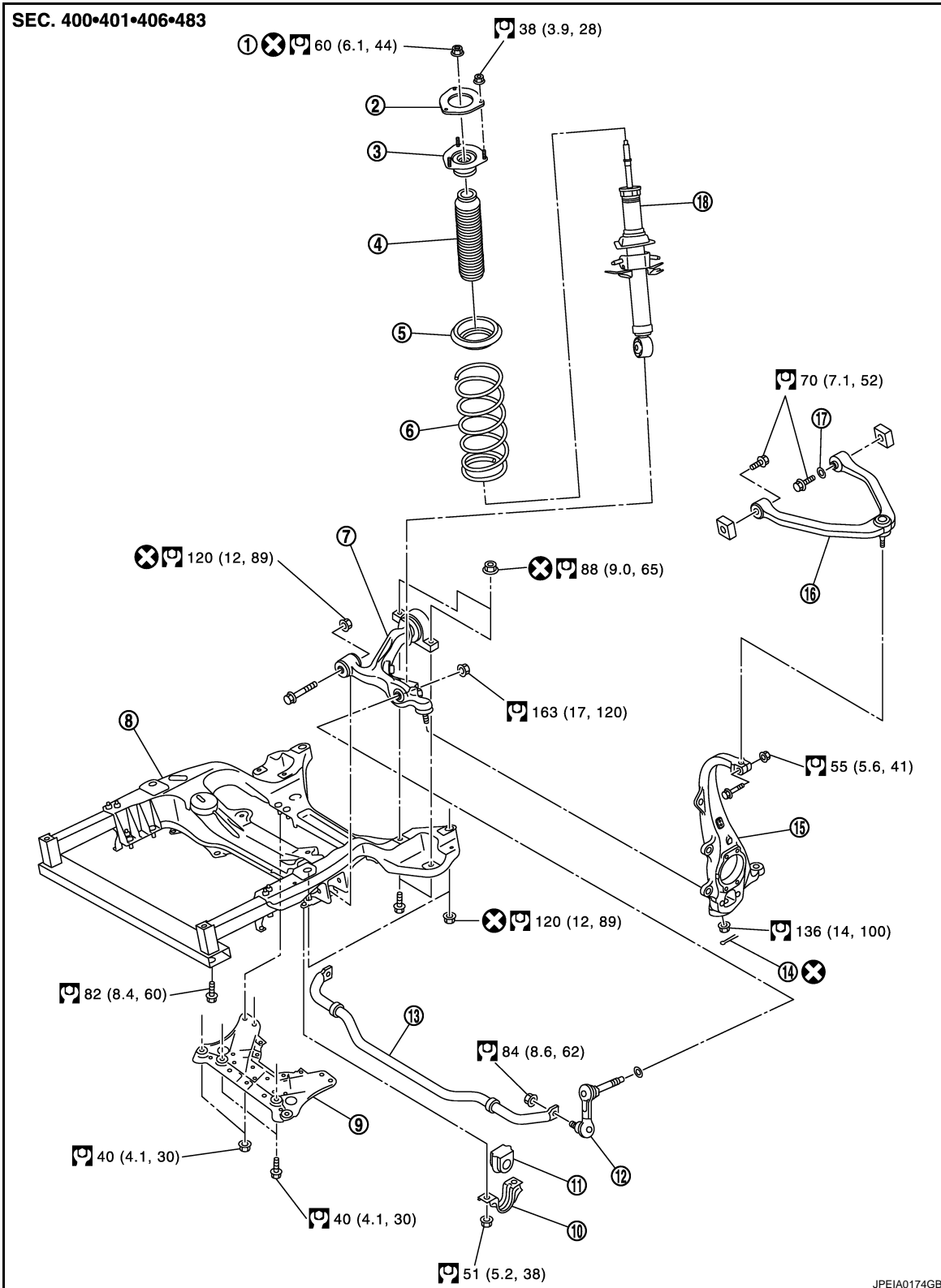

A

B

C

D

FSU

F

G

H

I

J

K

L

M

N

O

P

FRONT SUSPENSION MEMBER

< UNIT REMOVAL AND INSTALLATION >

[2WD]

- | | | |
|------------------------|----------------------------|------------------------------------|
| 1. Piston rod lock nut | 2. Mounting seal | 3. Shock absorber mounting bracket |
| 4. Bound bumper | 5. Rubber seat | 6. Coil spring |
| 7. Transverse link | 8. Front suspension member | 9. Suspension member stay |
| 10. Stabilizer clamp | 11. Stabilizer bushing | 12. Stabilizer connecting rod |
| 13. Stabilizer bar | 14. Cotter pin | 15. Steering knuckle |
| 16. Upper link | 17. Stopper rubber | 18. Shock absorber |

Refer to [GI-4, "Components"](#) for symbols in the figure.

Removal and Installation

INFOID:000000004670221

REMOVAL

1. Remove tire with power tool.
2. Remove under cover with power tool.
3. Remove suspension member stay with power tool.
4. Separate steering gear assembly and lower joint. Refer to [ST-24, "WITHOUT 4WAS : Exploded View"](#) (without 4WAS), [ST-25, "WITH 4WAS : Exploded View"](#) (with 4WAS).
5. Remove steering outer socket from steering knuckle. Refer to [ST-30, "2WD : Exploded View"](#).
6. Remove wheel sensor from steering knuckle. Refer to [BRC-100, "Exploded View"](#).
7. Remove stabilizer connecting rod from transverse link. Refer to [FSU-19, "Exploded View"](#).
8. Remove front stabilizer. Refer to [FSU-19, "Exploded View"](#).
9. Install engine slinger, and then hoist engine. Refer to [EM-69, "2WD : Removal and Installation"](#).
10. Remove transverse link from front suspension member. Refer to [FSU-14, "Exploded View"](#).
11. Remove steering hydraulic piping bracket and steering gear from front suspension member. Refer to [ST-59, "2WD : Exploded View"](#).
12. Set suitable jack front suspension member.
13. Remove mounting nuts between engine mounting insulator and from suspension member. Refer to [EM-69, "2WD : Exploded View"](#).
14. Remove mounting bolts and nuts of front suspension member with power tool.
15. Gradually lower jack to remove front suspension assembly from vehicle.

INSTALLATION

Note the following, and install in the reverse order of removal.

- Perform final tightening of installation position between front suspension member and transverse links (rubber bushing) under unladen condition with tires on level ground.

Inspection

INFOID:000000004670222

INSPECTION AFTER REMOVAL

Check the front suspension member for significant deformation, cracks, or damages. Replace if necessary.

INSPECTION AFTER INSTALLATION

- Check wheel sensor harness for proper connection. Refer to [BR-21, "FRONT : Exploded View"](#).
- Check wheel alignment. Refer to [FSU-8, "Inspection"](#).
- Adjust the neutral position of the steering angle sensor. Refer to [BRC-8, "ADJUSTMENT OF STEERING ANGLE SENSOR NEUTRAL POSITION : Special Repair Requirement"](#).

SERVICE DATA AND SPECIFICATIONS (SDS)

< SERVICE DATA AND SPECIFICATIONS (SDS)

[2WD]

SERVICE DATA AND SPECIFICATIONS (SDS)

SERVICE DATA AND SPECIFICATIONS (SDS)

Wheel Alignment

INFOID:000000004257338

Item		Standard	
Camber Degree minute (Decimal degree)	Minimum	-1° 10' (-1.17°)	
	Nominal	-0° 25' (-0.42°)	
	Maximum	0° 20' (0.33°)	
	Left and right difference	0° 33' (0.55°) or less	
Caster Degree minute (Decimal degree)	Minimum	4° 05' (4.08°)	
	Nominal	4° 50' (4.83°)	
	Maximum	5° 35' (5.58°)	
	Left and right difference	0° 39' (0.65°) or less	
Kingpin inclination Degree minute (Decimal degree)	Minimum	6° 40' (6.67°)	
	Nominal	7° 25' (7.42°)	
	Maximum	8° 10' (8.16°)	
Toe-in	Total toe-in Distance	Minimum	0 mm (0 in)
		Nominal	In 1 mm (0.04 in)
		Maximum	In 2 mm (0.08 in)
	Toe angle (left wheel or right wheel) Degree minute (Decimal degree)	Minimum	0° 00' (0.00°)
		Nominal	In 0° 02' 30" (0.04°)
		Maximum	In 0° 05' (0.08°)

Measure value under unladen* conditions.

*: Fuel, engine coolant and lubricant are full. Spare tire, jack, hand tools and mats are in designated positions.

Ball Joint

INFOID:000000004257339

Item		Standard
Swing torque	Transverse link	0.5 – 3.6 N·m (0.06 – 0.36 kg·m, 5 – 31 in-lb)
	Upper link	0 – 2.0 N·m (0 – 0.2 kg·m, 0 – 17 in-lb)
Measurement on spring balance	Transverse link	7.8 – 56.3 N (0.8 – 5.7 kg, 1.8 – 12.7 lb)
	Upper link	0 – 61.5 N (0 – 6.3 kg, 0 – 13.8 lb)
Rotating torque	Transverse link	0.5 – 3.9 N·m (0.06 – 0.39 kg·m, 5 – 34 in-lb)
Axial end play		0 mm (0 in)

Wheelarch Height

INFOID:000000004257340

Item	Standard		
	Except for sports models		For sports models
Wheel size	18 inch	19 inch	
Front (Hf)	712 mm (28.03 in)	715 mm (28.15 in)	716 mm (28.19 in)

SERVICE DATA AND SPECIFICATIONS (SDS)

< SERVICE DATA AND SPECIFICATIONS (SDS)

[2WD]

Item	Standard		
	Except for sports models		For sports models
Applied model			
Wheel size	18 inch	19 inch	
Rear (Hr)	702 mm (27.64 in)	705 mm (27.76 in)	706 mm (27.80 in)

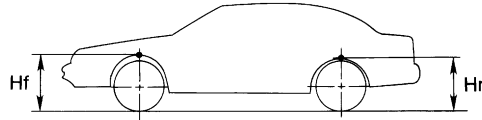

SFA818A

Measure value under unladen* conditions

*: Fuel, engine coolant and lubricant are full. Spare tire, jack, hand tools and mats are in designated positions.

NOISE, VIBRATION AND HARSHNESS (NVH) TROUBLESHOOTING

< SYMPTOM DIAGNOSIS >

[AWD]

SYMPTOM DIAGNOSIS

NOISE, VIBRATION AND HARSHNESS (NVH) TROUBLESHOOTING

NVH Troubleshooting Chart

INFOID:000000004670173

Use chart below to find the cause of the symptom. If necessary, repair or replace these parts.

Symptom	FRONT SUSPENSION	Possible cause and SUSPECTED PARTS		Reference page	
		Improper installation, looseness	Shock absorber deformation, damage or deflection	FSU-31, FSU-36, FSU-39, FSU-41, FSU-43	FSU-34
		Bushing or mounting deterioration			
		Parts interference			
		Spring fatigue			
		Suspension looseness		FSU-31, FSU-36, FSU-39, FSU-41, FSU-43	
		Incorrect wheel alignment		FSU-30	
		Stabilizer bar fatigue		FSU-42	
		PROPELLER SHAFT		NVH in DLN section.	
		DIFFERENTIAL		NVH in RFD section.	
		FRONT AXLE AND FRONT SUSPENSION		NVH in FAX and FSU sections.	
		TIRE		NVH in WT section.	
		ROAD WHEEL		NVH in WT section.	
		DRIVE SHAFT		NVH in FAX section.	
		BRAKE		NVH in BR section.	
		STEERING		NVH in ST section.	
		Noise	x	x	x
		Shake	x	x	x
		Vibration	x	x	x
		Shimmy	x	x	x
		Judder	x	x	x
		Poor quality ride or handling	x	x	x

x: Applicable

A
B
C
D
E
F
G
H
I
J
K
L
M
N
O
P

FSU

PRECAUTION

PRECAUTIONS

Precaution for Supplemental Restraint System (SRS) "AIR BAG" and "SEAT BELT PRE-TENSIONER"

INFOID:000000004679097

The Supplemental Restraint System such as "AIR BAG" and "SEAT BELT PRE-TENSIONER", used along with a front seat belt, helps to reduce the risk or severity of injury to the driver and front passenger for certain types of collision. This system includes seat belt switch inputs and dual stage front air bag modules. The SRS system uses the seat belt switches to determine the front air bag deployment, and may only deploy one front air bag, depending on the severity of a collision and whether the front occupants are belted or unbelted. Information necessary to service the system safely is included in the "SRS AIR BAG" and "SEAT BELT" of this Service Manual.

WARNING:

- To avoid rendering the SRS inoperative, which could increase the risk of personal injury or death in the event of a collision which would result in air bag inflation, all maintenance must be performed by an authorized NISSAN/INFINITI dealer.
- Improper maintenance, including incorrect removal and installation of the SRS, can lead to personal injury caused by unintentional activation of the system. For removal of Spiral Cable and Air Bag Module, see the "SRS AIR BAG".
- Do not use electrical test equipment on any circuit related to the SRS unless instructed to in this Service Manual. SRS wiring harnesses can be identified by yellow and/or orange harnesses or harness connectors.

PRECAUTIONS WHEN USING POWER TOOLS (AIR OR ELECTRIC) AND HAMMERS

WARNING:

- When working near the Air Bag Diagnosis Sensor Unit or other Air Bag System sensors with the ignition ON or engine running, DO NOT use air or electric power tools or strike near the sensor(s) with a hammer. Heavy vibration could activate the sensor(s) and deploy the air bag(s), possibly causing serious injury.
- When using air or electric power tools or hammers, always switch the ignition OFF, disconnect the battery, and wait at least 3 minutes before performing any service.

Precaution Necessary for Steering Wheel Rotation after Battery Disconnect

INFOID:000000004679099

NOTE:

- Before removing and installing any control units, first turn the push-button ignition switch to the LOCK position, then disconnect both battery cables.
- After finishing work, confirm that all control unit connectors are connected properly, then re-connect both battery cables.
- Always use CONSULT-III to perform self-diagnosis as a part of each function inspection after finishing work. If a DTC is detected, perform trouble diagnosis according to self-diagnosis results.

For vehicle with steering lock unit, if the battery is disconnected or discharged, the steering wheel will lock and cannot be turned.

If turning the steering wheel is required with the battery disconnected or discharged, follow the operation procedure below before starting the repair operation.

OPERATION PROCEDURE

1. Connect both battery cables.

NOTE:

Supply power using jumper cables if battery is discharged.

2. Turn the push-button ignition switch to ACC position.
(At this time, the steering lock will be released.)
3. Disconnect both battery cables. The steering lock will remain released with both battery cables disconnected and the steering wheel can be turned.
4. Perform the necessary repair operation.

PRECAUTIONS

[AWD]

< PRECAUTION >

5. When the repair work is completed, re-connect both battery cables. With the brake pedal released, turn the push-button ignition switch from ACC position to ON position, then to LOCK position. (The steering wheel will lock when the push-button ignition switch is turned to LOCK position.)
6. Perform self-diagnosis check of all control units using CONSULT-III.

Precaution for Procedure without Cowl Top Cover

INFOID:000000004679100

When performing the procedure after removing cowl top cover, cover the lower end of windshield with urethane, etc.

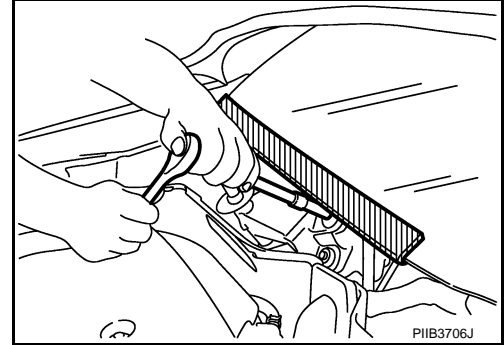

Precautions for Suspension

INFOID:000000004670177

- When installing rubber bushings, the final tightening must be carried out under unladen conditions with tires on ground. Spilled oil might shorten the life of rubber bushings. Be sure to wipe off any spilled oil.
- Unladen conditions mean that fuel, engine coolant and lubricant are full. Spare tire, jack, hand tools and mats are in designated positions.
- After servicing suspension parts, be sure to check wheel alignment.
- Self-lock nuts are not reusable. Always use new ones when installing. Since new self-lock nuts are pre-oiled, tighten as they are.

PREPARATION

< PREPARATION >

[AWD]

PREPARATION

PREPARATION

Special Service Tool

INFOID:000000004670178

The actual shapes of Kent-Moore tools may differ from those of special service tools illustrated here.

Tool number (Kent-Moore No.) Tool name	Description
ST35652000 (-) Shock absorber attachment	Disassembling and assembling shock absorber
ST3127S000 (J-25765-A) Preload gauge	Measuring rotating torque of ball joint

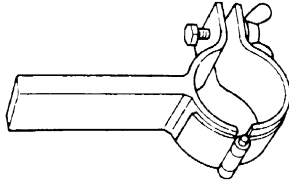

ZZA0807D

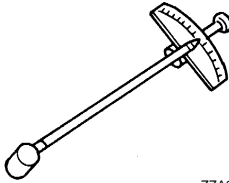

ZZA0806D

Commercial Service Tool

INFOID:000000004670179

Tool name	Description
Power tool	Loosening bolts and nuts
Spring compressor	Removing and installing coil spring

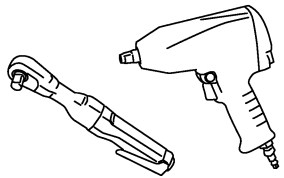

PBIC0190E

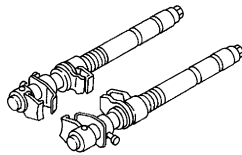

S-NT717

FRONT SUSPENSION ASSEMBLY

< PERIODIC MAINTENANCE >

[AWD]

PERIODIC MAINTENANCE

FRONT SUSPENSION ASSEMBLY

Inspection

INFOID:000000004670180

MOUNTING INSPECTION

Make sure the mounting conditions (looseness, backlash) of each component and component conditions (wear, damage) are normal.

BALL JOINT AXIAL END PLAY

1. Set front wheels in a straight-ahead position.

CAUTION:

Never depress brake pedal.

2. Place an iron bar or equivalent between transverse link or upper link and steering knuckle.
3. Measure axial end play by prying it up and down.

Standard

Axial end play : Refer to [FSU-45, "Ball Joint"](#).

CAUTION:

Be careful not to damage ball joint boot. never damage the installation position by applying excessive force.

SHOCK ABSORBER

Check for oil leakage, damage and replace if malfunction is detected.

A
B
C
D
E
F
G
H
I
J
K
L
M
N
O
P

FSU

WHEEL ALIGNMENT

Inspection

INFOID:000000004670181

DESCRIPTION

CAUTION:

- **Camber, caster, kingpin inclination angles cannot be adjusted.**
- **If camber, caster, or kingpin inclination angle is outside the standard, check front suspension parts for wear and damage. Replace suspect parts if a malfunction is detected.**
- **Kingpin inclination angle is reference value, no inspection is required.**
- **Measure wheel alignment under unladen conditions.**

NOTE:

“Unladen conditions” means that fuel, engine coolant, and lubricant are full. Spare tire, jack, hand tools and mats are in designated positions.

GENERAL INFORMATION AND RECOMMENDATIONS

- A four-wheel thrust alignment should be performed.
- This type of alignment is recommended for any NISSAN/INFINITI vehicle.
- The four-wheel “thrust” process helps ensure that the vehicle is properly aligned and the steering wheel is centered.
- The alignment rack itself should be capable of accepting any NISSAN/INFINITI vehicle.
- The rack should be checked to ensure that it is level.
- Make sure the machine is properly calibrated.
- Your alignment equipment should be regularly calibrated in order to give correct information.
- Check with the manufacturer of your specific equipment for their recommended Service/Calibration Schedule.

ALIGNMENT PROCESS

IMPORTANT:

Use only the alignment specifications listed in this Service Manual.

- When displaying the alignment settings, many alignment machines use “indicators”: (Green/red, plus or minus, Go/No Go). **Never use these indicators.**
- The alignment specifications programmed into your machine that operate these indicators may not be correct.
- This may result in an ERROR.
- Some newer alignment machines are equipped with an optional “Rolling Compensation” method to “compensate” the sensors (alignment targets or head units). **Never use this “Rolling Compensation” method.**
- Use the “Jacking Compensation Method”. After installing the alignment targets or head units, raise the vehicle and rotate the wheels 1/2 turn both ways.
- See Instructions in the alignment machine you're using for more information on this.

PRELIMINARY CHECK

Check the following:

- Tires for improper air pressure and wear.
- Road wheels for runout. Refer to [WT-95, "Inspection"](#).
- Wheel bearing axial end play. Refer to [FAX-17, "Inspection"](#).
- Transverse link or upper link ball joint axial end play. Refer to [FSU-37, "Inspection"](#), [FSU-40, "Inspection"](#).
- Shock absorber operation.
- Each mounting part of axle and suspension for looseness and deformation.
- Each of suspension member, shock absorber, upper link and transverse link for cracks, deformation and other damage.
- Vehicle height (posture).

FRONT COIL SPRING AND SHOCK ABSORBER

< REMOVAL AND INSTALLATION >

[AWD]

REMOVAL AND INSTALLATION

FRONT COIL SPRING AND SHOCK ABSORBER

Exploded View

INFOID:000000004670182

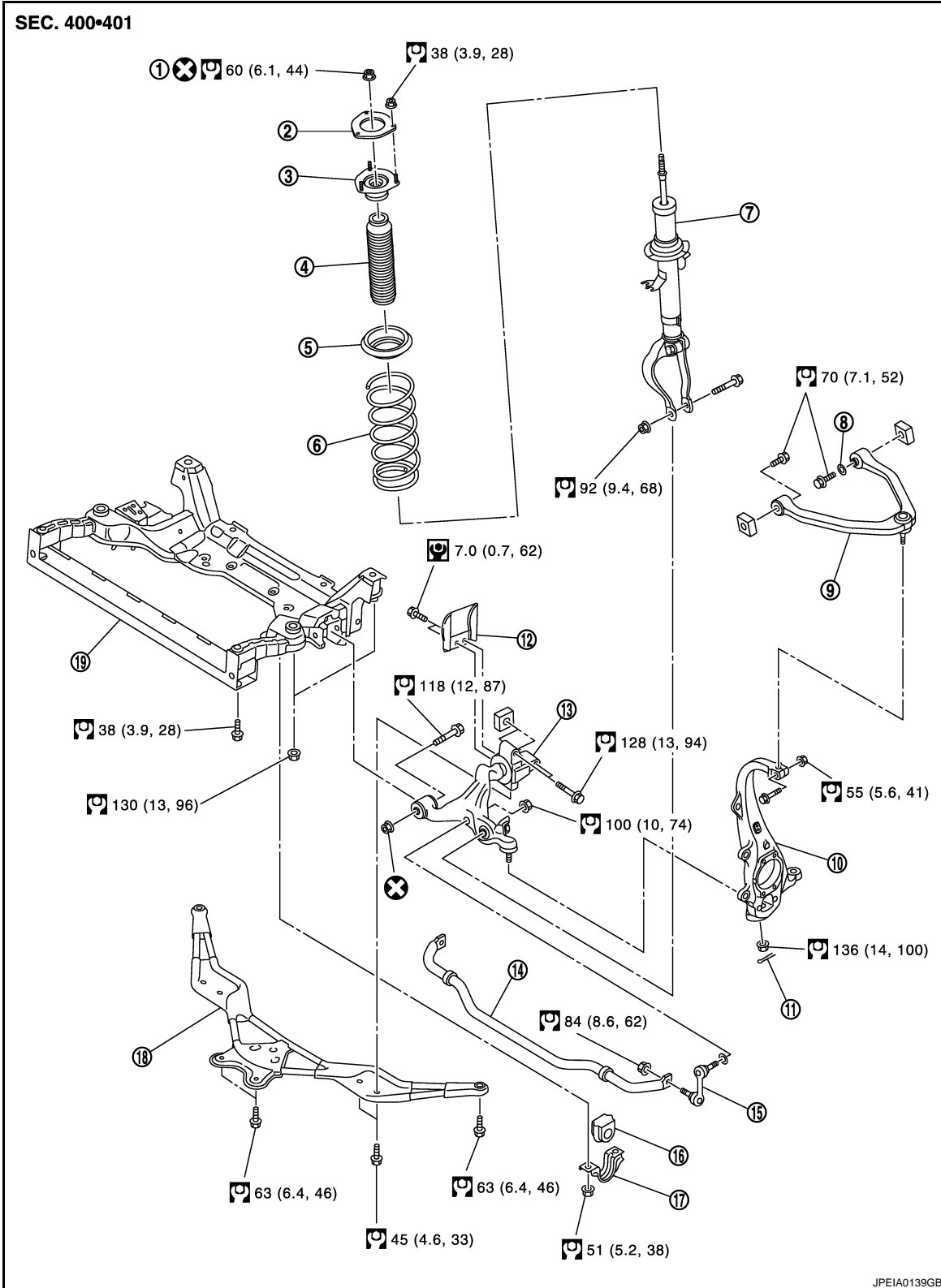

A
B
C
D
E
FSU
F
G
H
I
J
K
L
M
N
O
P

FRONT COIL SPRING AND SHOCK ABSORBER

< REMOVAL AND INSTALLATION >

[AWD]

- | | | |
|-----------------------------|----------------------|------------------------------------|
| 1. Piston rod lock nut | 2. Mounting seal | 3. Shock absorber mounting bracket |
| 4. Bound bumper | 5. Rubber seat | 6. Coil spring |
| 7. Shock absorber | 8. Stopper rubber | 9. Upper link |
| 10. Steering knuckle | 11. Cotter pin | 12. Insulator |
| 13. Transverse link | 14. Stabilizer bar | 15. Stabilizer connecting rod |
| 16. Stabilizer bushing | 17. Stabilizer clamp | 18. Front cross bar |
| 19. Front suspension member | | |

Refer to [GI-4, "Components"](#) for symbols in the figure.

Removal and Installation

INFOID:000000004670183

REMOVAL

1. Remove tires with power tool.
2. Remove stabilizer connecting rod mounting nuts (upper side) with power tool, and then remove stabilizer connecting rod from transverse link.
3. Remove shock absorber mounting bolts and nuts (lower side) with power tool, and then remove shock absorber from transverse link.
4. Remove drive shaft. Refer to [FAX-22, "Exploded View"](#).
5. Separate upper link from steering knuckle.
6. Remove the mounting nuts of shock absorber mounting bracket, then remove shock absorber assembly.

INSTALLATION

Note the following, and install in the reverse order of removal.

CAUTION:

Never tap on the ball joint cap of the stabilizer connecting rod with a hammer or a similar item when inserting the stabilizer connecting rod into the transverse link.

- Perform final tightening of bolts and nuts at the shock absorber lower side (rubber bushing), under unladen conditions with tires on level ground.

Disassembly and Assembly

INFOID:000000004670184

DISASSEMBLY

CAUTION:

Never damage shock absorber piston rod when removing components from shock absorber.

1. Install shock absorber attachment (A) [SST: ST35652000 (-)] to shock absorber and secure it in a vise.

CAUTION:

When installing the shock absorbershock absorber attachment to shock absorber, wrap a shop cloth around shock absorber to protect it from damage.

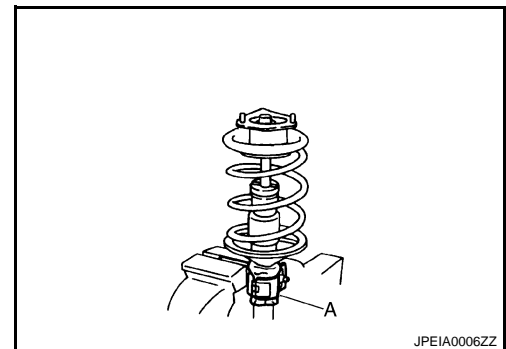

FRONT COIL SPRING AND SHOCK ABSORBER

[AWD]

< REMOVAL AND INSTALLATION >

- Using a spring compressor (A) (commercial service tool), compress coil spring between rubber seat and shock absorber until coil spring with a spring compressor is free.

CAUTION:

Be sure a spring compressor is securely attached coil spring. Compress coil spring

- Make sure coil spring with a spring compressor between rubber seat and shock absorber is free and then remove piston rod lock nut while securing the piston rod tip so that piston rod does not turn.
- Remove mounting seal, shock absorber mounting bracket, rubber seat, bound bumper from shock absorber.
- Remove coil spring with a spring compressor, and then gradually release a spring compressor.

CAUTION:

Loosen while making sure coil spring attachment position does not move.

- Remove the shock absorber attachment from shock absorber.

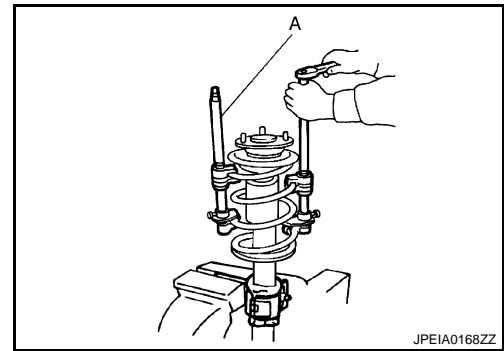

ASSEMBLY

- Install shock absorber attachment (A) [SST: ST35652000 (-)] to shock absorber and secure it in a vise.

CAUTION:

When installing the shock absorber attachment to shock absorber, wrap a shop cloth around shock absorber to protect it from damage.

- Compress coil spring using a spring compressor (commercial service tool), and install it onto shock absorber.

CAUTION:

- Install with the large-diameter side (A) facing up and the small-diameter side (B) facing down.
- Be sure a spring compress or is securely attached to coil spring. Compress coil spring.

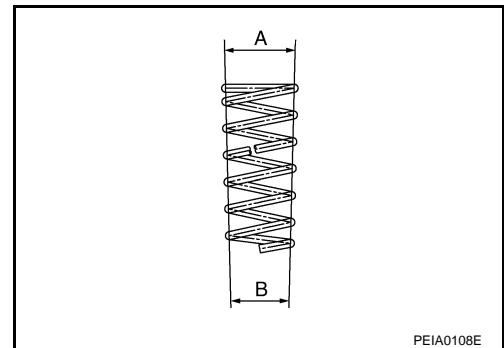

- Install the shock absorber mounting bracket and rubber seat.

CAUTION:

Align the paint mark (A) to the stud bolt (1) position when assembling.

- Apply soapy water to bound bumper.

CAUTION:

Never use machine oil.

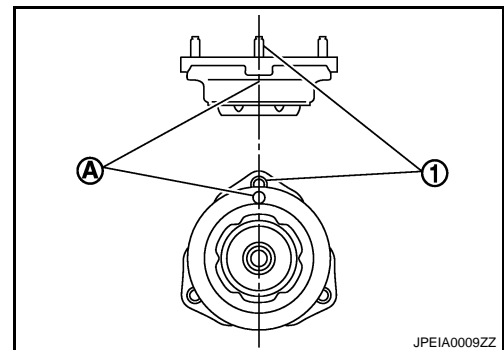

A
B
C
D
F
G
H
I
J
K
L
M
N
O
P

FSU

FRONT COIL SPRING AND SHOCK ABSORBER

< REMOVAL AND INSTALLATION >

[AWD]

5. Insert bound bumper into shock absorber mounting bracket, and then install it to shock absorber together with rubber seat.

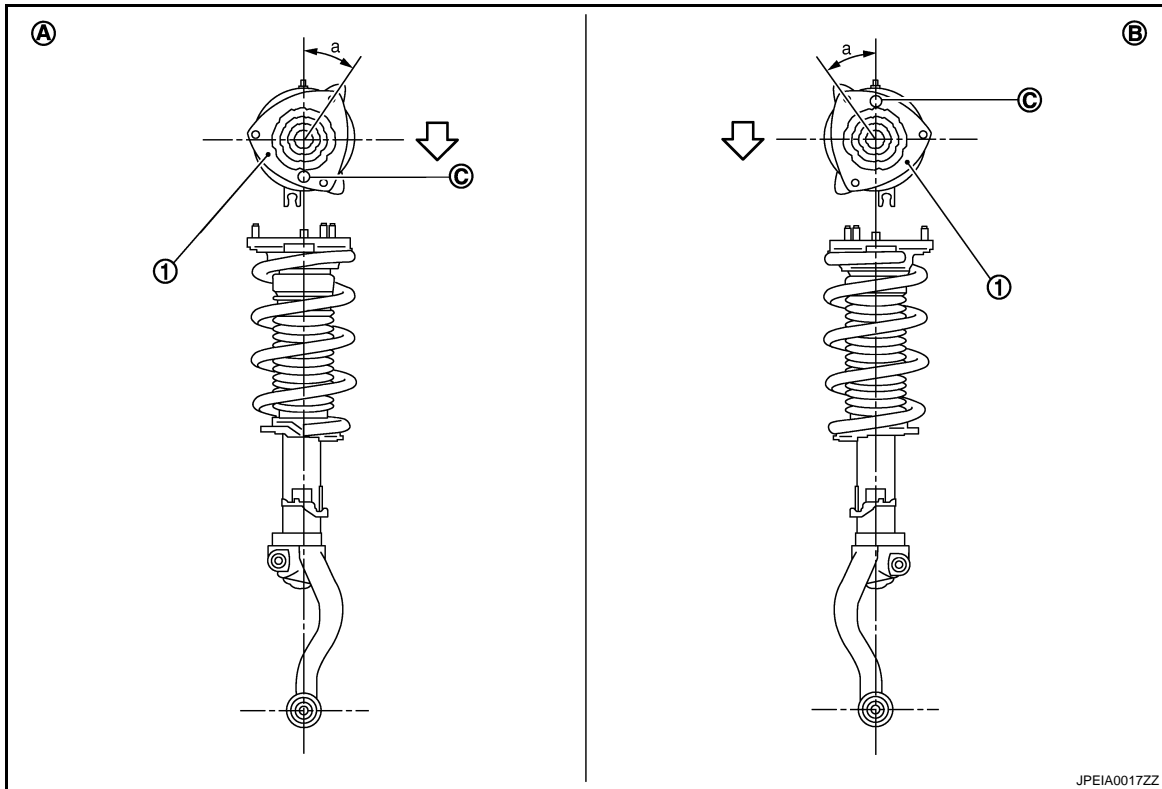

1. Shock absorber mounting bracket

A. Right side

B. Left side

C. Coil spring lower end position

⇐ : Vehicle front

- Install the shock absorber mounting bracket as shown in the figure.

Angle (a) : 35.4°

- Check that the lower end of the coil spring is positioned at the spring lower seat of the shock absorber.

6. Secure piston rod tip so that piston rod does not turn, then tighten piston rod lock nut with specified torque.
7. Gradually release a spring compressor, and remove coil spring.

CAUTION:

Loosen while making sure coil spring attachment position does not move.

8. Remove the shock absorber attachment from shock absorber.
9. Install the mounting seal to shock absorber mounting bracket.

Inspection

INFOID:000000004670185

INSPECTION AFTER DISASSEMBLY

Shock Absorber

Check the following items, and replace the part if necessary.

- Shock absorber for deformation, cracks or damage.
- Piston rod for damage, uneven wear or distortion.
- Oil leakage.

Shock Absorber Mounting Bracket and Rubber Parts Inspection

Check shock absorber mounting bracket for cracks and rubber parts for wear. Replace it if necessary.

Coil Spring

Check coil spring for cracks, wear or damage, and replace it if necessary.

FRONT COIL SPRING AND SHOCK ABSORBER

< REMOVAL AND INSTALLATION >

[AWD]

INSPECTION AFTER INSTALLATION

1. Check wheel sensor harness for proper connection. Refer to [BRC-100, "Exploded View"](#).
2. Check wheel alignment. Refer to [FSU-30, "Inspection"](#).
3. Adjust neutral position of steering angle sensor. Refer to [BRC-8, "ADJUSTMENT OF STEERING ANGLE SENSOR NEUTRAL POSITION : Special Repair Requirement"](#).

A

B

C

D

FSU

F

G

H

I

J

K

L

M

N

O

P

TRANSVERSE LINK

< REMOVAL AND INSTALLATION >

[AWD]

TRANSVERSE LINK

Exploded View

INFOID:000000004670186

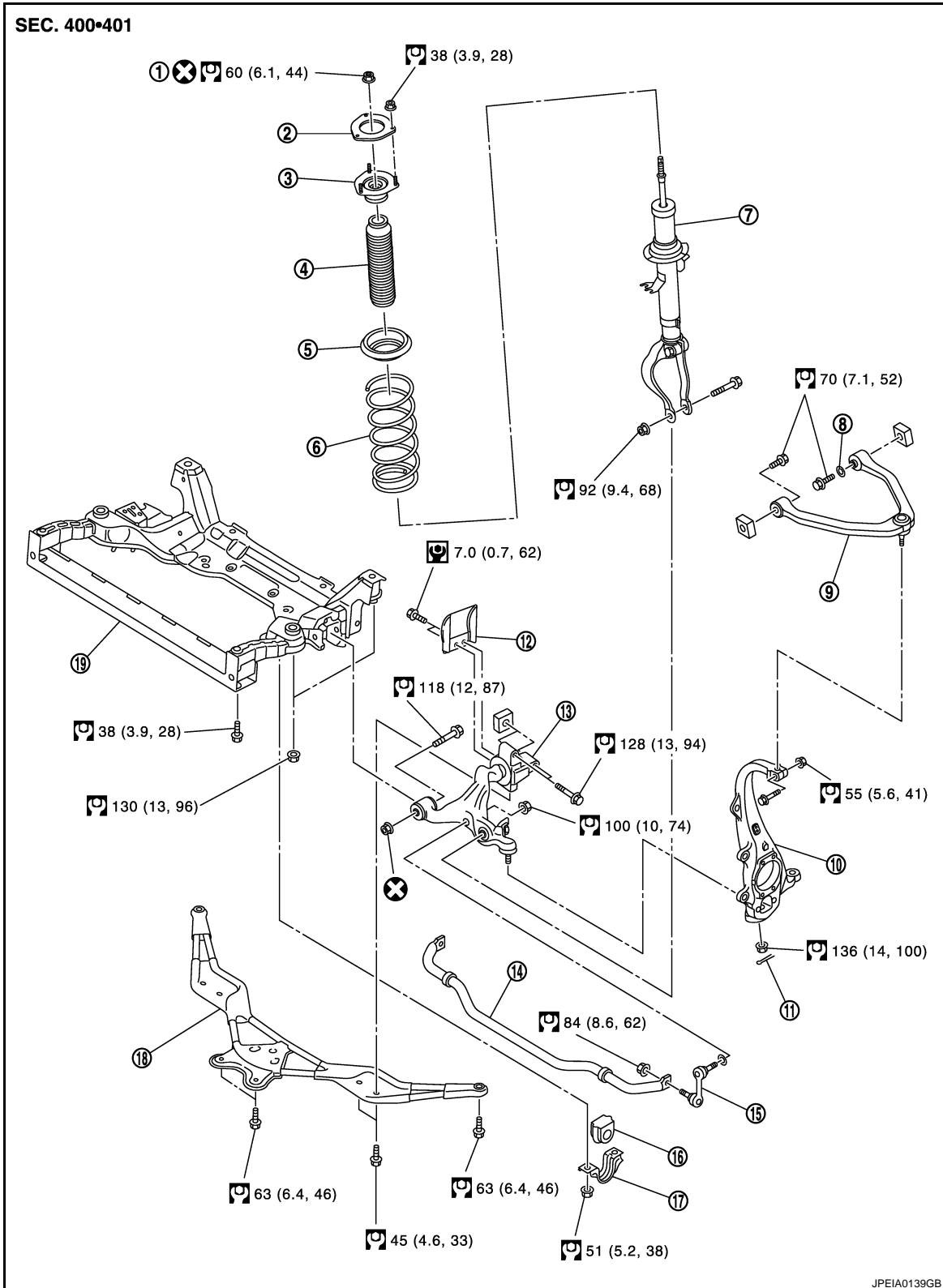

JPEIA0139GB

- | | | |
|------------------------|-------------------|------------------------------------|
| 1. Piston rod lock nut | 2. Mounting seal | 3. Shock absorber mounting bracket |
| 4. Bound bumper | 5. Rubber seat | 6. Coil spring |
| 7. Shock absorber | 8. Stopper rubber | 9. Upper link |

TRANSVERSE LINK

[AWD]

< REMOVAL AND INSTALLATION >

- | | | |
|-----------------------------|----------------------|-------------------------------|
| 10. Steering knuckle | 11. Cotter pin | 12. Insulator |
| 13. Transverse link | 14. Stabilizer bar | 15. Stabilizer connecting rod |
| 16. Stabilizer bushing | 17. Stabilizer clamp | 18. Front cross bar |
| 19. Front suspension member | | |

Refer to [GI-4, "Components"](#) for symbols in the figure.

Removal and Installation

INFOID:000000004670187

REMOVAL

1. Remove tires with power tool.
2. Remove under cover with power tool.
3. Remove shock absorber. Refer to [FSU-31, "Exploded View"](#).
4. Remove front crossbar.
5. Remove steering outer socket from steering knuckle. Refer to [ST-37, "AWD : Exploded View"](#).
6. Remove transverse link from steering knuckle.
7. Set suitable jack under transverse link.
8. Remove mounting bolts and nuts, and then remove transverse link.

INSTALLATION

Note the following, and install in the reverse order of removal.

- Never tap on the ball joint cap of the stabilizer connecting rod with a hammer or a similar item when inserting the stabilizer connecting rod into the transverse link.
- Perform final tightening of bolts and nuts at the front suspension member installation and shock absorber lower side (rubber bushing), under unladen conditions with tires on level ground.

Inspection

INFOID:000000004670188

INSPECTION AFTER REMOVAL

Appearance

Check the following items, and replace the part if necessary.

- Transverse link and bushing for deformation, cracks or damage.
- Ball joint boot for cracks or other damage, and also for grease leakage.

Ball Joint Inspection

Manually move ball stud to confirm it moves smoothly with no binding.

Swing Torque Inspection

NOTE:

Before measurement, move ball stud at least ten times by hand to check for smooth movement.

- Hook a spring balance (A) at cotter pin mounting hole. Confirm spring balance measurement value is within specifications when ball stud begins moving.

Standard

Swing torque :Refer to [FSU-45, "Ball Joint"](#).

- If it is outside the specified range, replace transverse link assembly.

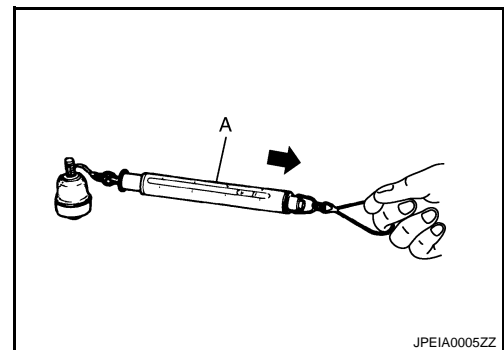

Rotating Torque Inspection

TRANSVERSE LINK

[AWD]

< REMOVAL AND INSTALLATION >

- Attach mounting nut to ball stud. Make sure that rotating torque is within specifications with a preload gauge (A) [SST: 3127S000 (J-25765-A)].

Standard

Rotating torque : Refer to [FSU-45, "Ball Joint"](#).

- If it is outside the specified range, replace transverse link assembly.

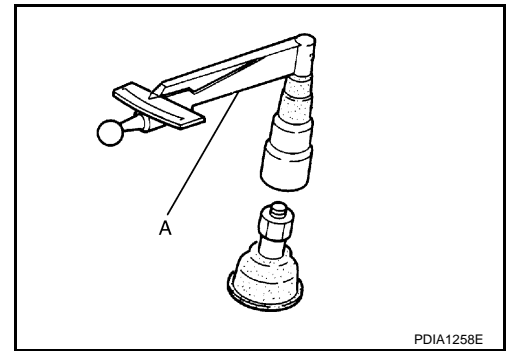

Axial End Play Inspection

- Move tip of ball stud in axial direction to check for looseness.

Standard

Axial end play : Refer to [FSU-45, "Ball Joint"](#).

- If it is outside the specified range, replace transverse link assembly.

INSPECTION AFTER INSTALLATION

1. Check wheel sensor harness for proper connection. Refer to [BRC-100, "Exploded View"](#).
2. Check wheel alignment. Refer to [FSU-30, "Inspection"](#).
3. Adjust neutral position of steering angle sensor. Refer to [BRC-8, "ADJUSTMENT OF STEERING ANGLE SENSOR NEUTRAL POSITION : Special Repair Requirement"](#).

UPPER LINK

< REMOVAL AND INSTALLATION >

[AWD]

UPPER LINK

Exploded View

INFOID:000000004670189

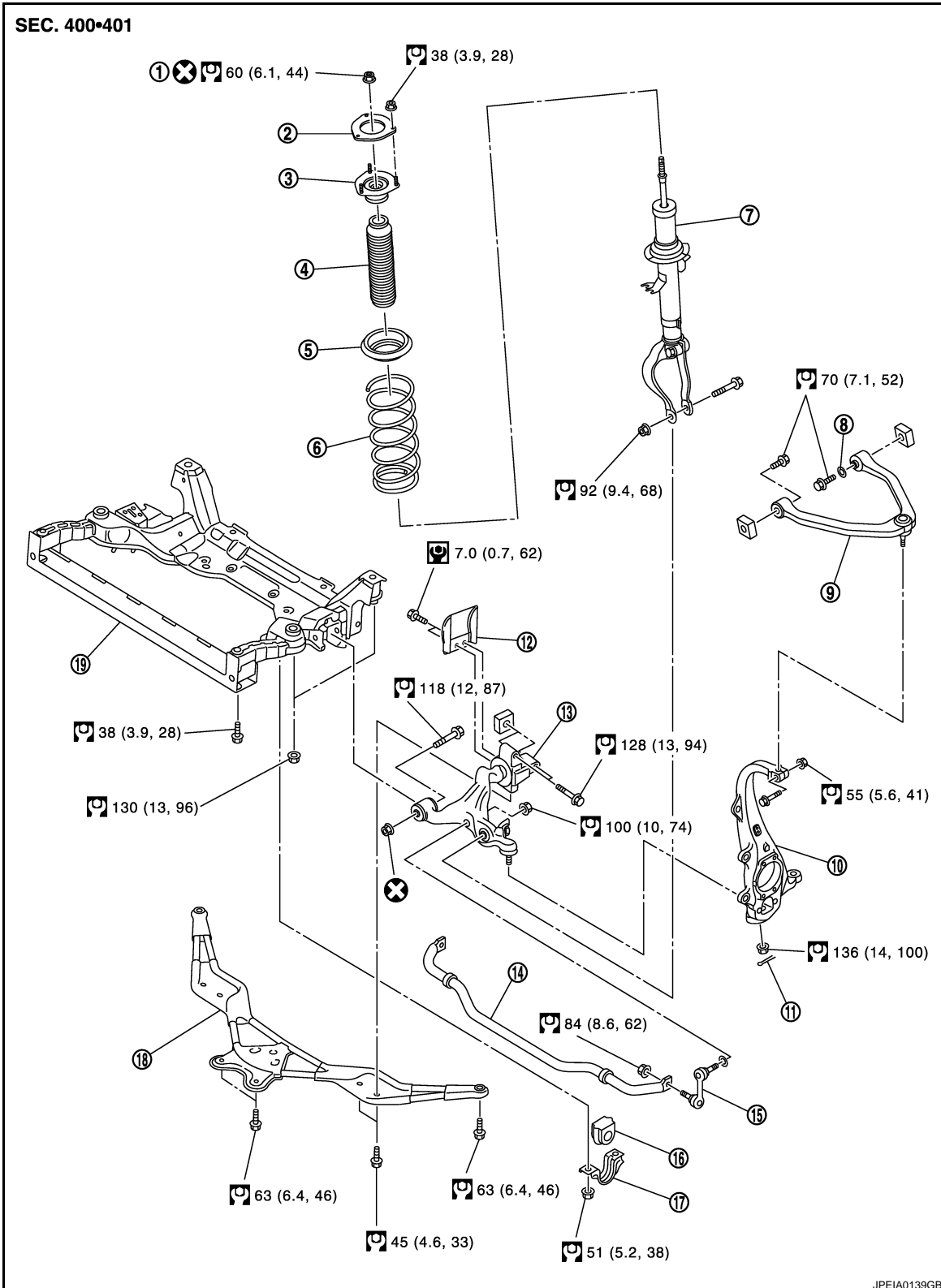

- | | | |
|------------------------|-------------------|------------------------------------|
| 1. Piston rod lock nut | 2. Mounting seal | 3. Shock absorber mounting bracket |
| 4. Bound bumper | 5. Rubber seat | 6. Coil spring |
| 7. Shock absorber | 8. Stopper rubber | 9. Upper link |

UPPER LINK

[AWD]

< REMOVAL AND INSTALLATION >

- | | | |
|-----------------------------|----------------------|-------------------------------|
| 10. Steering knuckle | 11. Cotter pin | 12. Insulator |
| 13. Transverse link | 14. Stabilizer bar | 15. Stabilizer connecting rod |
| 16. Stabilizer bushing | 17. Stabilizer clamp | 18. Front cross bar |
| 19. Front suspension member | | |

Refer to [GI-4, "Components"](#) for symbols in the figure.

Removal and Installation

INFOID:000000004670190

REMOVAL

1. Remove tires from with power tool.
2. Remove shock absorber. Refer to [FSU-31, "Exploded View"](#).
3. Remove mounting bolts and nuts with power tool, and then remove upper link from steering knuckle.
4. Remove mounting bolts and nuts, and then remove upper link and stopper rubber.

INSTALLATION

Note the following, and install in the reverse order of removal.

- Perform final tightening of bolts and nuts at the vehicle installation position (rubber bushing), under unladen conditions with tires on level ground.

Inspection

INFOID:000000004670191

INSPECTION AFTER REMOVAL

Appearance

Check the following items, and replace the part if necessary.

- Upper link and bushing for deformation, cracks or damage.
- Ball joint boot for cracks or other damage, and also for grease leakage.

Ball Joint Inspection

Manually move ball stud to confirm it moves smoothly with no binding.

Swing Torque Inspection

NOTE:

Before measurement, move ball stud at least ten times by hand to check for smooth movement.

- Hook a spring balance (A) at cutout on ball stud. Confirm spring balance measurement value is within specifications when ball stud begins moving.

Standard

Swing torque : Refer to [FSU-45, "Ball Joint"](#).

- If it is outside the specified range, replace upper link assembly.

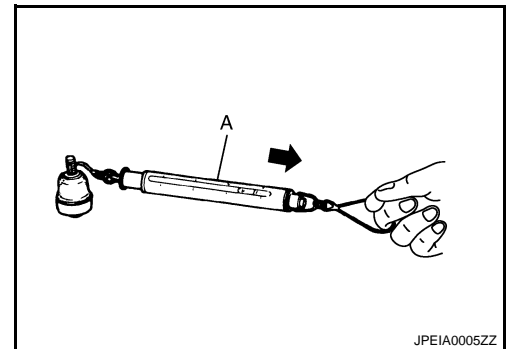

Axial End Play Inspection

- Move tip of ball stud in axial direction to check for looseness.

Standard

Axial end play : Refer to [FSU-45, "Ball Joint"](#).

- If it is outside the specified range, replace upper link assembly.

INSPECTION AFTER INSTALLATION

1. Check wheel sensor harness for proper connection. Refer to [BRC-100, "Exploded View"](#).
2. Check wheel alignment. Refer to [FSU-30, "Inspection"](#).
3. Adjust neutral position of steering angle sensor. Refer to [BRC-8, "ADJUSTMENT OF STEERING ANGLE SENSOR NEUTRAL POSITION : Special Repair Requirement"](#).

FRONT STABILIZER

< REMOVAL AND INSTALLATION >

[AWD]

FRONT STABILIZER

Exploded View

INFOID:000000004670192

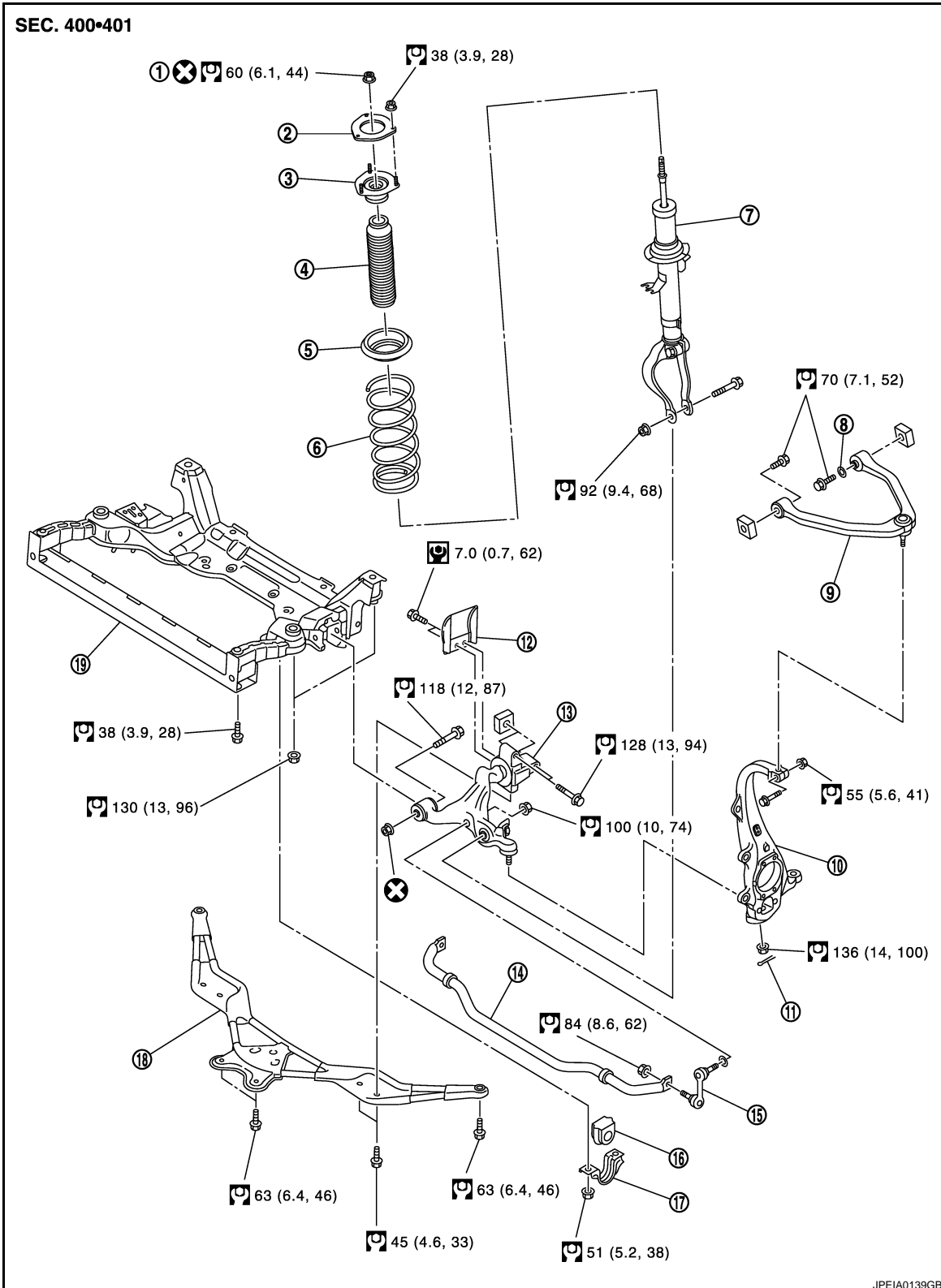

- | | | |
|------------------------|-------------------|------------------------------------|
| 1. Piston rod lock nut | 2. Mounting seal | 3. Shock absorber mounting bracket |
| 4. Bound bumper | 5. Rubber seat | 6. Coil spring |
| 7. Shock absorber | 8. Stopper rubber | 9. Upper link |

FRONT STABILIZER

< REMOVAL AND INSTALLATION >

[AWD]

- | | | |
|-----------------------------|----------------------|-------------------------------|
| 10. Steering knuckle | 11. Cotter pin | 12. Insulator |
| 13. Transverse link | 14. Stabilizer bar | 15. Stabilizer connecting rod |
| 16. Stabilizer bushing | 17. Stabilizer clamp | 18. Front cross bar |
| 19. Front suspension member | | |

Refer to [GI-4. "Components"](#) for symbols in the figure.

Removal and Installation

INFOID:000000004670193

REMOVAL

1. Remove tires with power tool.
2. Remove under cover with power tool.
3. Remove stabilizer connecting rod.

CAUTION:

Apply a matching mark to identify the installation position.

4. Remove the stabilizer clamp and stabilizer bushing.
5. Remove stabilizer bar.

INSTALLATION

Note the following, and install in the reverse order of removal.

- Check the mounting mark when installing.
- Tighten the mounting nut to the specified torque while holding a hexagonal part of stabilizer connecting rod side.

Inspection

INFOID:000000004670194

INSPECTION AFTER REMOVAL

Check stabilizer bar, stabilizer connecting rod, stabilizer bushing and stabilizer clamp for deformation, cracks or damage. Replace it if necessary.

FRONT SUSPENSION MEMBER

< UNIT REMOVAL AND INSTALLATION >

[AWD]

UNIT REMOVAL AND INSTALLATION

FRONT SUSPENSION MEMBER

Exploded View

INFOID:000000004670195

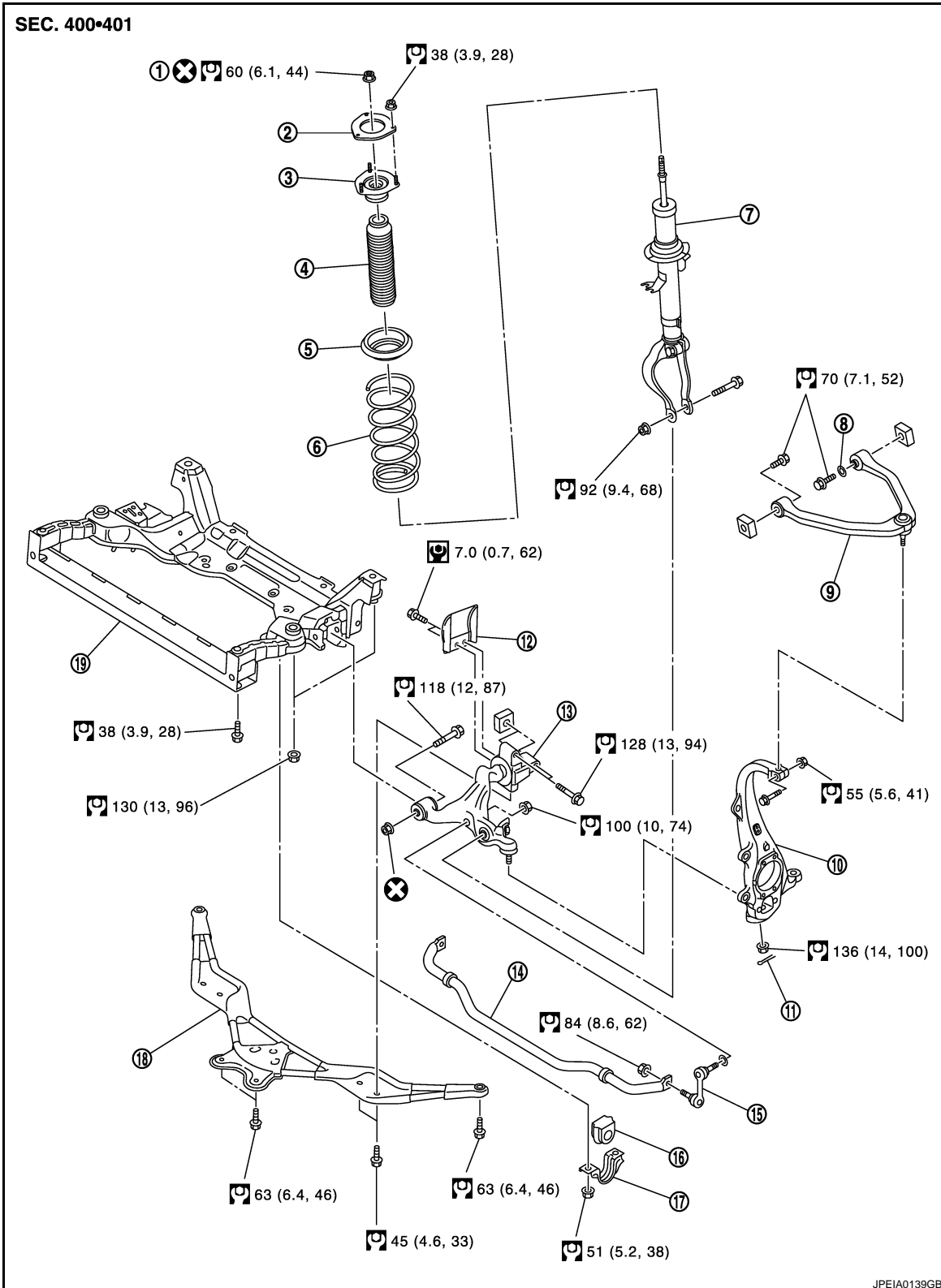

A

B

C

D

FSU

F

G

H

I

J

K

L

M

N

O

P

FRONT SUSPENSION MEMBER

< UNIT REMOVAL AND INSTALLATION >

[AWD]

- | | | |
|-----------------------------|----------------------|------------------------------------|
| 1. Piston rod lock nut | 2. Mounting seal | 3. Shock absorber mounting bracket |
| 4. Bound bumper | 5. Rubber seat | 6. Coil spring |
| 7. Shock absorber | 8. Stopper rubber | 9. Upper link |
| 10. Steering knuckle | 11. Cotter pin | 12. Insulator |
| 13. Transverse link | 14. Stabilizer bar | 15. Stabilizer connecting rod |
| 16. Stabilizer bushing | 17. Stabilizer clamp | 18. Front cross bar |
| 19. Front suspension member | | |

Refer to [GI-4, "Components"](#) for symbols in the figure.

Removal and Installation

INFOID:000000004670196

REMOVAL

1. Remove tire with power tool.
2. Remove under cover with power tool.
3. Remove front cross bar.
4. Separate steering gear assembly and lower joint. Refer to [ST-24, "WITHOUT 4WAS : Exploded View"](#).
5. Remove steering outer socket from steering knuckle. Refer to [ST-37, "AWD : Exploded View"](#).
6. Remove wheel sensor from steering knuckle. Refer to [BRC-100, "Exploded View"](#).
7. Remove shock absorber. Refer to [FSU-31, "Exploded View"](#).
8. Remove front stabilizer. Refer to [FSU-41, "Exploded View"](#).
9. Install engine slinger, and then hoist engine. Refer to [EM-74, "AWD : Removal and Installation"](#).
10. Remove transverse link from front suspension member with power tool. Refer to [FSU-36, "Exploded View"](#).
11. Remove steering hydraulic piping bracket and steering gear from front suspension member. Refer to [ST-61, "AWD : Exploded View"](#).
12. Set suitable jack front suspension member.
13. Remove mounting nuts between engine mounting insulator and from suspension member. Refer to [EM-73, "AWD : Exploded View"](#).
14. Remove mounting bolts and nuts of front suspension member with power tool.
15. Gradually lower jack to remove front suspension assembly from vehicle.

INSTALLATION

Note the following, and install in the reverse order of removal.

- Perform final tightening of installation position between front suspension member and transverse links (rubber bushing) under unladen condition with tires on level ground.

Inspection

INFOID:000000004670197

INSPECTION AFTER REMOVAL

Check the front suspension member for significant deformation, cracks, or damages. Replace if necessary.

INSPECTION AFTER INSTALLATION

1. Check wheel sensor harness for proper connection. Refer to [BRC-100, "Exploded View"](#).
2. Check wheel alignment. Refer to [FSU-30, "Inspection"](#).
3. Adjust the neutral position of the steering angle sensor. Refer to [BRC-8, "ADJUSTMENT OF STEERING ANGLE SENSOR NEUTRAL POSITION : Special Repair Requirement"](#).

SERVICE DATA AND SPECIFICATIONS (SDS)

< SERVICE DATA AND SPECIFICATIONS (SDS)

[AWD]

SERVICE DATA AND SPECIFICATIONS (SDS)

SERVICE DATA AND SPECIFICATIONS (SDS)

Wheel Alignment

INFOID:000000004499007

Item		Standard	
Camber Degree minute (Decimal degree)	Minimum	-1° 10' (-1.17°)	
	Nominal	-0° 25' (-0.42°)	
	Maximum	0° 20' (0.33°)	
	Left and right difference	0° 33' (0.55°) or less	
Caster Degree minute (Decimal degree)	Minimum	3° 30' (3.50°)	
	Nominal	4° 15' (4.25°)	
	Maximum	5° 00' (5.00°)	
	Left and right difference	0° 39' (0.65°) or less	
Kingpin inclination Degree minute (Decimal degree)	Minimum	6° 40' (6.67°)	
	Nominal	7° 25' (7.42°)	
	Maximum	8° 10' (8.16°)	
Toe-in	Total toe-in Distance	Minimum	0 mm (0 in)
		Nominal	In 1 mm (0.04 in)
		Maximum	In 2 mm (0.08 in)
	Toe angle (left wheel or right wheel) Degree minute (Decimal degree)	Minimum	0° 00' (0.00°)
		Nominal	In 0° 02' 30" (0.04°)
		Maximum	In 0° 05' (0.08°)

Measure value under unladen* conditions.

*Fuel, engine coolant and lubricant are full. Spare tire, jack, hand tools and mats are in designated positions.

Ball Joint

INFOID:000000004499008

Item		Standard
Swing torque	Transverse link	0.5 – 3.6 N·m (0.06 – 0.36 kg·m, 5 – 31 in-lb)
	Upper link	0 – 2.0 N·m (0 – 0.2 kg·m, 0 – 17 in-lb)
Measurement on spring balance	Transverse link	7.8 – 56.3 N (0.8 – 5.7 kg, 1.8 – 12.5 lb)
	Upper link	0 – 61.5 N (0 – 6.3 kg, 0 – 13.8 lb)
Rotating torque	Transverse link	0.5 – 3.9 N·m (0.06 – 0.39 kg·m, 5 – 34 in-lb)
Axial end play		0 mm (0 in)

Wheelarch Height

INFOID:000000004499009

Item	Standard
Front (Hf)	726 mm (28.58 in)

SERVICE DATA AND SPECIFICATIONS (SDS)

< SERVICE DATA AND SPECIFICATIONS (SDS)

[AWD]

Item	Standard
Rear (Hr)	718 mm (28.27 in)

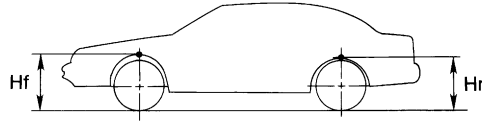

SFA818A

Measure value under unladen* conditions.

*: Fuel, engine coolant and lubricant are full. Spare tire, jack, hand tools and mats are in designated positions.