

SECTION HAC

HEATER & AIR CONDITIONING CONTROL SYSTEM

CONTENTS

AUTOMATIC AIR CONDITIONER		
BASIC INSPECTION	4	
DIAGNOSIS AND REPAIR WORKFLOW	4	
Work Flow	4	
INSPECTION AND ADJUSTMENT	5	
WITHOUT PLASMACLUSTER SYSTEM	5	
WITHOUT PLASMACLUSTER SYSTEM : De- scription & Inspection	5	
WITHOUT PLASMACLUSTER SYSTEM : Tem- perature Setting Trimmer	7	
WITHOUT PLASMACLUSTER SYSTEM : Foot Position Setting Trimmer	9	
WITHOUT PLASMACLUSTER SYSTEM : Inlet Port Memory Function	10	
WITH PLASMACLUSTER SYSTEM	10	
WITH PLASMACLUSTER SYSTEM : Description & Inspection	10	
WITH PLASMACLUSTER SYSTEM : Tempera- ture Setting Trimmer	13	
WITH PLASMACLUSTER SYSTEM : Foot Posi- tion Setting Trimmer	14	
WITH PLASMACLUSTER SYSTEM : Inlet Port Memory Function	15	
WITH PLASMACLUSTER SYSTEM : Gas Sensor Sensitivity Adjustment Function	15	
WITH PLASMACLUSTER SYSTEM : Auto Intake Interlocking Movement Change Function	16	
SYSTEM DESCRIPTION	17	
COMPRESSOR CONTROL FUNCTION	17	
Description	17	
Fail-safe	17	
Component Part Location	18	
Component Description	21	
AUTOMATIC AIR CONDITIONER SYSTEM	22	
WITHOUT LEFT AND RIGHT VENTILATION TEM- PERATURE SEPARATELY CONTROL SYSTEM	22	
WITHOUT LEFT AND RIGHT VENTILATION TEMPERATURE SEPARATELY CONTROL SYSTEM : System Diagram	22	
WITHOUT LEFT AND RIGHT VENTILATION TEMPERATURE SEPARATELY CONTROL SYSTEM : System Description	22	
WITHOUT LEFT AND RIGHT VENTILATION TEMPERATURE SEPARATELY CONTROL SYSTEM : Component Part Location	27	
WITHOUT LEFT AND RIGHT VENTILATION TEMPERATURE SEPARATELY CONTROL SYSTEM : Component Description	29	
WITH LEFT AND RIGHT VENTILATION TEMPER- ATURE SEPARATELY CONTROL SYSTEM	30	
WITH LEFT AND RIGHT VENTILATION TEM- PERATURE SEPARATELY CONTROL SYSTEM : System Diagram	30	
WITH LEFT AND RIGHT VENTILATION TEM- PERATURE SEPARATELY CONTROL SYSTEM : System Description	31	
WITH LEFT AND RIGHT VENTILATION TEM- PERATURE SEPARATELY CONTROL SYSTEM : Component Part Location	39	
WITH LEFT AND RIGHT VENTILATION TEM- PERATURE SEPARATELY CONTROL SYSTEM : Component Description	41	
PLASMACLUSTER SYSTEM	43	
System Diagram	43	
System Description	43	
Component Part Location	45	
Component Description	46	
CAN COMMUNICATION SYSTEM	47	
System Description	47	
MODE DOOR CONTROL SYSTEM	48	
System Diagram	48	

A
B
C
D
E
F
G
H
HAC
J
K
L
M
N
O
P

System Description	48	WITH LEFT AND RIGHT VENTILATION TEMPERATURE SEPARATELY CONTROL SYSTEM : Description	74
AIR MIX DOOR CONTROL SYSTEM	50	WITH LEFT AND RIGHT VENTILATION TEMPERATURE SEPARATELY CONTROL SYSTEM : Component Function Check	75
System Diagram	50	WITH LEFT AND RIGHT VENTILATION TEMPERATURE SEPARATELY CONTROL SYSTEM : Diagnosis Procedure	75
System Description	50	INTAKE DOOR MOTOR	77
INTAKE DOOR CONTROL SYSTEM	52	Description	77
System Diagram	52	Component Function Check	77
System Description	52	Diagnosis Procedure	77
BLOWER MOTOR CONTROL SYSTEM	54	BLOWER MOTOR	79
System Diagram	54	Description	79
System Description	54	Component Function Check	79
MAGNET CLUTCH CONTROL SYSTEM	56	Diagnosis Procedure	79
System Diagram	56	Component Inspection	81
System Description	56	MAGNET CLUTCH	83
DIAGNOSIS SYSTEM (UNIFIED METER & A/C AMP.)	58	Description	83
WITHOUT PLASMACLUSTER SYSTEM	58	Component Function Check	83
WITHOUT PLASMACLUSTER SYSTEM : Diagnosis Description	58	Diagnosis Procedure	83
WITH PLASMACLUSTER SYSTEM	63	ECV (ELECTRICAL CONTROL VALVE)	85
WITH PLASMACLUSTER SYSTEM : Diagnosis Description	63	Description	85
DTC/CIRCUIT DIAGNOSIS	69	Diagnosis Procedure	85
POWER SUPPLY AND GROUND CIRCUIT	69	AMBIENT SENSOR	87
UNIFIED METER AND A/C AMP.	69	Description	87
UNIFIED METER AND A/C AMP. : Diagnosis Procedure	69	Component Function Check	87
UNIFIED METER AND A/C AMP.	70	Diagnosis Procedure	87
Description	70	Component Inspection	88
Component Function Check	70	IN-VEHICLE SENSOR	90
Diagnosis Procedure	70	Description	90
MODE DOOR MOTOR	71	Component Function Check	90
Description	71	Diagnosis Procedure	90
Component Function Check	71	Component Inspection	91
Diagnosis Procedure	71	SUNLOAD SENSOR	93
AIR MIX DOOR MOTOR	73	Description	93
WITHOUT LEFT AND RIGHT VENTILATION TEMPERATURE SEPARATELY CONTROL SYSTEM ...	73	Component Function Check	93
WITHOUT LEFT AND RIGHT VENTILATION TEMPERATURE SEPARATELY CONTROL SYSTEM : Description	73	Diagnosis Procedure	93
WITHOUT LEFT AND RIGHT VENTILATION TEMPERATURE SEPARATELY CONTROL SYSTEM : Component Function Check	73	Component Inspection	94
WITHOUT LEFT AND RIGHT VENTILATION TEMPERATURE SEPARATELY CONTROL SYSTEM : Diagnosis Procedure	73	INTAKE SENSOR	96
WITH LEFT AND RIGHT VENTILATION TEMPERATURE SEPARATELY CONTROL SYSTEM	74	Description	96
		Component Function Check	96
		Diagnosis Procedure	96
		Component Inspection	97
		GAS SENSOR	98
		Description	98
		Component Function Check	98
		Diagnosis Procedure	98
		IONIZER	101
		Description	101

Component Function Check	101	Precaution Necessary for Steering Wheel Rotation after Battery Disconnect	139	A
Diagnosis Procedure	101	Precaution for Battery Service	140	
ECU DIAGNOSIS INFORMATION	103	REMOVAL AND INSTALLATION	141	B
ECM	103	PRESET SWITCH	141	C
Reference Value	103	Exploded View	141	
UNIFIED METER AND A/C AMP.	119	Removal and Installation	141	D
Reference Value	119	UNIFIED METER AND A/C AMP.	142	E
Wiring Diagram - AIR CONDITIONER CONTROL SYSTEM -	121	Exploded View	142	
Fail-safe	128	Removal and Installation	142	F
SYMPTOM DIAGNOSIS	130	AMBIENT SENSOR	143	G
AIR CONDITIONER CONTROL	130	Exploded View	143	
Diagnosis Chart By Symptom	130	Removal and Installation	143	H
INSUFFICIENT COOLING	131	IN-VEHICLE SENSOR	144	I
Description	131	Exploded View	144	
Inspection procedure	131	Removal and Installation	144	J
INSUFFICIENT HEATING	133	SUNLOAD SENSOR	145	K
Description	133	Exploded View	145	
Inspection procedure	133	Removal and Installation	145	L
NOISE	135	INTAKE SENSOR	146	M
Description	135	Exploded View	146	
Inspection procedure	135	Removal and Installation	146	N
SELF-DIAGNOSIS CANNOT BE PERFORMED	137	REFRIGERANT PRESSURE SENSOR	147	O
Description	137	Exploded View	147	
Inspection procedure	137	Removal and Installation	147	P
MEMORY FUNCTION DOES NOT OPERATE.	138	DOOR MOTOR	148	
Description	138	Exploded View	148	
Inspection procedure	138	MODE DOOR MOTOR	148	
PRECAUTION	139	MODE DOOR MOTOR : Removal and Installation.	148	
PRECAUTIONS	139	AIR MIX DOOR MOTOR	148	
Precaution for Supplemental Restraint System (SRS) "AIR BAG" and "SEAT BELT PRE-TENSIONER"	139	AIR MIX DOOR MOTOR : Removal and Installation	149	
		INTAKE DOOR MOTOR	149	
		INTAKE DOOR MOTOR : Removal and Installation	149	

HAC

BASIC INSPECTION

DIAGNOSIS AND REPAIR WORKFLOW

Work Flow

INFOID:000000005649476

DETAILED FLOW

1. LISTEN TO CUSTOMER COMPLAINT

Listen to customer complaint. (Get detailed information about the conditions and environment when the symptom occurs.)

>> GO TO 2.

2. VERIFY THE SYMPTOM WITH OPERATIONAL CHECK

Verify the symptom with operational check. Refer to [HAC-5, "WITHOUT PLASMA CLUSTER SYSTEM : Description & Inspection"](#).

>> GO TO 3.

3. GO TO APPROPRIATE TROUBLE DIAGNOSIS

Go to appropriate trouble diagnosis. Refer to [HAC-130, "Diagnosis Chart By Symptom"](#).

>> GO TO 4.

4. REPAIR OR REPLACE

Repair or replace the specific parts.

>> GO TO 5.

5. FINAL CHECK

Final check.

Is the inspection result normal?

YES >> INSPECTION END

NO >> GO TO 3.

INSPECTION AND ADJUSTMENT

< BASIC INSPECTION >

[AUTOMATIC AIR CONDITIONER]

INSPECTION AND ADJUSTMENT WITHOUT PLASMACLUSTER SYSTEM

WITHOUT PLASMACLUSTER SYSTEM : Description & Inspection

INFOID:000000005649477

DESCRIPTION

The purpose of the operational check is to check that the individual system operates normally.

Conditions : Engine running at normal operating temperature

INSPECTION PROCEDURE

1. CHECK MEMORY FUNCTION

1. Start the engine.
2. Turn temperature control dial (driver side) clockwise until 32.0°C (90°F) is displayed.
3. Press the OFF switch.
4. Turn the ignition switch OFF.
5. Turn the ignition switch ON.
6. Press the AUTO switch.
7. Check that the temperature setting before turning the ignition switch OFF is stored.

Is the inspection result normal?

YES >> GO TO 2

NO >> Memory function malfunction: [HAC-138. "Inspection procedure"](#).

2. CHECK BLOWER MOTOR SPEED

1. Start the engine.
2. Press fan (UP: +) switch*¹ (turn fan control dial clockwise*²). Check that the fan speed is changed. Check the operation for all fan speeds.

NOTE:

*1: With left and right ventilation temperature separately system.

*2: Without left and right ventilation temperature separately system.

3. Set the fan speed to max speed.

Is the inspection result normal?





YES >> GO TO 3

NO >> Blower motor system malfunction: [HAC-79. "Diagnosis Procedure"](#).

3. CHECK DISCHARGE AIR

1. Press the MODE switch and the DEF switch.
2. Each position indicator should change shape.
3. Confirm that discharge air comes out according to the air distribution table as follows:

Without left and right ventilation temperature separately control system





Discharge air flow				
Mode position indication	Air outlet/distribution			
	VENT	FOOT		DEF
		Front	Rear	
	100%	—	—	—
	53%	29%	18%	—
	11%	39%	24%	26%
	9%	33%	21%	37%
	16%	—	—	84%

INSPECTION AND ADJUSTMENT

< BASIC INSPECTION >

[AUTOMATIC AIR CONDITIONER]

With left and right ventilation temperature separately control system

Discharge air flow					
Mode position indication	Condition	Air outlet/distribution			
		VENT	FOOT		DEF
			Front	Rear	
	DUAL switch: OFF	100%	—	—	—
		53%	29%	18%	—
		11%	39%	24%	26%
		9%	33%	21%	37%
		16%	—	—	84%

NOTE:

Confirm that the compressor clutch is engaged (sound or visual inspection) and the intake door position is at FRE when D/F or DEF is selected.

Is the inspection result normal?

YES >> GO TO 4

NO >> Mode door system malfunction: [HAC-71. "Diagnosis Procedure"](#).

4.CHECK INTAKE AIR

1. Press intake switch. REC indicator turns ON.
2. Press intake switch again. FRE indicator turns ON.
3. Listen for intake door position change. (Slight change of blower sound can be heard.)

NOTE:

Confirm that the compressor clutch is engaged (sound or visual inspection) and the intake door position is at FRE when D/F or DEF is selected.

Is the inspection result normal?

YES >> GO TO 5

NO >> Intake door system malfunction: [HAC-77. "Diagnosis Procedure"](#).

5.CHECK A/C SWITCH

1. Press the A/C switch.
2. A/C switch indicator turns ON.
Confirm that the compressor clutch engages (sound or visual inspection).

Is the inspection result normal?

YES >> GO TO 6

NO >> Magnet clutch system malfunction: [HAC-83. "Diagnosis Procedure"](#).

6.CHECK WITH TEMPERATURE SETTING LOWERED

1. Turn temperature control dial (driver side) counterclockwise until 18°C (64°F) is displayed.
2. Check that the cool air blows from the outlets.

Is the inspection result normal?

YES >> GO TO 7

NO >> Insufficient cooling: [HAC-131. "Inspection procedure"](#).

7.CHECK WITH TEMPERATURE SETTING RAISED

1. Turn temperature control dial (driver side) clockwise until 32°C (90°F) is displayed.
2. Check that the warm air blows from the outlets.

Is the inspection result normal?

YES-1 >> With left and right ventilation temperature separately system. GO TO 8

YES-2 >> Without left and right ventilation temperature separately system. GO TO 9

NO >> Insufficient heating: [HAC-133. "Inspection procedure"](#).

8.CHECK LEFT AND RIGHT VENTILATION TEMPERATURE SEPARATELY CONTROL SYSTEM FUNCTION

1. Press the DUAL switch, and then check that "DUAL" is shown on the display.

INSPECTION AND ADJUSTMENT

[AUTOMATIC AIR CONDITIONER]

< BASIC INSPECTION >

2. Operate temperature control dial (driver side). Check that the discharge air temperature (driver side) changes. A
3. Operate the temperature control dial (passenger side). Check that the discharge air temperature (passenger side) changes. B
4. Press the DUAL switch, and then check that the temperature setting (LH/RH) is unified to the driver side temperature setting. B

Is the inspection result normal?

YES >> GO TO 9.

NO >> Refer to [HAC-130, "Diagnosis Chart By Symptom"](#) and perform the appropriate diagnosis. C

9. CHECK AUTO MODE

1. Press the AUTO switch, and then check that "AUTO" is shown on the display. D
2. Check that the discharge air and fan speed depend on ambient temperature, in-vehicle temperature and temperature setting. D

Is the inspection result normal?

YES >> INSPECTION END E

NO >> Refer to [HAC-130, "Diagnosis Chart By Symptom"](#) and perform the appropriate diagnosis. E

WITHOUT PLASMACLUSTER SYSTEM : Temperature Setting Trimmer

INFOID:000000005649478 F

DESCRIPTION

The trimmer compensates for differences in range of $\pm 3^{\circ}\text{C}$ ($\pm 6^{\circ}\text{F}$) between temperature setting (displayed digitally) and temperature felt by customer. G

Operating procedures for this trimmer are as per the following:

1. Begin self-diagnosis STEP-5 mode. Refer to [HAC-58, "WITHOUT PLASMACLUSTER SYSTEM : Diagnosis Description"](#). H

2. Press fan (UP: +) switch*¹ (turn fan control dial clockwise*²) to set system in auxiliary mode. HAC

NOTE:

*1: With left and right ventilation temperature separately system.

*2: Without left and right ventilation temperature separately system.

3. Display shows "61" in auxiliary mechanism. It takes approximately 3 seconds to enable setting operation. J
4. Turn temperature control dial (driver side) as desired. Temperature will change at a rate of 0.5°C (1.0°F) each time a dial is turned. J

CAUTION:

A decimal point is not indicated on the display. K

INSPECTION AND ADJUSTMENT

< BASIC INSPECTION >

[AUTOMATIC AIR CONDITIONER]

Without left and right ventilation temperature separately system

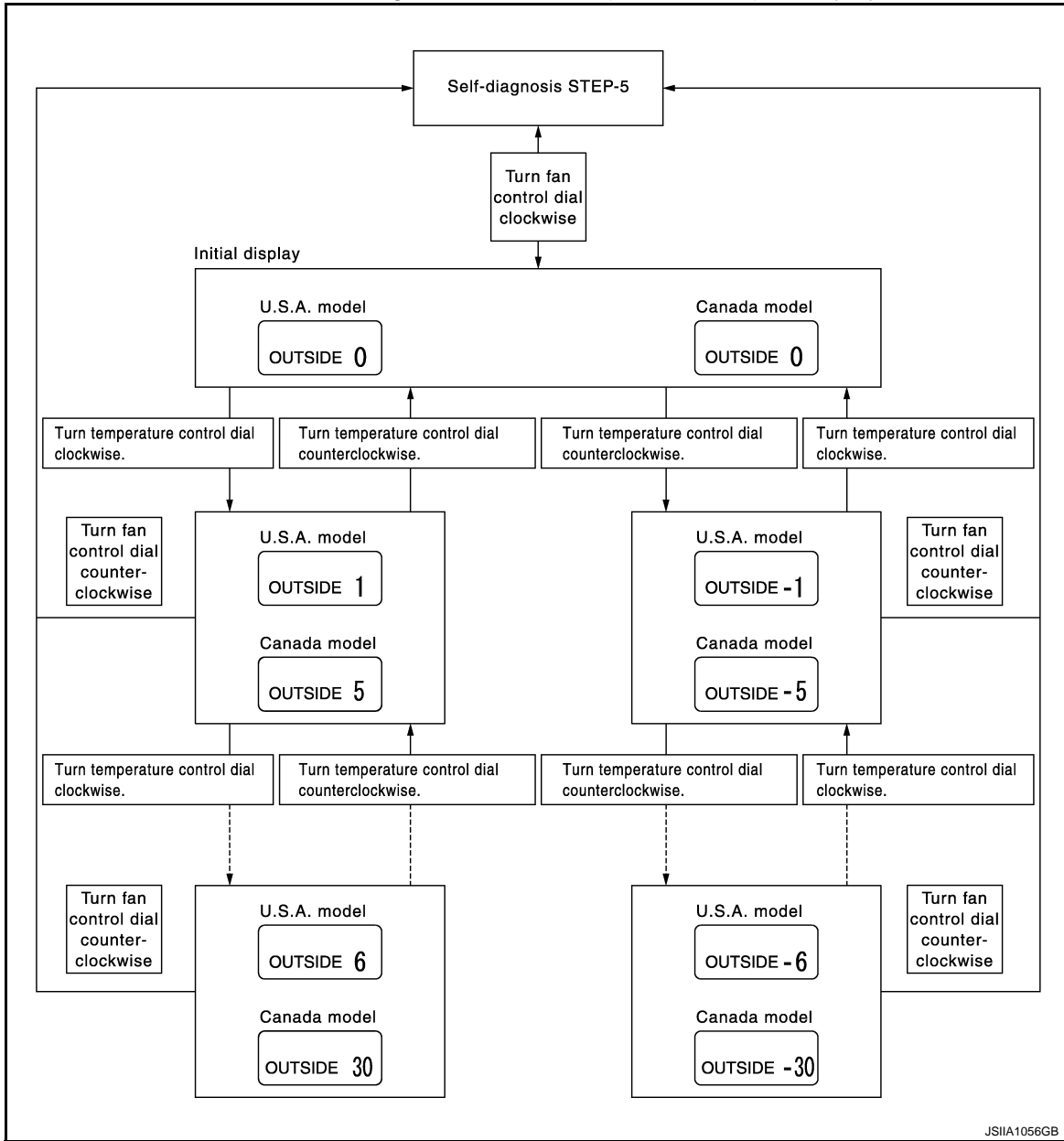

INSPECTION AND ADJUSTMENT

< BASIC INSPECTION >

[AUTOMATIC AIR CONDITIONER]

With left and right ventilation temperature separately system

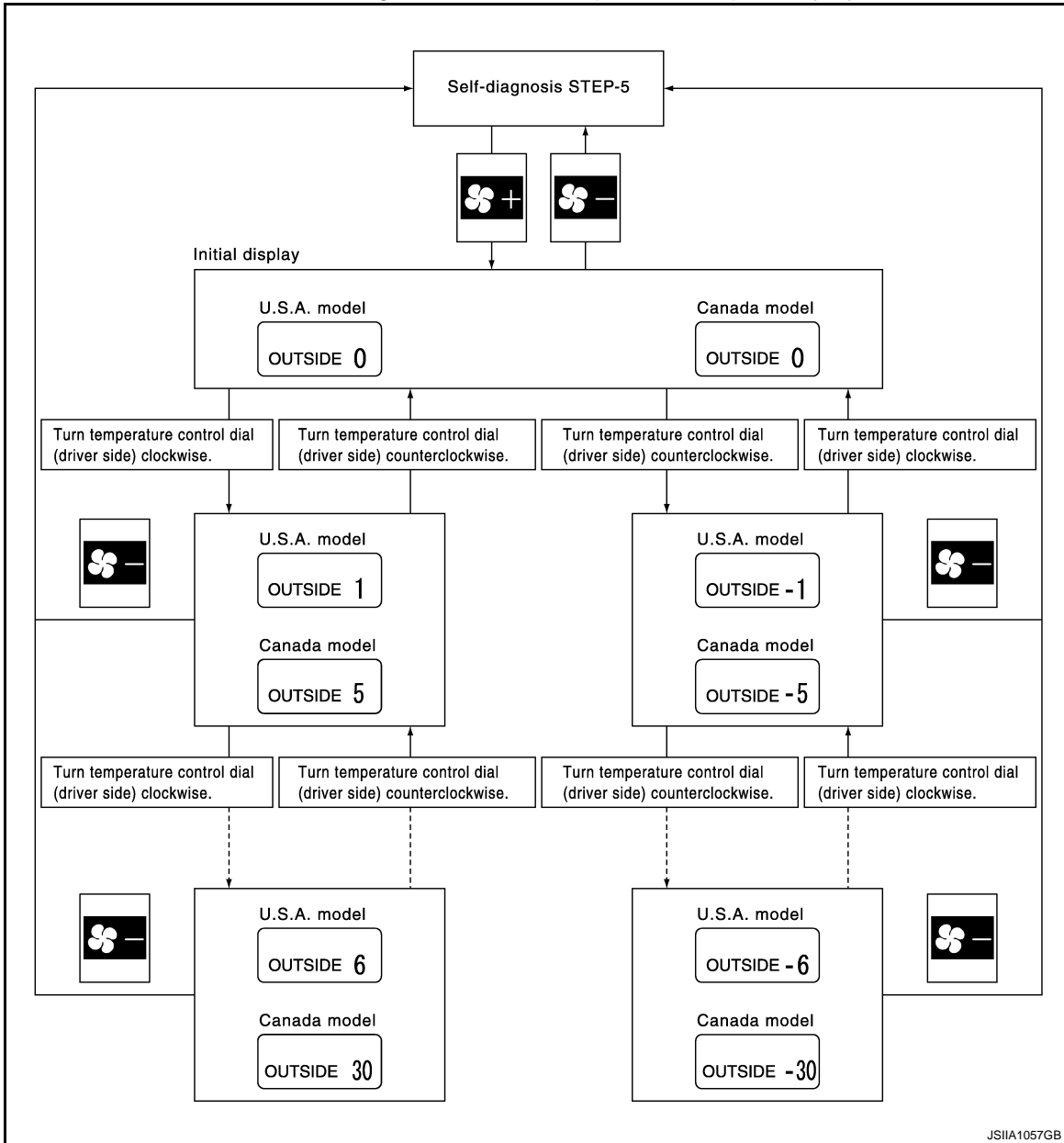

NOTE:

When battery cable is disconnected or battery voltage is below 10 V, trimmer operation is canceled. Temperature set becomes that of initial condition, i.e. 0°C (0°F).

WITHOUT PLASMACLUSTER SYSTEM : Foot Position Setting Trimmer

INFOID:000000005649479

DESCRIPTION

Wind distribution ratio in FOOT mode can be set.

Operating procedures for this trimmer are as per the following:

1. Begin self-diagnosis STEP-5 mode. Refer to [HAC-58. "WITHOUT PLASMACLUSTER SYSTEM : Diagnosis Description"](#).
2. Press fan (UP: +) switch*¹ (turn fancontrol dial clockwise*²) to set system in auxiliary mode.

NOTE:

*1: With left and right ventilation temperature separately system.



*2: Without left and right ventilation temperature separately system.

INSPECTION AND ADJUSTMENT

< BASIC INSPECTION >

[AUTOMATIC AIR CONDITIONER]

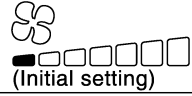
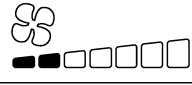
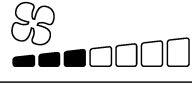
3. Press mode switch as desired.

Display	Discharge air flow							
	Automatically controls the mode door				Manually controls the mode door			
	VENT	FOOT		DEF	VENT	FOOT		DEF
Front		Rear	Front			Rear		
	11%	39%	24%	26%	11%	39%	24%	26%
	11%	39%	24%	26%	15%	53%	32%	—
	15%	53%	32%	—	11%	39%	24%	26%
	15%	53%	32%	—	15%	53%	32%	—

JSIIA0864GB

NOTE:

When battery cable is disconnected or battery voltage is below 10 V, trimmer operation is canceled. Air distribution ratio set becomes that of initial condition.

WITHOUT PLASMACLUSTER SYSTEM : Inlet Port Memory Function

INFOID:000000005649480

DESCRIPTION

When ignition switch is turned from OFF to ON, inlet port can be set to AUTO or manual.

Operating procedures for this trimmer are as per the following:

1. Begin self-diagnosis STEP-5 mode. Refer to [HAC-58. "WITHOUT PLASMACLUSTER SYSTEM : Diagnosis Description"](#).
2. Press fan (UP: +) switch*1 (turn fan control dial clockwise*2) to set system in auxiliary mode.

NOTE:

*1: With left and right ventilation temperature separately system.

*2: Without left and right ventilation temperature separately system.

3. Press intake switch as desired.

FRE indicator	REC indicator	Setting status		Setting changeover method
		FRE	REC	
OFF	ON	AUTO control (Initial setting)	Manual REC status is memorized. (Initial setting)	Intake switch: ON
ON	ON	Manual FRE status is memorized.	Manual REC status is memorized.	
ON	OFF	Manual FRE status is memorized.	AUTO control	
OFF	OFF	AUTO control	AUTO control	

NOTE:

When battery cable is disconnected or battery voltage is below 10 V, memory function is canceled. Memory function set becomes that of initial condition.

WITH PLASMACLUSTER SYSTEM

WITH PLASMACLUSTER SYSTEM : Description & Inspection

INFOID:000000005874575

DESCRIPTION

The purpose of the operational check is to check that the individual system operates normally.

Conditions : Engine running at normal operating temperature

INSPECTION PROCEDURE

INSPECTION AND ADJUSTMENT

< BASIC INSPECTION >

[AUTOMATIC AIR CONDITIONER]

1. CHECK MEMORY FUNCTION

1. Start the engine.
2. Turn temperature control dial (driver side) clockwise until 32.0°C (90°F) is displayed.
3. Press the OFF switch.
4. Turn the ignition switch OFF.
5. Turn the ignition switch ON.
6. Press the AUTO switch.
7. Check that the temperature setting before turning the ignition switch OFF is stored.

Is the inspection result normal?

YES >> GO TO 2

NO >> Memory function malfunction: [HAC-138, "Inspection procedure"](#).

2. CHECK BLOWER MOTOR SPEED

1. Start the engine.
2. Press fan (UP: +) switch. Check that the fan speed is changed. Check the operation for all fan speeds.
3. Set the fan speed to max speed.

Is the inspection result normal?

YES >> GO TO 3

NO >> Blower motor system malfunction: [HAC-79, "Diagnosis Procedure"](#).

3. CHECK DISCHARGE AIR

1. Press the MODE switch and the DEF switch.
2. Each position indicator should change shape.
3. Confirm that discharge air comes out according to the air distribution table as follows:

Discharge air flow					
Mode position indication	Condition	Air outlet/distribution			
		VENT	FOOT		DEF
			Front	Rear	
	DUAL switch: OFF	100%	—	—	—
		53%	29%	18%	—
		11%	39%	24%	26%
		9%	33%	21%	37%
		16%	—	—	84%

NOTE:

Confirm that the compressor clutch is engaged (sound or visual inspection) and the intake door position is at FRE when D/F or DEF is selected.

Is the inspection result normal?

YES >> GO TO 4

NO >> Mode door system malfunction: [HAC-71, "Diagnosis Procedure"](#).

4. CHECK INTAKE AIR

1. Press AUTO switch. AUTO INTAKE indicator and REC indicator turns ON (auto intake mode).
2. Press intake switch. AUTO INTAKE indicator and REC indicator turns OFF (fixed FRE mode).
3. Press intake switch again. REC indicator turns ON (fixed REC mode).
4. Press intake switch again. AUTO INTAKE indicator and REC indicator turns ON (auto intake mode).
5. Listen for intake door position change. (Slight change of blower sound can be heard.)

NOTE:

Confirm that the compressor clutch is engaged (sound or visual inspection) and the intake door position is at FRE when D/F or DEF is selected.

Is the inspection result normal?

YES >> GO TO 5.

NO >> Intake door system malfunction: [HAC-77, "Diagnosis Procedure"](#).

INSPECTION AND ADJUSTMENT

< BASIC INSPECTION >

[AUTOMATIC AIR CONDITIONER]

5. CHECK A/C SWITCH

1. Press the A/C switch.
2. A/C switch indicator turns ON.
Confirm that the compressor clutch engages (sound or visual inspection).

Is the inspection result normal?

YES >> GO TO 6

NO >> Magnet clutch system malfunction: [HAC-83, "Diagnosis Procedure"](#).

6. CHECK WITH TEMPERATURE SETTING LOWERED

1. Turn temperature control dial (driver side) counterclockwise until 18°C (64°F) is displayed.
2. Check that the cool air blows from the outlets.

Is the inspection result normal?

YES >> GO TO 7

NO >> Insufficient cooling: [HAC-131, "Inspection procedure"](#).

7. CHECK WITH TEMPERATURE SETTING RAISED

1. Turn temperature control dial (driver side) clockwise until 32°C (90°F) is displayed.
2. Check that the warm air blows from the outlets.

Is the inspection result normal?

YES >> GO TO 8

NO >> Insufficient heating: [HAC-133, "Inspection procedure"](#).

8. CHECK LEFT AND RIGHT VENTILATION TEMPERATURE SEPARATELY CONTROL SYSTEM FUNCTION

1. Press the DUAL switch, and then check that "DUAL" is shown on the display.
2. Operate temperature control dial (driver side). Check that the discharge air temperature (driver side) changes.
3. Operate the temperature control dial (passenger side). Check that the discharge air temperature (passenger side) changes.
4. Press the DUAL switch, and then check that the temperature setting (LH/RH) is unified to the driver side temperature setting.

Is the inspection result normal?

YES >> GO TO 9.

NO >> Refer to [HAC-130, "Diagnosis Chart By Symptom"](#) and perform the appropriate diagnosis.

9. CHECK AUTO MODE

1. Press the AUTO switch, and then check that "AUTO" is shown on the display.
2. Check that the discharge air and fan speed depend on ambient temperature, in-vehicle temperature and temperature setting.

Is the inspection result normal?

YES >> GO TO 10.

NO >> Refer to [HAC-130, "Diagnosis Chart By Symptom"](#) and perform the appropriate diagnosis.

10. CHECK PLASMA CLUSTER ION CONTROL FUNCTION

1. Turn ignition switch OFF and restart the engine.
2. Ion indicator is shown on the display.
3. Press OFF switch.
4. Ion indicator is turned OFF.

Is the inspection result normal?

YES >> GO TO 11.

NO >> Refer to [HAC-101, "Diagnosis Procedure"](#).

11. CHECK ION CONTROL MODE

1. Turn ignition switch OFF and restart the engine.
2. Operate fan control dial to the blower fan lowest speed and highest speed. Check display of ion indicator each time blower fan is at lowest speed and at highest speed.

INSPECTION AND ADJUSTMENT

< BASIC INSPECTION >

[AUTOMATIC AIR CONDITIONER]

When blower fan speed is at lowest speed: **CLEAN**

When blower fan speed is at highest speed: **QUICK CLEAN**

Is the inspection result normal?

YES >> INSPECTION END

NO >> Replace unified meter and A/C amp.

WITH PLASMACLUSTER SYSTEM : Temperature Setting Trimmer

INFOID:000000005874576

DESCRIPTION

The trimmer compensates for differences in range of $\pm 3^{\circ}\text{C}$ ($\pm 6^{\circ}\text{F}$) between temperature setting (displayed digitally) and temperature felt by customer.

Operating procedures for this trimmer are as per the following:

1. Begin self-diagnosis STEP-5 mode. Refer to [HAC-58. "WITHOUT PLASMACLUSTER SYSTEM : Diagnosis Description"](#).
2. Press fan (UP: +) switch to set system in auxiliary mode.
3. Display shows "61" in auxiliary mechanism. It takes approximately 3 seconds to enable setting operation.
4. Turn temperature control dial (driver side) as desired. Temperature will change at a rate of 0.5°C (1.0°F) each time a dial is turned.

CAUTION:

A
B
C
D
E
F
G
H
J
K
L
M
N
O
P

HAC

INSPECTION AND ADJUSTMENT

< BASIC INSPECTION >

[AUTOMATIC AIR CONDITIONER]

A decimal point is not indicated on the display.

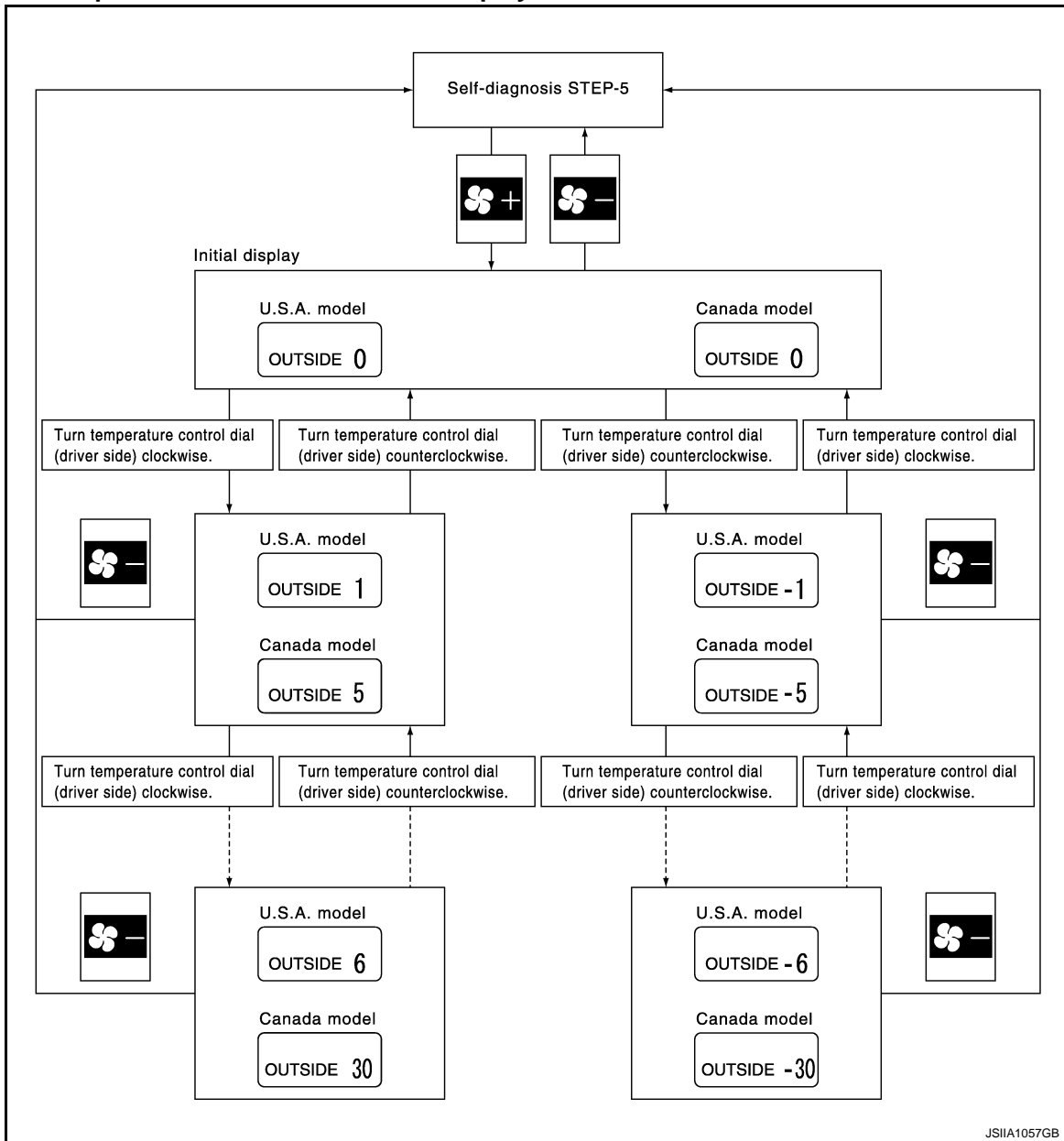

NOTE:

When battery cable is disconnected or battery voltage is below 10 V, trimmer operation is canceled. Temperature set becomes that of initial condition, i.e. 0°C (0°F).

WITH PLASMACLUSTER SYSTEM : Foot Position Setting Trimmer

INFOID:000000005874577

DESCRIPTION

Wind distribution ratio in FOOT mode can be set.

Operating procedures for this trimmer are as per the following:

1. Begin self-diagnosis STEP-5 mode. Refer to [HAC-58, "WITHOUT PLASMACLUSTER SYSTEM : Diagnosis Description"](#).
2. Press fan (UP: +) switch to set system in auxiliary mode.

INSPECTION AND ADJUSTMENT

< BASIC INSPECTION >

[AUTOMATIC AIR CONDITIONER]

3. Press mode switch as desired.

Display	Discharge air flow							
	Automatically controls the mode door				Manually controls the mode door			
	VENT	FOOT		DEF	VENT	FOOT		DEF
Front		Rear	Front			Rear		
	11%	39%	24%	26%	11%	39%	24%	26%
	11%	39%	24%	26%	15%	53%	32%	—
	15%	53%	32%	—	11%	39%	24%	26%
	15%	53%	32%	—	15%	53%	32%	—

JSIIA0864GB

NOTE:

When battery cable is disconnected or battery voltage is below 10 V, trimmer operation is canceled. Air distribution ratio set becomes that of initial condition.

WITH PLASMACLUSTER SYSTEM : Inlet Port Memory Function

INFOID:000000005874578

DESCRIPTION

When ignition switch is turned from OFF to ON, inlet port can be set to AUTO or manual.

Operating procedures for this trimmer are as per the following:

1. Begin self-diagnosis STEP-5 mode. Refer to [HAC-58, "WITHOUT PLASMACLUSTER SYSTEM : Diagnosis Description"](#).
2. Press fan (UP: +) switch to set system in auxiliary mode.
3. Press intake switch as desired.

FRE indicator	REC indicator	Setting status		Setting changeover method
		FRE	REC	
OFF	ON	AUTO control (Initial setting)	Manual REC status is memorized. (Initial setting)	Intake switch: ON
ON	ON	Manual FRE status is memorized.	Manual REC status is memorized.	
ON	OFF	Manual FRE status is memorized.	AUTO control	
OFF	OFF	AUTO control	AUTO control	

NOTE:

When battery cable is disconnected or battery voltage is below 10 V, memory function is canceled. Memory function set becomes that of initial condition.

WITH PLASMACLUSTER SYSTEM : Gas Sensor Sensitivity Adjustment Function

INFOID:000000005874579

DESCRIPTION

According to customer's sense of smell, gas sensor sensitivity can be changed.

Operating procedures for this trimmer are as follows:

1. Begin self-diagnosis STEP-5 mode. Refer to [HAC-63, "WITH PLASMACLUSTER SYSTEM : Diagnosis Description"](#).
2. Press fan (UP: +) switch two times to set system in auxiliary mode.
3. Turn temperature control dial (driver side) as desired.

INSPECTION AND ADJUSTMENT

< BASIC INSPECTION >

[AUTOMATIC AIR CONDITIONER]

Display	Setting
71	Less sensitive setting than display 72 setting (the change to REC is later than display 72 operation)
72	Less sensitive setting than normal setting (the change to REC is later than normal operation)
73	Normal (Initial setting)
74	More sensitive setting than normal setting (the change to REC is earlier than normal operation)
75	More sensitive setting than display 74 setting (the change to REC is earlier than display 74 operation)

NOTE:

When battery cable is disconnected or battery voltage is below 10 V, Gas sensor sensitivity adjustment function is canceled. Gas sensor sensitivity adjustment function set becomes that of initial condition.

WITH PLASMACLUSTER SYSTEM : Auto Intake Interlocking Movement Change Function

INFOID:000000005874580

DESCRIPTION

Conditions for interlocking movement of intake switch (auto intake mode) and A/C switch can be changed. In addition, operation of the intake switch, which activates the auto intake control system, can be set to become available when the A/C switch is ON.

Operating procedures for this trimmer are as follows:

1. Begin self-diagnosis STEP-5 mode. Refer to [HAC-63, "WITH PLASMACLUSTER SYSTEM : Diagnosis Description"](#).
2. Press fan (UP:+) switch three times to set system in auxiliary mode.
3. Press A/C switch and intake switch as desired.

A/C indicator	AUTO IN-TAKE indicator	Setting status
ON	ON	A/C switch indicator turns ON automatically when auto intake mode is selected with Intake switch. Auto intake mode continues after A/C switch turns OFF.
OFF	ON	A/C switch indicator stays OFF when auto intake mode is selected with Intake switch. Auto intake mode continues after A/C switch turns OFF.
ON	OFF	A/C switch indicator turns ON automatically when auto intake mode is selected with Intake switch. When A/C switch turns OFF, auto intake mode turns OFF automatically. (Initial setting)
OFF	OFF	Auto intake mode can be set only when A/C switch is ON. When A/C switch turns OFF, auto intake mode turns OFF automatically.

NOTE:

When battery cable is disconnected or battery voltage is below 10 V, auto intake interlocking movement change function is canceled. Auto intake interlocking movement change function set becomes that of initial condition.

COMPRESSOR CONTROL FUNCTION

< SYSTEM DESCRIPTION >

[AUTOMATIC AIR CONDITIONER]

SYSTEM DESCRIPTION

COMPRESSOR CONTROL FUNCTION

Description

INFOID:000000005649481

PRINCIPLE OF OPERATION

Compressor is not activated.

Functional Circuit Diagram

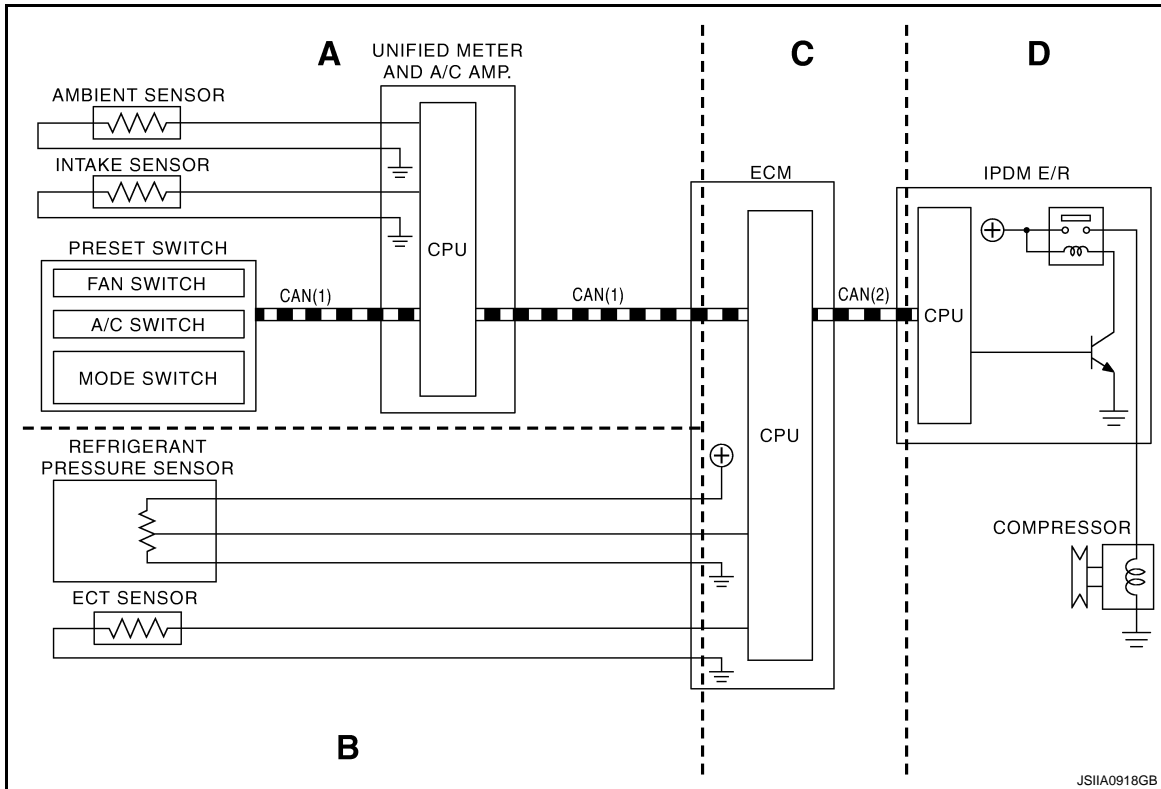

CAN(1) : A/C switch signal
: Blower fan motor switch signal

CAN(2) : A/C compressor request signal

Functional Initial Inspection Chart

x: Applicable

Control unit	Diagnosis Item	Location			
		A	B	C	D
Unified meter and A/C amp.	Self-diagnosis function	x	-	-	-
ECM	⊕ "ENGINE" Self-diagnosis (CAN system diagnosis)	-	-	x	-
	Data monitor	x	x	x	-
IPDM E/R	⊕ "IPDM E/R" Self-diagnosis (CAN system diagnosis)	-	-	-	x
	Data monitor	-	-	x	-
	Auto active test	-	-	-	x

Fail-safe

INFOID:000000005649482

FAIL-SAFE FUNCTION

- If a communication error exists between the unified meter and A/C amp., and the AV control unit and preset switch for 30 seconds or longer, air conditioner is controlled under the following conditions:

COMPRESSOR CONTROL FUNCTION

< SYSTEM DESCRIPTION >

[AUTOMATIC AIR CONDITIONER]

Compressor	: ON
Air outlet	: AUTO
Air inlet	: FRE (Fresh)
Fan speed	: AUTO
Set temperature	: Setting before communication error occurs

Component Part Location

INFOID:000000005649483

ENGINE COMPARTMENT

COMPRESSOR CONTROL FUNCTION

< SYSTEM DESCRIPTION >

[AUTOMATIC AIR CONDITIONER]

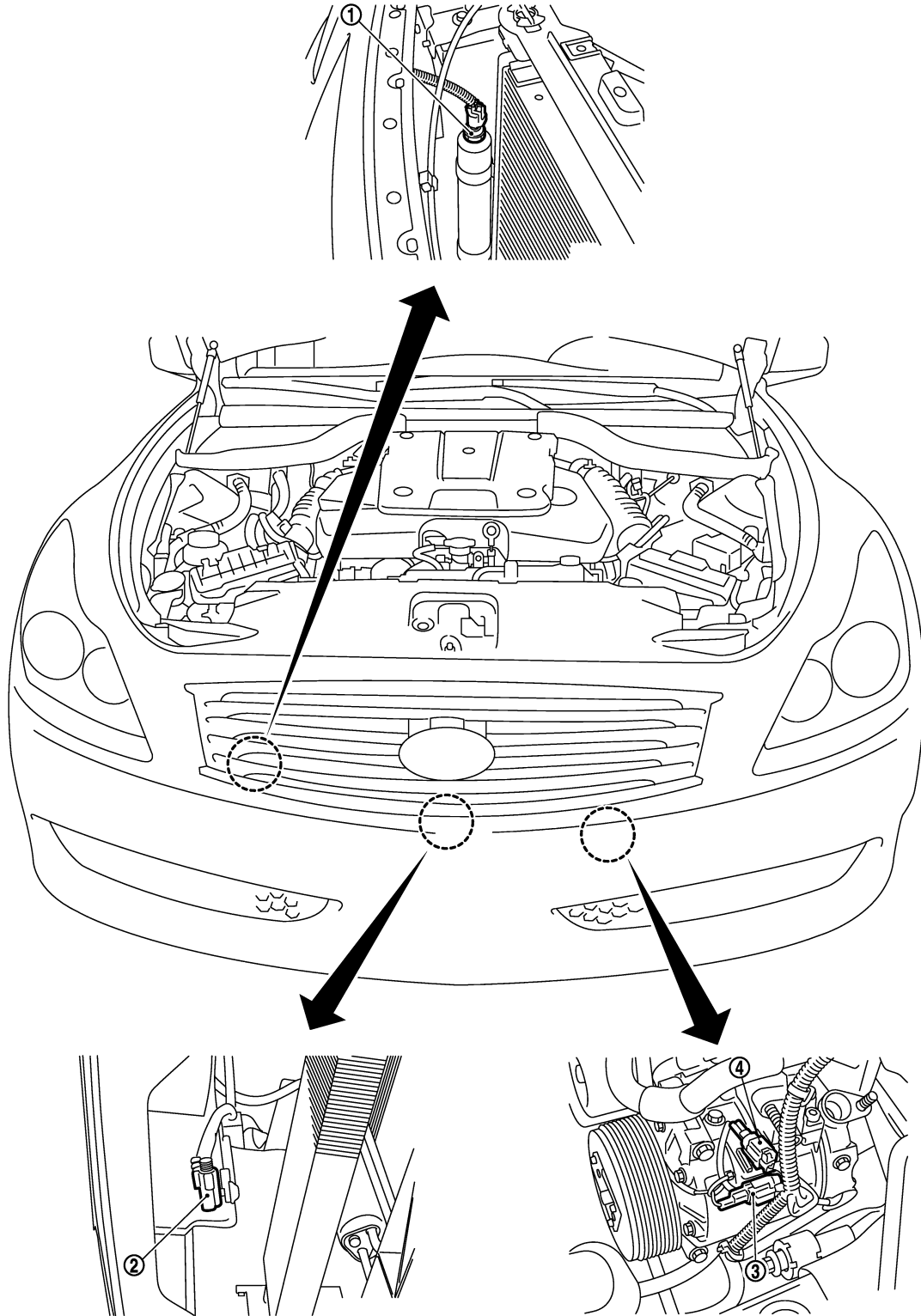

A
B
C
D
E
F
G
H
HAC
J
K
L
M
N
O
P

- 1. Refrigerant pressure sensor
- 2. Ambient sensor
- 3. Compressor (magnet clutch)
- 4. Compressor (ECV)

JSIIA0746ZZ

PASSENGER COMPARTMENT

COMPRESSOR CONTROL FUNCTION

< SYSTEM DESCRIPTION >

[AUTOMATIC AIR CONDITIONER]

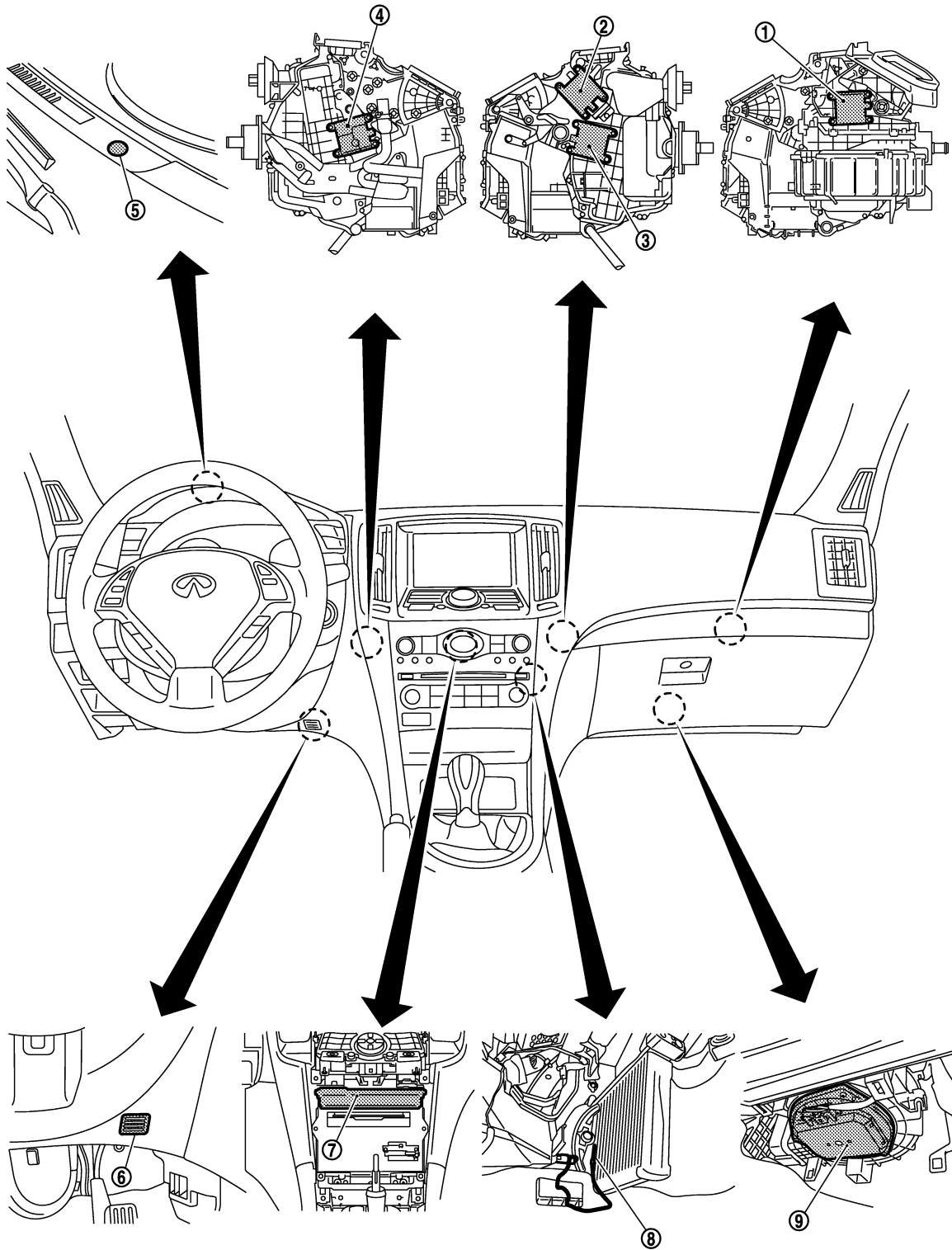

JSIIA1415ZZ

- | | | |
|--------------------------------------|--------------------|--|
| 1. Intake door motor | 2. Mode door motor | 3. Air mix door motor (passenger side) |
| 4. Air mix door motor (driver side)* | 5. Sunload sensor | 6. In-vehicle sensor |
| 7. Unified meter and A/C amp. | 8. Intake sensor | 9. Blower motor |

*: With left and right ventilation temperature separately control system.

COMPRESSOR CONTROL FUNCTION

< SYSTEM DESCRIPTION >

[AUTOMATIC AIR CONDITIONER]

Component Description

INFOID:000000005649484

Component	Reference
Air mix door motor ^{*1}	HAC-73. "WITHOUT LEFT AND RIGHT VENTILATION TEMPERATURE SEPARATELY CONTROL SYSTEM : Description"
Air mix door motor (driver side) ^{*2}	HAC-74. "WITH LEFT AND RIGHT VENTILATION TEMPERATURE SEPARATELY CONTROL SYSTEM : Description"
Air mix door motor (passenger side) ^{*2}	
Ambient sensor	HAC-87. "Description"
Blower motor	HAC-79. "Description"
Compressor	HAC-83. "Description"
Intake door motor	HAC-77. "Description"
Intake sensor	HAC-96. "Description"
In-vehicle sensor	HAC-90. "Description"
Mode door motor	HAC-71. "Description"
Refrigerant pressure sensor	EC-520. "Description"
Sunload sensor	HAC-93. "Description"
Unified meter and A/C amp.	HAC-70. "Description"

*1: Without left and right ventilation temperature separately control system.

*2: With left and right ventilation temperature separately control system.

A
B
C
D
E
F
G
H
J
K
L
M
N
O
P

HAC

AUTOMATIC AIR CONDITIONER SYSTEM

< SYSTEM DESCRIPTION >

[AUTOMATIC AIR CONDITIONER]

AUTOMATIC AIR CONDITIONER SYSTEM

WITHOUT LEFT AND RIGHT VENTILATION TEMPERATURE SEPARATELY CONTROL SYSTEM

WITHOUT LEFT AND RIGHT VENTILATION TEMPERATURE SEPARATELY CONTROL SYSTEM : System Diagram

INFOID:000000005874786

CONTROL SYSTEM

The control system consists of input sensors, switches, unified meter and A/C amp. (microcomputer) and outputs. The relationship of these components is as shown in the figure below:

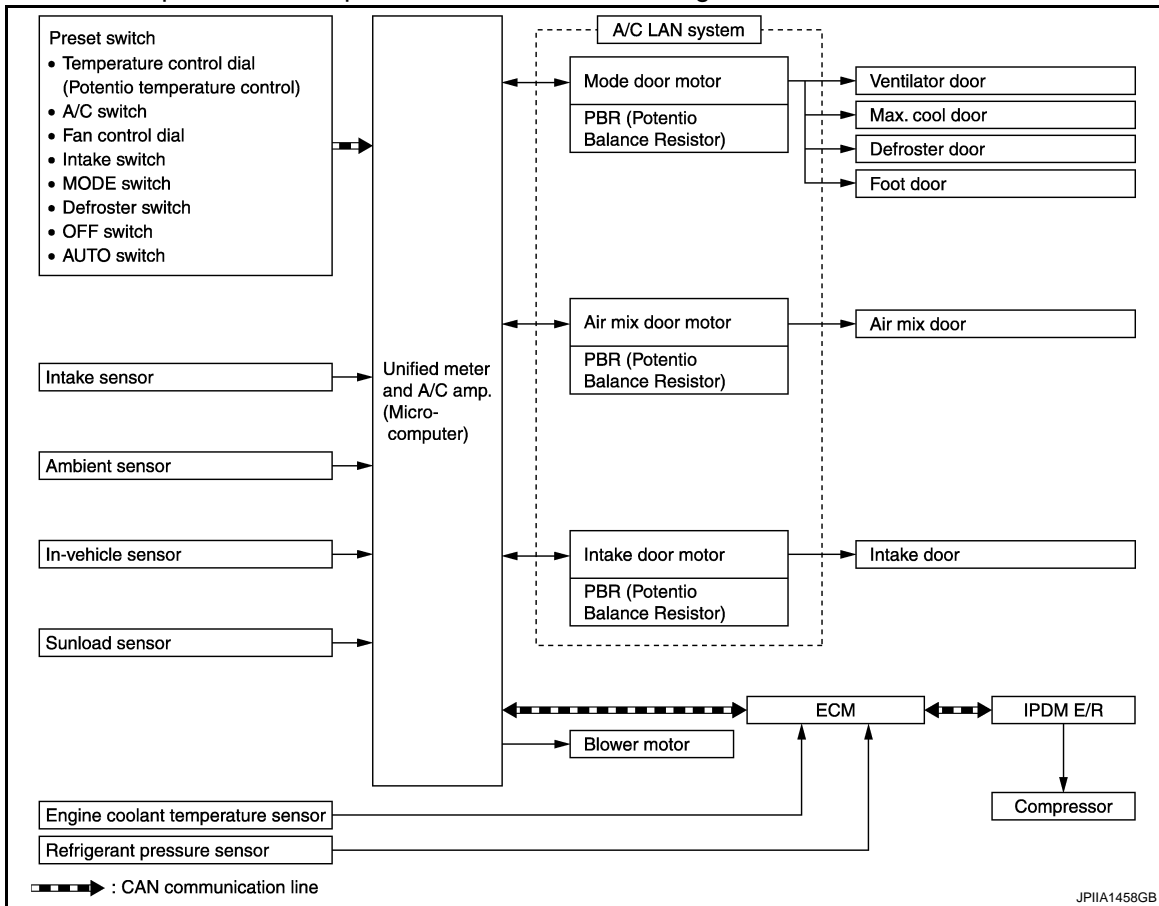

WITHOUT LEFT AND RIGHT VENTILATION TEMPERATURE SEPARATELY CONTROL SYSTEM : System Description

INFOID:000000005874787

CONTROL OPERATION

Display Screen

The operation status of the system is displayed on the screen.

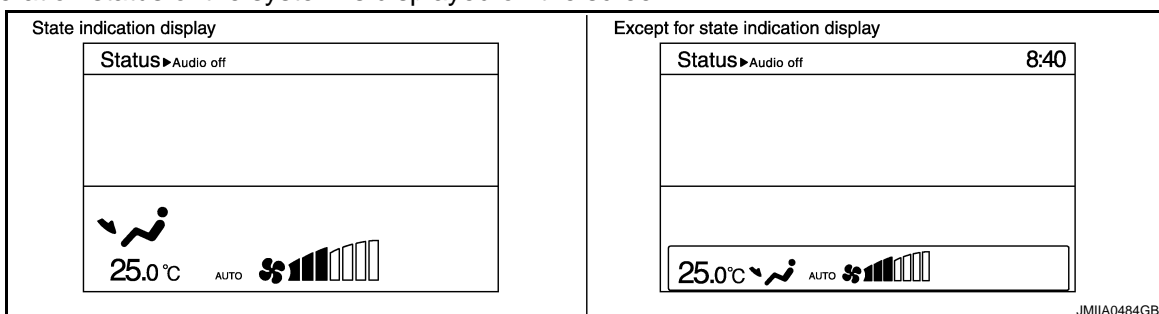

AUTOMATIC AIR CONDITIONER SYSTEM

< SYSTEM DESCRIPTION >

[AUTOMATIC AIR CONDITIONER]

Preset Switch

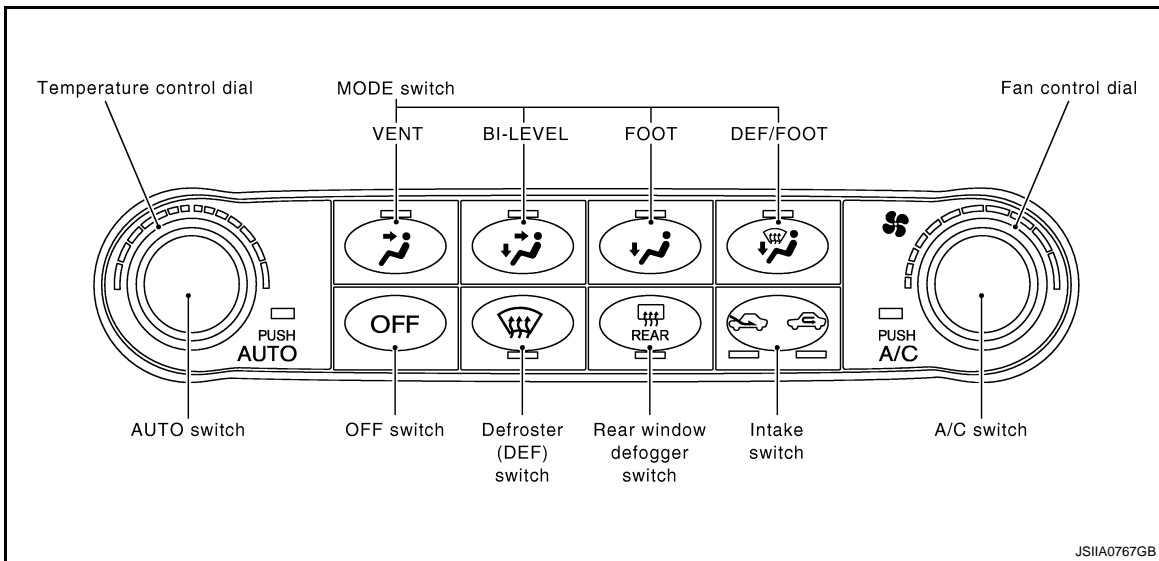

MODE Switch

The air discharge outlets is controlled with this switch.

Temperature Control Dial (Potentio Temperature Control)

The set temperature is increased or decreased with this dial.

AUTO Switch

- The compressor, intake doors, air mix doors, mode doors and fan speed are automatically controlled so that the in-vehicle temperature will reach, and be maintained at the set temperature selected by the operator.
- When pressing AUTO switch, air inlet, air outlet, fan speed, and discharge air temperature are automatically controlled.

Defroster (DEF) Switch

Mode doors are set to the defrost position with this switch. Also, intake doors are set to the outside air position, and compressor turns ON.

A/C Switch

Compressor is ON or OFF with this switch.

(Pressing the A/C switch when the A/C switch is ON turns OFF the A/C switch and compressor.)

FAN Control Dial

The fan speed is manually controlled with this switch. Seven speeds are available for manual control (as shown on the display screen).

OFF Switch

Compressor and blower are OFF, air inlet is set to FRE, and mode position is set to foot position.

Rear Window Defogger Switch

When indicator is ON, rear window is defogged.

Intake Switch

- When intake switch is ON, FRE indicator turns ON, and air inlet is fixed to FRE.
- When intake switch is pressed again, REC indicator turns ON, and air inlet is fixed to REC.
- When intake switch is pressed for approximately 1.5 seconds or longer, FRE and REC indicators blink twice. Then, automatic control mode is entered. Inlet status is displayed by indicator even during automatic controlled.
- When FRE indicator is turned ON, shifting mode position to D/F or DEF, or when compressor is turned from ON to OFF, intake switch is automatically turned OFF (fixed to FRE mode). REC mode can be re-entered by pressing intake switch again, and then compressor is turned ON. (Except D/F or DEF position)

A

B

C

D

E

F

G

H

HAC

J

K

L

M

N

O

P

AUTOMATIC AIR CONDITIONER SYSTEM

< SYSTEM DESCRIPTION >

[AUTOMATIC AIR CONDITIONER]

DISCHARGE AIR FLOW

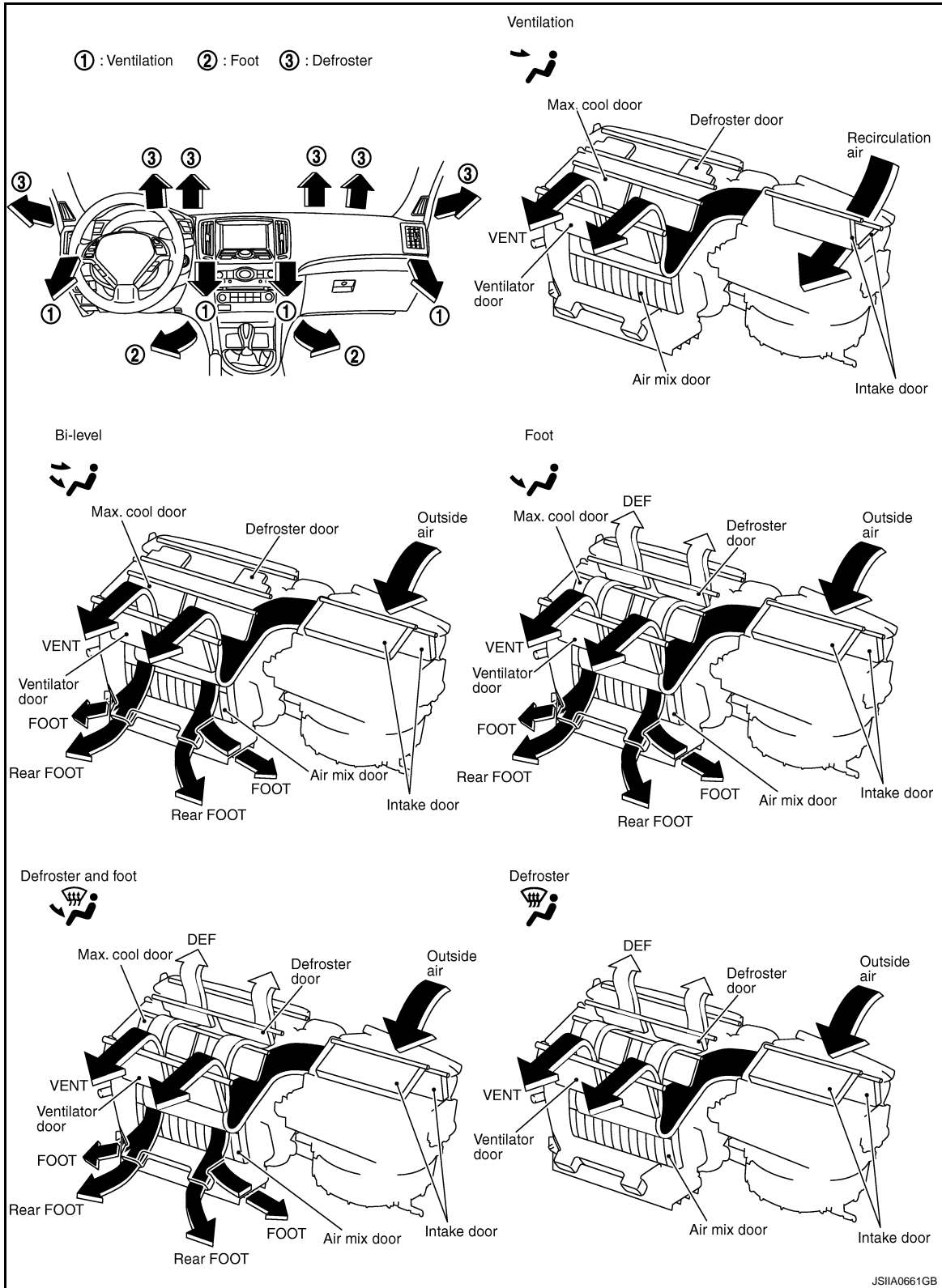

AUTOMATIC AIR CONDITIONER SYSTEM

< SYSTEM DESCRIPTION >

[AUTOMATIC AIR CONDITIONER]

SWITCHES AND THEIR CONTROL FUNCTION

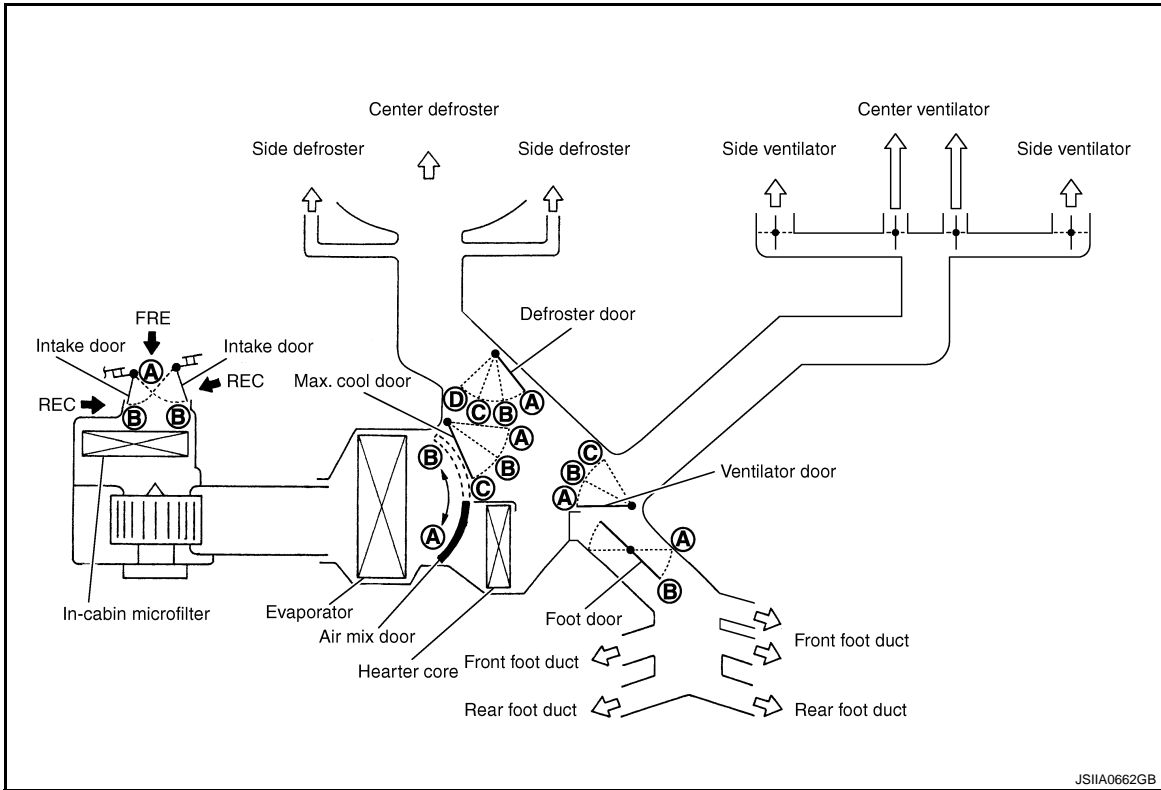

JSIIA0662GB

A
B
C
D
E
F
G
H

HAC

Position or switch	MODE switch				DEF switch		AUTO switch	Intake switch		Temperature control dial			OFF switch
	VENT	B/L	FOOT	D/F	ON	OFF		FRE	REC				
										18°C (60°F)	↔	32°C (90°F)	
Ventilator door	(A)	(B)	(C)	(C)	(C)		AUTO	—	—	—			(C)
Max.cool door	(A)	(B)	(C)	(C)	(C)			—	—	—			(C)
Defroster door	(D)	(D)	(C)	(B)	(A)			—	—	—			(C)
Foot door	(B)	(B)	(B)	(B)	(A)			—	—	—			(B)
Intake door	—			(B)	(B)			(B)*	(A)*	—			(B)
Air mix door	—									(A)	AUTO	(B)	—

*:Inlet status is displayed by LED when activating automatic control.

JSIIA1104GB

J
K
L
M
N
O
P

AIR CONDITIONER LAN CONTROL SYSTEM

The LAN (Local Area Network) system consists of unified meter and A/C amp., mode door motor, air mix door motors and intake door motor.

A configuration of these components is as shown in the figure below.

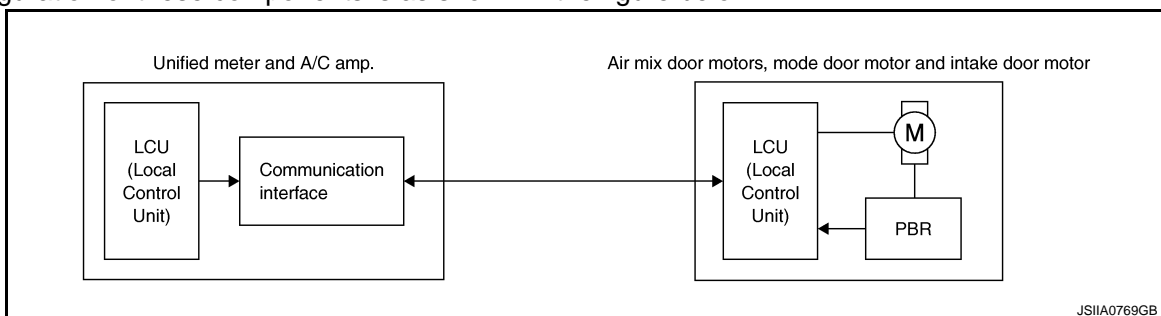

JSIIA0769GB

AUTOMATIC AIR CONDITIONER SYSTEM

[AUTOMATIC AIR CONDITIONER]

< SYSTEM DESCRIPTION >

SYSTEM CONSTRUCTION

A small network is constructed between the unified meter and A/C amp., mode door motor, air mix door motors and intake door motor. The unified meter and A/C amp. and motors are connected by data transmission lines and motor power supply lines. The LAN network is built through the ground circuits of each door motor.

Addresses, motor opening angle signals, motor stop signals and error checking messages are all transmitted through the data transmission lines connecting the unified meter and A/C amp. and each door motor.

The following functions are contained in LCUs built into the mode door motor, the air mix door motors and the intake door motor.

- Address
- Motor opening angle signals
- Data transmission
- Motor stop and drive decision
- Opening angle sensor (PBR function)
- Comparison
- Decision (Unified meter and A/C amp. indicated value and motor opening angle comparison)

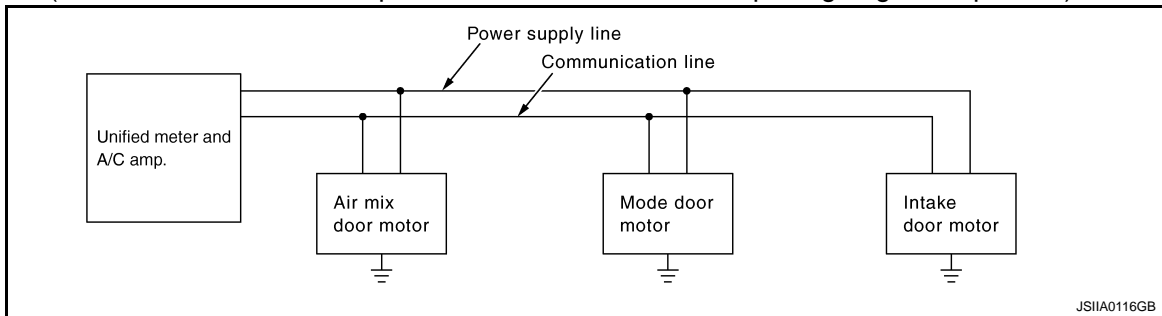

Operation

The unified meter and A/C amp. receives data from each of the sensors. The unified meter and A/C amp. sends mode door, air mix door and intake door opening angle data to the mode door motor LCU, air mix door motor LCUs and intake door motor LCU.

The mode door motor, air mix door motors and intake door motor read their respective signals according to the address signal. Opening angle indication signals received from the unified meter and A/C amp. and each of the motor position sensors is compared by the LCUs in each door motor with the existing decision and opening angles. Subsequently, HOT/COLD, DEF/VENT and FRE/REC operation is selected. The new selection data is returned to the unified meter and A/C amp.

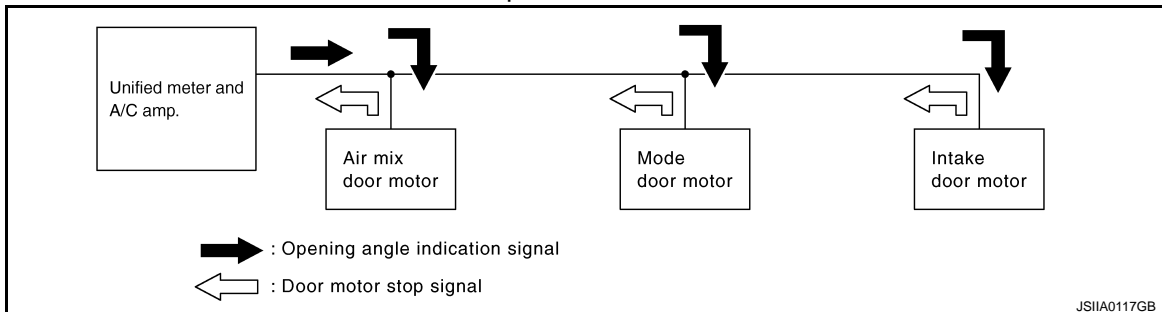

Transmission Data and Transmission Order

Unified meter and A/C amp. data is transmitted consecutively to each of the doors motor following the form as shown in the figure below.

START:

- Initial compulsory signal is sent to each of the door motors.

ADDRESS:

- Data sent from the unified meter and A/C amp. are selected according to data-based decisions made by the mode door motor, air mix door motors and intake door motor.
- If the addresses are identical, the opening angle data and error check signals are received by the door motor LCUs. The LCUs then make the appropriate error decision. If the opening angle data have no error, door control begins.
- If an error exists, the received data are rejected and corrected data received. Finally, door control is based upon the corrected opening angle data.

AUTOMATIC AIR CONDITIONER SYSTEM

[AUTOMATIC AIR CONDITIONER]

< SYSTEM DESCRIPTION >

OPENING ANGLE:

- Data that shows the indicated door opening angle of each door motor.

ERROR CHECK:

- In this procedure, transmitted and received data is checked for errors. Error data are then compiled. The error check prevents corrupted data from being used by the mode door motor, the air mix door motors and the intake door motor. Error data can be related to the following symptoms.
 - Malfunction of electrical frequency
 - Poor electrical connections
 - Signal leakage from transmission lines
 - Signal level fluctuation

STOP SIGNAL:

- At the end of each transmission, a stop operation, in-operation, or internal malfunction message is delivered to the unified meter and A/C amp. This completes one data transmission and control cycle.

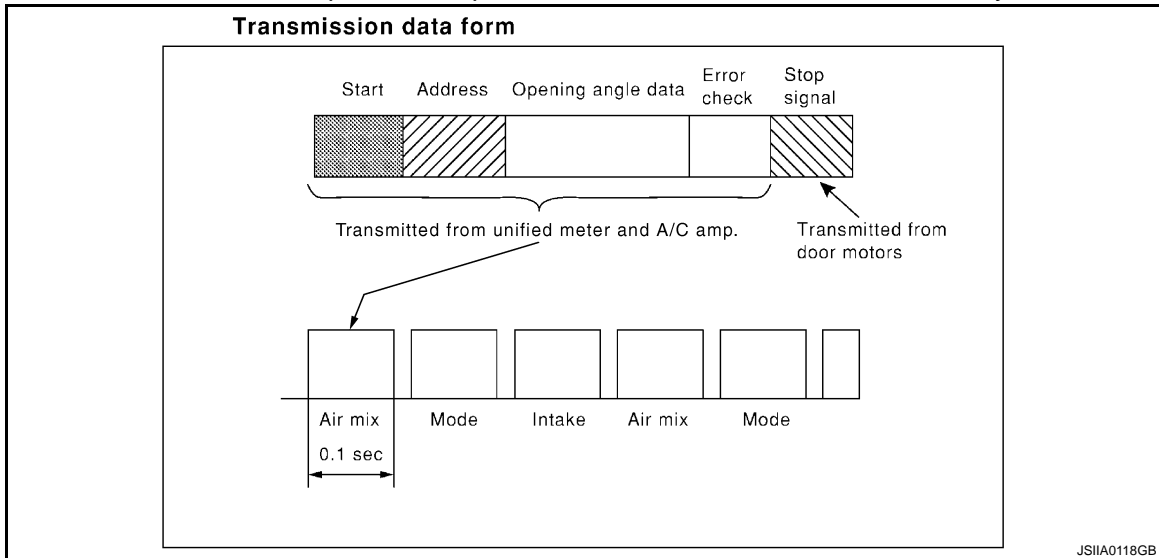

WITHOUT LEFT AND RIGHT VENTILATION TEMPERATURE SEPARATELY CONTROL SYSTEM : Component Part Location

INFOID:000000005874788

ENGINE COMPARTMENT

A
B
C
D
E
F
G
H
HAC
J
K
L
M
N
O
P

AUTOMATIC AIR CONDITIONER SYSTEM

< SYSTEM DESCRIPTION >

[AUTOMATIC AIR CONDITIONER]

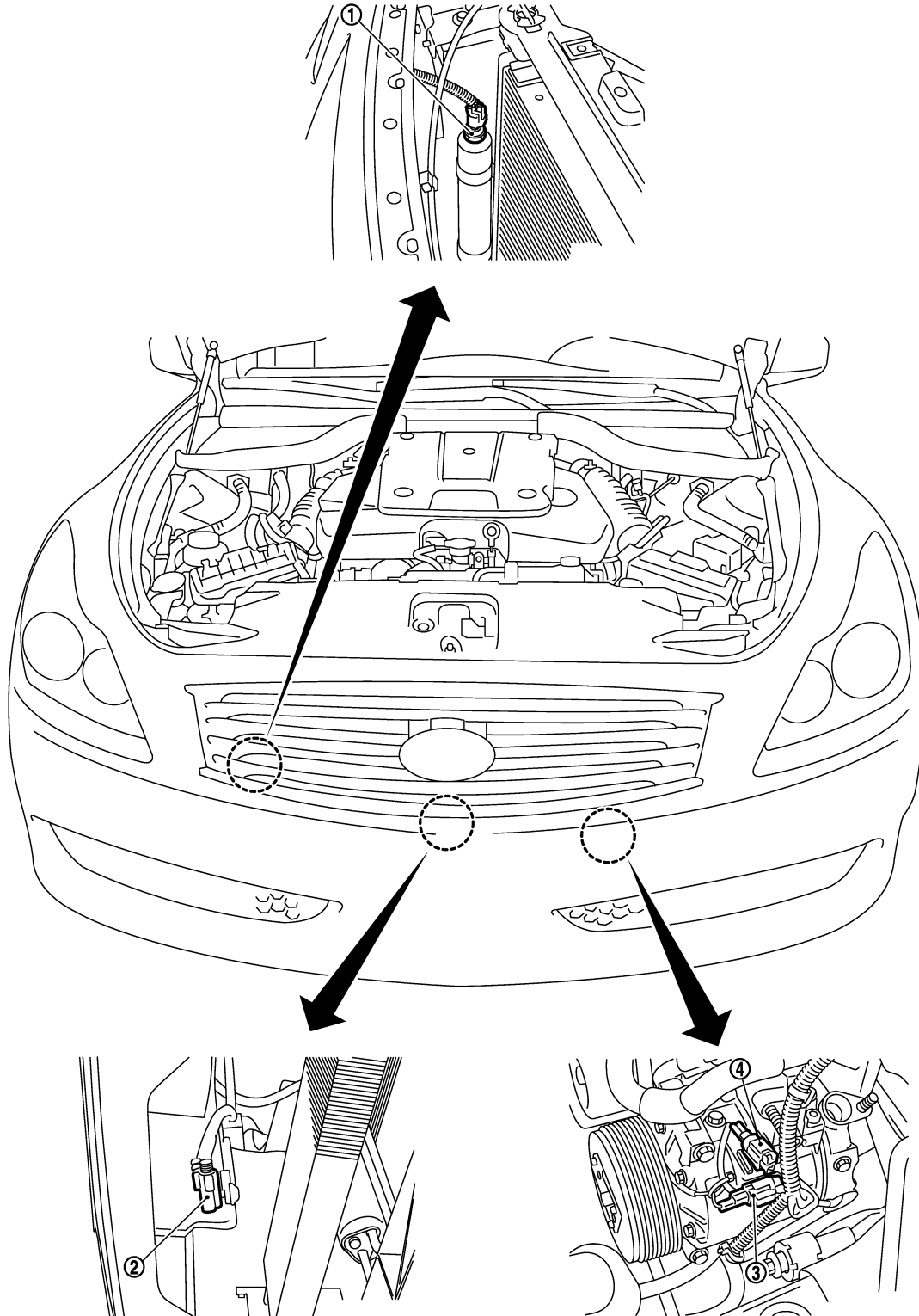

JS1IA0746ZZ

- 1. Refrigerant pressure sensor
- 4. Compressor (ECV)

- 2. Ambient sensor

- 3. Compressor (magnet clutch)

PASSENGER COMPARTMENT

AUTOMATIC AIR CONDITIONER SYSTEM

< SYSTEM DESCRIPTION >

[AUTOMATIC AIR CONDITIONER]

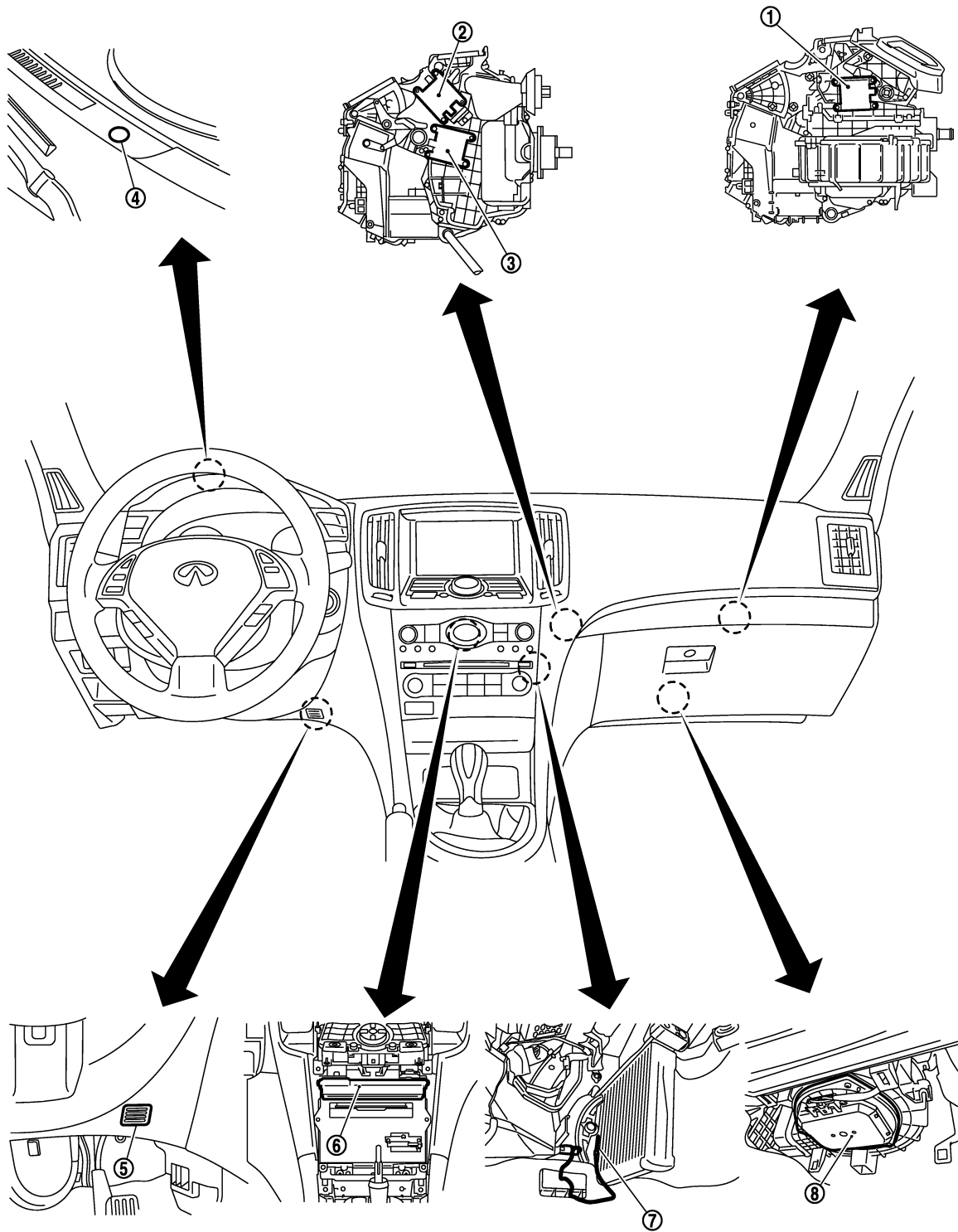

A
B
C
D
E
F
G
H
HAC
J
K
L
M
N
O
P

- | | | |
|----------------------|----------------------|-------------------------------|
| 1. Intake door motor | 2. Mode door motor | 3. Air mix door motor |
| 4. Sunload sensor | 5. In-vehicle sensor | 6. Unified meter and A/C amp. |
| 7. Intake sensor | 8. Blower motor | |

JSIIA0122ZZ

WITHOUT LEFT AND RIGHT VENTILATION TEMPERATURE SEPARATELY CON-

AUTOMATIC AIR CONDITIONER SYSTEM

< SYSTEM DESCRIPTION >

[AUTOMATIC AIR CONDITIONER]

TROL SYSTEM : Component Description

INFOID:000000005874795

Component	Reference
Air mix door motor	HAC-73. "WITHOUT LEFT AND RIGHT VENTILATION TEMPERATURE SEPARATELY CONTROL SYSTEM : Description"
Ambient sensor	HAC-87. "Description"
Blower motor	HAC-79. "Description"
Compressor	HAC-83. "Description"
Intake door motor	HAC-77. "Description"
Intake sensor	HAC-96. "Description"
In-vehicle sensor	HAC-90. "Description"
Mode door motor	HAC-71. "Description"
Refrigerant pressure sensor	EC-520. "Description"
Sunload sensor	HAC-93. "Description"
Unified meter and A/C amp.	HAC-70. "Description"

WITH LEFT AND RIGHT VENTILATION TEMPERATURE SEPARATELY CONTROL SYSTEM

WITH LEFT AND RIGHT VENTILATION TEMPERATURE SEPARATELY CONTROL SYSTEM : System Diagram

INFOID:000000005874790

CONTROL SYSTEM

The control system consists of input sensors, switches, unified meter and A/C amp. (microcomputer) and outputs. The relationship of these components is as shown in the figure below:

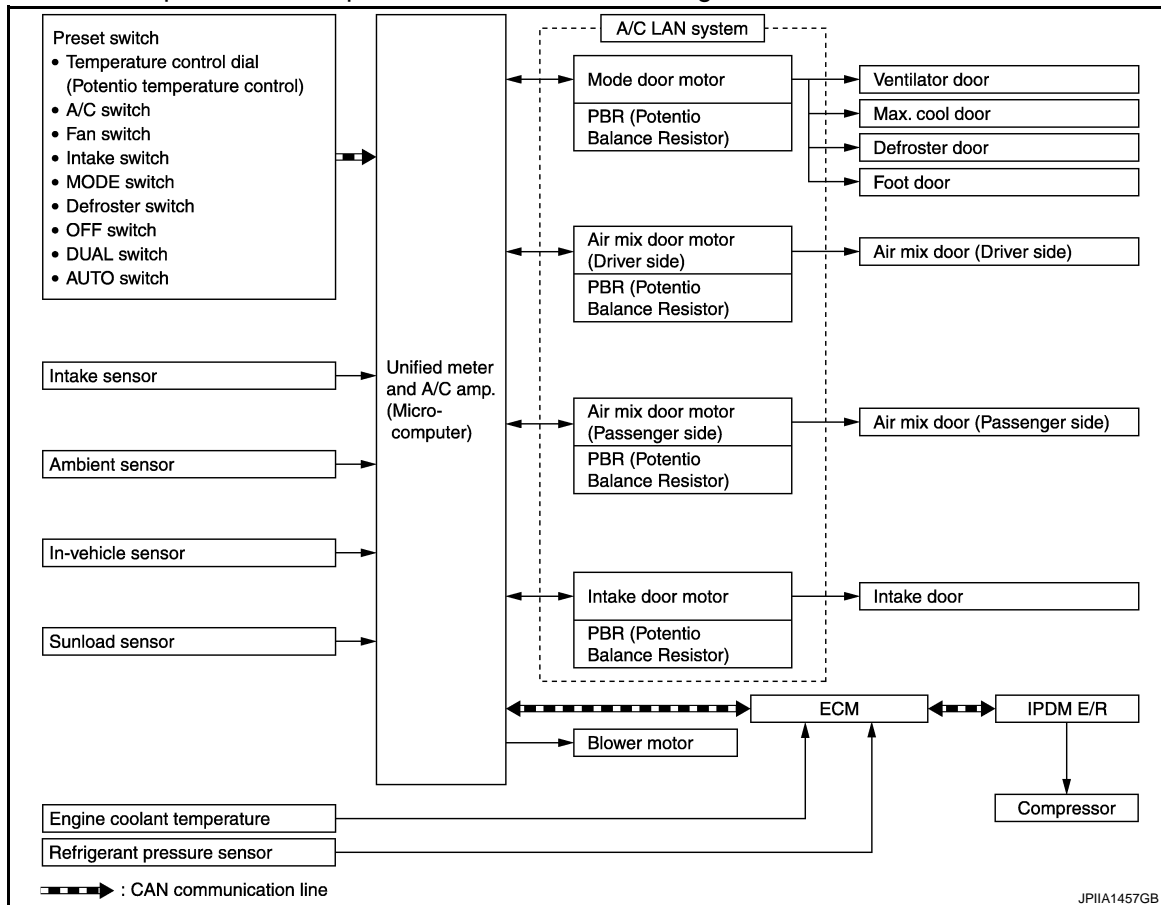

AUTOMATIC AIR CONDITIONER SYSTEM

< SYSTEM DESCRIPTION >

[AUTOMATIC AIR CONDITIONER]

WITH LEFT AND RIGHT VENTILATION TEMPERATURE SEPARATELY CONTROL SYSTEM : System Description

INFOID:000000005874791

CONTROL OPERATION

Display Screen

The operation status of the system is displayed on the screen.

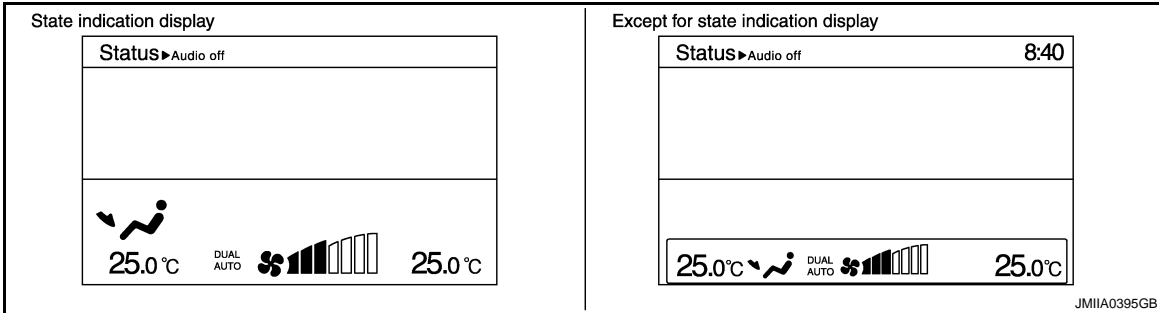

Preset Switch (Without Plusmacluster System)

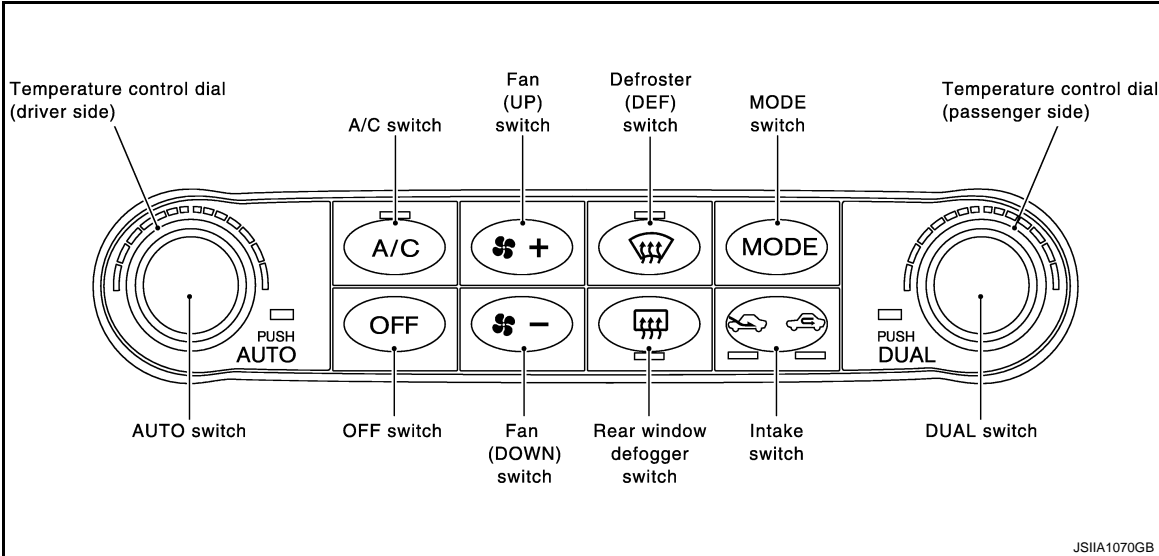

Preset Switch (With Plusmacluster System)

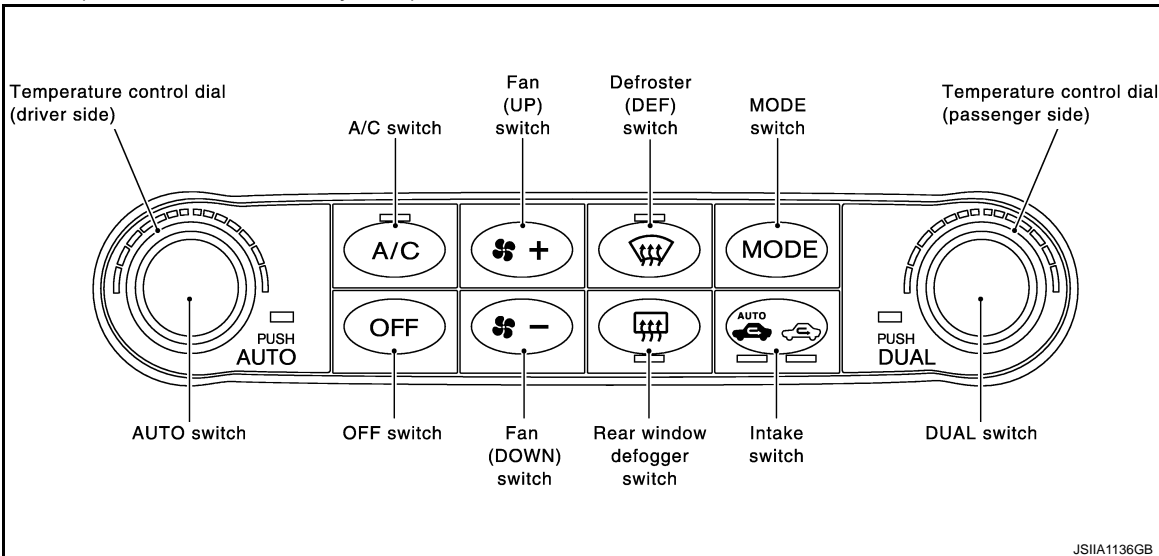

MODE Switch

The air discharge outlets is controlled with this switch.

Temperature Control Dial (Potentio Temperature Control) (Driver Side)

A
B
C
D
E
F
G
H
I
J
K
L
M
N
O
P

HAC

AUTOMATIC AIR CONDITIONER SYSTEM

[AUTOMATIC AIR CONDITIONER]

< SYSTEM DESCRIPTION >

The set temperature is increased or decreased with this dial.

Temperature Control Dial (Potentio Temperature Control) (Passenger Side)

- The set temperature is increased or decreased with this dial.
- When the temperature control dial is turned, DUAL switch indicator turns ON.

AUTO Switch

- The compressor, intake doors, air mix doors, mode doors and fan speed are automatically controlled so that the in-vehicle temperature will reach, and be maintained at the set temperature selected by the operator.
- When pressing AUTO switch, air inlet, air outlet, fan speed, and discharge air temperature are automatically controlled.

Defroster (DEF) Switch

Mode doors are set to the defrost position with this switch. Also, intake doors are set to the outside air position, and compressor turns ON.

A/C Switch

Compressor is ON or OFF with this switch.

(Pressing the A/C switch when the A/C switch is ON turns OFF the A/C switch and compressor.)

FAN Switches

The fan speed is manually controlled with this switch. Seven speeds are available for manual control (as shown on the display screen).

OFF Switch

Compressor and blower are OFF, air inlet is set to FRE, and mode position is set to foot position.

Rear Window Defogger Switch

When indicator is ON, rear window is defogged.

Intake Switch (Without Plasmacluster System)

- When intake switch is ON, FRE indicator turns ON, and air inlet is fixed to FRE.
- When intake switch is pressed again, REC indicator turns ON, and air inlet is fixed to REC.
- When intake switch is pressed for approximately 1.5 seconds or longer, FRE and REC indicators blink twice. Then, automatic control mode is entered. Inlet status is displayed by indicator even during automatic controlled.
- When FRE indicator is turned ON, shifting mode position to D/F or DEF, or when compressor is turned from ON to OFF, intake switch is automatically turned OFF (fixed to FRE mode). REC mode can be re-entered by pressing intake switch again, and then compressor is turned ON. (Except D/F or DEF position)

Intake Switch (With Plasmacluster System)

- When AUTO switch is pressed, AUTO intake indicator and REC indicator turns ON, and air inlet is automatic control.
- When intake switch is pressed, AUTO intake indicator and REC indicator turns OFF, and air inlet is fixed to FRE.
- When intake switch is pressed again, REC indicator turns ON, and air inlet is fixed to REC.
- Then auto intake mode is entered, inlet status is displayed by REC indicator even during automatic controlled.
- When REC indicator is turned OFF, shifting mode position to D/F or DEF or when compressor is turned from ON to OFF, intake mode position is fixed to FRE mode. REC mode can be re-entered by pressing intake switch again, and then compressor is turned ON. (Except D/F or DEF position)

DUAL Switch

- When the DUAL switch indicator is ON, the driver side and passenger side, temperature can each be set independently.
- When the DUAL switch indicator is OFF, the driver side outlet and setting temperature is applied to both sides.

AUTOMATIC AIR CONDITIONER SYSTEM

< SYSTEM DESCRIPTION >

[AUTOMATIC AIR CONDITIONER]

DISCHARGE AIR FLOW

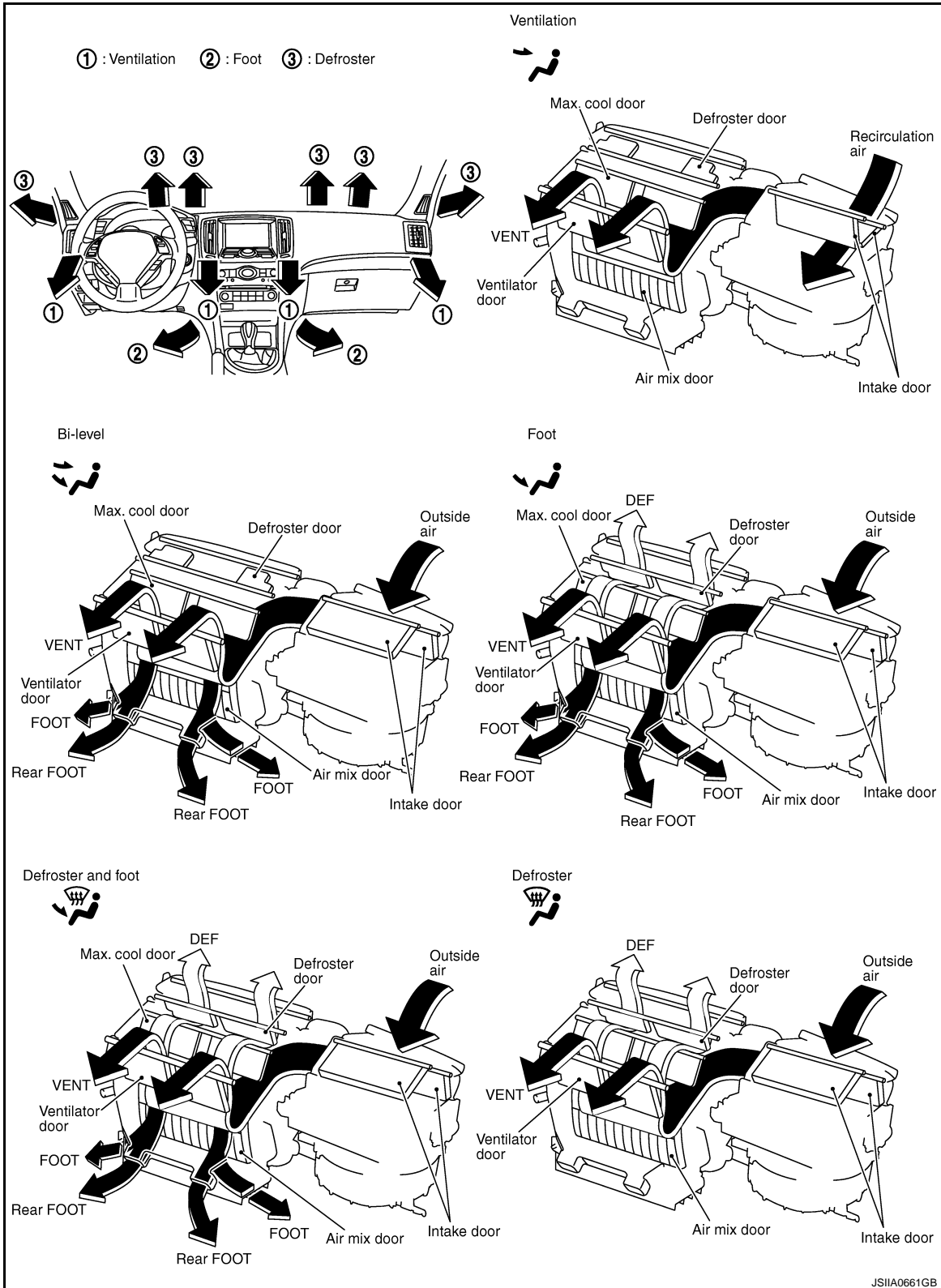

A
B
C
D
E
F
G
H
HAC
J
K
L
M
N
O
P

SWITCHES AND THEIR CONTROL FUNCTION

AUTOMATIC AIR CONDITIONER SYSTEM

< SYSTEM DESCRIPTION >

[AUTOMATIC AIR CONDITIONER]

Without Plasmacluster System

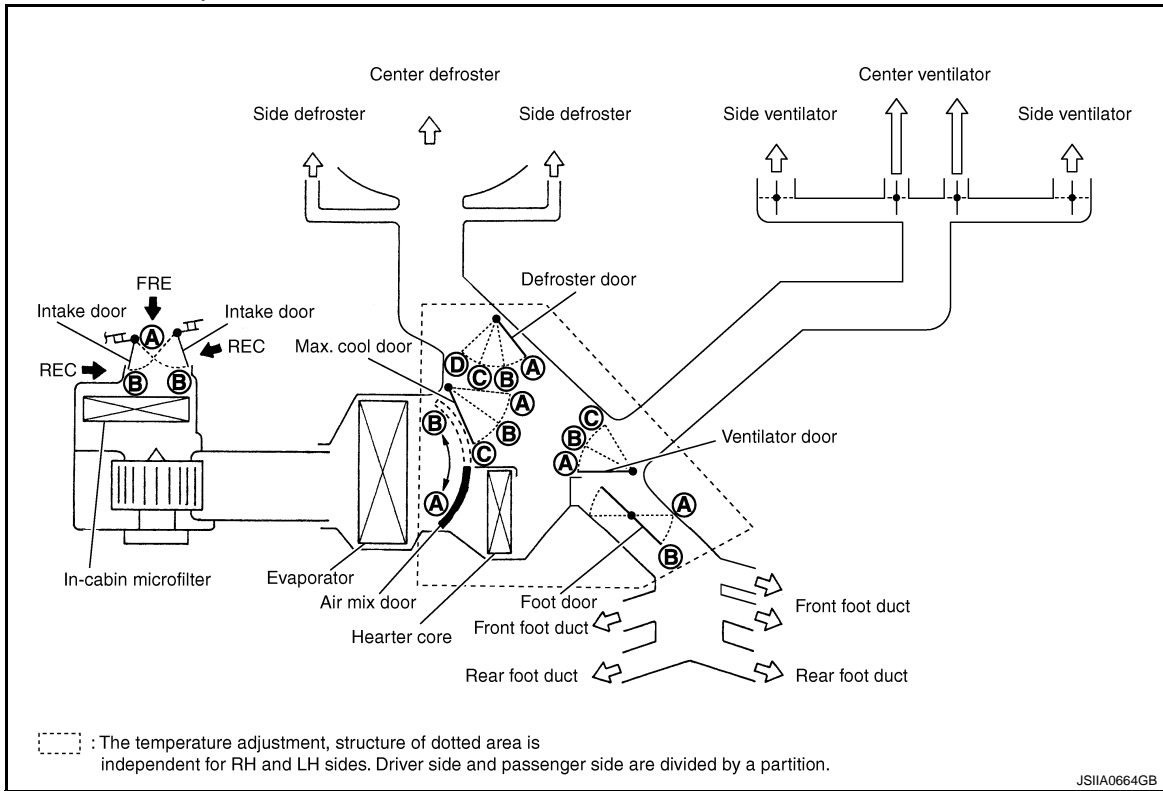













Switch position		Door position					
		Ventilator door	Max. cool door	Defroster door	Foot door	Intake door	Air mix door (Driver side)
AUTO switch		AUTO					

AUTOMATIC AIR CONDITIONER SYSTEM

< SYSTEM DESCRIPTION >

[AUTOMATIC AIR CONDITIONER]

Switch position			Door position						Air mix door (Driver side)	Air mix door (Passenger side)
			Ventilator door	Max. cool door	Defroster door	Foot door	Intake door			
MODE switch	VENT		A	A	D	B	—	—	—	
	B/L		B	B	D	B				
	FOOT		C	C	C	B				
	D/F				B	B				B
DEF switch		 	—	—	—	—	—	—	—	
Intake switch	FRE	 								
	REC	 								
DUAL switch	DUAL									—
	OFF		OFF							
Temperature control dial (Driver side)	DUAL switch: OFF	18.0°C (60°F)	—	—	—	—	—	—	A	
		18.5°C ⇄ 31.5°C (61°F ⇄ 89°F)							AUTO	
		32.0°C (90°F)							B	
Temperature control dial (Driver side)	DUAL switch: ON	18.0°C (60°F)	—	—	—	—	—	—	A	
		18.5°C ⇄ 31.5°C (61°F ⇄ 89°F)							AUTO	
		32.0°C (90°F)							B	
Temperature control dial (Passenger side)	DUAL switch: ON	18.0°C (60°F)	—	—	—	—	—	—	A	
		18.5°C ⇄ 31.5°C (61°F ⇄ 89°F)							AUTO	
		32.0°C (90°F)							B	
OFF switch			C	C	C	B	B	—	—	

*: Inlet status is displayed by indicator when activating automatic control

A
B
C
D
E
F
G
H
J
K
L
M
N
O
P

HAC

AUTOMATIC AIR CONDITIONER SYSTEM

< SYSTEM DESCRIPTION >

[AUTOMATIC AIR CONDITIONER]

With Plasmacluster System

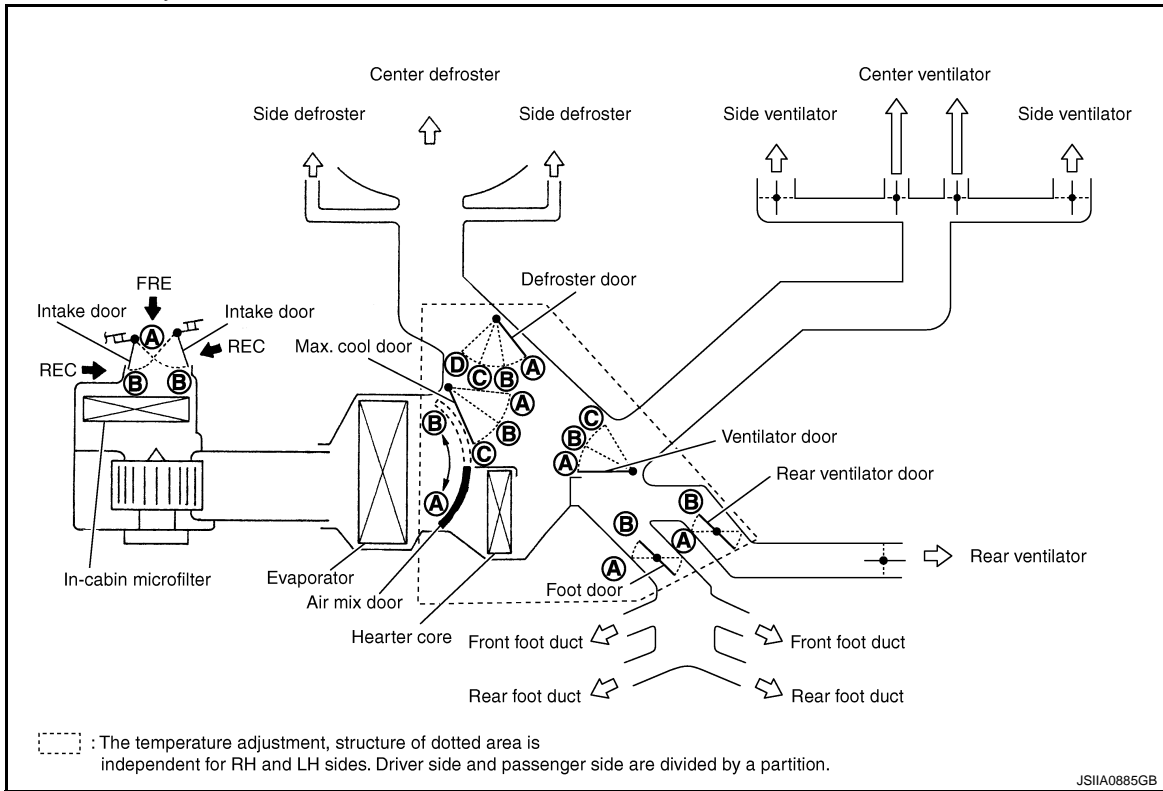











Switch position		Door position					
		Ventilator door	Max. cool door	Defroster door	Foot door	Intake door	Air mix door (Driver side)
AUTO switch		AUTO					

AUTOMATIC AIR CONDITIONER SYSTEM

< SYSTEM DESCRIPTION >

[AUTOMATIC AIR CONDITIONER]

Switch position			Door position						
			Ventilator door	Max. cool door	Defroster door	Foot door	Intake door	Air mix door (Driver side)	Air mix door (Passenger side)
MODE switch	VENT		A	A	D	B	—	—	
	B/L		B	B	D	B			
	FOOT		C	C	C	B			B
	D/F				B	B			B
DEF switch					A	A	B	—	
Intake switch	AUTO		—	—	—	—	AUTO* ²	—	
	REC						A* ¹		
	FRE						B* ¹		
DUAL switch	DUAL		—	—	—	—	—	ON	
	OFF							OFF	
Temperature control dial (Driver side)	DUAL switch: OFF	18.0°C (60°F)	—	—	—	—	—	A	
		18.5°C ↔ 31.5°C (61°F ↔ 89°F)						AUTO	
		32.0°C (90°F)						B	
Temperature control dial (Driver side)	DUAL switch: ON	18.0°C (60°F)	—	—	—	—	—	A	
		18.5°C ↔ 31.5°C (61°F ↔ 89°F)						AUTO	
		32.0°C (90°F)						B	
Temperature control dial (Passenger side)	DUAL switch: ON	18.0°C (60°F)	—	—	—	—	—	A	
		18.5°C ↔ 31.5°C (61°F ↔ 89°F)						AUTO	
		32.0°C (90°F)						B	
OFF switch			C	C	C	B	B	—	—

*1: Inlet status is displayed by indicator when activating automatic control

*2: Intake door control applies a gas sensor

AIR CONDITIONER LAN CONTROL SYSTEM

The LAN (Local Area Network) system consists of unified meter and A/C amp., mode door motor, air mix door motors and intake door motor.

A configuration of these components is as shown in the figure below.

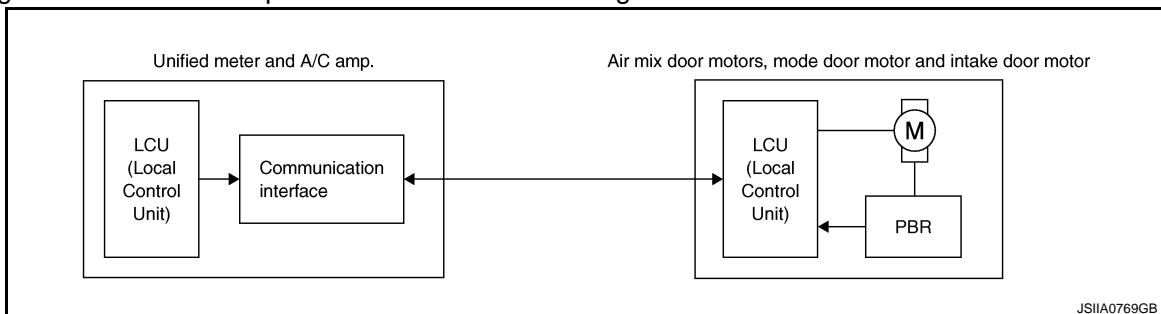

AUTOMATIC AIR CONDITIONER SYSTEM

[AUTOMATIC AIR CONDITIONER]

< SYSTEM DESCRIPTION >

SYSTEM CONSTRUCTION

A small network is constructed between the unified meter and A/C amp., mode door motor, air mix door motors and intake door motor. The unified meter and A/C amp. and motors are connected by data transmission lines and motor power supply lines. The LAN network is built through the ground circuits of each door motor.

Addresses, motor opening angle signals, motor stop signals and error checking messages are all transmitted through the data transmission lines connecting the unified meter and A/C amp. and each door motor.

The following functions are contained in LCUs built into the mode door motor, the air mix door motors and the intake door motor.

- Address
- Motor opening angle signals
- Data transmission
- Motor stop and drive decision
- Opening angle sensor (PBR function)
- Comparison
- Decision (Unified meter and A/C amp. indicated value and motor opening angle comparison)

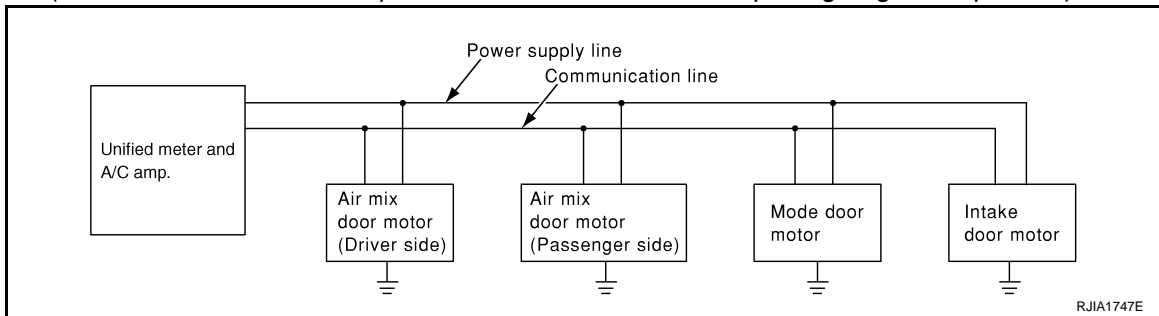

Operation

The unified meter and A/C amp. receives data from each of the sensors. The unified meter and A/C amp. sends mode door, air mix door and intake door opening angle data to the mode door motor LCU, air mix door motor LCUs and intake door motor LCU.

The mode door motor, air mix door motors and intake door motor read their respective signals according to the address signal. Opening angle indication signals received from the unified meter and A/C amp. and each of the motor position sensors is compared by the LCUs in each door motor with the existing decision and opening angles. Subsequently, HOT/COLD, DEF/VENT and FRE/REC operation is selected. The new selection data is returned to the unified meter and A/C amp.

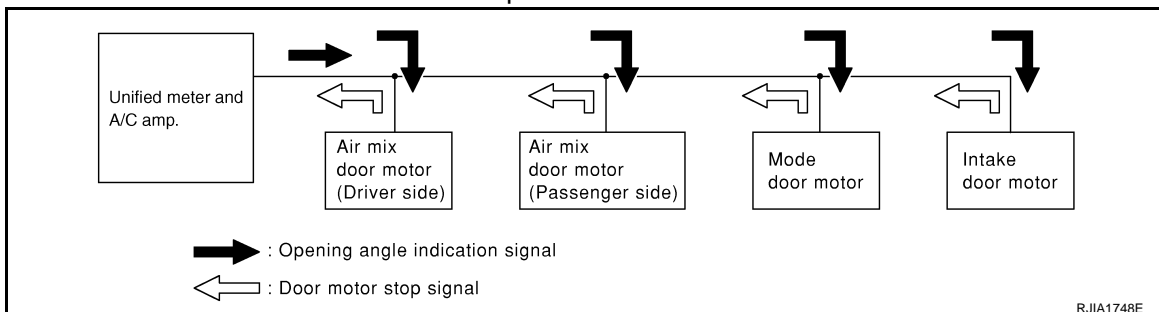

Transmission Data and Transmission Order

Unified meter and A/C amp. data is transmitted consecutively to each of the doors motor following the form as shown in the figure below.

START:

- Initial compulsory signal is sent to each of the door motors.

ADDRESS:

- Data sent from the unified meter and A/C amp. are selected according to data-based decisions made by the mode door motor, air mix door motors and intake door motor.
- If the addresses are identical, the opening angle data and error check signals are received by the door motor LCUs. The LCUs then make the appropriate error decision. If the opening angle data have no error, door control begins.
- If an error exists, the received data are rejected and corrected data received. Finally, door control is based upon the corrected opening angle data.

AUTOMATIC AIR CONDITIONER SYSTEM

[AUTOMATIC AIR CONDITIONER]

< SYSTEM DESCRIPTION >

OPENING ANGLE:

- Data that shows the indicated door opening angle of each door motor.

ERROR CHECK:

- In this procedure, transmitted and received data is checked for errors. Error data are then compiled. The error check prevents corrupted data from being used by the mode door motor, the air mix door motors and the intake door motor. Error data can be related to the following symptoms.
 - Malfunction of electrical frequency
 - Poor electrical connections
 - Signal leakage from transmission lines
 - Signal level fluctuation

STOP SIGNAL:

- At the end of each transmission, a stop operation, in-operation, or internal malfunction message is delivered to the unified meter and A/C amp. This completes one data transmission and control cycle.

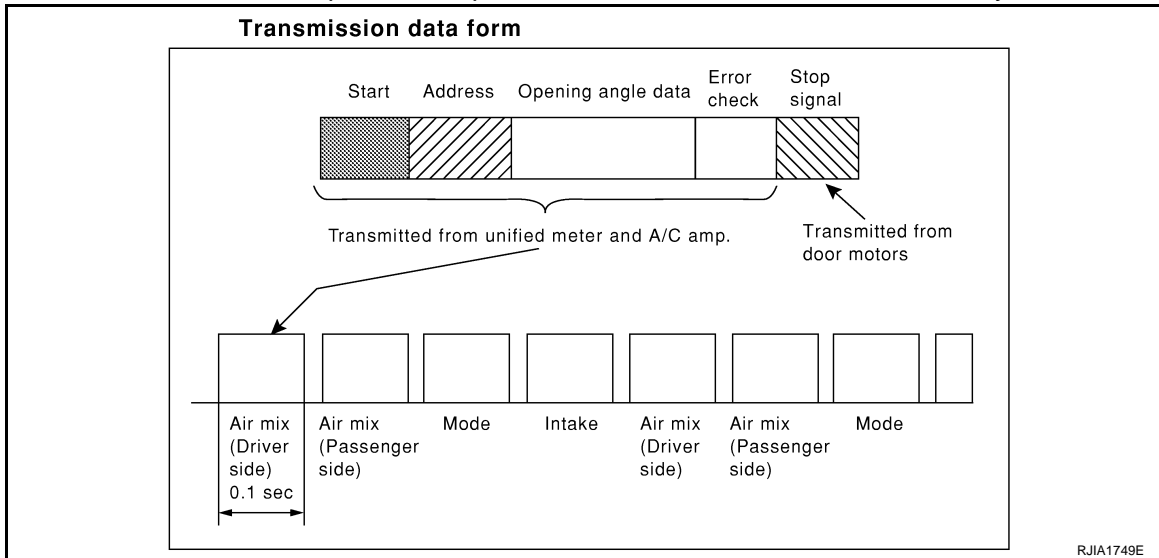

WITH LEFT AND RIGHT VENTILATION TEMPERATURE SEPARATELY CONTROL SYSTEM : Component Part Location

INFOID:000000005874792

ENGINE COMPARTMENT

AUTOMATIC AIR CONDITIONER SYSTEM

< SYSTEM DESCRIPTION >

[AUTOMATIC AIR CONDITIONER]

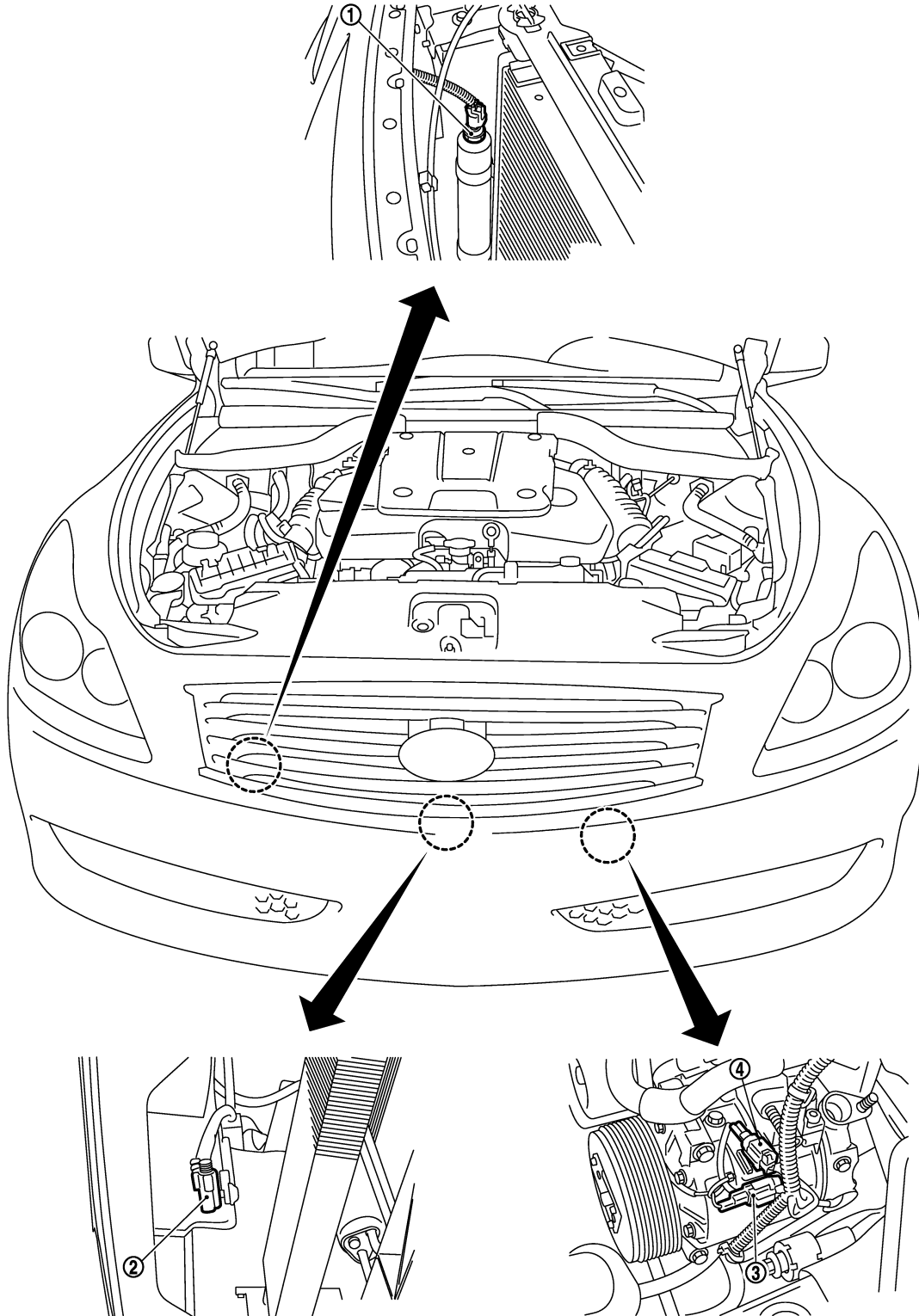

JS1IA0746ZZ

- 1. Refrigerant pressure sensor
- 4. Compressor (ECV)

- 2. Ambient sensor

- 3. Compressor (magnet clutch)

PASSENGER COMPARTMENT

AUTOMATIC AIR CONDITIONER SYSTEM

< SYSTEM DESCRIPTION >

[AUTOMATIC AIR CONDITIONER]

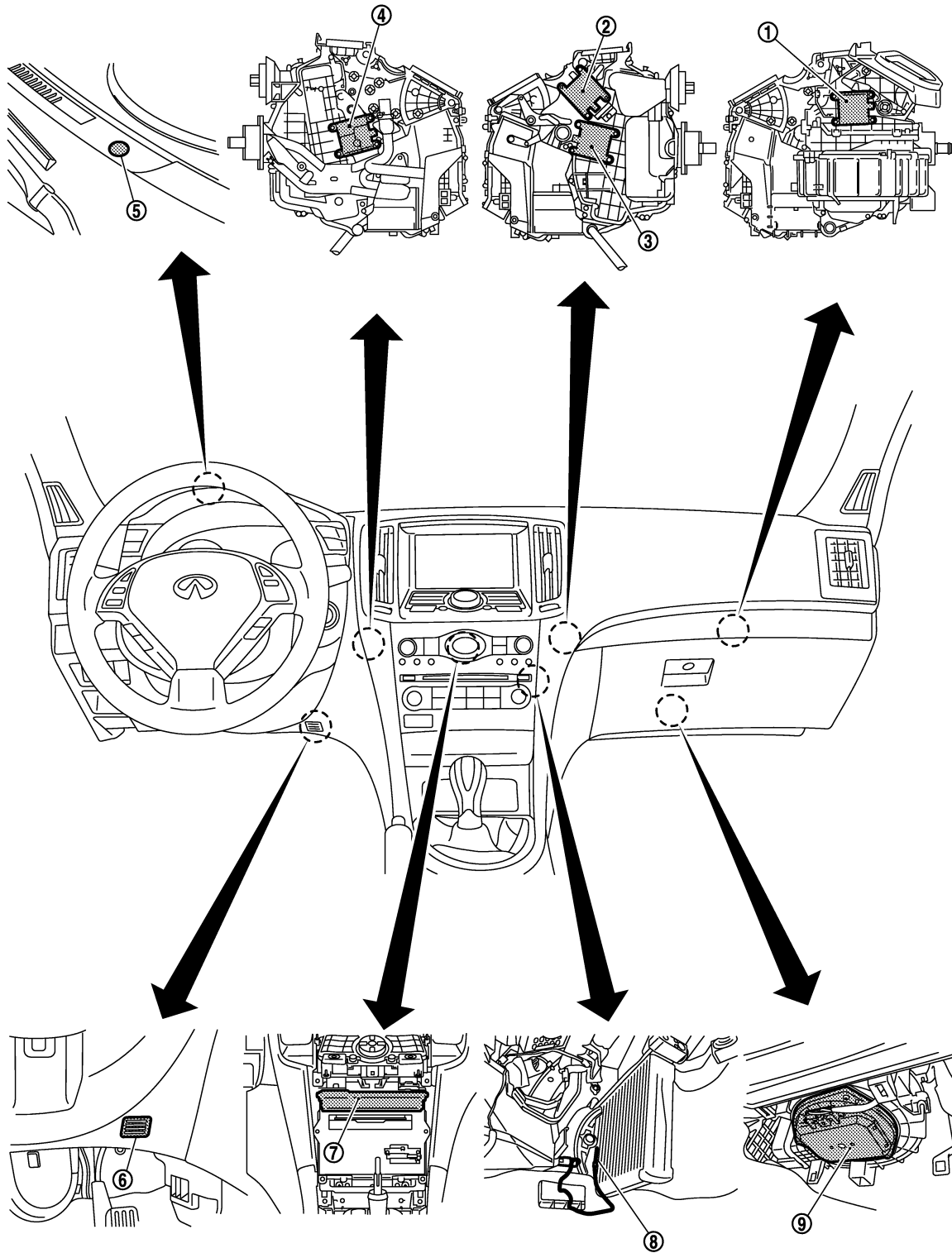

A
B
C
D
E
F
G
H
HAC
J
K
L
M
N
O
P

- | | | |
|-------------------------------------|--------------------|--|
| 1. Intake door motor | 2. Mode door motor | 3. Air mix door motor (passenger side) |
| 4. Air mix door motor (driver side) | 5. Sunload sensor | 6. In-vehicle sensor |
| 7. Unified meter and A/C amp. | 8. Intake sensor | 9. Blower motor |

JSIIA1415ZZ

WITH LEFT AND RIGHT VENTILATION TEMPERATURE SEPARATELY CONTROL

AUTOMATIC AIR CONDITIONER SYSTEM

< SYSTEM DESCRIPTION >

[AUTOMATIC AIR CONDITIONER]

SYSTEM : Component Description

INFOID:000000005874794

Component	Reference
Air mix door motor (driver side)	HAC-74. "WITH LEFT AND RIGHT VENTILATION TEMPERATURE SEPARATELY CONTROL SYSTEM : Description"
Air mix door motor (passenger side)	
Ambient sensor	HAC-87. "Description"
Blower motor	HAC-79. "Description"
Compressor	HAC-83. "Description"
Intake door motor	HAC-77. "Description"
Intake sensor	HAC-96. "Description"
In-vehicle sensor	HAC-90. "Description"
Mode door motor	HAC-71. "Description"
Refrigerant pressure sensor	EC-520. "Description"
Sunload sensor	HAC-93. "Description"
Unified meter and A/C amp.	HAC-70. "Description"

PLASMACLUSTER SYSTEM

System Diagram

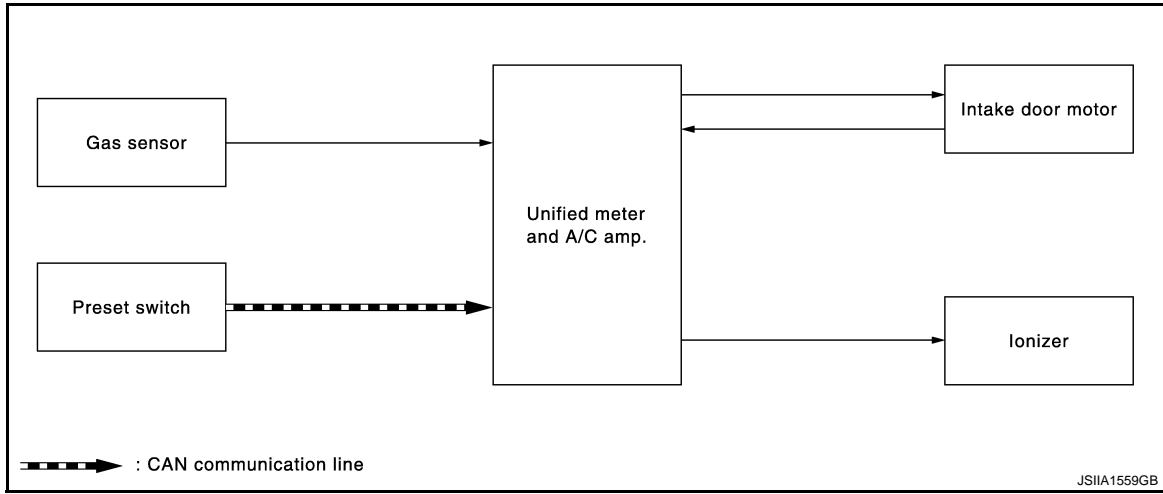

System Description

INFOID:000000005874854

The adoption of the ACCS (advance climate control system) enables the maintenance of clean air in the vehicle by combining the plasmacluster™ ion generation function, the automatic recirculation control function, and a high performance filter.

NOTE:

- Plasmacluster™ ion technology developed by Sharp Corporation is installed in this item.
- Plasmacluster™ is a trademark of Sharp Corporation.

OPERATION DESCRIPTION

- The Plasmacluster™ ion generation function operates synchronized with the blower motor. The Plasmacluster™ ion generation function operates when the blower motor operates.
 - Operating state of Plasmacluster™ system is displayed.
 - Plasmacluster™ system switches display according to air flow volume as shown in the following figure.
- When air flow is low.

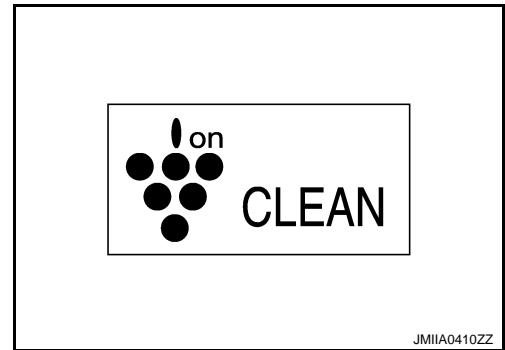

- When air flow is high.

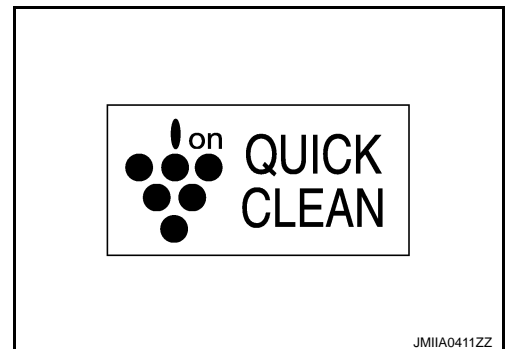

A
B
C
D
E
F
G
H
J
K
L
M
N
O
P

HAC

PLASMACLUSTER SYSTEM

< SYSTEM DESCRIPTION >

[AUTOMATIC AIR CONDITIONER]

AUTO INTAKE CONTROL SYSTEM

In addition to the regular automatic control, intake door condition is controlled by gas sensor output signal when auto intake mode is selected. This system automatically controls the inlet to prevent a smell of exhaust gas from getting into vehicle by receiving signals from the gas sensor that detects ambient atmospheric CO and NO₂.

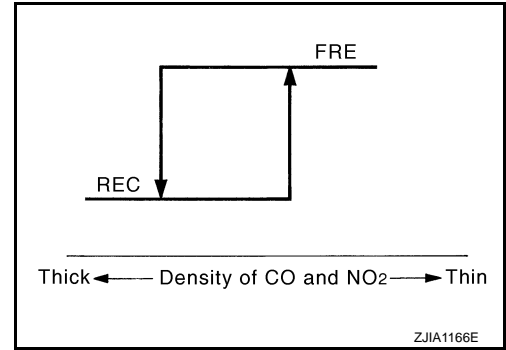

PLASMACLUSTER SYSTEM

[AUTOMATIC AIR CONDITIONER]

< SYSTEM DESCRIPTION >

Component Part Location

INFOID:000000005874855

A
B
C
D
E
F
G
H
HAC
J
K
L
M
N
O
P

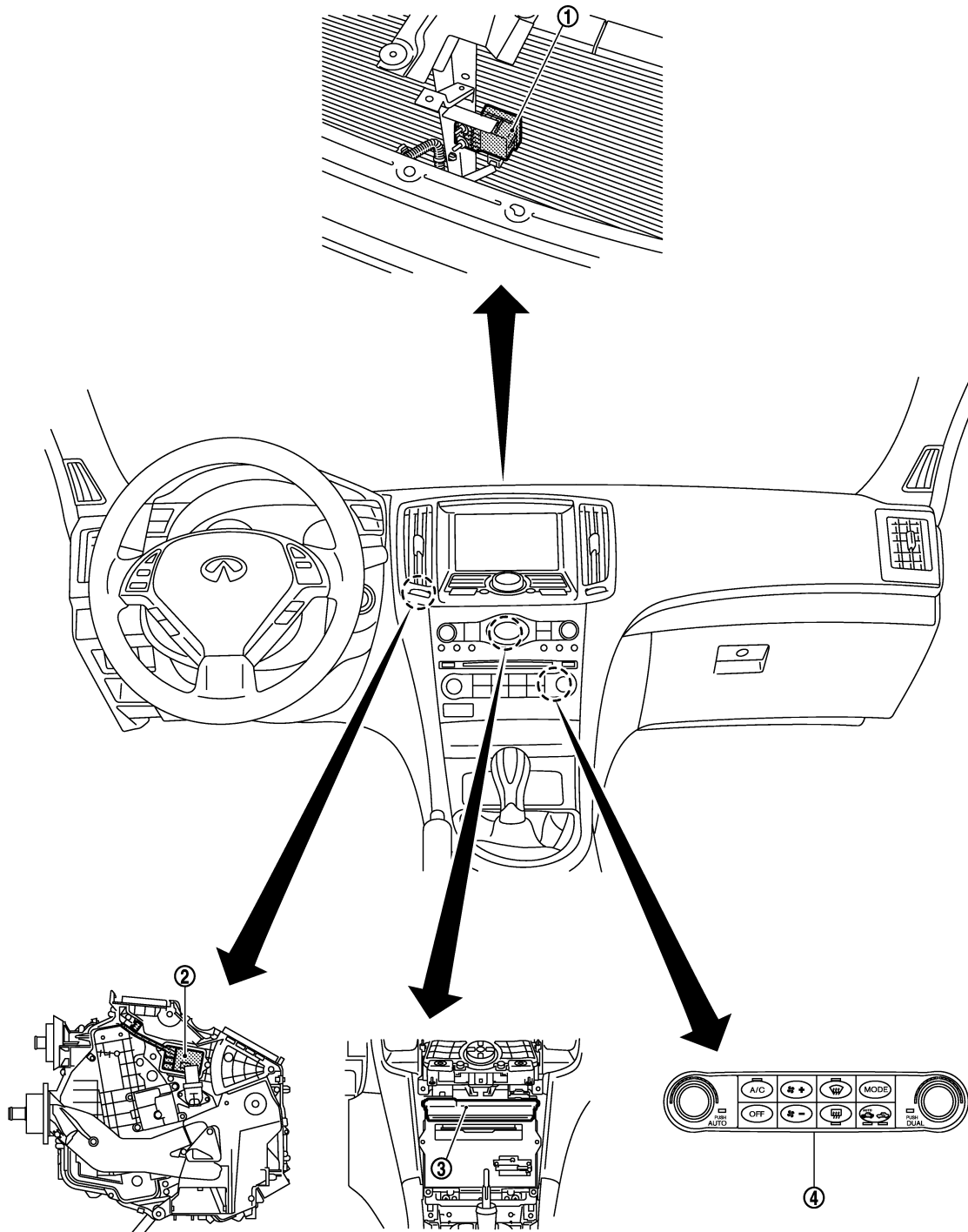

- 1. Gas sensor (engine room)
- 4. Preset switch

- 2. Ionizer

- 3. Unified meter and A/C amp.

JMIIA0566ZZ

PLASMACLUSTER SYSTEM

< SYSTEM DESCRIPTION >

[AUTOMATIC AIR CONDITIONER]

Component Description

INFOID:000000005874856

Component	Description
Ion indicator	Plasmacluster ion generation function operating condition is displayed in the ion indicator in the display.
Gas sensor	HAC-98. "Description"
Ionizer	HAC-101. "Description"
Unified meter and A/C amp.	The unified meter and A/C amp. controls ionizer ON/OFF and shifts an ion generation function.
Preset switch (AUTO intake indicator)	The auto intake control system is ON or OFF by the AUTO intake indicator is turned ON.

CAN COMMUNICATION SYSTEM

< SYSTEM DESCRIPTION >

[AUTOMATIC AIR CONDITIONER]

CAN COMMUNICATION SYSTEM

System Description

INFOID:000000005649489

CAN (Controller Area Network) is a serial communication line for real time application. It is an on-vehicle multiplex communication line with high data communication speed and excellent error detection ability. Many electronic control units are equipped onto a vehicle, and each control unit shares information and links with other control units during operation (not independent). In CAN communication, control units are connected with 2 communication lines (CAN-H line, CAN-L line) allowing a high rate of information transmission with less wiring. Each control unit transmits/receives data but selectively reads required data only. For details, refer to [LAN-27, "CAN System Specification Chart"](#).

A
B
C
D
E
F
G
H
J
K
L
M
N
O
P

HAC

MODE DOOR CONTROL SYSTEM

< SYSTEM DESCRIPTION >

[AUTOMATIC AIR CONDITIONER]

MODE DOOR CONTROL SYSTEM

System Diagram

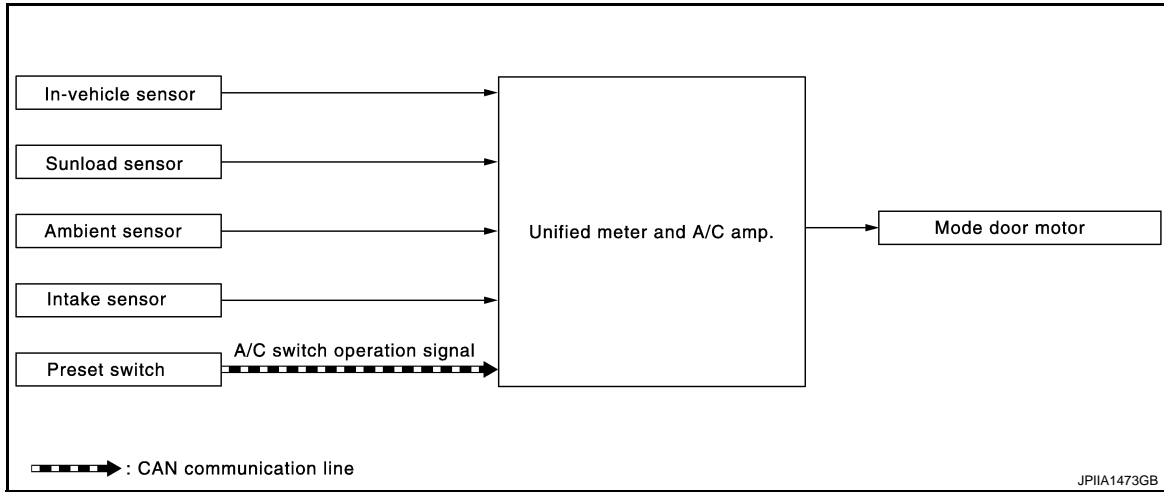

System Description

INFOID:000000005649491

The mode door is automatically controlled by the temperature setting, ambient temperature, in-vehicle temperature, intake temperature and amount of sunload.

SYSTEM OPERATION

- The unified meter and A/C amp. receives data from each of the sensors.
- The unified meter and A/C amp. sends air mix door, mode door and intake door opening angle data to the air mix door motor LCUs, mode door motor LCU and intake door motor LCU.
- The air mix door motors, mode door motor and intake door motor read their respective signals according to the address signal. Opening angle indication signals received from the unified meter and A/C amp. and each of the motor position sensors are compared by the LCUs in each door motor with the existing decision and opening angles.
- Subsequently, HOT/COLD, DEF/VENT and FRE/REC operation is selected. The new selection data are returned to the unified meter and A/C amp.

Door Motor Circuit

Without left and right ventilation temperature separately control system

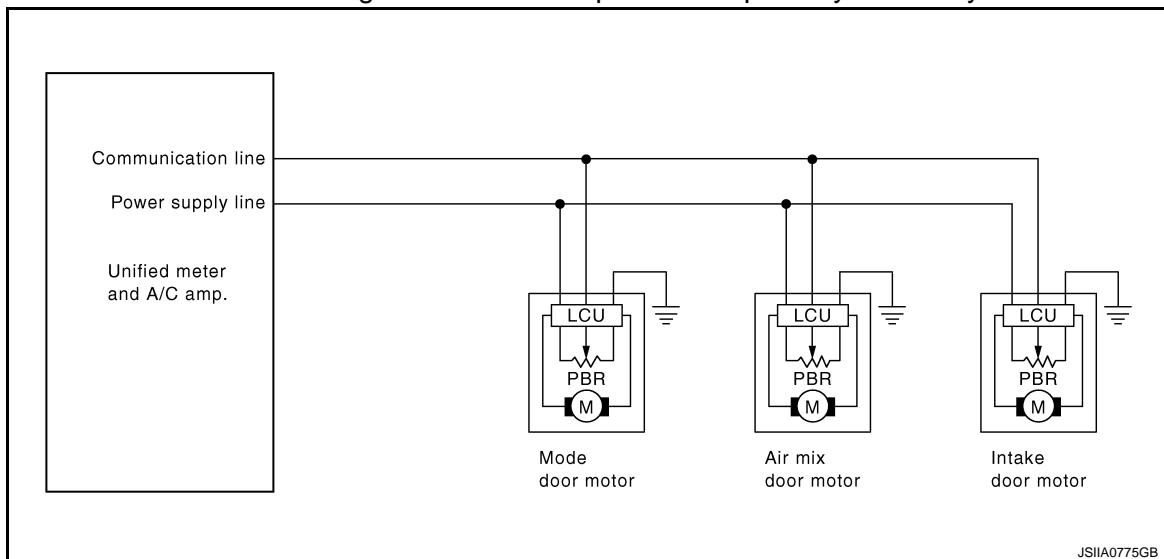

MODE DOOR CONTROL SYSTEM

< SYSTEM DESCRIPTION >

[AUTOMATIC AIR CONDITIONER]

With left and right ventilation temperature separately control system

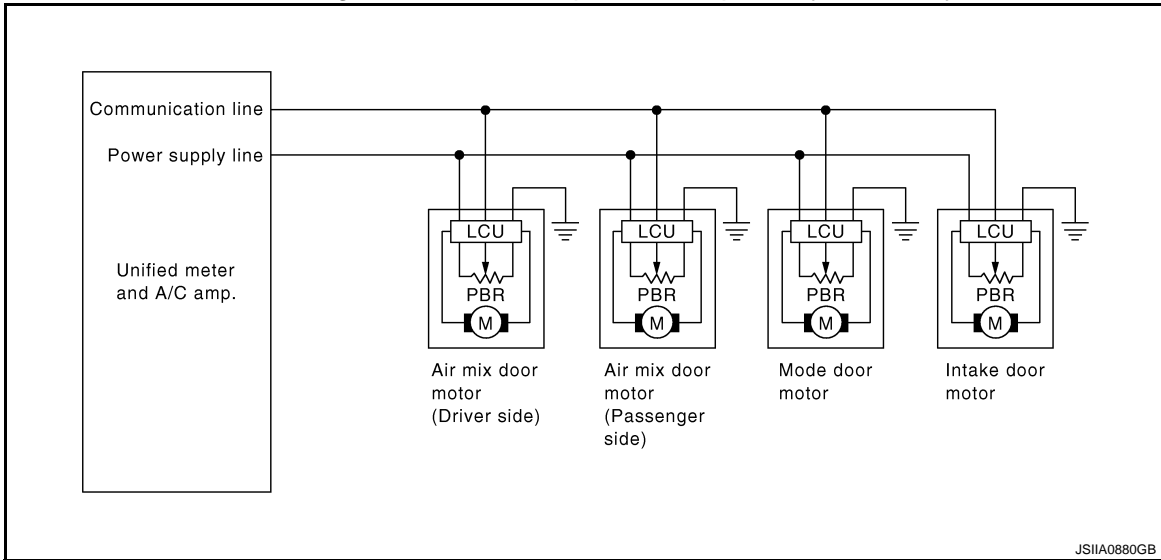

Mode Door Control Specification

Mode position can be selected manually by pressing MODE switch or DEF switch of the preset switch. This enables to fix a mode position. Automatic control by unified meter and A/C amp. Pressing AUTO switch allows automatic control by unified meter and A/C amp. During the automatic control of mode position, a mode door position (VENT, B/L, FOOT, or D/F) is selected based on a target air mix door opening angle and sunload depending on a temperature calculated by unified meter and A/C amp. In addition, D/F is selected to prevent windshield fogging only when ambient temperature is extremely low with mode position FOOT.

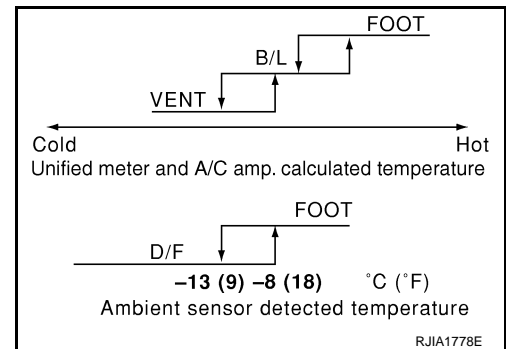

A
B
C
D
E
F
G
H
HAC
J
K
L
M
N
O
P

AIR MIX DOOR CONTROL SYSTEM

< SYSTEM DESCRIPTION >

[AUTOMATIC AIR CONDITIONER]

AIR MIX DOOR CONTROL SYSTEM

System Diagram

INFOID:000000005649492

WITHOUT LEFT AND RIGHT VENTILATION TEMPERATURE SEPARATELY CONTROL SYSTEM

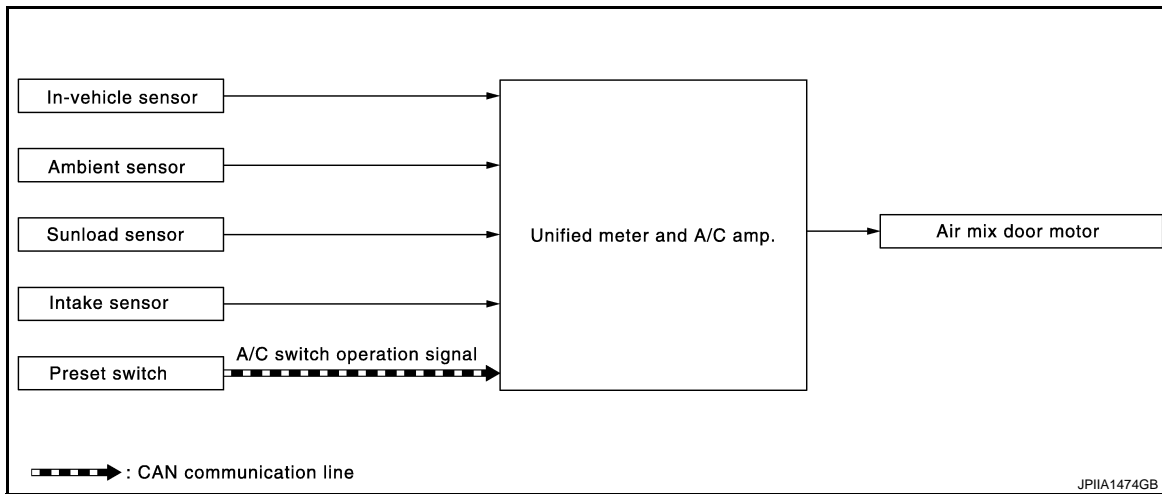

WITH LEFT AND RIGHT VENTILATION TEMPERATURE SEPARATELY CONTROL SYSTEM

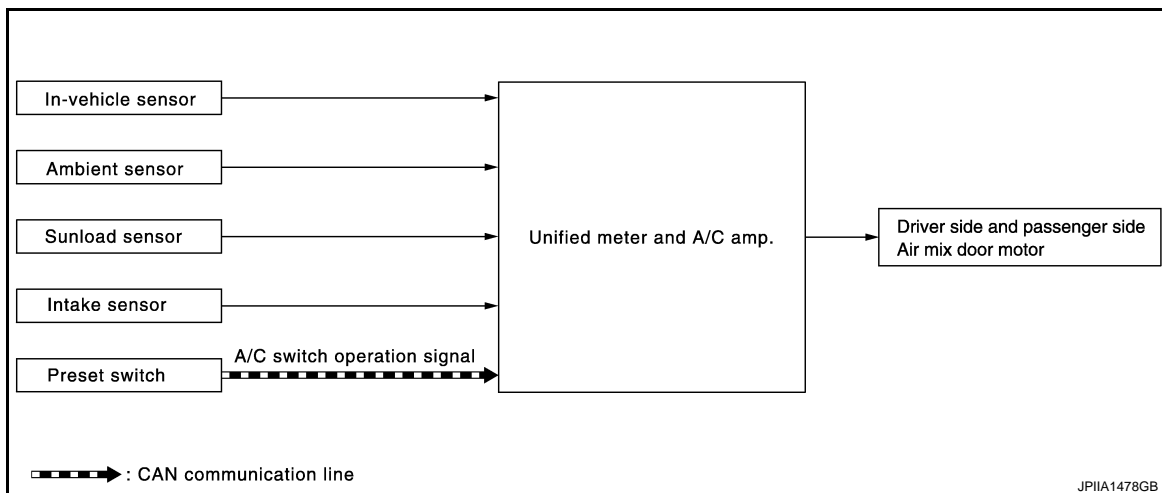

System Description

INFOID:000000005649493

The air mix doors are automatically controlled so that in-vehicle temperature is maintained at a predetermined value by the temperature setting, ambient temperature, in-vehicle temperature and amount of sunload.

SYSTEM OPERATION

- The unified meter and A/C amp. receives data from each of the sensors. The unified meter and A/C amp. sends air mix doors, mode door and intake door opening angle data to the air mix door motor LCUs, mode door motor LCU and intake door motor LCU.
- The air mix door motors, mode door motor and intake door motor read their respective signals according to the address signal. Opening angle indication signals received from the unified meter and A/C amp. and each of the motor position sensors are compared by the LCUs in each door motor with the existing decision and opening angles. Subsequently, HOT/COLD, DEF/VENT and FRE/REC operation is selected. The new selection data are returned to the unified meter and A/C amp.

Door Motor Circuit

AIR MIX DOOR CONTROL SYSTEM

< SYSTEM DESCRIPTION >

[AUTOMATIC AIR CONDITIONER]

Without left and right ventilation temperature separately control system

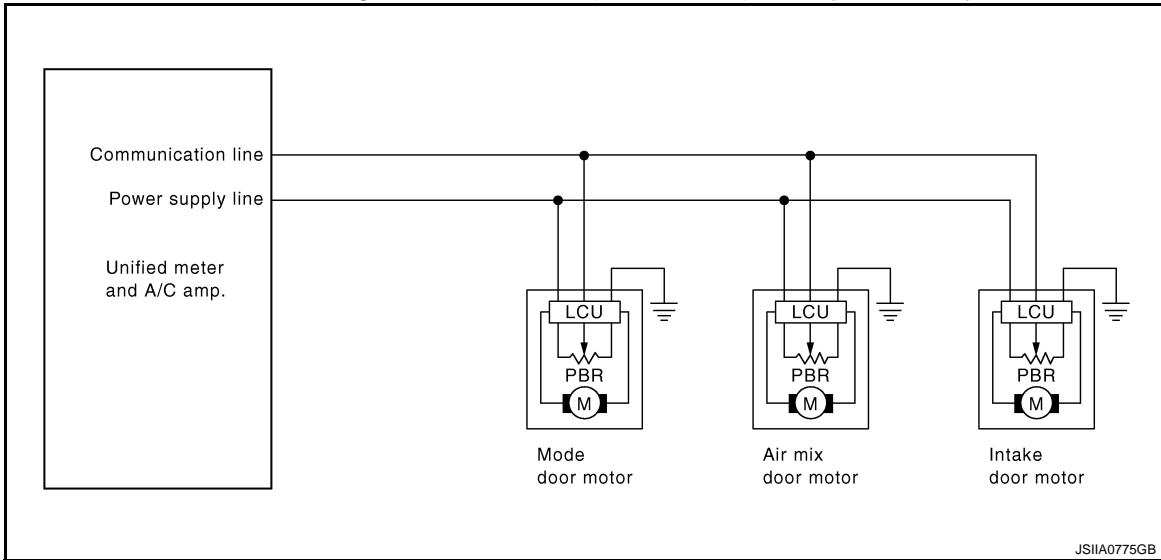

With left and right ventilation temperature separately control system

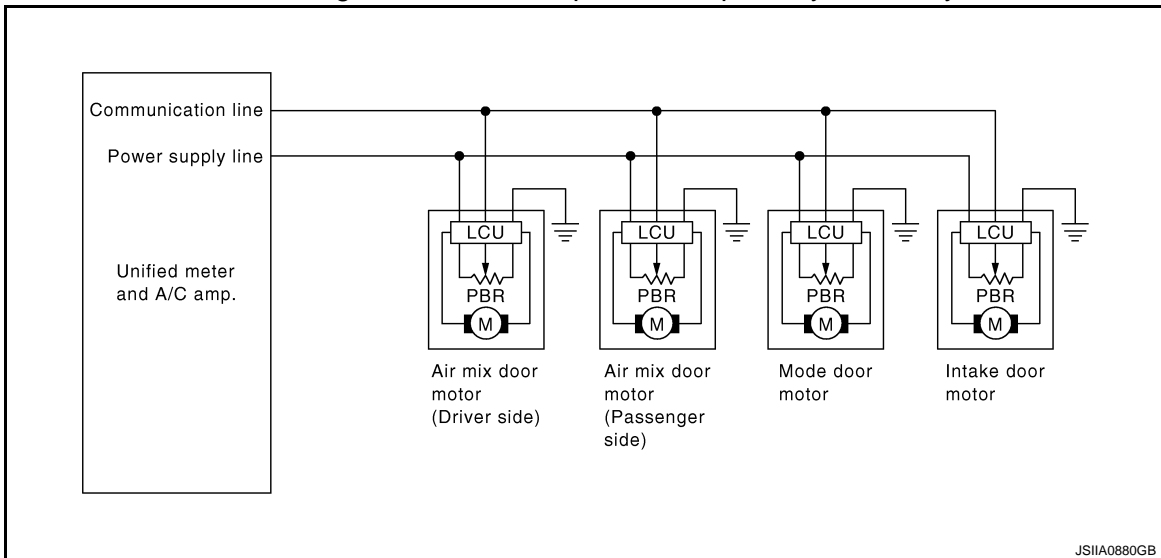

Air Mix Door Control Specification

When ignition switch is ON, unified meter and A/C amp. continuously and automatically controls temperatures regardless of air conditioner operational condition. When setting a target temperature with temperature control dial, unified meter and A/C amp. corrects the set temperature and decides a target air mix door opening angle. Unified meter and A/C amp. controls air mix door according to the target air mix door opening angle and current air mix door opening angle for keeping an optimum air mix door opening angle. When a temperature is set at 18°C (64°F), air mix door is fixed at full cold, and when a temperature is set at 32°C (90°F), it is set at full hot.

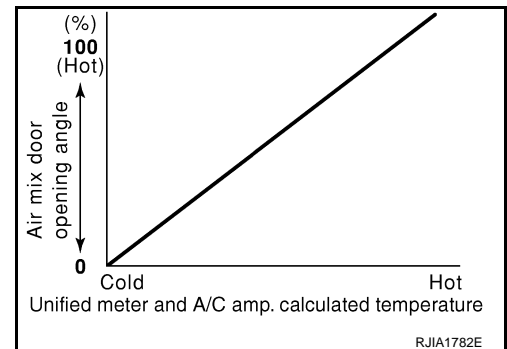

INTAKE DOOR CONTROL SYSTEM

< SYSTEM DESCRIPTION >

[AUTOMATIC AIR CONDITIONER]

INTAKE DOOR CONTROL SYSTEM

System Diagram

INFOID:000000005649494

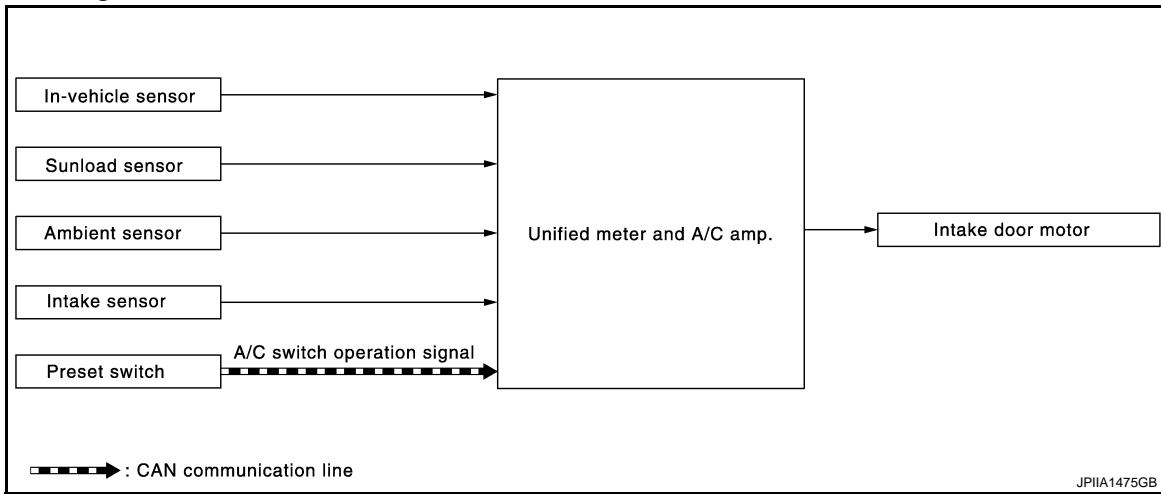

System Description

INFOID:000000005649495

The intake door is automatically controlled by the temperature setting, ambient temperature, in-vehicle temperature, intake temperature, amount of sunload and ON/OFF operation of the compressor.

SYSTEM OPERATION

The intake door control judges intake door position based on the ambient temperature, the intake air temperature and the in-vehicle temperature. When shifting mode position D/F, when the DEF or OFF switches are pressed, or when A/C switch is OFF, the unified meter and A/C amp. sets the intake door at the FRE position.

Door Motor Circuit

Without left and right ventilation temperature separately control system

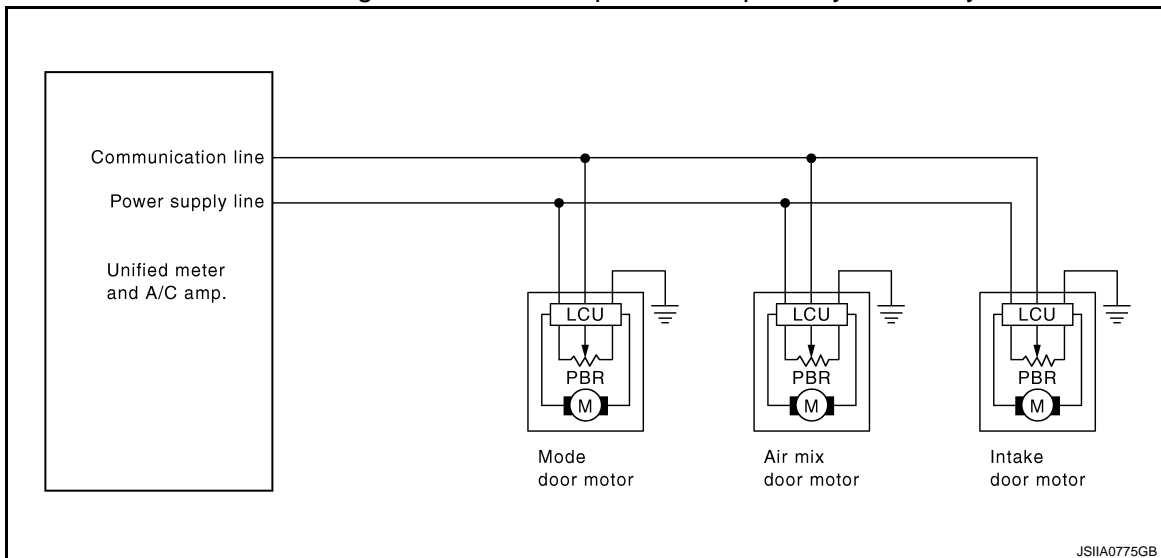

INTAKE DOOR CONTROL SYSTEM

[AUTOMATIC AIR CONDITIONER]

< SYSTEM DESCRIPTION >

With left and right ventilation temperature separately control system

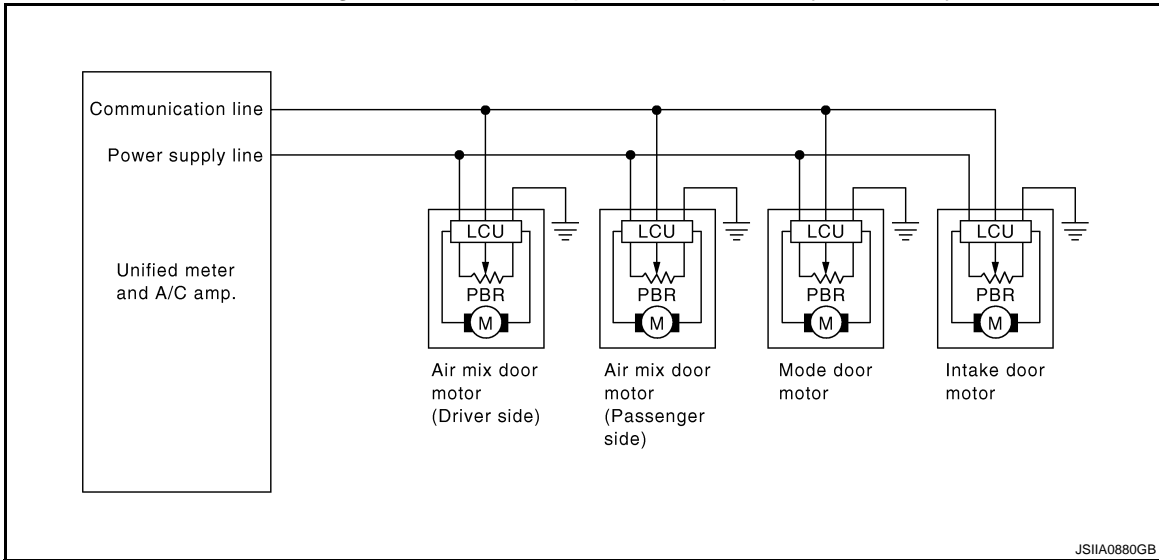

Intake Door Control Specification

- Intake door position is basically fixed at FRE when FRE indicator of intake switch is ON or DEF switch is ON.
- Intake door position is basically fixed at REC when REC indicator of intake switch is ON.
- Intake door automatic control selects FRE, 20 - 80% FRE, or REC depending on a target air mix door opening angle, based on in-vehicle temperature, ambient temperature, and sunload.

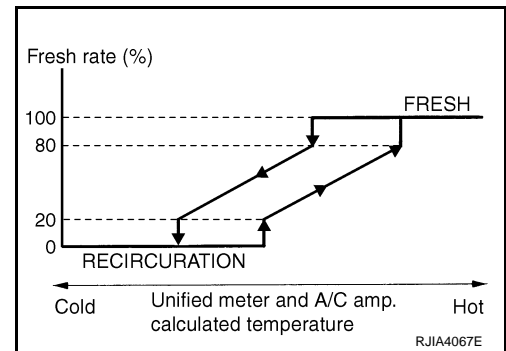

BLOWER MOTOR CONTROL SYSTEM

< SYSTEM DESCRIPTION >

[AUTOMATIC AIR CONDITIONER]

BLOWER MOTOR CONTROL SYSTEM

System Diagram

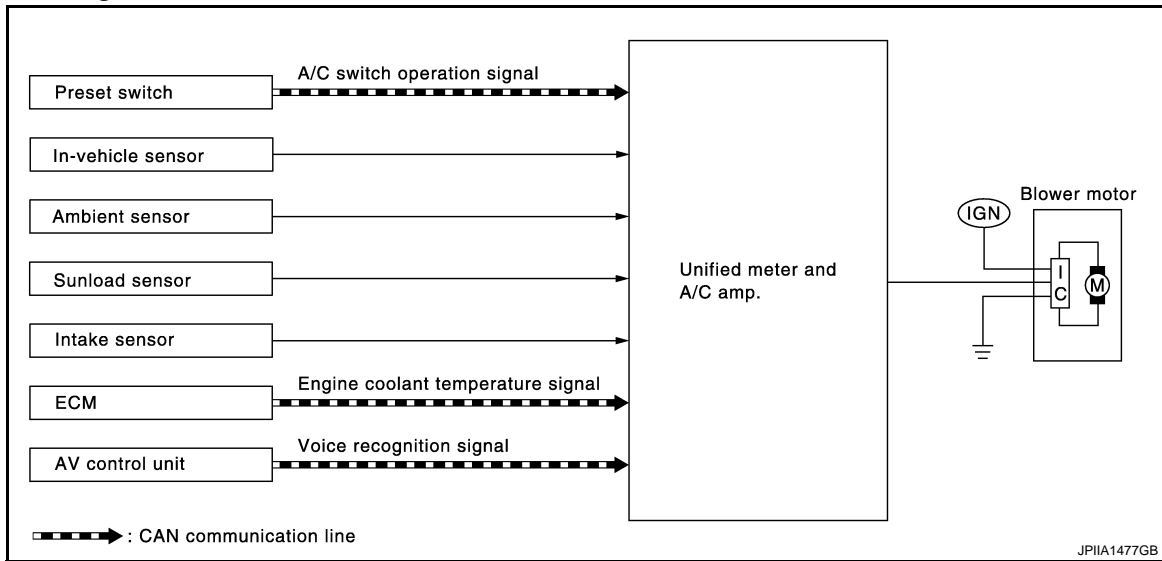

System Description

INFOID:000000005649497

Fan speed is automatically controlled by the temperature setting, ambient temperature, in-vehicle temperature, intake temperature, amount of sunload and air mix door position.

With pressing AUTO switch, the blower motor starts to gradually increase air flow volume.

When engine coolant temperature is low, the blower motor operation is delayed to prevent cool air from flowing.

SYSTEM OPERATION

Automatic Mode

In the automatic mode, the blower motor speed is calculated by the unified meter and A/C amp. based on the input from the PBR, in-vehicle sensor, sunload sensor, intake sensor and ambient sensor.

When the air flow is increased, the duty ratio of the blower motor control signal is changed at 4%/sec. to prevent a sudden increase in air flow.

In addition to manual air flow control and the usual automatic air flow control, starting air flow control, low water temperature starting control and high passenger compartment temperature starting control are available.

Starting Fan Speed Control

Start up from COLD SOAK Condition (Automatic mode)

In a cold start up condition where the engine coolant temperature is below 56°C (133°F), the blower does not operate for a short period of time (up to 150 seconds). The exact start delay time varies depending on the ambient and engine coolant temperature.

In the most extreme case (very low ambient) the blower start delay is 150 seconds as described above. After this delay, the blower will operate at low speed until the engine coolant temperature rises above 56°C (133°F), and then the fan speed increases to the objective speed.

Start up from usual or HOT SOAK Condition (Automatic mode)

The blower will begin operation momentarily after the AUTO switch is pressed. The fan speed rises gradually to the objective speed over a time period of 3 seconds or less (actual time depends on the objective fan speed).

Fan speed Compensation

Sunload

When the in-vehicle temperature and the set temperature are very close, the blower operates at low speed. The low speed varies depending on the sunload. During conditions of low or no sunload, the fan speed is at duty ratio 25%. During high sunload conditions, the unified meter and A/C amp. raise the fan speed (duty ratio 49%).

BLOWER MOTOR CONTROL SYSTEM

[AUTOMATIC AIR CONDITIONER]

< SYSTEM DESCRIPTION >

Fan Speed Control Specification

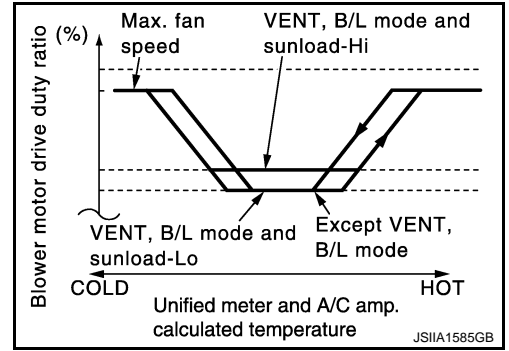

A
B
C
D
E
F
G
H
J
K
L
M
N
O
P

HAC

MAGNET CLUTCH CONTROL SYSTEM

< SYSTEM DESCRIPTION >

[AUTOMATIC AIR CONDITIONER]

MAGNET CLUTCH CONTROL SYSTEM

System Diagram

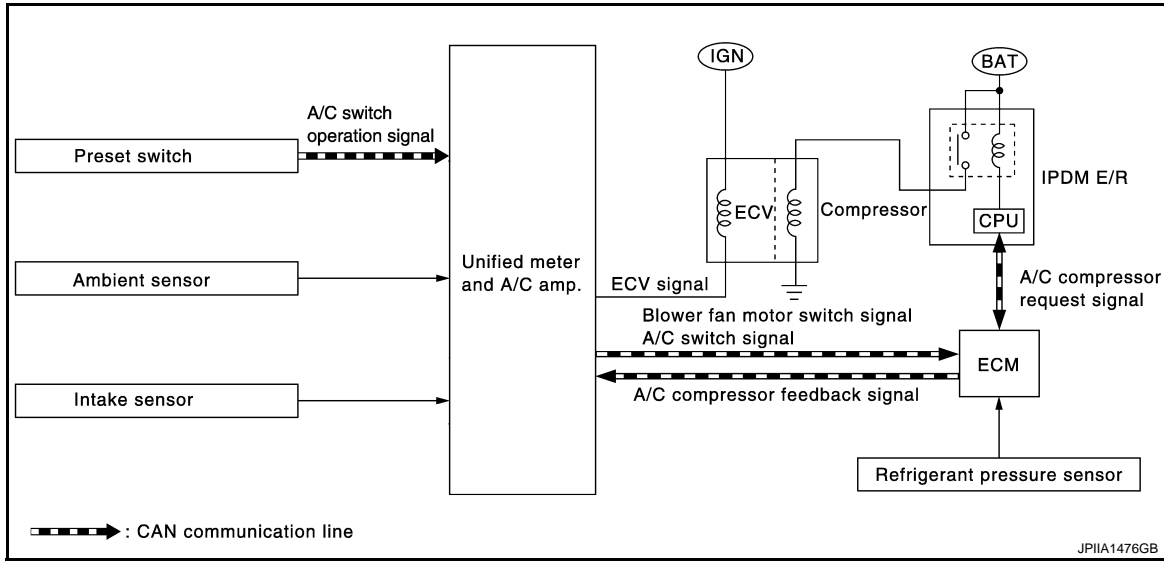

System Description

Unified meter and A/C amp. controls compressor operation by ambient temperature, intake air temperature and signal from ECM.

SYSTEM OPERATION

When A/C switch, AUTO switch, DEF switch is pressed or when shifting mode position D/F, unified meter and A/C amp. transmits A/C switch signal and blower fan motor switch signal to ECM, via CAN communication.

ECM judges whether compressor can be turned ON, based on each sensor status (refrigerant-pressure sensor signal, throttle angle, etc.). If it judges compressor can be turned ON, it sends A/C compressor request signal to IPDM E/R, via CAN communication.

Upon receipt of A/C compressor request signal from ECM, IPDM E/R turns A/C relay ON to operate compressor.

When sending A/C compressor request signal to IPDM E/R via CAN communication line, ECM simultaneously sends A/C compressor feedback signal to unified meter and A/C amp. via CAN communication line.

ECM sends A/C compressor feedback signal to unified meter and A/C amp., then, uses input A/C compressor feedback signal to control air inlet.

Compressor Protection Control

ECM makes the A/C relay go OFF and stops the compressor when pressure on the high-pressure side detected by refrigerant pressure sensor is over approximately 3,119 kPa (31.8 kg/cm², 452 psi), or below approximately 118 kPa (1.2 kg/cm², 17 psi).

Low Temperature Protection Control

Unified meter and A/C amp. turns compressor ON or OFF as judged by a signal detected by ambient sensor and intake sensor.

When ambient temperature is higher than -2°C (28°F), the compressor turns ON. The compressor turns OFF when ambient temperature is lower than -5°C (23°F).

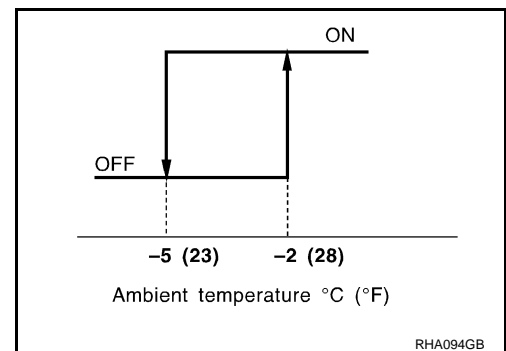

MAGNET CLUTCH CONTROL SYSTEM

[AUTOMATIC AIR CONDITIONER]

< SYSTEM DESCRIPTION >

When intake air temperature is higher than 1°C (34°F), the compressor turns ON. The compressor turns OFF when intake air temperature is lower than -5°C (23°F).

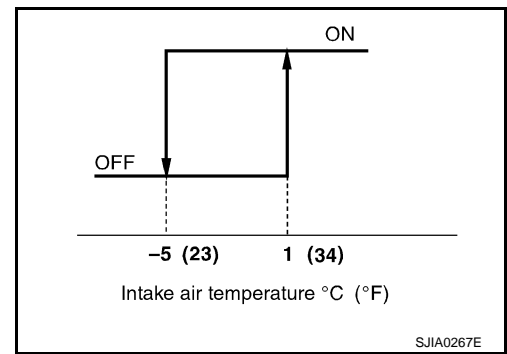

A
B
C
D
E
F
G
H
J
K
L
M
N
O
P

HAC

DIAGNOSIS SYSTEM (UNIFIED METER & A/C AMP.)

< SYSTEM DESCRIPTION >

[AUTOMATIC AIR CONDITIONER]

DIAGNOSIS SYSTEM (UNIFIED METER & A/C AMP.)

WITHOUT PLASMACLUSTER SYSTEM

WITHOUT PLASMACLUSTER SYSTEM : Diagnosis Description

INFOID:000000005649500

SELF-DIAGNOSIS SYSTEM

The self-diagnosis system is built into the unified meter and A/C amp. to quickly locate the cause of malfunctions. The self-diagnosis system diagnoses sensors, door motors, blower motor, etc. by system line. Refer to applicable sections (items) for details.

OPERATION PROCEDURE

1. Start the engine (turn ignition switch ON).

NOTE:

When checking the procedure except step-4, it is possible to perform in the state of ignition switch ON.

2. Press the OFF switch at 5 seconds or more (within 10 seconds after ignition switch is turned ON).
3. Unified meter and A/C amp. self diagnosis mode starts.
4. "Test item" are changed by the following operation.

Test item		Operation	
STEP-1	Indicator and display screen are checked.	Former STEP-1 does not exist in this self-diagnosis function.	
STEP-2	Input signals from each sensor are checked.	Turn temperature control dial (driver side) clockwise	⇒ STEP-3
STEP-3	Mode and intake door motor positions are checked.	Turn temperature control dial (driver side) clockwise	⇒ STEP-4
		Turn temperature control dial (driver side) counterclockwise	⇒ STEP-2
STEP-4*1	Motors are checked.	Turn temperature control dial (driver side) clockwise	⇒ STEP-5 (1)
		Turn temperature control dial (driver side) counterclockwise	⇒ STEP-3
STEP-5 (1)	Temperature detected by each sensor is checked.	Turn temperature control dial (driver side) counterclockwise	⇒ STEP-4
		Press intake switch	⇒ STEP-5 (2)
		Press fan (UP:+) switch*2 Turn fan control dial clockwise*3	⇒ AUXILIARY MECHANISM
STEP-5 (2)	Communication error.	Turn temperature control dial (driver side) counterclockwise	⇒ STEP-4
		Press intake switch	⇒ STEP-5 (1)
		Press fan (UP:+) switch*2 Turn fan control dial clockwise*3	⇒ AUXILIARY MECHANISM
AUXILIARY MECHANISM	Temperature setting trimmer.	Press fan (DOWN:-) switch*2 Turn fan control dial counterclockwise*3	⇒ STEP-5 (1)
	Foot position setting trimmer.		
	Inlet port memory function.		

*1: Engine must be running for compressor to operate.

*2: With left and right ventilation temperature separately control system.

*3: Without left and right ventilation temperature separately control system.

5. Self-diagnosis mode is canceled by either pressing AUTO switch or turning the ignition switch OFF.

CONFORMATION METHOD

1.SET IN SELF-DIAGNOSIS MODE

1. Turn ignition switch ON.
2. Set in self-diagnosis mode as per the following. Press OFF switch for at least 5 seconds Within 10 seconds after starting engine (ignition switch is turned ON).

DIAGNOSIS SYSTEM (UNIFIED METER & A/C AMP.)

[AUTOMATIC AIR CONDITIONER]

< SYSTEM DESCRIPTION >

NOTE:

- If battery voltage drops below 12 V during diagnosis STEP-3, door motor speed becomes slower and as a result, the system may generate an error even when operation is normal. Start engine before performing this diagnosis to avoid this.
- Former STEP-1 (indicators and display screen are checked) does not exist in this self-diagnosis function.
- OFF switch may not be recognized according to the timing of pressing it. Operate OFF switch after the intake switch indicators are turned ON.

>> GO TO 2.

2. STEP-2: SENSOR AND DOOR MOTOR CIRCUITS ARE CHECKED FOR OPEN OR SHORT CIRCUIT

Does code No. 20 appear on the display?

- YES >> GO TO 3.
- NO >> GO TO 11.

Display (when all sensors are in good order)

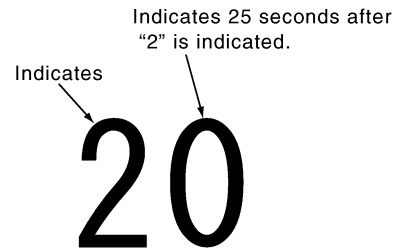

SJIA1778E

3. STEP-3: MODE DOOR AND INTAKE DOOR POSITIONS ARE CHECKED

Turn temperature control dial (driver side) clockwise.

Does code No. 30 appear on the display?

- YES >> GO TO 4.
- NO >> GO TO 12.

Display (when all doors are in good order)

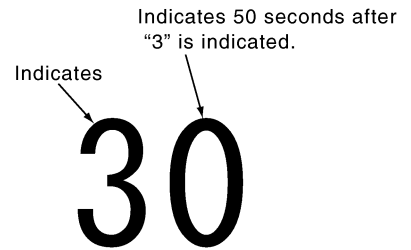

SJIA1779E

4. STEP-4: OPERATION OF EACH DOOR MOTOR IS CHECKED

1. Turn temperature control dial (driver side) clockwise.
2. Press DEF (DEF) switch. Code No. of each door motor test is indicated on the display.

>> GO TO 5.

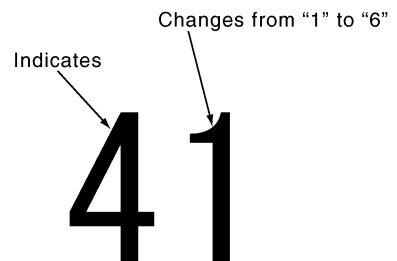

SJIA1780E

5. CHECK MOTORS

Refer to the following chart and check discharge air flow, air temperature, blower motor duty ratio and compressor operation.

Code No.	41	42	43	44	45	46
Mode door position	VENT	B/L 1	B/L 2	FOOT*	D/F	DEF
Intake door position	REC	REC	20% FRE	FRE	FRE	FRE
Air mix door position	FULL COLD	FULL COLD	FULL HOT	FULL HOT	FULL HOT	FULL HOT

DIAGNOSIS SYSTEM (UNIFIED METER & A/C AMP.)

< SYSTEM DESCRIPTION >

[AUTOMATIC AIR CONDITIONER]

Code No.	41	42	43	44	45	46
Mode door position	VENT	B/L 1	B/L 2	FOOT*	D/F	DEF
Blower motor duty ratio	37%	91%	65%	65%	65%	91%
Compressor (Magnet clutch)	ON	ON	OFF	OFF	ON	ON
Electronic control valve (ECV) duty ratio	100%	100%	0%	0%	50%	100%

*:Mode door position is in a condition of FOOT mode setting trimmer (automatic control).

Checks must be made visually, by listening the sound, or by touching air outlets with hand, etc. for improper operation.

Without left and right ventilation temperature separately control system

Discharge air flow				
Mode position indication	Air outlet/distribution			
	VENT	FOOT		DEF
		Front	Rear	
	100%	—	—	—
	53%	29%	18%	—
	11%	39%	24%	26%
	9%	33%	21%	37%
	16%	—	—	84%

With left and right ventilation temperature separately control system

Discharge air flow					
Mode position indication	Condition	Air outlet/distribution			
		VENT	FOOT		DEF
			Front	Rear	
	DUAL switch: OFF	100%	—	—	—
		53%	29%	18%	—
		11%	39%	24%	26%
		9%	33%	21%	37%
		16%	—	—	84%

Is this inspection result normal?

YES >> GO TO 6.

NO-1 >> Air outlet does not change. Refer to [HAC-71, "Diagnosis Procedure"](#).

NO-2 >> Intake door does not change. Refer to [HAC-77, "Diagnosis Procedure"](#).

NO-3 >> • Discharge air temperature does not change.*¹ Refer to [HAC-73, "WITHOUT LEFT AND RIGHT VENTILATION TEMPERATURE SEPARATELY CONTROL SYSTEM : Diagnosis Procedure"](#).

• Discharge air temperature (driver side) does not change.*² Refer to [HAC-75, "WITH LEFT AND RIGHT VENTILATION TEMPERATURE SEPARATELY CONTROL SYSTEM : Diagnosis Procedure"](#).

• Discharge air temperature (passenger side) does not change.*² Refer to [HAC-75, "WITH LEFT AND RIGHT VENTILATION TEMPERATURE SEPARATELY CONTROL SYSTEM : Diagnosis Procedure"](#).

NOTE:

*1: Without left and right ventilation temperature separately control system.

*2: With left and right ventilation temperature separately control system.

NO-5 >> Blower motor operation is malfunctioning. Refer to [HAC-79, "Diagnosis Procedure"](#).

NO-6 >> Magnet clutch does not engage. Refer to [HAC-83, "Diagnosis Procedure"](#).

6.STEP-5: TEMPERATURE OF EACH SENSOR IS CHECKED

DIAGNOSIS SYSTEM (UNIFIED METER & A/C AMP.)

[AUTOMATIC AIR CONDITIONER]

< SYSTEM DESCRIPTION >

1. Turn temperature control dial (driver side) clockwise.
2. Code No. 51 appears on the display.

>> GO TO 7.

7. CHECK AMBIENT SENSOR

Press DEF (☞) switch one time. Temperature detected by ambient sensor is indicated on the display.

NOTE:

Check sensor circuit first if the temperature indicated on the display greatly differs from the actual temperature, and then check sensor.

Is this inspection result normal?

YES >> GO TO 8.

NO >> Go to Ambient Sensor Circuit. Refer to [HAC-87, "Diagnosis Procedure"](#).

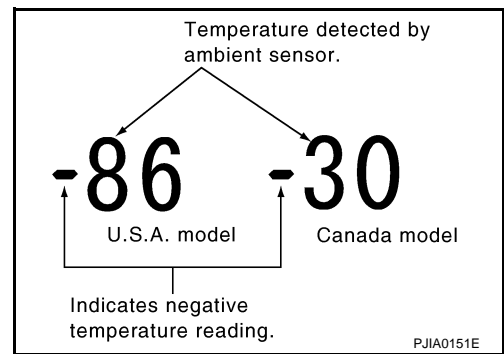

8. CHECK IN-VEHICLE SENSOR

Press DEF (☞) switch for the second time. Temperature detected by in-vehicle sensor is indicated on the display.

NOTE:

Check sensor circuit first if the temperature indicated on the display greatly differs from the actual temperature, and then check sensor.

Is this inspection result normal?

YES >> GO TO 9.

NO >> Go to In-vehicle Sensor Circuit. Refer to [HAC-90, "Diagnosis Procedure"](#).

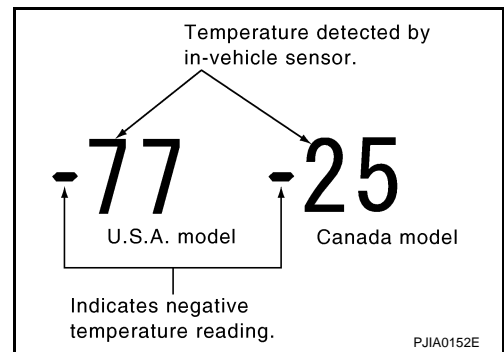

9. CHECK INTAKE SENSOR

Press DEF (☞) switch for the third time. Temperature detected by intake sensor is indicated on the display.

NOTE:

Check sensor circuit first if the temperature indicated on the display greatly differs from the actual temperature, and then check sensor.

Is this inspection result normal?

YES >> GO TO 10.

NO >> Go to Intake Sensor Circuit. Refer to [HAC-96, "Diagnosis Procedure"](#).

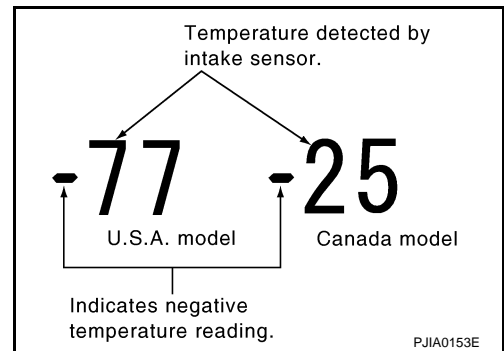

10. CHECK CAN COMMUNICATION ERROR

1. Press intake switch.
2. CAN communication error between each unit that uses the unified meter and A/C amp. can be detected as self-diagnosis results. (The display of each error will blink twice for 0.5 second intervals if plural errors occur.)

Is the inspection result normal?

YES >> INSPECTION END

NO >> Go to CAN communication (Unified meter and A/C amp. - AV control unit). Refer to [MWI-41, "Diagnosis Procedure"](#).

Display	CAN communication error
52	In good order
52 ■■■■■	AV Control unit ⇨ Unified meter and A/C amp.
52 ■■■■■	Unified meter and A/C amp. ⇨ All unit

JP1IA1360GB

11. CHECK MALFUNCTIONING SENSOR AND DOOR MOTOR

Refer to the following chart for malfunctioning code No.

A
B
C
D
E
F
G
H
J
K
L
M
N
O
P

HAC

DIAGNOSIS SYSTEM (UNIFIED METER & A/C AMP.)

[AUTOMATIC AIR CONDITIONER]

< SYSTEM DESCRIPTION >

(Corresponding code Nos. indicates 1 second each if two or more sensors and door motors malfunction.)

(Corresponding code Nos. indicates 0.5 second each if two door motors malfunction.)

Code No.	Malfunctioning sensor and door motor (Including circuits)	Reference
21 / -21	Ambient sensor	HAC-87. "Diagnosis Procedure"
22 / -22	In-vehicle sensor	HAC-90. "Diagnosis Procedure"
24 / -24	Intake sensor	HAC-96. "Diagnosis Procedure"
25 / -25	Sunload sensor *1	HAC-93. "Diagnosis Procedure"
26 / -26	Air mix door motor PBR*2	HAC-73. "WITHOUT LEFT AND RIGHT VENTILATION TEMPERATURE SEPARATELY CONTROL SYSTEM : Diagnosis Procedure"
	Air mix door motor PBR (driver side)*3	HAC-75. "WITH LEFT AND RIGHT VENTILATION TEMPERATURE SEPARATELY CONTROL SYSTEM : Diagnosis Procedure"
27 / -27	Air mix door motor PBR (passenger side)*3	HAC-75. "WITH LEFT AND RIGHT VENTILATION TEMPERATURE SEPARATELY CONTROL SYSTEM : Diagnosis Procedure"

*1: Perform self-diagnosis STEP-2 under sunshine.

*2: Without left and right ventilation temperature separately control system.

*3: With left and right ventilation temperature separately control system.

When performing indoors, aim a light (more than 60 W) at sunload sensor, otherwise code No. 25 indicates despite that sunload sensor is functioning normally.

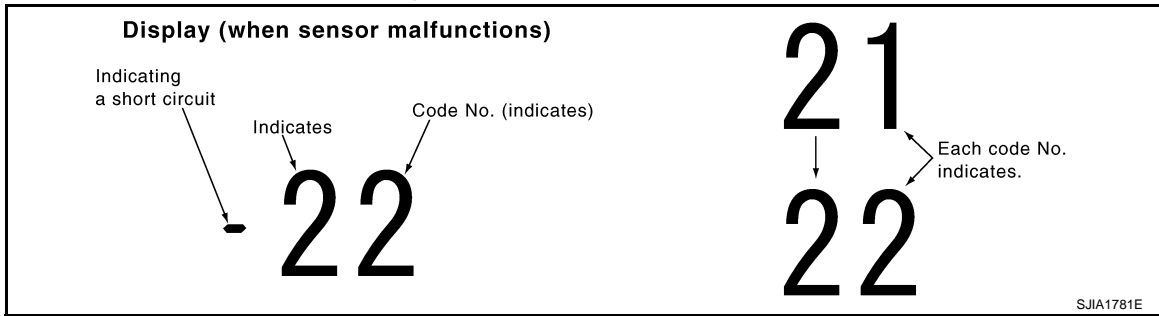

>> INSPECTION END

12.CHECK MALFUNCTIONING DOOR MOTOR POSITION SWITCH

Mode and/or intake door motor PBR (s) is/are malfunctioning.

Code No. *1 *2	Mode or intake door position	Reference
31	VENT	HAC-71. "Diagnosis Procedure"
32	DEF	
37	FRE	
38	20% FRE	HAC-77. "Diagnosis Procedure"
39	REC	

(Corresponding code Nos. indicates 1 second each if two or more mode or intake door motor malfunction.)

*1: The following display pattern will appear if mode door motor harness connector is disconnected.

31→32→Return to 31

*2: The following display pattern will appear if intake door motor harness connector is disconnected.

DIAGNOSIS SYSTEM (UNIFIED METER & A/C AMP.)

< SYSTEM DESCRIPTION >

[AUTOMATIC AIR CONDITIONER]

37→38→39→Return to 37

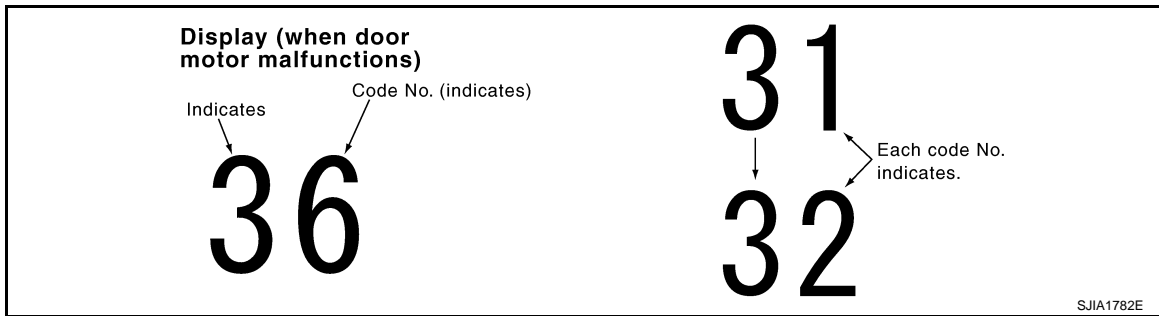

>> INSPECTION END
WITH PLASMACLUSTER SYSTEM

WITH PLASMACLUSTER SYSTEM : Diagnosis Description

INFOID:000000005874861

SELF-DIAGNOSIS SYSTEM

The self-diagnosis system is built into the unified meter and A/C amp. to quickly locate the cause of malfunctions. The self-diagnosis system diagnoses sensors, door motors, blower motor, etc. by system line. Refer to applicable sections (items) for details.

OPERATION PROCEDURE

1. Start the engine (turn ignition switch ON).

NOTE:

When checking the procedure except step-4, it is possible to perform in the state of ignition switch ON.

2. Press the OFF switch at 5 seconds or more (within 10 seconds after ignition switch is turned ON).
3. Unified meter and A/C amp. self diagnosis mode starts.
4. "Test item" are changed by the following operation.

Test item		Operation	
STEP-1	Indicator and display screen are checked.	Former STEP-1 does not exist in this self-diagnosis function.	
STEP-2	Input signals from each sensor are checked.	Turn temperature control dial (driver side) clockwise	⇒ STEP-3
STEP-3	Mode and intake door motor positions are checked.	Turn temperature control dial (driver side) clockwise	⇒ STEP-4
		Turn temperature control dial (driver side) counterclockwise	⇒ STEP-2
STEP-4*	Motors are checked.	Turn temperature control dial (driver side) clockwise	⇒ STEP-5 (1)
		Turn temperature control dial (driver side) counterclockwise	⇒ STEP-3
STEP-5 (1)	Temperature detected by each sensor is checked.	Turn temperature control dial (driver side) counterclockwise	⇒ STEP-4
		Press intake switch	⇒ STEP-5 (2)
		Press fan (UP:+) switch	⇒ AUXILIARY MECHANISM
STEP-5 (2)	Communication error.	Turn temperature control dial (driver side) counterclockwise	⇒ STEP-4
		Press intake switch	⇒ STEP-5 (1)
		Press fan (UP:+) switch	⇒ AUXILIARY MECHANISM

DIAGNOSIS SYSTEM (UNIFIED METER & A/C AMP.)

< SYSTEM DESCRIPTION >

[AUTOMATIC AIR CONDITIONER]

	Test item	Operation
AUXILIARY MECHANISM	Temperature setting trimmer.	Press fan (DOWN:-) switch ⇒ STEP-5 (1)
	Foot position setting trimmer.	
	Inlet port memory function.	
	Gas sensor sensitivity adjustment function	
	Auto intake interlocking movement change function	

*: Engine must be running for compressor to operate.

5. Self-diagnosis mode is canceled by either pressing AUTO switch or turning the ignition switch OFF.

CONFIRMATION METHOD

1.SET IN SELF-DIAGNOSIS MODE

1. Turn ignition switch ON.
2. Set in self-diagnosis mode as per the following. Press OFF switch for at least 5 seconds Within 10 seconds after starting engine (ignition switch is turned ON).

NOTE:

- If battery voltage drops below 12 V during diagnosis STEP-3, door motor speed becomes slower and as a result, the system may generate an error even when operation is normal. Start engine before performing this diagnosis to avoid this.
- Former STEP-1 (indicators and display screen are checked) does not exist in this self-diagnosis function.
- OFF switch may not be recognized according to the timing of pressing it. Operate OFF switch after the intake switch indicators are turned ON.

>> GO TO 2.

2.STEP-2: SENSOR AND DOOR MOTOR CIRCUITS ARE CHECKED FOR OPEN OR SHORT CIRCUIT

Does code No. 20 appear on the display?

- YES >> GO TO 3.
NO >> GO TO 11.

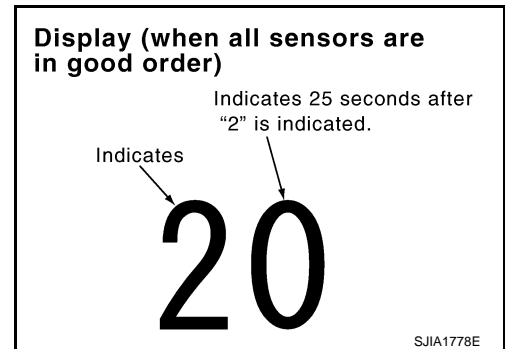

3.STEP-3: MODE DOOR AND INTAKE DOOR POSITIONS ARE CHECKED

Turn temperature control dial (driver side) clockwise.

Does code No. 30 appear on the display?

- YES >> GO TO 4.
NO >> GO TO 12.

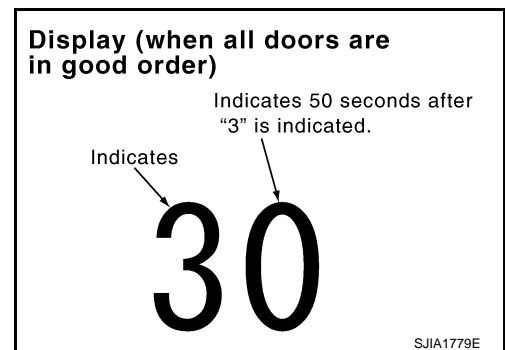

4.STEP-4: OPERATION OF EACH DOOR MOTOR IS CHECKED

DIAGNOSIS SYSTEM (UNIFIED METER & A/C AMP.)

[AUTOMATIC AIR CONDITIONER]

< SYSTEM DESCRIPTION >

1. Turn temperature control dial (driver side) clockwise.
2. Press DEF (DEF) switch. Code No. of each door motor test is indicated on the display.

>> GO TO 5.

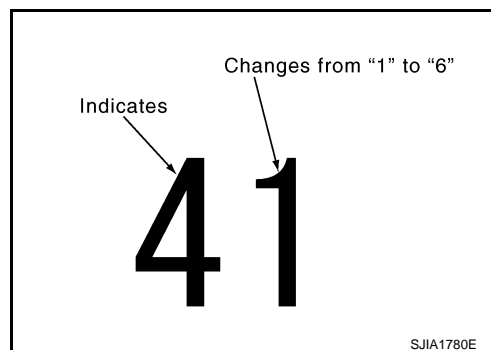

5.CHECK MOTORS

Refer to the following chart and check discharge air flow, air temperature, blower motor duty ratio and compressor operation.

Code No.	41	42	43	44	45	46
Mode door position	VENT	B/L 1	B/L 2	FOOT*	D/F	DEF
Intake door position	REC	REC	20% FRE	FRE	FRE	FRE
Air mix door position	FULL COLD	FULL COLD	FULL HOT	FULL HOT	FULL HOT	FULL HOT
Blower motor duty ratio	37%	91%	65%	65%	65%	91%
Compressor (Magnet clutch)	ON	ON	OFF	OFF	ON	ON
Electronic control valve (ECV) duty ratio	100%	100%	0%	0%	50%	100%
Ionizer	ON	ON	ON	ON	ON	OFF
Ion mode	CLEAN	QUICK CLEAN	QUICK CLEAN	QUICK CLEAN	QUICK CLEAN	OFF

*:Mode door position is in a condition of FOOT mode setting trimmer (automatic control).

Checks must be made visually, by listening the sound, or by touching air outlets with hand, etc. for improper operation.

Discharge air flow

Mode position indication	Condition	Air outlet/distribution			
		VENT	FOOT		DEF
			Front	Rear	
	DUAL switch: OFF	100%	—	—	—
		53%	29%	18%	—
		11%	39%	24%	26%
		9%	33%	21%	37%
		16%	—	—	84%

Is this inspection result normal?

YES >> GO TO 6.

NO-1 >> Air outlet does not change. Refer to [HAC-71, "Diagnosis Procedure"](#).

NO-2 >> Intake door does not change. Refer to [HAC-77, "Diagnosis Procedure"](#).

- NO-3 >> • Discharge air temperature (driver side) does not change. Refer to [HAC-75, "WITH LEFT AND RIGHT VENTILATION TEMPERATURE SEPARATELY CONTROL SYSTEM : Diagnosis Procedure"](#).
- Discharge air temperature (passenger side) does not change. Refer to [HAC-75, "WITH LEFT AND RIGHT VENTILATION TEMPERATURE SEPARATELY CONTROL SYSTEM : Diagnosis Procedure"](#).

NO-5 >> Blower motor operation is malfunctioning. Refer to [HAC-79, "Diagnosis Procedure"](#).

DIAGNOSIS SYSTEM (UNIFIED METER & A/C AMP.)

[AUTOMATIC AIR CONDITIONER]

< SYSTEM DESCRIPTION >

NO-6 >> Magnet clutch does not engage. Refer to [HAC-83. "Diagnosis Procedure"](#).

6. STEP-5: TEMPERATURE OF EACH SENSOR IS CHECKED

1. Turn temperature control dial (driver side) clockwise.
2. Code No. 51 appears on the display.

>> GO TO 7.

7. CHECK AMBIENT SENSOR

Press DEF (☞) switch one time. Temperature detected by ambient sensor is indicated on the display.

NOTE:

Check sensor circuit first if the temperature indicated on the display greatly differs from the actual temperature, and then check sensor.

Is this inspection result normal?

YES >> GO TO 8.

NO >> Go to Ambient Sensor Circuit. Refer to [HAC-87. "Diagnosis Procedure"](#).

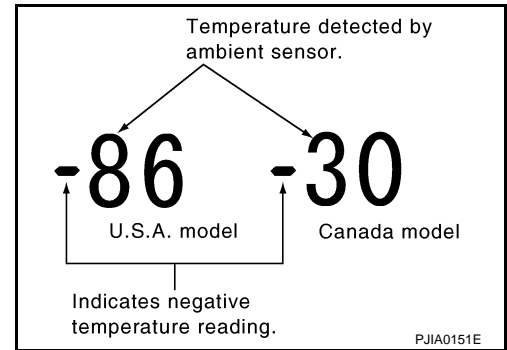

8. CHECK IN-VEHICLE SENSOR

Press DEF (☞) switch for the second time. Temperature detected by in-vehicle sensor is indicated on the display.

NOTE:

Check sensor circuit first if the temperature indicated on the display greatly differs from the actual temperature, and then check sensor.

Is this inspection result normal?

YES >> GO TO 9.

NO >> Go to In-vehicle Sensor Circuit. Refer to [HAC-90. "Diagnosis Procedure"](#).

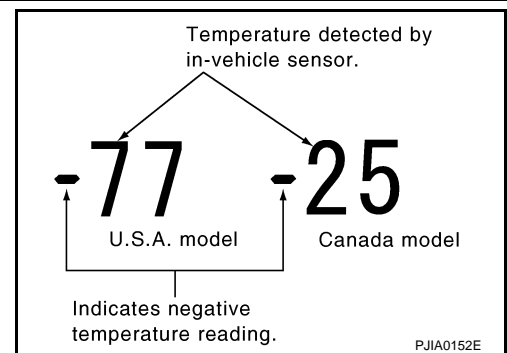

9. CHECK INTAKE SENSOR

Press DEF (☞) switch for the third time. Temperature detected by intake sensor is indicated on the display.

NOTE:

Check sensor circuit first if the temperature indicated on the display greatly differs from the actual temperature, and then check sensor.

Is this inspection result normal?

YES >> GO TO 10.

NO >> Go to Intake Sensor Circuit. Refer to [HAC-96. "Diagnosis Procedure"](#).

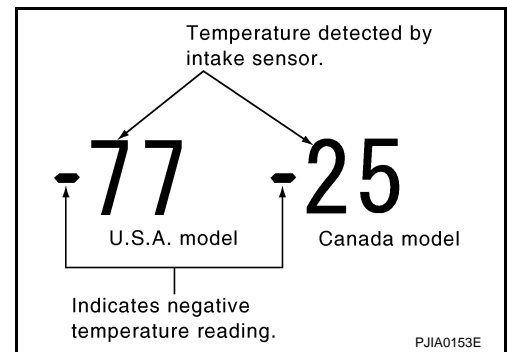

10. CHECK CAN COMMUNICATION ERROR

1. Press intake switch.
2. CAN communication error between each unit that uses the unified meter and A/C amp. can be detected as self-diagnosis results. (The display of each error will blink twice for 0.5 second intervals if plural errors occur.)

Is the inspection result normal?

YES >> INSPECTION END

NO >> Go to CAN communication (Unified meter and A/C amp. - AV control unit). Refer to [MWI-41. "Diagnosis Procedure"](#).

Display	CAN communication error
52	In good order
52 ■■■■■■	AV Control unit ⇨ Unified meter and A/C amp.
52 ■■■■■■	Unified meter and A/C amp. ⇨ All unit

PJIA1360GB

DIAGNOSIS SYSTEM (UNIFIED METER & A/C AMP.)

< SYSTEM DESCRIPTION >

[AUTOMATIC AIR CONDITIONER]

11. CHECK MALFUNCTIONING SENSOR AND DOOR MOTOR

Refer to the following chart for malfunctioning code No.

(Corresponding code Nos. indicates 1 second each if two or more sensors and door motors malfunction.)

(Corresponding code Nos. indicates 0.5 second each if two door motors malfunction.)

Code No.	Malfunctioning sensor and door motor (Including circuits)	Reference
21 / -21	Ambient sensor	HAC-87, "Diagnosis Procedure"
22 / -22	In-vehicle sensor	HAC-90, "Diagnosis Procedure"
24 / -24	Intake sensor	HAC-96, "Diagnosis Procedure"
25 / -25	Sunload sensor *	HAC-93, "Diagnosis Procedure"
26 / -26	Air mix door motor PBR	HAC-73, "WITHOUT LEFT AND RIGHT VENTILATION TEMPERATURE SEPARATELY CONTROL SYSTEM : Diagnosis Procedure"
	Air mix door motor PBR (driver side)	HAC-75, "WITH LEFT AND RIGHT VENTILATION TEMPERATURE SEPARATELY CONTROL SYSTEM : Diagnosis Procedure"
27 / -27	Air mix door motor PBR (passenger side)	HAC-75, "WITH LEFT AND RIGHT VENTILATION TEMPERATURE SEPARATELY CONTROL SYSTEM : Diagnosis Procedure"
28 / -28	Gas sensor *	HAC-98, "Diagnosis Procedure"
29 / -29	Harness of gas sensor *	

*: Perform self-diagnosis STEP-2 under sunshine.

When performing indoors, aim a light (more than 60 W) at sunload sensor, otherwise code No. 25 indicates despite that sunload sensor is functioning normally.

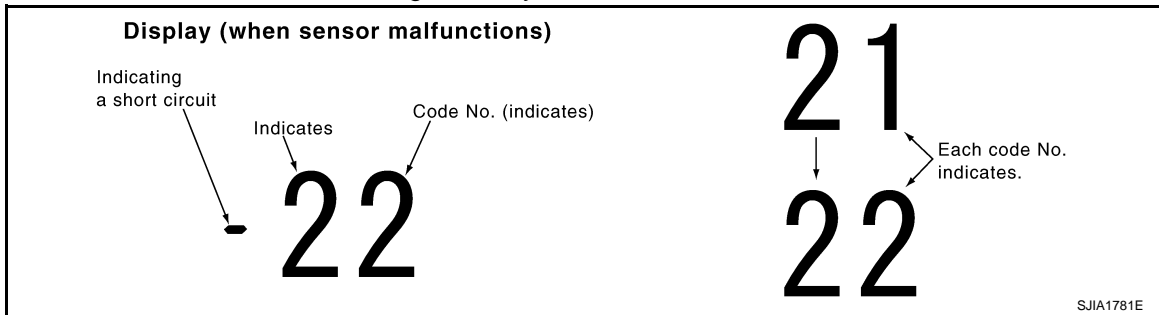

>> INSPECTION END

12. CHECK MALFUNCTIONING DOOR MOTOR POSITION SWITCH

Mode and/or intake door motor PBR (s) is/are malfunctioning.

Code No. *1 *2	Mode or intake door position	Reference
31	VENT	HAC-71, "Diagnosis Procedure"
32	DEF	
37	FRE	
38	20% FRE	HAC-77, "Diagnosis Procedure"
39	REC	

(Corresponding code Nos. indicates 1 second each if two or more mode or intake door motor malfunction.)

*1: The following display pattern will appear if mode door motor harness connector is disconnected.

31→32→Return to 31

*2: The following display pattern will appear if intake door motor harness connector is disconnected.

DIAGNOSIS SYSTEM (UNIFIED METER & A/C AMP.)

< SYSTEM DESCRIPTION >

[AUTOMATIC AIR CONDITIONER]

37→38→39→Return to 37



>> INSPECTION END

POWER SUPPLY AND GROUND CIRCUIT

< DTC/CIRCUIT DIAGNOSIS >

[AUTOMATIC AIR CONDITIONER]

DTC/CIRCUIT DIAGNOSIS

POWER SUPPLY AND GROUND CIRCUIT UNIFIED METER AND A/C AMP.

UNIFIED METER AND A/C AMP. : Diagnosis Procedure

INFOID:000000005649501

1. CHECK FUSE

Check 10A fuses [Nos. 3, 11 and 19, located in the fuse block (J/B)].

NOTE:

Refer to [PG-115, "Fuse, Connector and Terminal Arrangement"](#).

Is the inspection result normal?

YES >> GO TO 2.

NO >> Check harness for short circuit and replace fuse.

2. CHECK POWER SUPPLY CIRCUIT FOR UNIFIED METER AND A/C AMP.

1. Disconnect unified meter and A/C amp. connector.
2. Check voltage between unified meter and A/C amp. harness connector and ground.

(+)		(-)	Voltage		
Unified meter and A/C amp.		—	Ignition switch position		
Connector	Terminal		OFF	ACC	ON
M67	41	Ground	Approx. 0 V	Battery voltage	Battery voltage
	53		Approx. 0 V	Approx. 0 V	Battery voltage
	54		Battery voltage	Battery voltage	Battery voltage

Is the inspection result normal?

YES >> GO TO 3.

NO >> Repair harness or connector.

3. CHECK GROUND CIRCUIT FOR UNIFIED METER AND A/C AMP.

1. Turn ignition switch OFF.
2. Check continuity between unified meter and A/C amp. harness connector and ground.

Unified meter and A/C amp.		(-)	Continuity
Connector	Terminal	—	Continuity
M67	55		
	71		

Is the inspection result normal?

YES >> INSPECTION END

NO >> Repair harness or connector.

A
B
C
D
E
F
G
H
HAC
J
K
L
M
N
O
P

UNIFIED METER AND A/C AMP.

< DTC/CIRCUIT DIAGNOSIS >

[AUTOMATIC AIR CONDITIONER]

UNIFIED METER AND A/C AMP.

Description

INFOID:000000005649502

COMPONENT DESCRIPTION

Unified Meter and A/C Amp. (Automatic Amplifier)

The unified meter and A/C amp. (1) has a built-in microcomputer which processes information sent from various sensors needed for air conditioner operation. The air mix door motors, mode door motor, intake door motor, blower motor and compressor are then controlled. When the various switches and temperature control dial are operated, data is input to the unified meter and A/C amp. from the AV control unit using CAN communication.

Self-diagnosis functions are also built into unified meter and A/C amp. to provide quick check of malfunctions in the auto air conditioner system.

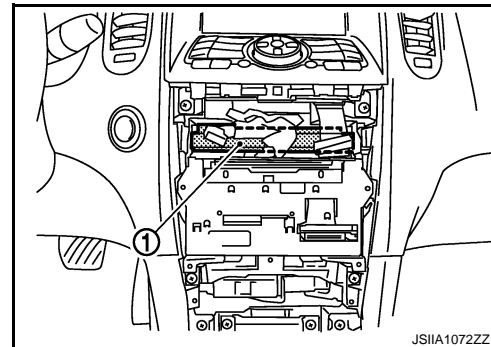

Component Function Check

INFOID:000000005649503

1. CONFIRM SYMPTOM BY PERFORMING THE FOLLOWING OPERATIONAL CHECK

1. Press AUTO switch.
2. Display should indicate AUTO. Confirm that the compressor clutch engages (sound or visual inspection). (Discharge air and fan speed depend on ambient, in-vehicle and set temperatures.)

Does magnet clutch engaged?

YES >> INSPECTION END

NO >> Go to Diagnosis Procedure. Refer to [HAC-70. "Diagnosis Procedure"](#).

Diagnosis Procedure

INFOID:000000005649504

1. INSPECTION BY FAIL-SAFE FUNCTION

1. Turn the ignition switch ON.
2. After approximately 30 seconds, check that the air conditioner is operated by the fail-safe function (the operation display of air conditioner is not performed). Refer to [HAC-128. "Fail-safe"](#).

Is the fail-safe function operated?

YES >> GO TO 3.

NO >> GO TO 2.

2. CHECK UNIFIED METER AND A/C AMP. POWER SUPPLY CIRCUIT AND GROUND

Check unified meter and A/C amp. power supply circuit and ground circuit. Refer to [HAC-69. "UNIFIED METER AND A/C AMP. : Diagnosis Procedure"](#).

Is the inspection result normal?

YES >> GO TO 3.

NO >> Repair or replace parts according to the inspection results.

3. CHECK PRESET SWITCH

Check preset switch. Refer to [AV-82. "Symptom Table"](#) (BASE AUDIO WITHOUT REAR VIEW CAMERA), [AV-195. "Symptom Table"](#) (BASE AUDIO WITH REAR VIEW CAMERA), [AV-322. "Symptom Table"](#) (BOSE AUDIO WITHOUT NAVIGATION), or [AV-467. "Symptom Table"](#) (BOSE AUDIO WITH NAVIGATION).

Is the inspection result normal?

YES >> Replace unified meter and A/C amp.

NO >> Repair or replace malfunctioning part.

MODE DOOR MOTOR

[AUTOMATIC AIR CONDITIONER]

< DTC/CIRCUIT DIAGNOSIS >

MODE DOOR MOTOR

Description

INFOID:000000005649505

COMPONENT DESCRIPTION

Mode Door Motor

The mode door motor (1) is attached to the heater & cooling unit assembly. It rotates so that air is discharged from the outlet set by the unified meter and A/C amp. Motor rotation is conveyed to a link which activates the mode door.

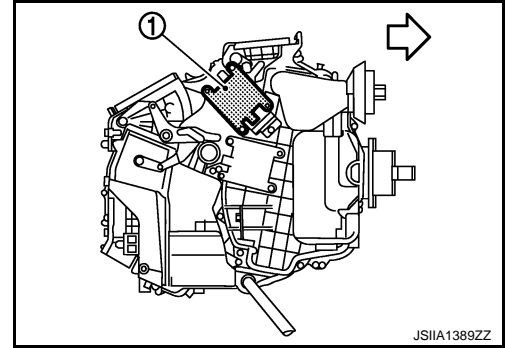

←: Vehicle front

Component Function Check

INFOID:000000005649506

1. CONFIRM SYMPTOM BY PERFORMING THE FOLLOWING OPERATIONAL CHECK

1. Press MODE switch and DEF switch.
2. Each position indicator should change shape.
3. Confirm that discharge air comes out according to the air distribution table. Refer to [VTL-5, "System Description"](#).

NOTE:

Confirm that the compressor clutch is engaged (Sound or visual inspection) and intake door position is at FRE when D/F or DEF is selected.

Is the inspection result normal?

YES >> INSPECTION END

NO >> Go to diagnosis procedure. Refer to [HAC-71, "Diagnosis Procedure"](#).

Diagnosis Procedure

INFOID:000000005649507

1. PERFORM SELF-DIAGNOSIS

Perform self-diagnosis function. Refer to [HAC-58, "WITHOUT PLASMA CLUSTER SYSTEM : Diagnosis Description"](#).

Is the inspection result normal?

YES >> GO TO 5.

NO >> GO TO 2.

2. CHECK POWER SUPPLY FOR MODE DOOR MOTOR

Check voltage between mode door motor harness connector and ground.

(+)		(-)	Voltage (Approx.)
Mode door motor		—	
Connector	Terminal		
M253	1	Ground	12 V

Is the inspection result normal?

YES >> GO TO 3.

NO >> Repair harness or connector.

3. CHECK SIGNAL FOR MODE DOOR MOTOR

Confirm A/C LAN signal between mode door motor harness connector and ground using an oscilloscope.

MODE DOOR MOTOR

< DTC/CIRCUIT DIAGNOSIS >

[AUTOMATIC AIR CONDITIONER]

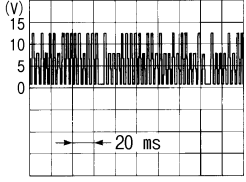
(+)		(-)	Voltage
Mode door motor		—	
Connector	Terminal		
M253	3	Ground	

Is the inspection result normal?

YES >> GO TO 4.

NO >> Repair harness or connector.

4. CHECK MODE DOOR MOTOR GROUND CIRCUIT

1. Turn ignition switch OFF.
2. Disconnect mode door motor connector.
3. Check continuity between mode door motor harness connector and ground.

Mode door motor		—	Continuity
Connector	Terminal		
M253	2	Ground	Existed

Is the inspection result normal?

YES >> Replace mode door motor.

NO >> Repair harness or connector.

5. CHECK MODE DOOR CONTROL LINKAGE

Check mode door control linkage is properly installed. Refer to [HAC-148. "Exploded View"](#).

Is it installed normally?

YES >> INSPECTION END

NO >> Repair or adjust control linkage.

AIR MIX DOOR MOTOR

< DTC/CIRCUIT DIAGNOSIS >

[AUTOMATIC AIR CONDITIONER]

AIR MIX DOOR MOTOR

WITHOUT LEFT AND RIGHT VENTILATION TEMPERATURE SEPARATELY CONTROL SYSTEM

WITHOUT LEFT AND RIGHT VENTILATION TEMPERATURE SEPARATELY CONTROL SYSTEM : Description

INFOID:000000005649508

COMPONENT DESCRIPTION

Air Mix Door Motor

The air mix door motor (1) is attached to the heater & cooling unit assembly. It rotates so that the air mix door is opened or closed to a position set by the unified meter and A/C amp. Motor rotation is then conveyed through a shaft and the air mix door position feedback is then sent to the unified meter and A/C amp. by PBR built-in air mix door motors.

←: Vehicle front

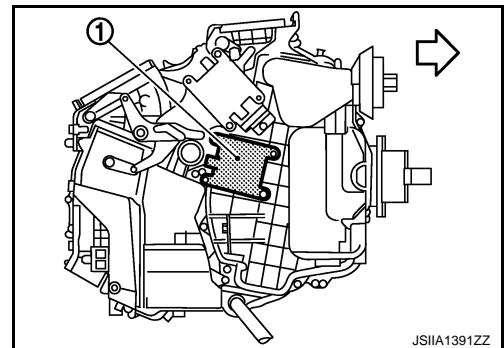

WITHOUT LEFT AND RIGHT VENTILATION TEMPERATURE SEPARATELY CONTROL SYSTEM : Component Function Check

INFOID:000000005649509

1.CONFIRM SYMPTOM BY PERFORMING THE FOLLOWING OPERATIONAL CHECK

1. Turn temperature control dial clockwise until 32°C (90°F) is displayed.
2. Check for warm air at discharge air outlets.
3. Turn temperature control dial counterclockwise until 18°C (64°F) is displayed.
4. Check for cool air at discharge air outlets.

Is the inspection result normal?

YES >> INSPECTION END

NO >> Go to diagnosis procedure. Refer to [HAC-73, "WITHOUT LEFT AND RIGHT VENTILATION TEMPERATURE SEPARATELY CONTROL SYSTEM : Diagnosis Procedure"](#).

WITHOUT LEFT AND RIGHT VENTILATION TEMPERATURE SEPARATELY CONTROL SYSTEM : Diagnosis Procedure

INFOID:000000005649510

1.PERFORM SELF-DIAGNOSIS

Perform self-diagnosis function. Refer to [HAC-58, "WITHOUT PLASMACLUSTER SYSTEM : Diagnosis Description"](#).

Is the inspection result normal?

YES >> GO TO 5.

NO >> GO TO 2.

2.CHECK POWER SUPPLY FOR AIR MIX DOOR MOTOR

Check voltage between air mix door motor harness connector and ground.

(+)		(-)	Voltage (Approx.)
Air mix door motor		—	
Connector	Terminal		
M255	1	Ground	12 V

Is the inspection result normal?

YES >> GO TO 3.

AIR MIX DOOR MOTOR

[AUTOMATIC AIR CONDITIONER]

< DTC/CIRCUIT DIAGNOSIS >

NO >> Repair harness or connector.

3. CHECK SIGNAL FOR AIR MIX DOOR MOTOR

Confirm A/C LAN signal between air mix door motor harness connector and ground using an oscilloscope.

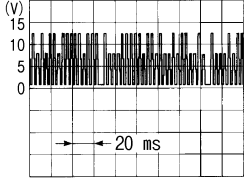
(+)		(-)	Voltage
Connector	Terminal	—	
M255	3	Ground	

Is the inspection result normal?

YES >> GO TO 4.

NO >> Repair harness or connector.

4. CHECK AIR MIX DOOR MOTOR GROUND CIRCUIT

1. Turn ignition switch OFF.
2. Disconnect air mix door motor connector.
3. Check continuity between air mix door motor harness connector and ground.

Air mix door motor		—	Continuity
Connector	Terminal	—	
M255	2	Ground	Existed

Is the inspection result normal?

YES >> Replace air mix door motor.

NO >> Repair harness or connector.

5. CHECK INSTALLATION OF AIR MIX DOOR MOTOR

Check air mix door motor is properly installed. Refer to [HAC-148, "Exploded View"](#).

Is it installed normally?

YES >> INSPECTION END

NO >> Repair or replace air mix door motor.

WITH LEFT AND RIGHT VENTILATION TEMPERATURE SEPARATELY CONTROL SYSTEM

WITH LEFT AND RIGHT VENTILATION TEMPERATURE SEPARATELY CONTROL SYSTEM : Description

INFOID:000000005649511

COMPONENT DESCRIPTION

Air Mix Door Motor

The air mix door motor (1) is attached to the heater & cooling unit assembly. It rotates so that the air mix door is opened or closed to a position set by the unified meter and A/C amp. Motor rotation is then conveyed through a shaft and the air mix door position feedback is then sent to the unified meter and A/C amp. by PBR built-in air mix door motors.

↩ Vehicle front

AIR MIX DOOR MOTOR

< DTC/CIRCUIT DIAGNOSIS >

[AUTOMATIC AIR CONDITIONER]

Driver side (LH)

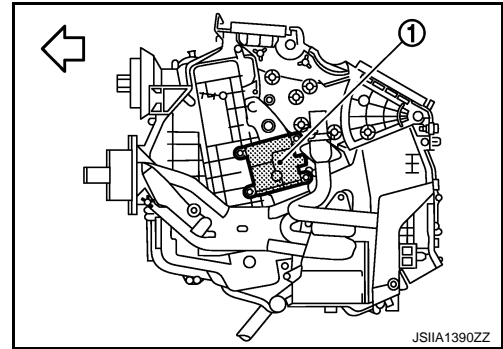

Passenger side (RH)

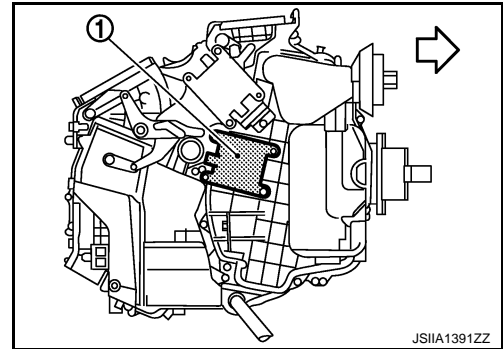

WITH LEFT AND RIGHT VENTILATION TEMPERATURE SEPARATELY CONTROL SYSTEM : Component Function Check

INFOID:000000005649512

DRIVER SIDE

1. CONFIRM SYMPTOM BY PERFORMING THE FOLLOWING OPERATIONAL CHECK

1. Turn temperature control dial (driver side) clockwise until 32°C (90°F) is displayed.
2. Check for warm air at discharge air outlets.
3. Turn temperature control dial (driver side) counterclockwise until 18°C (64°F) is displayed.
4. Check for cool air at discharge air outlets.

Is the inspection result normal?

YES >> INSPECTION END

NO >> Go to diagnosis procedure. Refer to [HAC-75, "WITH LEFT AND RIGHT VENTILATION TEMPERATURE SEPARATELY CONTROL SYSTEM : Diagnosis Procedure"](#).

PASSENGER SIDE

1. CONFIRM SYMPTOM BY PERFORMING THE FOLLOWING OPERATIONAL CHECK

1. Turn temperature control dial (passenger side) clockwise until 32°C (90°F) is displayed.
2. Check for warm air at discharge air outlets.
3. Turn temperature control dial (passenger side) counterclockwise until 18°C (64°F) is displayed.
4. Check for cool air at discharge air outlets.

Is the inspection result normal?

YES >> INSPECTION END

NO >> Go to diagnosis procedure. Refer to [HAC-75, "WITH LEFT AND RIGHT VENTILATION TEMPERATURE SEPARATELY CONTROL SYSTEM : Diagnosis Procedure"](#).

WITH LEFT AND RIGHT VENTILATION TEMPERATURE SEPARATELY CONTROL SYSTEM : Diagnosis Procedure

INFOID:000000005649513

1. PERFORM SELF-DIAGNOSIS

Perform self-diagnosis function. Refer to [HAC-58, "WITHOUT PLASMA CLUSTER SYSTEM : Diagnosis Description"](#).

AIR MIX DOOR MOTOR

[AUTOMATIC AIR CONDITIONER]

< DTC/CIRCUIT DIAGNOSIS >

Is the inspection result normal?

- YES >> GO TO 5.
- NO >> GO TO 2.

2. CHECK POWER SUPPLY FOR AIR MIX DOOR MOTOR

Check voltage between air mix door motor harness connector and ground.

(+)		(-)	Voltage (Approx.)
Air mix door motor		—	
Connector	Terminal		
M255 (RH) M252 (LH)	1	Ground	12 V

Is the inspection result normal?

- YES >> GO TO 3.
- NO >> Repair harness or connector.

3. CHECK SIGNAL FOR AIR MIX DOOR MOTOR

Confirm A/C LAN signal between air mix door motor harness connector and ground using an oscilloscope.

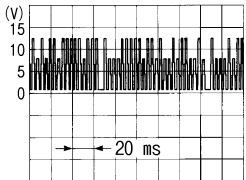
(+)		(-)	Voltage
Air mix door motor		—	
Connector	Terminal		
M255 (RH) M252 (LH)	3	Ground	 SJIA1453J

Is the inspection result normal?

- YES >> GO TO 4.
- NO >> Repair harness or connector.

4. CHECK AIR MIX DOOR MOTOR GROUND CIRCUIT

1. Turn ignition switch OFF.
2. Disconnect air mix door motor connector.
3. Check continuity between air mix door motor harness connector and ground.

Air mix door motor		—	Continuity
Connector	Terminal		
M255 (RH) M252 (LH)	2	Ground	Existed

Is the inspection result normal?

- YES >> Replace air mix door motor.
- NO >> Repair harness or connector.

5. CHECK INSTALLATION OF AIR MIX DOOR MOTOR

Check air mix door motor is properly installed. Refer to [HAC-148, "Exploded View"](#).

Is it installed normally?

- YES >> INSPECTION END
- NO >> Repair or replace air mix door motor.

INTAKE DOOR MOTOR

< DTC/CIRCUIT DIAGNOSIS >

[AUTOMATIC AIR CONDITIONER]

INTAKE DOOR MOTOR

Description

INFOID:000000005649514

COMPONENT DESCRIPTION

Intake Door Motor

The intake door motor (1) is attached to the blower unit. It rotates so that air is drawn from inlets set by the unified meter and A/C amp. Motor rotation is conveyed to a lever which activates the intake door.

←: Vehicle front

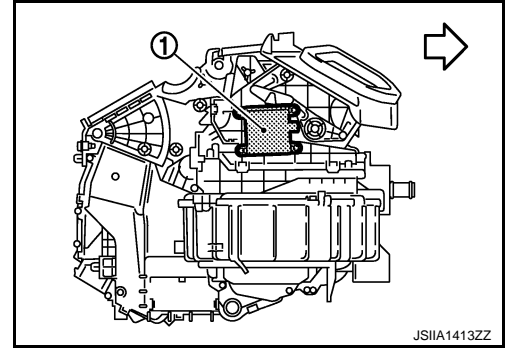

Component Function Check

INFOID:000000005649515

1.CONFIRM SYMPTOM BY PERFORMING THE FOLLOWING OPERATIONAL CHECK

1. Press intake switch.
2. REC indicator turns ON.
3. Listen for intake door position change (Slight change of blower sound can be heard.).
4. Press intake switch again.
5. FRE indicator turns ON.

Is the inspection result normal?

YES >> INSPECTION END

NO >> Go to diagnosis procedure. Refer to [HAC-77, "Diagnosis Procedure"](#).

Diagnosis Procedure

INFOID:000000005649516

1.PERFORM SELF-DIAGNOSIS

Perform self-diagnosis function. Refer to [HAC-58, "WITHOUT PLASMA CLUSTER SYSTEM : Diagnosis Description"](#).

Is the inspection result normal?

YES >> GO TO 5.

NO >> GO TO 2.

2.CHECK POWER SUPPLY FOR INTAKE DOOR MOTOR

Check voltage between intake door motor harness connector and ground.

(+)		(-)	Voltage (Approx.)
Intake door motor		—	
Connector	Terminal		
M254	1	Ground	

Is the inspection result normal?

YES >> GO TO 3.

NO >> Repair harness or connector.

3.CHECK SIGNAL FOR INTAKE DOOR MOTOR

Confirm A/C LAN signal between intake door motor harness connector and ground using an oscilloscope.

INTAKE DOOR MOTOR

< DTC/CIRCUIT DIAGNOSIS >

[AUTOMATIC AIR CONDITIONER]

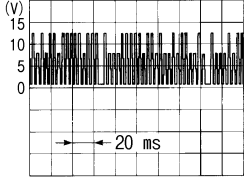
(+)		(-)	Voltage
Intake door motor		—	
Connector	Terminal		
M254	3	Ground	

SJIA1453J

Is the inspection result normal?

- YES >> GO TO 4.
- NO >> Repair harness or connector.

4. CHECK INTAKE DOOR MOTOR GROUND CIRCUIT

1. Turn ignition switch OFF.
2. Disconnect intake door motor connector.
3. Check continuity between intake door motor harness connector and ground.

Intake door motor		—	Continuity
Connector	Terminal		
M254	2	Ground	Existed

Is the inspection result normal?

- YES >> Replace intake door motor.
- NO >> Repair harness or connector.

5. CHECK INTAKE DOOR CONTROL LINKAGE

Check intake door control linkage is properly installed. Refer to [HAC-148. "Exploded View"](#).

Is it installed normally?

- YES >> INSPECTION END
- NO >> Repair or adjust control linkage.

BLOWER MOTOR

< DTC/CIRCUIT DIAGNOSIS >

[AUTOMATIC AIR CONDITIONER]

BLOWER MOTOR

Description

INFOID:000000005649517

COMPONENT DESCRIPTION

Brush-less Motor

The blower motor utilizes a brush-less motor with a rotating magnet. Quietness is improved over previous motors where the brush was the point of contact and the coil rotated.

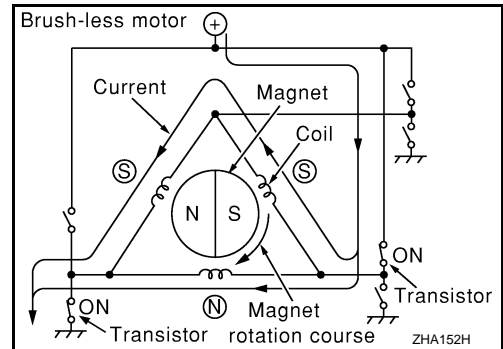
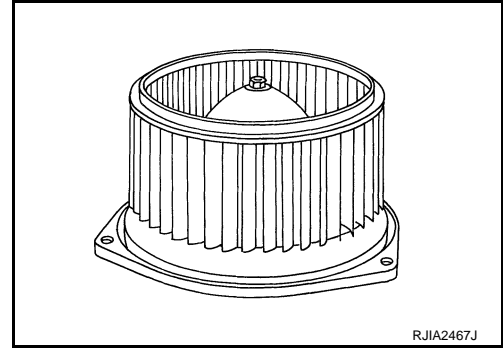

Component Function Check

INFOID:000000005649518

1. CONFIRM SYMPTOM BY PERFORMING THE FOLLOWING OPERATIONAL CHECK

- Press fan (UP: +) switch*¹ (turn fan control dial clockwise*²). Blower should operate on low speed.
NOTE:
 *1: With left and right ventilation temperature separately control system.
 *2: Without left and right ventilation temperature separately control system.
- Press fan (UP: +) switch*¹ (turn control dial clockwise*²), and continue checking fan speed and fan symbol until all speeds checked.
NOTE:
 *1: With left and right ventilation temperature separately control system.
 *2: Without left and right ventilation temperature separately control system.

Is the inspection result normal?

YES >> INSPECTION END

NO >> Go to diagnosis procedure. Refer to [HAC-79, "Diagnosis Procedure"](#).

Diagnosis Procedure

INFOID:000000005649519

1. PERFORM SELF-DIAGNOSIS STEP-4

Perform self-diagnosis STEP-4. Refer to [HAC-58, "WITHOUT PLASMA CLUSTER SYSTEM : Diagnosis Description"](#), see Nos. 1 to 5.

Code No.	41	42	43	44	45	46
Blower motor duty ratio	37%	91%	65%	65%	65%	91%

Does blower motor speed change according to each code No.?

YES >> INSPECTION END

BLOWER MOTOR

[AUTOMATIC AIR CONDITIONER]

< DTC/CIRCUIT DIAGNOSIS >

NO >> GO TO 2.

2. CHECK POWER SUPPLY FOR BLOWER MOTOR

1. Disconnect blower motor connector.
2. Turn ignition switch ON.
3. Check voltage between blower motor harness connector and ground.

(+)		(-)	Voltage
Blower motor		—	
Connector	Terminal		
M109	1	Ground	Battery voltage

Is the inspection result normal?

YES >> GO TO 3.

NO >> GO TO 6.

3. CHECK BLOWER MOTOR GROUND CIRCUIT

1. Turn ignition switch OFF.
2. Check continuity between blower motor harness connector and ground.

Blower motor		—	Continuity
Connector	Terminal		
M109	3	Ground	Existed

Is the inspection result normal?

YES >> GO TO 4.

NO >> Repair harness or connector.

4. CHECK CIRCUIT CONTINUITY BETWEEN BLOWER MOTOR AND UNIFIED METER AND A/C AMP.

1. Disconnect unified meter and A/C amp. connector.
2. Check continuity between blower motor harness connector and unified meter and A/C amp. harness connector.

Blower motor		Unified meter and A/C amp.		Continuity
Connector	Terminal	Connector	Terminal	
M109	2	M66	38	Existed

3. Check continuity between blower motor harness connector and ground.

Blower motor		—	Continuity
Connector	Terminal		
M109	2	ground	Not existed

Is the inspection result normal?

YES >> GO TO 5.

NO >> Repair harness or connector.

5. CHECK UNIFIED METER AND A/C AMP. OUTPUT SIGNAL

1. Reconnect blower motor connector and unified meter and A/C amp. connector.
2. Turn ignition switch ON.
3. Set MODE switch to VENT position.
4. Change fan speed from Lo to Hi, and check duty ratios between blower motor harness connector and ground by using an oscilloscope.

NOTE:

Calculate the drive signal duty ratio as shown in the figure.

BLOWER MOTOR

< DTC/CIRCUIT DIAGNOSIS >

[AUTOMATIC AIR CONDITIONER]

T2 = 1.6 ms

Blower motor		Condition	Duty ratio (Approx.)
Connector	Terminal	<ul style="list-style-type: none"> fan speed: manual Vent mode 	
M109	2	1st	25 %
		2nd	33 %
		3rd	41 %
		4th	51 %
		5th	61 %
		6th	71 %
		7th	83 %

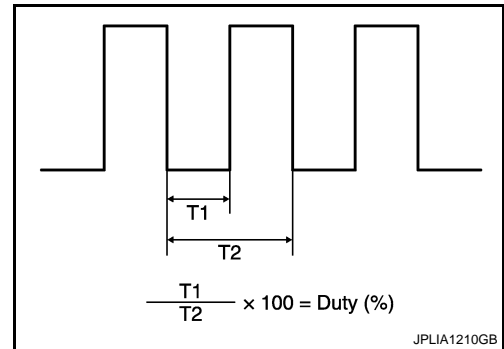

Is the inspection result normal?

- YES >> Replace blower motor after confirming the fan air flow does not change.
 NO >> Replace unified meter and A/C amp.

6. CHECK POWER VOLTAGE OF BLOWER RELAY

- Turn ignition switch OFF.
- Remove blower relay. Refer to [PG-115, "Fuse, Connector and Terminal Arrangement"](#).
- Turn ignition switch ON.
- Check the voltage between blower relay fuse block terminals and ground. Refer to [PG-113, "Description"](#) for relay terminal assignment.

(+)	(-)	Voltage
Blower relay	—	
1	Ground	Battery voltage
3		

Is the inspection result normal?

- YES >> GO TO 7.
 NO >> Check ignition power supply circuit. Refer to [PG-63, "Wiring Diagram - IGNITION POWER SUPPLY -"](#).

7. CHECK BLOWER RELAY

- Turn ignition switch OFF.
- Install blower relay. Refer to [PG-115, "Fuse, Connector and Terminal Arrangement"](#).
- Check operation sound of the blower relay after switching ignition switch ON.

Is the inspection result normal?

- YES >> GO TO 8.
 NO >> Replace blower relay.

8. CHECK FUSE

Check fuse 15A [Nos 21 and 22, located in the fuse block (J/B)]. Refer to [PG-115, "Fuse, Connector and Terminal Arrangement"](#).

Is the inspection result normal?

- YES >> Repair harness or connector.
 NO >> Be sure to eliminate cause of malfunction before installing new fuse.

Component Inspection

INFOID:000000005649520

1. CHECK BLOWER MOTOR

- Remove blower motor. Refer to [VTL-16, "Exploded View"](#).
- Confirm smooth rotation of the blower motor.

Is the inspection result normal?

BLOWER MOTOR

< DTC/CIRCUIT DIAGNOSIS >

[AUTOMATIC AIR CONDITIONER]

YES >> INSPECTION END
NO >> Replace blower motor.

MAGNET CLUTCH

< DTC/CIRCUIT DIAGNOSIS >

[AUTOMATIC AIR CONDITIONER]

MAGNET CLUTCH

Description

INFOID:000000005649521

Magnet clutch drives a compressor, by a signal of IPDM E/R.

Component Function Check

INFOID:000000005649522

1. CONFIRM SYMPTOM BY PERFORMING THE FOLLOWING OPERATIONAL CHECK

1. Press AUTO switch.
2. Display should indicate AUTO. Confirm that the magnet clutch engages (sound or visual inspection). (Discharge air and fan speed depend on ambient, in-vehicle and set temperatures.)

Does the magnet clutch operate?

- YES >> INSPECTION END
NO >> Go to Diagnosis Procedure. Refer to [HAC-83, "Diagnosis Procedure"](#).

Diagnosis Procedure

INFOID:000000005649523

1. PERFORM SELF-DIAGNOSIS

Perform self-diagnosis function. Refer to [HAC-58, "WITHOUT PLASMA CLUSTER SYSTEM : Diagnosis Description"](#).

Is the inspection result normal?

- YES >> INSPECTION END
NO >> GO TO 2.

2. PERFORM IPDM E/R AUTO ACTIVE TEST

Perform IPDM E/R auto active test. Refer to [PCS-9, "Diagnosis Description"](#).

Does the magnet clutch operate?

- YES-1 >> WITH CONSULT-III: GO TO 6.
YES-2 >> WITHOUT CONSULT-III: GO TO 5.
NO >> Check 10A fuse (No. 49, located in IPDM E/R), and GO TO 3.

3. CHECK CIRCUIT CONTINUITY BETWEEN IPDM E/R AND COMPRESSOR

1. Turn ignition switch OFF.
2. Disconnect IPDM E/R connector and compressor connector.
3. Check continuity between IPDM E/R harness connector and compressor harness connector.

IPDM E/R		Compressor		Continuity
Connector	Terminal	Connector	Terminal	
E7	48	F43	1	Existed

Is the inspection result normal?

- YES >> GO TO 4.
NO >> Repair harness or connector.

4. CHECK MAGNET CLUTCH CIRCUIT

Check for operation sound when applying battery voltage direct current to terminal.

Is the inspection result normal?

- YES >> Replace IPDM E/R.
NO >> Replace compressor.

5. CHECK REFRIGERANT PRESSURE SENSOR (WITHOUT CONSULT-III)

1. Start the engine.
2. Check voltage between ECM harness connector and ground.

MAGNET CLUTCH

< DTC/CIRCUIT DIAGNOSIS >

[AUTOMATIC AIR CONDITIONER]

(+)		(-)	Condition	Voltage (Approx.)
ECM		—		
connector	Terminal			
M107	105	Ground	A/C switch: ON (Blower motor operates.)	1.0 - 4.0 V

Is the inspection result normal?

- YES >> Repair harness or connector.
NO >> Refer to [EC-520, "Diagnosis Procedure"](#).

6. CHECK ECM INPUT SIGNAL-1

Check A/C switch signal in "Data monitor". Refer to [EC-525, "Reference Value"](#).

Monitor item	Condition	Status
AIR COND SIG	A/C switch: OFF	Off
	A/C switch: ON	On

Is the inspection result normal?

- YES >> GO TO 9.
NO >> GO TO 7.

7. CHECK REFRIGERANT PRESSURE SENSOR (WITH CONSULT-III)

1. Start the engine.
2. Check voltage of refrigerant pressure sensor in "Data monitor". Refer to [EC-525, "Reference Value"](#).

Is the inspection result normal?

- YES >> GO TO 8.
NO >> Refer to [EC-520, "Diagnosis Procedure"](#).

8. CHECK ECM INPUT SIGNAL-2

Check blower fan motor switch signal in "Data monitor". Refer to [EC-525, "Reference Value"](#).

Monitor item	Condition	Status
HEATER FAN SW	Fan switch: OFF	Off
	Fan switch: ON	On

Is the inspection result normal?

- YES >> GO TO 9.
NO >> Repair harness or connector.

9. CHECK CAN COMMUNICATION

Check CAN communication. Refer to [LAN-18, "Trouble Diagnosis Flow Chart"](#).

- ECM – IPDM E/R
- ECM – Unified meter and A/C amp.

Is the inspection result normal?

- YES >> Replace ECM.
NO >> Repair or replace malfunctioning part.

ECV (ELECTRICAL CONTROL VALVE)

[AUTOMATIC AIR CONDITIONER]

< DTC/CIRCUIT DIAGNOSIS >

ECV (ELECTRICAL CONTROL VALVE)

Description

INFOID:000000005649524

The ECV (electrical control valve) is installed in the compressor and controls it for emitting appropriate amount of refrigerant when necessary.

Diagnosis Procedure

INFOID:000000005649525

1. CHECK POWER SUPPLY FOR ECV (ELECTRIC CONTROL VALVE)

1. Disconnect compressor (ECV) connector.
2. Turn ignition switch ON.
3. Check voltage between compressor (ECV) harness connector and ground.

(+)		(-)		Voltage
Connector	Terminal	—		
F44	2	Ground		Battery voltage

Is the inspection result normal?

- YES >> GO TO 3
NO >> GO TO 2

2. CHECK FUSE

Check power supply circuit and 10A fuse [No. 3, located in the fuse block (J/B)]. Refer to [PG-115, "Fuse, Connector and Terminal Arrangement"](#).

Is the inspection result normal?

- YES >> Check harness for open circuit. Repair or replace if necessary.
NO >> Replace fuse and check harness for short circuit. Repair or replace if necessary.

3. CHECK ECV CONTROL SIGNAL

1. Turn ignition switch OFF.
2. Reconnect compressor (ECV) connector.
3. Perform self-diagnosis. Refer to [HAC-58, "WITHOUT PLASMA CLUSTER SYSTEM : Diagnosis Description"](#).
4. Set in self-diagnosis STEP-4 (Code No. 45).
5. Confirm ECV control signal between unified meter and A/C amp harness connector M67 terminal 65 and ground using an oscilloscope.

Is the inspection result normal?

- YES >> Replace compressor.
NO >> GO TO 4

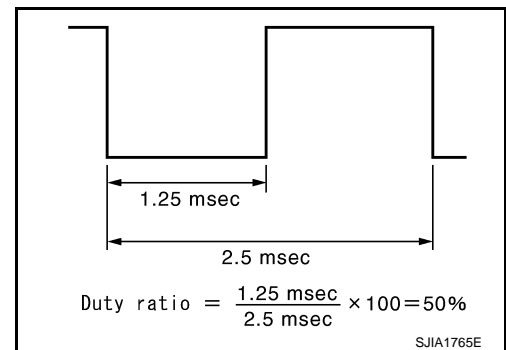

4. CHECK CIRCUIT CONTINUITY BETWEEN ECV AND UNIFIED METER AND A/C AMP.

1. Turn ignition switch OFF.
2. Disconnect compressor (ECV) connector and unified meter and A/C amp. connector.
3. Check continuity between compressor (ECV) harness connector and unified meter and A/C amp harness connector.

Compressor (ECV)		Unified meter and A/C amp.		Continuity
Connector	Terminal	Connector	Terminal	
F44	3	M67	65	Existed

ECV (ELECTRICAL CONTROL VALVE)

[AUTOMATIC AIR CONDITIONER]

< DTC/CIRCUIT DIAGNOSIS >

Is the inspection result normal?

YES >> GO TO 5

NO >> Repair the harnesses or connectors.

5.CHECK ECV

Check continuity between compressor (ECV) connector.

Compressor (ECV)				Continuity
Connector	Terminal	Connector	Terminal	
F44	2	F44	3	Existed

Is the inspection result normal?

YES >> Replace the unified meter and A/C amp.

NO >> Replace the compressor.

AMBIENT SENSOR

< DTC/CIRCUIT DIAGNOSIS >

[AUTOMATIC AIR CONDITIONER]

AMBIENT SENSOR

Description

INFOID:000000005649526

COMPONENT DESCRIPTION

Ambient Sensor

The ambient sensor (1) is attached on hood lock stay assembly. It detects ambient temperature and converts it into a resistance value which is then input into the unified meter and A/C amp.

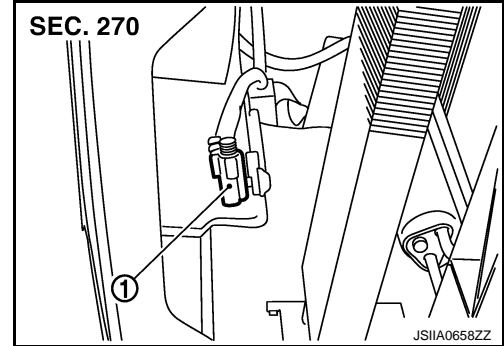

AMBIENT TEMPERATURE INPUT PROCESS

The unified meter and A/C amp. equips a processing circuit for the ambient sensor input. However, when the temperature detected by the ambient sensor increases quickly, the processing circuit retards the unified meter and A/C amp. function. It only allows the unified meter and A/C amp. to recognize an ambient temperature increase of 0.33°C (0.6°F) per 100 seconds.

As an example, consider stopping for a few minutes after high speed driving. Although the actual ambient temperature has not changed, the temperature detected by the ambient sensor increases. This is because the heat from the engine compartment can radiate to the front bumper area, location of the ambient sensor.

Component Function Check

INFOID:000000005649527

1. PERFORM SELF-DIAGNOSIS

Perform self-diagnosis function STEP-2. Refer to [HAC-58, "WITHOUT PLASMA CLUSTER SYSTEM : Diagnosis Description"](#).

21 or -21 is displayed.

- YES >> Go to Diagnosis Procedure. Refer to [HAC-87, "Diagnosis Procedure"](#).
- NO >> INSPECTION END

Diagnosis Procedure

INFOID:000000005649528

1. CHECK VOLTAGE BETWEEN AMBIENT SENSOR AND GROUND

1. Disconnect ambient sensor connector.
2. Turn ignition switch ON.
3. Check voltage between ambient sensor harness connector and ground.

(+)		(-)	Voltage (Approx.)
Ambient sensor		—	
Connector	Terminal		
E76	1	Ground	5 V

Is the inspection result normal?

- YES >> GO TO 2.
- NO >> GO TO 4.

2. CHECK CIRCUIT CONTINUITY BETWEEN AMBIENT SENSOR AND UNIFIED METER AND A/C AMP.

1. Turn ignition switch OFF.
2. Disconnect unified meter and A/C amp. connector.
3. Check continuity between ambient sensor harness connector and unified meter and A/C amp. harness connector.

AMBIENT SENSOR

< DTC/CIRCUIT DIAGNOSIS >

[AUTOMATIC AIR CONDITIONER]

Ambient sensor		Unified meter and A/C amp.		Continuity
Connector	Terminal	Connector	Terminal	
E76	2	M67	61	Existed

Is the inspection result normal?

YES >> GO TO 3.

NO >> Repair harness or connector.

3.CHECK AMBIENT SENSOR

Check ambient sensor. Refer to [HAC-88, "Component Inspection"](#).

Is the inspection result normal?

YES >> Replace unified meter and A/C amp.

NO >> Replace ambient sensor.

4.CHECK CIRCUIT CONTINUITY BETWEEN AMBIENT SENSOR AND UNIFIED METER AND A/C AMP.

1. Turn ignition switch OFF.
2. Disconnect unified meter and A/C amp. connector.
3. Check continuity between ambient sensor harness connector and unified meter and A/C amp. harness connector.

Ambient sensor		Unified meter and A/C amp.		Continuity
Connector	Terminal	Connector	Terminal	
E76	1	M67	45	Existed

4. Check continuity between ambient sensor harness connector and ground.

Ambient sensor		—	Continuity
Connector	Terminal		
E76	1	Ground	Not existed

Is the inspection result normal?

YES >> Replace unified meter and A/C amp.

NO >> Repair harness or connector.

Component Inspection

INFOID:000000005649529

1.CHECK AMBIENT SENSOR

1. Turn ignition switch OFF.
2. Disconnect ambient sensor connector. Refer to [HAC-143, "Exploded View"](#).
3. Check resistance between ambient sensor terminals.

AMBIENT SENSOR

< DTC/CIRCUIT DIAGNOSIS >

[AUTOMATIC AIR CONDITIONER]

Terminal		Condition	Resistance kΩ
		Temperature °C (°F)	
1	2	-15 (5)	12.73
		-10 (14)	9.92
		-5 (23)	7.80
		0 (32)	6.19
		5 (41)	4.95
		10 (50)	3.99
		15 (59)	3.24
		20 (68)	2.65
		25 (77)	2.19
		30 (86)	1.81
		35 (95)	1.51
		40 (104)	1.27
		45 (113)	1.07

Is the inspection result normal?

- YES >> INSPECTION END
- NO >> Replace ambient sensor.

A
B
C
D
E
F
G
H
J
K
L
M
N
O
P

HAC

IN-VEHICLE SENSOR

Description

INFOID:000000005649530

COMPONENT DESCRIPTION

In-vehicle Sensor

The in-vehicle sensor (1) is located on instrument driver lower panel. It converts variations in compartment air temperature drawn from the aspirator into a resistance value. It is then input into the unified meter and A/C amp.

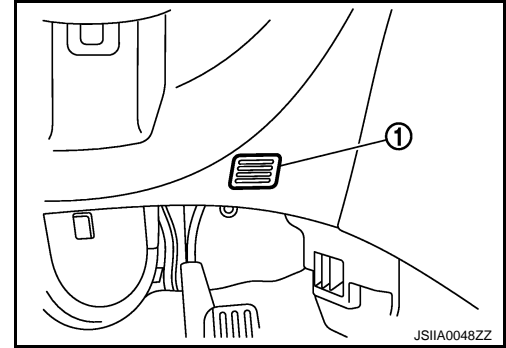

Aspirator

The aspirator (1) is located on driver's side of heater & cooling unit assembly. It produces vacuum pressure due to air discharged from the heater & cooling unit assembly, continuously taking compartment air in the aspirator.

← Vehicle front

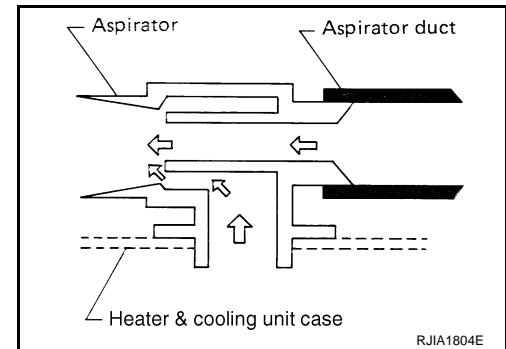
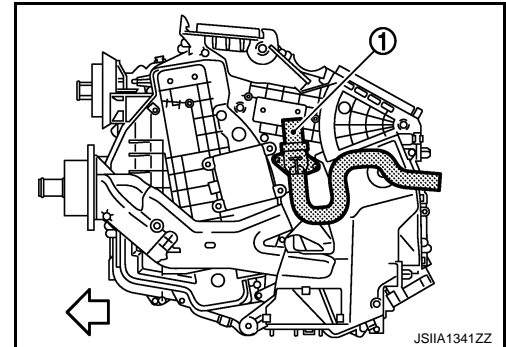

Component Function Check

INFOID:000000005649531

1.PERFORM SELF-DIAGNOSIS

Perform self-diagnosis function STEP-2. Refer to [HAC-58. "WITHOUT PLASMACLUSTER SYSTEM : Diagnosis Description"](#).

22 or -22 is displayed.

- YES >> Go to Diagnosis Procedure. Refer to [HAC-90. "Diagnosis Procedure"](#).
- NO >> INSPECTION END

Diagnosis Procedure

INFOID:000000005649532

1.CHECK VOLTAGE BETWEEN IN-VEHICLE SENSOR AND GROUND

1. Disconnect in-vehicle sensor connector.
2. Turn ignition switch ON.
3. Check voltage between in-vehicle sensor harness connector and ground.

IN-VEHICLE SENSOR

< DTC/CIRCUIT DIAGNOSIS >

[AUTOMATIC AIR CONDITIONER]

(+)		(-)	Voltage (Approx.)
In-vehicle sensor		—	
Connector	Terminal		
M61	1	Ground	5 V

Is the inspection result normal?

YES >> GO TO 2.

NO >> GO TO 4.

2. CHECK CIRCUIT CONTINUITY BETWEEN IN-VEHICLE SENSOR AND UNIFIED METER AND A/C AMP.

1. Turn ignition switch OFF.
2. Disconnect unified meter and A/C amp. connector.
3. Check continuity between in-vehicle sensor harness connector and unified meter and A/C amp. harness connector.

In-vehicle sensor		Unified meter and A/C amp.		Continuity
Connector	Terminal	Connector	Terminal	
M61	2	M67	60	Existed

Is the inspection result normal?

YES >> GO TO 3.

NO >> Repair harness or connector.

3. CHECK IN-VEHICLE SENSOR

Check in-vehicle sensor. Refer to [HAC-91, "Component Inspection"](#).

Is the inspection result normal?

YES >> Replace unified meter and A/C amp.

NO >> Replace in-vehicle sensor.

4. CHECK CIRCUIT CONTINUITY BETWEEN IN-VEHICLE SENSOR AND UNIFIED METER AND A/C AMP.

1. Turn ignition switch OFF.
2. Disconnect unified meter and A/C amp. connector.
3. Check continuity between in-vehicle sensor harness connector and unified meter and A/C amp. harness connector.

In-vehicle sensor		Unified meter and A/C amp.		Continuity
Connector	Terminal	Connector	Terminal	
M61	1	M67	44	Existed

4. Check continuity between in-vehicle sensor harness connector and ground.

In-vehicle sensor		(-)	Continuity
Connector	Terminal		
M61	1	Ground	Not existed

Is the inspection result normal?

YES >> Replace unified meter and A/C amp.

NO >> Repair harness or connector.

Component Inspection

INFOID:000000005649533

1. CHECK IN-VEHICLE SENSOR

1. Turn ignition switch OFF.
2. Disconnect in-vehicle sensor connector. Refer to [HAC-144, "Exploded View"](#).
3. Check resistance between in-vehicle sensor terminals.

IN-VEHICLE SENSOR

< DTC/CIRCUIT DIAGNOSIS >

[AUTOMATIC AIR CONDITIONER]

Terminal		Condition	Resistance kΩ
		Temperature °C (°F)	
1	2	-15 (5)	12.73
		-10 (14)	9.92
		-5 (23)	7.80
		0 (32)	6.19
		5 (41)	4.95
		10 (50)	3.99
		15 (59)	3.24
		20 (68)	2.65
		25 (77)	2.19
		30 (86)	1.81
		35 (95)	1.51
		40 (104)	1.27
		45 (113)	1.07

Is the inspection result normal?

YES >> INSPECTION END

NO >> Replace in-vehicle sensor.

SUNLOAD SENSOR

< DTC/CIRCUIT DIAGNOSIS >

[AUTOMATIC AIR CONDITIONER]

SUNLOAD SENSOR

Description

INFOID:000000005649534

COMPONENT DESCRIPTION

Sunload Sensor

The sunload sensor (1) is located on the front defroster grille LH. It detects sunload entering through windshield by means of a photo diode. The sensor converts the sunload into a current value which is then input into the unified meter and A/C amp.

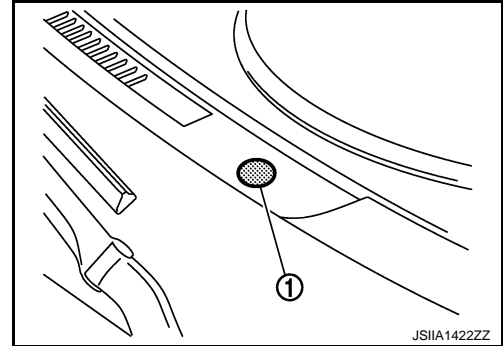

SUNLOAD INPUT PROCESS

The unified meter and A/C amp. also equips a processing circuit which averages the variations in detected sunload over a period of time. This prevents drastic swings in the air temperature control system operation due to small or quick variations in detected sunload.

For example, consider driving along a road bordered by an occasional group of large trees. The sunload detected by the sunload sensor varies whenever the trees obstruct the sunlight. The processing circuit averages the detected sunload over a period of time, so that the (insignificant) effect of the trees momentarily obstructing the sunlight does not cause any change in the air temperature control system operation. On the other hand, shortly after entering a long tunnel, the system recognizes the change in sunload, and the system reacts accordingly.

Component Function Check

INFOID:000000005649535

1.PERFORM SELF-DIAGNOSIS

Perform self-diagnosis function STEP-2. Refer to [HAC-58, "WITHOUT PLASMACLUSTER SYSTEM : Diagnosis Description"](#).

25 or -25 is displayed.

- YES >> Go to Diagnosis Procedure. Refer to [HAC-93, "Diagnosis Procedure"](#).
NO >> INSPECTION END

Diagnosis Procedure

INFOID:000000005649536

1.CHECK VOLTAGE BETWEEN SUNLOAD SENSOR AND GROUND

1. Disconnect sunload sensor connector.
2. Turn ignition switch ON.
3. Check voltage between sunload sensor harness connector and ground.

(+)		(-)	Voltage (Approx.)
Sunload sensor		—	
Connector	Terminal		
M46	1	Ground	5 V

Is the inspection result normal?

- YES >> GO TO 2.
NO >> GO TO 4.

2.CHECK CIRCUIT CONTINUITY BETWEEN SUNLOAD SENSOR AND UNIFIED METER AND A/C AMP.

1. Turn ignition switch OFF.
2. Disconnect unified meter and A/C amp. connector.

SUNLOAD SENSOR

[AUTOMATIC AIR CONDITIONER]

< DTC/CIRCUIT DIAGNOSIS >

3. Check continuity between sunload sensor harness connector and unified meter and A/C amp. harness connector.

Sunload sensor		Unified meter and A/C amp.		Continuity
Connector	Terminal	Connector	Terminal	
M46	2	M67	62	Existed

Is the inspection result normal?

YES >> GO TO 3.

NO >> Repair harness or connector.

3.CHECK SUNLOAD SENSOR

1. Reconnect sunload sensor connector and unified meter and A/C amp. connector.
2. Check sunload sensor. Refer to [HAC-94. "Component Inspection"](#).

Is the inspection result normal?

YES >> Replace unified meter and A/C amp.

NO >> Replace sunload sensor.

4.CHECK CIRCUIT CONTINUITY BETWEEN SUNLOAD SENSOR AND UNIFIED METER AND A/C AMP.

1. Turn ignition switch OFF.
2. Disconnect unified meter and A/C amp. connector.
3. Check continuity between sunload sensor harness connector and unified meter and A/C amp. harness connector.

Sunload sensor		Unified meter and A/C amp.		Continuity
Connector	Terminal	Connector	Terminal	
M46	1	M67	46	Existed

4. Check continuity between sunload sensor harness connector and ground.

Sunload sensor		—	Continuity
Connector	Terminal		
M46	1	Ground	Not existed

Is the inspection result normal?

YES >> Replace unified meter and A/C amp.

NO >> Repair harness or connector.

Component Inspection

INFOID:000000005649537

1.CHECK SUNLOAD SENSOR

1. Turn ignition switch ON.
2. Check voltage between unified meter and A/C amp. harness connector and ground.

(+)		(-)	
Unified meter and A/C amp.		—	
Connector	Terminal		
M67	46	Ground	

SUNLOAD SENSOR

< DTC/CIRCUIT DIAGNOSIS >

[AUTOMATIC AIR CONDITIONER]

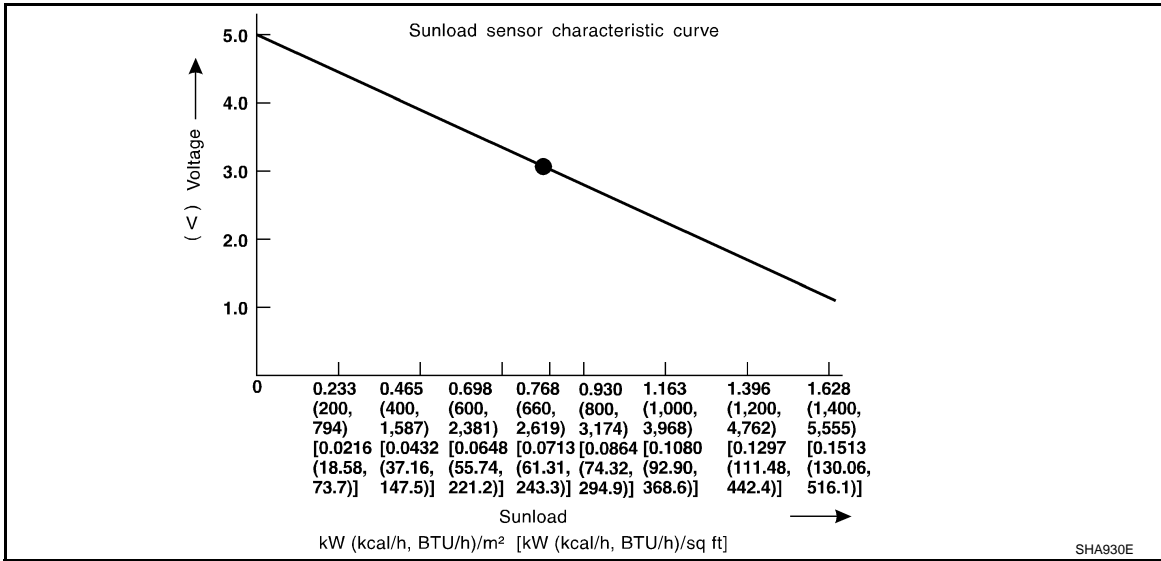

NOTE:

Select a place where sunshine directly on it when checking sunload sensor.

Is the inspection result normal?

- YES >> INSPECTION END
- NO >> Replace sunload sensor.

A
B
C
D
E
F
G
H
J
K
L
M
N
O
P

HAC

INTAKE SENSOR

Description

INFOID:000000005649538

COMPONENT DESCRIPTION

Intake Sensor

The intake sensor (1) is located on the evaporator. It converts air temperature after it passes through the evaporator (2) into a resistance value which is then input to the unified meter and A/C amp.

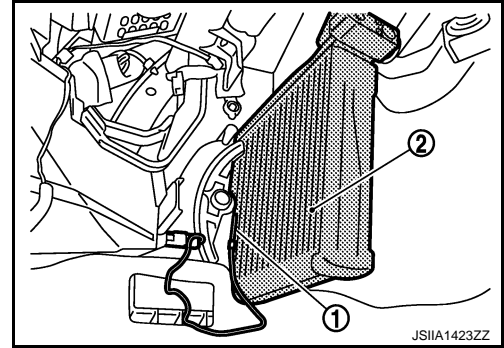

Component Function Check

INFOID:000000005649539

1.PERFORM SELF-DIAGNOSIS

Perform self-diagnosis function STEP-2. Refer to [HAC-58, "WITHOUT PLASMACLUSTER SYSTEM : Diagnosis Description"](#).

24 or -24 is displayed.

- YES >> Go to Diagnosis Procedure. Refer to [HAC-96, "Diagnosis Procedure"](#).
- NO >> INSPECTION END

Diagnosis Procedure

INFOID:000000005649540

1.CHECK VOLTAGE BETWEEN INTAKE SENSOR AND GROUND

1. Disconnect intake sensor connector.
2. Turn ignition switch ON.
3. Check voltage between intake sensor harness connector and ground.

(+)		(-)	Voltage (Approx.)
Intake sensor		—	
Connector	Terminal		
M77	1	Ground	5 V

Is the inspection result normal?

- YES >> GO TO 2.
- NO >> GO TO 4.

2.CHECK CIRCUIT CONTINUITY BETWEEN INTAKE SENSOR AND UNIFIED METER AND A/C AMP.

1. Turn ignition switch OFF.
2. Disconnect unified meter and A/C amp. connector.
3. Check continuity between intake sensor harness connector and unified meter and A/C amp. harness connector.

Intake sensor		Unified meter and A/C amp.		Continuity
Connector	Terminal	Connector	Terminal	
M77	2	M67	59	Existed

Is the inspection result normal?

- YES >> GO TO 3.
- NO >> Repair harness or connector.

INTAKE SENSOR

< DTC/CIRCUIT DIAGNOSIS >

[AUTOMATIC AIR CONDITIONER]

3.CHECK INTAKE SENSOR

Check intake sensor. Refer to [HAC-97. "Component Inspection"](#).

Is the inspection result normal?

YES >> Replace unified meter and A/C amp.

NO >> Replace intake sensor.

4.CHECK CIRCUIT CONTINUITY BETWEEN INTAKE SENSOR AND UNIFIED METER AND A/C AMP.

1. Turn ignition switch OFF.
2. Disconnect unified meter and A/C amp. connector.
3. Check continuity between intake sensor harness connector and unified meter and A/C amp. harness connector.

Intake sensor		Unified meter and A/C amp.		Continuity
Connector	Terminal	Connector	Terminal	
M77	1	M67	43	Existed

4. Check continuity between intake sensor harness connector and ground.

Intake sensor		—	Continuity
Connector	Terminal		
M77	1	Ground	Not existed

Is the inspection result normal?

YES >> Replace unified meter and A/C amp.

NO >> Repair harness or connector.

Component Inspection

INFOID:000000005649541

HAC

1.CHECK INTAKE SENSOR

1. Turn ignition switch OFF.
2. Disconnect intake sensor connector.
3. Check resistance between intake sensor terminals.

Terminal		Condition	Resistance kΩ
		Temperature °C (°F)	
1	2	-15 (5)	12.28
		-10 (14)	9.58
		-5 (23)	7.55
		0 (32)	6.00
		5 (41)	4.81
		10 (50)	3.88
		15 (59)	3.16
		20 (68)	2.59
		25 (77)	2.14
		30 (86)	1.77
		35 (95)	1.48
		40 (104)	1.24
45 (113)	1.05		

Is the inspection result normal?

YES >> INSPECTION END

NO >> Replace intake sensor.

GAS SENSOR

Description

INFOID:000000005874895

COMPONENT DESCRIPTION

Gas Sensor

The gas sensor (1) is attached on the radiator core support. It detects smell of exhaust gas and converts it into a duty ratio which is then input into the unified meter and A/C amp.

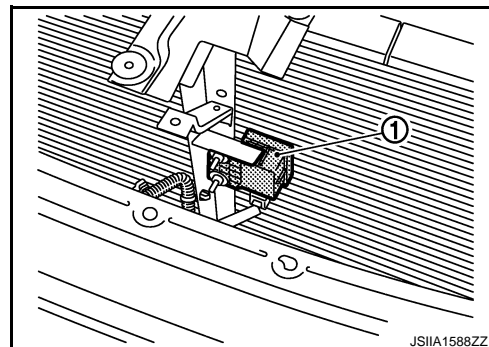

SMELL OF EXHAUST GAS INPUT PROCESS

Gas sensor detects ambient atmospheric CO and NO₂, and converts them to values of resistance. The values are converted to signals with the gas sensor internal circuit, then the unified meter and A/C amp. inputs the signals.

Gas sensor has a construction that detects CO and NO₂ by gas sensor element from the air intake of the case through a filter (waterproof sheet). It sends output signals to the unified meter and A/C amp. in response to a resistance value conversion by gas sensor elements. Output signals prevent a smell of exhaust gas from getting into vehicle by performing corrections according to various driving conditions.

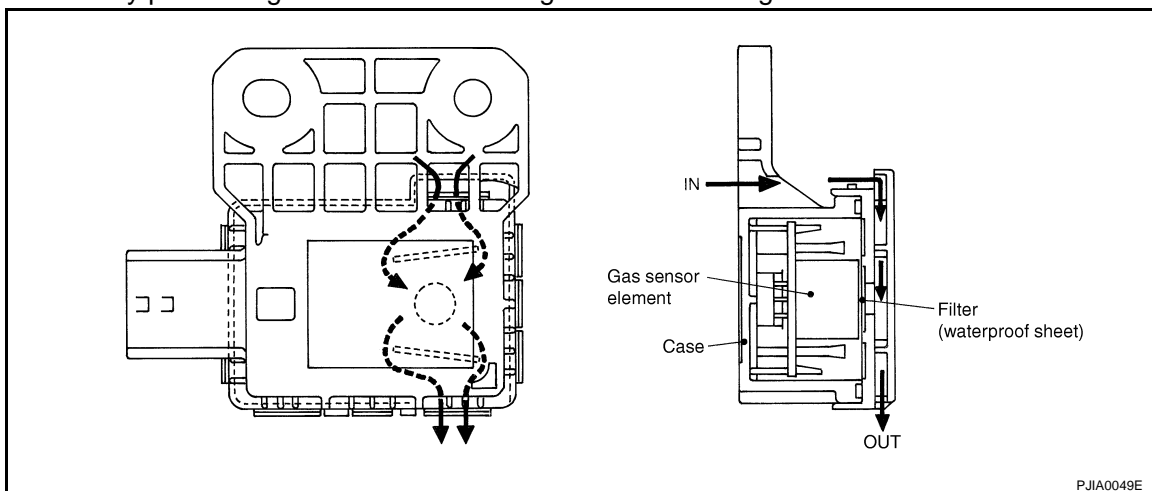

Component Function Check

INFOID:000000005874896

1. PERFORM SELF-DIAGNOSIS STEP-2

Perform self-diagnosis STEP-2. Refer to [HAC-63, "WITH PLASMACLUSTER SYSTEM : Diagnosis Description"](#), see Nos. 1 to 2.

28, -28, 29 or -29 is displayed.

YES >> Go to Diagnosis Procedure. Refer to [HAC-98, "Diagnosis Procedure"](#).

NO >> INSPECTION END

Diagnosis Procedure

INFOID:000000005874897

1. ADJUST GAS SENSOR SENSITIVITY

1. Turn ignition switch ON.
2. Adjust the gas sensor sensitivity. Refer to [HAC-15, "WITH PLASMACLUSTER SYSTEM : Gas Sensor Sensitivity Adjustment Function"](#).

GAS SENSOR

[AUTOMATIC AIR CONDITIONER]

< DTC/CIRCUIT DIAGNOSIS >

Are the symptoms solved?

YES >> INSPECTION END

NO >> GO TO 2.

2.CHECK POWER SUPPLY FOR GAS SENSOR

1. Turn ignition switch OFF.
2. Disconnect gas sensor connector.
3. Turn ignition switch ON.
4. Check voltage between gas sensor harness connector and ground.

(+)		(-)	Voltage
Gas sensor		—	
Connector	Terminal		
E75	1	Ground	Battery voltage

Is the inspection result normal?

YES >> GO TO 3.

NO >> Check power supply circuit and 10A fuse (No. 3, located in the fuse block). Refer to [PG-115](#), "[Fuse, Connector and Terminal Arrangement](#)".

- If fuse is OK, check harness for open circuit. Repair or replace if necessary.
- If fuse is NG, check harness for short circuit and replace fuse.

3.CHECK GROUND CIRCUIT FOR GAS SENSOR

1. Turn ignition switch OFF.
2. Check continuity between gas sensor harness connector and ground.

Gas sensor		—	Continuity
Connector	Terminal		
E75	2	Ground	Existed

Is the inspection result normal?

YES >> GO TO 4.

NO >> Repair harness or connector.

4.CHECK GAS SENSOR SIGNAL

1. Reconnect gas sensor connector.
2. Turn ignition switch ON.
3. Check signal between gas sensor harness connector and ground using an oscilloscope.

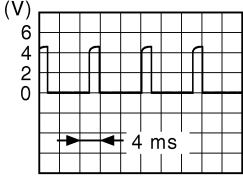
(+)		(-)	Voltage
Gas sensor		—	
Connector	Terminal		
E75	3	Ground	

NOTE:

The signal is different by measurement environment of a vehicle.

Is the inspection result normal?

YES >> GO TO 5.

NO >> Replace gas sensor.

5.CHECK CIRCUIT CONTINUITY BETWEEN UNIFIED METER AND A/C AMP. AND GAS SENSOR

GAS SENSOR

< DTC/CIRCUIT DIAGNOSIS >

[AUTOMATIC AIR CONDITIONER]

1. Turn ignition switch OFF.
2. Disconnect unified meter and A/C amp. connector.
3. Check continuity between unified meter and A/C amp. harness connector and gas sensor harness connector.

Gas sensor		Unified meter and A/C amp.		Continuity
Connector	Terminal	Connector	Terminal	
E75	3	M67	47	Existed

Is the inspection result normal?

- YES >> Replace unified meter and A/C amp.
NO >> Repair harnesses or connectors.

IONIZER

Description

INFOID:000000005874898

Ionizer generates an approximately equal proportional amount of positive and negative ions in the air.

Component Function Check

INFOID:000000005874899

1.CHECK IONIZER OPERATION SOUND

1. Turn ignition switch ON.
2. Press AUTO switch.
3. Ion indicator is shown on the display.
4. Check the ionizer operation sound (whirring sound) in the duct by putting an ear to the center ventilator grille (LH) outlet.

Is the inspection result normal?

- YES >> INSPECTION END
 NO >> Go to Diagnosis Procedure. Refer to [HAC-101, "Diagnosis Procedure"](#).

Diagnosis Procedure

INFOID:000000005874900

1.CHECK POWER SUPPLY FOR IONIZER

1. Turn ignition switch OFF.
2. Disconnect ionizer connector.
3. Turn ignition switch ON.
4. Press fan (UP:+) switch.
5. Check voltage between ionizer harness connector and ground.

(+)		(-)	Voltage
Ionizer		—	
Connector	Terminal		
M98	1	Ground	Battery voltage

Is the inspection result normal?

- YES >> GO TO 2.
 NO >> Check 10A fuse (No. 3, located in the fuse block). Refer to [PG-115, "Fuse, Connector and Terminal Arrangement"](#).
- If fuse is OK, check harness for open circuit. Repair or replace if necessary.
 - If fuse is NG, replace fuse and check for short circuit. Repair or replace if necessary.

2.CHECK CIRCUIT CONTINUITY BETWEEN IONIZER AND GROUND

1. Turn ignition switch OFF.
2. Check continuity between ionizer harness connector and ground.

Ionizer		—	Continuity
Connector	Terminal		
M98	3	Ground	Existed

Is the inspection result normal?

- YES >> GO TO 3.
 NO >> Repair harnesses or connectors.

3.CHECK ION ON/OFF SIGNAL

Check voltage between ionizer harness connector and ground.

A
B
C
D
E
F
G
H
J
K
L
M
N
O
P

HAC

IONIZER

< DTC/CIRCUIT DIAGNOSIS >

[AUTOMATIC AIR CONDITIONER]

(+)		(-)	Condition	Voltage
Ionizer				
Connector	Terminal			
M98	4	Ground	Blower motor: OFF	12 V
			Blower motor: ON	0 V

Is the inspection result normal?

- YES >> Replace ionizer.
NO >> GO TO 4.

4. CHECK CIRCUIT CONTINUITY BETWEEN UNIFIED METER AND A/C AMP. AND IONIZER

1. Turn ignition switch OFF.
2. Disconnect unified meter and A/C amp. connector.
3. Check continuity between unified meter and A/C amp. harness connector and ionizer harness connector.

Ionizer		Unified meter and A/C amp.		Continuity
Connector	Terminal	Connector	Terminal	
M98	4	M66	20	Existed

4. Check continuity between ionizer harness connector and ground.

Ionizer		—	Continuity
Connector	Terminal		
M98	4	Ground	Not existed

Is the inspection result normal?

- YES >> Replace unified meter and A/C amp.
NO >> Repair harnesses or connectors.

ECU DIAGNOSIS INFORMATION

ECM

Reference Value

INFOID:000000005900403

VALUES ON THE DIAGNOSIS TOOL

NOTE:

- Specification data are reference values.
- Specification data are output/input values which are detected or supplied by the ECM at the connector.
 - * Specification data may not be directly related to their components signals/values/operations.
 - i.e. Adjust ignition timing with a timing light before monitoring IGN TIMING, because the monitor may show the specification data in spite of the ignition timing not being adjusted to the specification data. This IGN TIMING monitors the data calculated by the ECM according to the signals input from the camshaft position sensor and other ignition timing related sensors.

CONSULT-III MONITOR ITEM

Monitor Item	Condition		Values/Status
ENG SPEED	• Run engine and compare CONSULT-III value with the tachometer indication.		Almost the same speed as the tachometer indication
MAS A/F SE-B1	See EC-144, "Description" .		
MAS A/F SE-B2	See EC-144, "Description" .		
B/FUEL SCHDL	See EC-144, "Description" .		
A/F ALPHA-B1	See EC-144, "Description" .		
A/F ALPHA-B2	See EC-144, "Description" .		
COOLAN TEMP/S	• Ignition switch: ON		Indicates engine coolant temperature
A/F SEN1 (B1)	• Engine: After warming up	Maintaining engine speed at 2,000 rpm	Fluctuates around 2.2 V
A/F SEN1 (B2)	• Engine: After warming up	Maintaining engine speed at 2,000 rpm	Fluctuates around 2.2 V
HO2S2 (B1)	<ul style="list-style-type: none"> • Revving engine from idle up to 3,000 rpm quickly after the following conditions are met. - Engine: After warming up - After keeping engine speed between 3,500 and 4,000 rpm for 1 minute and at idle for 1 minute under no load 		0 - 0.3 V ↔ Approx. 0.6 - 1.0 V
HO2S2 (B2)	<ul style="list-style-type: none"> • Revving engine from idle up to 3,000 rpm quickly after the following conditions are met. - Engine: After warming up - After keeping engine speed between 3,500 and 4,000 rpm for 1 minute and at idle for 1 minute under no load 		0 - 0.3 V ↔ Approx. 0.6 - 1.0 V
HO2S2 MNTR (B1)	<ul style="list-style-type: none"> • Revving engine from idle up to 3,000 rpm quickly after the following conditions are met. - Engine: After warming up - After keeping engine speed between 3,500 and 4,000 rpm for 1 minute and at idle for 1 minute under no load 		LEAN ↔ RICH
HO2S2 MNTR (B2)	<ul style="list-style-type: none"> • Revving engine from idle up to 3,000 rpm quickly after the following conditions are met. - Engine: After warming up - After keeping engine speed between 3,500 and 4,000 rpm for 1 minute and at idle for 1 minute under no load 		LEAN ↔ RICH
VHCL SPEED SE	• Turn drive wheels and compare CONSULT-III value with the speedometer indication.		Almost the same speed as speedometer indication
BATTERY VOLT	• Ignition switch: ON (Engine stopped)		11 - 14 V
ACCEL SEN 1	• Ignition switch: ON (Engine stopped)	Accelerator pedal: Fully released	0.45 - 1.00 V
		Accelerator pedal: Fully depressed	4.4 - 4.8 V
ACCEL SEN 2*1	• Ignition switch: ON (Engine stopped)	Accelerator pedal: Fully released	0.45 - 1.00 V
		Accelerator pedal: Fully depressed	4.3 - 4.8 V

ECM

< ECU DIAGNOSIS INFORMATION >

[AUTOMATIC AIR CONDITIONER]

Monitor Item	Condition		Values/Status
TP SEN 1-B1	<ul style="list-style-type: none"> Ignition switch: ON (Engine stopped) Selector lever: D (A/T) or 1st (M/T) 	Accelerator pedal: Fully released	More than 0.36 V
		Accelerator pedal: Fully depressed	Less than 4.75 V
TP SEN 2-B1*1	<ul style="list-style-type: none"> Ignition switch: ON (Engine stopped) Selector lever: D (A/T) or 1st (M/T) 	Accelerator pedal: Fully released	More than 0.36 V
		Accelerator pedal: Fully depressed	Less than 4.75 V
FUEL T/TMP SE	<ul style="list-style-type: none"> Ignition switch: ON 		Indicates fuel tank temperature
INT/A TEMP SE	<ul style="list-style-type: none"> Ignition switch: ON 		Indicates intake air temperature
EVAP SYS PRES	<ul style="list-style-type: none"> Ignition switch: ON 		Approx. 1.8 - 4.8 V
FUEL LEVEL SE	<ul style="list-style-type: none"> Ignition switch: ON 		Depending on fuel level of fuel tank
START SIGNAL	<ul style="list-style-type: none"> Ignition switch: ON → START → ON 		OFF → ON → OFF
CLSD THL POS	<ul style="list-style-type: none"> Ignition switch: ON (Engine stopped) 	Accelerator pedal: Fully released	ON
		Accelerator pedal: Slightly depressed	OFF
AIR COND SIG	<ul style="list-style-type: none"> Engine: After warming up, idle the engine 	Air conditioner switch: OFF	OFF
		Air conditioner switch: ON (Compressor operates.)	ON
P/N POSI SW	<ul style="list-style-type: none"> Ignition switch: ON 	Selector lever: P or N (A/T), Neutral (M/T)	ON
		Selector lever: Except above	OFF
PW/ST SIGNAL	<ul style="list-style-type: none"> Engine: After warming up, idle the engine 	Steering wheel: Not being turned	OFF
		Steering wheel: Being turned	ON
LOAD SIGNAL	<ul style="list-style-type: none"> Ignition switch: ON 	Rear window defogger switch: ON and/or Lighting switch: 2nd position	ON
		Rear window defogger switch and lighting switch: OFF	OFF
IGNITION SW	<ul style="list-style-type: none"> Ignition switch: ON → OFF → ON 		ON → OFF → ON
HEATER FAN SW	<ul style="list-style-type: none"> Engine: After warming up, idle the engine 	Heater fan switch: ON	ON
		Heater fan switch: OFF	OFF
BRAKE SW	<ul style="list-style-type: none"> Ignition switch: ON 	Brake pedal: Fully released	OFF
		Brake pedal: Slightly depressed	ON
INJ PULSE-B1	<ul style="list-style-type: none"> Engine: After warming up Selector lever: P or N (A/T), Neutral (M/T) Air conditioner switch: OFF No load 	Idle	2.0 - 3.0 msec
		2,000 rpm	1.9 - 2.9 msec
INJ PULSE-B2	<ul style="list-style-type: none"> Engine: After warming up Selector lever: P or N (A/T), Neutral (M/T) Air conditioner switch: OFF No load 	Idle	2.0 - 3.0 msec
		2,000 rpm	1.9 - 2.9 msec
IGN TIMING	<ul style="list-style-type: none"> Engine: After warming up Selector lever: P or N (A/T), Neutral (M/T) Air conditioner switch: OFF No load 	Idle	7° BTDC
		2,000 rpm	25° - 45° BTDC
CAL/LD VALUE	<ul style="list-style-type: none"> Engine: After warming up Selector lever: P or N (A/T), Neutral (M/T) Air conditioner switch: OFF No load 	Idle	5% - 35%
		2,500 rpm	5% - 35%

ECM

< ECU DIAGNOSIS INFORMATION >

[AUTOMATIC AIR CONDITIONER]

Monitor Item	Condition	Values/Status		
MASS AIRFLOW	• Engine: After warming up • Selector lever: P or N (A/T), Neutral (M/T) • Air conditioner switch: OFF • No load	Idle	2.0 - 6.0 g·m/s	A
		2,500 rpm	7.0 - 20.0 g·m/s	B
PURG VOL C/V	• Engine: After warming up • Selector lever: P or N (A/T), Neutral (M/T) • Air conditioner switch: OFF • No load	Idle (Accelerator pedal: Not depressed even slightly, after engine starting.)	0%	C
		2,000 rpm	—	
INT/V TIM (B1)	• Engine: After warming up • Selector lever: P or N (A/T), Neutral (M/T) • Air conditioner switch: OFF • No load	Idle	- 5 - 5°C	D
		2,000 rpm	Approx. 0 - 30°C	E
INT/V TIM (B2)	• Engine: After warming up • Selector lever: P or N (A/T), Neutral (M/T) • Air conditioner switch: OFF • No load	Idle	- 5 - 5°C	F
		2,000 rpm	Approx. 0 - 30°C	
INT/V SOL (B1)	• Engine: After warming up • Selector lever: P or N (A/T), Neutral (M/T) • Air conditioner switch: OFF • No load	Idle	0 - 2%	G
		2,000 rpm	Approx. 0 - 50%	H
INT/V SOL (B2)	• Engine: After warming up • Selector lever: P or N (A/T), Neutral (M/T) • Air conditioner switch: OFF • No load	Idle	0 - 2%	HAC
		2,000 rpm	Approx. 0 - 50%	
TP SEN 1-B2	• Ignition switch: ON (Engine stopped) • Selector lever: D (A/T) or 1st (M/T)	Accelerator pedal: Fully released	More than 0.36 V	J
		Accelerator pedal: Fully depressed	Less than 4.75 V	
TP SEN 2-B2*1	• Ignition switch: ON (Engine stopped) • Selector lever: D (A/T) or 1st (M/T)	Accelerator pedal: Fully released	More than 0.36 V	K
		Accelerator pedal: Fully depressed	Less than 4.75 V	
AIR COND RLY	• Engine: After warming up, idle the engine	Air conditioner switch: OFF	OFF	L
		Air conditioner switch: ON (Compressor operates)	ON	
FUEL PUMP RLY	• For 1 second after turning ignition switch: ON • Engine running or cranking		ON	M
	• Except above		OFF	
VENT CONT/V	• Ignition switch: ON		OFF	N
THRTL RELAY	• Ignition switch: ON		ON	
HO2S2 HTR (B1)	• Engine speed: Below 3,600 rpm after the following conditions are met. - Engine: After warming up - Keeping the engine speed between 3,500 and 4,000 rpm for 1 minute and at idle for 1 minute under no load		ON	O
	• Engine speed: Above 3,600 rpm		OFF	
HO2S2 HTR (B2)	• Engine speed: Below 3,600 rpm after the following conditions are met. - Engine: After warming up - Keeping the engine speed between 3,500 and 4,000 rpm for 1 minute and at idle for 1 minute under no load		ON	P
	• Engine speed: Above 3,600 rpm		OFF	
I/P PULLY SPD	• Vehicle speed: More than 20 km/h (12 MPH)		Almost the same speed as the tachometer indication	

ECM

< ECU DIAGNOSIS INFORMATION >

[AUTOMATIC AIR CONDITIONER]

Monitor Item	Condition		Values/Status
VEHICLE SPEED	• Turn drive wheels and compare CONSULT-III value with the speedometer indication.		Almost the same speed as the speedometer indication
IDL A/V LEARN	• Engine: Running	Idle air volume learning has not been performed yet.	YET
		Idle air volume learning has already been performed successfully.	CMPLT
SNOW MODE SW	• Ignition switch: ON	Snow mode switch: Pressed	ON
		Snow mode switch: Released	OFF
ENG OIL TEMP	• Engine: After warming up		More than 70°C (158°F)
TRVL AFTER MIL	• Ignition switch: ON	Vehicle has traveled after MIL has illuminated.	0 - 65,535 km (0 - 40,723 miles)
A/F S1 HTR (B1)	• Engine: After warming up, idle the engine (More than 140 seconds after starting engine)		4 - 100%
A/F S1 HTR (B2)	• Engine: After warming up, idle the engine (More than 140 seconds after starting engine)		4 - 100%
AC PRESS SEN	• Engine: Idle • Both A/C switch and blower fan switch: ON (Compressor operates)		1.0 - 4.0 V
VHCL SPEED SE	• Turn drive wheels and compare CONSULT-III value with the speedometer indication.		Almost the same speed as the speedometer indication
SET VHCL SPD	• Engine: Running	ASCD: Operating	The preset vehicle speed is displayed
MAIN SW	• Ignition switch: ON	MAIN switch: Pressed	ON
		MAIN switch: Released	OFF
CANCEL SW	• Ignition switch: ON	CANCEL switch: Pressed	ON
		CANCEL switch: Released	OFF
RESUME/ACC SW	• Ignition switch: ON	RESUME/ACCELERATE switch: Pressed	ON
		RESUME/ACCELERATE switch: Released	OFF
SET SW	• Ignition switch: ON	SET/COAST switch: Pressed	ON
		SET/COAST switch: Released	OFF
BRAKE SW1 (ICC/ASCD brake switch)	• Ignition switch: ON	Brake pedal: Fully released	ON
		Brake pedal: Slightly depressed	OFF
BRAKE SW2 (Stop lamp switch)	• Ignition switch: ON	Brake pedal: Fully released	OFF
		Brake pedal: Slightly depressed	ON
DIST SW	• Ignition switch: ON	DISTANCE switch: Pressed	ON
		DISTANCE switch: Released	OFF
CRUISE LAMP	• Ignition switch: ON	MAIN switch: Pressed at the 1st time → at the 2nd time	ON → OFF
BAT CUR SEN	<ul style="list-style-type: none"> • Engine speed: Idle • Battery: Fully charged*2 • Selector lever: P or N (A/T), Neutral (M/T) • Air conditioner switch: OFF • No load 		Approx. 2,600 - 3,500 mV
ALT DUTY	• Engine: Idle		0 - 80%
ATOM PRES SEN	• This item is displayed but is not applicable to this model.		
BRAKE BST PRES SE	• This item is displayed but is not applicable to this model.		

ECM

< ECU DIAGNOSIS INFORMATION >

[AUTOMATIC AIR CONDITIONER]

Monitor Item	Condition	Values/Status
VVEL POSITION SEN-B1	• Engine: After warming up • Selector lever: P or N (A/T), Neutral (M/T) • Air conditioner switch: OFF • No load	Idle Approx. 0.25 - 1.40 V
		When revving engine up to 2,000 rpm quickly Approx. 0.25 - 4.75 V
VVEL POSITION SEN-B2	• Engine: After warming up • Selector lever: P or N (A/T), Neutral (M/T) • Air conditioner switch: OFF • No load	Idle Approx. 0.25 - 1.40 V
		When revving engine up to 2,000 rpm quickly Approx. 0.25 - 4.75 V
VVEL TIM-B1	• Engine: After warming up • Selector lever: P or N (A/T), Neutral (M/T) • Air conditioner switch: OFF • No load	Idle Approx. 0 - 20 deg
		When revving engine up to 2,000 rpm quickly Approx. 0 - 90 deg
VVEL TIM-B2	• Engine: After warming up • Selector lever: P or N (A/T), Neutral (M/T) • Air conditioner switch: OFF • No load	Idle Approx. 0 - 20 deg
		When revving engine up to 2,000 rpm quickly Approx. 0 - 90 deg
VVEL LEARN	• Ignition switch: OFF → ON (After warming up)	VVEL learning has not been performed yet. YET
		VVEL learning has already been performed successfully. DONE
VVEL SEN LEARN-B1	• VVEL learning has already been performed successfully	Approx. 0.30 - 0.80 V
VVEL SEN LEARN-B2	• VVEL learning has already been performed successfully	Approx. 0.30 - 0.80 V
A/F ADJ-B1	• Engine: Running	-0.330 - 0.330
A/F ADJ-B2	• Engine: Running	-0.330 - 0.330
FAN DUTY	• Engine: Running	0 - 100%
ALT DUTY SIG	• Power generation voltage variable control: Operating	ON
	• Power generation voltage variable control: Not operating	OFF
EVAP LEAK DIAG	• Ignition switch: ON	Depending on condition of EVAP leak diagnosis
EVAP DIAG READY	• Ignition switch: ON (READY)	Depending on ready condition of EVAP leak diagnosis
HO2 S2 DIAG2 (B1)	• This item is displayed but is not applicable to this model.	
HO2 S2 DIAG2 (B2)	• This item is displayed but is not applicable to this model.	
A/F SEN1 DIAG2 (B1)	• This item is displayed but is not applicable to this model.	
A/F SEN1 DIAG2 (B2)	• This item is displayed but is not applicable to this model.	

*1: Accelerator pedal position sensor 2 signal and throttle position sensor 2 signal are converted by ECM internally. Thus, they differ from ECM terminals voltage signal.

*2: Before measuring the terminal voltage, confirm that the battery is fully charged. Refer to [PG-3, "How to Handle Battery"](#).

ECM

< ECU DIAGNOSIS INFORMATION >

[AUTOMATIC AIR CONDITIONER]

TERMINAL LAYOUT

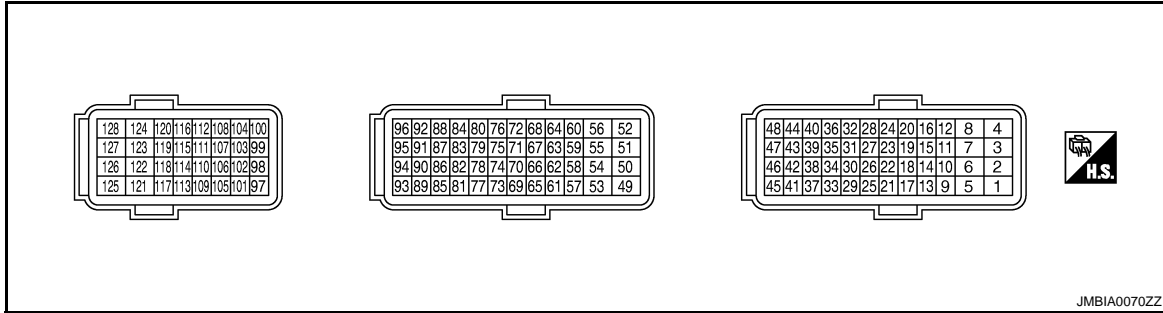

PHYSICAL VALUES

NOTE:

- ECM is located behind the instrument assist lower panel. For this inspection, remove passenger side instrument lower panel.
- Specification data are reference values and are measured between each terminal and ground.
- Pulse signal is measured by CONSULT-III.

Terminal No. (Wire color)		Description		Condition	Value (Approx.)
+	—	Signal name	Input/ Output		
1 (W)	128 (B)	A/F sensor 1 heater (bank 1)	Output	[Engine is running] <ul style="list-style-type: none"> • Warm-up condition • Idle speed (More than 140 seconds after starting engine) 	2.9 - 8.8 V★ JMBIA0030GB
2 (G)	128 (B)	Throttle control motor (Open) (bank 1)	Output	[Ignition switch: ON] <ul style="list-style-type: none"> • Engine stopped • Selector lever: D (A/T) or 1st (M/T) • Accelerator pedal: Fully depressed 	0 - 14 V★ JMBIA0031GB
				[Ignition switch: ON] <ul style="list-style-type: none"> • Engine stopped • Selector lever: D (A/T) or 1st (M/T) • Accelerator pedal: Fully released 	0 - 14 V★ JMBIA0032GB
3 (R)	128 (B)	Throttle control motor power supply (bank 1)	Input	[Ignition switch: ON]	BATTERY VOLTAGE (11 - 14 V)
4 (BR)	128 (B)	Throttle control motor (Close) (bank 1)	Output	[Ignition switch: ON] <ul style="list-style-type: none"> • Engine stopped • Selector lever: D (A/T) or 1st (M/T) • Accelerator pedal: In the middle of re- leasing operation 	0 - 14 V★ JMBIA0033GB

ECM

< ECU DIAGNOSIS INFORMATION >

[AUTOMATIC AIR CONDITIONER]

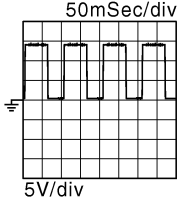
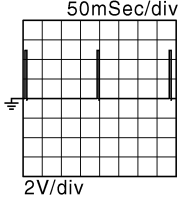
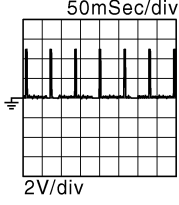
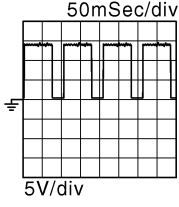
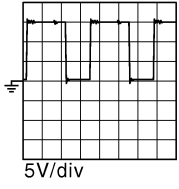
Terminal No. (Wire color)		Description		Condition	Value (Approx.)
+	--	Signal name	Input/ Output		
5 (W)	128 (B)	A/F sensor 1 heater (bank 2)	Output	[Engine is running] • Warm-up condition • Idle speed (More than 140 seconds after starting engine)	2.9 - 8.8 V★  50mSec/div 5V/div JMBIA0030GB
8 (B)	—	ECM ground	—	—	—
11 (GR)	128 (B)	Ignition signal No. 4	Output	[Engine is running] • Warm-up condition • Idle speed NOTE: The pulse cycle changes depending on rpm at idle	0 - 0.2 V★  50mSec/div 2V/div JMBIA0035GB
12 (L)		Ignition signal No. 3			
15 (V)		Ignition signal No. 5			
16 (G)		Ignition signal No. 2			
19 (SB)		Ignition signal No. 6			
20 (Y)	Ignition signal No. 1			[Engine is running] • Warm-up condition • Engine speed: 2,000 rpm	0.1 - 0.4 V★  50mSec/div 2V/div JMBIA0036GB
17 (P)	128 (B)	Heated oxygen sensor 2 heater (bank 1)	Output	[Engine is running] • Engine speed: Below 3,600 rpm after the following conditions are met - Engine: after warming up - Keeping the engine speed between 3,500 and 4,000 rpm for 1 minute and at idle for 1 minute under no load	10 V★  50mSec/div 5V/div JMBIA0037GB
				[Ignition switch: ON] • Engine stopped [Engine is running] • Engine speed: Above 3,600 rpm	BATTERY VOLTAGE (11 - 14 V)
18 (W)	128 (B)	Intake valve timing control solenoid valve (bank 1)	Output	[Engine is running] • Warm-up condition • Idle speed	BATTERY VOLTAGE (11 - 14 V)
				[Engine is running] • Warm-up condition • Engine speed: 2,000rpm	7 - 12 V★  5V/div JMBIA0038GB

A
B
C
D
E
F
G
H
HAC
J
K
L
M
N
O
P

ECM

< ECU DIAGNOSIS INFORMATION >

[AUTOMATIC AIR CONDITIONER]

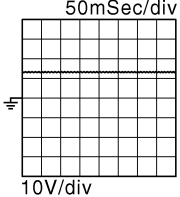
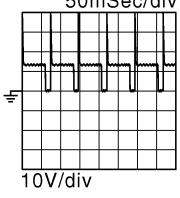
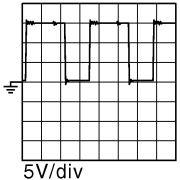
Terminal No. (Wire color)		Description		Condition	Value (Approx.)
+	-	Signal name	Input/ Output		
21 (GR)	128 (B)	EVAP canister purge volume control solenoid valve	Output	[Engine is running] • Idle speed • Accelerator pedal: Not depressed even slightly, after engine starting	BATTERY VOLTAGE (11 - 14 V)★ 
				[Engine is running] • Engine speed: About 2,000 rpm (More than 100 seconds after starting engine)	BATTERY VOLTAGE (11 - 14 V)★ 
22 (R)	128 (B)	Fuel pump relay	Output	[Ignition switch: ON] • For 1 second after turning ignition switch ON	0 - 1.5 V
				[Engine is running] • More than 1 second after turning ignition switch ON	BATTERY VOLTAGE (11 - 14 V)
24 (P)	128 (B)	ECM relay (Self shut-off)	Output	[Engine is running] [Ignition switch: OFF] • A few seconds after turning ignition switch OFF	0 - 1.5 V
				[Ignition switch: OFF] • More than a few seconds after turning ignition switch OFF	BATTERY VOLTAGE (11 - 14 V)
25 (O)	128 (B)	Throttle control motor relay	Output	[Ignition switch: ON → OFF]	0 - 1.0 V ↓ BATTERY VOLTAGE (11 - 14 V) ↓ 0 V
				[Ignition switch: ON]	0 - 1.0 V
28 (BR)	128 (B)	VVEL actuator motor relay abort signal [VVEL control module]	Output	[Engine is running] • Warm-up condition • Idle speed	0 V
29 (G)	128 (B)	Intake valve timing control solenoid valve (bank 2)	Output	[Engine is running] • Warm-up condition • Idle speed	BATTERY VOLTAGE (11 - 14 V)
				[Engine is running] • Warm-up condition • Engine speed: 2,000rpm	7 - 12 V★ 

ECM

< ECU DIAGNOSIS INFORMATION >

[AUTOMATIC AIR CONDITIONER]

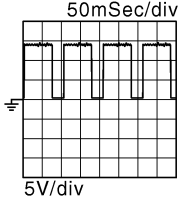
Terminal No. (Wire color)		Description		Condition	Value (Approx.)
+	--	Signal name	Input/ Output		
30 (Y)	40 (R)	Throttle position sensor 1 (bank 1)	Input	[Ignition switch: ON] • Engine stopped • Selector lever: D (A/T) or 1st (M/T) • Accelerator pedal: Fully released	More than 0.36 V
				[Ignition switch: ON] • Engine stopped • Selector lever: D (A/T) or 1st (M/T) • Accelerator pedal: Fully depressed	Less than 4.75 V
31 (R)	48 (B)	Throttle position sensor 1 (bank 2)	Input	[Ignition switch: ON] • Engine stopped • Selector lever: D (A/T) or 1st (M/T) • Accelerator pedal: Fully released	More than 0.36 V
				[Ignition switch: ON] • Engine stopped • Selector lever: D (A/T) or 1st (M/T) • Accelerator pedal: Fully depressed	Less than 4.75 V
33 (SB)	128 (B)	Heated oxygen sensor 2 heater (bank 2)	Output	[Engine is running] • Engine speed: Below 3,600 rpm after the following conditions are met - Engine: after warming up - Keeping the engine speed between 3,500 and 4,000 rpm for 1 minute and at idle for 1 minute under no load	10 V★ 
				[Ignition switch: ON] • Engine stopped [Engine is running] • Engine speed: Above 3,600 rpm	BATTERY VOLTAGE (11 - 14 V)
34 (B)	40 (R)	Throttle position sensor 2 (bank 1)	Input	[Ignition switch: ON] • Engine stopped • Selector lever: D (A/T) or 1st (M/T) • Accelerator pedal: Fully released	Less than 4.75 V
				[Ignition switch: ON] • Engine stopped • Selector lever: D (A/T) or 1st (M/T) • Accelerator pedal: Fully depressed	More than 0.36 V
35 (W)	48 (B)	Throttle position sensor 2 (bank 2)	Input	[Ignition switch: ON] • Engine stopped • Selector lever: D (A/T) or 1st (M/T) • Accelerator pedal: Fully released	Less than 4.75 V
				[Ignition switch: ON] • Engine stopped • Selector lever: D (A/T) or 1st (M/T) • Accelerator pedal: Fully depressed	More than 0.36 V
36 (O)	—	Sensor ground [Brake booster pressure sensor]	—	—	—

A
B
C
D
E
F
G
H
J
K
L
M
N
O
P

HAC

ECM

< ECU DIAGNOSIS INFORMATION >

[AUTOMATIC AIR CONDITIONER]

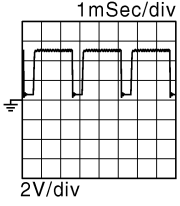
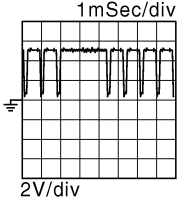
Terminal No. (Wire color)		Description		Condition	Value (Approx.)
+	-	Signal name	Input/ Output		
37 (W)	128 (B)	Crankshaft position sensor (POS)	Input	[Engine is running] • Warm-up condition • Idle speed NOTE: The pulse cycle changes depending on rpm at idle	4.0 - 5.0 V★  JMBIA0041GB
				[Engine is running] • Engine speed: 2,000 rpm	4.0 - 5.0 V★  JMBIA0042GB
38 (O)	96 (P)	Manifold absolute pressure (MAP) sensor	Input	[Engine is running] • Warm-up condition • Idle speed	1.2 V
				[Engine is running] • Warm-up condition • Engine speed: 2,000 rpm	1.5 V
39 (P)	36 (O)	Brake booster pressure sensor	Input	[Engine is running] • Warm-up condition • Idle speed • Brake pedal: Fully released	1.2 V
				[Engine is running] • Warm-up condition • Idle speed • Brake pedal: Fully depressed	3.0 V
40 (R)	—	Sensor ground [Throttle position sensor (bank 1)]	—	—	—
43 (G)	48 (B)	Sensor power supply [Throttle position sensor (bank 2)]	—	[Ignition switch: ON]	5 V
44 (L)	40 (R)	Sensor power supply [Throttle position sensor (bank 1)]	—	[Ignition switch: ON]	5 V
45 (LG)	36 (O)	Sensor power supply [Brake booster pressure sensor]	—	[Ignition switch: ON]	5 V
46 (R)	128 (B)	Sensor power supply [Crankshaft position sensor (POS)]	—	[Ignition switch: ON]	5 V
47 (Y)	—	Sensor ground [Crankshaft position sensor (POS)]	—	—	—
48 (B)	—	Sensor ground [Throttle position sensor (bank 2)]	—	—	—

ECM

< ECU DIAGNOSIS INFORMATION >

[AUTOMATIC AIR CONDITIONER]

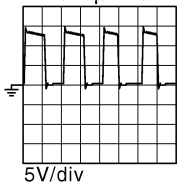
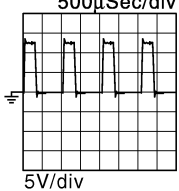
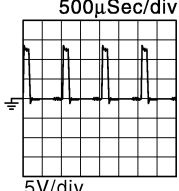
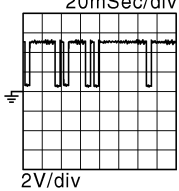
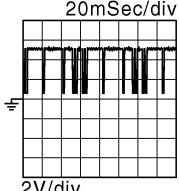
Terminal No. (Wire color)		Description		Condition	Value (Approx.)
+	--	Signal name	Input/ Output		
49 (GR)	128 (B)	Throttle control motor (Close) (bank 2)	Output	[Ignition switch: ON] • Engine stopped • Selector lever: D (A/T) or 1st (M/T) • Accelerator pedal: In the middle of re- leasing operation	0 - 14 V★  500µSec/div 5V/div JMBIA0033GB
50 (V)	128 (B)	Throttle control motor (Open) (bank 2)	Output	[Ignition switch: ON] • Engine stopped • Selector lever: D (A/T) or 1st (M/T) • Accelerator pedal: Fully depressed	0 - 14 V★  500µSec/div 5V/div JMBIA0031GB
				[Ignition switch: ON] • Engine stopped • Selector lever: D (A/T) or 1st (M/T) • Accelerator pedal: Fully released	0 - 14 V★  500µSec/div 5V/div JMBIA0032GB
52 (R)	128 (B)	Throttle control motor power supply (bank 2)	Input	[Ignition switch: ON]	BATTERY VOLTAGE (11 - 14 V)
53 (W)	128 (B)	Ignition switch	Input	[Ignition switch: OFF]	0 V
				[Ignition switch: ON]	BATTERY VOLTAGE (11 - 14 V)
54 (Y)	—	CAN communication line [VVEL control module]	Input/ output	—	—
55 (LG)	—	CAN communication line [VVEL control module]	Input/ output	—	—
57 (L)	128 (B)	A/F sensor 1 (bank 1)	Input	[Ignition switch: ON]	2.2 V
59 (O)	128 (B)	Camshaft position sen- sor (PHASE) (bank 1)	Input	[Engine is running] • Warm-up condition • Idle speed NOTE: The pulse cycle changes depending on rpm at idle	3.0 - 5.0 V★  20mSec/div 2V/div JMBIA0045GB
				[Engine is running] • Engine speed: 2,000 rpm	3.0 - 5.0 V★  20mSec/div 2V/div JMBIA0046GB

A
B
C
D
E
F
G
H
J
K
L
M
N
O
P

HAC

ECM

< ECU DIAGNOSIS INFORMATION >

[AUTOMATIC AIR CONDITIONER]

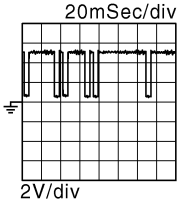
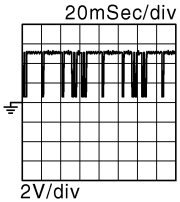
Terminal No. (Wire color)		Description		Condition	Value (Approx.)
+	--	Signal name	Input/ Output		
60 (G)	128 (B)	Sensor power supply [Camshaft position sensor (PHASE) (bank 1), Manifold absolute pressure (MAP) sensor, Power steering pressure sensor]	—	[Ignition switch: ON]	5 V
61 (R)	128 (B)	A/F sensor 1 (bank 1)	Input	[Engine is running] • Warm-up condition • Engine speed: 2,000 rpm	1.8 V Output voltage varies with air fuel ratio.
63 (L)	128 (B)	Camshaft position sensor (PHASE) (bank 2)	Input	[Engine is running] • Warm-up condition • Idle speed NOTE: The pulse cycle changes depending on rpm at idle	3.0 - 5.0 V★ 
				[Engine is running] • Engine speed: 2,000 rpm	3.0 - 5.0 V★ 
64 (SB)	128 (B)	Sensor power supply [Camshaft position sensor (PHASE) (bank 2), Battery current sensor]	—	[Ignition switch: ON]	5 V
65 (LG)	128 (B)	A/F sensor 1 (bank 2)	Input	[Ignition switch: ON]	2.2 V
66 (V)	128 (B)	A/F sensor 1 (bank 2)	Input	[Engine is running] • Warm-up condition • Engine speed: 2,000 rpm	1.8 V Output voltage varies with air fuel ratio.
67 (P)	128 (B)	Intake air temperature sensor	Input	[Engine is running]	0 - 4.8 V Output voltage varies with intake air temperature.
68 (LG)	—	Sensor ground [Mass air flow sensor (bank 1), Intake air temperature sensor]	—	—	—
69 (W)	128 (B)	Knock sensor (bank 2)	Input	[Engine is running] • Idle speed	2.5 V*1
71 (Y)	128 (B)	Engine coolant temperature sensor	Input	[Engine is running]	0 - 4.8 V Output voltage varies with engine coolant temperature.
72 (—)	—	Sensor ground (Knock sensor)	—	—	—
73 (W)	128 (B)	Knock sensor (bank 1)	Input	[Engine is running] • Idle speed	2.5 V*1

ECM

< ECU DIAGNOSIS INFORMATION >

[AUTOMATIC AIR CONDITIONER]

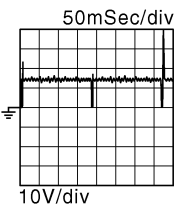
Terminal No. (Wire color)		Description		Condition	Value (Approx.)
+	--	Signal name	Input/ Output		
76 (W)	128 (B)	Heated oxygen sensor 2 (bank 1)	Input	[Engine is running] • Revving engine from idle to 3,000 rpm quickly after the following conditions are met - Engine: after warming up - Keeping the engine speed between 3,500 and 4,000 rpm for 1 minute and at idle for 1 minute under no load	0 - 1.0 V
77 (SB)	68 (LG)	Mass air flow sensor (bank 1)	Input	[Engine is running] • Warm-up condition • Idle speed	0.7 - 1.2 V
				[Engine is running] • Warm-up condition • Engine speed: 2,500 rpm	1.3 - 1.7 V
78 (G)	84 (B)	Engine oil temperature sensor	Input	[Engine is running]	0 - 4.8 V Output voltage varies with engine oil temperature.
79 (BR)	94 (Y)	Mass air flow sensor (bank 2)	Input	[Engine is running] • Warm-up condition • Idle speed	0.7 - 1.2 V
				[Engine is running] • Warm-up condition • Engine speed: 2,500 rpm	1.3 - 1.7 V
80 (O)	128 (B)	Heated oxygen sensor 2 (bank 2)	Input	[Engine is running] • Revving engine from idle to 3,000 rpm quickly after the following conditions are met - Engine: after warming up - Keeping the engine speed between 3,500 and 4,000 rpm for 1 minute and at idle for 1 minute under no load	0 - 1.0 V
81 (R)	128 (B)	Fuel injector No. 3	Output	[Engine is running] • Warm-up condition • Idle speed NOTE: The pulse cycle changes depending on rpm at idle	BATTERY VOLTAGE (11 - 14 V)★ 
82 (V)		Fuel injector No. 6			
85 (BR)		Fuel injector No. 2			
86 (W)		Fuel injector No. 5			
89 (GR)		Fuel injector No. 1			
90 (O)		Fuel injector No. 4			
84 (B)	--	Sensor ground (Heated oxygen sensor 2, Engine coolant temperature sensor, Engine oil temperature sensor)	--	--	--

A
B
C
D
E
F
G
H
HAC
J
K
L
M
N
O
P

ECM

< ECU DIAGNOSIS INFORMATION >

[AUTOMATIC AIR CONDITIONER]

Terminal No. (Wire color)		Description		Condition	Value (Approx.)
+	--	Signal name	Input/ Output		
87 (Y)	96 (P)	Power steering pressure sensor	Output	[Engine is running] • Steering wheel: Being turned	0.5 - 4.5 V
				[Engine is running] • Steering wheel: Not being turned	0.4 - 0.8 V
91 (SB)	95 (G)	Battery current sensor	Input	[Engine is running] • Battery: Fully charged*2 • Idle speed	2.6 - 3.5 V
92 (G)	—	Sensor ground [Camshaft position sensor (PHASE) (bank 2)]	—	—	—
93 (P)	128 (B)	Power supply for ECM (Back-up)	Input	[Ignition switch: OFF]	BATTERY VOLTAGE (11 - 14 V)
94 (Y)	—	Sensor ground [Mass air flow sensor (bank 2)]	—	—	—
95 (G)	—	Sensor ground (Battery current sensor)	—	—	—
96 (P)	—	Sensor ground [Camshaft position sensor (PHASE) (bank 1), Manifold absolute pressure (MAP) sensor, Power steering pressure sensor]	—	—	—
97 (R)	100 (W)	Accelerator pedal position sensor 1	Input	[Ignition switch: ON] • Engine stopped • Accelerator pedal: Fully released	0.45 - 1.00 V
				[Ignition switch: ON] • Engine stopped • Accelerator pedal: Fully depressed	4.2 - 4.8 V
98 (P)	104 (V)	Accelerator pedal position sensor 2	Input	[Ignition switch: ON] • Engine stopped • Accelerator pedal: Fully released	0.22 - 0.50 V
				[Ignition switch: ON] • Engine stopped • Accelerator pedal: Fully depressed	2.1 - 2.5 V
99 (L)	100 (W)	Sensor power supply (Accelerator pedal position sensor 1)	—	[Ignition switch: ON]	5 V
100 (W)	—	Sensor ground (Accelerator pedal position sensor 1)	—	—	—

ECM

< ECU DIAGNOSIS INFORMATION >

[AUTOMATIC AIR CONDITIONER]

Terminal No. (Wire color)		Description	Input/ Output	Condition	Value (Approx.)	
+	--	Signal name				
101 (SB)	108 (Y)	ICC steering switch (models with ICC system)	Input	[Ignition switch: ON] • ICC steering switch: OFF	4.3 V	A
				[Ignition switch: ON] • MAIN switch: Pressed	0 V	B
				[Ignition switch: ON] • CANCEL switch: Pressed	1.3 V	C
				[Ignition switch: ON] • RESUME/ACCELERATE switch: Pressed	3.7 V	D
				[Ignition switch: ON] • SET/COAST switch: Pressed	3 V	E
				[Ignition switch: ON] • DISTANCE switch: Pressed	2.2 V	F
101 (SB)	108 (Y)	ASCD steering switch (models with ASCD system)	Input	[Ignition switch: ON] • ASCD steering switch: OFF	4 V	G
				[Ignition switch: ON] • MAIN switch: Pressed	0 V	H
				[Ignition switch: ON] • CANCEL switch: Pressed	1 V	HAC
				[Ignition switch: ON] • RESUME/ACCELERATE switch: Pressed	3 V	
				[Ignition switch: ON] • SET/COAST switch: Pressed	2 V	
102 (W)	112 (L)	EVAP control system pressure sensor	Input	[Ignition switch: ON]	1.8 - 4.8 V	J
103 (GR)	104 (V)	Sensor power supply (Accelerator pedal position sensor 2)	—	[Ignition switch: ON]	5 V	K
104 (V)	—	Sensor ground (Accelerator pedal position sensor 2)	—	—	—	L
105 (L)	112 (L)	Refrigerant pressure sensor	Input	[Engine is running] • Warm-up condition • Both A/C switch and blower fan motor switch: ON (Compressor operates)	1.0 - 4.0 V	M
106 (W)	128 (B)	Fuel tank temperature sensor	Input	[Engine is running]	0 - 4.8 V Output voltage varies with fuel tank temperature.	N
107 (BG)	112 (L)	Sensor power supply (EVAP control system pressure sensor, Refrigerant pressure sensor)	—	[Ignition switch: ON]	5 V	O
108 (Y)	—	Sensor ground (ASCD/ICC steering switch)	—	—	—	P
109 (G)	128 (B)	PNP signal	Input	[Ignition switch: ON] • Selector lever: P or N (A/T), Neutral (M/ T)	BATTERY VOLTAGE (11 - 14 V)	
				[Ignition switch: ON] • Selector lever: Except above	0 V	

ECM

< ECU DIAGNOSIS INFORMATION >

[AUTOMATIC AIR CONDITIONER]

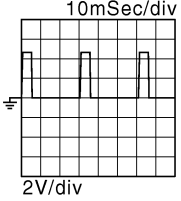
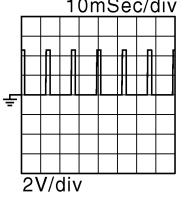
Terminal No. (Wire color)		Description		Condition	Value (Approx.)
+	-	Signal name	Input/ Output		
110 (R)	128 (B)	Engine speed output signal	Output	[Engine is running] • Warm-up condition • Idle speed NOTE: The pulse cycle changes depending on rpm at idle	1 V★  2V/div JMBIA0076GB
				[Engine is running] • Engine speed is 2,000 rpm	1 V★  2V/div JMBIA0077GB
112 (L)	—	Sensor ground (EVAP control system pressure sensor, Refrigerant pressure sensor)	—	—	—
113 (P)	—	CAN communication line	Input/ Output	—	—
114 (L)	—	CAN communication line	Input/ Output	—	—
117 (V)	128 (B)	Data link connector	Input/ Output	—	—
121 (LG)	128 (B)	EVAP canister vent control valve	Output	[Ignition switch: ON]	BATTERY VOLTAGE (11 - 14 V)
122 (P)	128 (B)	Stop lamp switch	Input	[Ignition switch: OFF] • Brake pedal: Fully released	0 V
				[Ignition switch: OFF] • Brake pedal: Slightly depressed	BATTERY VOLTAGE (11 - 14 V)
123 (B) 124 (B)	—	ECM ground	—	—	—
125 (R)	128 (B)	Power supply for ECM	Input	[Ignition switch: ON]	BATTERY VOLTAGE (11 - 14 V)
126 (BR)	128 (B)	ICC brake switch (models with ICC system) ASCDC brake switch (models with ASCDC system)	Input	[Ignition switch: ON] • Brake pedal: Slightly depressed	0 V
				[Ignition switch: ON] • Brake pedal: Fully released	BATTERY VOLTAGE (11 - 14 V)
127 (B) 128 (B)	—	ECM ground	—	—	—

★: Average voltage for pulse signal (Actual pulse signal can be confirmed by oscilloscope.)

*1: This may vary depending on internal resistance of the tester.

*2: Before measuring the terminal voltage, confirm that the battery is fully charged. Refer to [PG-3, "How to Handle Battery"](#).

UNIFIED METER AND A/C AMP.

< ECU DIAGNOSIS INFORMATION >

[AUTOMATIC AIR CONDITIONER]

UNIFIED METER AND A/C AMP.

Reference Value

INFOID:000000005649543

TERMINAL LAYOUT

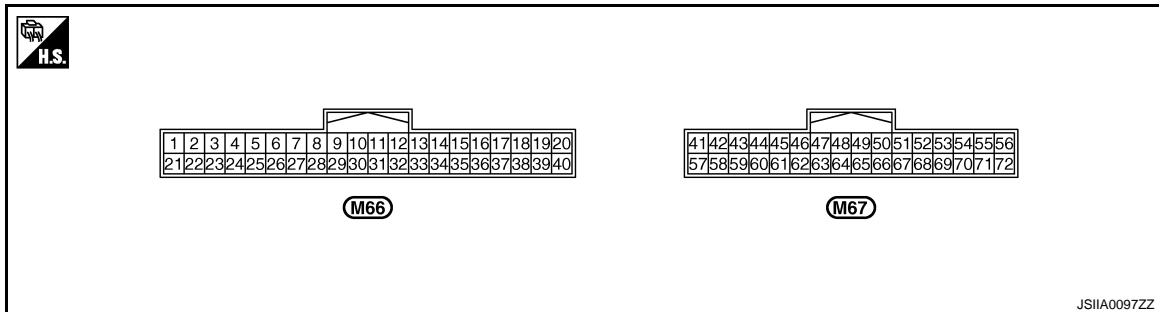

PHYSICAL VALUES

Terminal No. (Wire color)		Description		Condition	Value (Approx.)
+	-	Signal name	Input/ Output		
20*1 (G)	Ground	ION ON/OFF signal	Output	<ul style="list-style-type: none"> Ignition switch ON Blower motor: ON 	0V
				<ul style="list-style-type: none"> Ignition switch ON Blower motor: OFF 	12V
38 (P)	Ground	Blower motor control signal	Output	<ul style="list-style-type: none"> Ignition switch ON Fan speed: 1st speed (manual) 	
					JSIA0096ZZ
41 (L)	Ground	ACC power supply	—	Ignition switch ACC	Battery voltage
43 (V)	Ground	Intake sensor signal	Input	Ignition switch ON	0 – 4.8 V Output voltage varies with intake temperature.
44 (LG)	Ground	In-vehicle sensor signal	Input	Ignition switch ON	0 – 4.8 V Output voltage varies with intake temperature.
45 (V)	Ground	Ambient sensor signal	Input	Ignition switch ON	0 – 4.8 V Output voltage varies with intake temperature.
46 (GR)	Ground	Sunload sensor signal	Input	Ignition switch ON	0 – 4.8 V Output voltage varies with intake temperature.
47*1 (W)	Ground	Gas sensor signal	Input	Ignition switch ON NOTE: The signal is different by measurement environment of a vehicle.	
					ZJIA1163J

A
B
C
D
E
F
G
H
HAC
J
K
L
M
N
O
P

UNIFIED METER AND A/C AMP.

< ECU DIAGNOSIS INFORMATION >

[AUTOMATIC AIR CONDITIONER]

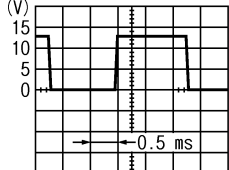
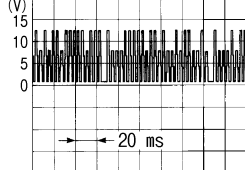
Terminal No. (Wire color)		Description		Condition	Value (Approx.)
+	-	Signal name	Input/ Output		
53 (G)	Ground	Ignition power supply	—	Ignition switch ON	Battery voltage
54 (Y)	Ground	Battery power supply	—	Ignition switch OFF	Battery voltage
55 (B)	Ground	Ground	—	Ignition switch ON	0 V
56 (L)	Ground	CAN-H	—	—	—
59 (Y)	Ground	Intake sensor ground	—	—	0 V
60 (W)	Ground	In-vehicle sensor ground	—	Ignition switch ON	0 V
61 (R)	Ground	Ambient sensor ground	—	Ignition switch ON	0 V
62 (SB)	Ground	Sunload sensor ground	—	Ignition switch ON	0 V
63*2 (L)	—	—	—	—	—
65 (BG)	Ground	ECV (Electrical Control Valve) signal	Output	<ul style="list-style-type: none"> Ignition switch ON Self-diagnosis. STEP-4 (Code No. 45) 	 <p style="text-align: right; font-size: small;">SJA1607E</p>
69 (P)	Ground	A/C LAN signal	Input/ Output	Ignition switch ON	 <p style="text-align: right; font-size: small;">SJA1453J</p>
70 (R)	Ground	Each door motor power supply	Output	Ignition switch ON	12 V
71 (GR)	Ground	Ground	—	Ignition switch ON	0 V
72 (P)	Ground	CAN-L	—	—	—

*1: With Plasmacluster system.

*2: Unified meter and A/C amp. is not used for control.

UNIFIED METER AND A/C AMP.

< ECU DIAGNOSIS INFORMATION >

[AUTOMATIC AIR CONDITIONER]

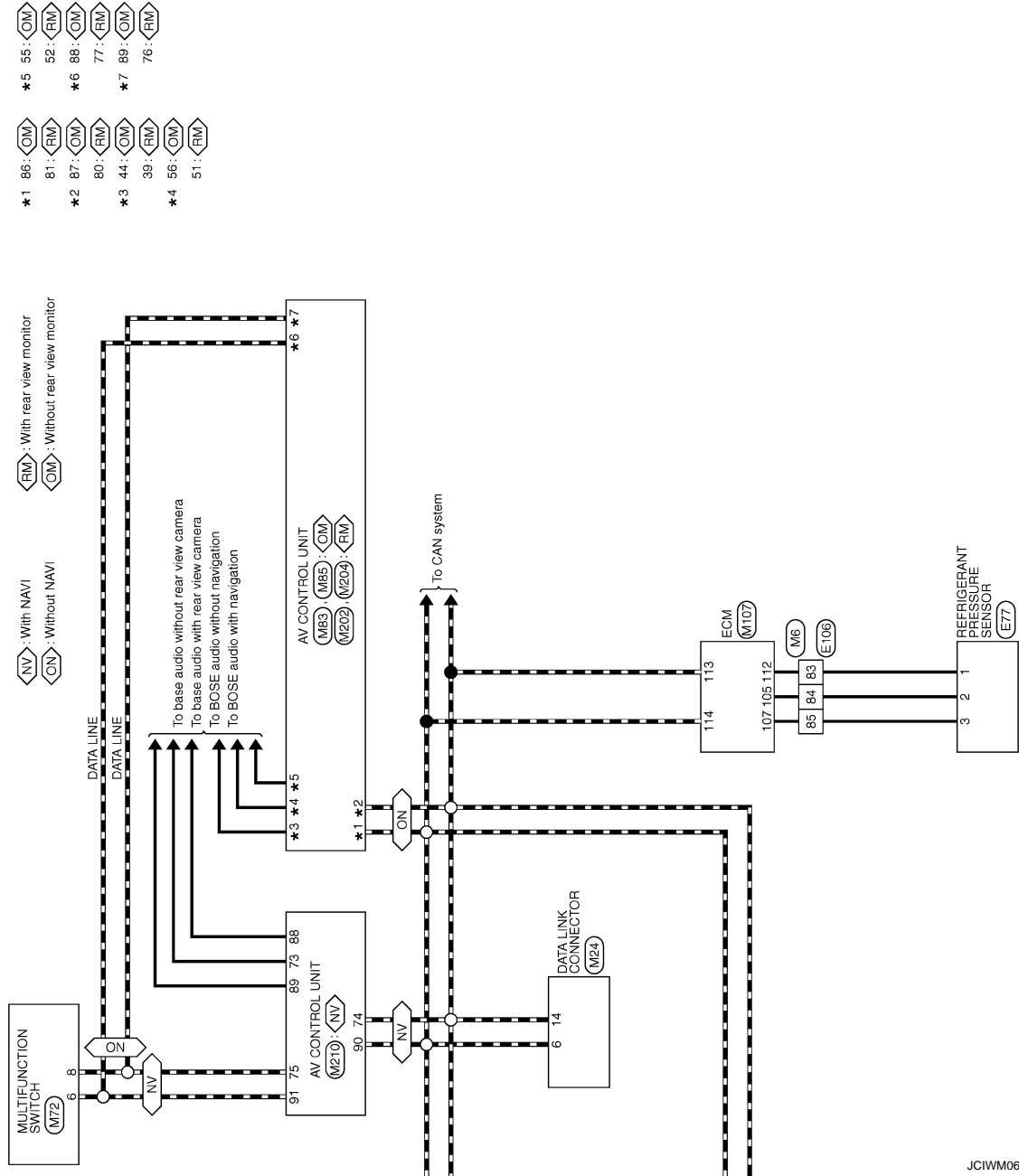

JCIWM0685GB

UNIFIED METER AND A/C AMP.

< ECU DIAGNOSIS INFORMATION >

[AUTOMATIC AIR CONDITIONER]

AIR CONDITIONER CONTROL

Connector No.	E3
Connector Name	WIRE TO WIRE
Connector Type	SA33MB-F32-SH2B

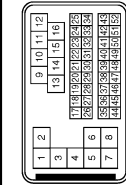

Terminal No.	Color of Wire	Signal Name [Specification]
1	L/Y	-
2	SHIELD	-
3	L/B	-
4	SHIELD	-
5	BR	-
7	G	-
8	W	-
9	W	-
10	Y	-
11	P	-
12	SB	-
13	BR	-
14	G	-
15	R	-
16	LG	-
17	P	-
18	Y	-
19	BG	-
20	B	-
21	SB	-
22	W	-
23	L	-
24	G	-
25	V	-
27	GR	-
28	V	-
29	P	-
30	R	-
31	BR	-
32	Y	-
33	G	-
34	BG	-
37	SHIELD	-
38	L	-
39	P	-
40	R	-
41	W	-
42	LG	-

43	G	-
45	BG	-
46	SHIELD	-
47	W	-
48	BR	-
49	G	-
50	B	-
51	SB	-
52	R	-

Connector No.	E5
Connector Name	SPM E/R INTELLIGENT POWER DISTRIBUTION MODULE (ENGINE ROOM)
Connector Type	TH20FW-CS12-M4-1V

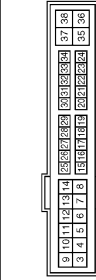

Terminal No.	Color of Wire	Signal Name [Specification]
4	V	-
5	L	-
7	R	-
11	BR	-
12	B/W	-
13	Y	-
16	LG	-
19	W	-
25	G	-
26	R	-
27	BG	-
28	L	-
29	GR	-
30	V	-
32	V	-
33	P	-
36	G	-

Connector No.	E6
Connector Name	SPM E/R INTELLIGENT POWER DISTRIBUTION MODULE (ENGINE ROOM)
Connector Type	TH20FW-MH

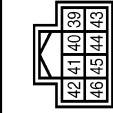

Terminal No.	Color of Wire	Signal Name [Specification]
39	P	-
40	L	-
41	B/W	-
42	Y	-
43	SB	-
44	LG	-
45	G	-
46	W	-

Connector No.	E7
Connector Name	SPM E/R INTELLIGENT POWER DISTRIBUTION MODULE (ENGINE ROOM)
Connector Type	TH20FW-CS12-M4

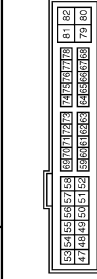

Terminal No.	Color of Wire	Signal Name [Specification]
48	BR	-
49	BG	-
51	Y	-
53	W	-
54	P	-
55	SB	-
56	LG	-
57	G	-
58	GR	-
69	BR	-
70	BG	-
73	P	-
74	G	-
75	SB	-

76	Y	-
77	R	-
80	W	-

Connector No.	E75
Connector Name	GAS SENSOR
Connector Type	RH03FB



Terminal No.	Color of Wire	Signal Name [Specification]
1	Y	POWER
2	B	GND
3	LG	GAS SENSOR SIGNAL

Connector No.	E76
Connector Name	AMBIENT SENSOR
Connector Type	RS02FB



Terminal No.	Color of Wire	Signal Name [Specification]
1	G	-
2	P	-

A
B
C
D
E
F
G
H
HAC
J
K
L
M
N
O
P

UNIFIED METER AND A/C AMP.

< ECU DIAGNOSIS INFORMATION >

[AUTOMATIC AIR CONDITIONER]

AIR CONDITIONER CONTROL

Connector No.	E77
Connector Name	REFRIGERANT PRESSURE SENSOR
Connector Type	RK03FB



Terminal No.	Color of Wire	Signal Name [Specification]
1	V	-
2	L	-
3	EG	-

Connector No.	E106
Connector Name	WIRE TO WIRE
Connector Type	THB0FW-C516-TM4

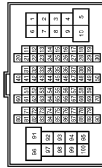

Terminal No.	Color of Wire	Signal Name [Specification]
1	GR	-
3	EG	-
5	G	-
6	EG	-
7	LG	-
10	W	-
11	V	-
12	R	-
13	L	-
14	GR	-
15	P	-
16	W	-
17	V	-
18	BG	-
19	GR	-
20	LG	-
30	R	-
31	L	-
32	EG	-

33	P	-
34	V	-
35	BR	-
36	W	-
37	Y	-
38	R	-
39	B	-
40	G	-
41	W	-
42	LG	-
43	SB	-
44	GR	-
45	BG	-
46	LG	-
47	V	-
48	P	-
49	L	-
59	B	-
66	LG	-
67	SB	-
68	R	-
69	W	-
70	G	-
80	W	-
81	P	-
82	G	-
83	V	-
84	L	-
85	BG	-
86	LG	-
87	Y	-
88	GR	-
89	W	-
91	G	-
93	GR	-
95	Y	-
96	Y	-
97	BR	-
98	SHIELD	-
99	L	-
100	P	-

Connector No.	F1
Connector Name	WIRE TO WIRE
Connector Type	SAA38FB-RS8-S1Z8

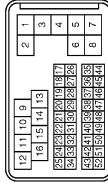

Terminal No.	Color of Wire	Signal Name [Specification]
1	L/Y	-
2	SHIELD	-
3	L/B	-
4	SHIELD	-
5	BR	-
7	G	-
8	W	-
9	W	-
10	G	-
11	R	-
12	P	-
13	L	-
14	LG	-
15	R	-
16	Y	-
17	W	-
18	LG	-
19	P	-
20	O	-
21	BR	-
22	G	-
23	Y	-
24	LG	-
25	V	-
26	GR	-
28	BR	-
29	L	-
30	R	-
31	P	-
32	W	-
33	SB	-
34	O	-
37	SHIELD	-
38	W	-
39	Y	-
40	B	-
41	G	-
42	GR	-

43	R	-
45	O	-
46	SHIELD	-
47	W/L	-
48	LG	-
49	O/L	-
50	L/Y	-
51	W	-
52	L/G	-

Connector No.	F43
Connector Name	COMPRESSOR
Connector Type	RS01FB



Terminal No.	Color of Wire	Signal Name [Specification]
1	L	-

Connector No.	F44
Connector Name	COMPRESSOR
Connector Type	RK02FGY



Terminal No.	Color of Wire	Signal Name [Specification]
2	Y	-
3	O	-

UNIFIED METER AND A/C AMP.

< ECU DIAGNOSIS INFORMATION >

[AUTOMATIC AIR CONDITIONER]

AIR CONDITIONER CONTROL

Connector No.	F103
Connector Name	WIRE TO WIRE
Connector Type	TK30FW-MS10

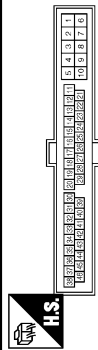

Terminal No.	Color of Wire	Signal Name [Specification]
1	G	
2	W	
3	R	
4	B	
5	Y	
6	GR	
7	O	
8	LG	
9	B	
10	GR	
11	O	
12	Y	
13	B	
14	P	
15	Y	
16	G	
17	O	
18	BR	
19	P	
20	Y	
21	B	
22	LG	
23	R	
24	R	
25	B	
26	B	
27	Y	
28	B	
29	LG	
30	R	
31	R	
32	B	
33	B	
34	B	
35	L	
36	P	
37	Y	
38	G	
39	G	
40	O	
41	O	
42	BR	
43	P	
44	L	
45	G	
46	V	

Connector No.	M1
Connector Name	FUSE BLOCK (J/B)
Connector Type	NS08FW-MZ

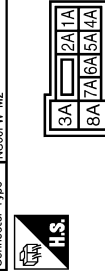

Terminal No.	Color of Wire	Signal Name [Specification]
1A	V	
2A	LG	
3A	L	
4A	SB	
5A	L	
6A	BR	
7A	R	
8A	L	

Connector No.	M3
Connector Name	FUSE BLOCK (J/B)
Connector Type	NS12FW-CS



Terminal No.	Color of Wire	Signal Name [Specification]
6C	V	
7C	B	
8C	W	
9C	BG	
10C	L	
11C	LG	
12C	GR	

Connector No.	M6
Connector Name	WIRE TO WIRE
Connector Type	TH80MW-CSI6-TM4

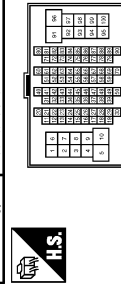

Terminal No.	Color of Wire	Signal Name [Specification]
1	BG	
3	R	
5	G	

95	Y	-
96	R	-
97	P	-
98	SHIELD	-
99	V	-
100	SB	-

Connector No.	M24
Connector Name	DATA LINK CONNECTOR
Connector Type	BD10FW-P

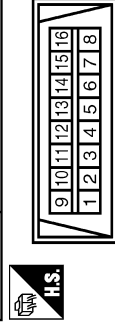

Terminal No.	Color of Wire	Signal Name [Specification]
3	LG	
4	B	
5	B	
6	L	
7	V	
8	LG	
11	SB	
14	P	
16	Y	

Connector No.	M46
Connector Name	SUNLOAD SENSOR
Connector Type	K02FB

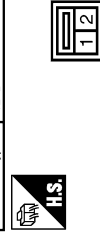

Terminal No.	Color of Wire	Signal Name [Specification]
1	GR	
2	SB	

6	L	-
7	W	-
10	W	-
11	V	-
12	R	-
13	L	-
14	GR	-
15	P	-
16	W	-
17	BR	-
18	BG	-
19	L	-
20	L	-
30	R	-
31	SB	-
32	Y	-
33	BG	-
34	R	-
35	BR	-
36	SB	-
37	Y	-
38	LG	-
39	SB	-
40	P	-
41	W	-
42	LG	-
43	R	-
44	Y	- [With A/T]
45	P	- [With M/T]
46	BG	-
47	G	-
48	V	-
49	L	-
50	B	-
66	GR	-
67	P	-
68	L	-
69	W	-
70	BR	-
80	L	-
81	R	-
82	V	-
83	W	-
84	L	-
85	BG	-
86	W	-
87	G	-
88	B	-
89	SB	-
91	L	-
93	Y	-

A
B
C
D
E
F
G
H
HAC
J
K
L
M
N
O
P

UNIFIED METER AND A/C AMP.

< ECU DIAGNOSIS INFORMATION >

[AUTOMATIC AIR CONDITIONER]

AIR CONDITIONER CONTROL

Connector No.	M61
Connector Name	IN-VEHICLE SENSOR
Connector Type	ACC2FW



Terminal No.	Color of Wire	Signal Name [Specification]
1	LG	-
2	W	-

Connector No.	M66
Connector Name	UNIFIED METER AND A/C AMP.
Connector Type	TH40FW-NH



Terminal No.	Color of Wire	Signal Name [Specification]
4	SB	STOP LAMP SWITCH
5	L	SHIFT UP
6	EG	PADDLE UP
7	GR	COMMUNICATION SIGNAL (AMP->METER)
8	L	VEHICLE SPEED (2-PULSE)
9	SB	SEAT BELT BUCKLE SWITCH (DRIVER SIDE)
10	W	MANUAL MODE
11	G	NON-MANUAL MODE
14	BR	COMMUNICATION SIGNAL (LGD->AMP)
20	G	ION ON / OFF SIGNAL
23	L	AT SNOW SW
25	V	SHIFT DOWN
26	G	PADDLE DOWN
27	LG	COMMUNICATION SIGNAL (METER->AMP)
28	G	VEHICLE SPEED (8-PULSE)
30	EG	PARKING BRAKE SWITCH
34	Y	COMMUNICATION SIGNAL (AMP->LCD)
36	P	BLOWER MOTOR CONTROL SIGNAL

Connector No.	M67
Connector Name	UNIFIED METER AND A/C AMP.
Connector Type	TH42FW-NH

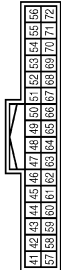

Terminal No.	Color of Wire	Signal Name [Specification]
41	L	ACC POWER SUPPLY
42	BR	FUEL LEVEL SENSOR SIGNAL
43	V	INTAKE SENSOR SIGNAL
44	LG	IN-VEHICLE SENSOR SIGNAL
45	V	AMBIENT SENSOR SIGNAL
46	GR	SUNLOAD SENSOR SIGNAL
47	W	GAS SENSOR SIGNAL
53	G	IGNITION POWER SUPPLY
54	Y	BATTERY POWER SUPPLY
55	B	GROUND
56	L	CAN-H
57	LG	BRAKE FLUID LEVEL SWITCH
58	P	FUEL LEVEL SENSOR GROUND
59	Y	INTAKE SENSOR GROUND
60	W	IN-VEHICLE SENSOR GROUND
61	R	AMBIENT SENSOR GROUND
62	SB	SUNLOAD SENSOR GROUND
63	L	ION CONTROL MODE OUTPUT SIGNAL
65	EG	ECV SIGNAL
69	P	A/C LAN SIGNAL
70	R	EACH DOOR MOTOR POWER SUPPLY
71	GR	GROUND
72	P	CAN-L

Connector No.	M72
Connector Name	MULTIFUNCTION SWITCH
Connector Type	TH16FW-NH

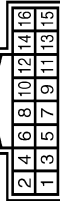

Terminal No.	Color of Wire	Signal Name [Specification]
1	B	GND
2	Y	ACC
4	EG	ILL
5	B	ILL CONT
6	SB	AV COMM (H)
8	LG	AV COMM (L)
9	BR	SW GND
14	LG	DISK EJECT SIGNAL
16	G	HAZARD ON

Connector No.	M77
Connector Name	INTAKE SENSOR
Connector Type	TK44FW



Terminal No.	Color of Wire	Signal Name [Specification]
1	V	-
2	Y	-

Connector No.	M83
Connector Name	AV CONTROL UNIT
Connector Type	TH24FW-NH

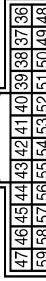

Terminal No.	Color of Wire	Signal Name [Specification]
36	SB	AUX IMAGE SIGNAL
37	V	AUX IMAGE GND
38	P	RGB (B/BLUE) SIGNAL
39	L	RGB (G/GREEN) SIGNAL
40	G	RGB (R/RED) SIGNAL
41	W	RGB SYNC
42	SHIELD	SHIELD

Terminal No.	Color of Wire	Signal Name [Specification]
43	B	RGB AREA (YS) SIGNAL
44	L	COMM (DISP->CONT)
45	R	HP
46	LC	SIGNAL GND
47	EG	SIGNAL VCC
48	BR	SHIELD
49	Y	SHIELD
50	SHIELD	SHIELD
55	B	SHIELD
56	LG	COMM (CONT->DISP)
57	G	VP
58	BR	INVERTER GND
59	Y	INVERTER VCC

Connector No.	M85
Connector Name	AV CONTROL UNIT
Connector Type	TH42FW-NH



Terminal No.	Color of Wire	Signal Name [Specification]
85	B	GND
86	L	CAN-H
87	P	CAN-L
88	SB	AV COMM (H)
89	LG	AV COMM (L)
90	SB	AV COMM (H)
91	LG	AV COMM (L)
95	R	AUX SOUND SIGNAL RH (+)
96	W	AUX SOUND SIGNAL LH (+)
97	B	AUX SOUND SIGNAL GND
101	BR	SW GND
103	LG	EJECT SIGNAL
104	R	IGNITION
105	EG	REVERSE
106	SB	PARKING BRAKE
107	GR	VEHICLE SPEED (8-PULSE)

UNIFIED METER AND A/C AMP.

< ECU DIAGNOSIS INFORMATION >

[AUTOMATIC AIR CONDITIONER]

AIR CONDITIONER CONTROL

Connector No.	M81
Connector Name	WIRE TO WIRE
Connector Type	AC3MW-P

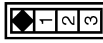

Terminal No.	Color of Wire	Signal Name [Specification]
1	R	-
2	B	-
3	P	-

Connector No.	M88
Connector Name	IONIZER
Connector Type	TH14FW-NH

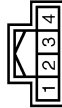

Terminal No.	Color of Wire	Signal Name [Specification]
1	V	IGN
2	L	ION MODE
3	B	GND
4	G	ION ON / OFF

Connector No.	M107
Connector Name	ECM
Connector Type	RH24FGY-R28-R-LH-Z



Terminal No.	Color of Wire	Signal Name [Specification]
87	R	APS 1
88	P	APS 2
89	L	AVCC-T-APS 1
100	W	GND-APS 1
101	SB	ASCDSW
102	W	FTRRS
103	GR	AVCC-P-APS 2
104	V	GND-APS 2
105	L	PDPRESS
106	W	TF
107	BG	AVCC-PDPRES
108	Y	GND ASCDSW
109	G	NEUT-H
110	R	TACHO
112	L	GND-PDPRES
113	P	VEHCAN-H
114	L	VEHCAN-HT
117	V	KLINE
121	LG	CDCV
122	P	BRAKE
123	B	GND
124	B	GND
125	R	VBR
126	BR	BNGSW
127	B	GND
128	B	GND

Connector No.	M109
Connector Name	BLOWER MOTOR
Connector Type	NS3QFW-M3

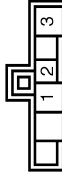

Terminal No.	Color of Wire	Signal Name [Specification]
1	L	-
2	P	-
3	B	-

Connector No.	M116
Connector Name	WIRE TO WIRE
Connector Type	TK38MW-NS10



Terminal No.	Color of Wire	Signal Name [Specification]
2	W	-
3	BG	-
4	P	-
5	B	-
9	R	-
10	R	-
19	BG	-
20	Y	-
28	B	-
29	LG	-
30	BR	-
31	W	-
33	B	-
34	B	-
35	L	-
36	P	-
37	V	-
38	SB	-
41	BG	-
42	G	-
43	P	-
44	L	-
45	Y	-
46	V	-

Connector No.	M202
Connector Name	AV CONTROL UNIT
Connector Type	TH24FW-NH

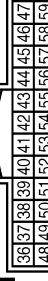

Terminal No.	Color of Wire	Signal Name [Specification]
36	BG	SIGNAL VCC
37	LG	SIGNAL GND
38	R	HP
39	L	COMM (DISP->CONT)
40	B	RGB AREA Y/SIGNAL
41	SHIELD	SHIELD
42	W	RGB SYNC
43	G	RGB (RED) SIGNAL
44	L	RGB (GREEN) SIGNAL
45	P	RGB (BLUE) SIGNAL
46	V	COMPOSITE IMAGE GND
47	SB	COMPOSITE IMAGE SIGNAL
48	Y	INVERTER VCC
49	BR	INVERTER GND
50	G	VP
51	LG	COMM (CONT->DISP)
52	B	SHIELD
57	SHIELD	SHIELD
58	SHIELD	SHIELD

Connector No.	M204
Connector Name	AV CONTROL UNIT
Connector Type	TH32FW-NH

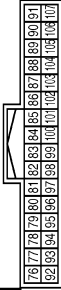

Terminal No.	Color of Wire	Signal Name [Specification]
76	LG	AV COMM (L)
77	SB	AV COMM (R)
78	LG	AV COMM (L)
79	SB	AV COMM (R)
80	P	CAN-L
81	L	CAN-H
82	BR	SW GND
86	SHIELD	SHIELD
87	L	TEL VOICE SIGNAL (-)
88	P	TEL VOICE SIGNAL (+)
92	GR	VEHICLE SPEED (8-PULSE)
93	SB	PARKING BRAKE REVERSE
94	BG	REVERSE
95	R	IGNITION
86	LG	DISK EJECT SIGNAL

A
B
C
D
E
F
G
H
I
J
K
L
M
N
O
P

HAC

UNIFIED METER AND A/C AMP.

< ECU DIAGNOSIS INFORMATION >

[AUTOMATIC AIR CONDITIONER]

AIR CONDITIONER CONTROL

Connector No.	M210
Connector Name	AV CONTROL UNIT
Connector Type	TH2FTV-IN1



61	62	63	64	65	66	67	68	69	70	71	72	73	74	75	76	77	78	79	80	81	82	83	84	85	86	87	88	89	90	91	92
----	----	----	----	----	----	----	----	----	----	----	----	----	----	----	----	----	----	----	----	----	----	----	----	----	----	----	----	----	----	----	----

Terminal No.	Color of Wire	Signal Name [Specification]
65	SB	PARKING BRAKE
67	Y	COMPOSITE IMAGE SIGNAL GND
68	BR	COMPOSITE IMAGE SIGNAL
71	SHIELD	MICROPHONE GND
72	G	MICROPHONE VCC
73	LG	COMM (CONT->DISP)
74	P	CAN-L
75	LG	AV COMM (L)
76	LG	AV COMM (L)
79	L	ILLUMINATION
80	R	IGNITION
81	BG	REVERSE
82	GR	VEHICLE SPEED (8-PULSE)
83	SHIELD	SHIELD
87	R	MICROPHONE SIGNAL
88	B	SHIELD
89	L	COMM (DISP->CONT)
90	L	CAN-H
91	SB	AV COMM (H)
92	SB	AV COMM (H)

Connector No.	M251
Connector Name	WIRE TO WIRE
Connector Type	A03FW



1	2	3
---	---	---

Terminal No.	Color of Wire	Signal Name [Specification]
1	L	
2	B	

3	L	
---	---	--

Connector No.	M252
Connector Name	AIR MIX DOOR MOTOR LH
Connector Type	A03FW



1	2	3
---	---	---

Terminal No.	Color of Wire	Signal Name [Specification]
1	L	
2	B	
3	L	

Connector No.	M253
Connector Name	MODE DOOR MOTOR
Connector Type	A03FW



1	2	3
---	---	---

Terminal No.	Color of Wire	Signal Name [Specification]
1	L	
2	B	
3	L	

Connector No.	M254
Connector Name	INTAKE DOOR MOTOR
Connector Type	A03FW



1	2	3
---	---	---

Terminal No.	Color of Wire	Signal Name [Specification]
1	L	
2	B	
3	L	

Connector No.	M255
Connector Name	AIR MIX DOOR MOTOR RH
Connector Type	A03FW



1	2	3
---	---	---

Terminal No.	Color of Wire	Signal Name [Specification]
1	L	
2	B	
3	L	

JCIWM0691 GB

INFOID:000000005649545

Fail-safe

FAIL-SAFE FUNCTION

- If a communication error exists between the unified meter and A/C amp., and the AV control unit and preset switch for 30 seconds or longer, air conditioner is controlled under the following conditions:

UNIFIED METER AND A/C AMP.

< ECU DIAGNOSIS INFORMATION >

[AUTOMATIC AIR CONDITIONER]

Compressor : ON
Air outlet : AUTO
Air inlet : FRE (Fresh)
Fan speed : AUTO
Set temperature : Setting before communication error occurs

A

B

C

D

E

F

G

H

HAC

J

K

L

M

N

O

P

AIR CONDITIONER CONTROL

< SYMPTOM DIAGNOSIS >

[AUTOMATIC AIR CONDITIONER]

SYMPTOM DIAGNOSIS

AIR CONDITIONER CONTROL

Diagnosis Chart By Symptom

INFOID:000000005649546

Symptom	Reference	
A/C system does not activate.	Go to Trouble Diagnosis Procedure for A/C System.	HAC-70, "Diagnosis Procedure"
A/C system cannot be controlled.	Go to Preset Switch System.	AV-82, "Symptom Table" (BASE AUDIO WITHOUT REAR VIEW CAMERA), AV-195, "Symptom Table" (BASE AUDIO WITH REAR VIEW CAMERA), AV-322, "Symptom Table" (BOSE AUDIO WITHOUT NAVIGATION) or AV-467, "Symptom Table" (BOSE AUDIO WITH NAVIGATION).
Air outlet does not change.	Go to Trouble Diagnosis Procedure for Mode Door Motor. (LAN)	HAC-71, "Diagnosis Procedure"
Mode door motor does not operate normally.		
Discharge air temperature does not change.* ¹	Go to Trouble Diagnosis Procedure for Air Mix Door Motor. (LAN)	HAC-73, "WITHOUT LEFT AND RIGHT VENTILATION TEMPERATURE SEPARATELY CONTROL SYSTEM : Diagnosis Procedure"
Air mix door motor does not operate normally.* ¹		
Discharge air temperature (driver side) does not change.* ²	Go to Trouble Diagnosis Procedure for Air Mix Door Motor (driver side). (LAN)	HAC-75, "WITH LEFT AND RIGHT VENTILATION TEMPERATURE SEPARATELY CONTROL SYSTEM : Diagnosis Procedure"
Air mix door motor (driver side) does not operate normally.* ²		
Discharge air temperature (passenger side) does not change.* ²	Go to Trouble Diagnosis Procedure for Air Mix Door Motor (passenger side). (LAN)	
Air mix door motor (passenger side) does not operate normally.* ²		
Intake door does not change.	Go to Trouble Diagnosis Procedure for Intake Door Motor. (LAN)	HAC-77, "Diagnosis Procedure"
Intake door motor does not operate normally.		
Blower motor operation is malfunctioning.	Go to Trouble Diagnosis Procedure for Blower Motor.	HAC-79, "Diagnosis Procedure"
Magnet clutch does not engage.	Go to Trouble Diagnosis Procedure for Magnet Clutch.	HAC-83, "Diagnosis Procedure"
Insufficient cooling	Go to Trouble Diagnosis Procedure for Insufficient Cooling.	HAC-131, "Inspection procedure"
No cool air comes out. (Air flow volume is normal.)		
Insufficient heating	Go to Trouble Diagnosis Procedure for Insufficient Heating.	HAC-133, "Inspection procedure"
No warm air comes out. (Air flow volume is normal.)		
Noise	Go to Trouble Diagnosis Procedure for Noise.	HAC-135, "Inspection procedure"
Self-diagnosis function cannot be performed normally.	Go to Trouble Diagnosis Procedure for Self-diagnosis.	HAC-137, "Inspection procedure"
Memory function does not operate normally.	Go to Trouble Diagnosis Procedure for Memory Function.	HAC-138, "Inspection procedure"
Plasmacluster system does not operate.	Go to Trouble Diagnosis Procedure for Plasmacluster system.	HAC-101, "Diagnosis Procedure"

*1: Without left and right ventilation temperature separately control system.

*2: With left and right ventilation temperature separately control system.

INSUFFICIENT COOLING

< SYMPTOM DIAGNOSIS >

[AUTOMATIC AIR CONDITIONER]

INSUFFICIENT COOLING

Description

INFOID:000000005649547

Symptom

- Insufficient cooling
- No cool air comes out. (Air flow volume is normal.)

Inspection procedure

INFOID:000000005649548

1. CHECK WITH A GAUGE OF RECOVERY/RECYCLING RECHARGING EQUIPMENT

Connect the recovery/recycling recharging equipment to the vehicle and perform the pressure inspection with the gauge.

Is there refrigerant?

- YES >> GO TO 2.
NO-1 >> Check for refrigerant leakages with the refrigerant leakage detecting fluorescent leak detector. Refer to [HA-35, "Inspection"](#).
NO-2 >> GO TO 2 after repairing or replacing the parts according to the inspection results.

2. CHECK CHARGED REFRIGERANT AMOUNT

1. Connect recovery/recycling recharging equipment to the vehicle and discharge the refrigerant. Refer to [HA-26, "Collection and Charge"](#).
2. Recharge with the proper amount of refrigerant. Refer to [HA-26, "Collection and Charge"](#).
3. Perform the inspection with the refrigerant leakage detecting fluorescent leak detector. Refer to [HA-35, "Inspection"](#).

Is the inspection result normal?

- YES >> GO TO 3.
NO >> Refill the refrigerant and repair or replace the parts according to the inspection results.

3. PERFORM THE PERFORMANCE TEST

Connect recovery/recycling recharging equipment to the vehicle and perform the performance test. Refer to [HA-33, "Performance Chart"](#).

Is the inspection result normal?

- YES >> GO TO 4.
NO >> Perform the diagnosis with the gauge pressure. Refer to [HA-7, "Trouble Diagnosis For Unusual Pressure"](#).

4. CHECK SETTING OF TEMPERATURE SETTING TRIMMER

Check the setting of temperature setting trimmer. Refer to [HAC-7, "WITHOUT PLASMA CLUSTER SYSTEM : Temperature Setting Trimmer"](#).

1. Check that the temperature setting trimmer is set to "+ direction".

NOTE:

The control temperature can be set with the setting of temperature setting trimmer.

2. Set temperature control dial to "0".

Are the symptoms solved?

- YES >> INSPECTION END
NO >> GO TO 5.

5. PERFORM SELF-DIAGNOSIS

Perform self-diagnosis function. Refer to [HAC-58, "WITHOUT PLASMA CLUSTER SYSTEM : Diagnosis Description"](#).

Is the inspection result normal?

- YES >> GO TO 6.
NO >> Repair or replace parts according to the inspection results.

6. CHECK DRIVE BELT

Check tension of the drive belt. Refer to [EM-13, "Checking"](#).

A

B

C

D

E

F

G

H

HAC

J

K

L

M

N

O

P

INSUFFICIENT COOLING

[AUTOMATIC AIR CONDITIONER]

< SYMPTOM DIAGNOSIS >

Is the inspection result normal?

YES >> GO TO 7.

NO >> Adjust or replace drive belt.

7.CHECK AIR LEAKAGE FROM DUCT

Check duct and nozzle, etc. of A/C system for air leakage.

Is the inspection result normal?

YES >> GO TO 8.

NO >> Repair or replace parts according to the inspection results.

8.CHECK ECV

Perform the ECV diagnosis procedure. Refer to [HAC-85, "Diagnosis Procedure"](#).

Is the inspection result normal?

YES >> Replace the unified meter and A/C amp.

NO >> Replace the compressor.

INSUFFICIENT HEATING

< SYMPTOM DIAGNOSIS >

[AUTOMATIC AIR CONDITIONER]

INSUFFICIENT HEATING

Description

INFOID:000000005649549

Symptom

- Insufficient heating
- No warm air comes out. (Air flow volume is normal.)

Inspection procedure

INFOID:000000005649550

1.CHECK COOLING SYSTEM

1. Check engine coolant level and check for leakage. Refer to [CO-7, "Inspection"](#).
2. Check radiator cap. Refer to [CO-11, "RADIATOR CAP : Inspection"](#).
3. Check water flow sounds of engine coolant. Refer to [CO-8, "Refilling"](#).

Is the inspection result normal?

YES >> GO TO 2.

NO >> Refill the engine coolant and repair or replace the parts according to the inspection results.

2.CHECK SETTING OF TEMPERATURE SETTING TRIMMER

1. Check the setting of temperature setting trimmer. Refer to [HAC-7, "WITHOUT PLASMACLUSTER SYSTEM : Temperature Setting Trimmer"](#).
2. Check that the temperature setting trimmer is set to "– direction".

NOTE:

The control temperature can be set with the setting of temperature setting trimmer.

3. Set temperature control dial to "0".

Are the symptoms solved?

YES >> INSPECTION END

NO >> GO TO 3.

3.CHECK OPERATION

1. Turn temperature dial (driver side) and raise temperature setting to 32°C (90°F) after warming up the engine.
2. Check that warm air blows from outlets.

Is the inspection result normal?

YES >> INSPECTION END

NO >> GO TO 4.

4.PERFORM SELF-DIAGNOSIS

Perform self-diagnosis function. Refer to [HAC-58, "WITHOUT PLASMACLUSTER SYSTEM : Diagnosis Description"](#).

Is the inspection result normal?

YES >> GO TO 5.

NO >> Repair or replace parts according to the inspection results.

5.CHECK AIR LEAKAGE FROM DUCT

Check duct and nozzle, etc. of A/C system for air leakage.

Is the inspection result normal?

YES >> GO TO 6.

NO >> Repair or replace parts according to the inspection results.

6.CHECK HEATER HOSE INSTALLATION CONDITION

Check the heater hose installation condition visually (for twist, crush, etc.).

Is the inspection result normal?

YES >> GO TO 7.

NO >> Repair or replace parts according to the inspection results.

7.CHECK TEMPERATURE OF HEATER HOSE

A

B

C

D

E

F

G

H

HAC

J

K

L

M

N

O

P

INSUFFICIENT HEATING

[AUTOMATIC AIR CONDITIONER]

< SYMPTOM DIAGNOSIS >

1. Check the temperature of inlet hose and outlet hose of heater core.
2. Check that the inlet side of heater core is hot and the outlet side is slightly lower than/almost equal to the inlet side.

CAUTION:

The temperature inspection should be performed in a short time because the engine coolant temperature is too hot.

Is the inspection result normal?

YES >> GO TO 8.

NO >> Replace the heater core after performing the procedures after the cooling system inspection again. GO TO 1.

8.REPLACE HEATER CORE

Replace the heater core. Refer to heater core. Refer to [HA-50, "Exploded View"](#).

Are the symptoms solved?

YES >> INSPECTION END

NO >> Perform the procedures after the cooling system inspection again. GO TO 1.

NOISE

Description

INFOID:000000005649551

Symptom

- Noise
- Noise is heard when the A/C system operates.

Inspection procedure

INFOID:000000005649552

1.CHECK OPERATION

1. Operate the A/C system and check the operation. Refer to [HAC-5, "WITHOUT PLASMACLUSTER SYSTEM : Description & Inspection"](#).
2. Check the parts where noise is occurring.

Can the parts where noise is occurring be checked?

- YES-1 >> Noise from blower motor: GO TO 2.
 YES-2 >> Noise from compressor: GO TO 3.
 YES-3 >> Noise from expansion valve: GO TO 4.
 YES-4 >> Noise from A/C piping (pipe, flexible hose): GO TO 6.
 YES-5 >> Noise from drive belt: GO TO 7.
 NO >> INSPECTION END

2.CHECK BLOWER MOTOR

1. Remove blower motor.
2. Remove in-cabin microfilter.
3. Remove foreign materials that are in the blower unit.
4. Check the noise from blower motor again.

Is the inspection result normal?

- YES >> INSPECTION END
 NO >> Replace blower motor.

3.REPLACE COMPRESSOR

1. Correct the refrigerant with recovery/recycling recharging equipment.
2. Recharge with the proper amount of the collected refrigerant after recycling or new refrigerant.
3. Check for the noise from compressor again.

Is the inspection result normal?

- YES >> INSPECTION END
 NO >> Replace compressor.

4.CHECK WITH GAUGE PRESSURE

Perform the diagnosis with the gauge pressure. Refer to [HA-7, "Trouble Diagnosis For Unusual Pressure"](#).

Is the inspection result normal?

- YES >> GO TO 5.
 NO >> Repair or replace malfunctioning part.

5.REPLACE EXPANSION VALVE

1. Correct the refrigerant with recovery/recycling recharging equipment.
2. Recharge with the proper amount of the collected refrigerant after recycling or new refrigerant.
3. Check for the noise from expansion valve again.

Are the symptoms solved?

- YES >> INSPECTION END
 NO >> Replace expansion valve.

6.CHECK A/C PIPING (PIPE, FLEXIBLE HOSE)

1. Check A/C piping (pipe, flexible hose) (for deformation and damage, etc.).
2. Check the installation condition of clips and brackets, etc. of A/C piping (pipe, flexible hose).

Is the inspection result normal?

NOISE

< SYMPTOM DIAGNOSIS >

[AUTOMATIC AIR CONDITIONER]

YES >> Fix the line with rubber or come vibration absorbing material.

NO >> Repair or replace parts according to the inspection results.

7.CHECK DRIVE BELT

Check tension of the drive belt. Refer to [EM-13. "Checking"](#).

Is the inspection result normal?

YES >> Check the noise from compressor: GO TO 3.

NO >> Adjust or replace drive belt according to the inspection results.

SELF-DIAGNOSIS CANNOT BE PERFORMED

< SYMPTOM DIAGNOSIS >

[AUTOMATIC AIR CONDITIONER]

SELF-DIAGNOSIS CANNOT BE PERFORMED

Description

INFOID:000000005649553

Symptom: Self-diagnosis function does not operate normally.

Inspection procedure

INFOID:000000005649554

1. CHECK SELF-DIAGNOSIS FUNCTION

1. Turn ignition switch ON.
2. Set in self-diagnosis mode as per the following. Within 10 seconds after starting engine (ignition switch is turned ON.), press OFF switch for at least 5 seconds.

NOTE:

- If battery voltage drops below 12 V during diagnosis STEP-3, door motor speed becomes slower and as a result, the system may generate an error even when operation is normal. Start engine before performing this diagnosis to avoid this.
- Former STEP-1 (indicators and display screen are checked) does not exist in this self-diagnosis function.
- OFF switch may not be recognized according to the timing of pressing it. Operate OFF switch after the intake switch indicators are turned ON.

Does self-diagnosis function operate?

YES >> INSPECTION END
NO >> GO TO 2.

2. CHECK POWER SUPPLY AND GROUND CIRCUIT OF UNIFIED METER AND A/C AMP.

Check power supply and ground circuit of unified meter and A/C amp. Refer to [HAC-69. "UNIFIED METER AND A/C AMP. : Diagnosis Procedure"](#).

Is the inspection result normal?

YES >> Replace unified meter and A/C amp.
NO >> Repair or replace malfunctioning part.

A
B
C
D
E
F
G
H
J
K
L
M
N
O
P

HAC

MEMORY FUNCTION DOES NOT OPERATE

< SYMPTOM DIAGNOSIS >

[AUTOMATIC AIR CONDITIONER]

MEMORY FUNCTION DOES NOT OPERATE

Description

INFOID:000000005649555

Symptom

- Memory function does not operate normally.
- The setting is not maintained. (It returns to the initial condition.)

Inspection procedure

INFOID:000000005649556

1.CHECK OPERATION

1. Set temperature control dial to 32°C (90°F).
2. Press OFF switch.
3. Turn ignition switch OFF.
4. Turn ignition switch ON.
5. Press AUTO switch.
6. Check that the set temperature is maintained.

Is the inspection result normal?

- YES >> INSPECTION END
NO >> GO TO 2.

2.CHECK POWER SUPPLY AND GROUND CIRCUIT OF UNIFIED METER AND A/C AMP

Check power supply and ground circuit of unified meter and A/C amp. Refer to [HAC-69. "UNIFIED METER AND A/C AMP. : Diagnosis Procedure"](#).

Is the inspection result normal?

- YES >> Replace unified meter and A/C amp.
NO >> Repair or replace malfunctioning part.

PRECAUTION

PRECAUTIONS

Precaution for Supplemental Restraint System (SRS) "AIR BAG" and "SEAT BELT PRE-TENSIONER"

INFOID:000000005886049

The Supplemental Restraint System such as "AIR BAG" and "SEAT BELT PRE-TENSIONER", used along with a front seat belt, helps to reduce the risk or severity of injury to the driver and front passenger for certain types of collision. This system includes seat belt switch inputs and dual stage front air bag modules. The SRS system uses the seat belt switches to determine the front air bag deployment, and may only deploy one front air bag, depending on the severity of a collision and whether the front occupants are belted or unbelted. Information necessary to service the system safely is included in the "SRS AIR BAG" and "SEAT BELT" of this Service Manual.

WARNING:

- To avoid rendering the SRS inoperative, which could increase the risk of personal injury or death in the event of a collision which would result in air bag inflation, all maintenance must be performed by an authorized NISSAN/INFINITI dealer.
- Improper maintenance, including incorrect removal and installation of the SRS, can lead to personal injury caused by unintentional activation of the system. For removal of Spiral Cable and Air Bag Module, see the "SRS AIR BAG".
- Do not use electrical test equipment on any circuit related to the SRS unless instructed to in this Service Manual. SRS wiring harnesses can be identified by yellow and/or orange harnesses or harness connectors.

PRECAUTIONS WHEN USING POWER TOOLS (AIR OR ELECTRIC) AND HAMMERS

WARNING:

- When working near the Air Bag Diagnosis Sensor Unit or other Air Bag System sensors with the ignition ON or engine running, DO NOT use air or electric power tools or strike near the sensor(s) with a hammer. Heavy vibration could activate the sensor(s) and deploy the air bag(s), possibly causing serious injury.
- When using air or electric power tools or hammers, always switch the ignition OFF, disconnect the battery, and wait at least 3 minutes before performing any service.

Precaution Necessary for Steering Wheel Rotation after Battery Disconnect

INFOID:000000005649558

NOTE:

- Before removing and installing any control units, first turn the push-button ignition switch to the LOCK position, then disconnect both battery cables.
- After finishing work, confirm that all control unit connectors are connected properly, then re-connect both battery cables.
- Always use CONSULT-III to perform self-diagnosis as a part of each function inspection after finishing work. If a DTC is detected, perform trouble diagnosis according to self-diagnosis results.

For vehicle with steering lock unit, if the battery is disconnected or discharged, the steering wheel will lock and cannot be turned.

If turning the steering wheel is required with the battery disconnected or discharged, follow the operation procedure below before starting the repair operation.

OPERATION PROCEDURE

1. Connect both battery cables.
 - NOTE:**
Supply power using jumper cables if battery is discharged.
2. Turn the push-button ignition switch to ACC position.
(At this time, the steering lock will be released.)
3. Disconnect both battery cables. The steering lock will remain released with both battery cables disconnected and the steering wheel can be turned.
4. Perform the necessary repair operation.

A
B
C
D
E
F
G
H
HAC
J
K
L
M
N
O
P

PRECAUTIONS

< PRECAUTION >

[AUTOMATIC AIR CONDITIONER]

5. When the repair work is completed, re-connect both battery cables. With the brake pedal released, turn the push-button ignition switch from ACC position to ON position, then to LOCK position. (The steering wheel will lock when the push-button ignition switch is turned to LOCK position.)
6. Perform self-diagnosis check of all control units using CONSULT-III.

Precaution for Battery Service

INFOID:000000005649559

Before disconnecting the battery, lower both the driver and passenger windows. This will prevent any interference between the window edge and the vehicle when the door is opened/closed. During normal operation, the window slightly raises and lowers automatically to prevent any window to vehicle interference. The automatic window function will not work with the battery disconnected.

PRESET SWITCH

< REMOVAL AND INSTALLATION >

[AUTOMATIC AIR CONDITIONER]

REMOVAL AND INSTALLATION

PRESET SWITCH

Exploded View

INFOID:000000005649560

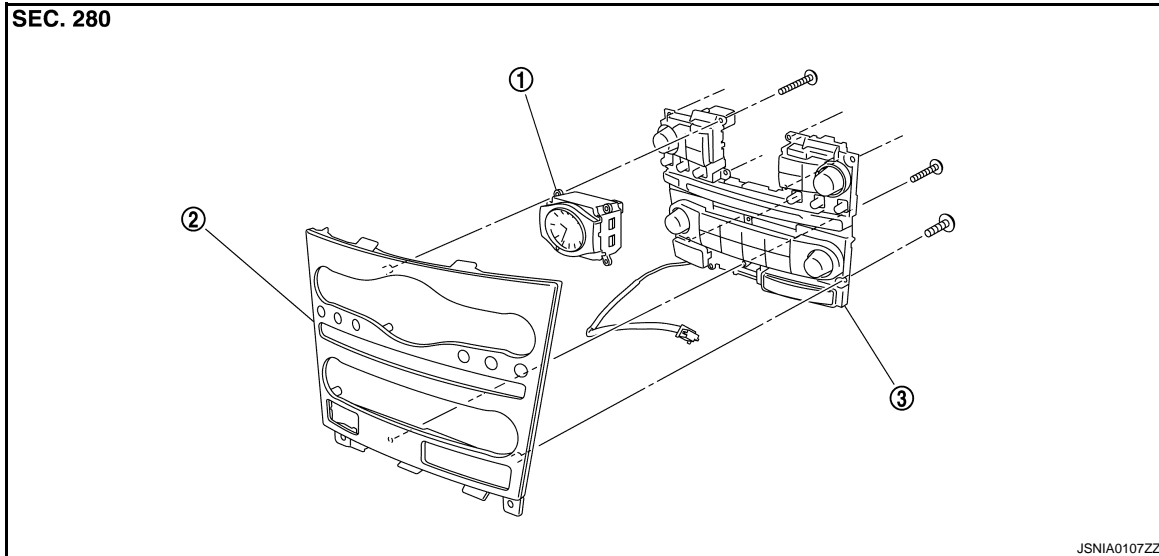

1. Clock

2. Cluster lid C

3. Preset switch

Removal and Installation

INFOID:000000005649561

HAC

REMOVAL

Refer to [AV-98. "Exploded View"](#) (BASE AUDIO WITHOUT REAR VIEW CAMERA), [AV-210. "Exploded View"](#) (BASE WITH REAR VIEW CAMERA), [AV-342. "Exploded View"](#) (BOSE AUDIO WITHOUT NAVIGATION) or [AV-490. "Exploded View"](#) (BOSE AUDIO WITH NAVIGATION).

INSTALLATION

Installation is basically the reverse order of removal.

UNIFIED METER AND A/C AMP.

< REMOVAL AND INSTALLATION >

[AUTOMATIC AIR CONDITIONER]

UNIFIED METER AND A/C AMP.

Exploded View

INFOID:000000005649562

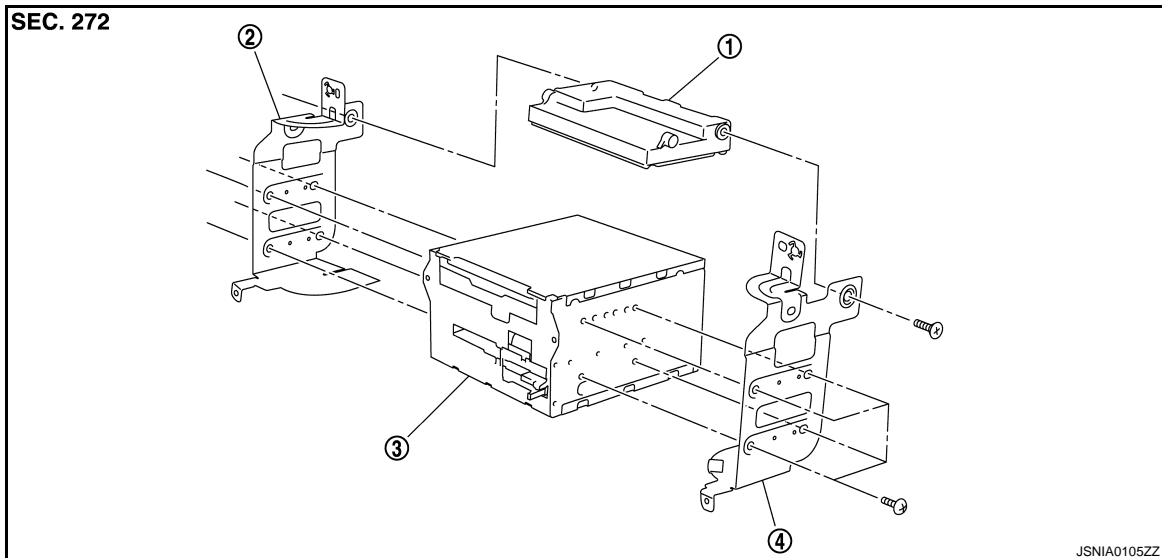

1. Unified meter and A/C amp.
2. Bracket (LH)
3. Audio unit
4. Bracket (RH)

Removal and Installation

INFOID:000000005649563

REMOVAL

1. Remove audio unit. Refer to [AV-89, "Exploded View"](#) (BASE AUDIO WITHOUT REAR VIEW CAMERA), [AV-201, "Exploded View"](#) (BASE AUDIO WITH REAR VIEW CAMERA), [AV-328, "Exploded View"](#) (BOSE AUDIO WITHOUT NAVIGATION) or [AV-477, "Exploded View"](#) (BOSE AUDIO WITH NAVIGATION).
2. Remove mounting screws, and then remove unified meter and A/C amp.

INSTALLATION

Installation is basically the reverse order of removal.

CAUTION:

Since unified meter and A/C amp. connector and AV control unit connector have the same form, be careful not to insert them wrongly.

AMBIENT SENSOR

< REMOVAL AND INSTALLATION >

[AUTOMATIC AIR CONDITIONER]

AMBIENT SENSOR

Exploded View

INFOID:000000005649564

1. Ambient sensor

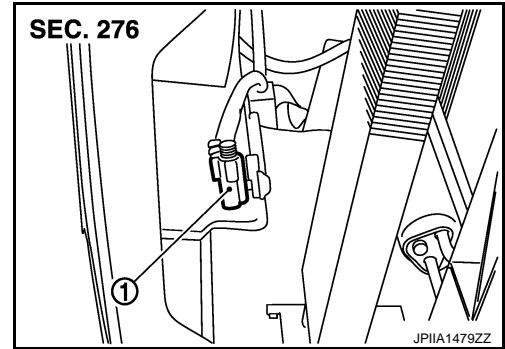

Removal and Installation

INFOID:000000005649565

REMOVAL

1. Remove front grille. Refer to [EXT-20, "Exploded View"](#).
2. Disconnect ambient sensor connector, and then remove ambient sensor.

INSTALLATION

Installation is basically the reverse order of removal.

A
B
C
D
E
F
G
H
J
K
L
M
N
O
P

HAC

IN-VEHICLE SENSOR

< REMOVAL AND INSTALLATION >

[AUTOMATIC AIR CONDITIONER]

IN-VEHICLE SENSOR

Exploded View

INFOID:000000005649566

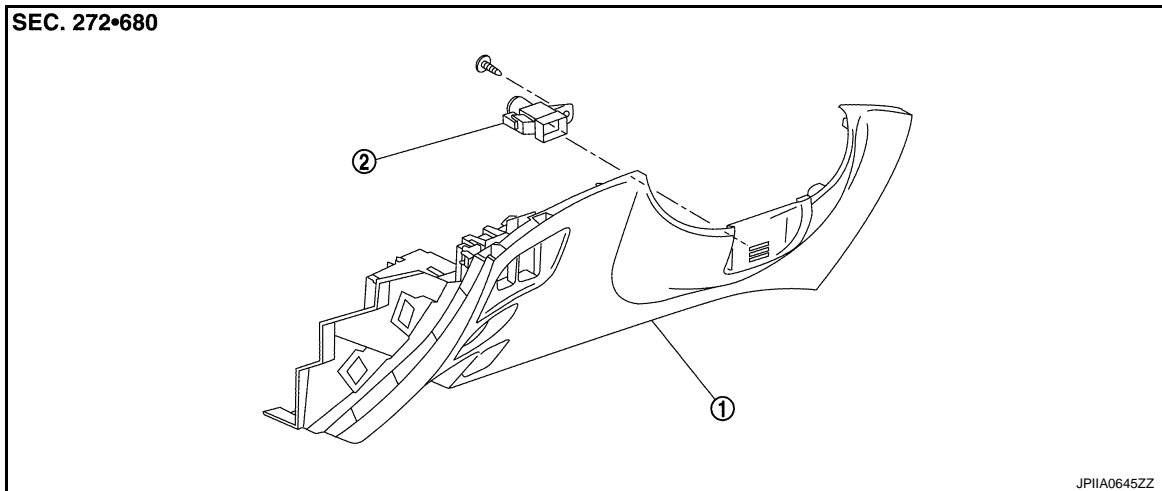

1. Instrument lower panel LH
2. In-vehicle sensor

Removal and Installation

INFOID:000000005649567

REMOVAL

1. Remove instrument lower panel LH. Refer to [IP-12, "A/T MODELS : Exploded View"](#) (A/T models) or [IP-22, "M/T MODELS : Exploded View"](#) (M/T models).
2. Remove mounting screw, and then remove in-vehicle sensor.

INSTALLATION

Installation is basically the reverse order of removal.

SUNLOAD SENSOR

< REMOVAL AND INSTALLATION >

[AUTOMATIC AIR CONDITIONER]

SUNLOAD SENSOR

Exploded View

INFOID:000000005649568

1. Front defroster grille LH
2. Sunload sensor

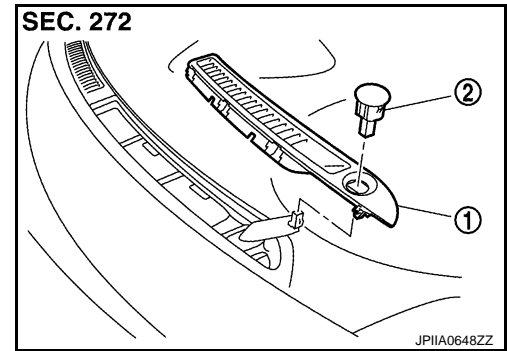

Removal and Installation

INFOID:000000005649569

REMOVAL

1. Remove front defroster grille LH. Refer to [VTL-10, "Exploded View"](#).
2. Disconnect sunload sensor connector, and then remove sunload sensor.

INSTALLATION

Installation is basically the reverse order of removal.

A
B
C
D
E
F
G
H
J
K
L
M
N
O
P

HAC

INTAKE SENSOR

< REMOVAL AND INSTALLATION >

[AUTOMATIC AIR CONDITIONER]

INTAKE SENSOR

Exploded View

INFOID:000000005649570

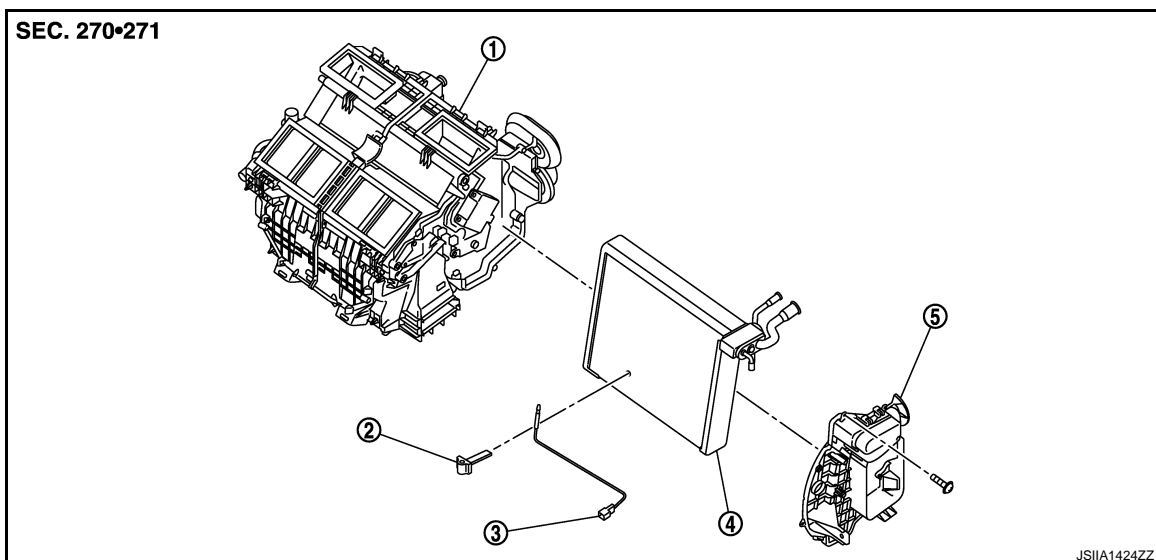

- | | | |
|-----------------------------------|--------------------------|------------------|
| 1. Heater & cooling unit assembly | 2. Intake sensor bracket | 3. Intake sensor |
| 4. Evaporator assembly | 5. Evaporator cover | |

Removal and Installation

INFOID:000000005649571

REMOVAL

1. Remove low-pressure pipe 1 and high-pressure pipe 2. Refer to [HA-41, "Exploded View"](#).
CAUTION:
Cap or wrap the joint of the A/C piping with suitable material such as vinyl tape to avoid the entry of air.
2. Slide evaporator to passenger side, and then remove intake sensor.

INSTALLATION

Installation is basically the reverse order of removal.

CAUTION:

- Replace O-rings with new ones. Then apply compressor oil to them when installing.
- Mark the mounting position of intake sensor bracket prior to removal so that the reinstalled sensor can be located in the same position.
- Female-side piping connection is thin and easy to deform. Slowly insert the male-side piping straight in axial direction.
- Insert piping securely until a click is heard.
- After piping connection is completed, pull male-side piping by hand to make sure that connection does not come loose.
- Check for leakages when recharging refrigerant.

REFRIGERANT PRESSURE SENSOR

< REMOVAL AND INSTALLATION >

[AUTOMATIC AIR CONDITIONER]

REFRIGERANT PRESSURE SENSOR

Exploded View

INFOID:000000005649572

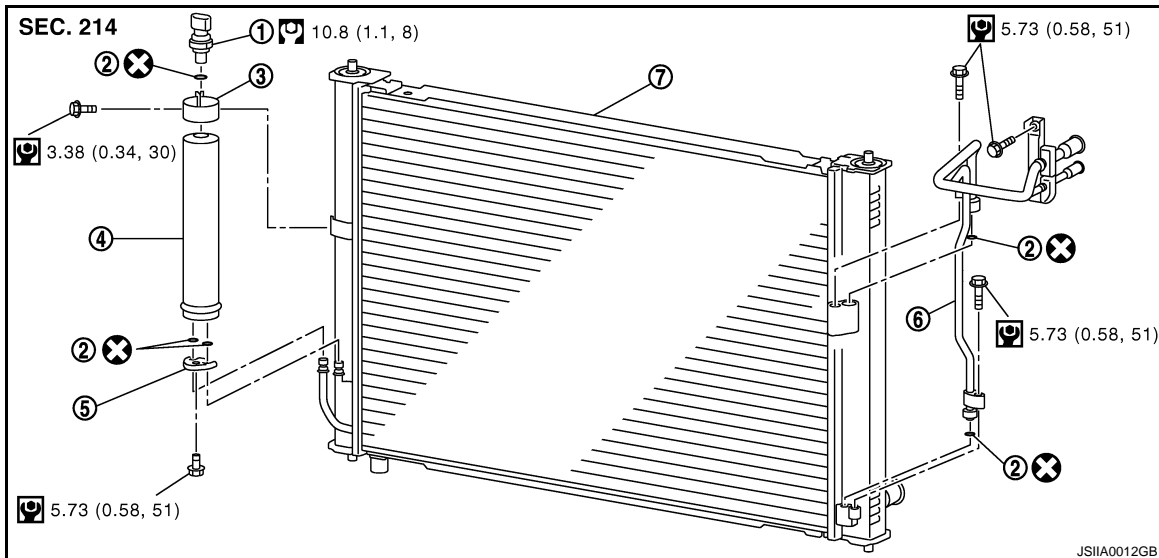

- | | | |
|----------------------------------|------------|----------------------------|
| 1. Refrigerant pressure sensor | 2. O-ring | 3. Liquid tank bracket |
| 4. Liquid tank | 5. Bracket | 6. Condenser pipe assembly |
| 7. Radiator & condenser assembly | | |

Refer to [GI-4, "Components"](#) for symbols in the figure.

Removal and Installation

INFOID:000000005649573

REMOVAL

1. Remove liquid tank. Refer to [HA-47, "Exploded View"](#).
2. Fix the liquid tank (1) with a vise (A). Remove the refrigerant pressure sensor (2) with a wrench (B).

CAUTION:

Be careful not to damage liquid tank.

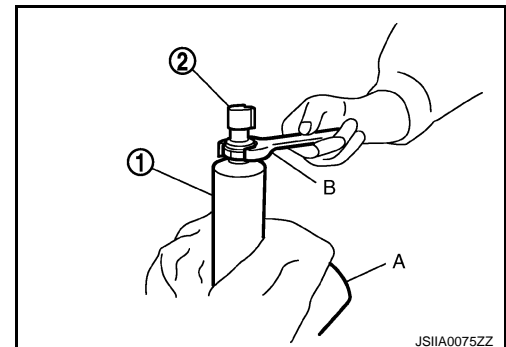

INSTALLATION

Installation is basically the reverse order of removal.

CAUTION:

- Replace O-ring with new one. Then apply compressor oil to them when installing.
- Check for leakages when recharging refrigerant.

DOOR MOTOR

< REMOVAL AND INSTALLATION >

[AUTOMATIC AIR CONDITIONER]

DOOR MOTOR

Exploded View

INFOID:000000005649574

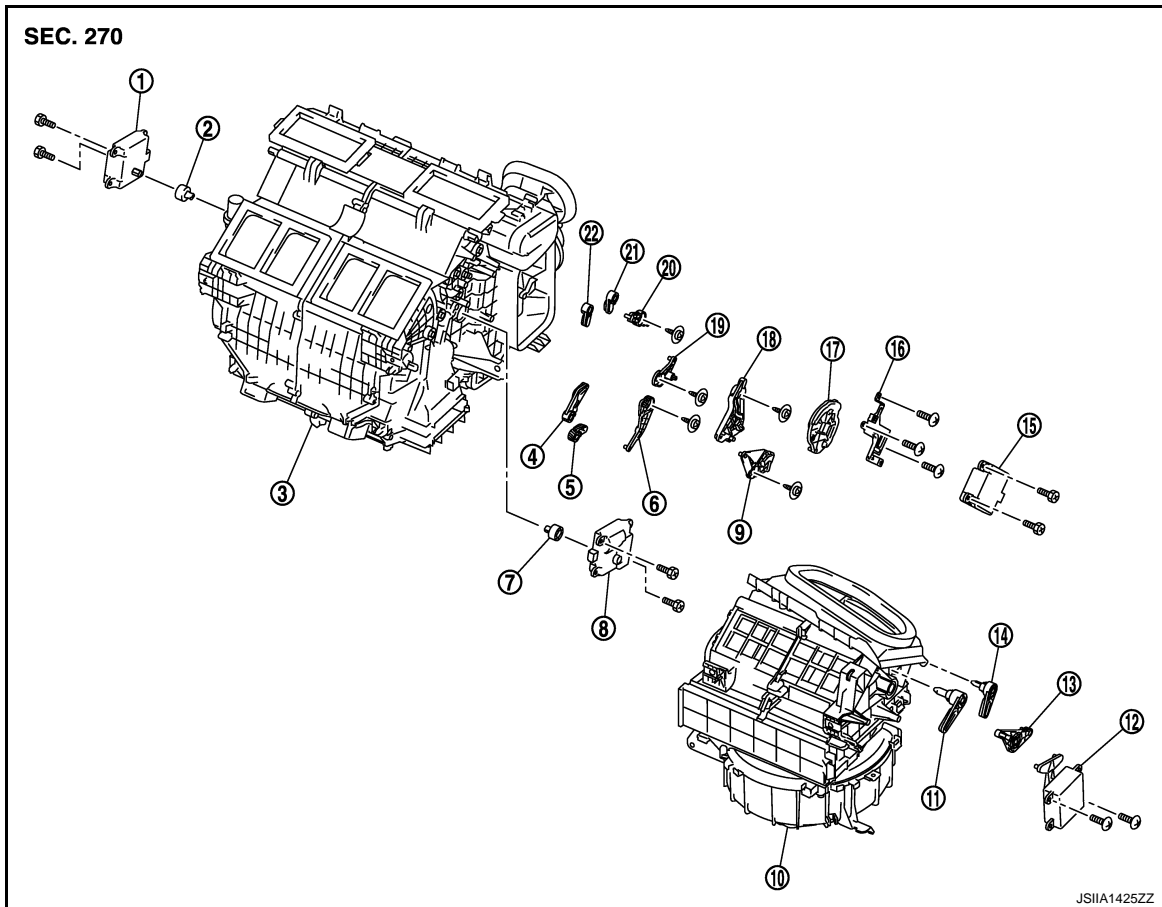

- | | | |
|--------------------------------------|--|-----------------------------------|
| 1. Air mix door motor (driver side)* | 2. Air mix door motor adapter | 3. Heater & cooling unit assembly |
| 4. Ventilator door lever | 5. Foot door lever | 6. Foot door link |
| 7. Air mix door motor adapter | 8. Air mix door motor (passenger side) | 9. Ventilator door link |
| 10. Blower unit | 11. Intake door lever 2 | 12. Intake door motor |
| 13. Intake door link | 14. Intake door lever 1 | 15. Mode door motor |
| 16. Mode door motor bracket | 17. Main link | 18. Main link sub |
| 19. Max.cool door link | 20. Defroster door link | 21. Max.cool door lever |
| 22. Defroster door lever | | |

*: With left and right ventilation temperature separately control system.

MODE DOOR MOTOR

MODE DOOR MOTOR : Removal and Installation

INFOID:000000005649575

REMOVAL

1. Remove blower unit. Refer to [VTL-16. "Exploded View"](#).
2. Remove mounting screws, and then remove mode door motor.
3. Disconnect mode door motor connector.

INSTALLATION

installation is basically the reverse order of removal.

AIR MIX DOOR MOTOR

DOOR MOTOR

< REMOVAL AND INSTALLATION >

[AUTOMATIC AIR CONDITIONER]

AIR MIX DOOR MOTOR : Removal and Installation

INFOID:000000005649576

REMOVAL

Without left and right ventilation temperature separately control system

1. Set the temperature at 18°C (64°F).

CAUTION:

The angle may be out, when installing the air mix door motor to the air mix door, unless the above procedure is performed.

2. Disconnect the battery cable from the negative terminal.
3. Remove blower unit. Refer to [VTL-16. "Exploded View"](#).
4. Remove mounting screws, and then remove air mix door motor.
5. Disconnect air mix door motor connector.

With left and right ventilation temperature separately control system

Driver side

1. Set the temperature (driver side) at 18°C (64°F).

CAUTION:

The angle may be out, when installing the air mix door motor to the air mix door, unless the above procedure is performed.

2. Disconnect the battery cable from the negative terminal.
3. Remove Instrument driver lower panel. Refer to [IP-12. "A/T MODELS : Exploded View"](#) (A/T models) or [IP-22. "M/T MODELS : Exploded View"](#) (M/T models).
4. Remove Accelerator pedal bracket and lever assembly. Refer to [ACC-3. "Exploded View"](#).
5. Remove mounting screws, and then remove air mix door motor (driver side).
6. Disconnect air mix door motor connector.

Passenger side

1. Set the temperature (passenger side) at 18°C (64°F).

CAUTION:

The angle may be out, when installing the air mix door motor to the air mix door, unless the above procedure is performed.

2. Disconnect the battery cable from the negative terminal.
3. Remove blower unit. Refer to [VTL-16. "Exploded View"](#).
4. Remove mounting screws, and then remove air mix door motor (passenger side).
5. Disconnect air mix door motor connector.

INSTALLATION

Installation is basically the reverse order of removal.

INTAKE DOOR MOTOR

INTAKE DOOR MOTOR : Removal and Installation

INFOID:000000005649577

REMOVAL

1. Remove ECM and power steering control unit with bracket attached. Refer to [VTL-17. "BLOWER UNIT : Removal and Installation"](#).
2. Remove mounting screws, and then remove intake door motor from blower unit.
3. Disconnect intake door motor connector.

INSTALLATION

Installation is basically the reverse order of removal.

A
B
C
D
E
F
G
H
J
K
L
M
N
O
P

HAC