

SECTION **SN**
SONAR SYSTEM

A
B
C
D
E
F
G
H
I
J
K
L
M
N
O
P

CONTENTS

PRECAUTION	3	Description	32
PRECAUTIONS	3	DTC Logic	32
Precaution for Supplemental Restraint System (SRS) "AIR BAG" and "SEAT BELT PRE-TENSIONER"	3	B2705 SENSOR HARNESS OPEN [CR-RL]	33
Precaution for Battery Service	3	Description	33
SYSTEM DESCRIPTION	4	DTC Logic	33
COMPONENT PARTS	4	Diagnosis Procedure	33
Component Parts Location	4	B2706 CORNER SENSOR [RR]	34
Component Description	4	Description	34
SONAR SYSTEM	6	DTC Logic	34
System Diagram	6	B2707 SENSOR HARNESS OPEN [CR-RR] ...	35
System Description	7	Description	35
Fail-Safe	10	DTC Logic	35
DIAGNOSIS SYSTEM (SONAR CONTROL UNIT)	11	Diagnosis Procedure	35
CONSULT-III Function	11	B2708 CENTER SENSOR [BL]	36
ECU DIAGNOSIS INFORMATION	13	Description	36
SONAR CONTROL UNIT	13	DTC Logic	36
Reference Value	13	B2709 SENSOR HARNESS OPEN [CT-BL]	37
Fail-Safe	15	Description	37
DTC Index	16	DTC Logic	37
WIRING DIAGRAM	17	Diagnosis Procedure	37
SONAR SYSTEM	17	B270A CENTER SENSOR [BR]	38
Wiring Diagram	17	Description	38
BASIC INSPECTION	30	DTC Logic	38
DIAGNOSIS AND REPAIR WORKFLOW	30	B270B SENSOR HARNESS OPEN [CT-BR] ...	39
Work Flow	30	Description	39
DTC/CIRCUIT DIAGNOSIS	32	DTC Logic	39
B2704 CORNER SENSOR [RL]	32	Diagnosis Procedure	39
		POWER SUPPLY AND GROUND CIRCUIT	40
		SONAR CONTROL UNIT	40
		SONAR CONTROL UNIT : Diagnosis Procedure....	40
		R RANGE SIGNAL CIRCUIT	41
		Description	41
		Component Function Check	41

SN

Diagnosis Procedure	41	SONAR CONTROL UNIT	45
SONAR CANCEL SWITCH CIRCUIT	42	Exploded View	45
Description	42	Removal and Installation	45
Component Function Check	42	SONAR SENSOR	46
Diagnosis Procedure	42	Exploded View	46
SYMPTOM DIAGNOSIS	44	Removal and Installation	46
SONAR SYSTEM SYMPTOMS	44	SONAR CANCEL SWITCH	47
Symptom Table	44	Exploded View	47
REMOVAL AND INSTALLATION	45	Removal and Installation	47

PRECAUTIONS

< PRECAUTION >

PRECAUTION

PRECAUTIONS

Precaution for Supplemental Restraint System (SRS) "AIR BAG" and "SEAT BELT PRE-TENSIONER"

INFOID:000000006458054

The Supplemental Restraint System such as "AIR BAG" and "SEAT BELT PRE-TENSIONER", used along with a front seat belt, helps to reduce the risk or severity of injury to the driver and front passenger for certain types of collision. This system includes seat belt switch inputs and dual stage front air bag modules. The SRS system uses the seat belt switches to determine the front air bag deployment, and may only deploy one front air bag, depending on the severity of a collision and whether the front occupants are belted or unbelted. Information necessary to service the system safely is included in the "SRS AIR BAG" and "SEAT BELT" of this Service Manual.

WARNING:

Always observe the following items for preventing accidental activation.

- To avoid rendering the SRS inoperative, which could increase the risk of personal injury or death in the event of a collision that would result in air bag inflation, all maintenance must be performed by an authorized NISSAN/INFINITI dealer.
- Improper maintenance, including incorrect removal and installation of the SRS, can lead to personal injury caused by unintentional activation of the system. For removal of Spiral Cable and Air Bag Module, see "SRS AIR BAG".
- Never use electrical test equipment on any circuit related to the SRS unless instructed to in this Service Manual. SRS wiring harnesses can be identified by yellow and/or orange harnesses or harness connectors.

PRECAUTIONS WHEN USING POWER TOOLS (AIR OR ELECTRIC) AND HAMMERS

WARNING:

Always observe the following items for preventing accidental activation.

- When working near the Air Bag Diagnosis Sensor Unit or other Air Bag System sensors with the ignition ON or engine running, never use air or electric power tools or strike near the sensor(s) with a hammer. Heavy vibration could activate the sensor(s) and deploy the air bag(s), possibly causing serious injury.
- When using air or electric power tools or hammers, always switch the ignition OFF, disconnect the battery, and wait at least 3 minutes before performing any service.

Precaution for Battery Service

INFOID:000000006458055

Before disconnecting the battery, lower both the driver and passenger windows. This will prevent any interference between the window edge and the vehicle when the door is opened/closed. During normal operation, the window slightly raises and lowers automatically to prevent any window to vehicle interference. The automatic window function will not work with the battery disconnected.

A
B
C
D
E
F
G
H
I
J
K
L
M
O
P

SN

COMPONENT PARTS

< SYSTEM DESCRIPTION >

SYSTEM DESCRIPTION

COMPONENT PARTS

Component Parts Location

INFOID:000000006458056

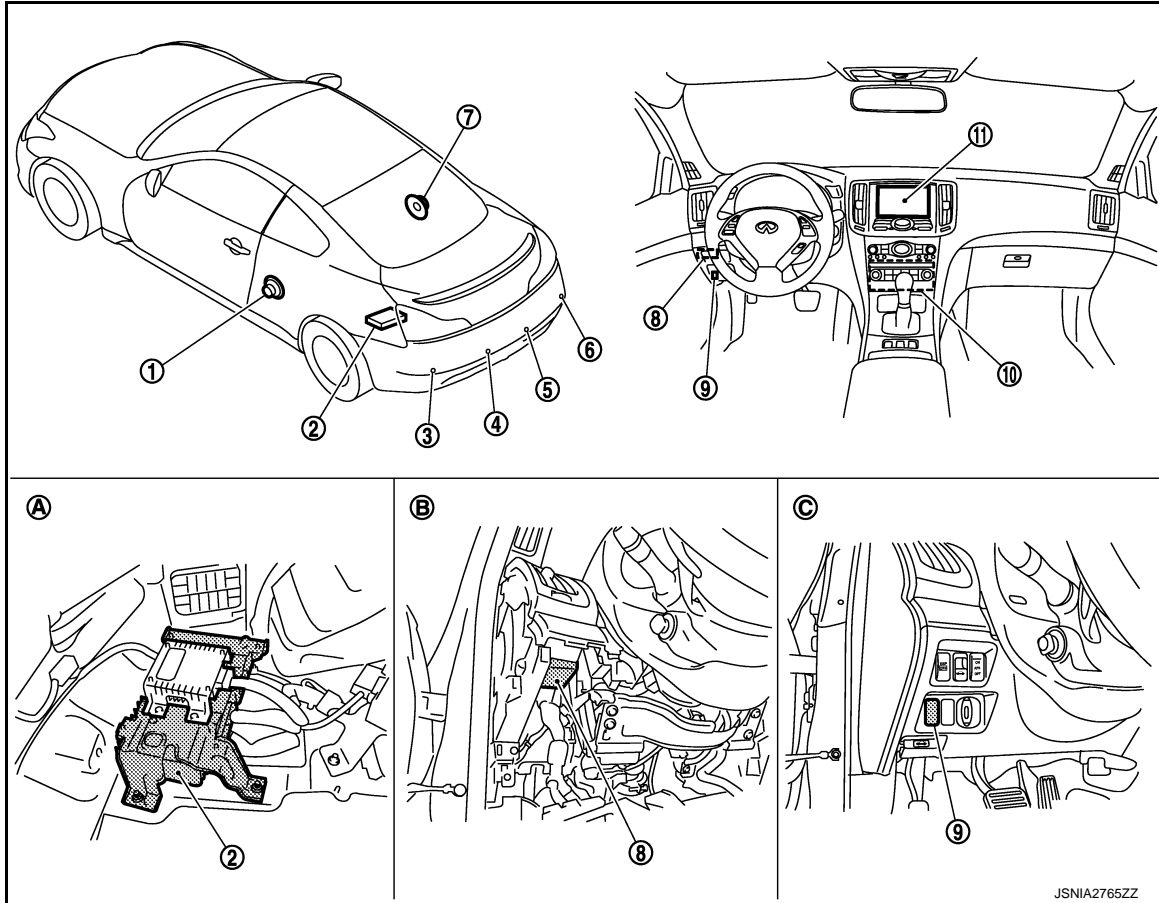

- | | | |
|------------------------------------|--|----------------------------------|
| 1. Rear speaker LH | 2. BOSE amp. | 3. Corner sensor rear LH |
| 4. Center sensor rear LH | 5. Center sensor rear RH | 6. Corner sensor rear RH |
| 7. Rear speaker RH | 8. Sonar control unit | 9. Sonar cancel switch |
| 10. AV control unit | 11. Display unit | |
| A. Lower part of rear parcel shelf | B. Instrument driver lower panel removed condition | C. Instrument driver lower panel |

Component Description

INFOID:000000006458057

WITHOUT NAVIGATION

Component	Description
SONAR CONTROL UNIT	<ul style="list-style-type: none"> An integrated warning buzzer sounds when receiving a sensor signal from the corner/center sensor. The sonar system starts when receiving a reverse signal. Converts a signal received from the corner sensor and the center sensor into a distance signal (center sensor: four levels, corner sensor: three levels) to transmit it to the AV control unit via AV communication. The sonar system turns OFF when receiving a sonar cancel switch signal. Capable of system settings and trouble diagnoses with CONSULT-III (K-LINE).
CORNER SENSOR REAR (LH, RH)	When a distance from an obstacle is detected, a distance signal is transmitted to the sonar control unit.

COMPONENT PARTS

< SYSTEM DESCRIPTION >

Component	Description
CENTER SENSOR REAR (LH, RH)	When a distance from an obstacle is detected, a distance signal is transmitted to the sonar control unit.
SONAR CANCEL SWITCH	The sonar cancel switch signal is transmitted to the sonar control unit.
AV CONTROL UNIT	<ul style="list-style-type: none"> • An image on the display is switched between the AV control unit and the display unit via serial communication. • An RGB image signal is transmitted to the AV control unit.
DISPLAY UNIT	<ul style="list-style-type: none"> • An RGB image signal is transmitted from the AV control unit. • An image on the display is switched between the AV control unit and the display unit via serial communication.

WITH NAVIGATION

Component	Description
SONAR CONTROL UNIT	<ul style="list-style-type: none"> • Converts a signal received from the corner sensor and the center sensor into a distance signal (center sensor: four levels, corner sensor: three levels) to transmit it to the AV control unit via AV communication. • The sonar system starts when receiving a reverse signal. • The sonar system turns OFF when receiving a sonar cancel switch signal. • Capable of system settings and trouble diagnoses with CONSULT-III (K-LINE).
CORNER SENSOR REAR (LH, RH)	When a distance from an obstacle is detected, a distance signal is transmitted to the sonar control unit.
CENTER SENSOR REAR (LH, RH)	When a distance from an obstacle is detected, a distance signal is transmitted to the sonar control unit.
SONAR CANCEL SWITCH	The sonar cancel switch signal is transmitted to the sonar control unit.
AV CONTROL UNIT	<ul style="list-style-type: none"> • An image on the display is switched between the AV control unit and the display unit via serial communication. • Transmits an RGB digital image signal to the display unit and a sound signal (buzzer) to the BOSE amp., based on the signal received from the sonar control unit via AV communication.
DISPLAY UNIT	<ul style="list-style-type: none"> • An RGB digital image signal is transmitted from the AV control unit. • An image on the display is switched between the AV control unit and the display unit via serial communication.
BOSE AMP.	Receives a sound signal (buzzer) from the AV control unit and transmits the signal to the rear speaker (LH, RH).
REAR SPEAKER (LH, RH)	Receives a sound signal (buzzer) from the AV control unit to allow the buzzer to sound.

A
B
C
D
E
F
G
H
I
J
K
L
M

SN

O
P

SONAR SYSTEM

< SYSTEM DESCRIPTION >

SONAR SYSTEM

System Diagram

INFOID:000000006458058

WITHOUT NAVIGATION

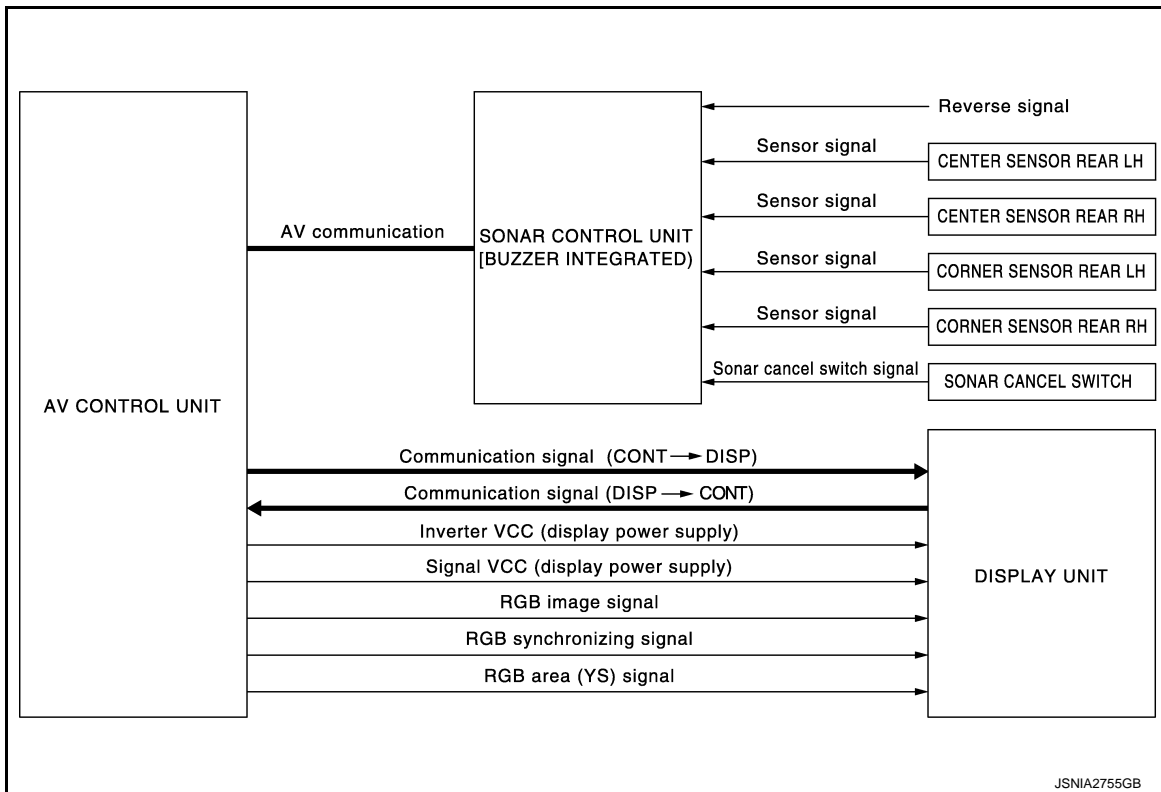

WITH NAVIGATION

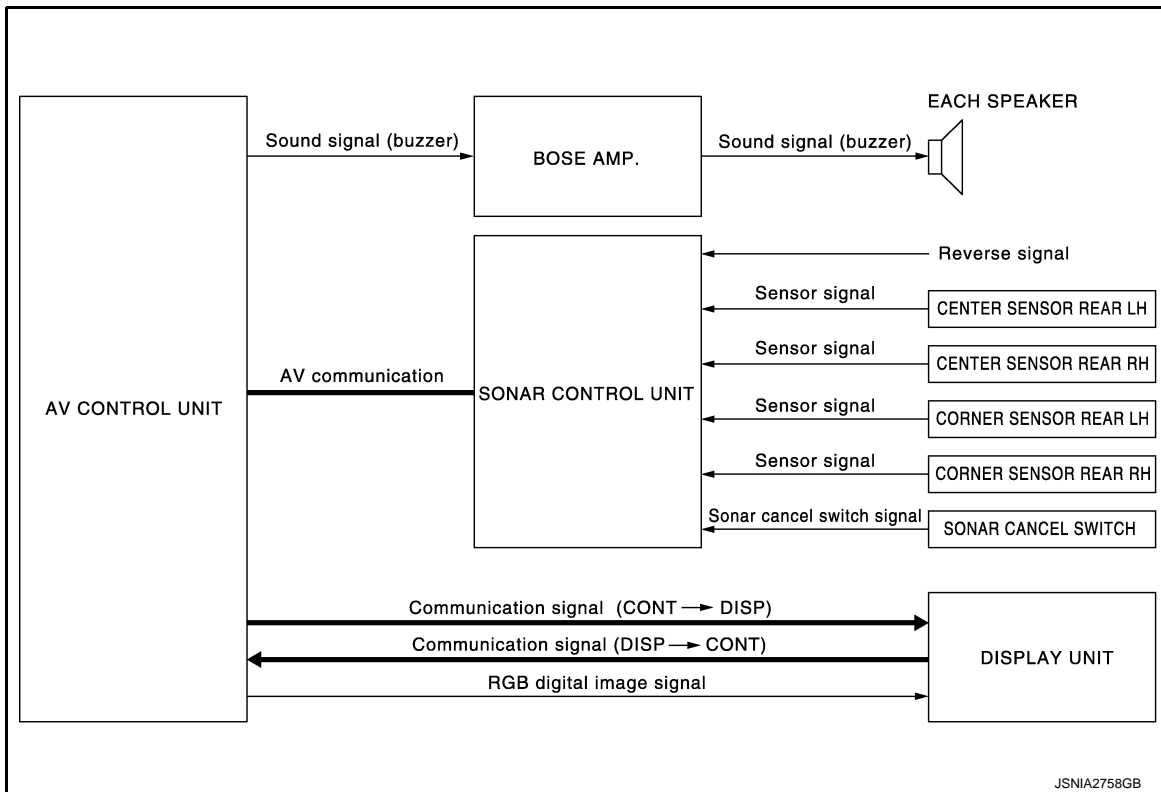

SONAR SYSTEM

< SYSTEM DESCRIPTION >

System Description

INFOID:000000006458059

WITHOUT NAVIGATION

- The sonar sensor installed to the rear bumper detects obstacles around the rear bumper.
- When the rear corner sensor or the rear center sensor detects an obstacle during rear view monitor indication, the buzzer built in the sonar control unit sounds and the location of the obstacle is indicated on the display unit by displaying an icon.
- Sonar system turns ON/OFF with the sonar cancel switch.
- The sonar control unit is connected to the AV control unit via the AV communication.
- The sonar control unit is connected to the diagnosis connector via K-Line and allows diagnoses with CONSULT-III.

WITH NAVIGATION

- The sonar sensor installed to the rear bumper detects obstacles around the rear bumper.
- When the rear corner sensor or the rear center sensor detects an obstacle during rear view monitor indication, the buzzer sounds via each speaker and the location of the obstacle is indicated on the display unit by displaying an icon.
- Sonar system turns ON/OFF with the sonar cancel switch.
- The sonar control unit is connected to the AV control unit via the AV communication.
- Sonar control unit is connected to the diagnosis connector via K-Line and allows diagnoses with CONSULT-III.

Warning by Buzzer (Without Navigation)

- The cycle of buzzer changes according to the distance from an obstacle: the center sensor, in four levels; the corner sensor, in three levels.
- Each sonar sensor transmits a sensor signal to the sonar control unit when detecting an obstacle.
- When receiving a sensor signal, the buzzer built in the sonar control unit sounds if an obstacle is detected on the rear side of the vehicle.

Warning by Buzzer (With Navigation)

- The cycle of buzzer changes according to the distance from an obstacle: the center sensor, in four levels; the corner sensor, in three levels.
- Each sonar sensor transmits a sensor signal to the sonar control unit when detecting an obstacle.
- The sonar control unit converts a signal received from each sonar sensor into a distance signal (center sensor: four levels, corner sensor: three levels) and transmits it to the AV control unit via AV communication.
- The AV control unit transmits a sound signal (buzzer) to the BOSE amp. when receiving a distance signal from the sonar control unit.
- When receiving a sound signal (buzzer), the BOSE amp. transmits the sound signal (buzzer) to each speaker.
- When each speaker receives a sound signal (buzzer), buzzer sounds.
- When the rear center sensor or the rear corner sensor detects an obstacle, a buzzer is heard from the speakers on the rear side.

Warning by Indicator

- Detecting an obstacle when in reverse gear, the direction and the distance to the obstacle are displayed on the rear view monitor with icons.
- The color and the number of blinks of the sonar indicator changes, according to the distance to an obstacle (during icon indication).
- The sonar display function can be turned ON/OFF from "SETTING" of "Other". In this case, buzzer sounds by turning OFF the display function.
- Each sonar sensor transmits a sensor signal to the sonar control unit when detecting an obstacle.
- The sonar control unit converts a signal received from each sonar sensor into a distance signal (center sensor: four levels, corner sensor: three levels) and transmits it to the AV control unit via AV communication.
- The AV control unit transmits an RGB image signal to the display unit, based on the received signal. (Without navigation)
- The AV control unit transmits an RGB digital image signal to the display unit, based on the received signal. (With navigation)
- When receiving an RGB image signal, the display unit indicates "Icon display." (Without navigation)
- When receiving an RGB digital image signal, the display unit indicates "Icon display." (With navigation)

A

B

C

D

E

F

G

H

I

J

K

L

M

SN

O

P

SONAR SYSTEM

< SYSTEM DESCRIPTION >

- Warning indications of the sonar system on the display are generated by the AV control unit.

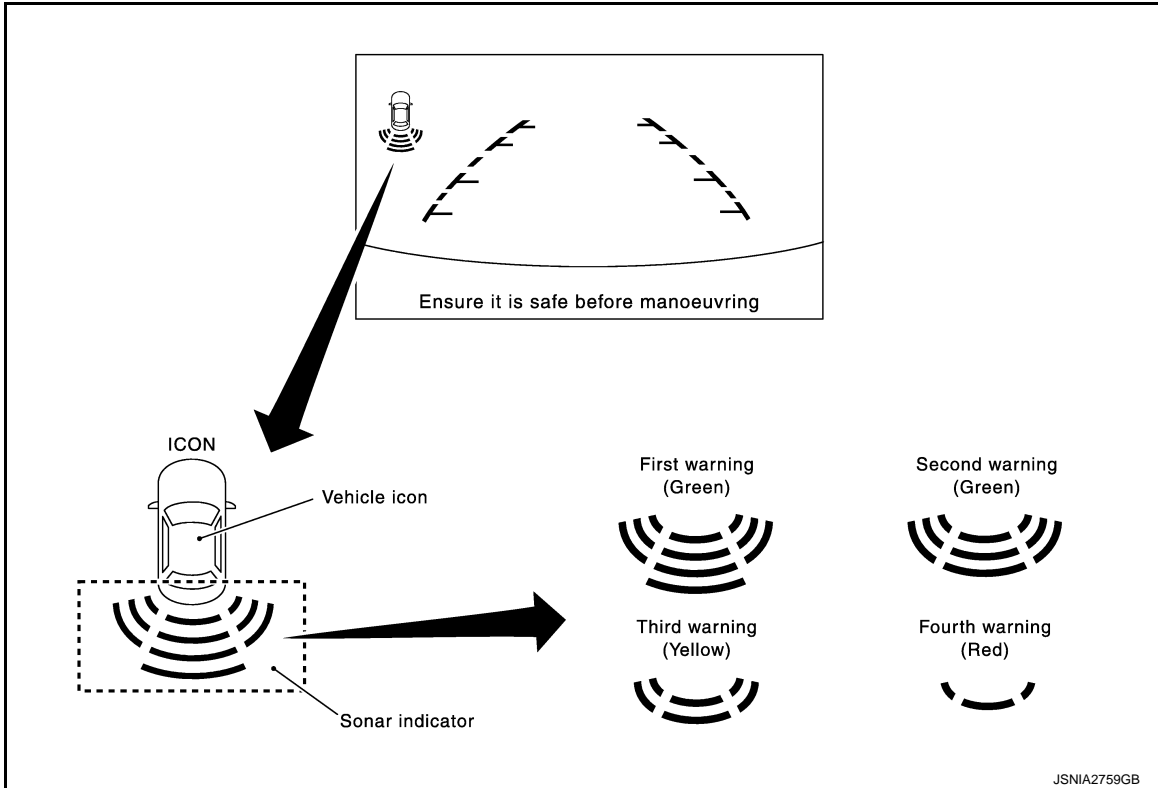

ACTIVATION CONDITION

The rear sensor activates under the following conditions:

- Sonar cancel switch OFF
- Reverse position
- During obstacle detection

x: applicable

Sonar cancel switch	Reverse signal	Sonar sensor
OFF	ON	X*
OFF	OFF	—

NOTE:

*: When the rear sensors simultaneously detect different obstacle:

- The sonar sensor detecting shorter distance from the object has priority to sound a buzzer.

OBSTACLE DETECTION DISTANCE

- The sonar control unit controls the obstacle detection distance. The detection distance differs between the corner sensor and the center sensor.
- The sonar control unit controls a warning buzzer cycle which changes in 4 levels (for center) or in 3 levels (for corner), according to the detection distance.
- The detection condition setting is adjustable in 4 levels with CONSULT-III. Refer to [SN-11, "CONSULT-III Function"](#).
- CONSULT-III enables the center sensor (rear) not to detect the range of 40 cm (15.75 in) or less to prevent from the trailer hitch vehicle detection error. Refer to [SN-11, "CONSULT-III Function"](#).

SONAR SYSTEM

< SYSTEM DESCRIPTION >

Obstacle detection range image

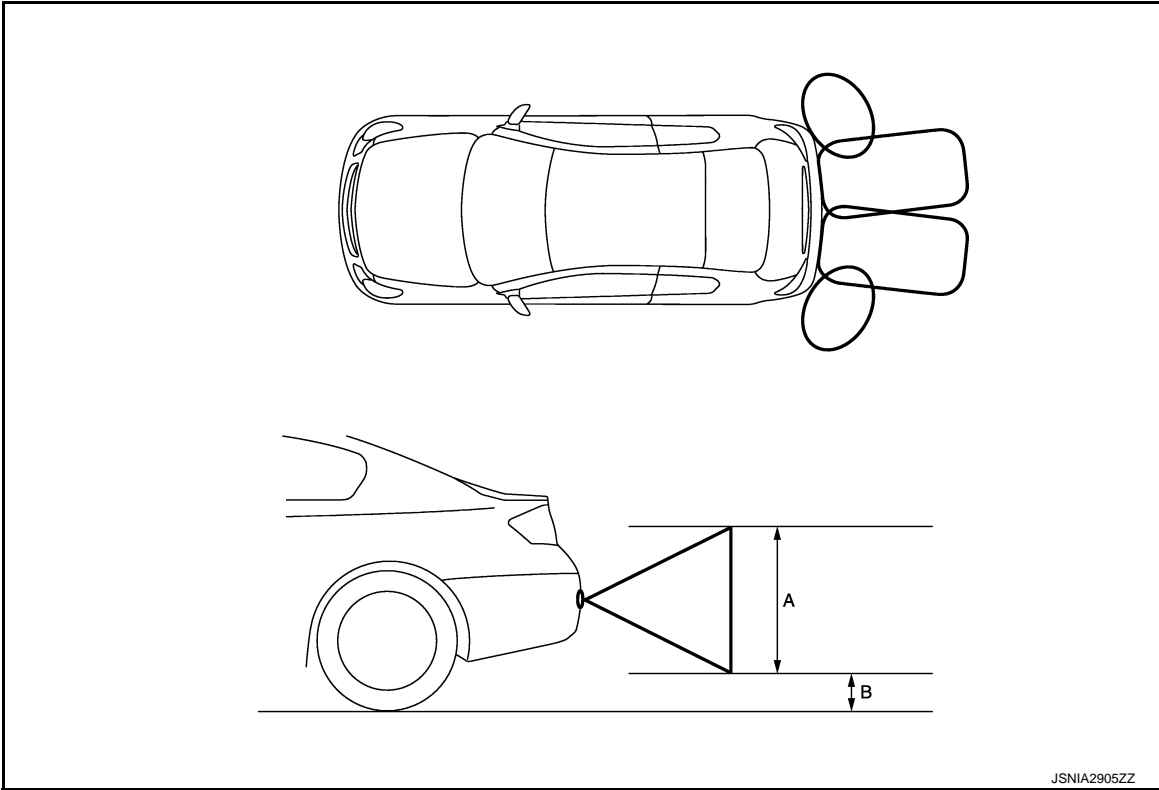

A. Approx. 50 cm (19.6 in)

B. Approx. 15 cm (5.9 in)

Detection distance (default value)

Warning item	Corner sensor	Center sensor
First warning	—	60 – 100 cm (23.6 – 39.3 in)
Second warning	50 – 60 cm (19.6 – 23.6 in)	50 – 60 cm (19.6 – 23.6 in)
Third warning	30 – 50 cm (11.8 – 19.6 in)	30 – 50 cm (11.8 – 19.6 in)
Fourth warning	Less than 30 cm (11.8 in)	Less than 30 cm (11.8 in)

Warning Buzzer Frequency

- The warning buzzer cycle changes between 4 levels (for rear center) and 3 levels (for rear corner), according to the detection distance.

A
B
C
D
E
F
G
H
I
J
K
L
M
O
P

SN

SONAR SYSTEM

< SYSTEM DESCRIPTION >

- The nearest sensor from the detected obstacle determines the buzzer cycle if plural sensors simultaneously detect obstacles.

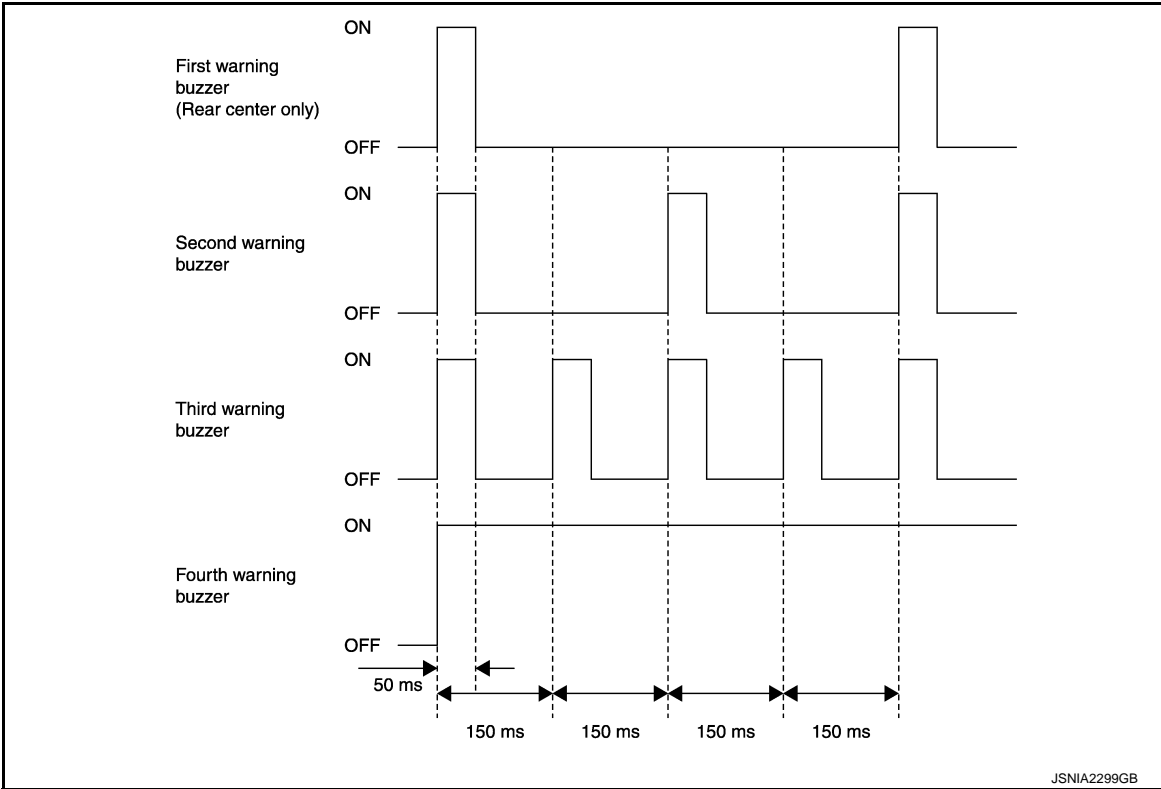

NOTE:

The warning buzzer of the corner sensor sounds as follows:

- As for the second and third stages, the warning buzzer sounds for 3 seconds at maximum.
- As for the fourth stage, the warning buzzer does not stop even after a lapse of 3 seconds.
- Buzzer stops when the vehicle moves away from an obstacle and the warning level decreases.

Fail-Safe

INFOID:000000006458060

The warning buzzer function is deactivated and the cancel switch indicator blinks when a sensor system error is detected.

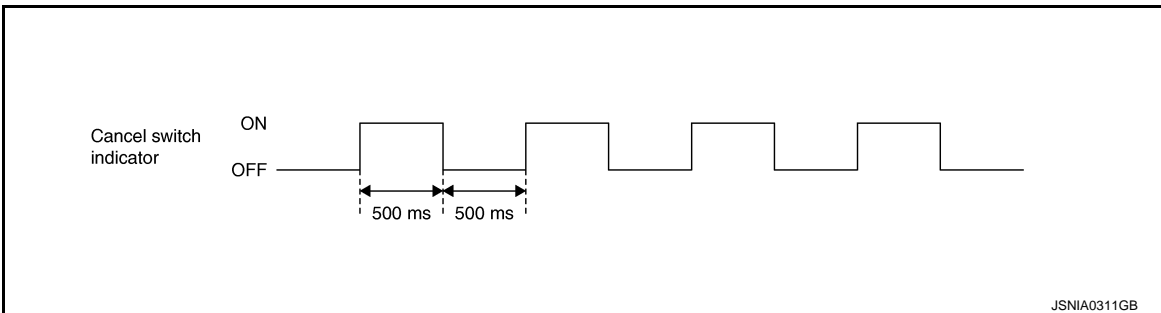

DIAGNOSIS SYSTEM (SONAR CONTROL UNIT)

< SYSTEM DESCRIPTION >

DIAGNOSIS SYSTEM (SONAR CONTROL UNIT)

CONSULT-III Function

INFOID:000000006458061

DESCRIPTION

CONSULT-III can display each diagnostic item using the diagnostic test modes shown as follows:

Test mode	Function
Ecu Identification	Sonar control unit part number can be read.
Self Diagnostic Results	Sonar control unit checks the conditions and displays memorized error.
Data Monitor	Sonar control unit input/output data in real time.
Active Test	Gives a drive signal to a load to check the operation.
Work support	Changes setting of each function.

ECU IDENTIFICATION

Displays the part number of the sonar control unit.

SELF-DIAGNOSTIC RESULTS

For details, refer to [SN-16, "DTC Index"](#).

DATA MONITOR

Monitor Item	Display	Description
REAR BUZZER	On	Buzzer output condition.
	Off	Buzzer non-output condition.
REVERSE RANGE	On	Shift the selector lever to R position.
	Off	Shift the selector lever other than R position.
CANCEL SW	On	While pressing the sonar cancel switch.
	Off	Other than above.
CANCEL SW IND	On	When sonar cancel switch indicator lamp is ON.
	Blink	When sonar cancel switch indicator lamp is blinking.
	Off	When sonar cancel switch indicator lamp is OFF.
CR SEN [RL] CR SEN [RR]	ERROR	When a sensor is abnormal.
	LV.0	When a sensor is not detection.
	LV.2	The distance between the center sensor and an obstacle is 50 cm (19.6 in) or more and less than 60 cm (23.6 in).
	LV.3	The distance between the center sensor and an obstacle is 30 cm (11.8 in) or more and less than 50 cm (19.6 in).
	LV.4	The distance between center sensor and an obstacle less than 30 cm (11.8 in).
CTR SEN [RL] CTR SEN [RR]	ERROR	When a sensor is abnormal.
	LV.0	When a sensor is not detection.
	LV.1	The distance between the center sensor and an obstacle is 60 cm (23.6 in) or more and less than 100 cm (39.3 in).
	LV.2	The distance between the center sensor and an obstacle is 50 cm (19.6 in) or more and less than 60 cm (23.6 in).
	LV.3	The distance between the center sensor and an obstacle is 30 cm (11.8 in) or more and less than 50 cm (19.6 in).
	LV.4	The distance between center sensor and an obstacle less than 30 cm (11.8 in).
DISPLAY INFO	On	Icon display indication condition.
	Off	Icon display non-indication condition.

DIAGNOSIS SYSTEM (SONAR CONTROL UNIT)

< SYSTEM DESCRIPTION >

ACTIVE TEST

Active test item	Function
BUZZER	This test is able to check buzzer operation.
CANCEL SW	This test is able to check cancel indicator lamp operation.
SONAR SENSOR	This test is able to check each sonar sensor operation.

WORK SUPPORT

Work support item	Function
CORNER SEN DISTANCE SET	Corner sensor warning buzzer distance is adjustable to 4 phases.
CENTER SEN DISTANCE SET	Center sensor warning buzzer distance is adjustable to 4 phases.
VOLUME SETTING*	Warning buzzer volume can set it 2 phases.
TRAILER HITCH MODE	Center sensor (RR, RL) only is adjustable not to detect the distance less than 40 cm (15.7 in). NOTE: This adjustment is for preventing to miss detect the distance when installing the trailer hitch.

*: Without navigation models

CORNER SEN DISTANCE SET

Corner sensor warning buzzer distance can set it to 4 phases as follows.

Warning item	FARTHER	FAR	NORMAL (Default)	NEAR
Second stage warning	70 – 80 cm (27.5 – 31.4 in)	60 – 70 cm (23.6 – 27.5 in)	50 – 60 cm (19.6 – 23.6 in)	40 – 50 cm (15.7 – 19.6 in)
Third stage warning	50 – 70 cm (19.6 – 27.5 in)	40 – 60 cm (15.7 – 23.6 in)	30 – 50 cm (11.8 – 19.6 in)	30 – 40 cm (11.8 – 15.7 in)
Fourth stage warning	Less than 50 cm (19.6 in)	Less than 40 cm (15.7 in)	Less than 30 cm (11.8 in)	Less than 30 cm (11.8 in)

The default of this model is "NORMAL".

CENTER SEN DISTANCE SET

Center sensor warning buzzer distance can set it to 4 phases as follows.

Warning item	FARTHER	FAR	NORMAL (Default)	NEAR
First stage warning	80 – 120 cm (31.4 – 47.2 in)	70 – 110 cm (27.5 – 43.3 in)	60 – 100 cm (23.6 – 39.3 in)	50 – 90 cm (19.6 – 35.4 in)
Second stage warning	70 – 80 cm (27.5 – 31.4 in)	60 – 70 cm (23.6 – 27.5 in)	50 – 60 cm (19.6 – 23.6 in)	40 – 50 cm (15.7 – 19.6 in)
Third stage warning	50 – 70 cm (19.6 – 27.5 in)	40 – 60 cm (15.7 – 23.6 in)	30 – 50 cm (11.8 – 19.6 in)	30 – 40 cm (11.8 – 15.7 in)
Fourth stage warning	Less than 50 cm (19.6 in)	Less than 40 cm (15.7 in)	Less than 30 cm (11.8 in)	Less than 30 cm (11.8 in)

The default of this model is "NORMAL".

VOLUME SETTING

Warning buzzer volume can set it to 2 phases.

TRAILER HITCH MODE

Center sensor (RR, RL) only is adjustable not to detect the distance less than 40 cm (15.7 in).

When installing the trailer hitch : ON

When not installing the trailer hitch : OFF

SONAR CONTROL UNIT

< ECU DIAGNOSIS INFORMATION >

ECU DIAGNOSIS INFORMATION

SONAR CONTROL UNIT

Reference Value

INFOID:000000006458062

VALUES ON THE DIAGNOSIS TOOL

CONSULT-III MONITOR ITEM

Monitor Item	Condition		Value/Status
REAR BUZZER	Ignition switch ON	Buzzer output condition.	On
		Buzzer non-output condition.	Off
REVERSE RANGE	Ignition switch ON	Selector lever in reverse position.	On
		Other than selector lever in reverse position.	Off
CANCEL SW	Ignition switch ON	While pressing the sonar cancel switch.	On
		Other than above.	Off
CANCEL SW IND	Ignition switch ON	When sonar cancel switch indicator lamp is ON.	On
		When sonar cancel switch indicator lamp is blinking	Blink
		When sonar cancel switch indicator lamp is OFF.	Off
CR SEN [RL]	Ignition switch ON	When a sensor is abnormal.	ERROR
		When a sensor is not detection.	LV.0
		The distance between the corner sensor and an obstacle is 50 cm (19.6 in) or more and less then 60 cm (23.6 in).	LV.2
		The distance between the corner sensor and an obstacle is 30 cm (11.8 in) or more and less then 50 cm (19.6 in).	LV.3
		The distance between corner sensor and an obstacle less than 30 cm (11.8 in).	LV.4
CR SEN [RR]	Ignition switch ON	When a sensor is abnormal.	ERROR
		When a sensor is not detection.	LV.0
		The distance between the corner sensor and an obstacle is 50 cm (19.6 in) or more and less then 60 cm (23.6 in).	LV.2
		The distance between the corner sensor and an obstacle is 30 cm (11.8 in) or more and less then 50 cm (19.6 in).	LV.3
		The distance between corner sensor and an obstacle less than 30 cm (11.8 in).	LV.4
CTR SEN [RL]	Ignition switch ON	When a sensor is abnormal.	ERROR
		When a sensor is not detection.	LV.0
		The distance between the center sensor and an obstacle is 60 cm (23.6 in) or more and less then 100 cm (39.3 in).	LV.1
		The distance between the center sensor and an obstacle is 50 cm (19.6 in) or more and less then 60 cm (23.6 in).	LV.2
		The distance between the center sensor and an obstacle is 30 cm (11.8 in) or more and less then 50 cm (19.6 in).	LV.3
		The distance between center sensor and an obstacle less than 30 cm (11.8 in).	LV.4

A
B
C
D
E
F
G
H
I
J
K
L
M
SN
O
P

SONAR CONTROL UNIT

< ECU DIAGNOSIS INFORMATION >

Monitor Item	Condition		Value/Status
CTR SEN [RR]	Ignition switch ON	When a sensor is abnormal.	ERROR
		When a sensor is not detection.	LV.0
		The distance between the center sensor and an obstacle is 60 cm (23.6 in) or more and less then 100 cm (39.3 in).	LV.1
		The distance between the center sensor and an obstacle is 50 cm (19.6 in) or more and less then 60 cm (23.6 in).	LV.2
		The distance between the center sensor and an obstacle is 30 cm (11.8 in) or more and less then 50 cm (19.6 in).	LV.3
		The distance between center sensor and an obstacle less than 30 cm (11.8 in).	LV.4
DISPLAY INFO	Ignition switch ON	Icon display indication condition.	On
		Icon display non-indication condition.	Off

TERMINAL LAYOUT

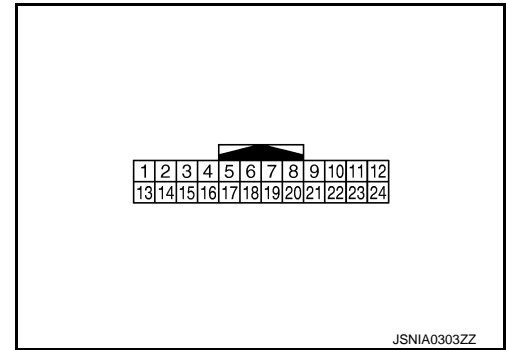

PHYSICAL VALUES

Terminal No. (Wire color)		Description		Condition		Value (Approx.)
+	-	Signal name	Input/ Output			
1 (LG)	Ground	Ignition signal	Input	Ignition switch ON	—	12.0 V
2 (SB)	Ground	Sonar cancel switch signal	Input	Ignition switch ON	Turns ON while pressing sonar cancel switch ON.	2.0 V
					Other than while pressing sonar cancel switch ON.	12.0 V
5 (W)	12 (B)	Corner sensor signal rear LH	Input	Ignition switch ON	Shift position in reverse position.	
6 (Y)	12 (B)	Corner sensor signal rear RH	Input	Ignition switch ON	Selector lever in reverse position.	

SONAR CONTROL UNIT

< ECU DIAGNOSIS INFORMATION >

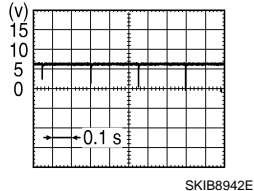
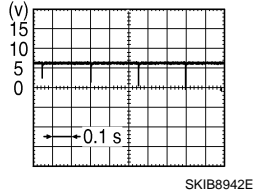
Terminal No. (Wire color)		Description		Condition		Value (Approx.)
+	-	Signal name	Input/ Output			
7 (G)	12 (B)	Center sensor signal rear LH	Input	Ignition switch ON	Selector lever in R position.	
8 (R)	12 (B)	Center sensor signal rear RH	Input	Ignition switch ON	Selector lever in R position.	
11 (B)	Ground	Sonar cancel switch indicator signal	Output	Ignition switch ON	Sonar system ON	12.0 V
				Ignition switch ON	Sonar system OFF	0 V
13 (GR)	Ground	ACC power supply	Input	Ignition switch ACC	—	Battery voltage
17 (BG)	Ground	Reverse range signal	Input	Ignition switch ON	Shift position in R position.	12.0 V
				Ignition switch ON	Other than shift position in R position.	0 V
18 (V)	—	K-line (CONSULT-III)	—	—	—	—
19 (SB)	—	AV communication signal (H)	Input/ Output	—	—	—
20 (LG)	—	AV communication signal (L)	Input/ Output	—	—	—
24 (B)	Ground	Ground	—	Ignition switch ON	—	0 V

Fail-Safe

INFOID:000000006458063

The warning buzzer function shuts off and the cancel switch indicator blinks when the sensor system error is detected.

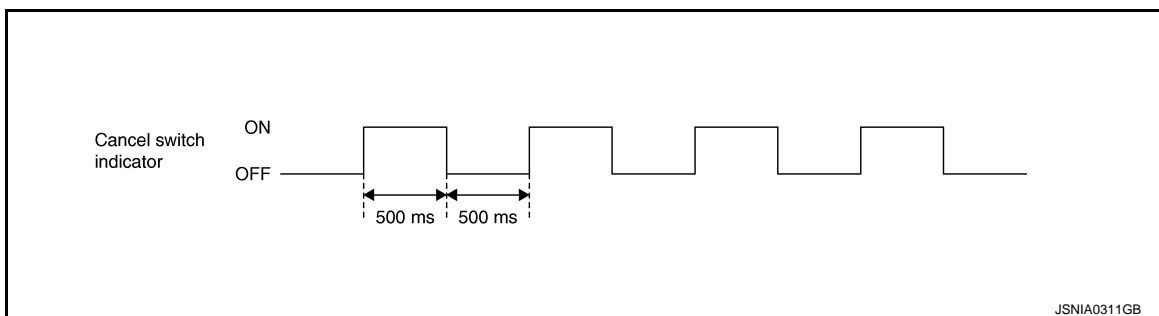

A
B
C
D
E
F
G
H
I
J
K
L
M
O
P

SN

SONAR CONTROL UNIT

< ECU DIAGNOSIS INFORMATION >

DTC Index

INFOID:000000006458064

DTC	Display item [Code]	Malfunction is detected when...	Reference
B2704	CORNER SENSOR [RL] [B2704]	Corner sensor rear LH is malfunctioning.	SN-32
B2705	SENSOR HARNESS OPEN [CR-RL] [B2705]	Corner sensor rear LH harness circuit is open.	SN-33
B2706	CORNER SENSOR [RR] [B2706]	Corner sensor rear RH is malfunctioning.	SN-34
B2707	SENSOR HARNESS OPEN [CR-RR] [B2707]	Corner sensor rear RH harness circuit is open.	SN-35
B2708	CENTER SENSOR [BL] [B2708]	Center sensor rear LH is malfunctioning.	SN-36
B2709	SENSOR HARNESS OPEN [CT-BL] [B2709]	Center sensor rear LH harness circuit is open.	SN-37
B270A	CENTER SENSOR [BR] [B270A]	Center sensor rear RH is malfunctioning.	SN-38
B270B	SENSOR HARNESS OPEN [CT-BR] [B270B]	Center sensor rear RH harness circuit is open.	SN-39

NOTE:

"TIME" means the following.

- 0: Means detected malfunction at present. (From malfunction detection to turning ignition switch OFF)
- 1–39: Means detected malfunction in past.

SONAR SYSTEM

< WIRING DIAGRAM >

WIRING DIAGRAM

SONAR SYSTEM

Wiring Diagram

WITH NAVIGATION

INFOID:000000006458065

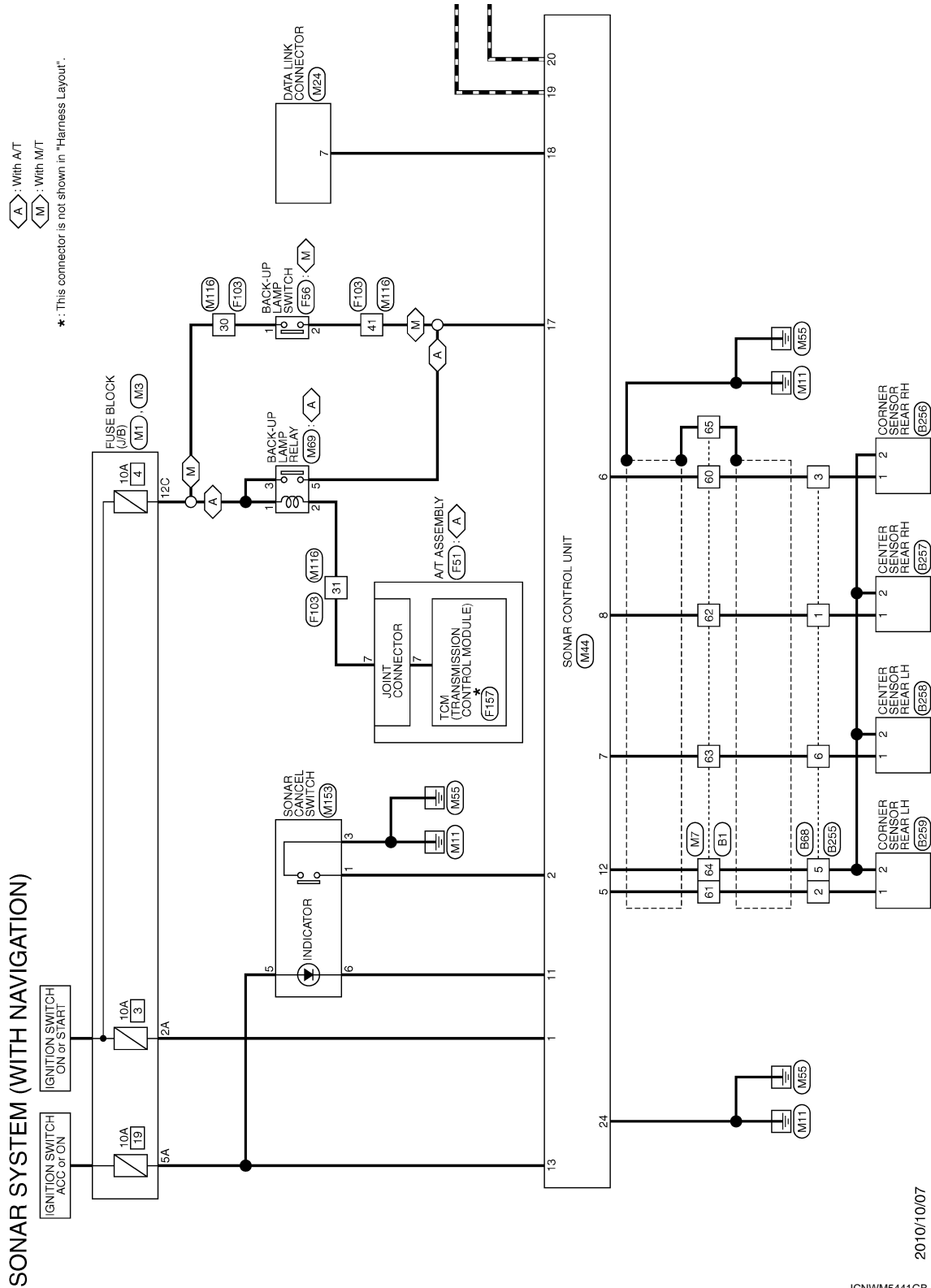

A
B
C
D
E
F
G
H
I
J
K
L
M
N
O
P

SN

2010/10/07

JCNWM5441GB

SONAR SYSTEM

< WIRING DIAGRAM >

*: This connector is not shown in "Harness Layout".

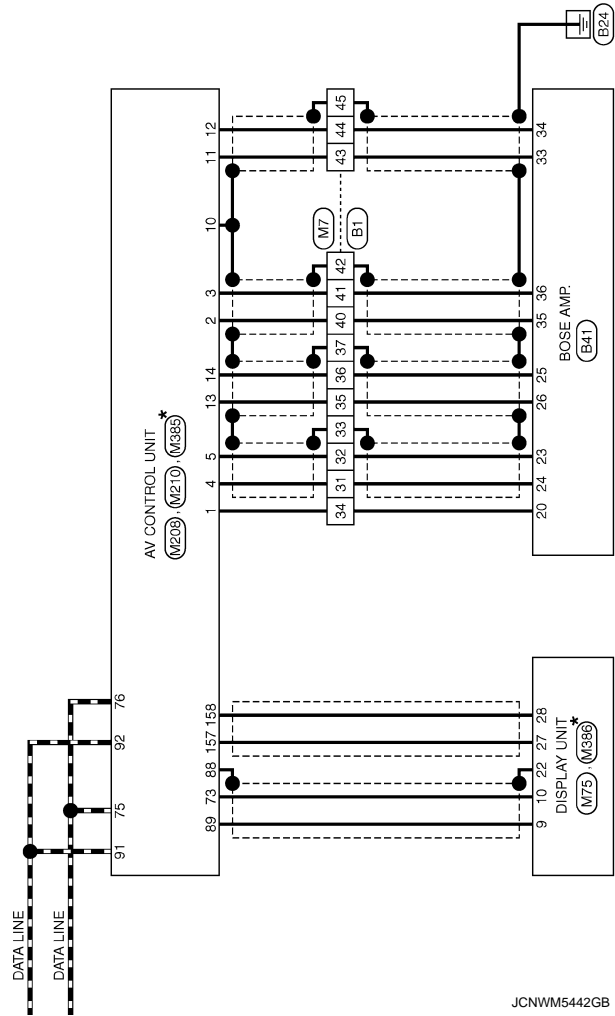

JCNWM5442GB

SONAR SYSTEM

< WIRING DIAGRAM >

SONAR SYSTEM (WITH NAVIGATION)

Connector No.	B1
Connector Name	WIRE TO WIRE
Connector Type	TH807V-CS16-TM4

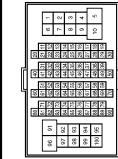

Terminal No.	Color of Wire	Signal Name [Specification]
1	GR	-
2	G	-
3	SB	-
4	Y	-
6	Y	-
15	V	-
16	BR	-
17	LG	-
18	W	-
20	L	-
21	P	-
22	L	-
23	P	-
24	GR	-
25	SB	-
26	G	-
27	W	-
28	G	-
31	V	-
32	SB	-
33	SHIELD	-
34	W	-
35	BR	-
36	Y	-
37	SHIELD	-
38	Y	-
39	LG	-
40	P	-
41	L	-
42	SHIELD	-
43	R	-
44	G	-
45	SHIELD	-
46	SB	-
48	L	-
50	P	-
55	P	-
56	G	-

58	V	-
59	LG	-
60	BR	-
61	W	-
62	R	-
63	L	-
64	Y	-
65	SHIELD	-
71	BR	-
72	SB	-
73	P	-
74	L	-
81	R	-
82	B	-
84	Y	-
85	L	-
86	GR	-
87	R	-
88	V	-
89	GR	-
91	EG	-
96	R	-
100	V	-

Connector No.	B41
Connector Name	BOSE AMP.
Connector Type	SCA19FRF-SGA4

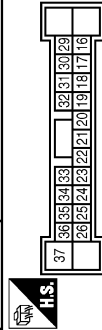

Terminal No.	Color of Wire	Signal Name [Specification]
16	SB	SOUND SIGNAL REAR WOOFER (+)
17	V	SOUND SIGNAL REAR WOOFER (-)
18	LG	SOUND SIGNAL REAR LH (+)
19	Y	SOUND SIGNAL REAR LH (-)
20	W	AMP. ON SIGNAL
21	SHIELD	SHIELD
22	GR	WOOFER AMP. ON SIGNAL
23	SB	-
24	V	SOUND SIGNAL REAR LH (+)
25	Y	SOUND SIGNAL REAR LH (-)
26	BR	SOUND SIGNAL REAR RH (+)
28	L	SOUND SIGNAL CENTER (+)

30	BG	SOUND SIGNAL CENTER (-)
31	L	SOUND SIGNAL REAR RH (+)
32	P	SOUND SIGNAL REAR RH (-)
33	R	SOUND SIGNAL FRONT RH (+)
34	G	SOUND SIGNAL FRONT RH (-)
35	P	SOUND SIGNAL FRONT LH (+)
36	L	SOUND SIGNAL FRONT LH (-)
37	SB	MODE CHANGE SIGNAL

Connector No.	B68
Connector Name	WIRE TO WIRE
Connector Type	RK08FGY

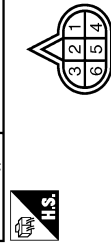

Terminal No.	Color of Wire	Signal Name [Specification]
1	R	-
2	W	-
3	BR	-
5	Y	-
6	L	-

Connector No.	B235
Connector Name	WIRE TO WIRE
Connector Type	RK08ANGY

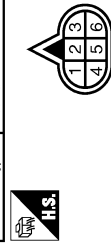

Terminal No.	Color of Wire	Signal Name [Specification]
1	R	-
2	W	-
3	B	-
5	Y	-
6	G	-

Connector No.	B236
Connector Name	CORNER SENSOR REAR RH
Connector Type	YDX02FB



Terminal No.	Color of Wire	Signal Name [Specification]
1	B	-
2	Y	-

Connector No.	B237
Connector Name	CENTER SENSOR REAR RH
Connector Type	YDX02FB

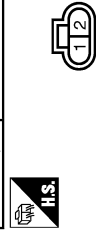

Terminal No.	Color of Wire	Signal Name [Specification]
1	R	-
2	Y	-

Connector No.	B238
Connector Name	CENTER SENSOR REAR LH
Connector Type	YDX02FB

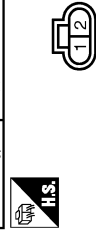

Terminal No.	Color of Wire	Signal Name [Specification]
1	G	-
2	Y	-

A
B
C
D
E
F
G
H
I
J
K
L
M
N
O
P

SN

SONAR SYSTEM

< WIRING DIAGRAM >

SONAR SYSTEM (WITH NAVIGATION)

Connector No.	B239
Connector Name	CORNER SENSOR REAR LH
Connector Type	YD202FB



Terminal No.	Color of Wire	Signal Name [Specification]
1	W	
2	Y	

Connector No.	F51
Connector Name	A/T ASSEMBLY
Connector Type	RK10FG-DGY

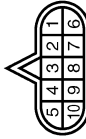

Terminal No.	Color of Wire	Signal Name [Specification]
1	Y	
2	R	
3	L	
4	V	
5	B	
6	G	
7	R	
8	P	
9	GR	
10	B	

Connector No.	F16
Connector Name	BACK-UP LAMP SWITCH
Connector Type	RK02FB



Terminal No.	Color of Wire	Signal Name [Specification]
1	R	
2	O	

Connector No.	F103
Connector Name	WIRE TO WIRE
Connector Type	TK30FW-NS10



Terminal No.	Color of Wire	Signal Name [Specification]
2	G	
3	W	
4	R	
5	B	
6	Y	
7	GR	
8	O	
9	Y	
10	LG	
11	R	
12	B	
13	L	
14	P	
15	G	
16	O	
17	B	
18	R	
19	B	
20	Y	
21	B	
22	LG	
23	R	
24	B	
25	L	
26	P	
27	Y	
28	G	
29	O	
30	B	
31	R	
32	B	
33	B	
34	L	
35	L	
36	P	
37	Y	
38	G	
39	O	
40	B	
41	O	
42	BR	

43	P	-
44	L	-
45	G	-
46	V	-

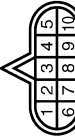

Connector No.	F157
Connector Name	TCM (TRANSMISSION CONTROL MODULE)
Connector Type	SP10FG



Terminal No.	Color of Wire	Signal Name [Specification]
1	-	VGN
2	-	BATT
3	-	CAN-H
4	-	K-LINE
5	-	GND
6	-	VGN
7	-	REV LAMP RLY
8	-	CAN-L
9	-	STARTER RLY
10	-	GND

Connector No.	M1
Connector Name	FUSE BLOCK (J/E)
Connector Type	NS08FW-M2



Terminal No.	Color of Wire	Signal Name [Specification]
1A	V	
2A	G	
3A	L	
4A	P	
5A	L	
6A	Y	

7A	R	-
8A	L	-

Connector No.	M3
Connector Name	FUSE BLOCK (J/B)
Connector Type	NS12FW-CS



Terminal No.	Color of Wire	Signal Name [Specification]
6C	SB	
7C	B	
8C	W	
9C	BG	
10C	L	
11C	LG	
12C	G	

JCNWM5444GB

SONAR SYSTEM

< WIRING DIAGRAM >

SONAR SYSTEM (WITH NAVIGATION)

Connector No.	M7
Connector Name	WIRE TO WIRE
Connector Type	TH80MW-CS (F-TM4)

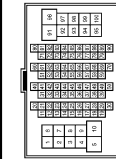

Terminal No.	Color of Wire	Signal Name [Specification]
1	GR	-
2	P	-
3	SB	- [With automatic drive positioner]
4	P	- [Without automatic drive positioner]
5	Y	-
6	L	-
7	R	-
8	BR	-
9	P	-
10	V	-
11	L	-
12	P	-
13	LG	-
14	LG	-
15	LG	-
16	BR	-
17	P	-
18	V	-
19	L	-
20	L	-
21	P	-
22	L	-
23	P	-
24	V	-
25	LG	-
26	BR	-
27	EG	-
28	LG	-
29	LG	-
30	V	-
31	V	-
32	LG	-
33	SHIELD	-
34	GR	-
35	BR	-
36	Y	-
37	SHIELD	-
38	SB	-
39	LG	-
40	O	-
41	W	-
42	SHIELD	-
43	R	-
44	G	-
45	SHIELD	-
46	SB	-
48	L	-
50	P	-
55	W	-

56	B	-
58	V	-
59	Y	-
60	Y	-
61	W	-
62	R	-
63	G	-
64	B	-
65	SHIELD	-
71	V	-
72	P	-
73	SB	-
74	V	-
81	W	-
82	BR	-
84	LG	-
85	EG	-
86	SB	-
87	G	-
88	GR	-
90	P	-
91	EG	-
95	EG	-
96	Y	-
100	P	-

Connector No.	M24
Connector Name	DATA LINK CONNECTOR
Connector Type	BD18FW-P

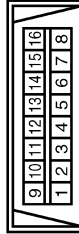

Terminal No.	Color of Wire	Signal Name [Specification]
3	LG	-
4	B	-
5	B	-
6	L	-
7	V	-
8	G	-
11	SB	-
14	P	-
16	R	-

Connector No.	M44
Connector Name	SONAR CONTROL UNIT
Connector Type	TH24FW-NH



Terminal No.	Color of Wire	Signal Name [Specification]
1	LG	IGN
2	SB	CANCEL SW SIGNAL
5	W	CORNER SENSOR SIGNAL REAR LH
6	Y	CORNER SENSOR SIGNAL REAR RH
7	G	CENTER SENSOR SIGNAL REAR LH
8	R	CENTER SENSOR SIGNAL REAR RH
11	B	CANCEL SW INDICATOR
12	B	SENSOR GND
13	GR	ACC
17	BG	R RANGE SIGNAL
18	V	K LINE
19	SB	AV COMM (H)
20	LG	AV COMM (L)
24	B	GND

Connector No.	M89
Connector Name	BACK-UP LAMP RELAY
Connector Type	MS2PFL-M2-LC



Terminal No.	Color of Wire	Signal Name [Specification]
1	R	-
2	W	-
3	LG	-
5	BG	-

Connector No.	M75
Connector Name	DISPLAY UNIT
Connector Type	TH24FW-NH



Terminal No.	Color of Wire	Signal Name [Specification]
6	SHIELD	SHIELD
7	SHIELD	SHIELD
8	W	CAMERA IMAGE SIGNAL
9	L	COMM (DSP->CONT)
10	P	COMM (CONT->DSP)
11	Y	BATTERY
12	B	GND
18	L	COMPOSITE IMAGE SIGNAL
19	P	COMPOSITE IMAGE GND
22	SHIELD	SHIELD
23	LG	ACC

A
B
C
D
E
F
G
H
I
J
K
L
M
N
O
P

SN

SONAR SYSTEM

< WIRING DIAGRAM >

SONAR SYSTEM (WITH NAVIGATION)

Connector No.	M116
Connector Name	WIRE TO WIRE
Connector Type	TK36MW-NS10

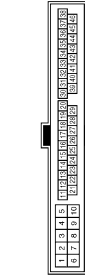

Terminal No.	Color of Wire	Signal Name [Specification]
2	W	-
3	EG	-
4	P	-
5	B	-
9	R	-
10	R	-
18	EG	-
20	Y	-
28	B	-
28	LG	-
30	LG	-
31	W	-
33	B	-
34	B	-
35	L	-
36	P	-
37	R	-
38	SB	-
41	EG	-
42	G	-
43	P	-
44	L	-
45	Y	-
46	SB	-

Connector No.	M153
Connector Name	SONAR CANCEL SWITCH
Connector Type	TK08FW

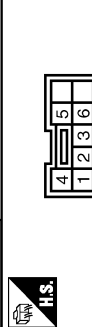

Terminal No.	Color of Wire	Signal Name [Specification]
1	SB	-
2	B	-
3	B	-
4	R	-
5	L	-
6	B	-

Connector No.	M208
Connector Name	AV CONTROL UNIT
Connector Type	TH18FW-CSZ

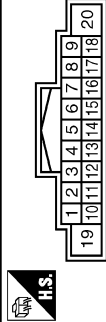

Terminal No.	Color of Wire	Signal Name [Specification]
1	GR	AMP ON SIGNAL
2	O	SOUND SIGNAL FRONT LH (+)
3	W	SOUND SIGNAL FRONT LH (-)
4	V	SOUND SIGNAL REAR LH (+)
5	LG	SOUND SIGNAL REAR LH (-)
6	P	STRG SW A
7	V	ACC
10	B	SHIELD
11	R	SOUND SIGNAL FRONT RH (+)
12	G	SOUND SIGNAL FRONT RH (-)
13	BR	SOUND SIGNAL REAR RH (+)
14	Y	SOUND SIGNAL REAR RH (-)
15	B	STRG SW GND
16	L	STRG SW B
19	Y	BATTERY
20	B	GND

Connector No.	M210
Connector Name	AV CONTROL UNIT
Connector Type	TH22FW-NH



Terminal No.	Color of Wire	Signal Name [Specification]
65	SB	PARKING BRAKE
67	P	COMPOSITE IMAGE GND
68	L	COMPOSITE IMAGE SIGNAL
71	SHIELD	MICROPHONE GND
72	G	MICROPHONE VCC
73	P	COMM (CONT->DISP)
74	P	CAN-L
75	LG	AV COMM (L)
76	LG	AV COMM (L)
79	L	ILLUMINATION
80	G	IGNITION
81	BG	REVERSE
82	R	VEHICLE SPEED (8-PULSE)
83	SHIELD	SHIELD
87	R	MICROPHONE SIGNAL
88	SHIELD	SHIELD
89	L	COMM (DISP->CONT)
90	L	CAN-H
91	SB	AV COMM (H)
92	SB	AV COMM (H)

Connector No.	M385
Connector Name	AV CONTROL UNIT
Connector Type	GT17HNF-4DS-HU

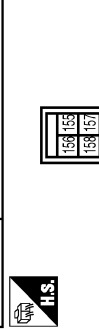

Terminal No.	Color of Wire	Signal Name [Specification]
157	-	RGB DIGITAL IMAGE SIGNAL (-)
158	-	RGB DIGITAL IMAGE SIGNAL (+)

Connector No.	M386
Connector Name	DISPLAY UNIT
Connector Type	GT17HNF-4DS-HU



Terminal No.	Color of Wire	Signal Name [Specification]
27	-	RGB DIGITAL IMAGE SIGNAL (-)
28	-	RGB DIGITAL IMAGE SIGNAL (+)

SONAR SYSTEM

< WIRING DIAGRAM >
WITHOUT NAVIGATION

SONAR SYSTEM (WITHOUT NAVIGATION)

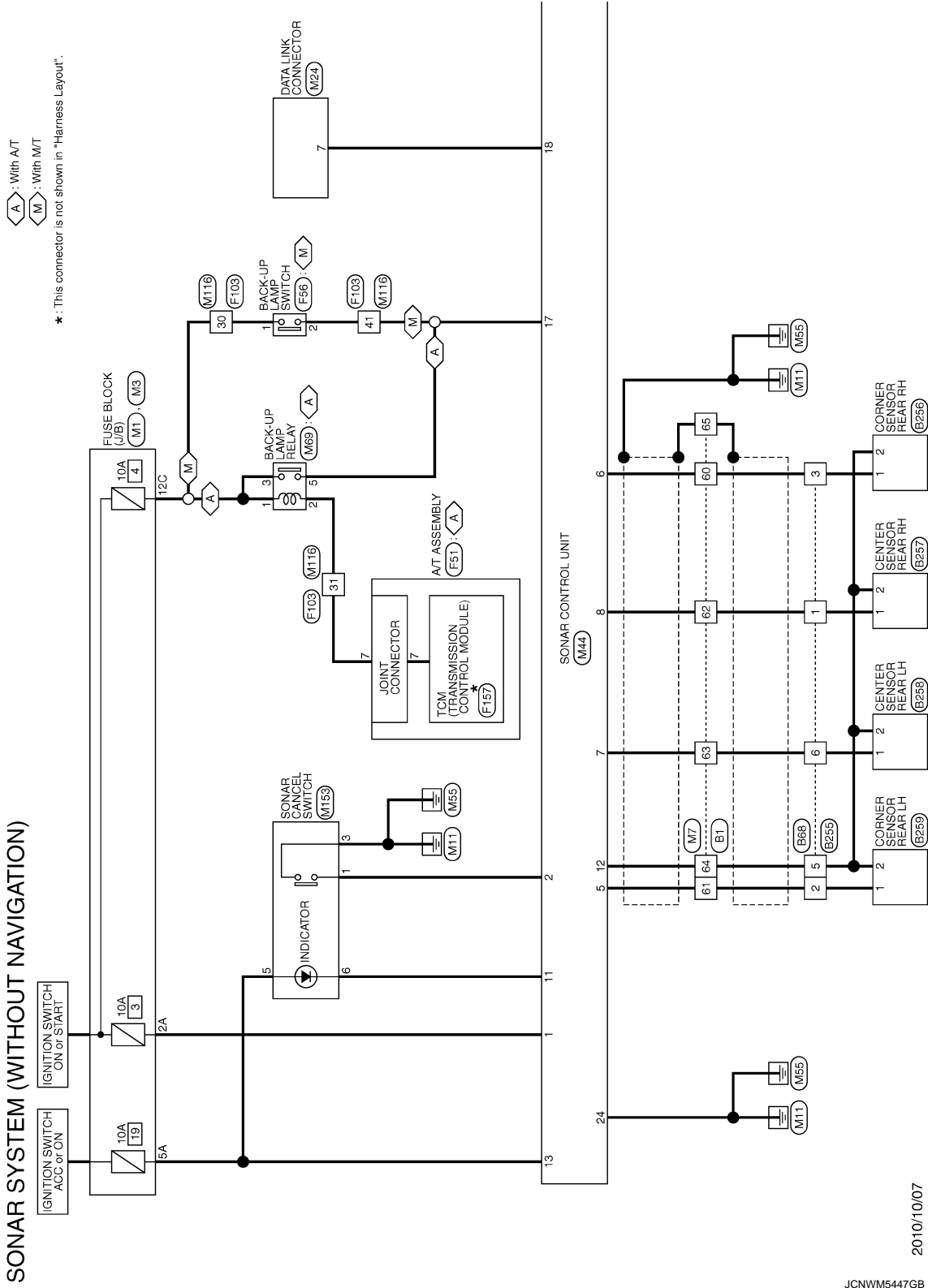

2010/10/07

JCNWM5447GB

A
B
C
D
E
F
G
H
I
J
K
L
M
N
O
P

SN

SONAR SYSTEM

< WIRING DIAGRAM >

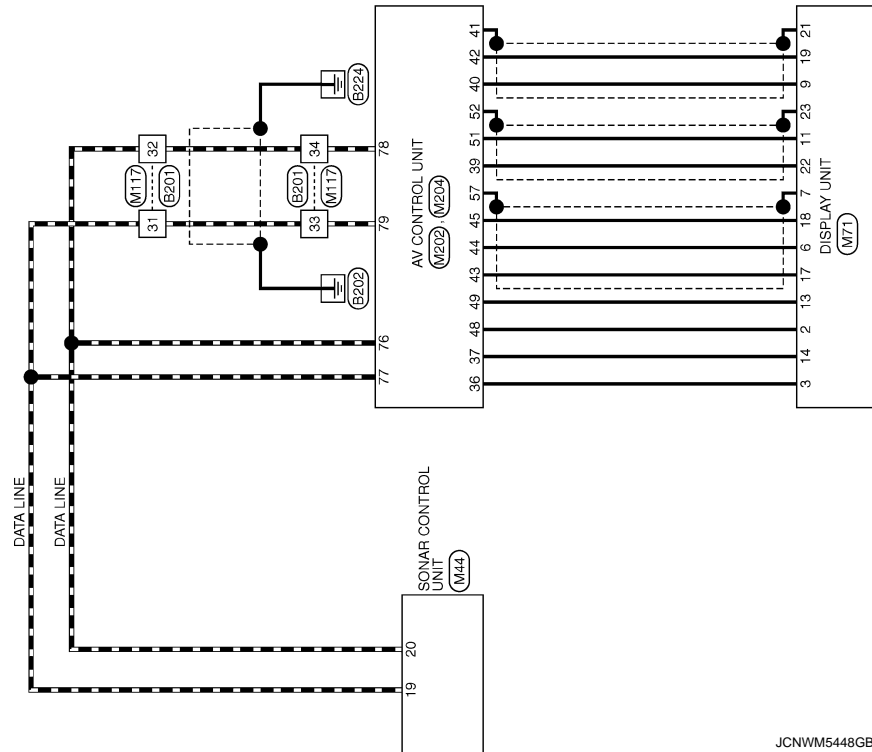

JCNWM5448GB

SONAR SYSTEM

< WIRING DIAGRAM >

SONAR SYSTEM (WITHOUT NAVIGATION)

Connector No.	B1
Connector Name	WIRE TO WIRE
Connector Type	TH80FN-CS16-TM4

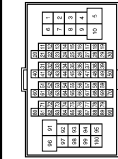

Terminal No.	Color of Wire	Signal Name [Specification]
1	GR	-
2	G	-
3	SB	-
4	Y	-
6	Y	-
15	V	-
16	BR	-
17	LG	-
18	W	-
20	L	-
21	P	-
22	L	-
23	P	-
24	GR	-
25	SB	-
26	G	-
27	W	-
28	G	-
31	V	-
32	SB	-
33	SHIELD	-
34	W	-
35	BR	-
36	Y	-
37	SHIELD	-
38	Y	-
39	LG	-
40	P	-
41	L	-
42	SHIELD	-
43	R	-
44	G	-
45	SHIELD	-
46	SB	-
48	L	-
50	P	-
55	P	-
56	G	-

58	V	-
59	LG	-
60	BR	-
61	W	-
62	R	-
63	L	-
64	Y	-
65	SHIELD	-
71	BR	-
72	SB	-
73	P	-
74	L	-
81	R	-
82	B	-
84	Y	-
85	L	-
86	GR	-
87	R	-
88	V	-
89	GR	-
91	Y	-
95	EG	-
96	R	-
100	V	-



Connector No.	B201
Connector Name	WIRE TO WIRE
Connector Type	TH80FN-CS16-TM4

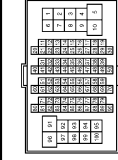

Terminal No.	Color of Wire	Signal Name [Specification]
1	GR	-
5	Y	-
6	G	-
7	BG	-
9	LG	-
10	R	-
30	B	-
31	L	-
32	P	-
33	SB	-
34	V	-
40	GR	-
41	LG	-
42	BG	-
43	R	-
45	G	-
46	SHIELD	-
47	G	-
48	Y	-
48	SHIELD	-
50	P	-
59	BG	-
71	R	-
72	V	-
80	V	-
81	SHIELD	-
82	Y	-
83	BR	-
84	O	-
85	SHIELD	-
86	G	-
87	R	-
88	W	-
89	B	-
90	SB	-
91	V	-
94	W	-
95	G	-

97	BR	-
----	----	---



Connector No.	B255
Connector Name	WIRE TO WIRE
Connector Type	RK08MGY



Terminal No.	Color of Wire	Signal Name [Specification]
1	R	-
2	W	-
3	B	-
5	Y	-
6	G	-

Connector No.	B256
Connector Name	CORNER SENSOR REAR RH
Connector Type	YDX02FB



Terminal No.	1	2
Color of Wire	R	B
Signal Name [Specification]	-	-

Terminal No.	1	2
Color of Wire	B	Y
Signal Name [Specification]	-	-



Connector No.	B63
Connector Name	WIRE TO WIRE
Connector Type	RK08FGY



Terminal No.	Color of Wire	Signal Name [Specification]
1	R	-
2	W	-
3	BR	-
5	Y	-
6	L	-

JCNWM5449GB

A
B
C
D
E
F
G
H
I
J
K
L
M
N
O
P

SN

SONAR SYSTEM

< WIRING DIAGRAM >

SONAR SYSTEM (WITHOUT NAVIGATION)

Connector No.	B257
Connector Name	CENTER SENSOR REAR RH
Connector Type	YDX0ZFE



Terminal No.	Color of Wire	Signal Name [Specification]
1	R	-
2	Y	-

Connector No.	B258
Connector Name	CENTER SENSOR REAR LH
Connector Type	YDX0ZFE



Terminal No.	Color of Wire	Signal Name [Specification]
1	G	-
2	Y	-

Connector No.	B259
Connector Name	CORNER SENSOR REAR LH
Connector Type	YDX0ZFE



Terminal No.	Color of Wire	Signal Name [Specification]
1	W	-
2	Y	-

Connector No.	F51
Connector Name	A/T ASSEMBLY
Connector Type	RK10FG-DGY

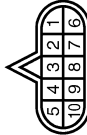

Terminal No.	Color of Wire	Signal Name [Specification]
1	Y	-
2	R	-
3	L	-
4	V	-
5	B	-
6	G	-
7	R	-
8	P	-
9	GR	-
10	B	-

Connector No.	F56
Connector Name	BACK-UP LAMP SWITCH
Connector Type	RK0ZFE



Terminal No.	Color of Wire	Signal Name [Specification]
1	R	-
2	O	-

Connector No.	F103
Connector Name	WIRE TO WIRE
Connector Type	TK3BFW-NS10

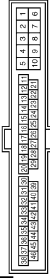

Terminal No.	Color of Wire	Signal Name [Specification]
2	G	-
3	W	-
4	R	-
5	B	-
9	Y	-
10	GR	-
18	O	-
20	B	-
28	B	-
29	LG	-
30	R	-
31	R	-
33	B	-
34	B	-
35	L	-
36	P	-
37	Y	-
38	G	-
41	O	-
42	BR	-
43	P	-
44	L	-
45	G	-
46	V	-

Connector No.	F157
Connector Name	TCM (TRANSMISSION CONTROL MODULE)
Connector Type	SP10FG



Terminal No.	Color of Wire	Signal Name [Specification]
1	-	-
2	-	VGN
3	-	BATT
4	-	CAN-H
5	-	K-LINE
6	-	GND
7	-	VIGN
8	-	REV LAMP RLY
9	-	CAN-L
10	-	STARTER RLY
		GND

Connector No.	M1
Connector Name	FUSE BLOCK (J/B)
Connector Type	NSJ06FW-M2



Terminal No.	Color of Wire	Signal Name [Specification]
1A	V	-
2A	G	-
3A	L	-
4A	P	-
5A	L	-
6A	Y	-
7A	R	-
8A	L	-

SONAR SYSTEM

< WIRING DIAGRAM >

SONAR SYSTEM (WITHOUT NAVIGATION)

Connector No.	M3
Connector Name	FUSE BLOCK (J/B)
Connector Type	MS12FW-CS



Terminal No.	Color of Wire	Signal Name [Specification]
6C	SB	-
7C	B	-
8C	W	-
9C	EG	-
10C	L	-
11C	LG	-
12C	G	-

Connector No.	M7
Connector Name	WIPE TO WIPE
Connector Type	THROMW-CS16-TM4

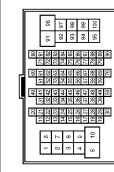

Terminal No.	Color of Wire	Signal Name [Specification]
1	GR	-
2	P	-
3	SB	- [With automatic drive positioner]
4	Y	- [Without automatic drive positioner]
6	L	-
15	R	-
16	BR	-
17	P	-
18	V	-
20	L	-
21	P	-
22	L	-
23	P	-
24	V	-

25	LG	-
26	BR	-
27	EG	-
28	LG	-
31	V	-
32	LG	-
33	SHIELD	-
34	GR	-
35	BR	-
36	Y	-
37	SHIELD	-
38	SB	-
39	LG	-
40	O	-
41	W	-
42	SHIELD	-
43	R	-
44	G	-
45	SHIELD	-
46	SB	-
49	L	-
50	P	-
55	W	-
56	B	-
58	V	-
59	Y	-
60	Y	-
62	R	-
63	G	-
64	B	-
65	SHIELD	-
71	V	-
72	P	-
73	SB	-
74	V	-
81	W	-
82	BR	-
84	LG	-
85	EG	-
86	SB	-
87	G	-
88	GR	-
90	P	-
91	EG	-
95	BG	-
96	Y	-
100	P	-

Connector No.	M24
Connector Name	DATA LINK CONNECTOR
Connector Type	BD16FN-P

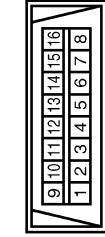

Terminal No.	Color of Wire	Signal Name [Specification]
3	LG	-
4	B	-
5	B	-
6	L	-
7	V	-
8	G	-
11	SB	-
14	P	-
16	R	-

Connector No.	M44
Connector Name	SONAR CONTROL UNIT
Connector Type	TH24FW-RH

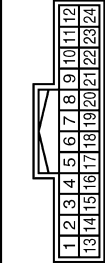

Terminal No.	Color of Wire	Signal Name [Specification]
1	LG	IGN
2	SB	CANCEL SW SIGNAL
5	W	CORNER SENSOR SIGNAL REAR LH
6	Y	CORNER SENSOR SIGNAL REAR RH
7	G	CENTER SENSOR SIGNAL REAR LH
8	R	CENTER SENSOR SIGNAL REAR RH
11	B	CANCEL SW INDICATOR
12	B	SENSOR GND
13	GR	ACC
17	BG	R RANGE SIGNAL
18	V	K LINE
19	SB	AV COMM (H)
20	LG	AV COMM (L)

24	B	GND
----	---	-----



Connector No.	M89
Connector Name	BACK-UP LAMP RELAY
Connector Type	MS02FL-M2-LC



Terminal No.	Color of Wire	Signal Name [Specification]
1	R	-
2	W	-
3	LG	-
5	BG	-

A
B
C
D
E
F
G
H
I
J
K
L
M
SN
O
P

SONAR SYSTEM

< WIRING DIAGRAM >

A
B
C
D
E
F
G
H
I
J
K
L
M
N
O
P

SONAR SYSTEM (WITHOUT NAVIGATION)

Connector No.	M224
Connector Name	AV CONTROL UNIT
Connector Type	TH2FVN-NH



66	77	78	79	80	81	82	83	84	85	86	87	88	89	90	91
92	93	94	95	96	97	98	99	100	101	102	103	104	105	106	107

Terminal No.	Color of Wire	Signal Name [Specification]
76	LG	AV COMM (L)
77	SB	AV COMM (H)
78	LG	AV COMM (L)
79	SB	AV COMM (H)
80	P	CAN-L
81	L	CAN-H
82	BR	SW GND
86	SHIELD	SHIELD
87	L	TEL VOICE SIGNAL (+)
88	P	TEL VOICE SIGNAL (-)
92	R	VEHICLE SPEED (8-PULSE)
93	SB	PARKING BRAKE
94	BG	REVERSE
95	G	IGNITION
96	V	DISK EJECT SIGNAL

SN

JCNWM5453GB

DIAGNOSIS AND REPAIR WORKFLOW

< BASIC INSPECTION >

BASIC INSPECTION

DIAGNOSIS AND REPAIR WORKFLOW

Work Flow

INFOID:000000006458066

OVERALL SEQUENCE

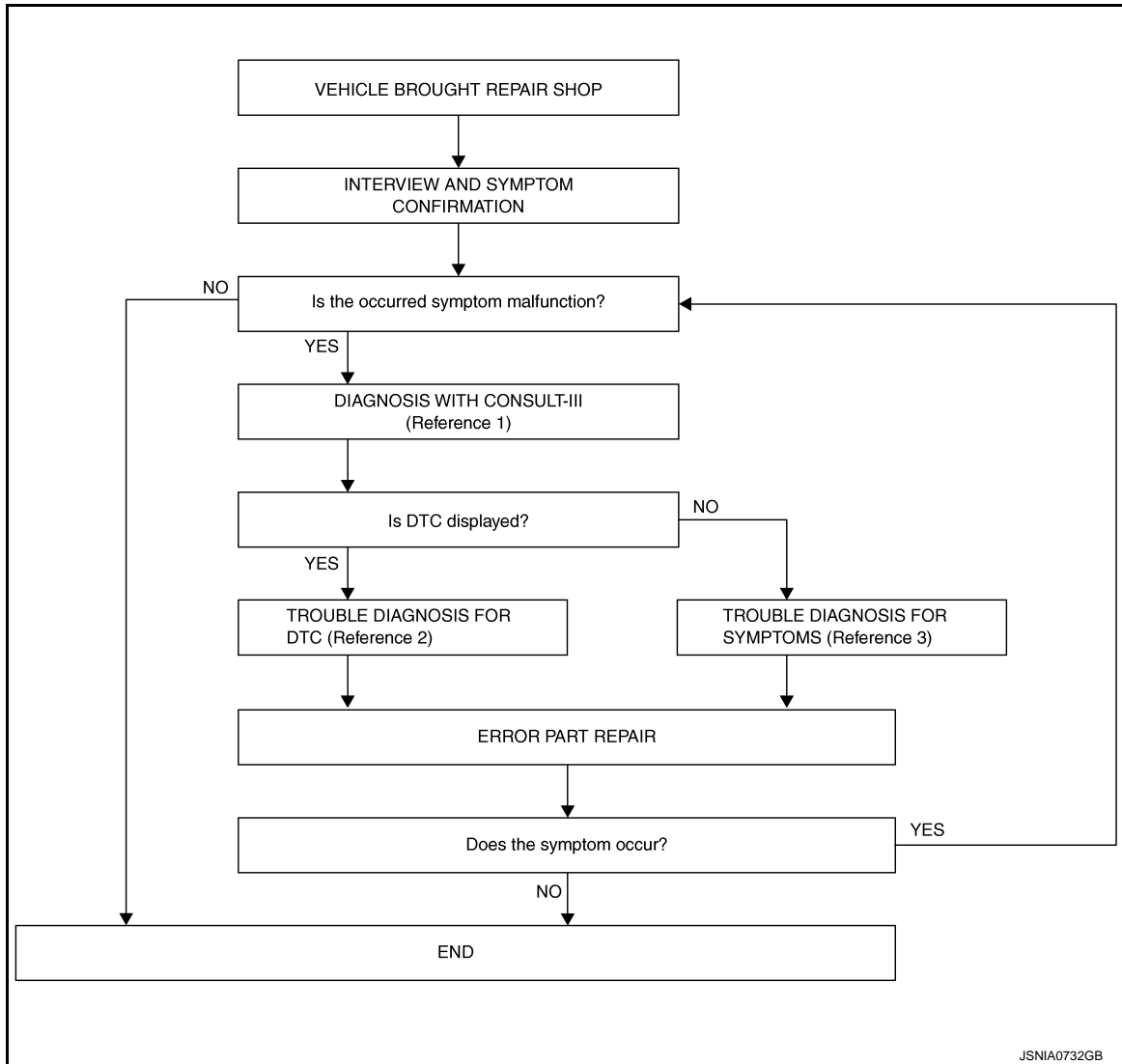

JSNIA0732GB

- Reference 1... Refer to [SN-11, "CONSULT-III Function"](#).
- Reference 2... Refer to [SN-16, "DTC Index"](#).
- Reference 3... Refer to [SN-44, "Symptom Table"](#).

DETAILED FLOW

1. INTERVIEW AND SYMPTOM CONFIRMATION

Check the malfunction symptoms by performing the following items.

- Interview the customer to obtain the malfunction information (conditions and environment when the malfunction occurred).
- Check if mud, or other foreign objects are not adhering to the sonar sensor.
- Check if there is no deformation, scratches, or other damage to the sonar sensor.
- Check if water has not accumulated in the sonar sensor.
- Check the symptom.

Is the occurred symptom malfunction?

YES >> GO TO 2.

DIAGNOSIS AND REPAIR WORKFLOW

< BASIC INSPECTION >

NO >> INSPECTION END

2. DIAGNOSIS WITH CONSULT-III

1. Connect CONSULT-III and perform a self-diagnosis for "SONAR". Refer to [SN-11, "CONSULT-III Function"](#).
2. Check if any DTC is displayed in the self-diagnosis results.

Is DTC displayed?

YES >> GO TO 3.

NO >> GO TO 4.

3. TROUBLE DIAGNOSIS FOR DTC

1. Check the DTC indicated in the self-diagnosis results.
2. Perform the relevant diagnosis referring to the DTC Index. Refer to [SN-16, "DTC Index"](#).

>> GO TO 5.

4. TROUBLE DIAGNOSIS FOR SYMPTOMS

Perform the relevant diagnosis referring to the diagnosis chart by symptom. Refer to [SN-44, "Symptom Table"](#).

>> GO TO 5.

5. ERROR PART REPAIR

1. Repair or replace the identified malfunctioning parts.
2. Perform a self-diagnosis for "SONAR" with CONSULT-III.
3. Check that the symptom does not occur.

Does the symptom occur?

YES >> GO TO 1.

NO >> INSPECTION END

A
B
C
D
E
F
G
H
I
J
K
L
M
O
P

SN

B2704 CORNER SENSOR [RL]

< DTC/CIRCUIT DIAGNOSIS >

DTC/CIRCUIT DIAGNOSIS

B2704 CORNER SENSOR [RL]

Description

INFOID:000000006458067

Component	Description
CORNER/CENTER SENSOR	The obstacle distance is detected. The signal is transmitted to the sonar control unit.

DTC Logic

INFOID:000000006458068

DTC DETECTION LOGIC

DTC No.	CONSULT-III indication	DTC detection condition	Troubleshooting
B2704	CORNER SENSOR [RL] [B2704]	Corner sensor rear LH is malfunctioning.	Replace corner sensor rear LH Refer to SN-46, "Removal and Installation"

B2705 SENSOR HARNESS OPEN [CR-RL]

< DTC/CIRCUIT DIAGNOSIS >

B2705 SENSOR HARNESS OPEN [CR-RL]

Description

INFOID:000000006458069

Component	Description
CORNER/CENTER SENSOR	The obstacle distance is detected. The signal is transmitted to the sonar control unit.

DTC Logic

INFOID:000000006458070

DTC DETECTION LOGIC

DTC No.	CONSULT-III indication	DTC detection condition	Troubleshooting
B2705	SENSOR HARNESS OPEN [CR-RL] [B2705]	Corner sensor rear LH harness circuit is open.	Check corner sensor rear LH circuit

Diagnosis Procedure

INFOID:000000006458071

1. CHECK HARNESS CORNER SENSOR REAR LH SIGNAL CIRCUIT

1. Turn ignition switch OFF.
2. Disconnect sonar control unit connector and corner sensor rear LH connector.
3. Check continuity between sonar control unit harness connector and corner sensor rear LH harness connector.

Sonar control unit		Corner sensor rear LH		Continuity
Connector	Terminal	Connector	Terminal	
M44	5	B259	1	Existed

4. Check continuity between sonar control unit harness connector and ground.

Sonar control unit		Ground	Continuity
Connector	Terminal		
M44	5		Not existed

Is the inspection result normal?

YES >> GO TO 2.

NO >> Repair harness or connector.

2. CHECK HARNESS CORNER SENSOR REAR LH GROUND CIRCUIT

Check continuity between sonar control unit harness connector and corner sensor rear LH harness connector.

Sonar control unit		Corner sensor rear LH		Continuity
Connector	Terminal	Connector	Terminal	
M44	12	B259	2	Existed

Is the inspection result normal?

YES >> INSPECTION END

NO >> Repair harness or connector.

A
B
C
D
E
F
G
H
I
J
K
L
M
O
P

SN

B2706 CORNER SENSOR [RR]

< DTC/CIRCUIT DIAGNOSIS >

B2706 CORNER SENSOR [RR]

Description

INFOID:000000006458072

Component	Description
CORNER/CENTER SENSOR	The obstacle distance is detected. The signal is transmitted to the sonar control unit.

DTC Logic

INFOID:000000006458073

DTC DETECTION LOGIC

DTC No.	CONSULT-III indication	DTC detection condition	Troubleshooting
B2706	CORNER SENSOR [RR] [B2706]	Corner sensor rear RH is malfunctioning.	Replace corner sensor rear RH Refer to SN-46. "Removal and Installation"

B2707 SENSOR HARNESS OPEN [CR-RR]

< DTC/CIRCUIT DIAGNOSIS >

B2707 SENSOR HARNESS OPEN [CR-RR]

Description

INFOID:000000006458074

Component	Description
CORNER/CENTER SENSOR	The obstacle distance is detected. The signal is transmitted to the sonar control unit.

DTC Logic

INFOID:000000006458075

DTC DETECTION LOGIC

DTC No.	CONSULT-III indication	DTC detection condition	Troubleshooting
B2707	SENSOR HARNESS OPEN [CR-RR] [B2707]	Corner sensor rear RH harness circuit is open.	Check corner sensor rear RH circuit

Diagnosis Procedure

INFOID:000000006458076

1. CHECK HARNESS CORNER SENSOR REAR RH SIGNAL CIRCUIT

1. Turn ignition switch OFF.
2. Disconnect sonar control unit connector and corner sensor rear RH connector.
3. Check continuity between sonar control unit harness connector and corner sensor rear RH harness connector.

Sonar control unit		Corner sensor rear RH		Continuity
Connector	Terminal	Connector	Terminal	
M44	6	B256	1	Existed

4. Check continuity between sonar control unit harness connector and ground.

Sonar control unit		Ground	Continuity
Connector	Terminal		
M44	6		Not existed

Is the inspection result normal?

YES >> GO TO 2.

NO >> Repair harness or connector.

2. CHECK HARNESS CORNER SENSOR REAR RH GROUND CIRCUIT

Check continuity between sonar control unit harness connector and corner sensor rear RH harness connector.

Sonar control unit		Corner sensor rear RH		Continuity
Connector	Terminal	Connector	Terminal	
M44	12	B256	2	Existed

Is the inspection result normal?

YES >> INSPECTION END

NO >> Repair harness or connector.

A
B
C
D
E
F
G
H
I
J
K
L
M
SN
O
P

B2708 CENTER SENSOR [BL]

< DTC/CIRCUIT DIAGNOSIS >

B2708 CENTER SENSOR [BL]

Description

INFOID:000000006458077

Component	Description
CORNER/CENTER SENSOR	The obstacle distance is detected. The signal is transmitted to the sonar control unit.

DTC Logic

INFOID:000000006458078

DTC DETECTION LOGIC

DTC No.	CONSULT-III indication	DTC detection condition	Troubleshooting
B2708	CENTER SENSOR [BL] [B2708]	Center sensor rear LH is malfunctioning.	Replace center sensor rear LH Refer to SN-46. "Removal and Installation"

B2709 SENSOR HARNESS OPEN [CT-BL]

< DTC/CIRCUIT DIAGNOSIS >

B2709 SENSOR HARNESS OPEN [CT-BL]

Description

INFOID:000000006458079

Component	Description
CORNER/CENTER SENSOR	The obstacle distance is detected. The signal is transmitted to the sonar control unit.

DTC Logic

INFOID:000000006458080

DTC DETECTION LOGIC

DTC No.	CONSULT-III indication	DTC detection condition	Troubleshooting
B2709	SENSOR HARNESS OPEN [CT-BL] [B2709]	Center sensor rear LH harness circuit is open.	Check center sensor rear LH circuit

Diagnosis Procedure

INFOID:000000006458081

1. CHECK HARNESS CENTER SENSOR REAR LH SIGNAL CIRCUIT

1. Turn ignition switch OFF.
2. Disconnect sonar control unit connector and center sensor rear LH connector.
3. Check continuity between sonar control unit harness connector and center sensor rear LH harness connector.

Sonar control unit		Center sensor rear LH		Continuity
Connector	Terminal	Connector	Terminal	
M44	7	B258	1	Existed

4. Check continuity between sonar control unit harness connector and ground.

Sonar control unit		Ground	Continuity
Connector	Terminal		
M44	7		Not existed

Is the inspection result normal?

YES >> GO TO 2.

NO >> Repair harness or connector.

2. CHECK HARNESS CENTER SENSOR REAR LH GROUND CIRCUIT

Check continuity between sonar control unit harness connector and center sensor rear LH harness connector.

Sonar control unit		Center sensor rear LH		Continuity
Connector	Terminal	Connector	Terminal	
M44	12	B258	2	Existed

Is the inspection result normal?

YES >> INSPECTION END

NO >> Repair harness or connector.

A
B
C
D
E
F
G
H
I
J
K
L
M
O
P

SN

B270A CENTER SENSOR [BR]

< DTC/CIRCUIT DIAGNOSIS >

B270A CENTER SENSOR [BR]

Description

INFOID:000000006458082

Component	Description
CORNER/CENTER SENSOR	The obstacle distance is detected. The signal is transmitted to the sonar control unit.

DTC Logic

INFOID:000000006458083

DTC DETECTION LOGIC

DTC No.	CONSULT-III indication	DTC detection condition	Troubleshooting
B270A	CENTER SENSOR [BR] [B270A]	Center sensor rear RH is malfunctioning.	Replace center sensor rear RH Refer to SN-46. "Removal and Installation"

B270B SENSOR HARNESS OPEN [CT-BR]

< DTC/CIRCUIT DIAGNOSIS >

B270B SENSOR HARNESS OPEN [CT-BR]

Description

INFOID:000000006458084

Component	Description
CORNER/CENTER SENSOR	The obstacle distance is detected. The signal is transmitted to the sonar control unit.

DTC Logic

INFOID:000000006458085

DTC DETECTION LOGIC

DTC No.	CONSULT-III indication	DTC detection condition	Troubleshooting
B270B	SENSOR HARNESS OPEN [CT-BR] [B270B]	Center sensor rear RH harness circuit is open.	Check center sensor rear RH circuit

Diagnosis Procedure

INFOID:000000006458086

1. CHECK HARNESS CENTER SENSOR REAR RH SIGNAL CIRCUIT

1. Turn ignition switch OFF.
2. Disconnect sonar control unit connector and center sensor rear RH connector.
3. Check continuity between sonar control unit harness connector and center sensor rear RH harness connector.

Sonar control unit		Center sensor rear RH		Continuity
Connector	Terminal	Connector	Terminal	
M44	8	B257	1	Existed

4. Check continuity between sonar control unit harness connector and ground.

Sonar control unit		Ground	Continuity
Connector	Terminal		
M44	8		Not existed

Is the inspection result normal?

YES >> GO TO 2.

NO >> Repair harness or connector.

2. CHECK HARNESS CENTER SENSOR REAR RH GROUND CIRCUIT

Check continuity between sonar control unit harness connector and center sensor rear RH harness connector.

Sonar control unit		Center sensor rear RH		Continuity
Connector	Terminal	Connector	Terminal	
M44	12	B257	2	Existed

Is the inspection result normal?

YES >> INSPECTION END

NO >> Repair harness or connector.

A
B
C
D
E
F
G
H
I
J
K
L
M
O
P

SN

POWER SUPPLY AND GROUND CIRCUIT

< DTC/CIRCUIT DIAGNOSIS >

POWER SUPPLY AND GROUND CIRCUIT SONAR CONTROL UNIT

SONAR CONTROL UNIT : Diagnosis Procedure

INFOID:000000006458087

1.CHECK FUSE

Check for blown fuses.

Power source	Fuse No.
Ignition switch ACC or ON	19
Ignition switch ON or START	3

Is the inspection result normal?

YES >> GO TO 2.

NO >> Be sure to eliminate cause of malfunction before installing new fuse.

2.CHECK POWER SUPPLY CIRCUIT

1. Turn ignition switch ON.
2. Check voltage between sonar control unit harness connector and ground.

Signal name	Connector No.	Terminal No.	Ignition switch position	Value (Approx.)
Battery power supply	M44	13	OFF	Battery voltage
Ignition signal	M44	1	ON	Battery voltage

Is the inspection result normal?

YES >> GO TO 3.

NO >> Repair or replace sonar control unit power supply harness.

3.CHECK GROUND CIRCUIT

1. Turn ignition switch OFF.
2. Disconnect sonar control unit connector.
3. Check continuity between sonar control unit harness connector and ground.

Sonar control unit		Ground	Continuity
Connector	Terminal		
M44	24		Existed

Is the inspection result normal?

YES >> INSPECTION END

NO >> Repair or replace sonar control unit ground harness.

R RANGE SIGNAL CIRCUIT

< DTC/CIRCUIT DIAGNOSIS >

R RANGE SIGNAL CIRCUIT

Description

INFOID:000000006458088

The sonar control unit turns the sonar system activation OFF when inputting the reverse signal.

Component Function Check

INFOID:000000006458089

1. SONAR CONTROL UNIT DATA MONITOR INSPECTION

Check "REVERSE RANGE" with "DATA MONITOR" of "SONAR".

REVERSE RANGE

Vehicle condition	Indication
Shift position in R position	: On
Other than shift position in R position	: Off

>> INSPECTION END

Diagnosis Procedure

INFOID:000000006458090

1. CHECK P RANGE SIGNAL

1. Turn ignition switch ON.
2. Check voltage between sonar control unit harness connector and ground.

(+) Sonar control unit		(-)	Condition	Voltage (Approx.)
Connector	Terminal			
M44	17	Ground	Shift position in R position.	12.0 V
			Other than shift position in R position.	0 V

Is the inspection result normal?

- YES >> INSPECTION END
NO >> Repair harness or connector.

A
B
C
D
E
F
G
H
I
J
K
L
M

SN

O
P

SONAR CANCEL SWITCH CIRCUIT

< DTC/CIRCUIT DIAGNOSIS >

SONAR CANCEL SWITCH CIRCUIT

Description

INFOID:000000006458091

The sonar control unit turns the sonar system activation OFF when inputting the cancel switch signal.

Component Function Check

INFOID:000000006458092

1. SONAR CONTROL UNIT DATA MONITOR INSPECTION

Check "CANCEL SW" with "DATA MONITOR" of "SONAR".

Cancel switch

Vehicle condition	Indication
While pressing the sonar cancel switch	: On
Other than above	: Off

>> INSPECTION END

Diagnosis Procedure

INFOID:000000006458093

1. CHECK HARNESS CANCEL SWITCH SIGNAL CIRCUIT

1. Disconnect sonar control unit connector and cancel switch connector.
2. Check continuity between sonar control unit harness connector and cancel switch harness connector.

Sonar control unit		Cancel switch		Continuity
Connector	Terminal	Connector	Terminal	
M44	2	M153	1	Existed

3. Check continuity between sonar control unit harness connector and ground.

Sonar control unit		Ground	Continuity
Connector	Terminal		
M44	2		Not existed

Is the inspection result normal?

YES >> GO TO 2.

NO >> Repair harness or connector.

2. CHECK VOLTAGE SONAR CONTROL UNIT

1. Connect sonar control unit connector.
2. Turn ignition switch ON.
3. Check voltage between sonar control unit harness connector and ground.

(+)		(-)	Voltage (Approx.)
Connector	Terminal		
M44	2	Ground	12.0 V

Is the inspection result normal?

YES >> GO TO 3.

NO >> Replace sonar control unit. Refer to [SN-45. "Removal and Installation"](#).

3. CHECK CANCEL SWITCH

1. Turn ignition switch OFF.
2. Check sonar cancel switch function. Refer to [SN-42. "Component Function Check"](#).

SONAR CANCEL SWITCH CIRCUIT

< DTC/CIRCUIT DIAGNOSIS >

Is the inspection result normal?

YES >> GO TO 4.

NO >> Replace sonar cancel switch. Refer to [SN-47. "Removal and Installation"](#).

4. CHECK HARNESS CANCEL SWITCH GROUND CIRCUIT

1. Turn ignition switch ON.
2. Check continuity between cancel switch harness connector and ground.

Cancel switch		Ground	Continuity
Connector	Terminal		
M153	3		Existed

Is the inspection result normal?

YES >> INSPECTION END

NO >> Repair harness or connector.

A
B
C
D
E
F
G
H
I
J
K
L
M
N
O
P

SN

SONAR SYSTEM SYMPTOMS

< SYMPTOM DIAGNOSIS >

SYMPTOM DIAGNOSIS

SONAR SYSTEM SYMPTOMS

Symptom Table

INFOID:000000006458094

Symptom	Check item	Diagnosis method
All sonar sensors do not activate.	"SONAR" is indicated on "SELECT SYSTEM" screen after connection CONSULT-III.	<ul style="list-style-type: none"> Perform "Self Diagnostic Result" of "SONAR" with CONSULT-III. Refer to SN-11, "CONSULT-III Function". Perform the on board diagnosis of MULTI AV. Refer to AV-232, "On Board Diagnosis Function" (BOSE audio without navigation) or AV-369, "On Board Diagnosis Function" (BOSE audio with navigation). Check reverse signal for sonar control unit. Refer to SN-41, "Diagnosis Procedure".
	"SONAR" is not indicated on "SELECT SYSTEM" screen after connection CONSULT-III.	Check sonar control unit power supply and ground circuit. Refer to SN-40, "SONAR CONTROL UNIT : Diagnosis Procedure" .
Any sonar sensor does not activate.	—	Perform "Self Diagnostic Result" of "SONAR" with CONSULT-III. Refer to SN-11, "CONSULT-III Function" .
Sonar indicator is not displayed by display unit.	—	Perform the on board diagnosis of MULTI AV. Refer to AV-232, "On Board Diagnosis Function" (BOSE audio without navigation) or AV-369, "On Board Diagnosis Function" (BOSE audio with navigation).

SONAR CONTROL UNIT

< REMOVAL AND INSTALLATION >

REMOVAL AND INSTALLATION

SONAR CONTROL UNIT

Exploded View

INFOID:000000006458095

1. Sonar control unit

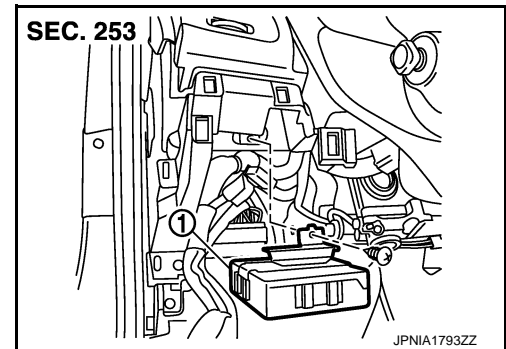

Removal and Installation

INFOID:000000006458096

REMOVAL

1. Remove the instrument finisher A. Refer to [IP-13, "A/T MODELS : Removal and Installation"](#) (A/T models) or [IP-24, "M/T MODELS : Removal and Installation"](#) (M/T models).
2. Remove sonar control unit screw, then disconnect sonar control unit connector and remove the sonar control unit.

INSTALLATION

Install in the reverse order of removal.

A
B
C
D
E
F
G
H
I
J
K
L
M
SN
O
P

SONAR SENSOR

< REMOVAL AND INSTALLATION >

SONAR SENSOR

Exploded View

INFOID:000000006458097

1. Rear bumper
2. Corner sensor rear
3. Center sensor rear

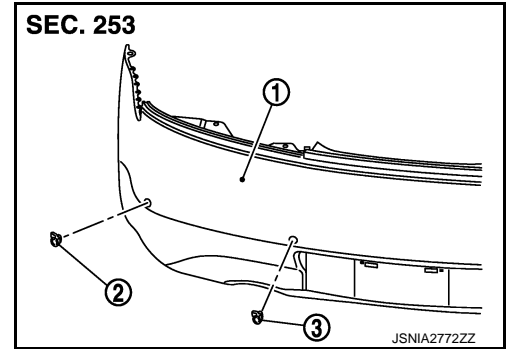

Removal and Installation

INFOID:000000006458098

REMOVAL

1. Remove the rear bumper.
2. Disconnect rear sensor connector.
3. Press the spring fixing the sensor (1) (black arrows).
4. Remove the sensor to the white arrow direction.

2 : rear bumper

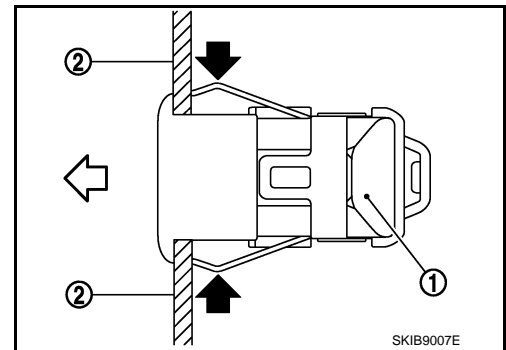

INSTALLATION

Install in the reverse order of removal.

CAUTION:

The connector direction is within $\pm 10^\circ$ from the horizontal position when assembling the bumper.

A : Horizontal position
a : 10°

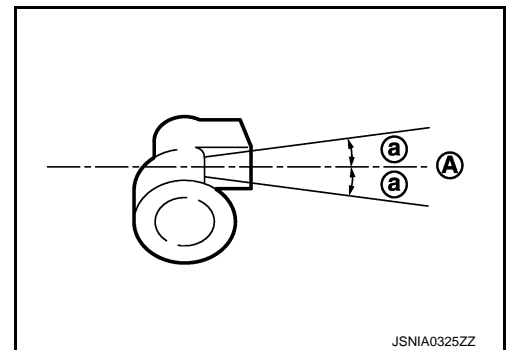

SONAR CANCEL SWITCH

< REMOVAL AND INSTALLATION >

SONAR CANCEL SWITCH

Exploded View

- 1 : Sonar cancel switch
- A : Pawls

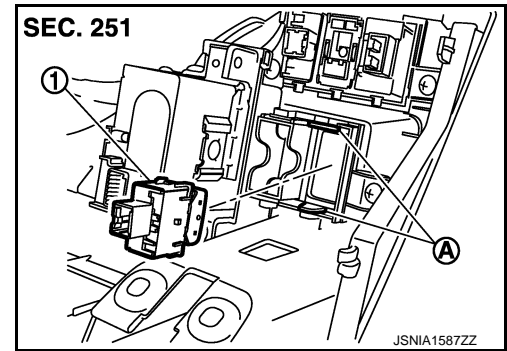

Removal and Installation

INFOID:000000006458100

REMOVAL

1. Remove the instrument driver lower panel. Refer to [IP-13, "A/T MODELS : Removal and Installation"](#) (A/T models) or [IP-24, "M/T MODELS : Removal and Installation"](#) (M/T models).
2. Disengage the pawls. And then remove sonar cancel switch.

INSTALLATION

Install in the reverse order of removal.

A
B
C
D
E
F
G
H
I
J
K
L
M
N
O
P

SN