

SECTION **DEF**
DEFOGGER

A
B
C
D
E
F
G
H
I
J
K
DEF
M
N
O
P

CONTENTS

SYSTEM DESCRIPTION	3	REAR WINDOW DEFOGGER AND DOOR MIRROR DEFOGGER DO NOT OPERATE ...	19
REAR WINDOW DEFOGGER SYSTEM	3	Diagnosis Procedure	19
System Diagram	3	REAR WINDOW DEFOGGER DOES NOT OPERATE BUT BOTH DOOR MIRROR DEFOGGER OPERATE	20
System Description	3	Diagnosis Procedure	20
Component Parts Location	4	DOOR MIRROR DEFOGGER DOES NOT OPERATE	21
Component Description	4	BOTH SIDES	21
DTC/CIRCUIT DIAGNOSIS	6	BOTH SIDES : Diagnosis Procedure	21
POWER SUPPLY AND GROUND CIRCUIT	6	DRIVER SIDE	21
Diagnosis Procedure	6	DRIVER SIDE : Diagnosis Procedure	21
REAR WINDOW DEFOGGER SWITCH	7	PASSENGER SIDE	21
Component Function Check	7	PASSENGER SIDE : Diagnosis Procedure	21
Diagnosis Procedure	7	REAR WINDOW DEFOGGER INDICATOR DOES NOT ILLUMINATE	22
REAR WINDOW DEFOGGER RELAY	8	Diagnosis Procedure	22
Diagnosis Procedure	8	PRECAUTION	23
Component Inspection	9	PRECAUTIONS	23
REAR WINDOW DEFOGGER	10	Precaution for Working Range at a Regular Dealership	23
Diagnosis Procedure	10	Precaution for Supplemental Restraint System (SRS) "AIR BAG" and "SEAT BELT PRE-TENSIONER"	23
DOOR MIRROR DEFOGGER	12	Precautions Necessary for Steering Wheel Rotation After Battery Disconnection	23
Diagnosis Procedure	12	Precaution for Battery Service	24
DRIVER SIDE DOOR MIRROR DEFOGGER	13	REMOVAL AND INSTALLATION	25
Diagnosis Procedure	13	FILAMENT	25
PASSENGER SIDE DOOR MIRROR DEFOGGER	15	Inspection and Repair	25
Diagnosis Procedure	15	CONDENSER	27
REAR WINDOW DEFOGGER SYSTEM	17		
Wiring Diagram - DEFOGGER SYSTEM -	17		
SYMPTOM DIAGNOSIS	18		
REAR WINDOW DEFOGGER DOES NOT OPERATE	18		
Diagnosis Procedure	18		

Exploded View	27	Removal and Installation	27
---------------------	----	--------------------------------	----

REAR WINDOW DEFOGGER SYSTEM

< SYSTEM DESCRIPTION >

SYSTEM DESCRIPTION

REAR WINDOW DEFOGGER SYSTEM

System Diagram

INFOID:000000009161586

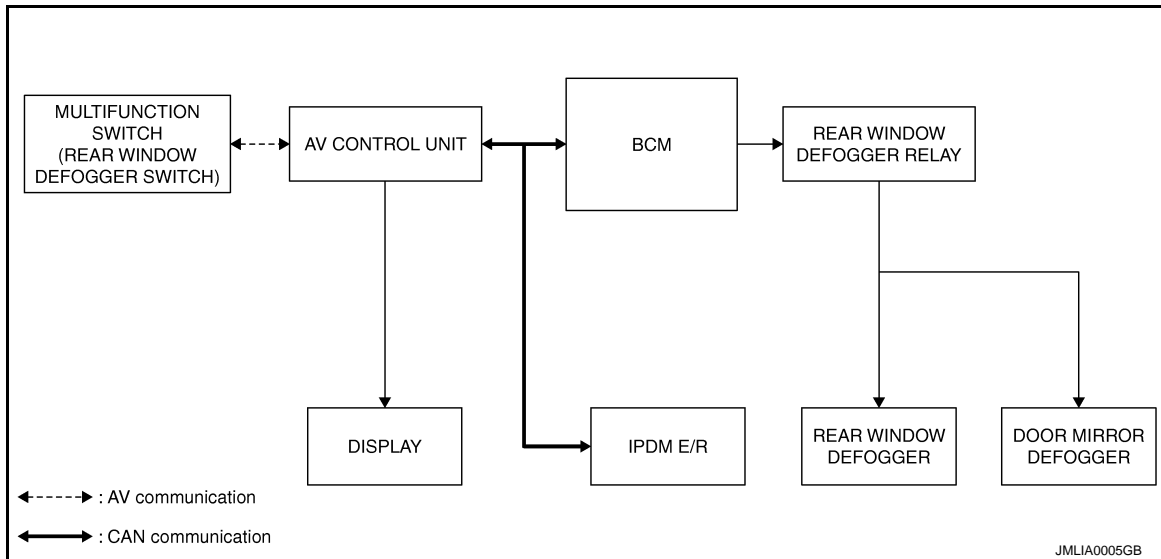

System Description

INFOID:000000009161587

Operation Description

- Turn rear window defogger switch ON while the ignition switch is turned ON. Then multifunction switch (rear window defogger switch) transmits rear window defogger switch signal to AV control unit via AV communication. AV control unit transmits rear window defogger switch signal to BCM via CAN communication.
- BCM turns rear window defogger relay ON and transmits rear window defogger control signal to IPDM E/R via CAN communication when rear window defogger switch signal is received.
- Rear window defogger and door mirror defogger are supplied with power and operate when rear window defogger relay turns ON.
- IPDM E/R transmits rear window defogger control signal to AV control unit via CAN communication.
- AV control unit transmits rear defogger feedback signal to multifunction switch (rear window defogger switch) via AV communication then rear window defogger indicator is illuminated.

Timer function

- BCM turns rear window defogger relay ON for approximately 15 minutes when rear window defogger switch is turned ON. It makes rear window defogger and door mirror defogger operate.
- Timer is canceled after pressing rear window defogger switch again during timer operation. Then BCM turns rear window defogger relay OFF. The same reaction also occurs during timer operation, if the ignition switch is turned OFF.

REAR WINDOW DEFOGGER SYSTEM

< SYSTEM DESCRIPTION >

Component Parts Location

INFOID:000000009161588

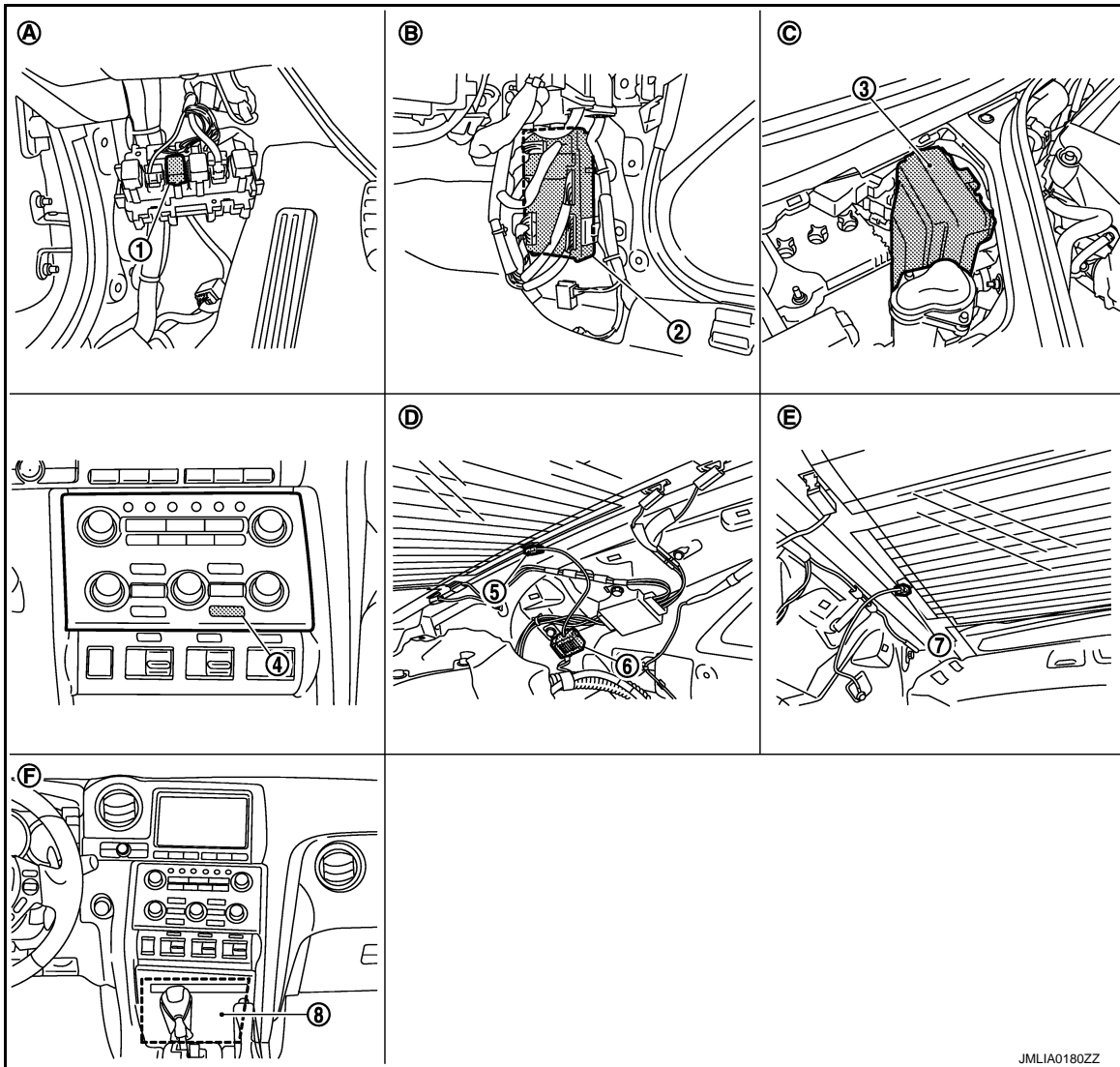

JMLIA0180ZZ

- | | | |
|--------------------------------------------------------------------|----------------------------------------|--------------------------------|
| 1. Rear window defogger relay (built-in relay box) | 2. BCM M118, M119, M122, M123 | 3. IPDM E/R E6 |
| 4. Rear window defogger switch (built-in multifunction switch M72) | 5. Rear window defogger connector B471 | 6. Condenser B33 |
| 7. Rear window defogger connector B472 | 8. AV control unit M81, M82 | |
| A. Dash side lower (driver side) | B. Dash side lower (passenger side) | C. Engine room dash panel (RH) |
| D. Behind rear pillar finisher (LH) | E. Behind rear pillar finisher (RH) | F. Behind cluster lid C |

Component Description

INFOID:000000009161589

Item	Function
BCM	<ul style="list-style-type: none"> Operates the rear window defogger with the operation of rear window defogger switch. Performs the timer control of rear window defogger.
Rear window defogger relay	Operates the rear window defogger and the door mirror defogger with the control signal from BCM.
IPDM E/R	Transmit rear window defogger control signal to AV control unit via CAN communication.

REAR WINDOW DEFOGGER SYSTEM

< SYSTEM DESCRIPTION >

Multifunction switch (Rear window defogger switch)	<ul style="list-style-type: none">• The rear window defogger switch is installed.• Turns the indicator lamp ON when detecting the operation of rear window defogger.	A
AV control unit	Displays the rear window defogger ON to the display when detecting the operation of rear window defogger.	B
Rear window defogger	Heats the heating wire with the power supply from the rear window defogger relay to prevent the rear window from fogging up.	C
Door mirror defogger	Heats the heating wire with the power supply from the rear window defogger relay to prevent the door mirror from fogging up.	C

A

B

C

D

E

F

G

H

I

J

K

DEF

M

N

O

P

POWER SUPPLY AND GROUND CIRCUIT

< DTC/CIRCUIT DIAGNOSIS >

DTC/CIRCUIT DIAGNOSIS

POWER SUPPLY AND GROUND CIRCUIT

Diagnosis Procedure

INFOID:000000009161592

1. CHECK FUSE AND FUSIBLE LINK

Check that the following fuse and fusible link are not blown.

Signal name	Fuse and fusible link No.
Battery power supply	I
	10

Is the fuse fusing?

YES >> Replace the blown fuse or fusible link after repairing the affected circuit if a fuse or fusible link is blown.

NO >> GO TO 2.

2. CHECK POWER SUPPLY CIRCUIT

1. Turn ignition switch OFF.
2. Disconnect BCM connectors.
3. Check voltage between BCM harness connector and ground.

Terminals		Voltage (Approx.)
(+)	(-)	
BCM		Ground Battery voltage
Connector	Terminal	
M118	1	
M119	11	

Is the measurement value normal?

YES >> GO TO 3.

NO >> Repair harness or connector.

3. CHECK GROUND CIRCUIT

Check continuity between BCM harness connector and ground.

BCM		Ground	Continuity
Connector	Terminal		
M119	13		Existed

Does continuity exist?

YES >> INSPECTION END

NO >> Repair harness or connector.

REAR WINDOW DEFOGGER SWITCH

< DTC/CIRCUIT DIAGNOSIS >

REAR WINDOW DEFOGGER SWITCH

Component Function Check

INFOID:000000009161593

1.CHECK REAR WINDOW DEFOGGER SWITCH FUNCTION

Check that the indicator lamp of rear window defogger illuminates when rear window defogger switch ON.

Is the inspection result normal?

- YES >> Rear window defogger switch function is OK.
- NO >> Refer to [DEF-7, "Diagnosis Procedure"](#)

Diagnosis Procedure

INFOID:000000009161594

1.CHECK REAR WINDOW DEFOGGER SWITCH

Does rear window defogger switch operate normally?

- Base audio with navigation system. Refer to [AV-67, "Symptom Table"](#)
- Bose audio with navigation system. Refer to [AV-158, "Symptom Table"](#)

Is the inspection result normal?

- YES >> INSPECTION END
- NO >> Replace preset switch (rear window defogger switch). Refer to [AV-87, "Removal and Installation"](#) (Base audio with navigation) or [AV-180, "Removal and Installation"](#) (Bose audio with navigation).

A
B
C
D
E
F
G
H
I
J
K

DEF

M
N
O
P

REAR WINDOW DEFOGGER RELAY

< DTC/CIRCUIT DIAGNOSIS >

REAR WINDOW DEFOGGER RELAY

Diagnosis Procedure

INFOID:000000009161596

1. CHECK FUSE

1. Turn ignition switch OFF.
2. Check 10A fuse [No.3, located in fuse block (J/B)].

Is the inspection result normal?

- YES >> GO TO 2.
NO >> Replace the blown fuse after repairing the affected circuit if a fuse is blown.

2. CHECK REAR WINDOW DEFOGGER CIRCUIT 1

1. Turn ignition switch ON.
2. Check voltage between BCM harness connector and ground.

(+)		(-)	Condition	Voltage (V) (Approx.)
BCM				
Connector	Terminal			
M123	151	Ground	Rear window defogger switch: ON	0
			Rear window defogger switch: OFF	Battery voltage

Is the inspection result normal?

- YES >> Rear window defogger power supply circuit is OK.
NO >> GO TO 3.

3. CHECK REAR WINDOW DEFOGGER CIRCUIT 2

1. Turn ignition switch OFF.
2. Disconnect BCM connector and fuse block (J/B).
3. Check continuity between BCM harness connector and fuse block (J/B) harness connector.

BCM		Fuse block (J/B)		Continuity
Connector	Terminal	Connector	Terminal	
M123	151	M2	4B	Existed

Is the inspection result normal?

- YES >> GO TO 4.
NO >> Repair or replace harness.

4. CHECK REAR WINDOW DEFOGGER RELAY

1. Disconnect rear window defogger relay,
2. Check rear window defogger relay.
Refer to [DEF-9. "Component Inspection"](#)

Is the inspection result normal?

- YES >> GO TO 5.
NO >> Replace rear window defogger relay.

5. CHECK FUSE BLOCK (J/B)

1. Install the rear window defogger relay.
2. Turn ignition switch ON.
3. Check voltage between fuse block (J/B) connector (fuse block side) and ground.

(+)		(-)	Voltage (V) (Approx.)
Fuse block (J/B)			
Connector	Terminal		
M2	4B	Ground	Battery voltage

Is the inspection result normal?

REAR WINDOW DEFOGGER RELAY

< DTC/CIRCUIT DIAGNOSIS >

- YES >> GO TO 6.
 NO >> Replace fuse block (J/B).

6.CHECK INTERMITTENT INCIDENT

Check intermittent incident.
 Refer to [GI-38. "Intermittent Incident"](#)

>> INSPECTION END

Component Inspection

INFOID:000000009161597

1.CHECK REAR WINDOW DEFOGGER RELAY

1. Turn ignition switch OFF.
2. Disconnect rear window defogger relay.
3. Check rear window defogger relay.

Rear window defogger relay		Condition	Continuity
Terminal			
3	5	12 V direct current supply between terminals 1 and 2.	Existed
		No current supply	Not existed

Is the inspection result normal?

- YES >> INSPECTION END
 NO >> Replace rear window defogger relay.

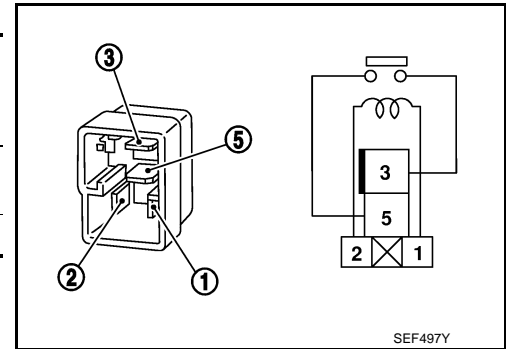

A
B
C
D
E
F
G
H
I
J
K
DEF
M
N
O
P

REAR WINDOW DEFOGGER

< DTC/CIRCUIT DIAGNOSIS >

REAR WINDOW DEFOGGER

Diagnosis Procedure

INFOID:000000009161599

1. CHECK FUSE

1. Turn ignition switch OFF.
2. Check the following.
 - 20A fuse [No.15, located in fuse block (J/B)]

Is the inspection result normal?

- YES >> GO TO 2.
NO >> Replace the blown fuse after repairing the affected circuit if a fuse is blown.

2. CHECK POWER SUPPLY CIRCUIT

1. Turn ignition switch ON.
2. Check voltage between rear window defogger harness connector and ground.

(+)		(-)	Condition	Voltage (V) (Approx.)
Rear window defogger				
Connector	Terminal			
B471	1	Ground	Rear window defogger switch: ON	Battery voltage
			Rear window defogger switch: OFF	0

Is the inspection result normal?

- YES >> GO TO 3.
NO >> GO TO 4.

3. CHECK GROUND CIRCUIT

1. Turn ignition switch OFF.
2. Disconnect rear window defogger connector.
3. Check continuity between rear window defogger harness connector and ground.

Rear window defogger		Ground	Continuity
Connector	Terminal		
B472	2		Existed

Is the inspection result normal?

- YES >> GO TO 7.
NO >> Repair or replace harness between rear window defogger and ground.

4. CHECK REAR WINDOW DEFOGGER CIRCUIT 1

1. Turn ignition switch OFF.
2. Disconnect condenser connector.
3. Check continuity between condenser harness connector and rear window defogger harness connector.

Condenser		Rear window defogger		Continuity
Connector	Terminal	Connector	Terminal	
B33	1	B471	1	Existed

4. Check continuity between condenser harness connector and ground.

Condenser		Ground	Continuity
Connector	Terminal		
B33	1		Not existed

Is the inspection result normal?

- YES >> GO TO 5.
NO >> Repair or replace harness between condenser and rear window defogger.

REAR WINDOW DEFOGGER

< DTC/CIRCUIT DIAGNOSIS >

5. CHECK REAR WINDOW DEFOGGER CIRCUIT 2

1. Disconnect fuse block (J/B) connector.
2. Check continuity between fuse block (J/B) harness connector and condenser harness connector.

Fuse block (J/B)		Condenser		Continuity
Connector	Terminal	Connector	Terminal	
B6	10G	B33	1	Existed

3. Check continuity between fuse block (J/B) harness connector and ground.

Fuse block (J/B)		Ground	Continuity
Connector	Terminal		
B6	10G		Not existed

Is the inspection result normal?

YES >> GO TO 6.

NO >> Repair or replace harness between fuse block (J/B) and condenser.

6. CHECK FUSE BLOCK (J/B)

1. Turn ignition switch ON.
2. Check voltage between fuse block (J/B) (fuse block side) and ground.

(+)		(-)	Condition	Voltage (V) (Approx.)
Fuse block (J/B)				
Connector	Terminal			
B6	10G	Ground	Rear window defogger switch: ON	Battery voltage
			Rear window defogger switch: OFF	0

Is the inspection result normal?

YES >> GO TO 8.

NO >> Replace fuse block (J/B).

7. CHECK FILAMENT

Check the filament for damage or blown.

Refer to [DEF-25. "Inspection and Repair"](#)

Is the inspection result normal?

YES >> GO TO 8.

NO >> Repair filament.

8. CHECK INTERMITTENT INCIDENT

Check intermittent incident.

Refer to [GI-38. "Intermittent Incident"](#)

>> INSPECTION END

A
B
C
D
E
F
G
H
I
J
K
M
N
O
P

DEF

DOOR MIRROR DEFOGGER

< DTC/CIRCUIT DIAGNOSIS >

DOOR MIRROR DEFOGGER

Diagnosis Procedure

INFOID:000000009161601

1. CHECK FUSE

1. Turn ignition switch OFF.
2. Check 10A fuse [No.13, located in fuse block (J/B)].

Is the inspection result normal?

YES >> GO TO 2.

NO >> Replace the blown fuse after repairing the affected circuit if a fuse is blown.

2. CHECK FUSE BLOCK (J/B)

1. Disconnect fuse block (J/B) connector.
2. Turn ignition switch ON.
3. Check voltage between fuse block (J/B) connector (fuse block side) and ground.

(+)		(-)	Condition	Voltage (V) (Approx.)
Fuse block (J/B)				
Connector	Terminal			
M3	9C	Ground	Rear window defogger switch: ON	Battery voltage
			Rear window defogger switch: OFF	0
	10C		Rear window defogger switch: ON	Battery voltage
			Rear window defogger switch: OFF	0

Is the inspection result normal?

YES >> GO TO 3.

NO >> Replace fuse block (J/B).

3. CHECK INTERMITTENT INCIDENT

Check intermittent incident.

Refer to [GI-38, "Intermittent Incident"](#).

>> INSPECTION END

DRIVER SIDE DOOR MIRROR DEFOGGER

< DTC/CIRCUIT DIAGNOSIS >

DRIVER SIDE DOOR MIRROR DEFOGGER

Diagnosis Procedure

INFOID:000000009161603

1. CHECK POWER SUPPLY CIRCUIT

1. Turn ignition switch OFF.
2. Disconnect door mirror (driver side) connector.
3. Turn ignition switch ON.
4. Check voltage between door mirror (driver side) harness connector and ground.

(+)		(-)	Condition	Voltage (V) (Approx.)
Door mirror (driver side)				
Connector	Terminal			
D3	1	Ground	Rear window defogger switch: ON	Battery voltage
			Rear window defogger switch: OFF	0

Is the inspection result normal?

- YES >> GO TO 4.
NO >> GO TO 2.

2. CHECK DRIVER SIDE DOOR MIRROR DEFOGGER CIRCUIT

1. Turn ignition switch OFF.
2. Disconnect fuse block (J/B) connector.
3. Check continuity between fuse block (J/B) harness connector and door mirror (driver side) harness connector.

Fuse block (J/B)		Door mirror (driver side)		Continuity
Connector	Terminal	Connector	Terminal	
M3	10C	D3	1	Existed

Is the inspection result normal?

- YES >> GO TO 3.
NO >> Repair or replace harness between fuse block (J/B) and door mirror (driver side).

3. CHECK FUSE BLOCK (J/B) OUTPUT SIGNAL

1. Turn ignition switch ON.
2. Check voltage between fuse block (J/B) harness connector and ground.

DEF

(+)		(-)	Condition	Voltage (V) (Approx.)
Fuse block (J/B)				
Connector	Terminal			
M3	10C	Ground	Rear window defogger switch: ON	Battery voltage
			Rear window defogger switch: OFF	0

Is the inspection result normal?

- YES >> GO TO 5.
NO >> Replace fuse block (J/B).

4. CHECK GROUND CIRCUIT

1. Turn ignition switch OFF.
2. Check continuity between door mirror (driver side) harness connector and ground.

Door mirror (driver side)		Ground	Continuity
Connector	Terminal		
D3	5		Existed

Is the inspection result normal?

DRIVER SIDE DOOR MIRROR DEFOGGER

< DTC/CIRCUIT DIAGNOSIS >

- YES >> Replace door mirror glass (driver side). Refer to [MIR-17, "GLASS MIRROR : Disassembly and Assembly"](#).
- NO >> Repair or replace harness between door mirror (driver side) and ground.

5.CHECK INTERMITTENT INCIDENT

Check intermittent incident.

Refer to [GI-38, "Intermittent Incident"](#)

>> INSPECTION END

PASSENGER SIDE DOOR MIRROR DEFOGGER

< DTC/CIRCUIT DIAGNOSIS >

PASSENGER SIDE DOOR MIRROR DEFOGGER

Diagnosis Procedure

INFOID:000000009161605

1. CHECK POWER SUPPLY CIRCUIT

1. Turn ignition switch OFF.
2. Disconnect door mirror (passenger side) connector.
3. Turn ignition switch ON.
4. Check voltage between door mirror (passenger side) harness connector and ground.

(+)		(-)	Condition	Voltage (V) (Approx.)
Door mirror (Passenger side)				
Connector	Terminal			
D33	1	Ground	Rear window defogger switch: ON	Battery voltage
			Rear window defogger switch: OFF	0

Is the inspection result normal?

- YES >> GO TO 4.
NO >> GO TO 2.

2. CHECK PASSENGER SIDE DOOR MIRROR DEFOGGER CIRCUIT

1. Turn ignition switch OFF.
2. Disconnect fuse block (J/B) connector.
3. Check continuity between fuse block (J/B) harness connector and door mirror (passenger side) harness connector.

Fuse block (J/B)		Door mirror (passenger side)		Continuity
Connector	Terminal	Connector	Terminal	
M3	9C	D33	1	Existed

Is the inspection result normal?

- YES >> GO TO 3.
NO >> Repair or replace harness between fuse block (J/B) and door mirror (passenger side).

3. CHECK FUSE BLOCK (J/B) OUTPUT SIGNAL

1. Turn ignition switch ON.
2. Check voltage between fuse block (J/B) harness connector and ground.

(+)		(-)	Condition	Voltage (V) (Approx.)
Fuse block (J/B)				
Connector	Terminal			
M3	9C	Ground	Rear window defogger switch: ON	Battery voltage
			Rear window defogger switch: OFF	0

Is the inspection result normal?

- YES >> GO TO 5.
NO >> Replace fuse block (J/B).

4. CHECK GROUND CIRCUIT

1. Turn ignition switch OFF.
2. Check continuity between door mirror (passenger side) harness connector and ground.

Door mirror (passenger side)		Ground	Continuity
Connector	Terminal		
D33	5		Existed

Is the inspection result normal?

PASSENGER SIDE DOOR MIRROR DEFOGGER

< DTC/CIRCUIT DIAGNOSIS >

- YES >> Replace door mirror glass (passenger side). Refer to [MIR-17, "GLASS MIRROR : Disassembly and Assembly"](#).
- NO >> Repair or replace harness between door mirror (passenger side) and ground.

5.CHECK INTERMITTENT INCIDENT

Check intermittent incident.

Refer to [GI-38, "Intermittent Incident"](#)

>> INSPECTION END

REAR WINDOW DEFOGGER SYSTEM

< DTC/CIRCUIT DIAGNOSIS >

REAR WINDOW DEFOGGER SYSTEM

Wiring Diagram - DEFOGGER SYSTEM -

INFOID:000000009161606

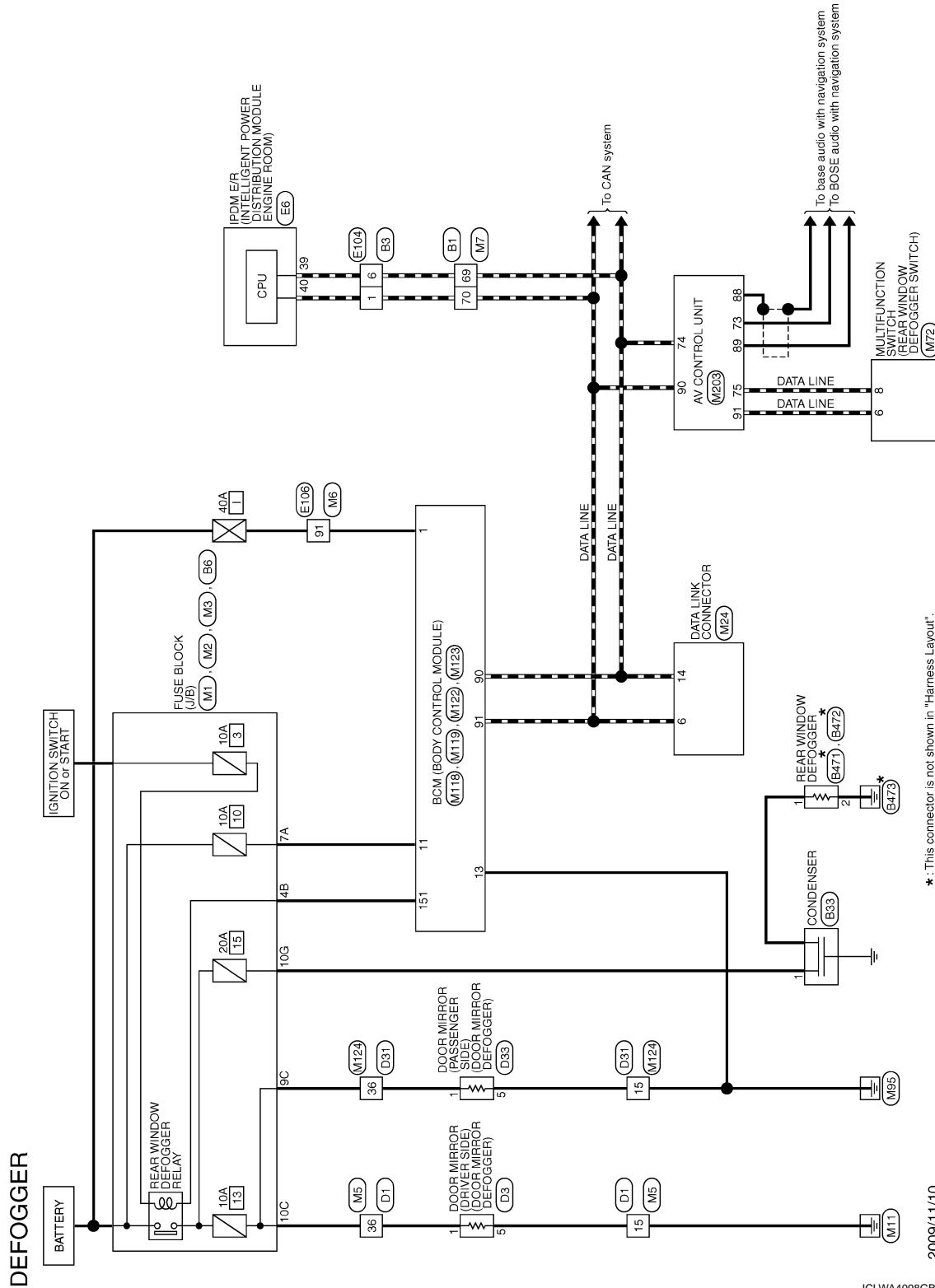

2009/11/10

JCLWA4098GB

A
B
C
D
E
F
G
H
I
J
K
DEF
M
N
O
P

REAR WINDOW DEFOGGER DOES NOT OPERATE

< SYMPTOM DIAGNOSIS >

SYMPTOM DIAGNOSIS

REAR WINDOW DEFOGGER DOES NOT OPERATE

Diagnosis Procedure

INFOID:000000009161612

1. CHECK POWER SUPPLY AND GROUND CIRCUIT

Check power supply and ground circuit.
Refer to [DEF-6. "Diagnosis Procedure"](#).

Is the inspection result normal?

- YES >> GO TO 2.
- NO >> Repair or replace the malfunctioning parts.

2. CHECK REAR WINDOW DEFOGGER SWITCH

Check rear window defogger switch.
Refer to [DEF-7. "Component Function Check"](#).

Is the inspection result normal?

- YES >> GO TO 3.
- NO >> Repair or replace the malfunctioning parts.

3. CHECK REAR WINDOW DEFOGGER RELAY

Check rear window defogger relay.
Refer to [DEF-8. "Diagnosis Procedure"](#).

Is the inspection result normal?

- YES >> GO TO 4.
- NO >> Repair or replace the malfunctioning parts.

4. CHECK REAR WINDOW DEFOGGER

Check rear window defogger.
Refer to [DEF-10. "Diagnosis Procedure"](#).

Is the inspection result normal?

- YES >> GO TO 5.
- NO >> Repair or replace the malfunctioning parts.

5. CONFIRM THE OPERATION

Confirm the operation again.

Is the inspection result normal?

- YES >> Check intermittent incident. Refer to [GI-38. "Intermittent Incident"](#).
- NO >> GO TO 1.

REAR WINDOW DEFOGGER AND DOOR MIRROR DEFOGGER DO NOT OPERATE

< SYMPTOM DIAGNOSIS >

REAR WINDOW DEFOGGER AND DOOR MIRROR DEFOGGER DO NOT OPERATE

Diagnosis Procedure

INFOID:000000009161613

1. CHECK POWER SUPPLY AND GROUND CIRCUIT

Check power supply and ground circuit.
Refer to [DEF-6, "Diagnosis Procedure"](#).

Is the inspection result normal?

YES >> GO TO 2.

NO >> Repair or replace the malfunctioning parts.

2. CHECK REAR WINDOW DEFOGGER SWITCH

Check rear window defogger switch.
Refer to [DEF-7, "Component Function Check"](#).

Is the inspection result normal?

YES >> GO TO 3.

NO >> Repair or replace the malfunctioning parts.

3. CHECK REAR WINDOW DEFOGGER RELAY

Check rear window defogger relay.
Refer to [DEF-8, "Diagnosis Procedure"](#).

Is the inspection result normal?

YES >> GO TO 4.

NO >> Repair or replace the malfunctioning parts.

4. CONFIRM THE OPERATION

Confirm the operation again.

Is the inspection result normal?

YES >> Check intermittent incident. Refer to [GI-38, "Intermittent Incident"](#).

NO >> GO TO 1.

A
B
C
D
E
F
G
H
I
J
K
M
N
O
P

DEF

REAR WINDOW DEFOGGER DOES NOT OPERATE BUT BOTH DOOR MIRROR DEFOGGERS OPERATE

< SYMPTOM DIAGNOSIS >

REAR WINDOW DEFOGGER DOES NOT OPERATE BUT BOTH DOOR MIRROR DEFOGGERS OPERATE

Diagnosis Procedure

INFOID:000000009161614

1. CHECK REAR WINDOW DEFOGGER

Check rear window defogger.

Refer to [DEF-10, "Diagnosis Procedure"](#).

Is the inspection result normal?

YES >> GO TO 2.

NO >> Repair or replace the malfunctioning parts.

2. CONFIRM THE OPERATION

Confirm the operation again

Is the inspection result normal?

YES >> Check intermittent incident. Refer to [GI-38, "Intermittent Incident"](#).

NO >> GO TO 1.

DOOR MIRROR DEFOGGER DOES NOT OPERATE

< SYMPTOM DIAGNOSIS >

DOOR MIRROR DEFOGGER DOES NOT OPERATE BOTH SIDES

BOTH SIDES : Diagnosis Procedure

INFOID:000000009161615

1.CHECK DOOR MIRROR DEFOGGER

Check door mirror defogger.

Refer to [DEF-12, "Diagnosis Procedure"](#).

Is the inspection result normal?

YES >> GO TO 2.

NO >> Repair or replace the malfunctioning parts.

2.CONFIRM THE OPERATION

Confirm the operation again.

Is the inspection result normal?

YES >> Check intermittent incident. Refer to [GI-38, "Intermittent Incident"](#).

NO >> GO TO 1.

DRIVER SIDE

DRIVER SIDE : Diagnosis Procedure

INFOID:000000009161616

1.CHECK DRIVER SIDE DOOR MIRROR DEFOGGER

Check driver side door mirror defogger.

Refer to [DEF-13, "Diagnosis Procedure"](#).

Is the inspection result normal?

YES >> GO TO 2.

NO >> Repair or replace the malfunctioning parts.

2.CONFIRM THE OPERATION

Confirm the operation again.

Is the inspection result normal?

YES >> Check intermittent incident. Refer to [GI-38, "Intermittent Incident"](#).

NO >> GO TO 1.

PASSENGER SIDE

PASSENGER SIDE : Diagnosis Procedure

INFOID:000000009161617

1.CHECK PASSENGER SIDE DOOR MIRROR DEFOGGER.

Check passenger side door mirror defogger.

Refer to [DEF-15, "Diagnosis Procedure"](#).

Is the inspection result normal?

YES >> GO TO 2.

NO >> Repair or replace the malfunctioning parts.

2.CONFIRM THE OPERATION

Confirm the operation again.

Is the inspection result normal?

YES >> Check intermittent incident. Refer to [GI-38, "Intermittent Incident"](#).

NO >> GO TO 1.

A
B
C
D
E
F
G
H
I
J
K
M
N
O
P

DEF

REAR WINDOW DEFOGGER INDICATOR DOES NOT ILLUMINATE

< SYMPTOM DIAGNOSIS >

REAR WINDOW DEFOGGER INDICATOR DOES NOT ILLUMINATE

Diagnosis Procedure

INFOID:000000009161619

1. CHECK REAR WINDOW DEFOGGER SWITCH

Check rear window defogger operate.

- YES >> Replace preset switch (rear window defogger switch). Refer to [AV-87, "Removal and Installation"](#) (Base audio with navigation) or [AV-180, "Removal and Installation"](#) (Bose audio with navigation).
- NO >> Check rear window defogger system.

PRECAUTIONS

< PRECAUTION >

PRECAUTION

PRECAUTIONS

Precaution for Working Range at a Regular Dealership

INFOID:000000009166467

CAUTION:

The service items unmentioned on this manual are recommended to be performed by a GT-R certified NISSAN dealer. Because those service items require special equipment and a GT-R certified technical staff who completed special training.

Precaution for Supplemental Restraint System (SRS) "AIR BAG" and "SEAT BELT PRE-TENSIONER"

INFOID:000000009161620

The Supplemental Restraint System such as "AIR BAG" and "SEAT BELT PRE-TENSIONER", used along with a front seat belt, helps to reduce the risk or severity of injury to the driver and front passenger for certain types of collision. This system includes seat belt switch inputs and dual stage front air bag modules. The SRS system uses the seat belt switches to determine the front air bag deployment, and may only deploy one front air bag, depending on the severity of a collision and whether the front occupants are belted or unbelted. Information necessary to service the system safely is included in the "SRS AIR BAG" and "SEAT BELT" of this Service Manual.

WARNING:

Always observe the following items for preventing accidental activation.

- To avoid rendering the SRS inoperative, which could increase the risk of personal injury or death in the event of a collision that would result in air bag inflation, all maintenance must be performed by an authorized NISSAN/INFINITI dealer.
- Improper maintenance, including incorrect removal and installation of the SRS, can lead to personal injury caused by unintentional activation of the system. For removal of Spiral Cable and Air Bag Module, see "SRS AIR BAG".
- Never use electrical test equipment on any circuit related to the SRS unless instructed to in this Service Manual. SRS wiring harnesses can be identified by yellow and/or orange harnesses or harness connectors.

PRECAUTIONS WHEN USING POWER TOOLS (AIR OR ELECTRIC) AND HAMMERS

WARNING:

Always observe the following items for preventing accidental activation.

- When working near the Air Bag Diagnosis Sensor Unit or other Air Bag System sensors with the ignition ON or engine running, never use air or electric power tools or strike near the sensor(s) with a hammer. Heavy vibration could activate the sensor(s) and deploy the air bag(s), possibly causing serious injury.
- When using air or electric power tools or hammers, always switch the ignition OFF, disconnect the battery, and wait at least 3 minutes before performing any service.

Precautions Necessary for Steering Wheel Rotation After Battery Disconnection

INFOID:000000009161621

CAUTION:

Comply with the following cautions to prevent any error and malfunction.

- Before removing and installing any control units, first turn the ignition switch to the LOCK position, then disconnect both battery cables.
- After finishing work, confirm that all control unit connectors are connected properly, then re-connect both battery cables.
- Always use CONSULT to perform self-diagnosis as a part of each function inspection after finishing work. If a DTC is detected, perform trouble diagnosis according to self-diagnosis results.

For vehicle with steering lock unit, if the battery is disconnected or discharged, the steering wheel will lock and cannot be turned.

If turning the steering wheel is required with the battery disconnected or discharged, follow the operation procedure below before starting the repair operation.

OPERATION PROCEDURE

1. Connect both battery cables.

A
B
C
D
E
F
G
H
I
J
K
DEF
M
N
O
P

PRECAUTIONS

< PRECAUTION >

NOTE:

Supply power using jumper cables if battery is discharged.

2. Turn the ignition switch to ACC position.
(At this time, the steering lock will be released.)
3. Disconnect both battery cables. The steering lock will remain released with both battery cables disconnected and the steering wheel can be turned.
4. Perform the necessary repair operation.
5. When the repair work is completed, re-connect both battery cables. With the brake pedal released, turn the ignition switch from ACC position to ON position, then to LOCK position. (The steering wheel will lock when the ignition switch is turned to LOCK position.)
6. Perform self-diagnosis check of all control units using CONSULT.

Precaution for Battery Service

INFOID:000000009161622

Before disconnecting the battery, lower both the driver and passenger windows. This will prevent any interference between the window edge and the vehicle when the door is opened/closed. During normal operation, the window slightly raises and lowers automatically to prevent any window to vehicle interference. The automatic window function will not work with the battery disconnected.

FILAMENT

< REMOVAL AND INSTALLATION >

REMOVAL AND INSTALLATION

FILAMENT

Inspection and Repair

INFOID:000000009161623

INSPECTION

1. When measuring voltage, wrap tin foil around the top of the negative probe. Then press the foil against the wire with your finger.

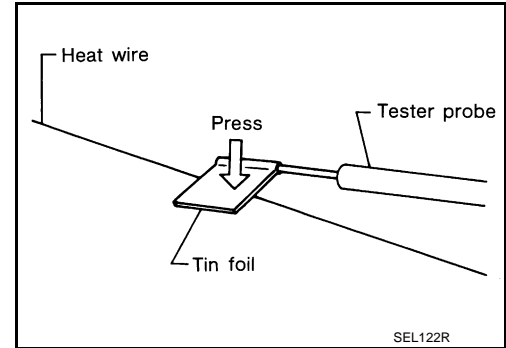

2. Attach probe circuit tester (in Volt range) to middle portion of each filament.

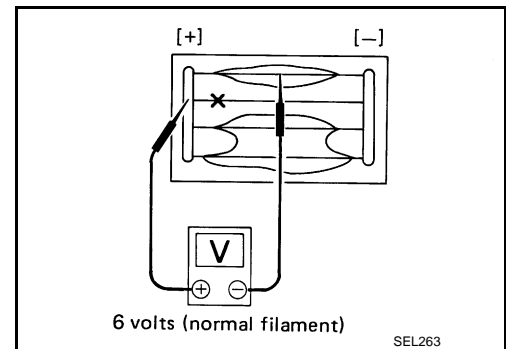

3. If a filament is burned out, circuit tester registers 0 or battery voltage.
4. To locate burned out point, move probe to left and right along filament. Test needle will swing abruptly when probe passes the point.

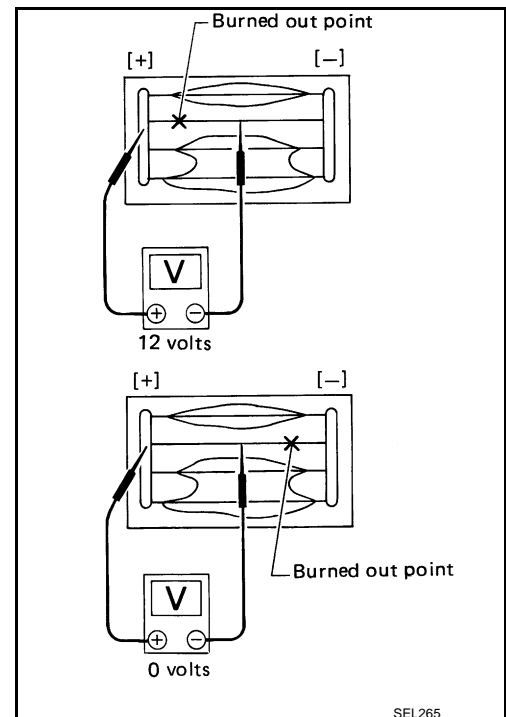

REPAIR

REPAIR EQUIPMENT

- Conductive silver composition (Dupont No. 4817 or equivalent)

A
B
C
D
E
F
G
H
I
J
K
DEF
M
N
O
P

FILAMENT

< REMOVAL AND INSTALLATION >

- Ruler 30 cm (11.8 in) long
- Drawing pen
- Heat gun
- Alcohol
- Cloth

REPAIRING PROCEDURE

1. Wipe broken heat wire and its surrounding area clean with a cloth dampened in alcohol.
2. Apply a small amount of conductive silver composition to tip of drawing pen. Shake silver composition container before use.
3. Place ruler on glass along broken line. Deposit conductive silver composition on break with drawing pen. Slightly overlap existing heat wire on both sides [preferably 5 mm (0.20 in)] of the break.

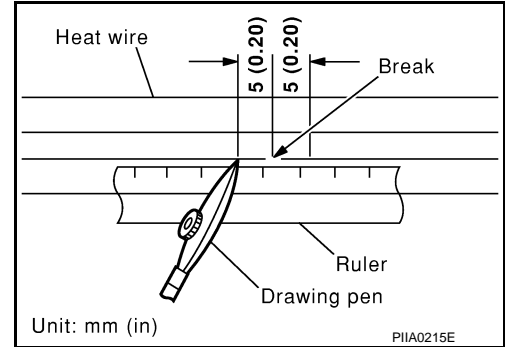

4. After repair has been completed, check repaired wire for continuity. This check should be conducted 10 minutes after silver composition is deposited. Do not touch repaired area while test is being conducted.

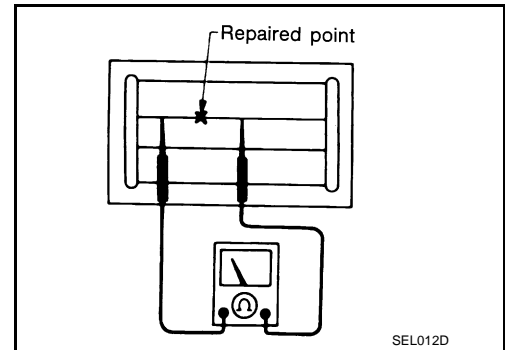

5. Apply a constant stream of hot air directly to the repaired area for approximately 20 minutes with a heat gun. A minimum distance of 3 cm (1.2 in) should be kept between repaired area and hot air outlet. If a heat gun is not available, let the repaired area dry for 24 hours.

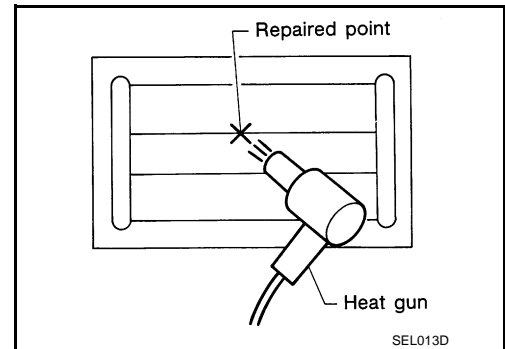

CONDENSER

< REMOVAL AND INSTALLATION >

CONDENSER

Exploded View

INFOID:000000009161624

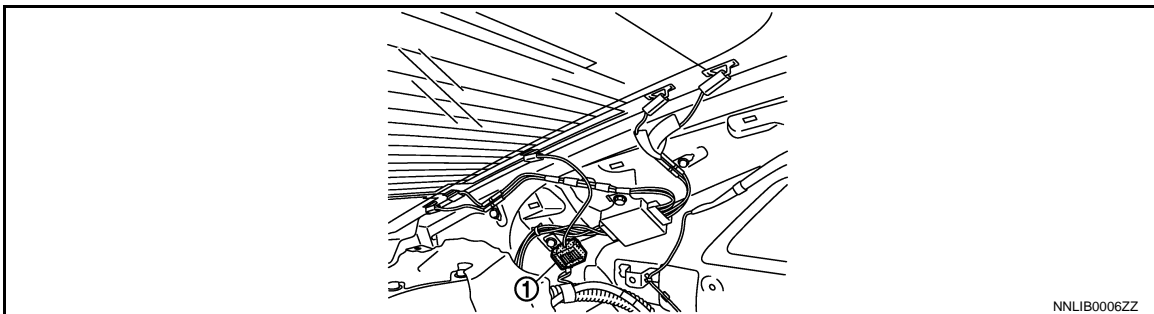

1. Condenser

Removal and Installation

INFOID:000000009161625

REMOVAL

1. Remove the rear seat cushion and the rear seatback.
Refer to [SE-56, "Removal and Installation"](#)
2. Remove the rear kickplate, rear wheel well garnish and the rear pillar finisher.
Refer to [INT-15, "Removal and Installation"](#)
3. Remove bolt (A), and then remove condenser (1) from the vehicle body.

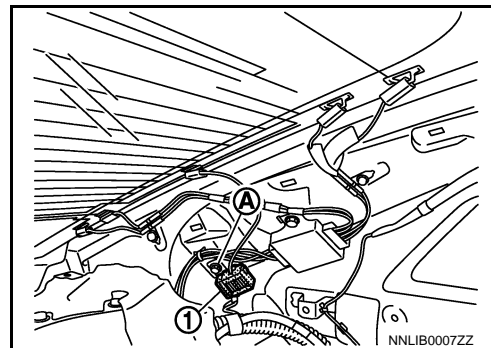

INSTALLATION

Install in the reverse order of removal.

A
B
C
D
E
F
G
H
I
J
K
DEF
M
N
O
P