

A
B
C
D
E
F
G
H
I
J
K
L
M
N
O
P

GW

SECTION

GLASS & WINDOW SYSTEM

CONTENTS

<p>SYMPTOM DIAGNOSIS 2</p> <p>SQUEAK AND RATTLE TROUBLE DIAGNOSES 2</p> <p style="padding-left: 20px;">Work Flow2</p> <p style="padding-left: 20px;">Inspection Procedure4</p> <p style="padding-left: 20px;">Diagnostic Worksheet6</p> <p>PRECAUTION 8</p> <p>PRECAUTIONS 8</p> <p style="padding-left: 20px;">Precaution for Supplemental Restraint System (SRS) "AIR BAG" and "SEAT BELT PRE-TENSIONER"8</p> <p style="padding-left: 20px;">Precautions Necessary for Steering Wheel Rotation After Battery Disconnection8</p> <p style="padding-left: 20px;">Precaution for Battery Service9</p> <p style="padding-left: 20px;">Precaution for Procedure without Cowl Top Cover.....9</p> <p style="padding-left: 20px;">Precaution for Work9</p> <p>PREPARATION10</p> <p>PREPARATION10</p> <p style="padding-left: 20px;">Special Service Tools 10</p> <p style="padding-left: 20px;">Commercial Service Tools 10</p> <p>REMOVAL AND INSTALLATION11</p> <p>WINDSHIELD GLASS11</p> <p style="padding-left: 20px;">Exploded View (GT-R certified NISSAN dealer) 11</p>	<p style="padding-left: 20px;">Removal and Installation (GT-R certified NISSAN dealer)12</p> <p style="padding-left: 20px;">Inspection (GT-R certified NISSAN dealer)15</p> <p>SIDE WINDOW GLASS16</p> <p style="padding-left: 20px;">Exploded View (GT-R certified NISSAN dealer)16</p> <p style="padding-left: 20px;">Removal and Installation (GT-R certified NISSAN dealer)17</p> <p style="padding-left: 20px;">Inspection (GT-R certified NISSAN dealer)18</p> <p>REAR WINDOW GLASS19</p> <p style="padding-left: 20px;">Exploded View (GT-R certified NISSAN dealer)19</p> <p style="padding-left: 20px;">Removal and Installation (GT-R certified NISSAN dealer)20</p> <p style="padding-left: 20px;">Inspection (GT-R certified NISSAN dealer)22</p> <p>DOOR GLASS23</p> <p style="padding-left: 20px;">Exploded View (GT-R certified NISSAN dealer)23</p> <p style="padding-left: 20px;">Removal and Installation (GT-R certified NISSAN dealer)23</p> <p style="padding-left: 20px;">Inspection and adjustment (GT-R certified NISSAN dealer)24</p> <p>DOOR REGULATOR27</p> <p style="padding-left: 20px;">Exploded View (GT-R certified NISSAN dealer)27</p> <p style="padding-left: 20px;">Removal and Installation (GT-R certified NISSAN dealer)27</p> <p style="padding-left: 20px;">Disassembly and assembly (GT-R certified NISSAN dealer)28</p> <p style="padding-left: 20px;">Inspection and adjustment (GT-R certified NISSAN dealer)29</p>
--	--

GW

SQUEAK AND RATTLE TROUBLE DIAGNOSES

< SYMPTOM DIAGNOSIS >

SYMPTOM DIAGNOSIS

SQUEAK AND RATTLE TROUBLE DIAGNOSES

Work Flow

INFOID:000000009161668

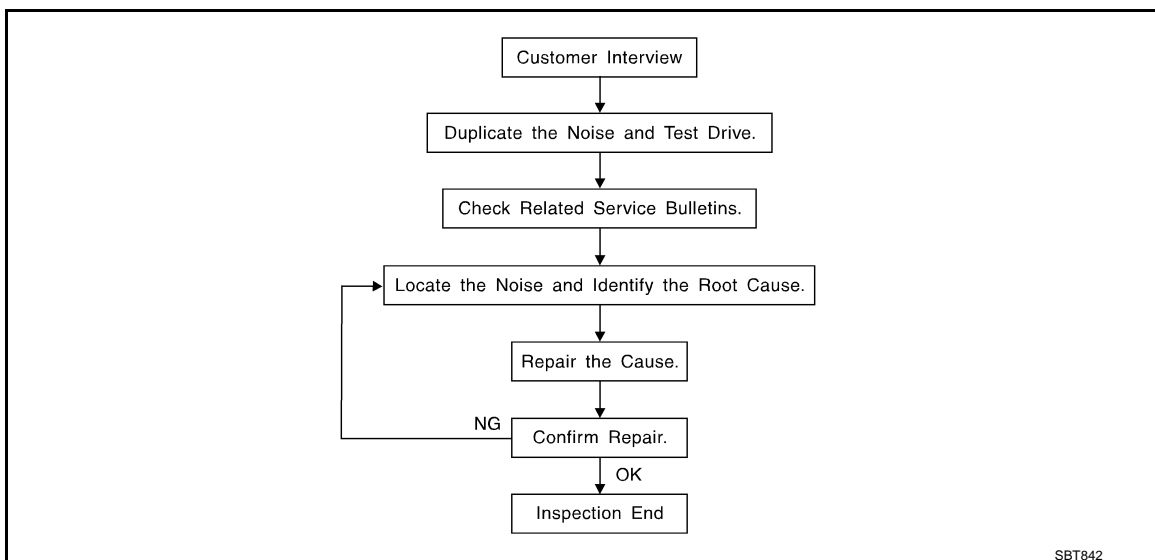

CUSTOMER INTERVIEW

Interview the customer if possible, to determine the conditions that exist when the noise occurs. Use the Diagnostic Worksheet during the interview to document the facts and conditions when the noise occurs and any of customer's comments; refer to [GW-6. "Diagnostic Worksheet"](#). This information is necessary to duplicate the conditions that exist when the noise occurs.

- The customer may not be able to provide a detailed description or the location of the noise. Attempt to obtain all the facts and conditions that exist when the noise occurs (or does not occur).
- If there is more than one noise in the vehicle, perform a diagnosis and repair the noise that the customer is concerned about. This can be accomplished by performing a cruise test on the vehicle with the customer.
- After identifying the type of noise, isolate the noise in terms of its characteristics. The noise characteristics are provided so the customer, service adviser and technician are all speaking the same language when defining the noise.
- Squeak – (Like tennis shoes on a clean floor)
Squeak characteristics include the light contact/fast movement/brought on by road conditions/hard surfaces = higher pitch noise/softer surfaces = lower pitch noises/edge to surface = chirping
- Creak – (Like walking on an old wooden floor)
Creak characteristics include firm contact/slow movement/twisting with a rotational movement/pitch dependent on materials/often brought on by activity.
- Rattle – (Like shaking a baby rattle)
Rattle characteristics include the fast repeated contact/vibration or similar movement/loose parts/missing clip or fastener/incorrect clearance.
- Knock – (Like a knock on a door)
Knock characteristics include hollow sounding/sometimes repeating/often brought on by driver action.
- Tick – (Like a clock second hand)
Tick characteristics include gentle contacting of light materials/loose components/can be caused by driver action or road conditions.
- Thump – (Heavy, muffled knock noise)
Thump characteristics include softer knock/dead sound often brought on by activity.
- Buzz – (Like a bumblebee)
Buzz characteristics include high frequency rattle/firm contact.
- Often the degree of acceptable noise level will vary depending up on the person. A noise that a technician may judge as acceptable may be very irritating to the customer.
- Weather conditions, especially humidity and temperature, may have a great effect on noise level.

DUPLICATE THE NOISE AND TEST DRIVE

SQUEAK AND RATTLE TROUBLE DIAGNOSES

< SYMPTOM DIAGNOSIS >

If possible, drive the vehicle with the customer until the noise is duplicated. Note any additional information on the Diagnostic Worksheet regarding the conditions or location of the noise. This information can be used to duplicate the same conditions when the repair is reconfirmed.

If the noise can be duplicated easily during the test drive, to help identify the source of the noise, try to duplicate the noise with the vehicle stopped by doing one or all of the following:

- 1) Close a door.
 - 2) Tap or push/pull around the area where the noise appears to be coming from.
 - 3) Rev the engine.
 - 4) Use a floor jack to recreate vehicle "twist".
 - 5) At idle, apply engine load (electrical load, half-clutch on M/T models, drive position on A/T models).
 - 6) Raise the vehicle on a hoist and hit a tire with a rubber hammer.
- Drive the vehicle and attempt to duplicate the conditions the customer states exist when the noise occurs.
 - If it is difficult to duplicate the noise, drive the vehicle slowly on an undulating or rough road to stress the vehicle body.

CHECK RELATED SERVICE BULLETINS

After verifying the customer concern or symptom, check ASIST for Technical Service Bulletins (TSBs) related to that concern or symptom.

If a TSB relates to the symptom, follow the procedure to repair the noise.

LOCATE THE NOISE AND IDENTIFY THE ROOT CAUSE

1. Narrow down the noise to a general area. To help pinpoint the source of the noise, use a listening tool (Chassis ear: J-39570, Engine ear and mechanics stethoscope).
2. Narrow down the noise to a more specific area and identify the cause of the noise by:
 - Removing the components in the area that is are suspected to be the cause of the noise.
Do not use too much force when removing clips and fasteners, otherwise clips and fastener can be broken or lost during the repair, resulting in the creation of new noise.
 - Tapping or pushing/pulling the component that is are suspected to be the cause of the noise.
Do not tap or push/pull the component with excessive force, otherwise the noise will be eliminated only temporarily.
 - Feeling for a vibration by hand by touching the component(s) that is are suspected to be the cause of the noise.
 - Placing a piece of paper between components that are suspected to be the cause of the noise.
 - Looking for loose components and contact marks.
Refer to [GW-4. "Inspection Procedure"](#).

REPAIR THE CAUSE

- If the cause is a loose component, tighten the component securely.
- If the cause is insufficient clearance between components:
 - Separate components by repositioning or loosening and retightening the component, if possible.
 - Insulate components with a suitable insulator such as urethane pads, foam blocks, felt cloth tape or urethane tape. A Nissan Squeak and Rattle Kit (J-43980) is available through the authorized Nissan Parts Department.

CAUTION:

Never use excessive force as many components are constructed of plastic and may be damaged.

NOTE:

Always check with the Parts Department for the latest parts information.

The following materials are contained in the Nissan Squeak and Rattle Kit (J-43980). Each item can be ordered separately as needed.

URETHANE PADS [1.5 mm (0.059 in) thick]

Insulates connectors, harness, etc.

- 76268-9E005: 100 × 135 mm (3.937 × 5.315 in)
- 76884-71L01: 60 × 85 mm (2.362 × 3.346 in)
- 76884-71L02: 15 × 25 mm (0.591 × 0.984 in)

INSULATOR (Foam blocks)

Insulates components from contact. Can be used to fill space behind a panel.

- 73982-9E000: 45 mm (1.772 in) thick, 50 × 50 mm (1.969 × 1.969 in)
- 73982-50Y00: 10 mm (0.394 in) thick, 50 × 50 mm (1.969 × 1.969 in)

INSULATOR (Light foam block)

- 80845-71L00: 30 mm (1.181 in) thick, 30 × 50 mm (1.181 × 1.969 in)

FELT CLOTHTAPE

SQUEAK AND RATTLE TROUBLE DIAGNOSES

< SYMPTOM DIAGNOSIS >

Used to insulate where movement does not occur. Ideal for instrument panel applications.

- 68370-4B000: 15 × 25 mm (0.59 × 0.984 in) pad
- 68239-13E00: 5 mm (0.197 in) wide tape roll

The following materials, not found in the kit, can also be used to repair squeaks and rattles.

UHMW (TEFLON) TAPE

Insulates where slight movement is present. Ideal for instrument panel applications.

SILICONE GREASE

Used in place of UHMW tape that is be visible or does not fit. Will only last a few months.

SILICONE SPRAY

Used when grease cannot be applied.

DUCT TAPE

Used to eliminate movement.

CONFIRM THE REPAIR

Confirm that the cause of a noise is repaired by test driving the vehicle. Operate the vehicle under the same conditions as when the noise originally occurred. Refer to the notes on the Diagnostic Worksheet.

Inspection Procedure

INFOID:000000009161669

Refer to Table of Contents for specific component removal and installation information.

INSTRUMENT PANEL

Most incidents are caused by contact and movement between:

1. The cluster lid A and instrument panel
2. Acrylic lens and combination meter housing
3. Instrument panel to front pillar garnish
4. Instrument panel to windshield
5. Instrument panel mounting pins
6. Wiring harnesses behind the combination meter
7. A/C defroster duct and duct joint

These incidents can usually be located by tapping or moving the components to duplicate the noise or by pressing on the components while driving to stop the noise. Most of these incidents can be repaired by applying felt cloth tape or silicon spray (in hard to reach areas). Urethane pads can be used to insulate wiring harness.

CAUTION:

Never use silicone spray to isolate a squeak or rattle. If the area is saturated with silicone, the recheck of repair becomes impossible.

CENTER CONSOLE

Components to pay attention to include:

1. Shifter assembly cover to finisher
2. A/C control unit and cluster lid C
3. Wiring harnesses behind audio and A/C control unit

The instrument panel repair and isolation procedures also apply to the center console.

DOORS

Pay attention to the following:

1. Finisher and inner panel making a slapping noise
2. Inside handle escutcheon to door finisher
3. Wiring harnesses tapping
4. Door striker out of alignment causing a popping noise on starts and stops

Tapping or moving the components or pressing on them while driving to duplicate the conditions can isolate many of these incidents. The areas can usually be insulated with felt cloth tape or insulator foam blocks from the Nissan Squeak and Rattle Kit (J-43980) to repair the noise.

TRUNK

Trunk noises are often caused by a loose jack or loose items put into the trunk by the customer.

In addition look for the following:

1. Trunk lid dumpers out of adjustment

SQUEAK AND RATTLE TROUBLE DIAGNOSES

< SYMPTOM DIAGNOSIS >

2. Trunk lid striker out of adjustment
3. The trunk lid torsion bars knocking together
4. A loose license plate or bracket

Most of these incidents can be repaired by adjusting, securing or insulating the item(s) or component(s) causing the noise.

SUNROOF/HEADLINING

Noises in the sunroof/headlining area can often be traced to one of the following:

1. Sunroof lid, rail, linkage or seals making a rattle or light knocking noise
2. Sunvisor shaft shaking in the holder
3. Front or rear windshield touching headlining and squeaking

Again, pressing on the components to stop the noise while duplicating the conditions can isolate most of these incidents. Repairs usually consist of insulating with felt cloth tape.

SEATS

When isolating seat noise it's important to note the position the seats in and the load placed on the seat when the noise occurs. These conditions should be duplicated when verifying and isolating the cause of the noise.

Cause of seat noise include:

1. Headrest rods and holder
2. A squeak between the seat pad cushion and frame
3. The rear seatback lock and bracket

These noises can be isolated by moving or pressing on the suspected components while duplicating the conditions under which the noise occurs. Most of these incidents can be repaired by repositioning the component or applying urethane tape to the contact area.

UNDERHOOD

Some interior noise may be caused by components under the hood or on the engine wall. The noise is then transmitted into the passenger compartment.

Causes of transmitted underhood noise include:

1. Any component mounted to the engine wall
2. Components that pass through the engine wall
3. Engine wall mounts and connectors
4. Loose radiator mounting pins
5. Hood bumpers out of adjustment
6. Hood striker out of adjustment

These noises can be difficult to isolate since they cannot be reached from the interior of the vehicle. The best method is to secure, move or insulate one component at a time and test drive the vehicle. Also, engine RPM or load can be changed to isolate the noise. Repairs can usually be made by moving, adjusting, securing, or insulating the component causing the noise.

A
B
C
D
E
F
G
H
I
J
L
M
N
O
P

GW

SQUEAK AND RATTLE TROUBLE DIAGNOSES

< SYMPTOM DIAGNOSIS >

Diagnostic Worksheet

INFOID:00000009161670



SQUEAK & RATTLE DIAGNOSTIC WORKSHEET

Dear Nissan Customer:

We are concerned about your satisfaction with your Nissan vehicle. Repairing a squeak or rattle sometimes can be very difficult. To help us fix your Nissan right the first time, please take a moment to note the area of the vehicle where the squeak or rattle occurs and under what conditions. You may be asked to take a test drive with a service advisor or technician to ensure we confirm the noise you are hearing.

I. WHERE DOES THE NOISE COME FROM? (circle the area of the vehicle)

The illustrations are for reference only, and may not reflect the actual configuration of your vehicle.

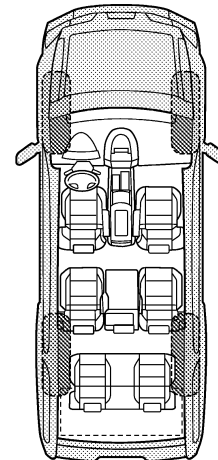
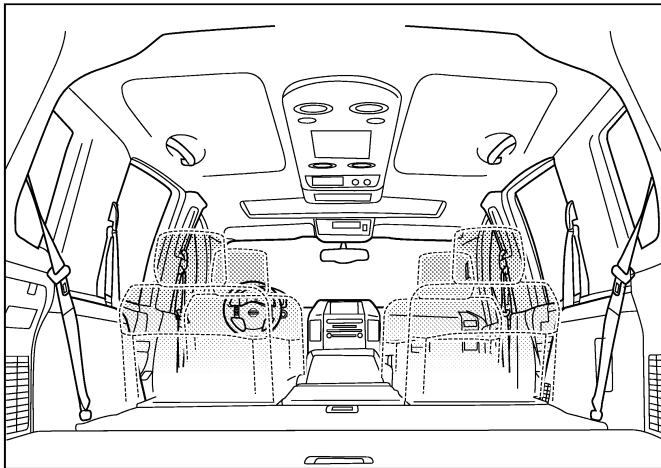
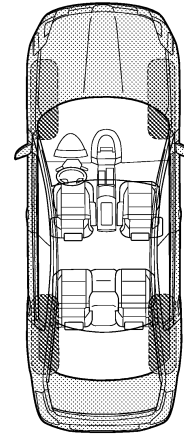
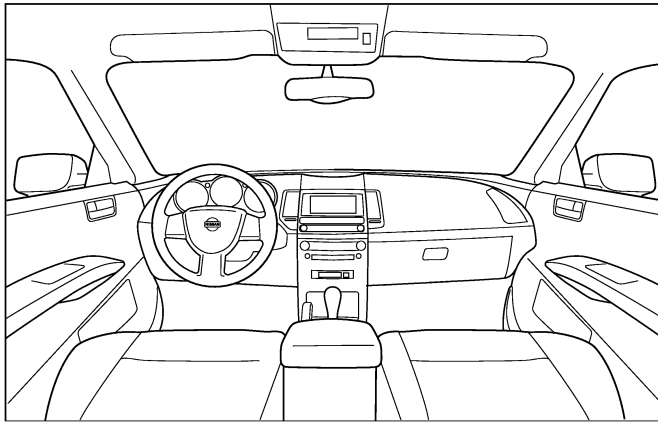

Continue to page 2 of the worksheet and briefly describe the location of the noise or rattle. In addition, please indicate the conditions which are present when the noise occurs.

PIIB8740E

SQUEAK AND RATTLE TROUBLE DIAGNOSES

< SYMPTOM DIAGNOSIS >

SQUEAK & RATTLE DIAGNOSTIC WORKSHEET - page 2

Briefly describe the location where the noise occurs:

II. WHEN DOES IT OCCUR? (please check the boxes that apply)

- | | |
|---|--|
| <input type="checkbox"/> anytime | <input type="checkbox"/> after sitting out in the rain |
| <input type="checkbox"/> 1st time in the morning | <input type="checkbox"/> when it is raining or wet |
| <input type="checkbox"/> only when it is cold outside | <input type="checkbox"/> dry or dusty conditions |
| <input type="checkbox"/> only when it is hot outside | <input type="checkbox"/> other: |

III. WHEN DRIVING:

- through driveways
- over rough roads
- over speed bumps
- only about ____ mph
- on acceleration
- coming to a stop
- on turns: left, right or either (circle)
- with passengers or cargo
- other: _____
- after driving ____ miles or ____ minutes

IV. WHAT TYPE OF NOISE

- squeak (like tennis shoes on a clean floor)
- creak (like walking on an old wooden floor)
- rattle (like shaking a baby rattle)
- knock (like a knock at the door)
- tick (like a clock second hand)
- thump (heavy, muffled knock noise)
- buzz (like a bumble bee)

TO BE COMPLETED BY DEALERSHIP PERSONNEL

Test Drive Notes:

	YES	NO	Initials of person performing
Vehicle test driven with customer	<input type="checkbox"/>	<input type="checkbox"/>	_____
- Noise verified on test drive	<input type="checkbox"/>	<input type="checkbox"/>	_____
- Noise source located and repaired	<input type="checkbox"/>	<input type="checkbox"/>	_____
- Follow up test drive performed to confirm repair	<input type="checkbox"/>	<input type="checkbox"/>	_____

VIN: _____ Customer Name: _____
W.O.# _____ Date: _____

This form must be attached to Work Order

PIIB8742E

A
B
C
D
E
F
G
H
I
J
L
M
N
O
P

GW

PRECAUTIONS

< PRECAUTION >

PRECAUTION

PRECAUTIONS

Precaution for Supplemental Restraint System (SRS) "AIR BAG" and "SEAT BELT PRE-TENSIONER"

INFOID:000000009161671

The Supplemental Restraint System such as "AIR BAG" and "SEAT BELT PRE-TENSIONER", used along with a front seat belt, helps to reduce the risk or severity of injury to the driver and front passenger for certain types of collision. This system includes seat belt switch inputs and dual stage front air bag modules. The SRS system uses the seat belt switches to determine the front air bag deployment, and may only deploy one front air bag, depending on the severity of a collision and whether the front occupants are belted or unbelted. Information necessary to service the system safely is included in the "SRS AIR BAG" and "SEAT BELT" of this Service Manual.

WARNING:

Always observe the following items for preventing accidental activation.

- To avoid rendering the SRS inoperative, which could increase the risk of personal injury or death in the event of a collision that would result in air bag inflation, all maintenance must be performed by an authorized NISSAN/INFINITI dealer.
- Improper maintenance, including incorrect removal and installation of the SRS, can lead to personal injury caused by unintentional activation of the system. For removal of Spiral Cable and Air Bag Module, see "SRS AIR BAG".
- Never use electrical test equipment on any circuit related to the SRS unless instructed to in this Service Manual. SRS wiring harnesses can be identified by yellow and/or orange harnesses or harness connectors.

PRECAUTIONS WHEN USING POWER TOOLS (AIR OR ELECTRIC) AND HAMMERS

WARNING:

Always observe the following items for preventing accidental activation.

- When working near the Air Bag Diagnosis Sensor Unit or other Air Bag System sensors with the ignition ON or engine running, never use air or electric power tools or strike near the sensor(s) with a hammer. Heavy vibration could activate the sensor(s) and deploy the air bag(s), possibly causing serious injury.
- When using air or electric power tools or hammers, always switch the ignition OFF, disconnect the battery, and wait at least 3 minutes before performing any service.

Precautions Necessary for Steering Wheel Rotation After Battery Disconnection

INFOID:000000009161672

CAUTION:

Comply with the following cautions to prevent any error and malfunction.

- Before removing and installing any control units, first turn the ignition switch to the LOCK position, then disconnect both battery cables.
- After finishing work, confirm that all control unit connectors are connected properly, then re-connect both battery cables.
- Always use CONSULT to perform self-diagnosis as a part of each function inspection after finishing work. If a DTC is detected, perform trouble diagnosis according to self-diagnosis results.

For vehicle with steering lock unit, if the battery is disconnected or discharged, the steering wheel will lock and cannot be turned.

If turning the steering wheel is required with the battery disconnected or discharged, follow the operation procedure below before starting the repair operation.

OPERATION PROCEDURE

1. Connect both battery cables.

NOTE:

Supply power using jumper cables if battery is discharged.

2. Turn the ignition switch to ACC position.
(At this time, the steering lock will be released.)
3. Disconnect both battery cables. The steering lock will remain released with both battery cables disconnected and the steering wheel can be turned.

PRECAUTIONS

< PRECAUTION >

4. Perform the necessary repair operation.
5. When the repair work is completed, re-connect both battery cables. With the brake pedal released, turn the ignition switch from ACC position to ON position, then to LOCK position. (The steering wheel will lock when the ignition switch is turned to LOCK position.)
6. Perform self-diagnosis check of all control units using CONSULT.

Precaution for Battery Service

INFOID:000000009161673

Before disconnecting the battery, lower both the driver and passenger windows. This will prevent any interference between the window edge and the vehicle when the door is opened/closed. During normal operation, the window slightly raises and lowers automatically to prevent any window to vehicle interference. The automatic window function will not work with the battery disconnected.

Precaution for Procedure without Cowl Top Cover

INFOID:000000009161674

When performing the procedure after removing cowl top cover, cover the lower end of windshield with urethane, etc to prevent damage to windshield.

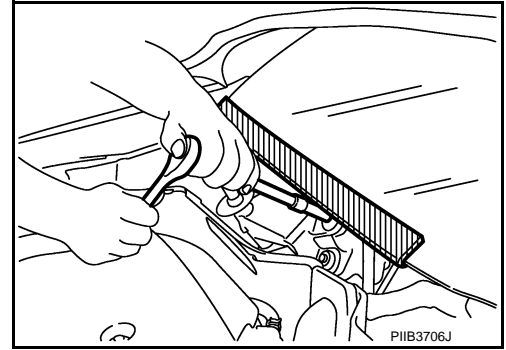

Precaution for Work

INFOID:000000009161675

- After removing and installing the opening/closing parts, be sure to carry out fitting adjustments to check their operation.
- Check the lubrication level, damage, and wear of each part. If necessary, grease or replace it.

GW

PREPARATION

< PREPARATION >

PREPARATION

PREPARATION

Special Service Tools

INFOID:000000009161676

The actual shapes of Kent-Moore tools may differ from those of special service tools illustrated here.

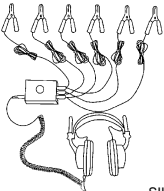
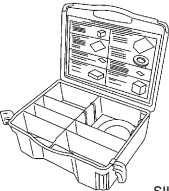
Tool number (Kent-Moore No.) Tool name	Description
<p>(J-39570) Chassis ear</p>  <p style="text-align: right;">SIIA0993E</p>	<p>Locates the noise</p>
<p>(J-43980) NISSAN Squeak and Rattle Kit</p>  <p style="text-align: right;">SIIA0994E</p>	<p>Repairs the cause of noise</p>

Commercial Service Tools

INFOID:000000009161677

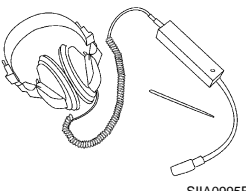
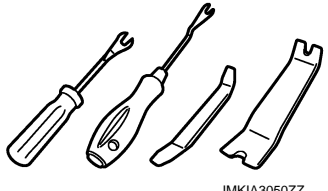
Tool name	Description
<p>Engine ear</p>  <p style="text-align: right;">SIIA0995E</p>	<p>Locates the noise</p>
<p>Remover tool</p>  <p style="text-align: right;">JMKIA3050ZZ</p>	<p>Removes clips, pawls and metal clips</p>

WINDSHIELD GLASS

< REMOVAL AND INSTALLATION >

REMOVAL AND INSTALLATION

WINDSHIELD GLASS

Exploded View (GT-R certified NISSAN dealer)

INFOID:000000009161678

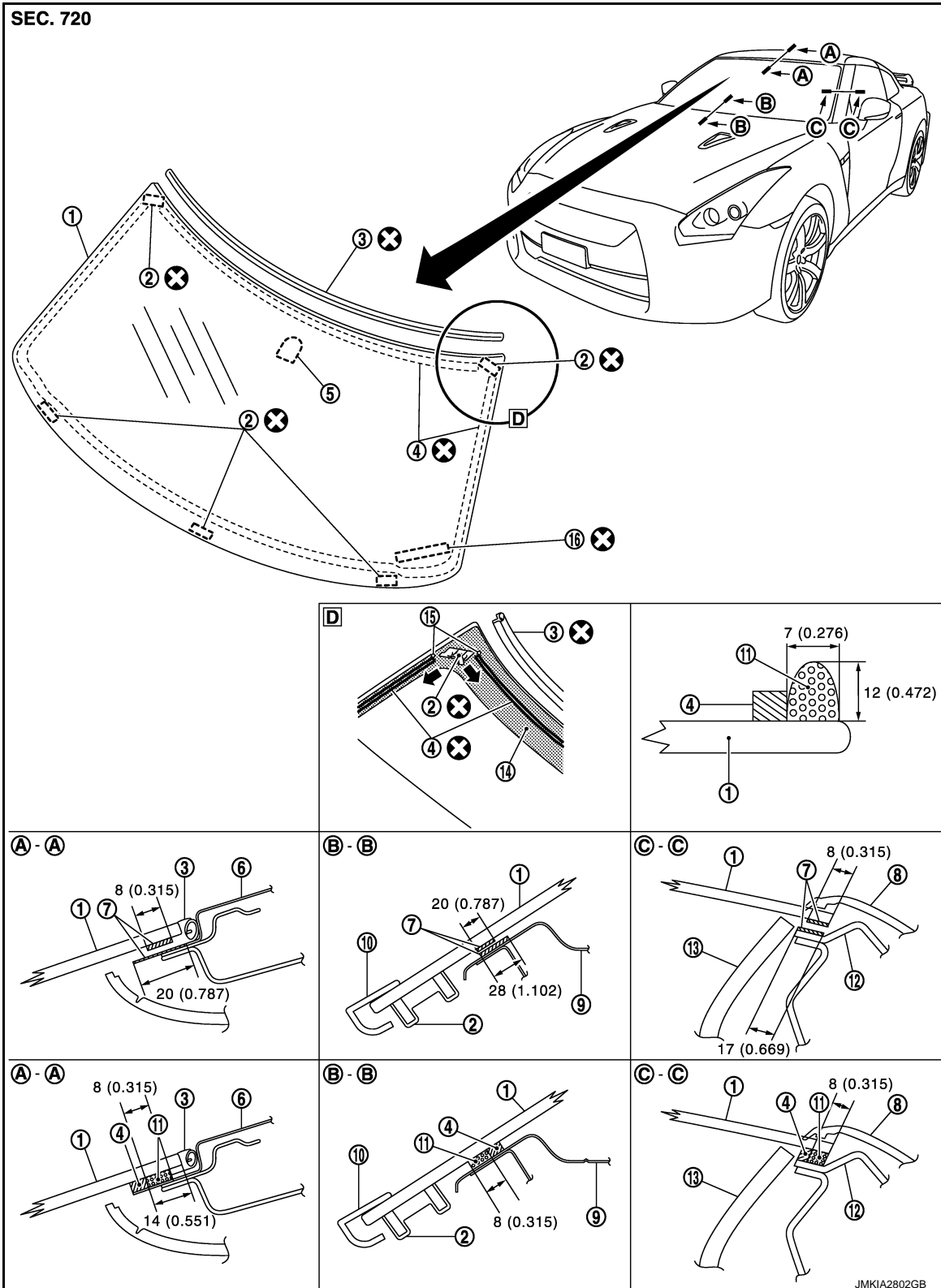

A
B
C
D
E
F
G
H
I
J
L
M
N
O
P

GW

WINDSHIELD GLASS

< REMOVAL AND INSTALLATION >

- | | | |
|---------------------------------|--------------------------|--------------------------------|
| 1. Windshield | 2. Spacer | 3. Windshield molding |
| 4. Dam rubber (upper and lower) | 5. Mirror base | 6. Roof panel |
| 7. Primer | 8. Front pillar finisher | 9. Dashboard upper crossmember |
| 10. Cowl top cover | 11. Adhesive | 12. Front pillar outer |
| 13. Front pillar garnish | 14. Black print | 15. Mark |

16. Insulator

Unit: mm (in)

Refer to [GI-4, "Components"](#) for the symbols shown in the figure.

Removal and Installation (GT-R certified NISSAN dealer)

INFOID:000000009161679

REMOVAL

1. Remove partially headlining (front edge). Refer to [INT-24, "Removal and Installation"](#).
2. Remove inside mirror. Refer to [MIR-15, "Removal and Installation"](#).
3. Remove the front wiper arms (LH/RH). Refer to [WW-21, "Removal and Installation"](#).
4. Remove cowl top cover. Refer to [EXT-27, "Removal and Installation"](#).
5. Remove roof side molding (LH/RH). Refer to [EXT-45, "Removal and Installation"](#).
6. Remove front pillar finisher (LH/RH). Refer to [INT-15, "Removal and Installation"](#).
7. Apply protective tape around windshield to prevent painted surface from being damaged.
8. Guiding a cutter knife along glass, cut the windshield molding.
9. Using a pair of pliers, pull molding remaining at the body flange out of bonded area of glass.
10. Paint matching marks on the body and glass if the windshield is reused.

NOTE:

- Positioning during installation can be easily performed.
- When installing a new windshield glass mount the glass on the body and put the matching marks after clearing the body side.

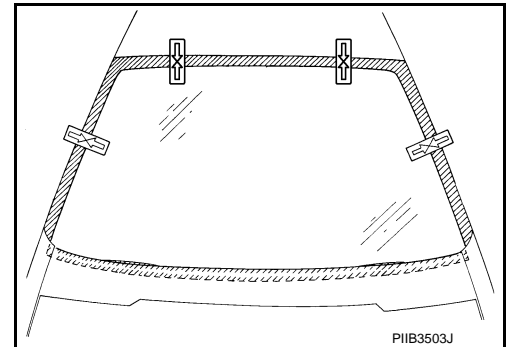

11. Cut the adhesive.
Depending on the tool in use, follow the procedures below:

CAUTION:

Never use a windshield cutter if the windshield is reused. (It may scratch the glass surface)

- a. With piano wire (when reusing glass)
 - i. Pass the piano wire (B) from the passenger room to the bonded area of glass using a wire pierce (A).

CAUTION:

- **Never press the piano wire excessively against the edge of the glass.**
- **Always use a Standish cover (C) to keep the piano wire clear of plastic parts such as the instrument panel.**
- **For the corner area, never insert the piano wire into the mating surfaces of glass.**
- **Never damage the harness around the glass.**

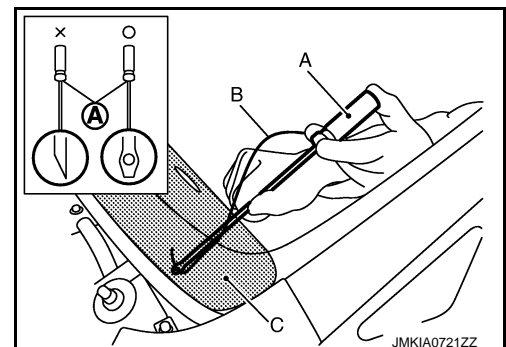

WINDSHIELD GLASS

< REMOVAL AND INSTALLATION >

- ii. Tie both ends of the piano wire (B) to the wire grip (A), etc.

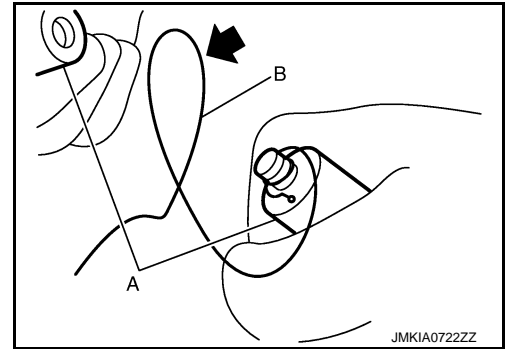

- iii. With 2 persons, one holding the piano wire (B) inside the vehicle along with the glass and the other holding it outside the vehicle along with the gap between the body and glass, pull it to cut off the adhesive.

CAUTION:

Always use a Standish cover (C) to keep the piano wire clear of plastic parts such as the instrument panel.

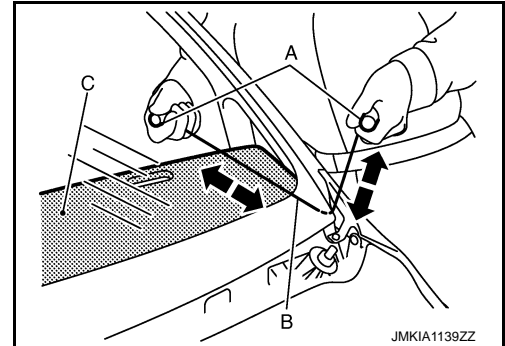

- b. With a windshield cutter (A) (when replacing glass)
 - i. Apply soapy water around the bonded area on the body for smooth movement of the windshield cutter.
 - ii. Insert the windshield cutter into the bonded area. Cut the adhesive by pulling the knife, keeping the tip parallel to the edge of the glass.

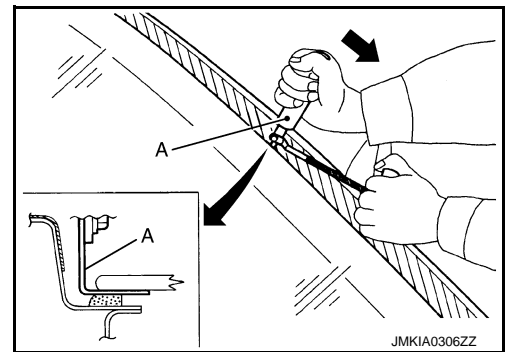

- 12. Use rubber suction cups or suction lifter (A), etc. to remove glass from the vehicle.

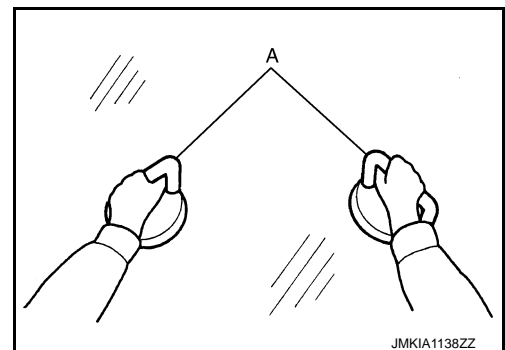

INSTALLATION

A
B
C
D
E
F
G
H
I
J
GW
L
M
N
O
P

WINDSHIELD GLASS

< REMOVAL AND INSTALLATION >

1. Using a scraper, remove remaining adhesive (sealant) on the body side down to approximately a depth that is 2.0 mm (0.079 in) thick (a) so that entire contour becomes smooth.

CAUTION:

If the bonded area on the body is scratched, repair it with a two-liquid type urethane paint. Never use lacquer type paint.

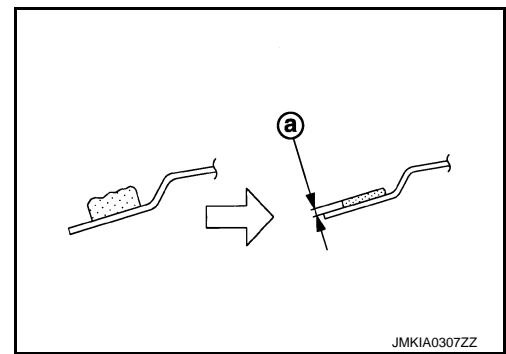

2. When reusing the glass (2), use the cutter (A) to remove the remaining adhesive (1) (sealant) and smooth out the surface.

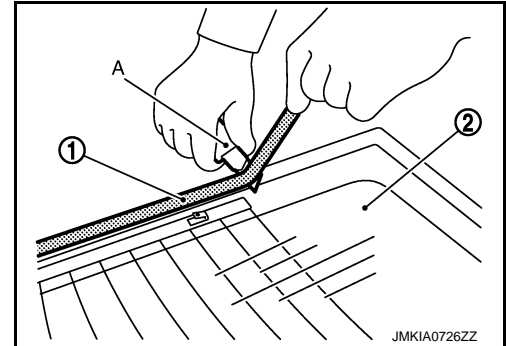

3. Mount the glass onto the vehicle and paint matching marks on the body and glass when installing new glass. Then remove the glass again.
4. Use the rubber suction cups or suction lifter (A) to set the glass (1) on the glass stand (B).

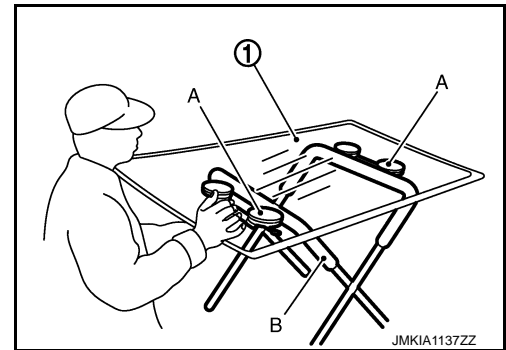

5. Clean the bonded area on the glass and body with white gasoline or degreasing agent.
6. Install new spacer.
7. Install new windshield molding.

NOTE:

Lightly affix the center of molding. Affix the whole length while checking the length on the left and right.

CAUTION:

- Always install the windshield molding before the adhesive hardens.
- After installing glass, keep the front door glass open until the adhesive is completely cured. Never drive the vehicle.

8. Apply primer for the glass along the entire circumference of the glass. Use the sealing kit for glass application and the special holder for cartridge or similar tools.

CAUTION:

There are 2 types of primer. Never confuse the application methods.

- Primer for painted surfaces
- Primer for glass

NOTE:

The essential function of primers is to strengthen adhesion between the glass and the painted surface.

9. Apply primer for the painted surface to the body side bonding surface.

CAUTION:

WINDSHIELD GLASS

< REMOVAL AND INSTALLATION >

- If the body side bonding surface is repaired with a two-liquid type urethane paint, always apply the primer after drying the paint.
- If primer for painted surfaces adheres to a painted surface other than the bonding area, or if it overflows, quickly remove it with white gasoline or degreasing agent.
- Always use a Standish cover (stainless plate) to prevent primer for painted surfaces from adhering to the instrument panel.

10. Affix the dam rubber and apply adhesive along the edge of the glass within the time period indicated in the service manual after applying primer.
- When reusing the glass, affix new dam rubber at the same place where old dam rubber is affixed.
 - When installing new glass, apply the dam rubber from the edge of the glass so as to hide the black print.

CAUTION:

- Apply the dam rubber (1) from the outline mark of black print as shown in Exploded View.
- Start to apply the dam rubber at the outline mark of black print. Apply it so as to only place it without pulling. Stop applying at another outline mark of black print.

NOTE:

Open adhesive by cutting off the nozzle tip and set it in a sealant gun.

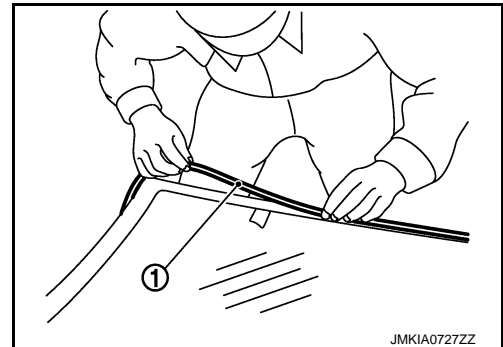

11. Use rubber suction cups or suction lifter (A) that are installed in advance, align the matching marks between the spacer and roof panel hole and between the body and glass (1) to install them on the vehicle.

CAUTION:

2 or more workers are required when installing the glass.

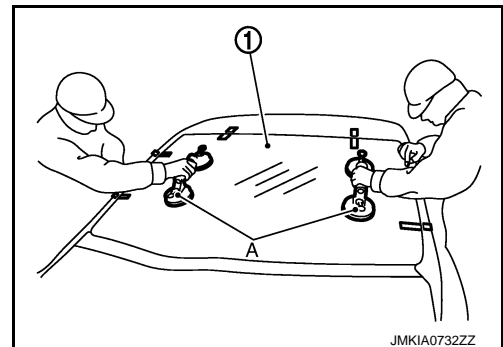

12. Press the entire surface of the glass lightly to fit it completely.
13. Correct any adhesive overflow or shortage using a spatula to make the surface smooth.
14. Remove the protective tape.
15. Install the removed parts.

CAUTION:

- Adjust the front wiper arms stop position. Refer to [WW-22. "Adjustment"](#).
- Check the mating area with surrounding parts. Adjust if necessary.

Inspection (GT-R certified NISSAN dealer)

INFOID:00000009161680

WATER LEAKAGE INSPECTION

CAUTION:

Wait at least 2 hours after installing the glass because the adhesive must be cured before performing the leakage test.

SIDE WINDOW GLASS

< REMOVAL AND INSTALLATION >

SIDE WINDOW GLASS

Exploded View (GT-R certified NISSAN dealer)

INFOID:00000009161681

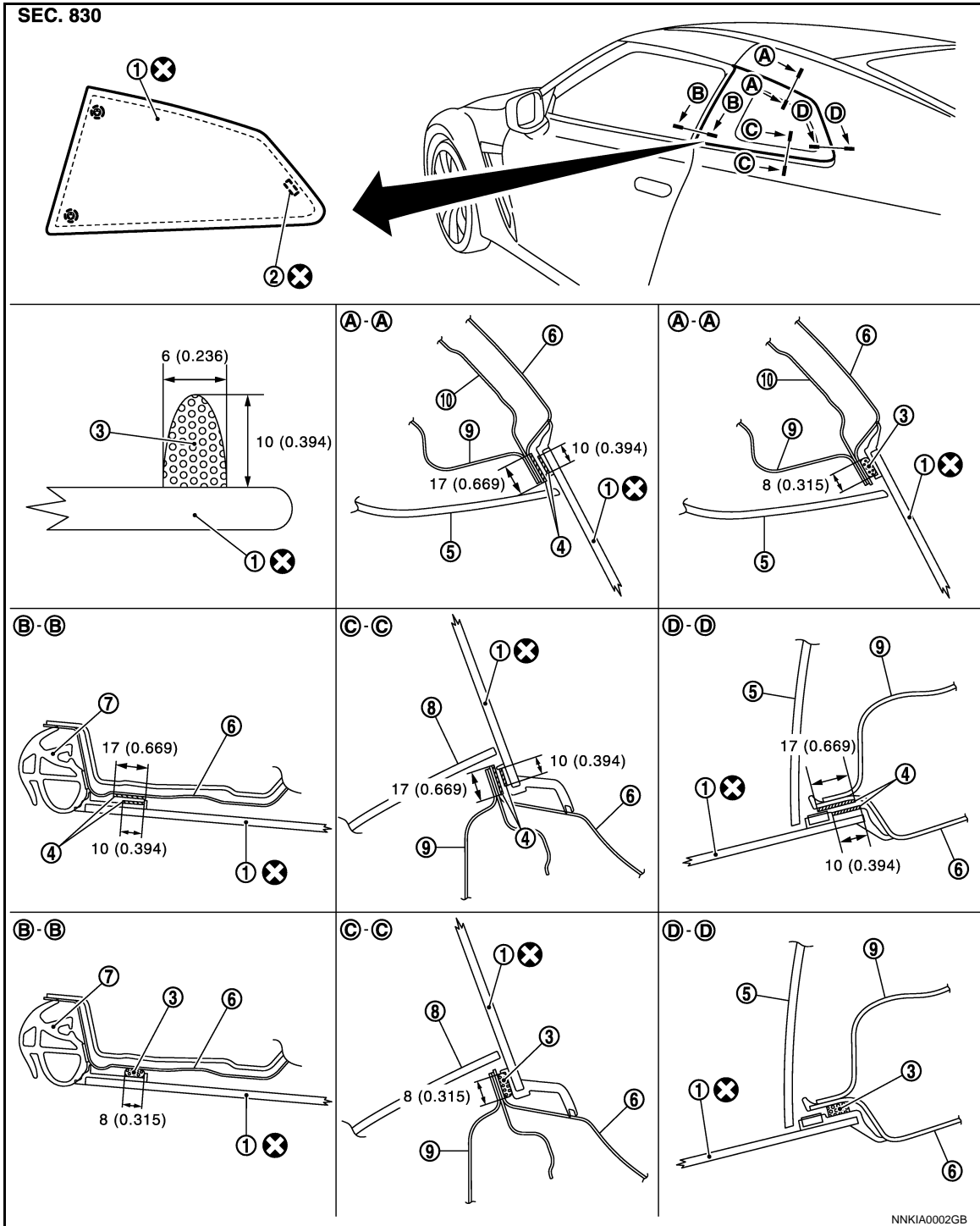

1. Side window glass
2. Spacer
3. Adhesive
4. Primer
5. Rear pillar finisher
6. Rear fender
7. Body side weather-strip
8. Rear side finisher
9. Rear pillar inner
10. Rear pillar outer

1. Side window glass
2. Spacer
3. Adhesive
4. Primer
5. Rear pillar finisher
6. Rear fender
7. Body side weather-strip
8. Rear side finisher
9. Rear pillar inner
10. Rear pillar outer

1. Side window glass
2. Spacer
3. Adhesive
4. Primer
5. Rear pillar finisher
6. Rear fender
7. Body side weather-strip
8. Rear side finisher
9. Rear pillar inner
10. Rear pillar outer

○ : Clip

Unit: mm (in)

SIDE WINDOW GLASS

< REMOVAL AND INSTALLATION >

Refer to [GI-4. "Components"](#) for the symbols shown in the figure.

Removal and Installation (GT-R certified NISSAN dealer)

INFOID:00000009161682

REMOVAL

1. Remove the rear pillar finisher. Refer to [INT-15. "Removal and Installation"](#).
2. Apply protective tape on body panel around side window glass to protect painted surfaces from damage.
3. Cut the adhesive from passenger room side.
Use a windshield cutter for straight section. For the area that the windshield cutter cannot be used, use piano wire or a cutter knife.

a. With a windshield cutter

- i. Apply soapy water around the bonded area on the body for smooth movement of the windshield cutter (A).
- ii. Insert windshield cutter into the bonded area. Cut adhesive by pulling the knife, keeping the tip parallel to body flange edge.

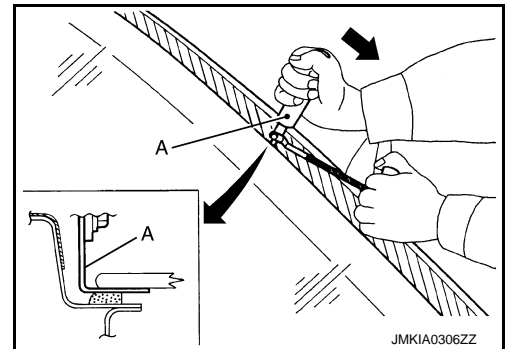

b. With piano wire

- i. Pass both sides of piano wire through each passenger room side from the area cut by the windshield cutter.

- ii. Tie both ends of the piano wire (B) to the wire grip (A), etc.

- iii. Lift up the molding using a plastic spatula, pass the piano wire through the inside of molding, and then cut the adhesive by pulling the wire grips alternately.

CAUTION:

Never contact the piano wire with the coated panel surface.

c. With a cutter knife

- i. Working from inside vehicle, insert cutter knife between side window glass and body panel. Guide cutter edge along molding to cut off adhesive.

CAUTION:

Never contact painted surfaces with the cutter knife tip.

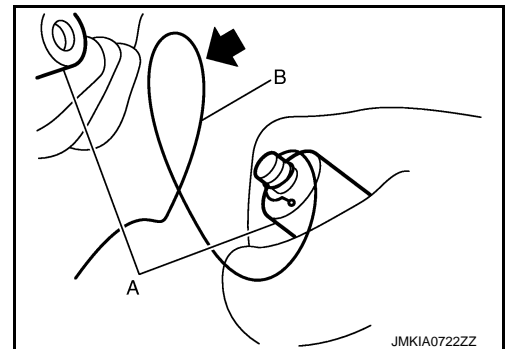

4. Use piano wire to cut the side window glass mounting clip. Use rubber suction cups or suction lifter to remove the glass from the vehicle.

INSTALLATION

1. Using a scraper, remove remaining adhesive on the body side down to approximately a depth that is 2.0mm (0.079in) thick (a) so that entire contour becomes smooth.

CAUTION:

If the bonded area on the body is scratched, repair it with a two-liquid type urethane paint. Never use lacquer type paint.

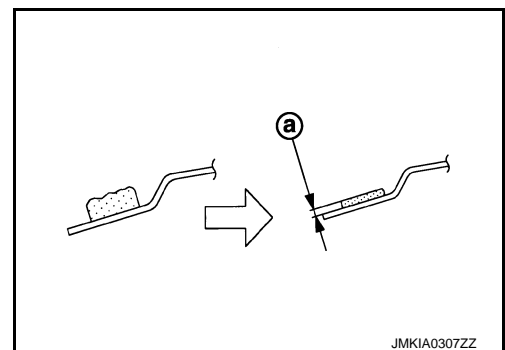

2. Clean bonded and surrounding area on glass with white gasoline or degreasing agent.
3. Apply primer for the glass along the entire circumference of the glass.
 - Use the sealing kit for glass application and the special holder for cartridge or similar tools.

CAUTION:

There are 2 types of primer. Never confuse the application methods.

- Primer for painted surfaces
- Primer for glass

NOTE:

SIDE WINDOW GLASS

< REMOVAL AND INSTALLATION >

The essential function of primers is to strengthen adhesion between glass and painted surface.

4. Apply primer for the painted surface to the body side bonding surface.

CAUTION:

- If the body side bonding surface is repaired with a two-liquid type urethane paint, always apply the primer after drying the paint.
- If primer for painted surfaces adheres to a painted surface other than the bonding area, or if it overflows, quickly remove it with white gasoline or degreasing agent.

5. Apply adhesive along glass edge within the time period indicated in the service manual after applying primer with the procedure shown in the Exploded View.

NOTE:

Open adhesive by cutting off the nozzle tip and set it in a sealant gun.

6. After setting rubber suction cups or suction lifter to glass, align matching marks on body and glass. Install glass to the body.

7. Press the entire surface of the glass lightly to fit it completely.

8. Correct any adhesive overflow or shortage using a spatula to make the surface smooth.

CAUTION:

After installing glass, keep the front door glass open until the adhesive has completely cured. Avoid driving the vehicle.

9. Remove the protective tape.

10. Install the removed parts.

Inspection (GT-R certified NISSAN dealer)

INFOID:00000009161683

WATER LEAKAGE INSPECTION

CAUTION:

Wait at least 2 hours after installing the glass because the adhesive must be cured before performing the leakage test.

REAR WINDOW GLASS

< REMOVAL AND INSTALLATION >

REAR WINDOW GLASS

Exploded View (GT-R certified NISSAN dealer)

INFOID:000000009161684

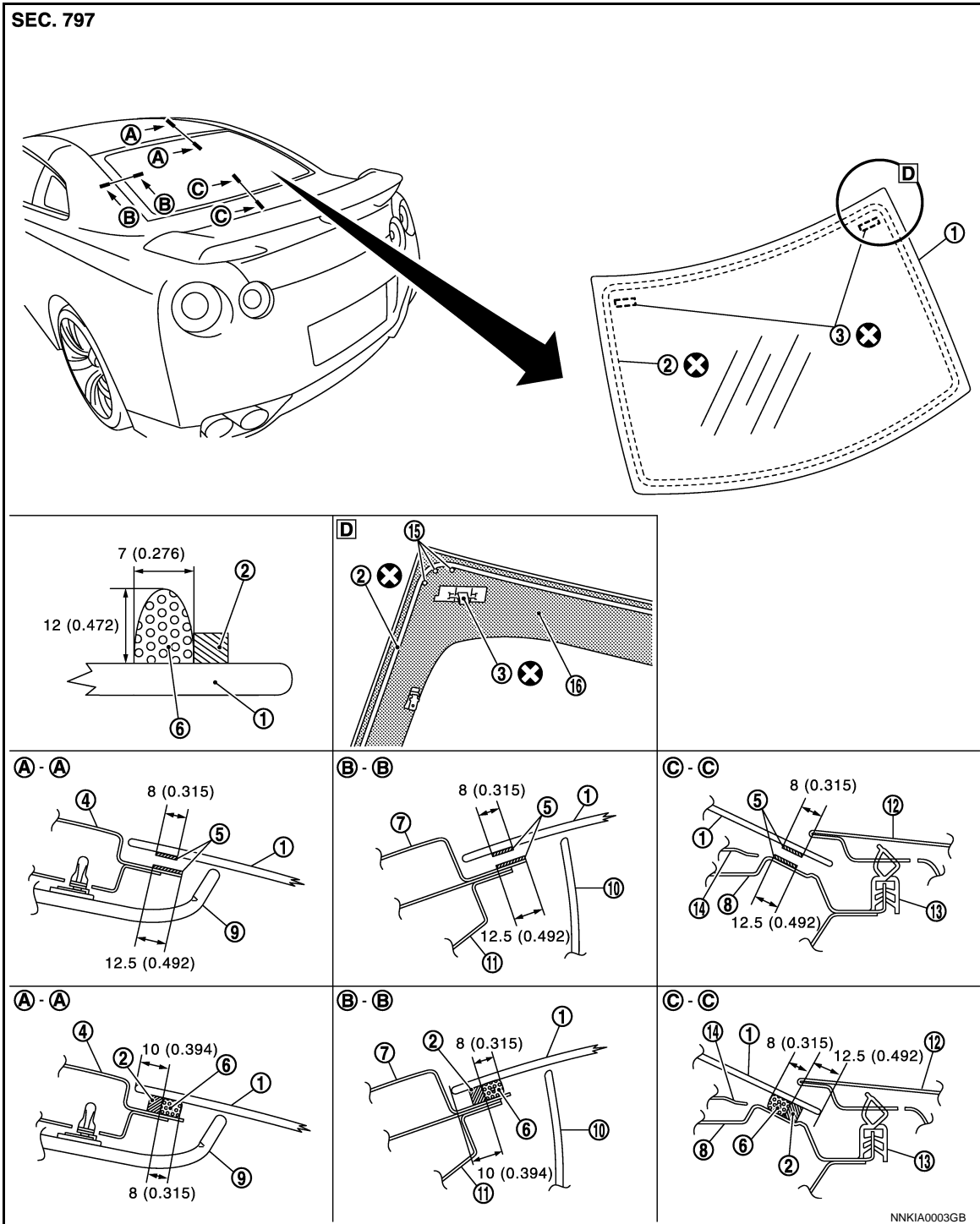

- | | | |
|-----------------------------|--------------------------------|---------------------|
| 1. Rear window glass | 2. Dam rubber | 3. Spacer |
| 4. Roof panel | 5. Primer | 6. Adhesive |
| 7. Body side outer panel | 8. Rear waist | 9. Headlining |
| 10. Rear pillar finisher | 11. Rear pillar inner | 12. Trunk lid outer |
| 13. Trunk lid weather-strip | 14. Rear parcel shelf finisher | 15. Mark |
| 16. Black print | | |

Unit: mm (in)

A
B
C
D
E
F
G
H
I
J
GW
L
M
N
O
P

REAR WINDOW GLASS

< REMOVAL AND INSTALLATION >

Refer to [GI-4, "Components"](#) for the symbols shown in the figure.

Removal and Installation (GT-R certified NISSAN dealer)

INFOID:000000009161685

REMOVAL

1. Remove rear pillar finisher (LH/RH). Refer to [INT-15, "Removal and Installation"](#).
2. Remove partially headlining (rear edge). Refer to [INT-24, "Removal and Installation"](#).
3. Remove rear parcel shelf finisher. Refer to [INT-19, "Removal and Installation"](#).
4. Remove connectors and grounds for rear window defogger and printed antenna.
5. Apply protective tape around rear window glass to prevent painted surface from being damaged.
6. If rear window glass will be reused, paint matching marks on the body and glass.

NOTE:

Positioning during installation can be easily performed. Mount the glass on the body and put the matching marks after clearing the body side especially when installing new glass.

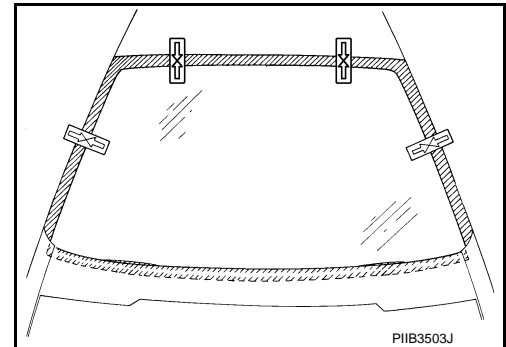

7. Cut the adhesive.
Use a windshield cutter for straight section. For the area that the windshield cutter cannot be used, use piano wire or a cutter knife.
 - a. With a windshield cutter
 - i. Apply soapy water around the bonded area on the body for smooth movement of the windshield cutter (A).
 - ii. Insert windshield knife into the bonded area from the passenger room side. Cut adhesive by pulling the knife, keeping the tip parallel to the edge of the glass.

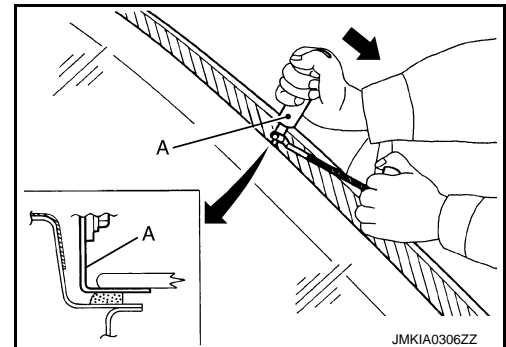

- b. With piano wire
For the area that the windshield cutter cannot be used, use piano wire.
 - i. From the area cut by the windshield cutter, pass the piano wire through the passenger room side and tie both sides to wire grips.
 - ii. Cut the adhesive by alternately pulling the piano wire along with the glass.
- c. With a cutter knife
 - i. Working from inside cabin, insert a cutter knife between rear window glass and body side outer panel. Work the cutter knife along the edge of the rear window glass to cut off the adhesive.

CAUTION:

Never contact painted surfaces with the cutter knife tip.

REAR WINDOW GLASS

< REMOVAL AND INSTALLATION >

8. Use rubber suction cups or suction lifter (A), etc. to remove glass from the vehicle.

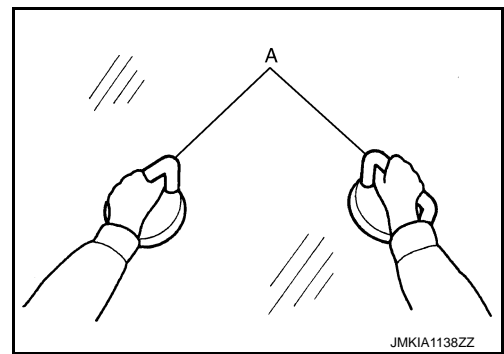

INSTALLATION

1. Using a scraper, remove remaining adhesive (sealant) on the body side down to approximately a depth that is 2.0 mm (0.079 in) thick (a) so that entire contour becomes smooth.

CAUTION:

If the bonded area on the body is scratched, repair it with a two-liquid type urethane paint. Never use lacquer type paint.

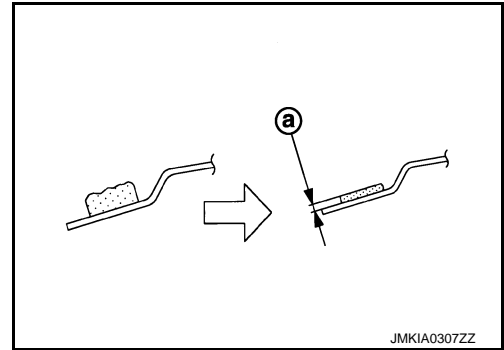

2. When reusing the glass (2), use the cutter (A) to remove the remaining adhesive (1) (sealant) and smooth out the surface.

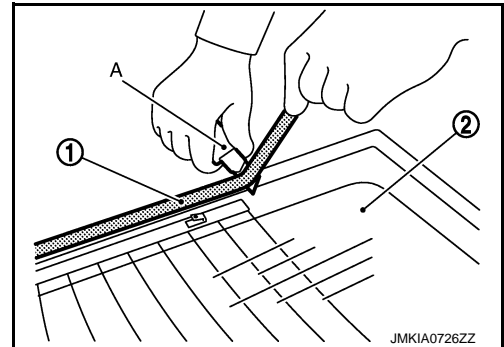

3. Mount the glass onto the vehicle and paint matching marks on the body and glass when installing new glass. Then remove the glass again.
4. Use the rubber suction cups or suction lifter (A) to set the glass (1) on the glass stand (B).

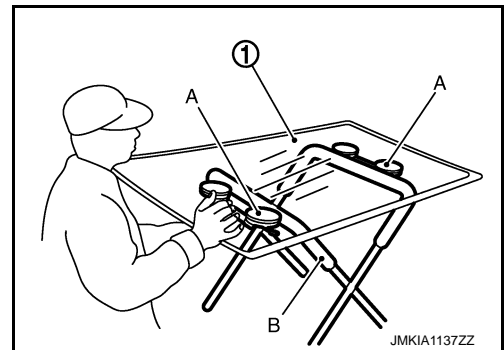

5. Clean the bonded area on the glass and body with white gasoline or degreasing agent.
6. Install new spacer.
7. Apply primer for the glass along the entire circumference of the glass.
Use the sealing kit for glass application and the special holder for cartridge or similar tools.

CAUTION:

There are 2 types of primer. Never confuse the application methods.

- Primer for painted surfaces

REAR WINDOW GLASS

< REMOVAL AND INSTALLATION >

- **Primer for glass**

NOTE:

The essential function of primers is to strengthen adhesion between glass and painted surface.

8. Apply primer for the painted surface to the body side bonding surface.

CAUTION:

- **If the body side bonding surface is repaired with a two-liquid type urethane paint, always apply the primer after drying the paint.**
- **If primer for painted surfaces adheres to a painted surface other than the bonding area, or if it overflows, quickly remove it with white gasoline or degreasing agent.**

9. Affix the dam rubber and apply adhesive along the edge of the glass within the time period indicated in the instruction manual after applying primer.

- When reusing the glass, affix new dam rubber at the same place where old dam rubber was affixed.

- When installing new glass, apply the dam rubber from the edge of the glass so as to hide the black print.

CAUTION:

Apply the dam rubber (1) to the outer edge of the outline mark of black print as shown in Exploded View. Apply it so as to only place it without pulling.

NOTE:

Open adhesive by cutting off the nozzle tip and set it in a sealant gun.

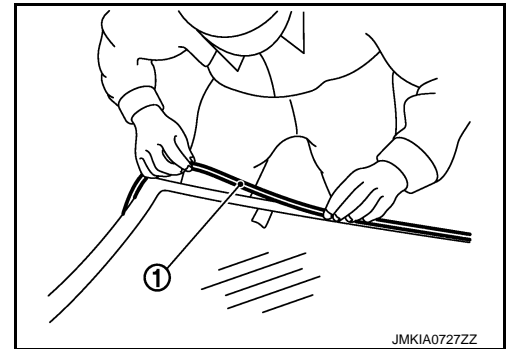

10. Use rubber suction cups or suction lifter (A) that are installed in advance, align the matching marks to install.

CAUTION:

2 or more workers are required when installing the glass.

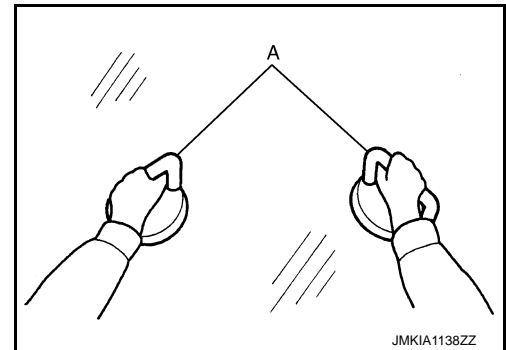

11. Press the entire surface of the glass lightly to fit it completely.

12. Correct any adhesive overflow or shortage using a spatula to make the surface smooth.

CAUTION:

After installing glass, keep the front door glass open until the adhesive is completely cured. Avoid driving the vehicle.

13. Remove the protective tape.

14. Install the removed parts.

CAUTION:

Check the mating area with surrounding parts. Adjust if necessary.

Inspection (GT-R certified NISSAN dealer)

INFOID:000000009161686

WATER LEAKAGE INSPECTION

CAUTION:

Wait at least 2 hours after installing the glass because the adhesive must be cured before performing the leakage test.

DOOR GLASS

< REMOVAL AND INSTALLATION >

DOOR GLASS

Exploded View (GT-R certified NISSAN dealer)

INFOID:000000009161687

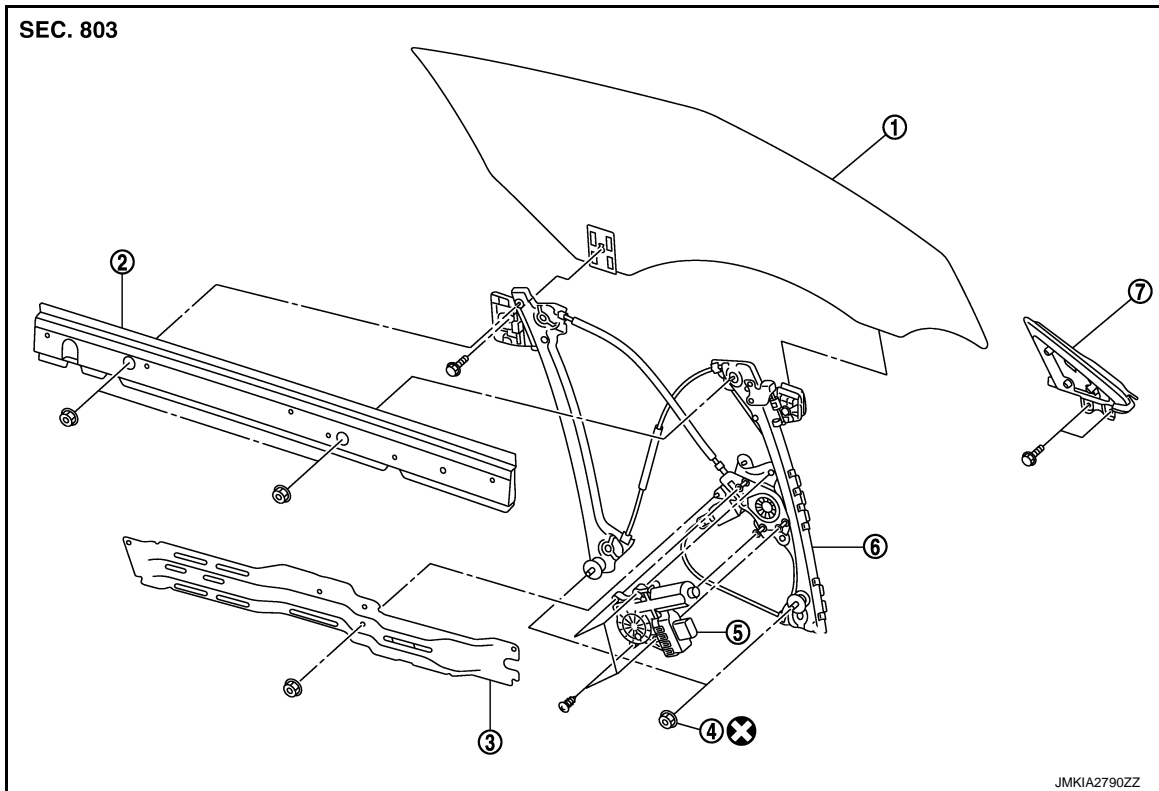

- | | | |
|--------------------------|-----------------------------|-----------------------|
| 1. Door glass assembly | 2. Door inner reinforcement | 3. Door module base |
| 4. Nut | 5. Power window motor | 6. Regulator assembly |
| 7. Corner piece assembly | | |

Refer to [GI-4. "Components"](#) for symbols in the figure.

Removal and Installation (GT-R certified NISSAN dealer)

INFOID:000000009161688

REMOVAL

1. Remove the door finisher. Refer to [INT-12. "Removal and Installation"](#).
2. Disconnect the tweeter harness connector. Refer to [AV-81. "Removal and Installation"](#).
3. Remove the door corner cover inner. Refer to [MIR-16. "DOOR MIRROR ASSEMBLY : Exploded View"](#).
4. Remove the corner piece mounting bolts (A), and then remove the corner piece (1) and the door inner seal (2).

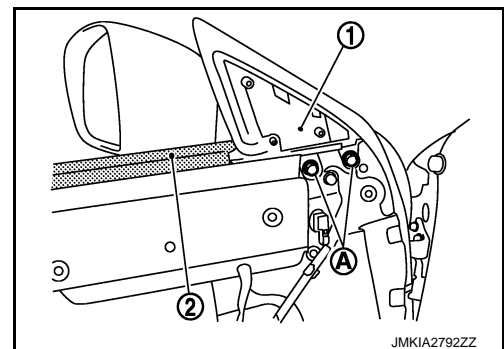

DOOR GLASS

< REMOVAL AND INSTALLATION >

5. Remove the sealing screen (1).

NOTE:

Cut butyl tape using a cutter knife so that tape remains on the sealing screen if the screen is reused.

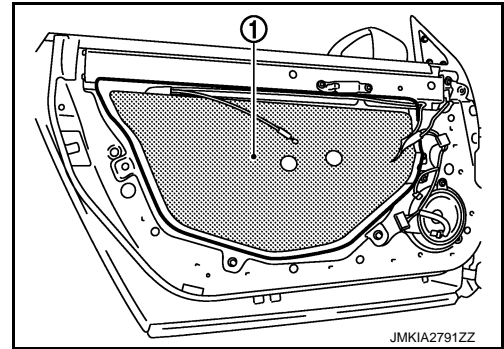

6. Operate the power window switch to raise/lower the door glass until the glass bolts can be seen.

NOTE:

Connect the harness connector to the power window switch.

7. Loosen the door glass mounting bolt (A), and then remove the mounting bolt (B).

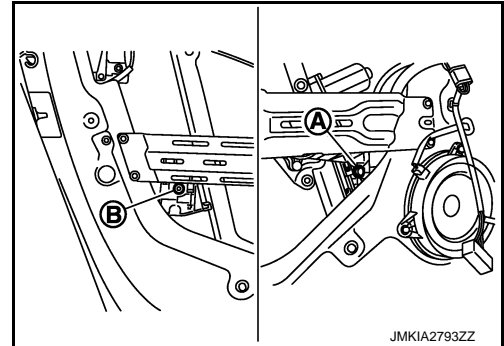

8. Pull the door glass (1) from the door panel while lifting it up over the door glass rear edge.

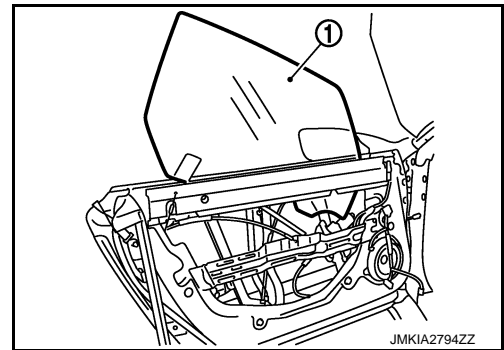

INSTALLATION

Install in the reverse order of removal.

NOTE:

Always perform the glass position adjustment.

Inspection and adjustment (GT-R certified NISSAN dealer)

INFOID:000000009161689

SYSTEM INITIALIZATION

Perform system initialization if the following operation is performed.

- When disconnecting the battery cable and when the power supplied to the power window motor and motor is cut off by blowout of power fuse
- Removal and installation of regulator assembly
- Removal and installation of motor from regulator assembly
- Removal and installation of power window switch harness connector
- Operation of regulator assembly as an independent unit
- Removal and installation of glass
- Removal and installation of door weather-strip

Initial Setting

After installing each component, follow the steps below:

1. Disconnect the battery negative terminal or power window main switch connector. Reconnect it after waiting a minute or more.
2. Close the door.

DOOR GLASS

< REMOVAL AND INSTALLATION >

3. Turn the ignition switch ON.
4. Operate the power window switch to fully open the glass. (This operation is unnecessary if the glass is already fully open)
5. Pull the power window switch UP (AUTO UP position). Even after the glass stops at the fully closed position, continue pulling the switch for 2 seconds or more.
6. Inspect anti-pinch function.

NOTE:

If the open/close operation is repeated continuously, the initial setting may be cancelled. Perform the initial setting in that situation.

CHECK ANTI-PINCH FUNCTION

1. Open the door glass fully.
2. Place a piece of wood (e.g., handle of wooden hammer) near the fully closed position.
3. Close the door glass fully with AUTO UP.
 - Check that the glass lowers approximately 150 mm after contacting the piece of wood and then stops.
 - Check that the glass does not rise when operating the power window main switch while lowering.

CAUTION:

- Be careful not to be pinched
- Check that the auto up function is normal before inspection following the system initialization

FITTING INSPECTION

1. Check that the overlap length with the body side weather-strip is maintained on the glass securely.
2. Check that the clearance with the side window is parallel when the glass is closed. If the clearance between glass and side window is not parallel, loosen the mounting nut of glass and carrier plate and correct the glass position.
3. Check for any operation that is not normal while raising and lowering the glass.

GLASS POSITION ADJUSTMENT

1. Raise glass to the fully closed position.
2. Rotate the adjustment nuts (a), (b), or (c) aligning with the upper side of glass and the body side weather-strip to adjustment.

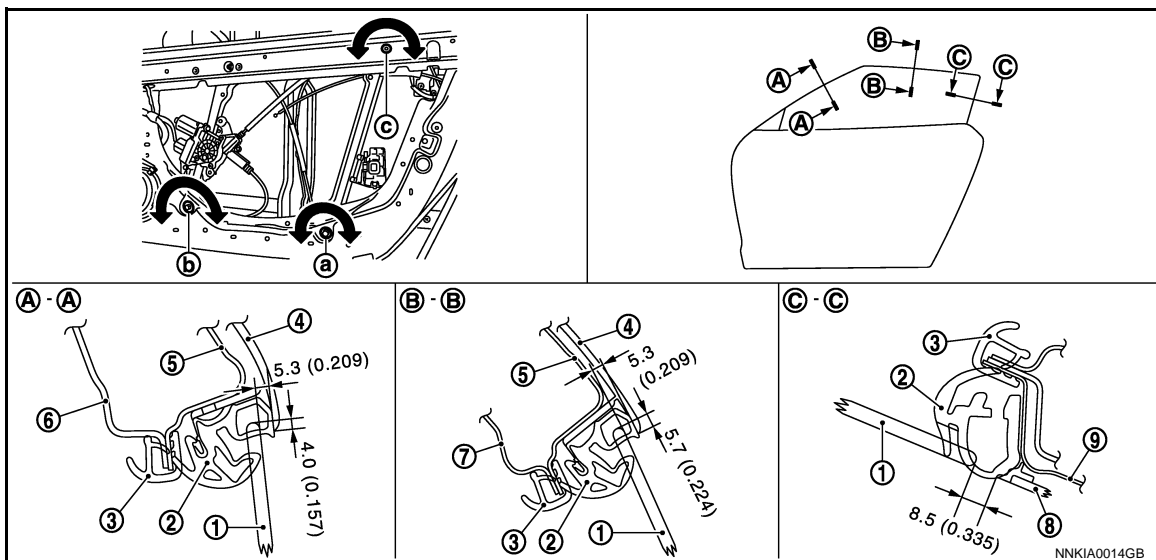

- | | | |
|--------------------------|----------------------------|---------------------------|
| 1. Door glass assembly | 2. Body side weather-strip | 3. Body side welt (front) |
| 4. Front pillar finisher | 5. Front pillar outer | 6. Front pillar inner |
| 7. Roof side inner rail | 8. Side window glass | 9. Rear fender |

NOTE:

- Basically perform the adjustment using the adjustment nut (a). Perform the adjustment using the adjustment nut (b) or (c) if the glass position is not adjusted correctly using the adjustment nut (a).
- Rotate the adjustment nut clockwise to move the door glass upper edge to the outside.

DOOR GLASS

< REMOVAL AND INSTALLATION >

- Rotate the adjustment nut counterclockwise to move the door glass upper edge to the inside.
- Be careful that the adjustment procedure for the adjustment nut (c) is opposite in the procedure for the adjustment nut (a) or (b).

DOOR REGULATOR

< REMOVAL AND INSTALLATION >

DOOR REGULATOR

Exploded View (GT-R certified NISSAN dealer)

INFOID:000000009161690

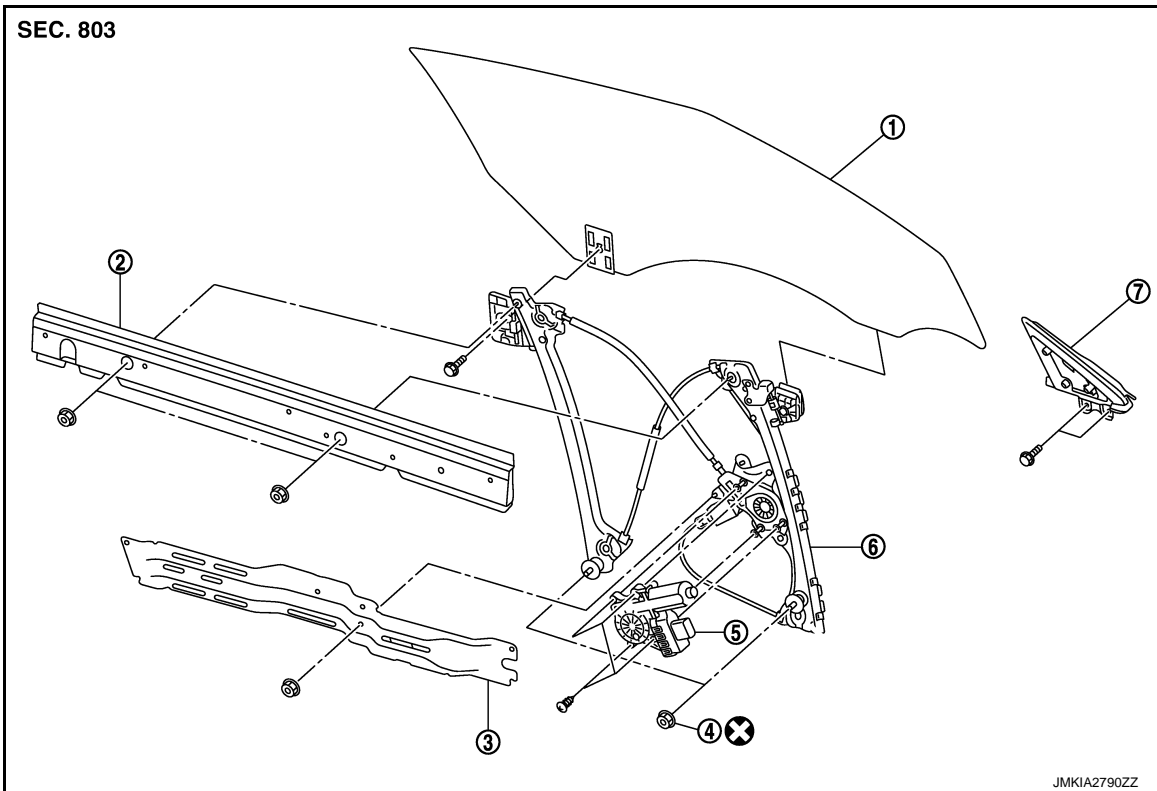

- | | | |
|--------------------------|-----------------------------|-----------------------|
| 1. Door glass assembly | 2. Door inner reinforcement | 3. Door module base |
| 4. Nut | 5. Power window motor | 6. Regulator assembly |
| 7. Corner piece assembly | | |

Refer to [GI-4, "Components"](#) for symbols in the figure.

Removal and Installation (GT-R certified NISSAN dealer)

INFOID:000000009161691

REGULATOR ASSEMBLY

Removal

1. Remove the door glass. Refer to [GW-23, "Removal and Installation \(GT-R certified NISSAN dealer\)"](#).
2. Remove the mounting nuts and bolts, and then remove the door module base (1).

← : Bolt

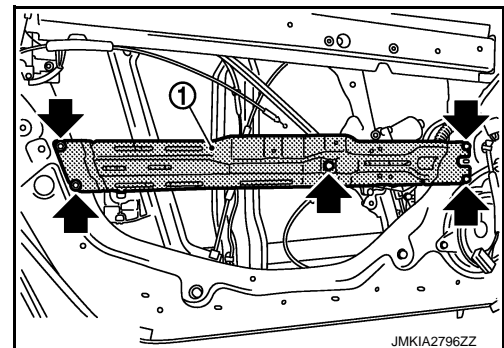

DOOR REGULATOR

< REMOVAL AND INSTALLATION >

3. Disconnect the power window motor harness connector (A).

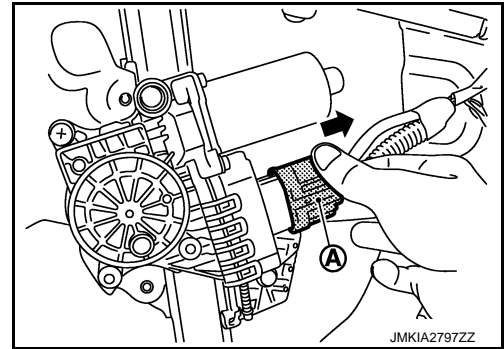

4. Remove the door finisher bracket (1) using a socket wrench (A).

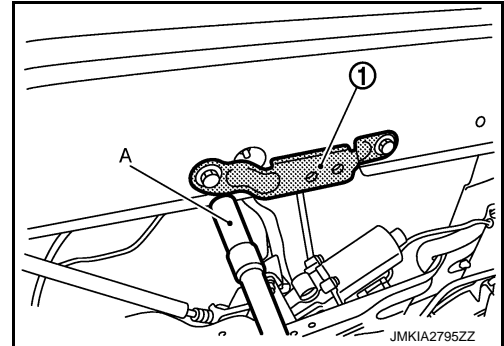

5. Remove the regulator assembly mounting nut using a socket wrench, and then remove the regulator assembly.

← : Nut

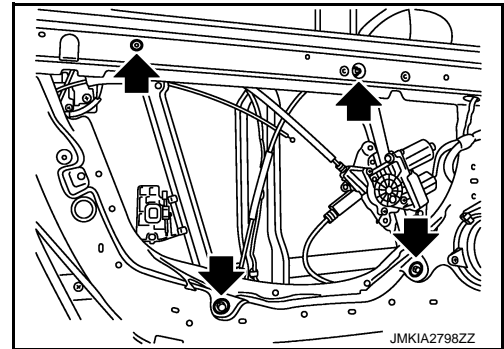

Installation

Install in the reverse order of removal.

NOTE:

Always perform the glass position adjustment.

CAUTION:

The regulator assembly mounting nuts (bottom side) can not be reused. Replace them by new nuts.

Inspection After Removal

Check regulator assembly for the following item. Replace if necessary.

- Wire wear
- Deformation of regulator assembly

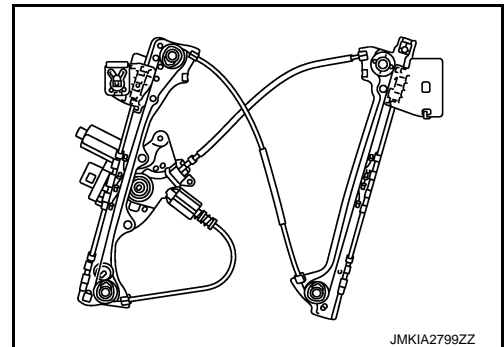

Disassembly and assembly (GT-R certified NISSAN dealer)

INFOID:000000009161692

DISASSEMBLY

1. Remove the regulator assembly from the door panel.

DOOR REGULATOR

< REMOVAL AND INSTALLATION >

2. Remove the power window motor from the regulator assembly.

ASSEMBLY

Assembly is the reverse order of disassembly.

Inspection and adjustment (GT-R certified NISSAN dealer)

INFOID:000000009161693

SYSTEM INITIALIZATION

Perform system initialization if the following operation is performed.

- When disconnecting the battery cable and when the power supplied to the power window motor and motor is cut off by blowout of power fuse
- Removal and installation of regulator assembly
- Removal and installation of motor from regulator assembly
- Removal and installation of power window switch harness connector
- Operation of regulator assembly as an independent unit
- Removal and installation of glass
- Removal and installation of door weather-strip

Initial Setting

After installing each component, follow the steps below:

1. Disconnect the battery negative terminal or power window main switch connector. Reconnect it after waiting a minute or more.
2. Close the door.
3. Turn the ignition switch ON.
4. Operate the power window switch to fully open the glass. (This operation is unnecessary if the glass is already fully open)
5. Pull the power window switch UP (AUTO UP position). Keep pulling the switch for 2 seconds or more even after glass stops at the fully closed position.
6. Inspect anti-pinch function.

NOTE:

If the open/close operation is repeated continuously, the initial setting may be cancelled. Perform the initial setting in that situation.

CHECK ANTI-PINCH FUNCTION

1. Open the door glass fully.
2. Place a piece of wood (e.g., handle of wooden hammer) near the fully closed position.
3. Close the door glass fully with AUTO UP.
 - Check that the glass lowers approximately 150 mm(5.906 in) after contacting the piece of wood and then stops.
However, when the objects of more than 60 mm(2.362 in) are pinched, it is lowered approximately 100 mm(3.937 in), and then it may stop.
 - Check that the glass does not rise when operating the power window main switch while lowering.

CAUTION:

- **Be careful not to be pinched**
- **Check that the auto up function is normal before the inspection following the system initialization**

FITTING INSPECTION

1. Check that the overlap length with the body side weather-strip is maintained on the glass securely.
2. Check that the clearance with the side window is parallel when the glass is closed. If the clearance between glass and side window is not parallel, loosen the mounting nut of glass and carrier plate and correct the glass position.
3. Check for any unusual operation while raising and lowering the glass.

GLASS POSITION ADJUSTMENT

1. Raise glass to the fully closed position.
2. Rotate the adjustment nuts (a), (b), or (c) aligning with the upper side of glass and the body side weather-strip to adjustment.

DOOR REGULATOR

< REMOVAL AND INSTALLATION >

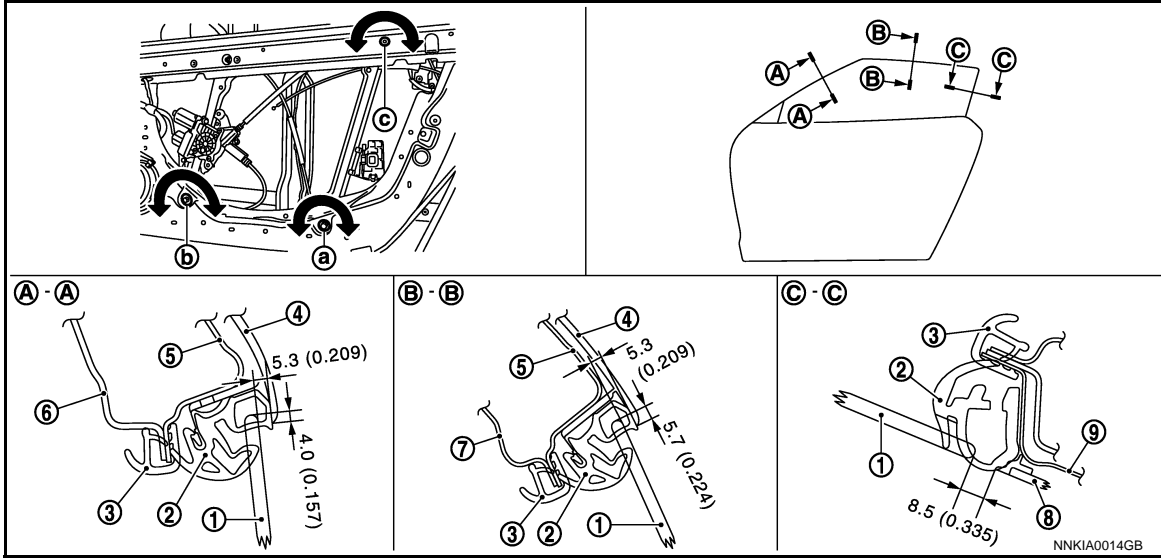

- | | | |
|--------------------------|----------------------------|---------------------------|
| 1. Door glass assembly | 2. Body side weather-strip | 3. Body side welt (front) |
| 4. Front pillar finisher | 5. Front pillar outer | 6. Front pillar inner |
| 7. Roof side inner rail | 8. Side window glass | 9. Rear fender |

NOTE:

- Basically perform the adjustment using the adjustment nut (a). Perform the adjustment using the adjustment nut (b) or (c) if the glass position is not adjusted correctly using the adjustment nut (a).
- Rotate the adjustment nut clockwise to move the door glass upper edge to the outside.
- Rotate the adjustment nut counterclockwise to move the door glass upper edge to the inside.
- Be careful that the adjustment procedure for the adjustment nut (c) is opposite in the procedure for the adjustment nut (a) or (b).