

SECTION **INT**  
INTERIOR

A  
B  
C  
D  
E  
F  
G  
H  
I  
INT  
K  
L  
M  
N  
O  
P

CONTENTS

<b>SYMPTOM DIAGNOSIS</b> .....	2	<b>REMOVAL AND INSTALLATION</b> .....	12
<b>SQUEAK AND RATTLE TROUBLE DIAG- NOSES</b> .....	2	<b>DOOR FINISHER</b> .....	12
Work Flow .....	2	Exploded View .....	12
Inspection Procedure .....	4	Removal and Installation .....	12
Diagnostic Worksheet .....	6	<b>BODY SIDE TRIM</b> .....	15
<b>PRECAUTION</b> .....	8	Exploded View .....	15
<b>PRECAUTIONS</b> .....	8	Removal and Installation .....	15
Precaution for Supplemental Restraint System (SRS) "AIR BAG" and "SEAT BELT PRE-TEN- SIONER" .....	8	<b>REAR PARCEL SHELF FINISHER</b> .....	19
Precautions Necessary for Steering Wheel Rota- tion After Battery Disconnection .....	8	Exploded View .....	19
Precaution for Procedure without Cowl Top Cover.....	9	Removal and Installation .....	19
Precaution for Work .....	9	<b>FLOOR TRIM</b> .....	22
<b>PREPARATION</b> .....	10	Exploded View .....	22
<b>PREPARATION</b> .....	10	Removal and Installation .....	22
Special Service Tools .....	10	<b>HEADLINING</b> .....	24
Commercial Service Tools .....	10	Exploded View .....	24
<b>CLIP LIST</b> .....	11	Removal and Installation .....	24
Clip List .....	11	<b>TRUNK ROOM TRIM</b> .....	27
		Exploded View .....	27
		Removal and Installation .....	27
		<b>TRUNK LID TRIM</b> .....	29
		Exploded View .....	29
		Removal and Installation .....	29

# SQUEAK AND RATTLE TROUBLE DIAGNOSES

< SYMPTOM DIAGNOSIS >

## SYMPTOM DIAGNOSIS

### SQUEAK AND RATTLE TROUBLE DIAGNOSES

#### Work Flow

INFOID:000000009162319

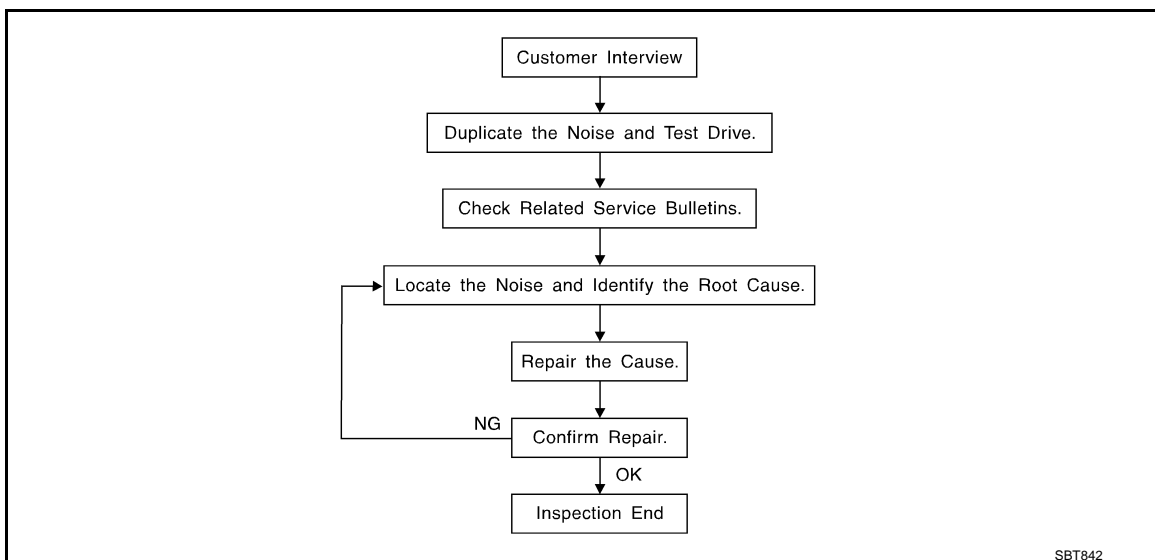

#### CUSTOMER INTERVIEW

Interview the customer if possible, to determine the conditions that exist when the noise occurs. Use the Diagnostic Worksheet during the interview to document the facts and conditions when the noise occurs and any of customer's comments; refer to [INT-6. "Diagnostic Worksheet"](#). This information is necessary to duplicate the conditions that exist when the noise occurs.

- The customer may not be able to provide a detailed description or the location of the noise. Attempt to obtain all the facts and conditions that exist when the noise occurs (or does not occur).
- If there is more than one noise in the vehicle, perform a diagnosis and repair the noise that the customer is concerned about. This can be accomplished by performing a cruise test on the vehicle with the customer.
- After identifying the type of noise, isolate the noise in terms of its characteristics. The noise characteristics are provided so the customer, service adviser and technician are all speaking the same language when defining the noise.
- Squeak – (Like tennis shoes on a clean floor)  
Squeak characteristics include the light contact/fast movement/brought on by road conditions/hard surfaces = higher pitch noise/softer surfaces = lower pitch noises/edge to surface = chirping
- Creak – (Like walking on an old wooden floor)  
Creak characteristics include firm contact/slow movement/twisting with a rotational movement/pitch dependent on materials/often brought on by activity.
- Rattle – (Like shaking a baby rattle)  
Rattle characteristics include the fast repeated contact/vibration or similar movement/loose parts/missing clip or fastener/incorrect clearance.
- Knock – (Like a knock on a door)  
Knock characteristics include hollow sounding/sometimes repeating/often brought on by driver action.
- Tick – (Like a clock second hand)  
Tick characteristics include gentle contacting of light materials/loose components/can be caused by driver action or road conditions.
- Thump – (Heavy, muffled knock noise)  
Thump characteristics include softer knock/dead sound often brought on by activity.
- Buzz – (Like a bumblebee)  
Buzz characteristics include high frequency rattle/firm contact.
- Often the degree of acceptable noise level will vary depending up on the person. A noise that a technician may judge as acceptable may be very irritating to the customer.
- Weather conditions, especially humidity and temperature, may have a great effect on noise level.

#### DUPLICATE THE NOISE AND TEST DRIVE

# SQUEAK AND RATTLE TROUBLE DIAGNOSES

## < SYMPTOM DIAGNOSIS >

If possible, drive the vehicle with the customer until the noise is duplicated. Note any additional information on the Diagnostic Worksheet regarding the conditions or location of the noise. This information can be used to duplicate the same conditions when the repair is reconfirmed.

If the noise can be duplicated easily during the test drive, to help identify the source of the noise, try to duplicate the noise with the vehicle stopped by doing one or all of the following:

- 1) Close a door.
  - 2) Tap or push/pull around the area where the noise appears to be coming from.
  - 3) Rev the engine.
  - 4) Use a floor jack to recreate vehicle "twist".
  - 5) At idle, apply engine load (electrical load, half-clutch on M/T models, drive position on A/T models).
  - 6) Raise the vehicle on a hoist and hit a tire with a rubber hammer.
- Drive the vehicle and attempt to duplicate the conditions the customer states exist when the noise occurs.
  - If it is difficult to duplicate the noise, drive the vehicle slowly on an undulating or rough road to stress the vehicle body.

## CHECK RELATED SERVICE BULLETINS

After verifying the customer concern or symptom, check ASIST for Technical Service Bulletins (TSBs) related to that concern or symptom.

If a TSB relates to the symptom, follow the procedure to repair the noise.

## LOCATE THE NOISE AND IDENTIFY THE ROOT CAUSE

1. Narrow down the noise to a general area. To help pinpoint the source of the noise, use a listening tool (Chassis ear: J-39570, Engine ear and mechanics stethoscope).
2. Narrow down the noise to a more specific area and identify the cause of the noise by:
  - Removing the components in the area that is are suspected to be the cause of the noise.  
Do not use too much force when removing clips and fasteners, otherwise clips and fastener can be broken or lost during the repair, resulting in the creation of new noise.
  - Tapping or pushing/pulling the component that is are suspected to be the cause of the noise.  
Do not tap or push/pull the component with excessive force, otherwise the noise will be eliminated only temporarily.
  - Feeling for a vibration by hand by touching the component(s) that is are suspected to be the cause of the noise.
  - Placing a piece of paper between components that are suspected to be the cause of the noise.
  - Looking for loose components and contact marks.  
Refer to [INT-4, "Inspection Procedure"](#).

## REPAIR THE CAUSE

- If the cause is a loose component, tighten the component securely.
- If the cause is insufficient clearance between components:
  - Separate components by repositioning or loosening and retightening the component, if possible.
  - Insulate components with a suitable insulator such as urethane pads, foam blocks, felt cloth tape or urethane tape. A Nissan Squeak and Rattle Kit (J-43980) is available through the authorized Nissan Parts Department.

### **CAUTION:**

**Never use excessive force as many components are constructed of plastic and may be damaged.**

### **NOTE:**

Always check with the Parts Department for the latest parts information.

The following materials are contained in the Nissan Squeak and Rattle Kit (J-43980). Each item can be ordered separately as needed.

URETHANE PADS [1.5 mm (0.059 in) thick]

Insulates connectors, harness, etc.

- 76268-9E005: 100 × 135 mm (3.937 × 5.315 in)
- 76884-71L01: 60 × 85 mm (2.362 × 3.346 in)
- 76884-71L02: 15 × 25 mm (0.591 × 0.984 in)

INSULATOR (Foam blocks)

Insulates components from contact. Can be used to fill space behind a panel.

- 73982-9E000: 45 mm (1.772 in) thick, 50 × 50 mm (1.969 × 1.969 in)
- 73982-50Y00: 10 mm (0.394 in) thick, 50 × 50 mm (1.969 × 1.969 in)

INSULATOR (Light foam block)

- 80845-71L00: 30 mm (1.181 in) thick, 30 × 50 mm (1.181 × 1.969 in)

FELT CLOTHTAPE

# SQUEAK AND RATTLE TROUBLE DIAGNOSES

## < SYMPTOM DIAGNOSIS >

---

Used to insulate where movement does not occur. Ideal for instrument panel applications.

- 68370-4B000: 15 × 25 mm (0.59 × 0.984 in) pad
- 68239-13E00: 5 mm (0.197 in) wide tape roll

The following materials, not found in the kit, can also be used to repair squeaks and rattles.

### UHMW (TEFLON) TAPE

Insulates where slight movement is present. Ideal for instrument panel applications.

### SILICONE GREASE

Used in place of UHMW tape that is be visible or does not fit. Will only last a few months.

### SILICONE SPRAY

Used when grease cannot be applied.

### DUCT TAPE

Used to eliminate movement.

## CONFIRM THE REPAIR

Confirm that the cause of a noise is repaired by test driving the vehicle. Operate the vehicle under the same conditions as when the noise originally occurred. Refer to the notes on the Diagnostic Worksheet.

## Inspection Procedure

INFOID:000000009162320

Refer to Table of Contents for specific component removal and installation information.

## INSTRUMENT PANEL

Most incidents are caused by contact and movement between:

1. The cluster lid A and instrument panel
2. Acrylic lens and combination meter housing
3. Instrument panel to front pillar garnish
4. Instrument panel to windshield
5. Instrument panel mounting pins
6. Wiring harnesses behind the combination meter
7. A/C defroster duct and duct joint

These incidents can usually be located by tapping or moving the components to duplicate the noise or by pressing on the components while driving to stop the noise. Most of these incidents can be repaired by applying felt cloth tape or silicon spray (in hard to reach areas). Urethane pads can be used to insulate wiring harness.

### **CAUTION:**

**Never use silicone spray to isolate a squeak or rattle. If the area is saturated with silicone, the recheck of repair becomes impossible.**

## CENTER CONSOLE

Components to pay attention to include:

1. Shifter assembly cover to finisher
2. A/C control unit and cluster lid C
3. Wiring harnesses behind audio and A/C control unit

The instrument panel repair and isolation procedures also apply to the center console.

## DOORS

Pay attention to the following:

1. Finisher and inner panel making a slapping noise
2. Inside handle escutcheon to door finisher
3. Wiring harnesses tapping
4. Door striker out of alignment causing a popping noise on starts and stops

Tapping or moving the components or pressing on them while driving to duplicate the conditions can isolate many of these incidents. The areas can usually be insulated with felt cloth tape or insulator foam blocks from the Nissan Squeak and Rattle Kit (J-43980) to repair the noise.

## TRUNK

Trunk noises are often caused by a loose jack or loose items put into the trunk by the customer.

In addition look for the following:

1. Trunk lid dumpers out of adjustment

# SQUEAK AND RATTLE TROUBLE DIAGNOSES

## < SYMPTOM DIAGNOSIS >

---

2. Trunk lid striker out of adjustment
3. The trunk lid torsion bars knocking together
4. A loose license plate or bracket

Most of these incidents can be repaired by adjusting, securing or insulating the item(s) or component(s) causing the noise.

## SUNROOF/HEADLINING

Noises in the sunroof/headlining area can often be traced to one of the following:

1. Sunroof lid, rail, linkage or seals making a rattle or light knocking noise
2. Sunvisor shaft shaking in the holder
3. Front or rear windshield touching headlining and squeaking

Again, pressing on the components to stop the noise while duplicating the conditions can isolate most of these incidents. Repairs usually consist of insulating with felt cloth tape.

## SEATS

When isolating seat noise it's important to note the position the seats in and the load placed on the seat when the noise occurs. These conditions should be duplicated when verifying and isolating the cause of the noise.

Cause of seat noise include:

1. Headrest rods and holder
2. A squeak between the seat pad cushion and frame
3. The rear seatback lock and bracket

These noises can be isolated by moving or pressing on the suspected components while duplicating the conditions under which the noise occurs. Most of these incidents can be repaired by repositioning the component or applying urethane tape to the contact area.

## UNDERHOOD

Some interior noise may be caused by components under the hood or on the engine wall. The noise is then transmitted into the passenger compartment.

Causes of transmitted underhood noise include:

1. Any component mounted to the engine wall
2. Components that pass through the engine wall
3. Engine wall mounts and connectors
4. Loose radiator mounting pins
5. Hood bumpers out of adjustment
6. Hood striker out of adjustment

These noises can be difficult to isolate since they cannot be reached from the interior of the vehicle. The best method is to secure, move or insulate one component at a time and test drive the vehicle. Also, engine RPM or load can be changed to isolate the noise. Repairs can usually be made by moving, adjusting, securing, or insulating the component causing the noise.

A

B

C

D

E

F

G

H

I

INT

K

L

M

N

O

P

# SQUEAK AND RATTLE TROUBLE DIAGNOSES

< SYMPTOM DIAGNOSIS >

## Diagnostic Worksheet

INFOID:000000009162321



### SQUEAK & RATTLE DIAGNOSTIC WORKSHEET

Dear Nissan Customer:

We are concerned about your satisfaction with your Nissan vehicle. Repairing a squeak or rattle sometimes can be very difficult. To help us fix your Nissan right the first time, please take a moment to note the area of the vehicle where the squeak or rattle occurs and under what conditions. You may be asked to take a test drive with a service advisor or technician to ensure we confirm the noise you are hearing.

#### I. WHERE DOES THE NOISE COME FROM? (circle the area of the vehicle)

The illustrations are for reference only, and may not reflect the actual configuration of your vehicle.

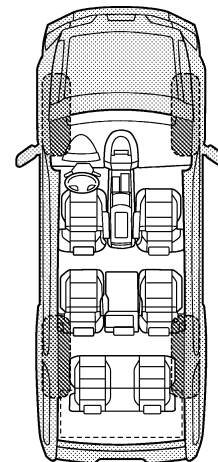
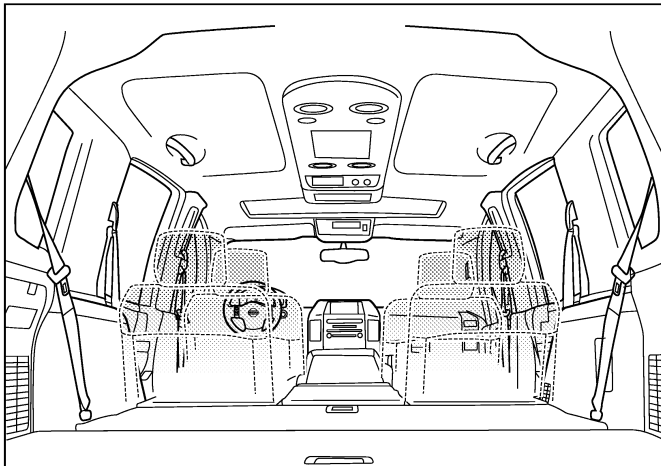
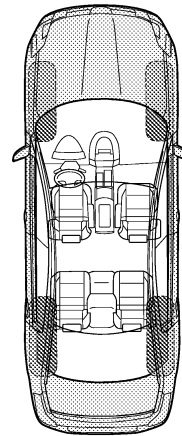
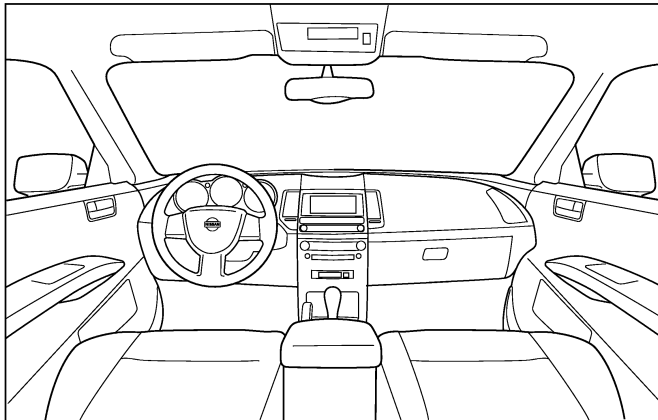

Continue to page 2 of the worksheet and briefly describe the location of the noise or rattle. In addition, please indicate the conditions which are present when the noise occurs.

PIIB8740E

# SQUEAK AND RATTLE TROUBLE DIAGNOSES

< SYMPTOM DIAGNOSIS >

## SQUEAK & RATTLE DIAGNOSTIC WORKSHEET - page 2

Briefly describe the location where the noise occurs:

---

---

### II. WHEN DOES IT OCCUR? (please check the boxes that apply)

- |                                                       |                                                        |
|-------------------------------------------------------|--------------------------------------------------------|
| <input type="checkbox"/> anytime                      | <input type="checkbox"/> after sitting out in the rain |
| <input type="checkbox"/> 1st time in the morning      | <input type="checkbox"/> when it is raining or wet     |
| <input type="checkbox"/> only when it is cold outside | <input type="checkbox"/> dry or dusty conditions       |
| <input type="checkbox"/> only when it is hot outside  | <input type="checkbox"/> other:                        |

### III. WHEN DRIVING:

- through driveways
- over rough roads
- over speed bumps
- only about \_\_\_\_ mph
- on acceleration
- coming to a stop
- on turns: left, right or either (circle)
- with passengers or cargo
- other: \_\_\_\_\_
- after driving \_\_\_\_ miles or \_\_\_\_ minutes

### IV. WHAT TYPE OF NOISE

- squeak (like tennis shoes on a clean floor)
- creak (like walking on an old wooden floor)
- rattle (like shaking a baby rattle)
- knock (like a knock at the door)
- tick (like a clock second hand)
- thump (heavy, muffled knock noise)
- buzz (like a bumble bee)

### TO BE COMPLETED BY DEALERSHIP PERSONNEL

#### Test Drive Notes:

---

---

---

	YES	NO	Initials of person performing
Vehicle test driven with customer	<input type="checkbox"/>	<input type="checkbox"/>	_____
- Noise verified on test drive	<input type="checkbox"/>	<input type="checkbox"/>	_____
- Noise source located and repaired	<input type="checkbox"/>	<input type="checkbox"/>	_____
- Follow up test drive performed to confirm repair	<input type="checkbox"/>	<input type="checkbox"/>	_____

VIN: \_\_\_\_\_ Customer Name: \_\_\_\_\_  
W.O.# \_\_\_\_\_ Date: \_\_\_\_\_

This form must be attached to Work Order

PIIB8742E

A  
B  
C  
D  
E  
F  
G  
H  
I  
INT  
K  
L  
M  
N  
O  
P

# PRECAUTIONS

< PRECAUTION >

## PRECAUTION

### PRECAUTIONS

#### Precaution for Supplemental Restraint System (SRS) "AIR BAG" and "SEAT BELT PRE-TENSIONER"

INFOID:000000009162322

The Supplemental Restraint System such as "AIR BAG" and "SEAT BELT PRE-TENSIONER", used along with a front seat belt, helps to reduce the risk or severity of injury to the driver and front passenger for certain types of collision. This system includes seat belt switch inputs and dual stage front air bag modules. The SRS system uses the seat belt switches to determine the front air bag deployment, and may only deploy one front air bag, depending on the severity of a collision and whether the front occupants are belted or unbelted. Information necessary to service the system safely is included in the "SRS AIR BAG" and "SEAT BELT" of this Service Manual.

#### **WARNING:**

Always observe the following items for preventing accidental activation.

- To avoid rendering the SRS inoperative, which could increase the risk of personal injury or death in the event of a collision that would result in air bag inflation, all maintenance must be performed by an authorized NISSAN/INFINITI dealer.
- Improper maintenance, including incorrect removal and installation of the SRS, can lead to personal injury caused by unintentional activation of the system. For removal of Spiral Cable and Air Bag Module, see "SRS AIR BAG".
- Never use electrical test equipment on any circuit related to the SRS unless instructed to in this Service Manual. SRS wiring harnesses can be identified by yellow and/or orange harnesses or harness connectors.

#### PRECAUTIONS WHEN USING POWER TOOLS (AIR OR ELECTRIC) AND HAMMERS

#### **WARNING:**

Always observe the following items for preventing accidental activation.

- When working near the Air Bag Diagnosis Sensor Unit or other Air Bag System sensors with the ignition ON or engine running, never use air or electric power tools or strike near the sensor(s) with a hammer. Heavy vibration could activate the sensor(s) and deploy the air bag(s), possibly causing serious injury.
- When using air or electric power tools or hammers, always switch the ignition OFF, disconnect the battery, and wait at least 3 minutes before performing any service.

#### Precautions Necessary for Steering Wheel Rotation After Battery Disconnection

INFOID:000000009162323

#### **CAUTION:**

Comply with the following cautions to prevent any error and malfunction.

- Before removing and installing any control units, first turn the ignition switch to the LOCK position, then disconnect both battery cables.
- After finishing work, confirm that all control unit connectors are connected properly, then re-connect both battery cables.
- Always use CONSULT to perform self-diagnosis as a part of each function inspection after finishing work. If a DTC is detected, perform trouble diagnosis according to self-diagnosis results.

For vehicle with steering lock unit, if the battery is disconnected or discharged, the steering wheel will lock and cannot be turned.

If turning the steering wheel is required with the battery disconnected or discharged, follow the operation procedure below before starting the repair operation.

#### OPERATION PROCEDURE

1. Connect both battery cables.

#### **NOTE:**

Supply power using jumper cables if battery is discharged.

2. Turn the ignition switch to ACC position.  
(At this time, the steering lock will be released.)
3. Disconnect both battery cables. The steering lock will remain released with both battery cables disconnected and the steering wheel can be turned.



# PRECAUTIONS

## < PRECAUTION >

4. Perform the necessary repair operation.
5. When the repair work is completed, re-connect both battery cables. With the brake pedal released, turn the ignition switch from ACC position to ON position, then to LOCK position. (The steering wheel will lock when the ignition switch is turned to LOCK position.)
6. Perform self-diagnosis check of all control units using CONSULT.

### Precaution for Procedure without Cowl Top Cover

INFOID:000000009162324

When performing the procedure after removing cowl top cover, cover the lower end of windshield with urethane, etc to prevent damage to windshield.

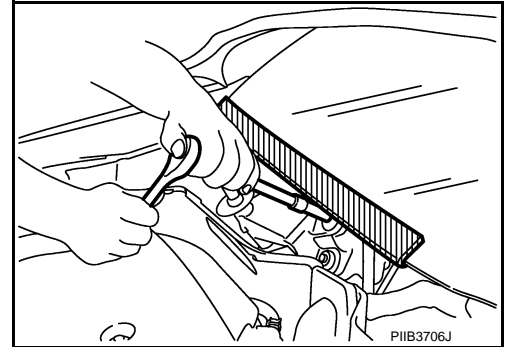

### Precaution for Work

INFOID:000000009162325

- After removing and installing the opening/closing parts, be sure to carry out fitting adjustments to check their operation.
- Check the lubrication level, damage, and wear of each part. If necessary, grease or replace it.

A  
B  
C  
D  
E  
F  
G  
H  
I  
K  
L  
M  
N  
O  
P

INT

# PREPARATION

< PREPARATION >

## PREPARATION

### PREPARATION

#### Special Service Tools

INFOID:000000009162326

The actual shapes of Kent-Moore tools may differ from those of special service tools illustrated here.

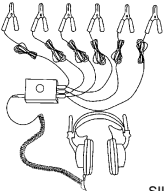
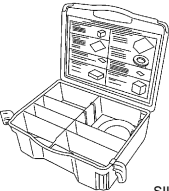
Tool number (Kent-Moore No.) Tool name	Description
<p>(J-39570) Chassis ear</p>  <p>SIIA0993E</p>	<p>Locates the noise</p>
<p>(J-43980) NISSAN Squeak and Rattle Kit</p>  <p>SIIA0994E</p>	<p>Repairs the cause of noise</p>

#### Commercial Service Tools

INFOID:000000009162327

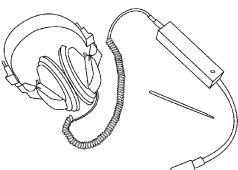
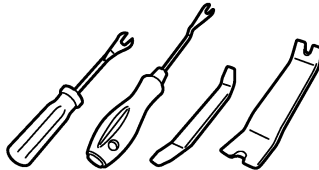
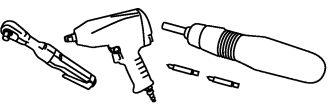
Tool name	Description
<p>Engine ear</p>  <p>SIIA0995E</p>	<p>Locates the noise</p>
<p>Remover tool</p>  <p>JMKIA3050ZZ</p>	<p>Removes clips, pawls and metal clips</p>
<p>Power tool</p>  <p>PIIB1407E</p>	

# CLIP LIST

< PREPARATION >

## CLIP LIST

### Clip List

INFOID:00000009162328

Shapes	Removal & Installation	Shapes	Removal & Installation
	<p><b>Removal:</b> Remove by bending up with flat-bladed screwdrivers or clip remover.</p>	<p>Clip A Clip B</p>	<p><b>Removal:</b> Finisher Clip A Flat-bladed screwdriver Clip B</p>
	<p><b>Removal:</b> Remove with a clip remover.</p>	<p>Clip A Clip B (Grommet)</p>	<p><b>Removal:</b> Flat-bladed screwdriver Finisher Body panel Clip A Clip B (Grommet)</p>
	<p><b>Removal:</b> Push center pin to catching position. (Do not remove center pin by hitting it.)</p> <p><b>Installation:</b> Push</p>		<p><b>Removal:</b> Holder portion of clip must be spread out to remove rod.</p>
	<p><b>Removal:</b> Remove by bending up with flat-bladed screwdrivers or clip remover.</p> <p>Clip Finisher</p>		<p><b>Removal:</b> 1. Screw out with a Phillips screwdriver. 2. Remove female portion with flat-bladed screwdriver.</p>
	<p><b>Removal:</b></p>		<p><b>Removal:</b> Rotate 45° to remove.</p> <p><b>Installation:</b></p>
	<p><b>Removal:</b></p>		<p><b>Removal:</b></p>

JMJIA3734GB

A  
B  
C  
D  
E  
F  
G  
H  
I  
INT  
K  
L  
M  
N  
O  
P

# DOOR FINISHER

< REMOVAL AND INSTALLATION >

## REMOVAL AND INSTALLATION

### DOOR FINISHER

Exploded View

INFOID:000000009162329

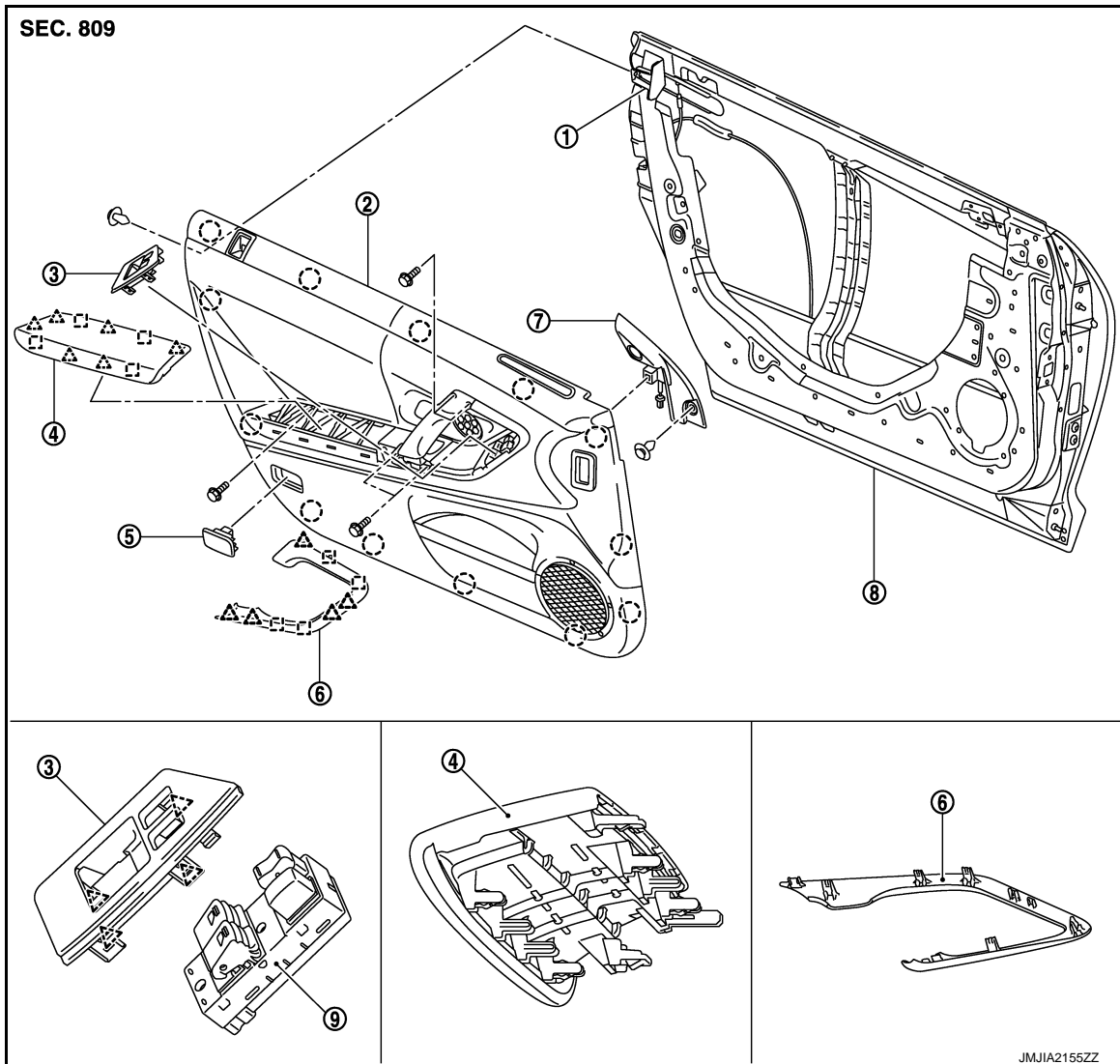

JMJIA2155ZZ

- |                            |                  |                                 |
|----------------------------|------------------|---------------------------------|
| 1. Bracket                 | 2. Door finisher | 3. Power window switch finisher |
| 4. Armrest                 | 5. Step lamp     | 6. Door grip cap                |
| 7. Door corner cover inner | 8. Door panel    | 9. Power window switch          |

- : Clip
- : Pawl
- : Metal clip

### Removal and Installation

INFOID:000000009162330

**CAUTION:**  
Wrap the tip of flat-bladed screwdriver with a shop cloth before remove.

#### REMOVAL

1. Fully open the door window.

# DOOR FINISHER

## < REMOVAL AND INSTALLATION >

2. Insert a remover tool (A) into the lower side of door grip cap (1), then disengage and remove the pawls and metal clips.

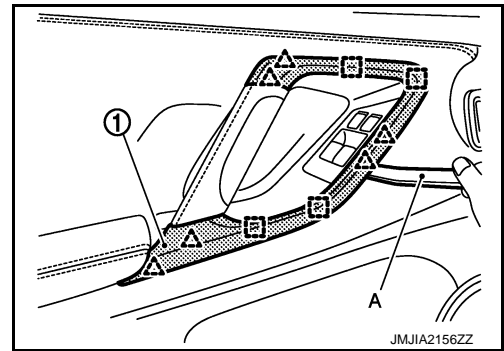
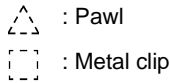

3. Insert a remover tool (A) between the door finisher and rear of armrest (1), disengage the pawls and metal clips and then remove the armrest.

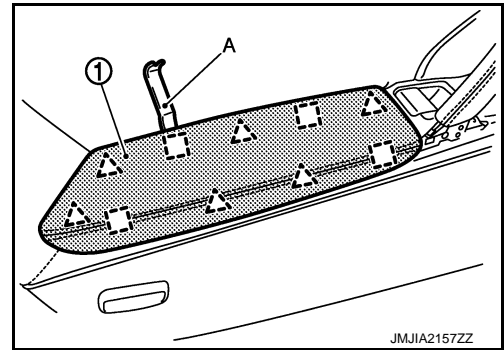
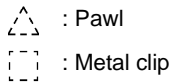

4. Remove the door finisher tightening bolts (A) shown in the figure.

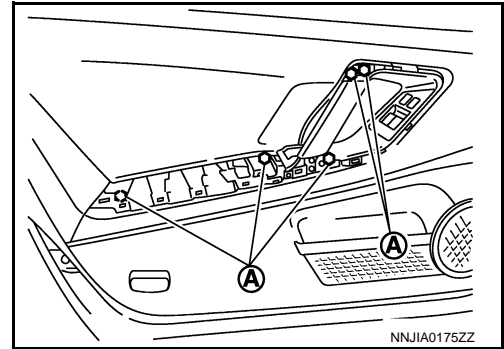

5. Remove the step lamp.
  1. Insert a remover tool (A) between the door finisher and the step (1) to disengage the metal clips and remove the step lamp.
  2. Remove the bolt located behind the step lamp.

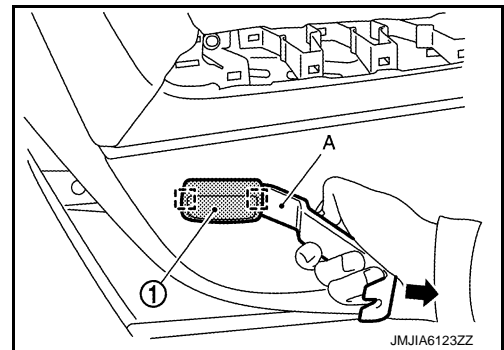
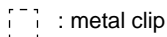

6. Remove the clip from the door finisher rear end. Refer to [INT-12, "Exploded View"](#).

A  
B  
C  
D  
E  
F  
G  
H  
I  
INT  
K  
L  
M  
N  
O  
P

# DOOR FINISHER

## < REMOVAL AND INSTALLATION >

7. Disengage the clips from the door finisher (1) rear side using a remover tool (A).

**CAUTION:**

Insert the remover tool between door panel and clip, and then disengage the clip.

 : Clip

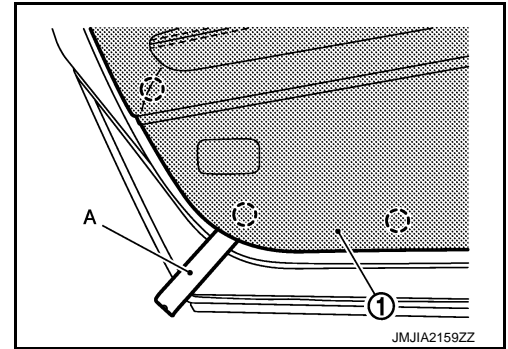

8. Remove the door finisher rear side lock knob cable (2) and the inside handle cable (1) from the inside handle (A).

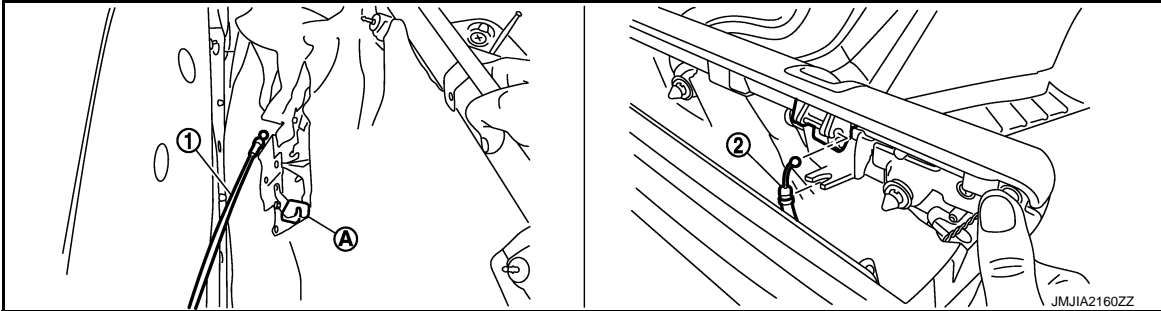

9. Lift up the door finisher and pull it out toward the passenger room. Disconnect the connectors (A) and (B) from the door finisher rear side.
10. Remove the door finisher.
11. Remove the front door squawker (BOSE AUDIO WITH NAVIGATION) after removing the door finisher. Refer to [AV-172](#), "[Removal and Installation](#)".

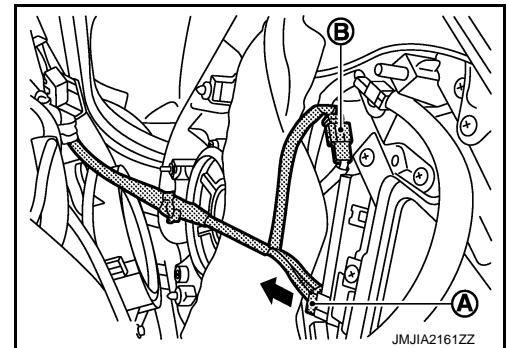

## INSTALLATION

Note the following, and install in the reverse order of removal.

**CAUTION:**

When installing the door finisher, check that the clips are securely fitted in panel holes, and then press them in.

# BODY SIDE TRIM

< REMOVAL AND INSTALLATION >

## BODY SIDE TRIM

Exploded View

INFOID:000000009162331

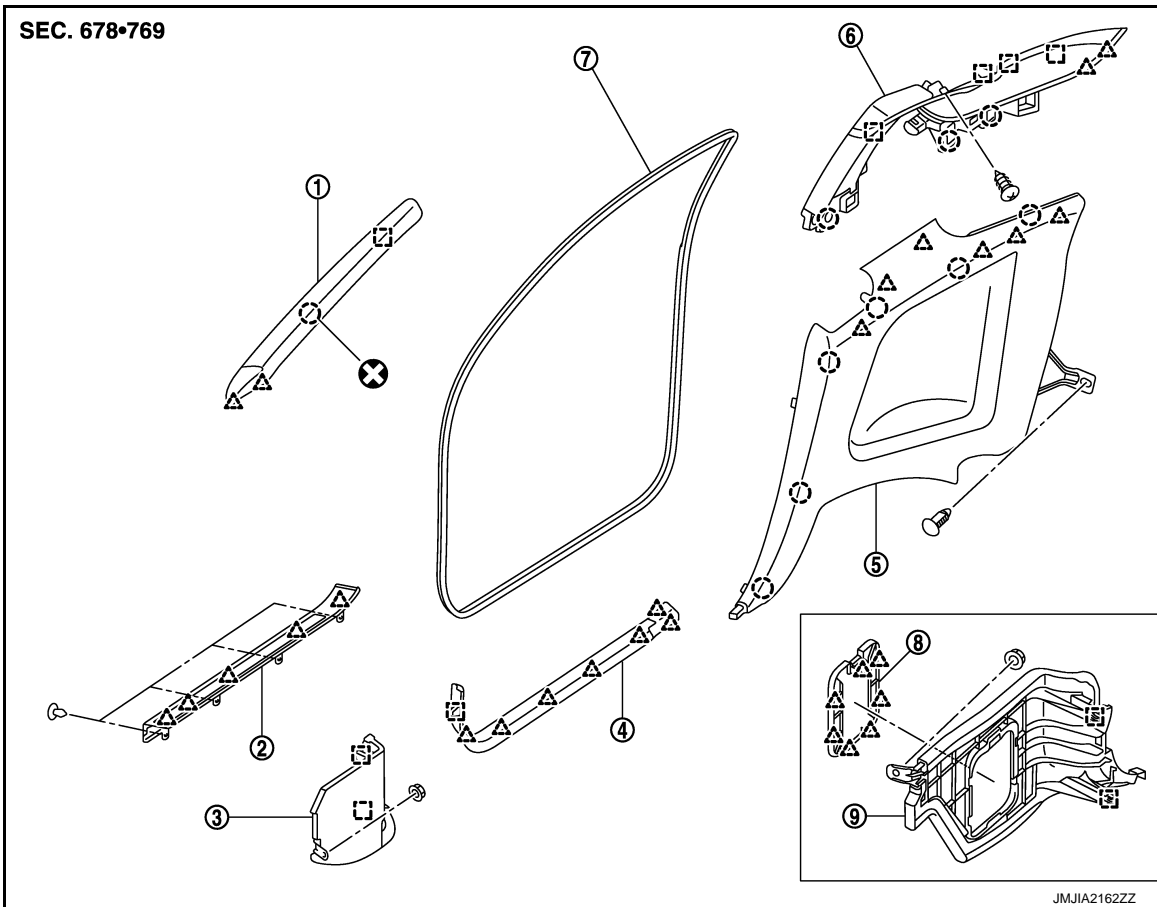

- |                         |                             |                            |
|-------------------------|-----------------------------|----------------------------|
| 1. Front pillar garnish | 2. Kicking plate outer      | 3. Dash side finisher (RH) |
| 4. Kicking plate inner  | 5. Rear side finisher       | 6. Rear pillar finisher    |
| 7. Body side welt       | 8. Dash side finisher cover | 9. Dash side finisher (LH) |

○ : Clip

△ : Pawl

□ : Metal clip

⊗ : Always replace after every disassembly

### Removal and Installation

INFOID:000000009162332

#### CAUTION:

Wrap the tools with shop cloth or tape to prevent damage when using the tools during removal.

#### REMOVAL

##### FRONT PILLAR GARNISH

1. Remove the front body side welt of the front pillar.

A  
B  
C  
D  
E  
F  
G  
H  
I  
INT  
K  
L  
M  
N  
O  
P

# BODY SIDE TRIM

## < REMOVAL AND INSTALLATION >

2. Insert the remover tool (A) into the clearance between the front pillar garnish (1) and the vehicle body, disengage the metal clips, cut the clip (2) and then remove the front pillar garnish.

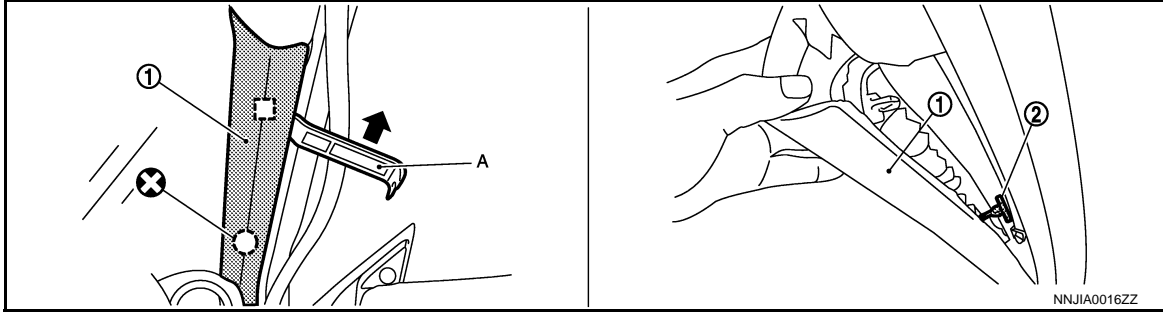

- : Clip
- : Metal clip

## KICKING PLATE INNER

1. Disengage pawls on rear end and side of kicking plate inner using a remover tool (A).

- △ : Pawl

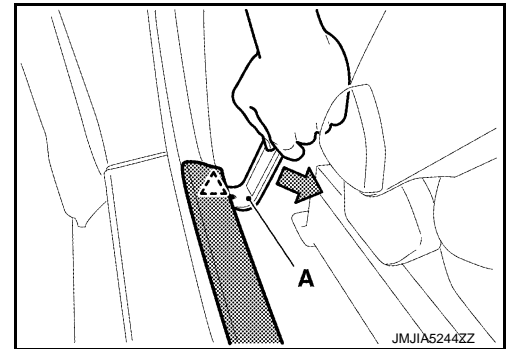

2. Disengage remaining pawls while rotating the kicking plate inner.
3. Pull kicking plate toward vehicle rear, disengage metal clips, and then remove kicking plate inner.

- △ : Pawl
- : Metal clip

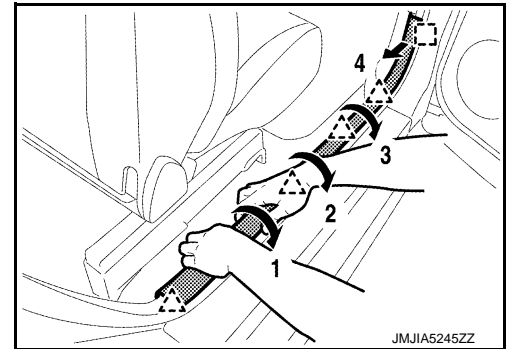

## DASH SIDE FINISHER

1. Remove the kicking plate inner.
2. Remove the clip (A) of the dash side finisher (1).
3. Disengage and remove the clips of the dash side finisher using the remover tool (B).

- : Metal clip

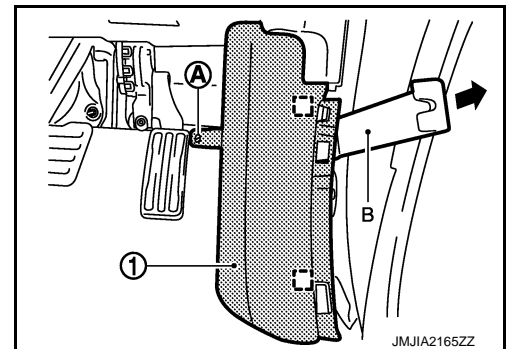

## KICKING PLATE OUTER

1. Remove the center mud guard. Refer to [EXT-34, "Removal and Installation"](#).



## BODY SIDE TRIM

### < REMOVAL AND INSTALLATION >

- Disengage and remove the pawls using a remover tool (A) after removing the clip of kicking plate outer.

 : Pawl

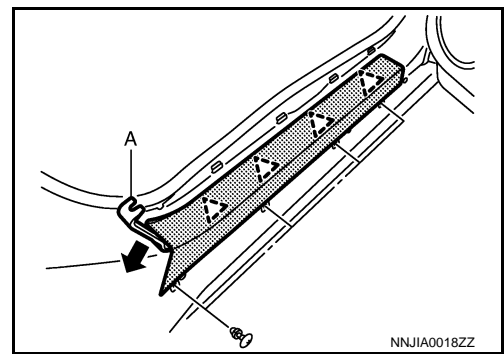



### BODY SIDE WELT

- Remove the kicking plate inner.
- Remove the body side welt from the panel flange.

### REAR SIDE FINISHER

- Remove the kicking plate inner.
- Remove the body side welt from the rear side finisher.
- Remove the rear seat cushion and the rear seatback. Refer to [SE-56. "Removal and Installation"](#).
- Remove rear side finisher fixing clip (2).
- Disengage rear side finisher (1) fixing clips and pawls with a remover tool (A), and then remove rear side finisher.

 : Clip

 : Pawl

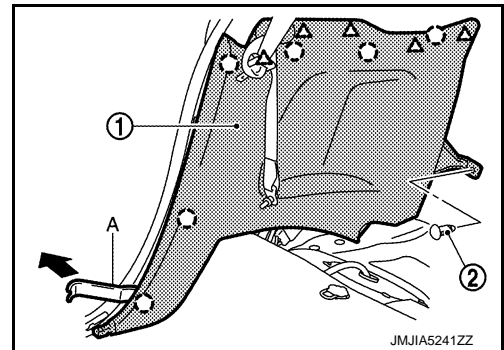

### REAR PILLAR FINISHER

- Remove the rear seat cushion and the rear seatback. Refer to [SE-56. "Removal and Installation"](#).
- Remove the kicking plate inner.
- Remove the rear side finisher and the body side welt of rear pillar finisher.
- Remove the rear side finisher.
- Remove the front seat belt shoulder anchor. Refer to [SB-6. "SEAT BELT RETRACTOR : Removal and Installation"](#).
- Remove the mounting screw from rear pillar finisher (1) using a screwdriver (A).
- Disengage the clips and the metal clips from the rear pillar finisher using the remover tool (A).

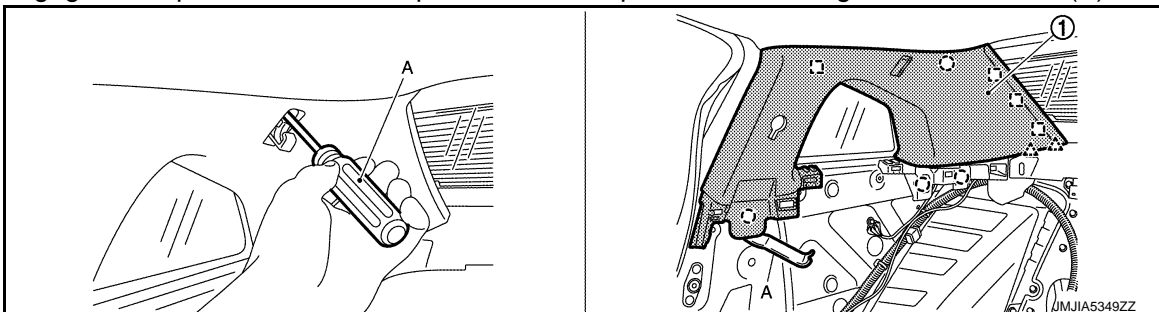

 : Clip

 : Pawl

 : Metal clip

### INSTALLATION

## BODY SIDE TRIM

### < REMOVAL AND INSTALLATION >

---

Note the following, and install in the reverse order of removal.

**CAUTION:**

**When installing body side trim, check that clips are securely fitted in panel holes on the body, and then press them in.**

# REAR PARCEL SHELF FINISHER

< REMOVAL AND INSTALLATION >

## REAR PARCEL SHELF FINISHER

Exploded View

INFOID:000000009162333

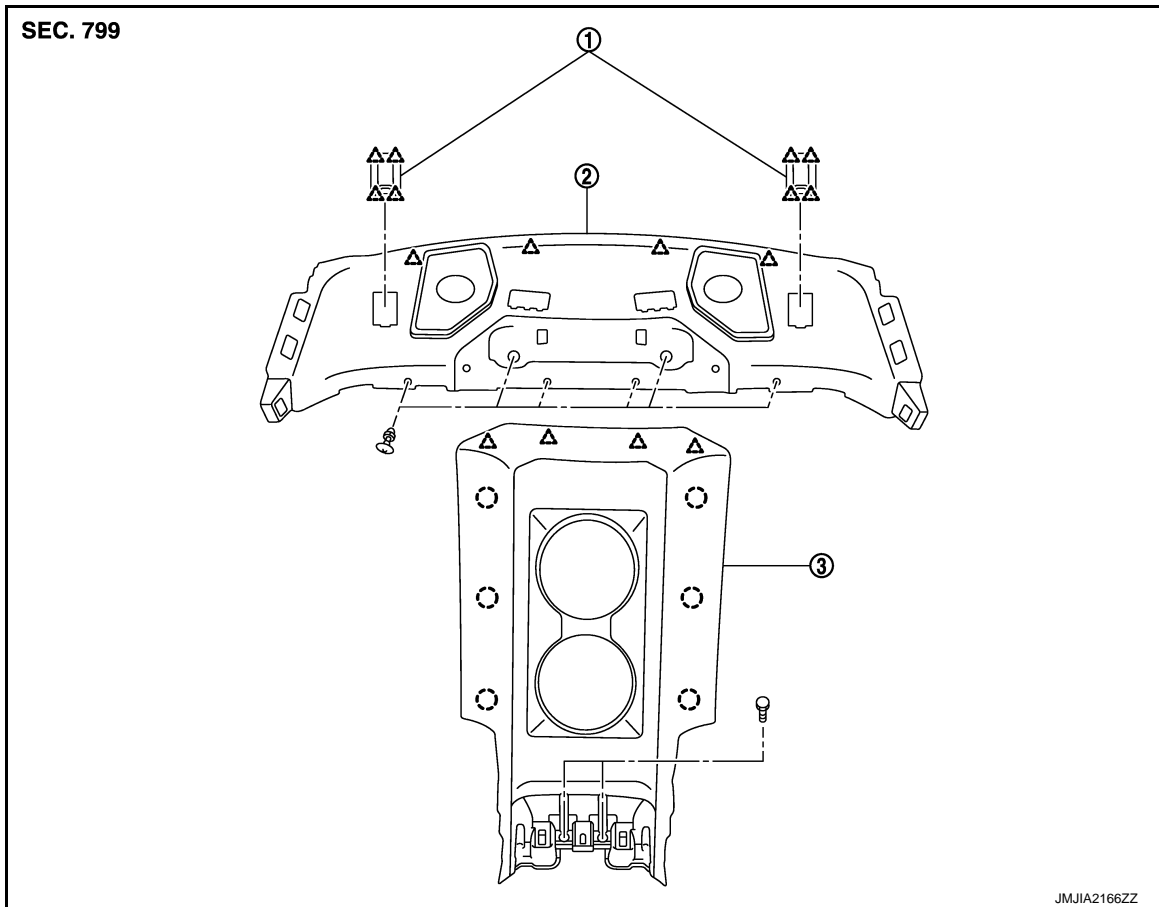

1. Child anchor cover

2. Rear parcel shelf finisher

3. Rear seat center finisher

○ : Clip

△ : Pawl

## Removal and Installation

INFOID:000000009162334

### REMOVAL

1. Remove the rear seat cushion and the rear seatback. Refer to [SE-56, "Removal and Installation"](#).
2. Remove the kicking plate inner (LH/RH) and body side welt (LH/RH). Refer to [INT-15, "Removal and Installation"](#).
3. Remove the rear side finisher (LH/RH). Refer to [INT-15, "Removal and Installation"](#).
4. Remove the rear pillar finisher (LH/RH). Refer to [INT-15, "Removal and Installation"](#).
5. Remove the rear console assembly. Refer to [IP-23, "Removal and Installation"](#).

## REAR PARCEL SHELF FINISHER

### < REMOVAL AND INSTALLATION >

6. Remove the rear seat center finisher mounting bolts (B) using socket wrench (A).

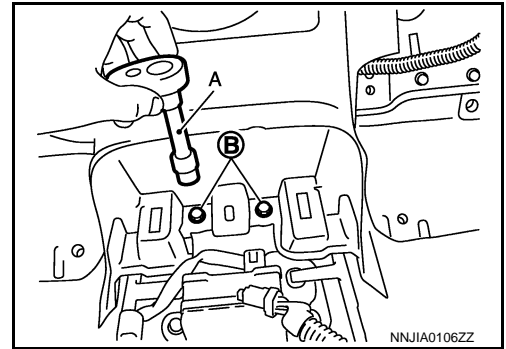

7. Insert the remover tool (A) into the clearance between the rear seat center finisher (1) and the vehicle body, and then disengage the clips.

 : Clip

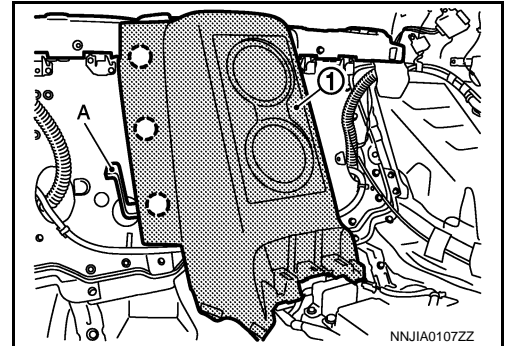

8. Remove the rear parcel shelf finisher mounting clips (A).

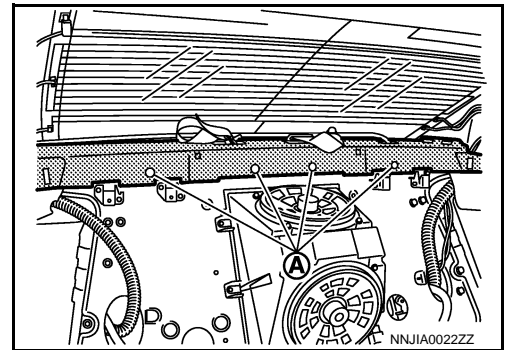

9. Remove the rear seat belt escutcheon.
10. Remove the rear seat belt inner anchor. Refer to [SB-11. "SEAT BELT RETRACTOR : Removal and Installation"](#).
11. Disengage the child anchor cover (1) fixing pawls, with a remover tool (A) and then remove the child anchor cover (LH/RH).

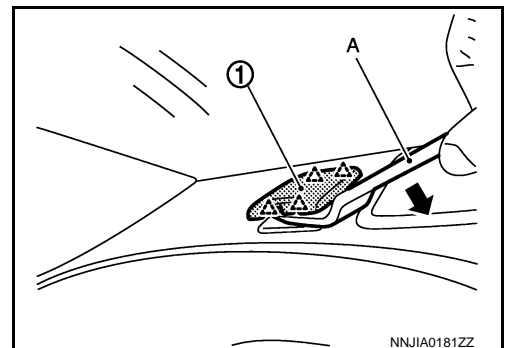

## REAR PARCEL SHELF FINISHER

### < REMOVAL AND INSTALLATION >

12. Remove the rear seat belt (1) through the hole of rear parcel shelf finisher (2) as shown in the figure.

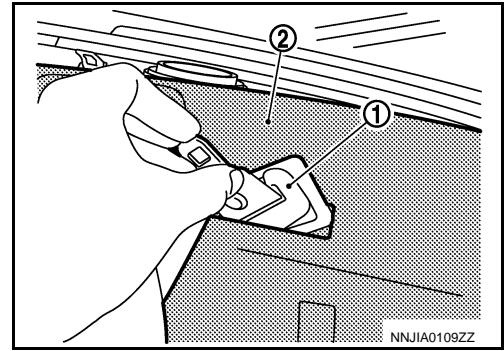

13. Pull and remove the rear parcel shelf finisher after disengaging the clip from the back side of rear parcel shelf finisher.

### INSTALLATION

Note the following, and install in the reverse order of removal.

**CAUTION:**

**Check that clips are securely fitted in panel holes on body when installing the rear parcel shelf finisher and then press in.**

A  
B  
C  
D  
E  
F  
G  
H  
I  
INT  
K  
L  
M  
N  
O  
P

# FLOOR TRIM

< REMOVAL AND INSTALLATION >

## FLOOR TRIM

Exploded View

INFOID:000000009162335

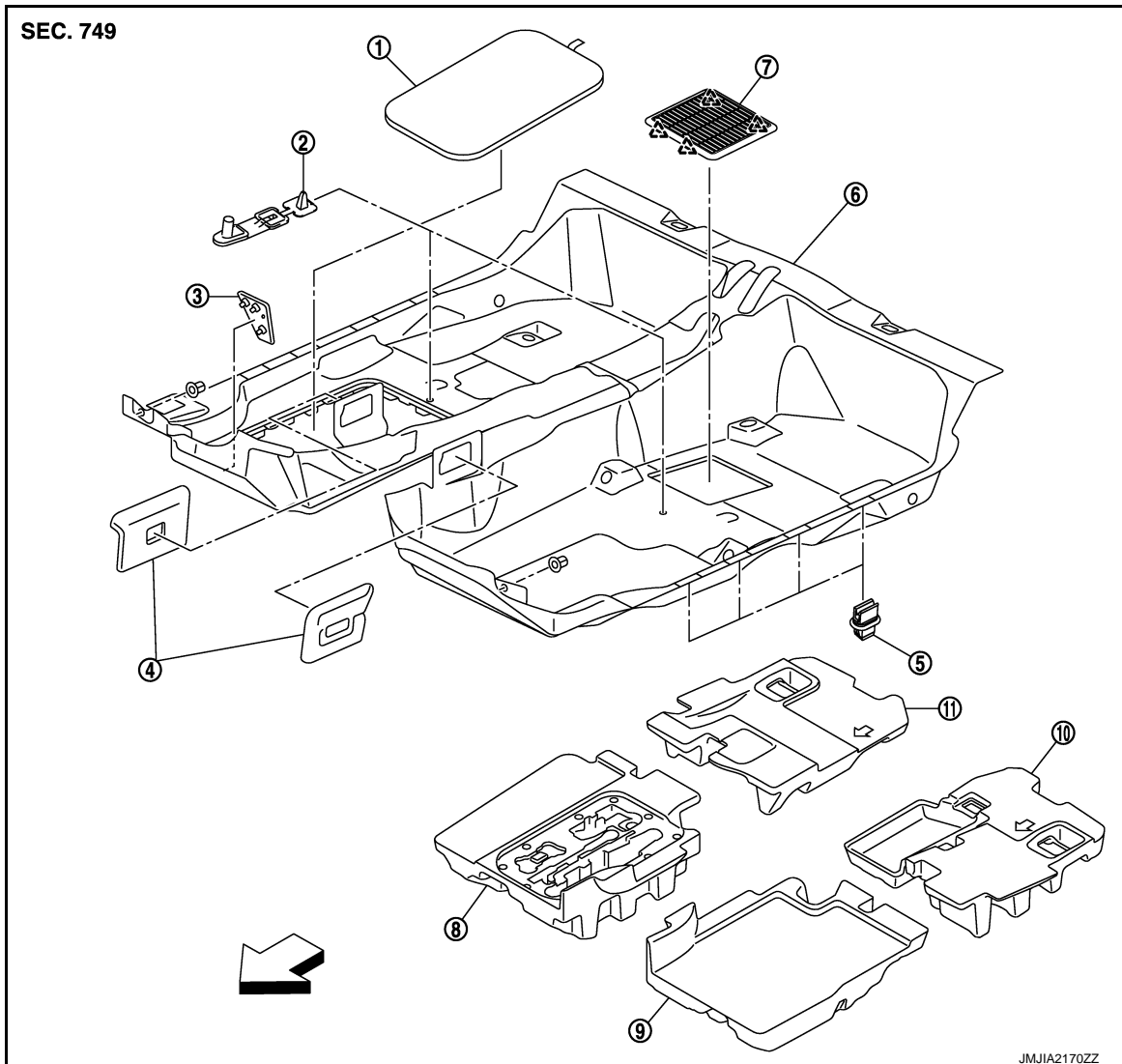

- |                            |                             |                            |
|----------------------------|-----------------------------|----------------------------|
| 1. Seal box cover          | 2. Floor carpet hook        | 3. Footrest                |
| 4. Foot duct               | 5. Floor carpet fixing clip | 6. Floor carpet            |
| 7. Grille                  | 8. Front floor spacer (RH)  | 9. Front floor spacer (LH) |
| 10. Rear floor spacer (LH) | 11. Rear floor spacer (RH)  |                            |

 : Pawl

 : Vehicle front

## Removal and Installation

INFOID:000000009162336

### REMOVAL

1. Remove the front seat assembly (LH/RH). Refer to [SE-49. "Removal and Installation"](#).
2. Remove rear seat cushion. Refer to [SE-56. "Removal and Installation"](#).
3. Remove the footrest.

# FLOOR TRIM

## < REMOVAL AND INSTALLATION >

- Disengage and remove the clips of floor carpet hook (1) using the remover tool (A).

 : Clip

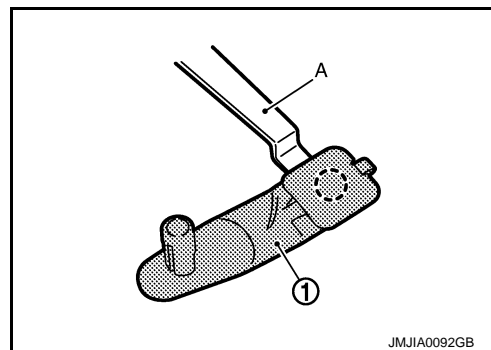

- Remove the floor side anchor bolt of front seat belt (LH/RH). Refer to [SB-6, "SEAT BELT RETRACTOR : Removal and Installation"](#).
- Remove the center console assembly. Refer to [IP-23, "Removal and Installation"](#).
- Remove the side instrument panel (LH/RH). Refer to [IP-13, "Removal and Installation"](#).
- Remove the foot duct (LH/RH) (1) and floor harness fixing clamp (B) using the remover tool (A).

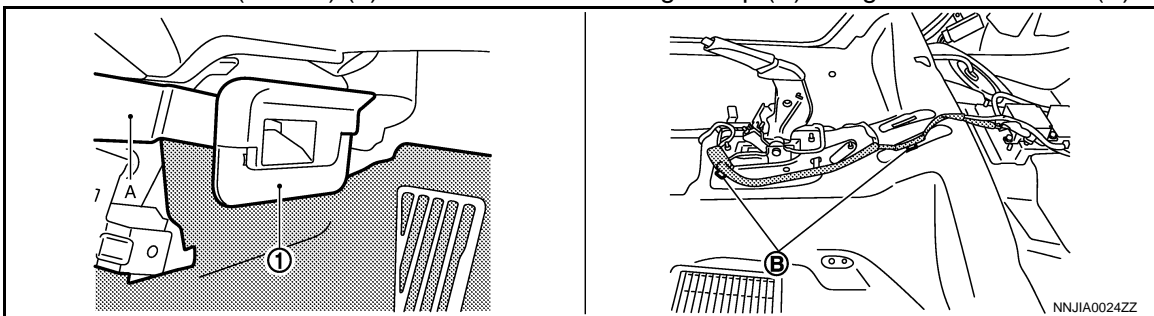

- Disconnect the center connector of diagnosis sensor unit. Refer to [SR-25, "Removal and Installation"](#).
- Remove the dash side finisher (LH/RH), kicking plate inner (LH/RH), and body side welt (LH/RH). Refer to [INT-15, "Removal and Installation"](#).
- Remove the front side of rear side finisher to obtain the space between rear side finisher and floor carpet.
- Disengage the floor carpet fixing clip and then remove the tool box cover and the amplifier cover.

## INSTALLATION

Install in the reverse order of removal.

# HEADLINING

< REMOVAL AND INSTALLATION >

## HEADLINING

Exploded View

INFOID:000000009162337

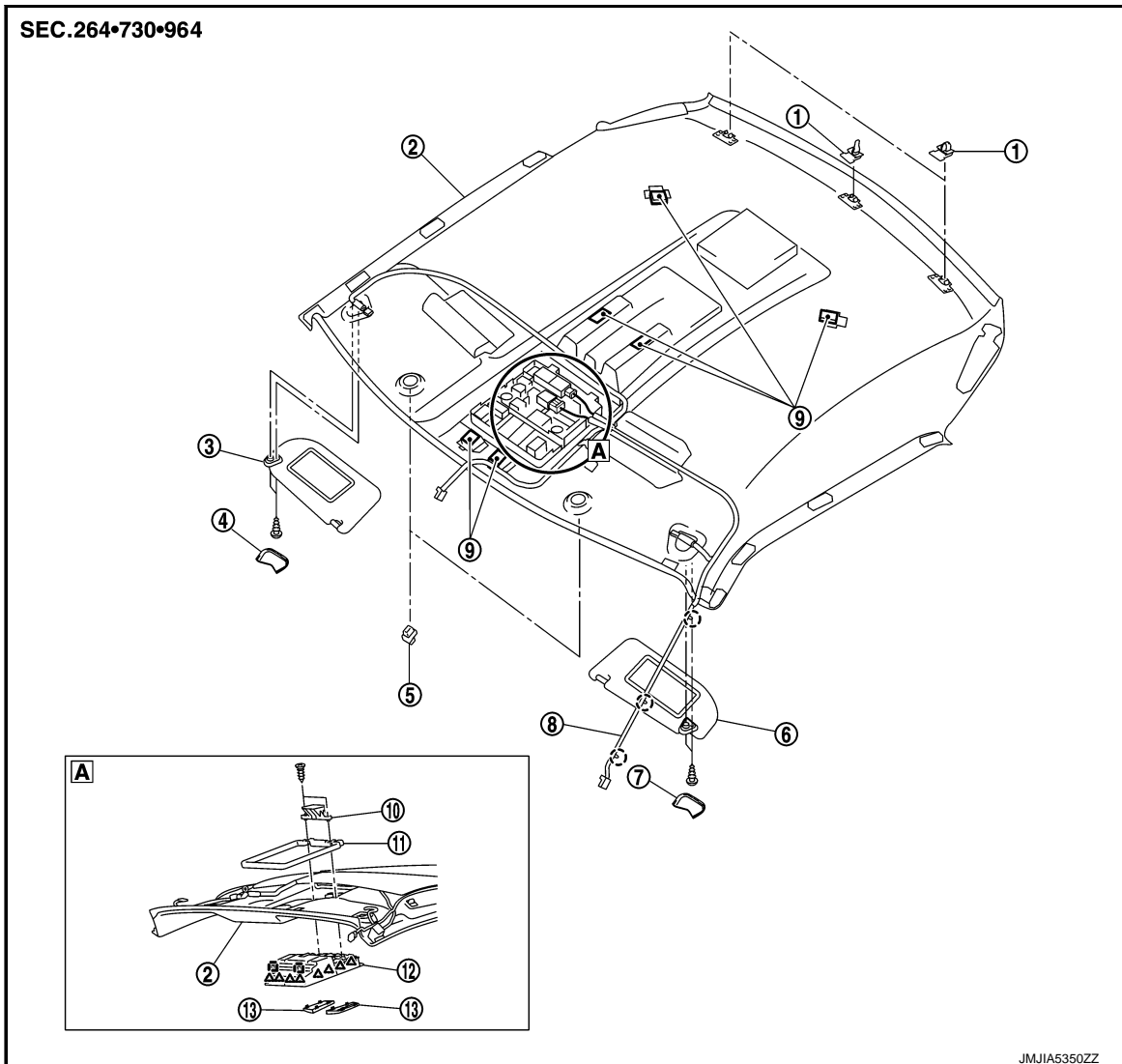

- |                       |                     |                          |
|-----------------------|---------------------|--------------------------|
| 1. Headlining clip    | 2. Headlining       | 3. Sun-visor assembly RH |
| 4. Sun-visor cover RH | 5. Sun-visor holder | 6. Sun-visor assembly LH |
| 7. Sun-visor cover LH | 8. Roof harness     | 9. Dual-lock fastener    |
| 10. Roof bracket      | 11. Roof plate      | 12. Map lamp lens        |
| 13. Map lamp lens     |                     |                          |

 : Pawl

 : Metal clip

 : Vehicle front

## Removal and Installation

INFOID:000000009162338

### REMOVAL

1. Remove the body side welt (LH/RH) and the front pillar garnish (LH/RH). Refer to [INT-15, "Removal and Installation"](#).
2. Disconnect the inside mirror harness connector. Refer to [MIR-15, "Removal and Installation"](#).



# HEADLINING

## < REMOVAL AND INSTALLATION >

3. Disengage the clips (B) and then, disconnect the connector (A) of roof harness of front pillar LH.

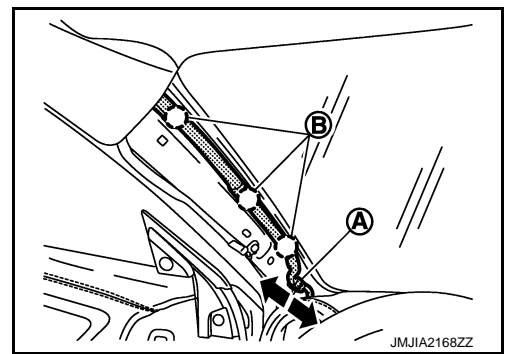

4. Remove the sun-visor assembly (LH/RH).
- Remove the sun-visor cover (LH/RH).
  - Remove the mounting screw (B) of sun-visor (1) (LH/RH) using screwdriver (A).
  - Disconnect the vanity mirror lamp harness connector.

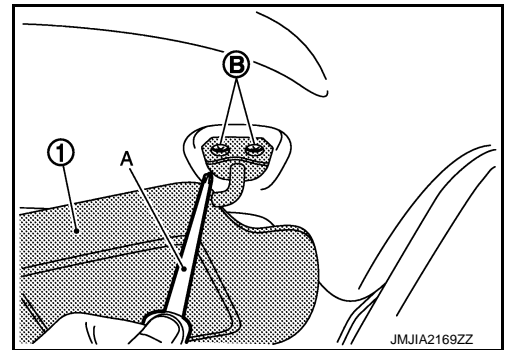

5. Rotate the sun-visor holder (1) 90 degrees counterclockwise, pull it downward, and then remove.

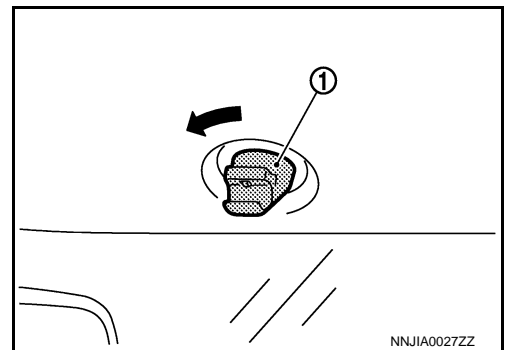

6. Remove the kicking plate inner (LH/RH), rear seat cushion back (LH/RH), rear side finisher (LH/RH), rear pillar finisher (LH/RH), and rear body side welt (LH/RH). Refer to [INT-15, "Removal and Installation"](#).
7. Remove the passenger side front seat. Refer to [SE-49, "Removal and Installation"](#).
8. Remove the A/T shift selector. Refer to [TM-16, "Removal and Installation"](#).
9. Remove the center console assembly. Refer to [IP-23, "Removal and Installation"](#).
10. Remove the rear hidden clips from the roof panel at the rear end of the headlining, using a remover tool.
11. Disengage the joint of dual-lock fastener (A) and metal clip (B) of roof console assembly.

 : Metal clip

12. Check that the dual-lock fastener on the front end of the headlining is removed. If it is not removed, use a remover tool to remove it.

### CAUTION:

- **Roof console assembly is crimped from the back of headlining. Remove it by disengaging the crimped area from back of roof console assembly after removing headlining from the vehicle.**
- **Never wrinkle the headlining by bending during work.**

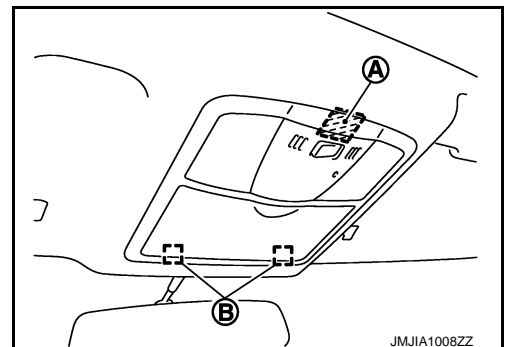

## HEADLINING

### < REMOVAL AND INSTALLATION >

---

13. Remove the headlining from passenger side door opening.

**CAUTION:**

- **2 workers are required for removal in order to prevent damage.**
- **Apply protective tape to the portion where contact may occur during work.**
- **Never bend headlining when removing.**

14. Remove the following parts after removing the headlining.

- Remove roof console assembly.
- Map lamp assembly. Refer to [INL-18, "Removal and Installation"](#).

### INSTALLATION

Note the following, and install in the reverse order of removal.

**CAUTION:**

- **First install the metal clip of map lamp and the clip of the rear end of the headlining for positioning.**
- **Never bend headlining when installing.**

# TRUNK ROOM TRIM

< REMOVAL AND INSTALLATION >

## TRUNK ROOM TRIM

Exploded View

INFOID:000000009162339

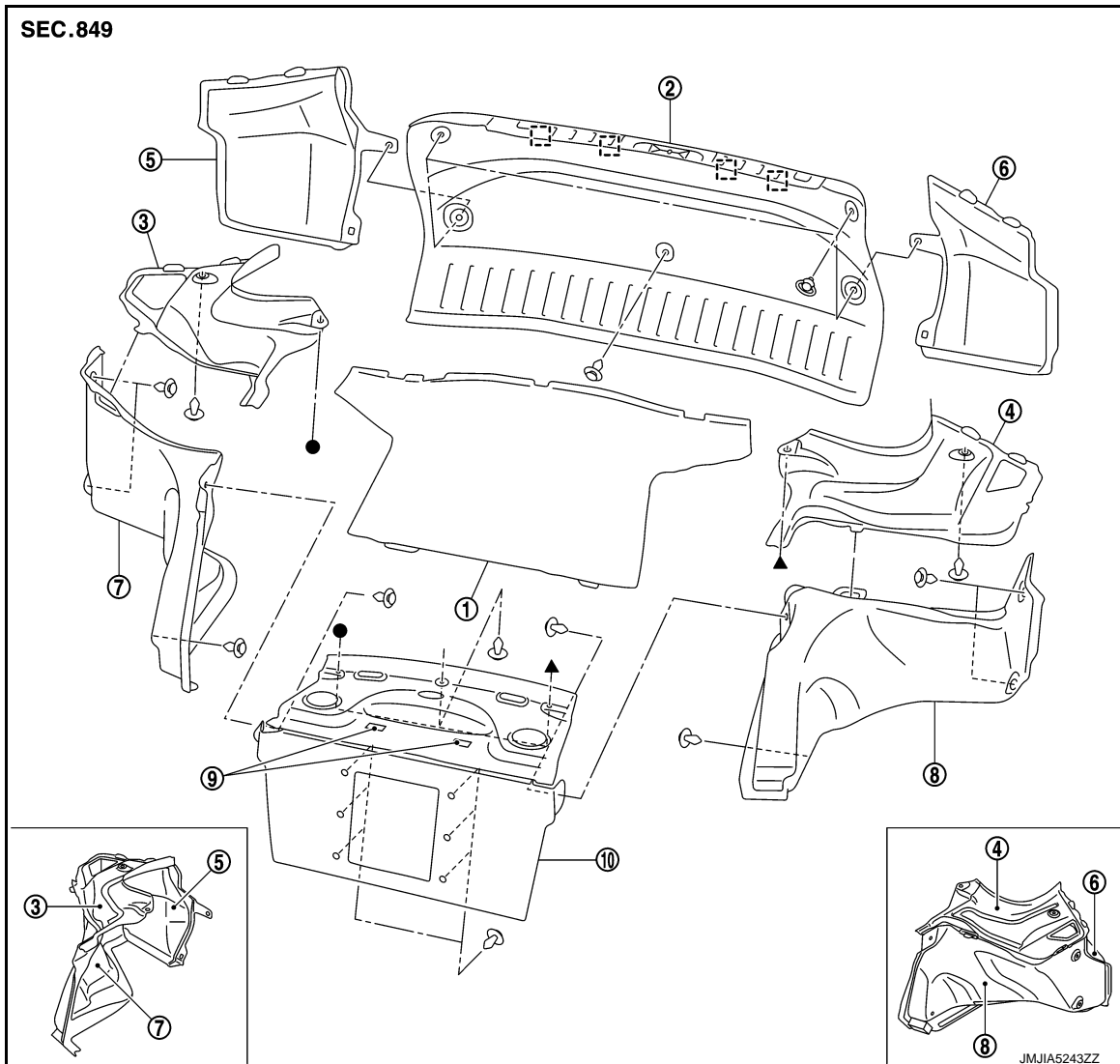

- |                                 |                                 |                                 |
|---------------------------------|---------------------------------|---------------------------------|
| 1. Trunk floor carpet           | 2. Trunk rear finisher          | 3. Trunk side finisher upper RH |
| 4. Trunk side finisher upper LH | 5. Trunk side finisher back RH  | 6. Trunk side finisher back LH  |
| 7. Trunk side finisher lower RH | 8. Trunk side finisher lower LH | 9. Trunk front finisher         |

- △ : Pawl  
□ : Metal clip

### CAUTION:

Each 3-5-7 and 4-6-8 is fixed by tuck.

## Removal and Installation

INFOID:000000009162340

### REMOVAL

1. Fully open the trunk lid.
2. Remove the trunk weather-strip.
3. Remove the trunk front finisher.
4. Remove the trunk side finisher (LH/RH).
5. Remove the trunk rear finisher.

A  
B  
C  
D  
E  
F  
G  
H  
I  
INT  
K  
L  
M  
N  
O  
P

## TRUNK ROOM TRIM

### < REMOVAL AND INSTALLATION >

---

6. Remove the trunk floor carpet.

### INSTALLATION

Install in the reverse order of removal.

# TRUNK LID TRIM

< REMOVAL AND INSTALLATION >

## TRUNK LID TRIM

Exploded View

INFOID:000000009162341

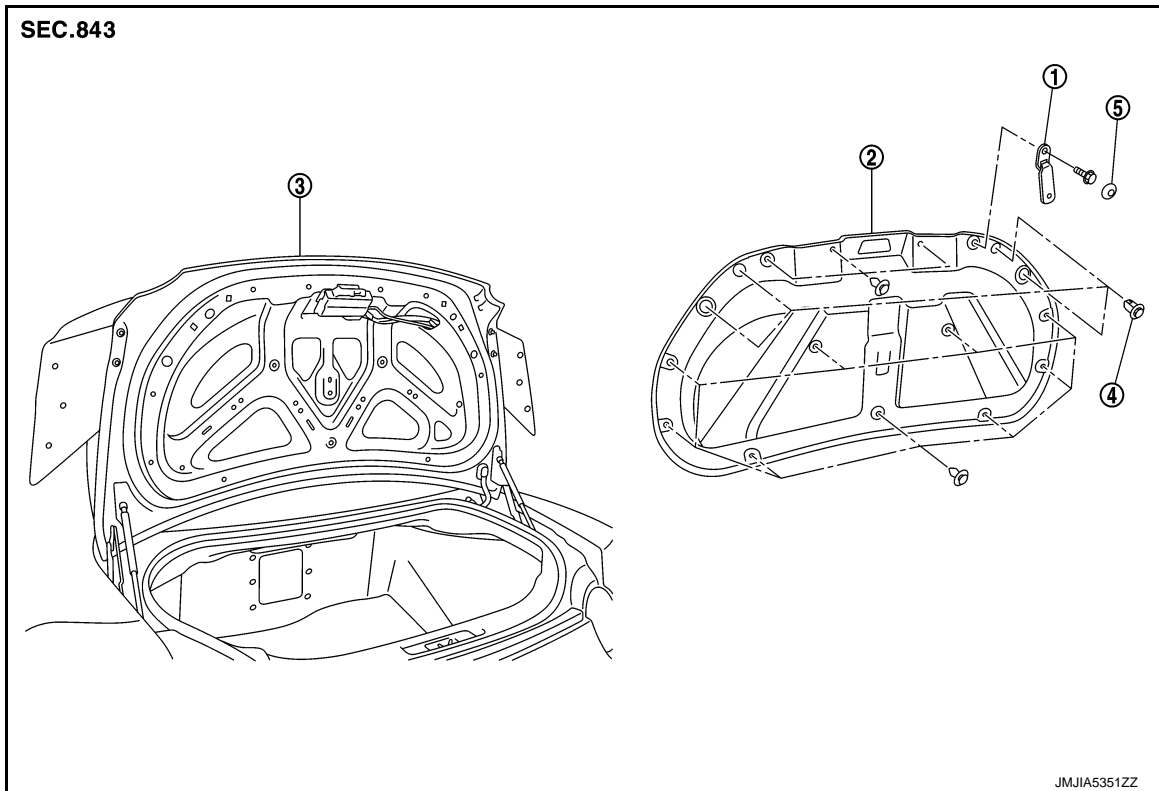

1. Trunk lid bumper rubber

2. Trunk lid finisher inner

3. Trunk lid assembly

### Removal and Installation

INFOID:000000009162342

#### REMOVAL

1. Fully open the trunk lid.
2. Remove the trunk lid finisher inner mounting clip and the trunk lid bumper rubber.
3. Remove the trunk lid finisher inner from the trunk lid assembly.

#### INSTALLATION

Install in the reverse order of removal.

A  
B  
C  
D  
E  
F  
G  
H  
I

INT

K  
L  
M  
N  
O  
P