

# HEATER AND AIR CONDITIONING

## SECTION HA

### CONTENTS

#### TROUBLE DIAGNOSES — Manual Air

<b>Conditioner</b> .....	2
Circuit Diagram for Quick Pinpoint Check.....	2
Wiring Diagram — Heater .....	3
Wiring Diagram .....	4
Diagnostic Procedure 1 .....	5
SYMPTOM: Blower motor does not rotate. ....	5
Diagnostic Procedure 2 .....	8
Symptom: Magnet clutch does not engage when A/C switch and fan switch are ON. ....	8

#### TROUBLE DIAGNOSES — Auto Air

<b>Conditioner</b> .....	13
Circuit Diagram for Quick Pinpoint Check.....	13
Wiring Diagram .....	14
Diagnostic Procedure 10 .....	16
Symptom: Magnet clutch does not engage when A/C switch and fan switch ON.....	16
Diagnostic Procedure 13 .....	21
Symptom: Sunload sensor circuit is open or shorted.....	21

**When you read wiring diagrams:**

- Read GI section, "HOW TO READ WIRING DIAGRAMS".
- See EL section, "POWER SUPPLY ROUTING" for power distribution circuit.

**When you perform trouble diagnoses, read GI section, "HOW TO FOLLOW FLOW CHART IN TROUBLE DIAGNOSES".**

GI

MA

EM

LC

EF &

EC

FE

GL

MT

AT

TF

PD

FA

RA

BR

ST

BF

**HA**

EL

IDX

Circuit Diagram for Quick Pinpoint Check

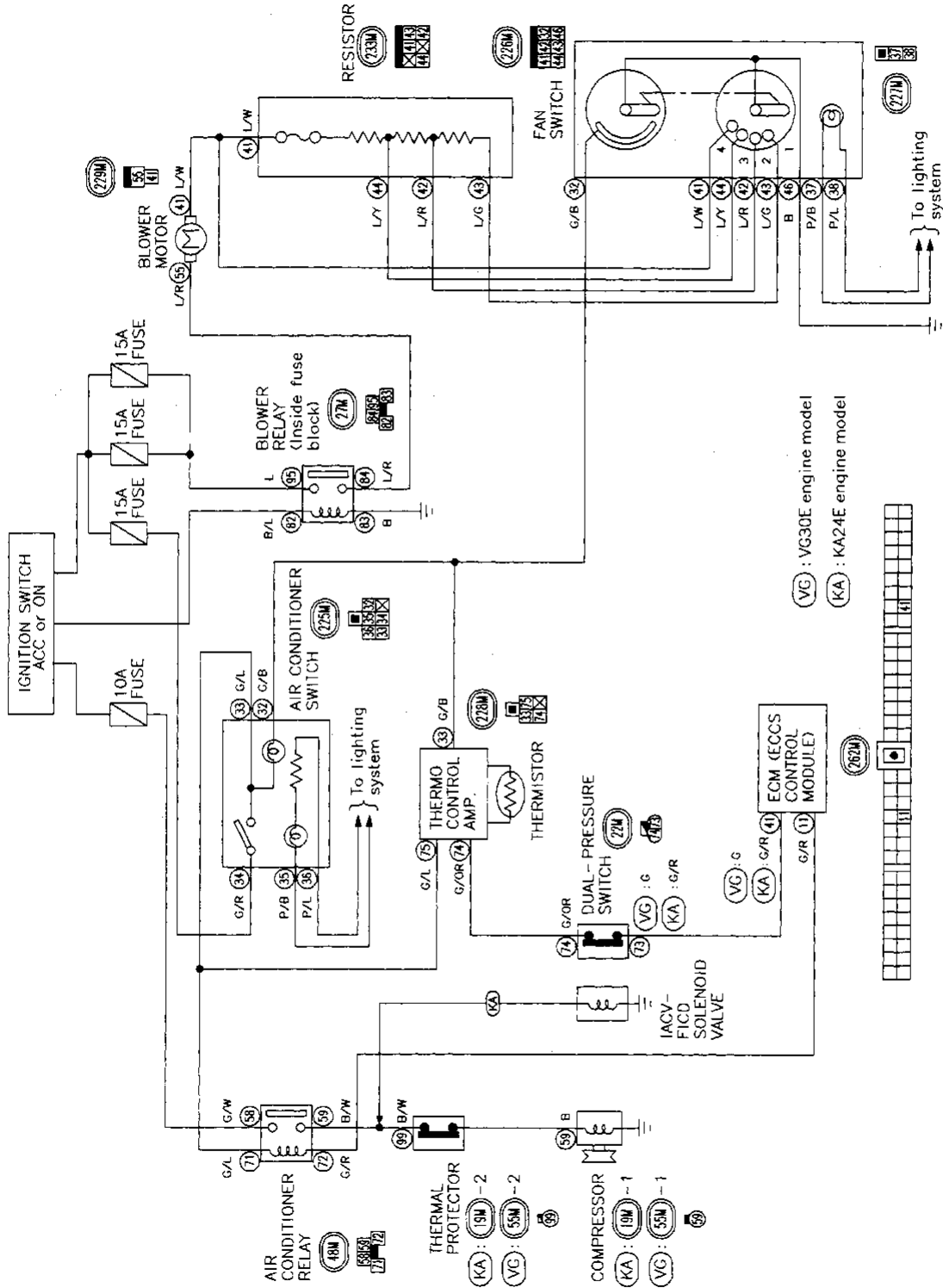

- All connectors shown in this illustration are unit side connectors.
- The unit side connectors with a double circle "◉" are connected to the harness side connectors shown in the "Harness Layout for A/C System".
- The terminal numbers in the connector coincide with the circuit numbers surrounded by a single circle "○".

Wiring Diagram — Heater

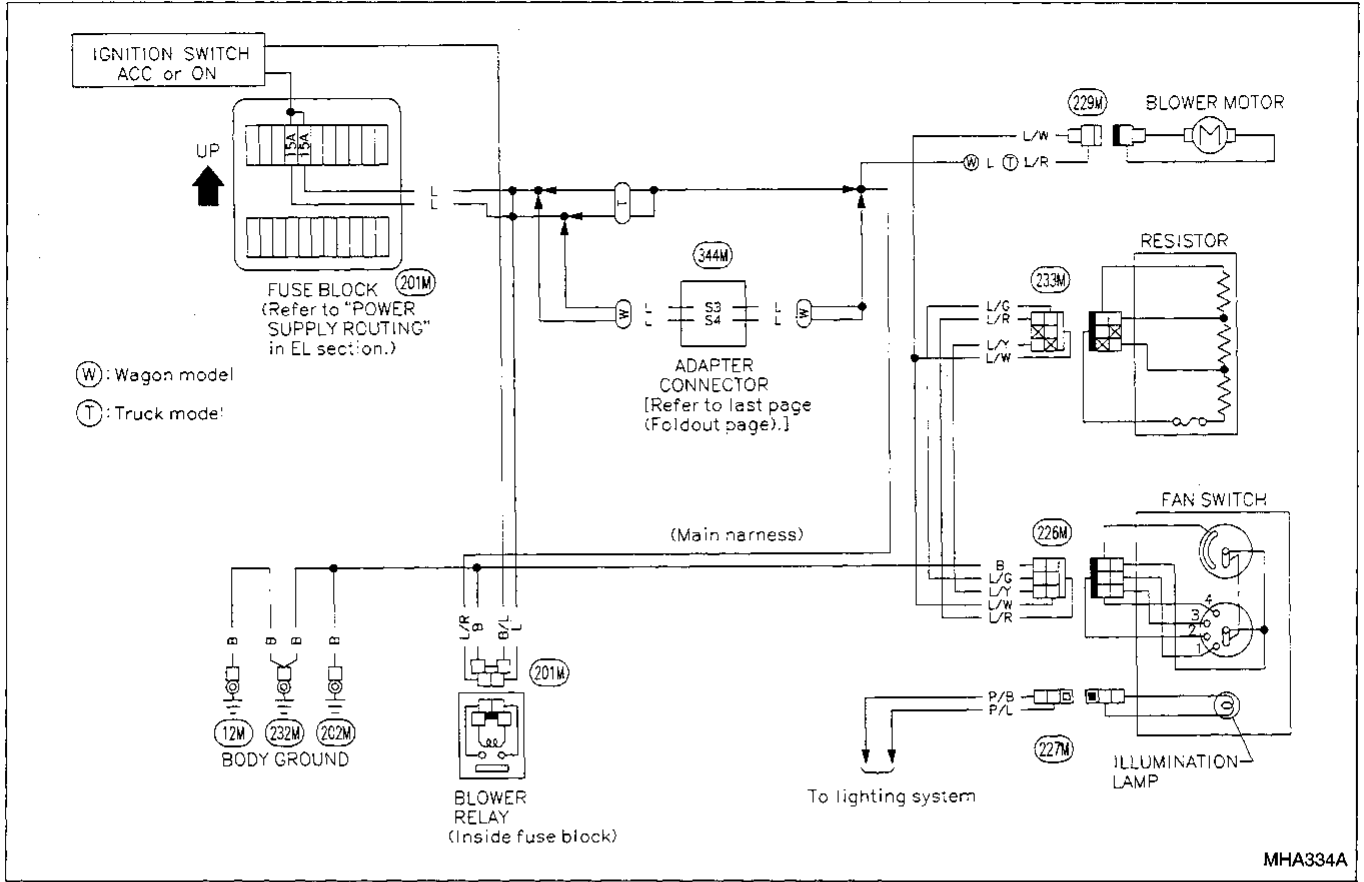

GI

MA

EM

LC

EF &  
EC

FE

CL

MT

AT

TF

PD

FA

RA

BR

ST

BF

HA

EL

IDX

Wiring Diagram

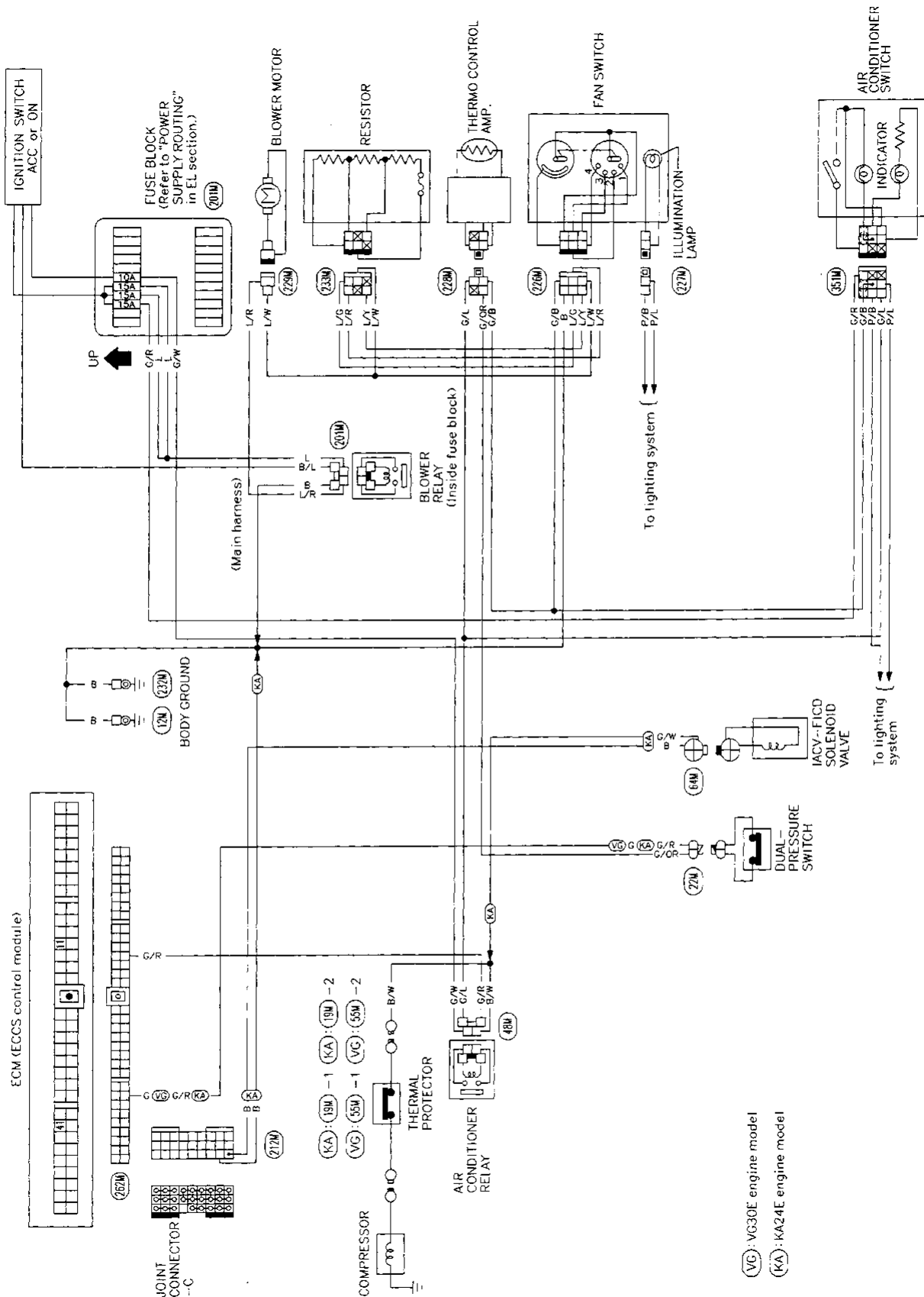

(VG) : VG30E engine model  
 (KA) : KA24E engine model

	INCIDENT	Flow chart No.
1	Fan fails to rotate.	1
2	Fan does not rotate at 1-speed.	2
3	Fan does not rotate at 2-speed.	3
4	Fan does not rotate at 3-speed.	4
5	Fan does not rotate at 4-speed.	5

## Diagnostic Procedure 1

**SYMPTOM: Blower motor does not rotate.**

- Perform **PRELIMINARY CHECK 2** before referring to the following flow chart.

Check if blower motor rotates properly at each fan speed.  
Conduct check as per flow chart at left.

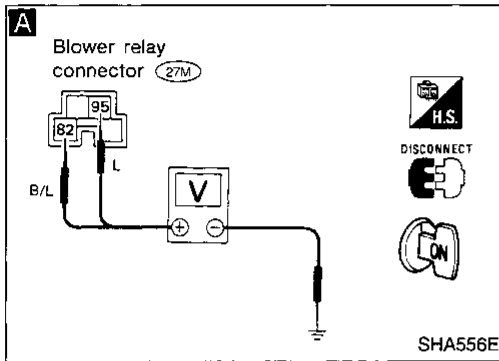
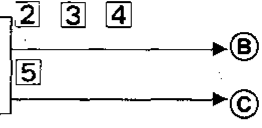

**A**

**CHECK POWER SUPPLY FOR BLOWER RELAY.**  
Do approx. 12 volts exist between blower relay harness terminal No. (82), (95) and body ground?

No → Check circuit between ignition switch and blower relay. (Refer to "POWER SUPPLY ROUTING" in EL section and Wiring Diagram.)

Yes

**B**

**Note**

Check circuit continuity between blower relay harness terminal No. (83), and body ground.

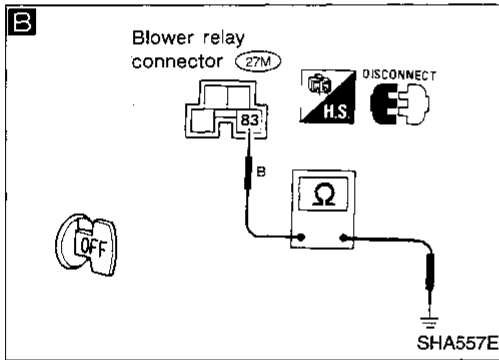

OK

**C**

**CHECK BLOWER RELAY AFTER DISCONNECTING IT.**  
Refer to "Electrical Components Inspection", HA-53 in the Service Manual.

NG → Replace blower relay.

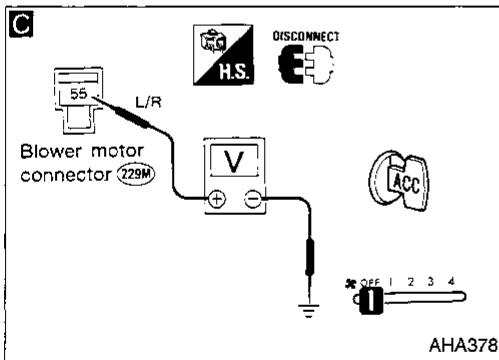

OK

**C**

**CHECK POWER SUPPLY FOR BLOWER MOTOR.**  
Disconnect blower motor harness connector. Do approx. 12 volts exist between blower motor harness terminal No. (55) and body ground?

No → **D**  
Check circuit continuity between blower motor harness terminal No. (55) and blower relay harness terminal No. (84).

Yes

**A**

(Go to next page.)

**Note:**  
If the result is NG after checking circuit continuity, repair harness or connector.

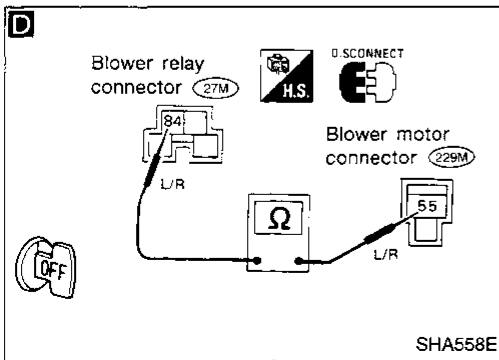

GI  
MA  
EM  
LC  
EF &  
EC  
FE  
CL  
MT  
AT  
TF  
PD  
FA  
RA  
BR  
ST  
BF  
HA  
EL  
IDX

# TROUBLE DIAGNOSES — Manual Air Conditioner

## Diagnostic Procedure 1 (Cont'd)

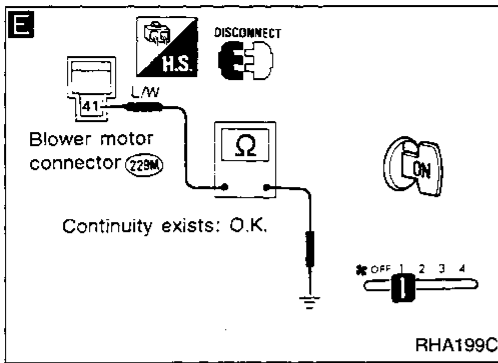

**E** Check circuit continuity between blower motor harness terminal No. (41) and body ground.

NG → Reconnect blower motor harness connector.

OK

**CHECK BLOWER MOTOR.**  
Refer to "Electrical Components Inspection", HA-52 in the Service Manual.

NG

Replace blower motor.

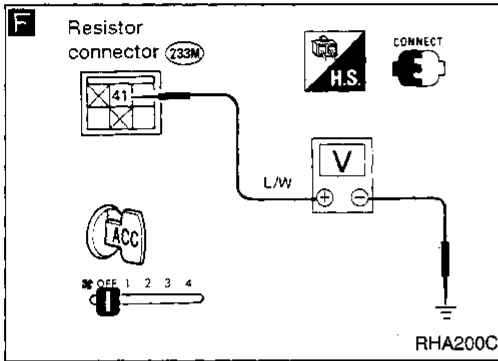

**F** CHECK BLOWER MOTOR CIRCUIT BETWEEN BLOWER MOTOR AND RESISTOR.  
Do approx. 12 volts exist between resistor harness terminal No. (41) and body ground?

No → Disconnect blower motor and resistor harness connectors.

**G** Note

Check circuit continuity between blower motor harness terminal No. (41) and resistor harness terminal No. (41).

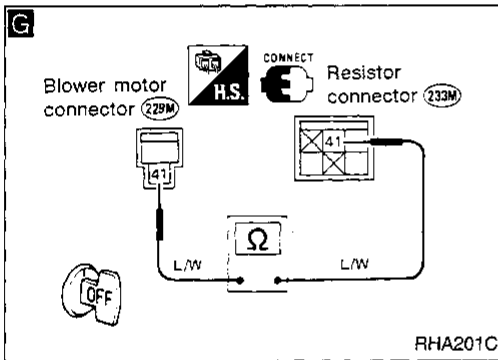

(Go to next page.)

**Note:**  
If the result is NG after checking circuit continuity, repair harness or connector.

# TROUBLE DIAGNOSES — Manual Air Conditioner

## Diagnostic Procedure 1 (Cont'd)

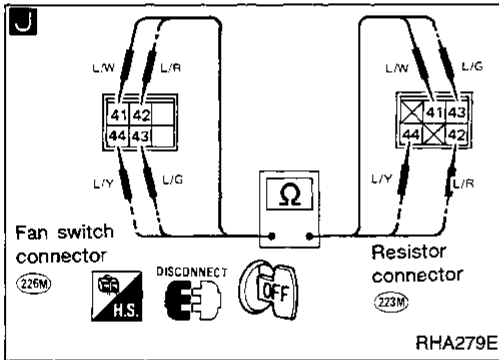
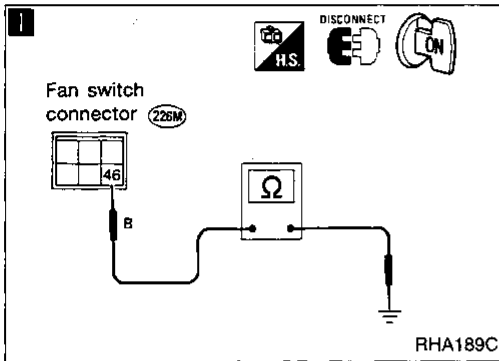
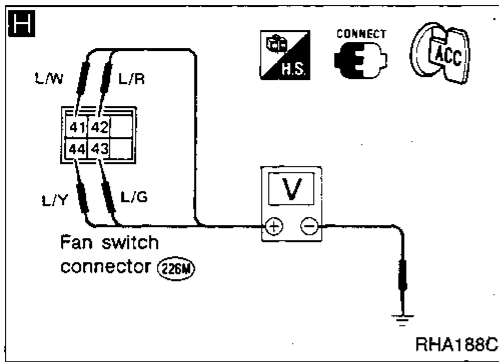

1 ↓      D ↓      B ↓      2 3 4

**CHECK RESISTOR AFTER DISCONNECTING IT.**  
Refer to "Electrical Components Inspection", HA-52 in the Service Manual.

OK ↓      NG ↓

Replace resistor.

Reconnect resistor harness connector.

1 ↓      2 ↓      3 ↓      4 ↓      C ↓      5 ↓

**CHECK FAN SWITCH CIRCUIT.**  
Do approx. 12 volts exist between each fan switch harness terminal and body ground?

Flow chart No.	Terminal No.		Voltage
	⊕	⊖	
2	(43)	Body ground	Approx. 12V
3	(42)		
4	(44)		
5	(41)		

OK ↓      NG ↓

**Check circuit continuity** between fan switch and resistor.

OK ↓      NG ↓

**CHECK FAN SWITCH AFTER DISCONNECTING IT.**  
Refer to "Electrical Components Inspection", HA-52 in the Service Manual.

Replace fan switch.

OK ↓      Note

**Check circuit continuity** between fan switch harness terminal No. (46) and body ground.

OK ↓

Replace blower motor.

**Note:**  
If the result is NG after checking circuit continuity, repair harness or connector.

GI  
MA  
EM  
LC  
EF & EC  
FE  
CL  
MT  
AT  
TF  
PD  
FA  
RA  
BR  
ST  
BF  
HA  
EL  
IDX

## Diagnostic Procedure 2

**SYMPTOM: Magnet clutch does not engage when A/C switch and fan switch are ON.**

- Perform PRELIMINARY CHECK 1 before referring to the following flow chart.

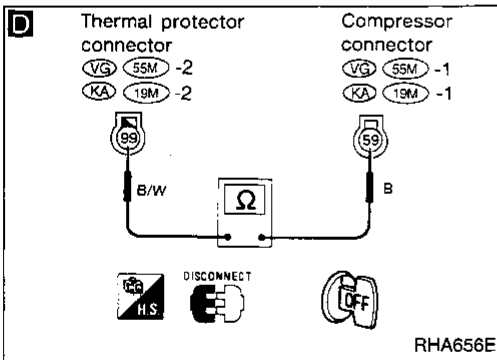
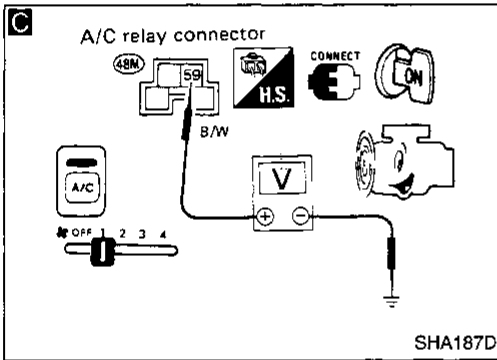
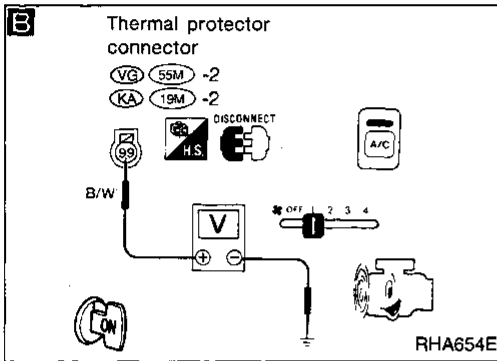
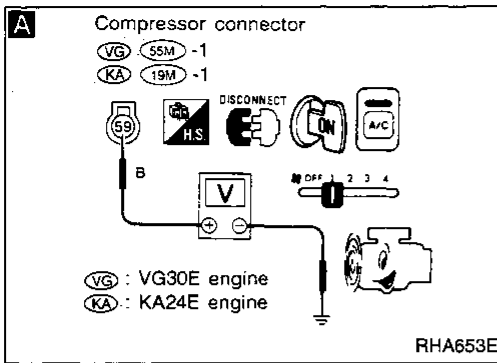

**A** CHECK POWER SUPPLY FOR COMPRESSOR.  
 Disconnect compressor harness connector.  
 Do approx. 12 volts exist between compressor harness terminal No. ⑤9 and body ground?

**B** CHECK POWER SUPPLY FOR THERMAL PROTECTOR.  
 Disconnect thermal protector harness connector.  
 Do approx. 12V exist between thermal protector harness terminal No. ⑨9 and body ground?

Check magnet clutch coil.

Replace magnet clutch.  
 Refer to "COMPRESSOR — Model DKV-14C (ZEXEL make)", HA-24 in the Service Manual.

**C** CHECK A/C RELAY OPERATION.  
 Do approx. 12 volts exist between A/C relay harness terminal No. ⑤9 and body ground.

OK → **A**  
 NG → **B**  
 (Go to next page.)

**D** CHECK THERMAL PROTECTOR.  
 Check circuit continuity between thermal protector harness terminal No. ⑨9 and compressor harness terminal No. ⑤9.

NG → Replace thermal protector.

**Note:**  
 If the result is NG after checking circuit continuity, repair harness or connector.



# TROUBLE DIAGNOSES — Manual Air Conditioner

## Diagnostic Procedure 2 (Cont'd)

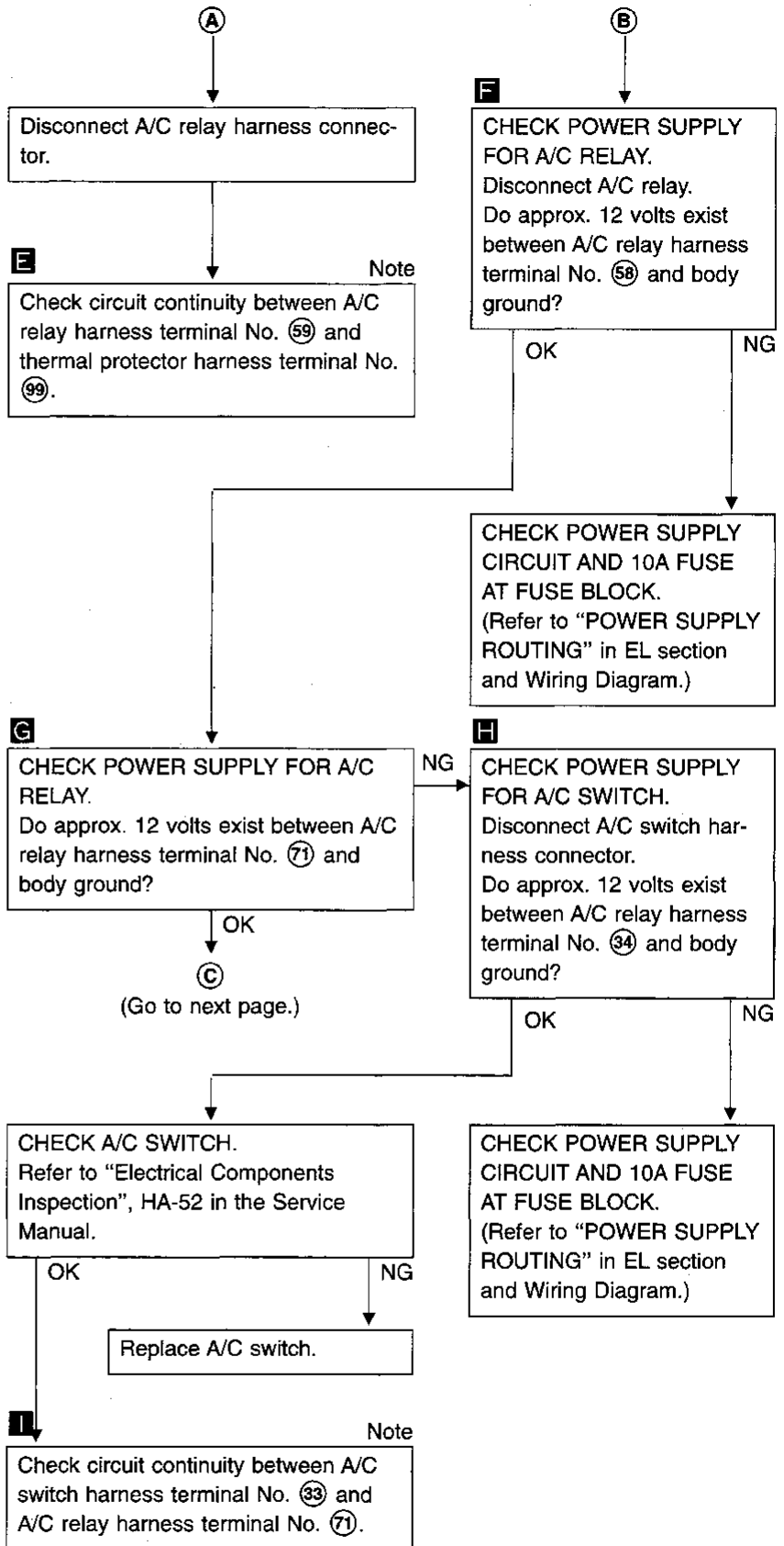
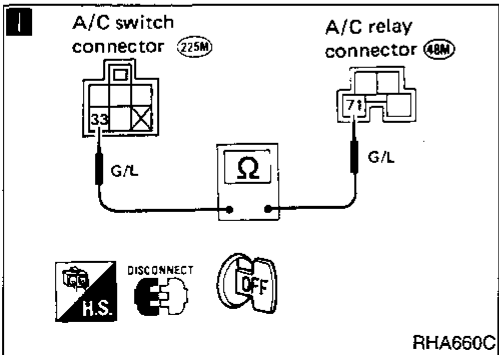
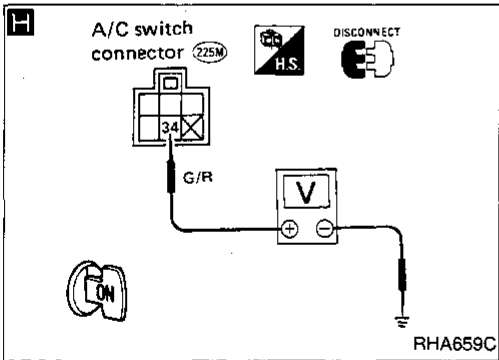
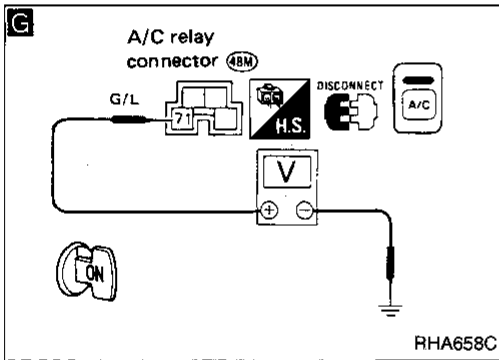
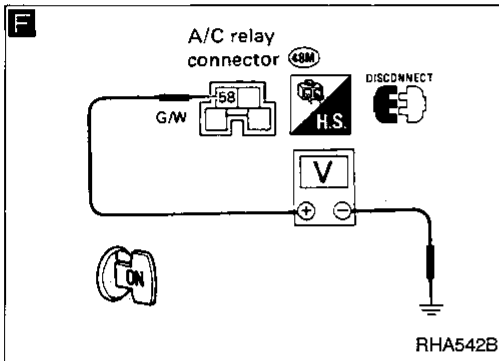
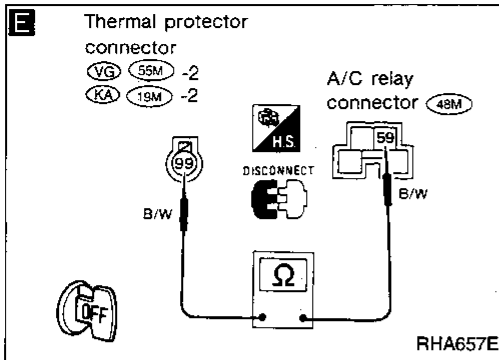

**Note:**

If the result is NG after checking circuit continuity, repair harness or connector.

GI  
 MA  
 EM  
 LC  
 EF & EC  
 FE  
 CL  
 MT  
 AT  
 TF  
 PD  
 FA  
 RA  
 BR  
 ST  
 BF  
 HA  
 EL  
 IDX

# TROUBLE DIAGNOSES — Manual Air Conditioner

## Diagnostic Procedure 2 (Cont'd)

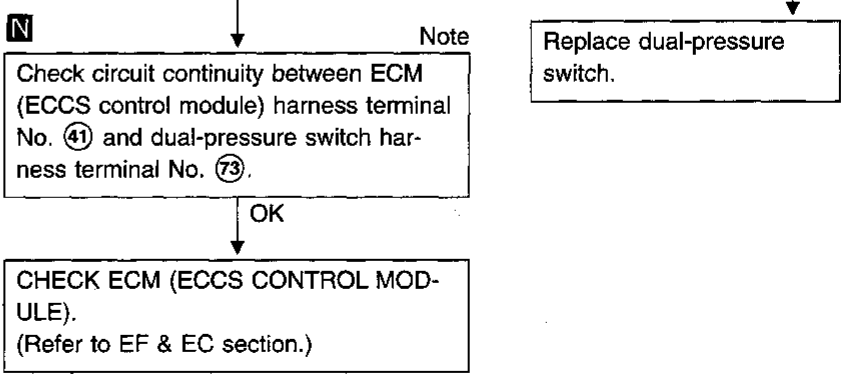
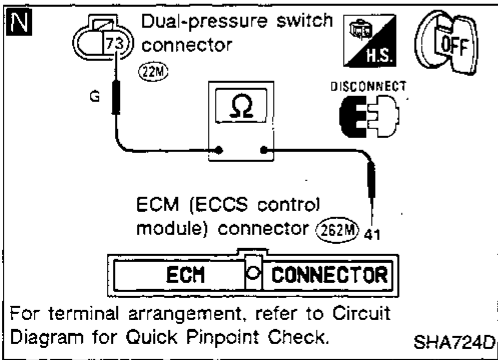
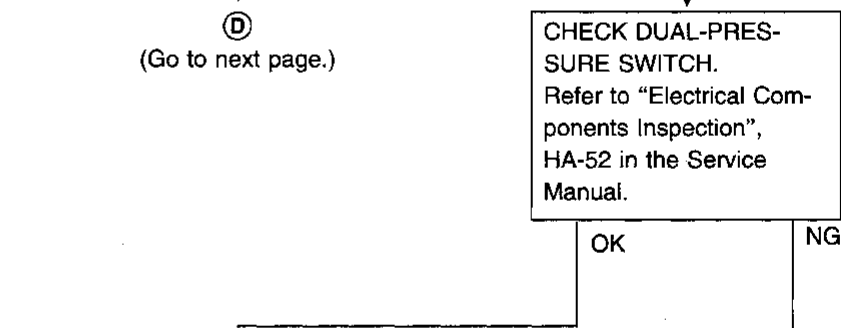
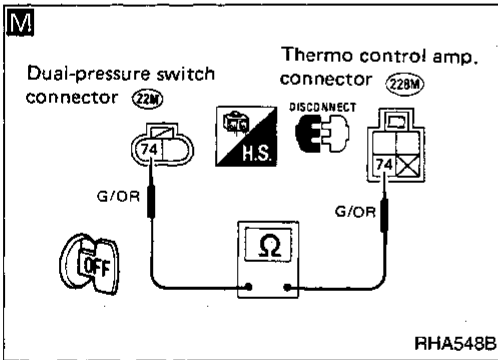
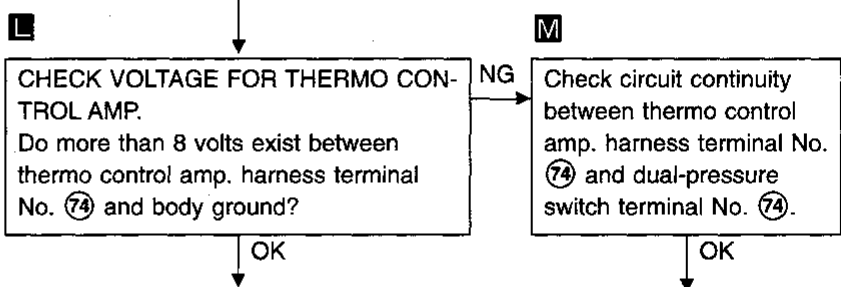
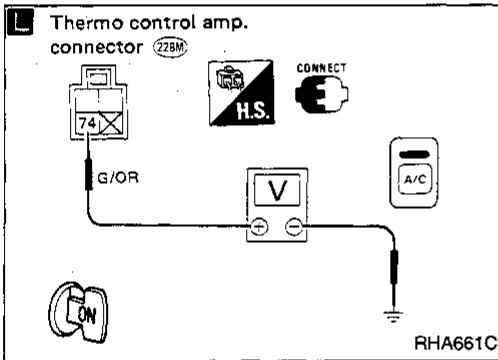
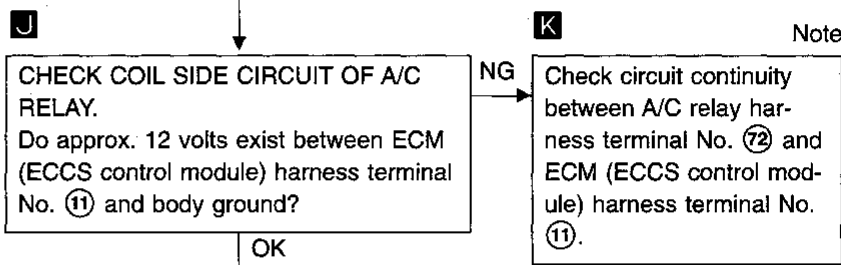
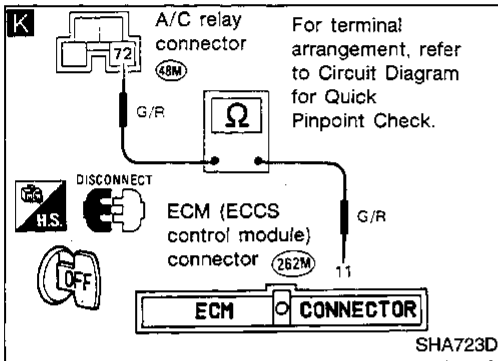
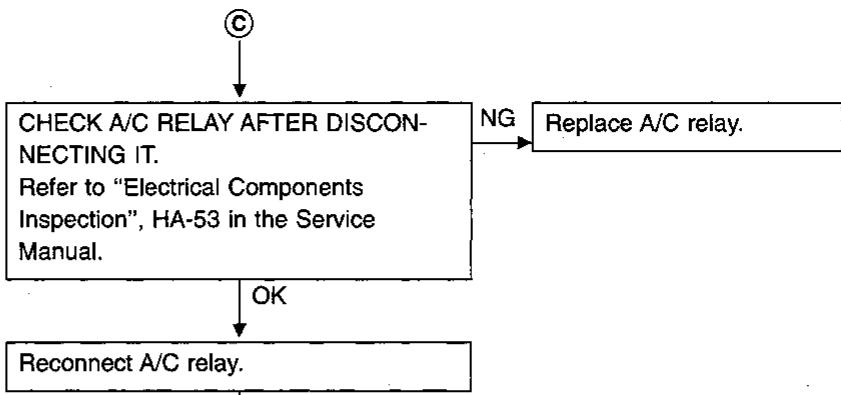
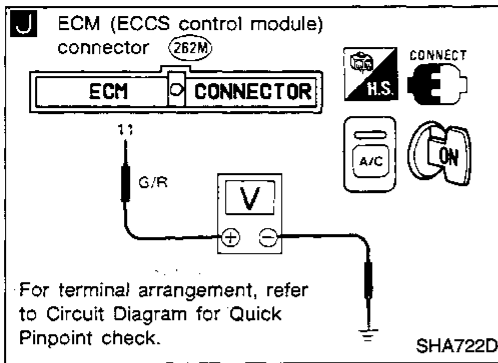

**Note:**  
If the result is NG after checking circuit continuity, repair harness or connector.

# TROUBLE DIAGNOSES — Manual Air Conditioner

## Diagnostic Procedure 2 (Cont'd)

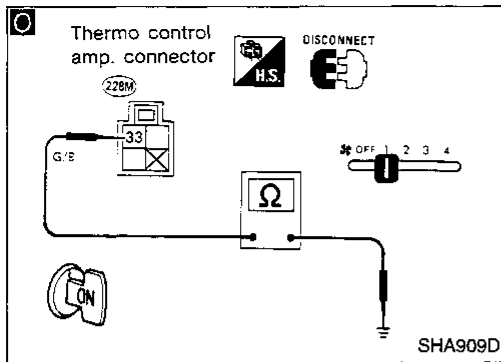

**D**

CHECK POWER SUPPLY FOR THERMO CONTROL AMP.  
Go to Main Power Supply and Ground Circuit Check.

OK

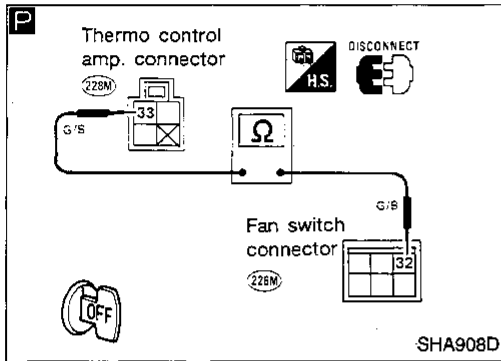

**O**

CHECK BODY GROUND CIRCUIT FOR THERMO CONTROL AMP.  
Disconnect thermo control amp. harness connector.  
Does continuity exist between thermo control amp. harness terminal No. (33) and body ground?

NG

Disconnect fan switch harness connector.

**P** Note

Check circuit continuity between thermo control amp. harness terminal No. (33) and fan switch harness terminal No. (32).

OK

OK

Replace thermo control amp.

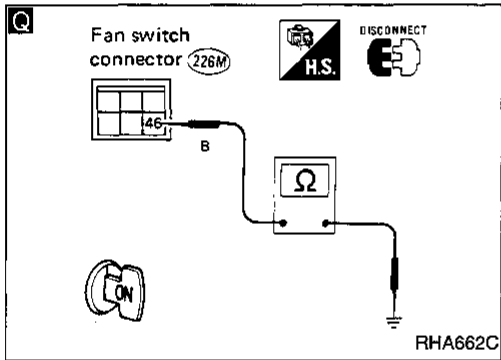

**Q** Note

CHECK BODY GROUND CIRCUIT FOR FAN SWITCH.  
Does continuity exist between fan switch harness terminal No. (46) and body ground?

OK

CHECK FAN SWITCH.  
Refer to "Electrical Components Inspection", HA-52 in the Service Manual.

Replace fan switch.

**Note:**  
If the result is NG after checking circuit continuity, repair harness or connector.

GI  
MA  
EM  
LC  
EF & EC  
FE  
CL  
MT  
AT  
TF  
PD  
FA  
RA  
BR  
ST  
BF  
HA  
EL  
IDX

**NOTE**

Circuit Diagram for Quick Pinpoint Check

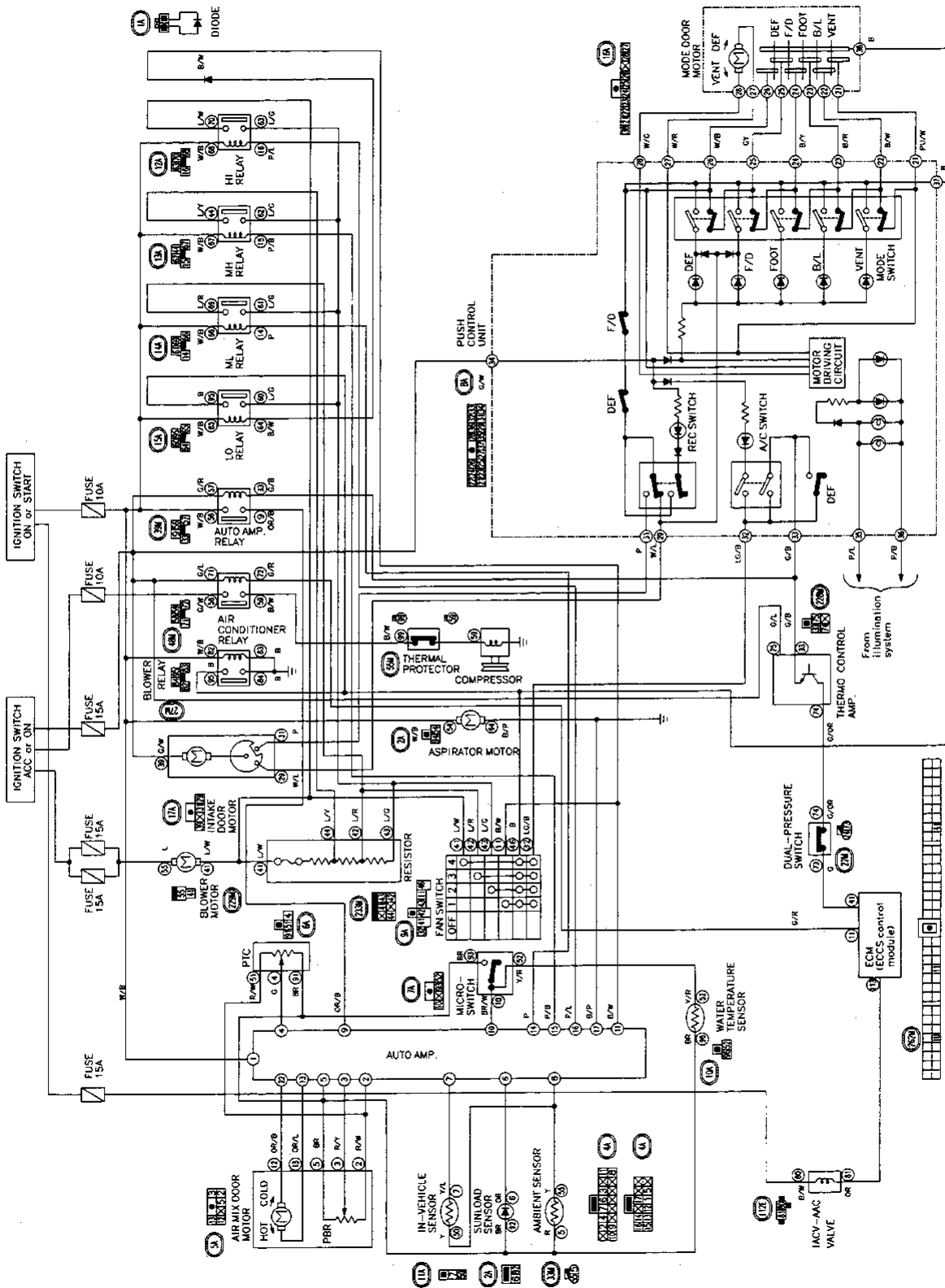

- All connectors shown in this illustration are unit side connectors.
- The unit side connectors with a double circle "⊖" are connected to the harness side connectors shown in the "Harness Layout for A/C System".
- The terminal numbers in the connector coincide with the circuit numbers by a single circle "○".

GI  
MA  
EM  
LC  
EF & EC  
FE  
CL  
MT  
AT  
TF  
PD  
FA  
RA  
BR  
ST  
BF  
HA  
EL  
IDX

## Wiring Diagram

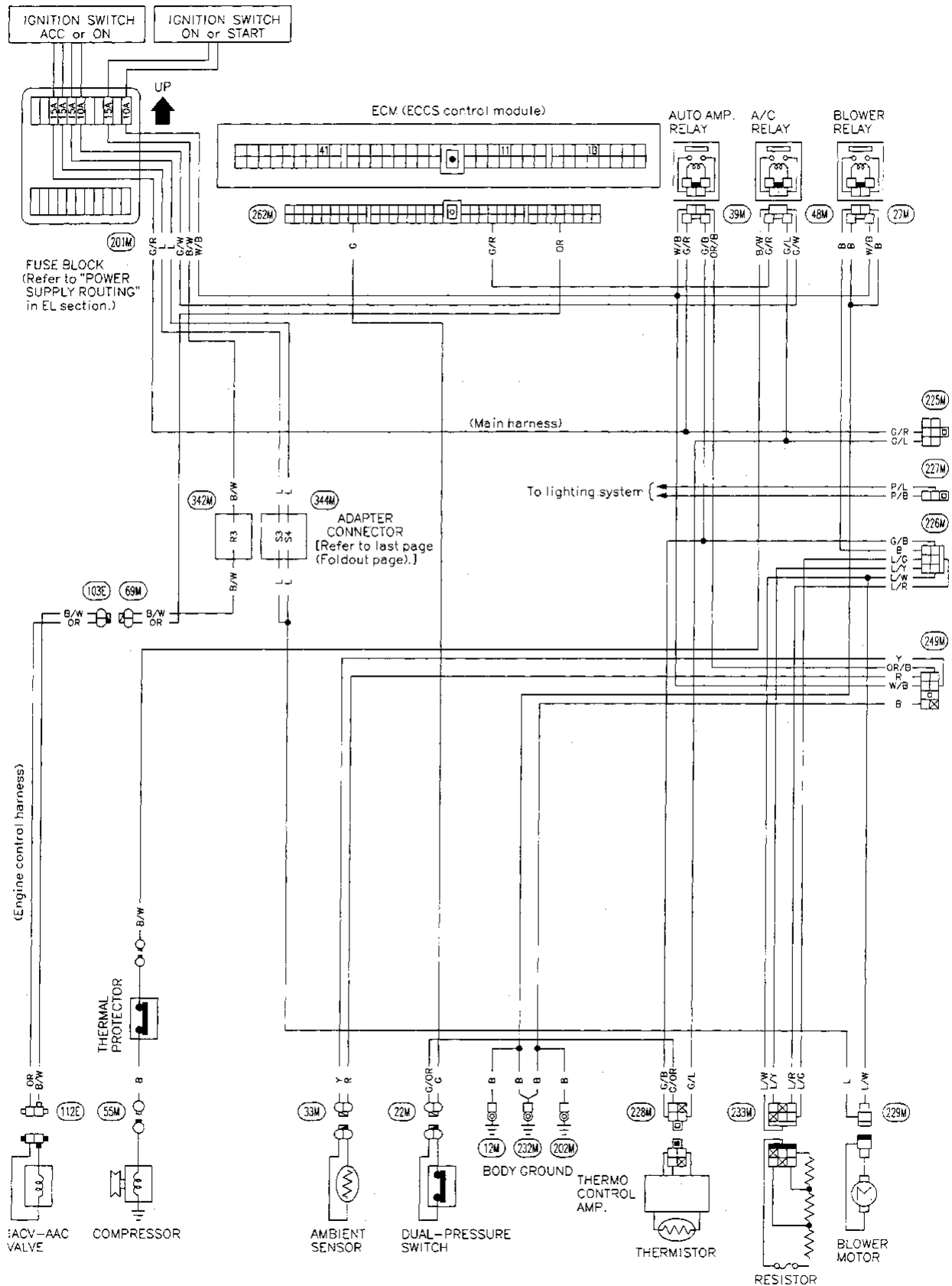

# TROUBLE DIAGNOSES — Auto Air Conditioner Wiring Diagram (Cont'd)

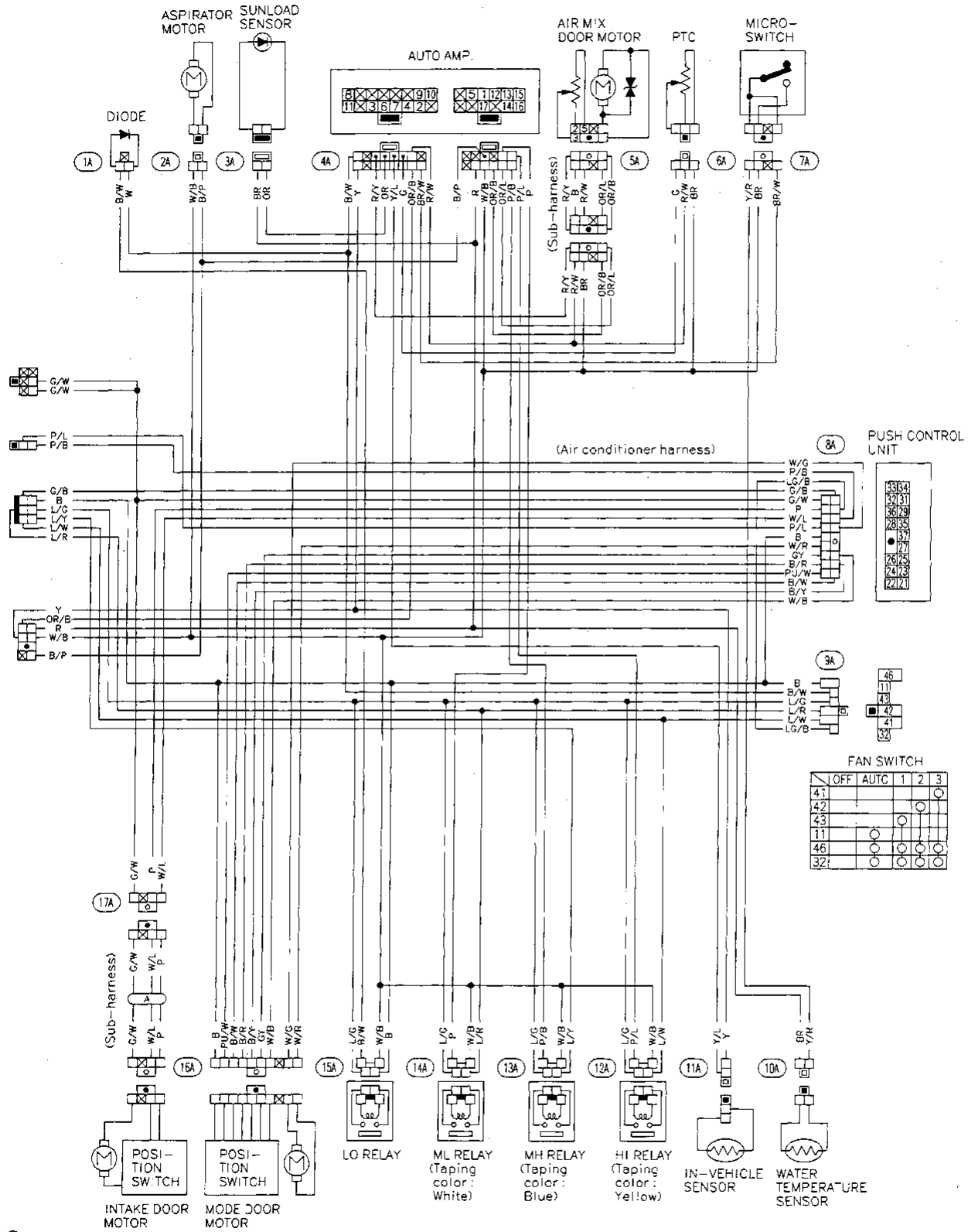

FAN SWITCH

	OFF	AUTC	1	2	3
41					
42					
43					
11					
46					
32					

(A) : A/C kit only

GI  
 MA  
 EM  
 LC  
 EF & EC  
 FE  
 CL  
 MT  
 AT  
 TF  
 PD  
 FA  
 RA  
 BR  
 ST  
 BF  
 HA  
 EL  
 IDX

## Diagnostic Procedure 10

**SYMPTOM: Magnet clutch does not engage when A/C switch and fan switch ON.**

- Perform PRELIMINARY CHECK 2 before referring to the following flow chart.

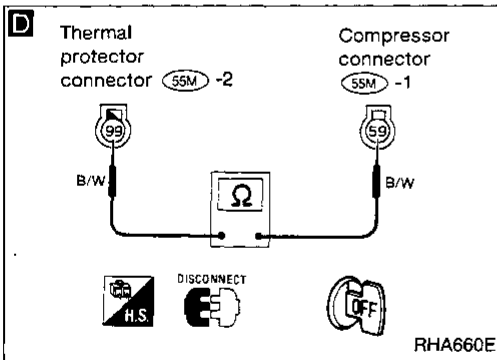
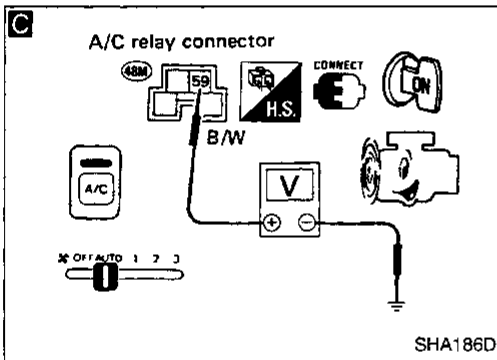
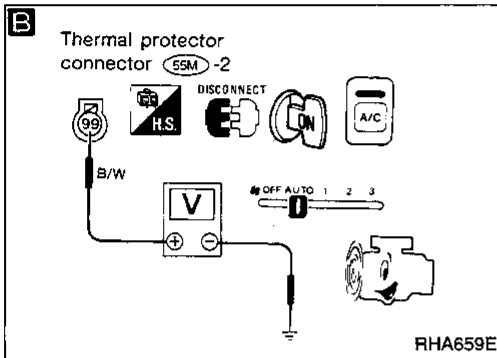
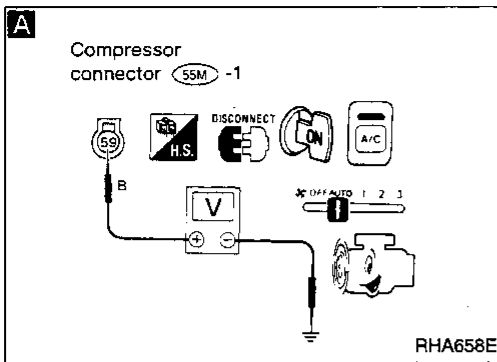

**A** CHECK POWER SUPPLY FOR COMPRESSOR.  
Disconnect compressor harness connector.  
Do approx. 12 volts exist between compressor harness terminal No. 59 and body ground?

Check magnet clutch coil.

Replace magnet clutch.  
Refer to "COMPRESSOR — Model DKV-14C (ZEXEL make)", HA-24 in the Service Manual.

**B** CHECK POWER SUPPLY FOR THERMAL PROTECTOR.  
Disconnect thermal protector harness connector.  
Do approx. 12V exist between thermal protector harness terminal No. 99 and body ground?

**C** CHECK A/C RELAY OPERATION.  
Do approx. 12 volts exist between A/C relay harness terminal No. 59 and body ground?

**D** CHECK THERMAL PROTECTOR.  
Check circuit continuity between thermal protector harness terminal No. 99 and compressor harness terminal No. 59.

Replace thermal protector.

**Note:**

If the result is NG after checking circuit continuity, repair harness or connector.



# TROUBLE DIAGNOSES — Auto Air Conditioner

## Diagnostic Procedure 10 (Cont'd)

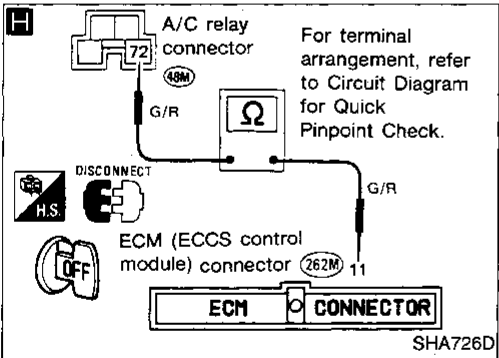
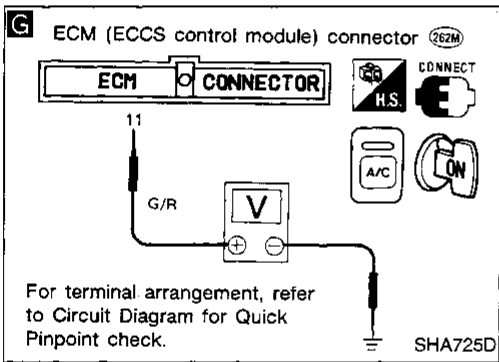
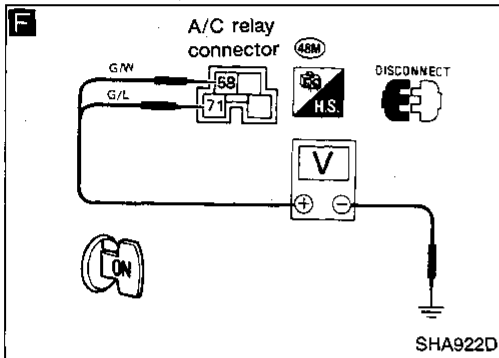
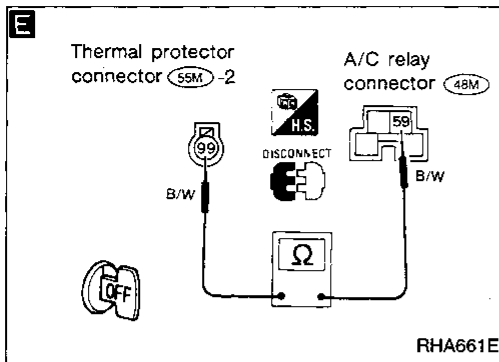

**A**

Disconnect A/C relay harness connector.

**E** Note

Check circuit continuity between A/C relay harness terminal No. (59) and thermal protector harness terminal No. (99).

**B**

**F** CHECK POWER SUPPLY FOR A/C RELAY. Disconnect A/C relay. Do approx. 12 volts exist between A/C relay harness terminal No. (58), (71) and body ground?

OK

NG

CHECK POWER SUPPLY CIRCUIT AND 10A FUSE AT FUSE BLOCK. (Refer to "POWER SUPPLY ROUTING" in EL section and Wiring Diagram.)

CHECK A/C RELAY AFTER DISCONNECTING IT. Refer to "Electrical Components Inspection", HA-53 in the Service Manual.

NG

Replace A/C relay.

OK

Reconnect A/C relay.

**G** CHECK COIL SIDE CIRCUIT OF A/C RELAY. Do approx. 12 volts exist between ECM (ECCS control module) harness terminal No. (11) and body ground?

**H** Note

Check circuit continuity between A/C relay harness terminal No. (72) and ECM (ECCS control module) harness terminal No. (11).

**C**

(Go to next page.)

**Note:**  
If the result is NG after checking circuit continuity, repair harness or connector.

GI  
MA  
EM  
LC  
EF & EC  
FE  
CL  
MT  
AT  
TF  
PD  
FA  
RA  
BR  
ST  
BF

HA

EL

IDX

# TROUBLE DIAGNOSES — Auto Air Conditioner

## Diagnostic Procedure 10 (Cont'd)

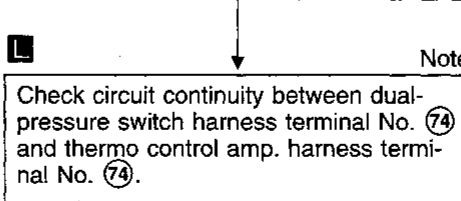
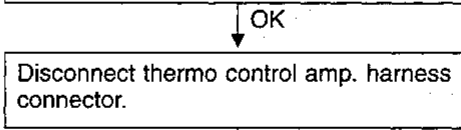
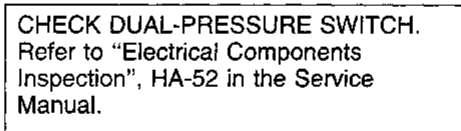
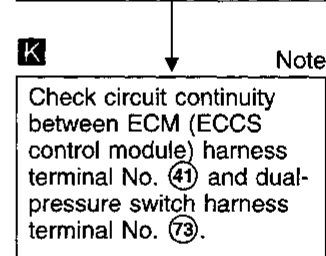
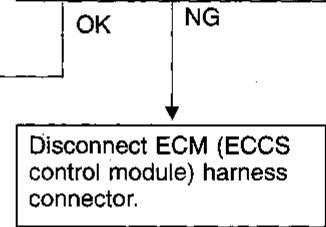
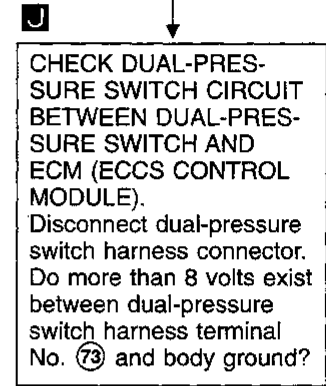
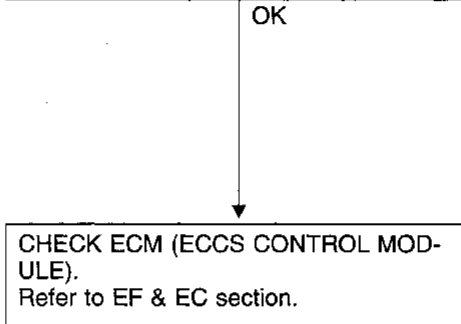
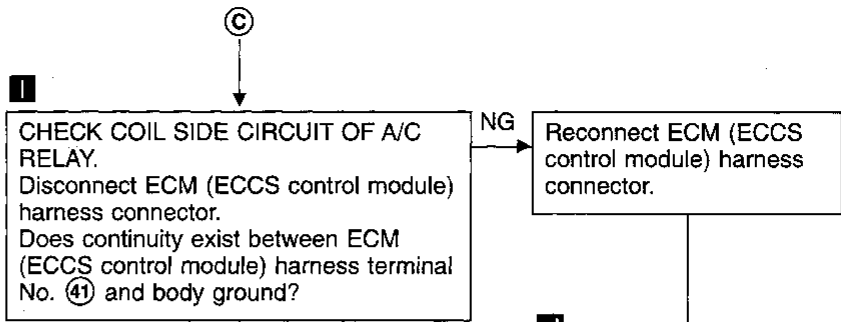
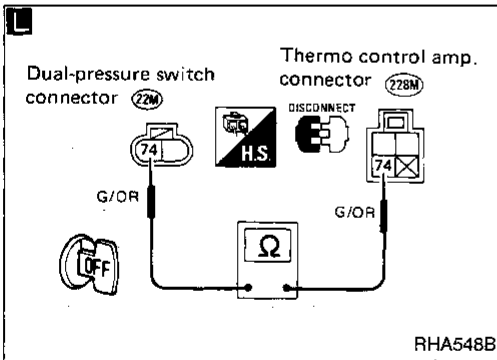
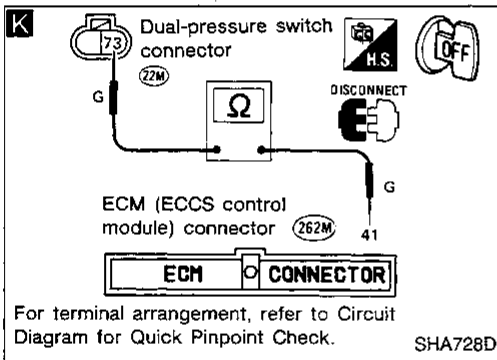
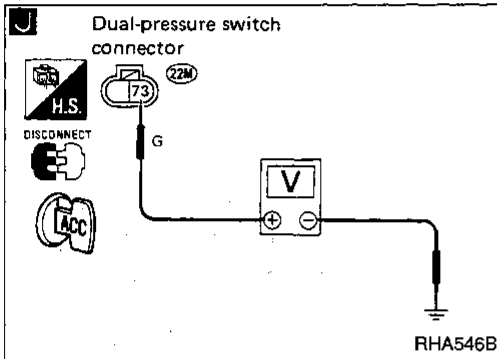
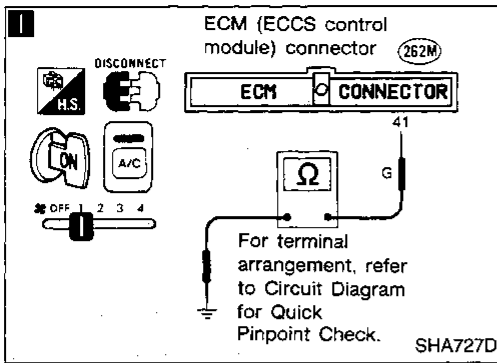

Ⓢ

(Go to next page.)

**Note:**

If the result is NG after checking circuit continuity, repair harness or connector.

# TROUBLE DIAGNOSES — Auto Air Conditioner

## Diagnostic Procedure 10 (Cont'd)

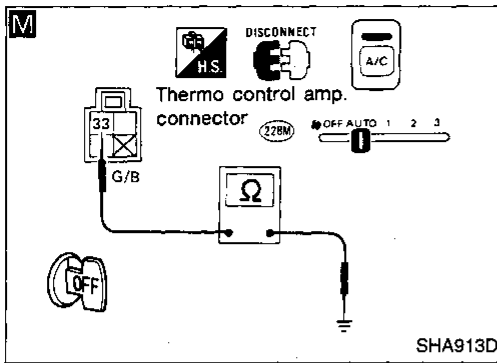

**D**

**CHECK POWER SUPPLY FOR THERMO CONTROL AMP.**  
Refer to Main Power Supply and Ground Circuit Check, HA-66 in the Service Manual.

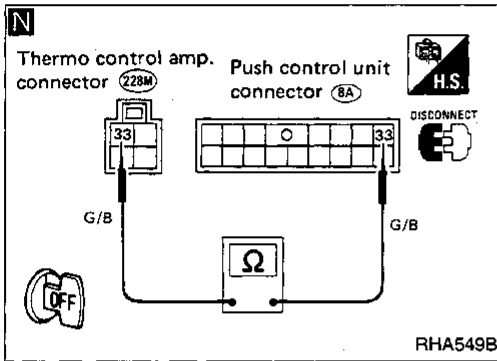

**M**

**CHECK BODY GROUND CIRCUIT FOR THERMO CONTROL AMP.**  
Disconnect thermo control amp. harness connector.  
Does continuity exist between thermo control amp. harness terminal No. (33) and body ground?

OK → Replace fan switch.

NG

Disconnect push control unit harness connector.

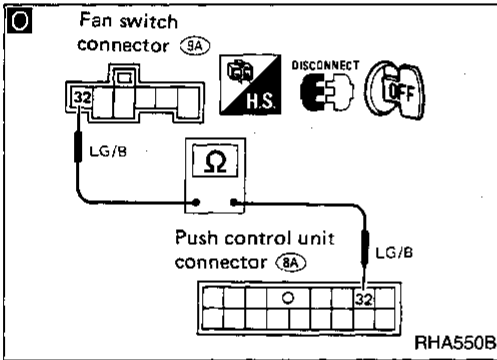

**N** Note

Check circuit continuity between thermo control amp. harness terminal No. (33) and push control unit harness terminal No. (33).

OK

**CHECK A/C SWITCH OF PUSH CONTROL UNIT.**  
Refer to "Electrical Components Inspection", HA-93 in the Service Manual.

NG → Replace control amp. built into push control unit.

OK

Disconnect fan switch harness connector.

**O** Note

Check circuit continuity between push control unit harness terminal No. (32) and fan switch harness terminal No. (32).

OK

**E**  
(Go to next page.)

**Note:**  
If the result is NG after checking circuit continuity, repair harness or connector.

GI  
MA  
EM  
LC  
EF & EC  
FE  
CL  
MT  
AT  
TF  
PD  
FA  
RA  
BR  
ST  
BF  
HA  
EL  
IDX

# TROUBLE DIAGNOSES — Auto Air Conditioner

## Diagnostic Procedure 10 (Cont'd)

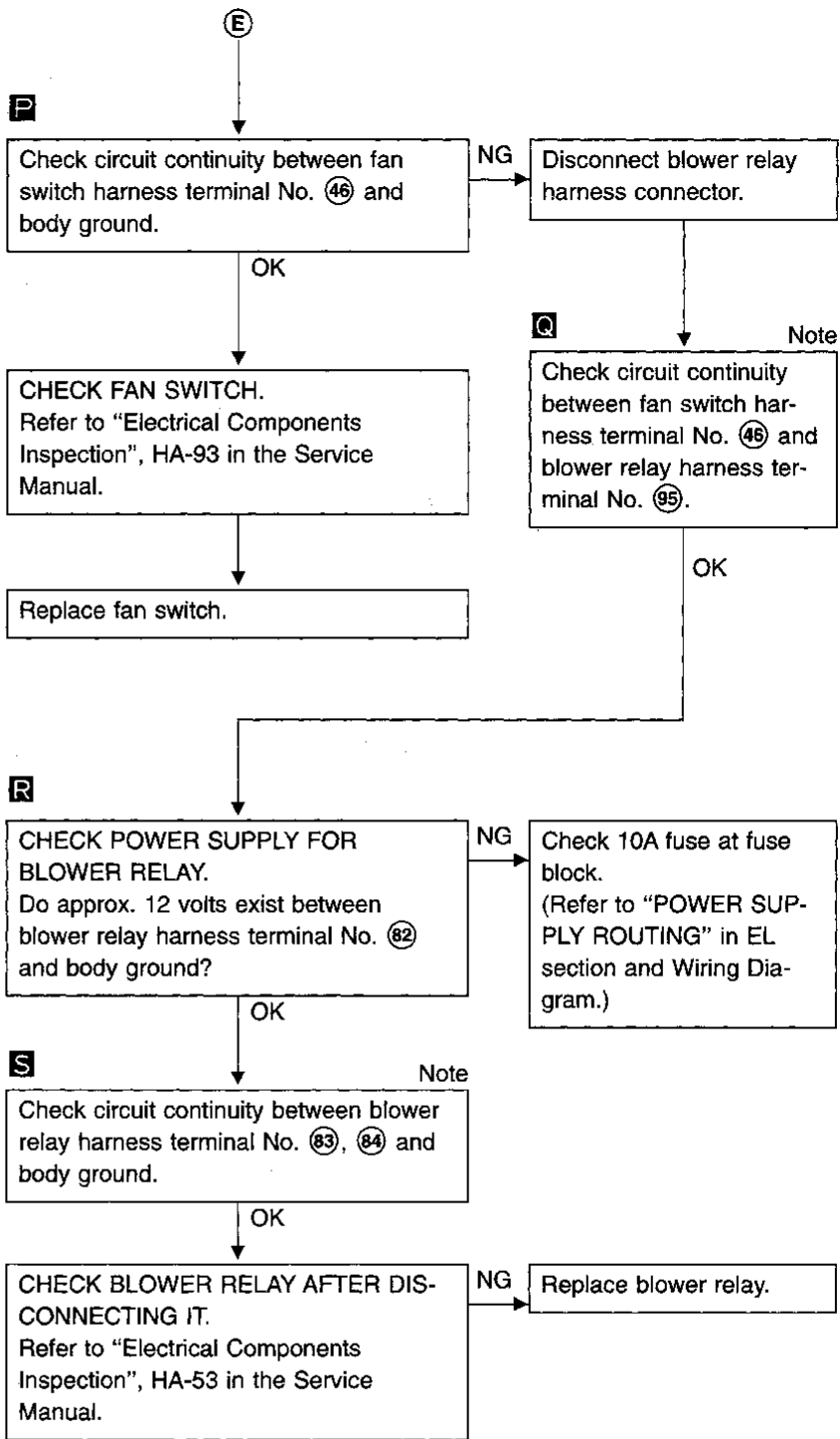
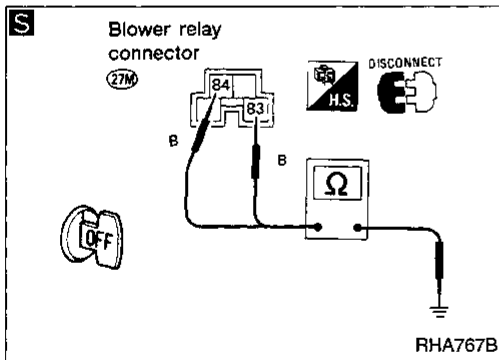
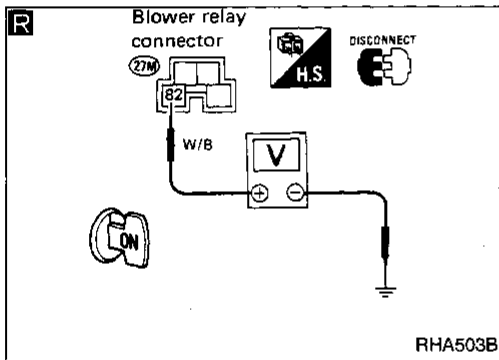
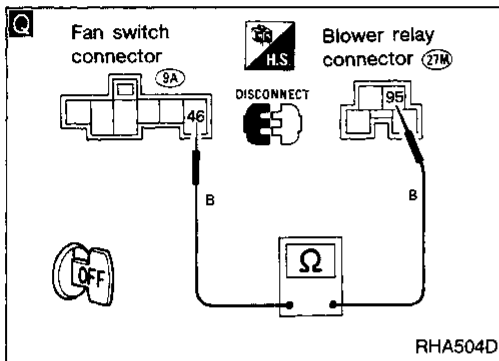
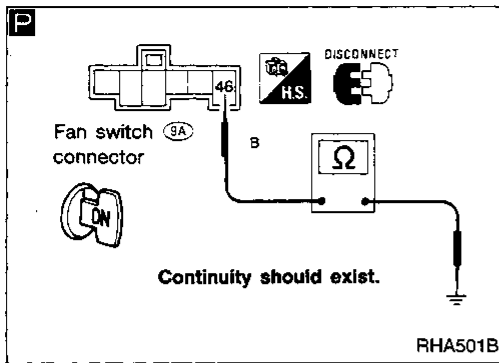

**Note:**

If the result is NG after checking circuit continuity, repair harness or connector.

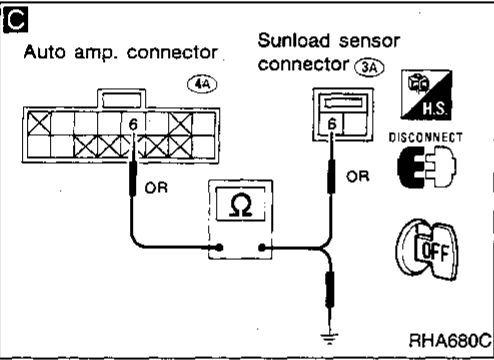
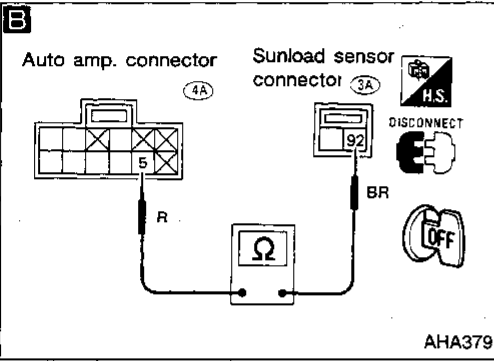
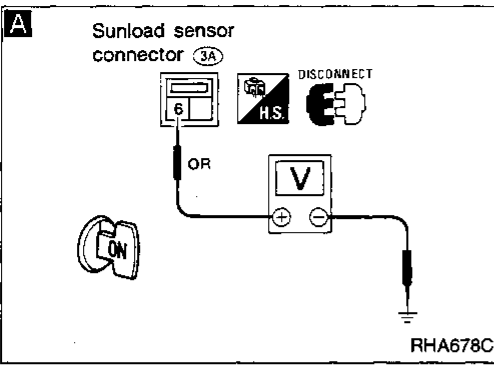

## Diagnostic Procedure 13

**SYMPTOM: Sunload sensor circuit is open or shorted.**

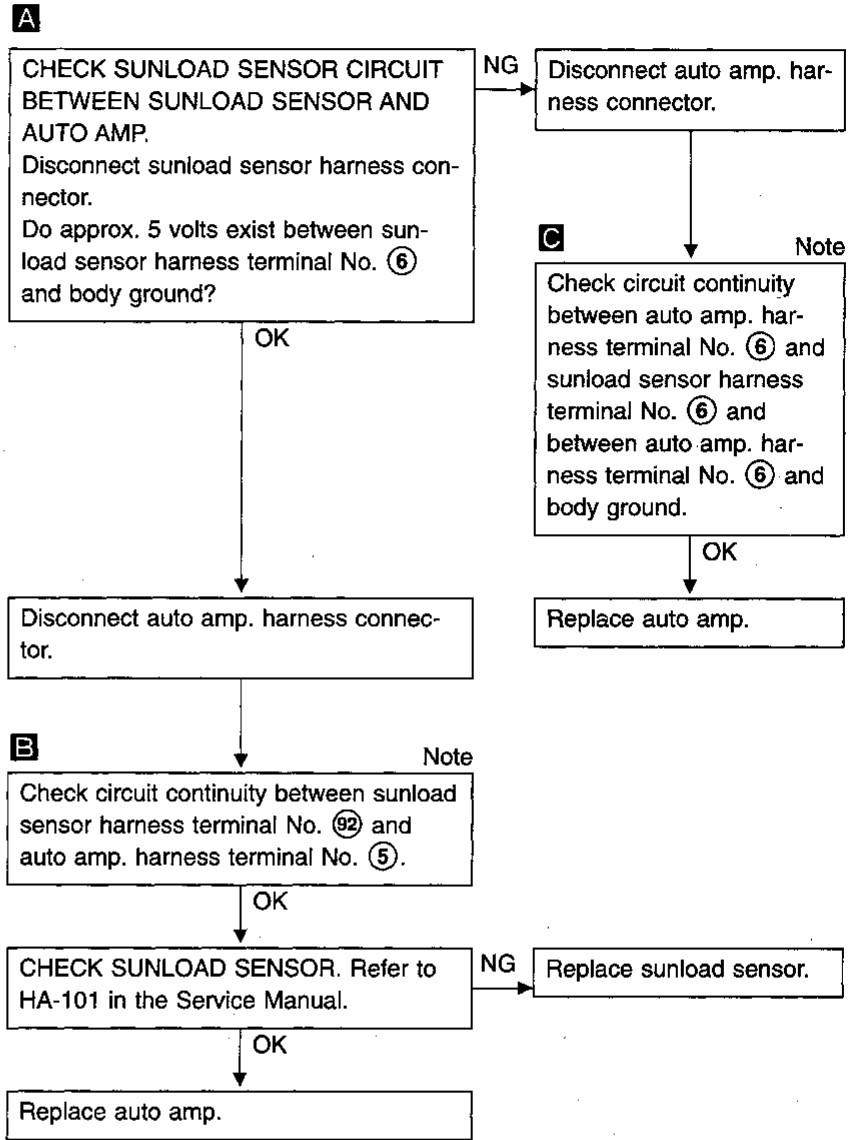

**Note:**  
If the result is NG after checking circuit continuity, repair harness or connector.

GI  
MA  
EM  
LC  
EF & EC  
FE  
CL  
MT  
AT  
TF  
PD  
FA  
RA  
BR  
ST  
BF  
HA  
EL  
IDX