

GI
MA
EM
LC
EC
FE
CL
MT
AT
TF
PD
FA
RA
BR
ST
RS
BT
HA
EL
IDX

SECTION RS

CONTENTS

PRECAUTION2	Checking Deployment Tool13
Supplemental Restraint System (SRS) "AIR BAG".....2	Deployment Procedures For Air Bag Module (Outside of Vehicle).....14
SEAT BELTS3	Deployment of Air Bag Module While Mounted In Vehicle.....15
Front Seat Belt.....4	Disposing of Air Bag Module15
Rear Seat Belt5	TROUBLE DIAGNOSES — Supplemental Restraint System (SRS)17
SUPPLEMENTAL RESTRAINT SYSTEM (SRS)6	How to Perform Trouble Diagnoses for Quick and Accurate Repair.....17
Precautions for SRS "Air Bag" Service6	Schematic19
Special Service Tools6	Wiring Diagram -SRS-20
Description7	Self-diagnosis22
SRS Component Parts Location8	Diagnostic Procedures22
Maintenance Items8	Trouble Diagnoses for Air Bag Warning Lamp.....36
Diagnosis Sensor Unit and Crash Zone Sensor.....9	Diagnostic Procedure.....36
Removal and Installation.....9	COLLISION DIAGNOSIS38
Air Bag Module and Spiral Cable.....10	SRS inspection.....38
Removal10	
Installation11	
Disposal of Air Bag Module.....13	

When you read wiring diagrams:

- Read GI section, "HOW TO READ WIRING DIAGRAMS".
- See EL section, "POWER SUPPLY ROUTING" for power distribution circuit.

When you perform trouble diagnoses, read GI section, "HOW TO FOLLOW FLOW CHART IN TROUBLE DIAGNOSES" and "HOW TO PERFORM EFFICIENT DIAGNOSIS FOR AN ELECTRICAL INCIDENT".

PRECAUTION

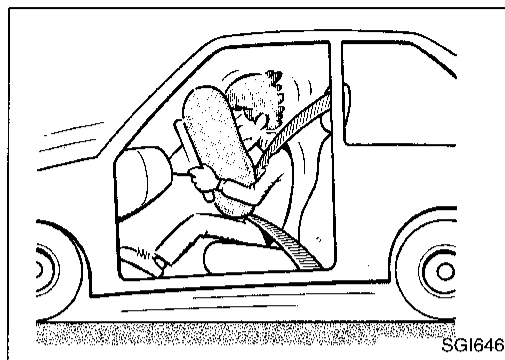

Supplemental Restraint System (SRS) "AIR BAG"

The Supplemental Restraint System "Air Bag", used along with a seat belt, helps to reduce the risk or severity of injury to the driver in a frontal collision. The Supplemental Restraint System consists of an air bag module (located in the center of the steering wheel), a diagnosis sensor unit, a crash zone sensor (4WD models), warning lamp, wiring harness and spiral cable.

WARNING:

- To avoid rendering the SRS inoperative, which could increase the risk of personal injury or death in the event of a collision which would result in air bag inflation, all maintenance must be performed by an authorized NISSAN dealer.
- Improper maintenance, including incorrect removal and installation of the SRS, can lead to personal injury caused by unintentional activation of the system.
- Do not use electrical test equipment on any circuit related to the SRS unless instructed to in this Service Manual. SRS wiring harnesses are covered with yellow insulation either just before the harness connectors or for the complete harness, for easy identification.

SEAT BELTS

CAUTION:

- Do not disassemble buckle or seat belt assembly.
- Replace anchor bolts if they are deformed or worn out.
- Never oil tongue and buckle.
- If any component of seat belt assembly is questionable, do not repair. Replace the seat belt assembly.
- If webbing is cut, frayed, or damaged, replace seat belt assembly.
- When replacing seat belt assembly, use a genuine NISSAN seat belt assembly.
- After any collision, inspect all seat belt assemblies, including retractors and other attached hardware.

GI

MA

EM

LC

EC

FE

CL

MT

AT

TF

PD

FA

RA

BR

ST

RS

BT

HA

EL

IDX

SEAT BELTS

Front Seat Belt

SEC. 868

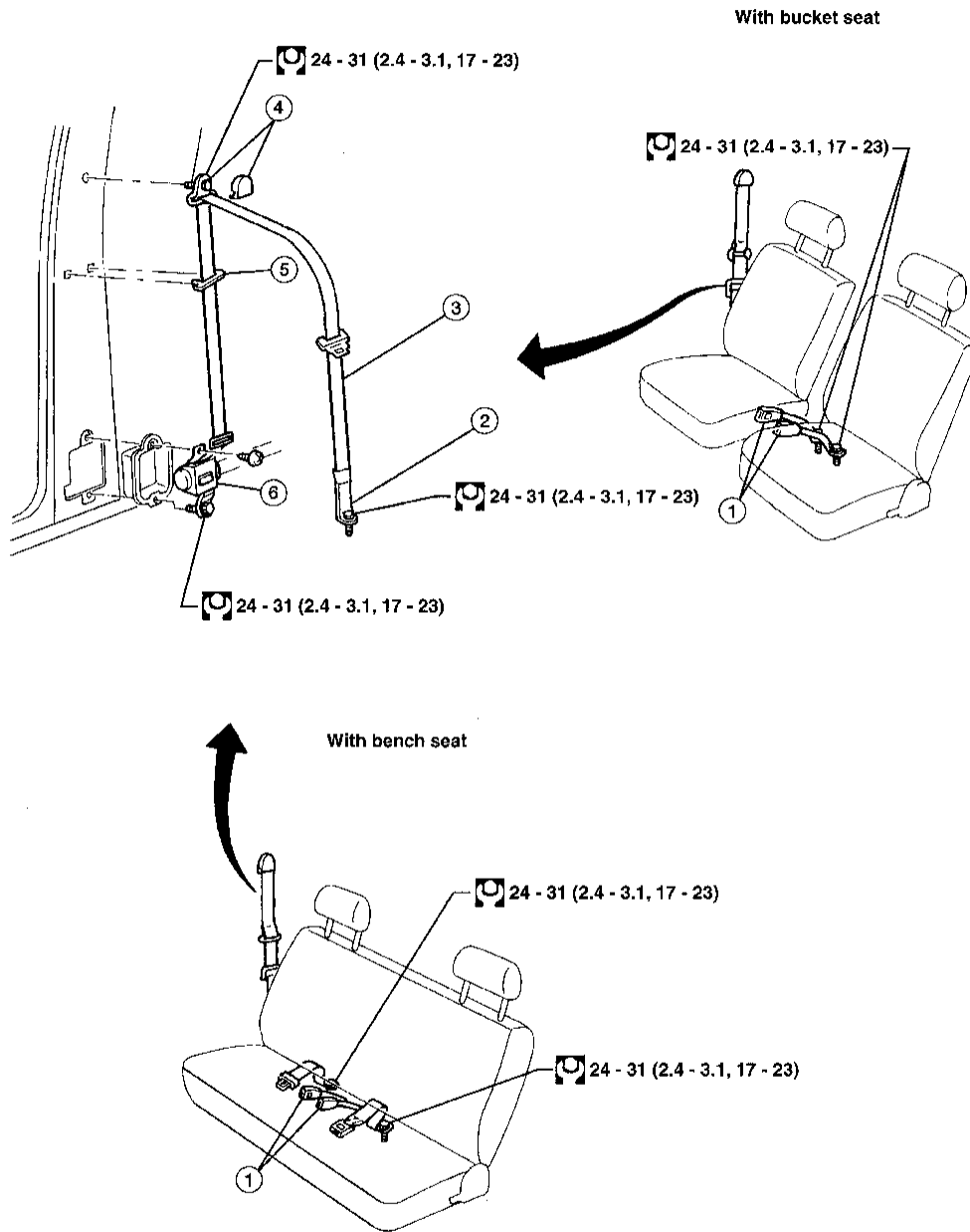

 : N·m (kg-m, ft-lb)

ARS126

Removal

Remove front seat. Refer to BT section ("Front Seat", "SEAT").

- ① Remove buckle.
- ② Remove floor anchor bolt.
- ③ Remove lower side finisher.
- ④ Remove pillar anchor cover and anchor bolt.
- ⑤ Remove guide plate.
- ⑥ Remove retractor bolts and remove retractor.

SEAT BELTS

Rear Seat Belt

SEC. 869

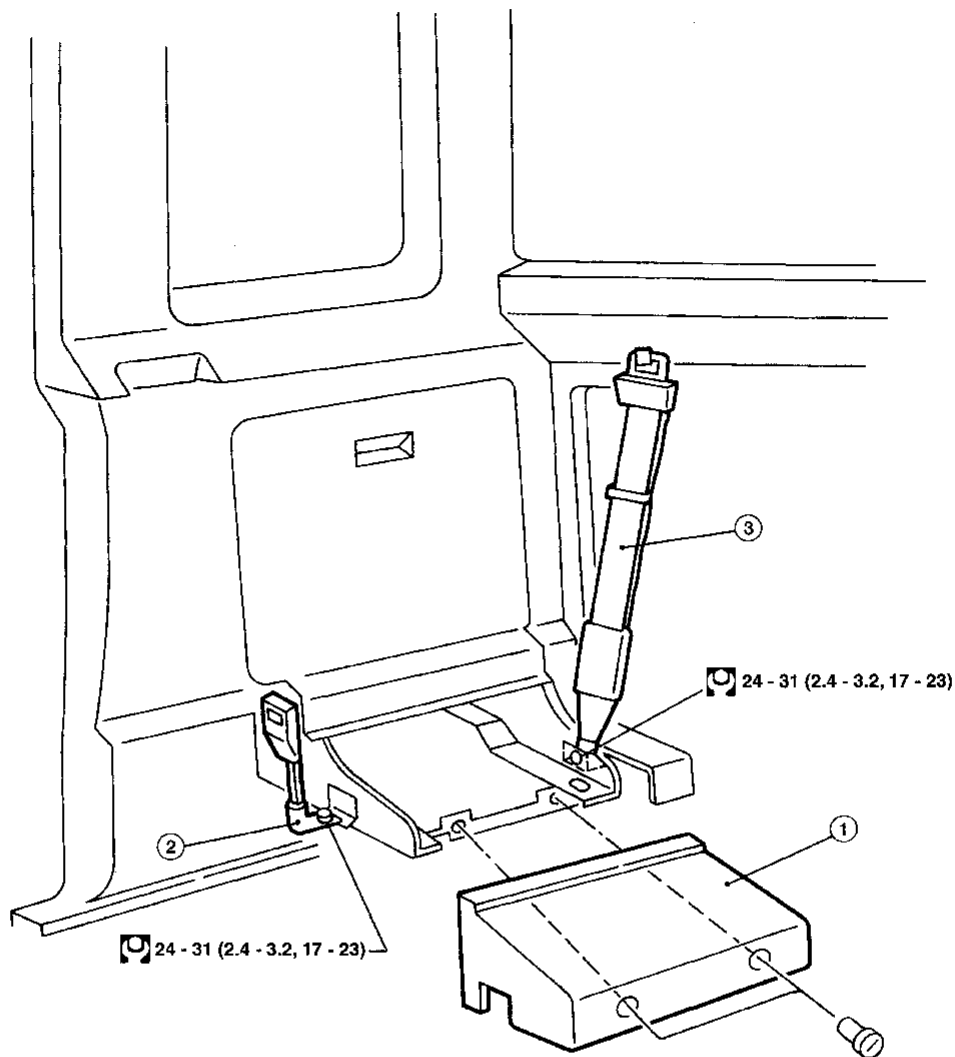

: N·m (kg-m, ft-lb)

Removal

- ① Remove underseat storage.
- ② Remove buckle
- ③ Remove seat belt anchor bolt.

CI
MA
EM
LC
EC
FE
CL
MT
AT
TF
PD
FA
RA
BR
ST
RS
BT
HA
EL
IDX

ARS125

SUPPLEMENTAL RESTRAINT SYSTEM (SRS)

Precautions for SRS "Air Bag" Service

- Do not use electrical test equipment on any circuit related to the SRS unless instructed to in this Service Manual. SRS wiring harnesses are covered with yellow insulation either just before the harness connectors or for the complete harness, for easy identification.
- Before servicing the SRS, turn ignition switch OFF, disconnect both battery cables and wait at least 10 minutes.
For approximately 10 minutes after the cables are removed it is still possible for the air bag to deploy. Therefore, do not work on any air bag system connectors or wires until at least 10 minutes have passed.
- Diagnosis sensor unit and crash zone sensor (4WD models) must always be installed with arrow mark "◊" pointing toward the front of the vehicle for proper operation. Also check diagnosis sensor unit for cracks, deformities or rust before installation and replace as required.
- The spiral cable must be aligned with the neutral position since its rotations are limited. Do not attempt to turn steering wheel or column after removal of steering gear.
- Handle air bag module carefully. Always place it with the pad side facing upward.
- Do not use old bolts after removing any SRS parts; replace with new bolts. Conduct self-diagnosis to check entire SRS for proper function.
- If front of vehicle is damaged in a collision, always check the crash zone sensor and the wiring harness (4WD models).

Special Service Tools

The actual shapes of Kent-Moore tools may differ from those of special service tools illustrated here.

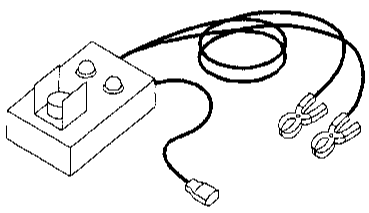
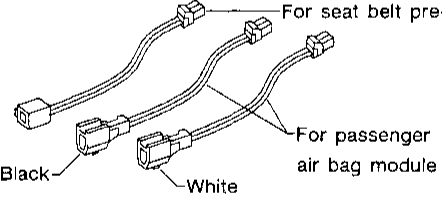
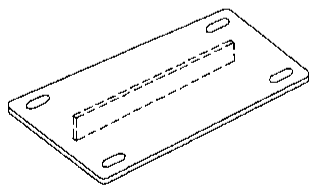
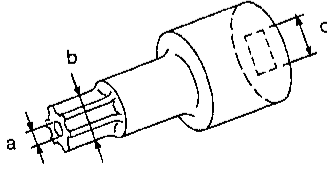
Tool number (Kent-Moore No.) Tool name	Description
KV991072S0 (J38381-KIT) Air bag deployment kit KV99106400 (J38381) Deployment tool	 <p>Disposing of air bag module</p> <p>NT357</p>
KV991065S0 (J38381-30) Deployment tool adapters	 <p>For seat belt pre-tensioner</p> <p>For passenger air bag module</p> <p>Black</p> <p>White</p> <p>NT353</p>
KV99105300 (J41246) Passenger air bag bracket	 <p>Anchor the passenger air bag module</p> <p>NT354</p>
HT61961000 and HT62152000 combined (J38219) *Special torx bit	 <p>Use for special bolts [TAMPER RESISTANT TORX (Size T50)]</p> <p>a: 3.5 (0.138) dia. b: 8.5 - 8.6 (0.335 - 0.339) dia. c: approx. 10 (0.39) sq.</p> <p>NT361</p> <p>Unit: mm (in)</p>

SUPPLEMENTAL RESTRAINT SYSTEM (SRS)

Description

2WD models

The diagnosis sensor unit will deploy the air bag if the G-sensor activates simultaneously with the safing sensor while the ignition switch is ON.

4WD models

The diagnosis sensor unit will deploy the air bag if the G-sensor and/or the crash zone sensor activates simultaneously with the safing sensor while the ignition switch is ON.

Ignition	Crash zone sensor (4WD models only)	Diagnosis sensor unit		Air bag signal
		G-sensor	Safing sensor	
ON		ON	ON	ON
ON	ON		ON	ON
ON	ON	ON	ON	ON

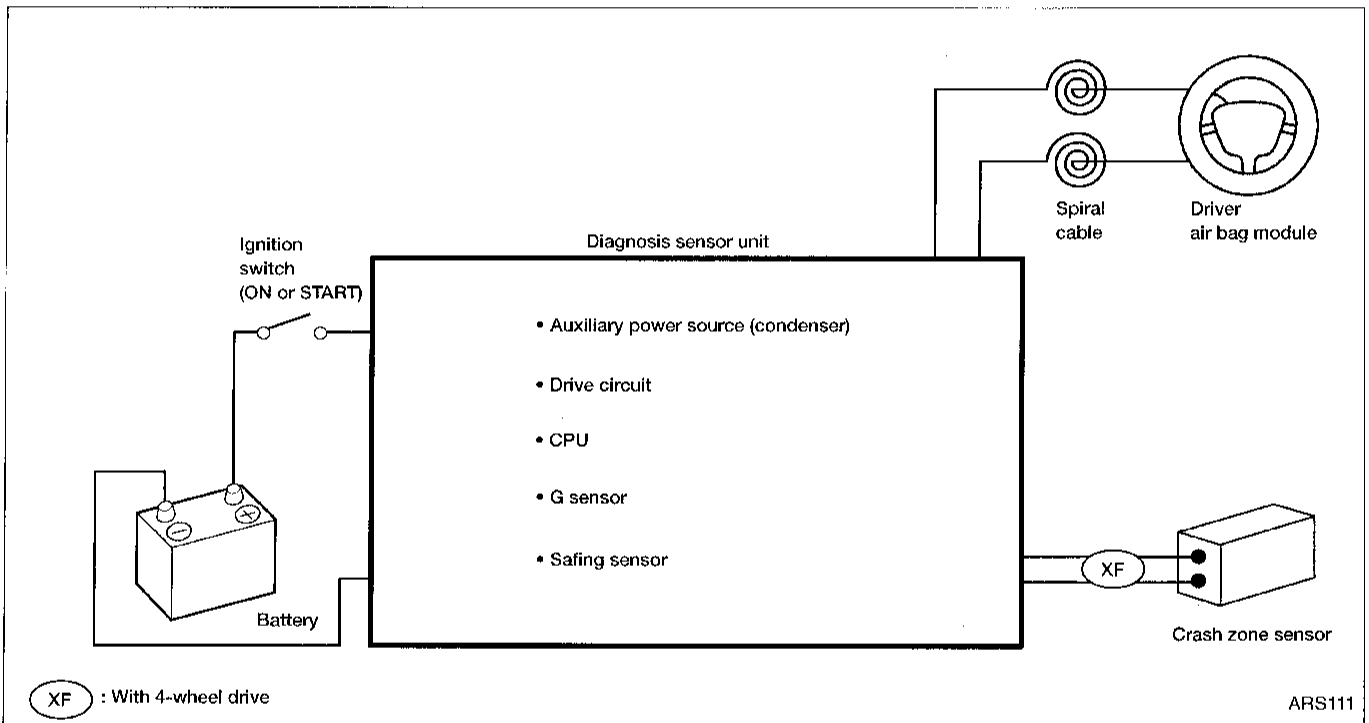

SUPPLEMENTAL RESTRAINT SYSTEM (SRS)

SRS Component Parts Location

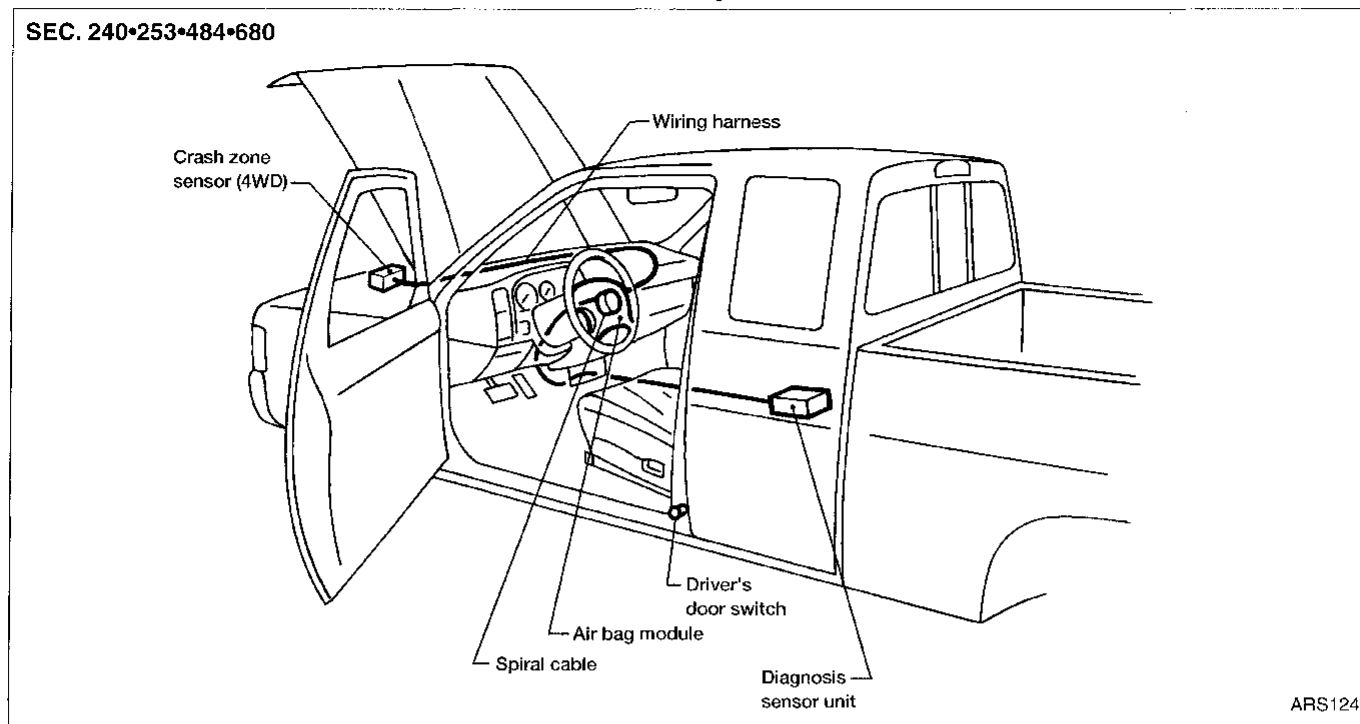

Maintenance Items

1. Check "AIR BAG" warning lamp operation
After turning ignition key to the ON position, "AIR BAG" warning lamp illuminates. The "AIR BAG" warning lamp will turn off after about 7 seconds if no malfunction is detected.
If any of the following air bag warning lamp conditions occur, immediately check the air bag system. Refer to RS-22 for details.
 - The warning lamp does not illuminate when the ignition switch is turned ON.
 - The warning lamp does not turn off about 7 seconds after the ignition switch is turned ON.
 - The warning lamp turns off about 7 seconds after the ignition switch is turned ON, but it turns on again or blinks.
2. Visually check SRS components
 - a. Crash zone sensor (4WD models)
 - Check crash zone sensor to ensure the arrow marks face the front of the vehicle.
 - Check body and sensor bracket for deformities or rust.
 - Check sensor case for dents, cracks, deformities or rust.
 - Check sensor harness for binding, connector for damage, and terminals for deformities.
 - b. Diagnosis sensor unit
 - Check diagnosis sensor unit and bracket for dents, cracks or deformities.
 - Check connectors for damage, and terminals for deformities.
 - c. Air bag module and steering wheel
 - Remove air bag module from steering wheel. Check harness cover and connectors for damage, terminals for deformities, and harness for binding.
 - Install air bag module to steering wheel to check fit or alignment with the wheel.
 - Check steering wheel for excessive free play.
 - d. Spiral cable
 - Check spiral cable and combination switch for damage.
 - Check connectors and protective tape for damage.
 - Check steering wheel for noise, binding or heavy operation.
 - e. Main harness and air bag harness
 - Check connectors for poor connections, damage, and terminals for deformities.
 - Check harnesses for binding, chafing or cuts.

CAUTION:

Replace previously used special bolts with new ones.

Diagnosis Sensor Unit and Crash Zone Sensor

CAUTION:

- Before servicing SRS, turn the ignition switch OFF, disconnect both battery cables and wait for at least 10 minutes.
- The special bolts are coated with bonding agent while the other bolt is for ground. Do not use old bolts after removal; replace with new coated bolts.
- Check diagnosis sensor unit for proper installation.
- Check diagnosis sensor unit to ensure no deformities, dents, cracks or rust exist. If there are any visible signs of damage, replace with new one.
- Check diagnosis sensor unit brackets to ensure they are free of deformities or rust.
- Replace diagnosis sensor unit if it has been dropped or sustained an impact.
- Check crash zone sensor for proper installation.
- Check crash zone sensor to ensure no deformities, dents, cracks or rust exist. If there are any visible signs of damage, replace the crash zone sensor.
- Check crash zone sensor bracket to ensure it is free of deformities or rust.

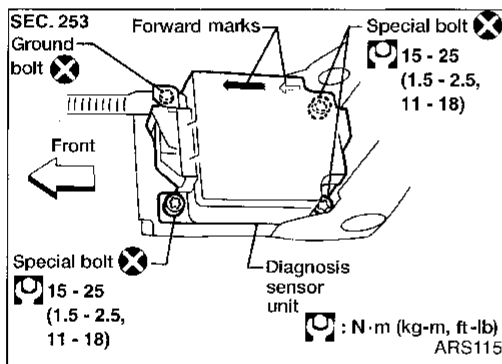

REMOVAL AND INSTALLATION

CAUTION:

Before servicing SRS, turn the ignition switch OFF, disconnect both battery cables and wait at least 10 minutes.

Diagnosis sensor unit

1. Disconnect driver air bag module connector.
2. Remove console box. Refer to BT section ("INSTRUMENT PANEL").
3. Disconnect diagnosis sensor unit connector.
4. Using the TAMPER RESISTANT TORX (Size T50), remove the three special bolts, then remove ground bolt. The diagnosis sensor unit can then be removed.

NOTE:

To install, reverse the removal procedure.

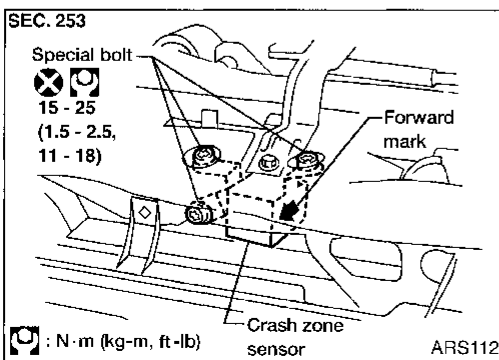

Crash zone sensor (4WD models)

1. Disconnect driver air bag module connector.
2. Disconnect crash zone sensor connector.
3. Using the TAMPER RESISTANT TORX (Size T50), remove the three special bolts. The crash zone sensor can then be removed.

NOTE:

To install, reverse the removal procedure.

SUPPLEMENTAL RESTRAINT SYSTEM (SRS)

Air Bag Module and Spiral Cable

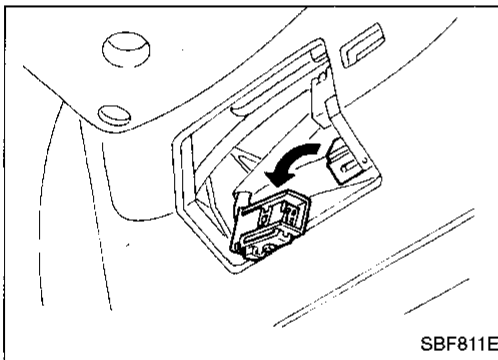
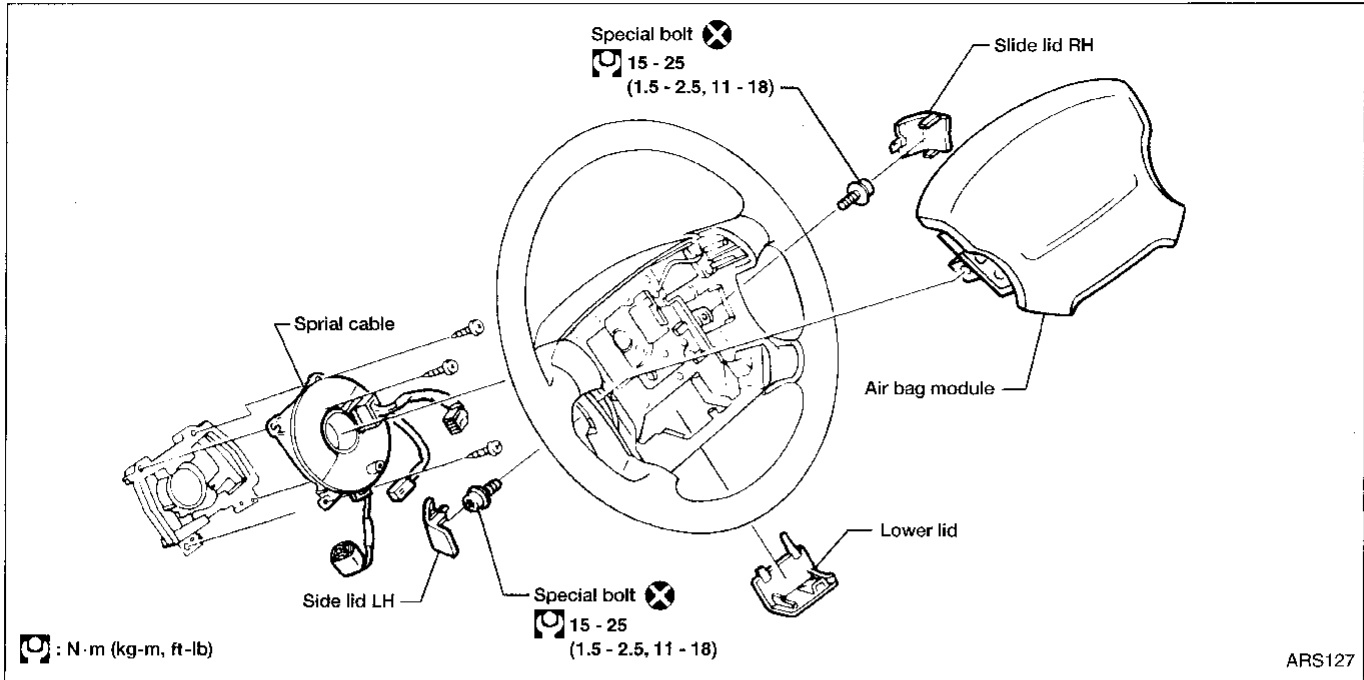

REMOVAL

CAUTION:

- Before servicing SRS, turn the ignition switch OFF, disconnect both battery cables and wait for at least 10 minutes.
- Always work from the side of air bag module.

1. Remove lower lid from steering wheel, and disconnect air bag module connector.

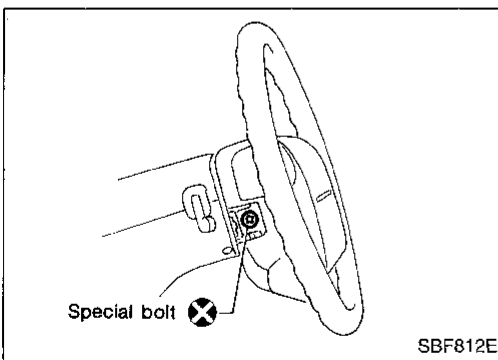

2. Remove side lids and ASCD steering switch (if so equipped). Using the TAMPER RESISTANT TORX (Size T50), remove left and right special bolts. The air bag module can then be removed.

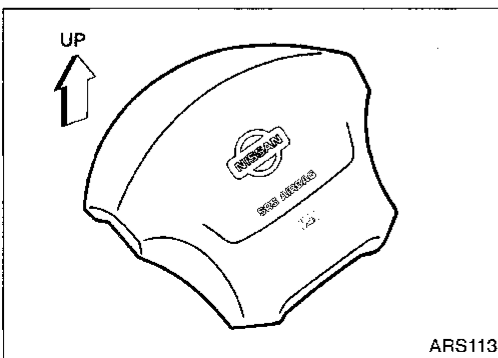

CAUTION:

- Always place air bag module with pad side facing upward.
- Do not attempt to disassemble air bag module.
- The special bolts are coated with bonding agent. Do not use old bolts after removal; replace with new coated bolts.

SUPPLEMENTAL RESTRAINT SYSTEM (SRS)

Air Bag Module and Spiral Cable (Cont'd)

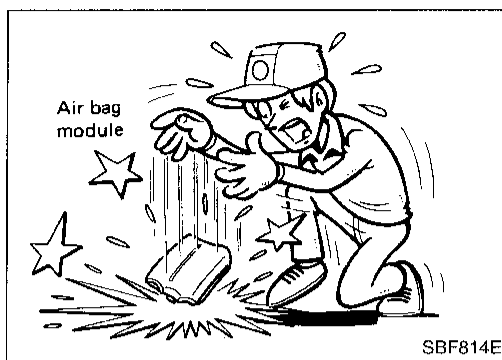

- Do not drop or impact air bag module. Replace air bag module if it has been dropped or sustained an impact.
- Do not expose the air bag module to temperatures exceeding 90°C (194°F).
- Do not allow oil, grease or water to contact the air bag module.

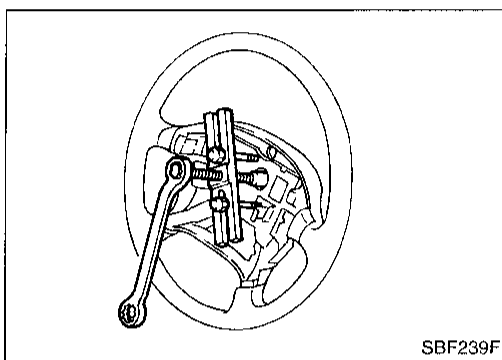

3. Set steering wheel in the neutral position.
4. Disconnect horn connector and remove steering wheel nut.
5. Remove steering wheel mass damper.
6. Using steering wheel puller, remove steering wheel. Be careful not to overtighten puller bolt on steering wheel.

CAUTION:

Do not tap or bump the steering wheel.

7. Remove steering column cover.
8. Disconnect air bag harness and main harness connectors.

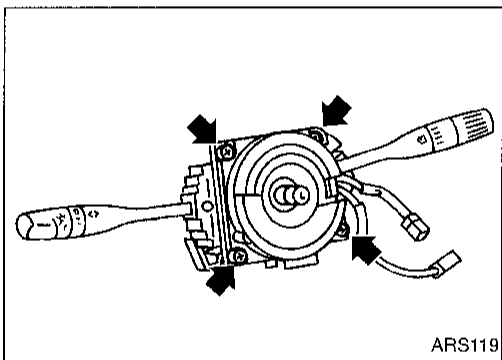

9. Remove the four spiral cable retaining screws. The spiral cable can then be removed.

CAUTION:

- Do not attempt to disassemble spiral cable.
- Do not apply lubricant to the spiral cable.

INSTALLATION

1. Set the front wheels in the straight-ahead position.
2. Rotate the spiral cable fully clockwise until tight.
3. Rotate spiral cable counterclockwise as specified below. Align the white pin with the alignment mark.

Specified turns for spiral cable:

Applied model	Specified turns from neutral position
With power steering	Approx. 2.5
Without power steering	Approx. 4

CAUTION:

The spiral cable may snap during steering operation if the cable is installed improperly. Also, with the steering linkage disconnected, the cable may snap by turning the steering wheel beyond the specified number of turns. Always perform SRS self-diagnosis after installing the air bag module.

4. Connect spiral cable air bag harness and main harness connectors and tighten screws. Install steering column cover.

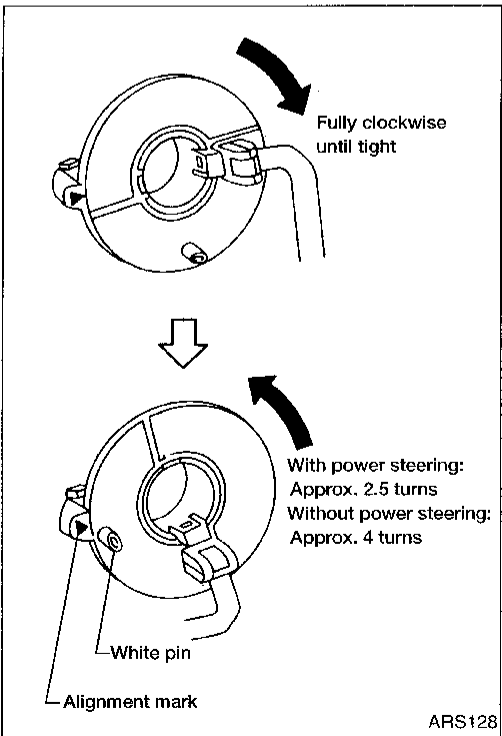

SUPPLEMENTAL RESTRAINT SYSTEM (SRS)

Air Bag Module and Spiral Cable (Cont'd)

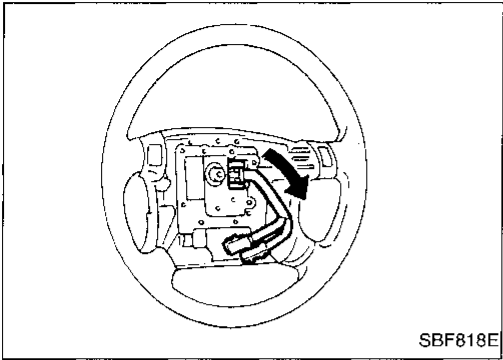

5. Install mass damper on steering wheel.
6. Install steering wheel by setting spiral cable pin guide, and pulling spiral cable harness through.
7. Connect horn connector.
8. Tighten steering wheel nut.

: 29 - 39 N·m (3.0 - 4.0 kg-m, 22 - 29 ft-lb)

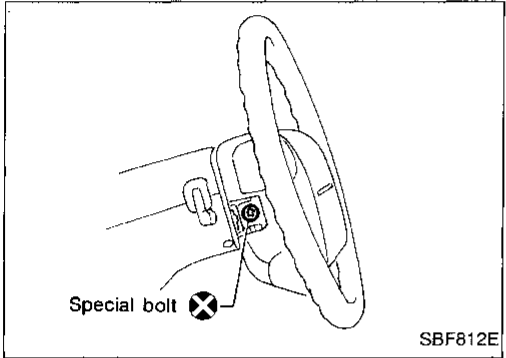

9. Position air bag module and tighten with new special bolts.
10. Connect air bag module connector.
11. Install ASCD switch and tighten screws.
12. Install all lids.
13. Connect both battery cables.
14. Conduct Self-diagnosis to ensure entire SRS operates properly. (Use CONSULT or warning lamp check.) Turn steering wheel to the left end and then to the right end fully to make sure that spiral cable is set in the neutral position.
15. If air bag warning lamp blinks (in User mode), it shows the spiral cable may be snapped due to its improper position. Perform Self-diagnosis again (Use CONSULT or warning lamp check). If a malfunction is detected, replace the spiral cable with a new one.

Disposal of Air Bag Module

- Make sure to deactivate air bag modules before disposing of them. Also, before disposing of a vehicle equipped with an air bag system, deactivate air bag modules. If such a system has already been deployed due to an accident, dispose of as indicated in "DISPOSING OF AIR BAG MODULE", RS-15.
- Do not dispose of the air bag module undeployed.
- When deploying the air bag module, always use the Special Service Tool; Deployment tool (Kent-Moore No. J38381).
- When deploying the air bag module, stand to the side of the module at least 5 m (16 ft) away.
- Due to heat, do not touch air bag module for at least 30 minutes after deployment.
- Be sure to wear gloves when handling a deployed air bag module.
- Never apply water to a deployed air bag module.
- Wash your hands clean after finishing work.

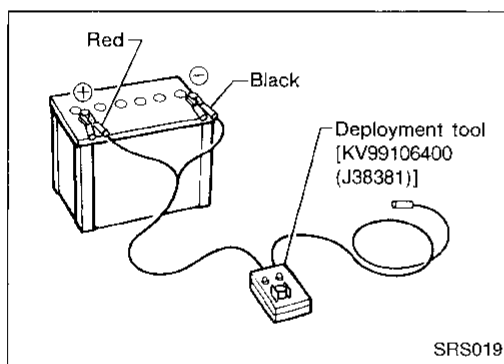

CHECKING DEPLOYMENT TOOL

Connecting to battery

- Place vehicle outdoors with at least 6 m (20 ft) of open space on all sides.
- Use a voltmeter to make sure the vehicle battery is fully charged.

CAUTION:

The battery must show voltage of 9.6V or more.

Remove the battery from the vehicle and place it on dry wood blocks approximately 5 m (16 ft) away from the vehicle.

- Wait 10 to 12 minutes after the vehicle battery is disconnected before proceeding.
- Connect red clip of deployment tool to battery positive terminal and black clip to negative terminal.

CAUTION:

Make sure the polarity is correct. The right side lamp in the tool, marked "deployment tool power", should glow with a green light. If the right side lamp glows red, reverse the connections to the battery.

Deployment tool check

Press the deployment tool switch to the ON position. The left side lamp in the tool, marked "air bag connector voltage" should illuminate. If it does not illuminate, replace the tool.

Air bag deployment tool lamp illumination chart (Battery connected)

Switch operation	Left side lamp, green* "AIR BAG CONNECTOR VOLTAGE"	Right side lamp, green* "DEPLOYMENT TOOL POWER"
OFF	OFF	ON
ON	ON	ON

*: If this lamp glows red, the tool is connected to the battery incorrectly. Reverse the connections and make sure the lamp glows green.

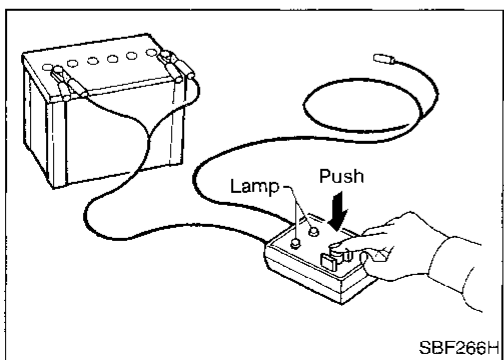

GI
MA
EM
LG
EC
FE
CL
MT
AT
TF
PD
FA
RA
BR
ST
RS
BT
HA
EL
IDX

SUPPLEMENTAL RESTRAINT SYSTEM (SRS)

Disposal of Air Bag Module (Cont'd)

DEPLOYMENT PROCEDURES FOR AIR BAG MODULE (OUTSIDE OF VEHICLE)

Deploying air bag module while it is mounted in vehicle may damage vehicle. Deploy air bag module as a unit except when disposing of vehicle.

Anchor air bag module in a vise secured to a firm foundation during deployment.

Deployment of driver air bag module (outside of vehicle)

1. Make an 8.5 mm (0.335 in) diameter hole in passenger air bag bracket (SST: J41246) at the position shown in figure at left.
2. Using wire, secure air bag module to passenger air bag bracket (SST: J41246) in two places as shown.

CAUTION:

Use wire of at least 1 mm (0.04 in) diameter.

3. Firmly secure passenger air bag bracket (SST: J41246) (with air bag module attached), in the vise.

Make sure vise is firmly secured and will not pivot.

4. Connect deployment tool (SST: J38381) to air bag module connector.

5. Connect red clip of deployment tool to battery positive terminal and black clip to negative terminal.
6. The lamp on the right side of the tool, marked "deployment tool power", should glow green, not red.
7. Press the button on the deployment tool. The left side lamp on the tool, marked "air bag connector voltage", will illuminate and the air bag module will deploy.

CAUTION:

When deploying the air bag module, stand to the side of the module at least 5 m (16 ft) away.

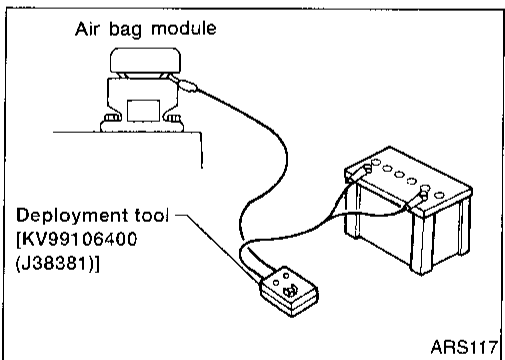
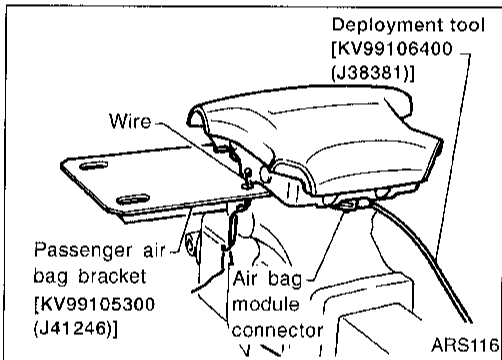
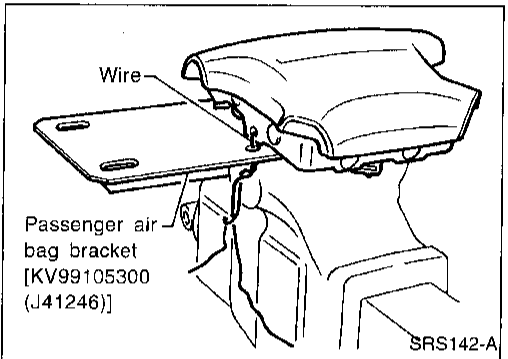
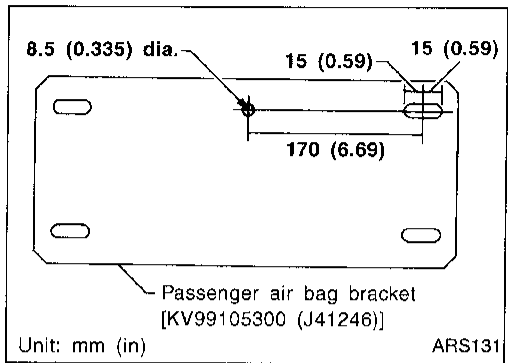

SUPPLEMENTAL RESTRAINT SYSTEM (SRS)

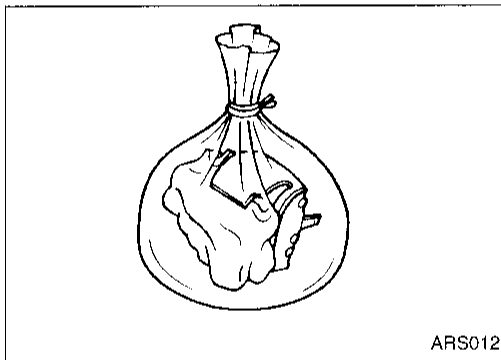
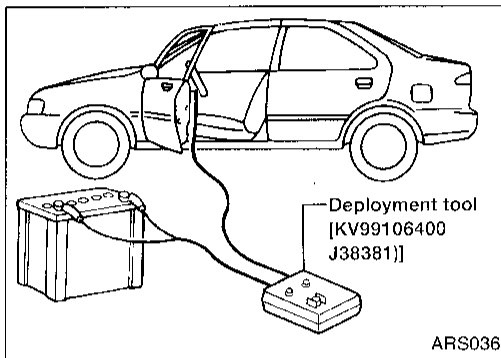
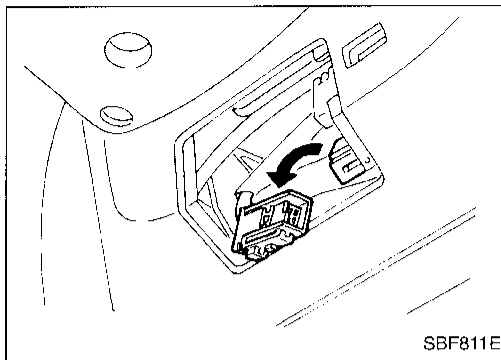

Disposal of Air Bag Module (Cont'd)

DEPLOYMENT OF AIR BAG MODULE WHILE MOUNTED IN VEHICLE

When disposing of a vehicle, deploy air bag module while it is mounted in vehicle.

CAUTION:

When deploying air bag module, ensure vehicle is empty.

1. Turn ignition switch OFF, disconnect both battery cables and wait at least 10 minutes.
2. Disconnect air bag module connector.
3. Connect deployment tool (SST: J38381) connector to air bag module.
4. Connect red clip of deployment tool to battery positive terminal and black clip to negative terminal.
5. The lamp on the right side of the tool, marked "deployment tool power", should glow green, not red.
6. Press the button on the deployment tool. The left side lamp on the tool, marked "air bag connector voltage", will illuminate and the air bag module will deploy.

DISPOSING OF AIR BAG MODULE

Deployed air bag module is very hot. Before disposing of air bag modules, wait at least 30 minutes. Seal them in a plastic bag before disposal.

CAUTION:

- Never apply water to a deployed air bag module.
- Be sure to wear gloves when handling a deployed air bag module.
- No poisonous gas is produced upon air bag module deployment. However, be careful not to inhale gas since it irritates throat and can cause choking.
- Do not attempt to disassemble air bag module.
- Air bag module cannot be reused.
- Wash your hands clean after finishing work.

GI

MA

EM

LC

EC

FE

CL

MT

AT

TF

PD

FA

RA

BR

ST

RS

BT

HA

EL

IDX

SUPPLEMENTAL RESTRAINT SYSTEM (SRS)

NOTES

How to Perform Trouble Diagnoses for Quick and Accurate Repair

A good understanding of the malfunction conditions can make troubleshooting faster and more accurate. In general, each customer feels differently about a problem. It is important to fully understand the symptoms or conditions for a customer complaint.

INFORMATION FROM CUSTOMER

WHAT Vehicle model
 WHEN Date, Frequencies
 WHERE Road conditions
 HOW Operating conditions, Symptoms

PRELIMINARY CHECK

Check that the following parts are in good order.

- Battery [Refer to EL section (“BATTERY”).]
- Fuse [Refer to EL section (“Fuse”, “POWER SUPPLY ROUTING”).]
- System component-to-harness connections

DIAGNOSIS FUNCTION

The SRS self-diagnosis results can be read by using “AIR BAG” warning lamp and/or CONSULT. The reading of these results is accomplished using one of two modes — “User mode” and “Diagnosis mode”.

The User mode is exclusively prepared for the customer (driver). This mode warns the driver of a system malfunction through the operation of the “AIR BAG” warning lamp.

The Diagnosis mode allows the technician to locate and inspect the malfunctioning part.

The mode applications for the “AIR BAG” warning lamp and CONSULT are as follows:

	User mode	Diagnosis mode	Display type
“AIR BAG” warning lamp	X	X	ON-OFF operation
CONSULT	—	X	Monitoring

DIAGNOSIS MODE FOR CONSULT

• SELF-DIAG [CURRENT]

A current Self-diagnosis result (also indicated by the number of warning lamp flashes in the Diagnosis mode) is displayed on the CONSULT screen in real time. This refers to a malfunctioning part requiring repairs.

• SELF-DIAG [PAST]

Diagnosis results previously stored in the memory (also indicated by the warning lamp flashes in the User mode) are displayed on the CONSULT screen. The stored results are not erased until memory erasing is executed.

• TROUBLE DIAG RECORD

With TROUBLE DIAG RECORD, diagnosis results previously erased by a reset operation can be displayed on the CONSULT screen.

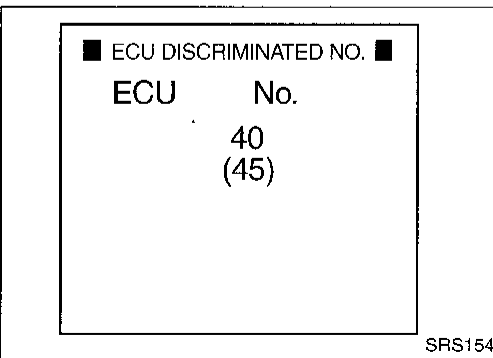

• ECU DISCRIMINATED NO.

The diagnosis sensor unit for each vehicle model is assigned with its own individual classification number. This number will be displayed on the CONSULT screen, as shown at left. When replacing the diagnosis sensor unit, refer to the part number for the compatibility. After installation, replacement with a correct unit can be checked by confirming this classification number on the CONSULT screen.

For NISSAN MODEL D21, the diagnosis sensor unit classification numbers assigned are as follows:

- 2WD models: 40
- 4WD models: 45

TROUBLE DIAGNOSES — Supplemental Restraint System (SRS)

How to Perform Trouble Diagnoses for Quick and Accurate Repair (Cont'd)

CAUTION:

- Do not use electrical test equipment on any circuit related to the SRS unless instructed to in this Service Manual. SRS wiring harnesses are covered with yellow insulation either just before the harness connectors or for the complete harness, for easy identification.
- Do not attempt to repair, splice or modify the SRS wiring harness. If the harness is damaged, replace it with a new one.
- Keep ground portion clean.

WORK FLOW

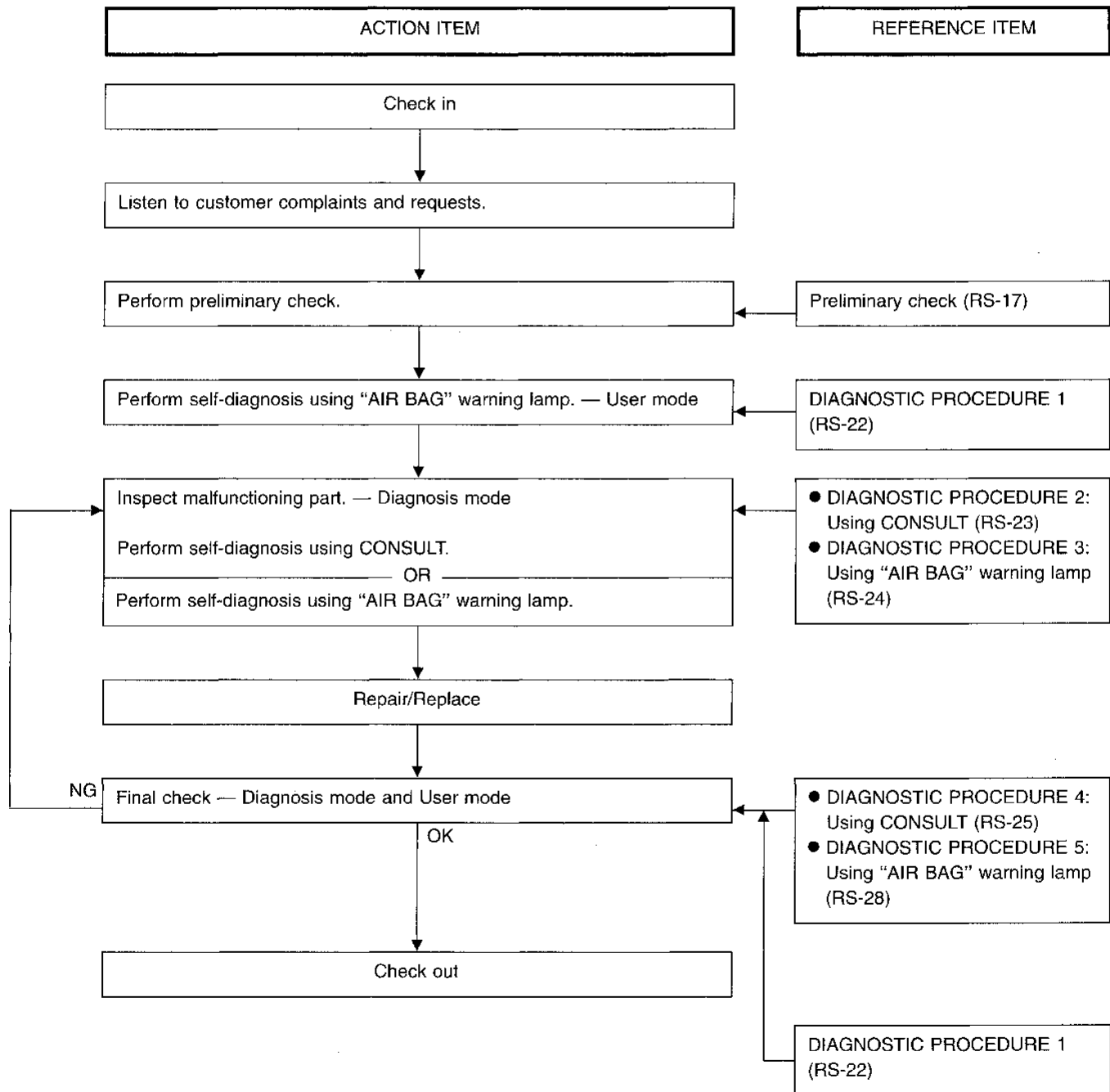

TROUBLE DIAGNOSES — Supplemental Restraint System (SRS)

Schematic

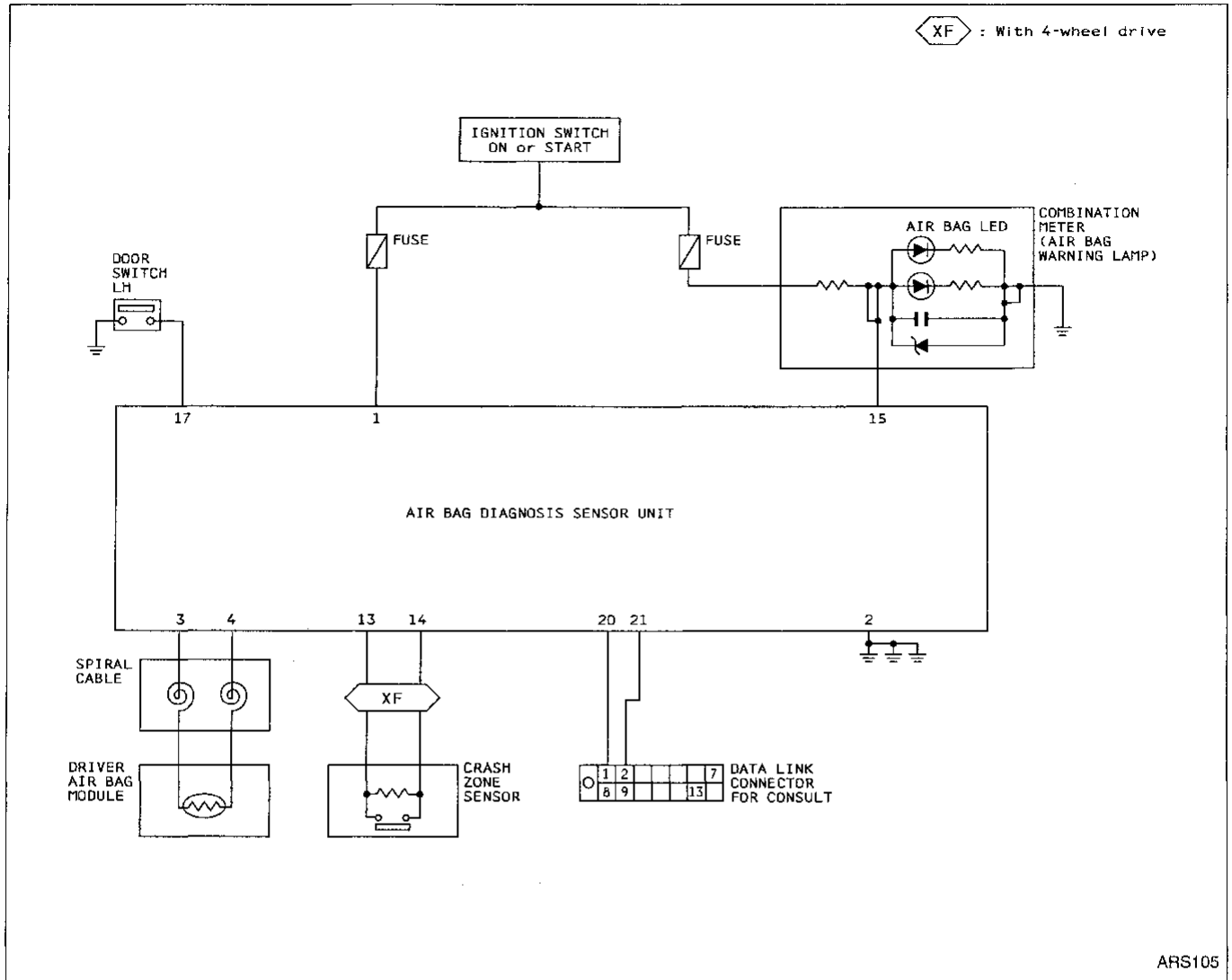

GI
MA
EM
LC
EC
FE
CL
MT
AT
TF
PD
FA
RA
BR
ST
RS
BT
HA
EL
IDX

TROUBLE DIAGNOSES — Supplemental Restraint System (SRS)

Wiring Diagram -SRS- (Cont'd)

RS-SRS-02

⬡XF : With 4-wheel drive

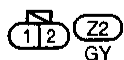
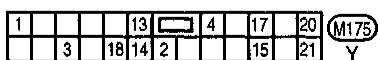
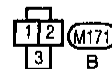
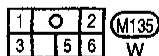
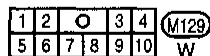
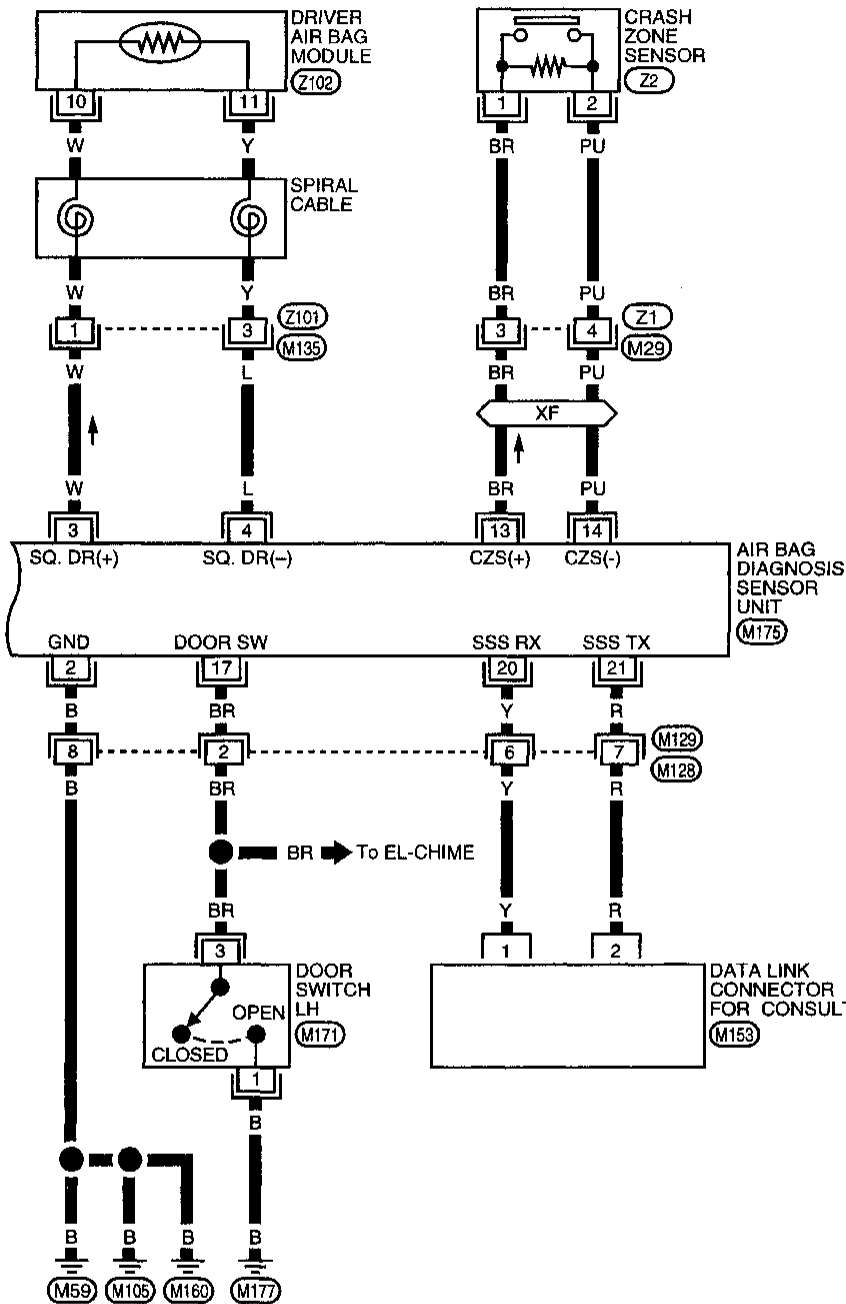

GI
MA
EM
LC
EC
FE
CL
MT
AT
TF
PD
FA
RA
BR
ST
RS
BT
HA
EL
IDX

TROUBLE DIAGNOSES — Supplemental Restraint System (SRS)

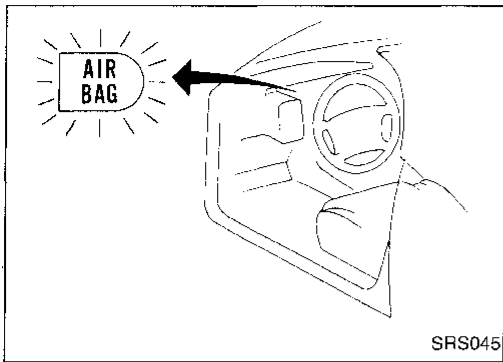

Self-diagnosis

DIAGNOSTIC PROCEDURE 1

Checking SRS operation by using "AIR BAG" warning lamp — User mode

1. After turning ignition switch from OFF to ON, "AIR BAG" warning lamp operates.
2. Compare "AIR BAG" warning lamp operation to the chart below.

"AIR BAG" warning lamp operation — User mode —	SRS condition	Reference item
<p>MRS095A</p>	No malfunction is detected. No further action is necessary.	—
<p>MRS096A</p>	The system has problem and needs to be repaired as indicated.	Go to DIAGNOSTIC PROCEDURE 2 or 3, RS-23 or 24.
<p>MRS097A</p>	Air bag is deployed.	Go to COLLISION DIAGNOSIS, RS-38.
<p>MRS098A</p>	Air bag fuse for diagnosis sensor unit or circuit is malfunctioning and needs to be repaired.	Go to DIAGNOSTIC PROCEDURE 8, RS-36.
<p>MRS098A</p>	One of the following has occurred and needs to be repaired: <ul style="list-style-type: none"> ● Meter fuse is open ● "AIR BAG" warning lamp circuit is shorted or open ● Diagnosis sensor unit is malfunctioning 	Go to DIAGNOSTIC PROCEDURE 9, RS-36.

NOTE:

If "AIR BAG" warning lamp operates differently from the operations shown above, refer to "AIR BAG" warning lamp operation — Diagnosis mode —, DIAGNOSTIC PROCEDURE 5, RS-28. Then repair as necessary.

TROUBLE DIAGNOSES — Supplemental Restraint System (SRS)

Self-diagnosis (Cont'd)

DIAGNOSTIC PROCEDURE 2 (CONSULT) with CONSULT

Inspecting SRS malfunctioning parts by using CONSULT — Diagnosis mode

1. Turn ignition switch OFF.
2. Connect CONSULT to Data link connector.

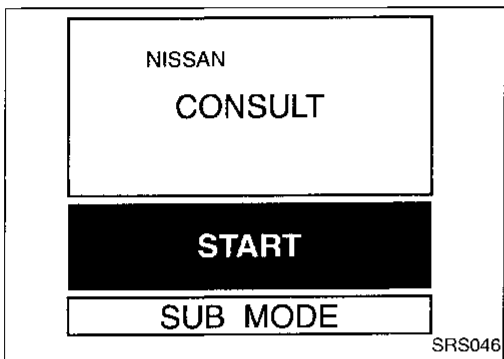
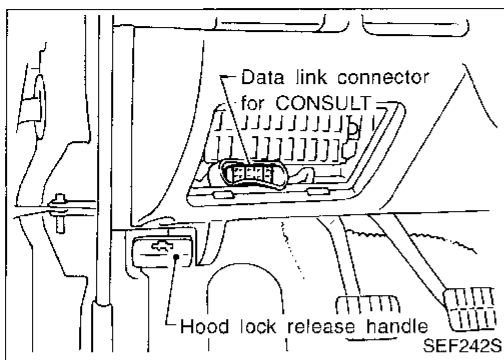

3. Turn ignition switch ON.
4. Touch START of CONSULT.

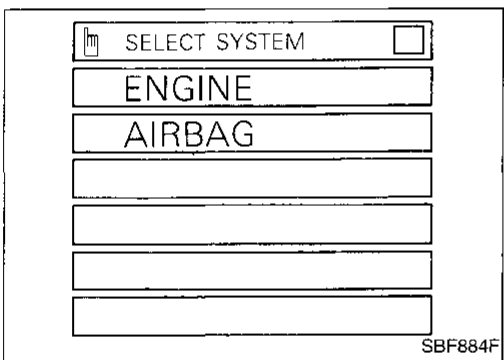

5. Touch AIRBAG.

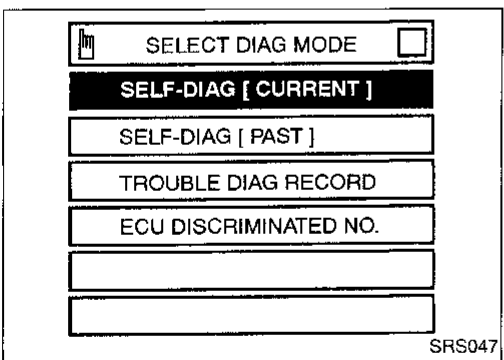

6. Touch SELF-DIAG [CURRENT].

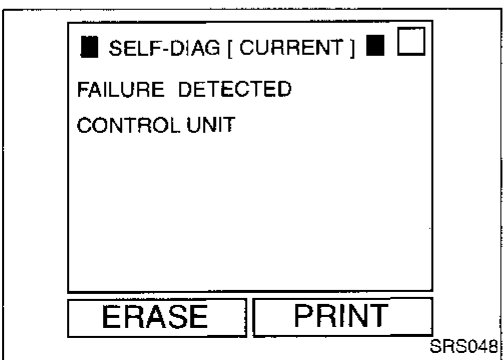

7. Diagnostic codes are displayed on SELF-DIAG [CURRENT].

GI
MA
EM
LC
EC
FE
CL
MT
AT
TF
PD
FA
RA
BR
ST
RS
BT
HA
EL
IDX

TROUBLE DIAGNOSES — Supplemental Restraint System (SRS)

Self-diagnosis (Cont'd)

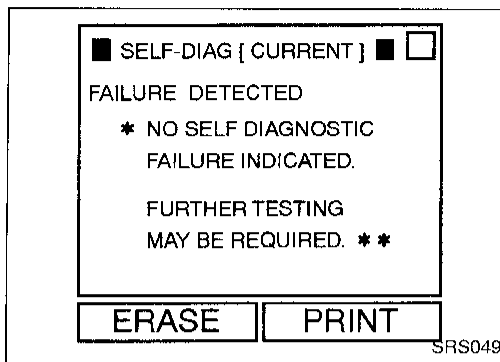

- If no self-diagnostic failure is detected on SELF-DIAG [CURRENT] but malfunction is indicated by the “AIR BAG” warning lamp, go to DIAGNOSTIC PROCEDURE 6, RS-30.

8. Touch PRINT.
9. Compare diagnostic codes to the CONSULT DIAGNOSTIC CODE CHART, RS-33.
10. Touch BACK key of CONSULT until SELECT SYSTEM MODE appears, then turn off CONSULT.
11. Turn ignition switch OFF, then disconnect CONSULT and both battery cables.
12. Repair the system as outlined by the “Repair order” that corresponds to the problem code in CONSULT DIAGNOSTIC CHART. For replacement procedure of component parts, refer to RS-9.
13. After repairing the system, go to DIAGNOSTIC PROCEDURE 4, RS-25.

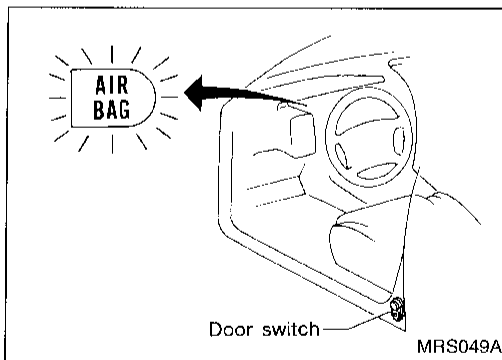

DIAGNOSTIC PROCEDURE 3 (without CONSULT) Inspecting SRS malfunctioning parts by using “AIR BAG” warning lamp — Diagnosis mode

NOTE:

SRS will not enter Diagnosis mode if no malfunction is detected in User mode.

1. Open driver's door.
2. Turn ignition switch from OFF to ON.
3. Press driver's door switch at least 5 times within 7 seconds after turning ignition switch ON.
SRS is now in Diagnosis mode.
4. “AIR BAG” warning lamp operates in diagnosis mode as follows:

NOTE:

If SRS does not enter diagnosis mode even though malfunction is detected in User mode, go to DIAGNOSTIC PROCEDURE 10, RS-37.

TROUBLE DIAGNOSES — Supplemental Restraint System (SRS)

Self-diagnosis (Cont'd)

No.	"AIR BAG" warning lamp operation — Diagnosis mode —	SRS condition
1	<div style="text-align: right; margin-bottom: 10px;">(a) through (b) are repeated.</div> <p style="text-align: center; margin-top: 10px;">MRS100A</p>	Intermittent problem has been detected in the past. Go to DIAGNOSTIC PROCEDURE 7, RS-31.
2	<div style="text-align: right; margin-bottom: 10px;">(a) through (d) are repeated.</div> <div style="margin-bottom: 10px;">NOTE:</div> <div style="margin-bottom: 10px;">(a) — Interval I</div> <div style="margin-bottom: 10px;">(b) — Start signal (Start signal identifies display modes)</div> <div style="margin-bottom: 10px;">(c) — Interval II</div> <div style="margin-bottom: 10px;">(d) — Indicates malfunctioning part (0.5 sec. ON and 0.5 sec. OFF is counted as one flash.)</div> <p style="text-align: center; margin-top: 10px;">MRS099A</p>	The system has a problem and needs to be repaired.

5. Malfunctioning part is indicated by the number of flashes (part (d)). Compare the number of flashes to WARNING LAMP FLASH CODE CHART, RS-34, and locate malfunctioning part.
6. Turn ignition switch OFF, and disconnect both battery cables.
7. Repair the system as outlined by the "Repair order" in WARNING LAMP FLASH CODE CHART that corresponds to the flash code. For replacement procedure of component parts, refer to RS-9.
8. After repairing the system, go to DIAGNOSTIC PROCEDURE 5, RS-28.

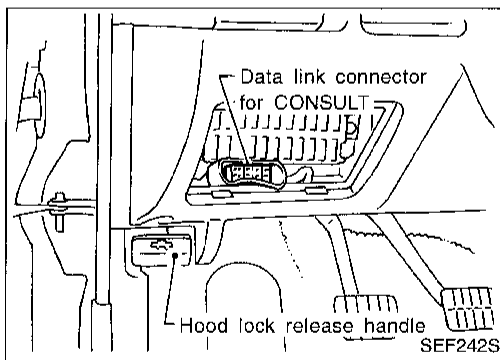

DIAGNOSTIC PROCEDURE 4 (CONSULT with CONSULT)

Final checking after repairing SRS by using CONSULT — Diagnosis mode

1. After repairing SRS, connect both battery cables.
2. Connect CONSULT to Data link connector.
3. Turn ignition switch from OFF to ON.
4. Touch START of CONSULT.

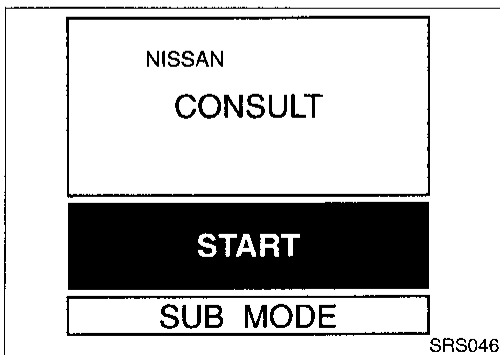

TROUBLE DIAGNOSES — Supplemental Restraint System (SRS)

Self-diagnosis (Cont'd)

SELECT SYSTEM

ENGINE

AIRBAG

SBF884F

5. Touch AIRBAG.

SELECT DIAG MODE

SELF-DIAG [CURRENT]

SELF-DIAG [PAST]

TROUBLE DIAG RECORD

ECU DISCRIMINATED NO.

SRS047

6. Touch SELF-DIAG [CURRENT].

SELF-DIAG [CURRENT]

FAILURE DETECTED

* NO SELF DIAGNOSTIC FAILURE INDICATED.

FURTHER TESTING MAY BE REQUIRED. **

ERASE PRINT

SRS049

7. If no malfunction is detected on SELF-DIAG [CURRENT], repair of SRS is completed. Touch ERASE.

NOTE:

Touch ERASE to erase problem (Trouble code) retained in memory. Otherwise, CONSULT will still sense a problem in memory when step 13 (Air bag warning lamp operation check) is performed. As a result, the "AIR BAG" warning lamp will still indicate a malfunction in the system.

SELF-DIAG [CURRENT]

FAILURE DETECTED

CONTROL UNIT

ERASE PRINT

SRS048

- If any problem code was displayed on SELF-DIAG [CURRENT], the malfunctioning part is not repaired completely or another malfunctioning part is detected. Go to DIAGNOSTIC PROCEDURE 2, RS-23, and repair malfunctioning part completely.

8. Touch BACK key of CONSULT.

SELECT DIAG MODE

SELF-DIAG [CURRENT]

SELF-DIAG [PAST]

TROUBLE DIAG RECORD

ECU DISCRIMINATED NO.

SRS050

9. Touch SELF-DIAG [PAST].

TROUBLE DIAGNOSES — Supplemental Restraint System (SRS)

Self-diagnosis (Cont'd)

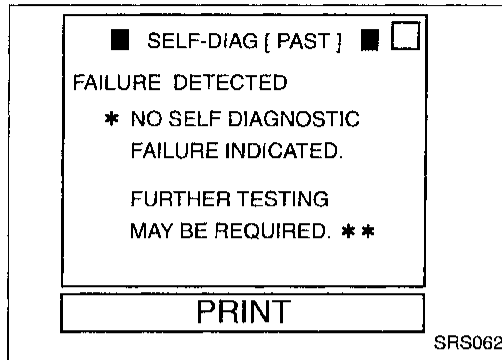

10. Check that no self-diagnostic failure is detected on SELF-DIAG [PAST].

11. Touch BACK key of CONSULT until SELECT SYSTEM MODE appears, turn off CONSULT, then disconnect CONSULT.
12. Turn ignition switch OFF.
13. Go to DIAGNOSTIC PROCEDURE 1, RS-22 to check SRS operation by using "AIR BAG" warning lamp with User mode.

GI
MA
EM
LC
EC
FE
CL
MT
AT
TF
PD
FA
RA
BR
ST
RS
BT
HA
EL
IDX

TROUBLE DIAGNOSES — Supplemental Restraint System (SRS)

Self-diagnosis (Cont'd)

DIAGNOSTIC PROCEDURE 5 (⌚ without CONSULT)

Final checking after repairing SRS by using "AIR BAG" warning lamp — Diagnosis mode and User mode

1. After repairing SRS connect both battery cables.
2. Open driver's door.
3. Turn ignition switch from OFF to ON.
4. "AIR BAG" warning lamp operates in diagnostic mode as follows:

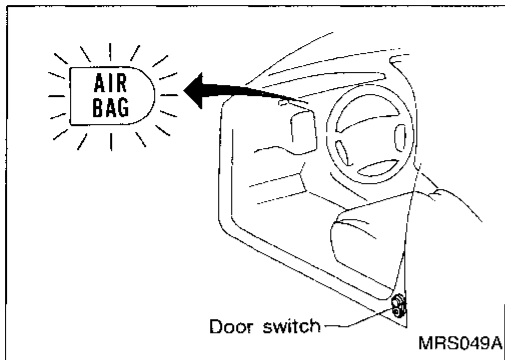

No.	"AIR BAG" warning lamp operation — Diagnosis mode —	SRS condition
1	<p style="text-align: right;">(a) through (b) are repeated.</p>	No malfunction is detected or repair is completed. No further action is necessary.
2	<p style="text-align: right;">(a) through (d) are repeated. NOTE: (a) — Interval I (b) — Start signal (Start signal identifies display modes) (c) — Interval II (d) — Indicates malfunctioning part (0.5 sec. ON and 0.5 sec. OFF is counted as one flash.)</p>	The system has a problem and needs to be repaired.

5. If "AIR BAG" warning lamp operates as shown in No. 1 in the chart above, turn ignition switch OFF to reset from Diagnosis mode to User mode, then go to step 6.

If "AIR BAG" warning lamp operates as in No. 2 in chart above, the malfunctioning part is not repaired completely, or another malfunctioning part is detected. Go to DIAGNOSTIC PROCEDURE 3, RS-24, and repair malfunctioning part completely.



TROUBLE DIAGNOSES — Supplemental Restraint System (SRS)

Self-diagnosis (Cont'd)

6. Turn ignition switch ON. "AIR BAG" warning lamp operates in User mode. Compare "AIR BAG" warning lamp operation to the chart below.

NOTE:

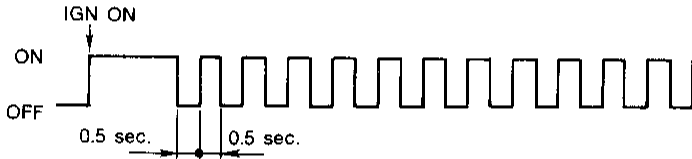
If switching Diagnosis mode to User mode is required while malfunction is being detected, turn ignition switch from OFF to ON. Then press driver's door switch at least 5 times within 7 seconds after turning ignition switch ON. SRS is now in User mode.

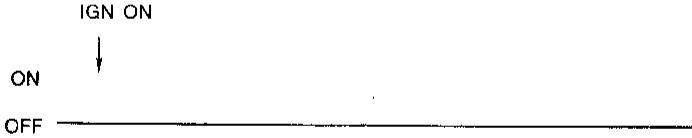
"AIR BAG" warning lamp operation — User mode —	SRS condition	Reference item
 <p style="text-align: right;">MRS095A</p>	<p>No malfunction is detected. No further action is necessary.</p>	<p style="text-align: center;">—</p>
 <p style="text-align: right;">MRS096A</p>	<p>The system has a problem and needs to be repaired as indicated.</p>	<p>Go to DIAGNOSTIC PROCEDURE 2 or 3, RS-23 or 24.</p>
 <p style="text-align: right;">MRS097A</p>	<p>Air bag is deployed.</p>	<p>Go to COLLISION DIAGNOSIS, RS-38.</p>
 <p style="text-align: right;">MRS098A</p>	<p>One of the following has occurred and needs to be repaired:</p> <ul style="list-style-type: none"> ● Meter fuse is open ● "AIR BAG" warning lamp circuit is shorted or open ● Diagnosis sensor unit is malfunctioning 	<p>Go to DIAGNOSTIC PROCEDURE 9, RS-36.</p>

GI
MA
EM
LC
EC
FE
CL
MT
AT
TF
PD
FA
RA
BR
ST
RS
BT
HA
EL
DX

TROUBLE DIAGNOSES — Supplemental Restraint System (SRS)

Self-diagnosis (Cont'd)

DIAGNOSTIC PROCEDURE 6 (Continued from DIAGNOSTIC PROCEDURE 2)

Inspecting SRS malfunctioning record and checking battery voltage

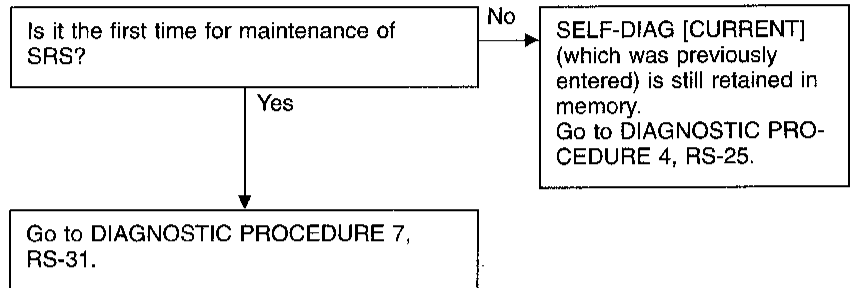

TROUBLE DIAGNOSES — Supplemental Restraint System (SRS)

Self-diagnosis (Cont'd)

DIAGNOSTIC PROCEDURE 7 (CONSULT) with CONSULT

Inspecting SRS intermittent problem by using CONSULT — Diagnosis mode

1. Turn ignition switch OFF.
2. Connect CONSULT to Data link connector.

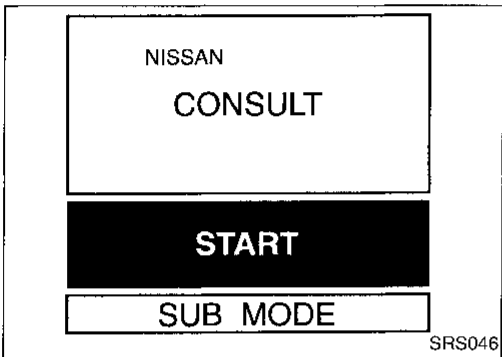
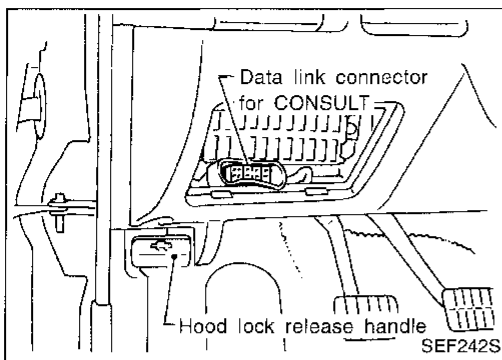

3. Turn ignition switch ON.
4. Touch START of CONSULT.

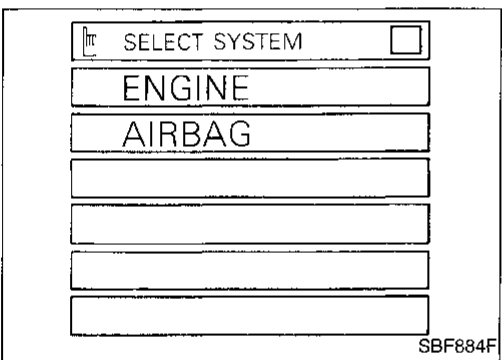

5. Touch AIRBAG.

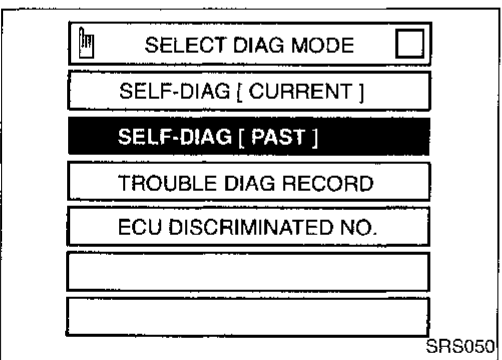

6. Touch SELF-DIAG [PAST].

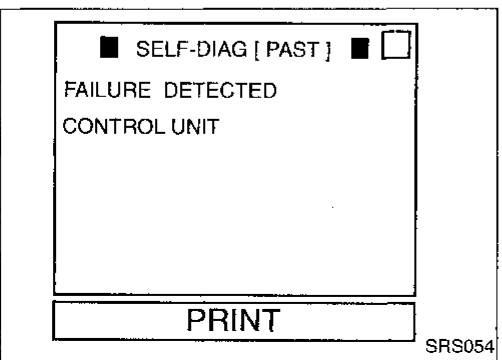

7. If diagnostic codes are displayed on SELF-DIAG [PAST], go to step 10.

GI
MA
EM
LG
EC
FE
CL
MT
AT
TF
PD
EA
RA
BR
ST
BT
HA
EL
IDX

RS

TROUBLE DIAGNOSES — Supplemental Restraint System (SRS)

Self-diagnosis (Cont'd)

If no self-diagnostic failure is detected on SELF-DIAG [PAST], touch BACK and go back to SELECT DIAG MODE.

■ SELF-DIAG [PAST] ■ □

FAILURE DETECTED

* NO SELF DIAGNOSTIC FAILURE INDICATED.

FURTHER TESTING MAY BE REQUIRED. **

PRINT

SRS062

SELECT DIAG MODE □

SELF-DIAG [CURRENT]

SELF-DIAG [PAST]

TROUBLE DIAG RECORD

ECU DISCRIMINATED NO.

SRS055

■ TROUBLE DIAG RECORD ■ □

FAILURE DETECTED

ASSIST A/B MODULE [OPEN]

PRINT

SRS056

8. Touch TROUBLE DIAG RECORD.

9. Diagnostic code is displayed on TROUBLE DIAG RECORD.

10. Touch PRINT.
11. Compare diagnostic codes to the INTERMITTENT PROBLEM DIAGNOSTIC CODE CHART, RS-35.
12. Touch BACK key of CONSULT until SELECT SYSTEM MODE appears, then turn off CONSULT.
13. Turn ignition switch OFF, then disconnect CONSULT and both battery cables.
14. Repair the system as outlined by the "Repair order" that corresponds to the problem code in INTERMITTENT PROBLEM DIAGNOSTIC CODE CHART. For replacement procedure of component parts, refer to RS-9.
15. Go to DIAGNOSTIC PROCEDURE 4, RS-25 to check operation by using CONSULT with Diagnosis mode.

TROUBLE DIAGNOSES — Supplemental Restraint System (SRS)

Self-diagnosis (Cont'd)

CONSULT DIAGNOSTIC CODE CHART

Diagnostic item	Explanation/Possible causes	Repair order *Recheck SRS using CONSULT at each replacement
NO SELF DIAGNOSTIC FAILURE INDICATED	<ul style="list-style-type: none"> No malfunction is detected. 	—
AIRBAG MODULE [OPEN]	<ul style="list-style-type: none"> Driver air bag module circuit is open (including the spiral cable). 	<ol style="list-style-type: none"> 1. Visually check wiring harness connections. 2. Replace spiral cable. 3. Replace driver air bag module. 4. Replace diagnosis sensor unit. 5. Replace main harness.
AIRBAG MODULE [VB-SHORT]	<ul style="list-style-type: none"> Driver air bag module circuit is shorted to some power supply circuit (including the spiral cable). 	
AIRBAG MODULE [GND-SHORT]	<ul style="list-style-type: none"> Driver air bag module circuit is shorted to ground (including the spiral cable). 	
AIRBAG MODULE [SHORT]	<ul style="list-style-type: none"> Driver air bag module circuits are shorted to each other. 	
CRASH ZONE SEN-CTR [OPEN/UPR-VB-SHORT] (4WD models)	<ul style="list-style-type: none"> Crash zone sensor circuit is open, or Crash zone sensor circuit is shorted to some power supply circuit. 	
CRASH ZONE SEN-CTR [SHORT/UPR-GND-SHORT] (4WD models)	<ul style="list-style-type: none"> Both crash zone sensor circuits are shorted, or Crash zone sensor circuit is shorted to ground. 	<ol style="list-style-type: none"> 4. Replace air bag harness for crash zone sensor. 5. Replace main harness.
CONTROL UNIT	<ul style="list-style-type: none"> Diagnosis sensor unit is out of order. 	<ol style="list-style-type: none"> 1. Visually check wiring harness connections. 2. Replace diagnosis sensor unit. 3. Replace main harness.
INDEFINITE FAILURES [AIR BAG]	<ul style="list-style-type: none"> Low battery or SRS system voltage. A problem which cannot be determined or specified occurs. 	<ol style="list-style-type: none"> 1. Check and, if necessary, charge battery, then go to DIAGNOSTIC PROCEDURE 4, RS-25. 2. Replace diagnosis sensor unit.

***Follow the procedures in numerical order when repairing malfunctioning parts. Confirm whether malfunction is eliminated using the air bag warning lamp (in User mode) or CONSULT each time repair is finished. If malfunction is still observed, proceed to the next step. When malfunction is eliminated, further repair work is not required.**

GI
MA
EM
LC
EC
FE
CL
MT
AT
TF
PD
FA
RA
BR
ST
RS
BT
HA
EL
IDX

TROUBLE DIAGNOSES — Supplemental Restraint System (SRS)

Self-diagnosis (Cont'd)

WARNING LAMP FLASH CODE CHART

Warning lamp	Flash code  (# of flashes)	Explanation	Repair order *Recheck SRS at each replacement
"AIR BAG" warning lamp	2	<ul style="list-style-type: none"> ● Driver air bag module circuit is out of order. 	<ol style="list-style-type: none"> 1. Visually check wiring harness connections. 2. Replace spiral cable. 3. Replace driver air bag module. (Before disposing of it, it must be deployed.) 4. Replace diagnosis sensor unit. 5. Replace main harness.
	6	<ul style="list-style-type: none"> ● Crash zone sensor is out of order. 	<ol style="list-style-type: none"> 1. Visually check wiring harness connections. 2. Replace crash zone sensor. 3. Replace diagnosis sensor unit. 4. Replace air bag harness for crash zone sensor. 5. Replace main harness.
	7	<ul style="list-style-type: none"> ● Diagnosis sensor unit is out of order. 	<ol style="list-style-type: none"> 1. Visually check wiring harness connections. 2. Replace diagnosis sensor unit. 3. Replace main harness.
	9	<ul style="list-style-type: none"> ● Low battery or SRS system voltage. ● A problem which cannot be determined or specified occurs. 	<ol style="list-style-type: none"> 1. Check and, if necessary, charge battery, then go to DIAGNOSTIC PROCEDURE 5, RS-28. 2. Replace diagnosis sensor unit.

***Follow the procedures in numerical order when repairing malfunctioning parts. Confirm whether malfunction is eliminated using the air bag warning lamp (in User mode) or CONSULT each time repair is finished. If malfunction is still observed, proceed to the next step. When malfunction is eliminated, further repair work is not required.**

TROUBLE DIAGNOSES — Supplemental Restraint System (SRS)

Self-diagnosis (Cont'd)

INTERMITTENT PROBLEM DIAGNOSTIC CODE CHART

Diagnostic item	Explanation	Repair order Recheck SRS at each replacement.
NO SELF DIAGNOSTIC FAILURE INDICATED.	<ul style="list-style-type: none"> ● No malfunction is detected. 	—
AIRBAG MODULE [VB-SHORT]	<ul style="list-style-type: none"> ● Driver air bag module circuit is shorted to some power supply circuit (including the spiral cable). 	<ol style="list-style-type: none"> 1. Visually check wiring harness connection. 2. Replace harness if it has visible damage. 3. Replace spiral cable.
AIRBAG MODULE [OPEN]	<ul style="list-style-type: none"> ● Driver air bag module circuit is open (including the spiral cable). 	<ol style="list-style-type: none"> 1. Visually check wiring harness connection. 2. Replace harness if it has visible damage. 3. Replace spiral cable.
AIRBAG MODULE [GND-SHORT]	<ul style="list-style-type: none"> ● Driver air bag module circuit is shorted to ground (including the spiral cable). 	<ol style="list-style-type: none"> 4. Replace driver air bag module. (Before disposing of it, it must be deployed.)
AIRBAG MODULE [SHORT]	<ul style="list-style-type: none"> ● Driver air bag module circuits are shorted to each other. 	
CRASH ZONE SEN-CTR [OPEN/UPR-VB-SHORT] (4WD models)	<ul style="list-style-type: none"> ● Crash zone sensor circuit is open, or ● Crash zone sensor circuit is shorted to a power supply circuit. 	<ol style="list-style-type: none"> 1. Visually check wiring harness connections. 2. Replace harness if it has visible damage.
CRASH ZONE SEN-CTR [SHORT/UPR-GND-SHORT] (4WD models)	<ul style="list-style-type: none"> ● Both crash zone sensor circuits are shorted, or ● Crash zone sensor circuit is shorted to ground. 	<ol style="list-style-type: none"> 1. Visually check wiring harness connections. 2. Replace harness if it has visible damage. 3. Replace crash zone sensor.
CONTROL UNIT	<ul style="list-style-type: none"> ● Diagnosis sensor unit is out of order. 	<ul style="list-style-type: none"> ● Replace diagnosis sensor unit.

GI
MA
EM
LC
EC
FE
CL
MT
AT
TF
PD
FA
RA
BR
ST
RS
BT
HA
EL
IDX

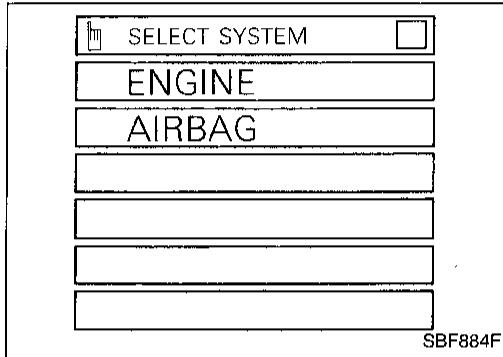
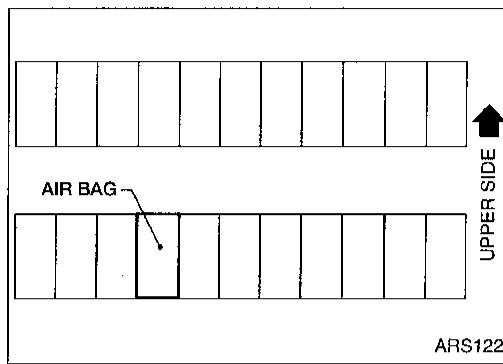

Trouble Diagnoses for Air Bag Warning Lamp DIAGNOSTIC PROCEDURE 8

SYMPTOM: "AIR BAG" warning lamp does not turn off.

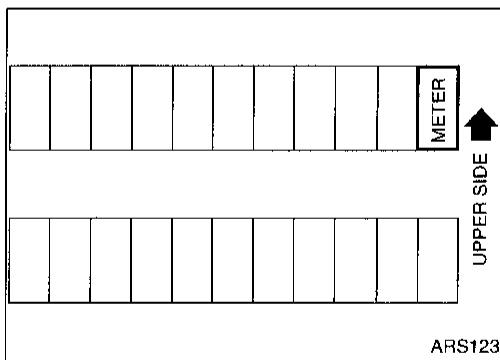
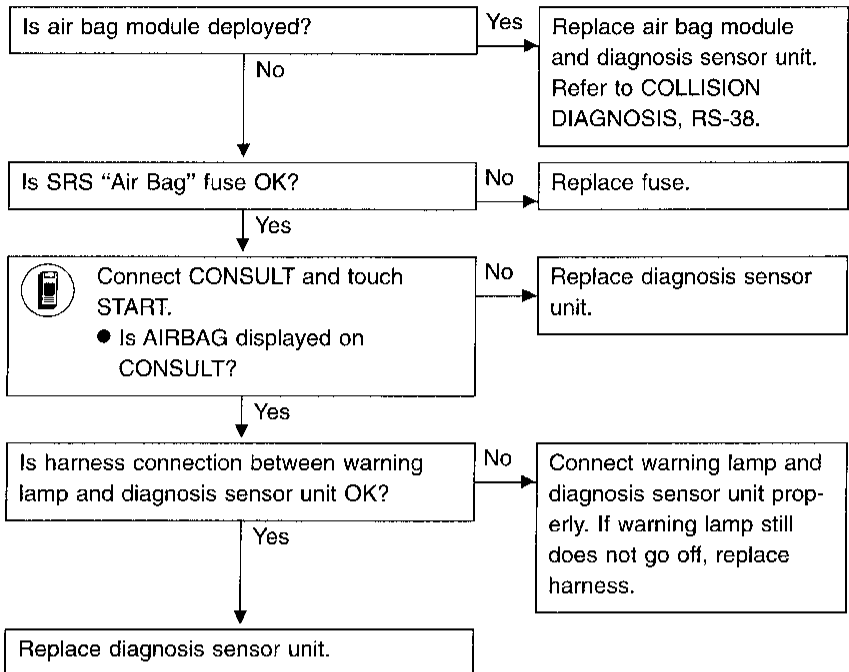

DIAGNOSTIC PROCEDURE 9

SYMPTOM: "AIR BAG" warning lamp does not turn on.

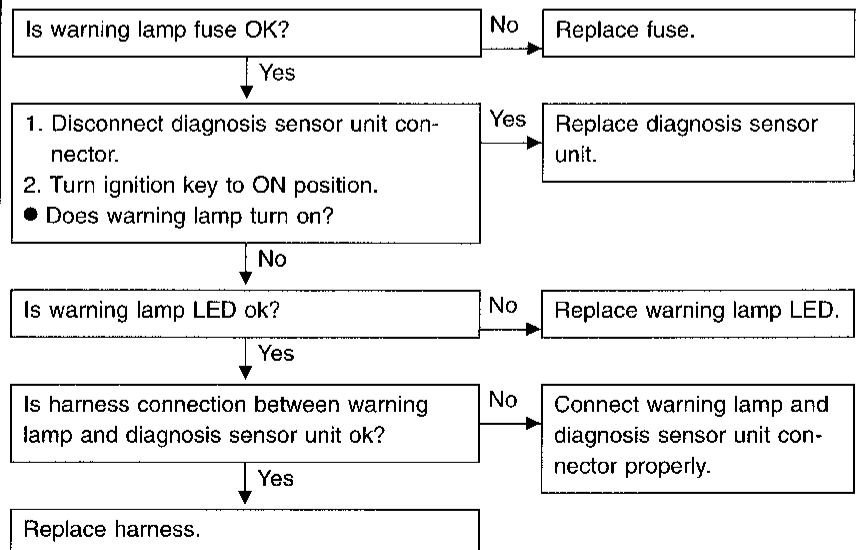

TROUBLE DIAGNOSES — Supplemental Restraint System (SRS)

Trouble Diagnoses for Air Bag Warning Lamp

(Cont'd)

DIAGNOSTIC PROCEDURE 10

SYMPTOM: SRS does not enter Diagnostic mode.

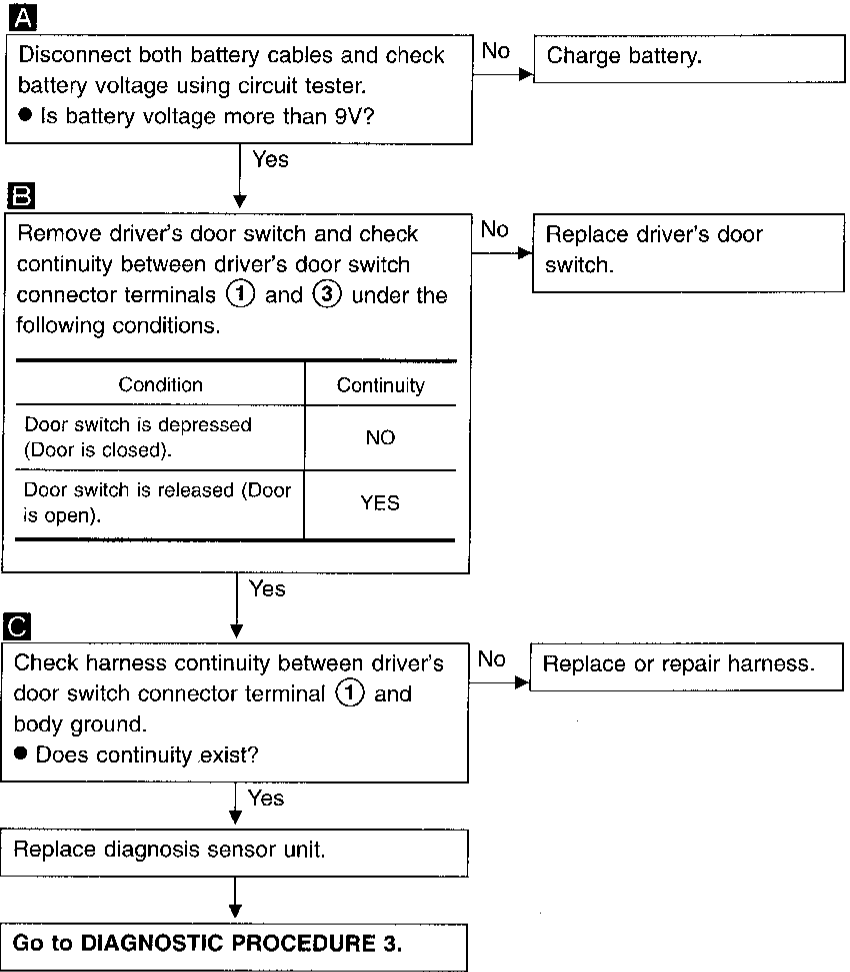
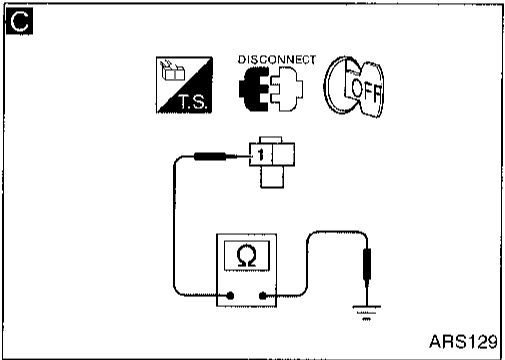
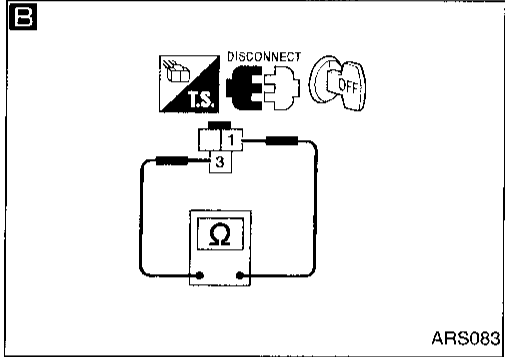
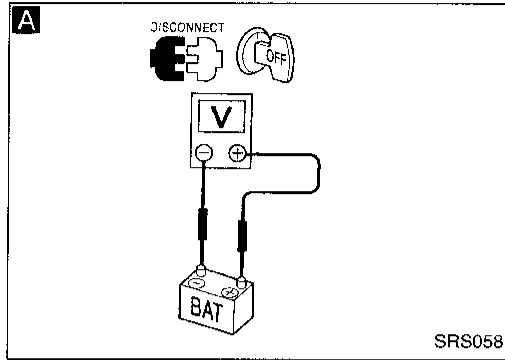

GI
MA
EM
LC
EC
FE
CL
MT
AT
TF
PD
FA
RA
BR
ST
RS
BT
HA
EL
IDX

COLLISION DIAGNOSIS

To repair the SRS, perform the following steps.

When SRS is activated in a collision:

- ① Replace the diagnosis sensor unit.
- ② Remove the air bag module.
- ③ Check the SRS components using the table shown below:
 - Replace any SRS components showing visible signs of damage (dents, cracks, deformation).
- ④ Conduct self-diagnosis. Refer to "Self-diagnosis", RS-22 for details. Ensure the remainder of the SRS is operating properly.
- ⑤ Install a new air bag module.
- ⑥ Conduct self-diagnosis again.

When SRS is not activated in a collision:

- ① Check the SRS components using the table shown below:
 - Replace any SRS components showing visible signs of damage (dents, cracks, deformation).
- ② Conduct self-diagnosis using CONSULT and "AIR BAG" warning lamp. Refer to "Self-diagnosis", RS-22 for details. Ensure entire SRS operates properly.

SRS inspection

Part	SRS is activated	SRS is NOT activated
Air bag module	REPLACE. Install with new bolts.	<ol style="list-style-type: none"> 1. Remove air bag module. Check harness cover and connectors for damage, terminals for deformities, and harness for binding. 2. Install driver air bag module into the steering wheel to check fit and alignment with the wheel. 3. If no damage is found, reinstall with new bolts. 4. If damaged—REPLACE. Air bag must be deployed before discarding.
Crash zone sensor (4WD models)	<ol style="list-style-type: none"> 1. Check body and sensor bracket for deformities or rust. 2. Check sensor case for dents, cracks, scratches, deformities or rust. 3. Check sensor harness, connector, and terminals for binding, damage, or deformities. 4. If no damage is found, reinstall with new bolts. 5. If damaged—REPLACE. 	
Diagnosis sensor unit	REPLACE. Install with new bolts.	<ol style="list-style-type: none"> 1. Check case and bracket for dents, cracks or deformities. 2. Check connectors for damage, and terminals for deformities. 3. If no damage is found, reinstall with new bolts. 4. If damaged—REPLACE.
Steering wheel	<ol style="list-style-type: none"> 1. Visually check steering wheel for deformities. 2. Check harness (built into steering wheel) and connectors for damage, and terminals for deformities. 3. Install air bag module to check fit or alignment with steering wheel. 4. Check steering wheel for excessive free play. 5. If no damage is found, reinstall with new bolts. 6. If damaged—REPLACE. 	
Spiral cable	<ol style="list-style-type: none"> 1. Visually check spiral cable and combination switch for damage. 2. Check connectors, flat cable and protective tape for damage. 3. Check steering wheel for noise, binding or heavy operation. 4. If no damage is found, reinstall with new bolts. 5. If damaged—REPLACE. 	
Harness and Connectors	<ol style="list-style-type: none"> 1. Check connectors for poor connection, damage, and terminals for deformities. 2. Check harness for binding, chafing, cuts, or deformities. 3. If no damage is found, reinstall. 4. Damaged—REPLACE damaged section of harness. Do not attempt to repair, splice or modify any SRS harness. 	