

ACCELERATOR CONTROL, FUEL & EXHAUST SYSTEMS

GI

MA

EM

LC

EC

FE

SECTION FE

CONTENTS

ACCELERATOR CONTROL SYSTEM	2	FUEL SYSTEM	3
Adjusting Accelerator Wire	2	Fuel Tank	3
		Fuel Pump and Gauge	6
		EXHAUST SYSTEM	7

CL

MT

AT

TF

PD

FA

RA

BR

ST

RS

BT

HA

EL

IDX

ACCELERATOR CONTROL SYSTEM

CAUTION:

- When removing accelerator wire, mark initial position of lock nut.
- Check that throttle valve opens fully when accelerator pedal is fully depressed. Check that throttle valve returns to idle position when accelerator pedal is released.
- Check accelerator control parts for improper contact with any adjacent parts.
- When connecting accelerator wire, do not twist or scratch the inner wire.
- For adjustment of A/T throttle wire, refer to AT section ("Throttle Wire Adjustment", "ON-VEHICLE SERVICE").

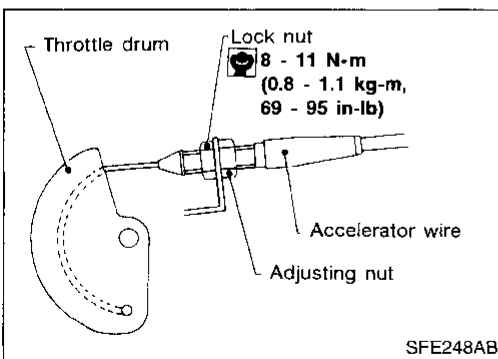
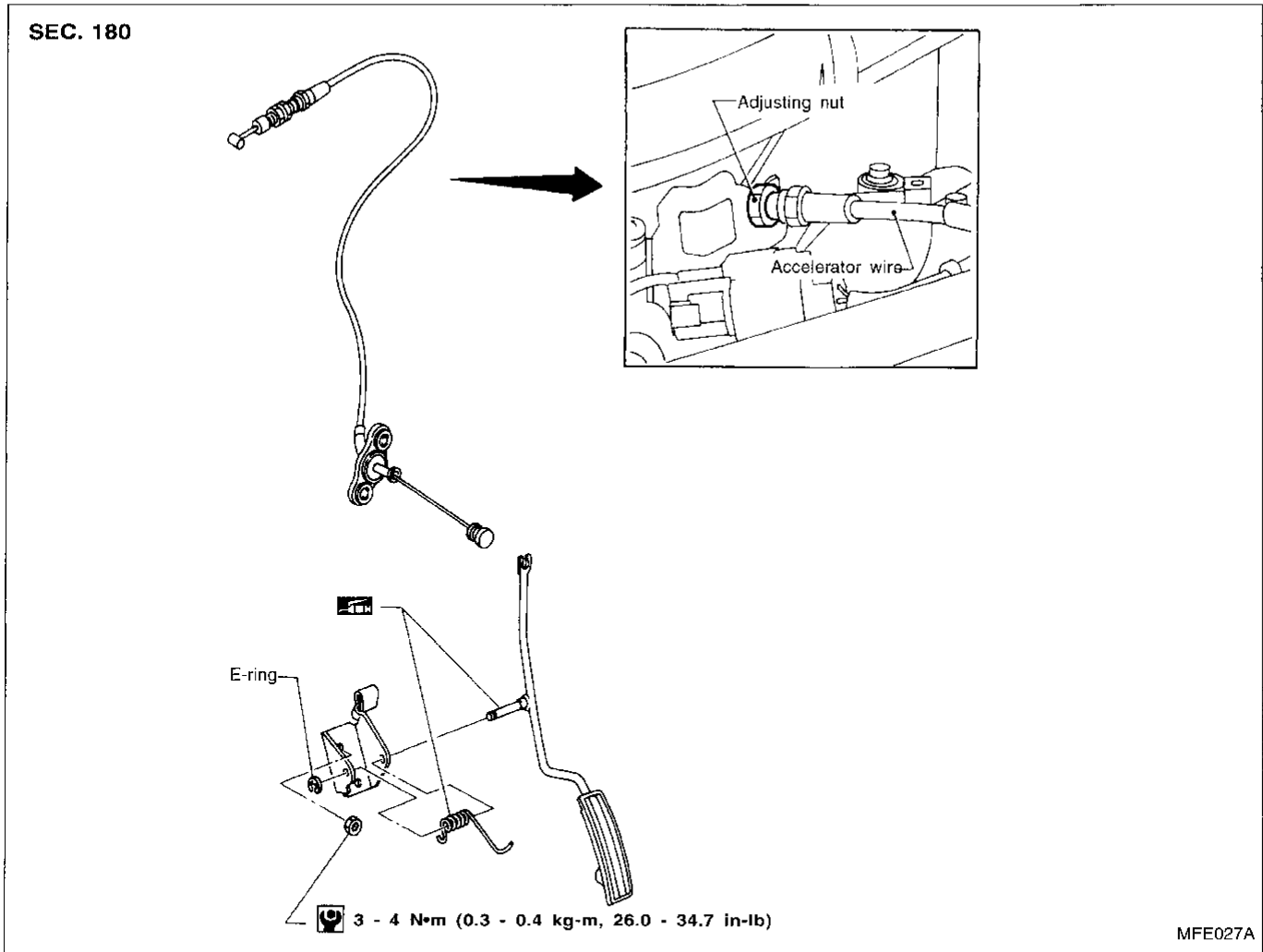

Adjusting Accelerator Wire

CAUTION:

- Make sure the ASCD wire is not pulling the throttle drum.
 - For ASCD wire adjustment, refer to EL section ["AUTOMATIC SPEED CONTROL DEVICE (ASCD)"].
1. Loosen lock nut, and tighten adjusting nut until throttle drum starts to move.
 2. Loosen adjusting nut 1.5 to 2 turns and tighten lock nut.

Fuel Tank

WARNING:

When replacing fuel line parts, be sure to observe the following:

- Put a "CAUTION: FLAMMABLE" sign in workshop.
- Do not smoke while servicing fuel system. Keep open flames and sparks away from work area.
- Furnish workshop with a CO₂ fire extinguisher.

CAUTION:

- Before removing fuel line parts, carry out the following procedures:
 - a. Put drained fuel in an explosion-proof container and put the lid on securely.
 - b. Release fuel pressure from fuel line. Refer to EC section ("Fuel Pressure Release", "BASIC SERVICE PROCEDURE").
 - c. Disconnect battery ground cable.
- When installing fuel check valve, install it in the correct direction. Refer to EC section ("EVAPORATIVE EMISSION SYSTEM").
- Always replace O-ring with a new one.
- Do not kink or twist tubes and hoses during installation.
- To avoid damaging hoses, do not tighten hose clamps excessively.
- After installing tubes, run engine and check for fuel leaks at connections.
- Use only a genuine fuel filler cap as a replacement. If an incorrect fuel filler cap is used, the MIL may turn on.
- For inspection of EVAP shut valve, refer to EC section ("EVAPORATIVE EMISSION SYSTEM").

SEC. 172

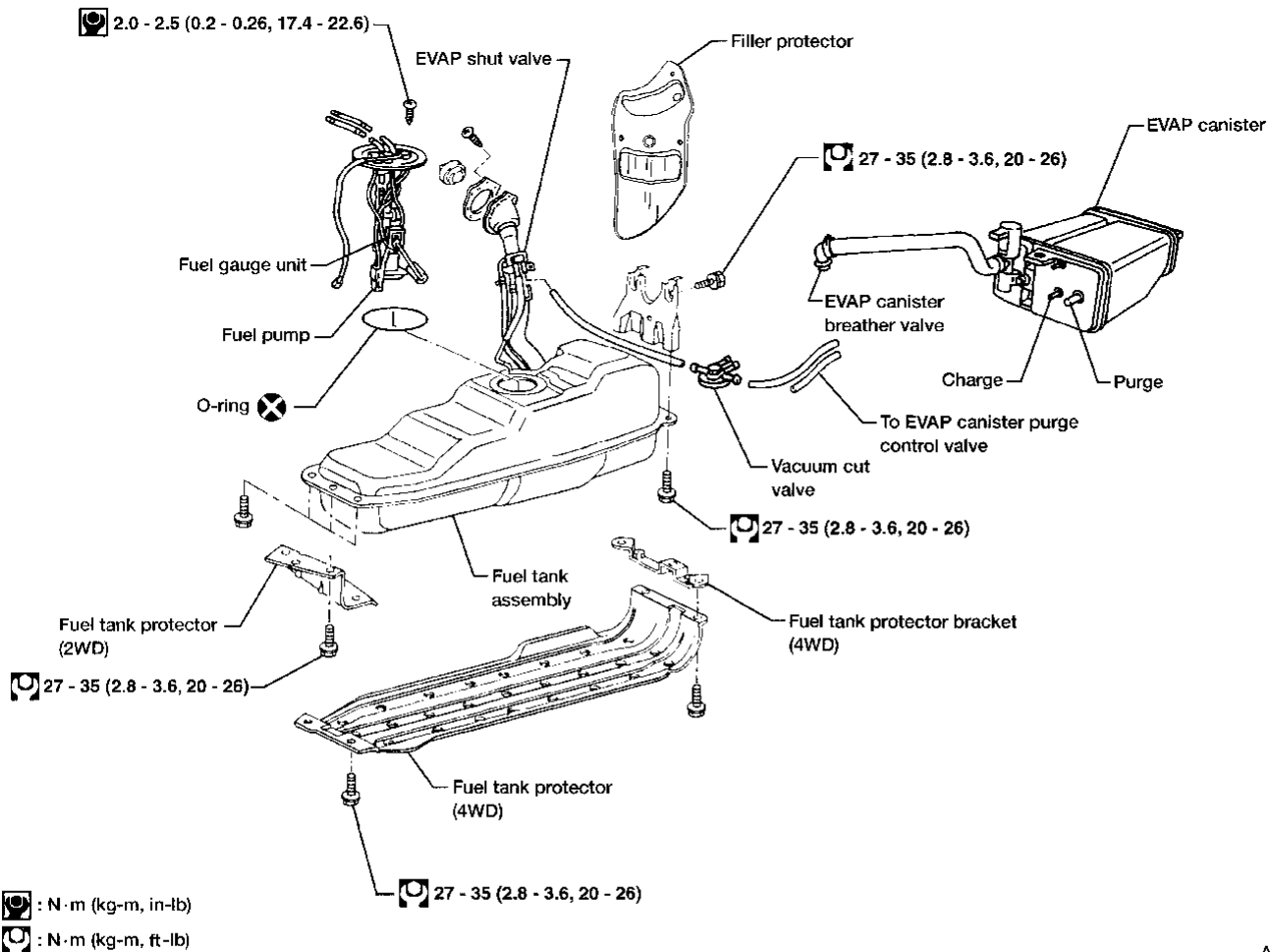

AFE065

FUEL SYSTEM

Fuel Tank (Cont'd)

REMOVAL

CAUTION:

- Do not disconnect any fuel line unless absolutely necessary.
- Plug hose and pipe openings to prevent entry of dust or dirt.

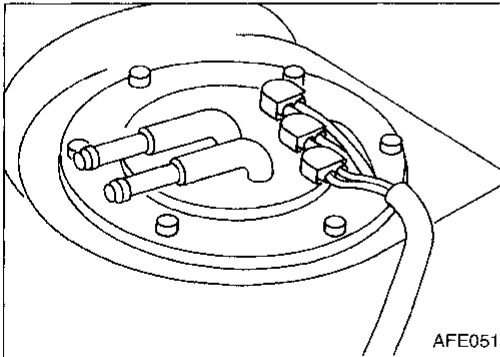

1. Release fuel pressure. Refer to EC section ("Fuel Pressure Release", "BASIC SERVICE PROCEDURE").
2. Disconnect battery ground cable.
3. Drain fuel from fuel tank.
4. Disconnect electrical connector.
5. Remove filler protector.
6. Disconnect filler tubes, fuel supply tube and fuel return tube.

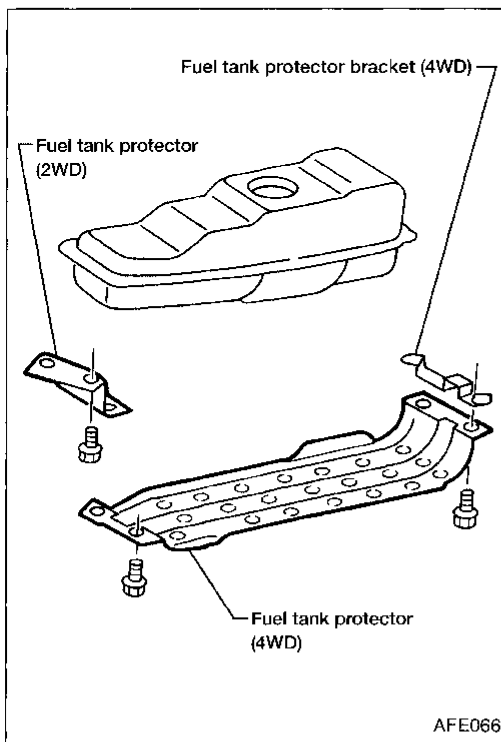

7. Remove fuel tank protector.

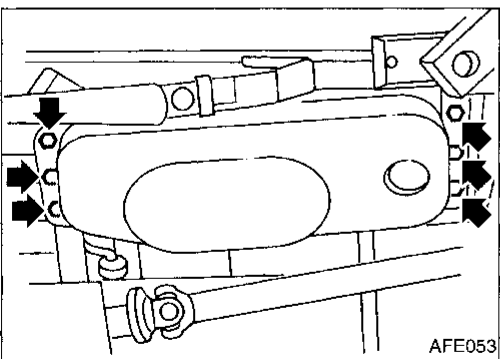

8. Remove six fuel tank mounting bolts while supporting fuel tank.

FUEL SYSTEM

Fuel Tank (Cont'd)

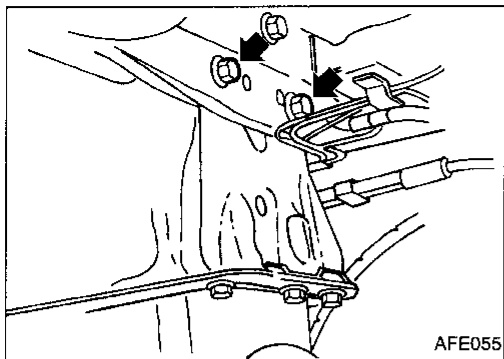

9. Remove rear fuel tank mounting bracket.

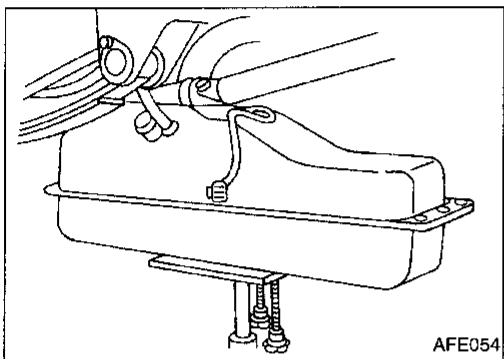

10. Remove fuel tank.

INSTALLATION

To install, reverse the removal procedure.

CAUTION:

- Do not kink or twist hoses and tubes during installation.
- To avoid damaging hoses, do not tighten hose clamps excessively.
- Tighten bolts to specified torque.
- After installation, run engine and check for leaks at connections.

GI

MA

EM

LC

EC

FE

CL

MT

AT

TF

PD

FA

RA

BR

ST

RS

BT

HA

EL

IDX

FUEL SYSTEM

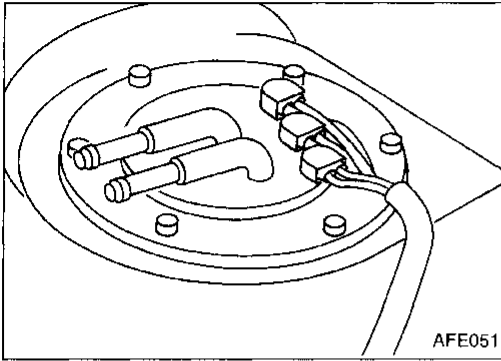

Fuel Pump and Gauge

REMOVAL

1. Remove fuel tank. Refer to FE-4.
2. Disconnect fuel supply tube, fuel return tube and electrical connector.
3. Remove the six screws.

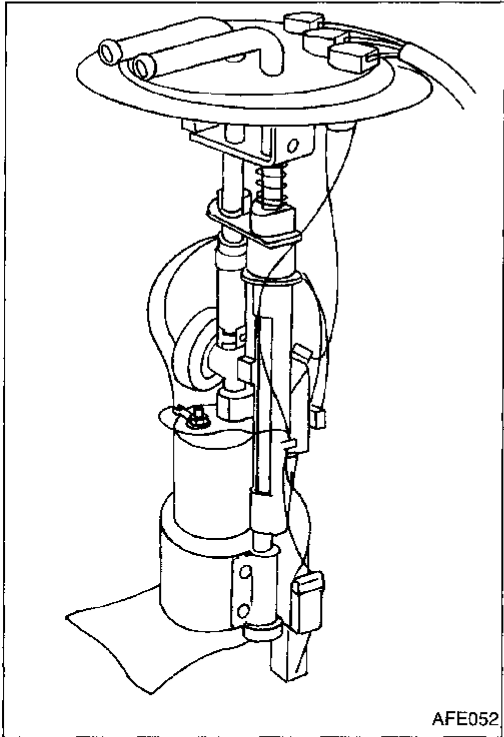

4. Remove fuel pump and gauge.

INSTALLATION

To install, reverse the removal procedure.

CAUTION:

- Tighten bolts to specified torque.
☑: 2.0 - 2.5 N·m (0.20 - 0.26 kg-m, 17.4 - 22.6 in-lb)
- Always replace O-ring with a new one.
- After installation, run engine and check for leaks at connections.

EXHAUST SYSTEM

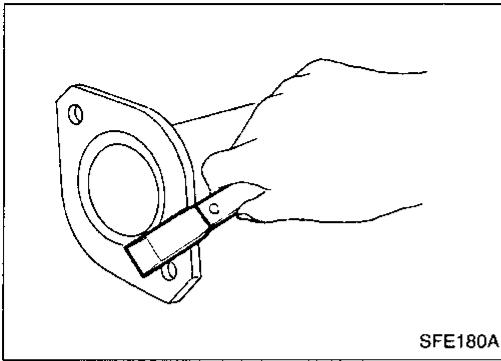

CAUTION:

- Replace exhaust gaskets with new ones when reassembling. If gasket remains on flange surface, scrape off completely as shown at left.
- With engine running, check all tube connections for exhaust gas leaks, and entire system for unusual noises.
- Check to ensure that mounting brackets and mounting insulators are installed properly and are free from undue stress. Improper installation could result in excessive noise or vibration.
- Discard any heated oxygen sensor dropped from a height of more than 0.5 m (19.7 in) onto a hard surface such as a concrete floor; use a new one.

2WD model
SEC. 200•208

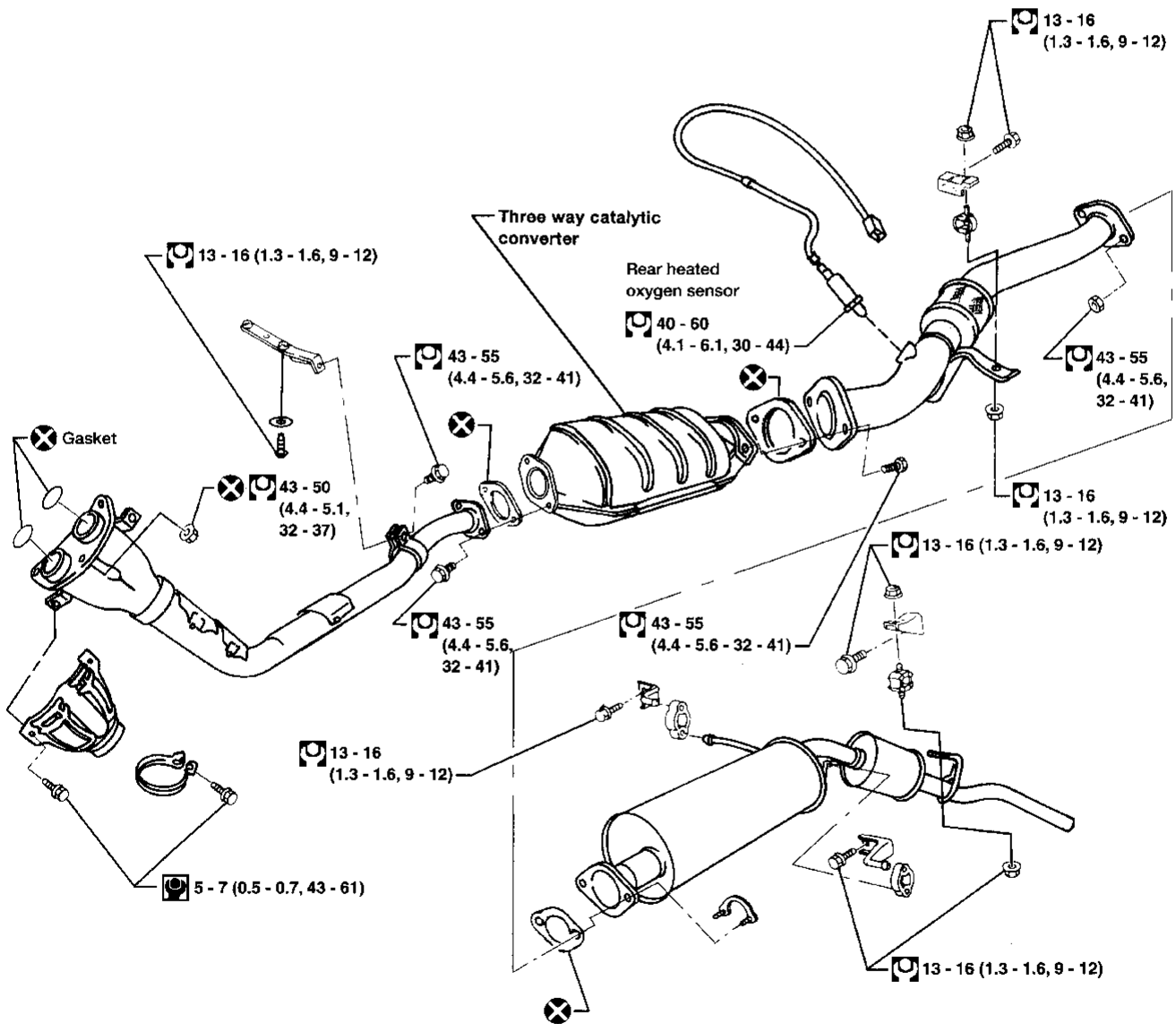

- ⊙ : N·m (kg-m, in-lb)
- ⊚ : N·m (kg-m, ft-lb)
- ⊗ : Always replace after every disassembly

AFE049

GI
MA
EM
LC
EC
FE
CL
MT
AT
TF
PD
FA
RA
BR
ST
RS
BT
HA
EL
IDX

EXHAUST SYSTEM

4WD model
SEC. 200•208

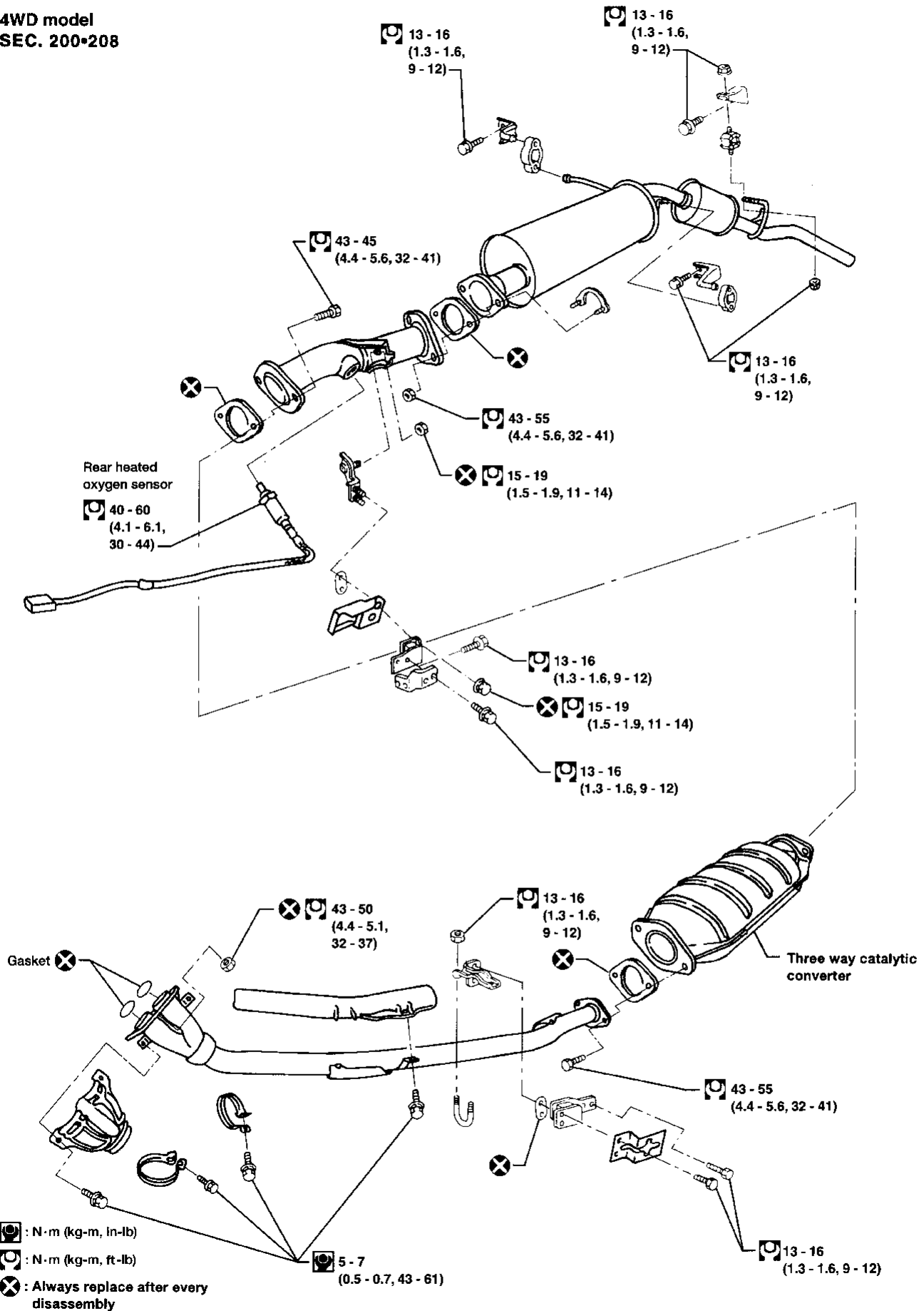

AFE050