

# STEERING SYSTEM

## SECTION **ST**

GI  
MA  
EM  
LC  
FF &  
EC

## CONTENTS

<b>PRECAUTIONS AND PREPARATION</b> .....	2	Assembly.....	27	FE
Supplemental Restraint System "AIR BAG" and "SEAT BELT PRE-TENSIONER" .....	2	<b>TWIN ORIFICE POWER STEERING SYSTEM</b> .....	29	
Preparation.....	2	Hydraulic Circuit.....	29	
<b>ON-VEHICLE SERVICE</b> .....	5	Schematic.....	29	AT
Checking Steering Wheel Play.....	5	Wiring Diagram.....	30	
Checking Neutral Position on Steering Wheel.....	5	<b>TWIN ORIFICE POWER STEERING SYSTEM —     Trouble Diagnoses</b> .....	31	PD
Front Wheel Turning Angle.....	5	Precautions.....	31	
Checking Gear Housing Movement.....	6	Diagnostic Procedure 1.....	32	FA
Adjusting Rack Retainer.....	6	Diagnostic Procedure 2.....	39	
Checking and Adjusting Drive Belts (For power steering).....	6	Control Unit Inspection Table.....	41	RA
Checking Fluid Level.....	6	Performance of Controller.....	41	
Checking Fluid Leakage.....	7	<b>SUPER HICAS SYSTEM</b> .....	42	
Bleeding Hydraulic System.....	7	HICAS Component Parts Location.....	42	BR
Checking Steering Wheel Turning Force (For power steering).....	8	System Diagram.....	42	
Checking Hydraulic System.....	8	<b>SUPER HICAS SYSTEM — On-vehicle Service</b> .....	43	<b>ST</b>
<b>STEERING WHEEL AND STEERING COLUMN</b> .....	10	Checking Fluid Level.....	43	
Removal.....	10	Checking Fluid Leakage.....	43	
Installation.....	11	Measuring Rear Toe-in.....	43	BF
Disassembly and Assembly.....	12	Inspection of HICAS System Operation.....	44	
Inspection.....	13	Bleeding Hydraulic System.....	46	
<b>POWER STEERING GEAR AND LINKAGE</b> .....	14	<b>SUPER HICAS SYSTEM — Repair of Component     Parts</b> .....	47	HA
Removal and Installation.....	14	Power Cylinder.....	47	
Disassembly.....	17	Oil Pump.....	52	EL
Inspection.....	17	HICAS Solenoid and Fail-safe Valve.....	56	
Assembly.....	19	Steering Angle Sensor.....	56	
Adjustment.....	24	Steering Wheel.....	57	IX
<b>POWER STEERING OIL PUMP</b> .....	26	<b>SUPER HICAS SYSTEM — Trouble Diagnoses</b> .....	58	
Pre-disassembly Inspection.....	26	Contents.....	58	
Disassembly.....	26	<b>SERVICE DATA AND SPECIFICATIONS (SDS)</b> .....	91	
Inspection.....	27	General Specifications.....	91	
		Inspection and Adjustment.....	91	

## PRECAUTIONS AND PREPARATION

### Supplemental Restraint System “AIR BAG” and “SEAT BELT PRE-TENSIONER”

The Supplemental Restraint System “Air Bag” and “Seat Belt Pre-tensioner” help to reduce the risk or severity of injury to the driver and front passenger in a frontal collision. The Supplemental Restraint System consists of air bags (located in the center of the steering wheel and on the instrument panel on the passenger side), seat belt pre-tensioners, sensors, a diagnostic unit, warning lamp, wiring harness and spiral cable. Information necessary to service the system safely is included in the **BF section** of this Service Manual.

#### WARNING:

- To avoid rendering the SRS inoperative, which could lead to personal injury or death in the event of a severe frontal collision, all maintenance must be performed by an authorized INFINITI dealer.
- Improper maintenance, including incorrect removal and installation of the SRS, can lead to personal injury caused by unintentional activation of the system.
- All SRS air bag electrical wiring harnesses and connectors are covered with yellow outer insulation. Do not use electrical test equipment on any circuit related to the SRS SYSTEM.

#### STEERING SYSTEM

- Before disassembly, thoroughly clean the outside of the unit.
- Disassembly should be done in a clean work area. It is important to prevent the internal parts from becoming contaminated by dirt or other foreign matter.
- When disassembling parts, be sure to place them in order in a parts rack so they can be reinstalled in their proper positions.
- Use nylon cloths or paper towels to clean the parts; common shop rags can leave lint that might interfere with their operation.
- Before inspection or reassembly, carefully clean all parts with a general purpose, non-flammable solvent.
- Before assembly, apply a coat of recommended ATF\* to hydraulic parts. Vaseline may be applied to O-rings and seals. Do not use any grease.
- Replace all gaskets, seals and O-rings. Avoid damaging O-rings, seals and gaskets during installation. Perform functional tests whenever designated.

\*: Automatic transmission fluid

#### Preparation

#### SPECIAL SERVICE TOOLS

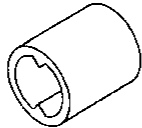
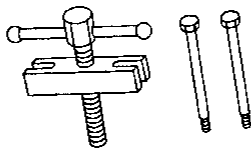
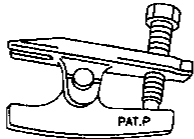
Tool number (Kent-Moore No.) Tool name	Description
KV48100700 (J26364) Torque adapter	 Measuring pinion rotating torque NT169
ST27180001 (J25726-A) Steering wheel puller	 Removing steering wheel NT170
HT72750000 (J24319-01) Ball joint remover	 Removing ball joint NT146

# PRECAUTIONS AND PREPARATION

## Preparation (Cont'd)

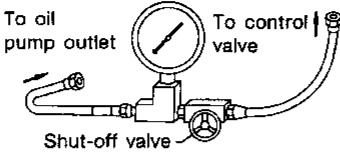
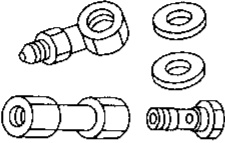
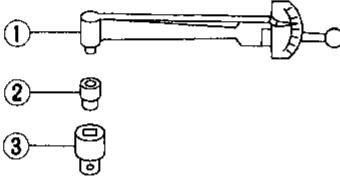
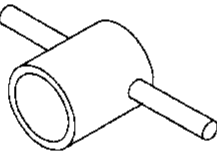
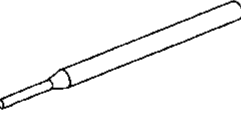
Tool number (Kent-Moore No.) Tool name	Description	
ST27091000 (J26357) Pressure gauge		Measuring oil pressure GI MA
NT176		
KV48102500 ( — ) Pressure gauge adapter		Measuring oil pressure EM LC
NT177		
ST3127S000 (See J25765-A) ① GG91030000 (J25765-A) Torque wrench ② HT6294000 ( — ) Socket adapter ③ HT629000000 ( — ) Socket adapter		Measuring turning torque EF & EC FE AT PD
NT124		
KV48104400 ( — ) Rack seal ring reformer		Reforming teflon ring FA RA BR
NT178		
KV32101100 ( — ) Pin punch		Removing and installing tube seat ST BF HA EL IDX
NT070		

# PRECAUTIONS AND PREPARATION

## Preparation (Cont'd) COMMERCIAL SERVICE TOOLS

Tool name	Description
Rear oil seal drift	<div data-bbox="1029 239 1273 296" data-label="Text"> <p>Installing rear oil seal a: 28 mm (1.10 in) dia.</p> </div> <div data-bbox="493 275 704 394" data-label="Image"> </div> <div data-bbox="386 415 444 436" data-label="Text"> <p>NT063</p> </div>
Pinion oil seal drift	<div data-bbox="1029 443 1289 499" data-label="Text"> <p>Installing pinion oil seal a: 35 mm (1.38 in) dia.</p> </div> <div data-bbox="493 478 704 598" data-label="Image"> </div> <div data-bbox="386 619 444 640" data-label="Text"> <p>NT063</p> </div>
Oil pump attachment	<div data-bbox="1029 646 1448 703" data-label="Text"> <p>Disassembling and assembling oil pump</p> </div> <div data-bbox="493 682 974 892" data-label="Diagram"> </div> <div data-bbox="1029 905 1166 926" data-label="Text"> <p>Unit: mm (in)</p> </div> <div data-bbox="386 936 444 957" data-label="Text"> <p>NT179</p> </div>

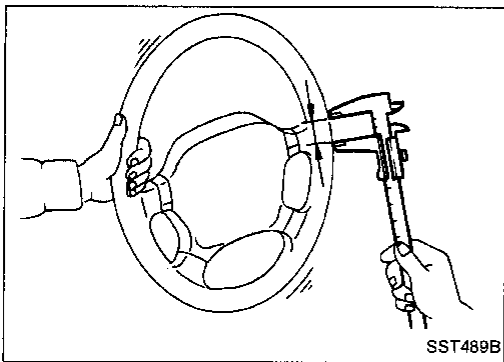

SST489B

### Checking Steering Wheel Play

- With wheels in a straight-ahead position, check steering wheel play.

**Steering wheel play:**

**35 mm (1.38 in) or less**

- If it is not within specification, check steering gear assembly when front suspension and axle, steering gear assembly and steering column are mounted correctly.

GI

MA

EM

LC

EF &  
EC

FE

AT

PD

FA

RA

BR

ST

BF

HA

EL

IDX

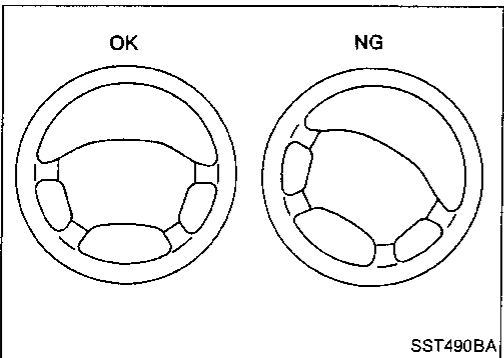

SST490BA

### Checking Neutral Position on Steering Wheel

#### Pre-checking

- Make sure that wheel alignment is correct.

**Wheel alignment:**

**Refer to SDS in FA section.**

- Verify that the steering gear is centered before removing the steering wheel.

#### Checking

1. Check that the steering wheel is in the neutral position when driving straight ahead.
2. If it is not in the neutral position, remove the steering wheel and reinstall it correctly.
3. If the neutral position is between two serrated teeth, loosen tie-rod lock nut and move tie-rod in the opposite direction by the same amount on both left and right sides to compensate for error in the neutral position.

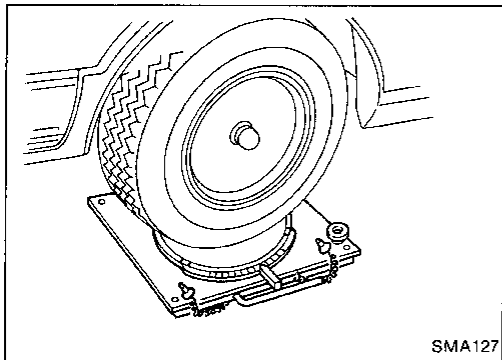

SMA127

### Front Wheel Turning Angle

1. Rotate steering wheel all the way right and left; measure turning angle.

**Turning angle of full turns:**

**Refer to SDS in FA section.**

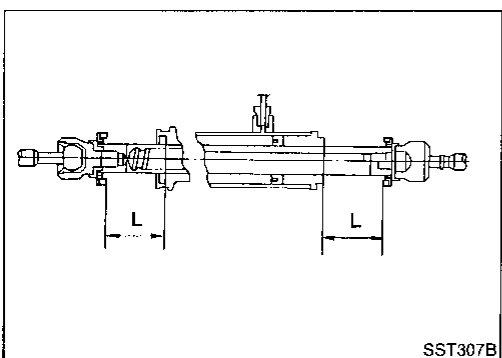

SST307B

2. If it is not within specification, check rack stroke.

**Rack stroke "L":**

**Refer to SDS (ST-91).**

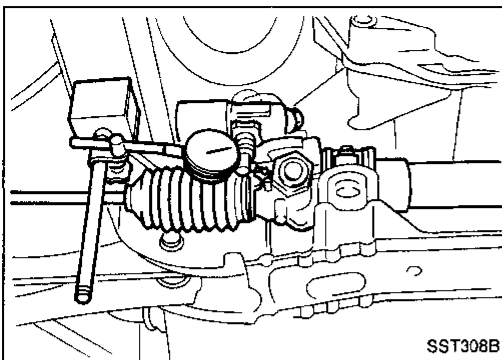

## Checking Gear Housing Movement

1. Check the movement of steering gear housing during stationary steering on a dry paved surface.
    - Apply a force of 49 N (5 kg, 11 lb) to steering wheel to check the gear housing movement.
- Turn off ignition key while checking.

### Movement of gear housing:

$\pm 2 \text{ mm } (\pm 0.08 \text{ in})$  or less

2. If movement exceeds the limit, replace mount insulator after confirming proper installation of gear housing clamps.

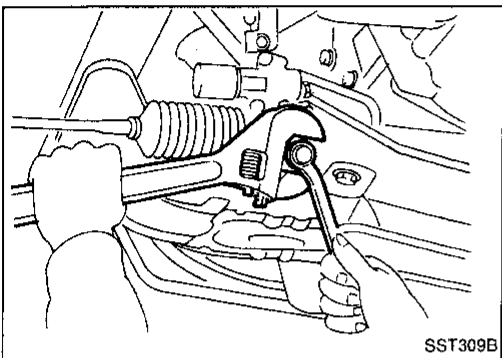

## Adjusting Rack Retainer

- Perform this driving test on a flat road.
1. Check whether vehicle moves in a straight line when steering wheel is released.
  2. Check whether steering wheel returns to neutral position when steering wheel is released from a slightly turned (approx. 20°) position.
- If any abnormality is found, correct it by resetting adjusting screw.

## Checking and Adjusting Drive Belts (For power steering)

Refer to "Checking Drive Belts" in MA section.

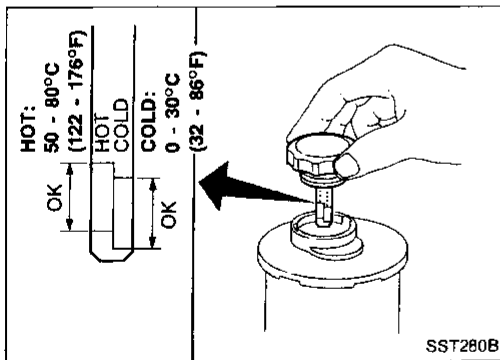

## Checking Fluid Level

Check fluid level.

Fluid level should be checked using "HOT" range on dipstick at fluid temperatures of 50 to 80°C (122 to 176°F) or using "COLD" range on dipstick at fluid temperatures of 0 to 30°C (32 to 86°F).

### CAUTION:

- Do not overfill.
- Recommended fluid is Automatic Transmission Fluid "DEXRON II™" type or equivalent.

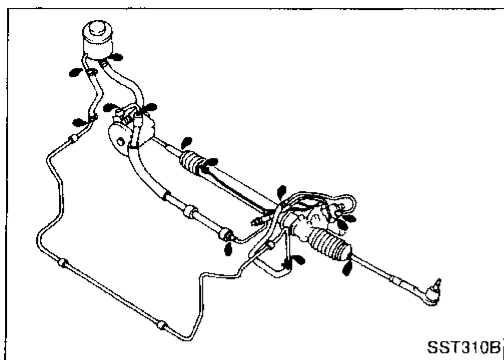

### Checking Fluid Leakage

Check the lines for improper attachment and for leaks, cracks, damage, loose connections, chafing or deterioration.

1. Run engine at idle speed or 1,000 rpm.

**Make sure temperature of fluid in oil tank rises to 60 to 80°C (140 to 176°F).**

2. Turn steering wheel right-to-left several times.
3. Hold steering wheel at each "lock" position for five seconds and carefully check for fluid leakage.

**CAUTION:**

**Do not hold the steering wheel in a locked position for more than 15 seconds.**

4. If fluid leakage at connectors is noticed, loosen flare nut and then retighten.

**Do not overtighten connector as this can damage O-ring, washer and connector.**

### Bleeding Hydraulic System

1. Raise front end of vehicle until wheels clear ground.
2. Add fluid into oil tank to specified level. Meanwhile, quickly turn steering wheel fully to right and left and lightly touch steering stoppers.

Repeat steering wheel operation until fluid level no longer decreases.

3. Start engine.  
Repeat step 2 above.

- Incomplete air bleeding will cause the following to occur. When this happens, bleed air again.

- a. Generation of air bubbles in reservoir tank
- b. Generation of clicking noise in oil pump
- c. Excessive buzzing in oil pump

While the vehicle is stationary or while turning the steering wheel slowly, fluid noise may occur in the valve or oil pump. This noise is inherent in this steering system, and it will not affect performance or durability of the system.

GI

MA

EM

LC

EF &  
EC

FE

AT

PD

FA

RA

BR

ST

BF

HA

EL

IDX

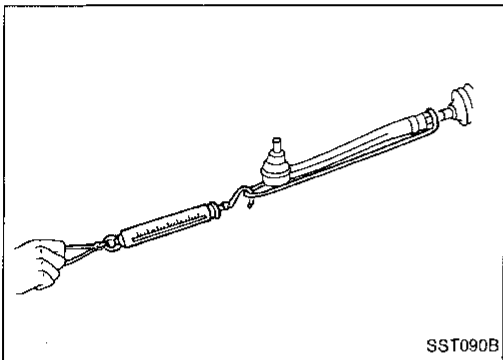
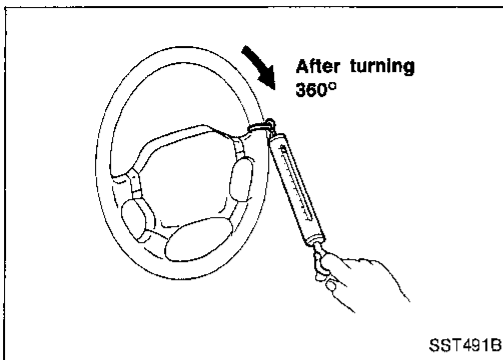

## Checking Steering Wheel Turning Force (For power steering)

1. Park vehicle on a level, dry surface and set parking brake.
2. Start engine.
3. Bring power steering fluid up to adequate operating temperature. [Make sure temperature of fluid is approximately 60 to 80°C (140 to 176°F).]

**Tires need to be inflated to normal pressure.**

4. Check steering wheel turning force when steering wheel has been turned 360° from the neutral position.

**Steering wheel turning force:**

**39 N (4 kg, 9 lb) or less**

5. If steering wheel turning force is out of specifications, check rack sliding force to detect condition of steering gear assembly.
  - a. Disconnect steering column lower joint and knuckle arms from the gear.
  - b. Start and run engine at idle to make sure steering fluid has reached normal operating temperature.
  - c. While pulling tie-rod slowly in the  $\pm 11.5$  mm ( $\pm 0.453$  in) range from the neutral position, make sure rack sliding force is within specification.

**Rack sliding force:**

**216 - 275 N (22 - 28 kg, 49 - 62 lb)**

- d. Check sliding force outside above range.

**Rack sliding force:**

**Not more than 294 N (30 kg, 66 lb)**

6. If rack sliding force is not within specification, overhaul steering gear assembly.

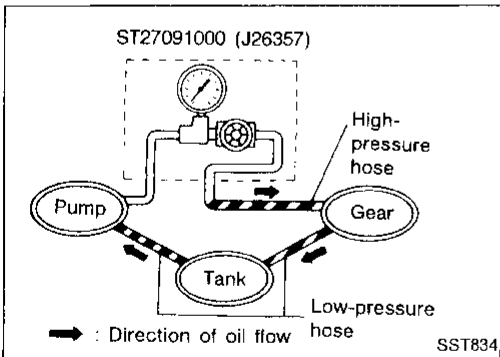

## Checking Hydraulic System

Before starting, check belt tension, driving pulley and tire pressure.

1. Set Tool. Open shut-off valve. Then bleed air. (See "Bleeding Hydraulic System".)
2. Run engine.

**Make sure temperature of fluid in tank rises to 60 to 80°C (140 to 176°F).**

**WARNING:**

**Warm up engine with shut-off valve fully opened. If engine is started with shut-off valve closed, oil pressure in oil pump will increase to relief pressure, resulting in an abnormal rise in oil temperature.**

3. Check pressure with steering wheel fully turned to left and right positions with engine idling at 1,000 rpm.

**CAUTION:**

**Do not hold the steering wheel in a locked position for more than 15 seconds.**

**Oil pump maximum standard pressure:**

**7,649 - 8,238 kPa (78 - 84 kg/cm<sup>2</sup>, 1,109 - 1,194 psi)**



## ON-VEHICLE SERVICE

---

### Checking Hydraulic System (Cont'd)

4. If oil pressure is below the standard pressure, slowly close shut-off valve and check pressure.
  - When pressure reaches standard pressure, gear is damaged.
  - When pressure remains below standard pressure, pump is damaged.

#### CAUTION:

**Do not close shut-off valve for more than 15 seconds.**

5. If oil pressure is higher than standard pressure, check oil pump flow control valve.
6. After checking hydraulic system, remove Tool and add fluid as necessary, then completely bleed air out of system.

GI

WA

EM

LC

EF &  
EC

FE

AT

PD

FA

RA

BR

**ST**

BF

HA

EL

IDX

# STEERING WHEEL AND STEERING COLUMN

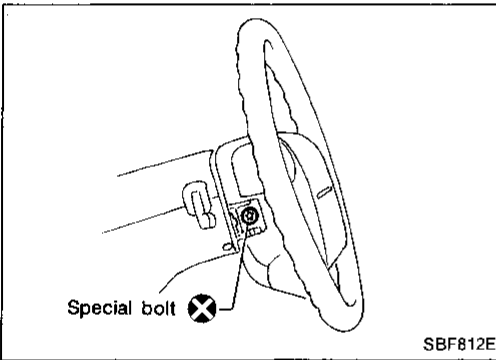
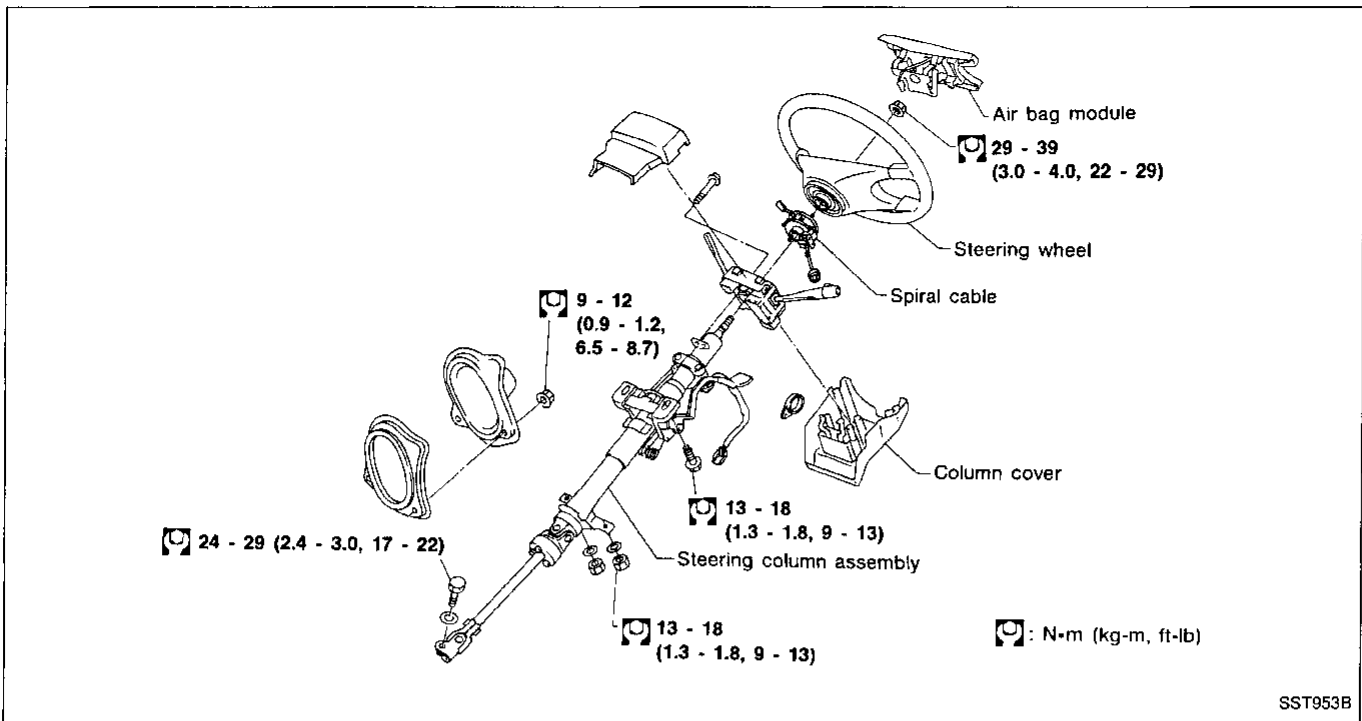

## Removal

### STEERING WHEEL (With air bag)

- Remove air bag module and spiral cable. Refer to BF section ("Removal — Air Bag Module and Spiral Cable", "SUPPLEMENTAL RESTRAINT SYSTEM").

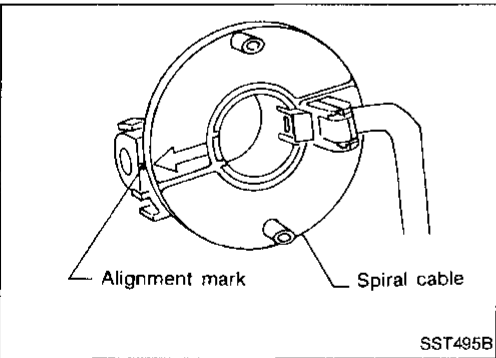

- Align spiral cable correctly when installing steering wheel.

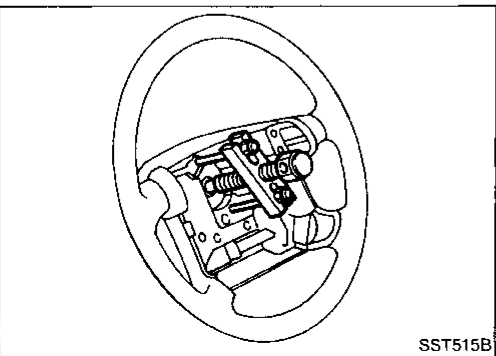

- Remove steering wheel with Tool.

# STEERING WHEEL AND STEERING COLUMN

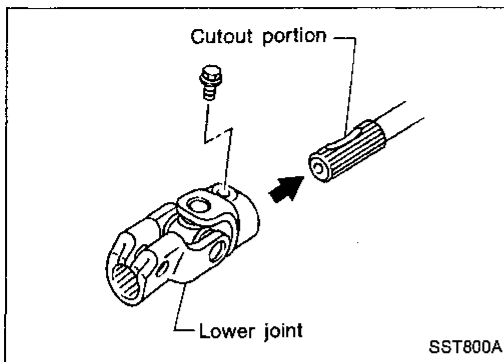

## Installation

### STEERING COLUMN

- When installing steering column, fingertighten all lower bracket and clamp retaining bolts; then tighten them securely. Do not apply undue stress to steering column.
- When attaching coupling joint, be sure tightening bolt faces cutout portion.

### CAUTION:

After installing steering column, turn steering wheel to make sure it moves smoothly and that the number of turns from the straight forward position to left and right locks are equal.

Be sure that the steering wheel is in a neutral position when driving straight ahead.

GI

MA

EM

LC

EF &  
EC

FE

AT

PD

FA

RA

BR

ST

BF

HA

EL

IDX

# STEERING WHEEL AND STEERING COLUMN

## Disassembly and Assembly

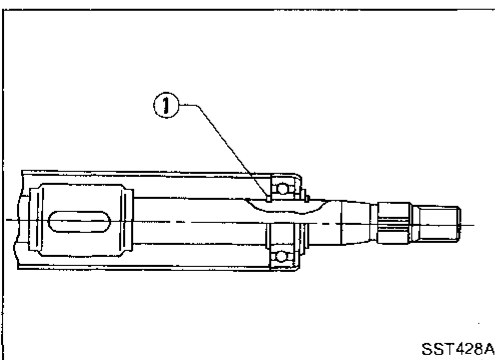
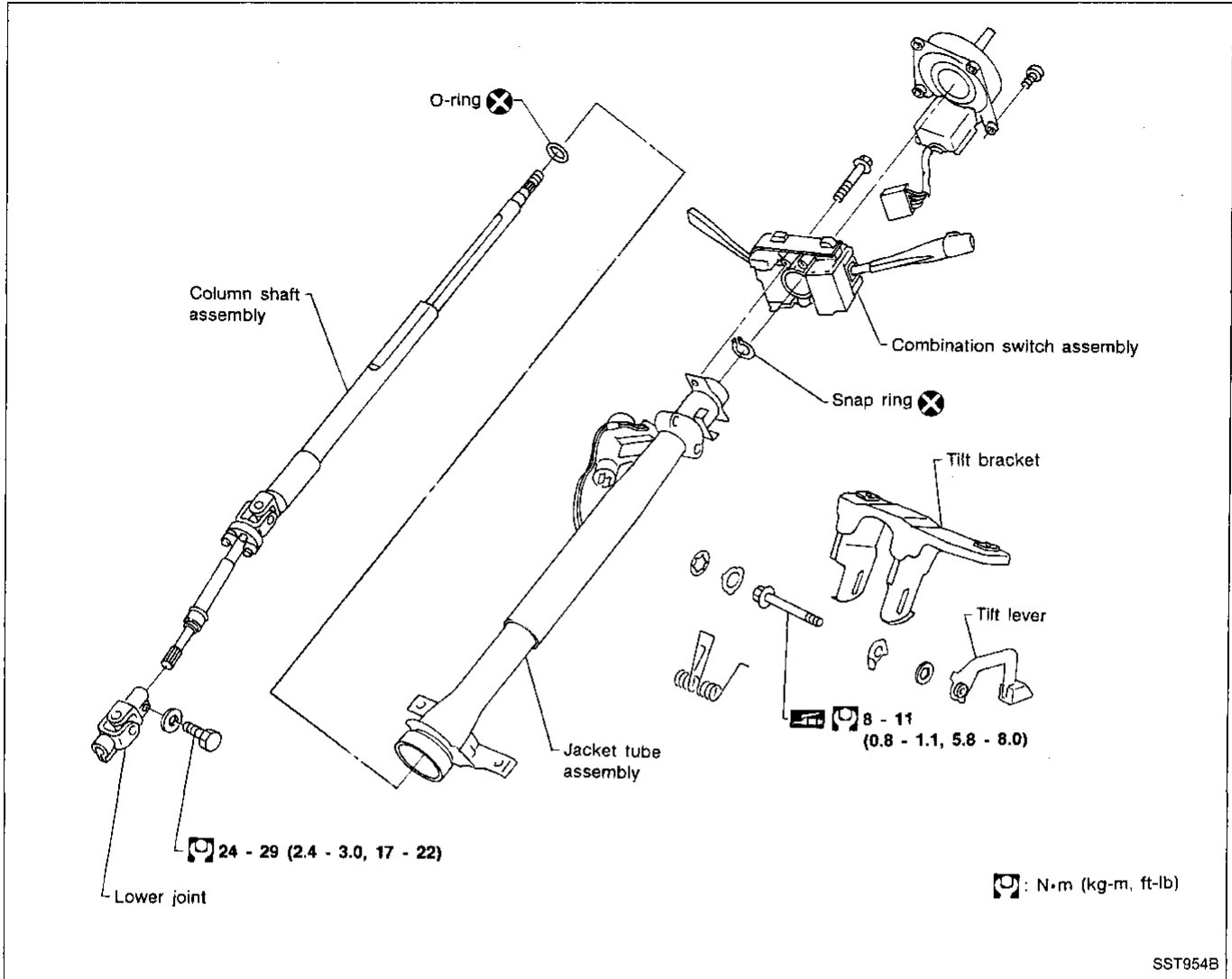

- When disassembling and assembling, unlock steering lock with key.
- Install O-ring ① before inserting shaft into jacket tube. Ensure that rounded surface of snap ring faces toward bearing when snap ring is installed.

# STEERING WHEEL AND STEERING COLUMN

## Disassembly and Assembly (Cont'd)

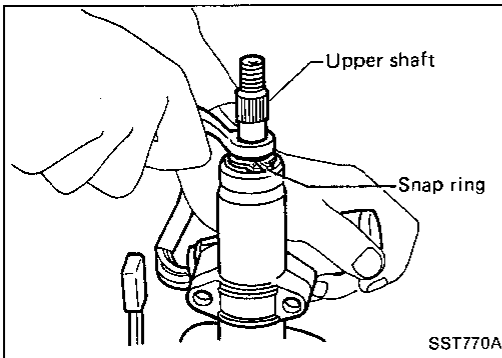

- Install snap ring on upper shaft with box wrench.

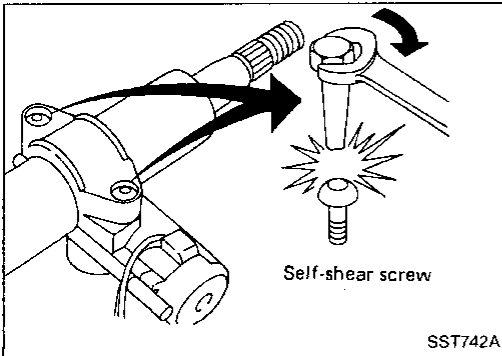

- Steering lock
  - a) Break self-shear type screws with a drill or other appropriate tool.
  - b) Install new self-shear type screws and then cut off self-shear type screw heads.

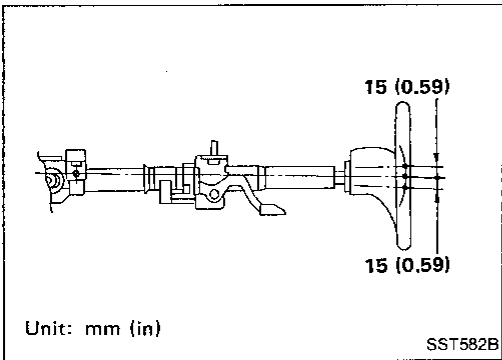

- After installing steering column, check tilt mechanism operation.

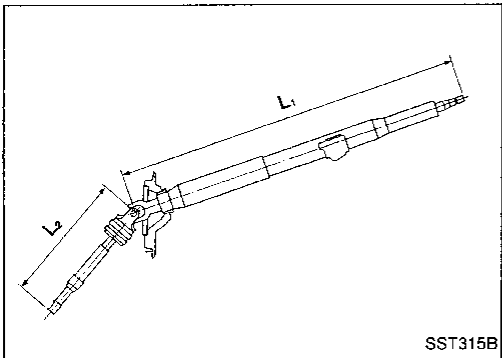

## Inspection

- When steering wheel can not be rotated smoothly, check the steering column for the following matters and replace damaged parts.
  - a. Check column bearings for damage or unevenness. Lubricate with recommended multi-purpose grease or replace steering column as an assembly, if necessary.
  - b. Check steering column lower shaft for deformation or breakage. Replace if necessary.
- When the vehicle is involved in a light collision, check steering column length "L<sub>1</sub>" and steering column lower shaft length "L<sub>2</sub>". If it is not within specifications, replace steering column as an assembly.

**Steering column length "L<sub>1</sub>":**

**642.2 - 643.8 mm (25.28 - 25.35 in)**

**Steering column lower shaft length "L<sub>2</sub>":**

**326.4 - 328.0 mm (12.85 - 12.91 in)**

GI

MA

EM

LC

EF &  
EC

FE

AT

PD

FA

RA

BR

ST

BF

HA

FL

IDX

# POWER STEERING GEAR AND LINKAGE

## Removal and Installation

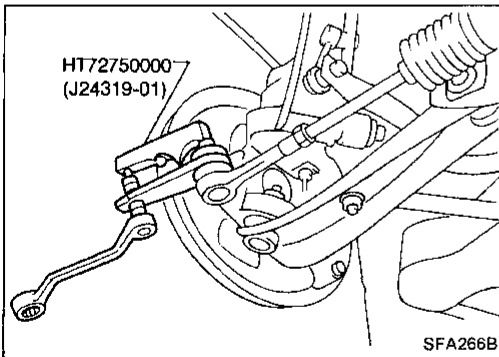
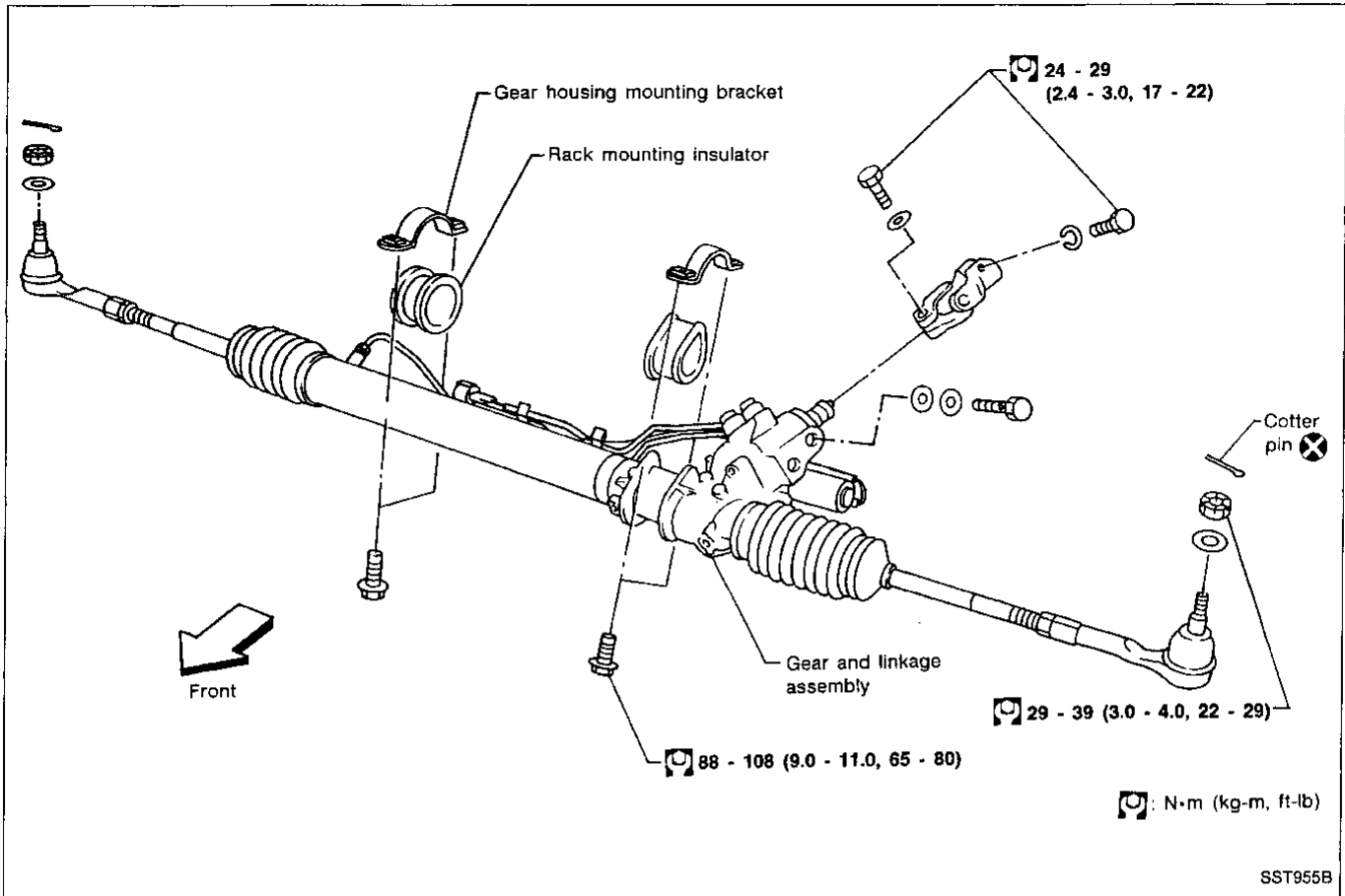

### CAUTION:

The rotation of the spiral cable (SRS "Air bag" component part) is limited. If the steering gear must be removed, set the front wheels in the straight-ahead direction. Do not rotate the steering column while the steering gear is removed.

- Detach tie-rod outer sockets from knuckle arms with Tool.

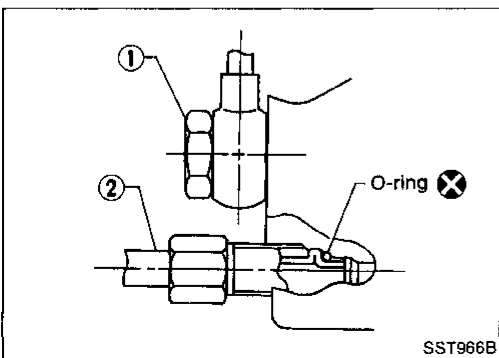

- Install pipe connector.

① Low-pressure side

⊗: 36 - 40 N·m (3.7 - 4.1 kg-m, 27 - 30 ft-lb)

② High-pressure side

⊗: 15 - 25 N·m (1.5 - 2.5 kg-m, 11 - 18 ft-lb)

# POWER STEERING GEAR AND LINKAGE

## Removal and Installation (Cont'd)

- Observe specified tightening torque when tightening high-pressure and low-pressure pipe connectors. Excessive tightening can damage threads or damaged connector O-ring.
- The O-ring in low-pressure pipe connector is larger than that in high-pressure connector. Take care to install the proper O-ring.

GI

MA

EM

LC

EF &  
EC

FE

AT

PD

FA

RA

BR

ST

BF

HA

EL

IDX

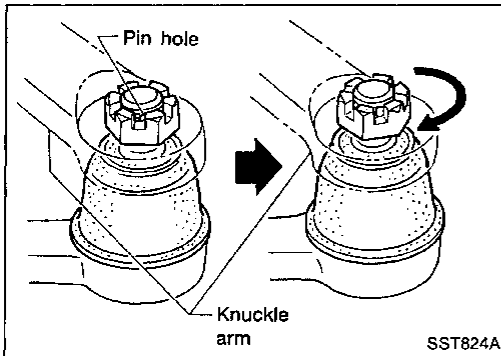

- Initially, tighten nut on tie-rod outer socket and knuckle arm to 29 to 39 N·m (3 to 4 kg·m, 22 to 29 ft·lb). Then tighten further to align nut groove with first pin hole so that cotter pin can be installed.

### CAUTION:

Tightening torque must not exceed 49 N·m (5 kg·m, 36 ft·lb).

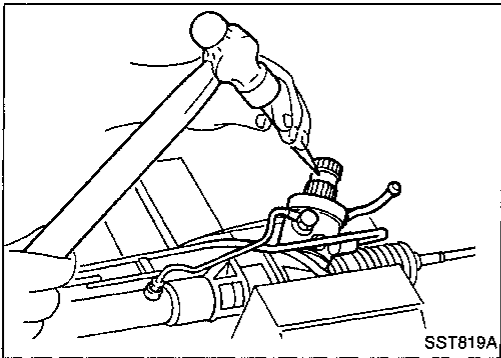

- Before removing lower joint from gear, set gear in neutral (wheels in straight-ahead position). After removing lower joint, put matchmarks on pinion shaft and pinion housing to record neutral position of gear.
- To install, set left and right dust boots to equal deflection, and attach lower joint by aligning matchmarks of pinion shaft and pinion housing.

# POWER STEERING GEAR AND LINKAGE

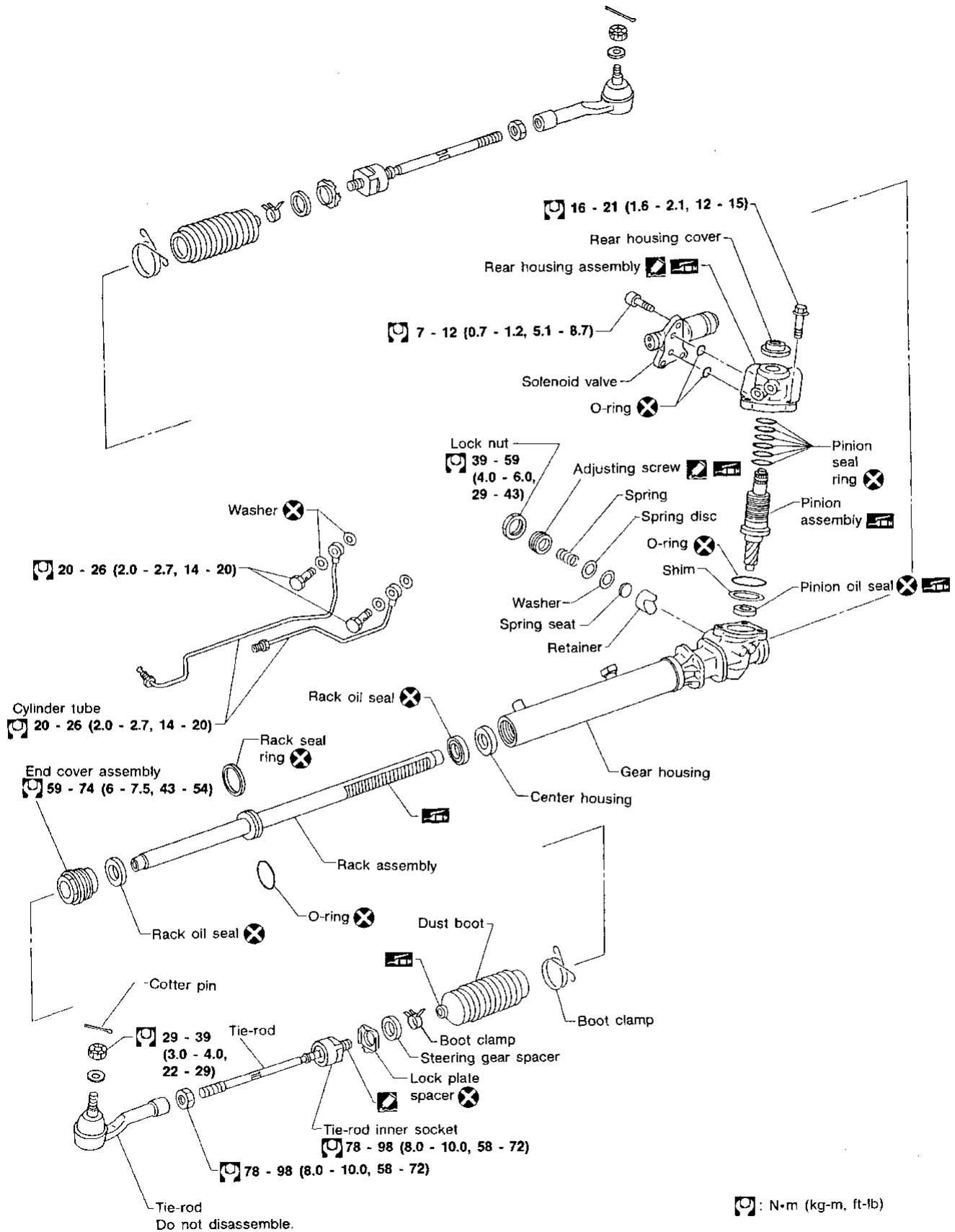



# POWER STEERING GEAR AND LINKAGE

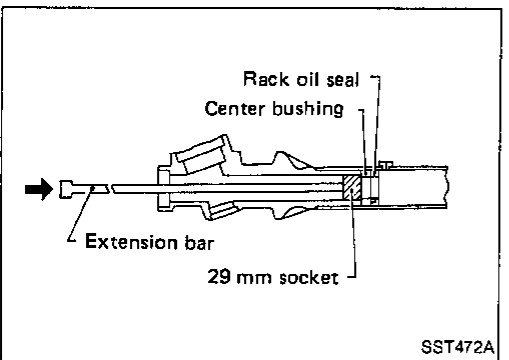
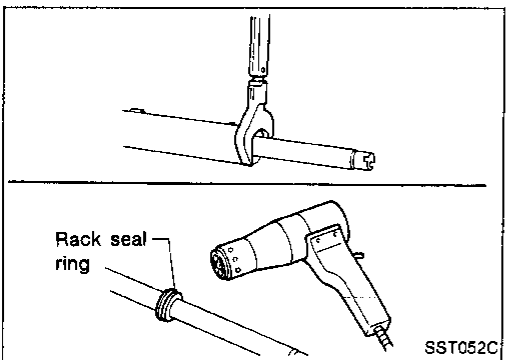
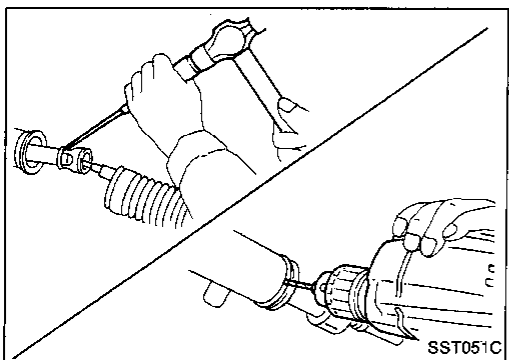
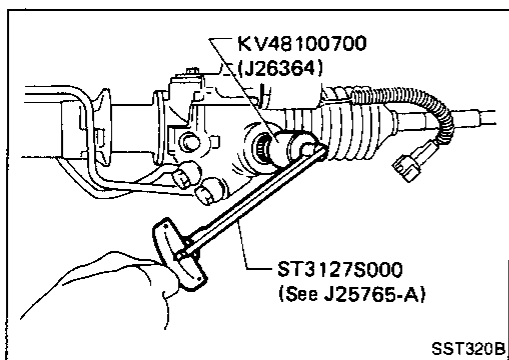

## Disassembly

1. Prior to disassembling, measure pinion rotating torque. Record the pinion rotating torque as a reference. Refer to step 12 of "Adjustment" for reference torque data.
    - Before measuring, disconnect cylinder tube and drain fluid.
    - Use soft jaws when holding steering gear housing. Handle gear housing carefully, as it is made of aluminum. Do not grip cylinder in a vise.
  2. Remove pinion gear.
    - Be careful not to damage pinion gear when removing pinion seal ring.
  3. Remove tie-rod outer sockets and boots.
  4. Loosen tie-rod inner socket by prying up staked portion, and remove socket.
  5. Remove retainer.
  6. Remove pinion assembly.
  7. Drill staked portion of cylinder end cover with drill of 2 to 2.5 mm (0.079 to 0.098 in) diameter, until the staking is eliminated.
  8. Remove gear housing end cover assembly with Tool.
  9. Draw out rack assembly.
  10. Remove rack seal ring.
    - Using a heat gun, heat rack seal to approximately 40°C (104°F).
    - Remove rack seal ring.
    - Replace rack seal ring and O-ring with new ones.
- Be careful not to damage rack.**

11. Remove center bushing and rack oil seal using tape wrapped socket and extension bar.
  - Do not scratch inner surfaces of pinion housing.

## Inspection

Thoroughly clean all parts in cleaning solvent or automatic transmission fluid "DEXRON II™" type, and blow dry with compressed air, if available.

### BOOT

Check condition of boot. If cracked excessively, replace it.

### RACK

Thoroughly examine rack gear. If damaged, cracked or worn, replace it.

GI  
MA  
EM  
LC  
EF & EC  
FE  
AT  
PD  
FA  
RA  
BR  
ST  
BF  
HA  
EL

IDX

## POWER STEERING GEAR AND LINKAGE

### Inspection (Cont'd)

#### PINION ASSEMBLY

- Thoroughly examine pinion gear. If pinion gear is damaged, cracked or worn, replace it.
- Inspect bearings to see that they roll freely and are free from cracked, pitted, or worn balls, rollers and races. Replace if necessary.

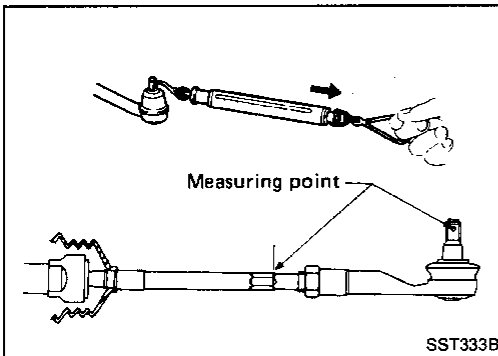

#### TIE-ROD OUTER AND INNER SOCKET

- Check ball joint for swinging force.

##### Tie-rod outer ball joint:

4.9 - 46.1 N  
(0.5 - 4.7 kg, 1.1 - 10.4 lb)

##### Tie-rod inner ball joint:

7.8 - 73.6 N  
(0.8 - 7.5 kg, 1.8 - 16.5 lb)

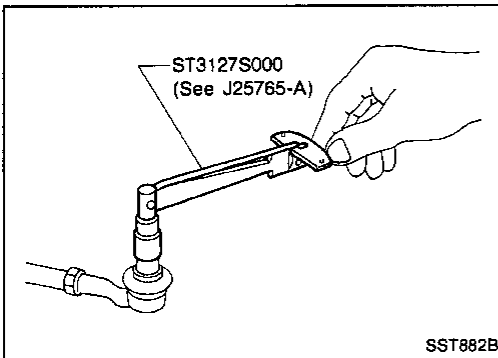

- Check ball joint for rotating torque.

##### Tie-rod outer ball joint:

0.29 - 2.94 N·m  
(3.0 - 30.0 kg-cm, 2.6 - 26.0 in-lb)

##### Tie-rod inner ball joint:

1.0 - 8.8 N·m (10 - 90 kg-cm, 8.7 - 78.1 in-lb)

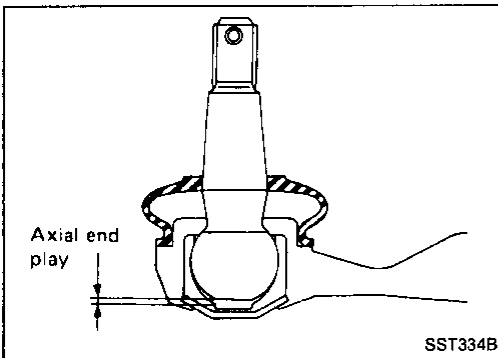

- Check ball joint for axial end play.

##### Tie-rod outer ball joint:

0 mm (0 in)

##### Tie-rod inner ball joint:

0 mm (0 in)

- Check condition of dust cover. If cracked excessively, replace it.

#### CYLINDER TUBES

Check cylinder tubes for scratches or other damage. Replace if necessary.

# POWER STEERING GEAR AND LINKAGE

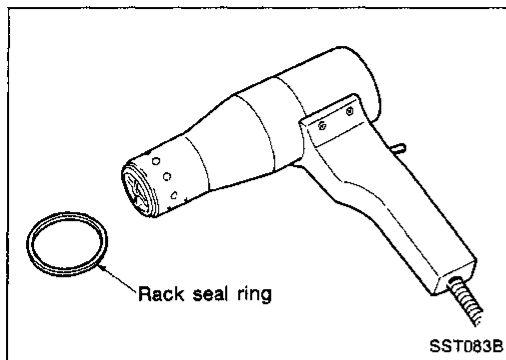

## Assembly

- Using a heat gun, heat rack seal ring (made of Teflon) to approximately 40°C (104°F) and install it onto rack with your hand.

GI

MA

EM

LC

EF &  
EC

FE

AT

PD

FA

RA

BR

ST

BF

HA

EL

IDX

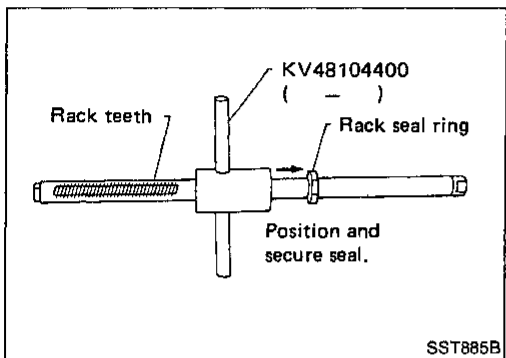

- Using Tool, compress periphery of rack seal ring (made of Teflon) to position and secure it on rack.

**Always Insert the tool from the rack gear side.**

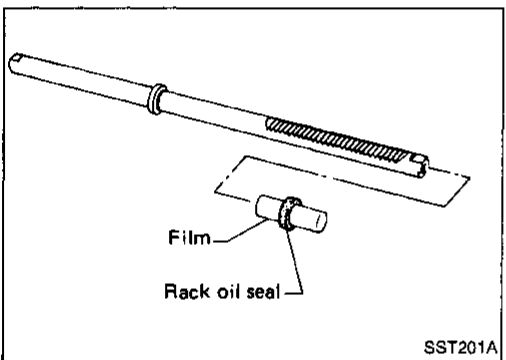

- Insert rack oil seal.

- Place plastic film into rack oil seal to prevent damage by rack teeth.
- Always remove plastic film after rack oil seal is positioned properly.
- Make sure lips of rack oil seal face each other.

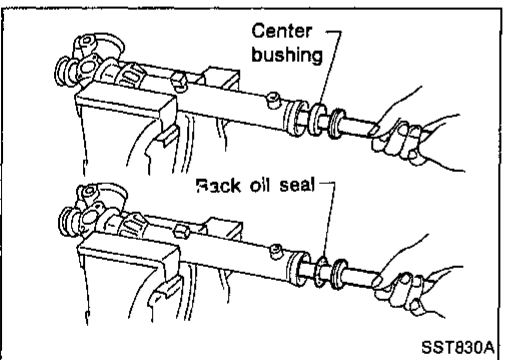

- Install center bushing and rack oil seal with rack assembly.

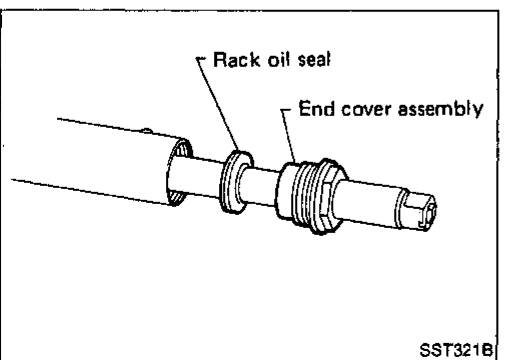

- Insert rack oil seal and end cover assembly to rack then tighten end cover assembly.

# POWER STEERING GEAR AND LINKAGE

## Assembly (Cont'd)

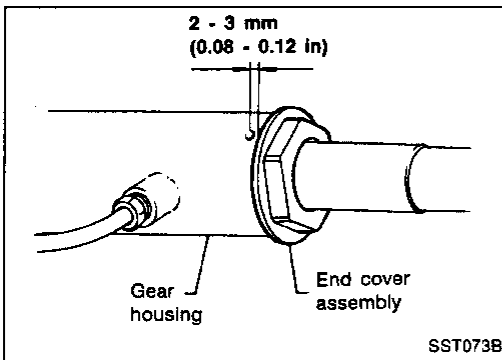

5. Fasten cylinder end cover assembly to gear housing by staking.

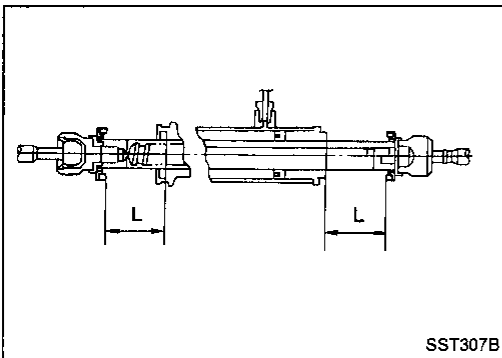

6. Set rack gear in neutral position.  
**Rack stroke "L":**  
Refer to SDS (ST-91).

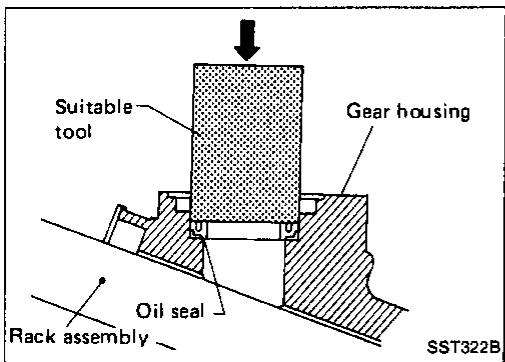

7. Coat seal lip of oil seal with multi-purpose grease and install new pinion oil seal to pinion housing with a suitable tool.
  - Make sure lip of oil seal faces up when installed.

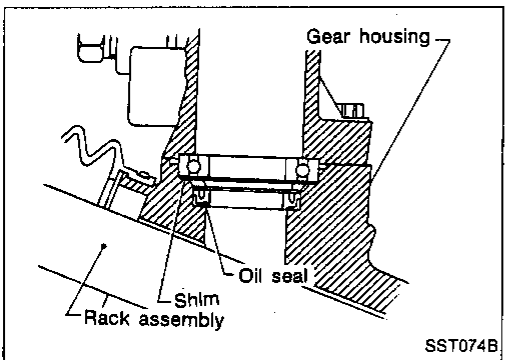

8. Install pinion bearing adjusting shim(s).
  - Whenever pinion assembly, gear housing and rear housing are disassembled, replace shim(s) with new ones. Always use the same number of shim(s) when replacing.

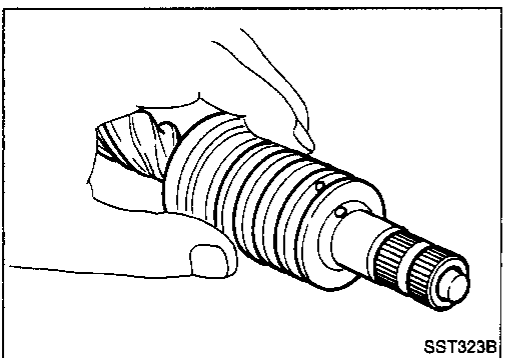

9. Install pinion seal ring on pinion gear assembly.
  - Using a heat gun, heat pinion seal ring to approximately 40°C (104°F) before installing it onto pinion gear assembly.
  - Make sure pinion seal ring is properly settled in valve groove.

# POWER STEERING GEAR AND LINKAGE

## Assembly (Cont'd)

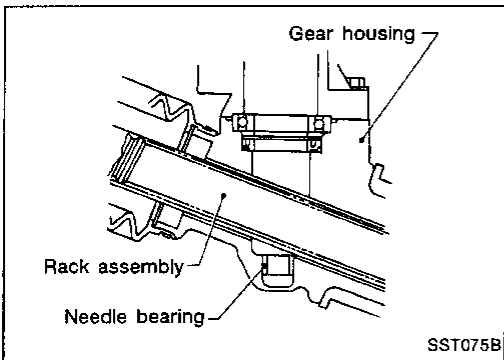

10. Apply a coat of multi-purpose grease to needle bearing roller and oil seal lip before installing pinion assembly in gear housing.

GI

MA

EM

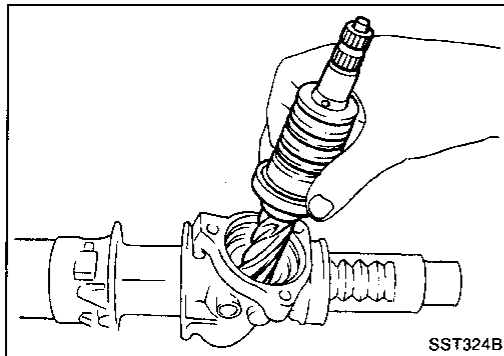

11. Install pinion assembly to pinion housing.  
**Be careful not to damage pinion oil seal.**

LC

EF &  
EC

FE

AT

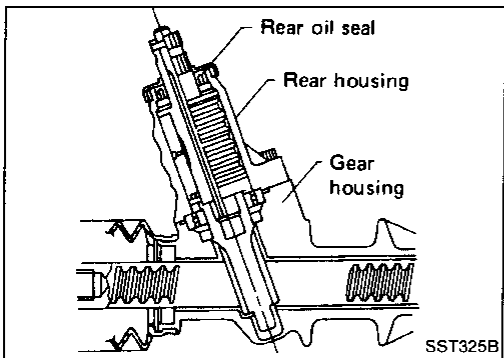

12. Apply a coat of multi-purpose grease to rear oil seal lip before installing rear housing.

PD

FA

RA

BR

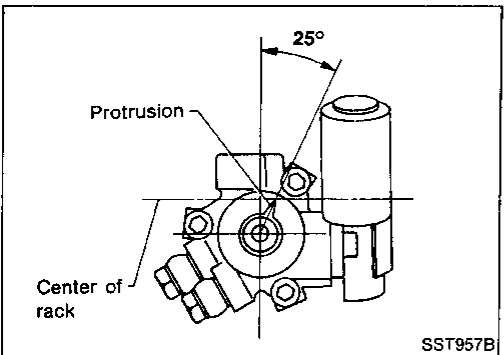

13. Install rear cover cap so that protrusion of rear housing cover is positioned as shown in figure at left.  
**Be careful not to damage worm ring and oil seal.**

ST

BF

HA

EL

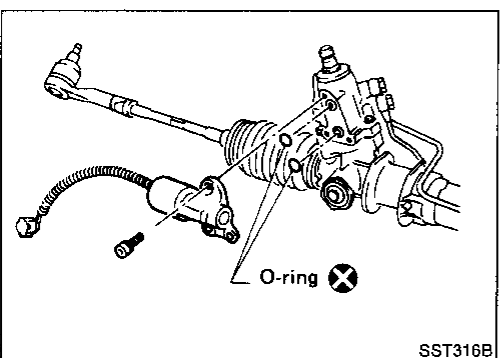

14. Install solenoid valve.

IDX

## POWER STEERING GEAR AND LINKAGE

### Assembly (Cont'd)

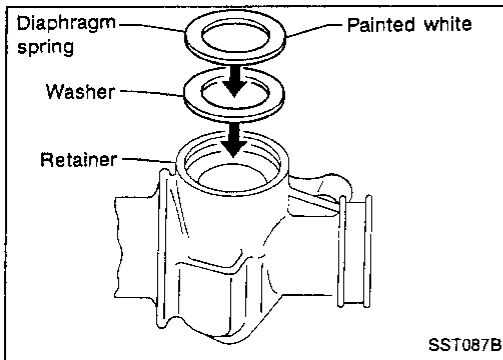

15. Install diaphragm spring at retainer.

- Always install retainer, spring washer and diaphragm spring in that order.
- Make sure convex end (painted white) of diaphragm spring faces outward when installing.

16. Install retainer spring and adjusting screw temporarily.

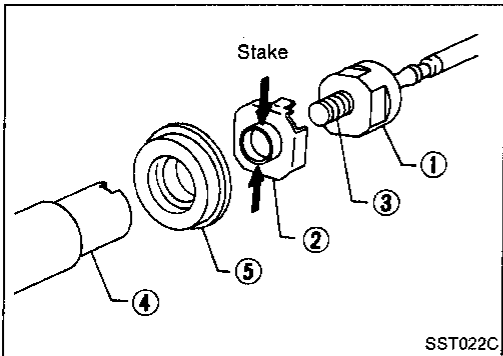

### CAUTION:

Ensure steering gear spacer is installed with rubber side facing rack.

- Attach lock plate ② to side rod inner socket ①.
- Insert steering gear spacer ⑤ to rack ④.
- Apply locking sealant to inner socket threads ③. Screw inner socket into rack ④ and tighten to specified torque.
- Stake lock plate at two places.

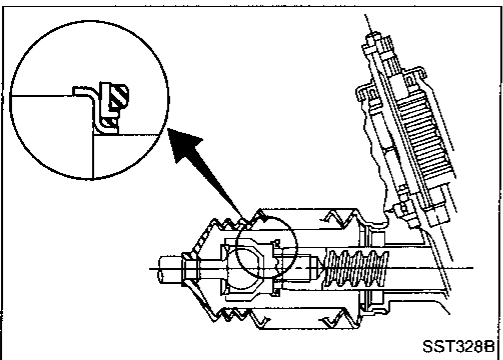

17. Install steering gear spacer ⑤ to lock plate ②.

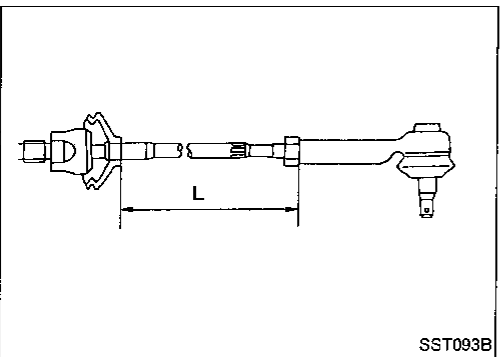

18. Tighten outer socket lock nut.

**Tie-rod length "L":**

**Refer to SDS (ST-91).**

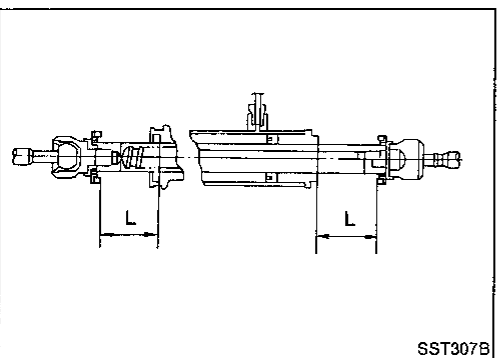

19. Measure rack stroke.

**Rack stroke "L":**

**Refer to SDS (ST-91).**

# POWER STEERING GEAR AND LINKAGE

## Assembly (Cont'd)

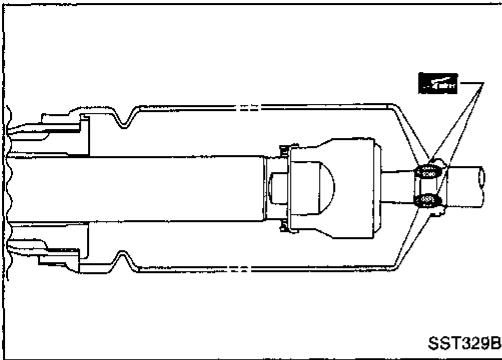

20. Before installing boot, coat the contact surfaces between boot and tie-rod with grease.

GI

MA

EM

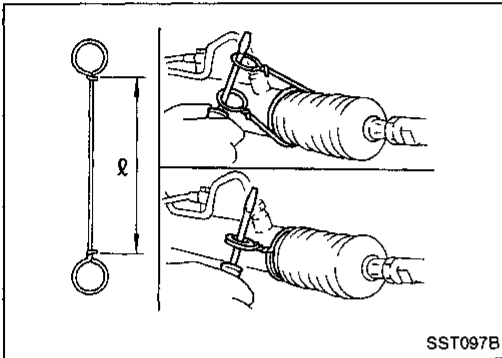

21. Install boot clamps.

- To install, wrap boot clamp around boot groove twice. Tighten clamp by twisting rings at both ends 4 to 4-1/2 turns with screwdriver while pulling with a force of approx. 98 N (10 kg, 22 lb).

LC

EF &  
EC

FE

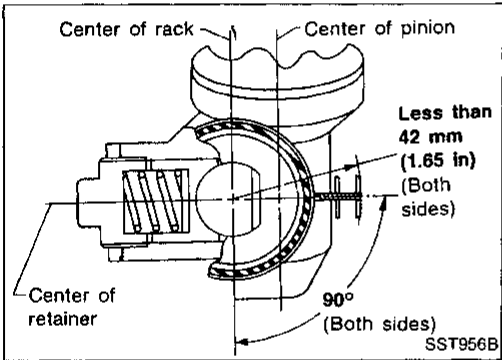

- Install boot clamp so that it is to the rear of the vehicle when gear housing is attached to the body. (This will prevent interference with other parts.)

AT

PD

FA

RA

BR

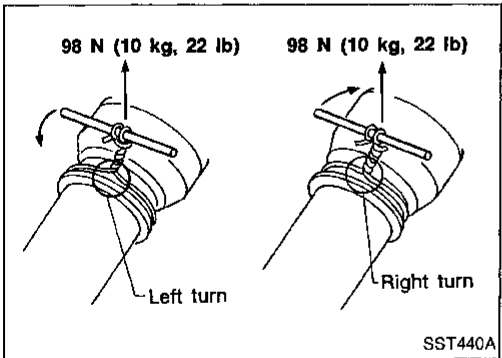

- Twist boot clamp in the direction shown in figure at left.

ST

BF

HA

EL

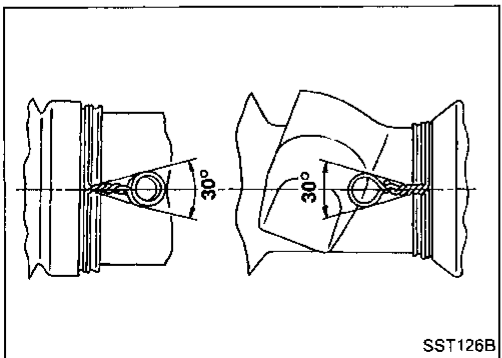

- After twisting boot clamp, bend twisted and diagonally so it does not contact boot.

IDX

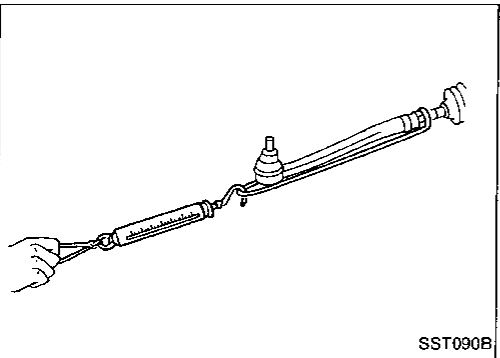
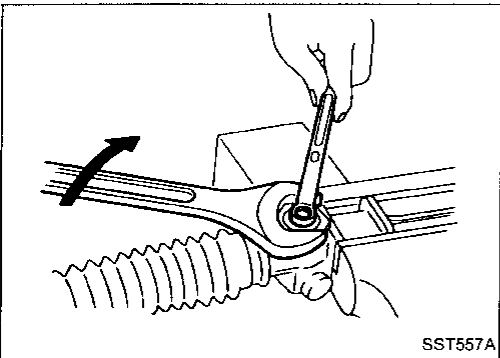
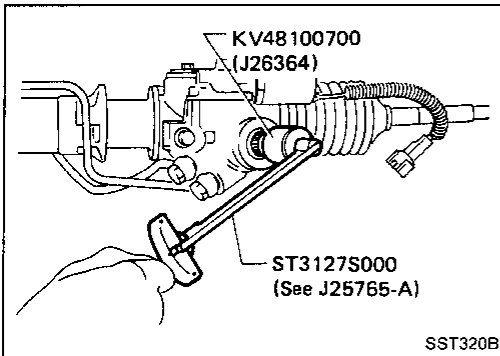
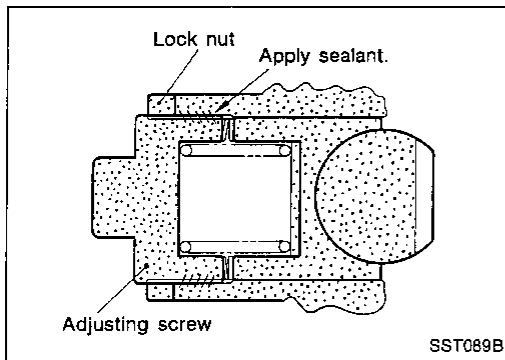

## Adjustment

Adjust pinion rotating torque as follows:

1. Set gears to Neutral without fluid in the gear.
2. Coat the adjusting screw with locking sealant and screw it in.
3. Lightly tighten lock nut.
4. Tighten adjusting screw to a torque of 4.9 to 5.9 N·m (50 to 60 kg-cm, 43 to 52 in-lb).
5. Loosen adjusting screw, then retighten it to 0.05 to 0.20 N·m (0.5 to 2 kg-cm, 0.43 to 1.74 in-lb).
6. Move rack over its entire stroke several times.
7. Measure pinion rotating torque within the range of 180° from neutral position.  
Stop the gear at the point of maximum torque.
8. Loosen adjusting screw, then retighten it to 4.9 N·m (50 kg-cm, 43 in-lb).
9. Loosen adjusting screw by 50° to 110°.

10. Prevent adjusting screw from turning, and tighten lock nut to specified torque.

11. Check steering gear for rack sliding frictional force.

**Around neutral point of rack stroke**

**± 5.5 mm (± 0.217 in):**

**122.6 - 166.7 N (12.5 - 17 kg, 27.6 - 37.5 lb)**

**Except for neutral point:**

**122.6 - 186.3 N (12.5 - 19 kg, 27.6 - 41.9 lb)**

- If sliding frictional force is out of specification, repeat the adjustment procedure, starting from No. 4.
- After the readjustment, if sliding force is still out of specification, steering gear is damaged.



# POWER STEERING GEAR AND LINKAGE

## Adjustment (Cont'd)

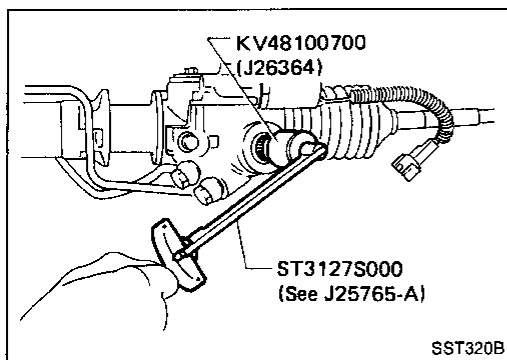

12. Measure pinion rotating torque within the range of  $\pm 100^\circ$  from the neutral point.

### Average rotating torque

[(Max. measured value + Min. measured value) x 0.5]:

0.8 - 1.3 N-m (8 - 13 kg-cm, 6.9 - 11.3 in-lb)

### Maximum torque increment:

Less than 0.4 N-m (4 kg-cm, 3.5 in-lb)

### Except for above mentioned measuring range:

#### Maximum rotating torque

1.9 N-m (19 kg-cm, 16 in-lb)

#### Maximum torque increment

Less than 0.6 N-m (6 kg-cm, 5.2 in-lb)

- If pinion rotating torque is not within specification, readjust it.
- After the readjustment, if pinion rotating torque is still out of specification, steering gear is damaged.

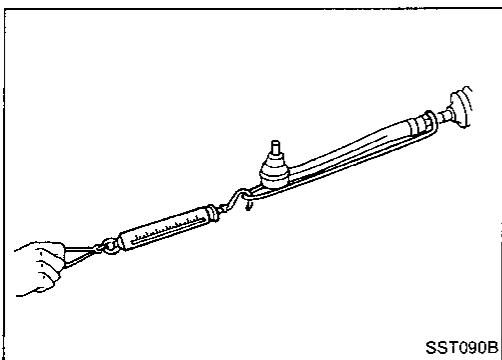

13. Check rack sliding force on vehicle as follows:
  - a. Install steering gear onto vehicle, but do not connect tie-rod to knuckle arm.
  - b. Connect all piping and fill with steering fluid.
  - c. Start engine and bleed air completely.
  - d. Disconnect steering column lower joint from the gear.
  - e. Keep engine at idle and make sure steering fluid has reached normal operating temperature.
  - f. While pulling tie-rod slowly in the  $\pm 11.5$  mm ( $\pm 0.453$  in) range from the neutral position, make sure rack sliding force is within specification.

### Rack sliding force:

216 - 275 N (22 - 28 kg, 49 - 62 lb)

- g. Check sliding force outside above range.

### Rack sliding force:

Not more than 294 N (30 kg, 66 lb)

- If rack sliding force is not within specification, readjust by repeating adjustment procedure from the beginning.
- If rack sliding force is still out of specification after readjustment, gear assembly needs to be replaced.

# POWER STEERING OIL PUMP

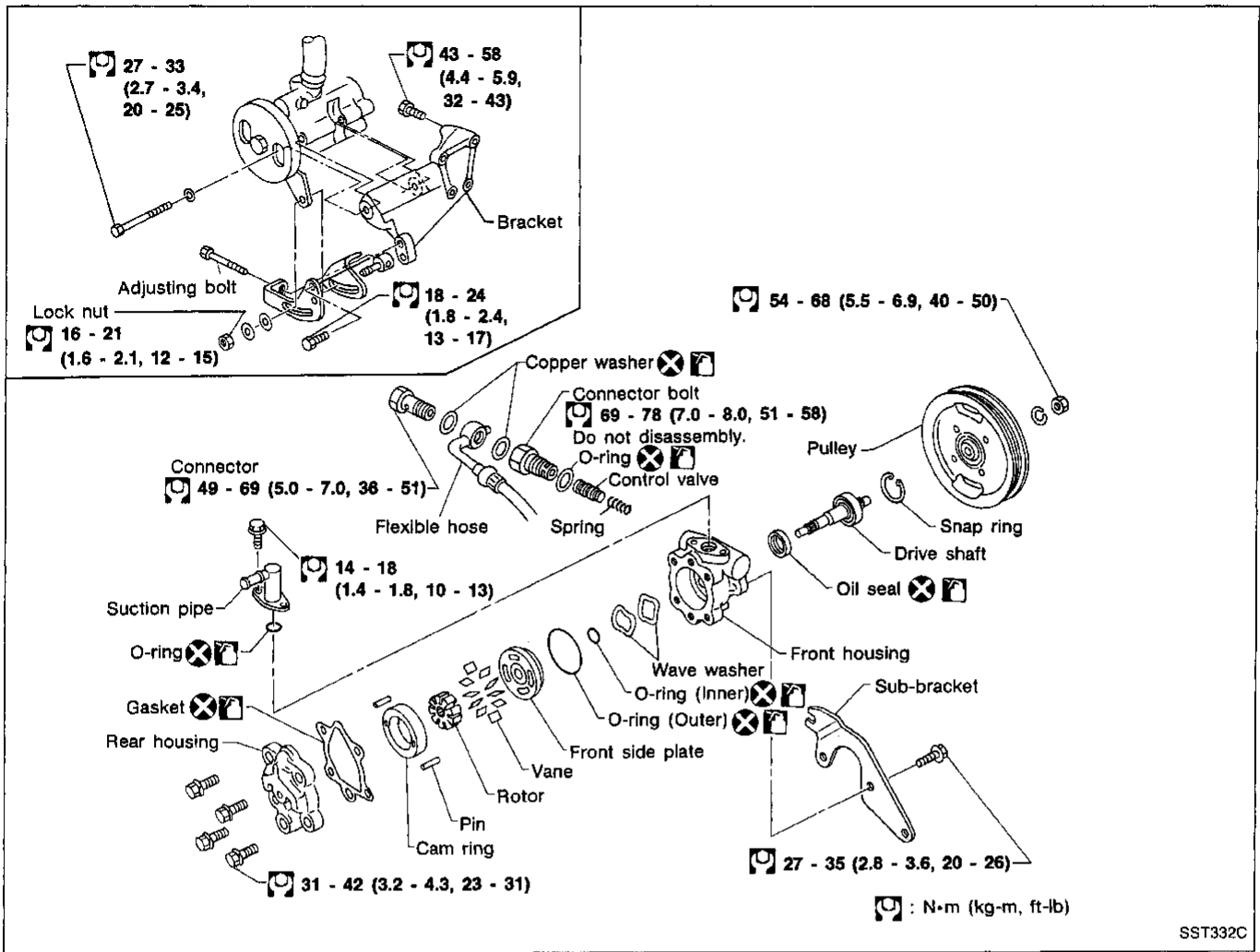

SST332C

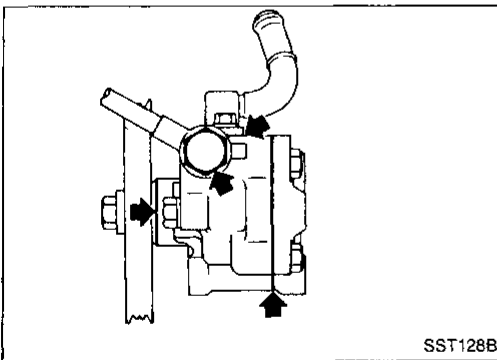

## Pre-disassembly Inspection

Disassemble the power steering oil pump only if the following items are found.

- Oil leak from any point shown in the figure.
- Deformed or damaged pulley.
- Poor performance

## Disassembly

### CAUTION:

- Parts which can be disassembled are strictly limited. Never disassemble parts other than those specified.
- Disassemble in as clean a place as possible.
- Clean your hands before disassembly.
- Do not use rags; use nylon cloths or paper towels.
- Follow the procedures and cautions in the Service Manual.
- When disassembling and reassembling, do not let foreign matter enter or contact the parts.

# POWER STEERING OIL PUMP

## Disassembly (Cont'd)

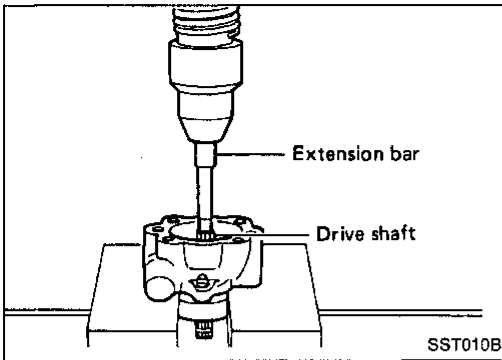

- Remove snap ring, then draw drive shaft out.  
**Be careful not to drop drive shaft.**

GI

MA

EM

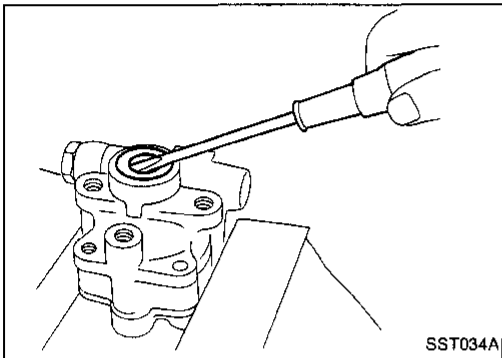

- Remove oil seal.  
**Be careful not to damage front housing.**

LC

EF &  
EC

FE

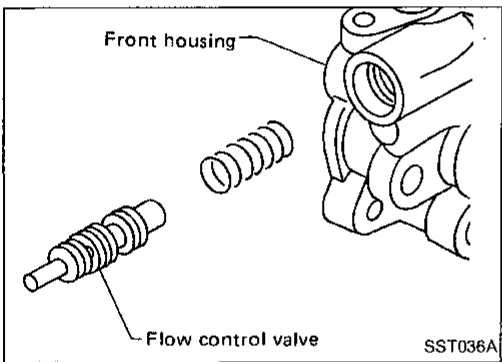

- Remove connector.  
**Be careful not to drop control valve.**

AT

PD

FA

RA

BR

## Inspection

Inspect each component part for wear, deformation, scratches, and cracks. If damage is found, replace the part.

ST

BF

HA

EL

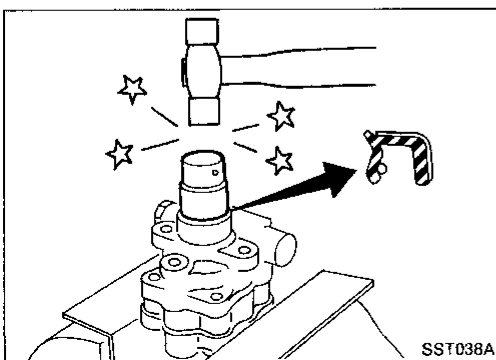

## Assembly

Assemble oil pump, noting the following instructions.

- Make sure O-rings and oil seal are properly installed.
- Always install new O-rings and oil seal.
- Be careful of oil seal direction.
- Cam ring, rotor and vanes must be replaced as a set if necessary.
- Coat each part with ATF when assembling.

IDX

# POWER STEERING OIL PUMP

## Assembly (Cont'd)

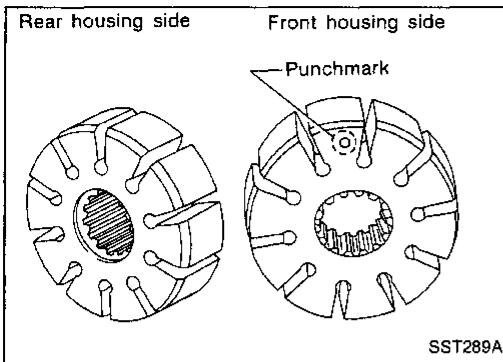

- Pay attention to rotor direction.

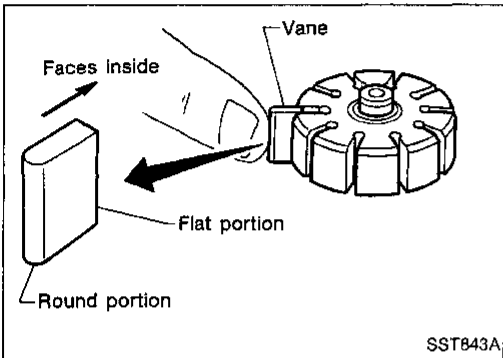

- When assembling vanes to rotor, rounded surfaces of vanes must face cam ring side.

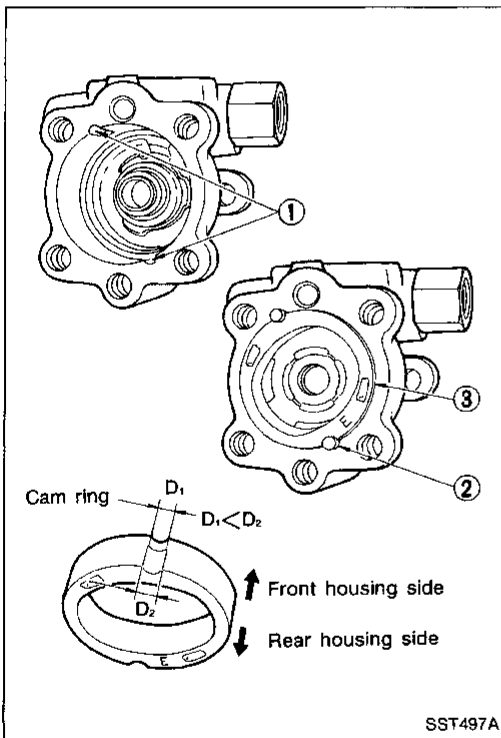

- Insert pin ② into pin groove ① of front housing and front side plate. Then install cam ring ③ as shown at left.

# TWIN ORIFICE POWER STEERING SYSTEM

## Hydraulic Circuit

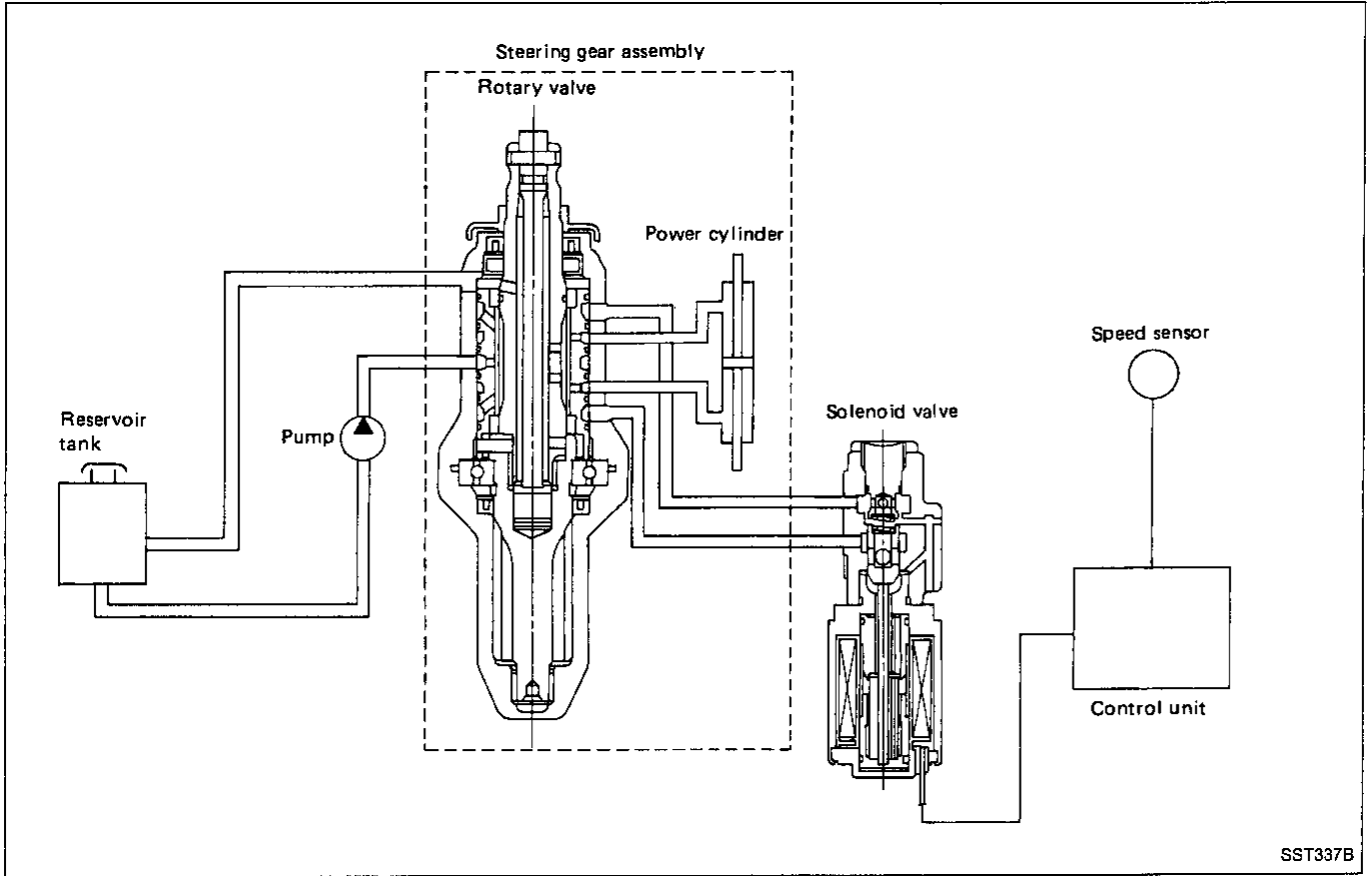

## Schematic

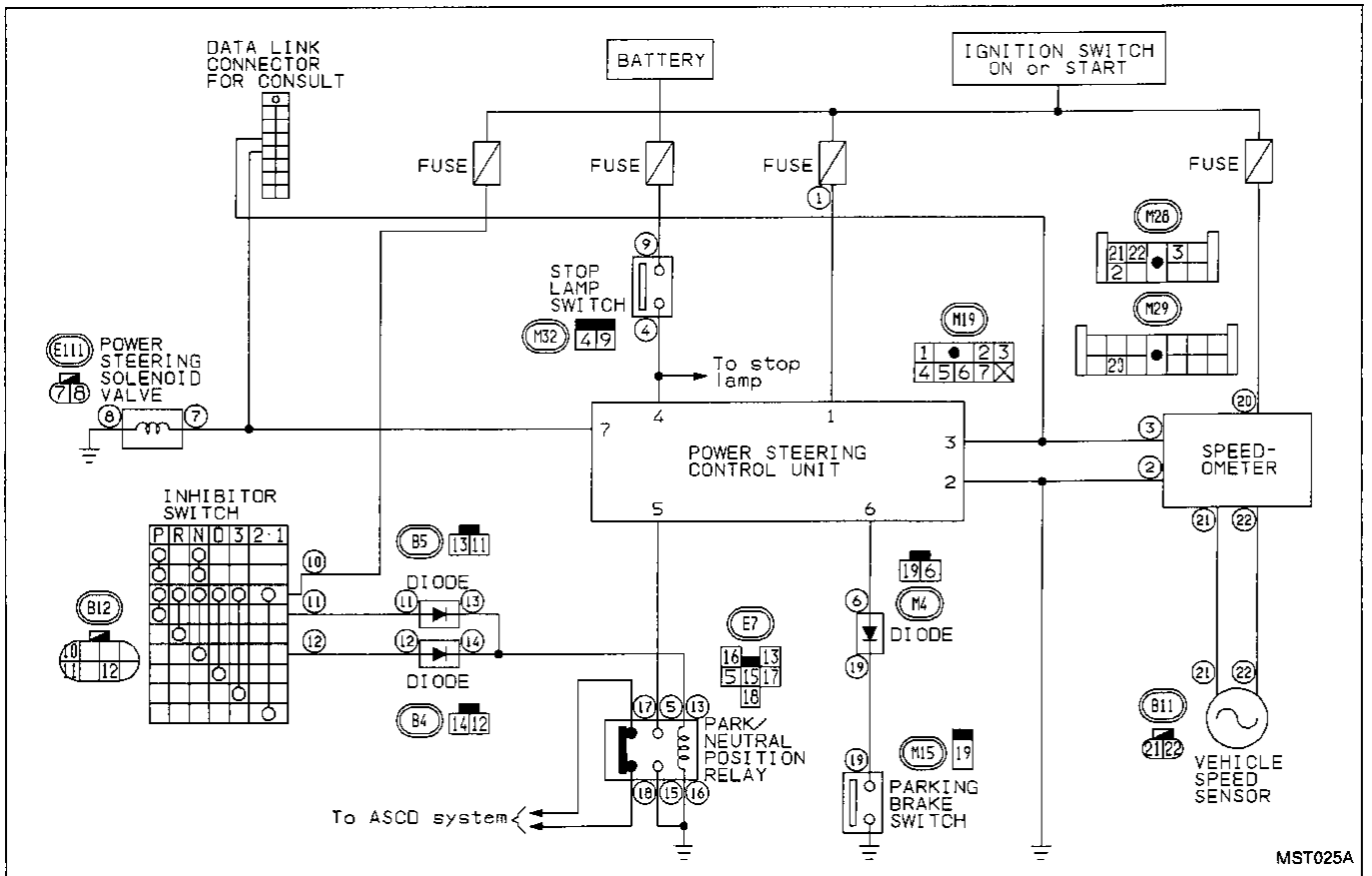

GI  
MA  
EM  
LC  
EF & EC  
FE  
AT  
PD  
FA  
RA  
BR  
ST  
BF  
HA  
EL  
IDX

# TWIN ORIFICE POWER STEERING SYSTEM

## Wiring Diagram

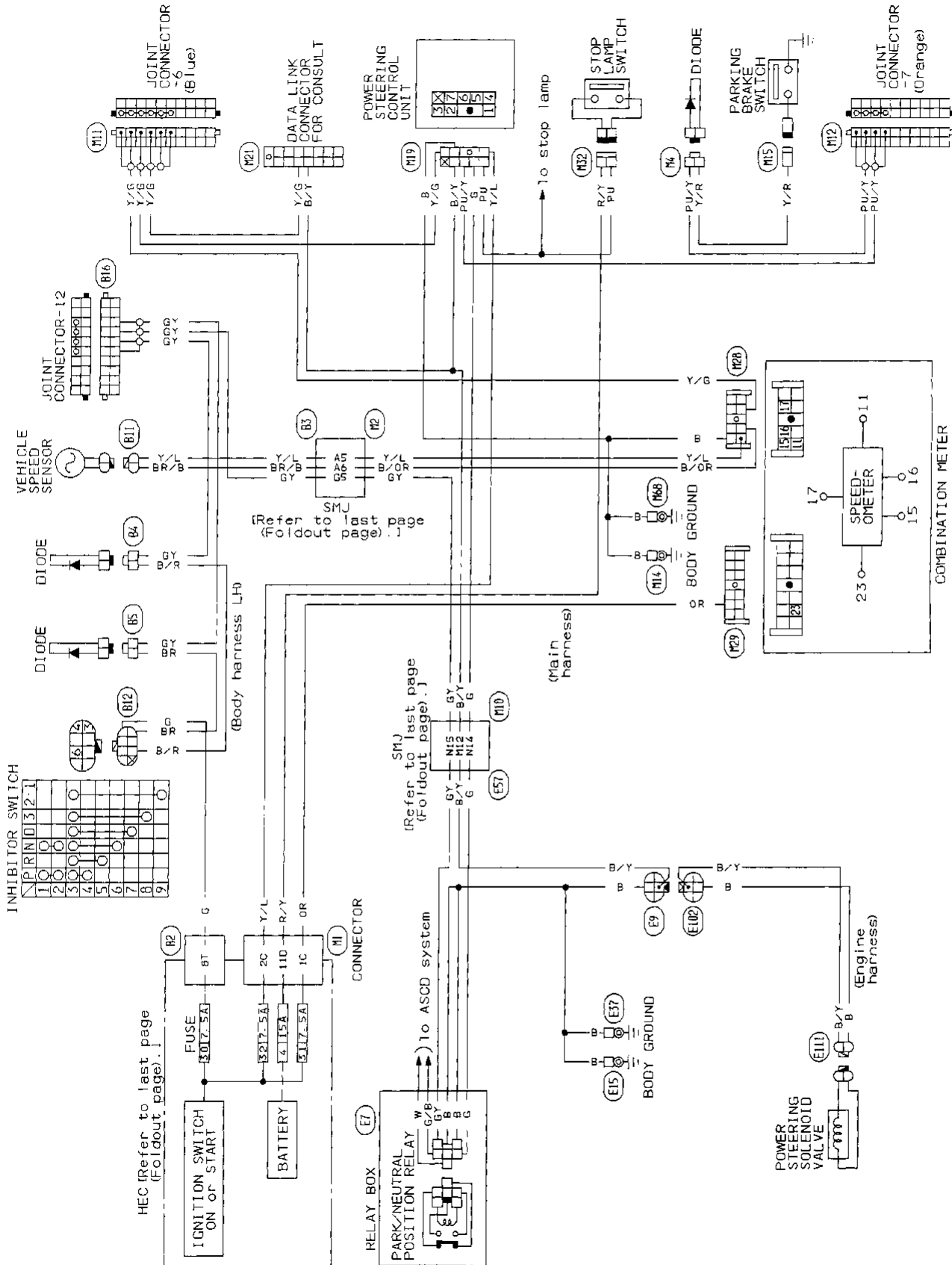

## Precautions

**BEFORE DIAGNOSING THE POWER STEERING SYSTEM, ENSURE THAT:**

### Vehicle stopped

- Power steering components (gears, oil pump, pipes, etc.) are free from leakage, and that oil level is correct.
- Tires are inflated to specified pressure and are of specified size, and that steering wheel is a genuine Nissan part.
- Wheel alignment is adjusted properly.
- Suspension utilizes the original design, and is free of modifications which increase vehicle weight.

### Vehicle in operation

- Understand the trouble symptoms.
- Engine is operating properly.

GI

MA

EM

LC

EF &  
EC

FE

AT

PD

FA

RA

BR

ST

BF

HA

EL

IDX

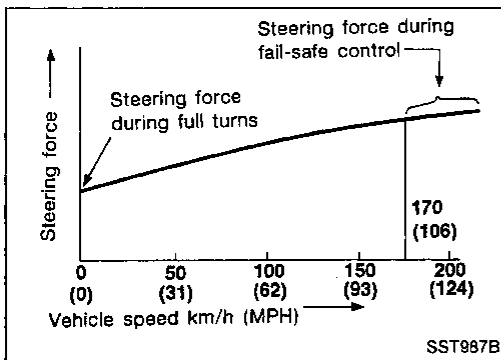

## PRELIMINARY KNOWLEDGE HELPFUL IN CONDUCTING DIAGNOSES

The power steering system is a twin orifice type, which uses a vehicle-speed sensing, electronic control design. Valve sensitivity is controlled in response to vehicle speed to achieve optimum steering effort. When a vehicle-speed signal is not entered into the power steering control unit for approximately 10 seconds during normal operation (see NOTE below), a fail-safe system activates to maintain the steering effort at a level similar to that experienced during high-speed operation.

More precisely, if a foot-brake signal, parking-brake signal and transmission position signal (N or P-range signal) are not entered, the power steering system is held in a "fail-safe" control state. When this happens, a symptom referred to as "heavy steering during stationary turns" sometimes occurs.

### NOTE:

Normal operation refers to a driving condition in which the foot brake pedal and parking brake lever are released, the shift lever is in any position other than "P" or "N".

## Diagnostic Procedure 1

### SYMPTOM:

Heavy steering operation during stationary turns

START

1) CHECK STOP LAMP SIGNAL.  
Turn ignition switch "ON" (with engine OFF), release foot brake pedal and parking brake lever.  
Set shift lever to any position except "P" and "N".

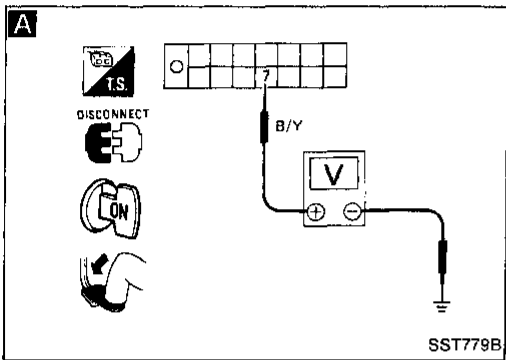

Depress brake pedal and measure voltage between solenoid valve terminals of data link connector for CONSULT.

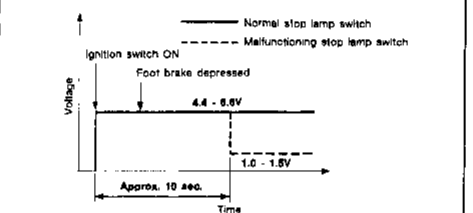

**Voltage:**  
4.4 - 6.6 volts (constant) ... OK  
Outside the above range or voltage fluctuations ... NG

Go to 2).

Check if terminal voltage drops to 1 - 1.5V range approx. 10 seconds after ignition switch is turned ON.  
**No change (outside 4.4 - 6.6V range) ... OK**  
**Voltage drop ... NG**

Go to 5).

Ⓐ



# TWIN ORIFICE POWER STEERING SYSTEM — Trouble Diagnoses

## Diagnostic Procedure 1 (Cont'd)

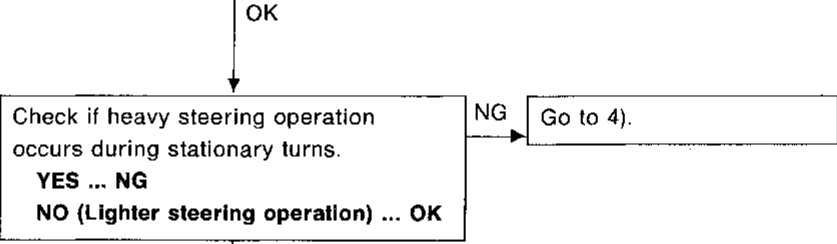
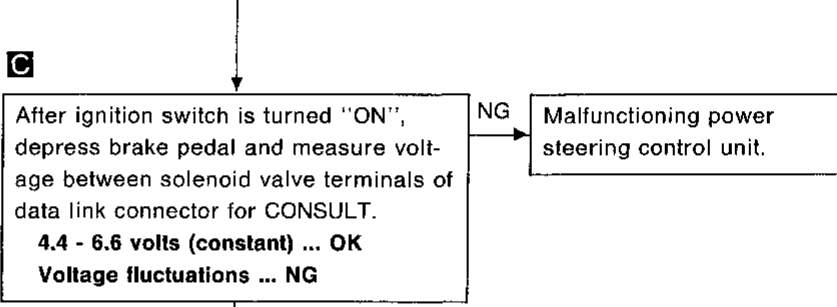
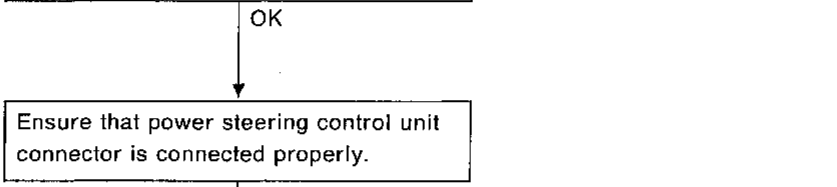
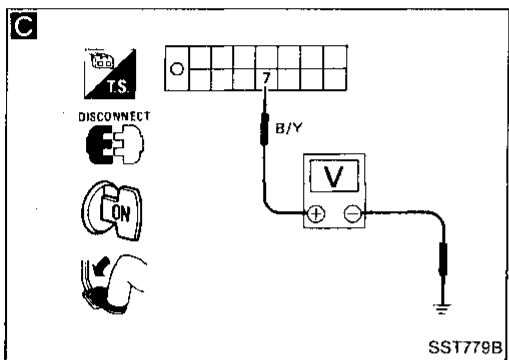
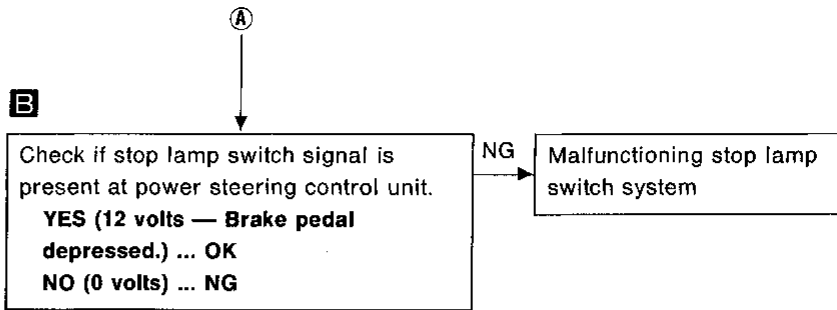
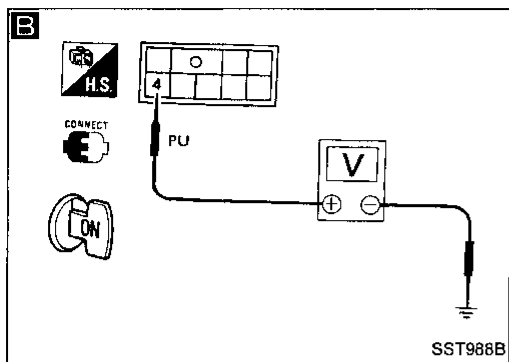

GI  
MA  
EM  
LC  
EF & EC  
FE  
AT  
PD  
FA  
RA  
BR  
ST  
BF  
HA  
EL  
IDX

# TWIN ORIFICE POWER STEERING SYSTEM — Trouble Diagnoses

## Diagnostic Procedure 1 (Cont'd)

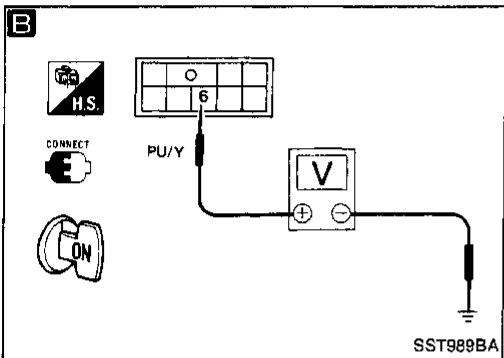
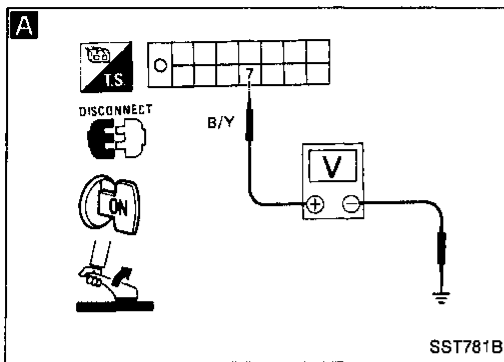

**A**

2) CHECK PARKING BRAKE SIGNAL.  
Release foot brake pedal and apply parking brake lever.  
Measure voltage between solenoid valve terminals of data link connector for CONSULT.

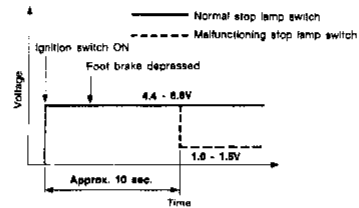

**Voltage:**  
4.4 - 6.6V (constant) ... OK  
Outside the above range or voltage fluctuations ... NG

OK → Go to 3).

NG ↓

Check if terminal voltage drops to 1.0 - 1.5V range approx. 10 seconds after ignition switch is turned ON.  
**No change (outside 4.4 - 6.6V range) ... OK**  
**Voltage drop ... NG**

OK → Go to 5).

NG ↓

**B**

Check if parking brake switch signal is present at power steering control unit.  
**YES (0 volts — Parking brake applied.) ... OK**  
**NO (12 volts) ... NG**

NG → Malfunctioning parking brake system

OK ↓

Ensure that power steering control unit connector is connected properly.

ⓑ

# TWIN ORIFICE POWER STEERING SYSTEM — Trouble Diagnoses

## Diagnostic Procedure 1 (Cont'd)

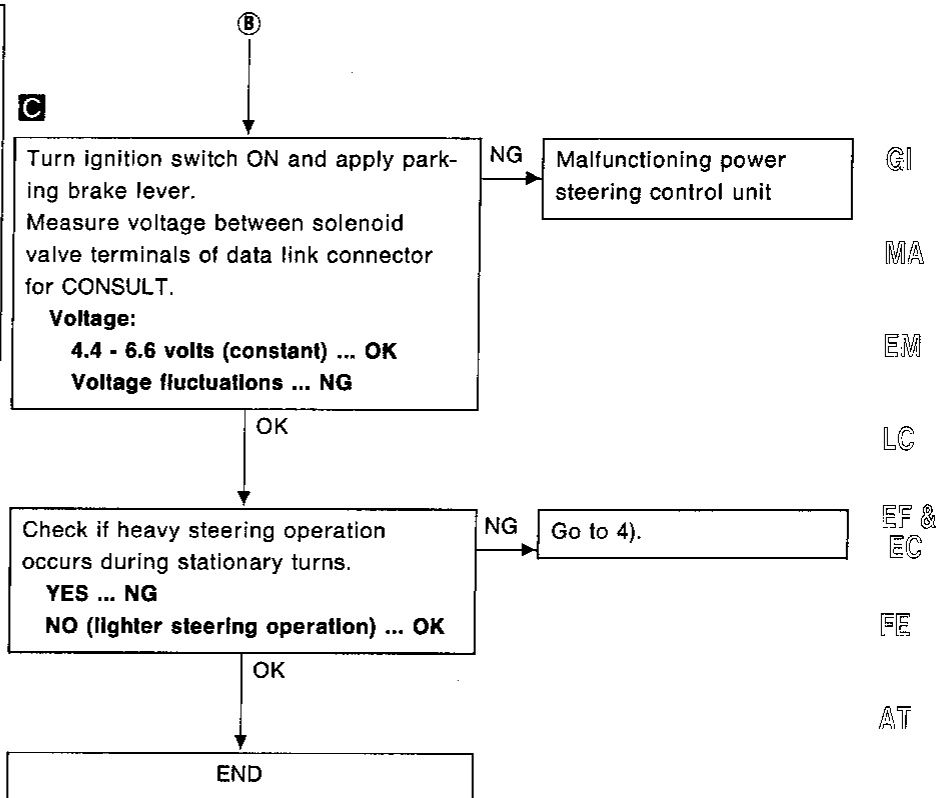
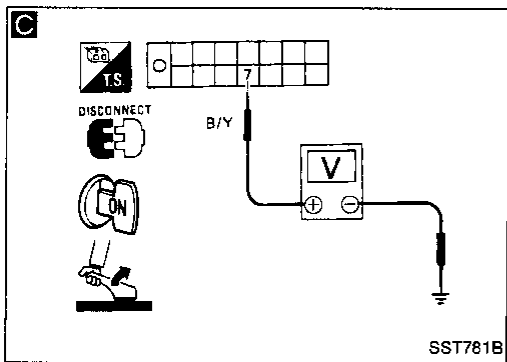

GI  
MA  
EM  
LC  
EF & EC  
FE  
AT  
PD  
FA  
RA  
BR  
ST  
BF  
HA  
EL  
IDX

# TWIN ORIFICE POWER STEERING SYSTEM — Trouble Diagnoses

## Diagnostic Procedure 1 (Cont'd)

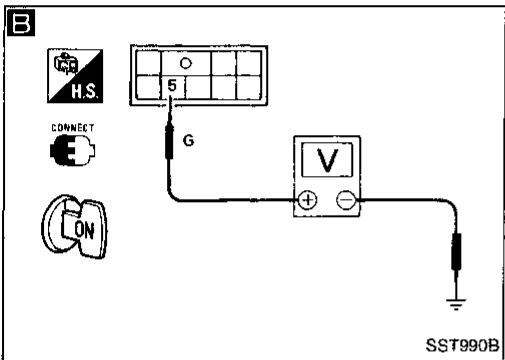
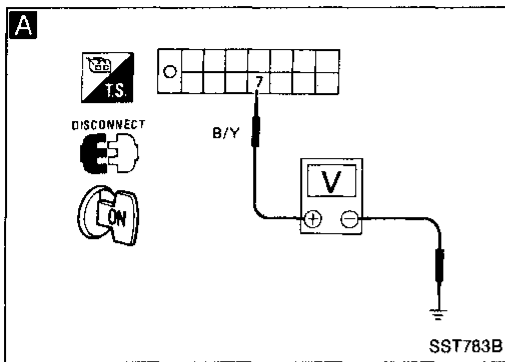

**A**

3) CHECK NEUTRAL POSITION SIGNAL.  
Release parking brake lever.  
Move shift lever to Neutral position.  
Measure voltage between solenoid valve terminals of data link connector for CONSULT.

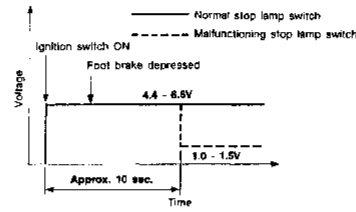

**Voltage:**  
4.4 - 6.6V (constant) ... OK  
Outside the 4.4 - 6.6V range or Voltage fluctuations ... NG

OK → Move shift lever to "P" position.  
Measure voltage between solenoid valve terminals at data link connector for CONSULT.  
**Voltage:**  
4.4 - 6.6V (constant) ... OK  
Outside the above range or voltage fluctuations ... NG

OK → Go to 4).

NG → Check if terminal voltage drops to 1.0 - 1.5V range approx. 10 seconds after ignition switch is turned ON.  
**No change (outside 4.4 - 6.6V range) ... OK**  
**Voltage drop ... NG**

OK → Go to 5).

**B**

Check if position switch signal is present at power steering control unit.  
**YES (0 volts, when position switch is ON) ... OK**  
**NO (4 - 5 volts) ... NG**

NG → Malfunctioning position switch system

OK → Ensure that power steering control unit connector is connected properly.

Ⓒ

# TWIN ORIFICE POWER STEERING SYSTEM — Trouble Diagnoses

## Diagnostic Procedure 1 (Cont'd)

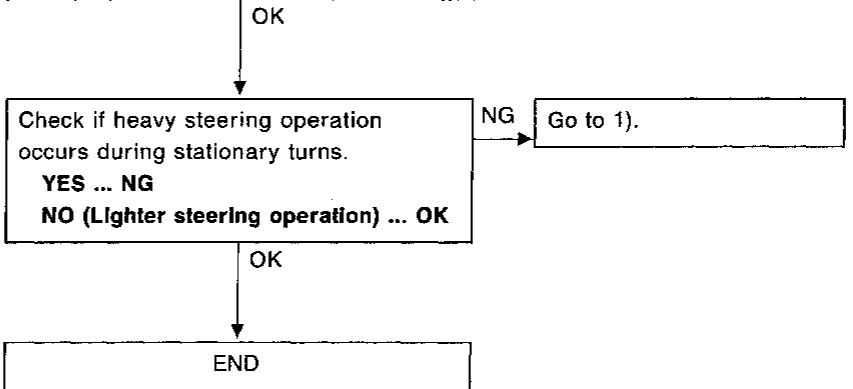
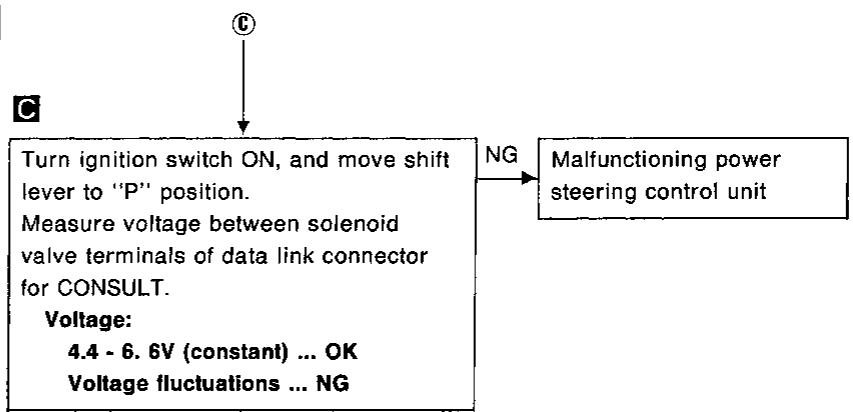
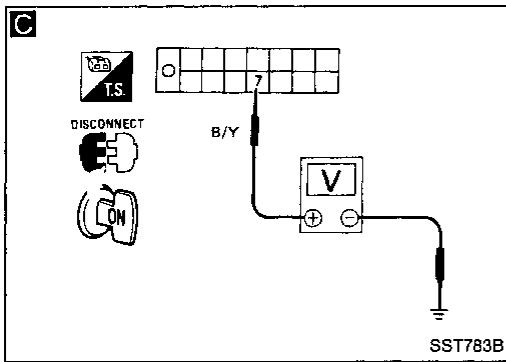

GI  
MA  
EM  
LC  
EF & EC  
FE  
AT  
PD

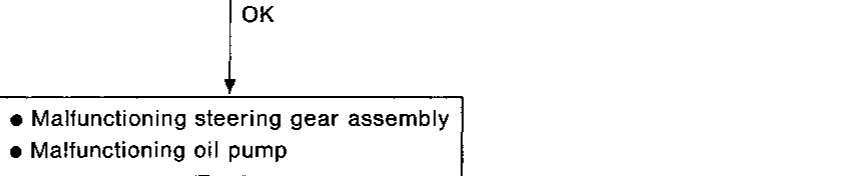
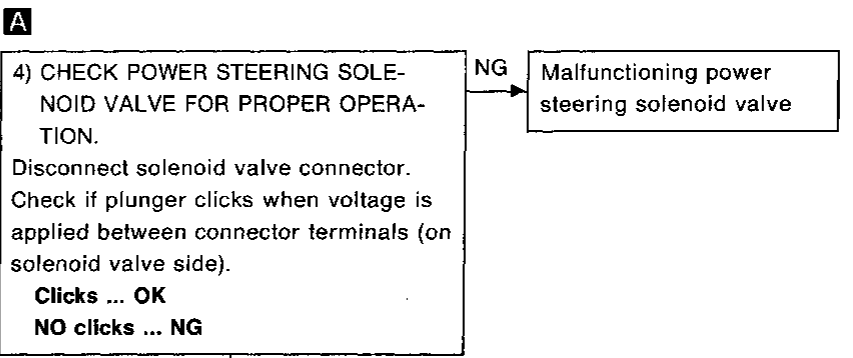
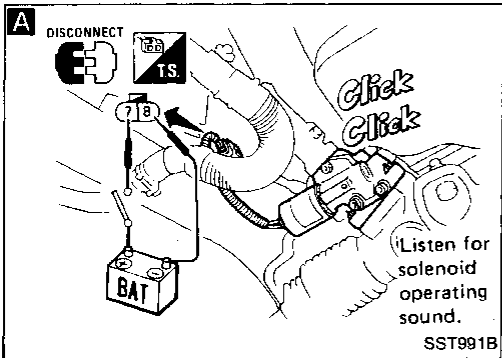

ST  
BF  
HA  
EL  
IDX

# TWIN ORIFICE POWER STEERING SYSTEM — Trouble Diagnoses

## Diagnostic Procedure 1 (Cont'd)

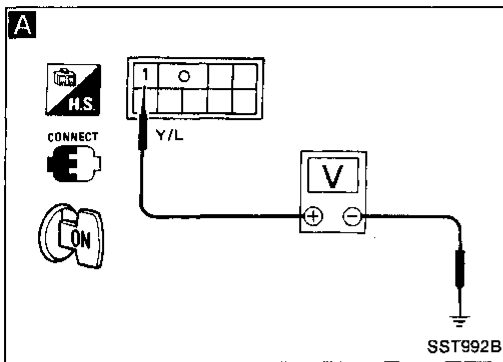

**A**

5) CHECK POWER STEERING CONTROL UNIT FOR PROPER OPERATION. Check if power voltage is present at power steering control unit.  
**YES (12V) ... OK**  
**NO (0V) ... NG**

NG → Malfunctioning ignition power circuit

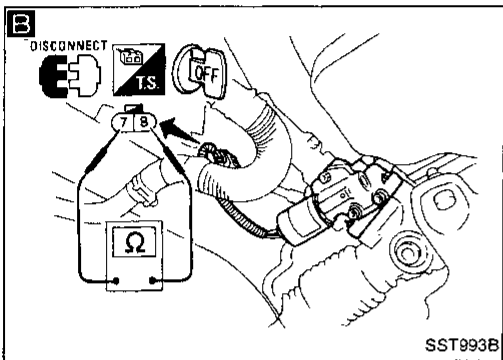

**B**

Measure solenoid valve resistance. Disconnect solenoid valve connector, and measure resistance between connector terminals (on solenoid valve side.)  
**Resistance:**  
**4 - 6 ohms ... OK**  
**0 ohms or infinite ... NG**

NG → Malfunctioning solenoid valve system

OK

Ensure that power steering control unit connector is connected properly.

Check if heavy steering operation occurs during stationary turns.  
**YES ... NG**  
**NO (Lighter steering operation) ... OK**

NG → Malfunctioning power steering control unit

OK

END

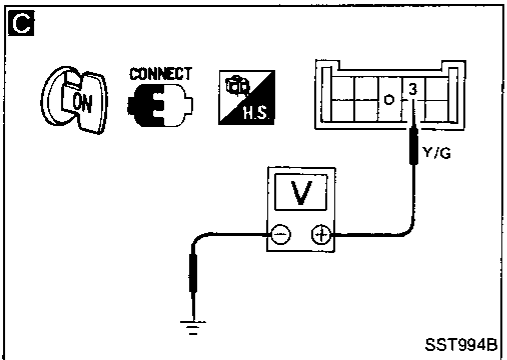
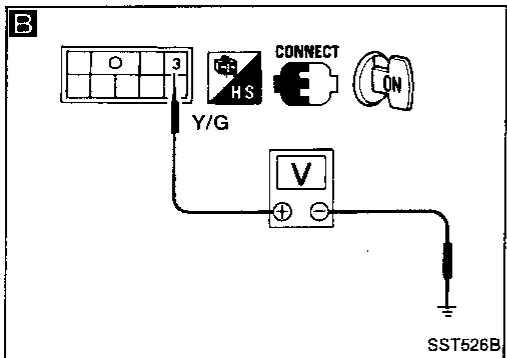
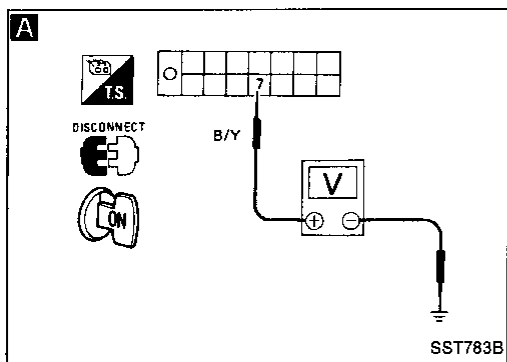

**Diagnostic Procedure 2**

**SYMPTOM:**

**Light steering operation during high-speed driving**

Raise rear wheels off ground and start engine.

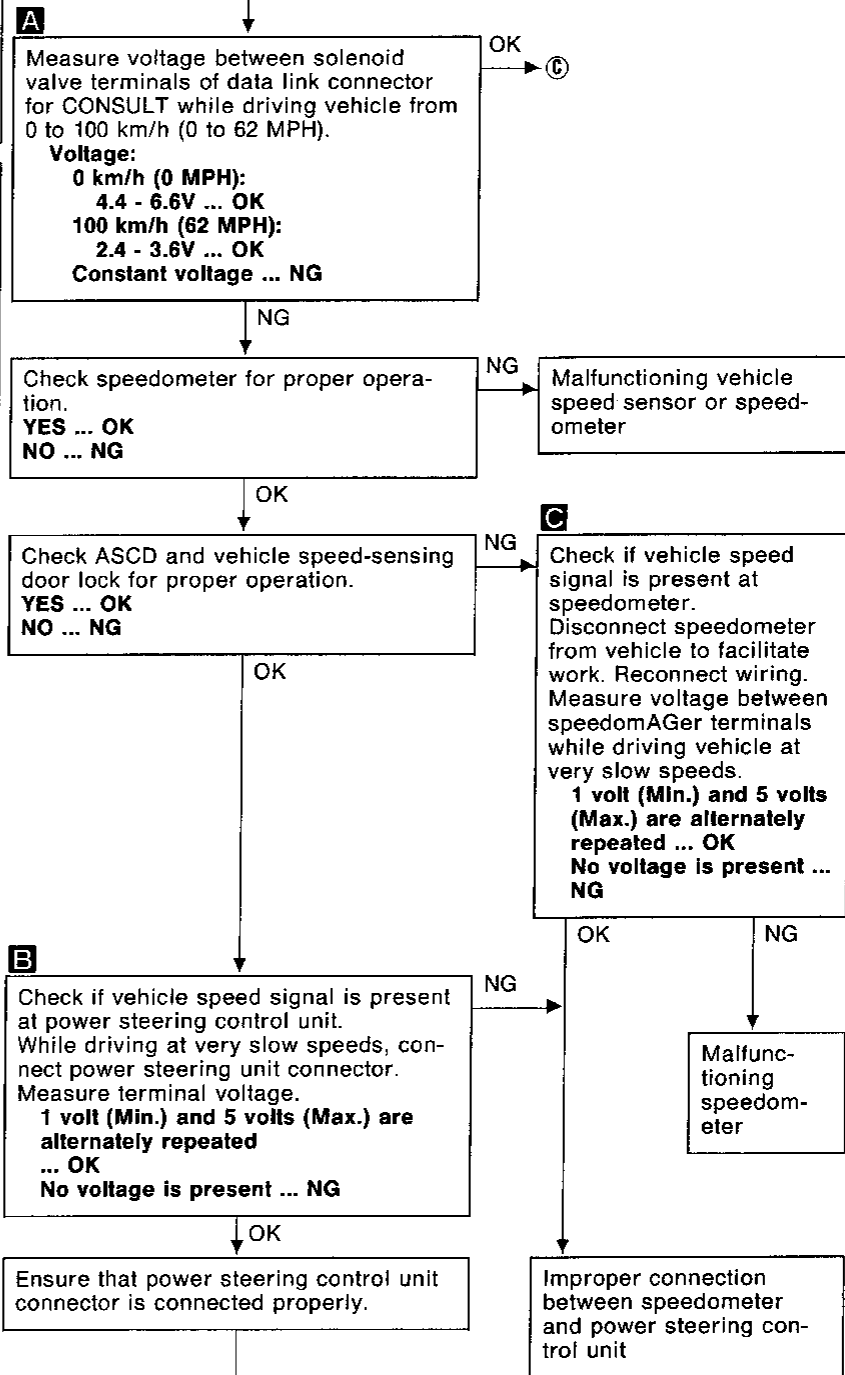

GI  
MA  
EM  
LC  
EF & EC  
FE  
AT  
PD  
FA  
RA  
BR  
ST  
BF  
HA  
EL  
IDX

# TWIN ORIFICE POWER STEERING SYSTEM — Trouble Diagnoses

## Diagnostic Procedure 2 (Cont'd)

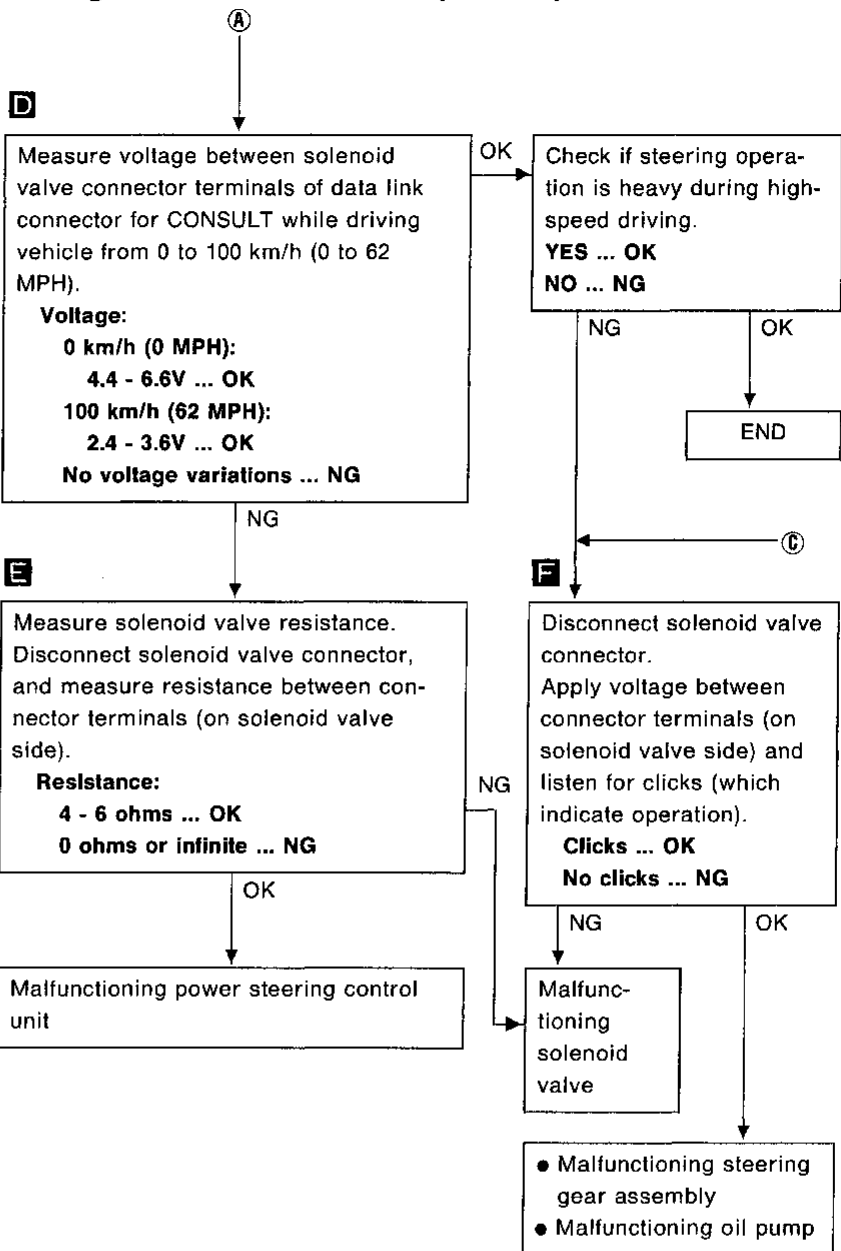
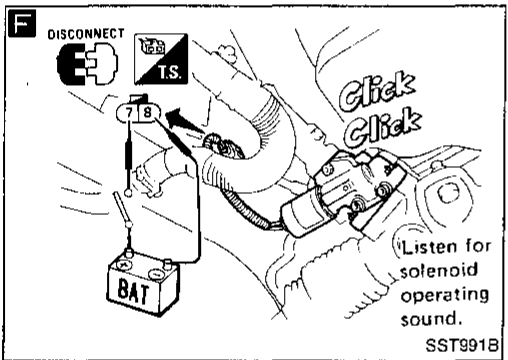
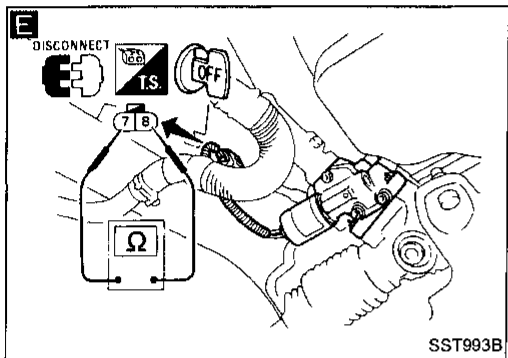
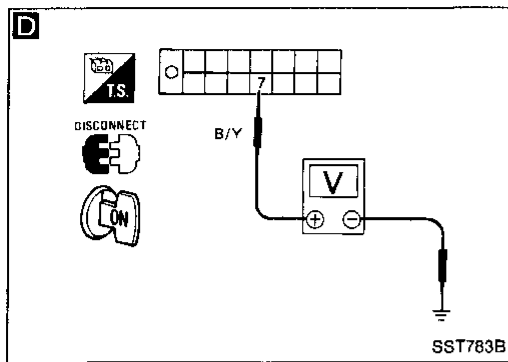



## Control Unit Inspection Table

The standard values (voltage), measured with an analog tester in contact with the control unit terminal, are shown below:

Terminal No.	Application	Standard value
1	Power	Approx. 12V
2	Ground	0V
3	Vehicle speed sensor input	1 volt (min.) and 5 volts (max.) are alternately repeated when vehicle is driven at very slow speeds.
4	Stop lamp switch input	Pressed: Approx. 12V Released: 0V
5	Neutral switch input	0V (selector lever in "N" or "P") 4 - 5V (except for the above)
6	Parking brake switch input	Applied: 0V Released: Approx. 12V
7	Power steering solenoid valve output	0 km/h 4.4 - 6.6V 100 km/h 2.4 - 3.6V Fail-safe 1.6 - 2.4V



1	○	2	3
4	5	6	7

SST995B

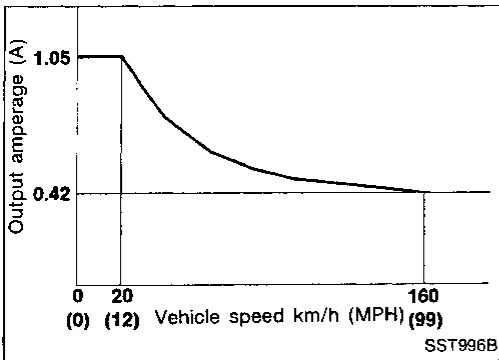

## Performance of Controller

GI

MA

EM

LC

EF &  
EC

FE

AT

PD

FA

RA

BR

**ST**

BF

HA

EL

IDX

# SUPER HICAS SYSTEM

## HICAS Component Parts Location

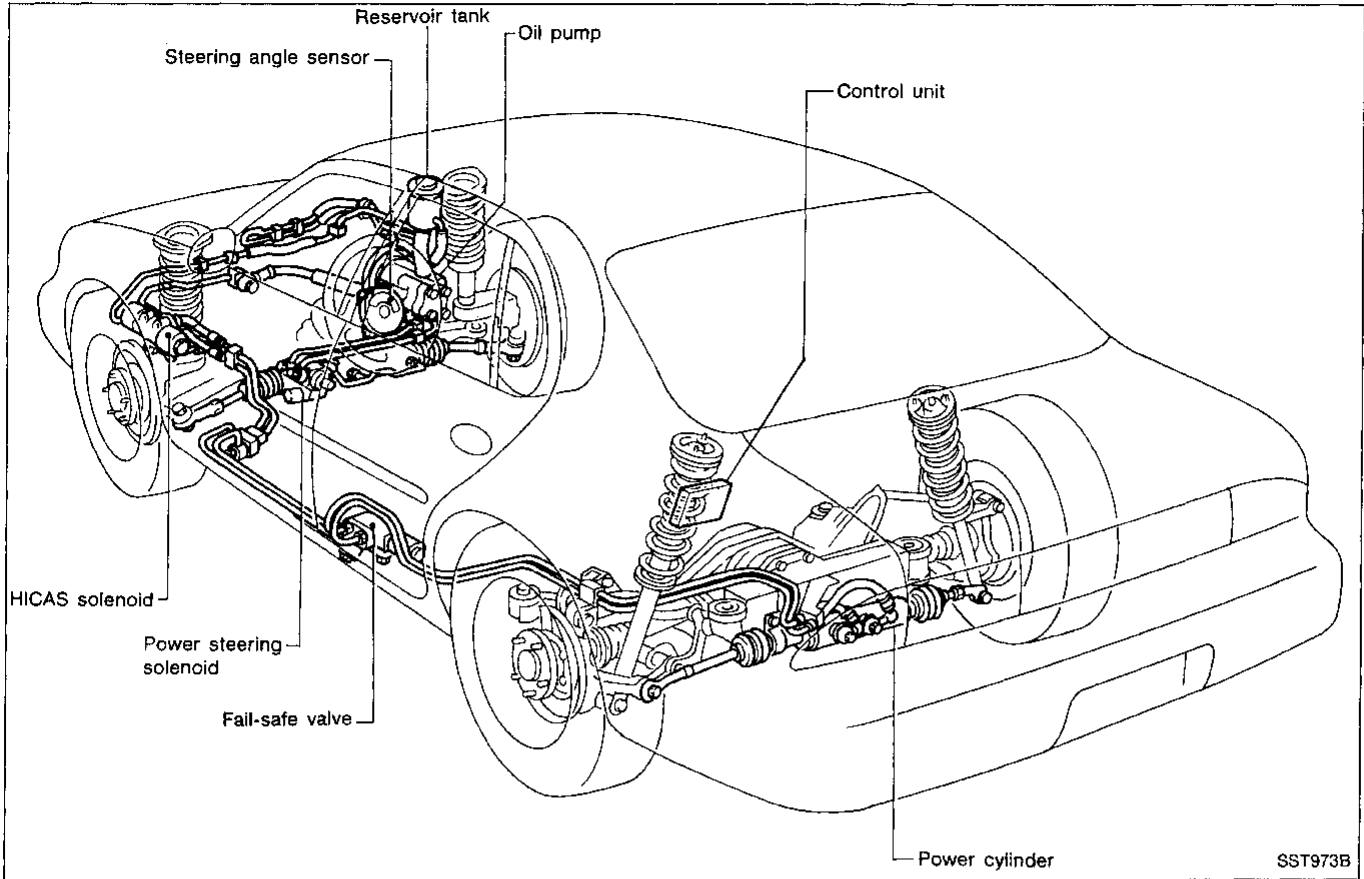

### System Diagram

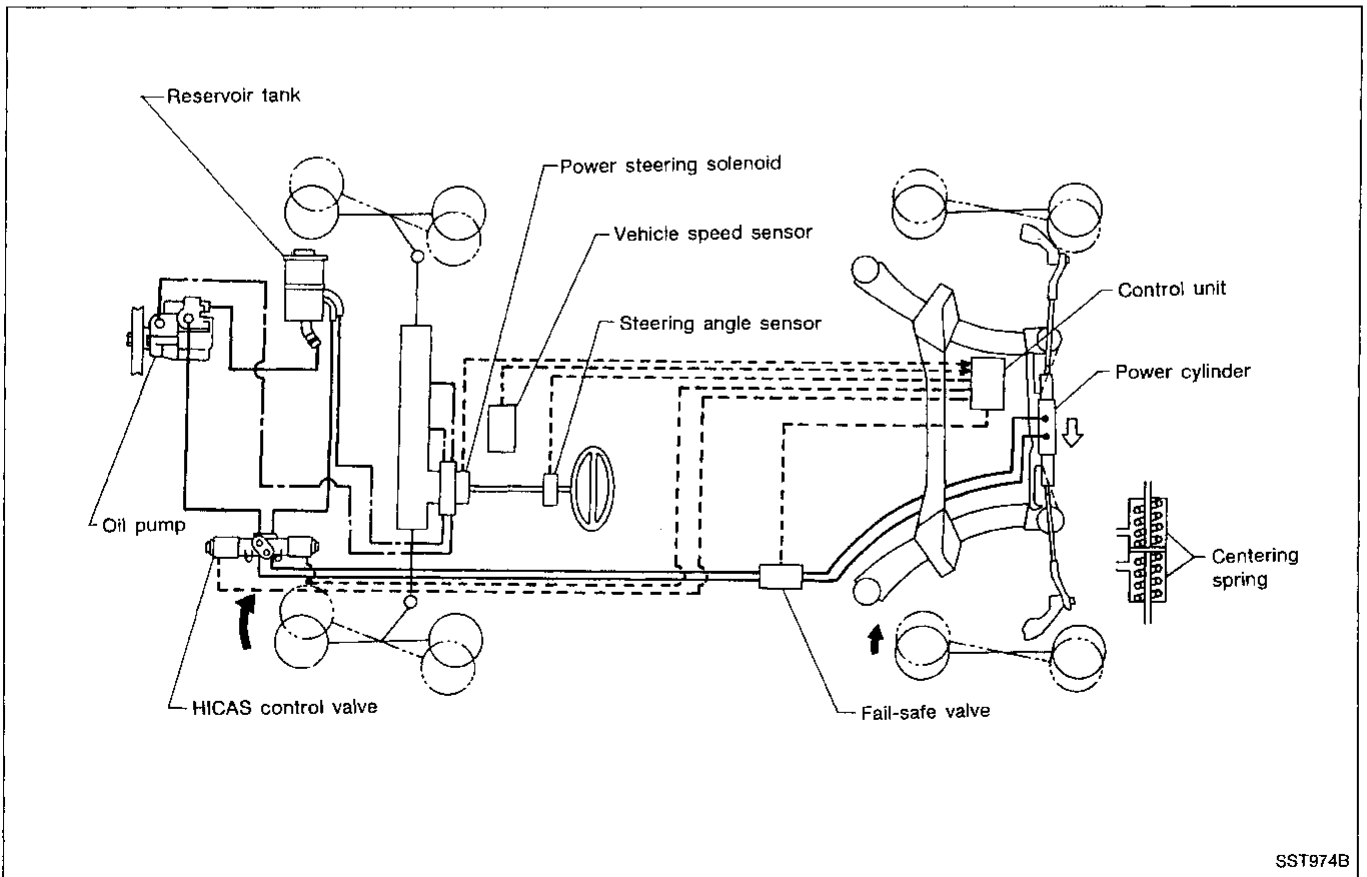

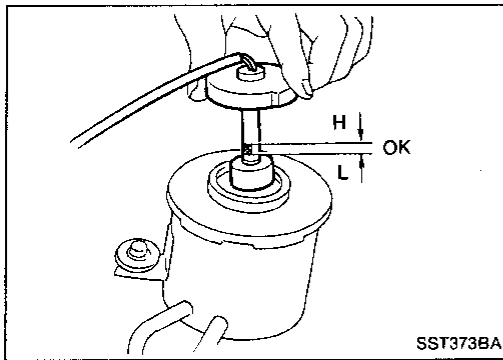

**Checking Fluid Level**

Maintain the fluid level so that the lower surface of the float is maintained between the "L" and "H" marks on the gauge rod. The fluid level should be checked when the engine is stopped and the fluid temperature is about 30°C (86°F).

**CAUTION:**

- Do not overfill.
- Recommended fluid is Automatic Transmission Fluid "DEXRON II™" type or equivalent.

**Checking Fluid Leakage**

Check lines for proper attachment, leaks, cracks, damage, loose connections, chafing and deterioration. Fluid leakage should be checked for when the oil temperature is normal with the engine idling.

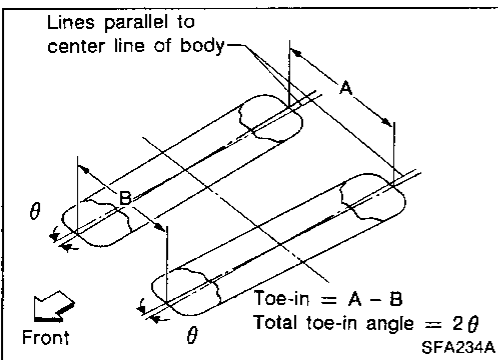
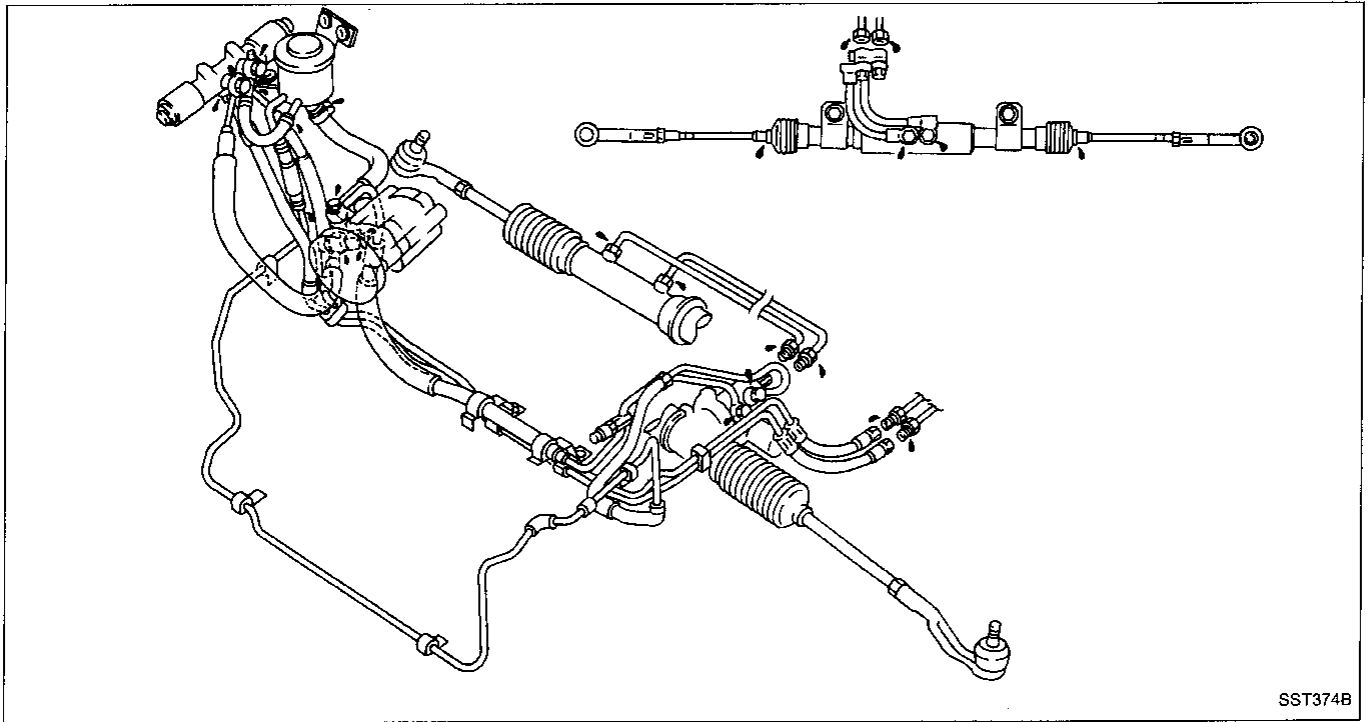

**Measuring Rear Toe-in**

Measure distance "A" and "B" at the same height as hub center.

Toe-in:

Refer to SDS in RA section.

GI

MA

EM

LC

EF & EC

FE

AT

PD

FA

RA

BR

**ST**

BF

HA

EL

IDX

### Inspection of HICAS System Operation

**CAUTION:**

Ensure that shift lever is set to "P" position before checking HICAS system operation.

When CONSULT is used: 

1. Have a helper sit in the driver's compartment and raise vehicle.  
(Use a two-pole lift or a center pole lift so that the four wheels are free to rotate.)
2. Connect CONSULT unit to data link connector and start engine.
3. Touch "START" on CONSULT display.
4. Touch "HICAS", "ACTIVE TEST" and "SIMULATED DRIVE" in that order.

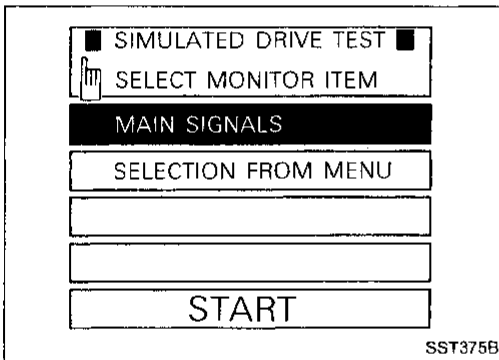

5. Touch "START" when MAIN SIGNALS display is reversed.

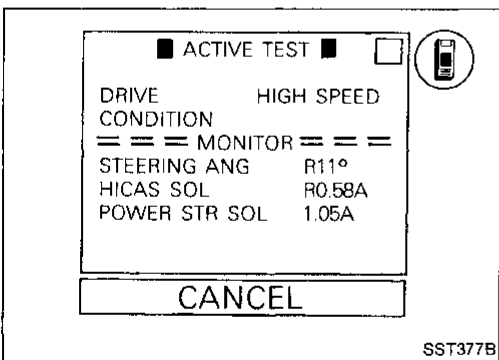

6. Touch "START".  
After simulated drive condition has continued for 5 minutes, it will automatically cancel and CONSULT unit will then show "TEST IS INTERRUPTED TO AVOID OIL TEMP. RISE" display. To cancel this mode during self-diagnosis, simply touch "CANCEL".

## Inspection of HICAS System Operation (Cont'd)

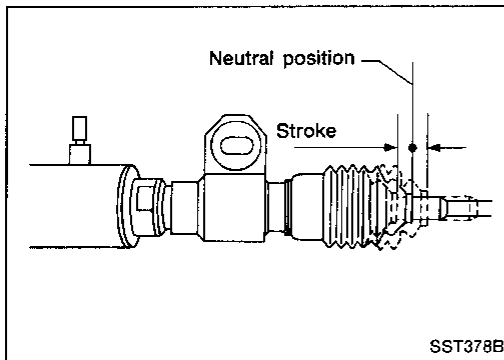

7. Operate engine at speeds greater than 2,000 rpm, and turn steering wheel 180° in one direction from the neutral position. Measure extension value of one power cylinder rod and retraction value of the other. Then, turn steering wheel 180° in the other direction from the neutral position, and measure extension value of one cylinder rod and retraction value of the other. Determine strokes of respective power cylinders by adding (measured) extension and retraction values.

**Measure rod strokes in as short a period of time as possible.**

### Specifications:

**When turned to the right**

**3 mm (0.12 in)**

**When turned to the left**

**3 mm (0.12 in)**

**Total stroke**

**6 mm (0.24 in)**

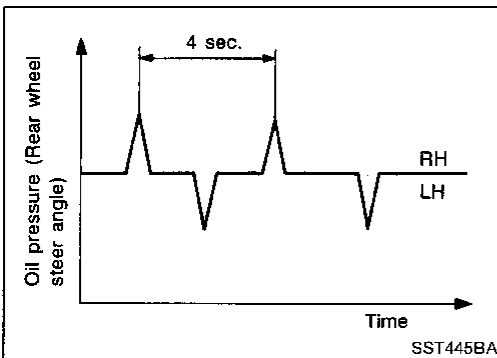

**When CONSULT is not used:**



1. Have a helper sit in the driver's compartment and raise vehicle.  
(Use a 2-pole lift or a center pole lift so that the four wheels are free to rotate.)
2. Set HICAS system in self-diagnosis mode.
  - (1) Turn ignition switch "OFF".
  - (2) Set shift lever to "P" or "N" position.
  - (3) Turn ignition switch "ON".
  - (4) Immediately start engine.
  - (5) Turn steering wheel from left to right (at least 20° from the neutral position ) 5 times or more, then depress foot brake pedal at least 5 times all within 10 seconds after ignition switch has been turned "ON".
3. Set steering wheel to a point approximately 10° from the neutral position and check to ensure that rear wheels turn to the left and right alternately.

## SUPER HICAS SYSTEM — On-vehicle Service

### Inspection of HICAS System Operation (Cont'd)

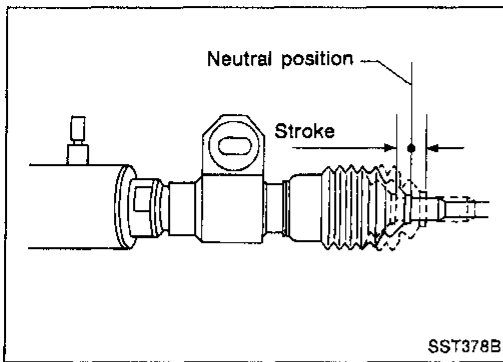

4. Operate engine at speeds greater than 2,000 rpm, and turn steering wheel 180° in one direction from the neutral position. Measure extension value of one power cylinder rod and retraction value of the other. Then, turn steering wheel 180° in the other direction from the neutral position, and measure extension value of one cylinder rod and retraction value of the other. Determine strokes of respective power cylinder rods by adding (measured) extension and retraction values.

**Measure rod strokes in as short a period of time as possible.**

#### Specifications:

**When turned to the right**

**3 mm (0.12 in)**

**When turned to the left**

**3 mm (0.12 in)**

**Total stroke**

**6 mm (0.24 in)**

**Do not depress foot brake pedal during operation check, otherwise the operation will be stopped.**

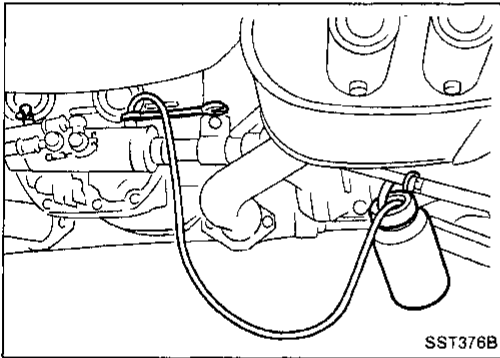

### Bleeding Hydraulic System

Before bleeding air from the HICAS system, be sure to bleed air from the power steering system.

Refer to "SUPER HICAS SYSTEM — Repair of Component Parts".

**Power Cylinder**

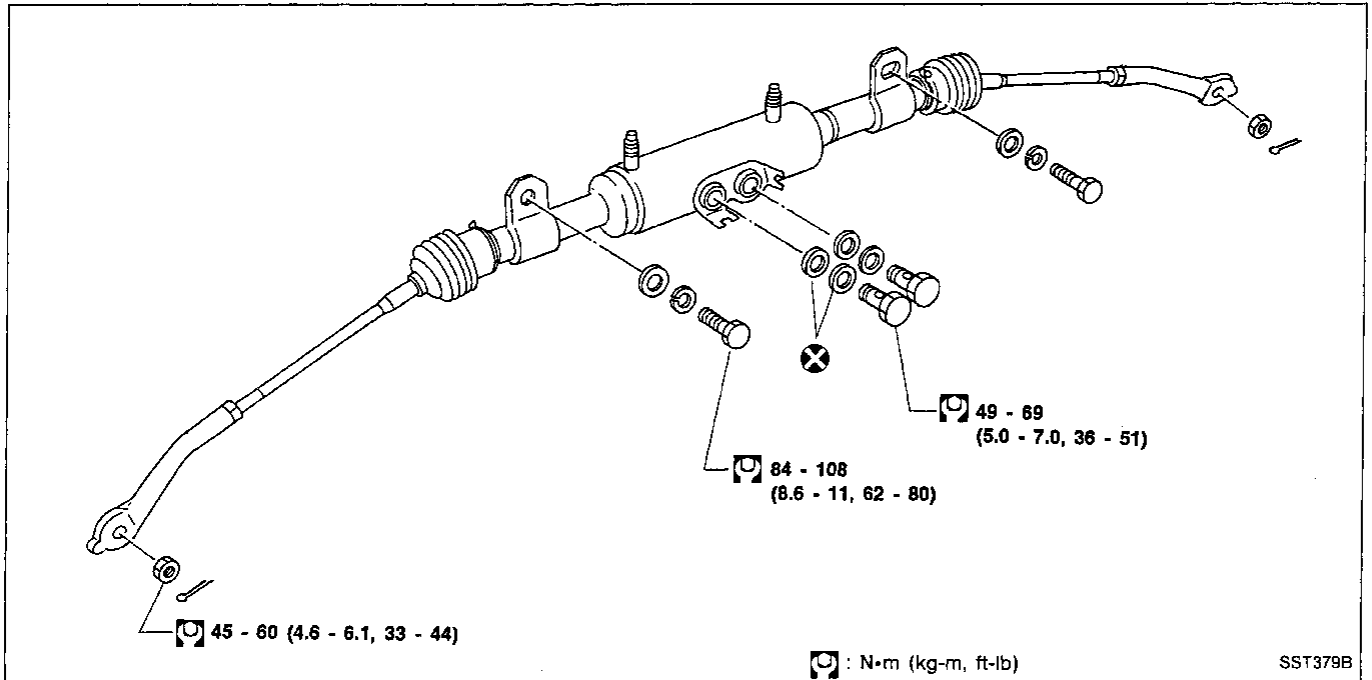

GI  
MA  
EM  
LC  
EF &  
EC  
FE  
AT

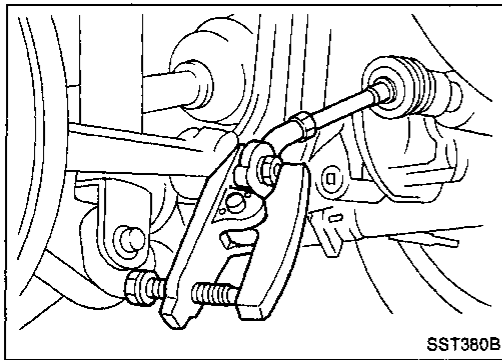

**REMOVAL**

- Detach power cylinder lower links from axle housing sockets with Tool.

PD  
FA  
RA  
BR

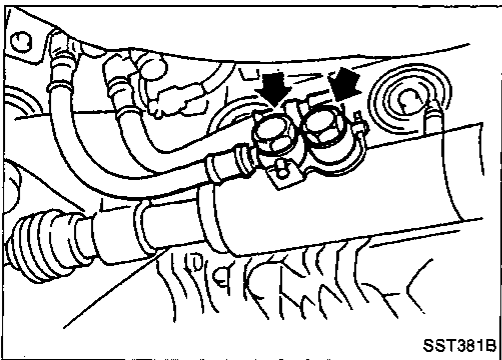

- Disconnect oil pipes from power cylinders and remove power cylinders.

**CAUTION:**

**Plug openings of oil pipes and power cylinders to prevent entry of foreign particles after removal.**

ST  
BF  
HA  
EL

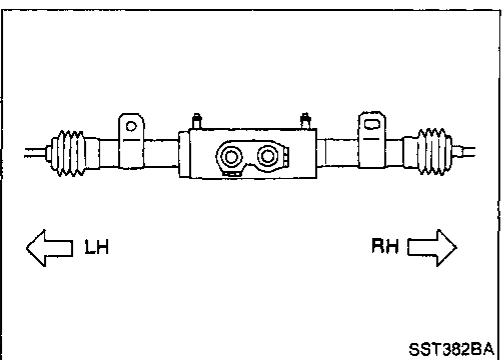

**INSTALLATION**

1. Before installing power cylinder on suspension member, wipe power cylinder bracket and mating surface of suspension member. Using the left side of the bracket as a reference point, locate the right side (oblong hole side) and install power cylinder.

**CAUTION:**

- a. To prevent entry of foreign particles, clean oil pipes and connectors using dry compressed air.
- b. Ensure that your hands are clean and free from foreign particles when connecting oil pipes.

IDX

## Power Cylinder (Cont'd)

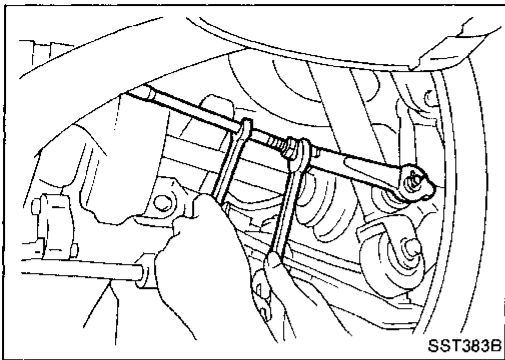

2. Install power cylinders and oil pipes.
3. After installing lower link assemblies, check toe-in to ensure that it is within specifications. If it is not within specifications, perform proper adjustments. Refer to RA section ("SUPER HICAS").

## BLEEDING HYDRAULIC SYSTEM

Before bleeding air from the HICAS system, be sure to bleed air from the power steering system.

### CAUTION:

Ensure that shift lever is set to "P" position.

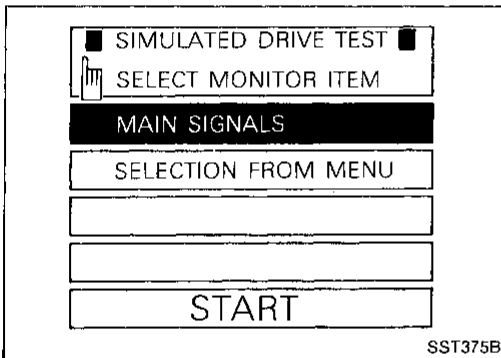

### When CONSULT is used:



1. Connect CONSULT unit to data link connector on body side.
2. Have a helper sit in the driver's compartment and raise vehicle.

**Use a two-pole lift or a center pole lift so that the four wheels are free to rotate.**

3. Start engine.
4. Touch "START" on CONSULT display. (Display will then change.)
5. Touch "HICAS", "ACTIVE TEST", "SIMULATED DRIVE" and "START" in that order.

**Before touching "START", ensure that MAIN SIGNALS display is reversed.**

6. Touch "START".



## Power Cylinder (Cont'd)

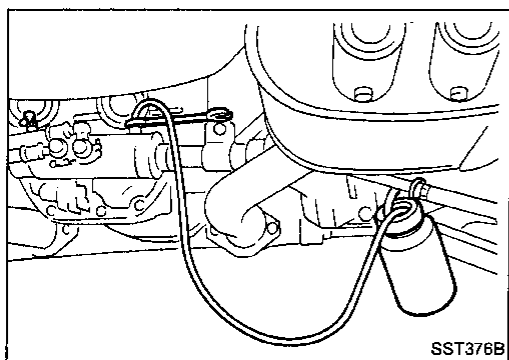

7. Operate engine at speeds greater than 2,000 rpm, and turn steering wheel 180° to the right from the neutral position. Loosen right power cylinder bleeder valve to bleed air, then retighten. Return steering wheel to the neutral position.
8. Operate engine at speeds greater than 2,000 rpm, and turn steering wheel 180° to the left from the neutral position. Loosen left power cylinder bleeder valve to bleed air, then retighten. Return steering wheel to the neutral position.
9. Repeat steps 7. and 8. until there are no air bubbles in fluid. While bleeding air from power cylinders, never allow fluid level to drop below inlet port of reservoir tank (by adding fluid as required).
10. Touch "CANCEL" on CONSULT display and turn ignition switch OFF.

GI

MA

EM

LC

EF &  
EC

FE

AT

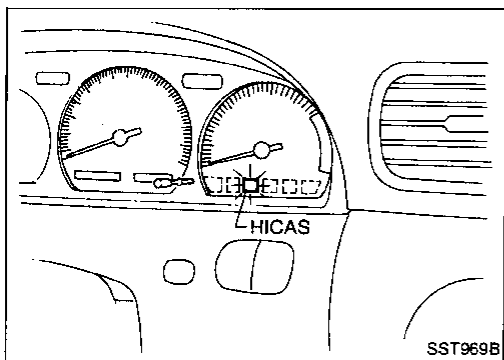

### When CONSULT is not used:

1. Have a helper sit in the driver's compartment, and raise vehicle.

PD

### Use a two-pole lift or center pole lift so that the four wheels are free to rotate.

FA

2. Set HICAS system in self-diagnosis mode.
  - (1) Turn ignition switch "OFF".
  - (2) Set shift lever to "P" or "N" position.
  - (3) Turn ignition switch "ON".
  - (4) Immediately start engine.
  - (5) Turn steering wheel from left to right (at least 20° from the neutral position ) 5 times or more, then depress foot brake pedal at least 5 times all within 10 seconds after ignition switch has been turned "ON".
3. Set steering wheel within 10° from the neutral position. Ensure that rear wheels turn to the left and right alternately.
4. Operate engine at idling speed, and turn steering wheel 180° to the right from the neutral position. Loosen right power cylinder bleeder valve to bleed air, then retighten. Return steering wheel to the neutral position.
5. Operate engine at idling speed, and turn steering wheel 180° to the left from the neutral position. Loosen left power cylinder bleeder valve to bleed air, then retighten. Return steering wheel to the neutral position.
6. Repeat steps 4. and 5. above until there are no air bubbles in fluid. While bleeding air from power cylinders, never allow fluid level to drop below inlet port of reservoir tank (by adding fluid as required).
7. Turn ignition switch OFF to complete self-diagnosis operation.

RA

BR

ST

BF

HA

EL

IDX

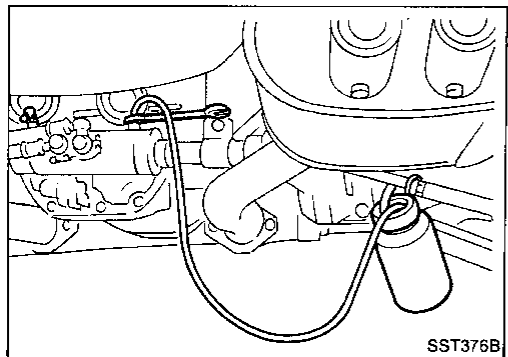

# SUPER HICAS SYSTEM — Repair of Component Parts

## Power Cylinder (Cont'd)

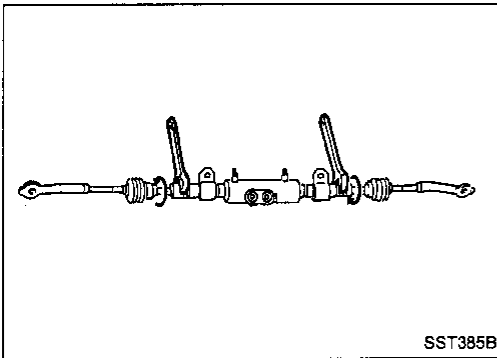
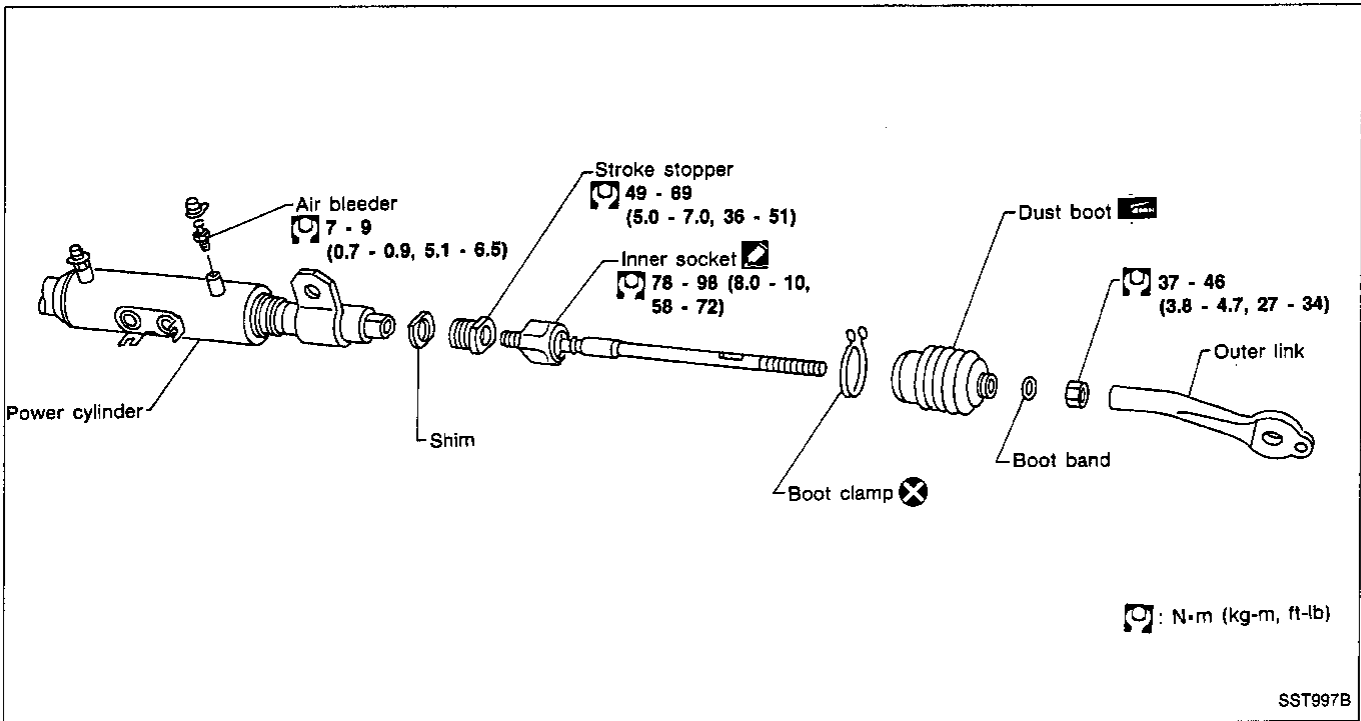

Power cylinder assembly cannot be disassembled. When it is malfunctioning, replace power cylinder as an assembly.

### DISASSEMBLY

1. Remove clamps from left and right dust boots, and move dust boots toward outer links.
2. Attach wrenches to left and right ball joint sockets, and turn in directions that loosen lower links. Remove one of loosened lower link assemblies.
3. Remove stroke stopper from which lower link assembly was removed.

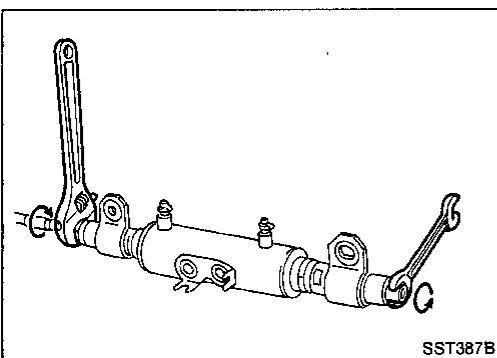
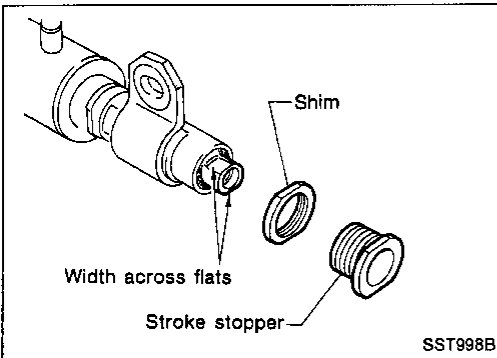

- While attaching a wrench to "width across flats" section of rod end from which stroke stopper was removed, remove the other lower link assembly.

# SUPER HICAS SYSTEM — Repair of Component Parts

## Power Cylinder (Cont'd)

### ASSEMBLY

1. Install stroke stopper and shim on the lower link assembly to be assembled.

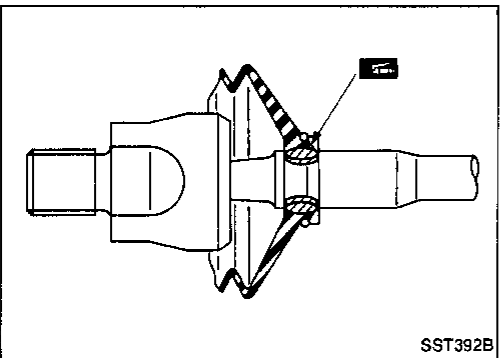
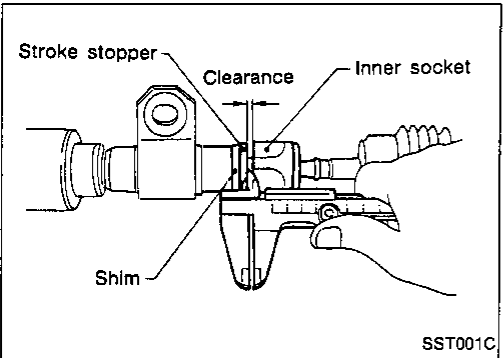
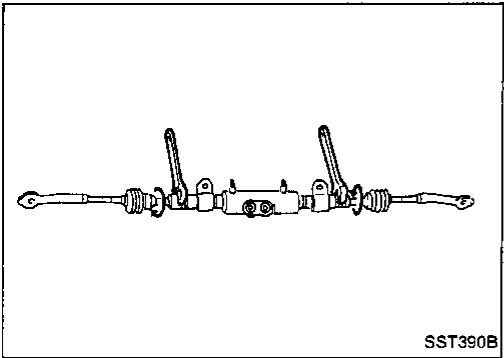
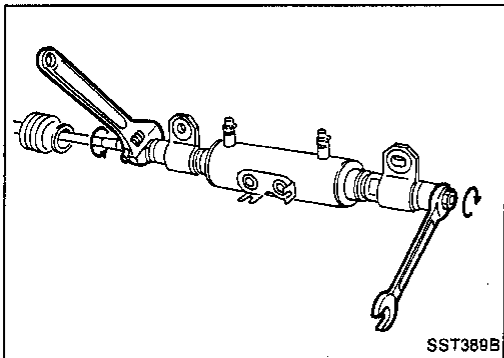
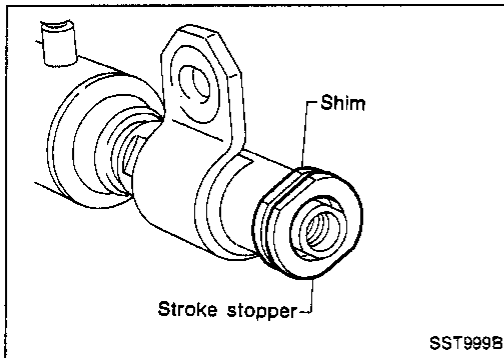

2. Apply Locktite to inner ball joint thread. Attach a wrench to "width across flats" section of piston rod (located on the other side) to prevent rod from turning. Install lower link assembly.

3. After installing stroke stopper and shim on the other lower link assembly, install lower link assembly. Attach a wrench to inner ball joint (to prevent it from turning), tighten inner socket to specified torque.

#### Inner socket:

: 78 - 98 N·m (8 - 10 kg-m, 58 - 72 ft-lb)

4. Tighten stroke stopper to the specified torque. Check clearance between inner socket and stroke stopper.

#### Clearance:

2.9 - 3.1 mm (0.114 - 0.122 in)

5. Install dust boot using new boot band and clamp.

- Apply a coat of grease to grooves at boot location.

GI

MA

EM

LC

EF &  
EC

FE

AT

PD

FA

RA

BR

ST

BF

HA

EL

IDX

**Oil Pump**

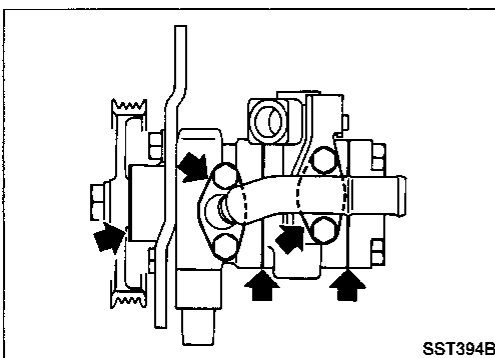
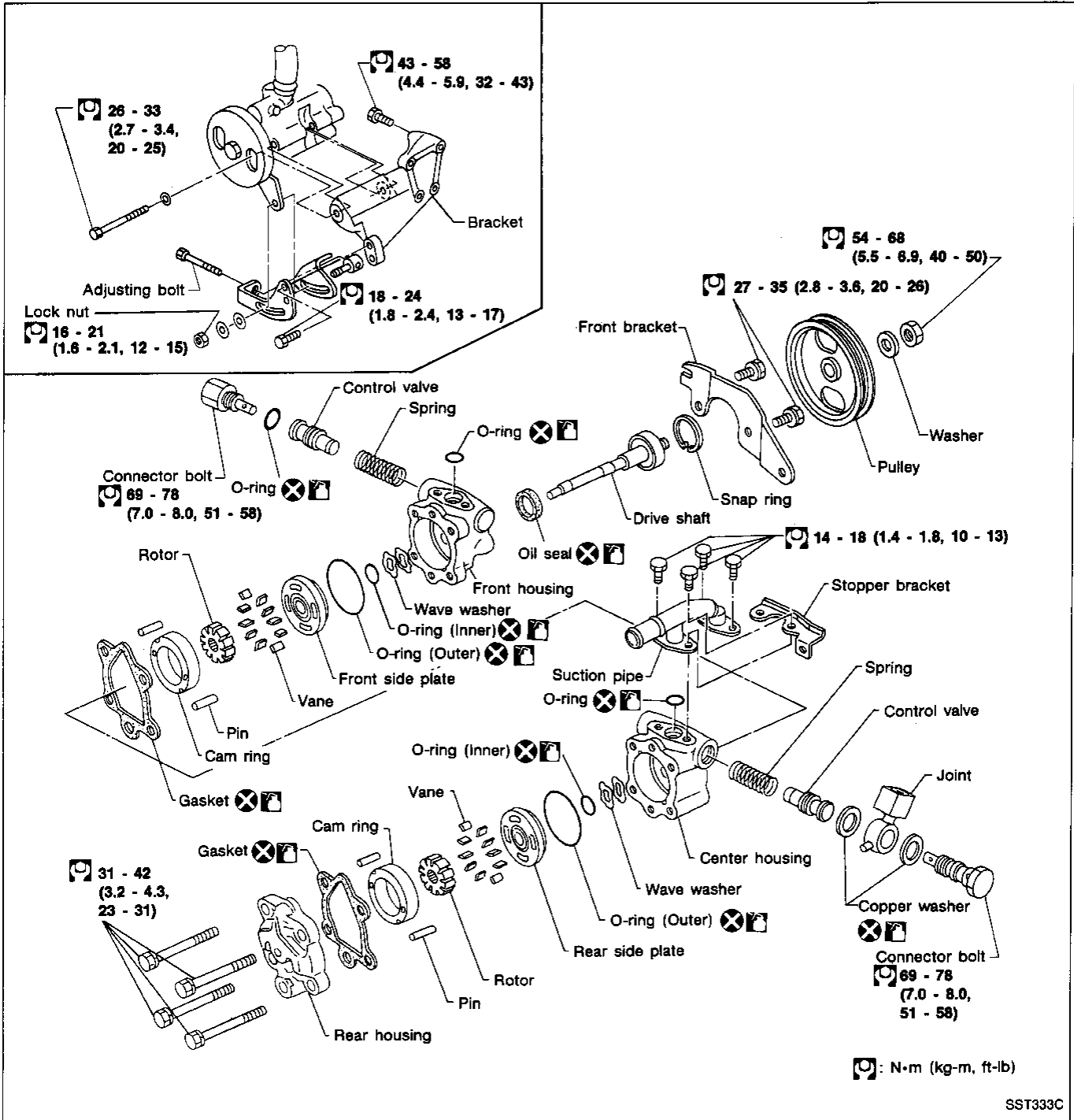

**PRE-DISASSEMBLY INSPECTION**

Disassemble the power steering oil pump only if the following items are found.

- Oil leak from any point shown in the figure.
- Deformed or damaged pulley.

Procedures for disassembly and assembly are the same as those for the power steering oil pump.

## Oil Pump (Cont'd)

### DISASSEMBLY

#### CAUTION:

- Parts which can be disassembled are strictly limited. Never disassemble parts other than those specified.
- Disassemble in as clean a place as possible.
- Clean your hands before disassembly.
- Do not use rags; use nylon cloths or paper towels.
- Follow the procedures and cautions in the Service Manual.
- When disassembling and reassembling, do not let foreign matter enter or contact the parts.

GI

MA

EM

LC

EF &  
EC

FE

AT

PD

FA

RA

BR

ST

BF

HA

EL

IDX

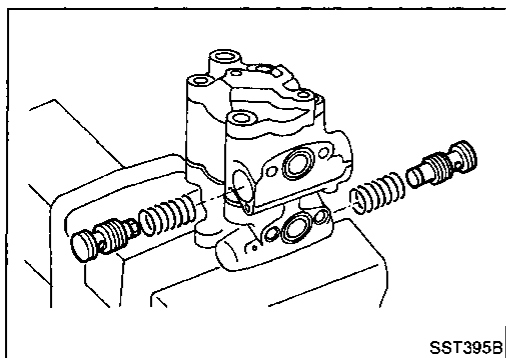

1. Remove connector.

**Be careful not to drop control valve.**

**Be careful not to confuse main side with sub side.**

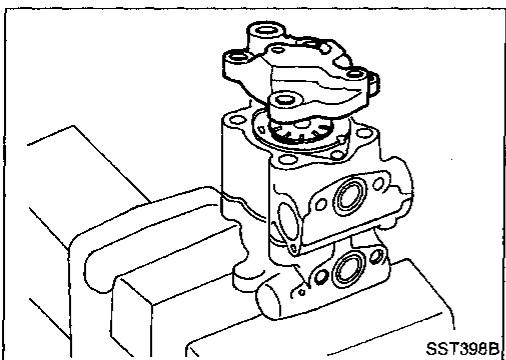

2. Remove rear housing.

3. Remove center housing.

4. Remove cam ring, rotor and other parts from center housing (sub side).

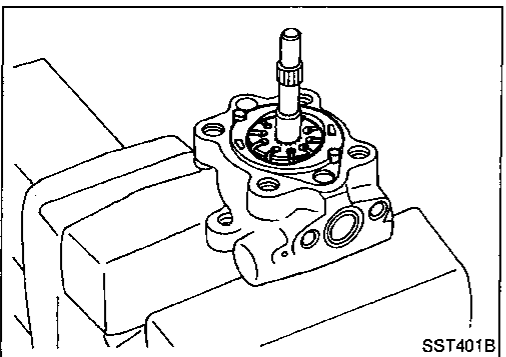

5. Remove cam ring, rotor and other parts from front housing (main side).

**Be careful not to confuse main side with sub side.**

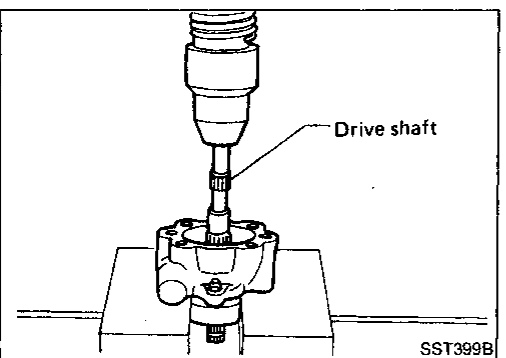

6. Remove snap ring, then draw drive shaft out.

**Be careful not to drop drive shaft.**

## SUPER HICAS SYSTEM — Repair of Component Parts

### Oil Pump (Cont'd)

7. Remove oil seal.

**Be careful not to damage front housing.**

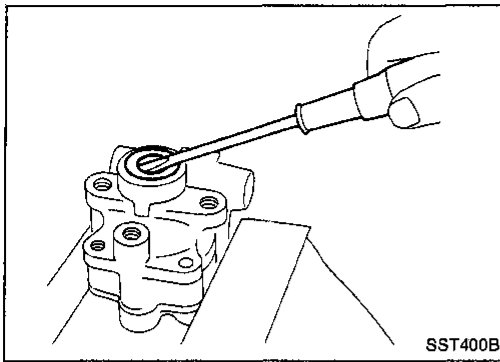

### INSPECTION

If any of the following parts are scratched or damaged, replace oil pump assembly.

- Mating surfaces of front housing and cam center housing
- Mating surfaces of rear housing and cam center housing
- Front housing bushing (at drive shaft support location)
- Flow control valve
- Drive shaft
- Rotor

### ASSEMBLY

Assemble oil pump in the reverse order of disassembly, noting the following instructions.

- Before installation, coat the O-rings and oil seal with ATF.
- Make sure O-rings and oil seal are properly installed.
- When assembling vanes to rotor, rounded surfaces of vanes must face cam case side.
- Always install new O-rings and oil seal.
- Be careful of oil seal direction.

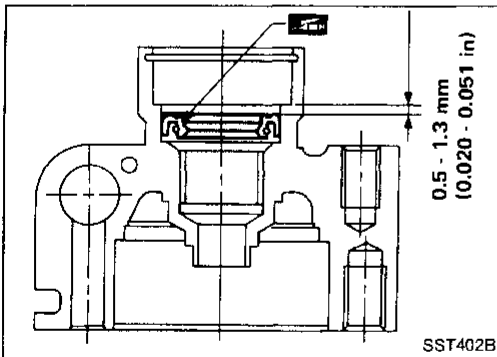

1. Press oil seal into front housing and apply grease to sealing lips.

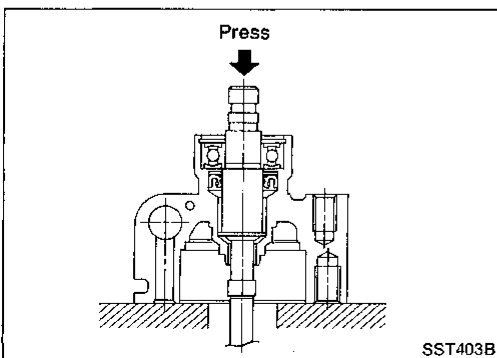

2. Press shaft assembly into front housing and install snap ring.

# SUPER HICAS SYSTEM — Repair of Component Parts

## Oil Pump (Cont'd)

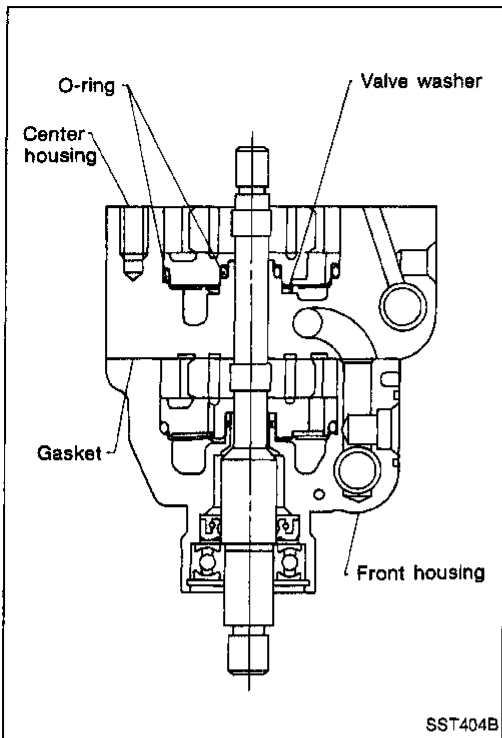

SST404B

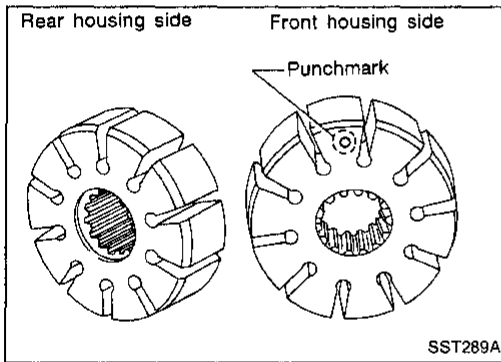

SST289A

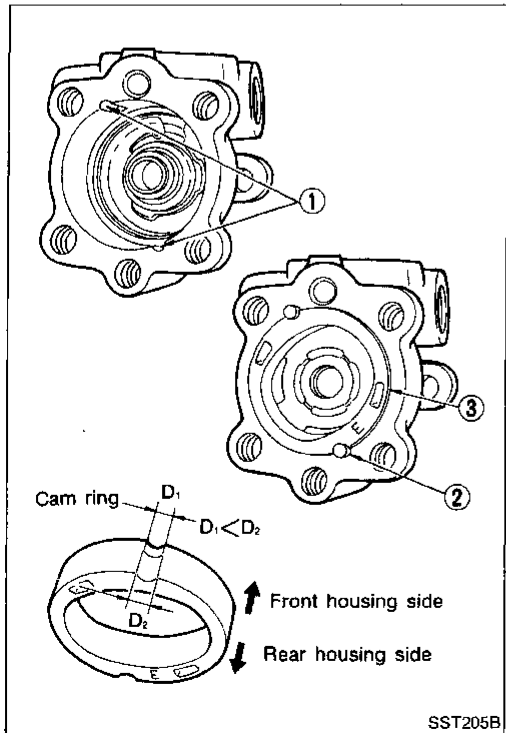

SST205B

3. Install component parts on front housing in the order indicated below:

- 1) O-ring x 2
  - 2) Wave washer
  - 3) Side plate
  - 4) Rotor [thickness: 16.25 mm (0.6398 in) (main side); 13 mm (0.51 in) (sub side)]
  - 5) Vane
  - 6) Pin
  - 7) Cam ring [thickness: 16.25 mm (0.6398 in) (main side); 13 mm (0.51 in) (sub side)]
4. Place packing on front housing and position center housing on the packing. In the manner similar to step 3. above, install component parts on front housing (sub side).

### CAUTION:

- Ensure that O-rings are positioned properly.
- Ensure that vane is installed with curved side facing cam ring.
- Use cam, rotor vane as original single unit.
- Ensure that control valve moves smoothly.

- Pay attention to rotor direction.

- Pay attention to cam ring direction.

GI

MA

EM

LC

EF &  
EC

FE

AT

- Pay attention to rotor direction.

PD

FA

RA

BR

ST

BF

HA

EL

IDX

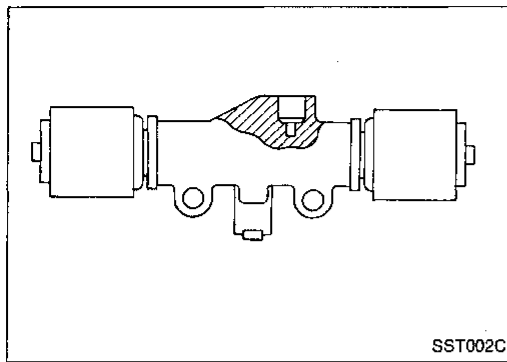

## HICAS Solenoid and Fail-safe Valve

- Do not loosen lock nut which secures solenoid since HICAS solenoid fail-safe valves are of types that should not be disassembled.
- If any part is found to be malfunctioning, always replace as a valve assembly.

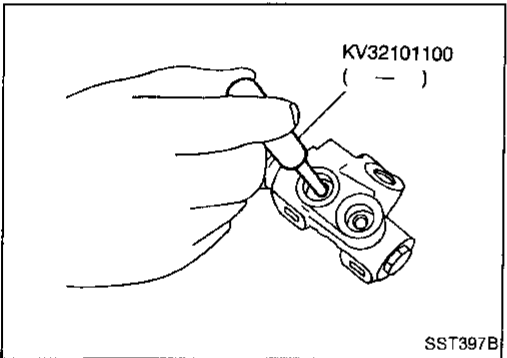
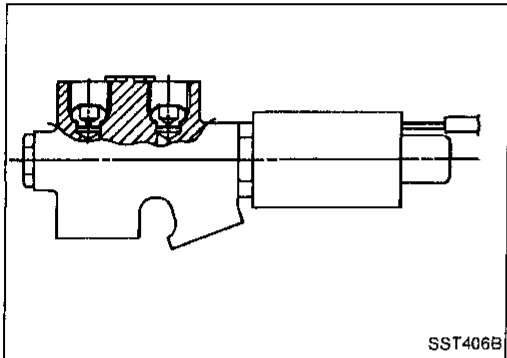

- Whenever tubes for fail-safe valves are disconnected, check tube seat for scratches or damage. A scratched or cracked tube seat may cause oil leakage. Replace it using pin punch.

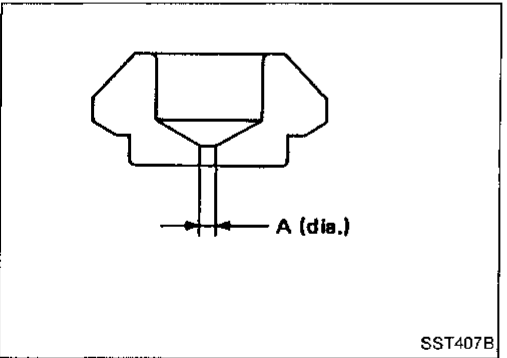

		Fail-safe valve
Part No.		49528-52L10
A (dia.)	mm (in)	6.5 (0.256)

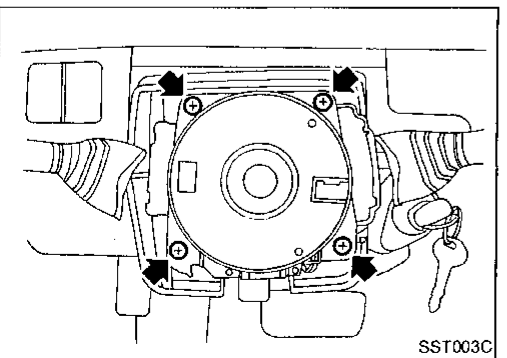

## Steering Angle Sensor

- Ensure that steering angle sensor bolts are secure and tight.
- If any part of steering angle sensor is malfunctioning, replace steering angle sensor assembly.



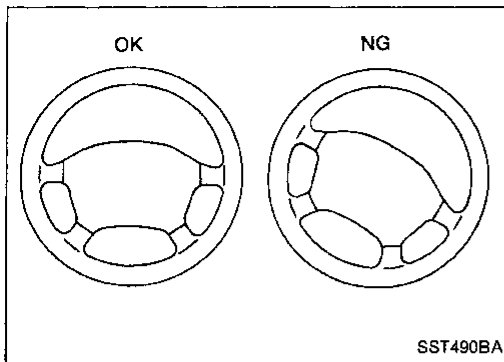

## Steering Wheel

### CHECKING NEUTRAL POSITION

- Check that steering wheel is in neutral position when driving straight ahead at a speed of at least 70 km/h (43 MPH).
- If it is not in neutral position, remove steering wheel and reinstall it correctly.
- If neutral position is between two serrated teeth, loosen tie-rod lock nut and move tie-rod in the opposite direction by the same amount on both left and right sides to compensate for error in neutral position.

GI

MA

EM

LC

EF &  
EC

FE

AT

PD

FA

RA

BR

**ST**

BF

HA

EL

IDX

**Contents**

<b>How to Perform Trouble Diagnoses for Quick and Accurate Repair</b> .....	ST-59
<b>Symptom Chart</b> .....	ST-60
<b>Preliminary Check</b> .....	ST-61
<b>Component Parts and Harness Connector Location</b> .....	ST-64
<b>Circuit Diagram for Quick Pinpoint Check</b> .....	ST-65
<b>Wiring Diagram</b> .....	ST-66
<b>Self-diagnosis</b> .....	ST-67
<b>Diagnostic Procedure 1</b> .....	ST-71
<b>Diagnostic Procedure 2</b> .....	ST-71
<b>Diagnostic Procedure 3</b> .....	ST-73
<b>Diagnostic Procedure 4</b> .....	ST-74
<b>Diagnostic Procedure 5</b> .....	ST-79
<b>Diagnostic Procedure 6</b> .....	ST-81
<b>Diagnostic Procedure 7</b> .....	ST-82
<b>Diagnostic Procedure 8</b> .....	ST-83
<b>Diagnostic Procedure 9</b> .....	ST-84
<b>Diagnostic Procedure 10</b> .....	ST-85
<b>Diagnostic Procedure 11</b> .....	ST-87
<b>Diagnostic Procedure 12</b> .....	ST-88
<b>Diagnostic Procedure 13</b> .....	ST-89
<b>Control Unit Inspection Table</b> .....	ST-90

**How to Perform Trouble Diagnoses for Quick and Accurate Repair**

**WORK FLOW**

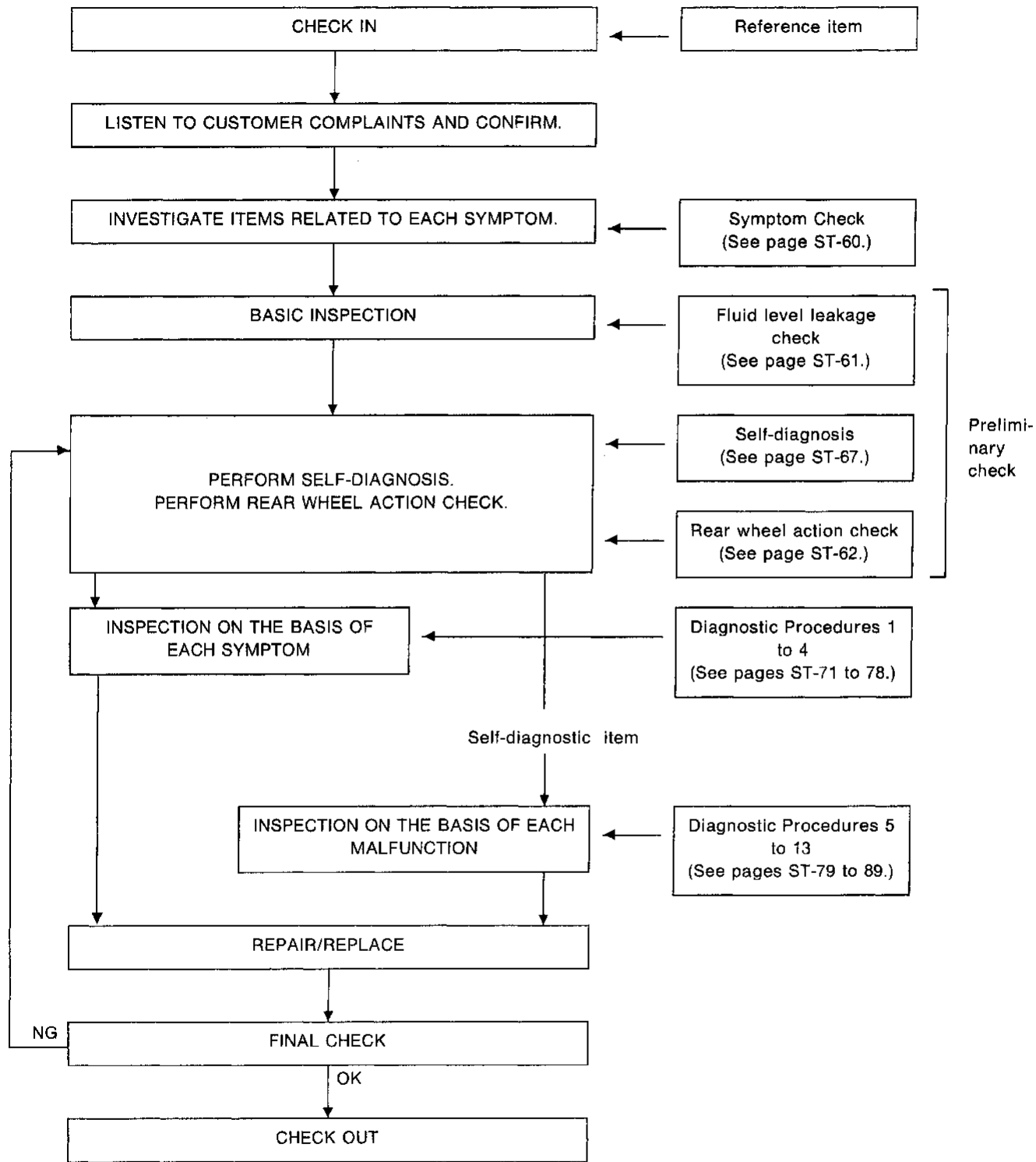

GI

MA

EM

LC

EF &  
EC

FE

AT

PD

FA

RA

BR

**ST**

BF

HA

EL

IDX

# SUPER HICAS SYSTEM — Trouble Diagnoses

## Symptom Chart

### DIAGNOSTIC TABLE

PROCEDURE			Preliminary Check			Diagnostic Procedure												
REFERENCE PAGE (ST-)			61	61	62	71	71	73	74	79	81	82	83	84	85	87	88	89
SYMPTOM			Preliminary check 1	Preliminary check 2	Preliminary check 3	Diagnostic procedure 1	Diagnostic procedure 2	Diagnostic procedure 3	Diagnostic procedure 4	Diagnostic procedure 5	Diagnostic procedure 6	Diagnostic procedure 7	Diagnostic procedure 8	Diagnostic procedure 9	Diagnostic procedure 10	Diagnostic procedure 11	Diagnostic procedure 12	Diagnostic procedure 13
No warning lamp comes on when Ignition switch is turned "ON"			○			○												
Warning lamp comes on when engine is running			○	○	○		○		○	○	○	○	○	○	○	○	○	
Abnormal noise is emitted.			○	○	○			○										
Vehicle behavior is unusual (due to malfunctioning HICAS system.)			○	○	○				○	○	○	○	○	○	○	○	○	
System is not set in self-diagnosis mode.										○								
Self-diagnostic results	Self-diagnosis code No.	Diagnosed part	CONSULT indication															
	1	HICAS solenoid (RH) output is not present.	HICAS SOLENOID-R [ABNORMAL SIGNAL]								○							
	2	HICAS solenoid (LH) output is not present.	HICAS SOLENOID-L [ABNORMAL SIGNAL]								○							
	3	Fail-safe valve output is not present.	FAIL-SAFE VALVE [ABNORMAL SIGNAL]									○						
	4	Power steering solenoid output is not present.	POWER STEERING SOL [ABNORMAL SIGNAL]										○					
	5	Vehicle speed signal is not present.	VEHICLE SPEED SENSOR [NO SIGNAL] (-a) VEHICLE SPEED SENSOR [SIG-SUDDEN TURN] (-b)											○				
	6	Steering angle sensor input is not present.	STEERING ANGLE SEN [NO ANG SIGNAL] (-a) STEERING ANGLE SEN [NO NEUT SIGNAL] (-b)													○		
	7		STEERING ANGLE SEN [NEUT SIG-360° OFF] (-c) STEERING ANGLE SEN [NEUT SIG-30° ON] (-d)															
	8	Parking brake input is not present.	—														○	
	9	Inhibitor switch input is not present.	—															○
10	Engine speed input is not present.	—																○

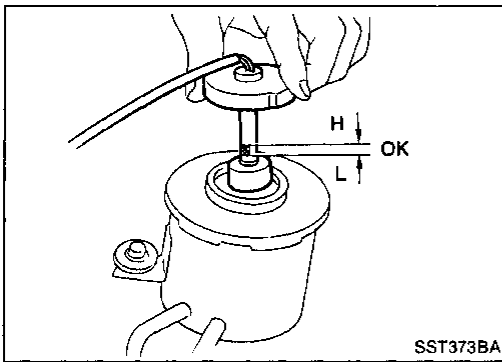

## Preliminary Check

### CHECK 1

#### Checking fluid level and fluid leakage

Refer to "SUPER HICAS SYSTEM — On-vehicle Service" on page ST-43.

GI

MA

EM

LC

EF &  
EC

FE

AT

PD

FA

RA

BR

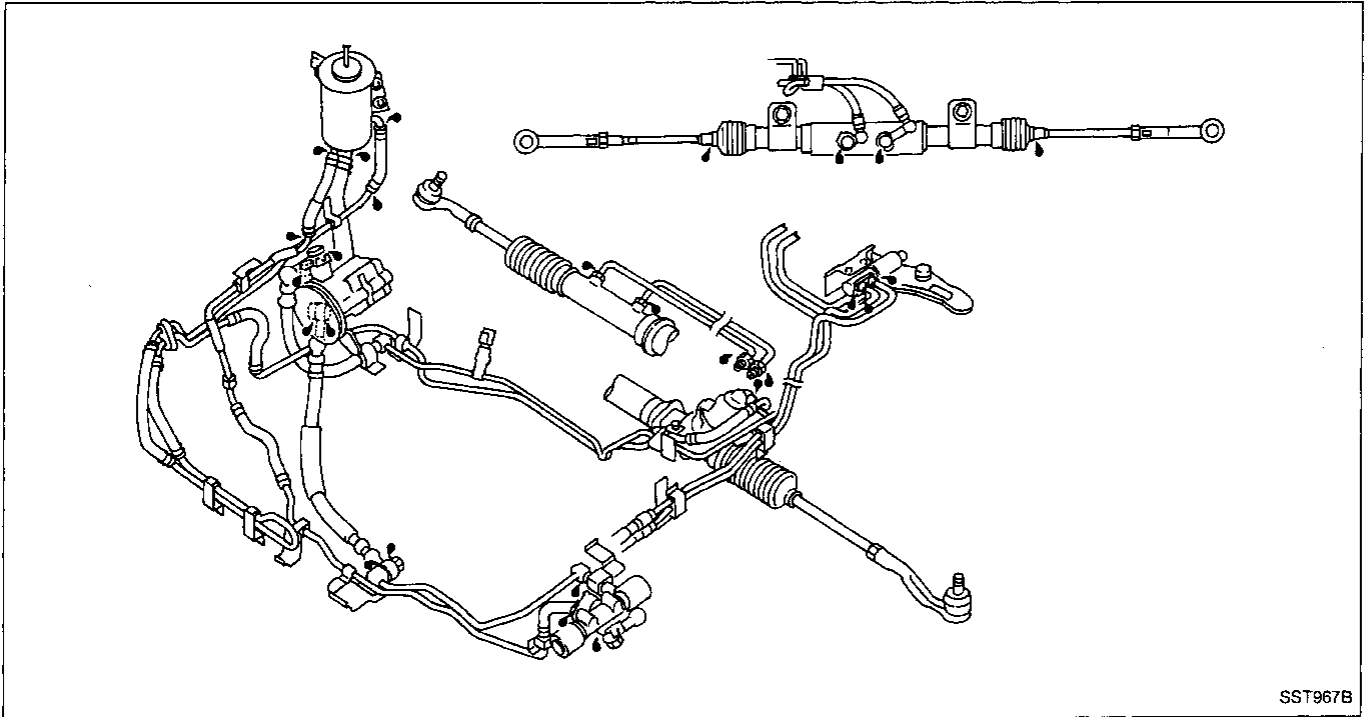

ST

BF

HA

EL

IDX

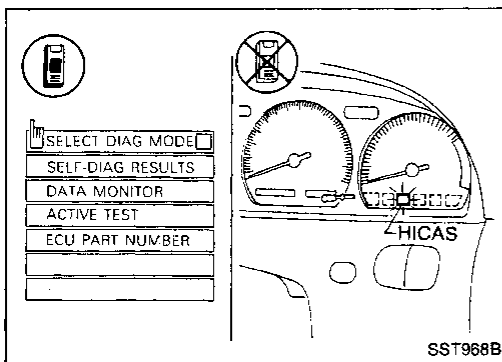

### CHECK 2

#### Perform self-diagnosis.

Refer to "Self-diagnosis" on page ST-67.

## Preliminary Check (Cont'd)

### CHECK 3

Perform rear wheel action check.

When CONSULT is used: 

1. Have a helper sit in the driver's compartment, and raise vehicle.  
(Use a two-pole lift or a center pole lift so that the four wheels are free to rotate.)
2. Connect CONSULT unit to data link connector and start engine.
3. Touch "START" on CONSULT display.
4. Touch "HICAS", "ACTIVE TEST" and "SIMULATED DRIVE" in that order.
5. Touch "START" when "MAIN SIGNALS" display is reversed.

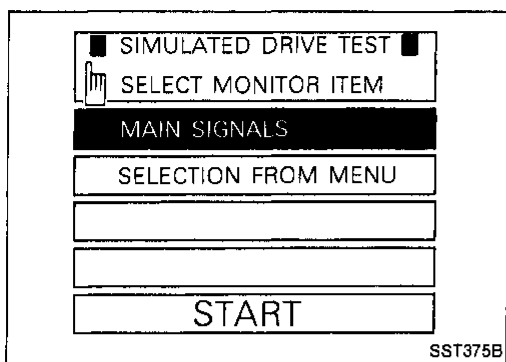

6. Touch "START".

After simulated drive condition has continued for 5 minutes, it will automatically cancel and CONSULT unit will then show "TEST IS INTERRUPTED TO AVOID OIL TEMP RISE" display. To cancel this mode during self-diagnosis, simply touch "CANCEL".

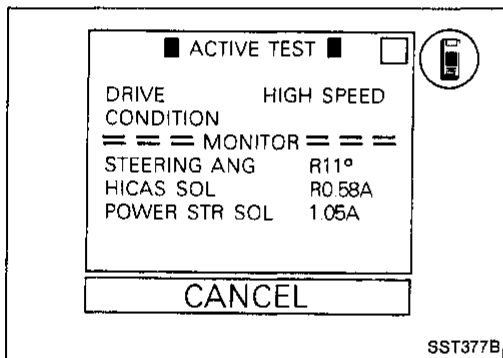

7. While running engine at speeds greater than 2,000 rpm, turn steering wheel 180° to the left and right from the neutral position. Ensure that rear wheels steer in response to rotation of steering wheel.

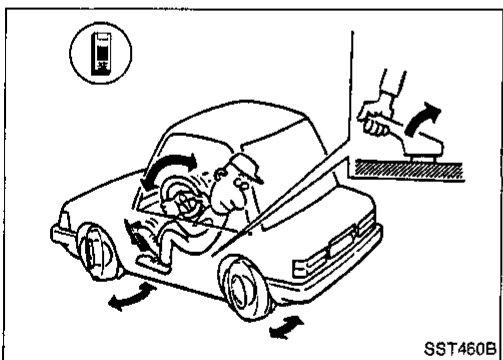

# SUPER HICAS SYSTEM — Trouble Diagnoses

## Preliminary Check (Cont'd)

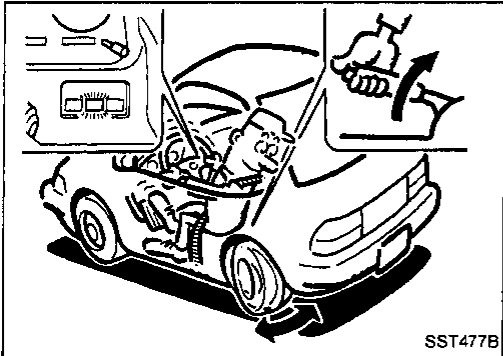
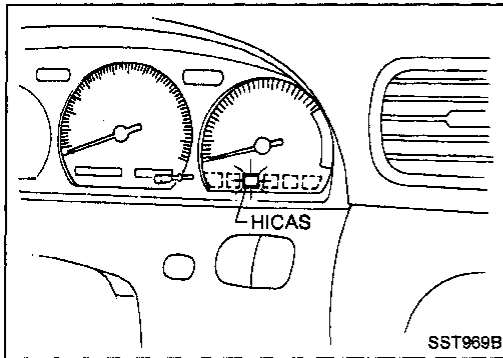

When CONSULT is not used:



1. Turn key switch "OFF".
2. Set HICAS system in self-diagnosis mode.
  - (1) Turn ignition switch "OFF".
  - (2) Set shift lever to "P" or "N" position.
  - (3) Turn ignition switch "ON".
  - (4) Immediately start engine.
  - (5) Turn steering wheel from left to right (at least 20° from the neutral position) 5 times or more, then depress foot brake pedal at least 5 times all within 10 seconds after ignition switch has been turned "ON".
3. Set steering wheel to a point approximately 10° from the neutral position and check to ensure that rear wheels turn to the left and right alternately.

GI

MA

EM

LC

EF &  
EC

FE

AT

PD

FA

RA

BR

**ST**

BF

HA

EL

IDX

**Component Parts and Harness Connector Location**

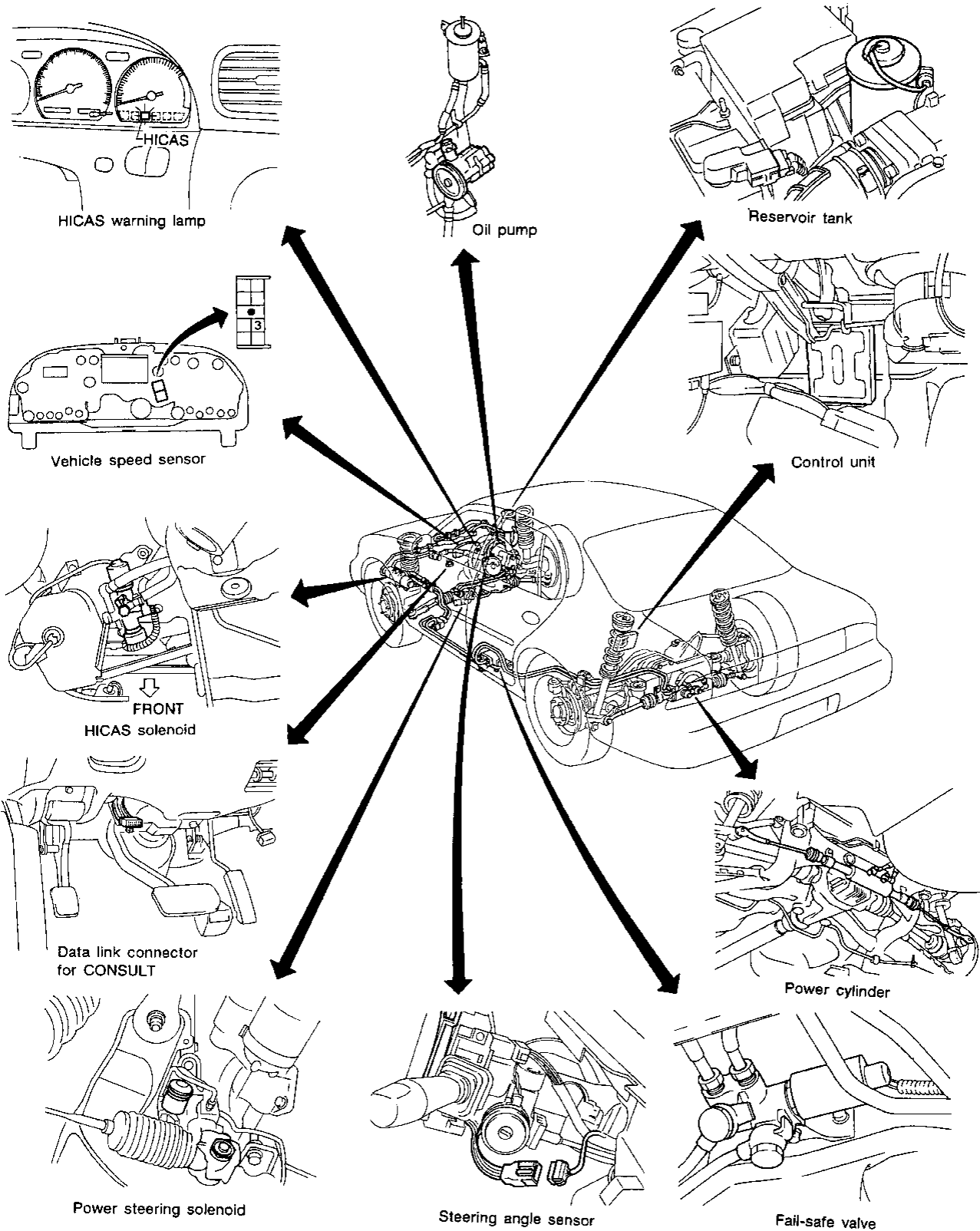



Circuit Diagram for Quick Pinpoint Check

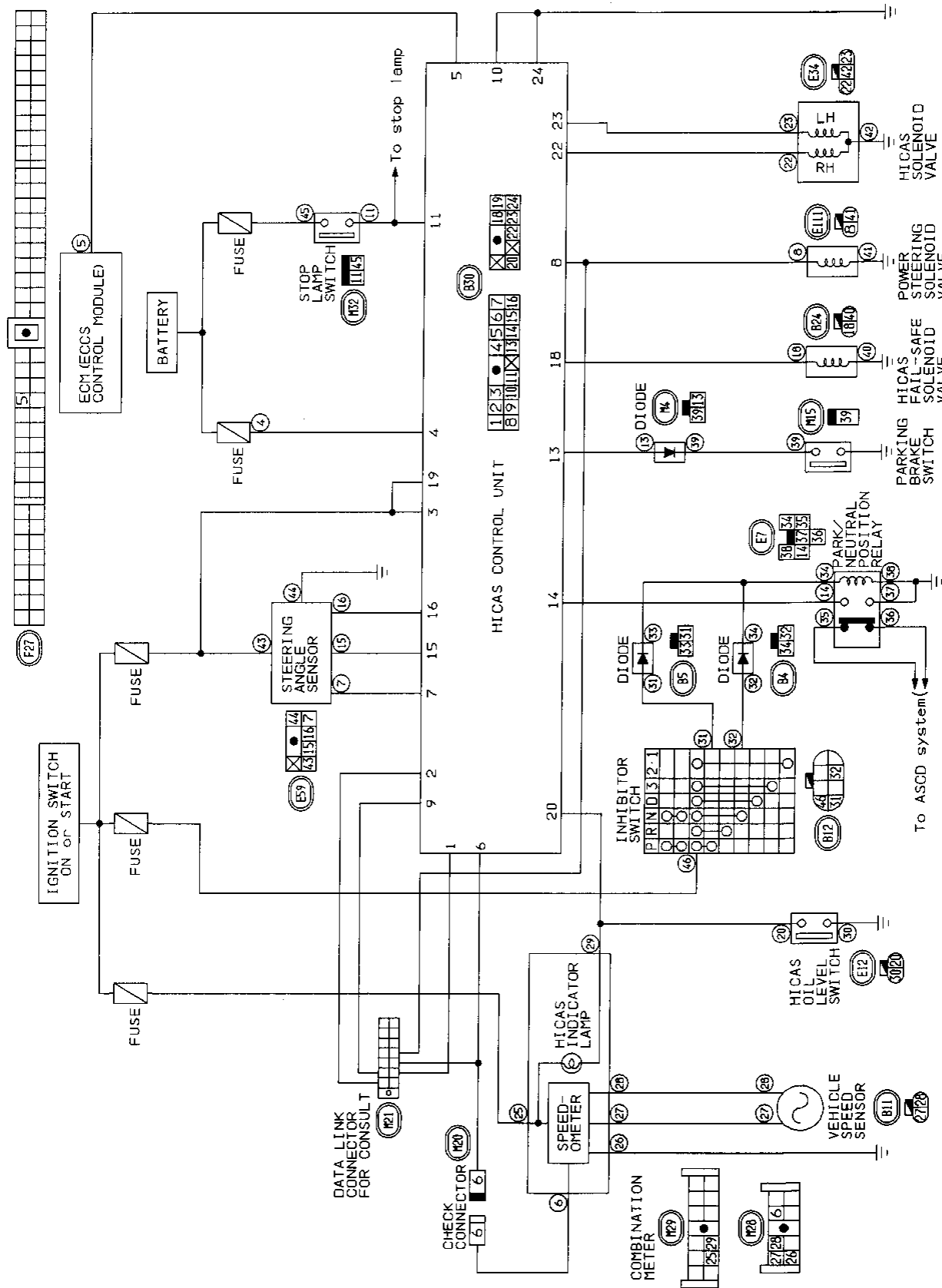

GI  
MA  
EM  
LC  
EF & EC  
FE  
AT  
PD  
FA  
RA  
BR  
**ST**  
BF  
HA  
EL  
DX

Wiring Diagram

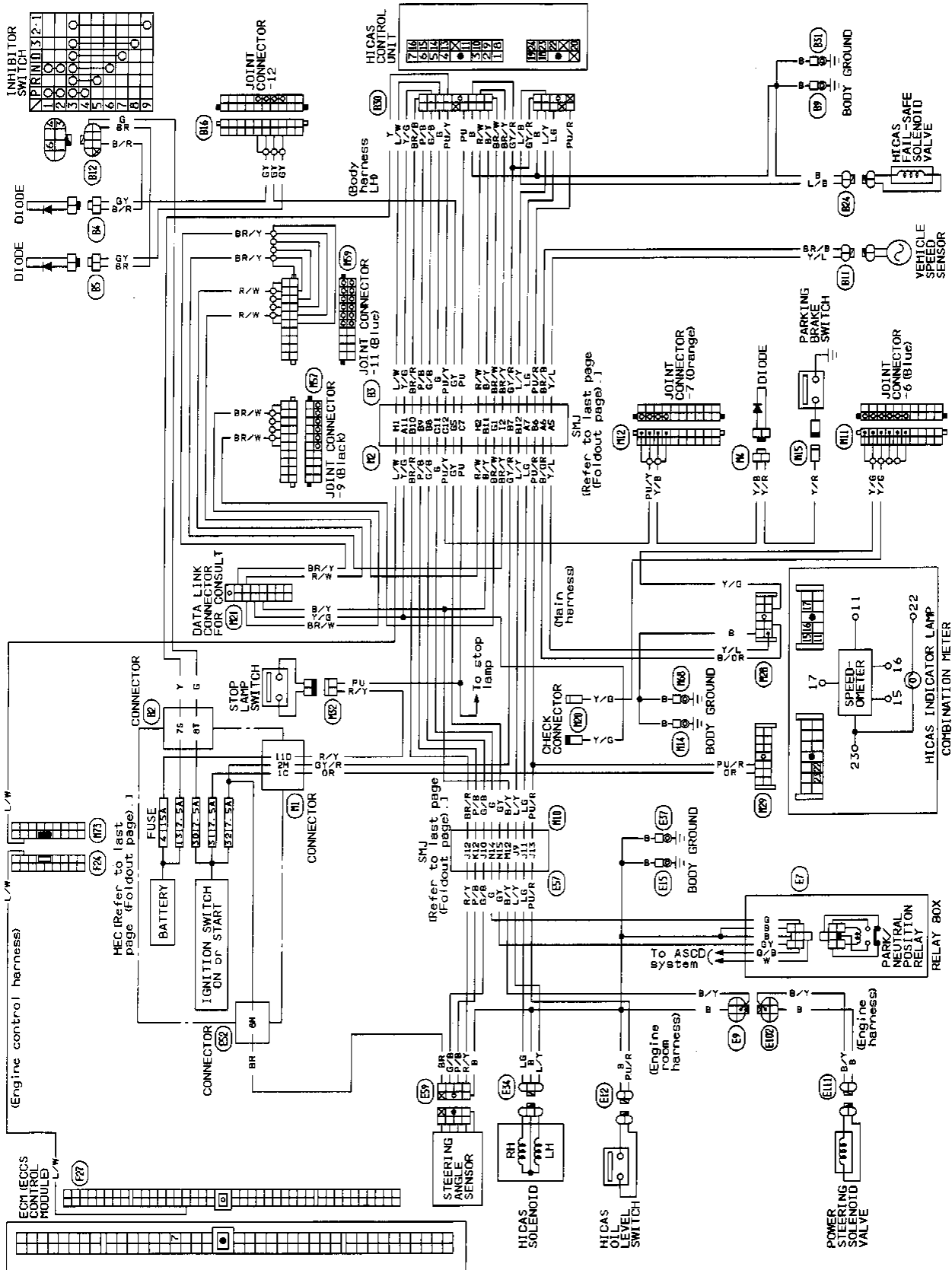

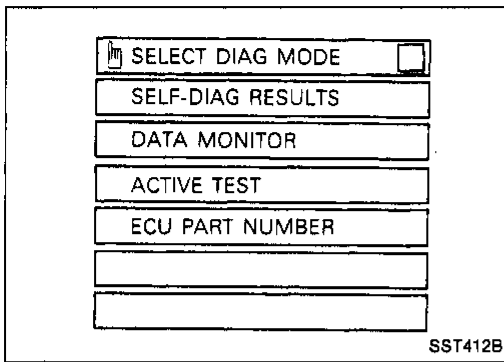

**Self-diagnosis (When CONSULT is used)** 

- Start engine.
- Touch START (on CONSULT display).
- Touch HICAS.
- Touch SELF-DIAG RESULTS.

Refer to CONSULT operation manual "HICAS" for details.

GI

MA

EM

LC

EF &  
EC

FE

AT

PD

FA

RA

BR

**ST**

BF

HA

EL

IDX

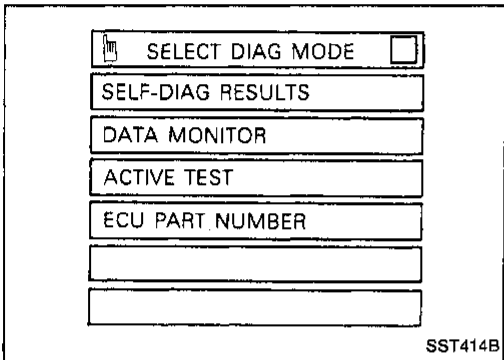

**For reference:**

**Recording input/output signals using data monitor function**

- Start engine.
- Touch START (on CONSULT display).
- Touch HICAS.
- Touch DATA MONITOR.

Refer to CONSULT operation manual "HICAS" for details.

## Self-diagnosis (When CONSULT is not used)



### SELF-DIAGNOSIS PROCEDURES

1. Input starting conditions for self-diagnosis.
  - (1) Turn ignition switch "OFF".
  - (2) Set shift lever to "P" or "N" position.
  - (3) Turn ignition switch "ON".
  - (4) Immediately start engine.
  - (5) Turn steering wheel from left to right (at least 20° from the neutral position ) 5 times or more, then depress foot brake pedal at least 5 times all within 10 seconds after ignition switch has been turned "ON".
2. Input self-diagnosis item.
  - (1) Depress and release foot brake pedal.
  - (2) Turn steering wheel from left to right (at least 20°) from the neutral position.
  - (3) Disengage and engage parking brake lever. Move shift lever to any position other than Neutral or Parking and return to Parking.
  - (4) Move car at least 3 meters (10 ft) forward and proceed at an indicated speed of at least 2 km/h (1 MPH) in self-diagnosis mode.
3. The self-diagnosis mode will then appear in the "HICAS" warning lamp.

#### When all systems are normal:

HICAS warning lamp flashes at 0.25-second intervals.

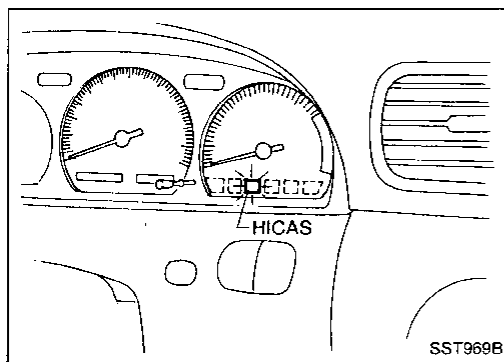

# SUPER HICAS SYSTEM — Trouble Diagnoses

## Self-diagnosis (When CONSULT is not used)



(Cont'd)

When there is a system malfunction:

Example: When ② HICAS solenoid LH, ④ power steering solenoid and ⑤ vehicle speed sensor have experienced a malfunction.

The warning lamp displays abnormal mode (1 sec. ON).

**A** If fail-safe system was operated (fail-safe valve is operating) when ignition switch was turned OFF for the last time, fail-safe items will be displayed in numerical order in modes indicated. After all items are displayed, display is repeated again.

- To change the display mode to **A**, turn OFF ignition switch after mode **B** is displayed.
- When battery charge is insufficient, mode **B** is displayed.

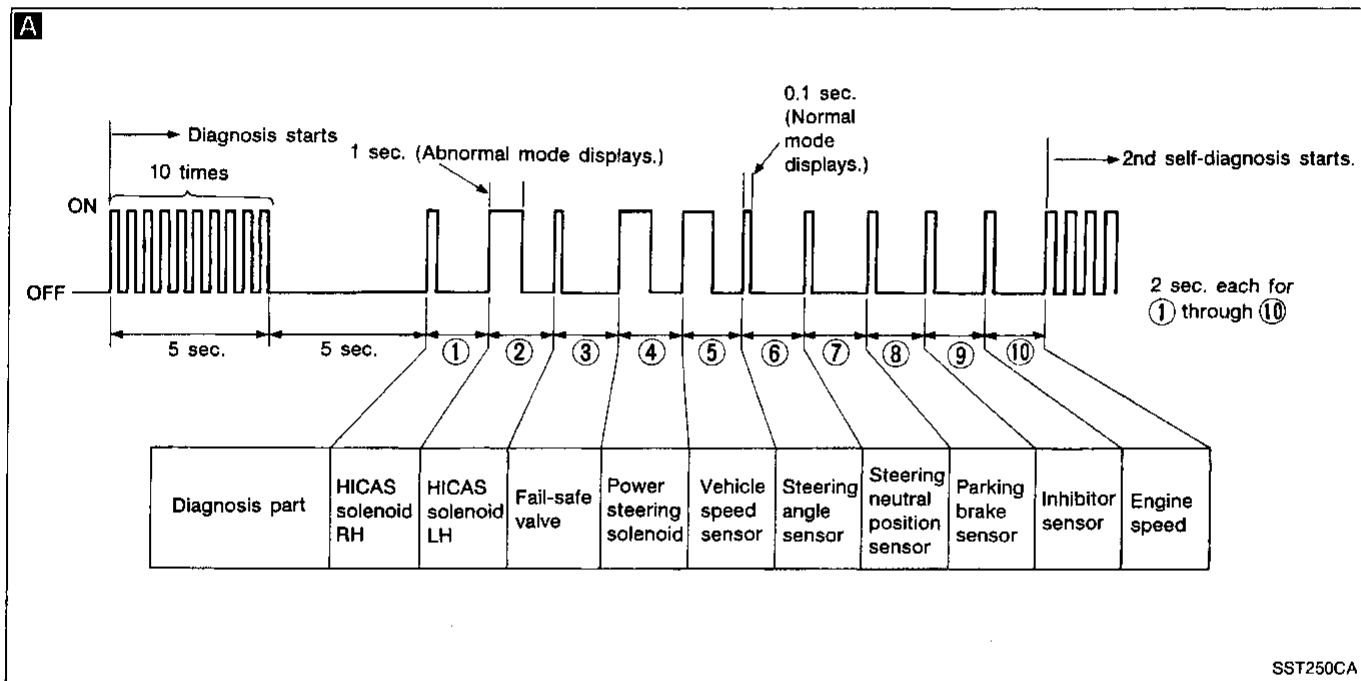

## SUPER HICAS SYSTEM — Trouble Diagnoses

### Self-diagnosis (When CONSULT is not used)

 (Cont'd)

- B** If fail-safe system was not operated when ignition switch was turned OFF for the last time, display will show self-diagnosis results in numerical sequence in modes indicated below. After all self-diagnosis results are shown, display is repeated again.

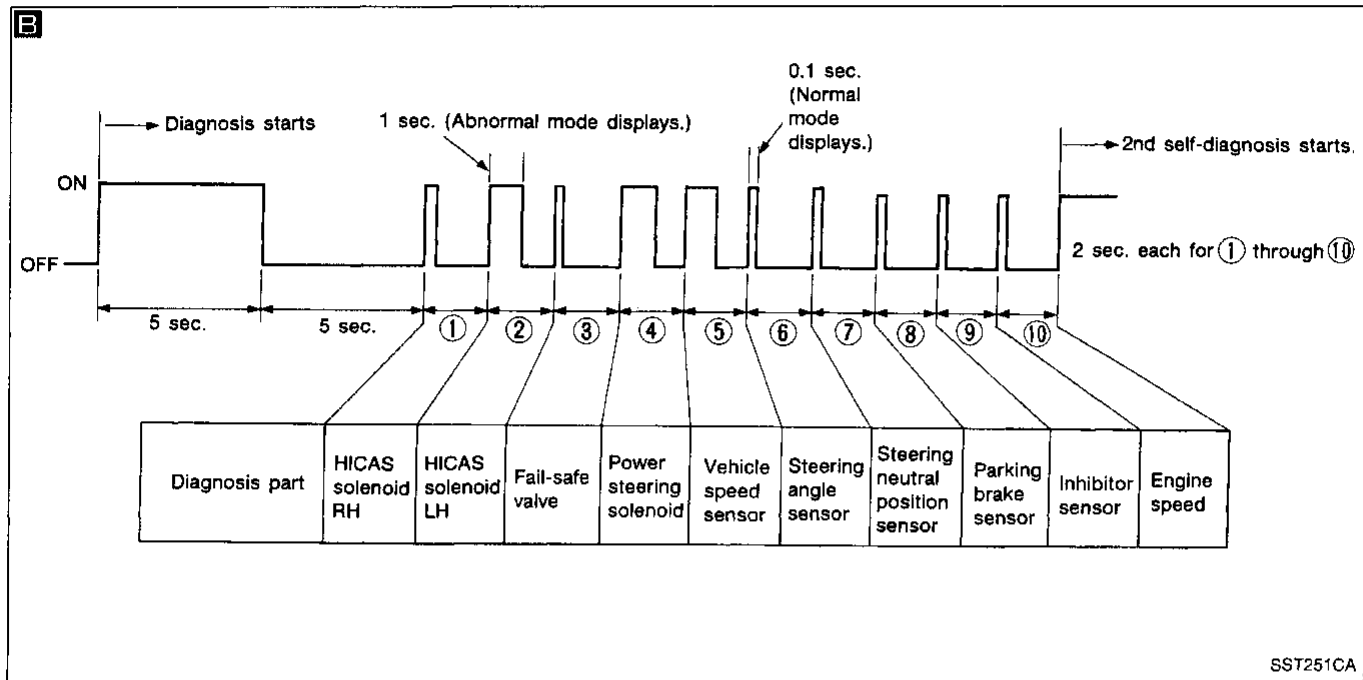

### CANCELING THE SELF-DIAGNOSIS FUNCTION

There are three methods for canceling the self-diagnosis function, as described below:

- The self-diagnosis system is canceled by the turning ignition switch "OFF".
- After self-diagnosing has been operated for approximately 5 minutes, the self-diagnosis system will be automatically canceled.
- The self-diagnosis system is canceled by a vehicle speed of 30 km/h (19 MPH) or over.

#### CAUTION:

When "Steering angle sensor error" in self-diagnosis [Code: "No neutral signal (\*b)"] is detected, check output of steering angle sensor.

If output is not good, replace steering angle sensor.

If output is OK, disconnect connector of HICAS control unit and connect it surely. Then perform SELF-DIAGNOSIS to erase memory of "Steering angle sensor error".

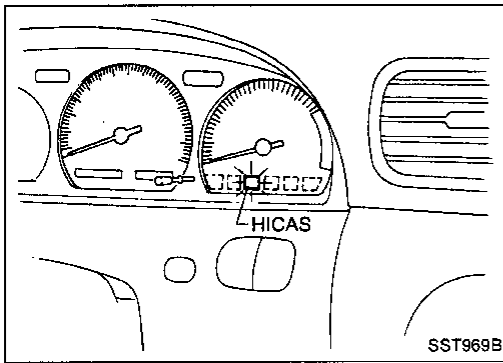

**Diagnostic Procedure 1**

**SYMPTOM:**

No warning lamp comes on when ignition switch is turned "ON".

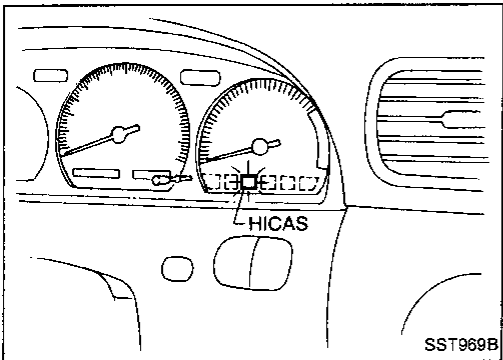
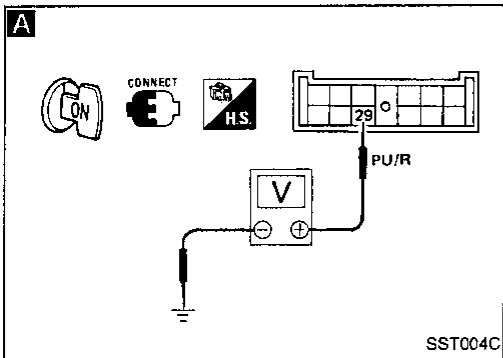
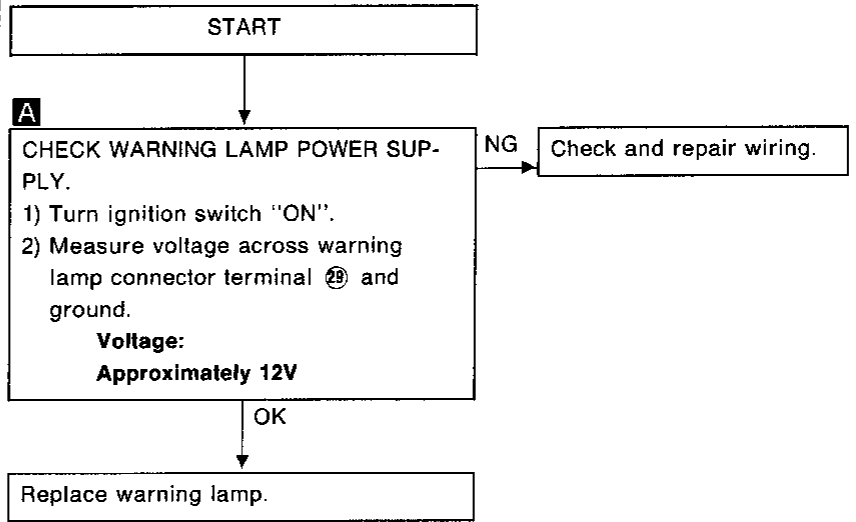

**Diagnostic Procedure 2**

**SYMPTOM (A):**

Warning lamp comes on during operation.

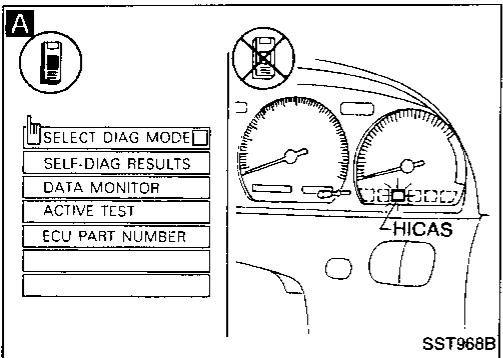
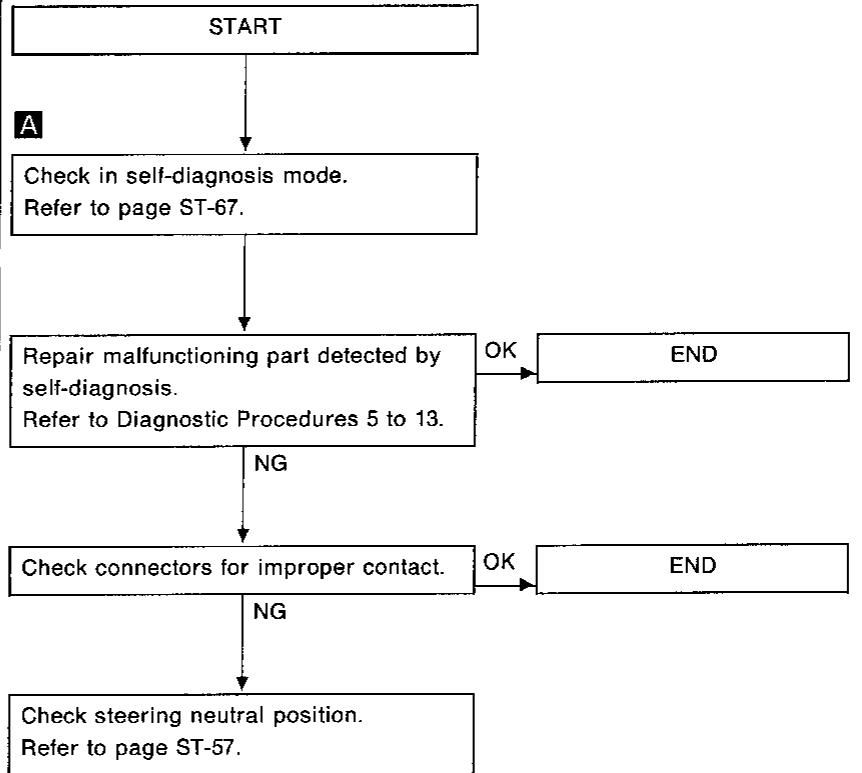

GI  
MA  
EM  
LC  
EF &  
EC  
FE  
AT  
PD  
FA  
RA  
BR  
ST  
BF  
HA  
EL  
IDX

# SUPER HICAS SYSTEM — Trouble Diagnoses

## Diagnostic Procedure 2 (Cont'd)

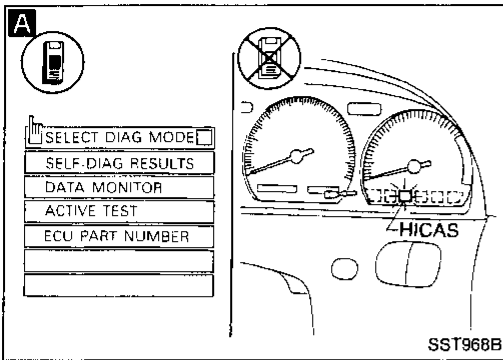

### SYMPTOM (B):

Warning lamp comes on when ignition switch is turned ON; however, it does not go out after engine start.

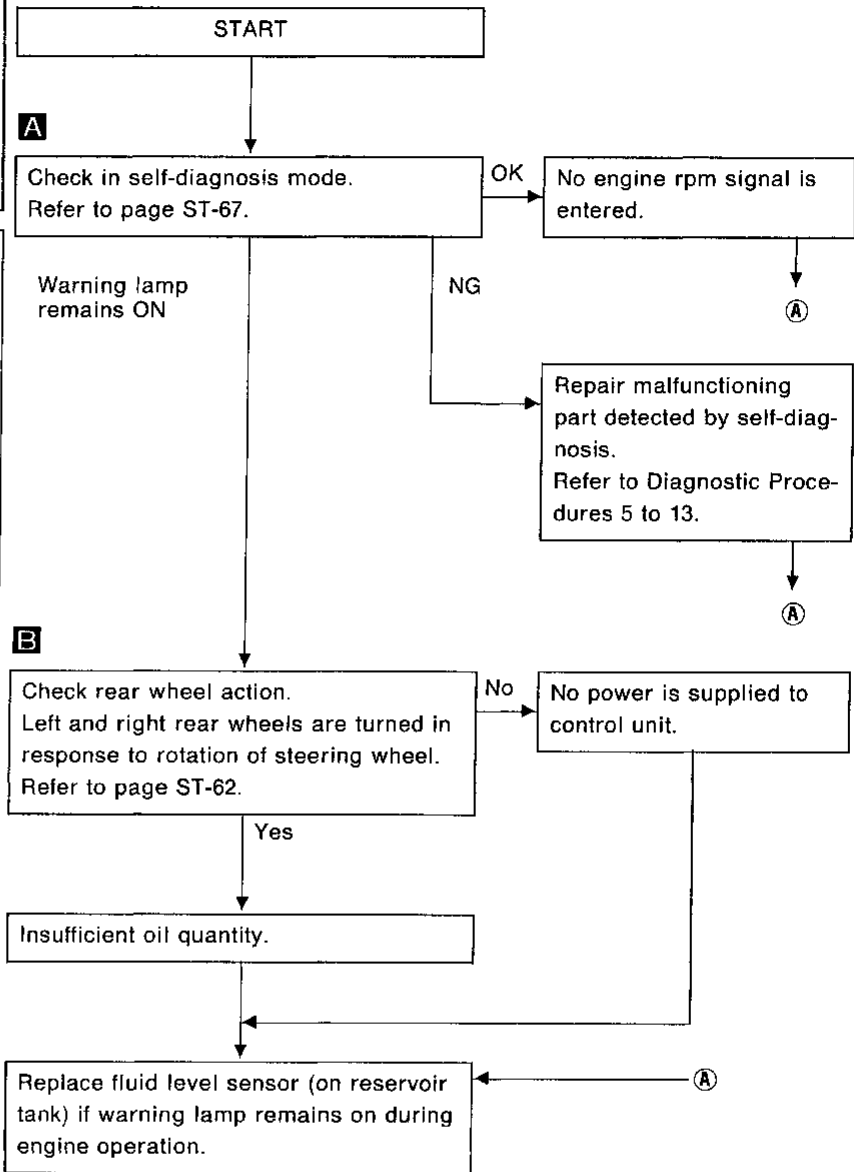
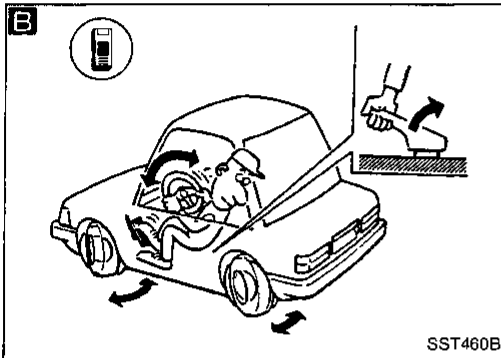



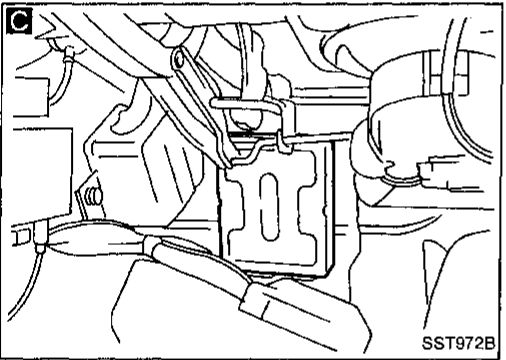
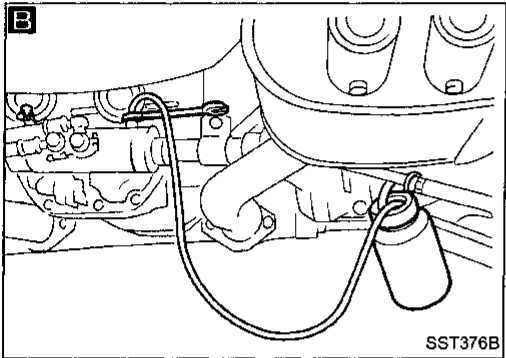
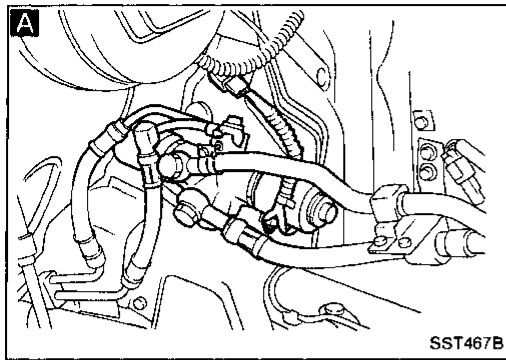

**Diagnostic Procedure 3**

**SYMPTOM:**  
Abnormal noise occurs.

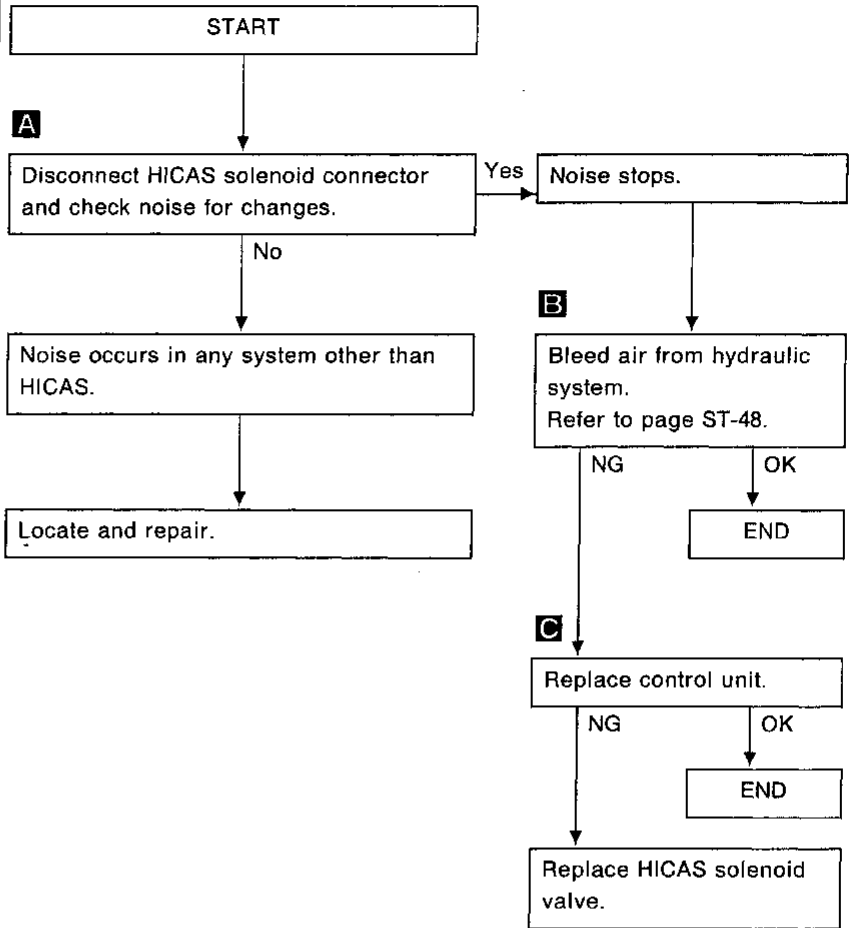

GI

MA

EM

LC

EF &  
EC

FE

AT

PD

FA

RA

BR

**ST**

BF

HA

EL

IDX

## Diagnostic Procedure 4

### SYMPTOM:

Vehicle behavior is abnormal. (Vehicle sways or jerks.)

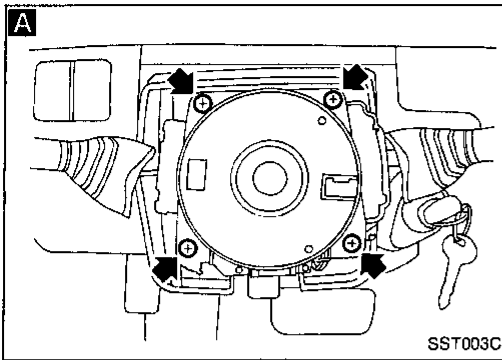

START

**A**  
Check steering wheel neutral position for misalignment and steering angle sensors for looseness.  
Refer to page ST-57.

OK → END

NG

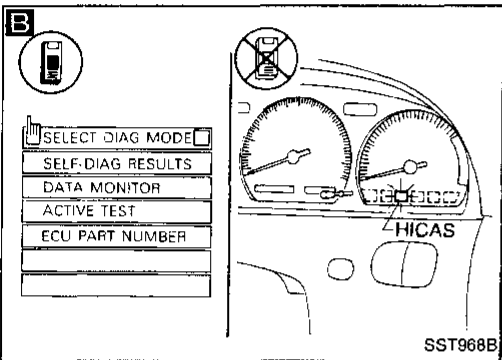

**B**  
Check in self-diagnosis mode.  
Refer to page ST-67.

NG → Repair malfunctioning system detected by self-diagnosis.  
Refer to Diagnostic Procedures 5 to 13.

OK

Check static HICAS characteristic performance.  
Refer to flow chart A on page ST-75.

Check dynamic HICAS characteristic performance.  
Refer to flow chart B on page ST-77.

# SUPER HICAS SYSTEM — Trouble Diagnoses

## Diagnostic Procedure 4 (Cont'd)

### A. Static HICAS characteristic performance check

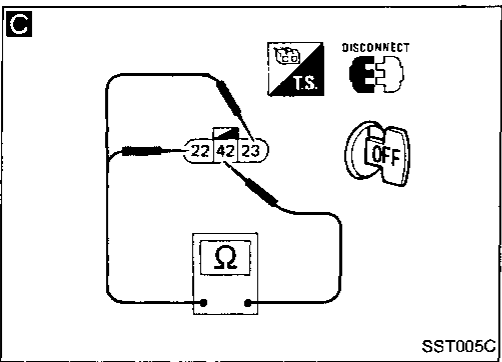
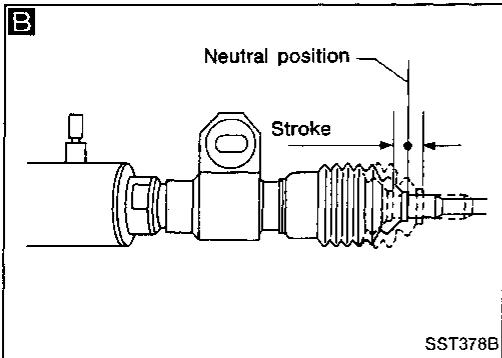
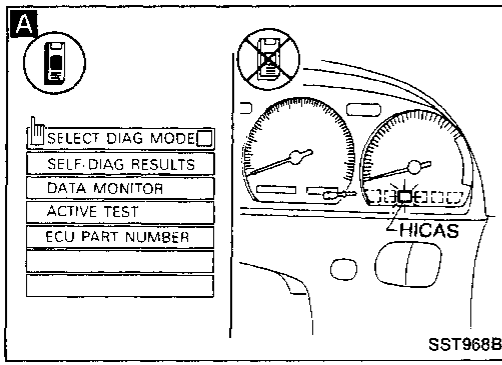

START

**A**

Set CONSULT in ACTIVE TEST mode.

OR

Set self-diagnosis mode. Refer to page ST-67.

**B**

- Run engine at a speed or less than 2,000 rpm.
- Turn steering wheel approximately 180° to the left or right.

CHECK POWER CYLINDER STROKES. Each stroke from neutral position: 2.9 - 3.1 mm (0.114 - 0.122 in) Refer to page ST-44.

OK → END

NG → B

**C**

CHECK RESISTANCE OF HICAS SOLENOID VALVE. Stop engine and disconnect HICAS solenoid valve. Measure resistance between HICAS solenoid connector terminals ② and ③, and ④.

Resistance: 4 - 6Ω

OK → A

NG → Replace HICAS solenoid valve. → B

GI  
MA  
EM  
LC  
EF & EC  
FE  
AT  
PD  
FA  
RA  
BR  
ST  
BF  
HA  
EL  
DX

# SUPER HICAS SYSTEM — Trouble Diagnoses

## Diagnostic Procedure 4 (Cont'd)

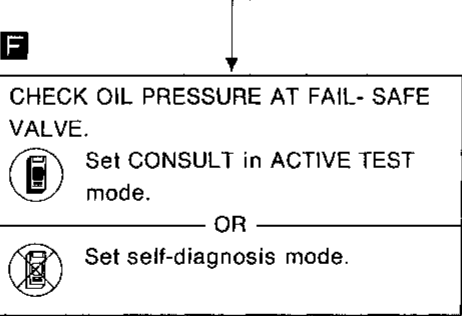
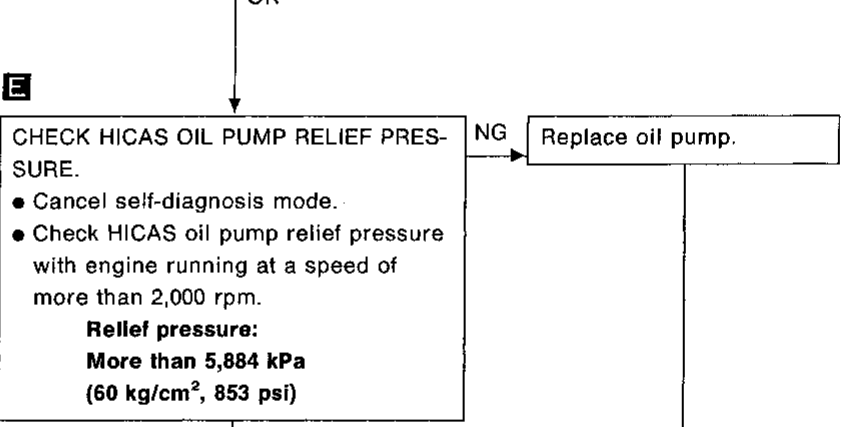
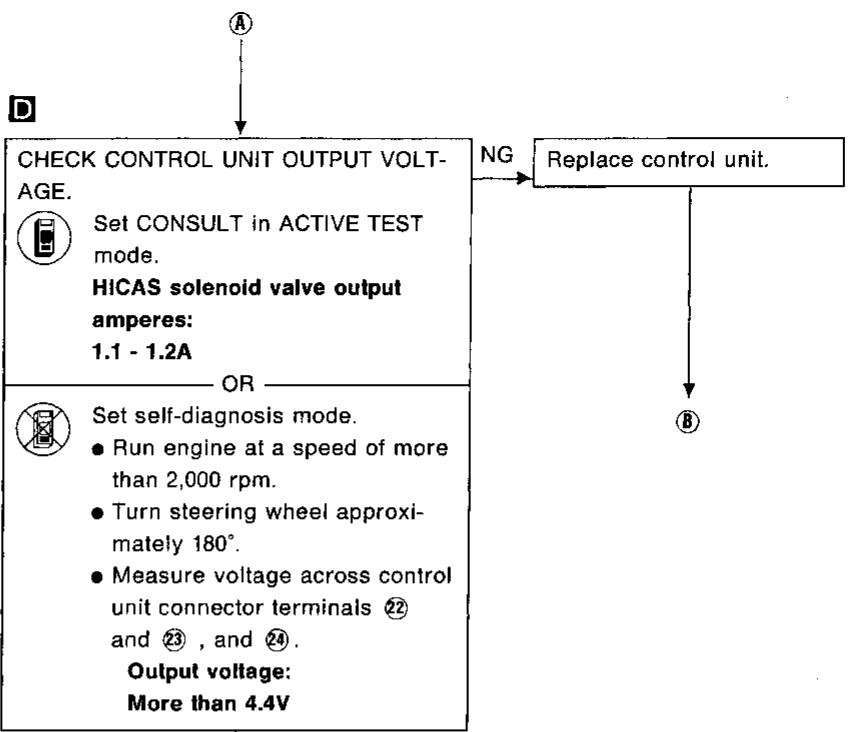
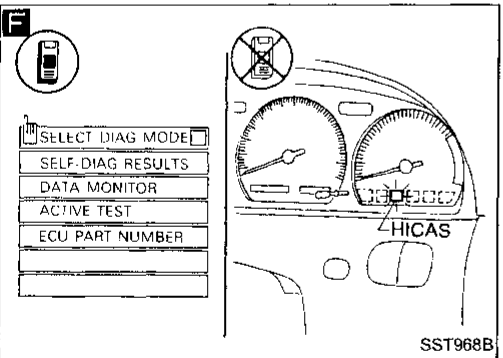
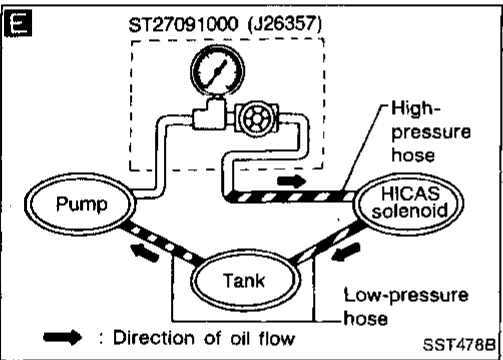
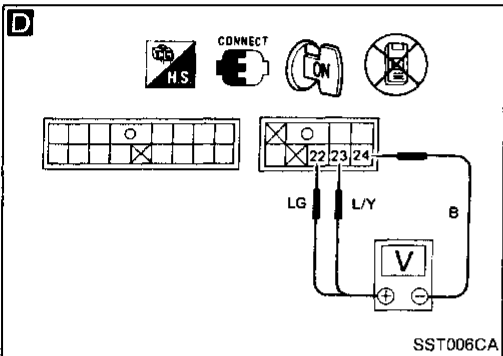
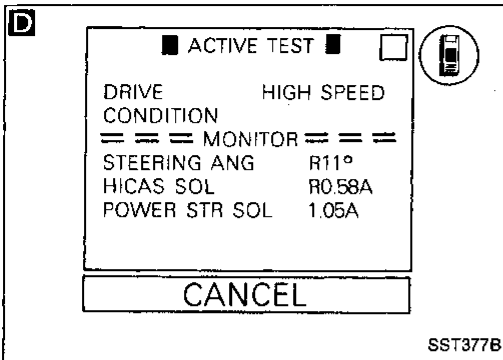

ⓐ

ⓑ

ⓑ

# SUPER HICAS SYSTEM — Trouble Diagnoses

## Diagnostic Procedure 4 (Cont'd)

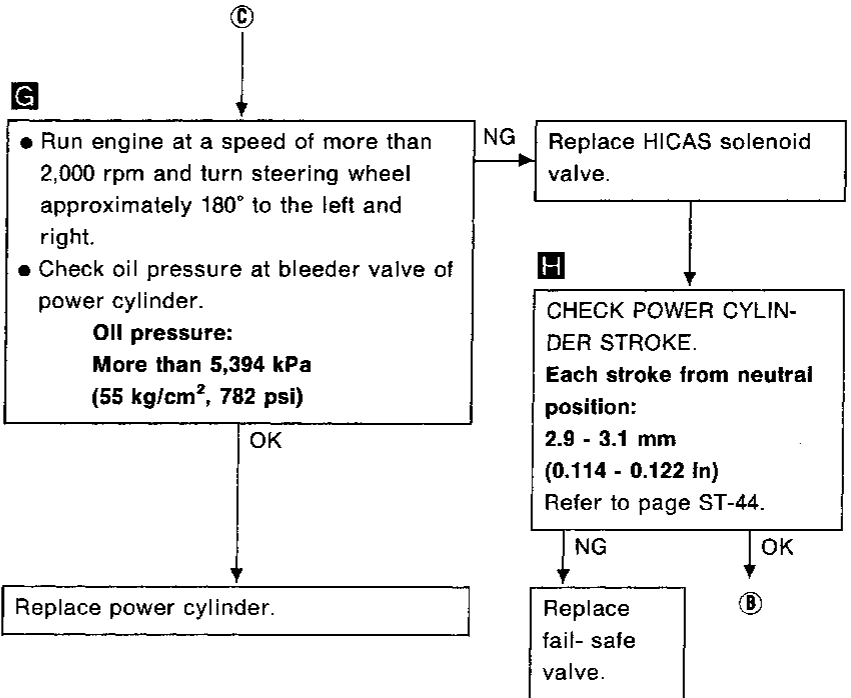
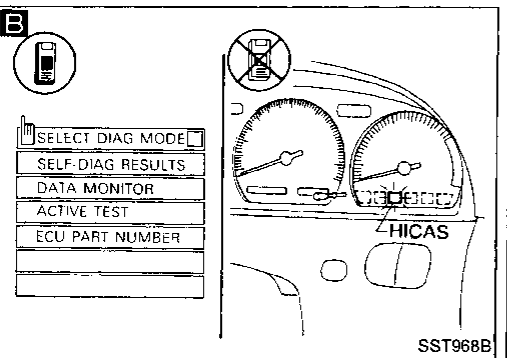
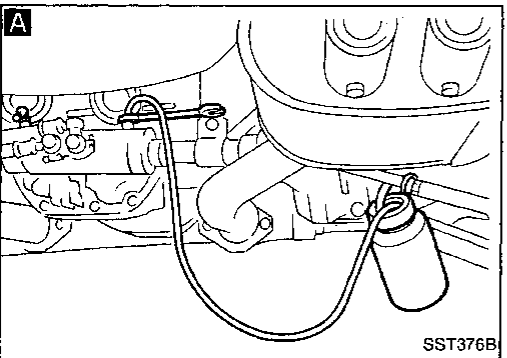
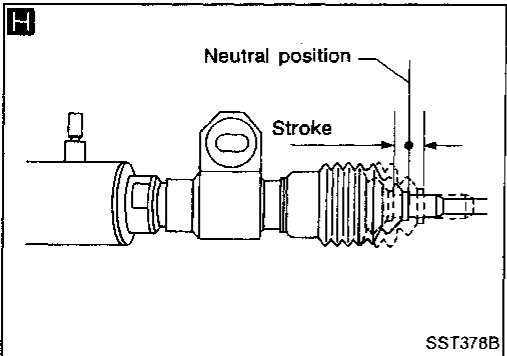
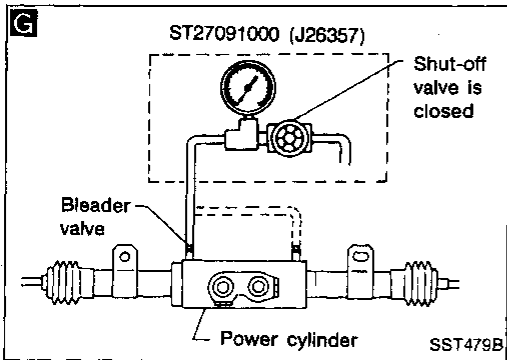

### B. Dynamic HICAS characteristic performance check

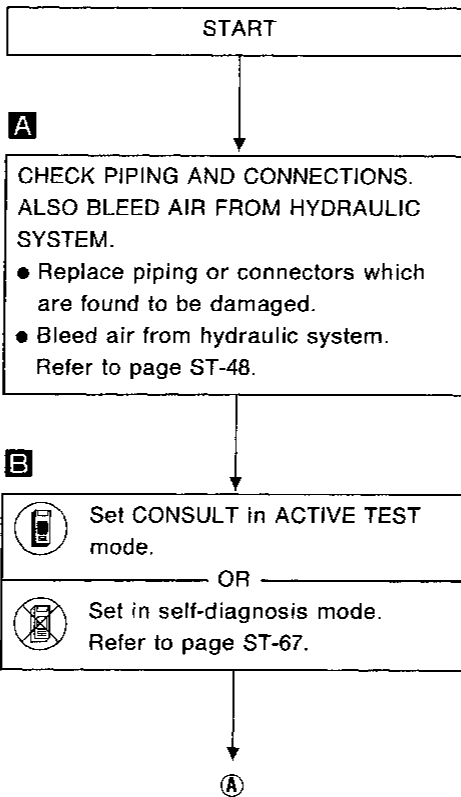

GI  
MA  
EM  
LC  
EF & EC  
FE  
AT  
PD  
FA  
RA  
BR  
ST  
BF  
HA  
EL  
IDX

# SUPER HICAS SYSTEM — Trouble Diagnoses

## Diagnostic Procedure 4 (Cont'd)

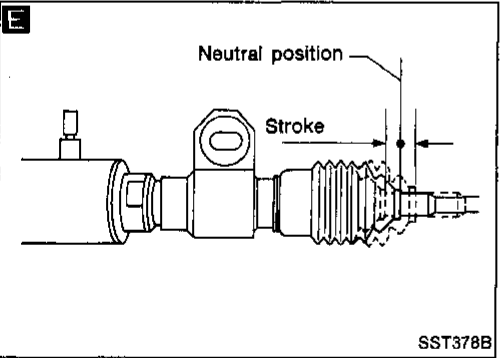
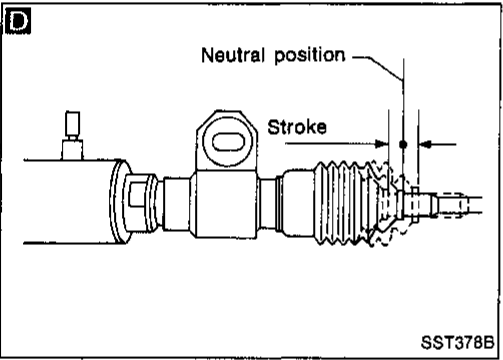
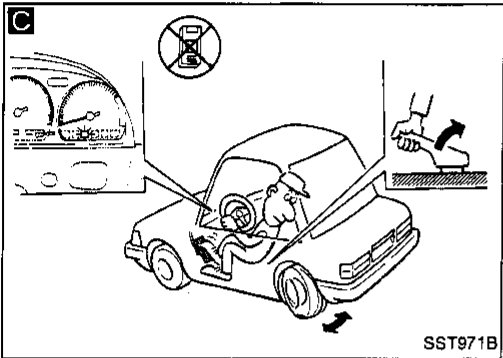
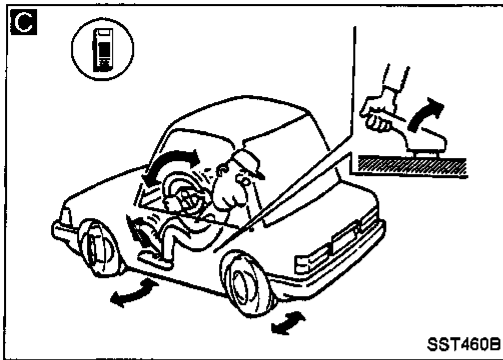

**A**

Run engine at a speed of more than 2,000 rpm.

**C**

CHECK REAR WHEELS FOR PROPER MOVEMENT.

Ensure that rear wheel turns to the left or right when steering wheel is turned to the left or right.

OR

Ensure that rear wheels intermittently turn to the left and right when steering wheel is set to the neutral position.

**D**

CHECK POWER CYLINDER STROKES.

Each stroke from neutral position:  
More than 2.0 mm (0.079 in)

OK → END

NG

Replace HICAS solenoid valve.

**E**

CHECK POWER CYLINDER STROKE.

● After replacing HICAS solenoid valve, check power cylinder stroke.

Each stroke from neutral position:  
More than 2.0 mm (0.079 in)

OK → END

NG

Replace power cylinder.

GI  
MA  
EM  
LC  
EF &  
EC  
FE  
AT  
PD  
FA  
RA  
BR  
ST  
BF  
HA  
EL  
IDX

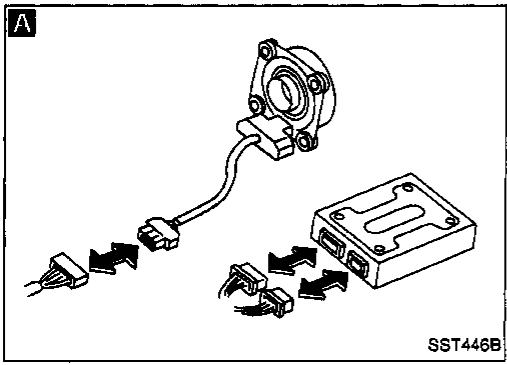

SST446B

**B**

☆ MONITOR	☆ NO FAIL	
VHCL SPEED SE	0km/h	
STEERING ANG	L8°	
NEUTRAL SIG	ON	
STOP LAMP SW	OFF	
PKB/CLUTCH SW	ON	
NEUT POSI SW	ON	
ENG SPEED	UNDER 1500	
HICAS SOL	R0.00A	
POWER STR SOL	1.05A	

**RECORD**

☆ MONITOR	☆ NO FAIL	
FAILSAFE/V	OFF	
FAILSAFE	NON	
WARNING LAMP	OFF	

**RECORD**

SST350C

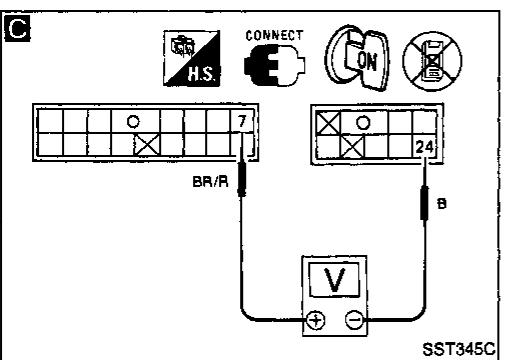
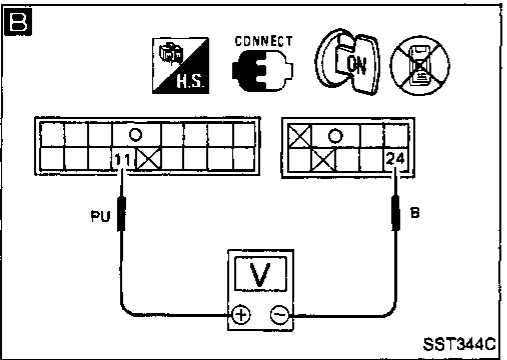

**Diagnostic Procedure 5**

**SYMPTOM:**  
System is not set in self-diagnosis mode.

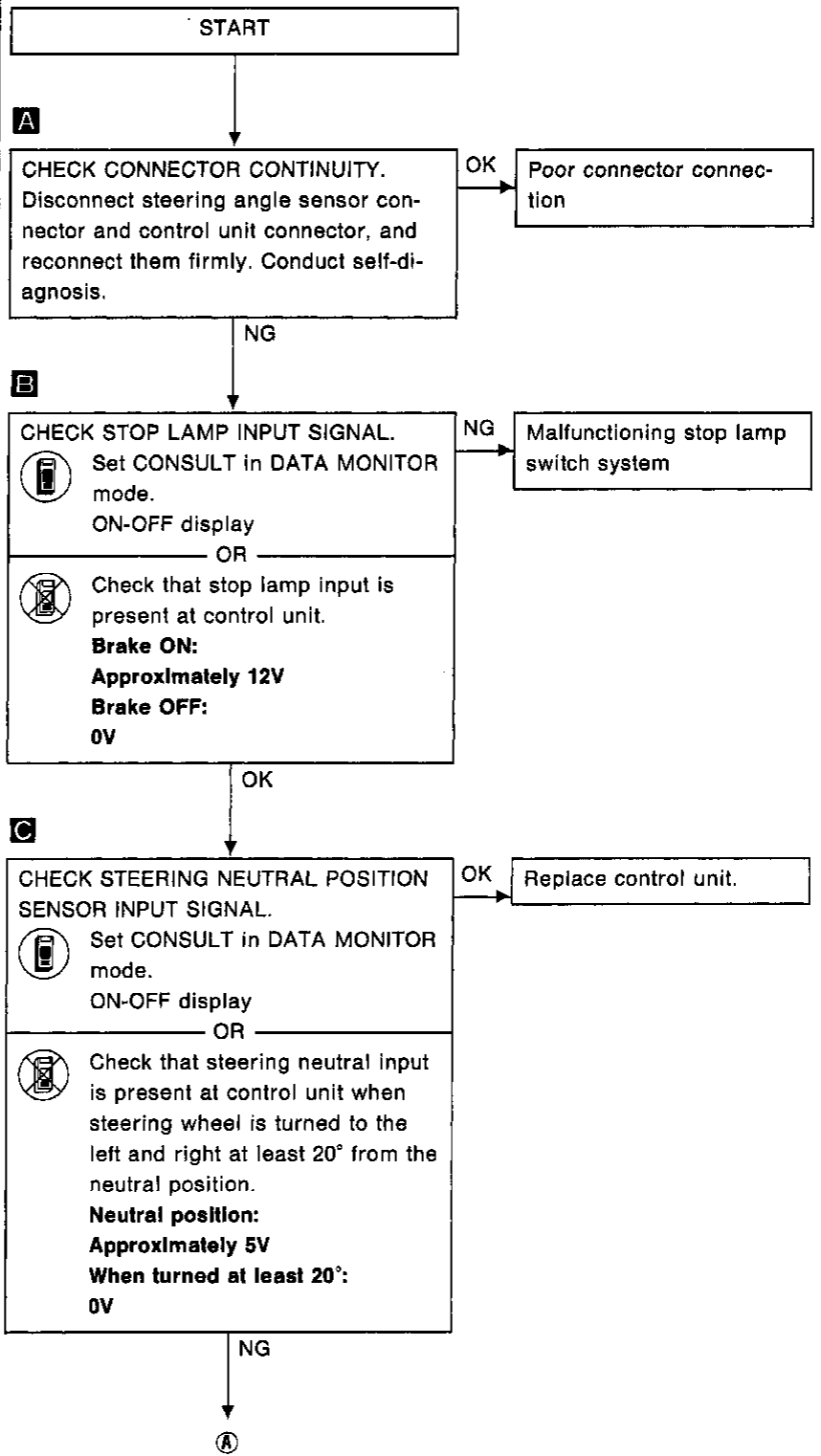

# SUPER HICAS SYSTEM — Trouble Diagnoses

## Diagnostic Procedure 5 (Cont'd)

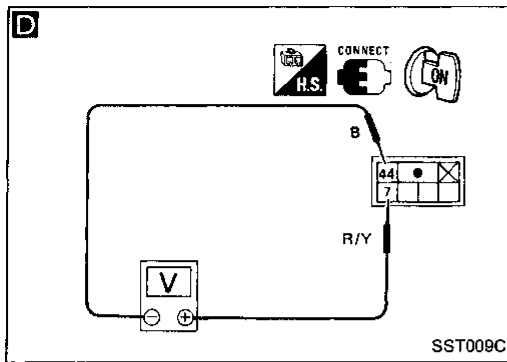

**D** CHECK STEERING NEUTRAL POSITION SENSOR OUTPUT SIGNAL.  
Check that steering neutral output is present when steering wheel is turned to the left and right at least 20° from the neutral position.  
**Neutral position:**  
**Approximately 5V**  
**When turned at least 20°:**  
**0V**

OK → Repair or replace harness between control unit and steering angle sensor.

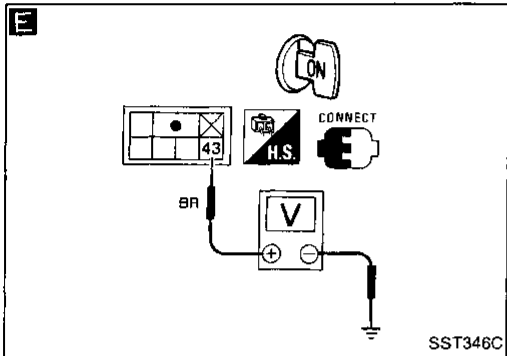

**E** CHECK STEERING ANGLE SENSOR POWER SUPPLY.  
1) Turn ignition switch "ON".  
2) Measure voltage across steering angle sensor connector terminal IGN and ground.  
**Voltage:**  
**Approximately 12V**

OK → Replace steering angle sensor.

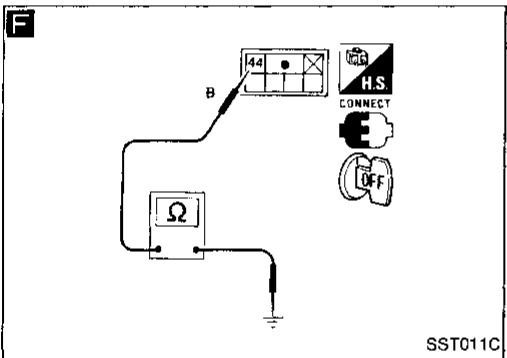

**F** CHECK STEERING ANGLE SENSOR GROUND CIRCUIT.  
Check continuity between steering angle sensor terminal GND and body metal (ground).  
**Continuity should exist.**

NG → Check and repair power supply harness or ground harness.



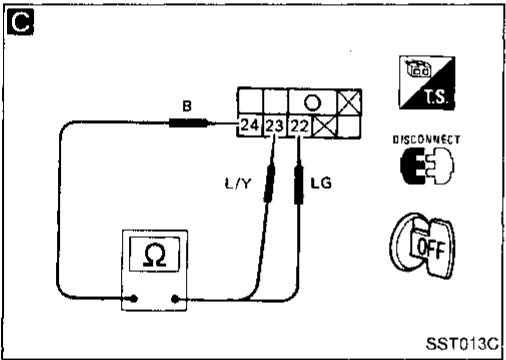
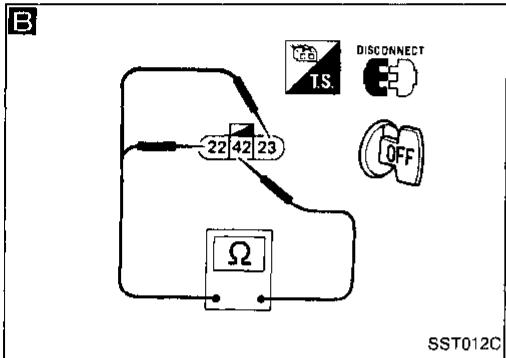
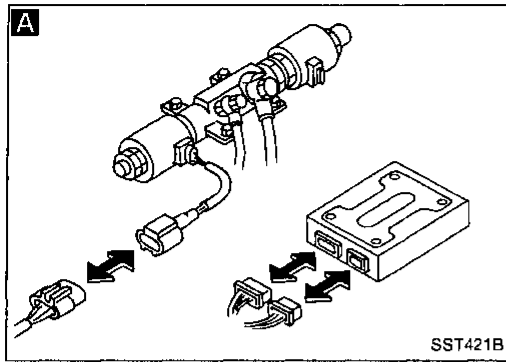

**Diagnostic Procedure 6**

**SYMPTOM:**

**HICAS solenoid (left and right) output is not present.**

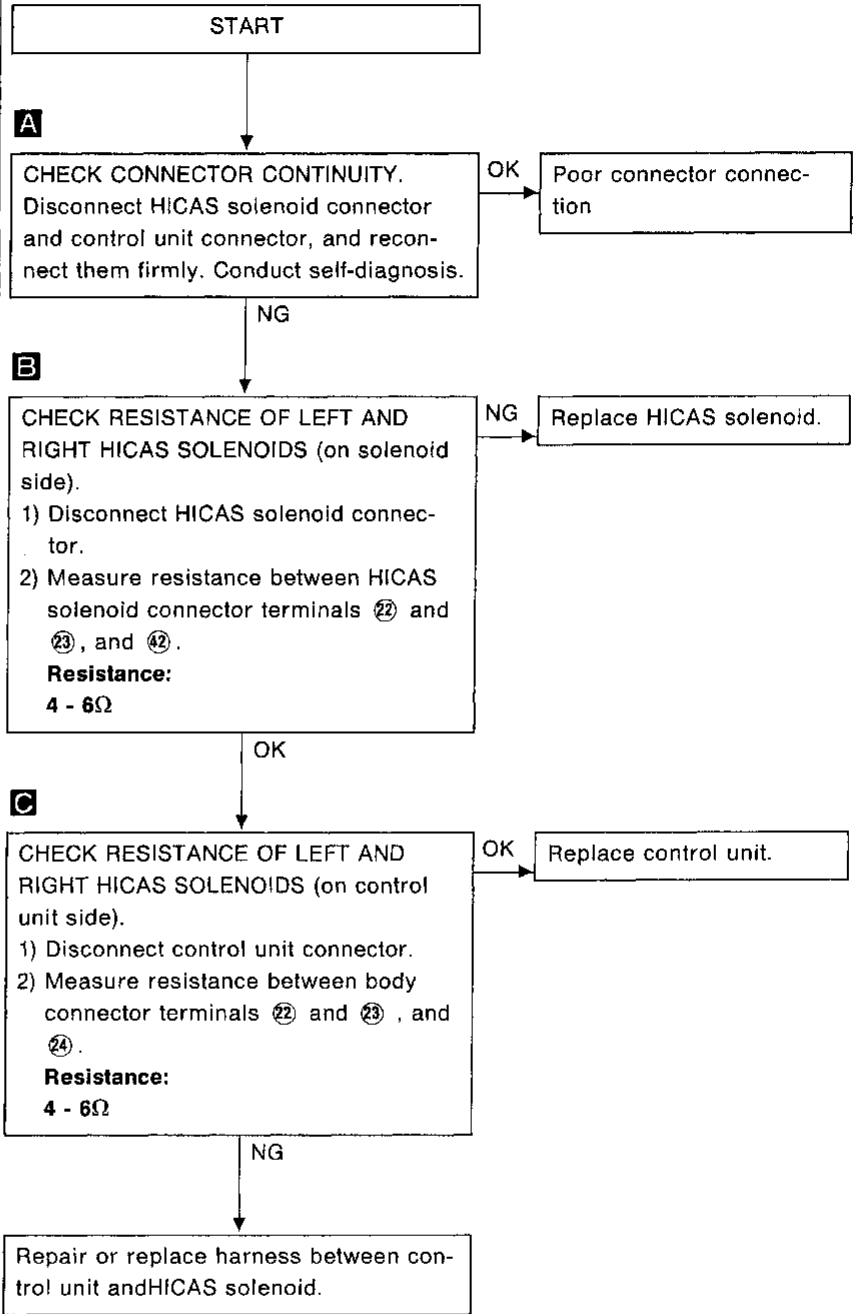

GI  
MA  
EM  
LC  
EF &  
EC  
FE  
AT  
PD  
FA  
RA  
BR  
ST  
BF  
HA  
EL  
IDX

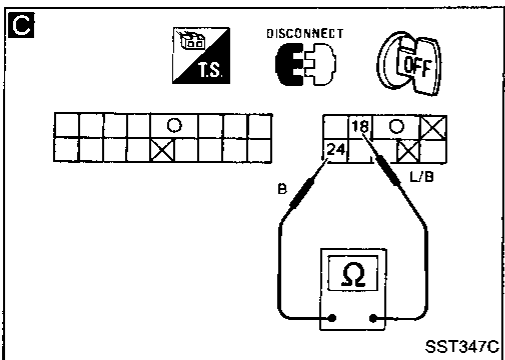
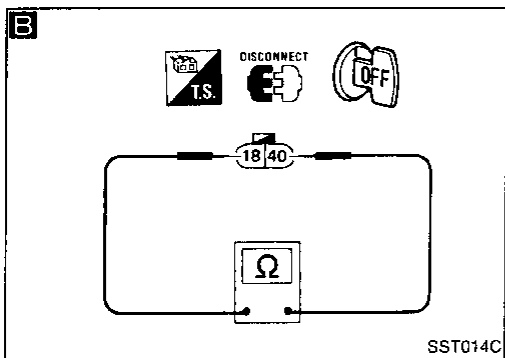
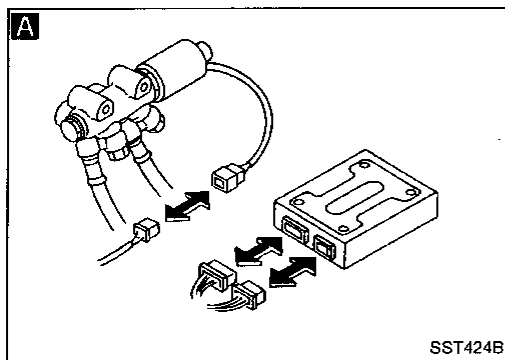

## Diagnostic Procedure 7

### SYMPTOM:

Fail-safe valve output is not present.

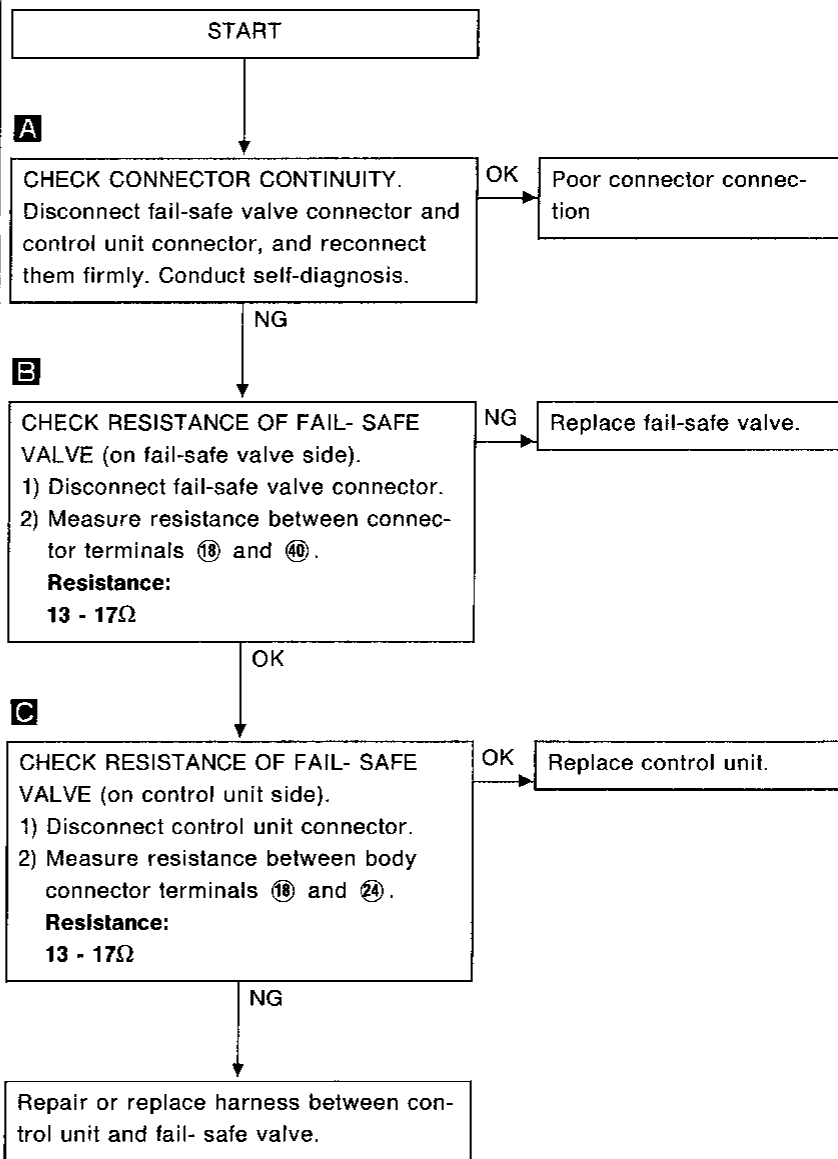

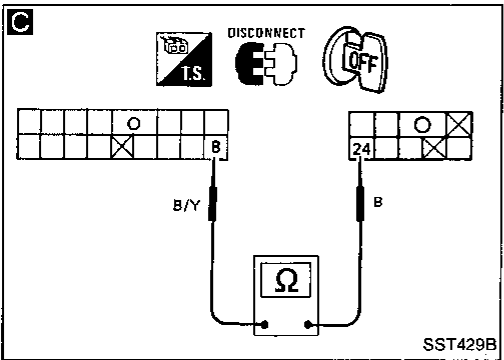
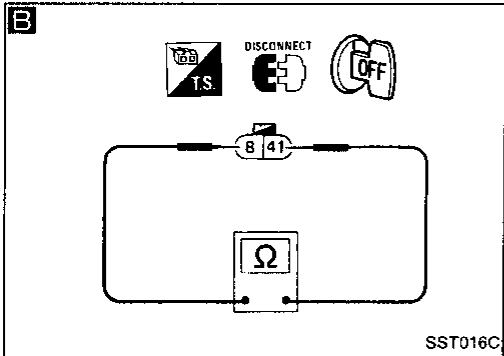
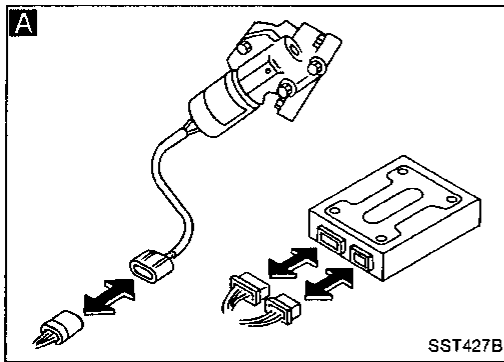

**Diagnostic Procedure 8**

**SYMPTOM:**  
Power steering solenoid output is not present.

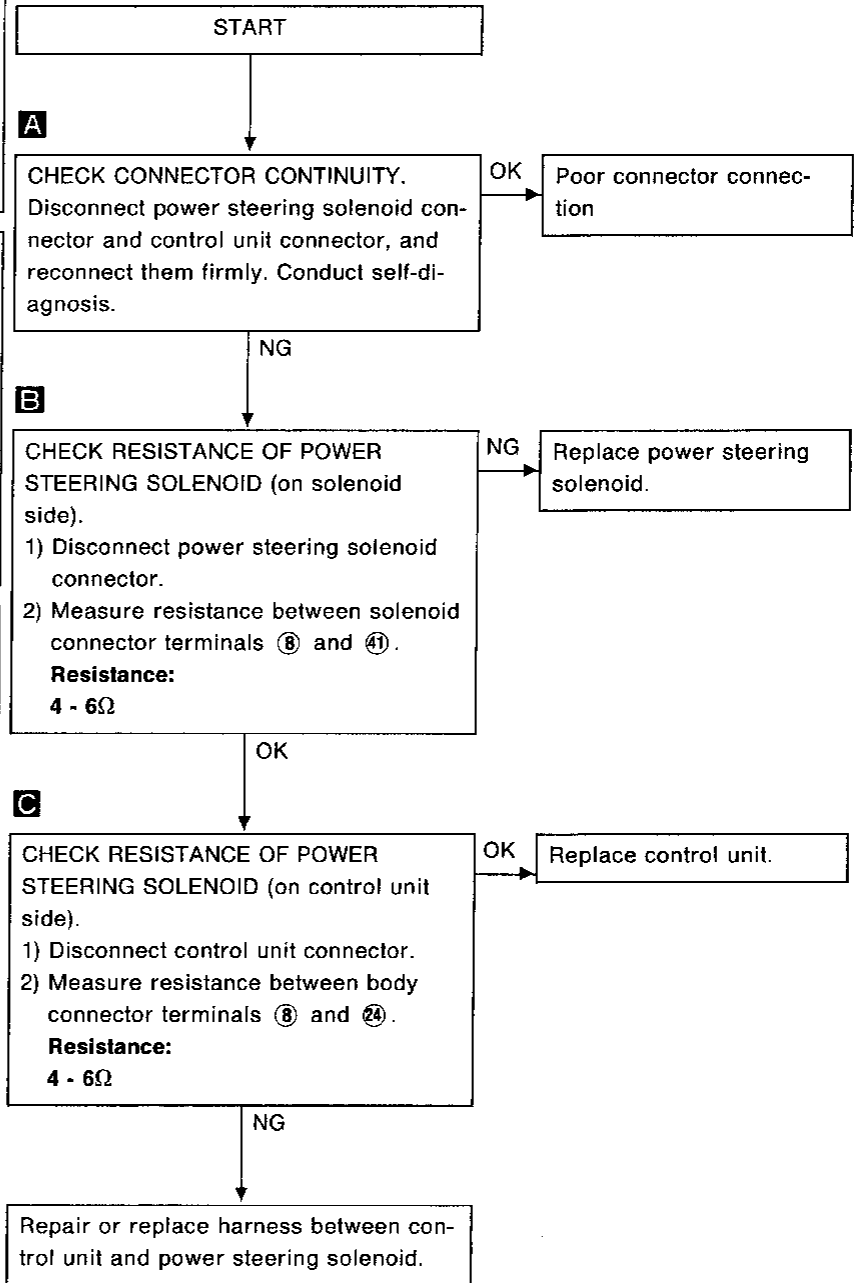

GI  
MA  
EM  
LC  
EF & EC  
FE  
AT  
PD  
FA  
RA  
BR  
ST  
BF  
HA  
EL  
IDX

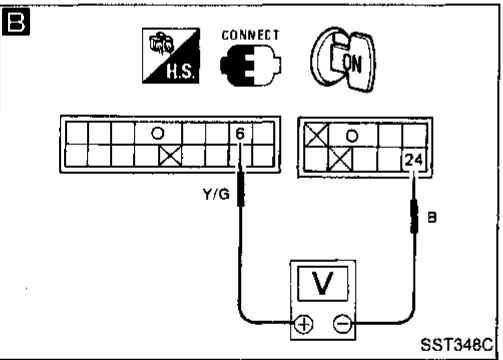
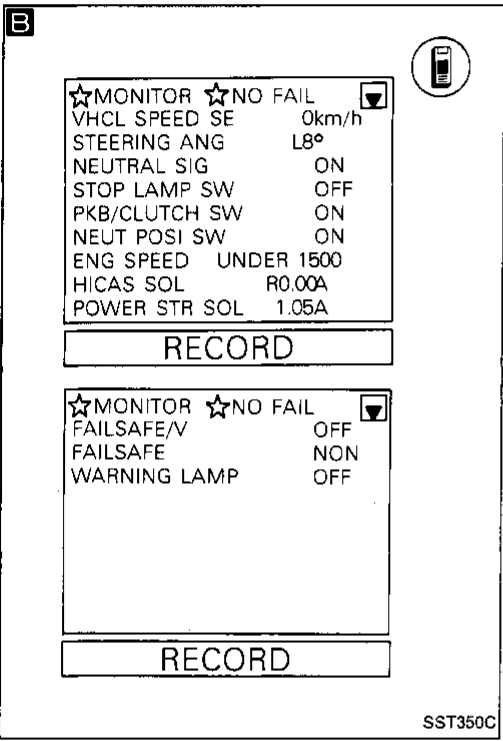
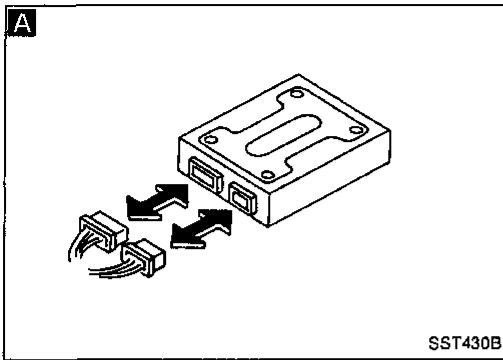

## Diagnostic Procedure 9

**SYMPTOM:**  
Vehicle speed signal is not present.

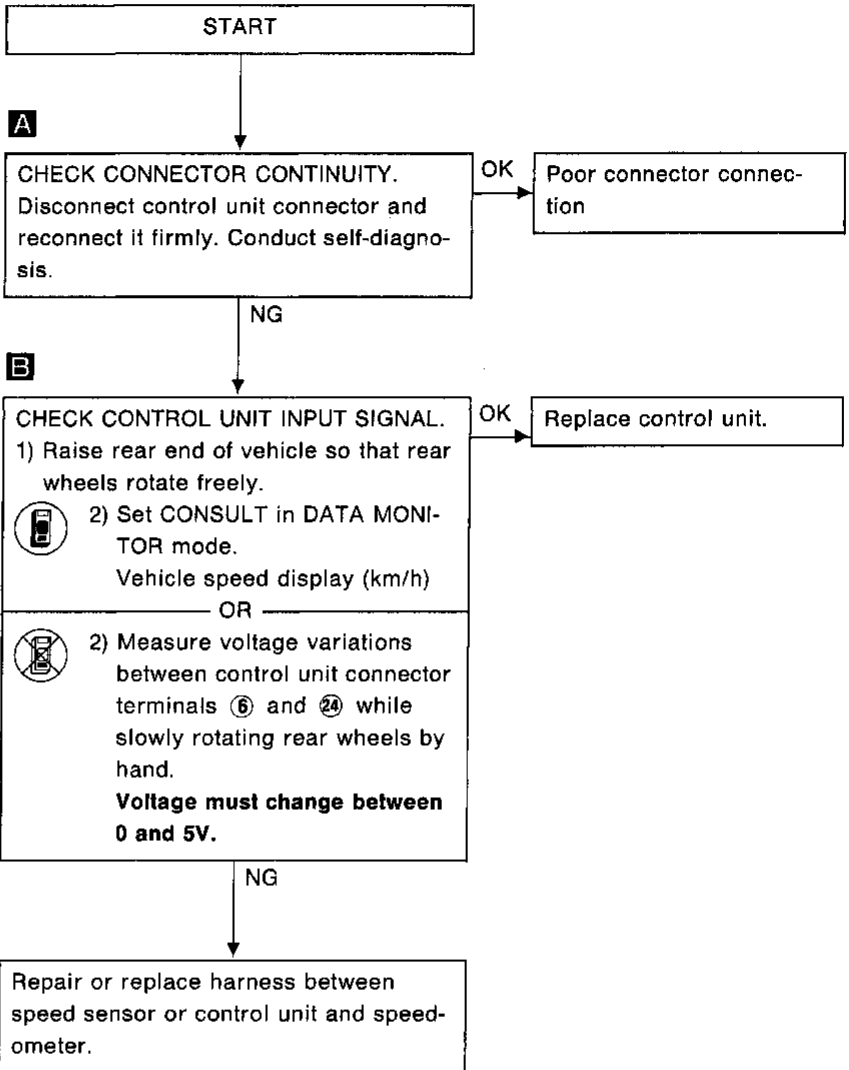

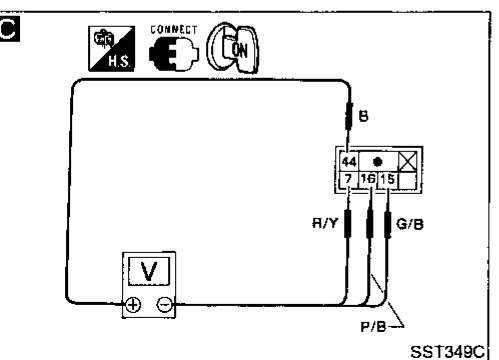
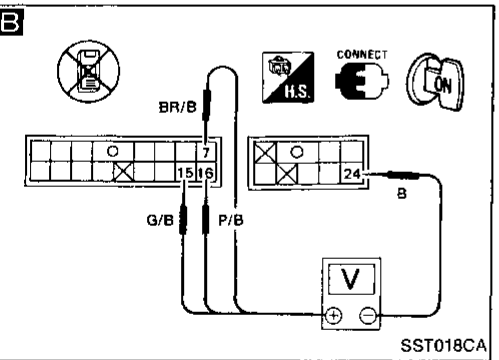
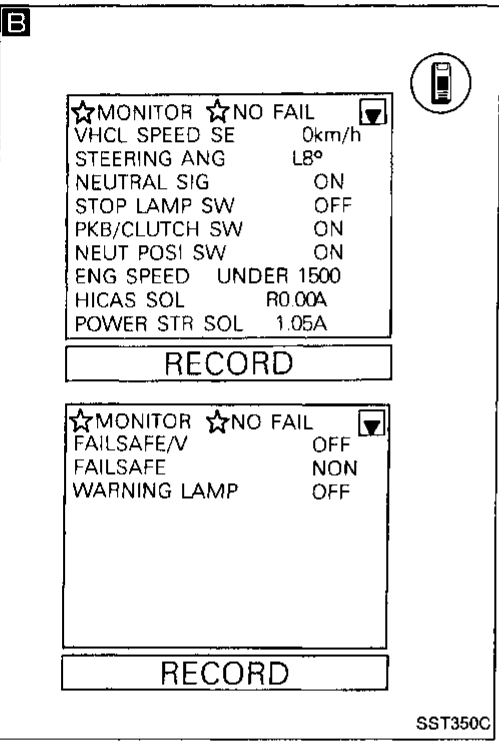
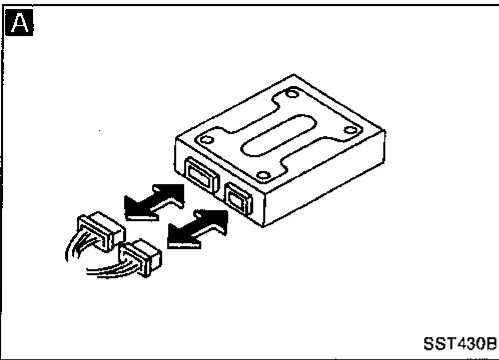

## Diagnostic Procedure 10

**SYMPTOM:**  
Steering angle sensor input is not present.

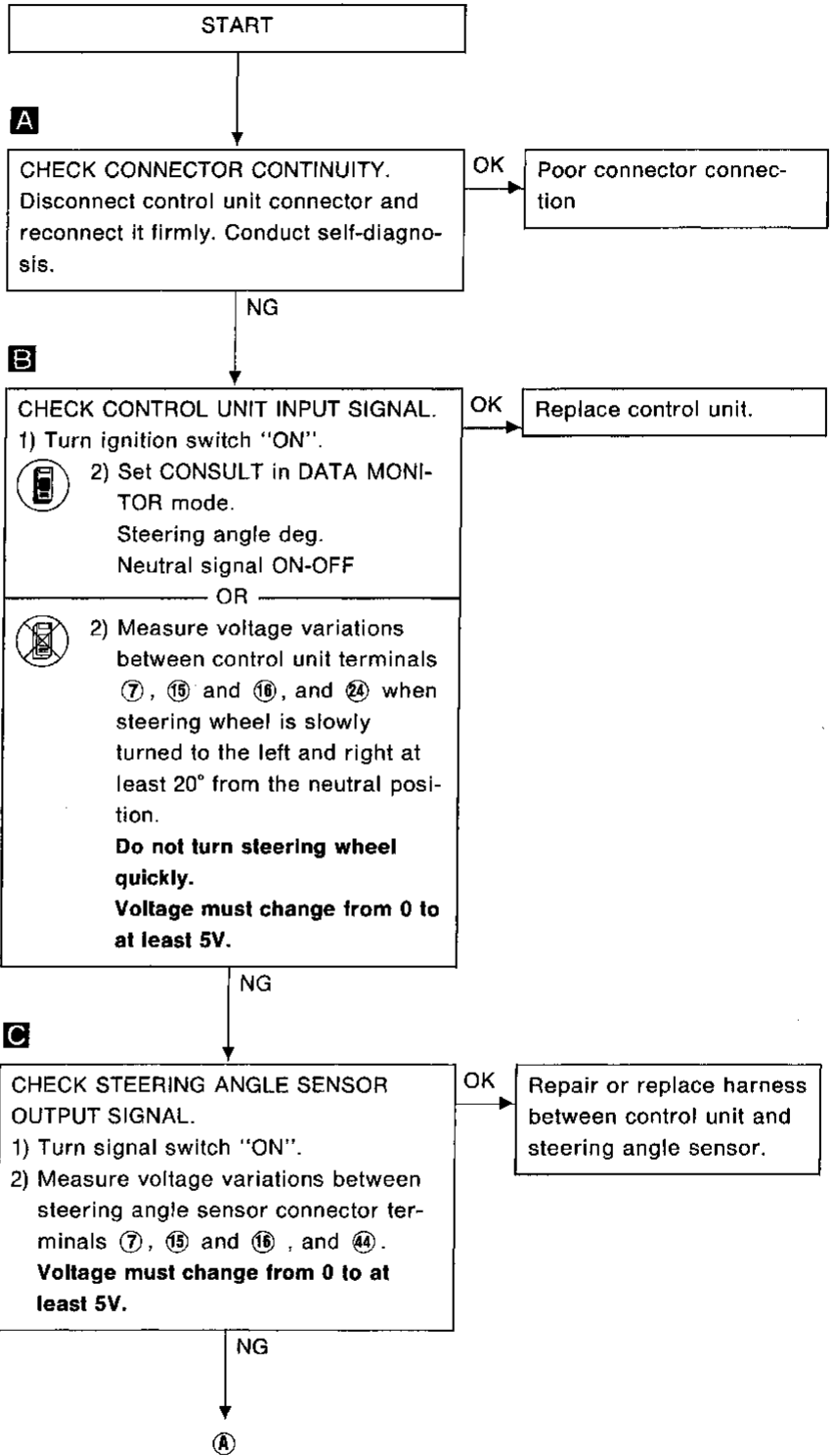

GI  
 MA  
 EM  
 LC  
 EF & EC  
 FE  
 AT  
 PD  
 FA  
 RA  
 BR  
 ST  
 BF  
 HA  
 EL  
 IDX

# SUPER HICAS SYSTEM — Trouble Diagnoses

## Diagnostic Procedure 10 (Cont'd)

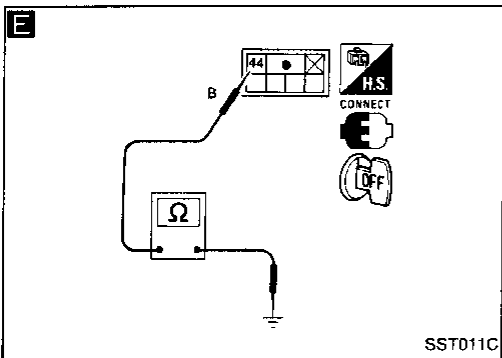
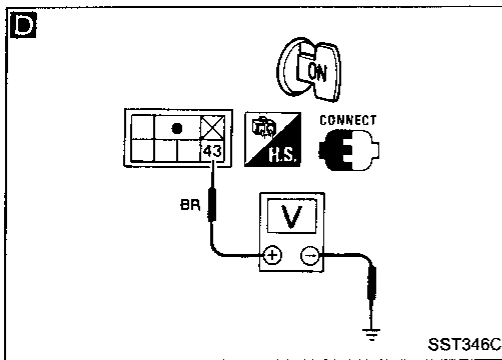

**D** CHECK STEERING ANGLE SENSOR POWER SUPPLY.

- 1) Turn ignition switch "ON".
- 2) Measure voltage across steering angle sensor connector terminal ④③ and ground.

**Voltage:**

**Approximately 12V**

**E** CHECK STEERING ANGLE SENSOR GROUND CIRCUIT.

Check continuity between steering angle sensor terminal ④④ and body metal (ground).

**Continuity should exist.**

OK → Replace steering angle sensor.

NG ↓  
Repair or replace power supply harness or ground harness.

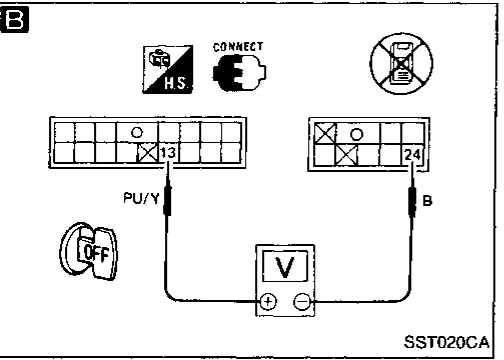
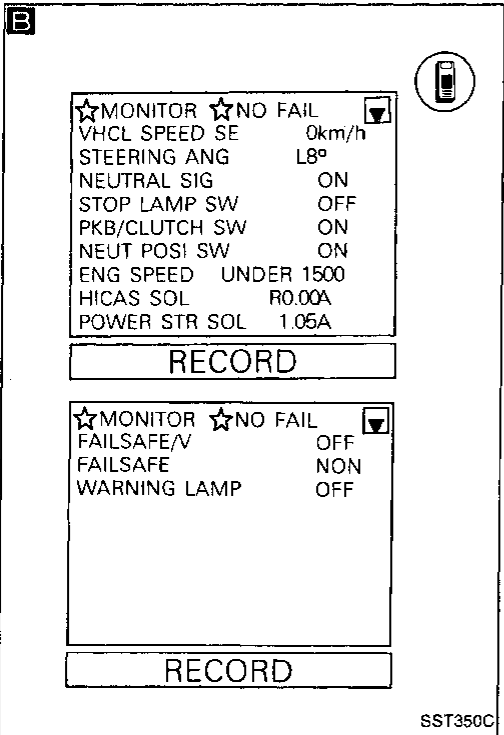
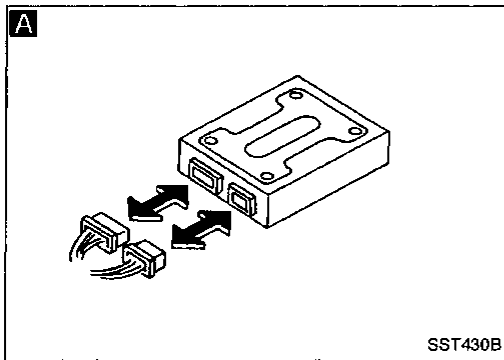

## Diagnostic Procedure 11

**SYMPTOM:**  
Parking brake input is not present.

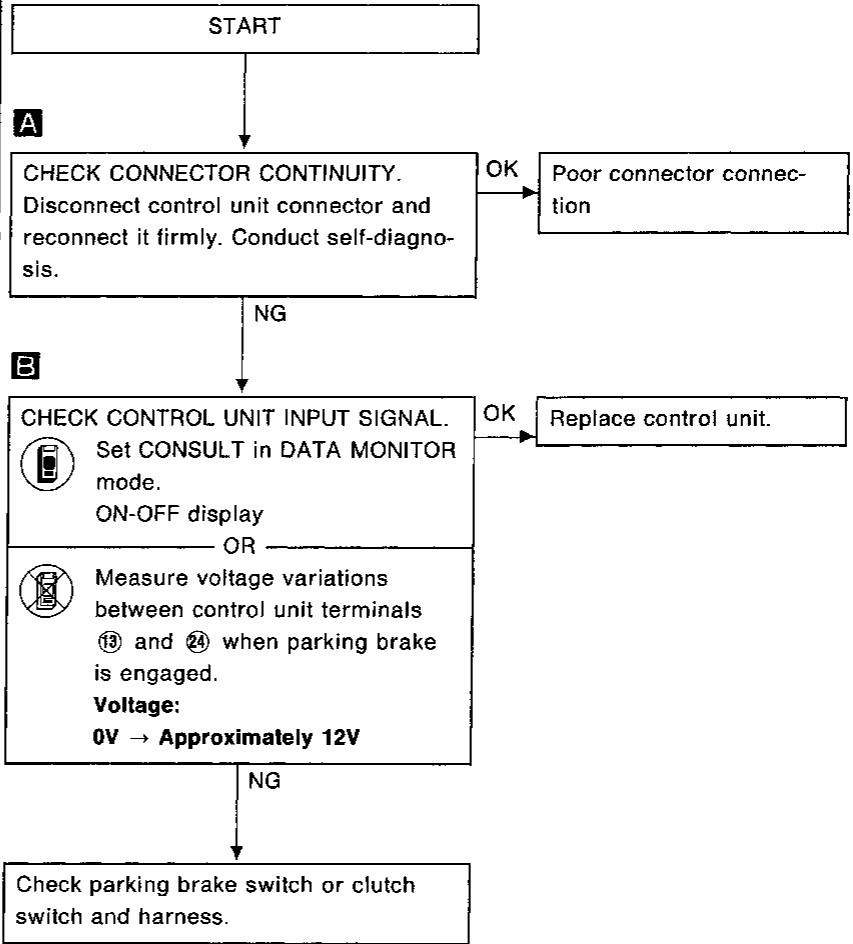

GI

MA

EM

LC

EF & EC

FE

AT

PD

FA

RA

BR

**ST**

BF

HA

EL

IDX

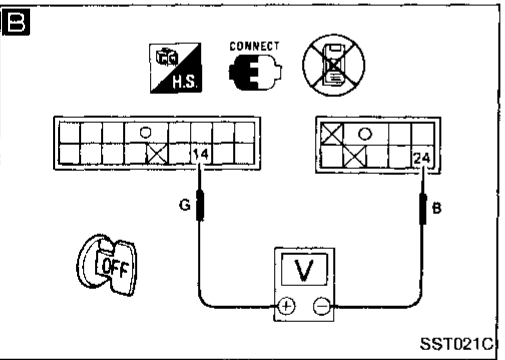
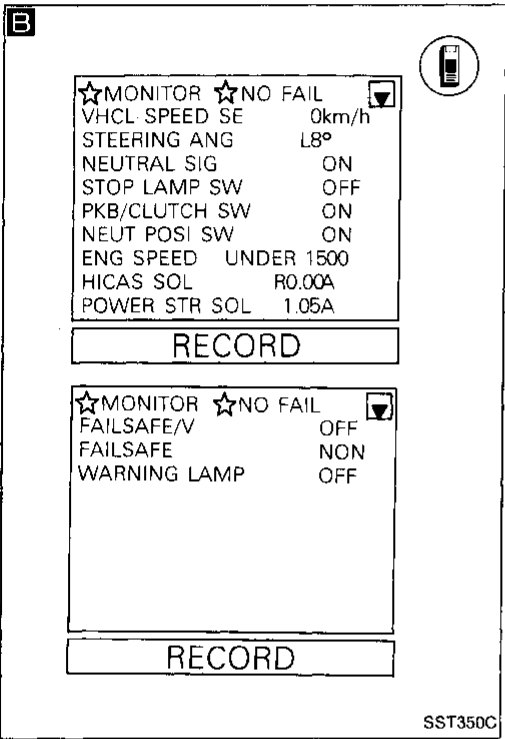
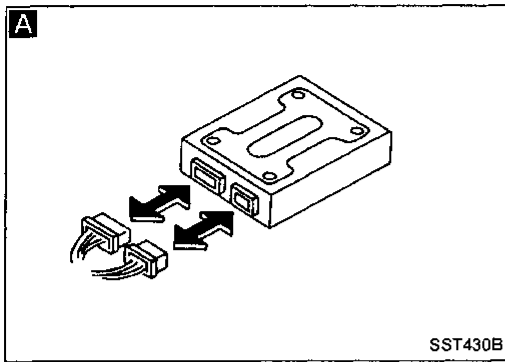

## Diagnostic Procedure 12

**SYMPTOM:**  
Inhibitor switch input is not present.

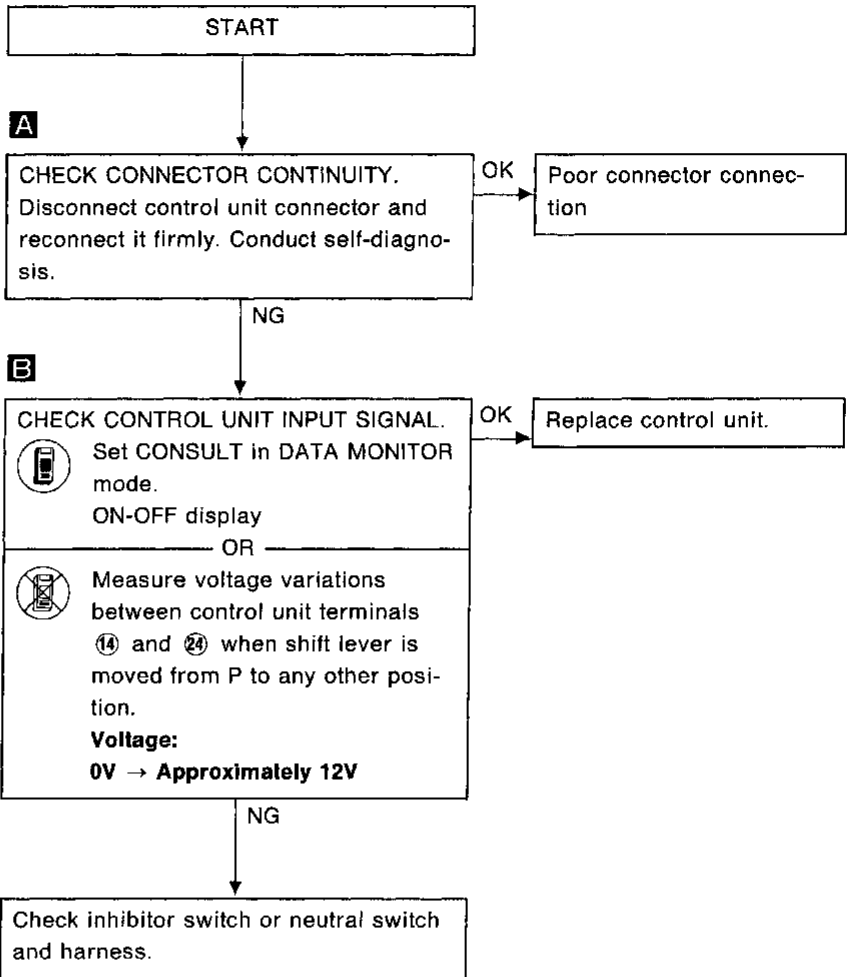



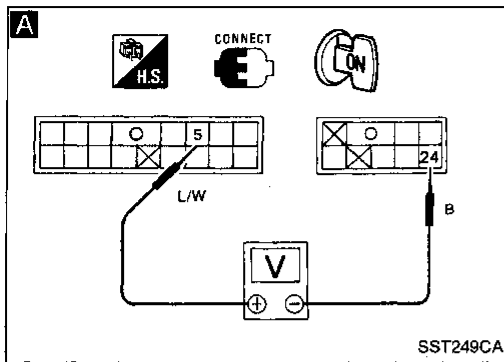

**Diagnostic Procedure 13**

**SYMPTOM:**

**Engine revolution input is not present.**

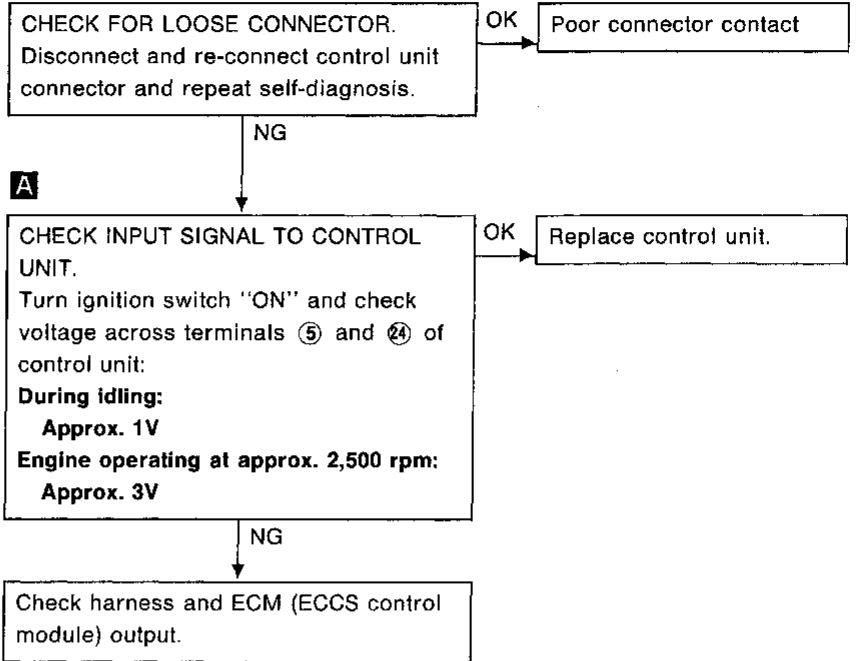

GI  
MA  
EM  
LC  
EF &  
EC  
FE  
AT  
PD  
FA  
RA  
BR  
ST  
BF  
HA  
EL  
IDX

# SUPER HICAS SYSTEM — Trouble Diagnoses

## Control Unit Inspection Table

The standard values (voltage) measured with an analog tester, in contact with the control unit terminal, are shown below:

Terminal No.	Application	Standard value
1	Service support CLK input	Pulse wave (153.6 kHz Approximately 7V)
2	Service support RX output (Reception from CONSULT)	(Not specified serial pulse data)
3	IGN power supply	Key switch ON: Approximately 12V Key switch in other position: 0V
4	Battery	Approximately 12V
5	Engine speed signal (ECM signal)	At idling: Approx. 1V At about 2,500 rpm: Approx. 3V
6	Vehicle speed signal	Rear wheel rotating 0V ↔ greater than 5V (approx.), intermittent
7	Steering neutral position sensor	Approximately 5V (Neutral position)
8	Resistance of power steering solenoid	4 - 6Ω
9	Service support TX output (Transmission for CONSULT)	(Not specified serial pulse data)
10	Ground	0V
11	Stop lamp switch signal	Brake ON: Approximately 12V Brake OFF: 0V
13	Parking brake signal	Parking brake engaged: Approximately 12V
14	Inhibitor signal	Shift lever in any position other than Parking: Approximately 12V
15	Steering angle sensor-1 signal	Steering wheel turned 0 ↔ Approximately 5V, intermittent
16	Steering angle sensor-2 signal	Steering wheel turned 0 ↔ Approximately 5V, intermittent
18	Resistance of fail-safe valve	13 - 17Ω
19	IGN power supply	Ignition switch ON: Approximately 12V Ignition switch in other position: 0V
20	HICAS warning lamp	Lamp ON: 0V Lamp OFF: Approximately 12V
22	Resistance of HICAS solenoid (RH)	4 - 6Ω (Voltage varies with steering operation.)
23	Resistance of HICAS solenoid (LH)	4 - 6Ω (Voltage varies with steering operation.)
24	Ground	0V

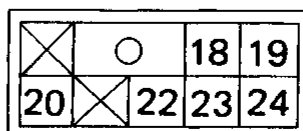
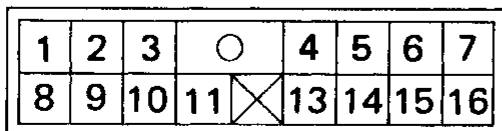

SST438B

# SERVICE DATA AND SPECIFICATIONS (SDS)

## General Specifications

	Without SUPER HICAS	With SUPER HICAS
Steering model	Power steering	
Steering gear type	PR26SE	
Steering overall gear ratio	17.0	
Turn of steering wheel (Lock to lock)	2.9	
Steering column type	Collapsible	

GI

MA

EM

## Inspection and Adjustment

### STEERING WHEEL

Steering wheel axial play mm (in)	0 (0)
Steering wheel play mm (in)	0 - 35 (0 - 1.38)

LC

EF &  
EC

FE

AT

### STEERING COLUMN

Steering column length "L <sub>1</sub> " mm (in)	642.2 - 643.8 (25.28 - 25.35)
Steering column lower shaft length "L <sub>2</sub> " mm (in)	326.4 - 328.0 (12.85 - 12.91)

PD

FA

RA

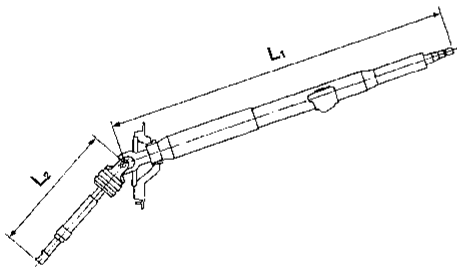

SST315B

### STEERING GEAR AND LINKAGE

Item	Steering gear type	PR26SE
Tie-rod outer ball joint		
Swinging force (at cotter pin hole) N (kg, lb)		4.9 - 46.1 (0.5 - 4.7, 1.1 - 10.4)
Rotating torque N·m (kg·cm, in·lb)		0.29 - 2.94 (3.0 - 30.0, 2.6 - 26.0)
Axial end play mm (in)		0 (0)
Tie-rod inner ball joint		
Swinging force* N (kg, lb)		7.8 - 73.6 (0.8 - 7.5, 1.8 - 16.5)
Rotating torque N·m (kg·cm, in·lb)		1.0 - 8.8 (10 - 90, 8.7 - 78.1)
Axial end play mm (in)		0 (0)
Tie-rod standard length "L" mm (in)		163.3 (6.43)

\*: Measuring point

BR

ST

BF

HA

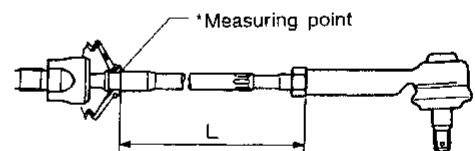

SST304B

Rack stroke "L"	mm (in)	65.5 (2.579)
-----------------	---------	--------------

EL

IDX

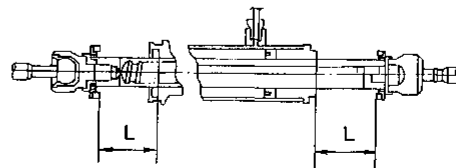

SST307B

# SERVICE DATA AND SPECIFICATIONS (SDS)

## Inspection and Adjustment (Cont'd)

### POWER STEERING

### POWER CYLINDER LOWER LINK (SUPER HICAS)

	Without SUPER HICAS	With SUPER HICAS
Rack sliding force N (kg, lb) Under normal operating oil pressure Range within $\pm 11.5$ mm ( $\pm 0.453$ in) from the neutral position Except above range	216 - 275 (22 - 28, 49 - 62)	Not more than 294 (30, 66)
Retainer adjustment Adjusting screw Initial tightening torque N·m (kg·cm, in·lb) Retightening torque after loosening Tightening torque after gear has settled Returning angle degree	4.9 - 5.9 (50 - 60, 43 - 52) 0.05 - 0.20 (0.5 - 2.0, 0.43 - 1.74) 4.9 (50, 43) 50° - 110°	
Pinion gear preload without gear oil N·m (kg·cm, in·lb) Within 100° from the neutral position Average rotating torque Maximum torque increment Except above range Maximum rotating torque Maximum torque increment	0.78 - 1.27 (8.0 - 13.0, 6.9 - 11.3) 0.4 (4, 3.5) 1.9 (19, 16) 0.6 (6, 5.2)	
Steering wheel turning force (Measured at one full turn from the neutral position) N (kg, lb)	39 (4, 9) or less	
Fluid capacity (Approximate) ℓ (US qt, Imp qt)	1.3 (1-3/8, 1-1/8)	2.0 (2-1/8, 1-3/4)
Oil pump maximum pressure kPa (kg/cm <sup>2</sup> , psi)	7,649 - 8,238 (78 - 84, 1,109 - 1,194)	Main: 7,649 - 8,238 (78 - 84, 1,109 - 1,194) Sub: 6,375 - 6,865 (65 - 70, 924 - 995)

Power cylinder lower link ball joint		
Swinging force*	N (kg, lb)	2.9 - 41.2 (0.3 - 4.2, 0.7 - 9.3)
Axial end play	mm (in)	0 (0)
Power cylinder lower link standard length "L"	mm (in)	309.5 (12.19)
Stroke (from neutral position)	mm (in)	3.0 (0.118)

\*: Measuring point

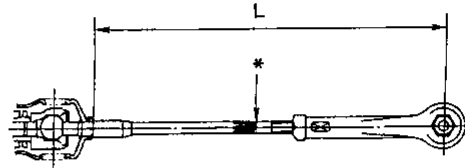

SST486B