

# SECTION ACC

## ACCELERATOR CONTROL SYSTEM

A  
ACC  
C  
D  
E  
F  
G  
H  
I  
J  
K  
L  
M  
N  
O  
P

### CONTENTS

<b>PRECAUTION</b> .....	2	<b>MODELS WITHOUT DISTANCE CONTROL ASSIST SYSTEM : Inspection</b> .....	4
<b>PRECAUTIONS</b> .....	2	<b>MODELS WITH DISTANCE CONTROL ASSIST SYSTEM</b> .....	4
Precaution for Supplemental Restraint System (SRS) "AIR BAG" and "SEAT BELT PRE-TENSIONER" .....	2	<b>MODELS WITH DISTANCE CONTROL ASSIST SYSTEM : Exploded View</b> .....	5
<b>REMOVAL AND INSTALLATION</b> .....	3	<b>MODELS WITH DISTANCE CONTROL ASSIST SYSTEM : Removal and Installation</b> .....	5
<b>ACCELERATOR CONTROL SYSTEM</b> .....	3	<b>MODELS WITH DISTANCE CONTROL ASSIST SYSTEM : Inspection</b> .....	5
<b>MODELS WITHOUT DISTANCE CONTROL ASSIST SYSTEM</b> .....	3	<b>SERVICE DATA AND SPECIFICATIONS (SDS)</b> .....	7
<b>MODELS WITHOUT DISTANCE CONTROL ASSIST SYSTEM : Exploded View</b> .....	3	<b>SERVICE DATA AND SPECIFICATIONS (SDS)</b> .....	7
<b>MODELS WITHOUT DISTANCE CONTROL ASSIST SYSTEM : Removal and Installation</b> .....	3	Accelerator Control .....	7

# PRECAUTIONS

< PRECAUTION >

## PRECAUTION

### PRECAUTIONS

#### Precaution for Supplemental Restraint System (SRS) "AIR BAG" and "SEAT BELT PRE-TENSIONER"

INFOID:000000008177556

The Supplemental Restraint System such as "AIR BAG" and "SEAT BELT PRE-TENSIONER", used along with a front seat belt, helps to reduce the risk or severity of injury to the driver and front passenger for certain types of collision. This system includes seat belt switch inputs and dual stage front air bag modules. The SRS system uses the seat belt switches to determine the front air bag deployment, and may only deploy one front air bag, depending on the severity of a collision and whether the front occupants are belted or unbelted. Information necessary to service the system safely is included in the SR and SB section of this Service Manual.

**WARNING:**

- To avoid rendering the SRS inoperative, which could increase the risk of personal injury or death in the event of a collision which would result in air bag inflation, all maintenance must be performed by an authorized NISSAN/INFINITI dealer.
- Improper maintenance, including incorrect removal and installation of the SRS, can lead to personal injury caused by unintentional activation of the system. For removal of Spiral Cable and Air Bag Module, see the SR section.
- Do not use electrical test equipment on any circuit related to the SRS unless instructed to in this Service Manual. SRS wiring harnesses can be identified by yellow and/or orange harnesses or harness connectors.

#### PRECAUTIONS WHEN USING POWER TOOLS (AIR OR ELECTRIC) AND HAMMERS

**WARNING:**

- When working near the Airbag Diagnosis Sensor Unit or other Airbag System sensors with the Ignition ON or engine running, DO NOT use air or electric power tools or strike near the sensor(s) with a hammer. Heavy vibration could activate the sensor(s) and deploy the air bag(s), possibly causing serious injury.
- When using air or electric power tools or hammers, always switch the Ignition OFF, disconnect the battery, and wait at least 3 minutes before performing any service.

# ACCELERATOR CONTROL SYSTEM

< REMOVAL AND INSTALLATION >

## REMOVAL AND INSTALLATION

### ACCELERATOR CONTROL SYSTEM

#### MODELS WITHOUT DISTANCE CONTROL ASSIST SYSTEM

#### MODELS WITHOUT DISTANCE CONTROL ASSIST SYSTEM : Exploded View

INFOID:000000007882968

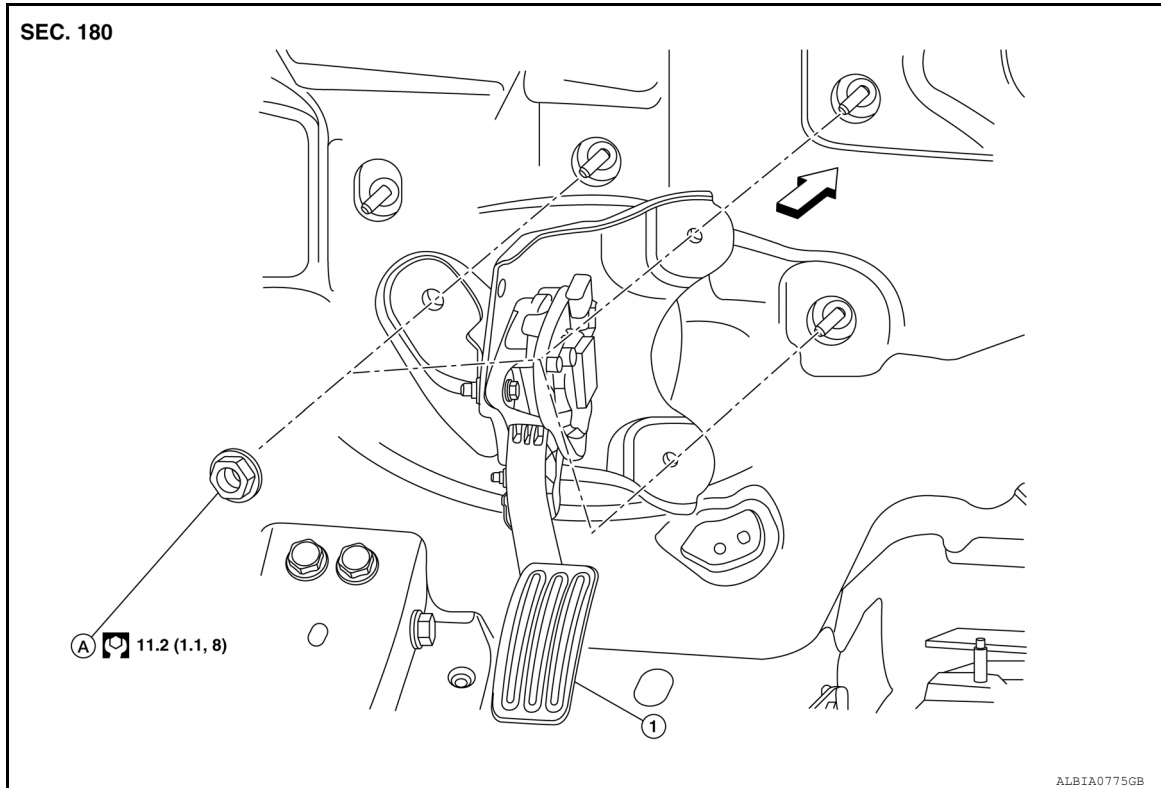

1. Accelerator pedal assembly

A. Nut

⇐ Front

### MODELS WITHOUT DISTANCE CONTROL ASSIST SYSTEM : Removal and Installation

INFOID:000000007882969

#### REMOVAL

1. Remove three accelerator pedal assembly nuts.
2. Disconnect harness connector (A) from the accelerator pedal assembly (1).

⇐ Front

3. Remove the accelerator pedal assembly from vehicle.

#### **CAUTION:**

- Do not disassemble accelerator pedal assembly.
- Do not drop or impact accelerator pedal assembly.
- Do not expose accelerator pedal assembly to water.

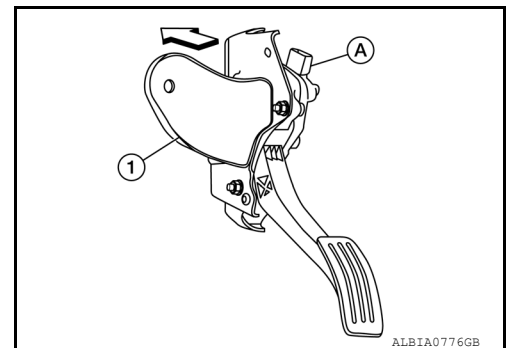

#### INSTALLATION

Installation is in the reverse order of removal.

#### **NOTE:**

For inspection, refer to [ACC-4. "MODELS WITHOUT DISTANCE CONTROL ASSIST SYSTEM : Inspection"](#).

# ACCELERATOR CONTROL SYSTEM

< REMOVAL AND INSTALLATION >

## MODELS WITHOUT DISTANCE CONTROL ASSIST SYSTEM : Inspection

INFOID:000000007882970

### INSPECTION AFTER INSTALLATION

- Check that the accelerator pedal moves smoothly within the specified range.

↶: Front

**Accelerator pedal stroke (A)** : Refer to [ACC-7, "Accelerator Control"](#)

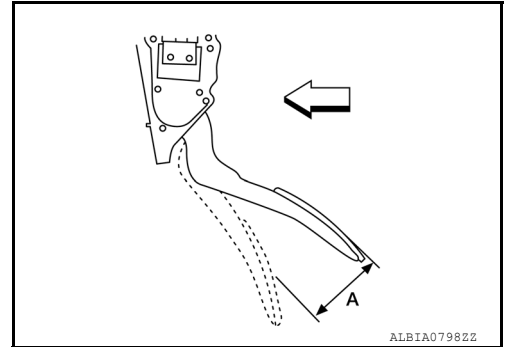

- Check the accelerator pedal height.

**Accelerator pedal height** : Refer to [ACC-7, "Accelerator Control"](#)

- Depress and release the accelerator pedal to check that it returns quickly and smoothly to the original released position.

#### **CAUTION:**

- **Whenever the harness connector of the accelerator pedal position sensor has been disconnected, perform "Accelerator Pedal Released Position Learning". Refer to [EC-158, "Work Procedure"](#).**
- **The accelerator pedal should operate smoothly without catching when the pedal operating force is released. The pedal should return smoothly to the fully raised position. The spring should be free from damage.**

## MODELS WITH DISTANCE CONTROL ASSIST SYSTEM

# ACCELERATOR CONTROL SYSTEM

< REMOVAL AND INSTALLATION >

## MODELS WITH DISTANCE CONTROL ASSIST SYSTEM : Exploded View

INFOID:000000007882971

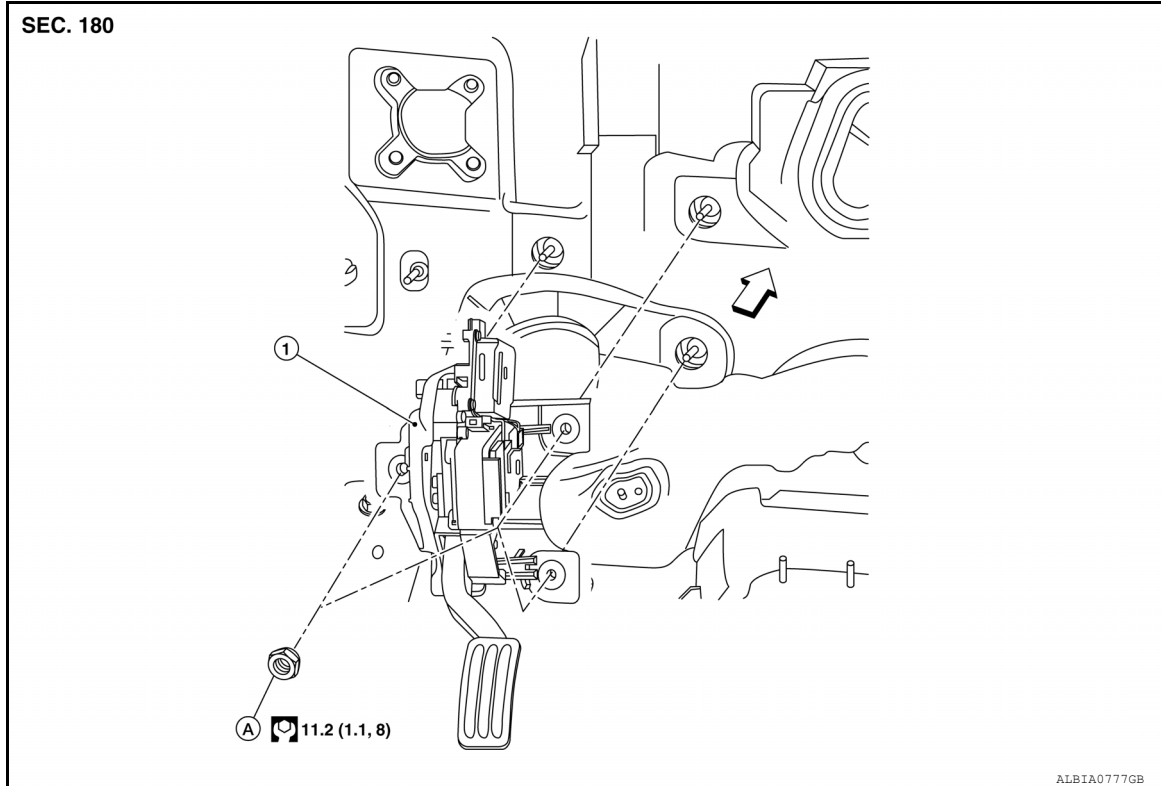

1. Accelerator pedal assembly

A. Nut

← Front

## MODELS WITH DISTANCE CONTROL ASSIST SYSTEM : Removal and Installation

INFOID:000000007882972

### REMOVAL

1. Remove three accelerator pedal assembly nuts.
2. Disconnect the two harness connectors (A, B) from the accelerator pedal assembly.  
← Front
3. Remove the accelerator pedal assembly from vehicle.

### CAUTION:

- Do not disassemble accelerator pedal assembly.
- Do not drop or impact accelerator pedal assembly.
- Do not expose accelerator pedal assembly to water.

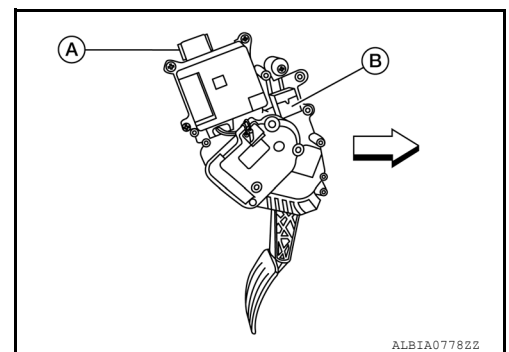

### INSTALLATION

Installation is in the reverse order of removal.

### NOTE:

For inspection, refer to [ACC-5. "MODELS WITH DISTANCE CONTROL ASSIST SYSTEM : Inspection"](#).

## MODELS WITH DISTANCE CONTROL ASSIST SYSTEM : Inspection

INFOID:000000007882973

### INSPECTION AFTER INSTALLATION

# ACCELERATOR CONTROL SYSTEM

## < REMOVAL AND INSTALLATION >

- Check that the accelerator pedal moves smoothly within the specified range.  
⇐: Front

**Accelerator pedal stroke (A)** : Refer to [ACC-7, "Accelerator Control"](#)

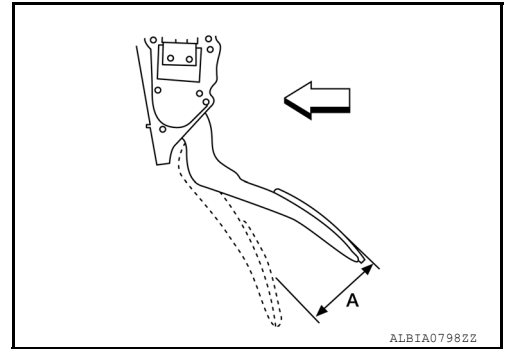

- Check the accelerator pedal height.

**Accelerator pedal height** : Refer to [ACC-7, "Accelerator Control"](#)

- Depress and release the accelerator pedal to check that it returns quickly and smoothly to the original released position.

### CAUTION:

- **Whenever the harness connector of the accelerator pedal position sensor has been disconnected, perform "Accelerator Pedal Released Position Learning". Refer to [EC-158, "Work Procedure"](#).**
- **The accelerator pedal should operate smoothly without catching when the pedal operating force is released. The pedal should return smoothly to the fully raised position. The spring should be free from damage.**

# SERVICE DATA AND SPECIFICATIONS (SDS)

< SERVICE DATA AND SPECIFICATIONS (SDS)

## SERVICE DATA AND SPECIFICATIONS (SDS)

### SERVICE DATA AND SPECIFICATIONS (SDS)

#### Accelerator Control

INFOID:000000008191946

ACC

#### MODELS WITH AND WITHOUT DISTANCE CONTROL ASSIST ACCELERATOR PEDAL

Unit: mm (in)

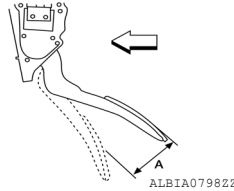

Models without distance control assist accelerator pedal stroke (A)	50.5 - 53.5 (1.99 - 2.11)
Models with distance control assist accelerator pedal stroke (A)	48.5 - 51.5 (1.91 - 2.03)
Accelerator pedal height	169.2 ± 5 (6.7 ± 0.2)

↔: Front